



HPE ProLiant Compute ML350 Gen12 User Guide

Part Number: 30-48EB0994-003

Published: April 2026

Edition: 3

HPE ProLiant Compute ML350 Gen12 User Guide

Abstract

This document is for the person who installs, administers, and troubleshoots servers and storage systems. Hewlett Packard Enterprise assumes you are qualified in the servicing of computer equipment and trained in recognizing hazards in products with hazardous energy levels, and are familiar with the weight and stability precautions for rack installations.

Part Number: 30-48EB0994-003

Published: April 2026

Edition: 3

© Copyright 2025–2026 Hewlett Packard Enterprise Development LP

Notices

The information provided here is subject to change without notice. Hewlett Packard Enterprise's products and services are covered only by the express warranty statements that come with them. This document does not constitute an additional warranty. Hewlett Packard Enterprise is not responsible for any technical or editorial errors or omissions in this document.

Confidential computer software. You must have a valid license from Hewlett Packard Enterprise to possess, use, or copy the software. In accordance with FAR 12.211 and 12.212, Commercial Computer Software, Computer Software Documentation, and Technical Data for Commercial Items are licensed to the U.S. Government under the vendor's standard commercial license.

Links to third-party websites will take you outside of the Hewlett Packard Enterprise website. Hewlett Packard Enterprise has no control over and is not responsible for the information outside the Hewlett Packard Enterprise website.

Acknowledgments

Intel®, Intel® Virtual RAID on CPU (Intel® VROC), and Xeon® are trademarks of Intel Corporation in the U.S. and other countries.

Linux® is the registered trademark of Linus Torvalds in the U.S. and other countries.

Microsoft®, Windows®, and Windows Server® are either registered trademarks or trademarks of Microsoft Corporation in the United States and/or other countries.

VMware® is a registered trademark or trademark of VMware, Inc. and its subsidiaries in the United States and other jurisdictions.

All third-party marks are property of their respective owners.

Table of contents

Component identification.....	9
Front panel components.....	10
Front panel LEDs and button.....	14
Server UID LED.....	15
Viewing the Server Health Summary.....	15
Rear panel components.....	17
Rear panel LEDs.....	19
Component touchpoints.....	20
System board components.....	22
System maintenance switch.....	24
DIMM label identification.....	25
DIMM slot numbering.....	26
Heatsink and processor socket components.....	27
Fan bay numbering.....	27
Drive bay numbering.....	28
LFF drive bay numbering.....	29
SFF drive bay numbering.....	30
Mixed drive bay numbering.....	32
E3.S drive bay numbering.....	48
Drive backplane naming.....	49
HPE Basic Drive LED definitions.....	50
EDSFF SSD LED definitions.....	52
HPE NS204i-u Boot Device V2 components.....	54
HPE NS204i-u Boot Device V2 LED definitions	55
Riser board components.....	56
Riser slot numbering.....	57
Media device screws.....	59
Setup.....	60
HPE Installation Service.....	60
Setting up the server.....	61
Removing the shipping brackets.....	63
Operational requirements.....	64
Space and airflow requirements.....	64
Temperature requirements.....	65

Power requirements.....	66
Electrical grounding requirements.....	66
Rack warnings and cautions.....	68
Server warnings and cautions.....	70
Electrostatic discharge.....	71
Operations.....	71
iLO service port.....	72
Intel VROC support.....	73
Server UID LED.....	73
Viewing the Server Health Summary.....	74
Monitor setup.....	74
Trusted Platform Module 2.0.....	75
Trusted Platform Module 2.0 guidelines.....	75
System battery information.....	76
Hardware options installation.....	76
Hewlett Packard Enterprise product QuickSpecs.....	77
Hardware option installation guidelines.....	78
Pre-installation procedures.....	78
Server data backup.....	79
Power down the server.....	80
Position the tower server for hardware configuration.....	80
Extend the server from the rack.....	82
Remove the server from the rack.....	83
Remove the front bezel.....	86
Remove the access panel.....	88
Remove the fan cage.....	90
Remove the drive cage	93
Remove the primary riser cage.....	96
Remove the secondary riser cage blank.....	97
Remove the secondary riser cage.....	99
Remove the energy pack and the energy pack holder.....	102
Remove the HPE NS204i-u Boot Device V2 on the power supply cage.....	104
Post-installation procedures.....	105
Install the front bezel.....	106
Install the access panel.....	107
Install the primary/secondary riser cage.....	108
Install the fan cage.....	111
Install the server into the rack.....	114

Installing the shipping hardware.....	118
Power up the server.....	123
Position the tower server for operation.....	123
Tower-to-rack conversion kit.....	124
Installing the tower-to-rack conversion kit	125
Install the rack rails and server tray.....	126
Install the server into the rack.....	132
Install the cable management arm.....	136
Drives.....	141
Drive installation guidelines.....	142
Installing a hot-plug LFF/SFF drive.....	142
Installing a hot-plug E3.S drive.....	147
Drive cages.....	151
Installing the 4 LFF drive cage	151
Installing the 8 SFF drive cage	155
Installing the 12 E3.S drive cage	158
Energy packs.....	161
HPE Smart Storage Battery.....	161
HPE Smart Storage Hybrid Capacitor.....	161
Minimum firmware versions.....	162
Installing an energy pack.....	162
Media device options.....	165
SAS LTO tape drive option.....	165
Installing a SAS LTO tape drive.....	165
Optical drive option	171
Installing an optical drive.....	171
Enable the increased cooling mode.....	177
Memory options.....	178
HPE SmartMemory speed and population information.....	178
DIMM installation guidelines.....	178
Installing a DIMM.....	179
Power supply options.....	182
Hot-plug power supply calculations.....	183
Power supply warnings and cautions.....	183
DC power supply warnings and cautions.....	184
DC power supply wire colors.....	185
Connecting a DC power cable to a DC power source.....	185
Installing an AC power supply.....	187

Installing a DC power supply.....	190
Management.....	200
Serial port option.....	200
Installing the serial port.....	201
Transceiver option.....	203
Transceiver warnings and cautions.....	204
Installing a transceiver.....	204
Fan options.....	206
Fan population.....	207
Fan redundancy support.....	208
Fan mode behavior.....	208
Installing an internal fan.....	209
Installing the external fan.....	212
Risers and riser cages.....	216
Installing the secondary riser cage.....	216
Installing the tertiary riser.....	218
GPUs.....	221
GPU options.....	221
GPU installation guidelines.....	221
Processors and heatsinks.....	222
Processor cautions.....	223
Installing the processor and heatsink options.....	223
Networking.....	245
OCP slot population rules.....	245
Installing the OCP NIC 3.0 adapter.....	246
Installing a PCIe NIC adapter in the primary/secondary riser cage.....	250
Installing a PCIe NIC adapter in the tertiary riser.....	253
OS boot device.....	257
HPE NS204i-u Boot Device V2 option.....	257
Installing the boot device in the front panel.....	257
Installing the boot device in the rear panel.....	264
Security.....	269
Installing the chassis intrusion detection switch.....	270
Storage controllers.....	272
Preparing the server for storage controller installation.....	272
Installing a type-p storage controller.....	273
Installing a type-o storage controller.....	276
Internal USB device options.....	279

Installing an internal USB device.....	279
Cabling.....	280
Cabling guidelines.....	281
Cabling diagrams.....	283
Internal cabling management.....	286
Storage cabling.....	287
Drive power cabling.....	287
Storage controller cabling.....	289
SFF drive controller cabling.....	289
LFF drive controller cabling.....	296
E3.S drive controller cabling.....	300
Mixed drive controller cabling.....	302
Storage controller backup power cabling.....	302
Energy pack cabling.....	304
Media device cabling.....	304
LTO tape drive cabling.....	305
Optical drive cabling.....	307
HPE NS204i-u Boot Device V2 cabling.....	308
GPU auxiliary power cabling.....	309
Fan cabling.....	311
OCP bandwidth enablement cabling.....	313
Tertiary riser signal cabling.....	316
Serial port cabling.....	317
Chassis intrusion detection switch cabling.....	318
Front I/O cabling.....	318
Configuration resources.....	319
Updating firmware or system ROM.....	320
Configuring the server.....	321
Configuring storage controllers.....	323
Deploying an OS.....	324
Configuring security.....	325
Server management.....	325
Managing Linux-based high performance compute clusters.....	326
Troubleshooting.....	326
NMI functionality.....	327
Front panel LED power fault codes.....	327
Troubleshooting resources.....	328
Safety, warranty, and regulatory information.....	328

Regulatory information.....	328
Notices for Eurasian Economic Union.....	329
Turkey RoHS material content declaration.....	330
Ukraine RoHS material content declaration.....	330
Warranty information.....	330
Specifications.....	330
Environmental specifications.....	330
Mechanical specifications.....	332
Power supply specifications.....	333
HPE 800 W Flex Slot Platinum Hot-plug Low Halogen Power Supply.....	333
HPE 1000 W Flex Slot Titanium Hot-plug Power Supply.....	334
HPE 1600 W Flex Slot Platinum Hot-plug Low Halogen Power Supply.....	335
HPE 1600 W Flex Slot -48 VDC Hot-plug Power Supply.....	335
HPE 1800-2200 W Flex Slot Titanium Power Supply.....	336
Websites.....	337
Support and other resources.....	337
Accessing Hewlett Packard Enterprise Support.....	338
HPE product registration.....	338
Accessing updates.....	339
Customer self repair.....	339
Remote support.....	339
Documentation feedback.....	340

Component identification

This chapter describes the external and internal server features and components.

Subtopics

Front panel components

Front panel LEDs and button

Rear panel components

Rear panel LEDs

Component touchpoints

System board components

Fan bay numbering

Drive bay numbering

Drive backplane naming

HPE Basic Drive LED definitions

EDSFF SSD LED definitions

HPE NS204i-u Boot Device V2 components

HPE NS204i-u Boot Device V2 LED definitions

Riser board components

Riser slot numbering

Media device screws

Front panel components

4/8/12 LFF drive configuration

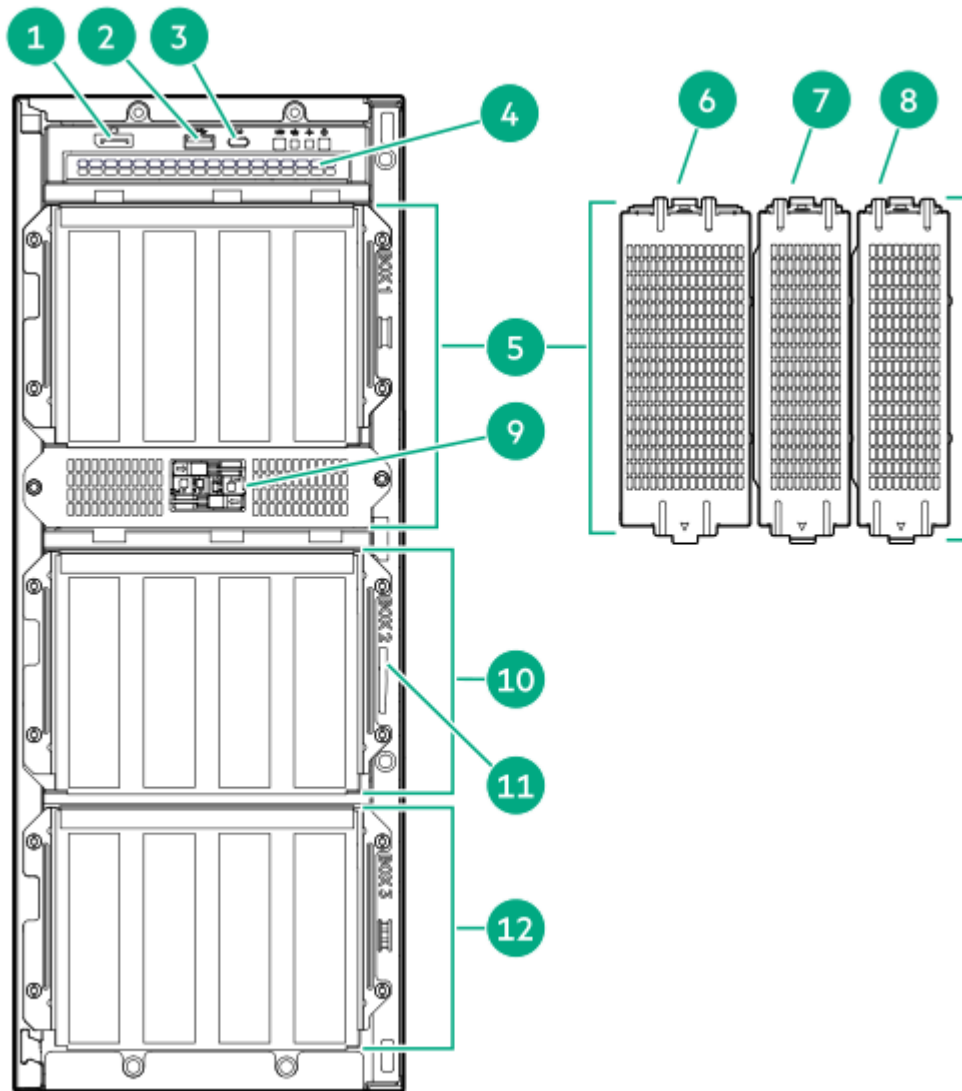

8/16/24 SFF drive configuration

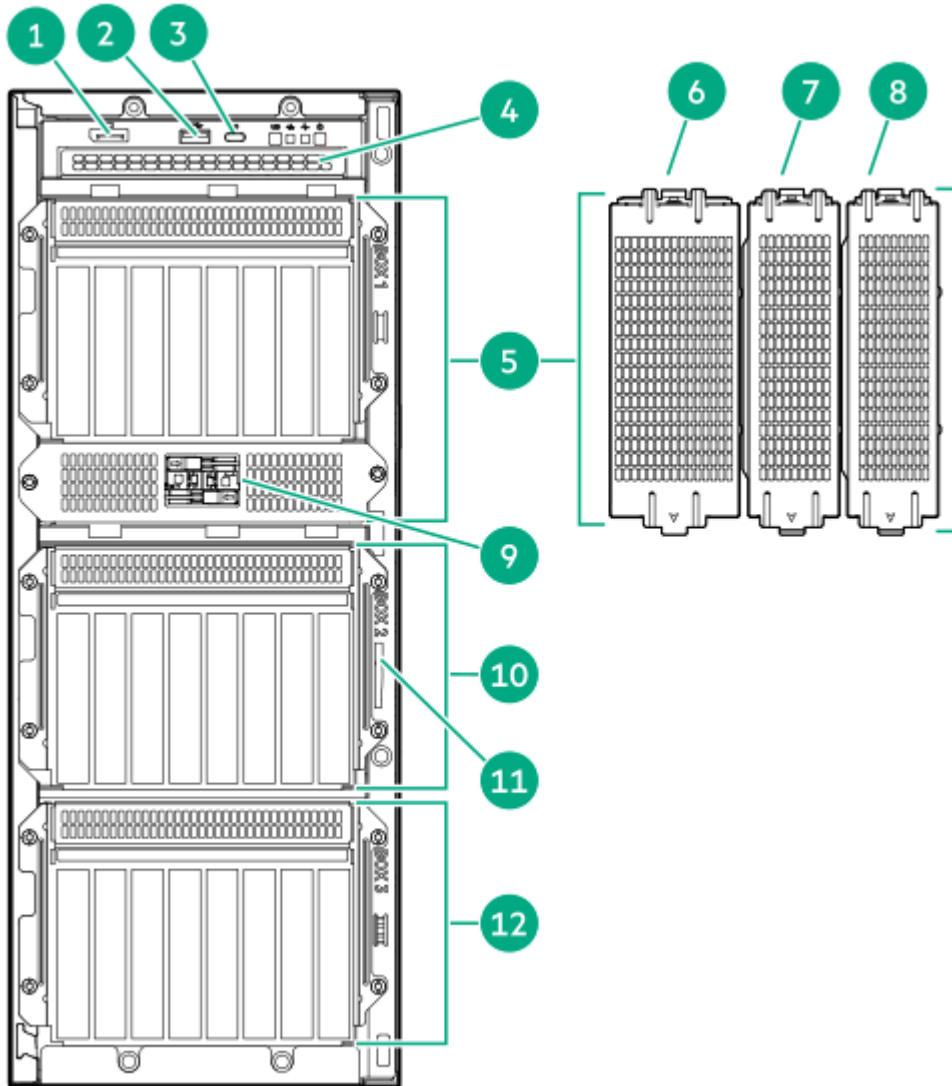

12 E3.S drive configuration

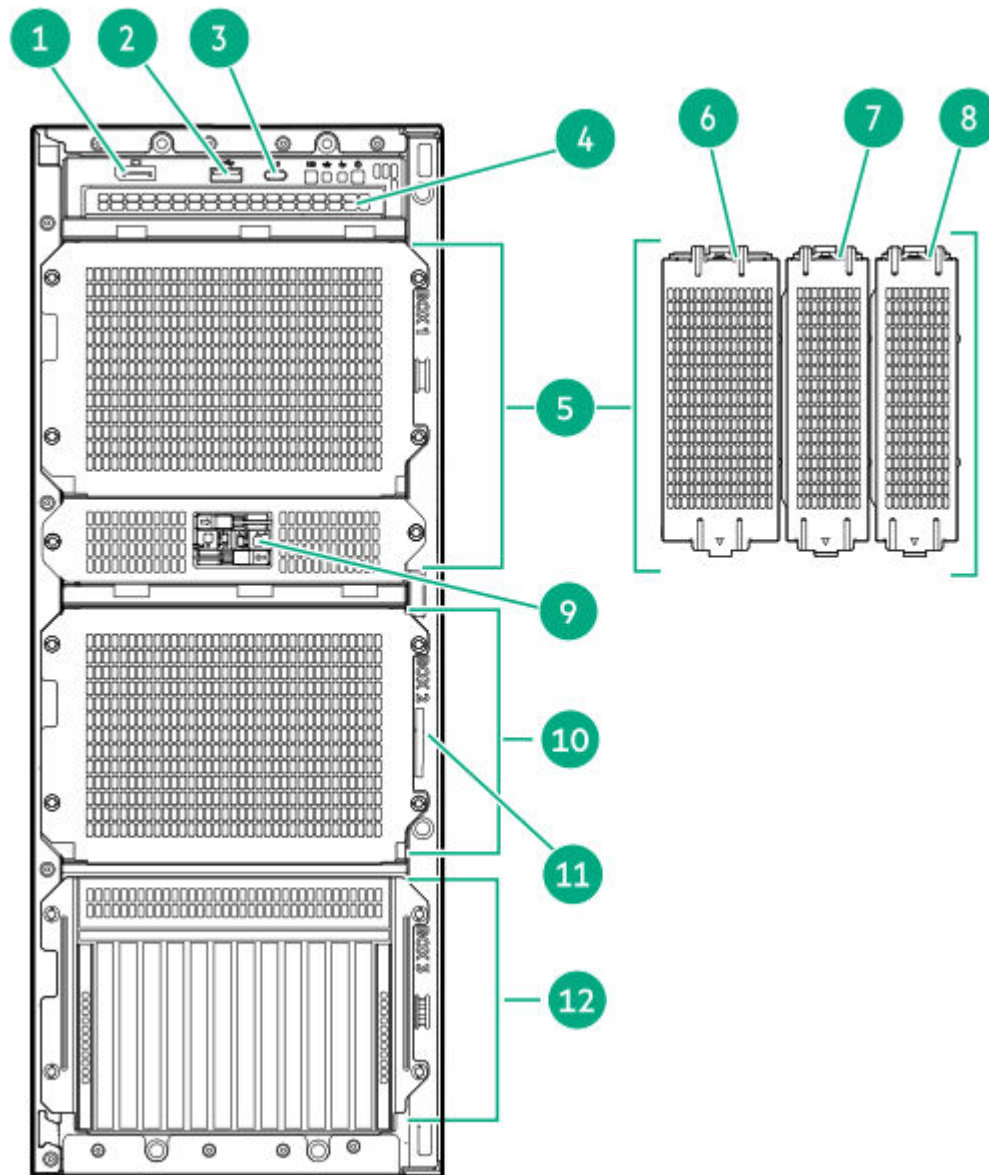

Item	Description
1	DisplayPort 1.1a
2	USB 3.2 Gen 1 port
3	iLO service port
4	Optical drive bay
5	Box 1 <u>1</u> <u>2</u>
6	Full-height media bay blank

Item	Description
7	Media bay 2
8	Media bay 1
9	NS204i-u device (optional)
10	Box 2 ¹ ₂
11	Serial number/iLO information pull tab ³ _—
12	Box 3 ⁴ ₅

¹ _— All three boxes support LFF and SFF drive cage options. This server supports mixed LFF + SFF hot-plug drive configurations.

² _— The x1 NVMe drives are supported in Box 1, 2, and 3.

³ _— The serial number/iLO information pull tab is double-sided. One side shows the server serial number and the customer asset tag label. The other side shows the default iLO account information.

⁴ _— E3.S drives are supported in Box 3. When the E3.S drives are installed, LFF/SFF drives are supported in Box 1 and 2. Two processors are required for E3.S drive installation.

⁵ _— The x4 NVMe drives are supported in Box 2 and 3 with a x4 cable and in Box 1, 2, and 3 with a x2 cable. The x4 NVMe drive backplane cannot be installed with other drive backplane types.

Front panel LEDs and button

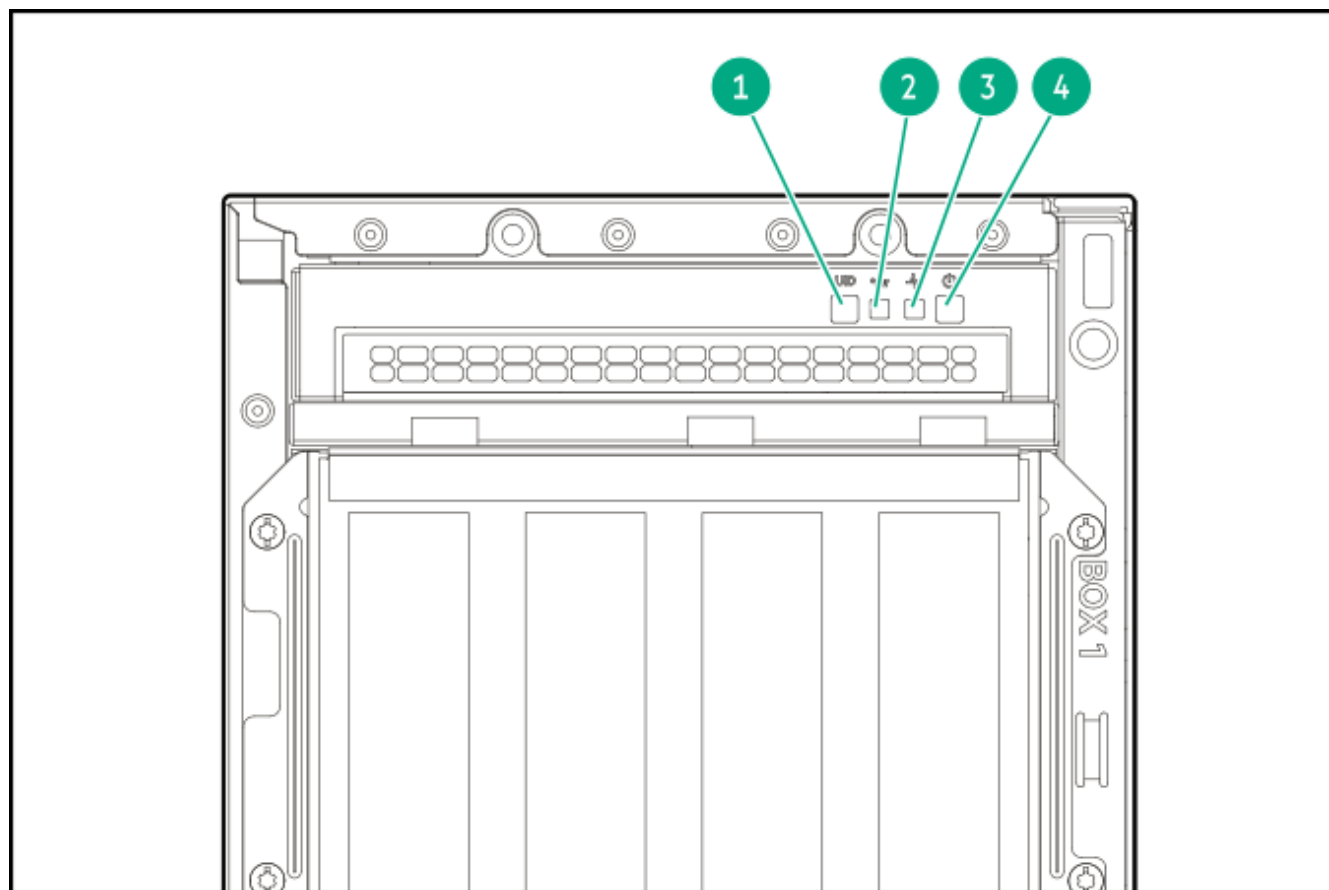

Item	Description	Status	Definition
1	UID button/LED <u>1</u>	Solid blue	Activated
		Flashing blue	<ul style="list-style-type: none"> 1 flash per second—Remote management or firmware upgrade in progress 4 flashes per second—iLO manual reboot sequence initiated 8 flashes per second—iLO manual reboot sequence in progress
		Off	Deactivated
2	NIC status LED <u>1</u>	Solid green	Linked to network
		Flashing green	Network active
		Off	No network activity
3	Health LED <u>1</u>	Solid green	Normal

Item	Description	Status	Definition
		Flashing green	iLO is rebooting
		Flashing amber	System degraded ²
		Flashing red	System critical ²
4	Power On/Standby button and system power LED ¹	Solid green	System on
		Flashing green	Performing power-on sequence
		Solid amber	System in standby
		Off	No power present ³

¹ When all LEDs described in this table flash simultaneously, a power fault has occurred. For more information, see [Front panel LED power fault codes](#).

² If the health LED indicates a degraded or critical state, review the system [Integrated Management Log \(IML\)](#) or use HPE iLO to review the system health status.

³ Facility power is not present, power cord is not attached, no power supplies are installed, power supply failure has occurred, or the front I/O cable is disconnected.

Subtopics

[Server UID LED](#)

[Viewing the Server Health Summary](#)

Server UID LED

The UID LED can be used to help an on-site technician quickly identify or locate a particular server when it is deployed in a dense rack with other equipment. It can also be used to identify if a remote management, firmware upgrade, or reboot sequence is in progress.

Viewing the Server Health Summary

Prerequisites

- An external monitor is connected.
- In the iLO web interface, the **Show Server Health on External Monitor** feature is enabled on the **Access Settings** page.

About this task

If the server does not power on, use the UID button to display the iLO **Server Health Summary** screen on an external monitor. This function works when the server is powered on or off.

For more information, see the iLO troubleshooting guide on the [Hewlett Packard Enterprise website](#).

Procedure

1. Press and release the UID button.



CAUTION

Be sure to press and release the UID button. Pressing the UID button at any time for more than five seconds will initiate a graceful iLO reboot or a hardware iLO reboot. Data loss or NVRAM corruption might occur during a hardware iLO reboot.

The **Server Health Summary** screen displays on the external monitor.

2. Press the UID button again to close the **Server Health Summary** screen.

Rear panel components

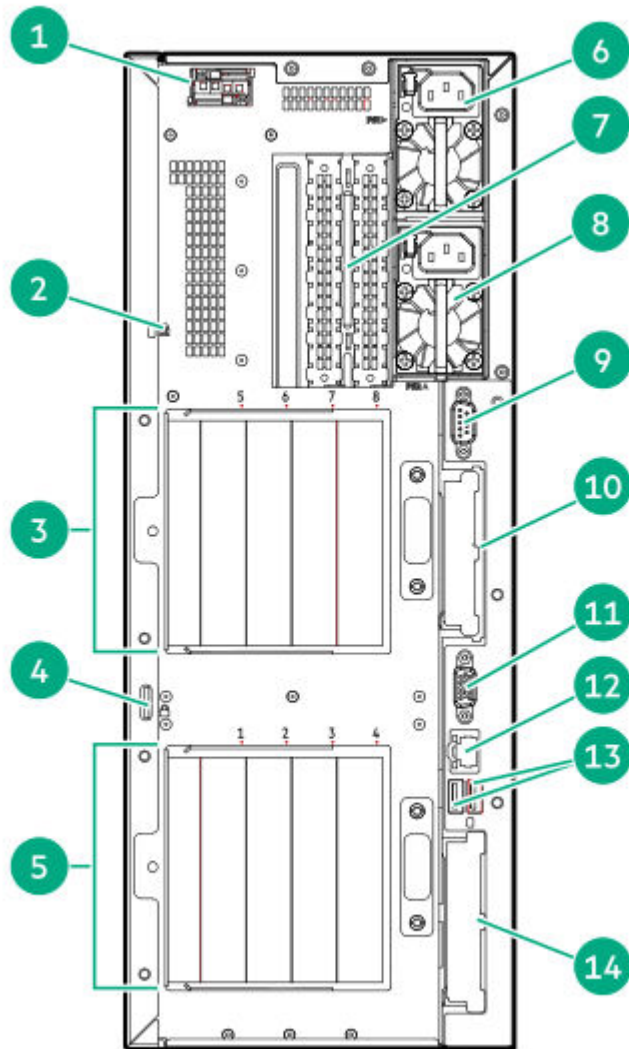

Item	Description
1	NS204i-u device (optional)
2	Kensington security slot
3	Slots 5–8 PCIe5 (secondary riser) ¹
4	Padlock eye
5	Slots 1–4 PCIe5 (primary riser)
6	Flexible Slot power supply 1
7	Slots 9–10 PCIe5 (tertiary riser) ¹
8	Flexible Slot power supply 2 (optional)

Item	Description
9	VGA port
10	Slot 15 OCP B PCIe5 x8/x16 ²
11	Serial port (optional)
12	iLO dedicated network port
13	USB 3.2 Gen 1 ports (2)
14	Slot 14 OCP A PCIe5 x8/x16 ³

¹ The PCIe signal from the secondary and tertiary riser requires that two processors are installed.

² This slot requires an OCP x8 or x16 bandwidth enablement cable option to function.

³ By default, this slot operates at x8 bandwidth speed. To enable x16 configuration, install the OCP bandwidth upgrade cable option.

Rear panel LEDs

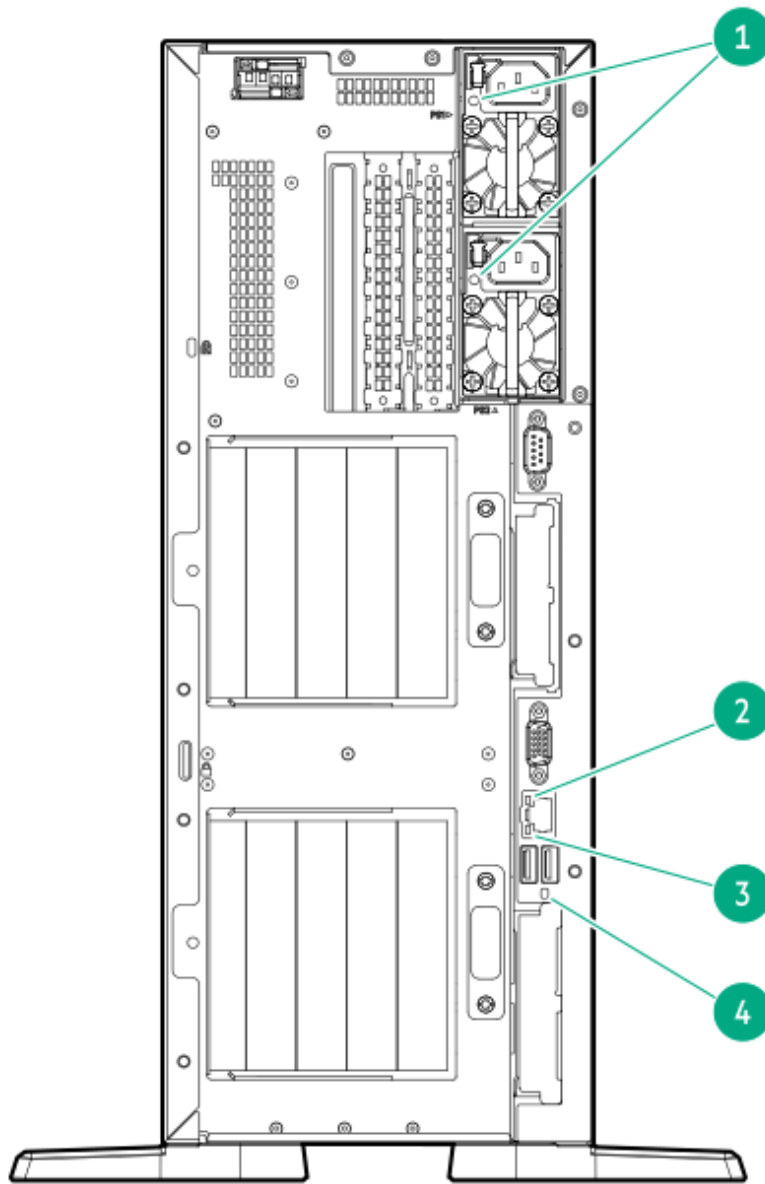

Item	Description	Status	Definition
1	Power supply	Solid green	The power supply is operating normally.
		Off	One or more of the following conditions exists: <ul style="list-style-type: none"> • Power is unavailable. • Power supply failure • Power supply is in standby mode. • Power supply error

Item	Description	Status	Definition
			<ul style="list-style-type: none"> Front I/O cable is disconnected.
2	iLO status	Solid green	Linked to network
		Flashing green	Network active
		Off	No network activity
3	iLO link	Solid green	Network link
		Off	No network link
4	UID	Solid blue	Activated
		Flashing blue	<ul style="list-style-type: none"> 1 flash per second—Remote management or firmware upgrade in progress 4 flashes per sec—iLO manual reboot sequence initiated 8 flashes per sec—iLO manual reboot sequence in progress
		Off	Deactivated

Component touchpoints

Certain components are color-coded. These colors represent the recommended touch areas for a removal process and indicate whether components require a system shutdown before removal.

The following diagrams are examples only.

HPE hot-plug red

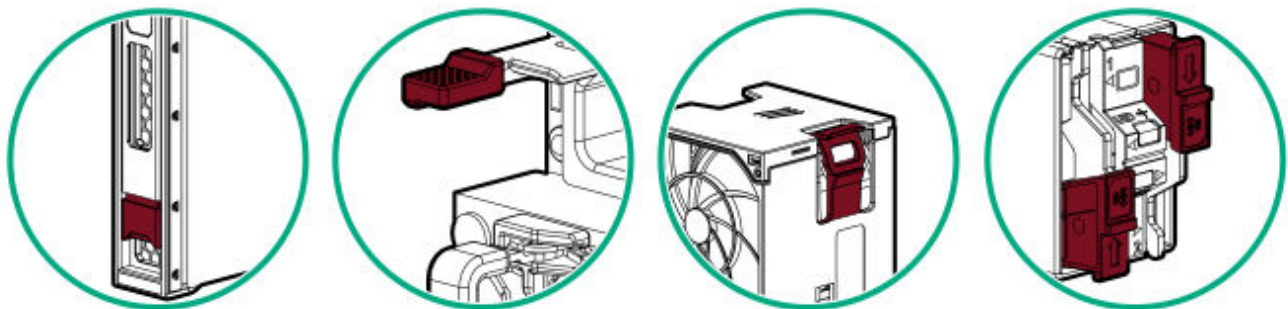

Hot-plug red indicates hot-pluggable components. These components can be removed and installed while the system is running, and doing so will not result in a system shutdown.

Component examples:

- Power supplies in a redundant power configuration
- Hot-plug fans
- Hot-plug drives
- M.2 SSDs in a hot-plug boot device

HPE touchpoint blue

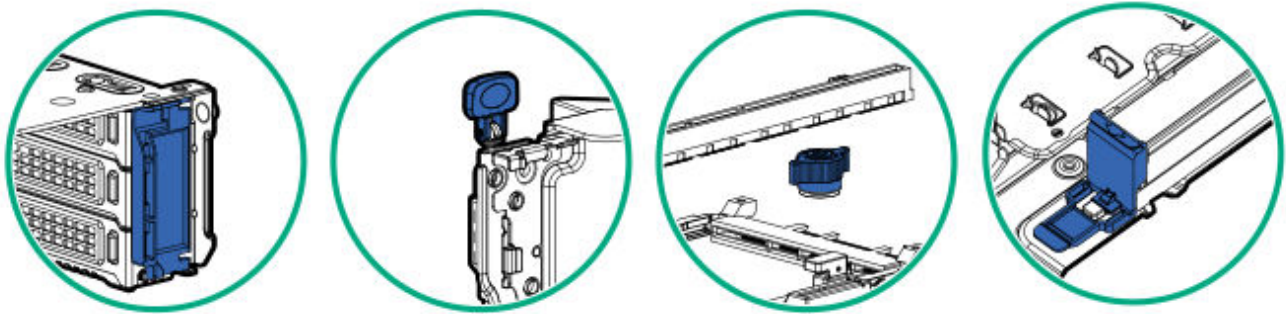

Touchpoint blue indicates cold-pluggable components. These components require a system shutdown. Failure to do so might result in system failure or data loss. Cold-pluggable components might also indicate touchpoints on non-electrical components.

Component examples:

- Storage devices
- Fan cages
- System boards
- Energy packs

System board components

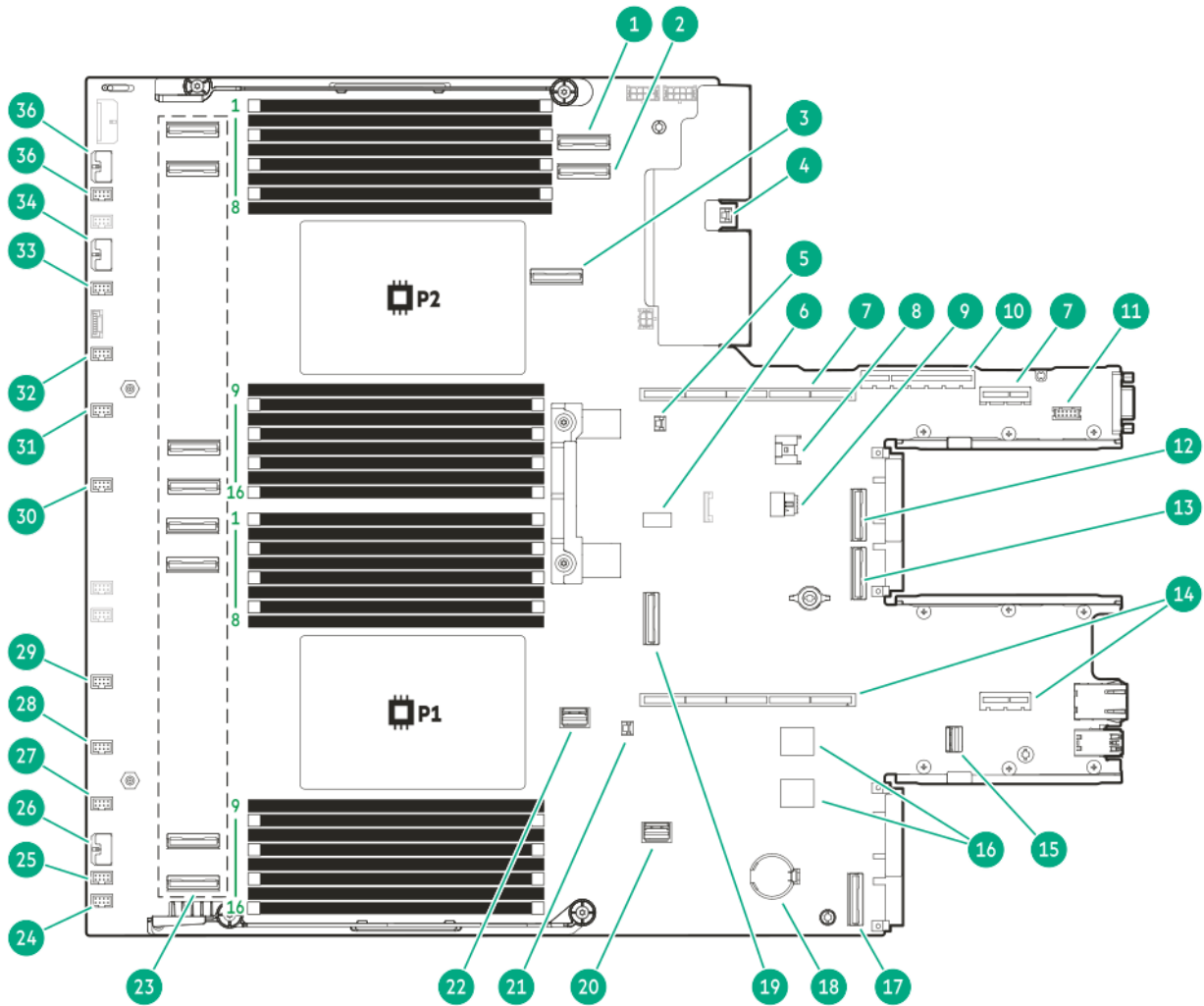

Item	Description
1	M-XIO port 9
2	M-XIO port 10
3	M-XIO port 11
4	Chassis intrusion detection switch connector
5	OCP slot B storage backup power connector
6	System maintenance switch
7	Secondary riser connectors
8	Energy pack connector
9	NS204i-u power connector

Item	Description
10	Tertiary riser sideband connector
11	Serial port cable connector
12	OCP B internal port 1
13	OCP B internal port 2
14	Primary riser connectors
15	DisplayPort & iLO service port connector
16	Dual USB 3.2 Gen 1 ports
17	OCP A internal port 1
18	System battery
19	M-XIO port 12
20	Front I/O connector
21	OCP slot A storage backup power connector
22	NS204i-u signal connector
23	M-XIO ports ¹ _—
24	Fan connector 10 ² _—
25	Fan connector 4 ² _—
26	Drive box 3 power connector
27	Fan connector 8 ² _—
28	Fan connector 7 ² _—
29	Fan connector 3 ² _—
30	Fan connector 2 ² _—
31	Fan connector 6 ² _—
32	Fan connector 5 ² _—
33	Fan connector 1 ² _—
34	Drive box 2 power connector
35	Fan connector 9 ² _—
36	Drive box 1 power connector

¹ These M-XIO ports are numbered 8-1 from top to bottom.

²_— The silkscreen markers on the system board do not match the actual fan numbering map for this server.

Subtopics

System maintenance switch

DIMM label identification

DIMM slot numbering

Heatsink and processor socket components

System maintenance switch

The system maintenance switch is a DIP switch block on the system board used during service and troubleshooting to temporarily override security or configuration settings. Each switch has an OFF (default) and ON position that enables a specific maintenance function.

To locate the system maintenance switch on your server, see [System board components](#).

Position	Default	Function
S1 ¹ _—	Off	<ul style="list-style-type: none">Off—iLO 7 security is enabled.On—iLO 7 security is disabled.
S2	Off	Reserved
S3	Off	Reserved
S4	Off	Reserved
S5 ¹ _—	Off	<ul style="list-style-type: none">Off—Power-on password is enabled.On—Power-on password is disabled.
S6 ^{1, 2, 3} _{—, —, —}	Off	<ul style="list-style-type: none">Off—No functionOn—Restore default manufacturing settings
S7	Off	Reserved
S8	Off	Reserved
S9	Off	Reserved
S10	Off	Reserved
S11	Off	Reserved
S12	Off	Reserved

¹ To access the redundant ROM, set S1, S5, and S6 to On.

² When the system maintenance switch position 6 is set to the On position, the system is prepared to restore all configuration settings to their manufacturing defaults.

- 3 When the system maintenance switch position 6 is set to the On position and Secure Boot is enabled, some configurations cannot be restored. For more information, see [Configuring the server](#).

DIMM label identification

To determine DIMM characteristics, see the label attached to the DIMM. The information in this section helps you to use the label to locate specific information about the DIMM.

For more information about product features, specifications, options, configurations, and compatibility, see the HPE DDR5 SmartMemory QuickSpecs:

<https://www.hpe.com/docs/server-memory>

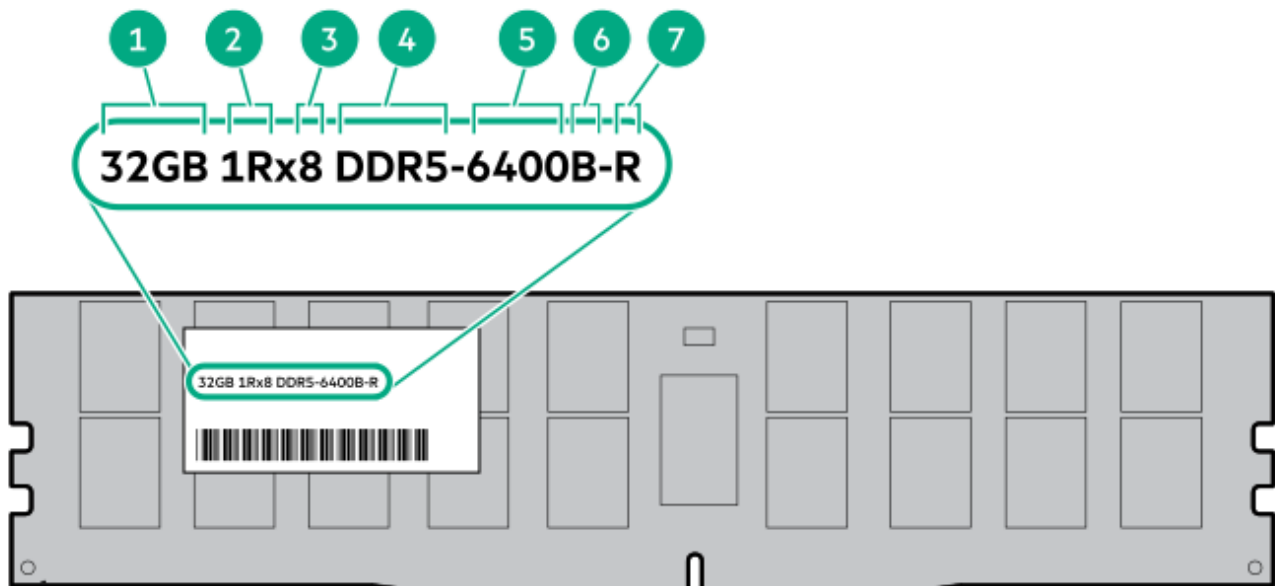

Item	Description	Example
1	Capacity*	16 GB 32 GB 64 GB 96 GB 128 GB 256 GB
2	Rank	1R—Single rank

Item	Description	Example
		2R—Dual rank 4R—Quad rank
3	Data width on DRAM	x4—4-bit x8—8-bit
4	Memory generation	PC5—DDR5
5	Maximum memory speed*	6400 MT/s
6	CAS latency	B—42-42-42
7	DIMM type	R—RDIMM (registered)

* The maximum memory speed and capacity is a function of the memory type, memory configuration, and processor model.

DIMM slot numbering

The arrow points to the front of the server.

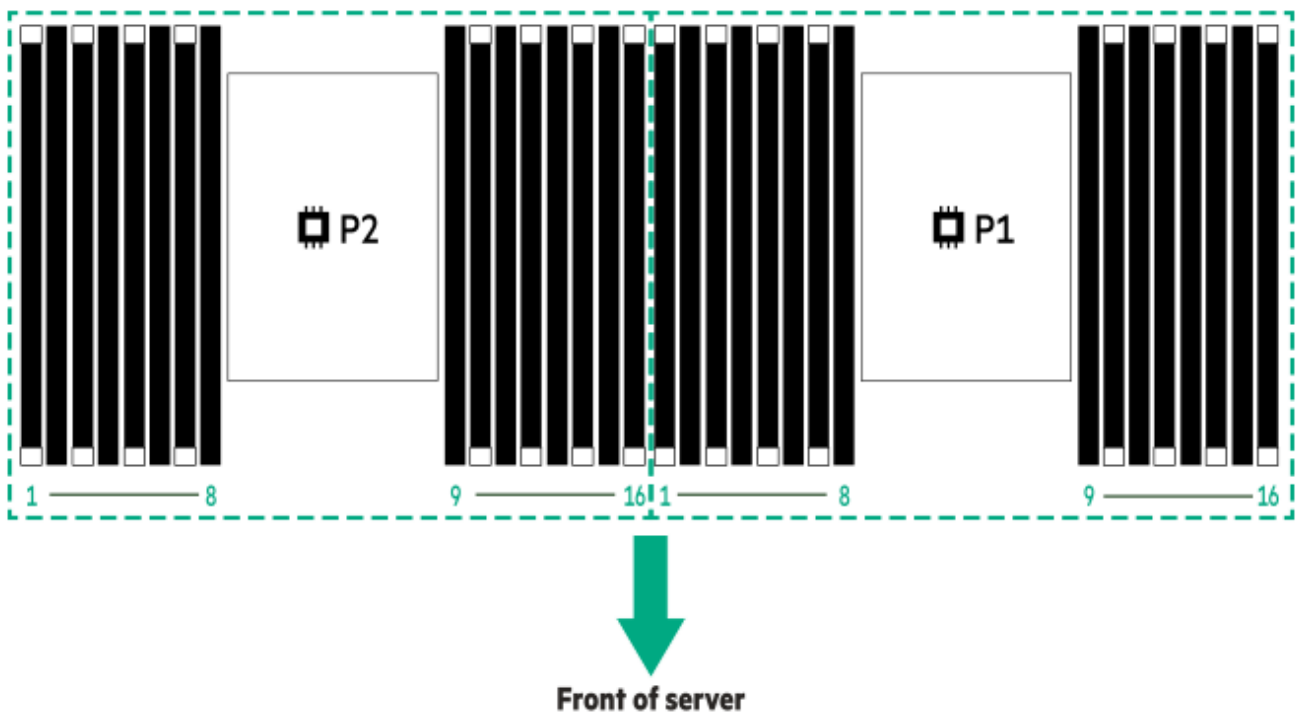

Heatsink and processor socket components

A standard heatsink is shown. Your heatsink might look different.

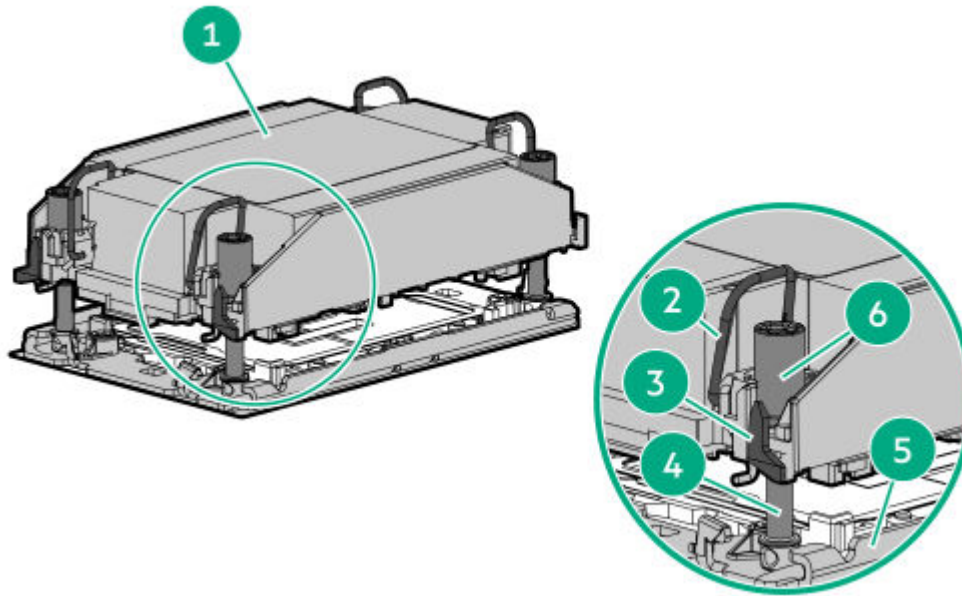

Item	Description
1	Processor-heat sink module *
2	Anti-tilt wires
3	Processor carrier release tabs
4	Bolster plate guide posts
5	Bolster plate
6	Heatsink screws

* This module consists of the heatsink attached to the processor that is already secured in its carrier.

Fan bay numbering

For more information on fan requirements for specific hardware configurations, see [Fan population](#).



Drive bay numbering



CAUTION

When a server is purchased without any drive installed, some drive bays might be empty while other drive bays might be populated with drive blanks. To maintain proper system cooling, do not operate the server without a drive or a drive blank installed.

Subtopics

[LFF drive bay numbering](#)

[SFF drive bay numbering](#)

[Mixed drive bay numbering](#)

[E3.S drive bay numbering](#)

LFF drive bay numbering

LFF drive box uses the 4 LFF 12G x1 SAS / SATA UBM3 drive backplane.

For more information on the drive backplane description, see [Drive backplane naming](#).

Tower orientation

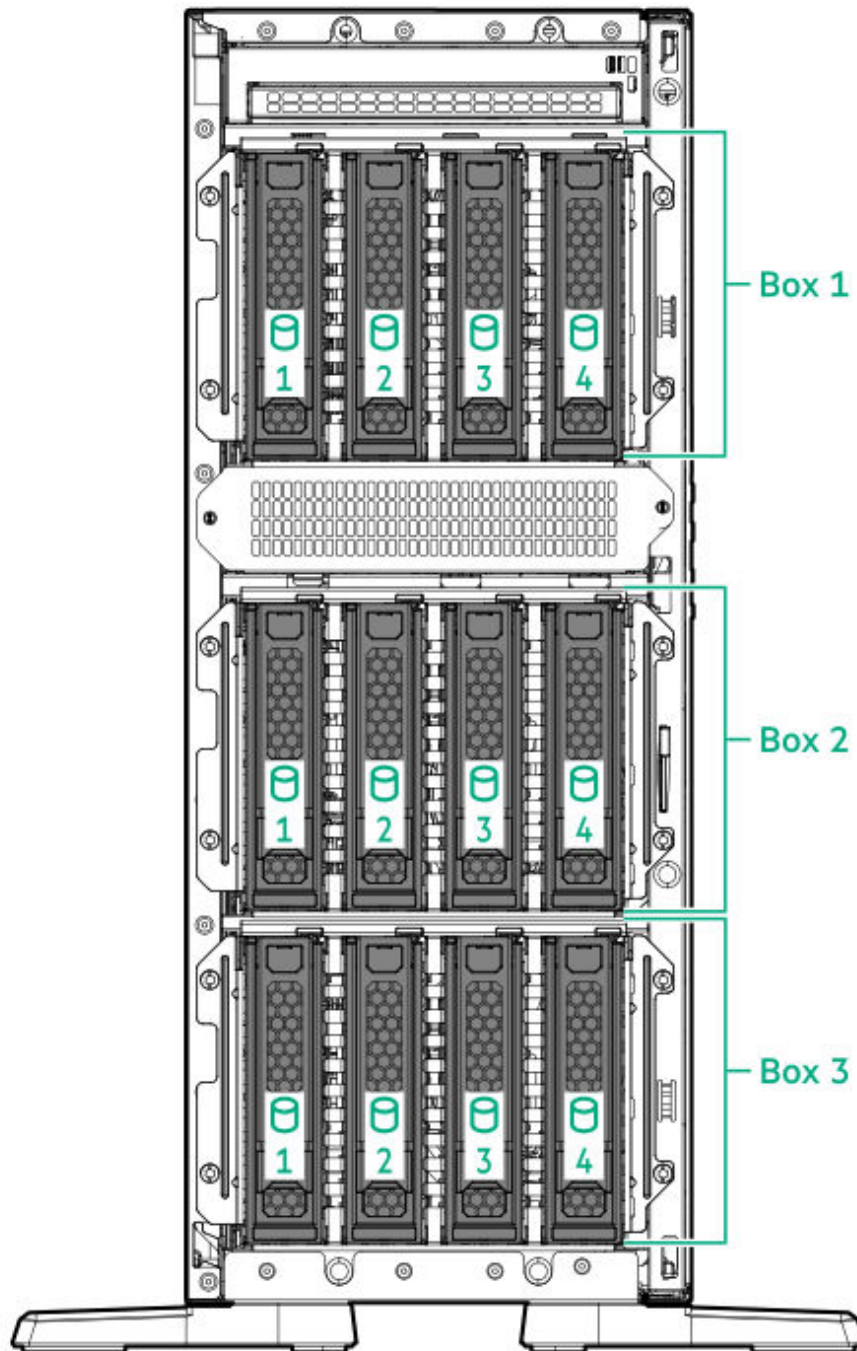

Rack orientation

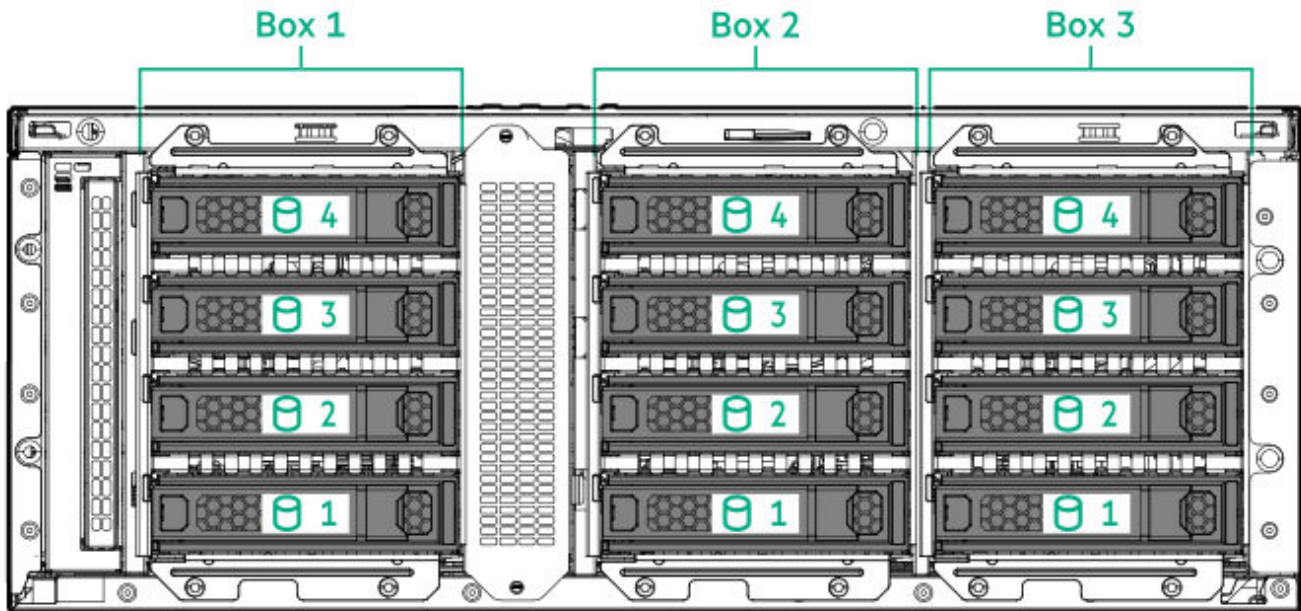

SFF drive bay numbering

The following drive backplane options are supported in SFF drive configurations:

- 8 SFF 24G x1 U.3 NVMe / SAS UBM3 BC
- 8 SFF 24G x1 U.3 NVMe / SAS UBM6 BC
- 8 SFF 24G x4 U.3 NVMe UBM3 BC
- 8 SFF 24G x4 U.3 NVMe UBM6 BC

For more information on the drive backplane description, see [Drive backplane naming convention](#).

Tower orientation

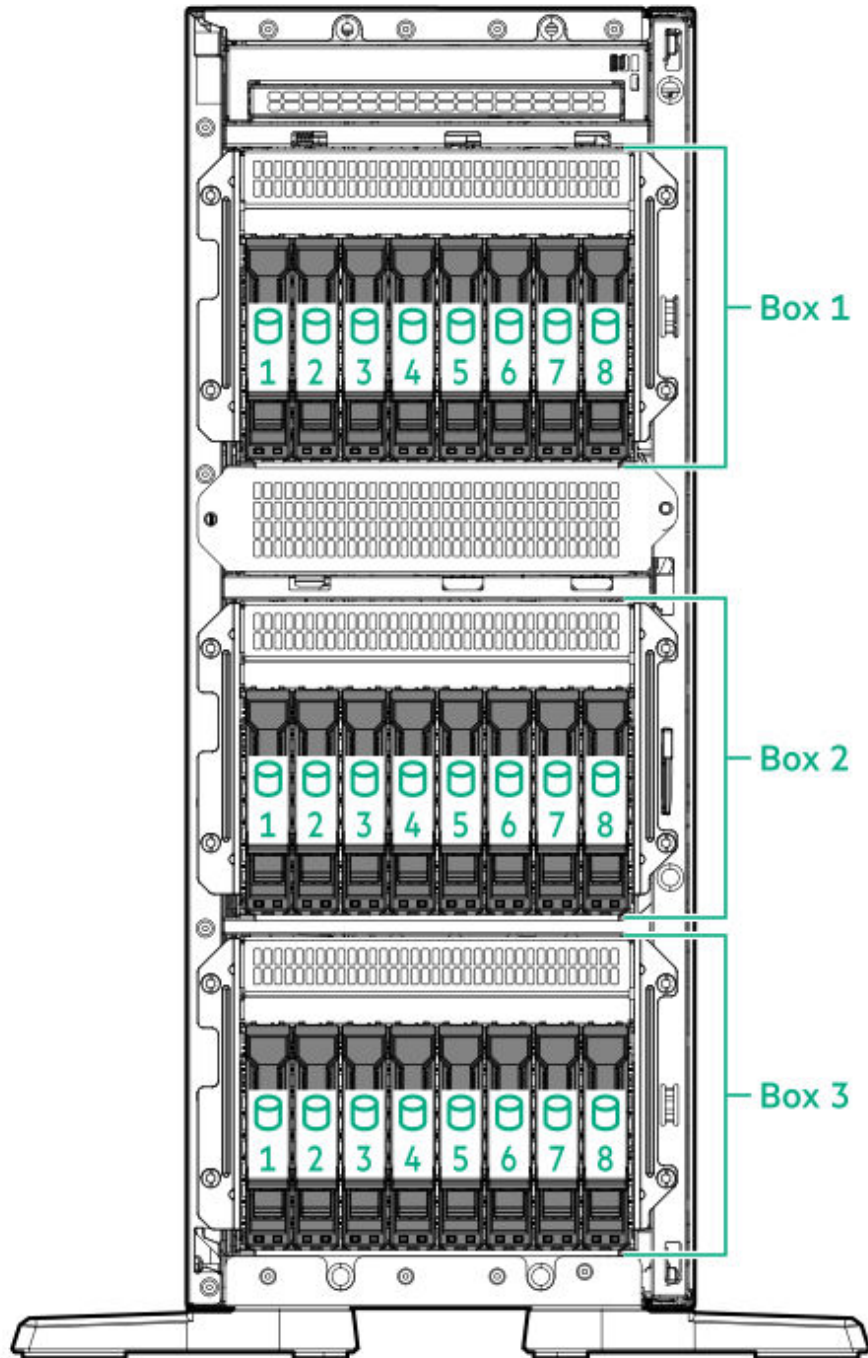

Rack orientation

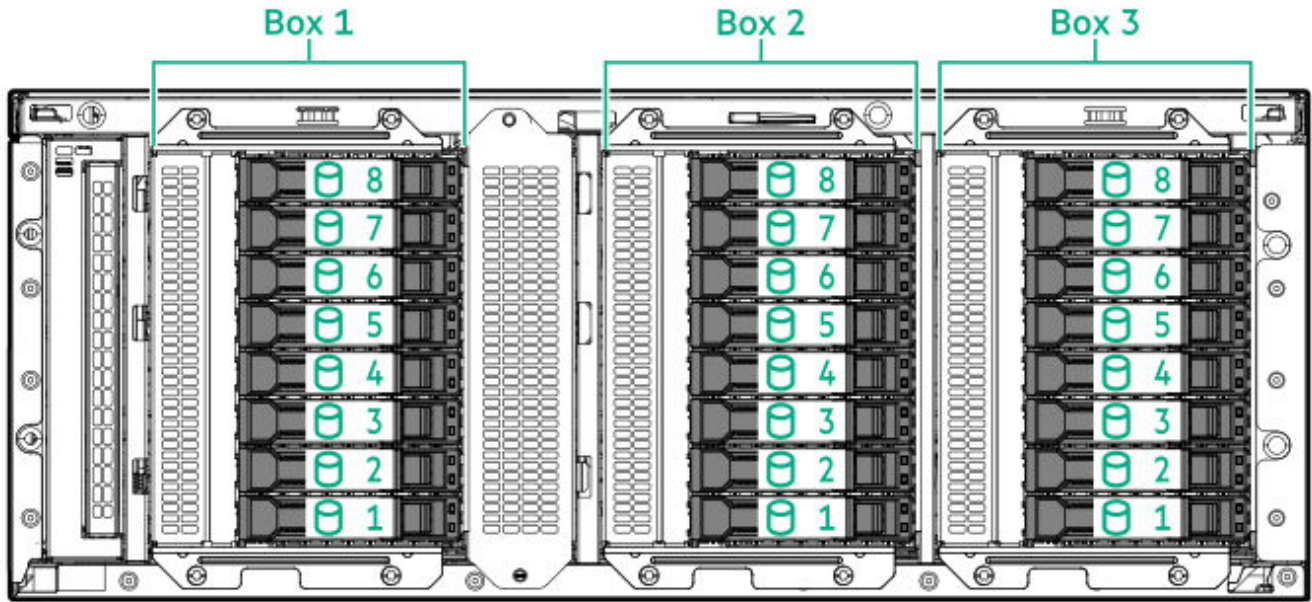

Mixed drive bay numbering

This server supports the following mixed hot-plug drive configurations.

4 LFF + 8 SFF

Tower orientation

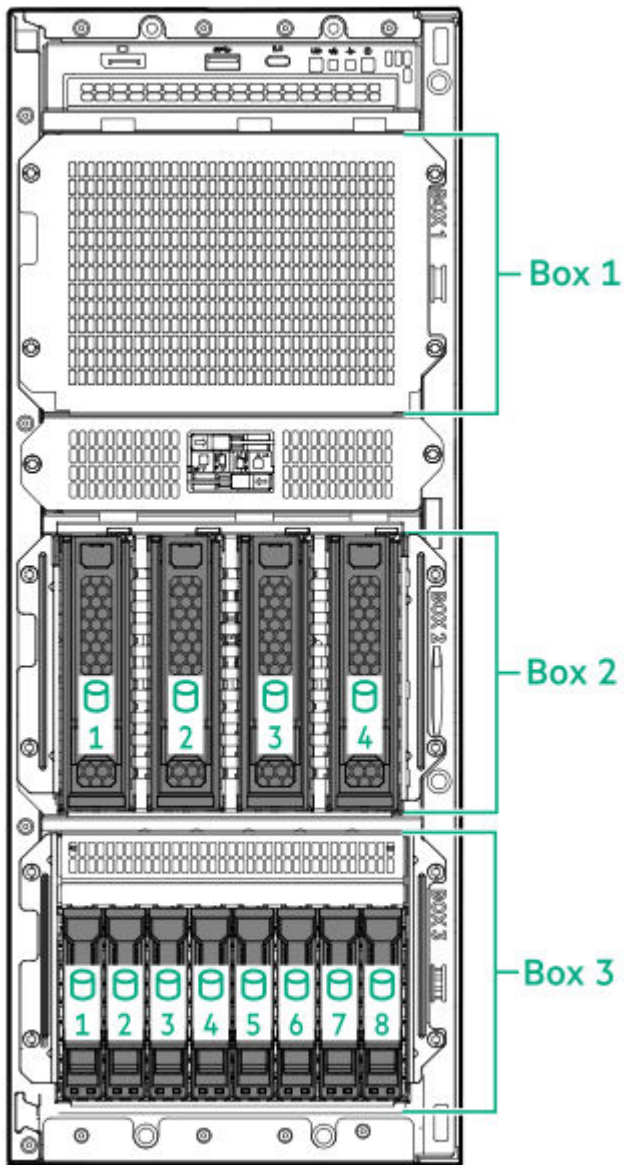

Rack orientation

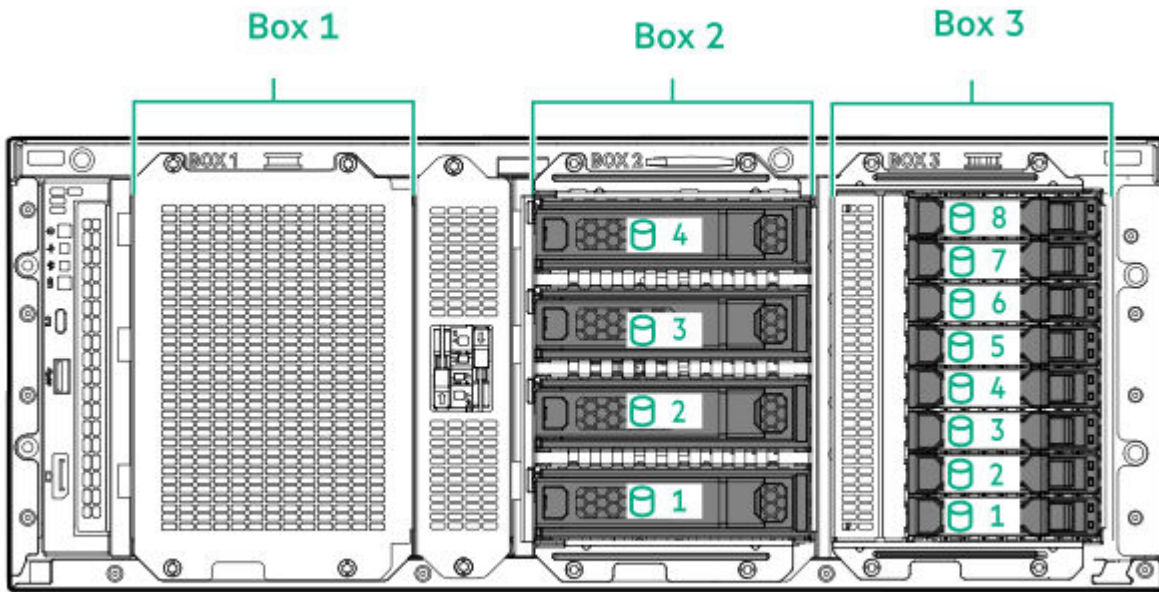

4 LFF + 16 SFF

Tower orientation

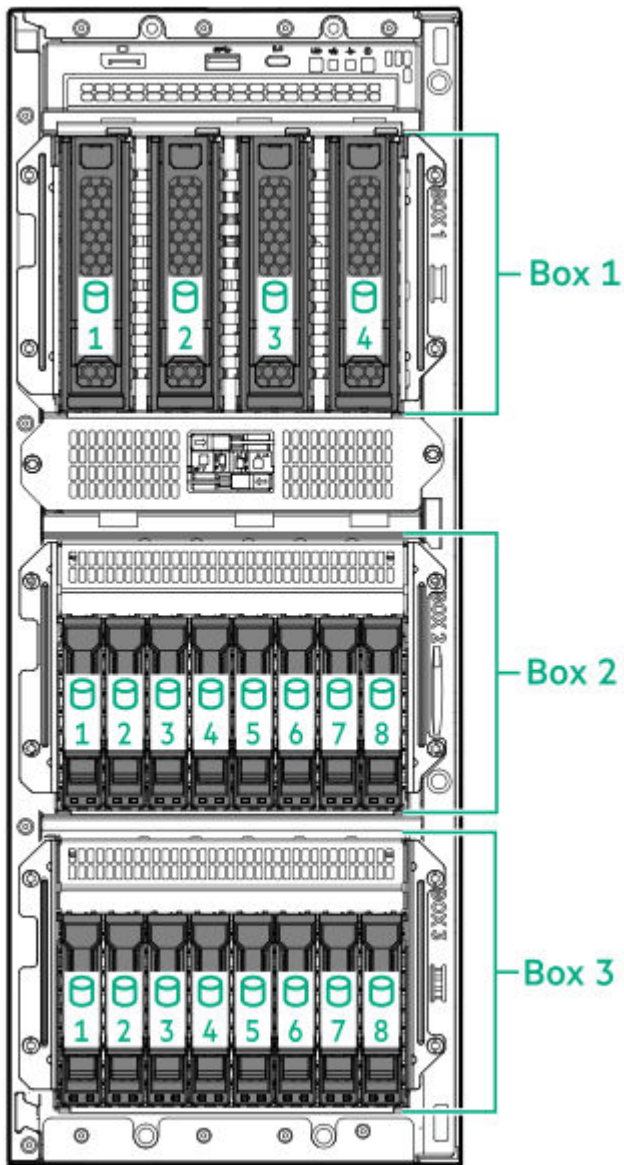

Rack orientation

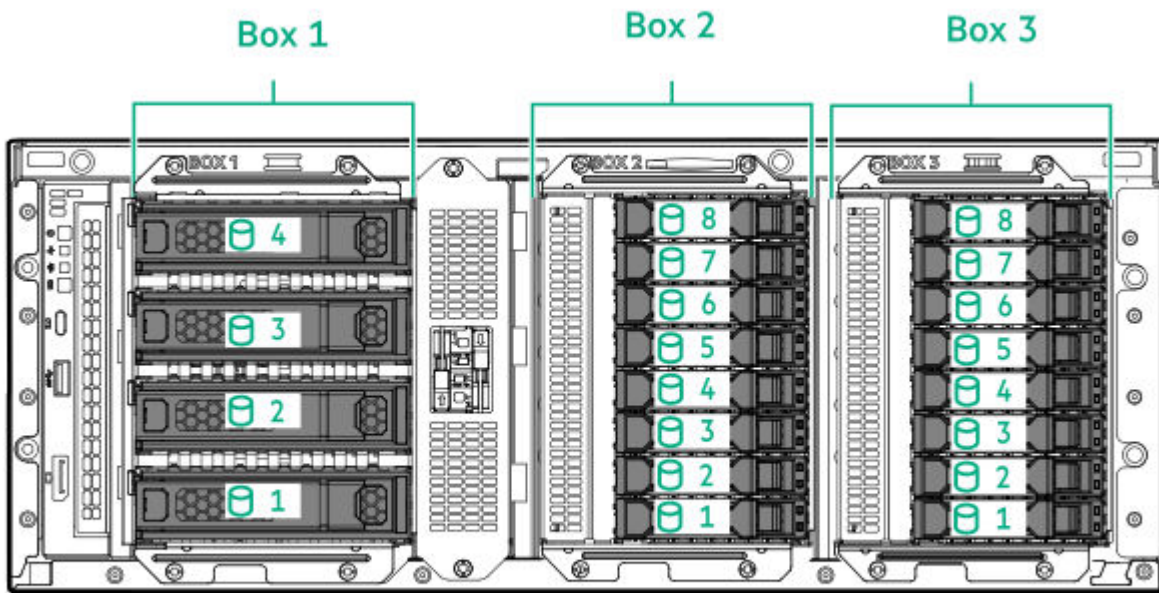

8 LFF + 8 SFF

Tower orientation

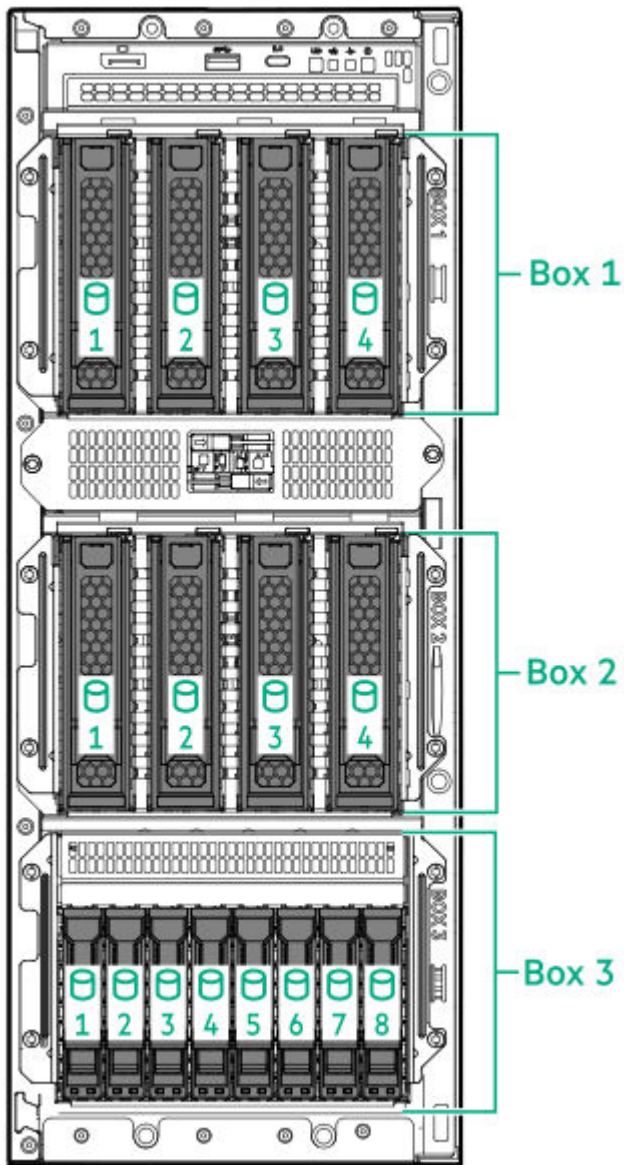

Rack orientation

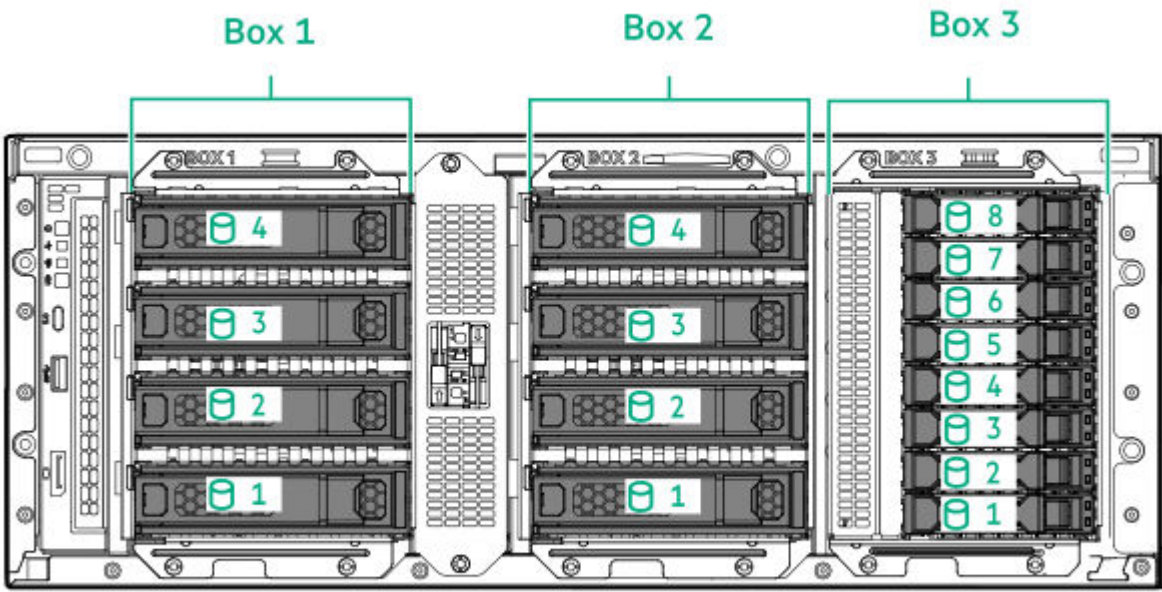

8 LFF + 12 E3.S

Tower orientation

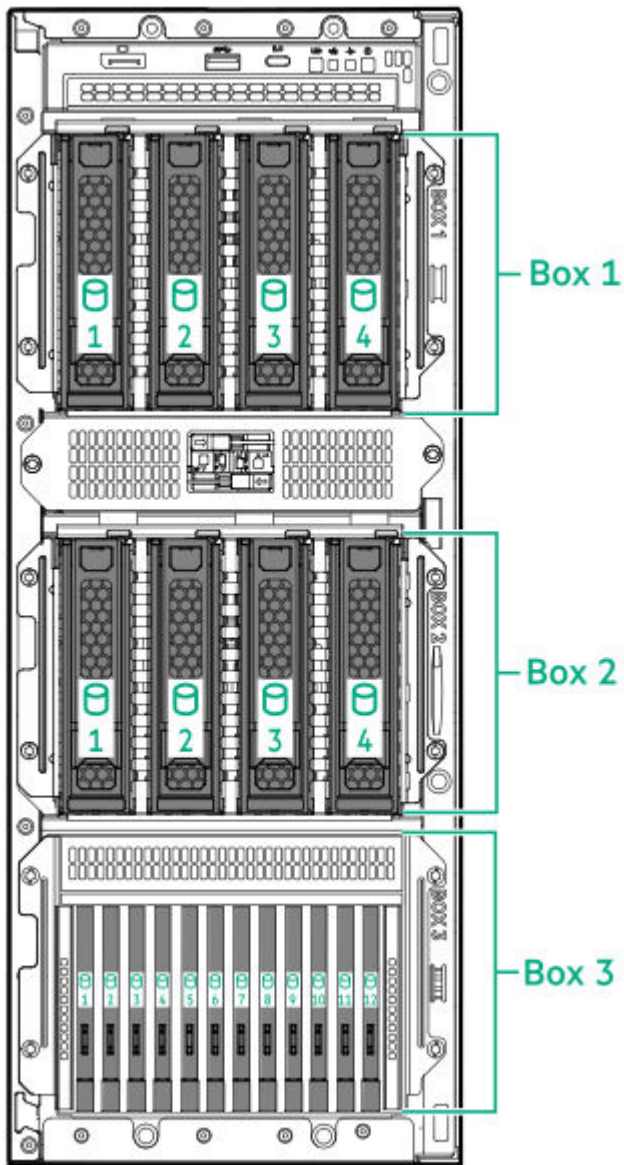

Rack orientation

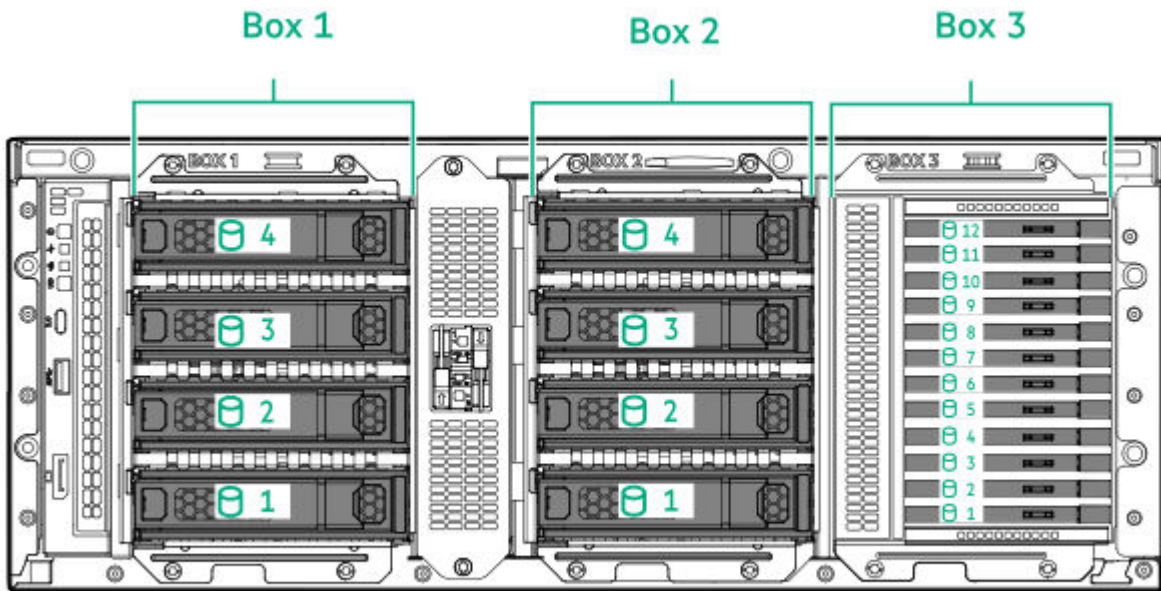

4 LFF + 12 E3.S

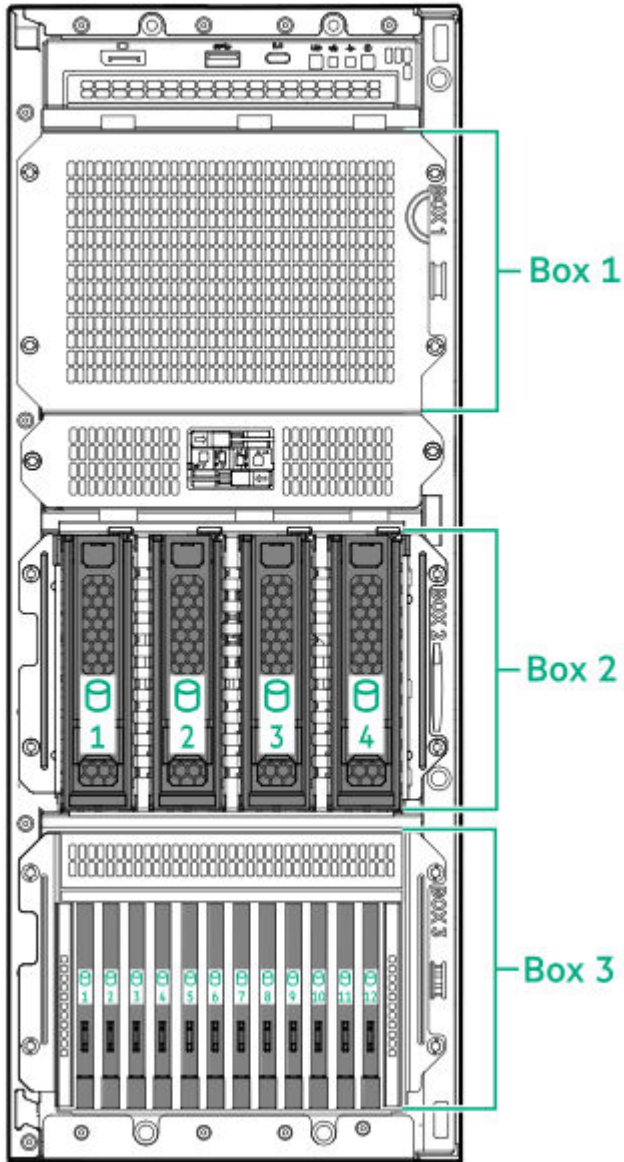

Rack orientation

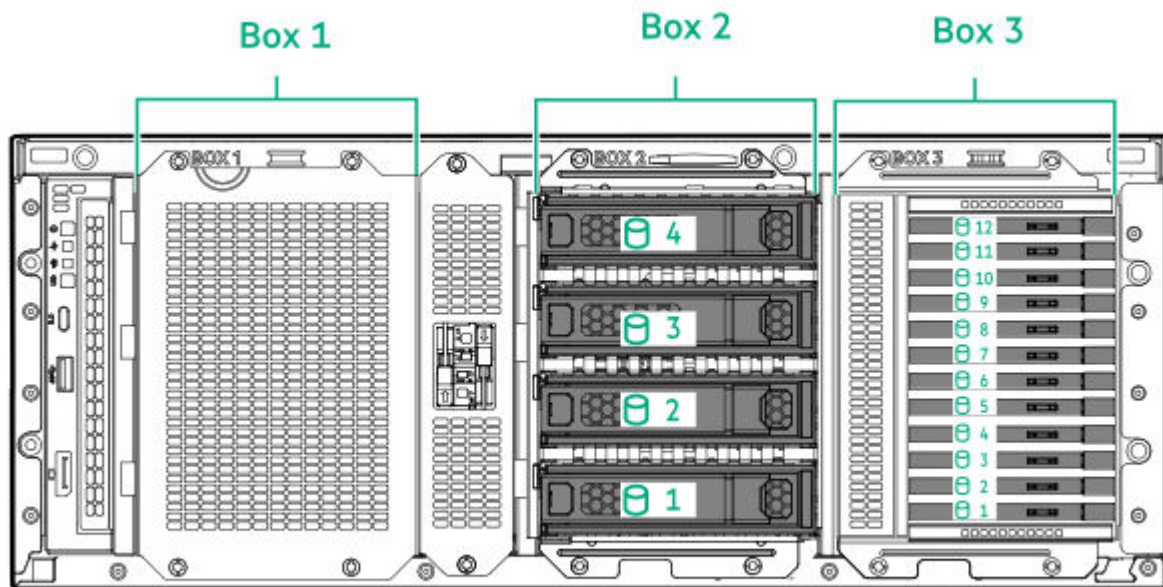

4 LFF + 8 SFF + 12 E3.S

Tower orientation

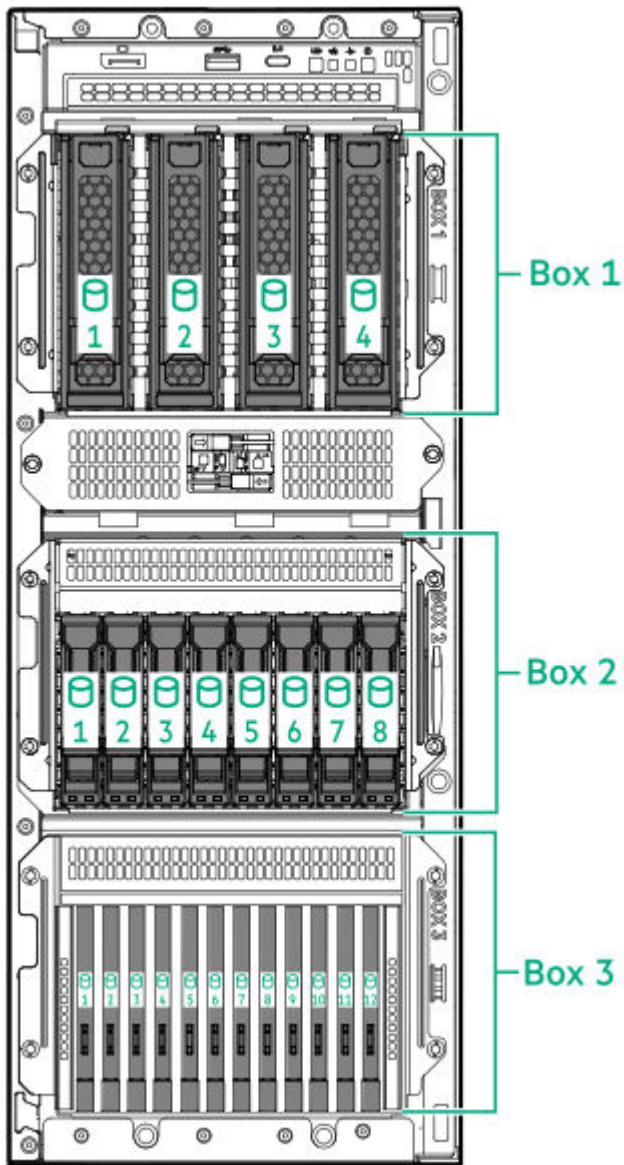

Rack orientation

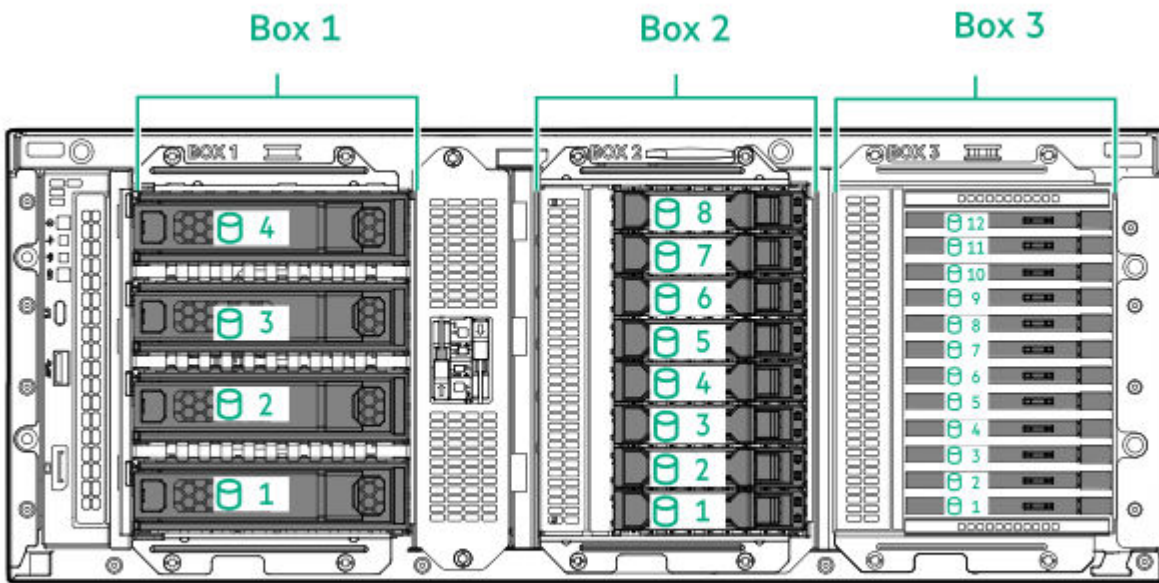

8 SFF + 12 E3.S

Tower orientation

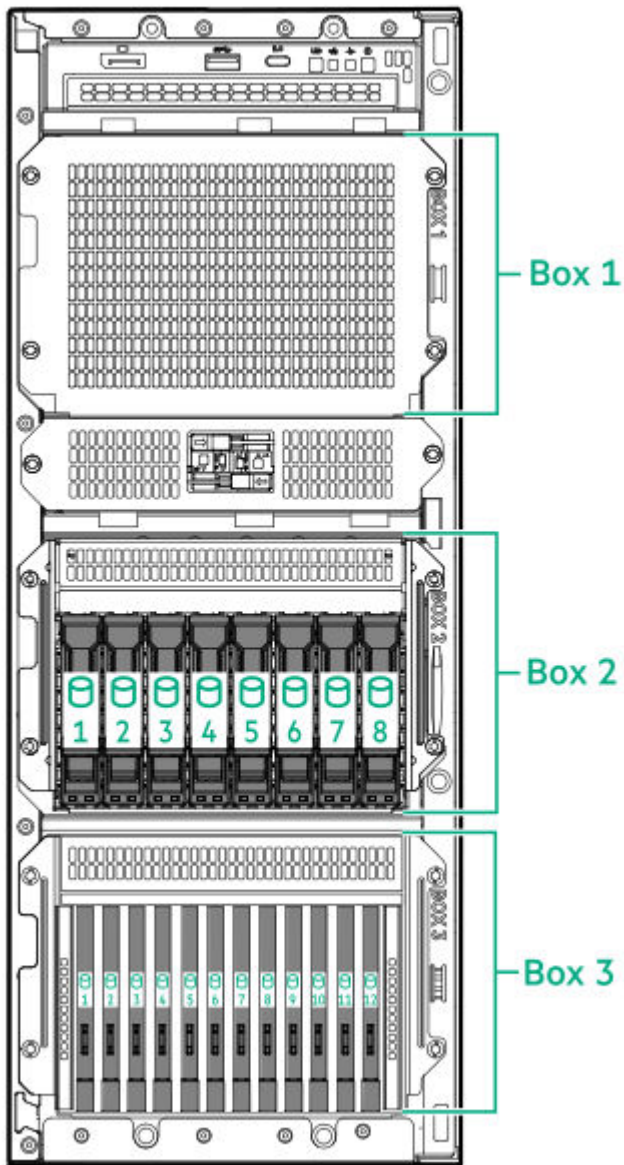

Rack orientation

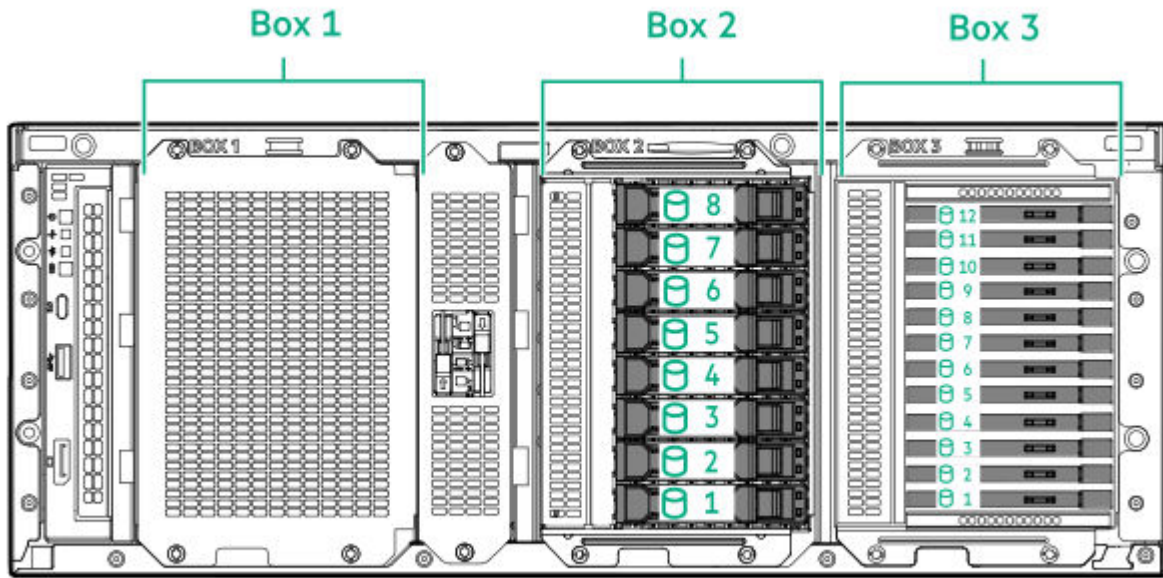

16 SFF + 12 E3.S

Tower orientation

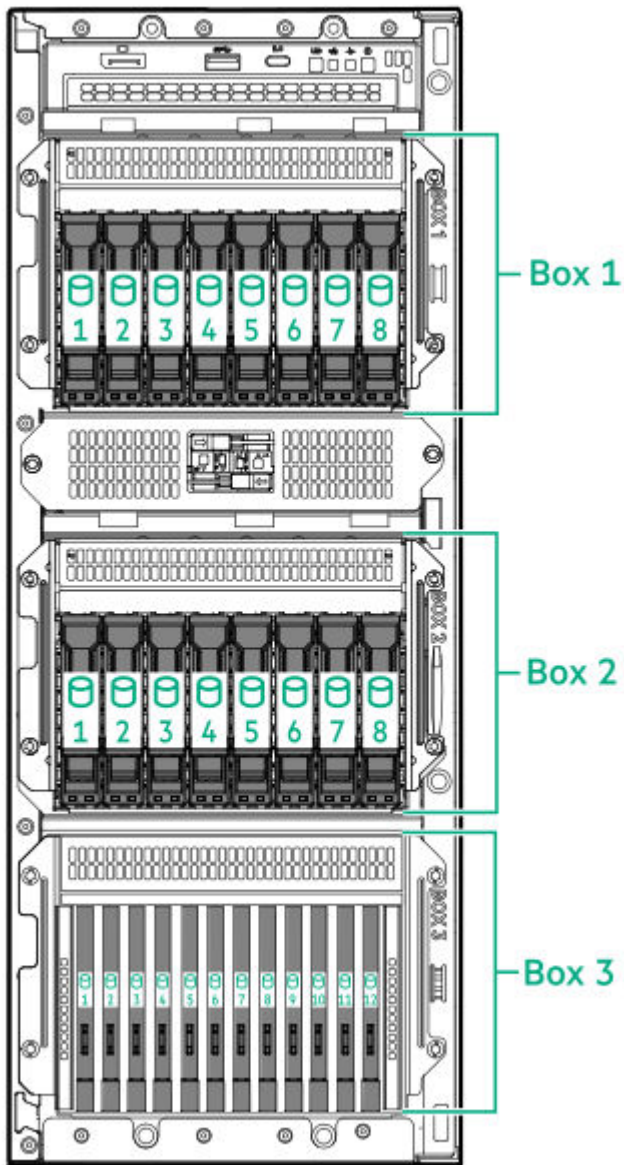

Rack orientation

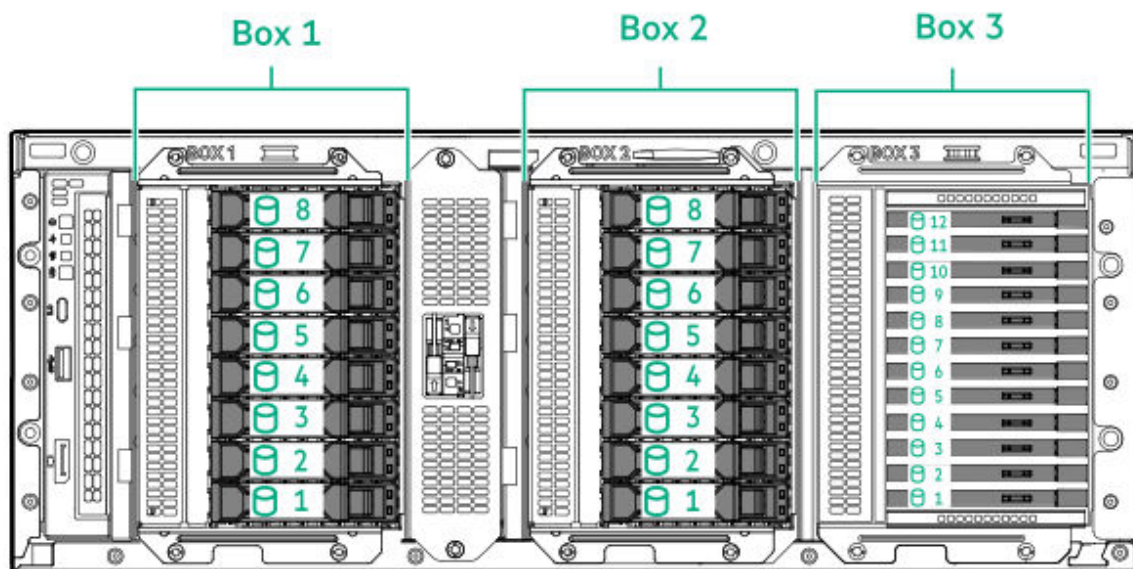

E3.S drive bay numbering

The 4 E3.S 32G x4 NVMe UBM10 EC drive backplane is supported in the E3.S drive box by default in Box 3.

For more information on the drive backplane description, see [Drive backplane naming](#).

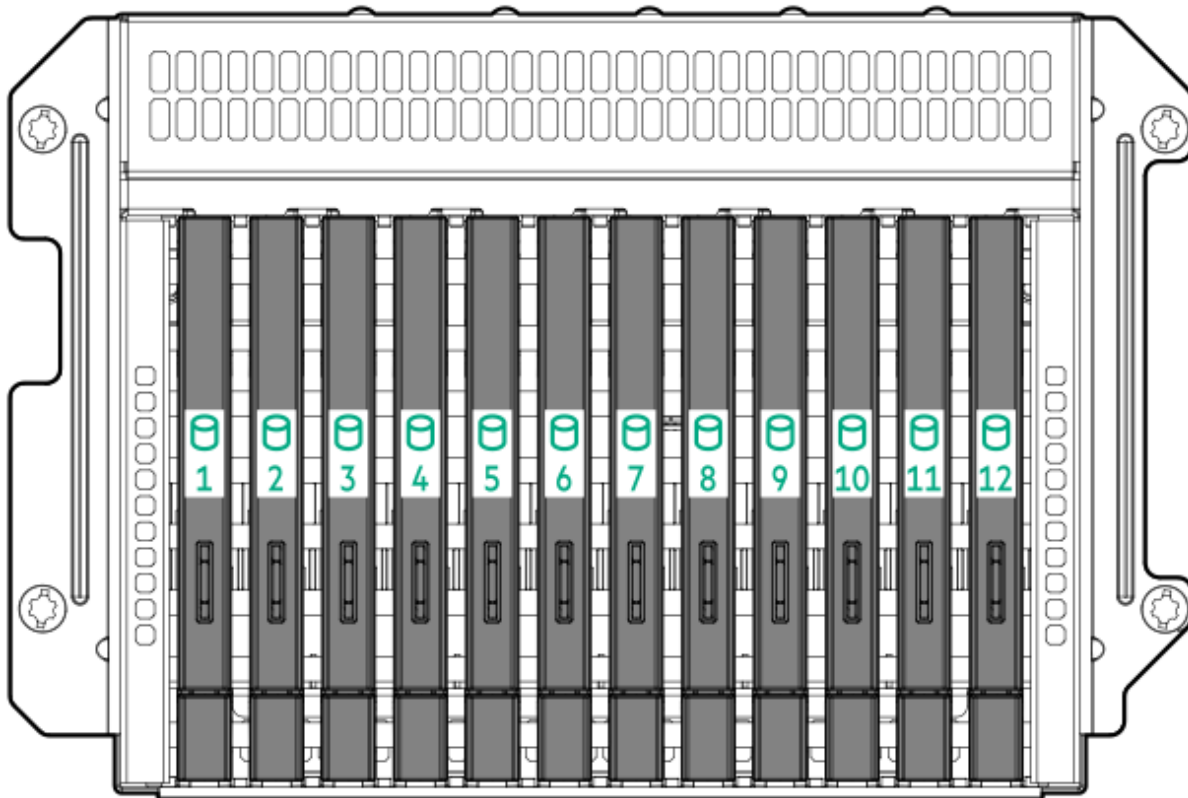

Drive backplane naming

This topic explains the features represented in the drive backplane naming. This naming convention was adopted starting in the HPE Gen11 server release. Your server might not support all the features listed in this topic. For server-specific support information, see the server guides:

- Drive backplane support, see [Drive bay numbering](#).
- Drive backplane cabling, see [Storage cabling](#).



Item	Description	Values
1	Drive bay count	Number of drive bays supported by the backplane.
2	Drive form factor	LFF—Large Form Factor
		SFF—Small Form Factor
		E3S—Enterprise and Datacenter Standard Form Factor (EDSFF E3.S)
3	Maximum link rate per lane (GT/s)	12G
		16G
		24G
		32G
4	Port link width and interface	x1 NVMe/SAS—U.3 NVMe, SAS, or SATA ¹
		x4 NVMe/SAS—U.3 NVMe, SAS, or SATA ²
		x4 NVMe—NVMe ³
		x4 NVMe—E3.S
5	Universal backplane manager (UBM) model	The UBM model defines the UBM firmware used by the backplane. Examples of UBM models: UBM2, UBM3, and etc.
6	Drive carrier type	BC—Basic carrier (SFF)
		LP—Low-profile carrier (LFF)
		EC—E3.S carrier

¹ Tri-mode controller support for x1 U.3 NVMe, SAS, and SATA drives. System board connection supports SATA drives only.

² CPU direct attach or tri-mode controller support for x4 U.3 NVMe, x2 (via a splitter cable) U.3 NVMe, or x1 SAS and SATA drives.

³ CPU direct attach or tri-mode controller support for x4 NVMe drives.

HPE Basic Drive LED definitions

The HPE Basic drive carrier has the following LEDs:

- Amber/blue LED—Managed by the drive backplane in conjunction with the storage controller and is used to indicate drive status.
- Green LED—Managed by the drive itself and indicates the drive activity.

LFF low-profile drive carrier

The LFF low-profile drive carrier supports hot-plug SAS and SATA drives.

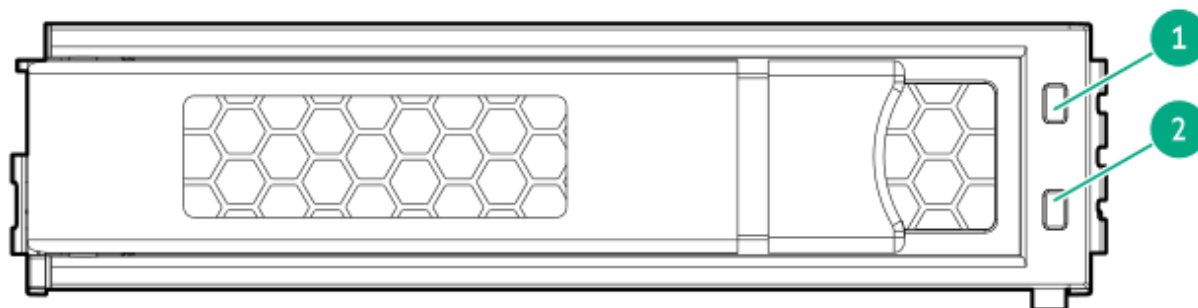

SFF basic drive carrier

The SFF basic drive carrier supports hot-plug SAS, SATA, and U.3 PCIe4 NVMe drives.

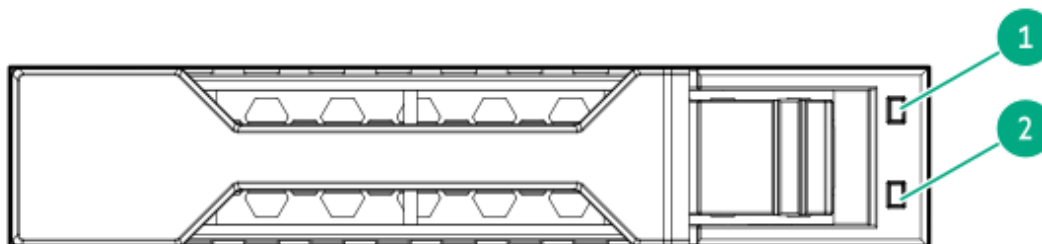

Item	LED	State	Definition
1	Fault/Locate	Solid amber	This drive has failed, is unsupported, or is invalid.
		Solid blue	The drive is operating normally and being identified by a management application.
		Flashing amber/blue (1 flash per second)	The drive has failed, or a predictive failure alert has been received for this drive. The drive has also been identified by a management application.
		Flashing amber (1 flash per second)	A predictive failure alert has been received for this drive. Replace the drive as soon as possible.

Item	LED	State	Definition
		Off	The drive is operating normally and not being identified by a management application.
2	Online/Activity	Solid green	The drive is online and has no activity.
		Flashing green (1 flash per second)	The drive is doing one of the following: <ul style="list-style-type: none"> • Rebuilding or performing a RAID • Performing a stripe size migration • Performing a capacity expansion • Performing a logical drive extension • Erasing • Spare part activation
		Flashing green (4 flashes per second)	The drive is operating normally and has activity.
		Off	The drive is not configured by a RAID controller or is a spare drive.

EDSFF SSD LED definitions

The EDSFF drive carrier has two LEDs:

- Amber/blue LED—Managed by the drive backplane in conjunction with the storage controller and is used to indicate drive status.
- Green LED—Managed by the drive itself and indicates the drive activity.

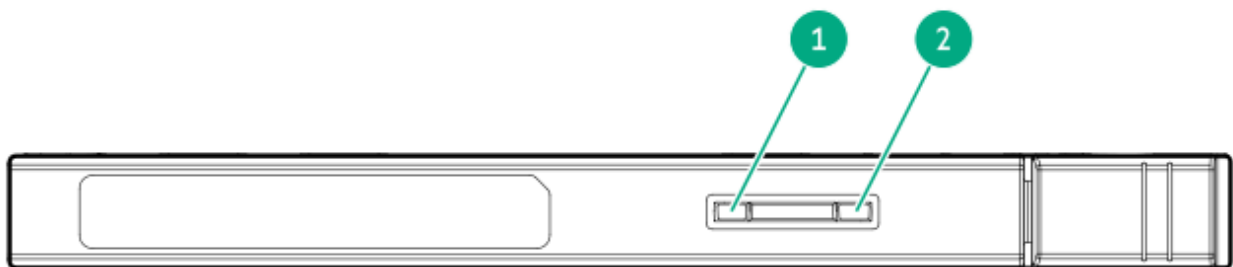

Item	LED	State	Definition
1	Fault/Locate	Solid amber	This drive has failed, is unsupported, or is invalid.
		Solid blue	The drive is operating normally and being identified by a management application.
		Flashing amber/blue (1 flash per second)	The drive has failed, or a predictive failure alert has been received for this drive. The drive has also been identified by a management application.
		Flashing amber (1 flash per second)	A predictive failure alert has been received for this drive. Replace the drive as soon as possible.
		Off	The drive is operating normally and not being identified by a management application.
2	Online/Activity	Solid green	The drive is online and has no activity.
		Flashing green (4 flashes per second)	The drive is operating normally and has activity.
		Off	No power present.

HPE NS204i-u Boot Device V2 components

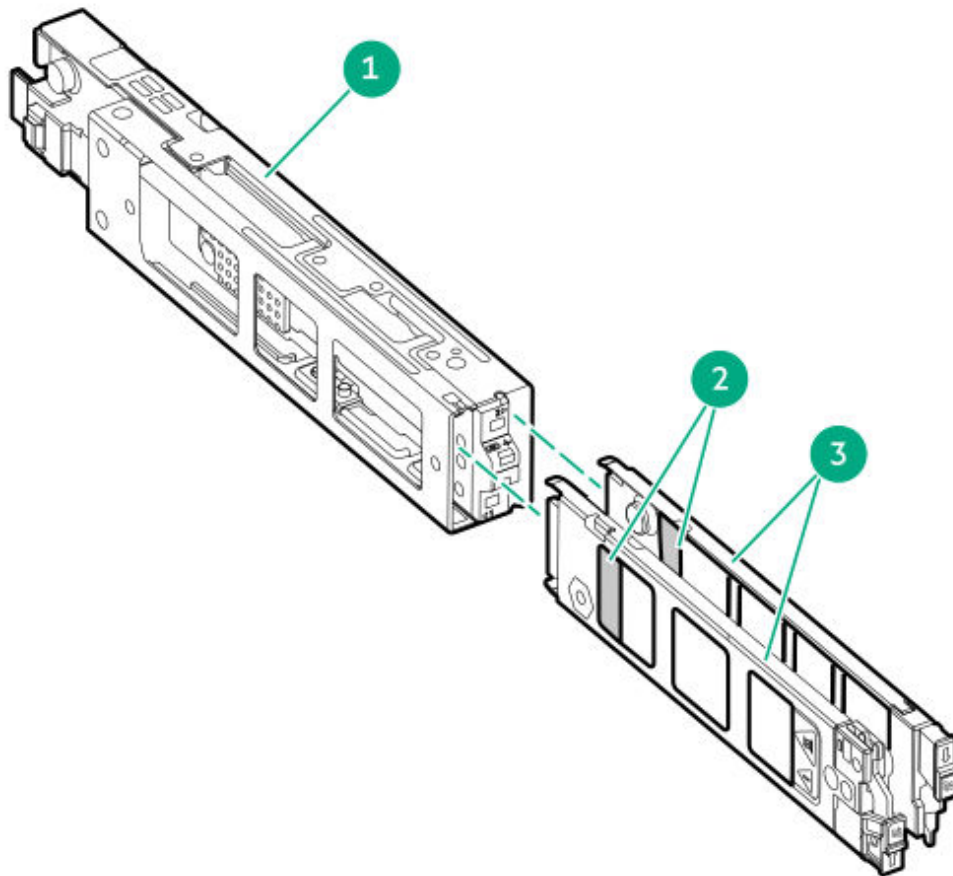

Item	Description
1	Boot device cage
2	M.2 slots
3	Boot device carriers

HPE NS204i-u Boot Device V2 LED definitions

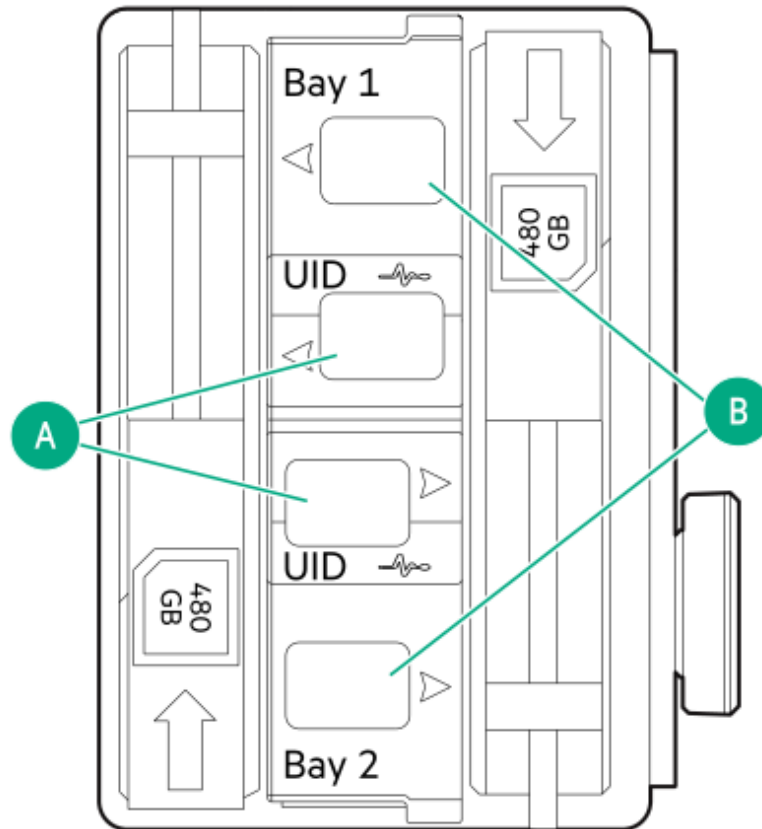

NOTE

The bay number can be found on the SSD carrier handle.

Item	LED	Status	Definition
A	Fault or Locate	Solid amber	Drive has failed, unsupported, or invalid.
		Solid blue	Drive is operating normally.
		Flashing amber or blue (one flash per second)	Drive has failed, or a predictive failure alert is received for the drive.
		Flashing amber (one flash per second)	Drive predictive failure alert is received. Replace the drive as soon as possible.
		Off	Drive is operating normally and is not identified by any application.
B	Online/Activity	Solid green	Drive is online and has no activity.

Item	LED	Status	Definition
		Flashing green (one flash per second)	Drive is doing one of the following: <ul style="list-style-type: none"> Rebuilding or performing a RAID Erasing
		Flashing green (4 flashes per second)	Drive is operating normally and has activity.
		Off	Drive is not configured by a RAID controller.

Riser board components

The PCIe5 4 x8 and PCIe5 2 x16 riser options can be installed in either the primary or the secondary riser location. This server supports mixed PCIe5 4 x8 + 2 x16 risers.

PCIe5 4 x8 riser components

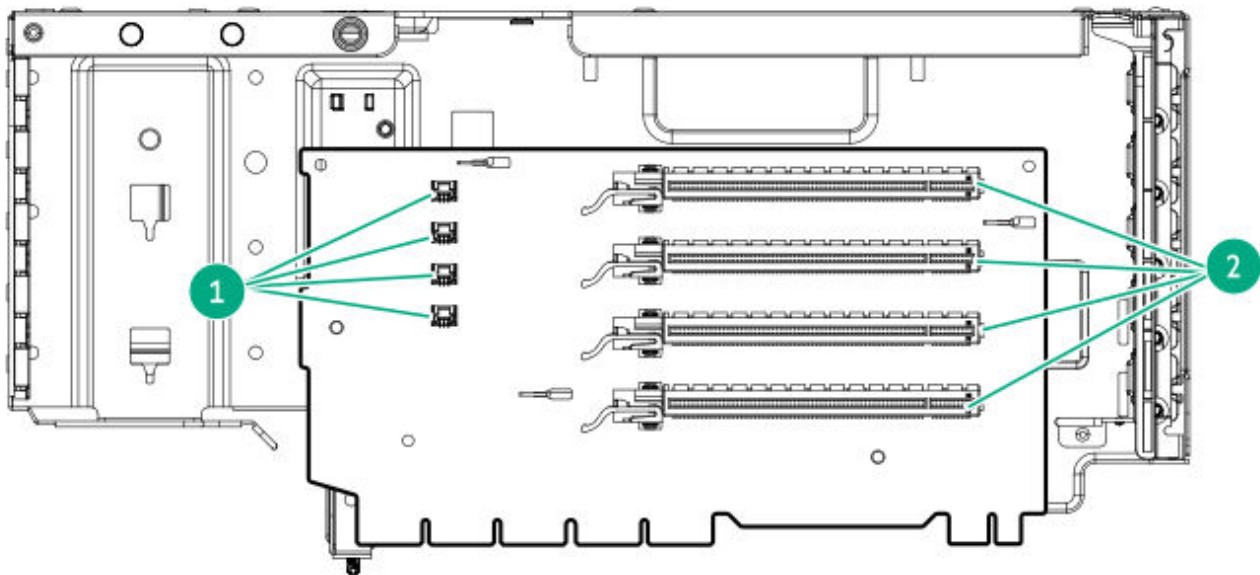

Item	Description
1	Storage controller backup power connectors
2	PCIe5 x16 (8, 4, 1) slots

PCIe 2 x16 riser components

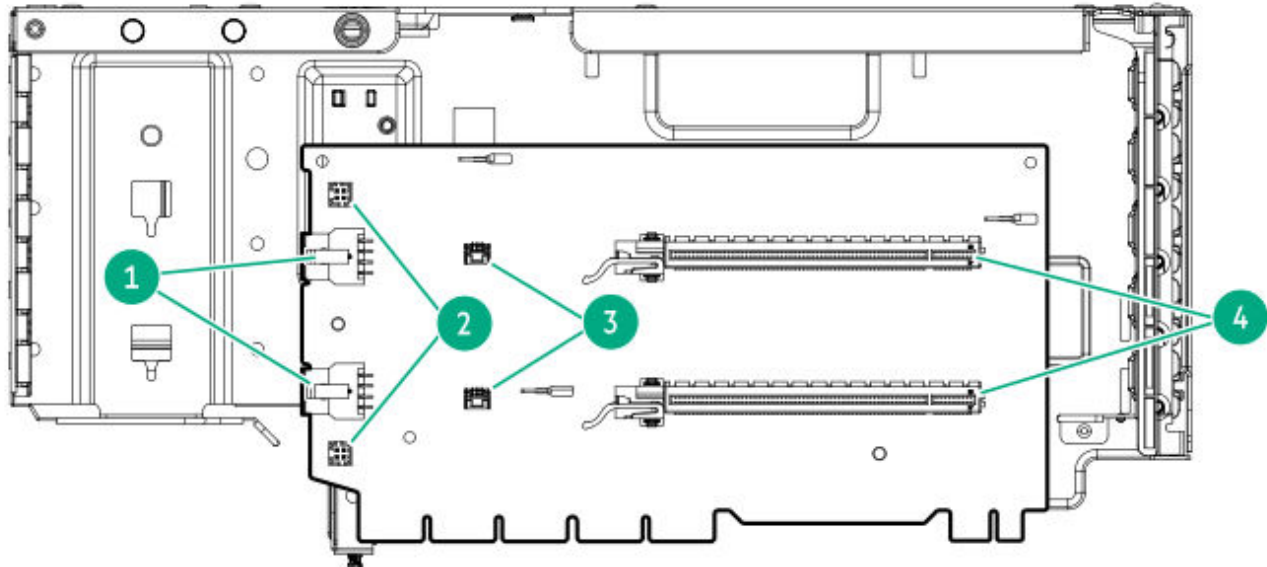

Item	Description
1	GPU auxiliary power connectors
2	GPU sideband connectors
3	Storage controller backup power connectors
4	PCIe x16 (16, 8, 4, 1) slots

Riser slot numbering

- Primary and secondary riser slots are PCIe5 x16 (16, 8, 4, 1) or PCIe5 x16 (8, 4, 1)
- Tertiary riser slots are PCIe5 x16 (8, 4, 1).

All riser slots are rated for a maximum power draw of 75 W each without an auxiliary power cable.

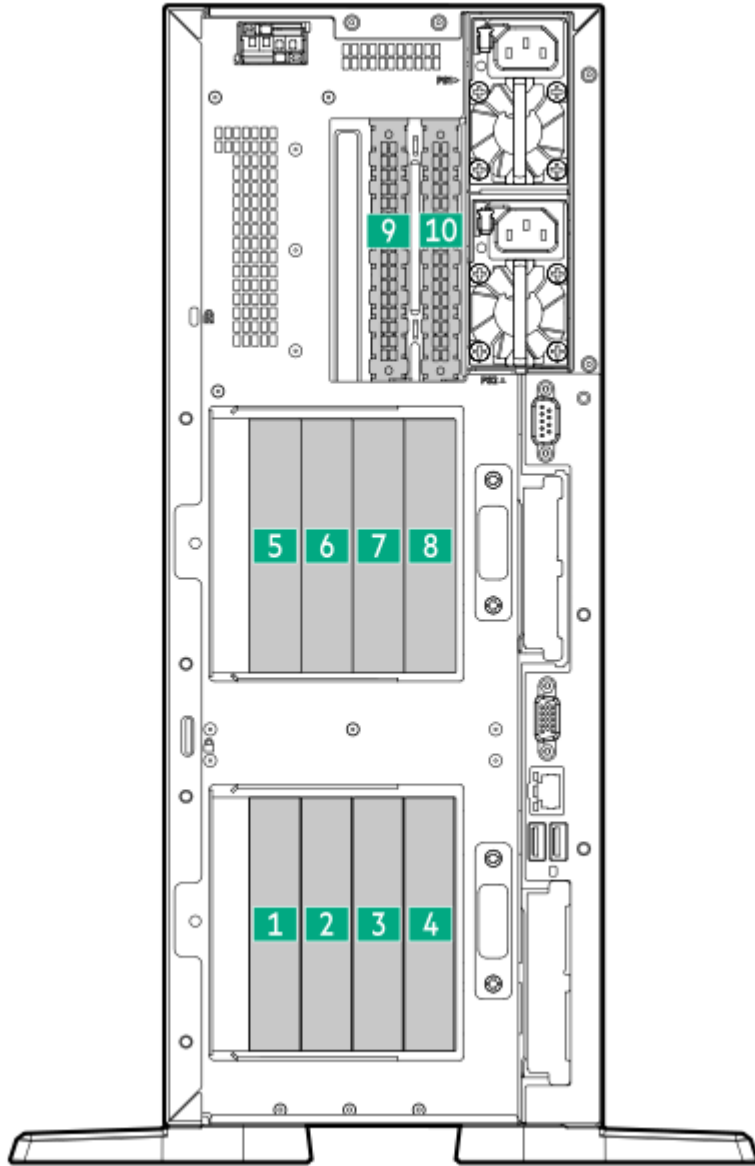

Slot number	Location	Supported form factors
1	Primary riser cage	<ul style="list-style-type: none"> • Full-height, full-length • Full-height, half-length • Half-height, half-length (low-profile)
2		
3		
4		
5	Secondary riser cage	
6		
7		
8		
9		
10		

Slot number	Location	Supported form factors
8 ¹		
9	Tertiary riser cage	Half-height, half-length (low-profile)
10		

¹ This slot on the PCIe5 2 x16 riser board supports double-width GPUs.

Media device screws

There are 12 T-15 Torx screws on the server chassis. These screws are provided as spare screws for installing media devices.

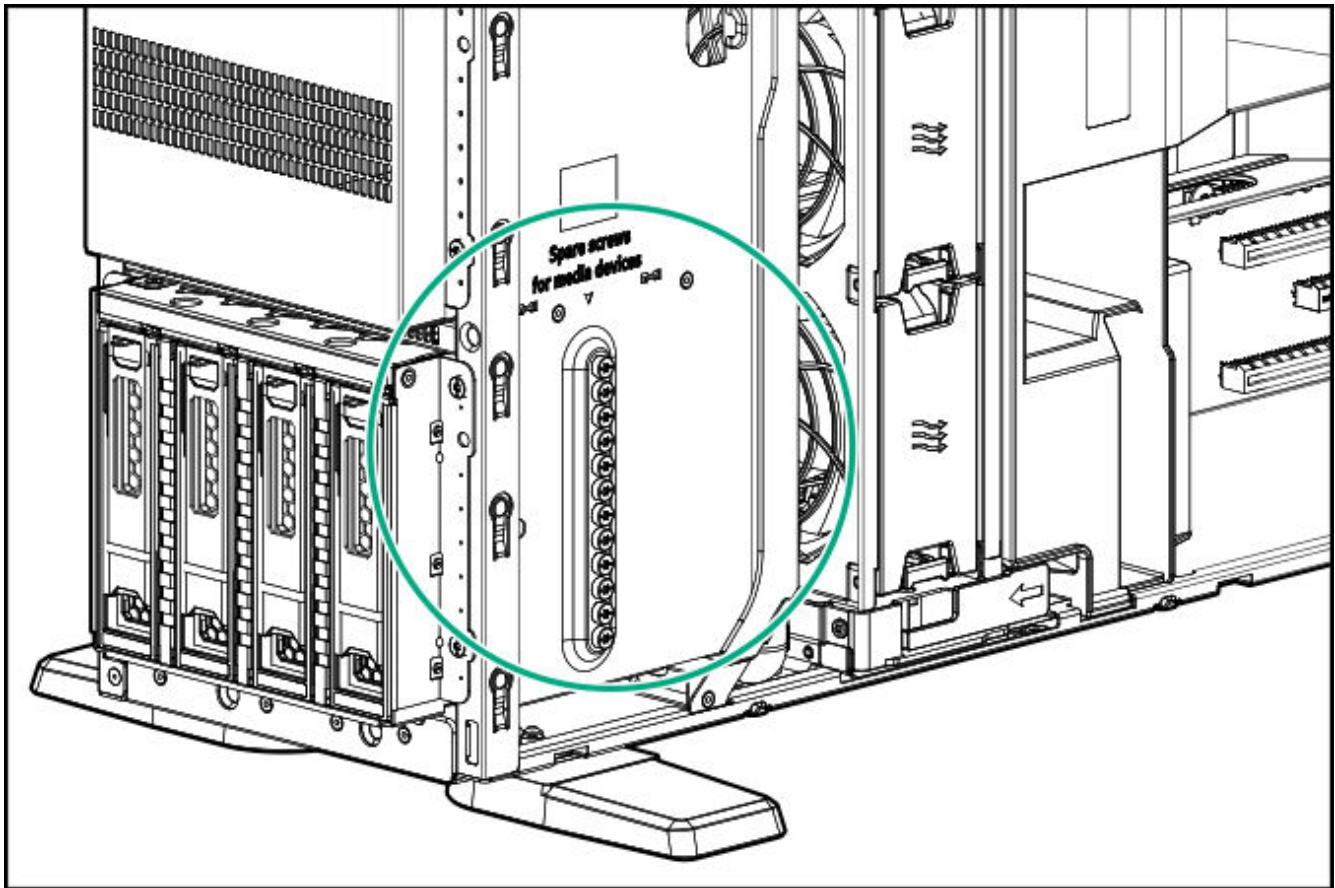

Setup

This chapter describes general operational requirements and safety reminders, as well as the initial setup procedure for the server.

Subtopics

HPE Installation Service

Setting up the server

Removing the shipping brackets

Operational requirements

Rack warnings and cautions

Server warnings and cautions

Electrostatic discharge

HPE Installation Service

HPE Installation Service provides basic installation of Hewlett Packard Enterprise branded equipment, software products, as well as HPE-supported products from other vendors that are sold by HPE or by HPE authorized resellers. The Installation Service is part of a suite of HPE deployment services that are designed to give users the peace of mind that comes from knowing that their HPE and HPE-supported products have been installed by an HPE specialist.

The HPE Installation Service provides the following benefits:

- Installation by an HPE authorized technical specialist.
- Verification prior to installation that all service prerequisites are met.
- Delivery of the service at a mutually scheduled time convenient to your organization.
- Allows your IT resources to stay focused on their core tasks and priorities.
- Full coverage during the warranty period for products that require installation by an HPE authorized technical specialist.

For more information on the features, limitations, provisions, and ordering information of the HPE Installation Service, see this Hewlett Packard Enterprise website:

<https://www.hpe.com/support/installation-service>

Setting up the server

Prerequisites

- As a best practice, Hewlett Packard Enterprise recommends installing the latest firmware, drivers, and system software before using the server for the first time. You have these options:
 - HPE Compute Ops Management is an advanced software-as-a-service platform that securely streamlines operations from edge-to-cloud and automates key life cycle tasks through a unified single browser-based interface. For more information on using HPE Compute Ops Management, see <https://www.hpe.com/info/com-docs>.
 - Use the **Firmware Update** option in Intelligent Provisioning—Intelligent Provisioning is a server deployment tool embedded in HPE ProLiant servers. To access Intelligent Provisioning, during the server boot process, press **F10**. For more information, see the Intelligent Provisioning user guide at <https://www.hpe.com/support/hpeintelligentprovisioning-quicklinks>.
 - Download the Service Pack for HPE ProLiant—SPP is a comprehensive system software and firmware update solution that is delivered as a single ISO image. This solution uses Smart Update Manager as the deployment tool.
 - The preferred method for downloading an SPP is by creating an SPP custom download at <https://www.hpe.com/servers/spp/custom>.

This option reduces the size of the SPP by excluding firmware and drivers for OS and server models that are not needed.
 - The SPP is also available for download from the SPP download page at <https://www.hpe.com/servers/spp/download>.
- Verify that your OS or virtualization software is supported:
<https://www.hpe.com/support/Servers-Certification-Matrices>
- Read the [Operational requirements](#) for the server.
- Read the safety and compliance information:
<https://www.hpe.com/support/safety-compliance-enterpriseproducts>

Procedure

1. Unbox the server and verify the contents:
 - Server
 - Power cord
 - Rack-mounting hardware (optional)

- Printed setup documentation

The server does not ship with OS media. All system software and firmware is preloaded on the server.

2. (Optional) Install the hardware options.

3. Select the server orientation:

- Tower orientation: Connect the peripheral cables and power cord.
- Rack orientation:
 - If the server was shipped with the tower-to-rack conversion kit, install the tower-to-rack conversion kit.
 - If the server was shipped in a rack, remove the shipping brackets.

4. Decide how to manage the server:

- Locally: Use a KVM switch or connect a keyboard, monitor, and mouse.
- Remotely: Connect to the iLO web interface and run a remote console:

a. Verify the following:

- iLO is licensed to use the remote console feature.
If iLO is not licensed, visit the HPE website:

<https://www.hpe.com/info/ilo>

- The iLO dedicated network port is connected to a secure network.

b. Using a browser, navigate to the iLO web interface, and then log in.

```
https://<iLO hostname or IP address>
```

Note the following:

- If a DHCP server assigns the IP address, the IP address appears on the boot screen.
- If a static IP address is assigned, use that IP address.

c. Enter the iLO login name and password, and then click **Log In**.

d. In the navigation tree, click the **Remote Console & Media** link, and then launch a remote console.

5. Press the Power On/Standby button.

For remote management, use the iLO virtual power button.

6. Configure the initial server setup.

7. Set up the storage.

8. Deploy an OS or virtualization software.
9. After the OS is installed, update the drivers.
10. Register the server.

Removing the shipping brackets

Prerequisites

Before you perform this procedure, make sure that you have a T-25 Torx screwdriver available.

About this task

A server shipped in a rack is secured by shipping brackets. To allow the server tray to be extended out of the rack during normal server operation, remove these shipping brackets.

Procedure

1. Remove the screws securing the shipping bracket.
2. Remove the shipping bracket from the front rack column.

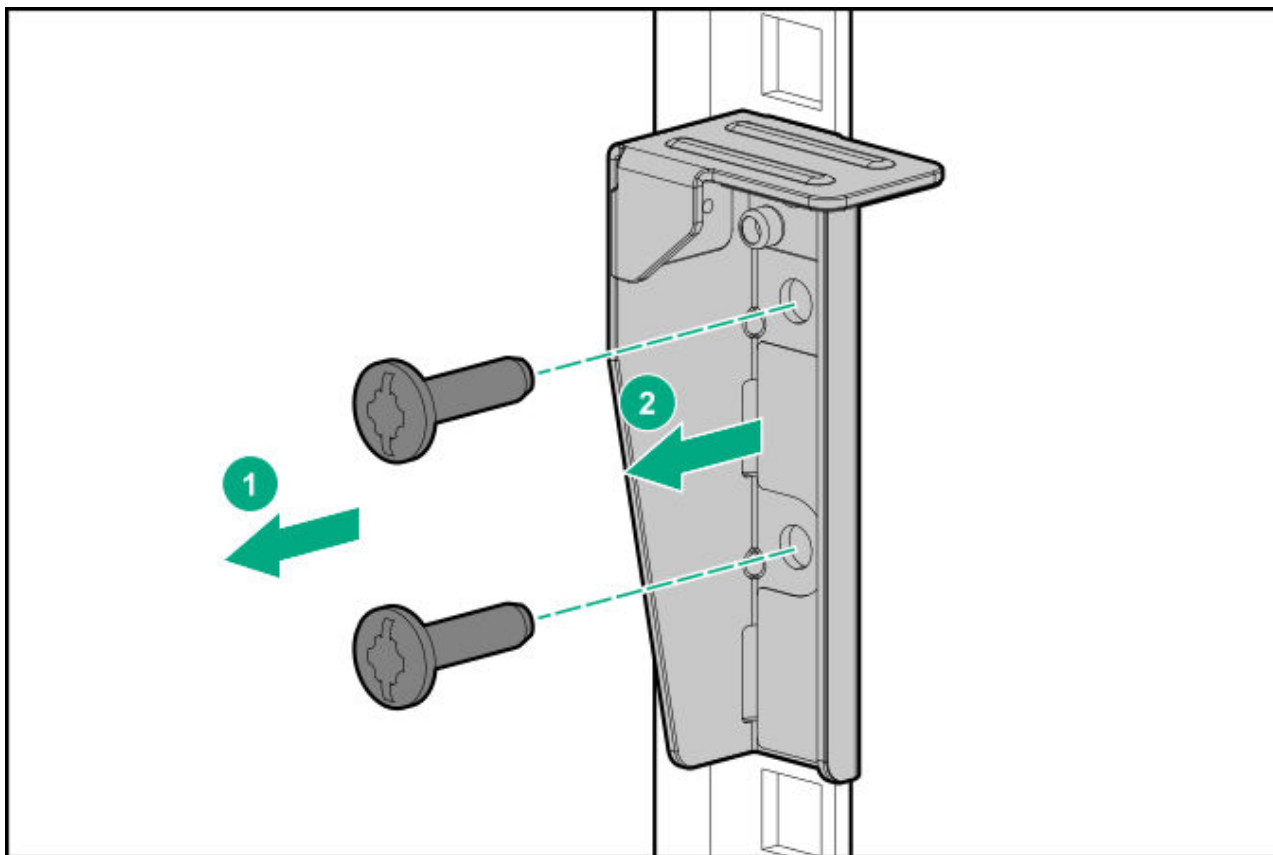

3. Repeat steps 1–2 to remove the bracket from the other opposite rack column.

Retain the shipping brackets and screws in case there is a need to ship or transport the rack-mounted server at a later date.

Operational requirements

When preparing and planning the installation, observe the following operational requirements:

- [Space and airflow requirements](#)
- [Temperature requirements](#)
- [Power requirements](#)
- [Electrical grounding requirements](#)

For environmental requirements, see [Environmental specifications](#).

Subtopics

[Space and airflow requirements](#)

[Temperature requirements](#)

[Power requirements](#)

[Electrical grounding requirements](#)

Space and airflow requirements

To allow for servicing and adequate airflow, observe the following space and airflow requirements when installing the server in an indoor commercial rack:

- 63.50 cm (25.00 in) in front of the rack
- 76.20 cm (30.00 in) behind the rack
- 121.90 cm (48.00 in) from the back of the rack to the back of another rack or row of racks

Observe the following:

- Servers draw in cool air through the front of the rack and expel warm air through the rear. The front and rear rack doors must be adequately ventilated to allow ambient air to enter the cabinet. The rear door must be adequately ventilated to allow the warm air to escape from the cabinet.

**CAUTION**

To prevent improper cooling and damage to the equipment, do not block the ventilation openings.

**CAUTION**

When the vertical space in the rack is not filled by a server or rack component, the gaps between the components can cause changes in airflow through the rack and around the servers. Cover all gaps with blanking panels to maintain proper airflow. Using a rack without blanking panels results in improper cooling which can lead to thermal damage.

- If a third-party rack is used, observe the following additional requirements to ensure adequate airflow and prevent damage to the equipment:
 - Front and rear doors—If the 42U rack includes closing front and rear doors, you must allow 5,350 sq cm (830 sq in) of holes evenly distributed from top to bottom to permit adequate airflow (equivalent to the required 64 percent open area for ventilation).
 - Side—The clearance between the installed rack component and the side panels of the rack must be a minimum of 7.00 cm (2.75 in).

Temperature requirements

To ensure continued safe and reliable equipment operation, install or position the system in a well-ventilated, climate-controlled environment.

The maximum recommended ambient operating temperature (TMRA) for most server products is 35°C (95°F). The temperature in the room where the rack is located must not exceed 35°C (95°F).



CAUTION

To reduce the risk of damage to the equipment when installing third-party options:

- Do not permit optional equipment to impede airflow around the server or to increase the internal rack temperature beyond the maximum allowable limits.
- Do not exceed the manufacturer's TMRA.

Power requirements

Installation of this equipment must comply with local and regional electrical regulations governing the installation of information technology equipment by licensed electricians. This equipment is designed to operate in installations covered by NFPA 70, 1999 Edition (National Electric Code) and NFPA-75, 1992 (code for Protection of Electronic Computer/Data Processing Equipment). For electrical power ratings on options, refer to the product rating label or the user documentation supplied with that option.



WARNING

To reduce the risk of personal injury, fire, or damage to the equipment, do not overload the AC supply branch circuit that provides power to the rack. Consult the electrical authority having jurisdiction over wiring and installation requirements of your facility.



CAUTION

Protect the server from power fluctuations and temporary interruptions with a regulating uninterruptible power supply. This device protects the hardware from damage caused by power surges and voltage spikes and keeps the system in operation during a power failure.

Electrical grounding requirements

The server must be grounded properly for proper operation and safety. In the United States, you must install the equipment in accordance with NFPA 70, National Electric Code Article 250, as well as any local and regional building codes. In Canada, you must install the equipment in accordance with Canadian Standards Association, CSA C22.1, Canadian Electrical Code. In all other countries, you must install the equipment in

accordance with any regional or national electrical wiring codes, such as the International Electrotechnical Commission (IEC) Code 364, parts 1 through 7. Furthermore, you must be sure that all power distribution devices used in the installation, such as branch wiring and receptacles, are listed or certified grounding-type devices.

Because of the high ground-leakage currents associated with multiple servers connected to the same power source, Hewlett Packard Enterprise recommends the use of a PDU that is either permanently wired to the building's branch circuit or includes a nondetachable cord that is wired to an industrial-style plug. NEMA locking-style plugs or those complying with IEC 60309 are considered suitable for this purpose. Using common power outlet strips for the server is not recommended.

Rack warnings and cautions



WARNING

When all components are removed, the server weighs 23.96 kg (58.22 lb). When all components are installed, the server can weigh up to 45.13 kg (99.49 lb).

Before configuring your rack solution, be sure to check the rack manufacturer weight limits and specifications. Failure to do so can result in physical injury or damage to the equipment and the facility.



WARNING

The server is heavy. To reduce the risk of personal injury or damage to the equipment, do the following:

- Observe local occupational health and safety requirements and guidelines for manual material handling.
- Get help to lift and stabilize the product during installation or removal, especially when the product is not fastened to the rails. The server weighs more than 23.96 kg (58.22 lb), so at least two people must lift the server into the rack together. An additional person may be required to help align the server if the server is installed higher than chest level.
- Use caution when installing the server in or removing the server from the rack.
- Adequately stabilize the rack before extending a component outside the rack. Extend only one component at a time. A rack may become unstable if more than one component is extended.
- Do not stack anything on top of rail-mounted component or use it as a work surface when extended from the rack.



WARNING

To reduce the risk of personal injury or damage to the equipment, be sure that:

- The rack has anti-tip measures in place. Such measures include floor-bolting, anti-tip feet, ballast, or a combination as specified by the rack manufacturer and applicable codes.
- The leveling jacks (feet) are extended to the floor.
- The full weight of the rack rests on the leveling jacks (feet).

Server warnings and cautions



WARNING

To reduce the risk of personal injury, electric shock, or damage to the equipment, disconnect the power cord to remove power from the server. Pressing the Power On/Standby button does not shut off system power completely. Portions of the power supply and some internal circuitry remain active until AC power is removed.



WARNING

To reduce the risk of personal injury from hot surfaces, allow the drives and the internal system components to cool before touching them.



WARNING

To reduce the risk of fire or burns after removing the energy pack:

- Do not disassemble, crush, or puncture the energy pack.
- Do not short external contacts.
- Do not dispose of the energy pack in fire or water.
- Do not expose the energy pack to low air pressure as it might lead to explosion or leakage of flammable liquid or gas.
- Do not expose the energy pack to temperatures higher than 60°C (140°F).

After power is disconnected, battery voltage might still be present for 1s to 160s.



CAUTION

Protect the server from power fluctuations and temporary interruptions with a regulating UPS. This device protects the hardware from damage caused by power surges and voltage spikes and keeps the server in operation during a power failure.



CAUTION

To prevent damage to electrical components, properly ground the server before beginning any installation, removal, or replacement procedure. Improper grounding can cause electrostatic discharge.



CAUTION

To avoid data loss, Hewlett Packard Enterprise recommends that you back up

Electrostatic discharge

Be aware of the precautions you must follow when setting up the system or handling components. A discharge of static electricity from a finger or other conductor may damage system boards or other static-sensitive devices. This type of damage may reduce the life expectancy of the system or component.

To prevent electrostatic damage:

- Avoid hand contact by transporting and storing products in static-safe containers.
- Keep electrostatic-sensitive parts in their containers until they arrive at static-free workstations.
- Place parts on a grounded surface before removing them from their containers.
- Avoid touching pins, leads, or circuitry.
- Always be properly grounded when touching a static-sensitive component or assembly. Use one or more of the following methods when handling or installing electrostatic-sensitive parts:
 - Use a wrist strap connected by a ground cord to a grounded workstation or computer chassis. Wrist straps are flexible straps with a minimum of 1 megohm \pm 10 percent resistance in the ground cords. To provide proper ground, wear the strap snug against the skin.
 - Use heel straps, toe straps, or boot straps at standing workstations. Wear the straps on both feet when standing on conductive floors or dissipating floor mats.
 - Use conductive field service tools.
 - Use a portable field service kit with a folding static-dissipating work mat.

If you do not have any of the suggested equipment for proper grounding, have an authorized reseller install the part.

For more information on static electricity or assistance with product installation, contact an authorized reseller.

Operations

This chapter describes the hardware operations carried out prior to and after installing or removing a hardware component, or performing a server maintenance or troubleshooting procedure. Before performing these hardware operations, review the:

- [Rack warnings and cautions](#)

- [Server warnings and cautions](#)

Subtopics

[iLO service port](#)

[Intel VROC support](#)

[Server UID LED](#)

[Monitor setup](#)

[Trusted Platform Module 2.0](#)

[Trusted Platform Module 2.0 guidelines](#)

[System battery information](#)

iLO service port

The iLO service port is a USB port with the label **iLO** on the front of the server.

When you have physical access to a server, you can use the iLO service port to:

- Download the Active Health System Log to a supported USB flash drive.

When you use this feature, the connected USB flash drive is not accessible by the host OS.

- Connect a host system (Windows/Mac/Linux laptop or desktop) using either a standard USB Type A-to-Type C cable or USB Type C-to-Type C cable to access the:
 - iLO web interface
 - Remote console
 - iLO RESTful API
 - CLI

When you use the iLO service port:

- Actions are logged in the iLO event log.
- The server UID flashes to indicate the iLO service port status.

You can also retrieve the iLO service port status by using a REST client and the iLO RESTful API.

- You cannot use the iLO service port to boot any device within the server, or the server itself.
- You cannot access the server by connecting to the iLO service port.
- You cannot access the connected device from the server.

For more information about the iLO service port, see the iLO user guide:

Intel VROC support

Intel Virtual RAID on CPU (Intel VROC) provides enterprise-level hybrid RAID support. Note the following information:

- Intel VROC provides RAID support for direct attached NVMe SSD.
- The Intel VROC driver is required. For the OS-specific driver download, see the following page:

<https://www.hpe.com/support/VROC-installation>

- If you plan to enable Intel VROC for NVMe devices, secure an Intel VROC Hybrid RAID License. For more information on Intel VROC licenses, see the server QuickSpecs:

<https://www.hpe.com/info/quickspecs>

- Intel VROC requires the server boot mode to be set to **UEFI Mode**.
- Intel VROC RAID support is disabled by default. In the pre-OS environment, use UEFI System Utilities to enable Intel VROC and create a VROC RAID volume. These tasks are not supported in Intelligent Provisioning.
- The VROC RAID volume must use drives of the same interface and form factor.
- Intel VROC supports RAID management through the following tools:
 - Non-OS specific: UEFI System Utilities
 - Windows: Intel VROC GUI, Intel VROC CLI
 - Linux: `mdadm` CLI

For more information on Intel VROC features and configuration, see [Configuring storage controllers](#).

Server UID LED

The UID LED can be used to help an on-site technician quickly identify or locate a particular server when it is deployed in a dense rack with other equipment. It can also be used to identify if a remote management, firmware upgrade, or reboot sequence is in progress.

Subtopics

[Viewing the Server Health Summary](#)

Viewing the Server Health Summary

Prerequisites

- An external monitor is connected.
- In the iLO web interface, the **Show Server Health on External Monitor** feature is enabled on the **Access Settings** page.

About this task

If the server does not power on, use the UID button to display the iLO **Server Health Summary** screen on an external monitor. This function works when the server is powered on or off.

For more information, see the iLO troubleshooting guide on the [Hewlett Packard Enterprise website](#).

Procedure

1. Press and release the UID button.



CAUTION

Be sure to press and release the UID button. Pressing the UID button at any time for more than five seconds will initiate a graceful iLO reboot or a hardware iLO reboot. Data loss or NVRAM corruption might occur during a hardware iLO reboot.

The **Server Health Summary** screen displays on the external monitor.

2. Press the UID button again to close the **Server Health Summary** screen.

Monitor setup

Before connecting a monitor, observe the following:

- The server supports both VGA port and DisplayPort 1.1a.
- If you connect two display devices to the server using both the VGA port and DisplayPort, the same image is mirrored on both devices.
- The embedded video controller in the iLO chipset does not support dual display or screen extension mode. To enable dual display, install a compatible graphics card.

- When using HDMI or DVI adapters for the DisplayPort, use an active-type adapter. Passive-type adapters marked with the DP++ symbol are not supported.
- Whenever possible, use the same display connection type. For example, if your monitor only has a VGA port, use the VGA port on the server. Using other adapters or converter cables or dongles might lead to decreased display quality or a lag over the connection.

Trusted Platform Module 2.0

The Trusted Platform Module 2.0 (TPM) is:

- Embedded on the system board
- A hardware-based system security feature that securely stores artifacts used to authenticate the platform. These artifacts can include passwords, certificates, and encryption keys
- Supported by specific operating systems such as Microsoft Windows Server 2012 R2 and later

For more information about operating system support, see the product QuickSpecs on the Hewlett Packard Enterprise website (<https://www.hpe.com/info/quickspecs>).

For more information about Microsoft Windows BitLocker Drive Encryption feature, see the Microsoft website (<https://www.microsoft.com>).

Trusted Platform Module 2.0 guidelines



CAUTION

- Always observe the TPM guidelines in this section. Failure to follow these guidelines can cause hardware damage or halt data access.
- If you do not follow procedures for modifying the server and suspending or disabling the TPM in the OS, an OS that is using TPM might lock all data access. This includes updating system or option firmware, replacing hardware such as the system board and drives, and modifying TPM OS settings.
- Changing the TPM mode after installing an OS might cause problems, including loss of data.

- Use the UEFI System Utilities to configure the TPM. From the **System Utilities** screen, select **System Configuration** > **BIOS/Platform Configuration (RBSU)** > **Server Security** > **Trusted Platform Module options**. For more information, see the UEFI user guide:

<https://www.hpe.com/support/hpeuefisystemutilities-quicklinks>

- When using the Microsoft Windows BitLocker Drive Encryption feature, always retain the recovery key or password. The recovery key or password is required to enter Recovery Mode after BitLocker detects a possible compromise of system integrity.
- HPE is not liable for blocked data access caused by improper TPM use. For operating instructions, see the documentation for the encryption technology feature provided by the operating system.

System battery information

The server contains an internal lithium manganese dioxide, a vanadium pentoxide, or an alkaline battery that provides power to the real-time clock.



WARNING

If this battery is not properly handled, a risk of fire or burning exists. To reduce the risk of personal injury:

- Do not attempt to recharge the battery.
- Do not expose the battery to temperatures higher than 60°C (140°F).
- Do not expose the battery to low air pressure as it might lead to explosion or leakage of flammable liquid or gas.
- Do not disassemble, crush, puncture, short external contacts, or dispose of the battery in fire or water.

Hardware options installation

This chapter provides instructions for installing supported hardware options. To ensure proper server deployment and operation, Hewlett Packard Enterprise recommends installing only HPE-validated hardware options. To see the list of validated options for this server, see the product QuickSpecs on the HPE website:

<https://www.hpe.com/info/quickspecs>

To view the warranty for your server and supported options, see [Warranty information](#).

Subtopics

[**Hewlett Packard Enterprise product QuickSpecs**](#)

[**Hardware option installation guidelines**](#)

[**Pre-installation procedures**](#)

[**Post-installation procedures**](#)

[**Tower-to-rack conversion kit**](#)

[**Drives**](#)

[**Drive cages**](#)

[**Energy packs**](#)

[**Media device options**](#)

[**Memory options**](#)

[**Power supply options**](#)

[**Management**](#)

[**Transceiver option**](#)

[**Fan options**](#)

[**Risers and riser cages**](#)

[**GPUs**](#)

[**Processors and heatsinks**](#)

[**Networking**](#)

[**OS boot device**](#)

[**Security**](#)

[**Storage controllers**](#)

[**Internal USB device options**](#)

Hewlett Packard Enterprise product QuickSpecs

To learn more about your product, search the Hewlett Packard Enterprise website (<https://www.hpe.com/info/quickspecs>) for the product QuickSpecs:

- Supported options
- Supported configurations
- Component compatibility
- New features
- Specifications
- Part numbers

Hardware option installation guidelines



WARNING

To reduce the risk of personal injury from hot surfaces, allow the drives and the internal system components to cool before touching them.



CAUTION

To avoid data loss, Hewlett Packard Enterprise recommends that you back up all server data before installing or removing a hardware option, or performing a server maintenance or troubleshooting procedure.



CAUTION

To prevent damage to electrical components, properly ground the server before beginning any installation, removal, or replacement procedure. Improper grounding can cause electrostatic discharge.

- Install any hardware options before initializing the server.
- If multiple options are being installed, read the installation instructions for all the hardware options to identify similar steps and streamline the installation process.
- If the hardware option installation involves internal cabling, review the Cabling guidelines.

Pre-installation procedures

Subtopics

Server data backup

Power down the server

Position the tower server for hardware configuration

Extend the server from the rack

Remove the server from the rack

Remove the front bezel

Remove the access panel

Remove the fan cage

Remove the drive cage

Remove the primary riser cage

Remove the secondary riser cage blank

Remove the secondary riser cage

Remove the energy pack and the energy pack holder

Remove the HPE NS204i-u Boot Device V2 on the power supply cage

Server data backup

To avoid data loss, make sure to back up all server data before installing or removing a hardware option, performing a server maintenance, or a troubleshooting procedure.

Server data in this context refers to information that may be required to return the system to a normal operating environment after completing a hardware maintenance or troubleshooting procedure. This information may include:

- User data files
- User account names and passwords
- Application settings and passwords
- Component drivers and firmware
- TPM recovery key/password
- BIOS configuration settings—Use the backup and restore function in UEFI System Utilities. For more information, see the UEFI user guide (<https://www.hpe.com/support/hpeuefisystemutilities-quicklinks>).
 - Custom default system settings
 - Security passwords including those required for power-on and BIOS admin access, persistent memory, and Server Configuration Lock (for HPE Trusted Supply Chain servers)
 - Server serial number and the product ID
- iLO-related data—Use the iLO backup and restore function. For more information, see the iLO user guide (<https://www.hpe.com/support/hpeilodocs-quicklinks>).
 - iLO license
 - Customer iLO user name, password, and DNS name
 - iLO configuration settings

Power down the server

Before powering down the server for any upgrade or maintenance procedures, perform a backup of critical server data and programs.



IMPORTANT

When the server is in standby mode, auxiliary power is still being provided to the system.

To power down the server, use one of the following methods:

- Press and release the Power On/Standby button.
This method activates a controlled shutdown of applications and the OS before the server enters standby mode. It can also activate a shutdown behavior governed by an OS configuration or policy.
- Press and hold the Power On/Standby button for more than 4 seconds to force the server to enter standby mode.
This method forces the server to enter standby mode without properly exiting applications and the OS. If an application stops responding, you can use this method to force a shutdown.
- Use a virtual power button selection through iLO 7.
This method initiates a controlled remote shutdown of applications and the OS before the server enters standby mode.

Before proceeding, verify that the server is in standby mode by observing that the system power LED is amber.

Position the tower server for hardware configuration

Procedure

1. Rotate the chassis feet inward.

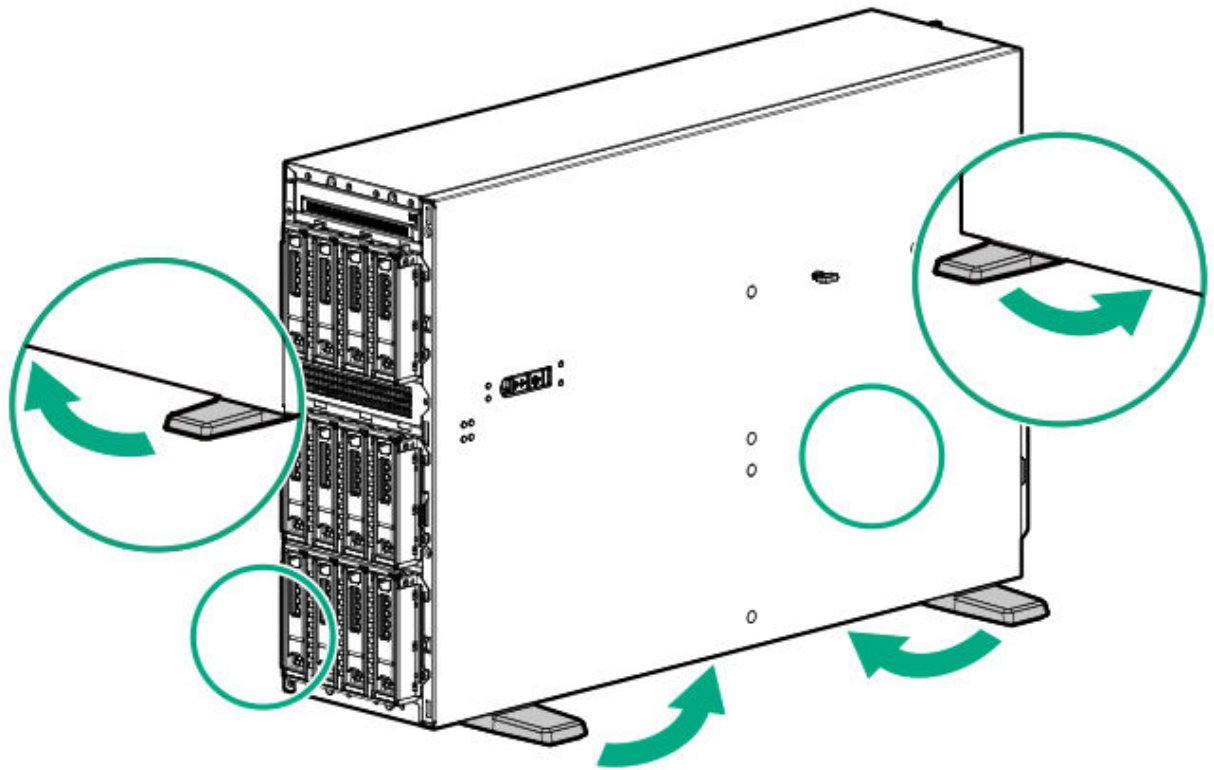

2. Place the server on a flat, level surface with the access panel facing up.

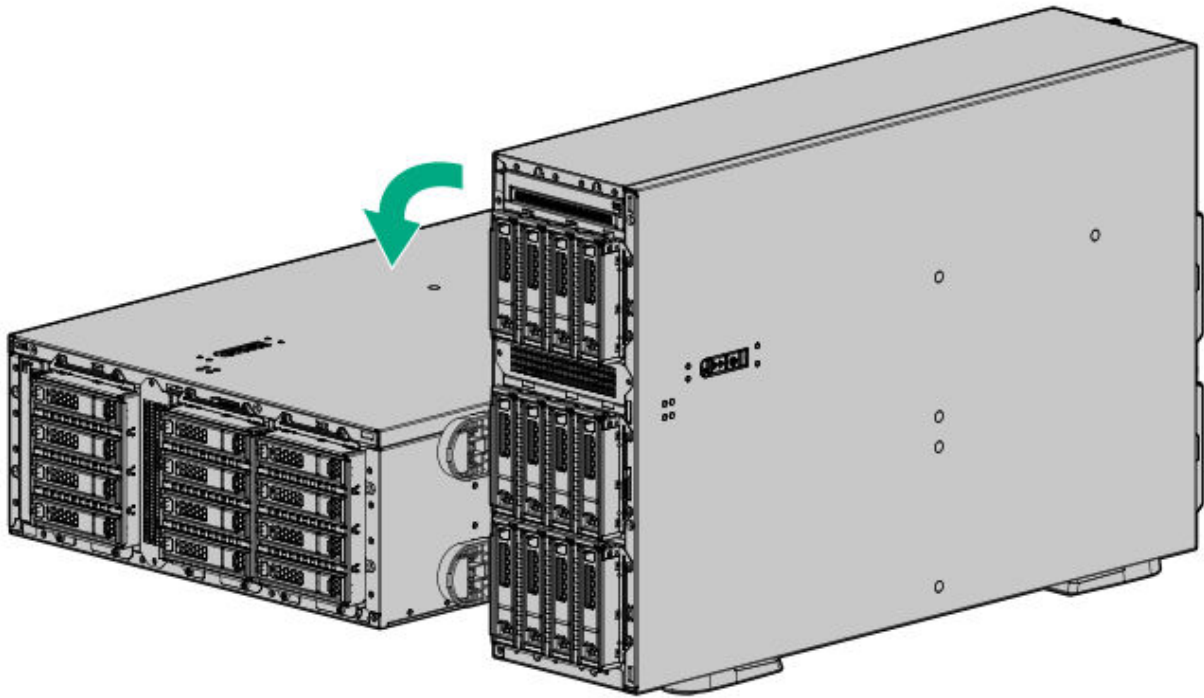

Extend the server from the rack

Prerequisites

Before you perform this procedure, review the [Rack warnings and cautions](#).

Procedure

Slide the server tray out of the rack:

1. Loosen the server tray thumbscrews.
2. Grasp the tray notch and slide the server out of the rack.

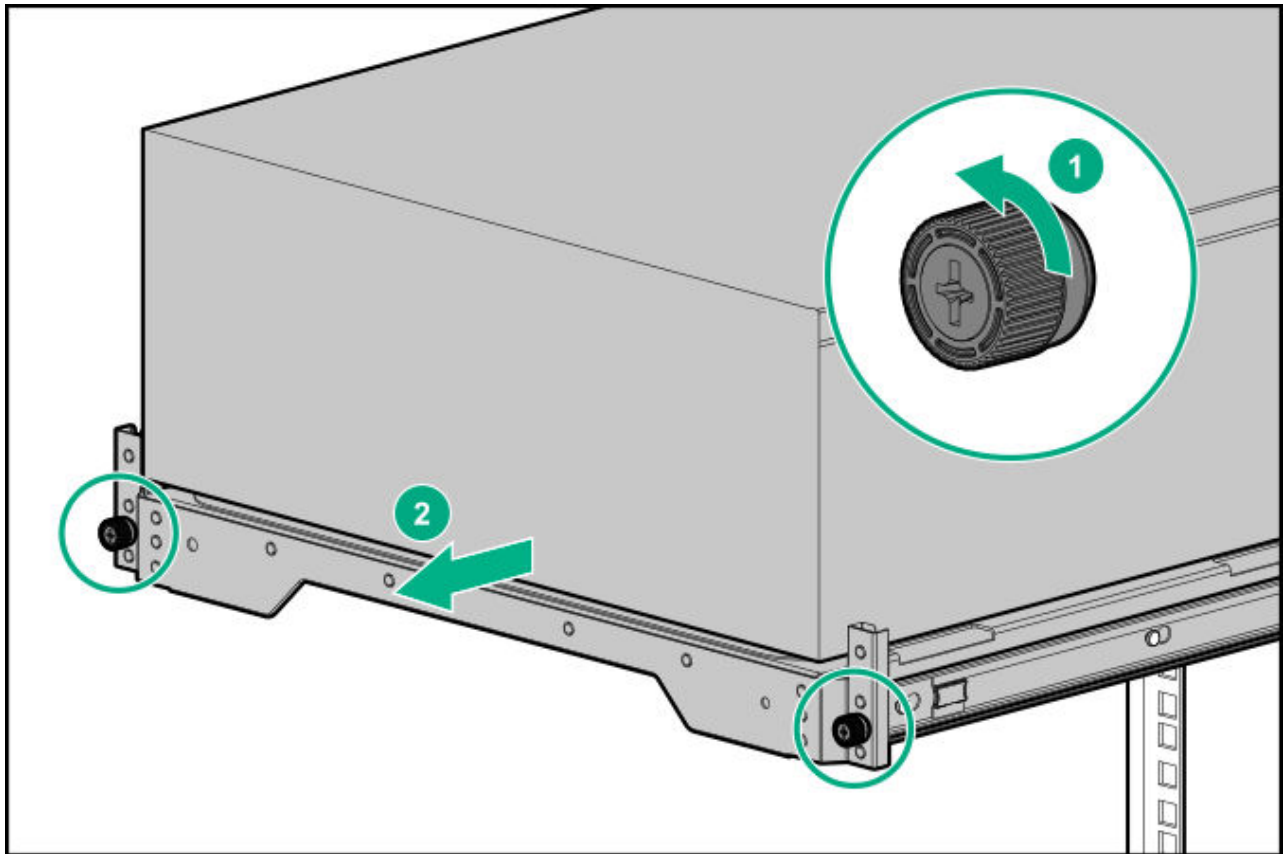

Remove the server from the rack

Prerequisites

- Get help to lift and stabilize the server during removal from the rack. **If the server is installed higher than chest level, additional two people might be required to help remove the server:** One person to support the server weight, and the other two to slide the server out of the rack.
- Before you perform this procedure, review the:
 - [Rack warnings and cautions](#)
 - [Server warnings and cautions](#)
- A fully populated server is heavy. Hewlett Packard Enterprise recommends removing the external chassis components before removing the server from a rack.
- Before you perform this procedure, make sure that you have a T-15 Torx screwdriver available.

Procedure

1. Power down the server.
2. Remove all power:
 - a. Disconnect each power cord from the power source.
 - b. Disconnect each power cord from the server.
3. Disconnect all peripheral cables from the server.
4. If installed, unlock and remove the security padlock and/or the Kensington security lock.
For more information, see the lock documentation.
5. Slide the server tray out of the rack:
 - a. Loosen the server tray thumbscrews.
 - b. Grasp the tray notch and slide the server out of the rack.

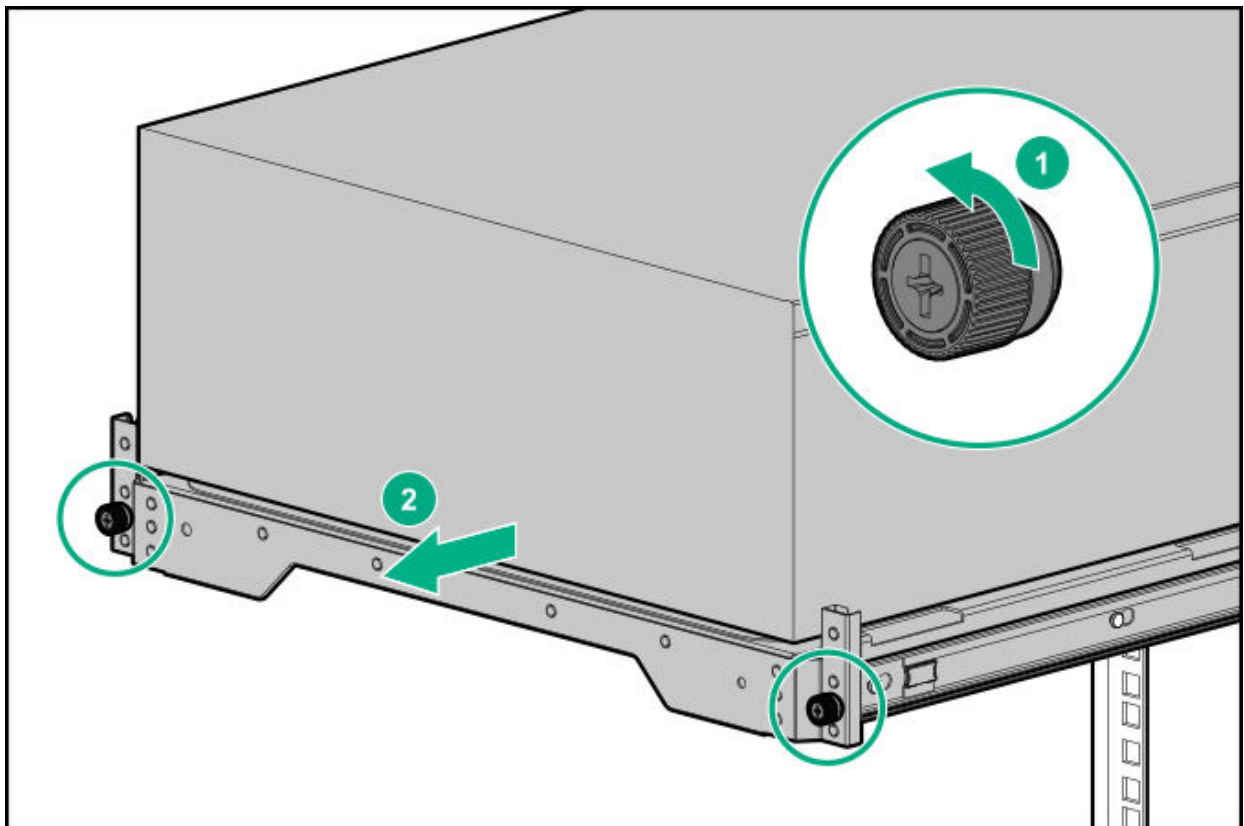

6. Remove the chassis rear bracket screws.

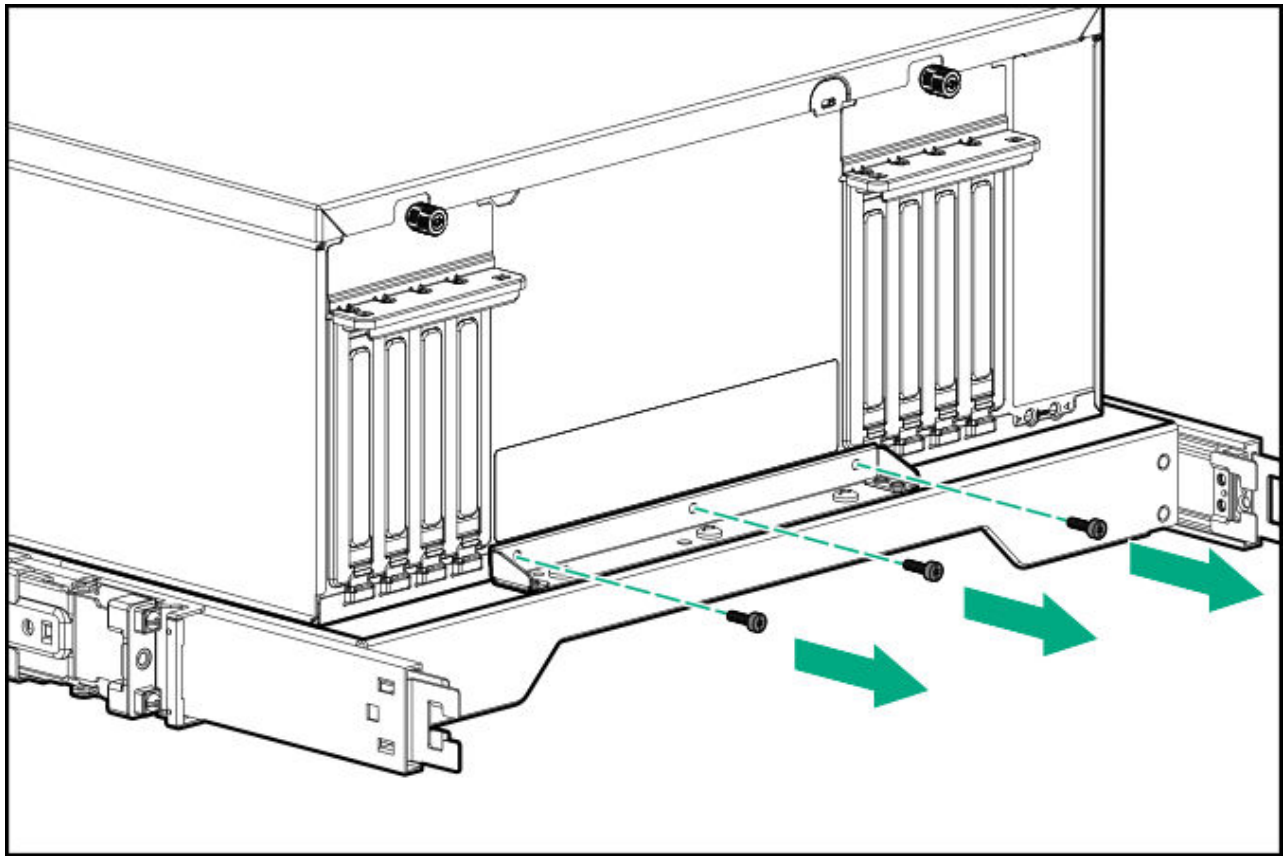

7. Remove the server from the tray.

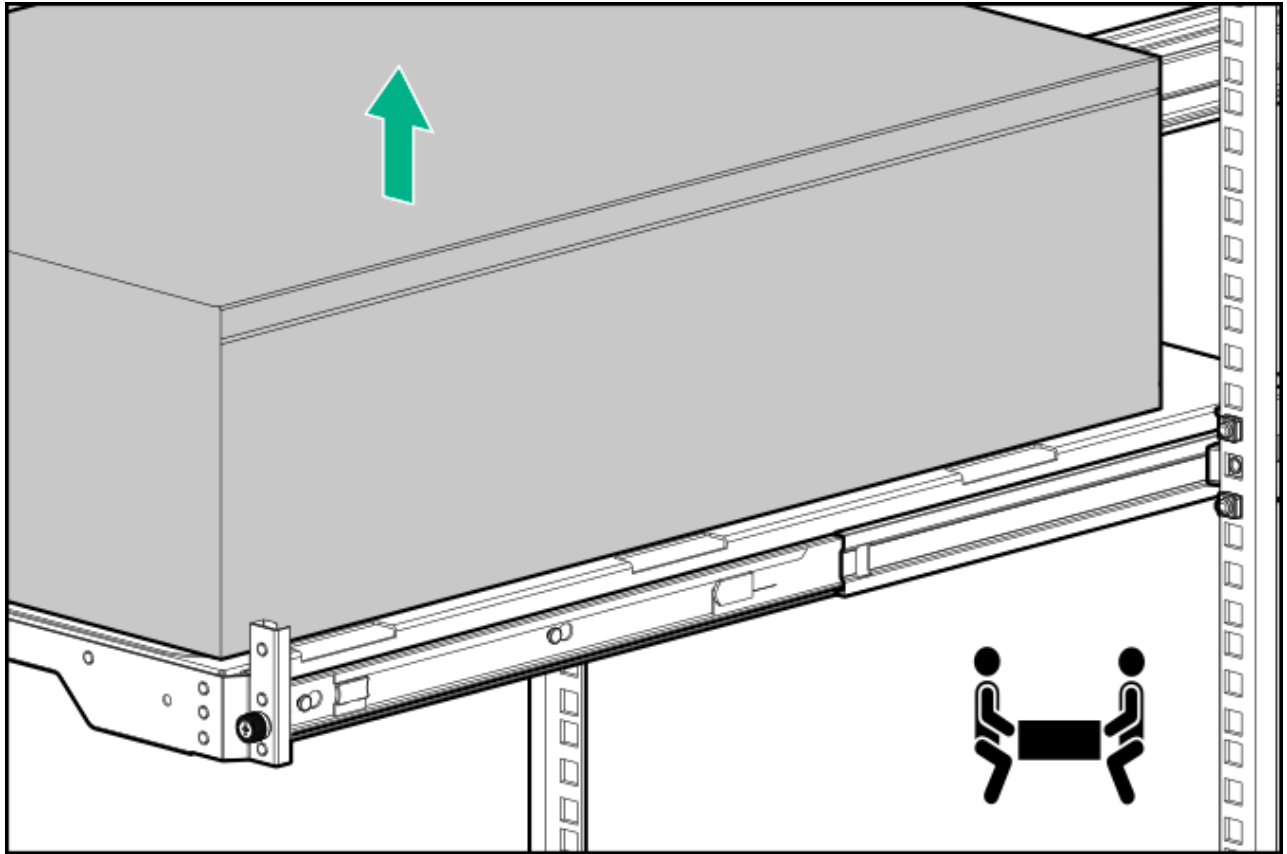

8. Place the server on a flat, level surface with the access panel facing up.

Remove the front bezel

Procedure

1. Unlock the front bezel.
2. Open the front bezel.

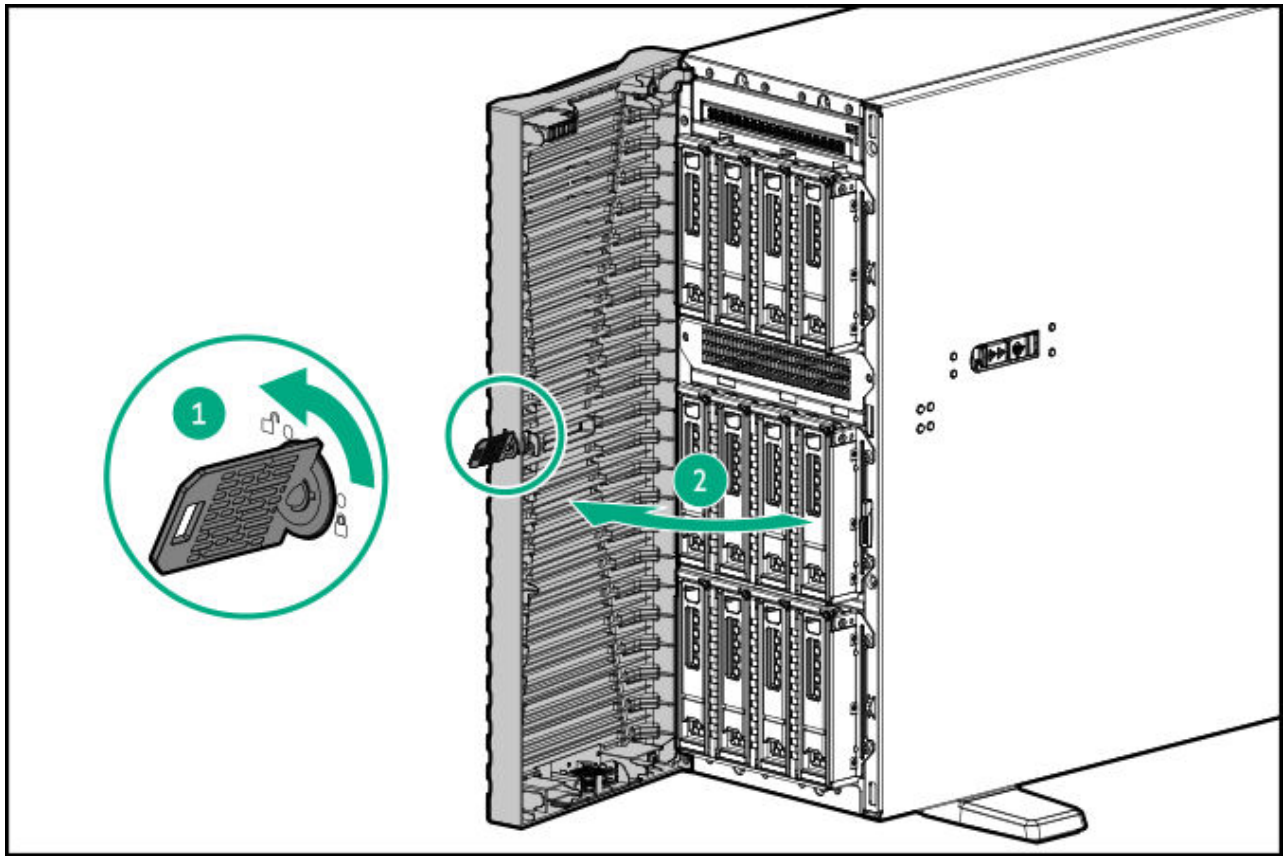

3. Release the bezel hooks from the front panel.

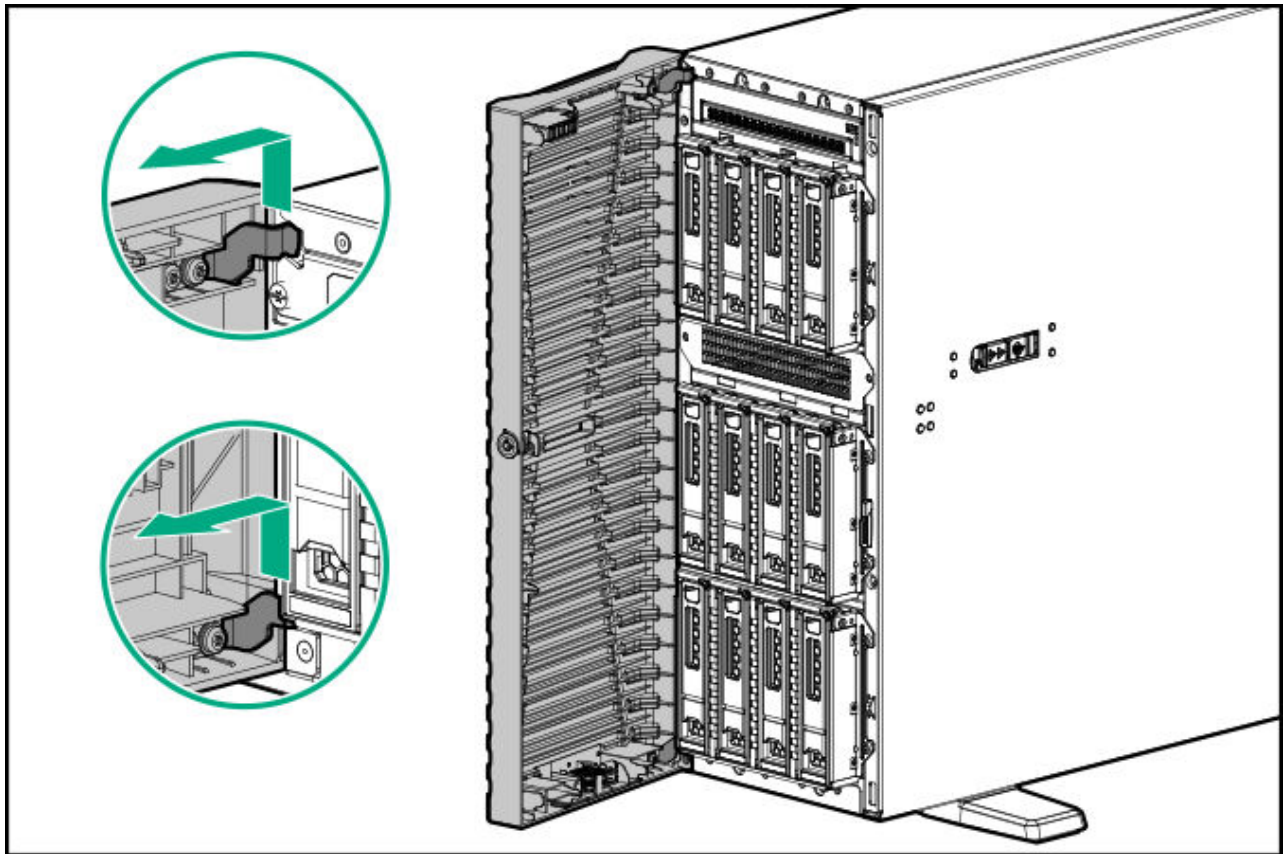

Remove the access panel

Prerequisites

Before you perform this procedure, make sure that you have a T-15 Torx screwdriver available.

About this task



WARNING

To reduce the risk of personal injury from hot surfaces, allow the drives and the internal system components to cool before touching them.



CAUTION

To prevent damage to electrical components, properly ground the server before beginning any installation, removal, or replacement procedure. Improper grounding can cause electrostatic discharge.



CAUTION

To maintain proper system cooling, do not operate the server for long period with the access panel open or removed. Operating the server in this manner results in an improper system airflow. For internal hot-plug component procedures, complete the procedure within 60 seconds. Failure to do so can cause the system temperature to increase and trip the safety threshold. When this happens:

- The health LED flashes amber.
- The operating system gracefully shuts down.

Procedure

1. Power down the server.
2. Remove all power:
 - a. Disconnect each power cord from the power source.
 - b. Disconnect each power cord from the server.
3. Disconnect all peripheral cables from the server.
4. If the server is in tower mode, place the server on a flat, level surface with the access panel facing up.
5. If the server is in rack mode, do one of the following:
 - Extend the server from the rack.
 - Remove the server from the rack.
6. Unlock the front bezel.
7. Remove the access panel:
 - a. If necessary, unlock the access panel latch.

- b. To disengage the access panel from the chassis, press the release button and pull up the latch.
- c. Lift the access panel.

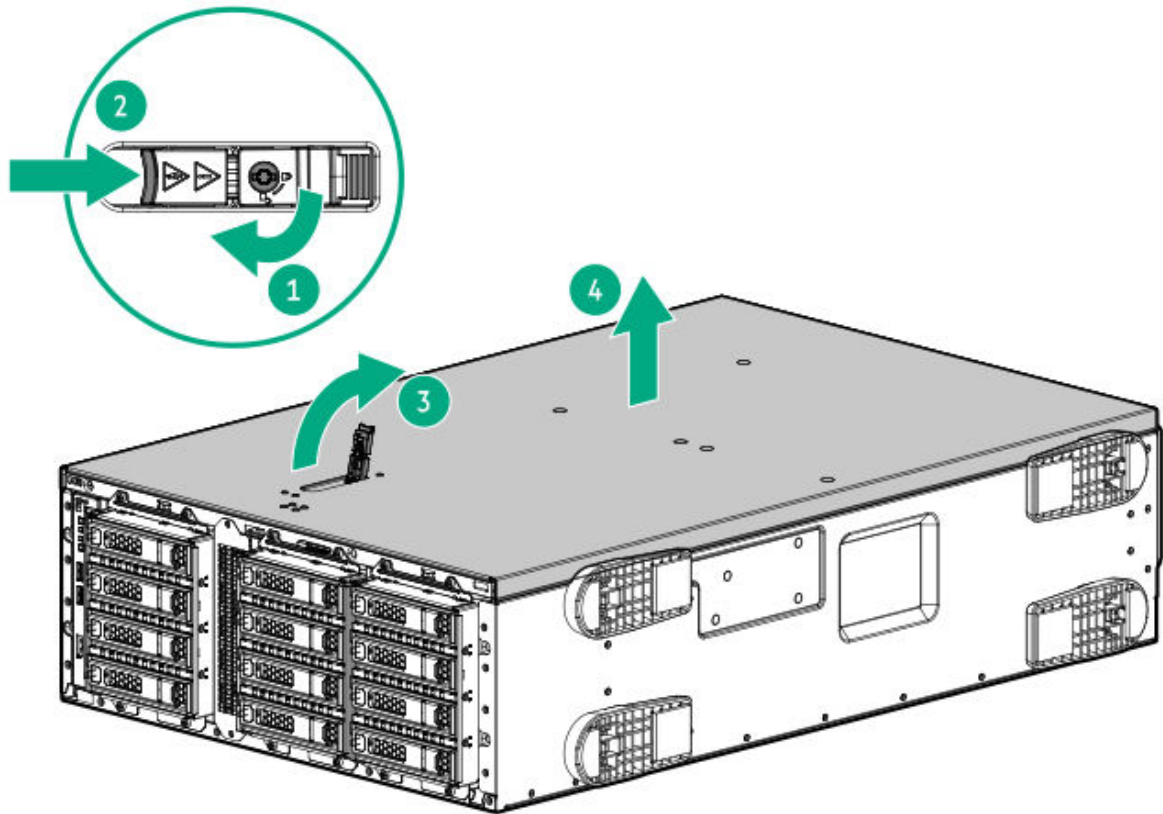

Remove the fan cage

Procedure

1. Power down the server.
2. Remove all power:
 - a. Disconnect each power cord from the power source.
 - b. Disconnect each power cord from the server.
3. Disconnect all peripheral cables from the server.
4. Do one of the following:
 - If the server is in tower mode, place the server on a flat, level surface with the access panel facing up.

- If the server is in rack mode, remove the server from the rack.

5. Unlock the front bezel.
6. Remove the access panel.
7. Press and hold the latch, and then lift the fan from the bay.

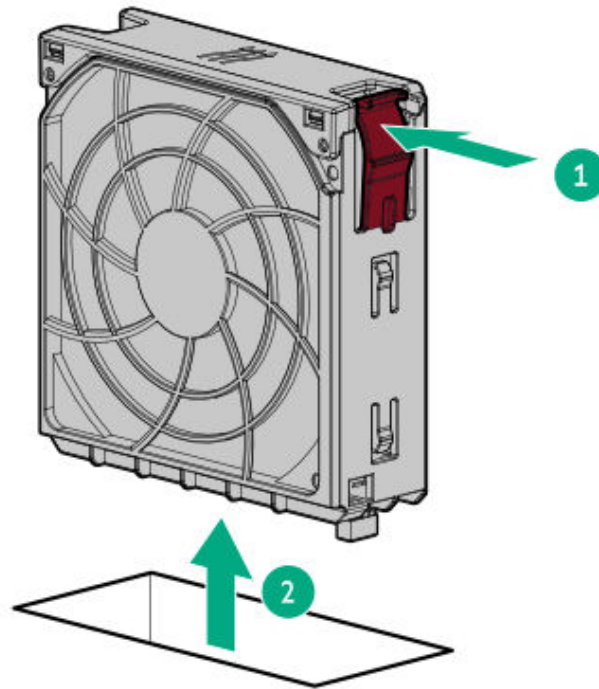

8. If installed, remove the fan blank from bay 1.

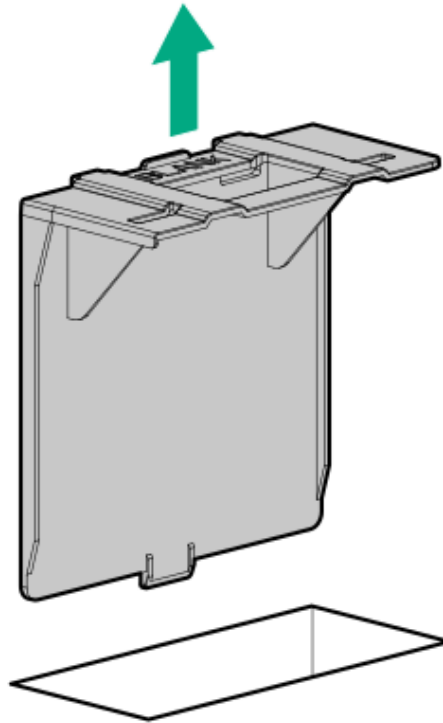

9. Disconnect the fan cage cables from the system board.
10. Remove the fan cage:
 - a. Open the fan cage latches.
 - b. Lift the fan cage away from the chassis.

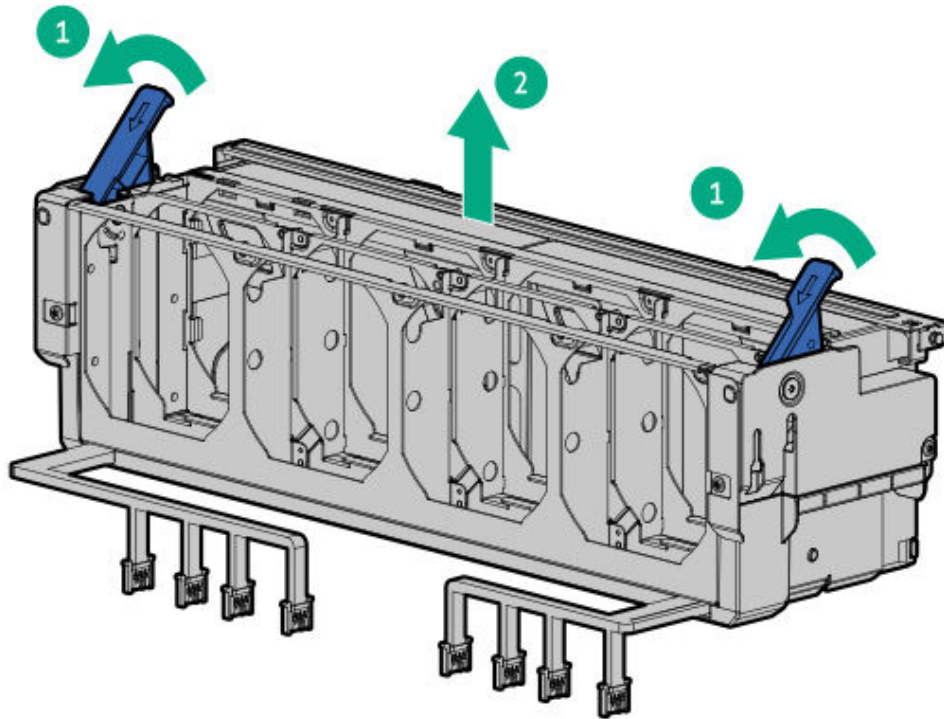

Remove the drive cage

Prerequisites

Before you perform this procedure, make sure that you have a T-15 Torx screwdriver available.

About this task



CAUTION

A discharge of static electricity from a finger or other conductor might damage system boards or other static-sensitive devices. To prevent damage, observe [antistatic precautions](#).



CAUTION

To prevent improper cooling and thermal damage, do not operate the server unless all bays are populated with either a component or a blank.

Procedure

1. Remove the front bezel.
2. Power down the server.
3. Remove all power:
 - a. Disconnect each power cord from the power source.
 - b. Disconnect each power cord from the server.
4. Disconnect all peripheral cables from the server.
5. Do one of the following:
 - If the server is in tower mode, place the server on a flat, level surface with the access panel facing up.
 - If the server is in rack mode, remove the server from the rack.
6. Remove the access panel.
7. Remove the fan cage.
8. Disconnect the drive cables.
9. Remove the drive cage:
 - 4 LFF drive:

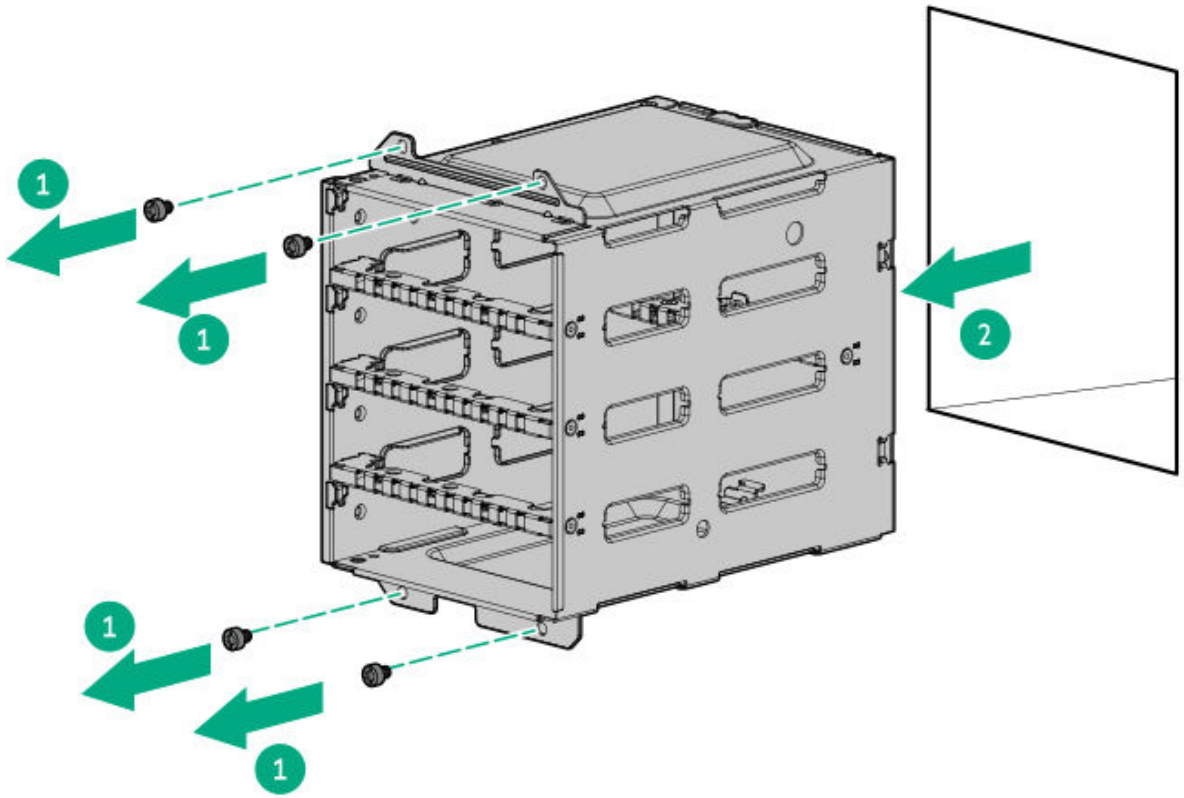

- 8 SFF drive:

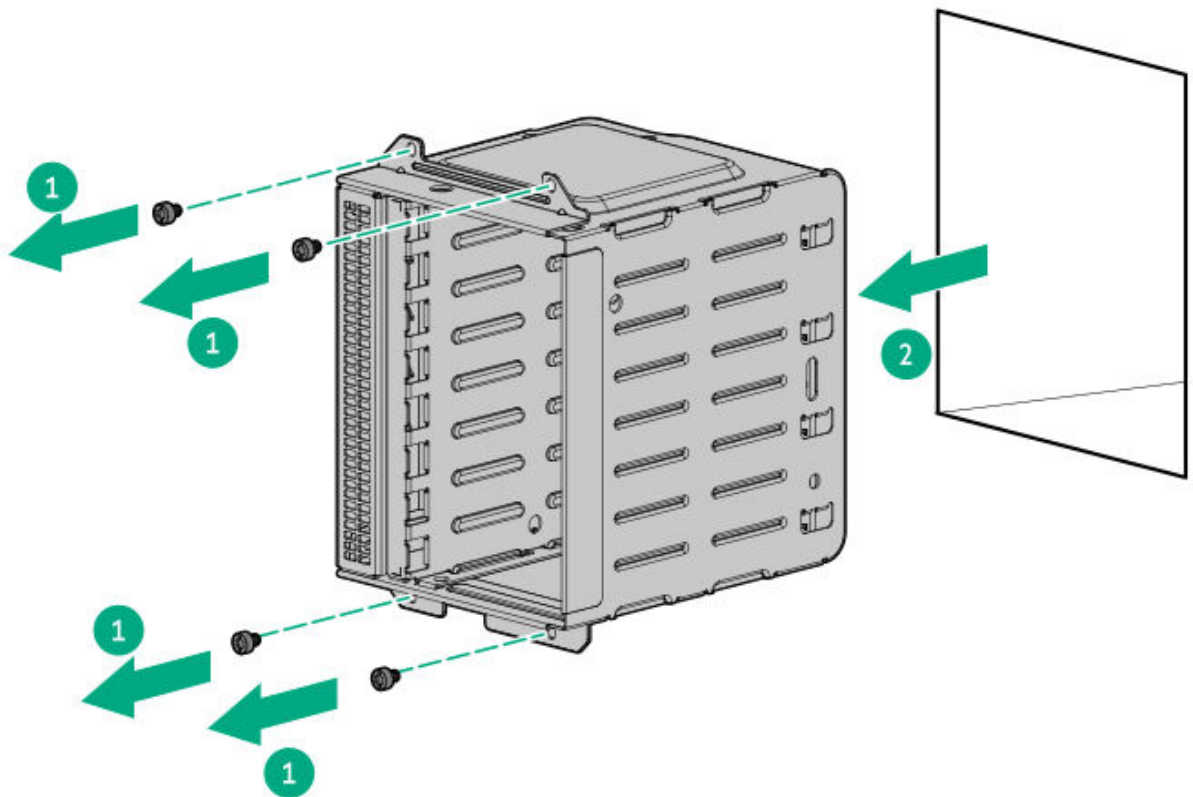

- 12 E3.S drive:

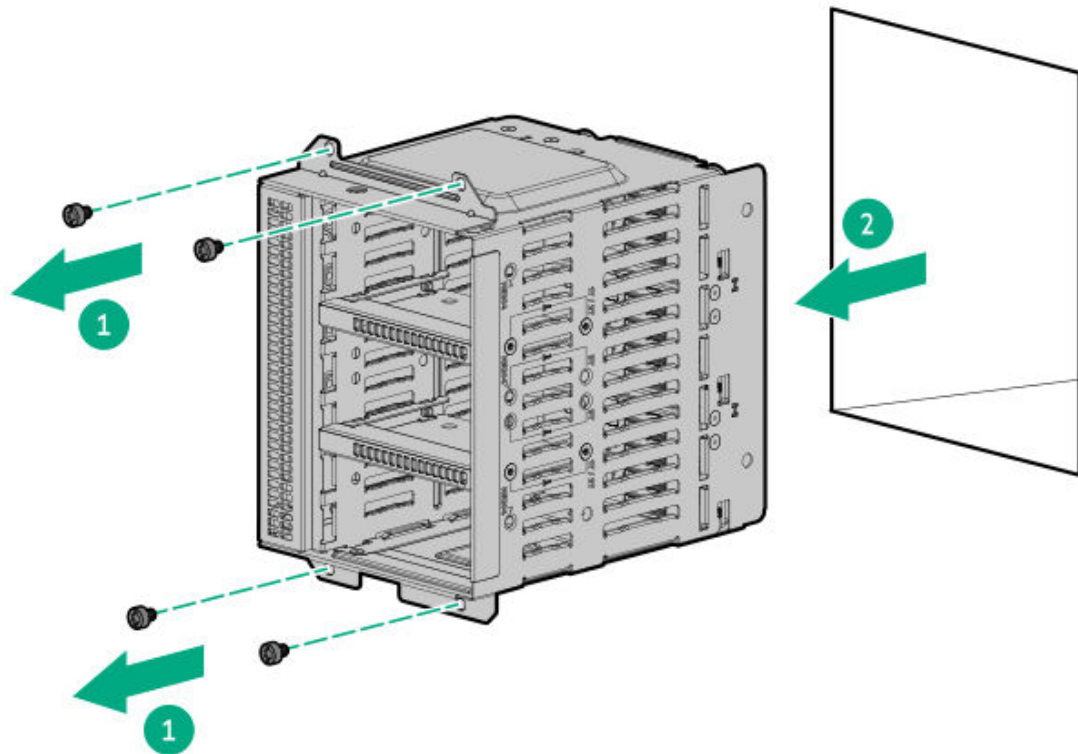

Remove the primary riser cage

About this task

Procedure

1. Power down the server.
2. Remove all power:
 - a. Disconnect each power cord from the power source.
 - b. Disconnect each power cord from the server.
3. Disconnect all peripheral cables from the server.
4. Do one of the following:
 - If the server is in tower mode, place the server on a flat, level surface with the access panel facing up.

- If the server is in rack mode, remove the server from the rack.

5. Unlock the front bezel.
6. Remove the access panel.
7. If an expansion card with internal cables is installed on the riser, disconnect all cables from the expansion card.
8. Remove the primary riser cage:
 - a. Release the half-turn spring latch.
 - b. Lift the riser cage off the system board.

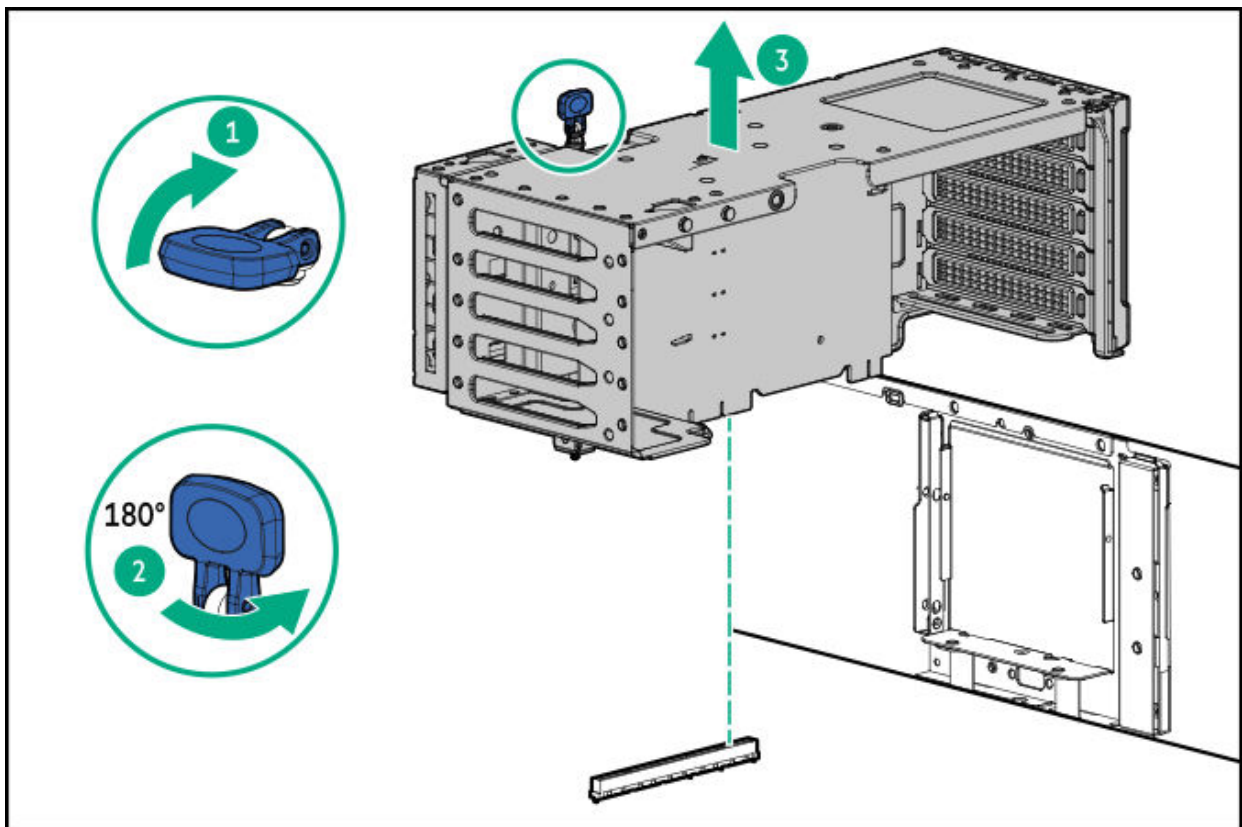

Remove the secondary riser cage blank

Prerequisites

Before you perform this procedure, make sure that you have a T-10 Torx screwdriver available.

About this task



CAUTION

To prevent improper cooling and thermal damage, do not operate the server unless all bays are populated with either a component or a blank.

Procedure

1. Power down the server.
2. Remove all power:
 - a. Disconnect each power cord from the power source.
 - b. Disconnect each power cord from the server.
3. Disconnect all peripheral cables from the server.
4. Do one of the following:
 - If the server is in tower mode, place the server on a flat, level surface with the access panel facing up.
 - If the server is in rack mode, remove the server from the rack.
5. Unlock the front bezel.
6. Remove the access panel.
7. Remove the secondary riser cage blank.

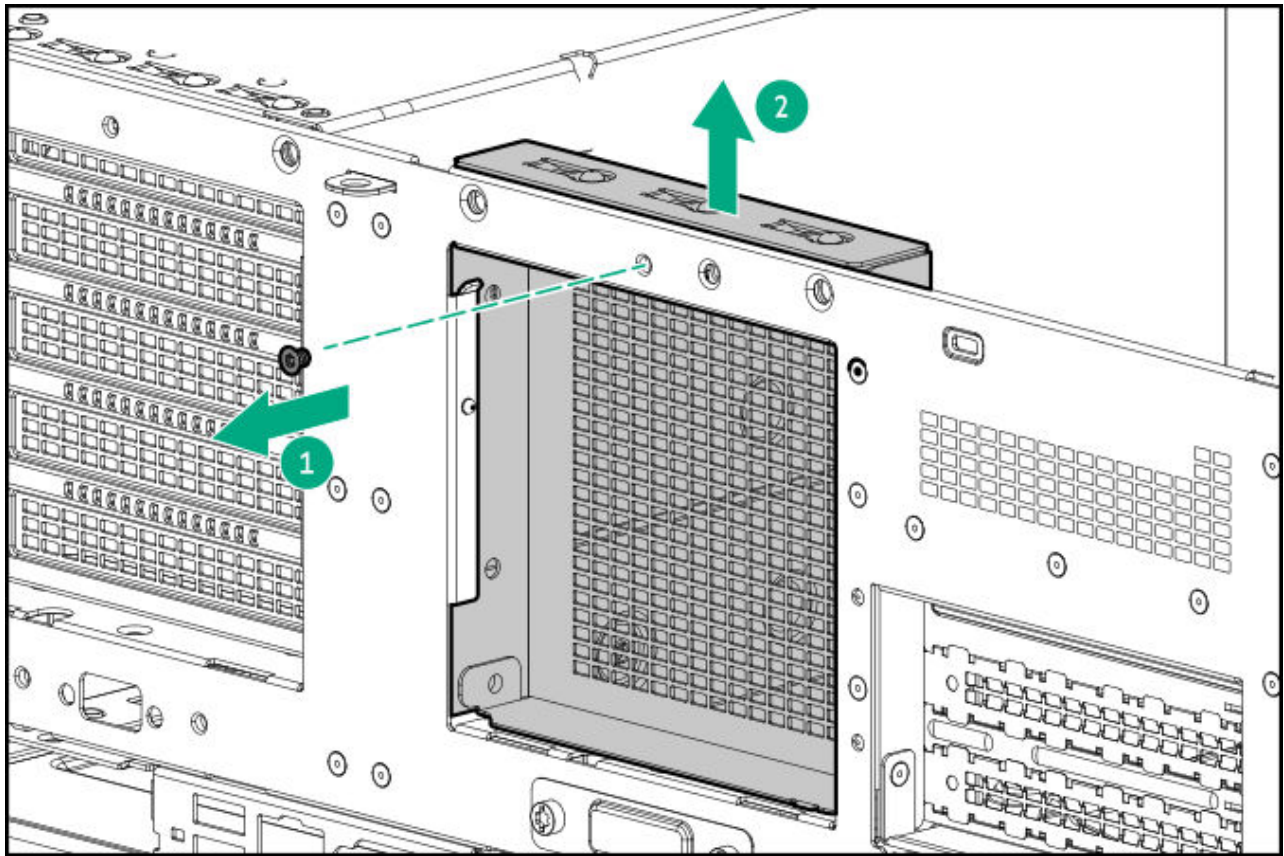

Remove the secondary riser cage

About this task

Procedure

1. Power down the server.
2. Remove all power:
 - a. Disconnect each power cord from the power source.
 - b. Disconnect each power cord from the server.
3. Disconnect all peripheral cables from the server.
4. Do one of the following:
 - If the server is in tower mode, place the server on a flat, level surface with the access panel facing up.

- If the server is in rack mode, remove the server from the rack.
5. Unlock the front bezel.
 6. Remove the access panel.
 7. If an expansion card with internal cables is installed on the riser, disconnect all cables from the expansion card.
 8. If installed, remove the expansion card from the tertiary riser:
 - a. If installed, remove the following components:
 - Boot device
 - Energy pack and energy pack holder
 - b. Loosen the stabilizer bracket captive screw, and then pull the stabilizer bracket from the expansion card.

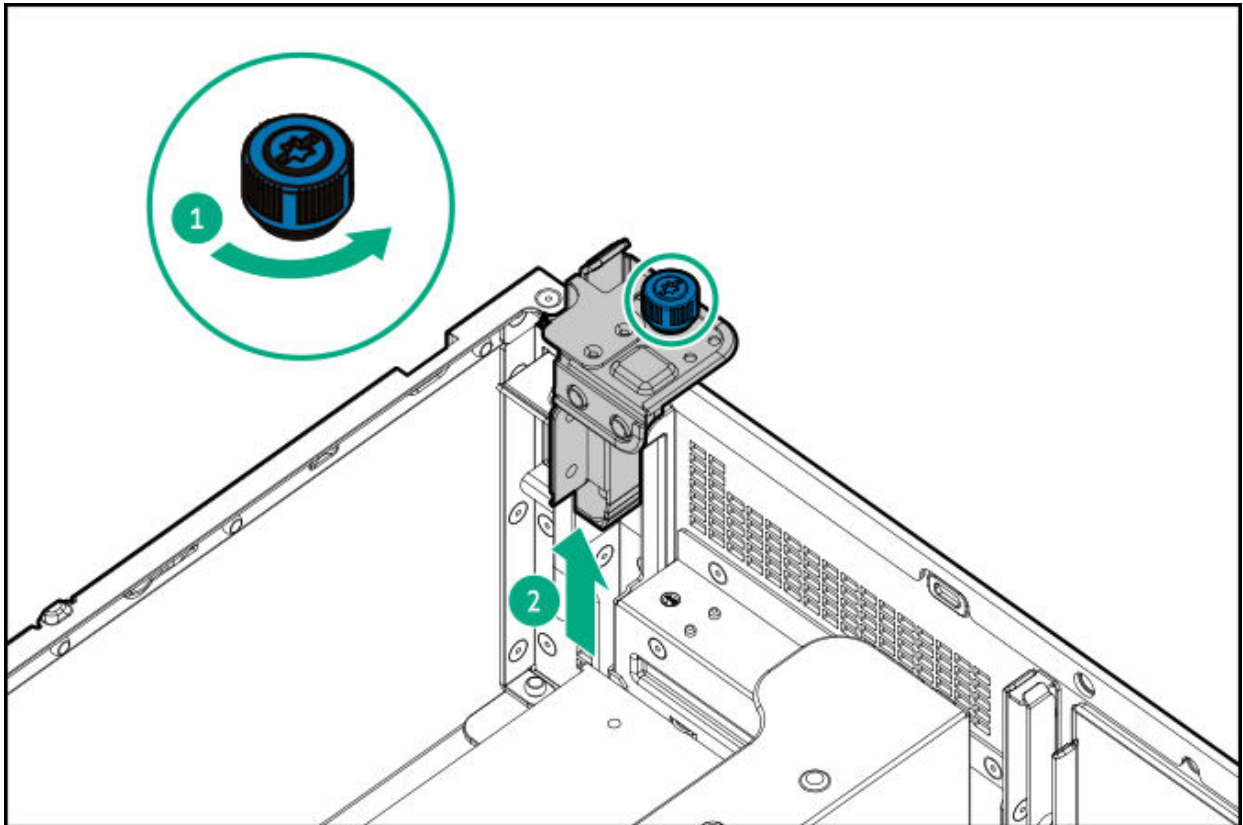

- c. Remove the expansion card from the tertiary riser.

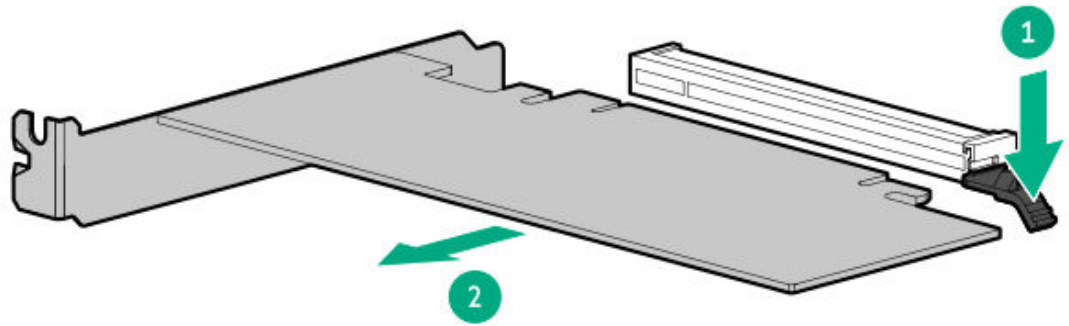

9. If installed, remove the tertiary riser.

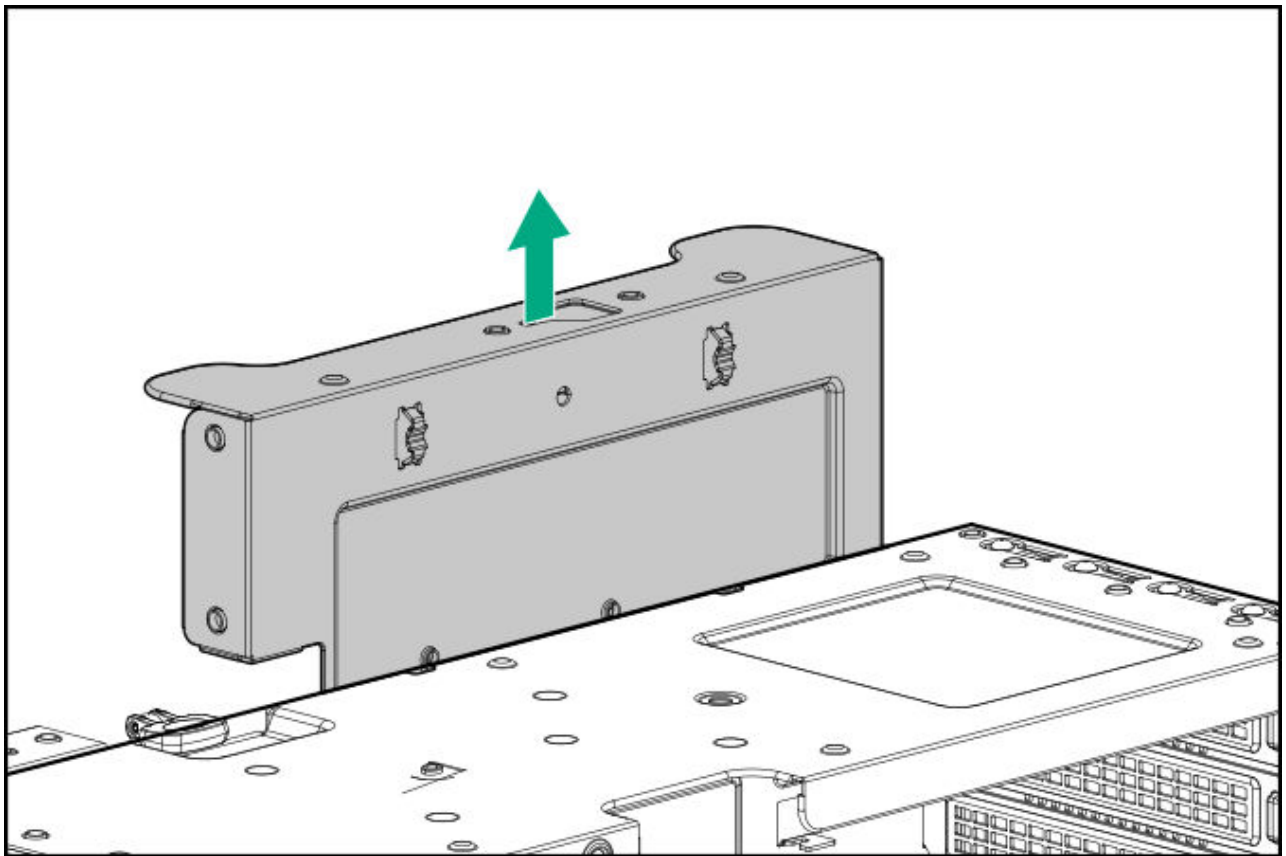

- 10. Remove the secondary riser cage:
 - a. Release the half-turn spring latch.
 - b. Lift the riser cage off the system board.

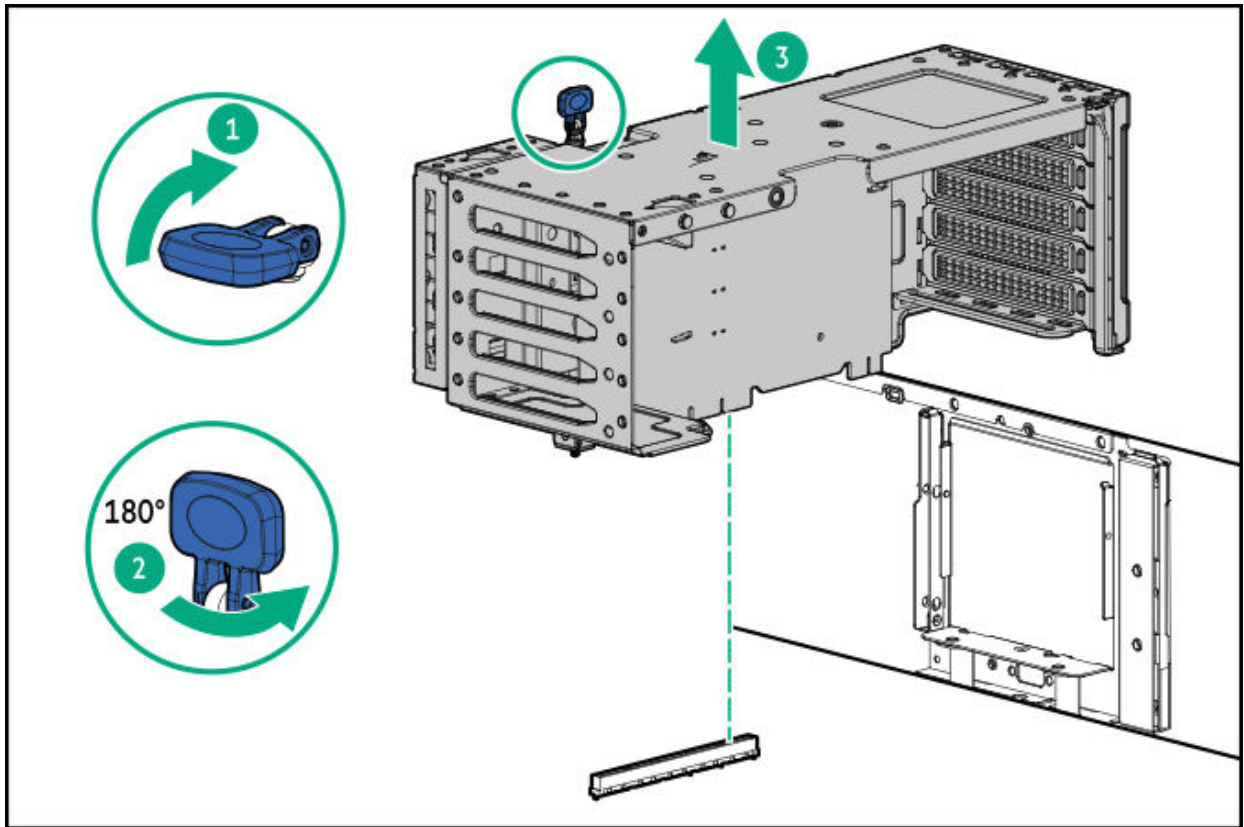

Remove the energy pack and the energy pack holder

About this task



CAUTION

A discharge of static electricity from a finger or other conductor might damage system boards or other static-sensitive devices. To prevent damage, observe [antistatic precautions](#).

Procedure

1. [Power down the server](#).
2. Remove all power:
 - a. Disconnect each power cord from the power source.
 - b. Disconnect each power cord from the server.
3. Disconnect all peripheral cables from the server.

4. Do one of the following:
 - If the server is in tower mode, place the server on a flat, level surface with the access panel facing up.
 - If the server is in rack mode, remove the server from the rack.
5. Unlock the front bezel.
6. Remove the access panel.
7. If installed, remove the boot device.
8. Remove the energy pack:
 - a. Disconnect the energy pack extension cable from the system board.
 - b. Press and hold the release latch.
 - c. Lift one end of the energy pack and release it from the holder.

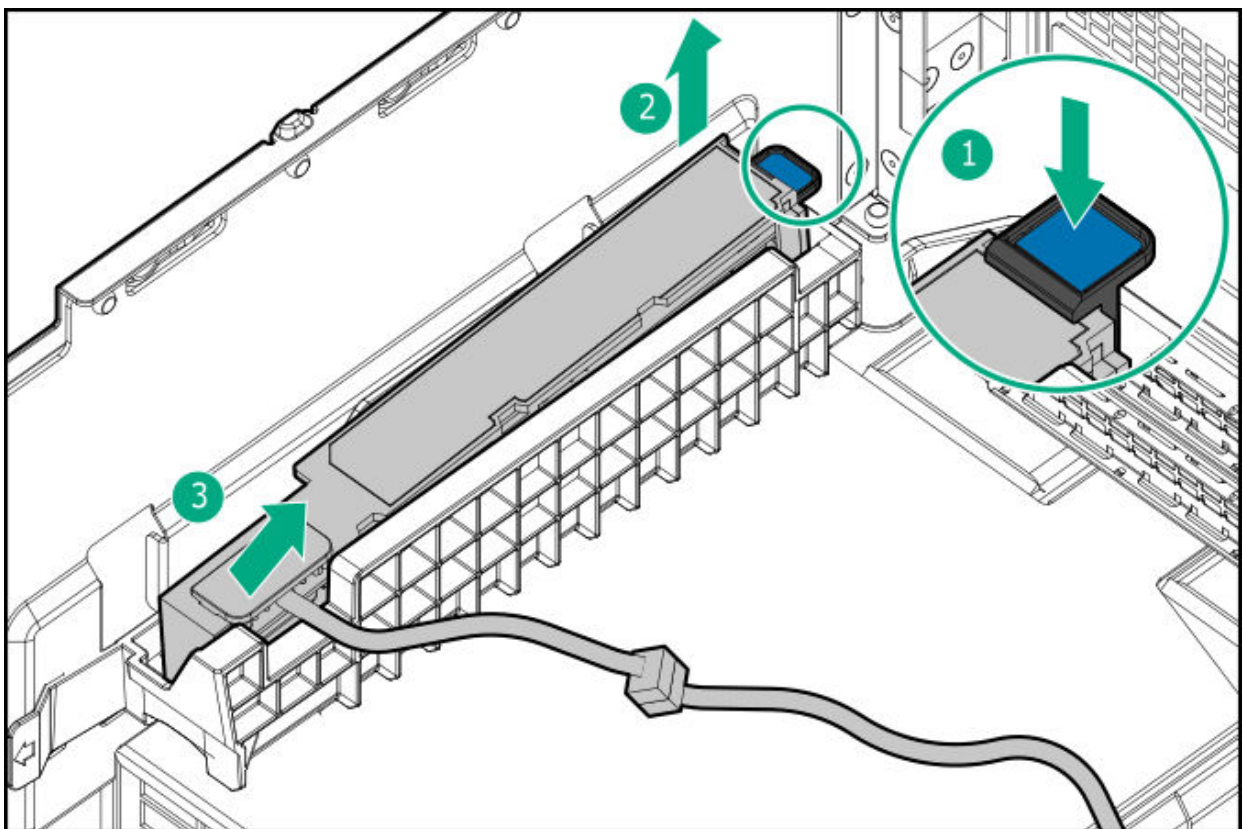

9. Remove the energy pack holder:
 - a. Press and hold the release latch on the holder.
 - b. Pull the holder towards the front panel to disengage from the chassis.

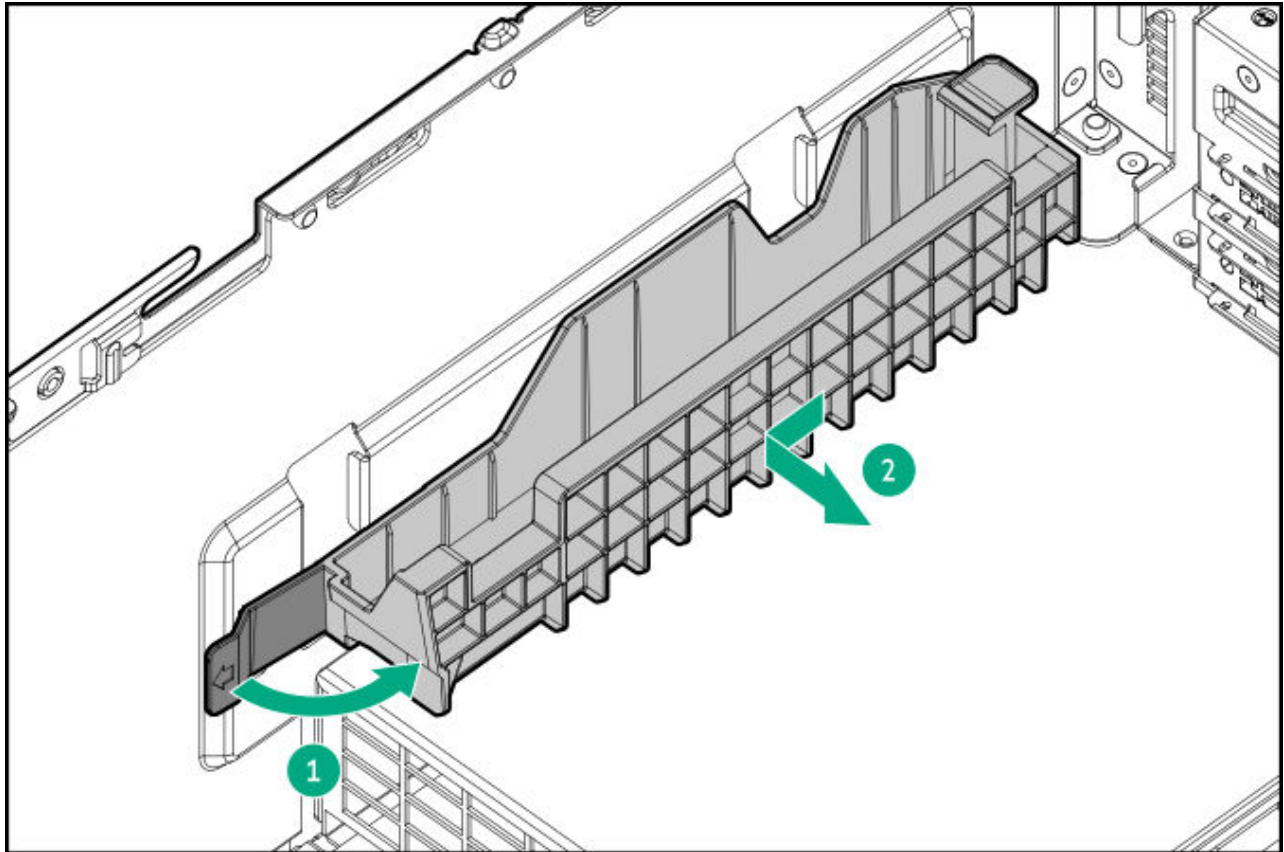

Remove the HPE NS204i-u Boot Device V2 on the power supply cage

Procedure

1. Power down the server.
2. Remove all power:
 - a. Disconnect each power cord from the power source.
 - b. Disconnect each power cord from the server.
3. Disconnect all peripheral cables from the server.
4. Do one of the following:
 - If the server is in tower mode, place the server on a flat, level surface with the access panel facing up.
 - If the server is in rack mode, remove the server from the rack.
5. Unlock the front bezel.

6. Remove the access panel.
7. Remove the boot device from the top of the power supply cage:
 - a. Pull and hold the latch.
 - b. Remove the boot device from the chassis side wall.

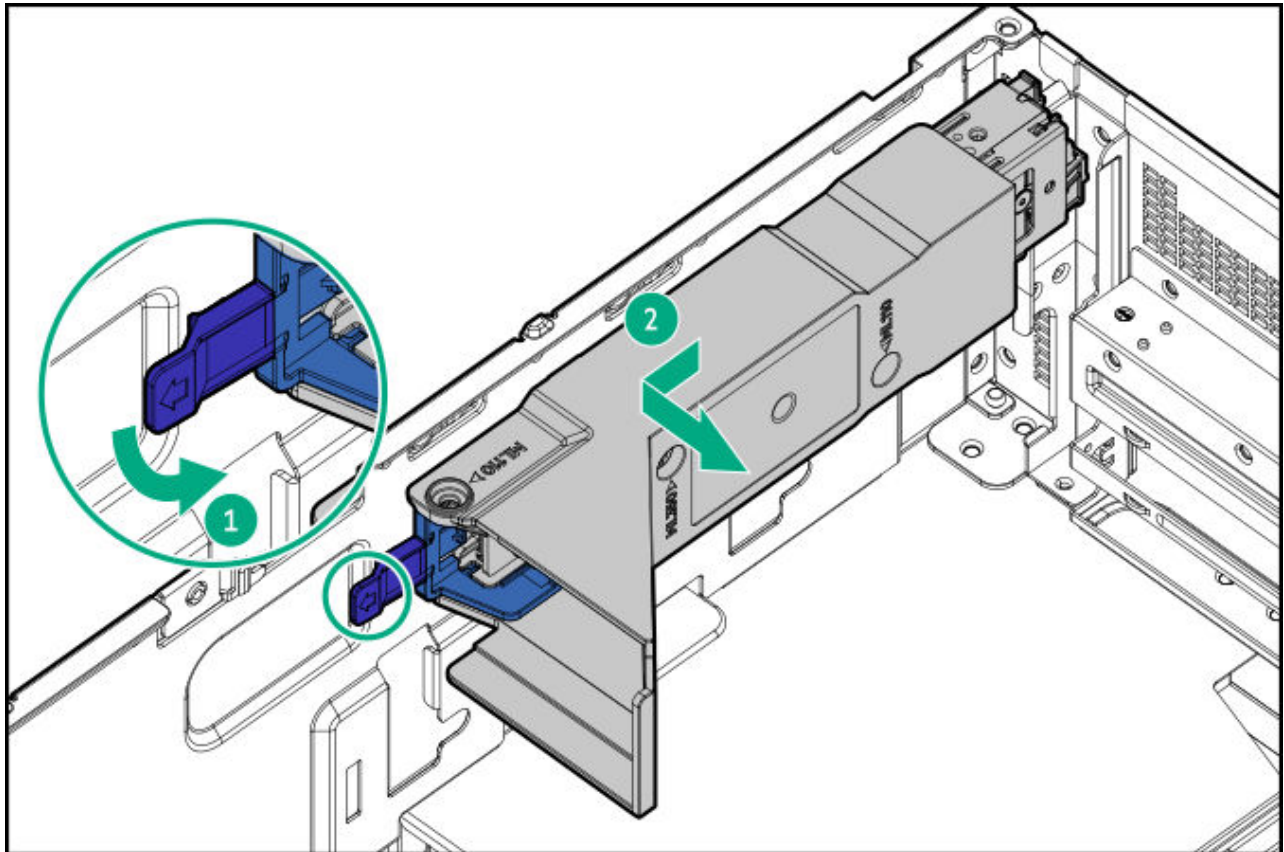

Post-installation procedures

Subtopics

Install the front bezel

Install the access panel

Install the primary/secondary riser cage

Install the fan cage

Install the server into the rack

Installing the shipping hardware

Power up the server

Position the tower server for operation

Install the front bezel

Procedure

1. Insert the front bezel hooks to the chassis.
2. Close the front bezel.
3. While pressing the key against the lock, rotate the key to the lock position.

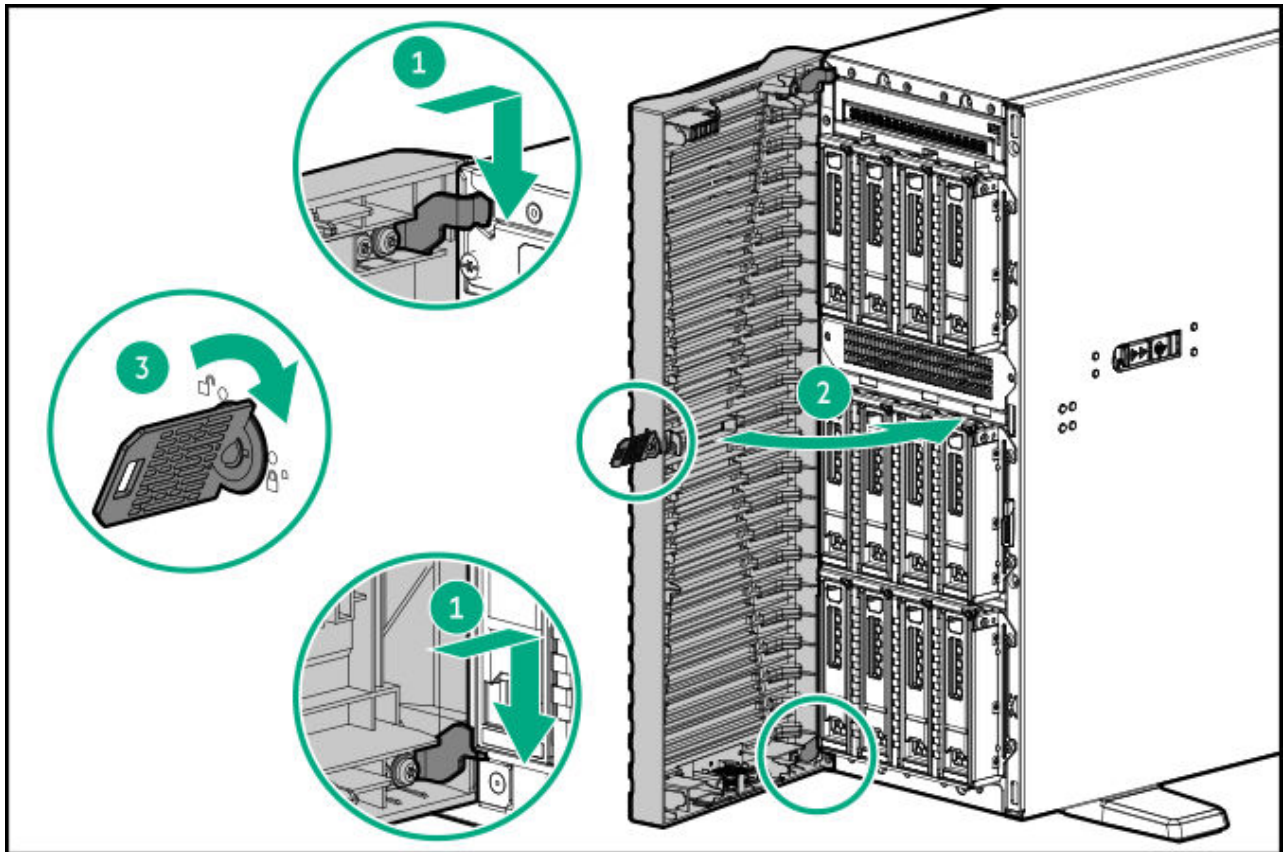

4. (Optional) For later use, store the front bezel keys inside the front bezel.

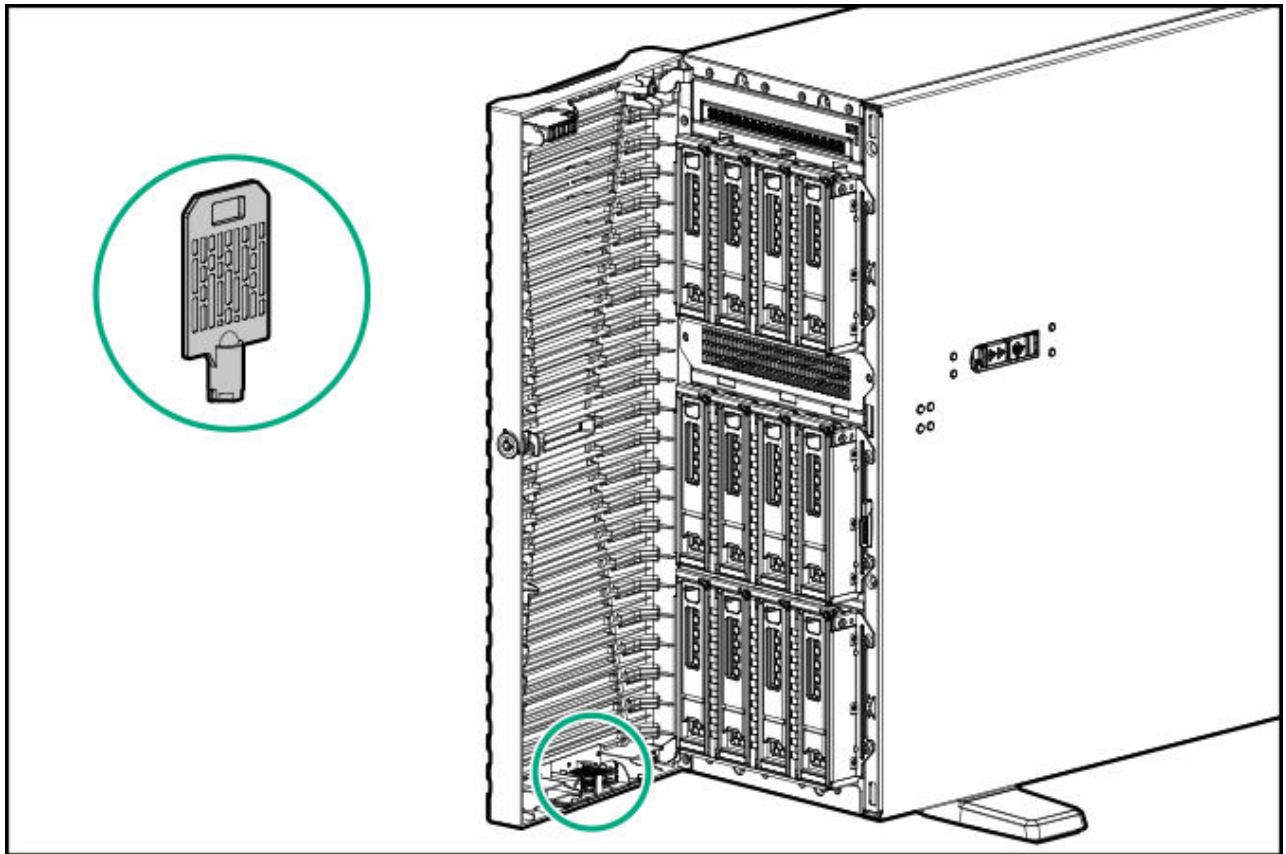

Install the access panel

Prerequisites

Before you perform this procedure, make sure that you have a T-15 Torx screwdriver available.

Procedure

1. With the access panel latch open, insert the guide pin on the chassis through the hole on the bottom side of the latch.
2. Close the access panel latch.
The access panel slides to the closed position.
3. Lock the access panel latch.

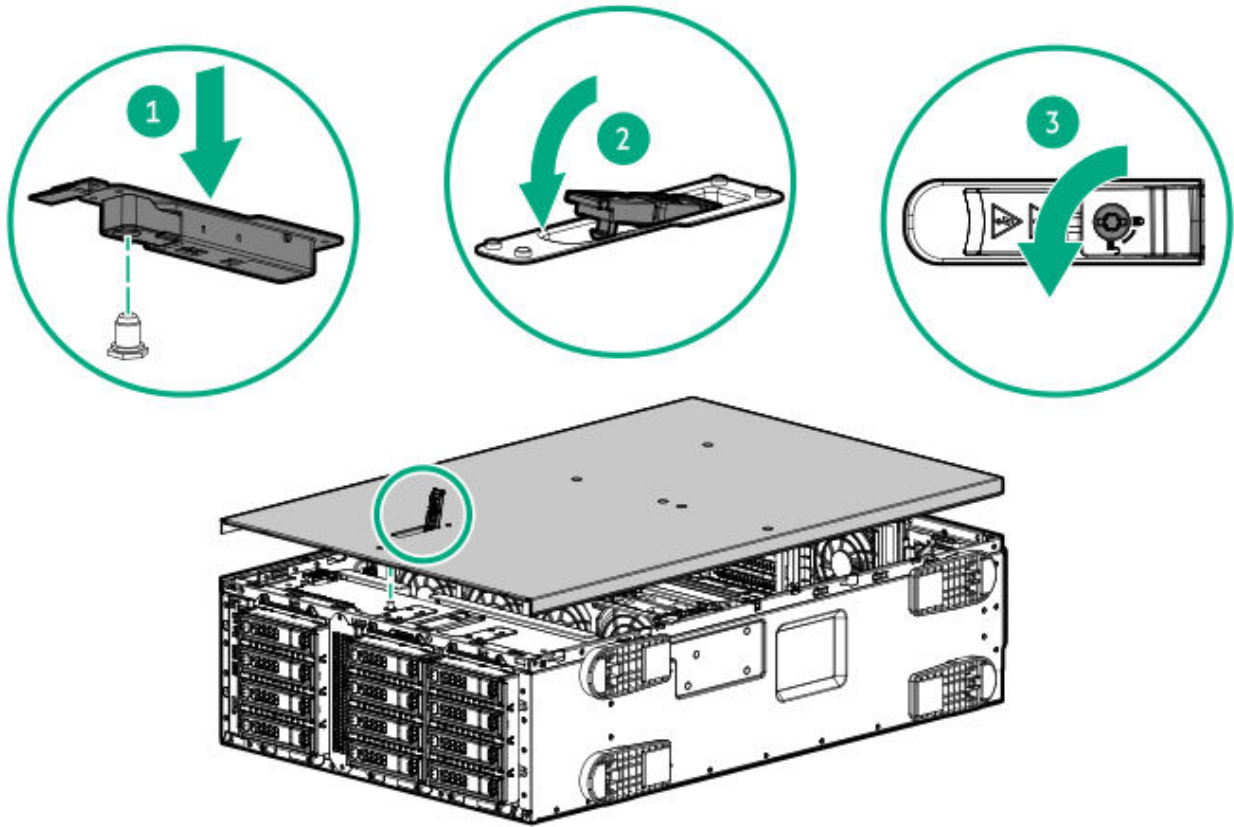

4. Perform the post-installation or maintenance steps required by the procedure that necessitates the removal of the access panel.

Install the primary/secondary riser cage

Procedure

1. Install the primary/secondary riser cage:
 - a. Carefully press the riser down on its system board connector.
Make sure that:
 - The riser cage is aligned with the rear chassis.
 - The riser board is firmly seated on the system board.
 - b. Simultaneously push and rotate the half-turn spring latch to 180°.
 - c. Close the spring latch.

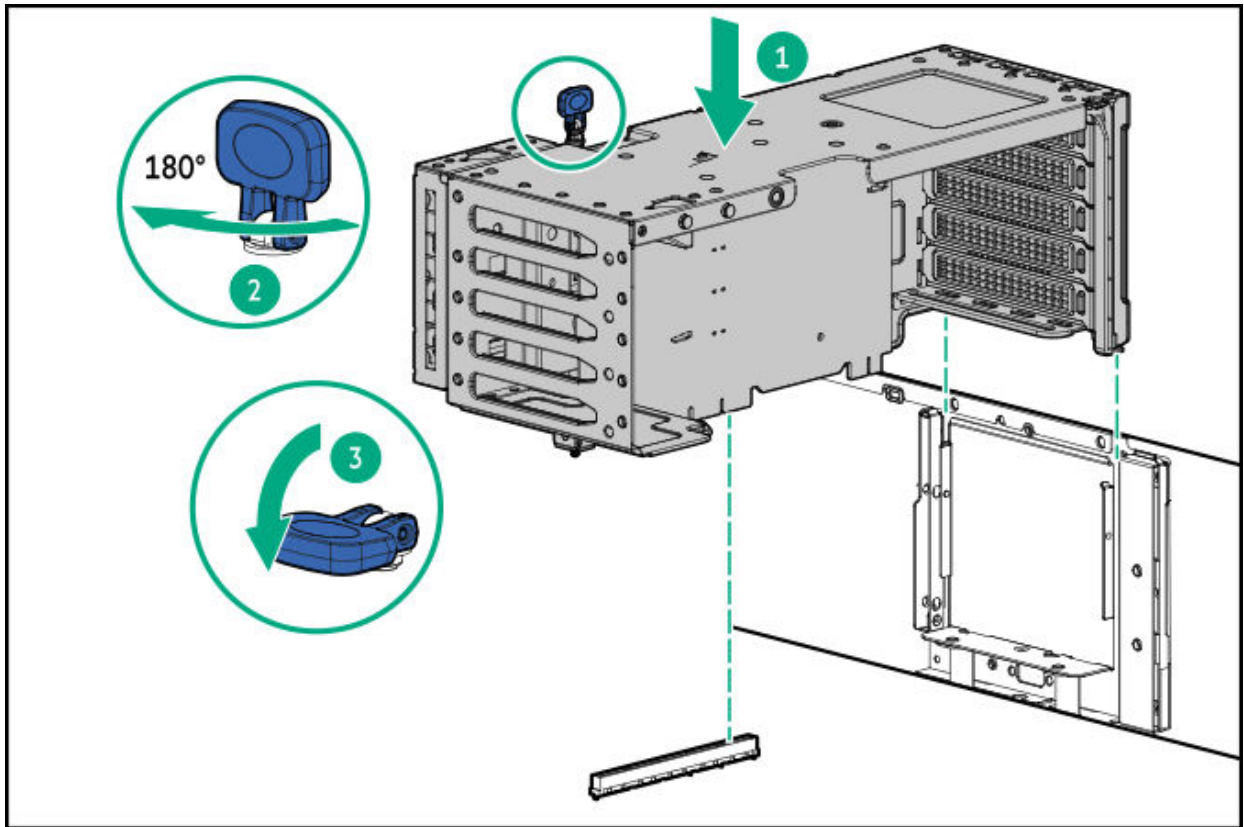

2. If removed, install the tertiary riser:
 - a. Install the tertiary riser on the secondary riser cage.

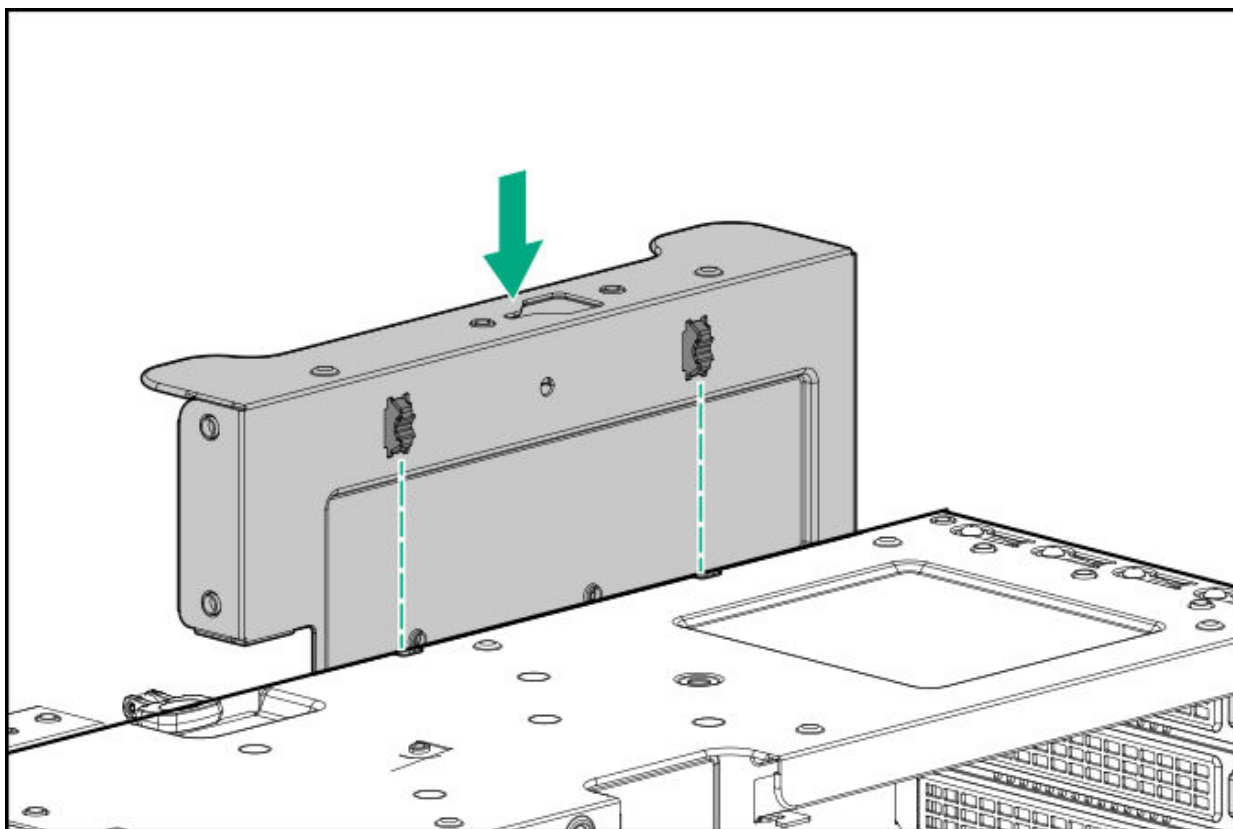

b. Install the expansion card.

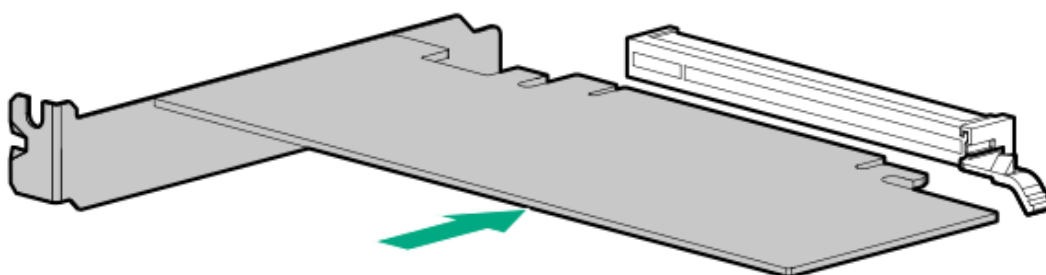

c. Press down the stabilizer bracket to secure the expansion card, and then tighten the captive screw.

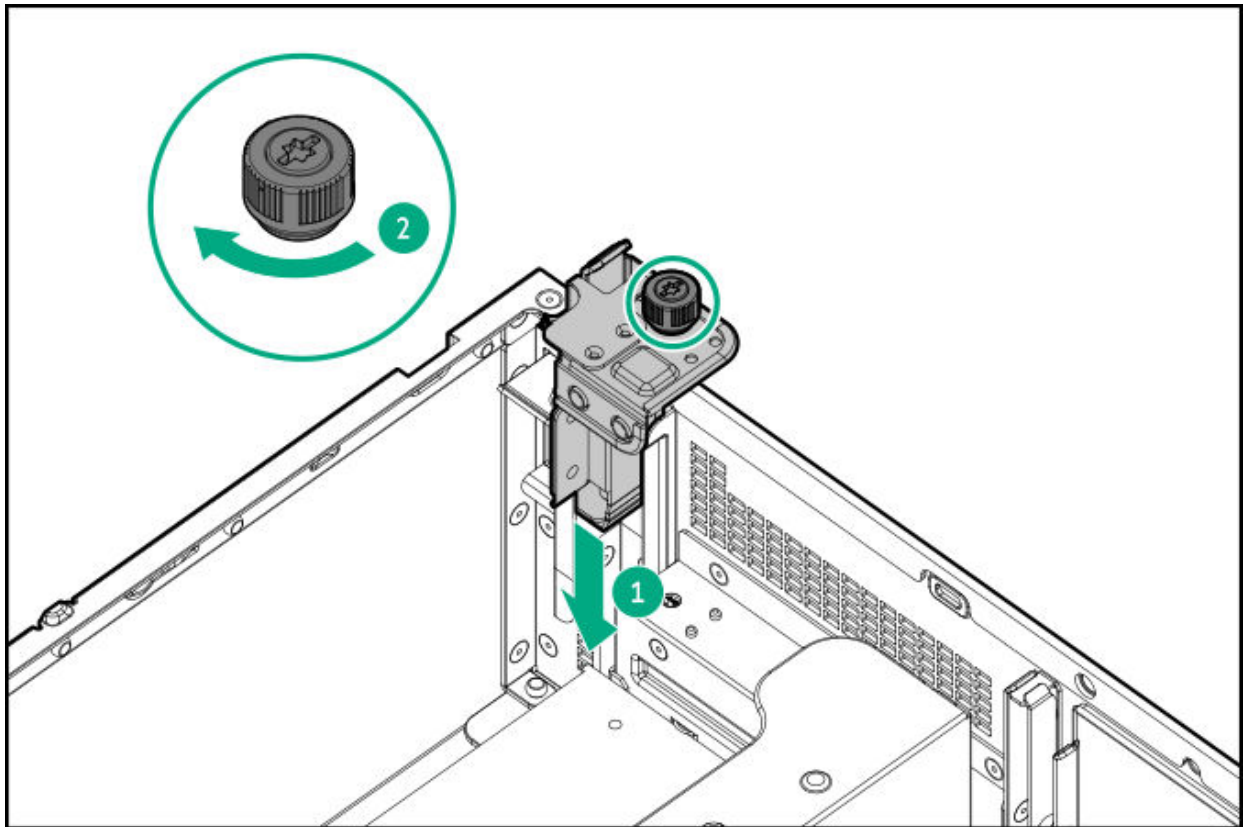

3. Perform the post-installation or maintenance steps required by the procedure that necessitates the removal of the riser cage.

Install the fan cage

Procedure

1. Install the fan cage:
 - a. Lower the fan cage into the chassis.
 - b. Close the fan cage latches.

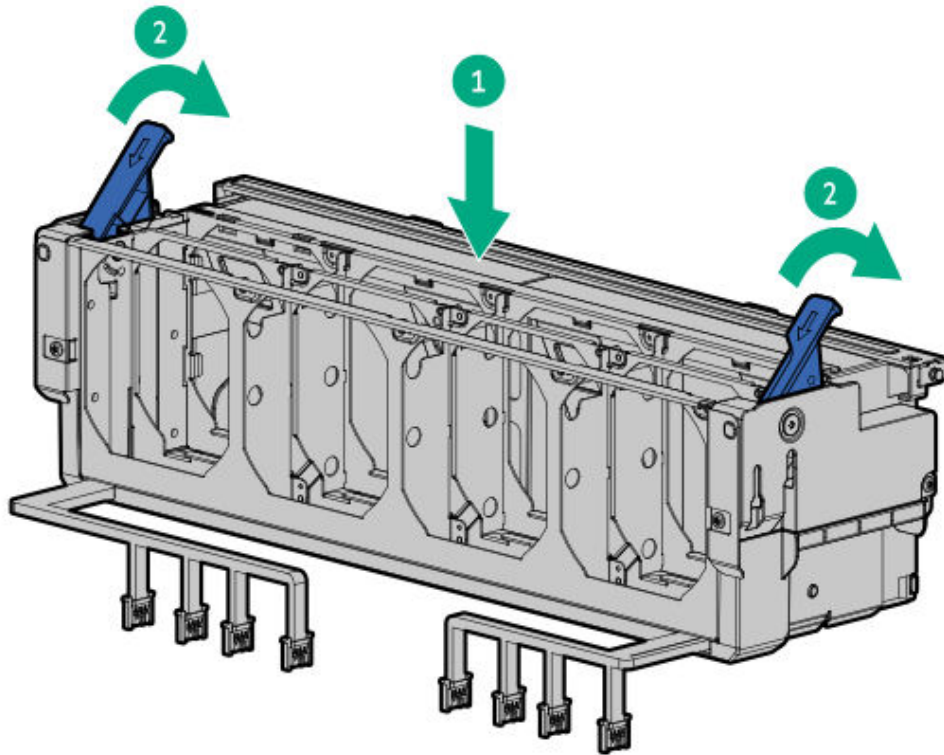

2. Connect the fan cage cables to the system board.
3. Install all internal fans:
 - a. Lower the fan into the bay.
 - b. Press down on the fan to make sure that it is seated firmly in the bay.

A click sound indicates that the fan is properly engaged.

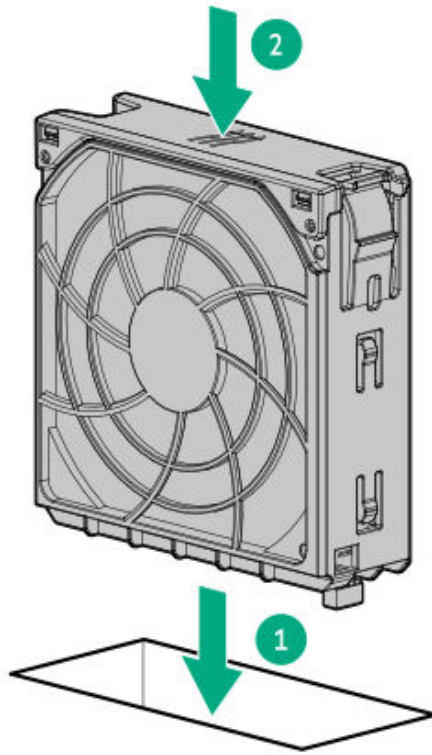

4. If removed, reinstall the fan blank into bay 1.

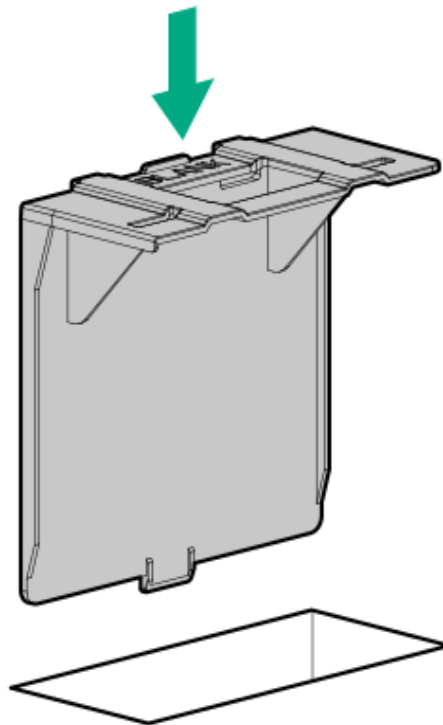

5. Perform the post-installation or maintenance steps required by the procedure that necessitates the removal of the fan cage.

Install the server into the rack

Prerequisites

- Get help to lift and stabilize the server during rack installation. **If the server is installed higher than chest level, additional two people might be required to help install the server:** One person to support the server weight, and the other two to slide the server into the rack.
- Before you perform this procedure, review the:
 - [Rack warnings and cautions](#)
 - [Server warnings and cautions](#)
- A fully populated server is heavy. Hewlett Packard Enterprise recommends removing the external chassis components before removing the server from the rack.
- Before you perform this procedure, make sure that you have a T-15 Torx screwdriver available.

Procedure

1. Grasp the tray notch to slide the tray out of the rack.

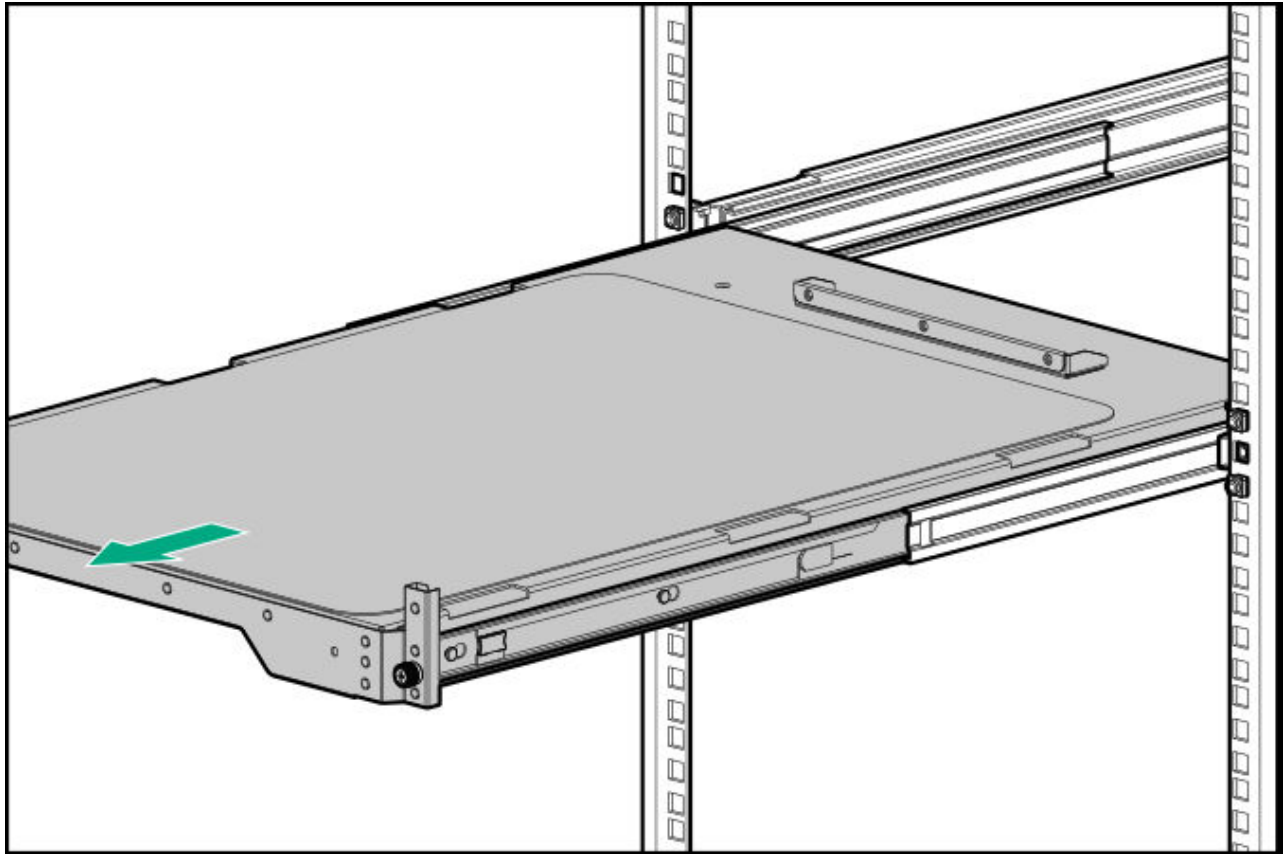

2. Place the server on the tray.

Verify that the front panel of the server is aligned with the front of the tray.

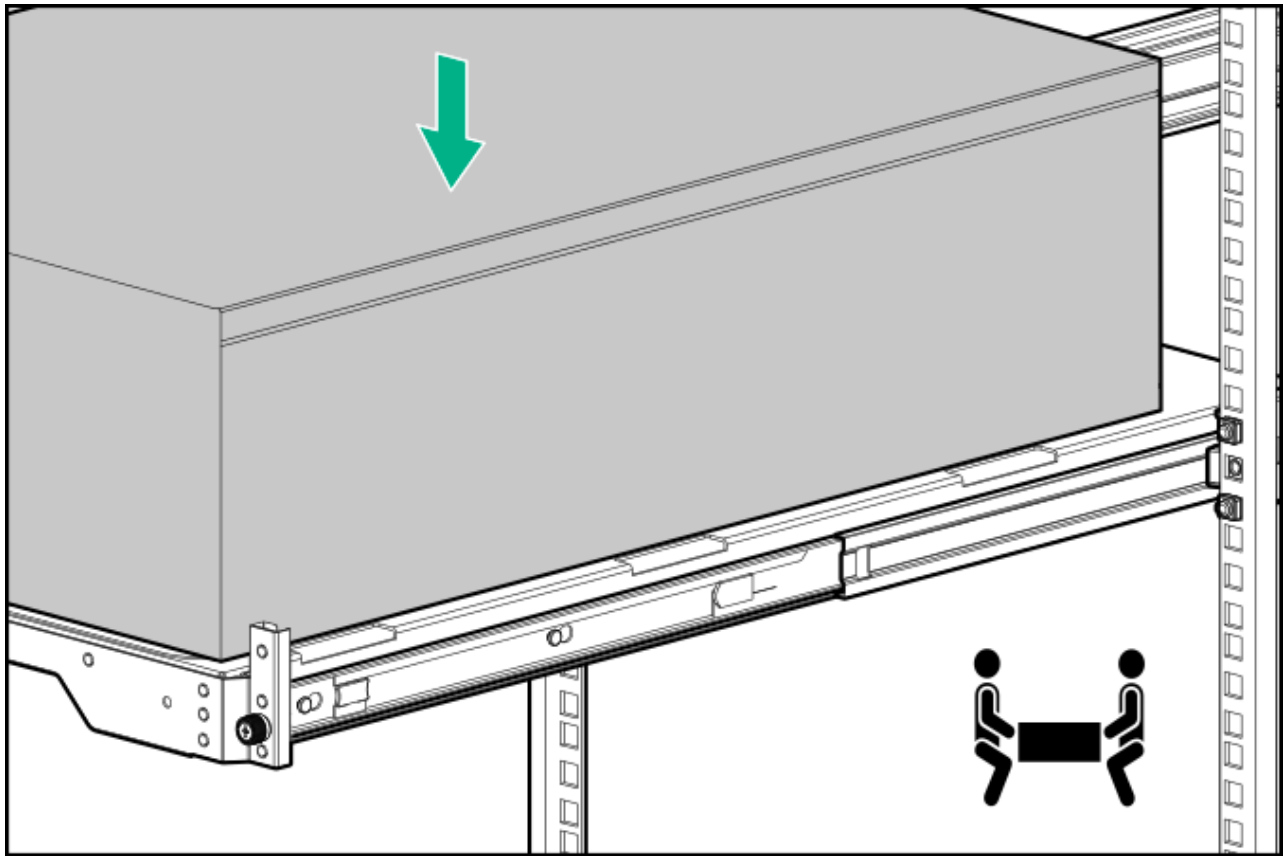

3. Install the chassis rear bracket screws.

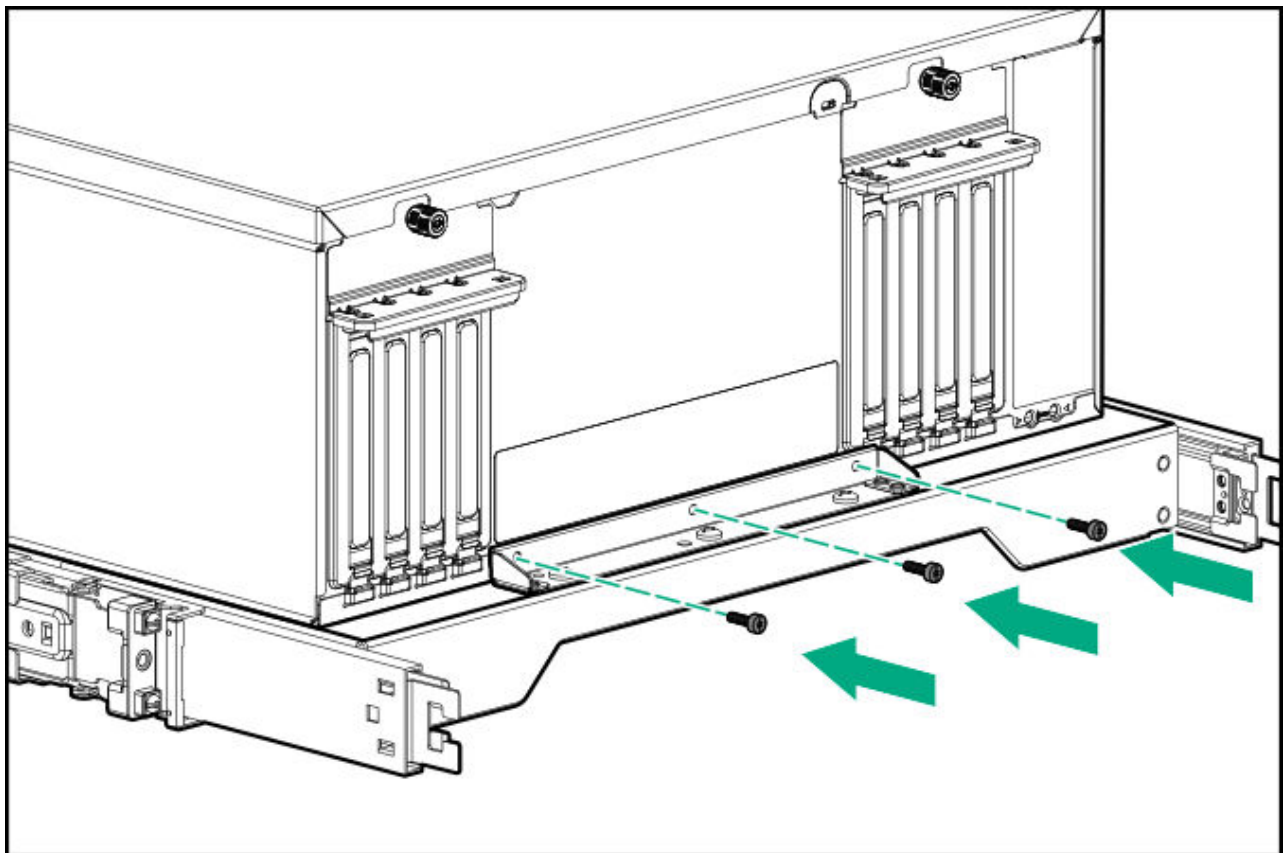

4. Press and hold the blue rail-release tabs, and then slide the tray back into the rack.

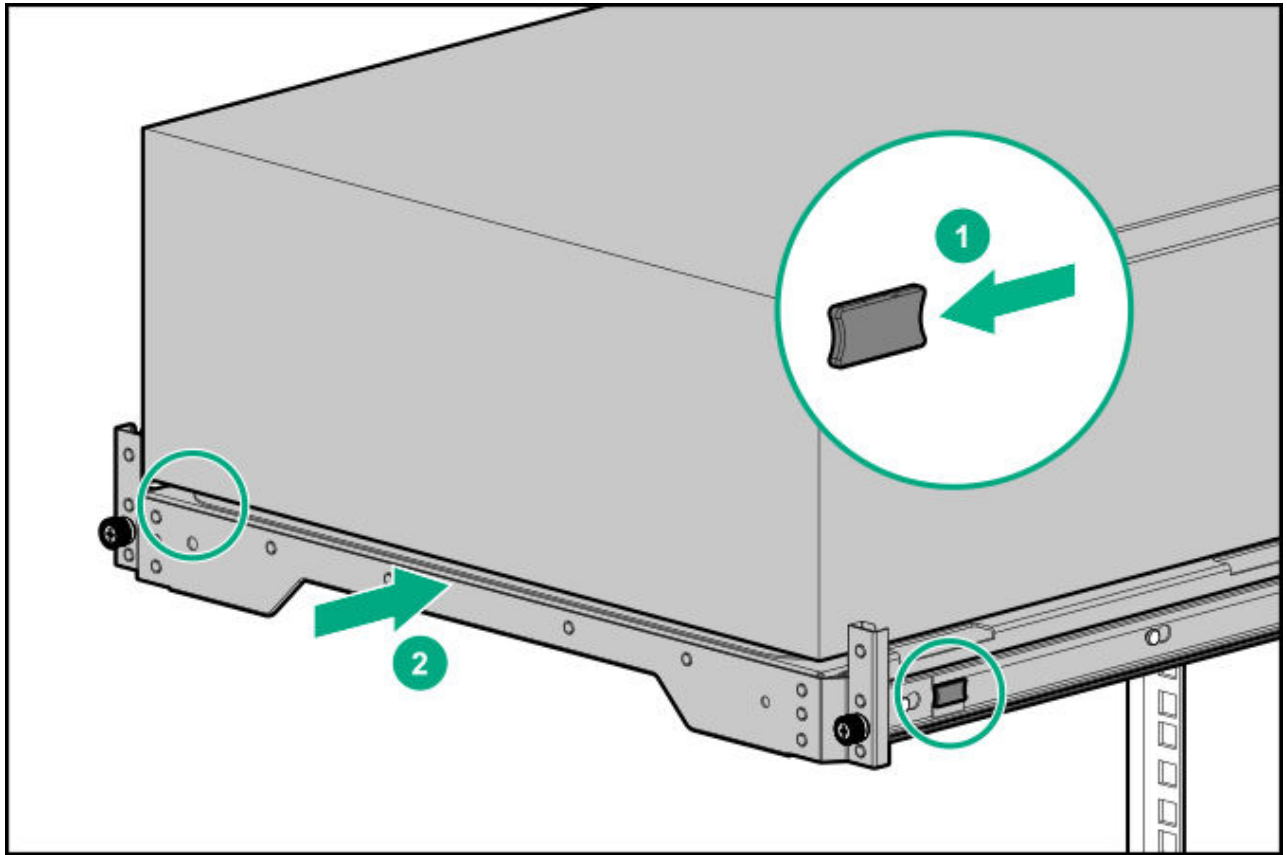

5. Tighten the server tray thumbscrews.

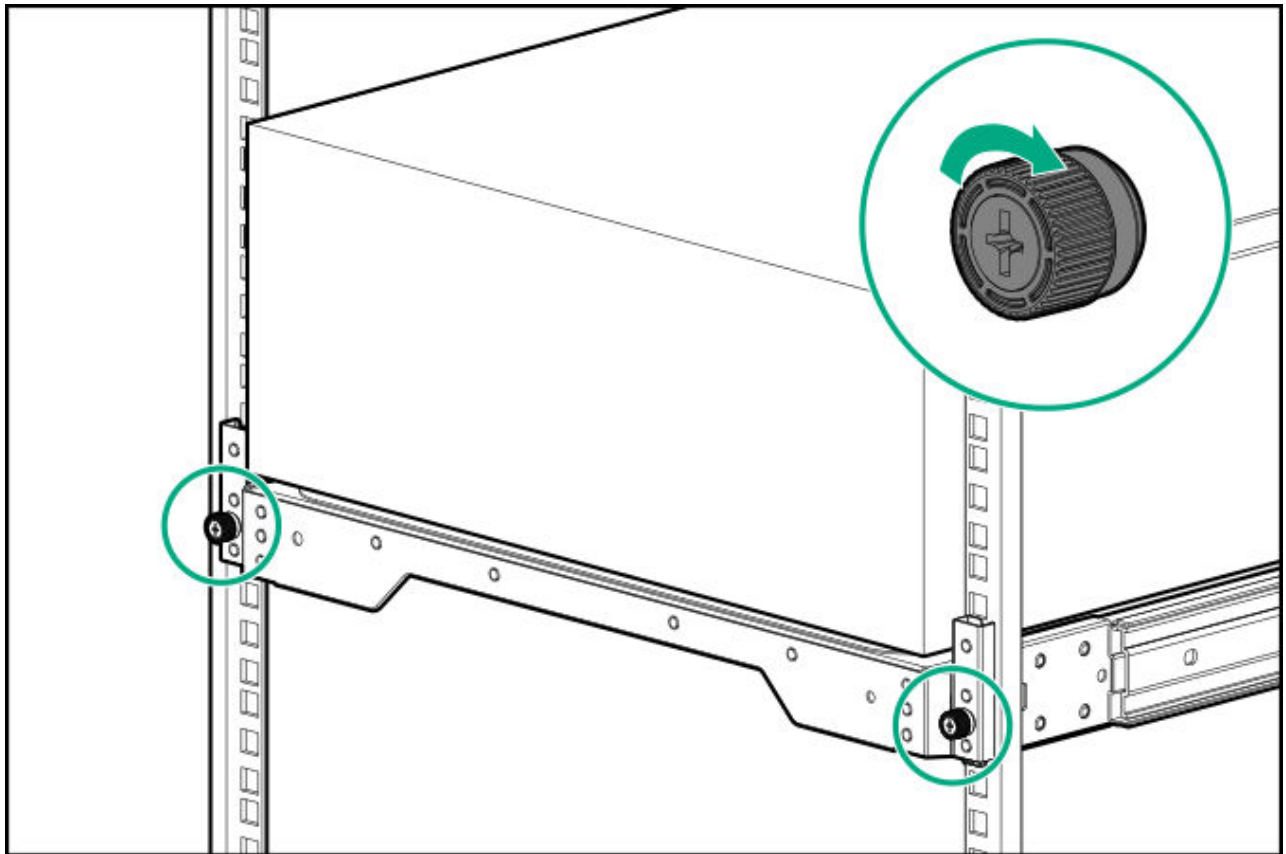

6. Connect all peripheral cables to the server.
7. Connect each power cord to the server.
8. Connect each power cord to the power source.
9. Power up the server.

Installing the shipping hardware

Prerequisites

Before you perform this procedure, make sure that you have the following items available:

- Cage nut insertion tool
- T-25 Torx screwdriver
- Phillips No. 2 screwdriver

About this task

If you intend to transport or ship a rack-mounted server to a new location, make sure that the shipping hardware is installed. The shipping hardware protects the server from vibration damage that might occur during server shipment.

Procedure

1. Power down the server.
2. Remove all power:
 - a. Disconnect each power cord from the power source.
 - b. Disconnect each power cord from the server.
3. Disconnect all peripheral cables from the server.
4. With the server installed in the rack, hold the shipping bracket against the rack column and note the correct mounting locations for both the brackets and the cage nuts as shown in the following image.

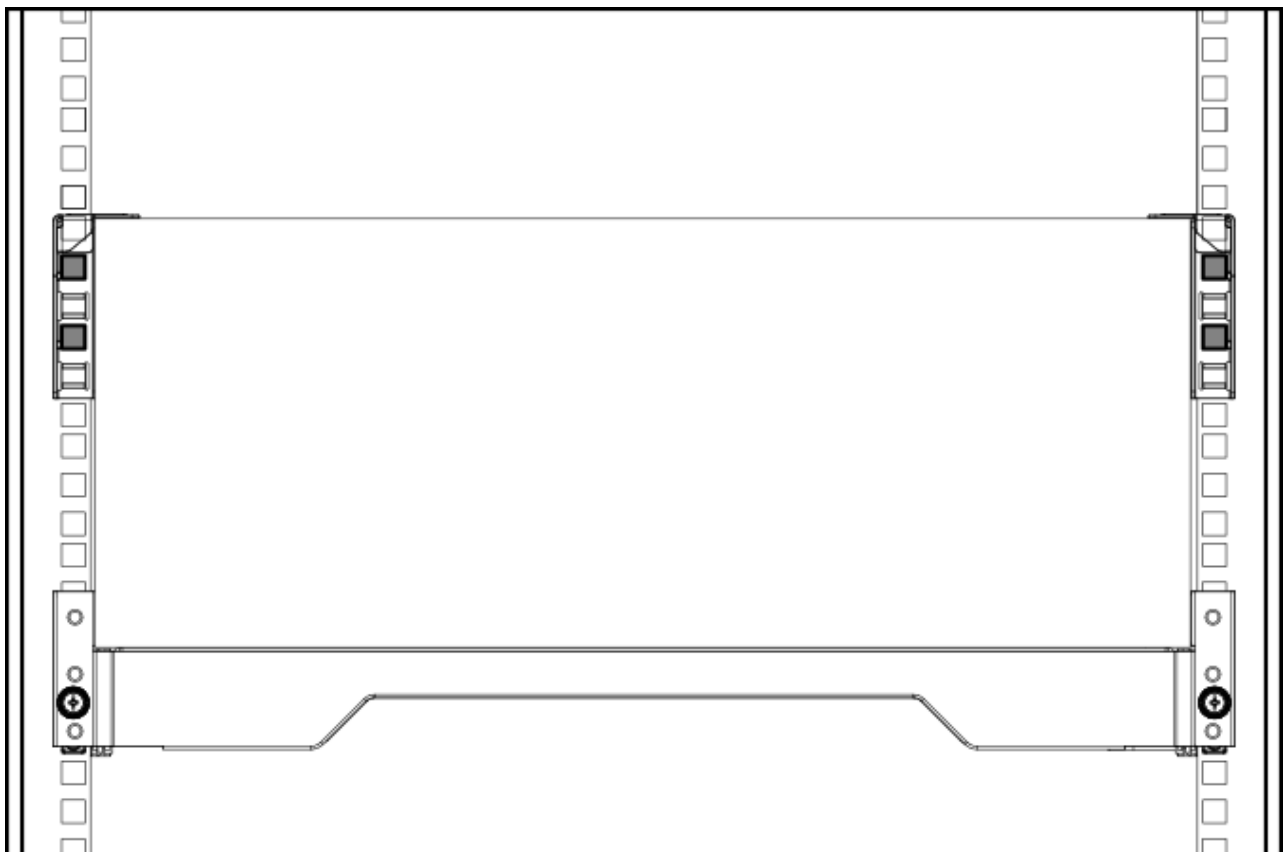

5. Slide the server tray out of the rack:
 - a. Loosen the server tray thumbscrews.

- b. Grasp the tray notch and slide the server out of the rack.

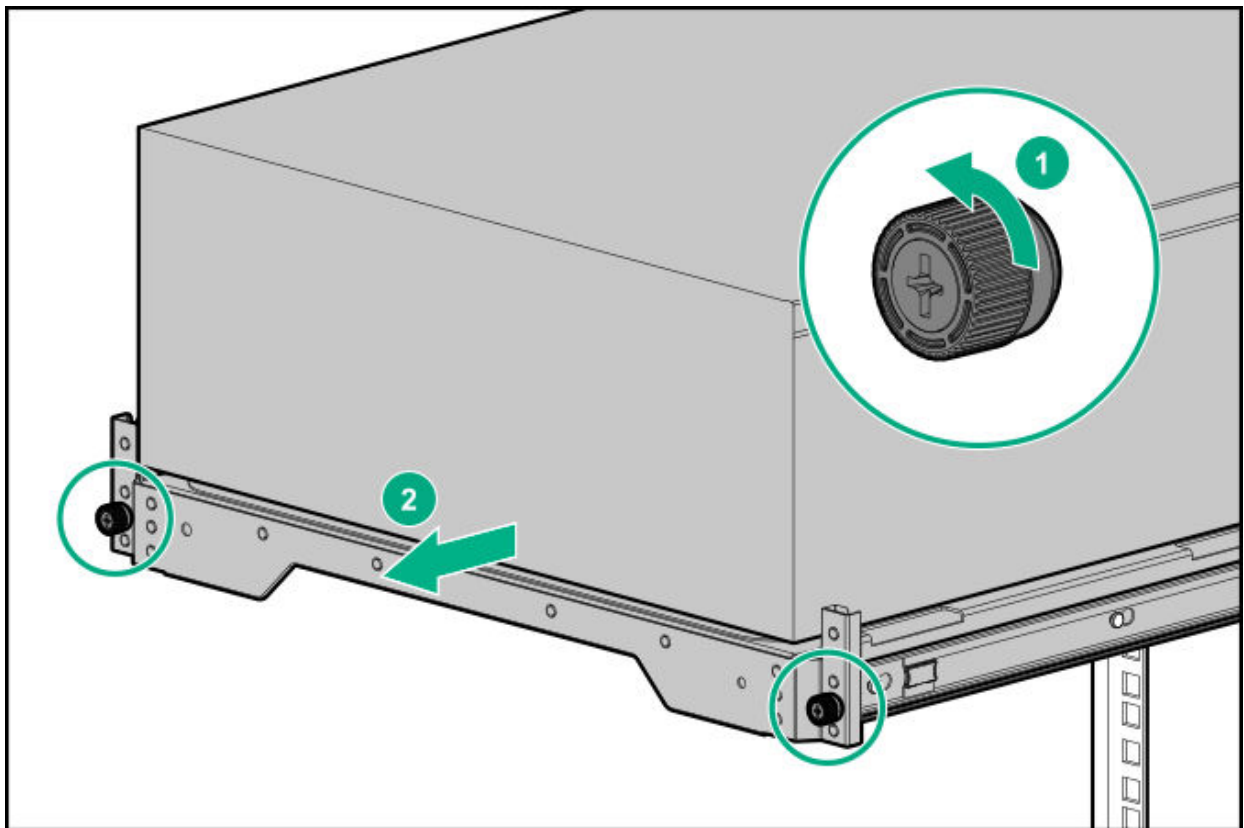

6. If you are installing the server in a square-hole rack, install the cage nuts. When installed, the flanges on the cage nut should face the outside of the rack:
 - a. Hook the bottom flange of the cage nut in the rack hole.
 - b. Insert the tip of the insertion tool through the hole and hook the top flange of the cage nut.
 - c. Use the insertion tool to pull the cage nut through the hole until the top flange snaps into position.

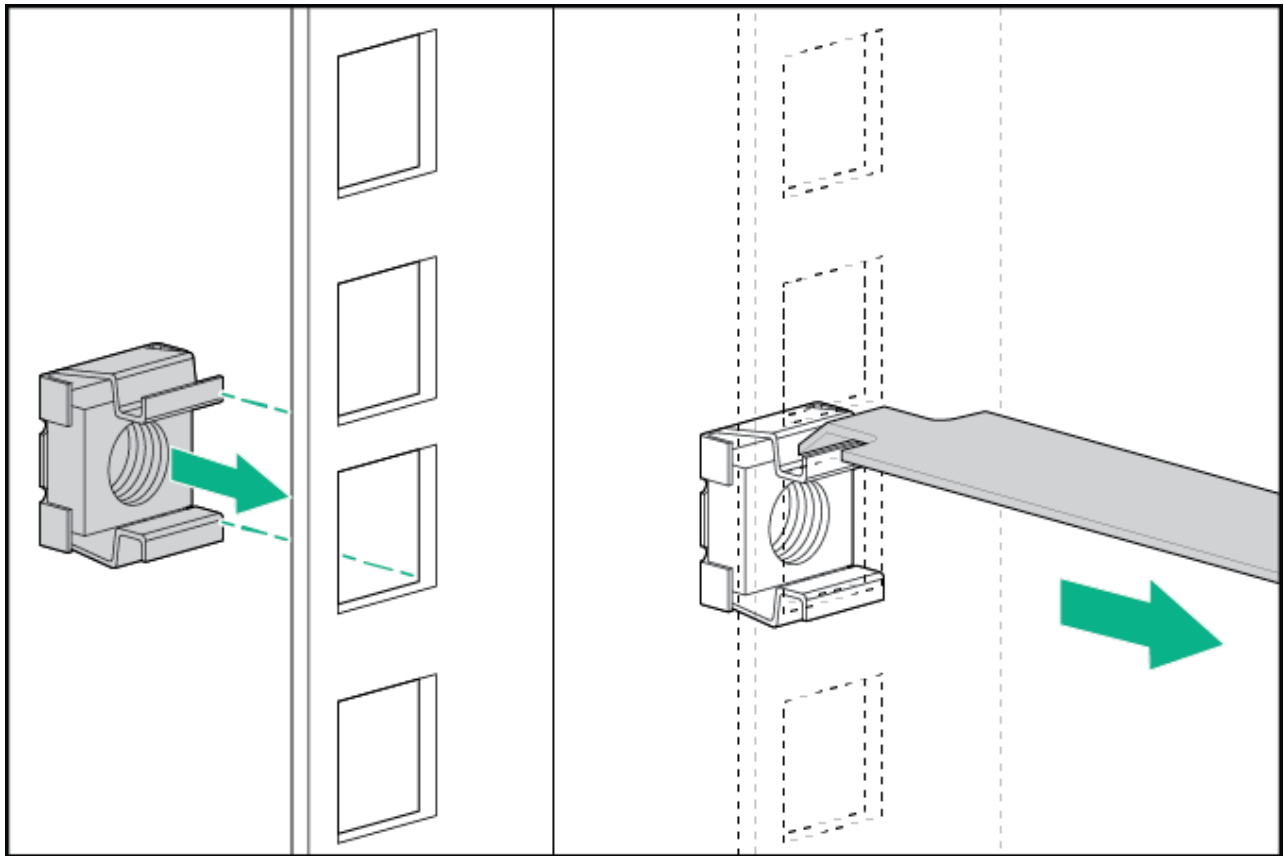

7. Secure the front end of rack rails to the rack columns with the shipping brackets.

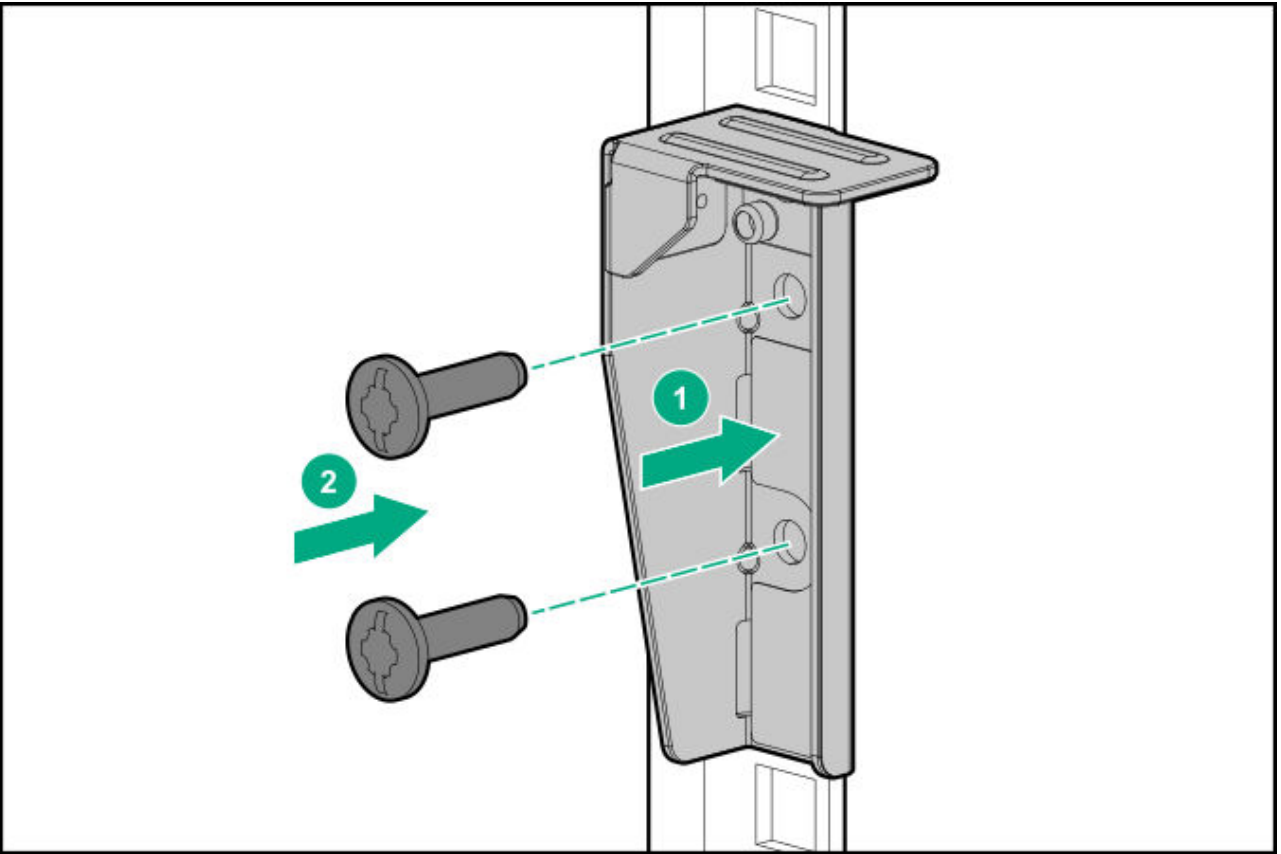

8. Secure the rear end of rack rails to the rack columns with the rear shipping screws.

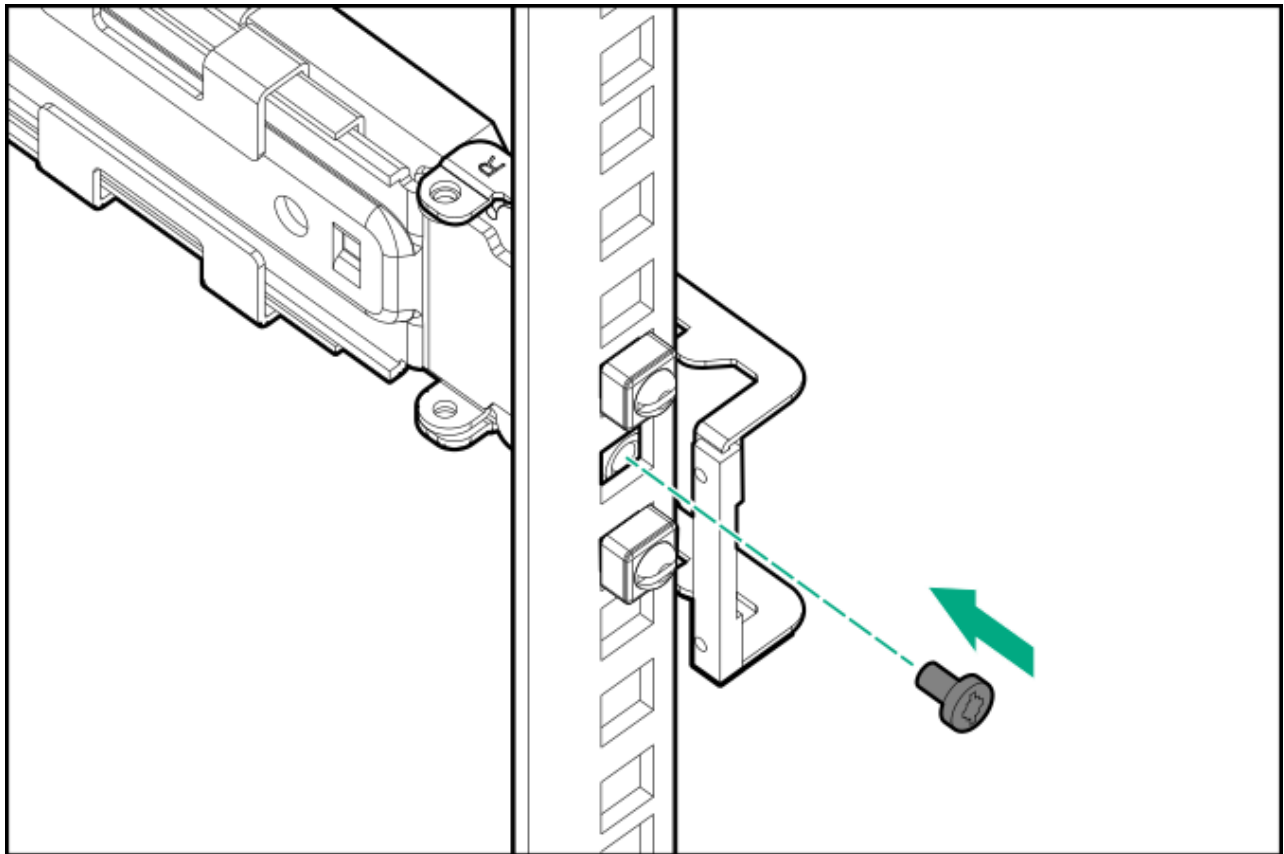

Results

The installation procedure is complete.

Power up the server

Procedure

- Press the Power On/Standby button.
- Use the virtual power button through iLO 7.

Position the tower server for operation

Procedure

1. Return the server to an upright position.

2. Rotate the chassis feet outward to stabilize the server.

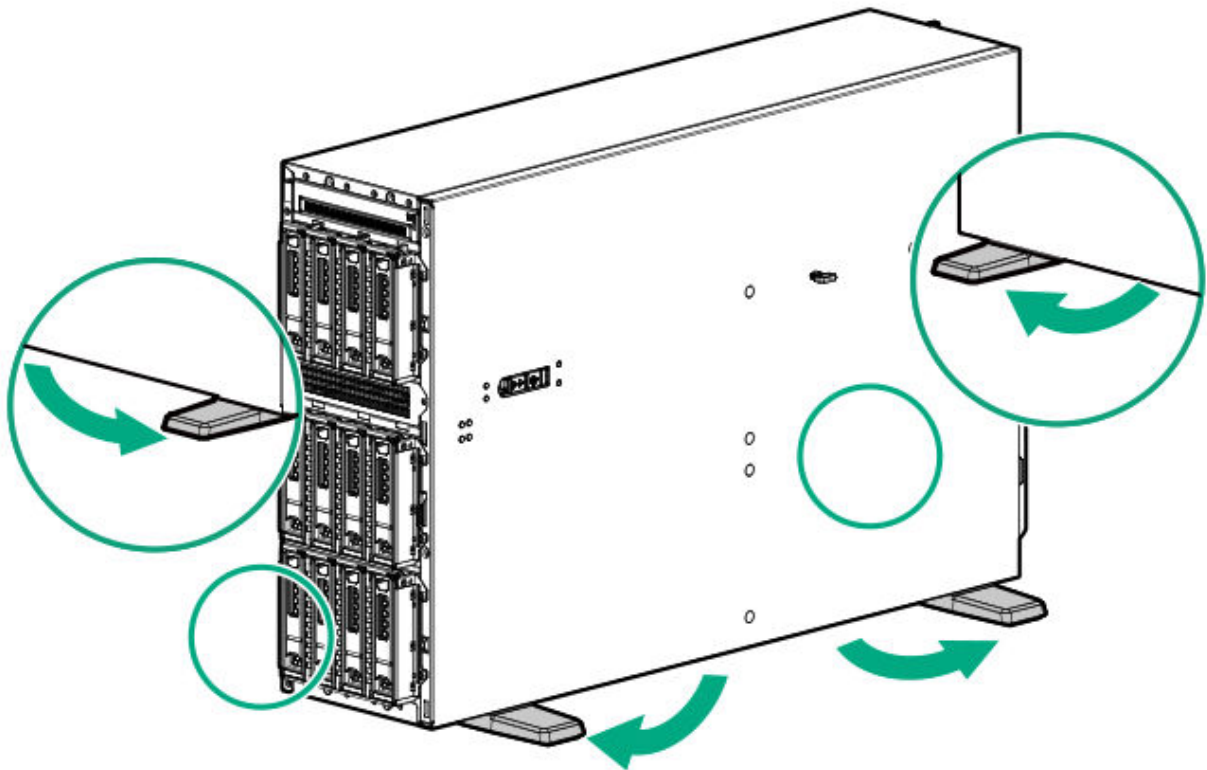

Tower-to-rack conversion kit

Use the tower-to-rack conversion kit to switch the tower server to rack mode operation. A rack-mounted server occupies 5U space in the rack and supports in-rack serviceability for all server components.

Kit contents

- Left and right rack rail assemblies
- Server tray
- Cable management arm
- Chassis rear bracket screws (3)
- Shipping hardware—Install these hardware only if you intend to transport or ship a rack-mounted server to a new location.
 - Shipping brackets (2)

- Shipping bracket screws (4)
- M5 square-hole cage nuts (4)
- Rear shipping screws (2)

Rack rail specifications

This server supports the HPE tower-to-rack conversion kit (P47394-B21). This tower-to-rack conversion kit supports the following specifications:

- Type: Ball-bearing (stab-in)
- Minimum rail length: 727.50 mm (28.64 in)
- Rail adjustability range: 570.00–812.00 mm (22.50–32.00 in)

Subtopics

Installing the tower-to-rack conversion kit

Installing the tower-to-rack conversion kit

About this task

In this procedure, left and right terminology is from the perspective of a user facing the front of the rack.

Procedure

1. Power down the server.
2. Remove all power:
 - a. Disconnect each power cord from the power source.
 - b. Disconnect each power cord from the server.
3. Disconnect all peripheral cables from the server.
4. If the server is in tower mode, place the server on a flat, level surface with the access panel facing up.
5. Remove the chassis feet:
 - a. Loosen the screws on the chassis.
 - b. Detach the chassis feet.

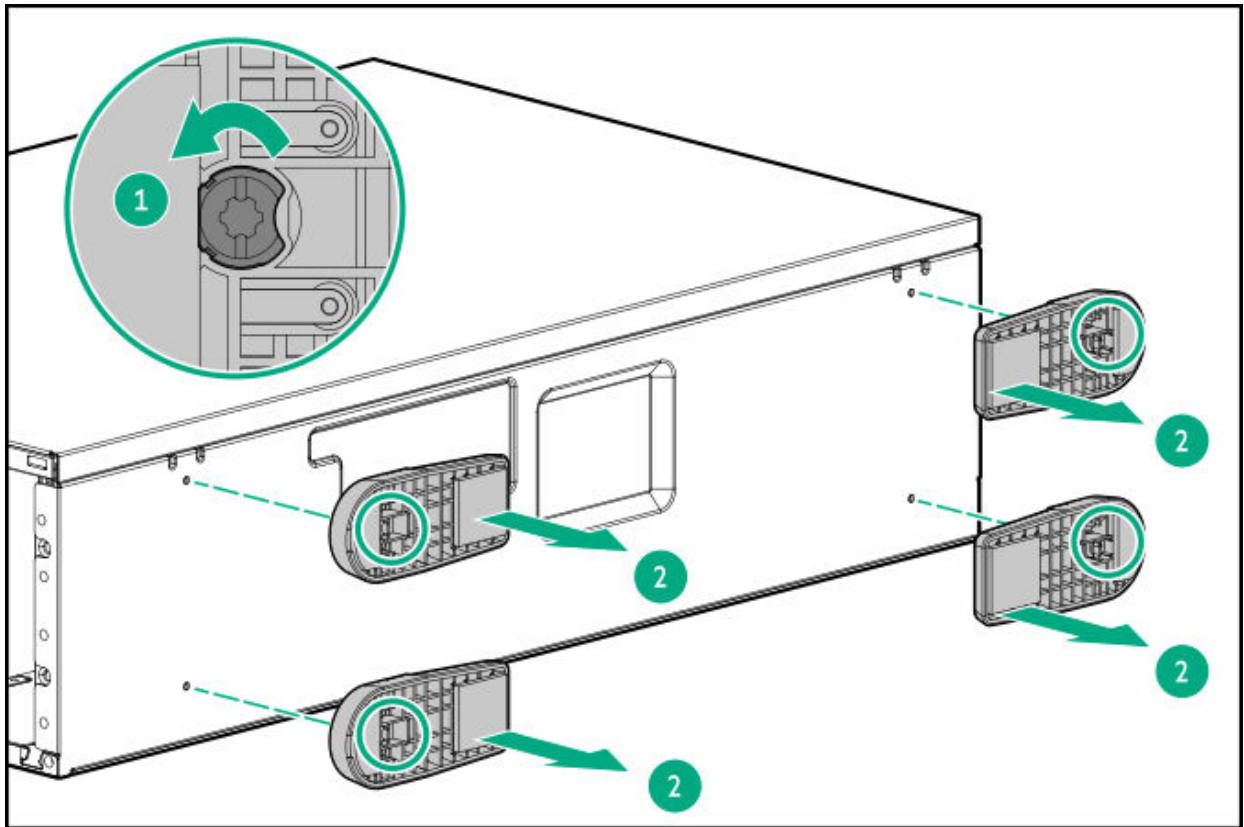

6. Install the rack rails and server tray.
7. Install the server into the rack.
8. Install the cable management arm.

Results

The installation procedure is complete.

Subtopics

- Install the rack rails and server tray**
- Install the server into the rack**
- Install the cable management arm**

Install the rack rails and server tray

About this task

The rack rails can be installed in a round-hole or a square-hole racks. The rack rails occupy 1U space in the rack.

Procedure

1. Disassemble the rack rail assemblies:
 - a. Pull out the inner sliding rail until it is fully extended.
 - b. Slide and hold the white release tab in the direction shown, and then remove the sliding rail from the mounting rail.

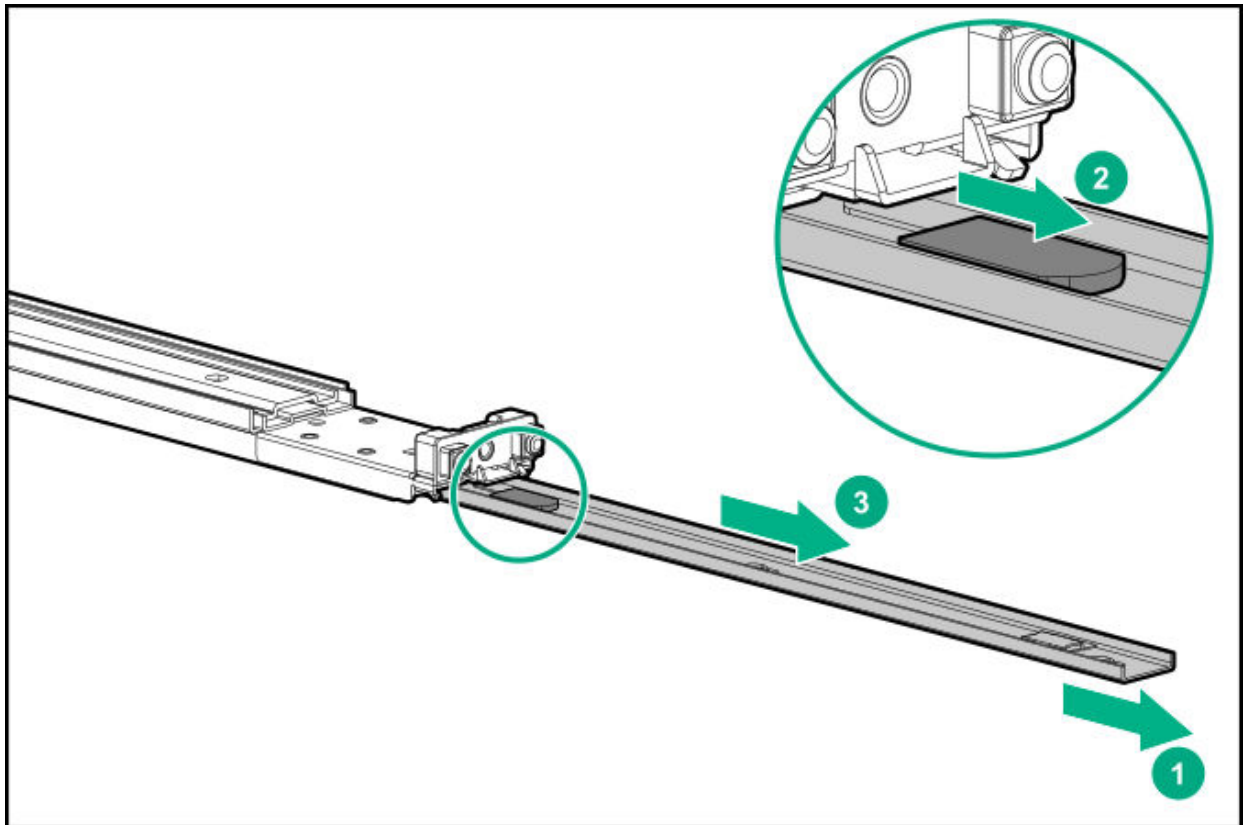

2. Install the sliding rails on the server tray:
 - a. Insert the spools on the sides of the server tray through the notches on the rails.
 - b. Slide the rail towards the rear of the tray to lock it into place.

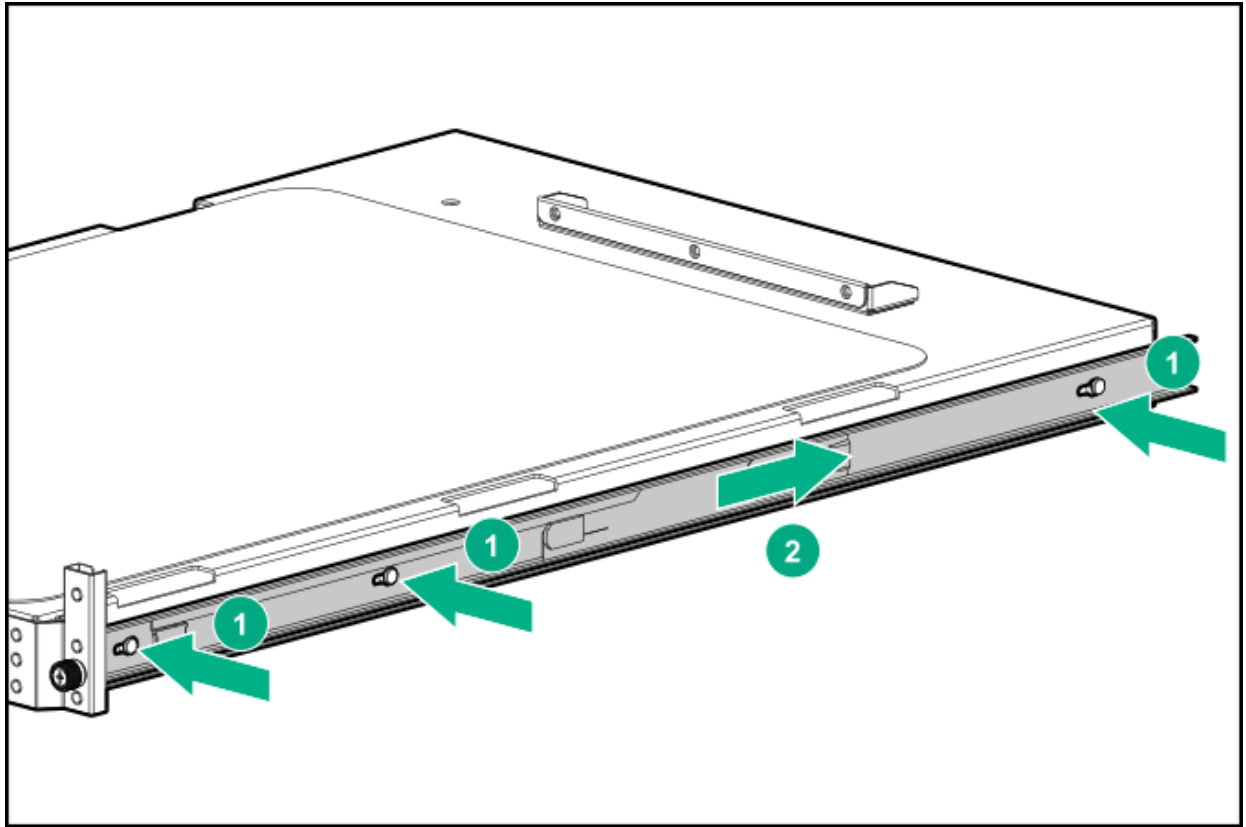

3. Locate the orientation markers on the mounting rails:

- The front end of the rails is marked **FRONT**.
- The rear end of the rail is marked with **L** for left and **R** for right.

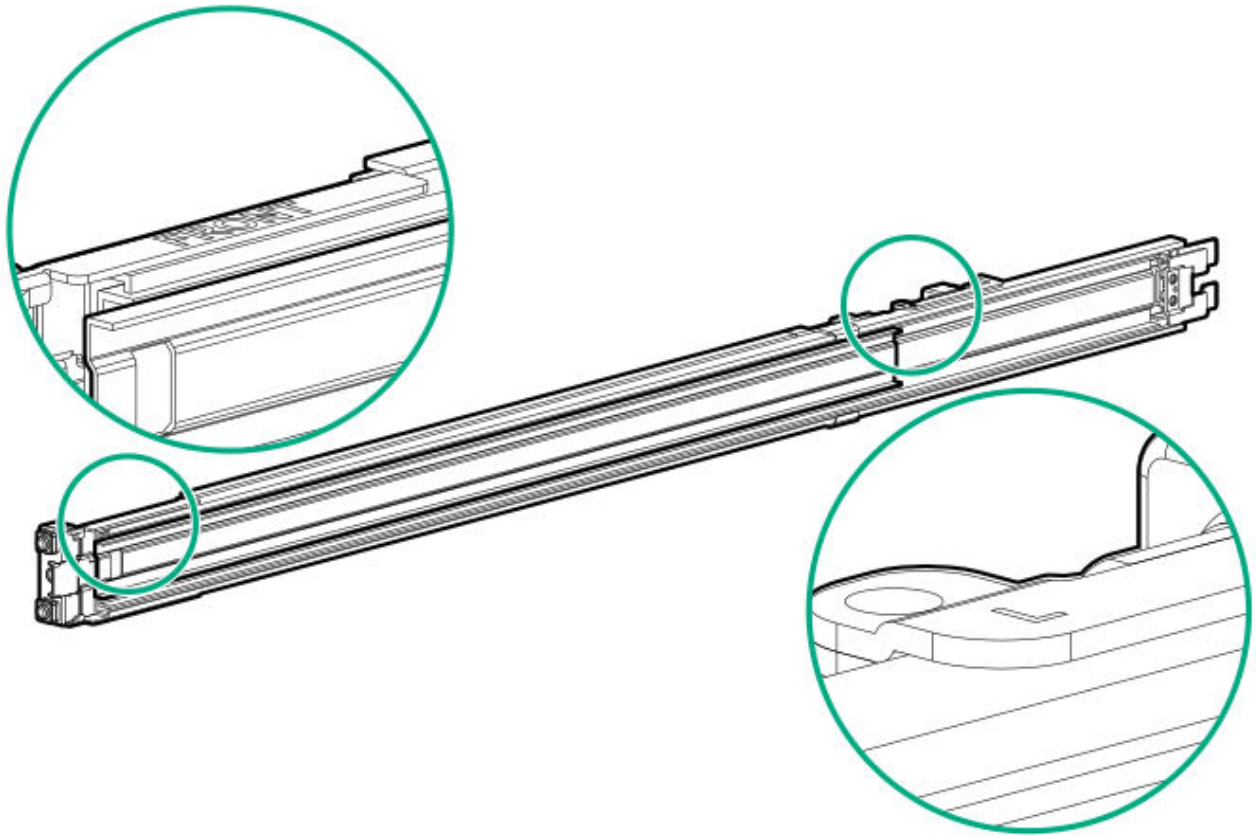

4. Fasten the mounting rails to the rack columns:
 - a. Retract and hold the rear retention bracket.
 - b. Insert the pins on the mounting flange into the rack column holes.
 - c. Release the rear retention bracket.

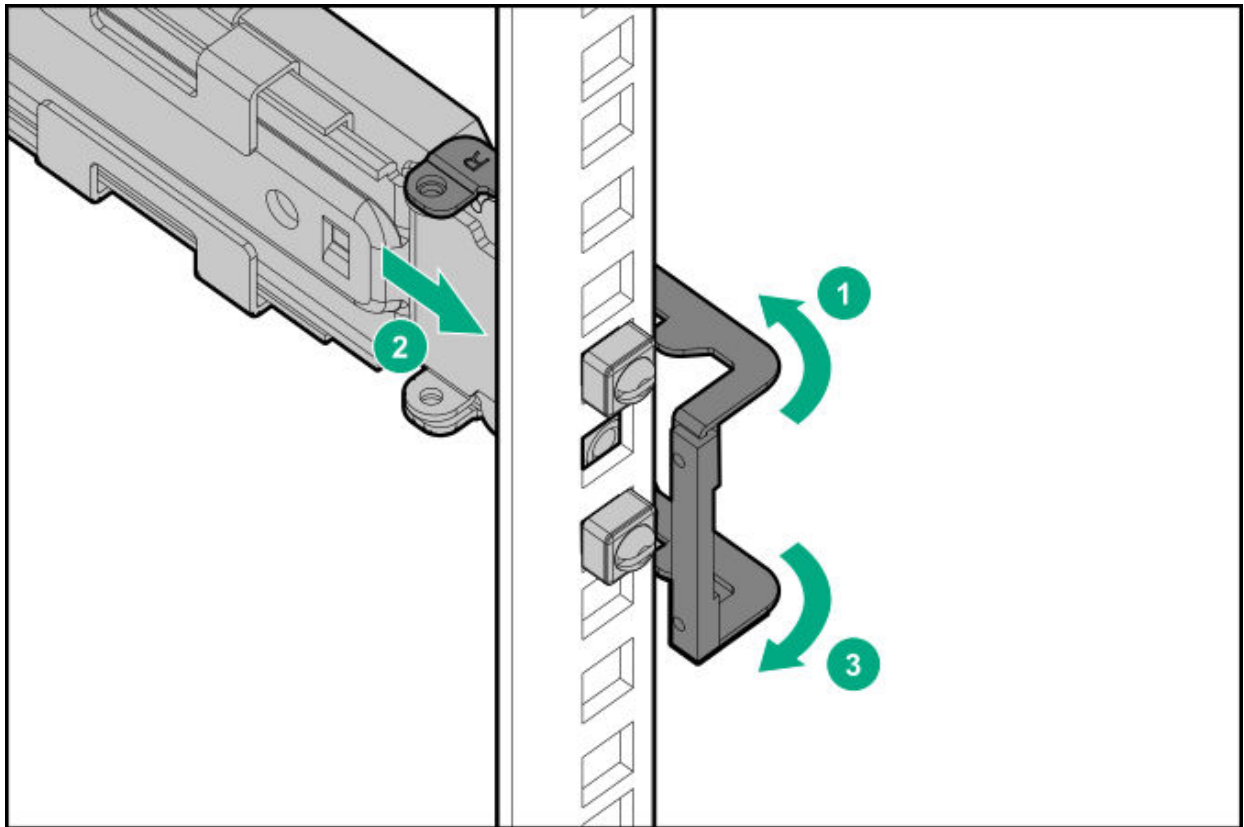

- d. Retract and hold the front retention bracket.
- e. Insert the pins on the mounting flange into the rack column holes.
- f. Release the front retention bracket.

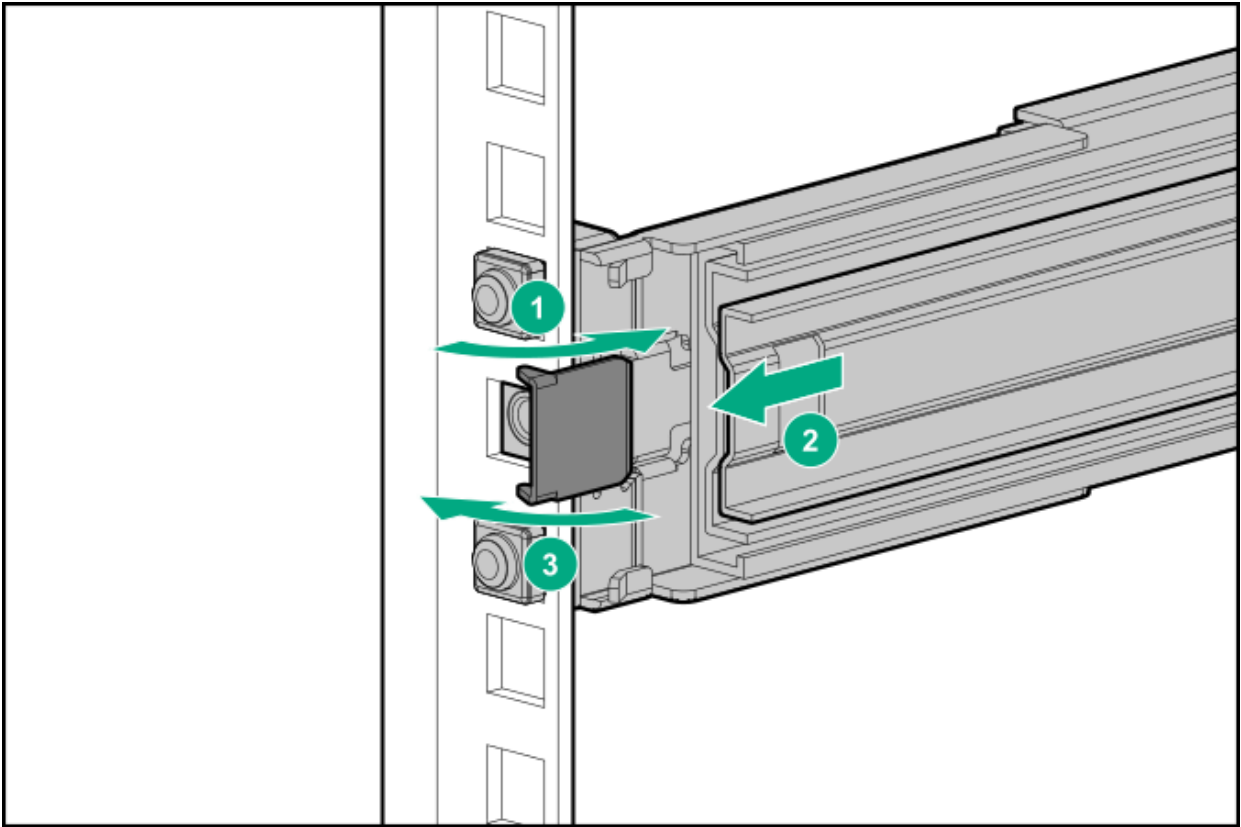

5. Extend the inner rail.

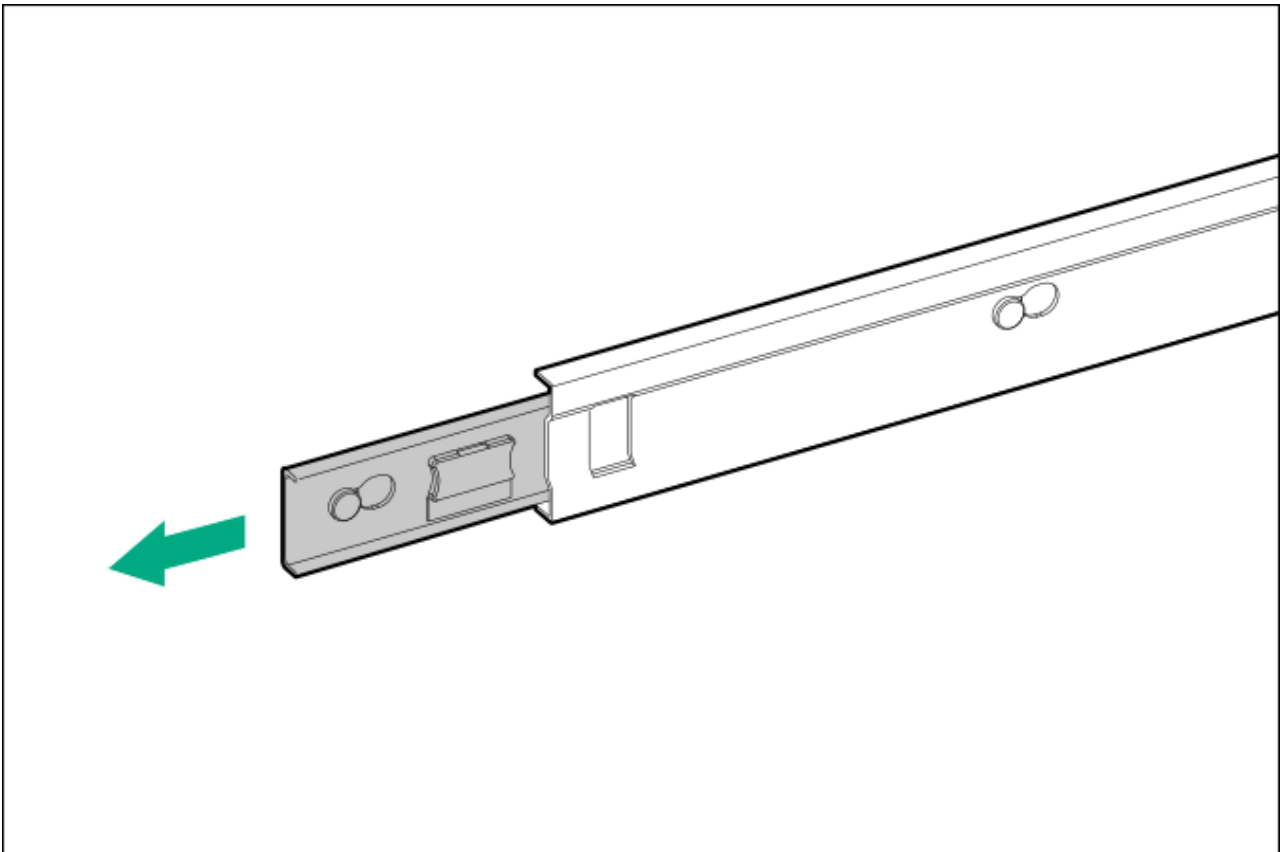

6. Slide the server tray into the rack.

The rack rails will click and lock into place when the tray is properly engaged.

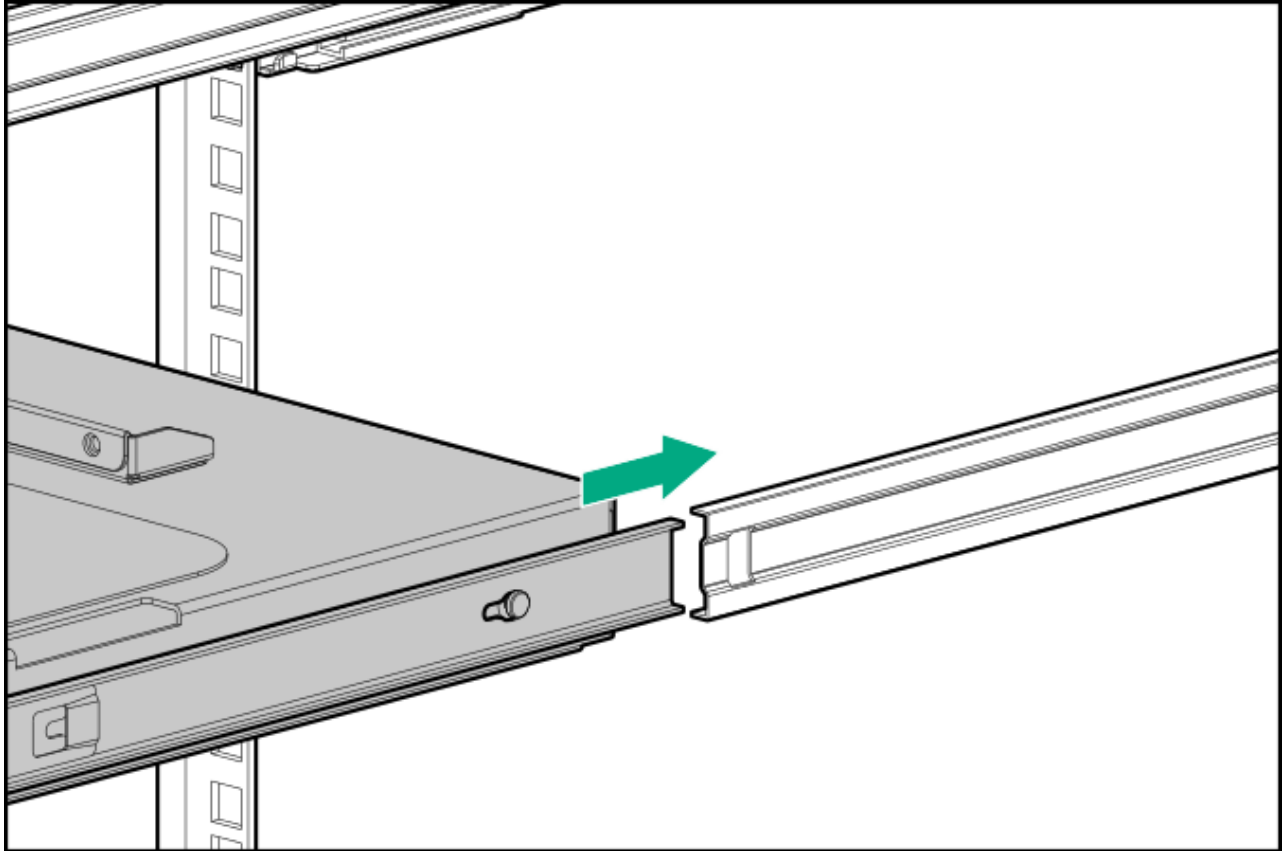

7. Install the server into the rack.

Install the server into the rack

Prerequisites

- Get help to lift and stabilize the server during rack installation. **If the server is installed higher than chest level, additional two people might be required to help install the server:** One person to support the server weight, and the other two to slide the server into the rack.
- Before you perform this procedure, review the:
 - Space and airflow requirements

- [Rack warnings and cautions](#)
- [Server warnings and cautions](#)
- A fully populated server is heavy. Hewlett Packard Enterprise recommends removing the external chassis components before installing the server into a rack.
- Before you perform this procedure, make sure that you have a T-15 Torx screwdriver available.

Procedure

1. Grasp the tray notch to slide the tray out of the rack.

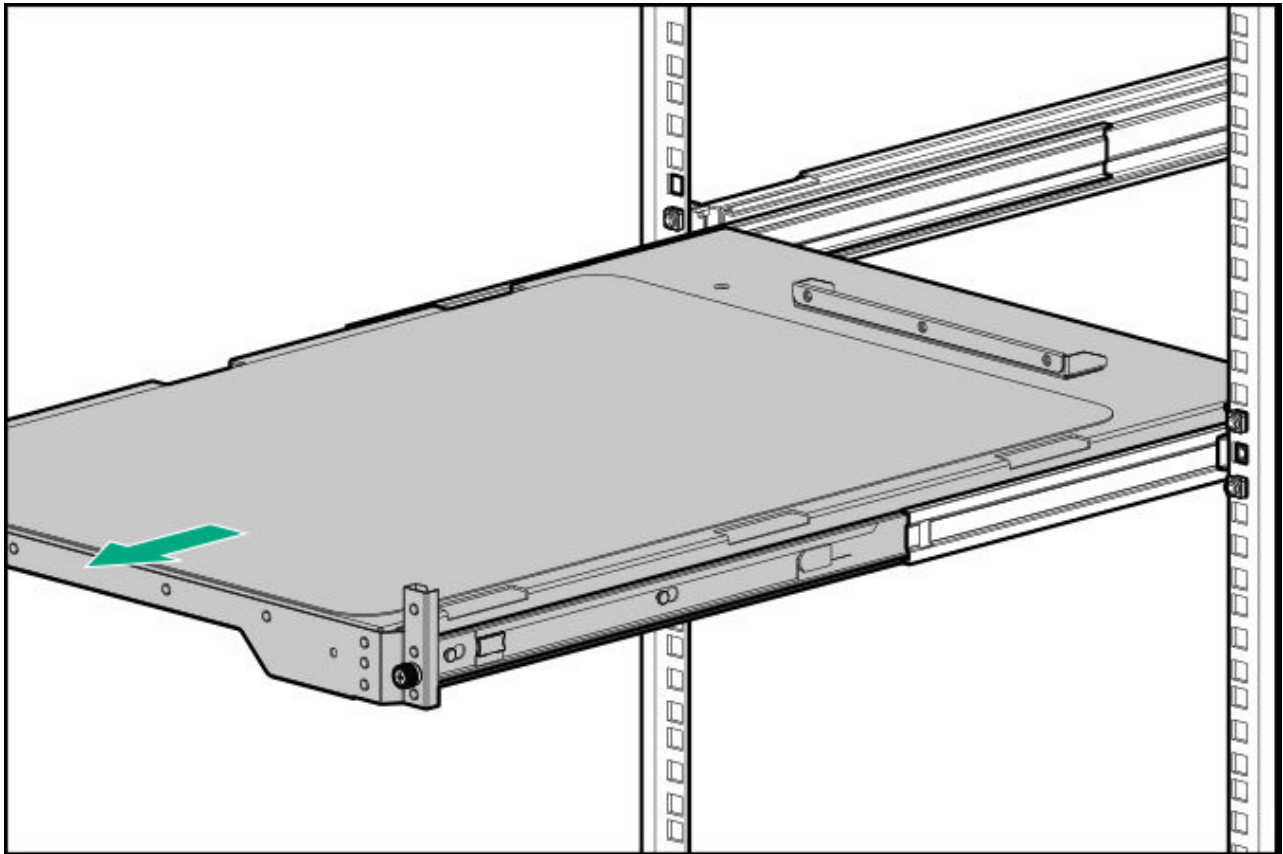

2. Place the server on the tray.

Verify that the front panel of the server is aligned with the front of the tray.

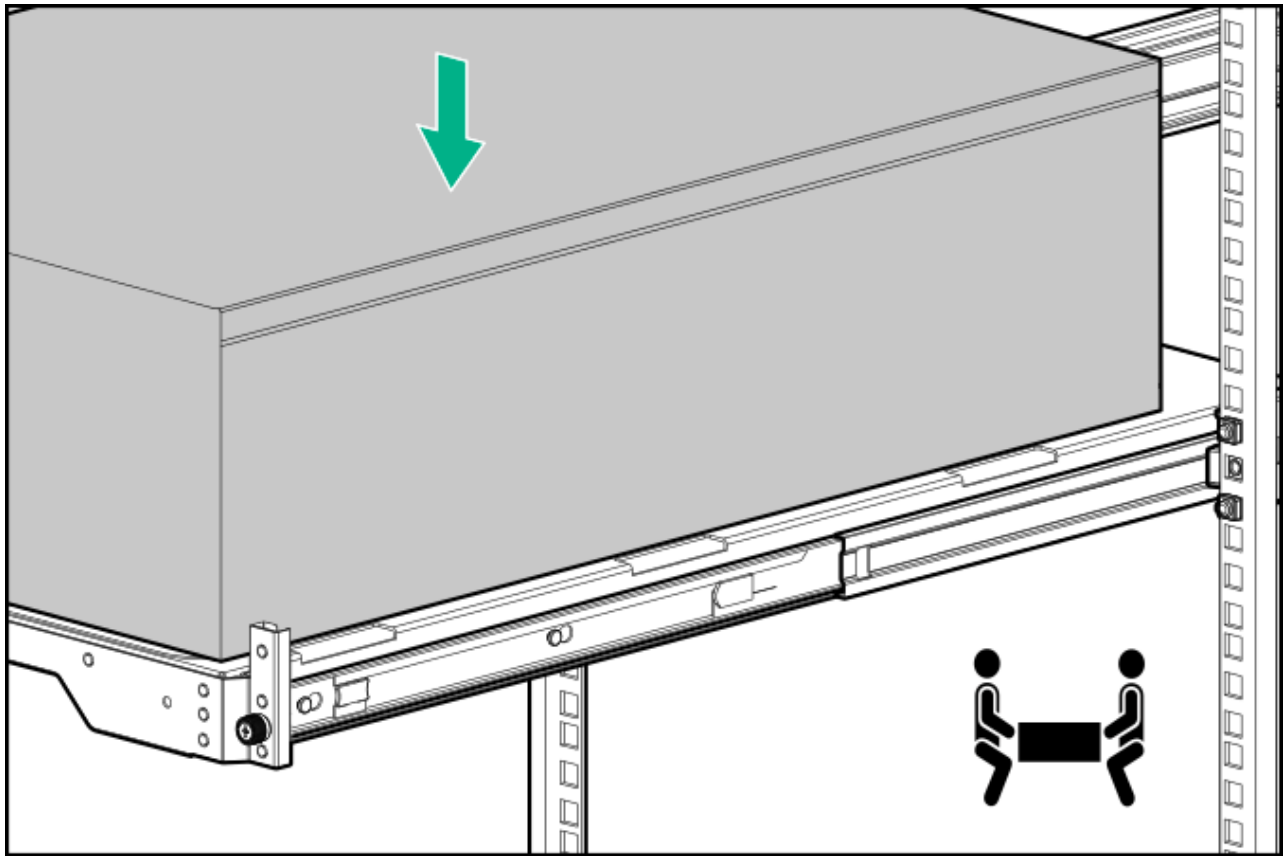

3. Install the chassis rear bracket screws.

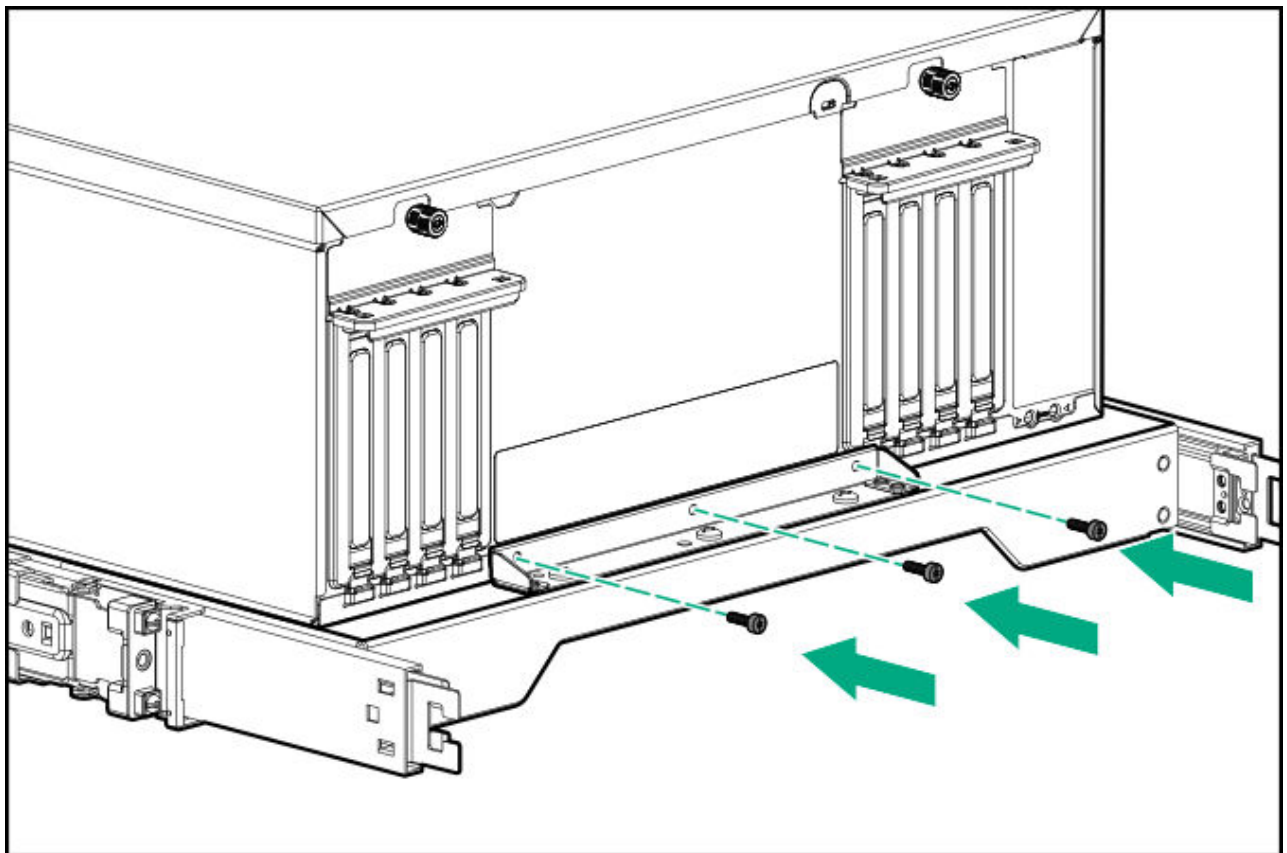

4. Press and hold the blue rail-release tabs, and then slide the tray back into the rack.

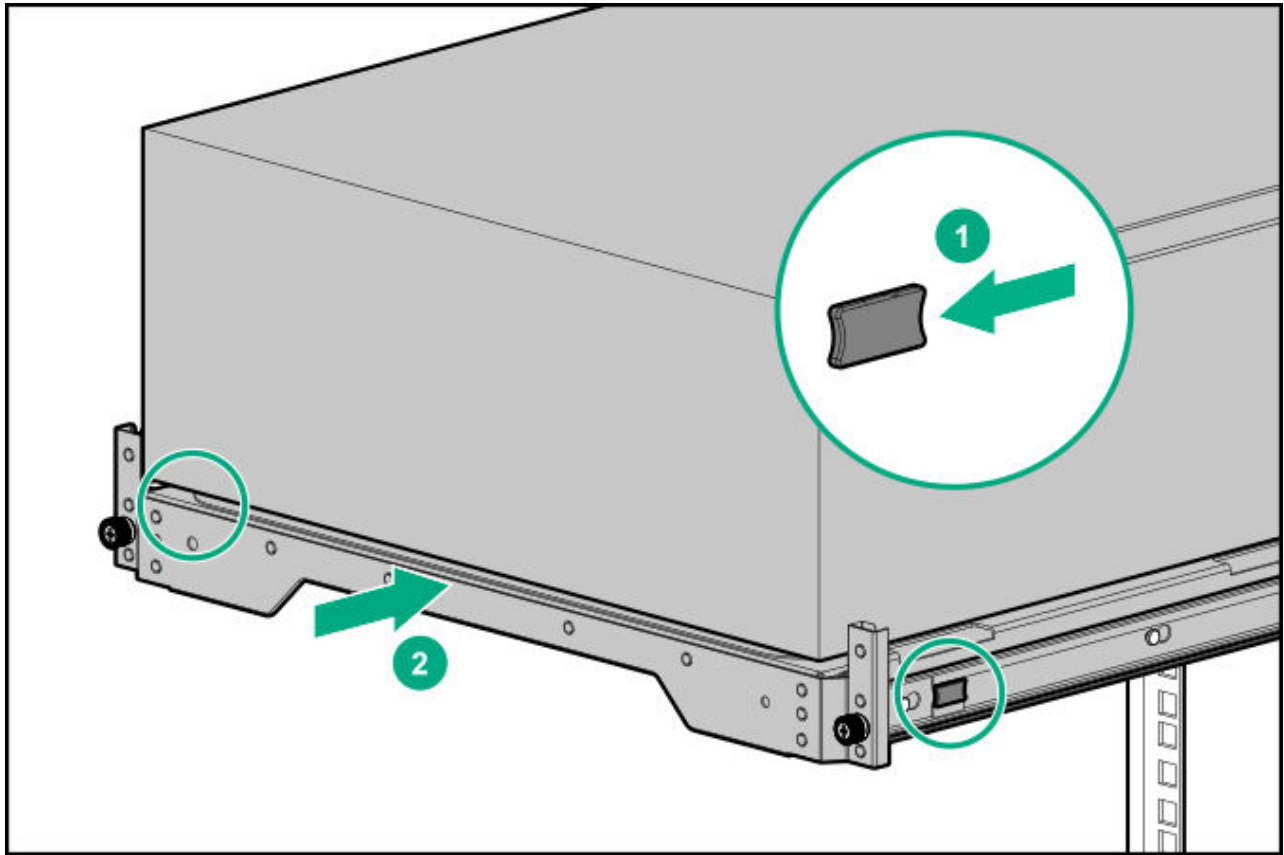

5. Connect all peripheral cables to the server.
6. Connect each power cord to the server.
7. Secure the power cord in the strain relief strap attached to the power supply handle:
 - a. Unwrap the strain relief strap from the power supply handle.



CAUTION

Avoid tight bend radii to prevent damaging the internal wires of a power cord or a server cable. Never bend power cords and server cables tight enough to cause a crease in the sheathing.

- b. Secure the power cord with the strain relief strap. Roll the extra length of the strap around the power supply handle.

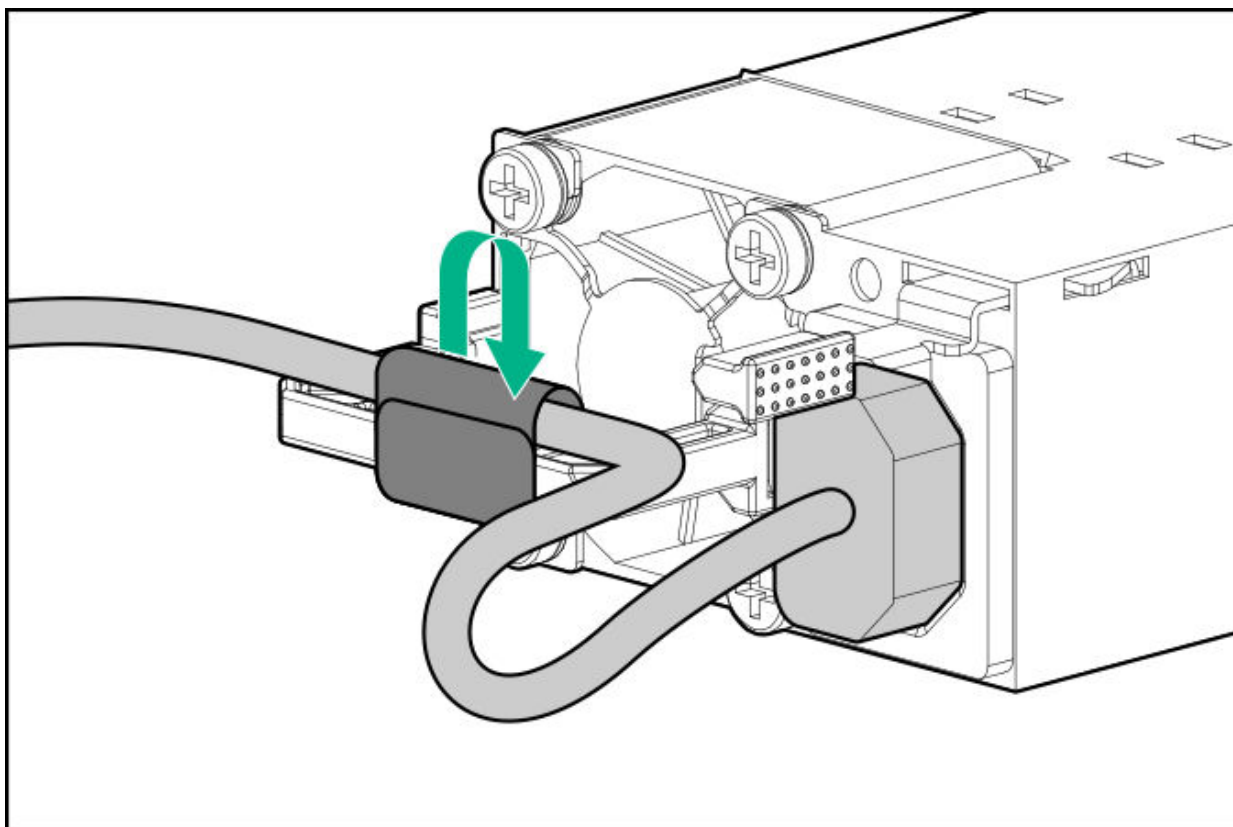

8. Install the cable management arm.

Install the cable management arm

About this task

The cable management arm (CMA) allows the server to be fully extended from the rack without the need to power off the system or disconnect any rear panel cables. This CMA is designed for ambidextrous implementation.

For the purpose of this procedure, left and right terminology is from the perspective of a user facing the front of the rack.



CAUTION

Support the CMA during the removal and replacement procedures. Do not allow the CMA to hang by its own weight during the procedure.

Procedure

1. (Optional) The CMA retention bracket can be rotated to fit a left- or right-hand CMA operation. Press and hold the rotate mechanism, and then rotate the bracket 180°.

There will be an audible click to indicate that the bracket is locked in its adjusted position.

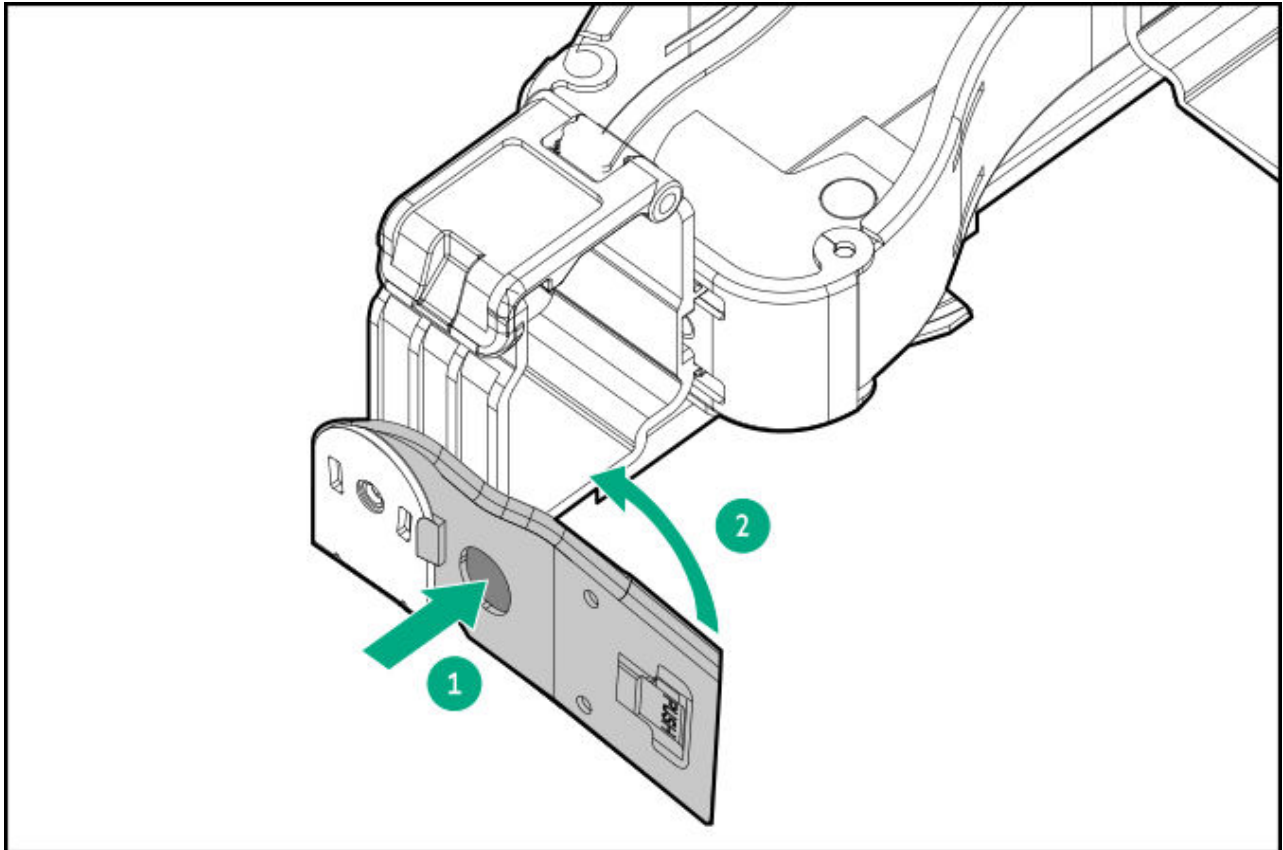

2. Connect the CMA hinged tabs and retention bracket to the rack rails:
 - a. Insert the inner tab into the slide rail.
 - b. Insert the outer tab into the mounting rail.
 - c. Insert the retention bracket into the opposite mounting rail.

There will be an audible click to indicate that the tabs and bracket are locked into place.

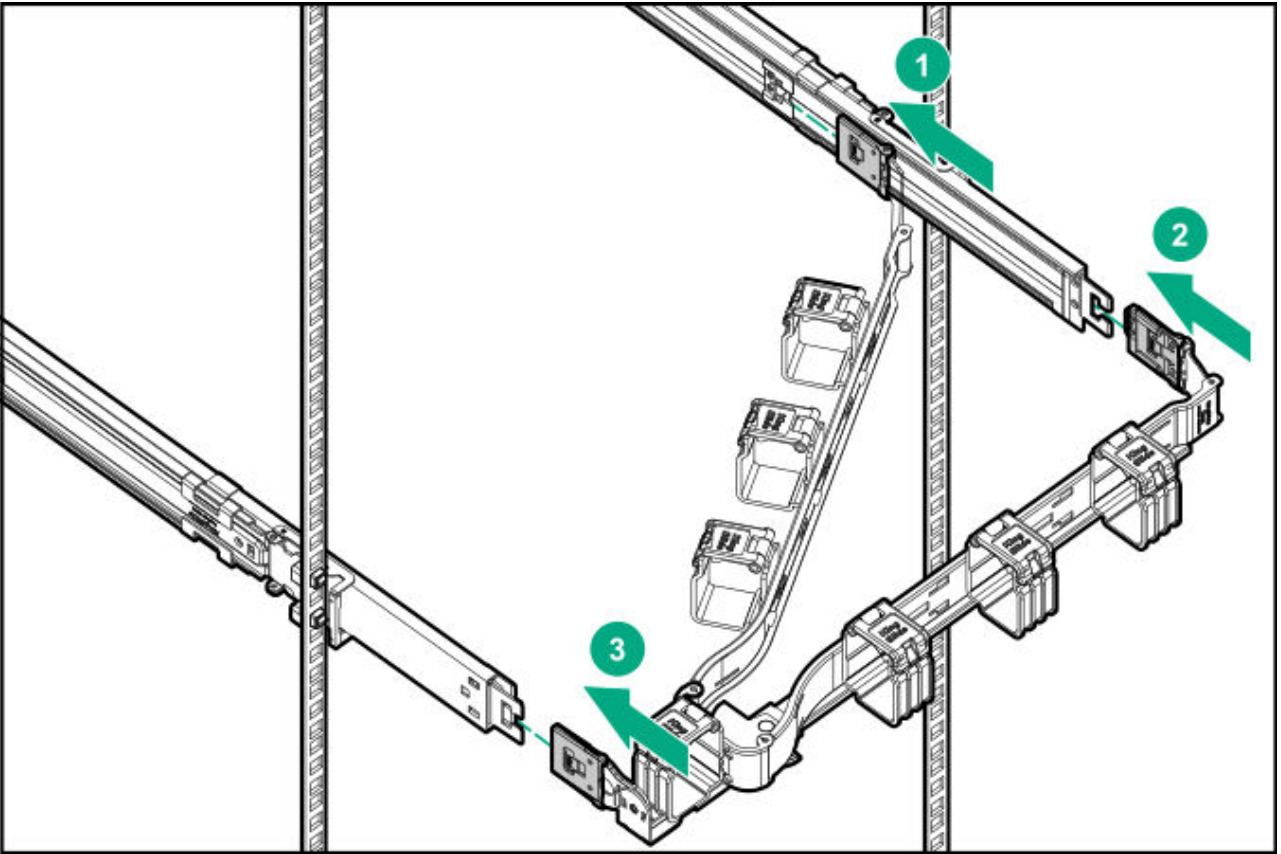

3. Open the cable clamps.

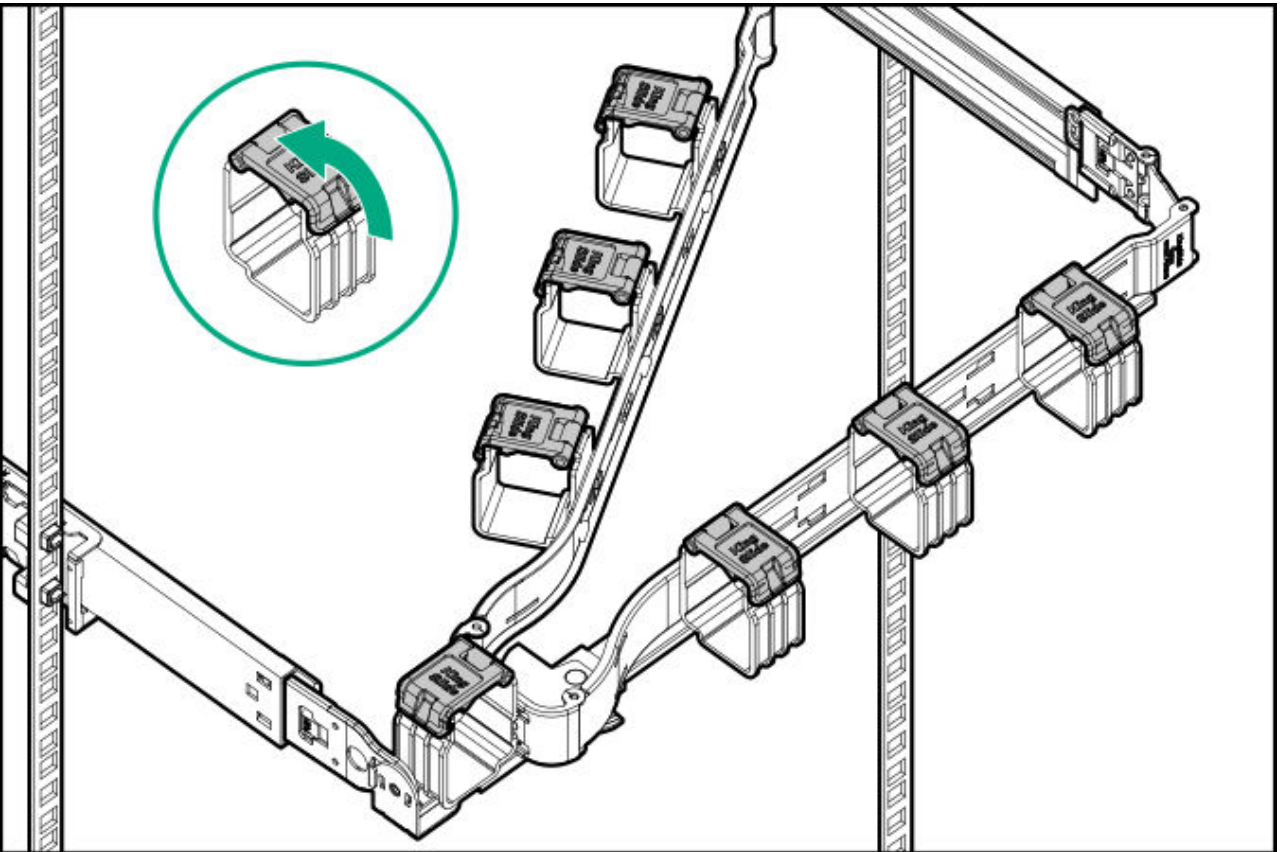

4.



CAUTION

Employ industry best practices in managing peripheral cables and power cords secured in the CMA. These are some of the more important points:

- Leave enough cable slack between the rear panel and the CMA to allow the full extension of the CMA when the server is extended out of the rack.
- However, there should be no excess cable slack inside the CMA; this might cause cable binding and could lead to cable damage.
- Make sure that the cables and power cords do not extend above the top or below the bottom of the server to which they are attached. Otherwise, the cables might snag on other equipment installed in the rack when the server is extended from or returned to the rack.

Route the peripheral cables and power cords through the cable clamps.

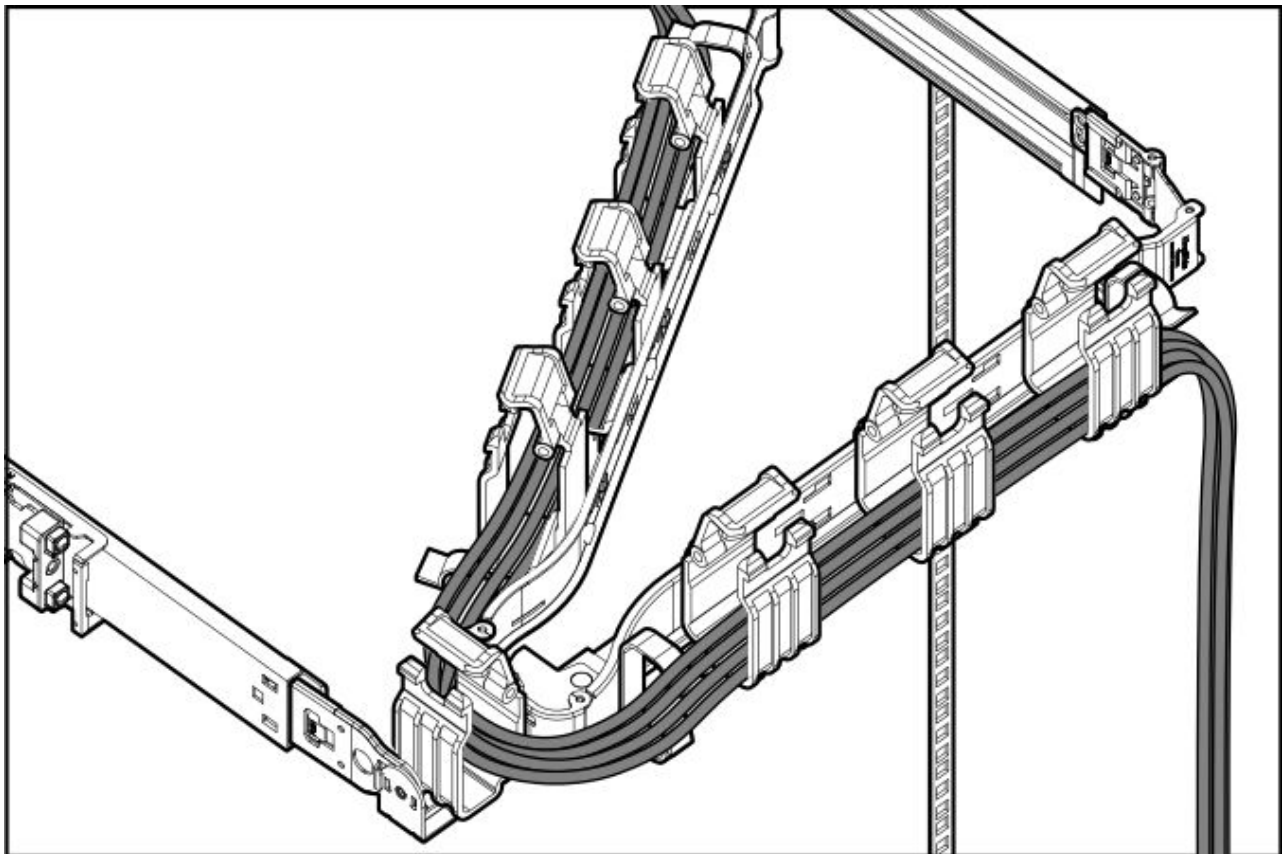

5. Close the cable clamps.

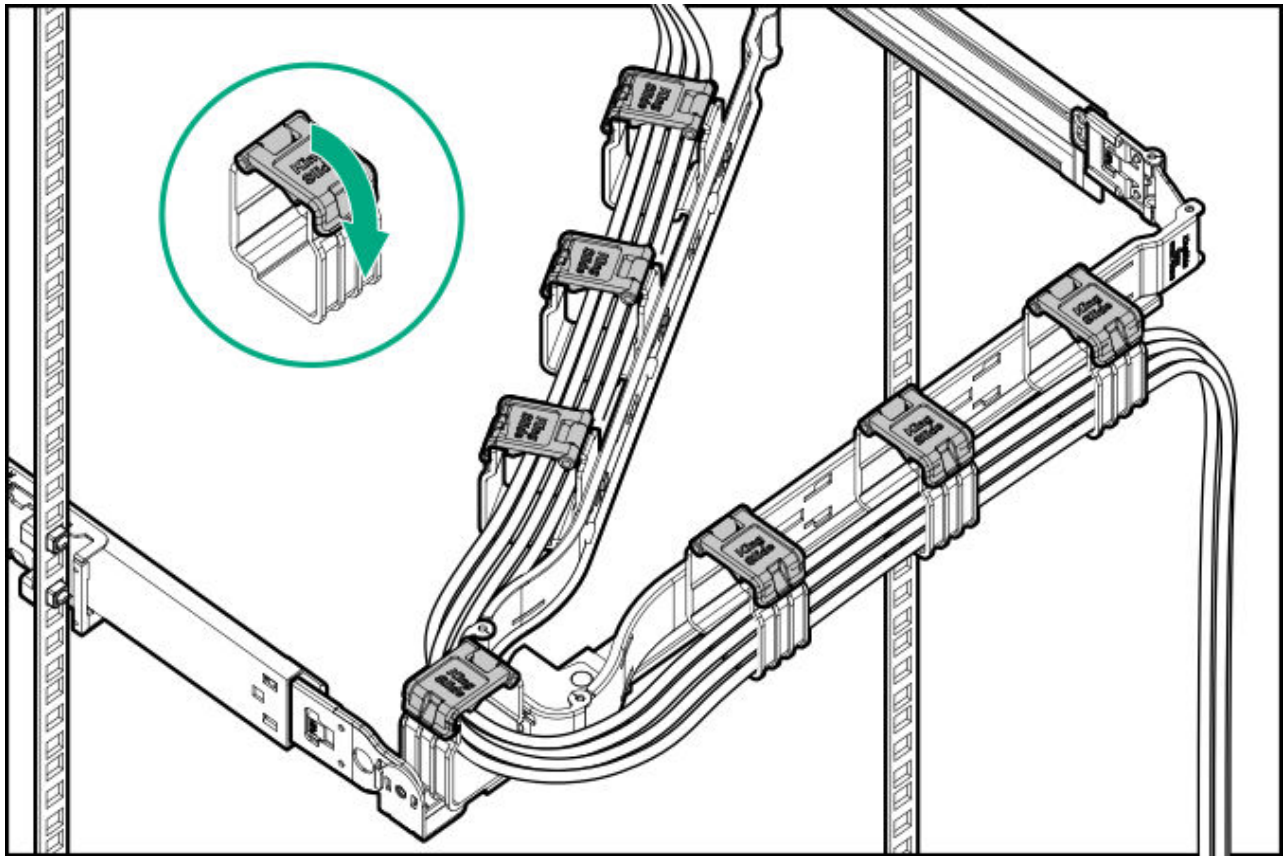

6. Verify that the peripheral cables and power cords are secured properly.

Two people is needed for this procedure: one to slide the server in and out of the rack, and the other to observe the peripheral cables and power cords.

- a. Fully extend the server tray out of the rack.
- b. Make sure that there is enough slack in the cables and cords for a full extension of the rack rails.

Make sure that there is no cable binding or crimping.

- c. Slide the server tray in and out of the rack to verify that there is no risk of accidental disconnection of the peripheral cables and power cords.

7. Tighten the server tray thumbscrews.

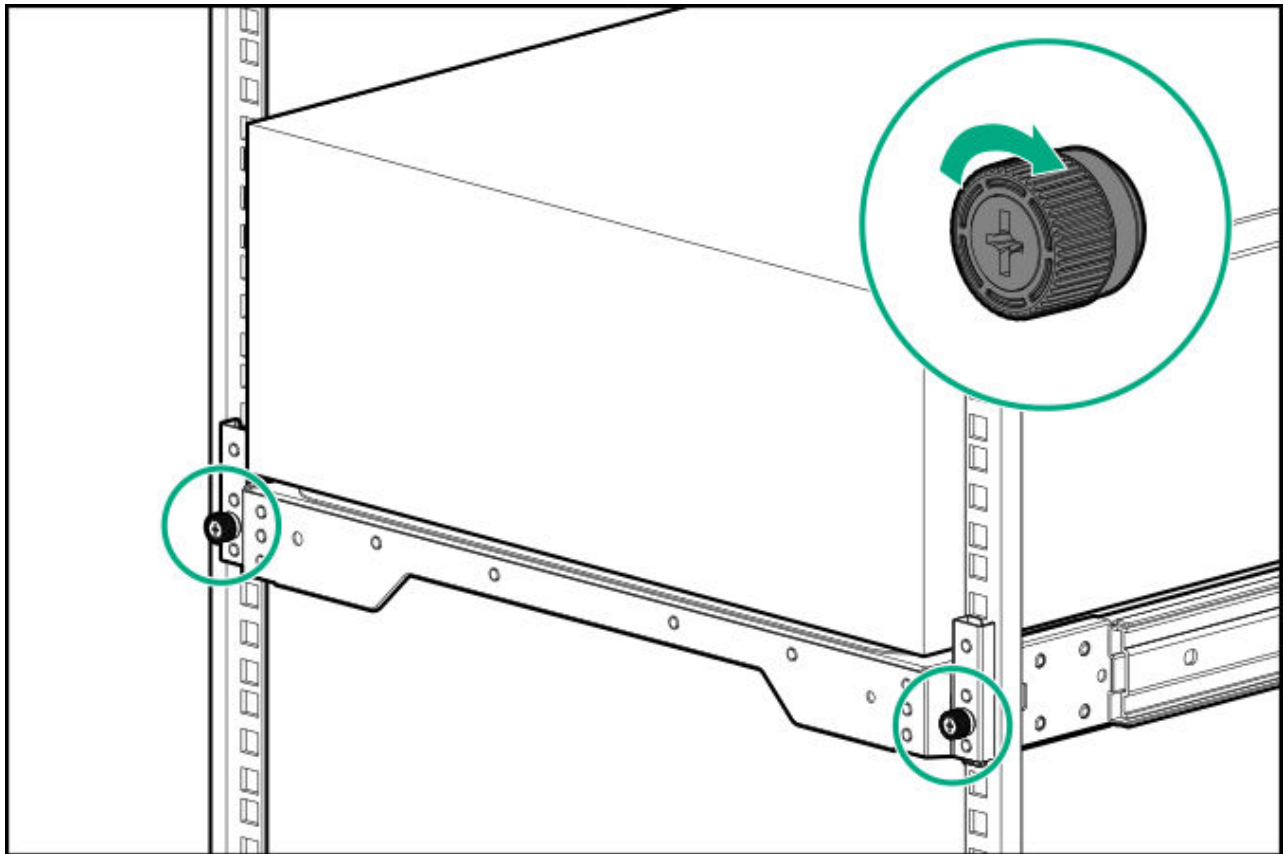

8. Connect each power cord to the power source.

9. Power up the server.

Results

The installation procedure is complete.

Drives

Subtopics

Drive installation guidelines

Installing a hot-plug LFF/SFF drive

Installing a hot-plug E3.S drive

Drive installation guidelines

Observe the following general guidelines:

- The system automatically sets all drive numbers.



CAUTION

When a server is purchased without any drive installed, some drive bays might be empty while other drive bays might be populated with drive blanks. To maintain proper system cooling, do not operate the server without a drive or a drive blank installed.

- If only one drive is used, install it in the bay with the lowest drive number. For drive numbering, see [Drive bay numbering](#).
- This server does not support mixed drive types.
- All drives grouped into the same drive array must meet the following criteria:
 - They must be either all hard drives or all solid-state drives.
 - Drives must be the same capacity to provide the greatest storage space efficiency.

Installing a hot-plug LFF/SFF drive

Prerequisites

When installing a high-power consumption SFF drive, [make sure that fans 1-8 are installed](#)

To determine if the SFF drive requires these prerequisites, see the server QuickSpecs on the Hewlett Packard Enterprise (<https://www.hpe.com/info/quickspecs>).

About this task



CAUTION

A discharge of static electricity from a finger or other conductor might damage system boards or other static-sensitive devices. To prevent damage, observe [antistatic precautions](#).



CAUTION

To prevent improper cooling and thermal damage, do not operate the server unless all bays are populated with either a component or a blank.

Procedure

1. Open the front bezel:
 - a. Unlock the front bezel.
 - b. Open the front bezel.

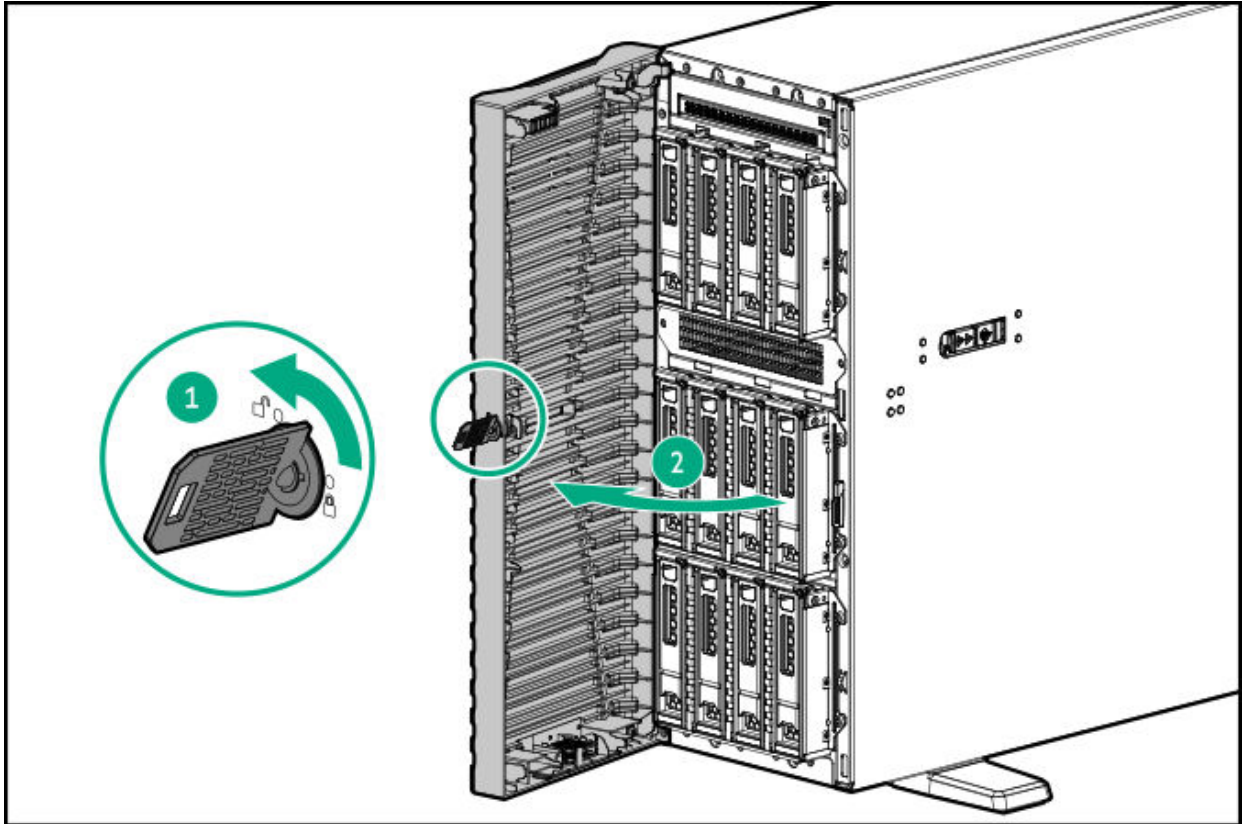

2. Remove the drive blank.
 - LFF drive blank

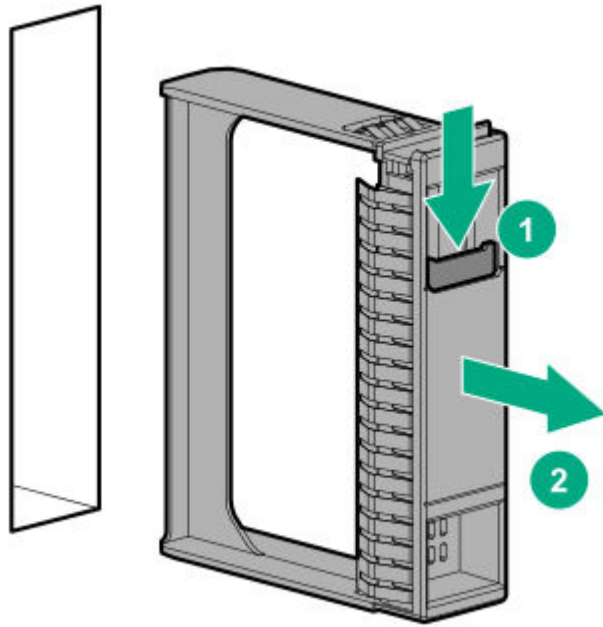

- SFF drive blank

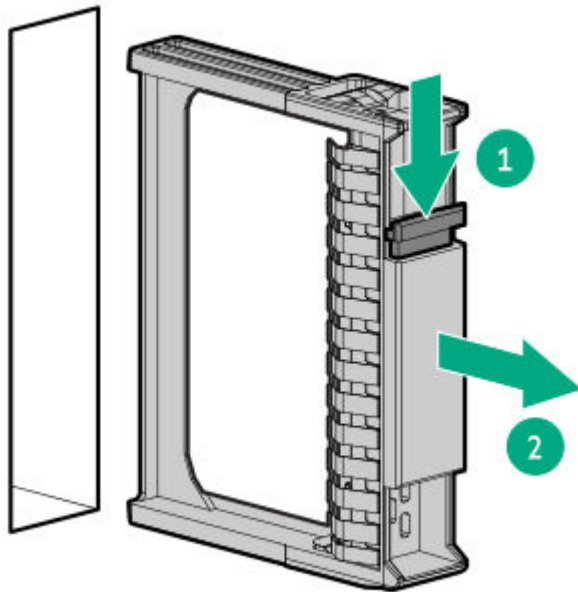

3. Prepare the drive.

- LFF drive

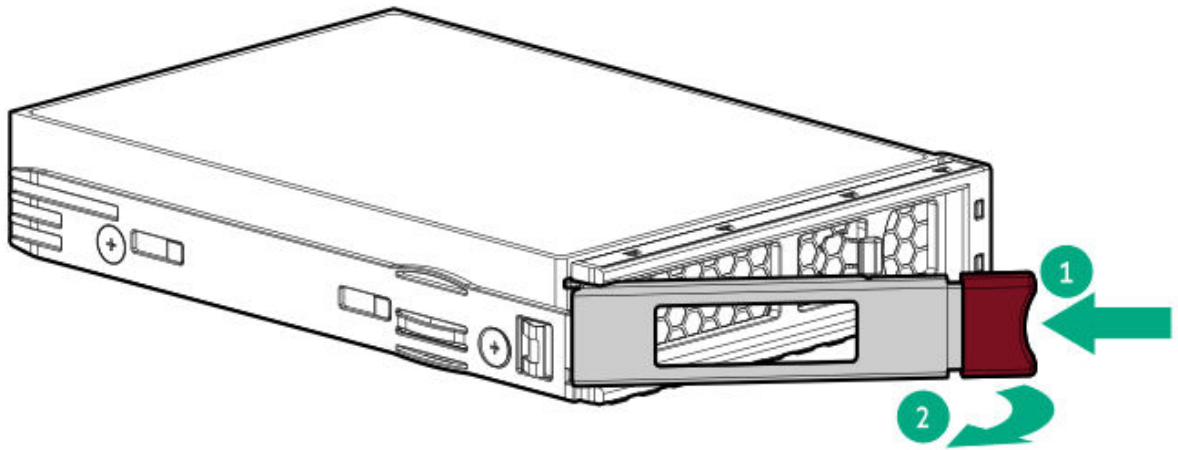

- SFF drive

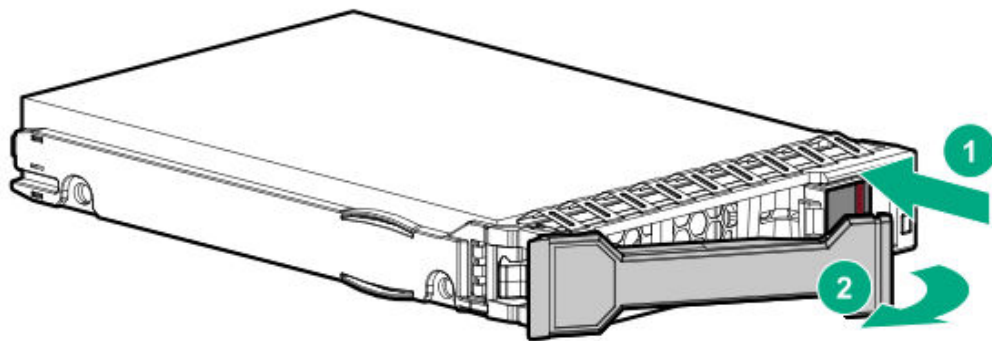

4. Install the drive.

- LFF drive

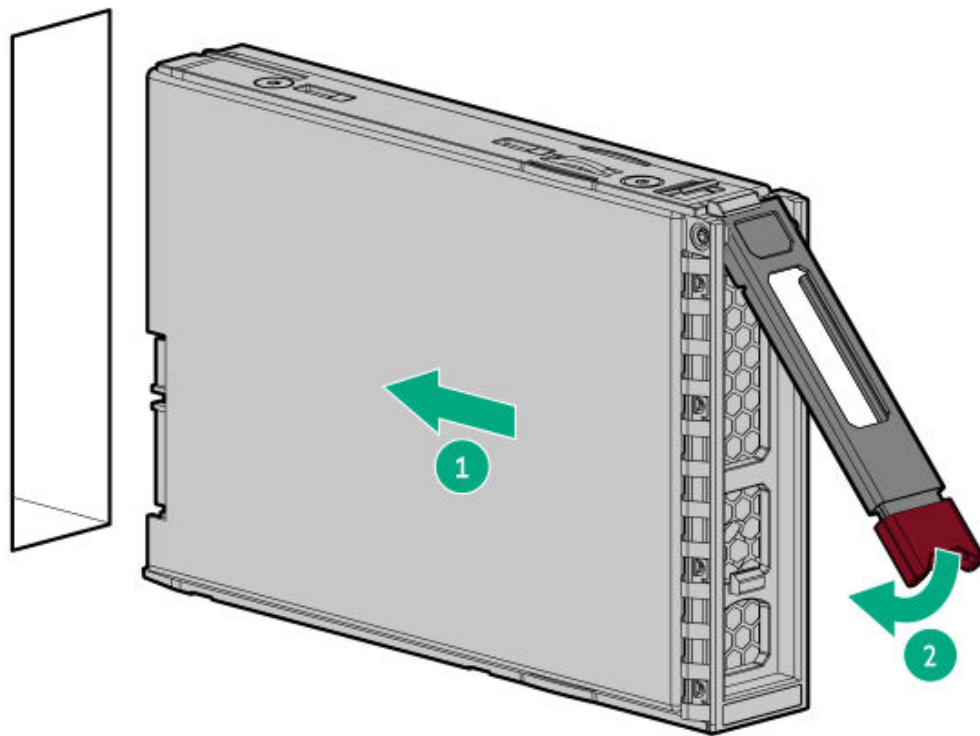

- SFF drive

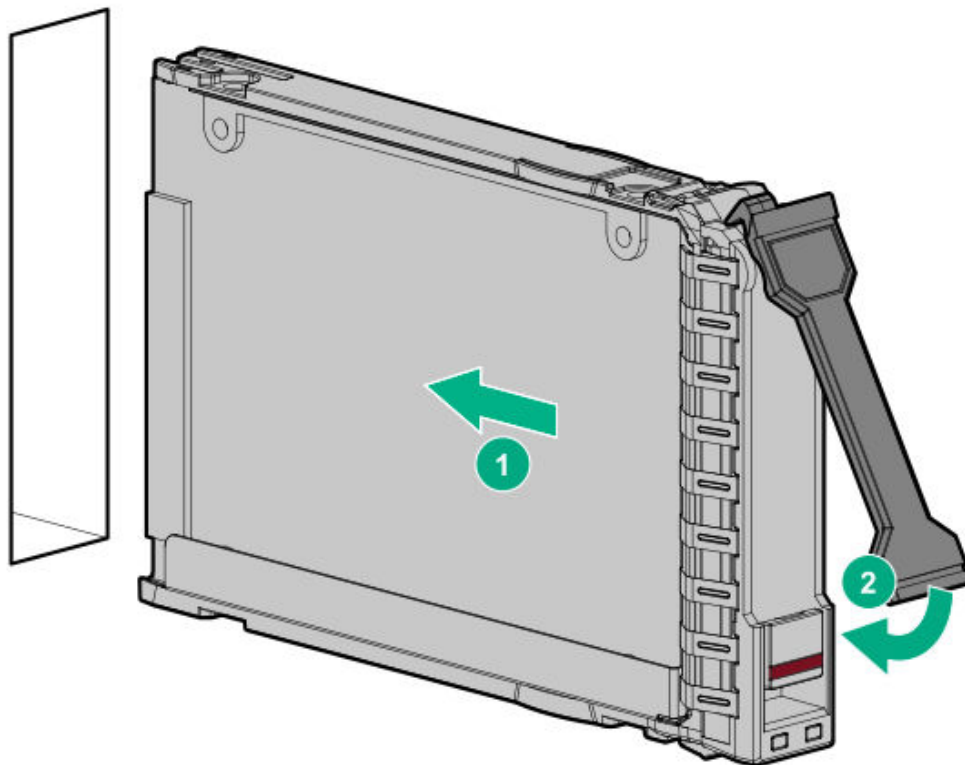

5. Determine the status of the drive from the drive LED definitions.

6. Close the front bezel:

- a. Close the front bezel.
- b. Lock the front bezel.

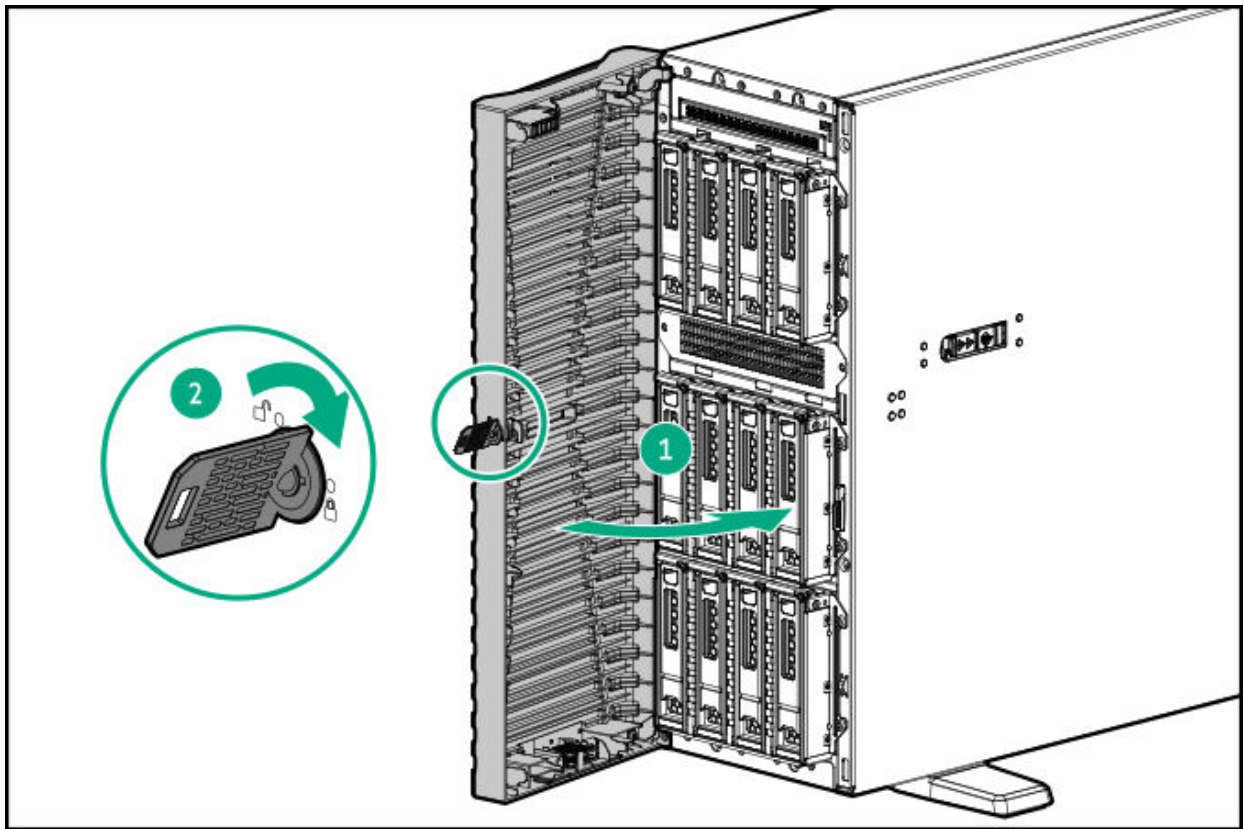

7. To configure drive arrays, see the [relevant storage controller guide](#).

Results

The installation procedure is complete.

Installing a hot-plug E3.S drive

Prerequisites

[Make sure that Fan 10 is installed.](#)

About this task



CAUTION

A discharge of static electricity from a finger or other conductor might damage system boards or other static-sensitive devices. To prevent damage, observe antistatic precautions.



CAUTION

To prevent improper cooling and thermal damage, do not operate the server unless all bays are populated with either a component or a blank.

Procedure

1. Open the front bezel:
 - a. Unlock the front bezel.
 - b. Open the front bezel.

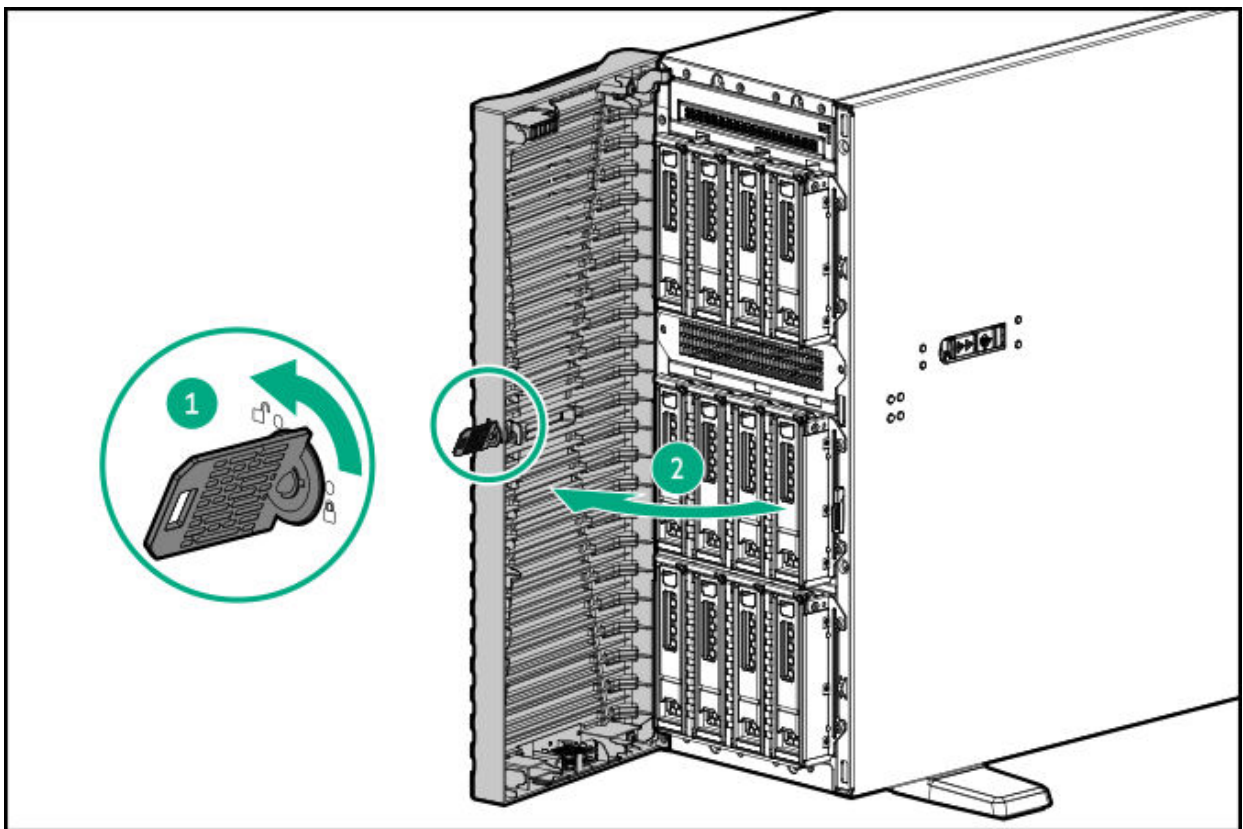

2. Remove the drive blank.
Retain the blank for future use.

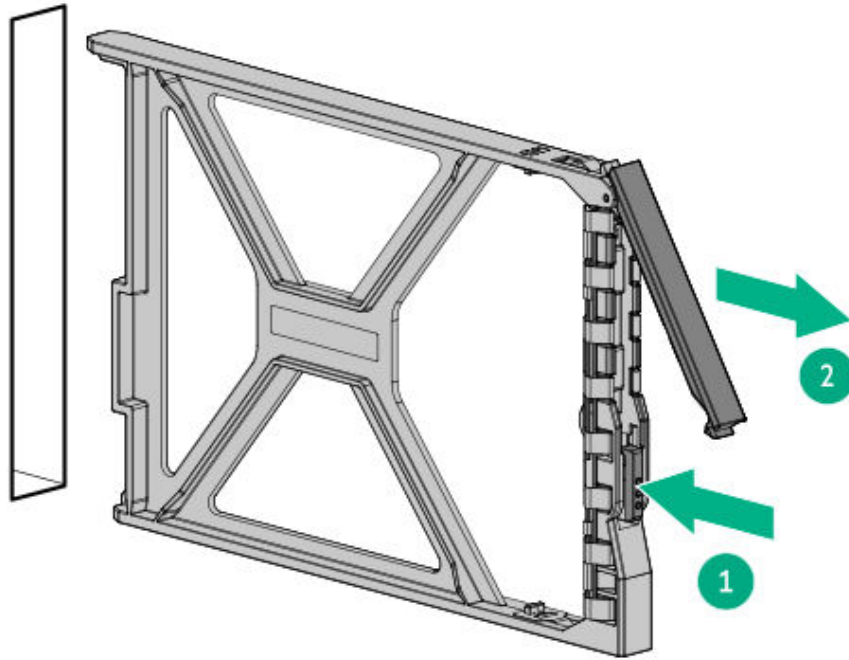

3. Prepare the drive.

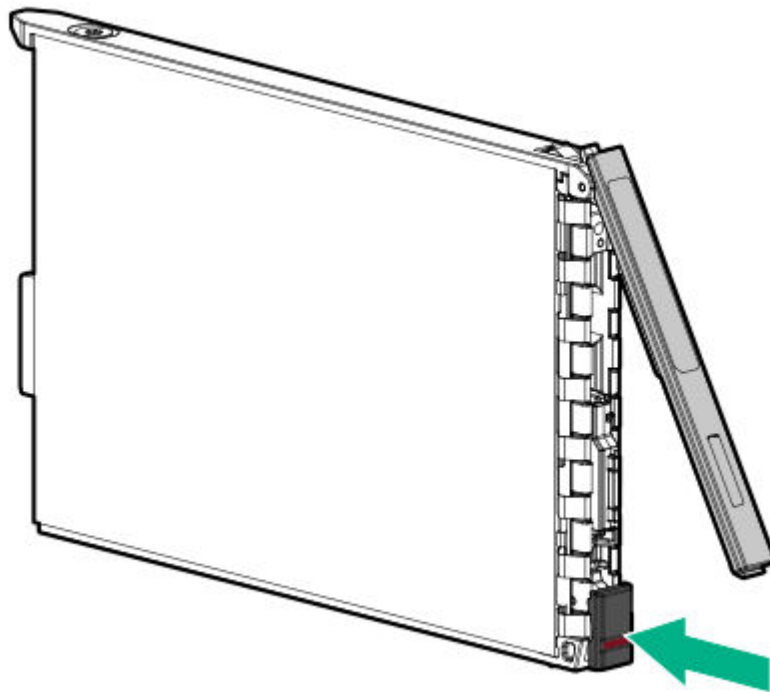

4. Install the drive.

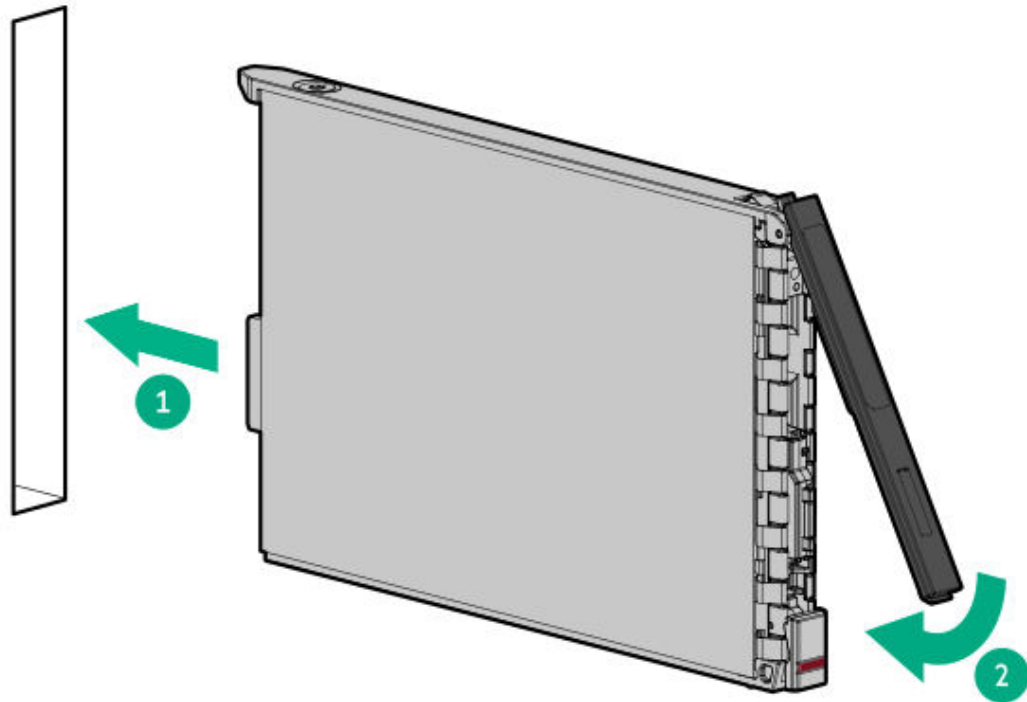

5. Determine the status of the drive from the drive LED definitions.

6. Close the front bezel:

- a. Close the front bezel.
- b. Lock the front bezel.

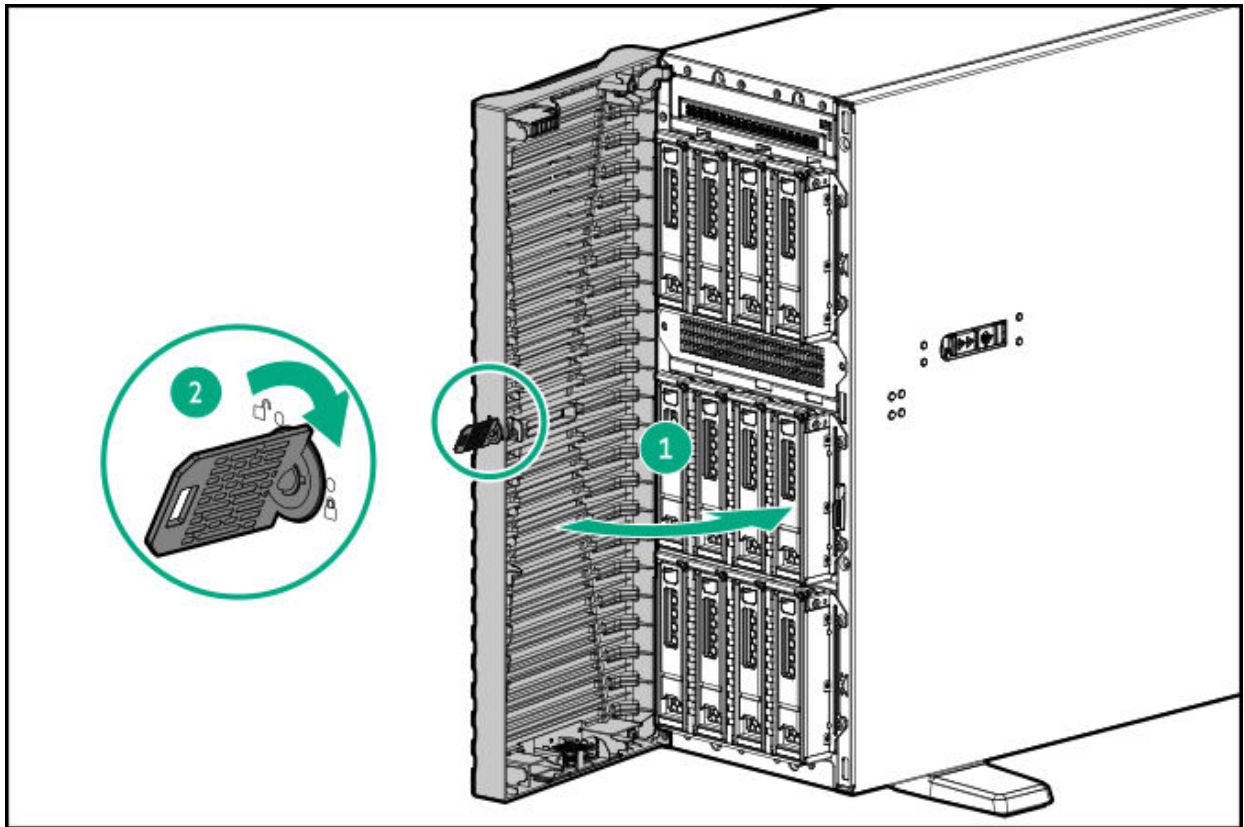

7. To configure drive arrays, see the [relevant storage controller guide](#).

Results

The installation procedure is complete.

Drive cages

Subtopics

[Installing the 4 LFF drive cage](#)

[Installing the 8 SFF drive cage](#)

[Installing the 12 E3.S drive cage](#)

Installing the 4 LFF drive cage

Prerequisites

Before you perform this procedure, make sure that you have a T-15 Torx screwdriver available.

About this task

The server supports the 4 LFF drive cage option. This option:

- Can be installed in boxes 1-3.
- Can be installed together with the 8 SFF drive cage option.
- Supports SAS and SATA drives.



CAUTION

A discharge of static electricity from a finger or other conductor might damage system boards or other static-sensitive devices. To prevent damage, observe antistatic precautions.



CAUTION

To prevent improper cooling and thermal damage, do not operate the server unless all bays are populated with either a component or a blank.

Procedure

1. Remove the front bezel.
2. Power down the server.
3. Remove all power:
 - a. Disconnect each power cord from the power source.
 - b. Disconnect each power cord from the server.
4. Disconnect all peripheral cables from the server.
5. Do one of the following:
 - If the server is in tower mode, place the server on a flat, level surface with the access panel facing up.
 - If the server is in rack mode, remove the server from the rack.
6. Remove the access panel.
7. Remove the fan cage.
8. Remove the drive box blank:
 - a. Remove the screws.
 - b. Remove the blank.

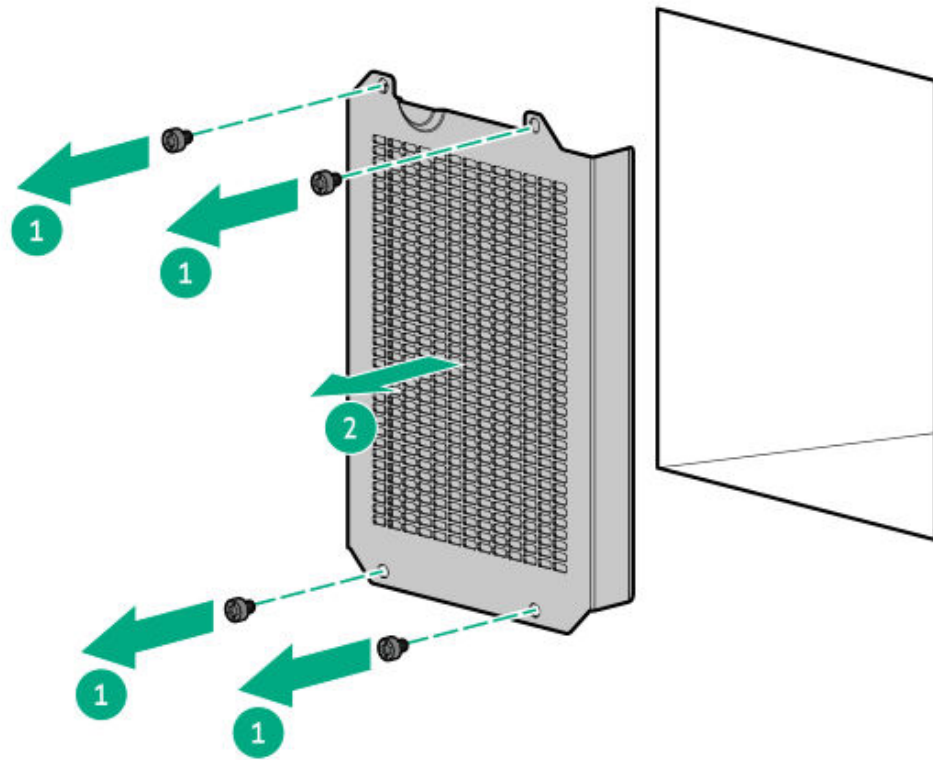

9. Install the 4 LFF drive cage:
 - a. Install the drive cage in the server.
 - b. Install the screws.

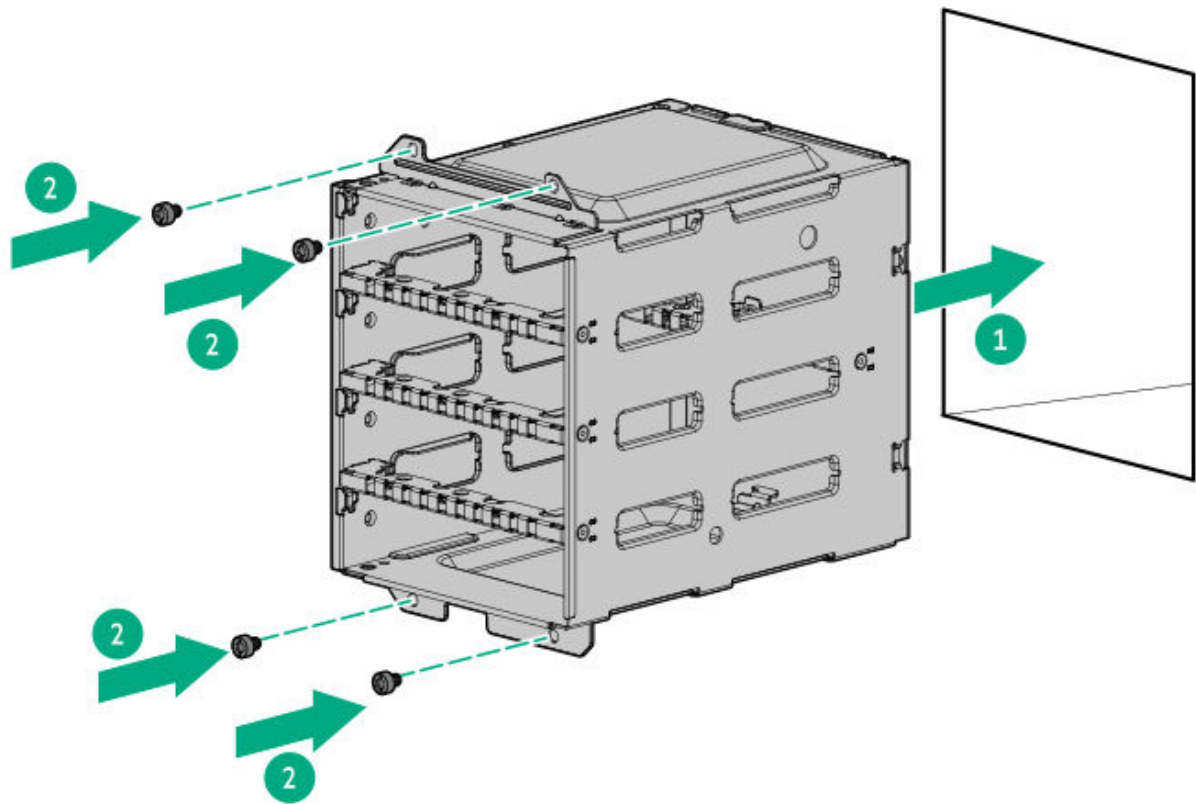

.0. Connect the drive cables:

- Storage controller cable
- Drive power cable

.1. Make sure that all the system cables that are routed through the front cable channel are properly secured in the metal cable tabs.

This is done to prevent system damage due to cables being inadvertently caught under the fan cage.

.2. Install the fan cage.

.3. Install the access panel.

.4. Do one of the following:

- Orient the server back in tower mode.
- Install the server into the rack.

.5. Connect all peripheral cables to the server.

.6. Connect each power cord to the server.

.7. Connect each power cord to the power source.

8. [Power up the server.](#)
9. [Install the LFF hot-plug drives.](#)
10. [Install the front bezel.](#)

Results

The installation procedure is complete.

Installing the 8 SFF drive cage

Prerequisites

Before you perform this procedure, make sure that you have a T-15 Torx screwdriver available.

About this task

This server supports several front 8 SFF drive cage options with [different backplanes](#). This option:

- Can be installed in boxes 1-3.
- [Can be installed together with the 4 LFF drive cage option.](#)
- Supports SAS, SATA, and U.3 PCIe4 NVMe drives.



CAUTION

A discharge of static electricity from a finger or other conductor might damage system boards or other static-sensitive devices. To prevent damage, observe [antistatic precautions](#).



CAUTION

To prevent improper cooling and thermal damage, do not operate the server unless all bays are populated with either a component or a blank.

Procedure

1. [Remove the front bezel.](#)
2. [Power down the server.](#)
3. Remove all power:
 - a. Disconnect each power cord from the power source.
 - b. Disconnect each power cord from the server.

4. Disconnect all peripheral cables from the server.
5. Do one of the following:
 - If the server is in tower mode, place the server on a flat, level surface with the access panel facing up.
 - If the server is in rack mode, remove the server from the rack.
6. Remove the access panel.
7. Remove the fan cage.
8. Remove the drive box blank:
 - a. Remove the screws.
 - b. Remove the blank.

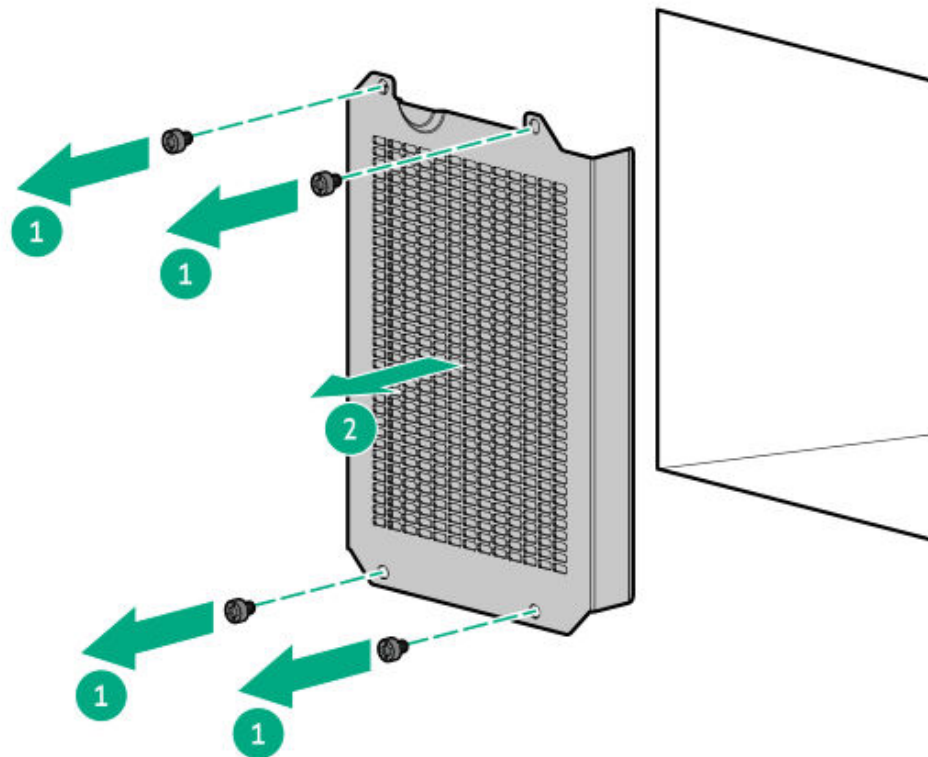

9. Install the 8 SFF drive cage:
 - a. Install the drive cage in the server.
 - b. Install the screws.

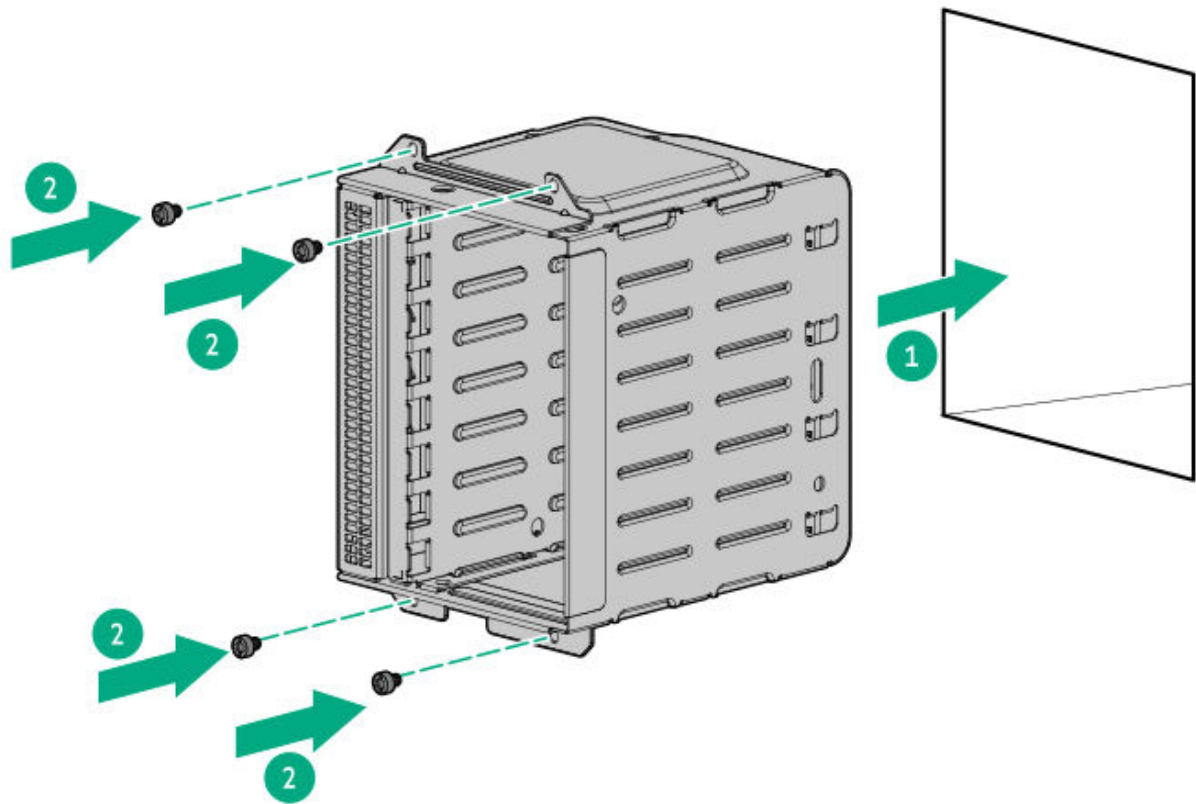

.0. Connect the drive cables:

- [Storage controller cable](#)
- [Drive power cable](#)

.1. Make sure that all the system cables that are routed through the front cable channel are properly secured in the metal cable tabs.

This is done to prevent system damage due to cables being inadvertently caught under the fan cage.

.2. [Install the fan cage.](#)

.3. [Install the access panel.](#)

.4. Do one of the following:

- [Orient the server back in tower mode.](#)
- [Install the server into the rack.](#)

.5. Connect all peripheral cables to the server.

.6. Connect each power cord to the server.

.7. Connect each power cord to the power source.

8. [Power up the server.](#)
9. [Install the LFF hot-plug drives.](#)
10. [Install the front bezel.](#)

Results

The installation procedure is complete.

Installing the 12 E3.S drive cage

Prerequisites

Before you perform this procedure, make sure that you have a T-15 Torx screwdriver available.

About this task

This server supports the 12 E3.S drive cage option. This option:

- Can be installed in box 3.
- [Can be installed together with the 8 SFF or 4 LFF drive cage option.](#)



CAUTION

A discharge of static electricity from a finger or other conductor might damage system boards or other static-sensitive devices. To prevent damage, observe [antistatic precautions](#).



CAUTION

To prevent improper cooling and thermal damage, do not operate the server unless all bays are populated with either a component or a blank.

Procedure

1. [Remove the front bezel.](#)
2. [Power down the server.](#)
3. Remove all power:
 - a. Disconnect each power cord from the power source.
 - b. Disconnect each power cord from the server.
4. Disconnect all peripheral cables from the server.

5. Do one of the following:
 - If the server is in tower mode, place the server on a flat, level surface with the access panel facing up.
 - If the server is in rack mode, remove the server from the rack.
6. Remove the access panel.
7. Remove the fan cage.
8. Remove the drive box blank:
 - a. Remove the screws.
 - b. Remove the blank.

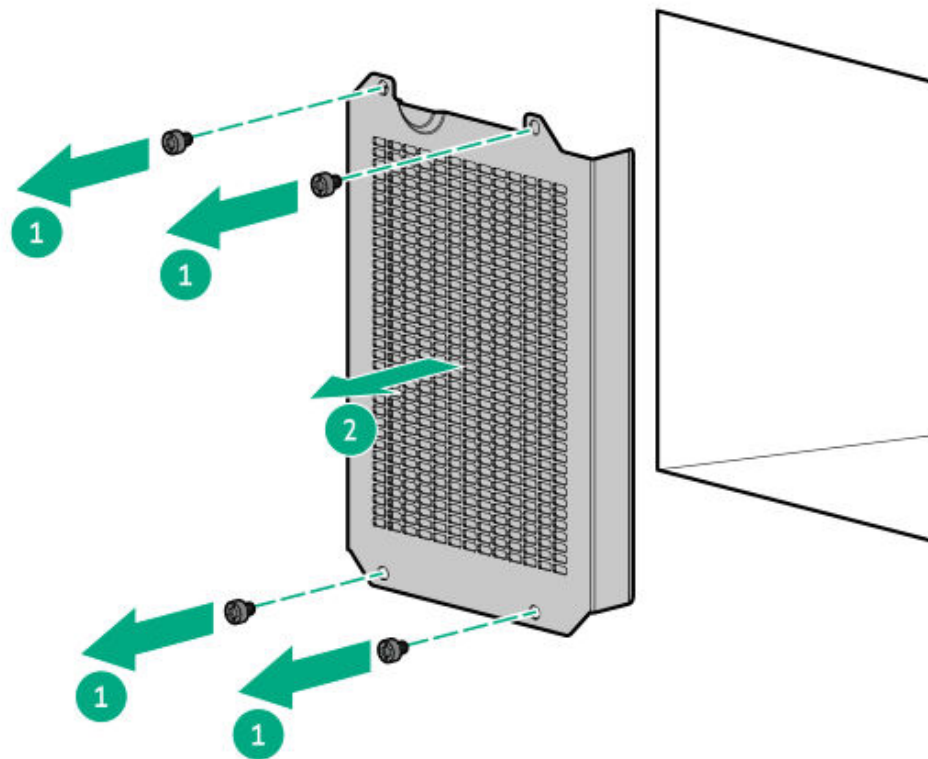

9. Connect the E3.S drive power cables to the backplanes.
0. Connect the E3.S drive power cable to the system board.
- .1. Install the 12 E3.S drive cage:
 - a. Install the drive cage in the server.
 - b. Install the screws.

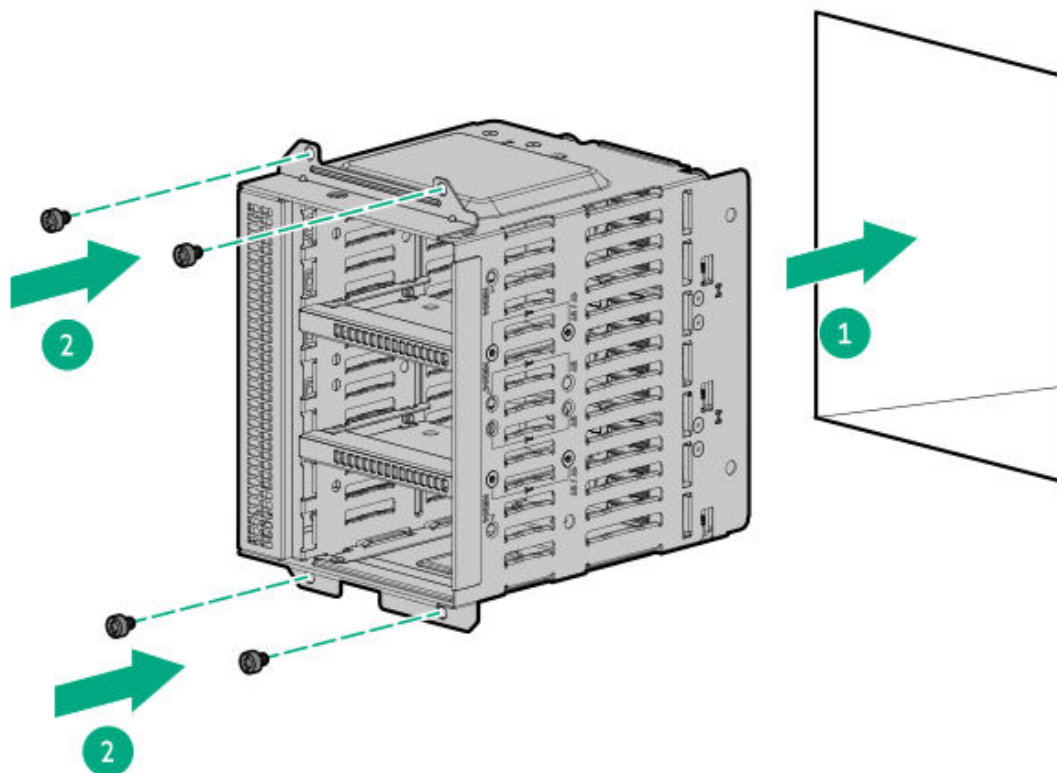

- .2. Connect the rest of the cables to the system board from the top down.

To manage the cables, use the cable clips located on the side of the server.

- .3. Make sure that all the system cables that are routed through the front cable channel are properly secured in the metal cable tabs.

This is done to prevent system damage due to cables being inadvertently caught under the fan cage.

- .4. Install the fan cage.
- .5. Install the access panel.
- .6. Do one of the following:
 - Orient the server back in tower mode.
 - Install the server into the rack.
- .7. Connect all peripheral cables to the server.
- .8. Connect each power cord to the server.
- .9. Connect each power cord to the power source.
- .10. Power up the server.

1. Install the E3.S hot-plug drives.
2. Install the front bezel.

Results

The installation procedure is complete.

Energy packs

Subtopics

HPE Smart Storage Battery

HPE Smart Storage Hybrid Capacitor

Installing an energy pack

HPE Smart Storage Battery

A single 96 W battery can support up to 24 devices.

After the battery is installed, it might take up to two hours to charge. Controller features requiring backup power are not re-enabled until the battery is capable of supporting the backup power.

This server supports the 96 W HPE Smart Storage Battery with the 260 mm cable.

For more information, see HPE Smart Storage Batteries and Hybrid Capacitors QuickSpecs:

https://www.hpe.com/psnow/doc/a00028553enw.pdf?jumpid=in_pdp-psnow-qs

HPE Smart Storage Hybrid Capacitor

The capacitor pack can support up to three devices.

This server supports the 12 W or 16 W HPE Smart Storage Hybrid Capacitor with the 260 mm cable.

Before installing the HPE Smart Storage Hybrid Capacitor, verify that the system BIOS meets the minimum firmware requirements to support the capacitor pack.



IMPORTANT

If the system BIOS or controller firmware is older than the minimum recommended firmware versions, the capacitor pack will only support one device.

The capacitor pack is fully charged after the system boots.

For more information, see HPE Smart Storage Batteries and Hybrid Capacitors QuickSpecs:

https://www.hpe.com/psnow/doc/a00028553enw.pdf?jumpid=in_pdp-psnow-qs

Subtopics

Minimum firmware versions

Minimum firmware versions

Product	Minimum firmware version
Server system ROM	1.20
HPE MR type-o and type-p Gen11 controllers	52.24.3-4948

Installing an energy pack

Prerequisites

- Make sure that a compatible type-p storage controller is installed.
- Make sure that you have the following items available:
 - Storage controller backup power cable (ships with the storage controller)
 - Energy pack extension cable (P58199-B21).
- If you are installing the HPE Smart Storage Hybrid Capacitor, verify that the system meets the minimum firmware version requirements.

Procedure

1. Power down the server.
2. Remove all power:
 - a. Disconnect each power cord from the power source.
 - b. Disconnect each power cord from the server.
3. Disconnect all peripheral cables from the server.
4. Do one of the following:
 - If the server is in tower mode, place the server on a flat, level surface with the access panel facing up.
 - If the server is in rack mode, remove the server from the rack.
5. Unlock the front bezel.
6. Remove the access panel.
7. If installed, remove the HPE NS204i-u Boot Device V2.
8. Connect the energy pack extension cable to the energy pack cable.
9. Install the energy pack:
 - a. Insert the energy pack at an angle.
 - b. Push the energy pack down from the other end.

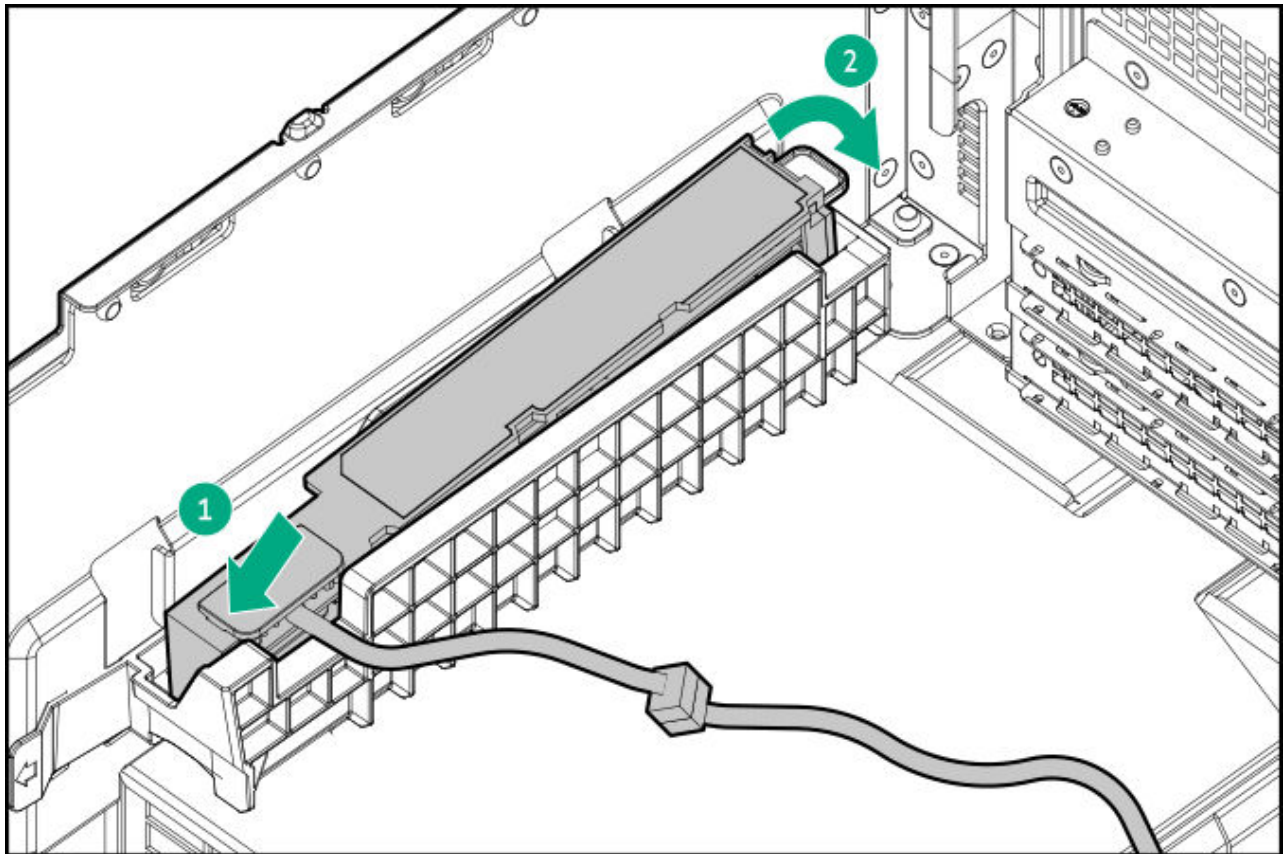

- .0. Connect the energy pack extension cable to the system board.
- .1. Connect the storage backup power cable.
- .2. Install the HPE NS204i-u Boot Device V2.
- .3. Install the access panel.
- .4. Lock the front bezel.
- .5. Do one of the following:
 - Orient the server back in tower mode.
 - Install the server into the rack.
- .6. Connect all peripheral cables to the server.
- .7. Connect each power cord to the server.
- .8. Connect each power cord to the power source.
- .9. Power up the server.

Results

The installation procedure is complete.

Media device options

Subtopics

[SAS LTO tape drive option](#)

[Optical drive option](#)

[Enable the increased cooling mode](#)

SAS LTO tape drive option

Install an LTO tape drive system as an economical and scalable option for long-term storage of infrequently accessed, yet essential data. The backup system consists of two components:

- Tape drive
- Tape cartridge

Subtopics

[Installing a SAS LTO tape drive](#)

Installing a SAS LTO tape drive

Prerequisites

Before you perform this procedure, make sure of the following:

- [A type-p controller is installed on the primary riser, or a type-o controller is installed in Slot 14 OCP A PCIe5.](#)
- [The tertiary riser is installed.](#)
- You have the following items available:
 - LTO tape drive option—The SAS and/or power cables that ship with the drive option will not be used in this server.

- LTO supplementary option kit (P77437-B21 or P77438-B21)
- T-15 Torx screwdriver

About this task

- This option can only be supported in the 4 or 8 LFF drive configuration.
- Media bay 1 supports the installation of an SAS LTO tape drive option.



CAUTION

A discharge of static electricity from a finger or other conductor might damage system boards or other static-sensitive devices. To prevent damage, observe antistatic precautions.



CAUTION

To prevent improper cooling and thermal damage, do not operate the server unless all bays are populated with either a component or a blank.

Procedure

1. Remove the front bezel.
2. Power down the server.
3. Remove all power:
 - a. Disconnect each power cord from the power source.
 - b. Disconnect each power cord from the server.
4. Disconnect all peripheral cables from the server.
5. Do one of the following:
 - If the server is in tower mode, place the server on a flat, level surface with the access panel facing up.
 - If the server is in rack mode, remove the server from the rack.
6. Remove the access panel.
7. Remove the fan cage.
8. Remove the drive box blank:
 - a. Remove the screws.
 - b. Remove the blank.

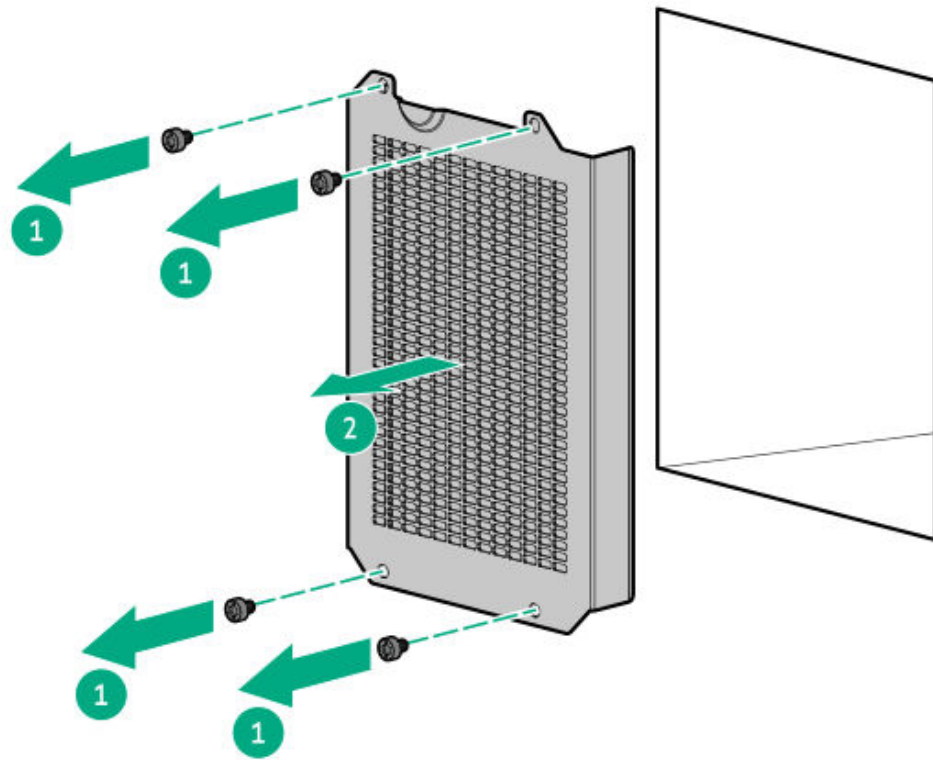

9. Remove the media bay filler panel:
 - a. Remove the media bay filler panel screws.
 - b. Remove the media bay filler panel.

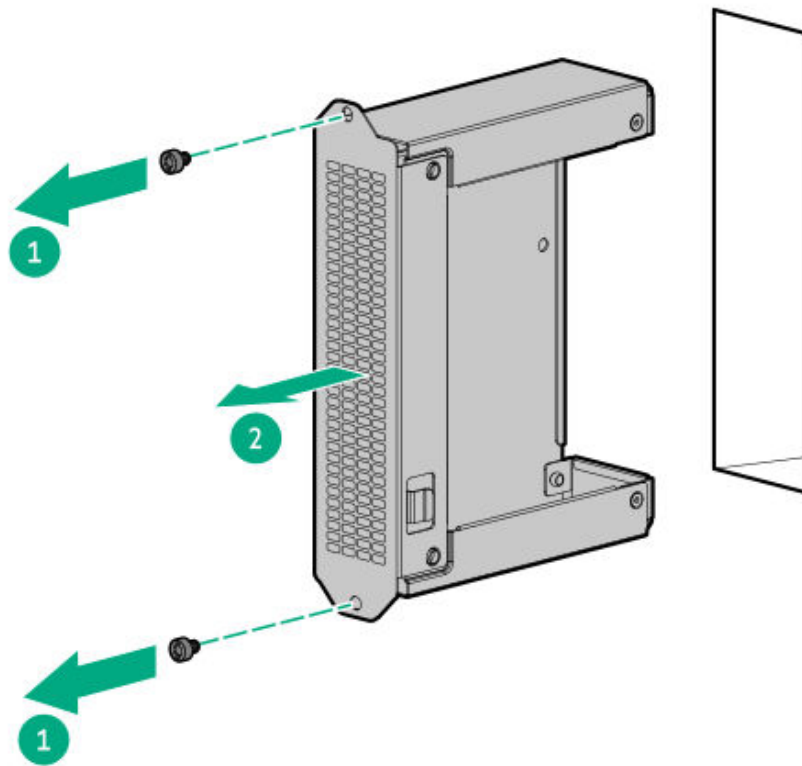

.0. Secure the metal shims on the LTO tape drive.

If the option kit does not include screws, use the [media device screws on the front panel](#).

The shims and the screws are included in the LTO tape drive option kit.

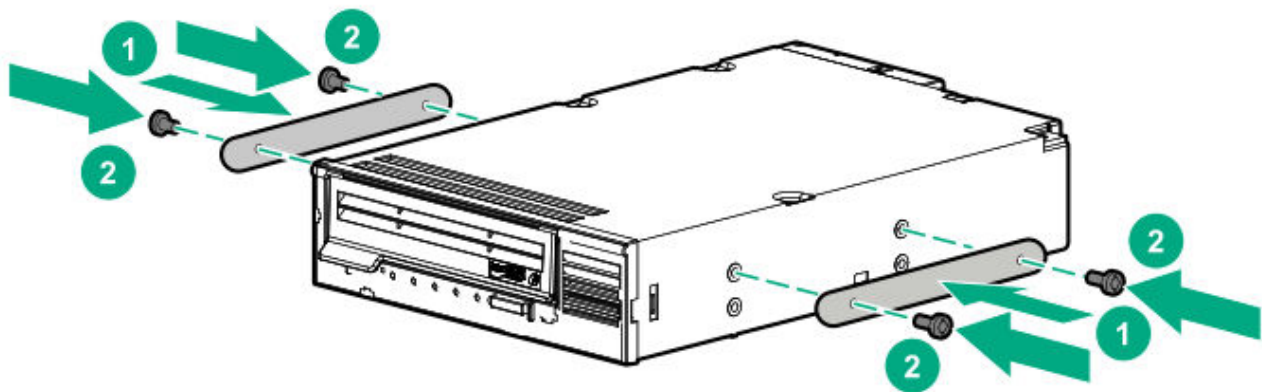

.1. Slide the LTO tape drive into the media bay.

Leave enough space on the rear to connect the drive cables.

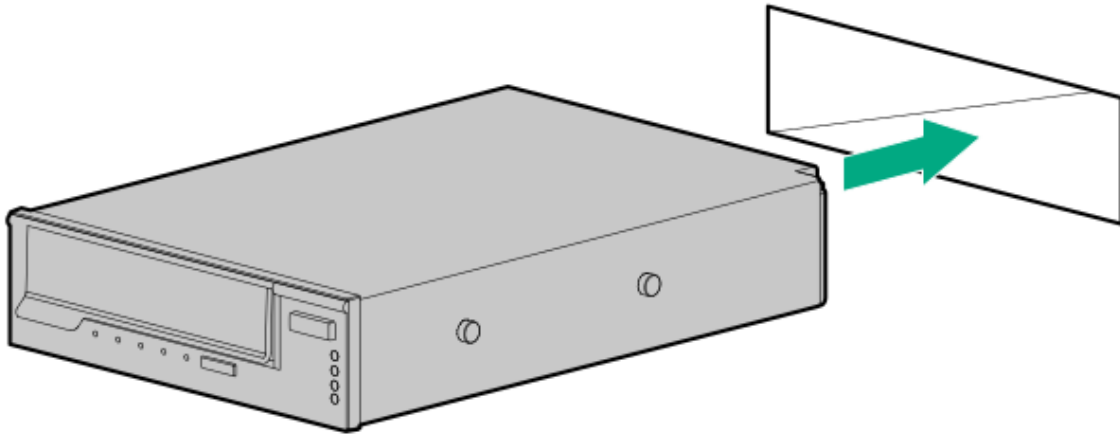

- .2. Connect the drive power and SAS cables.
- .3. Install the half-height media bay blank in media bay 1 or 2.

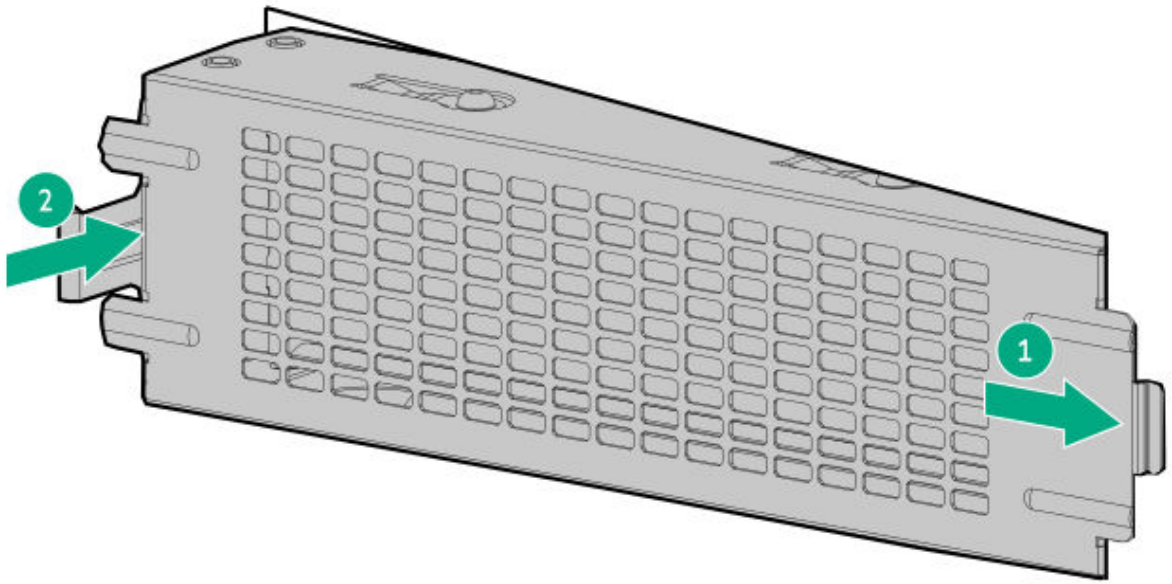

.4. Install the full-height media bay blank.

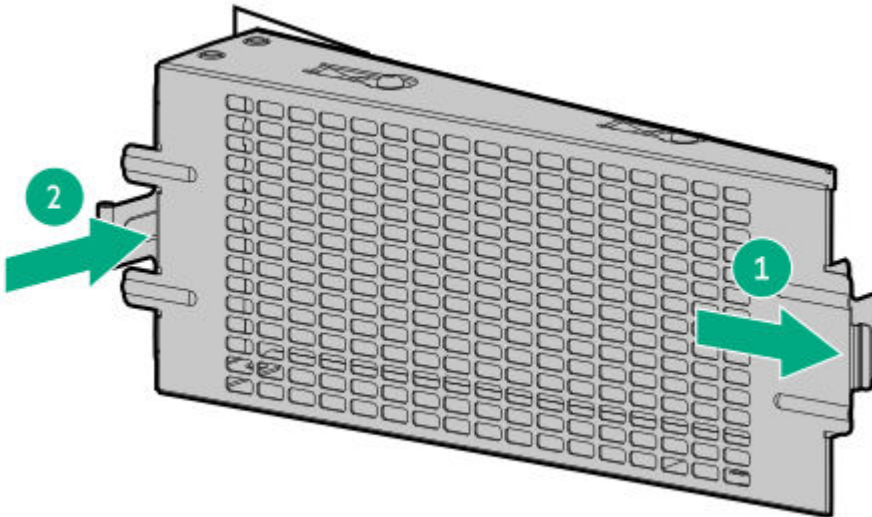

.5. Install the fan cage.

.6. Install the access panel.

- .7. Do one of the following:
 - Orient the server back in tower mode.
 - Install the server into the rack.
- .8. Connect all peripheral cables to the server.
- .9. Connect each power cord to the server.
- !0. Connect each power cord to the power source.
- !1. Power up the server.
- !2. Enable the increased cooling function.
- !3. Perform the configuration procedure required by the tape drive option.

For more information, see the drive documentation.

Results

The installation procedure is complete.

Optical drive option

Install a slim-type SATA optical drive to read/write data on optical discs.

Subtopics

Installing an optical drive

Installing an optical drive

Prerequisites

Before you perform this procedure, make sure that you have the following items available:

- Optical drive SATA-power cable that ships with the optical drive option
- T-10 Torx screwdriver
- Phillips No. 1 screwdriver
- Spudger or any small prying tool

About this task



CAUTION

A discharge of static electricity from a finger or other conductor might damage system boards or other static-sensitive devices. To prevent damage, observe antistatic precautions.



CAUTION

To prevent improper cooling and thermal damage, do not operate the server unless all bays are populated with either a component or a blank.

Procedure

1. Remove the front bezel.
2. Power down the server.
3. Remove all power:
 - a. Disconnect each power cord from the power source.
 - b. Disconnect each power cord from the server.
4. Disconnect all peripheral cables from the server.
5. Do one of the following:
 - If the server is in tower mode, place the server on a flat, level surface with the access panel facing up.
 - If the server is in rack mode, remove the server from the rack.
6. Remove the access panel.
7. Remove the fan cage.
8. Disconnect the front I/O cables from the system board.
9. Remove the front I/O cage:
 - a. Remove the cage screws.
 - b. Slide the cage out of the server.

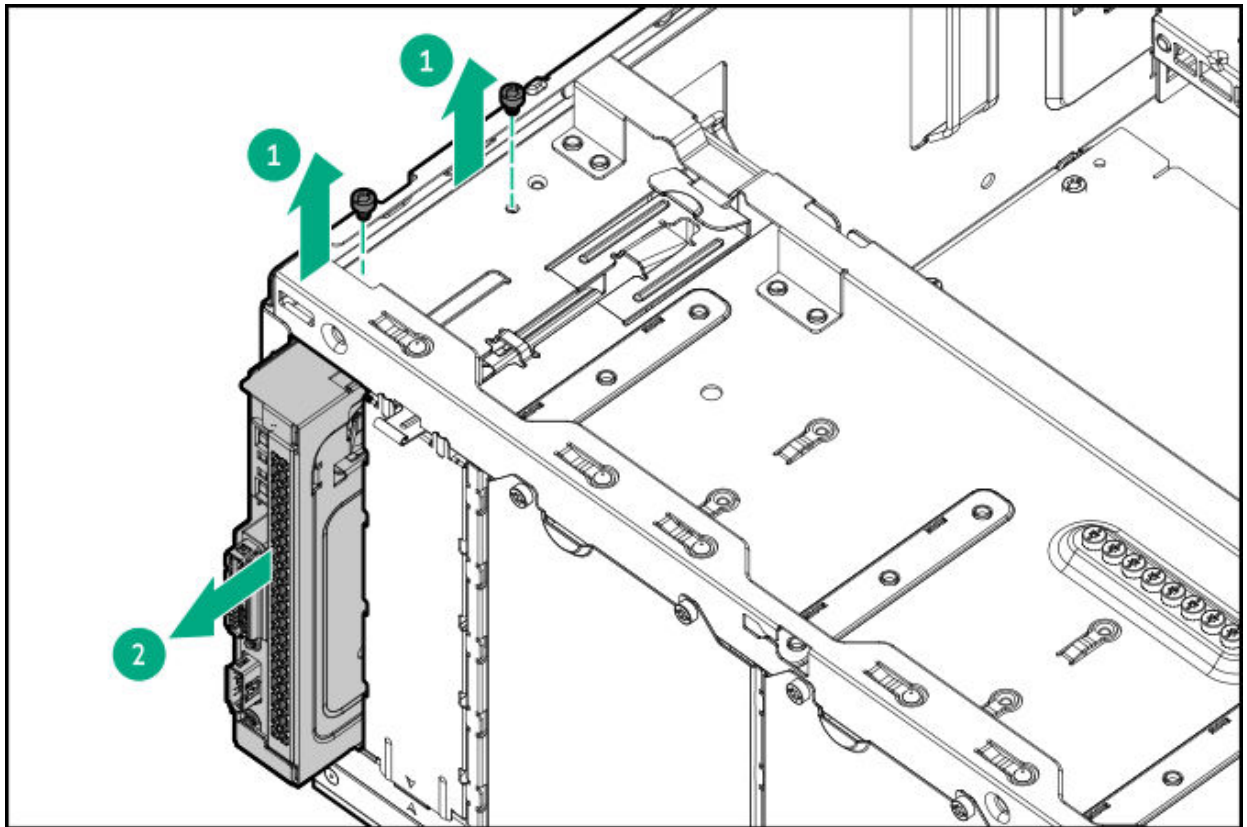

.0. Remove the optical drive bay blank:

- a. Use a plastic spudger to pry one side of the blank.
- b. Remove the optical drive bay blank from the front I/O cage.

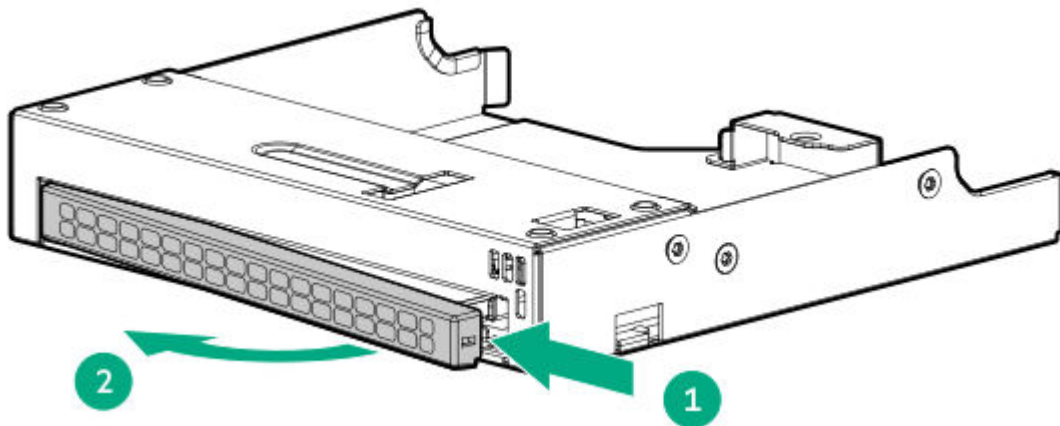

.1. Install the optical drive bracket.

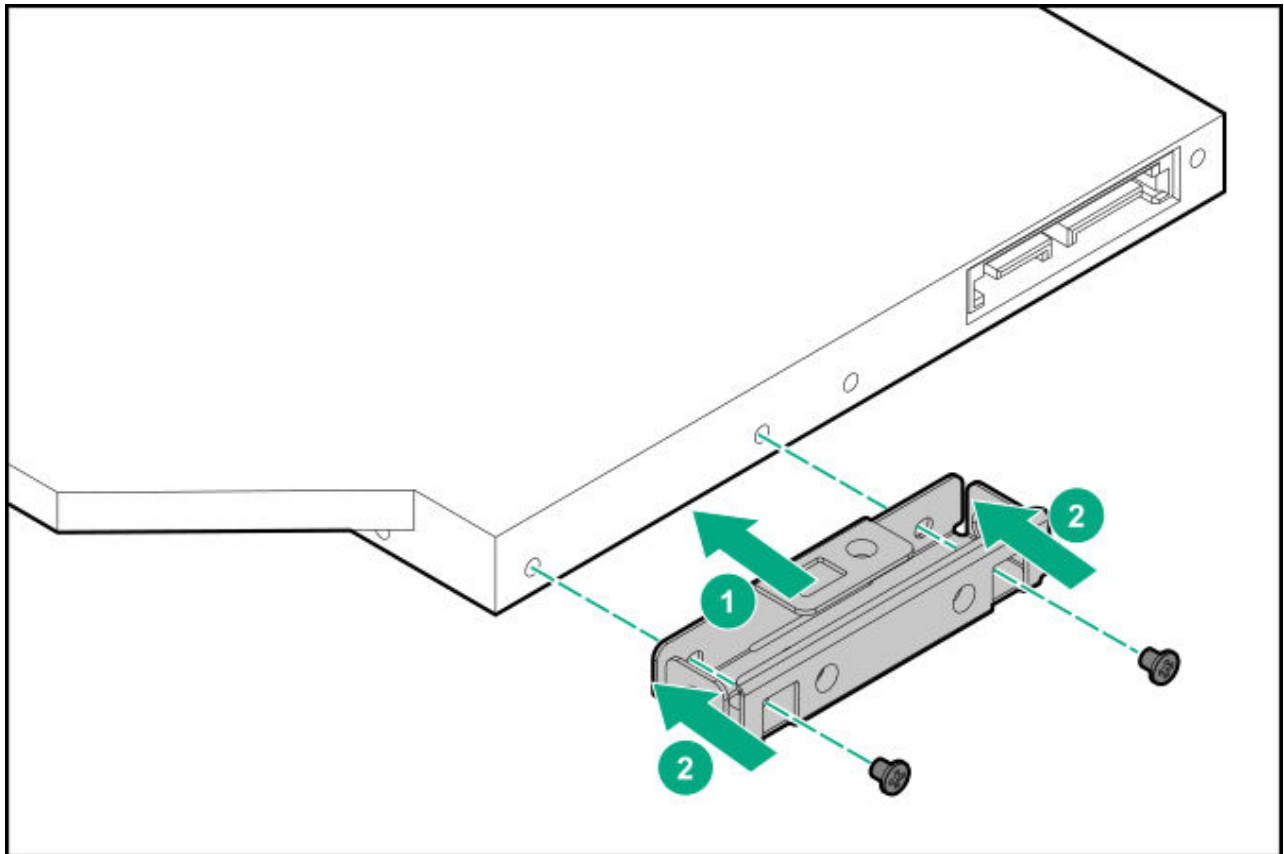

- .2. Install the optical drive in the front I/O cage:
 - a. Slide the optical drive into the front I/O cage.
 - b. Install the drive bracket screw.

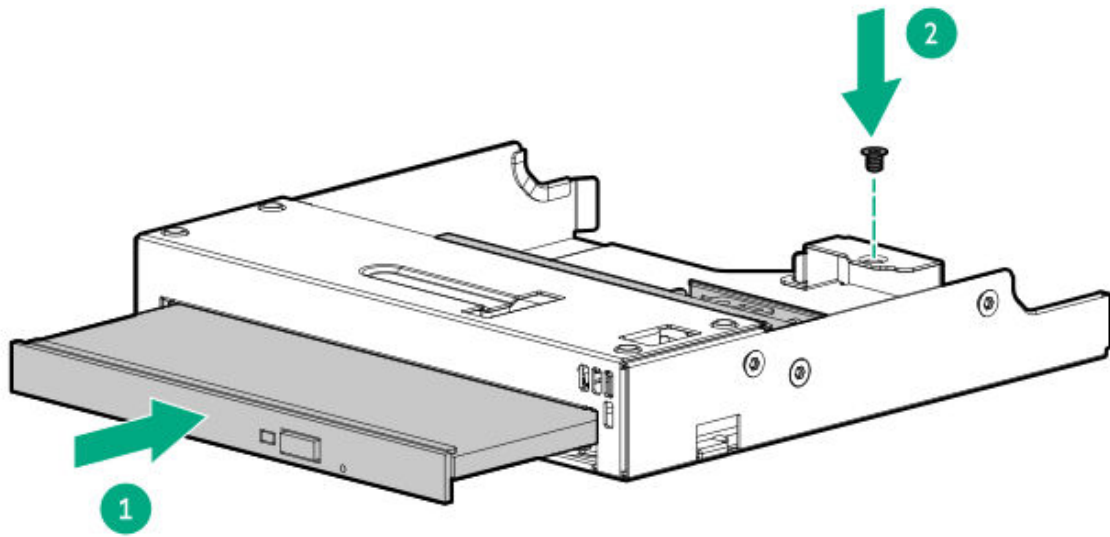

- .3. Install the front I/O cage:
 - a. Slide the cage into the server until it clicks into place.
 - b. Install the screws.

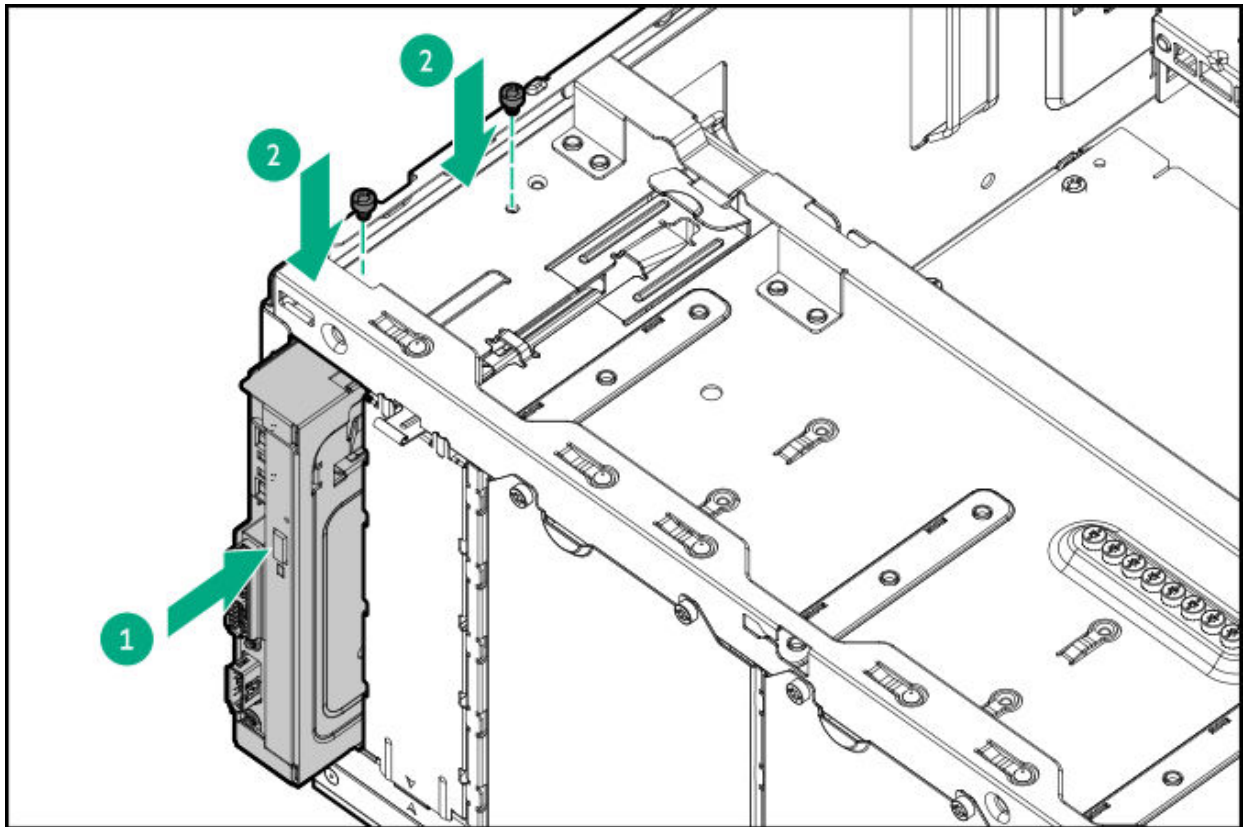

.4. Connect the SATA-power Y-cable to the optical drive.

.5. Connect the cables to the system board:

- [SATA-power Y-cable](#)
- [Front I/O cables](#)

.6. Make sure that all the system cables that are routed through the front cable channel are properly secured in the metal cable tabs.

This is done to prevent system damage due to cables being inadvertently caught under the fan cage.

.7. [Install the fan cage.](#)

.8. [Install the access panel.](#)

.9. Do one of the following:

- [Orient the server back in tower mode.](#)
- [Install the server into the rack.](#)

!0. Connect all peripheral cables to the server.

!1. Connect each power cord to the server.

- !2. Connect each power cord to the power source.
- !3. Power up the server.

Results

The installation procedure is complete.

Enable the increased cooling mode

About this task

Some components might generate more heat than others. To maintain proper cooling, increase the fan speed.

Procedure

1. To enable the increased cooling mode in the UEFI System Utilities:
 - a. From the **System Utilities** screen, select **System Configuration > BIOS/Platform Configuration (RBSU) > Advanced Options > Fan and Thermal Options > Thermal Configuration**.
 - b. Select **Increased Cooling**.
 - c. Save your setting.
 - d. Reboot the server. A reboot is required after the setting is saved.
2. To enable the increased cooling mode in the iLO web interface:
 - a. From the iLO web interface, select **Power & Thermal > Fans**.
 - b. Click  next to the **Summary** category.

The **Fan Settings** page opens.
 - c. Select **Increased Cooling**.
 - d. Click **OK**.

Memory options



IMPORTANT

This server does not support mixing LRDIMMs and RDIMMs. Attempting to mix any combination of these DIMMs can cause the server to halt during BIOS initialization. All memory installed in the server must be of the same type.

Subtopics

[HPE SmartMemory speed and population information](#)

[DIMM installation guidelines](#)

[Installing a DIMM](#)

HPE SmartMemory speed and population information

For information about memory speed and server-specific DIMM population rules for HPE servers using Intel Xeon 6 Processors, see the relevant memory technical paper in:

<https://www.hpe.com/docs/server-memory>

DIMM installation guidelines

When handling a DIMM, observe the following:

- Observe [antistatic precautions](#).
- Handle the DIMM only along the edges.
- Do not touch the components on the sides of the DIMM.
- Do not touch the connectors on the bottom of the DIMM.
- Never wrap your fingers around a DIMM.
- Never bend or flex the DIMM.

When installing a DIMM, observe the following:

- To align and seat the DIMM, use two fingers to hold the DIMM along the side edges.
- To seat the DIMM, use two fingers to apply gentle pressure along the top of the DIMM.

For more information, see the Hewlett Packard Enterprise website (<https://www.hpe.com/support/DIMM-20070214-CN>).

Installing a DIMM

Prerequisites

When installing 256 GB DIMMs, verify that fans 1-8 are installed.

About this task



CAUTION

A discharge of static electricity from a finger or other conductor might damage system boards or other static-sensitive devices. To prevent damage, observe antistatic precautions.

Procedure

1. Power down the server.
2. Remove all power:
 - a. Disconnect each power cord from the power source.
 - b. Disconnect each power cord from the server.
3. Disconnect all peripheral cables from the server.
4. Do one of the following:
 - If the server is in tower mode, place the server on a flat, level surface with the access panel facing up.
 - If the server is in rack mode, remove the server from the rack.
5. Unlock the front bezel.
6. Remove the access panel.
7. Remove the fan cage.
8. Install a DIMM in the standard heatsink configuration:
 - a. Open the DIMM slot latches.
 - b. Align the notch on the bottom edge of the DIMM with the keyed surface of the DIMM slot, and then fully press the DIMM into the slot until the latches snap back into place.

The DIMM slots are structured to ensure proper installation. If you try to insert a DIMM but it does not fit easily into the slot, you might have positioned it incorrectly. Reverse the orientation of the DIMM and insert it again.

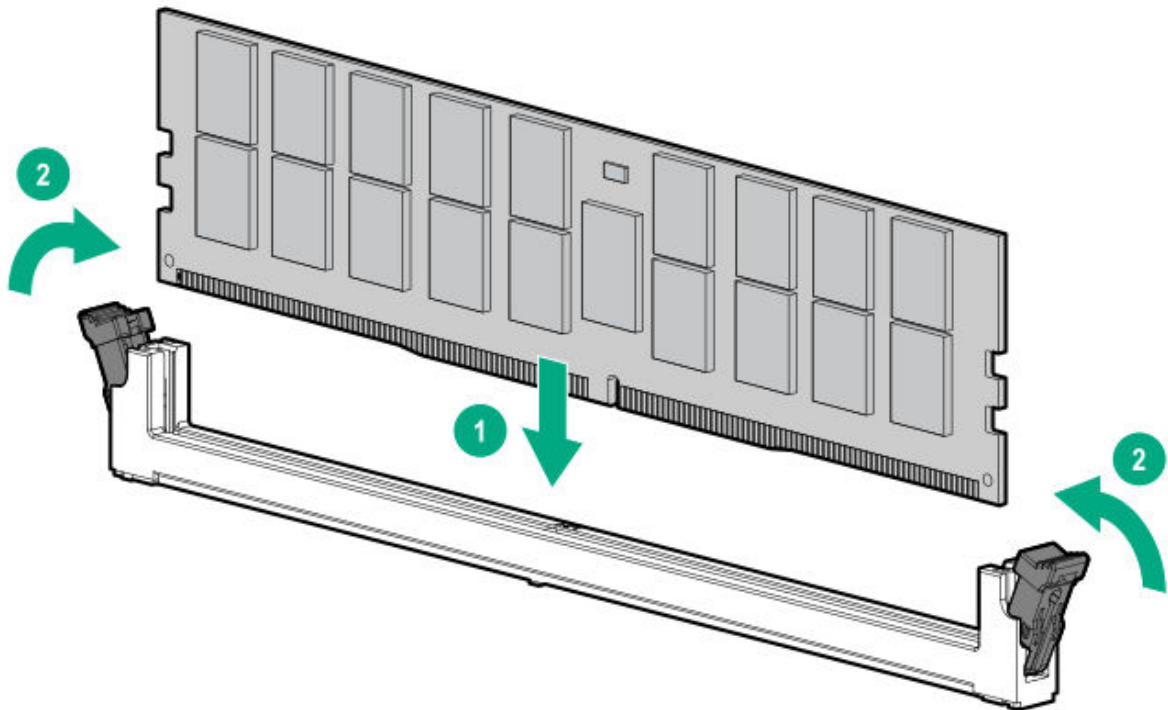

9. Install a DIMM in the performance heatsink configuration:

- a. Open the DIMM slot latches.
- b. Position the DIMM in a horizontal orientation and carefully slide the DIMM under the performance heatsink.

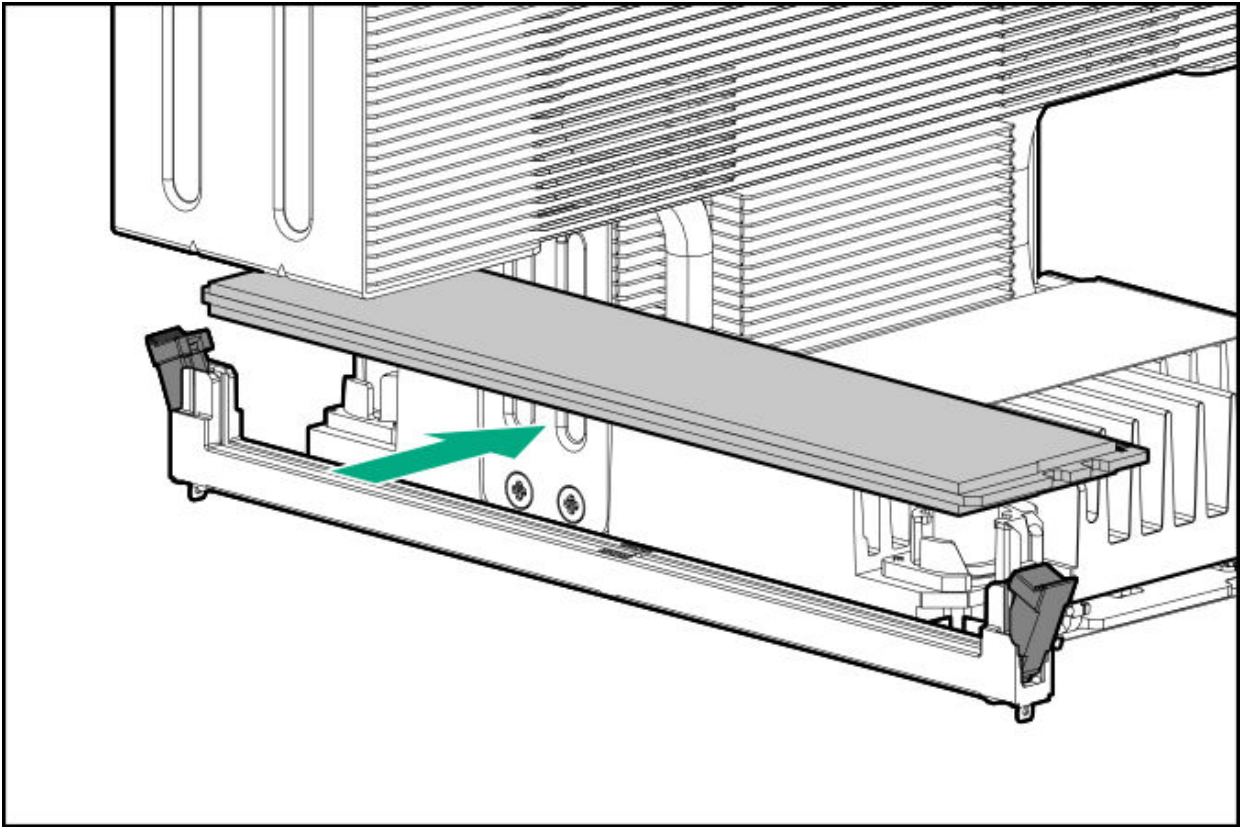

c. Fully press the DIMM into the slot until the latches snap back into place.

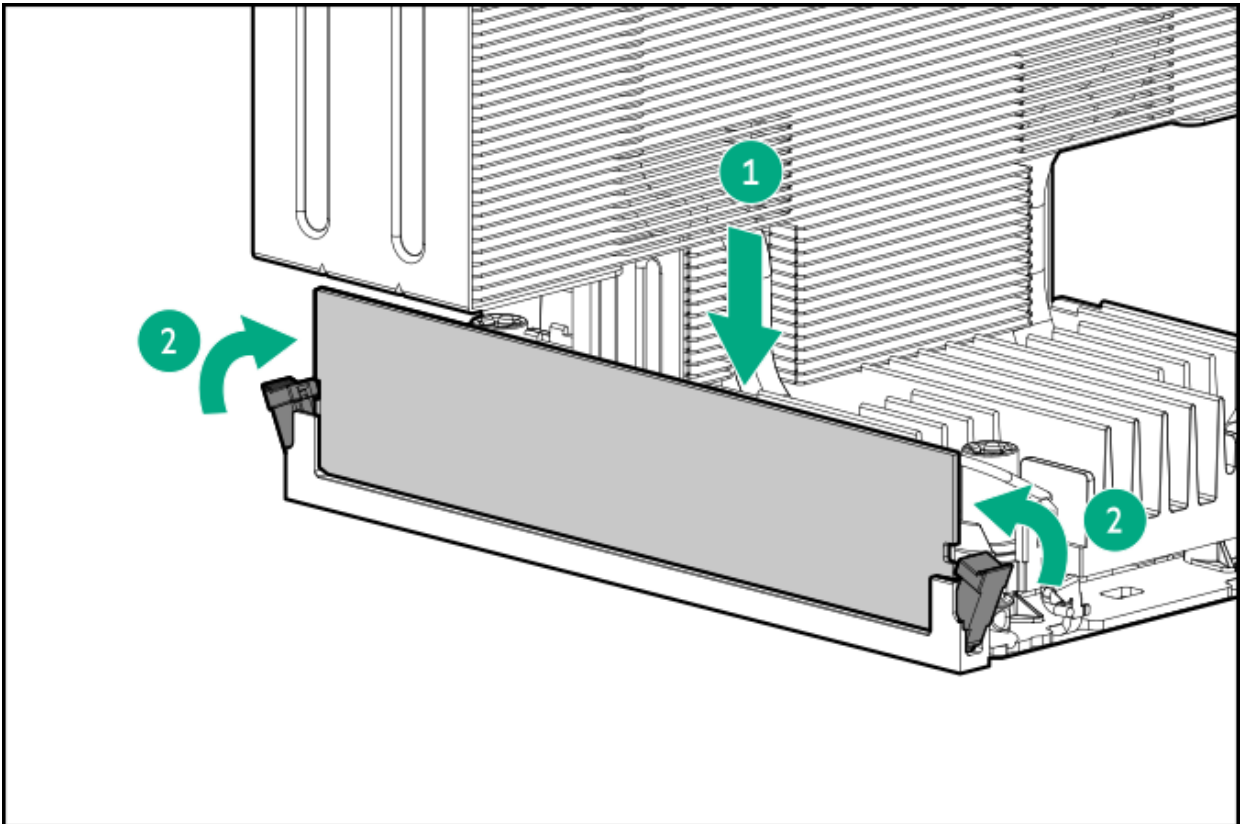

- .0. [Install the fan cage.](#)
- .1. [Install the access panel.](#)
- .2. Lock the front bezel.
- .3. Do one of the following:
 - [Orient the server back in tower mode.](#)
 - [Install the server into the rack.](#)
- .4. Connect all peripheral cables to the server.
- .5. Connect each power cord to the server.
- .6. Connect each power cord to the power source.
- .7. [Power up the server.](#)
- .8. To configure the memory settings:
 - a. From the boot screen, press **F9** to access the UEFI System Utilities.
 - b. From the **System Utilities** screen, select **System Configuration** > **BIOS/Platform Configuration (RBSU)** > **Memory Options**.

Results

The installation procedure is complete.

Power supply options

Depending on the installed options and the regional location where the server was purchased, the server can be configured with one of the supported [power supplies](#).

Subtopics

[Hot-plug power supply calculations](#)

[Power supply warnings and cautions](#)

[DC power supply warnings and cautions](#)

[DC power supply wire colors](#)

[Connecting a DC power cable to a DC power source](#)

[Installing an AC power supply](#)

[Installing a DC power supply](#)

Hot-plug power supply calculations

For hot-plug power supply specifications and calculators to determine electrical and heat loading for the server, see the Hewlett Packard Enterprise Power Advisor website (<https://www.hpe.com/info/poweradvisor/online>).

Power supply warnings and cautions



WARNING

To reduce the risk of electric shock or damage to the equipment:

- Do not disable the power cord grounding plug. The grounding plug is an important safety feature.
- Plug the power cord into a grounded (earthed) electrical outlet that is easily accessible at all times.
- Unplug the power cord from the power supply to disconnect power to the equipment.
- Do not route the power cord where it can be walked on or pinched by items placed against it. Pay particular attention to the plug, electrical outlet, and the point where the cord extends from the server.



WARNING

To reduce the risk of injury from electric shock hazards, do not open power supplies. Refer all maintenance, upgrades, and servicing to qualified personnel.



CAUTION

Mixing different types of power supplies in the same server might:

- Limit or disable some power supply features including support for power redundancy.
- Cause the system to become unstable and might shut down.

To ensure access to all available features, all power supplies in the same server should have the same output and efficiency ratings. Verify that all power supplies have the same part number and label color.

DC power supply warnings and cautions



WARNING

To reduce the risk of electric shock, be sure that the cable grounding kit is properly installed and connected to a suitable protective earth terminal before connecting the power source to the rack.



CAUTION

This equipment is designed to permit the connection of the earthed conductor of the DC supply circuit to the earthing conductor at the equipment. If this connection is made, all the following must be met:

- This equipment must be connected directly to the DC supply system earthing electrode conductor or to a bonding jumper from an earthing terminal bar or bus to which the DC supply system earthing electrode conductor is connected.
- This equipment must be located in the same immediate area (such as adjacent cabinets) as any other equipment that has a connection between the earthed conductor of the same DC supply circuit and the earthing conductor, and also the point of earthing of the DC system. The DC system must be earthed elsewhere.
- The DC supply source is to be located within the same premises as the equipment.
- Switching or disconnecting devices must not be in the earthed circuit conductor between the DC source and the point of connection of the earthing electrode conductor.

DC power supply wire colors

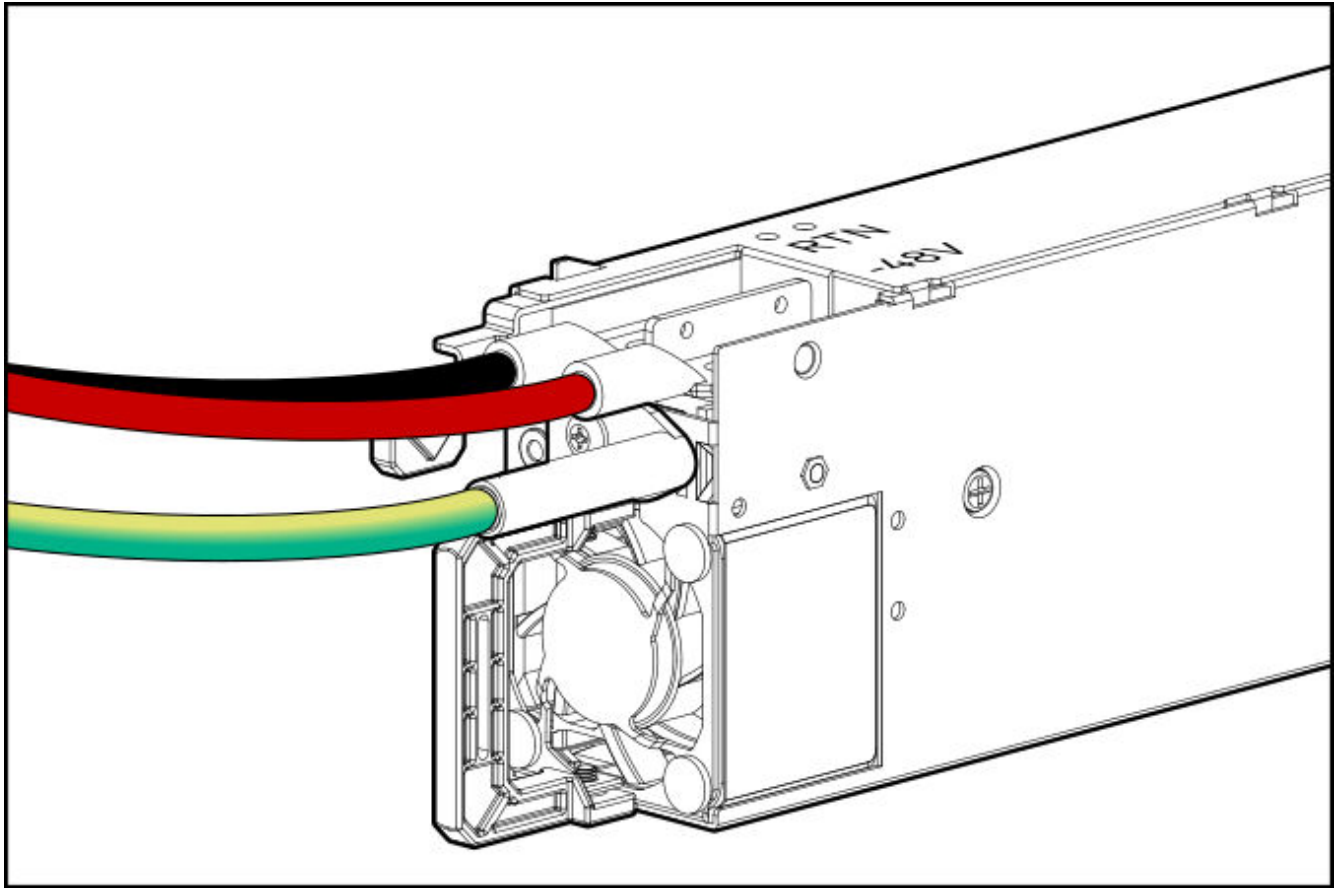

Wire color	Description	Wire slot
Red	Line wire	-48V
Black	Return wire	Return
Green + Yellow	Ground wire	Safety ground

Connecting a DC power cable to a DC power source

Prerequisites

Before you perform this procedure, make sure that you have the following items available:

- Electrical wire cutter
- Hand crimp tool

About this task



WARNING

To reduce the risk of electric shock or energy hazards:

- This equipment must be installed by trained service personnel and in accordance with local and regional electric codes and regulations
- Connect the equipment to a reliably grounded secondary circuit source. A secondary circuit has no direct connection to a primary circuit and derives its power from a transformer, converter, or equivalent isolation device.
- The overcurrent protection for the DC source must not exceed 45 A.



WARNING

When installing a DC power supply, the ground wire must be connected before the positive or negative leads.



WARNING

Remove power from the power supply before performing any installation steps or maintenance on the power supply.



CAUTION

The server equipment connects the earthed conductor of the DC supply circuit to the earthing conductor at the equipment. For more information, see the documentation that ships with the power supply.



CAUTION

If a DC connection exists between the earthed conductor of the DC supply circuit and the earthing conductor at the server equipment, the following conditions must be met:

- This equipment must be connected directly to the DC supply system earthing electrode conductor or to a bonding jumper from an earthing terminal bar or bus to which the DC supply system earthing electrode conductor is connected.
- Locate the equipment in the same immediate area (such as adjacent cabinets) as any other equipment that has a connection between the earthed conductor of the same DC supply circuit and the earthing conductor, and also the point of earthing of the DC system. The DC system must be earthed

Procedure

1. Cut the DC power cord ends no shorter than 150.00 cm (59.06 in).



IMPORTANT

The ring terminals must be UL approved and accommodate 6 AWG wires.



IMPORTANT

The minimum nominal thread diameter of a pillar or stud type terminal must be 3.50 mm (0.138 in). The diameter of a screw type terminal must be 5.00 mm (0.197 in).

2. If the power source requires ring tongues, use a crimping tool to install the ring tongues on the power cord wires and ground wire.
3. Stack each same-colored pair of wires and then attach them to the same power source.

For more information, see the documentation that ships with the power supply.

Installing an AC power supply

Prerequisites

Before installing a power supply option, review the [Power supply warnings and cautions](#).

About this task



WARNING

To reduce the risk of personal injury from hot surfaces, allow the power supply, power supply blank, or dual slot power supply adapter to cool before touching it.



CAUTION

To prevent improper cooling and thermal damage, do not operate the server unless all bays are populated with either a component or a blank.

Procedure

1. If you are installing a power supply in the power supply bay 2, remove the power supply blank.

Retain the blank for future use.

- Tower mode

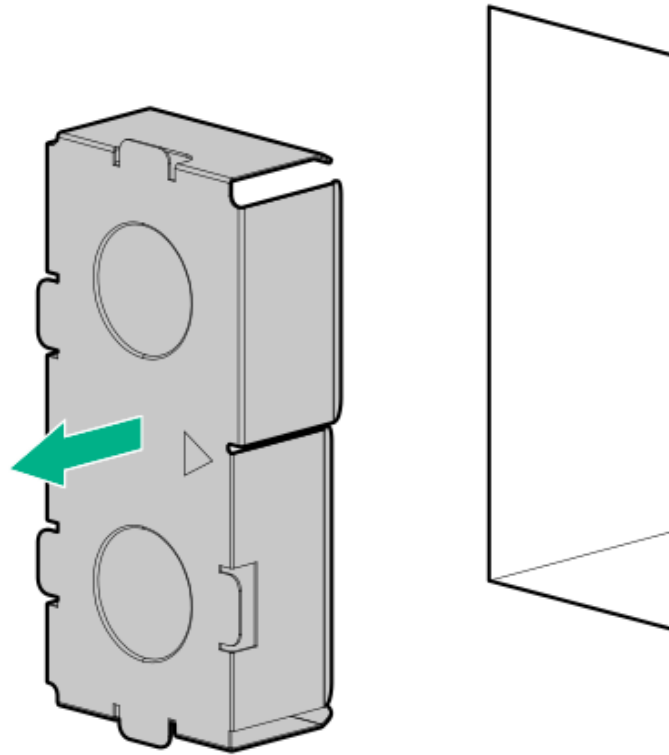

- Rack mode

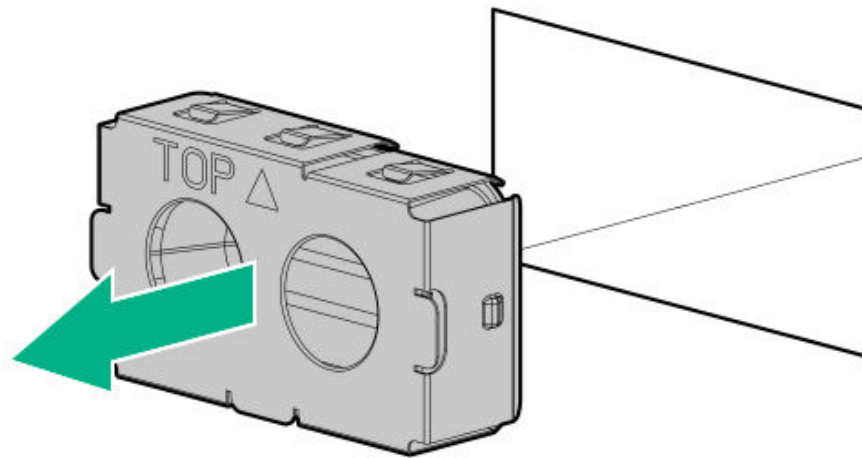

2. Immediately slide the power supply into the bay until it clicks into place.

- Tower mode

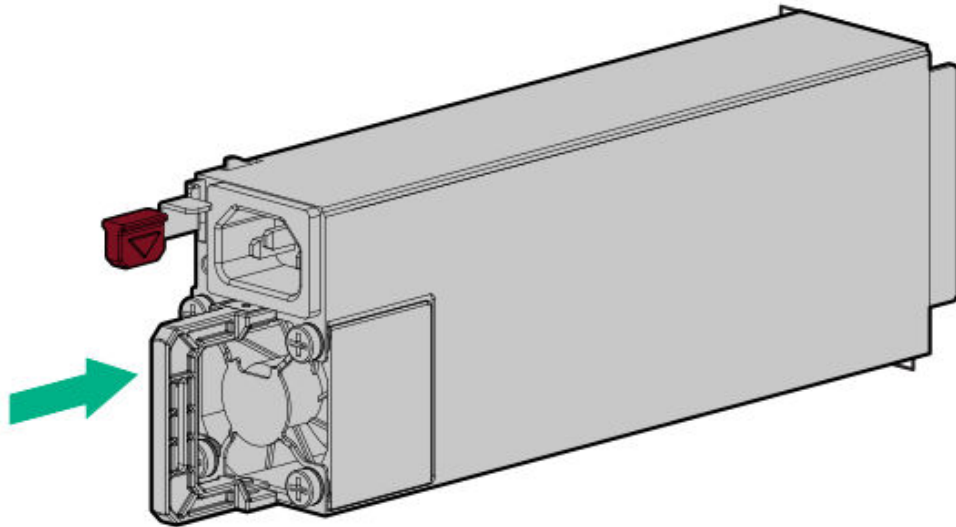

- Rack mode

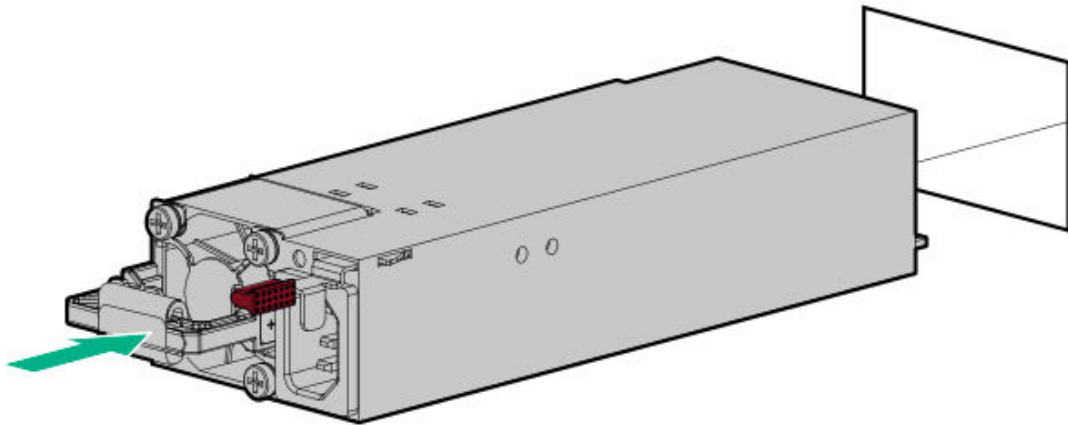

3. Connect the power cord to the power supply.
4. Secure the power cord in the strain relief strap attached to the power supply handle:
 - a. Unwrap the strain relief strap from the power supply handle.



CAUTION

Avoid tight bend radii to prevent damaging the internal wires of a power cord or a server cable. Never bend power cords and server cables tight enough to cause a crease in the sheathing.

- b. Secure the power cord with the strain relief strap. Roll the extra length of the strap around the power supply handle.

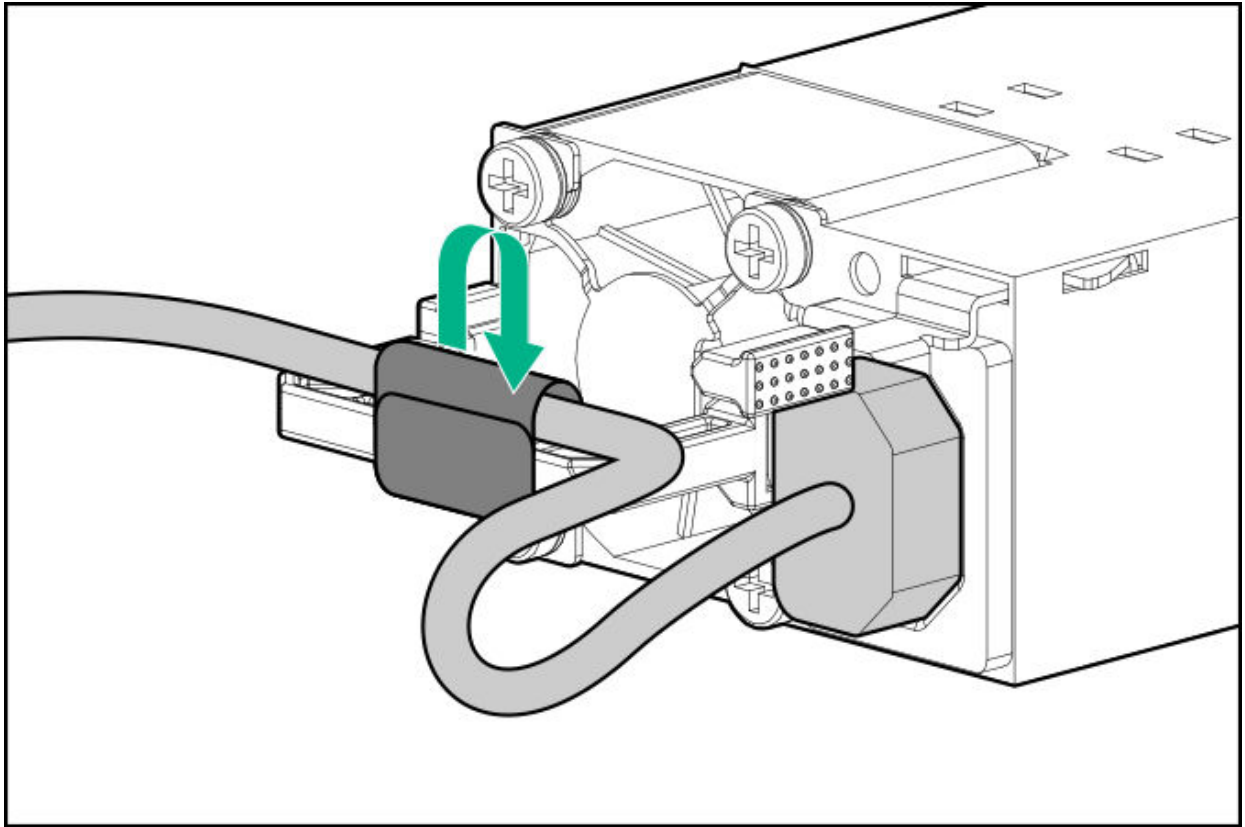

5. Connect the power cords:
 - a. Connect each power cord to the server.
 - b. Connect each power cord to the power source.
6. Make sure that the power supply LED is green.

Results

The installation procedure is complete.

Installing a DC power supply

Prerequisites

- Before installing a power supply, review the following:

- [Power supply warnings and cautions](#)
- [DC power supply warnings and cautions](#)
- [DC power supply wire colors](#)
- Before you perform this procedure, make sure that you have a Phillips No. 2 screwdriver available.
- Before connecting the power cables, review the following:
 - The optional P36877-B21 HPE lug kit can be purchased from an authorized HPE reseller for use with customer-supplied power cables. (The power cable and lug kit listed below can only be used with the 1600 W -48 VDC power supply.)
 - If you are using an input power cord option, the P22173-B21 HPE 1600 W DC PSU power cable kit can be purchased from an authorized HPE reseller.
 - The DC power supply option kits do not ship with a Power Supply DC cable Kit and may not include a Power Supply Cable Lug kit. The optional DC Cable kit or the optional DC Cable Lug Kit may be purchased directly from Hewlett Packard Enterprise or an authorized HPE reseller. For additional information, see the power supply QuickSpecs at <https://www.hpe.com/info/fsps-qs>.

About this task

If you are not using an input power cord option, the power supply cabling must be made in consultation with a licensed electrician and be compliant with local code.



WARNING

To reduce the risk of electric shock, fire, and damage to the equipment, you must install this product in accordance with the following guidelines:

- The HPE 1600 W Flex Slot -48 VDC hot-plug power supply is intended only for installation in servers located in a restricted access location.
- The HPE 1600 W Flex Slot -48 VDC hot-plug power supply is not intended for direct connection to the DC supply branch circuit. Only connect this power supply to a power distribution unit (PDU) that provides an independent overcurrent-protected output for each DC power supply. Each output overcurrent-protected device in the PDU must be suitable for interrupting fault current available from the DC power source and must be rated no more than 45 A.
- The PDU output must have a shut-off switch or a circuit breaker to disconnect power for each power supply. To completely remove power from the power supply, disconnect power at the PDU. The end product may have multiple power supplies. To remove all power from the product, disconnect the power for each power supply.
- In accordance with applicable national requirements for Information Technology Equipment and Telecommunications Equipment, this power supply only connects to DC power sources that are classified as SELV or TNV. Generally, these requirements are based on the International Standard for Information Technology Equipment, IEC 60950-1/IEC 62368-1. In accordance with local and regional electric codes and regulations, the DC source must have one pole (Neutral/Return) reliably connected to earth ground.
- You must connect the power supply ground screw located on the front of the power supply to a suitable ground (earth) terminal. In accordance with local and regional electric codes and regulations, this terminal must be connected to a suitable building ground (earth) terminal. Do not rely on the rack or cabinet chassis to provide adequate ground (earth) continuity.



WARNING

To reduce the risk of personal injury from hot surfaces, allow the power supply, power supply blank, or dual slot power supply adapter to cool before touching it.

Procedure

1. Remove the protective cover from the power supply.

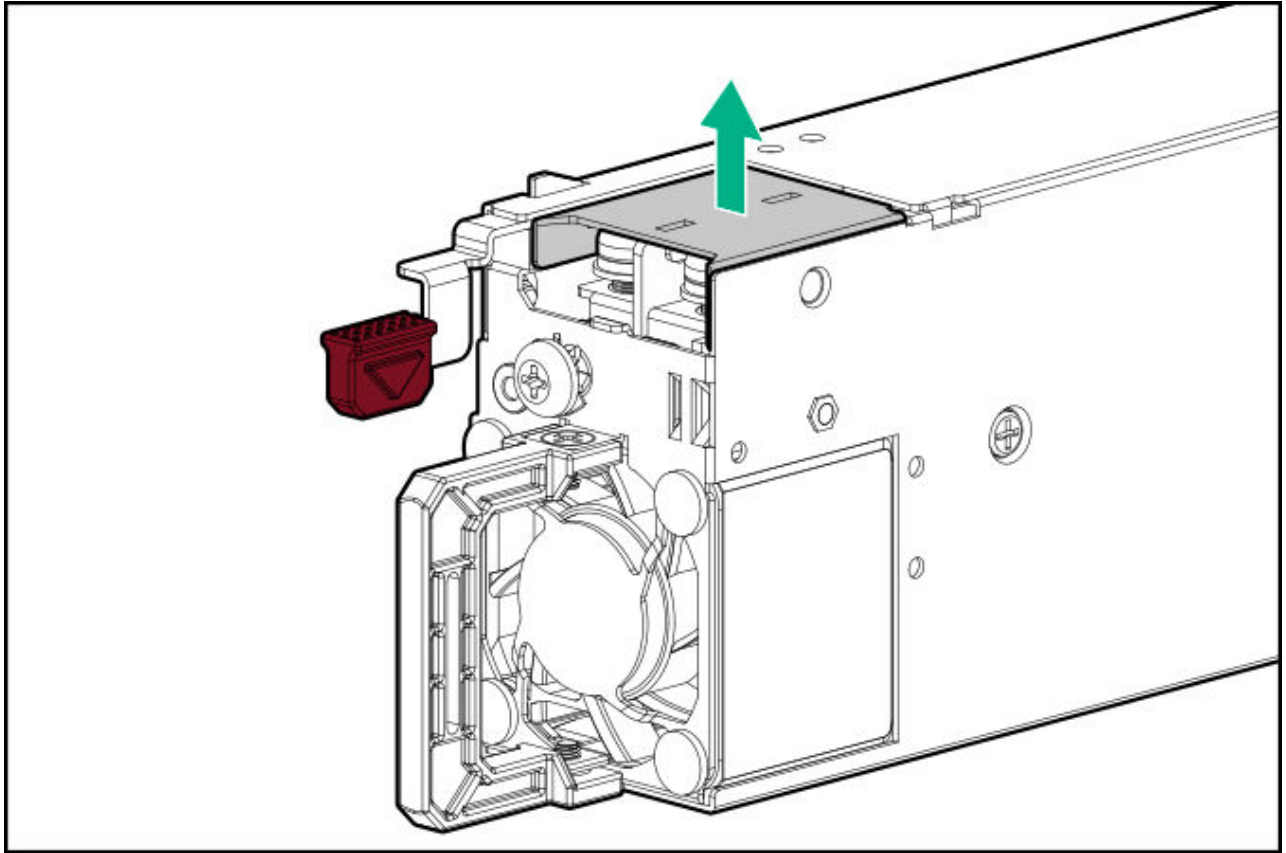

2. Remove the ground wire screw, and then remove the return wire and line wire screws.

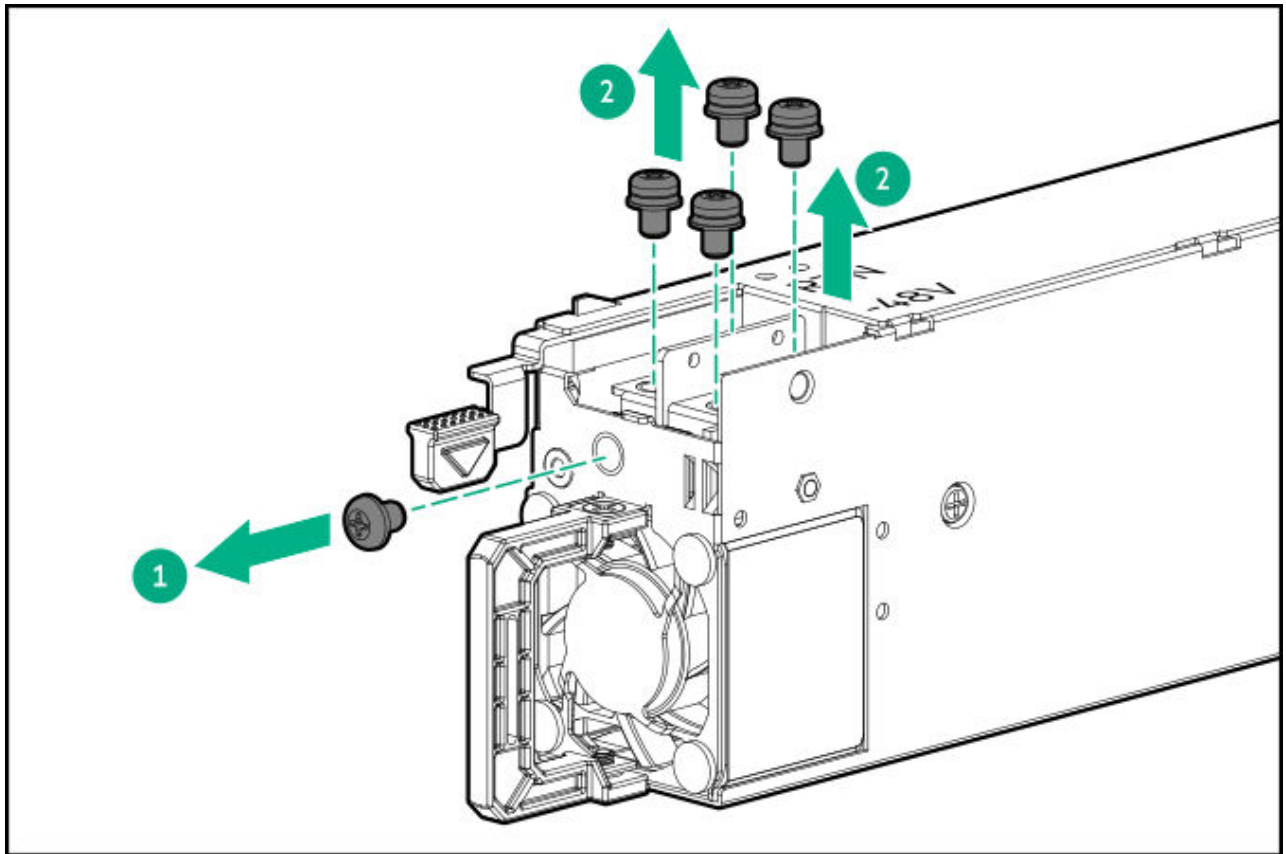

3. Attach the ground wire (green and yellow) to the DC power supply and tighten the screw and washer with 1.47 N-m (13 lbf-in).

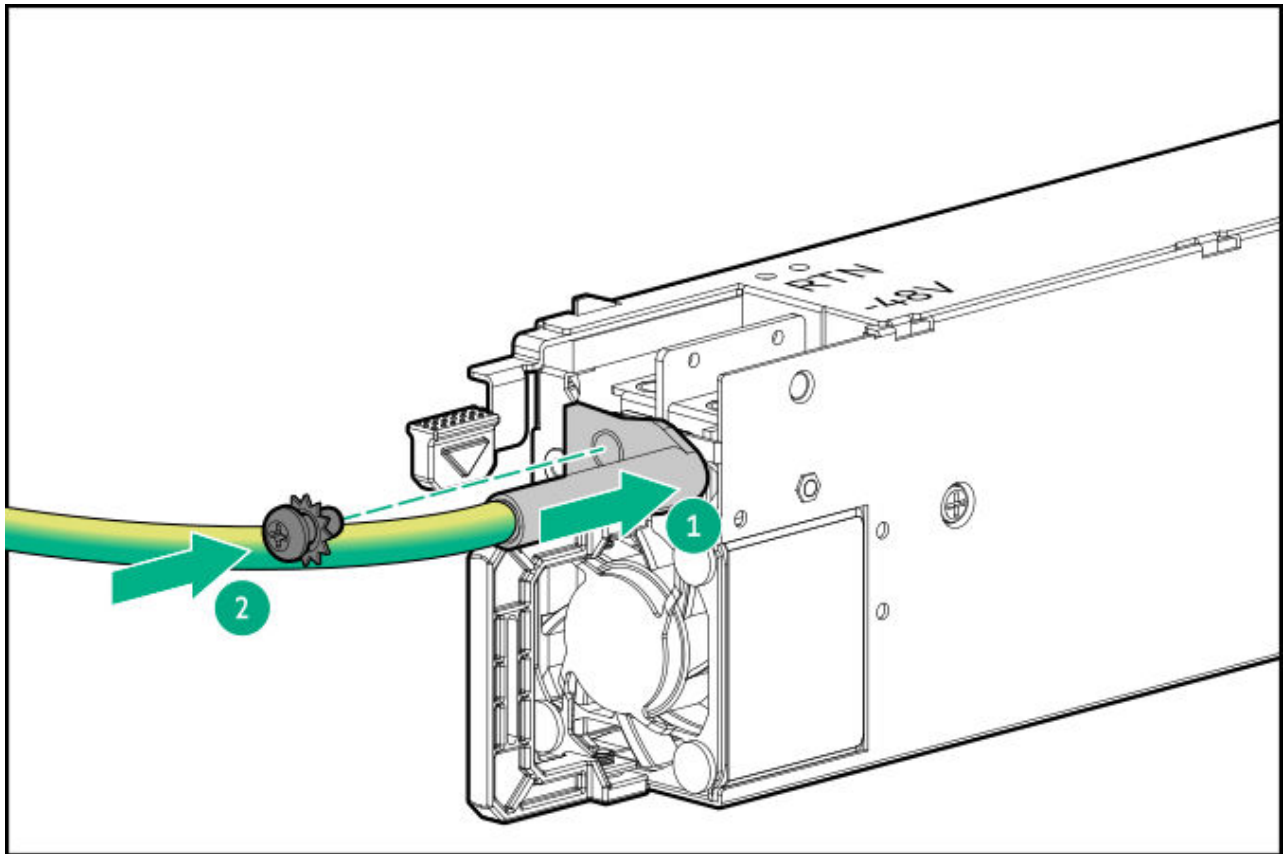

4. Install the return wire (black):

- a. Insert the return wire into the RTN slot on the DC power supply.
- b. Tighten the screw with 0.98 N-m (8.68 lbf-in).

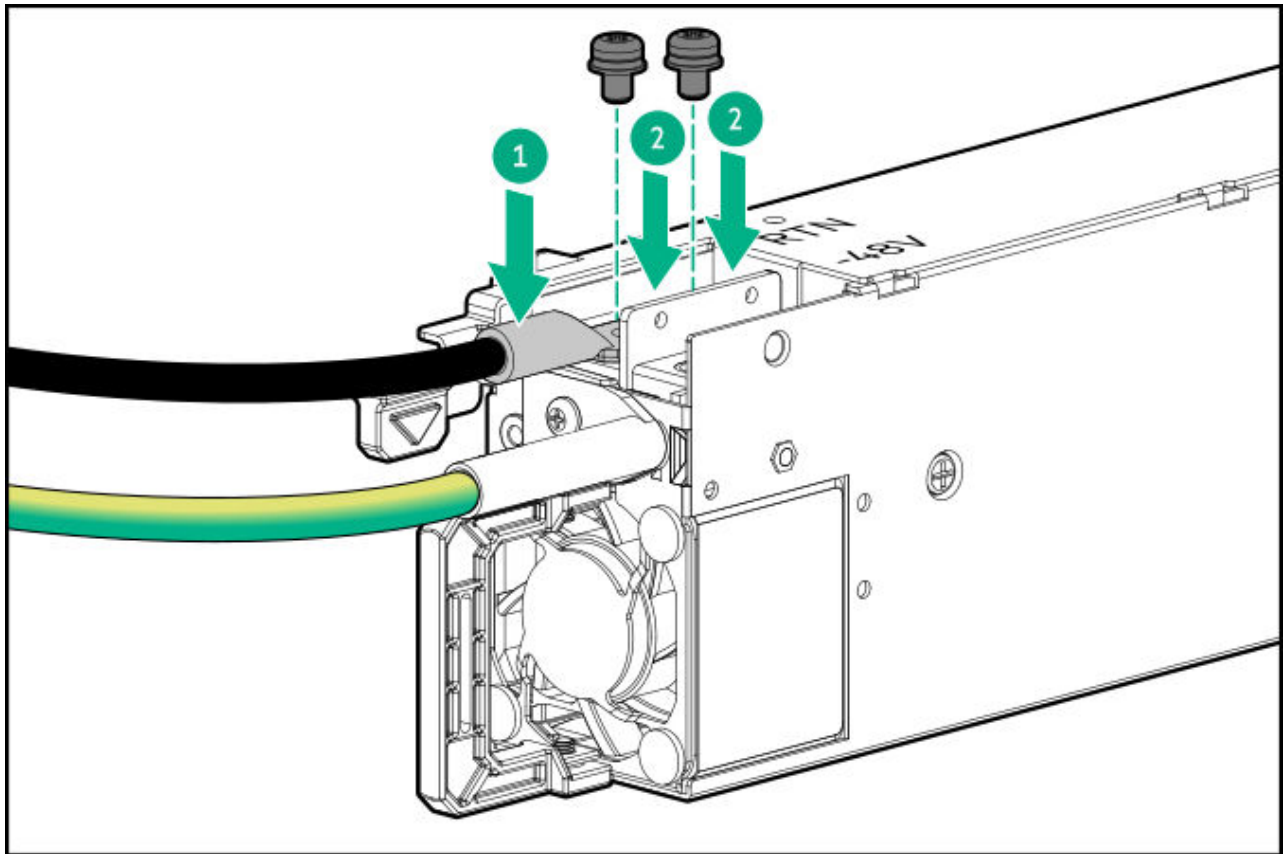

5. Install the line wire (red):

- a. Insert the line wire into the -48V slot on the DC power supply.
- b. Tighten the screw to 0.98 N-m (8.68 lbf-in).

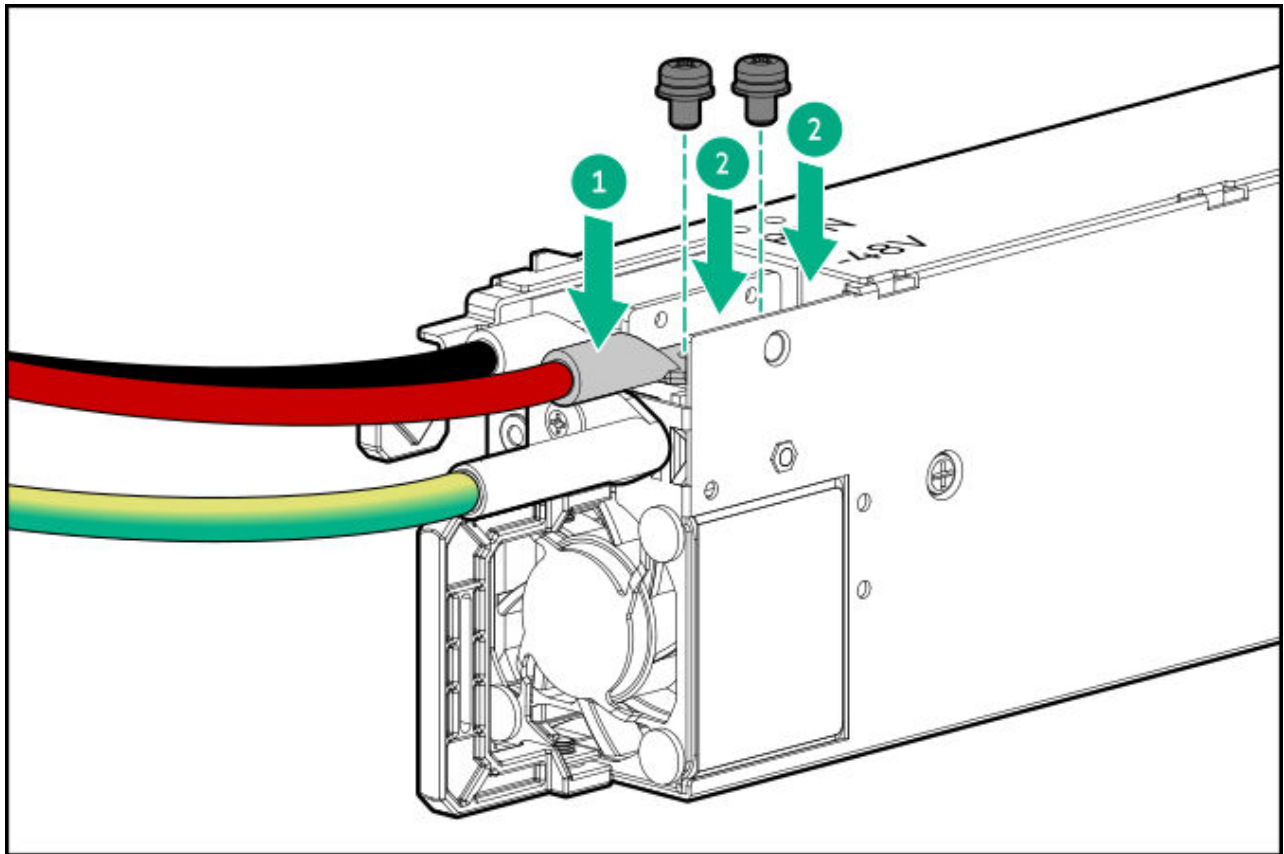

6. Install the protective cover on the DC power supply.

Make sure that the protective cover is locked.

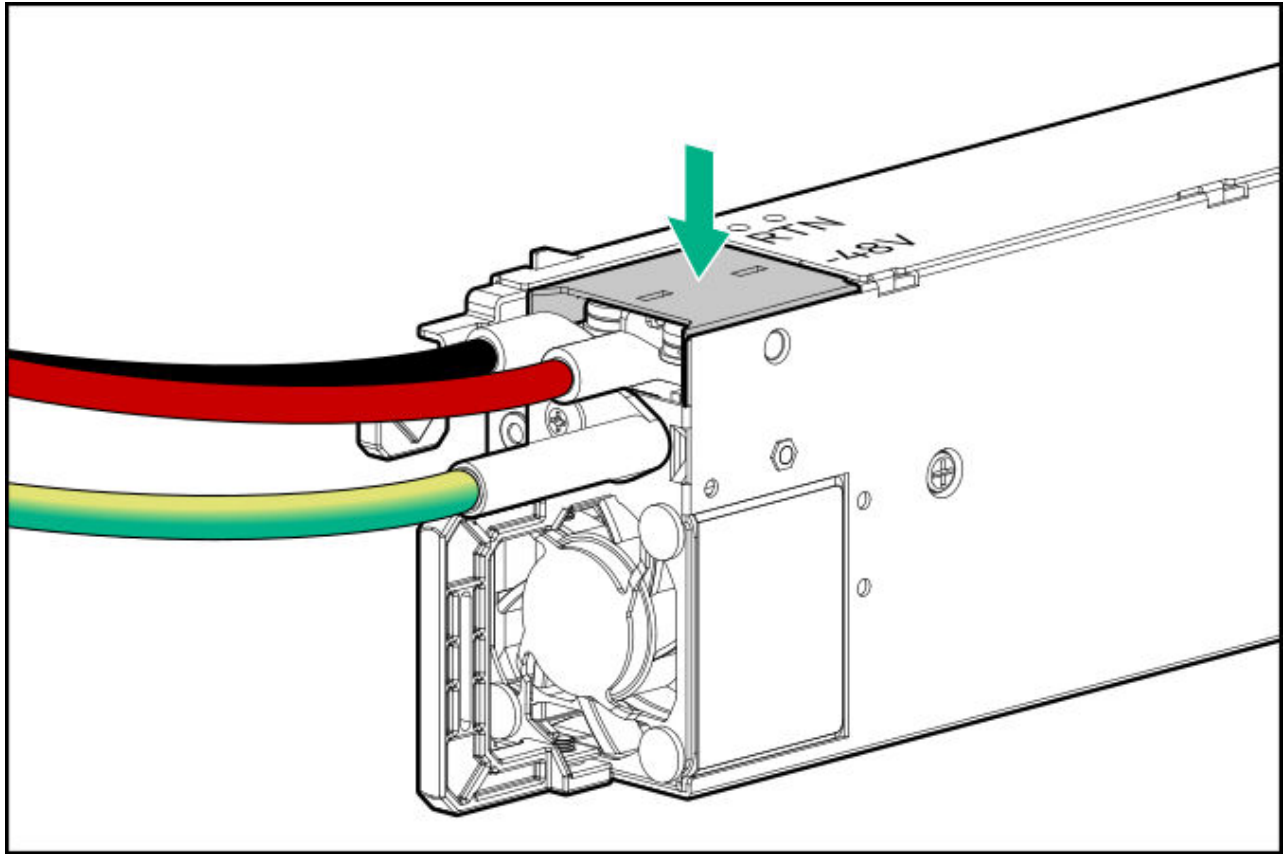

7. Secure the ground, positive return, and negative input wires in the strain relief strap.



CAUTION

Avoid tight bend radii to prevent damaging the internal wires of a power cord or a server cable. Never bend power cords and server cables tight enough to cause a crease in the sheathing.

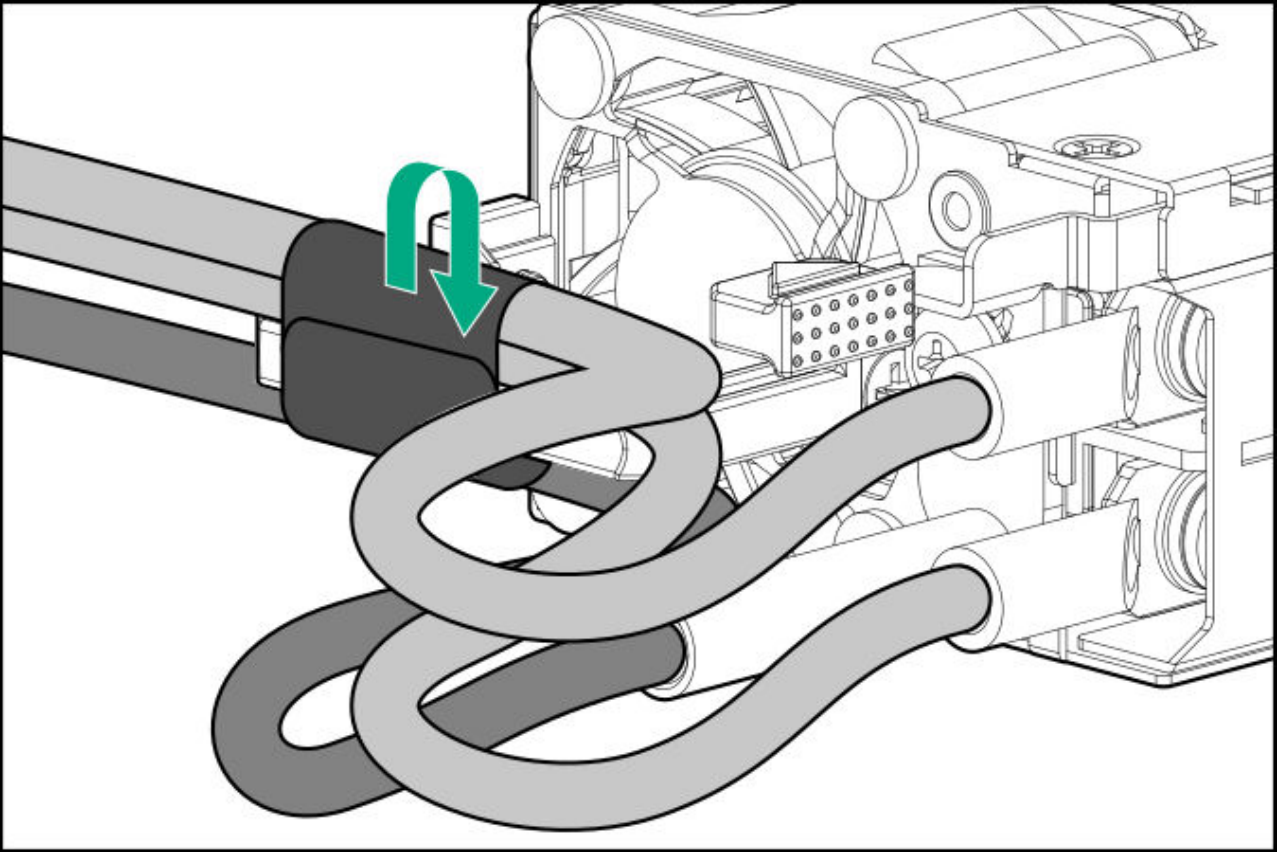

8. If you are installing a power supply in the power supply bay 2, remove the power supply blank.
Retain the blank for future use.

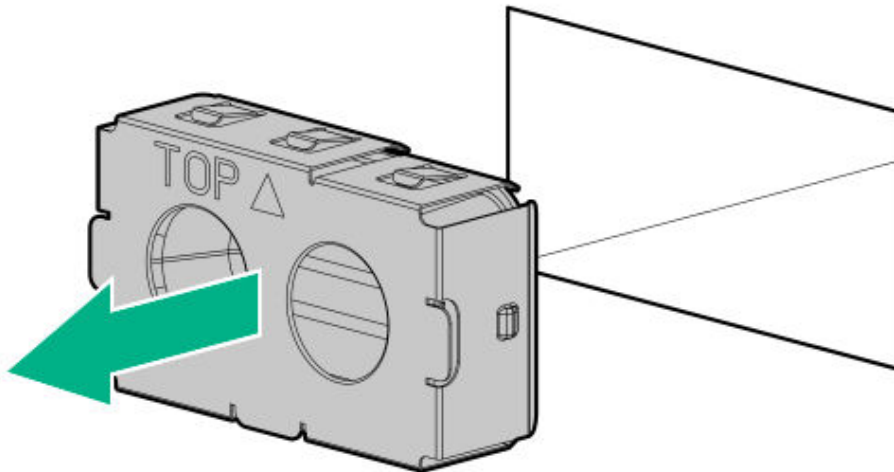

9. Immediately slide the power supply into the bay until it clicks into place.

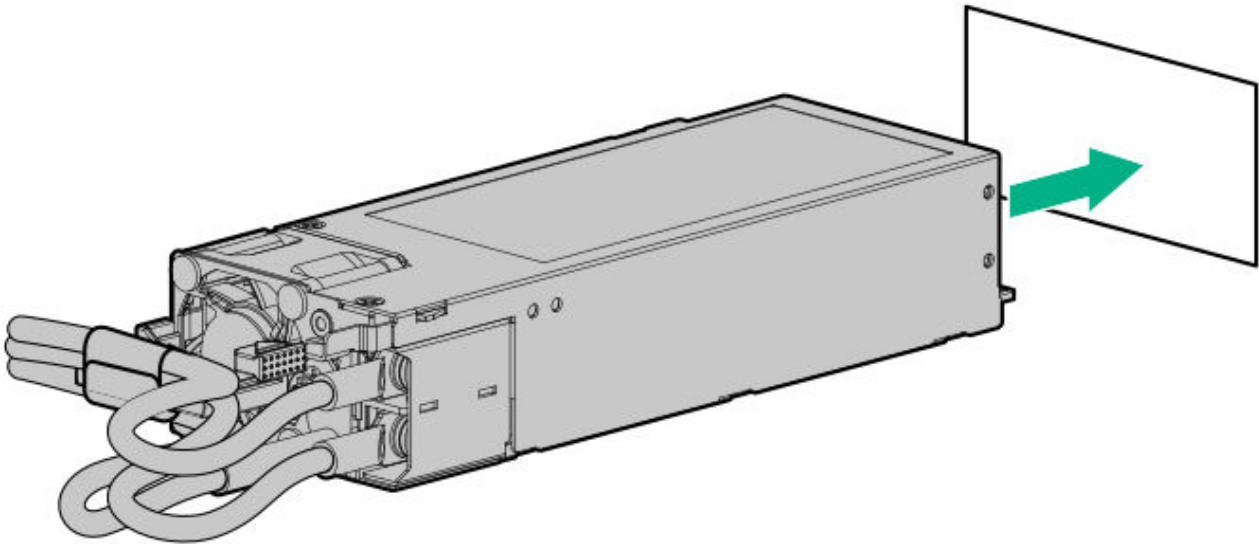

- .0. Make sure the -48 V DC power source is off or the PDU breaker is in the off position, and then connect the power cord to the -48 V DC power source or PDU.
- .1. Turn on the -48 V power source or switch the PDU breaker to the on position to supply -48 V to the power supply.
- .2. Connect a DC power cable to a DC power source.
- .3. Make sure that the power supply LED is green.

Results

The installation procedure is complete.

Management

Subtopics

Serial port option

Serial port option

Install the serial port option to enable communication to physical serial devices. You can also use the serial connection to remotely access the system BIOS and view POST error messages.

Subtopics

Installing the serial port

Installing the serial port

Prerequisites

Before you perform this procedure, make sure that you have a hex screwdriver available.

About this task



CAUTION

A discharge of static electricity from a finger or other conductor might damage system boards or other static-sensitive devices. To prevent damage, observe antistatic precautions.



CAUTION

The port blank provides EMI shielding and helps maintain proper thermal status inside the server. Do not operate the server when a port blank is removed without the corresponding I/O port option installed.

Procedure

1. Power down the server.
2. Remove all power:
 - a. Disconnect each power cord from the power source.
 - b. Disconnect each power cord from the server.
3. Disconnect all peripheral cables from the server.
4. Do one of the following:
 - If the server is in tower mode, place the server on a flat, level surface with the access panel facing up.
 - If the server is in rack mode, remove the server from the rack.
5. Unlock the front bezel.
6. Remove the access panel.
7. Remove the secondary riser cage.

8. Remove the serial port blank.

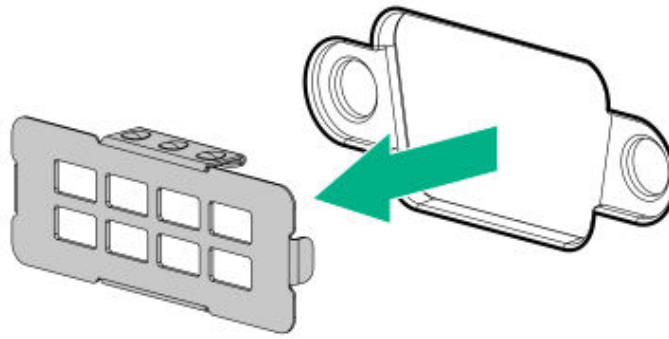

9. Install the serial port cable:

- a. Insert the serial port into the rear panel opening.
- b. Install the hex screws.

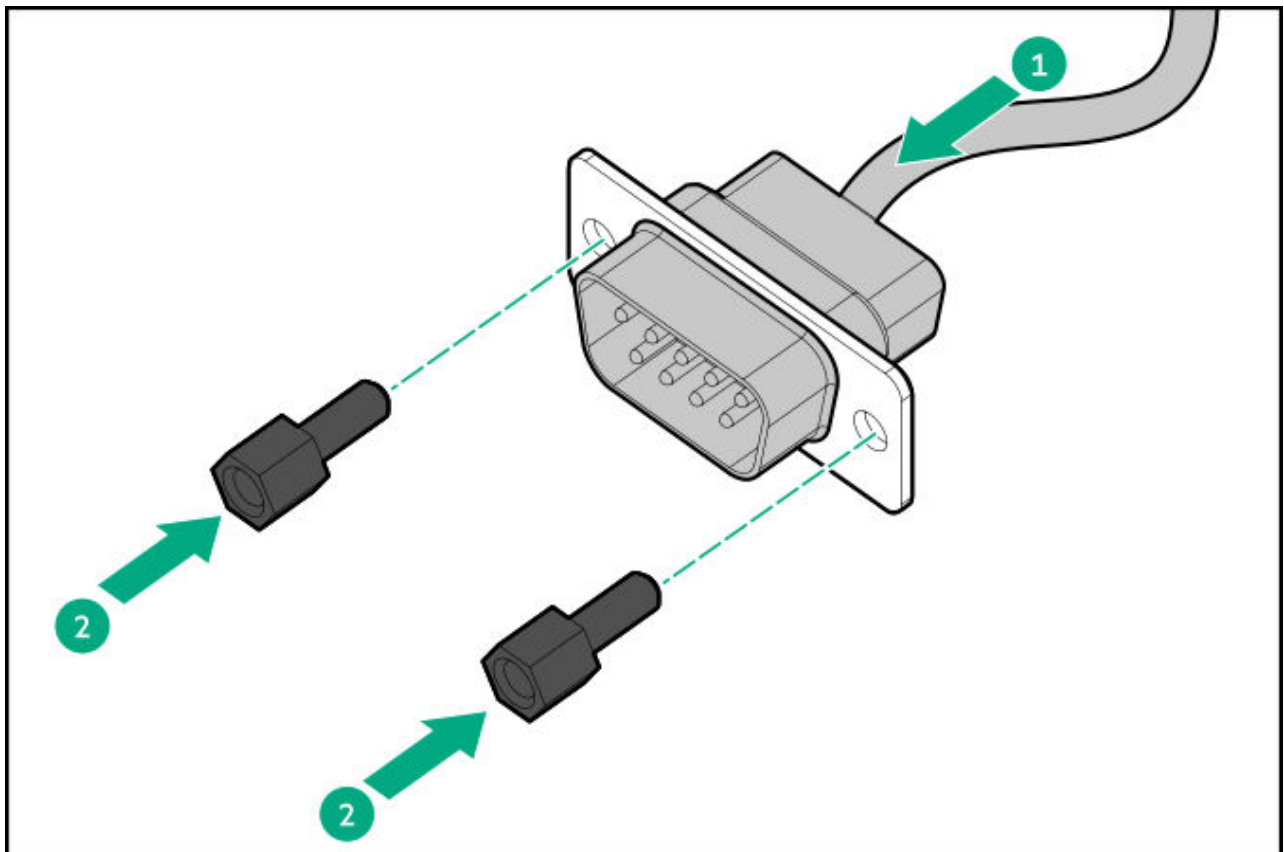

10. Connect the serial port cable to the system board.

11. Install the secondary riser cage.

- .2. Install the access panel.
- .3. Lock the front bezel.
- .4. Do one of the following:
 - Orient the server back in tower mode.
 - Install the server into the rack.
- .5. Connect all peripheral cables to the server.
- .6. Connect each power cord to the server.
- .7. Connect each power cord to the power source.
- .8. Power up the server.

Configuring the serial port

- .9. To configure the serial port setting:
 - a. From the boot screen, press **F9** to access the UEFI System Utilities.
 - b. From the **System Utilities** screen, select **System Configuration > BIOS/Platform Configuration (RBSU) > System Options > Serial Port Options > Embedded Serial Port.**
 - c. Select a setting.
 - d. Press **F12** key to save your selection.
 - e. Click **Yes-Save Changes.**
 - f. Click **Reboot.**

Results

The installation procedure is complete.

Transceiver option

Transceivers serve as the connection between the adapter and the network cable for maintaining high-speed performance.

Subtopics

Transceiver warnings and cautions

Installing a transceiver

Transceiver warnings and cautions



WARNING

Fiber-optic transceivers and fiber-optic cables connected to transceivers emit laser light that can damage your eyes. To avoid eye injuries, avoid direct eye exposure to the beam from the fiber-optic transceiver or into the ends of fiber-optic cables when they are powered-up.



CAUTION

The presence of dust in transceiver ports can cause poor cable connectivity. To prevent dust from entering, install a dust plug in an unused transceiver port.



CAUTION

Supported transceivers can be hot-swapped—removed and installed while the server is powered-on. However, to prevent potential damage to the transceiver or the fiber-optic cable, disconnect the cable from the transceiver before hot-swapping it.



CAUTION

Do not remove and install transceivers more often than is necessary. Doing so can shorten the useful life of the transceiver.



IMPORTANT

When you replace a transceiver with another of a different type, the server might retain selected port-specific configuration settings that were configured for the replaced transceiver. Be sure to validate or reconfigure port settings as required.

Installing a transceiver

Prerequisites

Before installing a transceiver option, review the following:

- [Transceiver warnings and cautions](#)
- Transceiver documentation for specific operational and cabling requirements

Procedure

1. Hold the transceiver by its sides and gently insert it into the network adapter port until it clicks into place.

Transceivers are keyed so that they can only be inserted in the correct orientation. If the transceiver does not fit easily into the port, you might have positioned it incorrectly. Reverse the orientation of the transceiver and insert it again.

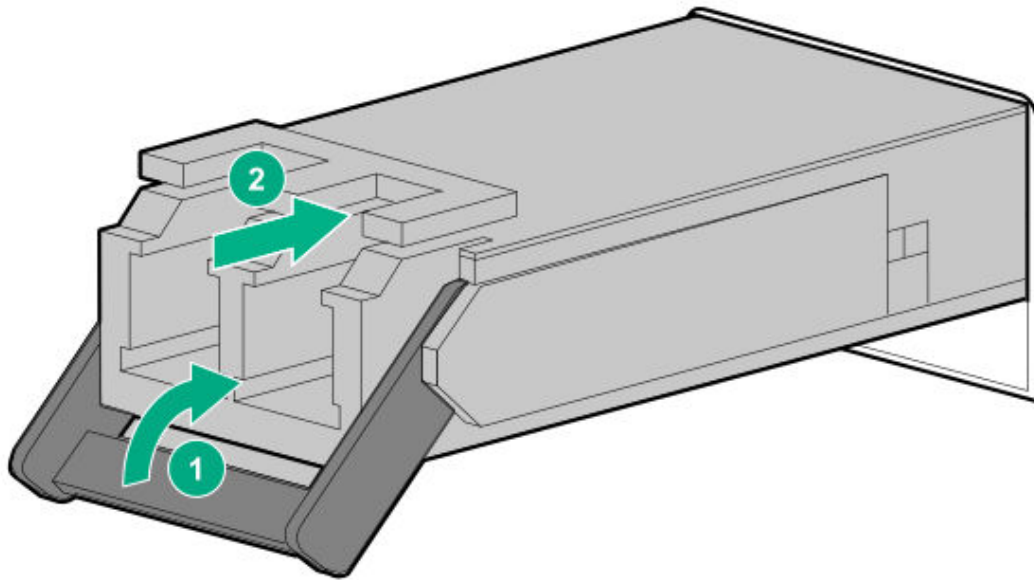

2. Remove the dust plug or protective cover from the transceiver.
3. Connect a compatible LAN segment cable to the transceiver.
4. Make sure that the NIC link LED on the port is solid green.

For more information on the port LED behavior, see the documentation that ships with the transceiver.

5. If needed, see the transceiver documentation for the model-specific fastening mechanism applicable to the transceiver.

Results

The installation procedure is complete.

Fan options



- Internal fans: Fan bays 1–8 in the fan cage.
- External fans: Fan bays 9–10 on the rear panel.

For more information on fan requirements for specific hardware configurations, see [Fan population](#).

Subtopics

[Fan population](#)

[Fan redundancy support](#)

[Fan mode behavior](#)

[Installing an internal fan](#)

[Installing the external fan](#)

Fan population

- In a single-processor system, nonredundant configuration, fans 2–4 are preinstalled in the fan cage and a fan blank is preinstalled in bay 1.
- In a dual-processor system, nonredundant configuration requires a fan in bay 1.
- To enable redundant fan mode in single- and dual-processor systems, install fans in bay 1, 5–8.
- In the E3.S drive configuration, the external fan 10 is default in the server.
- When installing GPU options in the primary and secondary risers, external fans 9–10 covering the rear side of riser slots are highly recommended.
- To maintain optimum system cooling, observe the following fan requirements for specific hardware components:

Hardware component	Bay 1	Bays 2–4	Bays 5–8	Bay 9	Bay 10	Fan redundancy
HPE NS204i-u Boot Device V2	Fan	Fan	—	—	—	Not supported
Tertiary riser	Fan	Fan	—	—	—	Not supported
Processor with a TDP of 300 W or higher	Fan	Fan	Fan	—	—	Supported
High power GPU <u>1</u> on the primary riser	Fan	Fan	Fan	—	Fan <u>2</u>	Supported
High power GPU <u>1</u> on the secondary riser	Fan	Fan	Fan	Fan <u>2</u>	—	Supported
E3.S drives	Fan	Fan	Fan	—	Fan	Supported
256 GB DIMM	Fan	Fan	Fan	—	—	Supported
200 Gb or faster Ethernet/InfiniBand adapter	Fan	Fan	Fan	—	—	Supported

- 1 For limited operating inlet ambient temperature requirements when GPUs are installed, see the server QuickSpecs on the Hewlett Packard Enterprise website (<https://www.hpe.com/info/quickspecs>).
- 2 For additional cooling support, Hewlett Packard Enterprise highly recommends installing an external fan.

Fan redundancy support

The number of fans installed in the server determines fan redundancy. When redundant fan mode is enabled, hot-plug fan operation is supported.

In this server, fan operation can either be:

- Hot-plug—A failed fan can be replaced without powering down the server.
- Non-hot-plug—To replace a failed fan, the user must either:
 - Keep the server powered on and complete the fan replacement within 60 seconds of opening the access panel, or
 - Power down and disconnect all power from the server before removing the access panel for fan replacement.

Fan mode behavior

- In nonredundant fan mode, a fan failure or a missing fan causes:
 - The system Health LED to flash amber.
 - The operating system to gracefully shut down.
- In redundant fan mode:
 - A fan failure or a missing fan will switch the system to nonredundant fan mode.

This change is indicated by the Health LED flashing amber. The system continues to operate normally in this mode.
 - A second fan failure or a missing fan causes the operating system to gracefully shut down.

Installing an internal fan

About this task

The server supports a second fan option (P47902-B21) for bay 1 and a redundant fan option (P47219-B21) for bays 5–8. The fan modules in both fan options are identical.



CAUTION

To prevent improper cooling and thermal damage, do not operate the server unless all bays are populated with either a component or a blank.

Procedure

1. Power down the server.
2. Remove all power:
 - a. Disconnect each power cord from the power source.
 - b. Disconnect each power cord from the server.
3. Disconnect all peripheral cables from the server.
4. If the server is in tower mode, place the server on a flat, level surface with the access panel facing up.
5. If the server is in rack mode, do one of the following:
 - Extend the server from the rack.
 - Remove the server from the rack.
6. Unlock the front bezel.
7. Remove the access panel.
8. If installing the internal fan 1, remove the fan blank.

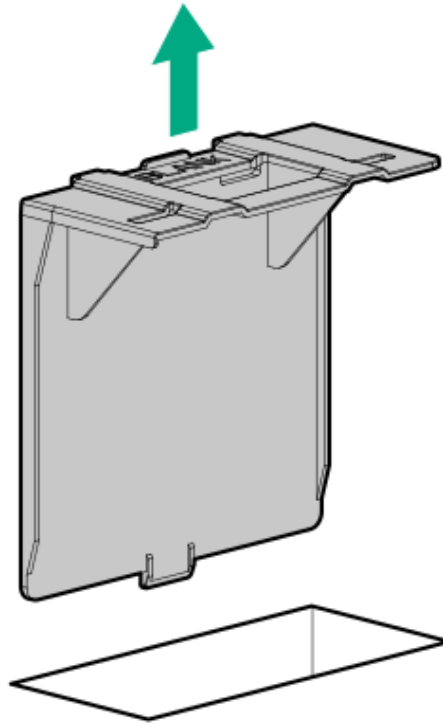

9. Install the internal fan:

- a. Lower the fan into the bay.
- b. Press down on the fan to make sure that it is seated firmly in the bay.

A click sound indicates that the fan is properly engaged.

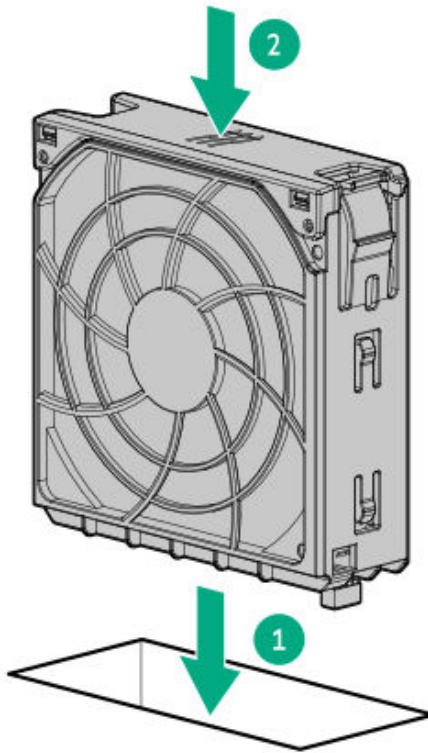

- .0. Install the access panel.
- .1. Lock the front bezel.
- .2. Do one of the following:
 - Orient the server back in tower mode.
 - Install the server into the rack.
- .3. Connect all peripheral cables to the server.
- .4. Connect each power cord to the server.
- .5. Connect each power cord to the power source.
- .6. Power up the server.

Results

The installation procedure is complete.

Installing the external fan

Prerequisites

Before you perform this procedure, make sure that you have the following items available:

- T-10 Torx screwdriver
- T-15 Torx screwdriver

About this task



CAUTION

To prevent improper cooling and thermal damage, do not operate the server unless all bays are populated with either a component or a blank.

Procedure

1. Power down the server.
2. Remove all power:
 - a. Disconnect each power cord from the power source.
 - b. Disconnect each power cord from the server.
3. Disconnect all peripheral cables from the server.
4. If the server is in tower mode, place the server on a flat, level surface with the access panel facing up.
5. If the server is in rack mode, do one of the following:
 - Extend the server from the rack.
 - Remove the server from the rack.
6. Unlock the front bezel.
7. Remove the access panel.
8. If installing the external fan 10, remove the primary riser cage.
9. If installing the external fan 9, do one of the following:
 - Remove the secondary riser cage blank.
 - If installed, remove the secondary riser cage
10. Remove the external fan connector blank.

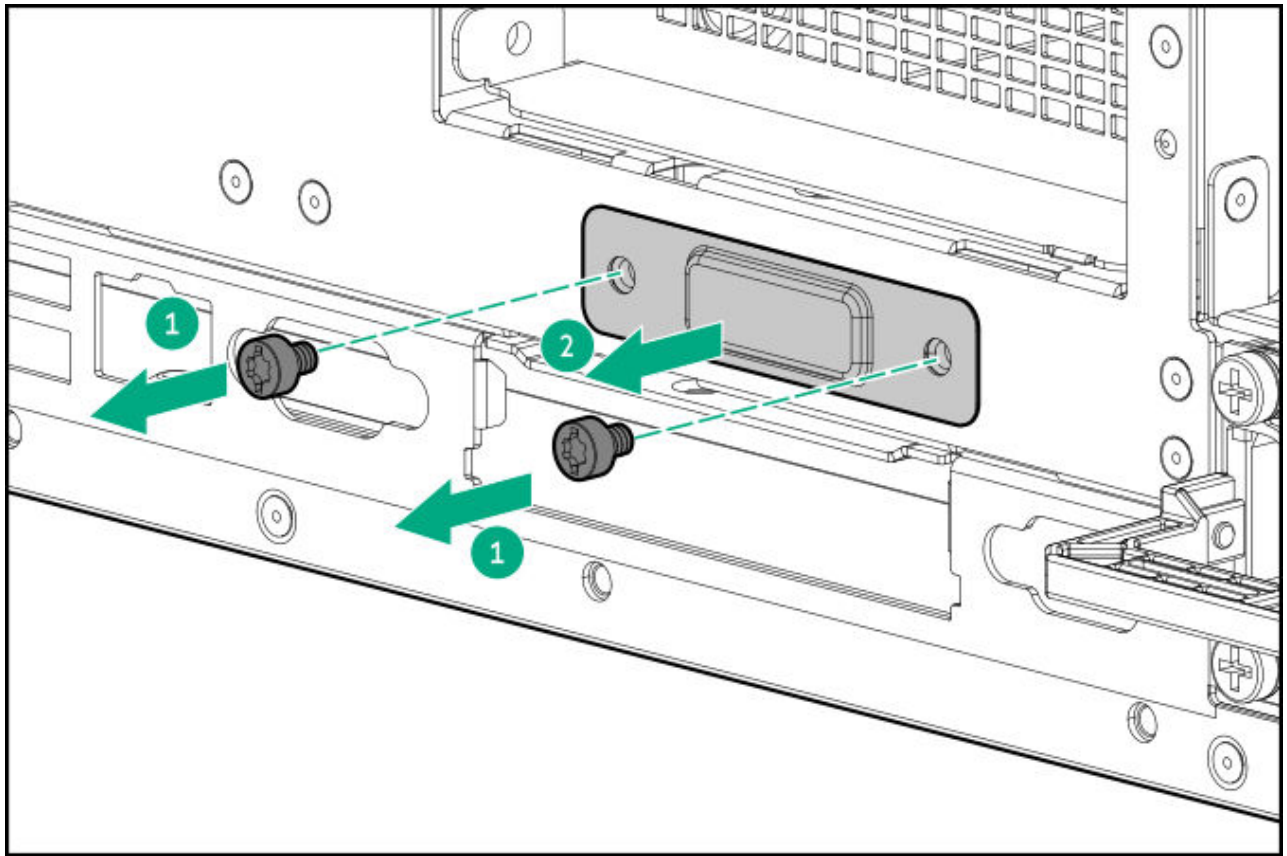

- .1. Install the external fan cable:
 - a. Install the cable in the cable connector slot.
 - b. Install the cable screw.

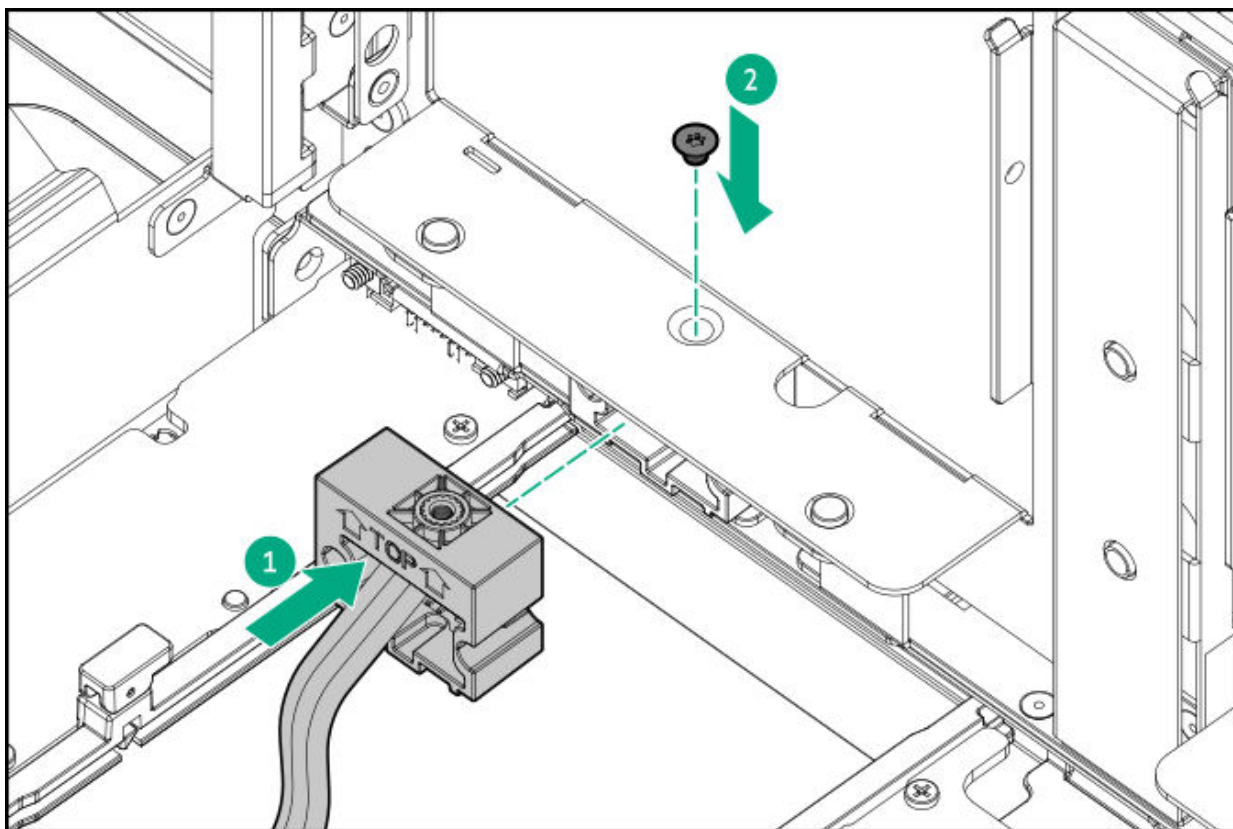

- .2. Install the external fan:
 - a. Install the external fan into the bay.
 - b. Tighten the captive screws.

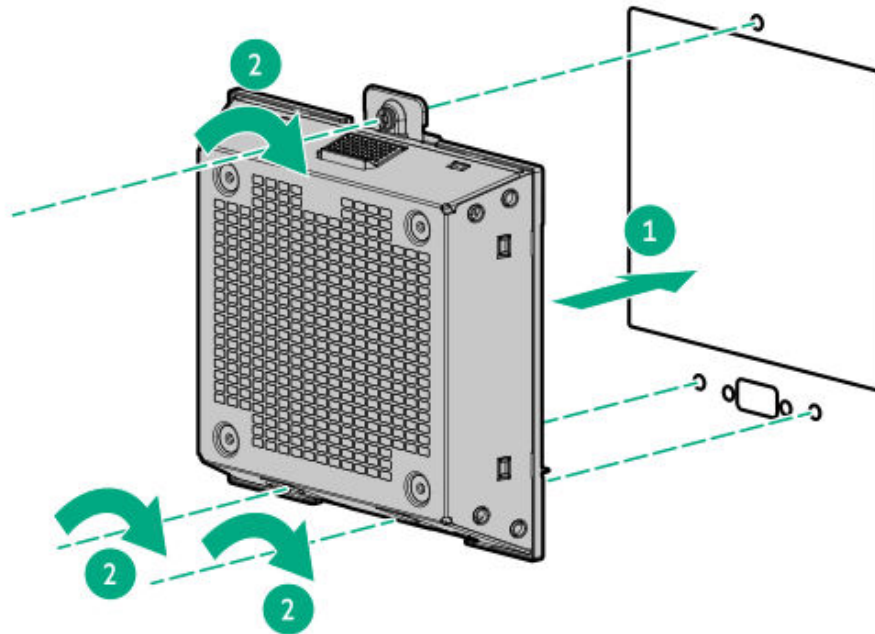

- .3. If removed, install the riser cage.
- .4. Install the access panel.
- .5. Lock the front bezel.
- .6. Do one of the following:
 - Orient the server back in tower mode.
 - Install the server into the rack.
- .7. Connect all peripheral cables to the server.
- .8. Connect each power cord to the server.
- .9. Connect each power cord to the power source.
- !0. Power up the server.

Results

The installation procedure is complete.

Risers and riser cages

Subtopics

[Installing the secondary riser cage](#)

[Installing the tertiary riser](#)

Installing the secondary riser cage

Prerequisites

- [Verify that the server is a dual-processor configuration.](#)
- [Verify that fan 1 is installed.](#)
- Before you perform this procedure, make sure that you have a T-10 Torx screwdriver available.

Procedure

1. [Power down the server.](#)
2. Remove all power:
 - a. Disconnect each power cord from the power source.
 - b. Disconnect each power cord from the server.
3. Disconnect all peripheral cables from the server.
4. Do one of the following:
 - If the server is in tower mode, [place the server on a flat, level surface with the access panel facing up.](#)
 - If the server is in rack mode, [remove the server from the rack.](#)
5. Unlock the front bezel.
6. [Remove the access panel.](#)
7. (Optional) [Install the expansion card.](#)
8. [Remove the secondary riser cage blank.](#)
9. Install the secondary riser cage:
 - a. Carefully press the riser down on its system board connector.

Make sure that:

- The riser cage is aligned with the rear chassis.
 - The riser board is firmly seated on the system board.
- b. Simultaneously push and rotate the half-turn spring latch to 180°.
 - c. Close the spring latch.

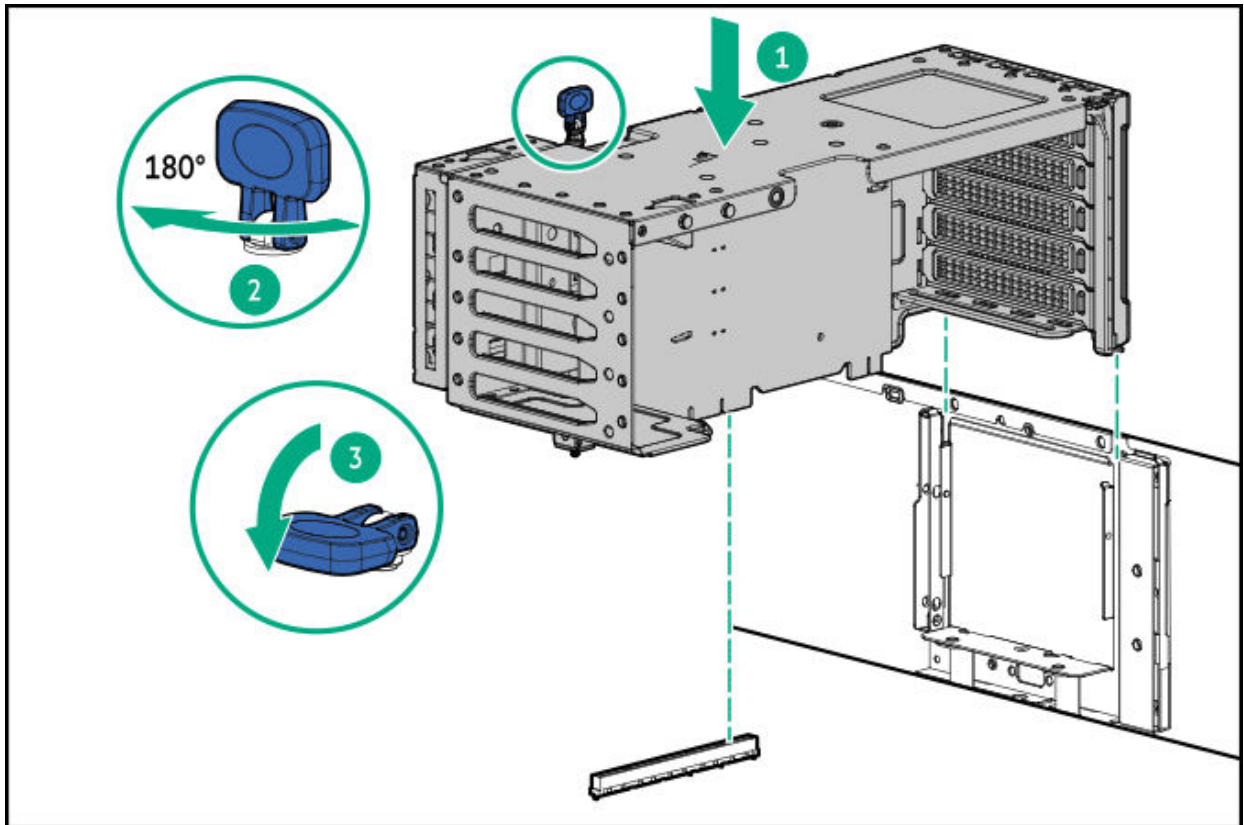

- .0. Install the access panel.
- .1. Lock the front bezel.
- .2. Do one of the following:
 - Orient the server back in tower mode.
 - Install the server into the rack.
- .3. Connect all peripheral cables to the server.
- .4. Connect each power cord to the server.
- .5. Connect each power cord to the power source.
- .6. Power up the server.

Results

The installation procedure is complete.

Installing the tertiary riser

Prerequisites

- - Verify that the server is in a dual-processor configuration.
 - Verify that fan 1 is installed.
- Before you perform this procedure, make sure that you have the tertiary riser option (P79317-B21) available. The option kit includes:
 - Tertiary riser
 - Tertiary riser signal cable
 - Five-slot riser cage—This riser cage is required only if the secondary riser is not preinstalled in the server.

Procedure

1. Power down the server.
2. Remove all power:
 - a. Disconnect each power cord from the power source.
 - b. Disconnect each power cord from the server.
3. Disconnect all peripheral cables from the server.
4. Do one of the following:
 - If the server is in tower mode, place the server on a flat, level surface with the access panel facing up.
 - If the server is in rack mode, remove the server from the rack.
5. Unlock the front bezel.
6. Remove the access panel.
7. If the secondary riser is not preinstalled, install the five-slot riser cage.

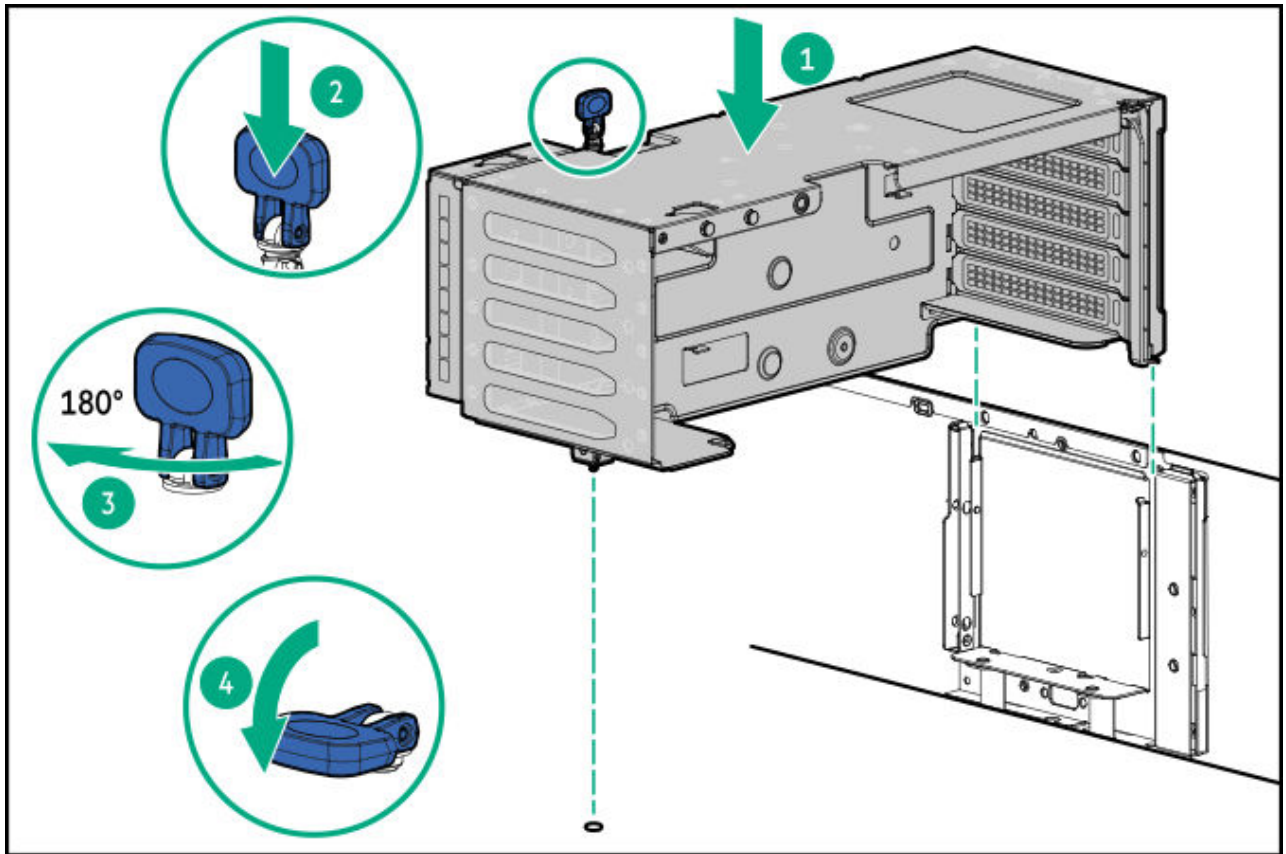

8. Install the tertiary riser on the secondary riser cage.

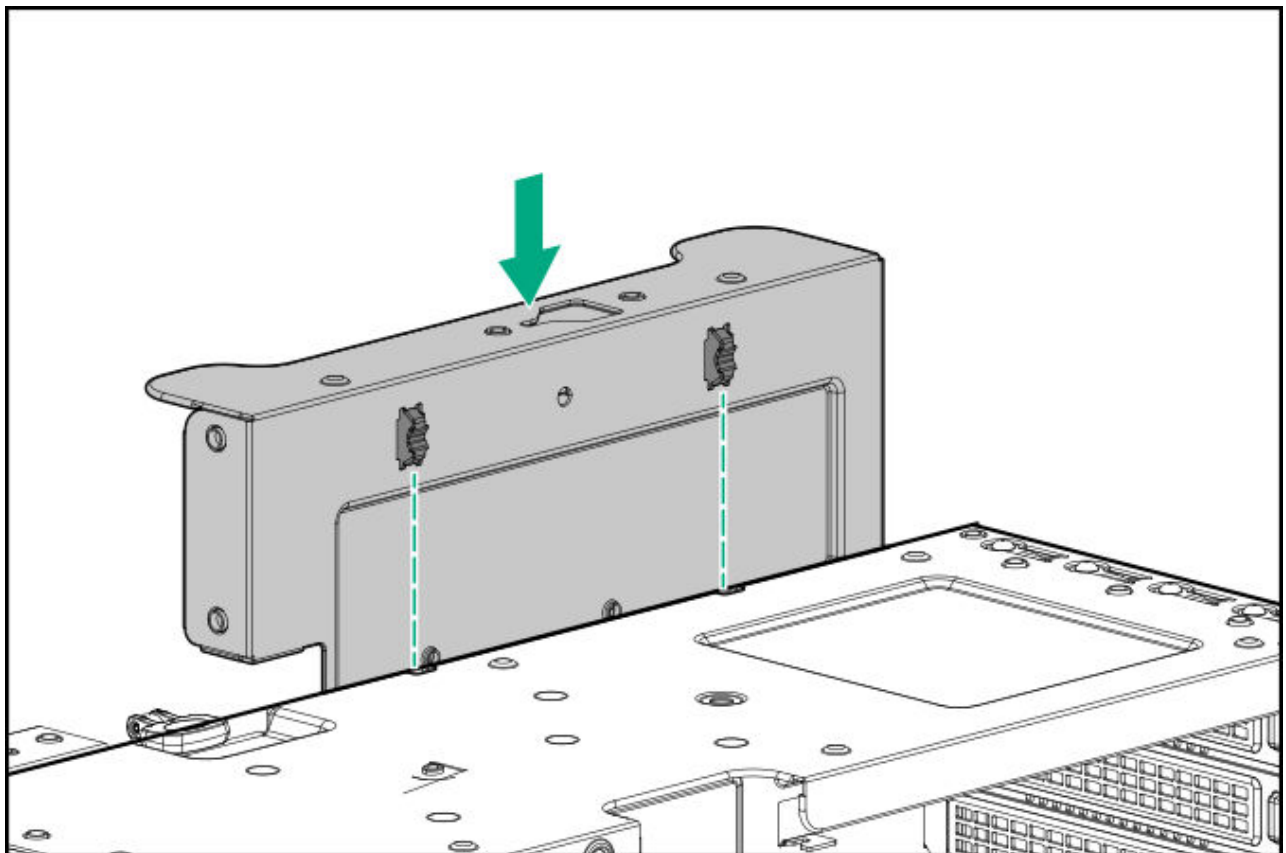

9. Insert the stabilizer bracket in the chassis.

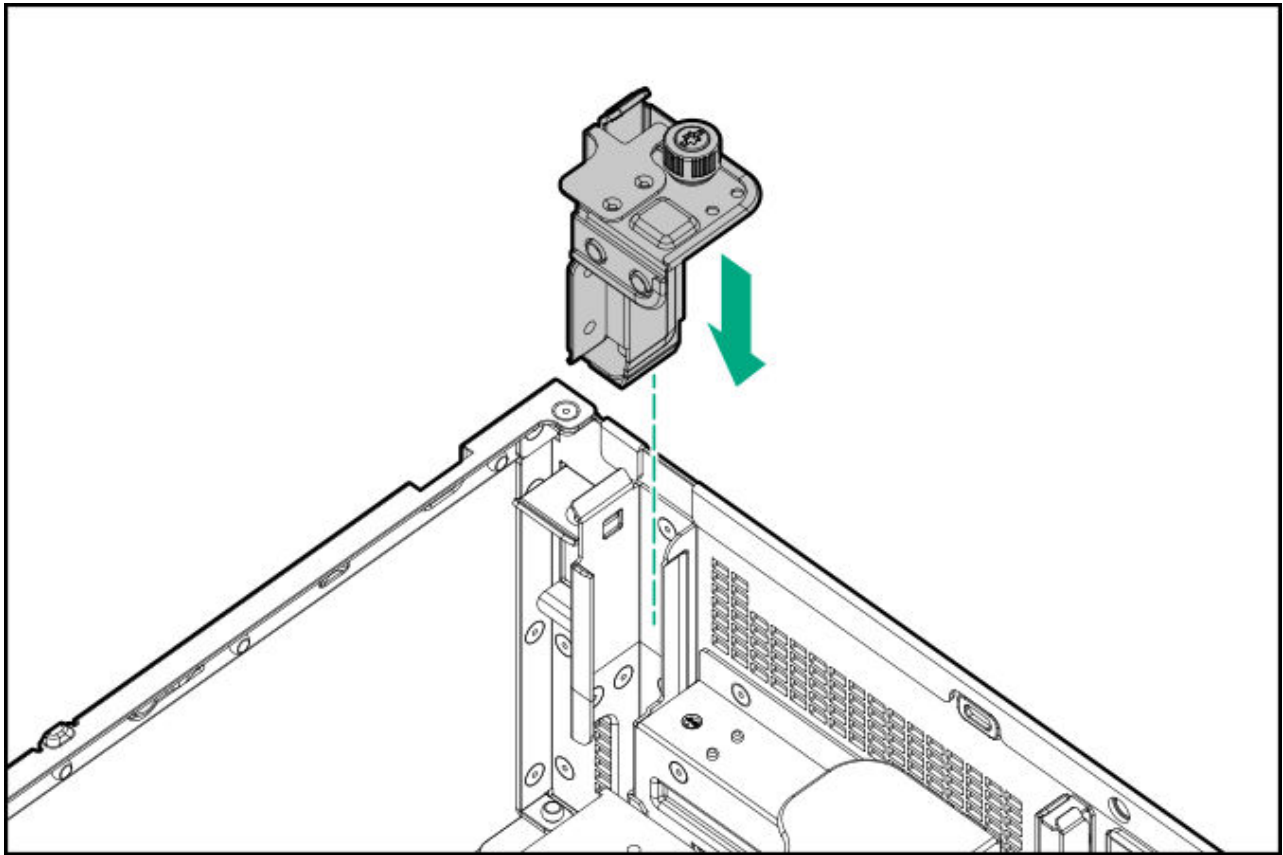

- .0. Cable the tertiary riser:
 - If installing the SAS LTO tape drive, connect the LTO power cable.
 - If installing the expansion card, connect the signal cables.
- .1. (Optional) Install the expansion card.
- .2. Install the access panel.
- .3. Lock the front bezel.
- .4. Do one of the following:
 - Orient the server back in tower mode.
 - Install the server into the rack.
- .5. Connect all peripheral cables to the server.
- .6. Connect each power cord to the server.

.7. Connect each power cord to the power source.

.8. Power up the server.

Results

The installation procedure is complete.

GPUs

Subtopics

[GPU options](#)

[GPU installation guidelines](#)

GPU options

This server supports various GPU options to meet your computational and graphics workload requirements. For a list of supported GPU models, see the server QuickSpecs on the Hewlett Packard Enterprise website (<https://www.hpe.com/info/quickspecs>).

- PCIe workload GPUs—These options are PCIe card-based, direct-attach solutions that use solid-state storage technology directly on the PCI bus to boost I/O performance and reduce latency to scale in line with your processing requirements.
- Computational and graphics GPUs—These options deliver accelerated compute performance for a range of deep learning, high-performance computing (HPC), and graphics-intensive applications.

GPU installation guidelines

- To support high power GPUs (TDP > 75 W), the following options are required:
 - [PCIe5 2 x16 riser option in the primary or secondary locations.](#)
Up to two GPUs are supported in each riser cage.
 - [GPU auxiliary power cable option.](#)
- This server does not support the installation of different GPU models in the same system.

- To maintain proper system cooling, all eight internal fans are required for GPU installation.
- For additional cooling support when a high power GPU is installed, Hewlett Packard Enterprise highly recommends installing the external GPU fan option.
- The limited operating inlet ambient temperatures required for GPUs vary based on the model and the server drive configuration. For more information, see the server QuickSpecs on the Hewlett Packard Enterprise website (<https://www.hpe.com/info/quickspecs>).



IMPORTANT

Workloads for high performance double-width GPUs with passive cooling can cause the internal fans to operate at high speeds to maintain optimum system cooling. Hewlett Packard Enterprise does not recommend operating the server under this passive cooling condition in or near a site where there is a reasonable expectation for a quiet environment.

Processors and heatsinks

Subtopics

Processor cautions

Installing the processor and heatsink options

Processor cautions



CAUTION

To avoid damage to the processor or system board, only authorized personnel should attempt to replace or install the processor in this server.



CAUTION

To prevent possible server malfunction and damage to the equipment, multiprocessor configurations must contain processors with the same part number.



CAUTION

The pins on the processor socket and on the processor are very fragile and easily damaged. To avoid component damage, **do not touch these pins.** Any damage to them might require replacing the system board and/or processor.



IMPORTANT

Processor socket 1 must be populated at all times or the server does not function.



IMPORTANT

If installing a processor with a faster speed, update the system ROM before installing the processor. To download firmware, see [Updating firmware or system ROM](#).

Installing the processor and heatsink options

Prerequisites

- When installing processors with a TDP \geq 225 W, performance heatsink (P72359-B21) is required.
- When installing processors with a TDP \geq 300 W, the redundant fan kit (P47219-B21) and the second CPU fan kit (P47902-B21) is required.
- [Review the fan population requirements for single and dual-processor configurations.](#)
- Before you perform this procedure, make sure that you have a T-30 Torx screwdriver available.

Procedure

1. Power down the server.
2. Remove all power:
 - a. Disconnect each power cord from the power source.
 - b. Disconnect each power cord from the server.
3. Disconnect all peripheral cables from the server.
4. Do one of the following:
 - If the server is in tower mode, place the server on a flat, level surface with the access panel facing up.
 - If the server is in rack mode, remove the server from the rack.
5. Unlock the front bezel.
6. Remove the access panel.
7. Remove the fan cage.
8. Remove the secondary riser cage.
9. Remove the protective film from the thermal interface material.



CAUTION

To prevent mechanical damage or depositing oil on your hands or other contaminants to the heatsink contact surface, hold the heatsink only by the edge of its base plate. Do not touch the heatsink fins.

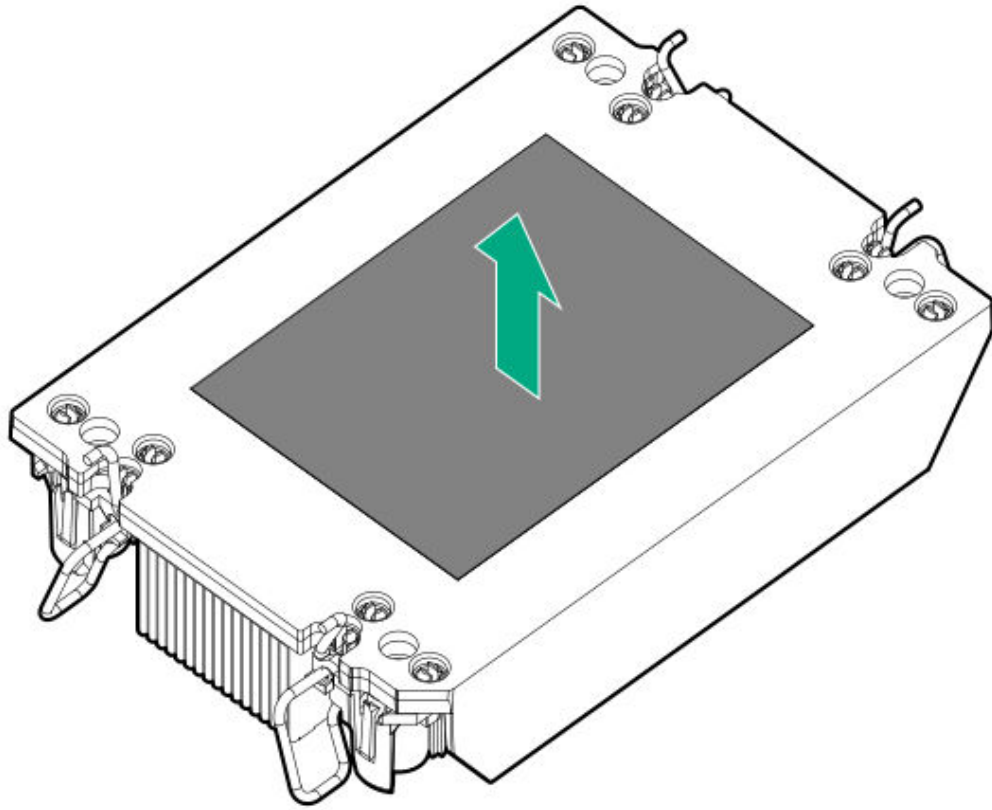

.0. Set the anti-tilt wires to the locked position.

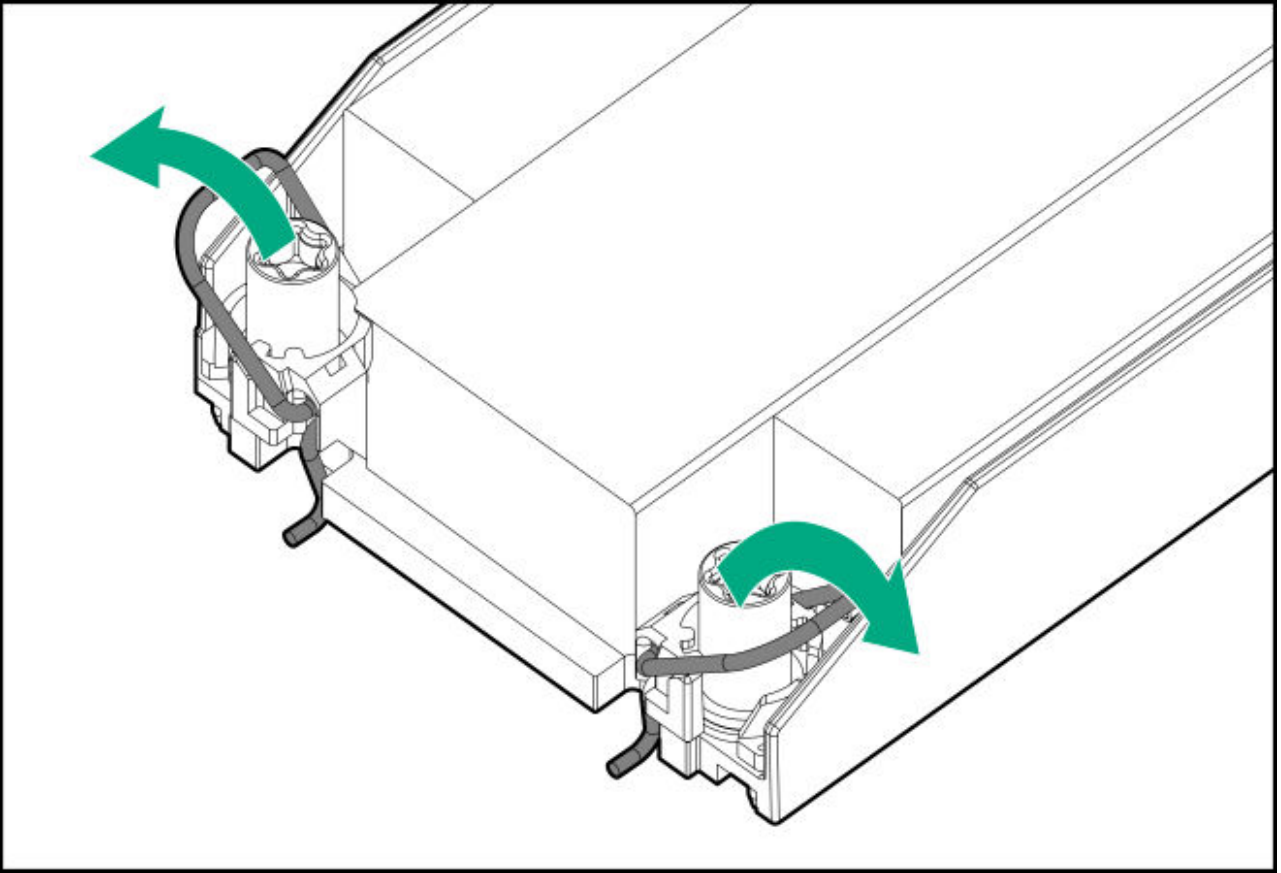

- .1. Verify that the processor is securely latched to the processor carrier.

The following illustration calls out the keying feature tabs that secure the processor. Different processor carriers will have these tabs in different locations.

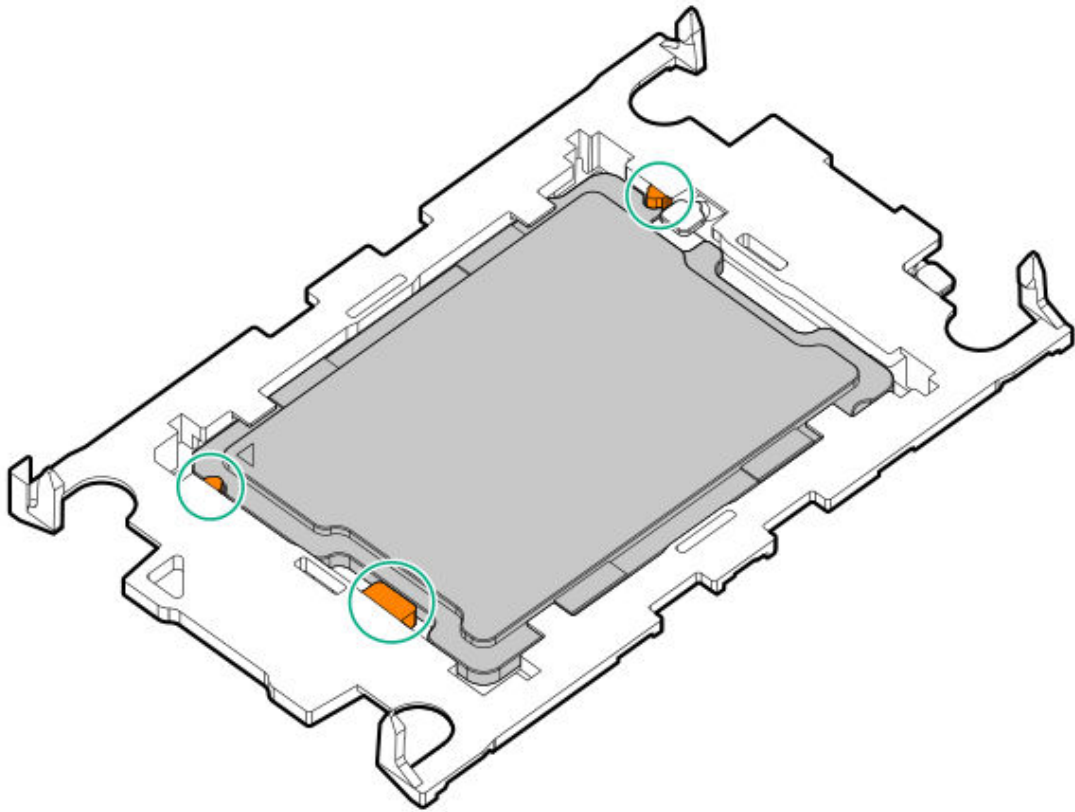

.2. Attach the heatsink to the processor carrier:

- a. Align the pin 1 indicator on the processor carrier with that on the heatsink.

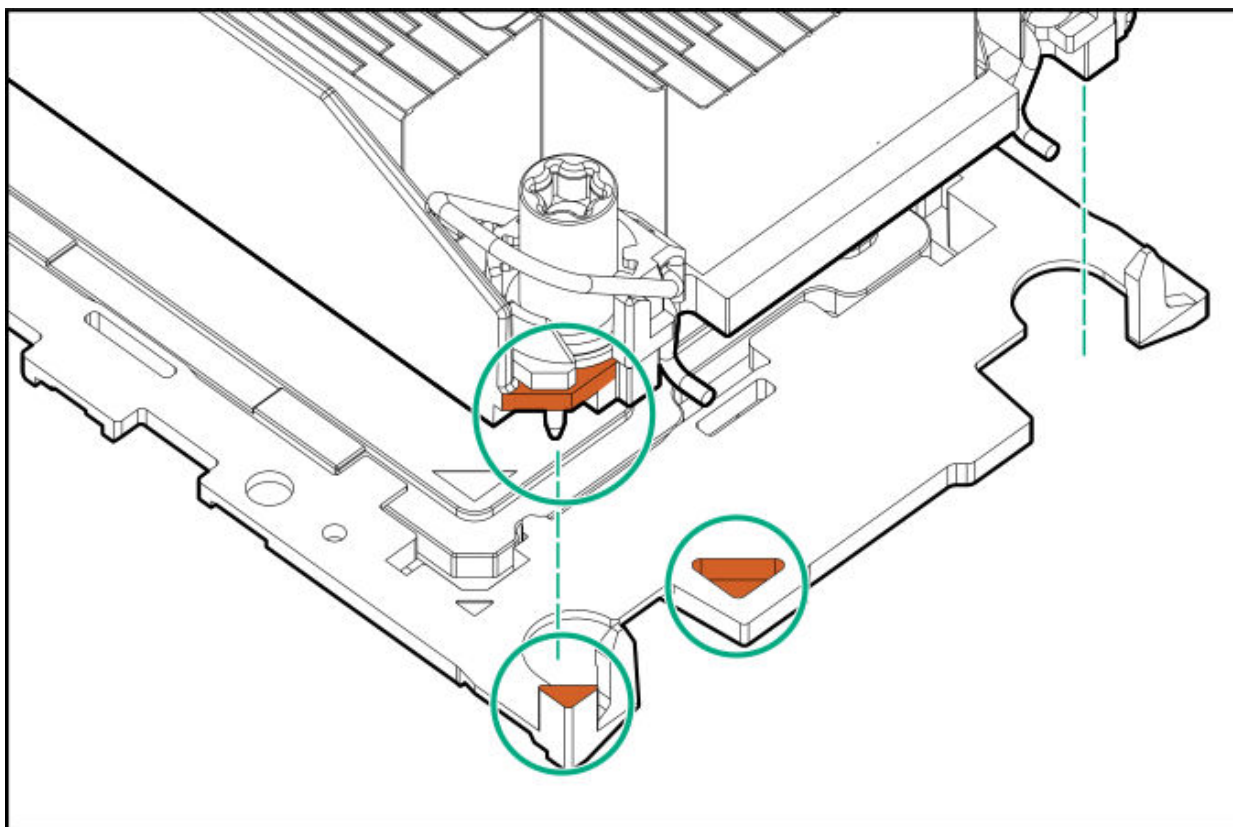

- b. Lower the heatsink on the processor carrier until the carrier tabs snap into place.

There will be an audible click to indicate that the heatsink is properly latched on the processor carrier.

- Standard heatsink

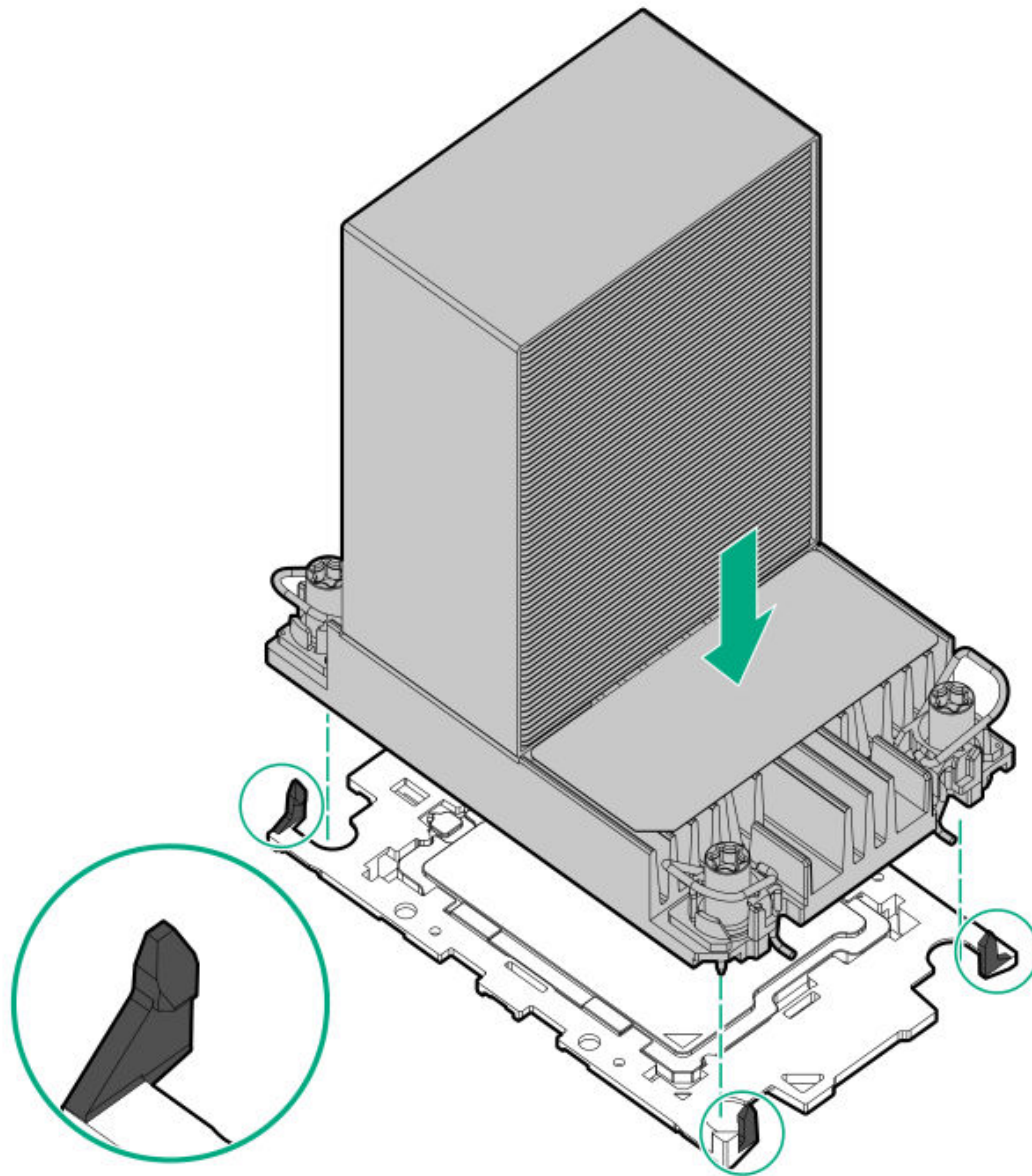

- Performance heatsink

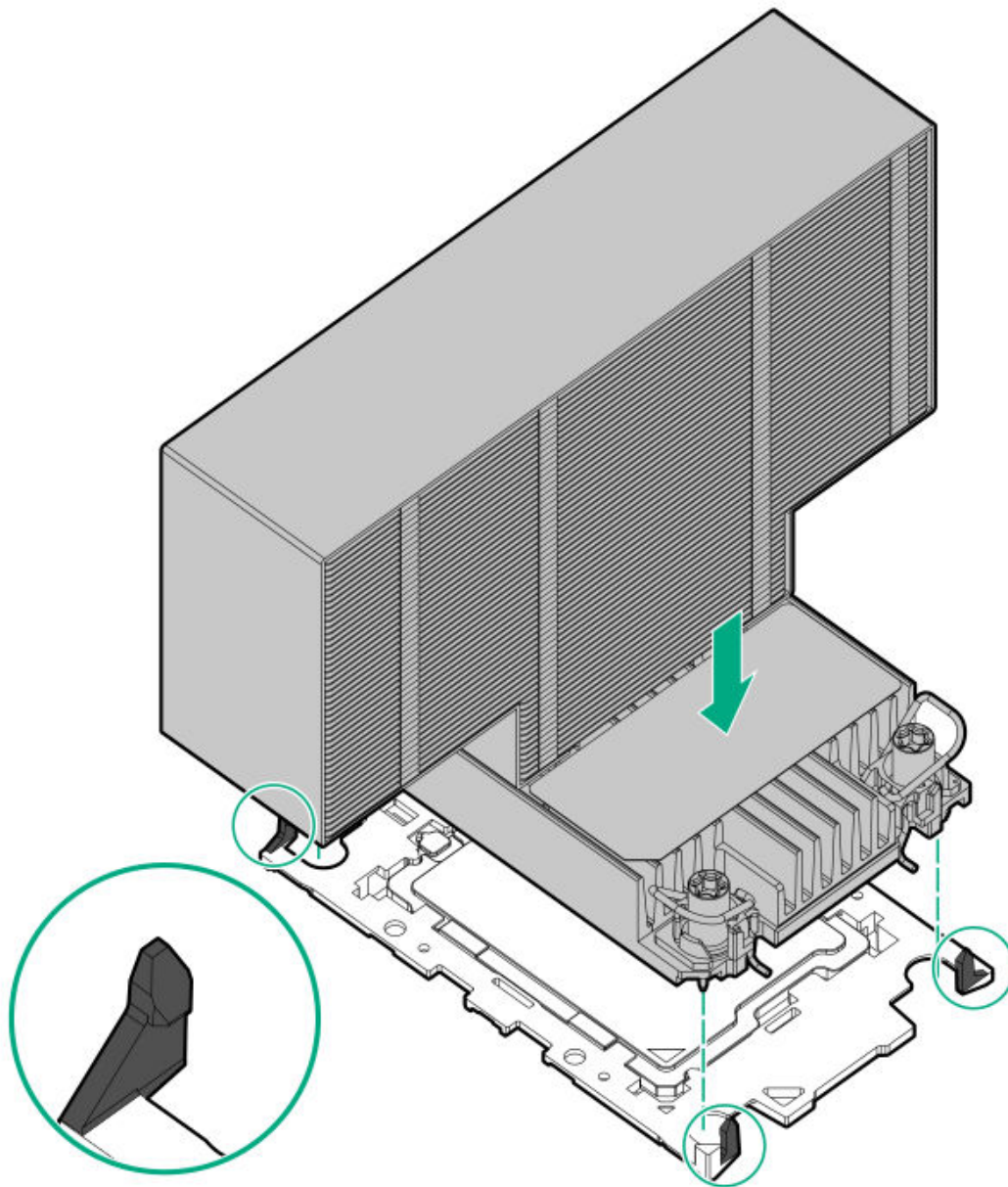

.3. Perform the following verification steps:

- a. Verify that the tabs on the processor carrier are securely latched on the heatsink.

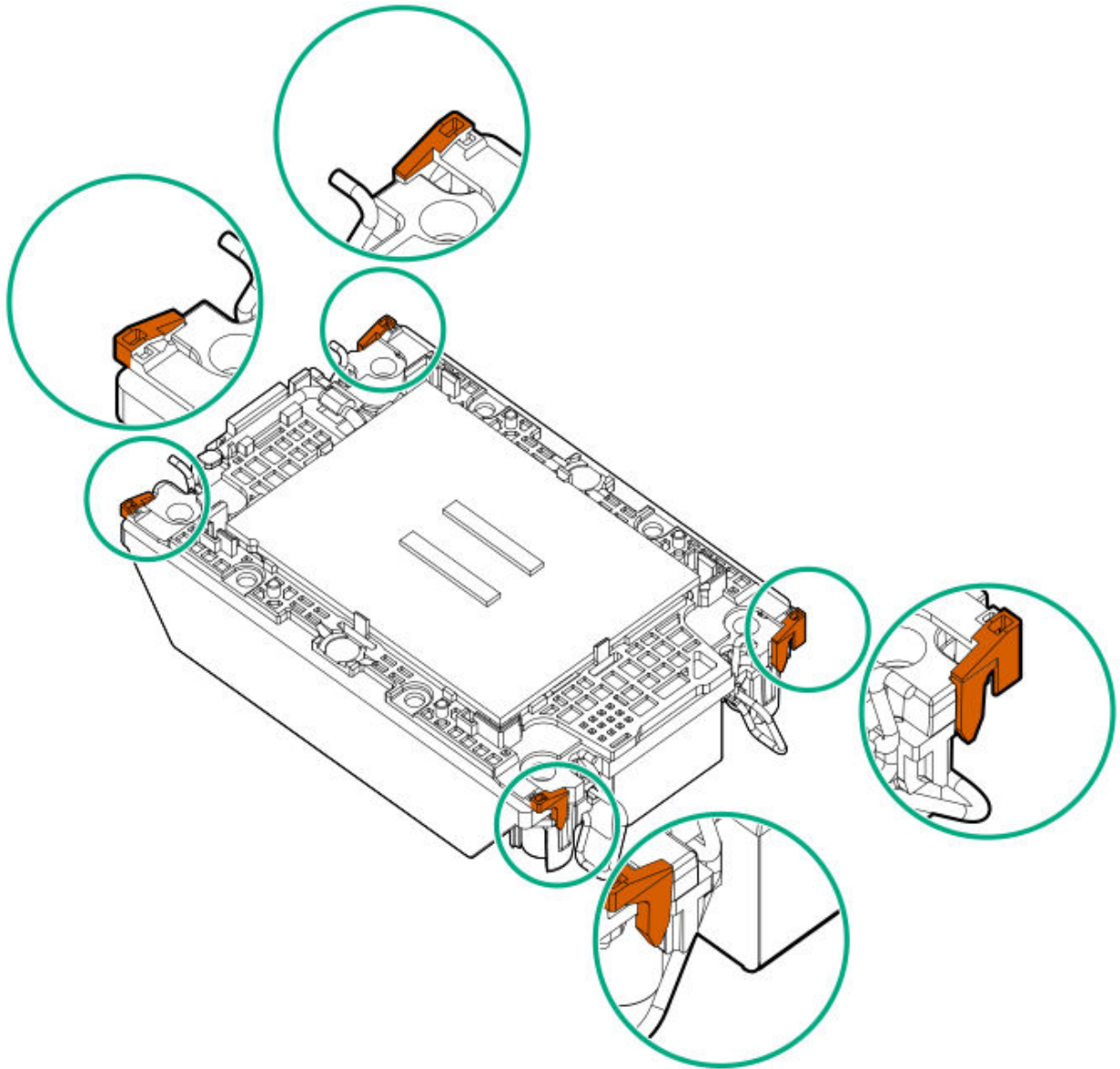

b. Verify that the pin 1 indicators on the processor and processor carrier are aligned.

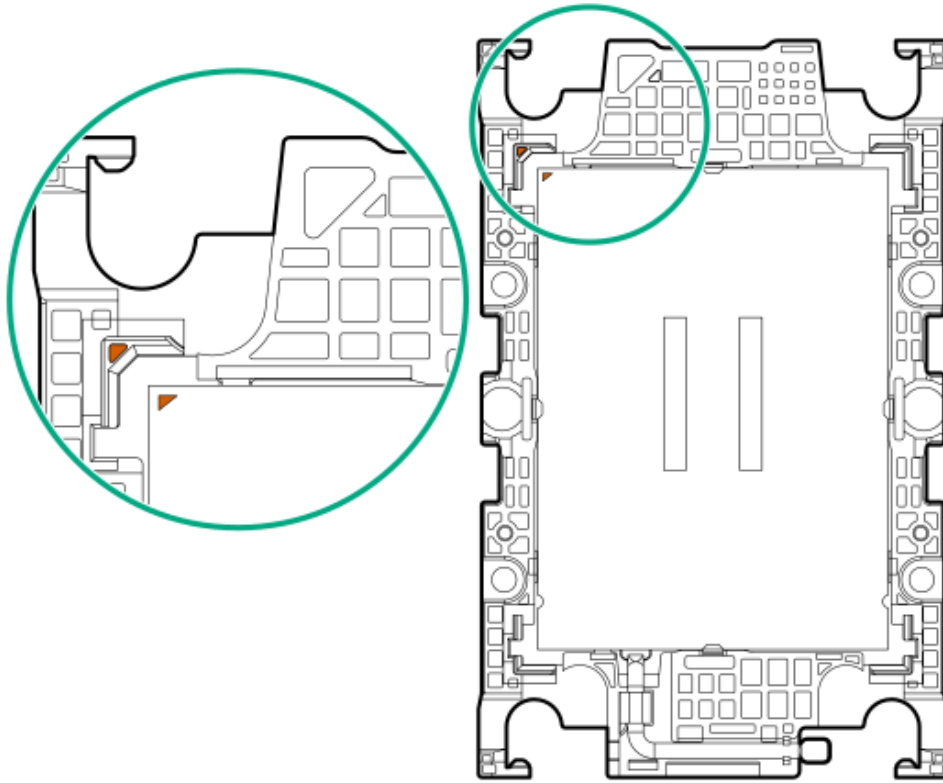

c. Verify that the processor is properly secured by the carrier snaps.

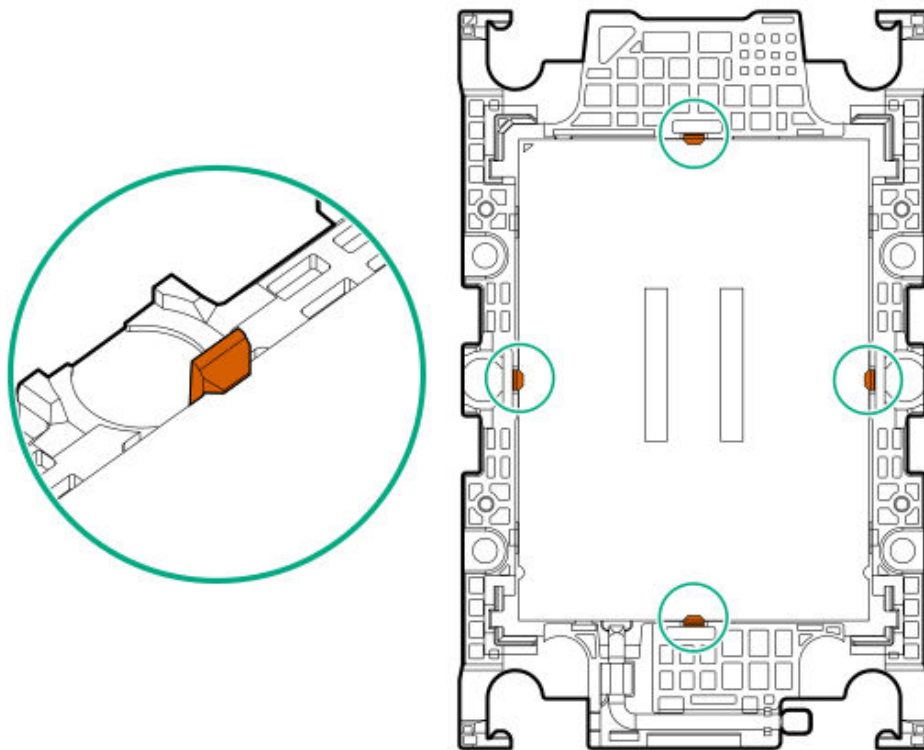

- .4. Remove the dust cover from the processor socket:
 - a. Press and hold the grip tabs on the dust cover.
 - b. Lift the dust cover away from the bolster plate.

Retain the cover for future use.

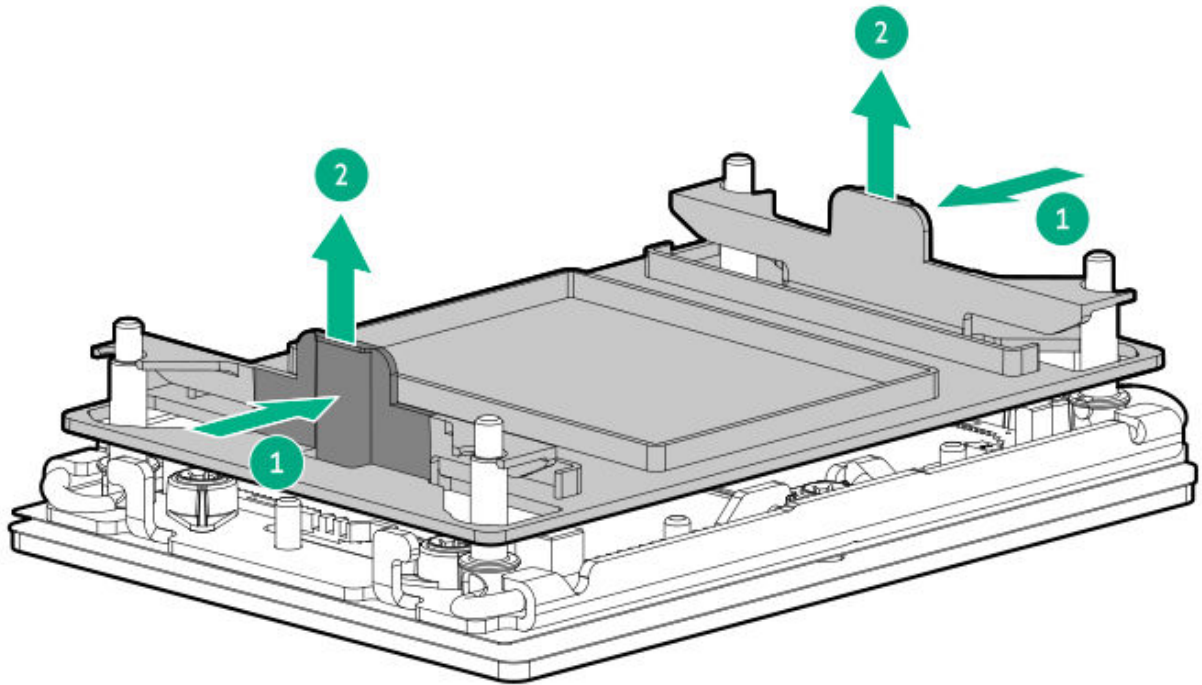

.5.



CAUTION

To prevent thermal failure or component damage, do not move the heatsink once the bottom of its base plate touches the top of the processor. Excessive heatsink movement can cause the thermal grease to smear and become uneven. Voids in the compound can adversely impact the transfer of heat away from the processor.

Install the processor-heatsink module:

- a. When using a torque wrench to tighten the heatsink screws, set 0.9 N-m (8 in-lb) of torque.
- b. Note the **Front of server** text on the heatsink label to correctly orient the processor-heatsink module over the bolster plate.
- c. Carefully lower the processor-heatsink module straight down onto the bolster plate guide posts.

The posts are keyed so that the module can only be installed one way. Make sure that the module is properly seated on the bolster plate before securing the screws.

- Standard heatsink

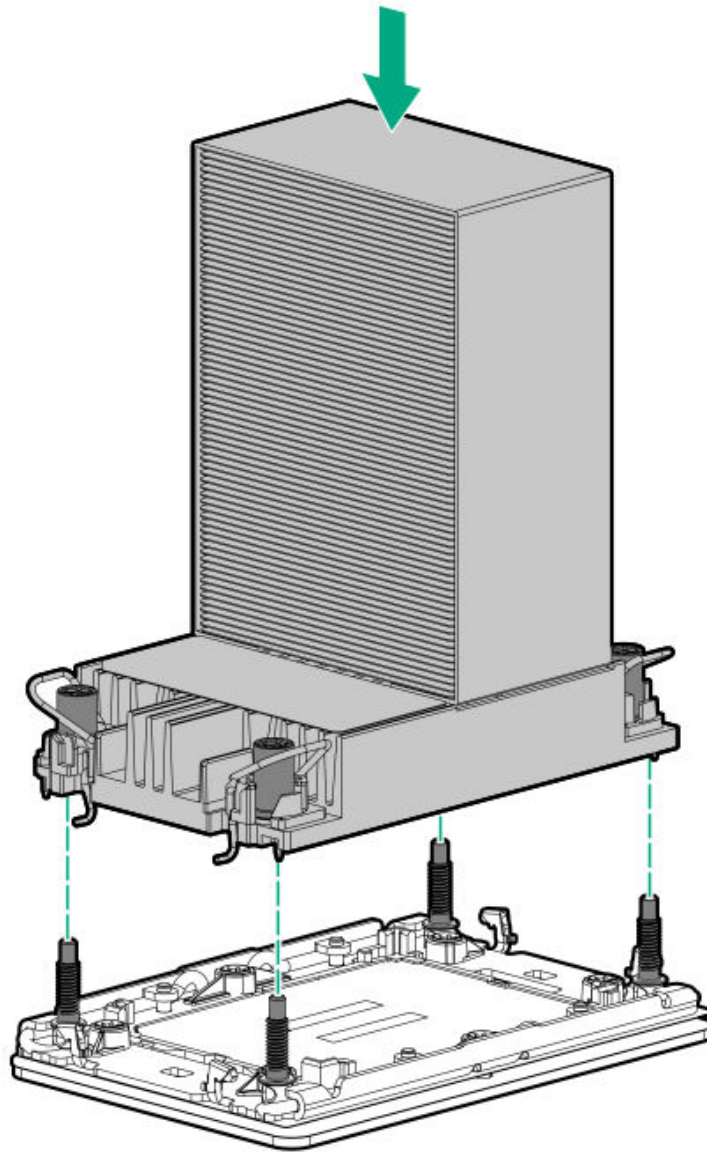

- Performance heatsink

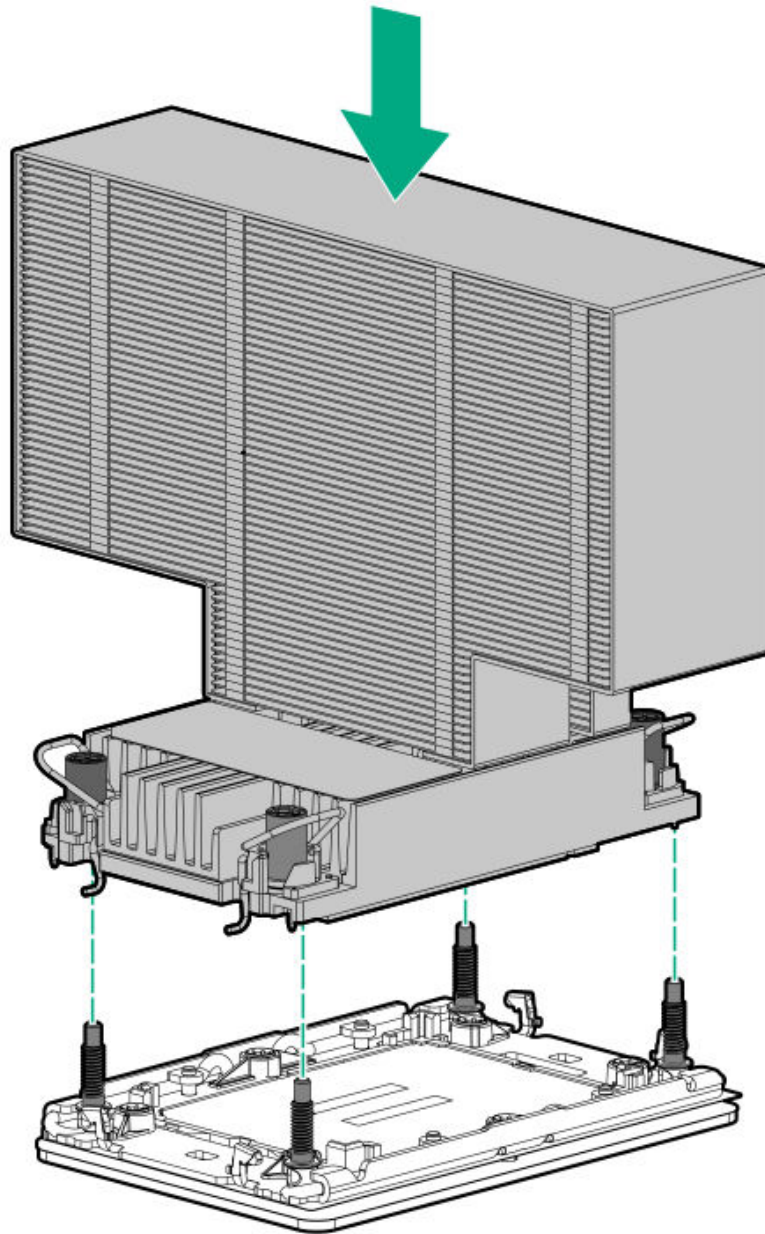

d. Set the anti-tilt wires to the locked position.

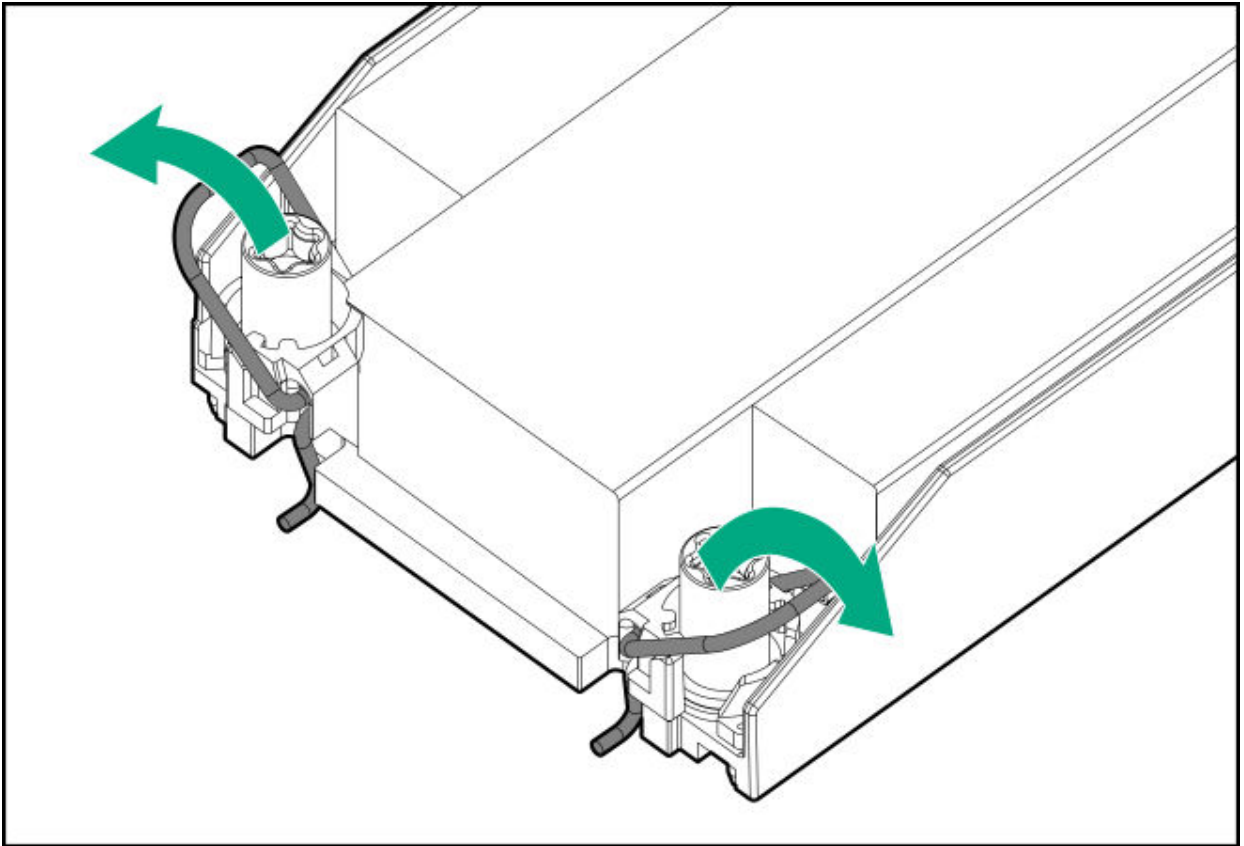

e. Tighten one pair of diagonally opposite heatsink screws, and then tighten the other pair of heatsink screws.

- Standard heatsink

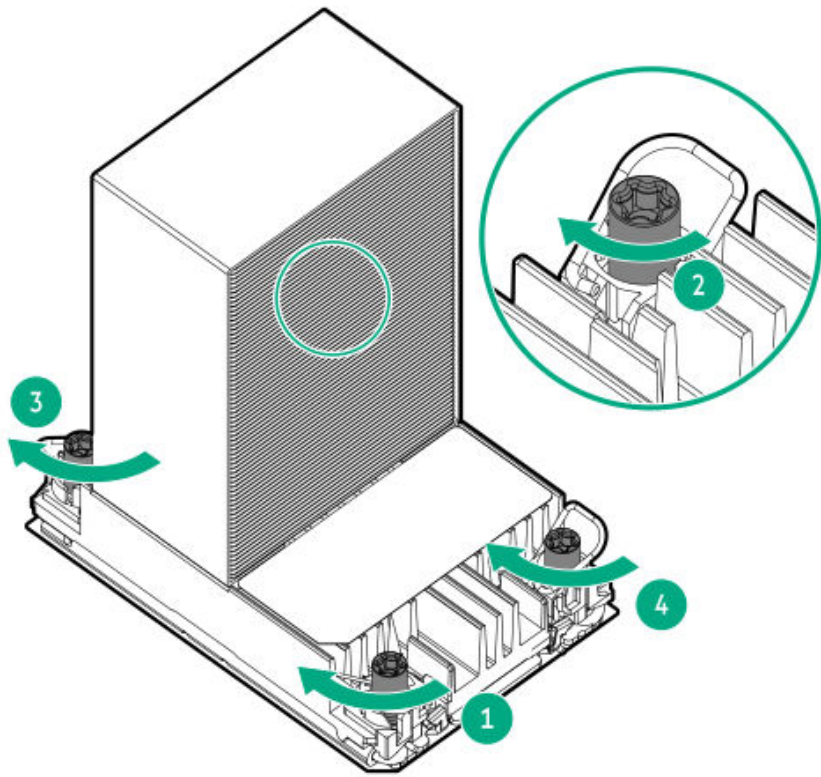

- Performance heatsink

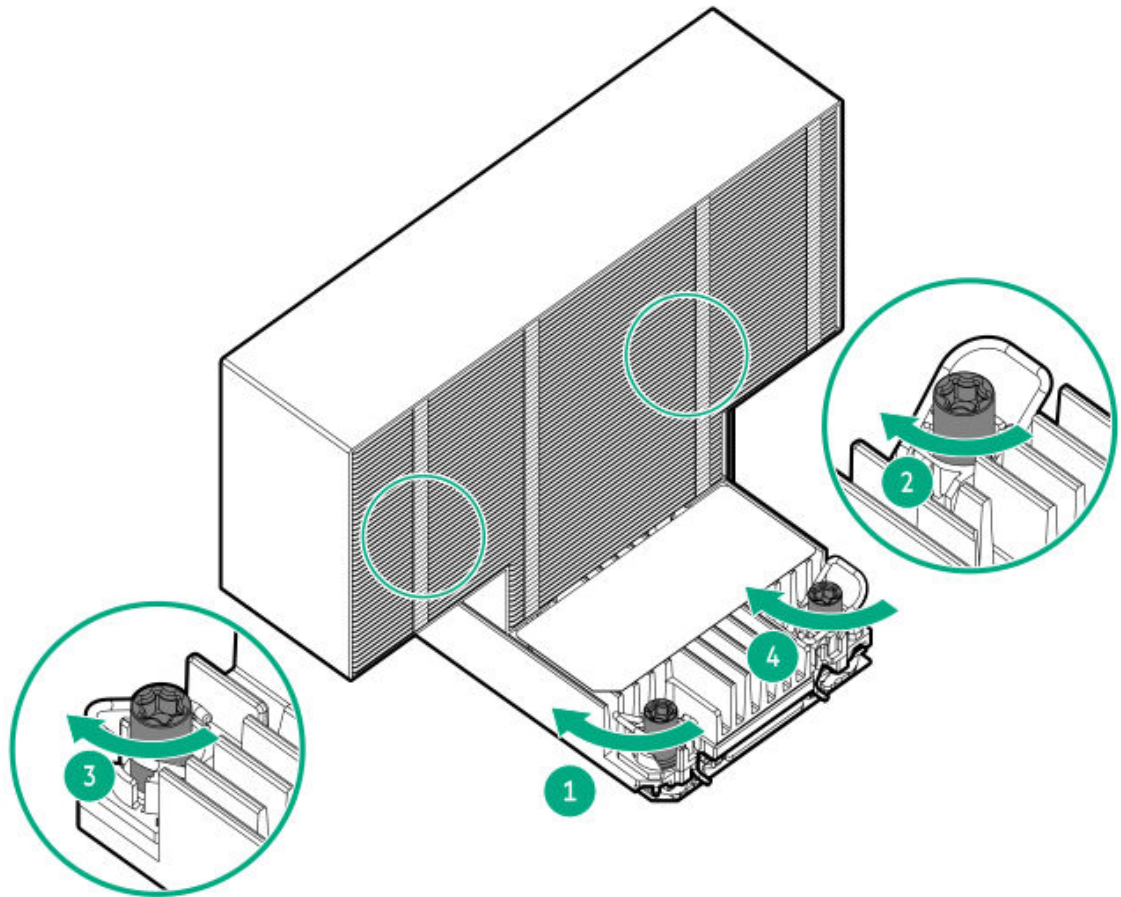

.6.



CAUTION

To prevent thermal failure or component damage, do not move the heatsink once the bottom of its base plate touches the top of the processor. Excessive heatsink movement can cause the thermal grease to smear and become uneven. Voids in the compound can adversely impact the transfer of heat away from the processor.

Install the processor-heatsink module:

- a. When using a torque wrench to tighten the heatsink screws, set 0.9 N-m (8 in-lb) of torque.
- b. Note the **Front of server** text on the heatsink label to correctly orient the processor-heatsink module over the bolster plate.
- c. Carefully lower the processor-heatsink module straight down onto the bolster plate guide posts.

The posts are keyed so that the module can only be installed one way. Make sure that the module is properly seated on the bolster plate before securing the screws.

- Standard heatsink

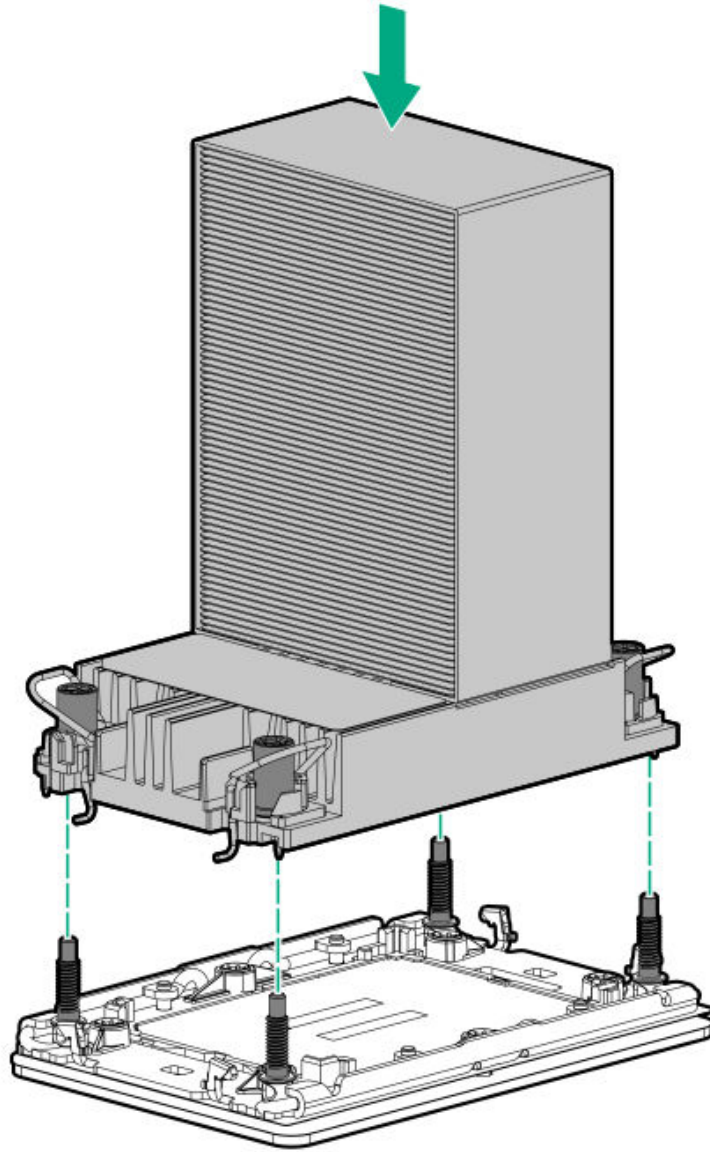

- Performance heatsink

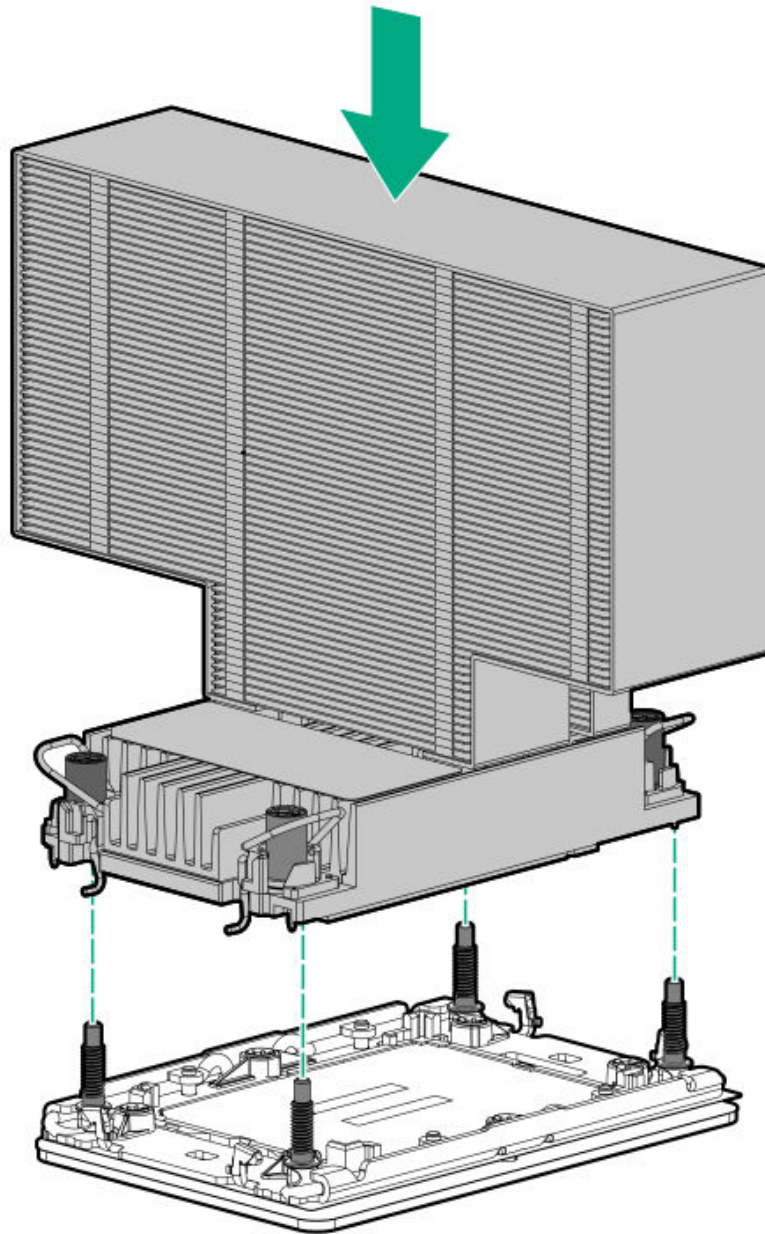

d. Set the anti-tilt wires to the locked position.

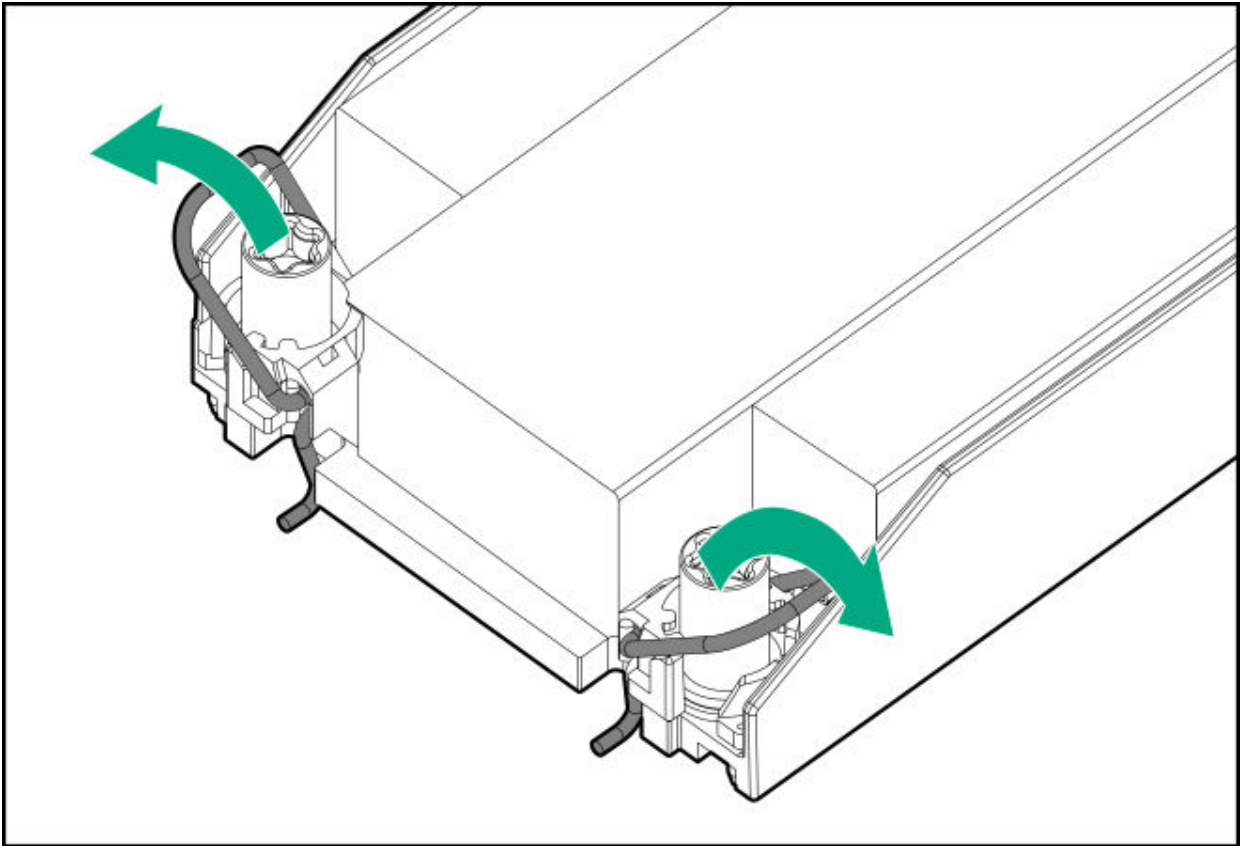

- e. Tighten one pair of diagonally opposite heatsink screws, and then tighten the other pair of heatsink screws.
- Standard heatsink

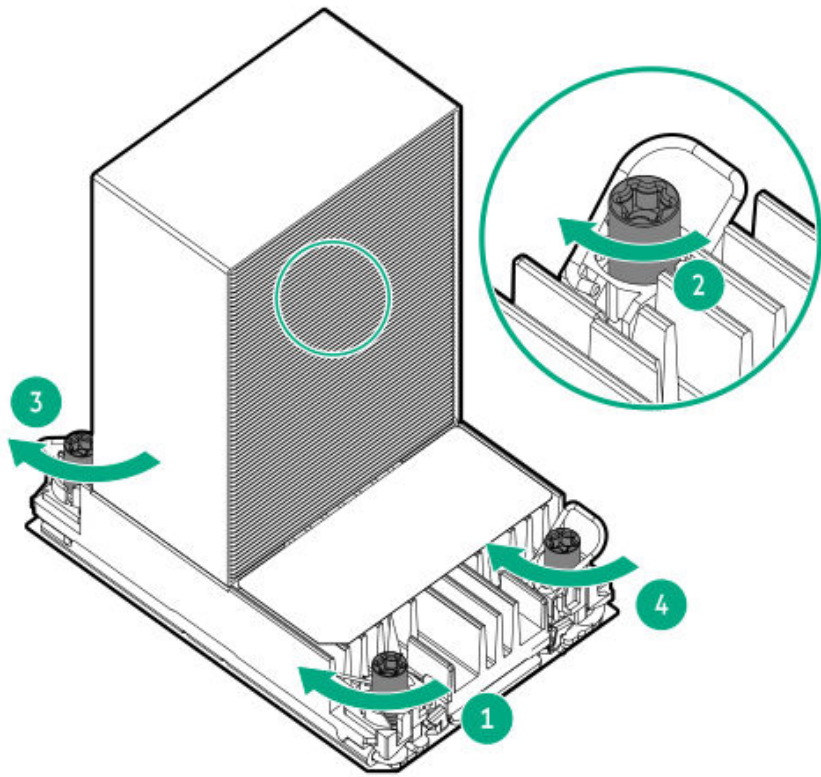

- Performance heatsink

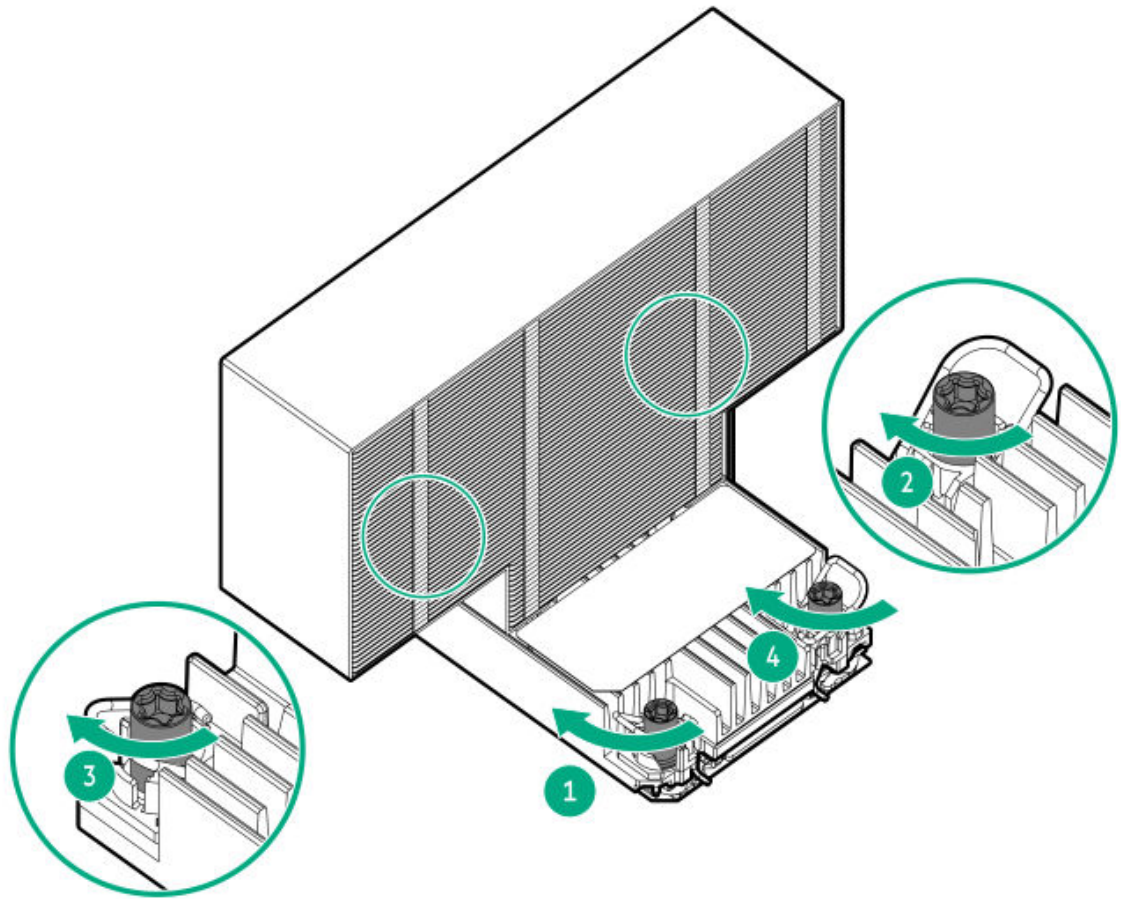

.7. If installing the performance heatsink, remove the fan cage baffle from the fan cage.

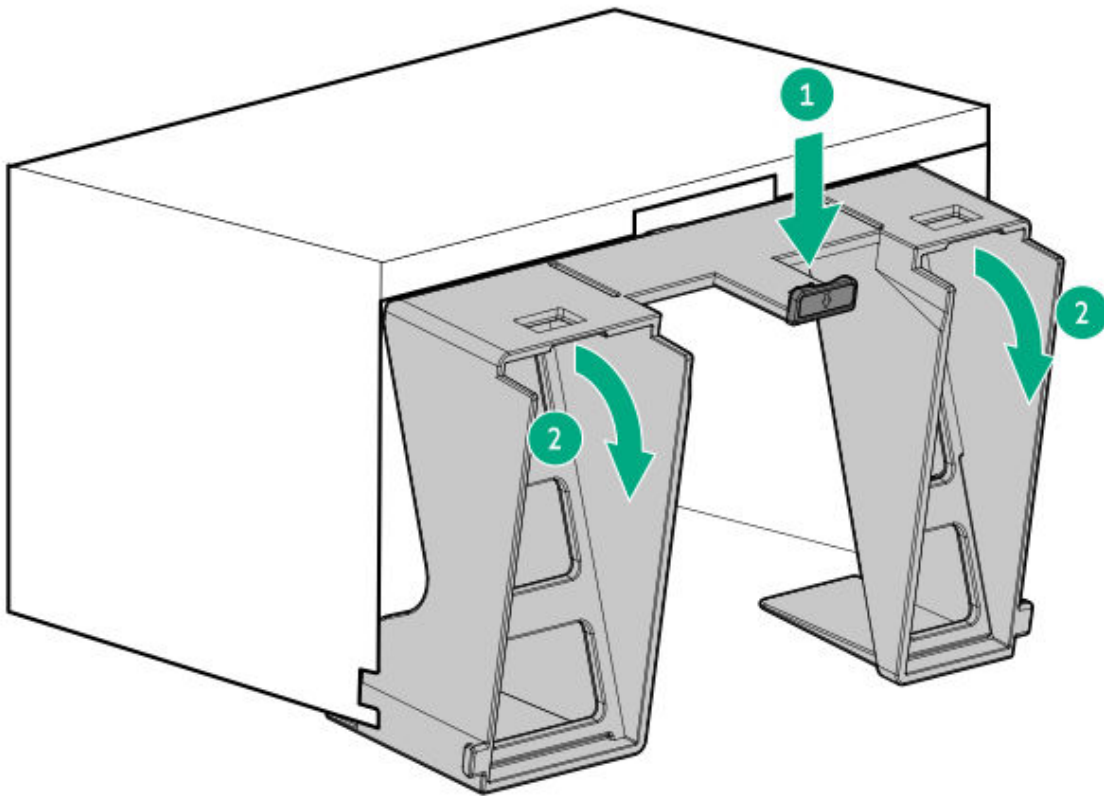

- .8. Install the fan cage.
- .9. Install the access panel.
- !0. Lock the front bezel.
- !1. Do one of the following:
 - Orient the server back in tower mode.
 - Install the server into the rack.
- !2. Connect all peripheral cables to the server.
- !3. Connect each power cord to the server.
- !4. Connect each power cord to the power source.
- !5. Power up the server.

Results

The installation procedure is complete.

Networking

Subtopics

[OCP slot population rules](#)

[Installing the OCP NIC 3.0 adapter](#)

[Installing a PCIe NIC adapter in the primary/secondary riser cage](#)

[Installing a PCIe NIC adapter in the tertiary riser](#)

OCP slot population rules

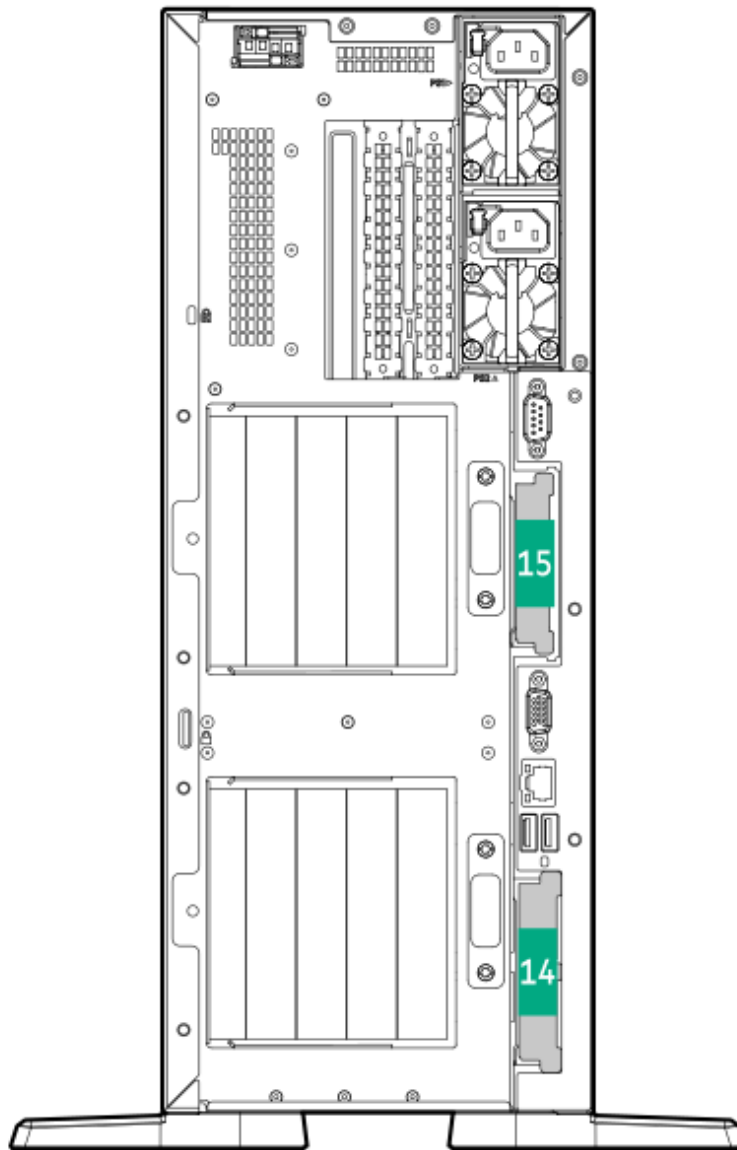

Item	Slot number	Supported hardware components
14	Slot 14 OCP A PCIe5 x8/x16	Type-o storage controller OCP NIC adapter
15	Slot 15 OCP B PCIe5 x8/x16 ¹ _—	OCP NIC adapter

¹_— When installing a single OCP NIC 3.0 adapter, install it in OCP slot B.

Installing the OCP NIC 3.0 adapter

Prerequisites

- Review the [OCP slot population rules](#).
- Before you install an OCP NIC 3.0 adapter in OCP slot 15, make sure that [the server is in a dual-processor configuration](#).
- Before you perform this procedure, make sure that you have the following items available:
 - T-10 Torx screwdriver
 - If you are installing an OCP NIC 3.0 x8 adapter in Slot 15 OCP B, the P72203-B21 OCP bandwidth enablement cable kit is required.
 - If you are installing an OCP NIC 3.0 x16 adapter, the following OCP bandwidth upgrade cable options are required:
 - Slot 14 OCP A: P72201-B21
 - Slot 15 OCP B: P72207-B21
- Before you perform this procedure, make sure that you have a T-10 Torx screwdriver available.

About this task



CAUTION

A discharge of static electricity from a finger or other conductor might damage system boards or other static-sensitive devices. To prevent damage, observe antistatic precautions.



CAUTION

The port blank provides EMI shielding and helps maintain proper thermal status inside the server. Do not operate the server when a port blank is removed without the corresponding I/O port option installed.

Procedure

1. Power down the server.
2. Remove all power:
 - a. Disconnect each power cord from the power source.
 - b. Disconnect each power cord from the server.
3. Disconnect all peripheral cables from the server.
4. Do one of the following:
 - If the server is in tower mode, place the server on a flat, level surface with the access panel facing up.
 - If the server is in rack mode, remove the server from the rack.
5. Unlock the front bezel.
6. Remove the access panel.
7. If installing an OCP adapter in Slot 14, remove the primary riser cage.
8. If installing an OCP adapter in Slot 15, and the secondary riser cage is installed, remove the secondary riser cage.
9. Remove the OCP slot blank:
 - a. Remove the blank screw.
 - b. Use a plastic spudger to pry the top side of the blank from the chassis.
 - c. Remove the blank.

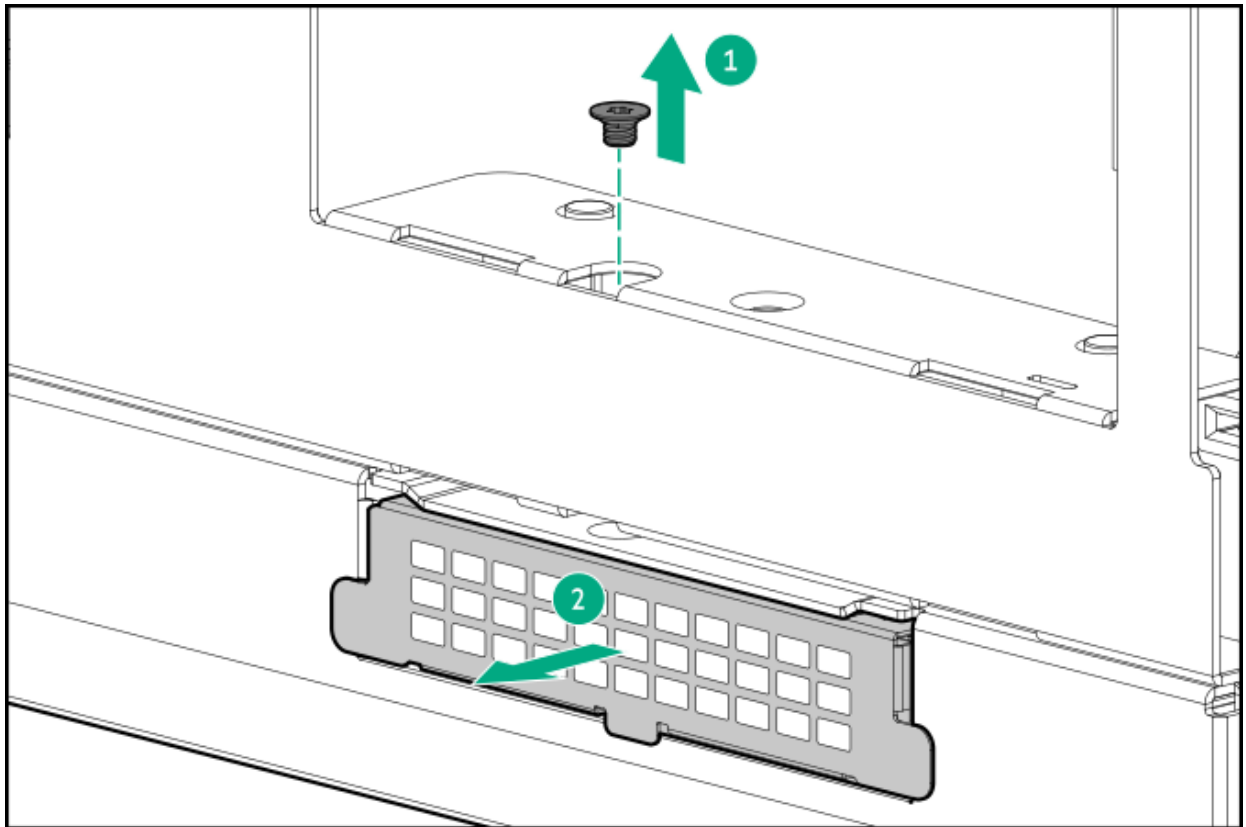

.0. Install the OCP NIC:

- a. Rotate the locking pin to the open (vertical) position.
- b. Slide the OCP NIC into the bay until it clicks into place.
Ensure that the OCP NIC is seated firmly in the slot.
- c. Rotate the locking pin to the close (horizontal) position.

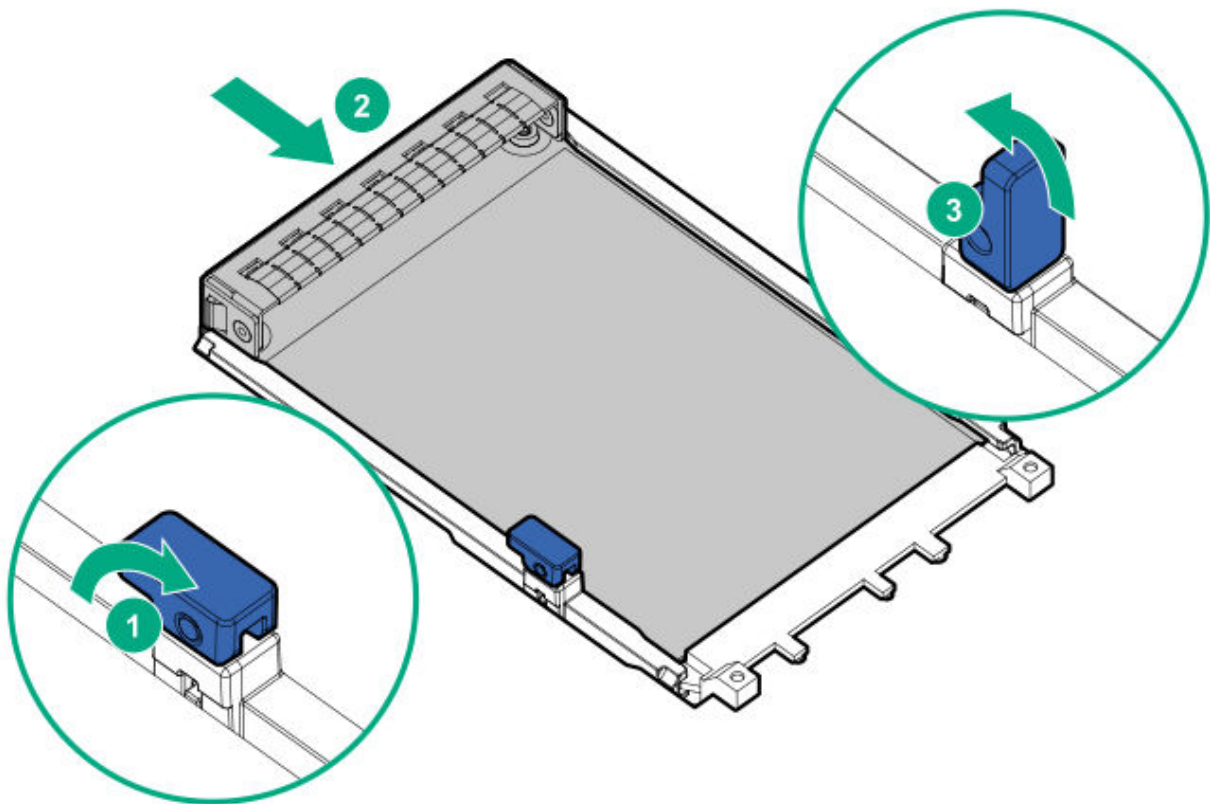

- .1. Install the necessary OCP bandwidth cable option.
- .2. If removed, install the riser cage.
- .3. Install the access panel.
- .4. Do one of the following:
 - Orient the server back in tower mode.
 - Install the server into the rack.
- .5. Connect all peripheral cables to the server.
- .6. Connect each power cord to the server.
- .7. Connect each power cord to the power source.
- .8. Power up the server.

Results

The installation procedure is complete.

Installing a PCIe NIC adapter in the primary/secondary riser cage

Prerequisites

- When installing a GPU, review the [GPU installation guidelines](#).
- Before you perform this procedure, make sure that you have a T-10 Torx screwdriver available.

About this task



CAUTION

A discharge of static electricity from a finger or other conductor might damage system boards or other static-sensitive devices. To prevent damage, observe [antistatic precautions](#).



CAUTION

To prevent improper cooling and thermal damage, do not operate the server unless all PCIe slots have either a riser slot blank or an expansion card installed.

Procedure

1. [Power down the server](#).
2. Remove all power:
 - a. Disconnect each power cord from the power source.
 - b. Disconnect each power cord from the server.
3. Disconnect all peripheral cables from the server.
4. Do one of the following:
 - If the server is in tower mode, [place the server on a flat, level surface with the access panel facing up](#).
 - If the server is in rack mode, [remove the server from the rack](#).
5. Unlock the front bezel.
6. [Remove the access panel](#).
7. Do one of the following:
 - [Remove the primary riser cage](#).
 - If installed, [remove the secondary riser cage](#).
8. Remove the riser slot blank:

- a. Simultaneously push and rotate to open the riser cage latch.
- b. Remove the screw and the riser slot blank.

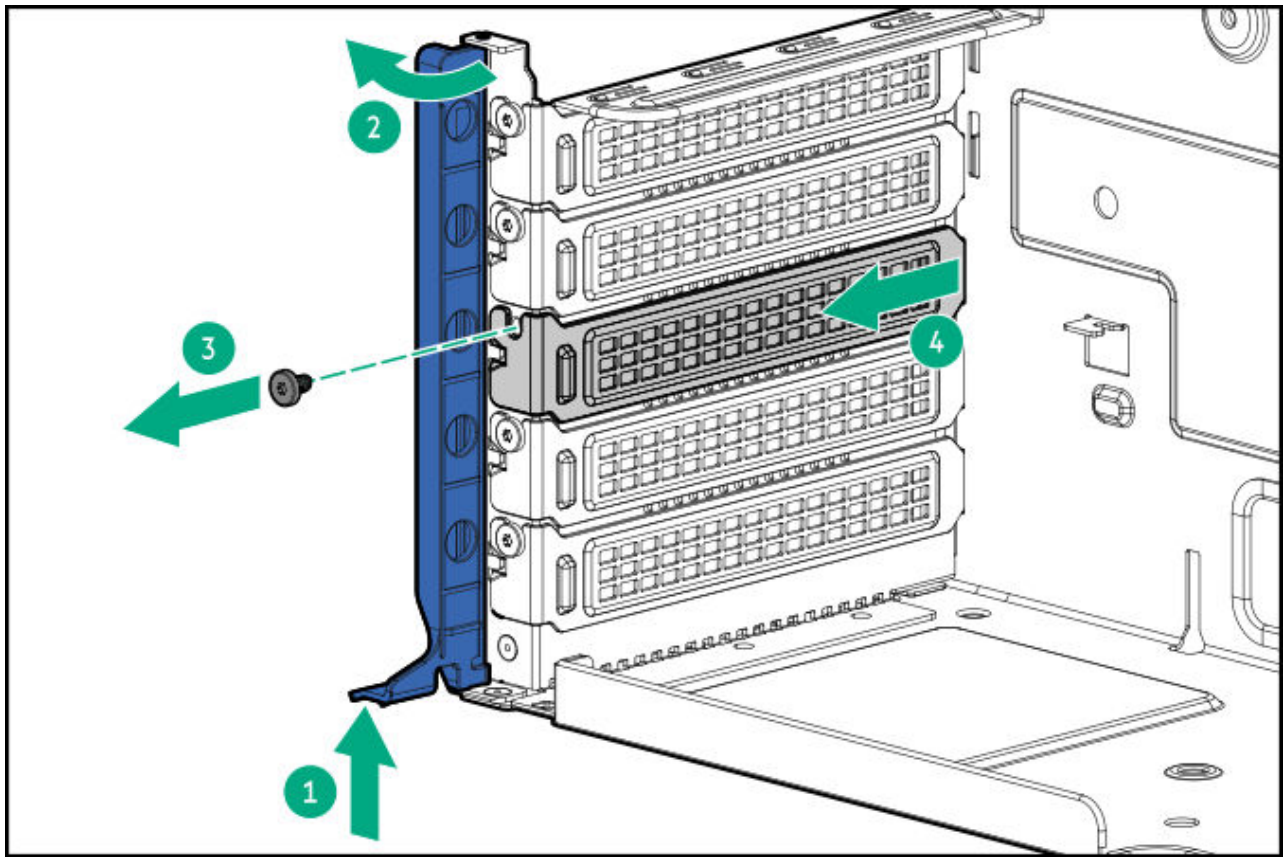

9. Make sure that any switches or jumpers on the expansion card are set properly.
For more information, see the documentation that ships with the expansion card option.
10. Install the expansion card:
 - a. Install the expansion card, and install the screw.
Make sure that the expansion card is seated firmly in the slot.
 - b. Simultaneously push and rotate to close the riser cage latch.

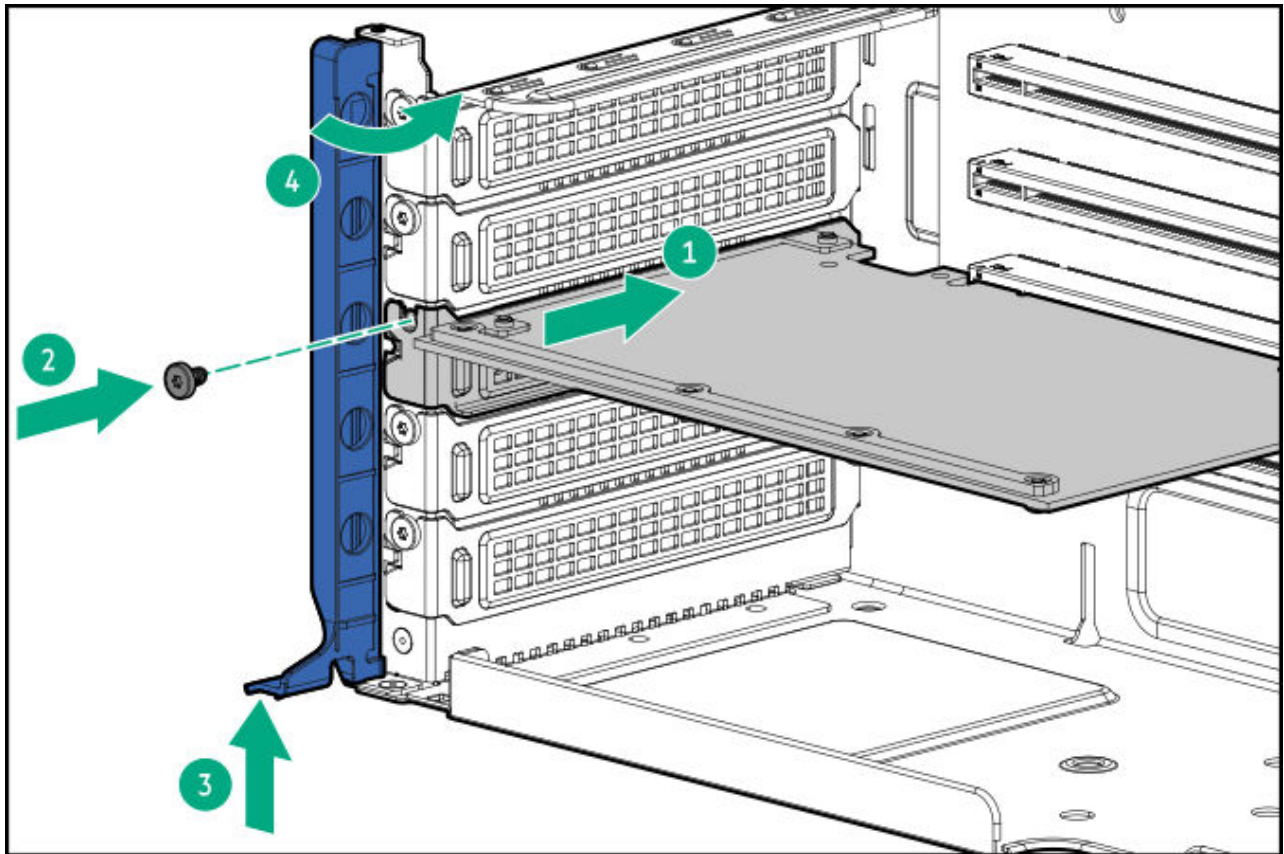

- .1. Connect all necessary internal cabling to the expansion card.
If a high power GPU is installed, connect the GPU auxiliary power cable.
- .2. Install the riser cage.
- .3. Install the access panel.
- .4. Lock the front bezel.
- .5. Do one of the following:
 - Orient the server back in tower mode.
 - Install the server into the rack.
- .6. Connect all peripheral cables to the server.
- .7. Connect each power cord to the server.
- .8. Connect each power cord to the power source.
- .9. Power up the server.

Results

The installation procedure is complete.

Installing a PCIe NIC adapter in the tertiary riser

Prerequisites

- Make sure that the server is in a dual-processor configuration.
- Before you perform this procedure, make sure that you have the following items available:
 - T-10 Torx screwdriver
 - Phillips No. 1 screwdriver

About this task



CAUTION

A discharge of static electricity from a finger or other conductor might damage system boards or other static-sensitive devices. To prevent damage, observe antistatic precautions.



CAUTION

To prevent improper cooling and thermal damage, do not operate the server unless all PCIe slots have either a riser slot blank or an expansion card installed.

Procedure

1. Power down the server.
2. Remove all power:
 - a. Disconnect each power cord from the power source.
 - b. Disconnect each power cord from the server.
3. Disconnect all peripheral cables from the server.
4. Do one of the following:
 - If the server is in tower mode, place the server on a flat, level surface with the access panel facing up.
 - If the server is in rack mode, remove the server from the rack.
5. Unlock the front bezel.
6. Remove the access panel.

7. If installed, remove the boot device.
8. If installed, remove the energy pack and the energy pack holder.
9. (Optional) Install the tertiary riser.
0. Remove the tertiary riser slot cover.

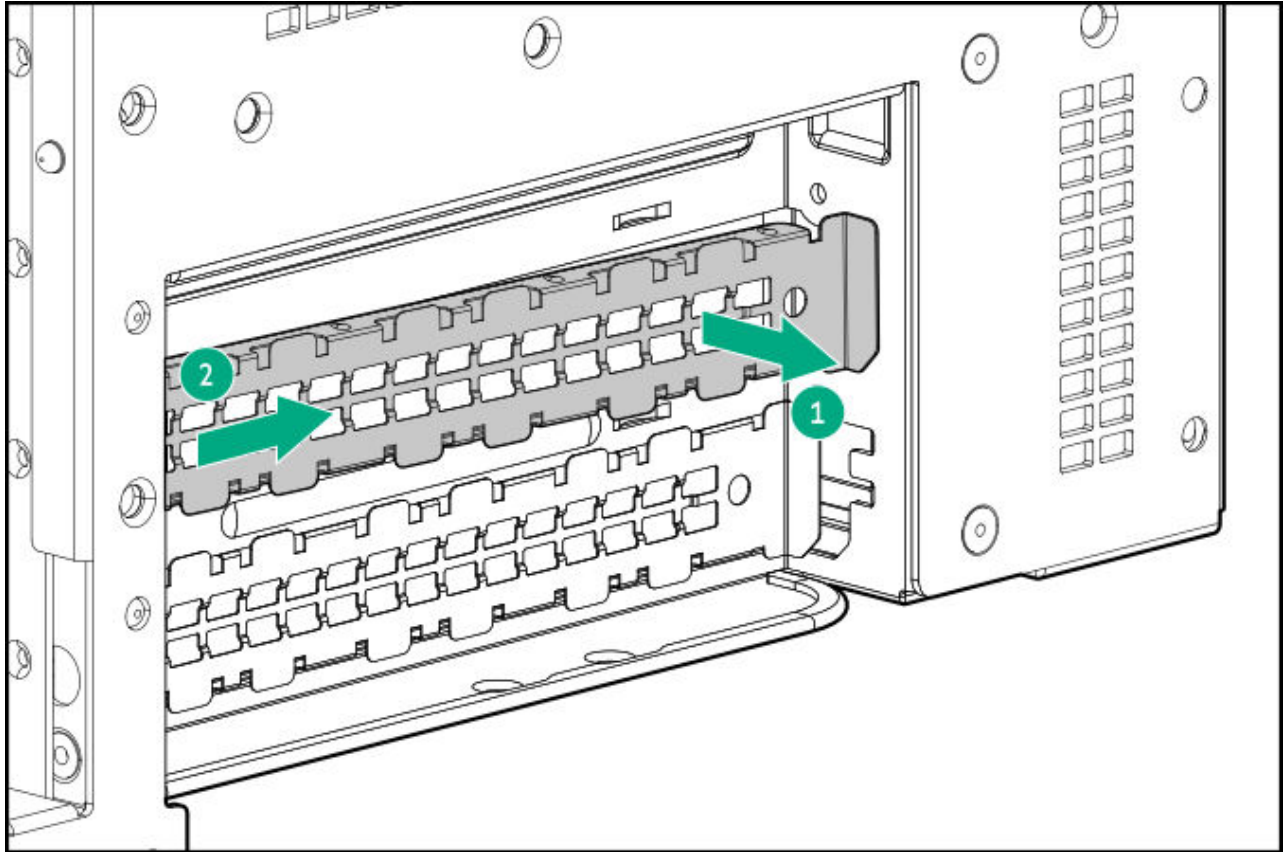

- .1. Make sure that any switches or jumpers on the expansion card are set properly.

For more information, see the documentation that ships with the expansion card option.

- .2. Install the expansion card.

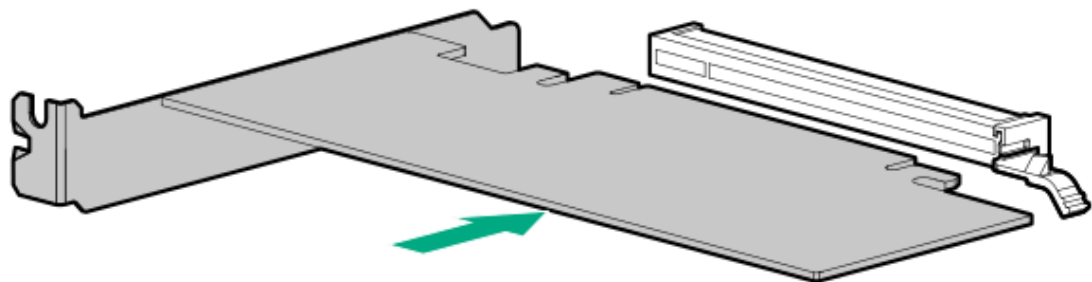

- .3. Install the stabilizer bracket to secure the expansion card:
 - a. Press down the stabilizer bracket onto the expansion card.
 - b. Tighten the captive screw.

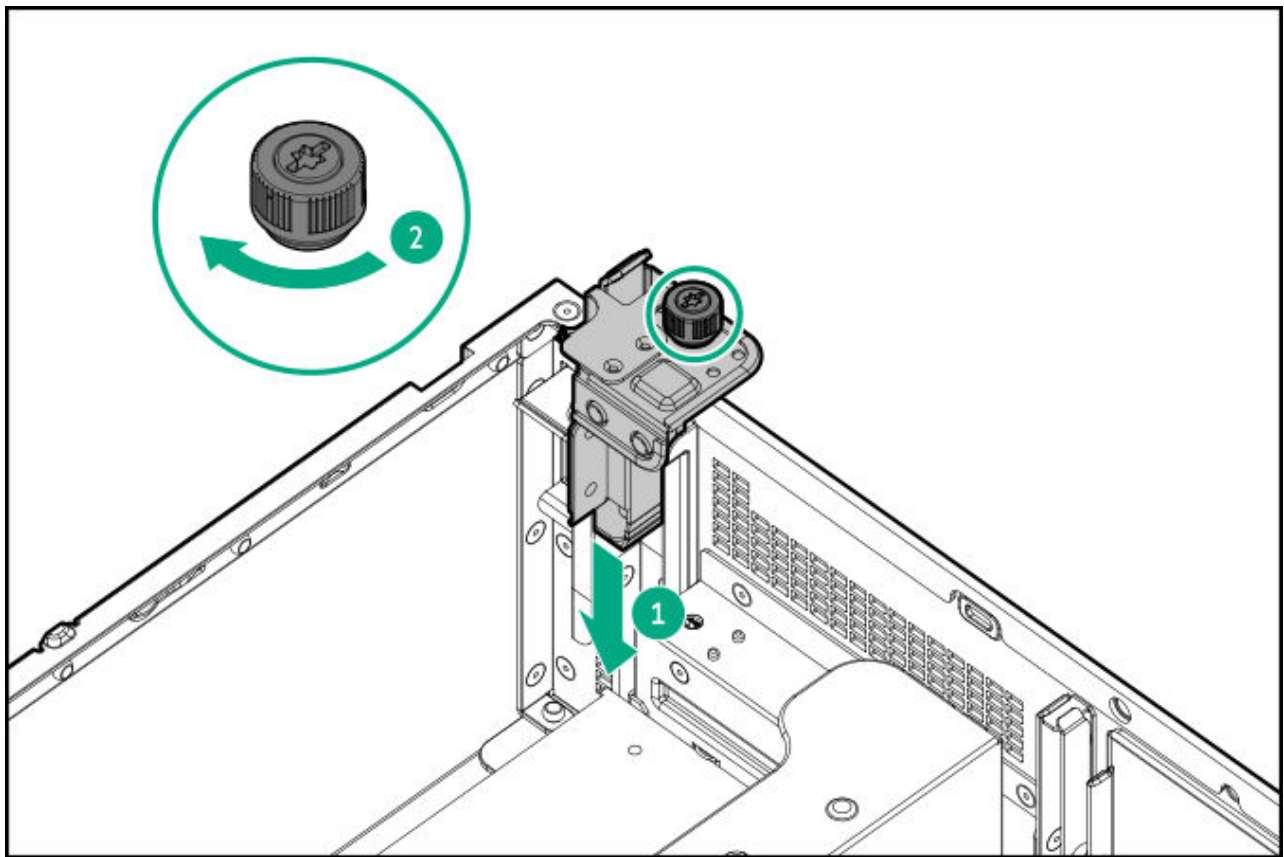

- .4. Connect all necessary internal cabling to the expansion card.
For more information on these cabling requirements, see the documentation that ships with the option.
- .5. Install the energy pack holder.

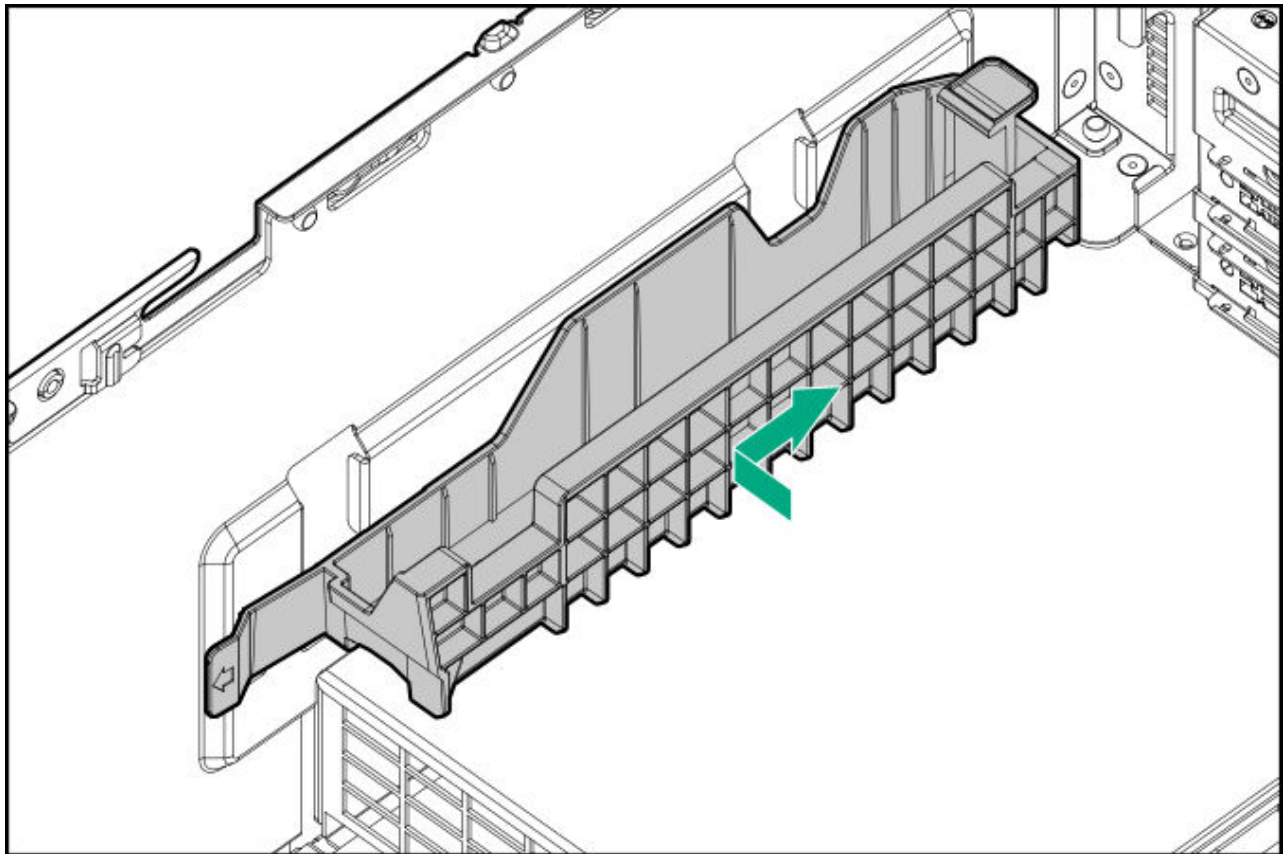

- .6. If removed, install the following components:
 - [The energy pack](#)
 - [The boot device](#)
- .7. [Install the access panel.](#)
- .8. Lock the front bezel.
- .9. Do one of the following:
 - [Orient the server back in tower mode.](#)
 - [Install the server into the rack.](#)
- !0. Connect all peripheral cables to the server.
- !1. Connect each power cord to the server.
- !2. Connect each power cord to the power source.
- !3. [Power up the server.](#)

Results

The installation procedure is complete.

OS boot device

Subtopics

HPE NS204i-u Boot Device V2 option

Installing the boot device in the front panel

Installing the boot device in the rear panel

HPE NS204i-u Boot Device V2 option

Note the following information about the HPE NS204i-u Boot Device V2 option:

- The HPE NS204i-u Boot Device V2 is a PCIe5 custom form factor module that includes two hot-pluggable 2280 M.2 NVMe SSDs.
- This boot device enables the deployed OS to be mirrored through a dedicated hardware RAID 1.
- The boot device auto-creates a RAID 1 volume during boot. This means the boot device does not require further RAID configuration.
- This boot device is compatible with the following native OS:
 - Windows
 - Linux
 - VMware
- This boot device uses native inbox OS NVMe drivers.

Installing the boot device in the front panel

Prerequisites

- Verify that your OS or virtualization software is supported:
<https://www.hpe.com/support/Servers-Certification-Matrices>
- Verify that you are running the latest iLO firmware and server BIOS version.
- Verify that fan 1 is installed.

The second processor CPU fan kit (P47902-B21) is required.

- Identify the HPE NS204i-u Boot Device V2 components.
- Before you perform this procedure, make sure that you have the following items available:
 - NS204i-u enablement option kit (P74252-B21)
 - T-10 Torx screwdriver
 - T-15 Torx screwdriver
 - Phillips No. 1 screwdriver

About this task



CAUTION

A discharge of static electricity from a finger or other conductor might damage system boards or other static-sensitive devices. To prevent damage, observe antistatic precautions.



CAUTION

To prevent improper cooling and thermal damage, do not operate the server unless all bays are populated with either a component or a blank.



IMPORTANT

For successful RAID 1 configuration, verify that the boot device SSDs have the same model number and firmware version:

- In the iLO web interface, see the **Storage** page.
- In UEFI System Utilities, see **System Configuration > HPE NS204i Boot Controller > Physical Device Information**.

Configurations with SSDs from different manufacturers are not supported.

Procedure

1. Power down the server.
2. Remove all power:
 - a. Disconnect each power cord from the power source.
 - b. Disconnect each power cord from the server.
3. Disconnect all peripheral cables from the server.

4. Do one of the following:
 - If the server is in tower mode, place the server on a flat, level surface with the access panel facing up.
 - If the server is in rack mode, remove the server from the rack.
5. Unlock the front bezel.
6. Remove the access panel.
7. Remove the fan cage.
8. If installed, remove the drive cage from box 1.
9. Remove the boot device cage blank.

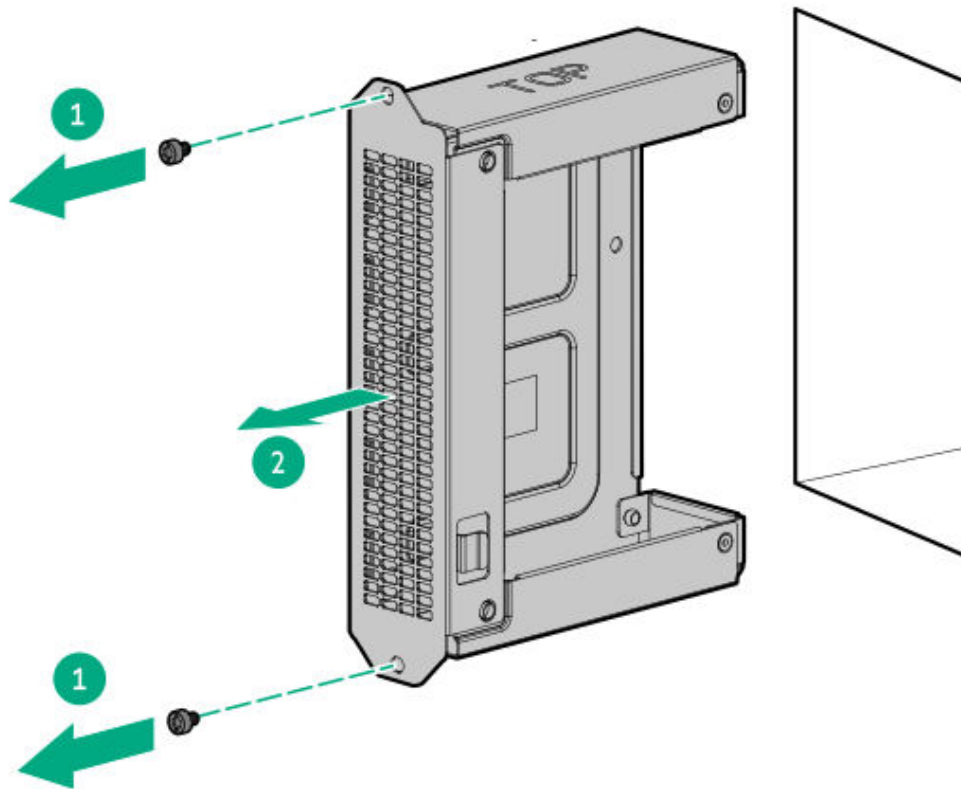

10. Remove the baffle from the boot device cage.

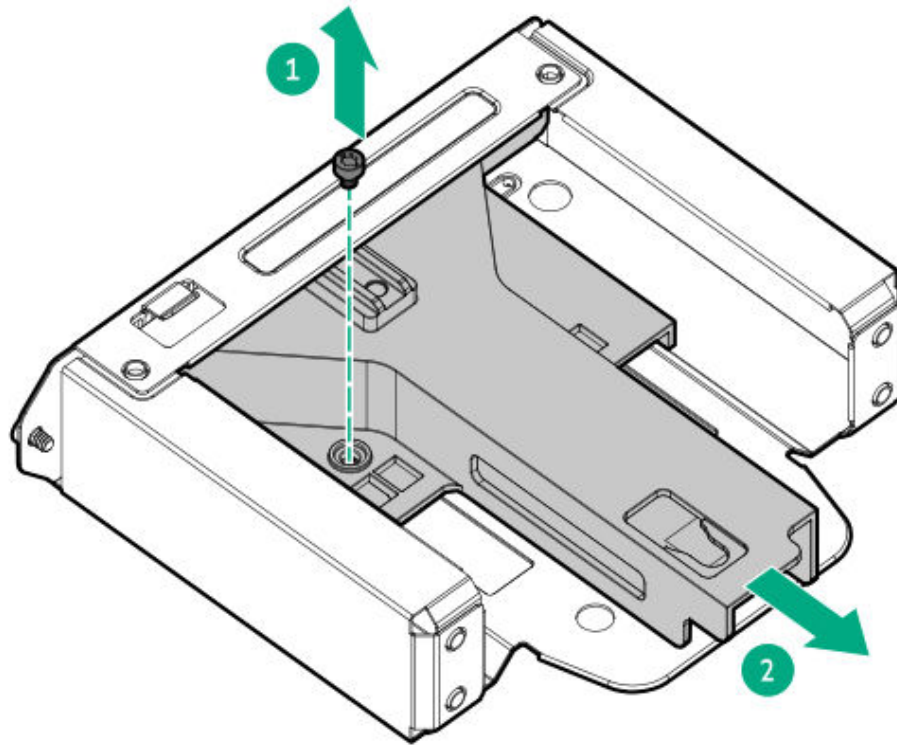

.1. Install the baffle onto the boot device.

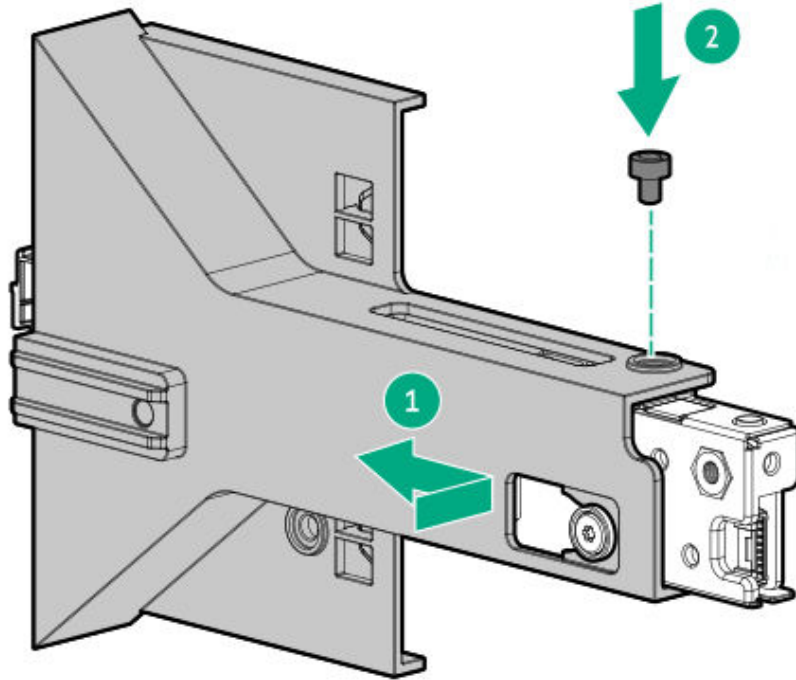

.2. Install the boot device onto the cage.

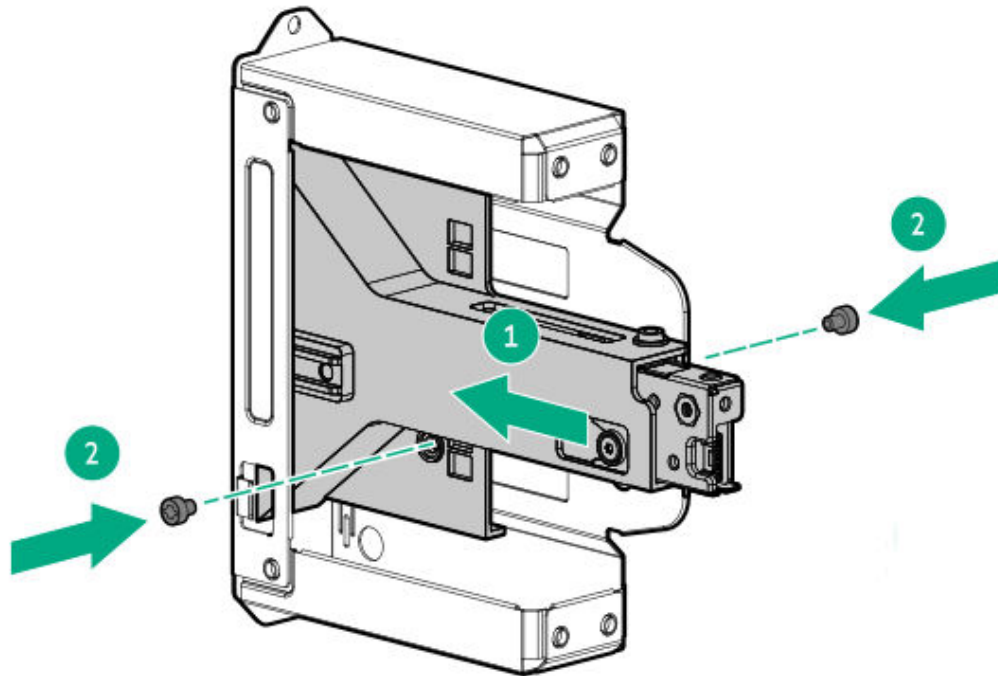

- .3. Connect the SlimSAS signal and power cables to the boot device.
- .4. Install the cage into the server.

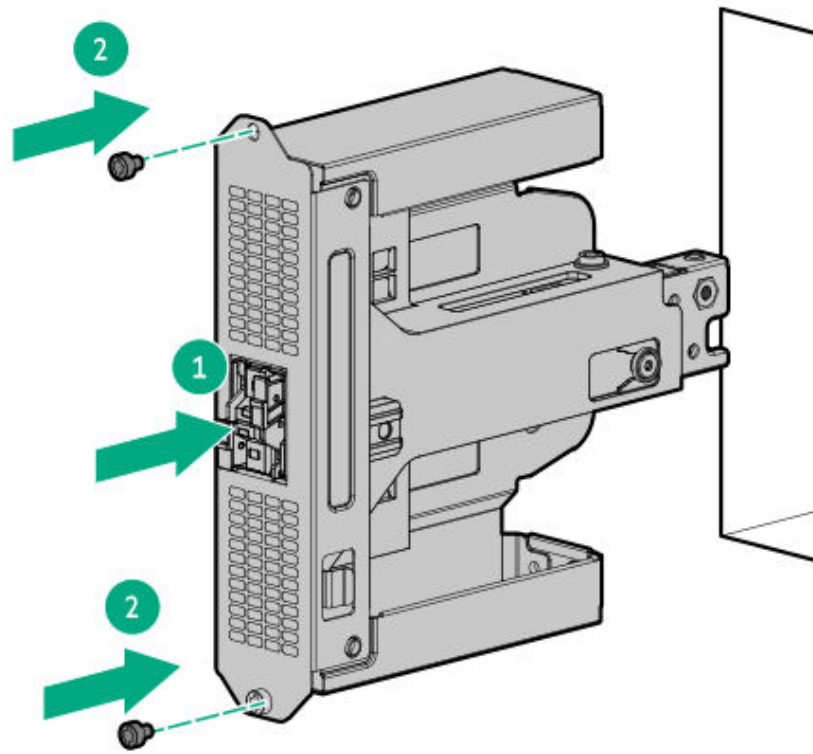

- .5. Connect the boot device signal and power cables to the system board.
- .6. Install the access panel.
- .7. Lock the front bezel.
- .8. Do one of the following:
 - Orient the server back in tower mode.
 - Install the server into the rack.
- .9. Connect all peripheral cables to the server.
- !0. Connect each power cord to the server.
- !1. Connect each power cord to the power source.
- !2. Power up the server.
- !3. Verify that the Online/Activity LEDs on the boot device are solid green.
- !4. Deploy a supported operating system to the boot device.
- !5. After the OS installation completes, the system automatically copies the operating system to the second, mirrored drive on the boot device.

Proceed with normal system setup and operation.

Results

The installation procedure is complete.

Installing the boot device in the rear panel

Prerequisites

- Verify that your OS or virtualization software is supported:

<https://www.hpe.com/support/Servers-Certification-Matrices>

- Verify that you are running the latest iLO firmware and server BIOS version.
- Verify that fan 1 is installed.
The second processor CPU fan kit (P47902-B21) is required.
- Identify the HPE NS204i-u Boot Device V2 components.
- Before you perform this procedure, make sure that you have the following items available:
 - NS204i-u enablement option kit (P72360-B21)
 - T-10 Torx screwdriver
 - T-15 Torx screwdriver
 - Phillips No. 1 screwdriver

About this task



CAUTION

A discharge of static electricity from a finger or other conductor might damage system boards or other static-sensitive devices. To prevent damage, observe antistatic precautions.



CAUTION

To prevent improper cooling and thermal damage, do not operate the server unless all bays are populated with either a component or a blank.



IMPORTANT

For successful RAID 1 configuration, verify that the boot device SSDs have the same model number and firmware version:

- In the iLO web interface, see the **Storage** page.
- In UEFI System Utilities, see **System Configuration > HPE NS204i Boot Controller > Physical Device Information**.

Configurations with SSDs from different manufacturers are not supported.

Procedure

1. Power down the server.
2. Remove all power:
 - a. Disconnect each power cord from the power source.
 - b. Disconnect each power cord from the server.
3. Disconnect all peripheral cables from the server.
4. Do one of the following:
 - If the server is in tower mode, place the server on a flat, level surface with the access panel facing up.
 - If the server is in rack mode, remove the server from the rack.
5. Unlock the front bezel.
6. Remove the access panel.
7. Install the boot device latch:
 - a. Insert the boot device latch on the boot device.

- b. Install the latch screw provided in the accessory bag.

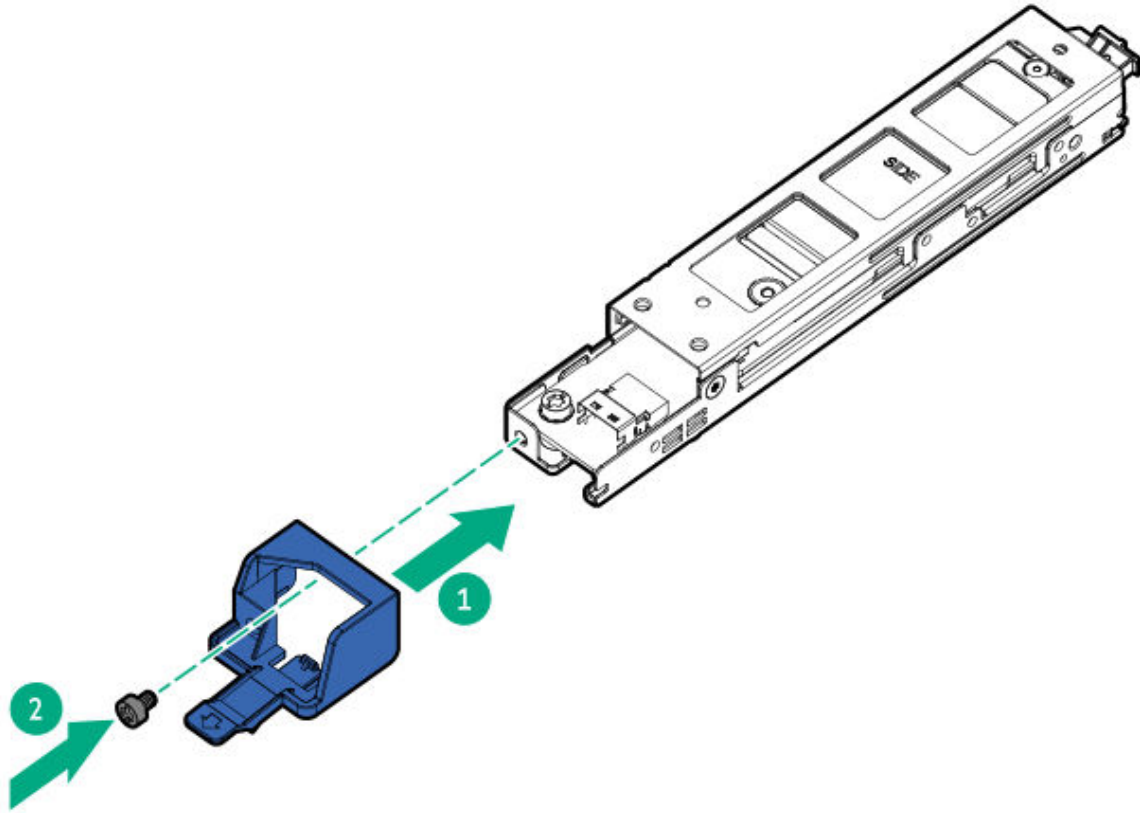

8. Install the boot device baffle:

- a. Install the baffle on top of the boot device.
- b. Install the boot device baffle screws provided in the accessory bag.

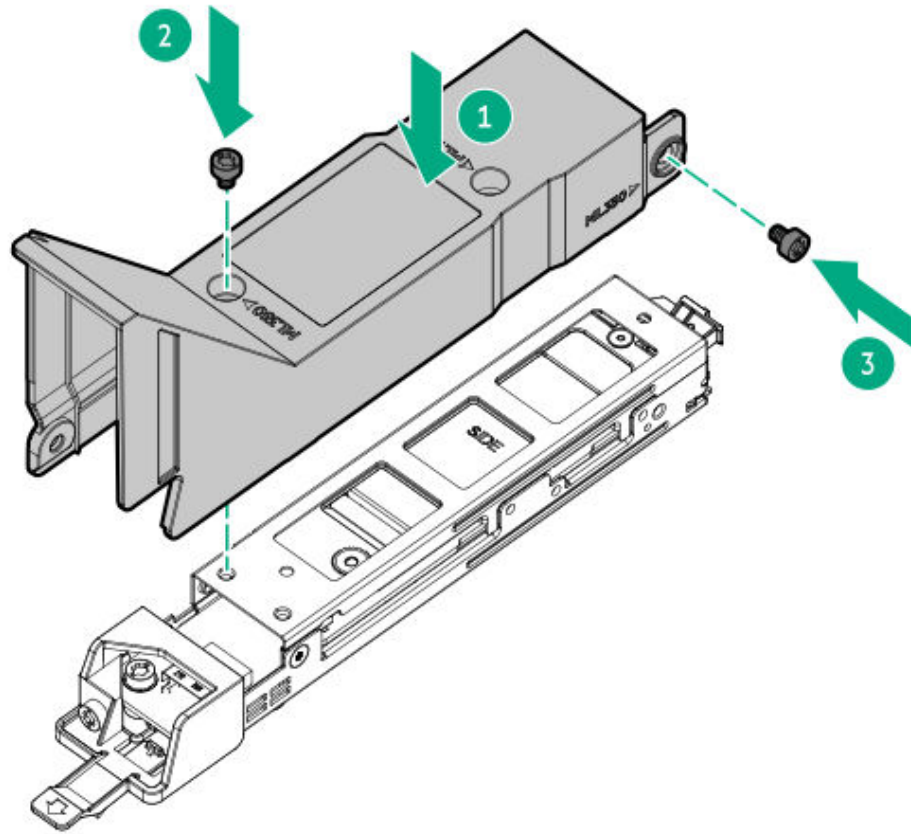

9. Connect the SlimSAS signal and power cables to the boot device.
10. To allow hot-plug access to the SSDs on the boot device, remove the blank.

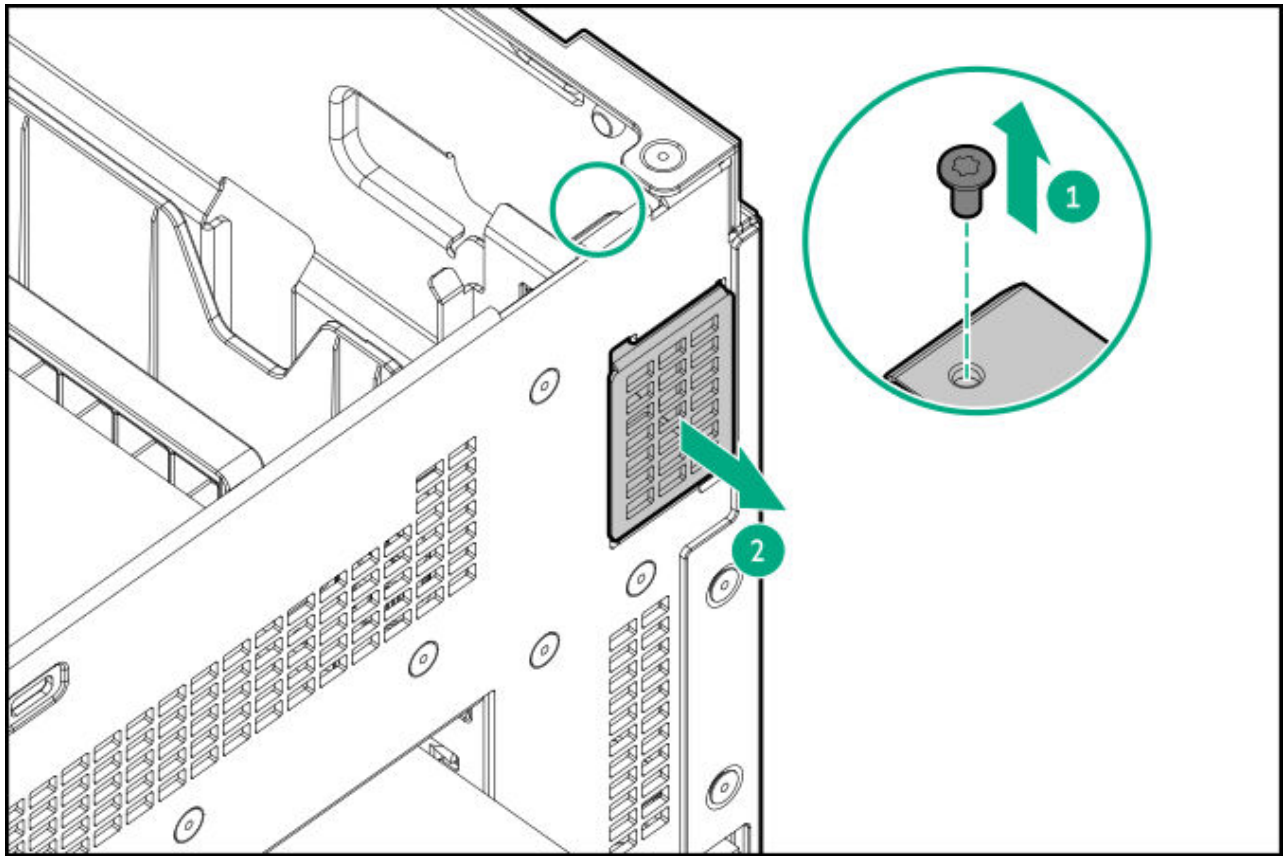

1. Align the pins on the boot device with holes on the chassis side wall to slide the boot device.

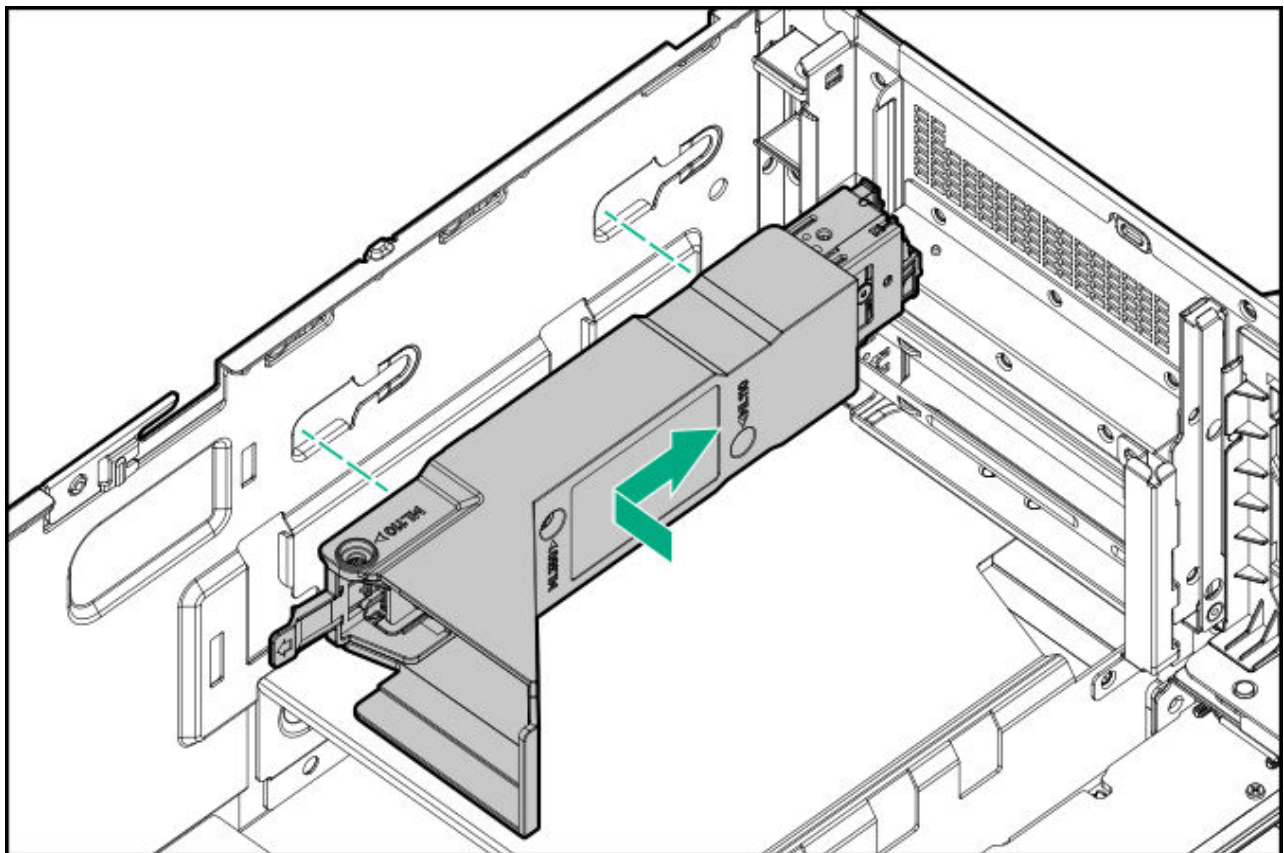

- .2. Connect the boot device signal and power cables to the system board.
- .3. Install the access panel.
- .4. Lock the front bezel.
- .5. Do one of the following:
 - Orient the server back in tower mode.
 - Install the server into the rack.
- .6. Connect all peripheral cables to the server.
- .7. Connect each power cord to the server.
- .8. Connect each power cord to the power source.
- .9. Power up the server.
- !0. Verify that the Online/Activity LEDs on the boot device are solid green.
- !1. Deploy a supported operating system to the boot device.
- !2. After the OS installation completes, the system automatically copies the operating system to the second, mirrored drive on the boot device.

Proceed with normal system setup and operation.

Results

The installation procedure is complete.

Security

Subtopics

Installing the chassis intrusion detection switch

Installing the chassis intrusion detection switch

Procedure

1. Power down the server.
2. Remove all power:
 - a. Disconnect each power cord from the power source.
 - b. Disconnect each power cord from the server.
3. Disconnect all peripheral cables from the server.
4. Do one of the following:
 - If the server is in tower mode, place the server on a flat, level surface with the access panel facing up.
 - If the server is in rack mode, remove the server from the rack.
5. Unlock the front bezel.
6. Remove the access panel.
7. Install the chassis intrusion detection switch:
 - a. Insert the switch tab into the chassis slot until the switch clicks into place.
 - b. Connect the switch cable and secure it in the cable clamp.

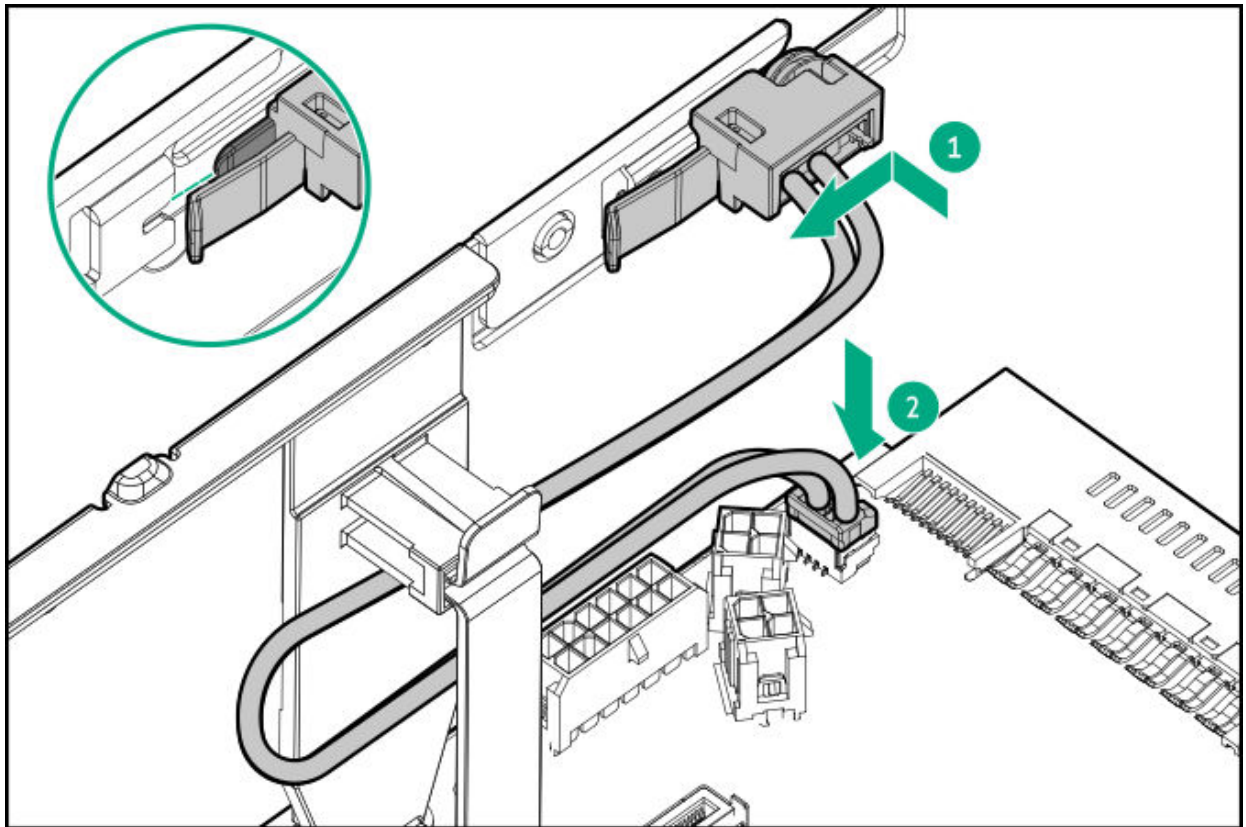

8. Install the access panel.
9. Lock the front bezel.
0. Do one of the following:
 - Orient the server back in tower mode.
 - Install the server into the rack.
- .1. Connect all peripheral cables to the server.
- .2. Connect each power cord to the server.
- .3. Connect each power cord to the power source.
- .4. Power up the server.

Results

The installation procedure is complete.

Storage controllers

Subtopics

[Preparing the server for storage controller installation](#)

[Installing a type-p storage controller](#)

[Installing a type-o storage controller](#)

Preparing the server for storage controller installation

Prerequisites

Before beginning this procedure, download the Service Pack for HPE ProLiant from the Hewlett Packard Enterprise website (<https://www.hpe.com/servers/spp/download>).

Procedure

1. If the server was previously configured:
 - a. [Back up data on the system.](#)
 - b. Close all applications.
 - c. Ensure that users are logged off and that all tasks are completed on the server.



CAUTION

In systems that use external data storage, be sure that the server is the first unit to be powered down and the last to be powered back up. Taking this precaution ensures that the system does not erroneously mark the drives as failed when the server is powered up.

2. If the server firmware is not the latest revision, [update the firmware.](#)
3. If the new controller is the new boot device, [install the controller drivers.](#)

Installing a type-p storage controller

Prerequisites

- To enable the flash-backed write cache (FBWC) feature of a storage controller option, install an energy pack.

For more information on the controller caching feature, see the controller QuickSpecs on the Hewlett Packard Enterprise website (<https://www.hpe.com/info/qs>).

- Before you perform this procedure, make sure that you have the following items available:
 - Compatible controller cable
 - T-10 Torx screwdriver

About this task



CAUTION

A discharge of static electricity from a finger or other conductor might damage system boards or other static-sensitive devices. To prevent damage, observe antistatic precautions.

Procedure

1. Power down the server.
2. Remove all power:
 - a. Disconnect each power cord from the power source.
 - b. Disconnect each power cord from the server.
3. Disconnect all peripheral cables from the server.
4. Do one of the following:
 - If the server is in tower mode, place the server on a flat, level surface with the access panel facing up.
 - If the server is in rack mode, remove the server from the rack.
5. Unlock the front bezel.
6. Remove the access panel.
7. Do one of the following:
 - Remove the primary riser cage.

- Remove the secondary riser cage.

8. Remove the riser slot blank.

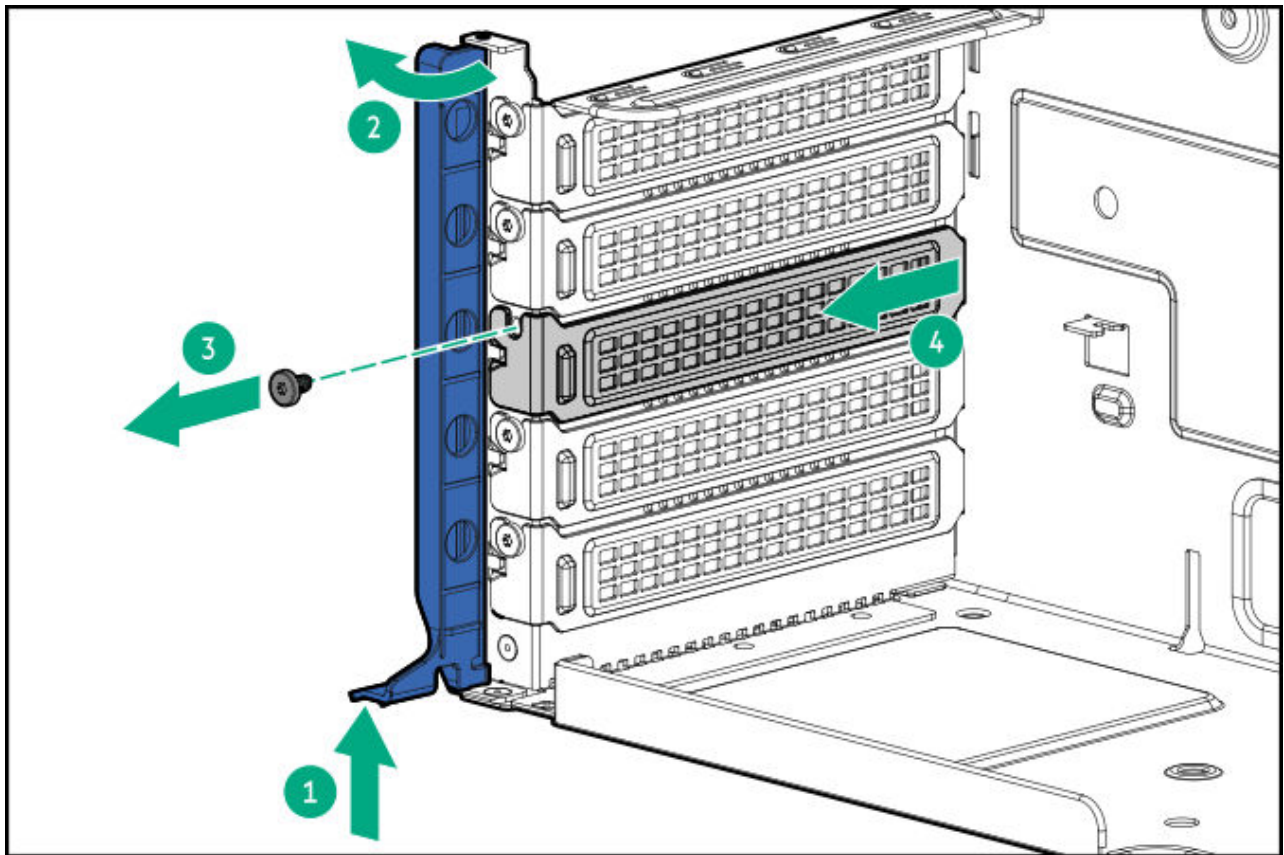

9. Install the type-p storage controller:

- a. Install the type-p storage controller, and install the screw.

Make sure that the controller is seated firmly in the slot.

- b. Simultaneously push and rotate to close the riser cage latch.

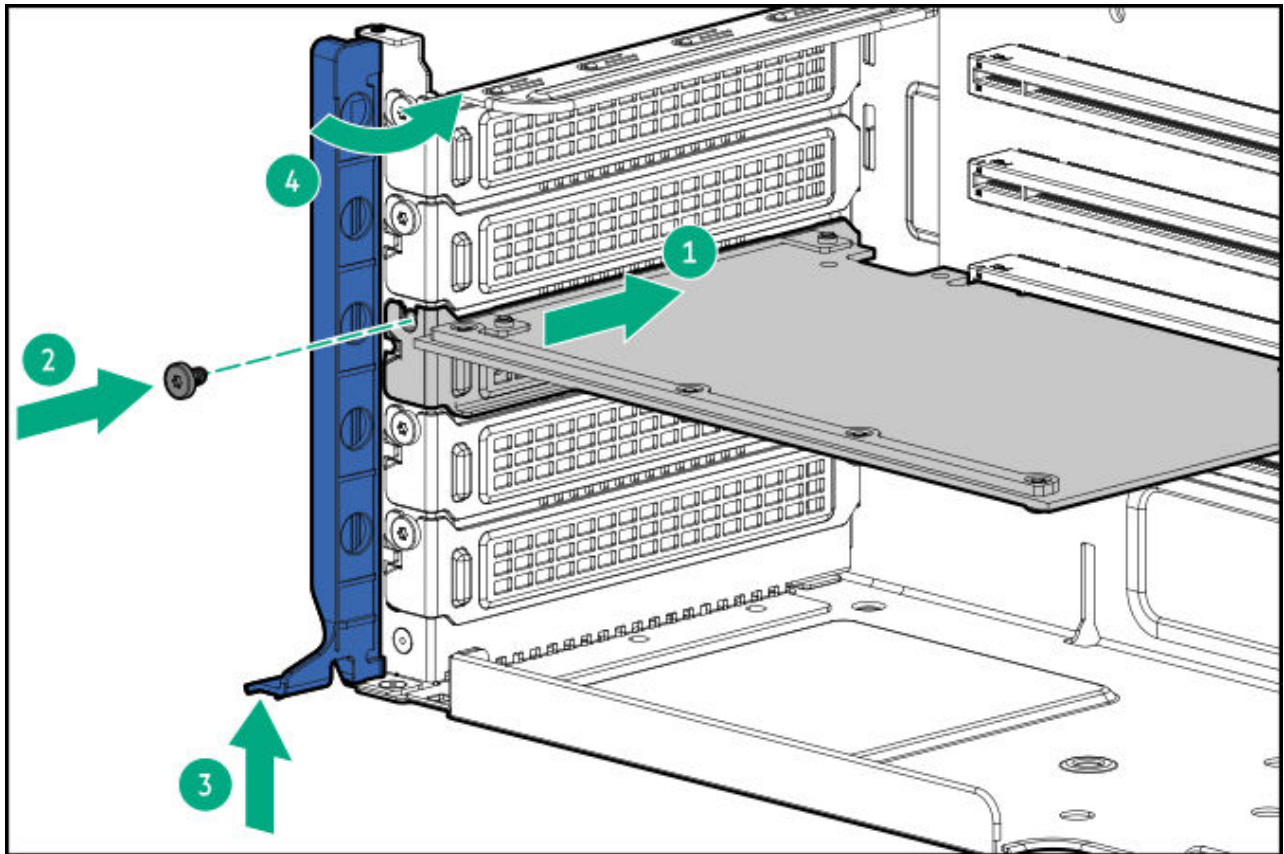

- .0. Install the primary riser cage.
- .1. Cable the type-p storage controller.
- .2. To enable the FBWC feature of the storage controller, install an energy pack.
- .3. Install the access panel.
- .4. Lock the front bezel.
- .5. Do one of the following:
 - Orient the server back in tower mode.
 - Install the server into the rack.
- .6. Connect all peripheral cables to the server.
- .7. Connect each power cord to the server.
- .8. Connect each power cord to the power source.
- .9. Power up the server.
- !0. Update the server and controller firmware if they are not the latest revision.

1. [Configure the controller.](#)

Results

The installation procedure is complete.

Installing a type-o storage controller

Prerequisites

- If you are installing an x16 type-o storage controller, [make sure that the P72201-B21 OCP bandwidth upgrade cable kit is installed.](#)
- [Compatible controller cable](#)
- Before you perform this procedure, make sure that you have a T-10 Torx screwdriver available.

About this task



CAUTION

A discharge of static electricity from a finger or other conductor might damage system boards or other static-sensitive devices. To prevent damage, observe [antistatic precautions](#).



CAUTION

The port blank provides EMI shielding and helps maintain proper thermal status inside the server. Do not operate the server when a port blank is removed without the corresponding I/O port option installed.

Procedure

1. [Power down the server.](#)
2. Remove all power:
 - a. Disconnect each power cord from the power source.
 - b. Disconnect each power cord from the server.
3. Disconnect all peripheral cables from the server.
4. Do one of the following:

- If the server is in tower mode, place the server on a flat, level surface with the access panel facing up.
 - If the server is in rack mode, remove the server from the rack.
5. Unlock the front bezel.
 6. Remove the access panel.
 7. Remove the primary riser cage.
 8. Remove the Slot 14 OCP A slot blank:
 - a. Remove the blank screw.
 - b. Use a plastic spudger to pry the top side of the blank from the chassis.
 - c. Remove the blank.

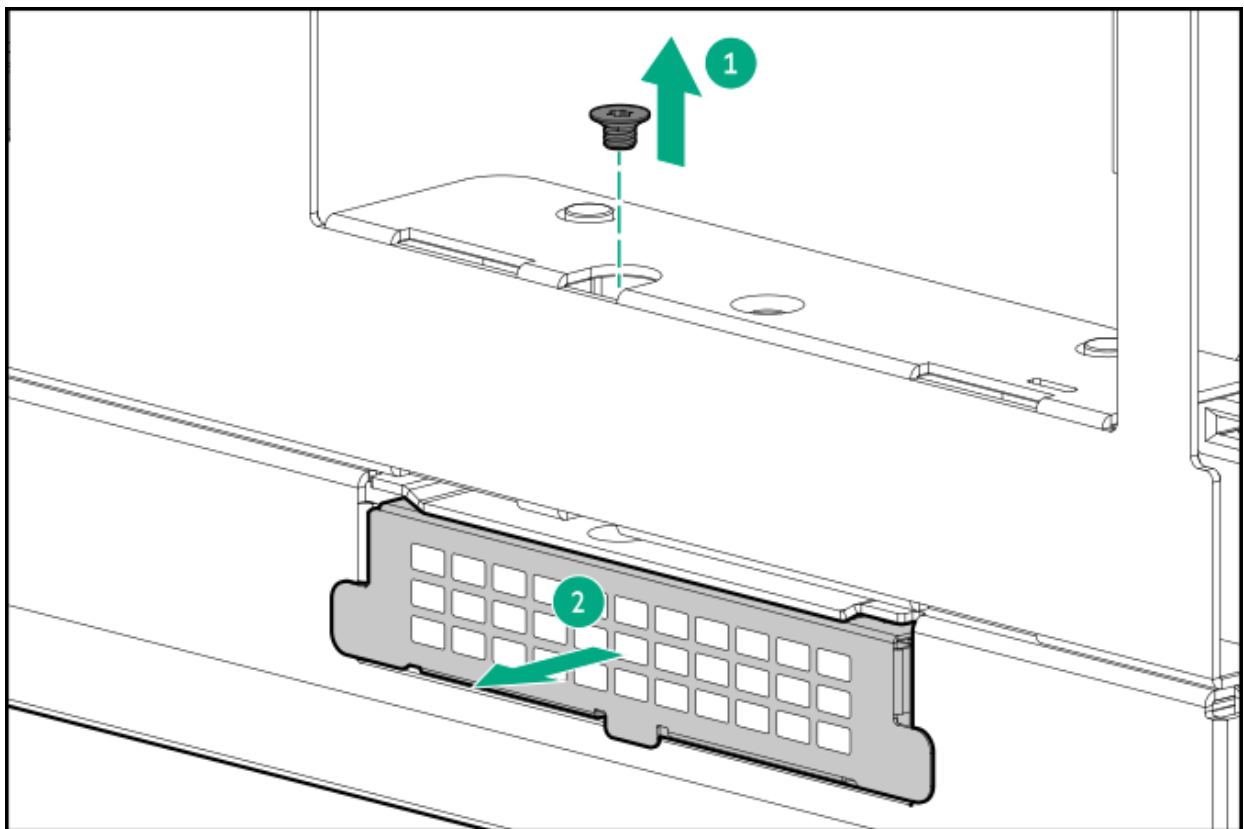

9. Install the type-o storage controller:
 - a. Rotate the locking pin to the open (vertical) position.
 - b. Slide the controller into the bay until it clicks into place.

Make sure that the controller is seated firmly in the slot.

c. Rotate the locking pin to the close (horizontal) position.

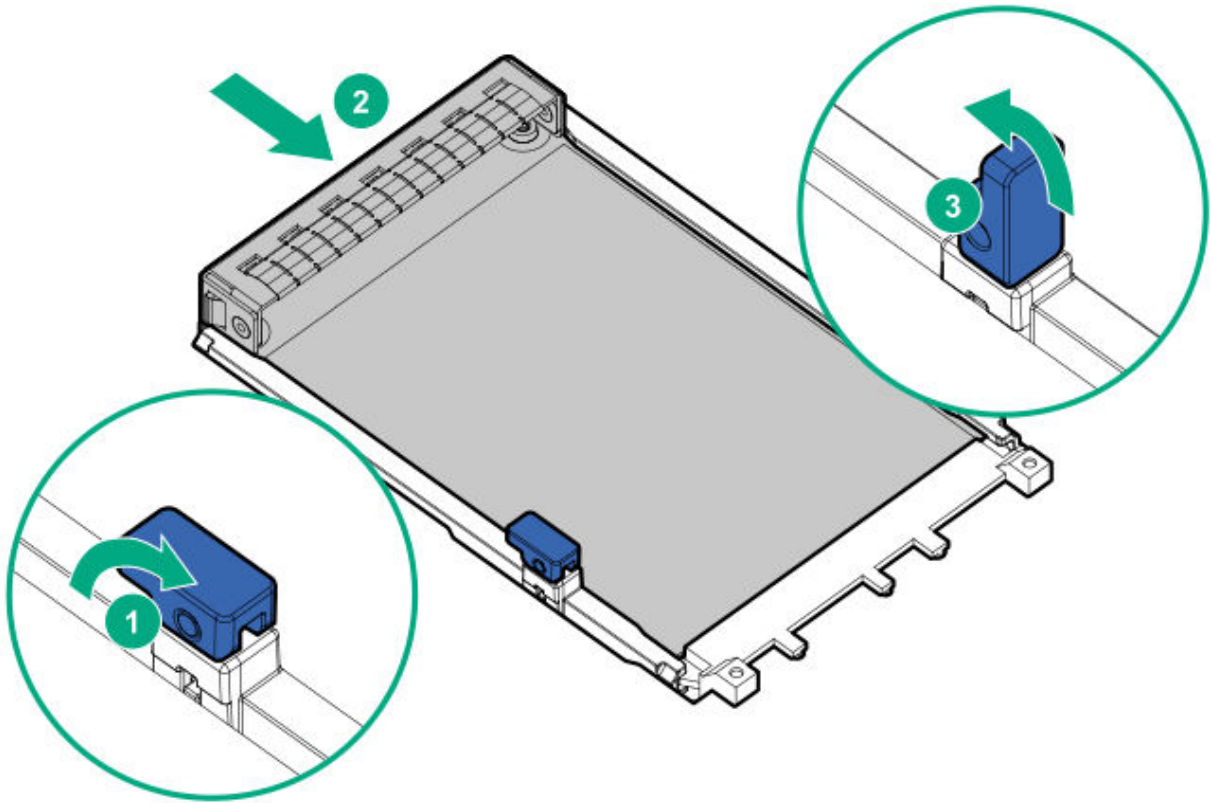

- .0. Cable the type-o storage controller.
- .1. Install the primary riser cage.
- .2. Install the access panel.
- .3. Lock the front bezel.
- .4. Do one of the following:
 - Orient the server back in tower mode.
 - Install the server into the rack.
- .5. Connect all peripheral cables to the server.
- .6. Connect each power cord to the server.
- .7. Connect each power cord to the power source.
- .8. Power up the server.
- .9. Update the server and controller firmware if they are not the latest revision.

!0. Configure the controller.

Results

The installation procedure is complete.

Internal USB device options

The server has one internal USB 2.0 port and one USB 3.2 Gen 1 port. Use these ports to install internal USB devices such as USB flash media devices for booting up from flash solutions or for data backup/redundancy.

Subtopics

Installing an internal USB device

Installing an internal USB device

Procedure

1. Power down the server.
2. Remove all power:
 - a. Disconnect each power cord from the power source.
 - b. Disconnect each power cord from the server.
3. Disconnect all peripheral cables from the server.
4. Do one of the following:
 - If the server is in tower mode, place the server on a flat, level surface with the access panel facing up.
 - If the server is in rack mode, remove the server from the rack.
5. Unlock the front bezel.
6. Remove the access panel.
7. Remove the primary riser cage.
8. Plug in the USB device into the USB port.

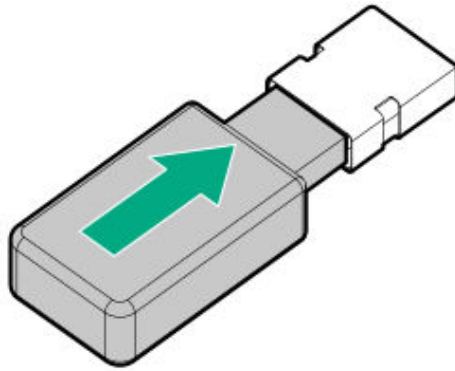

9. Install the primary riser cage.
0. Install the access panel.
1. Lock the front bezel.
2. Do one of the following:
 - Orient the server back in tower mode.
 - Install the server into the rack.
3. Connect all peripheral cables to the server.
4. Connect each power cord to the server.
5. Connect each power cord to the power source.
6. Power up the server.

Results

The installation procedure is complete.

Cabling

This chapter includes cabling guidelines and diagrams for internal component cabling.

Subtopics

Cabling guidelines

Cabling diagrams

Internal cabling management

Storage cabling

Media device cabling

- HPE NS204i-u Boot Device V2 cabling**
- GPU auxiliary power cabling**
- Fan cabling**
- OCP bandwidth enablement cabling**
- Tertiary riser signal cabling**
- Serial port cabling**
- Chassis intrusion detection switch cabling**
- Front I/O cabling**

Cabling guidelines

Observe the following:



NOTE

The colors in the cabling diagrams are for illustration purposes only.



CAUTION

To avoid damaging connectors, avoid repeated installation and removal of cables. Excessive handling can shorten the lifespan of the cable.

- For cable option kits, see the product QuickSpecs.
- For cable spare part numbers, see the Illustrated parts catalog in the maintenance and service guide.
- Some diagrams show alphabetical callouts such as A, B, C, etc. These callouts correspond to labels near the connectors on the cable.
- Some cables have more than one connector, such as a Y-cable, but not all connectors are used.
- Observe all guidelines when working with server cables.

Before connecting cables

- Note the port labels on the PCA components. Not all these components are used by all servers:
 - System board ports
 - Drive and power supply backplane ports
 - Expansion board ports (controllers, retimers, adapters, expanders, risers, and similar boards)
- Note the label near each cable connector. This label indicates the destination port for the cable connector.

- Some data cables are prebent. Do not unbend or manipulate the cables.
- To prevent mechanical damage or depositing oil that is present on your hands, and other contamination, do not touch the ends of the connectors.

When connecting cables

- Before connecting a cable to a port, lay the cable in place to verify the length of the cable.
- Use the internal cable management features to properly route and secure the cables.
- Route cables so that they do not contact or rest on cooling components, including heatsinks. Ensure that cable routing does not obstruct airflow to or from heatsinks or ventilation openings
- When routing cables, be sure that the cables are not in a position where they can be pinched or crimped.
- Avoid tight bend radii to prevent damaging the internal wires of a power cord or a server cable. Never bend power cords and server cables tight enough to cause a crease in the sheathing.
- Make sure that the excess length of cables is properly secured to avoid excess bends, interference issues, and airflow restriction.
- Before installing a new component or closing up the server, make sure that all cables are in their appropriate routing position. This cable check prevents component damage and potential signal interference.

When disconnecting cables

- Grip the body of the cable connector. Do not pull on the cable itself because this action can damage the internal wires of the cable or the pins on the port.

- If a cable does not disconnect easily, check for any release latch that must be pressed to disconnect the cable.

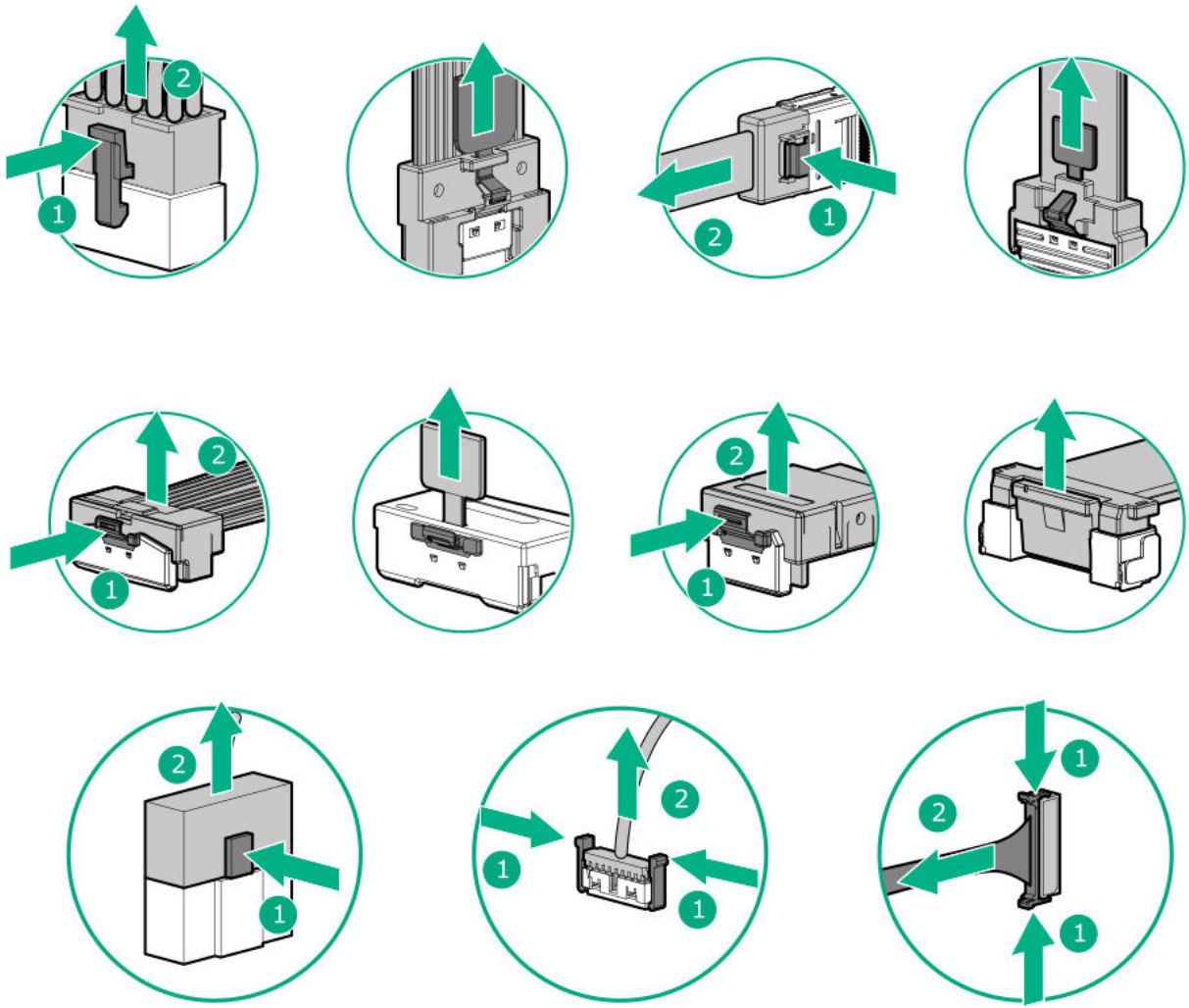

- Remove cables that are no longer being used. Retaining them inside the server can restrict airflow. If you intend to use the removed cables later, label and store them for future use.

Cabling diagrams

Observe the following:

- Before cabling components, see the [Cabling guidelines](#).
- Use the cable part number or search feature to find your diagram.

Component cabling	Cable part number
Drive power cabling	—
LFF/SFF drive power cabling	P75906-001
E3.S drive power cabling	P75277-001
SFF storage controller cabling	—
8/16 SFF drive: Onboard NVMe cabling	P75564-001
24 SFF drive: Direct attached cabling	P75563-001
8/16 SFF SAS/ NVMe x1 drive controller cabling: Type-o controller in Slot 14 OCP A	P45304-001
24 SFF SAS/ NVMe x1 drive controller cabling: Type-p controller in the primary riser	<ul style="list-style-type: none"> • P45296-001 • P45297-001
8 SFF NVMe x4 drive controller cabling in Box 3: MR932i-p in the primary riser	P76443-001
24 SFF NVMe x2 drive controller cabling: MR932i-p in the primary and secondary riser	P78631-001
LFF storage controller cabling	—
4 LFF SAS/SATA drive controller cabling: Type-o controller in Slot 14 OCP A	P49936-001
8/12 LFF SAS/SATA drive controller cabling: Type-o controller in Slot 14 OCP A	<ul style="list-style-type: none"> • P45306-001 • P49936-001
4 LFF SAS/SATA drive controller cabling: Type-p controller in the primary riser	P45300-001
8/12 LFF SAS/SATA drive controller cabling: Type-p controller in the primary riser	<ul style="list-style-type: none"> • P45301-001 • P45300-001
E3.S storage controller cabling	—
12 E3.S drive: Onboard NVMe cabling	P75568-001
12 E3.S drive controller cabling in Box 3: MR932i-p controller in the primary riser	P75570-001
Mixed drive storage controller cabling	—
4 LFF + 16 SFF drive controller cabling	<ul style="list-style-type: none"> • P45296-001

Component cabling	Cable part number
	<ul style="list-style-type: none"> • P49936-001
Energy pack cabling	873905-001
Media device cabling	—
LTO tape drive cabling	Type-o controller: <ul style="list-style-type: none"> • P45303-001 • P49007-001 Type-p controller: <ul style="list-style-type: none"> • P45303-001 • P49006-001
Optical drive cabling	P73776-002
HPE NS204i-u Boot Device V2 cabling	<ul style="list-style-type: none"> • P48956-001 • P74730-001 • P72024-001 • P54089-001
GPU auxiliary power cabling	P58422-001
Fan cabling	—
Internal fans 1-8	<ul style="list-style-type: none"> • P53695-001 • P53694-001
External fans 9-10	P45291-001
OCP bandwidth cabling	—
Slot 14 OCP A PCIe x16 configuration	P74890-001
Slot 15 OCP B PCIe x8 configuration (Single-process or configuration)	P74889-001
Slot 15 OCP B PCIe x16 configuration (Dual-process or configuration)	P74891-001
Miscellaneous cabling	—
Tertiary riser signal cabling	P79969-001
Serial port cabling	P45623-001
Chassis intrusion detection switch cabling	P47751-001

Component cabling

Cable part number

Front I/O cabling

- [P71909-001](#)
- [P75279-001](#)

Internal cabling management

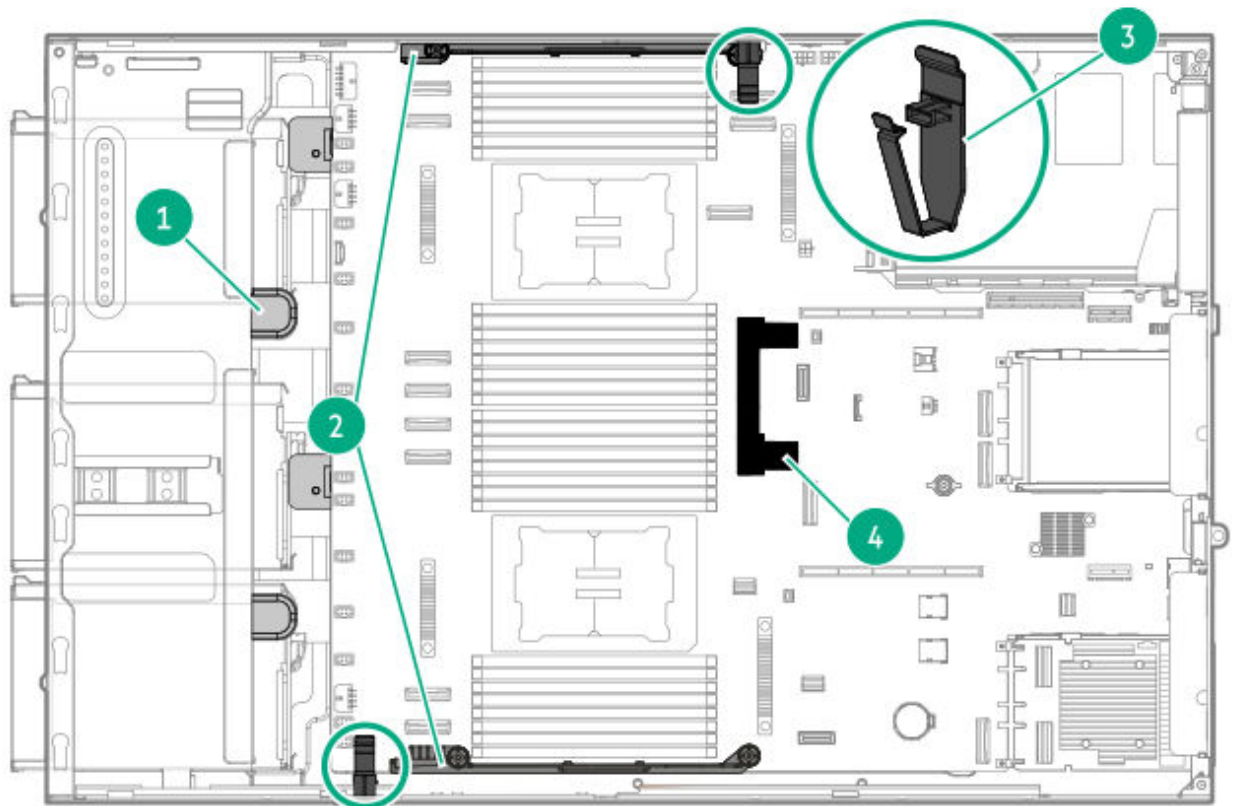

Item	Description
1	Metal tabs
2	DIMM guards
3	Cable clamps
4	System board handle

Storage cabling

Subtopics

Drive power cabling

Storage controller cabling

Energy pack cabling

Drive power cabling

Drive power cables are either preinstalled in the server or structured under the relevant storage controller cable option kit.

LFF/SFF drive power cabling

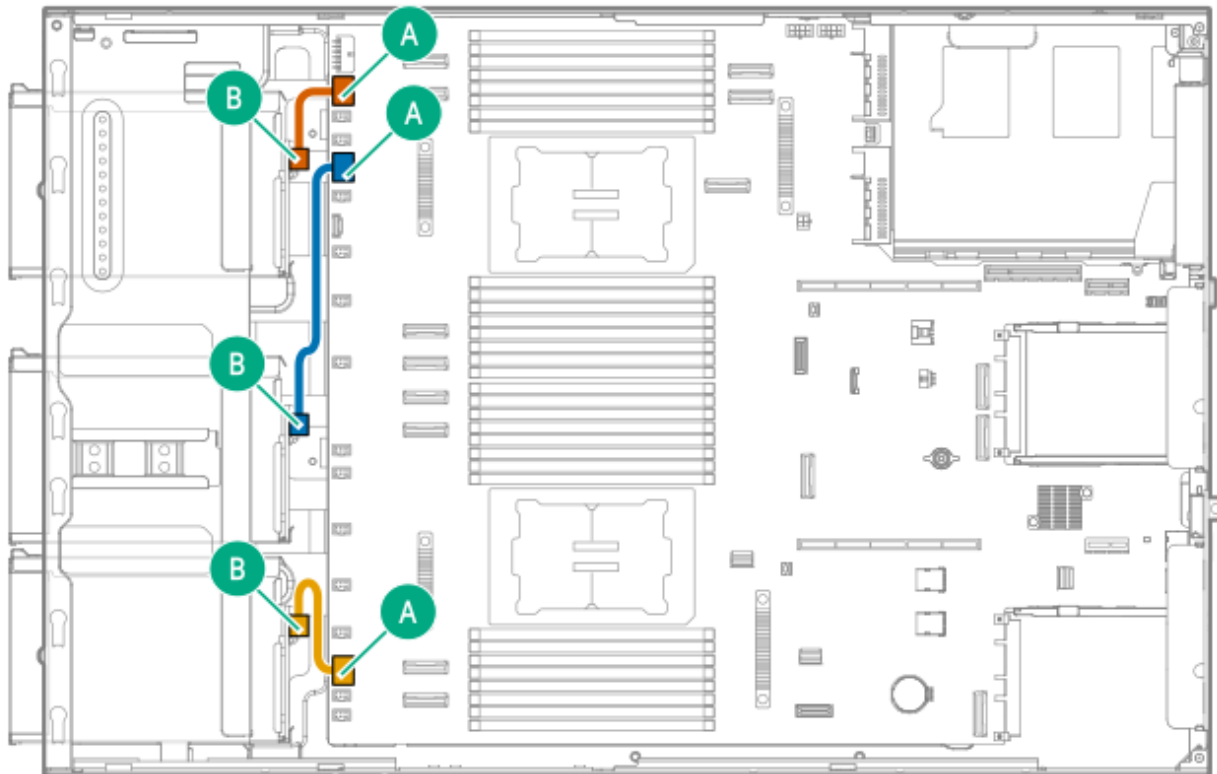

Cable part number	Color	From	To
P75906-001	Orange	Box 1 power connector	Drive box 1 power connector
	Blue	Box 2 power connector	Drive box 2 power connector
	Gold	Box 3 power connector	Drive box 3 power connector

E3.S drive power cabling

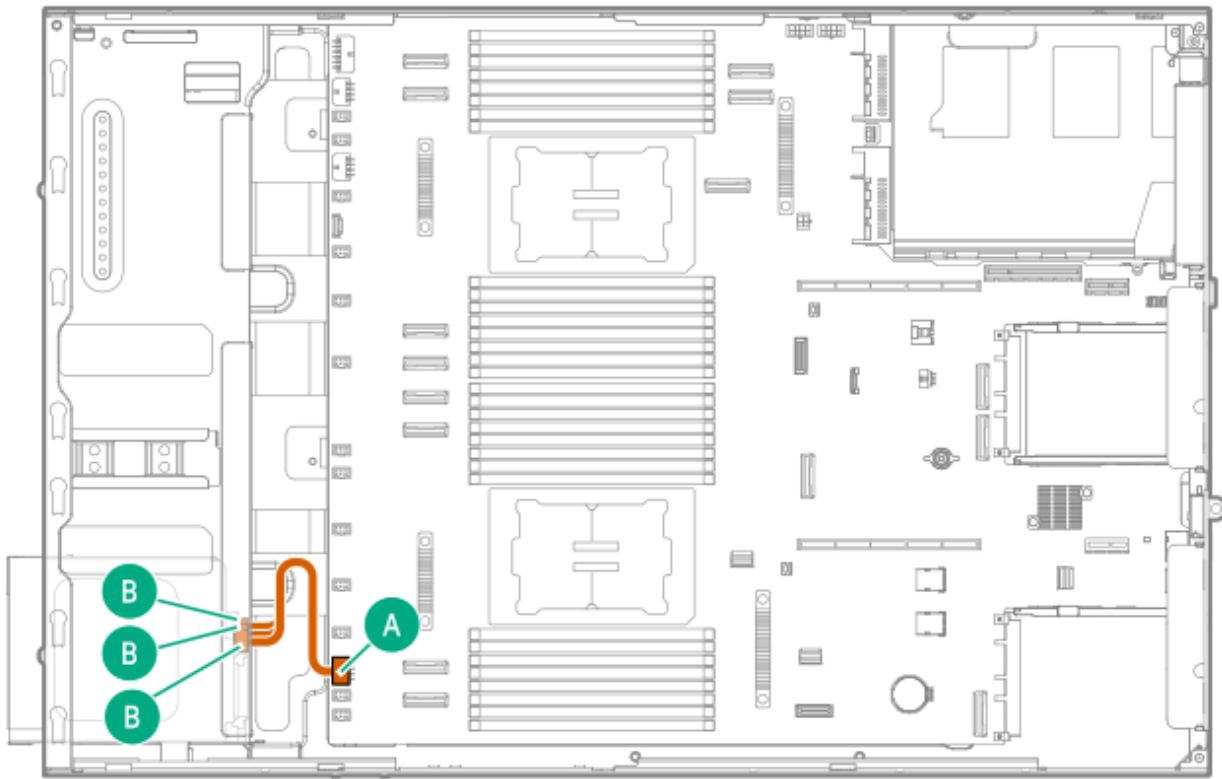

Cable part number	Color	From	To
P75277-001	Orange	Box 3 power connector	Drive box 3 power connector

Storage controller cabling

Subtopics

[SFF drive controller cabling](#)

[LFF drive controller cabling](#)

[E3.S drive controller cabling](#)

[Mixed drive controller cabling](#)

[Storage controller backup power cabling](#)

SFF drive controller cabling

8/16 SFF drive: Onboard NVMe cabling

- Box 2

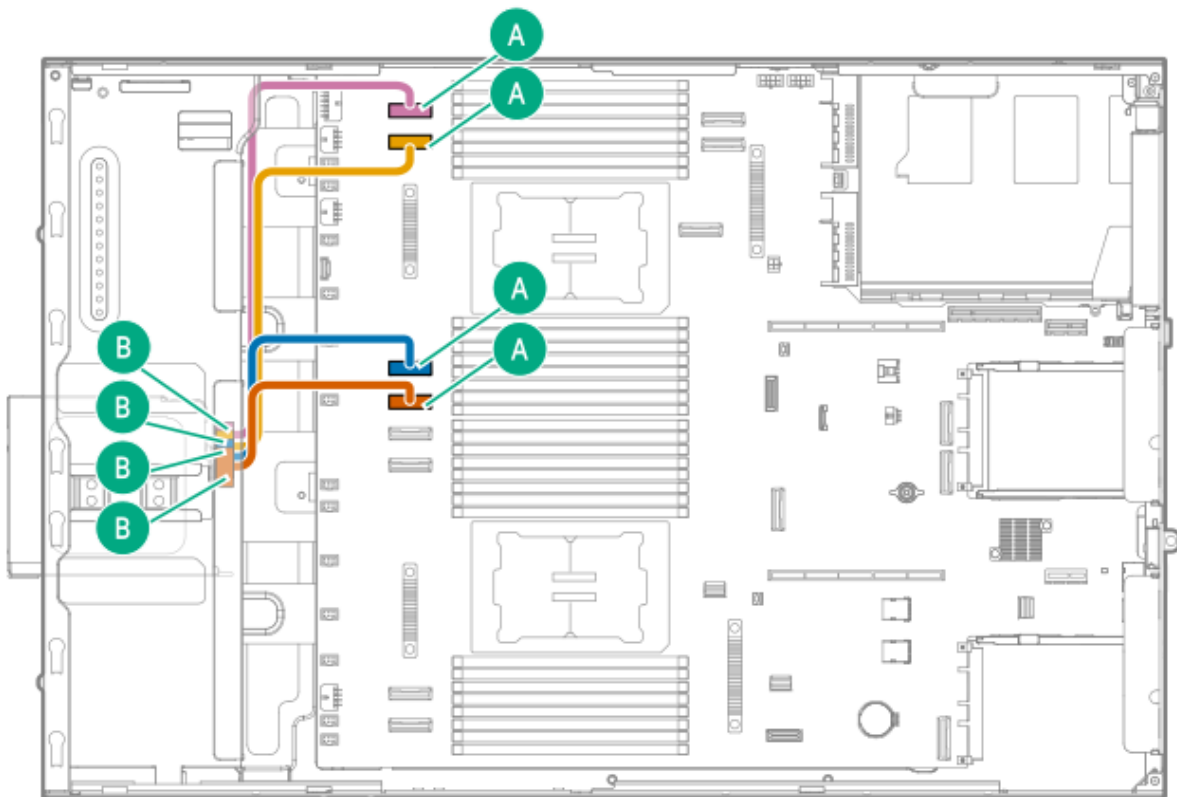

Cable part number	Color	From	To
P75564-001	Orange	Port 4	MCIO port 5

Cable part number	Color	From	To
	Blue	Port 3	MCIO port 6
	Gold	Port 2	MCIO port 7
	Pink	Port 1	MCIO port 8

- Box 3

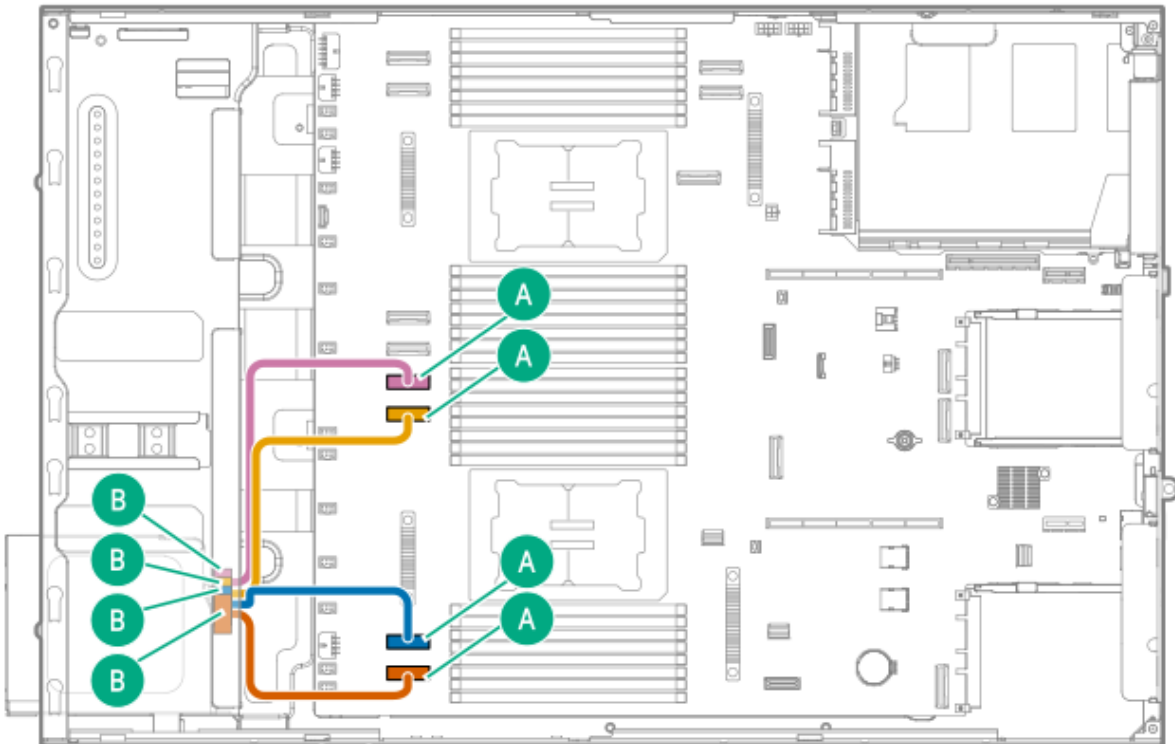

Cable part number	Color	From	To
P75564-001	Orange	Port 4	MCIO port 1
	Blue	Port 3	MCIO port 2
	Yellow	Port 2	MCIO port 3
	Gold	Port 1	MCIO port 4

24 SFF drive: Direct attached cabling

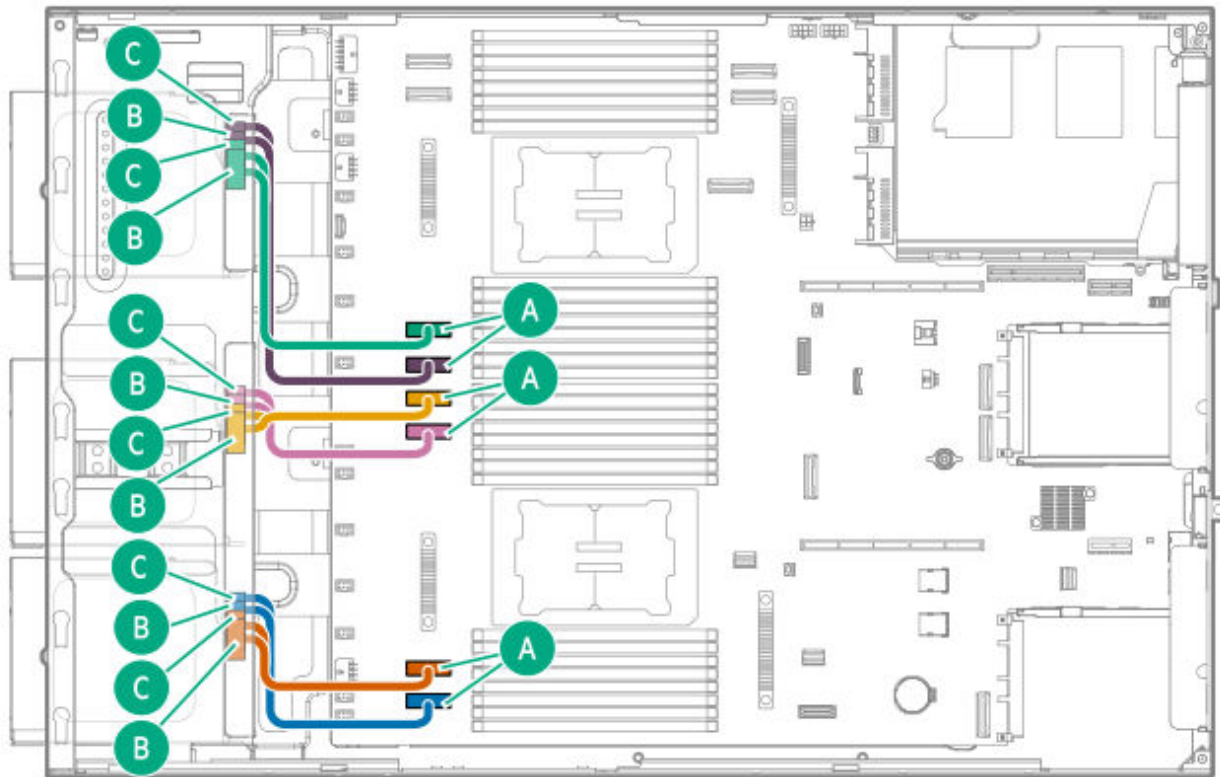

Cable part number	Color	From	To
P75563-001	Orange	Box 3 port 1 (B) and 2 (C)	MCI/O port 1
	Blue	Box 3 port 3 (B) and 4 (C)	MCI/O port 2
	Gold	Box 2 port 1 (B) and 2 (C)	MCI/O port 3
	Pink	Box 2 port 3 (B) and 4 (C)	MCI/O port 4
	Green	Box 1 port 1 (B) and 2 (C)	MCI/O port 5
	Purple	Box 1 port 3 (B) and 4 (C)	MCI/O port 6

8/16 SFF SAS/ NVMe x1 drive controller cabling: Type-o controller in Slot 14 OCP A

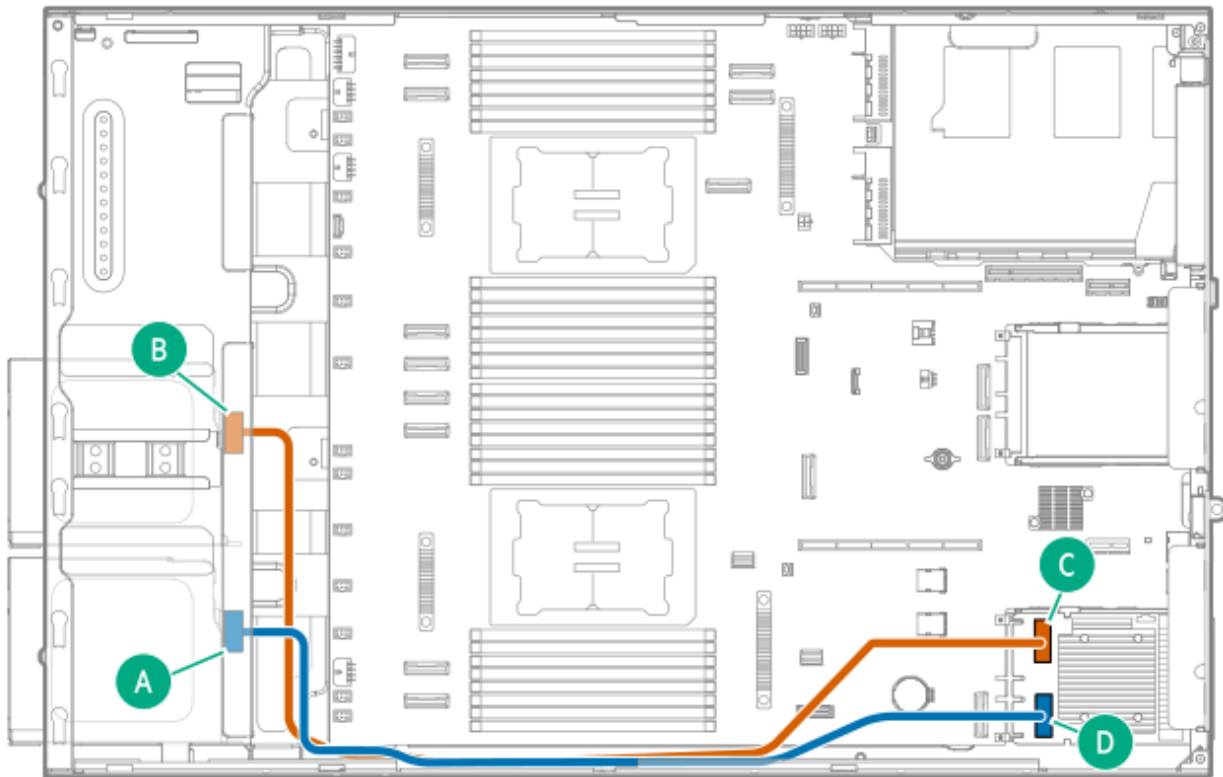

Cable part number	Color	From	To
P45304-001	Orange	Box 2 port 1	Type-o controller port 2
	Blue	Box 3 port 1	Type-o controller port 1

24 SFF SAS/ NVMe x1 drive controller cabling: Type-p controller in the primary riser

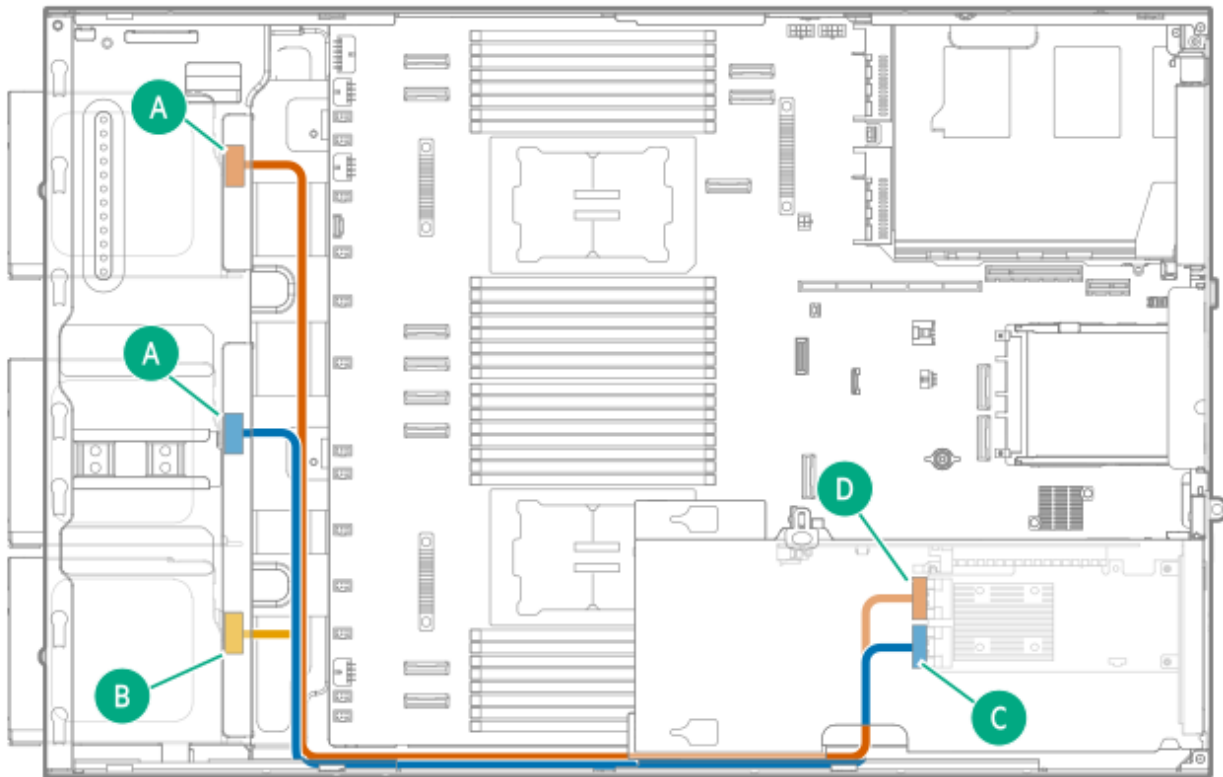

Cable part number	Color	From	To
P45296-001	Orange	Box 1 port 1	Type-p controller port 2
P45297-001	Blue	Box 2 port 1	Type-p controller port 1
	Gold	Box 3 port 1	Type-p controller port 2

8 SFF NVMe x4 drive controller cabling in Box 3: MR932i-p in the primary riser

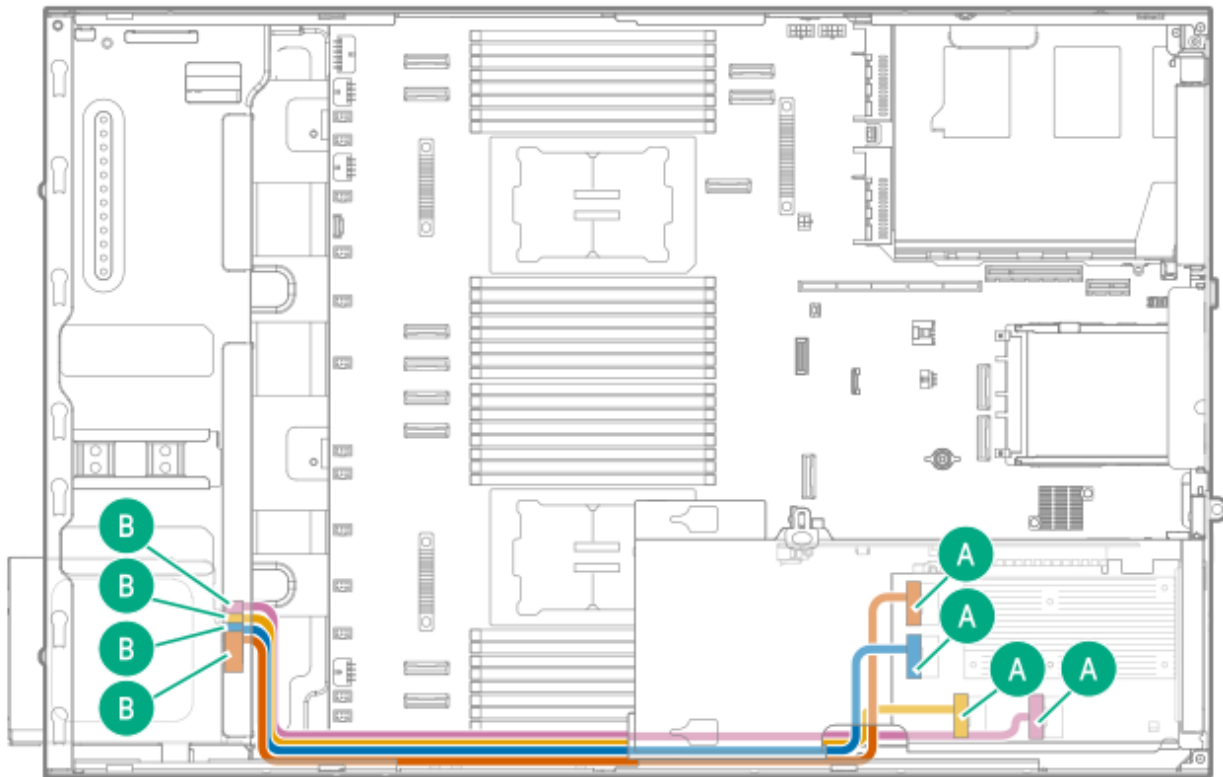

Cable part number	Color	From	To
P76443-001	Orange	Port 2	Port 2
	Blue	Port 1	Port 1
	Gold	Port 4	Port 4
	Pink	Port 3	Port 3

24 SFF NVMe x2 drive controller cabling: MR932i-p in the primary and secondary riser

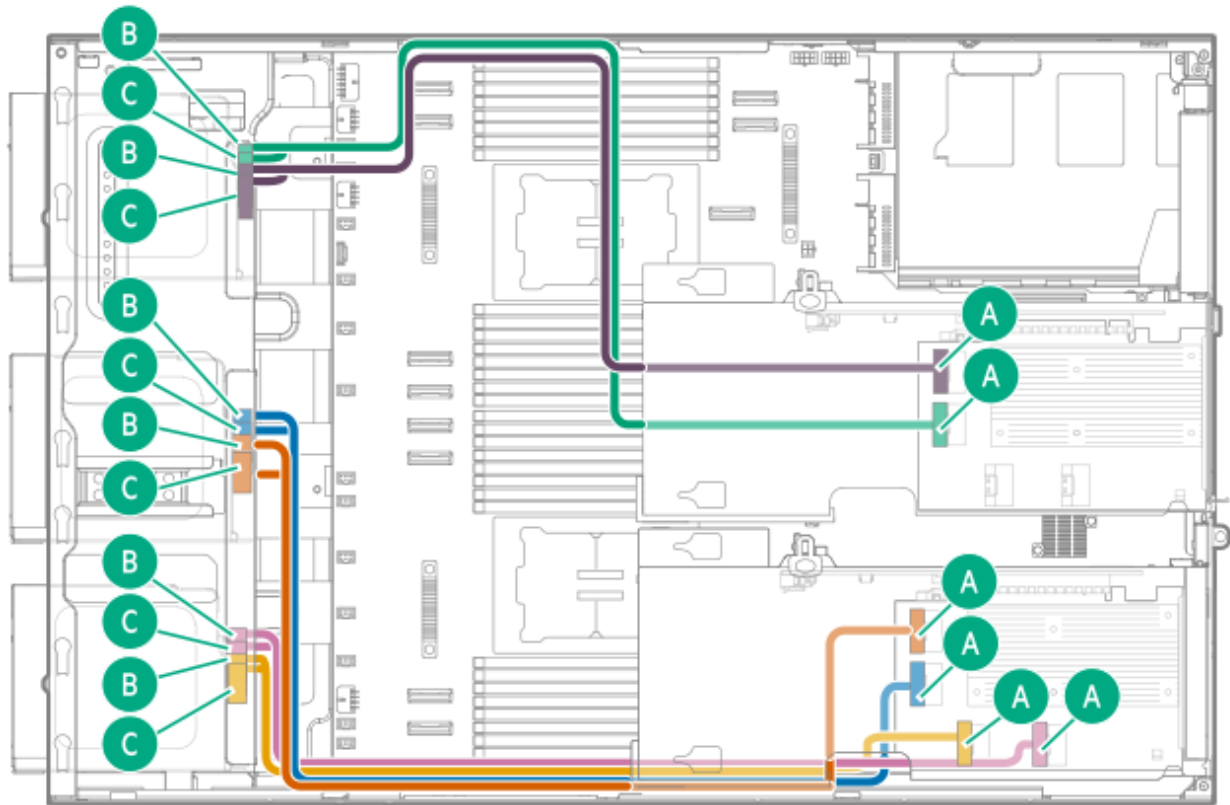

Cable part number	Color	From	To
P78631-001	Orange	Box 2 port 3 (B) and port 4 (C)	Type-p controller in the primary riser port 2
	Blue	Box 2 port 1 (B) and port 2 (C)	Type-p controller in the primary riser port 1
	Gold	Box 3 port 3 (B) and port 4 (C)	Type-p controller in the primary riser port 4
	Pink	Box 3 port 1 (B) and port 2 (C)	Type-p controller in the primary riser port 3
	Green	Box 1 port 1 (B) and port 2 (C)	Type-p controller in the secondary riser port 1
	Purple	Box 1 port 3 (B) and port 4 (C)	Type-p controller in the secondary riser port 2

LFF drive controller cabling

4 LFF SAS/SATA drive controller cabling: Type-o controller in Slot 14 OCP A

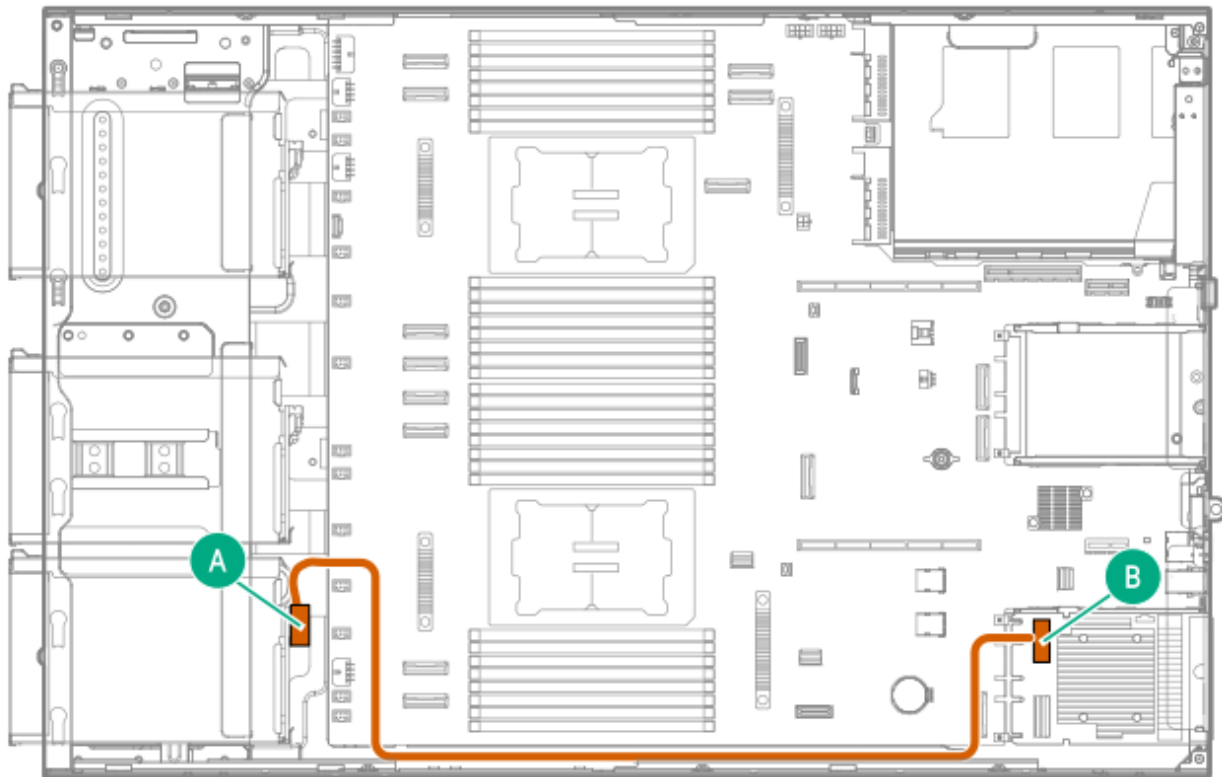

Cable part number	Color	From	To
P49936-001	Orange	Box 3 port 1	Type-o controller port 2

8/12 LFF SAS/SATA drive controller cabling: Type-o controller in Slot 14 OCP A



Cable part number	Color	From	To
P45306-001	Orange	Box 1 port 1 and Box 2 port 1	Type-o controller port 2
P49936-001	Blue	Box 3 port 1	Type-o controller port 1

4 LFF SAS/SATA drive controller cabling: Type-p controller in the primary riser



Cable part number	Color	From	To
P45300-001	Orange	Box 3 port 1	Type-p controller port 2

8/12 LFF SAS/SATA drive controller cabling: Type-p controller in the primary riser

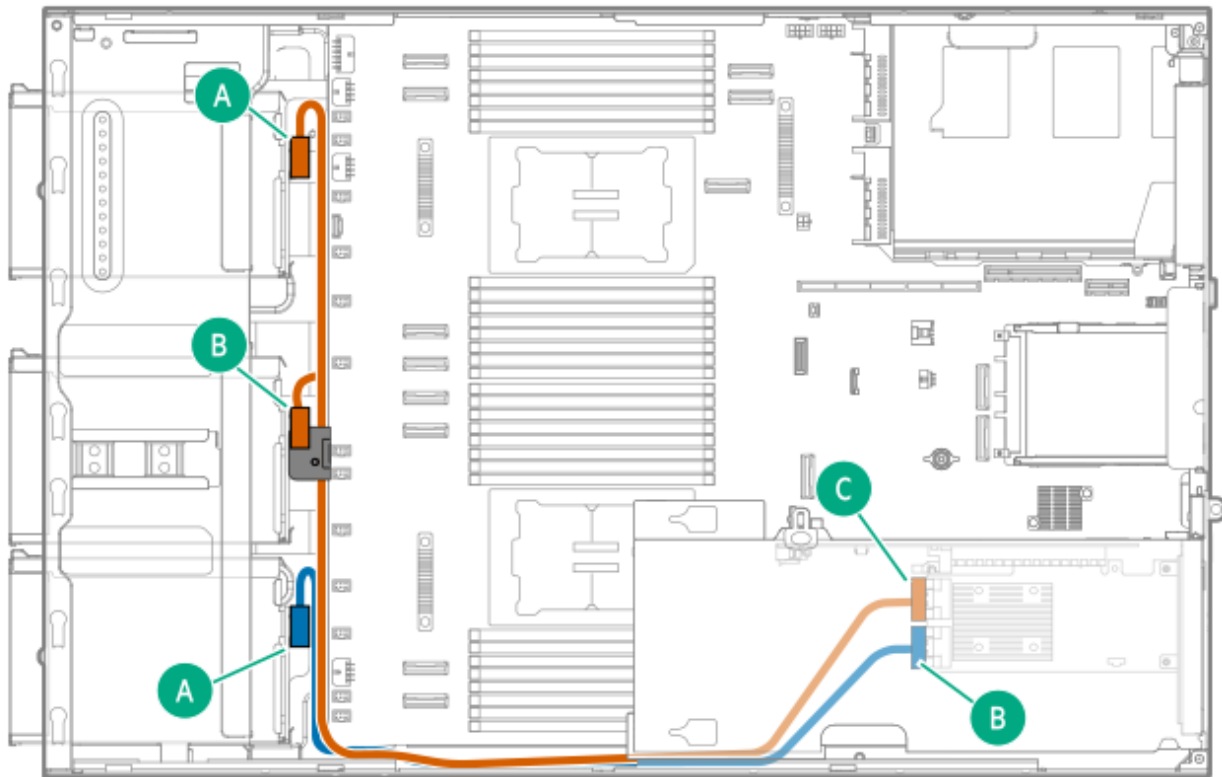

Cable part number	Color	From	To
P45301-001	Orange	Box 1 port 1 and Box 2 port 1	Type-p controller port 2
P45300-001	Blue	Box 3 port 1	Type-p controller port 1

E3.S drive controller cabling

12 E3.S drive: Onboard NVMe cabling

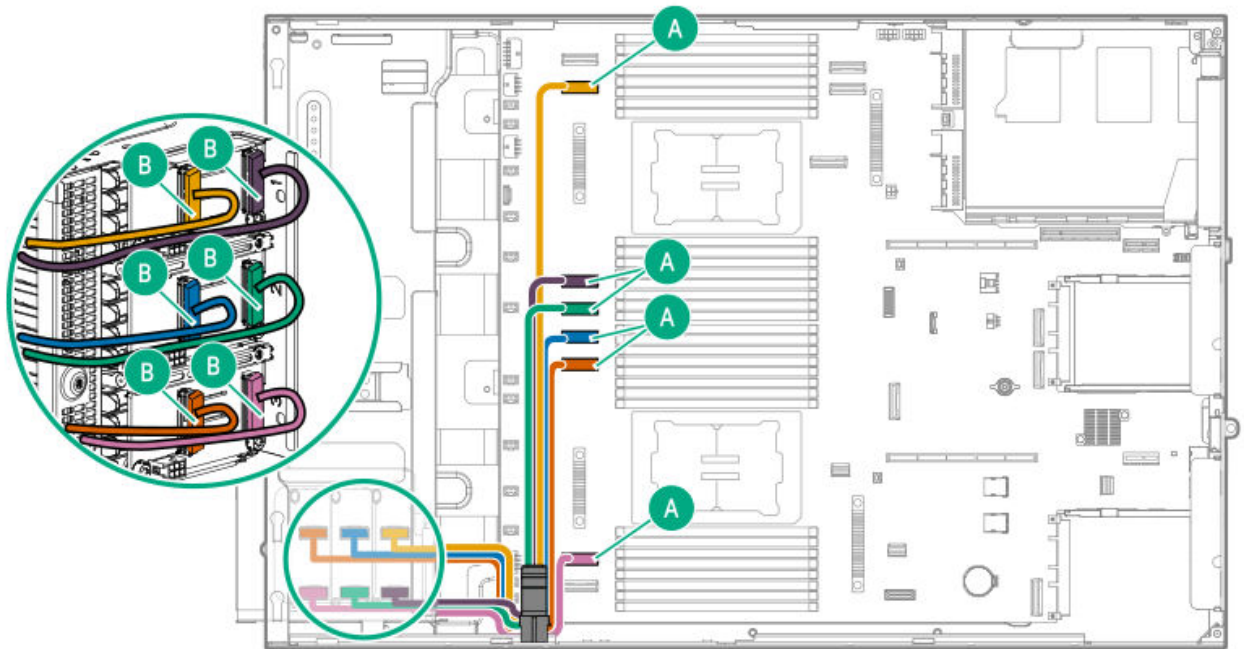

Cable part number	Color	From	To
P75568-001	Orange	Backplane 3 port 2	MCI/O port 3
	Blue	Backplane 2 port 2	MCI/O port 4
	Gold	Backplane 1 port 2	MCI/O port 7
	Pink	Backplane 3 port 1	MCI/O port 2
	Green	Backplane 2 port 1	MCI/O port 5
	Purple	Backplane 1 port 1	MCI/O port 6

12 E3.S drive controller cabling in Box 3: MR932i-p controller in the primary riser

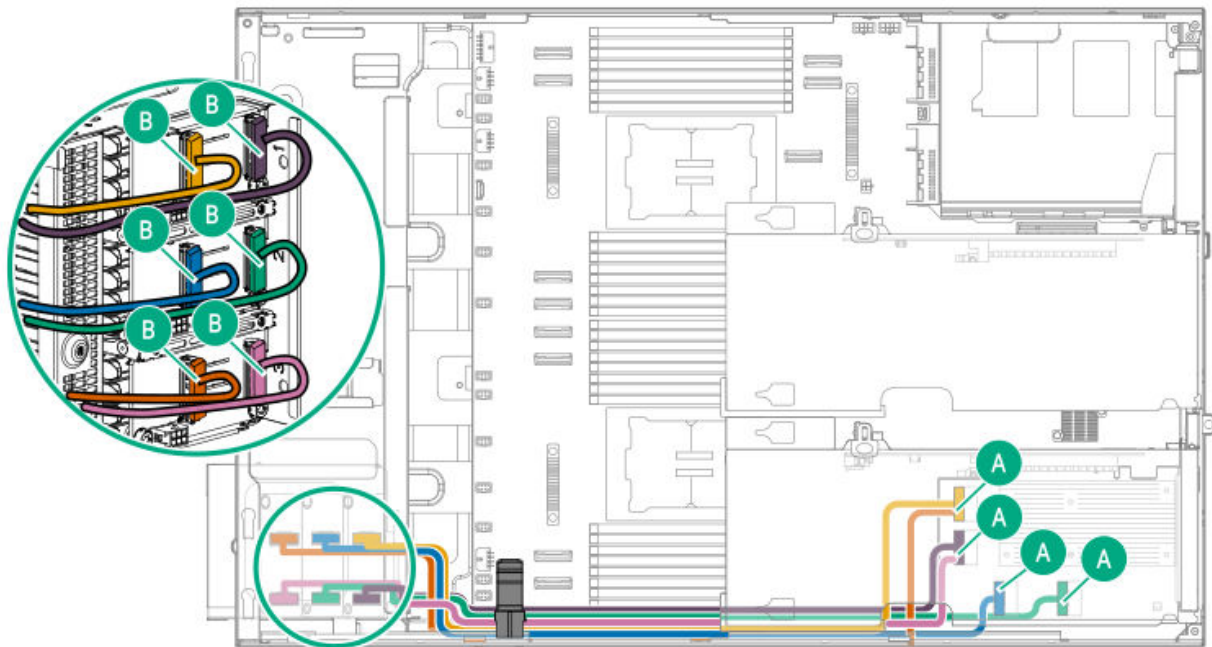

Cable part number	Color	From	To
P75570-001	Orange	Backplane 3 port 2	Type-p controller port 2
	Blue	Backplane 2 port 2	Type-p controller port 4
	Gold	Backplane 1 port 2	Type-p controller port 2
	Pink	Backplane 3 port 1	Type-p controller port 1
	Green	Backplane 2 port 1	Type-p controller port 3
	Purple	Backplane 1 port 1	Type-p controller port 1

Mixed drive controller cabling

4 LFF + 16 SFF drive controller cabling

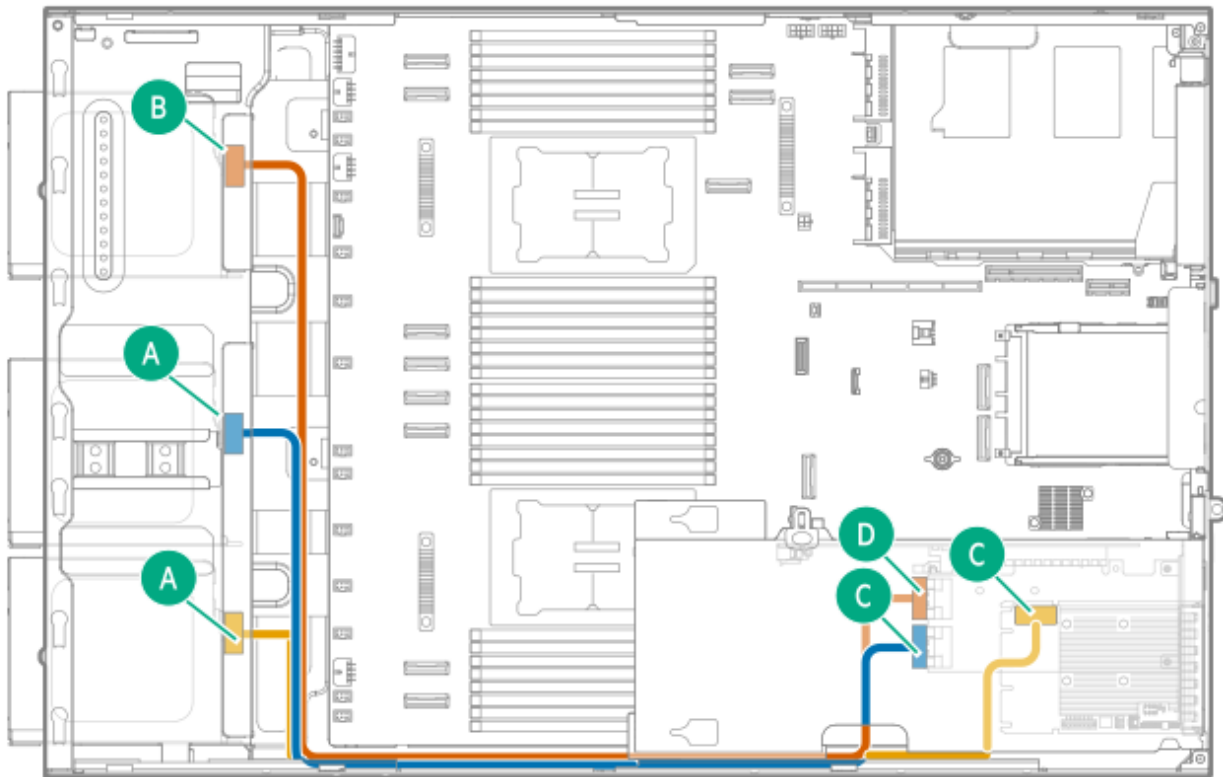

Cable part number	Color	From	To
P45296-001	Orange	Box 1 port 1	Type-p controller port 2
	Blue	Box 2 port 1	Type-p controller port 1
P49936-001	Gold	Box 3 port 1	Type-p controller port 1

Storage controller backup power cabling

The exact route of the storage controller backup power cabling will depend on:

- The riser slot where the controller is installed
- The location of the storage controller backup power connector on the controller

Use the following diagrams for reference only.

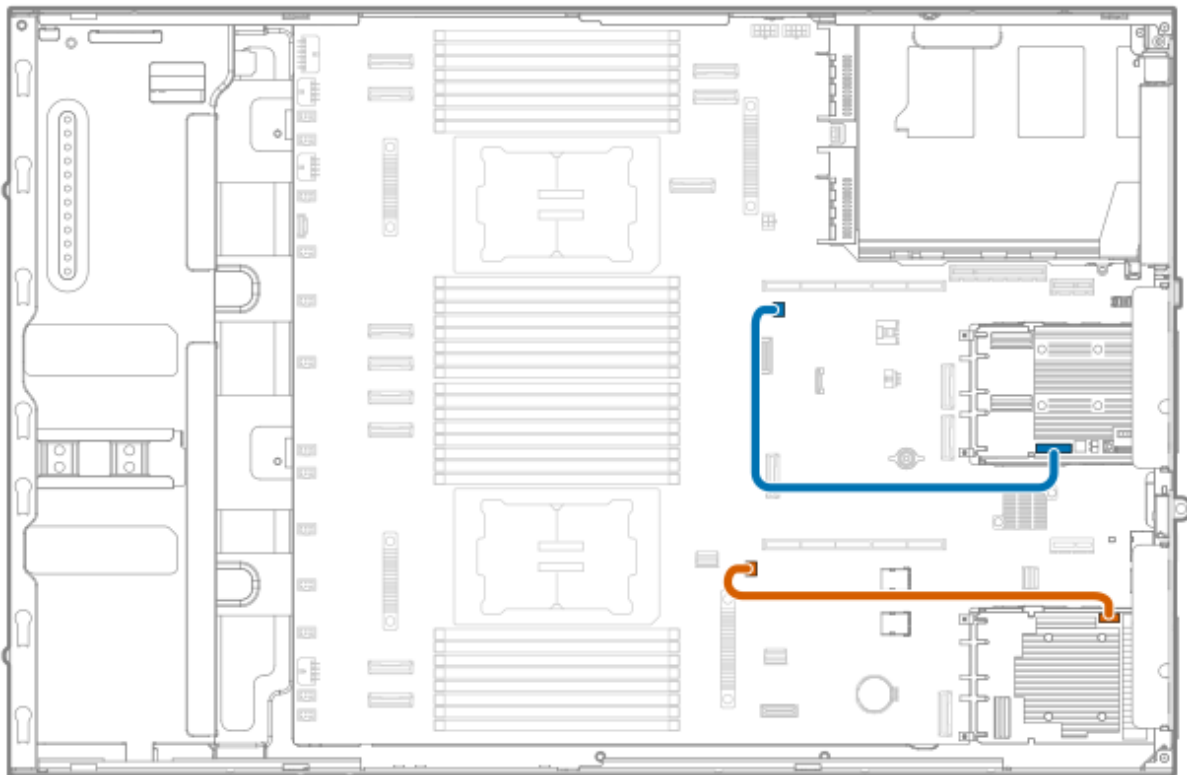

Cable part number	Color	From	To
—	Orange	Type-o controller	OCP slot A storage backup power connector
	Blue		OCP slot B storage backup power connector

Energy pack cabling

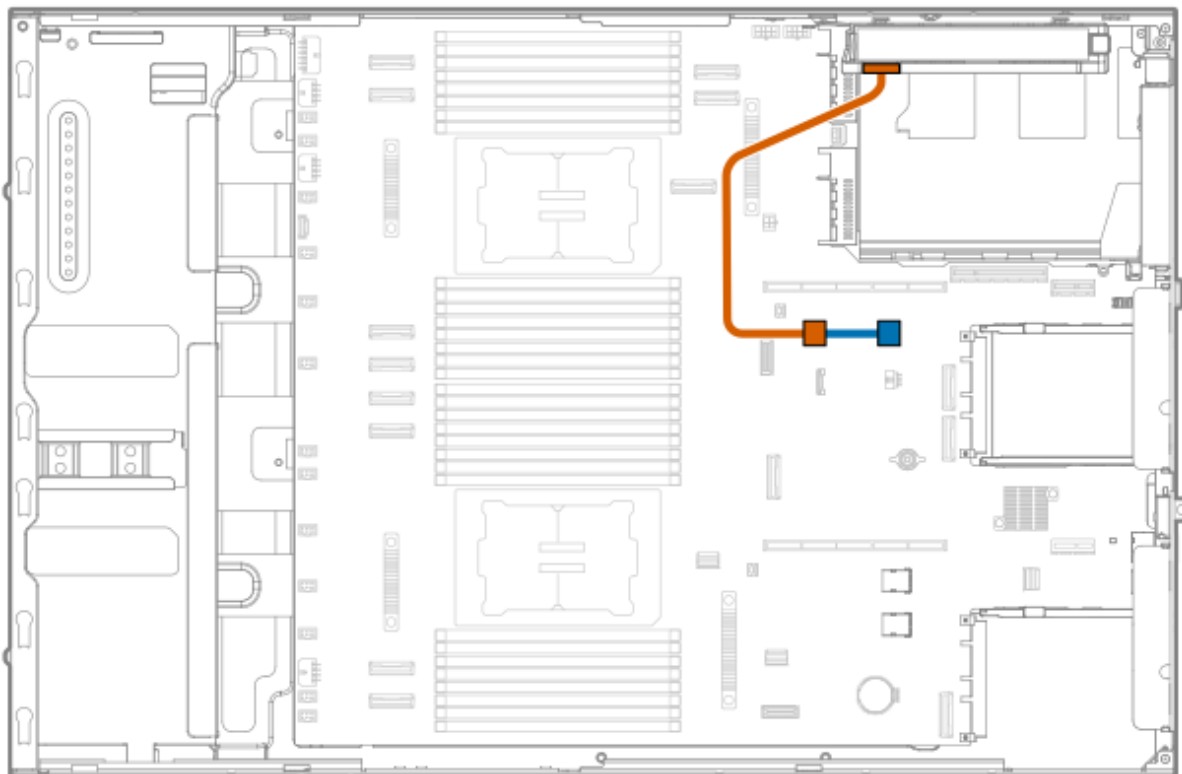

Cable part number	Color	From	To
873905-001	Blue	Energy pack cable	Energy pack connector

Media device cabling

Subtopics

[LTO tape drive cabling](#)

[Optical drive cabling](#)

LTO tape drive cabling

Type-o controller

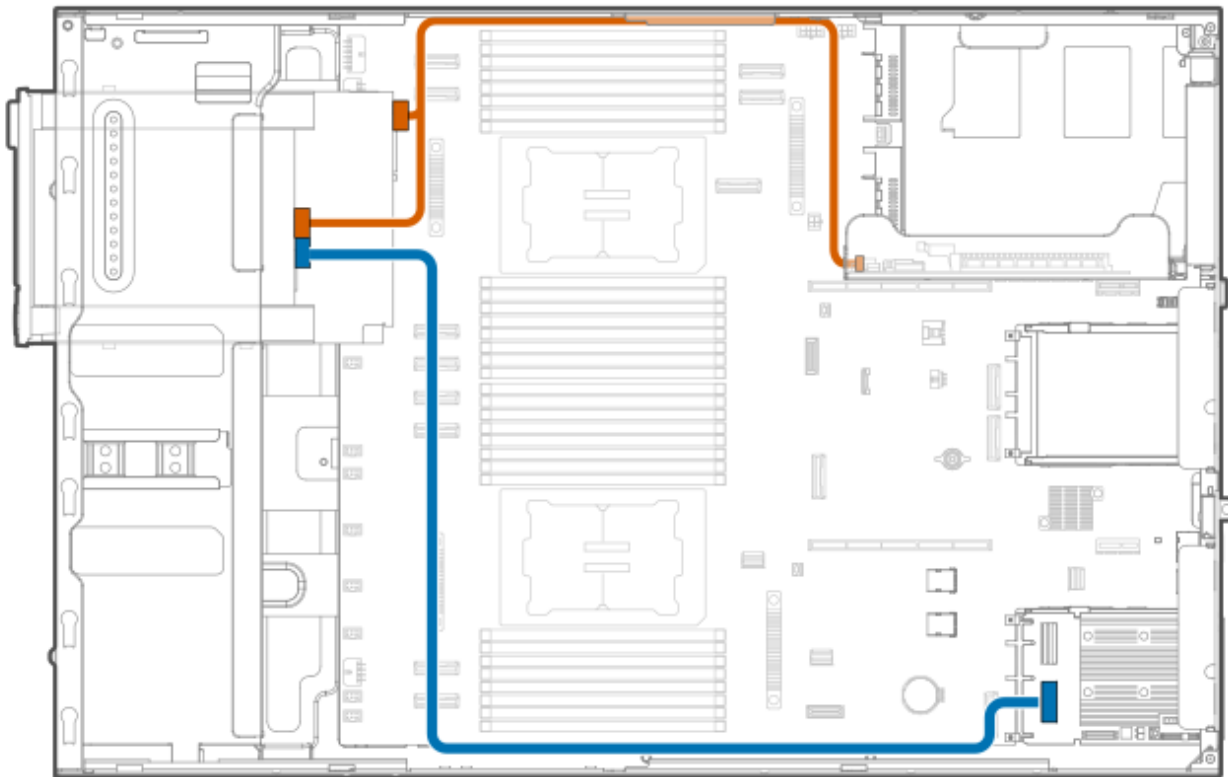

Cable part number	Color	From	To
P45303-001	Orange	LTO power connector	LTO power connector on the tertiary riser
P49007-001	Blue	SAS connector of the LTO tape drive	Type-o storage controller port 1

Type-p controller

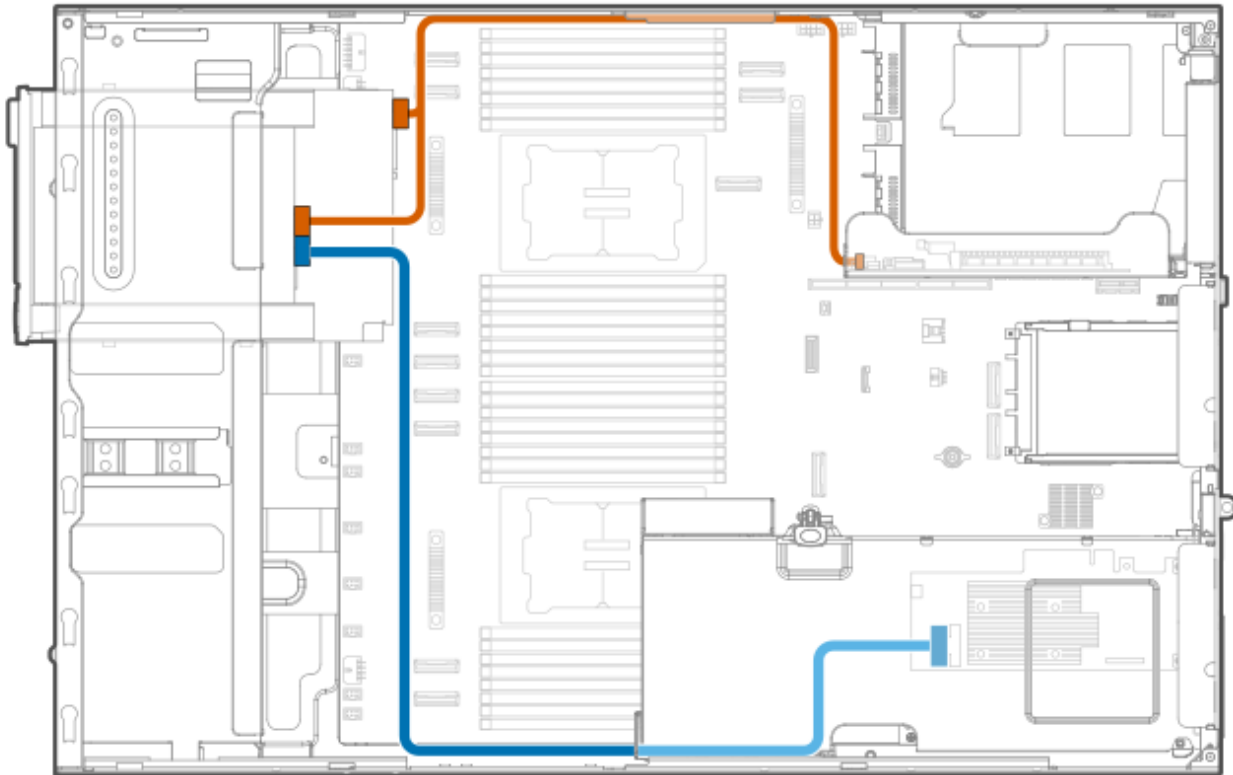

Cable part number	Color	From	To
P45303-001	Orange	LTO power connector	LTO power connector on the tertiary riser
P49006-001	Blue	SAS connector of the LTO tape drive	Type-p storage controller port 1

Optical drive cabling

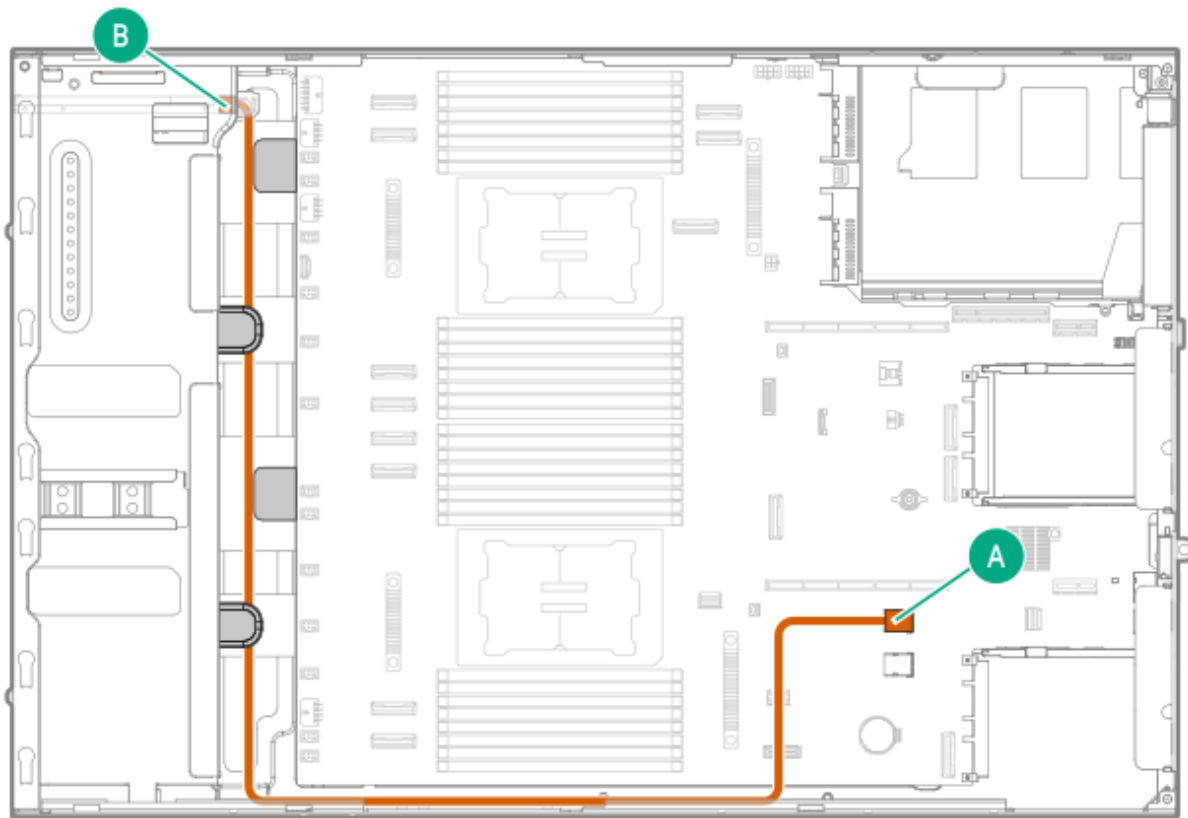

Cable part number	Color	From	To
P73776-002 ¹ / _—	Orange	Optical drive	Dual USB 3.2 Gen 1 ports

¹/_— This cable ships with the optical drive option.

HPE NS204i-u Boot Device V2 cabling

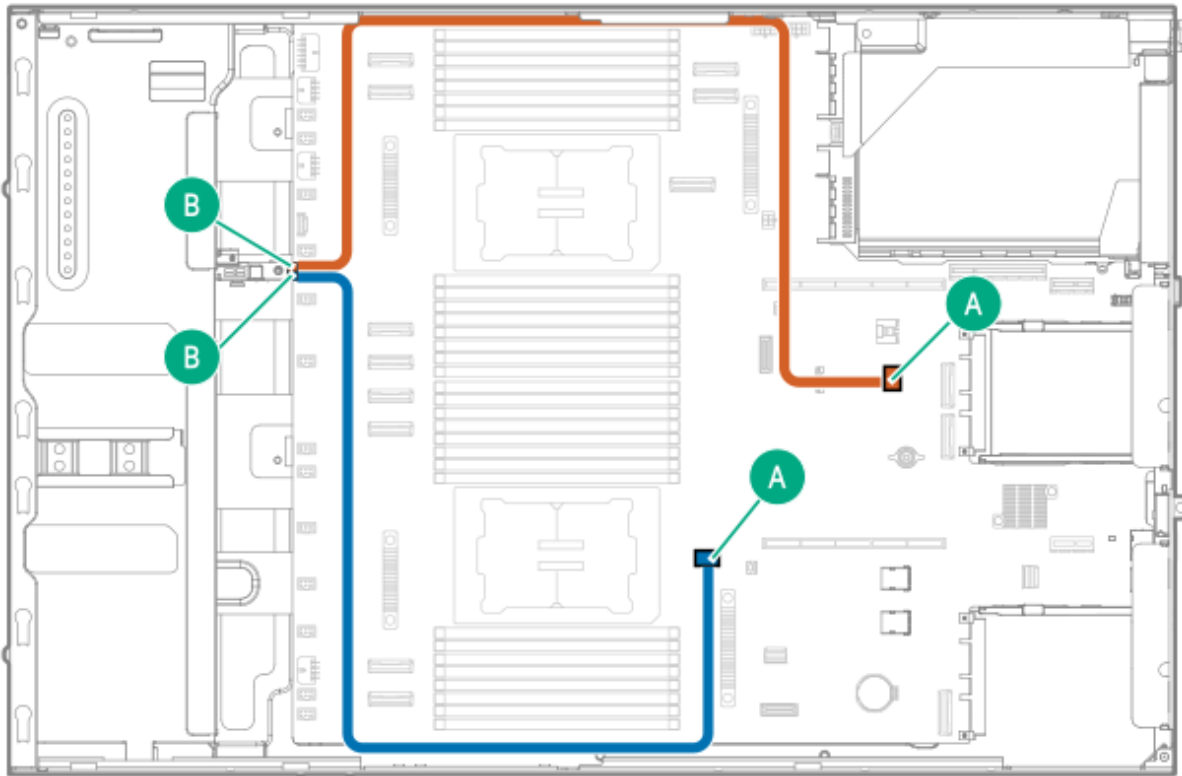

Cable part number	Color	From	To
P48956-001	Orange	Boot device power connector	NS204i-u power connector
P74730-001	Blue	Boot device signal connector	NS204i-u signal connector

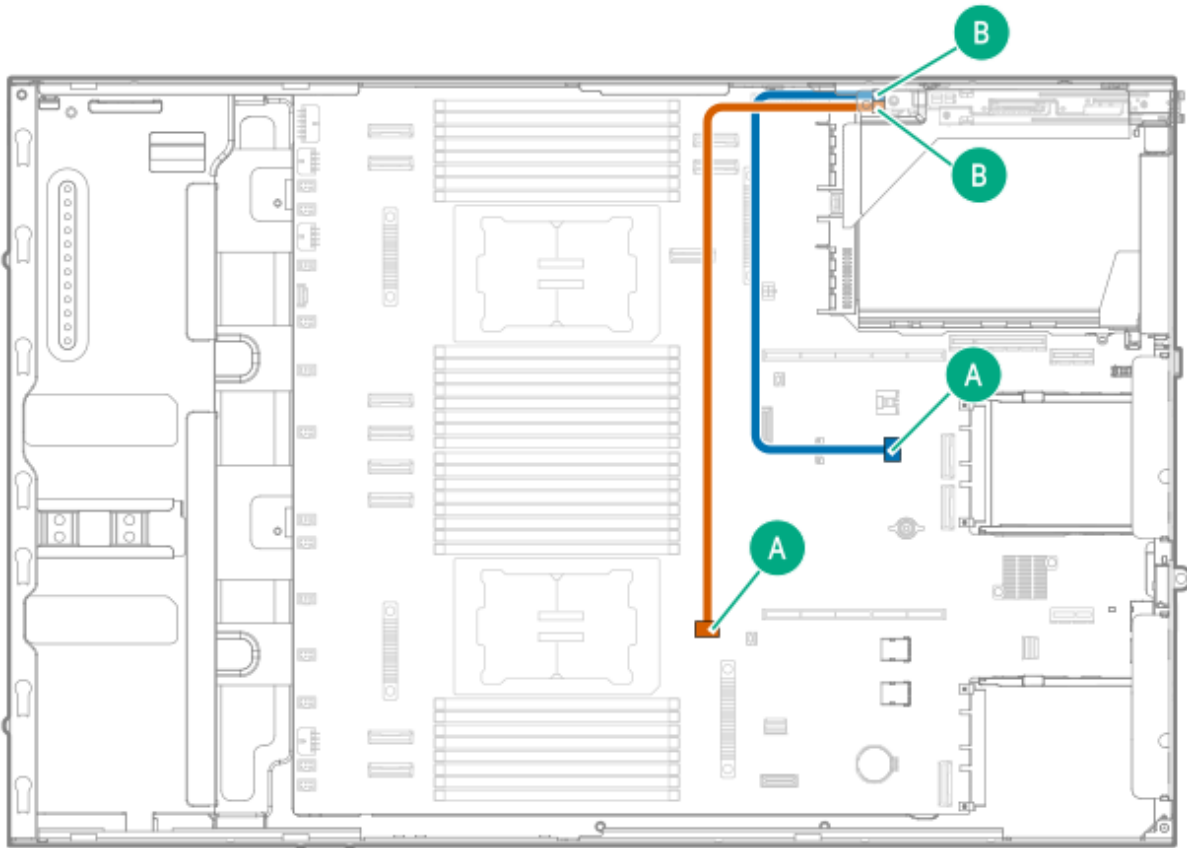

Cable part number	Color	From	To
P72024-001	Orange	Boot device signal connector	NS204i-u signal connector
P54089-001	Blue	Boot device power connector	NS204i-u power connector

GPU auxiliary power cabling

The exact route of the GPU auxiliary power cabling will depend on the:

- The riser cage where the GPU is installed.
- The location of the power connector on the GPU.

Use the following diagrams for reference only.

16-pin GPU auxiliary power Y-cable



Cable part number	Color	From	To
P58422-001	Orange	GPU power connector	<u>GPU auxiliary power connector on the PCIe5 2 x16 riser</u>
	Blue		<u>GPU sideband connector on the PCIe5 2 x16 riser</u>

Fan cabling

Internal fans 1-8



Cable part number	Color	From	To
P53695-001	Orange	Internal fans 3, 4, 7, and 8	Fan connector 9, 12, 10, 11
P53694-001	Blue	Internal fans 1, 2, 5, and 6	Fan connector 3, 6, 4, 5

External fans 9-10



Cable part number	Color	From	To
P45291-001	Orange	External fan 10	Fan connector 1
	Blue	External fan 9	Fan connector 13

OCP bandwidth enablement cabling

Slot 14 OCP A PCIe x16 configuration



Cable part number	Color	From	To
P74890-001	Orange	MCIO port 12	OCP slot A storage backup power connector

Slot 15 OCP B PCIe x8 configuration (Single-processor configuration)

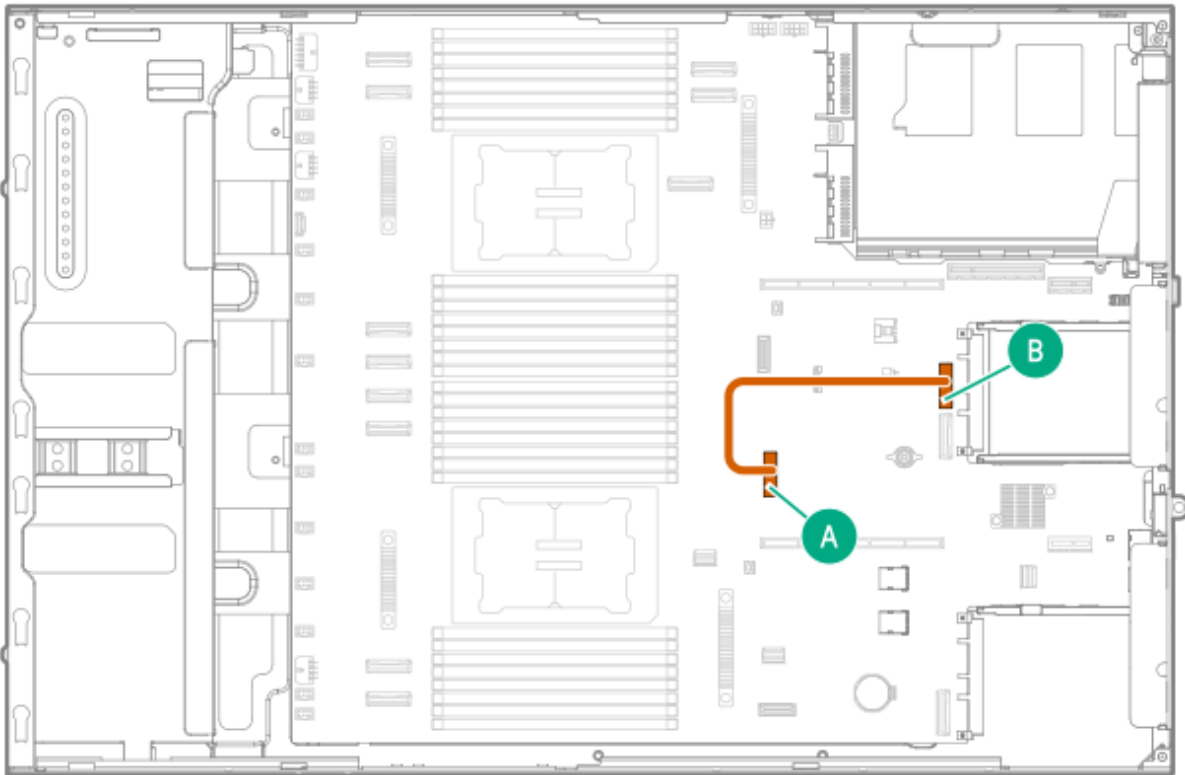

Cable part number	Color	From	To
P74889-001	Orange	MCIO port 12	OCP B internal port 1

Slot 15 OCP B PCIe x16 configuration (Dual-processor configuration)

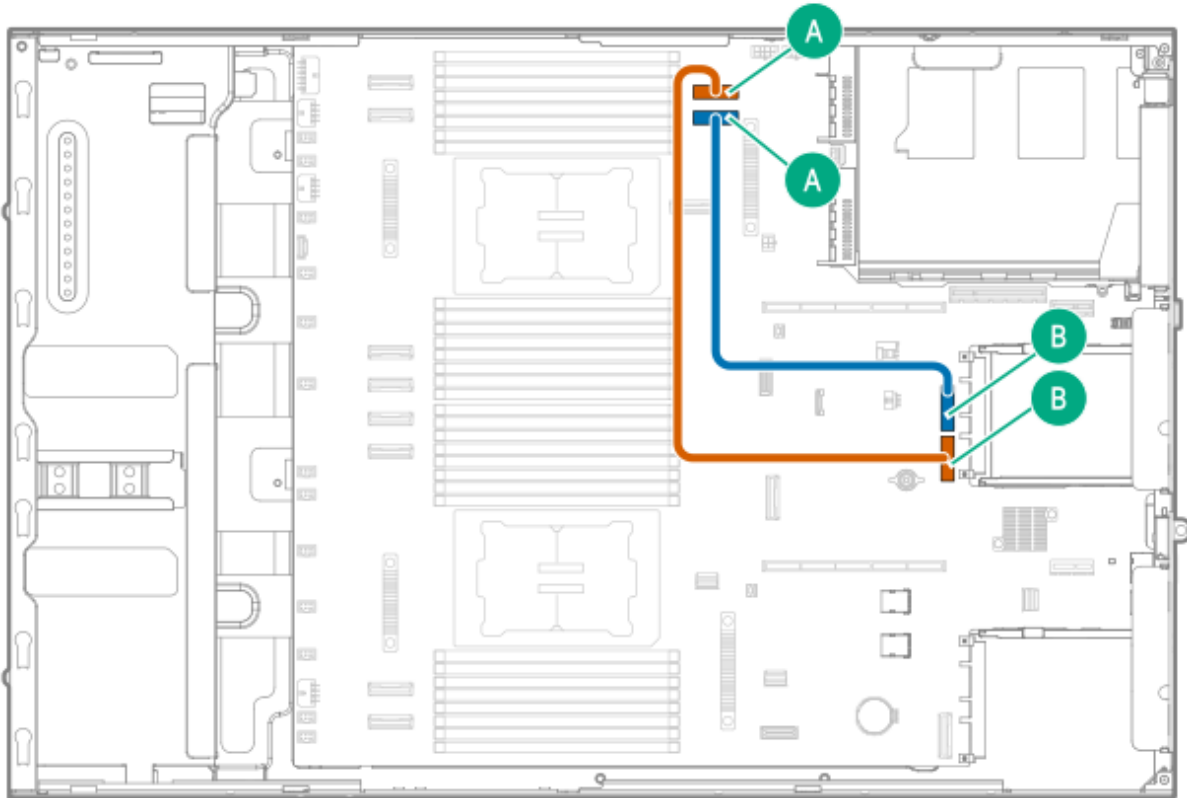

Cable part number	Color	From	To
P74891-001	Orange	MCIO port 9	OCP B internal port 2
	Blue	MCIO port 10	OCP B internal port 1

Tertiary riser signal cabling

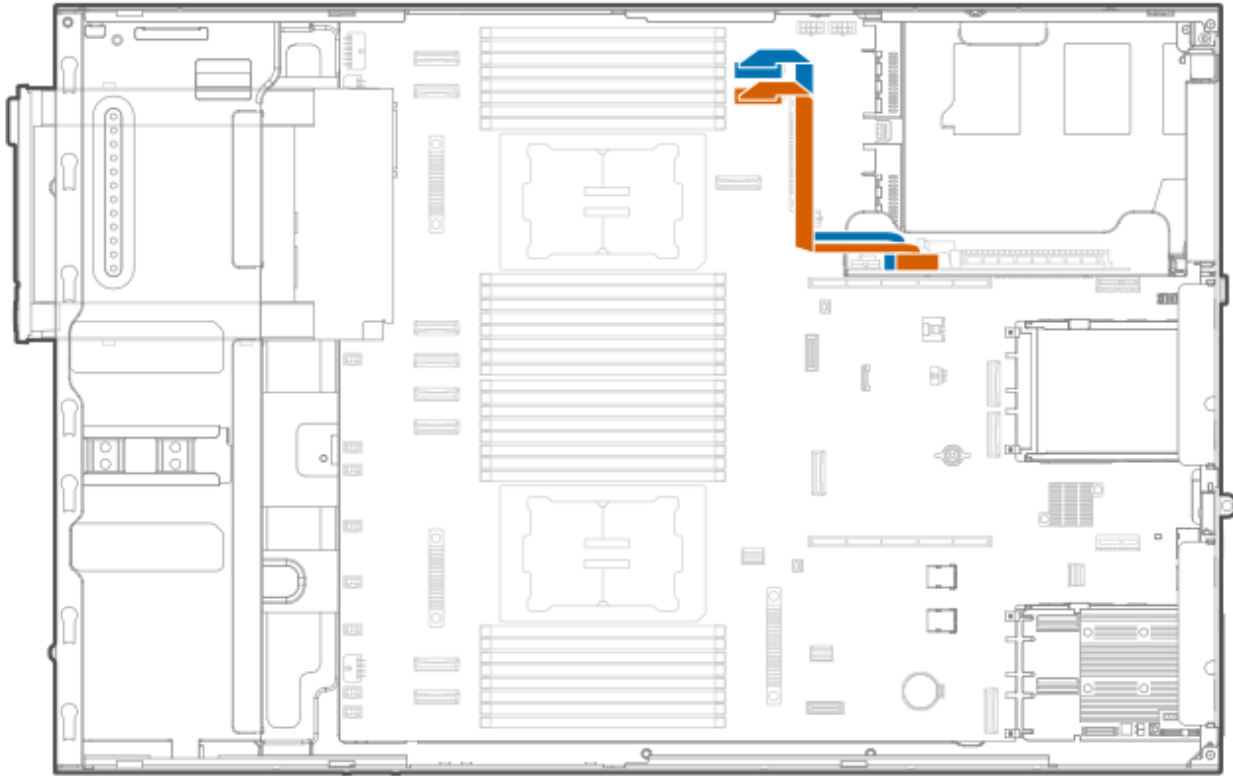

Cable part number	Color	From	To
P79969-001	Blue	M-XIO port 9	PCIe SlimSAS port 3
	Orange	M-XIO port 10	PCIe SlimSAS port 1

Serial port cabling



Cable part number	Color	From	To
P45623-001	Orange	Serial port	Serial port cable connector

Chassis intrusion detection switch cabling

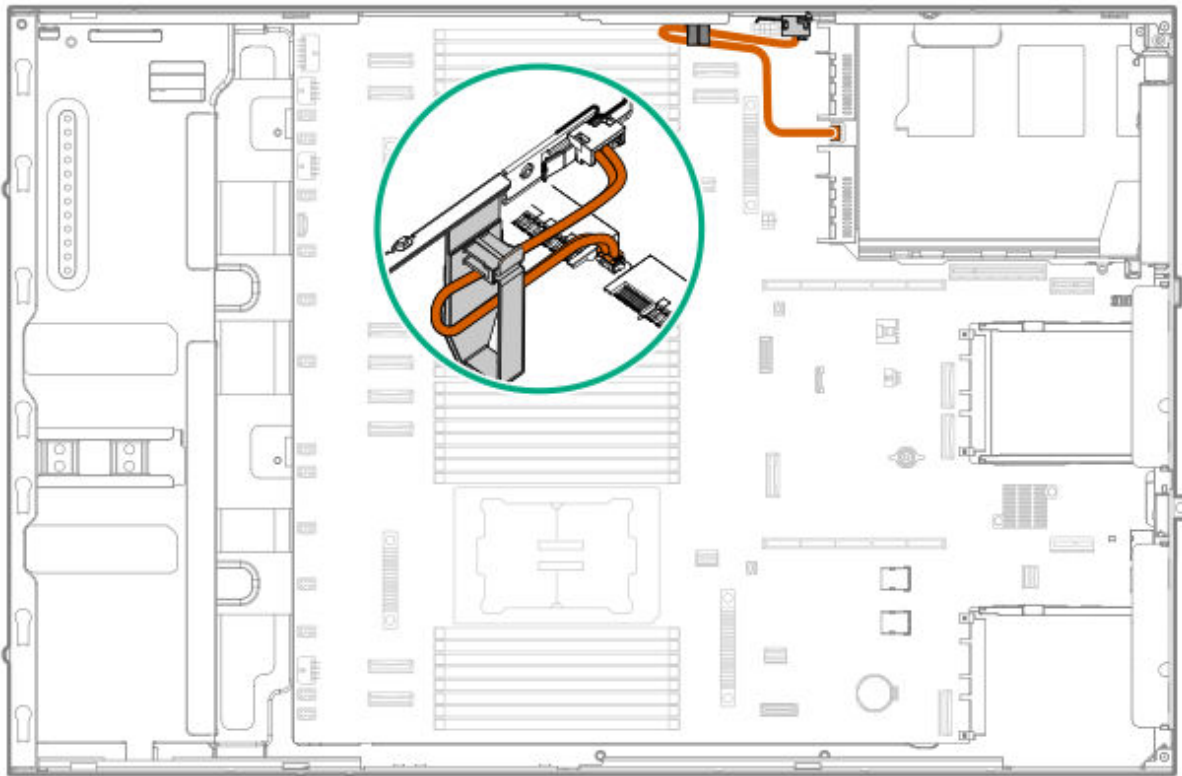

Cable part number	Color	From	To
P47751-001	Orange	Chassis intrusion detection switch	Chassis intrusion detection switch connector

Front I/O cabling

The front I/O cables are preinstalled in the server.

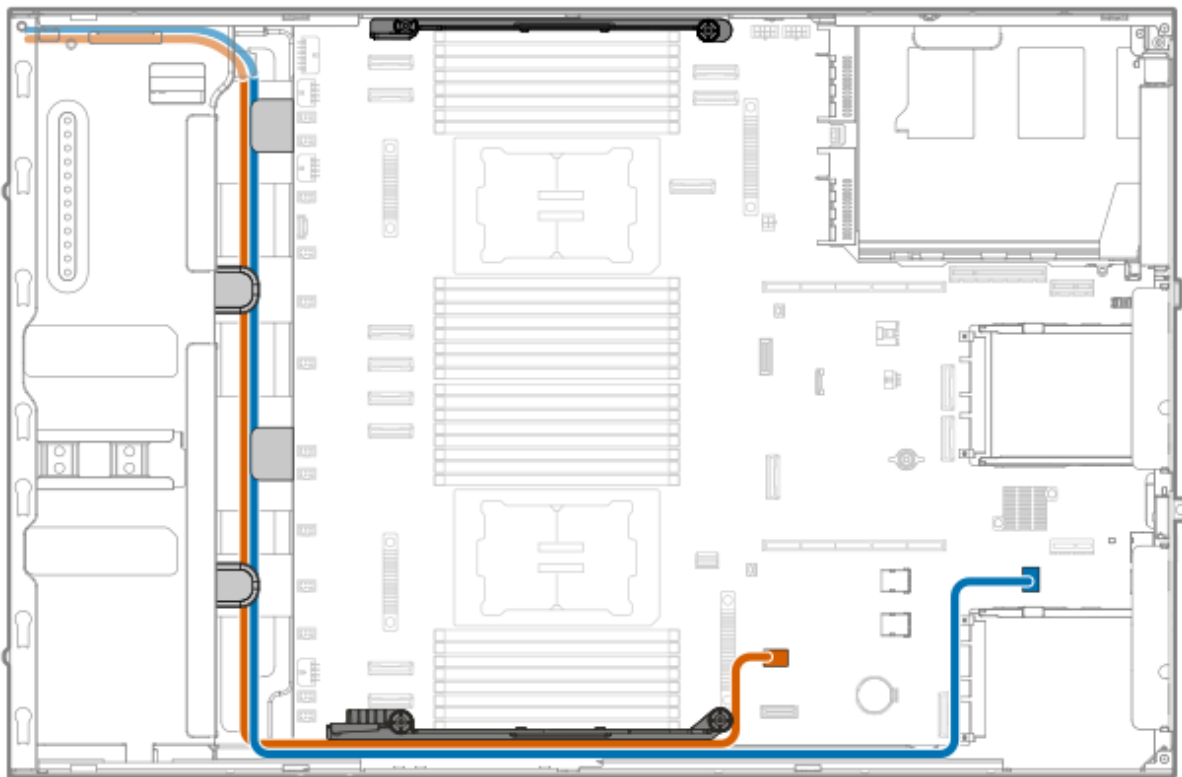

Cable part number	Color	From	To
P71909-001	Orange	Front I/O cage	Front I/O connector
P75279-001	Blue		DisplayPort & iLO service port connector

Configuration resources

Use the following resources to find documentation for configuring and managing your server.

- Some utilities might not apply to your server. For information about server compatibility with the products listed in this chapter, see the product QuickSpecs (<https://www.hpe.com/info/quickspecs>).
- Products ordered from HPE Factory Express might have already been configured with some or all the configurations in this chapter. To determine if any additional setup is required, see your HPE Factory Express order.

- For one-stop access to version-specific software and firmware documentation, including the latest product release notes, see this quick links page:

<https://www.hpe.com/support/hpeproductdocs-quicklinks>

Subtopics

[Updating firmware or system ROM](#)

[Configuring the server](#)

[Configuring storage controllers](#)

[Deploying an OS](#)

[Configuring security](#)

[Server management](#)

[Managing Linux-based high performance compute clusters](#)

Updating firmware or system ROM

To	Use
Download service packs	<ul style="list-style-type: none"> • Service Pack for HPE ProLiant <u>https://www.hpe.com/servers/spp/download</u> • Get an overview of SPP and its ecosystem <u>https://www.hpe.com/support/SPP-overview-views-en</u>
Deploy service packs to a single server	Smart Update Manager <u>https://www.hpe.com/support/hpesmartupdatemanager-quicklinks</u>
Deploy service packs to multiple servers	HPE OneView <u>https://www.hpe.com/support/hpeoneview-quicklinks</u>
Updating iLO or system firmware in a single server	iLO user guide <u>https://www.hpe.com/support/hpeilodocs-quicklinks</u>

To	Use
<ul style="list-style-type: none"> • Enable policy-based management of server or server group firmware for distributed server infrastructure • Monitor server compliance with a configured firmware baseline • Receive automatic iLO firmware updates • Receive baseline update alerts 	<p>HPE Compute Ops Management</p> <p>https://www.hpe.com/support/hpe-gl-com-quicklinks</p>

Configuring the server

To configure	Use
Single server (GUI)	<ul style="list-style-type: none"> • Intelligent Provisioning https://www.hpe.com/support/hpeintelligentprovisioning-quicklinks • iLO remote console or web interface https://www.hpe.com/support/hpeilodocs-quicklinks • UEFI System Utilities https://www.hpe.com/support/hpeuefisystemutilities-quicklinks • HPE Compute Ops Management https://www.hpe.com/support/hpe-gl-com-quicklinks
Single server (scripting)	<ul style="list-style-type: none"> • RESTful Interface Tool https://www.hpe.com/support/restfulinterface/docs

To configure

Use

- Python iLO Redfish Library (python-ilorest-library)
<https://github.com/HewlettPackard/python-ilorest-library>
- Scripting Tools for Windows Powershell
<https://www.hpe.com/info/powershell/docs>
- iLO RESTful API
<https://servermanagementportal.ext.hpe.com/>
- HPE Compute Ops Management API
<https://developer.greenlake.hpe.com/>

Multiple servers (either UI or scripting)

- HPE OneView ¹
<https://www.hpe.com/support/hpeoneview-quicklinks>
- HPE Compute Ops Management
<https://www.hpe.com/support/hpe-gl-com-quicklinks>
 - **Server settings:** Define server-specific parameters such as firmware baselines, and then apply them to server groups.
 - **Server groups:** Organize servers into custom-defined sets with associated server settings, and then apply group-specific policies to create a consistent configuration across the servers in the group.

¹ For servers running HPE OneView, do not use another tool, such as iLO, to delete or change certain settings. For more information about using HPE OneView and iLO to manage the same server, see the iLO user guide at <https://www.hpe.com/support/hpeilodocs-quicklinks>.

Configuring storage controllers

Controller type	Documentation
HPE MR controller user guides	<ul style="list-style-type: none">• HPE MR Gen11 Controller User Guide https://hpe.com/support/MR-Gen11-UG<ul style="list-style-type: none">◦ MR Gen11 controller configuration: https://www.hpe.com/support/MR-Gen11-configuration◦ MR Gen11 controller RAID creation: https://www.hpe.com/support/MR-Gen11-RAID-creation
HPE MR controller configuration guides	<ul style="list-style-type: none">• HPE MR Storage Administrator User Guide https://www.hpe.com/support/MRSA• HPE StorCLI User Guide https://www.hpe.com/support/StorCLI• HPE StorCLI2 User Guide https://www.hpe.com/support/StorCLI2
Intel VROC for HPE Gen12	<ul style="list-style-type: none">• Intel Virtual RAID on CPU for HPE User Guide https://www.hpe.com/support/VROC-UG• Intel VROC NVMe RAID quick installation: https://www.hpe.com/support/VROC-NVMe-RAID-installation <p>OS-specific configuration guides:</p> <ul style="list-style-type: none">• Intel Virtual RAID on CPU (Intel VROC) for Windows User Guide https://docs.graidtech.com/vroc/User_Guides/000094004_Intel_Virtual_RAID_on_CPU_Intel_VROC_User_Guide_for_Windows/

Controller type

Documentation

- Intel Virtual RAID on CPU (Intel VROC) for Linux User Guide

https://docs.graidtech.com/vroc/User_Guides/000094694_Intel_Virtual_RAID_on_CPU_Intel_VROC_User_Guide_for_Linux/

- Intel Volume Management Device Driver for VMware ESXi User Guide

https://docs.graidtech.com/vroc/User_Guides/000094787_Intel_Virtual_RAID_on_CPU_Intel_VROC_User_Guide_for_VMware_ESXi/

Deploying an OS

For a list of supported operating systems, see the HPE Servers Support & Certification Matrices:

<https://www.hpe.com/support/Servers-Certification-Matrices>

To

See

Deploy an OS using HPE Compute Ops Management

HPE Compute Ops Management User Guide

<https://www.hpe.com/support/hpe-gl-com-quicklinks>

Deploy an OS using Intelligent Provisioning

Intelligent Provisioning user guide

<https://www.hpe.com/support/hpeintelligentprovisioning-quicklinks>

Deploy an OS using iLO virtual media

iLO user guide

<https://www.hpe.com/support/hpeilodocs-quicklinks>

Configure the server to boot from a PXE server

UEFI System Utilities User Guide for HPE Compute servers

<https://www.hpe.com/support/UEFIGen12-UG-en>

Configure the server to boot from a SAN

HPE Boot from SAN Configuration Guide

To

See

<https://www.hpe.com/info/boot-from-san-config-guide>

Configuring security

To

See

Implement server security best practices.

- HPE Compute Security Reference Guide

<https://www.hpe.com/info/server-security-reference-en>

- HPE iLO 7 Security Technology Brief

<https://www.hpe.com/support/ilo7-security-en>

Configure and use the Server Configuration Lock feature on HPE Trusted Supply Chain servers and other servers that have the Server Configuration Lock feature enabled.

Server Configuration Lock User Guide for HPE ProLiant servers and HPE Synergy

<https://www.hpe.com/info/server-config-lock-UG-en>

Server management

To monitor

See

Single server

HPE iLO

<https://www.hpe.com/support/hpeilodocs-quicklinks>

Multiple servers

HPE OneView

To monitor	See
	https://www.hpe.com/support/hpeoneview-quicklinks
Single or multiple servers	HPE Compute Ops Management https://www.hpe.com/support/hpe-gl-com-quicklinks

Managing Linux-based high performance compute clusters

To	Use
Provision, manage, and monitor clusters.	HPE Performance Cluster Manager https://www.hpe.com/support/hpcm_manuals
Optimize your applications.	HPE Performance Analysis Tools https://www.hpe.com/info/perftools
Optimize software library for low latency and high bandwidth, both on-node and off-node, for point-to-point and collective communications.	HPE Cray Programming Environment User Guide https://www.hpe.com/info/cray-pe-user-guides

Troubleshooting

Subtopics

[NMI functionality](#)

[Front panel LED power fault codes](#)

[Troubleshooting resources](#)

NMI functionality

An NMI crash dump enables administrators to create crash dump files when a system is not responding to traditional debugging methods.

An analysis of the crash dump log is an essential part of diagnosing reliability problems, such as hanging operating systems, device drivers, and applications. Many crashes freeze a system, and the only available action for administrators is to cycle the system power. Resetting the system erases any information that could support problem analysis, but the NMI feature preserves that information by performing a memory dump before a hard reset.

To force the OS to initiate the NMI handler and generate a crash dump log, the administrator can use the iLO Generate NMI feature.

Front panel LED power fault codes

The following table provides a list of power fault codes, and the subsystems that are affected. Not all power faults are used by all servers.

Subsystem	LED behavior
System board	1 flash
Processor	2 flashes
Memory	3 flashes
Riser board PCIe slots	4 flashes
OCP adapter	5 flashes
Storage controller	6 flashes
System board PCIe slots	7 flashes
Power backplane	8 flashes
Storage backplane	9 flashes
Power supply	10 flashes
PCIe expansion cards installed in riser board	11 flashes
Chassis	12 flashes
GPU card	13 flashes

Troubleshooting resources

If you need help troubleshooting, see the latest articles for your server.

<https://www.hpe.com/info/ml350gen12-ts>

Safety, warranty, and regulatory information

Subtopics

[Regulatory information](#)

[Warranty information](#)

Regulatory information

To view the regulatory information for your product, view the Safety and Compliance Information for Server, Storage, Power, Networking, and Rack Products, available at the Hewlett Packard Enterprise Support Center:

<https://www.hpe.com/support/Safety-Compliance-EnterpriseProducts>

Additional regulatory information

Hewlett Packard Enterprise is committed to providing our customers with information about the chemical substances in our products as needed to comply with legal requirements such as REACH (Regulation EC No 1907/2006 of the European Parliament and the Council). A chemical information report for this product can be found at:

<https://www.hpe.com/info/reach>

For Hewlett Packard Enterprise product environmental and safety information and compliance data, including RoHS and REACH, see:

<https://www.hpe.com/info/ecodata>

For Hewlett Packard Enterprise environmental information, including company programs, product recycling, and energy efficiency, see:

<https://www.hpe.com/info/environment>

Subtopics

[Notices for Eurasian Economic Union](#)

[Turkey RoHS material content declaration](#)

Notices for Eurasian Economic Union



Manufacturer and Local Representative Information

Manufacturer information:

Hewlett Packard Enterprise Company, 1701 E Mossy Oaks Road, Spring, TX 77389 U.S.

Local representative information Russian:

- **Russia**
ООО "Хьюлетт Паккард Энтерпрайз", Российская Федерация, 125171, г. Москва, Ленинградское шоссе, 16А, стр.3, Телефон: +7 499 403 4248 Факс: +7 499 403 4677
- **Kazakhstan**
ТОО «Хьюлетт-Паккард (К)», Республика Казахстан, 050040, г. Алматы, Бостандыкский район, проспект Аль-Фараби, 77/7, Телефон/факс: + 7 727 355 35 50

Local representative information Kazakh:

- **Russia**
ЖШС "Хьюлетт Паккард Энтерпрайз", Ресей Федерациясы, 125171, Мәскеу, Ленинград тас жолы, 16А блок 3, Телефон: +7 499 403 4248 Факс: +7 499 403 4677
- **Kazakhstan**
ЖШС «Хьюлетт-Паккард (К)», Қазақстан Республикасы, 050040, Алматы қ., Бостандық ауданы, Әл-Фараби даңғылы, 77/7, Телефон/факс: +7 727 355 35 50

Manufacturing date:

The manufacturing date is defined by the serial number.

CCSYWWZZZZ (product serial number format)

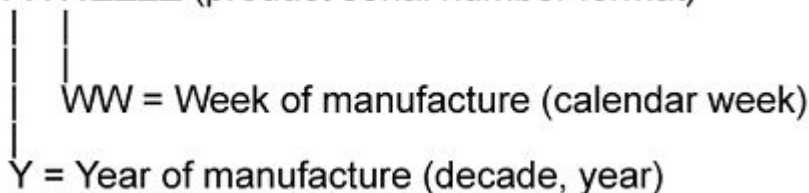

If you need help identifying the manufacturing date, contact tre@hpe.com.

Turkey RoHS material content declaration

Türkiye Cumhuriyeti: AEEE Yönetmeliğine Uygundur

Ukraine RoHS material content declaration

Обладнання відповідає вимогам Технічного регламенту щодо обмеження використання деяких небезпечних речовин в електричному та електронному обладнанні, затвердженого постановою Кабінету Міністрів України від 3 грудня 2008 № 1057

Warranty information

To view the warranty information for your product, see the [warranty check tool](#).

Specifications

Subtopics

[Environmental specifications](#)

[Mechanical specifications](#)

[Power supply specifications](#)

Environmental specifications

Specifications	Value
Temperature range	—

Specifications	Value
Operating	10°C to 35°C (50°F to 95°F)
Nonoperating	-30°C to 60°C (-22°F to 140°F)
Relative humidity (noncondensing)	—
Operating	8% to 90% 28°C (82.4°F) maximum wet bulb temperature, noncondensing
Nonoperating	5% to 95% 38.7°C (101.7°F) maximum wet bulb temperature, noncondensing
Altitude	—
Operating	3050 m (10,000 ft) This value may be limited by the type and number of options installed. Maximum allowable altitude change rate is 457 m/min (1,500 ft/min).
Nonoperating	9144 m (30,000 ft) Maximum allowable altitude change rate is 457 m/min (1,500 ft/min).

Standard operating support

10° to 35°C (50° to 95°F) at sea level with an altitude derating of 1.0°C per every 305 m (1.8°F per every 1,000 ft) above sea level to a maximum of 3,050 m (10,000 ft), no direct sustained sunlight. Maximum rate of change is 20°C/hr (36°F/hr). The upper limit and rate of change might be limited by the type and number of options installed.

System performance under standard operating support might be reduced if operating above 30°C (86°F) or with a faulty fan installed.

Extended ambient operating support

For approved hardware configurations, the supported system inlet range is extended to be:

- 5° to 10°C (41° to 50°F) and 35° to 40°C (95° to 104°F) at sea level with an altitude derating of 1.0°C per every 175 m (1.8°F per every 574 ft) above 900 m (2,953 ft) to a maximum of 3050 m (10,000 ft).
- 40°C to 45°C (104°F to 113°F) at sea level with an altitude derating of 1.0°C per every 125 m (1.8°F per every 410 ft) above 900 m (2,953 ft) to a maximum of 3,050 m (10,000 ft).

The approved hardware configurations for this system are listed in the Extended Ambient Temperature Guidelines for Gen12 Servers:

<https://www.hpe.com/support/ASHRAEGen12>

Mechanical specifications

Tower orientation

Specification	Value
Dimensions	—
Height (with chassis feet)	46.2 cm (18.19 in)
Height (without chassis feet)	44.5 cm (17.5 in)
Depth (without extended fan)	71.27 cm (28.07 in)
Depth (with extended fan)	74.43 cm (29.30 in)
Width (with chassis feet)	29.36 cm (11.56 in)
Width (without chassis feet)	17.4 cm (6.85 in)
Weight, approximate values	—
Minimum ¹	23.96 kg (58.22 lb)
Maximum ²	45.13 kg (99.49 lb)

¹ The minimum configuration includes 1 SFF drive, 1 processor, 1 DIMM, 1 standard heatsink, 1 power supply, 3 fans and 1 fan blank, primary riser and riser board, and 1 type-o storage controller.

² The maximum configuration includes 12 LFF drives, 1 slim optical disk drive, 2 processors, 32 DIMMs, 2 performance heatsink, 2 power supplies, 8 fans, all risers with riser boards, 2 type-o storage controllers, 4 double-width GPU cards, 2 full-height half-length PCIe cards, and 2 external fans.

Rack orientation

Specification	Value
Dimensions	—
Height (with chassis feet)	29.36 cm (11.56 in)
Height (without chassis feet)	17.4 cm (6.85 in)
Depth (without extended fan)	71.27 cm (28.07 in)
Depth (with extended fan)	74.43 cm (29.30 in)
Width	44.5 cm (17.5 in)
Weight, approximate values	—
Minimum	23.96 kg (58.22 lb)
Maximum	45.13 kg (99.49 lb)

Power supply specifications

Depending on the installed options and the regional location where the server was purchased, the server can be configured with one of the following power supplies. For detailed power supply specifications, see the QuickSpecs on the [Hewlett Packard Enterprise website](#).

Subtopics

[HPE 800 W Flex Slot Platinum Hot-plug Low Halogen Power Supply](#)

[HPE 1000 W Flex Slot Titanium Hot-plug Power Supply](#)

[HPE 1600 W Flex Slot Platinum Hot-plug Low Halogen Power Supply](#)

[HPE 1600 W Flex Slot -48 VDC Hot-plug Power Supply](#)

[HPE 1800-2200 W Flex Slot Titanium Power Supply](#)

HPE 800 W Flex Slot Platinum Hot-plug Low Halogen Power Supply

Specification	Value
Input requirements	—
Rated input voltage	100 VAC to 127 VAC 200 VAC to 240 VAC 240 VDC for China only
Rated input frequency	50 Hz to 60 Hz Not applicable to 240 VDC
Rated input current	9.4 A at 100 VAC 4.5 A at 200 VAC 3.8 A at 240 VDC for China only
Maximum rated input power	940 W at 100 VAC 900 W at 200 VAC 897 W at 240 VDC for China only
BTUs per hour	3067 at 100 VAC 2958 at 200 VAC 2949 at 240 VAC for China only

Specification	Value
Power supply output	—
Rated steady-state power	800 W at 100 VAC to 127 VAC input 800 W at 100 VAC to 240 VAC input 800 W at 240 VDC input for China only
Maximum peak power	800 W at 100 VAC to 127 VAC input 800 W at 100 VAC to 240 VAC input 800 W at 240 VDC input for China only

HPE 1000 W Flex Slot Titanium Hot-plug Power Supply

Specification	Value
Input requirements	—
Rated input voltage	100 VAC to 127 VAC 200 VAC to 240 VAC 240 VDC for China
Rated input frequency	50 Hz to 60 Hz
Rated input current	11.3 A at 100 VAC 6.1 A at 200 VAC
Maximum rated input power	1130 W at 100 VAC 1090 W at 200 VAC
BTUs per hour	3764 at 100 VAC 3629 at 200 VAC
Power supply output	—
Rated steady-state power	1000 W at 100 VAC to 127 VAC 1000 W at 200 VAC to 240 VAC input
Maximum peak power	1000 W at 100 VAC to 127 VAC 1000 W at 200 VAC to 240 VAC

HPE 1600 W Flex Slot Platinum Hot-plug Low Halogen Power Supply

Specification	Value
Input requirements	—
Rated input voltage	200 VAC to 240 VAC 240 VDC for China only
Rated input frequency	50 Hz to 60 Hz
Rated input current	8.7 A at 200 VAC 7.5 A at 230 VAC 7.2 A at 240 VDC
Maximum rated input power	1734 W at 200 VAC 1720 W at 240 VAC
BTUs per hour	5918 at 200 VAC 5891 at 230 VAC
Power supply output	—
Rated steady-state power	1600 W at 200 VAC to 240 VAC input 1600 W at 240 VDC input
Maximum peak power	1600 W for 1 ms (turbo mode) at 200 VAC to 240 VAC input

HPE 1600 W Flex Slot -48 VDC Hot-plug Power Supply

Specification	Value
Input requirements	—
Rated input voltage	-40 VDC to -72 VDC
Rated input frequency	DC

Specification	Value
Nominal input current	45 A DC at -40 VDC input 36.6 A DC at -48 VDC input 24.4 A DC at -72 VDC input
Maximum Rated Input Wattage Rating	1798 W at -40 VDC input 1758 W at -48 VDC input 1755 W at -72 VDC input
BTUs per hour	6026 at -40 VDC input 6000 at -48 VDC input 5989 at -72 VDC input
Power supply output	—
Rated steady-state power	1600 W at -40 VDC to -72 VDC
Maximum peak power	1600 W at -40 VDC to -72 VDC

HPE 1800-2200 W Flex Slot Titanium Power Supply

Specification	Value
Input requirements	—
Rated input voltage	200 VAC to 240 VAC 240 VDC for China only
Rated input frequency	50 Hz to 60 Hz
Rated input current	10 A at 200 VAC 10 A at 240 VAC 10 A at 240 VDC for China only
Maximum rated input power	1946 W at 200 VAC 2375 W at 240 VAC 2375 W at 240 VDC for China only
BTUs per hour	6497 at 200 VAC

Specification	Value
	7962 at 240 VAC
Power supply output	—
Rated steady-state power	1800 W at 200 VAC 2200 W at 240 VAC
Maximum peak power	2200 W for 1 ms (turbo mode) at 200 VAC to 240 VAC input

Websites

General websites

Single Point of Connectivity Knowledge (SPOCK) Storage compatibility matrix

<https://www.hpe.com/storage/spock>

Product white papers and analyst reports

<https://www.hpe.com/us/en/resource-library>

For additional websites, see [Support and other resources](#).

Product websites

HPE ProLiant Compute ML350 Gen12 Server user documents

<https://www.hpe.com/info/ml350gen12-docs>

Support and other resources

Subtopics

[Accessing Hewlett Packard Enterprise Support](#)

[HPE product registration](#)

[Accessing updates](#)

[Customer self repair](#)

[Remote support](#)

[Documentation feedback](#)

Accessing Hewlett Packard Enterprise Support

- For live assistance, go to the Contact Hewlett Packard Enterprise Worldwide website:

<https://www.hpe.com/info/assistance>

- To access documentation and support services, go to the Hewlett Packard Enterprise Support Center website:

<https://www.hpe.com/support/hpesc>

Information to collect

- Technical support registration number (if applicable)
- Product name, model or version, and serial number
- Operating system name and version
- Firmware version
- Error messages
- Product-specific reports and logs
- Add-on products or components
- Third-party products or components

HPE product registration

To gain the full benefits of the Hewlett Packard Enterprise Support Center and your purchased support services, add your contracts and products to your account on the HPESC.

- When you add your contracts and products, you receive enhanced personalization, workspace alerts, insights through the dashboards, and easier management of your environment.
- You will also receive recommendations and tailored product knowledge to self-solve any issues, as well as streamlined case creation for faster time to resolution when you must create a case.

To learn how to add your contracts and products, see **<https://www.hpe.com/info/add-products-contracts>**.

Accessing updates

- Some software products provide a mechanism for accessing software updates through the product interface. Review your product documentation to identify the recommended software update method.
- To download product updates:

Hewlett Packard Enterprise Support Center

<https://www.hpe.com/support/hpesc>

My HPE Software Center

<https://www.hpe.com/software/hpesoftwarecenter>

- To subscribe to eNewsletters and alerts:

<https://www.hpe.com/support/e-updates>

- To view and update your entitlements, and to link your contracts and warranties with your profile, go to the Hewlett Packard Enterprise Support Center **More Information on Access to Support Materials** page:

<https://www.hpe.com/support/AccessToSupportMaterials>



IMPORTANT

Access to some updates might require product entitlement when accessed through the Hewlett Packard Enterprise Support Center. You must have an HPE Account set up with relevant entitlements.

Customer self repair

Hewlett Packard Enterprise customer self repair (CSR) programs allow you to repair your product. If a CSR part needs to be replaced, it will be shipped directly to you so that you can install it at your convenience. Some parts do not qualify for CSR.

For more information about CSR, contact your local service provider.

Remote support

Remote support is available with supported devices as part of your warranty or contractual support agreement. It provides intelligent event diagnosis, and automatic, secure submission of hardware event

notifications to Hewlett Packard Enterprise, which initiates a fast and accurate resolution based on the service level of your product. Hewlett Packard Enterprise strongly recommends that you register your device for remote support.

If your product includes additional remote support details, use search to locate that information.

HPE Get Connected

<https://www.hpe.com/services/getconnected>

HPE Tech Care Service

<https://www.hpe.com/services/techcare>

HPE Complete Care Service

<https://www.hpe.com/services/completecure>

Documentation feedback

Hewlett Packard Enterprise is committed to providing documentation that meets your needs. To help us improve the documentation, click the **Feedback** button on the page of an opened document on the Hewlett Packard Enterprise Support Center portal (<https://www.hpe.com/support/hpesc>). Use this feature to send any errors, suggestions, or comments. This process captures all document information.