



HPE ProLiant Compute DL360 Gen12 User Guide

Part Number: 30-619DBC1F-006

Published: April 2026

Edition: 6

HPE ProLiant Compute DL360 Gen12 User Guide

Abstract

This document is for the person who installs, administers, and troubleshoots servers and storage systems. Hewlett Packard Enterprise assumes you are qualified in the servicing of computer equipment and trained in recognizing hazards in products with hazardous energy levels, and are familiar with the weight and stability precautions for rack installations.

Part Number: 30-619DBC1F-006

Published: April 2026

Edition: 6

© Copyright 2025–2026 Hewlett Packard Enterprise Development LP

Notices

The information provided here is subject to change without notice. Hewlett Packard Enterprise's products and services are covered only by the express warranty statements that come with them. This document does not constitute an additional warranty. Hewlett Packard Enterprise is not responsible for any technical or editorial errors or omissions in this document.

Confidential computer software. You must have a valid license from Hewlett Packard Enterprise to possess, use, or copy the software. In accordance with FAR 12.211 and 12.212, Commercial Computer Software, Computer Software Documentation, and Technical Data for Commercial Items are licensed to the U.S. Government under the vendor's standard commercial license.

Links to third-party websites will take you outside of the Hewlett Packard Enterprise website. Hewlett Packard Enterprise has no control over and is not responsible for the information outside the Hewlett Packard Enterprise website.

Acknowledgments

Intel®, the Intel logo, and Xeon® are trademarks of Intel Corporation in the U.S. and other countries.

Kensington® is a registered trademark of ACCO Brands.

Linux® is the registered trademark of Linus Torvalds in the U.S. and other countries.

Microsoft® and Windows® are either registered trademarks or trademarks of Microsoft Corporation in the United States and/or other countries.

VMware®, VMware NSX®, VMware vCenter®, and VMware vSphere® are registered trademarks or trademarks of VMware, Inc. and its subsidiaries in the United States and other jurisdictions.

All third-party marks are property of their respective owners.

Table of contents

Component identification.....	10
Front panel components.....	11
Front panel LEDs and buttons.....	15
UID button functionality.....	16
System Insight Display LEDs.....	16
System Insight Display combined LED descriptions.....	18
Rear panel components.....	20
Rear panel LEDs.....	22
Component touchpoints.....	23
System board components.....	25
System maintenance switch descriptions.....	27
DIMM label identification.....	28
DIMM slot locations.....	29
PCIe connector and processor matrix.....	30
Drive bay numbering.....	31
Drive backplane naming.....	32
OCP NIC 3.0 slot numbering.....	33
HPE Basic Drive LED definitions.....	35
EDSFF SSD LED definitions.....	37
Fan numbering.....	38
Fan and heatsink requirements.....	39
Heatsink and processor socket components.....	41
Closed-loop liquid cooling (CLLC) module components.....	42
DLC module components.....	43
Liquid cooling guidelines.....	46
HPE NS204i-u Boot Device V2 components.....	47
HPE NS204i-u Boot Device V2 LED definitions	48
Riser board components.....	49
Riser slot numbering.....	51
Setup.....	52
HPE Installation Service.....	52
Setting up the server.....	52
Operational requirements.....	55
Space and airflow requirements.....	55

Temperature requirements.....	56
Power requirements.....	57
Electrical grounding requirements.....	57
Rack warnings and cautions.....	59
Server warnings and cautions.....	61
Electrostatic discharge.....	62
Operations.....	62
iLO service port.....	63
Intel VROC support.....	64
Server UID LED.....	64
Viewing the Server Health Summary.....	65
Monitor setup.....	65
Trusted Platform Module 2.0.....	66
Trusted Platform Module 2.0 guidelines.....	66
System battery information.....	67
Hardware options.....	67
Hewlett Packard Enterprise product QuickSpecs.....	68
Hardware option installation guidelines.....	69
Pre-installation procedures.....	69
Server data backup.....	70
Power down the server.....	71
Extend the server from the rack.....	71
Release the cable management arm.....	72
Remove the server from the rack.....	73
Remove the bezel.....	74
Remove the access panel.....	76
Remove the air baffle.....	77
Remove the middle cover.....	79
Remove the fan wall.....	80
Remove the primary PCIe riser cage.....	84
Remove a hot-plug SAS / SATA / NVMe drive.....	85
Remove a hot-plug E3.S drive.....	87
Accessing the System Insight Display.....	87
Post-installation procedures.....	89
Install the primary PCIe riser cage.....	90
Install the fan wall.....	91
Install the middle cover.....	92
Install the access panel.....	93

Install the front bezel.....	94
Install the server into the rack.....	94
Power up the server.....	97
Cooling.....	97
Fan mode behavior.....	97
Requirements for redundant fan support.....	97
Installing a high performance fan.....	98
Installing the air baffle.....	100
Drives.....	102
Drive installation guidelines.....	103
Installing a hot-plug SAS, SATA, or NVMe drive.....	103
Installing an E3.S drive.....	106
Drive cages.....	108
Installing a 2 SFF drive cage in the 8 SFF drive configuration.....	108
Installing the 4 E3.S stacked drive cage	113
Installing the 2 SFF stacked drive cage.....	121
Energy packs.....	128
HPE Smart Storage Battery.....	128
HPE Smart Storage Hybrid Capacitor.....	128
Installing a smart storage battery/capacitor.....	129
GPUs.....	131
Installing a GPU in the primary riser cage.....	131
Management.....	134
Installing the System Insight Display.....	134
Installing the serial port option.....	137
Media devices.....	140
Installing the 4 LFF DisplayPort/USB option.....	140
Installing the 4 LFF optical disk drive.....	144
Installing the 8 SFF DisplayPort / USB / optical drive blank option.....	149
Installing the 8 SFF optical disk drive.....	153
Installing the DisplayPort / USB / optical drive blank and optical drive in the 10 SFF / 20 E3.S server.....	157
Memory.....	163
HPE SmartMemory speed and population information.....	163
DIMM installation guidelines.....	163
Installing a DIMM blank.....	164
Installing a DIMM.....	165
Networking.....	168

About the front OCP NIC enablement kits.....	168
Installing a front OCP NIC.....	173
Enabling the iLO shared network connection.....	187
Installing a rear OCP network adapter	188
Installing a PCIe network adapter.....	192
OS boot device.....	194
Installing boot device drives.....	194
Installing the internal or rear boot device.....	198
Installing the front NS204i-u in drive box 5 of the 10 SFF / 20 E3.S server.....	205
Power supplies.....	212
Hot-plug power supply calculations.....	212
Power supply warnings and cautions.....	213
DC power supply warnings and cautions.....	214
DC power supply wire colors.....	215
Installing a redundant hot-plug power supply.....	215
Installing a DC power supply.....	217
Connecting a DC power cable to a DC power source.....	227
Processors and heatsinks.....	229
Processor cautions.....	230
Installing a high performance heatsink.....	230
Installing the closed-loop liquid cooling module.....	249
Connecting the direct liquid cooling kit.....	280
Rack rail and CMA.....	283
Rack mounting interfaces.....	283
Rack rail options.....	284
Rail identification markers.....	284
Installing the rack rails.....	286
Installing the server into the rack.....	292
Installing the rack rail hook-and-loop strap.....	294
Installing the cable management arm.....	295
Risers and riser cages.....	302
Primary PCI riser cage options.....	302
Installing an expansion board in slot 1.....	303
Installing an expansion board in slot 2.....	304
Secondary PCI riser options.....	307
Installing a secondary low-profile riser option.....	307
Installing a secondary full-height riser option.....	309
Installing an expansion board in the secondary riser cage.....	316

Security.....	319
Installing the front bezel option.....	319
Installing the Chassis Intrusion Detection switch option.....	320
Storage controllers.....	322
Installing a type-p storage controller.....	322
Installing a type-o storage controller.....	324
Cabling.....	326
Cabling guidelines.....	327
Cabling diagrams.....	329
Internal cabling management.....	336
Storage cabling.....	336
4 LFF drive backplane cabling.....	337
8 SFF drive backplane cabling.....	338
8 + 2 SFF drive backplane cabling.....	341
4 E3.S stacked drive backplane cabling.....	358
Drive Box 1 cabling.....	359
Drive Box 2 cabling.....	361
Drive Box 3 cabling.....	363
Drive Box 4 cabling.....	365
Drive Box 5 cabling.....	368
Drive box cabling for Boxes 1–2.....	371
Drive box cabling for boxes 1 and 4.....	374
Drive box cabling for boxes 1 and 5.....	375
Drive box cabling for boxes 4–5.....	376
2 SFF stacked drive backplane cabling.....	377
Drive Box 1 cabling.....	378
Drive Box 2 cabling.....	381
Drive Box 3 cabling.....	385
Drive Box 4 cabling.....	391
Drive Box 5 cabling.....	396
Drive box cabling for boxes 1–2.....	404
Drive box cabling for boxes 4–5.....	410
Drive box cabling for boxes 1–5.....	416
Storage controller backup power cabling.....	417
Drive power cabling.....	420
Energy pack cabling.....	424
Optical drive cabling.....	427
Front DisplayPort / USB cabling.....	430

Internal boot device cabling.....	432
Front OCP NIC cabling.....	438
OCP bandwidth enablement cabling.....	440
Serial port cabling.....	444
Chassis intrusion detection switch cabling.....	445
Front I/O cabling.....	445
System Insight Display cabling.....	447
Liquid cooling module cabling.....	448
Configuration resources.....	449
Updating firmware or system ROM.....	450
Configuring the server.....	451
Configuring storage controllers.....	453
Deploying an OS.....	454
Configuring security.....	455
Server management.....	456
Managing Linux-based high performance compute clusters.....	456
Troubleshooting.....	456
NMI functionality.....	457
Front panel LED power fault codes.....	457
Troubleshooting resources.....	458
Safety, warranty, and regulatory information.....	458
Regulatory information.....	458
Notices for Eurasian Economic Union.....	459
Turkey RoHS material content declaration.....	460
Ukraine RoHS material content declaration.....	460
Warranty information.....	460
Specifications.....	460
Environmental specifications.....	461
Server and rackmounting specifications.....	462
Power supply specifications.....	465
HPE 800 W Flex Slot Platinum Hot-plug Low Halogen Power Supply.....	465
HPE 1000 W Flex Slot Titanium Hot-plug Power Supply.....	466
HPE 1600 W Flex Slot Platinum Hot-plug Low Halogen Power Supply.....	467
HPE 1600 W Flex Slot -48 VDC Hot-plug Power Supply.....	468
HPE 1800-2200 W Flex Slot Titanium Power Supply.....	468
Websites.....	469
Support and other resources.....	470
Accessing Hewlett Packard Enterprise Support.....	470

HPE product registration.....	471
Accessing updates.....	471
Customer self repair.....	472
Remote support.....	472
Documentation feedback.....	473

Component identification

Provides an overview of external and internal server features to support hardware installation and servicing.

Subtopics

Front panel components

Front panel LEDs and buttons

Rear panel components

Rear panel LEDs

Component touchpoints

System board components

Drive bay numbering

Drive backplane naming

OCP NIC 3.0 slot numbering

HPE Basic Drive LED definitions

EDSFF SSD LED definitions

Fan numbering

Heatsink and processor socket components

Closed-loop liquid cooling (CLLC) module components

DLC module components

Liquid cooling guidelines

HPE NS204i-u Boot Device V2 components

HPE NS204i-u Boot Device V2 LED definitions

Riser board components

Riser slot numbering

Front panel components

4 LFF

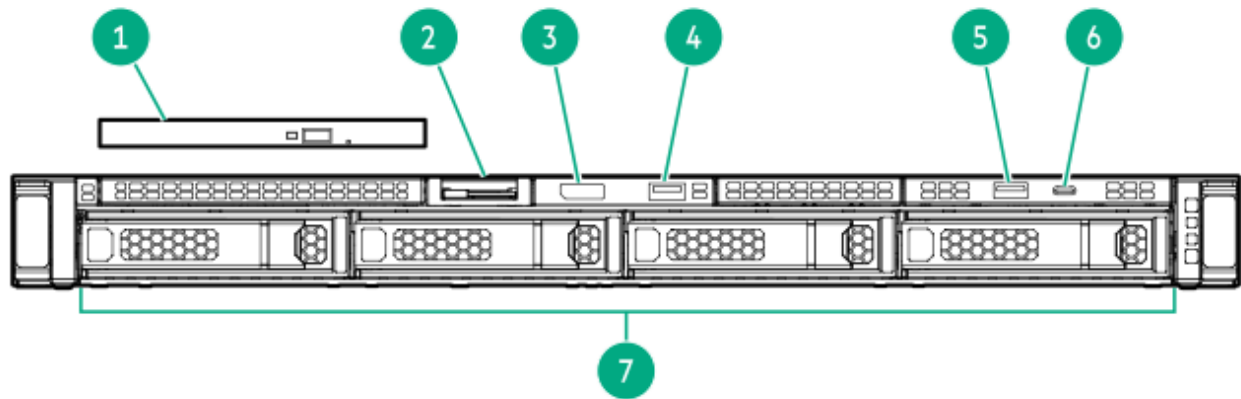

Item	Description
1	Optical drive (optional) ¹
2	Serial number/iLO information pull tab ²
3	DisplayPort (optional)
4	USB 2.0 port (optional)
5	USB 3.2 Gen 1 port
6	iLO service port (USB Type C) ³
7	Drive bays

¹ This option replaces a blank shown on the front panel.

² The serial number / iLO information pull tab is double-sided. One side shows the server serial number and the customer asset tag label. The other side shows the default iLO account information.

³ The operating system does not recognize this port as a USB port.

8 + 2 SFF

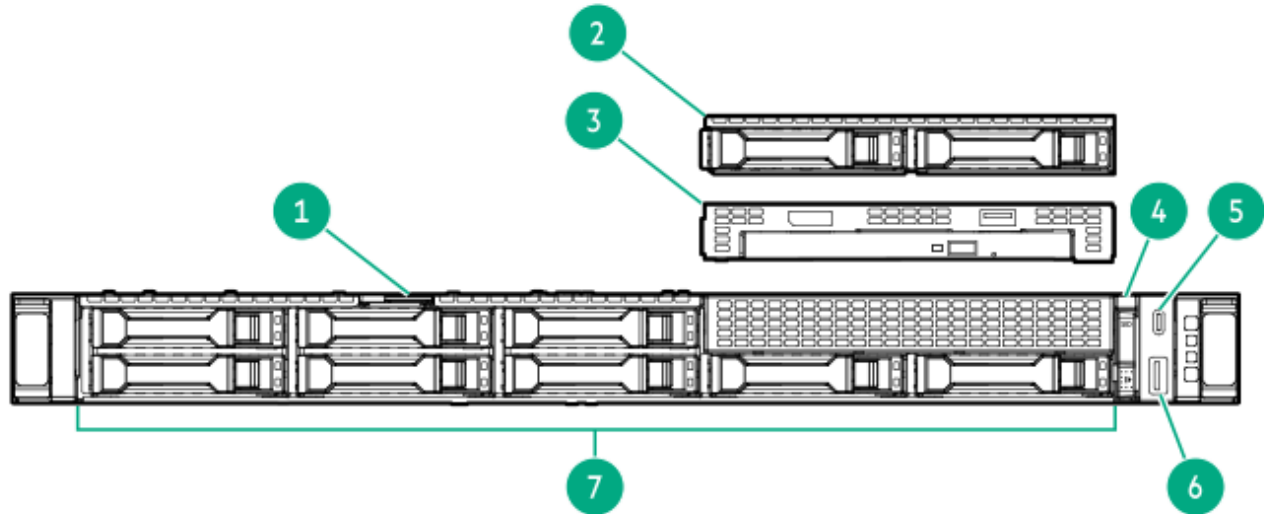

Item	Description
1	Serial number/iLO information pull tab ¹
2	2 SFF side-by-side drive cage assembly (optional) ²
3	DisplayPort / USB 2.0 / optical drive (optional) ²
4	System Insight Display (optional) ³
5	iLO service port (USB Type C) ⁴
6	USB 3.2 Gen 1 port
7	Drive bays

¹ The serial number / iLO information pull tab is double-sided. One side shows the server serial number and the customer asset tag label. The other side shows the default iLO account information.

² This option replaces a blank shown on the front panel.

³ This System Insight Display is only supported in the 8 SFF drive configuration.

⁴ The operating system does not recognize this port as a USB port.

10 SFF / 20 E3.S

The 10 SFF / 20 E3.S server supports hardware options for the mixed drive type configuration.

- 10 SFF

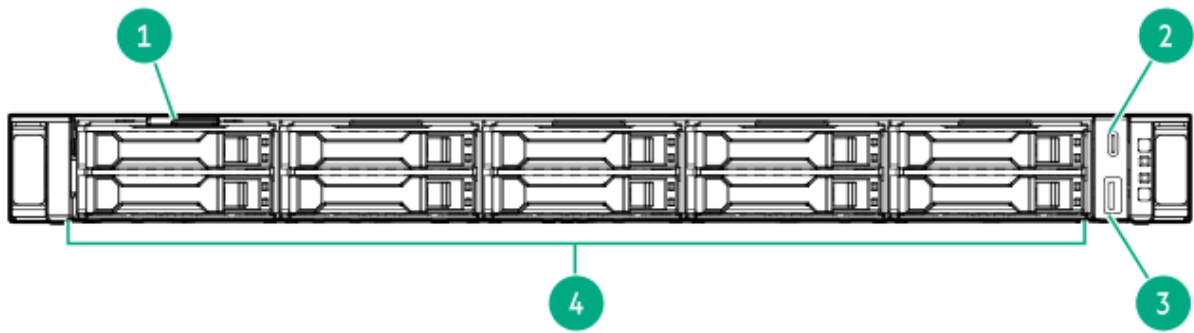

- 20 E3.S

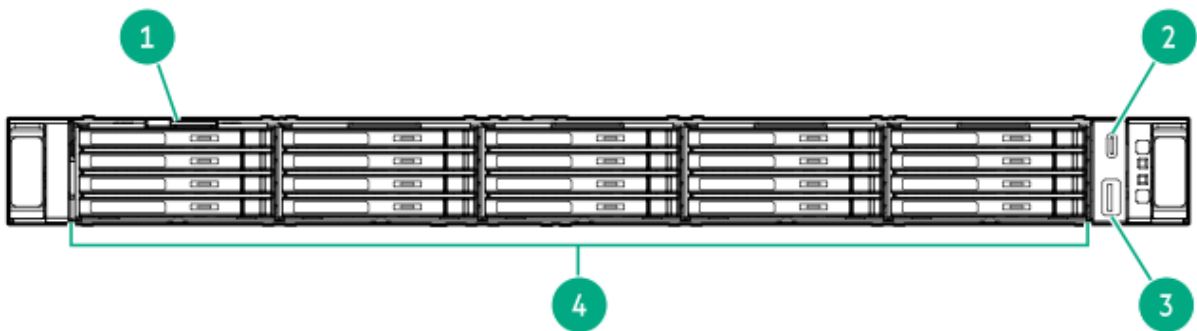

Item	Description
1	Serial number/iLO information pull tab ¹ ₂
2	iLO service port (USB Type C) ³ ₂
3	USB 3.2 Gen 1 port
4	Drive bays

¹ ₂ The serial number / iLO information pull tab is double-sided. One side shows the server serial number and the customer asset tag label. The other side shows the default iLO account information.

² ₂ A 2 SFF / 4 E3.S stacked drive cage must be installed in Drive Box 1 to support the serial number/iLO information pull tab.

³ ₂ The operating system does not recognize this port as a USB port.

Mixed drive type configuration with options

On the servers supporting mixed drive types, each of the drive boxes can have a different drive cage option or media device option installed.

For more information on the supported front drive cage options, see the product QuickSpecs on the Hewlett Packard Enterprise website (<https://www.hpe.com/info/quickspecs>).

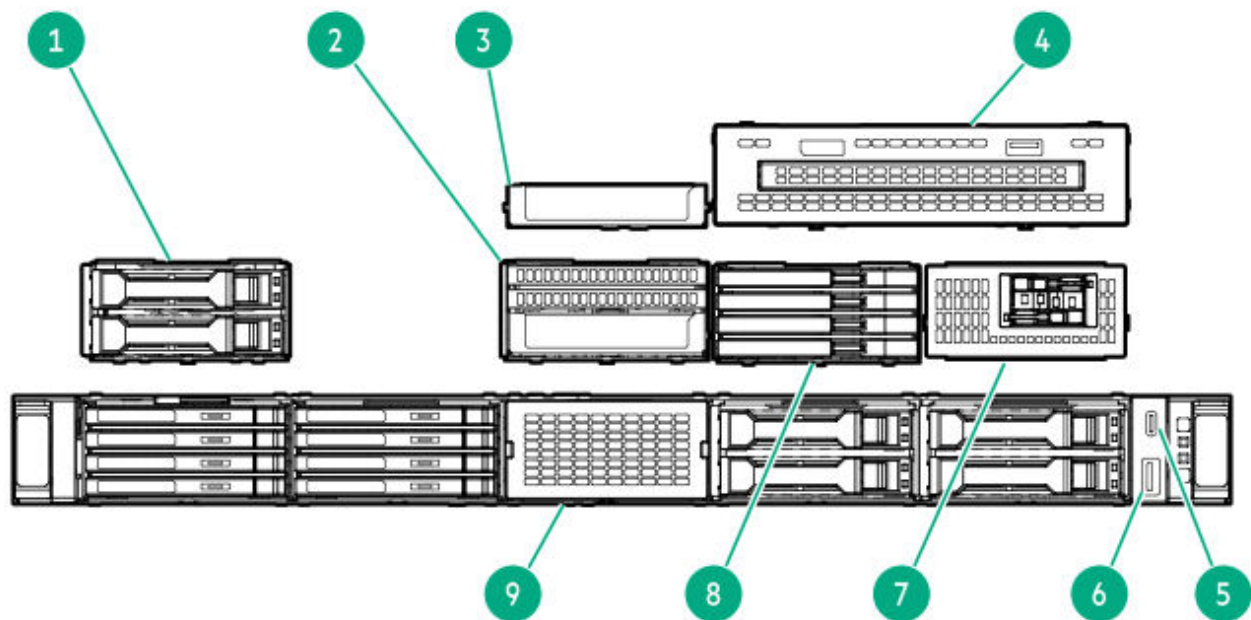

Item	Description
1	Stacked 2 SFF drive cage assembly (optional)
2	Primary front OCP NIC enablement kit (optional) ¹
3	Secondary front OCP NIC enablement kit (optional)
4	DisplayPort / USB 2.0 / optical drive (optional) ²
5	iLO service port (USB Type C) ³
6	USB 3.2 Gen 1 port
7	Front NS204i-u enablement kit (optional) ⁴
8	Stacked 4 E3.S drive cage assembly (optional)
9	Drive box blank ⁵

¹ The front OCP option is supported in Box 3.

² The media device option is supported in Boxes 4-5.

³ The operating system does not recognize this port as a USB port.

⁴ The front NS204i-u is supported in Box 5.

⁵ This blank is required if the drive box does not have an option installed.

Front panel LEDs and buttons

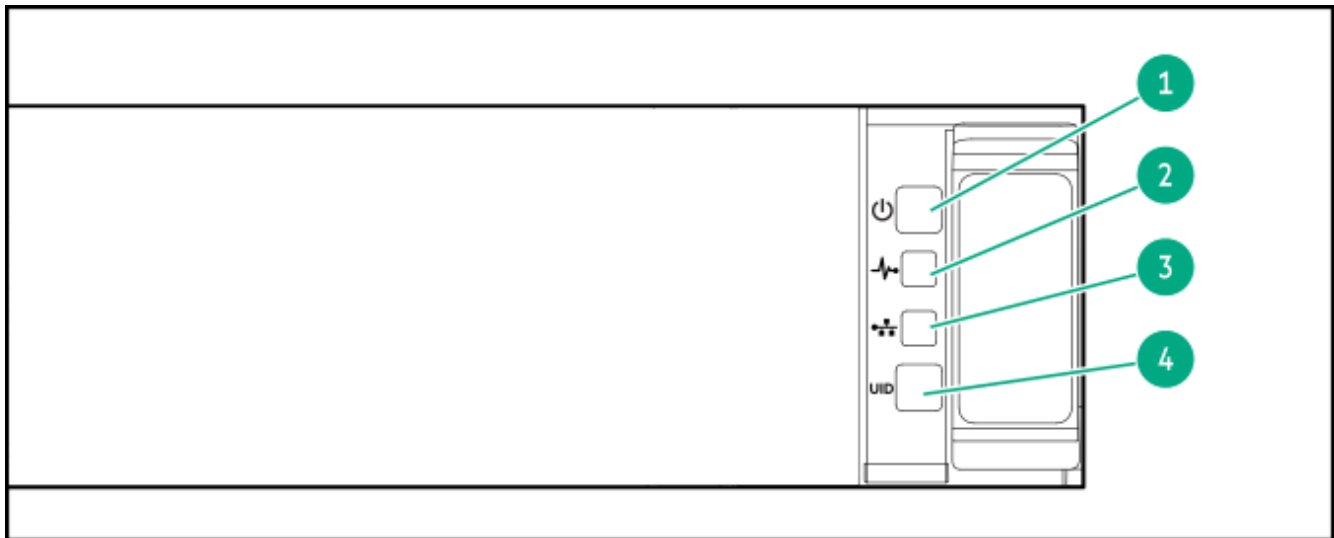

Item	Description	Status
1	Power On/Standby button and system power LED ¹	<p>Solid green = System on</p> <p>Flashing green = Performing power on sequence</p> <p>Solid amber = System in standby</p> <p>Off = No power present ¹</p>
2	Health LED ¹	<p>Solid green = Normal</p> <p>Flashing green = iLO is rebooting.</p> <p>Flashing amber = System degraded</p> <p>Flashing red = System critical ²</p>
3	NIC status LED ^{1, 3}	<p>Solid green = Link to network</p> <p>Flashing green = Network active</p> <p>Off = No network activity</p>
4	UID button/LED ⁴	<p>Solid blue = Activated</p> <p>Flashing blue:</p> <ul style="list-style-type: none"> • 1 Hz = Remote management or firmware upgrade in progress • 4 Hz = iLO manual reboot sequence initiated • 8 Hz = iLO manual reboot sequence in progress

Item	Description	Status
		Off = Deactivated

- 1 Facility power is not present, power cord is not attached, no power supplies are installed, power supply failure has occurred, or the power button cable is disconnected.
- 2 If the health LED indicates a degraded or critical state, review the system IML or use iLO to review the system health status.
- 3 NIC status LED does not support NIC LED ACT/LINK indication from OCP NICs without Scan Chain feature, or PCIe NICs.
- 4 When all four LEDs described in this table flash simultaneously, a power fault has occurred.

Subtopics

[UID button functionality](#)

[System Insight Display LEDs](#)

[System Insight Display combined LED descriptions](#)

UID button functionality

The UID button can be used to identify a specific server in a rack or display the Server Health Summary when the server will not power on. For more information, see the latest HPE iLO User Guide on the [Hewlett Packard Enterprise website](#).

System Insight Display LEDs

The System Insight Display (SID) LEDs represent components on the system board. The display enables component issue diagnosis even with the access panel installed.



IMPORTANT

If more than one DIMM slot LED is illuminated, further troubleshooting is required. Test each bank of DIMMs by removing all other DIMMs. Isolate the failed DIMM by replacing each DIMM in a bank with a known working DIMM.

For information about memory population rules, see the relevant memory technical paper in:

<https://www.hpe.com/docs/server-memory>

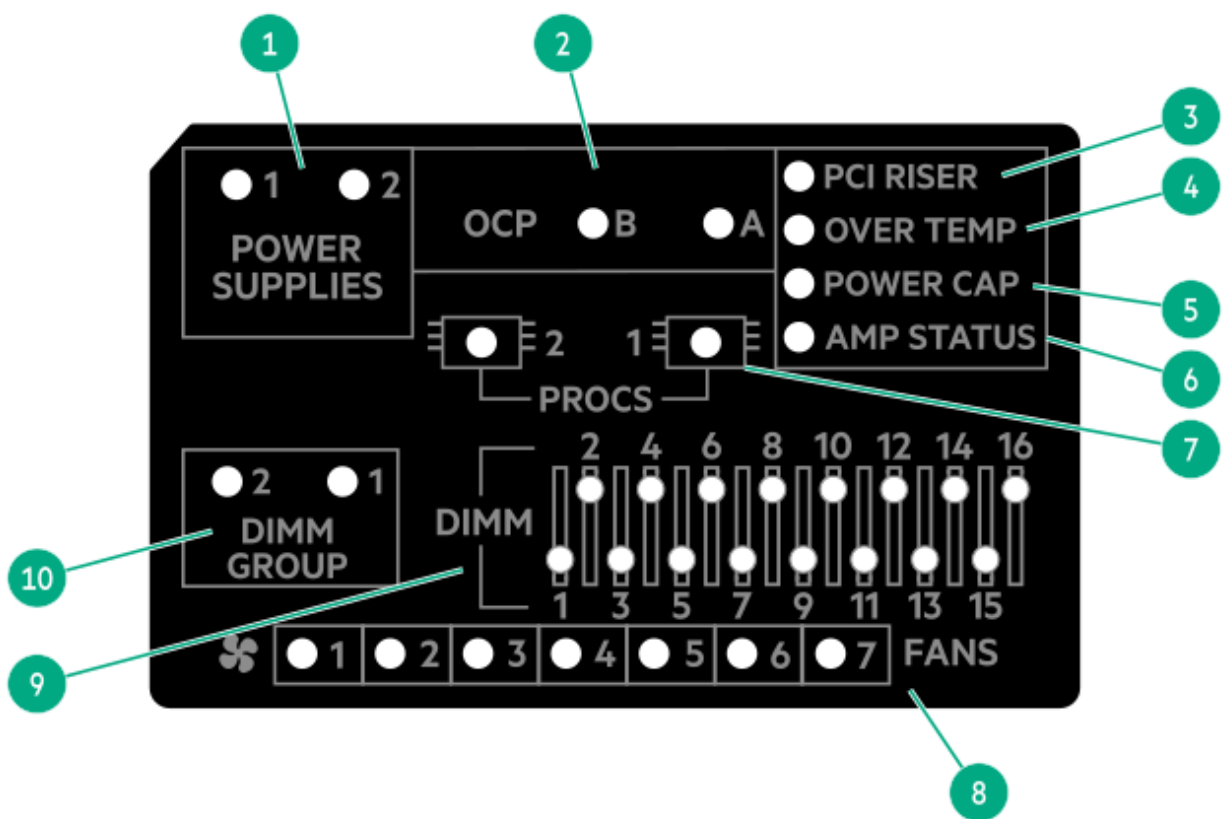

Item	LED	Status	Description
1	Power supply LEDs	Off	Normal
		Solid amber	One or more of the following conditions exists: <ul style="list-style-type: none"> Power subsystem degraded Power supply failure Input power lost
2	OCP LEDs	Solid green	Network link
		Flashing green	Network active
		Off	No network link
3	PCI riser LED	Off	Normal
		Solid amber	Incorrectly installed PCI riser cage
4	Over temp LED	Off	Normal
		Solid amber	High system temperature detected

Item	LED	Status	Description
5	Power cap LED	Solid green	Power cap applied
		Off	One or more of the following conditions exists: <ul style="list-style-type: none"> • System is in standby • No cap is set
6	AMP ¹	Solid green	AMP mode enabled
		Solid amber	Failover
		Flashing amber	Invalid configuration
		Off	AMP modes disabled
7	Processor LED	Off	Normal
		Solid amber	Failed processor
8	Fan LEDs	Off	Normal
		Solid amber	Failed fan or missing fan
9	DIMM LEDs	Off	Normal
		Solid amber	Failed DIMM or configuration issue
10	DIMM group LEDs	Off	Normal
		Solid amber	Failed DIMM group or configuration issue

¹ To enable Advanced Memory Protection (AMP), see the UEFI user guide (<https://www.hpe.com/support/hpeuefisystemutilities-quicklinks>).

When the health LED on the front panel illuminates either amber or red, the server is experiencing a health event. For more information on the combination of these LEDs, see [System Insight Display combined LED descriptions](#).

System Insight Display combined LED descriptions

The combined illumination of the following LEDs indicates a system condition:

- SID LEDs
- System power LED
- Health LED

SID LED status	Health LED status	System power LED status	LED Definition
Power supply (solid amber)	Flashing red	Solid amber	One or more of the following conditions exist: <ul style="list-style-type: none"> Only one power supply is installed and that power supply is in standby. Power supply fault. System board fault.
	Flashing amber	Solid green	One or more of the following conditions exist: <ul style="list-style-type: none"> Redundant power supply is installed and only one power supply is functional. AC power cord is not plugged into redundant power supply. Redundant power supply fault. Power supply mismatch at POST or power supply mismatch through hot-plug addition.
PCI riser (solid amber)	Flashing red	Solid green	The PCI riser cage is not seated properly.
Over temp (solid amber)	Flashing amber	Solid green	The Health Driver has detected a cautionary temperature level.
	Flashing red	Solid amber	The server has detected a hardware critical temperature level.
Power cap (solid green)	—	Solid green	Power is available.
Power cap (solid green)	—	Flashing green	Waiting for power
Power cap (flashing amber)	—	Solid amber	Power is not available.
Power cap (off)	—	Solid amber	Standby
Processor (solid amber)	Flashing red	Solid amber	One or more of the following conditions might exist: <ul style="list-style-type: none"> Processor in socket X has failed. Processor X is not installed in the socket. Processor X is unsupported. ROM detects a failed processor during POST.
	Flashing amber	Solid green	Processor in socket X is in a pre-failure condition.

SID LED status	Health LED status	System power LED status	Definition
Fan (solid amber)	Flashing amber	Solid green	One fan has failed or has been removed.
	Flashing red	Solid green	Two or more fans have failed or been removed.
DIMM (solid amber)	Flashing red	Solid green	One or more DIMMs have failed.
	Flashing amber	Solid green	DIMM in slot X is in a pre-failure condition.

Rear panel components

Rear panel with 3 PCIe slots

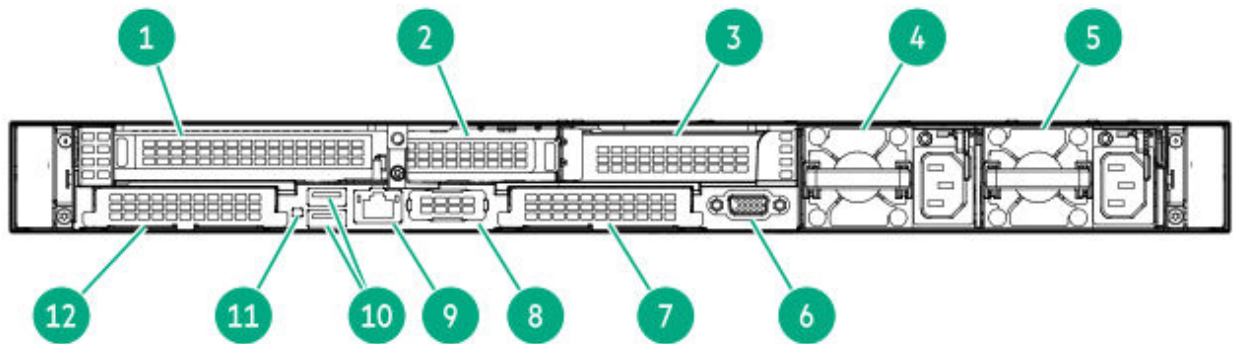

Item	Description
1	Slot 1 PCIe5 ¹
2	Slot 2 PCIe5 ²
3	Slot 3 PCIe5 (optional - requires the secondary processor) ³
4	Power supply 2 (PS2)
5	Power supply 1 (PS1)
6	Video (VGA) port
7	OCP 3.0 slot B (Slot 15)
8	Serial port (optional)
9	iLO Management Port
10	USB 3.2 Gen 1 ports
11	Rear UID button / LED

Item	Description
12	OCP 3.0 slot A (Slot 14)

- ¹ This slot supports the full-height PCIe form factor.
- ² This slot supports the low-profile PCIe form factor.
- ³ This slot requires the low-profile riser kit option (P48903-B21).

Rear panel with 2 PCIe slots

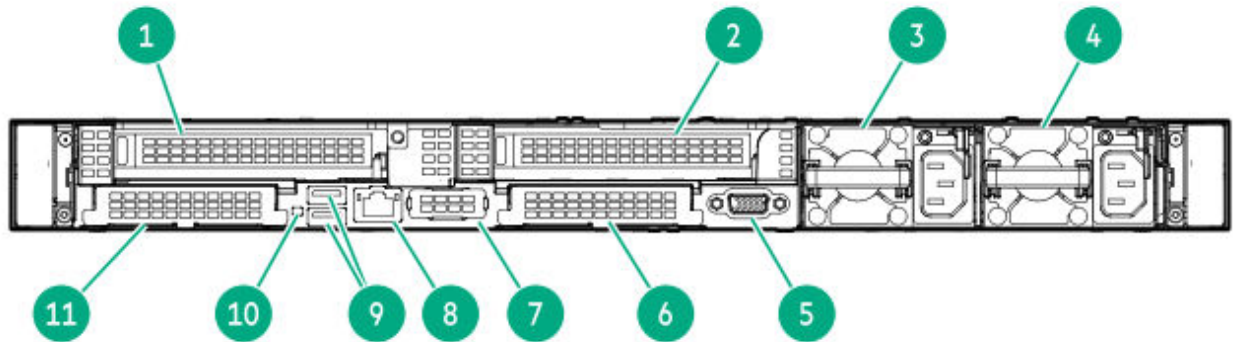

1	Slot 1 PCIe5 ¹
2	Slot 3 PCIe5 (optional - requires the secondary processor) ²
3	Power supply 2 (PS2)
4	Power supply 1 (PS1)
5	Video (VGA) port
6	OCP 3.0 slot B (Slot 15)
7	Serial port (optional)
8	iLO Management Port
9	USB 3.2 Gen 1 ports
10	Rear UID button / LED
11	OCP 3.0 slot A (Slot 14)

- ¹ This slot supports the full-height PCIe form factor.
- ² This slot requires the full-height riser kit option (P72598-B21).

Rear panel LEDs

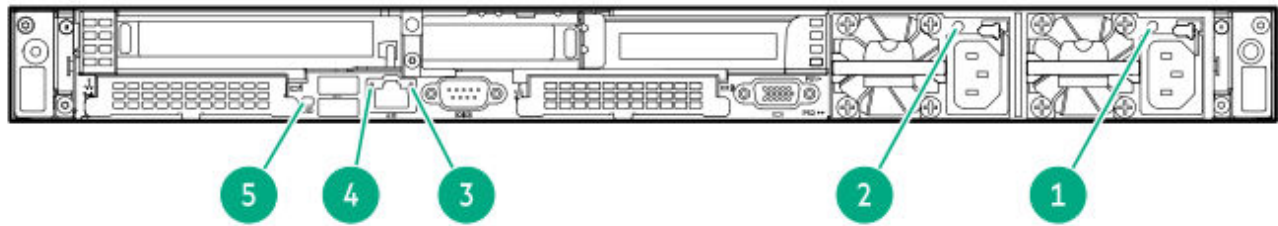

Item	Description	Status
1	Power supply 1 LED	<p>Solid green — Normal</p> <p>Off — One or more of the following conditions exists:</p> <ul style="list-style-type: none"> • AC power unavailable • Power supply failed • Power supply in standby mode • Power supply exceeded current limit. • Power cord is not attached.
2	Power supply 2 LED	<p>Solid green — Normal</p> <p>Off — One or more of the following conditions exists:</p> <ul style="list-style-type: none"> • AC power unavailable • Power supply failed • Power supply in standby mode • Power supply exceeded current limit. • Power cord is not attached.
3	iLO status	<p>Solid green — Linked to network</p> <p>Flashing green — Network active</p> <p>Off — No network activity</p>
4	iLO link	<p>Solid green — Link exists.</p> <p>Off — No link exists.</p>
5	UID LED	Solid blue — Identification is activated.

Item	Description	Status
		Flashing blue — System is being managed remotely.
		Off — Identification is deactivated.

Component touchpoints

Certain components are color-coded. These colors represent the recommended touch areas for a removal process and indicate whether components require a system shutdown before removal.

The following diagrams are examples only.

HPE hot-plug red

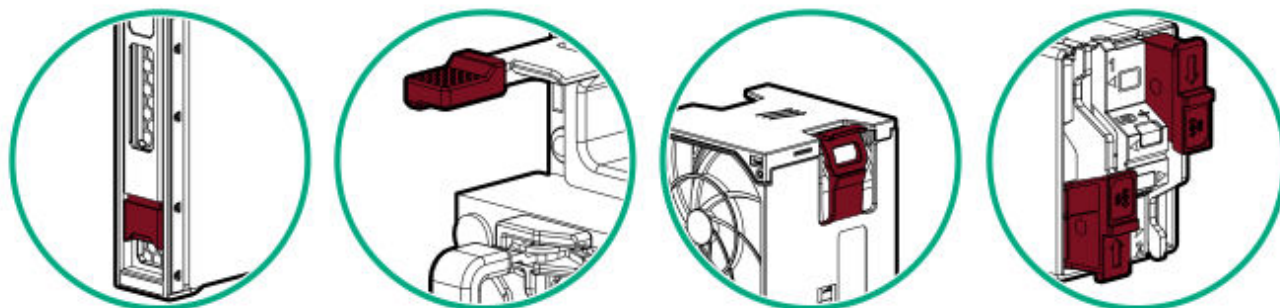

Hot-plug red indicates hot-pluggable components. These components can be removed and installed while the system is running, and doing so will not result in a system shutdown.

Component examples:

- Power supplies in a redundant power configuration
- Hot-plug fans
- Hot-plug drives
- M.2 SSDs in a hot-plug boot device

HPE touchpoint blue

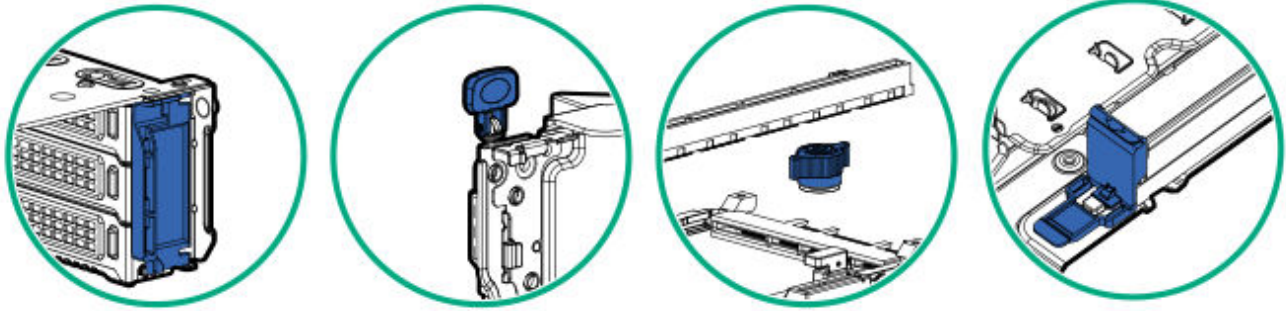

Touchpoint blue indicates cold-pluggable components. These components require a system shutdown. Failure to do so might result in system failure or data loss. Cold-pluggable components might also indicate touchpoints on non-electrical components.

Component examples:

- Storage devices
- Fan cages
- System boards
- Energy packs

System board components

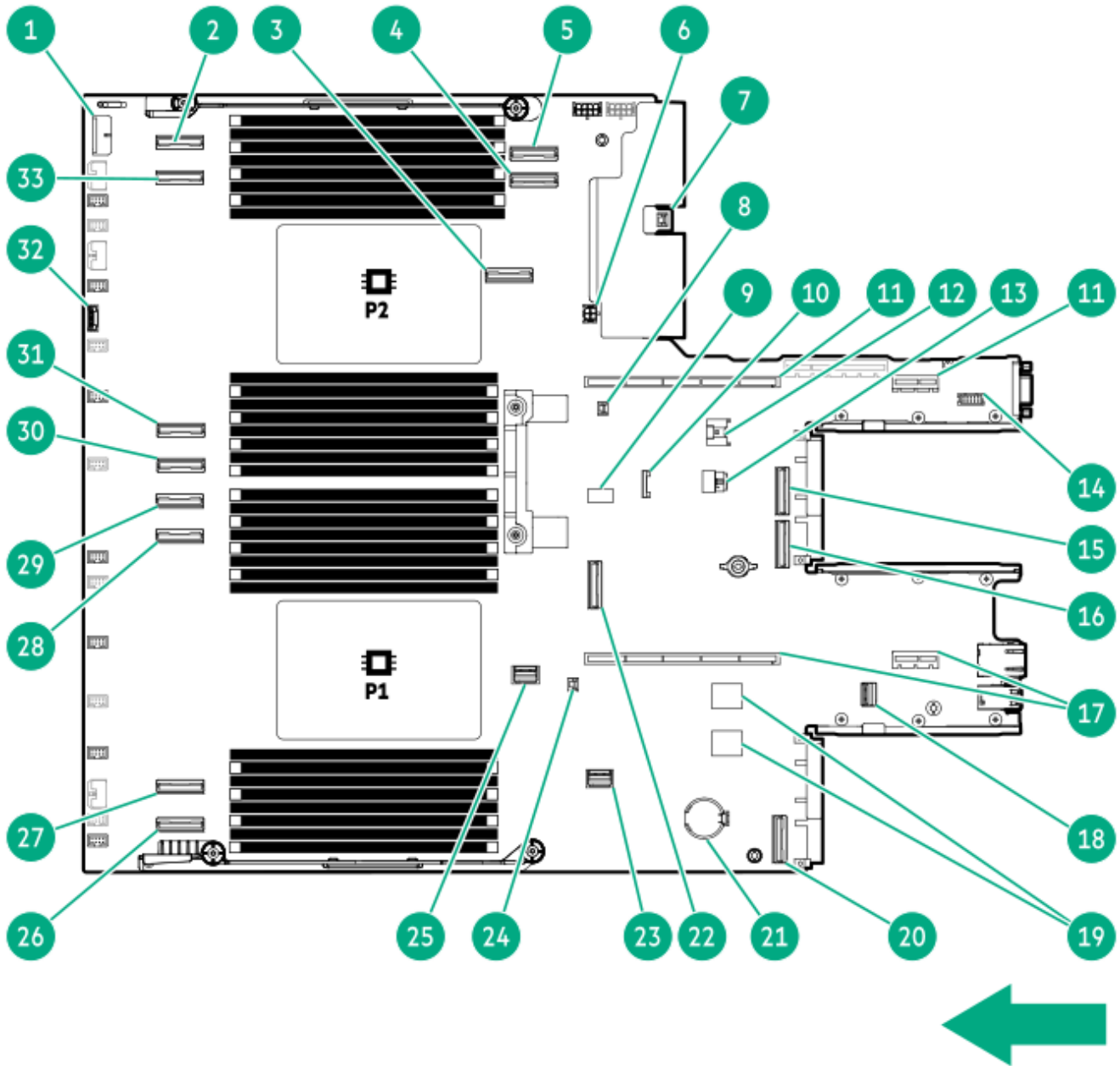

Item	Description
1	Box 1 drive backplane power connector
2	MCIO port 8
3	MCIO port 11
4	MCIO port 10

Item	Description
5	MCIO port 9
6	SmartNIC 4-pin power connector ¹ _—
7	Chassis Intrusion Detection switch connector
8	Storage backup power connector 2
9	<u>System maintenance switch</u>
10	SID connector
11	Secondary riser connectors
12	Energy pack connector
13	NS204i-u power connector
14	Serial port connector
15	OCP B internal port 1
16	OCP B internal port 2
17	Primary riser connectors
18	Front DisplayPort/USB 2.0 connector
19	Internal dual USB 3.2 Gen1 ports
20	OCP A internal port 1
21	System battery
22	MCIO port 12
23	Front I/O connector & USB 3.2 Gen 1 port connector
24	Storage backup power connector 1
25	NS204i-u signal connector
26	MCIO port 1
27	MCIO port 2
28	MCIO port 3
29	MCIO port 4
30	MCIO port 5
31	MCIO port 6
32	Cooling module connector
33	MCIO port 7

¹_— There is no available SmartNIC 4-pin power cable option.

Subtopics

System maintenance switch descriptions

DIMM label identification

DIMM slot locations

PCIe connector and processor matrix

System maintenance switch descriptions

Position	Default	Function
S1	Off	<ul style="list-style-type: none">Off—iLO 7 security is enabled.On—iLO 7 security is disabled.
S2	Off	Reserved
S3	Off	Reserved
S4	Off	Reserved
S5	Off	<ul style="list-style-type: none">Off—Power-on password is enabled.On—Power-on password is disabled.
S6 ^{1, 2}	Off	<ul style="list-style-type: none">Off—No functionOn—Restore default manufacturing settings
S7	Off	Reserved
S8	Off	Reserved
S9	Off	Reserved
S10	Off	Reserved
S11	Off	Reserved
S12	Off	Reserved

¹ When the system maintenance switch position 6 is set to the On position, the system is prepared to restore all configuration settings to their manufacturing defaults.

² When the system maintenance switch position 6 is set to the On position and Secure Boot is enabled, some configurations cannot be restored. For more information, see [Configuring the server](#).

DIMM label identification

To determine DIMM characteristics, see the label attached to the DIMM. The information in this section helps you to use the label to locate specific information about the DIMM.

For more information about product features, specifications, options, configurations, and compatibility, see the HPE DDR5 SmartMemory QuickSpecs:

<https://www.hpe.com/docs/server-memory>

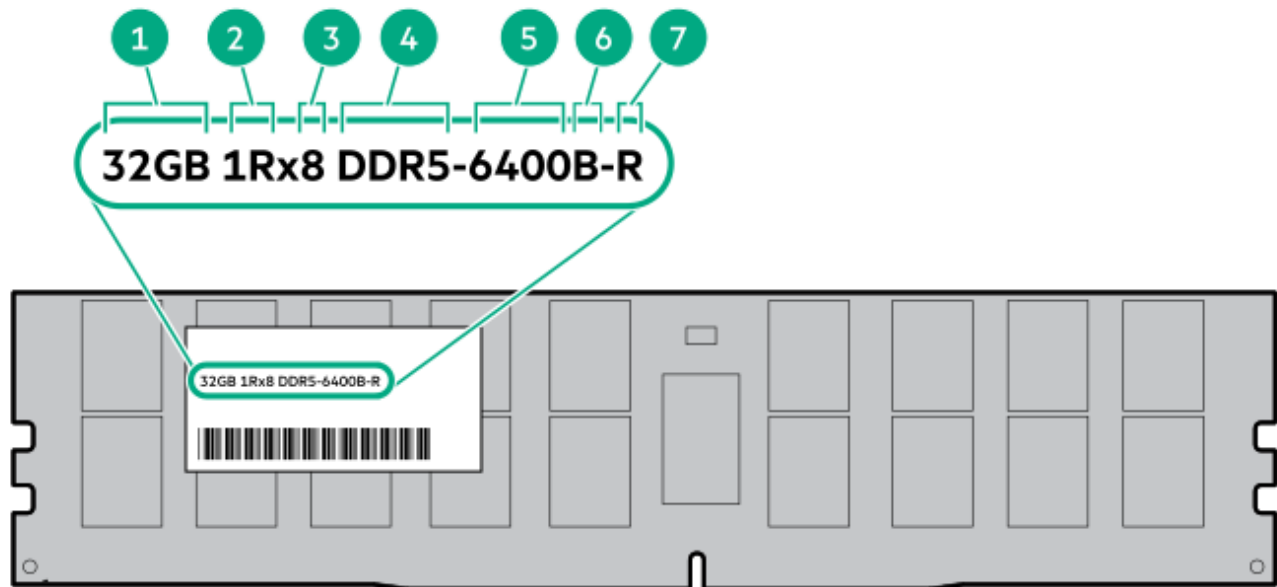

Item	Description	Example
1	Capacity*	16 GB 32 GB 64 GB 96 GB 128 GB 256 GB
2	Rank	1R—Single rank 2R—Dual rank 4R—Quad rank
3	Data width on DRAM	x4—4-bit x8—8-bit

Item	Description	Example
4	Memory generation	PC5—DDR5
5	Maximum memory speed*	6400 MT/s
6	CAS latency	B—42-42-42
7	DIMM type	R—RDIMM (registered)

* The maximum memory speed and capacity is a function of the memory type, memory configuration, and processor model.

DIMM slot locations

DIMM slots are numbered sequentially (1 through 16) for each processor.

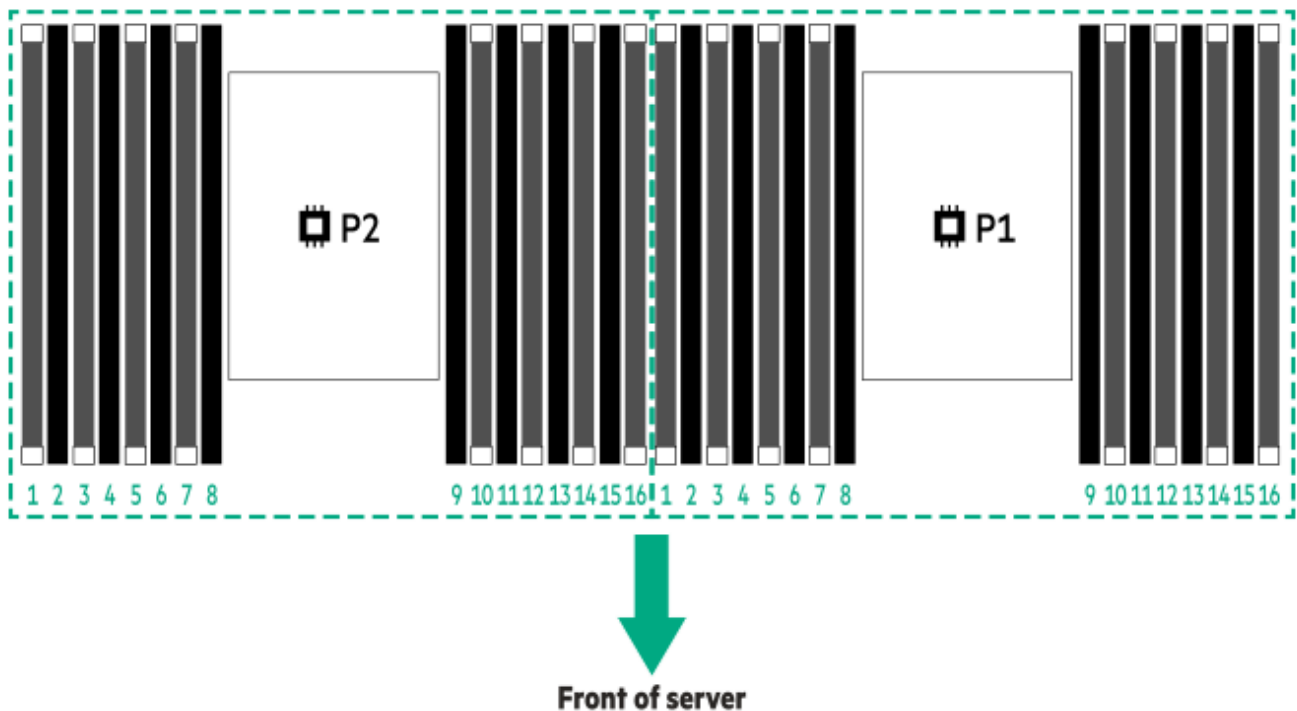

PCIe connector and processor matrix

The server's system board connectors support PCIe Gen5. Use the following table to identify the processors and the specific PCIe connectors to which devices are connected.

System board connector	PCIe lane configuration	Processor ¹
MCIO port 1	x8	Processor 1
MCIO port 2	x8	Processor 1
MCIO port 3	x8	Processor 1
MCIO port 4	x8	Processor 1
MCIO port 5	x8	Processor 2
MCIO port 6	x8	Processor 2
MCIO port 7	x8	Processor 2
MCIO port 8	x8	Processor 2
MCIO port 9	x8	Processor 2
MCIO port 10	x8	Processor 2
MCIO port 11	x8	Processor 2
MCIO port 12	x8	Processor 1
Primary riser slot 1 ²	x16	Processor 1
Primary riser slot 2 ²	x16	
Secondary riser slot 3	x16	Processor 2
NS204i-u signal	x4	Processor 1
Rear OCP A ³	x8	Processor 1

¹ Certain PCIe lanes are reserved for system functions and are not routed to a physical connector for use by PCIe devices.

² The primary riser supports two PCIe slots in the system.

³ Rear OCP B is connected to the processor using a cable option. For more information on the PCIe connection to rear OCP B in the system, see [OCP NIC 3.0 slot numbering](#).

Drive bay numbering



CAUTION

When a server is purchased without any drive installed, some drive bays might be empty while other drive bays might be populated with drive blanks. To maintain proper system cooling, do not operate the server without a drive or a drive blank installed.

4 LFF drive bay numbering

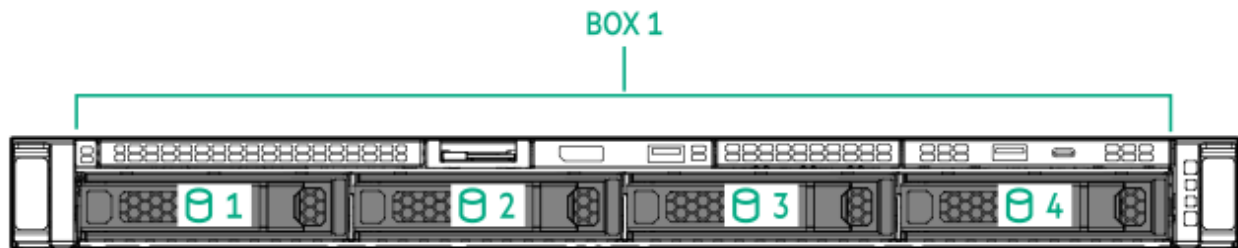

8 SFF drive bay numbering

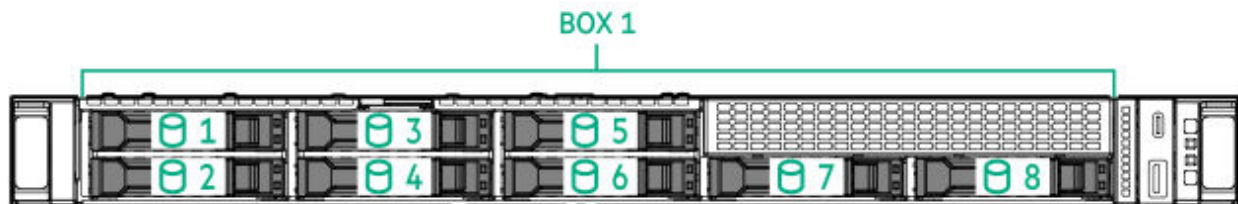

8 + 2 SFF drive bay numbering

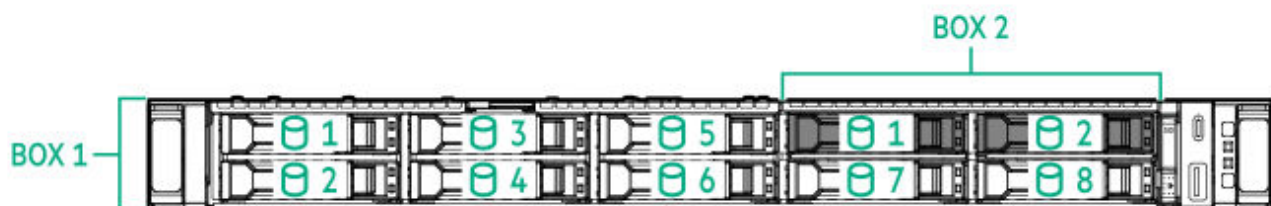

20 E3.S drive bay numbering

This configuration supports mixed drive types in the front drive cages.



10 SFF drive bay numbering

This configuration supports mixed drive types in the front drive cages.

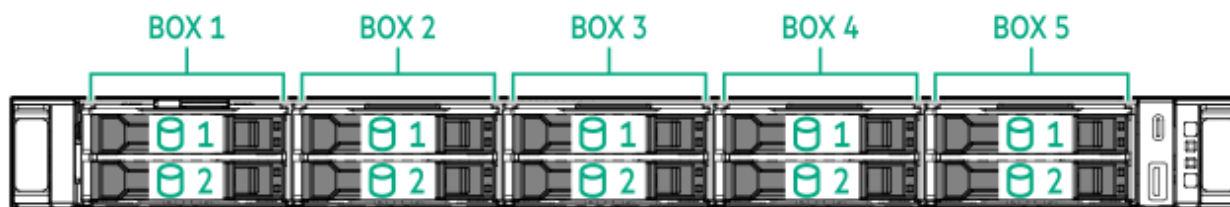

Drive backplane naming

This topic explains the features represented in the drive backplane naming. This naming convention was adopted starting in the HPE Gen11 server release. Your server might not support all the features listed in this topic. For server-specific support information, see the server guides:

- Drive backplane support, see [Drive bay numbering](#).
- Drive backplane cabling, see [Storage cabling](#).

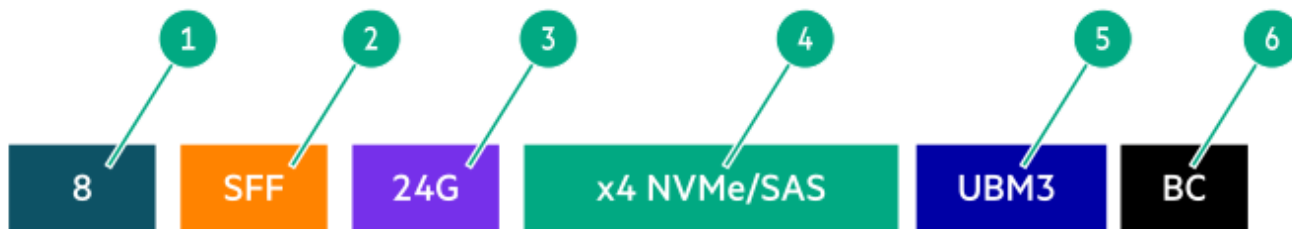

Item	Description	Values
1	Drive bay count	Number of drive bays supported by the backplane.

Item	Description	Values
2	Drive form factor	LFF—Large Form Factor SFF—Small Form Factor E3S—Enterprise and Datacenter Standard Form Factor (EDSFF E3.S)
3	Maximum link rate per lane (GT/s)	12G 16G 24G 32G
4	Port link width and interface	x1 NVMe/SAS—U.3 NVMe, SAS, or SATA ¹ x4 NVMe/SAS—U.3 NVMe, SAS, or SATA ² x4 NVMe—NVMe ³ x4 NVMe—E3.S
5	Universal backplane manager (UBM) model	The UBM model defines the UBM firmware used by the backplane. Examples of UBM models: UBM2, UBM3, and etc.
6	Drive carrier type	BC—Basic carrier (SFF) LP—Low-profile carrier (LFF) EC—E3.S carrier

¹ Tri-mode controller support for x1 U.3 NVMe, SAS, and SATA drives. System board connection supports SATA drives only.

² CPU direct attach or tri-mode controller support for x4 U.3 NVMe, x2 (via a splitter cable) U.3 NVMe, or x1 SAS and SATA drives.

³ CPU direct attach or tri-mode controller support for x4 NVMe drives.

OCP NIC 3.0 slot numbering

This server supports up to two OCP NIC 3.0 SFF slots in either the rear or the front panel.

Rear OCP NIC 3.0 slots

The rear OCP NIC 3.0 slots are standard in the system.

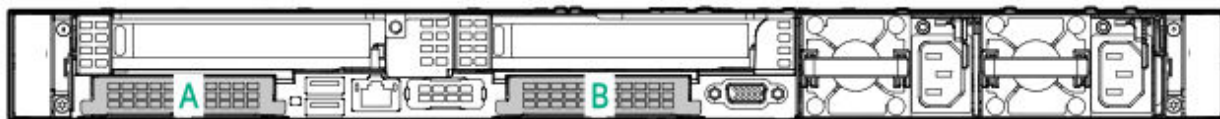

Item	Slot number	Supported options
1	Slot 14 OCP A PCIe5 x16 <u>1</u> , <u>2</u> , <u>3</u>	<ul style="list-style-type: none"> • OCP NIC • Type-o storage controller
2	Slot 15 OCP B PCIe5 x16 <u>3</u> , <u>4</u> , <u>5</u> , <u>6</u>	

- 1 When installing a single OCP NIC, install it in Slot 14 OCP A.
- 2 Slot 14 OCP A by default supports x8 connection from processor 1. To upgrade to x16 connection, an OCP A x16 enablement cable option (P72201-B21) is required.
- 3 The PCIe lane configuration for rear OCP slots varies depending on processor count and drive placement. For more information, see [OCP connection and direct attached drives](#).
- 4 To support Slot 15 OCP B x8 connection in a single-processor configuration, a CPU1-to-OCP-B cable option (P72203-B21) is required.
- 5 To support Slot 15 OCP B x8 connection in a dual-processor configuration, a CPU2-to-OCP-B cable option (P72205-B21) is required.
- 6 To upgrade to x16 connection in a dual processor configuration, an OCP B x 16 enablement cable option (P72207-B21) is required.

OCP connection and direct attached drives

In systems that use 4 EDSFF or 2 SFF stacked drives direct attached to the system board, the OCP PCIe connection varies based on the processor count and drive placement. When a data cable from Drive Box 5 occupies MCIO port 12, rear OCP B support may be affected. See the following table for detailed configuration options.

One processor:

Drives <u>1</u>	OCP slot	Connection bandwidth	OCP cable option
2 SFF stacked drives in Box 5	OCP A	x8 connection	Not required
	OCP B	Not supported	—
2 SFF stacked drives in Box 3 (relocated from Box 5) <u>2</u>	OCP A	Up to x16 connection	Required
	OCP B	Not supported	—
2 SFF stacked drives in Box 3 (relocated from Box 5) <u>2</u>	OCP A	x8 connection	Not required
	OCP B	x8 connection	Required

- 1 During the order configuration of the 10 SFF / 20 E3.S server, when multiple drive backplanes are selected, the drive boxes will be populated in the following sequence: 1, 2, 4, 5, and 3.
- 2 Choose either x16 bandwidth for OCP A or x8 bandwidth for both OCP A and OCP B.

Two processors:

Drives	OCP slot	Connection bandwidth	OCP cable option
4 EDSFF stacked drives in Box 5	OCP A	x8 connection	Not required
	OCP B	Up to x16 connection	Required

OCP NICs designed for PCIe x16 can still operate using a x8 connection and achieve maximum throughput with PCIe Gen5 when installed in the rear OCP A slot. For more information on the available OCP NIC options, see the product QuickSpecs (<https://www.hpe.com/info/quickspecs>).

Front OCP NIC 3.0 slots

The front OCP NIC 3.0 slots require the front OCP NIC enablement option kits (Bay 1:P72597-B21, Bay 3: P72596-B21). These slots support OCP NIC options.

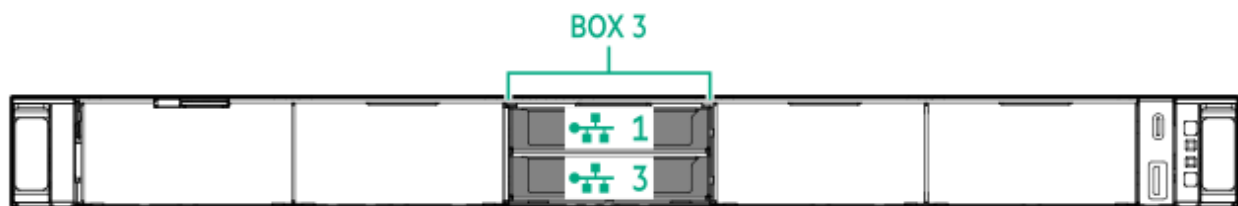

Bay	Slot number
1—Secondary*	Box 3: Bay 1 OCP slot PCIe5 x16
3—Primary	Box 3: Bay 3 OCP slot PCIe5 x16

* The secondary front OCP NIC option requires a dual-processor configuration.

HPE Basic Drive LED definitions

The HPE Basic drive carrier has the following LEDs:

- Amber/blue LED—Managed by the drive backplane in conjunction with the storage controller and is used to indicate drive status.

- Green LED—Managed by the drive itself and indicates the drive activity.

LFF low-profile drive carrier

The LFF low-profile drive carrier supports hot-plug SAS or SATA.

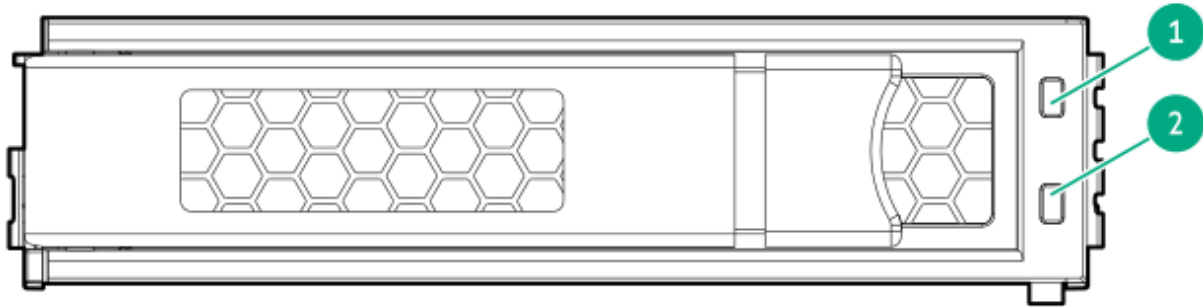

SFF basic drive carrier

The SFF basic drive carrier supports hot-plug U.3 NVMe drives.

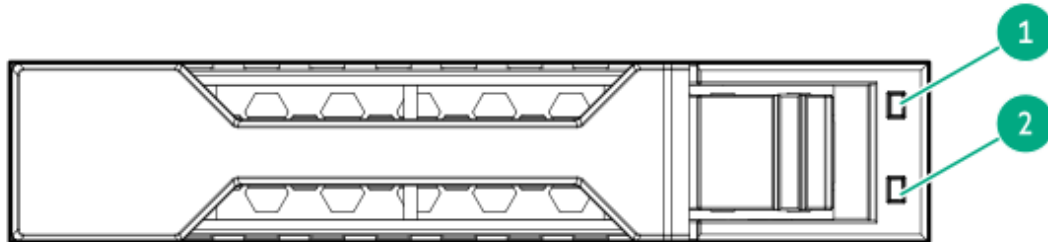

Item	LED	State	Definition
1	Fault/Locate	Solid amber	This drive has failed, is unsupported, or is invalid.
		Solid blue	The drive is operating normally and being identified by a management application.
		Flashing amber/blue (1 flash per second)	The drive has failed, or a predictive failure alert has been received for this drive. The drive has also been identified by a management application.

Item	LED	State	Definition
		Flashing amber (1 flash per second)	A predictive failure alert has been received for this drive. Replace the drive as soon as possible.
		Off	The drive is operating normally and not being identified by a management application.
2	Online/Activity	Solid green	The drive is online and has no activity.
		Flashing green (1 flash per second)	The drive is doing one of the following: <ul style="list-style-type: none"> • Rebuilding or performing a RAID • Performing a stripe size migration • Performing a capacity expansion • Performing a logical drive extension • Erasing • Spare part activation
		Flashing green (4 flashes per second)	The drive is operating normally and has activity.
		Off	The drive is not configured by a RAID controller or is a spare drive.

EDSFF SSD LED definitions

The EDSFF drive carrier has two LEDs:

- Amber/blue LED—Managed by the drive backplane in conjunction with the storage controller and is used to indicate drive status.
- Green LED—Managed by the drive itself and indicates the drive activity.



Item	LED	State	Definition
1	Fault/Locate	Solid amber	This drive has failed, is unsupported, or is invalid.
		Solid blue	The drive is operating normally and being identified by a management application.
		Flashing amber/blue (1 flash per second)	The drive has failed, or a predictive failure alert has been received for this drive. The drive has also been identified by a management application.
		Flashing amber (1 flash per second)	A predictive failure alert has been received for this drive. Replace the drive as soon as possible.
		Off	The drive is operating normally and not being identified by a management application.
2	Online/Activity	Solid green	The drive is online and has no activity.
		Flashing green (4 flashes per second)	The drive is operating normally and has activity.
		Off	No power present.

Fan numbering

The arrow points to the front of the server.

Single processor

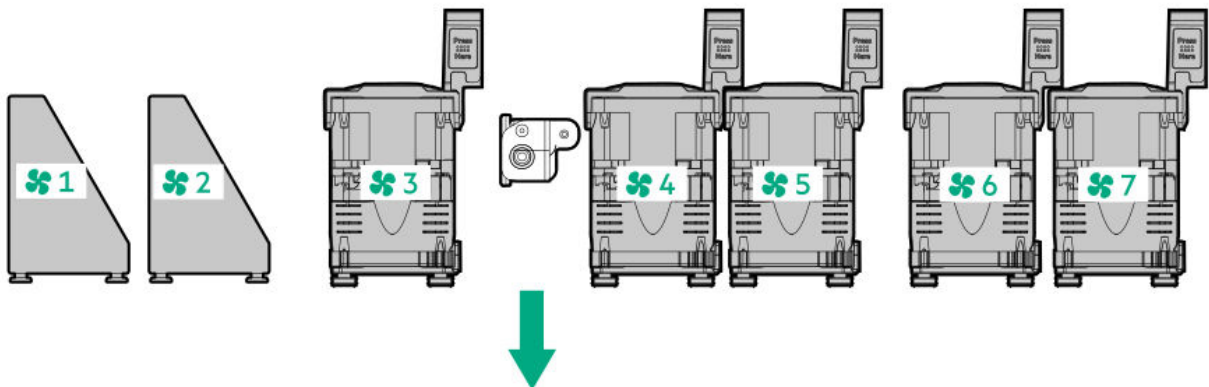

Single or dual processor

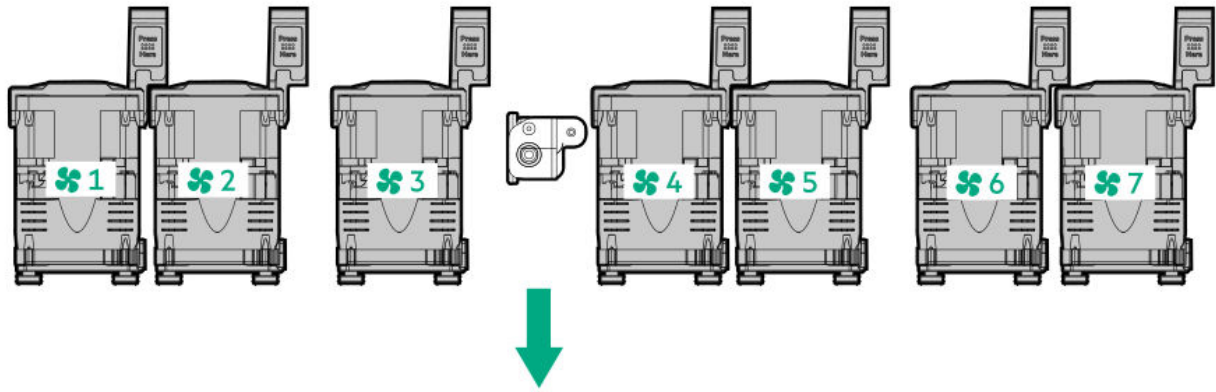

Subtopics

Fan and heatsink requirements

Fan and heatsink requirements

Fan and heatsink type

Processor TDP	Fan type	Heatsink type	Availability
Processor TDP ≤ 185 W	Standard fan	Standard heatsink	Full support
Processor TDP 186–250 W	High performance fan	High performance heatsink ¹	Full support
Processor TDP 251–270 W	High performance fan	High performance heatsink ¹	Limited configuration ²
Processor TDP 271–350 W	High performance fan	High performance heatsink ¹	Limited configuration ²
Processor TDP ≤ 270 W (One-processor configuration)	Closed-loop liquid cooling heatsink and fan		Full support
Processor TDP 271–350 W	Closed-loop liquid cooling heatsink and fan		Full support
Processor TDP ≤ 350 W	Direct liquid cooling (DLC) cold plate module (CPM)	DLC fan kit (High performance fan kit)	Full support

¹ To support the installation of the optional air baffle, the high performance heatsink must be installed.

² For additional information on limited configuration, see the product QuickSpecs on the Hewlett Packard Enterprise website (<https://www.hpe.com/info/quickspecs>).

Some hardware options require a specific fan or heatsink type.

Hardware option	Fan type	Heatsink type
SAS/SATA drives	Standard fan	Standard or high performance heatsink
E3.S / NVMe / SAS4 drives / boot device	High performance fan	Standard or high performance heatsink
¹ 256 GB or higher capacity DIMMs	High performance fan	Standard or high performance heatsink
Type-p Ethernet adapters or type-o InfiniBand adapters ≥ 100 Gb	High performance fan	Standard or high performance heatsink
OCP NIC 3.0 ≥ 100 Gb	High performance fan	Standard or high performance heatsink
GPU cards	High performance fan	Standard or high performance heatsink

¹ DIMM blank requirements may vary depending on the hardware configuration. For more information on DIMM blank requirements, see the product QuickSpecs on the Hewlett Packard Enterprise website (<https://www.hpe.com/info/quickspecs>).

Fan population



CAUTION

To avoid damage to server components, fan blanks must be installed in fan bays 1 and 2 in a single-processor configuration.



CAUTION

To avoid damage to the equipment, do not operate the server for extended periods of time if the server does not have the optimal number of fans installed. Although the server might boot, we do not recommend operating the server without the required fans installed and operating.

Air cooling

Processor configuration	Fan bay 1	Fan bay 2	Fan bays 3-7
One-processor configuration	Fan blank High performance fan	Fan blank High performance fan	Standard fan High performance fan

Processor configuration	Fan bay 1	Fan bay 2	Fan bays 3-7
Dual-processor configuration	Standard fan	Standard fan	Standard fan
	High performance fan	High performance fan	High performance fan

Closed-loop liquid cooling and direct liquid cooling

Cooling component	Fan bays 1-7
Closed-loop liquid cooling heatsink and fan	Liquid cooling fan
Direct liquid cooling kit	High performance fan

The server operates at variable fan speeds. The fans operate at a minimum speed until a temperature change requires the fan speed to increase and cool the server. If a single-rotor fan fails, redundancy is lost. If two single-rotor fans or one dual-rotor fan fails, the server initiates a shutdown. The server shuts down during the following temperature-related scenarios:

- At POST and in the OS, iLO 7 performs an orderly shutdown if a cautionary temperature level is detected. If the server hardware detects a critical temperature level before an orderly shutdown occurs, the server performs an immediate shutdown.
- When the Thermal Shutdown feature is disabled in the BIOS/Platform Configuration (RBSU), iLO 7 does not perform an orderly shutdown when a cautionary temperature level is detected. Disabling this feature does not disable the server hardware from performing an immediate shutdown when a critical temperature level is detected.



CAUTION

A thermal event can damage server components when the Thermal Shutdown feature is disabled in the BIOS/Platform Configuration (RBSU).

High performance fans are required for ASHRAE-compliant configurations. For more information on ASHRAE, see the Hewlett Packard Enterprise website (<https://www.hpe.com/support/ASHRAEGen12>).

Heatsink and processor socket components

A high performance heatsink is shown. Your heatsink might look different.

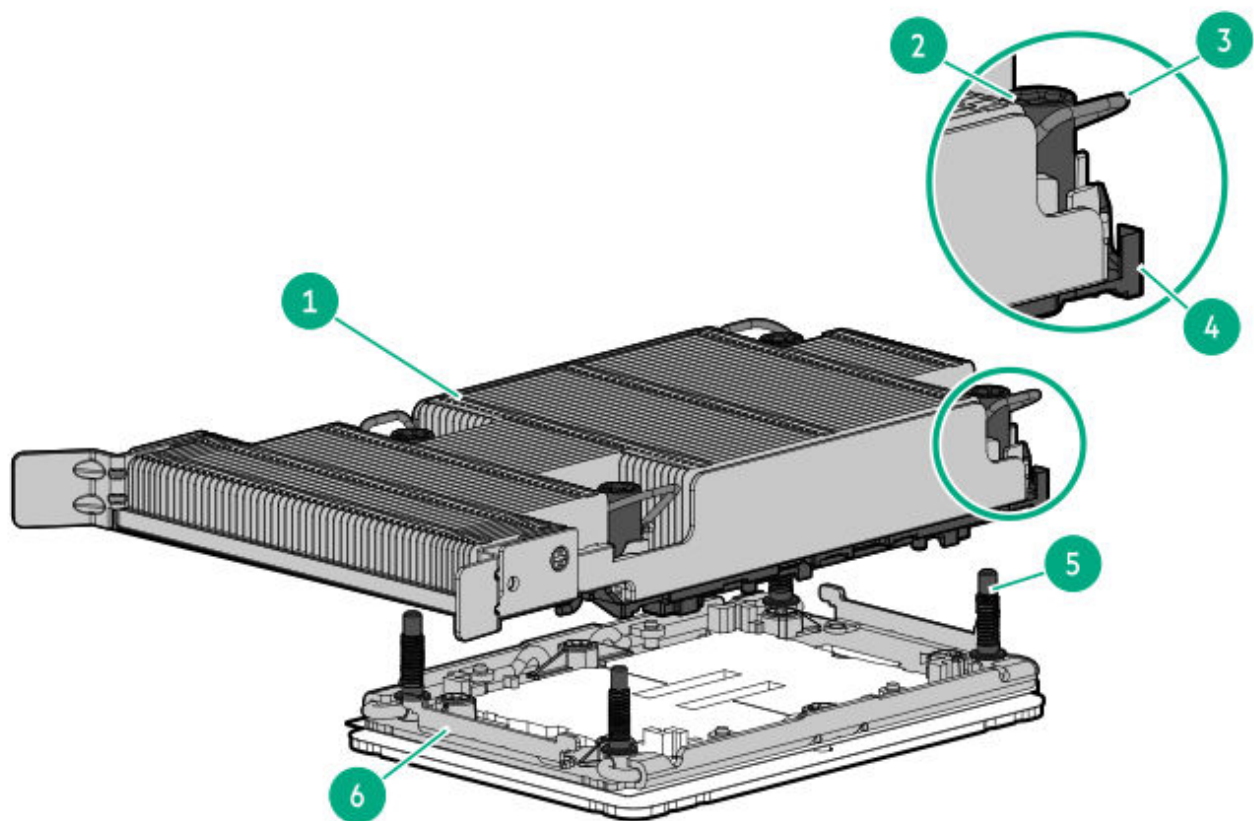

Item	Description
1	Processor-heatsink module ¹
2	Heatsink nuts
3	Heatsink latches
4	Processor carrier latches
5	Alignment screws
6	Bolster plate

¹ This module consists of the heatsink attached to the processor that is already secured in its carrier.

Closed-loop liquid cooling (CLLC) module components

For more information, see [Liquid cooling guidelines](#).

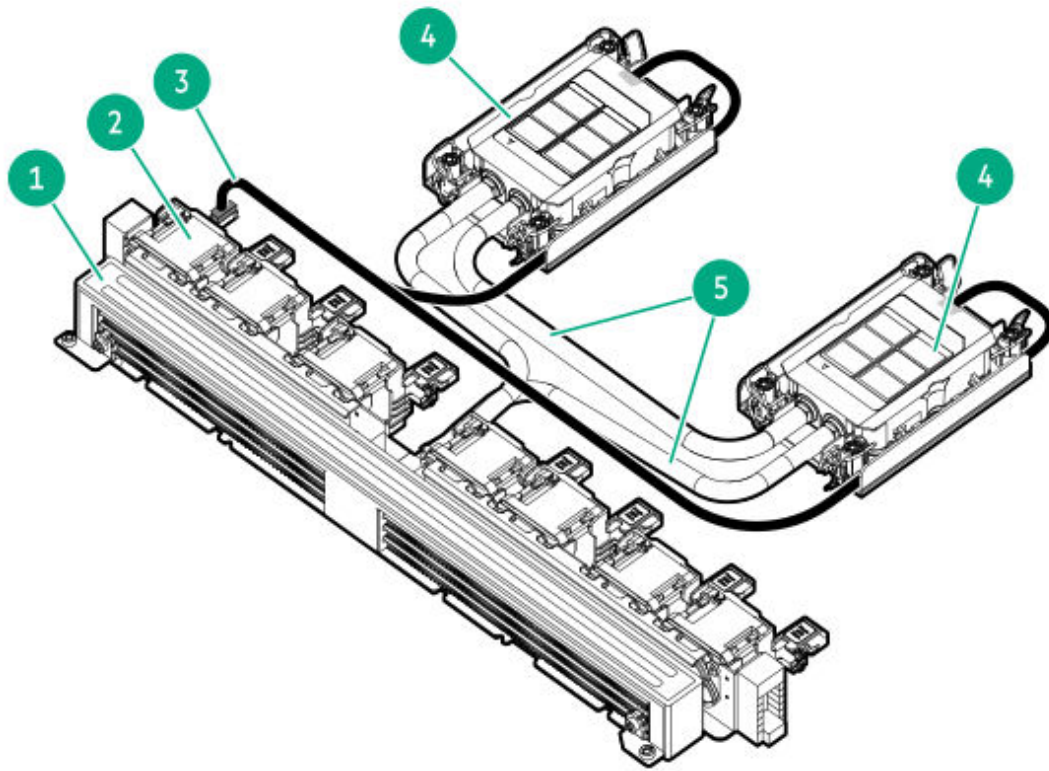

Item	Description
1	Radiator
2	Fans
3	Power and signal cable
4	Cold plates and pumps ¹
5	Coolant hoses
6	Leak detection cable ²

¹ Each of the closed-loop liquid cooling cold plates has two pumps for redundancy.

² Not shown

DLC module components

For more information, see [Liquid cooling guidelines](#).

The cable color is for illustration purpose only. There are two available direct liquid cooling (DLC) solutions:

- DLC cold plate module from PCIe (P74208-B21)

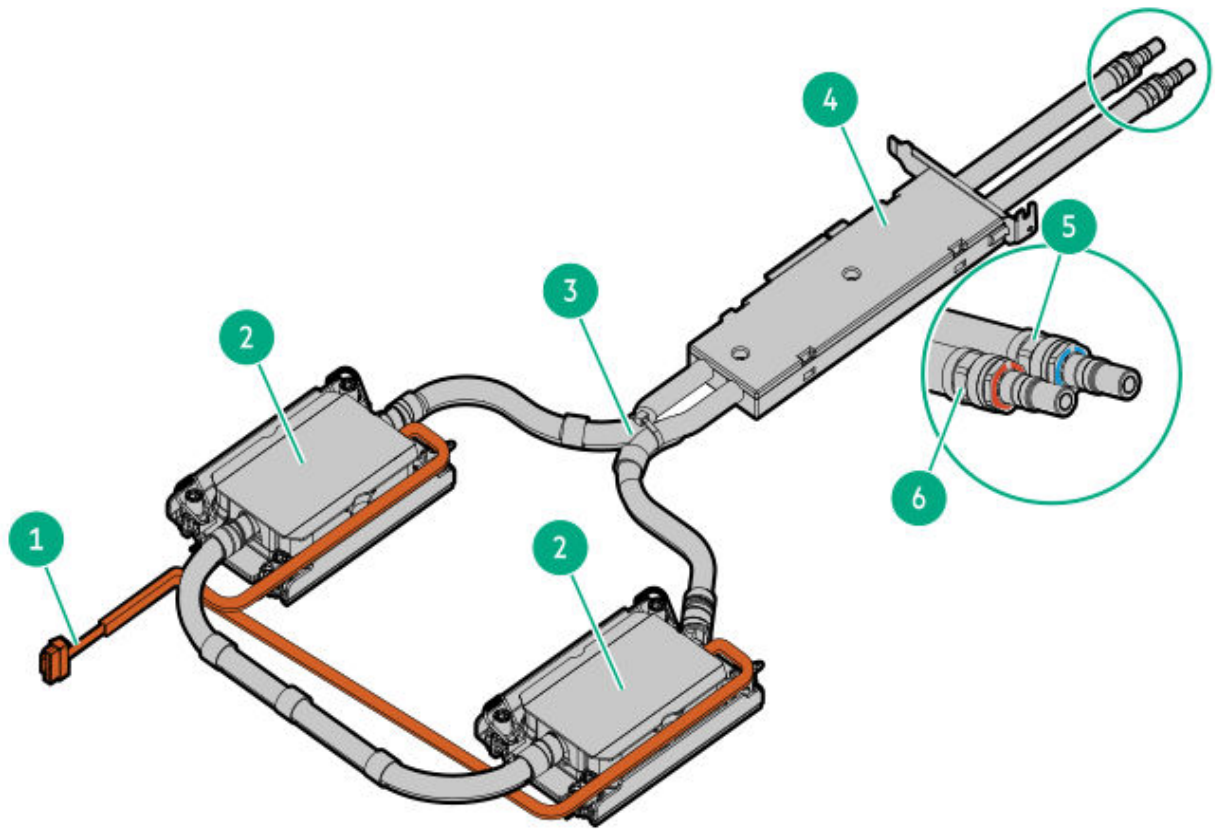

Item	Description
1	Power and signal cable
2	Open-loop liquid cooling cold plates
3	Coolant hoses
4	DLC hose holder
5	Supply hose
6	Return hose
7	Leak detection cable *

* Not shown

- DLC cold plate module from NS204 PCIe Slot 2 (P79273-B21)

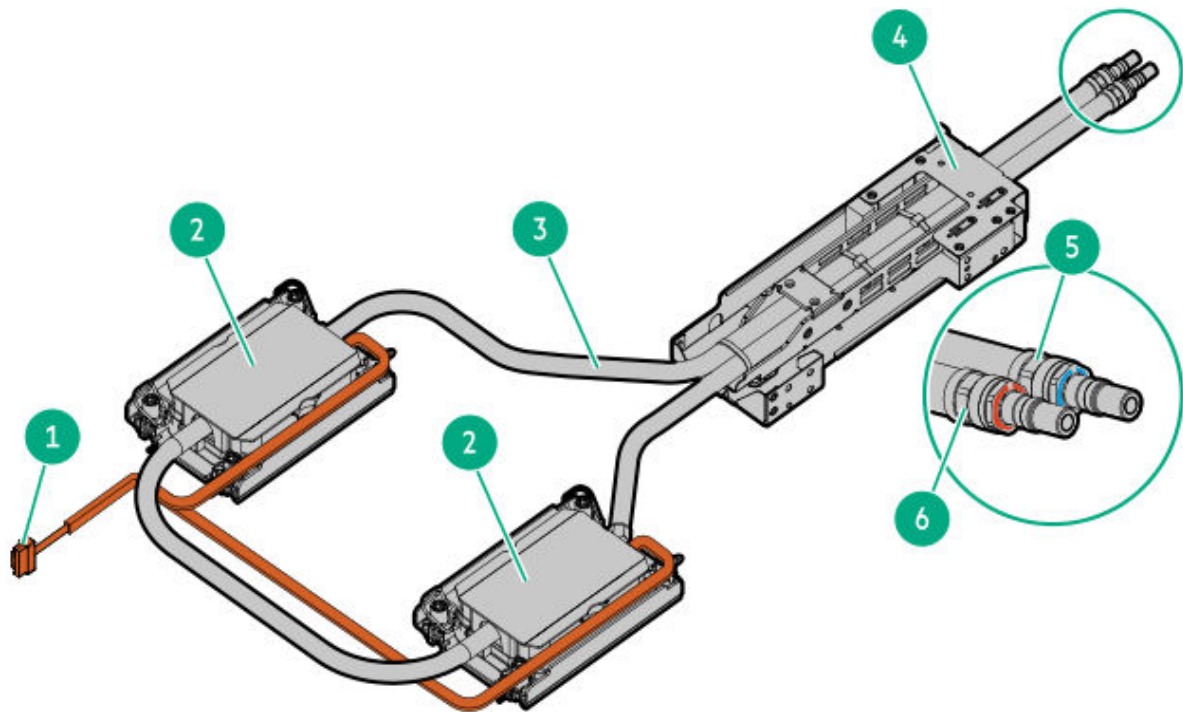

Item	Description
1	Power and signal cable
2	Open-loop liquid cooling cold plates
3	Coolant hoses
4	NS204i-u boot device bracket
5	Supply hose
6	Return hose
7	Leak detection cable *

* Not shown

DLC cold plate modules on this server are available as factory-installed options. For additional information, see the product QuickSpecs on the Hewlett Packard Enterprise website:

<https://www.hpe.com/info/quickspecs>

Liquid cooling guidelines

The closed-loop liquid cooling (CLLC) module hoses are prefilled with coolant. The coolant is a mixture of purified water and ethylene glycol with additional corrosion-resistant additives. The direct liquid cooling (DLC) module coolant is fed into the hoses through the rack manifolds.

CLLC module lifespan

HPE recommends replacing the module every five years. The coolant anti-corrosion additives degrade over time resulting in potential leaks in the system. For additional information on protecting the system, contact your local HPE representative.

Coolant leakage detection

If a liquid cooling module coolant leakage occurs, the following happens:

- iLO automatically detects it and:
 - Sends an iLO REST alert and Simple Network Management Protocol (SNMP) trap
 - Records the event in the Integrated Management Log (IML)
- The system initiates an immediate shutdown. The system will not power on until the leakage event is cleared, and a REST API operation for system recovery is performed.
- Follow the recommended procedure in Appendix I: Server coolant spill response of the server maintenance guide (<https://www.hpe.com/info/dl360gen12-msg>).

Do not attempt to replace the coolant in the CLLC module. For service inquiries, contact your local service provider.

Storage temperature

When storing a server with a liquid cooling module, maintain a temperature of -10°C to 60°C (14°F to 140°F). Allowing the liquid cooling module coolant to freeze can damage its metallic microstructures.

Facility water supply temperature

To maintain optimal cooling performance and prevent equipment damage from overheating:

- Do not allow the facility water supply temperature to exceed 40°C (104°F).
- Monitor environmental conditions year-round to anticipate temperature fluctuations.
- Install insulated plumbing as needed to ensure the water supply remains at or below 40°C (104°F).

HPE NS204i-u Boot Device V2 components

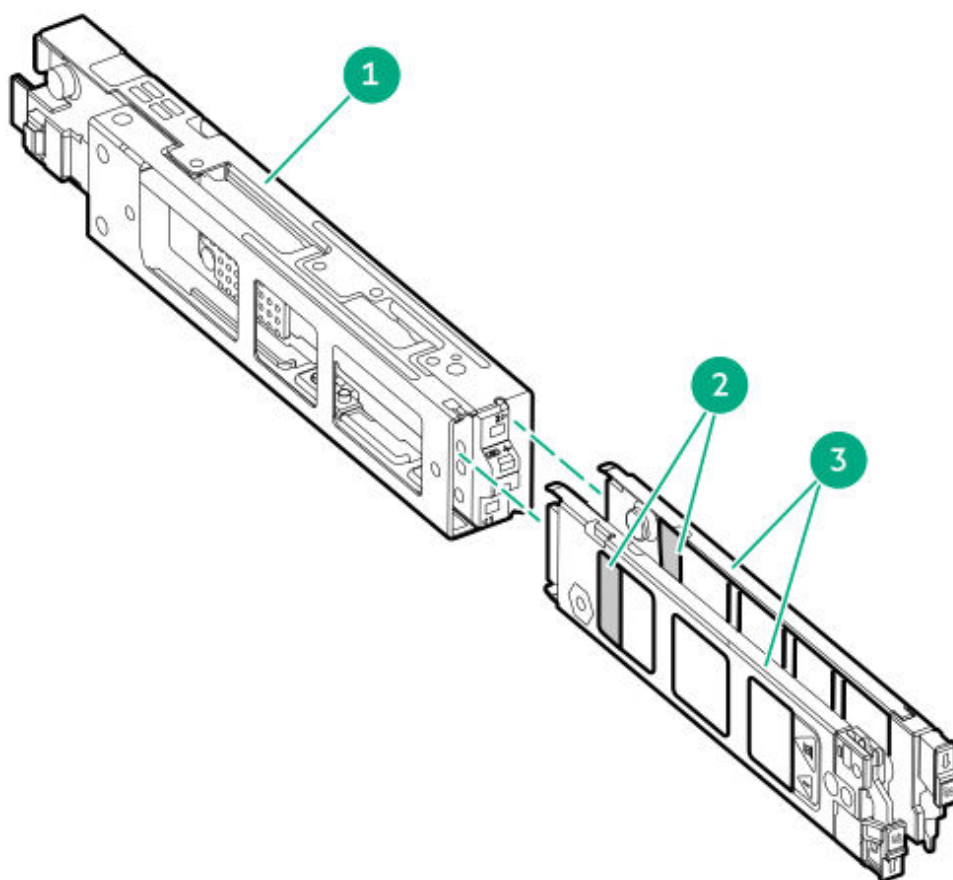

Item	Description
1	Boot device cage
2	M.2 slots
3	Boot device carriers

HPE NS204i-u Boot Device V2 LED definitions

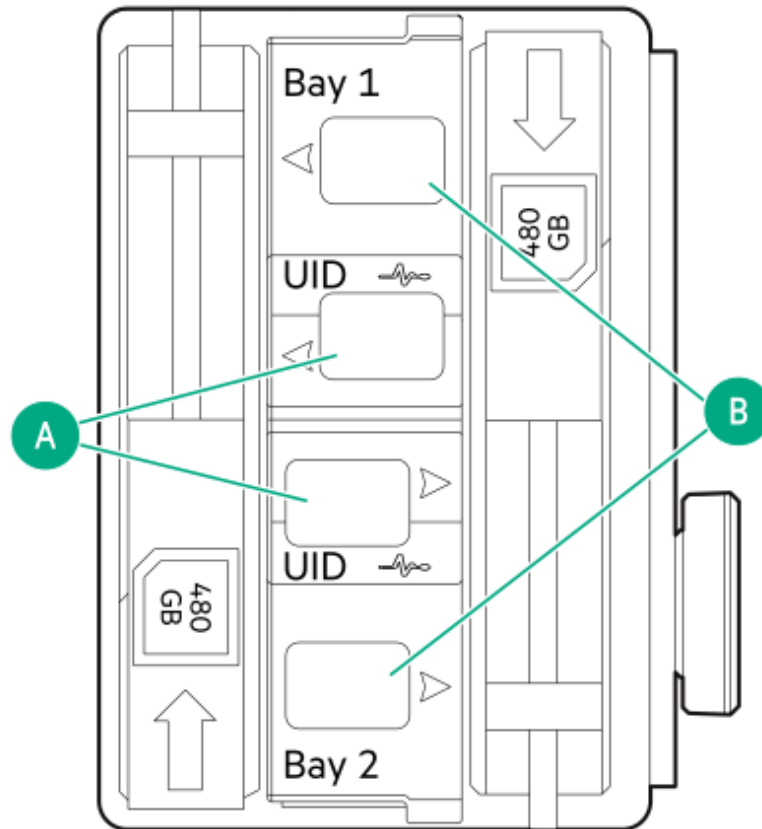

NOTE

The bay number can be found on the SSD carrier handle.

Item	LED	Status	Definition
A	Fault or Locate	Solid amber	Drive has failed, unsupported, or invalid.
		Solid blue	Drive is operating normally.
		Flashing amber or blue (one flash per second)	Drive has failed, or a predictive failure alert is received for the drive.
		Flashing amber (one flash per second)	Drive predictive failure alert is received. Replace the drive as soon as possible.
		Off	Drive is operating normally and is not identified by any application.
B	Online/Activity	Solid green	Drive is online and has no activity.

Item	LED	Status	Definition
		Flashing green (one flash per second)	Drive is doing one of the following: <ul style="list-style-type: none"> Rebuilding or performing a RAID Erasing
		Flashing green (4 flashes per second)	Drive is operating normally and has activity.
		Off	Drive is not configured by a RAID controller.

Riser board components

All riser slots are PCIe5 x16 (16, 8, 4, 1) and are rated for a maximum power draw of 75 W each.

Primary riser

This riser board supports Slots 1 and 2 in the three-slot configuration, or Slot 1 in the two-full-height slot configuration.

- Front: Slot 1

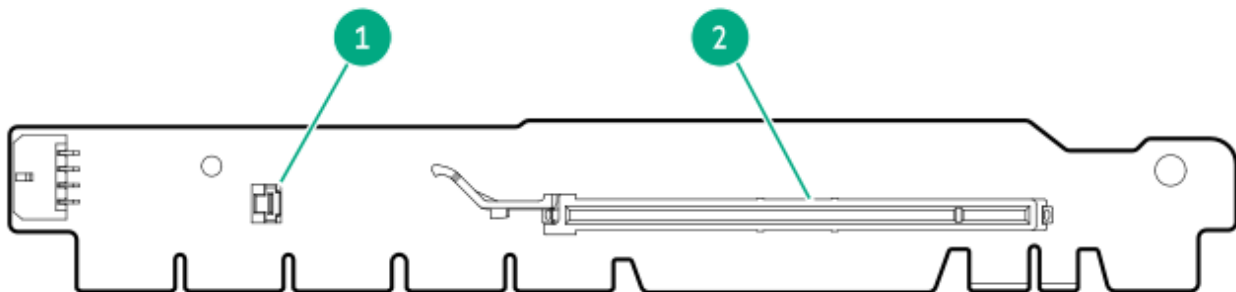

Item	Description	Supported form factors
1	Controller storage backup power connector	—
2	PCIe5 x16 (16, 8, 4, 1)	Full-height, up to 9.5" (or half-length)

- Back: Slot 2 in the three-slot configuration

This slot is not supported in the two-full-height-slot configuration.

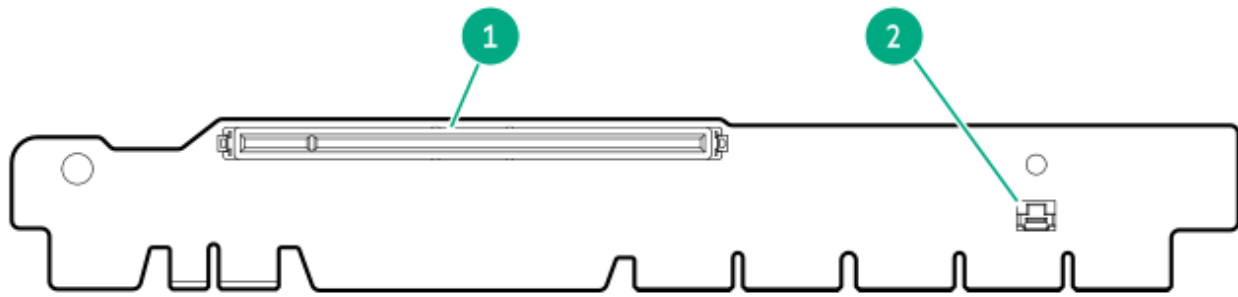

Item	Description	Supported form factors
1	PCIe5 x16 (16, 8, 4, 1)	Half-height, half-length (low-profile)*
2	Controller storage backup power connector	—

Secondary full-height riser

This riser board supports Slot 3 in the two-full-height-slot configuration, and is included in the secondary x16 full-height riser kit (P72598-B21).

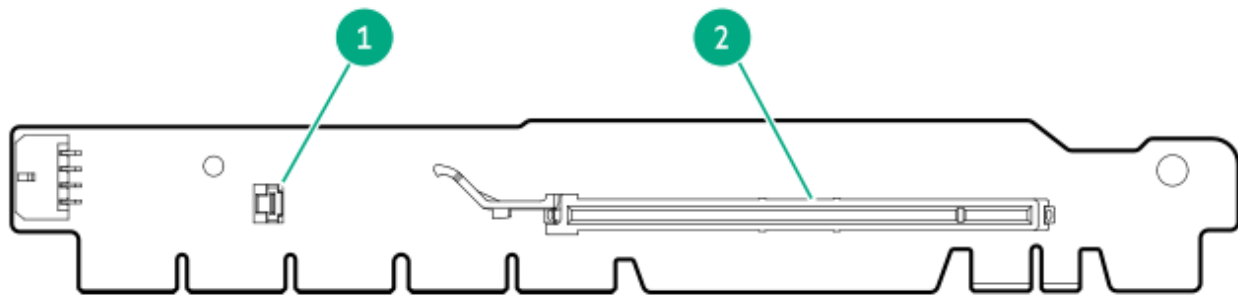

Item	Description	Supported form factors
1	Controller storage backup power connector	—
2	PCIe5 x16 (16, 8, 4, 1)	Full-height, up to 9.5" (or half-length)

Secondary low-profile riser

This riser board supports Slot 3 in the three-slot configuration, and is included in the secondary x16 low-profile riser kit (P48903-B21).

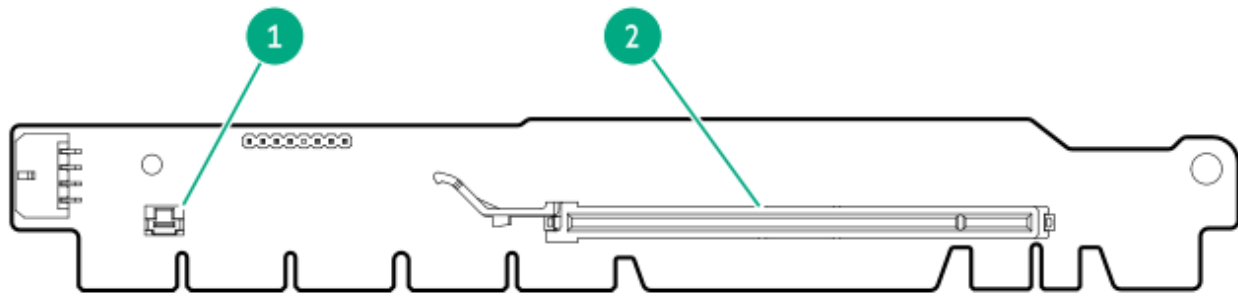

Item	Description	Supported form factors
1	Controller storage backup power connector	—
2	PCIe5 x16 (16, 8, 4, 1)	Half-height, half-length (low-profile)

Riser slot numbering

Slot 3 requires the secondary processor.

Three-slot configuration



Two-full-height-slot configuration



Setup

Provides initial setup procedures, operational requirements, and key safety cautions.

Subtopics

HPE Installation Service

Setting up the server

Operational requirements

Rack warnings and cautions

Server warnings and cautions

Electrostatic discharge

HPE Installation Service

HPE Installation Service provides basic installation of Hewlett Packard Enterprise branded equipment, software products, as well as HPE-supported products from other vendors that are sold by HPE or by HPE authorized resellers. The Installation Service is part of a suite of HPE deployment services that are designed to give users the peace of mind that comes from knowing that their HPE and HPE-supported products have been installed by an HPE specialist.

The HPE Installation Service provides the following benefits:

- Installation by an HPE authorized technical specialist.
- Verification prior to installation that all service prerequisites are met.
- Delivery of the service at a mutually scheduled time convenient to your organization.
- Allows your IT resources to stay focused on their core tasks and priorities.
- Full coverage during the warranty period for products that require installation by an HPE authorized technical specialist.

For more information on the features, limitations, provisions, and ordering information of the HPE Installation Service, see this Hewlett Packard Enterprise website:

<https://www.hpe.com/support/installation-service>

Setting up the server

Prerequisites

Before setting up the server:

- As a best practice, Hewlett Packard Enterprise recommends installing the latest firmware, drivers, and system software before using the server for the first time. You have these options:
 - HPE Compute Ops Management is an advanced software-as-a-service platform that securely streamlines operations from edge-to-cloud and automates key life cycle tasks through a unified single browser-based interface. For more information on using HPE Compute Ops Management, see <https://www.hpe.com/info/com-docs>.
 - Use the **Firmware Update** option in Intelligent Provisioning—Intelligent Provisioning is a server deployment tool embedded in HPE ProLiant servers. To access Intelligent Provisioning, during the server boot process, press **F10**. For more information, see the Intelligent Provisioning user guide at <https://www.hpe.com/support/hpeintelligentprovisioning-quicklinks>.
 - Download the Service Pack for HPE ProLiant—SPP is a comprehensive system software and firmware update solution that is delivered as a single ISO image. This solution uses Smart Update Manager as the deployment tool.
 - The preferred method for downloading an SPP is by creating an SPP custom download at <https://www.hpe.com/servers/spp/custom>.
This option reduces the size of the SPP by excluding firmware and drivers for OS and server models that are not needed.
 - The SPP is also available for download from the SPP download page at <https://www.hpe.com/servers/spp/download>.
- Verify that your OS or virtualization software is supported:
<https://www.hpe.com/support/Servers-Certification-Matrices>
- This server supports type-o and type-p storage controller options. For storage configuration, use Intel Virtual RAID on CPU (Intel VROC). If you plan to use Intel VROC, [review this important information before setting up the server](#).
- Read the [Operational requirements](#) for the server.
- Read the safety and compliance information:
<https://www.hpe.com/support/safety-compliance-enterpriseproducts>

Procedure

1. Unbox the server and verify the contents:
 - A server
 - A power cord
 - Rack-mounting hardware (optional)

- Documentation
2. (Optional) Install hardware options.
 3. Install the server in a rack.
 4. Decide how to manage the server:
 - Locally: Use a KVM switch or connect a keyboard, monitor, and mouse.
 - Remotely: Connect to the iLO web interface using remote console.
 - a. Verify the following:
 - iLO is licensed to use the remote console feature.
If iLO is not licensed, visit the HPE website:

<https://www.hpe.com/info/iLO>
 - The iLO management port is connected to a secure network.
 - b. Using a browser, navigate to the iLO web interface, and then log in.
`https://<iLO hostname or IP address>`
 - c. Enter the iLO login name and password, and then click **Log In**.
 - d. In the navigation tree, click **Host > Remote Console**, and then launch a remote console.
 5. Press the Power On/Standby button.

For remote management, use the iLO virtual power button.
 6. Configure the initial server setup.
 7. Set up the storage.
 8. Deploy an OS or virtualization software.
 9. After the OS is installed, update the drivers.
 10. Register the server.

Operational requirements

When preparing and planning the installation, observe the following operational requirements:

- [Space and airflow requirements](#)
- [Temperature requirements](#)
- [Power requirements](#)
- [Electrical grounding requirements](#)

For environmental requirements, see [Environmental specifications](#).

Subtopics

[Space and airflow requirements](#)

[Temperature requirements](#)

[Power requirements](#)

[Electrical grounding requirements](#)

Space and airflow requirements

To allow for servicing and adequate airflow, observe the following space and airflow requirements when installing the server in an indoor commercial rack:

- 63.50 cm (25.00 in) in front of the rack
- 76.20 cm (30.00 in) behind the rack
- 121.90 cm (48.00 in) from the back of the rack to the back of another rack or row of racks

Observe the following:

- Servers draw in cool air through the front of the rack and expel warm air through the rear. The front and rear rack doors must be adequately ventilated to allow ambient air to enter the cabinet. The rear door must be adequately ventilated to allow the warm air to escape from the cabinet.

**CAUTION**

To prevent improper cooling and damage to the equipment, do not block the ventilation openings.

**CAUTION**

When the vertical space in the rack is not filled by a server or rack component, the gaps between the components can cause changes in airflow through the rack and around the servers. Cover all gaps with blanking panels to maintain proper airflow. Using a rack without blanking panels results in improper cooling which can lead to thermal damage.

- If a third-party rack is used, observe the following additional requirements to ensure adequate airflow and prevent damage to the equipment:
 - Front and rear doors—If the 42U rack includes closing front and rear doors, you must allow 5,350 sq cm (830 sq in) of holes evenly distributed from top to bottom to permit adequate airflow (equivalent to the required 64 percent open area for ventilation).
 - Side—The clearance between the installed rack component and the side panels of the rack must be a minimum of 7.00 cm (2.75 in).

Temperature requirements

To ensure continued safe and reliable equipment operation, install or position the system in a well-ventilated, climate-controlled environment.

The maximum recommended ambient operating temperature (TMRA) for most server products is 35°C (95°F). The temperature in the room where the rack is located must not exceed 35°C (95°F).



CAUTION

To reduce the risk of damage to the equipment when installing third-party options:

- Do not permit optional equipment to impede airflow around the server or to increase the internal rack temperature beyond the maximum allowable limits.
- Do not exceed the manufacturer's TMRA.

Power requirements

Installation of this equipment must comply with local and regional electrical regulations governing the installation of information technology equipment by licensed electricians. This equipment is designed to operate in installations covered by NFPA 70, 1999 Edition (National Electric Code) and NFPA-75, 1992 (code for Protection of Electronic Computer/Data Processing Equipment). For electrical power ratings on options, refer to the product rating label or the user documentation supplied with that option.



WARNING

To reduce the risk of personal injury, fire, or damage to the equipment, do not overload the AC supply branch circuit that provides power to the rack. Consult the electrical authority having jurisdiction over wiring and installation requirements of your facility.



CAUTION

Protect the server from power fluctuations and temporary interruptions with a regulating uninterruptible power supply. This device protects the hardware from damage caused by power surges and voltage spikes and keeps the system in operation during a power failure.

Electrical grounding requirements

The server must be grounded properly for proper operation and safety. In the United States, you must install the equipment in accordance with NFPA 70, National Electric Code Article 250, as well as any local and regional building codes. In Canada, you must install the equipment in accordance with Canadian Standards Association, CSA C22.1, Canadian Electrical Code. In all other countries, you must install the equipment in

accordance with any regional or national electrical wiring codes, such as the International Electrotechnical Commission (IEC) Code 364, parts 1 through 7. Furthermore, you must be sure that all power distribution devices used in the installation, such as branch wiring and receptacles, are listed or certified grounding-type devices.

Because of the high ground-leakage currents associated with multiple servers connected to the same power source, Hewlett Packard Enterprise recommends the use of a PDU that is either permanently wired to the building's branch circuit or includes a nondetachable cord that is wired to an industrial-style plug. NEMA locking-style plugs or those complying with IEC 60309 are considered suitable for this purpose. Using common power outlet strips for the server is not recommended.

Rack warnings and cautions



WARNING

When all components are removed, the server weighs 14.87 kg (32.71 lb). When all components are installed, the server can weigh up to 21.38 kg (47.04 lb).

Before configuring your rack solution, be sure to check the rack manufacturer weight limits and specifications. Failure to do so can result in physical injury or damage to the equipment and the facility.



WARNING

The server is heavy. To reduce the risk of personal injury or damage to the equipment, do the following:

- Observe local occupational health and safety requirements and guidelines for manual material handling.
- Get help to lift and stabilize the product during installation or removal, especially when the product is not fastened to the rails. The server weighs more than 14.87 kg (32.71 lb), so at least two people must lift the server into the rack together. An additional person may be required to help align the server if the server is installed higher than chest level.
- Use caution when installing the server in or removing the server from the rack.
- Adequately stabilize the rack before extending a component outside the rack. Extend only one component at a time. A rack may become unstable if more than one component is extended.
- Do not stack anything on top of rail-mounted component or use it as a work surface when extended from the rack.



WARNING

To reduce the risk of personal injury or damage to the equipment, be sure that:

- The rack has anti-tip measures in place. Such measures include floor-bolting, anti-tip feet, ballast, or a combination as specified by the rack manufacturer and applicable codes.
- The leveling jacks (feet) are extended to the floor.
- The full weight of the rack rests on the leveling jacks (feet).

Server warnings and cautions



WARNING

To reduce the risk of personal injury, electric shock, or damage to the equipment, disconnect the power cord to remove power from the server. Pressing the Power On/Standby button does not shut off system power completely. Portions of the power supply and some internal circuitry remain active until AC power is removed.



WARNING

To reduce the risk of personal injury from hot surfaces, allow the drives and the internal system components to cool before touching them.



WARNING

To reduce the risk of fire or burns after removing the energy pack:

- Do not disassemble, crush, or puncture the energy pack.
- Do not short external contacts.
- Do not dispose of the energy pack in fire or water.
- Do not expose the energy pack to low air pressure as it might lead to explosion or leakage of flammable liquid or gas.
- Do not expose the energy pack to temperatures higher than 60°C (140°F).

After power is disconnected, battery voltage might still be present for 1s to 160s.



CAUTION

Protect the server from power fluctuations and temporary interruptions with a regulating UPS. This device protects the hardware from damage caused by power surges and voltage spikes and keeps the server in operation during a power failure.



CAUTION

To prevent damage to electrical components, properly ground the server before beginning any installation, removal, or replacement procedure. Improper grounding can cause electrostatic discharge.



CAUTION

To avoid data loss, Hewlett Packard Enterprise recommends that you back up

Electrostatic discharge

Be aware of the precautions you must follow when setting up the system or handling components. A discharge of static electricity from a finger or other conductor may damage system boards or other static-sensitive devices. This type of damage may reduce the life expectancy of the system or component.

To prevent electrostatic damage:

- Avoid hand contact by transporting and storing products in static-safe containers.
- Keep electrostatic-sensitive parts in their containers until they arrive at static-free workstations.
- Place parts on a grounded surface before removing them from their containers.
- Avoid touching pins, leads, or circuitry.
- Always be properly grounded when touching a static-sensitive component or assembly. Use one or more of the following methods when handling or installing electrostatic-sensitive parts:
 - Use a wrist strap connected by a ground cord to a grounded workstation or computer chassis. Wrist straps are flexible straps with a minimum of 1 megohm \pm 10 percent resistance in the ground cords. To provide proper ground, wear the strap snug against the skin.
 - Use heel straps, toe straps, or boot straps at standing workstations. Wear the straps on both feet when standing on conductive floors or dissipating floor mats.
 - Use conductive field service tools.
 - Use a portable field service kit with a folding static-dissipating work mat.

If you do not have any of the suggested equipment for proper grounding, have an authorized reseller install the part.

For more information on static electricity or assistance with product installation, contact an authorized reseller.

Operations

Provides an overview of selected server storage, security, and service features.

Subtopics

[iLO service port](#)

[Intel VROC support](#)

Server UID LED

Monitor setup

Trusted Platform Module 2.0

Trusted Platform Module 2.0 guidelines

System battery information

iLO service port

The iLO service port is a USB port with the label **iLO** on the front of the server.

When you have physical access to a server, you can use the iLO service port to:

- Download the Active Health System Log to a supported USB flash drive.

When you use this feature, the connected USB flash drive is not accessible by the host OS.

- Connect a host system (Windows/Mac/Linux laptop or desktop) using either a standard USB Type A-to-Type C cable or USB Type C-to-Type C cable to access the:
 - iLO web interface
 - Remote console
 - iLO RESTful API
 - CLI

When you use the iLO service port:

- Actions are logged in the iLO event log.
- The server UID flashes to indicate the iLO service port status.

You can also retrieve the iLO service port status by using a REST client and the iLO RESTful API.

- You cannot use the iLO service port to boot any device within the server, or the server itself.
- You cannot access the server by connecting to the iLO service port.
- You cannot access the connected device from the server.

For more information about the iLO service port, see the iLO user guide:

<https://www.hpe.com/support/hpeilodocs-quicklinks>

Intel VROC support

Intel Virtual RAID on CPU (Intel VROC) provides enterprise-level hybrid RAID support. Note the following information:

- Intel VROC provides RAID support for direct attached NVMe SSD.
- The Intel VROC driver is required. For the OS-specific driver download, see the following page:
<https://www.hpe.com/support/VROC-installation>
- If you plan to enable Intel VROC for NVMe devices, secure an Intel VROC Hybrid RAID License. For more information on Intel VROC licenses, see the server QuickSpecs:
<https://www.hpe.com/info/quickspecs>
- Intel VROC requires the server boot mode to be set to **UEFI Mode**.
- Intel VROC RAID support is disabled by default. In the pre-OS environment, use UEFI System Utilities to enable Intel VROC and create a VROC RAID volume. These tasks are not supported in Intelligent Provisioning.
- The VROC RAID volume must use drives of the same interface and form factor.
- Intel VROC supports RAID management through the following tools:
 - Non-OS specific: UEFI System Utilities
 - Windows: Intel VROC GUI, Intel VROC CLI
 - Linux: `mdadm` CLI

For more information on Intel VROC features and configuration, see [Configuring storage controllers](#).

Server UID LED

The UID LED can be used to help an on-site technician quickly identify or locate a particular server when it is deployed in a dense rack with other equipment. It can also be used to identify if a remote management, firmware upgrade, or reboot sequence is in progress.

Subtopics

[Viewing the Server Health Summary](#)

Viewing the Server Health Summary

Prerequisites

- An external monitor is connected.
- In the iLO web interface, the **Show Server Health on External Monitor** feature is enabled on the **Access Settings** page.

About this task

If the server does not power on, use the UID button to display the iLO **Server Health Summary** screen on an external monitor. This function works when the server is powered on or off.

For more information, see the iLO troubleshooting guide on the [Hewlett Packard Enterprise website](#).

Procedure

1. Press and release the UID button.



CAUTION

Be sure to press and release the UID button. Pressing the UID button at any time for more than five seconds will initiate a graceful iLO reboot or a hardware iLO reboot. Data loss or NVRAM corruption might occur during a hardware iLO reboot.

The **Server Health Summary** screen displays on the external monitor.

2. Press the UID button again to close the **Server Health Summary** screen.

Monitor setup

Before connecting a monitor, observe the following:

- The server supports both VGA port and DisplayPort 1.1a.
- If you connect two display devices to the server using both the VGA port and DisplayPort, the same image is mirrored on both devices.
- The embedded video controller in the iLO chipset does not support dual display or screen extension mode. To enable dual display, install a compatible graphics card.
- When using HDMI or DVI adapters for the DisplayPort, use an active-type adapter. Passive-type adapters marked with the DP++ symbol are not supported.

- Whenever possible, use the same display connection type. For example, if your monitor only has a VGA port, use the VGA port on the server. Using other adapters or converter cables or dongles might lead to decreased display quality or a lag over the connection.

Trusted Platform Module 2.0

The Trusted Platform Module 2.0 (TPM) is:

- Embedded on the system board
- A hardware-based system security feature that securely stores artifacts used to authenticate the platform. These artifacts can include passwords, certificates, and encryption keys
- Supported by specific operating systems such as Microsoft Windows Server 2012 R2 and later

For more information about operating system support, see the product QuickSpecs on the Hewlett Packard Enterprise website (<https://www.hpe.com/info/quickspecs>).

For more information about Microsoft Windows BitLocker Drive Encryption feature, see the Microsoft website (<https://www.microsoft.com>).

Trusted Platform Module 2.0 guidelines



CAUTION

- Always observe the TPM guidelines in this section. Failure to follow these guidelines can cause hardware damage or halt data access.
- If you do not follow procedures for modifying the server and suspending or disabling the TPM in the OS, an OS that is using TPM might lock all data access. This includes updating system or option firmware, replacing hardware such as the system board and drives, and modifying TPM OS settings.
- Changing the TPM mode after installing an OS might cause problems, including loss of data.

- Use the UEFI System Utilities to configure the TPM. From the **System Utilities** screen, select **System Configuration** > **BIOS/Platform Configuration (RBSU)** > **Server Security** > **Trusted Platform Module options**. For more information, see the UEFI user guide:

<https://www.hpe.com/support/hpeuefisystemutilities-quicklinks>

- When using the Microsoft Windows BitLocker Drive Encryption feature, always retain the recovery key or password. The recovery key or password is required to enter Recovery Mode after BitLocker detects a possible compromise of system integrity.
- HPE is not liable for blocked data access caused by improper TPM use. For operating instructions, see the documentation for the encryption technology feature provided by the operating system.

System battery information

The server contains an internal lithium manganese dioxide, a vanadium pentoxide, or an alkaline battery that provides power to the real-time clock.



WARNING

If this battery is not properly handled, a risk of fire or burning exists. To reduce the risk of personal injury:

- Do not attempt to recharge the battery.
- Do not expose the battery to temperatures higher than 60°C (140°F).
- Do not expose the battery to low air pressure as it might lead to explosion or leakage of flammable liquid or gas.
- Do not disassemble, crush, puncture, short external contacts, or dispose of the battery in fire or water.

Hardware options

Provides instructions for installing supported hardware options and required configuration information.

Subtopics

[**Hewlett Packard Enterprise product QuickSpecs**](#)

[**Hardware option installation guidelines**](#)

[**Pre-installation procedures**](#)

[**Post-installation procedures**](#)

[**Cooling**](#)

[**Drives**](#)

Drive cages

Energy packs

GPUs

Management

Media devices

Memory

Networking

OS boot device

Power supplies

Processors and heatsinks

Rack rail and CMA

Risers and riser cages

Security

Storage controllers

Hewlett Packard Enterprise product QuickSpecs

To learn more about your product, search the Hewlett Packard Enterprise website (<https://www.hpe.com/info/quickspecs>) for the product QuickSpecs:

- Supported options
- Supported configurations
- Component compatibility
- New features
- Specifications
- Part numbers

Hardware option installation guidelines



WARNING

To reduce the risk of personal injury from hot surfaces, allow the drives and the internal system components to cool before touching them.



CAUTION

To avoid data loss, Hewlett Packard Enterprise recommends that you back up all server data before installing or removing a hardware option, or performing a server maintenance or troubleshooting procedure.



CAUTION

To prevent damage to electrical components, properly ground the server before beginning any installation, removal, or replacement procedure. Improper grounding can cause electrostatic discharge.

- Install any hardware options before initializing the server.
- If multiple options are being installed, read the installation instructions for all the hardware options to identify similar steps and streamline the installation process.
- If the hardware option installation involves internal cabling, review the Cabling guidelines.

Pre-installation procedures

Subtopics

Server data backup

Power down the server

Extend the server from the rack

Release the cable management arm

Remove the server from the rack

Remove the bezel

Remove the access panel

Remove the air baffle

Remove the middle cover

Remove the fan wall

Remove the primary PCIe riser cage

Remove a hot-plug SAS / SATA / NVMe drive

Server data backup

To avoid data loss, make sure to back up all server data before installing or removing a hardware option, performing a server maintenance, or a troubleshooting procedure.

Server data in this context refers to information that may be required to return the system to a normal operating environment after completing a hardware maintenance or troubleshooting procedure. This information may include:

- User data files
- User account names and passwords
- Application settings and passwords
- Component drivers and firmware
- TPM recovery key/password
- BIOS configuration settings—Use the backup and restore function in UEFI System Utilities. For more information, see the UEFI user guide (<https://www.hpe.com/support/hpeuefisystemutilities-quicklinks>).
 - Custom default system settings
 - Security passwords including those required for power-on and BIOS admin access, persistent memory, and Server Configuration Lock (for HPE Trusted Supply Chain servers)
 - Server serial number and the product ID
- iLO-related data—Use the iLO backup and restore function. For more information, see the iLO user guide (<https://www.hpe.com/support/hpeilodocs-quicklinks>).
 - iLO license
 - Customer iLO user name, password, and DNS name
 - iLO configuration settings

Power down the server

Before powering down the server for any upgrade or maintenance procedures, perform a backup of critical server data and programs.



IMPORTANT

When the server is in standby mode, auxiliary power is still being provided to the system.

To power down the server, use one of the following methods:

- Press and release the Power On/Standby button.
This method activates a controlled shutdown of applications and the OS before the server enters standby mode. It can also activate a shutdown behavior governed by an OS configuration or policy.
- Press and hold the Power On/Standby button for more than 4 seconds to force the server to enter standby mode.
This method forces the server to enter standby mode without properly exiting applications and the OS. If an application stops responding, you can use this method to force a shutdown.
- Use a virtual power button selection through iLO 7.
This method initiates a controlled remote shutdown of applications and the OS before the server enters standby mode.

Before proceeding, verify that the server is in standby mode by observing that the system power LED is amber.

Extend the server from the rack

Prerequisites

- You might need a T-25 Torx screwdriver to loosen the shipping screws.
- Review the:
 - [Rack warnings and cautions](#)
 - [Server warnings and cautions](#)

Procedure

Extend the server from the rack.



WARNING

To reduce the risk of personal injury or equipment damage, be sure that the rack is adequately stabilized before extending anything from the rack.

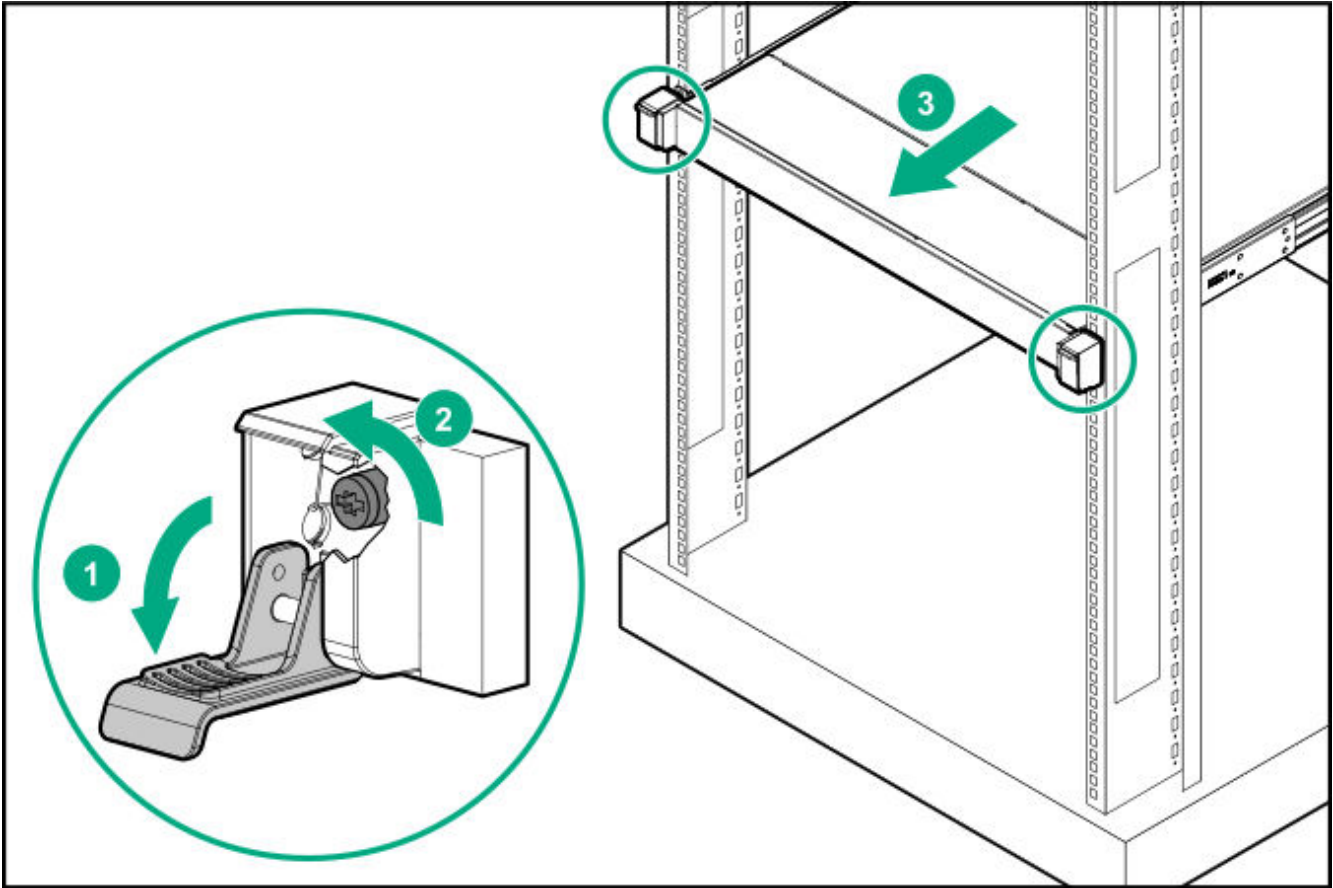

Release the cable management arm

About this task



CAUTION

To reduce the risk of personal injury, be careful when pressing the cable management or rail-release latches. The rails or latches could pinch your fingers.

Procedure

Release the cable management arm and swing away from the rack.

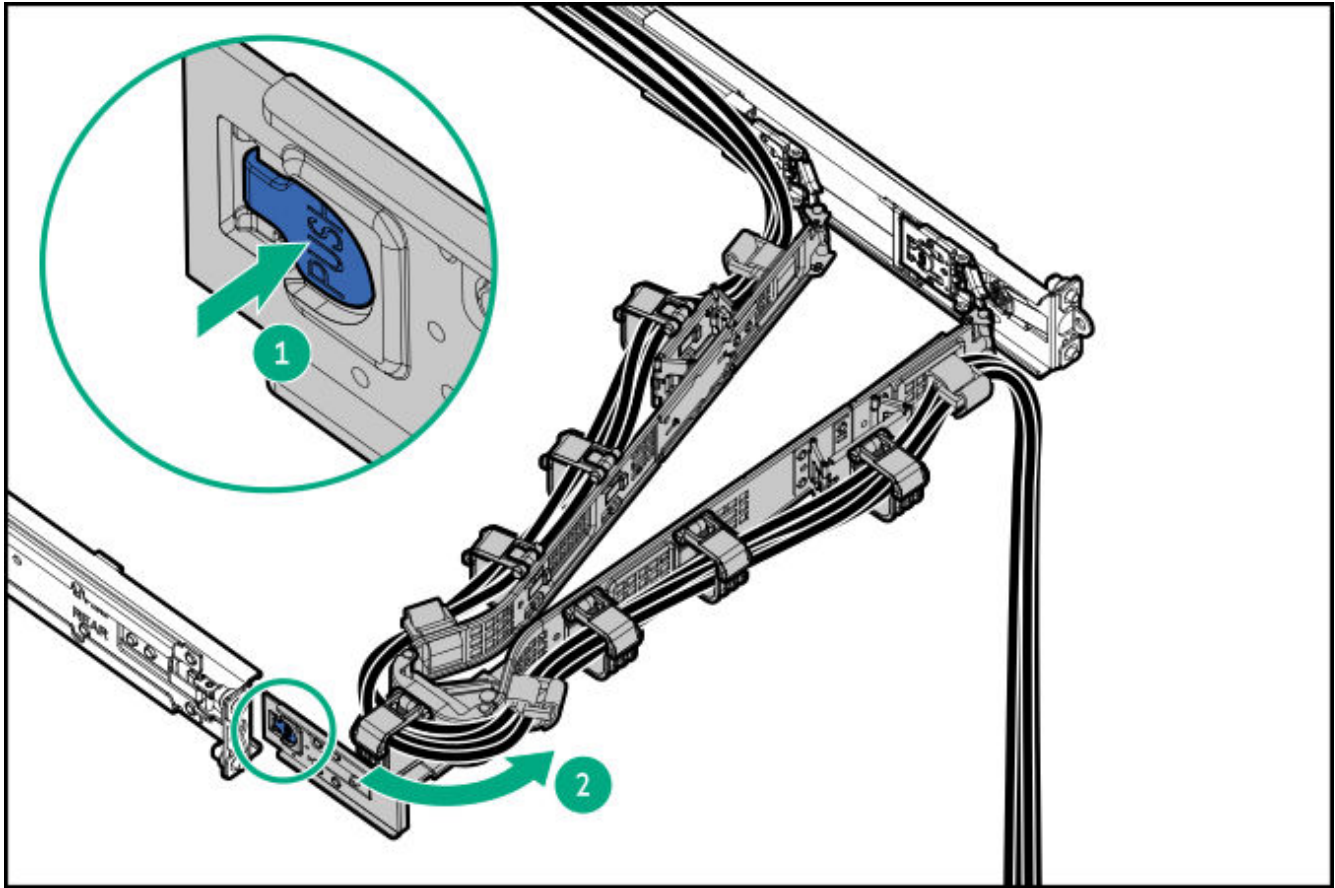

Remove the server from the rack

Prerequisites

Before you perform this procedure, review the:

- [Rack warnings and cautions](#)
- [Server warnings and cautions](#)

About this task



WARNING

To reduce the risk of personal injury or equipment damage, be sure that the rack is adequately stabilized before extending anything from the rack.

Procedure

1. [Power down the server.](#)

2. Release the cable management arm.
3. Disconnect the cabling from the rear panel.
4. Extend the server from the rack.
5. Remove the server from the rack:

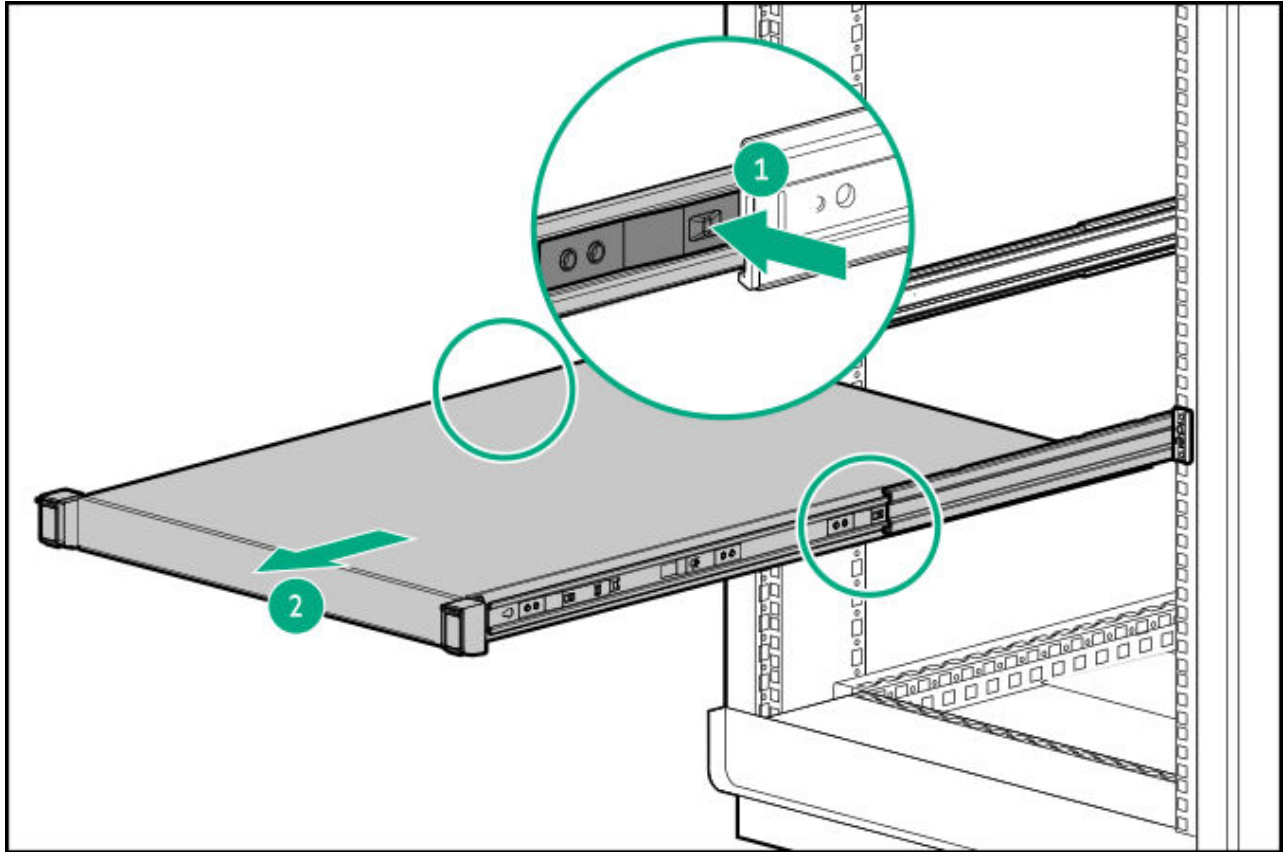

6. Place the server on a sturdy, level surface.

Remove the bezel

Procedure

1. If installed, remove the Kensington security lock.

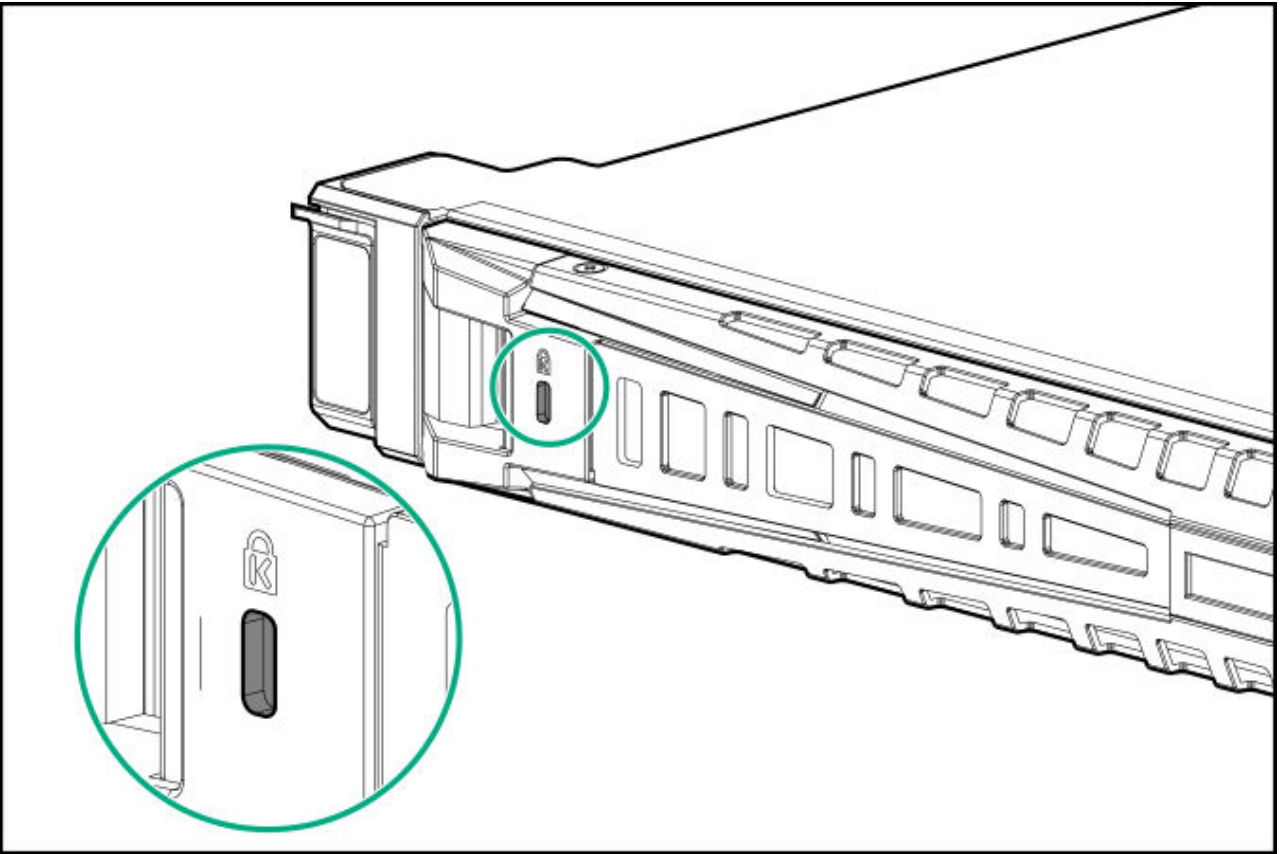

2. Remove the bezel.

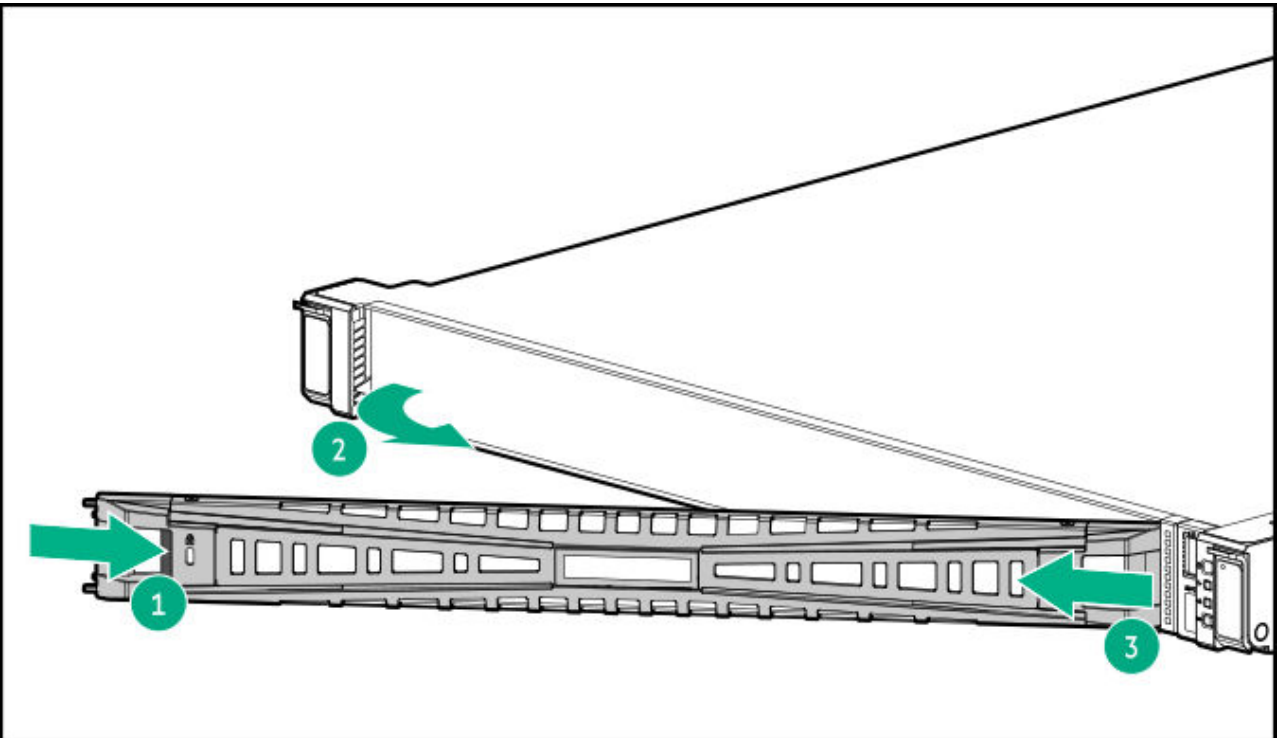

Remove the access panel

About this task



WARNING

To reduce the risk of personal injury from hot surfaces, allow the drives and the internal system components to cool before touching them.



CAUTION

Do not operate the server for long periods with the access panel open or removed. Operating the server in this manner results in improper airflow and improper cooling that can lead to thermal damage.

Procedure

1. Power down the server.
2. Extend the server from the rack.
3. Open or unlock the locking latch, slide the access panel to the rear of the chassis, and remove the access panel.

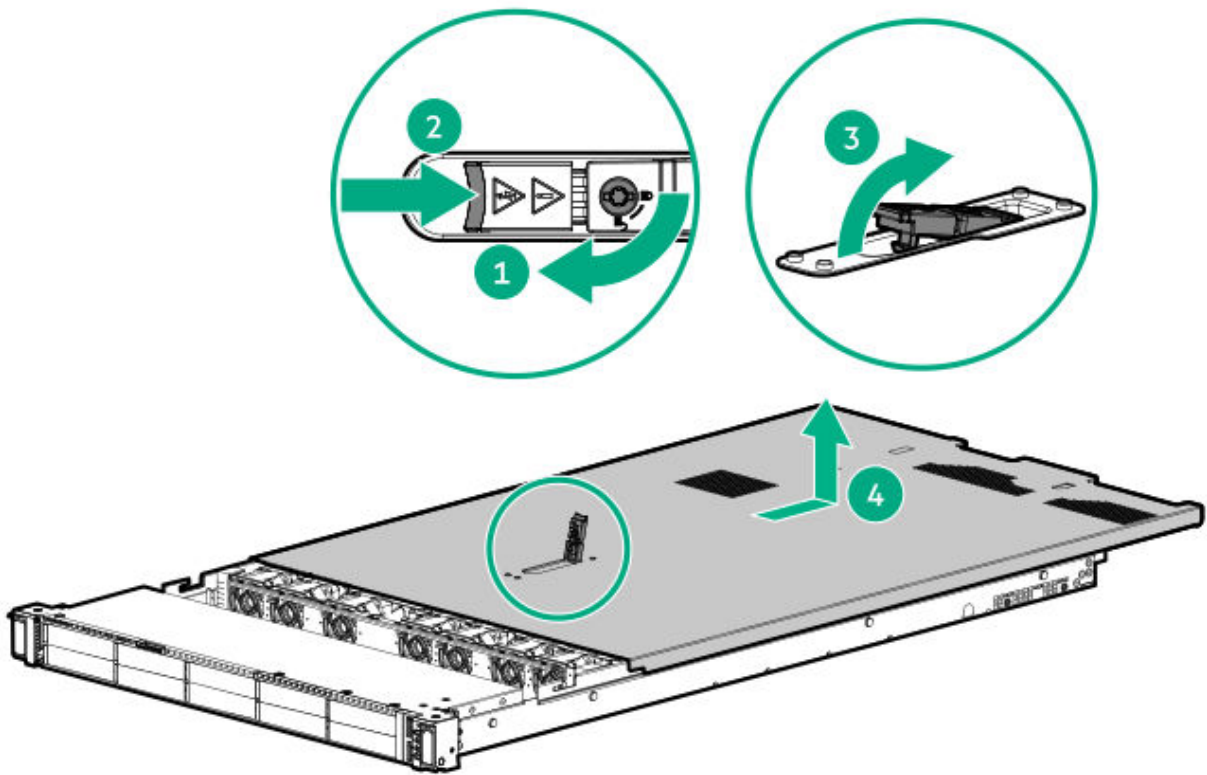

Remove the air baffle

Prerequisites

Review the [Fan and heatsink requirements](#).

About this task

The optional air baffle is supported on servers using high performance heatsinks.



CAUTION

For proper cooling, do not operate the server without the access panel, baffles, expansion slot covers, or blanks installed. If the server supports hot-plug components, minimize the amount of time the access panel is open.



CAUTION

To prevent damage to electrical components, properly ground the server before beginning any installation, removal, or replacement procedure. Improper grounding can cause electrostatic discharge.

Procedure

1. Power down the server.
2. Remove all power:
 - a. Disconnect each power cord from the power source.
 - b. Disconnect each power cord from the server.
3. Disconnect all peripheral cables from the server.
4. Remove the server from the rack.
5. Place the server on a flat, level work surface.
6. Remove the access panel.
7. Remove the air baffle.

An 8 SFF server is shown. The removal procedure is the same for all drive configurations.

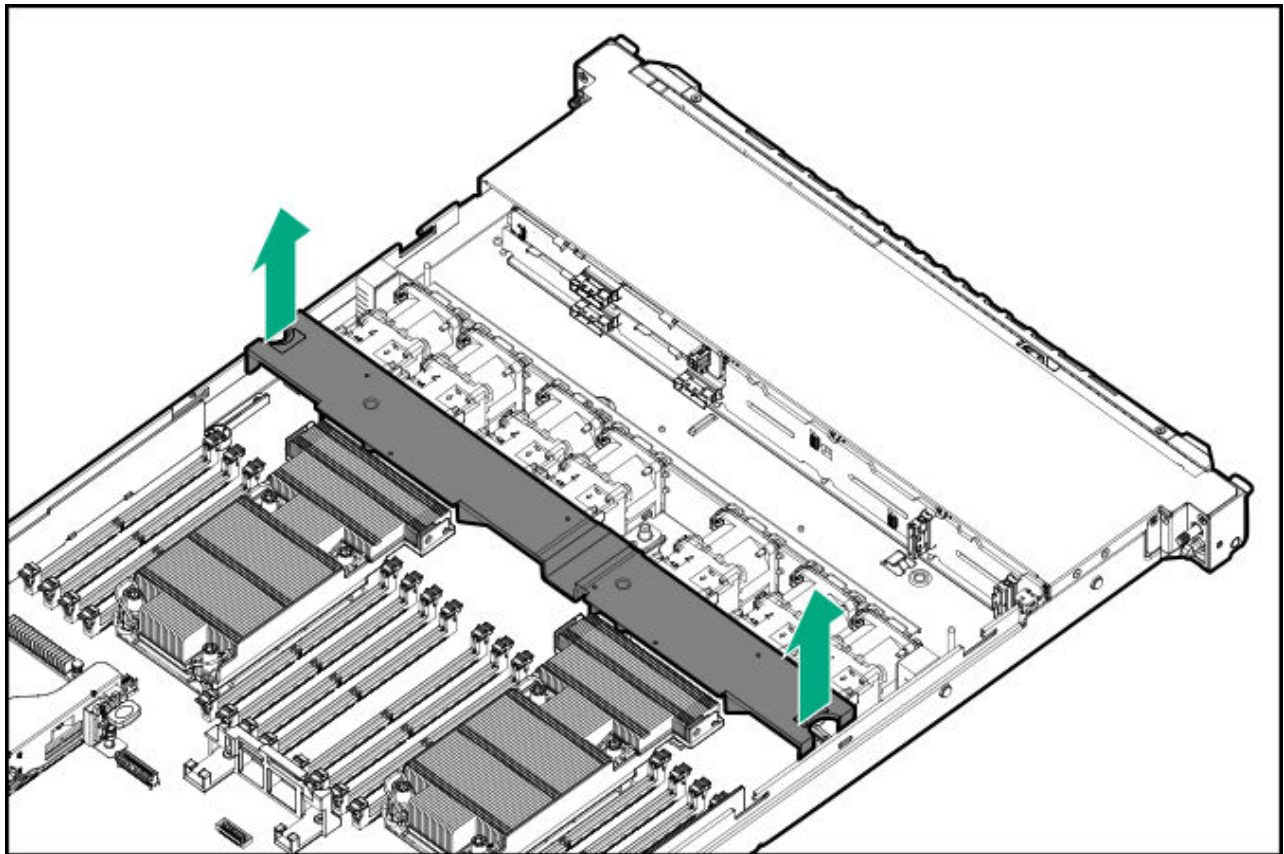

Remove the middle cover

About this task

The middle cover is available on the 10 SFF / 20 E3.S server.



CAUTION

For proper cooling, do not operate the server without the access panel, baffles, expansion slot covers, or blanks installed.



CAUTION

To prevent damage to electrical components, properly ground the server before beginning any installation, removal, or replacement procedure. Improper grounding can cause electrostatic discharge.

Procedure

1. Power down the server.

2. Remove all power:
 - a. Disconnect each power cord from the power source.
 - b. Disconnect each power cord from the server.
3. Disconnect all peripheral cables from the server.
4. Extend the server from the rack.
5. Remove the access panel.
6. Take both sides of the middle cover and detach it from the server.

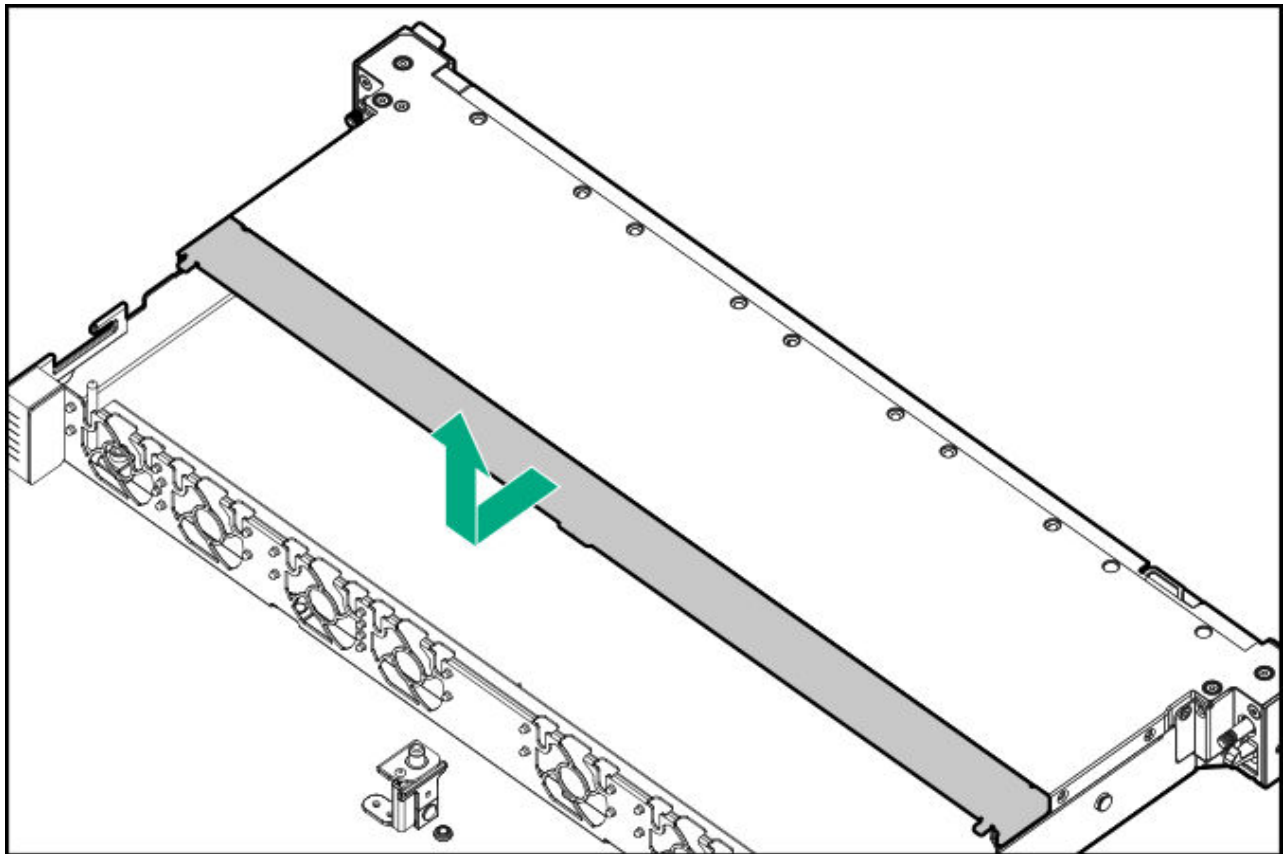

Remove the fan wall

Prerequisites

Before you perform this procedure, make sure that you have a T-15 Torx screwdriver available.

About this task

The fan wall is not available on servers with the liquid cooling heatsink and fan kit installed.



CAUTION

To prevent damage to electrical components, properly ground the server before beginning any installation, removal, or replacement procedure. Improper grounding can cause electrostatic discharge.

Procedure

1. Power down the server.
2. Remove all power:
 - a. Disconnect each power cord from the power source.
 - b. Disconnect each power cord from the server.
3. Disconnect all peripheral cables from the server.
4. Remove the server from the rack.
5. Place the server on a flat, level work surface.
6. Remove the access panel.
7. If installed, remove the air baffle.

An 8 SFF server is shown. The removal procedure is the same for all drive configurations.

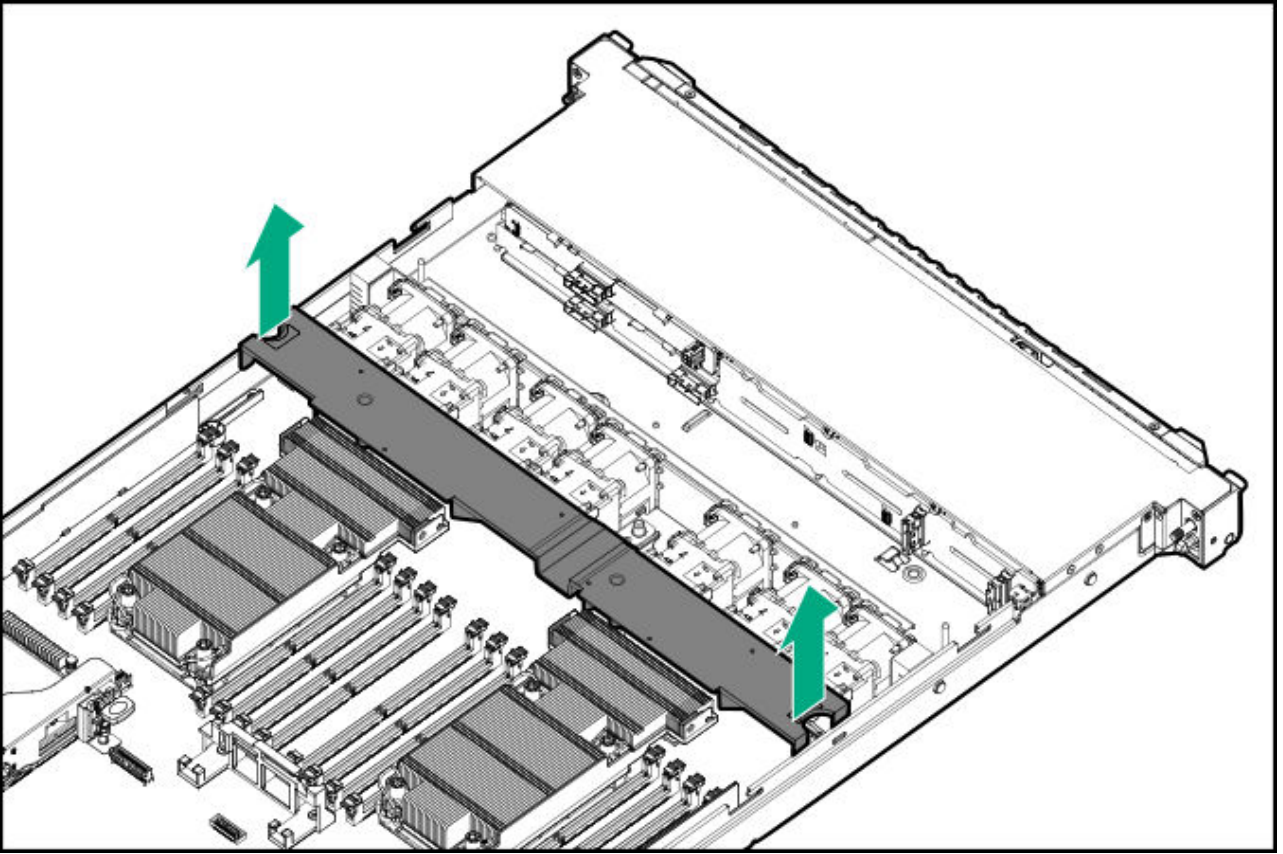

8. Remove the fans.

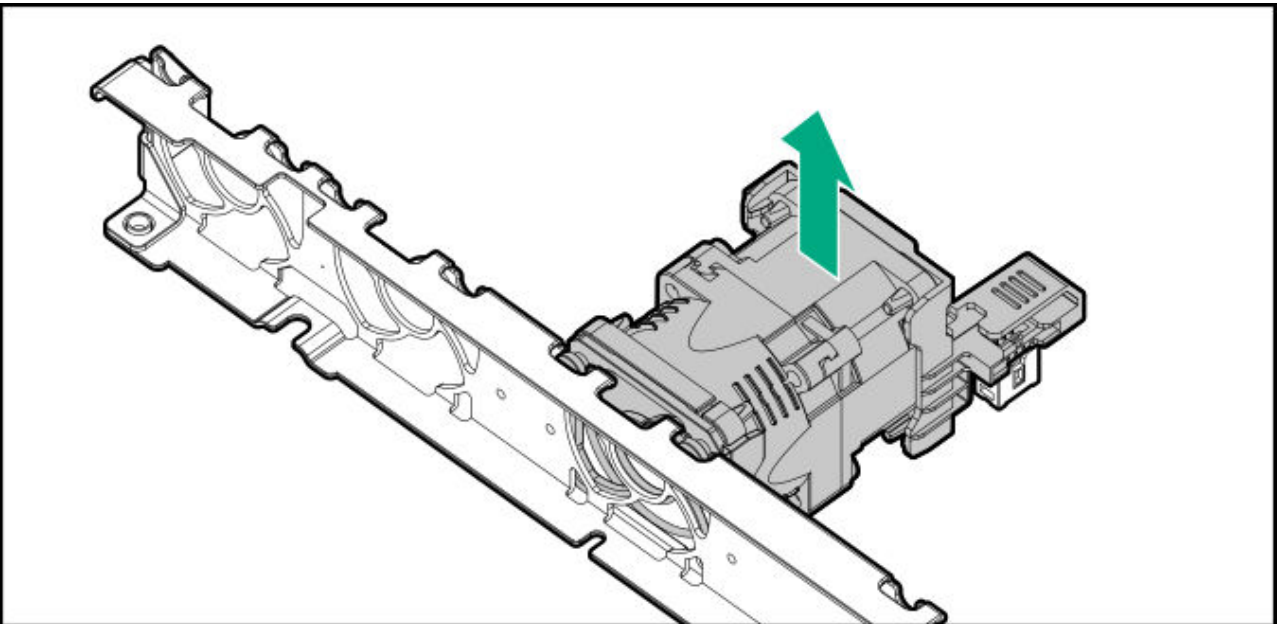

9. Remove the screws to remove the fan wall.

Retain the screws and fan wall. These screws will be used to secure the fan wall after replacing or installing the internal component.

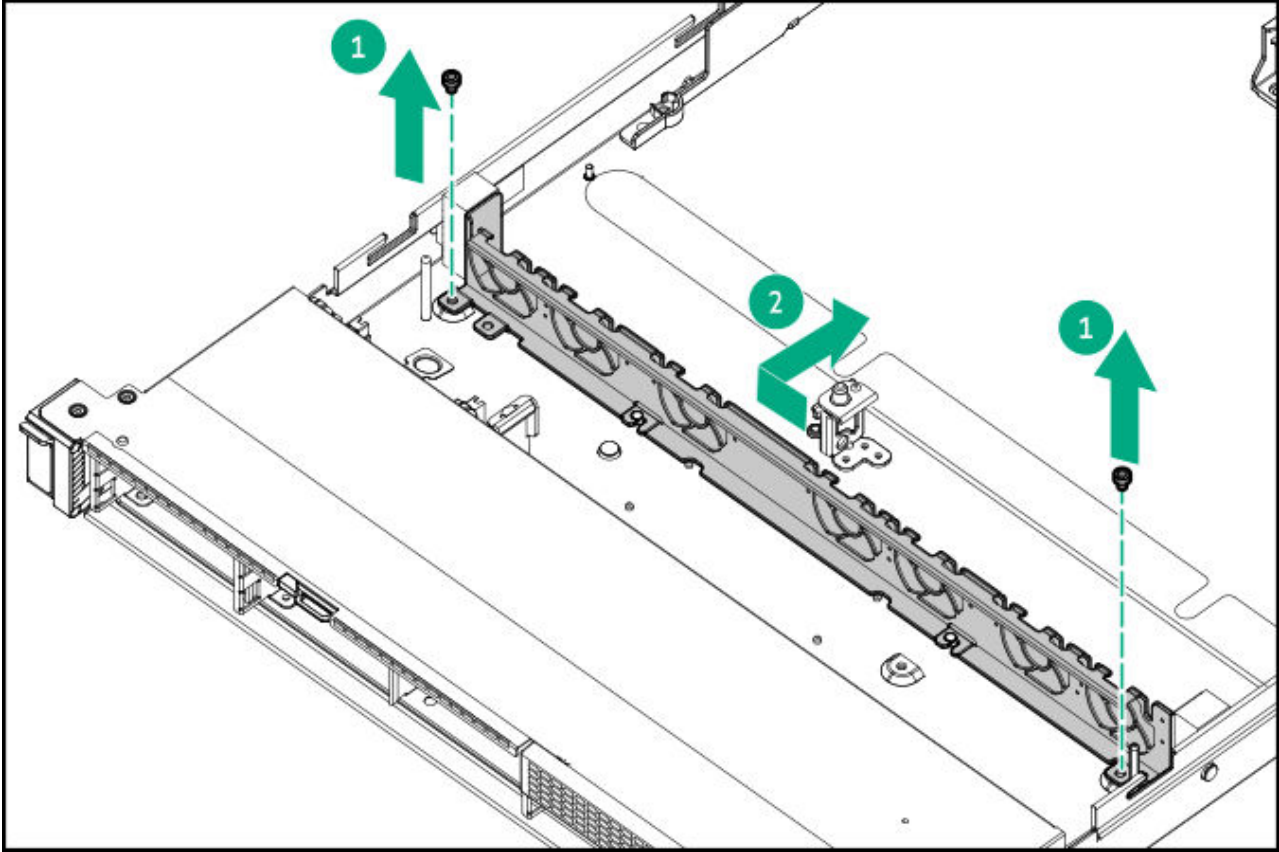

Remove the primary PCIe riser cage

About this task



WARNING

To reduce the risk of personal injury from hot surfaces, allow the drives and the internal system components to cool before touching them.



CAUTION

To prevent improper cooling and thermal damage, do not operate the server unless all bays are populated with either a component or a blank.



CAUTION

To prevent damage to electrical components, properly ground the server before beginning any installation, removal, or replacement procedure. Improper grounding can cause electrostatic discharge.

Procedure

1. Power down the server.
2. Remove all power:
 - a. Disconnect each power cord from the power source.
 - b. Disconnect each power cord from the server.
3. Do one of the following:
 - a. Extend the server from the rack.
 - b. Remove the server from the rack.
4. Remove the access panel.
5. Remove the secondary riser cage blank.
6. Remove the PCI riser cage.

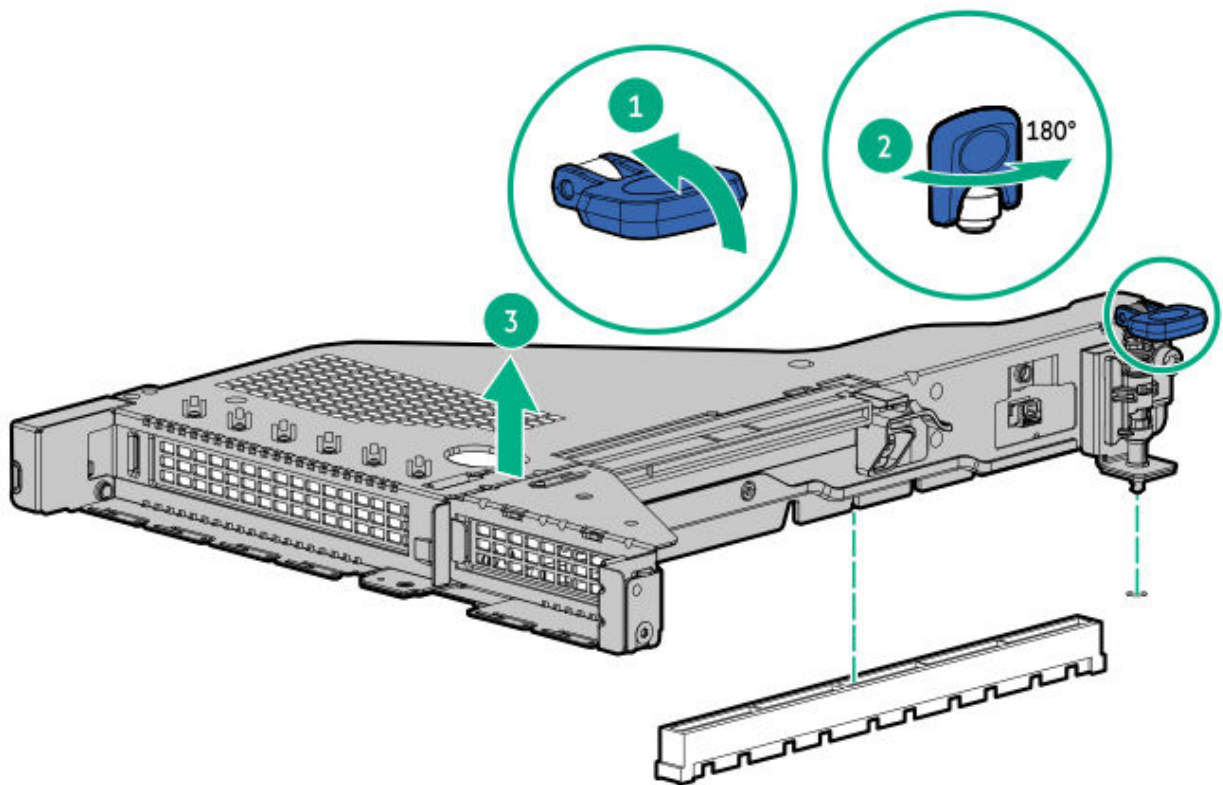

Remove a hot-plug SAS / SATA / NVMe drive

About this task



CAUTION

A discharge of static electricity from a finger or other conductor might damage system boards or other static-sensitive devices. To prevent damage, observe [antistatic precautions](#).



CAUTION

For proper cooling, do not operate the server without the access panel, baffles, expansion slot covers, or blanks installed. If the server supports hot-plug components, minimize the amount of time the access panel is open.

Procedure

1. If installed, [remove the front bezel](#).

2. Determine the status of the drive from the hot-plug drive LED definitions.
3. Back up all server data on the drive.
4. Remove the drive.
 - SFF drive

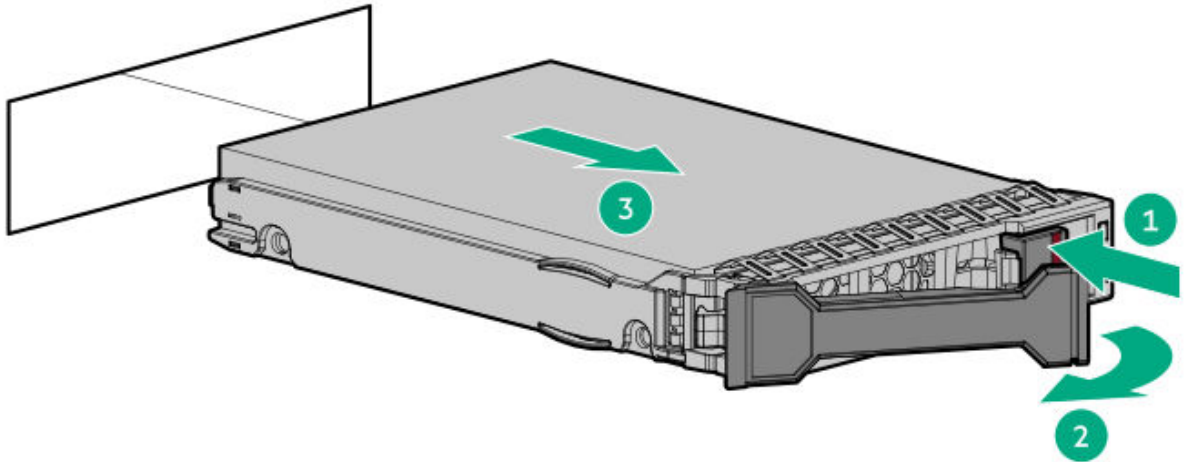

- LFF drive

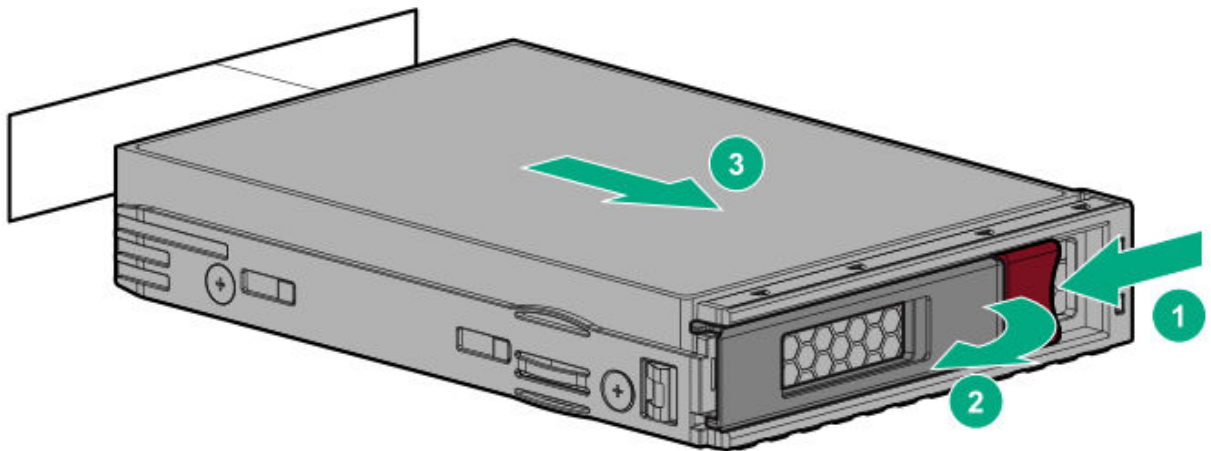

Remove a hot-plug E3.S drive

About this task



CAUTION

A discharge of static electricity from a finger or other conductor might damage system boards or other static-sensitive devices. To prevent damage, observe [antistatic precautions](#).



CAUTION

To prevent improper cooling and thermal damage, do not operate the server unless all bays are populated with either a component or a blank.

Procedure

1. [Back up all server data](#).
2. If installed, [remove the front bezel](#).
3. Observe the [drive LED status](#) and determine if the drive can be removed.
4. Remove the drive.

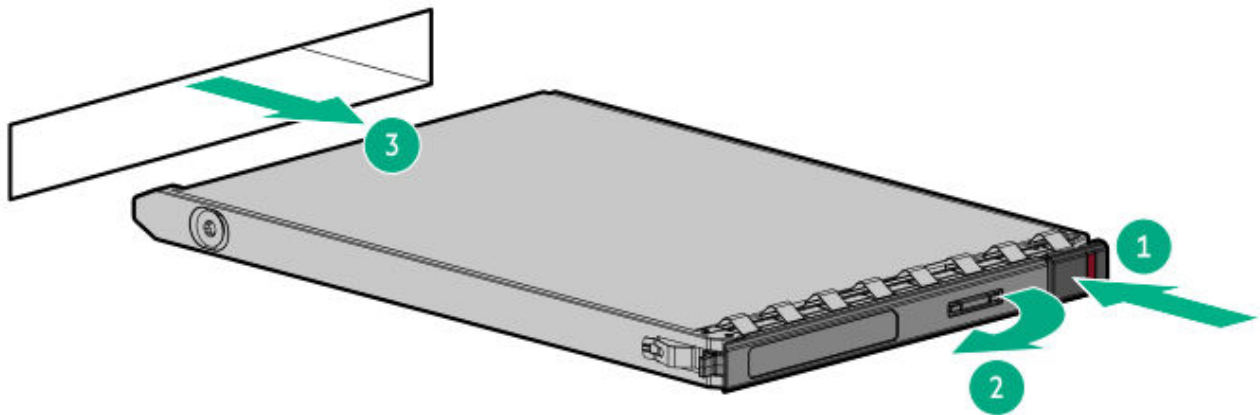

Accessing the System Insight Display

About this task

The System Insight Display is only available in the 8 SFF drive configuration.

Procedure

1. Press and release the panel.

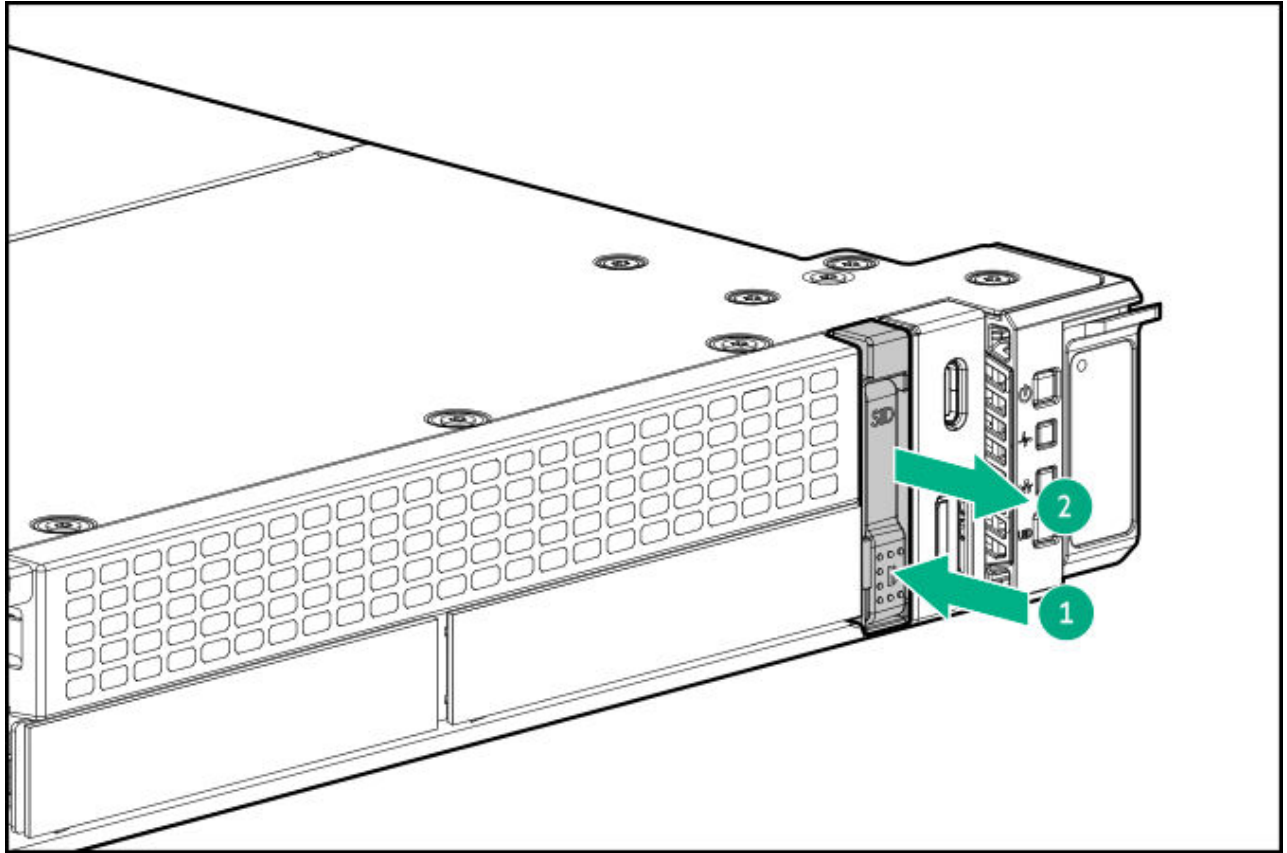

2. After the display ejects, rotate the display to view the LEDs.

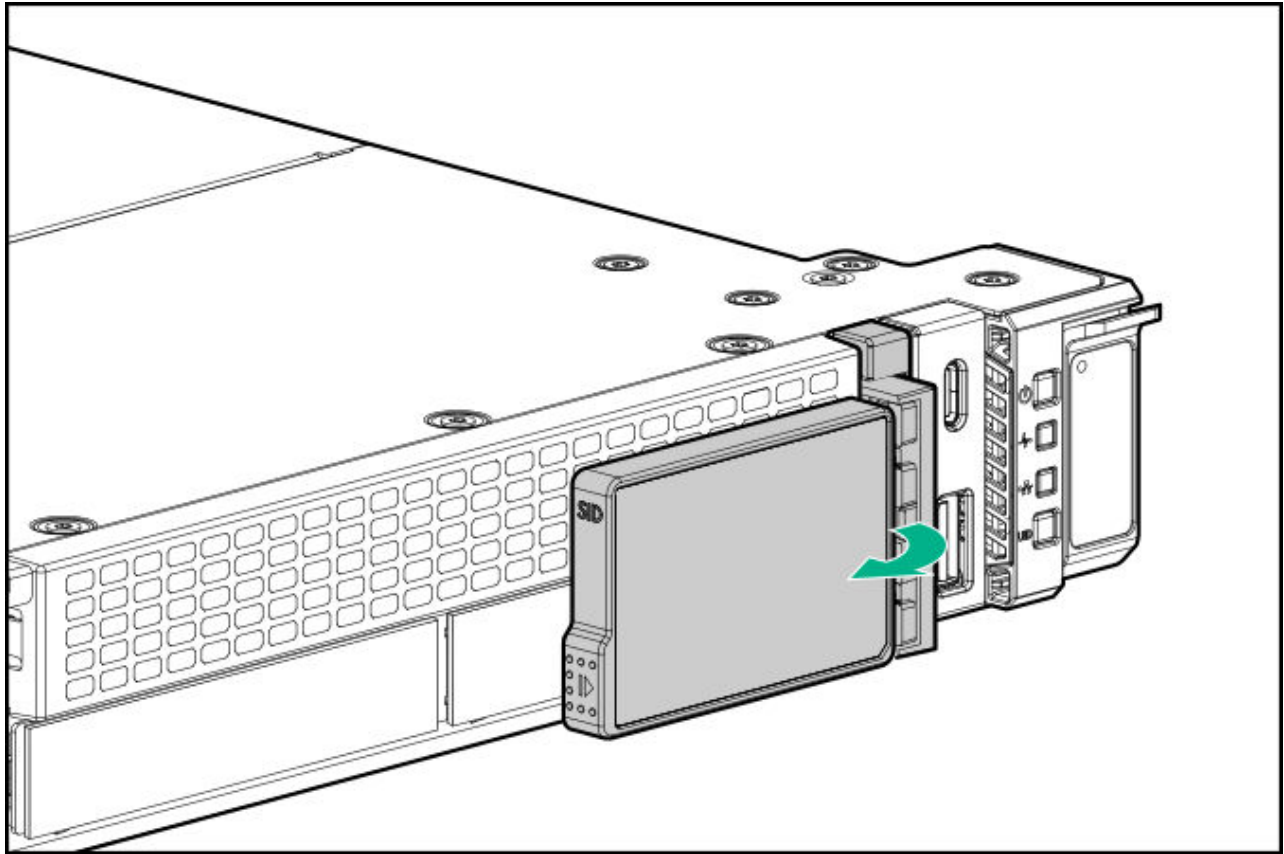

Post-installation procedures

Subtopics

[Install the primary PCIe riser cage](#)

[Install the fan wall](#)

[Install the middle cover](#)

[Install the access panel](#)

[Install the front bezel](#)

[Install the server into the rack](#)

[Power up the server](#)

Install the primary PCIe riser cage

Procedure

1. Install the primary PCI riser cage.

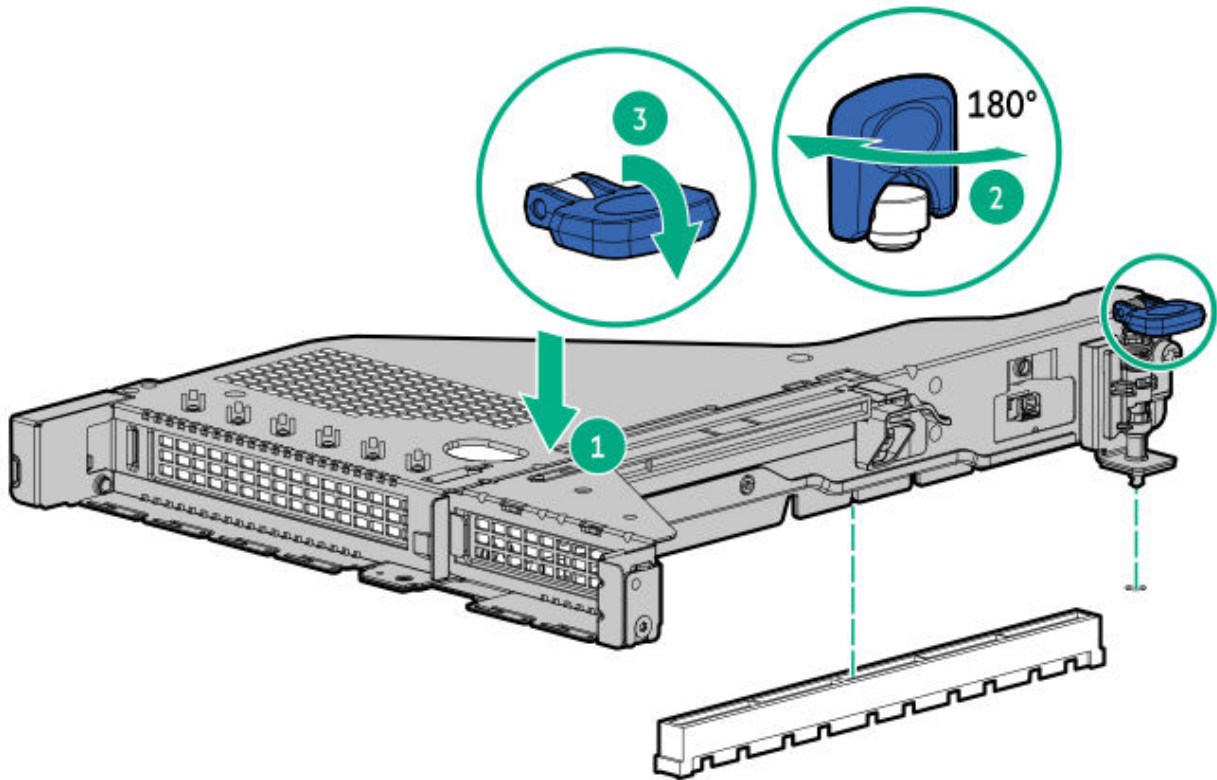

2. Install the secondary riser cage or riser blank.
3. Install the access panel.
4. Install the server into the rack.
5. Connect each power cord to the server.
6. Connect each power cord to the power source.
7. Power up the server.

Install the fan wall

Prerequisites

Before you perform this procedure, make sure that you have a T-15 Torx screwdriver available.

About this task

The fan wall is not available on servers with the liquid cooling heatsink and fan kit installed.



CAUTION

To prevent damage to electrical components, properly ground the server before beginning any installation, removal, or replacement procedure. Improper grounding can cause electrostatic discharge.

Procedure

Slide the fan wall to engage with the spools, and then install the screws.

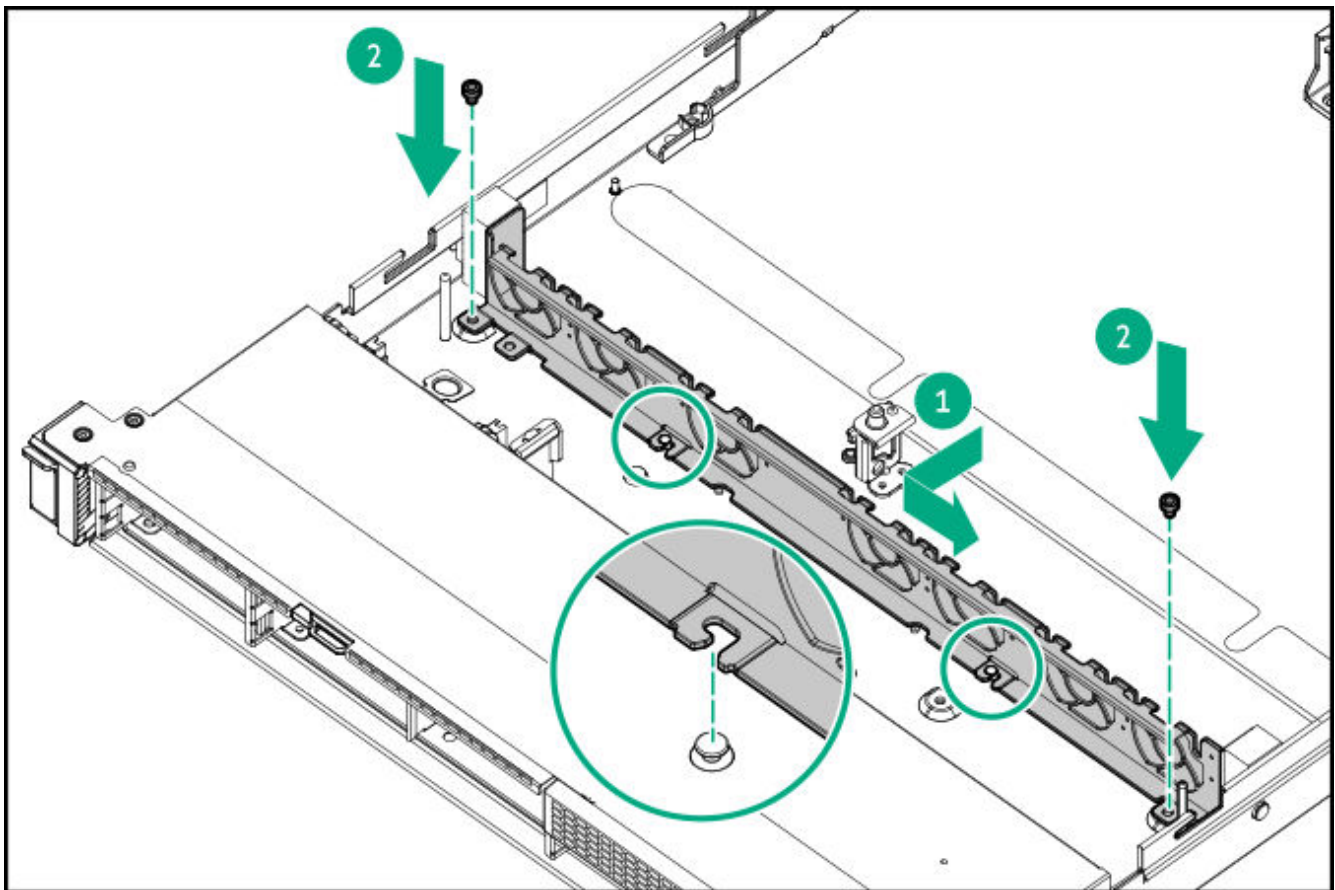

Install the middle cover

About this task

The middle cover is available in the 10 SFF / 20 E3.S server.



CAUTION

For proper cooling, do not operate the server without the access panel, baffles, expansion slot covers, or blanks installed.



CAUTION

To prevent damage to electrical components, properly ground the server before beginning any installation, removal, or replacement procedure. Improper grounding can cause electrostatic discharge.

Procedure

1. Take both sides of the middle cover and install it on the server.

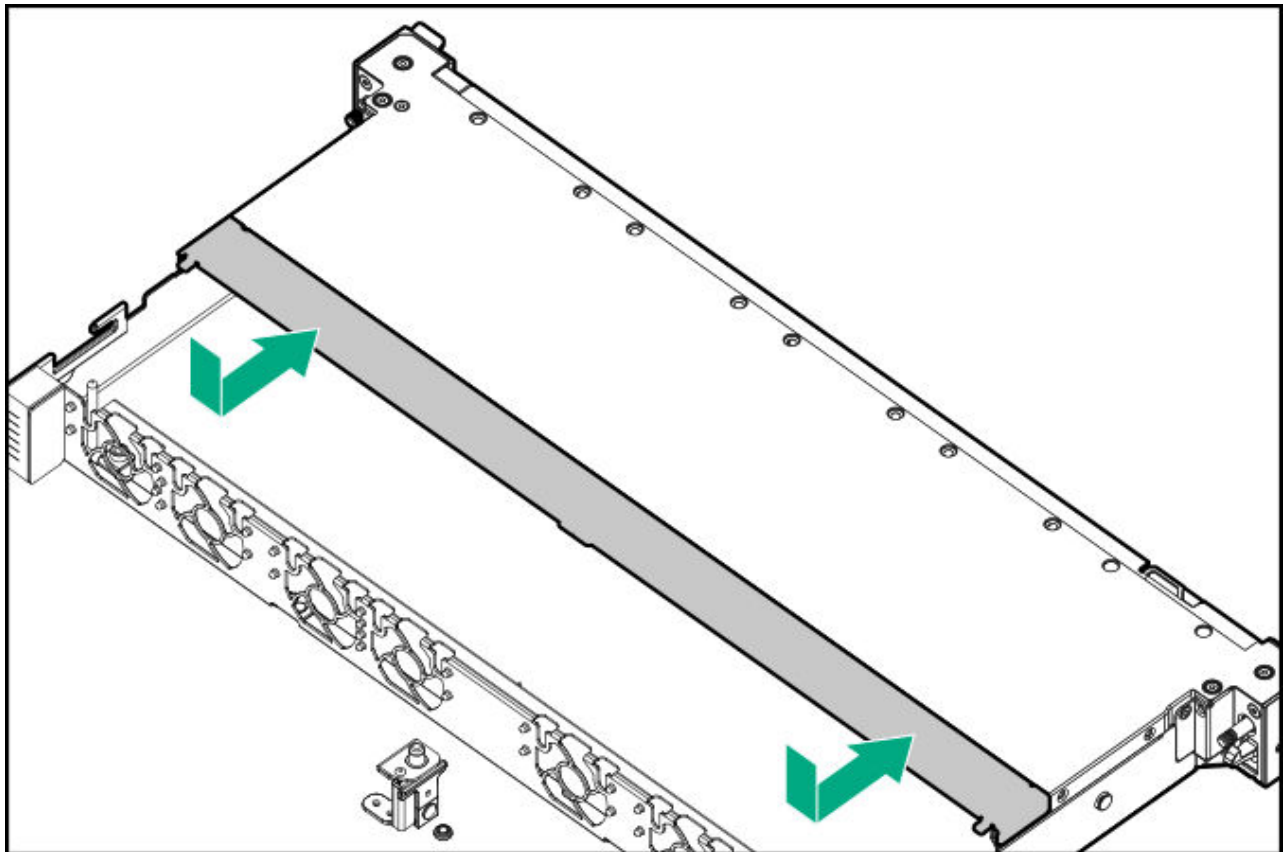

2. Install the access panel.

Install the access panel

Procedure

1. Place the access panel on top of the server with the latch open.

Allow the panel to extend past the rear of the server approximately 1.25 cm (0.5 in).

2. Push down on the latch.

The access panel slides to a closed position.

3. Tighten the security screw on the latch, if needed.

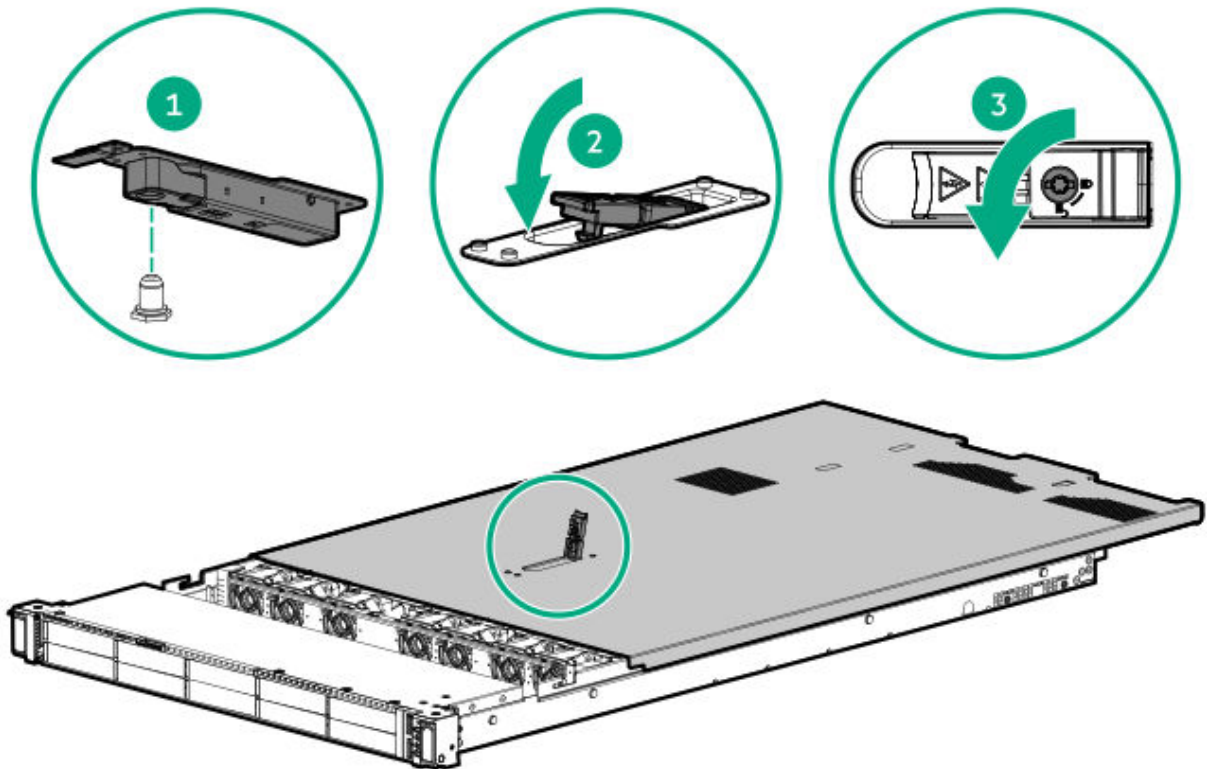

Install the front bezel

Procedure

1. Attach the front bezel to the right chassis ear.
2. Press and hold the front bezel release latch.
3. Close the front bezel.

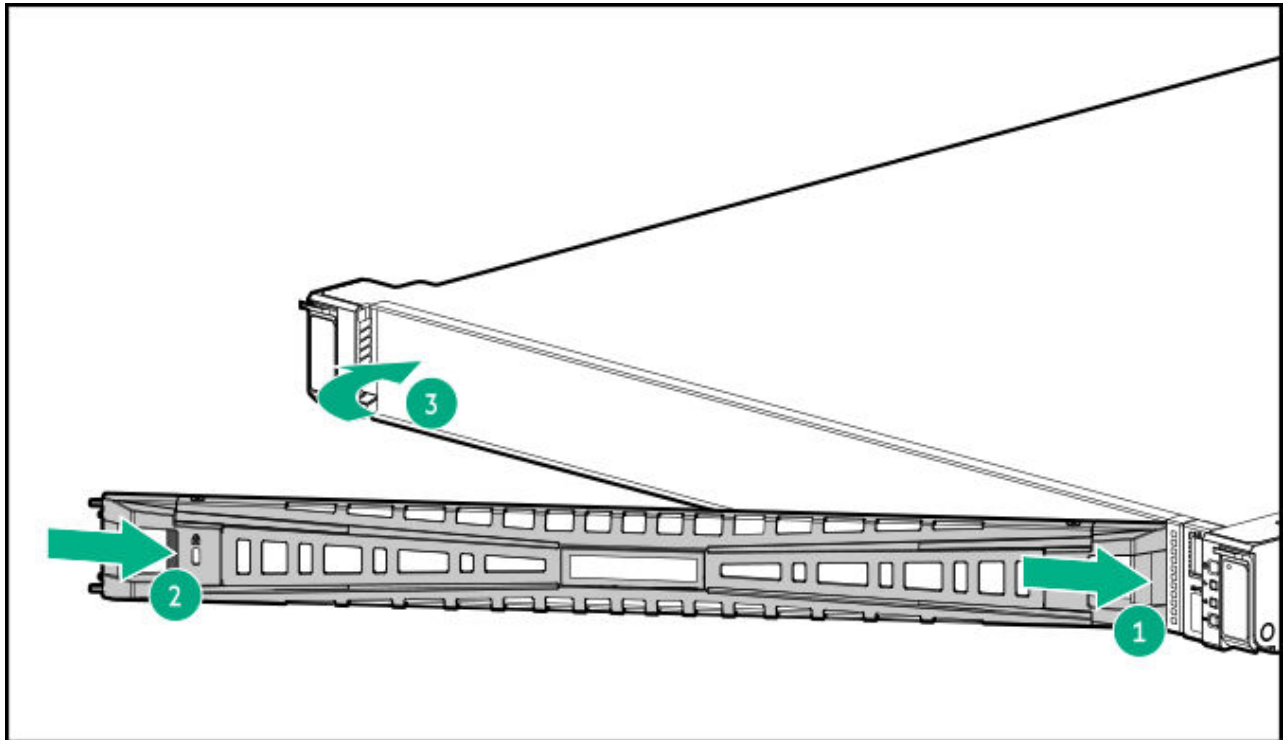

4. (Optional) Install the Kensington security lock.
For more information, see the lock documentation.

Install the server into the rack

Prerequisites

- Get help to lift and stabilize the server during rack installation. **If the server is installed higher than chest level, additional two people might be required to help install the server:** One person to support the server weight, and the other two to slide the server into the rack.
- Before you perform this procedure, review the:

- [Space and airflow requirements](#)
- [Rack warnings and cautions](#)
- [Server warnings and cautions](#)
- A fully populated server is heavy. Hewlett Packard Enterprise recommends removing the external chassis components before installing the server into a rack.
- Before you perform this procedure, make sure that you have a T-25 Torx screwdriver available.

Procedure

1. Install the server into the rack.

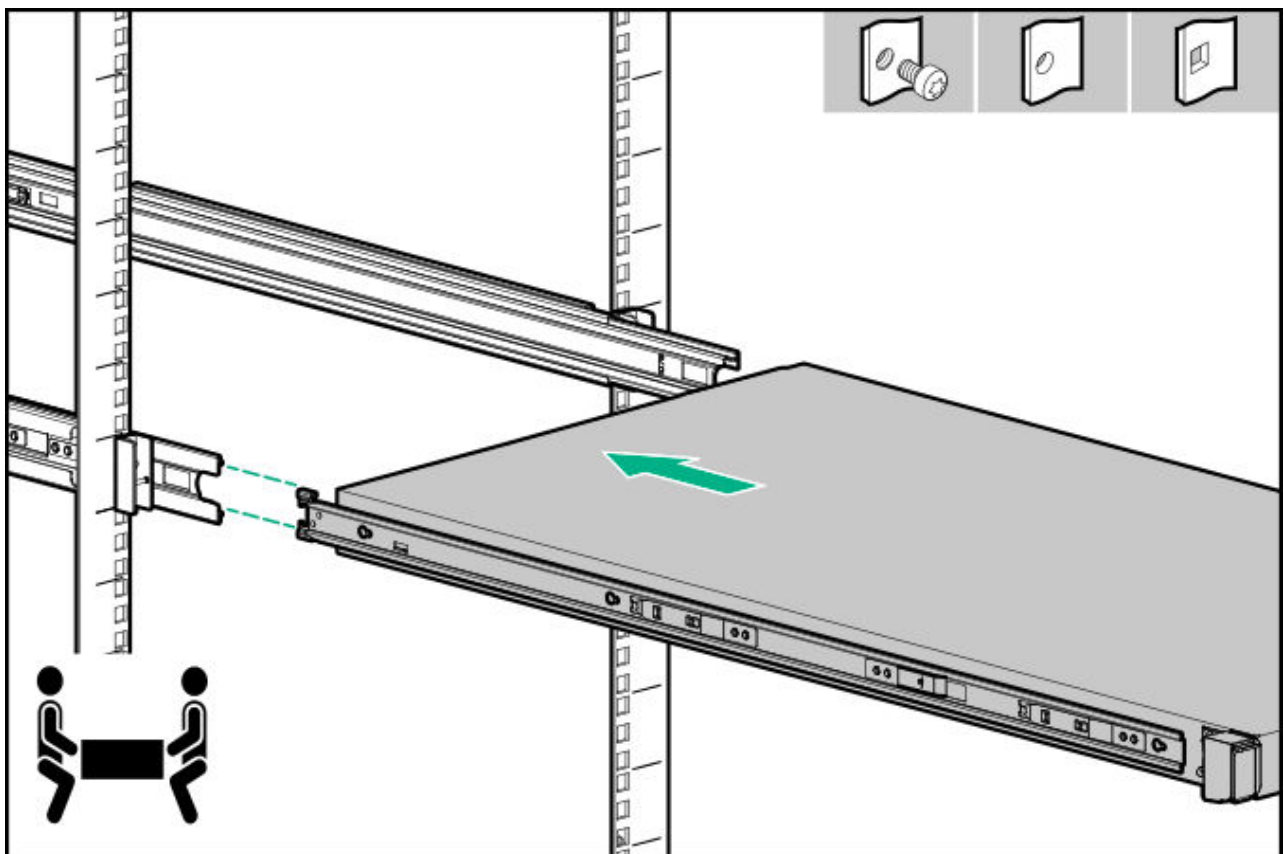

2. Open the chassis ears, and then tighten the shipping screws.

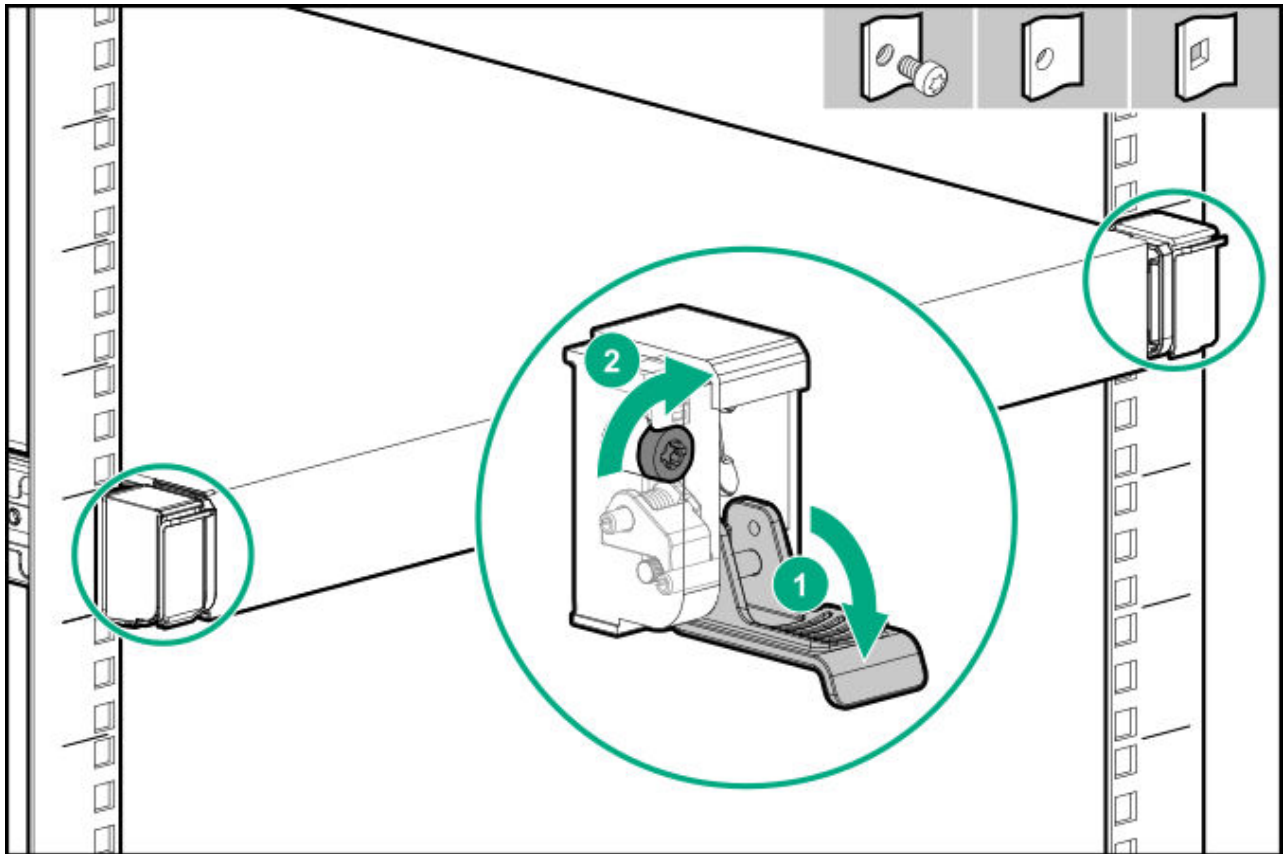

3. Connect all peripheral cables to the server.
4. Connect each power cord to the server.
5. Do one of the following:
 - Install the rack rail hook-and-loop strap.
 - Install the cable management arm.
6. Connect each power cord to the power source.
7. Power up the server.

Results

The installation procedure is complete.

Power up the server

Procedure

- Press the Power On/Standby button.
- Use the virtual power button through iLO 7.

Cooling

Subtopics

Fan mode behavior

Requirements for redundant fan support

Installing a high performance fan

Installing the air baffle

Fan mode behavior

The server supports 7 redundant fans.

- If a single fan rotor fails:
 - The system switches to non-redundant fan mode. The system continues to operate in this mode.
 - The system health LED flashes amber.
- If a second fan rotor fails or a fan is missing, the operating system gracefully shuts down.

For more information on the minimum requirements for fan redundancy, see [Requirements for redundant fan support](#).

Requirements for redundant fan support

The server must meet the minimum requirement for the number of functioning fan rotors to provide fan redundancy support. For the fan requirements, see the following table:

Fan configuration	Total number of rotors	Fan rotors required for redundancy	Fan rotors required for operation
7 standard fans (dual-rotor)	14	14	13
7 high performance fans (dual-rotor)			
5 standard fans (dual-rotor) *	10	10	9
7 liquid cooling fans (single-rotor)	7	7	6

* This is supported on servers using the one-processor configuration.

Installing a high performance fan

Prerequisites

Review the [Fan and heatsink requirements](#).

About this task

The installation and removal procedures for the standard and high performance fans are the same.



IMPORTANT

Do not mix standard and high performance fans in the same server.

Procedure

1. [Power down the server](#).
2. Remove all power:
 - a. Disconnect each power cord from the power source.
 - b. Disconnect each power cord from the server.
3. Do one of the following:
 - a. [Extend the server from the rack](#).
 - b. [Remove the server from the rack](#).
4. [Remove the access panel](#).
5. Remove any fan blanks.

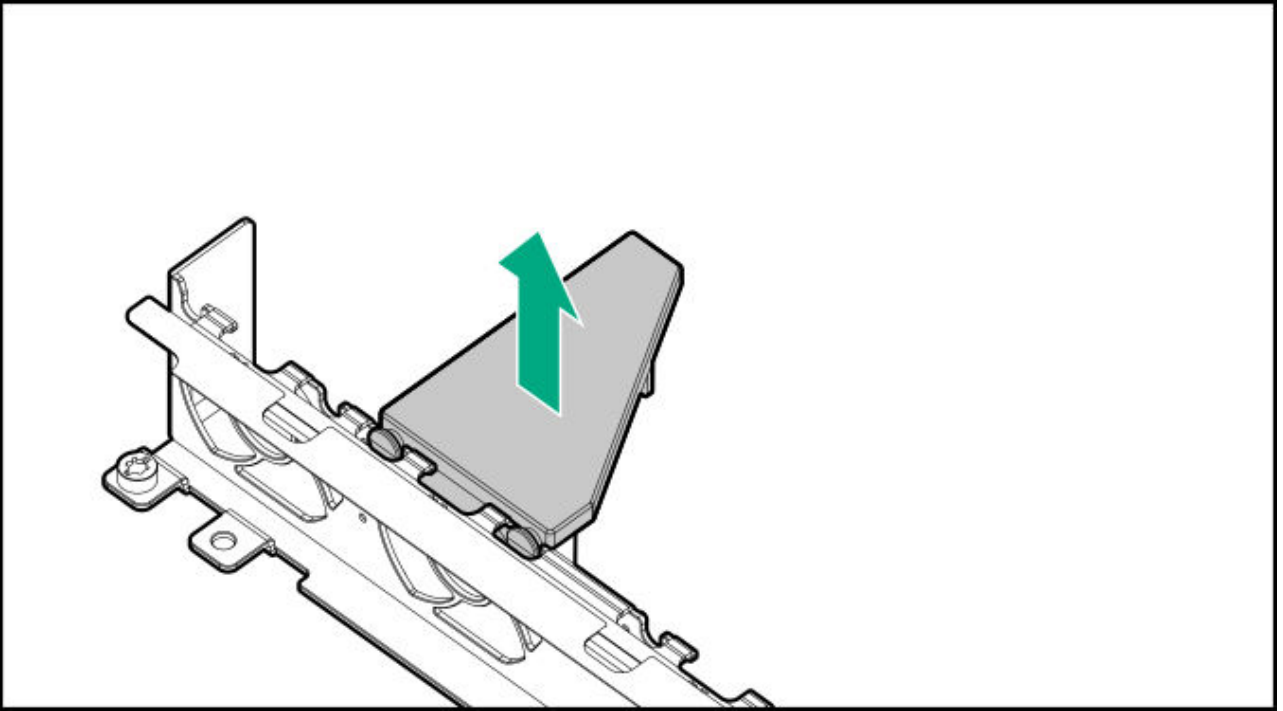

6. Remove all standard fans.

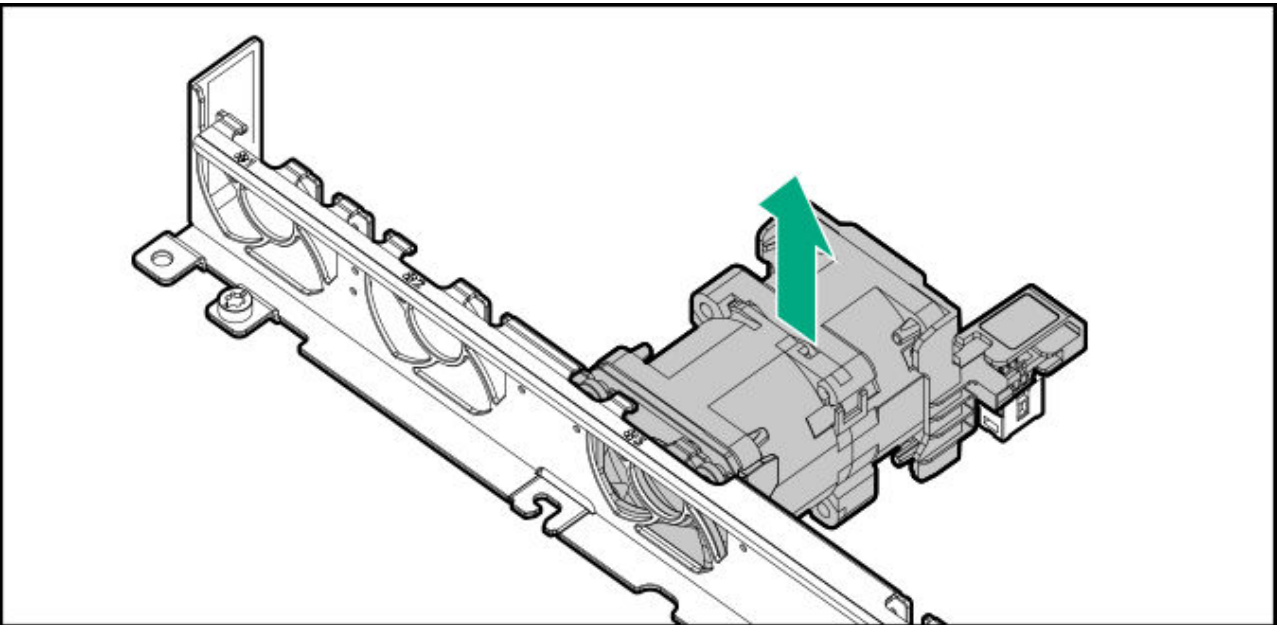

7. Install high performance fans.

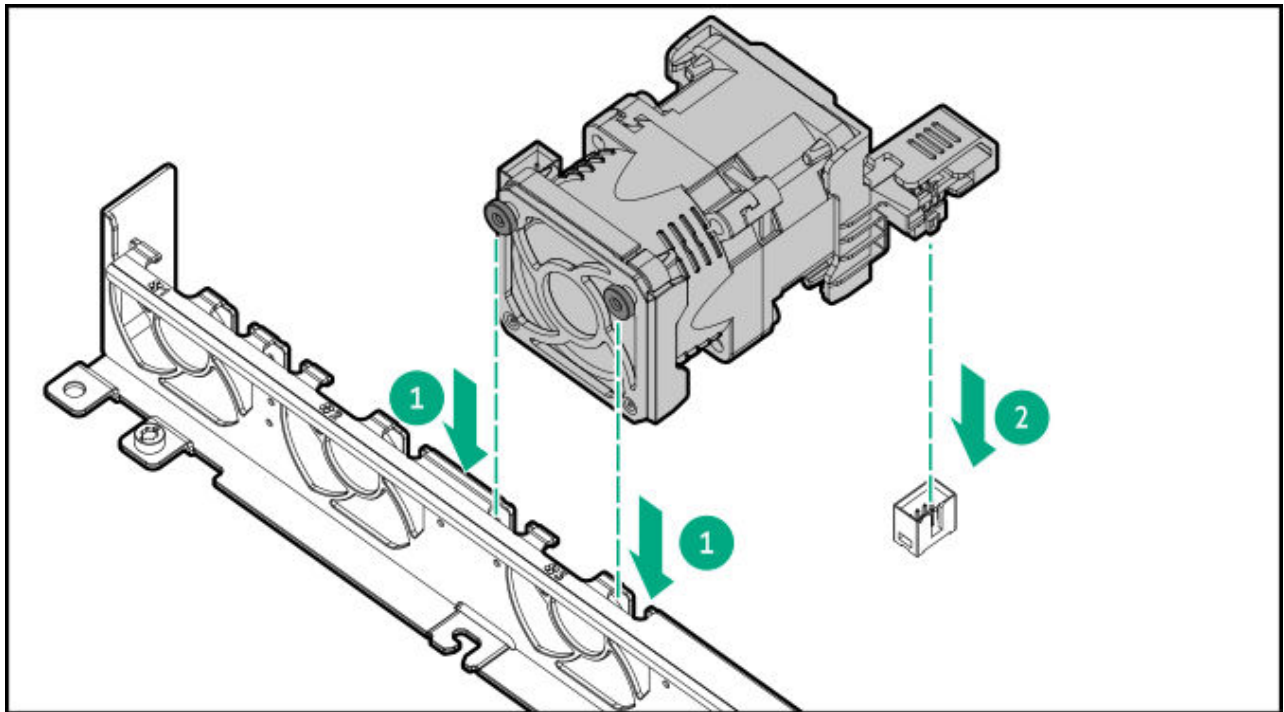

8. Install the access panel.
9. Return the server to the rack.
10. Connect each power cord to the server.
11. Connect each power cord to the power source.
12. Power up the server.

Results

The installation procedure is complete.

Installing the air baffle

Prerequisites

Review the Fan and heatsink requirements.

About this task

The optional air baffle is supported on servers using high performance heatsinks.



CAUTION

For proper cooling, do not operate the server without the access panel, baffles, expansion slot covers, or blanks installed. If the server supports hot-plug components, minimize the amount of time the access panel is open.



CAUTION

To prevent damage to electrical components, properly ground the server before beginning any installation, removal, or replacement procedure. Improper grounding can cause electrostatic discharge.

Procedure

1. Make sure that all internal cables have been properly routed and will not interfere with the air baffle installation.
2. Remove the heatsink baffles from the high performance heatsinks.

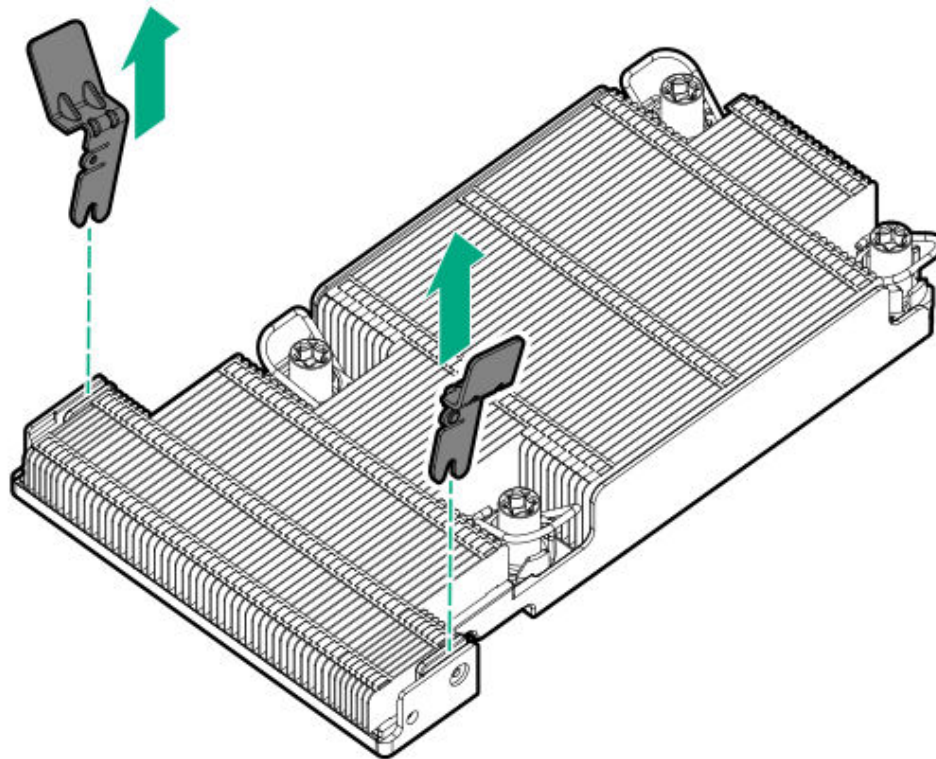

3. Install the air baffle.

Installation of the air baffle requires high performance heatsinks. The air baffle is secured by two system board standoffs in the chassis. These standoffs are preinstalled on the system. If your system does not include the required standoffs, contact **HPE support**.

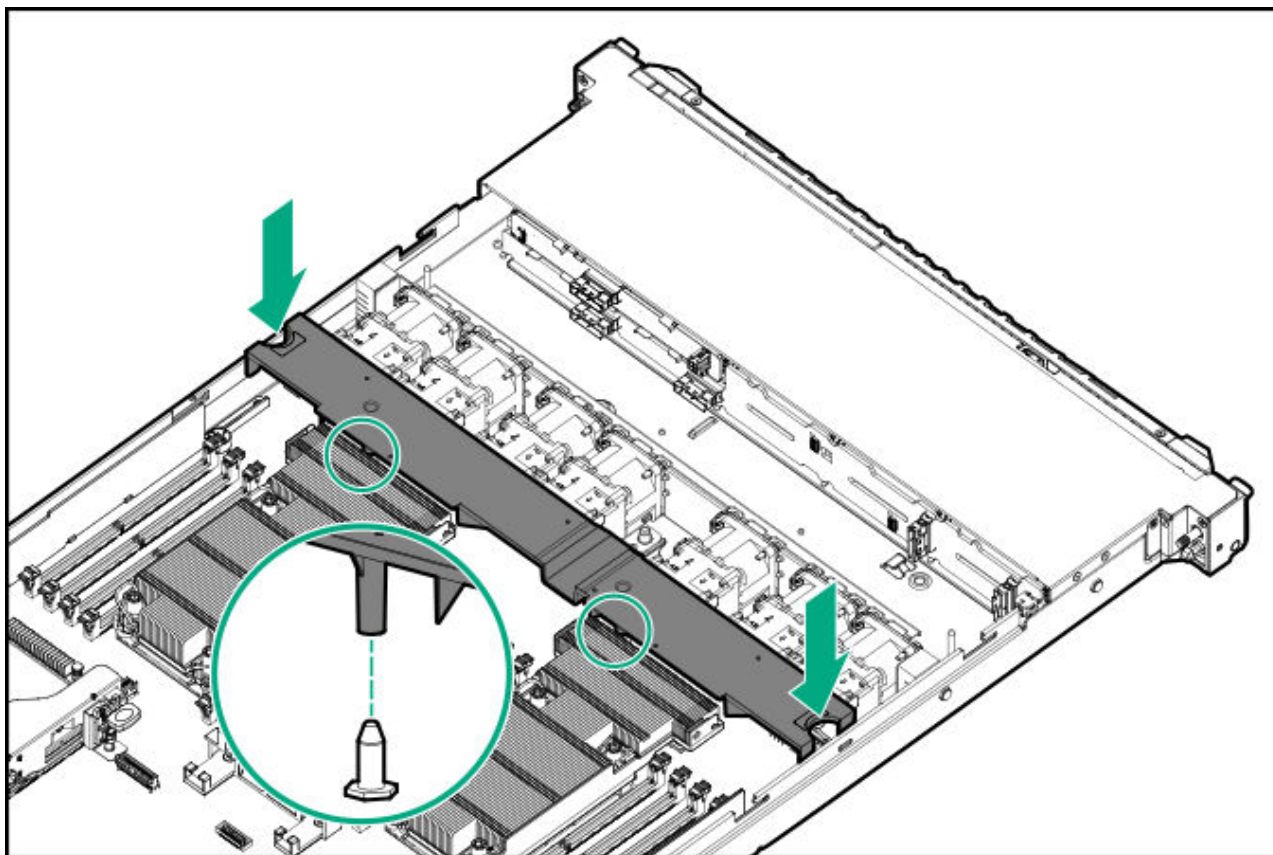

4. Install the access panel.
5. Return the server to the rack.
6. Connect each power cord to the server.
7. Connect each power cord to the power source.
8. Power up the server.

Results

The installation procedure is complete.

Drives

Subtopics

Drive installation guidelines

Installing a hot-plug SAS, SATA, or NVMe drive

Installing an E3.S drive

Drive installation guidelines

Observe the following general guidelines:

- The system automatically sets all drive numbers.



CAUTION

When a server is purchased without any drive installed, some drive bays might be empty while other drive bays might be populated with drive blanks. To maintain proper system cooling, do not operate the server without a drive or a drive blank installed.

- If only one drive is used, install it in the bay with the lowest drive number. For drive numbering, see [Drive bay numbering](#).
- This server does not support mixed drive types in the same drive box.
- When installing NVMe drives, install the same drive type. Mixed NVMe drives are not supported.
- All drives grouped into the same drive array must meet the following criteria:
 - They must be either all hard drives or all solid-state drives.
 - Drives must be the same capacity to provide the greatest storage space efficiency.

Installing a hot-plug SAS, SATA, or NVMe drive

Prerequisites

Before the installation, review the [Fan and heatsink requirements](#).

About this task



CAUTION

To prevent improper cooling and thermal damage, do not operate the server unless all bays are populated with either a component or a blank.

Procedure

1. Back up all server data.
2. If installed, remove the front bezel.
3. Remove the drive blank:
 - LFF drive blank

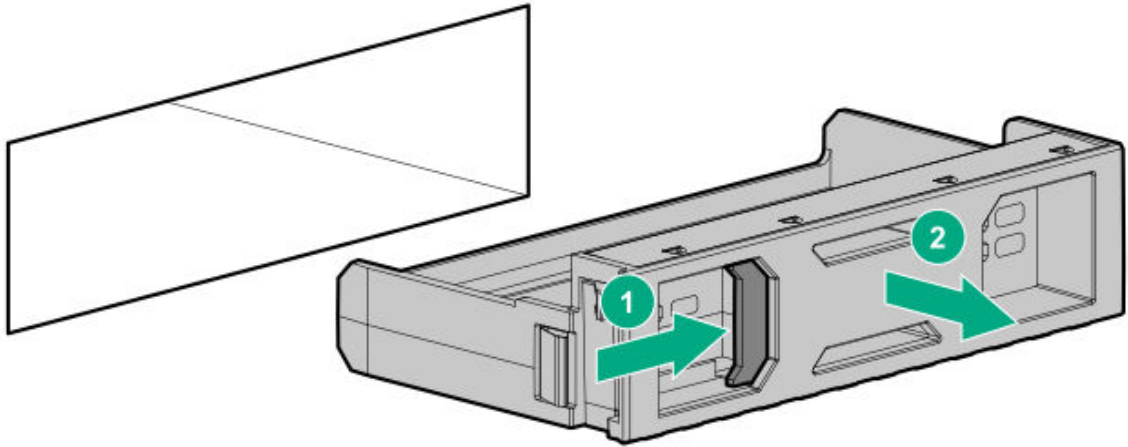

- SFF drive blank

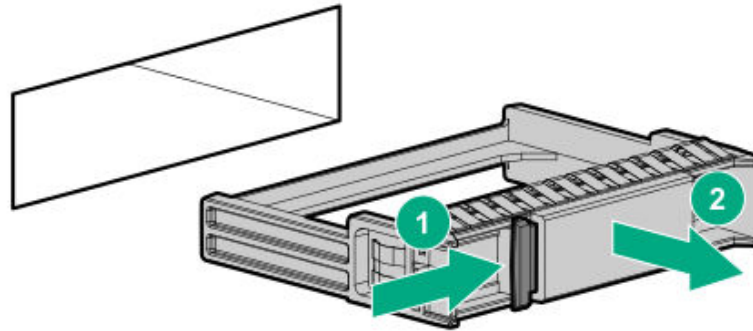

4. Prepare the drive.
 - LFF drive

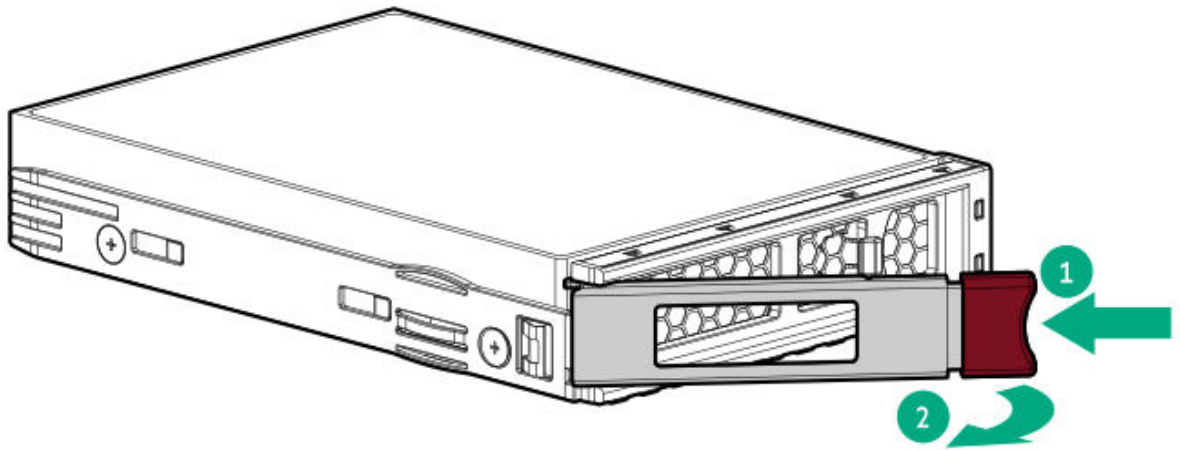

- SFF drive

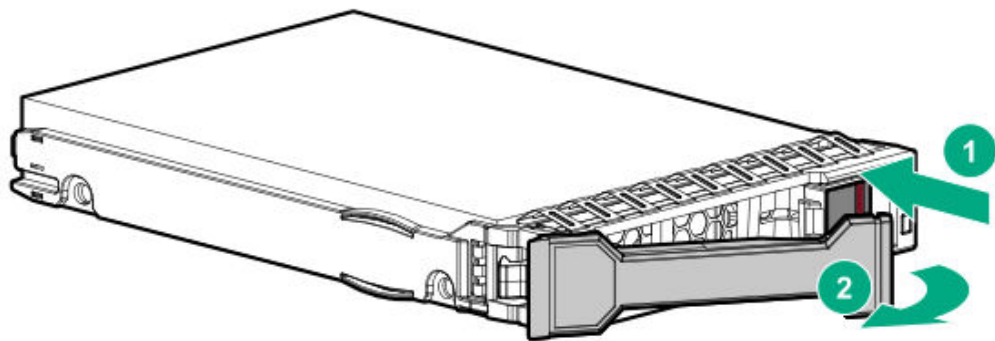

5. Install the drive.

- LFF drive

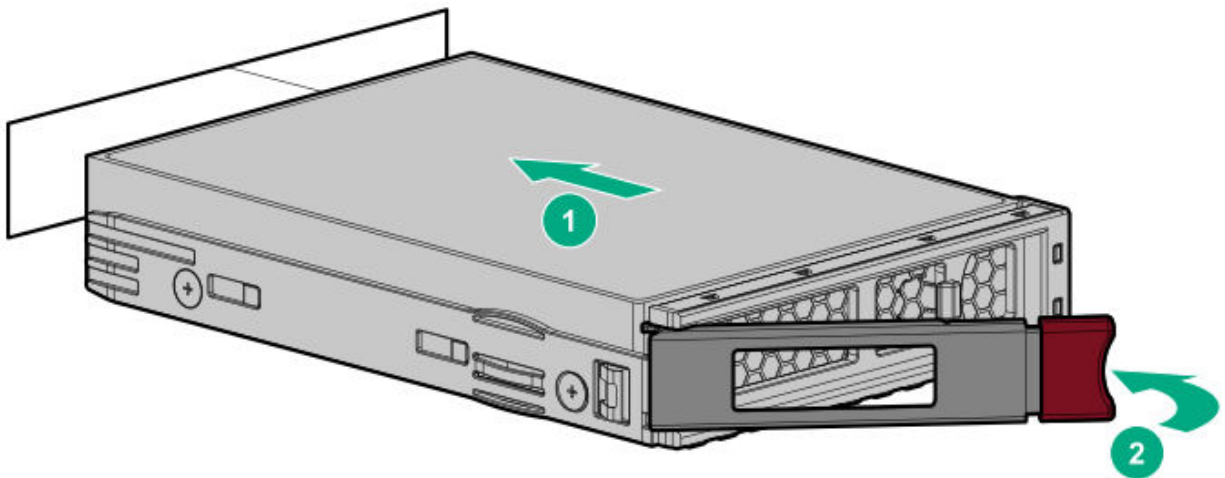

- SFF drive

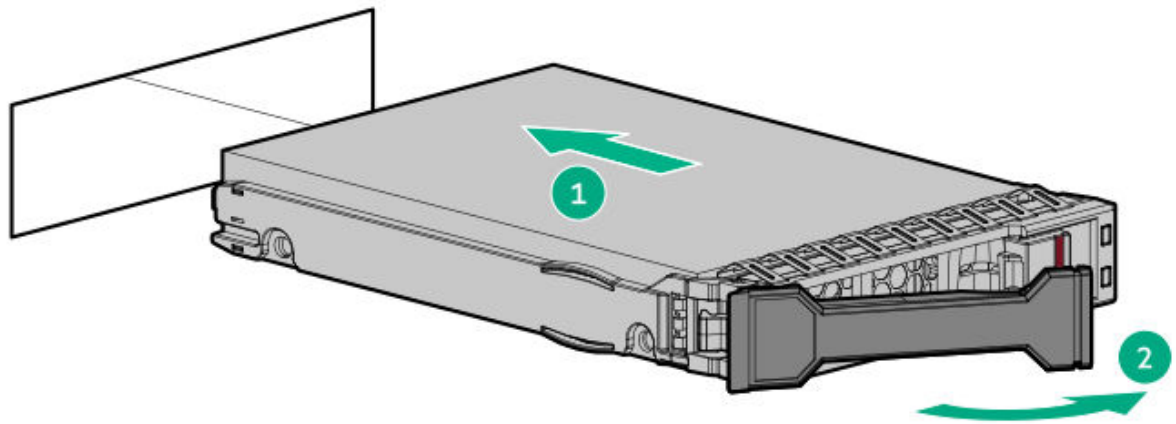

6. Determine the status of the drive from the drive LED definitions.
7. If removed, install the front bezel.
8. To configure drive arrays, see the relevant storage controller guide.

Results

The installation procedure is complete.

Installing an E3.S drive

Prerequisites

Before the installation, review the Fan and heatsink requirements.

About this task



CAUTION

To prevent improper cooling and thermal damage, do not operate the server unless all bays are populated with either a component or a blank.

Procedure

1. Back up all server data.
2. If installed, remove the front bezel.
3. Observe the drive LED status and determine if the drive can be removed.
4. Remove the drive blank.

Retain the blank for future use.

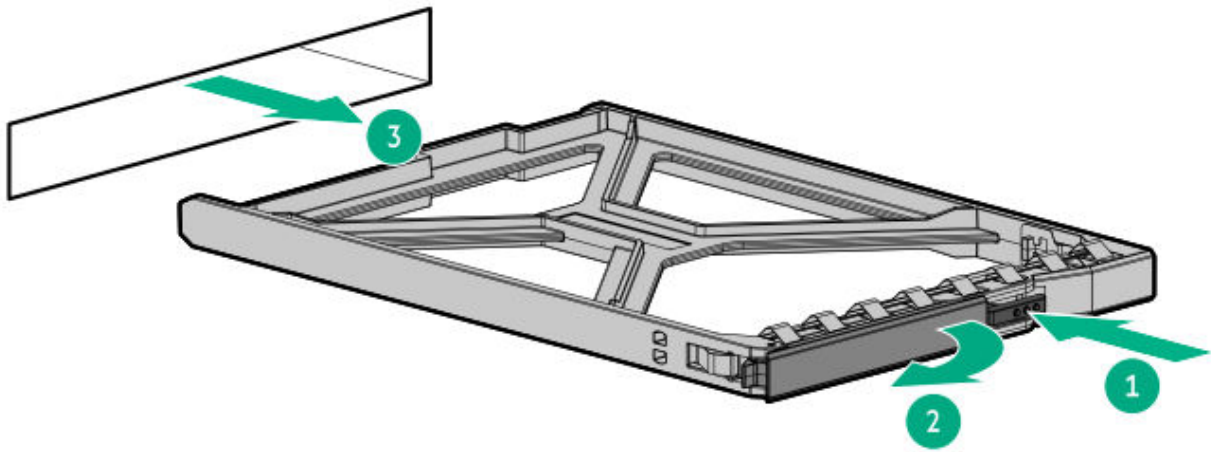

5. Prepare the drive.

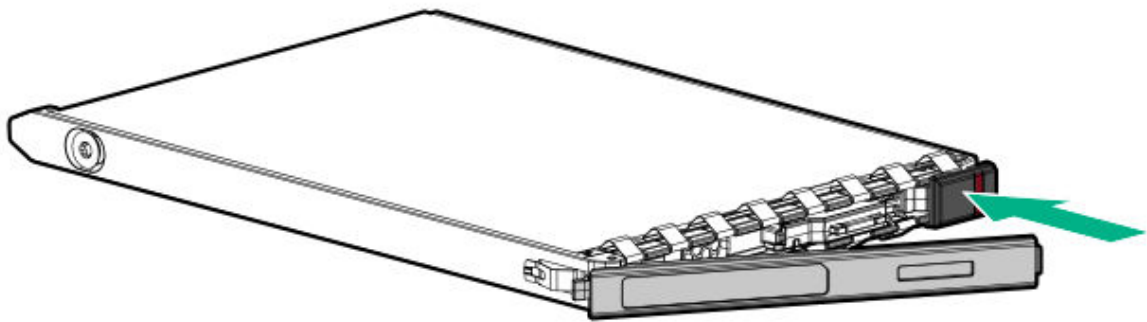

6.



NOTE

To make sure that the drive has installed successfully, ensure that the latch is engaged with the drive cage.

Install the drive.

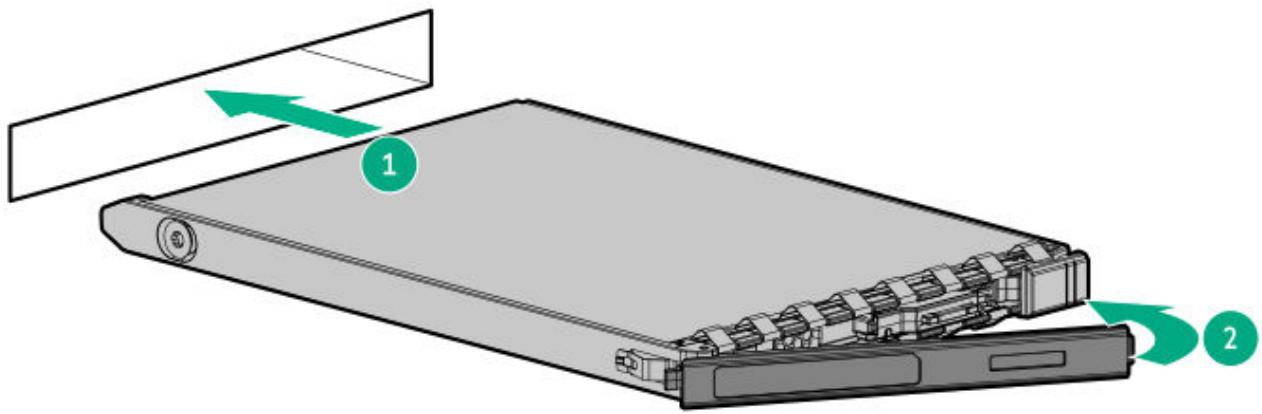

7. Determine the status of the drive from the drive LED definitions.
8. If removed, install the front bezel.
9. To configure drive arrays, see the relevant storage controller guide.

Drive cages

Subtopics

[Installing a 2 SFF drive cage in the 8 SFF drive configuration](#)

[Installing the 4 E3.S stacked drive cage](#)

[Installing the 2 SFF stacked drive cage](#)

Installing a 2 SFF drive cage in the 8 SFF drive configuration

Prerequisites

Be sure that you have the following:

- The components included with the option kit
- T-10 Torx screwdriver
- 2 SFF drives or drive blanks

About this task

The 2 SFF drive cage is supported in Box 2 in the 8 SFF drive configuration.



CAUTION

A discharge of static electricity from a finger or other conductor might damage system boards or other static-sensitive devices. To prevent damage, observe antistatic precautions.



CAUTION

To prevent improper cooling and thermal damage, do not operate the server unless all bays are populated with either a component or a blank.

Procedure

1. Back up all server data.
2. If installed, remove the front bezel.
3. Power down the server.
4. Remove all power:
 - a. Disconnect each power cord from the power source.
 - b. Disconnect each power cord from the server.
5. Do one of the following:
 - a. Extend the server from the rack.
 - b. Remove the server from the rack.
6. Place the server on a flat, level work surface.
7. Remove the universal media bay blank.

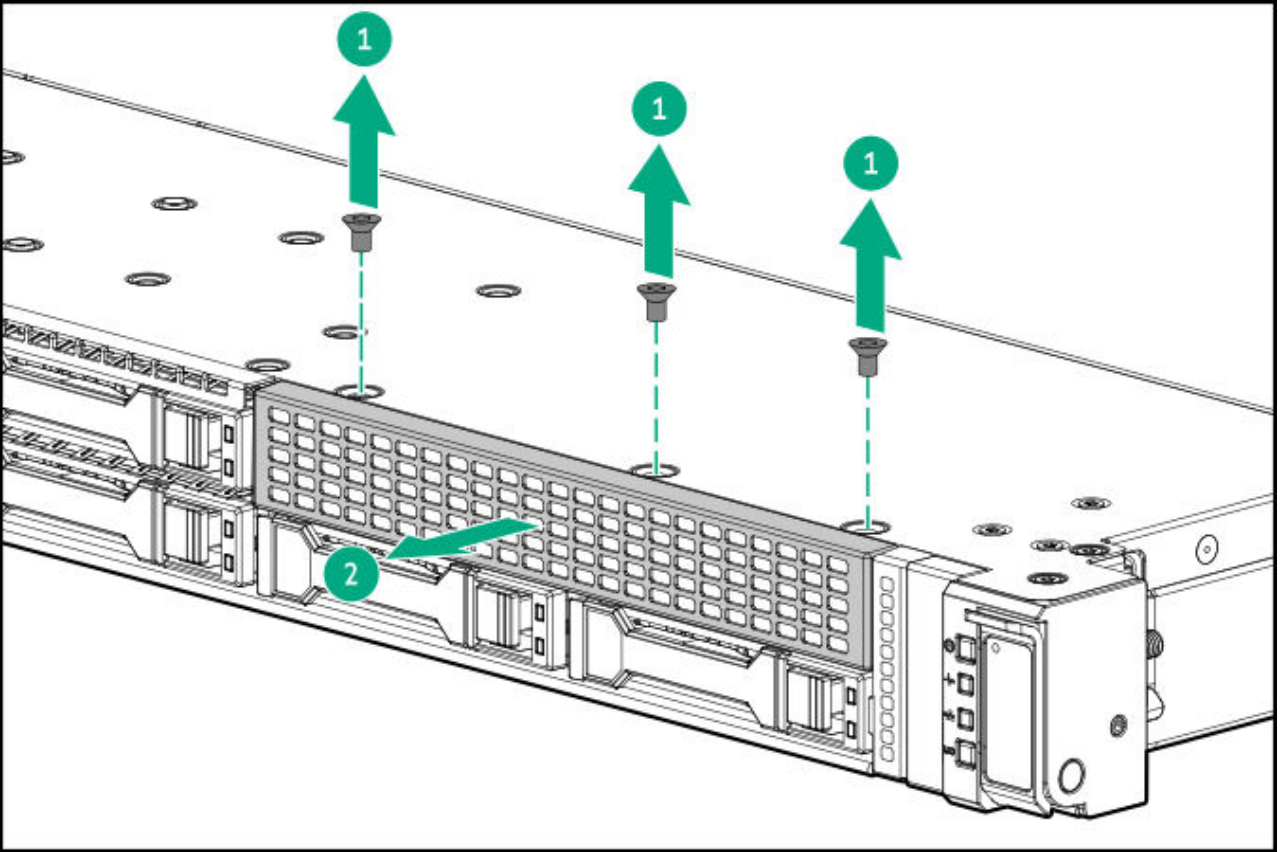

8. Install the 2 SFF drive cage.

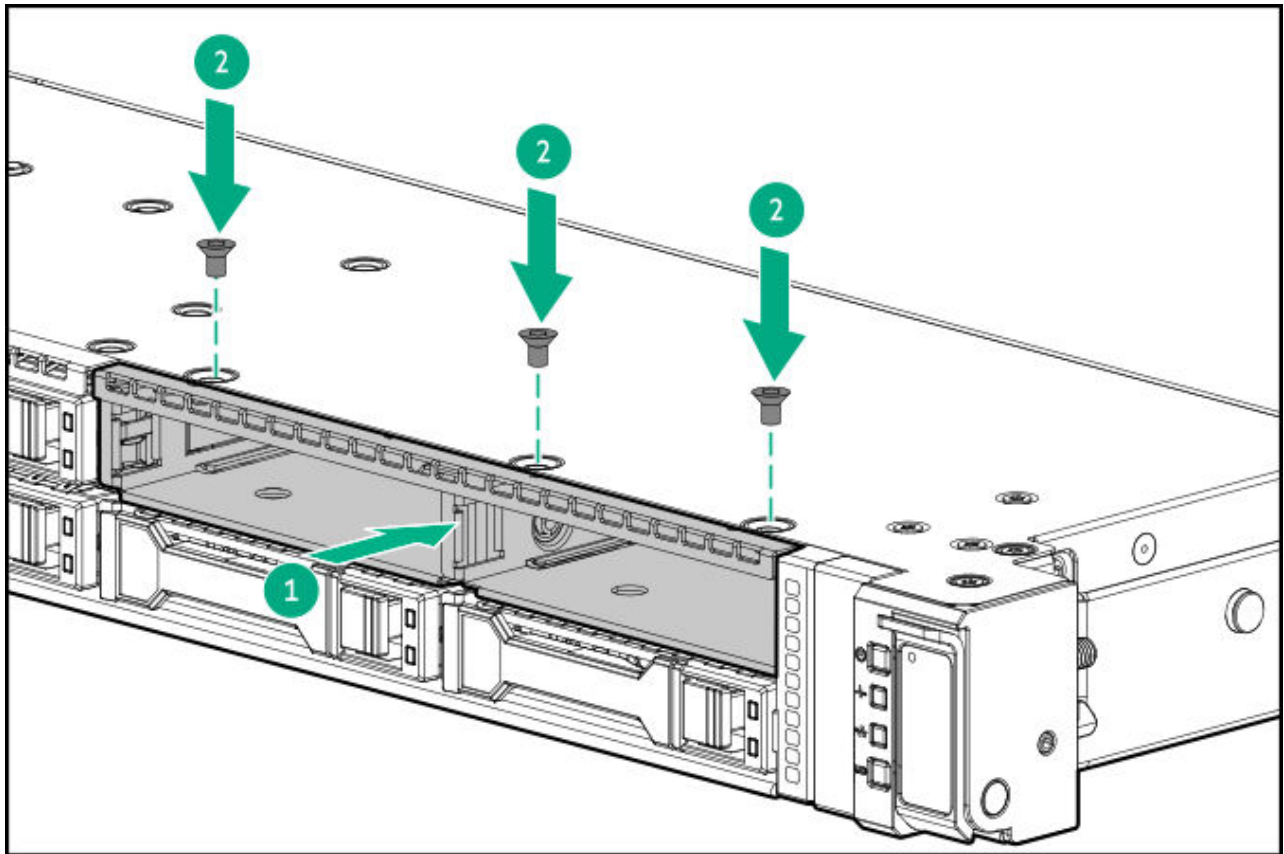

9. Remove the access panel.

10. If installed, remove the air baffle.

An 8 SFF server is shown. The removal procedure is the same for all drive configurations.

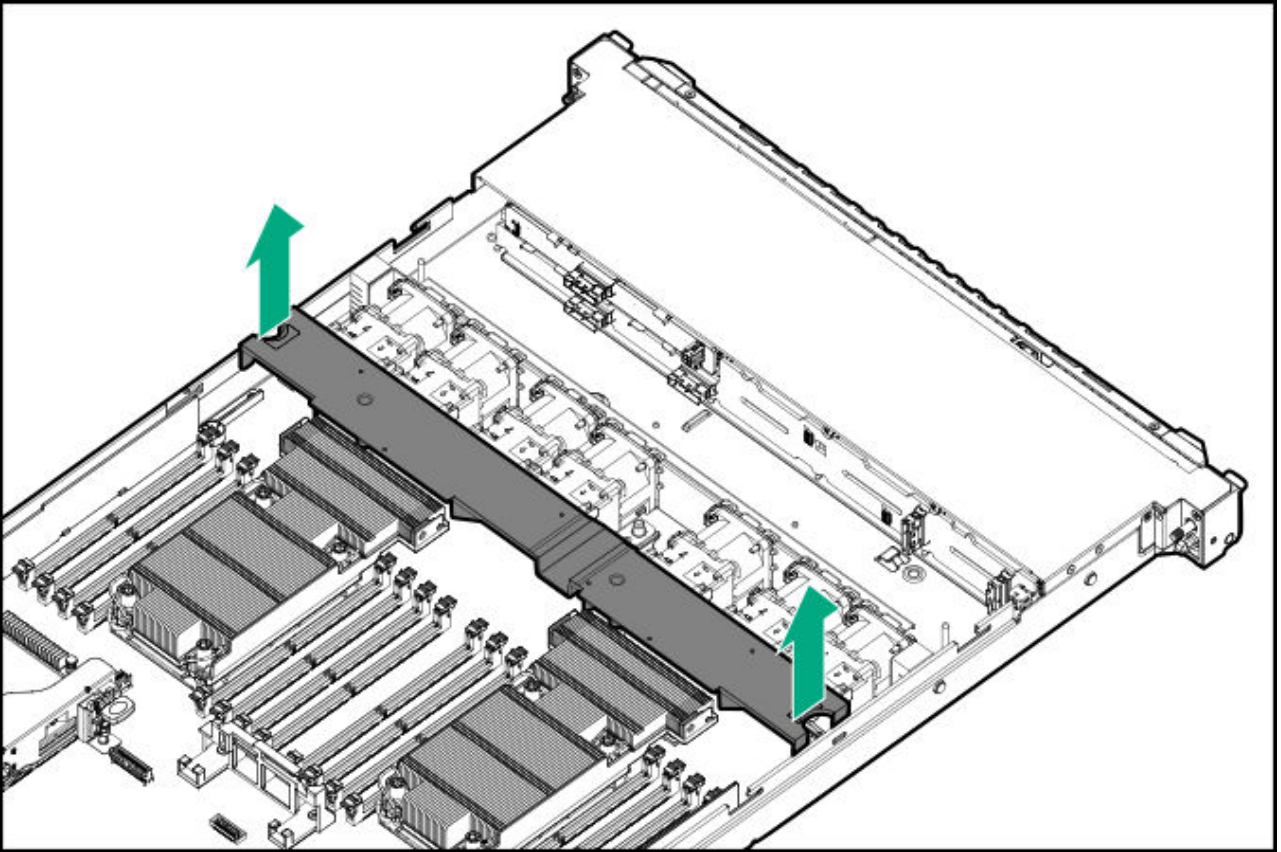

- .1. Connect the power cable to the 8SFF drive backplane.
- .2. Connect the signal cable.
- .3. Do one of the following:
 - Install drives.
 - Install drive blanks.

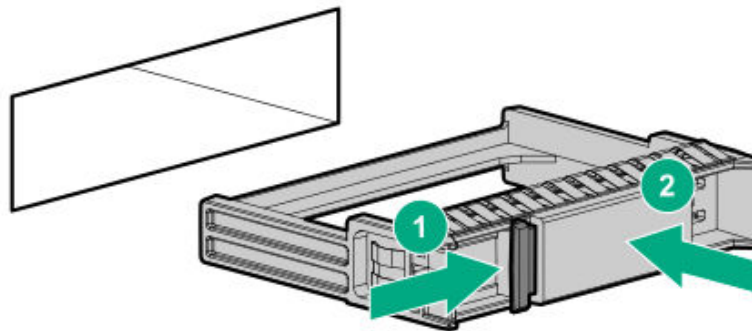

4. (Optional) Install the air baffle.
5. Install the access panel.
6. Install the server in the rack.
7. Connect all peripheral cables to the server.
8. Connect each power cord to the server.
9. Connect each power cord to the power source.
10. If removed, install the front bezel.
11. Power up the server.

Results

The installation procedure is complete.

Installing the 4 E3.S stacked drive cage

Prerequisites

- Be sure that you have the following:
 - The components included with the option kit
 - T-10 Torx screwdriver
 - 4 E3.S drives or drive blanks
- Review the Fan and heatsink requirements.

About this task

The 4 E3.S stacked drive cage is supported in Boxes 1–5 in the 10 SFF / 20 E3.S server or servers using the mixed drive type configuration.



CAUTION

Before replacing a DIMM, backplane, expansion card, riser board, or other similar PCA components due to a perceived hardware error, make sure first that the component is firmly seated in the slot.

When installing the replacement component:

- Observe antistatic precautions.
- Handle the PCA only along the edges.
- Do not touch the components and connectors on the PCA.
- Do not bend or flex the PCA.



CAUTION

To prevent improper cooling and thermal damage, do not operate the server unless all bays are populated with either a component or a blank.

Procedure

1. Back up all server data.
2. If installed, remove the front bezel.
3. Power down the server.
4. Remove all power:
 - a. Disconnect each power cord from the power source.
 - b. Disconnect each power cord from the server.
5. Do one of the following:
 - a. Extend the server from the rack.
 - b. Remove the server from the rack.
6. Place the server on a flat, level work surface.
7. Remove the access panel.
8. If installed, remove the air baffle.

An 8 SFF server is shown. The removal procedure is the same for all drive configurations.

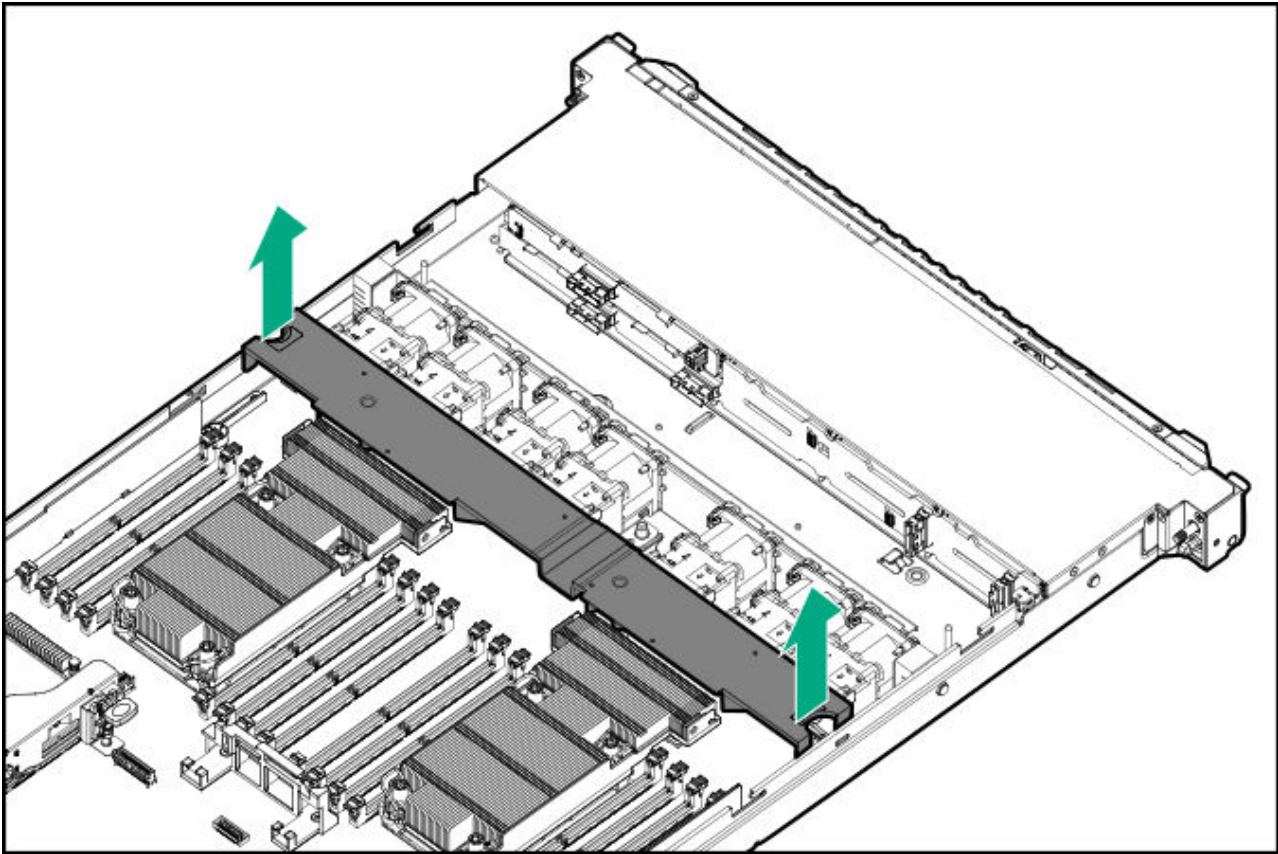

- 9. Install the 4 E3.S drive backplane onto the 4 E3.S drive cage.

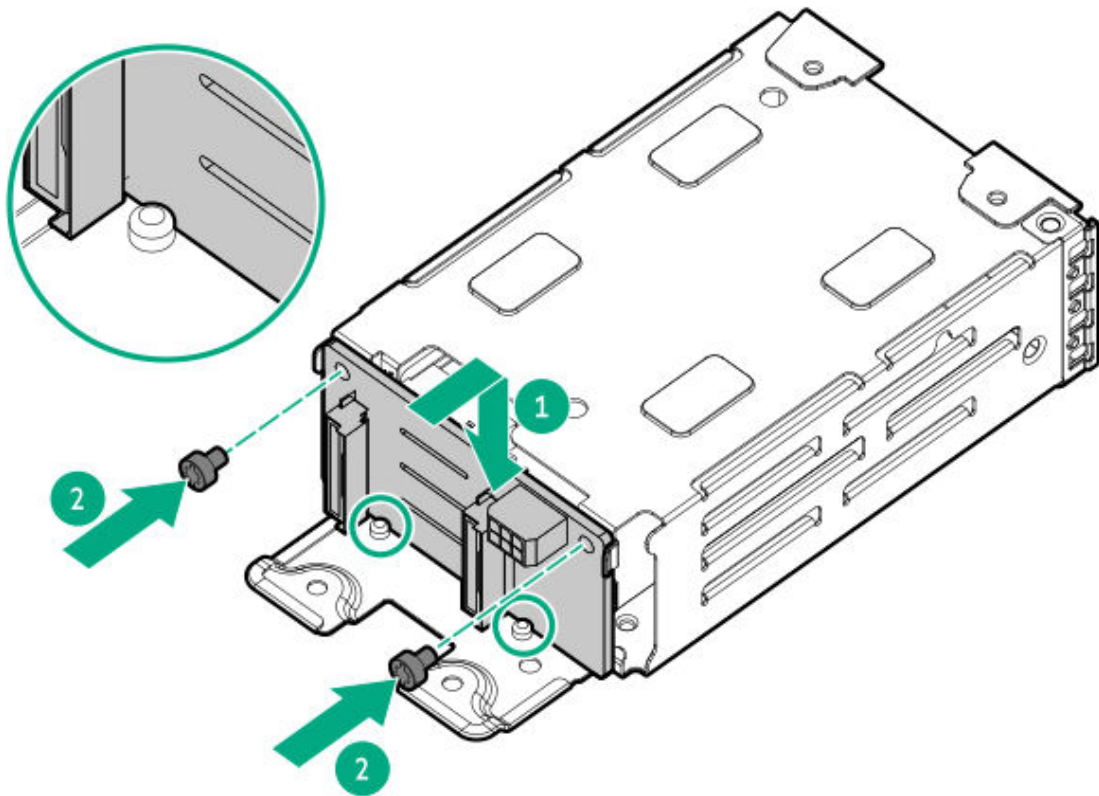

.0. Do one of the following:

- Install drives.
- Install drive blanks.

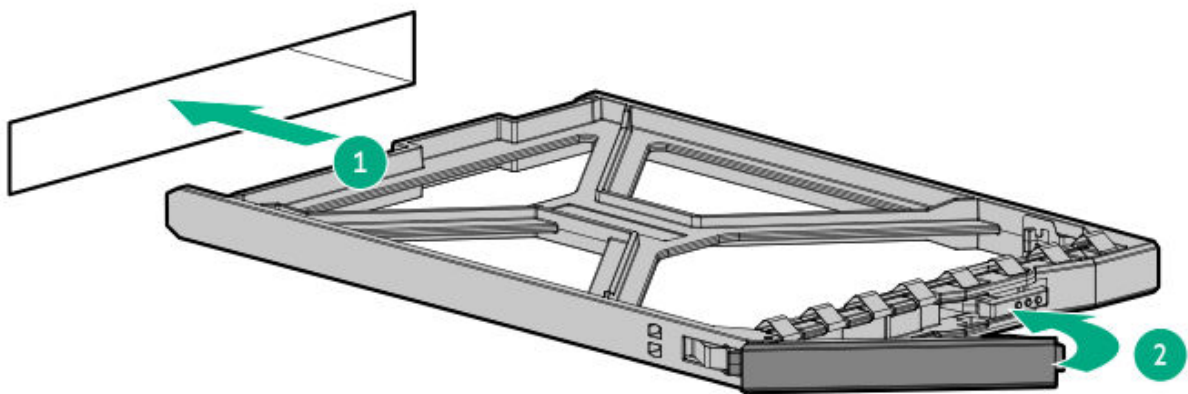

.1. Remove the drive box blank.

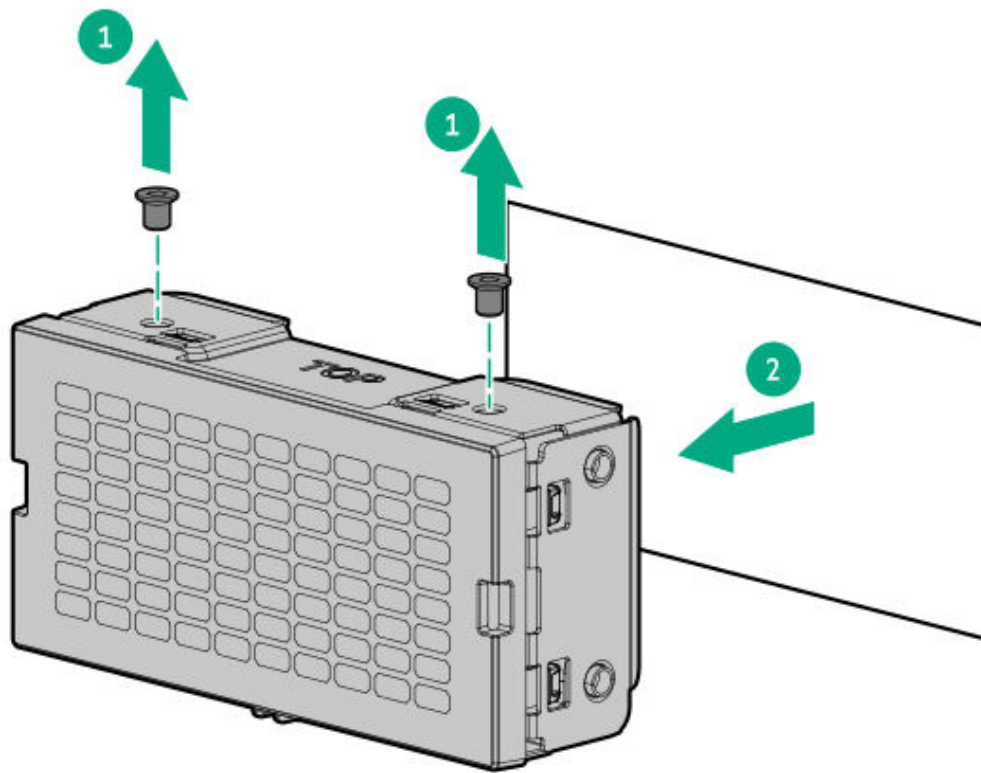

.2. Install the 4 E3.S drive cage.

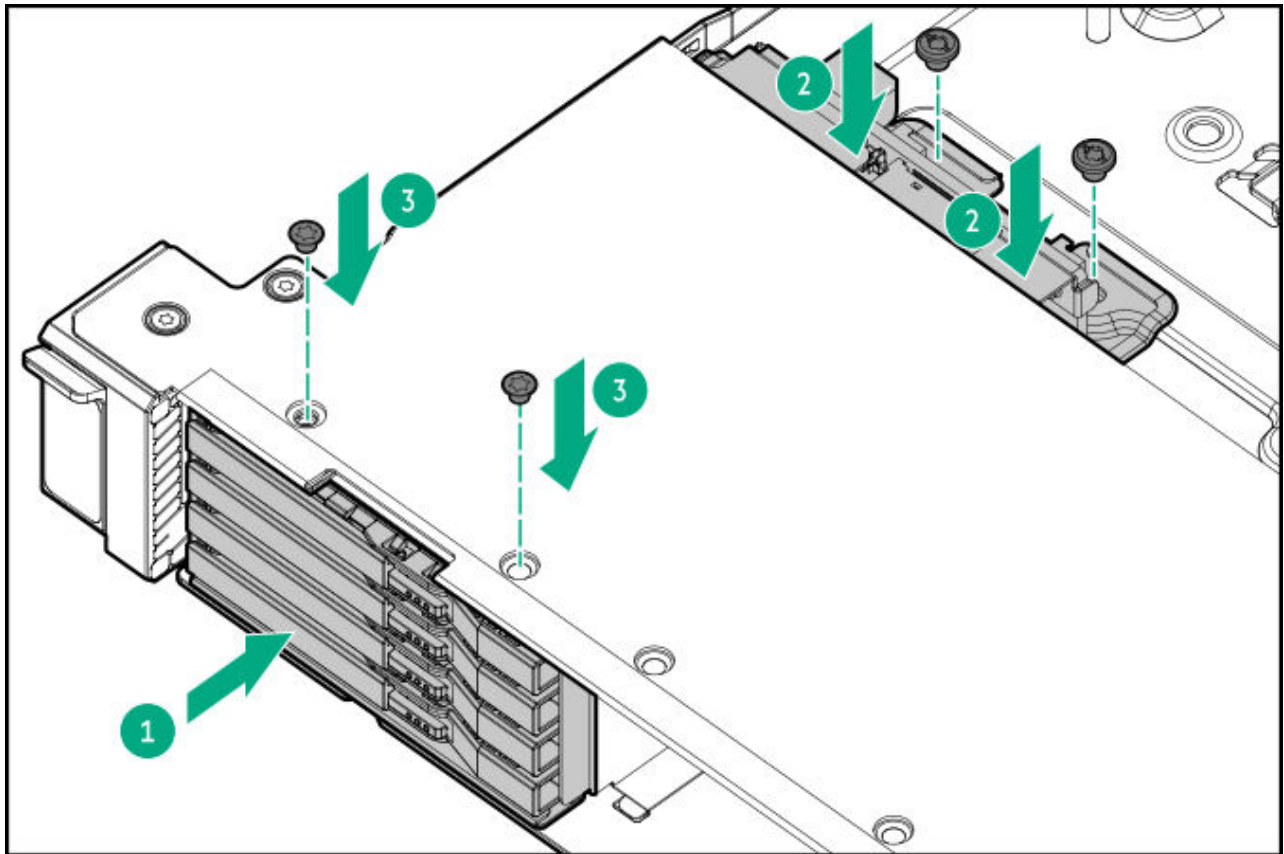

- .3. Connect the power cable to the 4 E3.S drive backplane.
- .4. Connect the data cables.

On systems with high performance heatsinks but no optional air baffle installed, pivot the heatsink baffles to the vertical orientation before connecting data cables to MCI0 ports 3–6. This will provide additional working room.

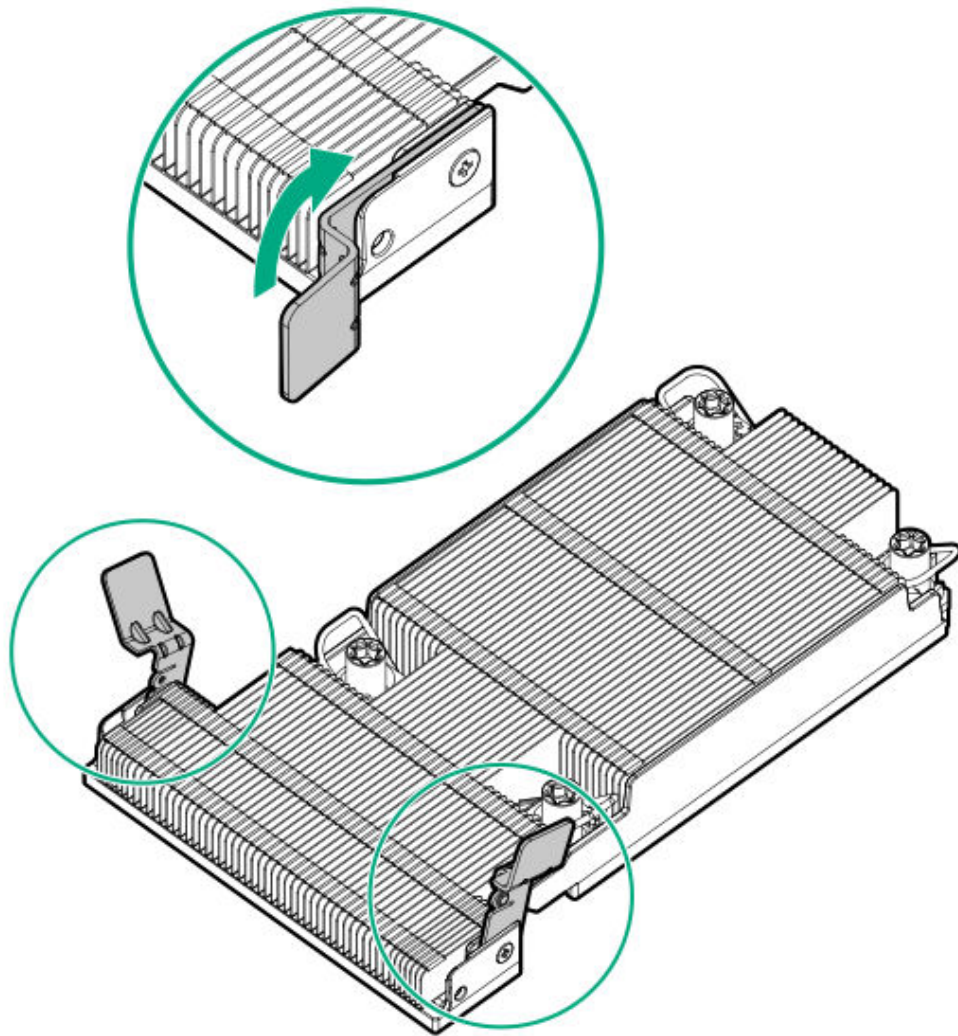

Pivot the heatsink baffles down to the horizontal orientation after installing the cables.

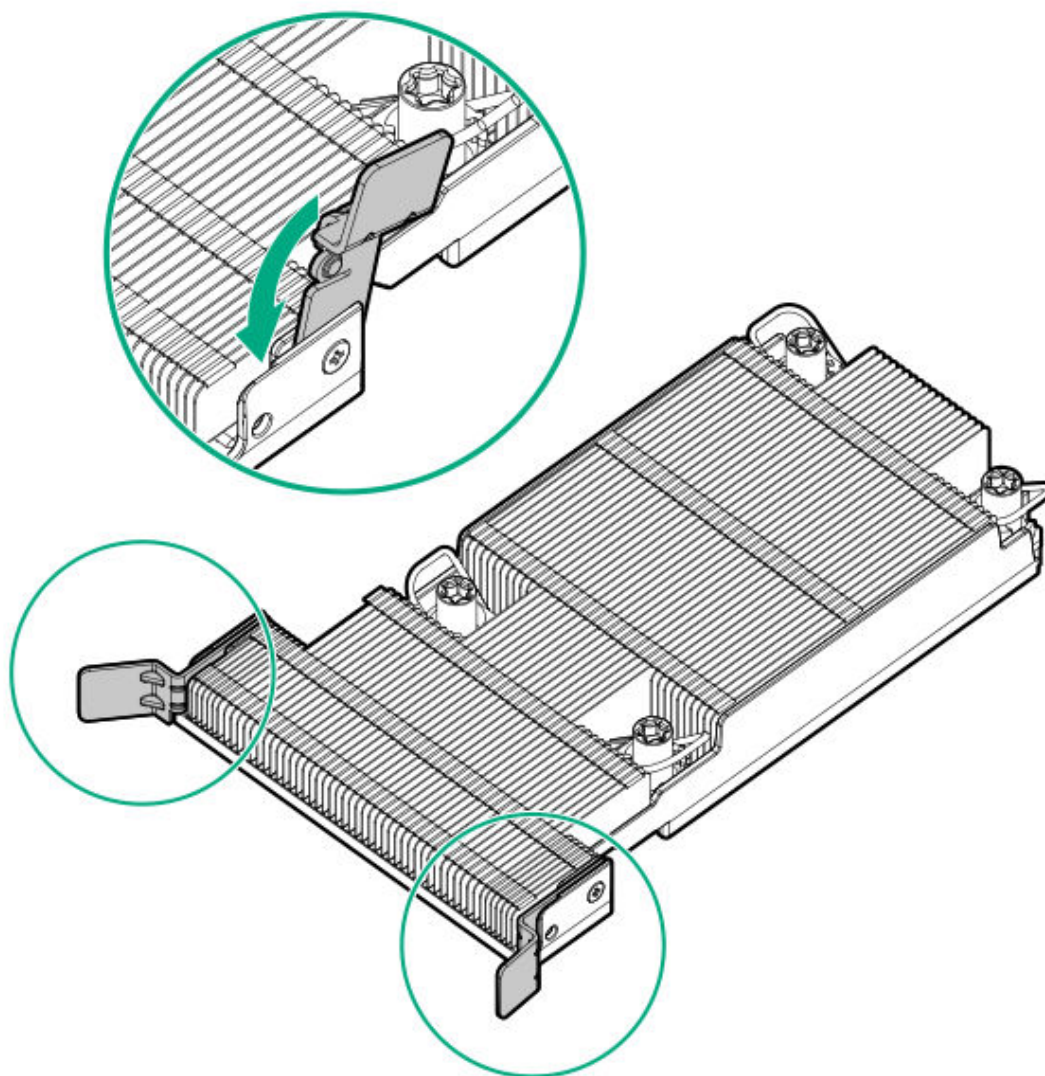

- .5. (Optional) Install the air baffle.
- .6. Install the access panel.
- .7. Install the server in the rack.
- .8. Connect all peripheral cables to the server.
- .9. Connect each power cord to the server.
- !0. Connect each power cord to the power source.
- !1. If removed, install the front bezel.
- !2. Power up the server.

Results

The installation procedure is complete.

Installing the 2 SFF stacked drive cage

Prerequisites

- Be sure that you have the following:
 - The components included with the option kit
 - T-10 Torx screwdriver
 - 2 SFF drives or drive blanks
- Review the [Fan and heatsink requirements](#).

About this task

The 2 SFF stacked drive cage is supported in Boxes 1–5 in the 10 SFF / 20 E3.S server or servers using the [mixed drive type configuration](#).



CAUTION

Before replacing a DIMM, backplane, expansion card, riser board, or other similar PCA components due to a perceived hardware error, make sure first that the component is firmly seated in the slot.

When installing the replacement component:

- Observe [antistatic precautions](#).
- Handle the PCA only along the edges.
- Do not touch the components and connectors on the PCA.
- Do not bend or flex the PCA.



CAUTION

To prevent improper cooling and thermal damage, do not operate the server unless all bays are populated with either a component or a blank.

Procedure

1. [Back up all server data](#).

2. If installed, remove the front bezel.
3. Power down the server.
4. Remove all power:
 - a. Disconnect each power cord from the power source.
 - b. Disconnect each power cord from the server.
5. Do one of the following:
 - a. Extend the server from the rack.
 - b. Remove the server from the rack.
6. Place the server on a flat, level work surface.
7. Install the 2 SFF drive backplane onto the 2 SFF drive cage.

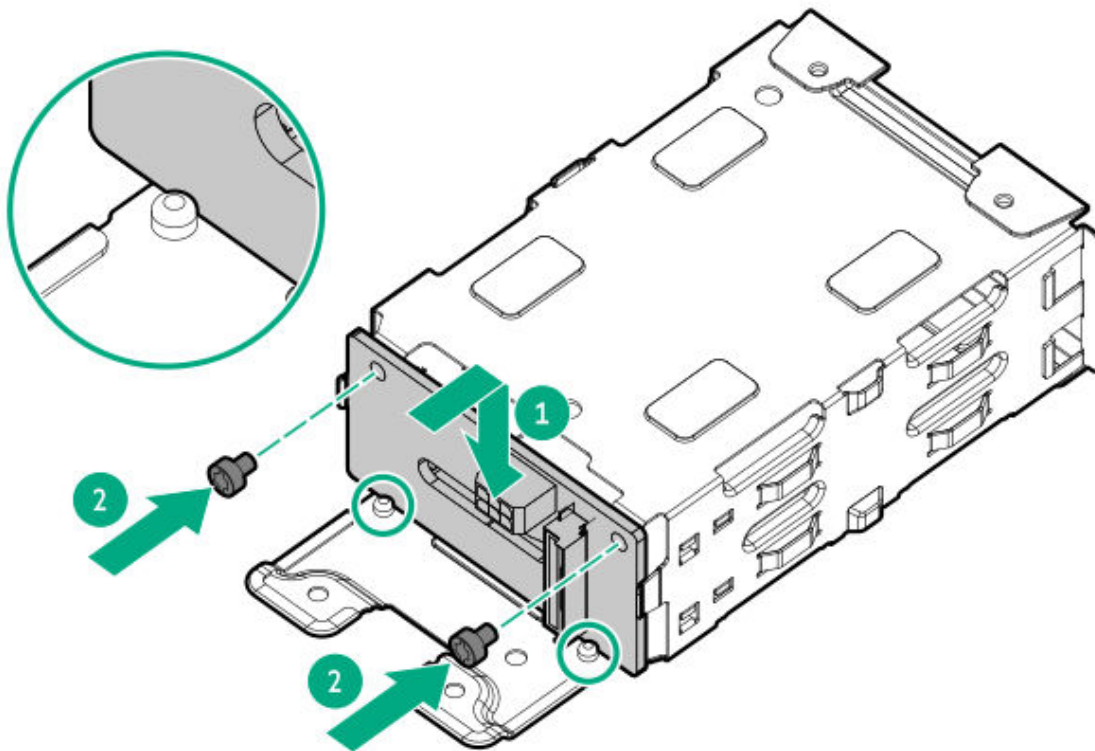

8. Do one of the following:
 - Install drives.
 - Install drive blanks.

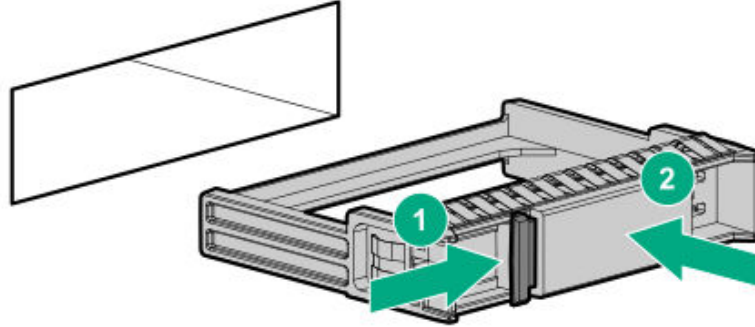

9. Remove the access panel.
0. If installed, remove the air baffle.

An 8 SFF server is shown. The removal procedure is the same for all drive configurations.

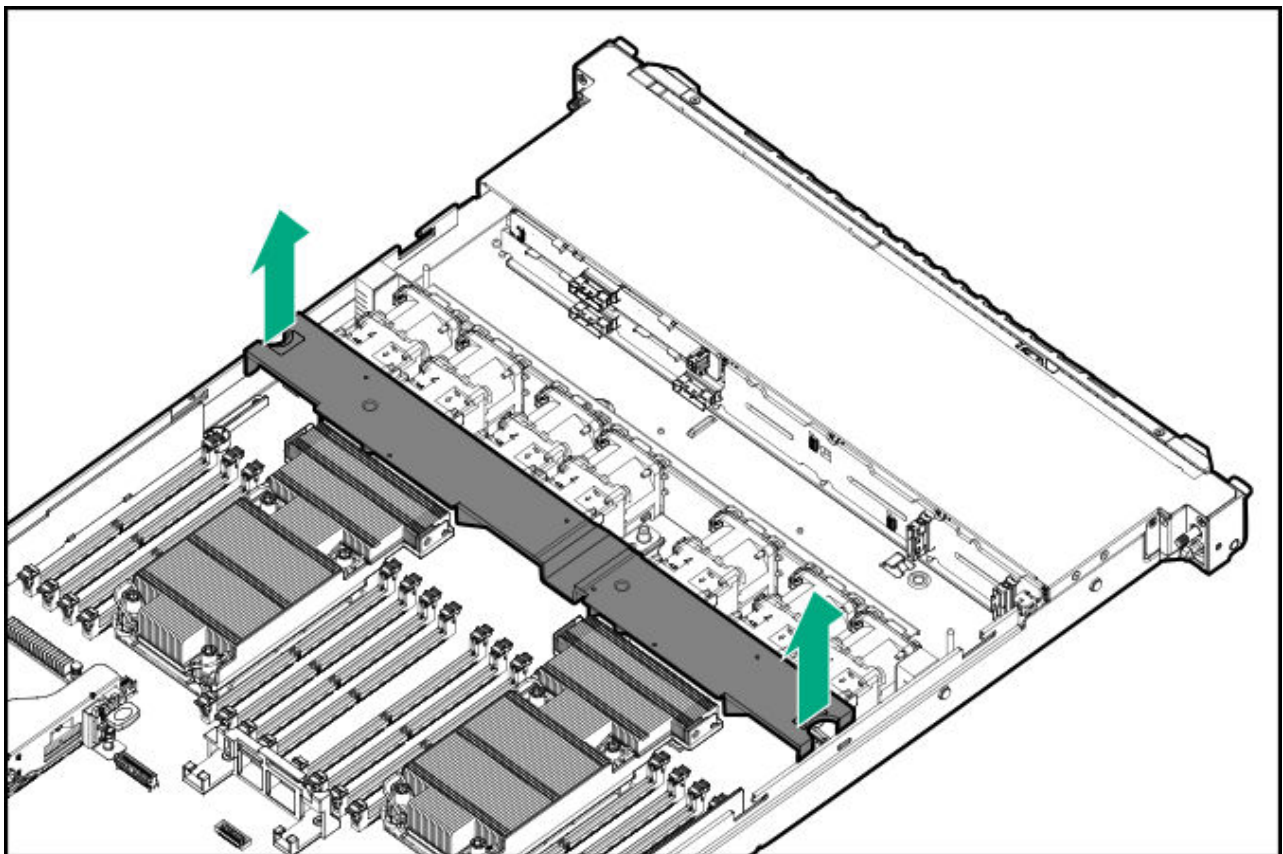

1. Remove the drive box blank.

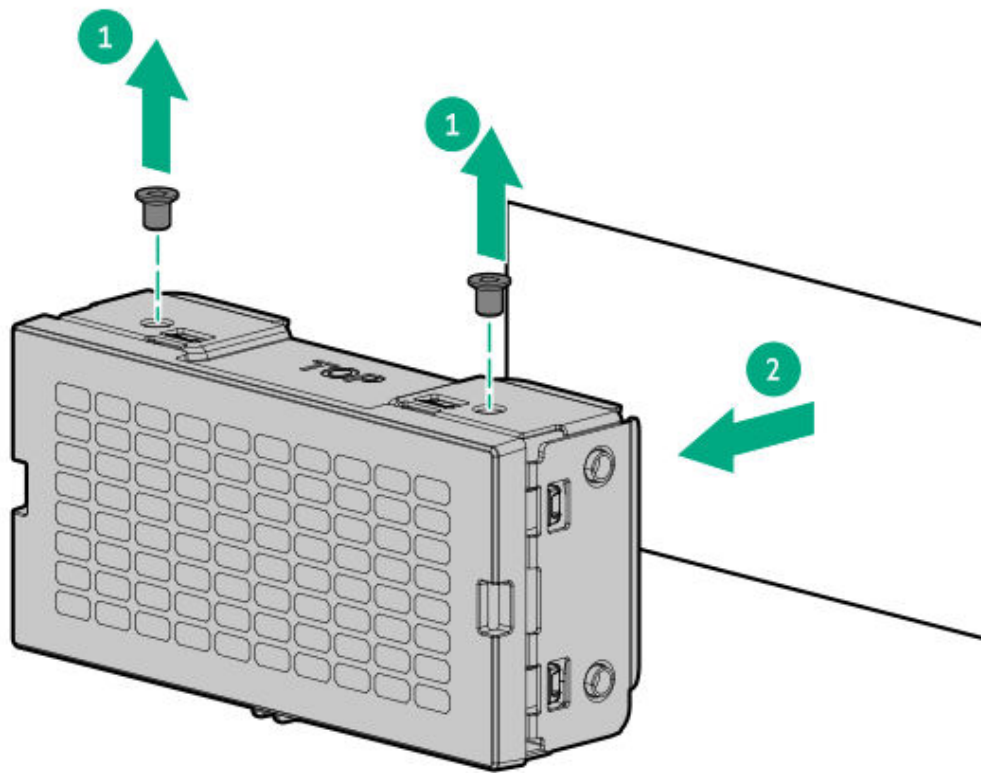

.2. Install the 2 SFF drive cage.

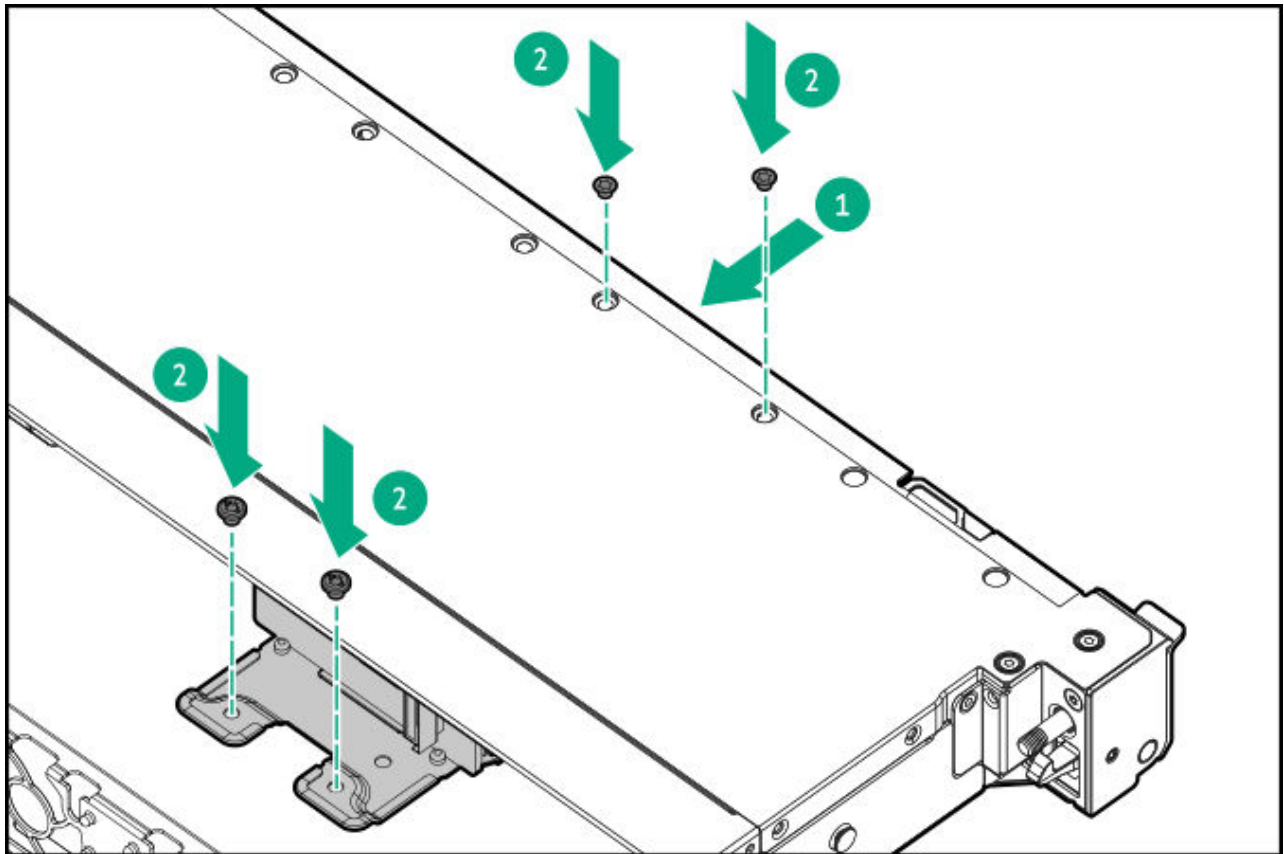

.3. Connect the power cable to the 2 SFF drive backplane.

.4. Connect the data cable.

On systems with high performance heatsinks but no optional air baffle installed, pivot the heatsink baffles to the vertical orientation before connecting data cables to MCI0 ports 3–6. This will provide additional working room.

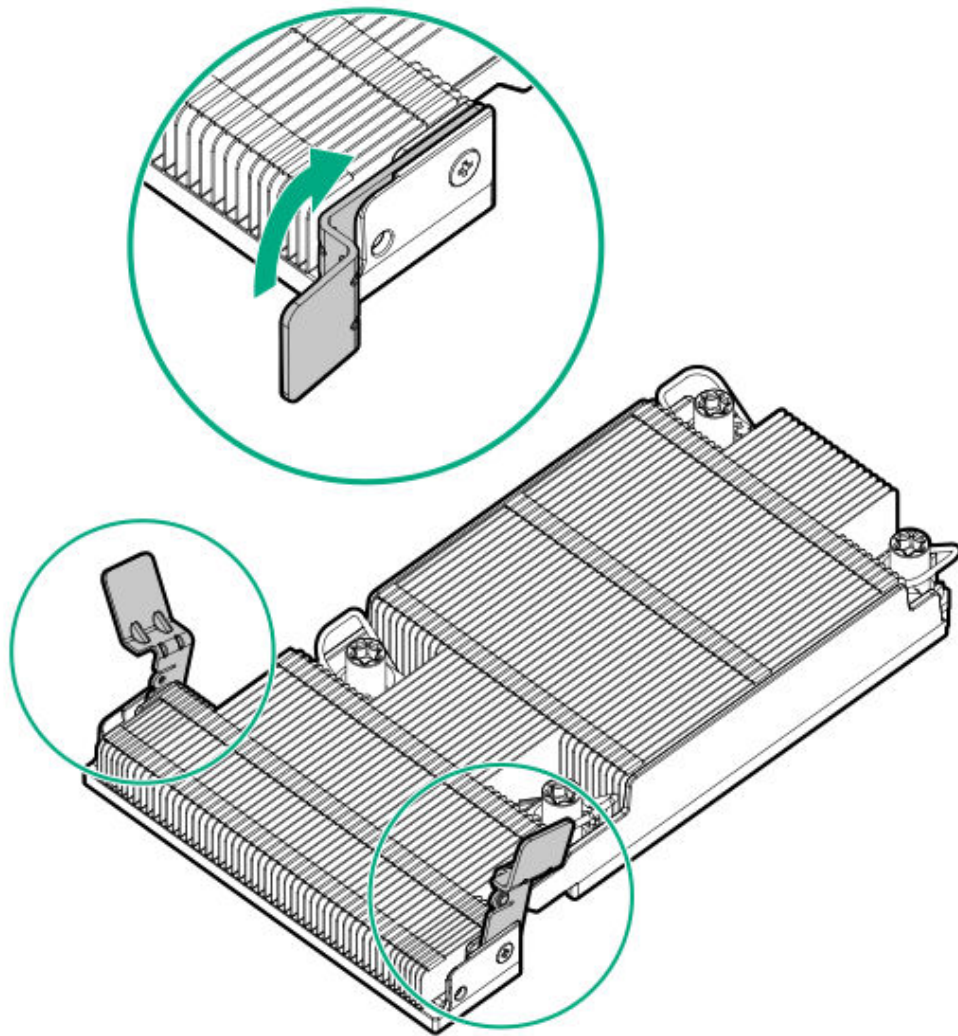

Pivot the heatsink baffles down to the horizontal orientation after installing the cables.

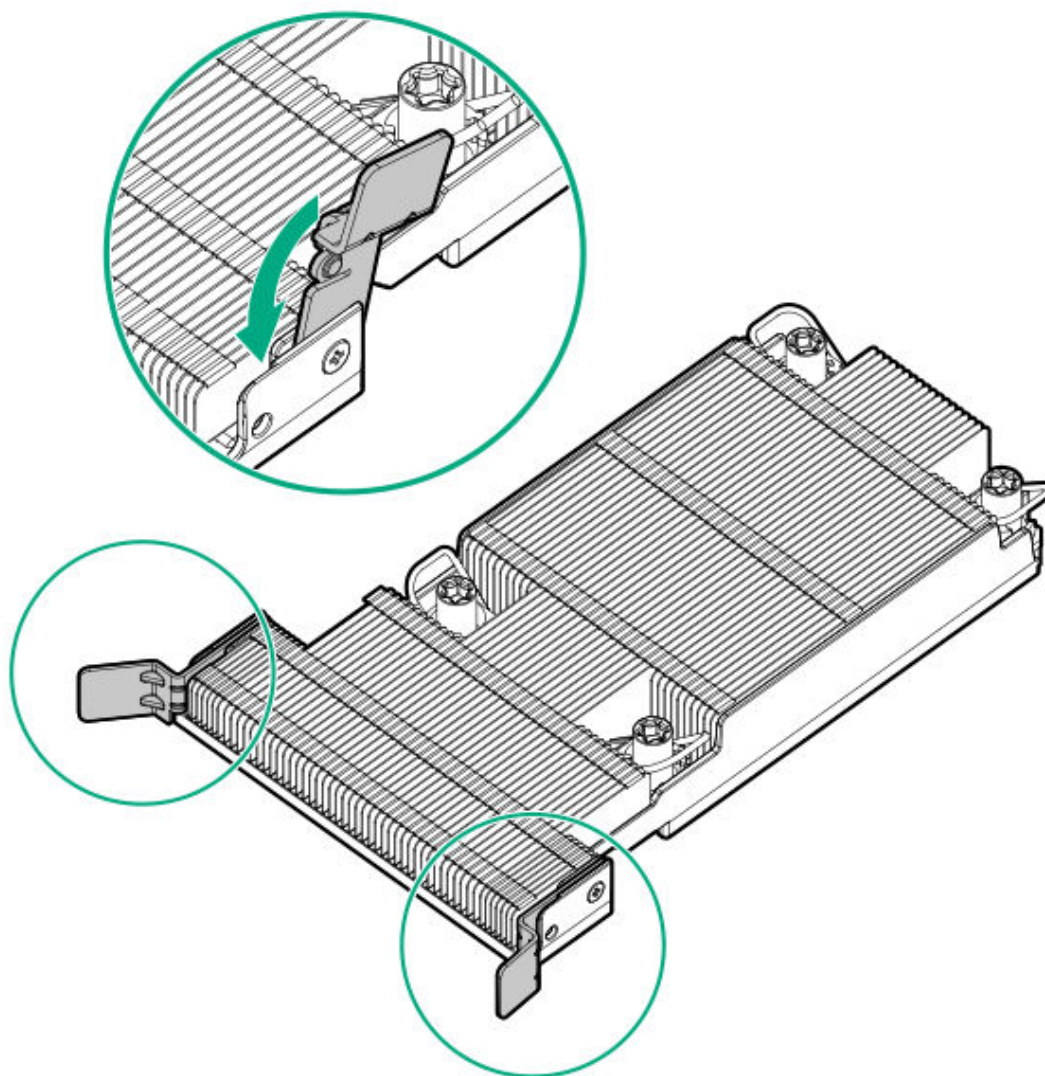

- .5. (Optional) Install the air baffle.
- .6. Install the access panel.
- .7. Install the server in the rack.
- .8. Connect all peripheral cables to the server.
- .9. Connect each power cord to the server.
- !0. Connect each power cord to the power source.
- !1. If removed, install the front bezel.
- !2. Power up the server.

Results

The installation procedure is complete.

Energy packs

Subtopics

[HPE Smart Storage Battery](#)

[HPE Smart Storage Hybrid Capacitor](#)

[Installing a smart storage battery/capacitor](#)

HPE Smart Storage Battery

A single 96 W battery can support up to 24 devices.

After the battery is installed, it might take up to two hours to charge. Controller features requiring backup power are not re-enabled until the battery is capable of supporting the backup power.

This server supports the 96 W HPE Smart Storage Battery with the 145 mm cable.

For more information, see HPE Smart Storage Batteries and Hybrid Capacitors QuickSpecs:

https://www.hpe.com/psnow/doc/a00028553enw.pdf?jumpid=in_pdp-psnow-qs

HPE Smart Storage Hybrid Capacitor

The capacitor pack can support up to three devices.

This server supports the 12 W or 16 W HPE Smart Storage Hybrid Capacitor with the 145 mm cable.

Before installing the HPE Smart Storage Hybrid Capacitor, verify that the system BIOS meets the minimum firmware requirements to support the capacitor pack.



IMPORTANT

If the system BIOS or controller firmware is older than the minimum recommended firmware versions, the capacitor pack will only support one device.

The capacitor pack is fully charged after the system boots.

For more information, see HPE Smart Storage Batteries and Hybrid Capacitors QuickSpecs:

https://www.hpe.com/psnow/doc/a00028553enw.pdf?jumpid=in_pdp-psnow-qs

Installing a smart storage battery/capacitor

Prerequisites

Be sure that you have the components included with the hardware option kit.

About this task



CAUTION

To prevent damage to electrical components, properly ground the server before beginning any installation, removal, or replacement procedure. Improper grounding can cause electrostatic discharge.

Procedure

1. Power down the server.
2. Remove all power:
 - a. Disconnect each power cord from the power source.
 - b. Disconnect each power cord from the server.
3. Do one of the following:
 - a. Extend the server from the rack.
 - b. Remove the server from the rack.
4. Place the server on a flat, level work surface.
5. Remove the access panel.
6. If installed, remove the air baffle.

An 8 SFF server is shown. The removal procedure is the same for all drive configurations.

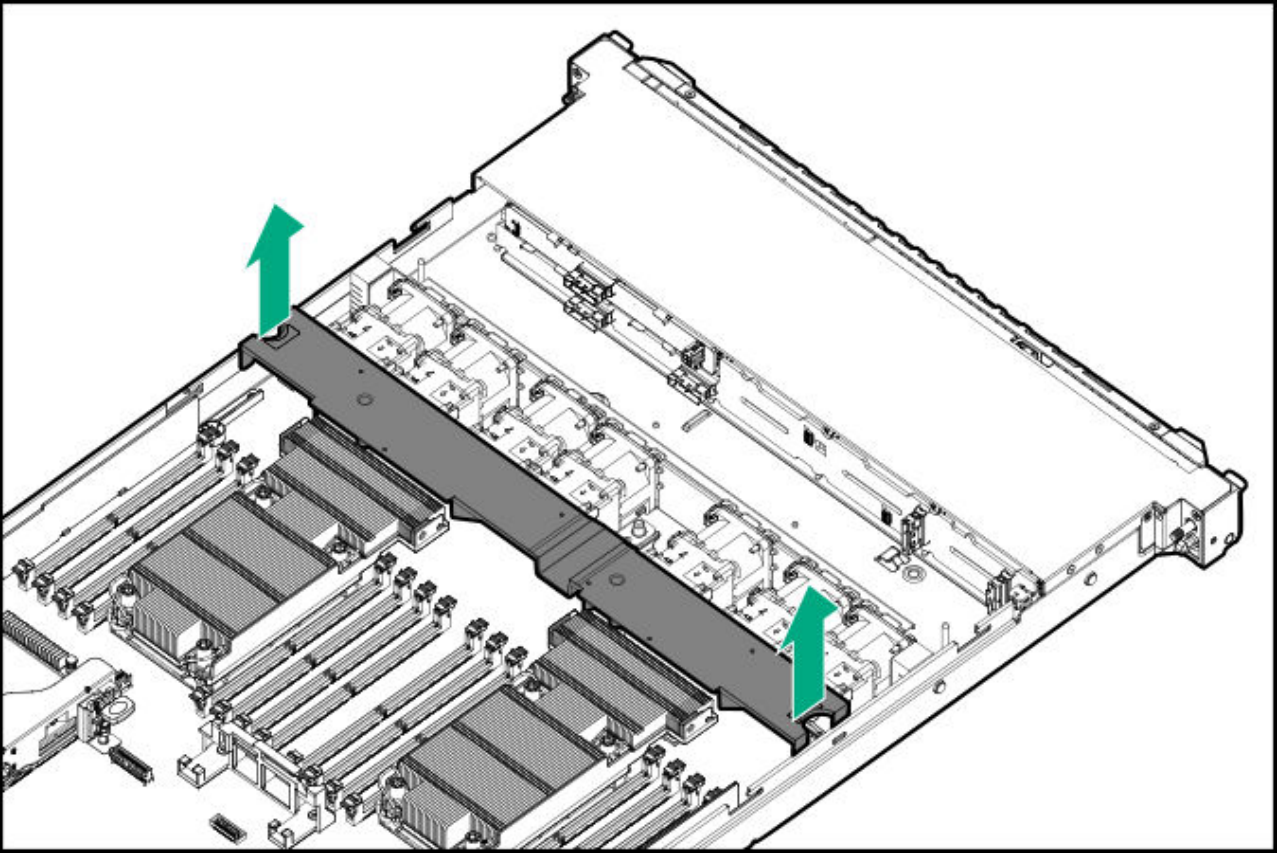

7. Install the energy pack.

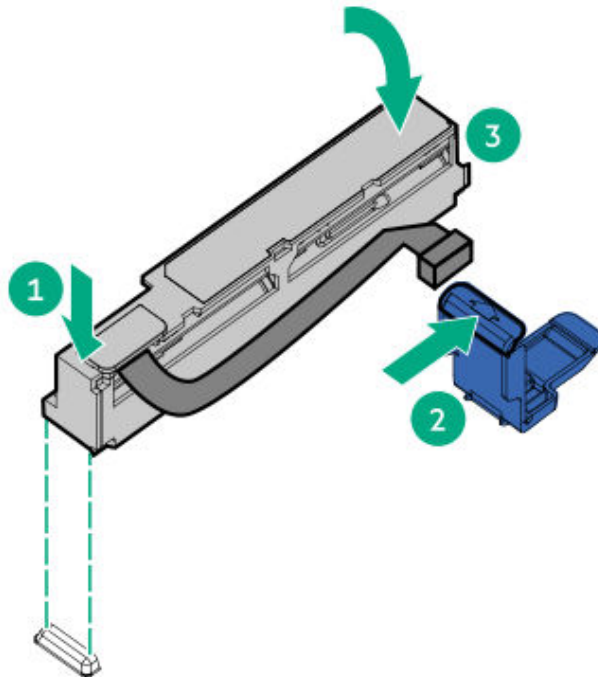

8. Connect the extension cable to the energy pack.
9. Connect the cable to the system board.
10. (Optional) Install the air baffle.
11. Install the access panel.
12. Install the server in the rack.
13. Connect all peripheral cables to the server.
14. Connect each power cord to the server.
15. Connect each power cord to the power source.
16. Power up the server.

Results

The installation procedure is complete.

GPUs

Subtopics

Installing a GPU in the primary riser cage

Installing a GPU in the primary riser cage

Prerequisites

Before installing this option, be sure that the power supplies support the installation of this option.

In addition, be sure that you have the components included with the hardware option kit.

About this task



CAUTION

Before replacing a DIMM, backplane, expansion card, riser board, or other similar PCA components due to a perceived hardware error, make sure first that the component is firmly seated in the slot.

When installing the replacement component:

- Observe antistatic precautions.
- Handle the PCA only along the edges.
- Do not touch the components and connectors on the PCA.
- Do not bend or flex the PCA.



WARNING

To reduce the risk of personal injury from hot surfaces, allow the drives and the internal system components to cool before touching them.

Procedure

1. Power down the server.
2. Remove all power:
 - a. Disconnect each power cord from the power source.
 - b. Disconnect each power cord from the server.
3. Do one of the following:
 - a. Extend the server from the rack.
 - b. Remove the server from the rack.
4. Place the server on a flat, level work surface.
5. Remove the access panel.
6. Remove the primary PCI riser cage.
7. Install the GPU bracket.

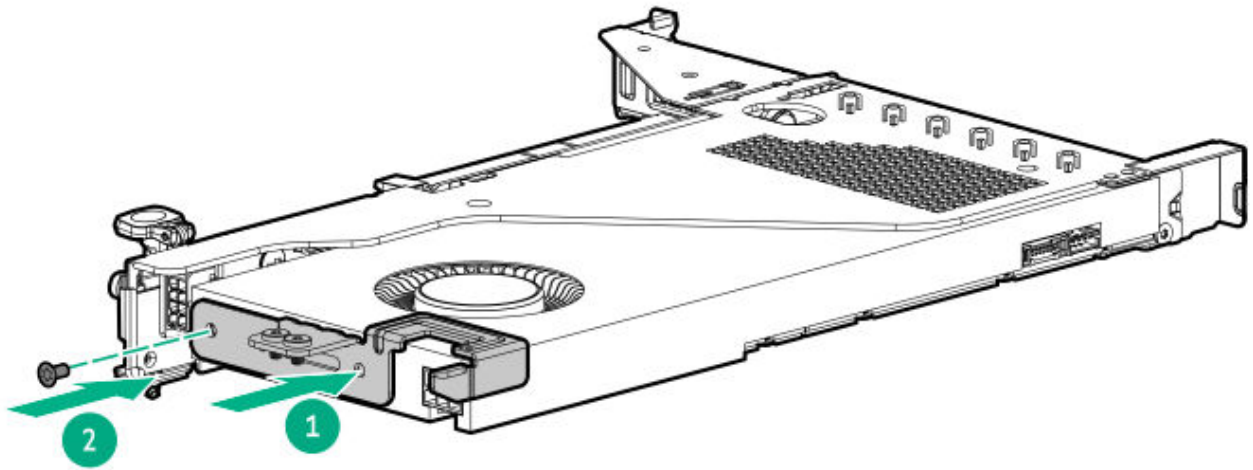

8. Install the GPU in the riser cage.

If installing a GPU requiring greater than 75W, connect the power cable to the system board.

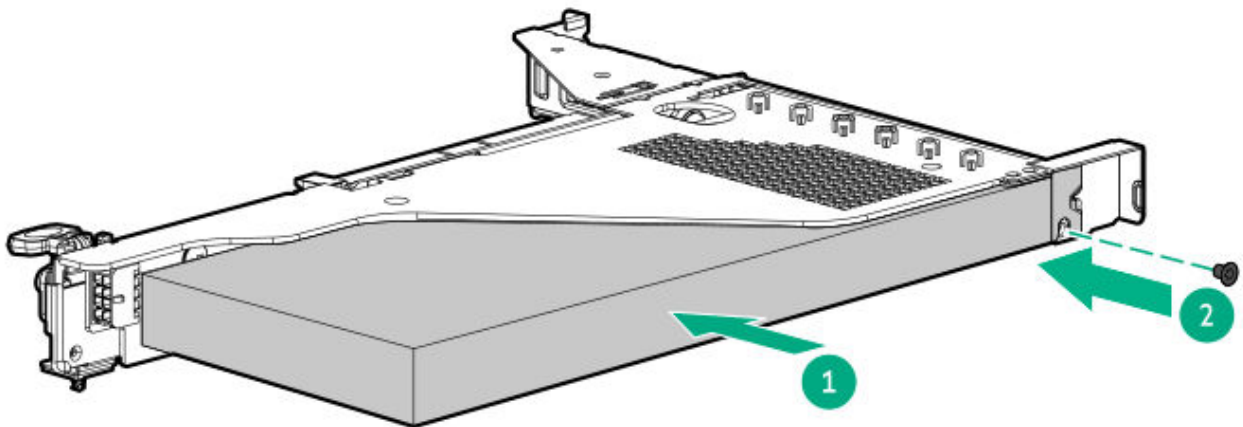

9. If the card requires rear support, install the GPU support bracket.

0. Install the primary PCI riser cage.
1. Install the access panel.
2. Install the server in the rack.
3. Connect each power cord to the server.
4. Connect each power cord to the power source.
5. Power up the server.

Results

The installation procedure is complete.

Management

Subtopics

[Installing the System Insight Display](#)

[Installing the serial port option](#)

Installing the System Insight Display

Prerequisites

Before installing this option, be sure that you have the following:

- The components included with the hardware option kit
- T-10 Torx screwdriver

About this task

The System Insight Display is supported in the 8 SFF drive configuration.



CAUTION

To prevent improper cooling and thermal damage, do not operate the server unless all bays are populated with either a component or a blank.



CAUTION

To prevent damage to electrical components, properly ground the server before beginning any installation, removal, or replacement procedure. Improper grounding can cause electrostatic discharge.

Procedure

1. [Power down the server](#).
2. If installed, [remove the front bezel](#).
3. Remove all power:

- a. Disconnect each power cord from the power source.
 - b. Disconnect each power cord from the server.
4. Do one of the following:
 - Extend the server from the rack.
 - Remove the server from the rack.
 5. Place the server on a flat, level work surface.
 6. Remove the access panel.
 7. Remove the SID blank.

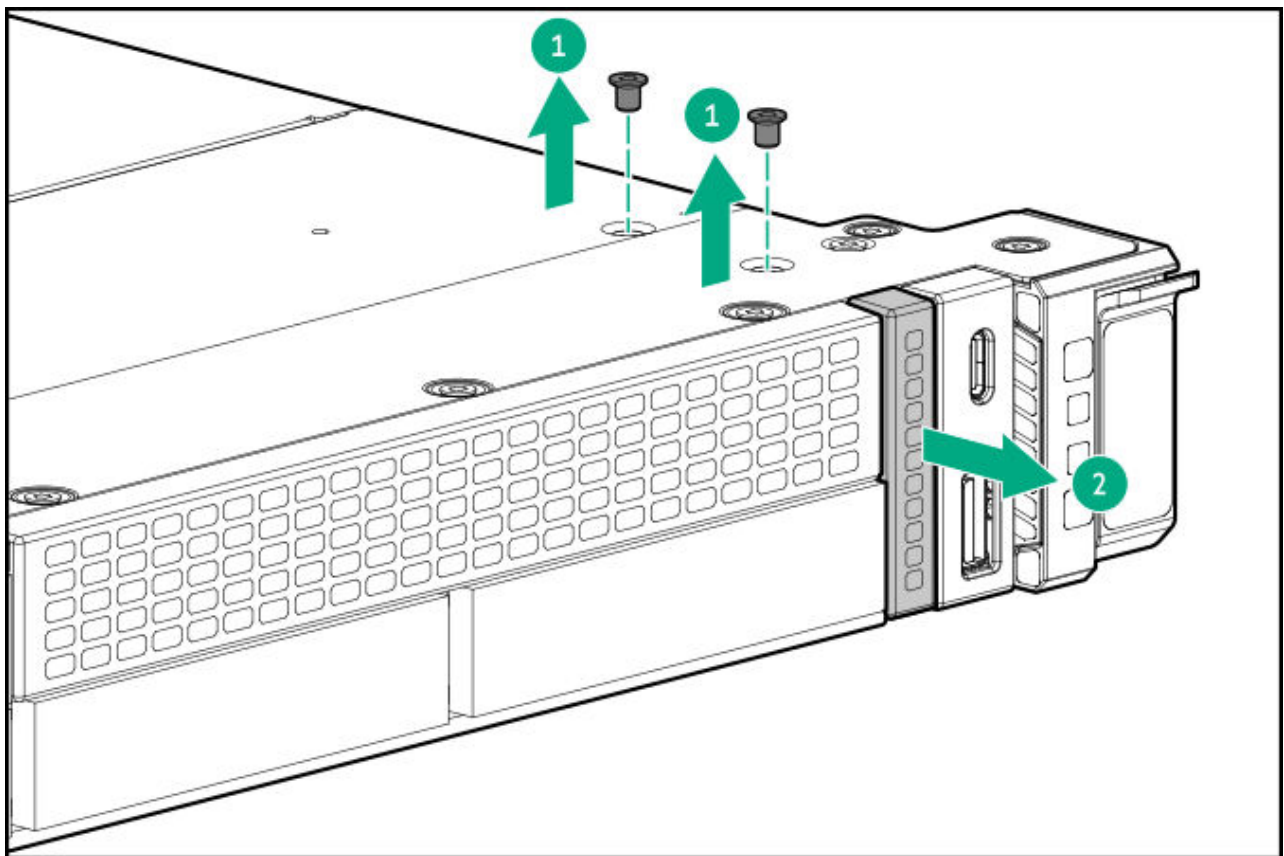

8. Guide the SID cable through the front of the server.

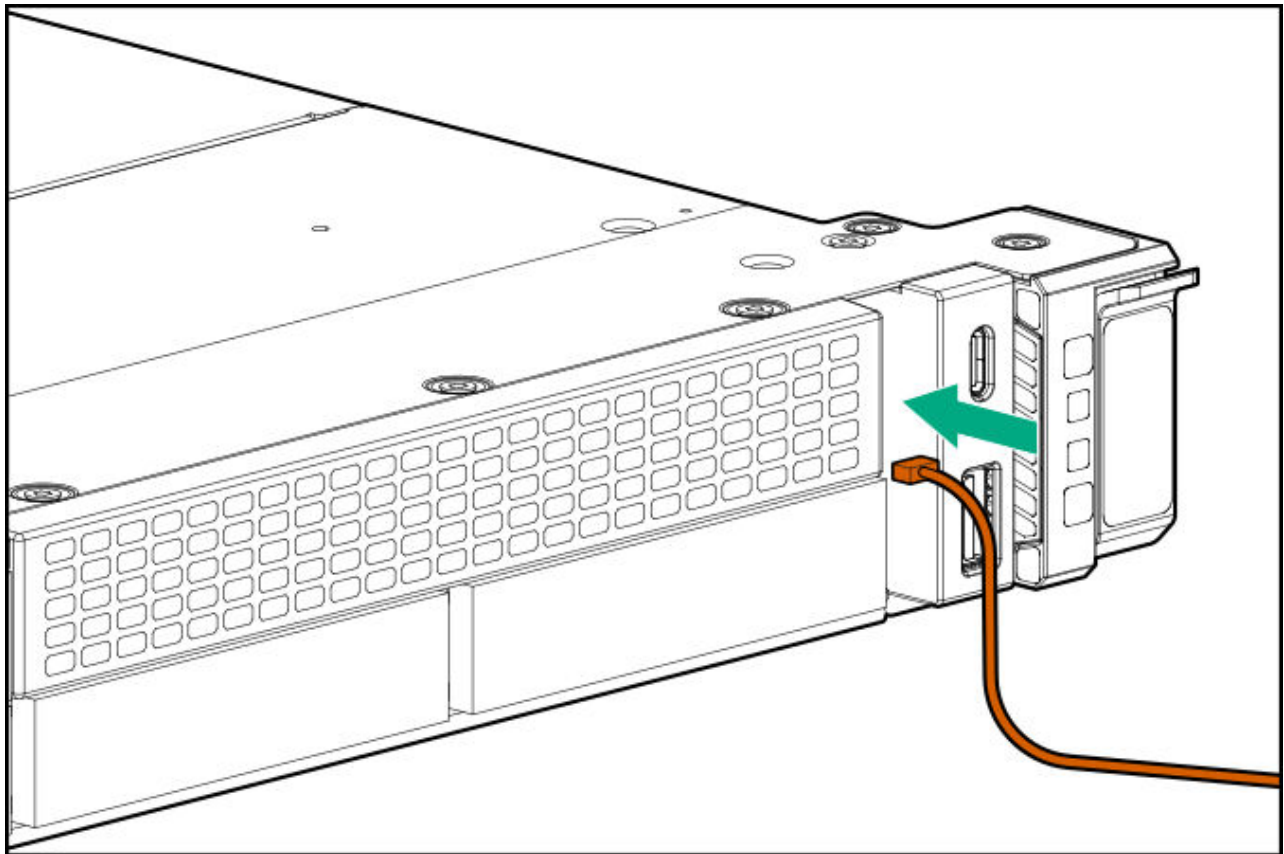

9. Install the SID module.

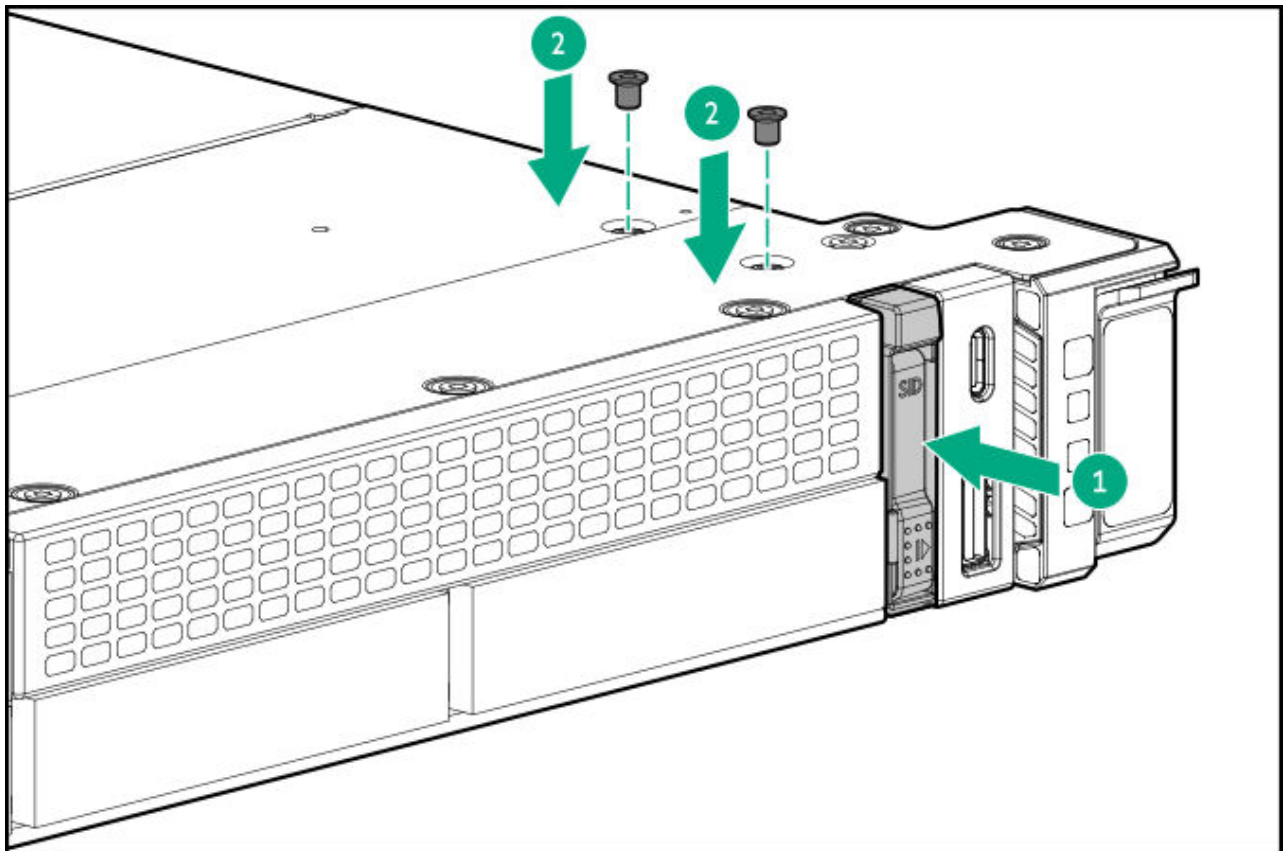

- .0. Connect the SID cable to the system board.
- .1. Install the access panel.
- .2. Install the server in the rack.
- .3. Connect all peripheral cables to the server.
- .4. Connect each power cord to the server.
- .5. Connect each power cord to the power source.
- .6. If removed, install the front bezel.
- .7. Power up the server.

Results

The installation procedure is complete.

Installing the serial port option

Prerequisites

Before installing this option, be sure you have the following:

- The components included with the hardware option kit
- 5 mm nut driver

About this task



CAUTION

A discharge of static electricity from a finger or other conductor might damage system boards or other static-sensitive devices. To prevent damage, observe antistatic precautions.



CAUTION

The port blank provides EMI shielding and helps maintain proper thermal status inside the server. Do not operate the server when a port blank is removed without the corresponding I/O port option installed.

Procedure

1. Power down the server.

2. Remove all power:
 - a. Disconnect each power cord from the power source.
 - b. Disconnect each power cord from the server.
3. Do one of the following:
 - a. Extend the server from the rack.
 - b. Remove the server from the rack.
4. Place the server on a flat, level work surface.
5. Remove the access panel.
6. Remove the serial port blank.

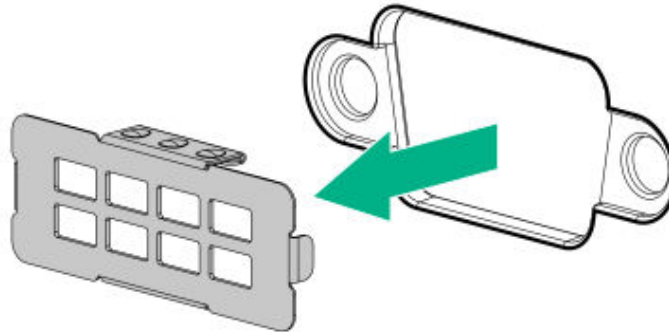

7. Using a 5 mm nut driver, install the serial cable.

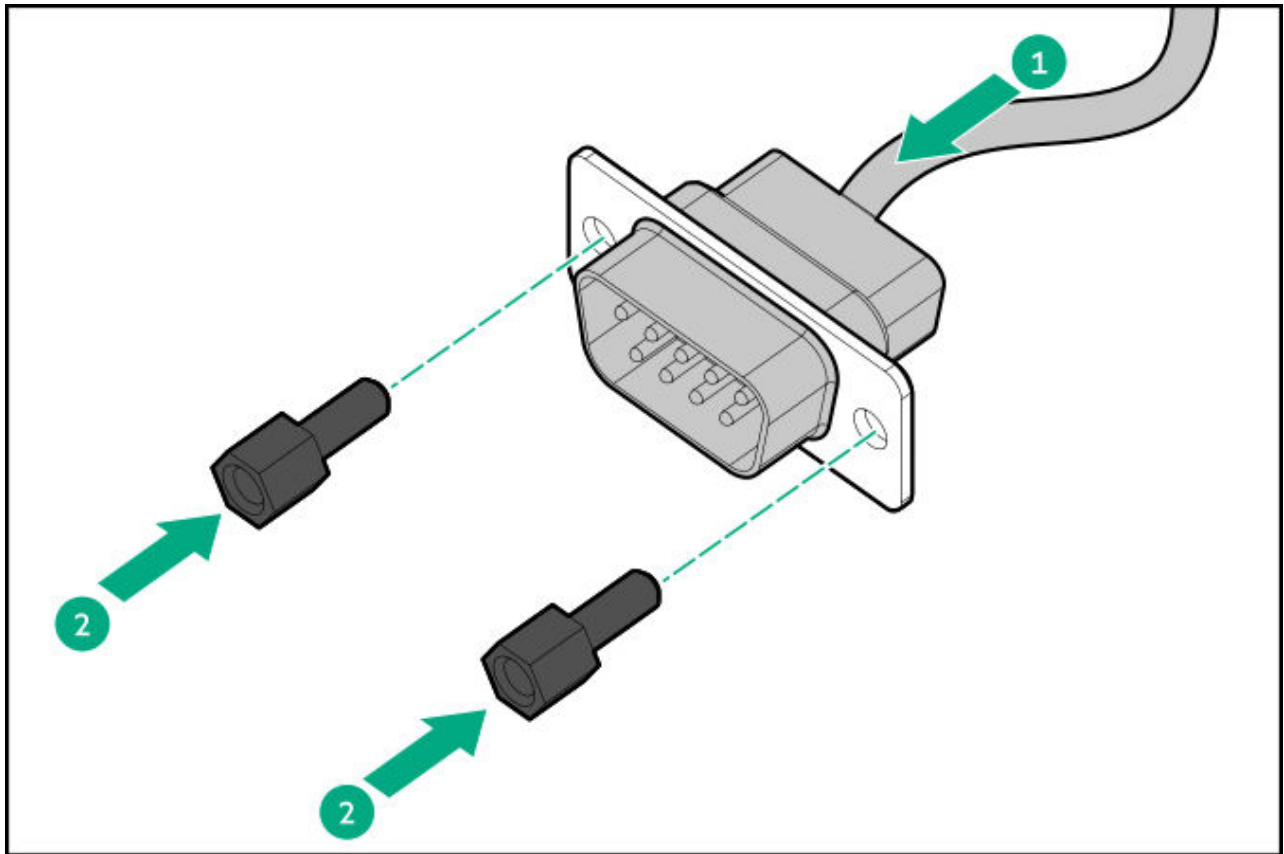

8. Connect the serial port cable to the system board.
9. Install the access panel.
0. Install the server in the rack.
- .1. Connect all peripheral cables to the server.
- .2. Connect each power cord to the server.
- .3. Connect each power cord to the power source.
- .4. Power up the server.

Configuring the serial port

- .5. To configure the serial port setting:
 - a. From the boot screen, press **F9** to access the UEFI System Utilities.
 - b. From the **System Utilities** screen, select **System Configuration** > **BIOS/Platform Configuration (RBSU)** > **System Options** > **Serial Port Options** > **Embedded Serial Port**.
 - c. Select a setting.
 - d. Press **F12** key to save your selection.

e. Click **Yes-Save Changes**.

f. Click **Reboot**.

Results

The installation procedure is complete.

Media devices

Subtopics

[Installing the 4 LFF DisplayPort/USB option](#)

[Installing the 4 LFF optical disk drive](#)

[Installing the 8 SFF DisplayPort / USB / optical drive blank option](#)

[Installing the 8 SFF optical disk drive](#)

[Installing the DisplayPort / USB / optical drive blank and optical drive in the 10 SFF / 20 E3.S server](#)

Installing the 4 LFF DisplayPort/USB option

Prerequisites

Be sure that you have the following:

- The components included with the hardware option kit
- T-10 Torx screwdriver

About this task



CAUTION

A discharge of static electricity from a finger or other conductor might damage system boards or other static-sensitive devices. To prevent damage, observe antistatic precautions.



CAUTION

To prevent improper cooling and thermal damage, do not operate the server unless all bays are populated with either a component or a blank.

Procedure

1. Power down the server.
2. If installed, remove the front bezel.
3. Remove all power:
 - a. Disconnect each power cord from the power source.
 - b. Disconnect each power cord from the server.
4. Do one of the following:
 - a. Extend the server from the rack.
 - b. Remove the server from the rack.
5. Place the server on a flat, level work surface.
6. Remove the access panel.
7. If installed, remove the air baffle.

An 8 SFF server is shown. The removal procedure is the same for all drive configurations.

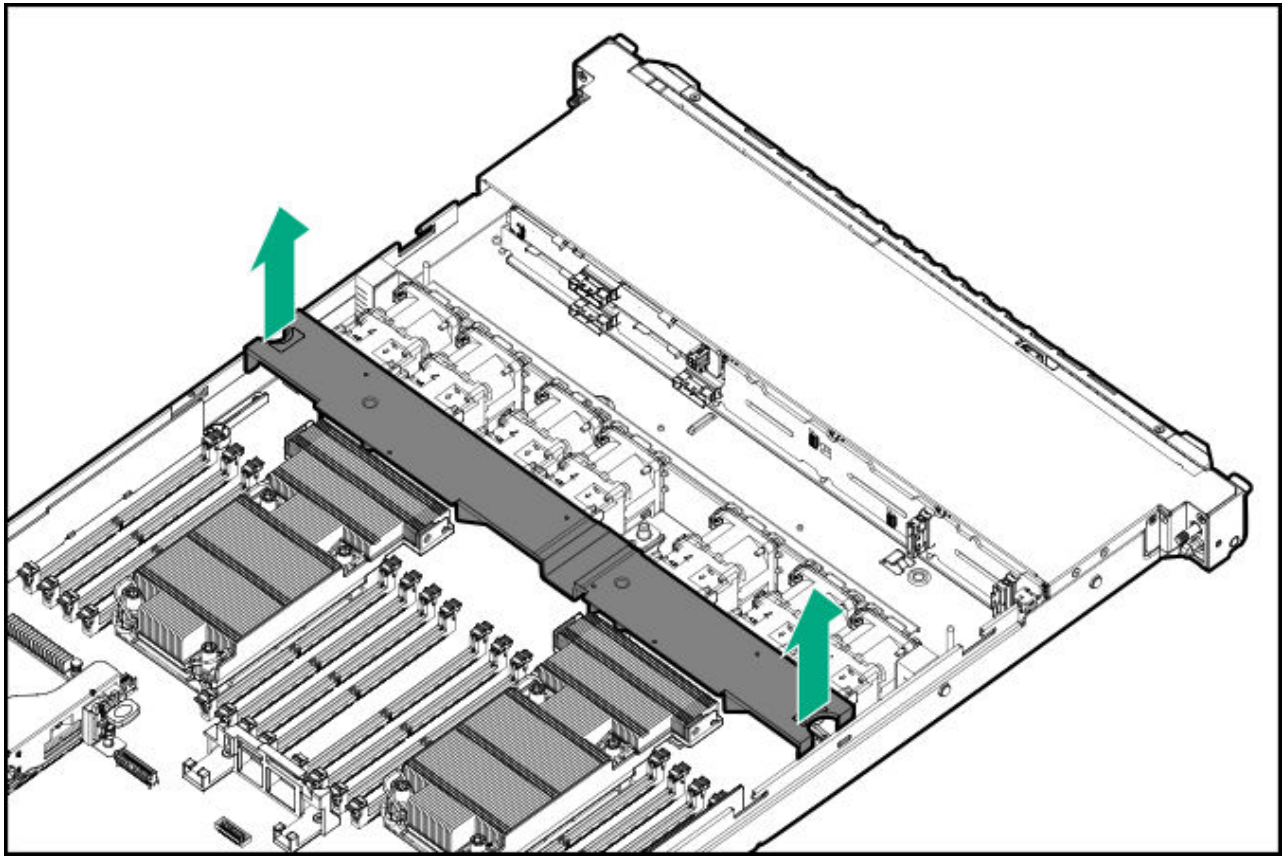

8. Using a Torx T-10 screwdriver, remove the 4 LFF DisplayPort / USB blank.

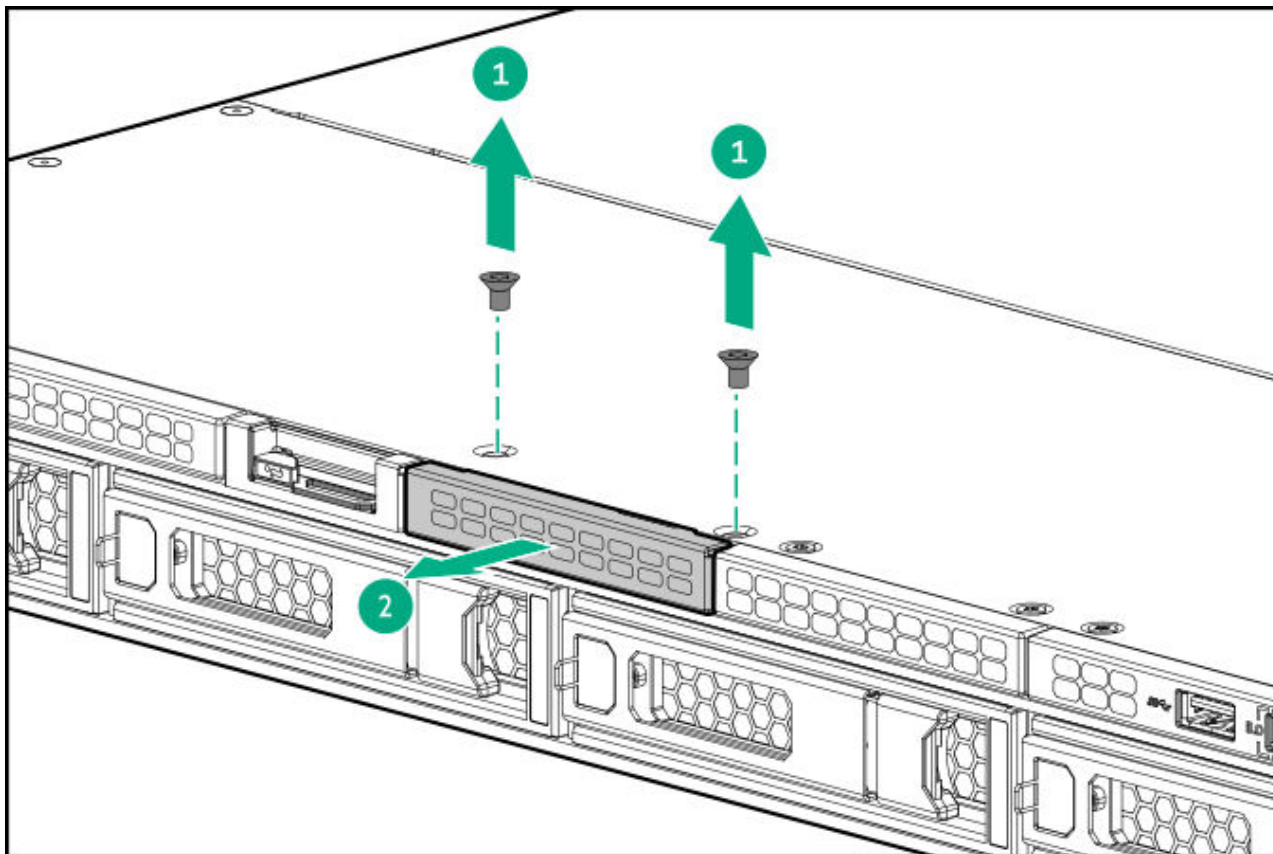

9. Install the 4 LFF DisplayPort / USB module.

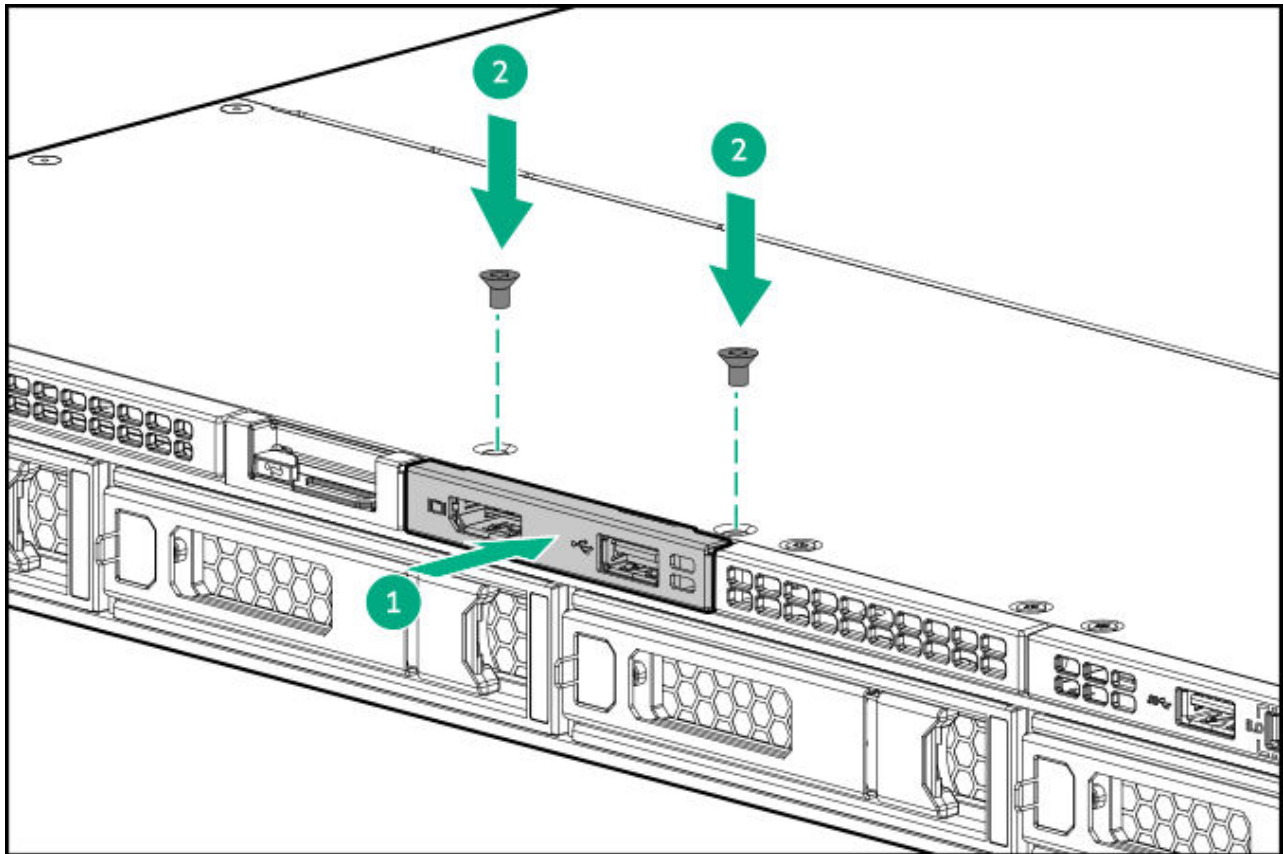

- .0. Connect the DisplayPort / USB cable to the system board.
- .1. (Optional) Install the air baffle.
- .2. Install the access panel.
- .3. Install the server in the rack.
- .4. Connect each power cord to the server.
- .5. Connect each power cord to the power source.
- .6. If removed, install the front bezel.
- .7. Power up the server.

Results

The installation procedure is complete.

Installing the 4 LFF optical disk drive

Prerequisites

Before installing this option, be sure that you have the following:

- The components included with the hardware option kit
- T-10 Torx screwdriver
- Phillips No. 1 screwdriver
- LFF optical cable option kit
- An optical disk drive

About this task



CAUTION

A discharge of static electricity from a finger or other conductor might damage system boards or other static-sensitive devices. To prevent damage, observe antistatic precautions.



CAUTION

To prevent improper cooling and thermal damage, do not operate the server unless all bays are populated with either a component or a blank.

Procedure

1. Back up all server data.
2. Power down the server.
3. Remove all power:
 - a. Disconnect each power cord from the power source.
 - b. Disconnect each power cord from the server.
4. Do one of the following:
 - a. Extend the server from the rack.
 - b. Remove the server from the rack.
5. Place the server on a flat, level work surface.
6. Remove the LFF optical drive bay blank.

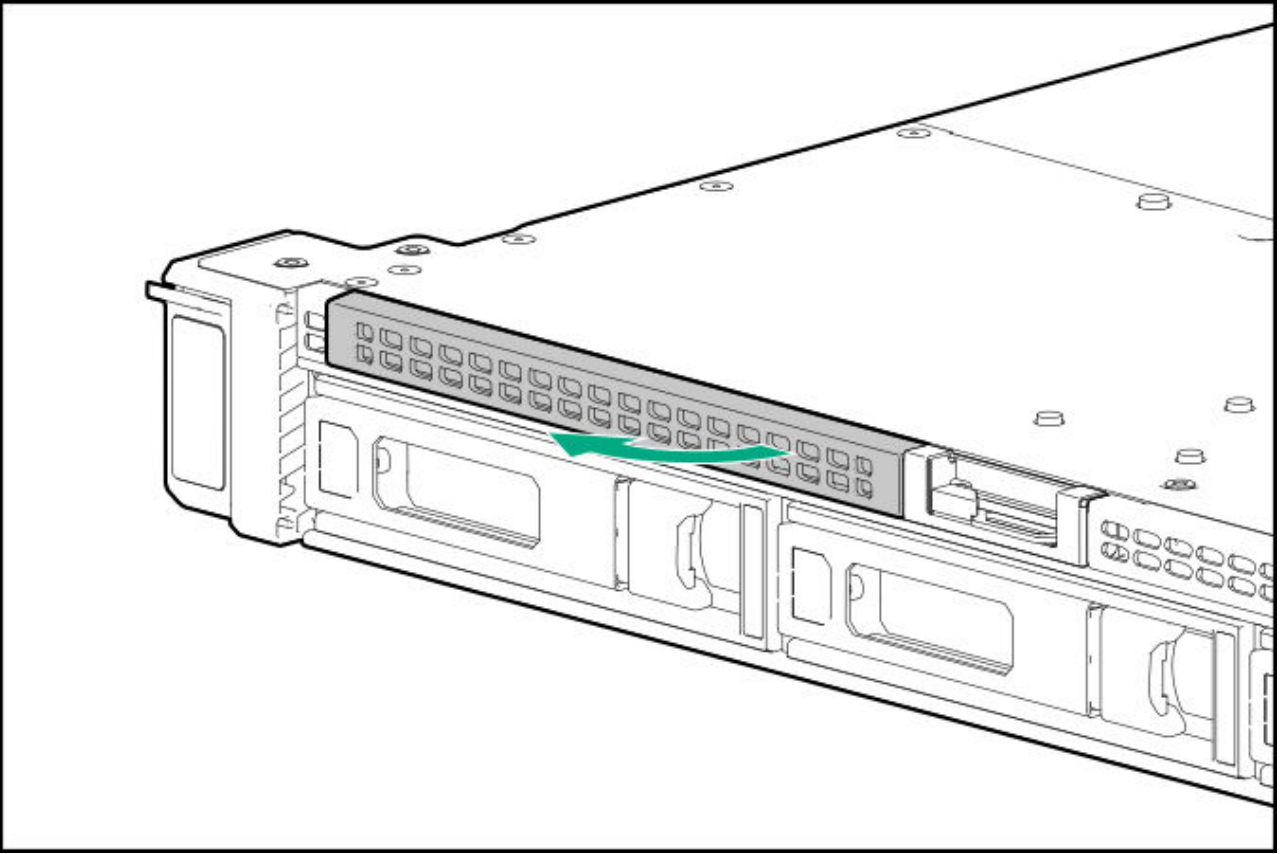

7. Install the optical drive bracket.

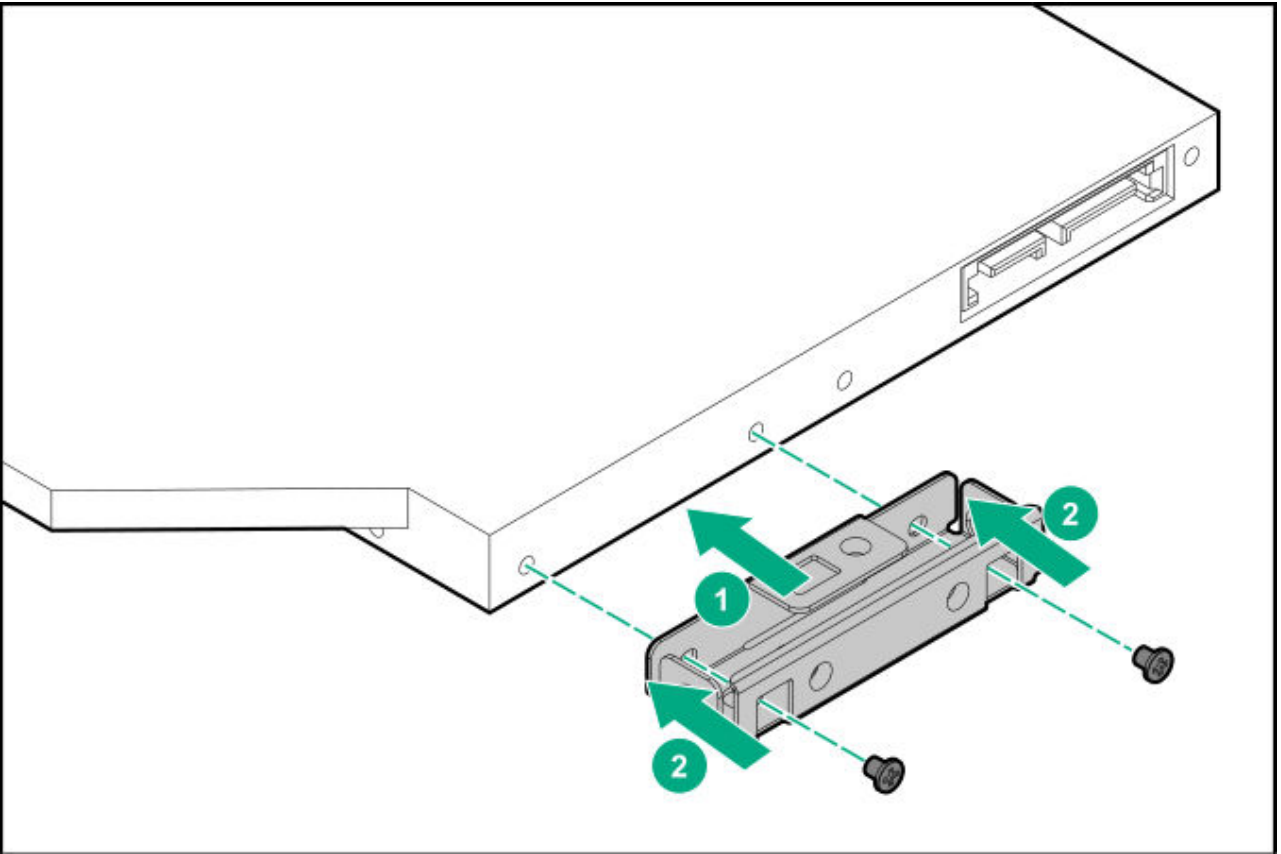

8. Install the optical drive.

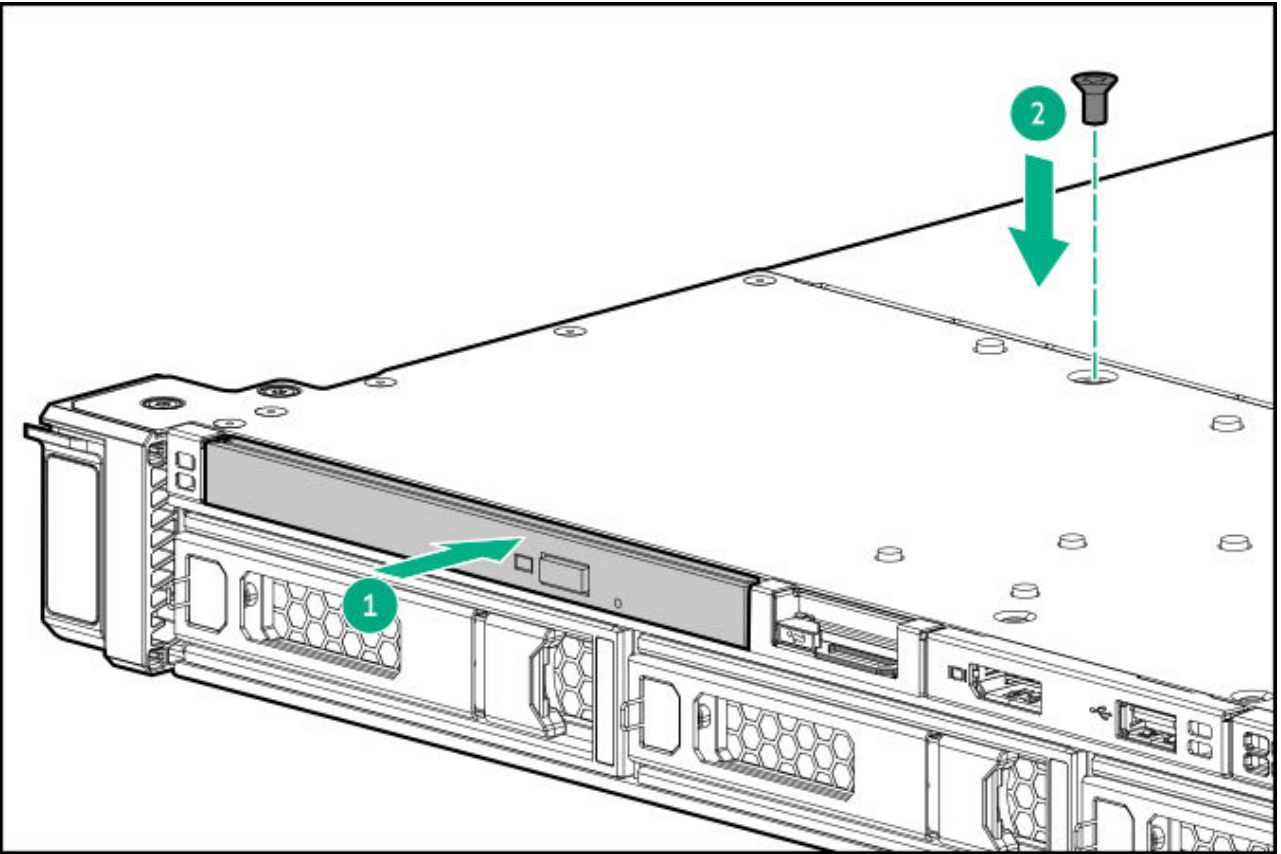

9. Remove the access panel.

10. If installed, remove the air baffle.

An 8 SFF server is shown. The removal procedure is the same for all drive configurations.

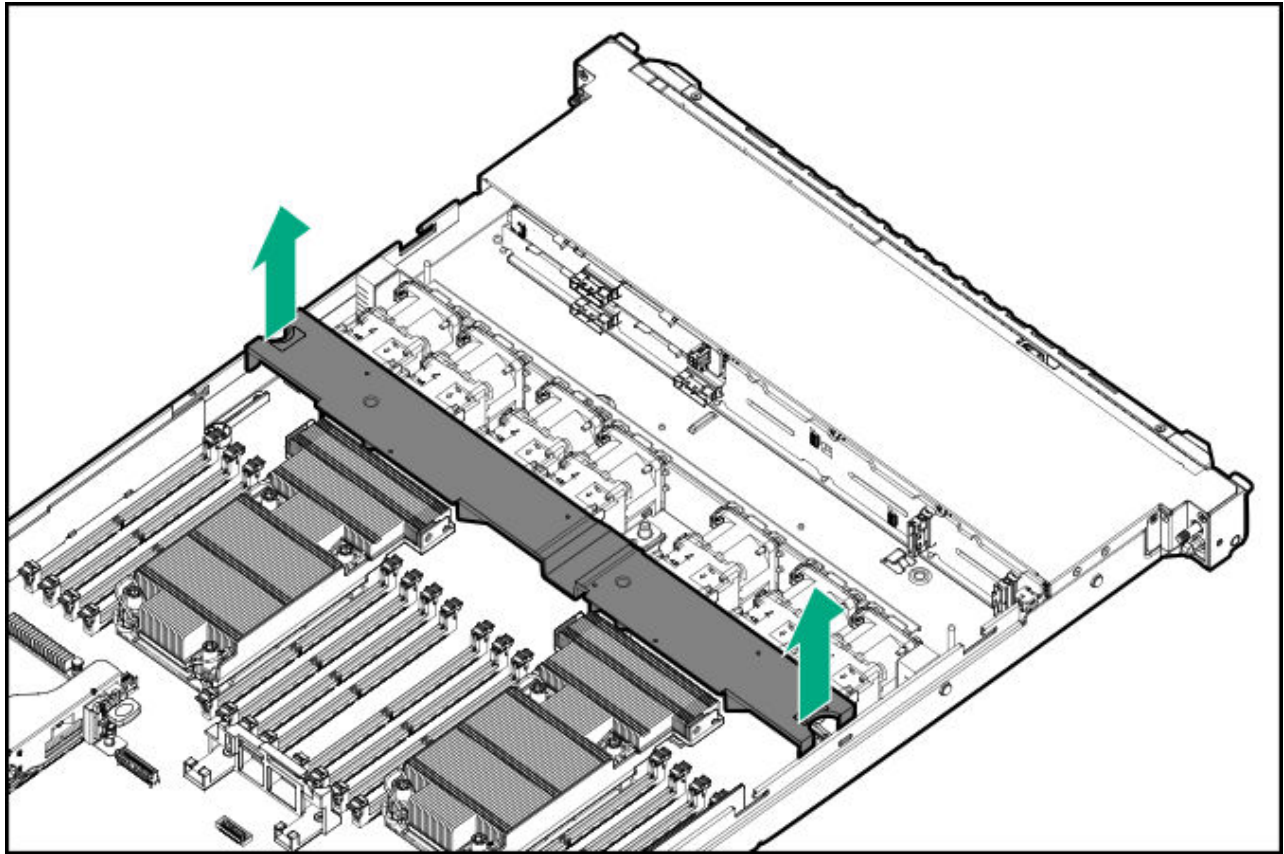

- .1. Connect the cable to the system board.
- .2. (Optional) Install the air baffle.
- .3. Install the access panel.
- .4. Install the server in the rack.
- .5. Connect each power cord to the server.
- .6. Connect each power cord to the power source.
- .7. Power up the server.

Results

The installation procedure is complete.

Installing the 8 SFF DisplayPort / USB / optical drive blank option

Prerequisites

Before installing this option, be sure that you have the following:

- The components included with the hardware option kit
- T-10 Torx screwdriver

About this task

The option supports the installation of a slim-type SATA optical drive.



CAUTION

A discharge of static electricity from a finger or other conductor might damage system boards or other static-sensitive devices. To prevent damage, observe [antistatic precautions](#).



CAUTION

To prevent improper cooling and thermal damage, do not operate the server unless all bays are populated with either a component or a blank.

Procedure

1. [Power down the server](#).
2. If installed, [remove the front bezel](#).
3. Remove all power:
 - a. Disconnect each power cord from the power source.
 - b. Disconnect each power cord from the server.
4. Do one of the following:
 - a. [Extend the server from the rack](#).
 - b. [Remove the server from the rack](#).
5. Place the server on a flat, level work surface.
6. [Remove the access panel](#).
7. If installed, remove the air baffle.

An 8 SFF server is shown. The removal procedure is the same for all drive configurations.

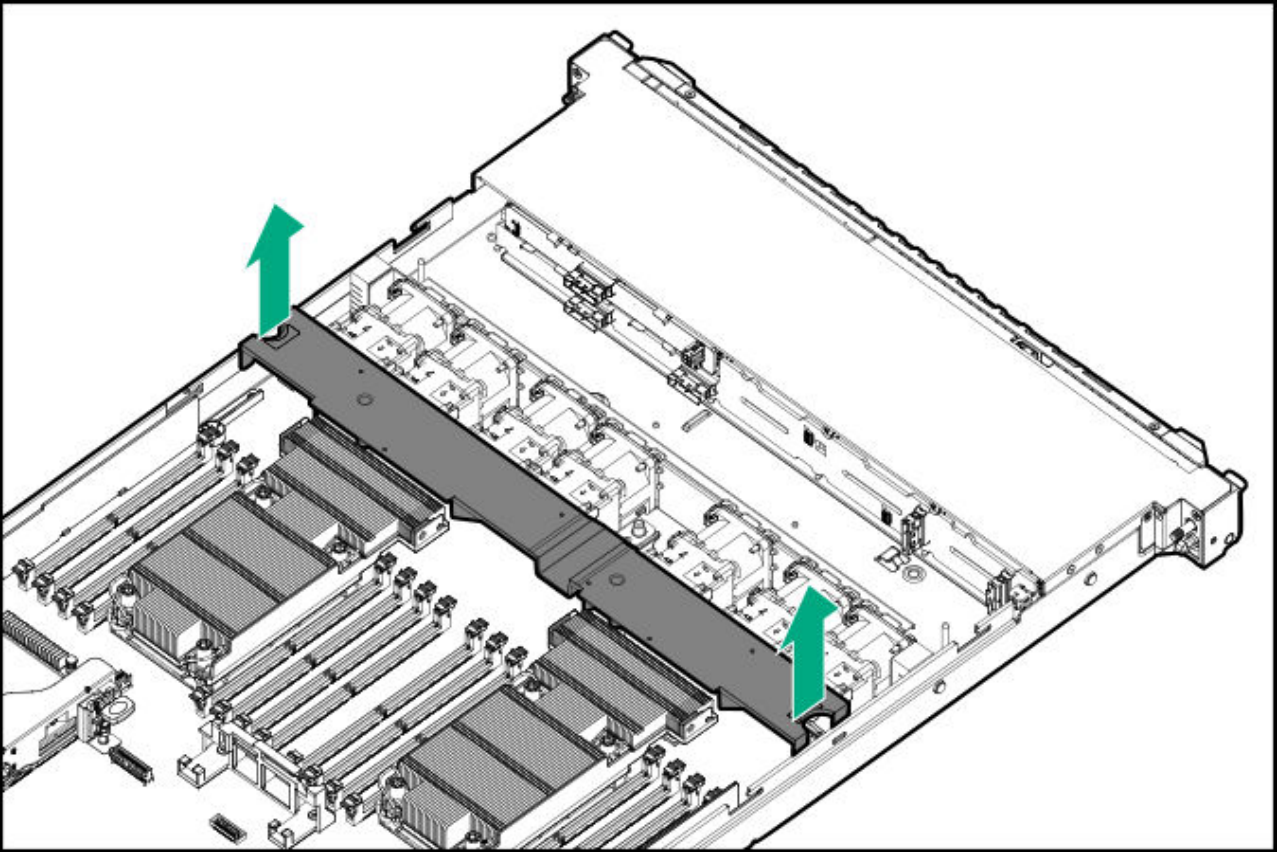

8. Remove the bay blank.

Retain the screws and blank. These screws will be used to secure the new optical drive cage.

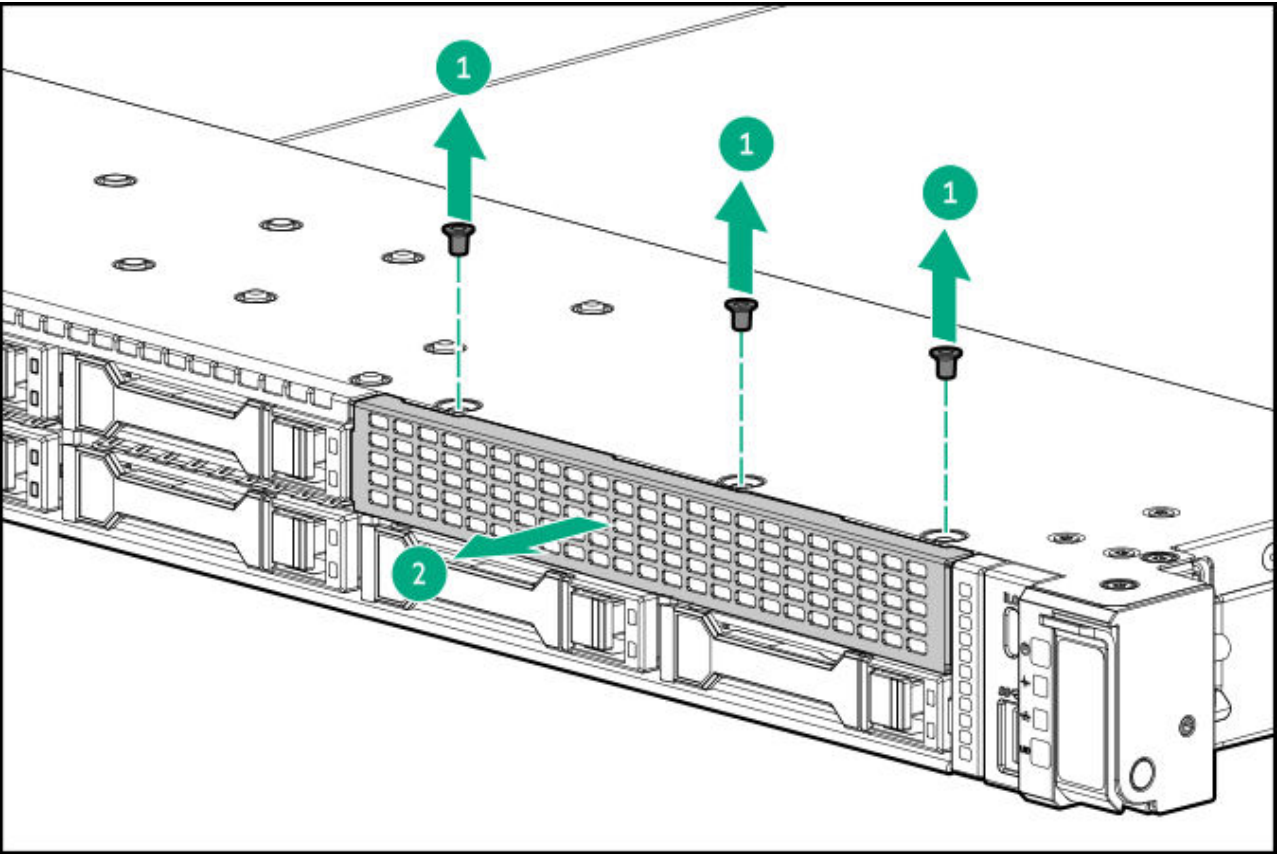

9. Install the 8 SFF display port/USB/optical option.

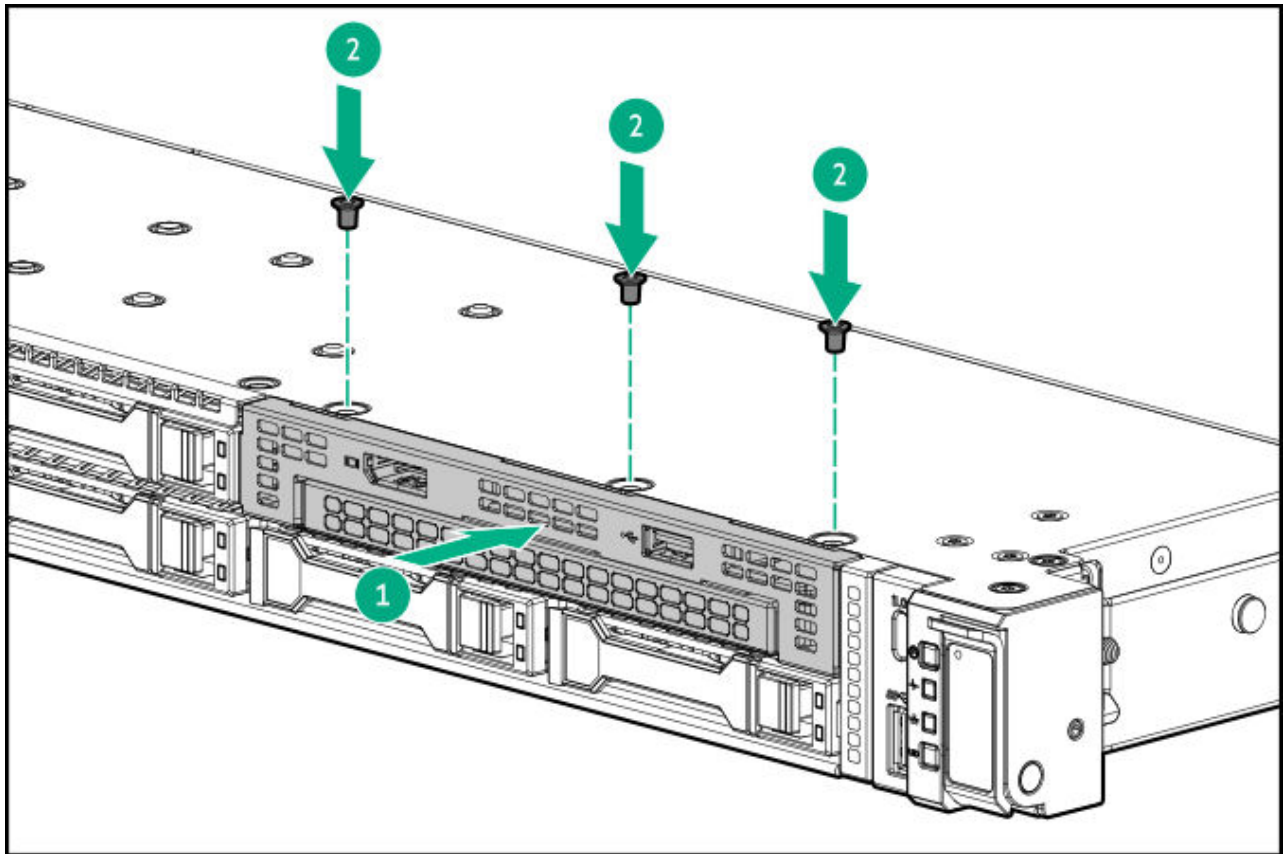

- .0. Connect the DisplayPort / USB cable to the system board.
- .1. If needed, install the optical drive.
- .2. (Optional) Install the air baffle.
- .3. Install the access panel.
- .4. Install the server in the rack.
- .5. Connect each power cord to the server.
- .6. Connect each power cord to the power source.
- .7. If removed, install the front bezel.
- .8. Power up the server.

Results

The installation procedure is complete.

Installing the 8 SFF optical disk drive

Prerequisites

- Install the [8 SFF DisplayPort/USB/optical blank option](#).
- Be sure that you have the following:
 - The components included with the hardware option kit
 - T-10 Torx screwdriver
 - Phillips No. 1 screwdriver
 - An optical disk drive

About this task



CAUTION

A discharge of static electricity from a finger or other conductor might damage system boards or other static-sensitive devices. To prevent damage, observe [antistatic precautions](#).



CAUTION

To prevent improper cooling and thermal damage, do not operate the server unless all bays are populated with either a component or a blank.

Procedure

1. [Back up all server data](#).
2. [Power down the server](#).
3. Remove all power:
 - a. Disconnect each power cord from the power source.
 - b. Disconnect each power cord from the server.
4. Do one of the following:
 - a. [Extend the server from the rack](#).
 - b. [Remove the server from the rack](#).
5. Place the server on a flat, level work surface.
6. [Remove the access panel](#).

7. If installed, remove the air baffle.

An 8 SFF server is shown. The removal procedure is the same for all drive configurations.

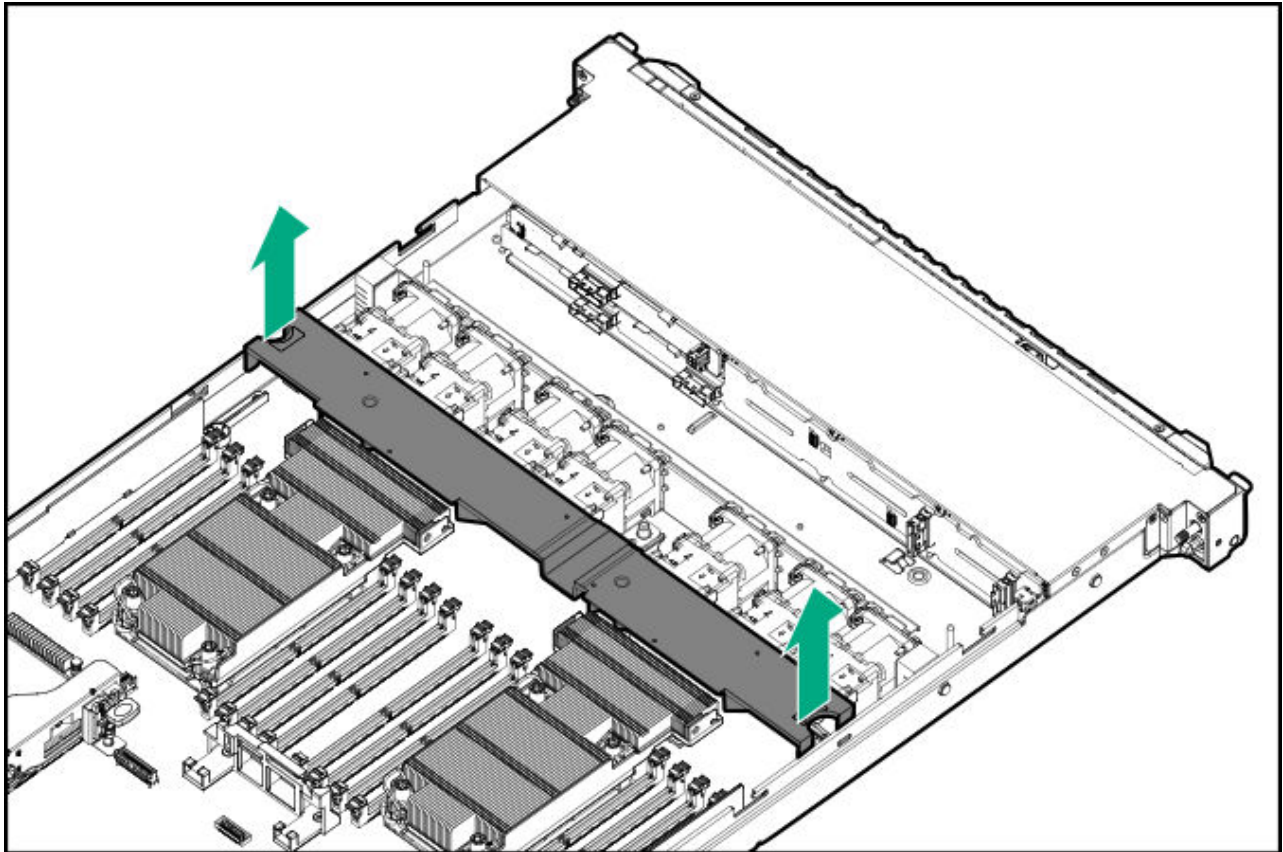

8. Remove the optical drive blank.

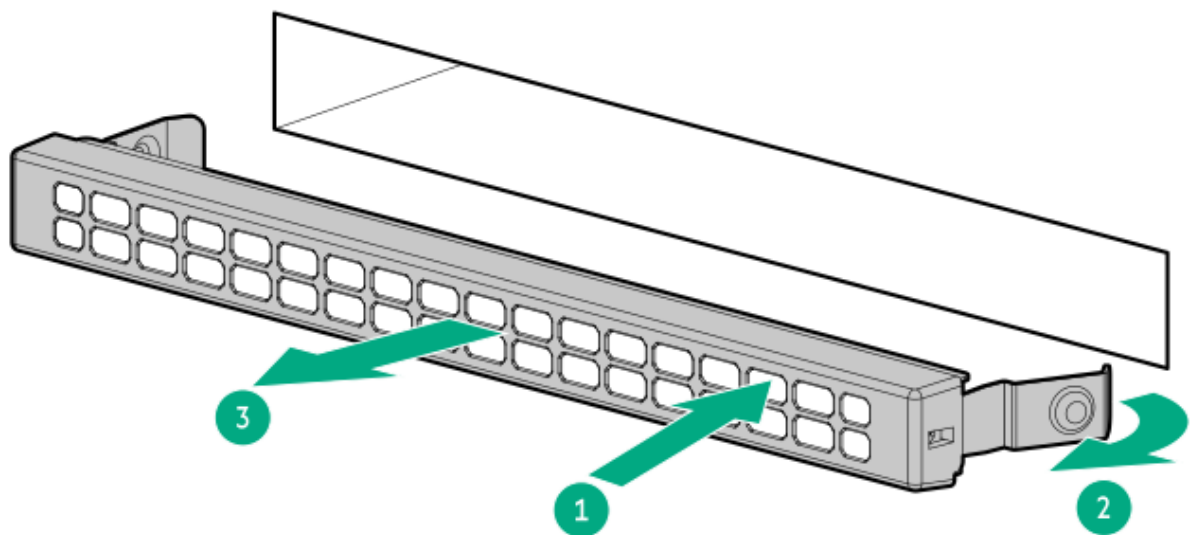

9. Install the optical drive bracket.

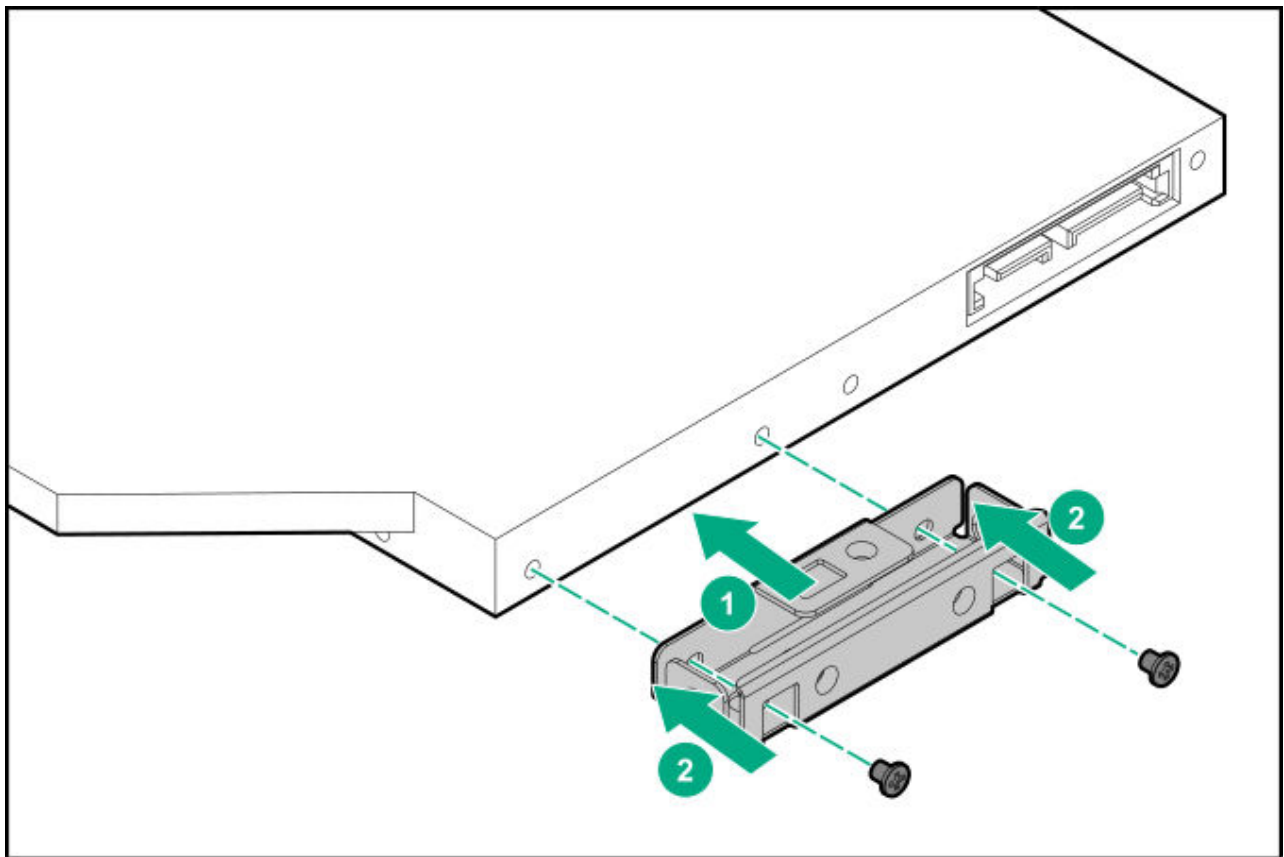

10. Install the optical drive.

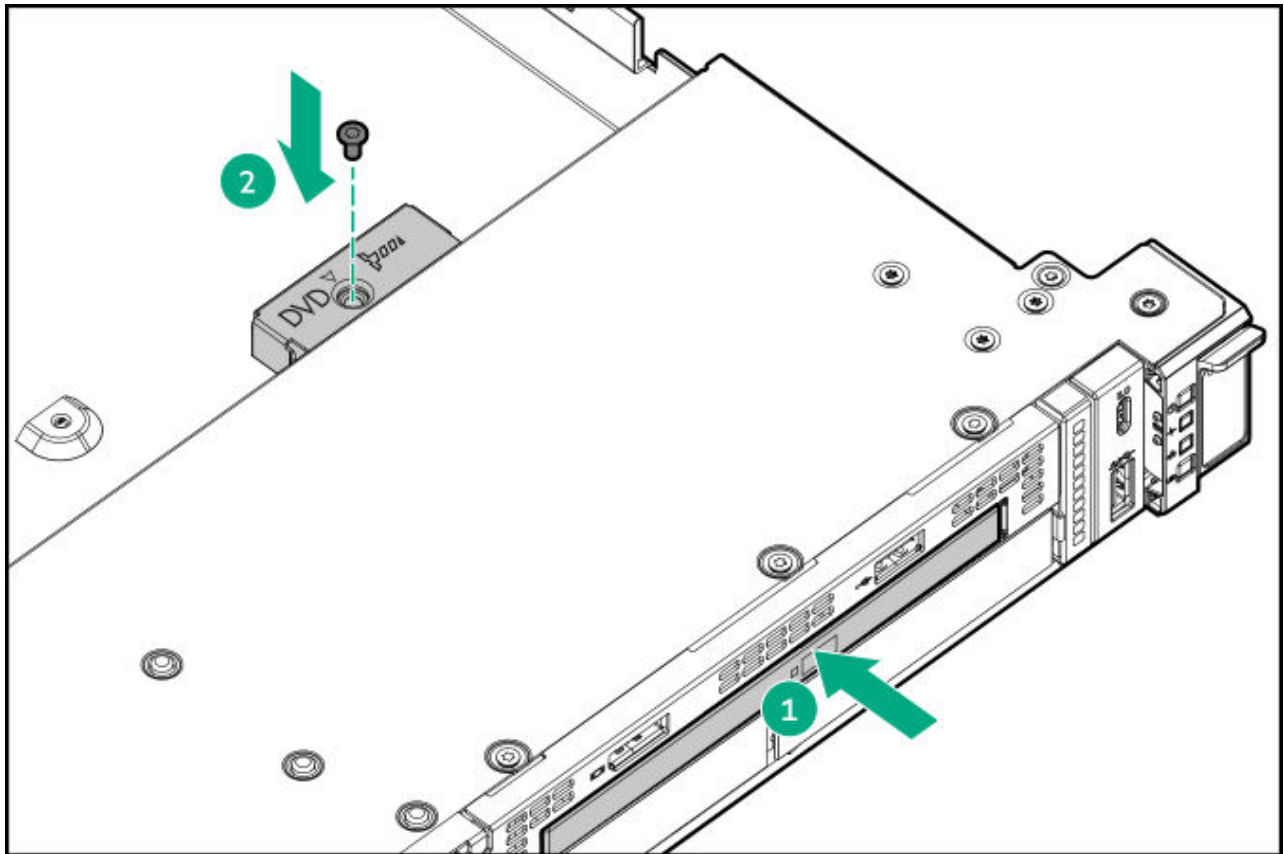

- .1. Connect the optical drive cable.
- .2. (Optional) Install the air baffle.
- .3. Install the access panel.
- .4. Install the server in the rack.
- .5. Connect each power cord to the server.
- .6. Connect each power cord to the power source.
- .7. Power up the server.

Results

The installation procedure is complete.

Installing the DisplayPort / USB / optical drive blank and optical drive in the 10 SFF / 20 E3.S server

Prerequisites

- Review the [Drive box numbering](#).
- Before installing these options, be sure that you have the following:
 - The components included with the hardware option kits
 - T-15 Torx screwdriver
 - T-10 Torx screwdriver
 - Phillips No. 1 screwdriver
 - (Optional) An optical disk drive

About this task

This option is supported in Boxes 4–5 in the 10 SFF / 20 E3.S server or servers using the [mixed drive type configuration](#).



CAUTION

A discharge of static electricity from a finger or other conductor might damage system boards or other static-sensitive devices. To prevent damage, observe [antistatic precautions](#).



CAUTION

To prevent improper cooling and thermal damage, do not operate the server unless all bays are populated with either a component or a blank.

Procedure

(Optional) Installing the optical disk drive

1. Remove the optical drive blank.

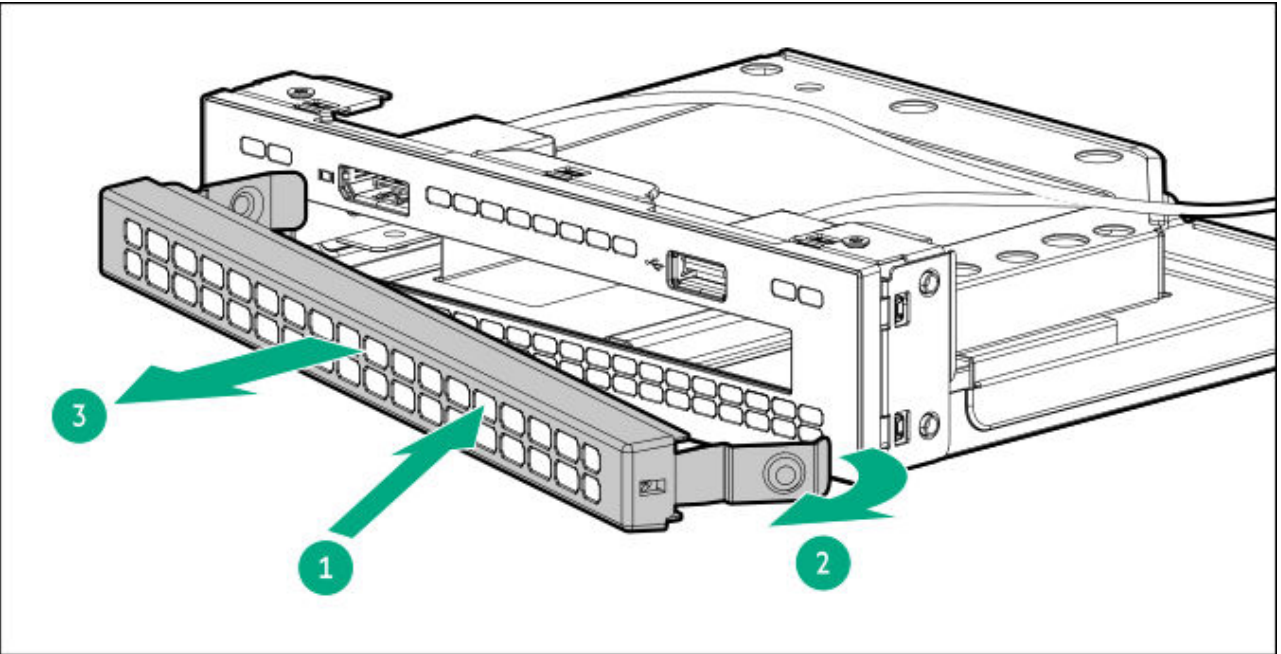

2. Install the optical drive bracket.

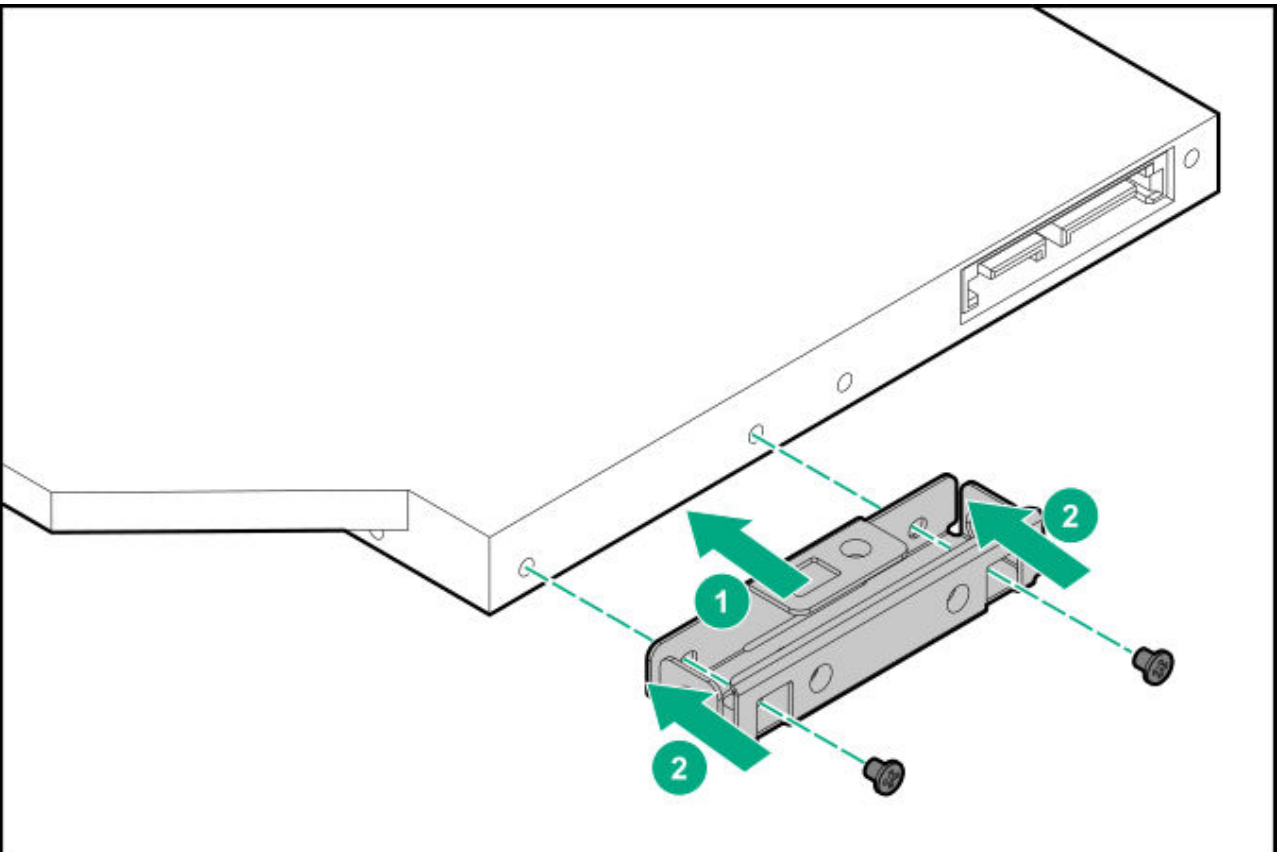

3. Install the optical drive.

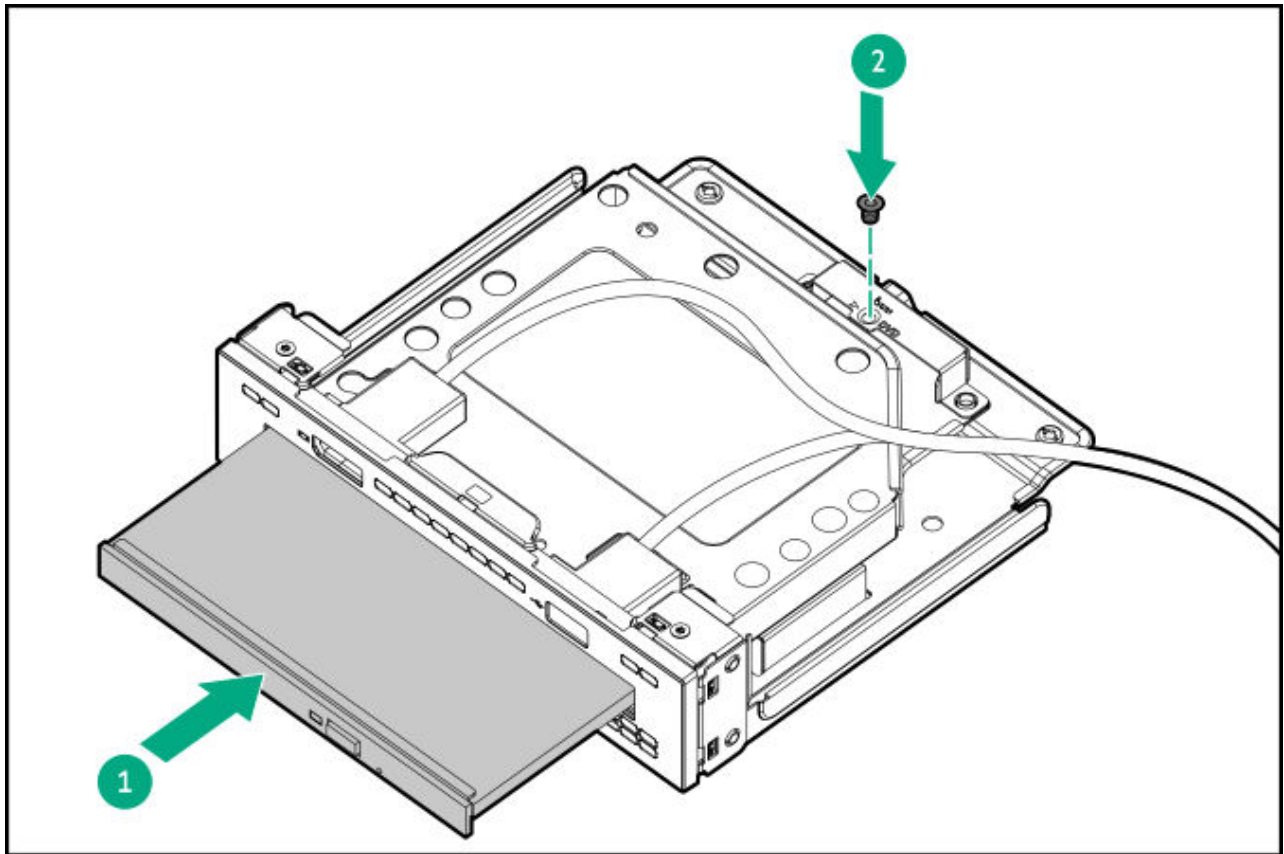

Installing the DisplayPort / USB / optical blank

4. Back up all server data.
5. If installed, remove the front bezel.
6. Power down the server.
7. Remove all power:
 - a. Disconnect each power cord from the power source.
 - b. Disconnect each power cord from the server.
8. Do one of the following:
 - a. Extend the server from the rack.
 - b. Remove the server from the rack.
9. Place the server on a flat, level work surface.
10. Remove the access panel.
11. If installed, remove the air baffle.

An 8 SFF server is shown. The removal procedure is the same for all drive configurations.

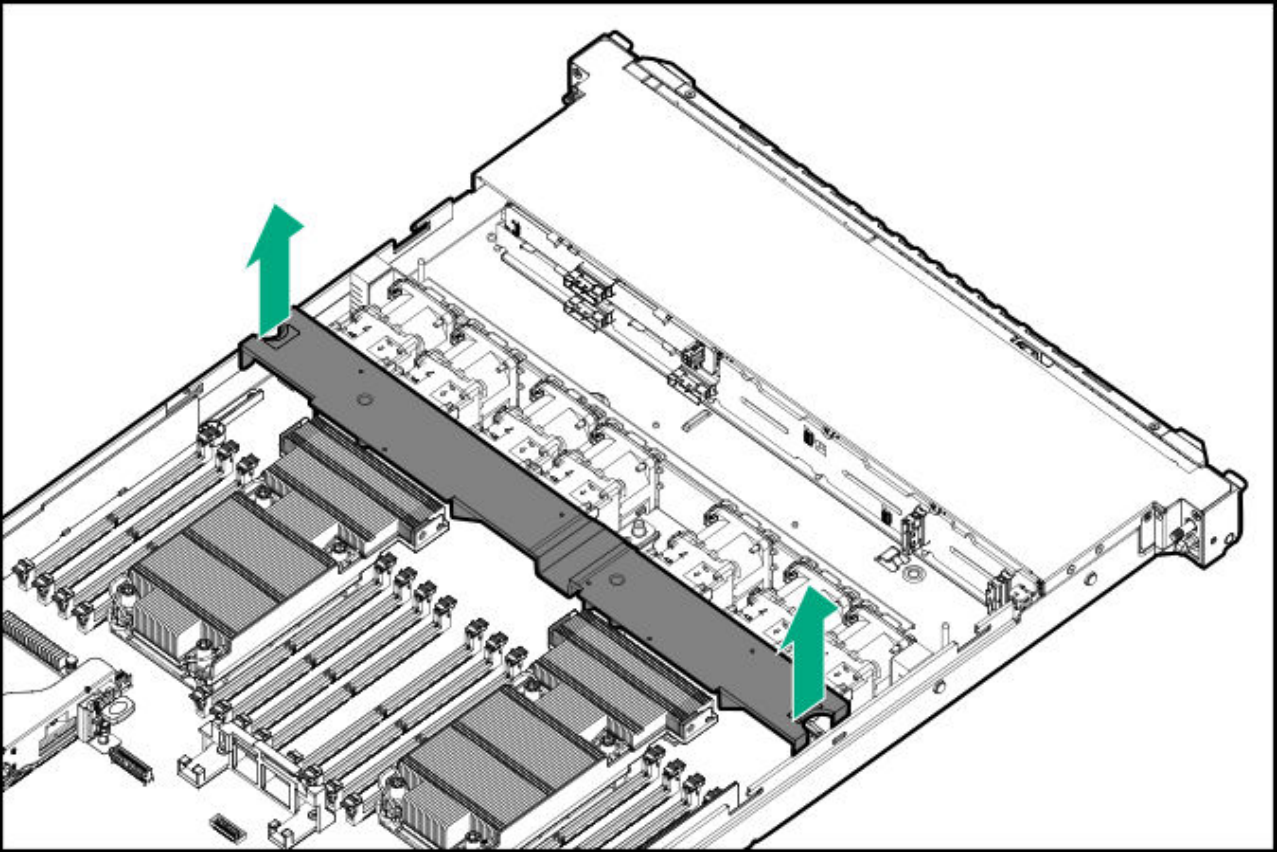

- .2. Remove the middle cover.
- .3. Remove the blanks from drive Box 4 and Box 5.

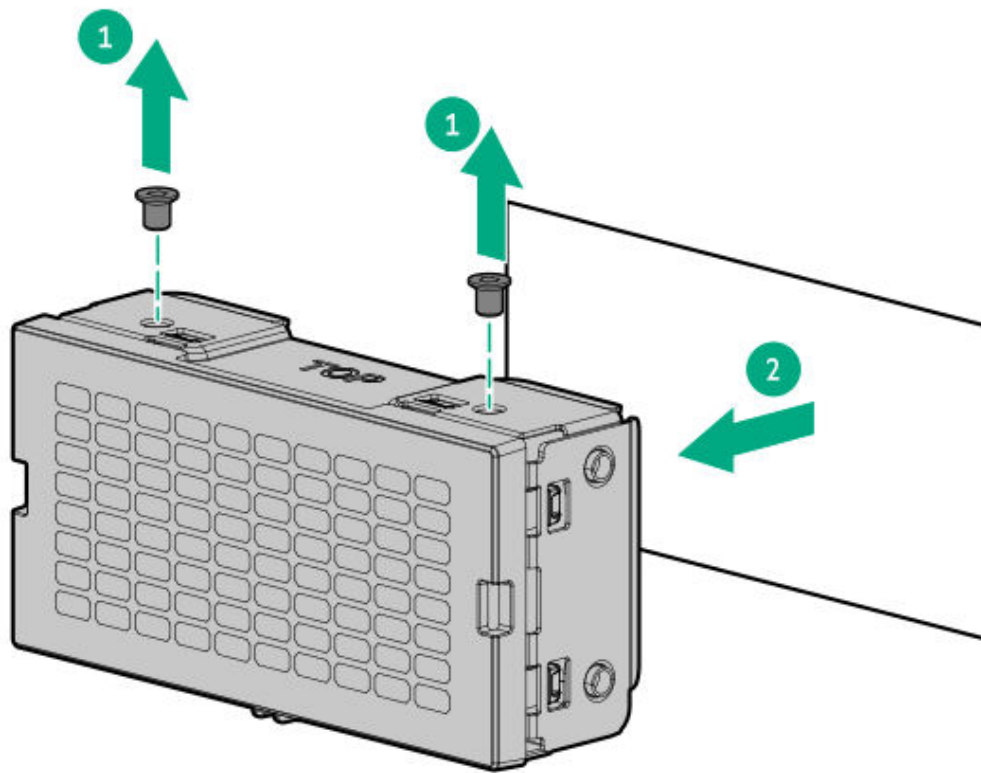

4. Install the DisplayPort / USB / optical blank option.

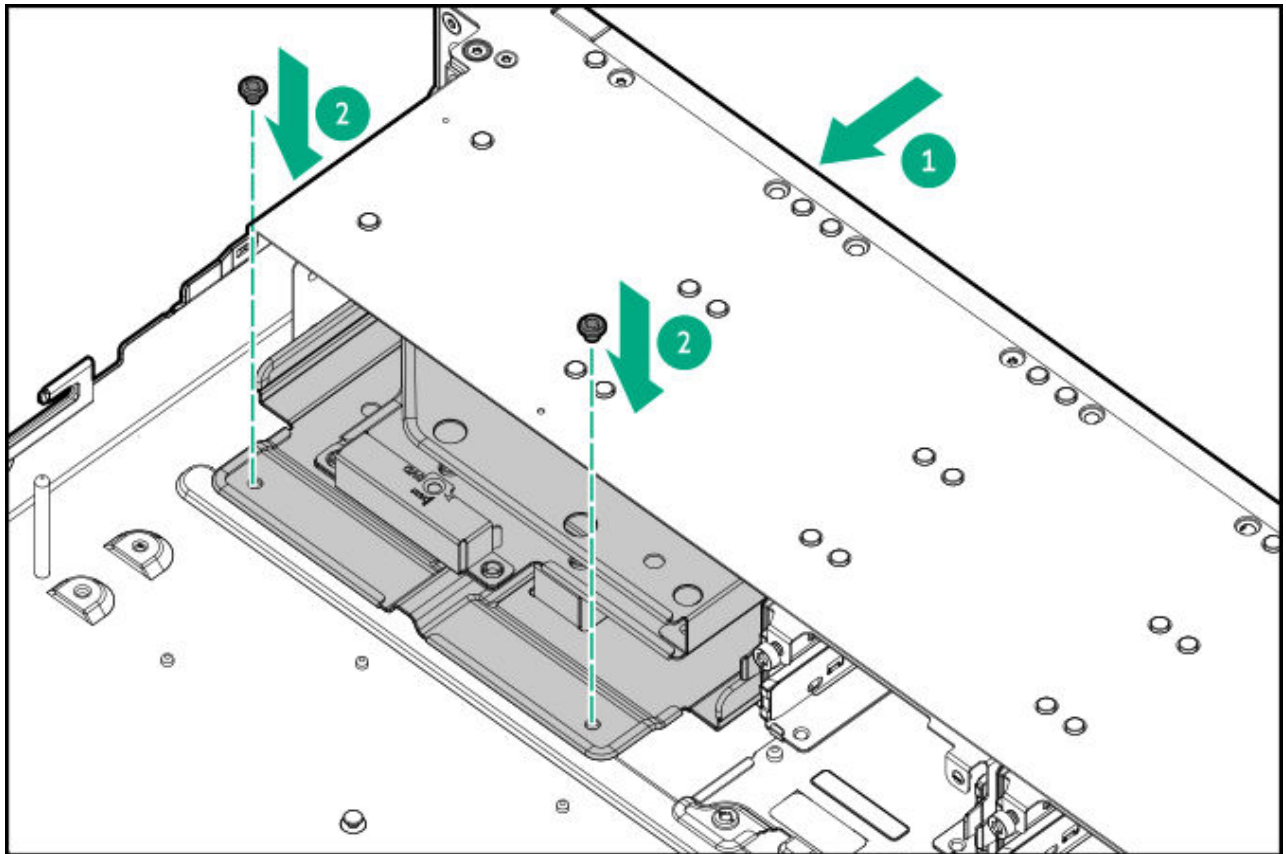

- .5. If the optical drive is installed, connect the optical drive cable.
- .6. Connect the DisplayPort / USB cable.
- .7. Install the middle cover.
- .8. (Optional) Install the air baffle.
- .9. Install the access panel.
- !0. Install the server in the rack.
- !1. Connect each power cord to the server.
- !2. Connect each power cord to the power source.
- !3. If removed, install the front bezel.
- !4. Power up the server.

Results

The installation procedure is complete.

Memory

Subtopics

[HPE SmartMemory speed and population information](#)

[DIMM installation guidelines](#)

[Installing a DIMM blank](#)

[Installing a DIMM](#)

HPE SmartMemory speed and population information

For information about memory speed and server-specific DIMM population rules for HPE servers using Intel Xeon 6 processors, see the relevant memory technical paper in:

<https://www.hpe.com/docs/server-memory>

DIMM installation guidelines

When handling a DIMM, observe the following:

- Observe [antistatic precautions](#).
- Handle the DIMM only along the edges.
- Do not touch the components on the sides of the DIMM.
- Do not touch the connectors on the bottom of the DIMM.
- Never wrap your fingers around a DIMM.
- Never bend or flex the DIMM.

When installing a DIMM, observe the following:

- To align and seat the DIMM, use two fingers to hold the DIMM along the side edges.
- To seat the DIMM, use two fingers to apply gentle pressure along the top of the DIMM.

For more information, see the Hewlett Packard Enterprise website (<https://www.hpe.com/support/DIMM-20070214-CN>).

Installing a DIMM blank

Prerequisites

Review the following:

- [DIMM population information](#)
- [DIMM installation guidelines](#)
- [Fan and heatsink requirements](#)

About this task

DIMM blank requirements may vary depending on the hardware configuration. For more information on DIMM blank requirements, see the product QuickSpecs on the Hewlett Packard Enterprise website (<https://www.hpe.com/info/quickspecs>).

Procedure

1. [Power down the server.](#)
2. Remove all power:
 - a. Disconnect each power cord from the power source.
 - b. Disconnect each power cord from the server.
3. Do one of the following:
 - a. [Extend the server from the rack.](#)
 - b. [Remove the server from the rack.](#)
4. [Remove the access panel.](#)
5. Open the DIMM slot latches.
6. Install the DIMM blank.

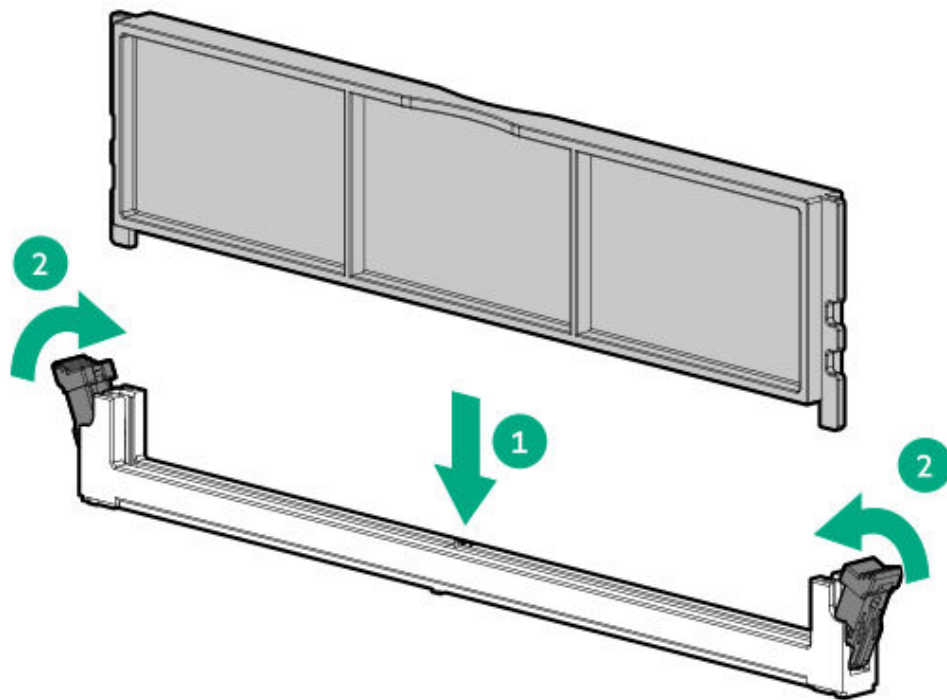

7. Install the access panel.
8. Slide the server into the rack.
9. Connect each power cord to the server.
10. Connect each power cord to the power source.
11. Power up the server.

Results

The installation procedure is complete.

Installing a DIMM

Prerequisites

- Be sure that you have the components included with the hardware option kit.
- Review the following:
 - [DIMM population information](#)
 - [DIMM installation guidelines](#)

- Fan and heatsink requirements
- If not all DIMM slots are populated and a standard or high performance heatsink is installed, install the DIMM blank kit (P07818-B21).

DIMM blank requirements may vary depending on the hardware configuration. For more information on DIMM blank requirements, see the product QuickSpecs on the Hewlett Packard Enterprise website (<https://www.hpe.com/info/quickspecs>).

About this task

The server supports up to 32 DIMMs.



CAUTION

Before replacing a DIMM, backplane, expansion card, riser board, or other similar PCA components due to a perceived hardware error, make sure first that the component is firmly seated in the slot.

When installing the replacement component:

- Observe antistatic precautions.
- Handle the PCA only along the edges.
- Do not touch the components and connectors on the PCA.
- Do not bend or flex the PCA.

Procedure

1. Power down the server.
2. Remove all power:
 - a. Disconnect each power cord from the power source.
 - b. Disconnect each power cord from the server.
3. Do one of the following:
 - a. Extend the server from the rack.
 - b. Remove the server from the rack.
4. Place the server on a flat, level work surface.
5. Remove the access panel.
6. Open the DIMM slot latches.

7. Install the DIMM.

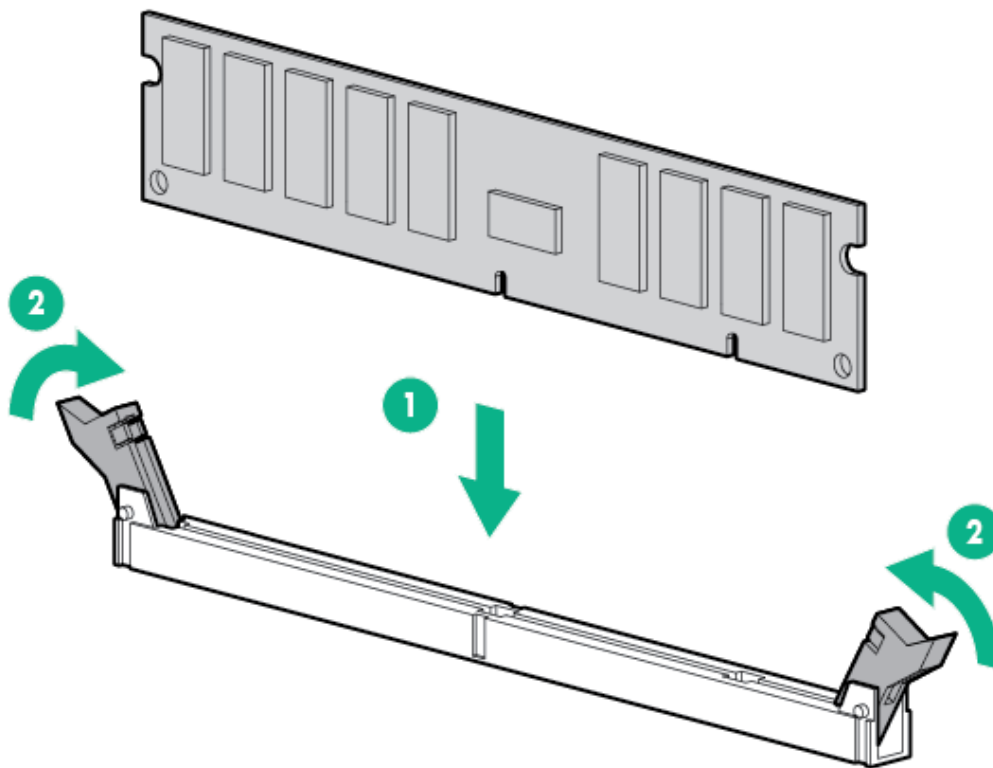

8. Install the access panel.

9. Install the server in the rack.

10. Connect all peripheral cables to the server.

11. Connect each power cord to the server.

12. Connect each power cord to the power source.

13. Power up the server.

14. To configure the memory settings:

a. From the boot screen, press **F9** to access the UEFI System Utilities.

b. From the **System Utilities** screen, select **System Configuration > BIOS/Platform Configuration (RBSU) > Memory Options**.

Results

The installation procedure is complete.

For more information about LEDs and troubleshooting failed DIMMs, see [System Insight Display combined LED descriptions](#).

Networking

Subtopics

[**About the front OCP NIC enablement kits**](#)

[**Installing a rear OCP network adapter**](#)

[**Installing a PCIe network adapter**](#)

About the front OCP NIC enablement kits

The 10 SFF / 20 E3.S server supports up to two OCP NIC 3.0 SFF slots in either the [front or the rear panel](#). The front OCP slots require the [front OCP enablement kits](#).

The front OCP NIC enablement kits transfer the NIC signal from the rear OCP slots to the OCP slots in Box 3 on the front panel. The front OCP NIC slots have the following advantages:

- More convenient access to network ports
- Better cooling condition for NIC installation

The front OCP NIC is only supported in Box 3 in the 10 SFF / 20 E3.S server.

The front OCP NIC can be deployed in a single-slot or dual-slot configuration using the following options:

- Primary front OCP NIC enablement kit (P72596-B21) — This kit is installed in Box 3 and enables the Bay 3 OCP slot.
- Secondary front OCP NIC enablement kit (P72597-B21) — Installation of this kit requires the primary front OCP NIC option. This kit is installed in Box 3 and enables the Bay 1 OCP slot.

Primary front OCP NIC enablement kit

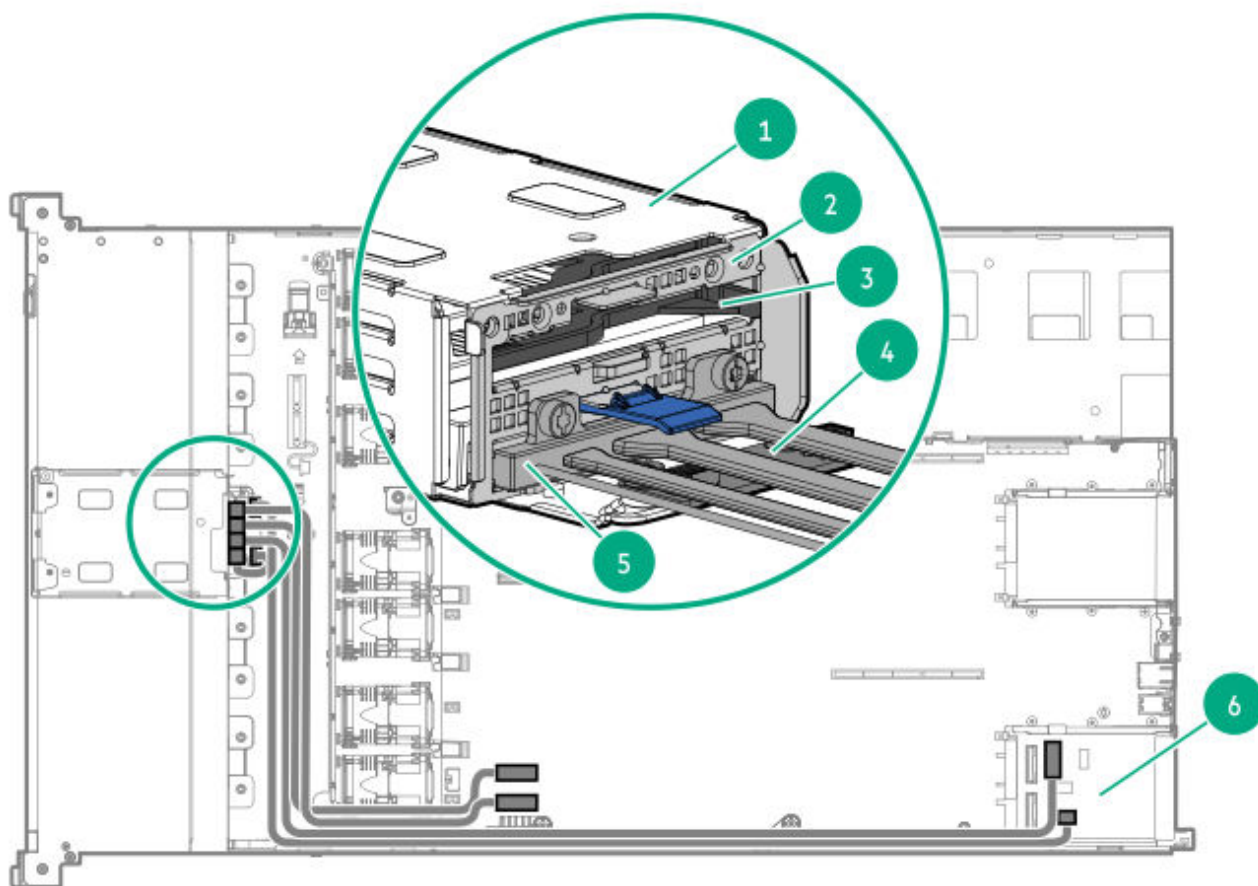

Item	Description
1	<p>4 E3.S drive cage</p> <p>This cage supports several options:</p> <ul style="list-style-type: none"> • Up to 4 E3.S drives • Up to 2 front OCP NICs
2	Front OCP NIC cable bracket
3	E3.S drive filler
4	<p><u>PHY board</u></p> <p>The PHY board serves as a transceiver that physically links the front OCP NIC to the OCP NIC interposer. When setting up an iLO shared network connection, the PHY board transfers the signal from the interposer in the rear Slot 14 OCP A PCIe5 x16 to the front OCP NIC.</p>

Item	Description
5	Primary front OCP NIC cable
6	OCP NIC interposer (in the rear Slot 14 OCP A PCIe5 x16) The interposer reroutes the NIC signal from the rear Slot 14 OCP A PCIe5 x16 to the front Box 3, Bay 3 OCP slot.

PHY board connectors

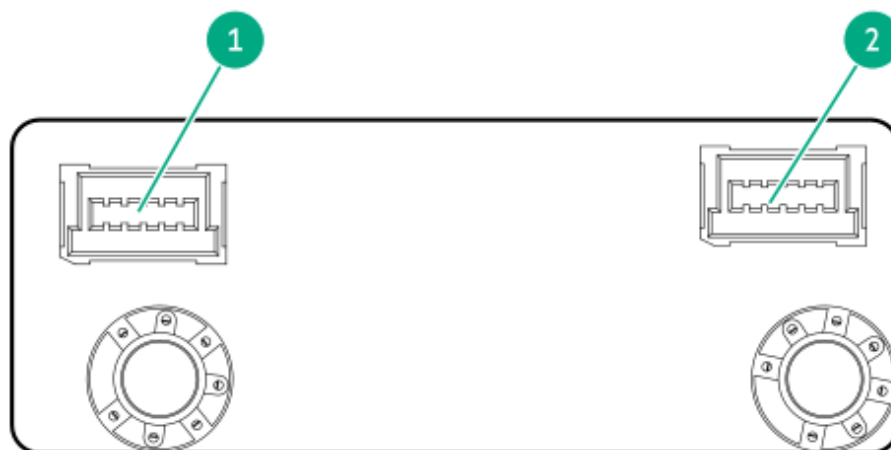

Item	Description
1	PHY board cable connector
2	Front OCP NIC cable connector

OCP NIC interposer connectors

The grayed out components in the image are not for use in this server.

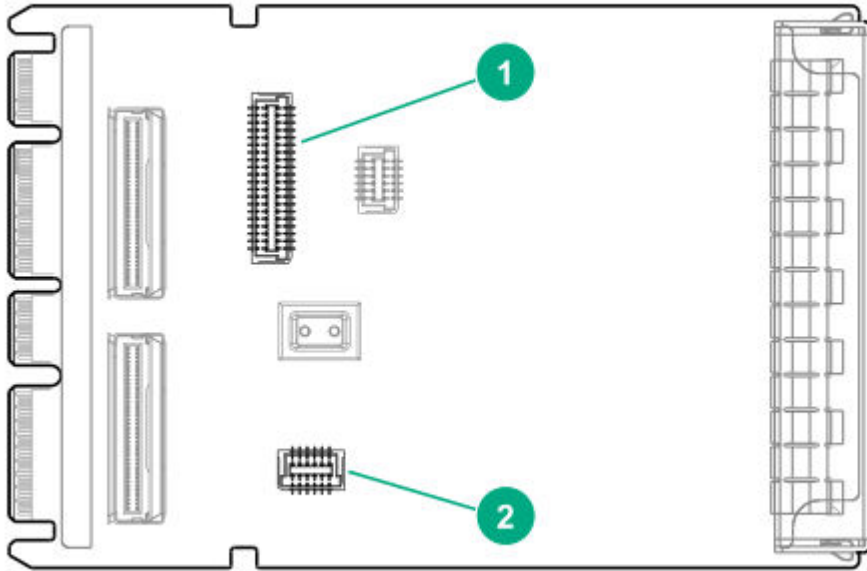

Item	Description
1	Front OCP NIC cable connector
2	PHY board cable connector

Front OCP NIC cable connectors

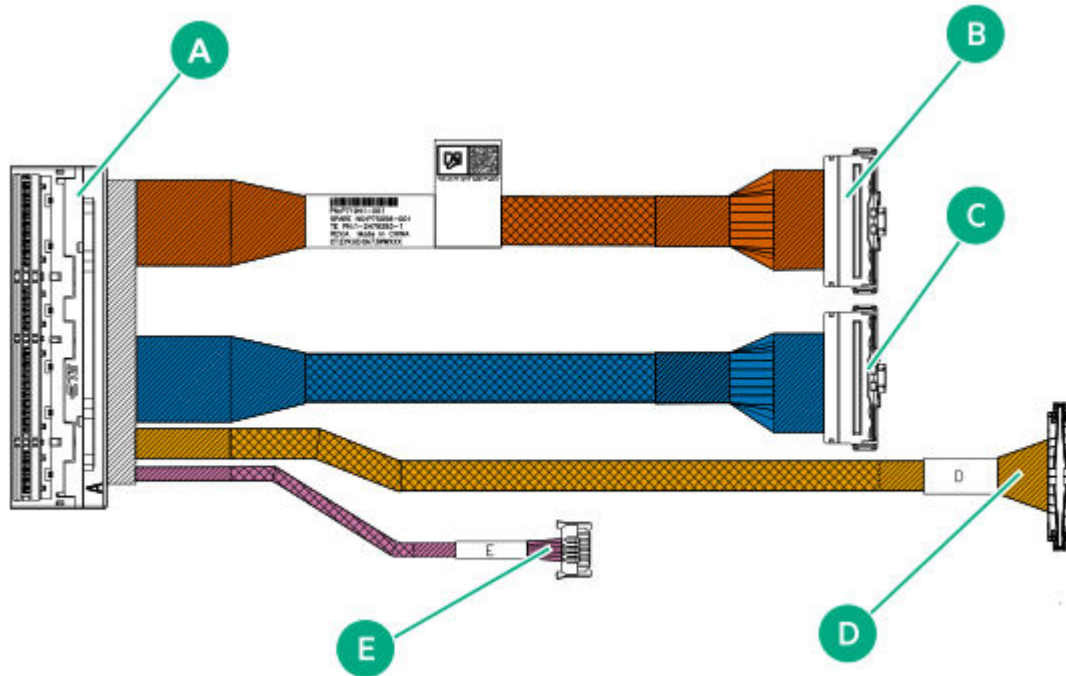

Cable color	Cable connector label	Cable function
Orange	A	OCP NIC 3.0 slot
	B	System board connector
Blue	C	System board connector
Gold	D	OCP NIC interposer connector
Pink	E	PHY board connector

PHY board cable connectors

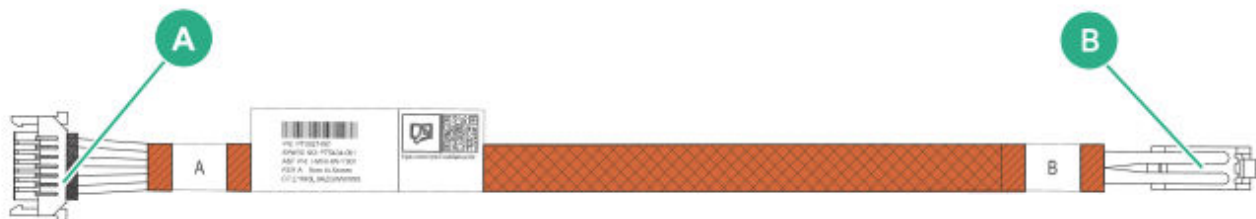

Cable color	Cable connector label	Cable function
Orange	A	PHY board connector

Cable color	Cable connector label	Cable function
	B	OCP NIC interposer connector

Subtopics

[Installing a front OCP NIC](#)

[Enabling the iLO shared network connection](#)

Installing a front OCP NIC

Prerequisites

- Before you begin this procedure, make sure that the components included with the hardware option kit are available.
- Review the following:
 - [OCP NIC 3.0 slot numbering](#)
 - [Fan and heatsink requirements](#) on hardware configurations involving OCP NICs
 - [About the front OCP NIC enablement kits](#)
- Before you perform this procedure, make sure that you have the following options available:
 - Primary front OCP NIC enablement kit (P72596-B21)
 - Secondary front OCP NIC enablement kit (P72597-B21)—This is required to install a second OCP NIC. Installation of this kit requires the primary front OCP NIC option.
 - OCP NICs
- Before you perform this procedure, make sure that you have the following items available:
 - T-15 Torx screwdriver—This tool is used to install the front OCP NIC bracket and cable, or secure the PHY board.
 - T-10 Torx screwdriver—This tool is used to remove the OCP slot blank, install the OCP bracket on the carrier, or remove the drive box blank.

About this task

The secondary front OCP NIC option requires a dual-processor configuration.



CAUTION

A discharge of static electricity from a finger or other conductor might damage system boards or other static-sensitive devices. To prevent damage, observe antistatic precautions.



CAUTION

The port blank provides EMI shielding and helps maintain proper thermal status inside the server. Do not operate the server when a port blank is removed without the corresponding I/O port option installed.

Procedure

Installing the front OCP NIC bracket

1. Slide the front OCP NIC bracket onto the E3.S drive cage included in the option kit, and then secure the bracket with two screws.

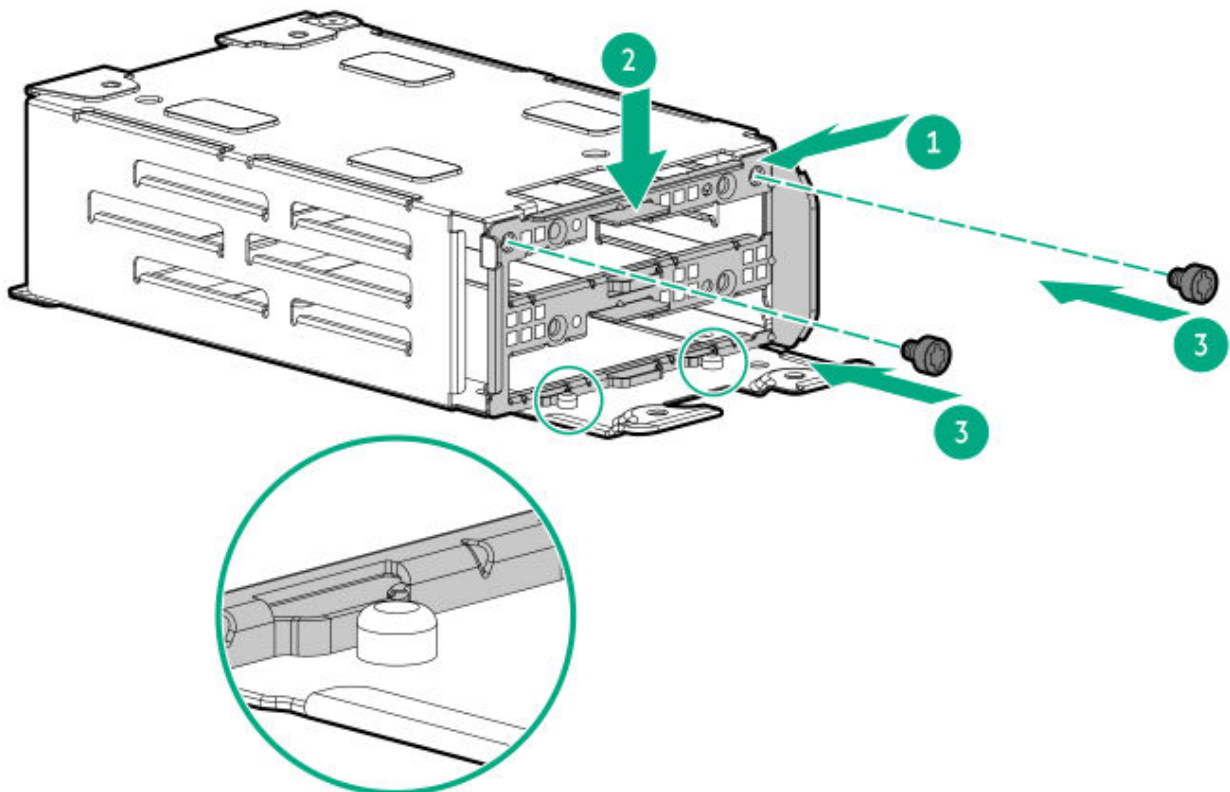

Installing the primary front OCP NIC cable

2. Insert the plastic tabs on the front OCP NIC cable connector into the notches on the bracket. Then secure the front OCP NIC cable with two screws.

Make sure that the plastic tabs are fully seated in the bracket.

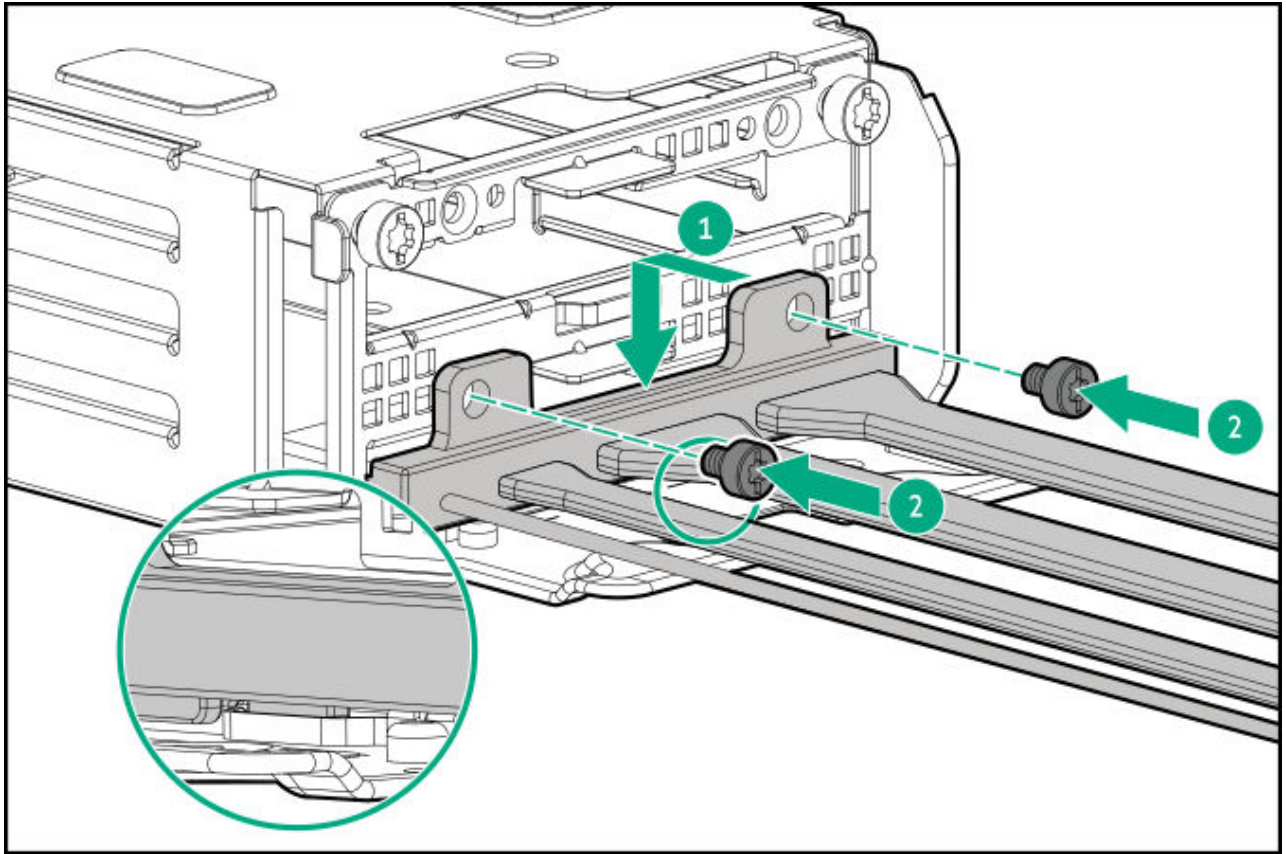

3. If you are not immediately installing the secondary front OCP NIC cable, install the other two screws on the bracket as spares.

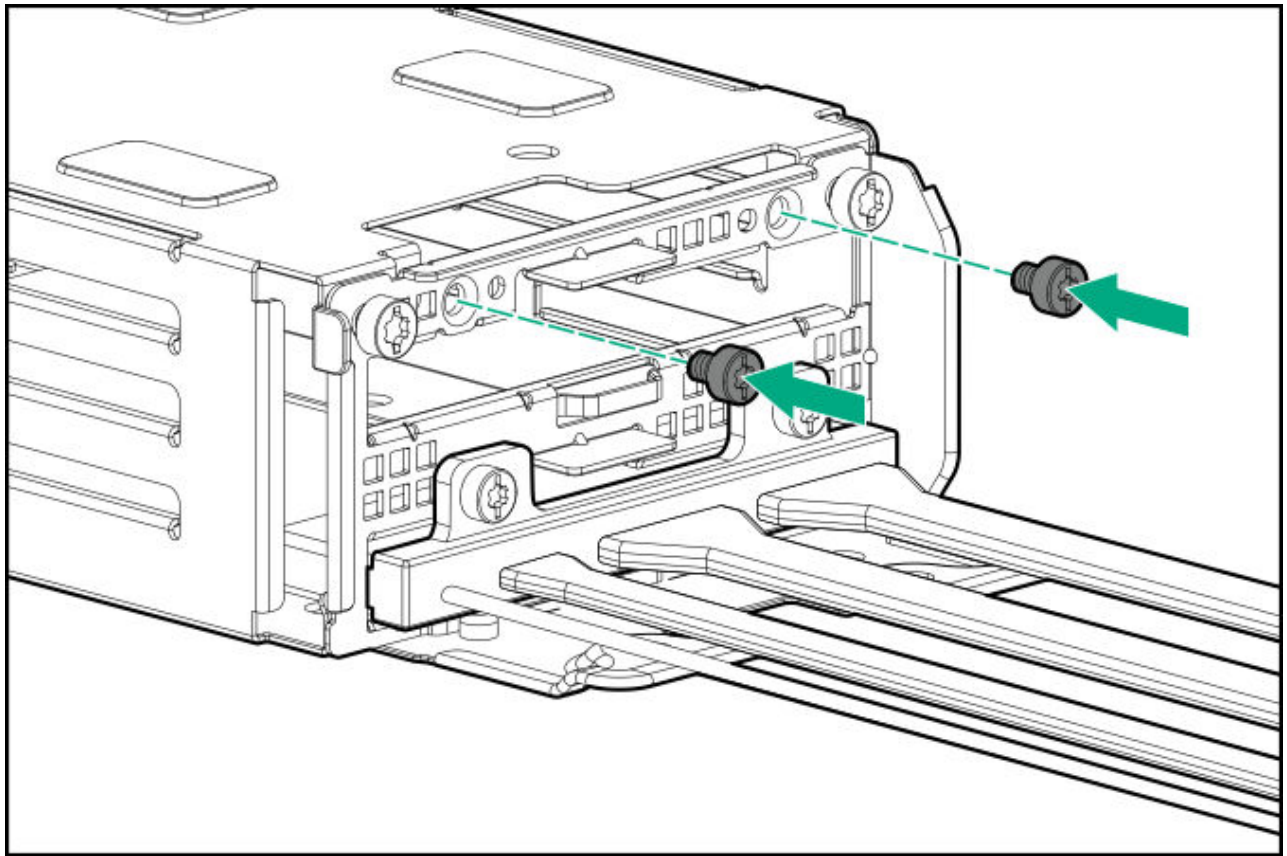

Installing the secondary front OCP NIC cable

4. If you are installing the secondary front OCP NIC cable, do the following:
 - a. If installed, remove these screws from the OCP NIC bracket.

Retain the screws. These screws will be used to secure the secondary OCP NIC cable.

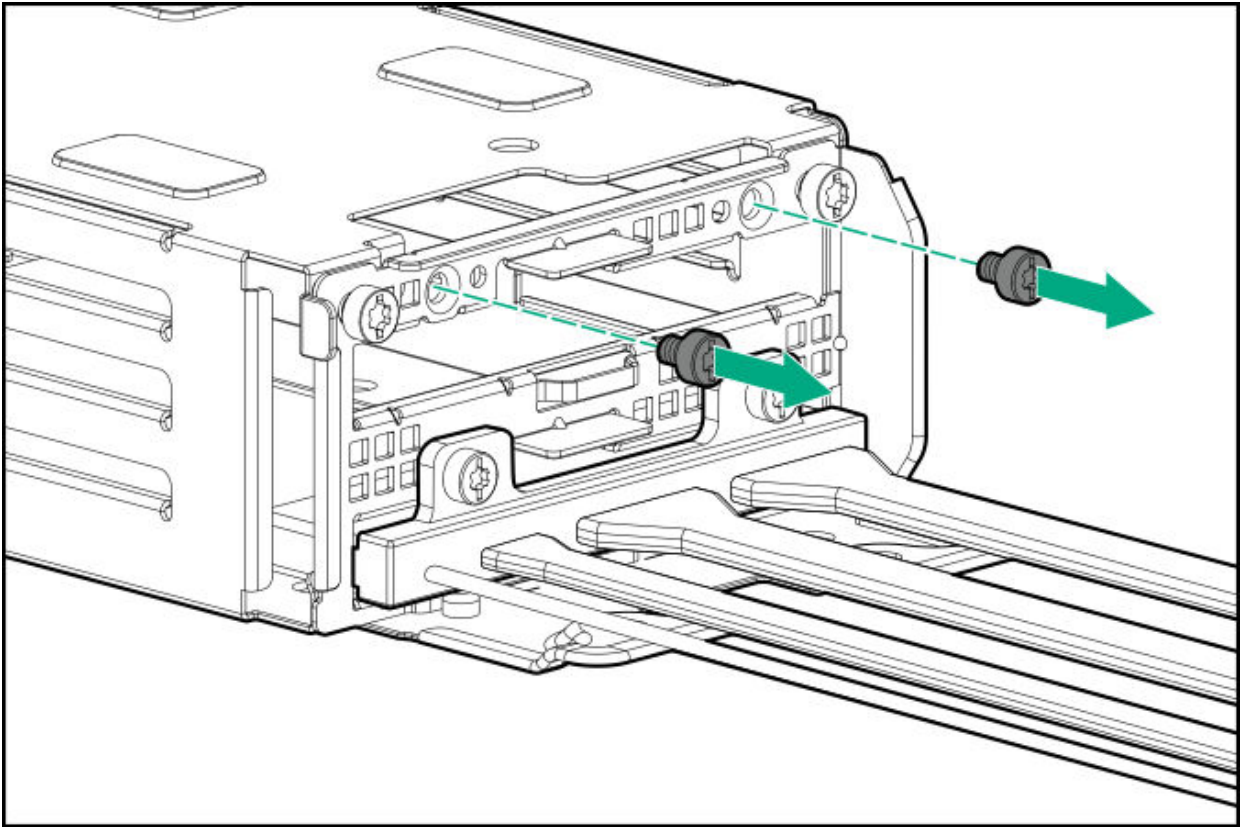

b. Repeat step 2 to install the secondary OCP NIC cable.

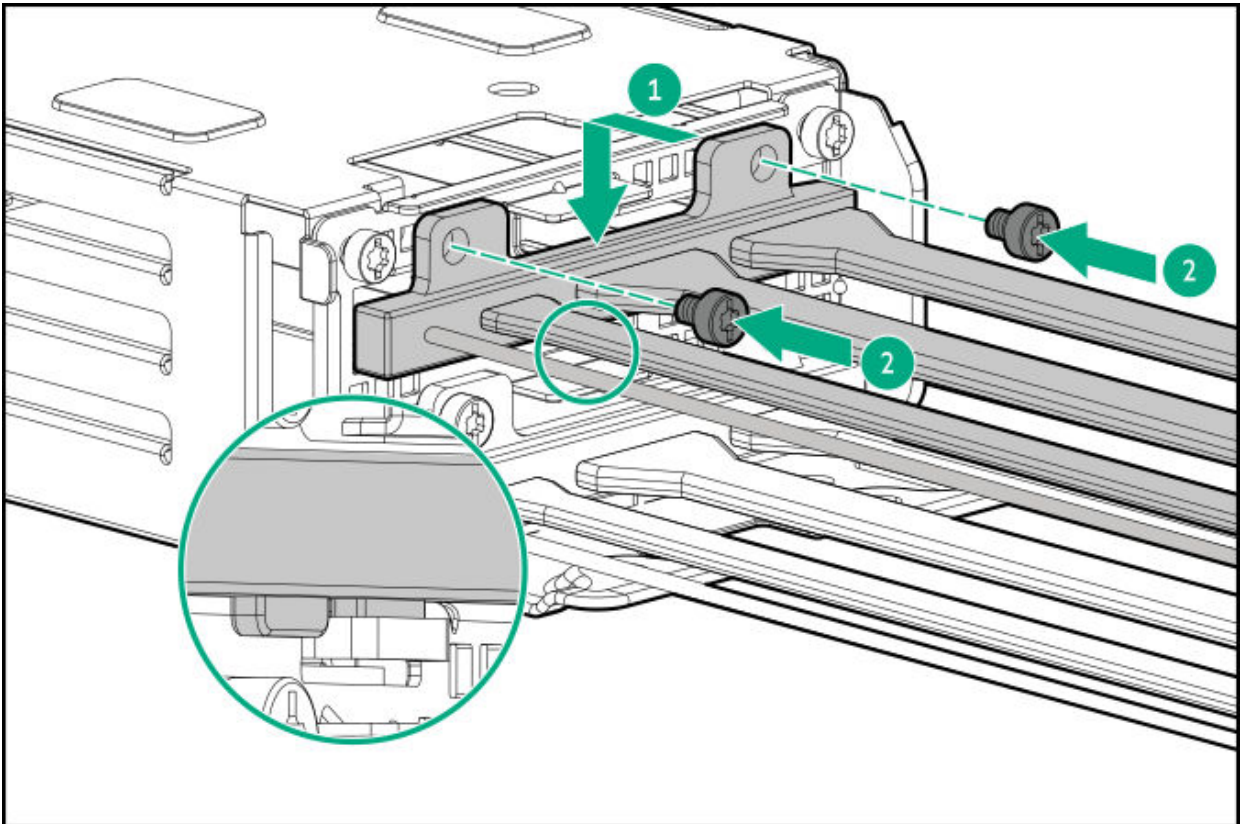

Installing the OCP NIC in the E3.S cage

5. Remove the OCP NIC bracket.

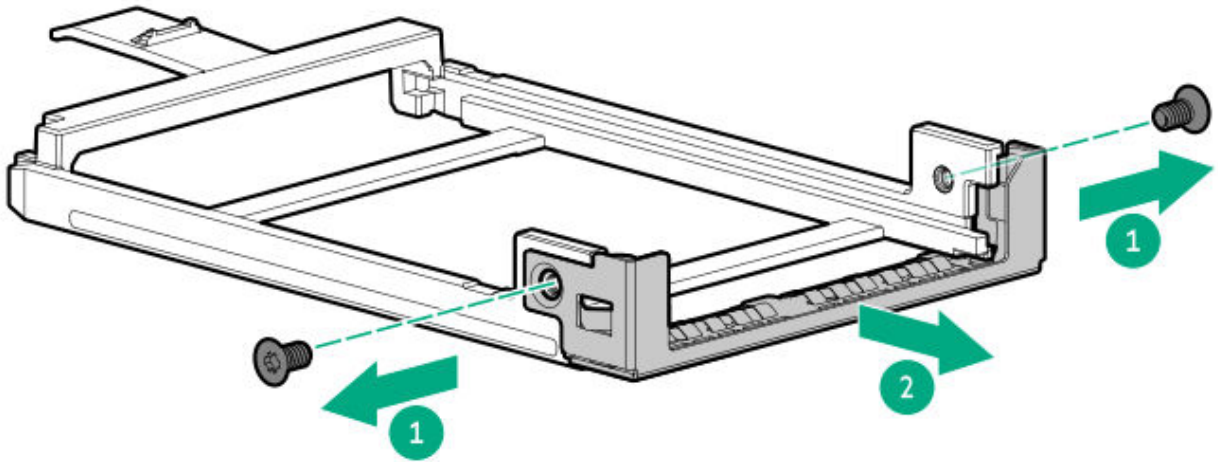

6. Slide the OCP NIC into the OCP NIC carrier.

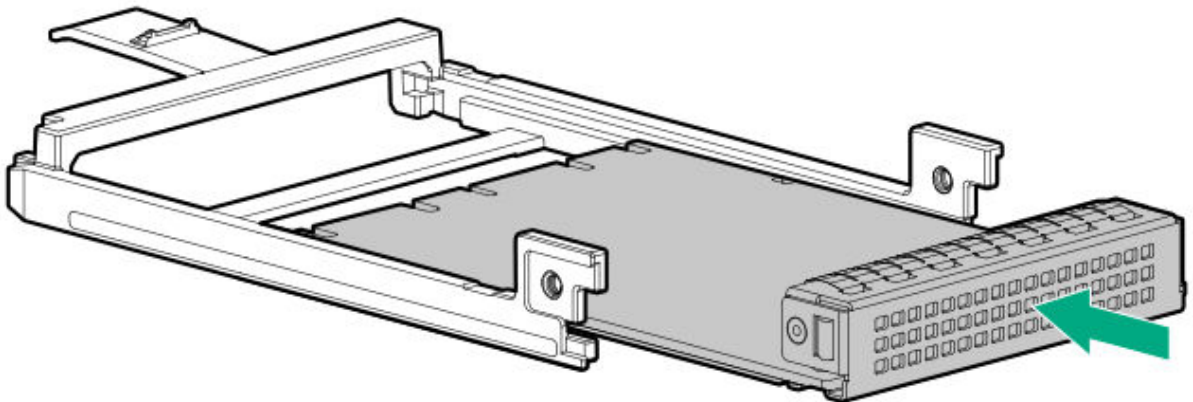

7. Install the OCP NIC bracket.

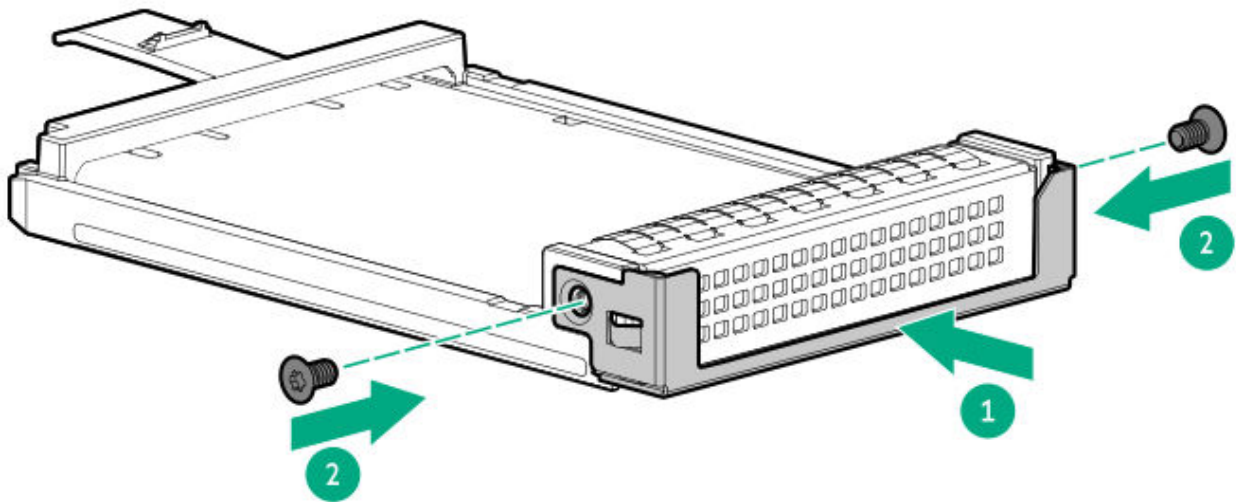

- Slide the OCP NIC carrier into the E3.S cage until the carrier tab engages with the front OCP NIC bracket.

There will be an audible click to indicate that the carrier tab is engaged with the bracket.

- Bay 3—Primary front OCP NIC

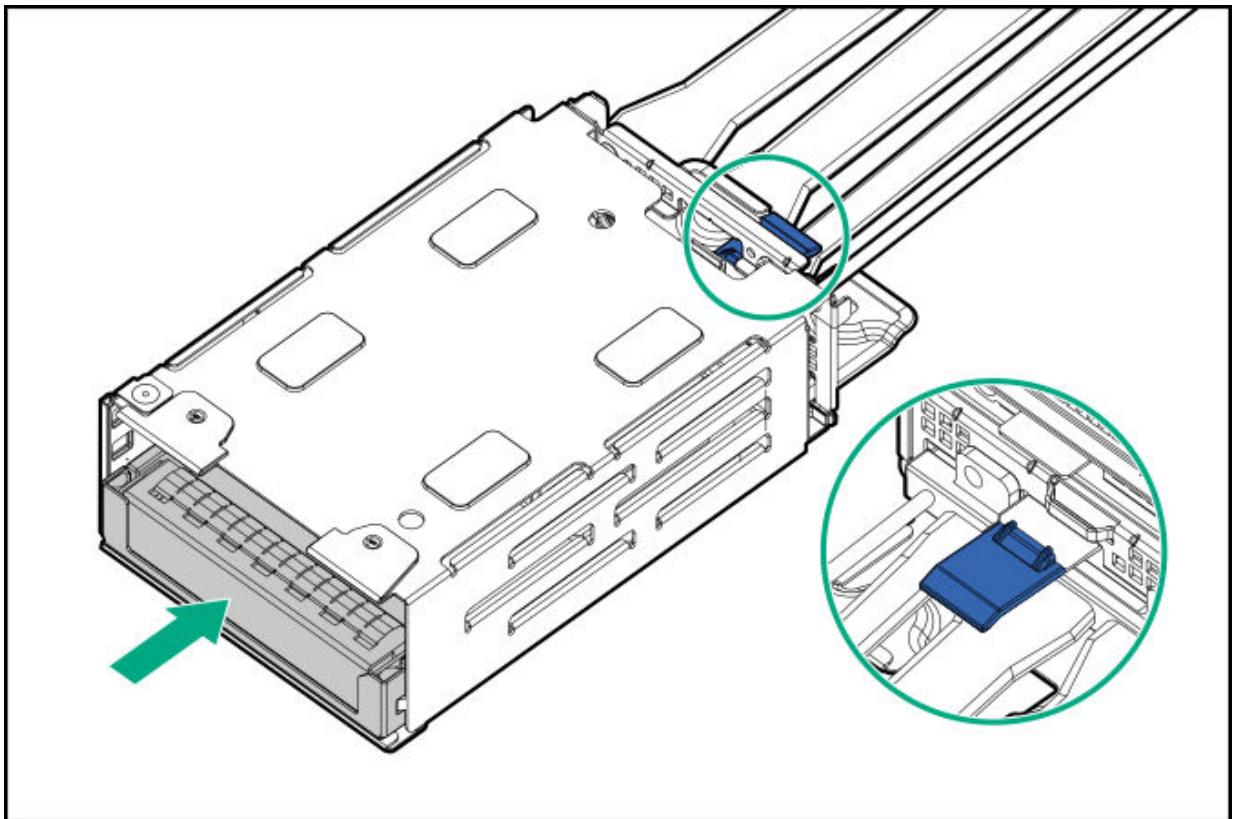

- Bay 1—Secondary front OCP NIC

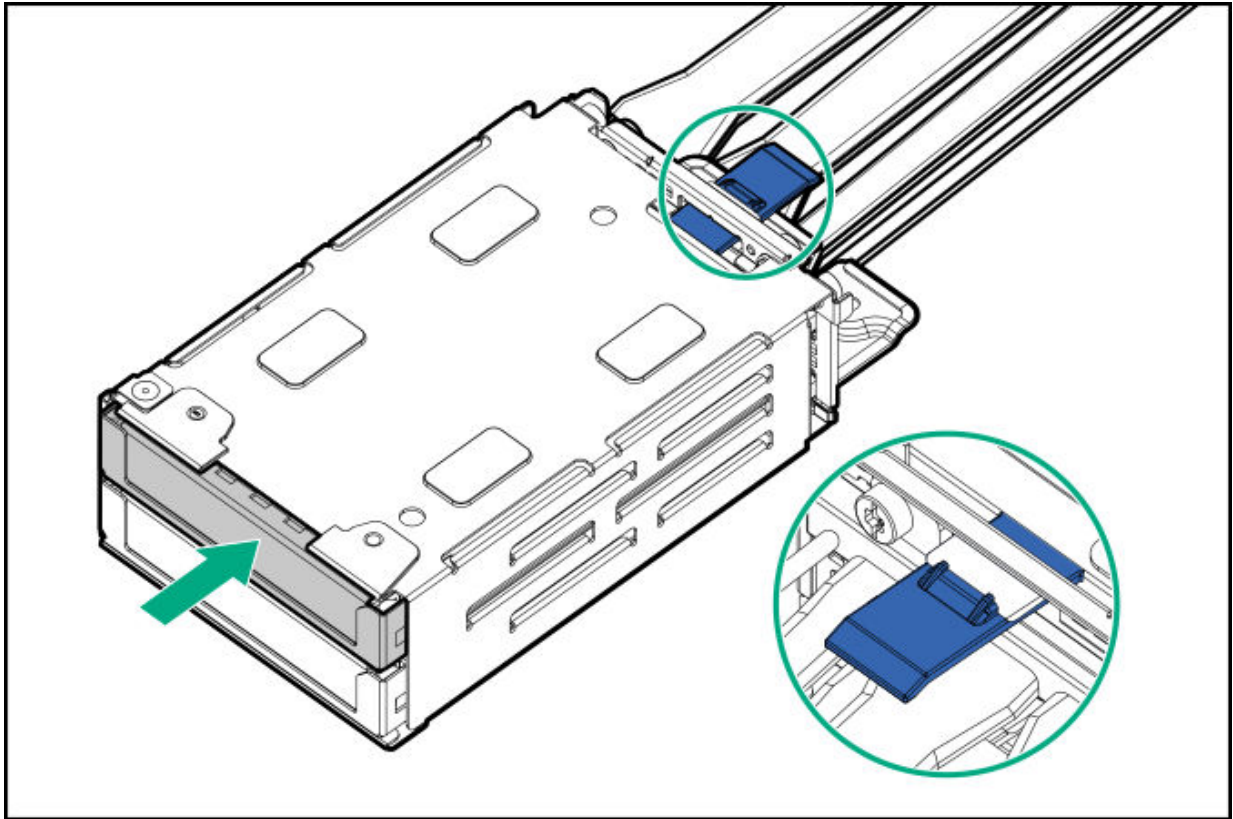

Installing the E3.S drive filler

9. If you are not immediately installing the secondary front OCP NIC, make sure that the E3.S drive fillers are installed in Bay 1 of the cage.

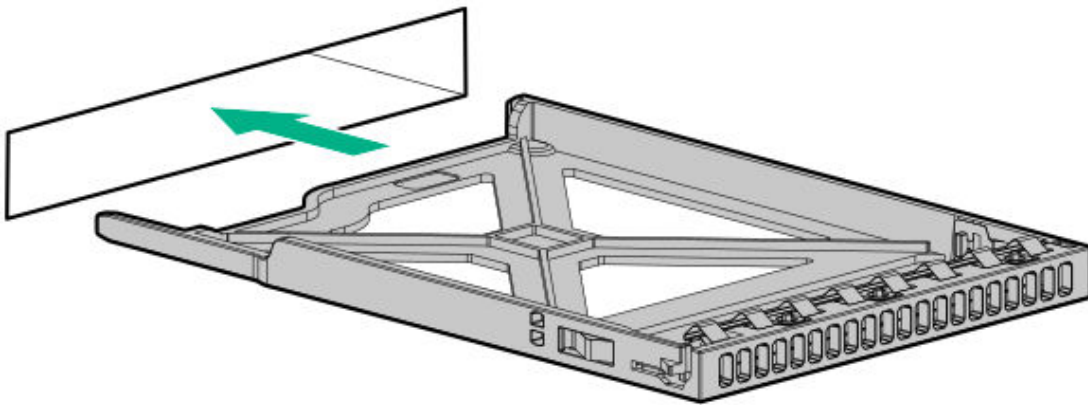

Installing the cage in the chassis

10. Power down the server.

- .1. If installed, release the cable management arm.
- .2. Remove all power:
 - a. Disconnect each power cord from the power source.
 - b. Disconnect each power cord from the server.
- .3. Disconnect all peripheral cables from the server.
- .4. Do one of the following:
 - Extend the server from the rack.
 - Remove the server from the rack.
- .5. Remove the access panel.
- .6. If installed, remove the air baffle.

An 8 SFF server is shown. The removal procedure is the same for all drive configurations.

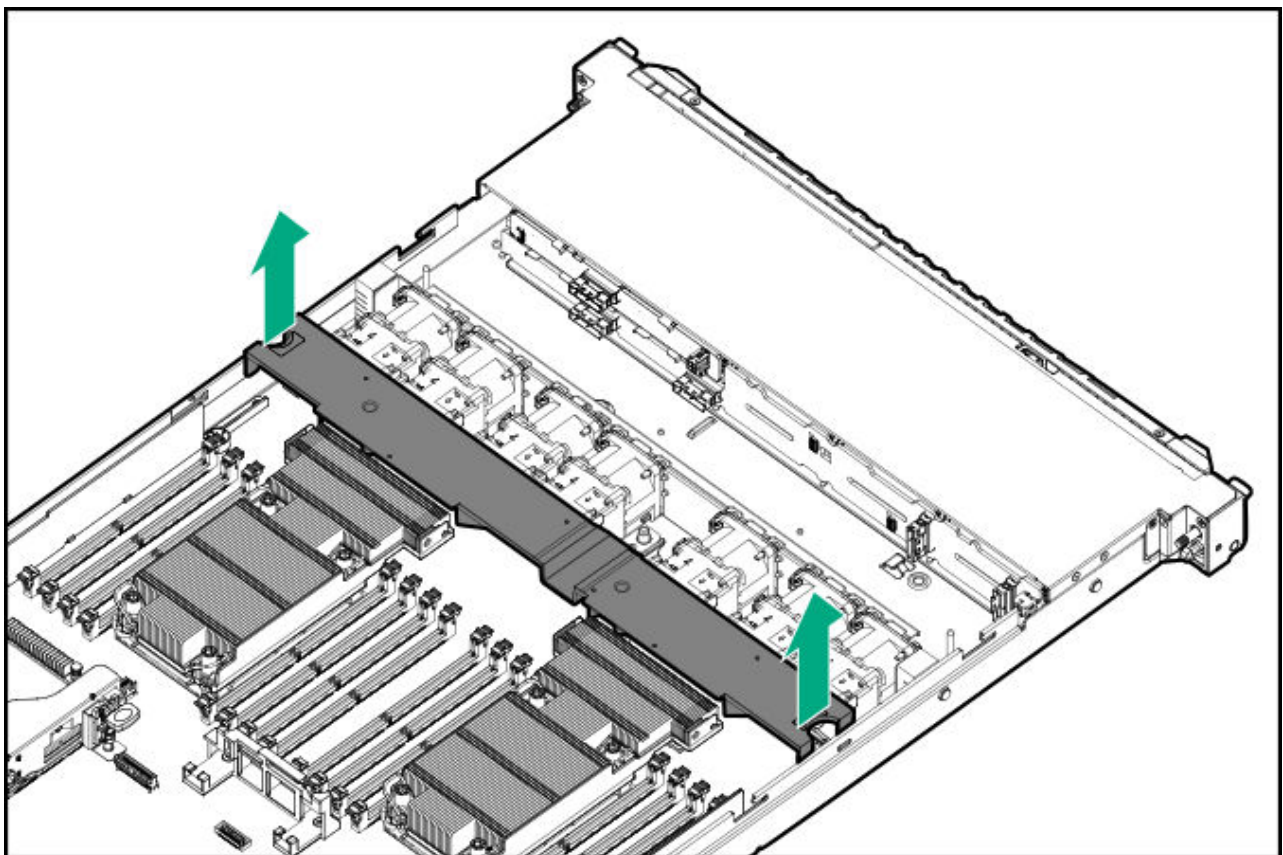

- .7. Remove the blank from drive box 3.

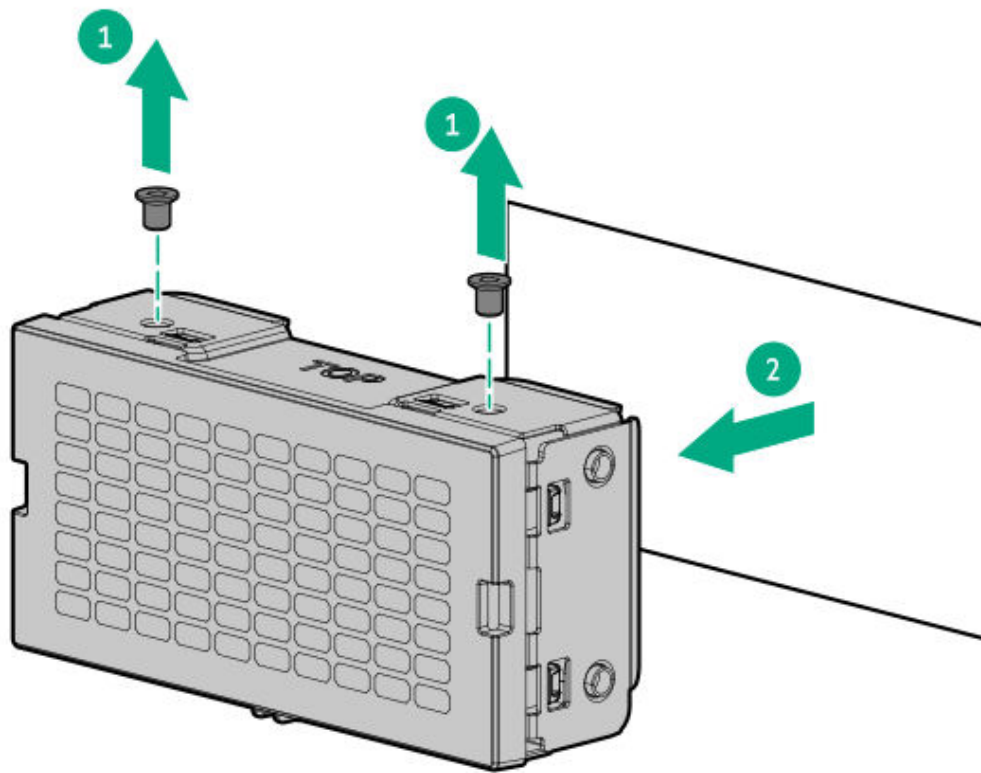

.8. Install the E3.S cage in Box 3:

- a. Feed the OCP NIC cables through the front panel, and slide the cage into Box 3.

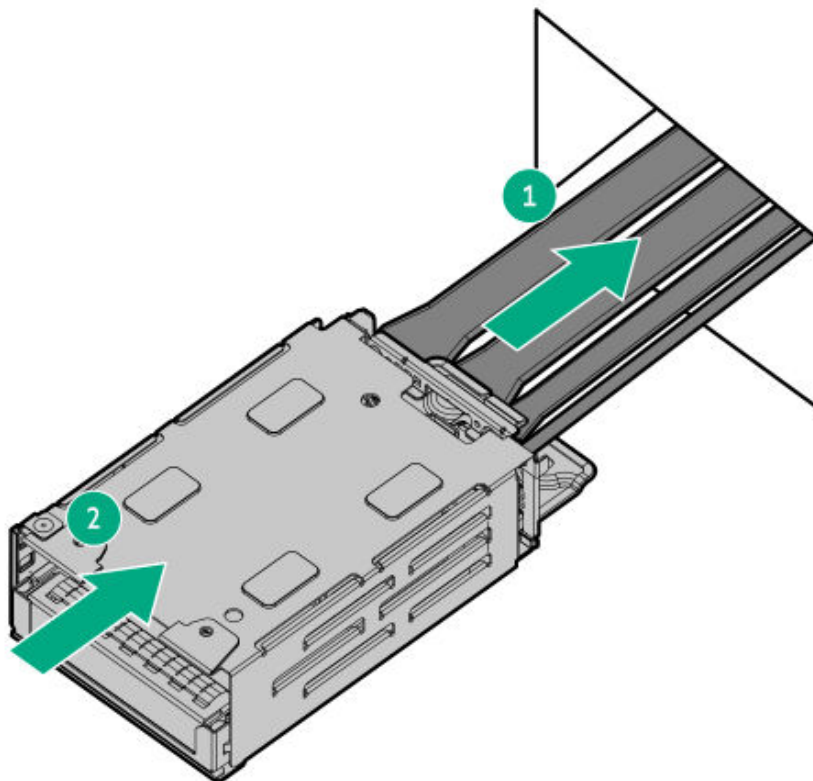

- b. Position the OCP NIC cables over the drive box as shown in the following illustration.
- c. While the cables are in this position, put the PHY board on the cage and install the screws.
- Bay 3 OCP NIC cables

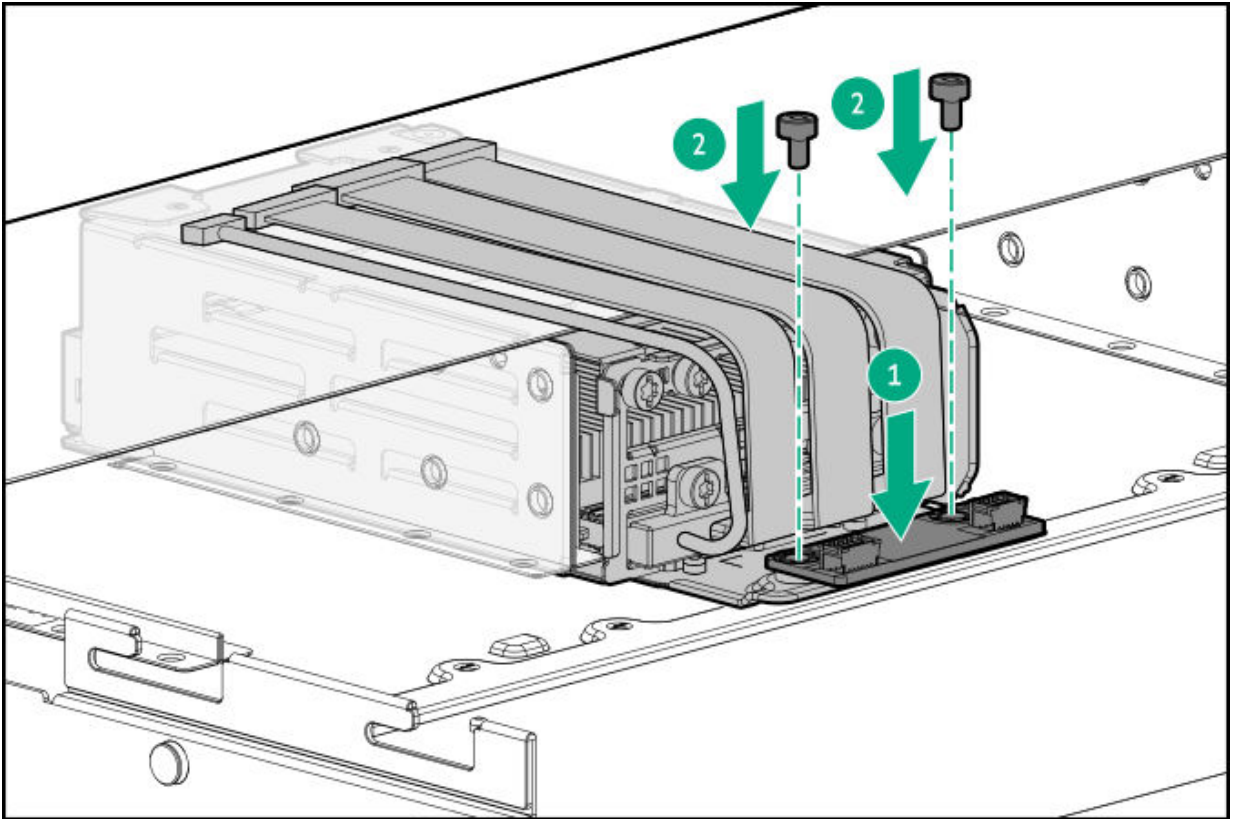

- Bay 1 and Bay 3 OCP NIC cables

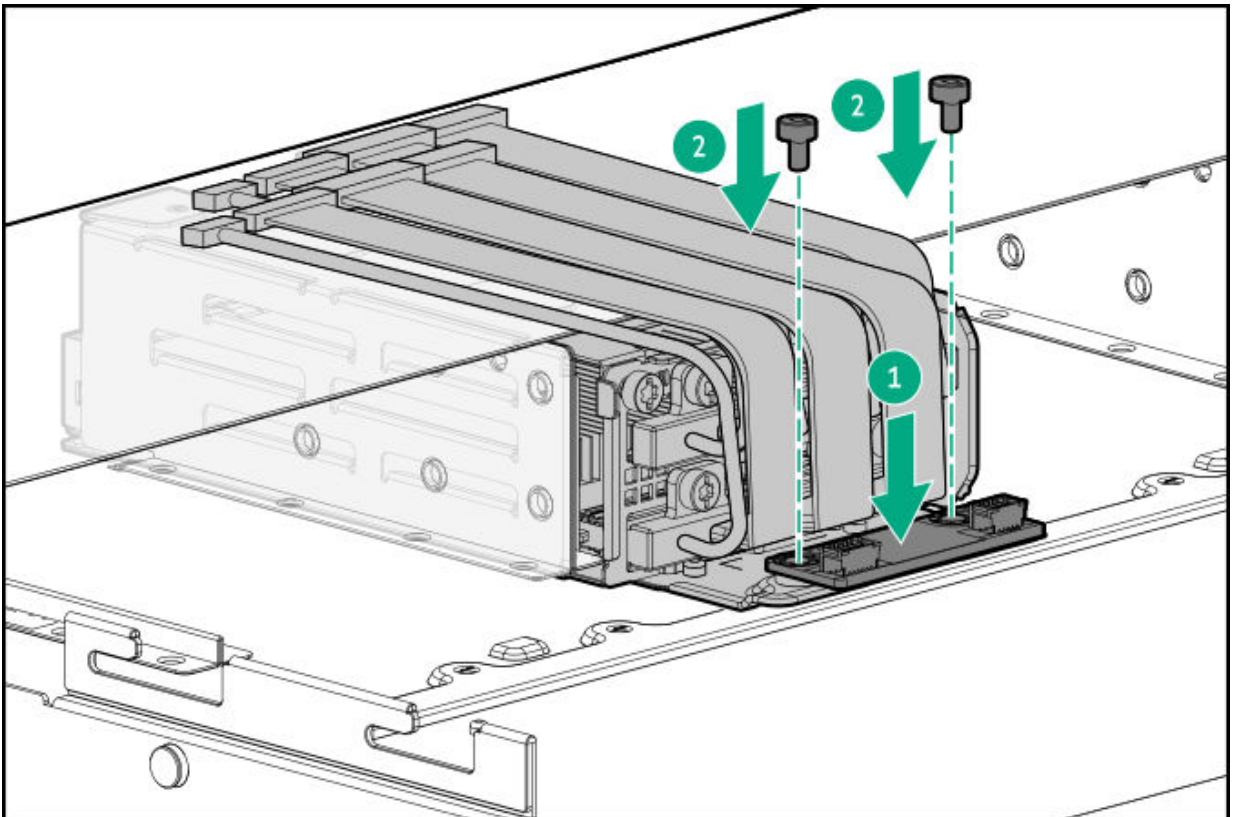

Installing the OCP NIC interposer

9. Remove the riser cages.

10. Remove the OCP slot blank:

- a. Remove the blank screw.
- b. Remove the blank.

Retain the screw and blank for future use.

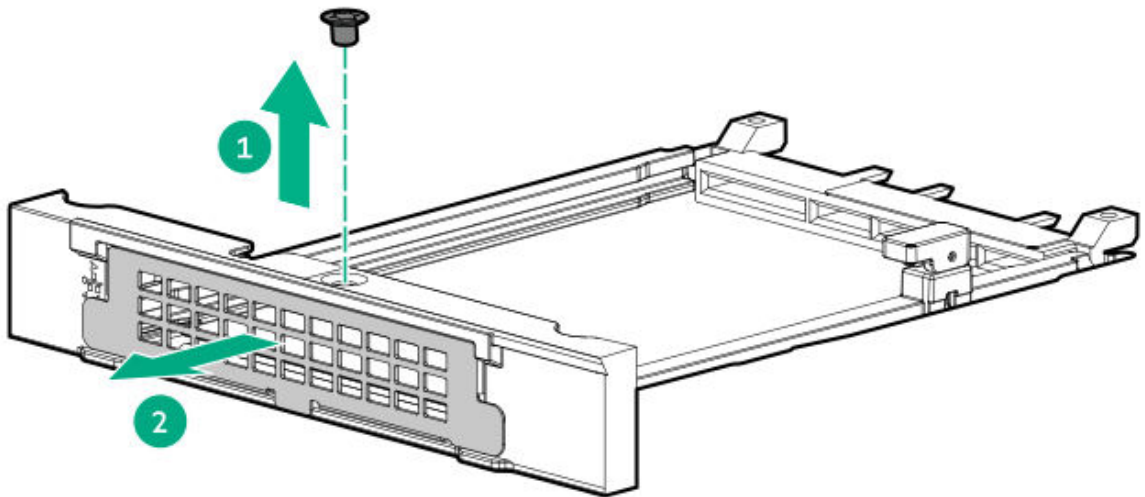

11. Install the OCP NIC interposer:

- a. Rotate the locking pin to the open (vertical) position.
- b. Slide the interposer into the slot until it clicks into place.
Make sure that the interposer is seated firmly in the slot.
- c. Rotate the locking pin to the close (horizontal) position.

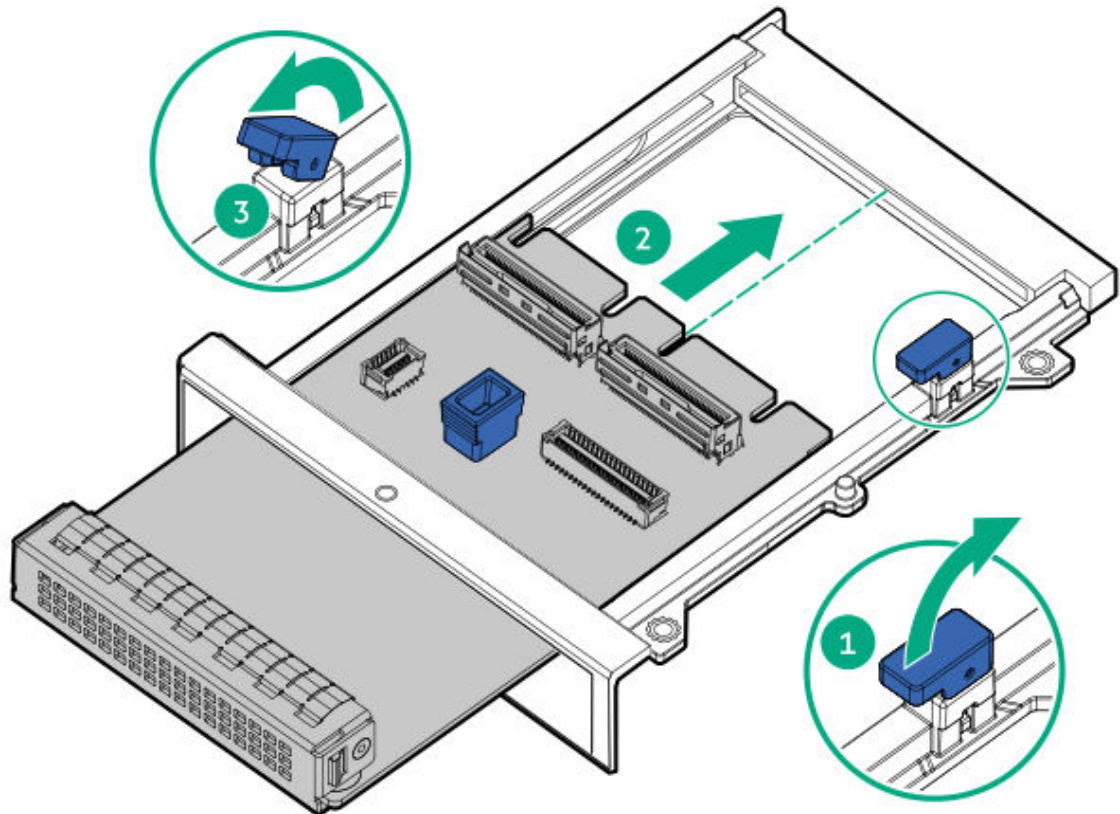

!2. If the secondary front OCP NIC is installed, repeat step 21–22 to install the second OCP NIC interposer.

Connecting the OCP NIC cables

!3. Connect the following connectors of the primary front OCP NIC cable:

- OCP NIC cable system board connectors (labeled B and C) to the system board
- OCP NIC cable interposer connector (labeled D) to the OCP NIC interposer
- OCP NIC cable PHY board connector (labeled E) to the PHY board

!4. (Optional) If you intend to use a front OCP NIC port as an iLO shared network port, connect the iLO shared connection cable (labeled B) from the PHY board to the OCP interposer.

The iLO shared connection through the front OCP NIC is supported in the primary OCP NIC slot.

!5. If the second front OCP NIC is installed, connect the following connectors of the secondary front OCP NIC cable:

- OCP NIC cable system board connectors (labeled B and C) to the system board
- OCP NIC cable interposer connector (labeled D) to the OCP NIC interposer

!6. Install the riser cages.

!7. (Optional) Install the air baffle.

8. Install the access panel.
9. Install the server into the rack.
10. Connect all peripheral cables to the server.
11. Connect each power cord to the server.
12. Connect each power cord to the power source.
13. Power up the server.
14. (Optional) To use a front OCP NIC port as an iLO shared network port, enable the iLO shared connection in the UEFI System Utilities.

Results

The installation procedure is complete.

Enabling the iLO shared network connection

About this task

This procedure applies to iLO 6 and iLO 7.



IMPORTANT

If the iLO configuration settings are reset to the default values, remote access to the machine will be lost. Access the physical machine and repeat the procedure described in this section to re-enable the iLO shared network port.

Procedure

1. From the boot screen, press **F9** to access the UEFI System Utilities.
2. From the **System Utilities** screen, select **System Configuration > iLO Configuration Utility > Network Options**.
3. Set the **Network Interface Adapter** field to **Shared Network Port - OCPA** or **Shared Network Port - OCPB**, and then press **Enter**.
4. Press **F10** to save your changes.
5. Press **Enter** to reboot the iLO settings.
6. Press **Esc** until the main menu is displayed.

7. Select **Reboot the System** to exit the utility and resume the boot process.

The IP address of the iLO shared network port appears on the POST screen on the subsequent boot-up. Access the **Network Options** screen again to view this IP address for later reference.

Installing a rear OCP network adapter

Prerequisites

- Review the following:
 - [OCP NIC 3.0 slot numbering](#)
 - [Fan and heatsink requirements](#)
- If you are installing an OCP NIC 3.0 x16 adapter, an [OCP bandwidth upgrade cable](#) is required.
- Before you perform this procedure, make sure that you have the following items available:
 - The components included with the hardware option kit
 - T-10 Torx screwdriver
 - Spudger or any small prying tool

About this task



WARNING

To reduce the risk of personal injury from hot surfaces, allow the drives and the internal system components to cool before touching them.



CAUTION

A discharge of static electricity from a finger or other conductor might damage system boards or other static-sensitive devices. To prevent damage, observe [antistatic precautions](#).



CAUTION

To prevent improper cooling and thermal damage, do not operate the server unless all OCP slots have either an OCP option or a slot blank installed.

Procedure

1. [Power down the server](#).

2. Remove all power:
 - a. Disconnect each power cord from the power source.
 - b. Disconnect each power cord from the server.
3. Do one of the following:
 - Extend the server from the rack.
 - Remove the server from the rack.
4. Place the server on a flat, level work surface.
5. Remove the access panel.
6. Do one of the following:
 - Remove the primary riser cage if installing an OCP network adapter in Slot 14 OCP A.
 - Remove the secondary riser cage or riser blank if installing an OCP network adapter in Slot 15 OCP B.
 - Secondary low-profile riser cage

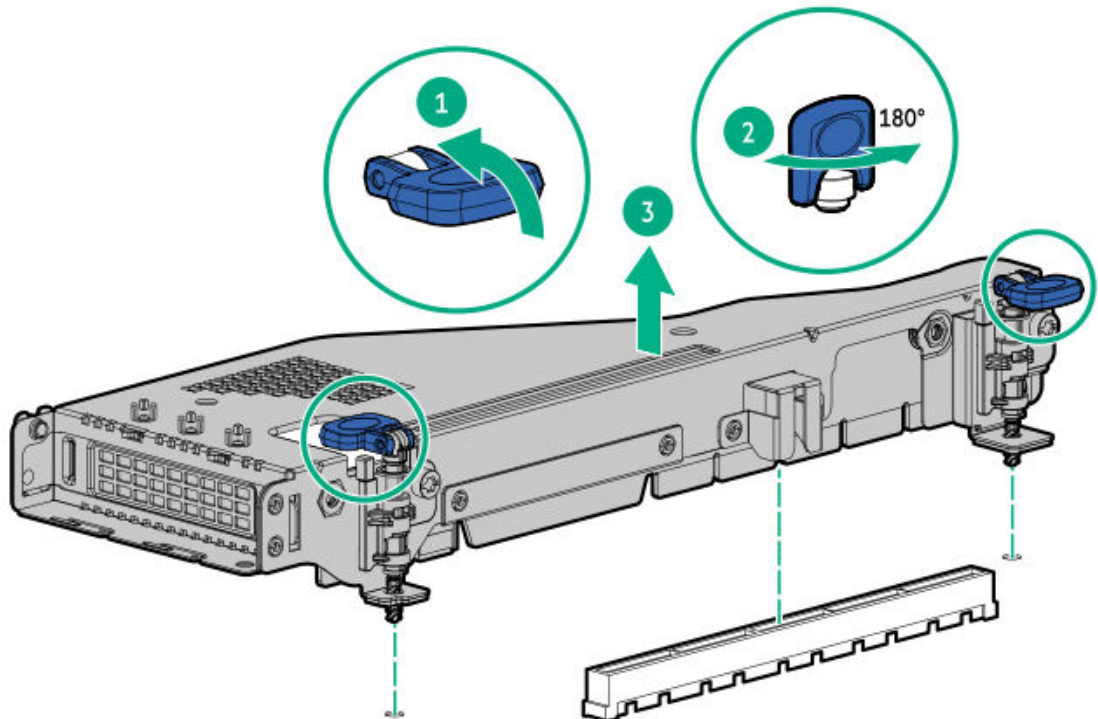

- Riser blank

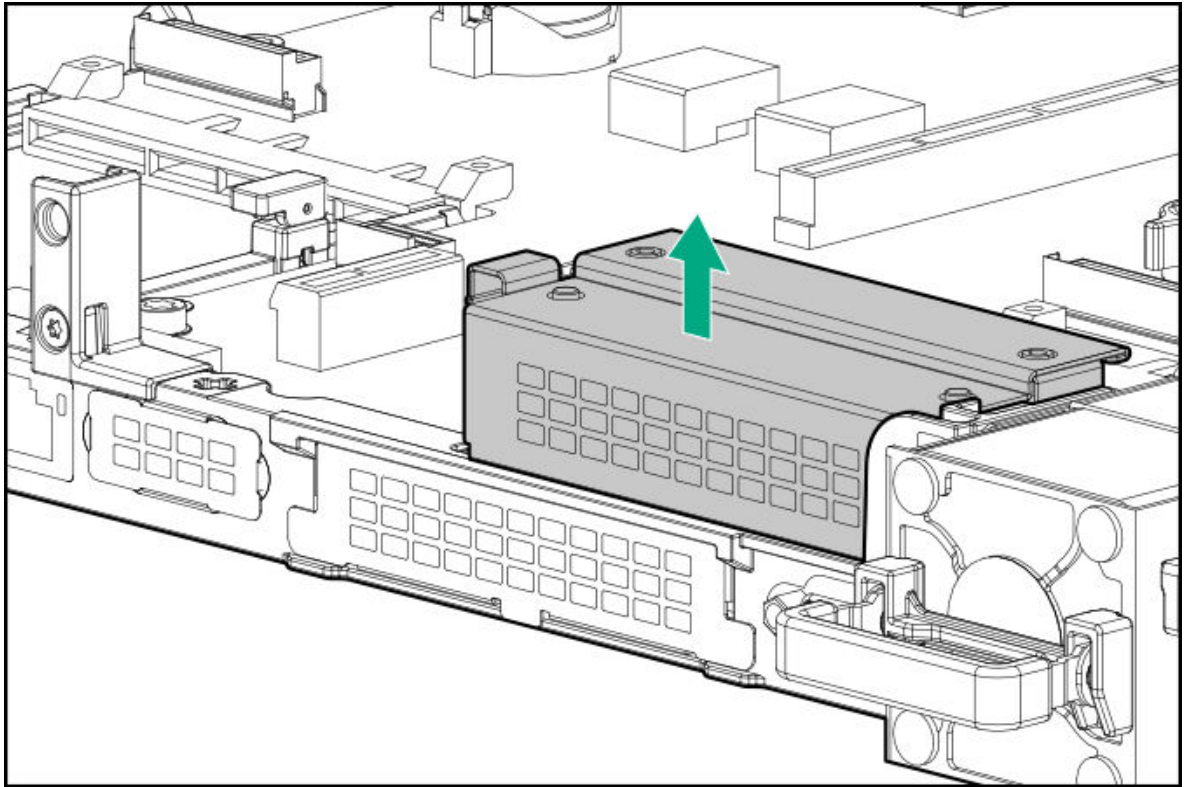

7. Remove the OCP adapter blank.

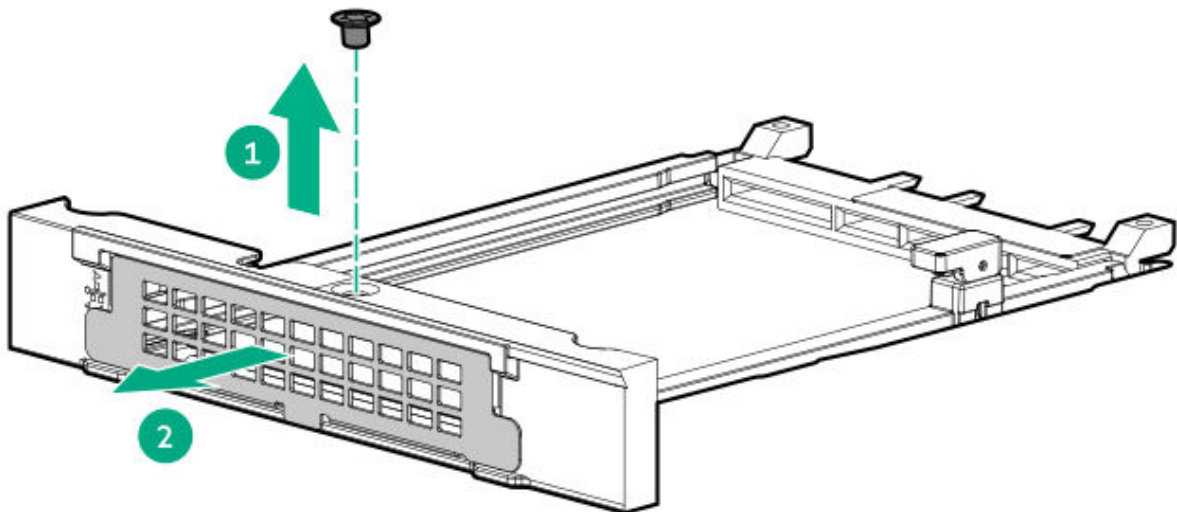

8. Install the network adapter.

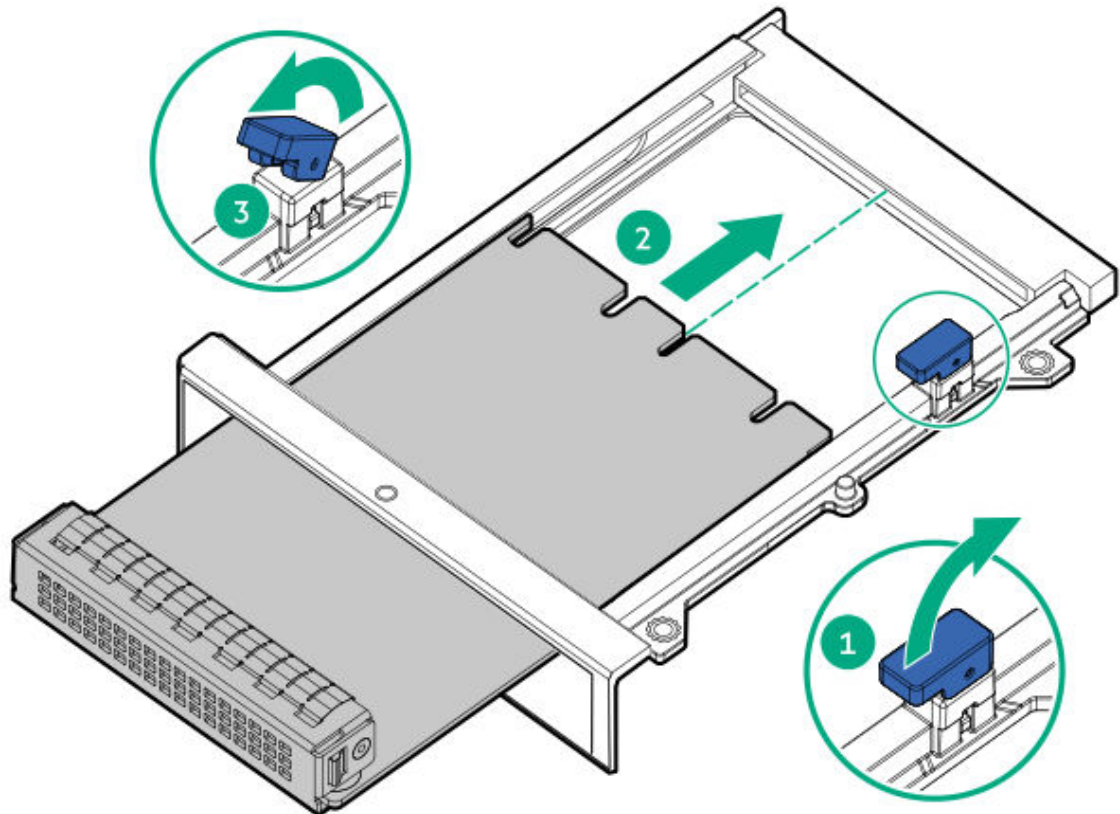

9. (Optional) connect the OCP bandwidth upgrade cable.
0. Do one of the following:
 - If removed, install the primary riser cage.
 - If removed, install the secondary riser cage or riser blank.
1. Install the access panel.
2. Slide the server into the rack.
3. Connect all peripheral cables to the server.
4. Connect each power cord to the server.
5. Connect each power cord to the power source.
6. Power up the server.

Results

The installation procedure is complete.

Installing a PCIe network adapter

Prerequisites

- Review the following:
 - [Riser slot numbering](#)
 - [Fan and heatsink requirements](#)
- Before installing this option, be sure that you have the following:
 - The components included with the hardware option kit
 - T-10 Torx screwdriver

About this task



WARNING

To reduce the risk of personal injury from hot surfaces, allow the drives and the internal system components to cool before touching them.



CAUTION

To prevent improper cooling and thermal damage, do not operate the server unless all PCIe slots have either a riser slot blank or an expansion card installed.



CAUTION

To prevent damage to electrical components, properly ground the server before beginning any installation procedure. Improper grounding can cause electrostatic discharge.

Procedure

1. [Power down the server.](#)
2. Remove all power:
 - a. Disconnect each power cord from the power source.
 - b. Disconnect each power cord from the server.
3. Do one of the following:
 - a. [Extend the server from the rack.](#)
 - b. [Remove the server from the rack.](#)

4. Place the server on a flat, level work surface.
5. Remove the access panel.
6. Do one of the following:
 - To install an adapter in Slot 1 of the primary riser:
 - a. Remove the primary PCI riser cage.
 - b. Remove the blank.
 - c. Install the adapter.

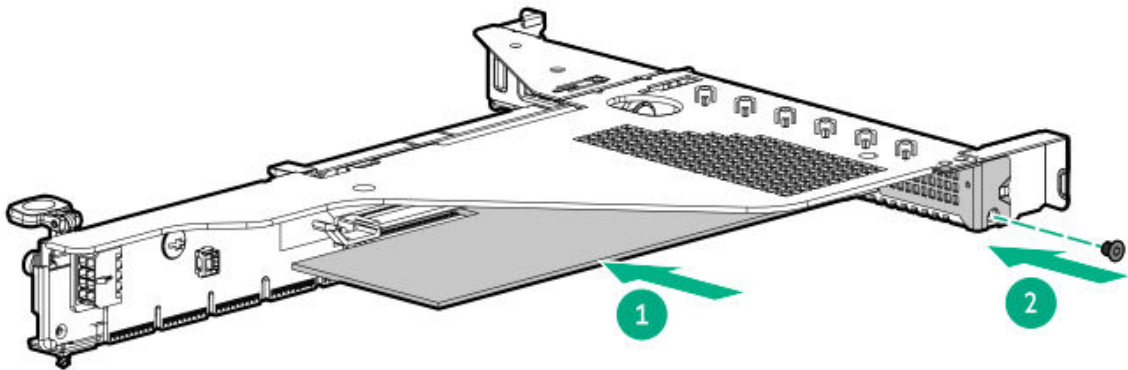

- To install an adapter in Slot 2 of the primary riser:
 - a. Remove the primary PCI riser cage
 - b. Remove the blank.
 - c. Install the adapter.

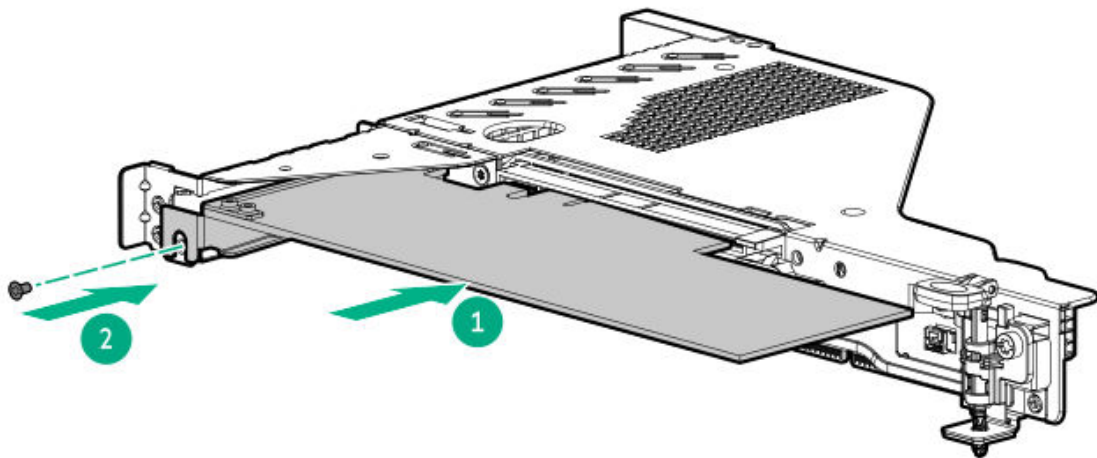

7. Install the riser cage.

8. Install the access panel.
9. Install the server in the rack.
10. Connect all peripheral cables to the server.
11. Connect each power cord to the server.
12. Connect each power cord to the power source.
13. Power up the server.

Results

The installation procedure is complete.

OS boot device

Subtopics

Installing boot device drives

Installing the internal or rear boot device

Installing the front NS204i-u in drive box 5 of the 10 SFF / 20 E3.S server

Installing boot device drives

Prerequisites

Before you perform this procedure, make sure that you have a Phillips No. 1 screwdriver available.

Procedure

1. Push the button to pull out the carrier.

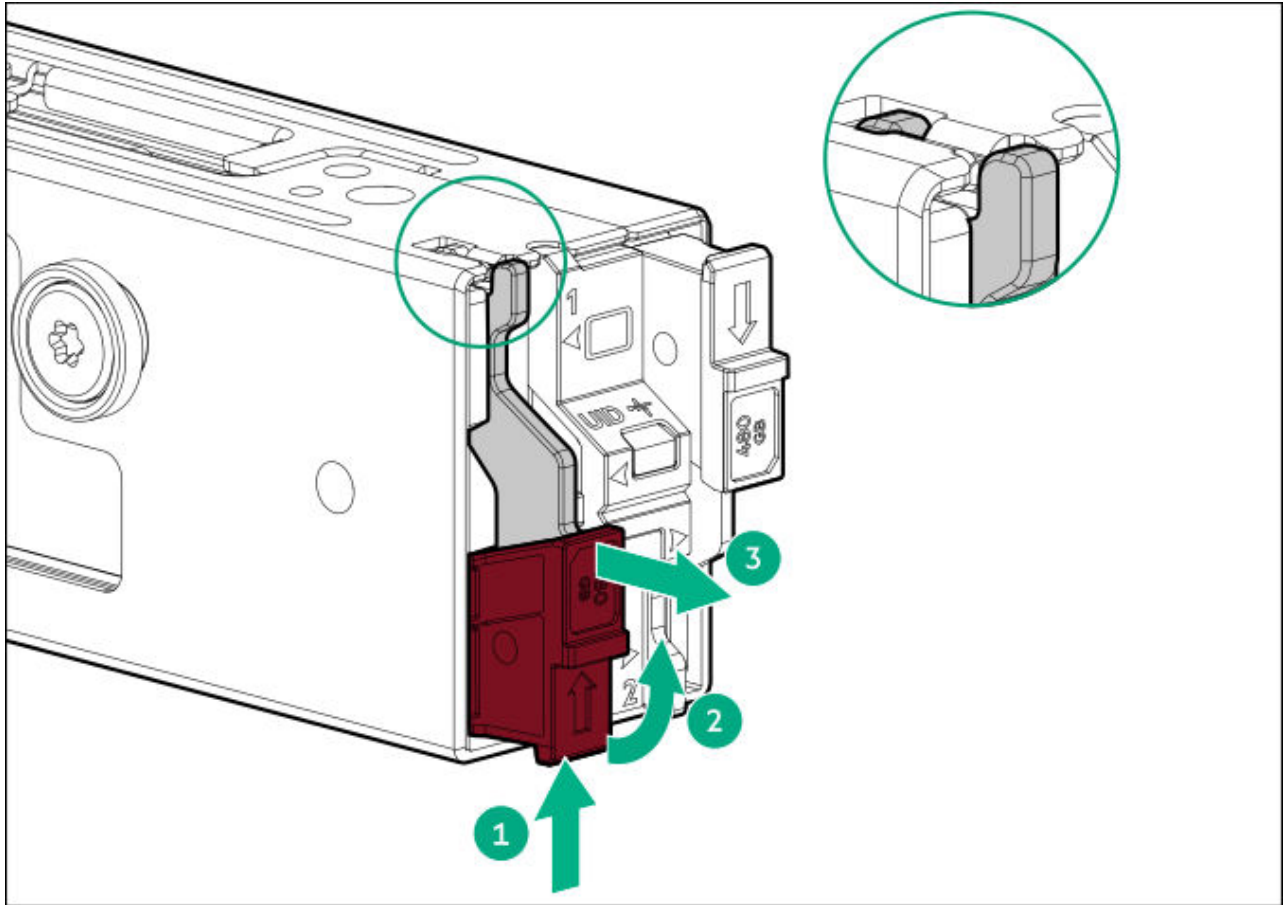

2. Remove the SSD mounting screw.

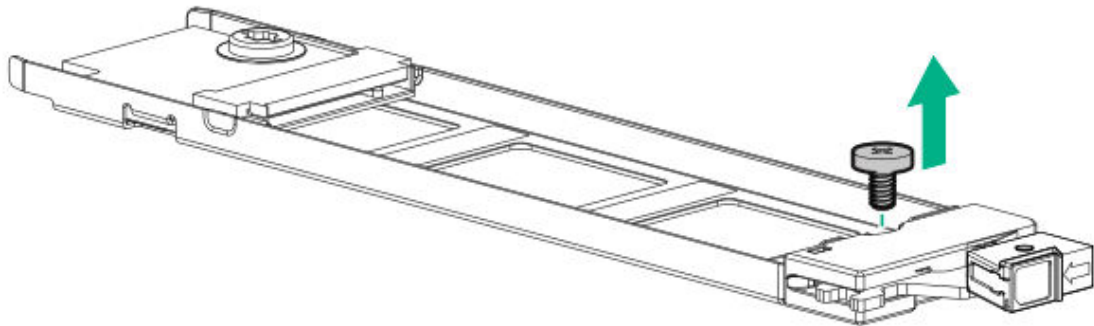

3. Insert the SSD into the M.2 slot at a 45° angle.
4. Carefully press the SSD down to the horizontal position.
5. Install the SSD mounting screw.

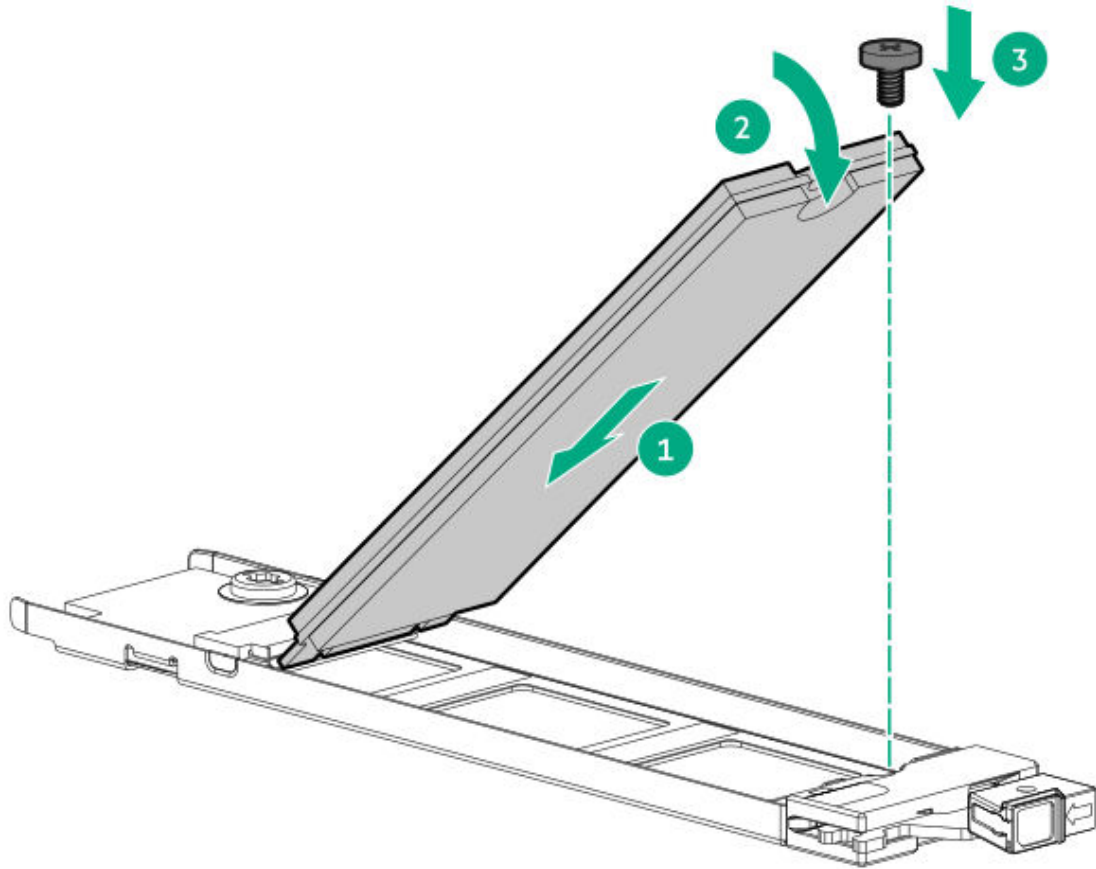

6. If the second M.2 SSD is installed on the carrier assembly, repeat steps 1 and 2.
7. Align and install the drive carrier.

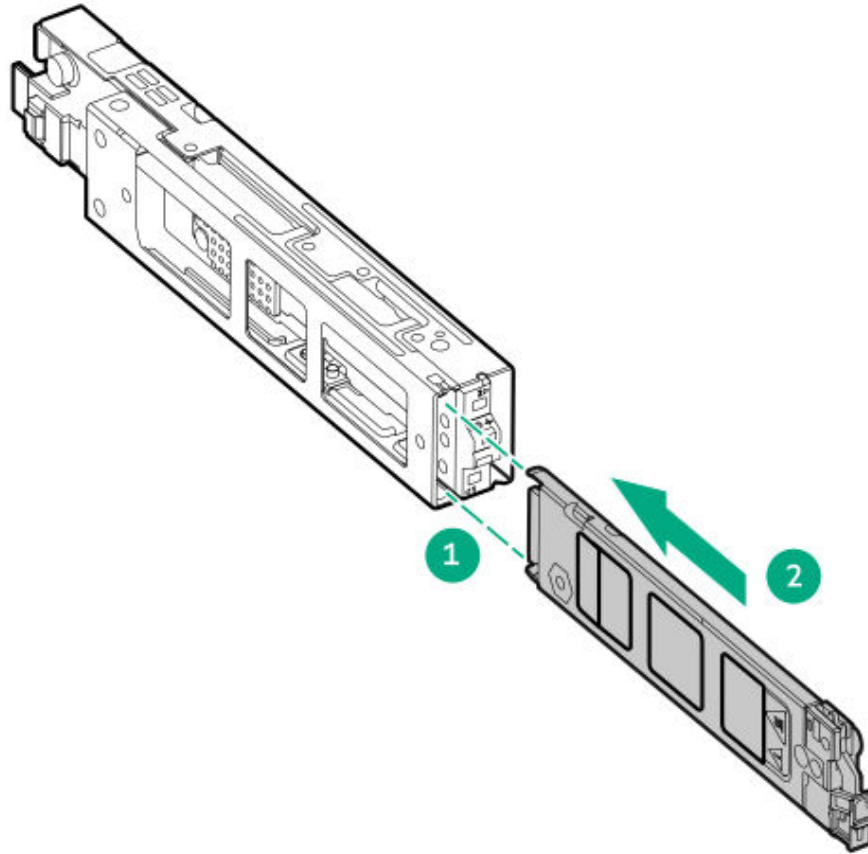

8. Secure the carrier and verify it latches to the device cage.

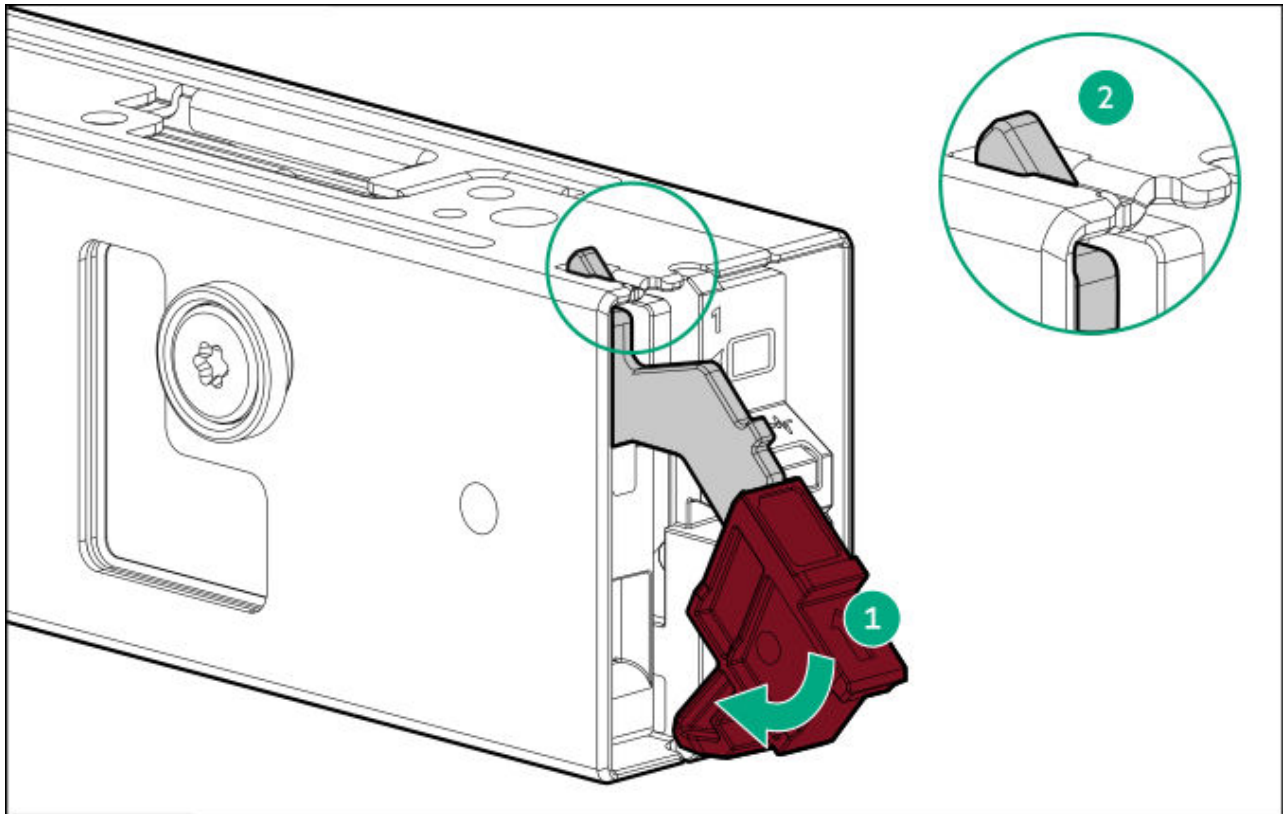

Installing the internal or rear boot device

Prerequisites

- Verify that your OS or virtualization software is supported:
<https://www.hpe.com/support/Servers-Certification-Matrices>
- [Verify that you are running the latest iLO firmware and server BIOS version.](#)
- [Identify the HPE NS204i-u Boot Device V2 components.](#)
- Before you perform this procedure, make sure that you have a T-10 Torx screwdriver available.

About this task

Note the following:

- The HPE NS204i-u Boot Device V2 is a custom form-factor module that includes two hot pluggable 2280 M.2 NVMe SSDs.

- HPE NS204i-u Boot Device V2 auto-creates a RAID1 volume during boot, and therefore does not require configuration.



WARNING

To reduce the risk of personal injury from hot surfaces, allow the drives and the internal system components to cool before touching them.



CAUTION

A discharge of static electricity from a finger or other conductor might damage system boards or other static-sensitive devices. To prevent damage, observe antistatic precautions.



IMPORTANT

For successful RAID 1 configuration, verify that the boot device SSDs have the same model number and firmware version:

- In the iLO web interface, see the **Storage** page.
- In UEFI System Utilities, see **System Configuration > HPE NS204i Boot Controller > Physical Device Information**.

Configurations with SSDs from different manufacturers are not supported.

Procedure

1. Install drives onto the boot device.
2. Back up all server data.
3. Power down the server.
4. Remove all power:
 - a. Disconnect each power cord from the power source.
 - b. Disconnect each power cord from the server.
5. Do one of the following:
 - Extend the server from the rack.
 - Remove the server from the rack.
6. Remove the access panel.

Installing the rear boot device in the riser cage

7. Remove the primary riser cage.

8. Remove the slot 2 bracket from the primary riser cage.

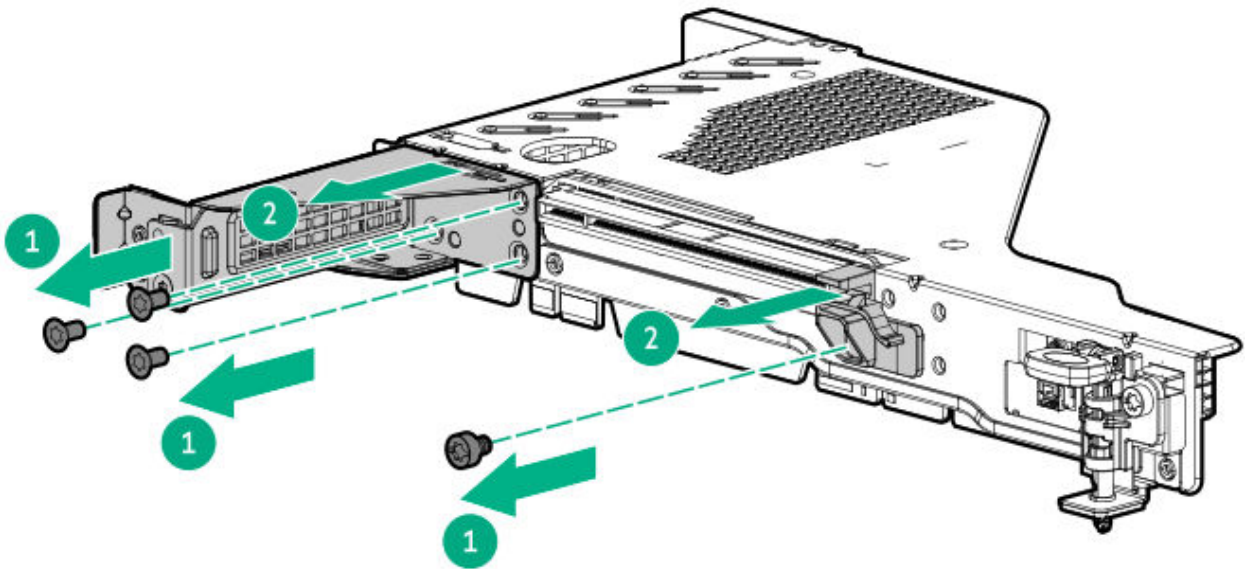

9. Install the boot device cage.

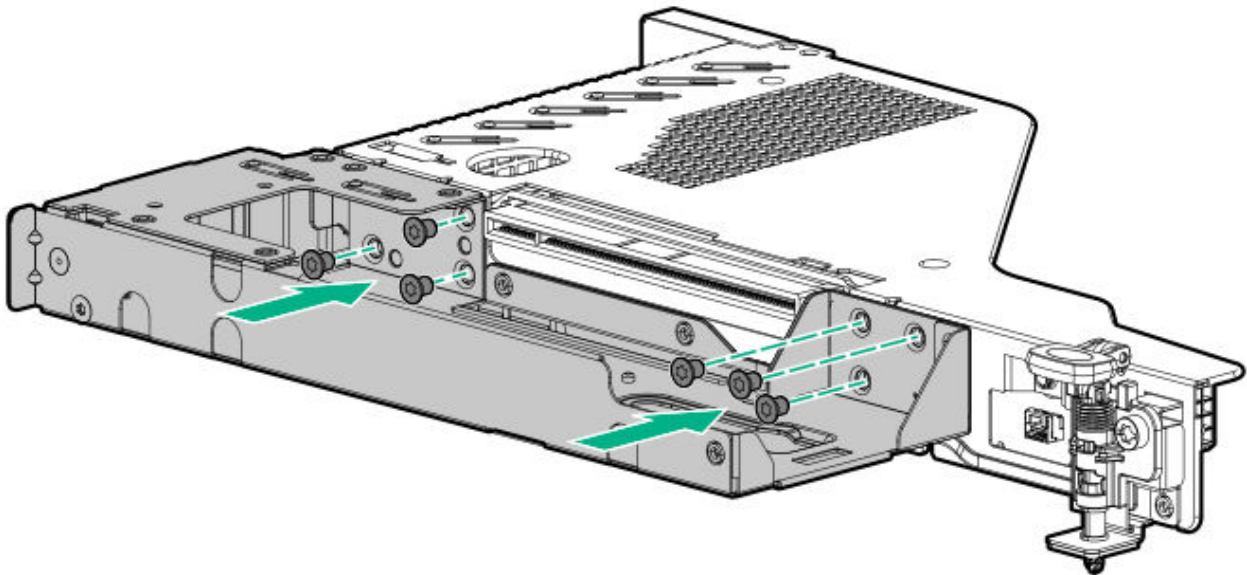

10. Install the boot device drives.

11. To install the boot device:

a. Install the latch.

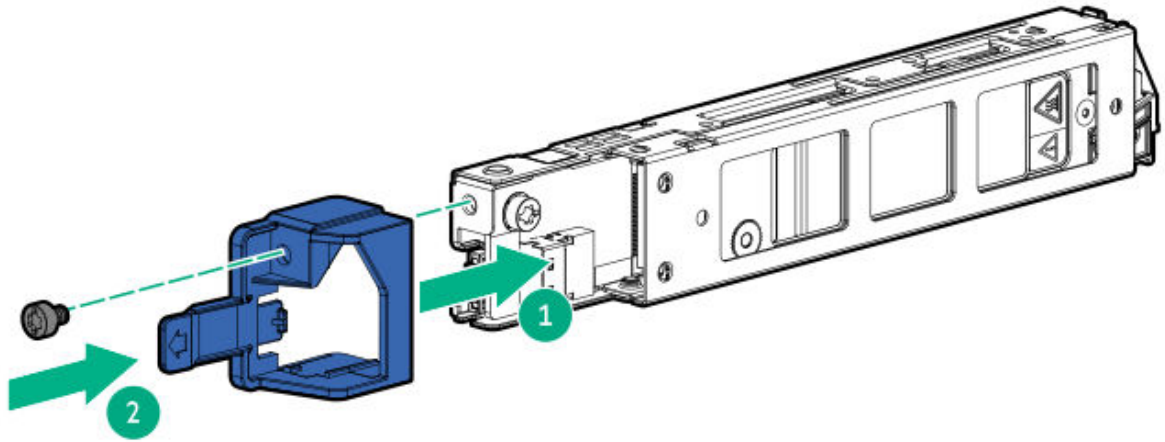

b. Install the device into the riser cage.

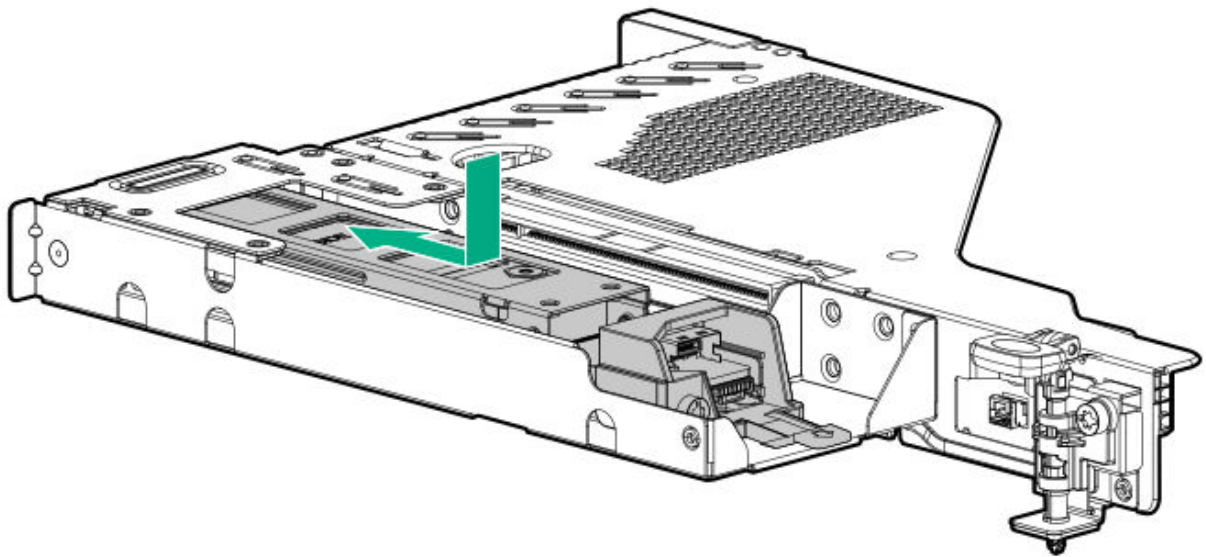

c. Install the riser cage.

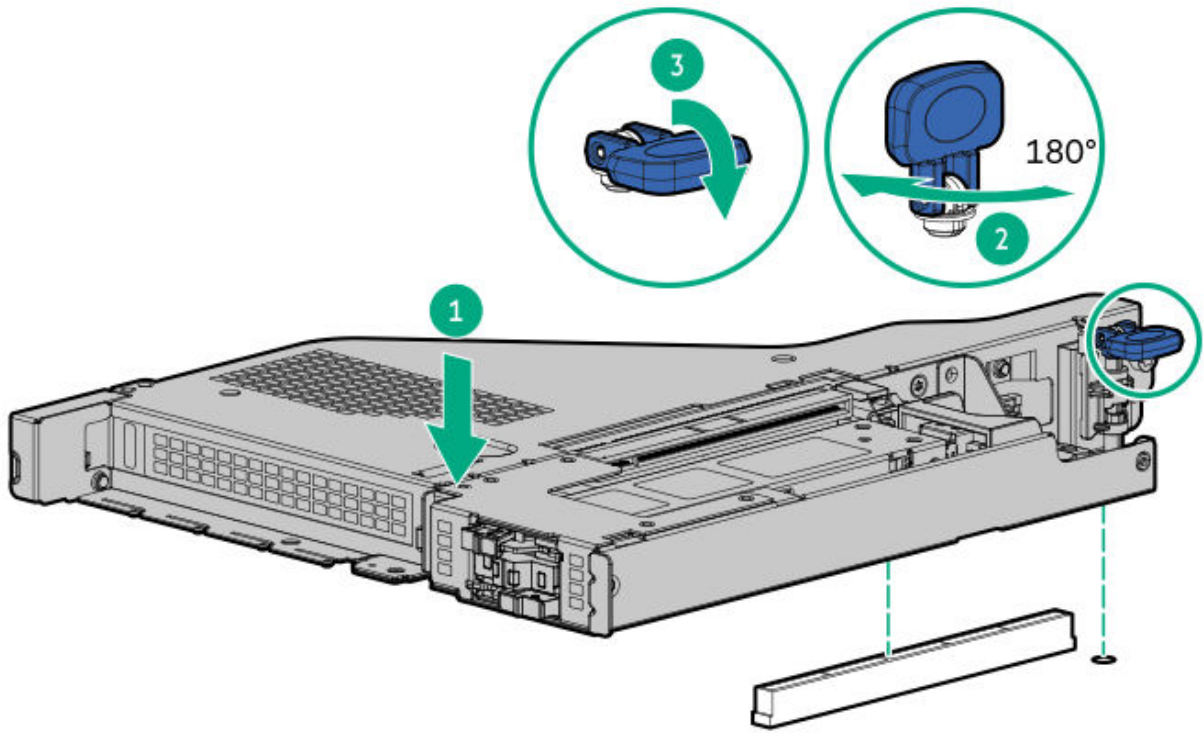

Installing the internal boot device

2. To install the internal boot device:

- a. Install the mounting bracket.

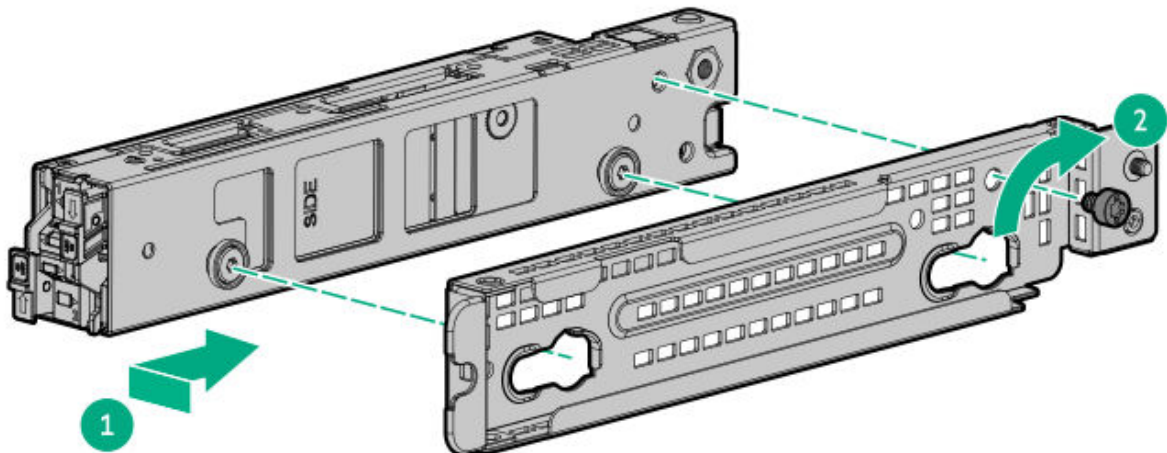

- b. Install the boot device in the server.

- 4 LFF drive configuration:

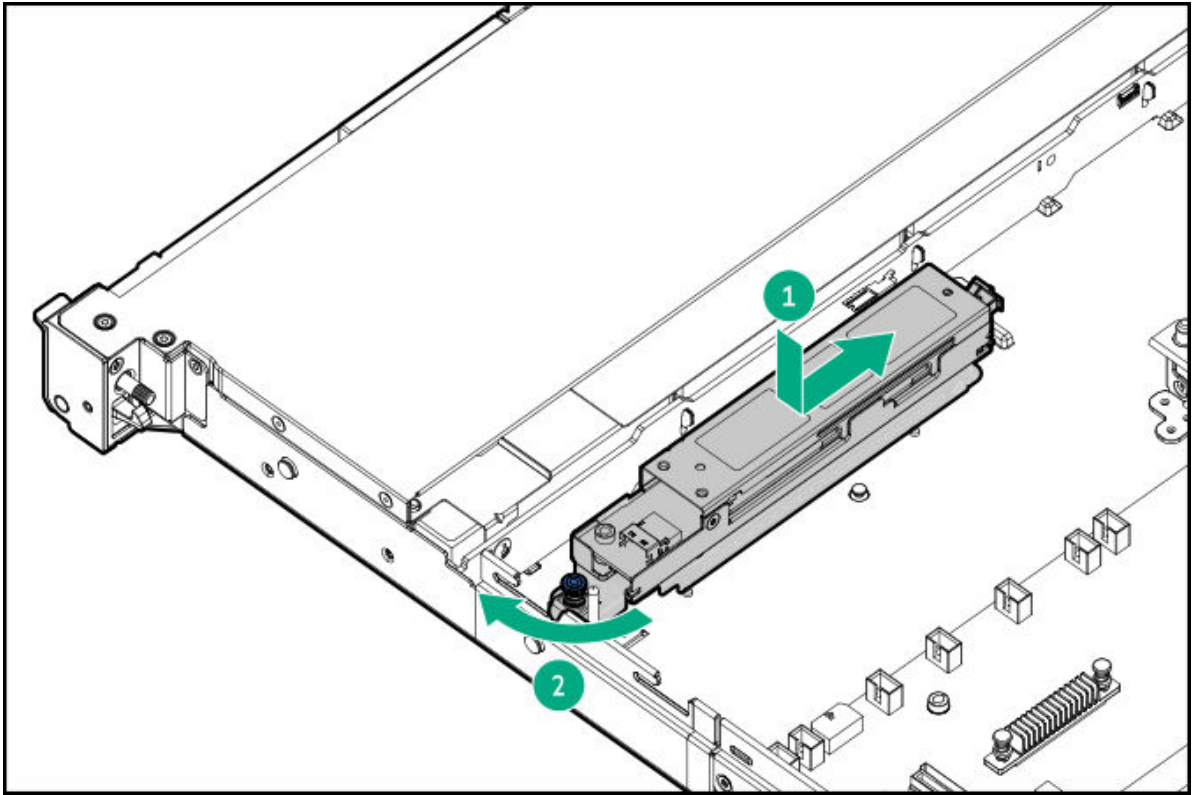

- 8 SFF drive configuration:

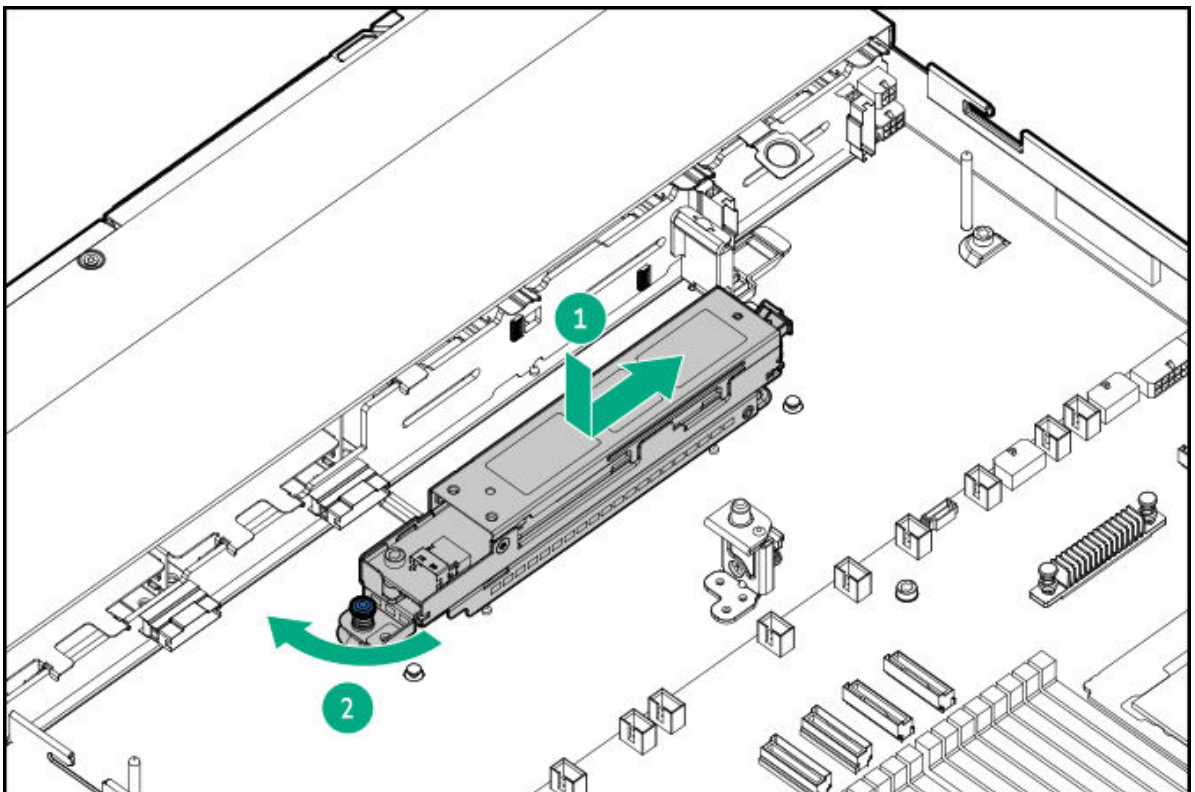

- 10 SFF / 20 E3.S / mixed drive type configuration:

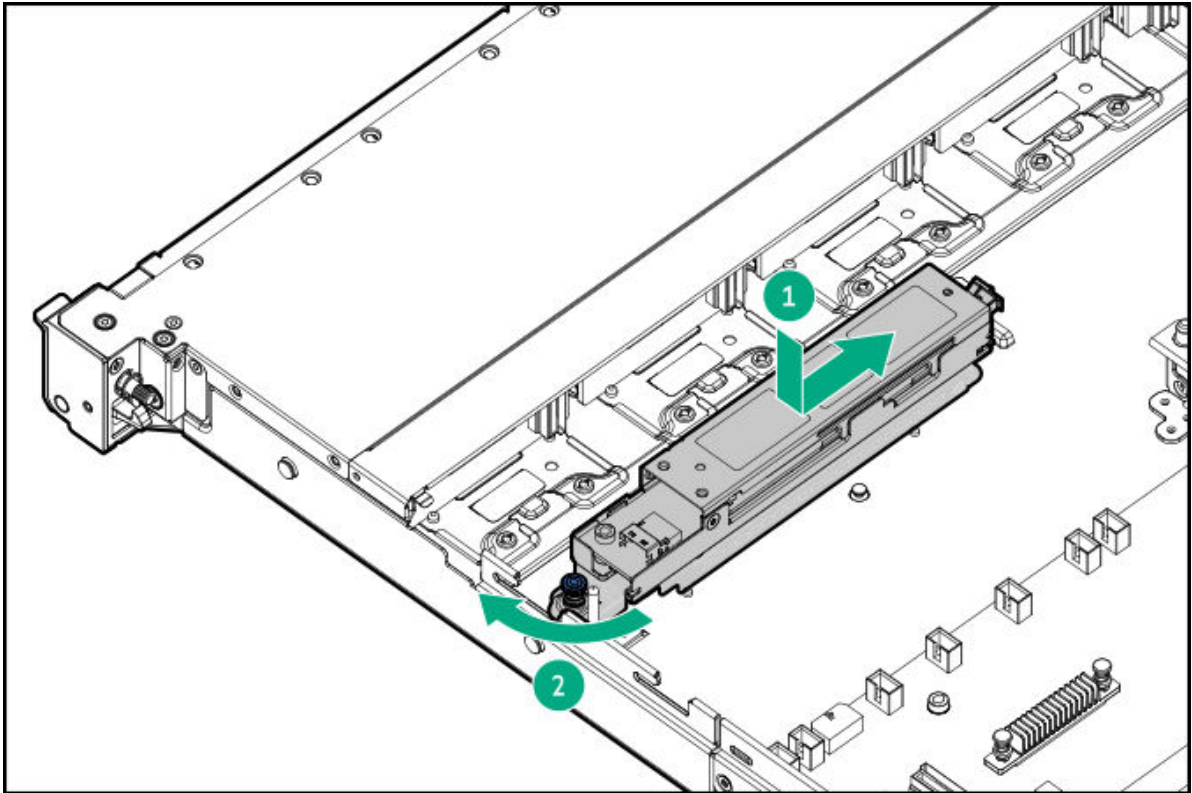

- .3. Connect the power and signal cables to the HPE NS204i Boot Device.
- .4. Install the access panel.
- .5. Install the server in the rack.
- .6. Connect all peripheral cables to the server.
- .7. Connect each power cord to the server.
- .8. Connect each power cord to the power source.
- .9. Power up the server.
- !0. Verify that the Online/Activity LEDs on the boot device are solid green.
- !1. Deploy a supported operating system to the boot device.
- !2. After the OS installation completes, the system automatically copies the operating system to the second, mirrored drive on the boot device.

Proceed with normal system setup and operation.

Results

The installation procedure is complete.

For information on using the UEFI System Utilities to manage the boot device, see the HPE NS204 Boot Device User Guide:

<https://www.hpe.com/support/NS204-UG>

Installing the front NS204i-u in drive box 5 of the 10 SFF / 20 E3.S server

Prerequisites

- Verify that your OS or virtualization software is supported:

<https://www.hpe.com/support/Servers-Certification-Matrices>

- Verify that you are running the latest iLO firmware and server BIOS version.
- Review the following:
 - Drive box numbering
 - HPE NS204i-u Boot Device V2 components
- Before you perform this procedure, make sure that you have the following items available:
 - Front NS204i-u enablement option (P77198-B21)—This option is supported in Box 5 in the 10 SFF / 20 E3.S server.
 - T-10 Torx screwdriver
 - Phillips No. 1 screwdriver—This tool is required only if the M.2 SSDs are not preinstalled on the boot device carriers.

About this task



WARNING

To reduce the risk of personal injury from hot surfaces, allow the drives and the internal system components to cool before touching them.



CAUTION

A discharge of static electricity from a finger or other conductor might damage system boards or other static-sensitive devices. To prevent damage, observe antistatic precautions.



IMPORTANT

For successful RAID 1 configuration, verify that the boot device SSDs have the same model number and firmware version:

- In the iLO web interface, see the **Storage** page.
- In UEFI System Utilities, see **System Configuration > HPE NS204i Boot Controller > Physical Device Information**.

Configurations with SSDs from different manufacturers are not supported.

Procedure

1. Install drives onto the boot device.
2. Back up all server data.
3. Power down the server.
4. Remove all power:
 - a. Disconnect each power cord from the power source.
 - b. Disconnect each power cord from the server.
5. Do one of the following:
 - Extend the server from the rack.
 - Remove the server from the rack.
6. Place the server on a flat, level work surface.
7. Remove the access panel.
8. If installed, remove the air baffle.

An 8 SFF server is shown. The removal procedure is the same for all drive configurations.

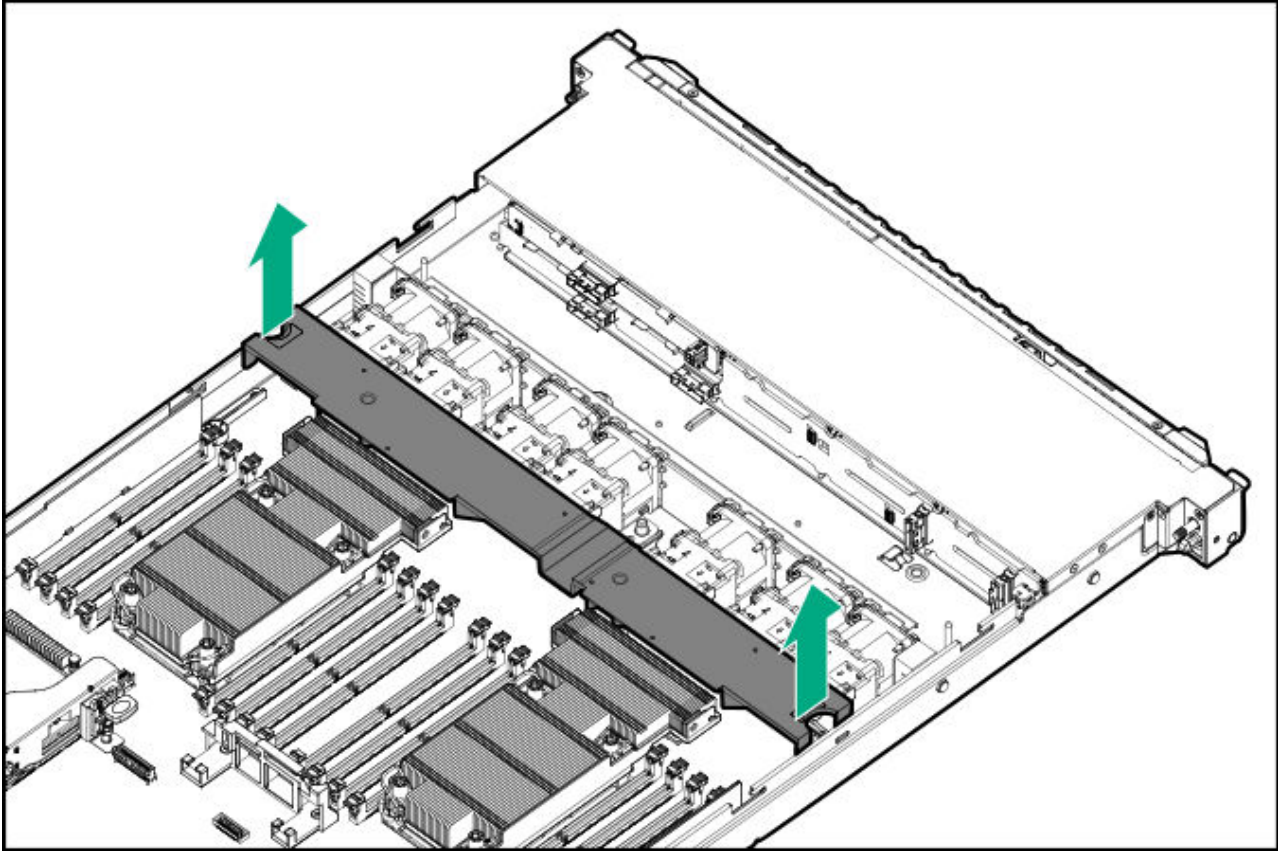

9. Install the boot device cage on the bracket.

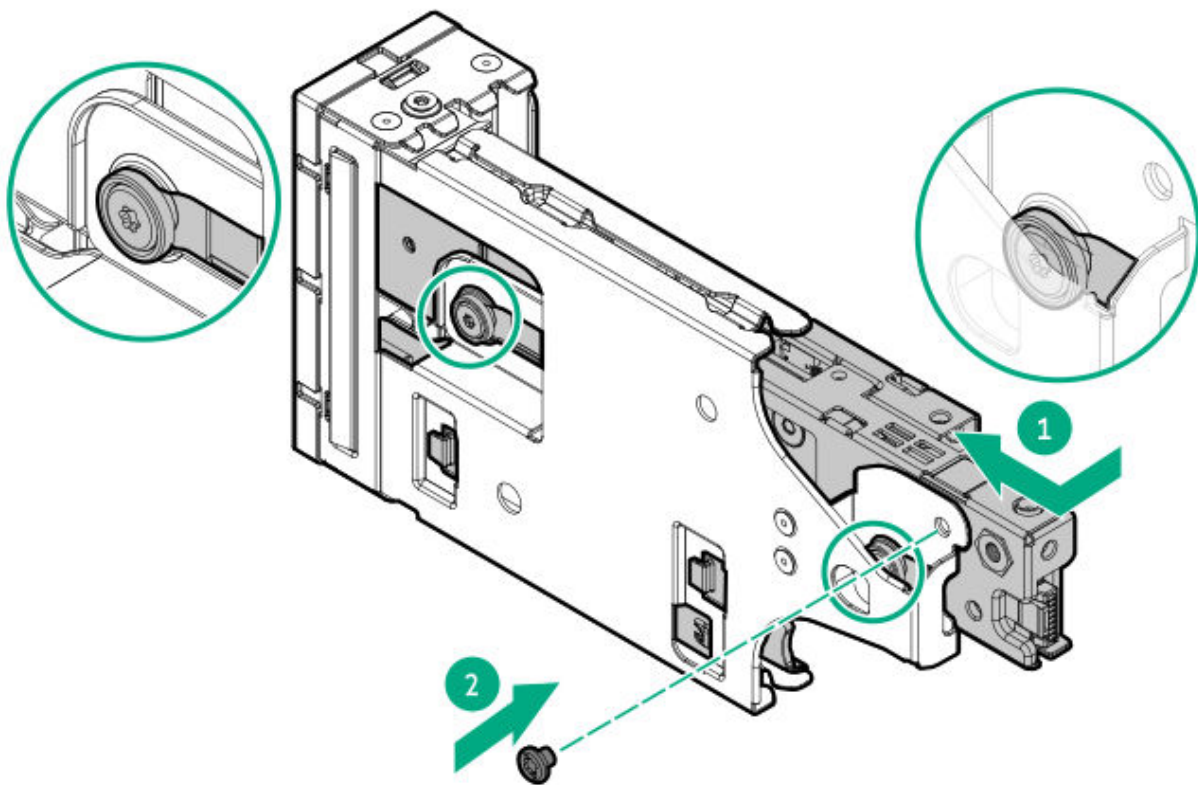

10. Install the boot device bracket into the multipurpose cage.

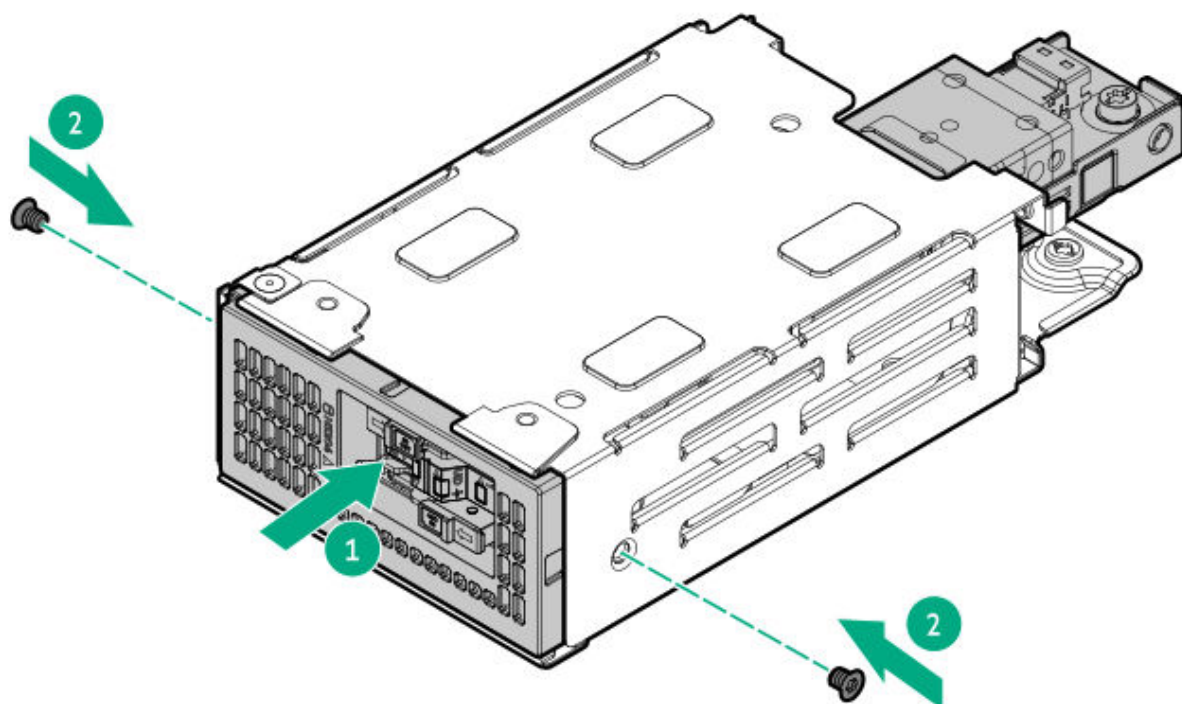

.1. Do one of the following:

- Remove the box blank from Box 5.

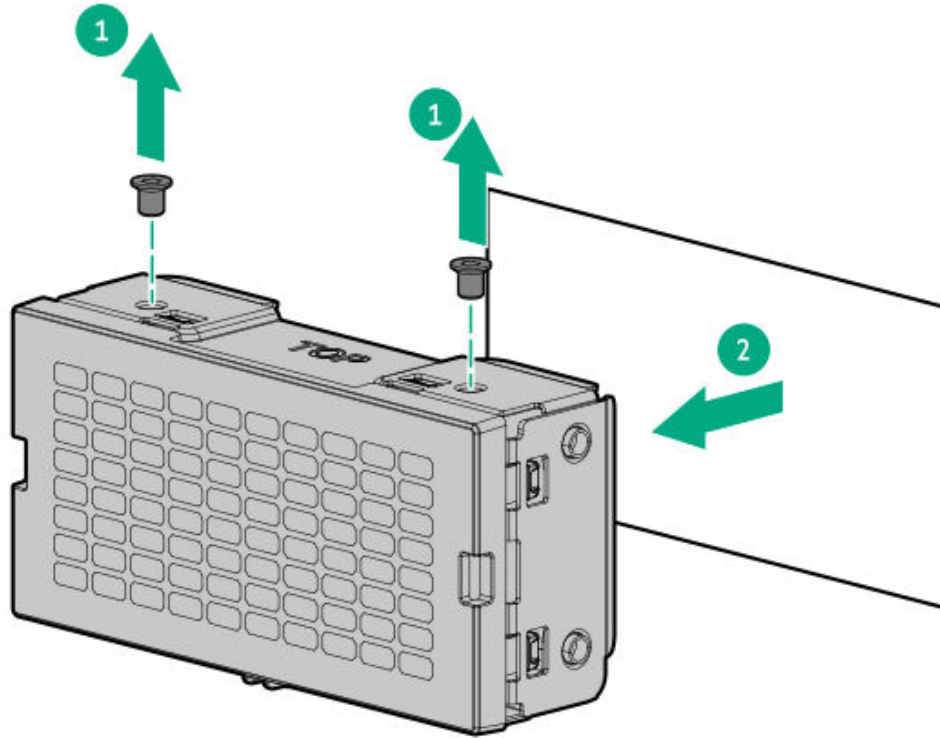

- If a drive cage is installed in Box 5, remove the drive cage.

Box 2 is shown. The removal procedures for all the boxes are the same.

- 2 SFF drive cage

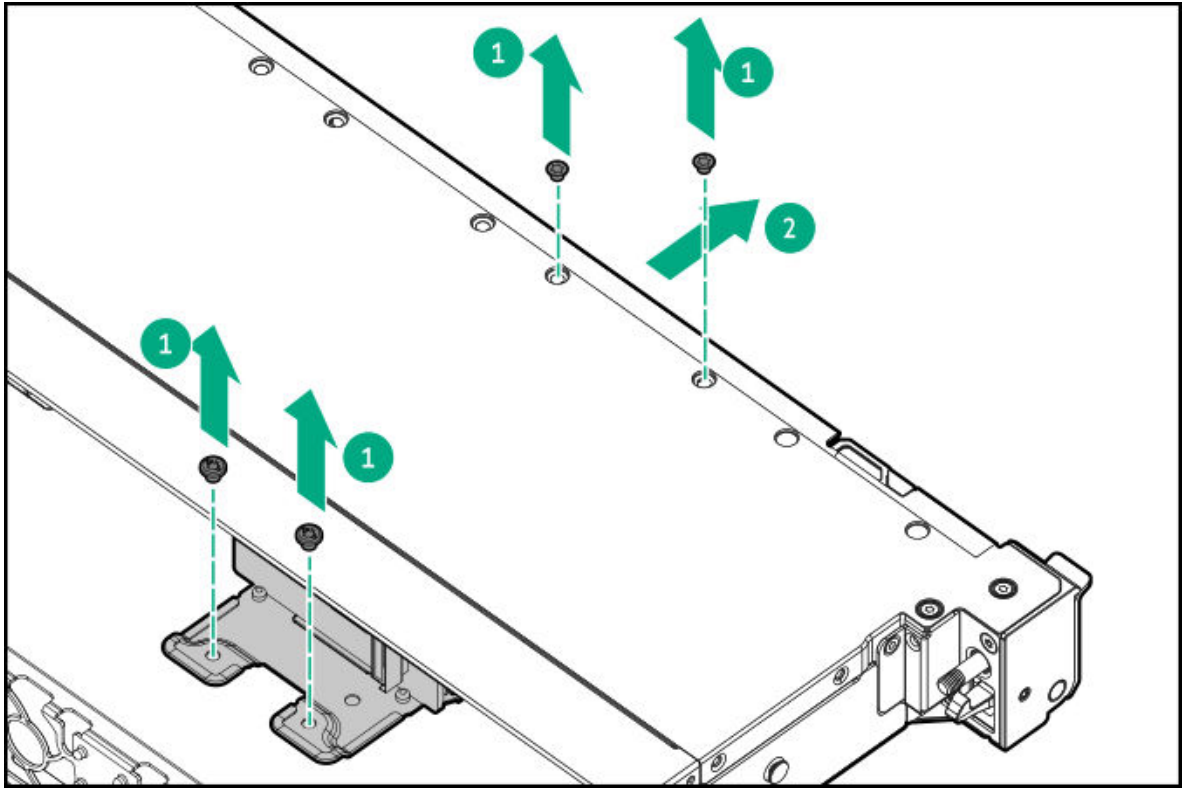

◦ 4 E3.S drive cage

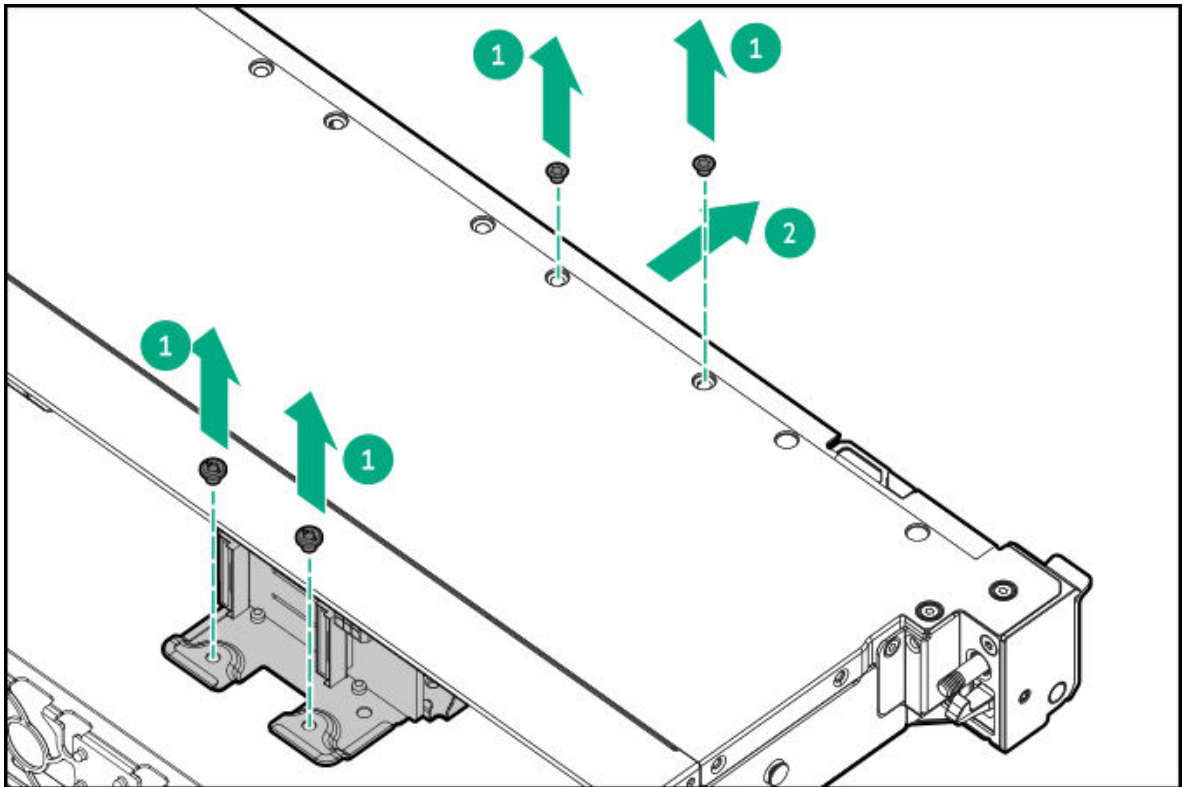

.2. Install the boot device cage into the server.

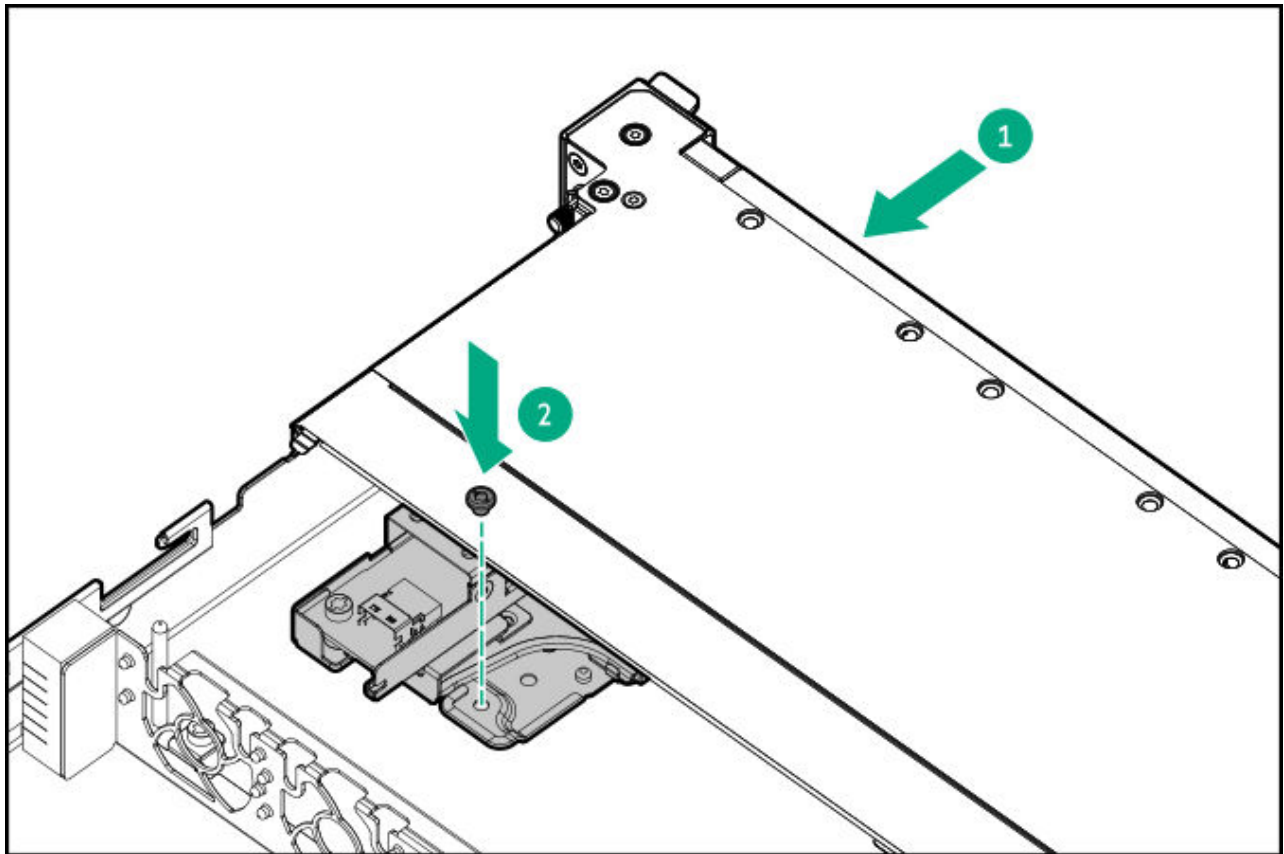

- .3. Connect the power and signal cables to the HPE NS204i Boot Device.
- .4. (Optional) Install the air baffle.
- .5. Install the access panel.
- .6. Install the server in the rack.
- .7. Connect all peripheral cables to the server.
- .8. Connect each power cord to the server.
- .9. Connect each power cord to the power source.
- !0. Power up the server.
- !1. Verify that the Online/Activity LEDs on the boot device are solid green.
- !2. Deploy a supported operating system to the boot device.
- !3. After the OS installation completes, the system automatically copies the operating system to the second, mirrored drive on the boot device.

Proceed with normal system setup and operation.

Results

The installation procedure is complete.

For information on using the UEFI System Utilities to manage the boot device, see the HPE NS204 Boot Device User Guide:

<https://www.hpe.com/support/NS204-UG>

Power supplies

Subtopics

[Hot-plug power supply calculations](#)

[Power supply warnings and cautions](#)

[DC power supply warnings and cautions](#)

[DC power supply wire colors](#)

[Installing a redundant hot-plug power supply](#)

[Installing a DC power supply](#)

[Connecting a DC power cable to a DC power source](#)

Hot-plug power supply calculations

For hot-plug power supply specifications and calculators to determine electrical and heat loading for the server, see the Hewlett Packard Enterprise Power Advisor website (<https://www.hpe.com/info/poweradvisor/online>).

Power supply warnings and cautions



WARNING

To reduce the risk of electric shock or damage to the equipment:

- Do not disable the power cord grounding plug. The grounding plug is an important safety feature.
- Plug the power cord into a grounded (earthed) electrical outlet that is easily accessible at all times.
- Unplug the power cord from the power supply to disconnect power to the equipment.
- Do not route the power cord where it can be walked on or pinched by items placed against it. Pay particular attention to the plug, electrical outlet, and the point where the cord extends from the server.



WARNING

To reduce the risk of injury from electric shock hazards, do not open power supplies. Refer all maintenance, upgrades, and servicing to qualified personnel.



CAUTION

Mixing different types of power supplies in the same server might:

- Limit or disable some power supply features including support for power redundancy.
- Cause the system to become unstable and might shut down.

To ensure access to all available features, all power supplies in the same server should have the same output and efficiency ratings. Verify that all power supplies have the same part number and label color.

DC power supply warnings and cautions



WARNING

To reduce the risk of electric shock, be sure that the cable grounding kit is properly installed and connected to a suitable protective earth terminal before connecting the power source to the rack.



CAUTION

This equipment is designed to permit the connection of the earthed conductor of the DC supply circuit to the earthing conductor at the equipment. If this connection is made, all the following must be met:

- This equipment must be connected directly to the DC supply system earthing electrode conductor or to a bonding jumper from an earthing terminal bar or bus to which the DC supply system earthing electrode conductor is connected.
- This equipment must be located in the same immediate area (such as adjacent cabinets) as any other equipment that has a connection between the earthed conductor of the same DC supply circuit and the earthing conductor, and also the point of earthing of the DC system. The DC system must be earthed elsewhere.
- The DC supply source is to be located within the same premises as the equipment.
- Switching or disconnecting devices must not be in the earthed circuit conductor between the DC source and the point of connection of the earthing electrode conductor.

DC power supply wire colors

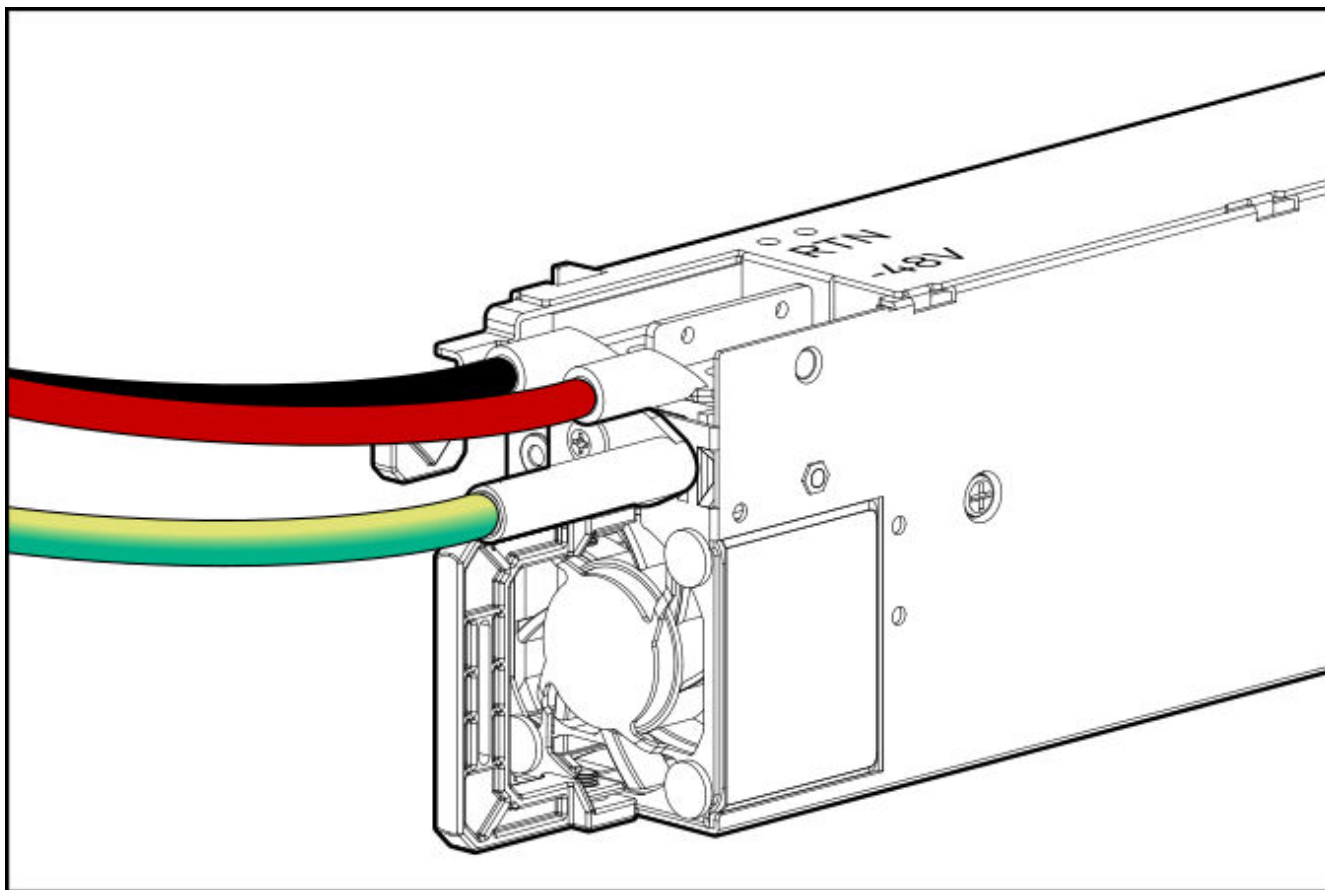

Wire color	Description	Wire slot
Red	Line wire	-48V
Black	Return wire	Return
Green + Yellow	Ground wire	Safety ground

Installing a redundant hot-plug power supply

Prerequisites

Before installing this option, be sure you have the components included with the hardware option kit.

About this task



CAUTION

All power supplies installed in the server must have the same output power capacity. Verify that all power supplies have the same part number and label color. The system becomes unstable and may shut down when it detects mismatched power supplies.



CAUTION

To prevent improper cooling and thermal damage, do not operate the server unless all bays are populated with either a component or a blank.

Procedure

1. [Access the product rear panel.](#)

2.



WARNING

To reduce the risk of personal injury from hot surfaces, allow the power supply, power supply blank, or dual slot power supply adapter to cool before touching it.

Remove the blank.

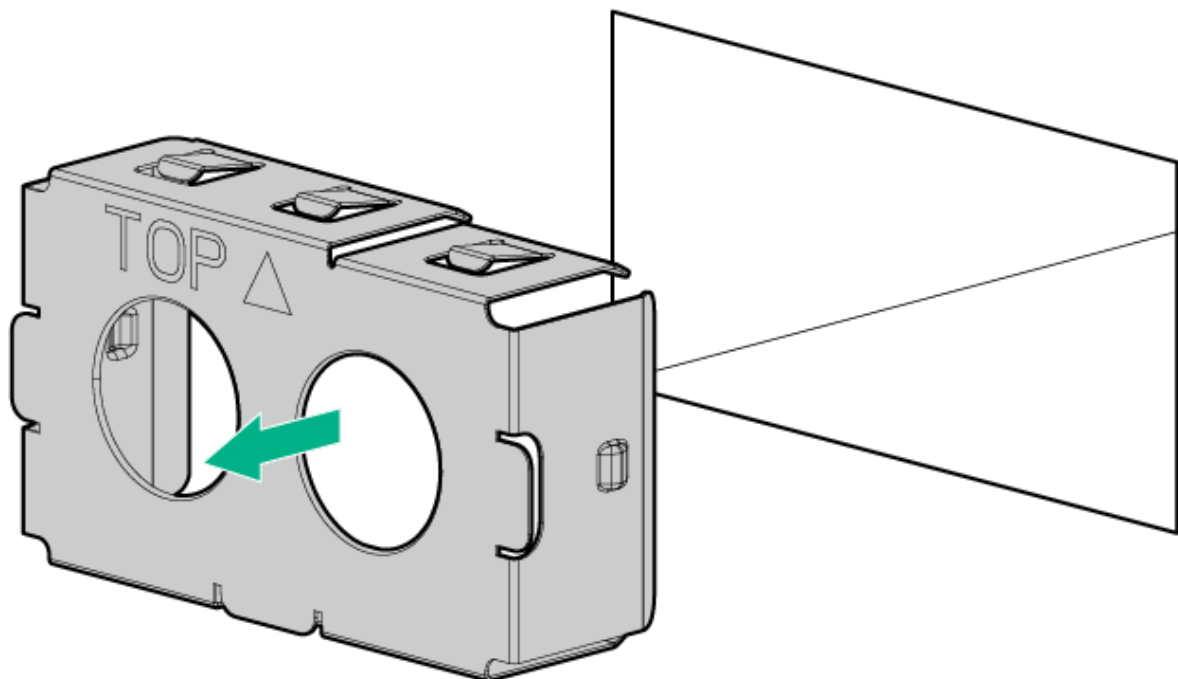

3. Insert the power supply into the power supply bay until it clicks into place.

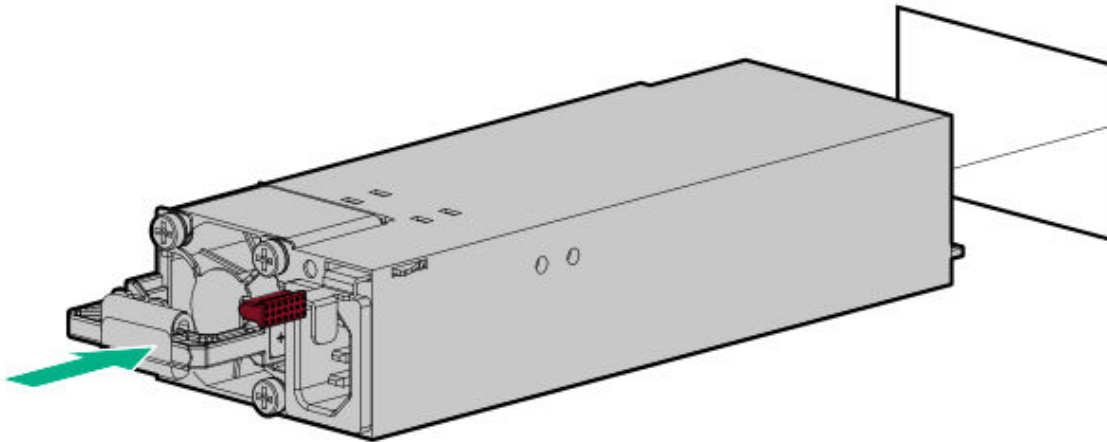

4. Connect the power cord to the power supply.
5. Route the power cord. Use best practices when routing power cords and other cables. A cable management arm is available to help with routing. To obtain a cable management arm, contact a Hewlett Packard Enterprise authorized reseller.
6. Connect the power cord to the AC power source.
7. Be sure that the power supply LED is green.

Results

The installation procedure is complete.

Installing a DC power supply

Prerequisites

- Before installing a power supply, review the following:
 - [Power supply warnings and cautions](#)
 - [DC power supply warnings and cautions](#)
 - [DC power supply wire colors](#)
- Before you perform this procedure, make sure that you have a Phillips No. 2 screwdriver available.

- Before connecting the power cables, review the following:
 - The optional P36877-B21 HPE lug kit can be purchased from an authorized HPE reseller for use with customer-supplied power cables. (The power cable and lug kit listed below can only be used with the 1600 W -48 VDC power supply.)
 - If you are using an input power cord option, the P22173-B21 HPE 1600 W DC PSU power cable kit can be purchased from an authorized HPE reseller.
 - The DC power supply option kits do not ship with a Power Supply DC cable Kit and may not include a Power Supply Cable Lug kit. The optional DC Cable kit or the optional DC Cable Lug Kit may be purchased directly from Hewlett Packard Enterprise or an authorized HPE reseller. For additional information, see the power supply QuickSpecs at <https://www.hpe.com/info/fsps-qs>.

About this task

If you are not using an input power cord option, the power supply cabling must be made in consultation with a licensed electrician and be compliant with local code.



WARNING

To reduce the risk of electric shock, fire, and damage to the equipment, you must install this product in accordance with the following guidelines:

- The HPE 1600 W Flex Slot -48 VDC hot-plug power supply is intended only for installation in servers located in a restricted access location.
- The HPE 1600 W Flex Slot -48 VDC hot-plug power supply is not intended for direct connection to the DC supply branch circuit. Only connect this power supply to a power distribution unit (PDU) that provides an independent overcurrent-protected output for each DC power supply. Each output overcurrent-protected device in the PDU must be suitable for interrupting fault current available from the DC power source and must be rated no more than 45 A.
- The PDU output must have a shut-off switch or a circuit breaker to disconnect power for each power supply. To completely remove power from the power supply, disconnect power at the PDU. The end product may have multiple power supplies. To remove all power from the product, disconnect the power for each power supply.
- In accordance with applicable national requirements for Information Technology Equipment and Telecommunications Equipment, this power supply only connects to DC power sources that are classified as SELV or TNV. Generally, these requirements are based on the International Standard for Information Technology Equipment, IEC 60950-1/IEC 62368-1. In accordance with local and regional electric codes and regulations, the DC source must have one pole (Neutral/Return) reliably connected to earth ground.
- You must connect the power supply ground screw located on the front of the power supply to a suitable ground (earth) terminal. In accordance with local and regional electric codes and regulations, this terminal must be connected to a suitable building ground (earth) terminal. Do not rely on the rack or cabinet chassis to provide adequate ground (earth) continuity.



WARNING

To reduce the risk of personal injury from hot surfaces, allow the power supply, power supply blank, or dual slot power supply adapter to cool before touching it.

Procedure

1. Remove the protective cover from the power supply.

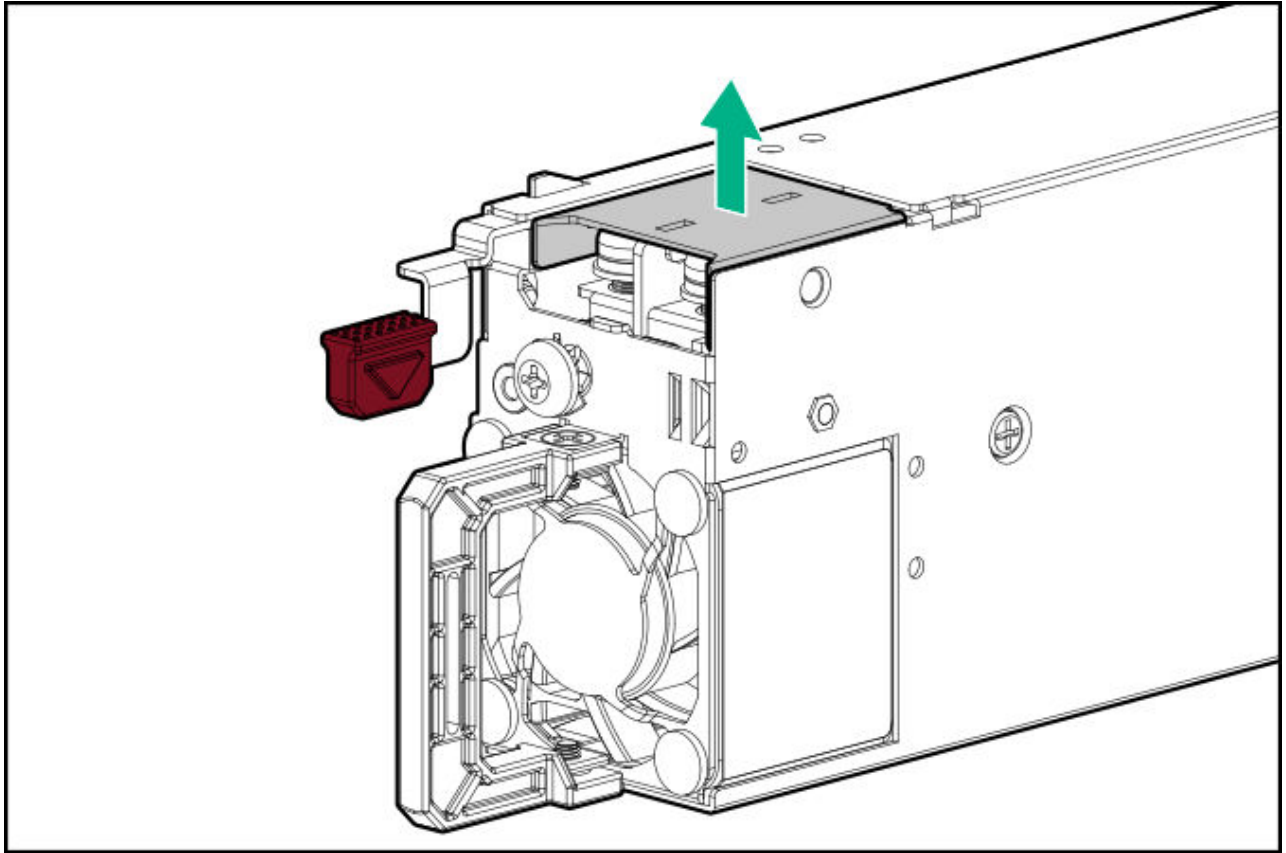

2. Remove the ground wire screw, and then remove the return wire and line wire screws.

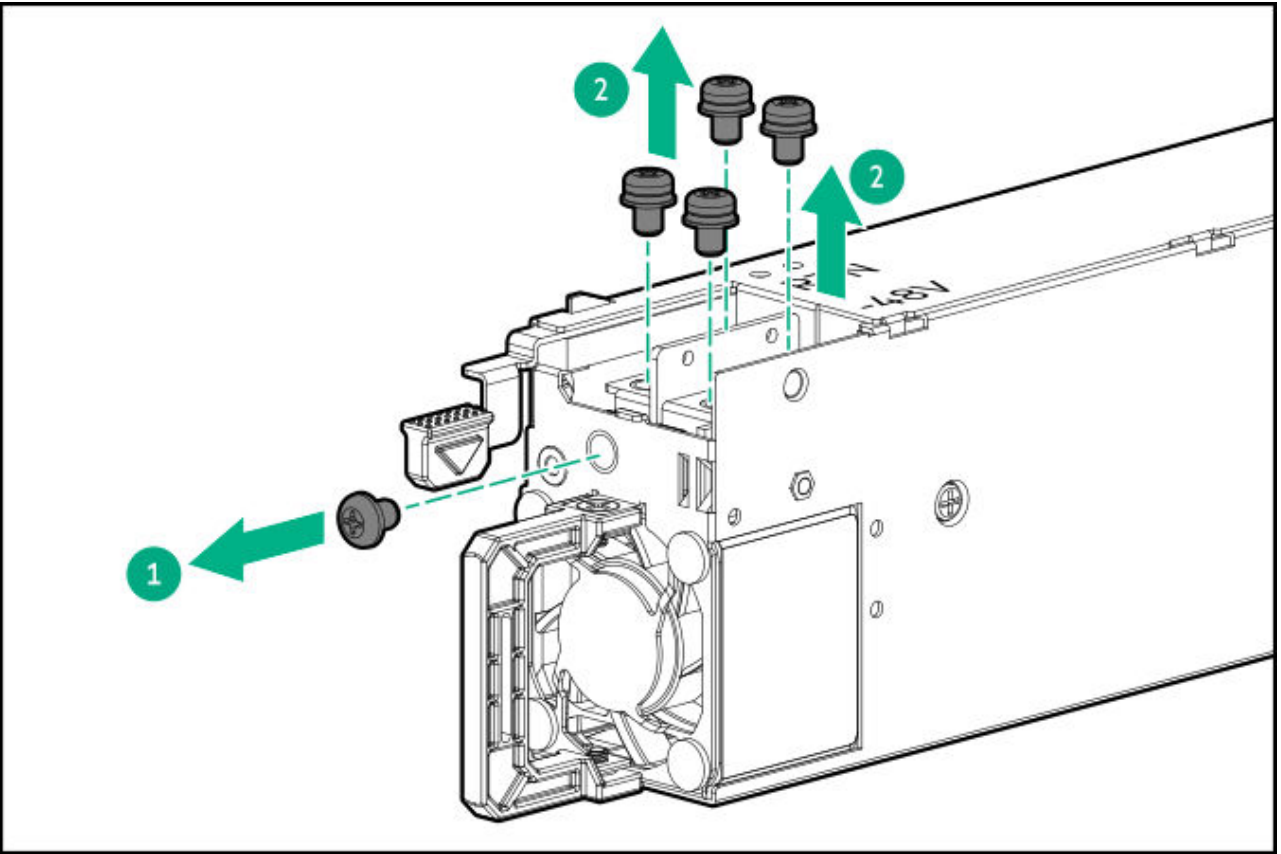

3. Attach the ground wire (green and yellow) to the DC power supply and tighten the screw and washer with 1.47 N-m (13 lbf-in).

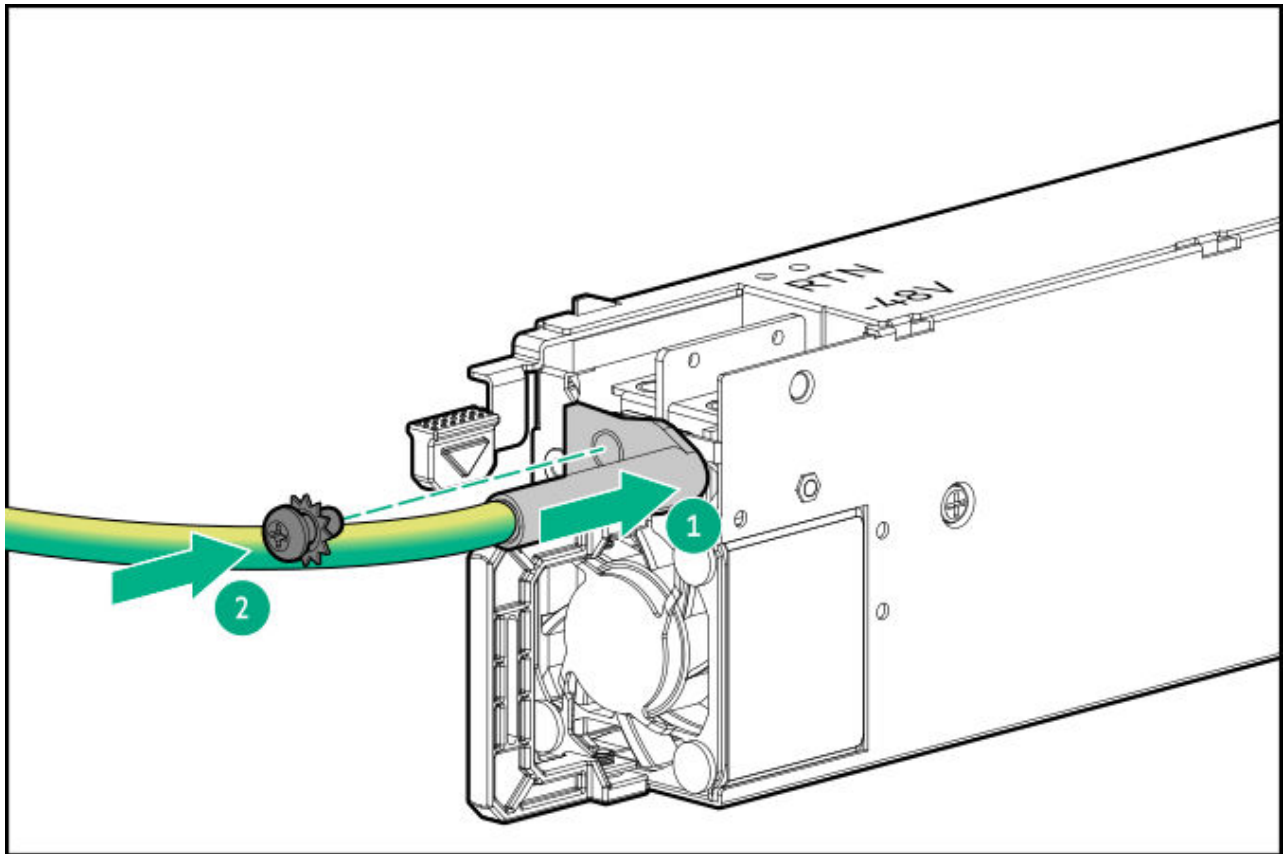

4. Install the return wire (black):

- a. Insert the return wire into the RTN slot on the DC power supply.
- b. Tighten the screw with 0.98 N-m (8.68 lbf-in).

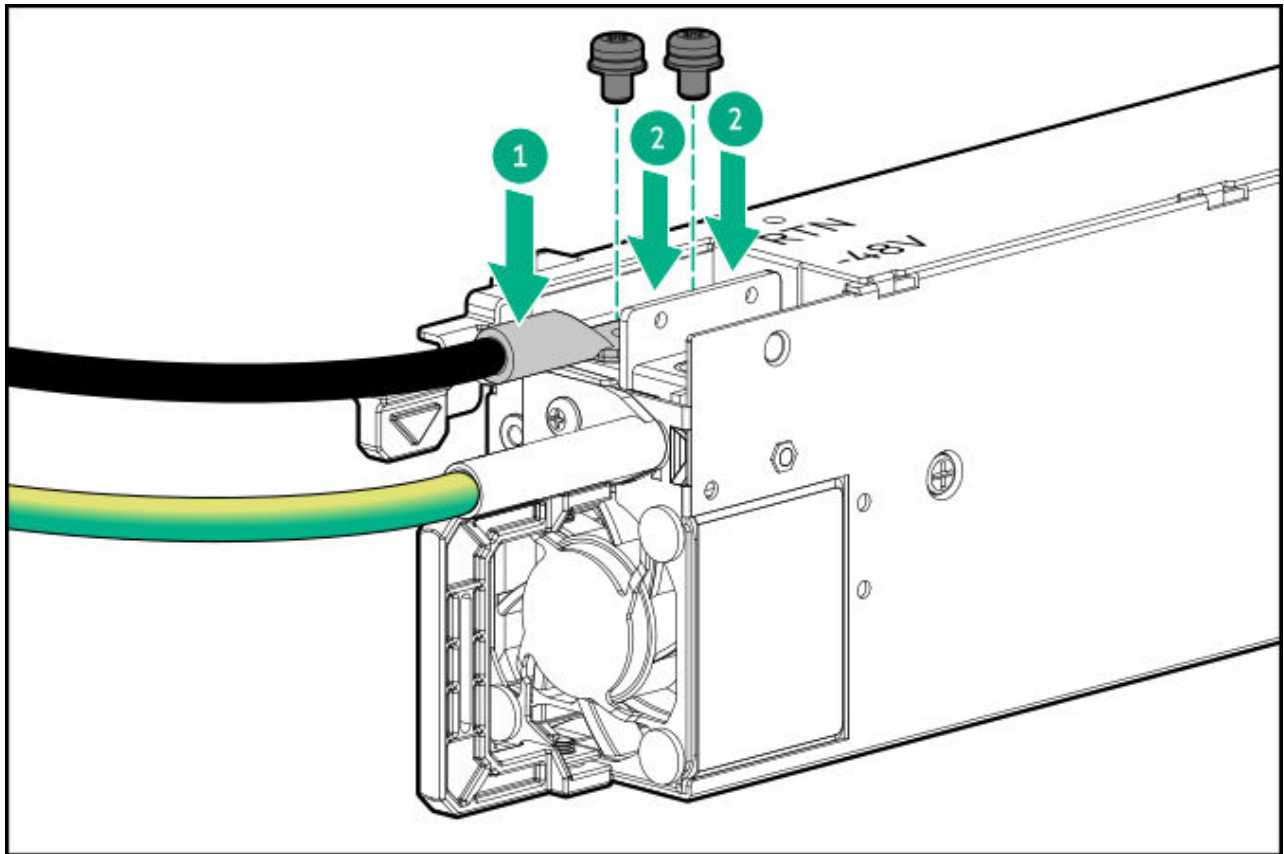

5. Install the line wire (red):

- a. Insert the line wire into the -48V slot on the DC power supply.
- b. Tighten the screw to 0.98 N-m (8.68 lbf-in).

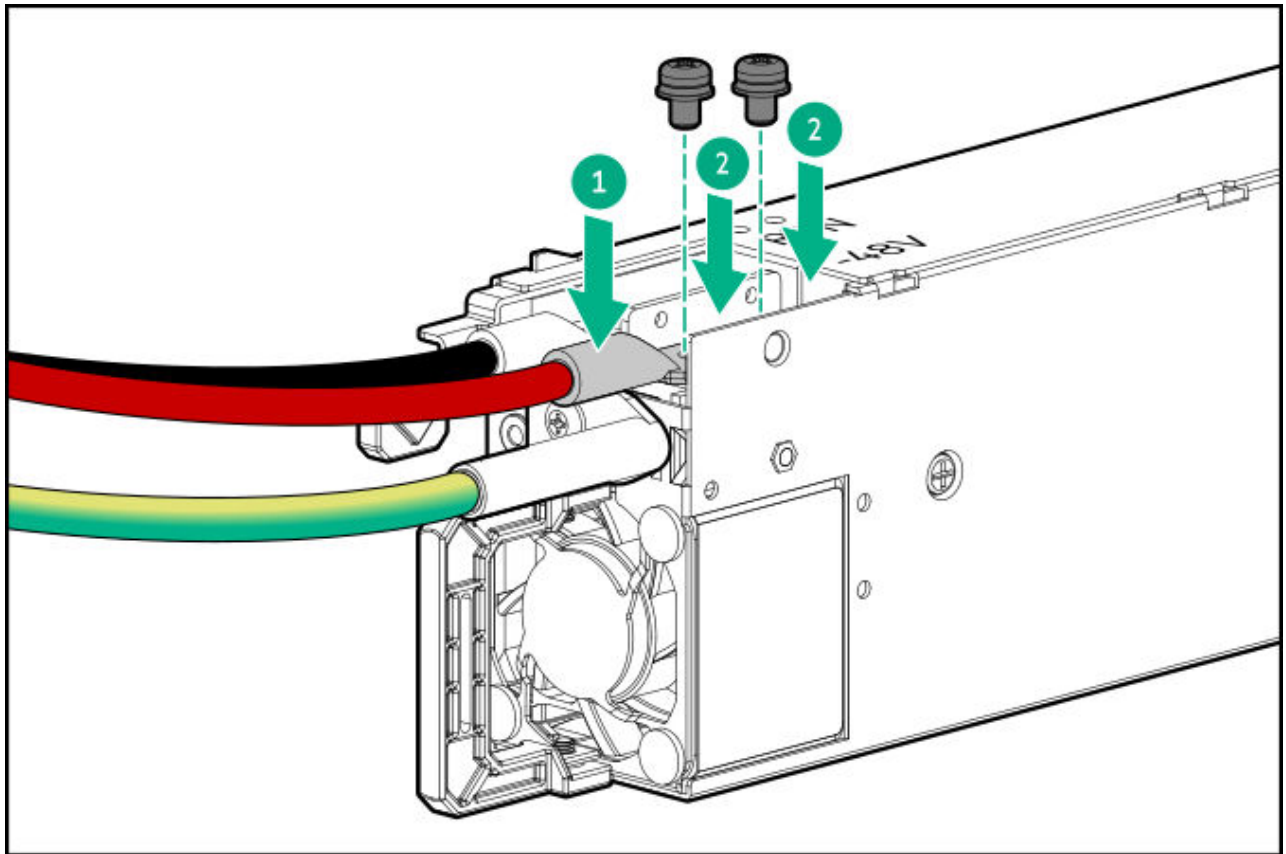

6. Install the protective cover on the DC power supply.

Make sure that the protective cover is locked.

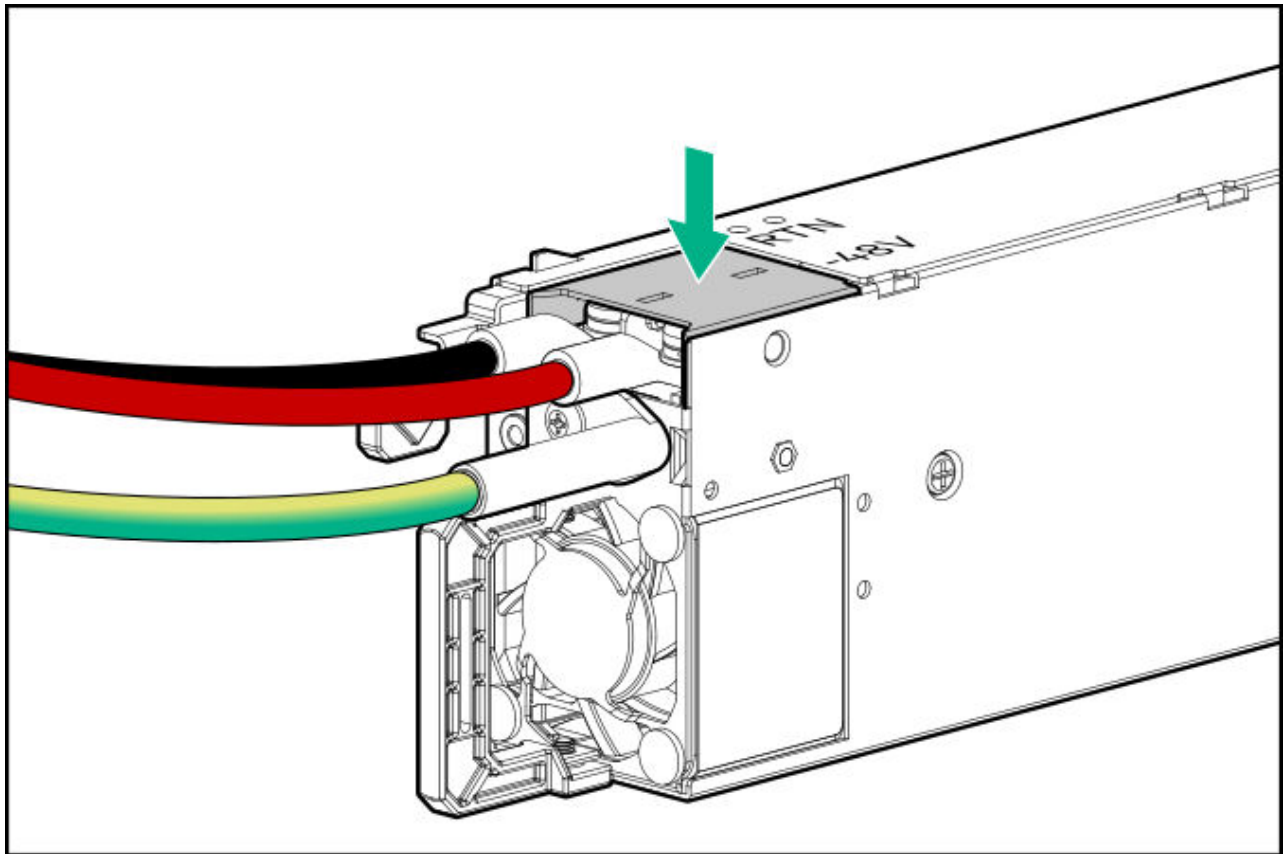

7. Secure the ground, positive return, and negative input wires in the strain relief strap.



CAUTION

Avoid tight bend radii to prevent damaging the internal wires of a power cord or a server cable. Never bend power cords and server cables tight enough to cause a crease in the sheathing.

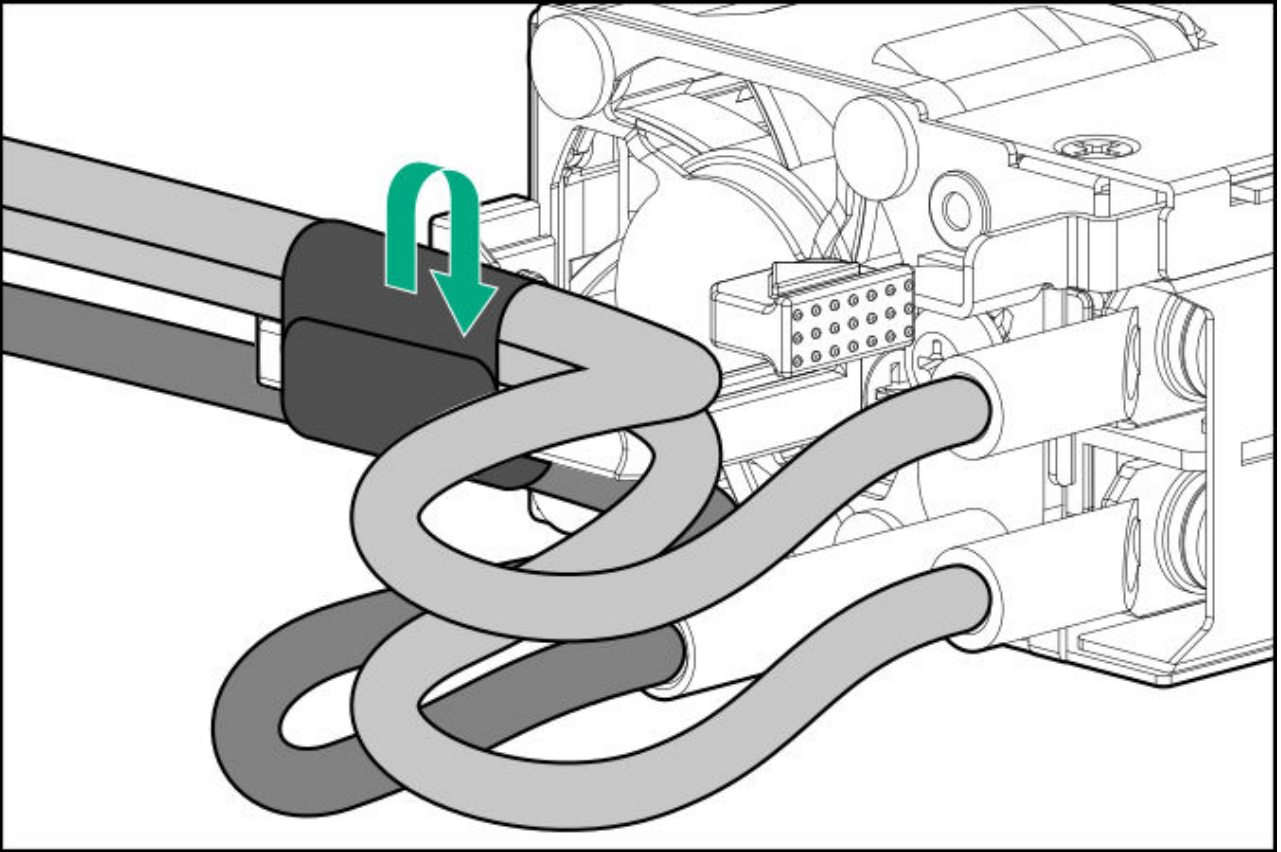

8. If you are installing a power supply in the power supply bay 2, remove the power supply blank.
Retain the blank for future use.

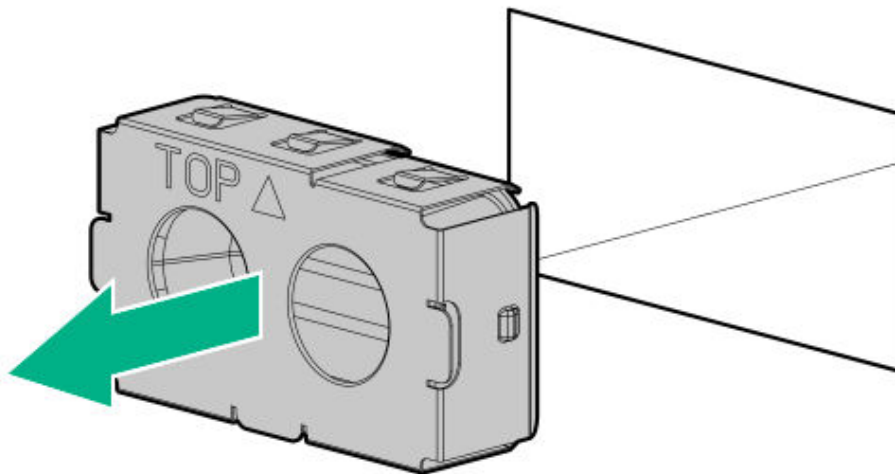

9. Immediately slide the power supply into the bay until it clicks into place.

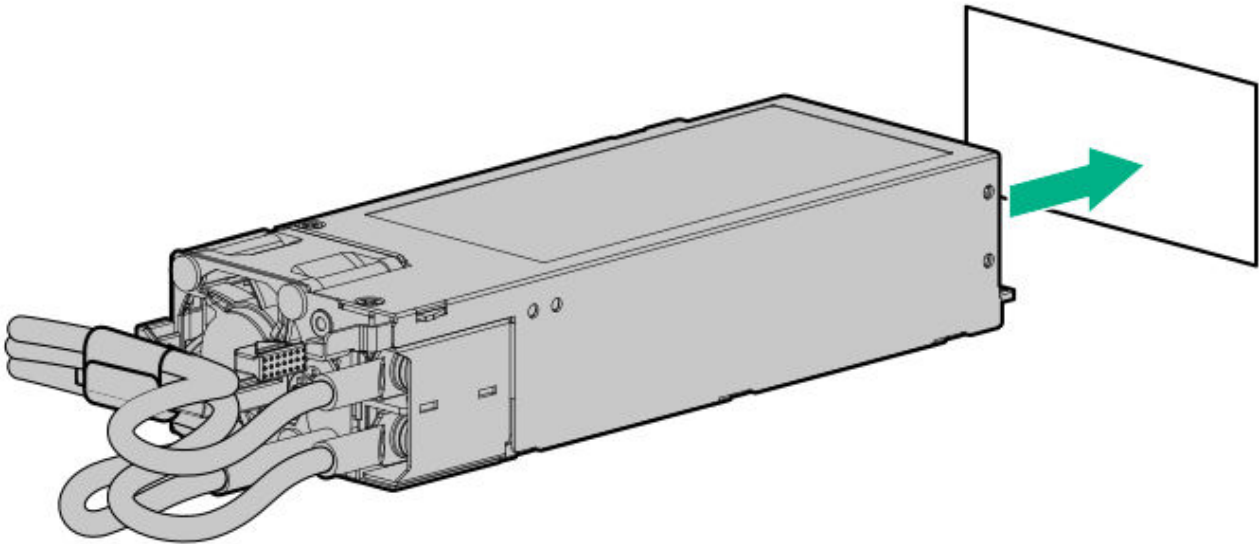

- .0. Make sure the -48 V DC power source is off or the PDU breaker is in the off position, and then connect the power cord to the -48 V DC power source or PDU.
- .1. Turn on the -48 V power source or switch the PDU breaker to the on position to supply -48 V to the power supply.
- .2. Connect a DC power cable to a DC power source.
- .3. Make sure that the power supply LED is green.

Results

The installation procedure is complete.

Connecting a DC power cable to a DC power source

Prerequisites

Before you perform this procedure, make sure that you have the following items available:

- Electrical wire cutter
- Hand crimp tool

About this task



WARNING

To reduce the risk of electric shock or energy hazards:

- This equipment must be installed by trained service personnel and in accordance with local and regional electric codes and regulations
- Connect the equipment to a reliably grounded secondary circuit source. A secondary circuit has no direct connection to a primary circuit and derives its power from a transformer, converter, or equivalent isolation device.
- The overcurrent protection for the DC source must not exceed 45 A.



WARNING

When installing a DC power supply, the ground wire must be connected before the positive or negative leads.



WARNING

Remove power from the power supply before performing any installation steps or maintenance on the power supply.



CAUTION

The server equipment connects the earthed conductor of the DC supply circuit to the earthing conductor at the equipment. For more information, see the documentation that ships with the power supply.



CAUTION

If a DC connection exists between the earthed conductor of the DC supply circuit and the earthing conductor at the server equipment, the following conditions must be met:

- This equipment must be connected directly to the DC supply system earthing electrode conductor or to a bonding jumper from an earthing terminal bar or bus to which the DC supply system earthing electrode conductor is connected.
- Locate the equipment in the same immediate area (such as adjacent cabinets) as any other equipment that has a connection between the earthed conductor of the same DC supply circuit and the earthing conductor, and also the point of earthing of the DC system. The DC system must be earthed

Procedure

1. Cut the DC power cord ends no shorter than 150.00 cm (59.06 in).



IMPORTANT

The ring terminals must be UL approved and accommodate 6 AWG wires.



IMPORTANT

The minimum nominal thread diameter of a pillar or stud type terminal must be 3.50 mm (0.138 in). The diameter of a screw type terminal must be 5.00 mm (0.197 in).

2. If the power source requires ring tongues, use a crimping tool to install the ring tongues on the power cord wires and ground wire.
3. Stack each same-colored pair of wires and then attach them to the same power source.

For more information, see the documentation that ships with the power supply.

Processors and heatsinks

Subtopics

Processor cautions

Installing a high performance heatsink

Installing the closed-loop liquid cooling module

Connecting the direct liquid cooling kit

Processor cautions



CAUTION

To avoid damage to the processor or system board, only authorized personnel should attempt to replace or install the processor in this server.



CAUTION

To prevent possible server malfunction and damage to the equipment, multiprocessor configurations must contain processors with the same part number.



CAUTION

The pins on the processor socket and on the processor are very fragile and easily damaged. To avoid component damage, **do not touch these pins.** Any damage to them might require replacing the system board and/or processor.



IMPORTANT

Processor socket 1 must be populated at all times or the server does not function.



IMPORTANT

If installing a processor with a faster speed, update the system ROM before installing the processor. To download firmware, go to the Hewlett Packard Enterprise Support Center website (<https://www.hpe.com/support/hpesc>).

Installing a high performance heatsink

Prerequisites

- Review the following:
 - [Heatsink and processor socket components](#)
 - [Processor cautions](#)
 - [Fan and heatsink requirements](#)
- Before you perform this procedure, make sure that you have a T-30 Torx screwdriver or a torque screwdriver with T-30 Torx bit available.

About this task



CAUTION

A discharge of static electricity from a finger or other conductor might damage system boards or other static-sensitive devices. To prevent damage, observe antistatic precautions.

Procedure

1. Power down the server.
2. Remove all power:
 - a. Disconnect each power cord from the power source.
 - b. Disconnect each power cord from the server.
3. If the server is installed in an enclosure or a rack, remove the server and place it on a flat, level work surface.
4. Remove the access panel.
5. Allow all internal system components to cool before continuing.

Removing the standard heatsink

6.



CAUTION

Heatsink screws must be tightened and loosened in alternating sequence. Do not overtighten the screws as this might damage the system board or the processor socket.

Use a T-30 Torx screwdriver to loosen one pair of diagonally opposite heatsink screws (callouts 1 and 2), and then loosen the other pair of heatsink screws (callouts 3 and 4).

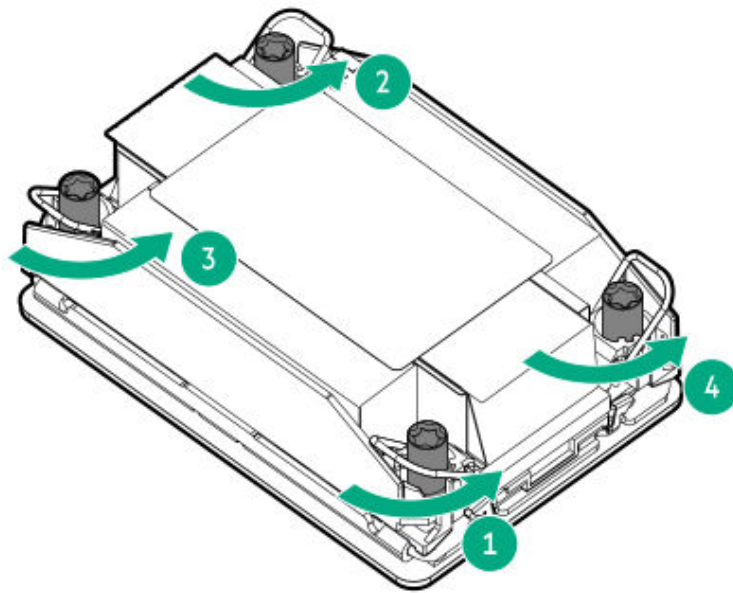

7. Set the anti-tilt wires to the unlocked position.

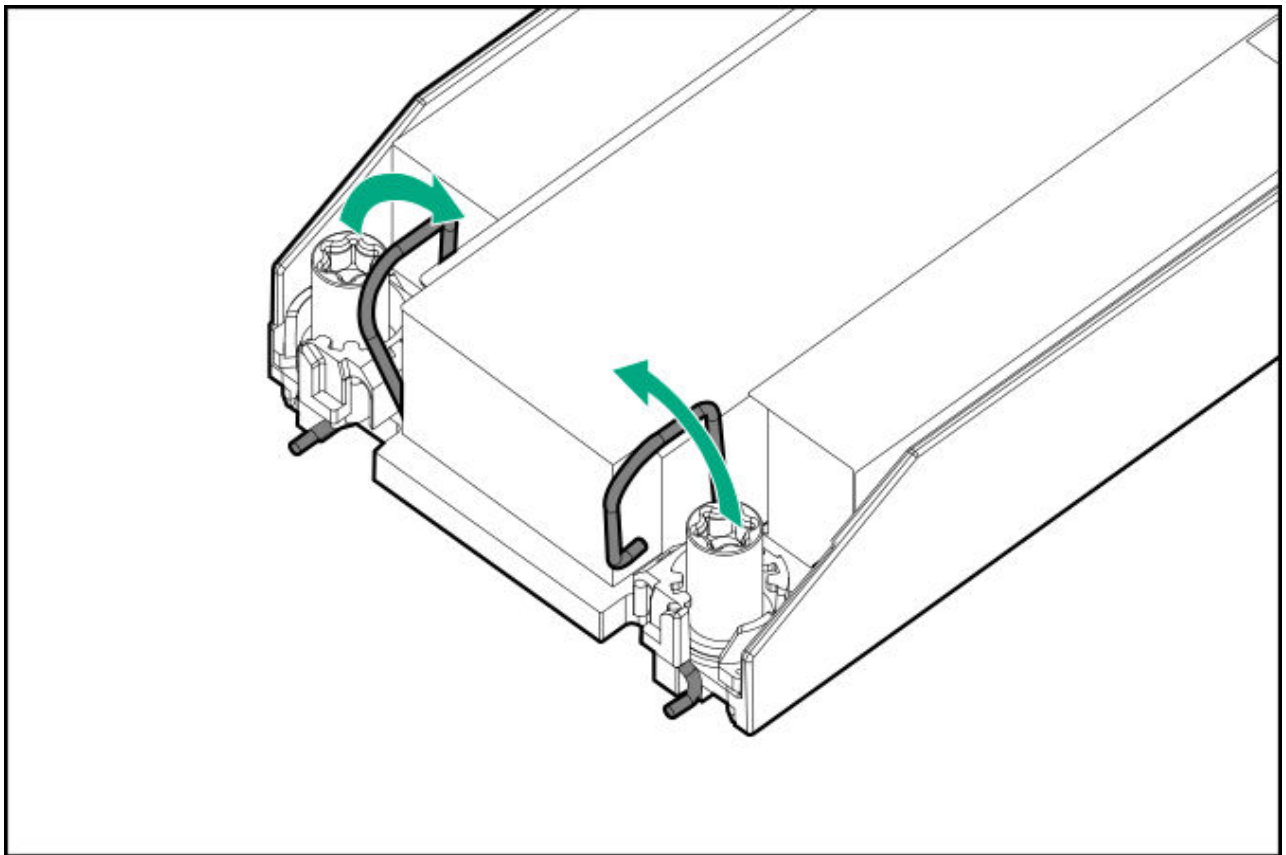

8.



CAUTION

To prevent mechanical damage or depositing oil on your hands or other contaminants to the heatsink contact surface, hold the heatsink only by the edge of its base plate. Do not touch the heatsink fins.

Lift the processor-heatsink module straight up from the system board.

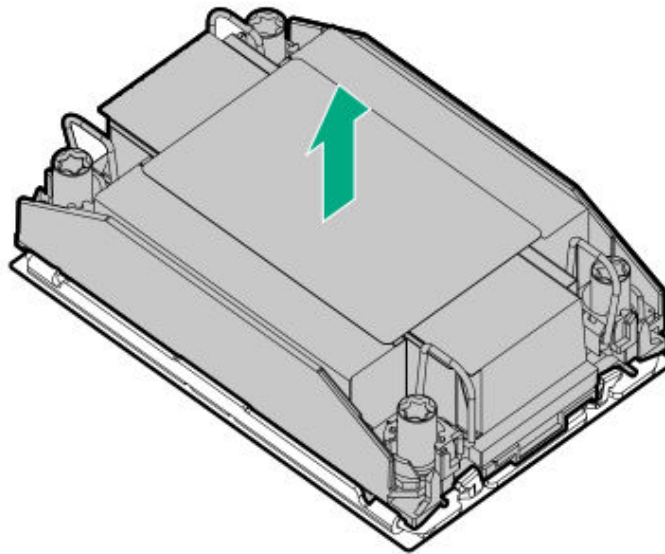

9. Place the processor-heatsink module on a flat work surface with its contact side facing up.

10. Do not touch the pins on the processor socket and the processor.



CAUTION

THE PINS ON THE PROCESSOR SOCKET AND ON THE PROCESSOR ARE VERY FRAGILE AND EASILY DAMAGED. Any damage to them might require replacing the system board.

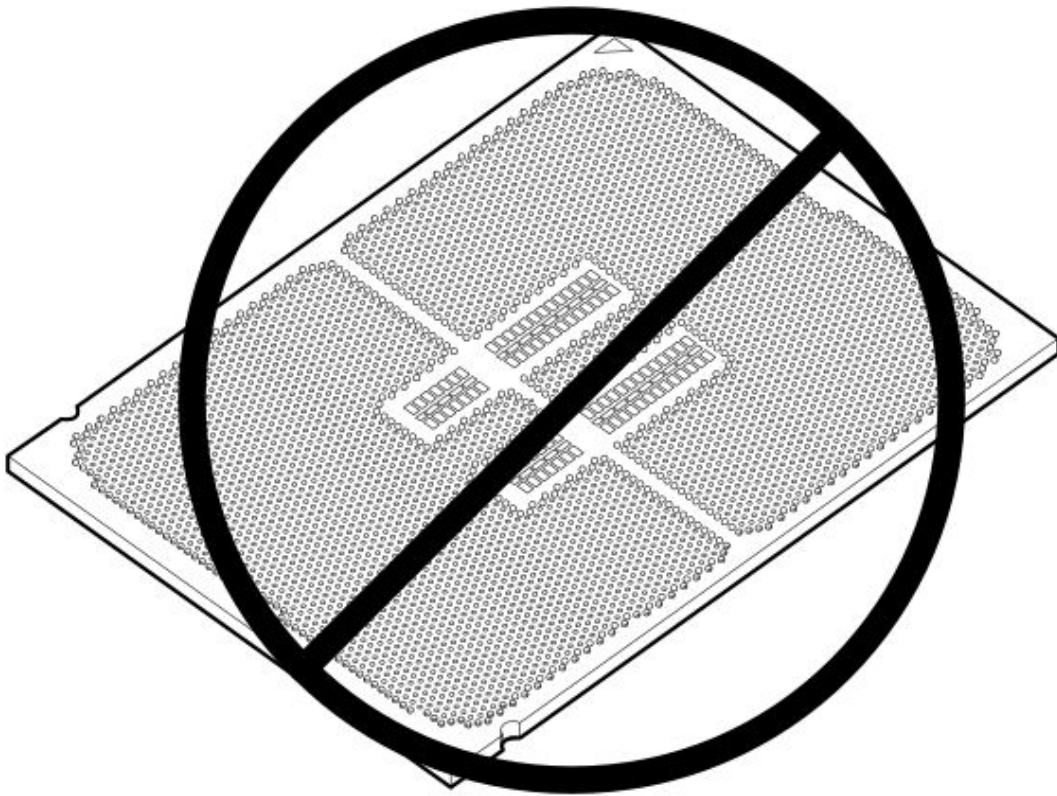
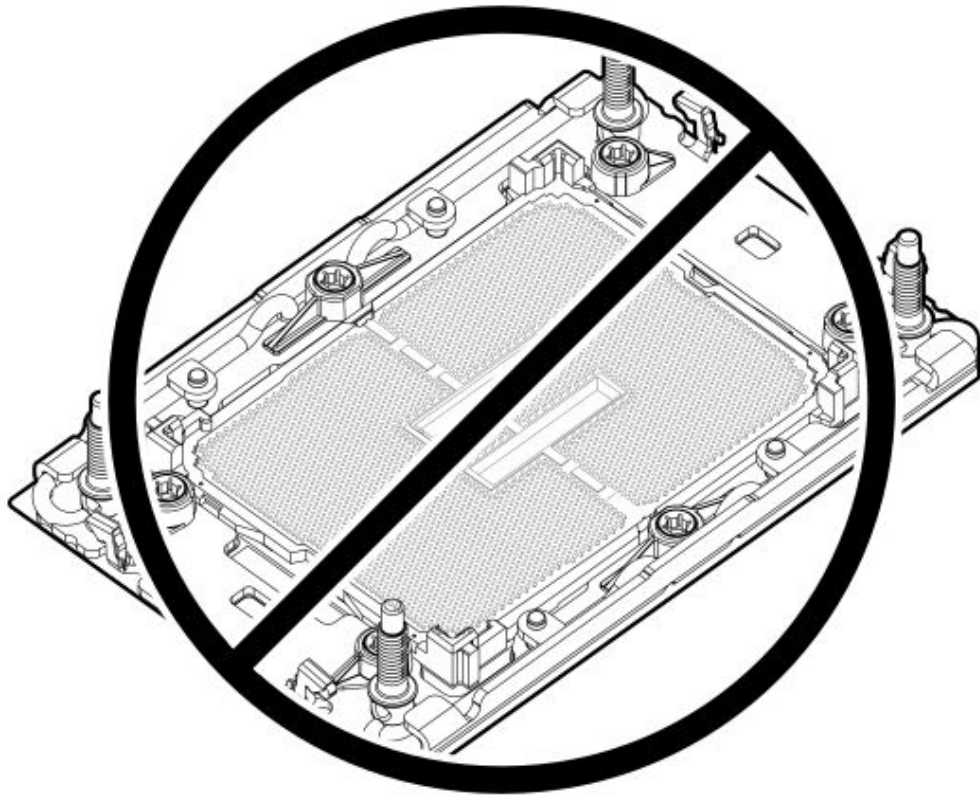

.1. Remove the processor from the heatsink:

a. Open the TIM breaker lever.

This action breaks the adhesion between the processor and the heatsink.

b. Hold the processor by its edges, and then remove it from the carrier.

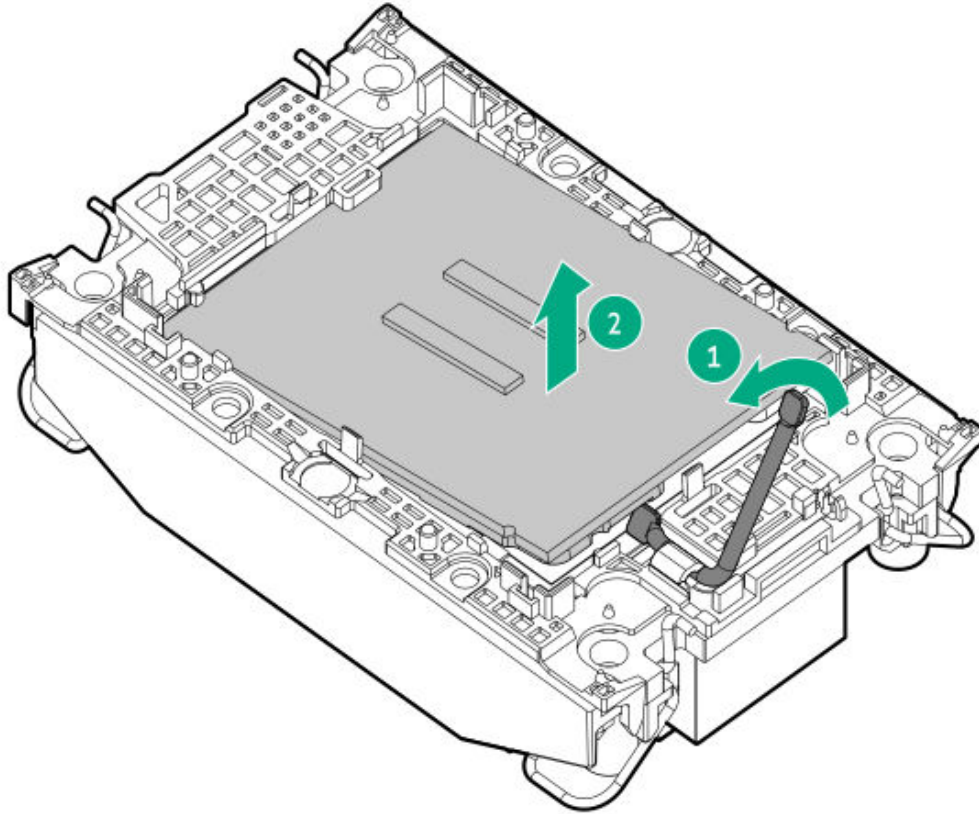

c. Starting from the pin 1 corner and moving in an opposite manner, disengage the processor carrier release tabs from the heatsink.

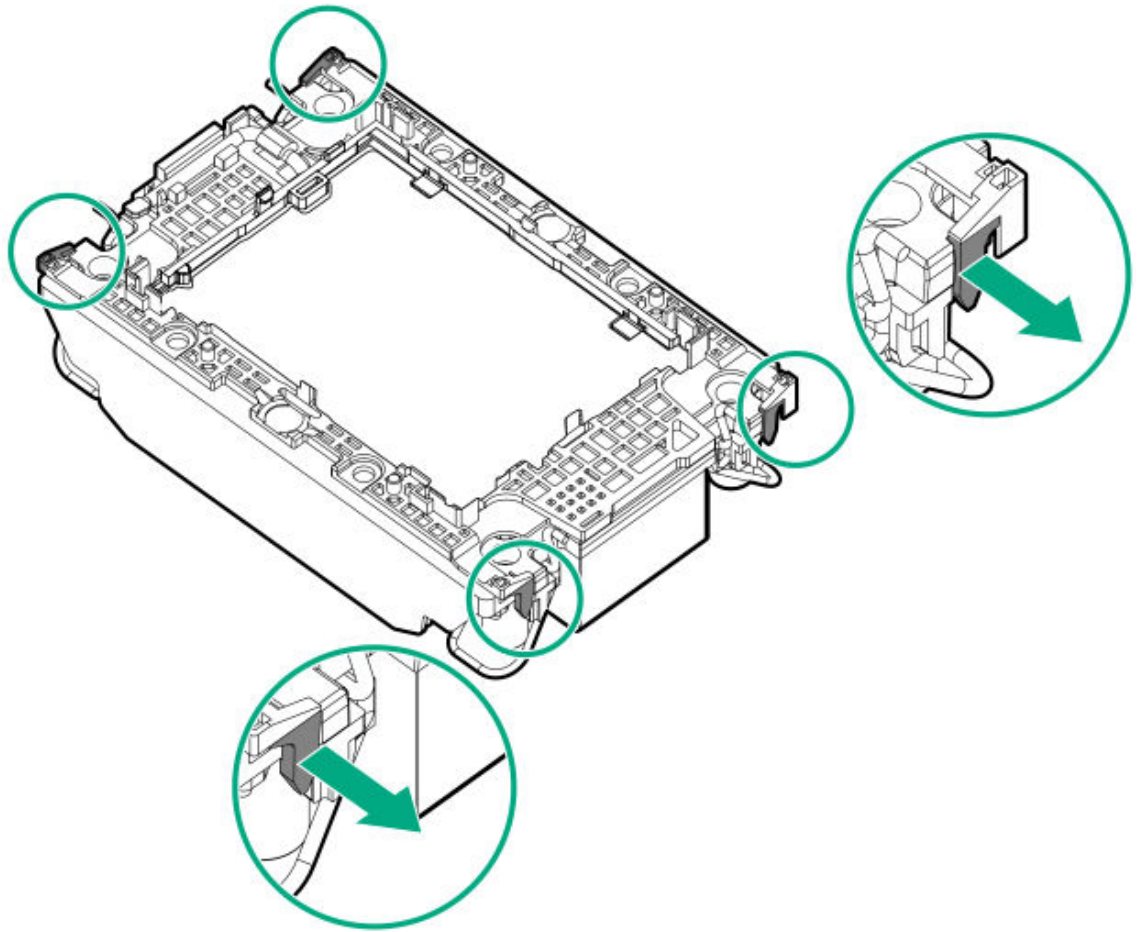

d. Lift the processor carrier away from the heatsink.

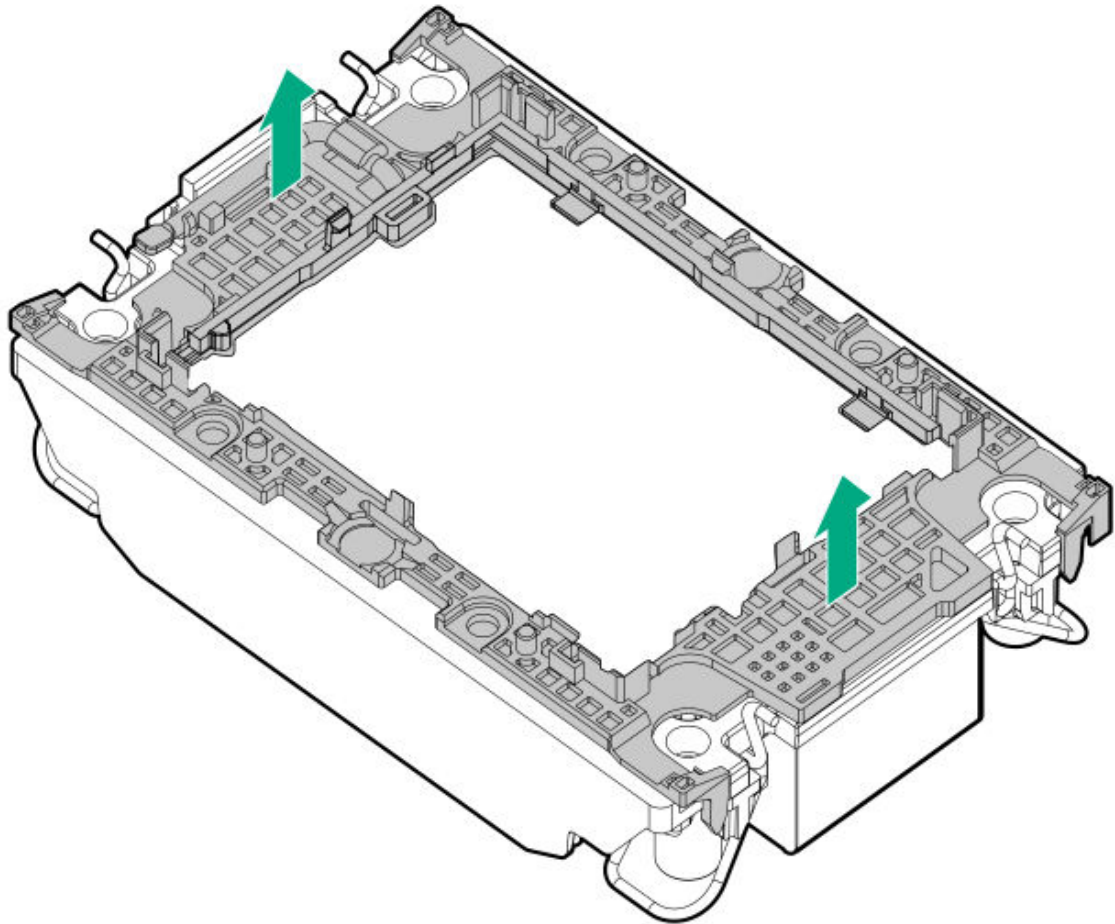

- .2. Using a cleaning solvent, such as alcohol wipes, remove the existing thermal grease from the processor and heatsink.

Allow the alcohol to evaporate before continuing.

Installing the high performance heatsink

- .3. Remove the protective film from the thermal interface material.



CAUTION

To prevent mechanical damage or depositing oil on your hands or other contaminants to the heatsink contact surface, hold the heatsink only by the edge of its base plate. Do not touch the heatsink fins.

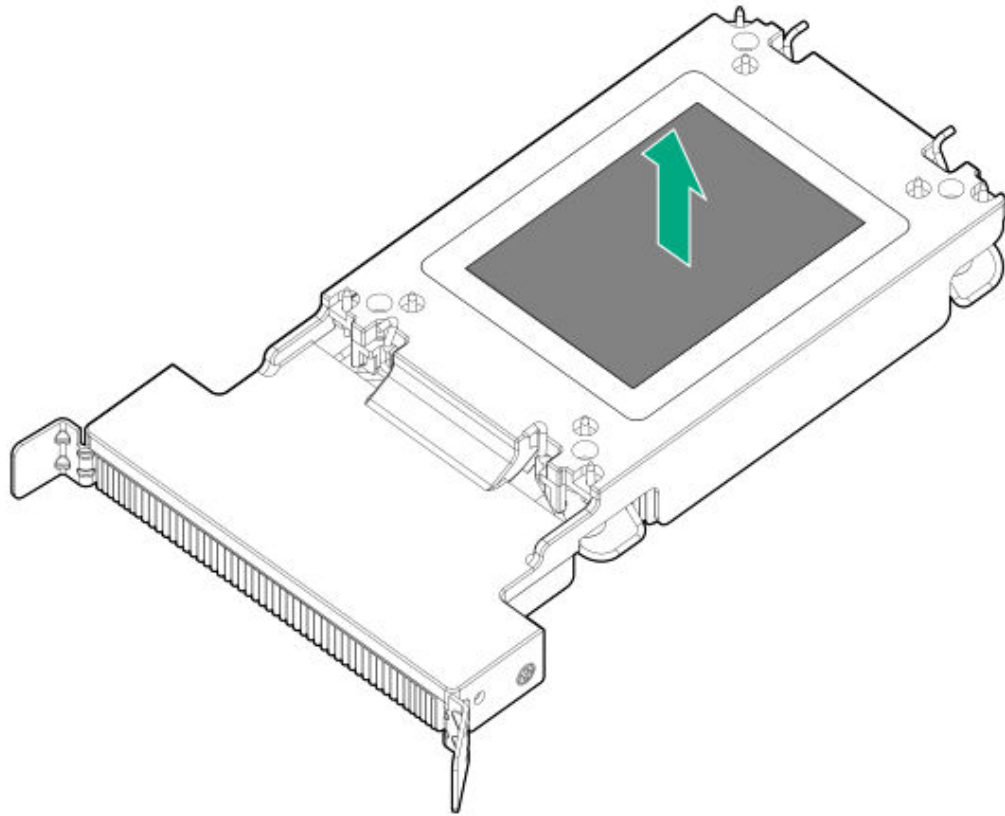

4. Set the anti-tilt wires to the locked position.

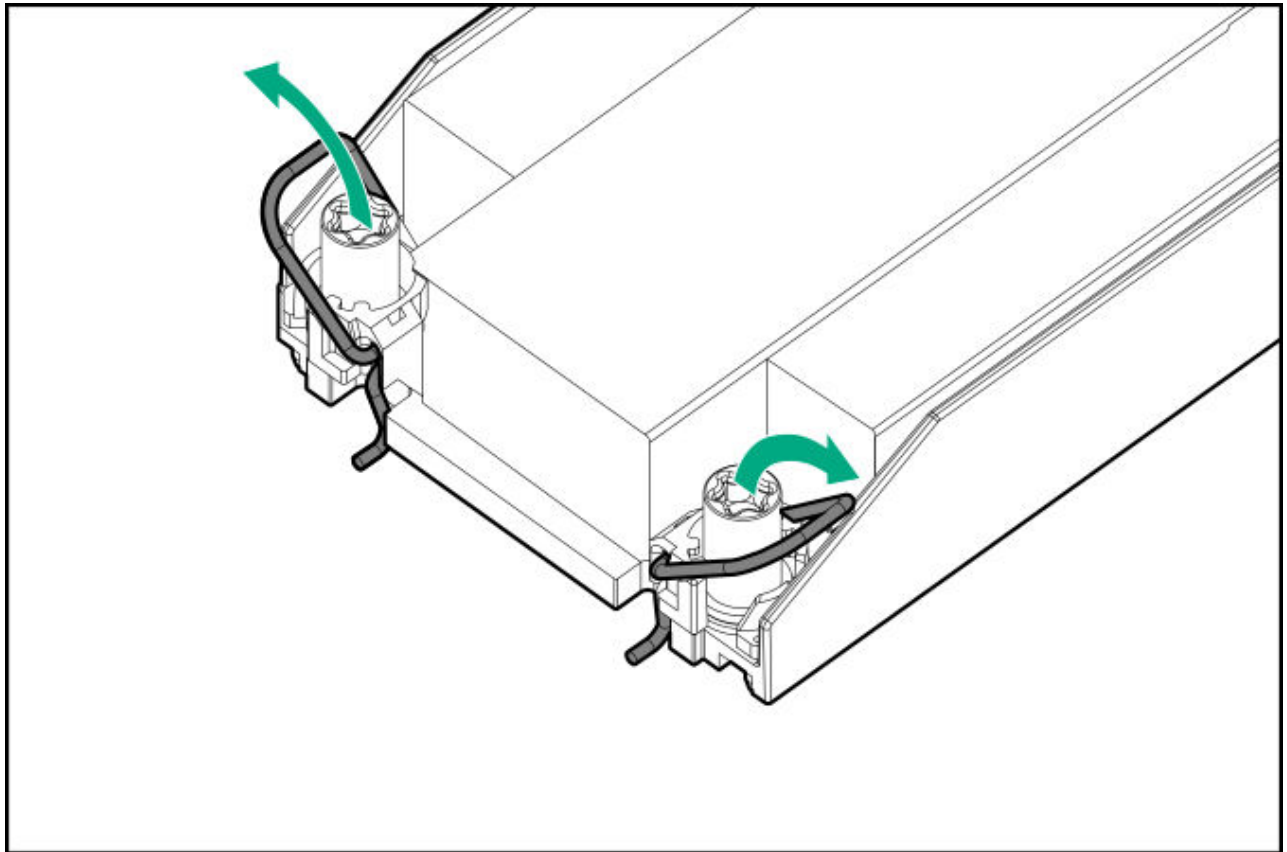

.5. Install the processor carrier on the processor:

- a. Align the pin 1 indicator on the processor carrier with that on the processor, and then press on the pair of opposite sides on the TIM breaker lever of the processor carrier until it clicks into place.

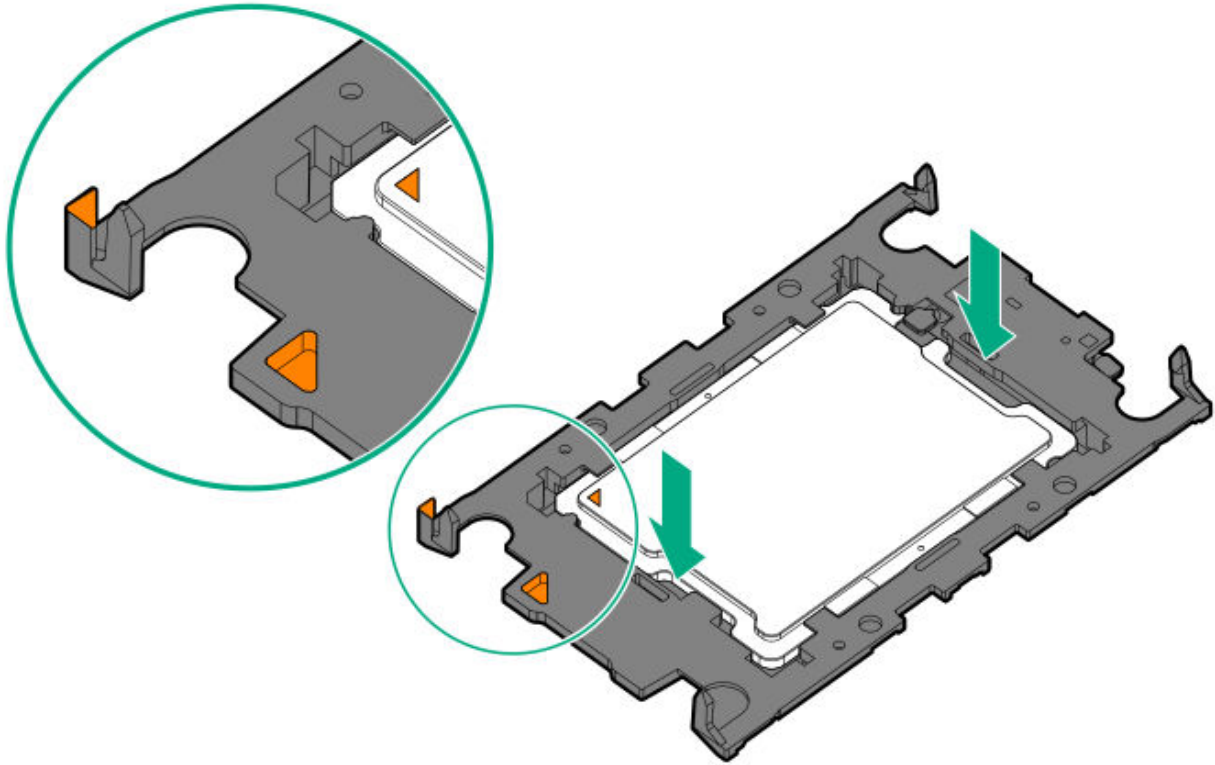

- b. Verify that the processor is properly latched on the processor carrier.

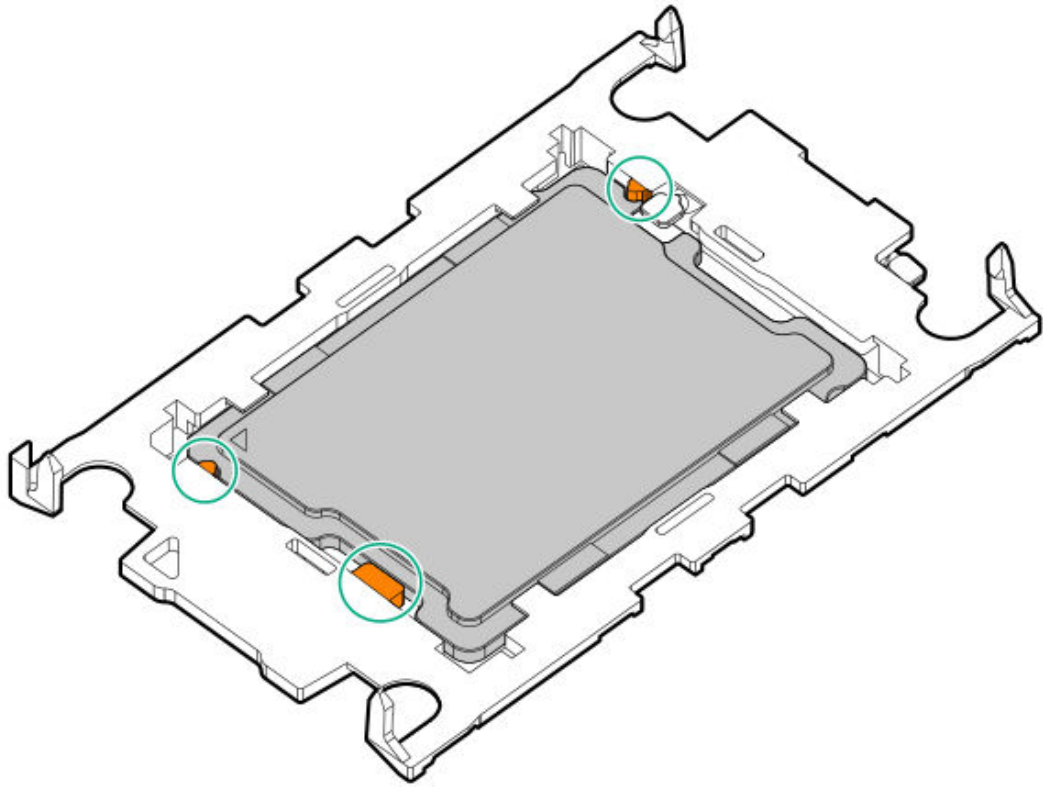

If not, press the other pair of opposite sides of the processor carrier until it clicks into place.

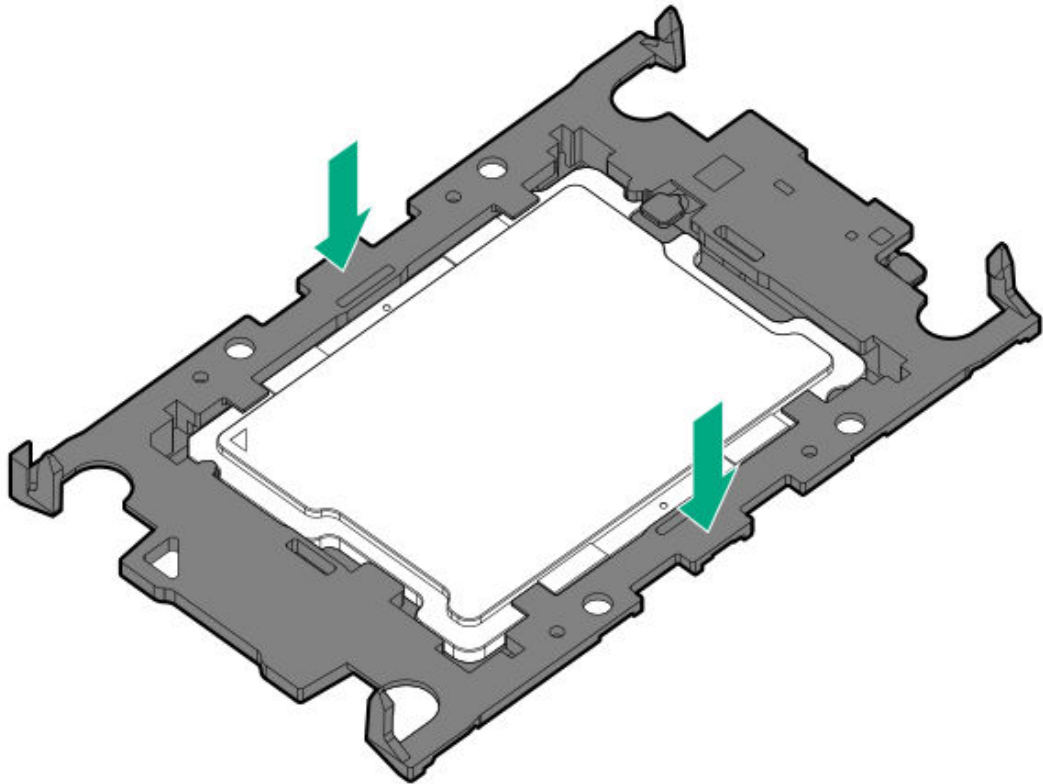

.6. Attach the heatsink to the processor carrier:

a. Align the pin 1 indicator on the processor carrier with that on the heatsink.

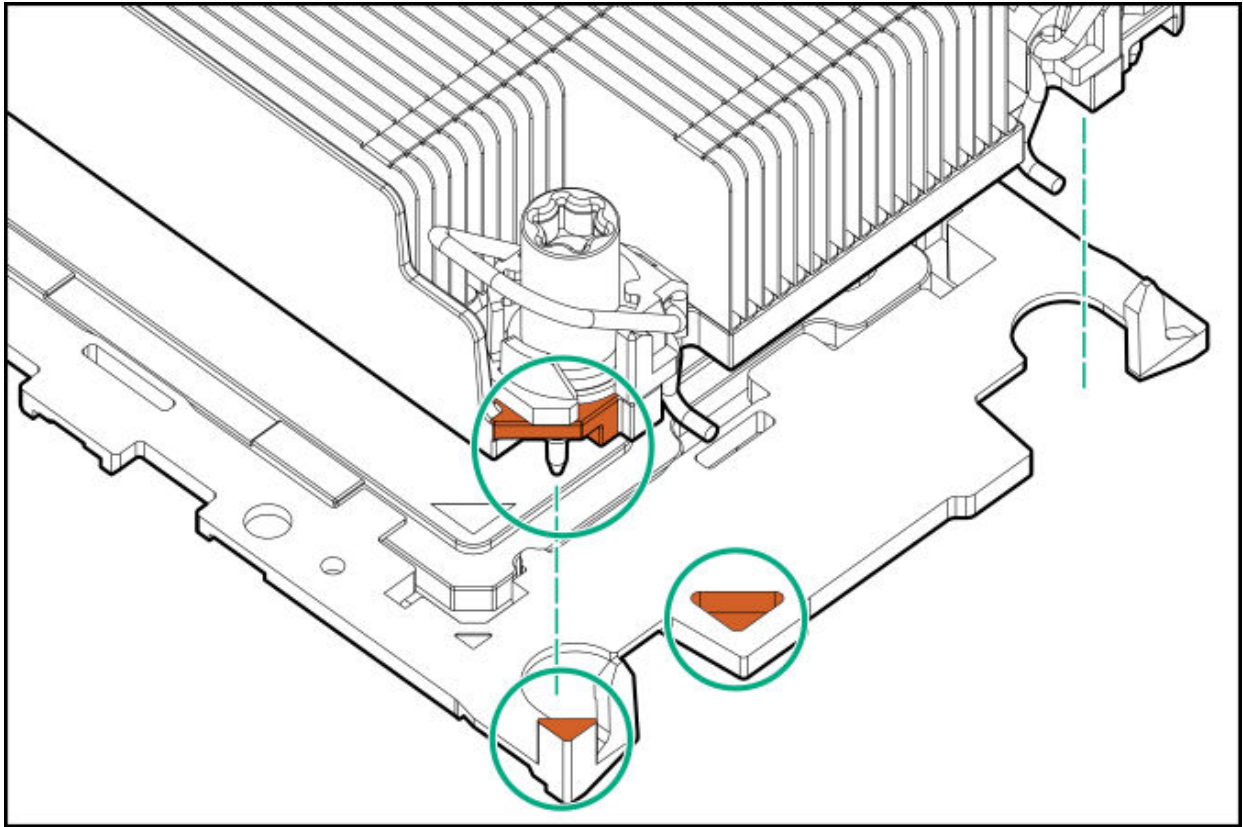

b. Lower the heatsink on the processor carrier until the carrier tabs snap into place.

There will be an audible click to indicate that the heatsink is properly latched on the processor carrier.

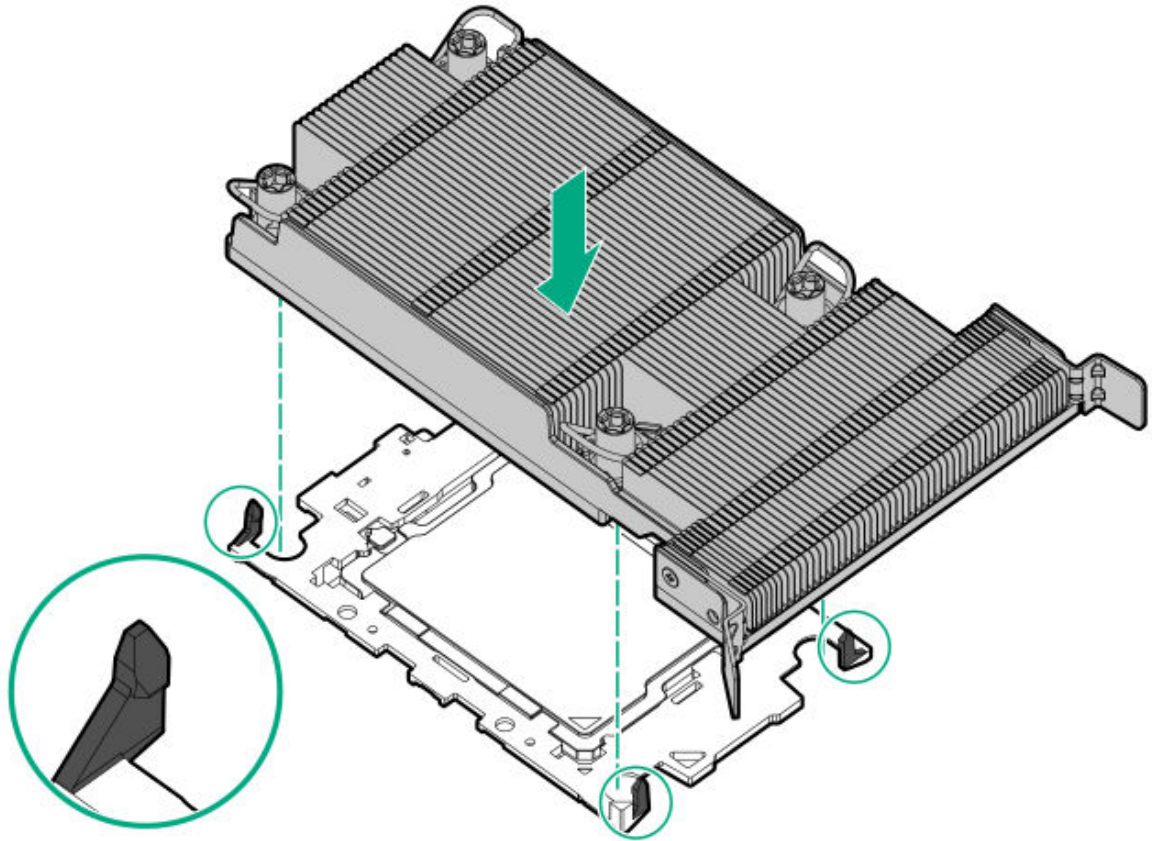

.7. Perform the following verification steps:

- a. Verify that the tabs on the processor carrier are securely latched on the heatsink.

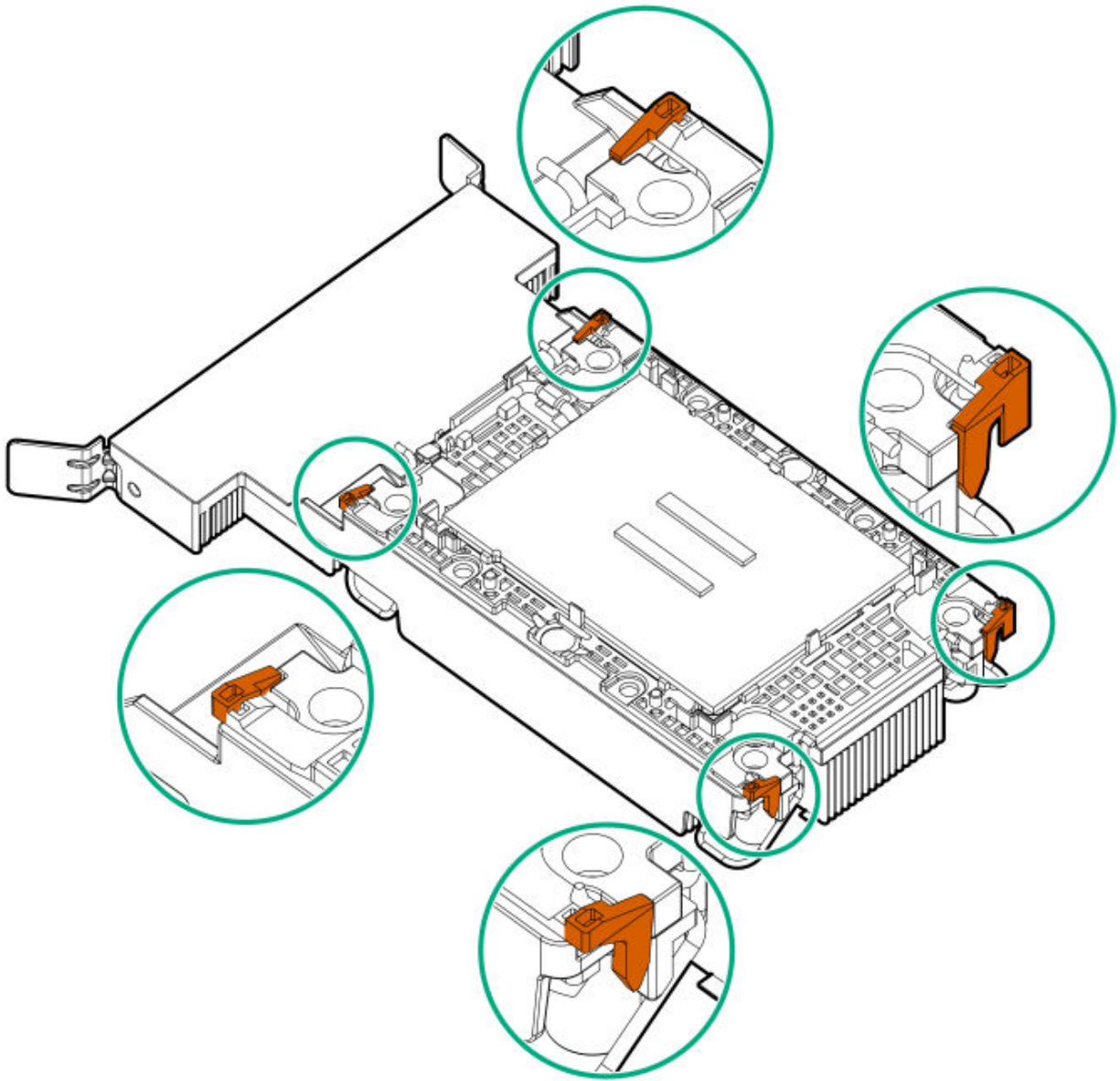

b. Verify that the pin 1 indicators on the processor and processor carrier are aligned.

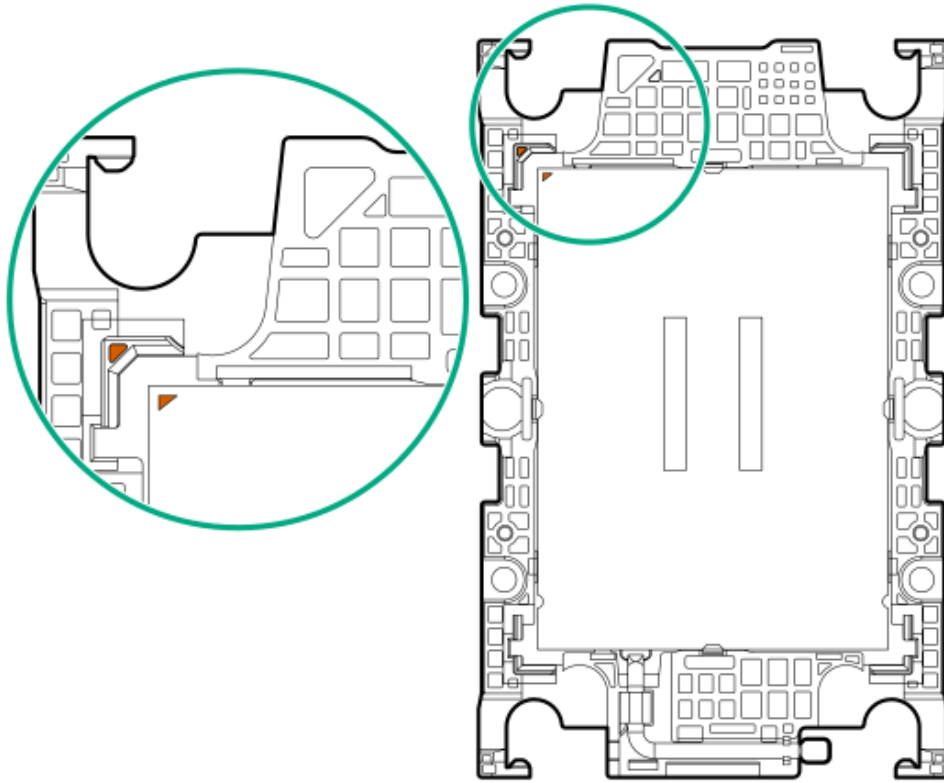

c. Verify that the processor is properly secured by the carrier snaps.

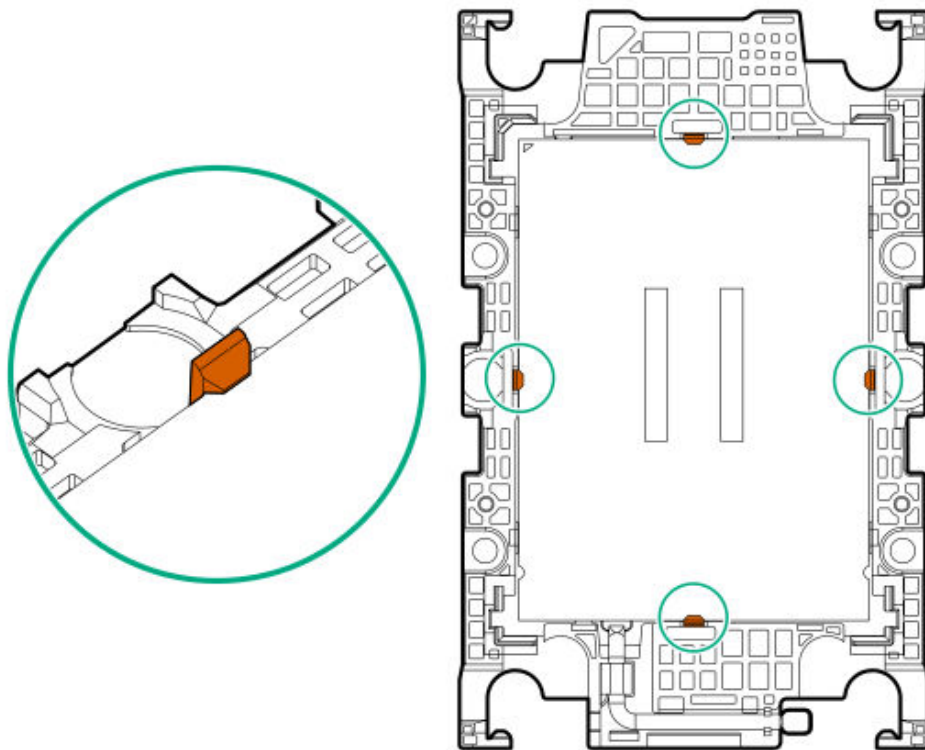

.8. Install the processor-heatsink module:



CAUTION

To prevent thermal failure or component damage, do not move the heatsink once the bottom of its base plate touches the top of the processor. Excessive heatsink movement can cause the thermal grease to smear and become uneven. Voids in the compound can adversely impact the transfer of heat away from the processor.

- a. When using a torque wrench to tighten the heatsink screws, set it to 0.9 N-m (8 in-lb) of torque.
- b. Note the **Front of server** text on the heatsink label to correctly orient the processor-heatsink module over the bolster plate.
- c. Carefully lower the processor-heatsink module onto the bolster plate guide posts.

The posts are keyed so that the module can only be installed one way. Make sure that the module is properly seated on the bolster plate before securing the screws.

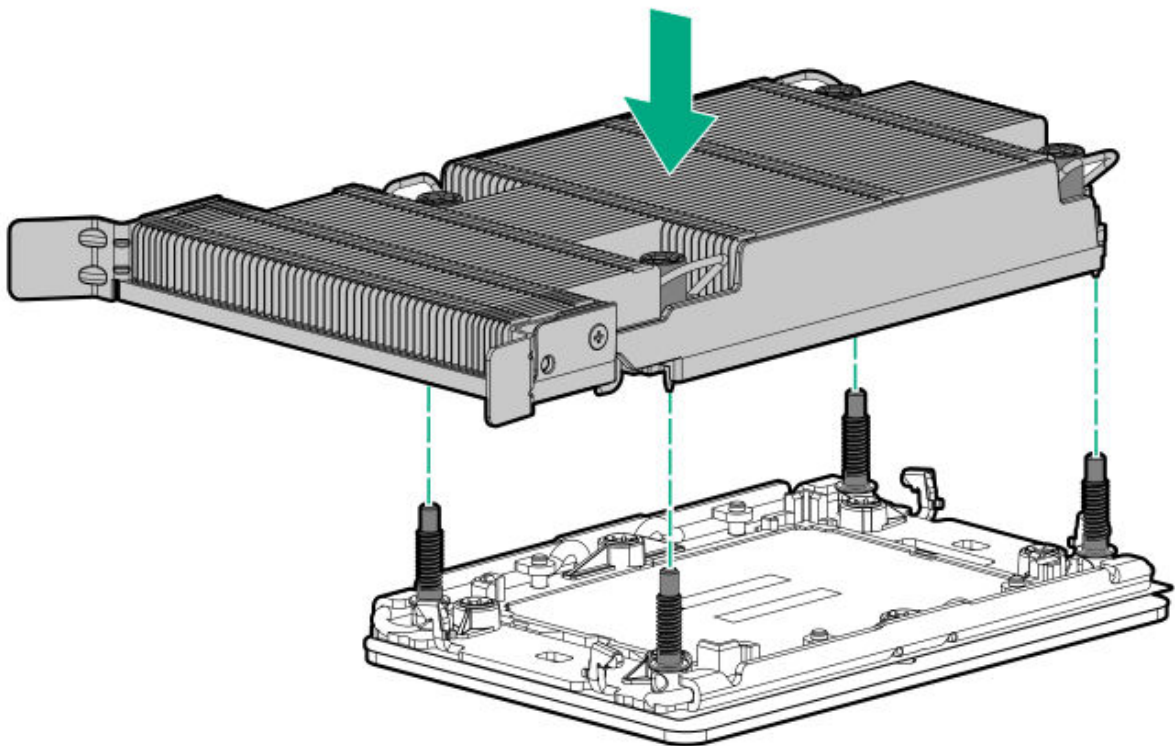

- d. Set the anti-tilt wires to the locked position.

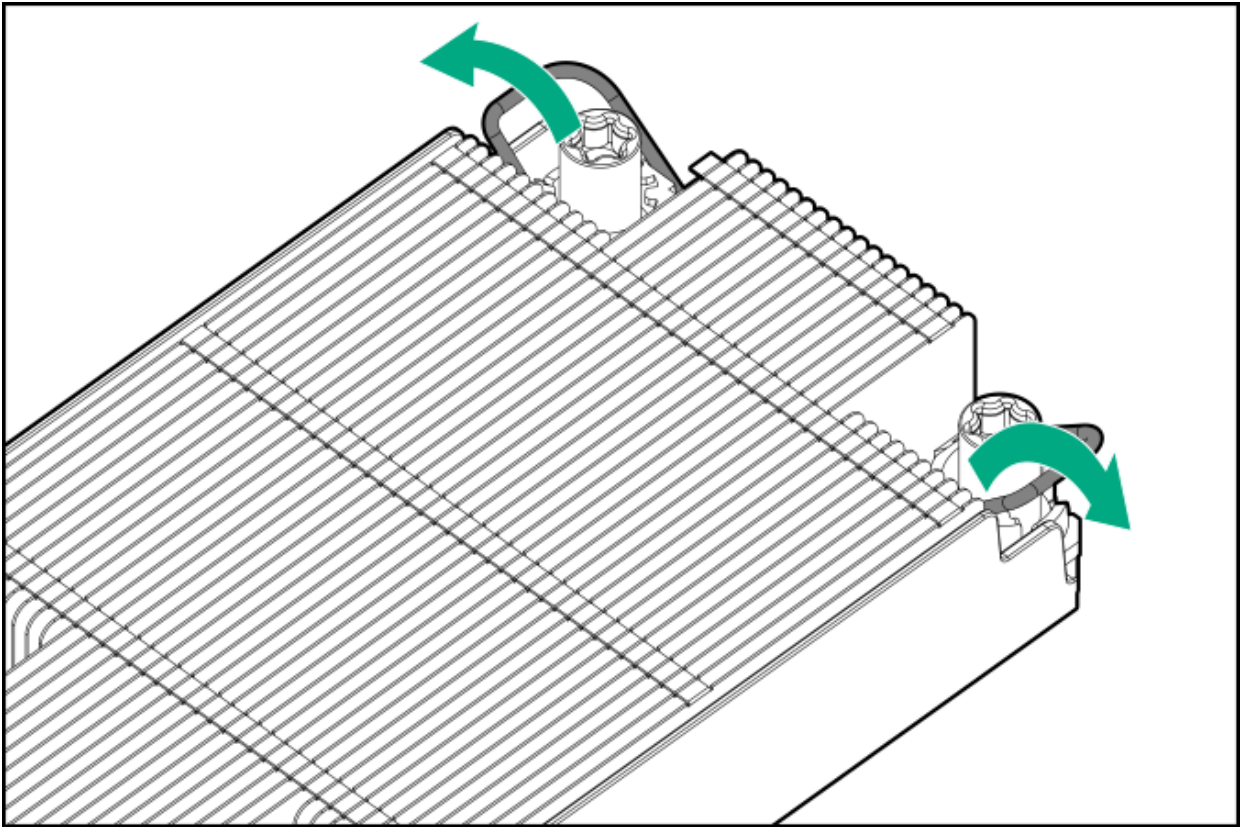

e. Tighten one pair of diagonally opposite heatsink screws, and then tighten the other pair of heatsink screws.

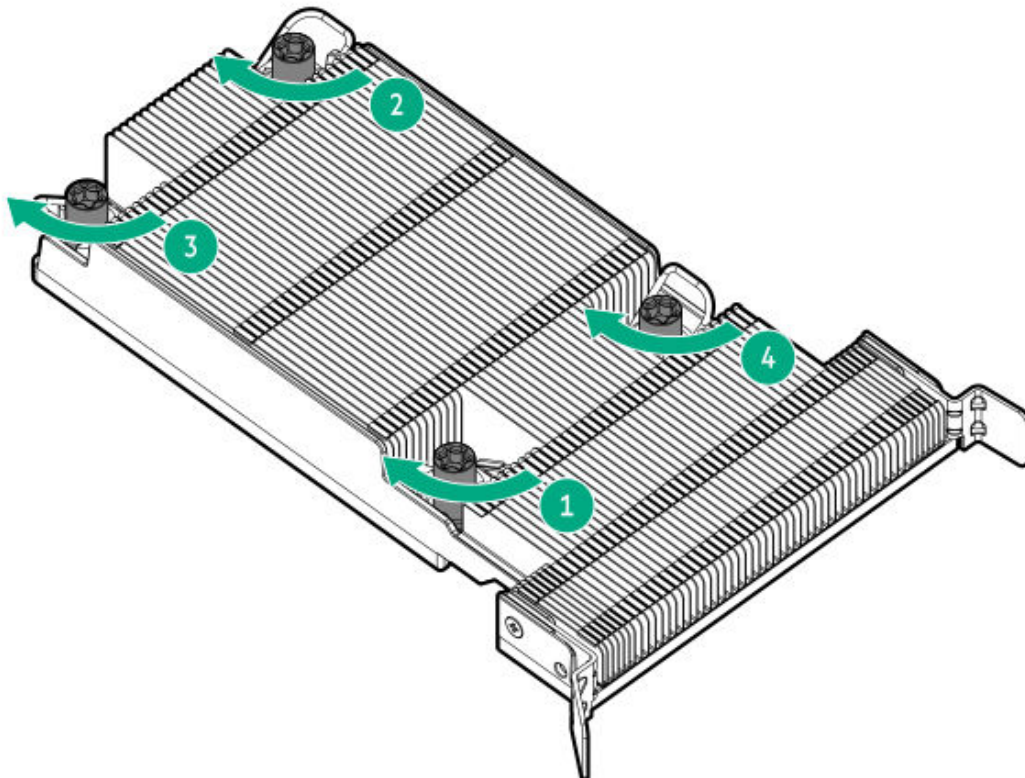

9. Install all removed components.
10. On systems that do not use the optional air baffle, pivot the heatsink baffles to the vertical orientation before connecting data cables to MCI O ports 3–6. This will provide additional working room.

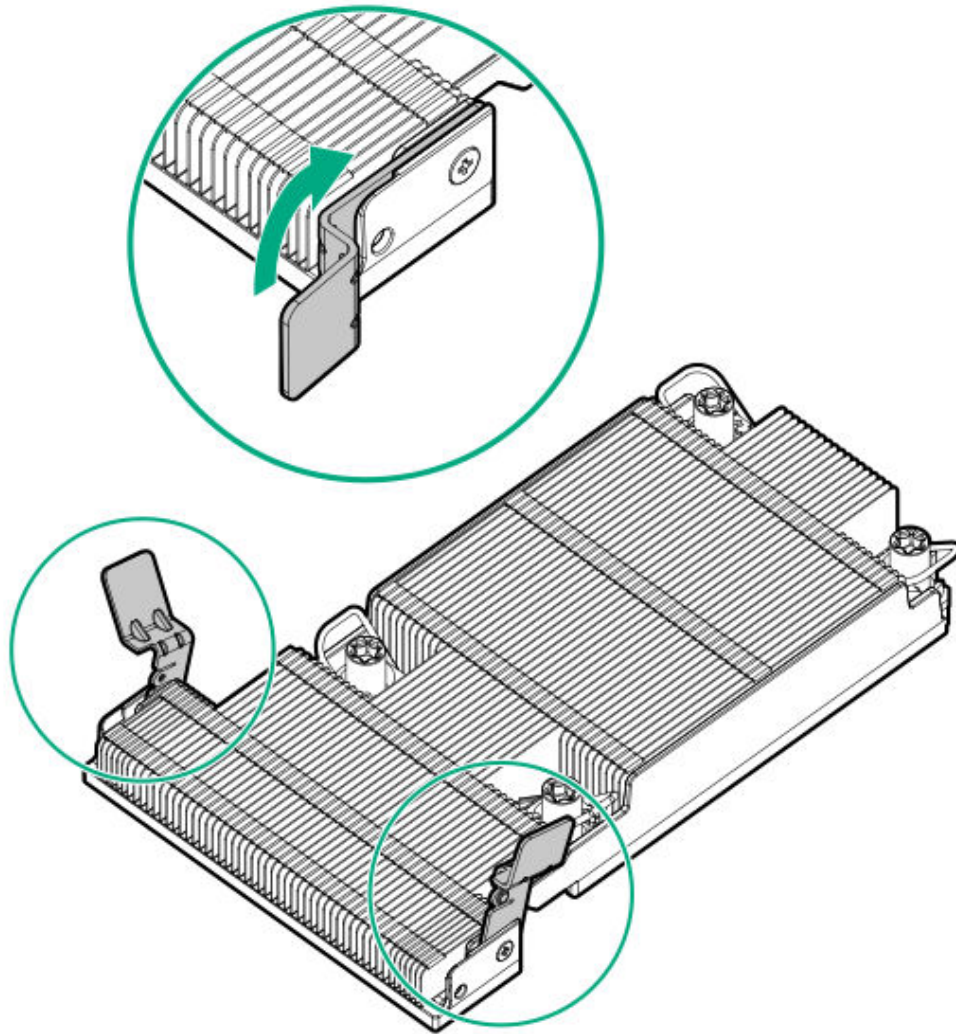

Pivot the baffles down to the horizontal orientation after installing the cables.

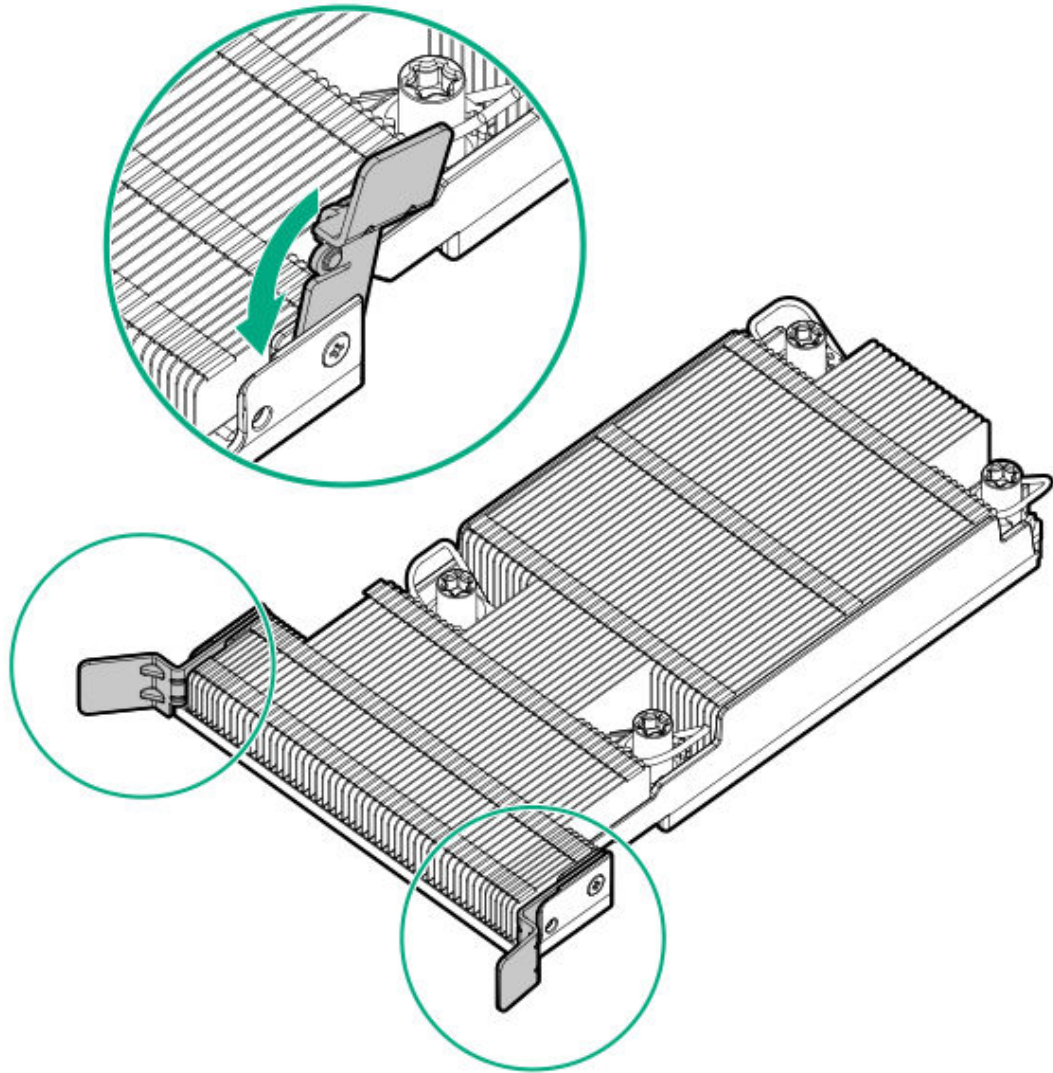

- !1. (Optional) Install the air baffle.
- !2. Install the access panel.
- !3. Install the server into the rack.
- !4. Connect all peripheral cables to the server.
- !5. Connect each power cord to the server.
- !6. Connect each power cord to the power source.
- !7. Power up the server.

Results

The installation procedure is complete.

Installing the closed-loop liquid cooling module

Prerequisites

- Review the following:
 - [Heatsink and processor socket components](#)
 - [Closed-loop liquid cooling \(CLLC\) module components](#)
 - [Liquid cooling guidelines](#)
 - [Processor cautions](#)
- Before you perform this procedure, make sure that you have the following items available:
 - Closed-loop liquid cooling module (P82009-B21)
 - Closed-loop liquid cooling handle (P82626-B21)
 - Closed-loop liquid cooling fan kit (P82559-B21), includes seven liquid cooling fans
 - T-30 Torx screwdriver or a bit driver with T-30 Torx bit
 - T-15 Torx screwdriver

About this task



CAUTION

A discharge of static electricity from a finger or other conductor might damage system boards or other static-sensitive devices. To prevent damage, observe [antistatic precautions](#).

Procedure

1. [Power down the server](#).
2. Remove all power:
 - a. Disconnect each power cord from the power source.
 - b. Disconnect each power cord from the server.
3. If the server is installed in an enclosure or a rack, remove the server and place it on a flat, level work surface.
4. [Remove the access panel](#).

5. Allow all internal system components to cool before continuing.
6. Remove all standard or high performance fans.

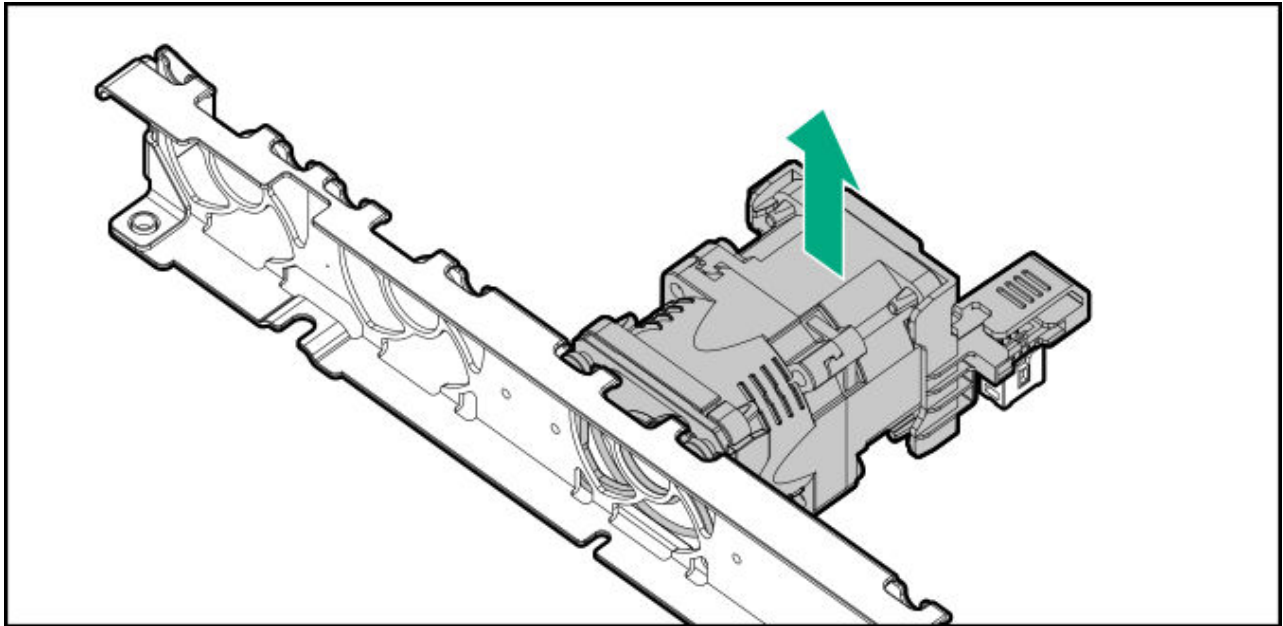

7. Remove the access panel guide pin.

Retain the guide pin. The guide pin will be re-installed after the liquid cooling module is installed.

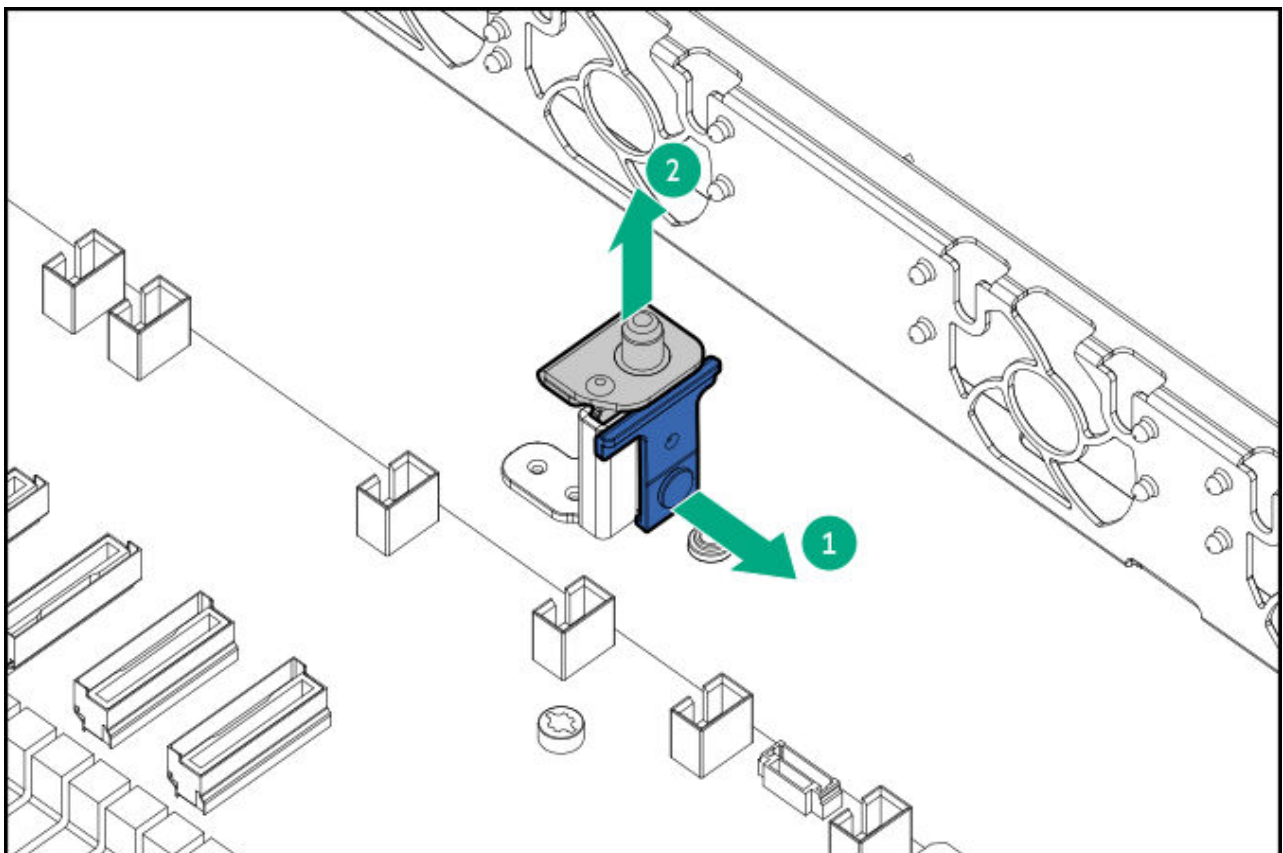

Removing the air cooling heatsinks

8.



CAUTION

Heatsink screws must be tightened and loosened in alternating sequence. Do not overtighten the screws as this might damage the system board or the processor socket.

Use a T-30 Torx screwdriver to loosen one pair of diagonally opposite heatsink screws (callouts 1 and 2), and then loosen the other pair of heatsink screws (callouts 3 and 4).

- Standard heatsink

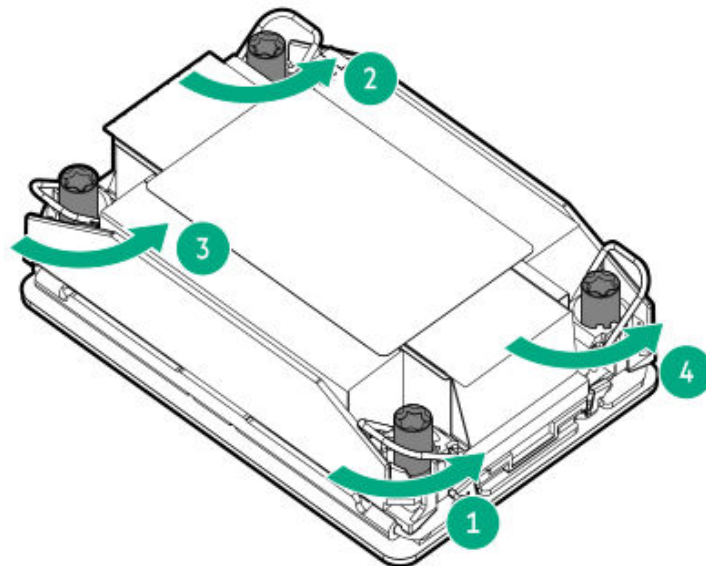

- High performance heatsink

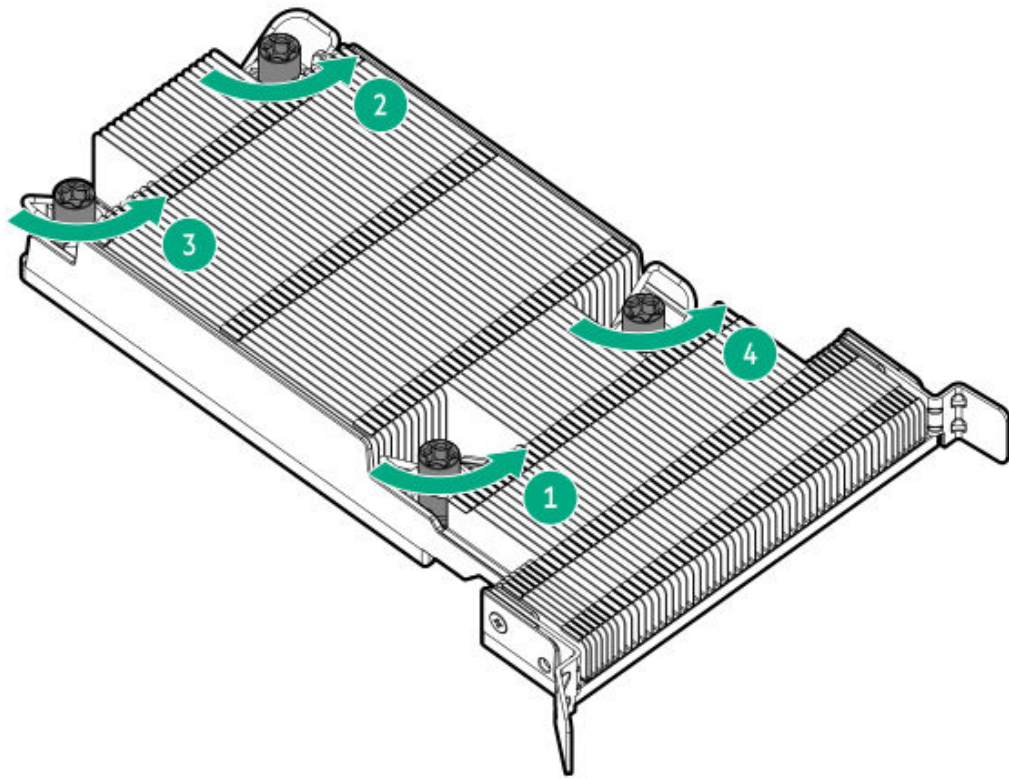

9. Set the anti-tilt wires to the unlocked position.

- Standard heatsink

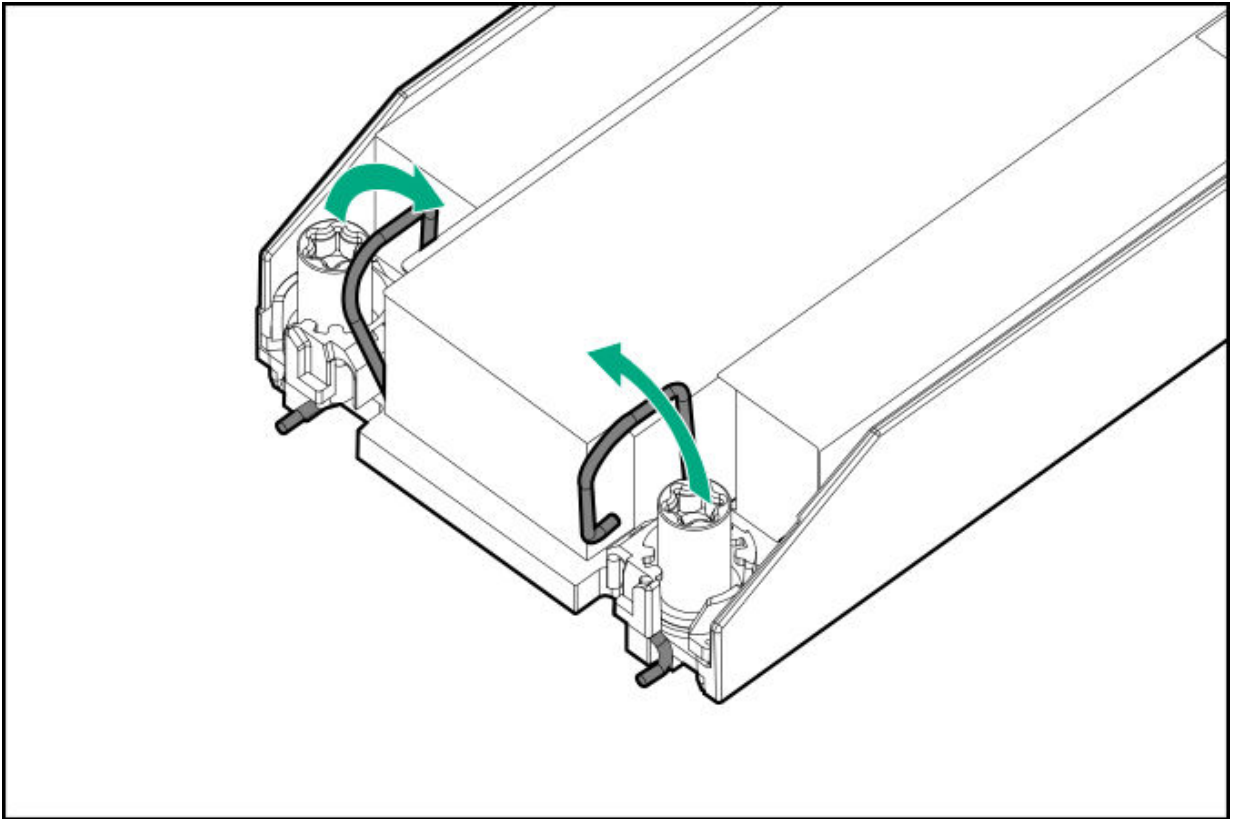

- High performance heatsink

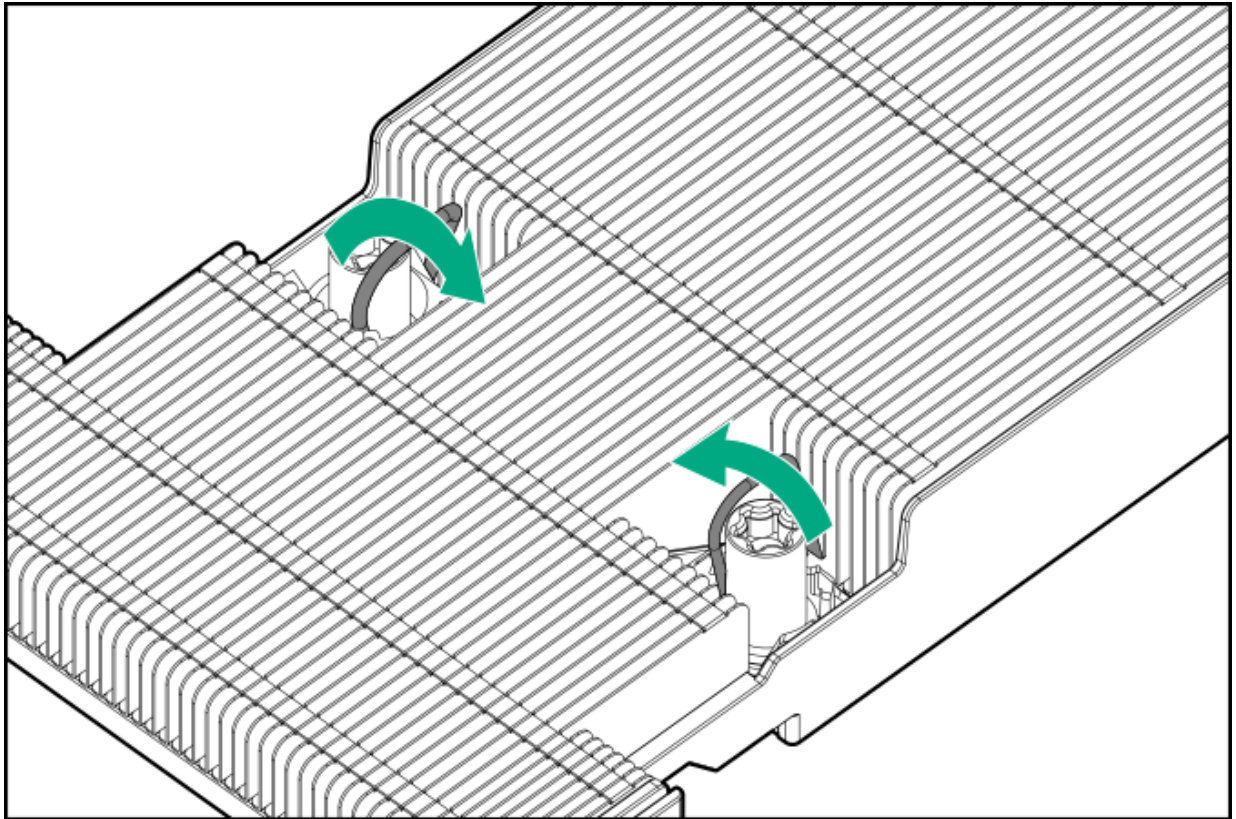

.0.



CAUTION

To prevent mechanical damage or depositing oil on your hands or other contaminants to the heatsink contact surface, hold the heatsink only by the edge of its base plate. Do not touch the heatsink fins.

Lift the processor-heatsink module straight up from the system board.

- Standard heatsink

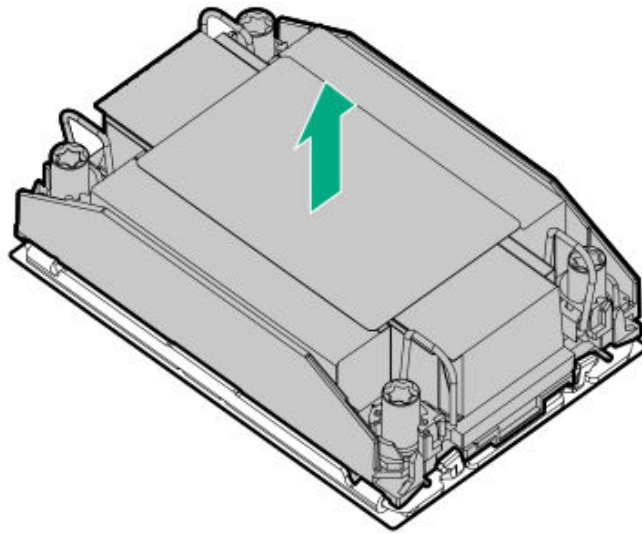

- High performance heatsink

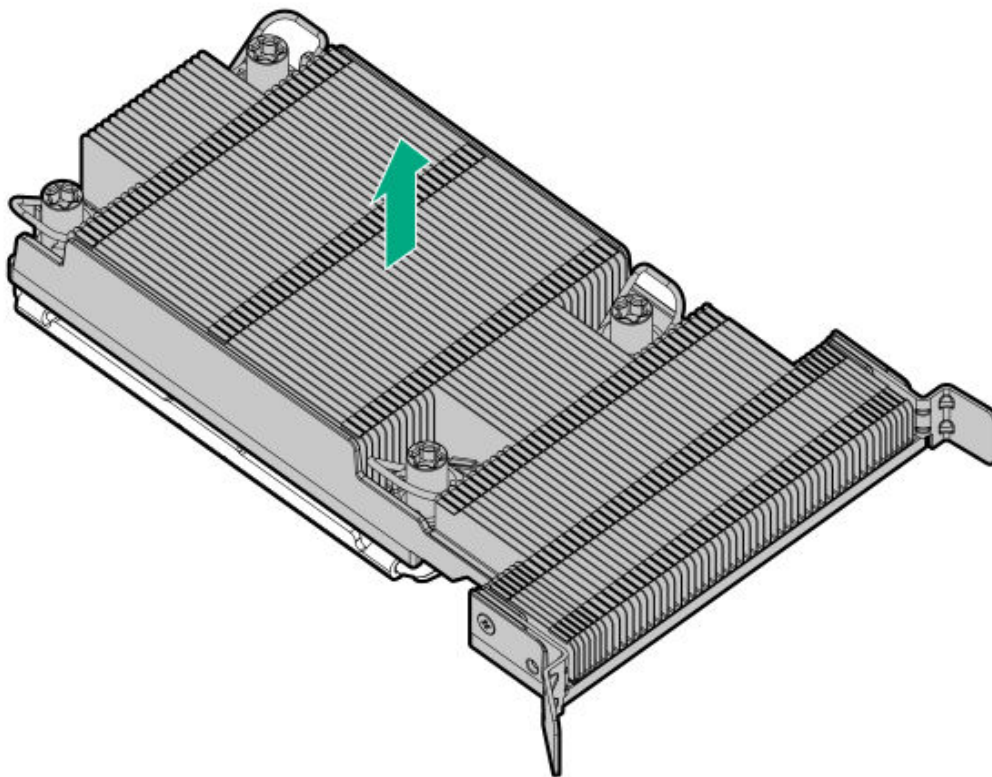

.1. Place the processor-heatsink module on a flat work surface with its contact side facing up.

- .2. If you are not immediately installing the replacement processor-heatsink module, install the dust cover on the empty processor socket:



CAUTION

Do not press down on the dust cover. Pressing down on the dust cover might damage the processor socket.

- a. Press and hold the grip tabs on the dust cover.
- b. Carefully lower the dust cover onto the bolster plate guide posts.

Make sure that the corner holes of the dust cover are properly engaged with the guide posts on the bolster plate.

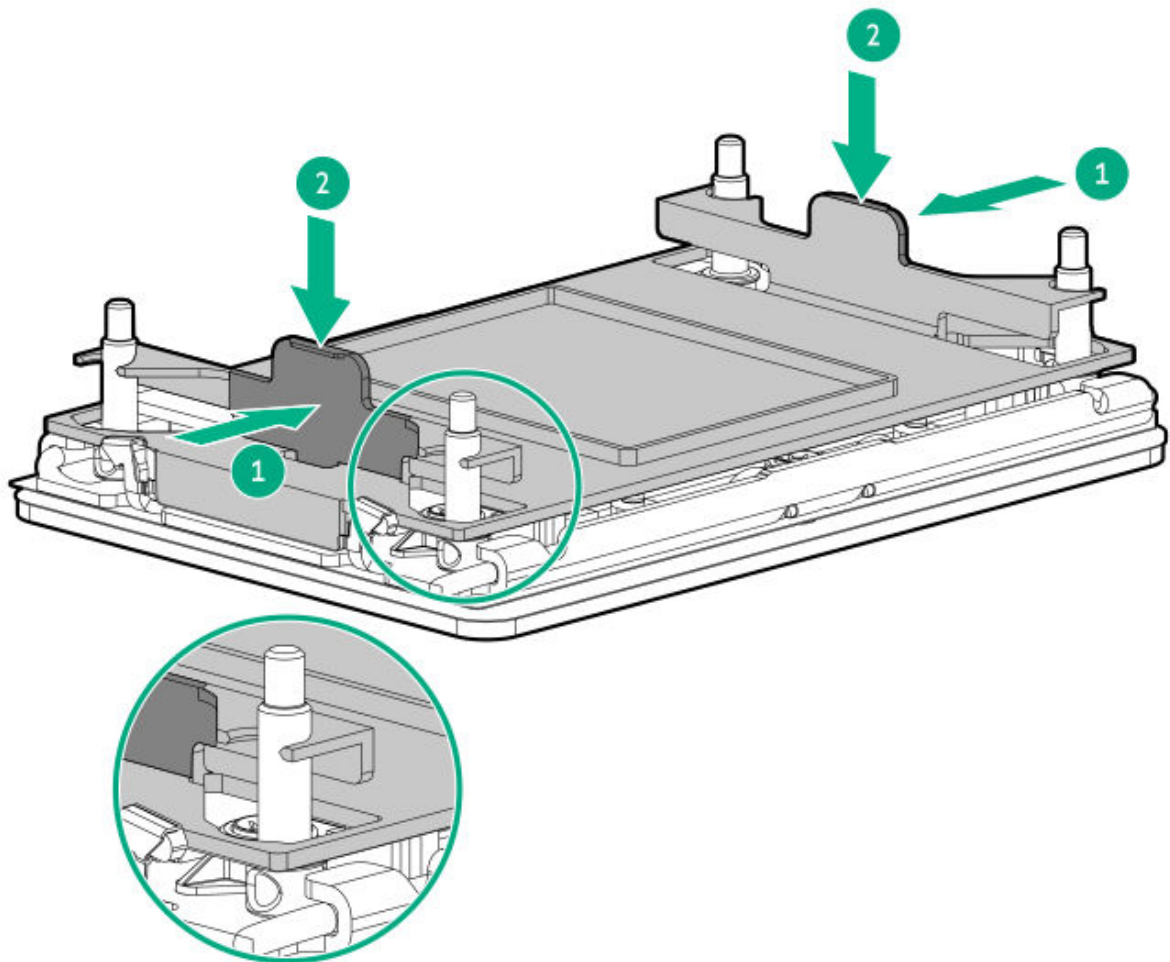

.3. Do not touch the pins on the processor socket and the processor.



CAUTION

THE PINS ON THE PROCESSOR SOCKET AND ON THE PROCESSOR ARE VERY FRAGILE AND EASILY DAMAGED. Any damage to them might require replacing the system board.

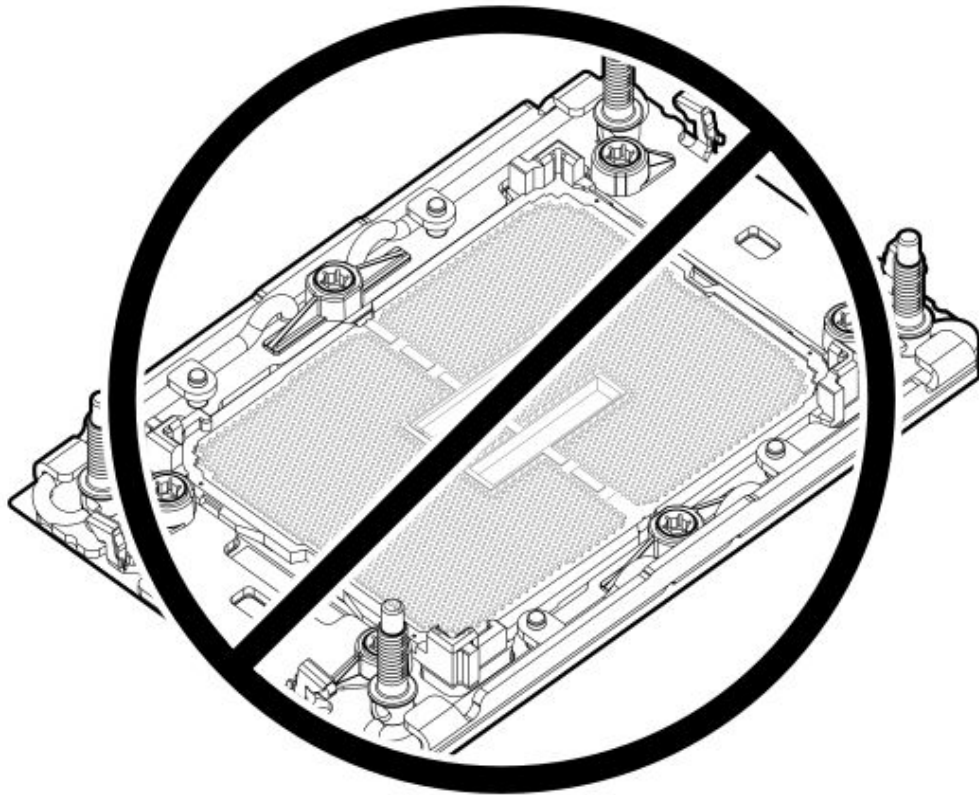

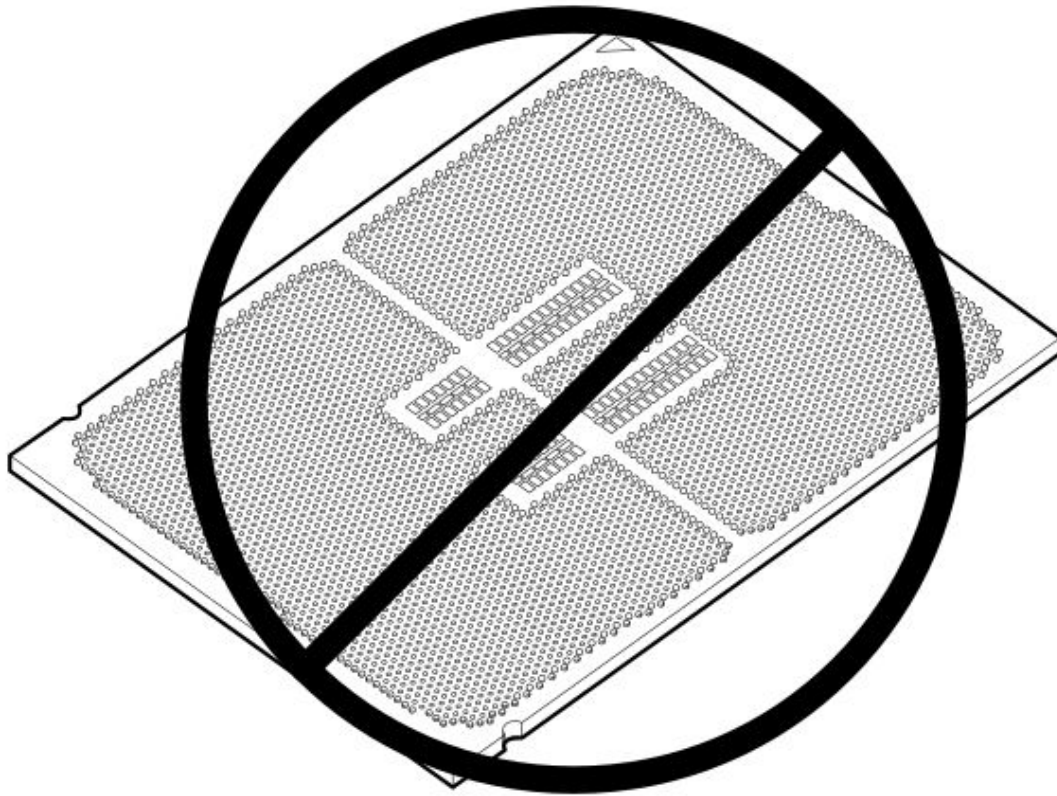

4. Remove the processor from the heatsink:

- a. Open the TIM breaker lever.

This action breaks the adhesion between the processor and the heatsink.

- b. Hold the processor by its edges, and then remove it from the carrier.

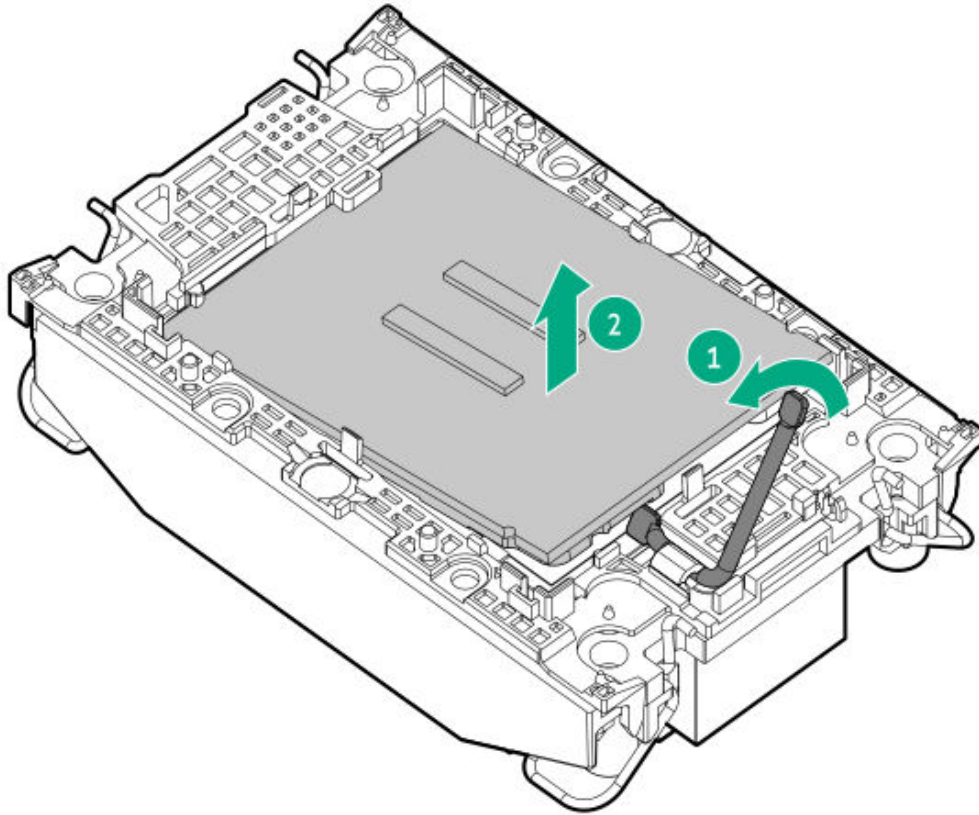

- c. Starting from the pin 1 corner and moving in an opposite manner, disengage the processor carrier release tabs from the heatsink.

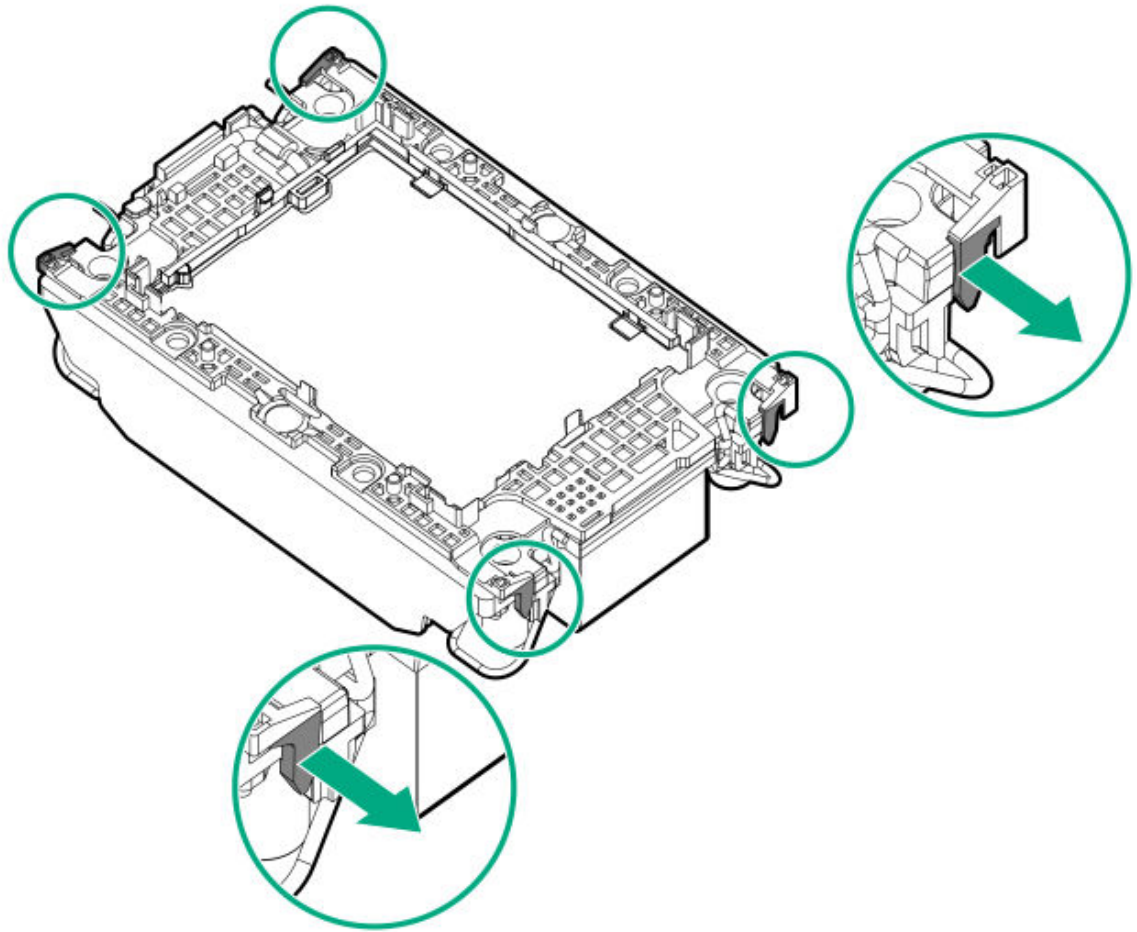

d. Lift the processor carrier away from the heatsink.

.5.

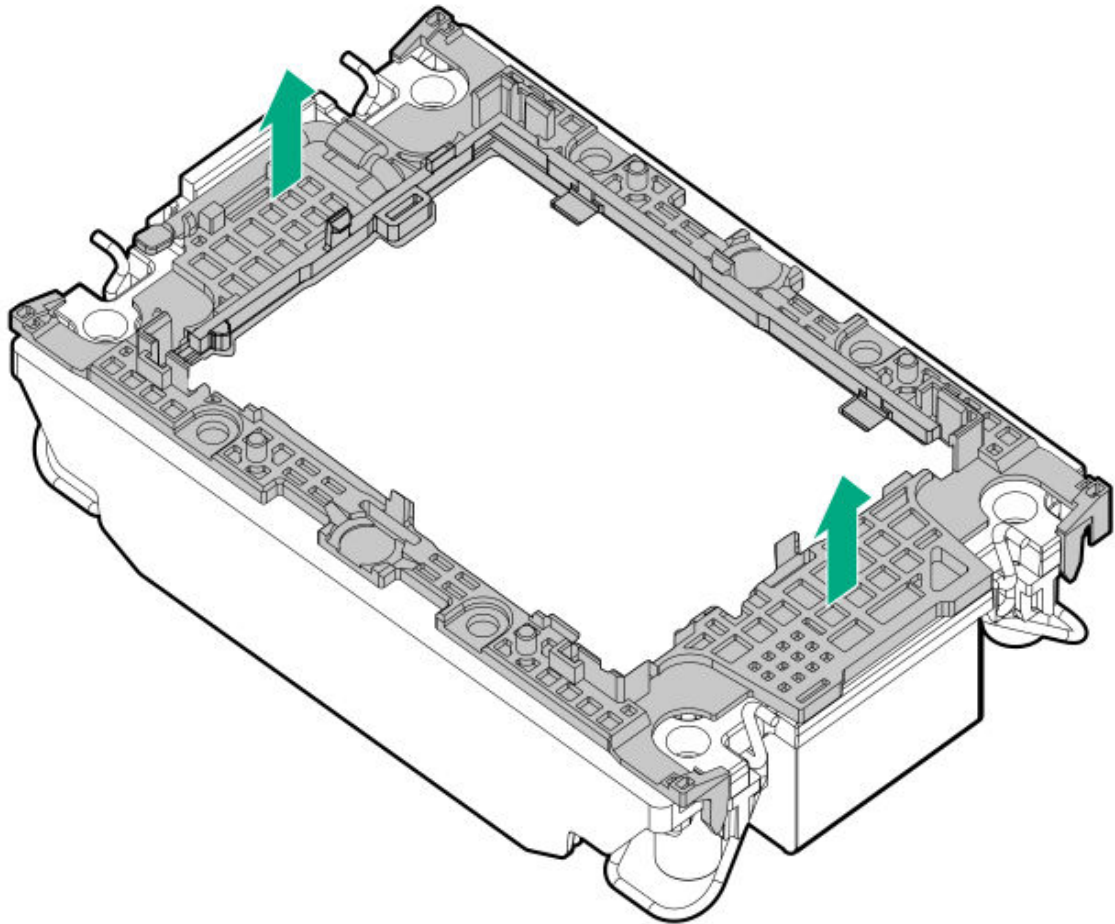

Installing the closed-loop liquid cooling module



IMPORTANT

If you are installing or replacing the liquid cooling module in a system using the one-processor configuration, note the following:

- To prevent any interference issues, remove the dust covers from both processor sockets before installing the cold plates.
- Do not touch or remove the thermal interface material on the contact side of the cold plate that does not have a processor-carrier assembly installed.

If installed, remove the dust covers from the processor sockets:

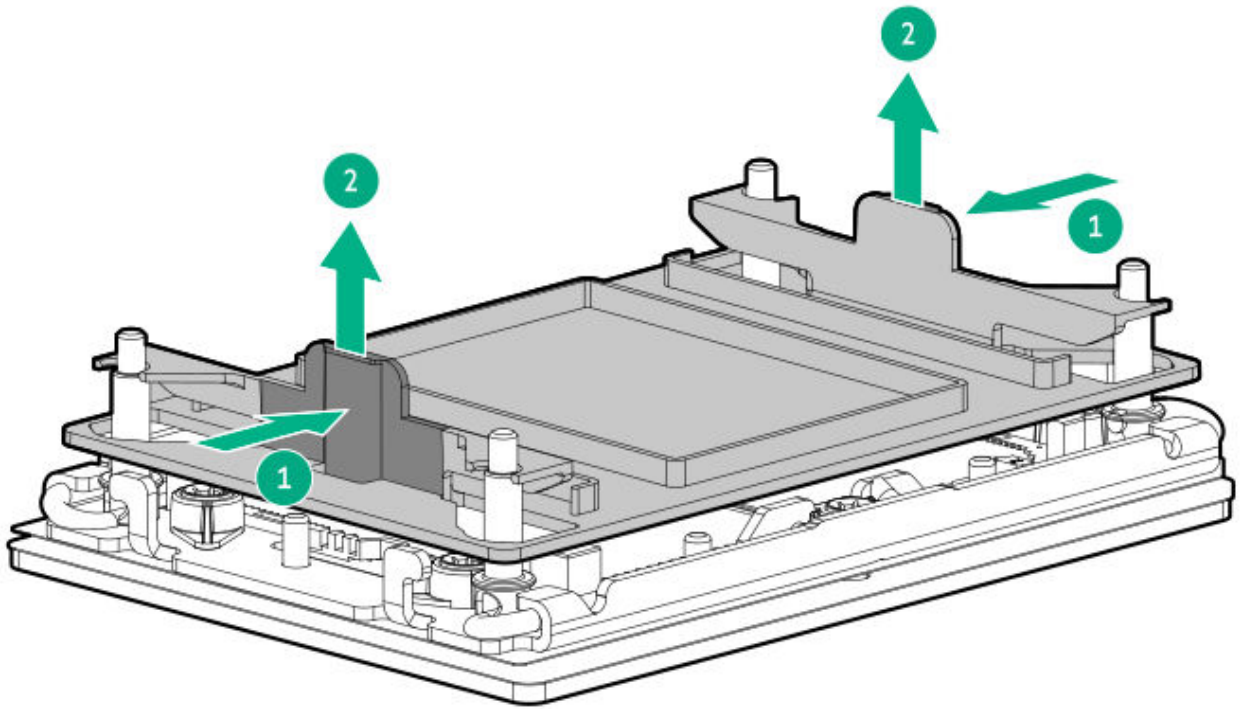

- .6. Set the liquid cooling module handle to the appropriate length.
 - a. Disengage the locking handle.
 - b. Extend the handle and align the edge to the line marked by the letter E.
 - c. Engage the locking handle.

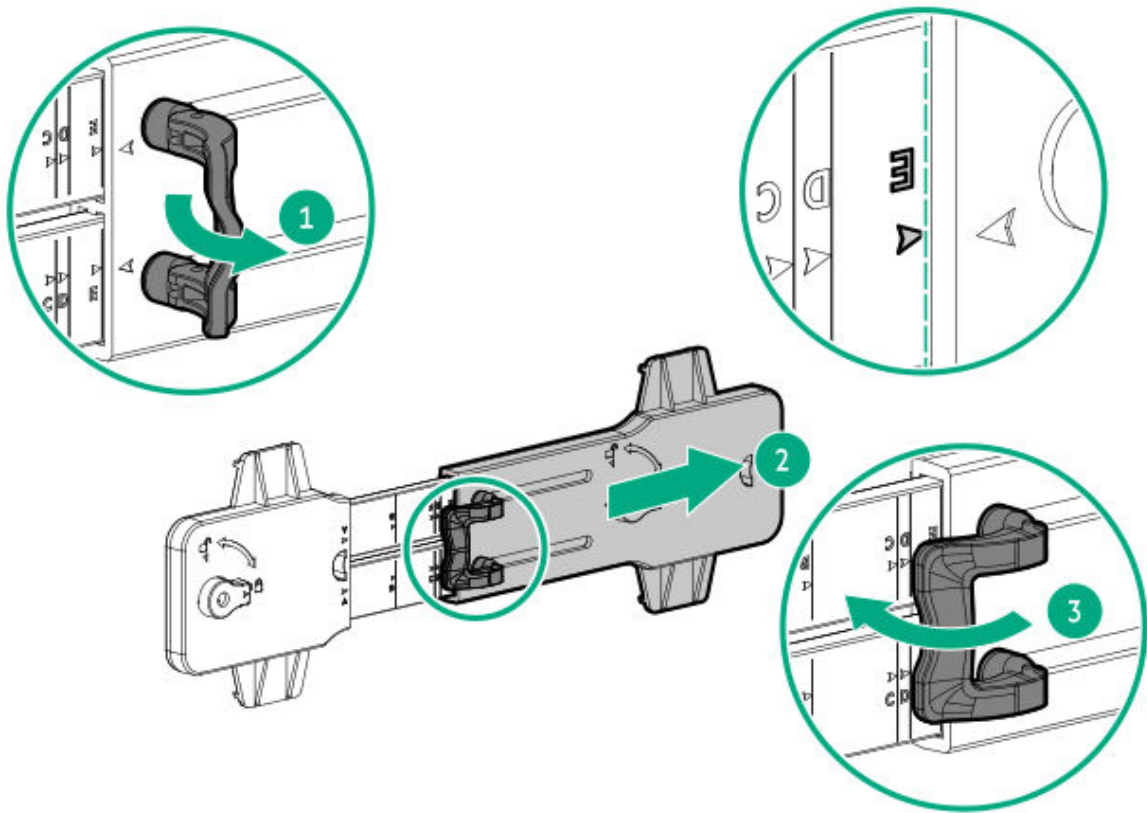

.7. Attach the handle to the pump-cold plates:

- a. Rotate the handle knobs anti-clockwise to the unlocked position.

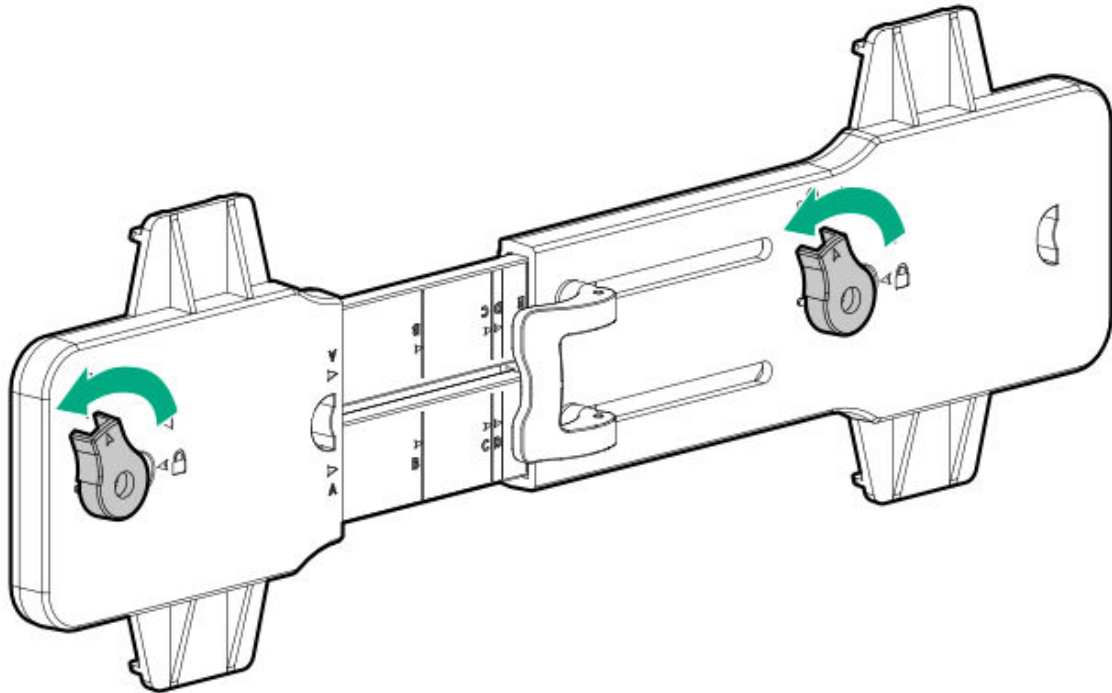

- b. Align the hooks on the handle with the notches on the pump-cold plates, and then attach the handle to the pump-cold plates.

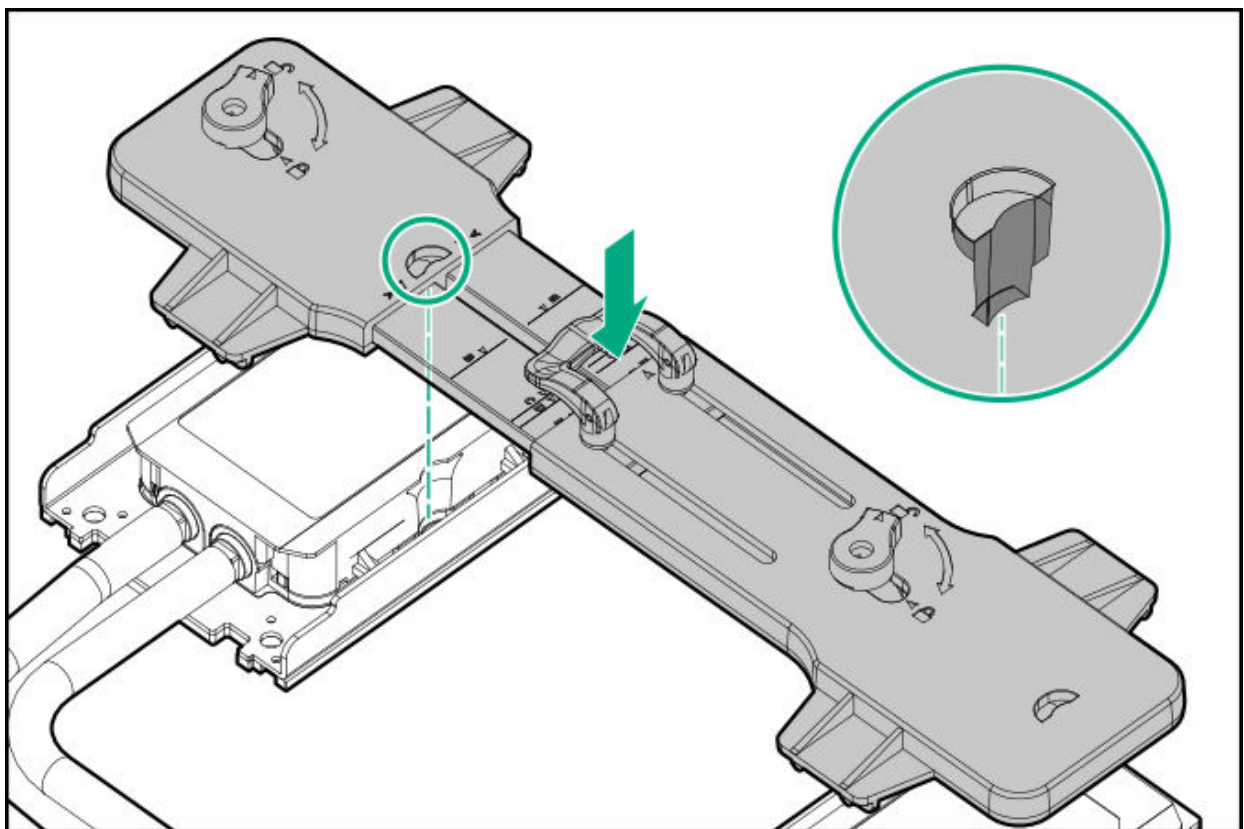

- c. Turn the handle knobs to the locked position.

Gently pull on the handle and verify that pump-cold plates are securely latched to the handle.

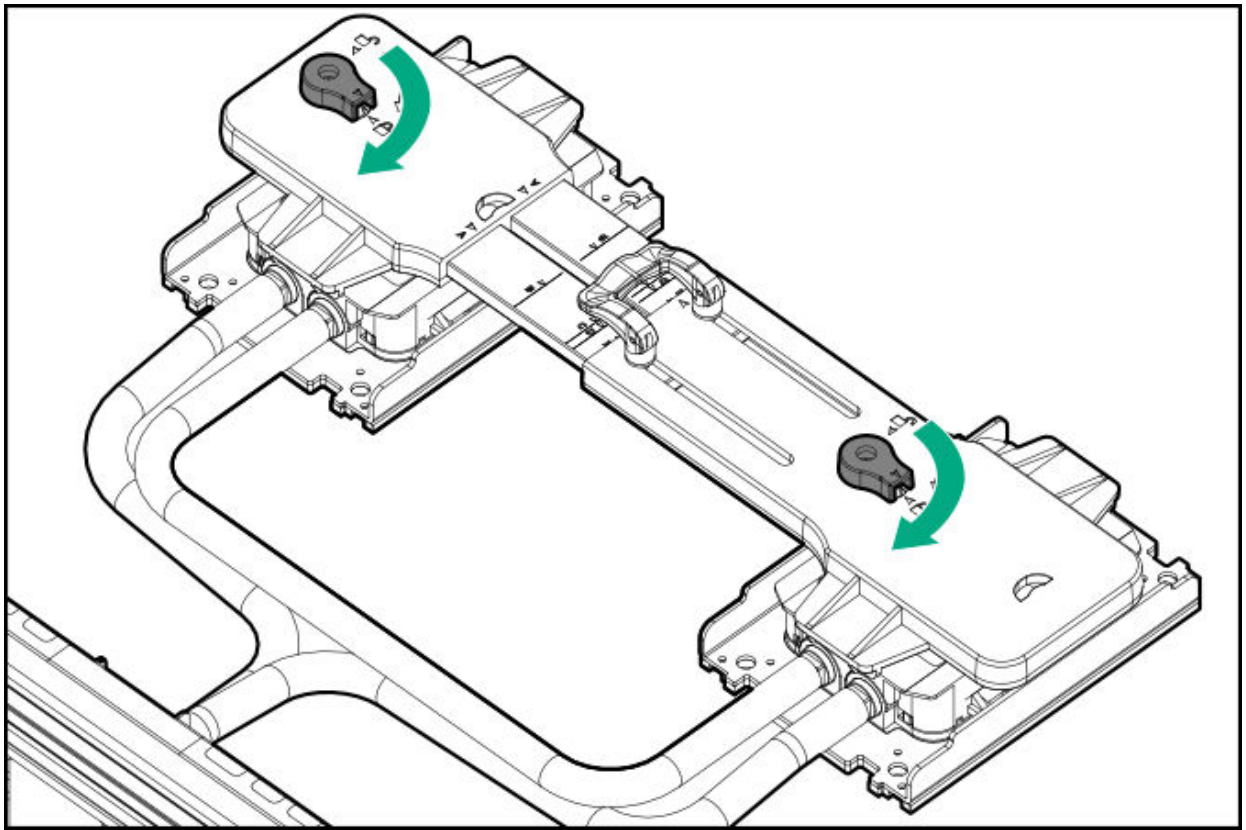

.8.



CAUTION

To avoid damaging the coolant hoses that might result in a coolant leak, do not bend the coolant hoses when installing or removing the liquid cooling module.

Place the liquid cooling module on a flat work surface with its contact side facing up.

- a. Hold the liquid cooling module handle and radiator in the middle.
- b. Lift and turn the liquid cooling module over, and place it on a flat and level surface.

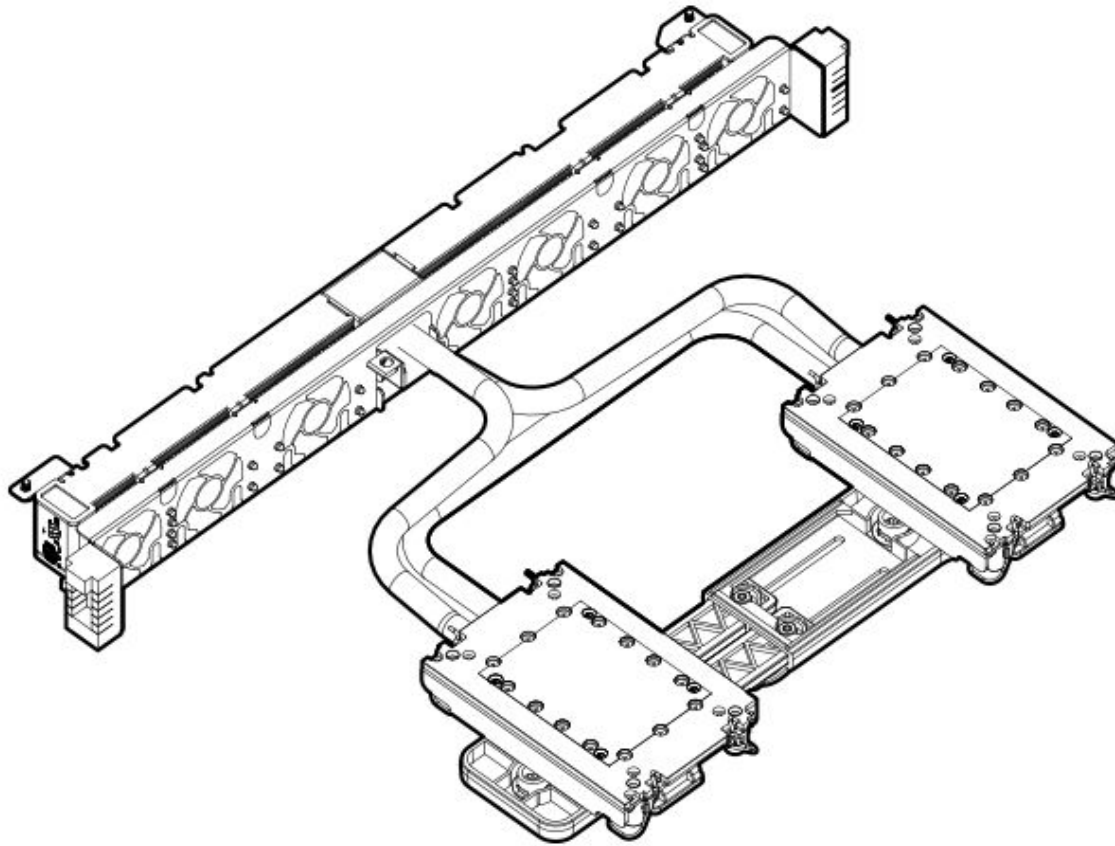

- .9. Remove the clear protective covers from the new liquid cooling cold plates and pumps.
- !0. Install the processor carrier on the processor:
 - a. Align the pin 1 indicator on the processor carrier with that on the processor, and then press on the pair of opposite sides on the TIM breaker lever of the processor carrier until it clicks into place.

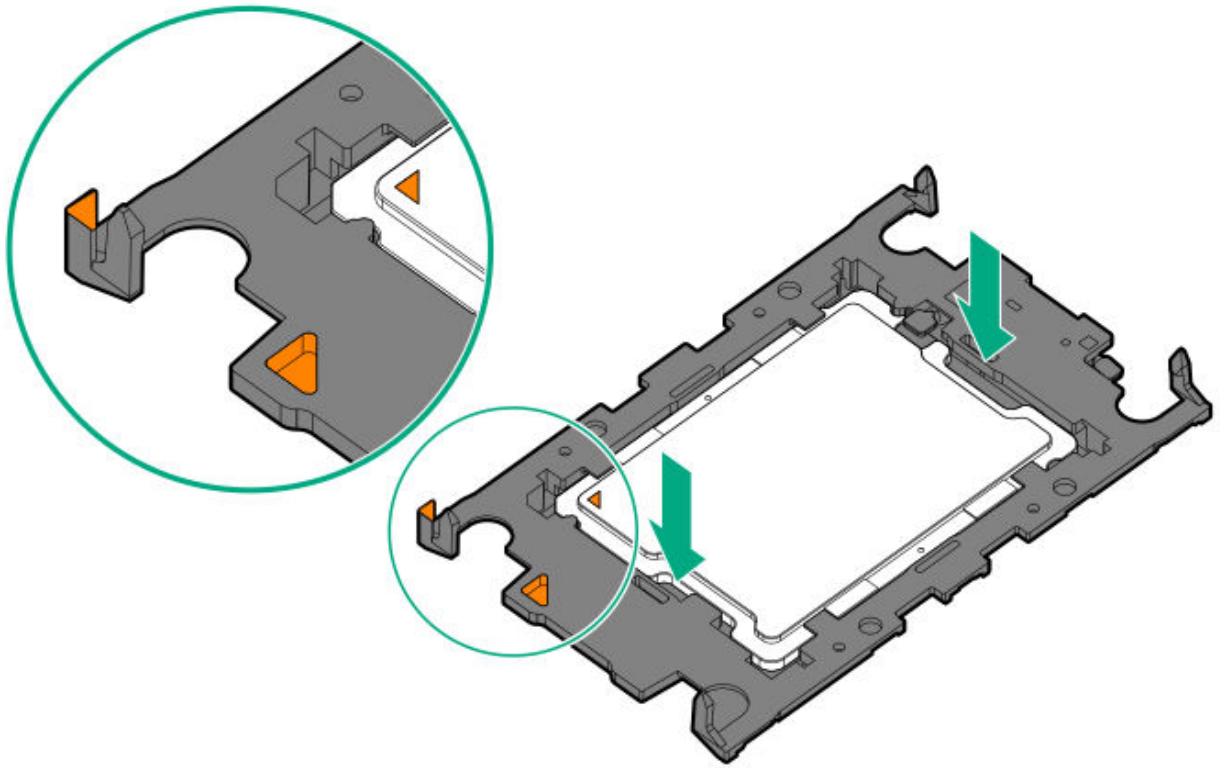

b. Verify that the processor is properly latched on the processor carrier.

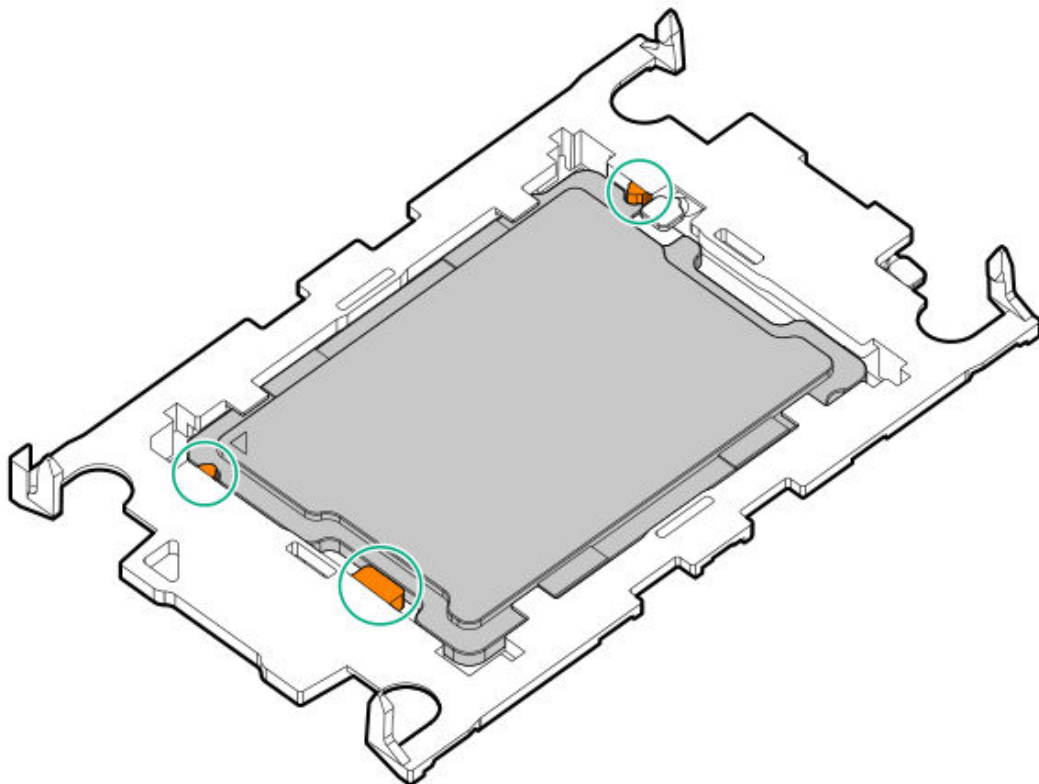

If not, press the other pair of opposite sides of the processor carrier until it clicks into place.

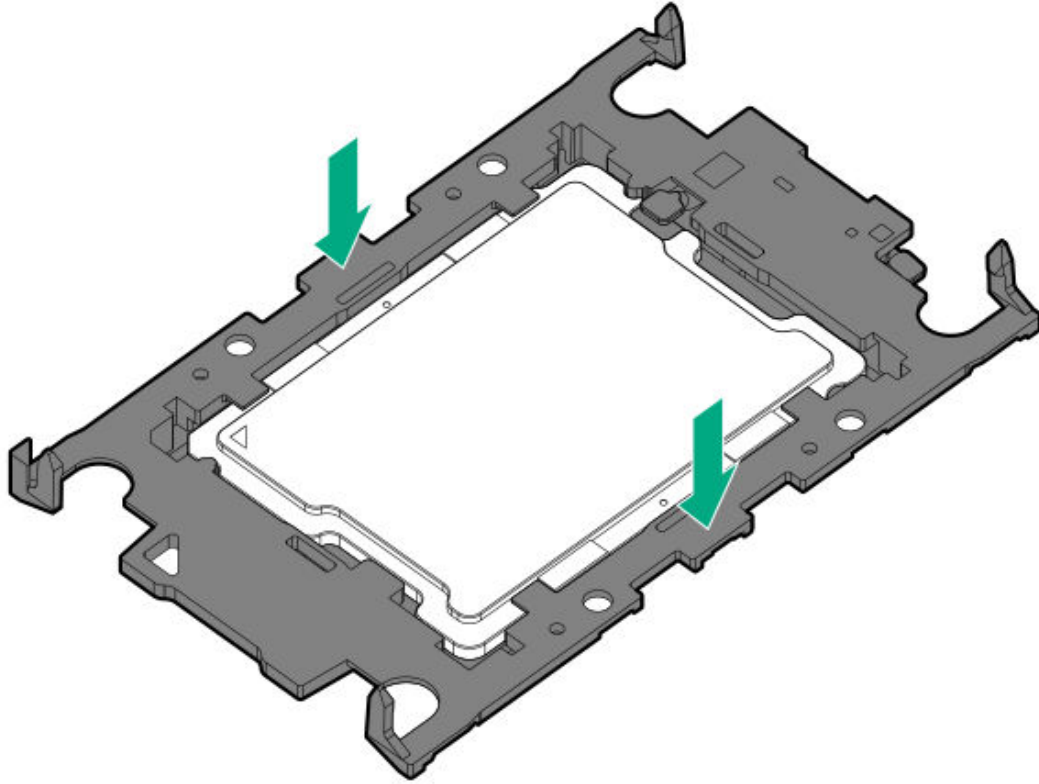

!1. Attach the processor carriers to the pump-cold plates:

- a. Align the pin 1 indicator on the processor carrier with that of the pump-cold plate.

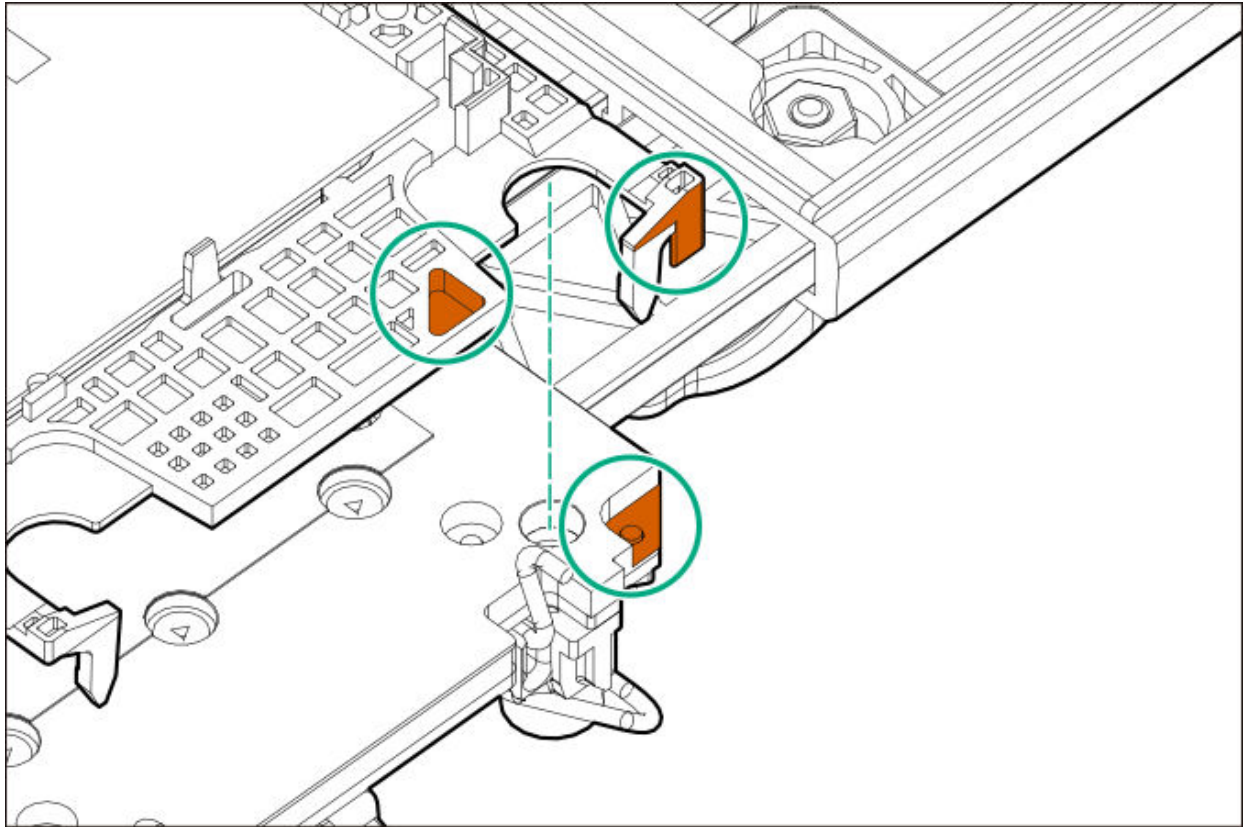

- b. Lower the processor carrier on the pump-cold plate until the carrier tabs snap into place.

There will be an audible click to indicate that the processor carrier is properly latched on the pump-cold plate.

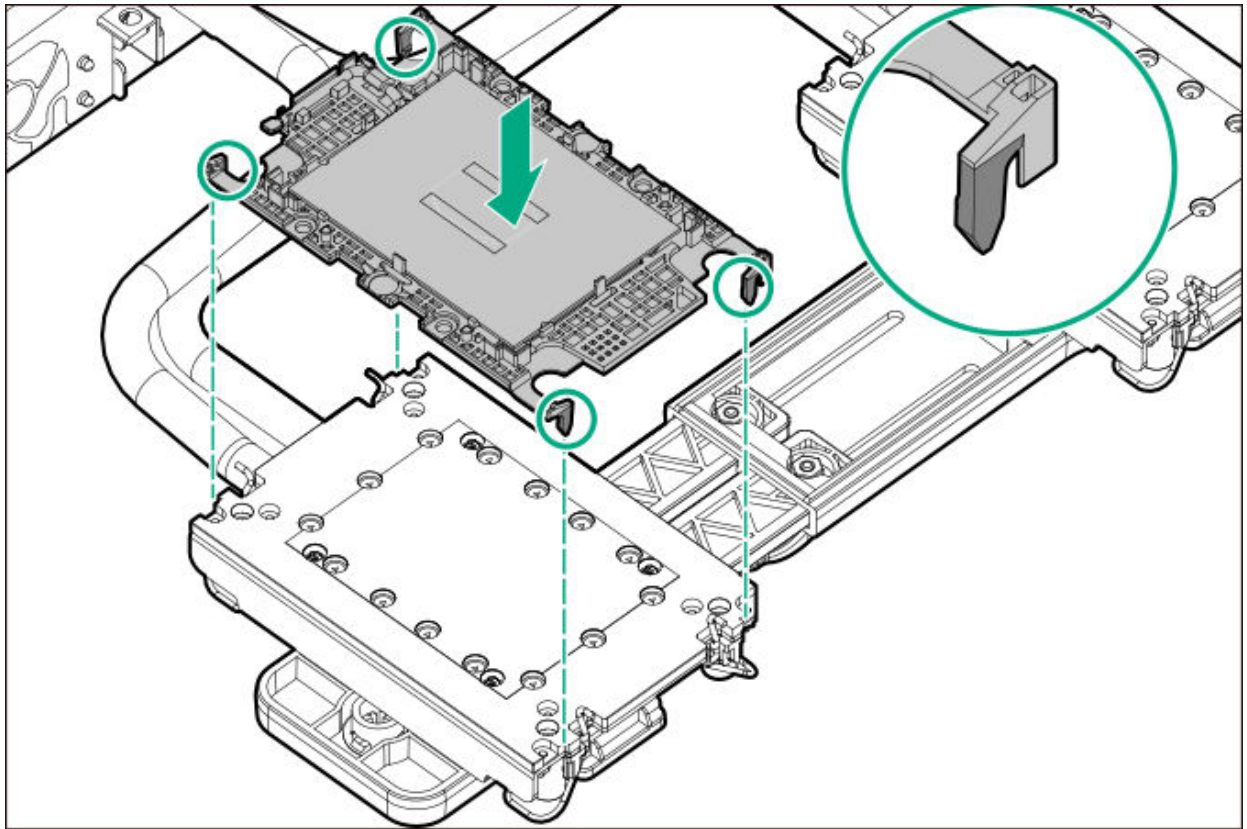

!2. Perform the following verification steps:

- a. Verify that the tabs on the processor carrier are securely latched on the heatsink.

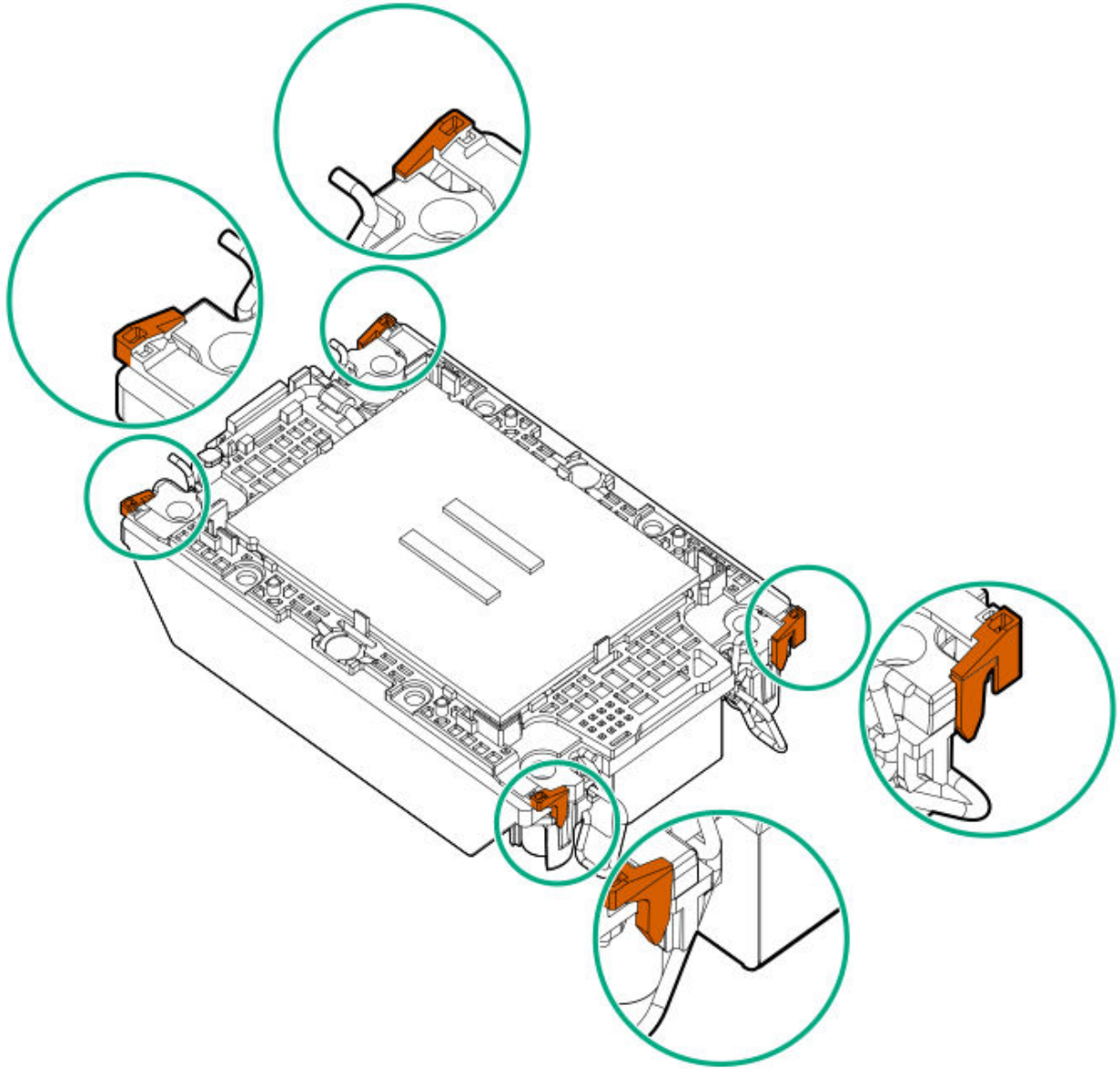

b. Verify that the pin 1 indicators on the processor and processor carrier are aligned.

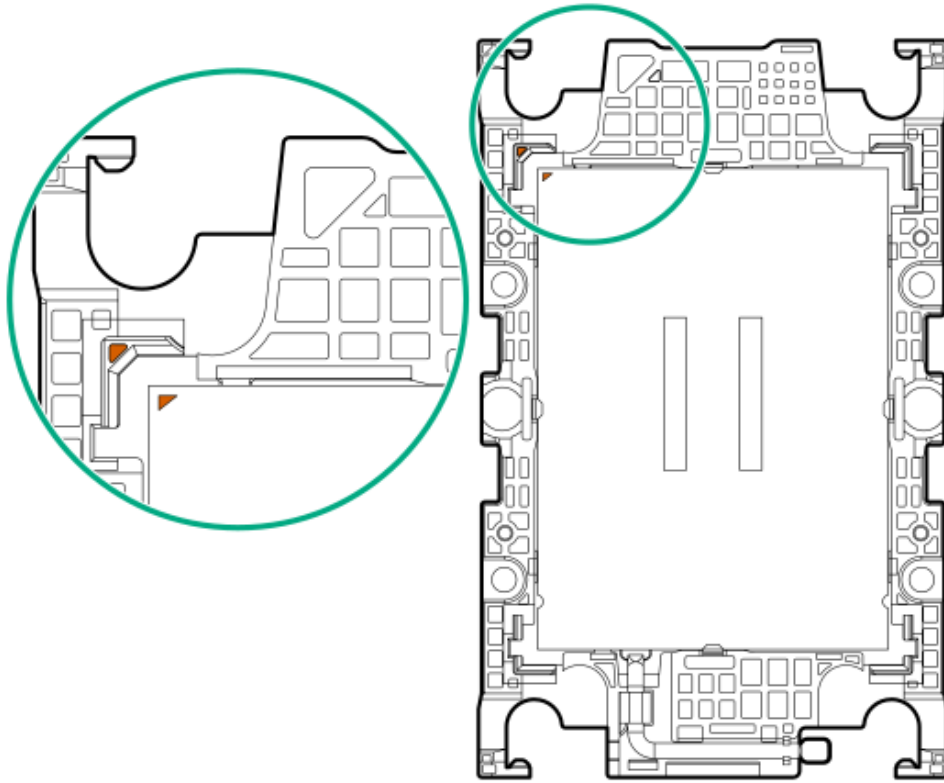

c. Verify that the processor is properly secured by the carrier snaps.

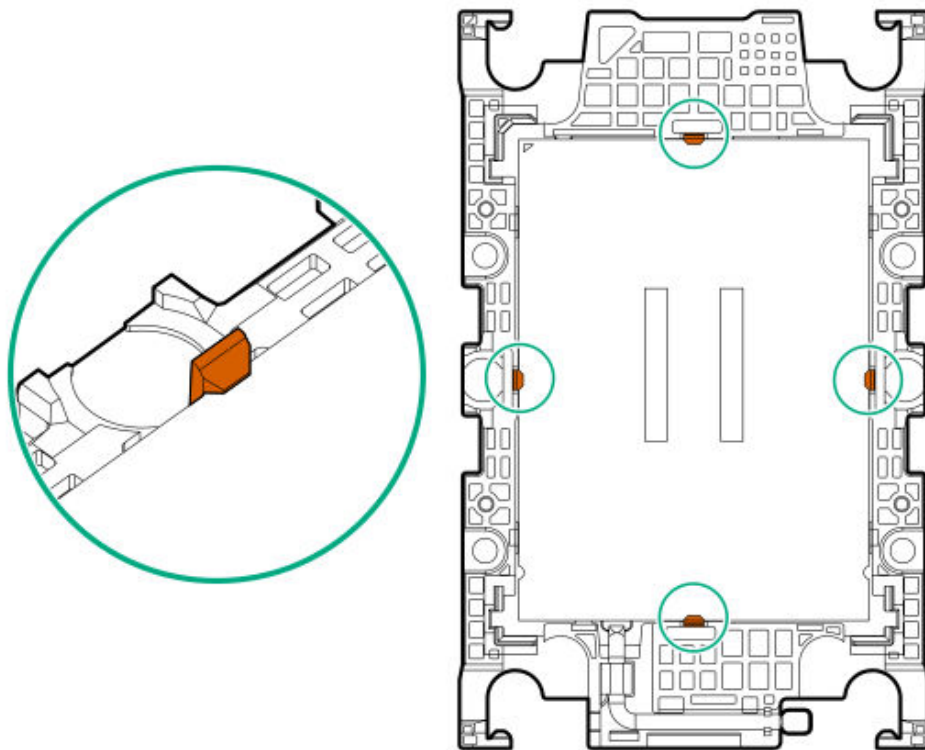

!3.



CAUTION

To avoid damaging the coolant hoses that might result in a coolant leak, do not bend the coolant hoses when installing or removing the liquid cooling module.

Hold the liquid cooling module handle and radiator in the middle.

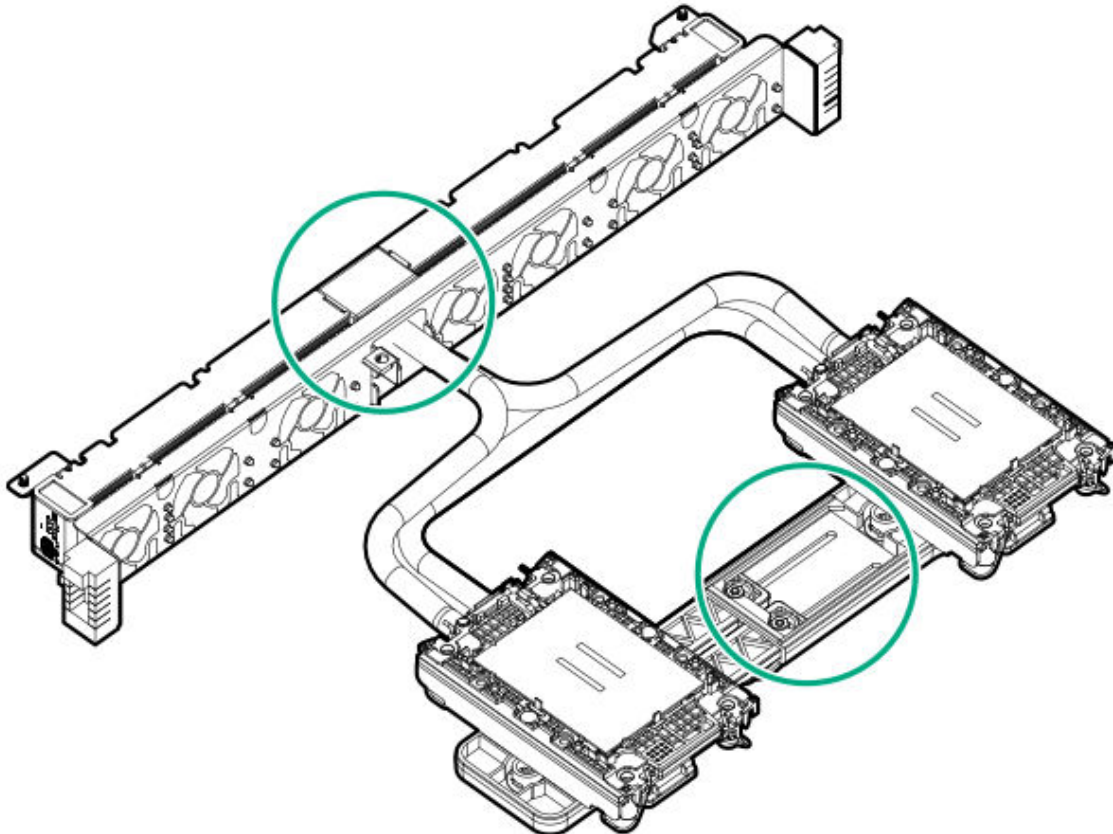

!4.



CAUTION

Extra caution is required when you are handling the liquid cooling module or processor-carrier assembly during its installation or removal process. **THE PINS ON THE PROCESSOR SOCKET AND ON THE PROCESSOR ARE VERY FRAGILE AND EASILY DAMAGED.**



CAUTION

To avoid damaging the coolant hoses that might result in a coolant leak, do not bend the coolant hoses when installing or removing the liquid cooling module.

Place the liquid cooling module on the system board, and slide the radiator to engage with the spools on the chassis.

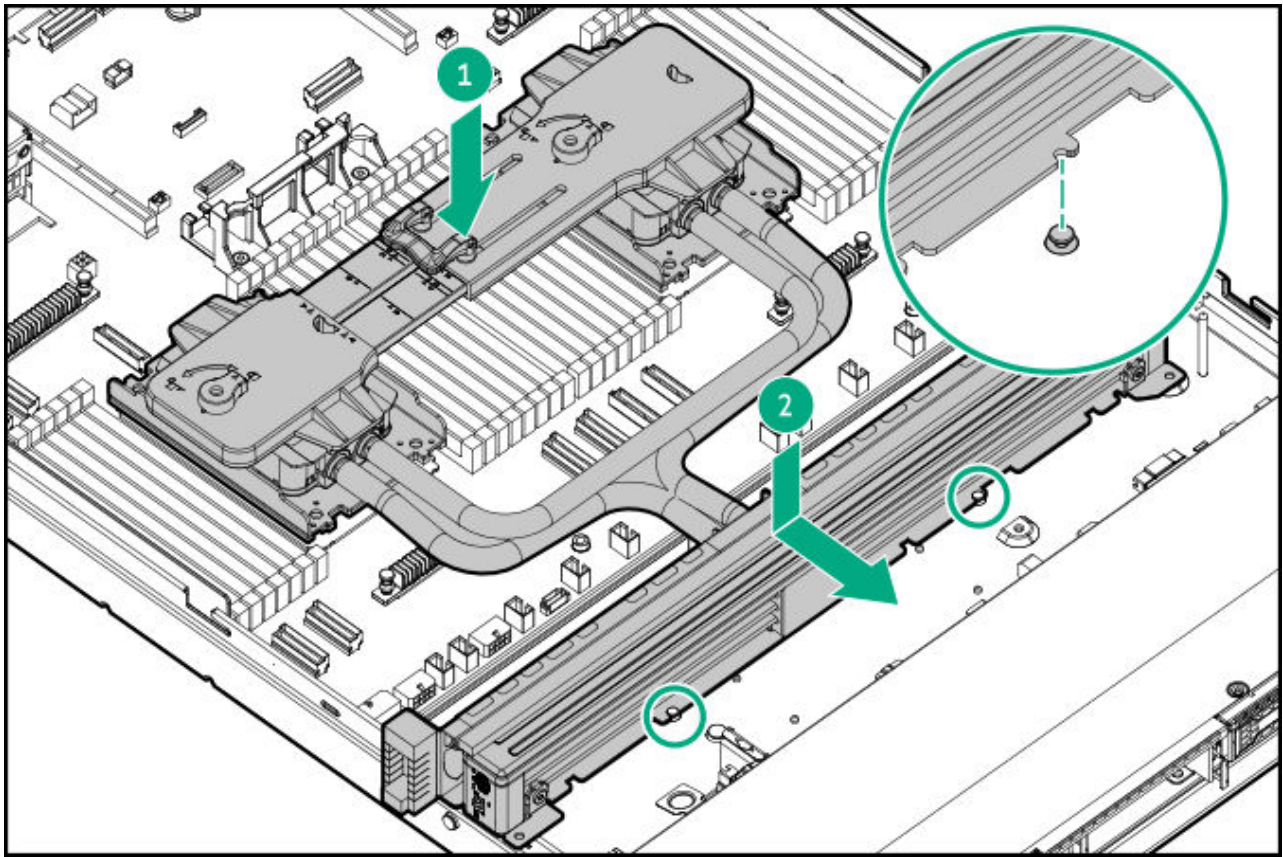

!5. Install the liquid cooling cold plates and pumps:

- a. When using a torque screwdriver to tighten the pump-cold plate screws, set 0.9 N-m (8 in-lb) of torque.
- b. Note the **Front of server** text on the pump-cold plate label to correctly orient the pump-cold plate over the bolster plate.
- c. Carefully lower the pump-cold plate onto the bolster plate guide posts.

The posts are keyed so that the module can only be installed one way. Make sure that the module is properly seated on the bolster plate before securing the screws.

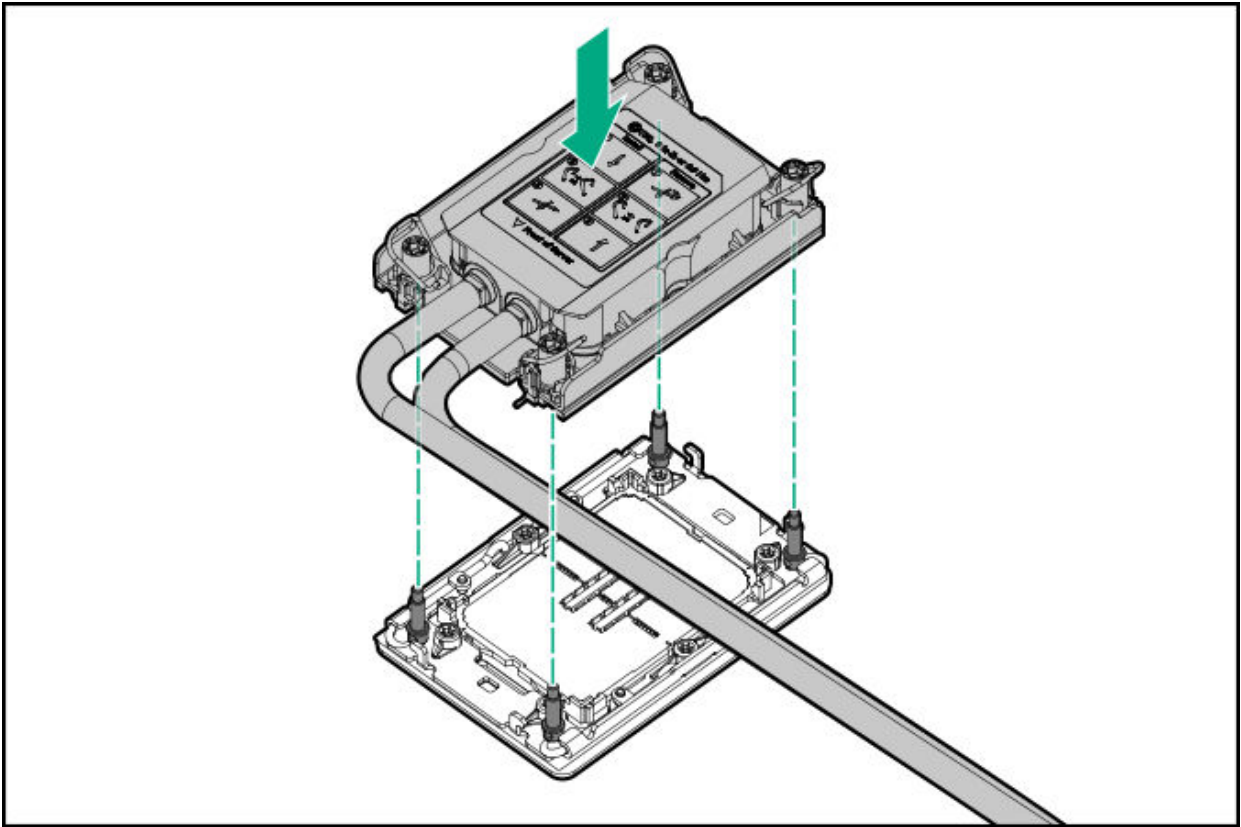

d. Set the anti-tilt wires to the locked position.

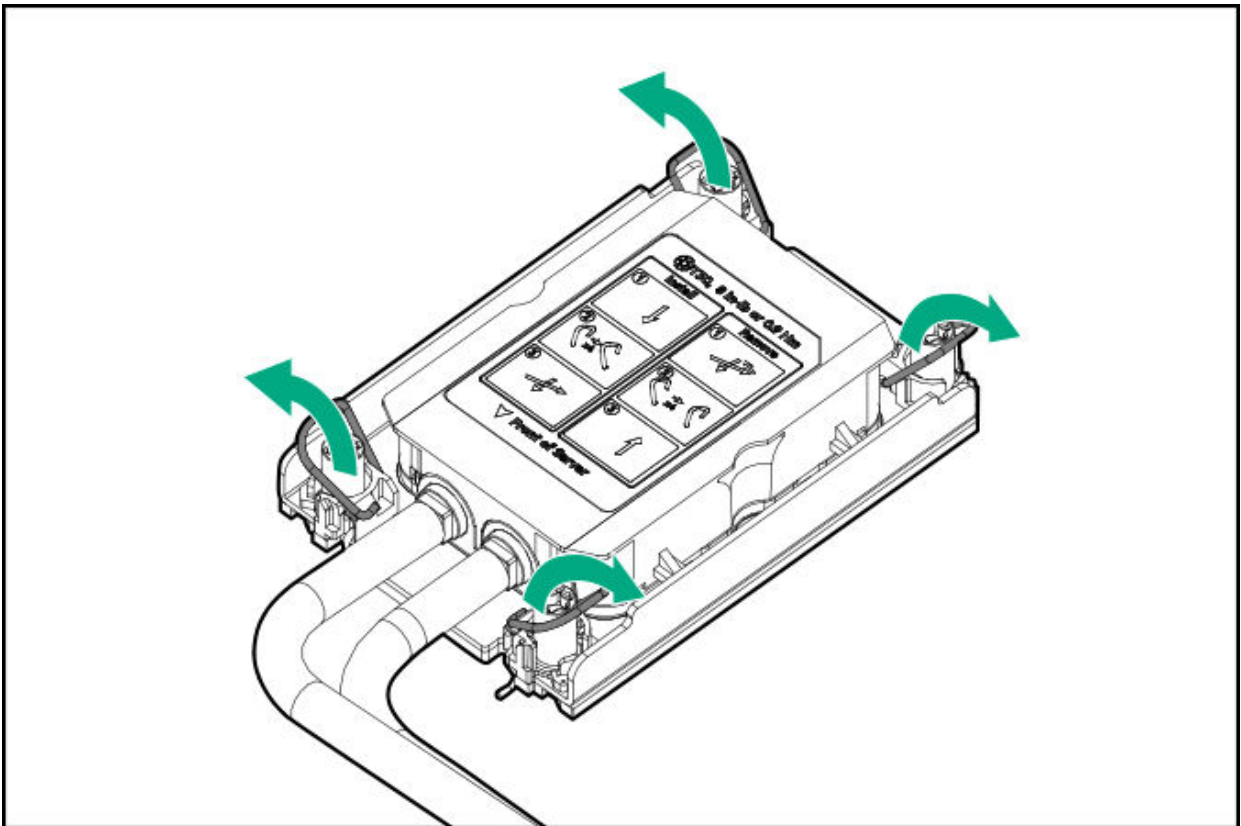

e. Tighten the pump-cold plate screws.

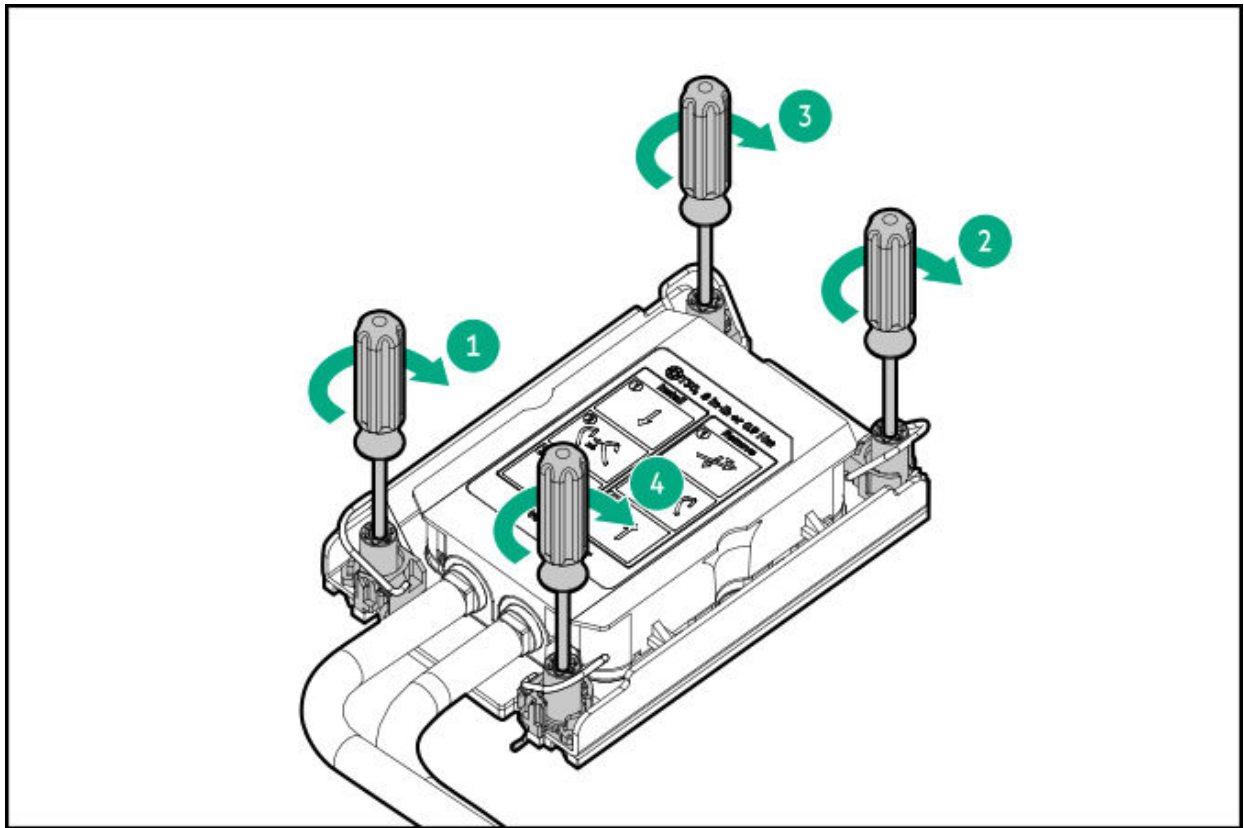

f. Remove the handle from the pump-cold plates.

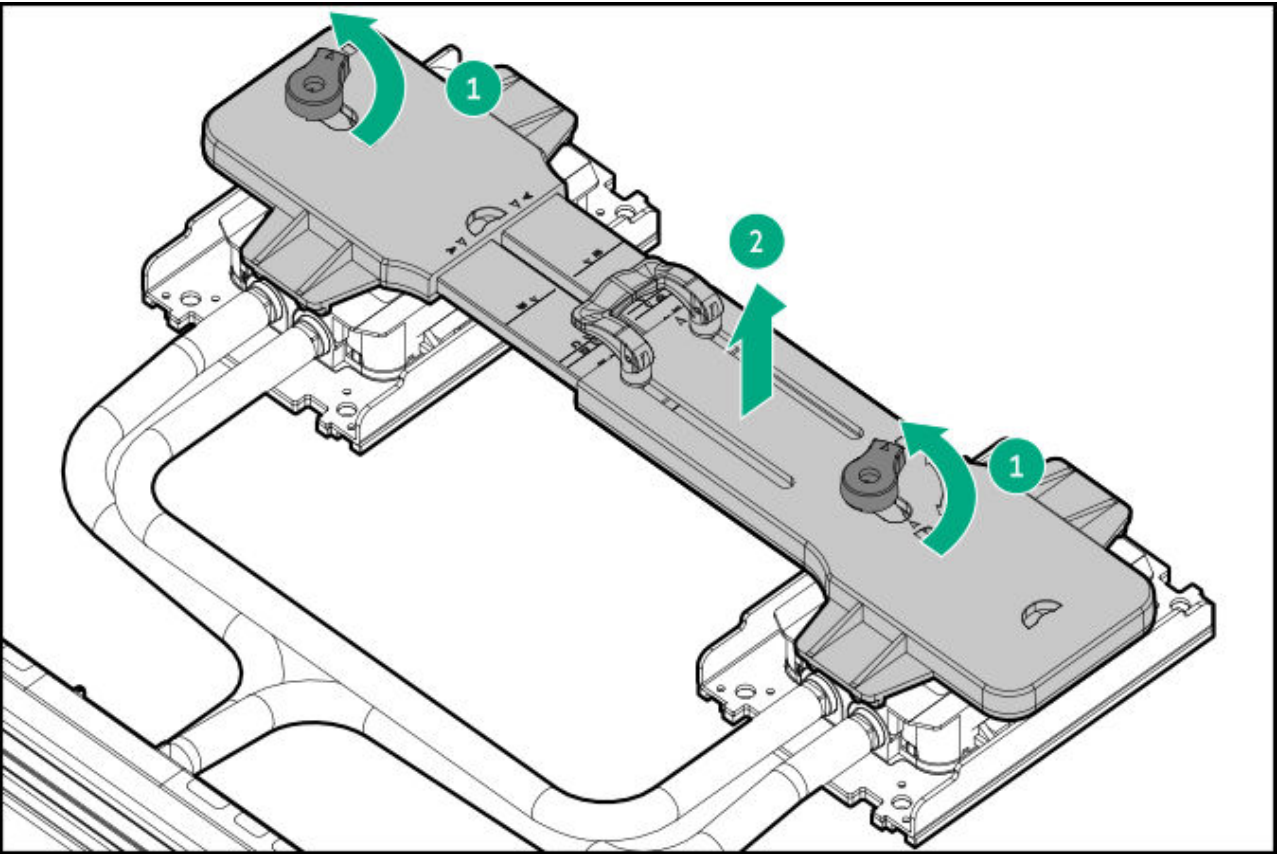

!7. Install the radiator screws on the chassis.

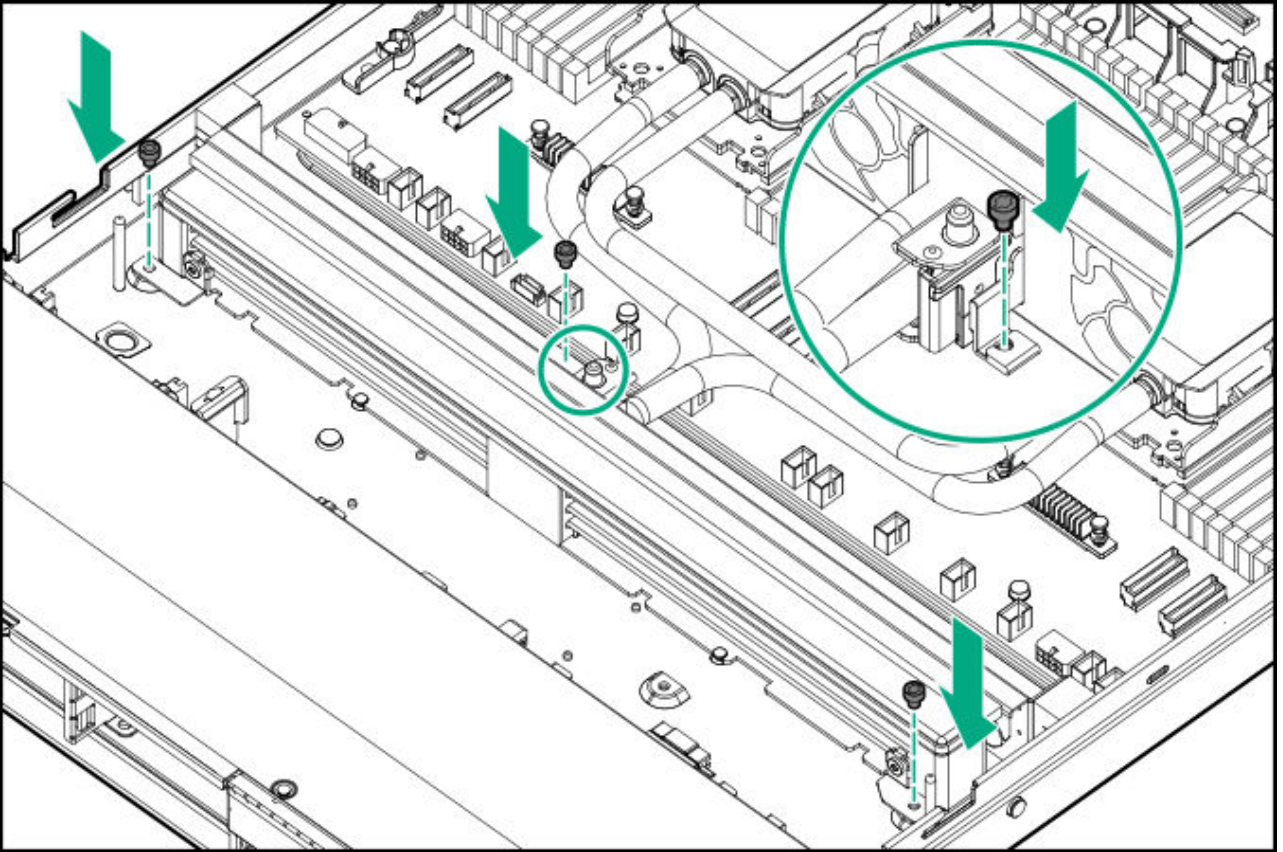

!8. Connect the pump signal cable to the system board.

!9. Install the access panel guide pin.

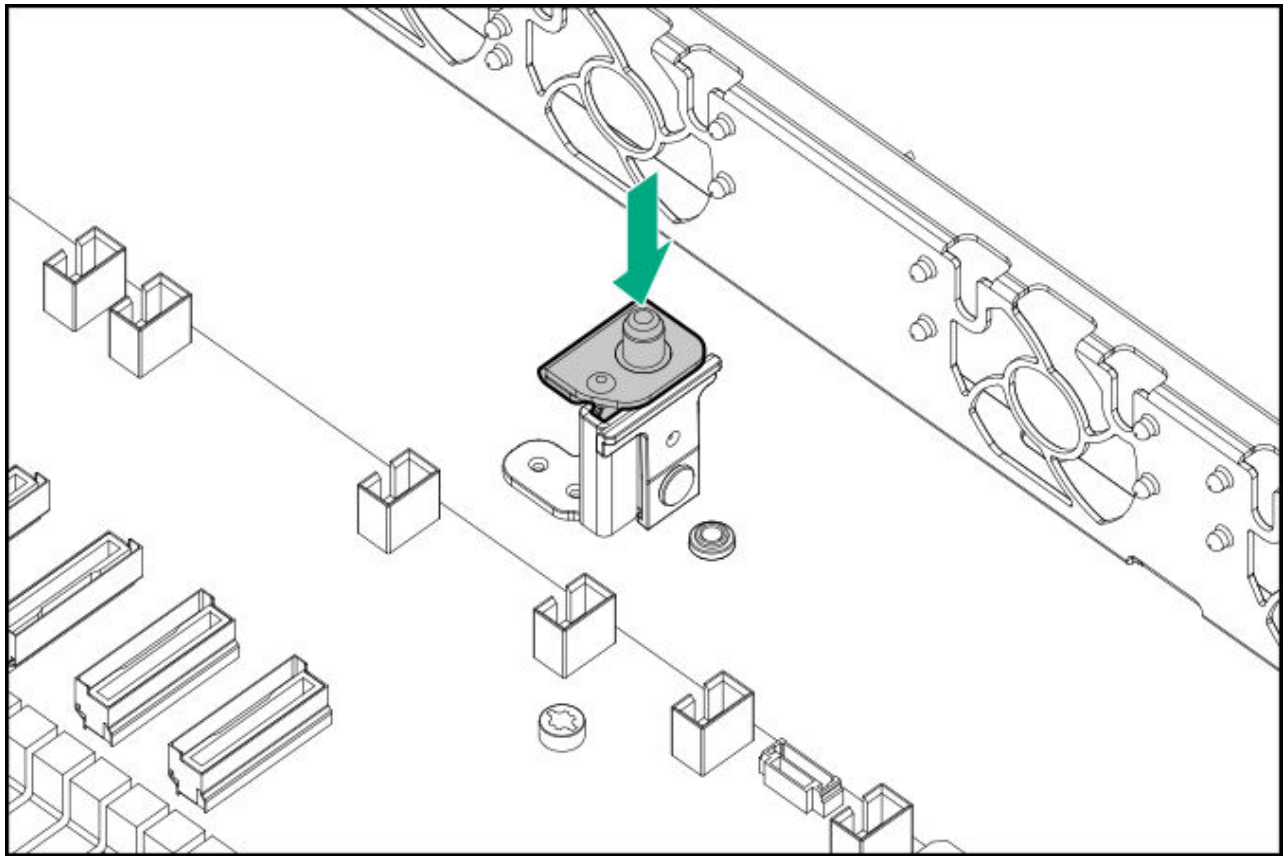

10. Install the liquid cooling fans.

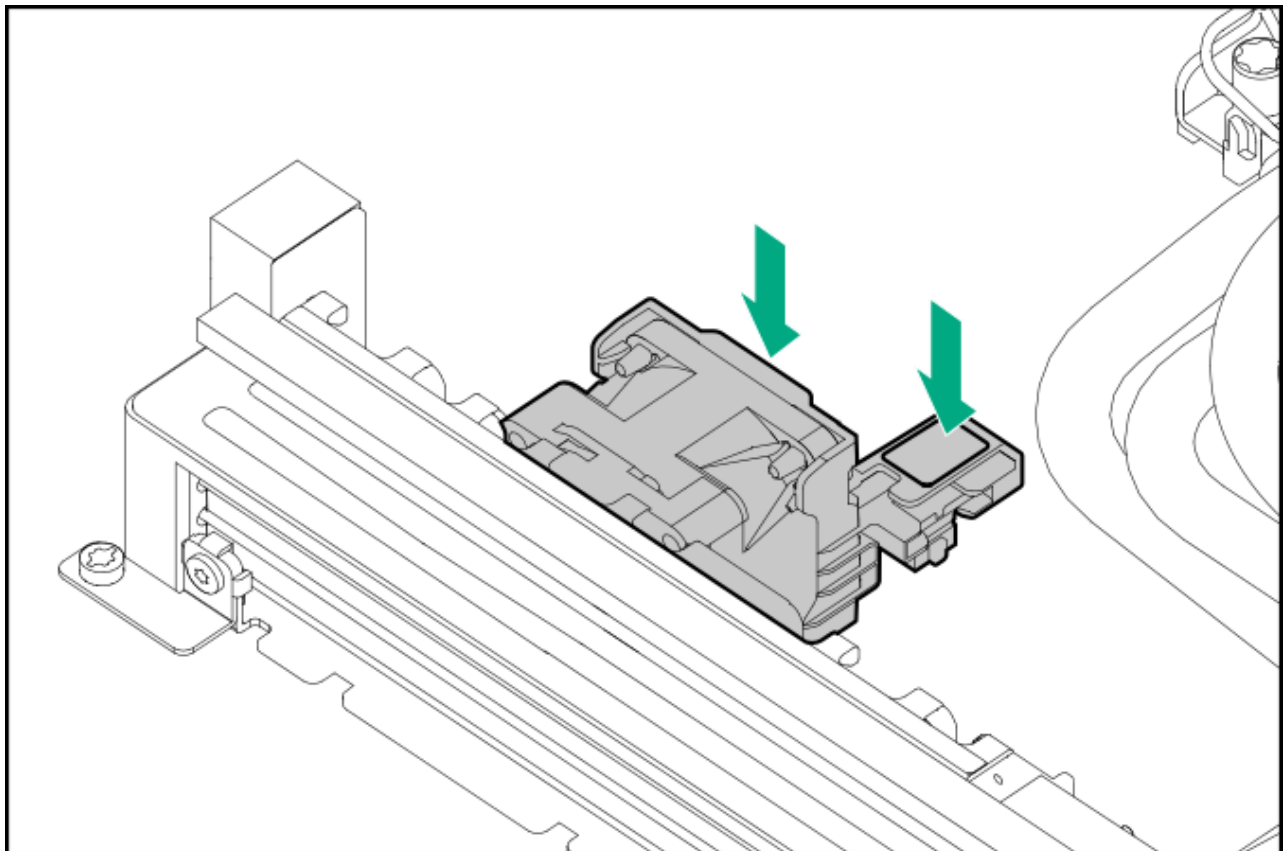

1. Install the access panel.
2. If the server was removed from an enclosure or a rack, reinstall it now.
3. Connect all peripheral cables to the server.
4. Connect each power cord to the server.
5. Connect each power cord to the power source.
6. Power up the server.
7. Use iLO to verify the status of the closed-loop liquid cooling module.

For more information on the available liquid cooling information in iLO, see the iLO 7 user guide:

<https://www.hpe.com/support/hpeilodocs-quicklinks>

Results

The installation procedure is complete.

Connecting the direct liquid cooling kit

Prerequisites

You need the DLC hose kit. The hose kit connects the DLC manifold to the processor cold plates.

About this task

For more information about the DLC system, see the **HPE Cray XD Direct Liquid Cooling System Site Preparation, User, and Maintenance Guide**:

<https://www.hpe.com/info/xdDLCguide>

Procedure

1. From the rear of the server, locate the hoses of the DLC module.



NOTE

The image is for identifying possible hose locations. Hoses will only come from the riser cage or the NS204i-u boot device bracket. They will not come from both.

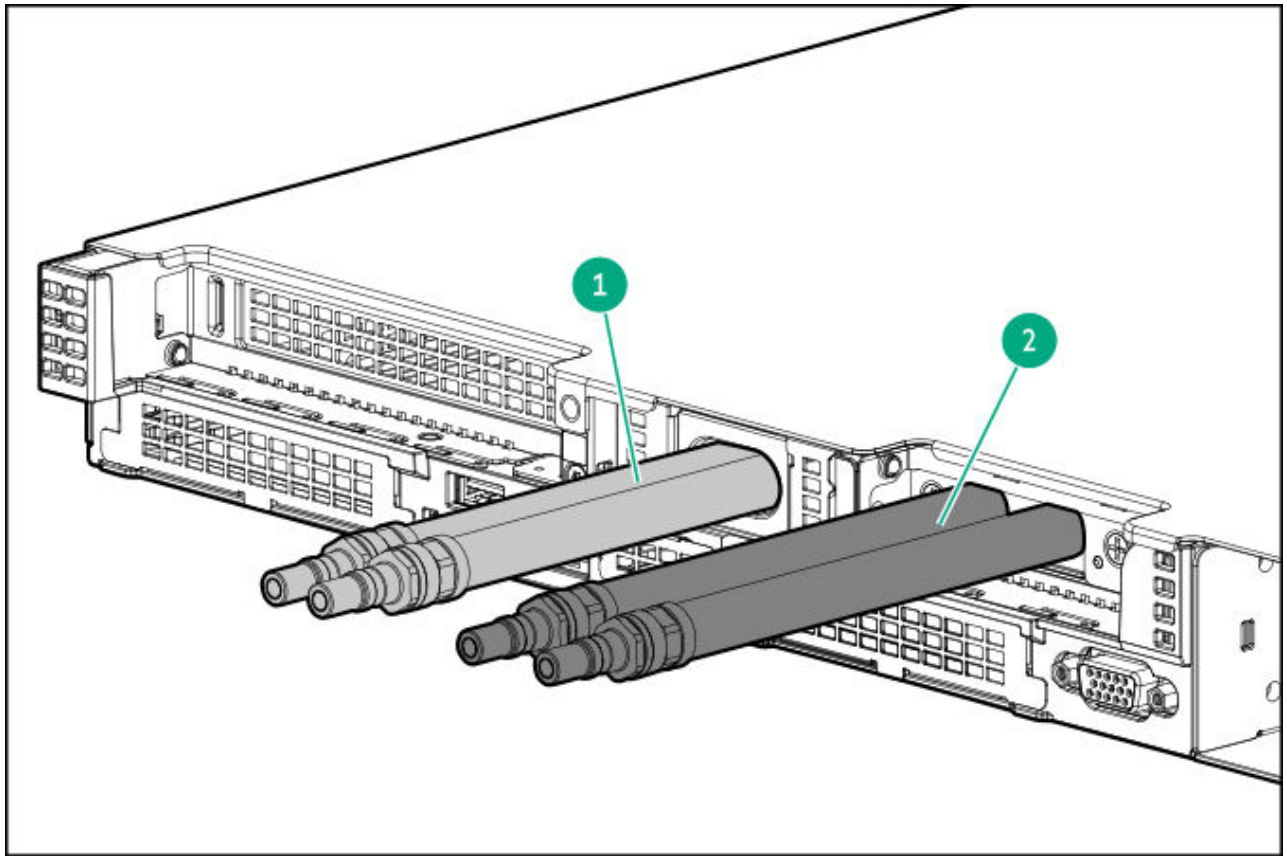

Item	Description
1	Coolant hoses coming from NS204i-u bracket
2	Coolant hoses coming from PCIe Slot 3

2. Remove the quick connector caps from the hoses.

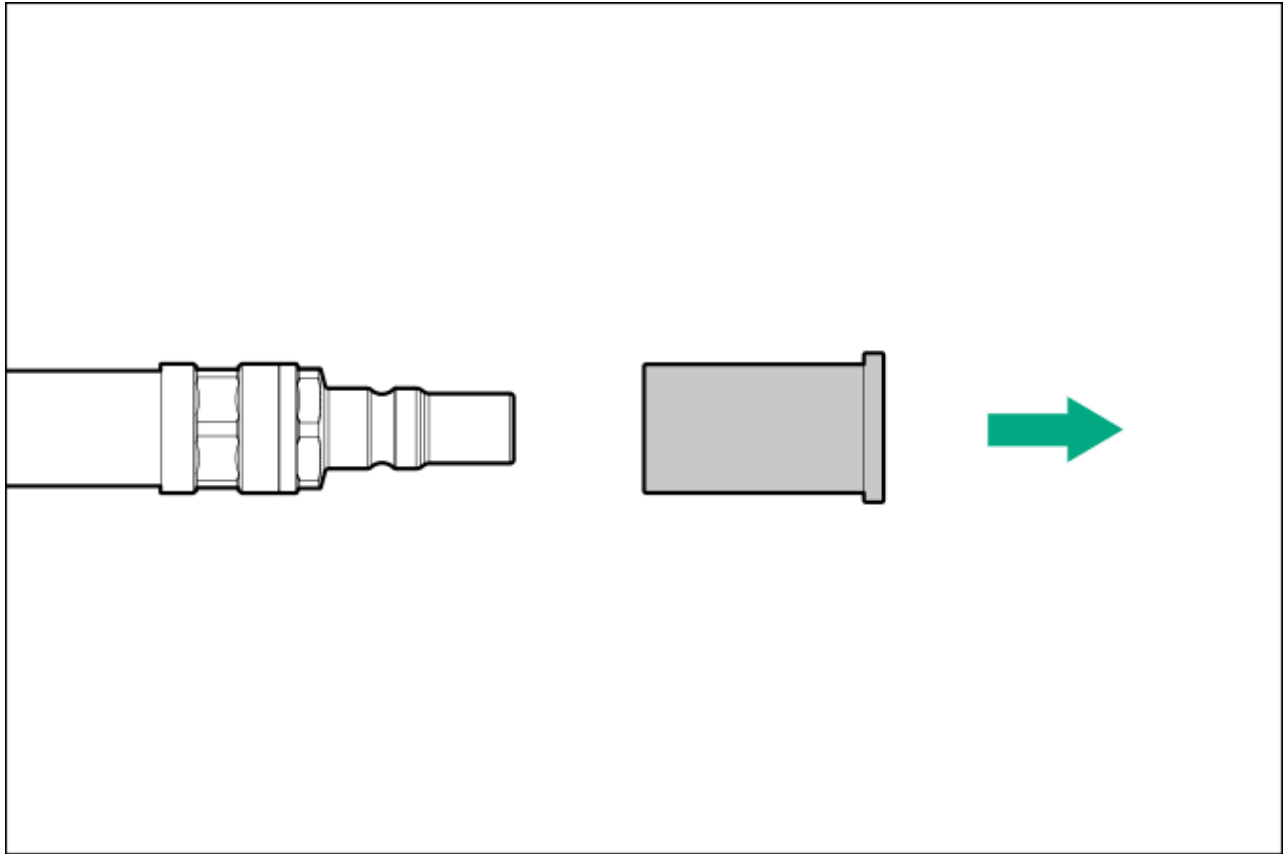

3. Connect the direct liquid cooling kit from the DLC manifold to the server.

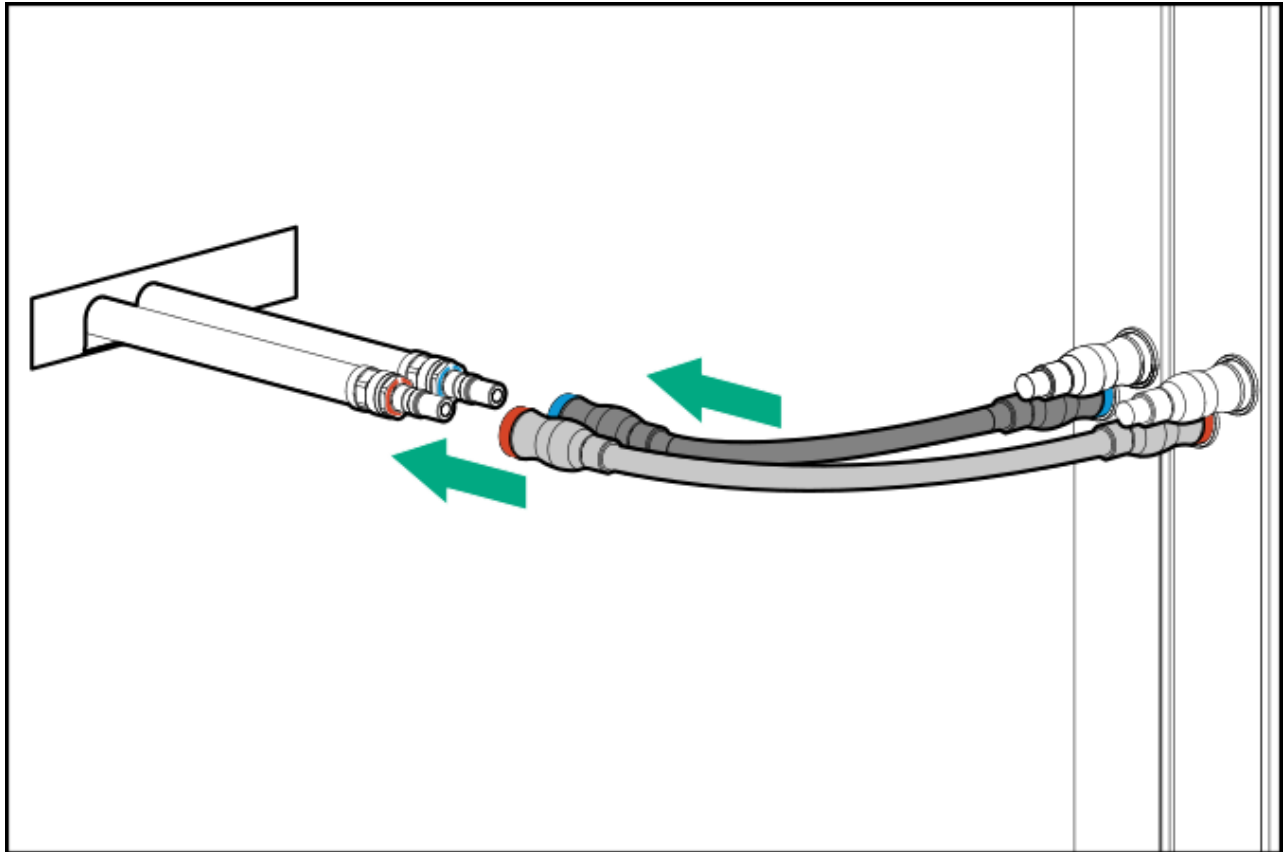

Rack rail and CMA

Subtopics

[Rack mounting interfaces](#)

[Rack rail options](#)

[Rail identification markers](#)

[Installing the rack rails](#)

[Installing the server into the rack](#)

[Installing the rack rail hook-and-loop strap](#)

[Installing the cable management arm](#)

Rack mounting interfaces

The rack rails can be installed in a rack that has the following mounting interfaces:

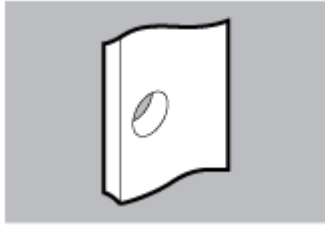

Round-hole

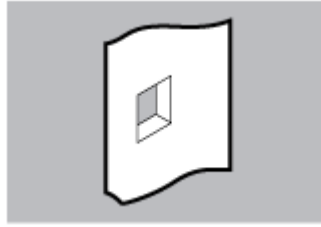

Square-hole

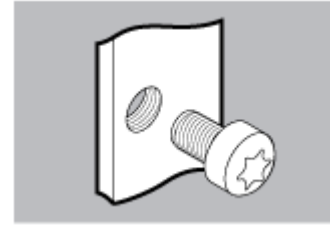

Threaded round-hole

The illustrations used in this procedure show an icon on the upper right corner of the image. This icon indicates the type of mounting interface for which the action illustrated in the image is valid.

Rack rail options

This server supports the following HPE Easy Install friction rack rail (stab-in) options:

Server configuration	Rack rail option	Minimum rail length	Adjustable rail range
8 SFF drive	Rail option #3 (P52341-B21)	787.55 mm (30.00 in)	609.60 mm to 918.10 mm (24.00 in to 36.15 in)
4 LFF / 10 SFF / 20 E 3.S drive*	Rail option #5 (P52343-B21)	808.69 mm (31.84 in)	

* The 10 SFF / 20 E3.S hardware configuration supports mixed drive types.

Rail identification markers

The rack rail option support is dependent on these two factors:

- The height and weight of the chassis as determined by the front- and rear-end server configurations.
- The depth of the chassis as measured from the edge of the front panel (without the front bezel) to the edge of the rear panel.

To ensure compatibility between the rack rails and the server, verify that the rail number labels on the chassis match the ones stamped on the rails.

- Rail number labels on the chassis

Rail #3 and #5

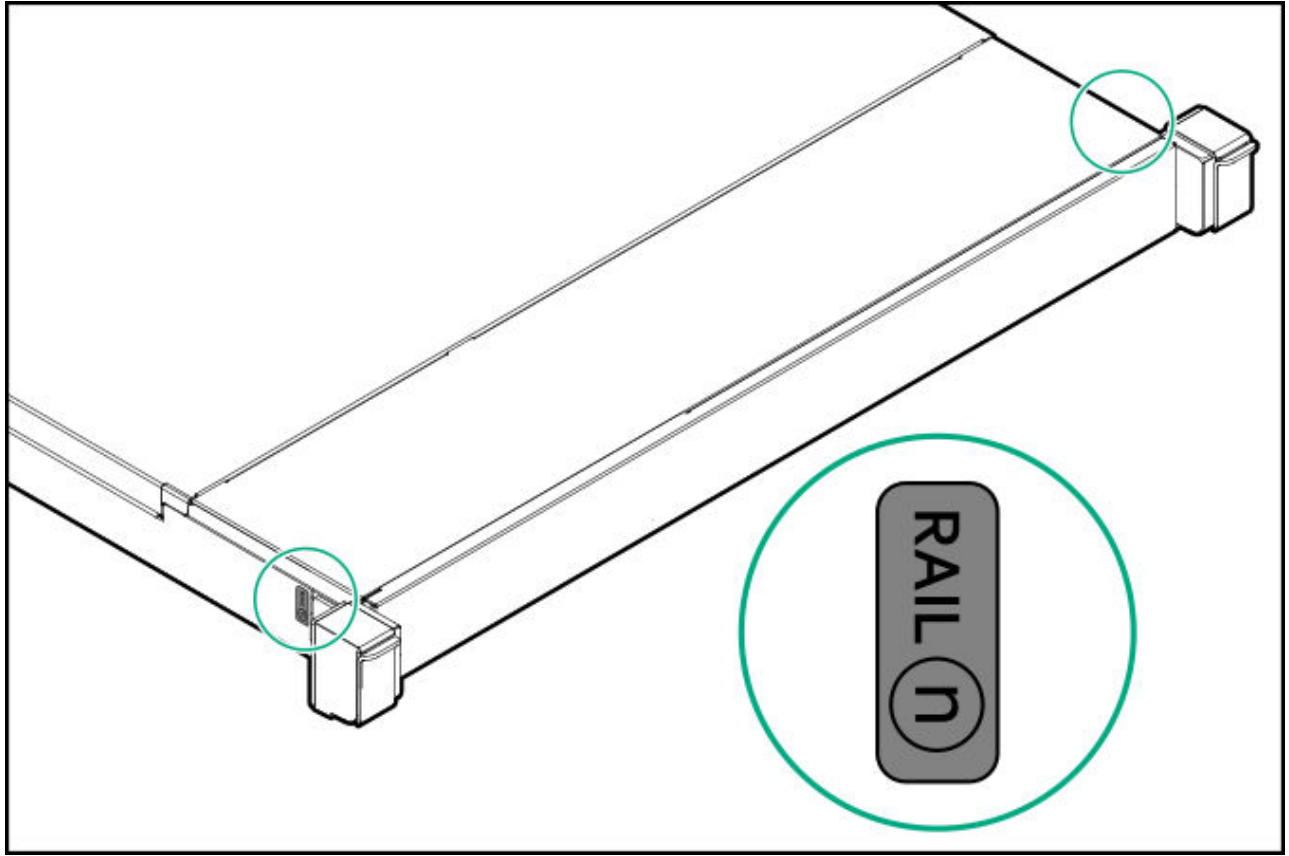

- Rail identifier stamps on the inner rail of the friction rack rail

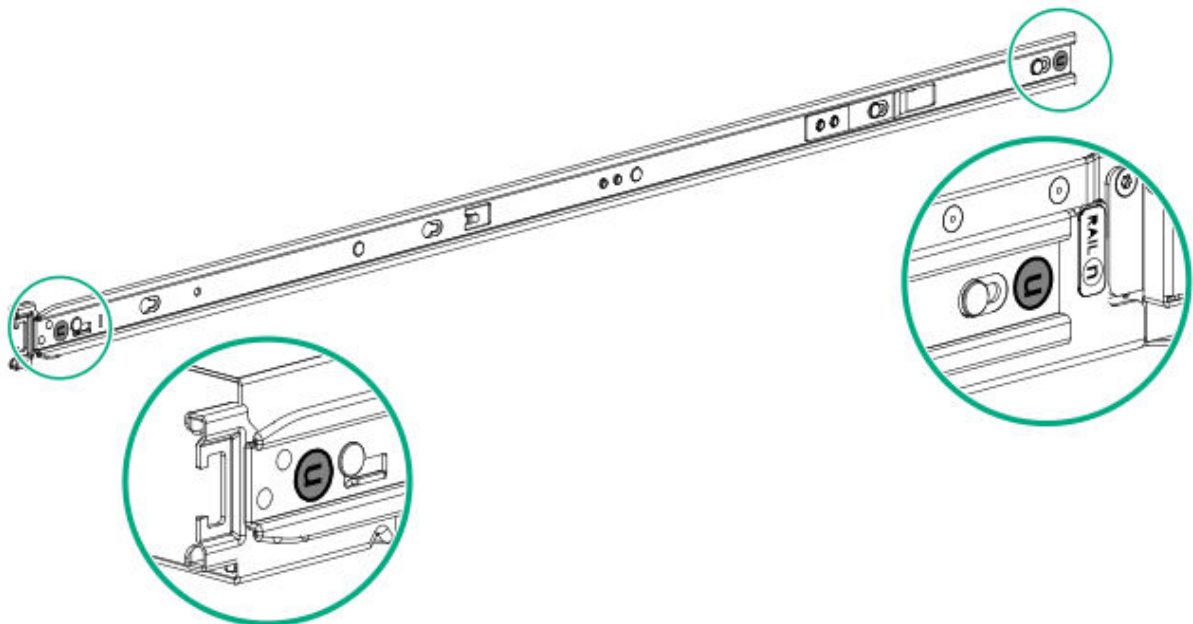

- Rail identifier stamps on the mounting rail of the friction rack rail

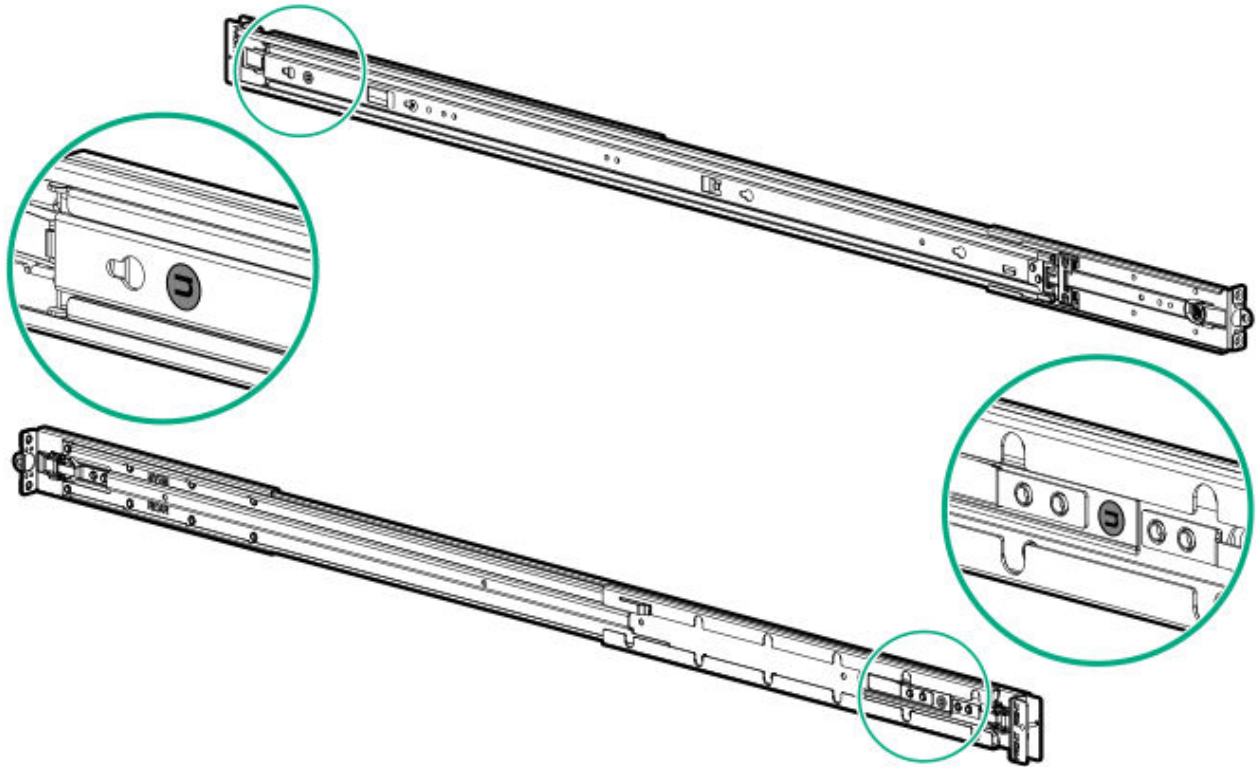

Installing the rack rails

Prerequisites

- Make sure that the rack rail option is compatible with the server configuration.
- If you are installing the server in a threaded round-hole rack, be sure to have a small slotted screwdriver.

Procedure

1. Install the server rails.

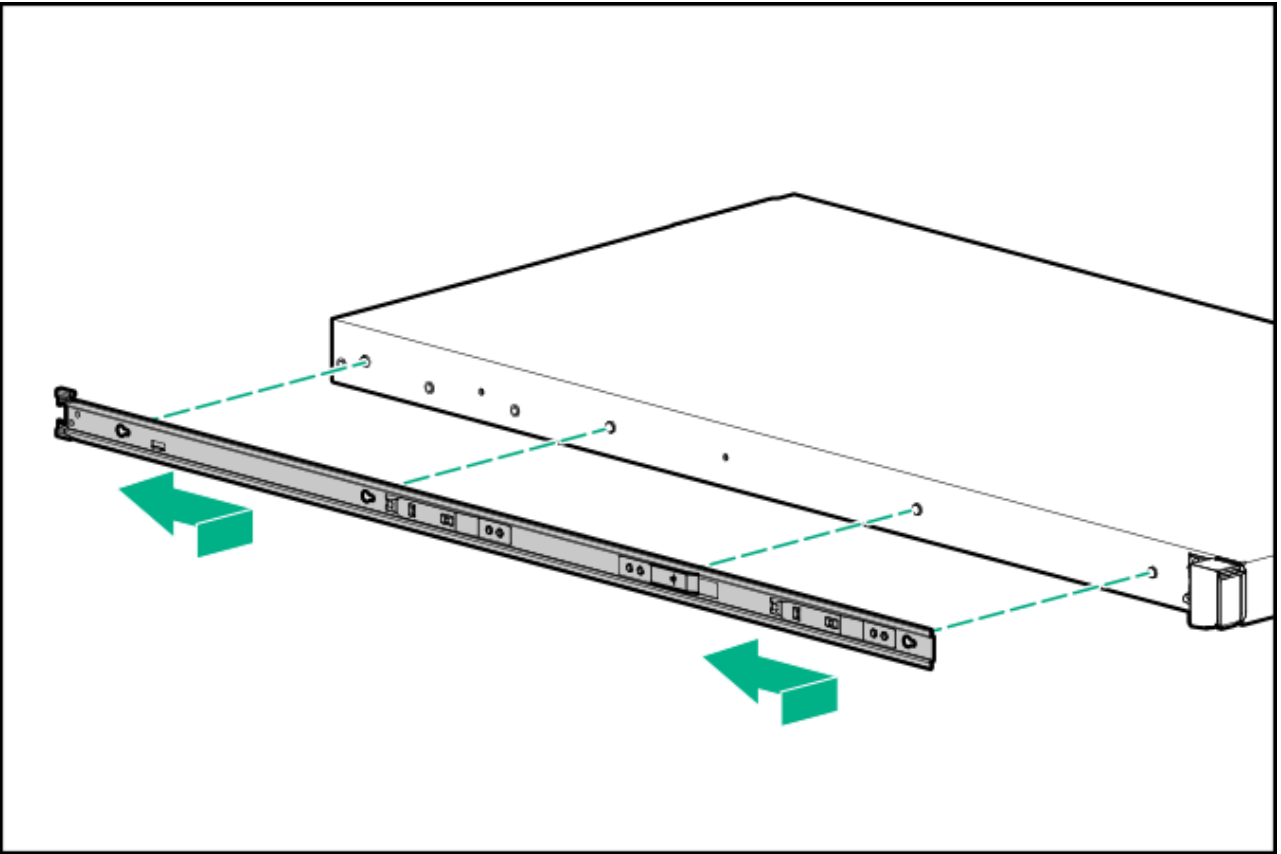

2. Identify the rack rails.

- The front end of the rails is marked as **FRONT LEFT** or **FRONT RIGHT**.
- The other end of the rails is marked as **REAR**.

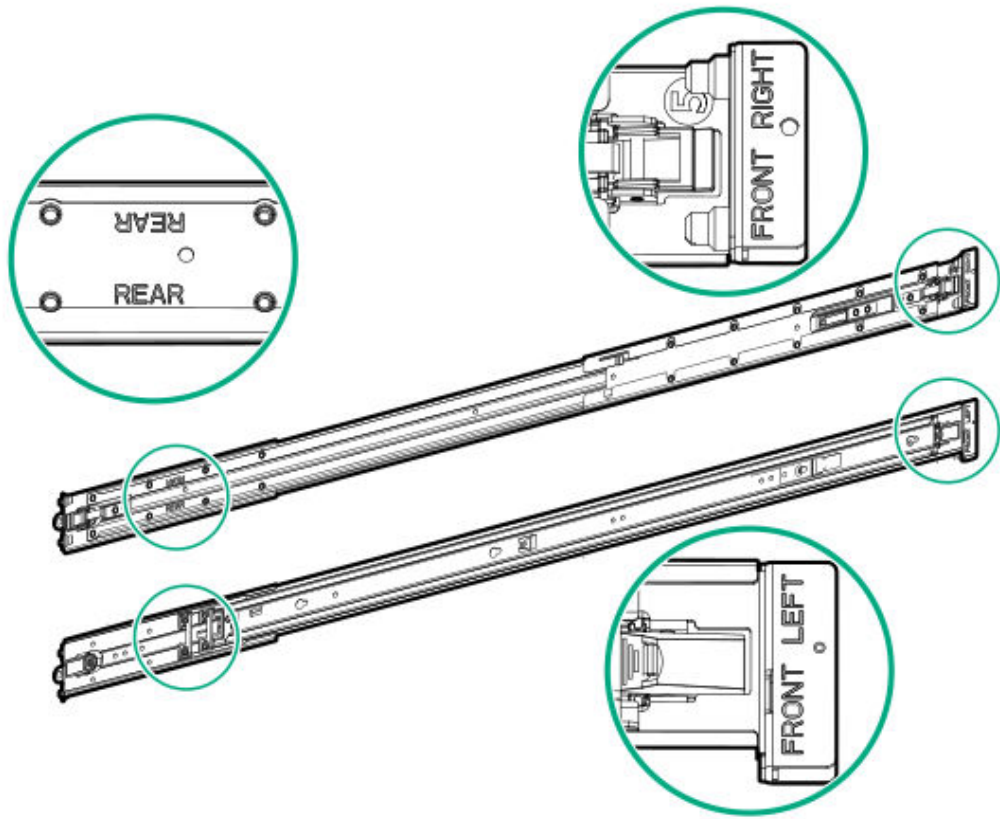

3. Extend the rack rails to align with the depth of the rack.

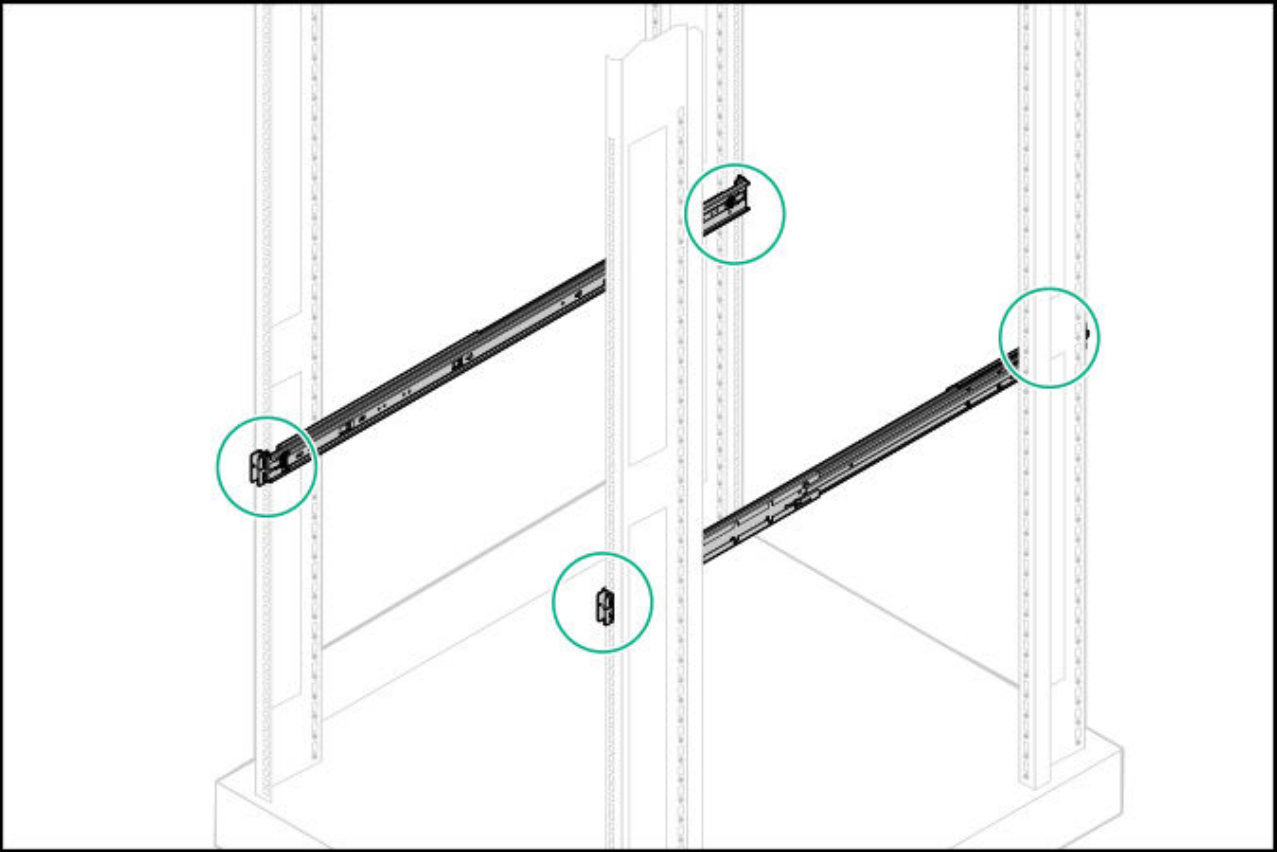

4. Install the rack rails.

- For round-hole or square-hole racks:

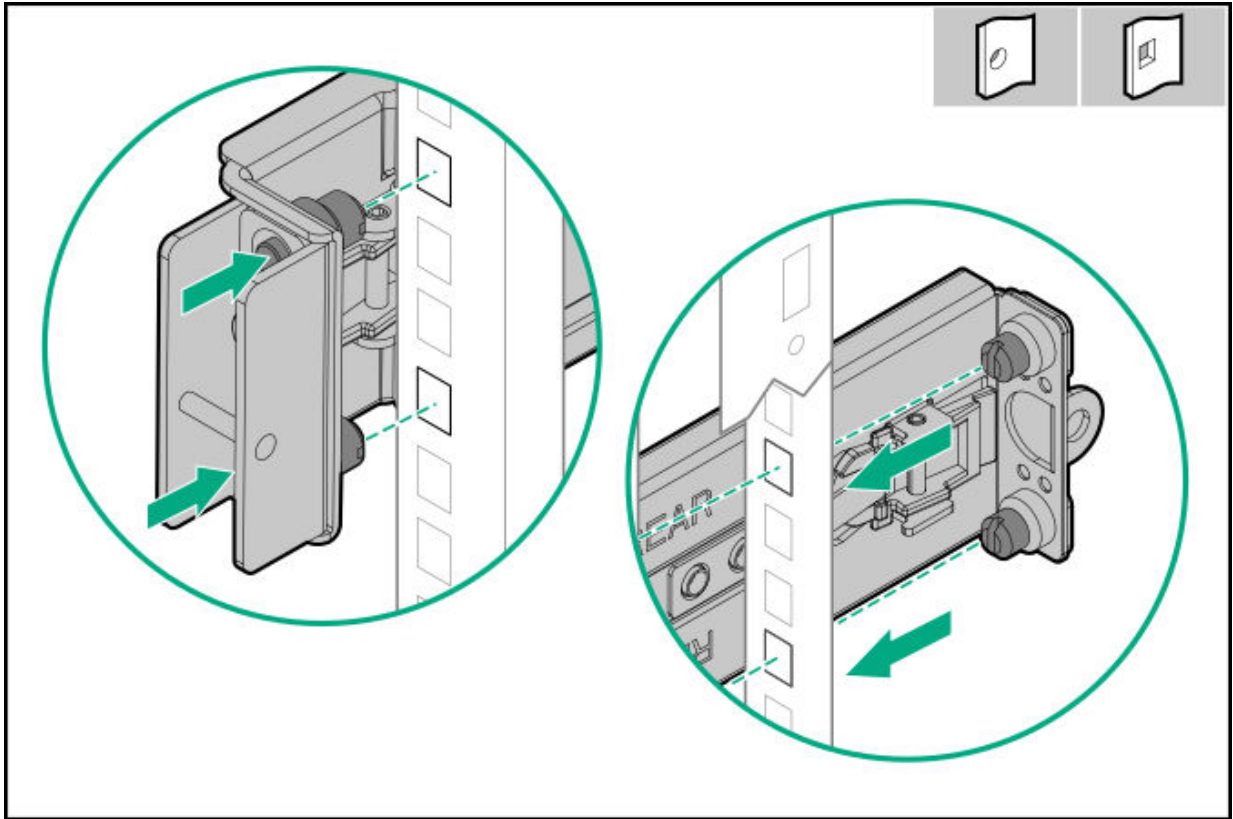

- For threaded round-hole racks:

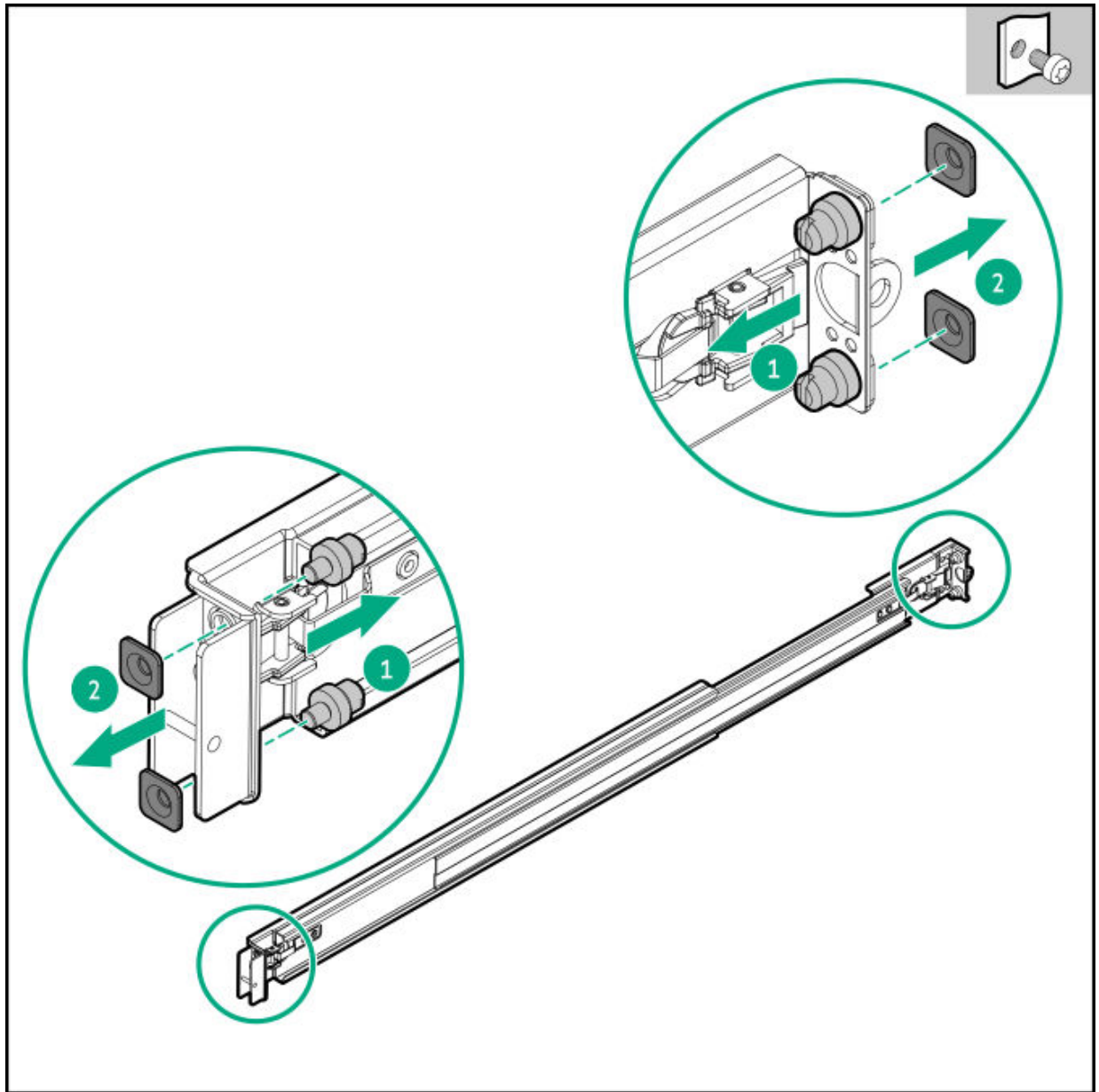

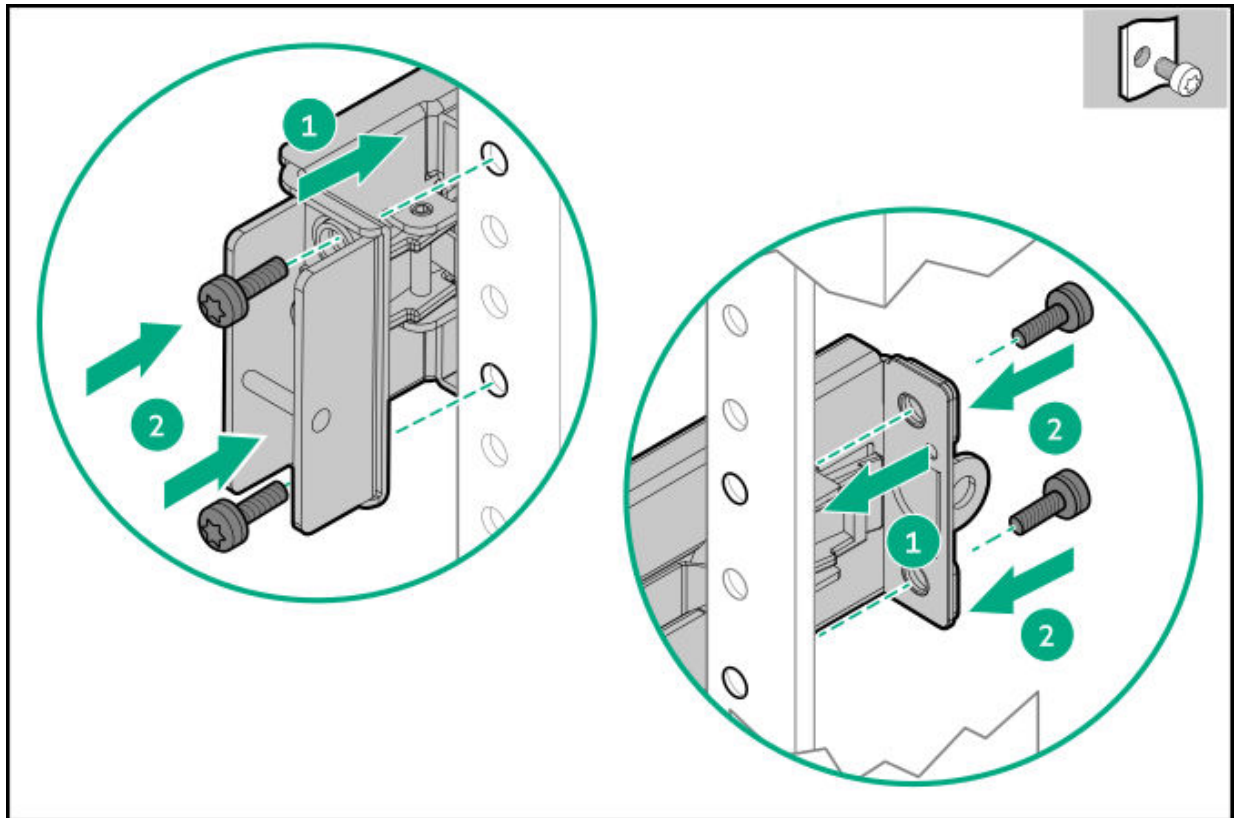

5. Install the server into the rack.

Installing the server into the rack

Prerequisites

- Before you perform this procedure, review the:
 - [Space and airflow requirements](#)
 - [Rack warnings and cautions](#)
 - [Server warnings and cautions](#)
- A fully populated server is heavy. Hewlett Packard Enterprise recommends removing the external chassis components before installing the server into a rack.
- Before you perform this procedure, make sure that you have a T-25 Torx screwdriver available.

Procedure

1. Install the server into the rack.

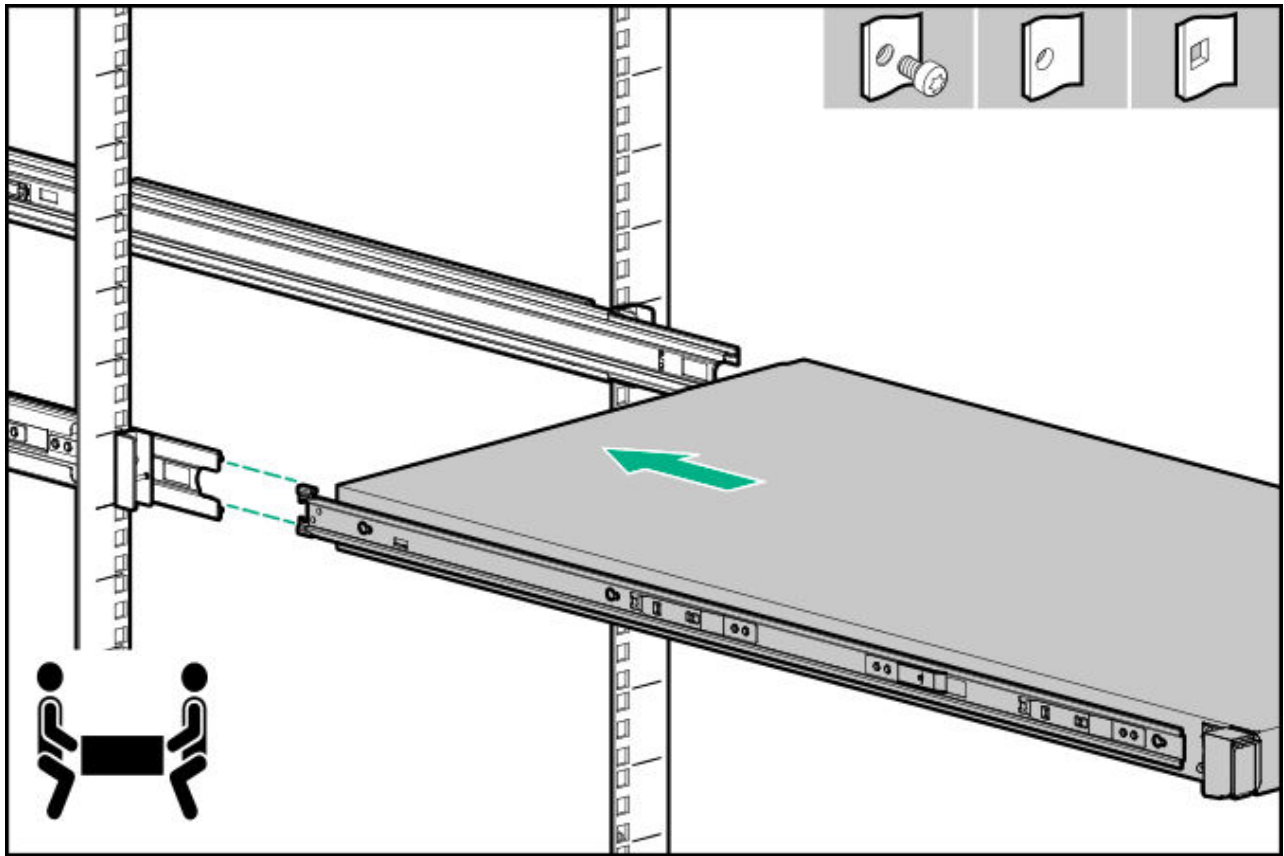

2. Tighten the shipping screws.

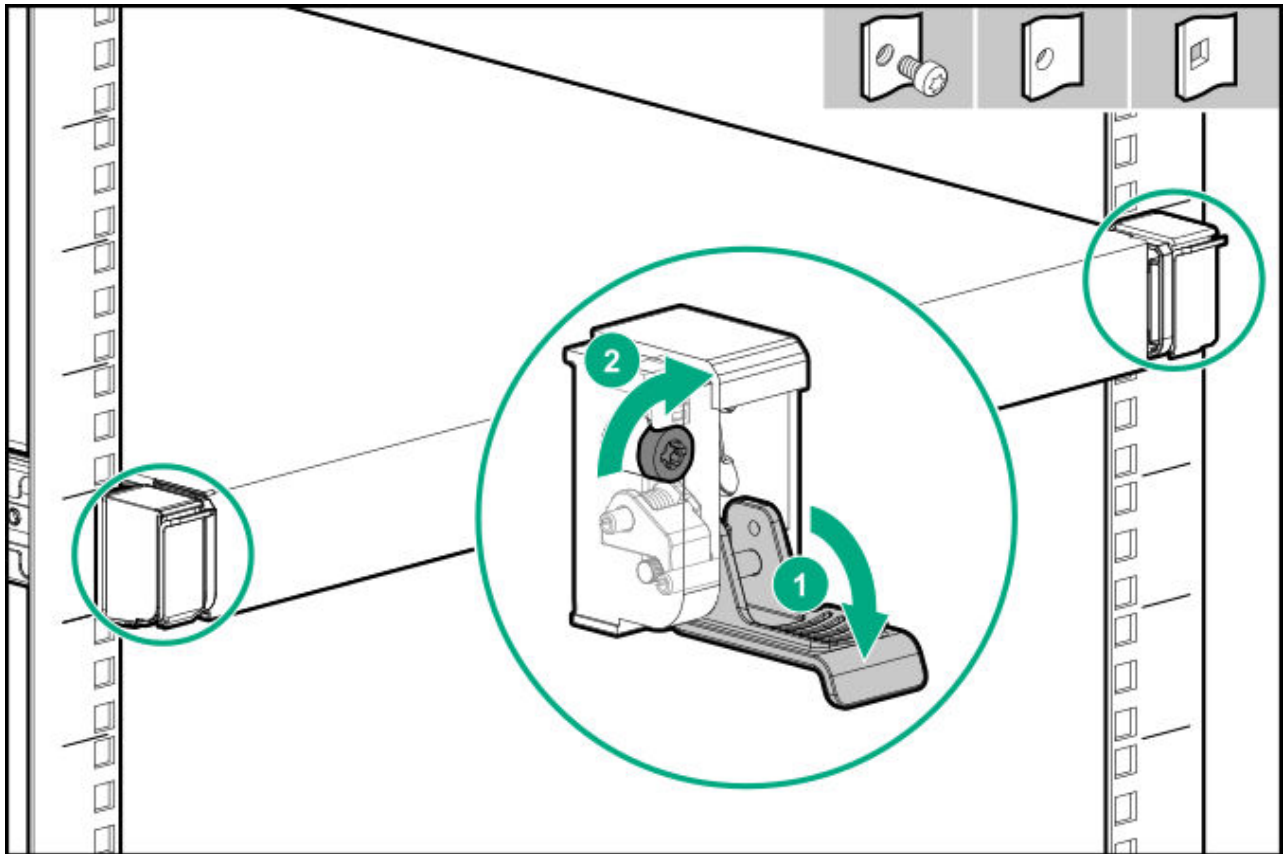

3. Connect all peripheral cables to the server.
4. Connect the power cords:
 - a. Connect each power cord to the server.
 - b. Connect each power cord to the power source.

Installing the rack rail hook-and-loop strap

About this task

The hook-and-loop strap can be installed on either the left or right rail.

Procedure

1. Attach the strap carabiner to the rail.
2. Bundle the cords and cables, and then wrap the strap around the cables.

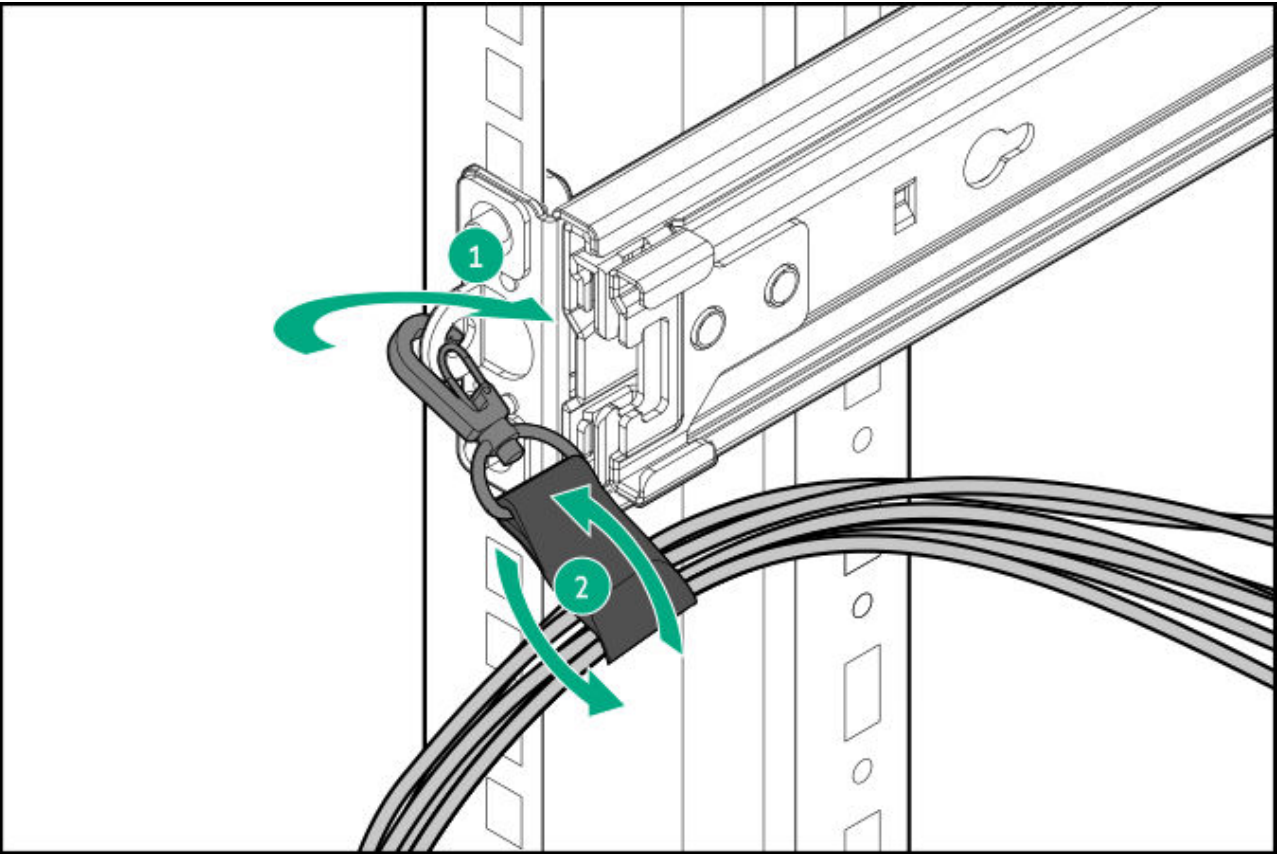

Results

The installation procedure is complete.

Installing the cable management arm

Prerequisites

Before you perform this procedure, review the [Rack warnings and cautions](#).

About this task

Your CMA bracket might look different than the images below, but the procedure is the same.



CAUTION

Support the CMA during the removal and replacement procedures. Do not allow the CMA to hang by its own weight during the procedure.



CAUTION

To reduce the risk of personal injury, be careful when pressing the cable management or rail-release latches. The rails or latches could pinch your fingers.

Procedure

1. Connect and secure all peripheral cables and power cords to the rear panel.
2. (Optional) Rotate the bracket.

The management arm can be installed to swing out from the left or right side of the rack. Before installing, rotate the elbow bracket according to your configuration.

There will be an audible click to indicate that the bracket is locked in its adjusted position.

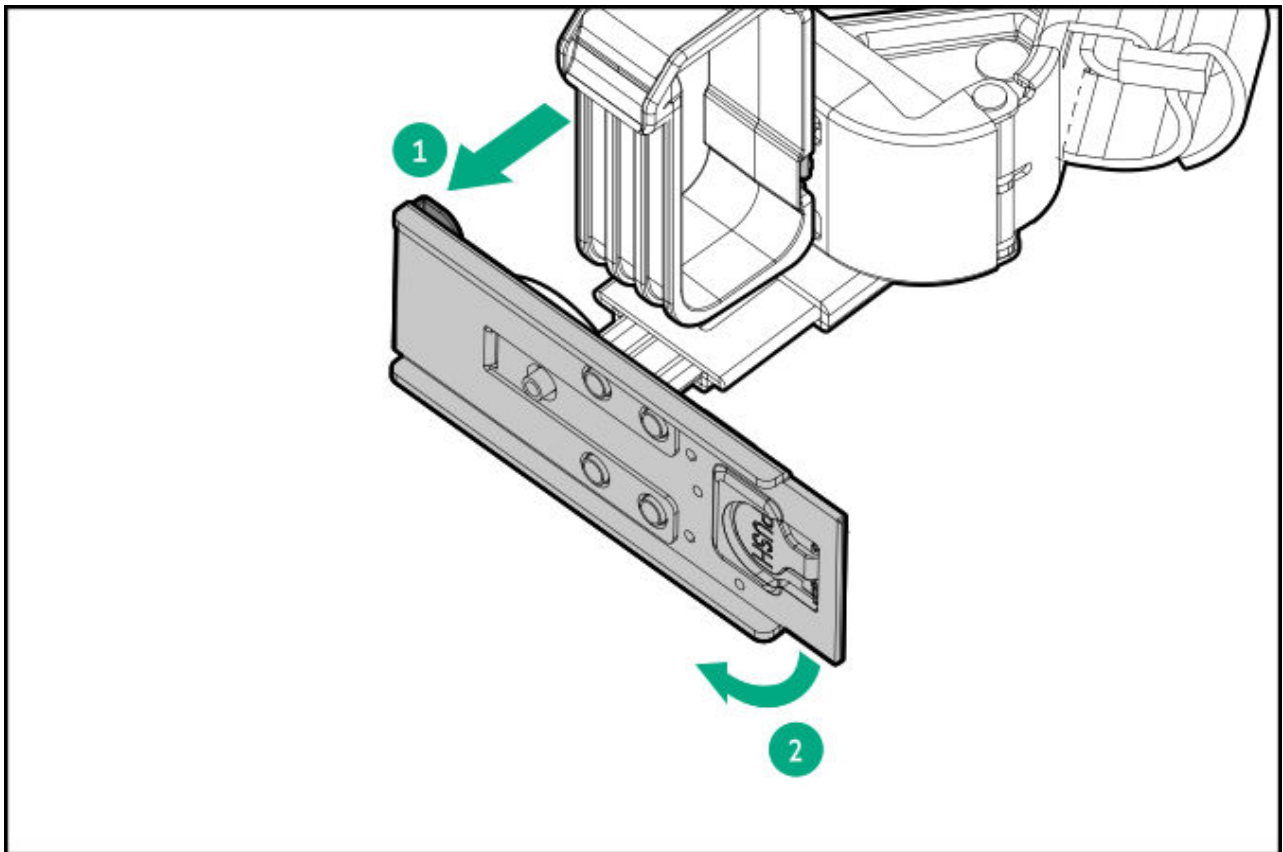

3. Install the CMA brackets to the inner and outer rails.

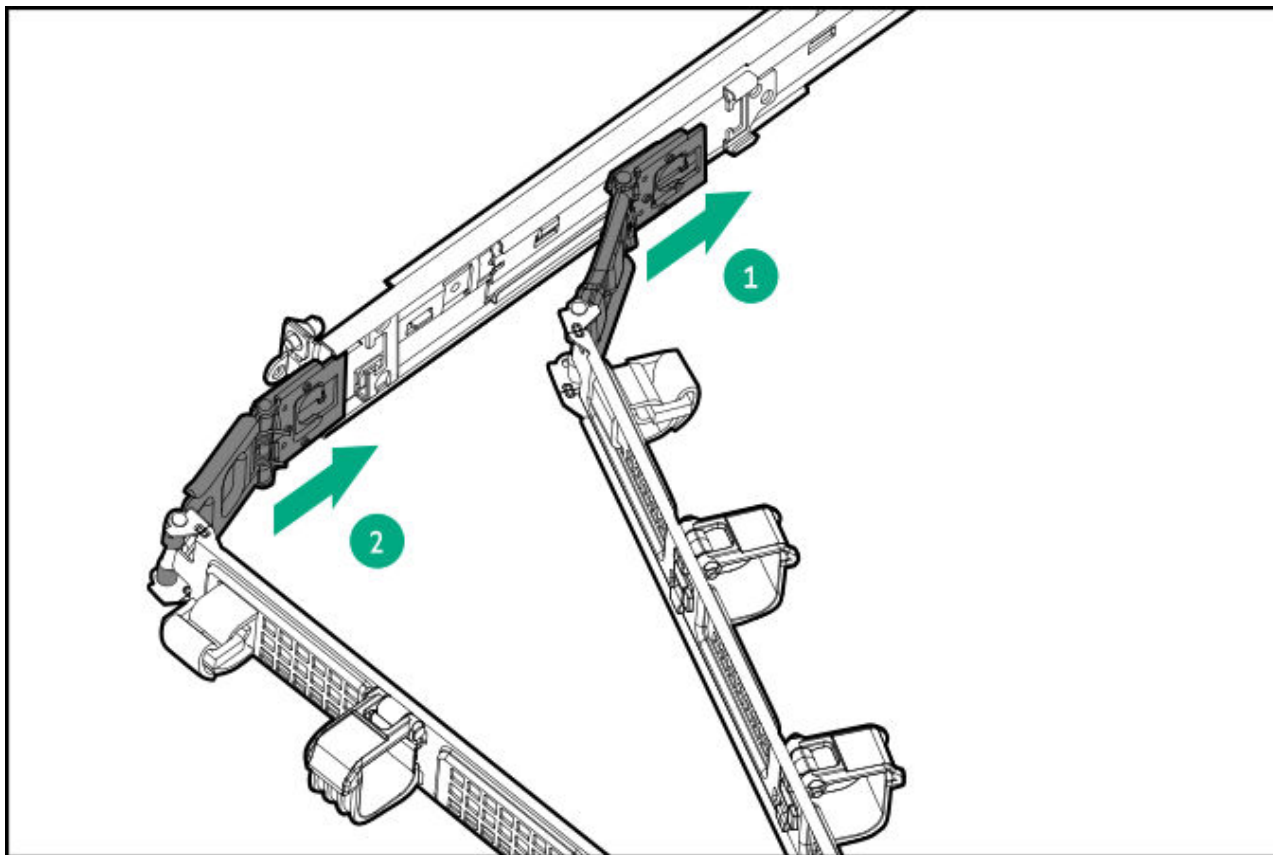

4. Open the straps and cable baskets.

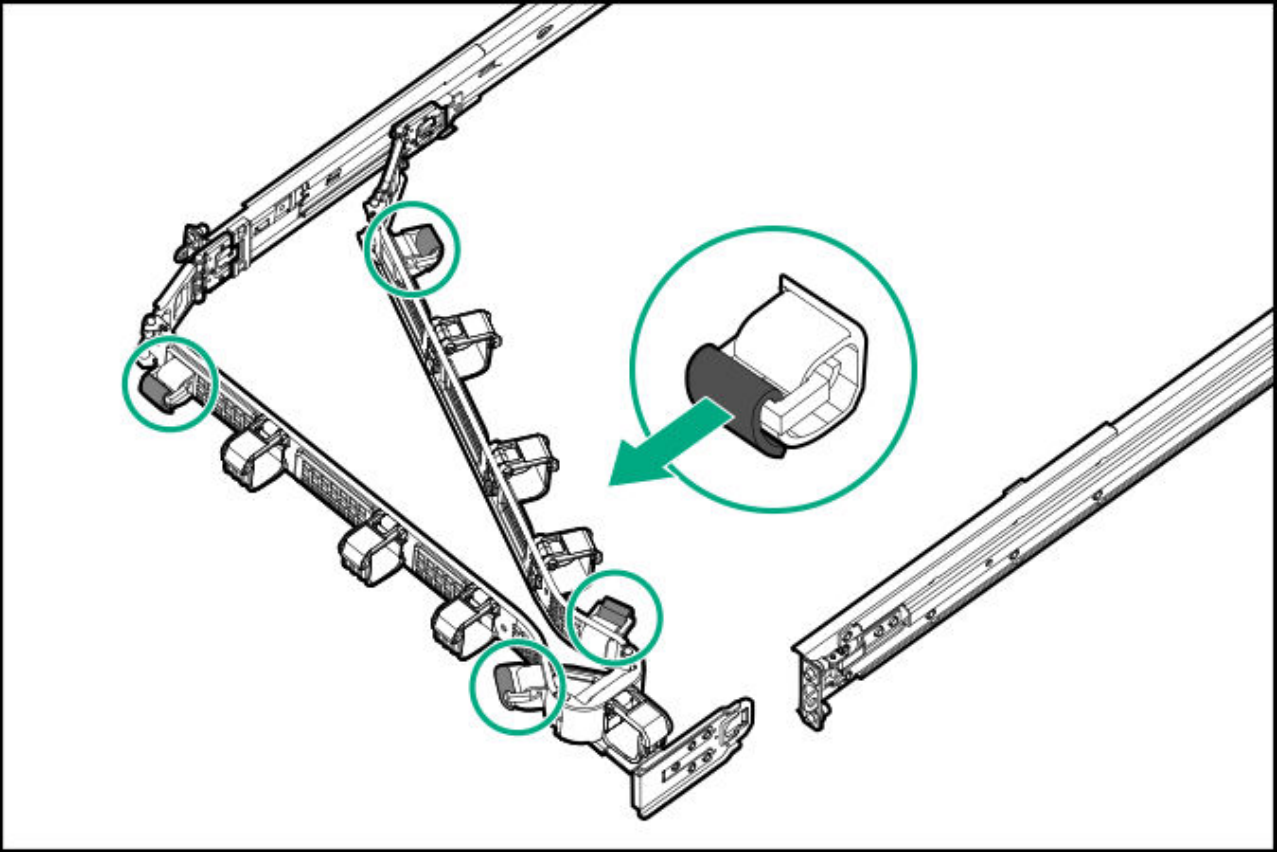

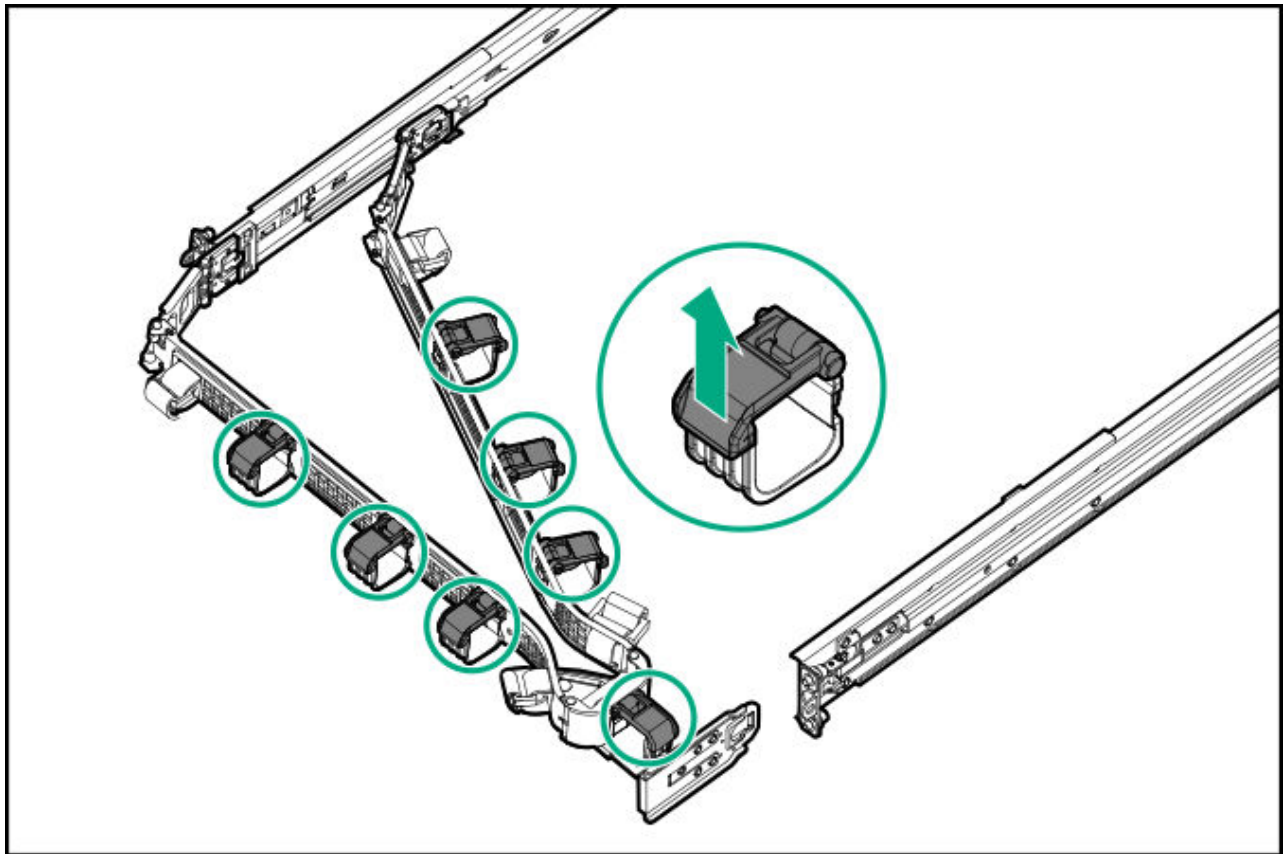

5.



CAUTION

Employ industry best practices in managing peripheral cables and power cords secured in the CMA. These are some of the more important points:

- Leave enough cable slack between the rear panel and the CMA to allow the full extension of the CMA when the server is extended out of the rack.
- However, there should be no excess cable slack inside the CMA; this might cause cable binding and could lead to cable damage.
- Make sure that the cables and power cords do not extend above the top or below the bottom of the server to which they are attached. Otherwise, the cables might snag on other equipment installed in the rack when the server is extended from or returned to the rack.

Install the cables.

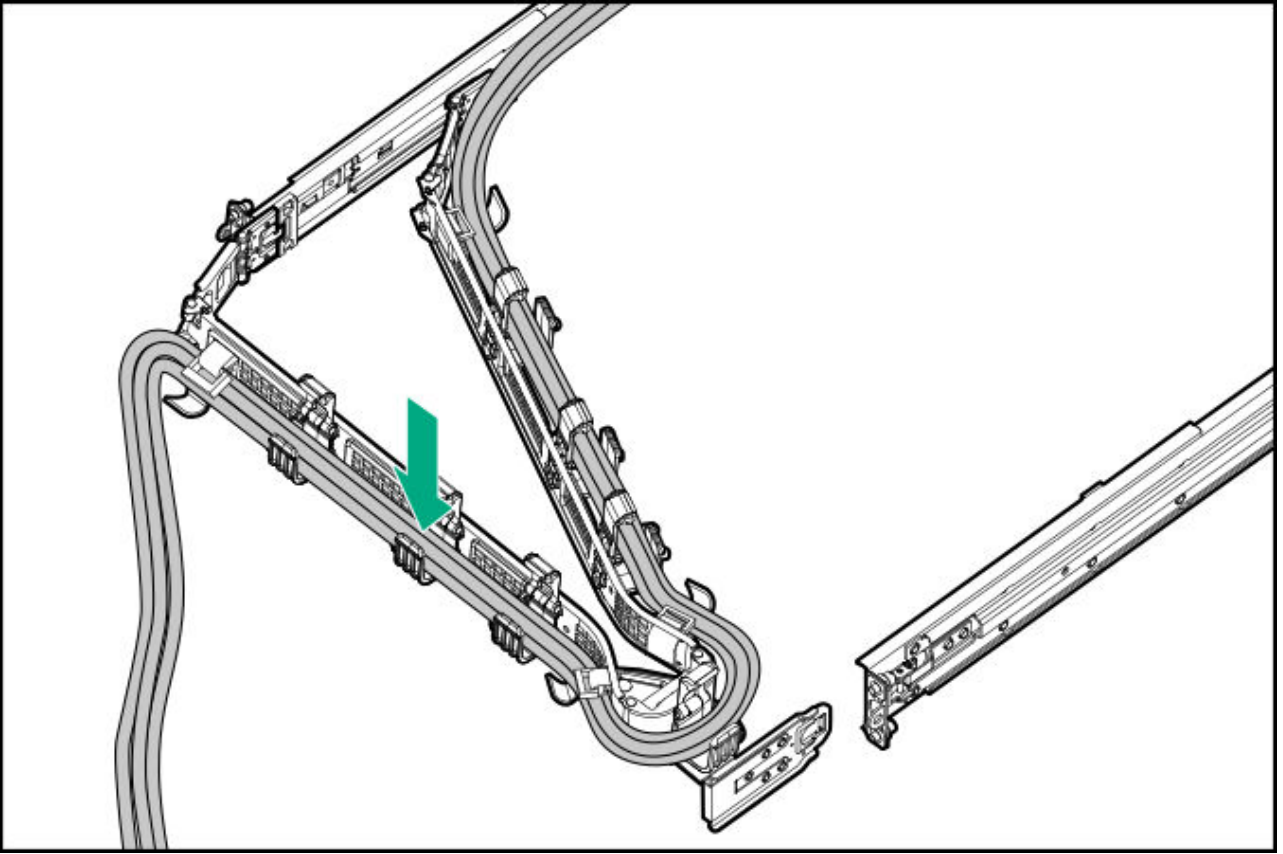

6. Close the baskets and secure the straps.

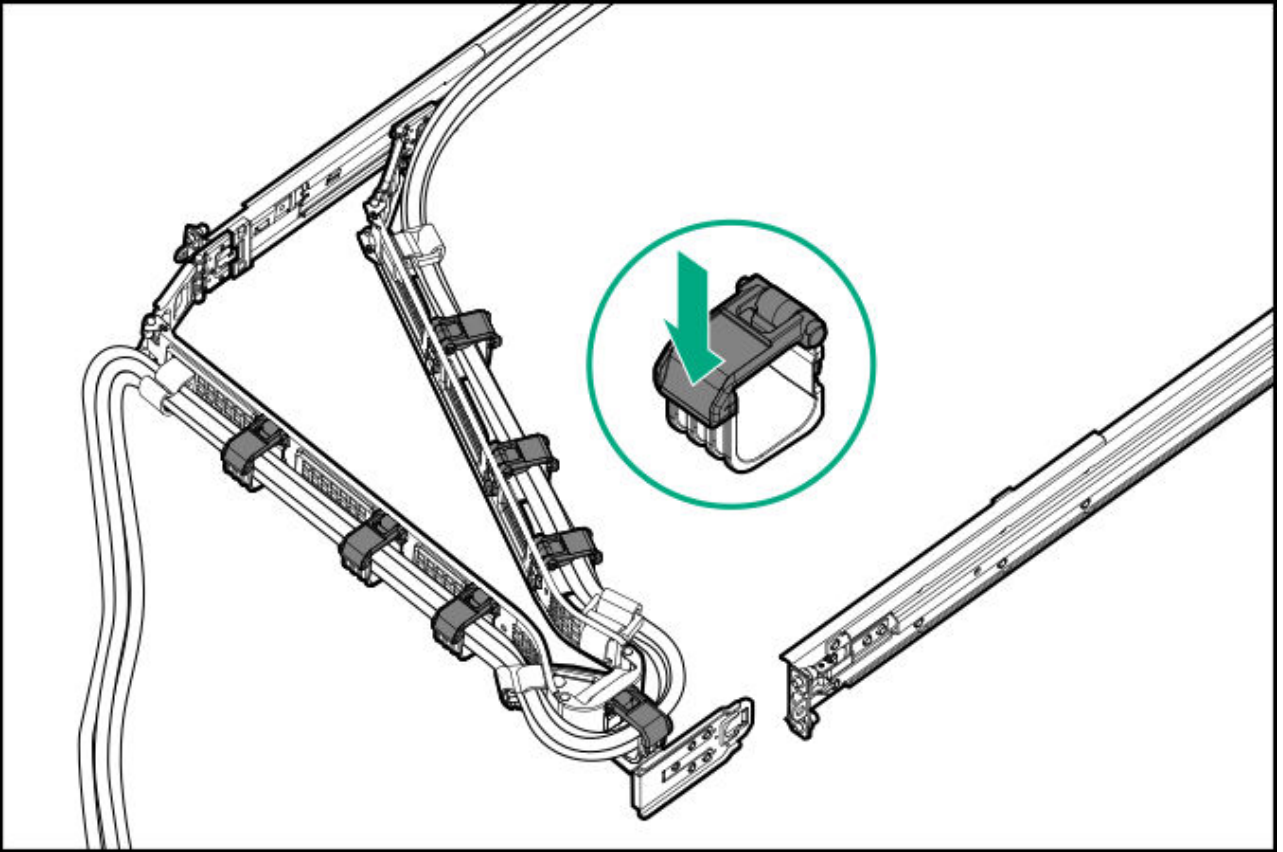

7. Align and install the elbow bracket.

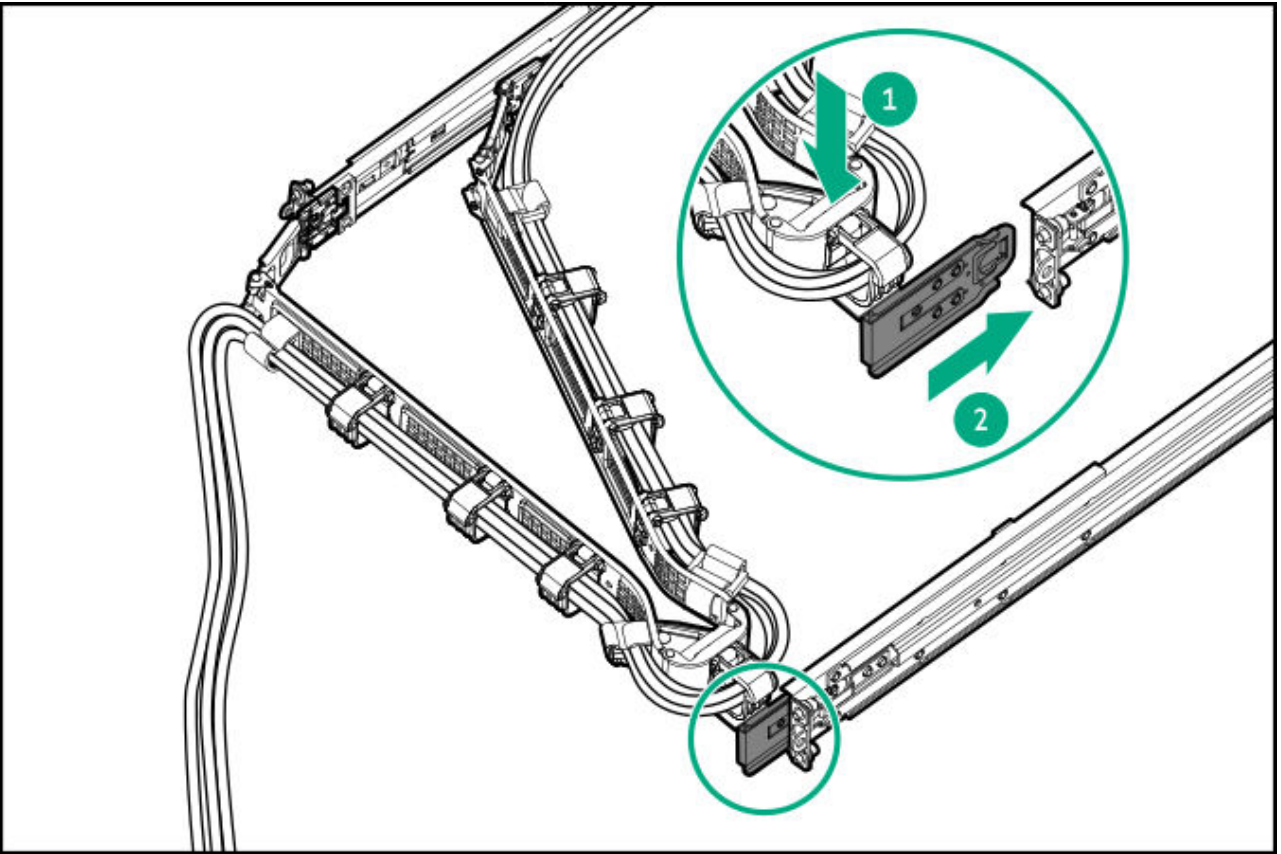

Results

The installation procedure is complete.

Risers and riser cages

Subtopics

[Primary PCI riser cage options](#)

[Secondary PCI riser options](#)

Primary PCI riser cage options

The standard primary riser supports the following:

- Slot 1 - 1x PCIe 5.0 x16 FHHL

- Slot 2 - 1x PCIe 5.0 x16 LP

Subtopics

[Installing an expansion board in slot 1](#)

[Installing an expansion board in slot 2](#)

Installing an expansion board in slot 1

Prerequisites

Before installing this option, be sure you have the following:

- The components included with the hardware option kit
- T-10 Torx screwdriver

Procedure

1. Observe the following alerts:



WARNING

To reduce the risk of personal injury from hot surfaces, allow the drives and the internal system components to cool before touching them.



CAUTION

To prevent damage to electrical components, properly ground the server before beginning any installation procedure. Improper grounding can cause electrostatic discharge.

2. Back up all server data.
3. [Power down the server.](#)
4. Remove all power:
 - a. Disconnect each power cord from the power source.
 - b. Disconnect each power cord from the server.
5. Do one of the following:
 - a. [Extend the server from the rack.](#)
 - b. [Remove the server from the rack.](#)

6. Remove the access panel.
7. Remove the primary PCI riser cage.
8. Install the expansion board.

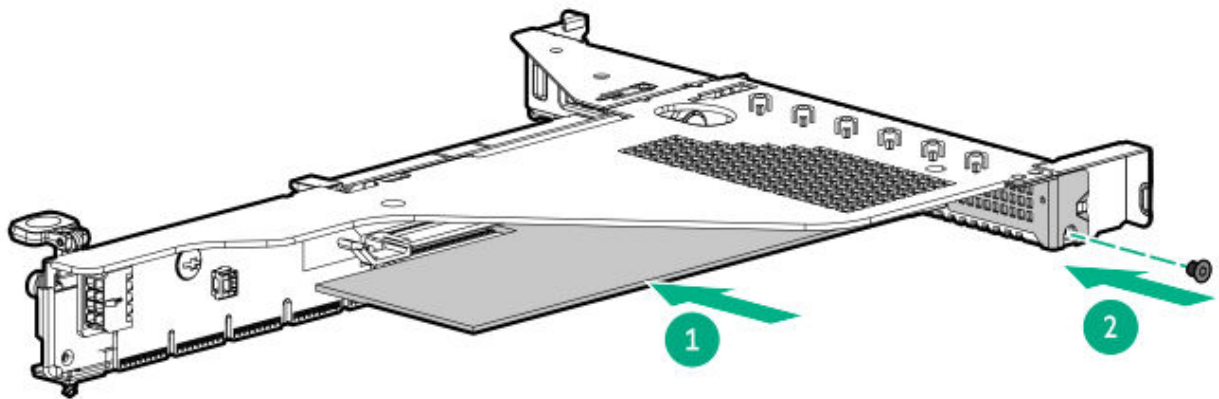

9. Connect any required internal or external cables to the expansion board.
0. Install the primary PCI riser cage.
- .1. Install the access panel.
- .2. Install the server in the rack.
- .3. Connect each power cord to the server.
- .4. Connect each power cord to the power source.
- .5. Power up the server.

Installing an expansion board in slot 2

Prerequisites

Before installing this option, be sure you have the following:

- The components included with the hardware option kit
- T-10 Torx screwdriver

About this task



WARNING

To reduce the risk of personal injury from hot surfaces, allow the drives and the internal system components to cool before touching them.



CAUTION

To prevent damage to electrical components, properly ground the server before beginning any installation procedure. Improper grounding can cause electrostatic discharge.

Procedure

1. Back up all server data.
2. Power down the server.
3. Remove all power:
 - a. Disconnect each power cord from the power source.
 - b. Disconnect each power cord from the server.
4. Do one of the following:
 - a. Extend the server from the rack.
 - b. Remove the server from the rack.
5. Remove the access panel.
6. Remove the primary PCIe riser cage.
7. Remove the expansion slot blank.

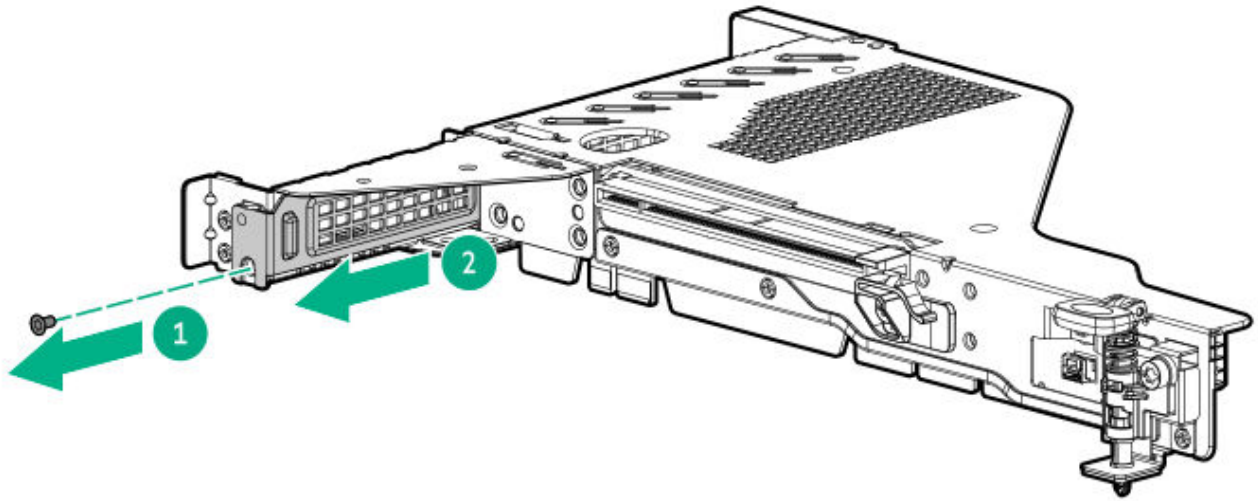

8. Use a T-10 Torx screwdriver to install the expansion board.

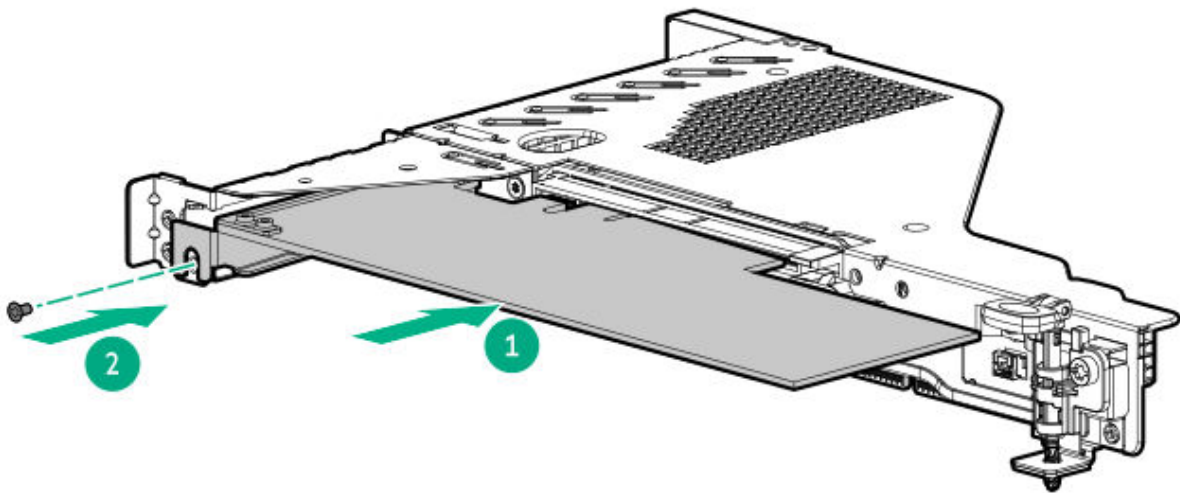

9. Connect any required internal or external cables to the expansion board.

10. Install the primary PCIe riser cage.

.1. Install the access panel.

.2. Install the server in the rack.

.3. Connect each power cord to the server.

.4. Connect each power cord to the power source.

.5. Power up the server.

Results

The installation procedure is complete.

Secondary PCI riser options

The secondary PCI riser cage supports the following options:

- x16 full-height riser kit
- x16 low-profile riser kit

Subtopics

[Installing a secondary low-profile riser option](#)

[Installing a secondary full-height riser option](#)

[Installing an expansion board in the secondary riser cage](#)

Installing a secondary low-profile riser option

Prerequisites

- Review the [Riser slot numbering](#).
- Before installing this option, be sure that you have the components included with the hardware option kit.

About this task

This option requires a dual processor configuration.

When installed, this riser cage provides an additional low profile slot and supports half-length/half-height expansion boards.



WARNING

To reduce the risk of personal injury from hot surfaces, allow the drives and the internal system components to cool before touching them.



CAUTION

A discharge of static electricity from a finger or other conductor might damage system boards or other static-sensitive devices. To prevent damage, observe [antistatic precautions](#).

Procedure

1. Back up all server data.
2. Power down the server .
3. Remove all power:
 - a. Disconnect each power cord from the power source.
 - b. Disconnect each power cord from the server.
4. Do one of the following:
 - a. Extend the server from the rack.
 - b. Remove the server from the rack.
5. Place the server on a flat, level work surface.
6. Remove the access panel.
7. Remove the secondary riser blank.

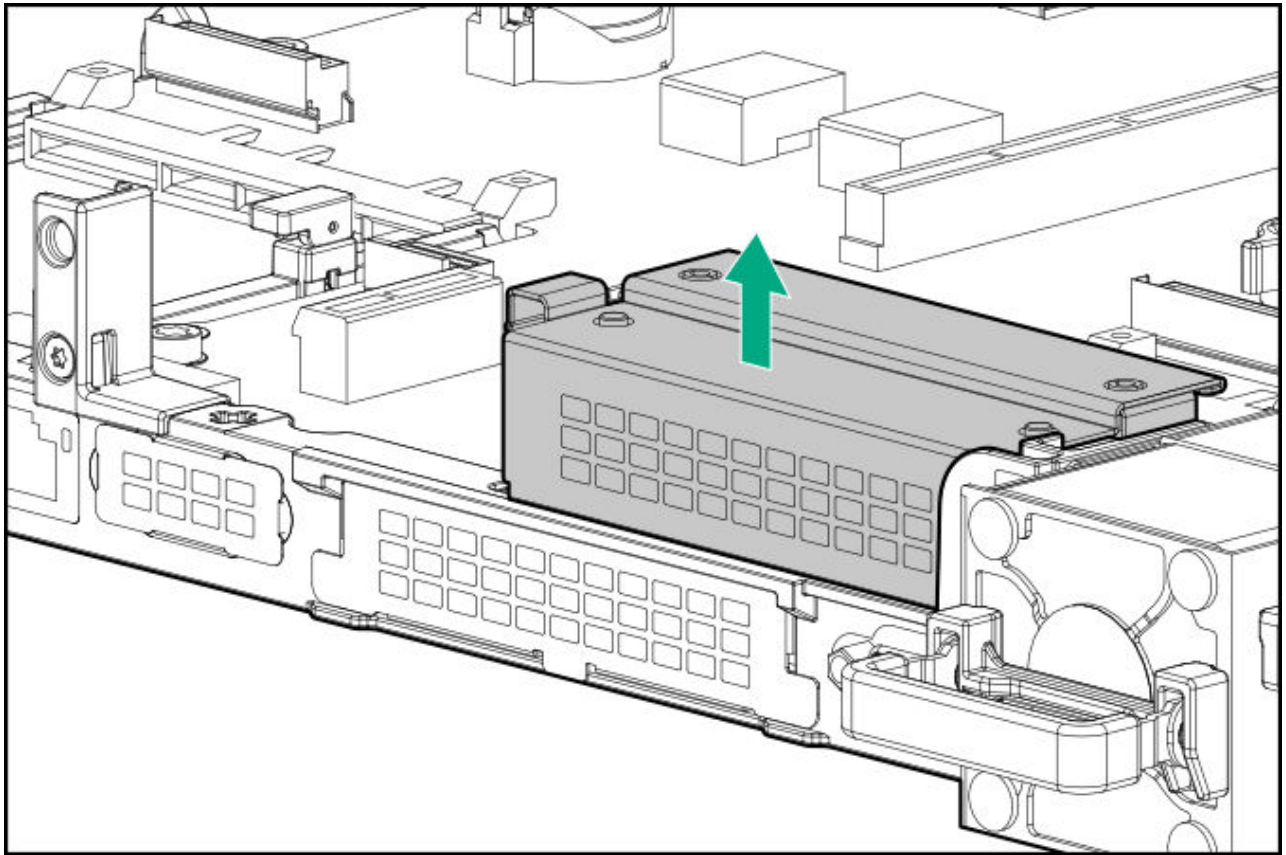

8. Install the secondary riser cage.

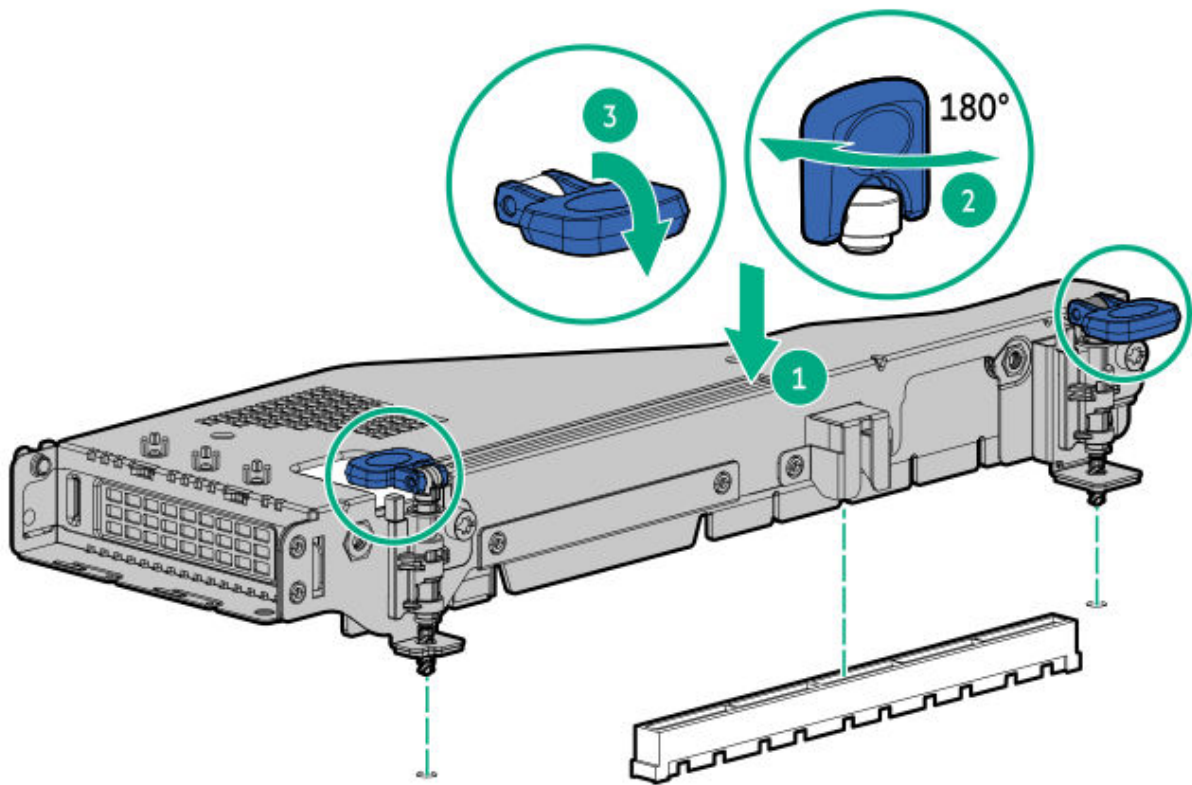

9. Install the access panel.
10. Install the server into the rack.
11. Connect each power cord to the server.
12. Connect each power cord to the power source.
13. Power up the server.

Results

The installation procedure is complete.

Installing a secondary full-height riser option

Prerequisites

- Review Riser slot numbering.
- Before installing this option, be sure that you have the following:

- The components included with the hardware option kit
- Any expansion boards or controllers you plan to install
- T-10 Torx screwdriver
- T-15 Torx screwdriver

About this task

This option requires a dual processor configuration.



WARNING

To reduce the risk of personal injury from hot surfaces, allow the drives and the internal system components to cool before touching them.



CAUTION

A discharge of static electricity from a finger or other conductor might damage system boards or other static-sensitive devices. To prevent damage, observe antistatic precautions.

Procedure

1. Back up all server data.
2. Power down the server.
3. Remove all power:
 - a. Disconnect each power cord from the power source.
 - b. Disconnect each power cord from the server.
4. Do one of the following:
 - a. Extend the server from the rack.
 - b. Remove the server from the rack.
5. Place the server on a flat, level work surface.
6. Remove the access panel.
7. Remove the primary PCI riser cage.
8. Use a T-10 Torx screwdriver to remove the slot 2 bracket from the primary riser cage.

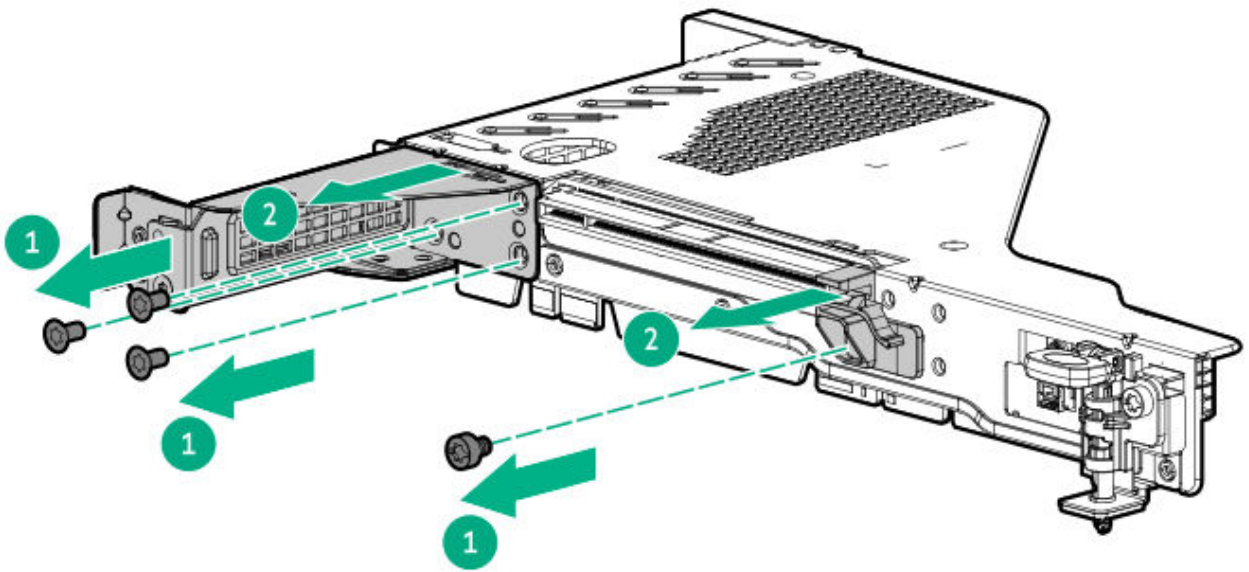

9. Remove the secondary riser blank.

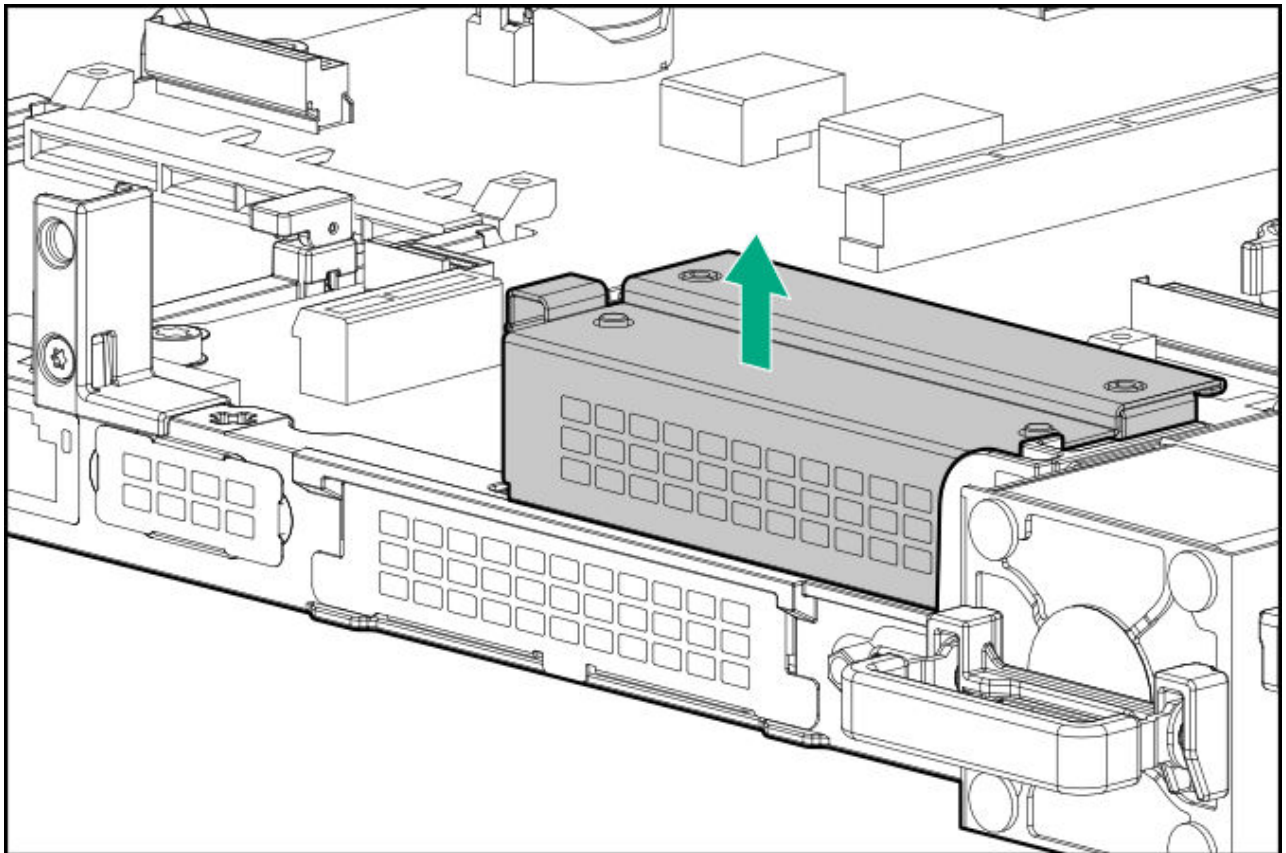

10. Using a T-15 Torx screwdriver, remove the rear riser support bracket.

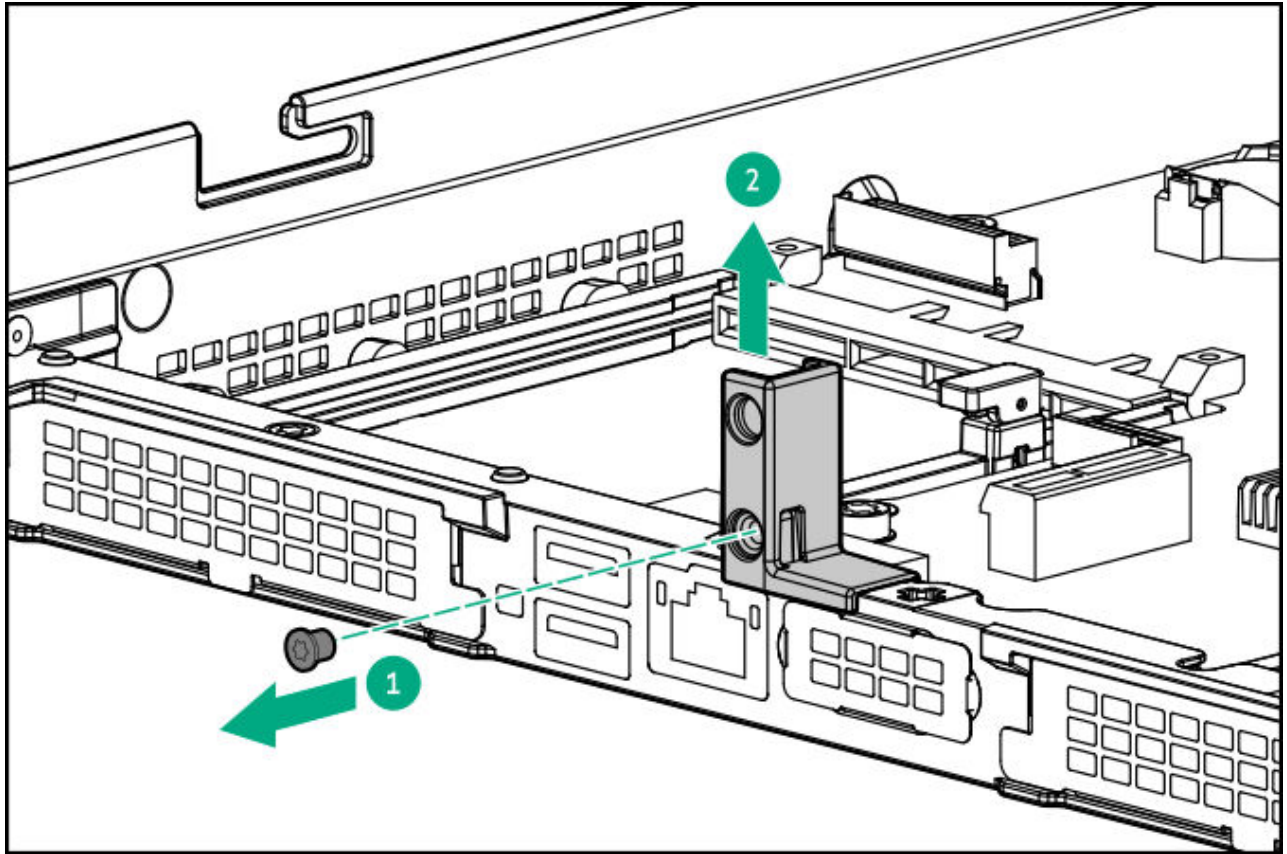

.1. Install the full-height riser support bracket.

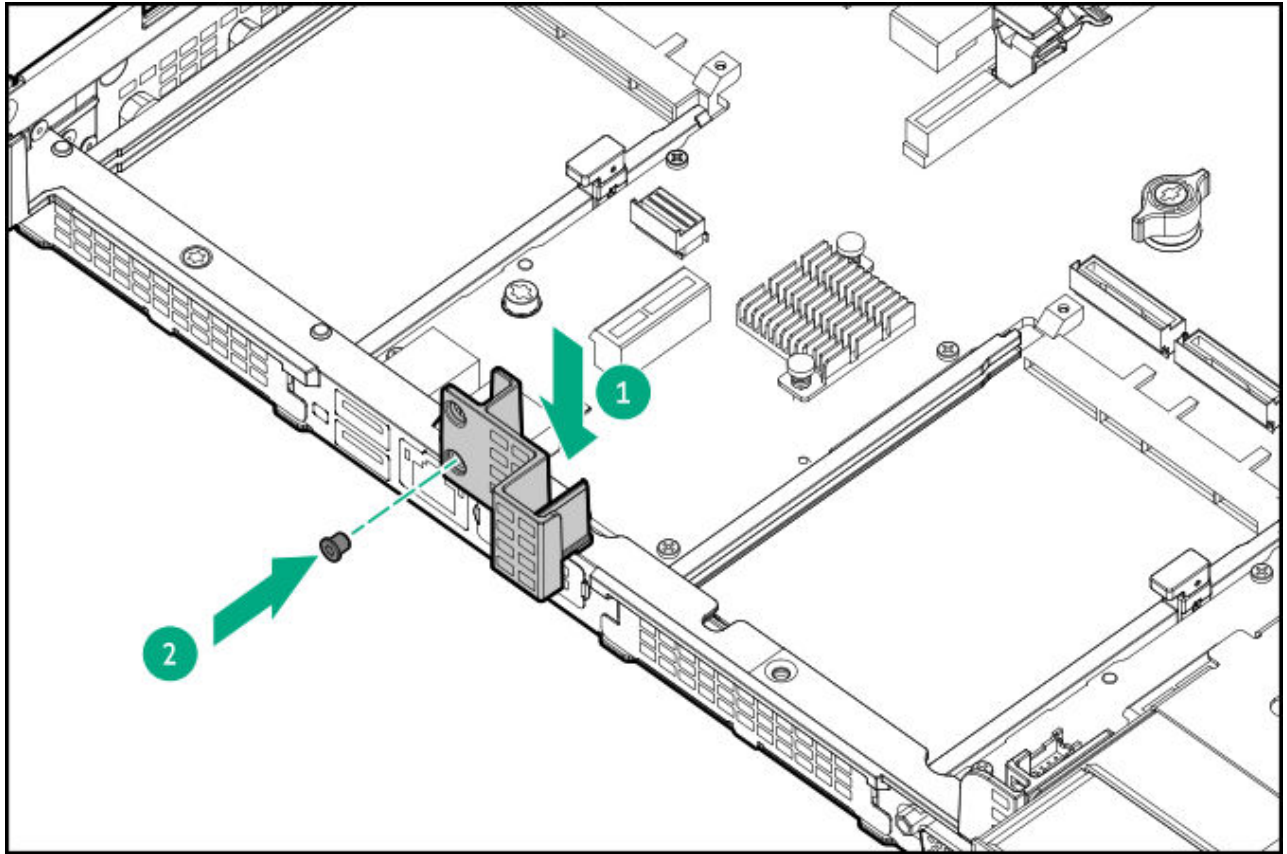

.2. Install the riser cage.

Primary:

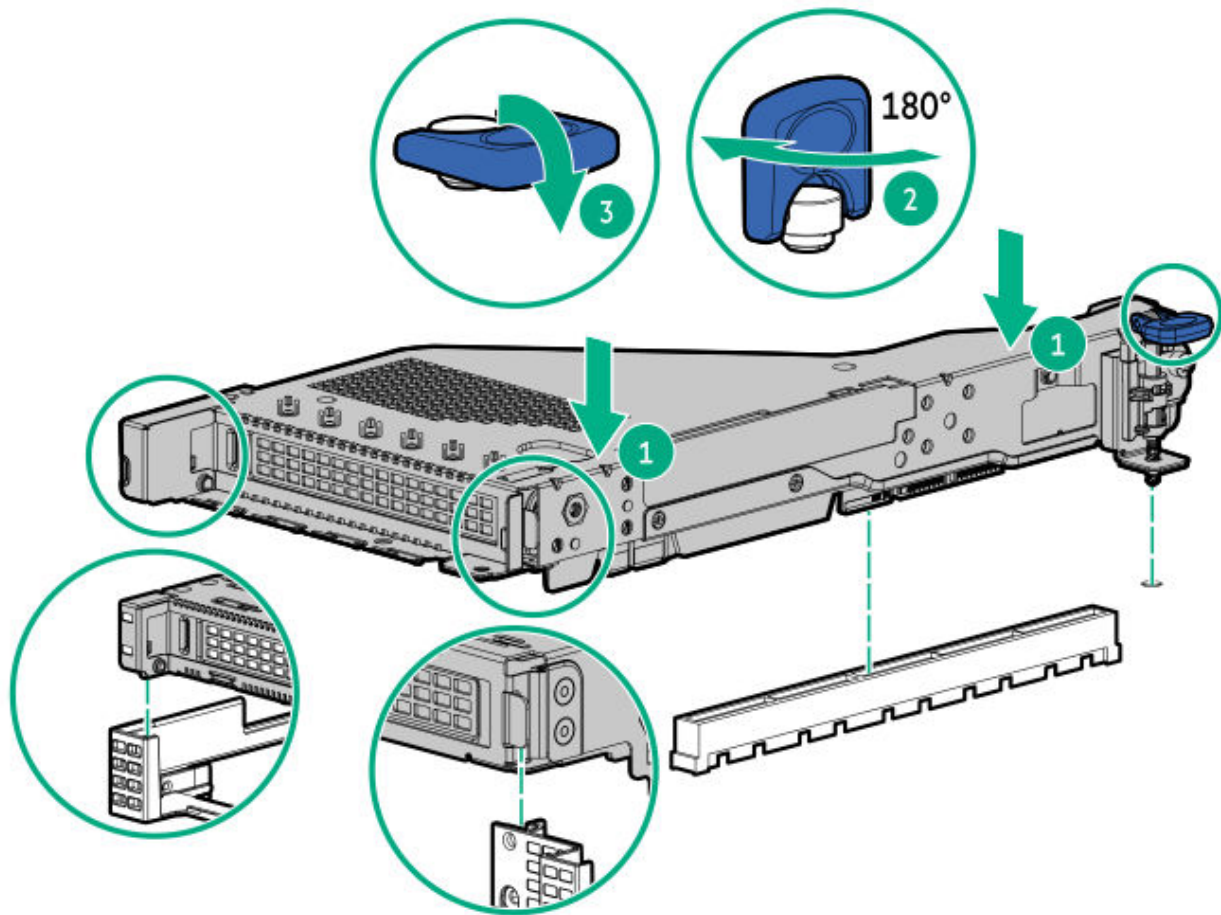

Secondary:

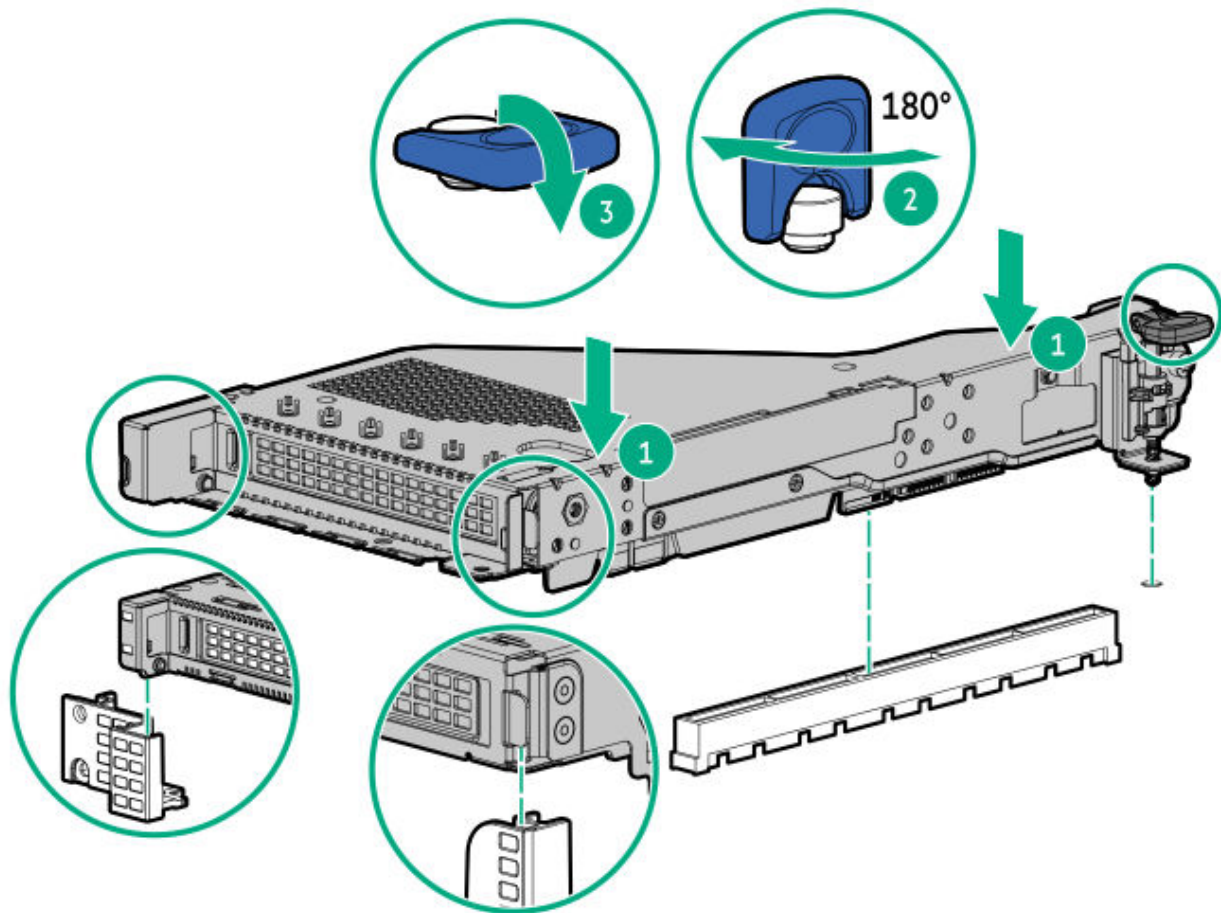

- .3. Install the access panel.
- .4. Install the server in the rack.
- .5. Connect all peripheral cables to the server.
- .6. Connect each power cord to the server.
- .7. Connect each power cord to the power source.
- .8. Power up the server.

Results

The installation procedure is complete.

Installing an expansion board in the secondary riser cage

Prerequisites

- Review the [Riser slot numbering](#).
- Before installing this option, be sure that you have the following:
 - The components included with the hardware option kit
 - T-10 Torx screwdriver

About this task



WARNING

To reduce the risk of personal injury from hot surfaces, allow the drives and the internal system components to cool before touching them.



CAUTION

To prevent damage to electrical components, properly ground the server before beginning any installation procedure. Improper grounding can cause electrostatic discharge.

Procedure

1. [Back up all server data](#).
2. [Power down the server](#).
3. Remove all power:
 - a. Disconnect each power cord from the power source.
 - b. Disconnect each power cord from the server.
4. Do one of the following:
 - a. [Extend the server from the rack](#).
 - b. [Remove the server from the rack](#).
5. [Remove the access panel](#).
6. Remove the secondary riser:
 - Secondary full-height

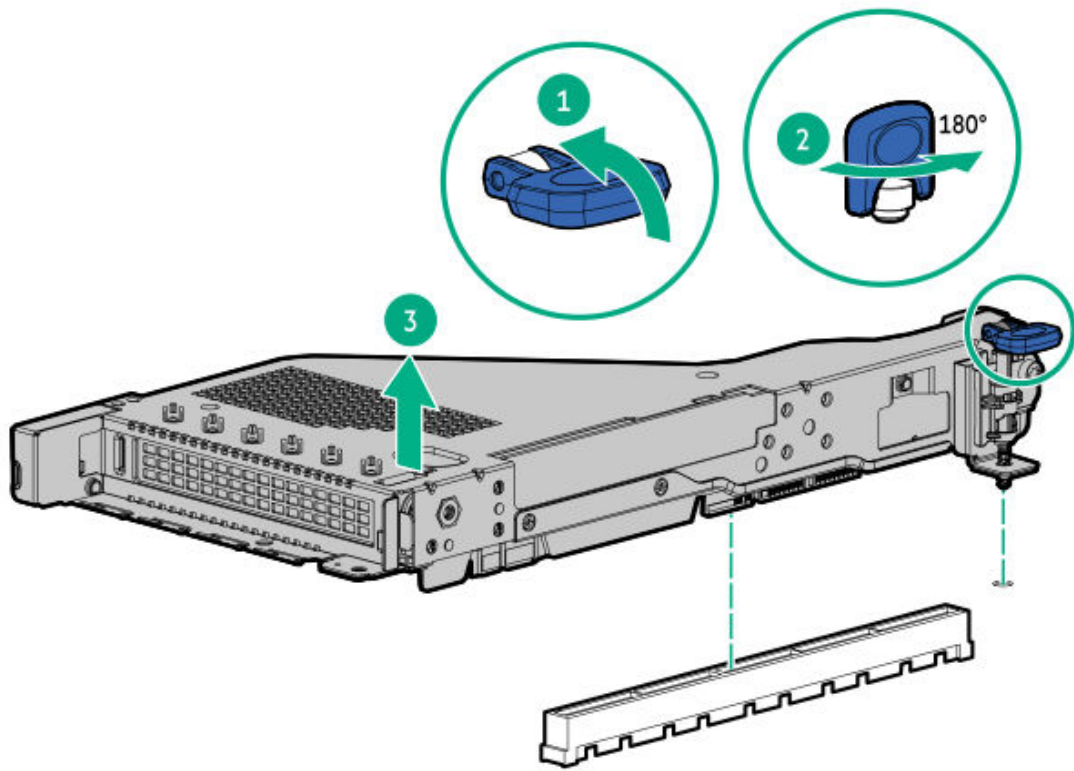

- Secondary low-profile

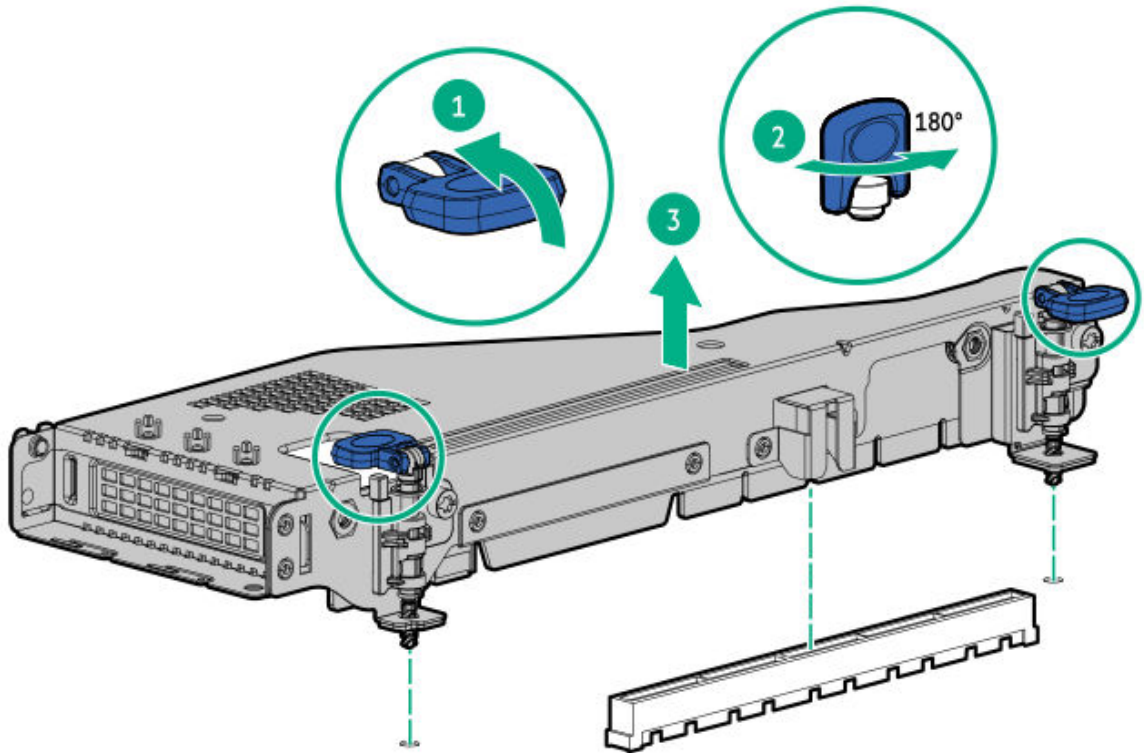

7. Install the expansion board:

- Secondary full-height
 - a. Remove the blank.
 - b. Using a Torx T-10 screwdriver, install the controller.

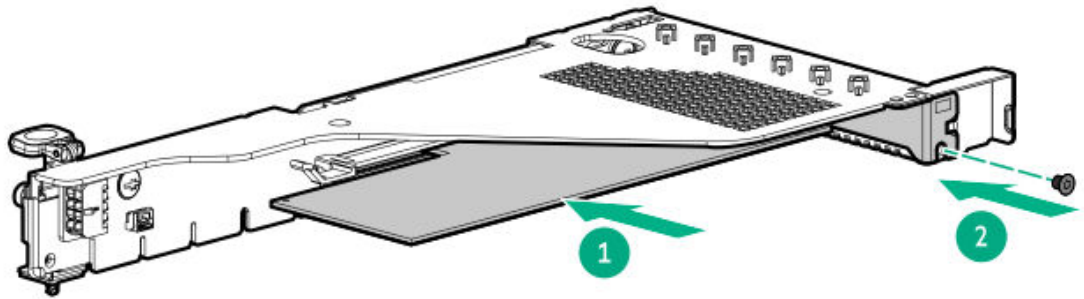

- Secondary half-height:
 - a. Remove the blank.
 - b. Using a Torx T-10 screwdriver, install the controller.

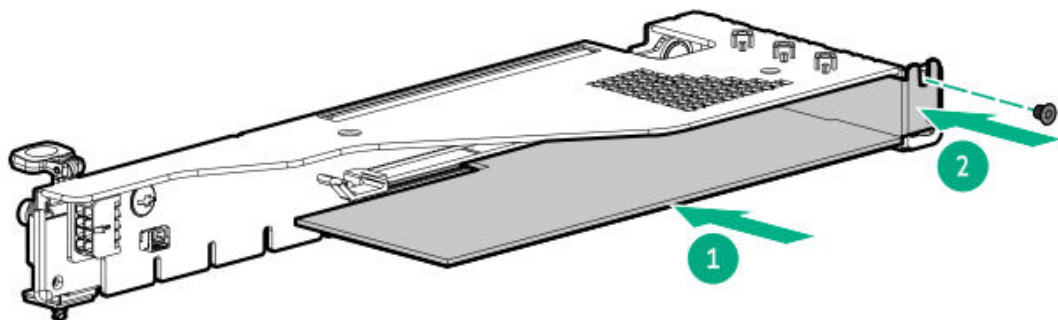

8. Connect any required internal or external cables to the expansion board.

9. Install the access panel.

10. Install the server in the rack.

11. Connect each power cord to the server.

- .2. Connect each power cord to the power source.
- .3. Power up the server.

Results

The installation procedure is complete.

Security

Subtopics

Installing the front bezel option

Installing the Chassis Intrusion Detection switch option

Installing the front bezel option

Procedure

1. Attach the front bezel to the right chassis ear.
2. Press and hold the front bezel release latch.
3. Close the front bezel.

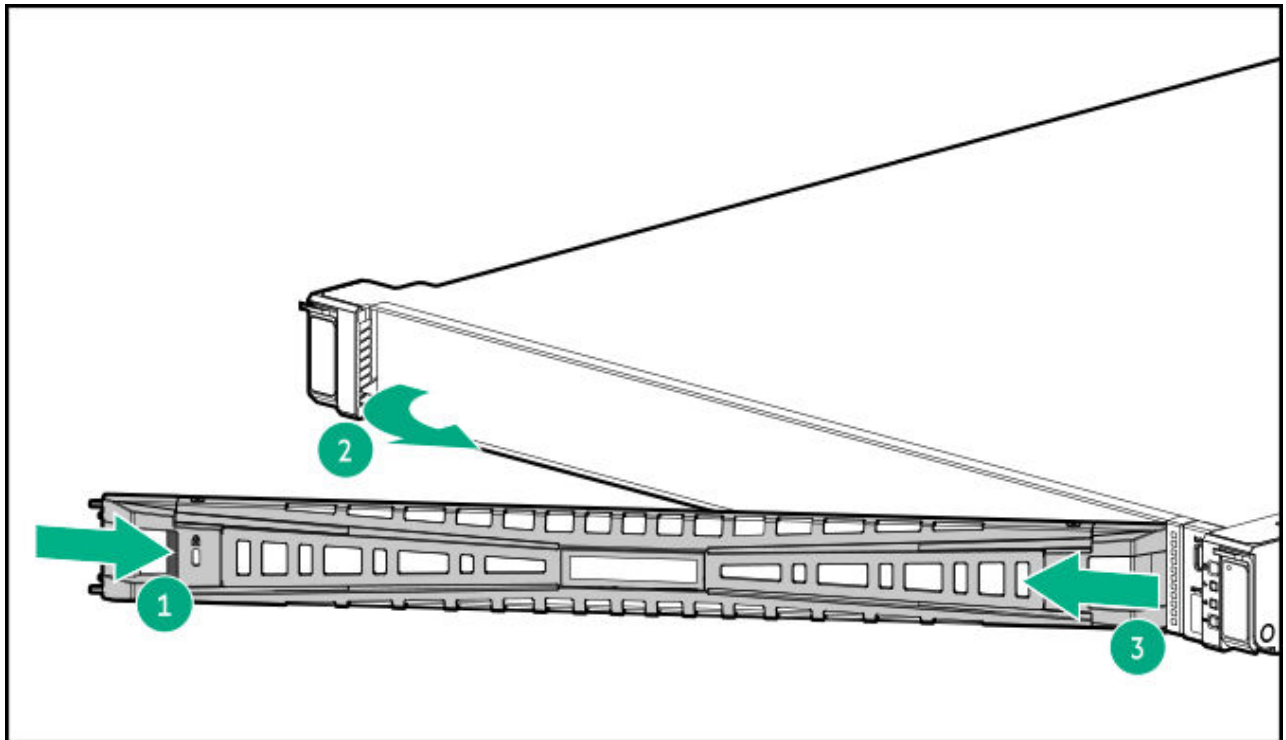

4. (Optional) Install the Kensington security lock.

For more information, see the lock documentation.

Results

The installation procedure is complete.

Installing the Chassis Intrusion Detection switch option

Prerequisites

Be sure you have the components included with the hardware option kit.

About this task



CAUTION

A discharge of static electricity from a finger or other conductor might damage system boards or other static-sensitive devices. To prevent damage, observe [antistatic precautions](#).

Procedure

1. Power down the server.
2. Remove all power:
 - a. Disconnect each power cord from the power source.
 - b. Disconnect each power cord from the server.
3. Do one of the following:
 - a. Extend the server from the rack.
 - b. Remove the server from the rack.
4. Place the server on a flat, level work surface.
5. Remove the access panel.
6. Install the chassis intrusion detection switch behind the power supply bays.

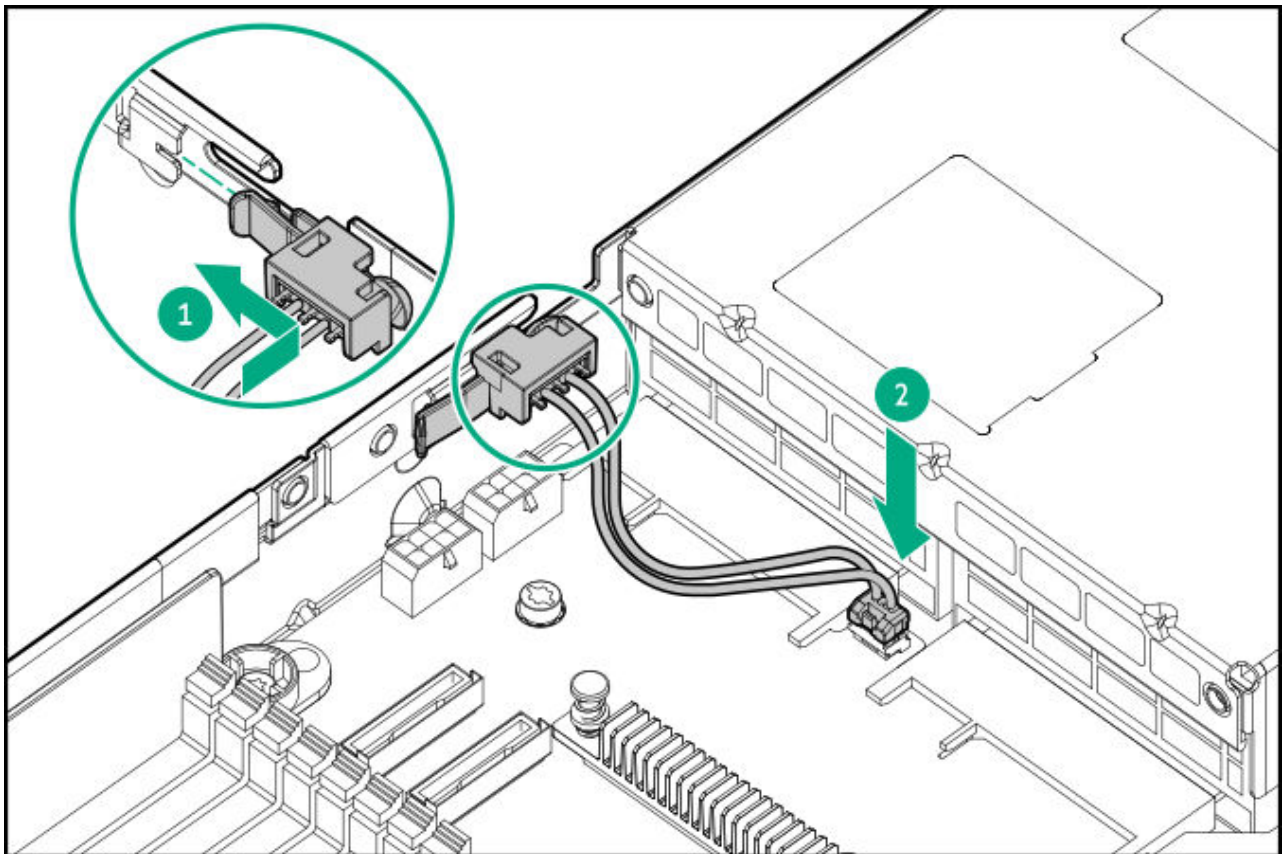

7. Install the access panel.
8. Install the server in the rack.

9. Connect all peripheral cables to the server.
10. Connect each power cord to the server.
11. Connect each power cord to the power source.
12. Power up the server.

Results

The installation procedure is complete.

Storage controllers

Subtopics

[Installing a type-p storage controller](#)

[Installing a type-o storage controller](#)

Installing a type-p storage controller

Prerequisites

Before installing this option, be sure that you have the following:

- The components included with the hardware option kit
- T-10 Torx screwdriver

About this task



WARNING

To reduce the risk of personal injury from hot surfaces, allow the drives and the internal system components to cool before touching them.



CAUTION

To prevent damage to electrical components, properly ground the server before beginning any installation procedure. Improper grounding can cause electrostatic discharge.

Procedure

1. Back up all server data.
2. Power down the server.
3. Remove all power:
 - a. Disconnect each power cord from the power source.
 - b. Disconnect each power cord from the server.
4. Do one of the following:
 - a. Extend the server from the rack.
 - b. Remove the server from the rack.
5. Remove the access panel.
6. Remove the primary riser cage.
7. Install the controller.

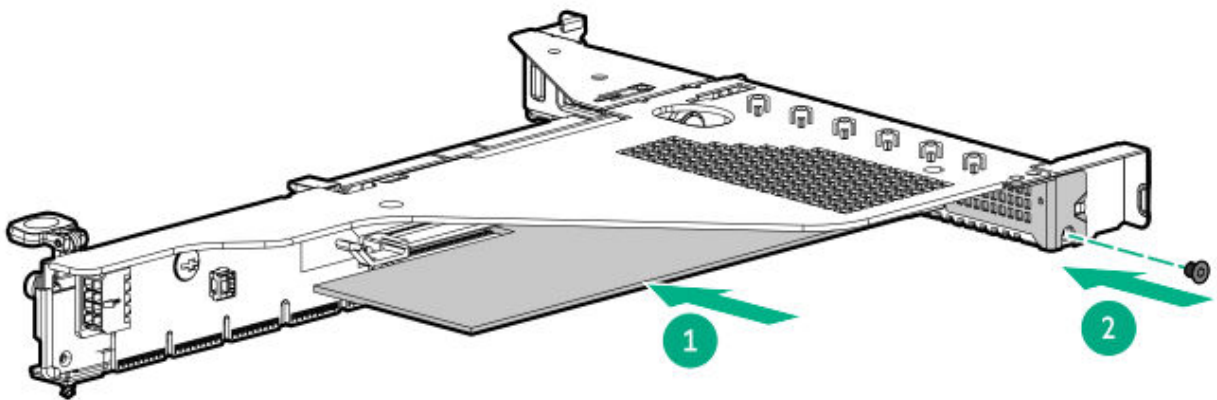

8. Install the riser cage.
9. Cable the controller.
0. Install the access panel.
- .1. Install the server in the rack.
- .2. Connect each power cord to the server.
- .3. Connect each power cord to the power source.
- .4. Power up the server.

- .5. Update the server firmware if they are not the latest revision.
- .6. Configure the controller.

Results

The installation procedure is complete.

Installing a type-o storage controller

Prerequisites

Before installing this option, be sure that you have the following:

- The components included with the hardware option kit
- T-10 Torx screwdriver

About this task



CAUTION

To prevent improper cooling and thermal damage, do not operate the server unless all OCP slots have either an OCP option or a slot blank installed.



CAUTION

To prevent damage to electrical components, properly ground the server before beginning any installation procedure. Improper grounding can cause electrostatic discharge.

Procedure

1. Back up all server data.
2. Power down the server.
3. Remove all power:
 - a. Disconnect each power cord from the power source.
 - b. Disconnect each power cord from the server.
4. Do one of the following:
 - Extend the server from the rack.

- Remove the server from the rack.

5. Remove the access panel.
6. Remove the rear wall blank or riser cage.
7. Remove the OCP adapter blank.

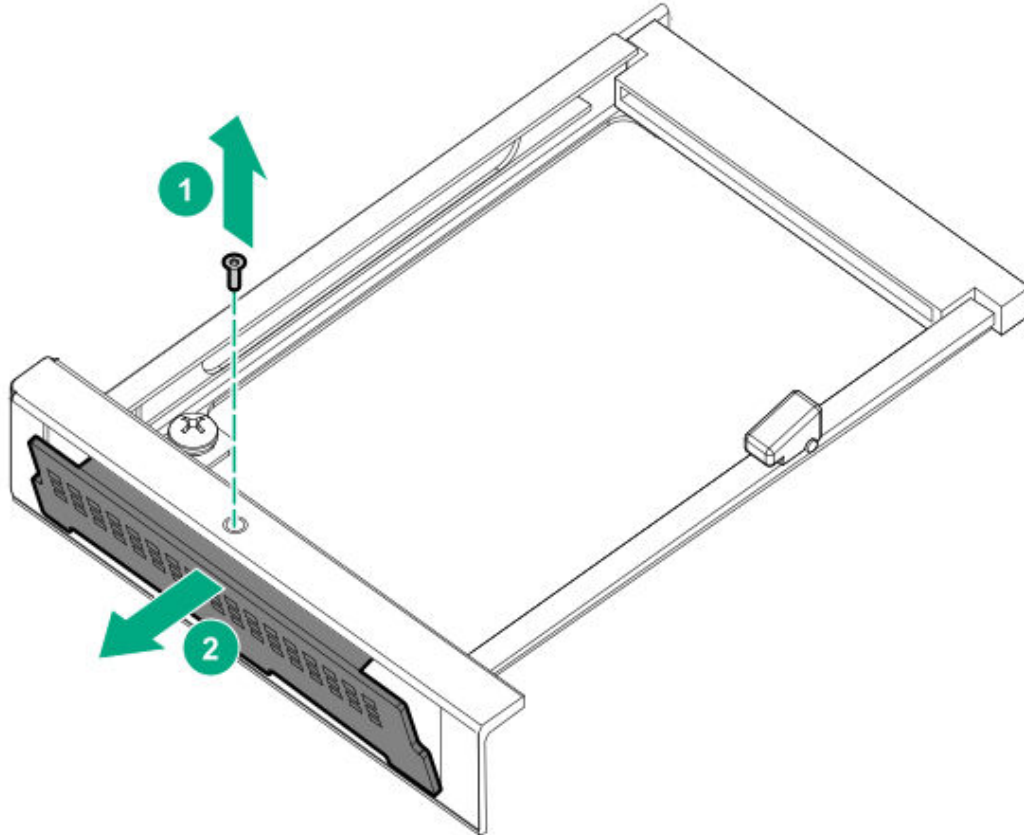

8. Install the storage controller.

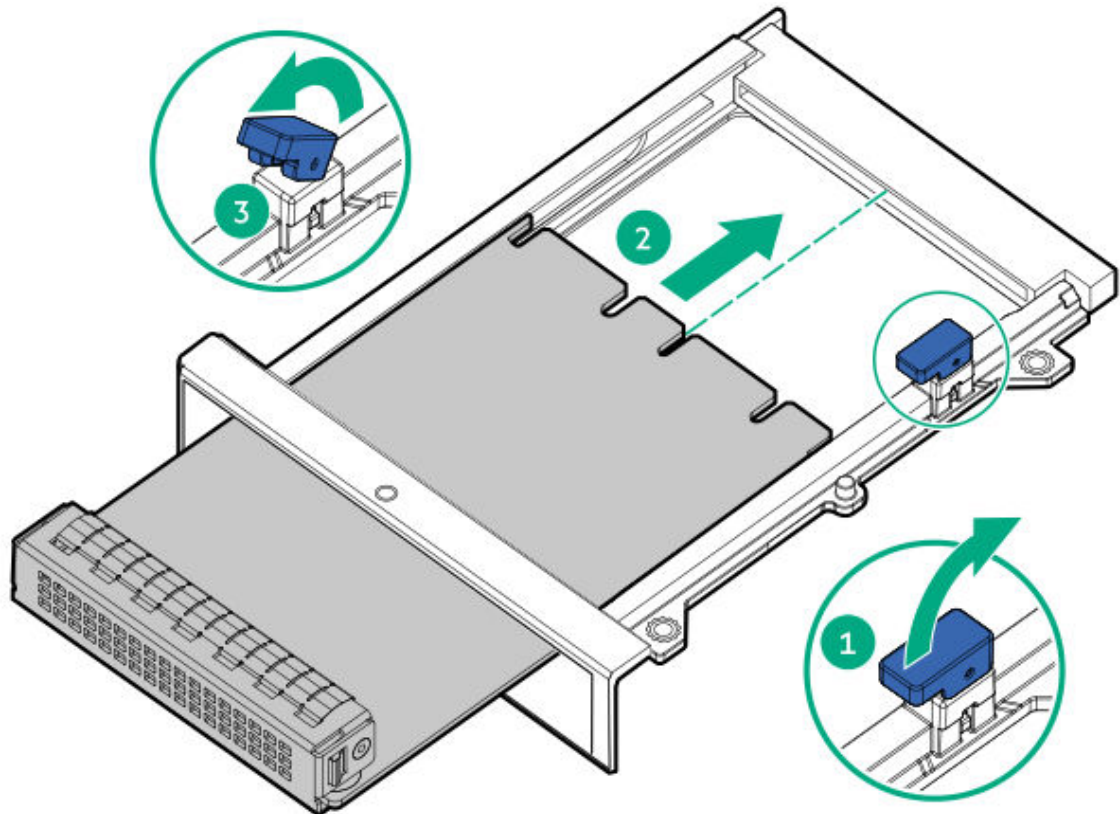

9. Connect the cables.
10. Install the access panel.
1. Slide the server into the rack.
2. Connect each power cord to the server.
3. Connect each power cord to the power source.
4. Power up the server.
5. Update the server firmware if they are not the latest revision.
6. Configure the controller.

Results

The installation procedure is complete.

Cabling

Provides internal cabling guidelines and diagrams for internal component cabling.

Subtopics

[Cabling guidelines](#)

[Cabling diagrams](#)

[Internal cabling management](#)

[Storage cabling](#)

[Drive power cabling](#)

[Energy pack cabling](#)

[Optical drive cabling](#)

[Front DisplayPort / USB cabling](#)

[Internal boot device cabling](#)

[Front OCP NIC cabling](#)

[OCP bandwidth enablement cabling](#)

[Serial port cabling](#)

[Chassis intrusion detection switch cabling](#)

[Front I/O cabling](#)

[System Insight Display cabling](#)

[Liquid cooling module cabling](#)

Cabling guidelines

Observe the following:



NOTE

The colors in the cabling diagrams are for illustration purposes only.



CAUTION

To avoid damaging connectors, avoid repeated installation and removal of cables. Excessive handling can shorten the lifespan of the cable.

- For cable option kits, see the product QuickSpecs.
- For cable spare part numbers, see the Illustrated parts catalog in the maintenance and service guide.
- Some diagrams show alphabetical callouts such as A, B, C, etc. These callouts correspond to labels near the connectors on the cable.
- Some cables have more than one connector, such as a Y-cable, but not all connectors are used.
- Observe all guidelines when working with server cables.

Before connecting cables

- Note the port labels on the PCA components. Not all these components are used by all servers:
 - System board ports
 - Drive and power supply backplane ports
 - Expansion board ports (controllers, retimers, adapters, expanders, risers, and similar boards)
- Note the label near each cable connector. This label indicates the destination port for the cable connector.
- Some data cables are prebent. Do not unbend or manipulate the cables.
- To prevent mechanical damage or depositing oil that is present on your hands, and other contamination, do not touch the ends of the connectors.

When connecting cables

- Before connecting a cable to a port, lay the cable in place to verify the length of the cable.
- Use the internal cable management features to properly route and secure the cables.
- Route cables so that they do not contact or rest on cooling components, including heatsinks. Ensure that cable routing does not obstruct airflow to or from heatsinks or ventilation openings
- When routing cables, be sure that the cables are not in a position where they can be pinched or crimped.
- Avoid tight bend radii to prevent damaging the internal wires of a power cord or a server cable. Never bend power cords and server cables tight enough to cause a crease in the sheathing.
- Make sure that the excess length of cables is properly secured to avoid excess bends, interference issues, and airflow restriction.
- Before installing a new component or closing up the server, make sure that all cables are in their appropriate routing position. This cable check prevents component damage and potential signal interference.

When disconnecting cables

- Grip the body of the cable connector. Do not pull on the cable itself because this action can damage the internal wires of the cable or the pins on the port.

- If a cable does not disconnect easily, check for any release latch that must be pressed to disconnect the cable.

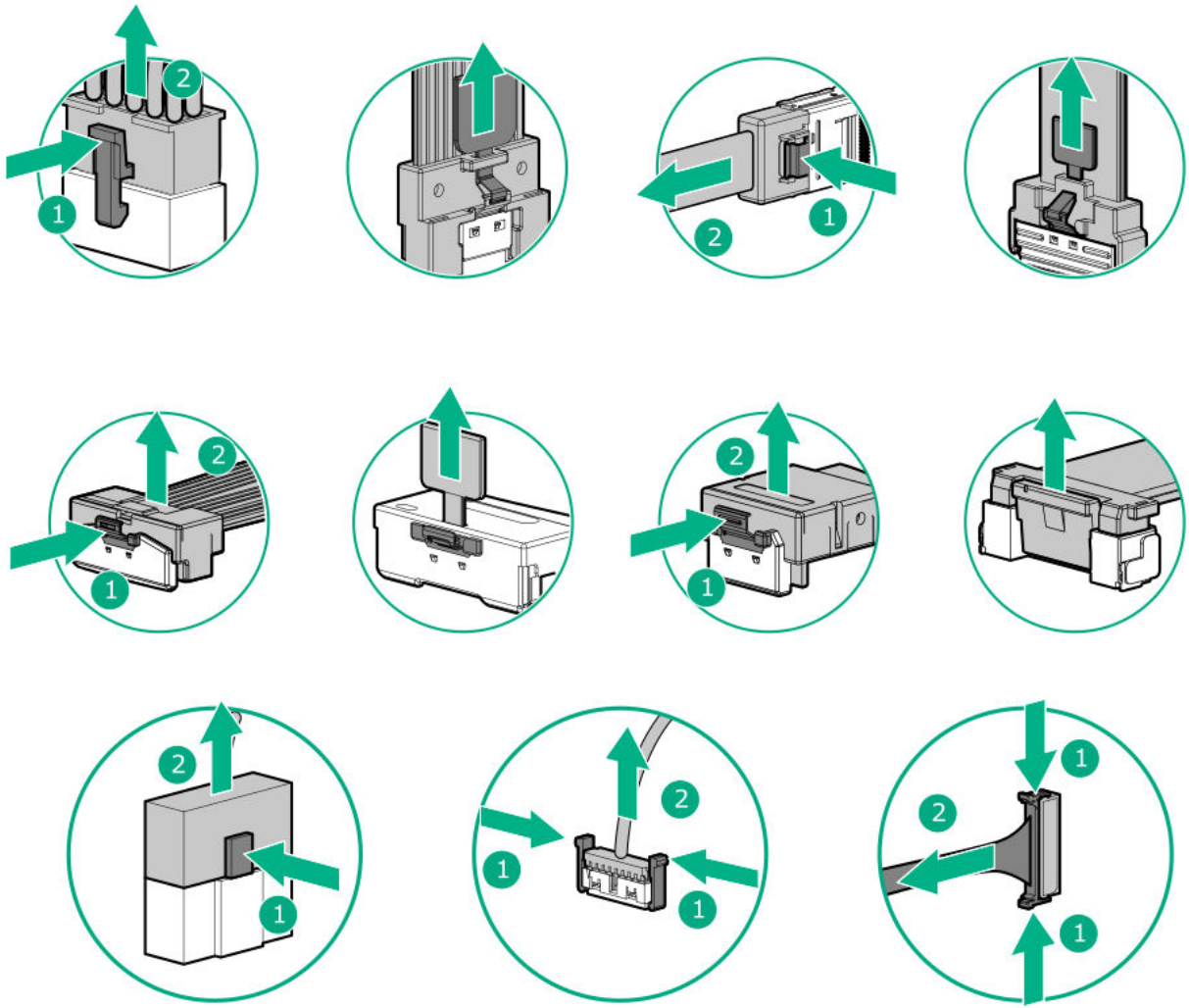

- Remove cables that are no longer being used. Retaining them inside the server can restrict airflow. If you intend to use the removed cables later, label and store them for future use.

Cabling diagrams

Observe the following:

- Before cabling components, see the [Cabling guidelines](#).
- Use the cable part number or search feature to find your diagram.

Component cabling	Cable part number
Storage controller cabling: 4 LFF drive configuration	—
4 LFF controller cable: type-p controller in the primary riser	P48970-001
4 LFF controller cable: type-o controller in Slot 14 OCP A	P48958-001
Storage controller cabling: 8 SFF drive configuration	—
8 SFF Box 1 x1 NVMe controller cable: type-o controller in Slot 14 OCP A	P48960-001
8 SFF Box 1 x1 NVMe controller cable: type-p controller in the primary riser	P45610-001
8 SFF Box 1 x1 NVMe controller cable: type-p controller in the primary riser	P79151-001 ¹
Storage controller cabling: 8 + 2 SFF drive configuration	—
8 SFF + 2 SFF x4 NVMe controller cables: type-o controller in Slot 14 OCP A	P48960-001 P48962-001
8 SFF + 2 SFF x4 NVMe controller cables: type-o controller in Slot 15 OCP B	P55357-001 P48961-001
8 SFF x1 NVMe + 2 SFF NVMe controller cables: type-p controller in Slot 1	P45610-001 P45611-001
8 SFF x1 NVMe to type-o controller in Slot 14 OCP A + 2 SFF x4 direct attach	P48960-001 P75946-001
8 SFF x1 NVMe to type-o controller + 2 SFF NVMe to type-p controller	P48960-001 P45611-001
8 SFF x1 NVMe to Slot 1 type-p controller + 2 SFF x4 NVMe to type-o controller in Slot 14 OCP A	P45610-001 P48962-001
8 SFF x1 NVMe to Slot 1 type-p controller + 2 SFF direct attach	P45610-001 P75946-001
8 SFF x1 NVMe to type-o controller in Slot 15 OCP B + 2 SFF to type-p controller in Slot 2	P55357-001 P45611-001

Component cabling	Cable part number
8 SFF x1 NVMe to type-o controller in Slot 15 OCP B + 2 SFF x4 NVMe direct attach	P55357-001 P75946-001
8 SFF x1 NVMe to type-o controller in Slot 15 OCP B + 2 SFF x4 NVMe to type-o controller in Slot 14 OCP A	P55357-001 P48962-001
8 SFF x1 NVMe + 2 SFF x4 NVMe to type-p controller in Slot 2	P45610-001 P45611-001
8 SFF x1 NVMe to type-o controller in Slot 14 OCP A + 2 SFF x4 NVMe to type-o controller in Slot 15 OCP B	P48960-001 P48961-001
8 SFF x1 NVMe to type-o controller in Slot 14 OCP A + 2 SFF x4 NVMe to Slot 2 type-p controller	P48960-001 P45611-001
8 SFF x1 NVMe + 2 SFF x4 NVMe to type-p controller in Slot 1	P79151-001 ¹ / _— P76443-001 ¹ / _—
8 SFF x1 NVMe to type-o controller + 2 SFF x4 NVMe to type-p controller in Slot 1	P48960-001 ¹ / _— P76443-001 ¹ / _—
8 SFF x1 NVMe to type-p controller in Slot 1 + 2 SFF x4 NVMe to type-o controller	P79151-001 ¹ / _— P48962-001 ¹ / _—
Storage controller cabling: 4 EDSFF stacked in the 10 SFF / 20 E3.S server —	
4 EDSFF Box 1: direct attach cable (unbalanced, 1 CPU)	P75568-001
4 EDSFF Box 1: direct attach cable (unbalanced)	P75568-001 P75278-001
4 EDSFF Box 1: secondary riser type-p controller cable	P74805-001
4 EDSFF Box 2: direct attach cable (unbalanced, 1 CPU)	P75567-001
4 EDSFF Box 2: direct attach cable (unbalanced)	P75317-001
4 EDSFF Box 3 x4 NVMe: direct attach cable	P75278-001
4 EDSFF Box 4 x4 NVMe: direct attach cable	P74806-001 P75278-001

Component cabling	Cable part number
4 EDSFF Box 4 x4 NVMe: type-p controller in Slot 1	P75590-001
4 EDSFF Box 4 x4 NVMe: type-p controller in Slot 2	P75590-001
4 EDSFF Box 5 x4 NVMe: direct attach cable	P75278-001 P75567-001
4 EDSFF Box 5 x4 NVMe: type-p controller in Slot 1	P76443-001 P75574-001
4 EDSFF Box 5 x4 NVMe: type-p controller in Slot 2	P76443-001 P75574-001
4 EDSFF Box 5 x4 NVMe: type-o controller cable (CPU1 and CPU2)	P75589-001
8 EDSFF Boxes 1–2 x4: direct attach cable	P75568-001 P75278-001 P75317-001
8 EDSFF Boxes 1–2 x4 NVMe to type-p controller in Slot 1 (1 CPU)	P75318-001 <u>1</u>
8 EDSFF Boxes 1–2 x4 NVMe to type-p controller in Slot 3	P75318-001 <u>1</u>
8 EDSFF Boxes 4–5 x4 NVMe to type-p controller in Slot 1	P75570-001 <u>1</u> P75569-001 <u>1</u>
8 EDSFF Boxes 1 and 4 x4 NVMe to type-p controller in Slot 1 (1 CPU)	P75570-001 <u>1</u> P75318-001 <u>1</u>
8 EDSFF Boxes 1 and 5 x4 NVMe to type-p controller in Slot 1 (1 CPU)	P75318-001 <u>1</u> P75570-001 <u>1</u> P75569-001 <u>1</u>
Storage controller cabling: 2 SFF stacked in the 10 SFF / 20 E3.S server	—
2 SFF Box 1 x4 NVMe: direct attach cable (1 CPU)	P75568-001
2 SFF Box 1 x4 NVMe: type-p controller in Slot 1	P75590-001
2 SFF Box 1 x4 NVMe: direct attach cable	P75317-001
2 SFF Box 1 x4 NVMe: type-p controller in Slot 3	P75590-001
2 SFF Box 2 x4 NVMe: direct attach cable (1 CPU)	P75568-001

Component cabling	Cable part number
2 SFF Box 2 x4 NVMe: direct attach cable (CPU1 and CPU 2)	<u>P75278-001</u>
2 SFF Box 2 x4 NVMe: type-p controller in Slot 1	<u>P75590-001</u>
2 SFF Box 2 x4 NVMe: type-p controller in Slot 3	<u>P75590-001</u>
2 SFF Box 3 x4 NVMe: direct attach (1 CPU)	<u>P75278-001</u>
2 SFF Box 3 x4 NVMe: direct attach (1 CPU and supporting OCP B)	<u>P75567-001</u>
2 SFF Box 3 x4 NVMe: type-o controller in Slot 14 OCP A (1 CPU)	<u>P75589-001</u>
2 SFF Box 3 x4 NVMe: type-o controller in Slot 15 OCP B	<u>P75587-001</u>
2 SFF Box 3 x4 NVMe: type-p controller in the primary riser	<u>P75590-001</u>
2 SFF Box 4 x4 NVMe: direct attach cable (1 CPU)	<u>P75317-001</u>
2 SFF Box 4 x4 NVMe: direct attach cable	<u>P75567-001</u>
2 SFF Box 4 x4 NVMe: type-o controller in Slot 14 OCP A	<u>P75589-001</u>
2 SFF Box 4 x4: type-o controller in Slot 15 OCP B	<u>P75589-001</u>
2 SFF Box 4 x4 NVMe: type-p controller in Slot 1	<u>P76443-001</u>
2 SFF Box 4 x4 NVMe: type-p controller in Slot 2	<u>P76443-001</u>
2 SFF Box 5 x4 NVMe: direct attach cable (1 CPU)	<u>P75567-001</u>
2 SFF Box 5 x4 NVMe: direct attach cable (1 CPU and supporting OCP B)	
2 SFF Box 5 x4 NVMe: type-p controller in Slot 2 (1 CPU and supporting OCP B)	<u>P75590-001</u>
2 SFF Box 5 x4: type-o controller in Slot 14 OCP A	<u>P75589-001</u>
2 SFF Box 5 x4: type-o controller in Slot 15 OCP B	
2 SFF Box 5 x4 NVMe: type-p controller in Slot 1	<u>P76443-001</u>
2 SFF Box 5 x4 NVMe: type-p controller in Slot 2	<u>P76443-001</u>
2 SFF Box 5 x4 NVMe: type-o controller cable	<u>P75589-001</u>
4 SFF Boxes 1-2 x4 (x2 BW) NVMe: type-p controller in Slot 1	<u>P75593-001</u>
2 SFF Boxes 1-2 x4 (x2 BW) NVMe: type-p controller in Slot 2	<u>P75593-001</u>
4 SFF Boxes 1-2 (x2 BW) NVMe: type-o controller in Slot 14 OCP A	<u>P75571-001</u>
4 SFF Boxes 1-2 x4 (x2 BW) NVMe: type-o controller in Slot 14 OCP A	<u>P75571-001</u>

Component cabling	Cable part number
4 SFF Boxes 1–2 x4 (x2 BW) NVMe: type-o controller in Slot 1 of 15 OCP B	P75573-001
4 SFF Boxes 1–2 x4 NVMe to type-p controller in Slot 1	P75318-001 ¹ / _—
4 SFF Boxes 4–5 x4 NVMe: direct attach cables	P75567-001 P75278-001
4 SFF Boxes 4–5 x4 (x2 BW) NVMe: type-o controller in Slot 1 of 14 OCP A	P75573-001
4 SFF Boxes 4–5 x4 (x2 BW) NVMe: type-o controller in Slot 1 of 15 OCP B	P75571-001
4 SFF Boxes 4–5 x4: type-o controller in Slot 15 OCP B	P75589-001
4 SFF Boxes 4–5 x4 (x2 BW) NVMe: type-p controller in Slot 1 of 1	P75572-001
4 SFF Boxes 4–5 x4 (x2 BW) NVMe: type-p controller in Slot 1 of 2	P75572-001
4 SFF Boxes 4–5 x4 NVMe to type-p controller in Slot 1	P75570-001 ¹ / _—
10 SFF Boxes 1–5 NVMe: type-p controller in Slot 1	P79152-001 ¹ / _— P79153-001 ¹ / _— P75275-001 ¹ / _—
Power cabling	—
4 LFF backplane power cable	P75565-001
8 SFF backplane power cable	P75566-001
2 SFF backplane power cable	869667-001
Stacked SFF / EDSFF backplane power cable in the 10 SFF / 20 E3.S server	P75316-001
Storage backup power cable	—
Energy pack cabling	—
Energy pack extension power cable	P45618-001
Optical drive cabling	—
Optical drive cable in the 4 LFF, 8 SFF, or 10 SFF / 20 E3.S server	P73776-002
Front I/O cabling	—
Front DisplayPort / USB cable in the 4 LFF, 8 SFF, or 10 SF F / 20 E3.S server	P73948-001
HPE NS204i-u Boot Device V2 cabling	—

Component cabling	Cable part number
HPE NS204i-u Boot Device V2 power cable	P48956-001
HPE NS204i-u Boot Device V2 signal cable	P74839-001
Riser cage HPE NS204i-u Boot Device V2 power cable	P54088-001
Riser cage HPE NS204i-u Boot Device V2 signal cable	P71913-001
OCP bandwidth enablement cabling	—
Slot 14 OCP A x16 enablement cable	P74890-001
CPU1 to Slot 15 OCP B x8 enablement cable	P74889-001
CPU2 to Slot 15 OCP B x8 / x16 enablement cable	P74891-001
Font OCP enablement cabling	—
Front OCP Bay 1 / 3 cable	P71942-001
Phy board cable	P73927-001
Miscellaneous component cabling	—
Serial port cable	P45623-001
Chassis intrusion detection switch cable	P47751-001
Front I/O cable (included in the right chassis ear assembly)	P71909-002
System Insight Display cable	P48971-001
Liquid cooling module cable	—

¹ This configuration uses the controller cable with the MR932i-p storage controller.

Internal cabling management

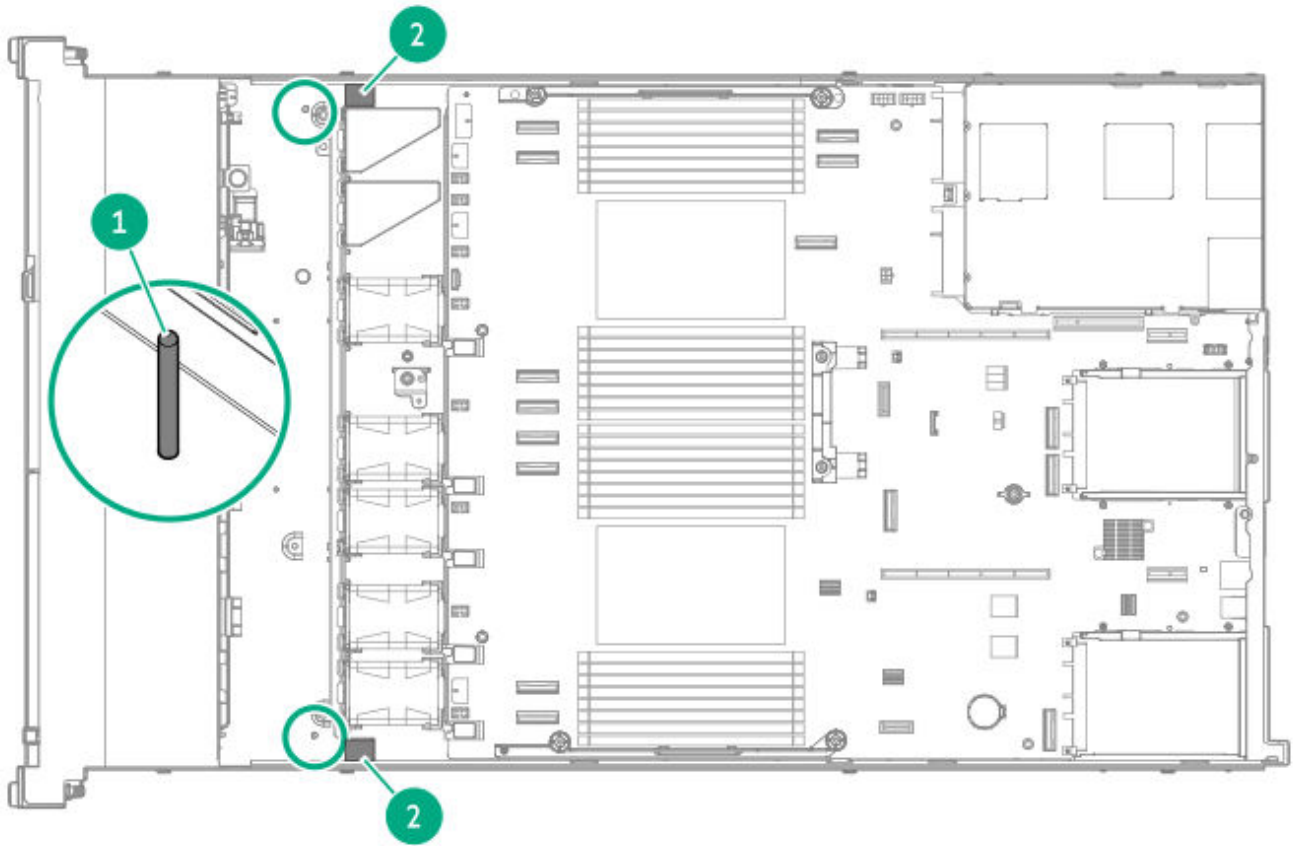

Item	Description
1	Cable routing posts
2	Cable routing foams

Storage cabling

Subtopics

- [4 LFF drive backplane cabling](#)
- [8 SFF drive backplane cabling](#)
- [8 + 2 SFF drive backplane cabling](#)
- [4 E3.S stacked drive backplane cabling](#)
- [2 SFF stacked drive backplane cabling](#)
- [Storage controller backup power cabling](#)

4 LFF drive backplane cabling

4 LFF Box 1: type-p controller in the primary riser

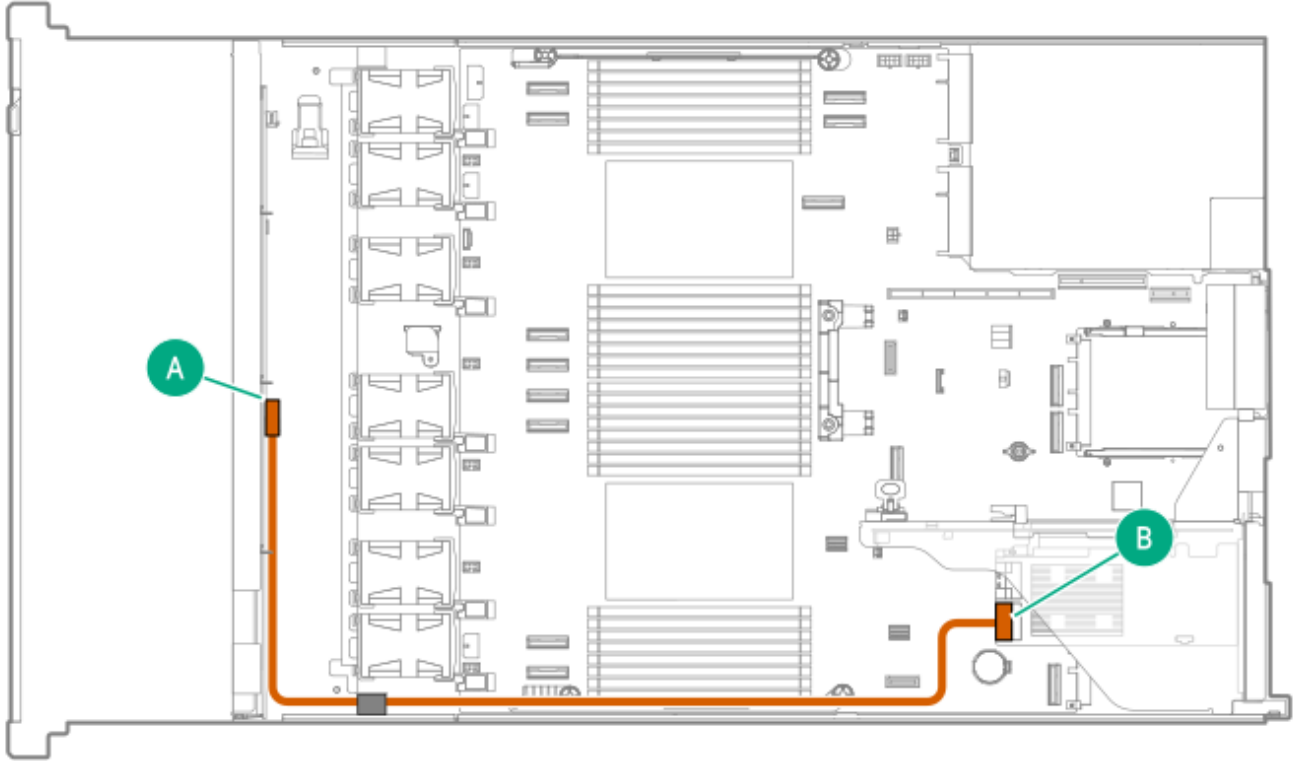

Cable part number	Color	From	To
P48970-001	Orange	Drive backplane	Slot 1 type-p controller Port 1i

4 LFF Box 1: type-o controller in Slot 14 OCP A

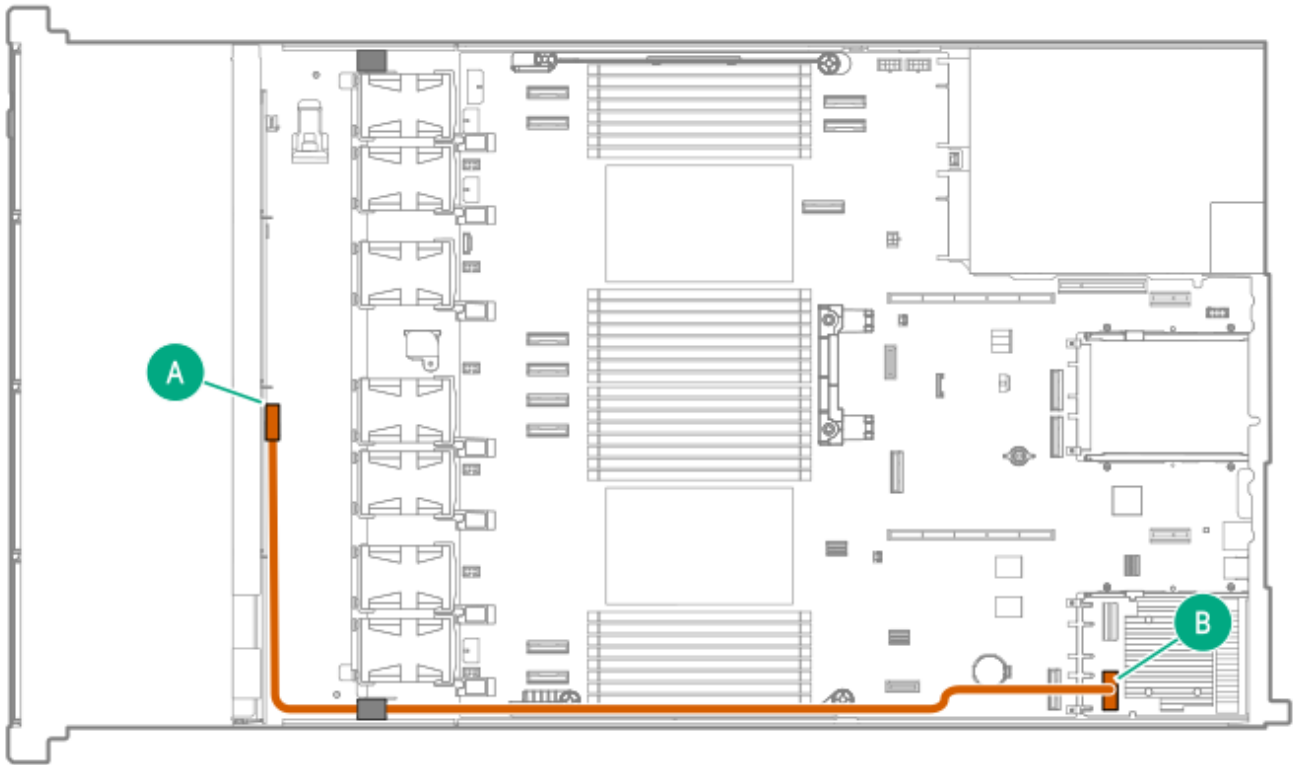

Cable part number	Color	From	To
P48958-001	Orange	Drive backplane	Slot 14 OCP A type-o controller Port 1i

8 SFF drive backplane cabling

8 SFF Box 1 x1 NVMe controller cabling: type-o controller in Slot 14 OCP A

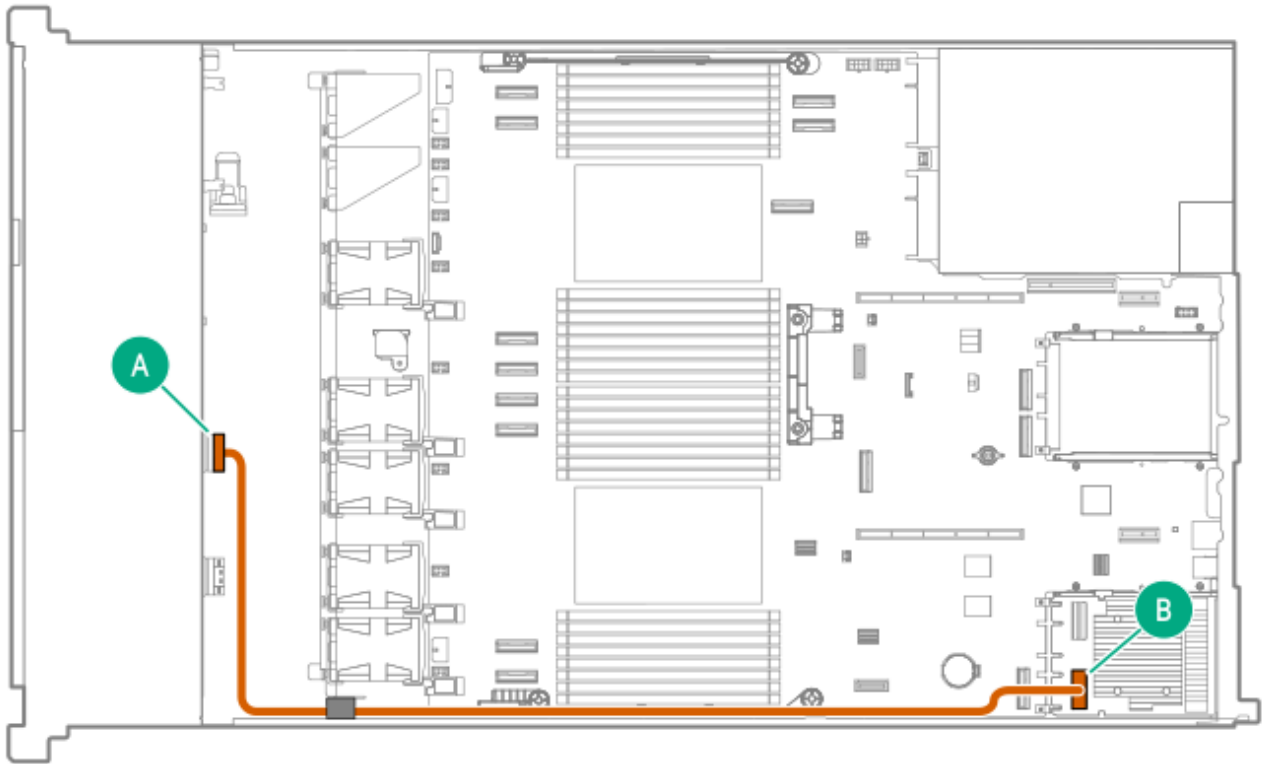

Cable part number	Color	From	To
P48960-001	Orange	Drive backplane	Slot 14 OCP A type-o controller Port 1i

8 SFF Box 1 x1 NVMe controller cabling: type-p controller in the primary riser

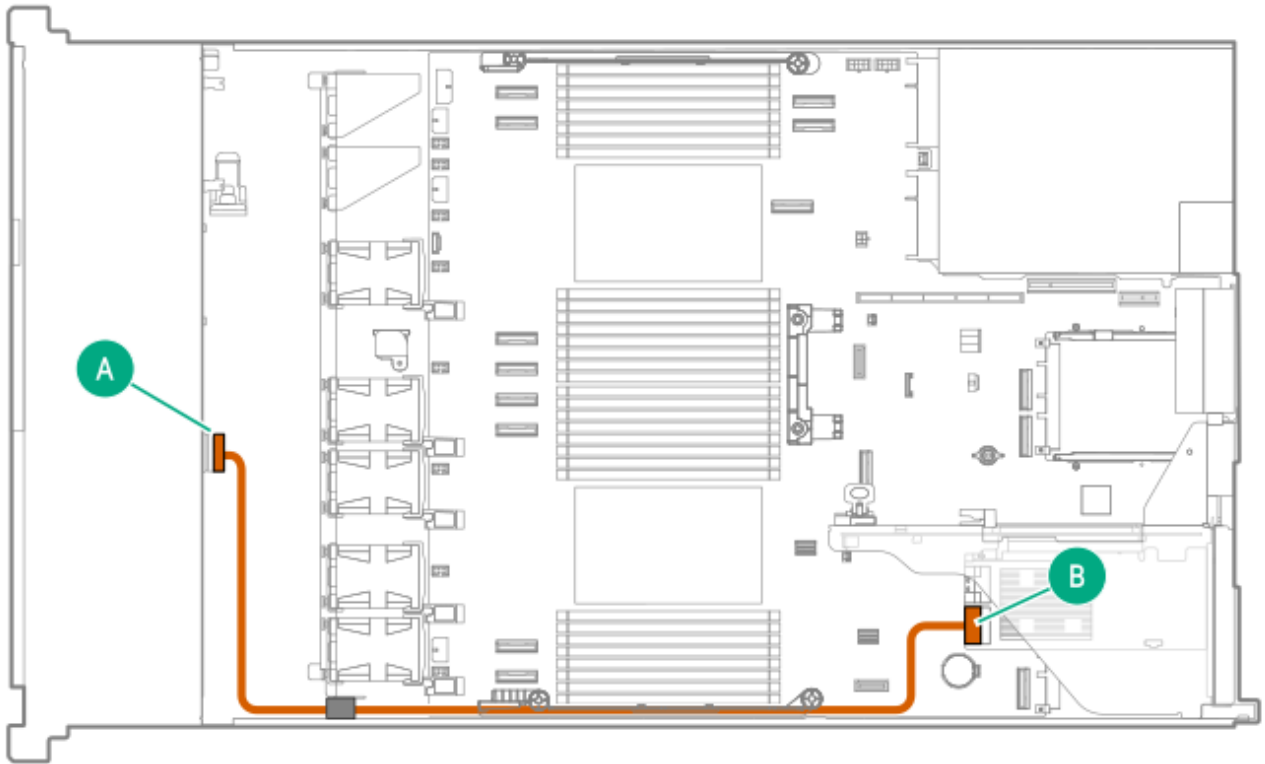

Cable part number	Color	From	To
P45610-001	Orange	Drive backplane	Primary type-p controller Port 1i

8 SFF Box 1 x1 NVMe controller cabling: type-p controller in the primary riser

MR932i-p:

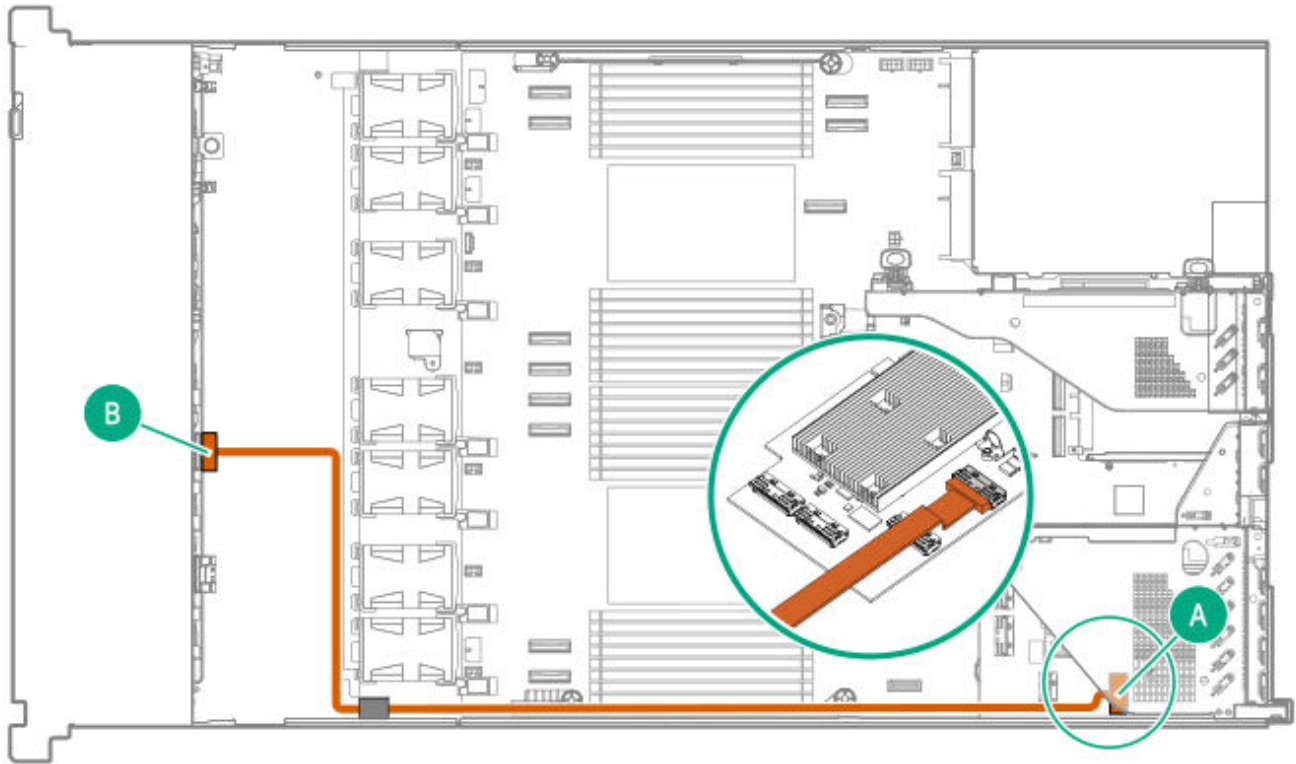

Cable part number	Color	From	To
P79151-001	Orange	Drive backplane	Primary type-p controller Port 3i

8 + 2 SFF drive backplane cabling

8 SFF x1 NVMe + 2 SFF x4 NVMe controller cabling: type-o controller in Slot 14 OCP A

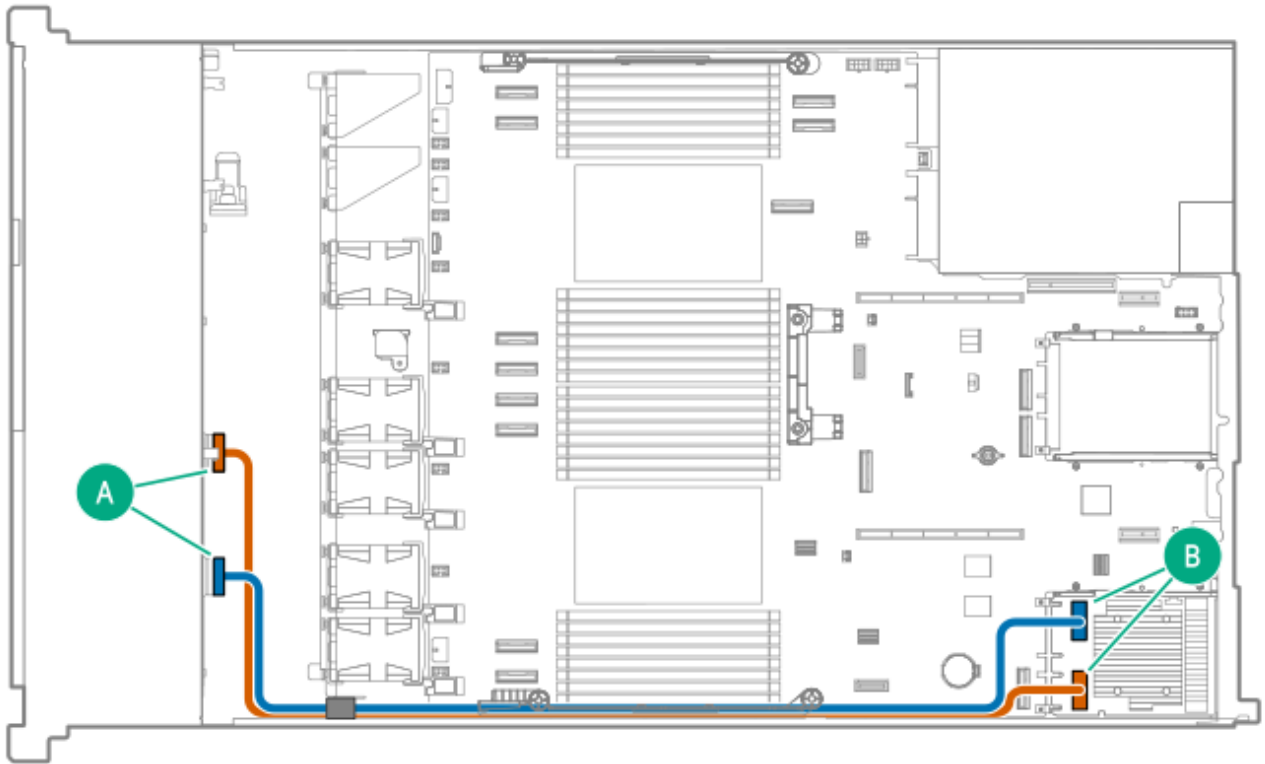

Cable part number	Color	From	To
P48960-001	Orange	8 SFF drive backplane	Slot 14 OCP A type-o controller Port 1i
P48962-001	Blue	2 SFF drive backplane	Slot 14 OCP A type-o controller Port 2i

8 SFF x1 NVMe + 2 SFF x4 NVMe controller cabling: type-o controller in Slot 15 OCP B

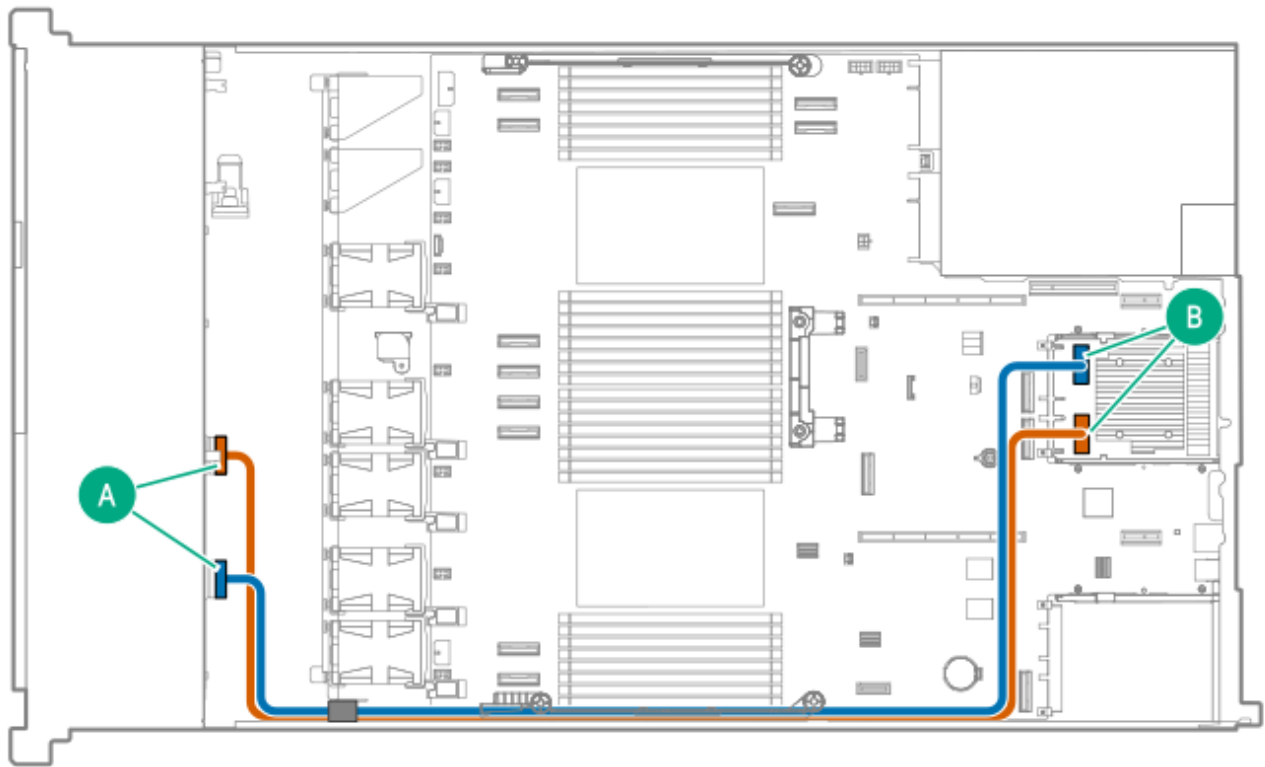

Cable part number	Color	From	To
P55357-001	Orange	8 SFF drive backplane	Slot 15 OCP B type-o controller Port 1i
P48961-001	Blue	2 SFF drive backplane	Slot 15 OCP B type-o controller Port 2i

8 SFF x1 NVMe + 2 SFF x4 NVMe controller cabling: type-p controller in Slot 1

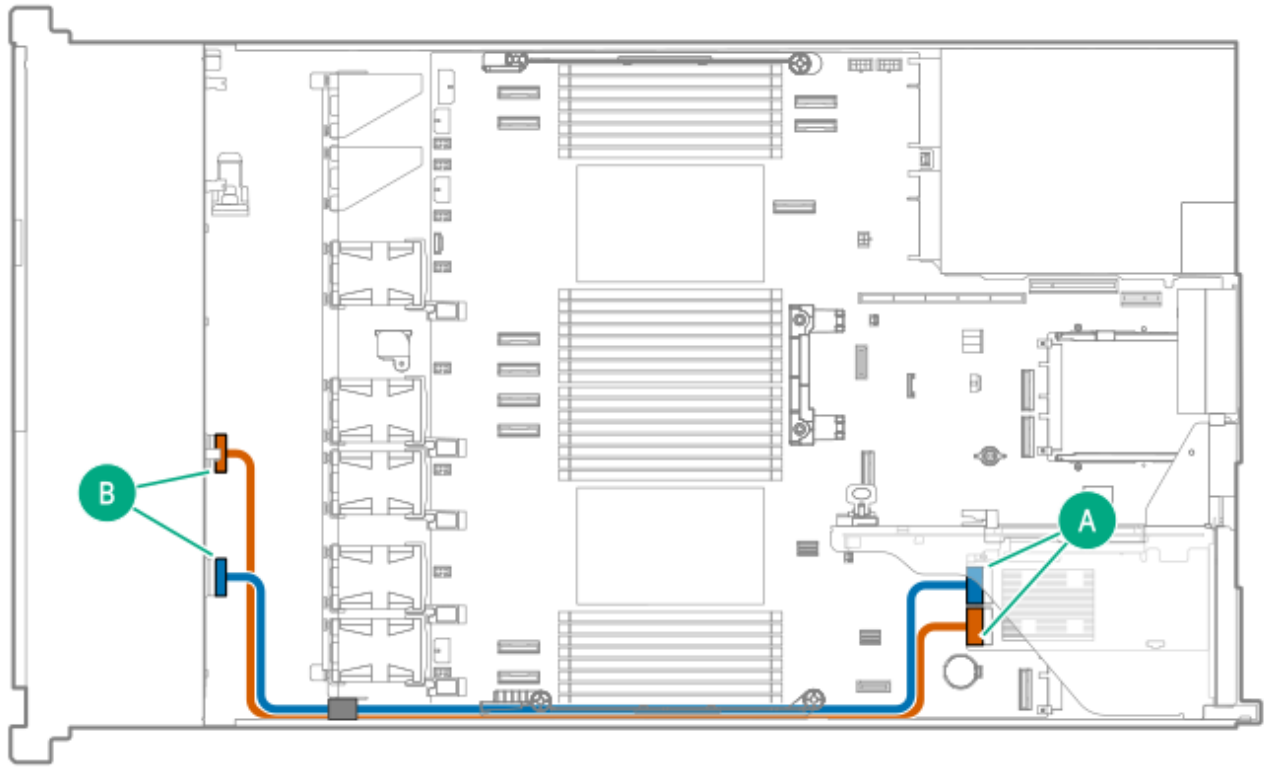

Cable part number	Color	From	To
P45610-001	Orange	8 SFF drive backplane	Slot 1 type-p controller Port 1i
P45611-001	Blue	2 SFF drive backplane	Slot 1 type-p controller Port 2i

8 SFF x1 NVMe to type-o controller in Slot 14 OCP A + 2 SFF x4 direct attach

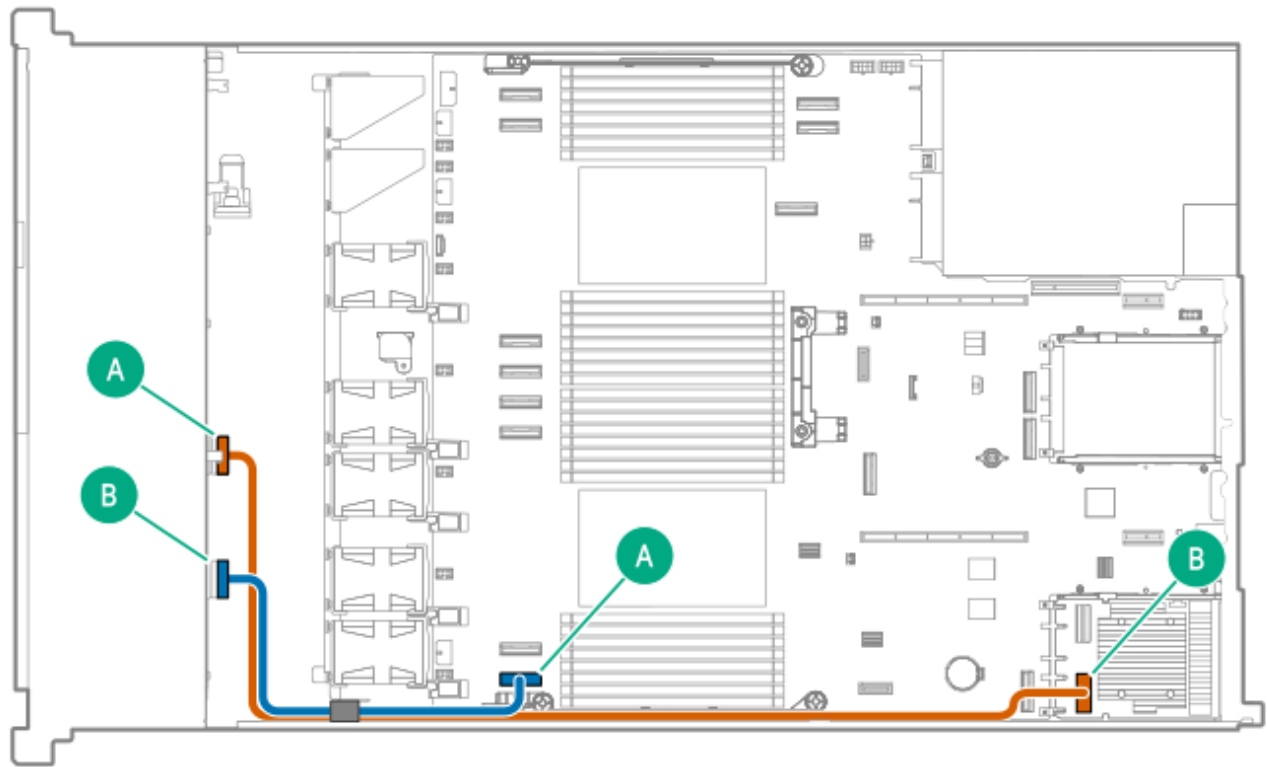

Cable part number	Color	From	To
P48960-001	Orange	8 SFF drive backplane	Slot 14 OCP A type-o controller Port 1i
P75946-001	Blue	2 SFF drive backplane	MCI0 port 1

8 SFF x1 NVMe to type-o controller + 2 SFF x4 NVMe to type-p controller

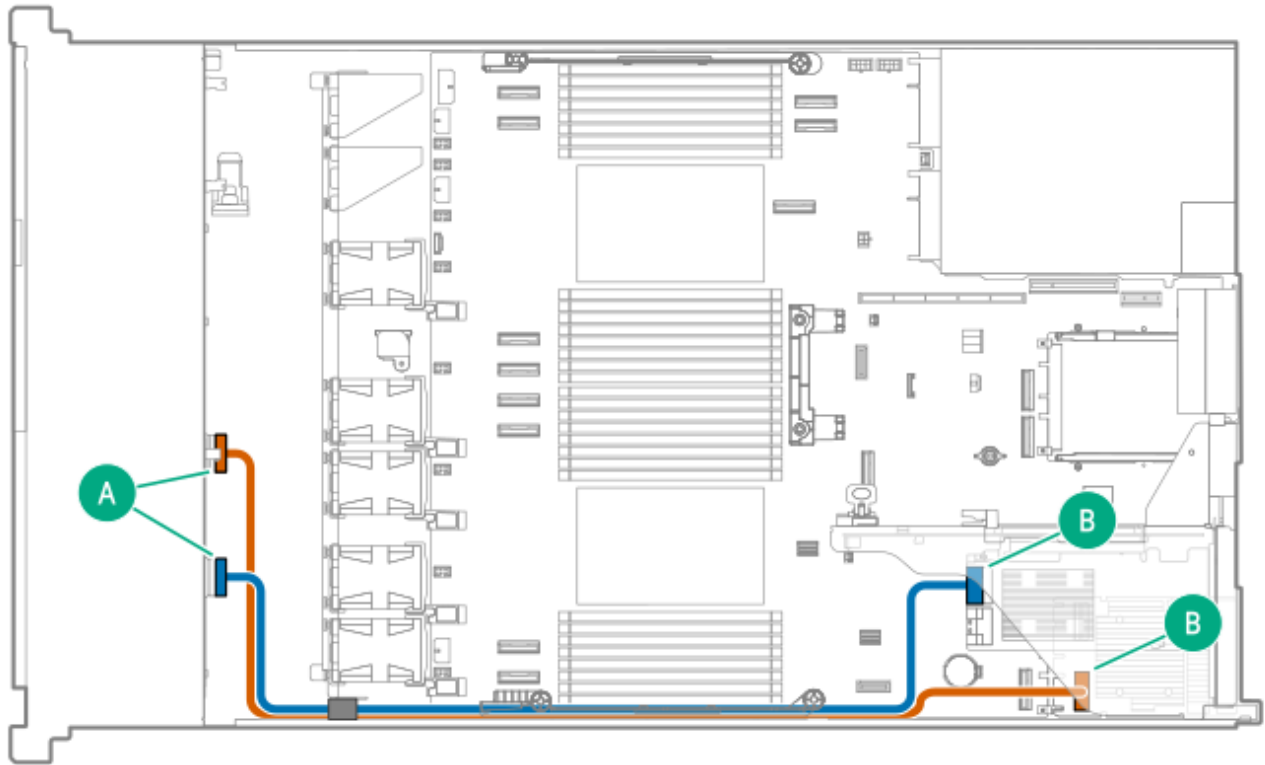

Cable part number	Color	From	To
P48960-001	Orange	8 SFF drive backplane	Slot 14 OCP A type-o controller Port 1i
P45611-001	Blue	2 SFF drive backplane	Slot 1 type-p controller Port 2i

8 SFF x1 NVMe to Slot 1 type-p controller + 2 SFF x4 NVMe to type-o controller in Slot 14 OCP A

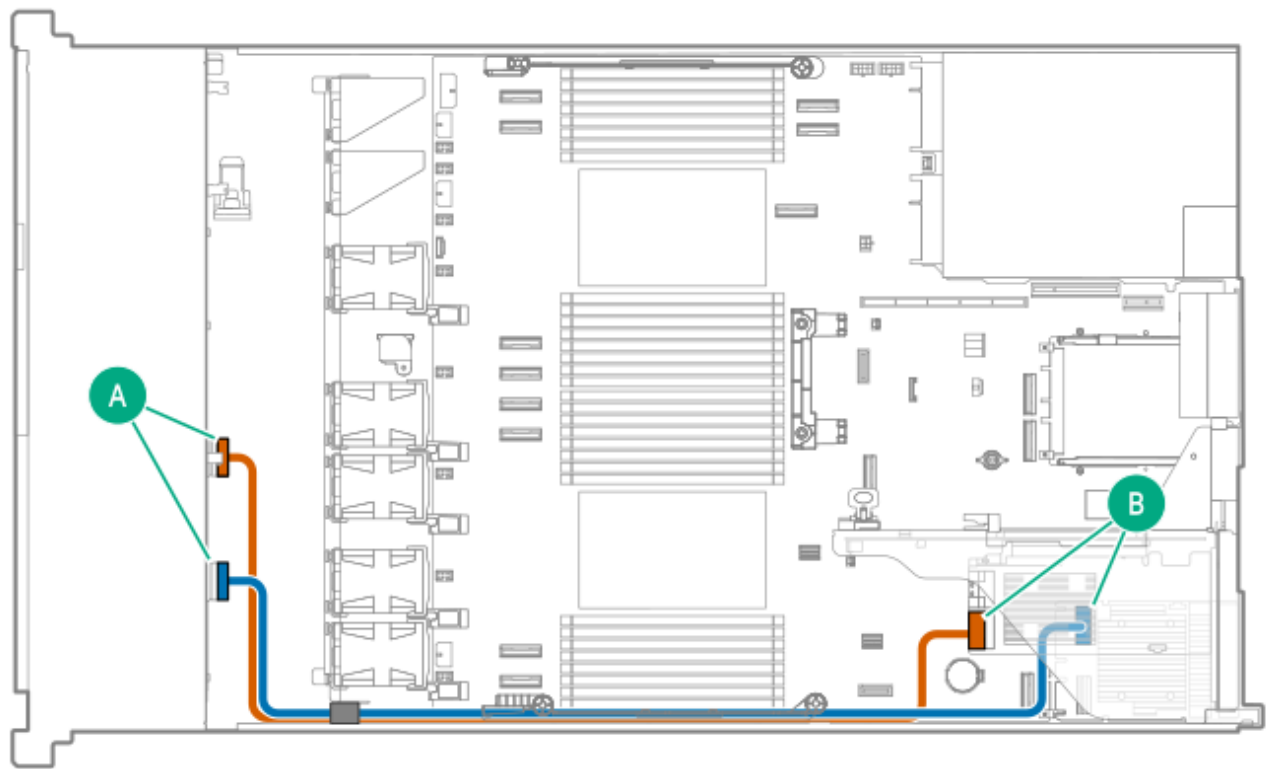

Cable part number	Color	From	To
P45610-001	Orange	8 SFF drive backplane	Slot 1 type-p controller Port 1i
P48962-001	Blue	2 SFF drive backplane	Slot 14 OCP A type-o controller Port 2i

8 SFF x1 NVMe to Slot 1 type-p controller + 2 SFF direct attach

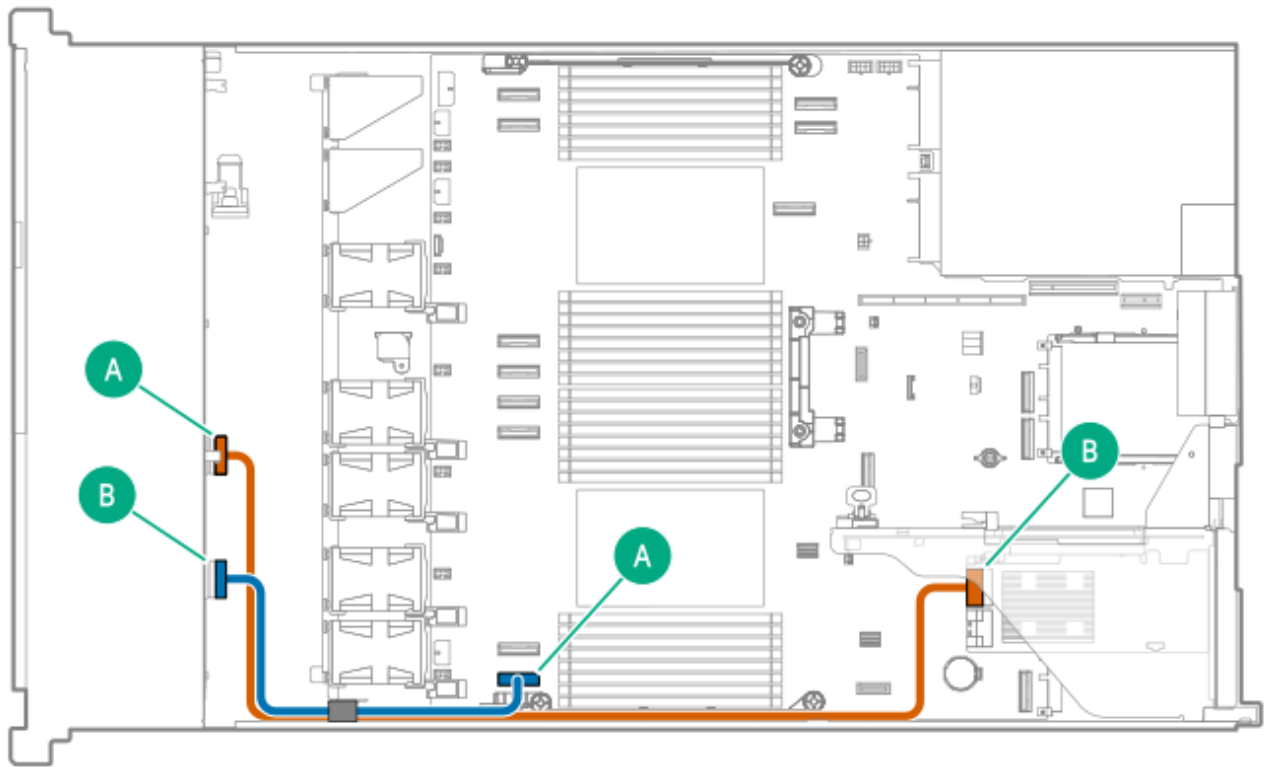

Cable part number	Color	From	To
P45610-001	Orange	8 SFF drive backplane	Slot 1 type-p controller Port 1i
P75946-001	Blue	2 SFF drive backplane	MCI0 port 1

8 SFF x1 NVMe to type-o controller in Slot 15 OCP B + 2 SFF x4 NVMe to type-p controller in Slot 2

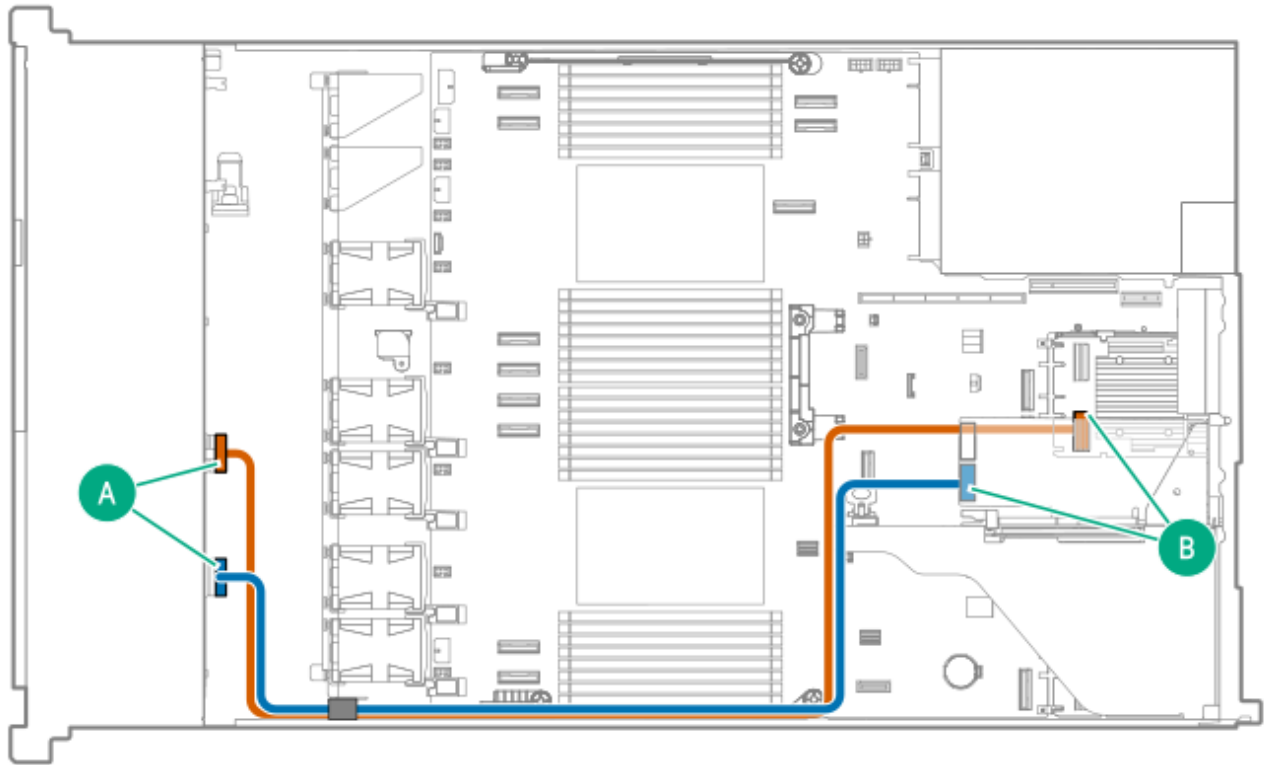

Cable part number	Color	From	To
P55357-001	Orange	8 SFF drive backplane	Slot 15 OCP B type-o controller Port 1i
P45611-001	Blue	2 SFF drive backplane	Slot 2 type-p controller Port 2i

8 SFF x1 NVMe to type-o controller in Slot 15 OCP B + 2 SFF x4 NVMe direct attach

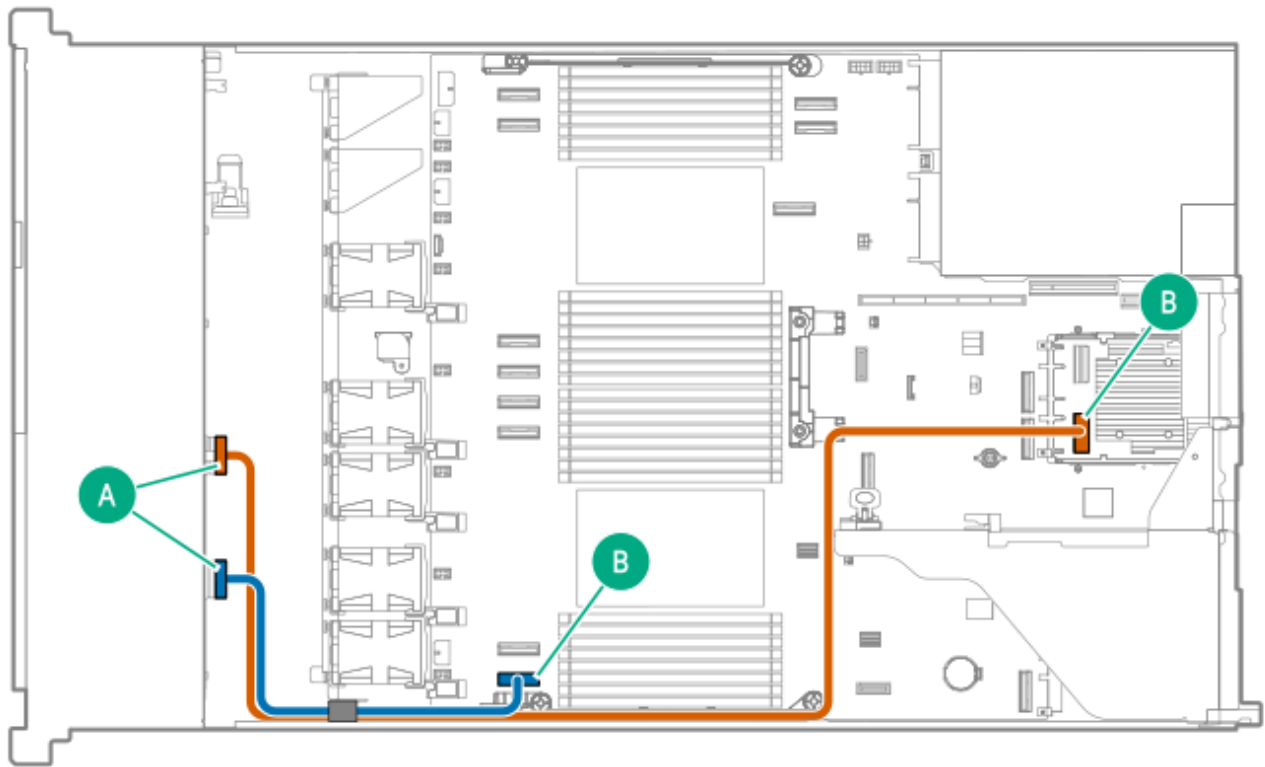

Cable part number	Color	From	To
P55357-001	Orange	8 SFF drive backplane	Slot 15 OCP B type-o controller Port 1i
P75946-001	Blue	2 SFF drive backplane	MCI0 port 1

8 SFF x1 NVMe to type-o controller in Slot 15 OCP B + 2 SFF x4 NVMe to type-o controller in Slot 14 OCP A

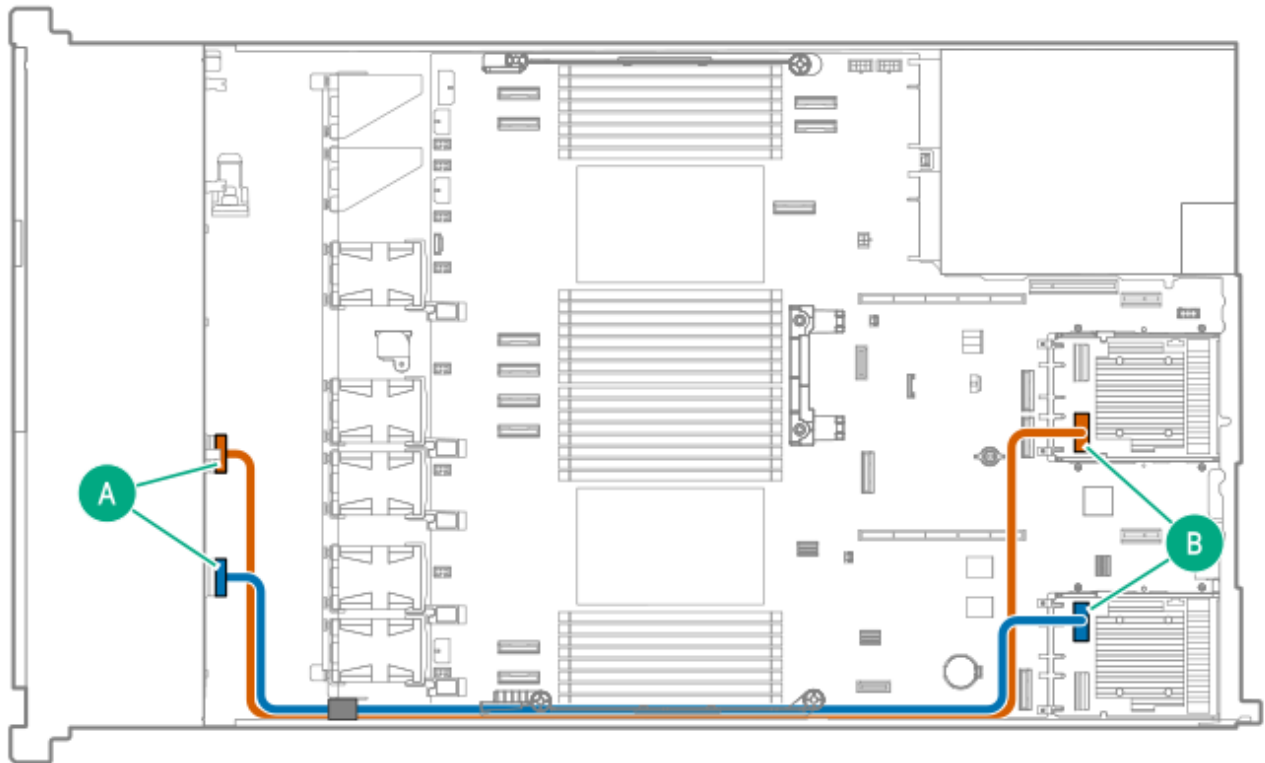

Cable part number	Color	From	To
P55357-001	Orange	8 SFF drive backplane	Slot 15 OCP B type-o controller Port 1i
P48962-001	Blue	2 SFF drive backplane	Slot 14 OCP A type-o controller Port 2i ¹

¹ When the MR408i-o is installed in OCP A, the cable is routed to Port 1i of the controller.

8 SFF x1 NVMe + 2 SFF x4 NVMe to type-p controller in Slot 2

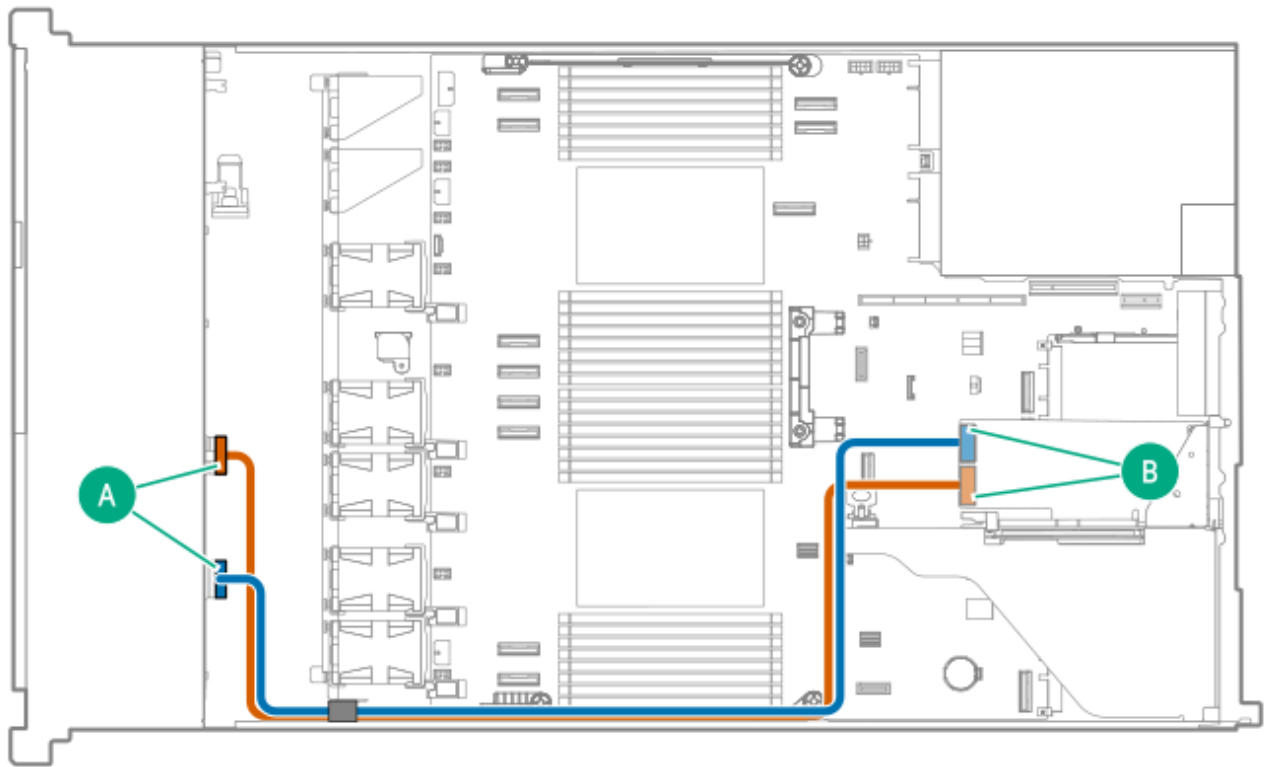

Cable part number	Color	From	To
P45610-001	Orange	8 SFF drive backplane	Slot 2 type-p controller Port 2i
P45611-001	Blue	2 SFF drive backplane	Slot 2 type-p controller Port 1i

8 SFF x1 NVMe to type-o controller in Slot 14 OCP A + 2 SFF x4 NVMe to type-o controller in Slot 15 OCP B

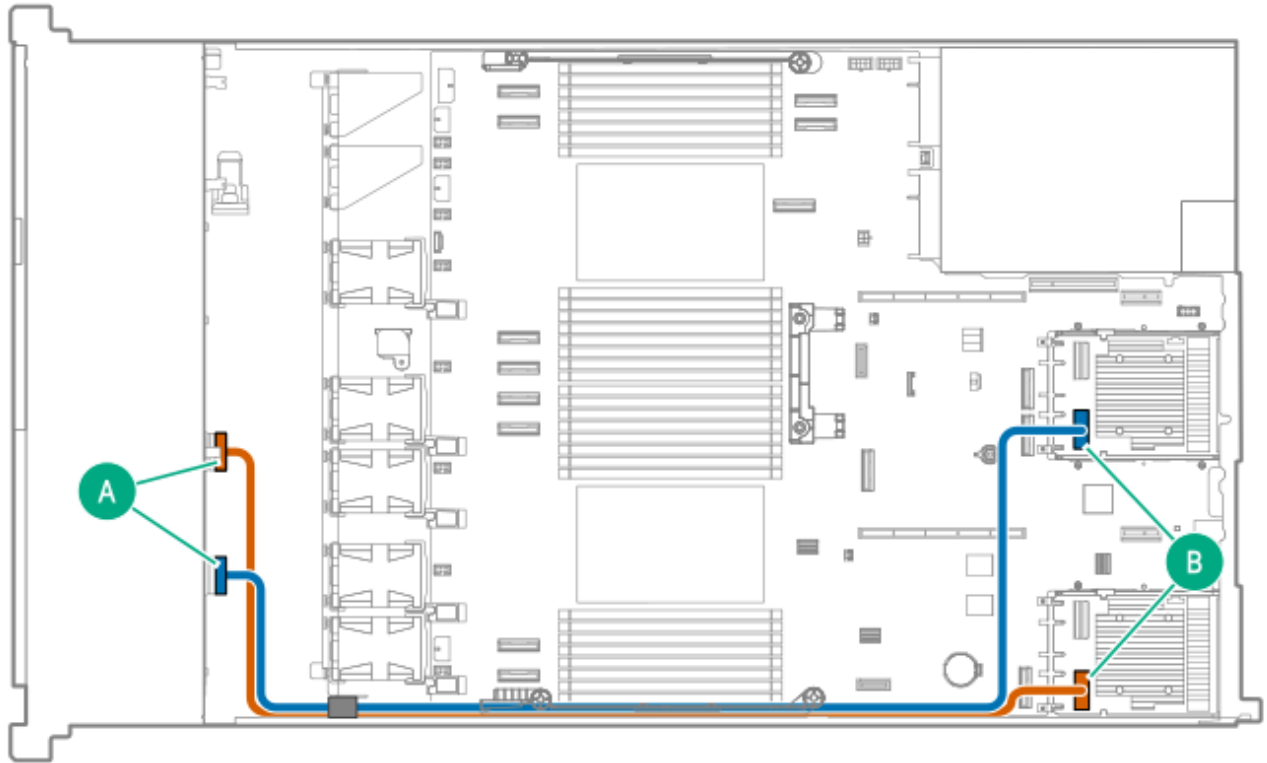

Cable part number	Color	From	To
P48960-001	Orange	8 SFF drive backplane	Slot 14 OCP A type-o controller Port 1i
P48961-001	Blue	2 SFF drive backplane	Slot 15 OCP B type-o controller Port 1i

8 SFF x1 NVMe to type-o controller in Slot 14 OCP A + 2 SFF x4 NVMe to Slot 2 type-p controller

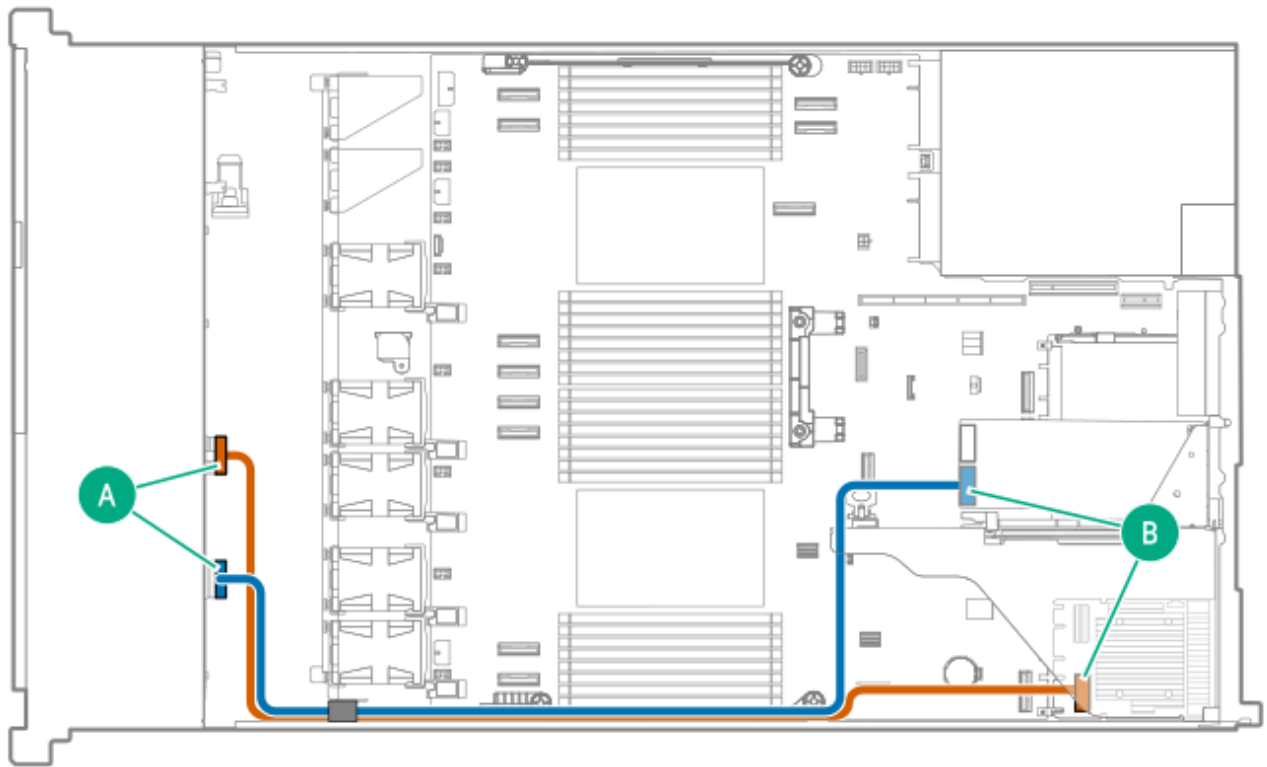

Cable part number	Color	From	To
P48960-001	Orange	8 SFF drive backplane	Slot 14 OCP A type-o controller Port 1i
P45611-001	Blue	2 SFF drive backplane	Slot 2 type-p controller Port 2i

8 SFF x1 NVMe + 2 SFF x4 NVMe to type-p controller in Slot 1

MR932i-p:

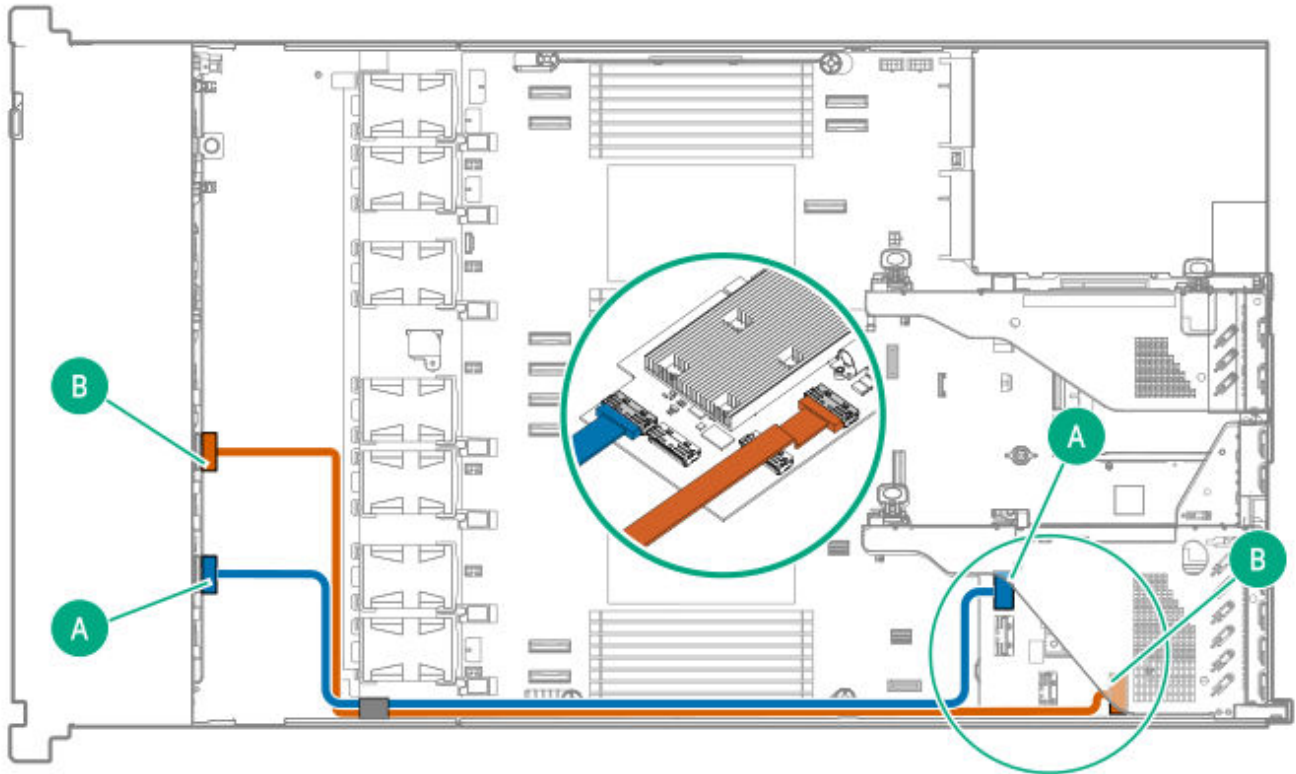

Cable part number	Color	From	To
P79151-001	Orange	8 SFF drive backplane	Slot 1 type-p controller Port 3i
P76443-001	Blue	2 SFF drive backplane	Slot 1 type-p controller Port 2i

8 SFF x1 NVMe to type-o controller + 2 SFF x4 NVMe to type-p controller in Slot 1

MR932i-p:

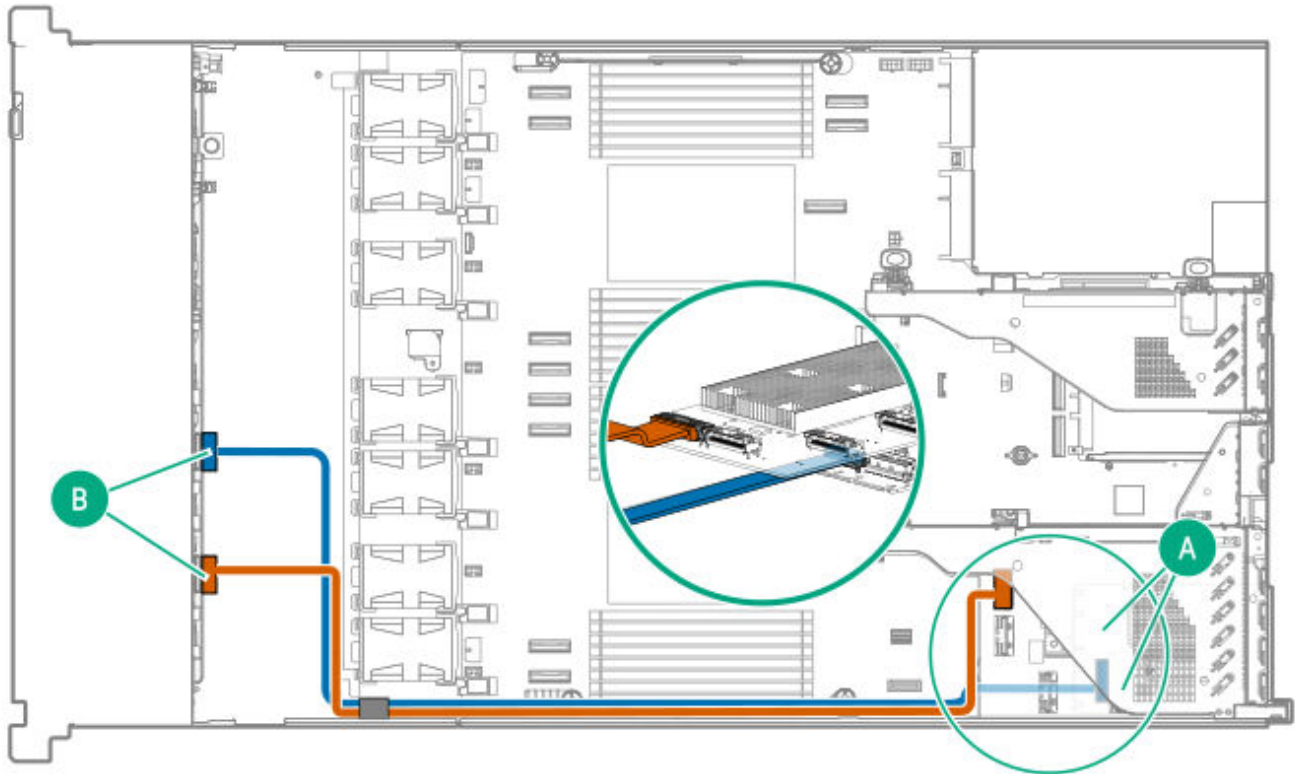

Cable part number	Color	From	To
P76443-001	Orange	2 SFF drive backplane	Slot 1 type-p controller Port 2i
P48960-001	Blue	8 SFF drive backplane	Slot 14 OCP A type-o controller Port 1i

8 SFF x1 NVMe to type-p controller in Slot 1 + 2 SFF x4 NVMe to type-o controller

MR932i-p:

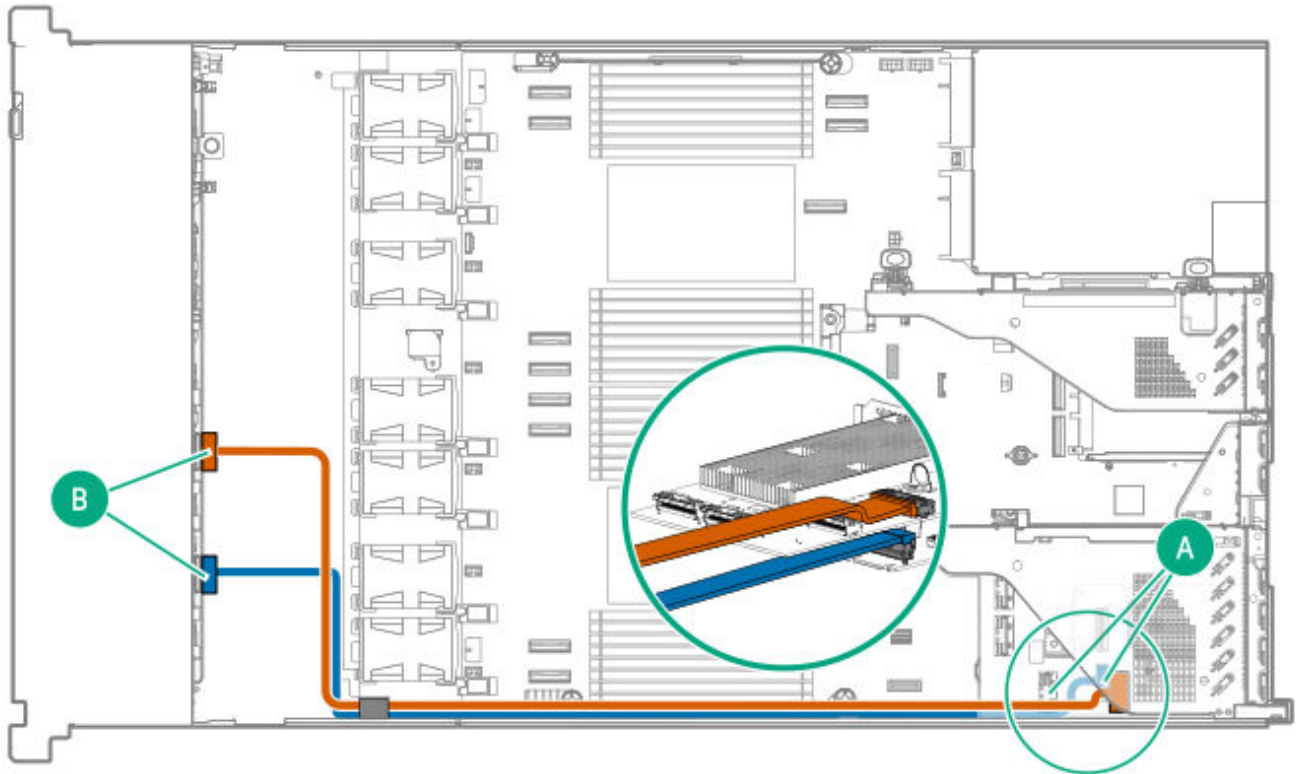

Cable part number	Color	From	To
P79151-001	Orange	8 SFF drive backplane	Slot 1 type-p controller Port 3i
P48962-001	Blue	2 SFF drive backplane	Slot 14 OCP A type-o controller Port 1i

8 SFF x1 NVMe to type-p controller in Slot 1 + 2 SFF x4 NVMe direct attach

MR932i-p:

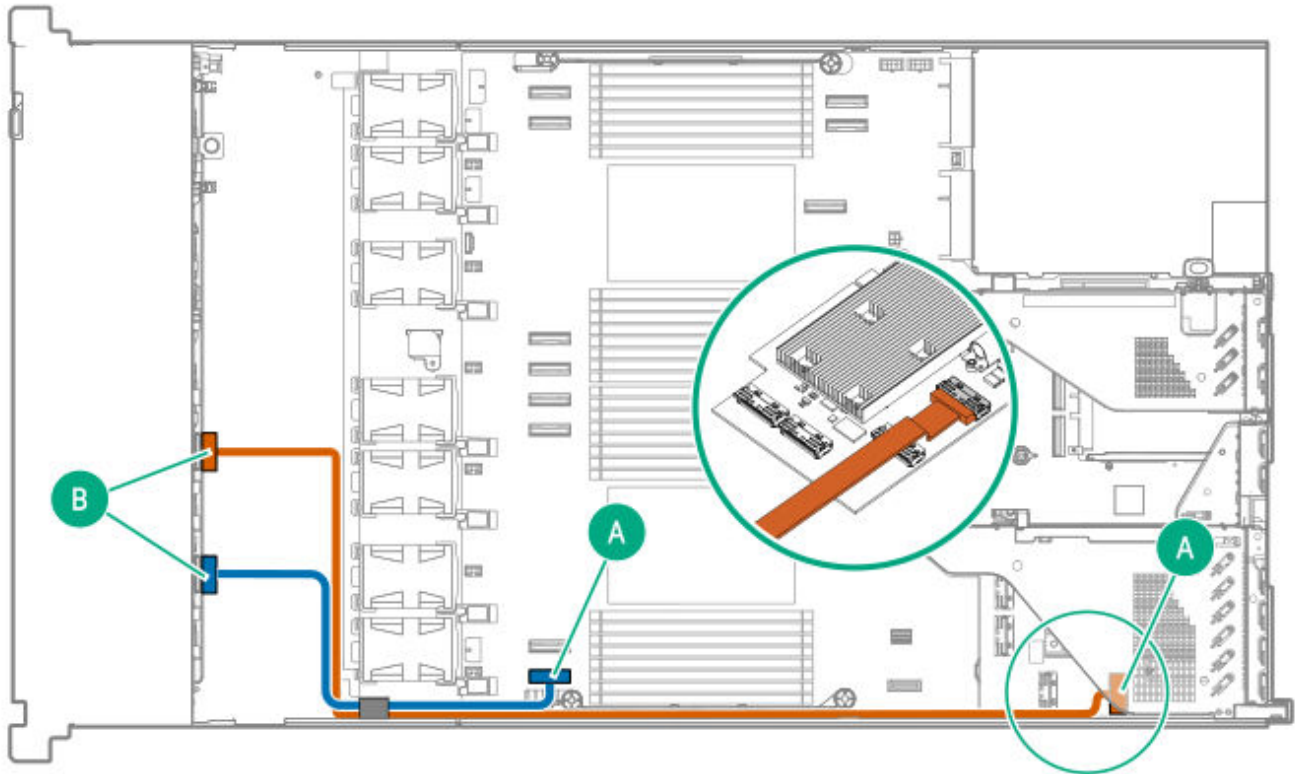

Cable part number	Color	From	To
P79151-001	Orange	8 SFF drive backplane	Slot 1 type-p controller Port 3i
P75946-001	Blue	2 SFF drive backplane	MCIO port 1

4 E3.S stacked drive backplane cabling

The 4 E3.S stacked drive backplane is supported in the 10 SFF / 20 E3.S server or servers using the mixed drive type configuration.

Subtopics

[Drive Box 1 cabling](#)

[Drive Box 2 cabling](#)

[Drive Box 3 cabling](#)

[Drive Box 4 cabling](#)

[Drive Box 5 cabling](#)

- Drive box cabling for Boxes 1-2**
- Drive box cabling for boxes 1 and 4**
- Drive box cabling for boxes 1 and 5**
- Drive box cabling for boxes 4-5**

Drive Box 1 cabling

4 EDSFF Box 1: direct attach (unbalanced, 1 CPU)

This cable routing is compatible with a single-processor configuration.

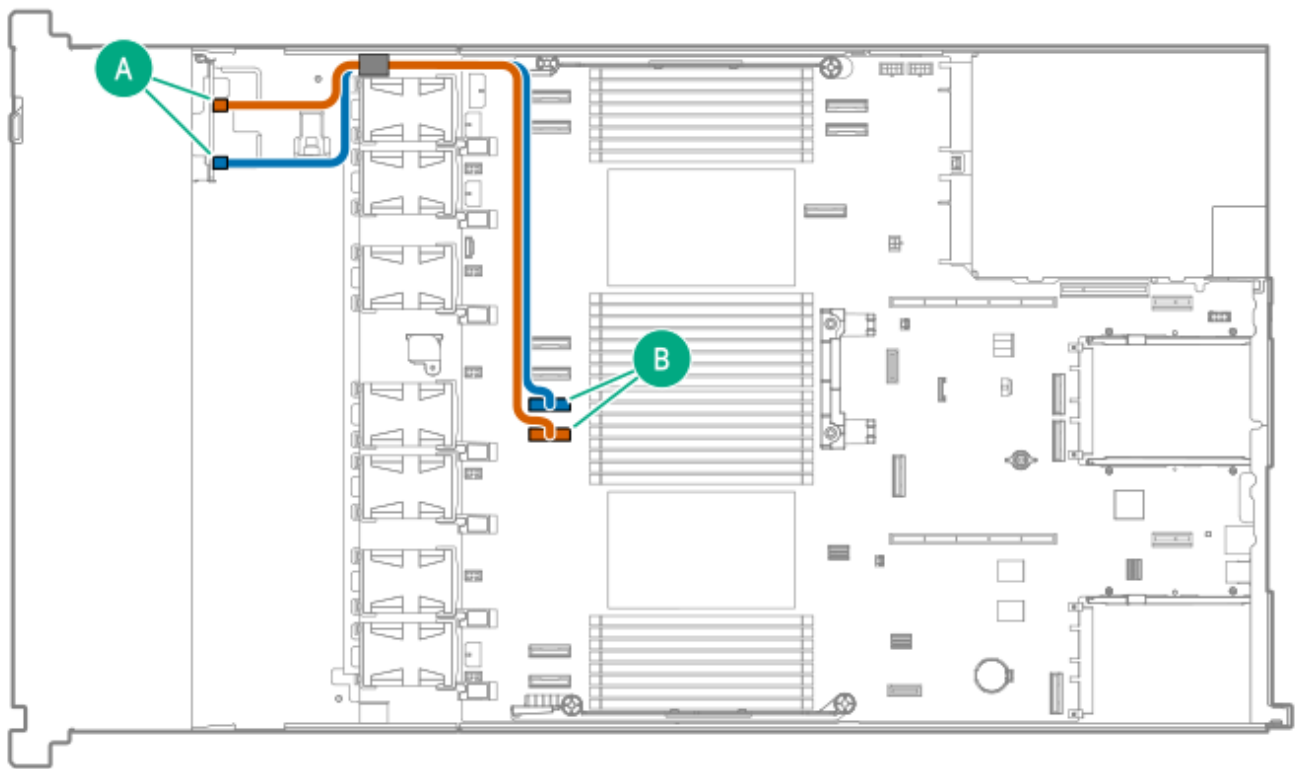

Cable part number	Color	From	To
P75568-001	Orange	Drive backplane port 1	MCIO port 3
P75568-001	Blue	Drive backplane port 2	MCIO port 4

4 EDSFF Box 1: direct attach (unbalanced)

This cable routing is compatible with a dual-processor configuration.

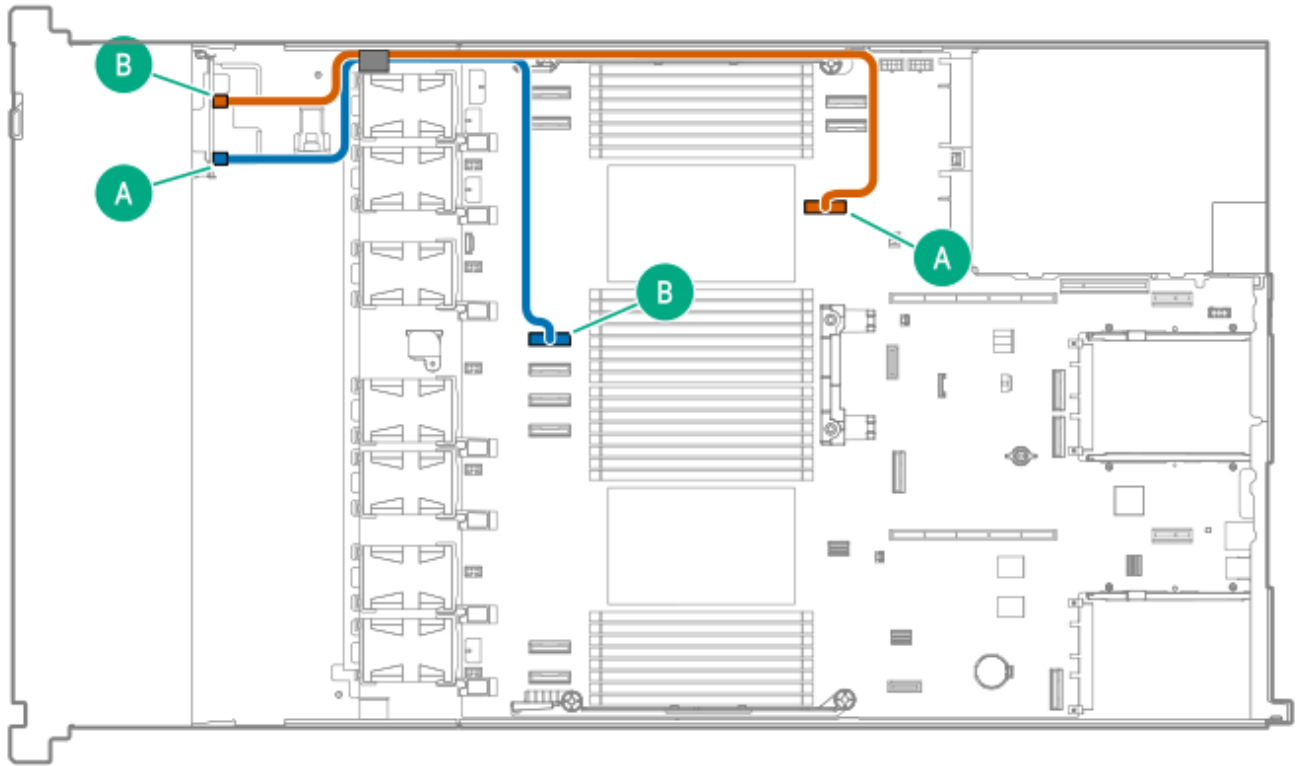

Cable part number	Color	From	To
P75568-001	Orange	Drive backplane port 1	MCIO port 11
P75278-001	Blue	Drive backplane port 2	MCIO port 6

4 EDSFF Box 1: type-p controller in the secondary riser

This configuration supports the closed-loop liquid cooling kit.

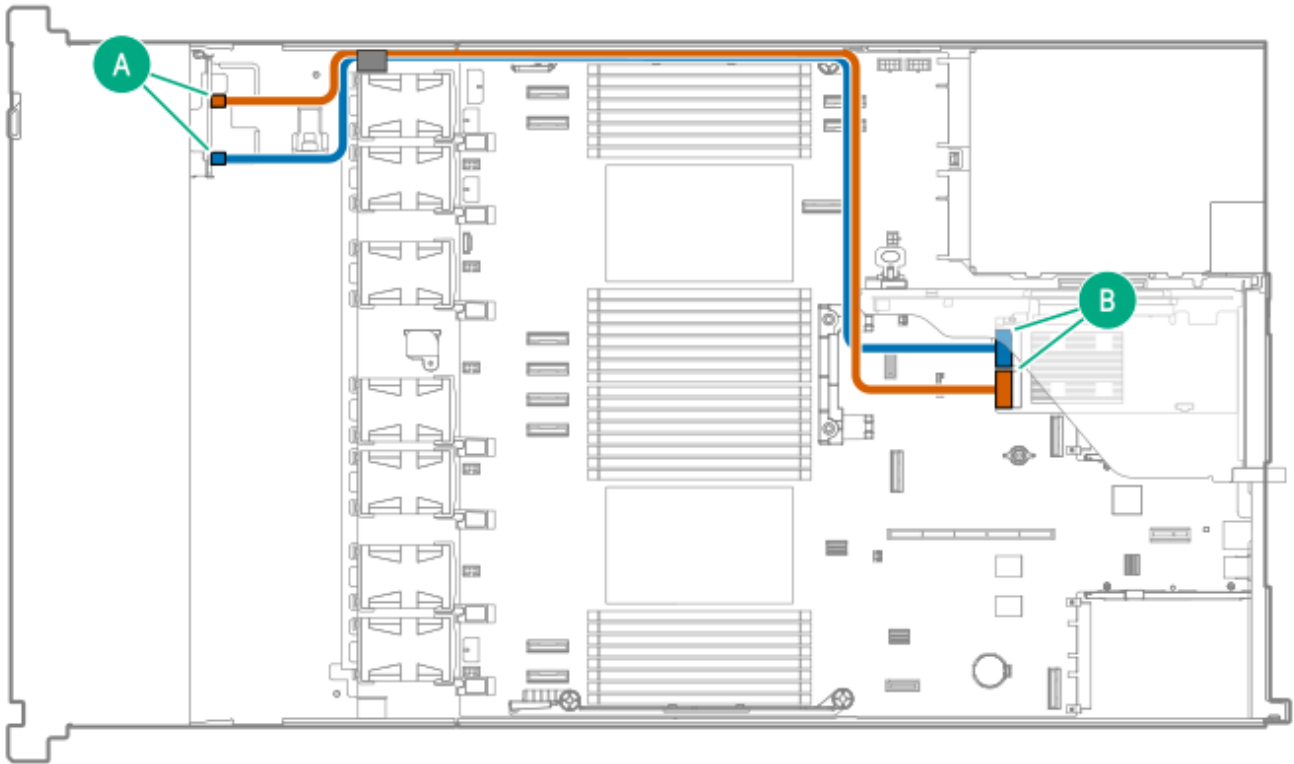

Cable part number	Color	From	To
P74805-001	Orange	Drive backplane port 1	Slot 3 type-p controller Port 1i
P74805-001	Blue	Drive backplane port 2	Slot 3 type-p controller Port 2i

Drive Box 2 cabling

4 EDSFF Box 2: direct attach (unbalanced, 1 CPU)

This cable routing is compatible with a single-processor configuration.

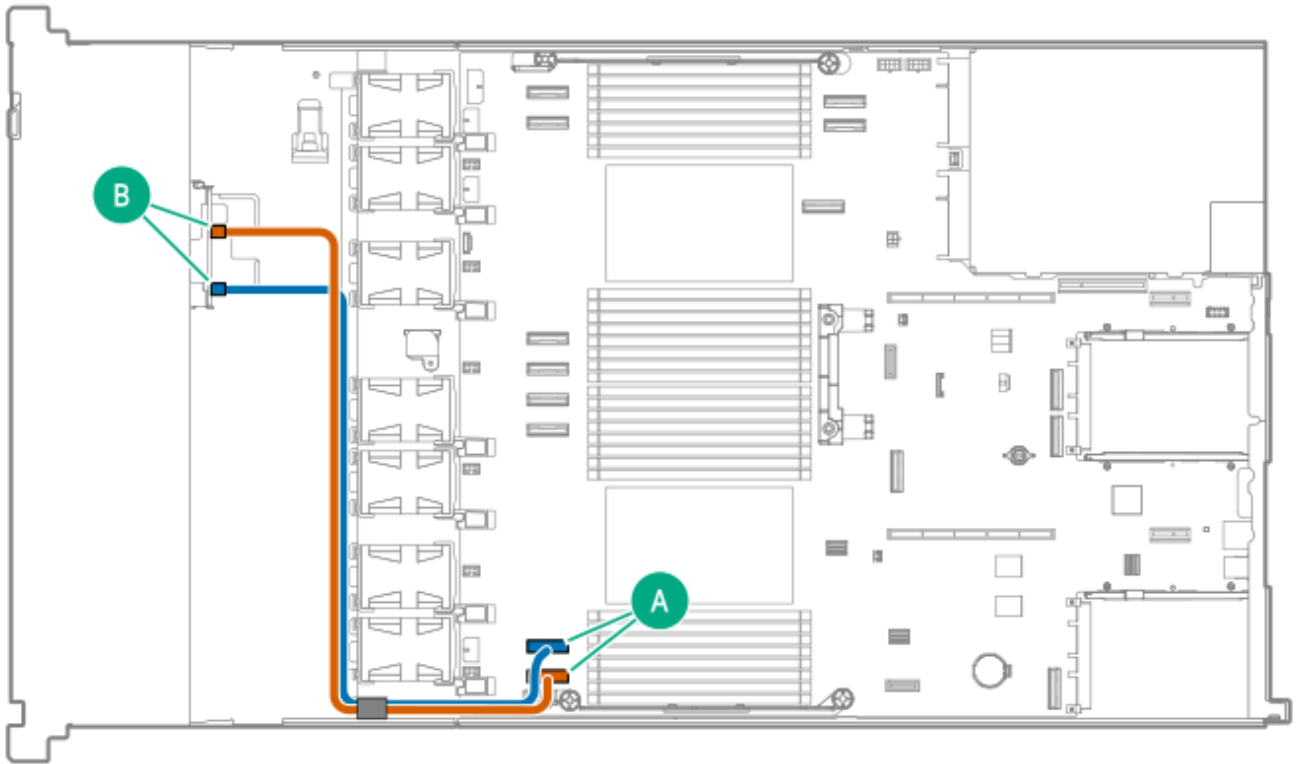

Cable part number	Color	From	To
P75567-001	Orange	Drive backplane port 1	MCI O port 1
P75567-001	Blue	Drive backplane port 2	MCI O port 2

4 EDSFF Box 2: direct attach (unbalanced)

This cable routing is compatible with a dual-processor configuration.

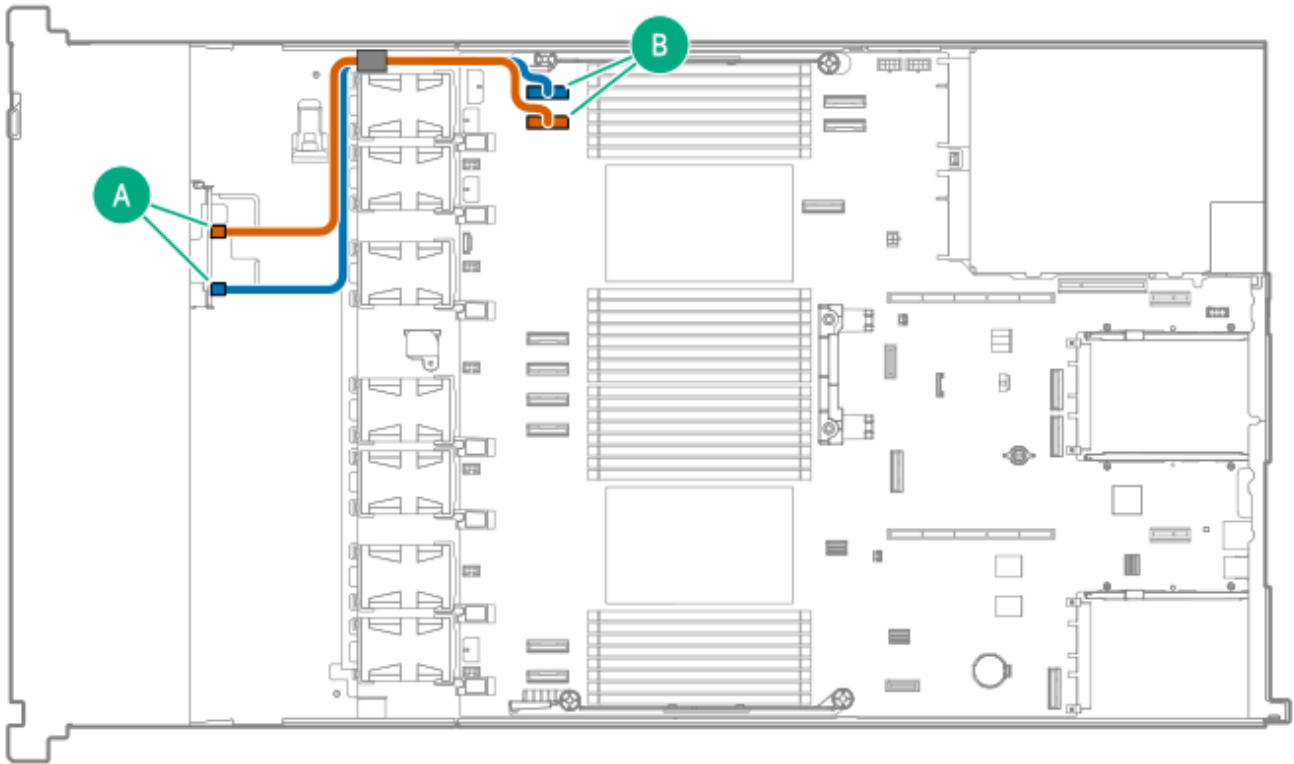

Cable part number	Color	From	To
P75317-001	Orange	Drive backplane port 1	MCI/O port 7
P75317-001	Blue	Drive backplane port 2	MCI/O port 8

Drive Box 3 cabling

4 EDSFF Box 3 x4 NVMe: direct attach

This cable routing is compatible with a dual-processor configuration.

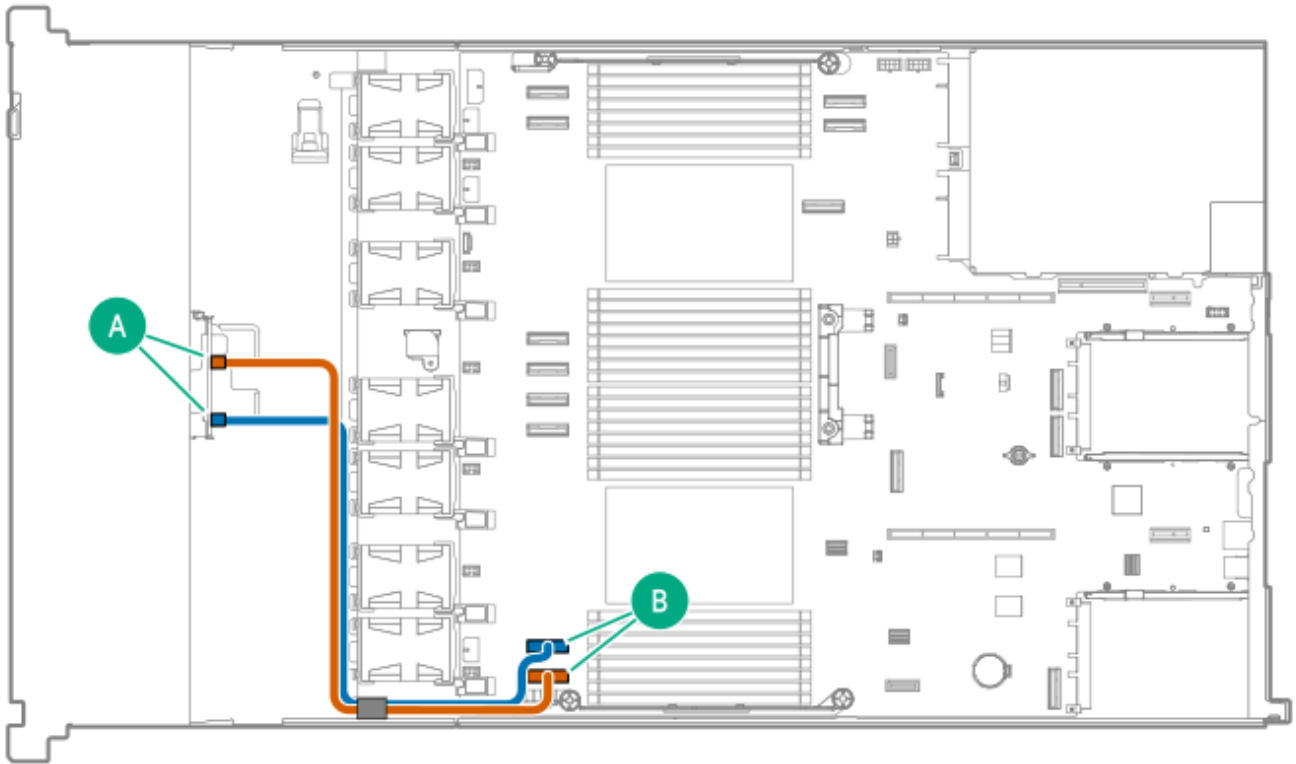

Cable part number	Color	From	To
P75278-001	Orange	Drive backplane port 1	MCIO port 1
P75278-001	Blue	Drive backplane port 2	MCIO port 2

Drive Box 4 cabling

4 EDSFF Box 4 x4 NVMe: direct attach

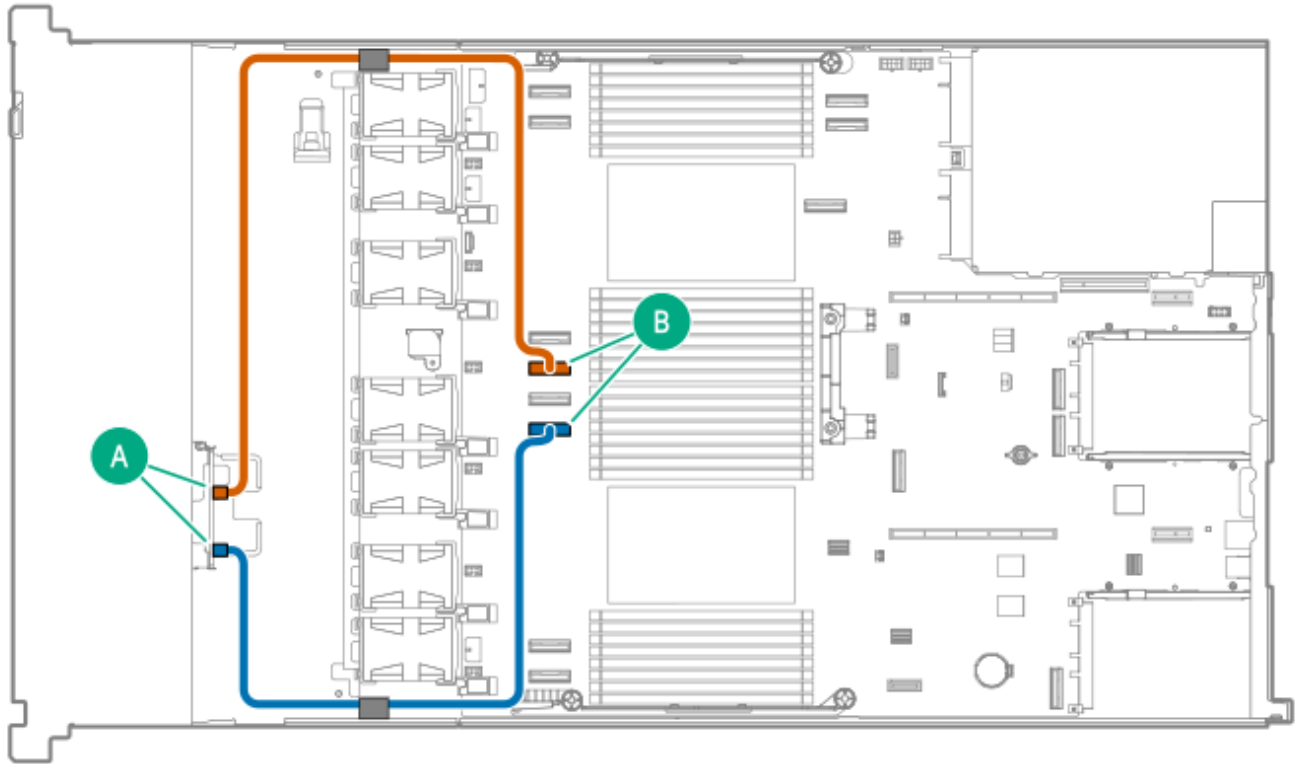

Cable part number	Color	From	To
P74806-001	Orange	Drive backplane port 1	MCI0 port 5
P75278-001	Blue	Drive backplane port 2	MCI0 port 3

4 EDSFF Box 4 x4 NVMe: type-p controller in Slot 1

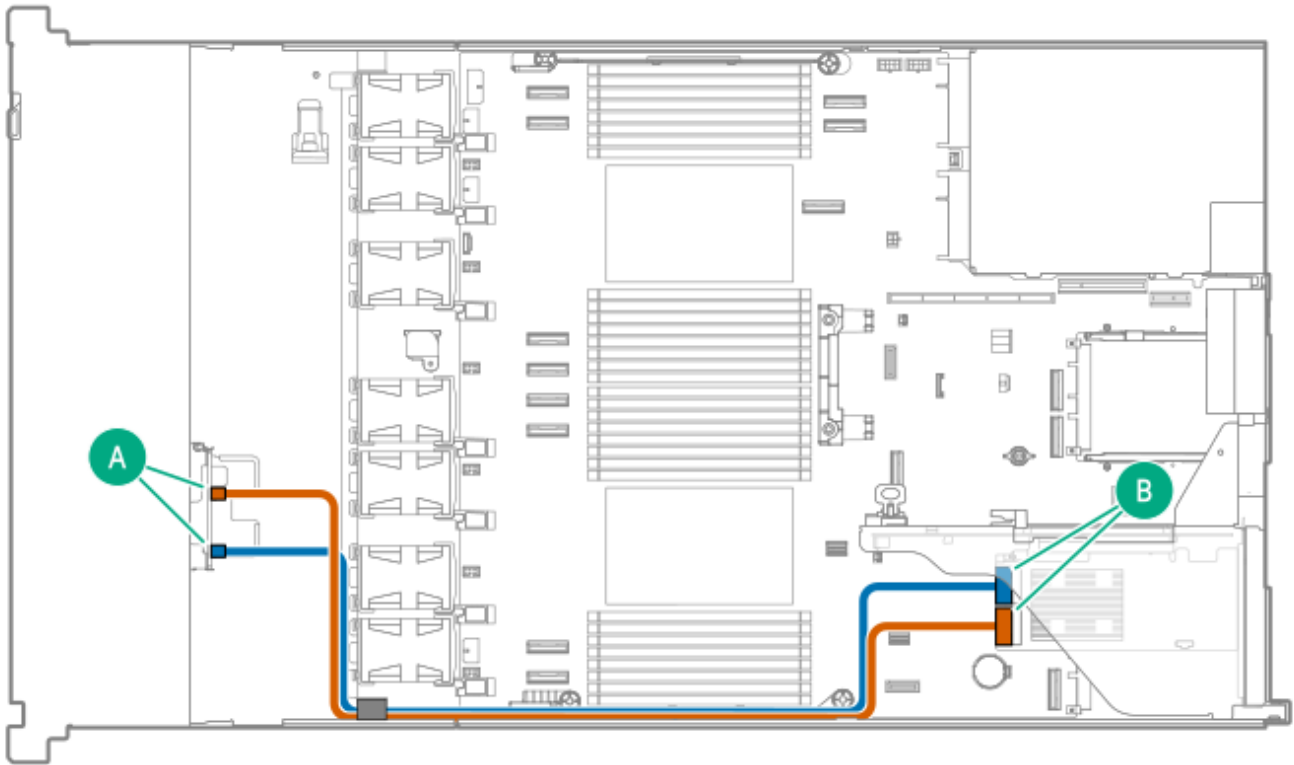

Cable part number	Color	From	To
P75590-001	Orange	Drive backplane port 1	Primary type-p controller Port 1i
	Blue	Drive backplane port 2	Primary type-p controller Port 2i

4 EDSFF Box 4 x4 NVMe: type-p controller in Slot 2

This configuration supports the closed-loop liquid cooling kit.

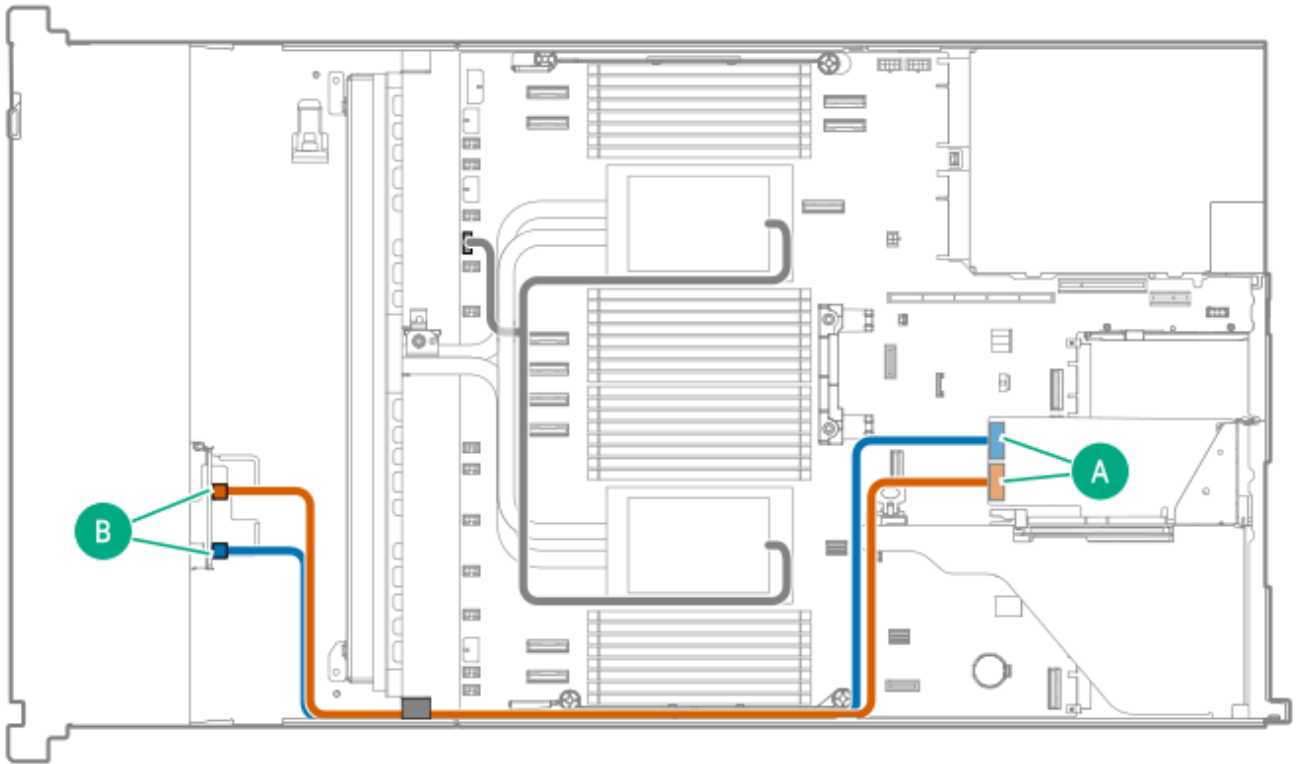

Cable part number	Color	From	To
P75590-001	Orange	Drive backplane port 1	Primary type-p controller Port 2i
	Blue	Drive backplane port 2	Primary type-p controller Port 1i

Drive Box 5 cabling

4 EDSFF Box 5 x4 NVMe: direct attach

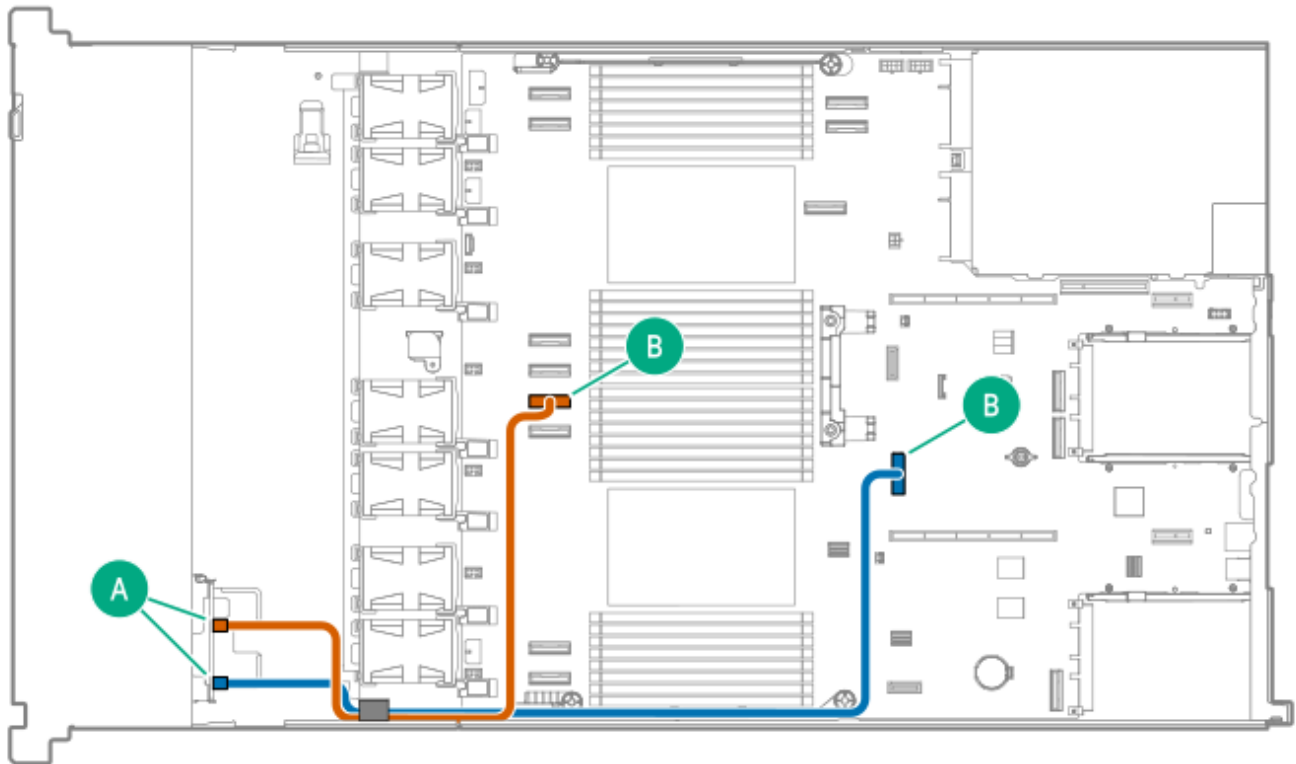

Cable part number	Color	From	To
P75278-001	Orange	Drive backplane port 1	MCI/O port 4
P75567-001	Blue	Drive backplane port 2	MCI/O port 12

4 EDSFF Box 5 x4 NVMe: type-p controller in Slot 1

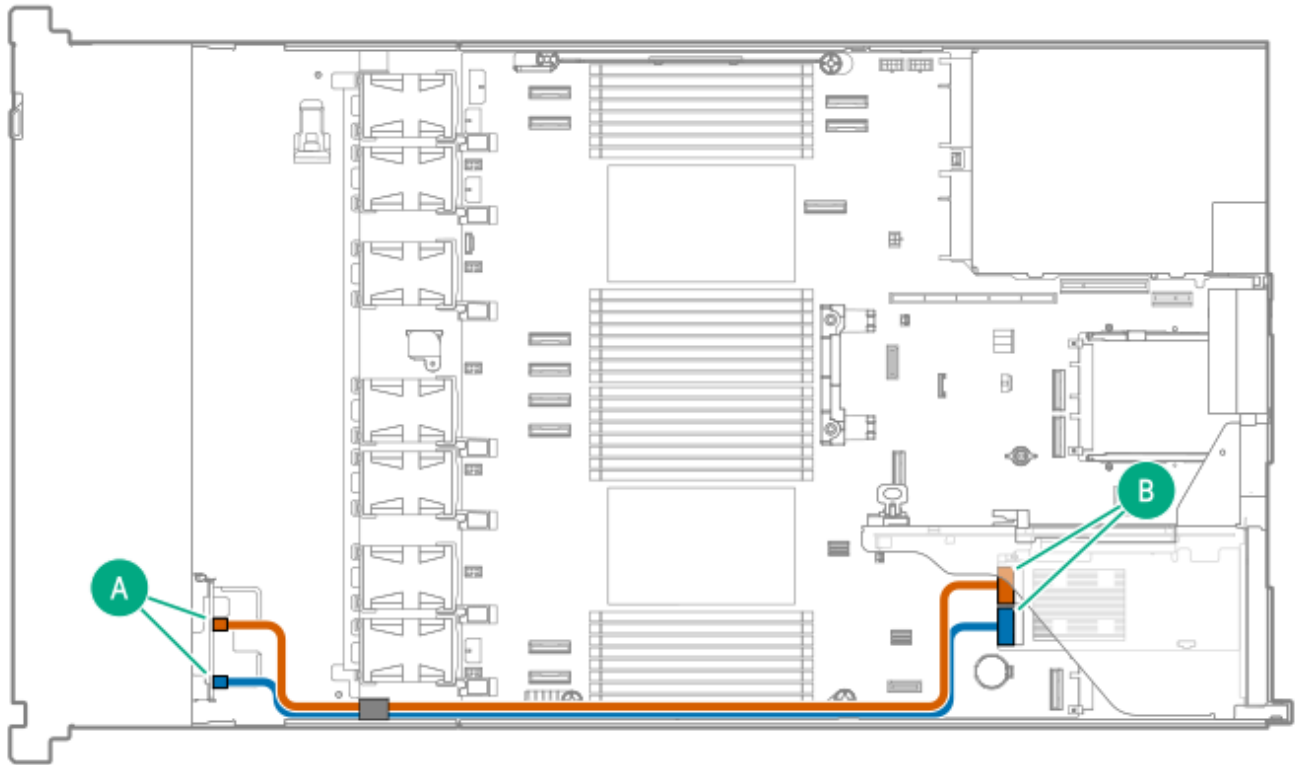

Cable part number	Color	From	To
P76443-001	Orange	Drive backplane port 1	Slot 1 type-p controller Port 2i
P75574-001	Blue	Drive backplane port 2	Slot 1 type-p controller Port 1i

4 EDSFF Box 5 x4 NVMe: type-p controller in Slot 2

This configuration supports the closed-loop liquid cooling kit.

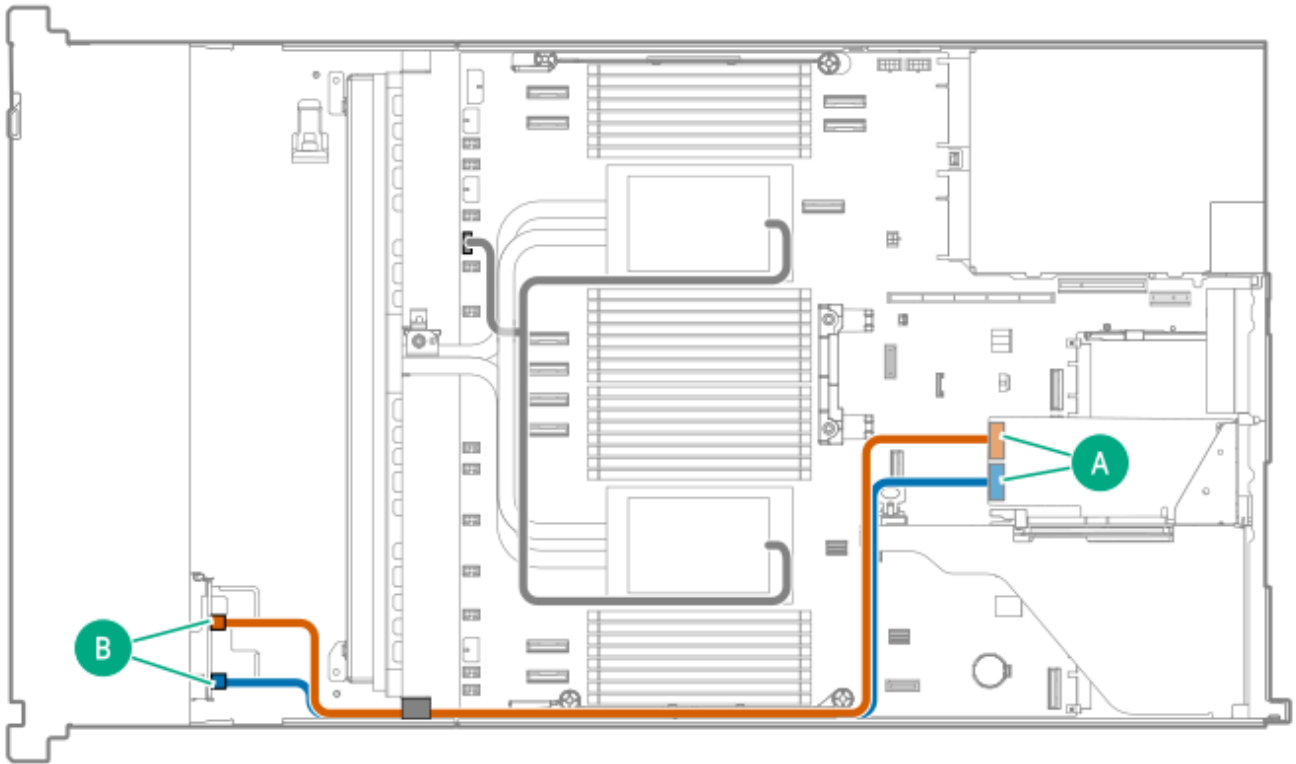

Cable part number	Color	From	To
P76443-001	Orange	Drive backplane port 1	Slot 2 type-p controller Port 1i
P75574-001	Blue	Drive backplane port 2	Slot 1 type-p controller Port 2i

4 EDSFF Box 5 x4 NVMe: type-o controller

This cable routing is compatible with a dual-processor configuration.

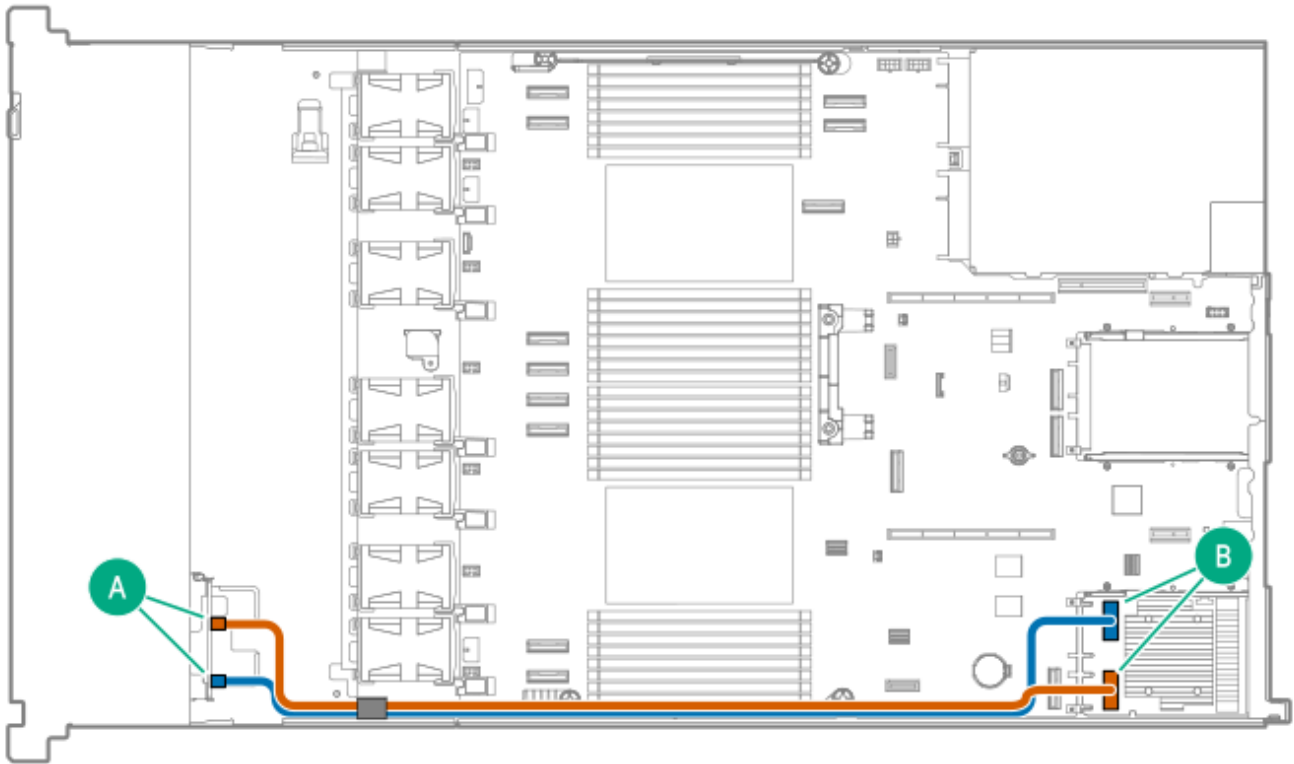

Cable part number	Color	From	To
P75589-001	Orange	Drive backplane port 1	Type-o controller Port 1i in Slot 14 OCP A
P75589-001	Blue	Drive backplane port 2	Type-o controller Port 2i in Slot 14 OCP A

Drive box cabling for Boxes 1-2

8 EDSFF Boxes 1-2: direct attach

This configuration supports the closed-loop liquid cooling kit.

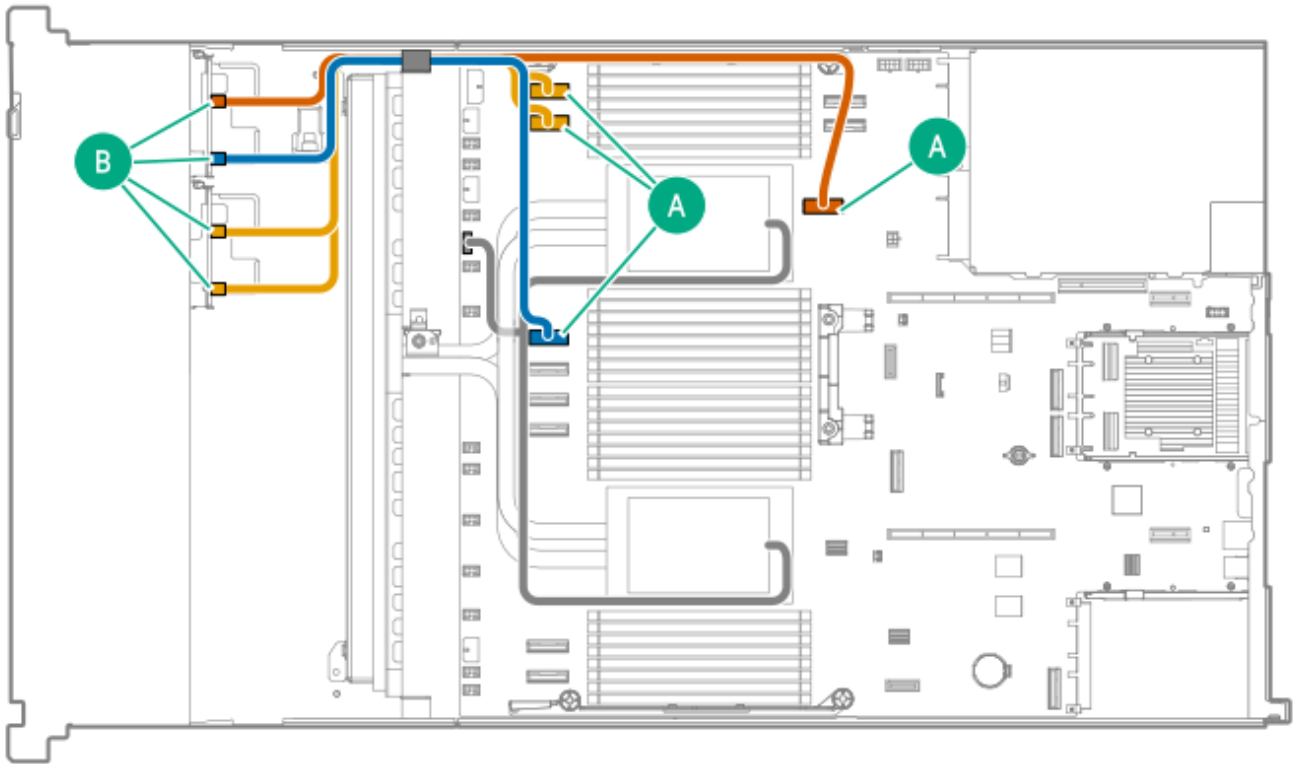

Cable part number	Color	From	To
P75568-001	Orange	Box 1: Drive backplane e port 1	MCIO port 11
P75278-001	Blue	Box 1: Drive backplane e port 2	MCIO port 6
P75317-001	Gold	Box 2: Drive backplane e port 1	MCIO port 7
		Box 2: Drive backplane e port 2	MCIO port 8

8 EDSFF Boxes 1–2 x4 NVMe to type-p controller in Slot 1 (1 CPU)

This cable routing is compatible with a single-processor configuration.

MR932i-p:

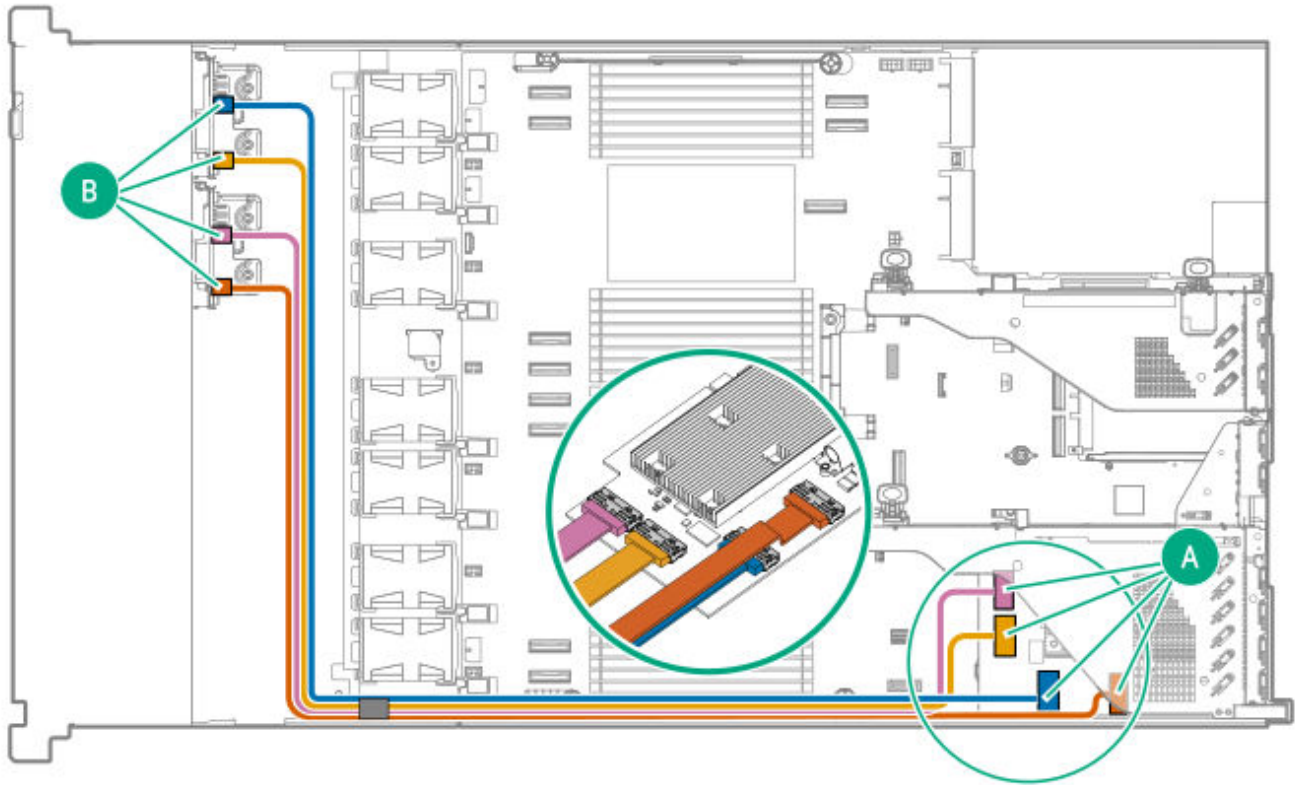

Cable part number	Color	From	To
P75318-001	Blue	Box 1: Drive backplane port 1	Slot 1 type-p controller Port 4i
	Gold	Box 1: Drive backplane port 2	Slot 1 type-p controller Port 1i
	Pink	Box 2: Drive backplane port 1	Slot 1 type-p controller Port 2i
	Orange	Box 2: Drive backplane port 2	Slot 1 type-p controller Port 3i

8 EDSFF x4 Boxes 1-2 NVMe to type-p controller in Slot 3

MR932i-p:

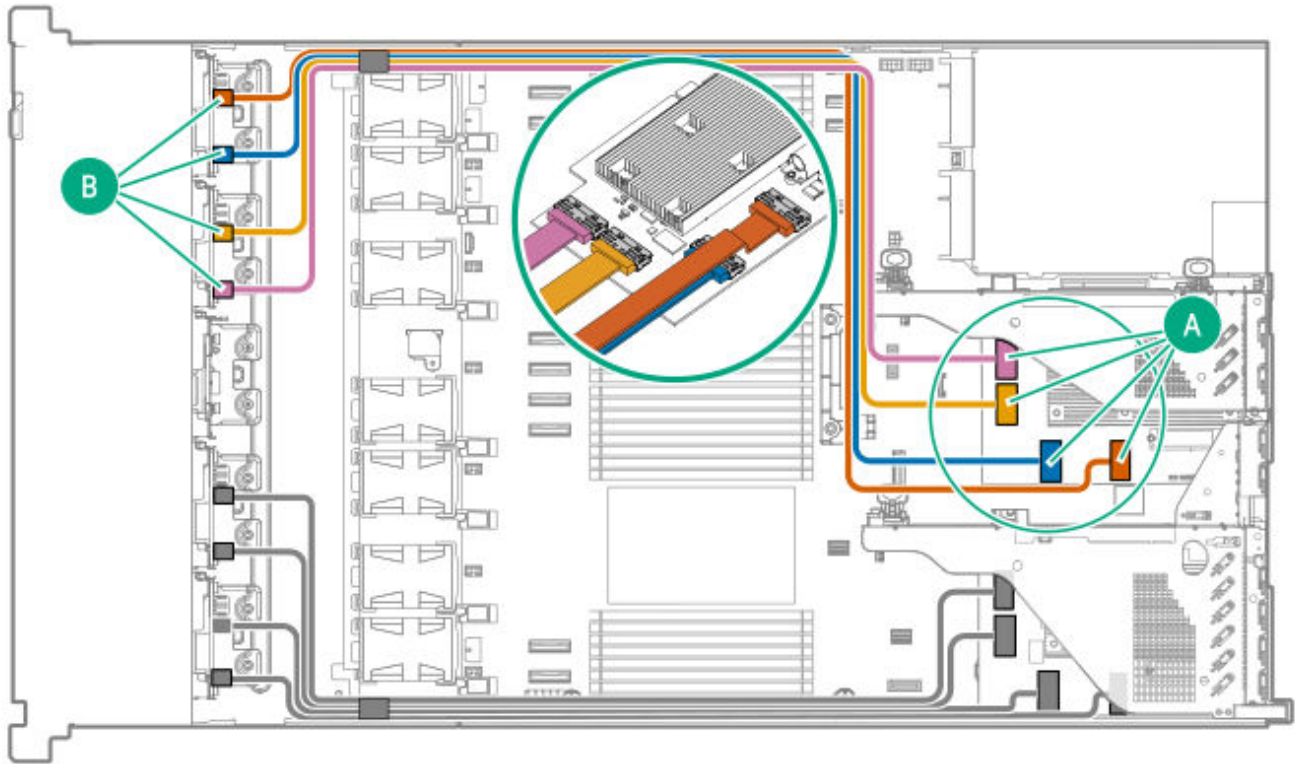

Cable part number	Color	From	To
P75318-001	Orange	Box 1: Drive backplane port 1	Slot 3 type-p controller Port 3i
	Blue	Box 1: Drive backplane port 2	Slot 3 type-p controller Port 4i
	Gold	Box 2: Drive backplane port 1	Slot 3 type-p controller Port 1i
	Pink	Box 2: Drive backplane port 2	Slot 3 type-p controller Port 2i

Drive box cabling for boxes 1 and 4

8 EDSFF Boxes 1 and 4 x4 NVMe to type-p controller in Slot 1 (1 CPU)

This cable routing is compatible with a single-processor configuration.

MR932i-p:

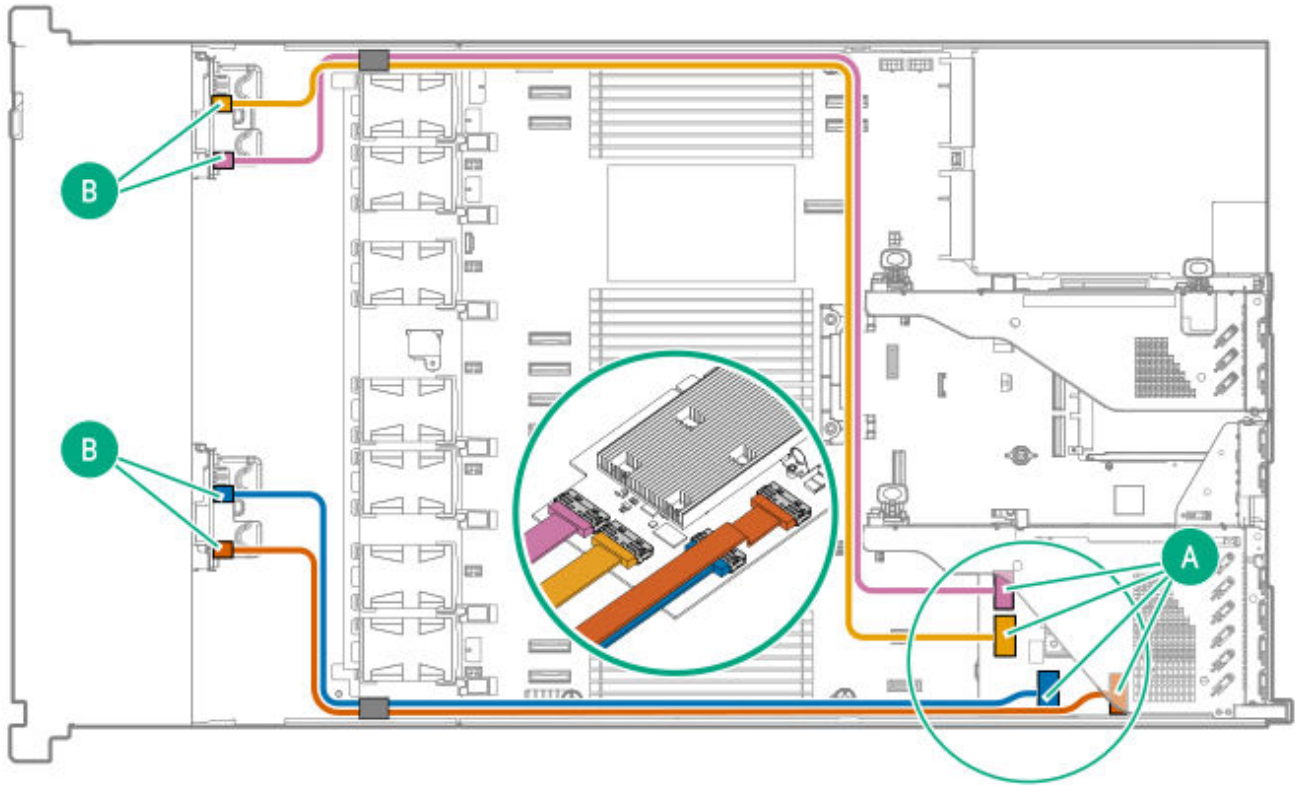

Cable part number	Color	From	To
P75318-001	Gold	Box 1: Drive backplane port 1	Slot 1 type-p controller Port 1i
	Pink	Box 1: Drive backplane port 2	Slot 1 type-p controller Port 2i
P75570-001	Blue	Box 4: Drive backplane port 1	Slot 1 type-p controller Port 4i
	Orange	Box 4: Drive backplane port 2	Slot 1 type-p controller Port 3i

Drive box cabling for boxes 1 and 5

8 EDSFF Boxes 1 and 5 x4 NVMe to type-p controller in Slot 1 (1 CPU)

This cable routing is compatible with a single-processor configuration.

MR932i-p:

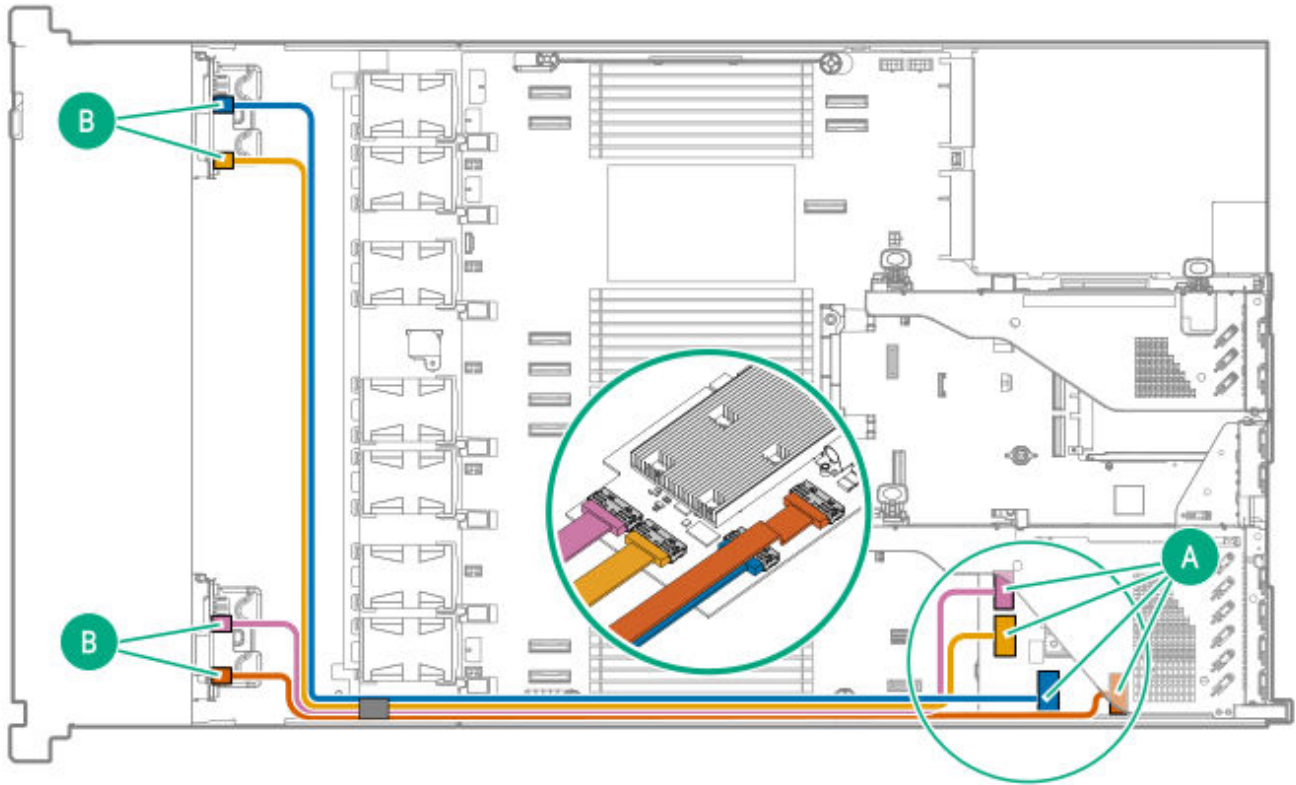

Cable part number	Color	From	To
P75318-001	Blue	Box 1: Drive backplane port 1	Slot 1 type-p controller Port 4i
	Gold	Box 1: Drive backplane port 2	Slot 1 type-p controller Port 1i
P75570-001	Pink	Box 5: Drive backplane port 1	Slot 1 type-p controller Port 2i
P75569-001	Orange	Box 5: Drive backplane port 2	Slot 1 type-p controller Port 3i

Drive box cabling for boxes 4-5

8 EDSFF Boxes 4-5 x4 NVMe to type-p controller in Slot 1

MR932i-p:

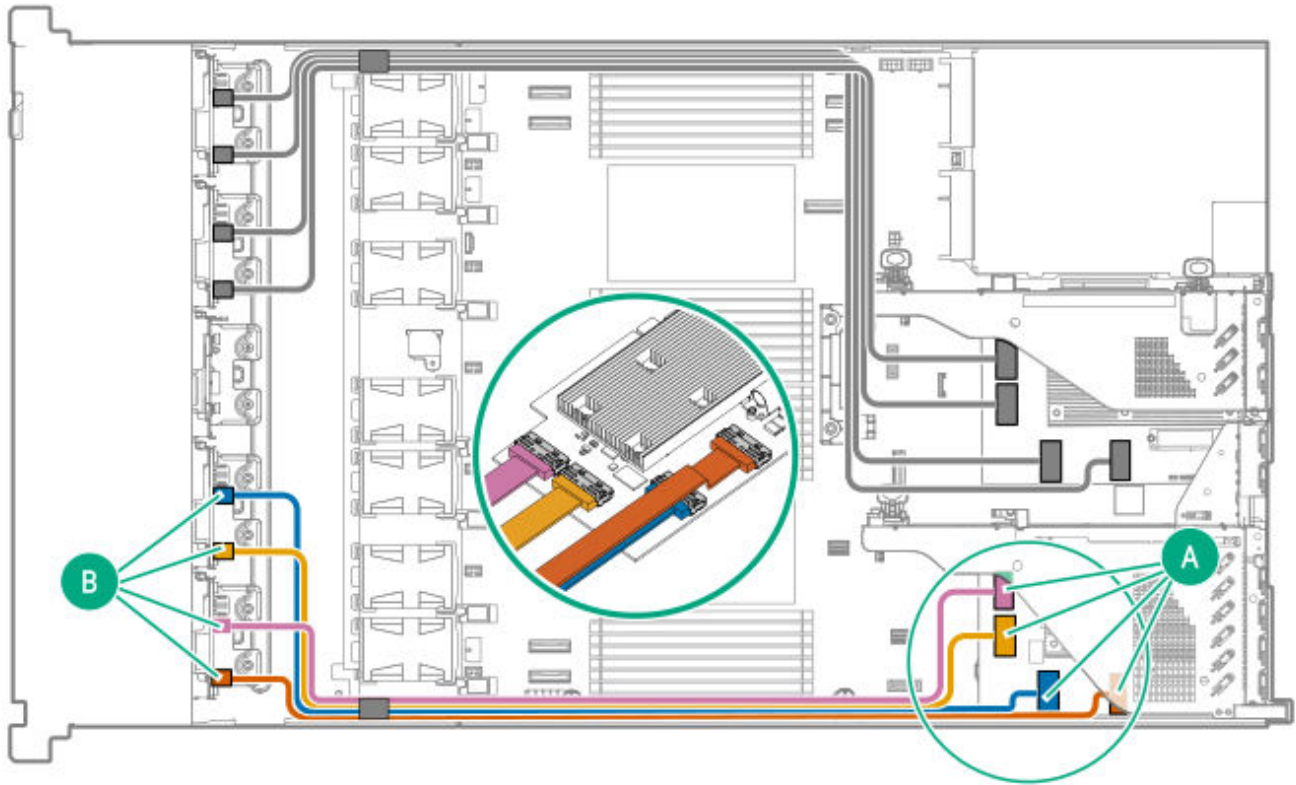

Cable part number	Color	From	To
P75570-001	Blue	Box 4: Drive backplane port 1	Slot 1 type-p controller Port 4i
	Gold	Box 4: Drive backplane port 2	Slot 1 type-p controller Port 1i
	Pink	Box 5: Drive backplane port 1	Slot 1 type-p controller Port 2i
P75569-001	Orange	Box 5: Drive backplane port 2	Slot 1 type-p controller Port 3i

2 SFF stacked drive backplane cabling

The 2 SFF stacked drive backplane is supported in the 10 SFF / 20 E3.S server or servers using the mixed drive type configuration.

Subtopics

Drive Box 1 cabling

Drive Box 2 cabling

Drive Box 3 cabling

Drive Box 4 cabling

Drive Box 5 cabling

Drive box cabling for boxes 1-2

Drive box cabling for boxes 4-5

Drive box cabling for boxes 1-5

Drive Box 1 cabling

2 SFF Box 1 x4 NVMe: direct attach (1 CPU)

This cable routing is compatible with a single-processor configuration.

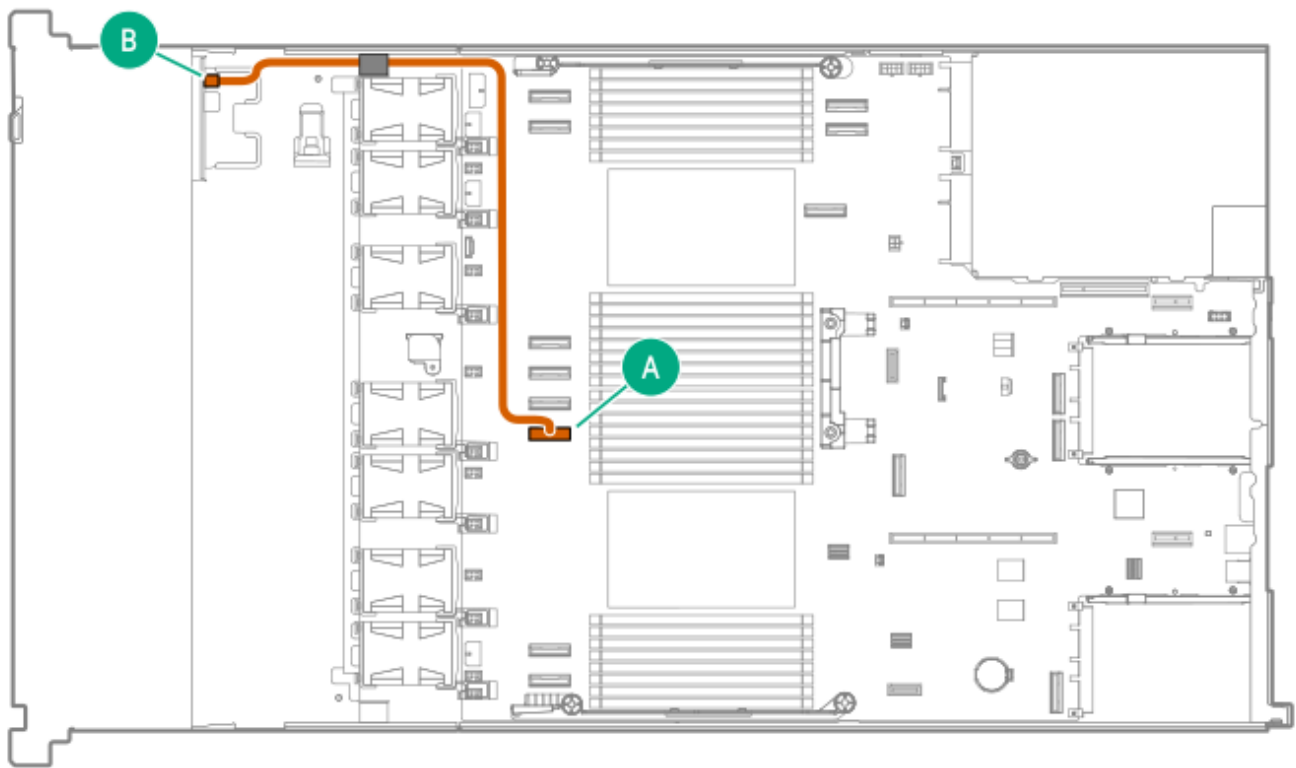

Cable part number	Color	From	To
P75568-001	Orange	Drive backplane	MCI0 port 3

2 SFF Box 1 x4 NVMe: Direct attach

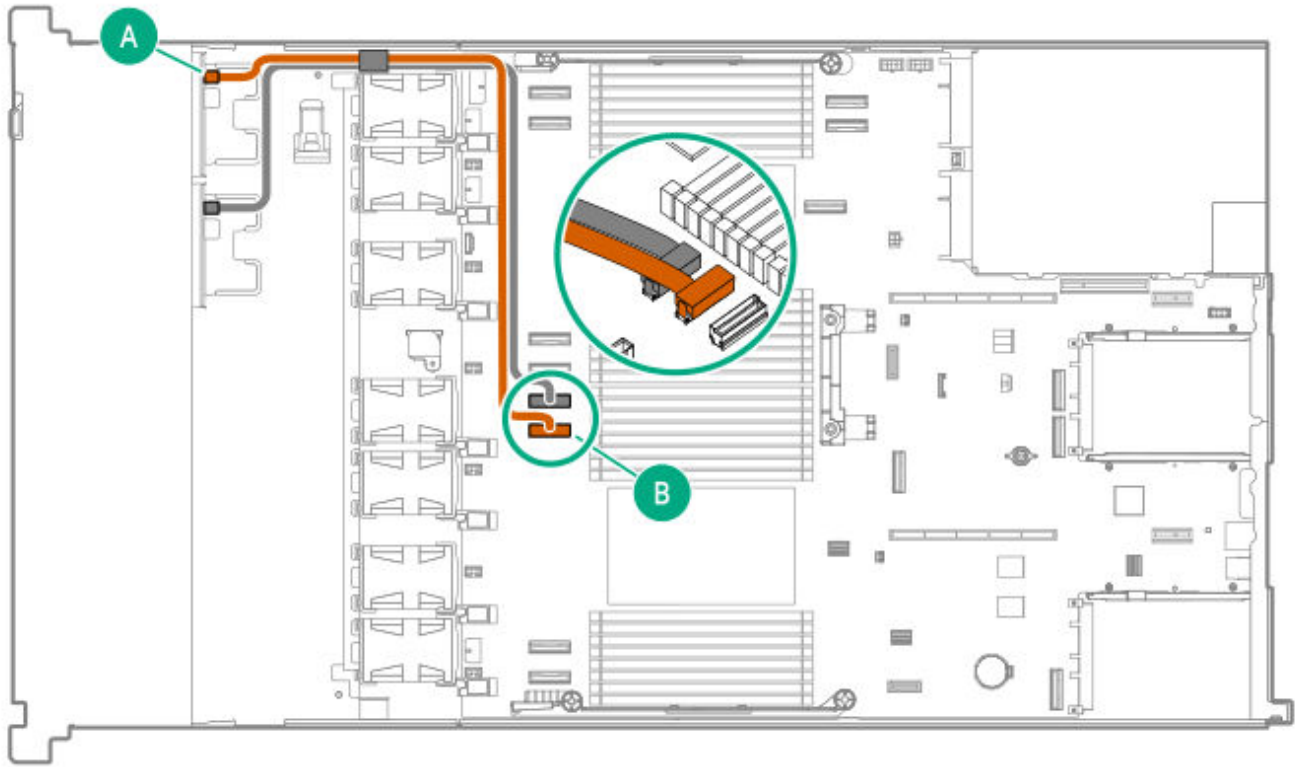

Cable part number	Color	From	To
P75317-001	Orange	Box 1 and 2: Drive backplane	MCI0 port 5

2 SFF Box 1 x4 NVMe: type-p controller

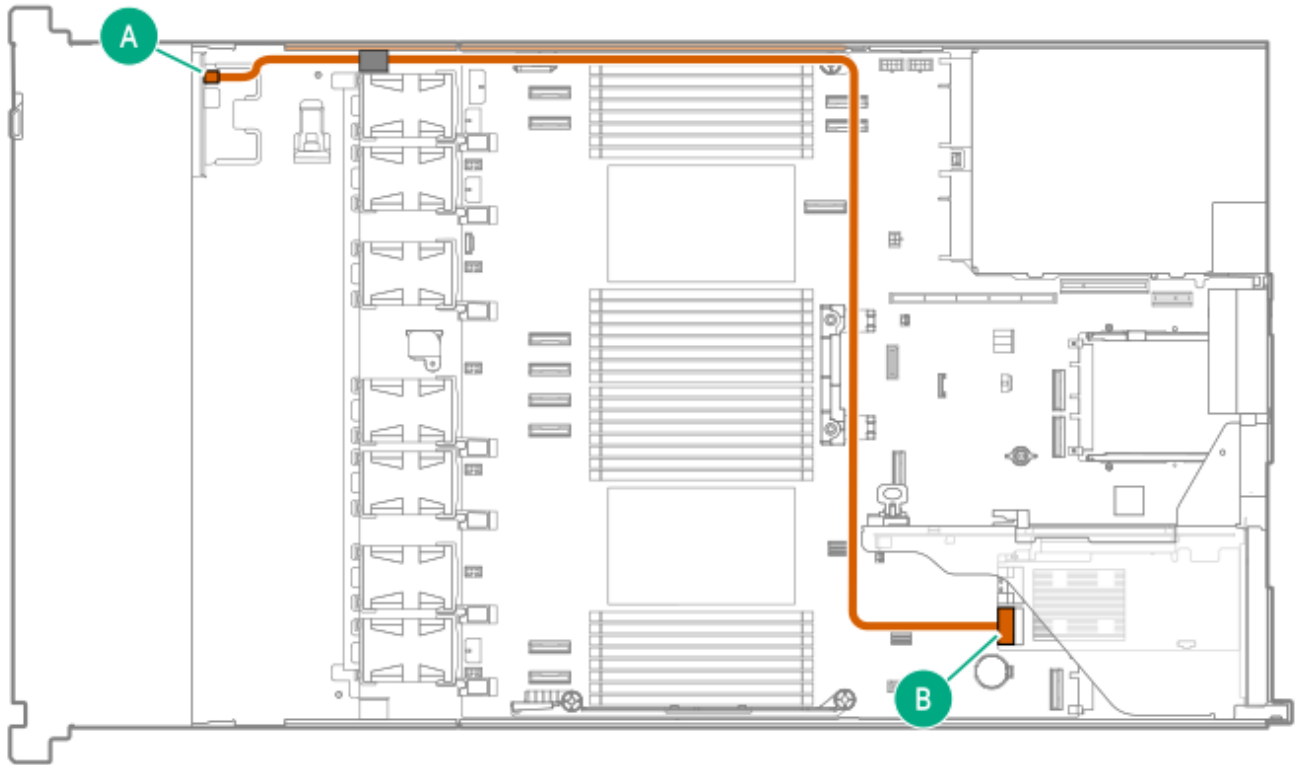

Cable part number	Color	From	To
P75590-001	Orange	Drive backplane	Primary type-p controller Port 1i

2 SFF Box 1 x4 NVMe: type-p controller in Slot 3

This configuration supports the closed-loop liquid cooling kit.

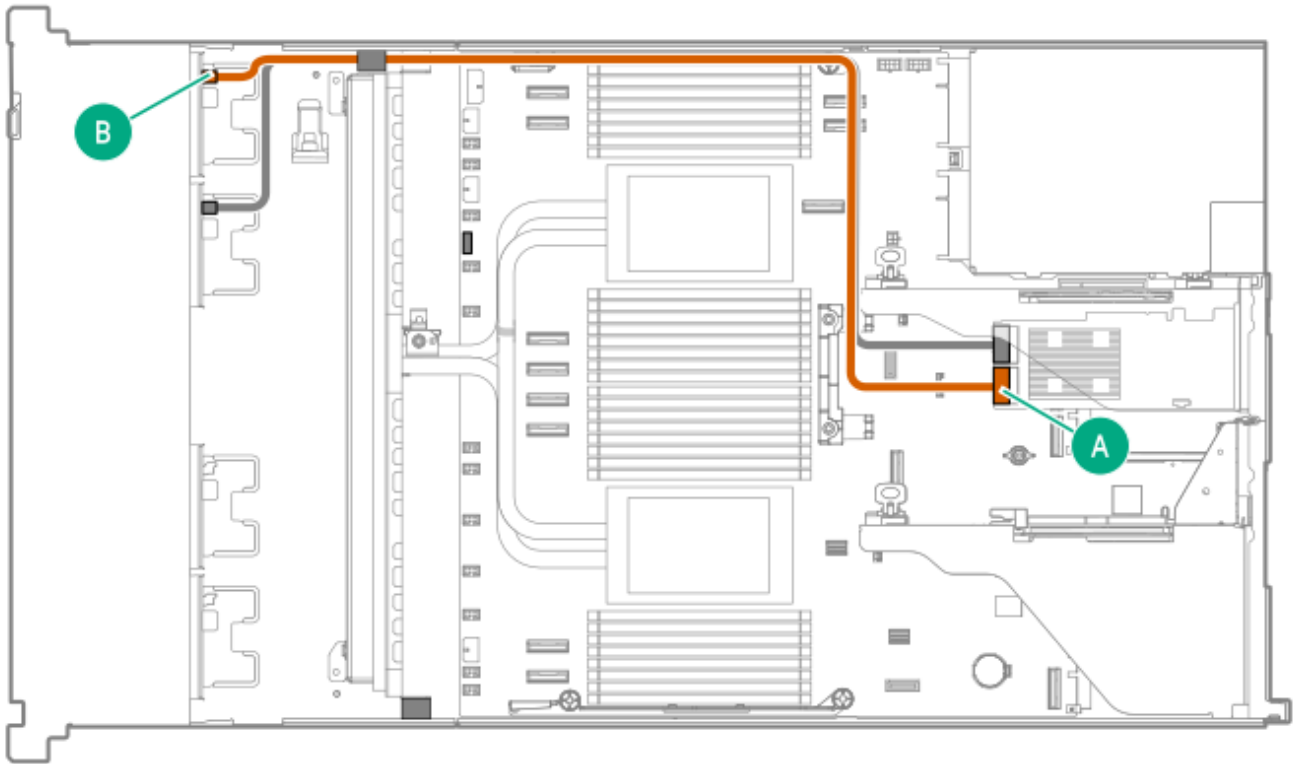

Cable part number	Color	From	To
P75590-001	Orange	Drive backplane	Slot 3 type-p controller Port 1i

Drive Box 2 cabling

2 SFF Box 2 x4 NVMe: direct attach (1 CPU)

This cable routing is compatible with a single-processor configuration.

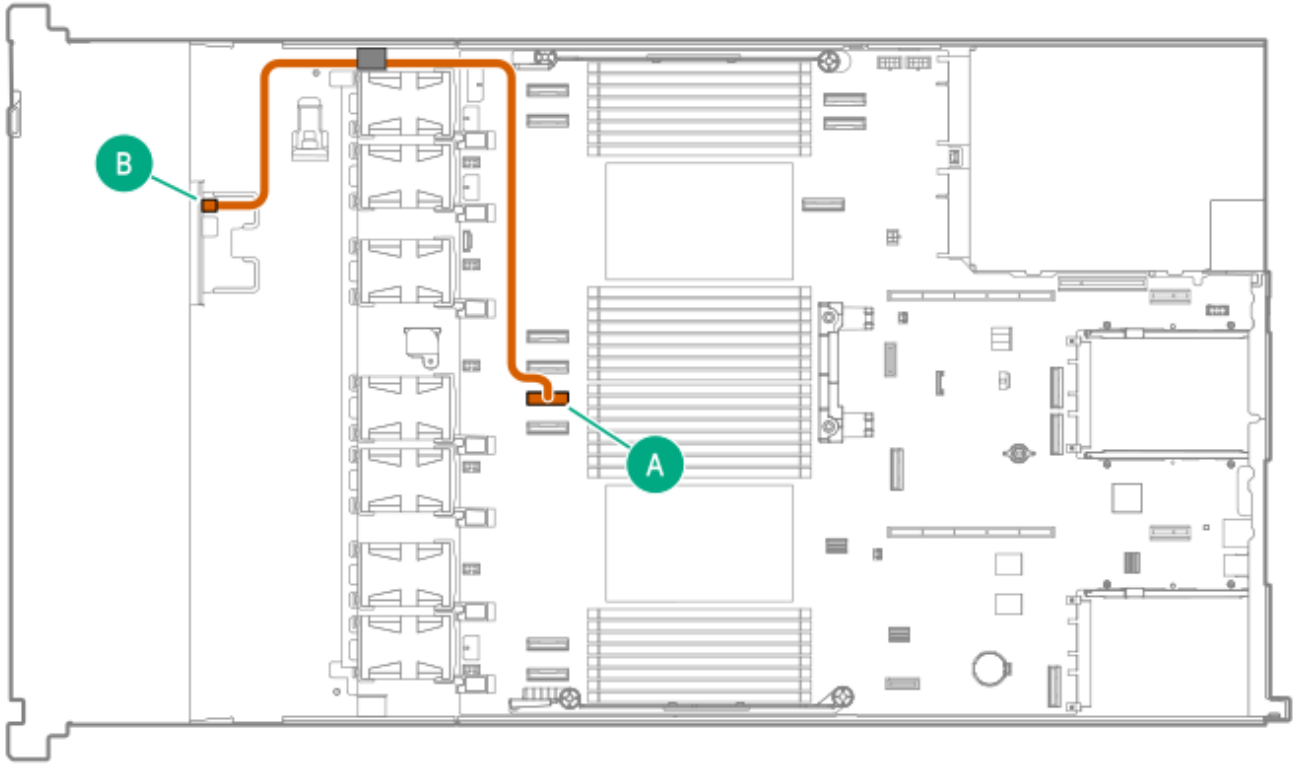

Cable part number	Color	From	To
P75568-001	Orange	Drive backplane	MCIO port 4

2 SFF Box 2 x4 NVMe: direct attach

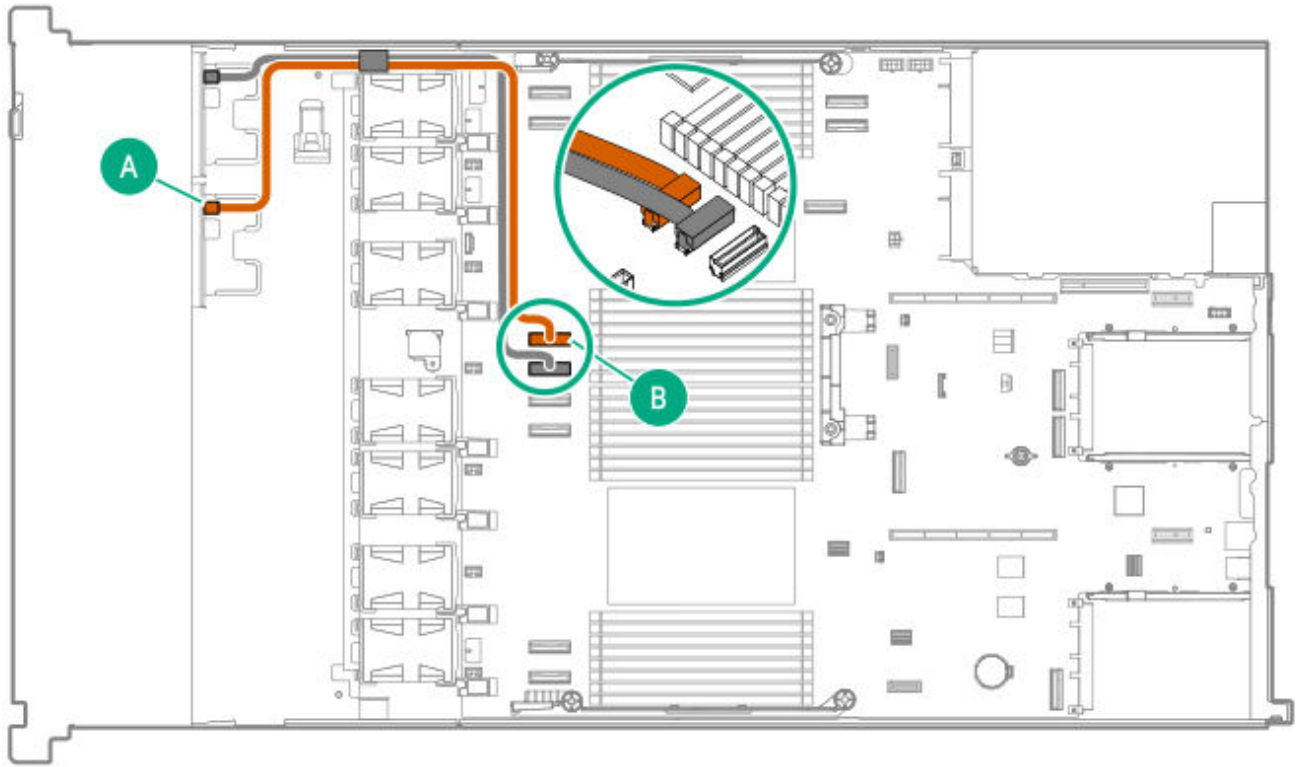

Cable part number	Color	From	To
P75278-001	Orange	Drive backplane	MCIO port 6

2 SFF Box 2 x4 NVMe: type-p controller in Slot 1

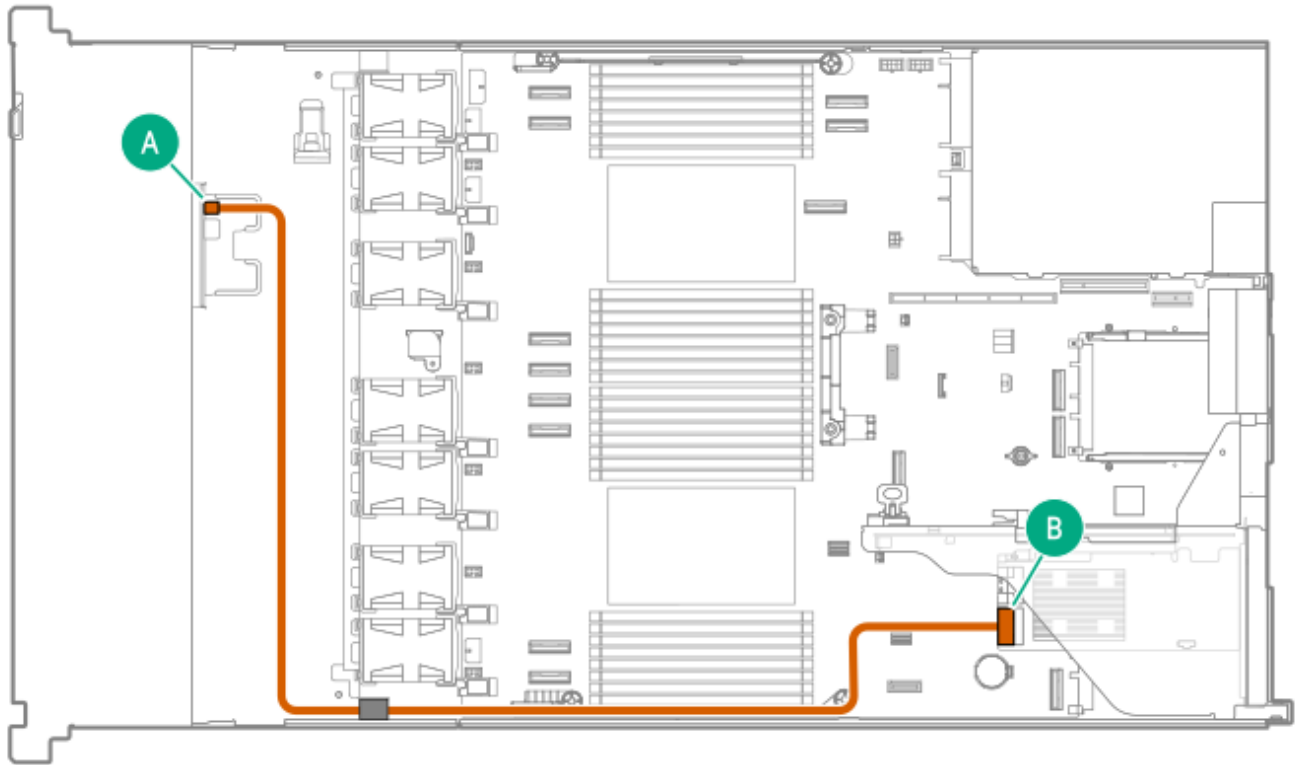

Cable part number	Color	From	To
P75590-001	Orange	Drive backplane	Primary type-p controller Port 1i

2 SFF Box 2 x4 NVMe: type-p controller in Slot 3

This configuration supports the closed-loop liquid cooling kit.

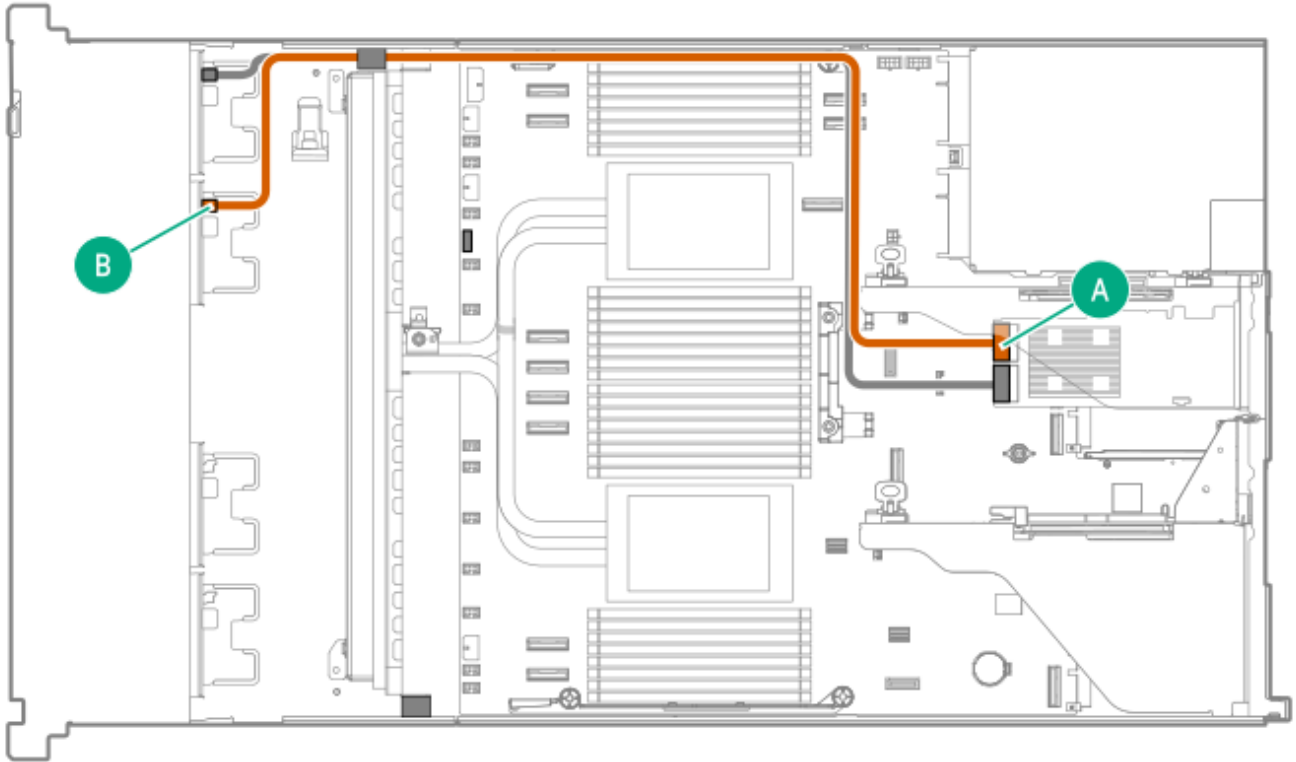

Cable part number	Color	From	To
P75590-001	Orange	Drive backplane	Slot 3 type-p controller Port 2i

Drive Box 3 cabling

2 SFF Box 3 x4 NVMe: direct attach cable and CPU1-to-OCP-B cable (1 CPU)

This cable routing is compatible with a single-processor configuration.

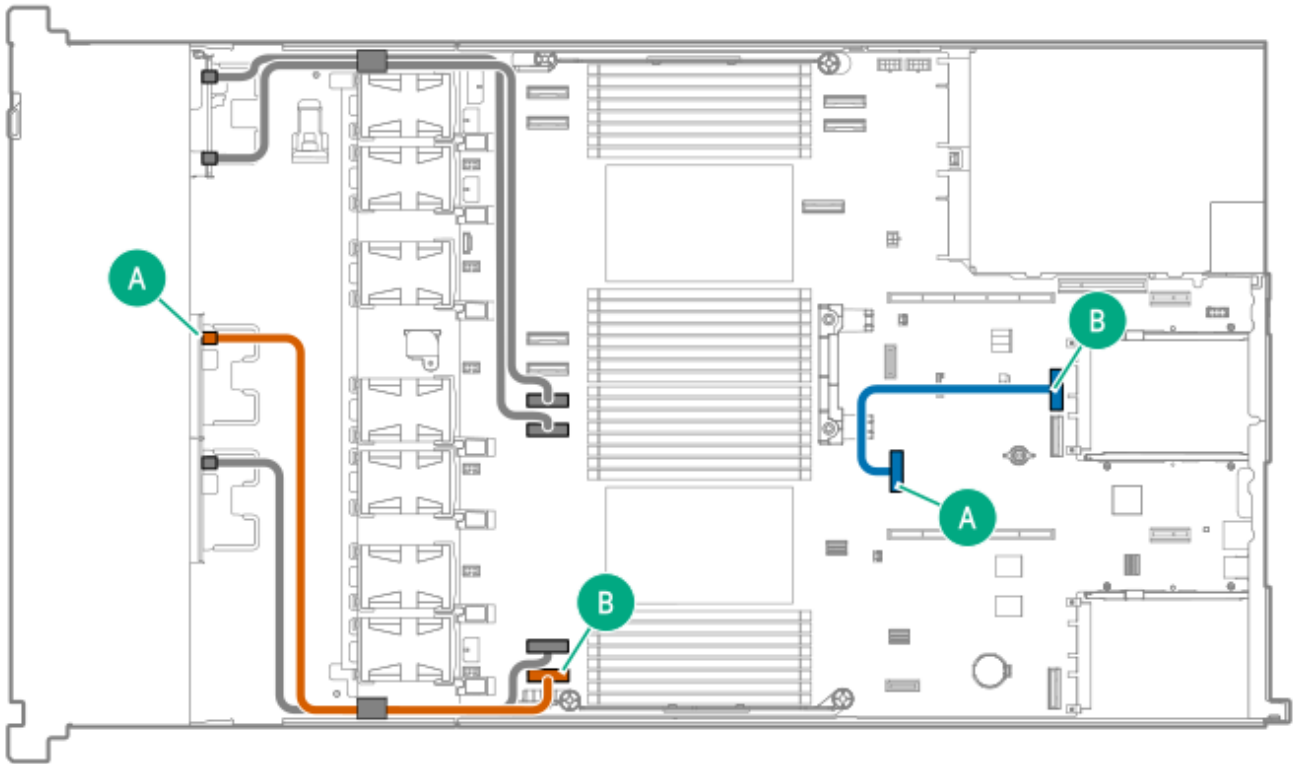

Cable part number	Color	From	To
P75567-001	Orange	Drive backplane	MCI0 port 1
P74889-001	Blue	OCP B internal port 1	MCI0 port 12

2 SFF Box 3 x4 NVMe: type-o controller in Slot 14 OCP A (1 CPU)

This cable routing is compatible with a single-processor configuration.

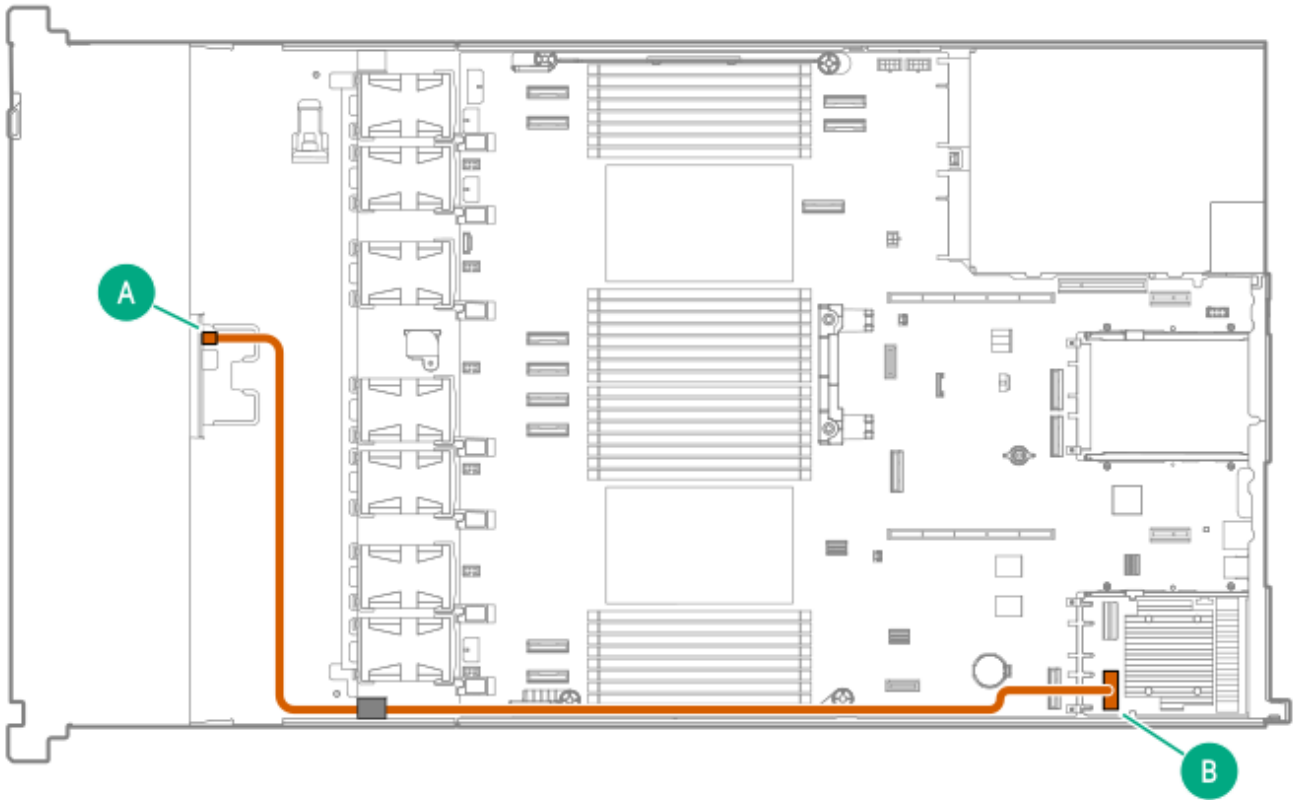

Cable part number	Color	From	To
P75589-001	Orange	Drive backplane	Slot 14 OCP A type-o controller Port 1i

2 SFF Box 3 x4 NVMe: direct attach

This cable routing supports both single-processor and dual-processor configurations.

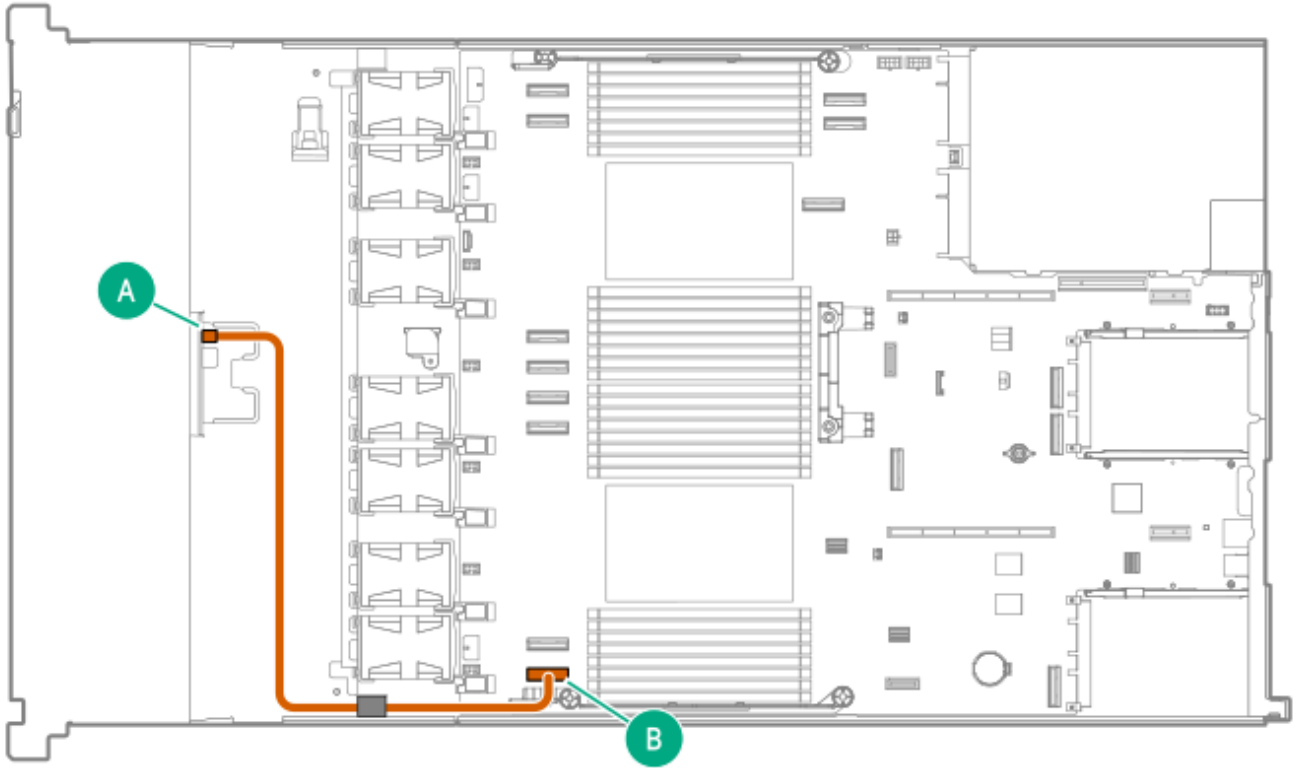

Cable part number	Color	From	To
P75278-001	Orange	Drive backplane	MCIO port 1

2 SFF Box 3 x4 NVMe: type-o controller in Slot 15 OCP B

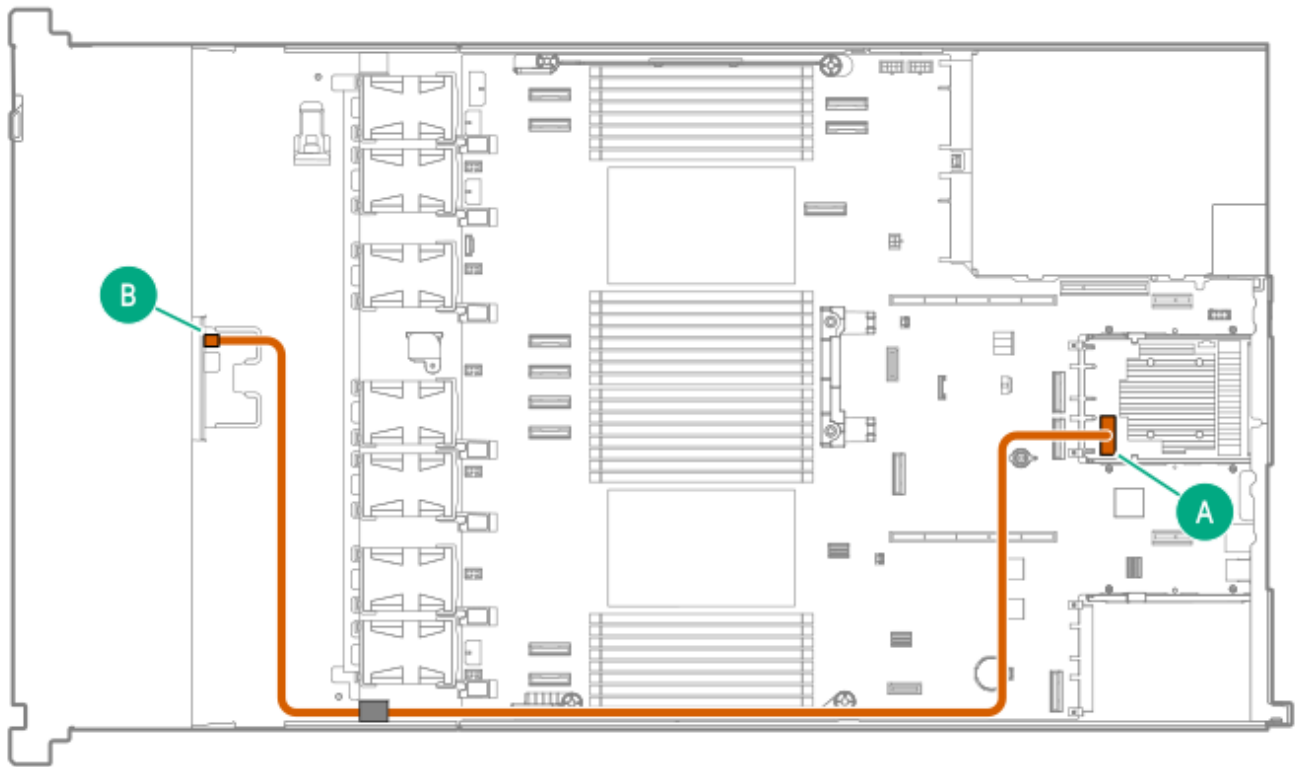

Cable part number	Color	From	To
P75587-001	Orange	Drive backplane	Slot 15 OCP B type-o controller Port 1i

2 SFF Box 3 x4 NVMe: type-p controller in Slot 1

MR416i-p / MR216i-p / MR408i-p in Slot 1

- Air-cooled system

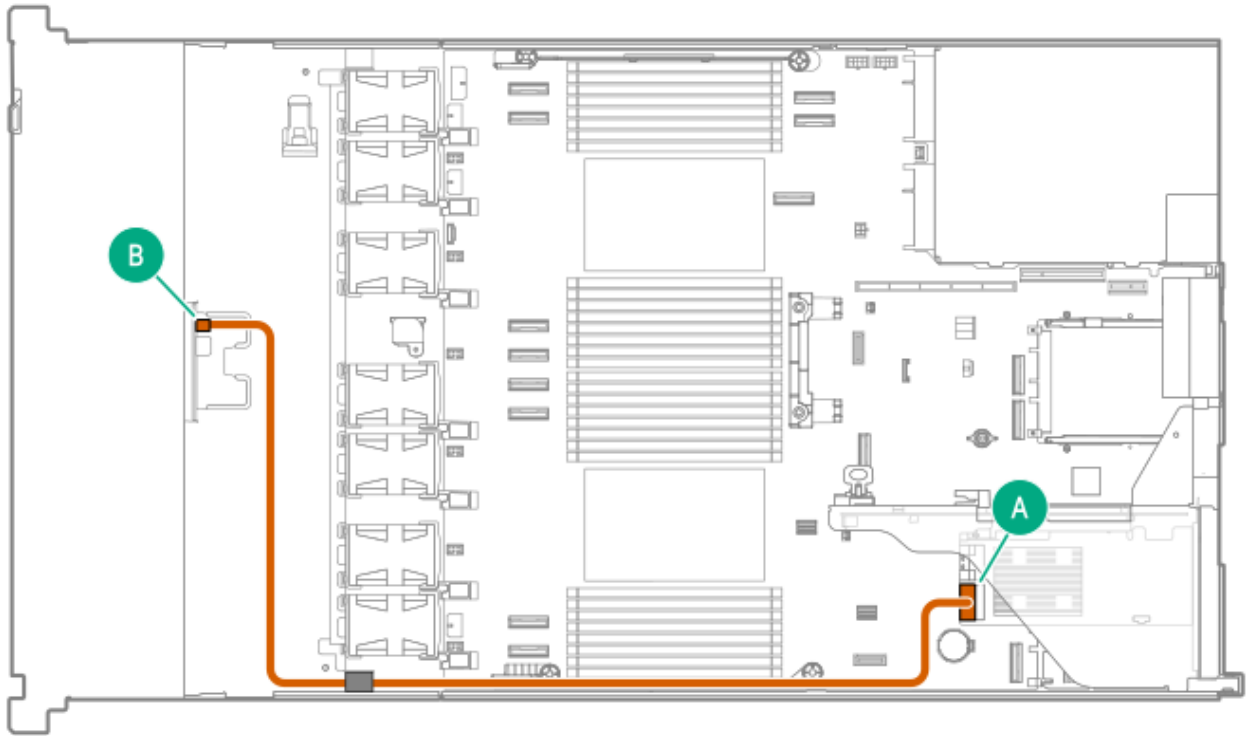

- Liquid-cooled system (CLLC)

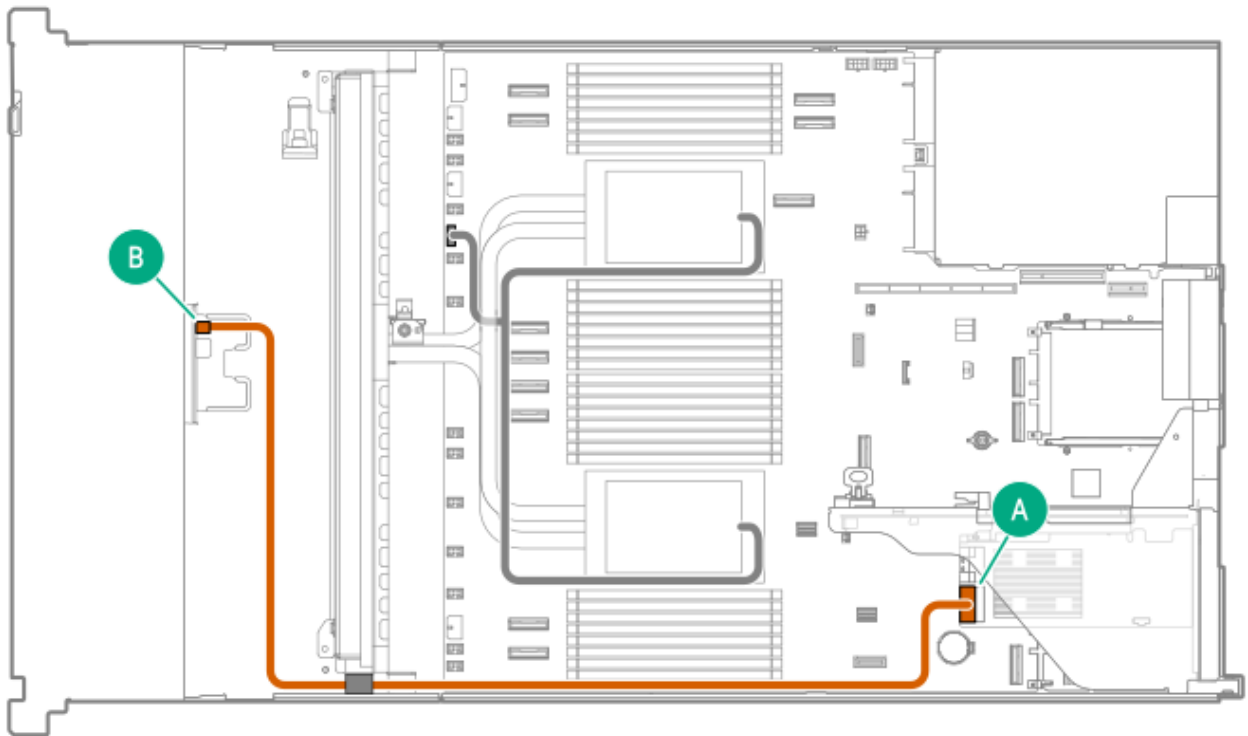

Cable part number	Color	From	To
P75590-001	Orange	Drive backplane	Primary type-p controller Port 1i

Drive Box 4 cabling

2 SFF Box 4 x4 NVMe: direct attach (1 CPU)

This cable routing is compatible with a single-processor configuration.

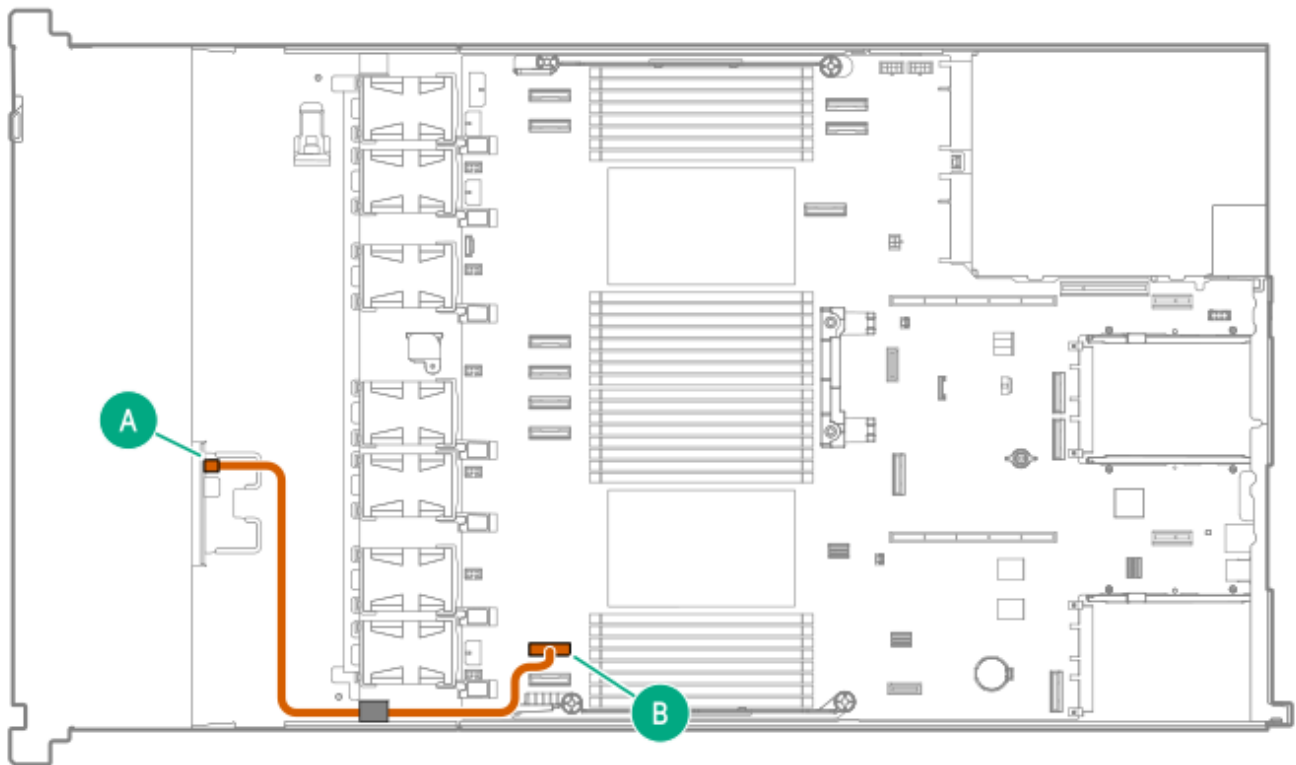

Cable part number	Color	From	To
P75317-001	Orange	Drive backplane	MCIO port 2

2 SFF Box 4 x4 NVMe: direct attach

This cable routing is compatible with a dual-processor configuration.

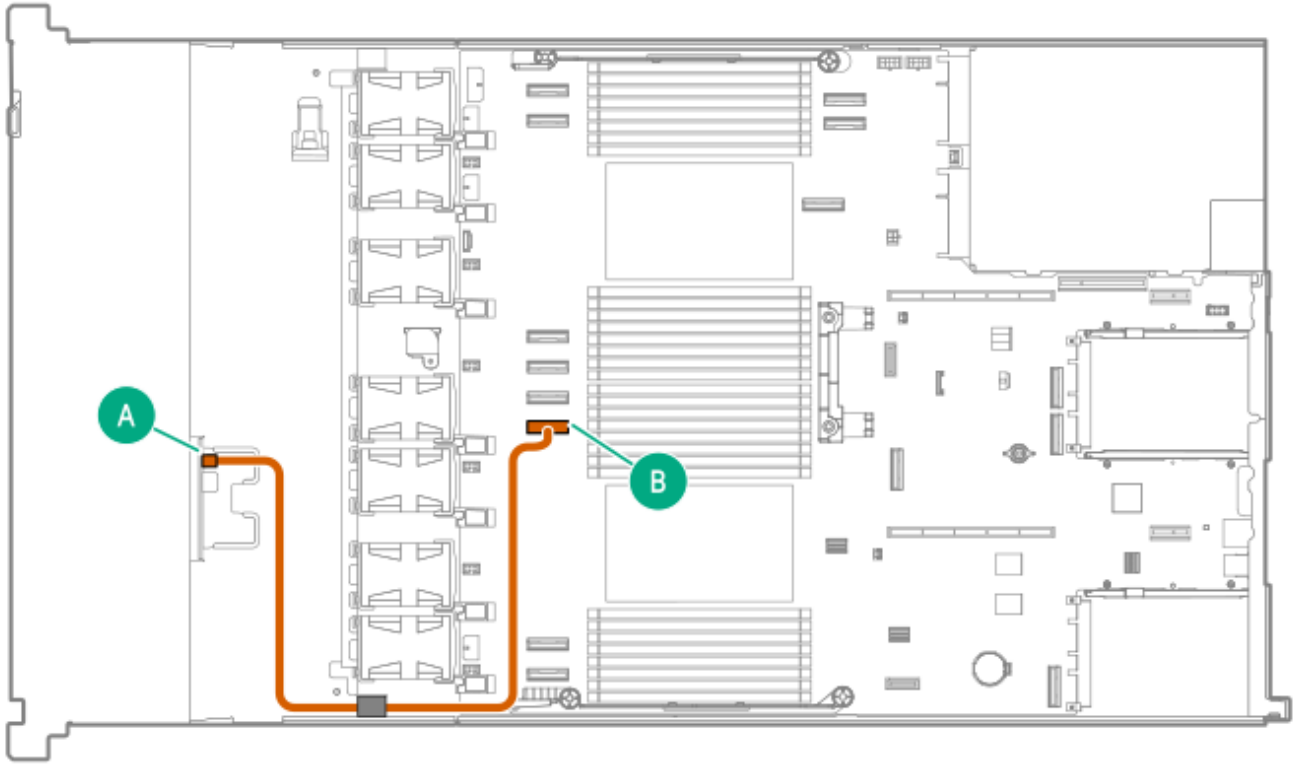

Cable part number	Color	From	To
P75567-001	Orange	Drive backplane	MCIO port 3

2 SFF Box 4 x4 NVMe: type-o controller in Slot 14 OCP A

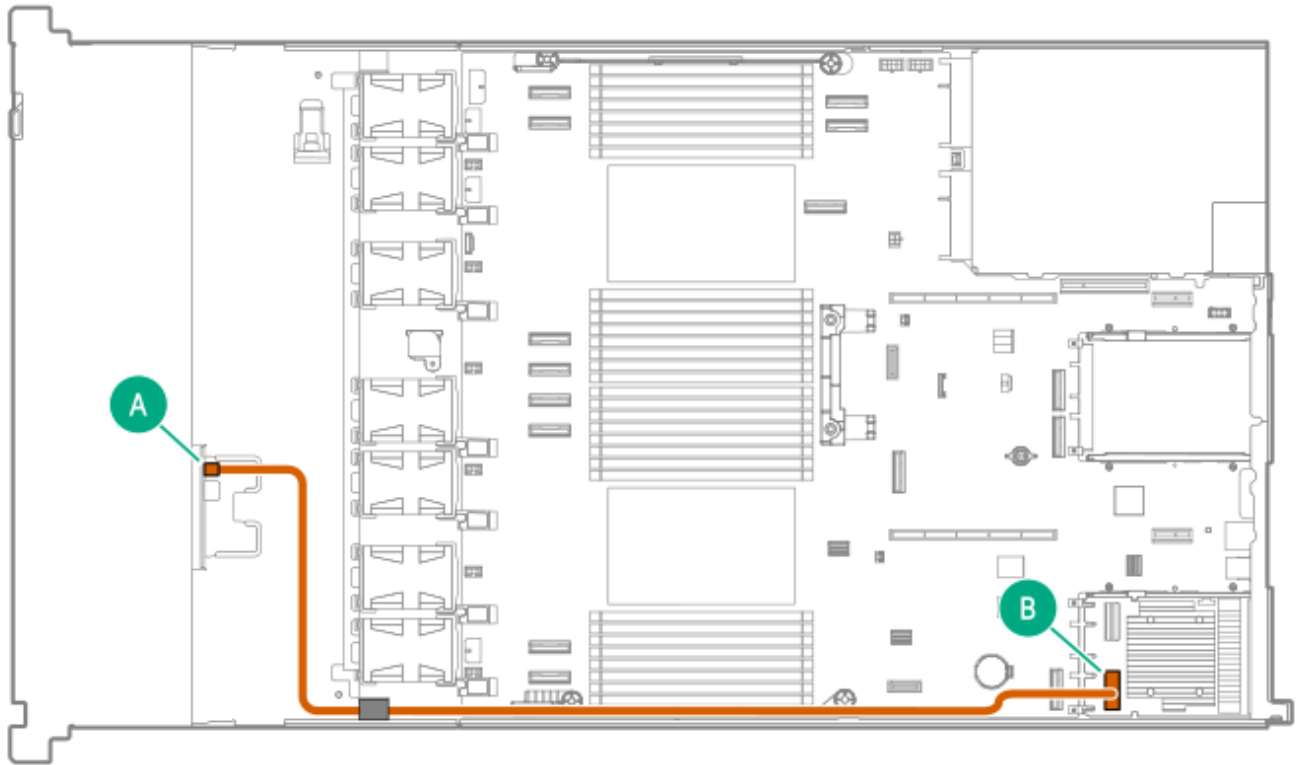

Cable part number	Color	From	To
P75589-001	Orange	Drive backplane	Slot 14 OCP A type-o controller Port 1i

2 SFF Box 4 x4 NVMe: type-p controller in Slot 1

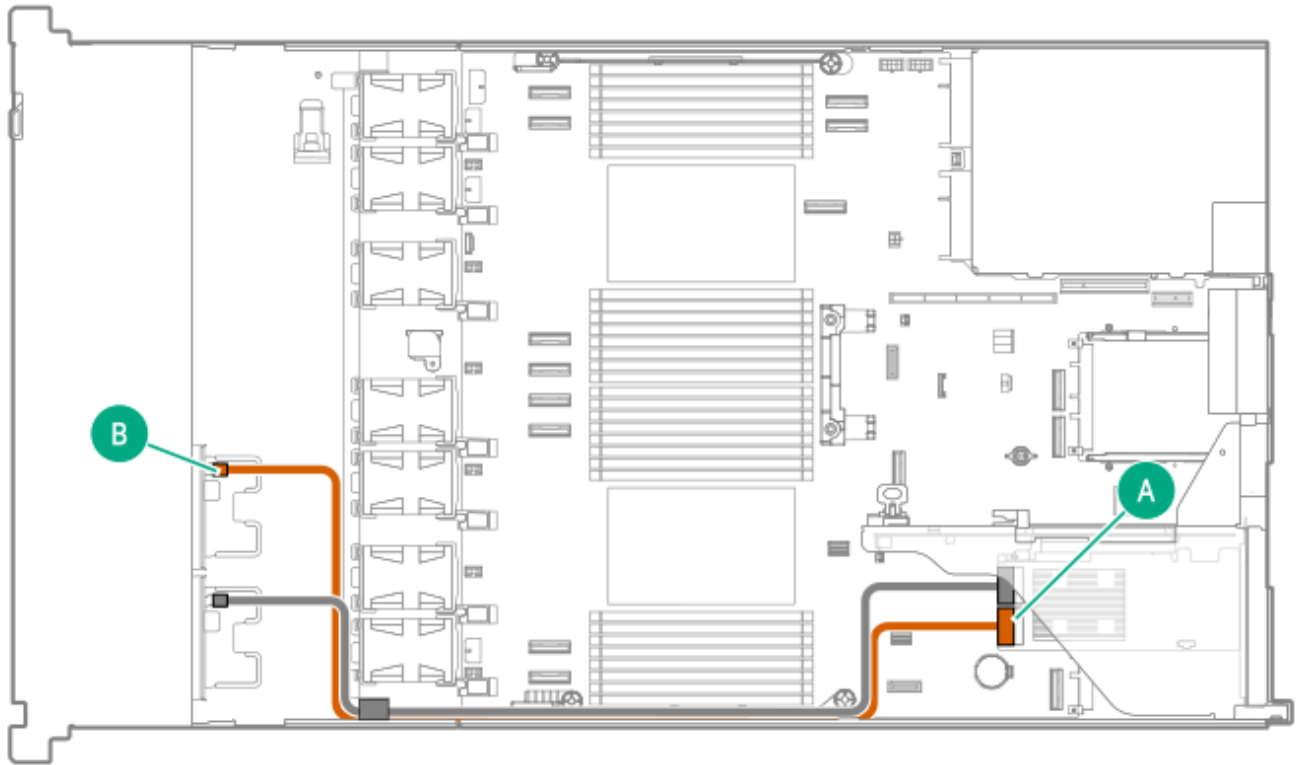

Cable part number	Color	From	To
P76443-001	Orange	Drive backplane	Primary type-p controller Port 1i

2 SFF Box 4 x4: type-o controller in Slot 15 OCP B

This configuration supports the closed-loop liquid cooling kit.

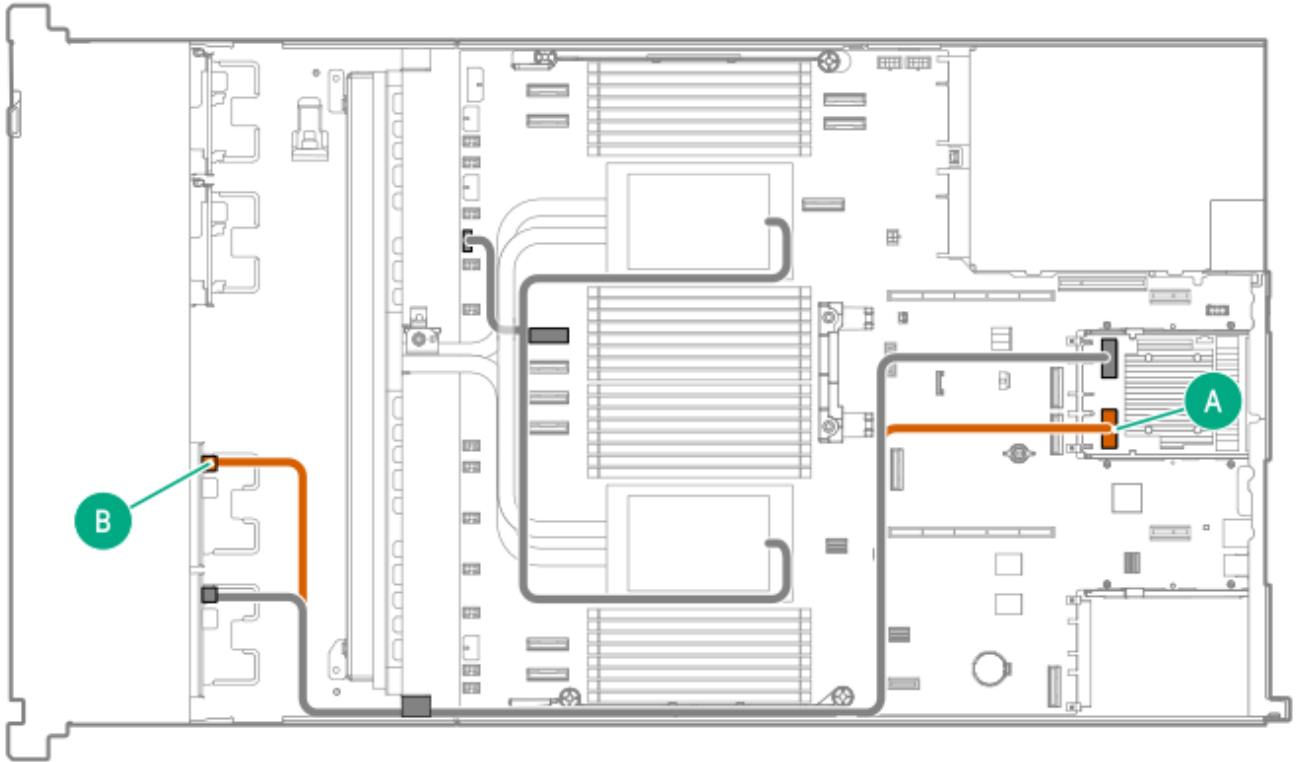

Cable part number	Color	From	To
P75589-001	Orange	Drive backplane	Slot 15 OCP B type-o controller Port 1i

2 SFF Box 4 x4 NVMe: type-p controller in Slot 2

This configuration supports the closed-loop liquid cooling kit.

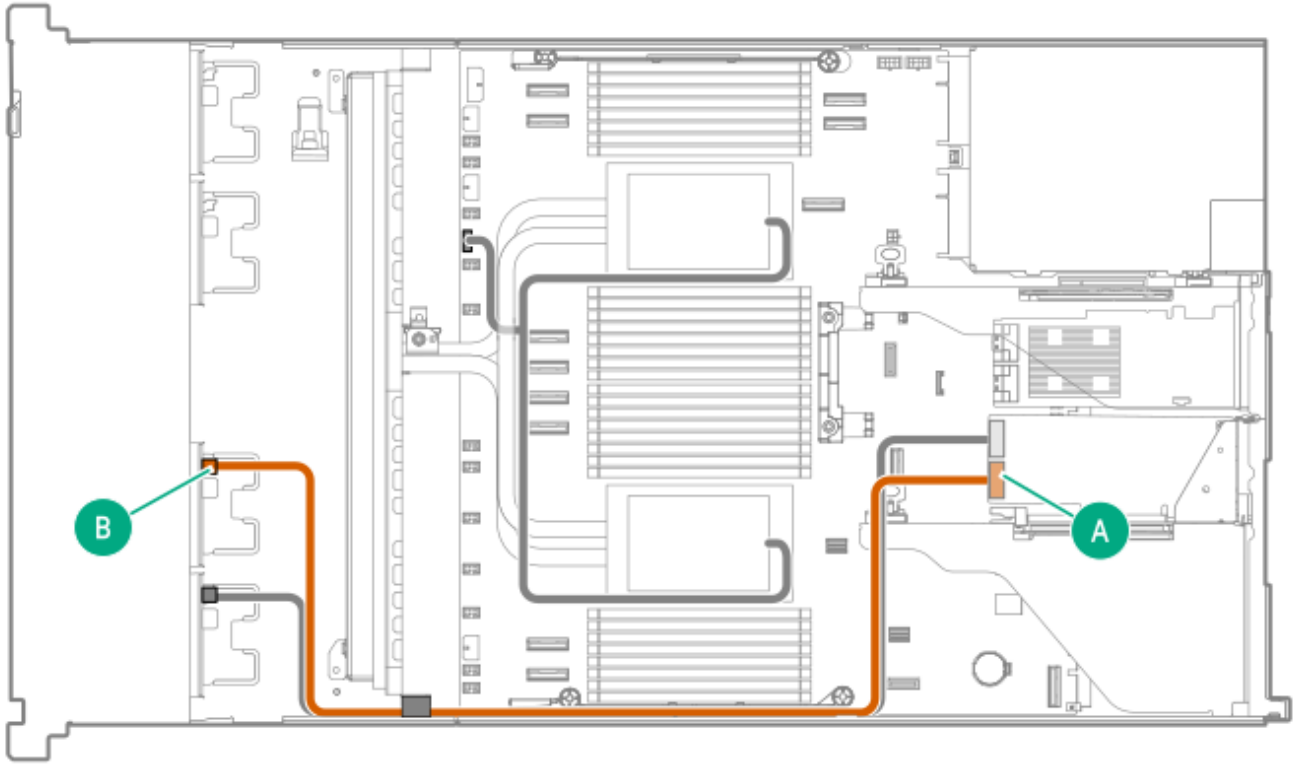

Cable part number	Color	From	To
P76443-001	Orange	Drive backplane	Slot 2 type-p controller Port 2i

Drive Box 5 cabling

2 SFF Box 5 x4 NVMe: direct attach (1 CPU)

This cable routing is compatible with a single-processor configuration.

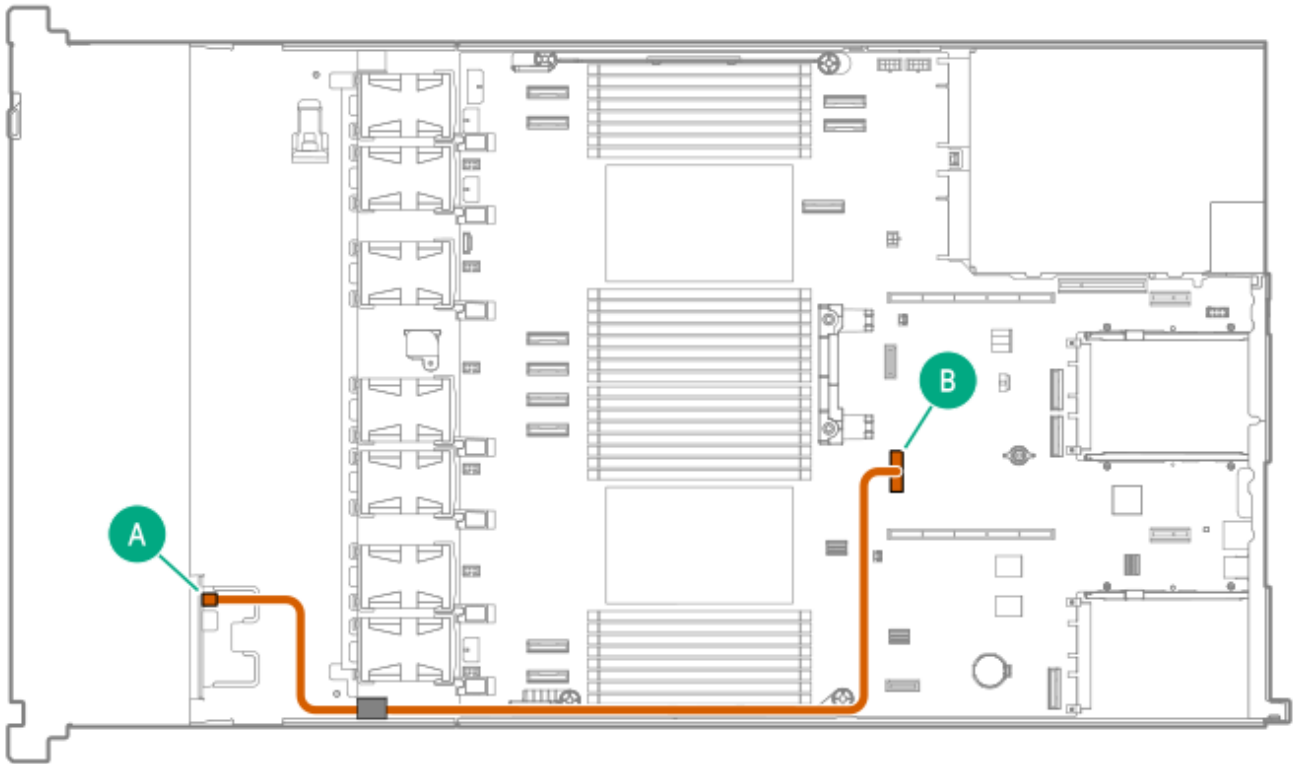

Cable part number	Color	From	To
P75567-001	Orange	Drive backplane	MCIO port 12

2 SFF Box 5 x4 NVMe direct attach cable and CPU1-to-OCP-B cable (1 CPU)

This cable routing is compatible with a single-processor configuration.

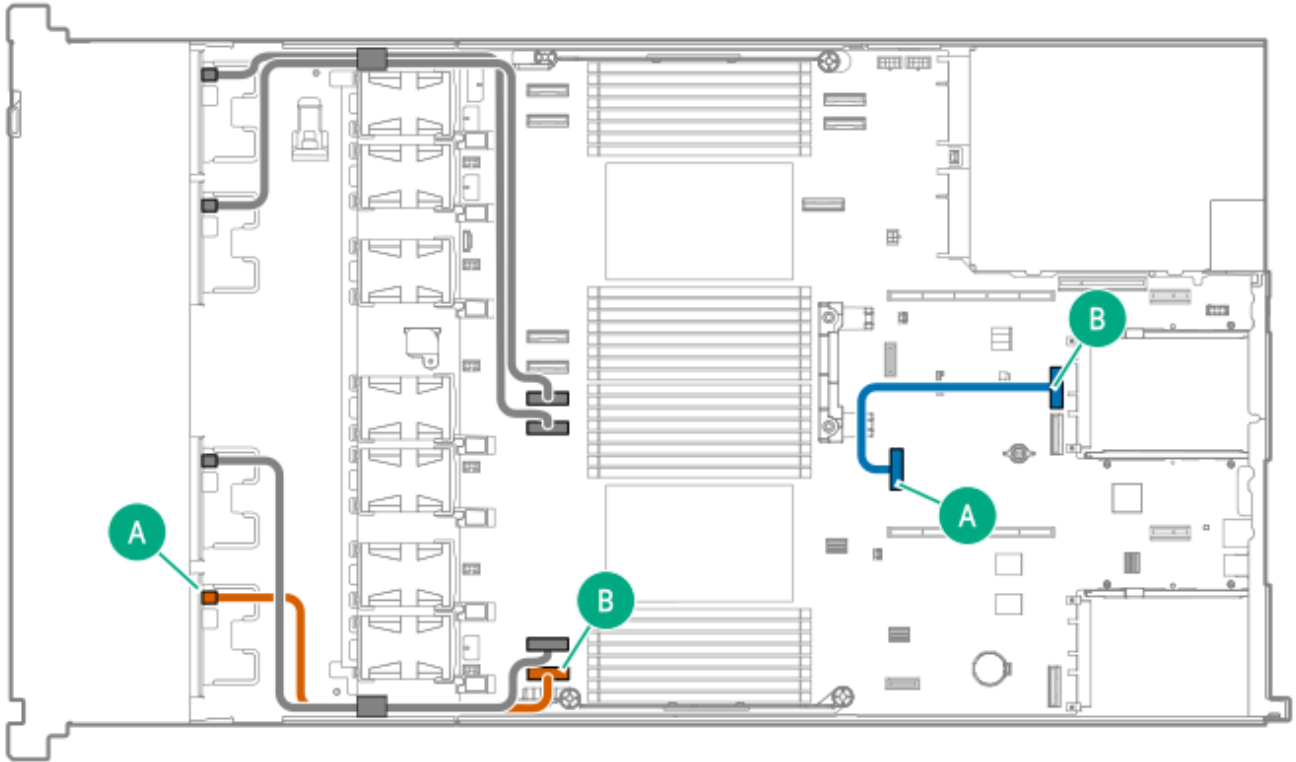

Cable part number	Color	From	To
P75567-001	Orange	Drive backplane	MCI0 port 1
P74889-001	Blue	OCP B internal port 1	MCI0 port 12

2 SFF Box 5 x4 NVMe type-p controller cable and CPU1-to-OCP-B cable (1 CPU)

This cable routing supports the closed-loop liquid cooling kit in the single-processor configuration.

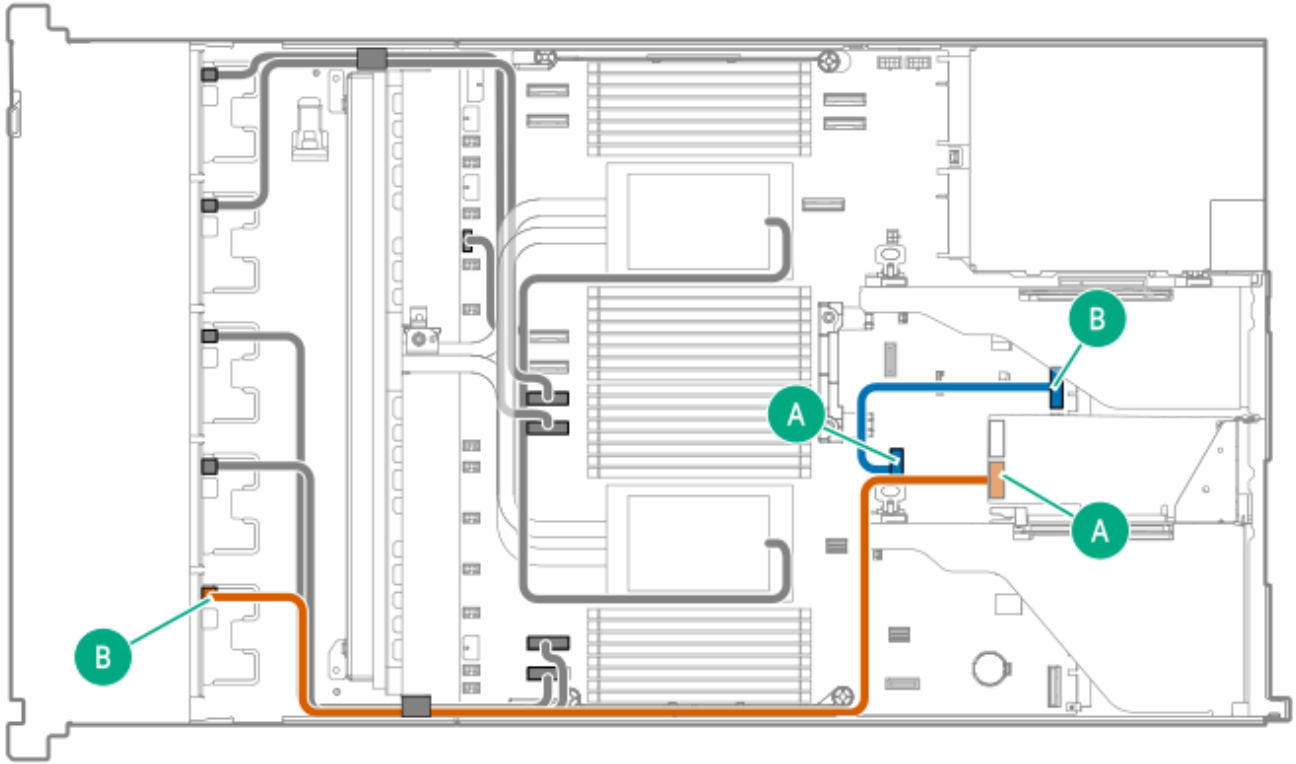

Cable part number	Color	From	To
P75590-001	Orange	Drive backplane	Slot 2 type-p controller Port 2i
P74889-001	Blue	OCP B internal port 1	MCIO port 12

2 SFF Box 5 x4 NVMe: type-o controller in Slot 14 OCP A

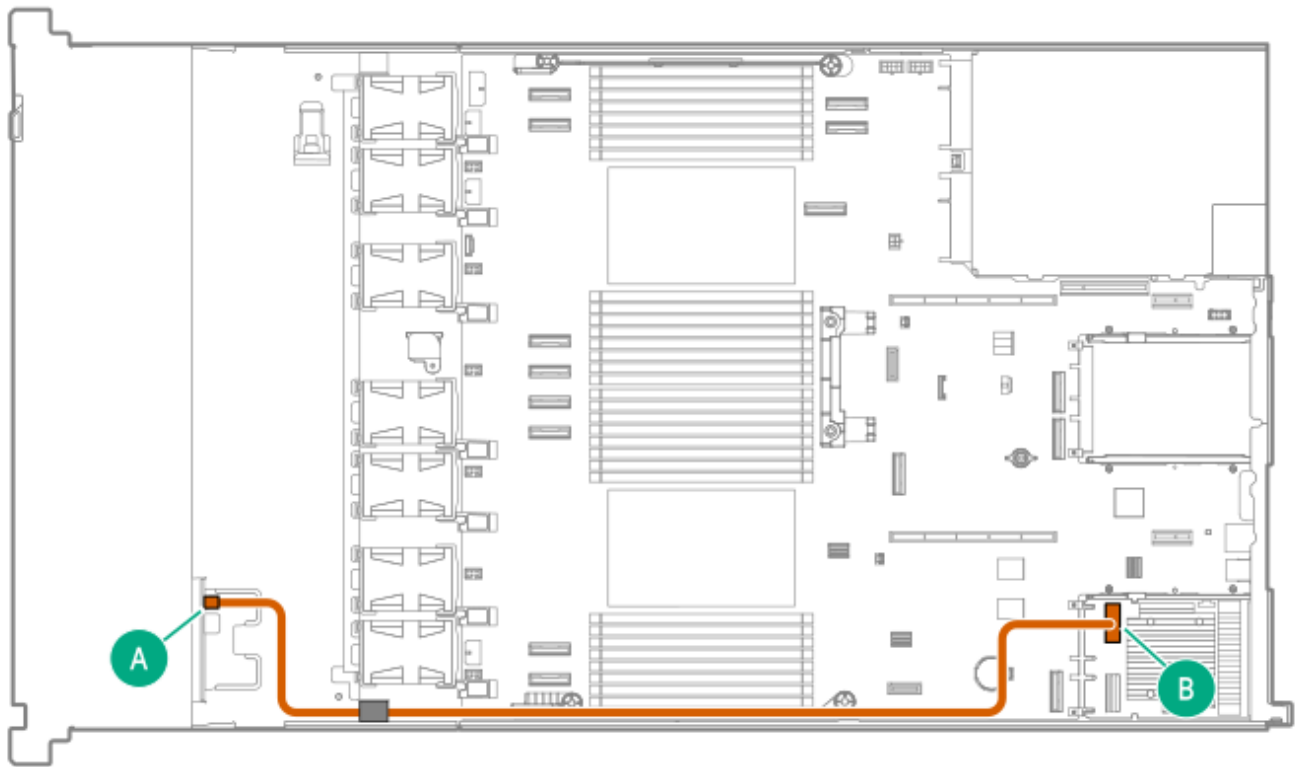

Cable part number	Color	From	To
P75589-001	Orange	Drive backplane	Slot 14 OCP A type-o controller Port 2i

2 SFF Box 5 x4 NVMe: type-o controller in Slot 15 OCP B

This configuration supports the closed-loop liquid cooling kit.

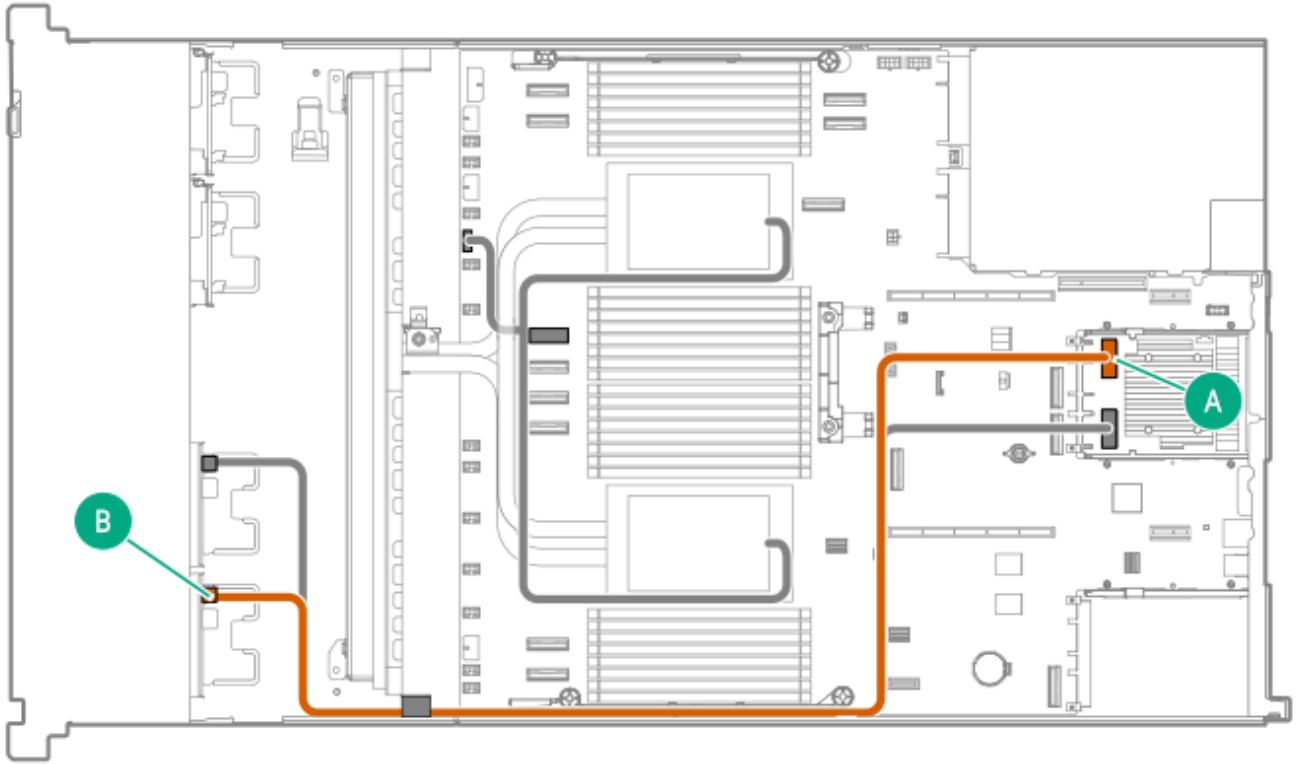

Cable part number	Color	From	To
P75589-001	Orange	Drive backplane	Slot 15 OCP B type-o controller Port 2i

2 SFF Box 5 x4 NVMe: type-p controller in Slot 1

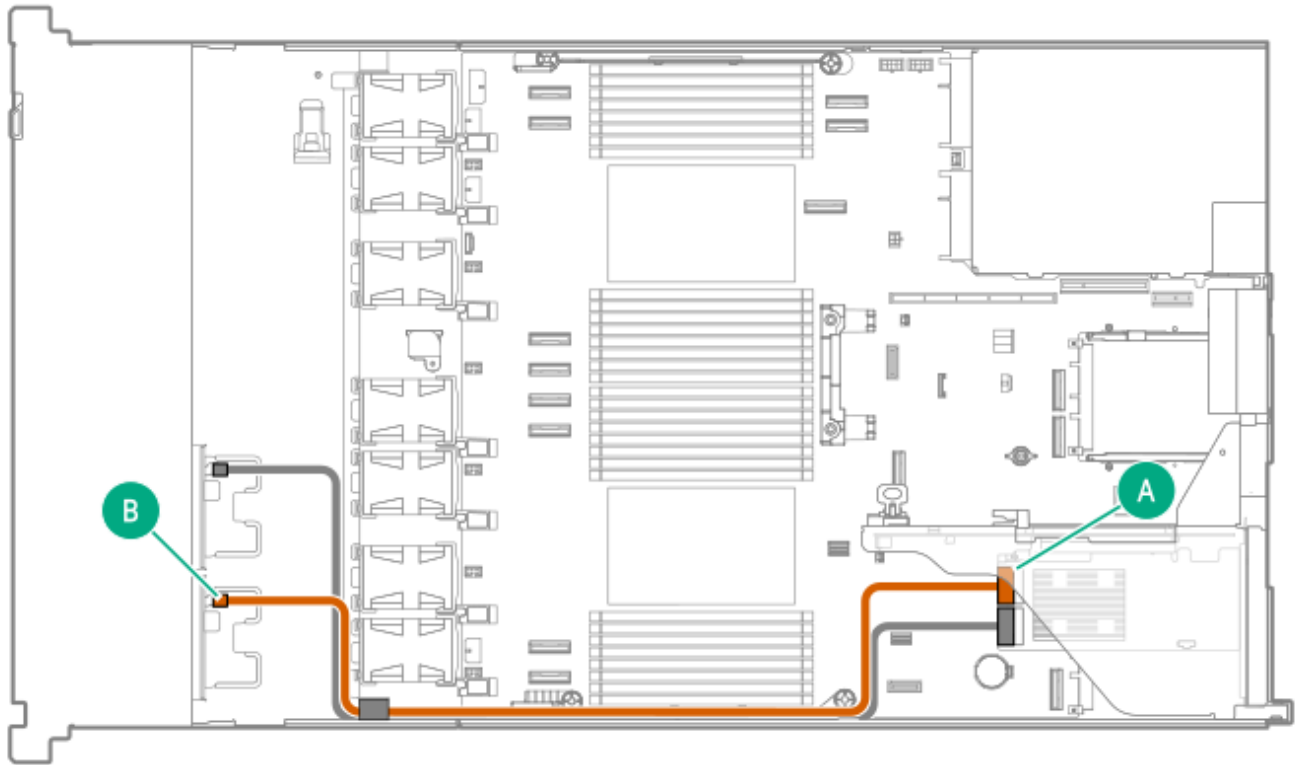

Cable part number	Color	From	To
P76443-001	Orange	Drive backplane	Primary type-p controller Port 2i

2 SFF Box 5 x4 NVMe: type-p controller in Slot 2

This configuration supports the closed-loop liquid cooling kit.

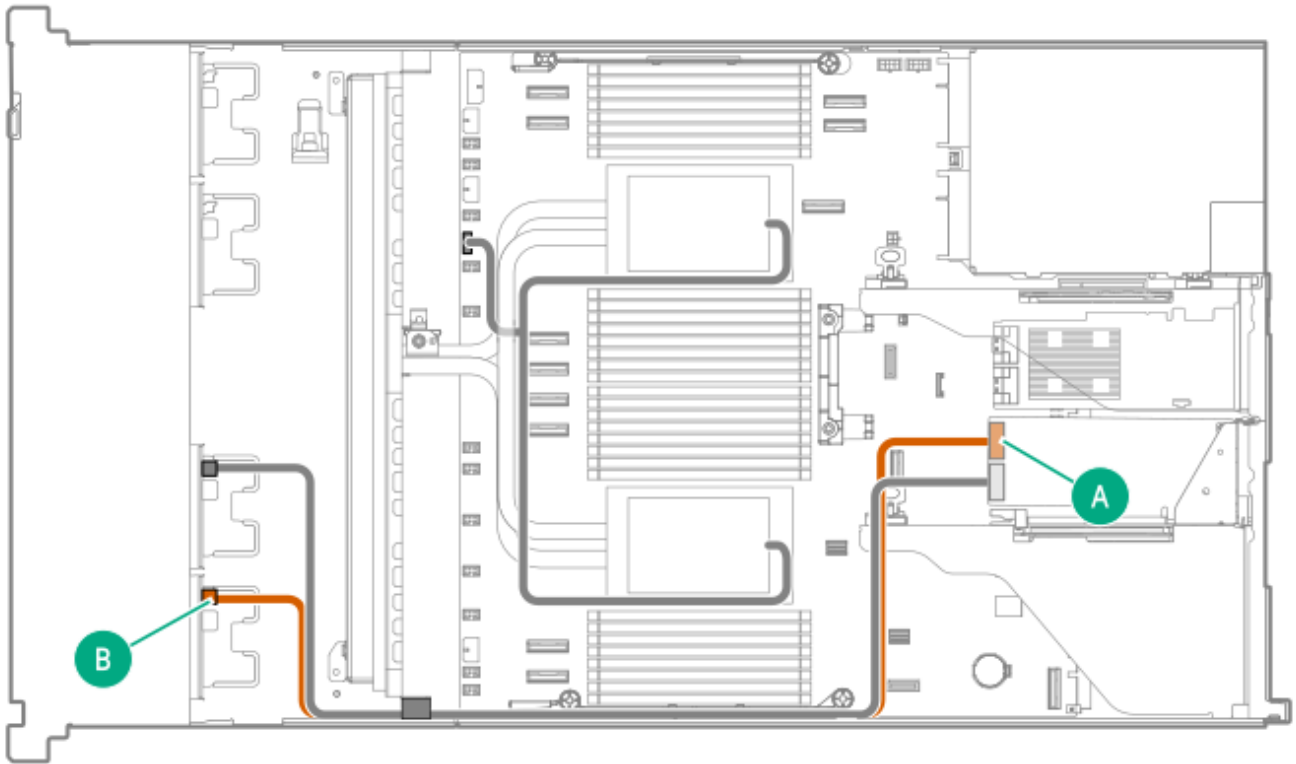

Cable part number	Color	From	To
P76443-001	Orange	Drive backplane	Slot 2 type-p controller Port 1i

Drive box cabling for boxes 1-2

4 SFF Boxes 1-2 x4 (x2 BW) NVMe: type-p controller in Slot 1

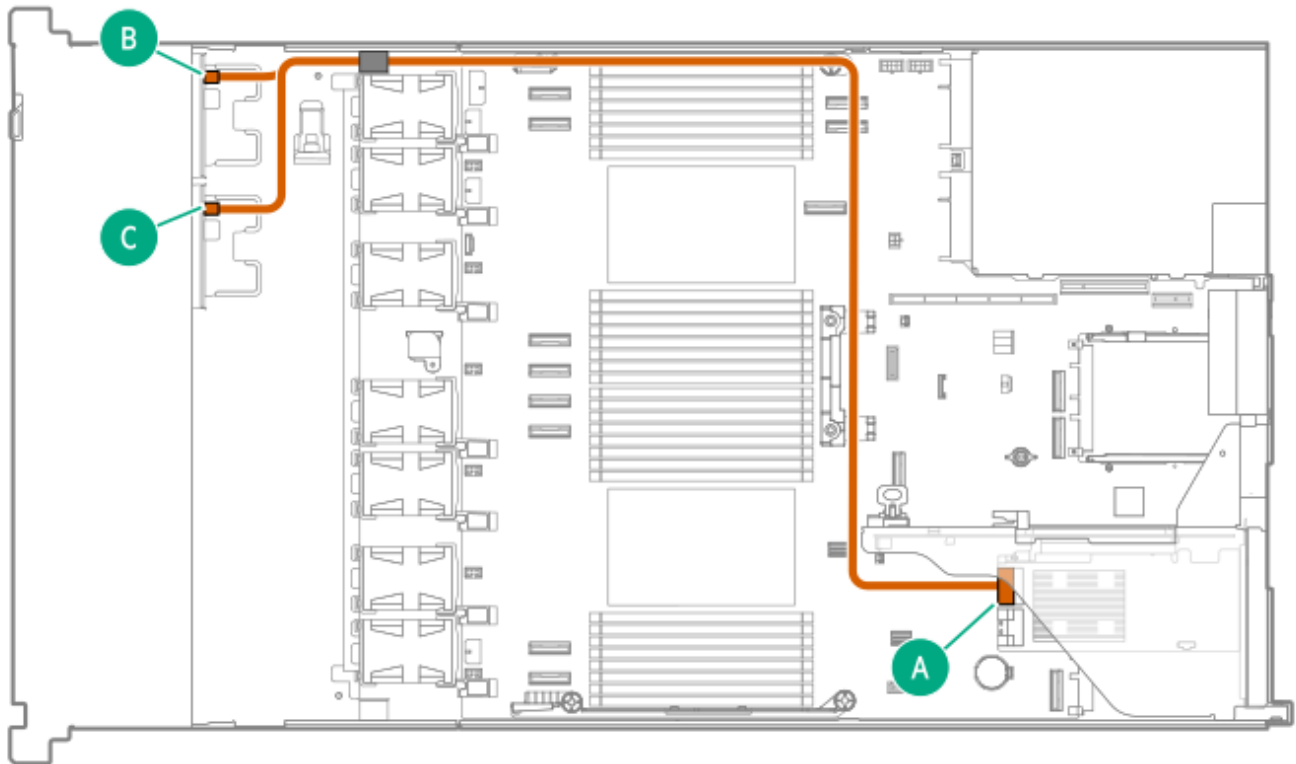

Cable part number	Color	From	To
P75593-001	Orange	Boxes 1-2: Drive backplane	Slot 1 type-p controller Port 2i

4 SFF Boxes 1-2 x4 (x2 BW) NVMe: type-p controller in Slot 2

This configuration supports the closed-loop liquid cooling kit.

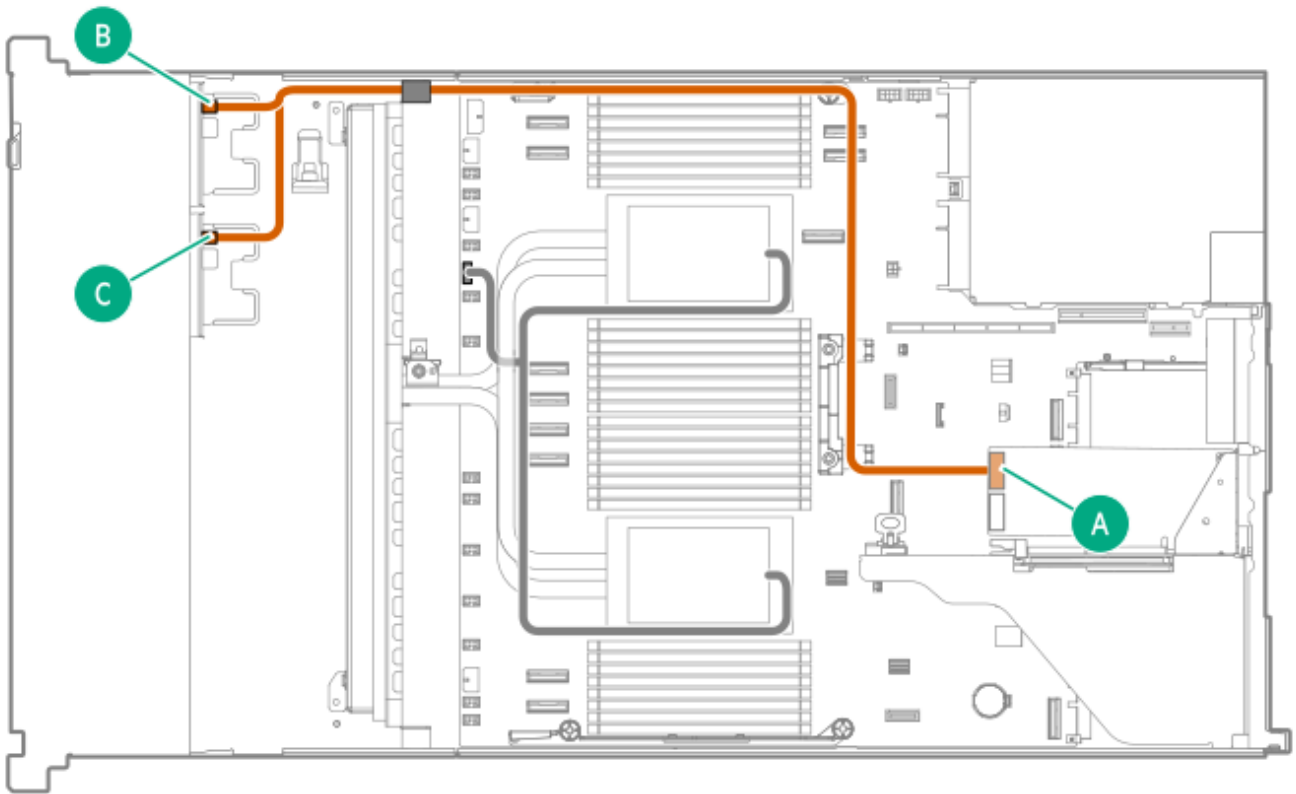

Cable part number	Color	From	To
P75593-001	Orange	Boxes 1–2: Drive backplane	Slot 2 type-p controller Port 1i

4 SFF Boxes 1-2 (x2 BW) NVMe: type-o controller in Slot 14 OCP A

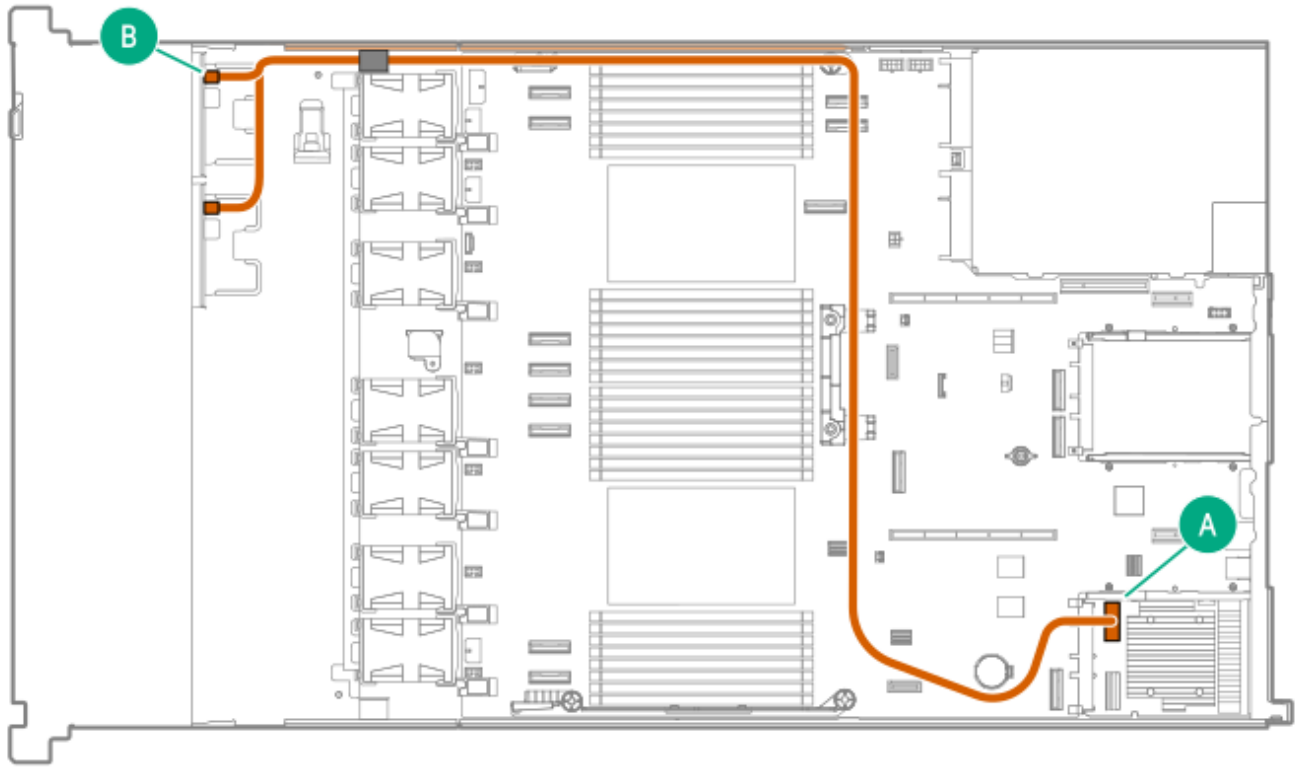

Cable part number	Color	From	To
P75571-001	Orange	Boxes 1-2: Drive backplane	Slot 14 OCP A type-o controller Port 2i

4 SFF Boxes 1-2 x4 (x2 BW) NVMe: type-o controller in Slot 14 OCP A

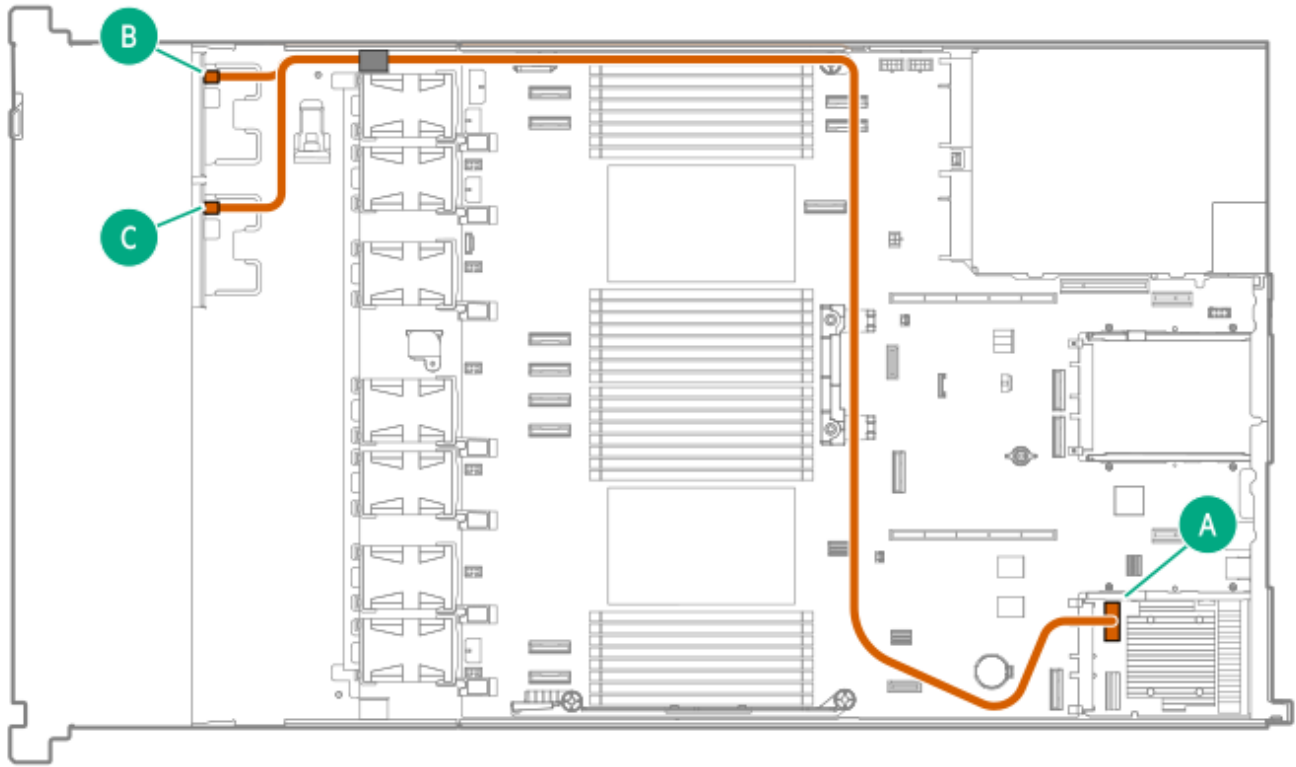

Cable part number	Color	From	To
P75571-001	Orange	Boxes 1-2: Drive back plane	Slot 14 OCP A type-o controller Port 2i

4 SFF Boxes 1-2 x4 (x2 BW) NVMe: type-o controller in Slot 15 OCP B

This configuration supports the closed-loop liquid cooling kit.

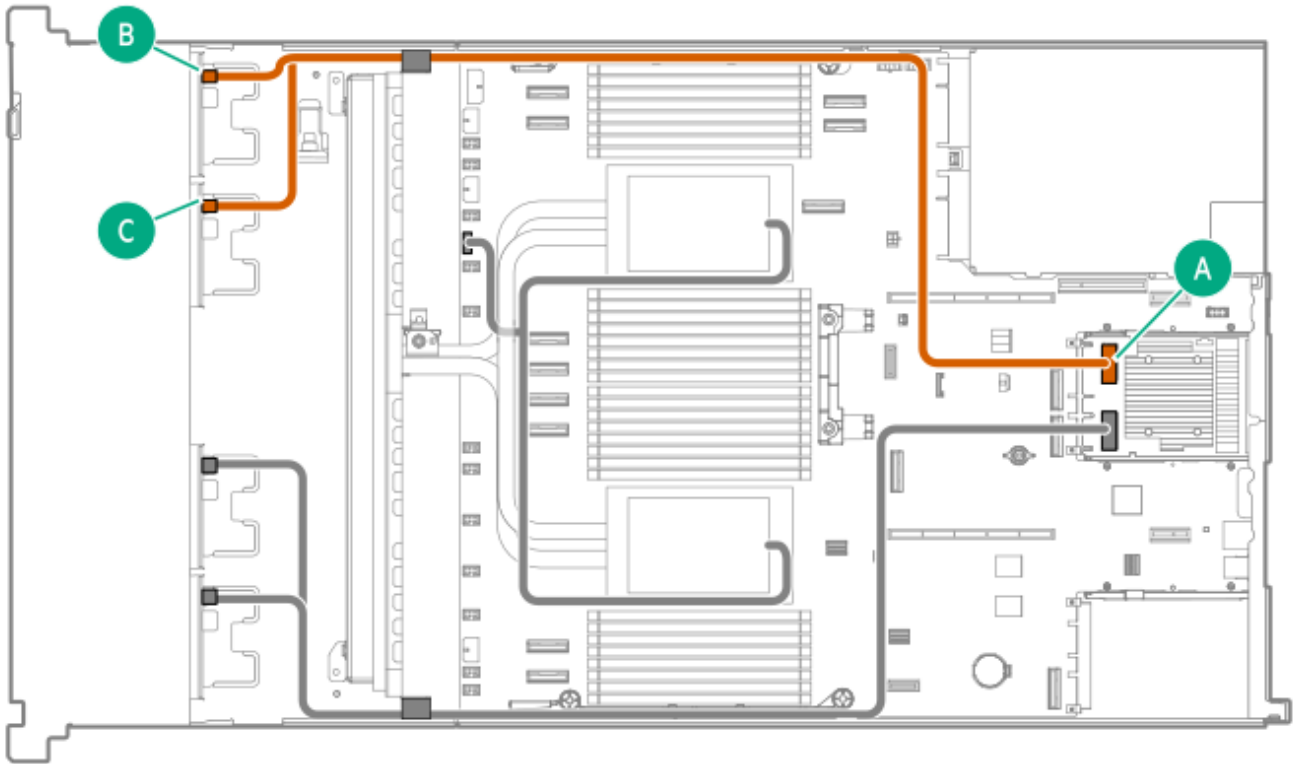

Cable part number	Color	From	To
P75573-001	Orange	Boxes 1–2: Drive back plane	Slot 15 OCP B type-o controller Port 2i

4 SFF Boxes 1–2 x4 NVMe to type-p controller in Slot 1

MR932i-p:

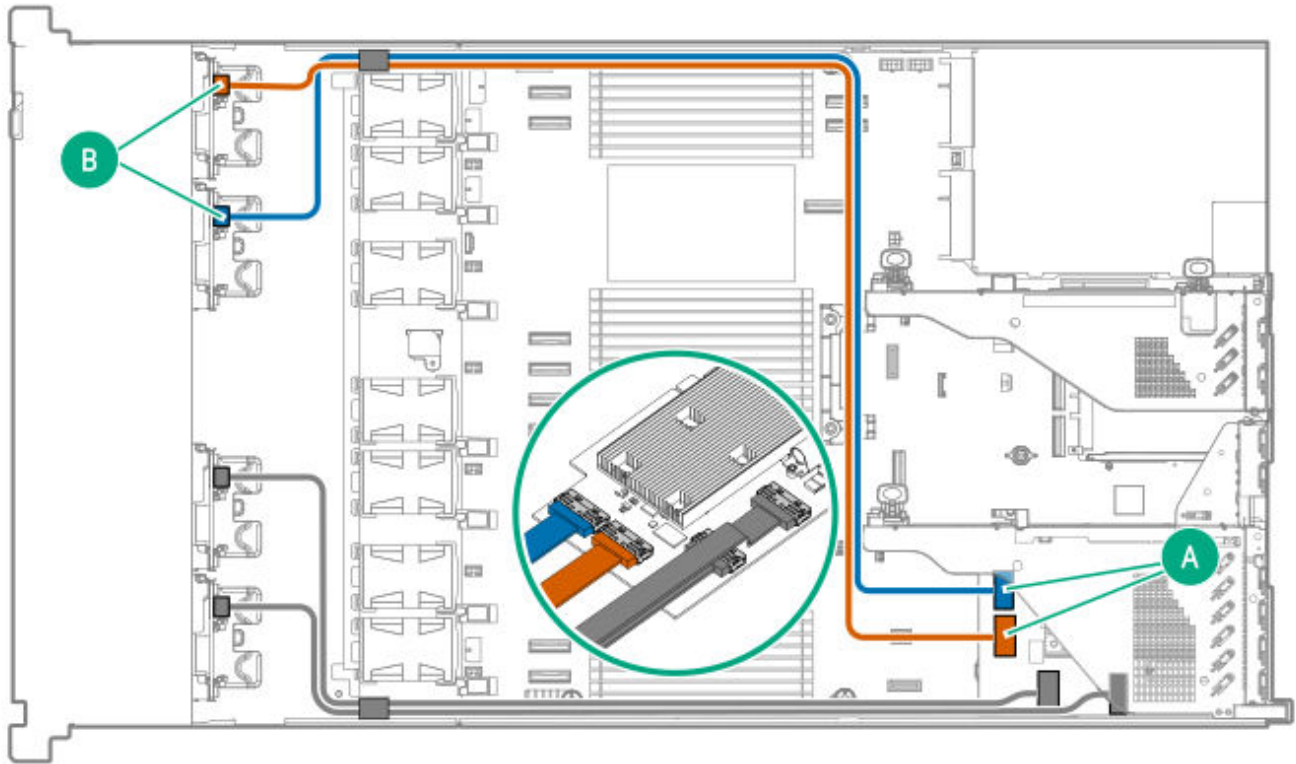

Cable part number	Color	From	To
P75318-001	Orange	Box 1: Drive backplane port	Slot 1 type-p controller Port 1i
	Blue	Box 2: Drive backplane port	Slot 1 type-p controller Port 2i

Drive box cabling for boxes 4-5

4 SFF Boxes 4-5 x4 NVMe: direct attach

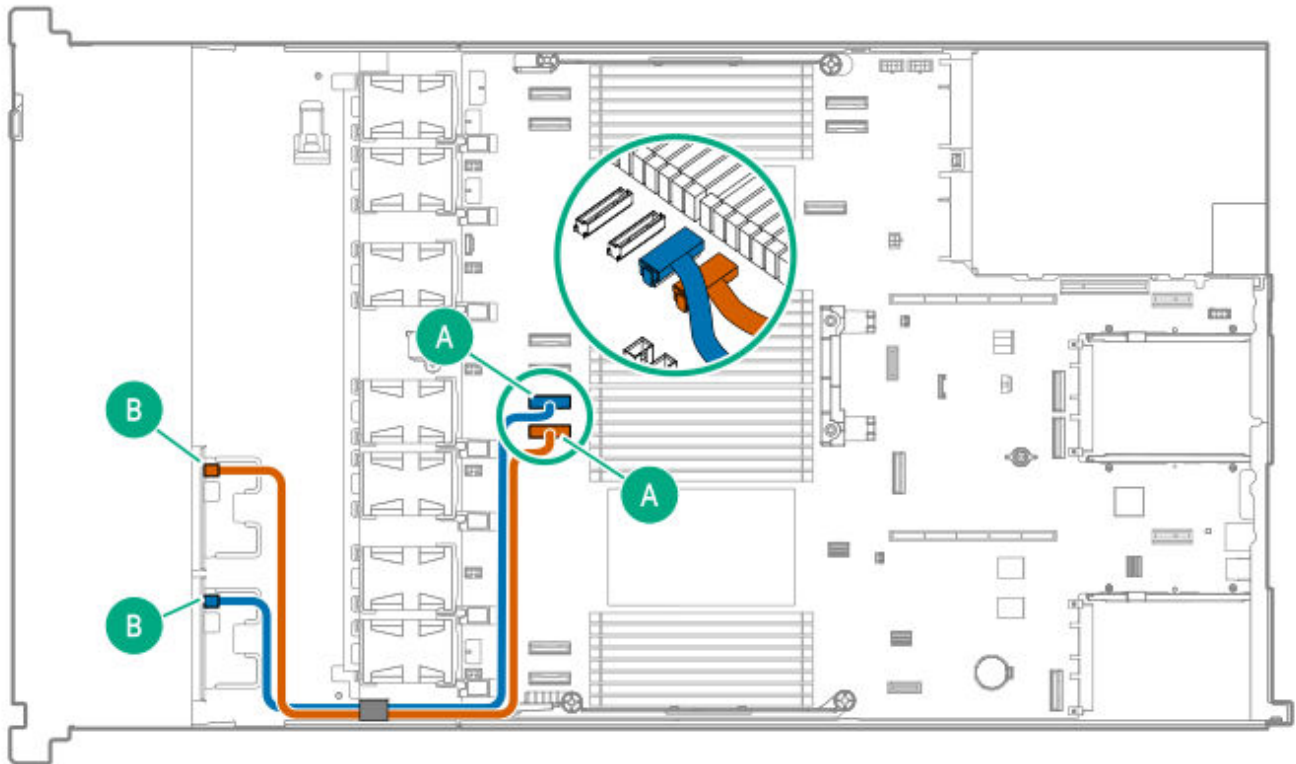

Cable part number	Color	From	To
P75567-001	Orange	Box 4: drive backplane	MCI0 port 3
P75278-001	Blue	Box 5: drive backplane	MCI0 port 4

4 SFF Boxes 4-5 x4 (x2 BW) NVMe: type-o controller in Slot 14 OCP A

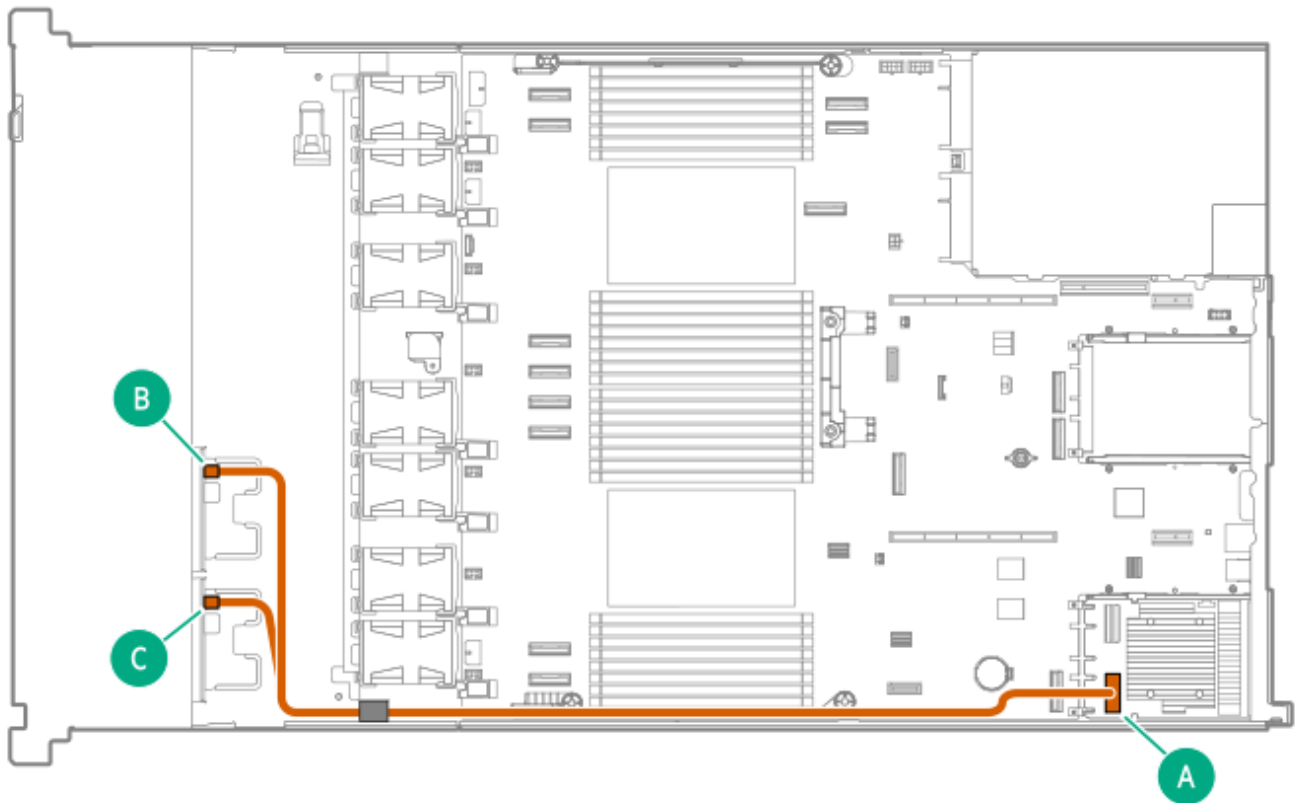

Cable part number	Color	From	To
P75573-001	Orange	Boxes 4-5: drive back plane	Slot 14 OCP A type-o controller Port 1i

4 SFF Boxes 4-5 x4 (x2 BW) NVMe: type-p controller in Slot 1

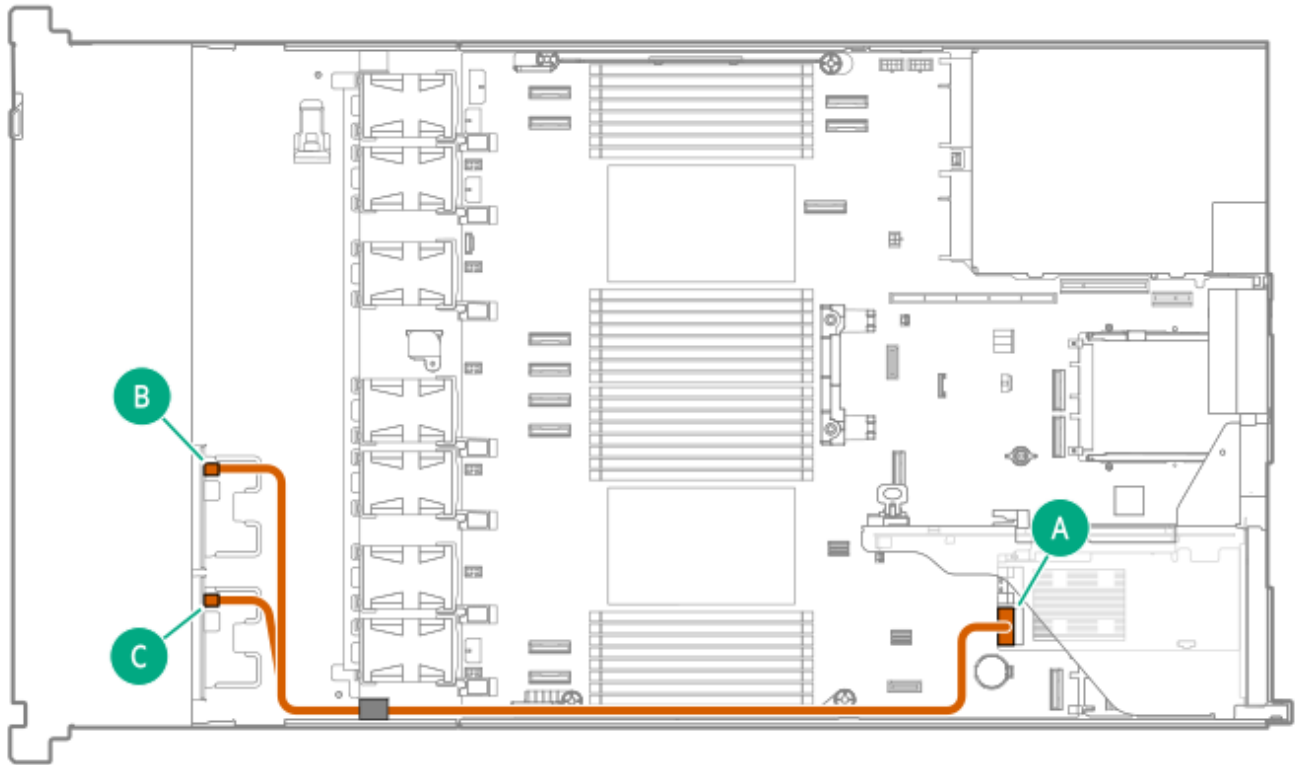

Cable part number	Color	From	To
P75572-001	Orange	Boxes 4-5: drive backplane	Slot 1 type-p controller Port 1i

4 SFF Boxes 4–5 x4 (x2 BW) NVMe: type-p controller in Slot 2

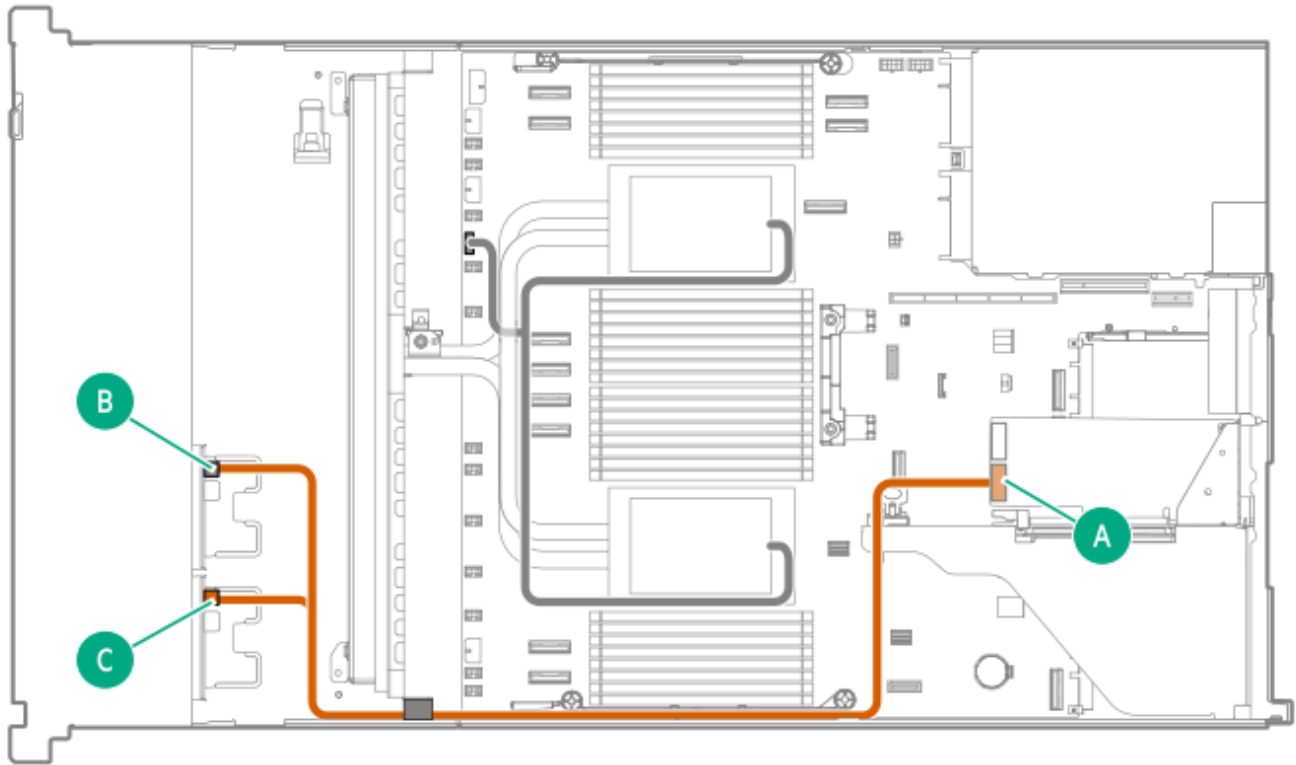

Cable part number	Color	From	To
P75572-001	Orange	Boxes 4–5: drive backplane	Slot 2 type-p controller Port 2i

4 SFF Boxes 4–5 x4 (x2 BW) NVMe: type-o controller in Slot 15 OCP B

This configuration supports the closed-loop liquid cooling kit.

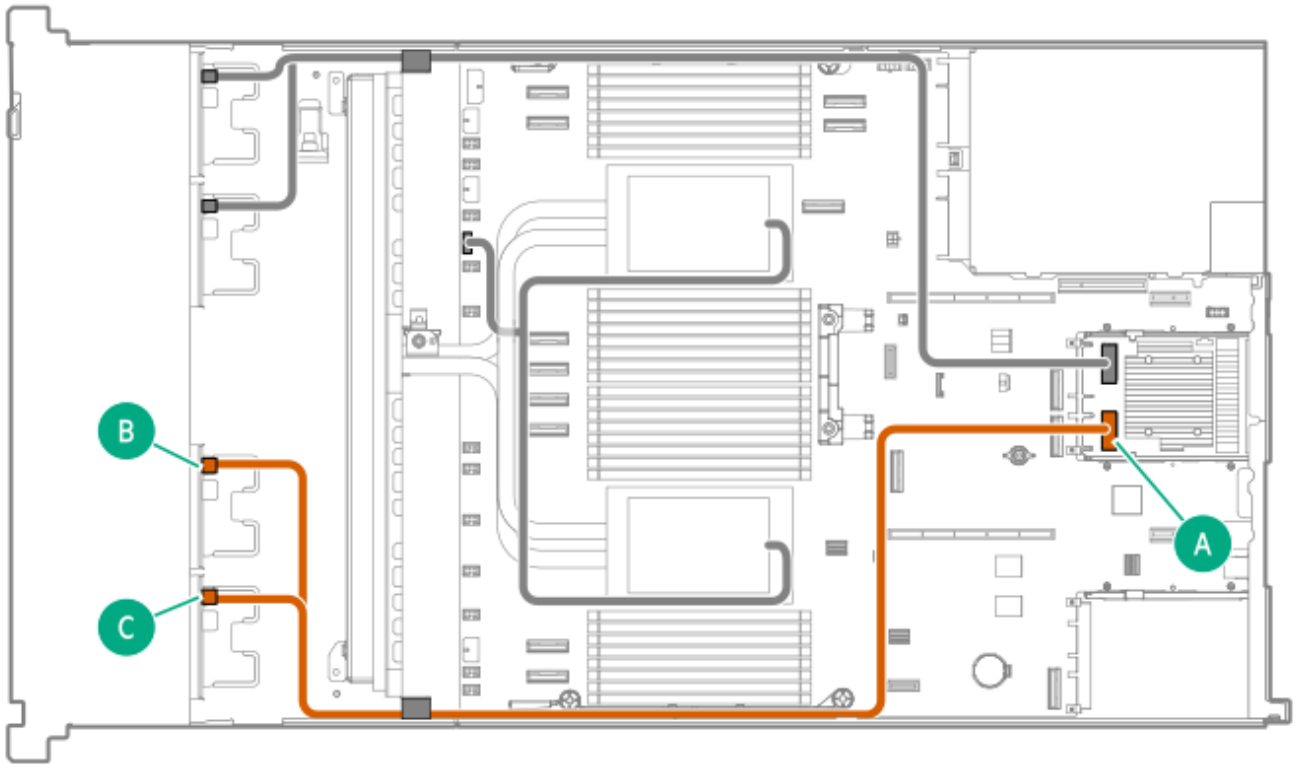

Cable part number	Color	From	To
P75571-001	Orange	Boxes 4–5: drive back plane	Slot 15 OCP B type-o controller Port 2i

4 SFF Boxes 4–5 x4 NVMe: type-o controller in Slot 15 OCP B

This configuration supports the closed-loop liquid cooling kit.

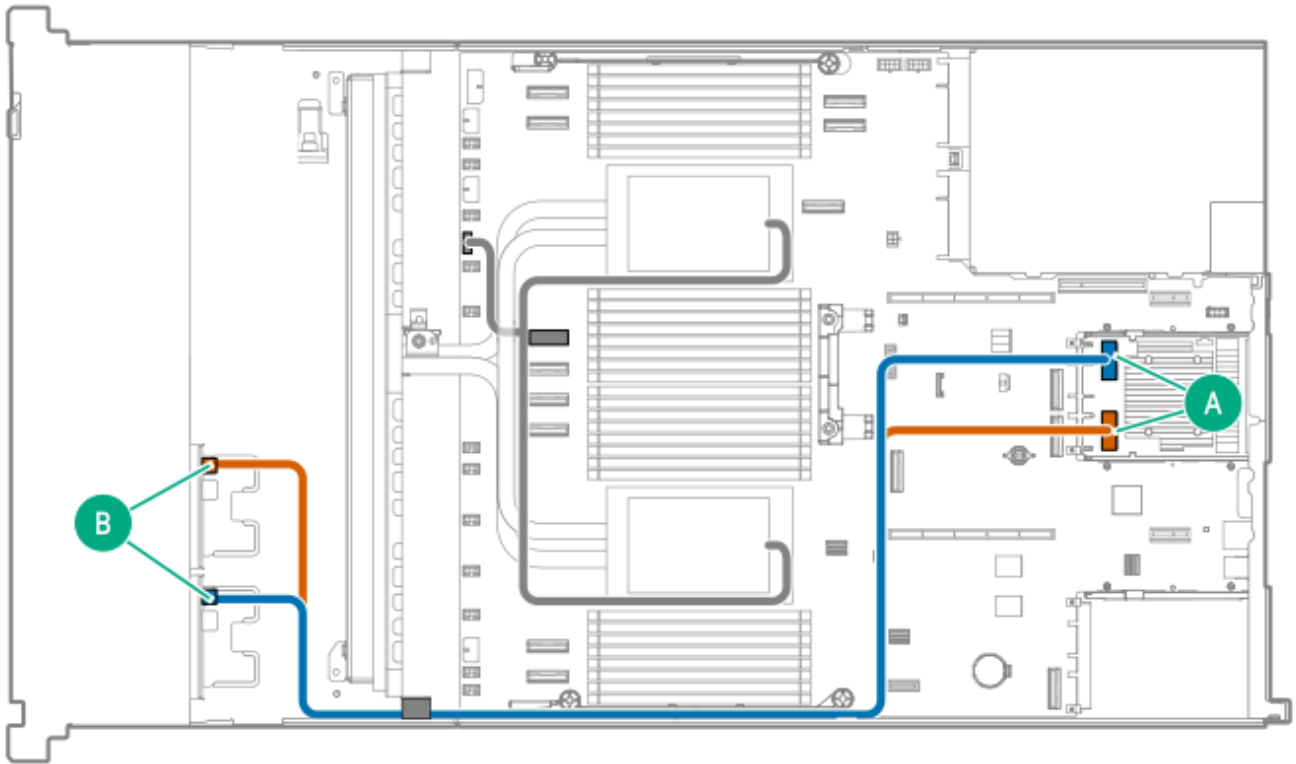

Cable part number	Color	From	To
P75589-001	Orange	Box 4: drive backplane	Slot 15 OCP B type-o controller Port 1i
	Blue	Box 5: drive backplane	Slot 15 OCP B type-o controller Port 2i

4 SFF Boxes 4–5 x4 NVMe to type-p controller in Slot 1

MR932i-p:

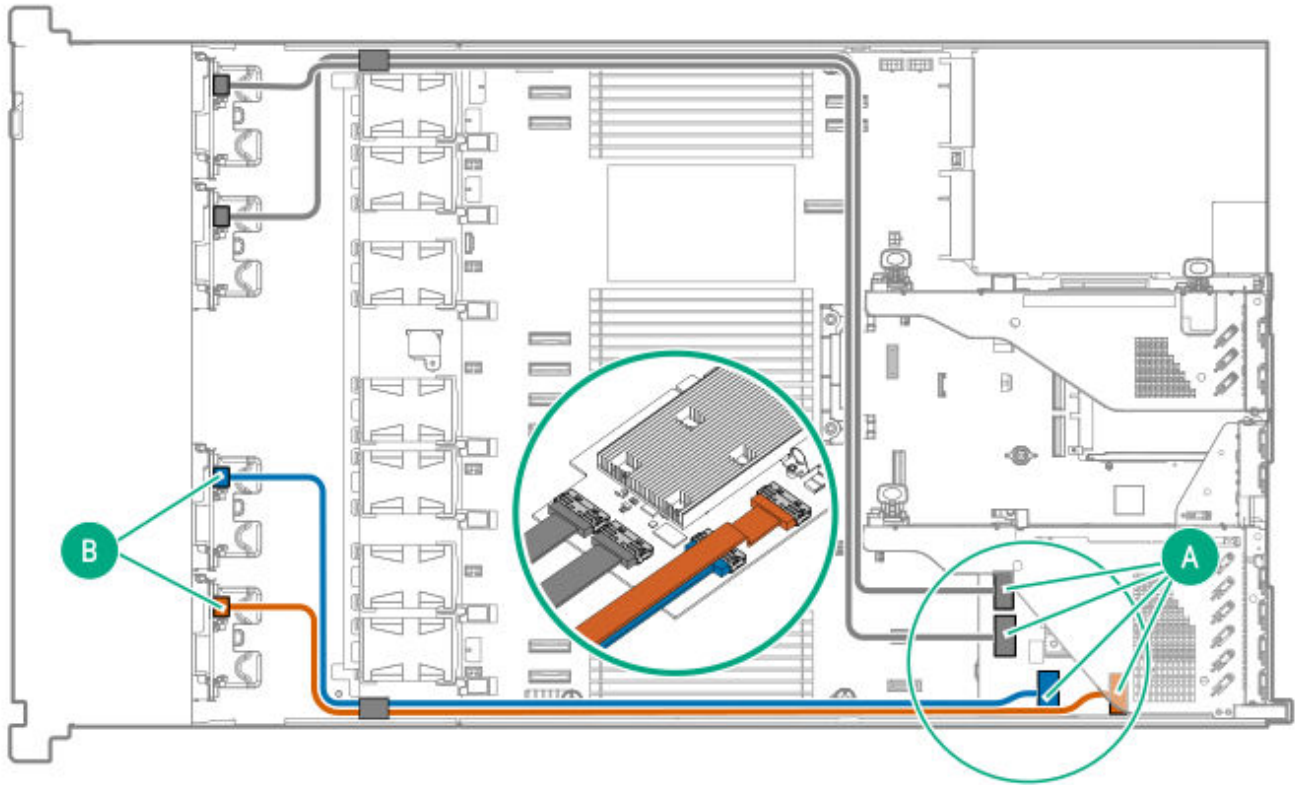

Cable part number	Color	From	To
P75570-001	Blue	Box 4: drive backplane port	Slot 1 type-p controller Port 4i
	Orange	Box 5: drive backplane port	Slot 1 type-p controller Port 3i

Drive box cabling for boxes 1-5

8 SFF Boxes 1-5 x4 (x2 BW) NVMe + 2 SFF x4 NVMe to type-p controller in Slot 1

MR932i-p:

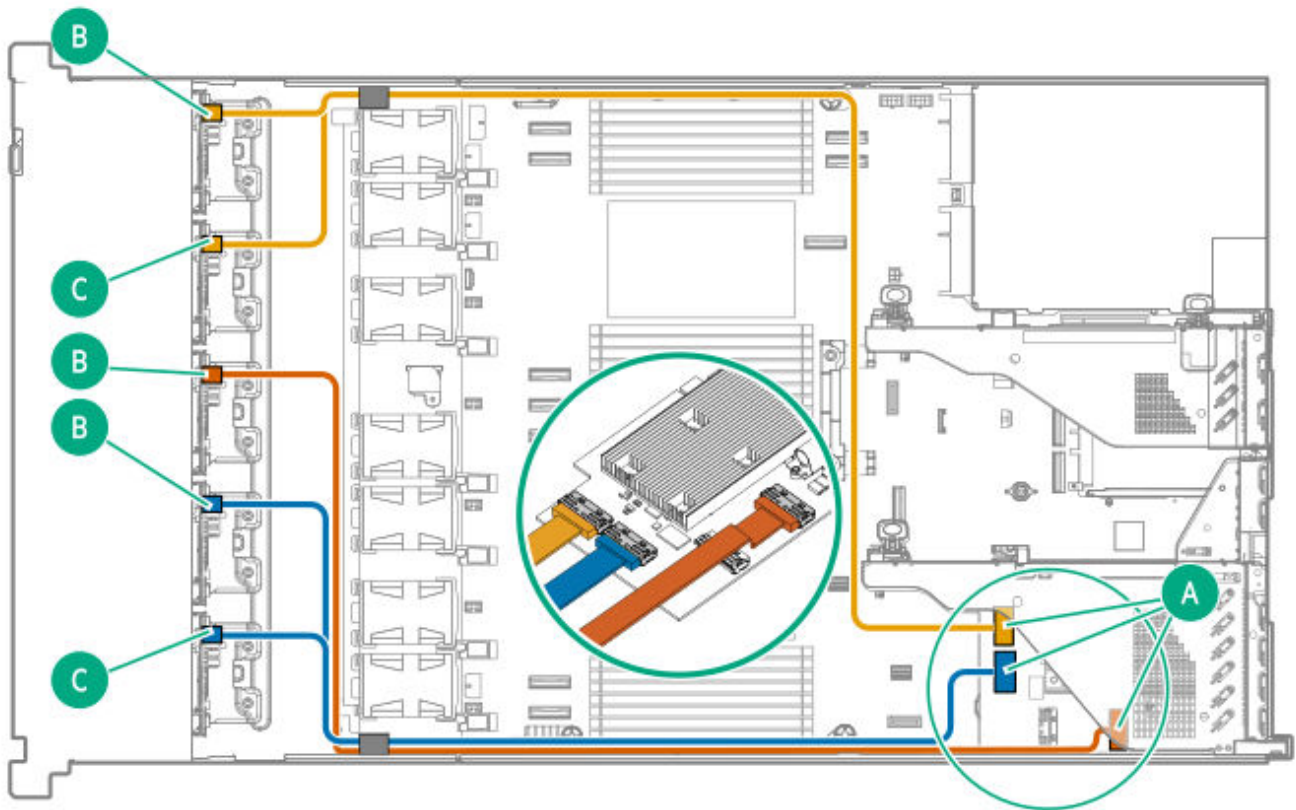

Cable part number	Color	From	To
P79152-001	Gold	Boxes 1–2: Drive backplane	Slot 1 type-p controller Port 2i
P79153-001	Orange	Box 3: Drive backplane	Slot 1 type-p controller Port 3i
P75275-001	Blue	Boxes 4–5: Drive backplane	Slot 1 type-p controller Port 1i

Storage controller backup power cabling

The exact route of the storage controller backup power cabling will depend on:

- The riser or OCP slot where the controller is installed
- The location of the backup power cable connector on the controller

Use the following diagrams for reference only.

Storage controller backup power cabling: type-o storage controllers

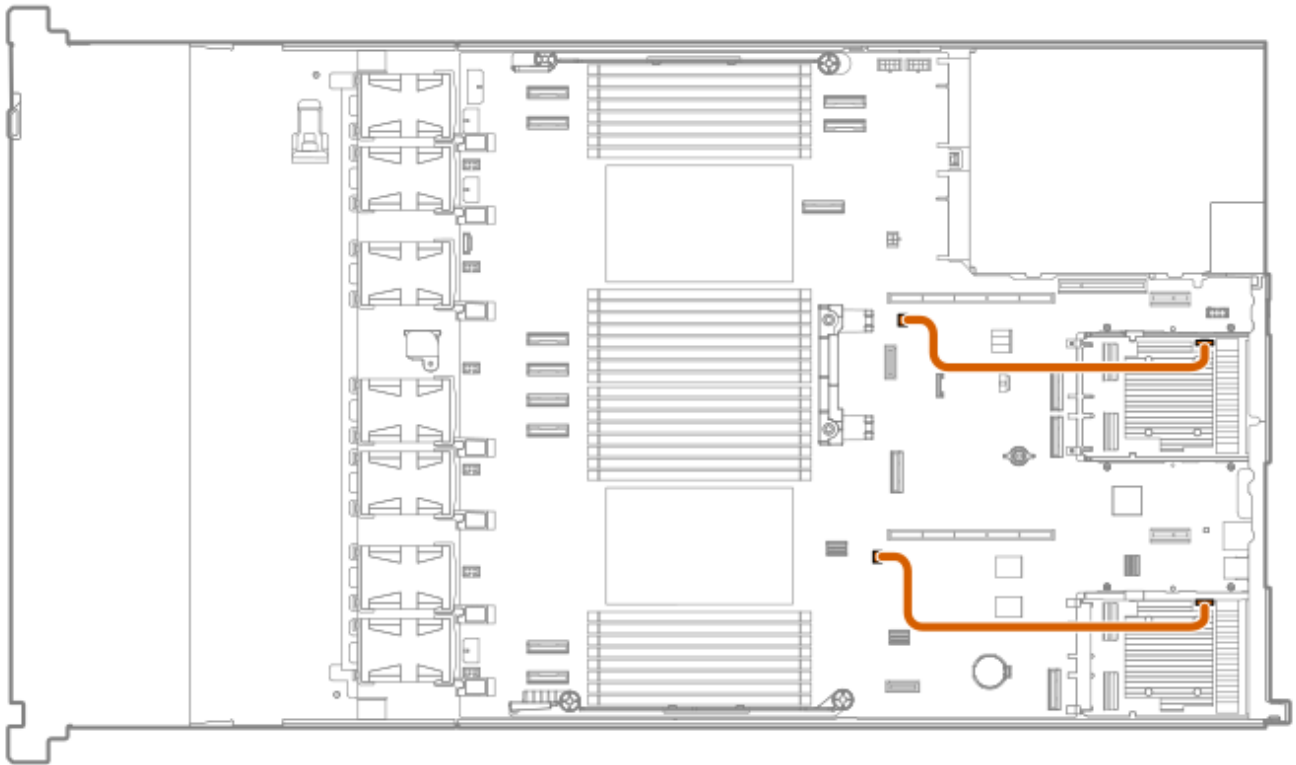

Cable color	From	To
Orange	Storage backup power connector 1	Slot 14 OROC storage backup power cable connector
	Storage backup power connector 2	Slot 15 OROC storage backup power cable connector

Storage controller backup power cabling: type-p storage controller in the primary riser

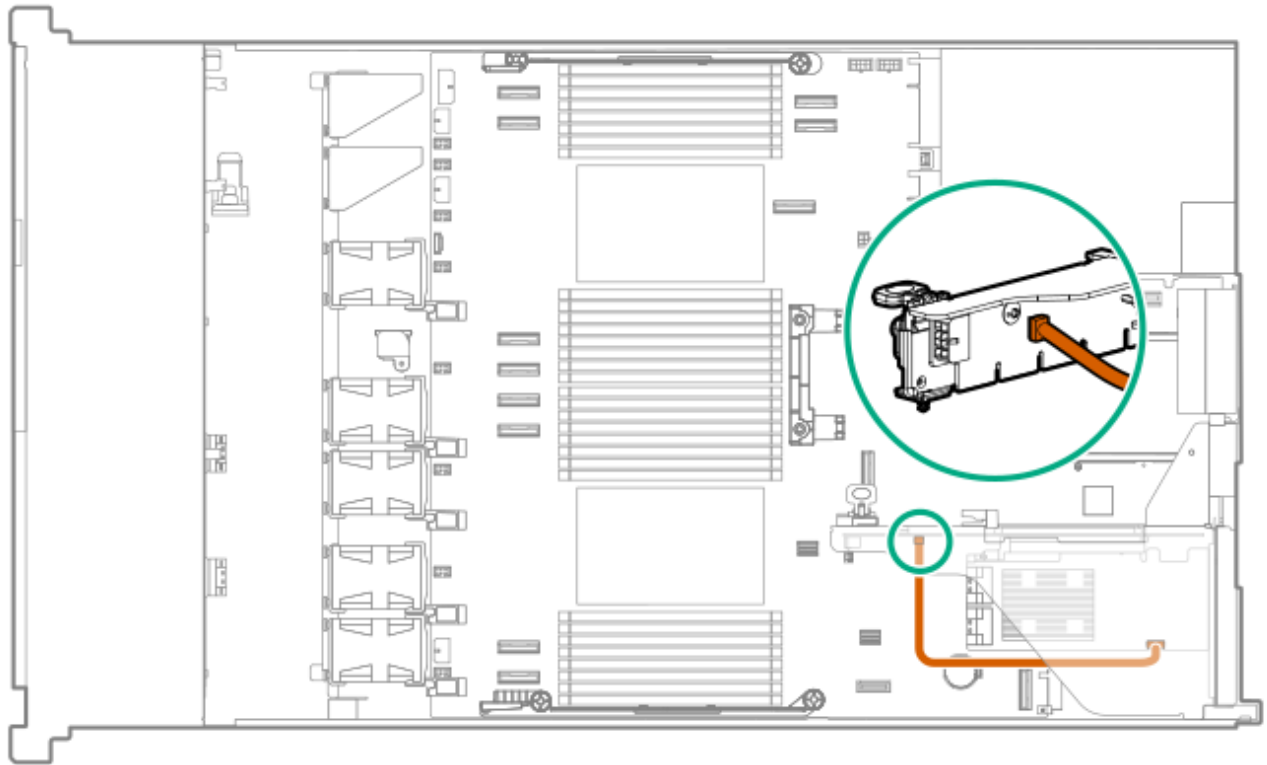

Cable color	From	To
Orange	Slot 1 primary butterfly riser: storage backup power connector	Primary type-p controller: storage backup power cable connector

Drive power cabling

4 LFF backplane power

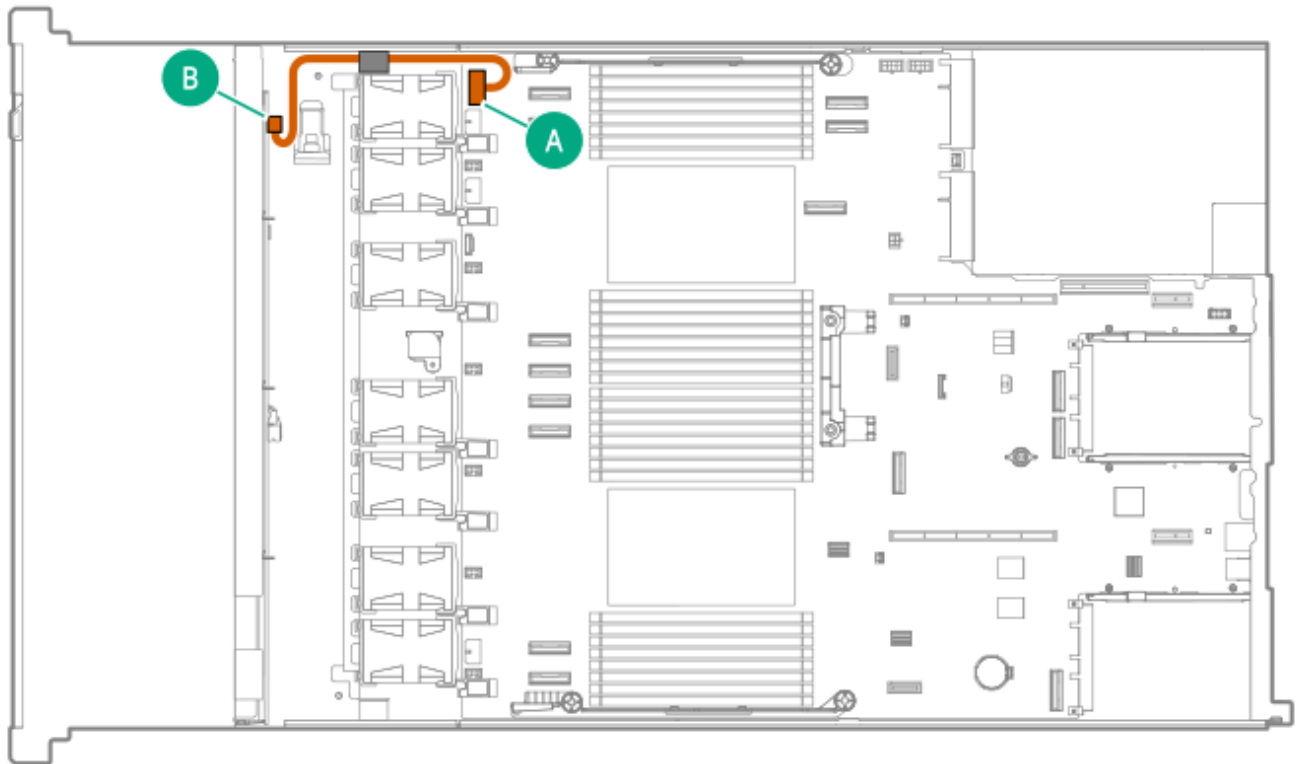

Cable part number	Color	From	To
P75565-001	Orange	4 LFF backplane	Backplane Box 1 power connector

8 SFF backplane power

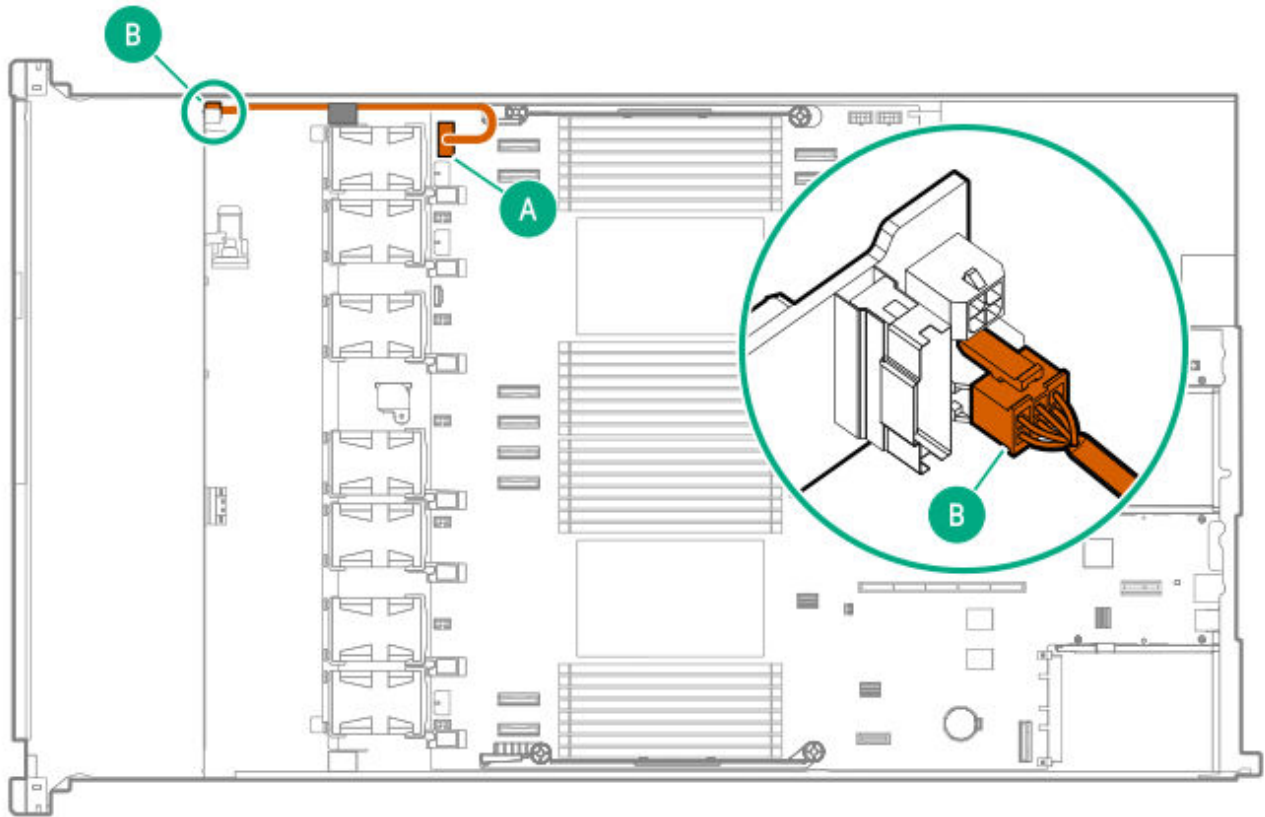

Cable part number	Color	From	To
P75566-001	Orange	8 SFF backplane	Backplane Box 1 power connector

2 SFF backplane power

This cable is supported in the 8 SFF drive configuration.

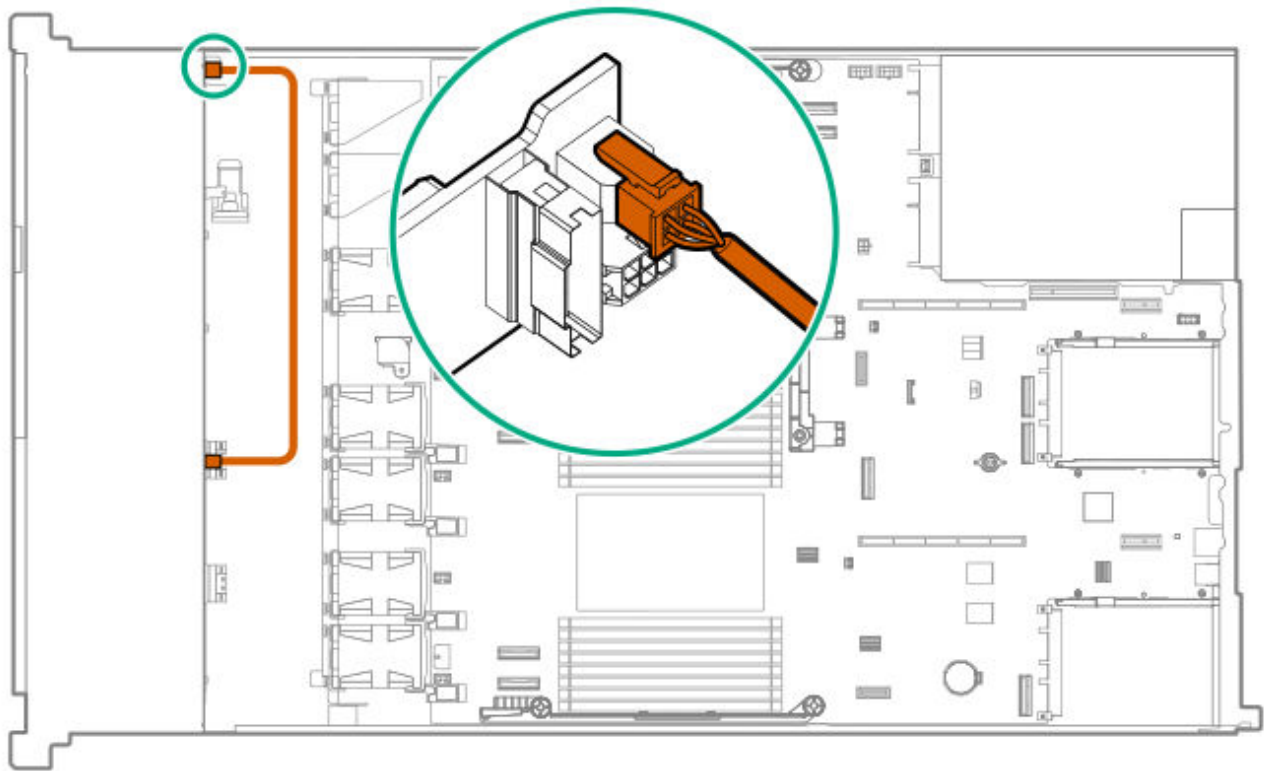

Cable part number	Color	From	To
869667-001	Orange	2 SFF backplane	8 SFF backplane

10 SFF / 20 E3.S server: Stacked 2 SFF / 4 EDSFF backplane power

This cable is supported in the 10 SFF / 20 E3.S server or servers using the mixed drive type configuration.

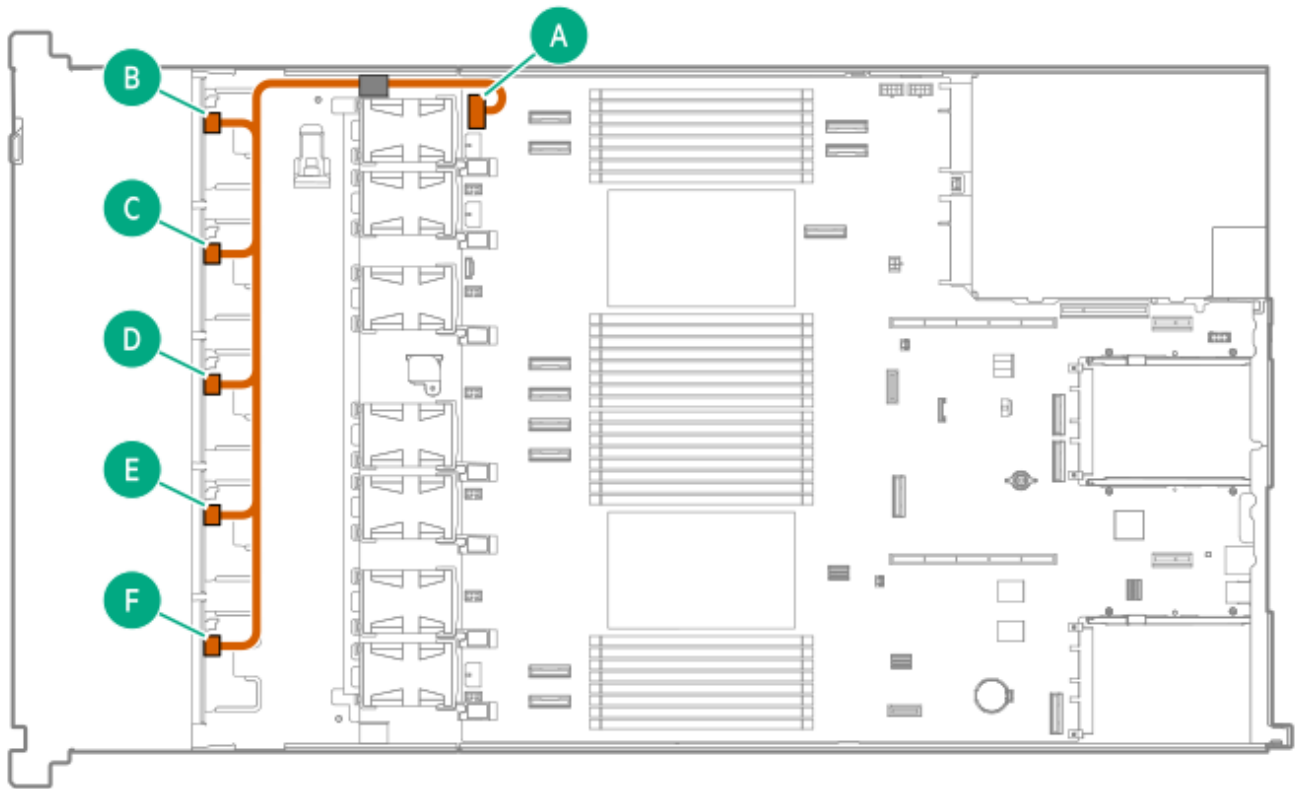

Cable part number	Color	From	To
P75316-001	Orange	SFF/ EDSFF backplane	Backplane power connector

Energy pack cabling

Energy pack cabling: 4 LFF drive configuration

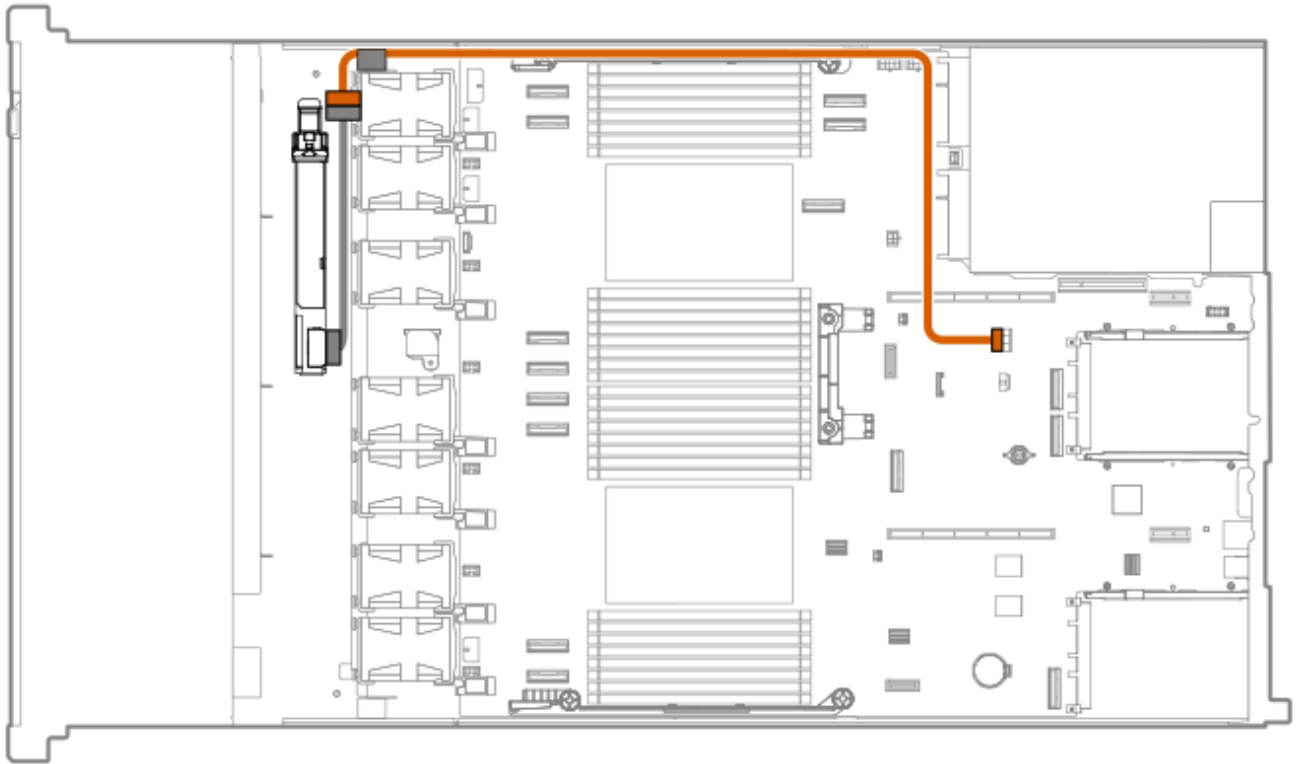

Cable part number	Color	From	To
P45618-001	Orange	Energy pack	Energy pack connector

Energy pack cabling: 8 SFF drive configuration

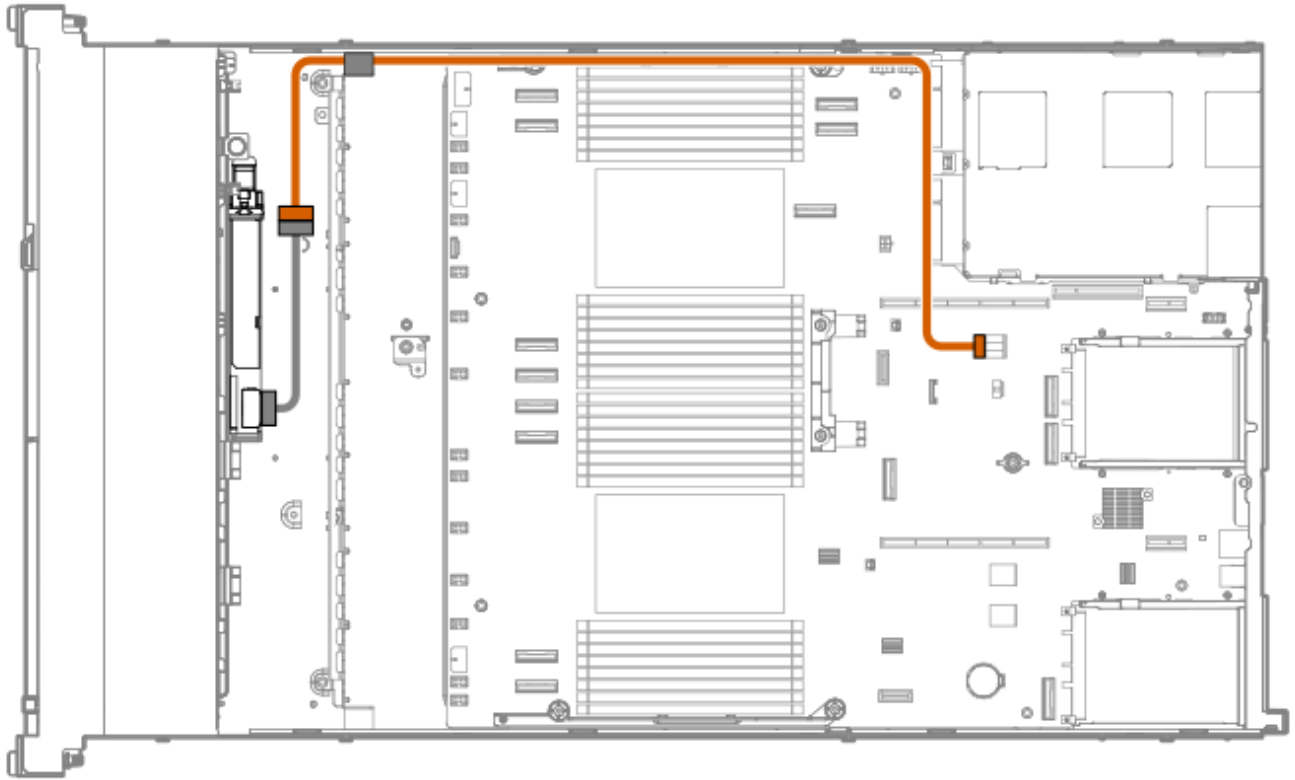

Cable part number	Cable color	From	To
P45618-001	Orange	Energy pack	Energy pack connector

Energy pack cabling: 10 SFF / 20 E3.S server

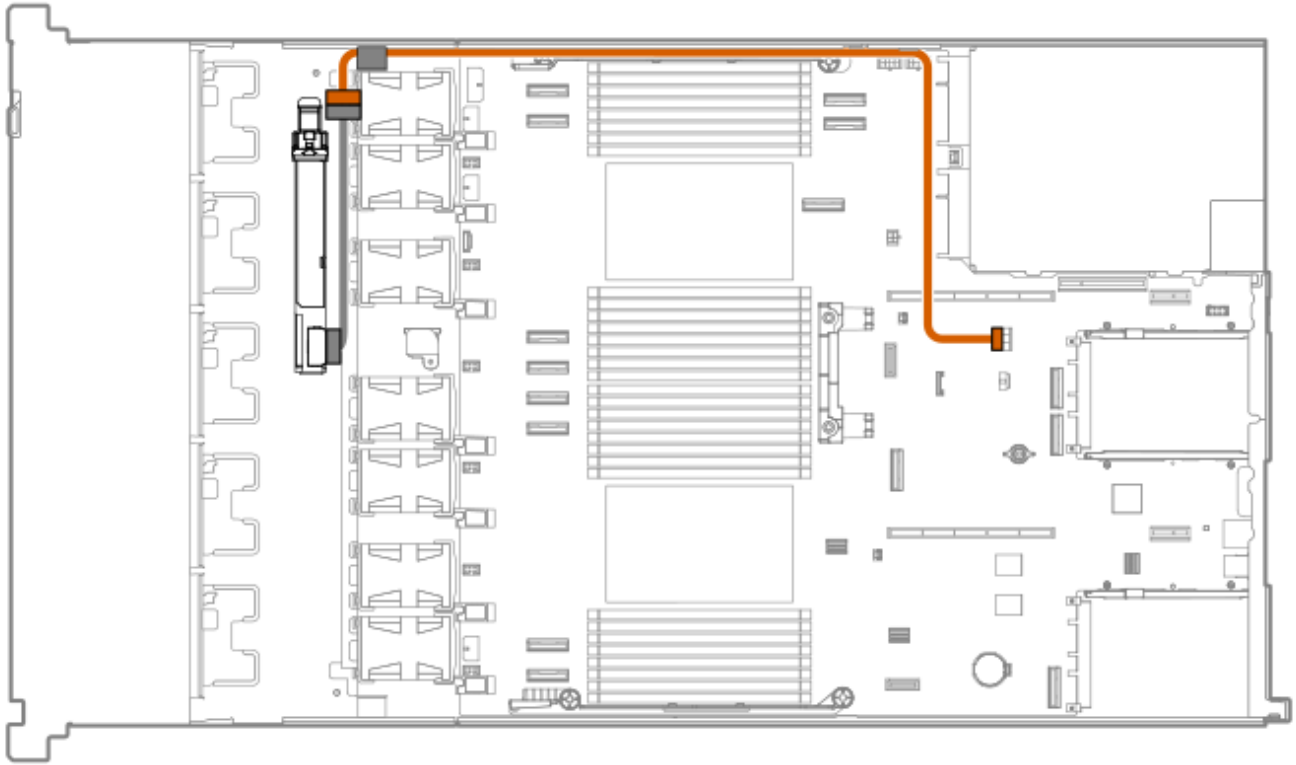

Cable part number	Cable color	From	To
P45618-001	Orange	Energy pack	Energy pack connector

Optical drive cabling

4 LFF drive configuration: optical drive cabling

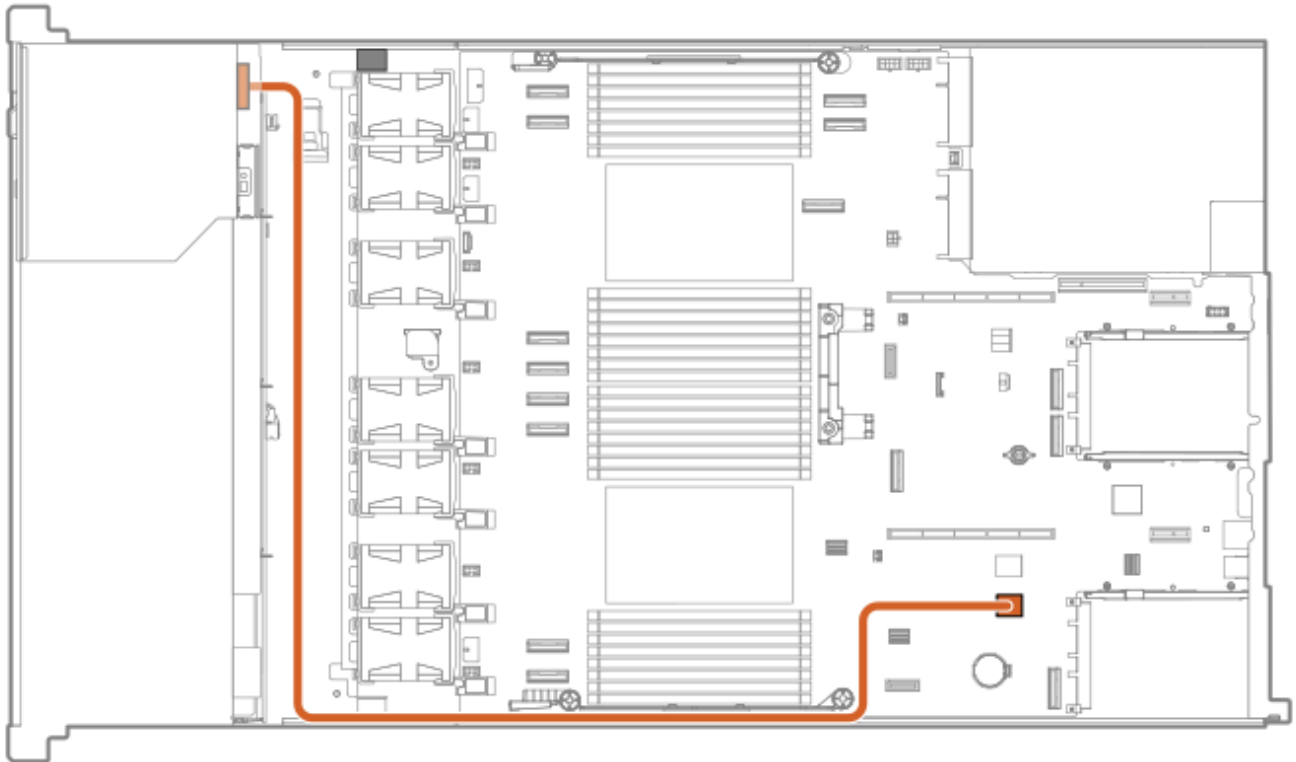

Cable part number	Color	From	To
P73776-002	Orange	Optical drive	Internal USB 3.2 Gen1 port

8 SFF drive configuration: optical drive cabling

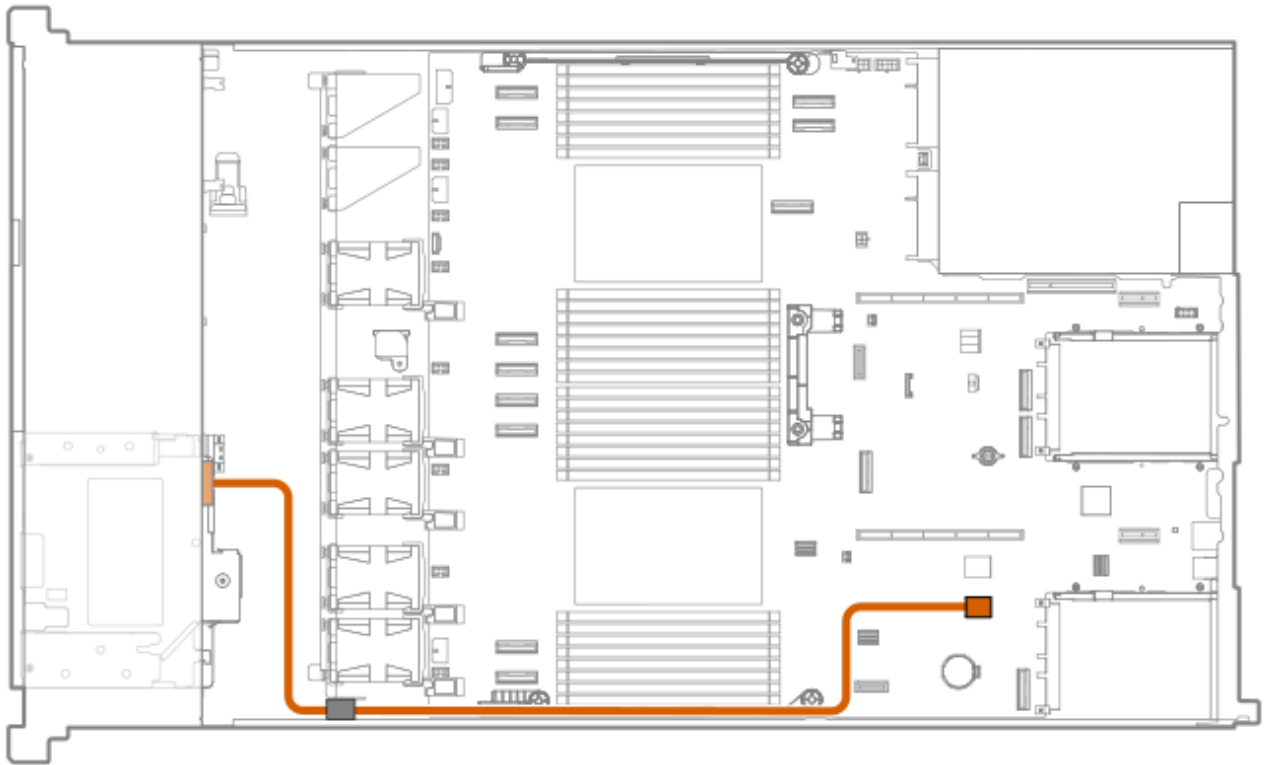

Cable part number	Color	From	To
P73776-002	Orange	Optical drive	Internal USB 3.2 Gen1 port

Mixed drive type configuration: optical drive cabling

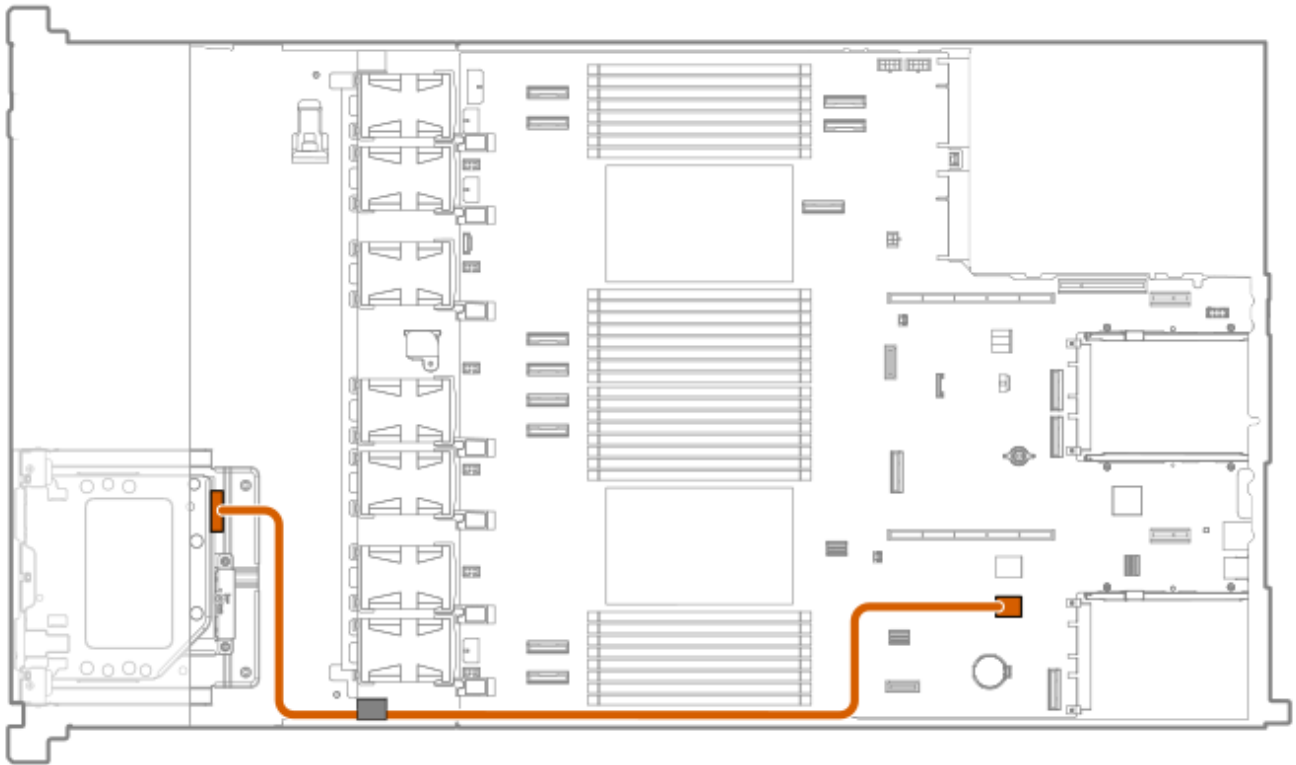

Cable part number	Color	From	To
P73776-002	Orange	Optical drive	Internal USB 3.2 Gen1 port

Front DisplayPort / USB cabling

4 LFF drive configuration: DisplayPort / USB cabling

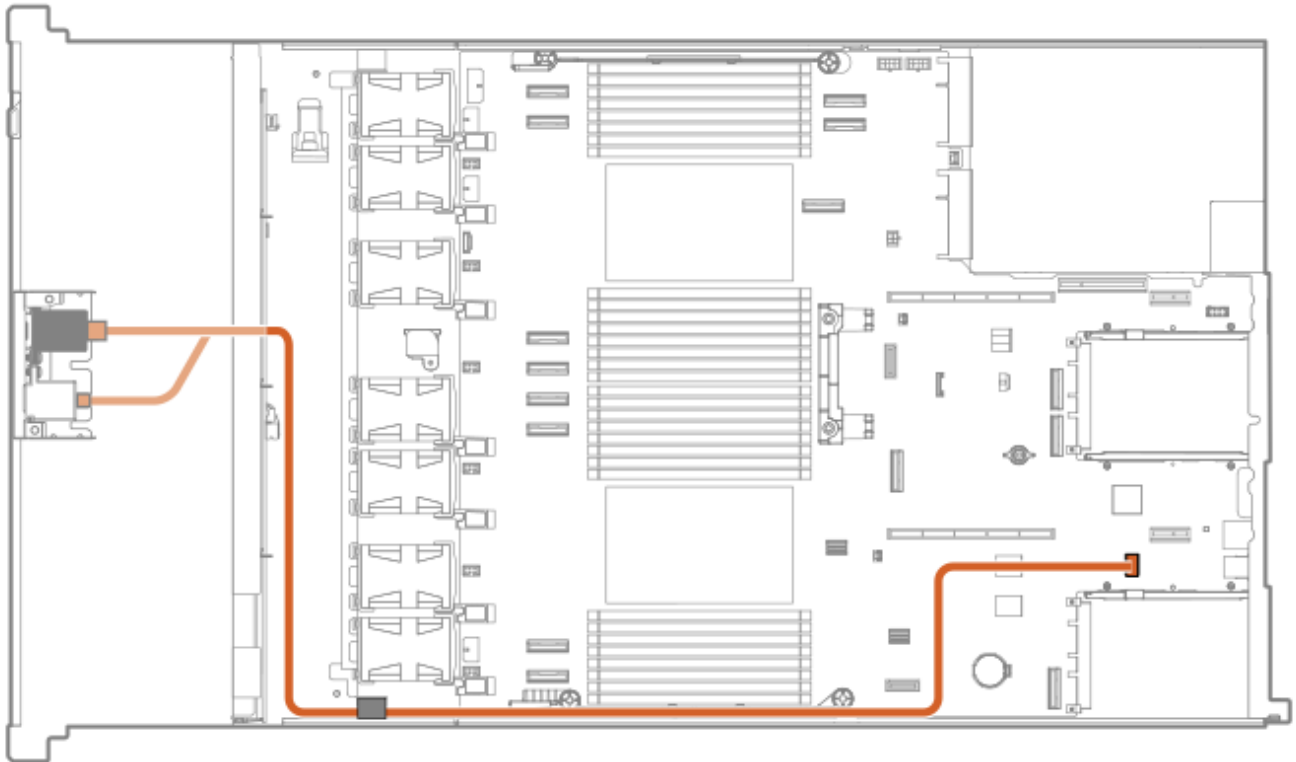

Cable part number	Color	From	To
P73948-001	Orange	4 LFF front display/USB B	DisplayPort and USB 2.0 port

8 SFF drive configuration: DisplayPort / USB cabling

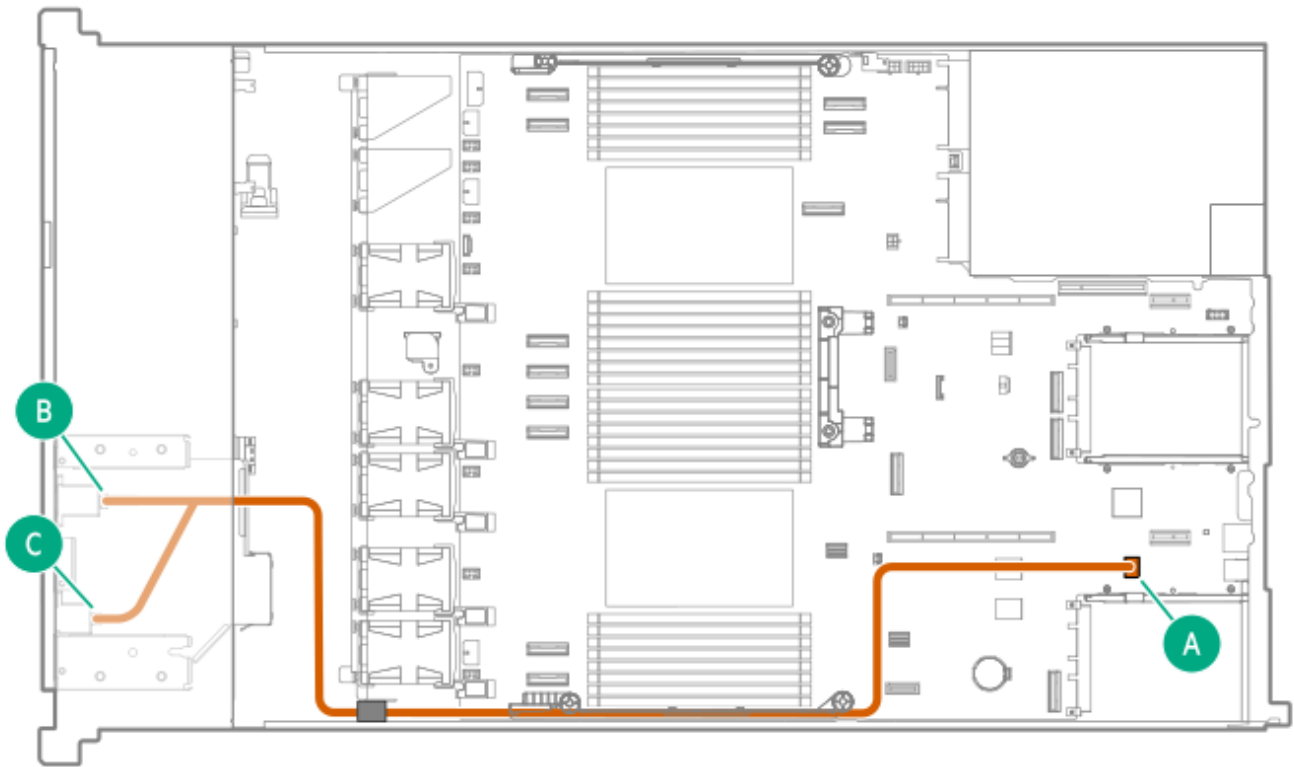

Cable part number	Color	From	To
P73948-001	Orange	8 SFF display/USB/OD D	DisplayPort and USB 2.0 port

Mixed drive type configuration: DisplayPort / USB cabling

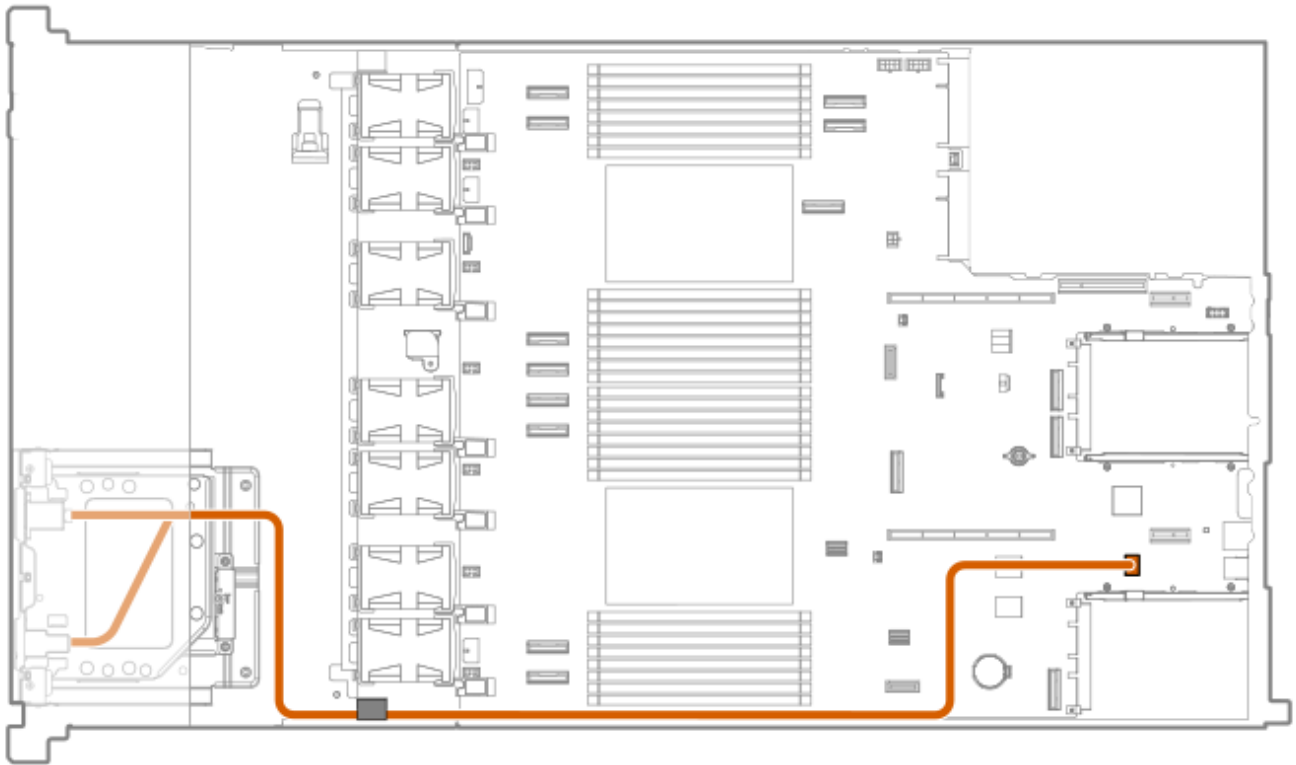

Cable part number	Color	From	To
P73948-001	Orange	Mixed drive type display/USB/ODD	DisplayPort and USB 2.0 port

Internal boot device cabling

- 4 LFF server

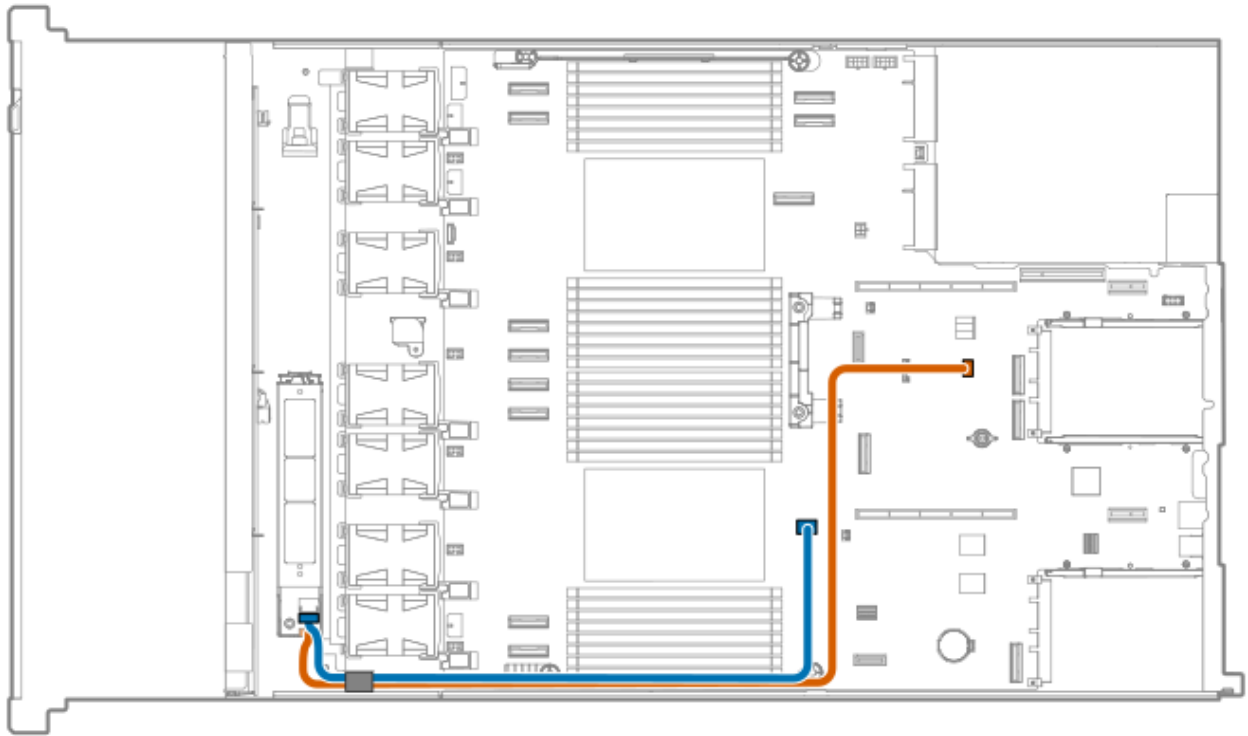

Cable part number	Color	From	To
P48956-001	Orange	Boot device power connector	NS204i-u power connector
P74839-001	Blue	Boot device signal connector	NS204i-u signal connector

- 8 SFF server

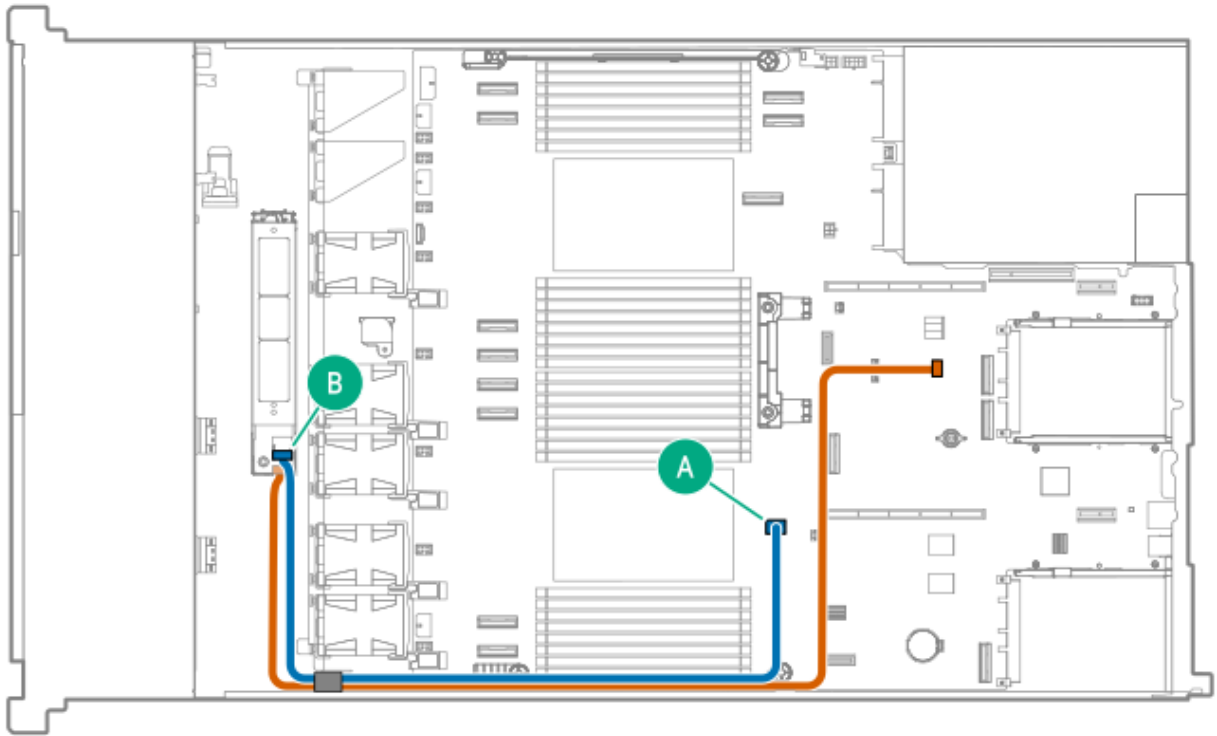

Cable part number	Color	From	To
P48956-001	Orange	Boot device power connector	NS204i-u power connector
P74839-001	Blue	Boot device signal connector	NS204i-u signal connector

- **10 SFF / 20 E3.S server**

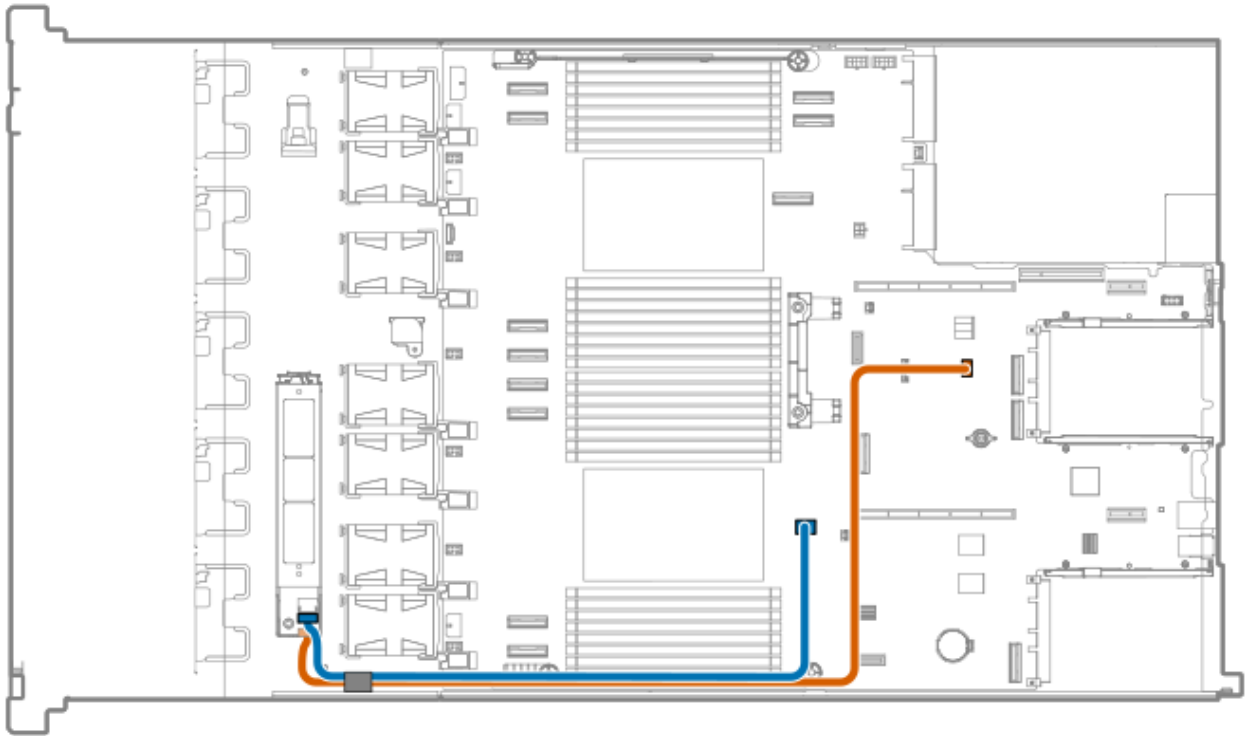

Cable part number	Color	From	To
P48956-001	Orange	Boot device power connector	NS204i-u power connector
P74839-001	Blue	Boot device signal connector	NS204i-u signal connector

Front panel boot device in the 10 SFF / 20 E3.S server or mixed drive type configuration

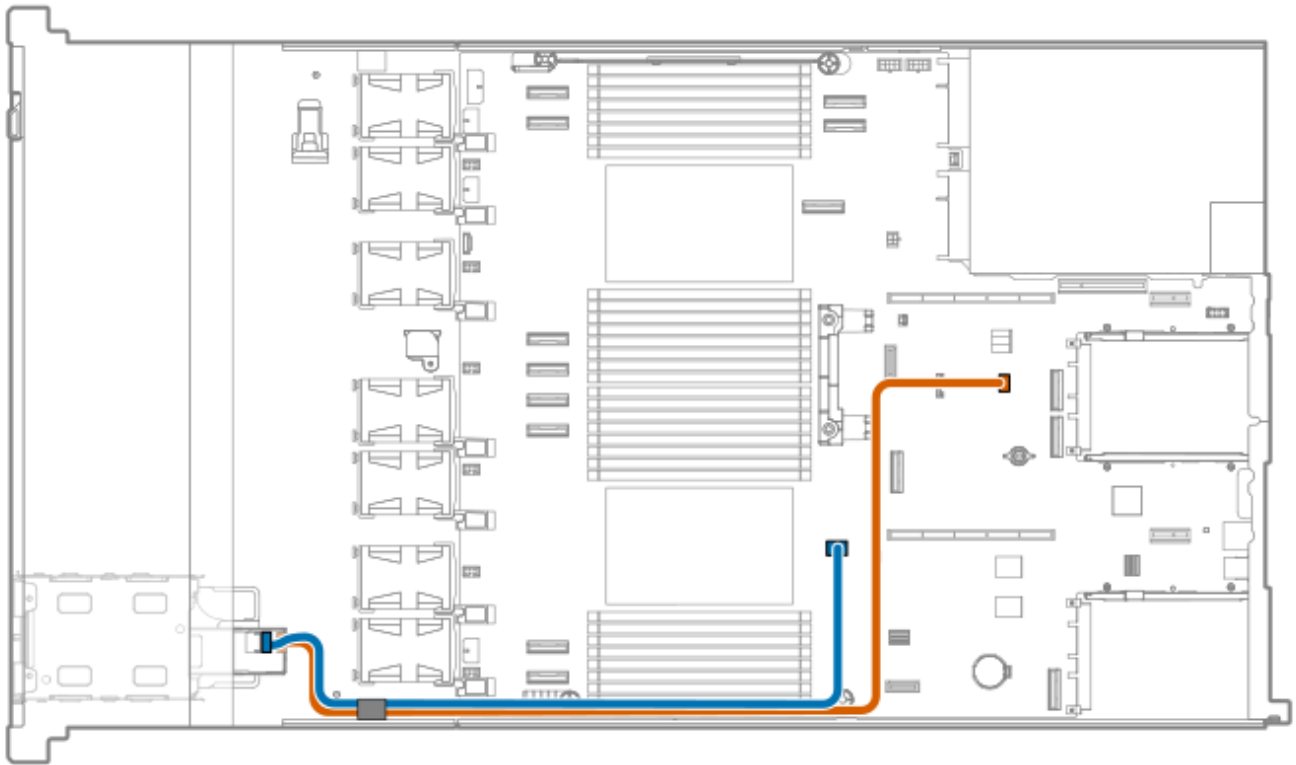

Cable part number	Color	From	To
P48956-001	Orange	Boot device power connector	NS204i-u power connector
P74839-001	Blue	Boot device signal connector	NS204i-u signal connector

Riser cage boot device cabling

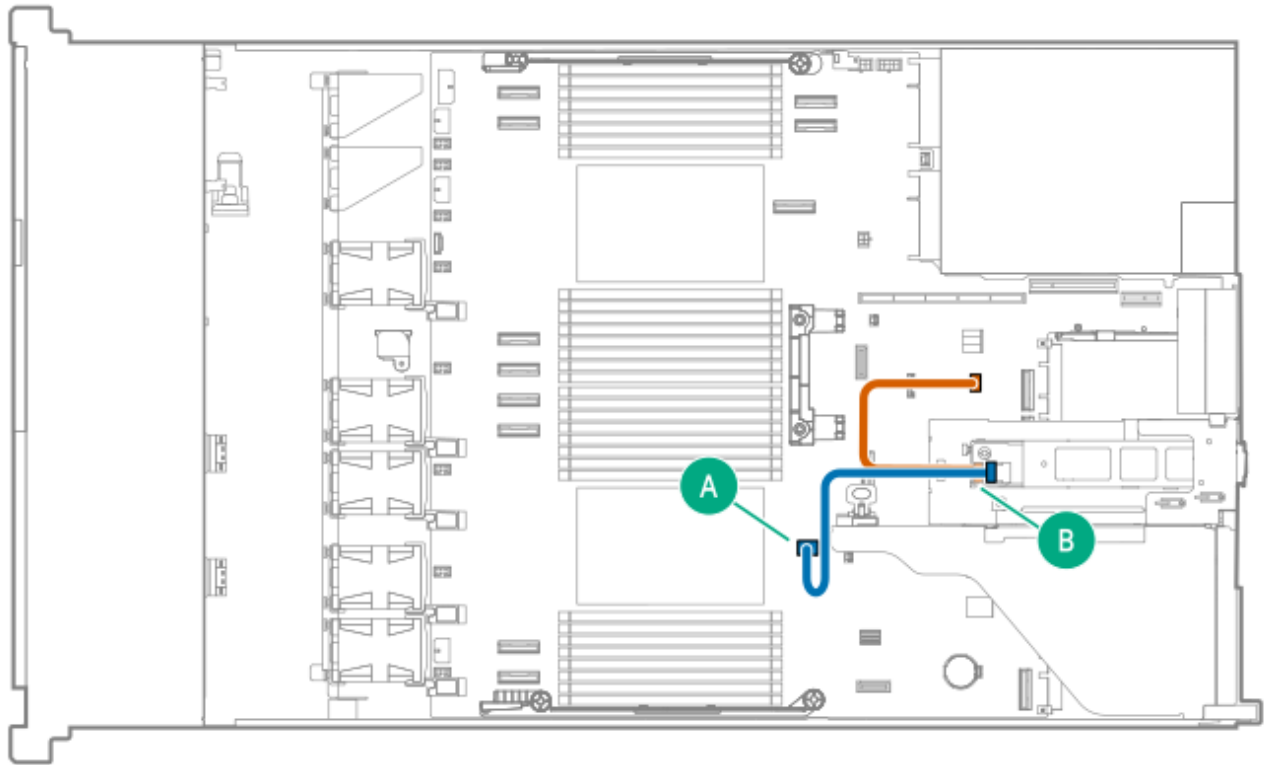

Cable part number	Color	From	To
P54088-001	Orange	Boot device power connector	NS204i-u power connector
P71913-001	Blue	Boot device signal connector	NS204i-u signal connector

Front OCP NIC cabling

Primary front OCP NIC cabling

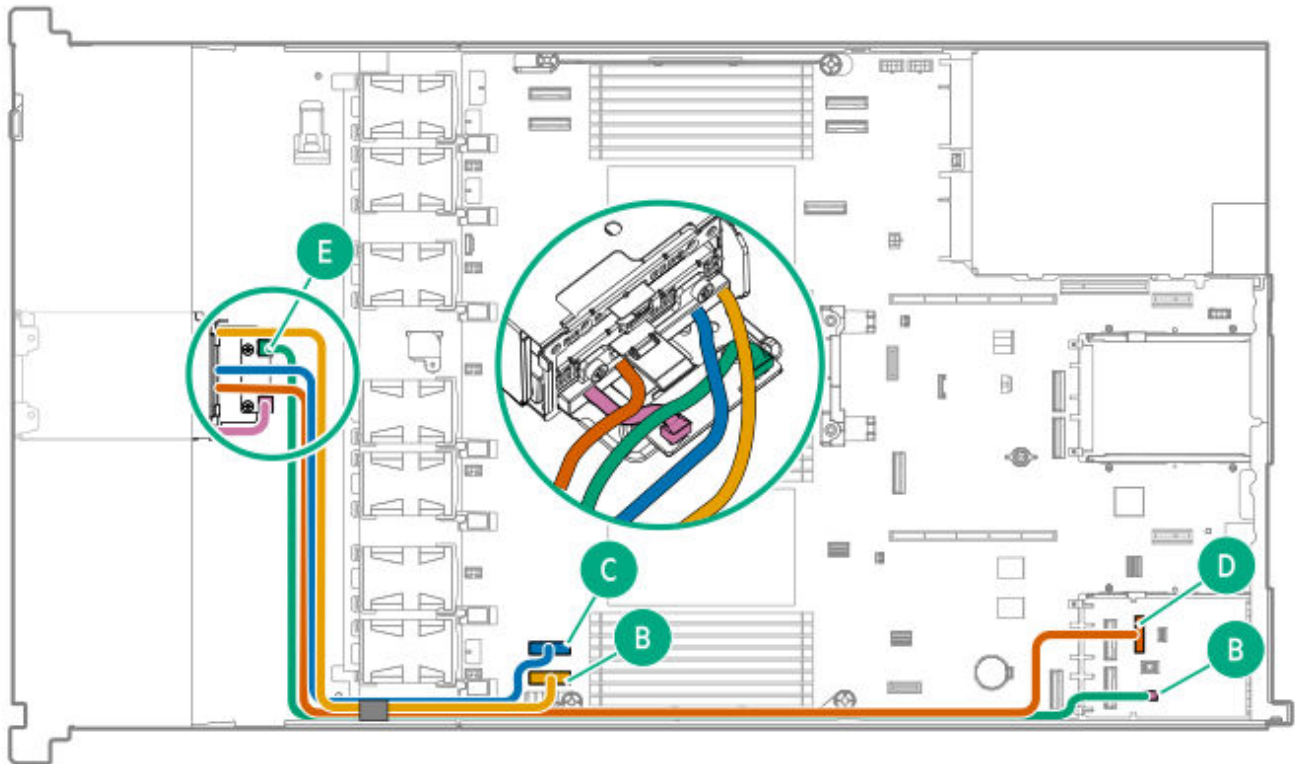

Cable part number	Color	From	To
P71942-001	Gold	Front OCP NIC cable	MCIO port 1
	Blue		MCIO port 2
	Orange		OCP NIC interposer: J35
	Pink		PHY board: J1 (to-INT)
P73927-001	Green	PHY board: J2 (to-OCP)	OCP NIC interposer: J4 (to-PHY)

Secondary front OCP NIC cabling

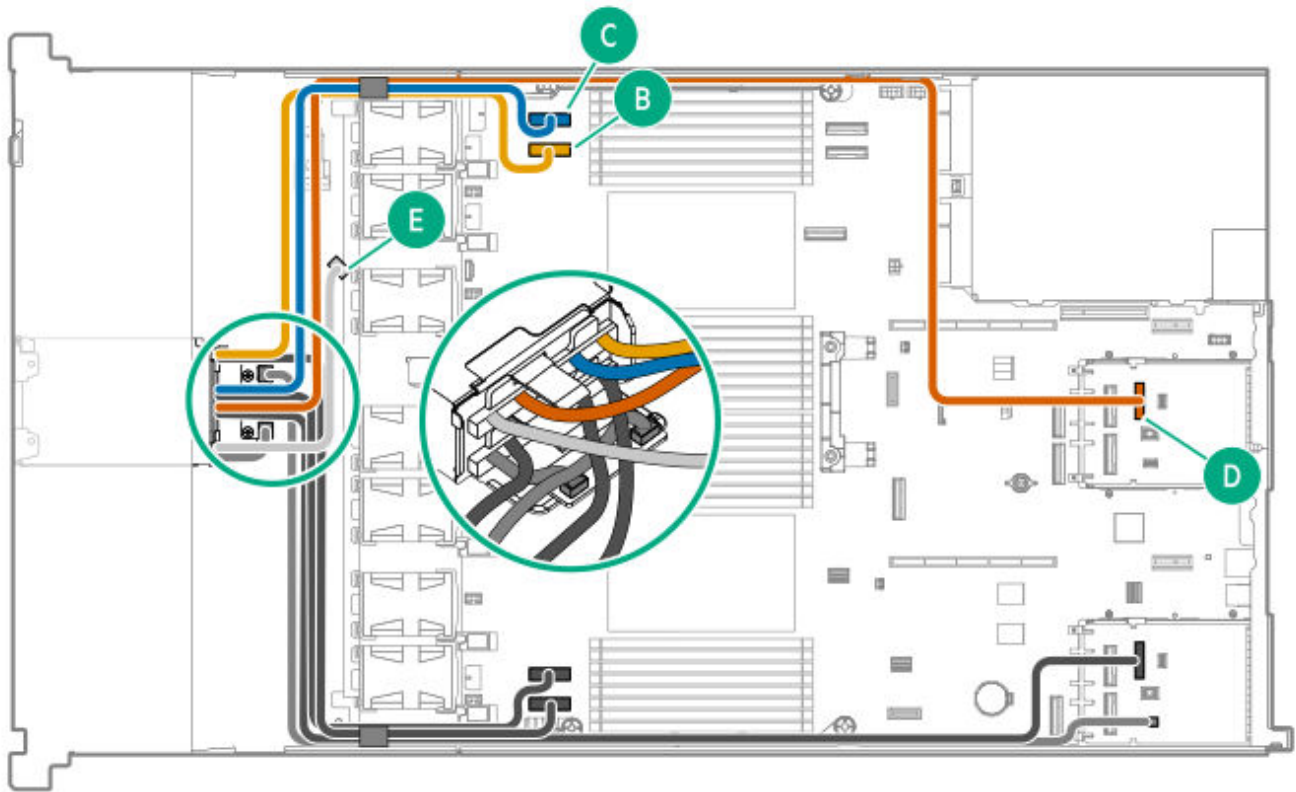

Cable part number	Color	From	To
P71942-001	Gold	Front OCP NIC cable	MCIO port 7
	Blue		MCIO port 8
	Orange		OCP NIC interposer: J35
	Light gray		—

OCP bandwidth enablement cabling

Slot 14 OCP A x16 enablement

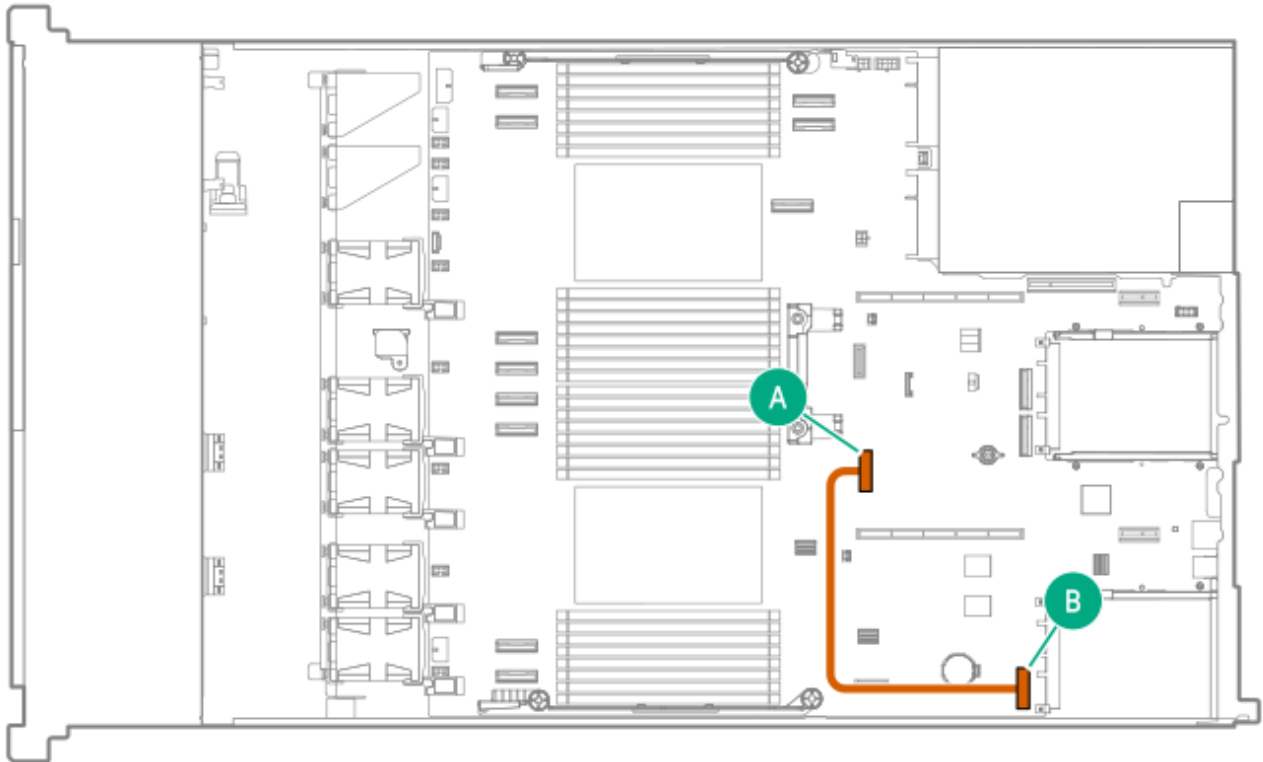

Cable part number	Color	From	To
P74890-001	Orange	OCP A internal port 1	MCIO port 12

CPU1 to Slot 15 OCP B x8 enablement

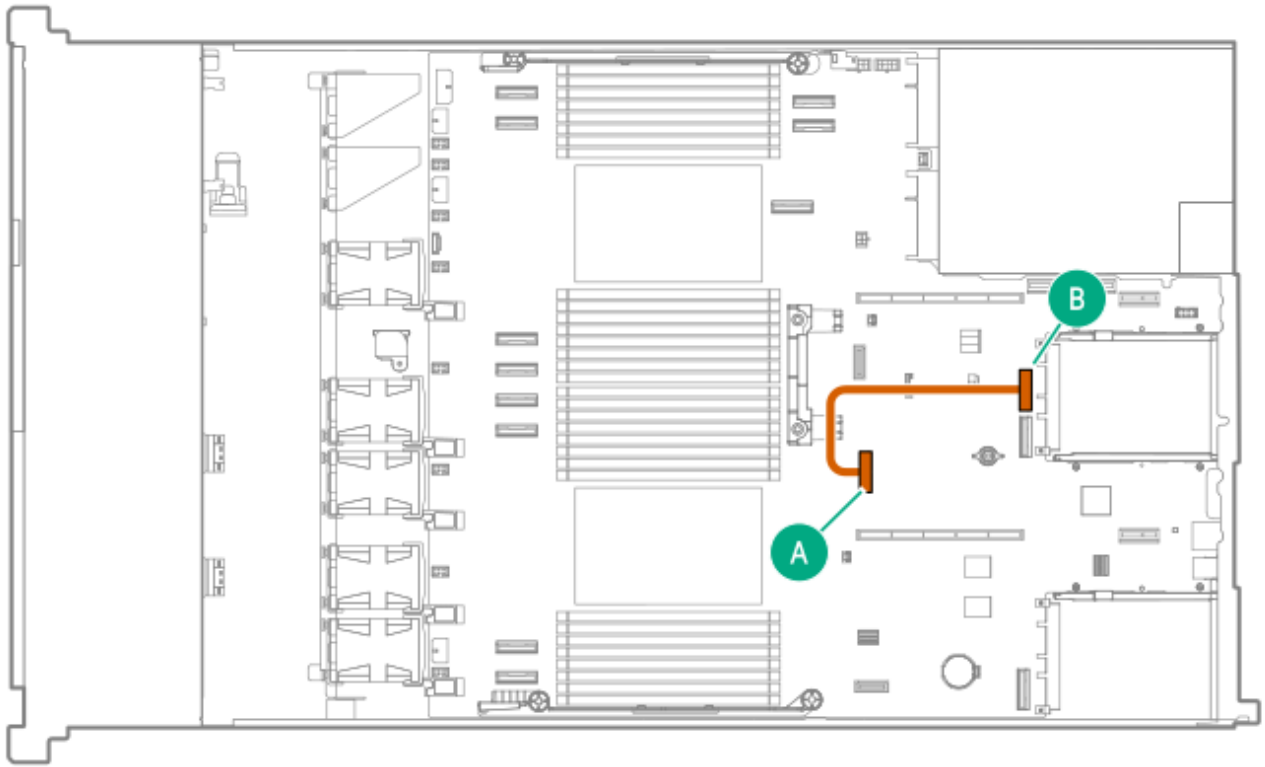

Cable part number	Color	From	To
P74889-001	Orange	OCP B internal port 1	MCIO port 12

CPU2 to Slot 15 OCP B x8 enablement

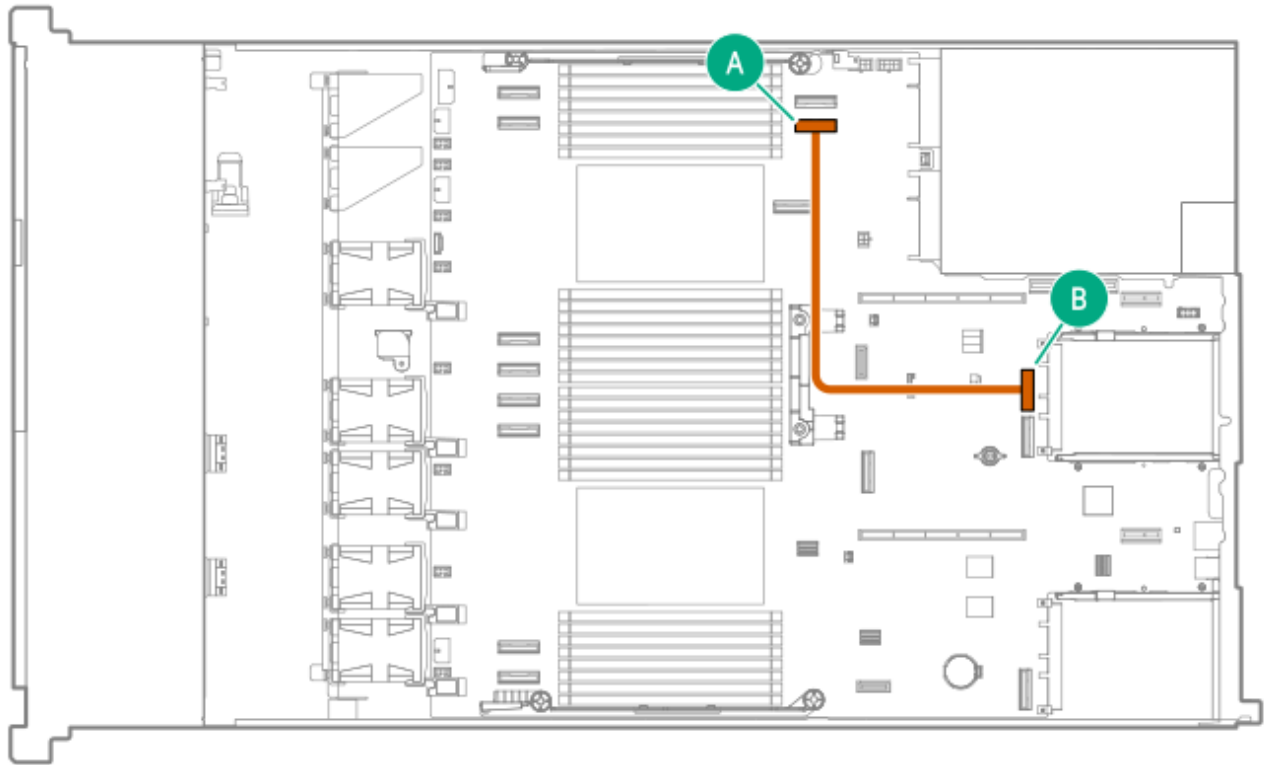

Cable part number	Color	From	To
P74891-001	Orange	OCP B internal port 1	MCIO port 10

CPU2 to Slot 15 OCP B x16 enablement

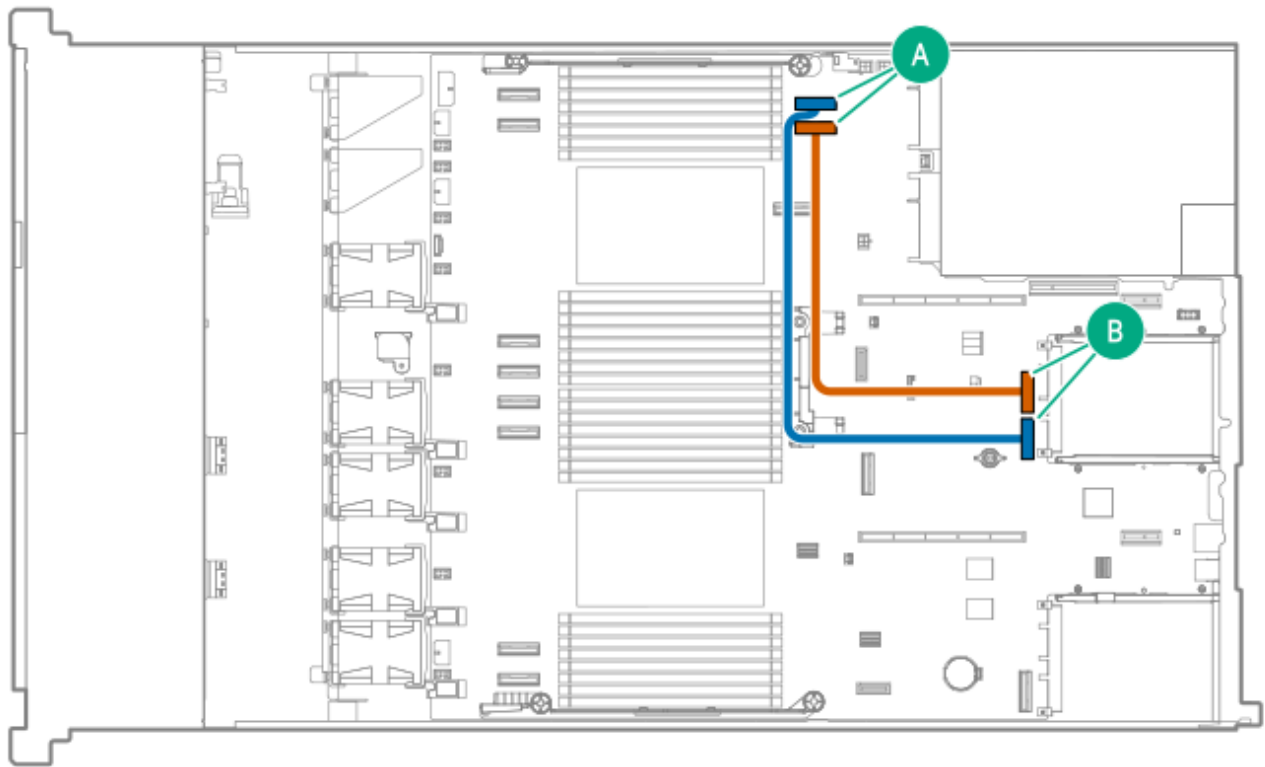

Cable part number	Color	From	To
P74891-001	Orange	OCP B internal port 1	MCI0 port 10
P74891-001	Blue	OCP B internal port 2	MCI0 port 9

Serial port cabling

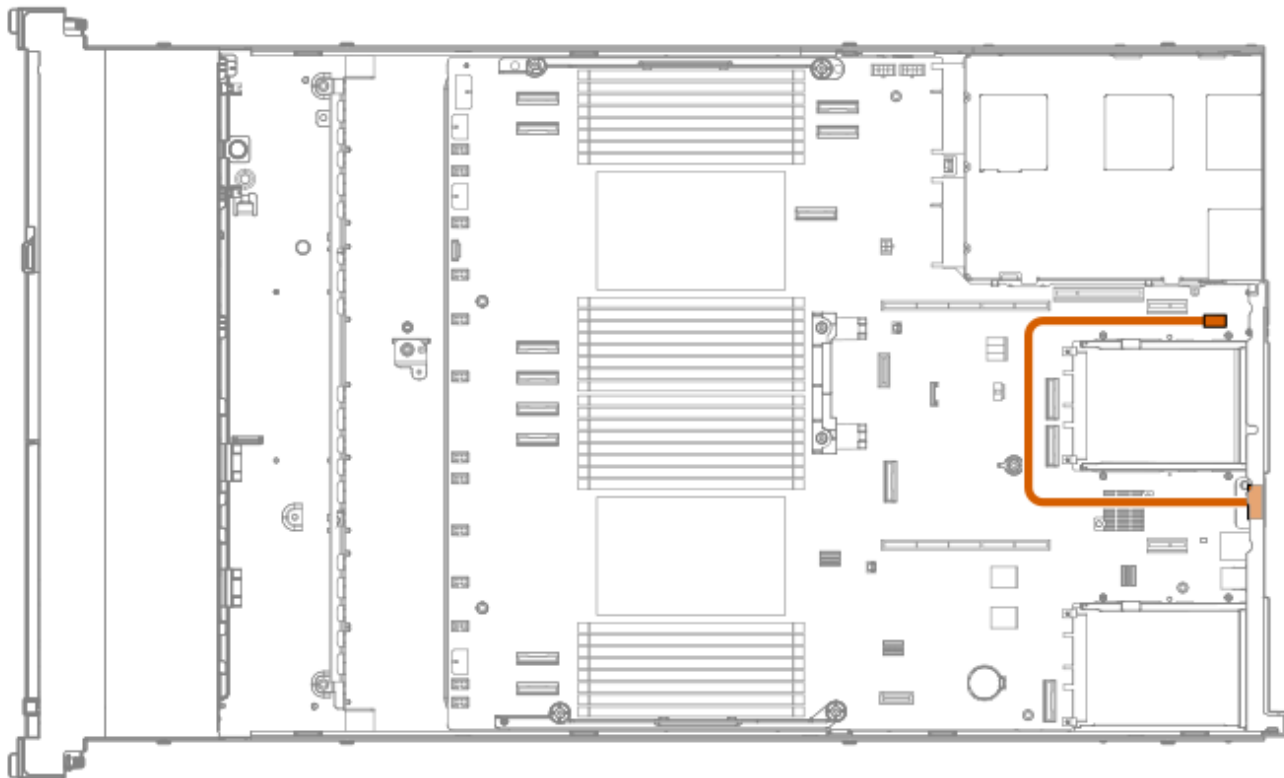

Cable part number	Color	From	To
P45623-001	Orange	Serial port	Serial port cable connector

Chassis intrusion detection switch cabling

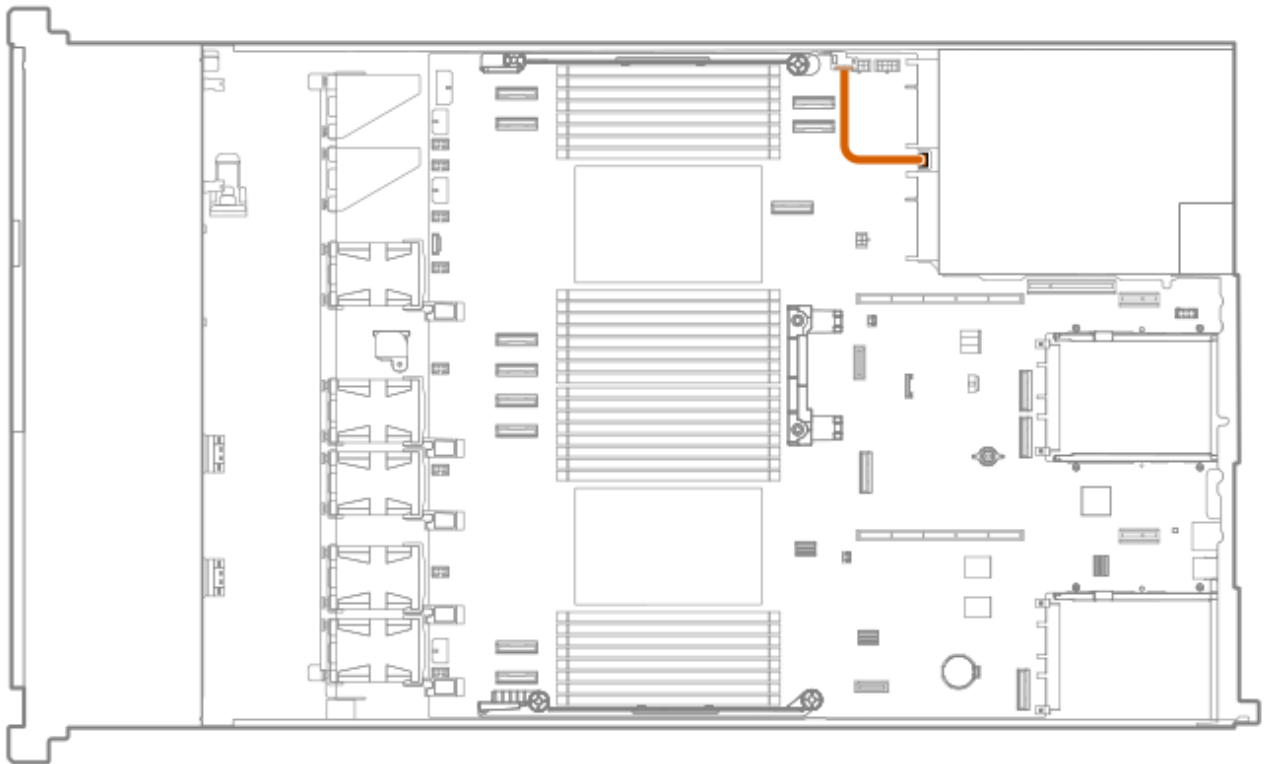

Cable part number	Color	From	To
P47751-001	Orange	Intrusion detection switch	Chassis intrusion detection switch connector

Front I/O cabling

Front I/O cables are preinstalled in the server.

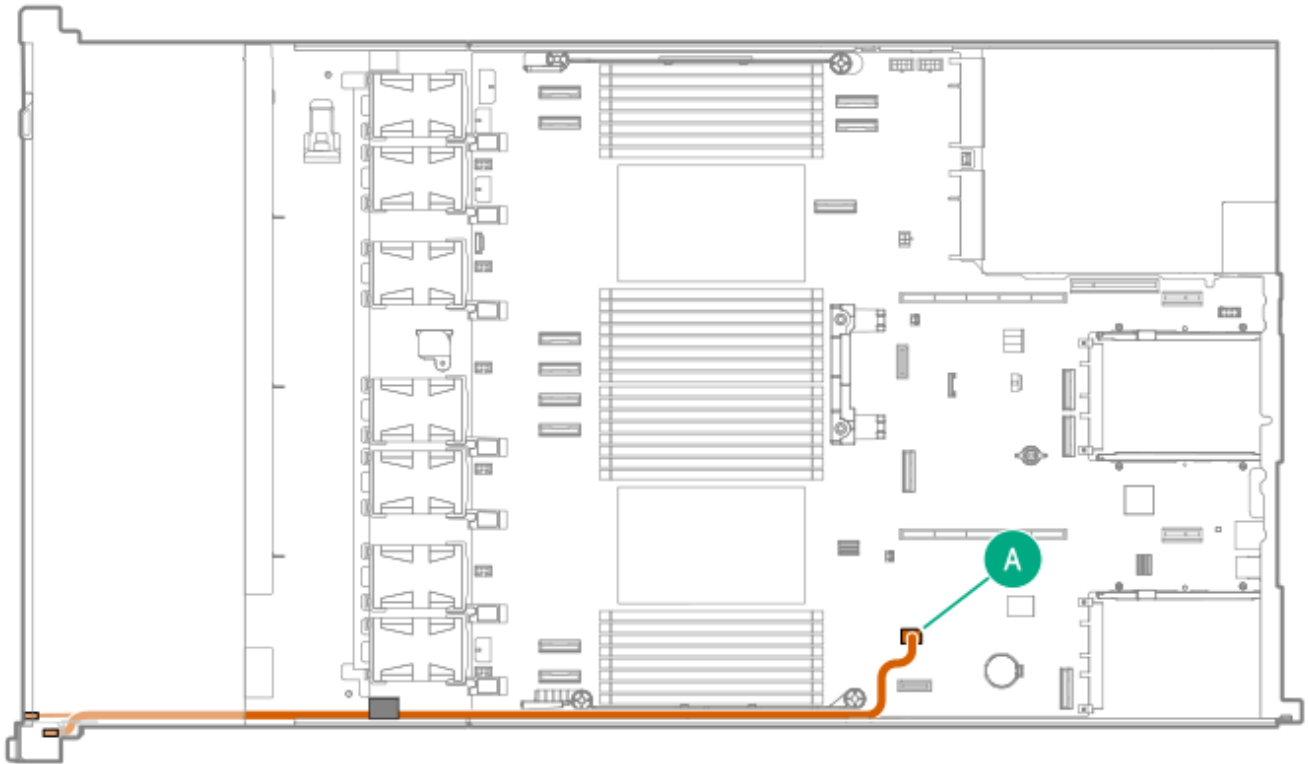

Cable part number	Color	From	To
P71909-002	Orange	Right chassis ear	Front I/O connector

System Insight Display cabling

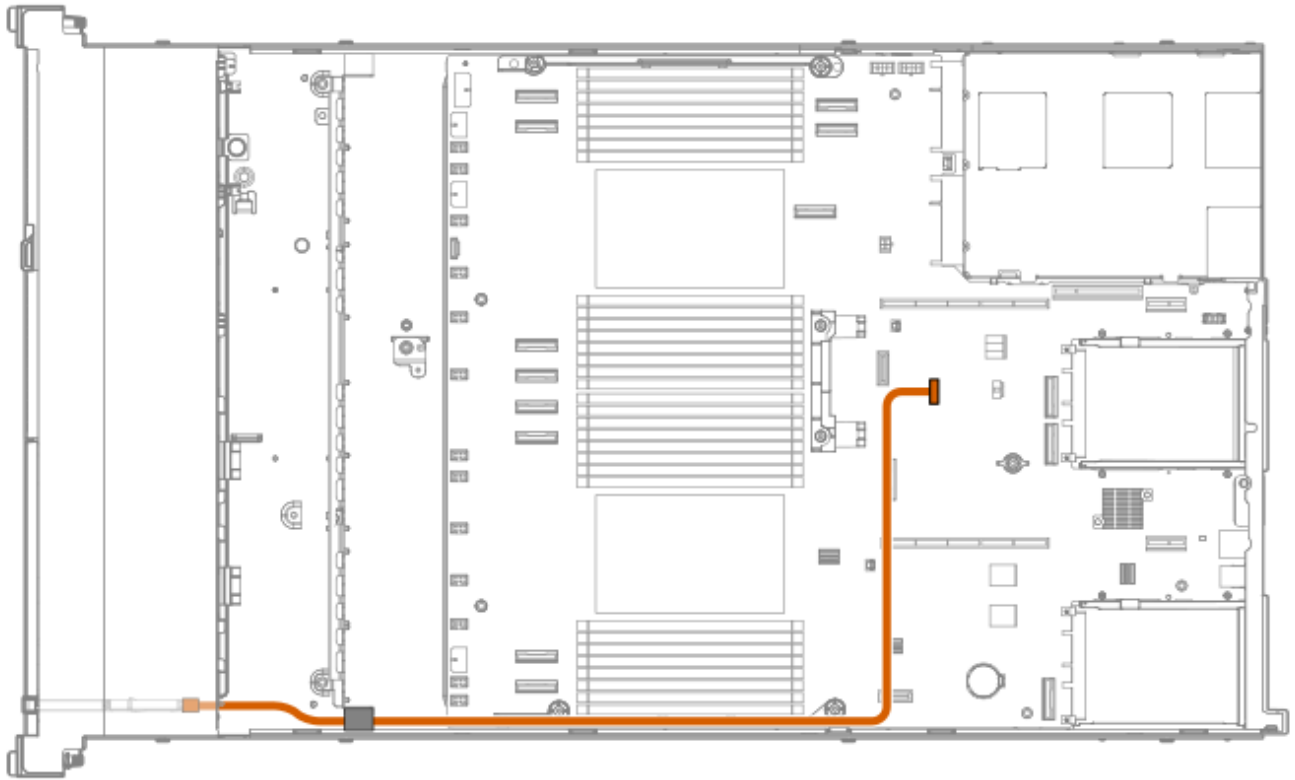

Cable part number	Color	From	To
P48971-001	Orange	System Insight Display	SID connector module

Liquid cooling module cabling

Closed-loop liquid cooling module cabling

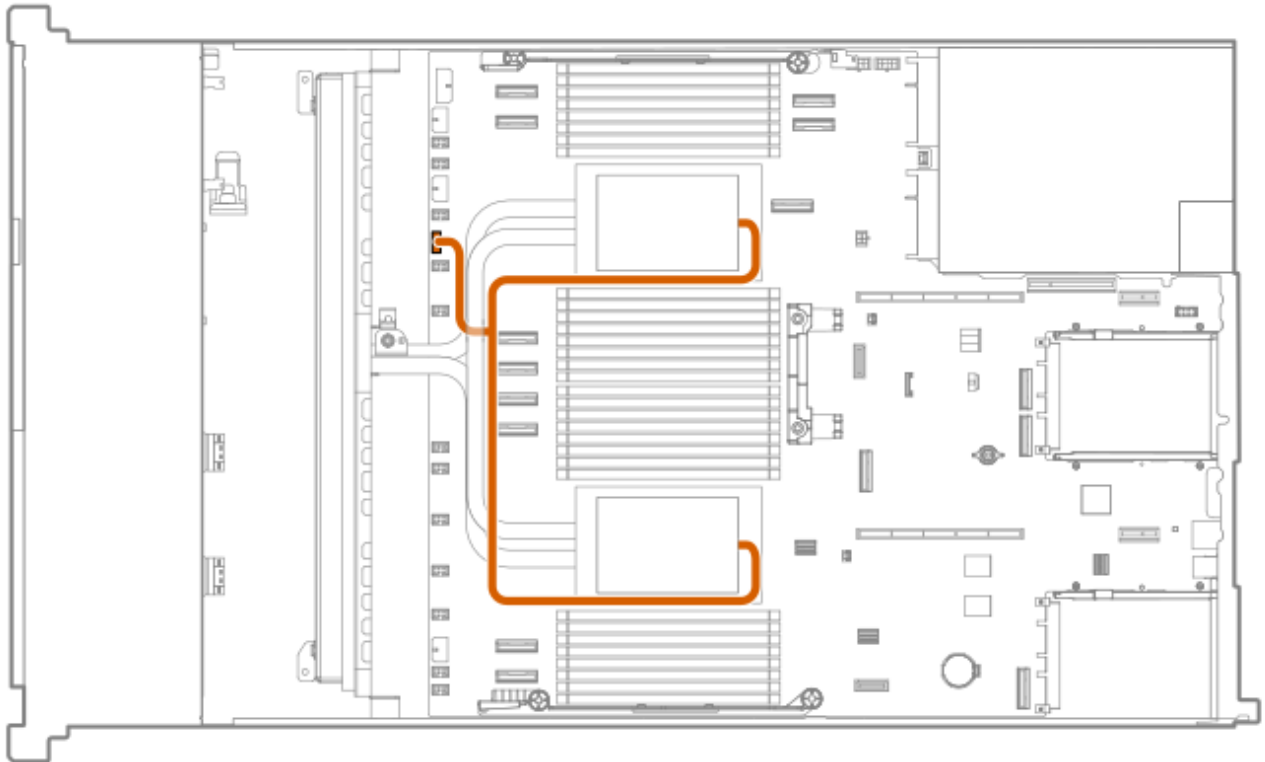

Option kit	Color	From	To
Closed-loop liquid cooling module	Orange	Liquid cooling heatsink	Liquid cooling module connector

Direct liquid cooling module cabling

The cable routing is identical for both available direct liquid cooling solutions (P74208-B21, P79273-B21).

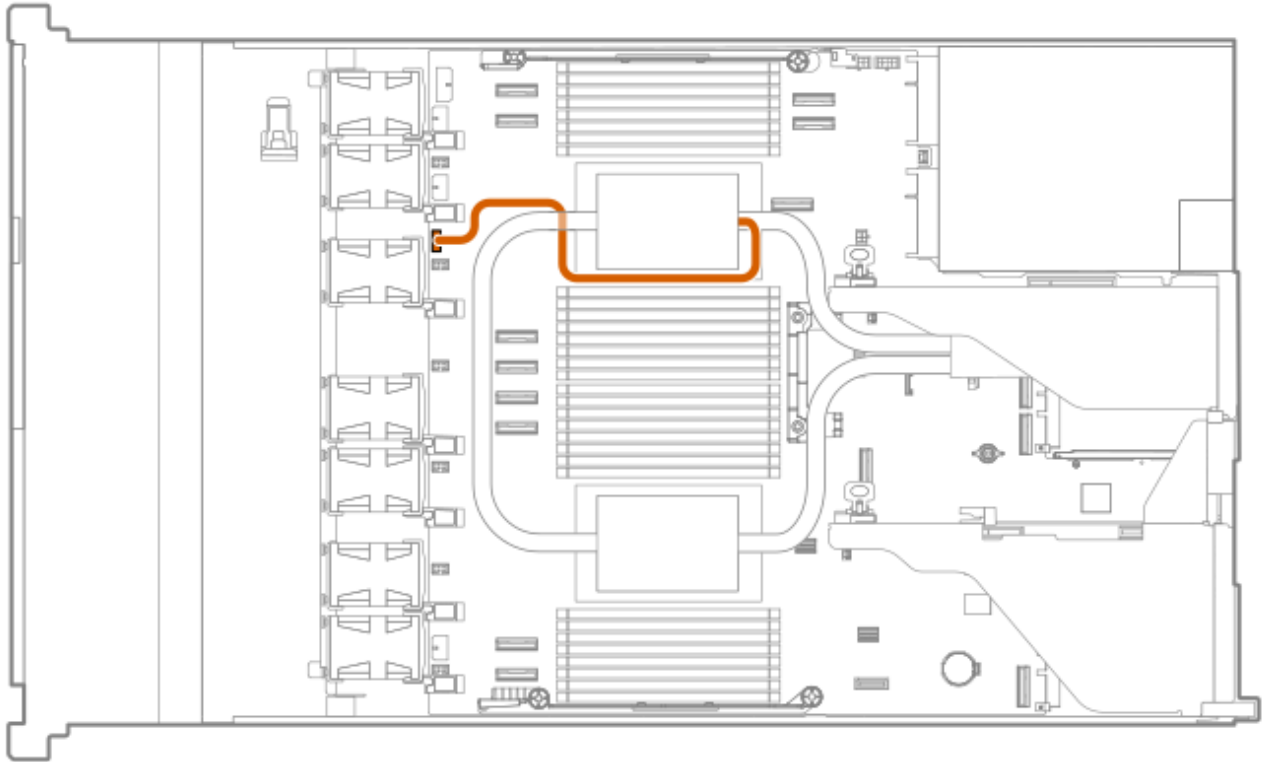

Option kit	Color	From	To
DLC cold plate module *	Orange	Cold plate module	Liquid cooling module connector

* The DLC cold plate modules are factory-installed options.

Configuration resources

Use the following resources to find documentation for configuring and managing your server.

- Some utilities might not apply to your server. For information about server compatibility with the products listed in this chapter, see the product QuickSpecs (<https://www.hpe.com/info/quickspecs>).
- Products ordered from HPE Factory Express might have already been configured with some or all the configurations in this chapter. To determine if any additional setup is required, see your HPE Factory Express order.

- For one-stop access to version-specific software and firmware documentation, including the latest product release notes, see this quick links page:

<https://www.hpe.com/support/hpeproductdocs-quicklinks>

Subtopics

[Updating firmware or system ROM](#)

[Configuring the server](#)

[Configuring storage controllers](#)

[Deploying an OS](#)

[Configuring security](#)

[Server management](#)

[Managing Linux-based high performance compute clusters](#)

Updating firmware or system ROM

To	Use
Download service packs	<ul style="list-style-type: none"> • Service Pack for HPE ProLiant <u>https://www.hpe.com/servers/spp/download</u> • Get an overview of SPP and its ecosystem <u>https://www.hpe.com/support/SPP-overview-views-en</u>
Deploy service packs to a single server	Smart Update Manager <u>https://www.hpe.com/support/hpesmartupdatemanager-quicklinks</u>
Deploy service packs to multiple servers	HPE OneView <u>https://www.hpe.com/support/hpeoneview-quicklinks</u>
Updating iLO or system firmware in a single server	iLO user guide <u>https://www.hpe.com/support/hpeilodocs-quicklinks</u>

To	Use
<ul style="list-style-type: none"> • Enable policy-based management of server or server group firmware for distributed server infrastructure • Monitor server compliance with a configured firmware baseline • Receive automatic iLO firmware updates • Receive baseline update alerts 	<p>HPE Compute Ops Management</p> <p>https://www.hpe.com/support/hpe-gl-com-quicklinks</p>

Configuring the server

To configure	Use
Single server (GUI)	<ul style="list-style-type: none"> • Intelligent Provisioning https://www.hpe.com/support/hpeintelligentprovisioning-quicklinks • iLO remote console or web interface https://www.hpe.com/support/hpeilodocs-quicklinks • UEFI System Utilities https://www.hpe.com/support/hpeuefisystemutilities-quicklinks • HPE Compute Ops Management https://www.hpe.com/support/hpe-gl-com-quicklinks
Single server (scripting)	<ul style="list-style-type: none"> • RESTful Interface Tool https://www.hpe.com/support/restfulinterface/docs

To configure

Use

- Python iLO Redfish Library (python-ilorest-library)
<https://github.com/HewlettPackard/python-ilorest-library>
- Scripting Tools for Windows Powershell
<https://www.hpe.com/info/powershell/docs>
- iLO RESTful API
<https://servermanagementportal.ext.hpe.com/>
- HPE Compute Ops Management API
<https://developer.greenlake.hpe.com/>

Multiple servers (either UI or scripting)

- HPE OneView ¹
<https://www.hpe.com/support/hpeoneview-quicklinks>
- HPE Compute Ops Management
<https://www.hpe.com/support/hpe-gl-com-quicklinks>
 - **Server settings:** Define server-specific parameters such as firmware baselines, and then apply them to server groups.
 - **Server groups:** Organize servers into custom-defined sets with associated server settings, and then apply group-specific policies to create a consistent configuration across the servers in the group.

¹ For servers running HPE OneView, do not use another tool, such as iLO, to delete or change certain settings. For more information about using HPE OneView and iLO to manage the same server, see the iLO user guide at <https://www.hpe.com/support/hpeilodocs-quicklinks>.

Configuring storage controllers

Controller type	Documentation
HPE MR controller user guides	<ul style="list-style-type: none">• HPE MR Gen11 Controller User Guide https://hpe.com/support/MR-Gen11-UG<ul style="list-style-type: none">◦ MR Gen11 controller configuration: https://www.hpe.com/support/MR-Gen11-configuration◦ MR Gen11 controller RAID creation: https://www.hpe.com/support/MR-Gen11-RAID-creation• HPE MR932i-p PCIe SPDM PI Storage Controller User Guide https://hpe.com/support/MR932i-UG<ul style="list-style-type: none">◦ MR932i-p controller configuration: www.hpe.com/support/MR932i-configuration◦ MR932i-p controller RAID creation: www.hpe.com/support/MR932i-RAID-creation
HPE MR controller configuration guides	<ul style="list-style-type: none">• HPE MR Storage Administrator User Guide https://www.hpe.com/support/MRSA• HPE StorCLI User Guide https://www.hpe.com/support/StorCLI• HPE StorCLI2 User Guide https://www.hpe.com/support/StorCLI2
Intel VROC for HPE Gen12	<ul style="list-style-type: none">• Intel Virtual RAID on CPU for HPE User Guide https://www.hpe.com/support/VROC-UG

Controller type

Documentation

- Intel VROC NVMe RAID quick installation:

<https://www.hpe.com/support/VROC-NVMe-RAID-installation>

OS-specific configuration guides:

- Intel Virtual RAID on CPU (Intel VROC) for Windows User Guide

https://docs.graidtech.com/vroc/User_Guides/000094004_Intel_Virtual_RAID_on_CPU_Intel_VROC_User_Guide_for_Windows/

- Intel Virtual RAID on CPU (Intel VROC) for Linux User Guide

https://docs.graidtech.com/vroc/User_Guides/000094694_Intel_Virtual_RAID_on_CPU_Intel_VROC_User_Guide_for_Linux/

- Intel Volume Management Device Driver for VMware ESXi User Guide

https://docs.graidtech.com/vroc/User_Guides/000094787_Intel_Virtual_RAID_on_CPU_Intel_VROC_User_Guide_for_VMware_ESXi/

Deploying an OS

For a list of supported operating systems, see the HPE Servers Support & Certification Matrices:

<https://www.hpe.com/support/Servers-Certification-Matrices>

To

See

Deploy an OS using HPE Compute Ops Management HPE Compute Ops Management User Guide

<https://www.hpe.com/support/hpe-gl-com-quicklinks>

Deploy an OS using Intelligent Provisioning

Intelligent Provisioning user guide

To	See
	https://www.hpe.com/support/hpeintelligentprovisioning-quicklinks
Deploy an OS using iLO virtual media	iLO user guide https://www.hpe.com/support/hpeilodocs-quicklinks
Configure the server to boot from a PXE server	UEFI System Utilities User Guide for HPE Compute servers https://www.hpe.com/support/UEFIGen12-UG-en
Configure the server to boot from a SAN	HPE Boot from SAN Configuration Guide https://www.hpe.com/info/boot-from-san-configuration-guide

Configuring security

To	See
Implement server security best practices.	<ul style="list-style-type: none"> HPE Compute Security Reference Guide https://www.hpe.com/info/server-security-reference-en HPE iLO 7 Security Technology Brief https://www.hpe.com/support/ilo7-security-en
Configure and use the Server Configuration Lock feature on HPE Trusted Supply Chain servers and other servers that have the Server Configuration Lock feature enabled.	Server Configuration Lock User Guide for HPE ProLiant servers and HPE Synergy https://www.hpe.com/info/server-config-lock-UG-en

Server management

To monitor	See
Single server	HPE iLO https://www.hpe.com/support/hpeilodocs-quicklinks
Multiple servers	HPE OneView https://www.hpe.com/support/hpeoneview-quicklinks
Single or multiple servers	HPE Compute Ops Management https://www.hpe.com/support/hpe-gl-com-quicklinks

Managing Linux-based high performance compute clusters

To	Use
Provision, manage, and monitor clusters.	HPE Performance Cluster Manager https://www.hpe.com/support/hpcm_manuals
Optimize your applications.	HPE Performance Analysis Tools https://www.hpe.com/info/perftools
Optimize software library for low latency and high bandwidth, both on-node and off-node, for point-to-point and collective communications.	HPE Cray Programming Environment User Guide https://www.hpe.com/info/cray-pe-user-guides

Troubleshooting

Subtopics

NMI functionality

An NMI crash dump enables administrators to create crash dump files when a system is not responding to traditional debugging methods.

An analysis of the crash dump log is an essential part of diagnosing reliability problems, such as hanging operating systems, device drivers, and applications. Many crashes freeze a system, and the only available action for administrators is to cycle the system power. Resetting the system erases any information that could support problem analysis, but the NMI feature preserves that information by performing a memory dump before a hard reset.

To force the OS to initiate the NMI handler and generate a crash dump log, the administrator can use the iLO Generate NMI feature.

Front panel LED power fault codes

The following table provides a list of power fault codes, and the subsystems that are affected. Not all power faults are used by all servers.

Subsystem	LED behavior
System board	1 flash
Processor	2 flashes
Memory	3 flashes
Riser board PCIe slots	4 flashes
OCP adapter	5 flashes
Storage controller	6 flashes
System board PCIe slots	7 flashes
Power backplane	8 flashes
Storage backplane	9 flashes
Power supply	10 flashes
PCIe expansion cards installed in riser board	11 flashes
Chassis	12 flashes
GPU card	13 flashes

Troubleshooting resources

If you need help troubleshooting, see the latest articles for your server.

<https://www.hpe.com/info/dl360gen12-troubleshooting>

Safety, warranty, and regulatory information

Subtopics

[Regulatory information](#)

[Warranty information](#)

Regulatory information

To view the regulatory information for your product, view the Safety and Compliance Information for Server, Storage, Power, Networking, and Rack Products, available at the Hewlett Packard Enterprise Support Center:

<https://www.hpe.com/support/Safety-Compliance-EnterpriseProducts>

Additional regulatory information

Hewlett Packard Enterprise is committed to providing our customers with information about the chemical substances in our products as needed to comply with legal requirements such as REACH (Regulation EC No 1907/2006 of the European Parliament and the Council). A chemical information report for this product can be found at:

<https://www.hpe.com/info/reach>

For Hewlett Packard Enterprise product environmental and safety information and compliance data, including RoHS and REACH, see:

<https://www.hpe.com/info/ecodata>

For Hewlett Packard Enterprise environmental information, including company programs, product recycling, and energy efficiency, see:

<https://www.hpe.com/info/environment>

Subtopics

Notices for Eurasian Economic Union



Manufacturer and Local Representative Information

Manufacturer information:

Hewlett Packard Enterprise Company, 1701 E Mossy Oaks Road, Spring, TX 77389 U.S.

Local representative information Russian:

- **Russia**
ООО "Хьюлетт Паккард Энтерпрайз", Российская Федерация, 125171, г. Москва, Ленинградское шоссе, 16А, стр.3, Телефон: +7 499 403 4248 Факс: +7 499 403 4677
- **Kazakhstan**
ТОО «Хьюлетт-Паккард (К)», Республика Казахстан, 050040, г. Алматы, Бостандыкский район, проспект Аль-Фараби, 77/7, Телефон/факс: + 7 727 355 35 50

Local representative information Kazakh:

- **Russia**
ЖШС "Хьюлетт Паккард Энтерпрайз", Ресей Федерациясы, 125171, Мәскеу, Ленинград тас жолы, 16А блок 3, Телефон: +7 499 403 4248 Факс: +7 499 403 4677
- **Kazakhstan**
ЖШС «Хьюлетт-Паккард (К)», Қазақстан Республикасы, 050040, Алматы к., Бостандык ауданы, Әл-Фараби даңғылы, 77/7, Телефон/факс: +7 727 355 35 50

Manufacturing date:

The manufacturing date is defined by the serial number.

CCSYWWZZZZ (product serial number format)

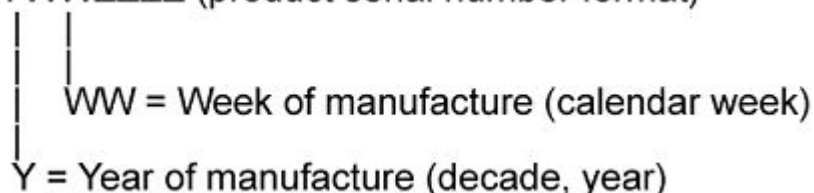

If you need help identifying the manufacturing date, contact tre@hpe.com.

Turkey RoHS material content declaration

Türkiye Cumhuriyeti: AEEE Yönetmeliğine Uygundur

Ukraine RoHS material content declaration

Обладнання відповідає вимогам Технічного регламенту щодо обмеження використання деяких небезпечних речовин в електричному та електронному обладнанні, затвердженого постановою Кабінету Міністрів України від 3 грудня 2008 № 1057

Warranty information

To view the warranty information for your product, see the [warranty check tool](#).

Specifications

Provides environmental, mechanical, and power supply specifications for the server.

Subtopics

[Environmental specifications](#)

[Server and rackmounting specifications](#)

[Power supply specifications](#)

Environmental specifications

Specifications	Value
Temperature range	—
Operating	10°C to 35°C (50°F to 95°F)
Nonoperating	Air-cooled systems: -30°C to 60°C (-22°F to 140°F) Liquid-cooled systems (DLC, CLLC): -10°C to 60°C (14°F to 140°F) CAUTION: To prevent freezing the coolant and damaging the liquid cooling module, do not keep the liquid-cooled systems below -10°C (14°F).
Relative humidity (noncondensing)	—
Operating	8% to 90% 28°C (82.4°F) maximum wet bulb temperature, noncondensing
Nonoperating	5% to 95% 38.7°C (101.7°F) maximum wet bulb temperature, noncondensing
Altitude	—
Operating	3050 m (10,000 ft) This value may be limited by the type and number of options installed. Maximum allowable altitude change rate is 457 m/min (1,500 ft/min).
Nonoperating	9144 m (30,000 ft) Maximum allowable altitude change rate is 457 m/min (1,500 ft/min).

Standard operating support

10° to 35°C (50° to 95°F) at sea level with an altitude derating of 1.0°C per every 305 m (1.8°F per every 1,000 ft) above sea level to a maximum of 3,050 m (10,000 ft), no direct sustained sunlight. Maximum rate of change is 20°C/hr (36°F/hr). The upper limit and rate of change might be limited by the type and number of options installed.

System performance under standard operating support might be reduced if operating above 30°C (86°F) or with a faulty fan installed.

Extended ambient operating support

For approved hardware configurations, the supported system inlet range is extended to be:

- 5° to 10°C (41° to 50°F) and 35° to 40°C (95° to 104°F) at sea level with an altitude derating of 1.0°C per every 175 m (1.8°F per every 574 ft) above 900 m (2,953 ft) to a maximum of 3050 m (10,000 ft).
- 40°C to 45°C (104°F to 113°F) at sea level with an altitude derating of 1.0°C per every 125 m (1.8°F per every 410 ft) above 900 m (2953 ft) to a maximum of 3,050 m (10,000 ft).

The approved hardware configurations for this system are listed in the Extended Ambient Temperature Guidelines for Gen12 Servers:

<https://www.hpe.com/support/ASHRAEGen12>

Server and rackmounting specifications

Server dimensions

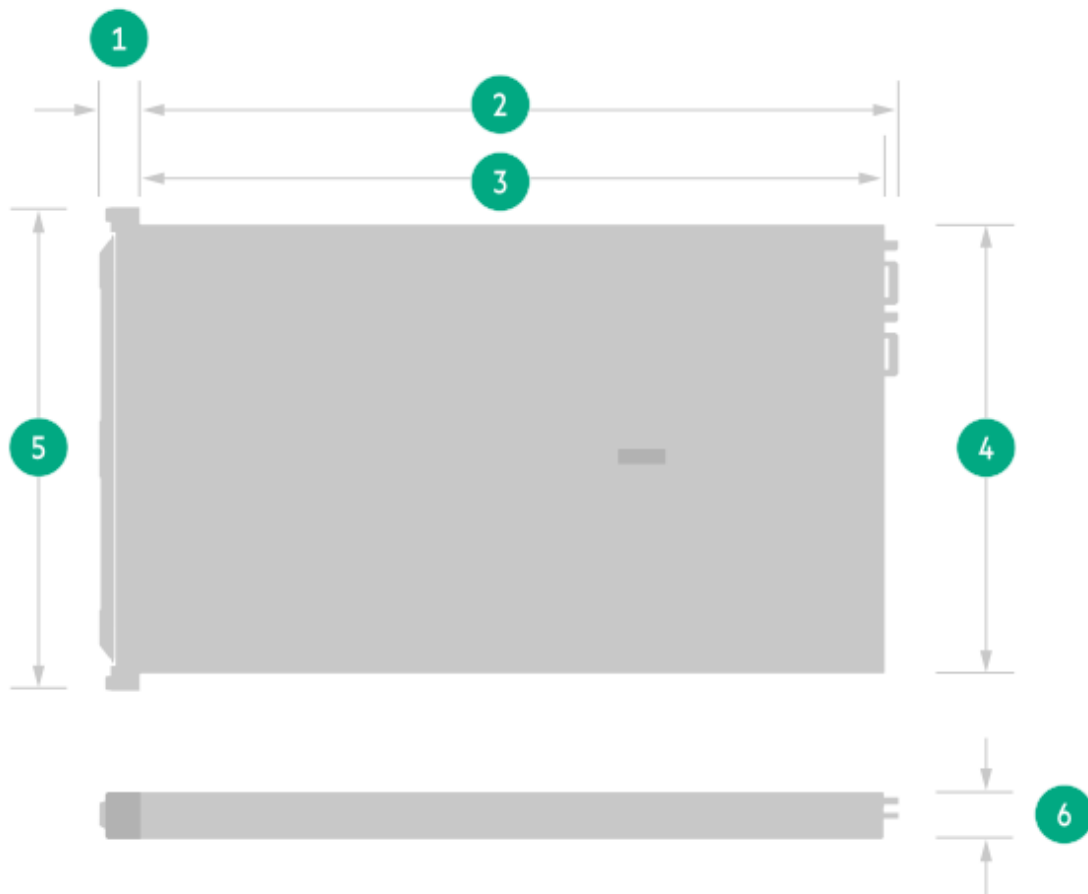

Item	Description	Dimension
1	Front bezel to rearmost edge of chassis ear	3.93 cm (1.55 in)
2	Rearmost edge of chassis ear to PSU	8 + 2 SFF: 78.28 cm (30.82 in) 4 LFF: 80.27 cm (31.61 in) 10 SFF / 20 EDSFF: 80.27 cm (31.61 in)
3	Rearmost edge of chassis ear to server rear I/O	8 + 2 SFF: 75.31 cm (29.65 in) 4 LFF: 77.30 cm (30.43 in) 10 SFF / 20 EDSFF: 77.30 cm (30.43 in)
4	Width	Chassis 43.46 cm (17.11 in)
5	Width	Ear-to-ear 48.26 cm (18.99 in)
6	Height	4.29 cm (1.69 in)

Rackmounting dimensions



Item	Description	Dimension
1	Front EIA mounting post to frontmost server feature	4.98 cm (1.96 in)
2	Front EIA mounting post to server rear I/O	8 SFF: 73.74 cm (29.03 in) 4 LFF or 10 SFF / 20 EDSFF: 75.73 cm (29.83 in)
3	Server rear I/O to rearmost CMA feature	16.85 cm (6.63 in)
4	Rail mount range (min to max) ¹	60.96 cm – 91.81 cm (24.00 in – 36.15 in) ²
5	Depth of front rail mount	1.57 cm (0.62 in)

¹ The range between the front and rear posts of the rack

² The minimum overall length of the rail kit is:

- 8 SFF: 78.76 cm (31.00 in)
- 4 LFF or 10 SFF / 20 EDSFF: 80.87 cm (31.84 in)

Server weight

Weight, approximate values	Value
Weight, 8 + 2 SFF minimum (One drive, one processor, one heatsink, one power supply, one Smart Array controller, and five fans installed)	14.87 kg (32.71 lb)
Weight, 8 + 2 SFF maximum (Ten drives, two processors, two heatsinks, two power supplies, one Smart Array controller, and seven fans installed)	19.94 kg (43.96 lb)
Weight, 4 LFF minimum (One drive, one processor, one heatsink, one power supply, one Smart Array controller, and five fans installed)	15.25 kg (33.55 lb)
Weight, 4 LFF maximum (Four drives, two processors, two heatsinks, two power supplies, one Smart Array controller, and seven fans installed)	20.92 kg (46.02 lb)
Weight, 10 SFF / 20 EDSFF minimum	14.92 kg (32.82 lb)

Weight, approximate values**Value**

(One drive, two processors, two heatsinks, one power supply, one Smart Array controller, and seven fans installed)

Weight, 10 SFF / 20 EDSFF maximum

21.38 kg (47.04 lb)

(Twenty drives, two processors, two heatsinks, two power supplies, one Smart Array controller, and seven fans installed)

Power supply specifications

Depending on the installed options and the regional location where the server was purchased, the server can be configured with one of the following power supplies. For detailed power supply specifications, see the QuickSpecs on the [Hewlett Packard Enterprise website](#).

Subtopics

[**HPE 800 W Flex Slot Platinum Hot-plug Low Halogen Power Supply**](#)

[**HPE 1000 W Flex Slot Titanium Hot-plug Power Supply**](#)

[**HPE 1600 W Flex Slot Platinum Hot-plug Low Halogen Power Supply**](#)

[**HPE 1600 W Flex Slot -48 VDC Hot-plug Power Supply**](#)

[**HPE 1800-2200 W Flex Slot Titanium Power Supply**](#)

HPE 800 W Flex Slot Platinum Hot-plug Low Halogen Power Supply

Specification	Value
Input requirements	—
Rated input voltage	100 VAC to 127 VAC 200 VAC to 240 VAC 240 VDC for China only
Rated input frequency	50 Hz to 60 Hz Not applicable to 240 VDC
Rated input current	9.4 A at 100 VAC

Specification	Value
	4.5 A at 200 VAC 3.8 A at 240 VDC for China only
Maximum rated input power	940 W at 100 VAC 900 W at 200 VAC 897 W at 240 VDC for China only
BTUs per hour	3067 at 100 VAC 2958 at 200 VAC 2949 at 240 VAC for China only
Power supply output	—
Rated steady-state power	800 W at 100 VAC to 127 VAC input 800 W at 100 VAC to 240 VAC input 800 W at 240 VDC input for China only
Maximum peak power	800 W at 100 VAC to 127 VAC input 800 W at 100 VAC to 240 VAC input 800 W at 240 VDC input for China only

HPE 1000 W Flex Slot Titanium Hot-plug Power Supply

Specification	Value
Input requirements	—
Rated input voltage	100 VAC to 127 VAC 200 VAC to 240 VAC 240 VDC for China
Rated input frequency	50 Hz to 60 Hz
Rated input current	11.3 A at 100 VAC 6.1 A at 200 VAC
Maximum rated input power	1130 W at 100 VAC

Specification	Value
	1090 W at 200 VAC
BTUs per hour	3764 at 100 VAC 3629 at 200 VAC
Power supply output	—
Rated steady-state power	1000 W at 100 VAC to 127 VAC 1000 W at 200 VAC to 240 VAC input
Maximum peak power	1000 W at 100 VAC to 127 VAC 1000 W at 200 VAC to 240 VAC

HPE 1600 W Flex Slot Platinum Hot-plug Low Halogen Power Supply

Specification	Value
Input requirements	—
Rated input voltage	200 VAC to 240 VAC 240 VDC for China only
Rated input frequency	50 Hz to 60 Hz
Rated input current	8.7 A at 200 VAC 7.5 A at 230 VAC 7.2 A at 240 VDC
Maximum rated input power	1734 W at 200 VAC 1720 W at 240 VAC
BTUs per hour	5918 at 200 VAC 5891 at 230 VAC
Power supply output	—
Rated steady-state power	1600 W at 200 VAC to 240 VAC input 1600 W at 240 VDC input

Specification	Value
Maximum peak power	1600 W for 1 ms (turbo mode) at 200 VAC to 240 VAC input

HPE 1600 W Flex Slot -48 VDC Hot-plug Power Supply

Specification	Value
Input requirements	—
Rated input voltage	-40 VDC to -72 VDC
Rated input frequency	DC
Nominal input current	45 A DC at -40 VDC input 36.6 A DC at -48 VDC input 24.4 A DC at -72 VDC input
Maximum Rated Input Wattage Rating	1798 W at -40 VDC input 1758 W at -48 VDC input 1755 W at -72 VDC input
BTUs per hour	6026 at -40 VDC input 6000 at -48 VDC input 5989 at -72 VDC input
Power supply output	—
Rated steady-state power	1600 W at -40 VDC to -72 VDC
Maximum peak power	1600 W at -40 VDC to -72 VDC

HPE 1800-2200 W Flex Slot Titanium Power Supply

Specification	Value
Input requirements	—

Specification	Value
Rated input voltage	200 VAC to 240 VAC 240 VDC for China only
Rated input frequency	50 Hz to 60 Hz
Rated input current	10 A at 200 VAC 10 A at 240 VAC 10 A at 240 VDC for China only
Maximum rated input power	1946 W at 200 VAC 2375 W at 240 VAC 2375 W at 240 VDC for China only
BTUs per hour	6497 at 200 VAC 7962 at 240 VAC
Power supply output	—
Rated steady-state power	1800 W at 200 VAC 2200 W at 240 VAC
Maximum peak power	2200 W for 1 ms (turbo mode) at 200 VAC to 240 VAC input

Websites

Websites provide links to HPE tools, resources, and product documentation.

General websites

Single Point of Connectivity Knowledge (SPOCK) Storage compatibility matrix

<https://www.hpe.com/storage/spock>

Product white papers and analyst reports

<https://www.hpe.com/us/en/resource-library>

For additional websites, see [Support and other resources](#).

Product websites

HPE ProLiant Compute DL360 Gen12 user documents

<https://www.hpe.com/info/dl360gen12-docs>

Support and other resources

Subtopics

[Accessing Hewlett Packard Enterprise Support](#)

[HPE product registration](#)

[Accessing updates](#)

[Customer self repair](#)

[Remote support](#)

[Documentation feedback](#)

Accessing Hewlett Packard Enterprise Support

- For live assistance, go to the Contact Hewlett Packard Enterprise Worldwide website:

<https://www.hpe.com/info/assistance>

- To access documentation and support services, go to the Hewlett Packard Enterprise Support Center website:

<https://www.hpe.com/support/hpesc>

Information to collect

- Technical support registration number (if applicable)
- Product name, model or version, and serial number
- Operating system name and version
- Firmware version
- Error messages
- Product-specific reports and logs
- Add-on products or components

- Third-party products or components

HPE product registration

To gain the full benefits of the Hewlett Packard Enterprise Support Center and your purchased support services, add your contracts and products to your account on the HPESC.

- When you add your contracts and products, you receive enhanced personalization, workspace alerts, insights through the dashboards, and easier management of your environment.
- You will also receive recommendations and tailored product knowledge to self-solve any issues, as well as streamlined case creation for faster time to resolution when you must create a case.

To learn how to add your contracts and products, see <https://www.hpe.com/info/add-products-contracts>.

Accessing updates

- Some software products provide a mechanism for accessing software updates through the product interface. Review your product documentation to identify the recommended software update method.
- To download product updates:

Hewlett Packard Enterprise Support Center

<https://www.hpe.com/support/hpesc>

My HPE Software Center

<https://www.hpe.com/software/hpesoftwarecenter>

- To subscribe to eNewsletters and alerts:

<https://www.hpe.com/support/e-updates>

- To view and update your entitlements, and to link your contracts and warranties with your profile, go to the Hewlett Packard Enterprise Support Center **More Information on Access to Support Materials** page:

<https://www.hpe.com/support/AccessToSupportMaterials>



IMPORTANT

Access to some updates might require product entitlement when accessed through the Hewlett Packard Enterprise Support Center. You must have an HPE Account set up with relevant entitlements.

Customer self repair

Hewlett Packard Enterprise customer self repair (CSR) programs allow you to repair your product. If a CSR part needs to be replaced, it will be shipped directly to you so that you can install it at your convenience. Some parts do not qualify for CSR.

For more information about CSR, contact your local service provider.

Remote support

Remote support is available with supported devices as part of your warranty or contractual support agreement. It provides intelligent event diagnosis, and automatic, secure submission of hardware event notifications to Hewlett Packard Enterprise, which initiates a fast and accurate resolution based on the service level of your product. Hewlett Packard Enterprise strongly recommends that you register your device for remote support.

If your product includes additional remote support details, use search to locate that information.

HPE Get Connected

<https://www.hpe.com/services/getconnected>

HPE Tech Care Service

<https://www.hpe.com/services/techcare>

HPE Complete Care Service

<https://www.hpe.com/services/completecure>

Documentation feedback

Hewlett Packard Enterprise is committed to providing documentation that meets your needs. To help us improve the documentation, click the **Feedback** button on the page of an opened document on the Hewlett Packard Enterprise Support Center portal (<https://www.hpe.com/support/hpesc>). Use this feature to send any errors, suggestions, or comments. This process captures all document information.