

Eaton PDU

Management operation instructions

DISCLAIMER OF WARRANTIES AND LIMITATION OF LIABILITY

The information, recommendations, descriptions, and safety notations in this document are based on Eaton Corporation's ("Eaton") experience and judgment and may not cover all contingencies. If further information is required, an Eaton sales office should be consulted. Sale of the product shown in this literature is subject to the terms and conditions outlined in appropriate Eaton selling policies or other contractual agreement between Eaton and the purchaser.

THERE ARE NO UNDERSTANDINGS, AGREEMENTS, WARRANTIES, EXPRESSED OR IMPLIED, INCLUDING WARRANTIES OF FITNESS FOR A PARTICULAR PURPOSE OR MERCHANTABILITY, OTHER THAN THOSE SPECIFICALLY SET OUT IN ANY EXISTING CONTRACT BETWEEN THE PARTIES. ANY SUCH CONTRACT STATES THE ENTIRE OBLIGATION OF EATON. THE CONTENTS OF THIS DOCUMENT SHALL NOT BECOME PART OF OR MODIFY ANY CONTRACT BETWEEN THE PARTIES.

In no event will Eaton be responsible to the purchaser or user in contract, in tort (including negligence), strict liability or other-wise for any special, indirect, incidental or consequential damage or loss whatsoever, including but not limited to damage or loss of use of equipment, plant or power system, cost of capital, loss of power, additional expenses in the use of existing power facilities, or claims against the purchaser or user by its customers resulting from the use of the information, recommendations and descriptions contained herein. The information contained in this manual is subject to change without notice.

About this manual

Thank you for choosing our power distribution unit (PDU).

This manual mainly introduces how to conduct software management and operation of PDU. As for the opening of the equipment and the connection, see PDU INSTALLATION MANUAL (downloaded from www.eaton.com).

This manual is developed for the FlexPDU G2 series PDUs.

NOTE

The web UI may vary with versions. The web UI actually displayed shall prevail.

Conventions

The symbols that may be found in this user manual are defined as follows.

Symbol	Definition
NOTE	Information notes call attention to important features or instructions. Ignoring this type of note may result in ineffective configuration, loss of data or damage to device.

Change history

Release date	Description
2025-03-03	First release.

Contents

1	Introduction	1
2	Default network user and password.....	2
3	Use PDU management page.....	3
3.1	Connect to network.....	3
3.2	Login	5
3.3	Management page introduction.....	6
3.4	Page screensaver and refresh	8
3.5	Shortcut page – Favorites	9
3.5.1	Tool page.....	9
3.5.2	Hosts page.....	9
3.5.3	INFO page.....	12
3.6	Power page – PDU.....	13
3.6.1	View/Set the PDU input	13
3.6.2	View/Set the input phase	13
3.7	Socket page – Outlets	15
3.7.1	View and set outlets.....	15
3.7.2	Outlet groups.....	16
3.7.3	View outlet details	16
3.7.4	Set outlet names and communication addresses.....	17
3.8	Sensor page – Sensors.....	18
3.8.1	View sensor info and set sensor alarm thresholds.....	18
3.8.2	View sensor events.....	18
3.8.3	Set sensor parameters.....	19
3.9	Grouping page – Groups.....	20
3.9.1	Group management.....	20
3.9.2	Group configuration	21
3.10	Current alarm page – Alarms	25
3.11	Log page– Logs.....	26
3.11.1	View/Clear history alarm logs	26

3.11.2	Download system operations logs	26
3.12	System page – System.....	27
3.12.1	Set network parameters.....	27
3.12.2	Enable/Disable network services.....	28
3.12.3	System settings.....	31
3.12.4	Backup and Restore	32
3.12.5	User settings	33
3.12.6	Schedule settings.....	35
3.12.7	Upgrade	38
3.12.8	Import a CA certificate.....	38
3.12.9	View/Modify system information	39
4	Use the PDU LCD panel	40
4.1	Welcome page and monitoring information page	41
4.2	Menu	42
5	Use the command line to manage the PDU	44
5.1	Connect to Telnet.....	44
5.2	Connect to SSH.....	46
5.3	Regular instruction for command line.....	48
5.4	Command instructions.....	49
5.4.1	Help command.....	49
5.4.2	Find and view object attributes	50
5.4.3	Read object data.....	50
5.4.4	Set object data	51
5.4.5	Synchronize object attributes.....	52
5.4.6	Use object names and serial numbers	52
5.4.7	Use a dot to indicate the last used object.....	53
5.5	Instructions for PDU management objects.....	54
6	Use SNMP to manage the PDU	59
6.1	Connect to SNMP	59
6.2	Set connection parameters	62
6.3	Example: Read and set management objects	64

6.3.1	Read the IP address	64
6.3.2	Read outlet current	64
6.3.3	Set outlet switches	65
7	Use the serial port terminal to manage the PDU.....	67
7.1	Physical port	67
7.2	Obtain PDU's communication address.....	68
7.3	Modbus parameter addresses.....	69
	Appendix Acronyms and abbreviations.....	84

1 Introduction

The FlexPDU G2 series PDUs can be installed horizontally or vertically.

The following figure shows a vertical PDU with eight switches as an example. For the appearance of other PDUs, please refer to the actual product.

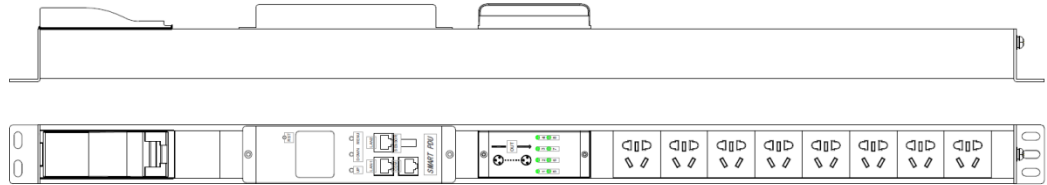

The FlexPDU G2 series PDUs have the following optional functions:

- Power switch
- Fuse
- Current, voltage electric energy
- Sensors: temperature sensor, humidity sensor, door sensor, smoke sensor, water sensor, infrared sensor
- Circuit breaker test

2 Default network user and password

The following table lists the default network parameters and services for the PDU.

Network parameter		Network service	
IP address	192.168.0.254	HTTP	Disabled
Subnet mask	255.255.255.0	HTTPS	Enabled
Gateway IP address	192.168.0.1	TELNET	Disabled
Preferred DNS		SSH	Enabled
Alternate DNS		SNMP v1/v2c	Disabled
IPv6 address	Display/web access	SNMP v3	Enabled
		Email	Disabled

The following table lists the default user names and passwords for network services of the PDU.

Service		Username	Password
Web page		admin	admin
Telnet		admin	admin
SSH	Connection password	sshd	123456
	User password	admin	admin
SNMP		Read Community	public
		Writing Community	private
		readWriteUser	authPassword
		readOnlyUser	privacyPassword
LCD		/	111111

3 Use PDU management page

3.1 Connect to network

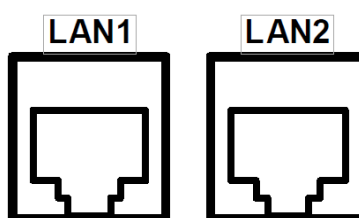

The LAN ports of the PDU are network management ports, through which HTTP (WEB), TELNET, SSH, SNMP and other protocols can be used for access.

PDUs with two LAN ports are equipped with built-in network switches. One of the LAN ports can be connected to the LAN port of the next PDU.

The operation of connecting the PDU to the network is as follows:

Step 1 Use a network cable to connect the LAN port of PDU to your computer, or use a router for connection.

NOTE

Set network parameters of your computer to access the PDU. If the PDU and your computer are located in the same LAN, set the IP address of your computer in the same network segment with the IP address of the PDU; otherwise, use a correct router or network bridge to connect the PDU.

Step 2 If multiple PDUs are used, use a network cable to connect the other LAN port of the first PDU to the LAN port of the next PDU, and repeat this step for other PDUs.

Step 3 Perform IPv6 network settings on your computer.

Step 4 Power on the PDU. Obtain the PDU's IPv6 address from **/Network/IP addr** on the PDU's LCD panel.

Step 5 Open a browser on your computer. Enter **[PDU's IPv6 address]** in the address bar to access the management page of the PDU, as shown in the following figure.

FLEX PDU FLEX PDU (Hide Top Bar) 中文 | English

- Favorites
- PDU
- Outlets
- Sensors
- Groups
- Alarms
- Logs
- System**
 - Network
 - Setup
 - Profile
 - Users

Login



User Name

Password

Login

-End

3.2 Login

After [network connection](#), enter your username and password to log in to the management page of the PDU. The default administrator username and password are both **admin**.

NOTE

If you log in as an administrator, you can [enable the setup mode or browsing mode](#) as required. If you log in as a read-only user, you can enter the browsing mode only.

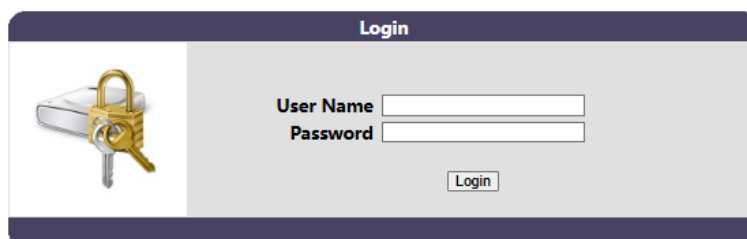

The screenshot shows a login window titled "Login". On the left is an icon of a padlock and keys. On the right, there are two input fields: "User Name" and "Password". Below these fields is a "Login" button.

Login interface (Radius protocol disabled)

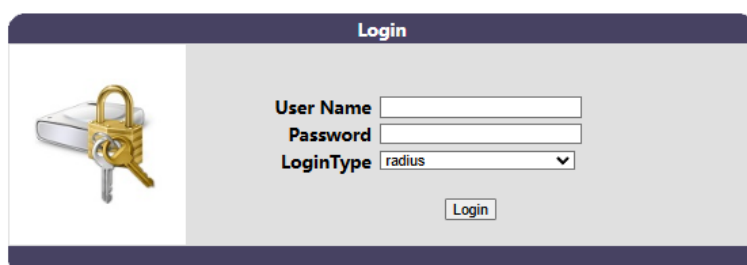

The screenshot shows a login window titled "Login". On the left is an icon of a padlock and keys. On the right, there are three input fields: "User Name", "Password", and "LoginType" (a dropdown menu with "radius" selected). Below these fields is a "Login" button.

Login interface (Radius protocol enabled)

When the Radius protocol is enabled, you can log in to the PDU management page using the **radius** or **local** login type.

- **radius:** Log in to the PDU using the username and password set on the Radius server.
- **local:** Log in to the PDU using the username and password of the PDU.
- If you enter incorrect passwords for 5 times continuously, the account will be locked for 24 hours. In this case, wait 24 hours or manually restart the PDU to retry login.
- If you forget your username and password, you can [restore the network settings through the LCD panel](#) to restore the default username and password.
- The username and password must be changed upon the first login. The password must contain 6 to 20 characters, including uppercase and lowercase letters, digits, and special characters.

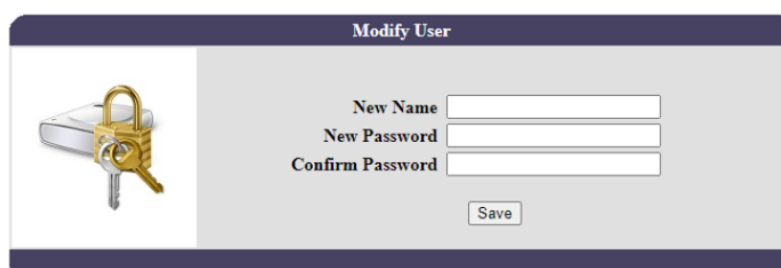

The screenshot shows a "Modify User" window. On the left is an icon of a padlock and keys. On the right, there are three input fields: "New Name", "New Password", and "Confirm Password". Below these fields is a "Save" button.



3.3 Management page introduction

The screenshot displays the FLEX PDU management interface. The top bar shows 'FLEX PDU' and 'FLEX PDU (Hide Top Bar)'. The left navigation bar includes 'Favorites', 'PDU', 'Outlets', 'Sensors', 'Groups', 'Alarms', 'Logs', and 'System'. The main content area is titled 'System INFO' and contains the following data:

System INFO	
Product Name	FLEX PDU
Product Model	FLXTMA116C2
Product P/N	P-FLXTMA116C2
Product S/N	EC5BCD500004
LAN MAC	EC-5B-CD-50-00-05
Software Version	NET-1.2.1a
Customize the info below for SNMP NMS	
System Name	<input type="text" value="FlexPDU"/> System name, example: pdu
System Contact	<input type="text"/> Contract info
System Location	<input type="text"/> Where the equipment is used.
<input type="button" value="Save"/>	
PDU INFO	
Outlets	
Outlet Count	12
Socket: IEC 320 C13	1, 2, 3, 4, 5, 6, 7, 8, 9, 10, 11, 12, Total: 12

The **INFO** page is used as an example to introduce the PDU management page.

Item	Description
Top bar	Displays company information and logo. You can click Hide Top Bar to hide the top bar.
Left navigation bar	Navigation bar, including Favorites , PDU , Outlets , Sensors , Groups , Alarms , Logs , and System .

Item	Description
Right content bar	<p>Displays the status and settings.</p> <p>The top title bar displays submenus and buttons such as the setup and automatic refresh checkboxes:</p> <ul style="list-style-type: none"> - Last Page: Return to the last visited web page. - Alarm: Displays the alarm status and quantity.  indicates that the alarm sound is turned on, and  indicates that the alarm sound is turned off (Note: After the PDU is restarted, the sound will be turned on again). - Setup: Select it to enable the setup mode, or unselect it to enable the browsing mode. In the setup mode, parameter settings are available. In the browsing mode, parameters are read-only and cannot be modified. <hr/> <p>NOTE</p> <p>To modify parameter values, select Setup using an administrator account. Read-only users cannot select Setup.</p> <hr/> <ul style="list-style-type: none"> - Refresh: Click to refresh the current page. - Auto: Select to enable automatic refresh of the current page to view status changes immediately. You can change the automatic refresh interval in System > Setup.

3.4 Page screensaver and refresh

- Page screensaver: The screensaver function is provided to ensure safety. If there is no operation for a certain period of time, the page will log out. You can set the screensaver time interval in **System > Setup** page. For detailed operations, see [System settings](#).
- Page refresh: After the page is submitted, it will refresh after 4 seconds. For some operations that take a long time (such as submission), the final operation results can be displayed correctly after delayed refresh.

3.5 Shortcut page – Favorites

For quick setup and information viewing, the following shortcut menus are provided:

- [Tool](#): Used to turn on/off buzzer, log out, restart, and view help information.
- [Hosts](#): Used to link other PDUs.
- [INFO](#): Used to view system and PDU information and set information for SNMP.

3.5.1 Tool page

[Log in to the PDU management page](#), click **Favorites** in the left menu bar, and then click **Tool** in the top title bar to access the Tool page.

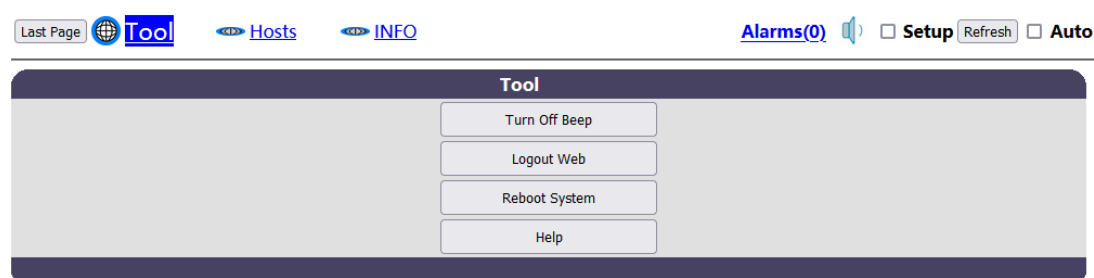

On this page, you can perform the following operations.

Operation	Description
Turn on/off buzzer	Click Turn On Beep or Turn Off Beep . The buzzer is enabled by default. If you restart the PDU after turning off the buzzer, the buzzer will be enabled again.
Log out	Click Logout Web , and then click OK in the displayed dialog box.
Restart the system	Click Reboot System , and then click OK in the displayed dialog box.
View help information	Click Help to see how to enable the setup mode.

3.5.2 Hosts page

[Log in to the PDU management page](#), click **Favorites** in the left menu bar, and then click **Hosts** in the top title bar to access the Hosts page. On this page, you can manage associated PDU links. After adding associated PDU links on this page, you can directly access the management pages of associated PDUs in the browsing mode, without the need to open a new browser window.

3.5.2.1 Add an associated PDU link

Step 1 [Log in to the PDU management page](#).

Step 2 Click **Favorites** in the left menu bar, and then click **Hosts** in the top title bar to access the Hosts page.

Step 3 Enter the PDU name after **Add a New Host**, and click **Add**.

2nd-PDU is added as an example.

NOTE

Only **a-z, A-Z, 0-9, _-+()#@** are allowed for the host name.

The screenshot shows the 'Hosts' management interface. At the top, there are navigation links: 'Last Page', 'Tool', 'Hosts', and 'INFO'. On the right, there are status indicators: 'Alarms(0)', a speaker icon, 'Setup', 'Refresh', and 'Auto'. The main content area is titled 'Hosts' and contains a table with the following structure:

Host Name	Host Uri	Operation
2nd-PDU		Delete

Below the table, there is a 'Save' button. Underneath, there is an 'Add a New Host' section with an input field and an 'Add' button. To the right of this section, a note states: 'The name string must be in a-z, A-Z, 0-9, _-+()#@'.

Step 4 Enter the PDU link under **Host Uri**, and click **Save**.

NOTE

The associated PDUs and the current PDU must be located in the same LAN. A maximum of 32 associated PDUs can be added.

192.168.0.163 is used as an example.

This screenshot is similar to the previous one, but the 'Host Uri' field for the '2nd-PDU' entry now contains the IP address '192.168.0.163'. The 'Save' button is still present below the table.

–End

3.5.2.2 Modify an associated PDU link

Step 1 [Log in to the PDU management page.](#)

Step 2 Click **Favorites** in the left menu bar, and then click **Hosts** in the top title bar to access the Hosts page.

Step 3 Modify the name and link of an existing associated PDU as required, and click **Save**.

Last Page Tool Hosts INFO Alarms(0) Setup Refresh Auto

Hosts		
Host Name	Host Uri	Operation
2nd-PDU	192.168.0.163	Delete
Save		
Add a New Host:	<input type="text"/> Add	The name string must be in a-z, A-Z, 0-9, _-+()#@

-End

3.5.2.3 Delete an associated PDU link

Step 1 [Log in to the PDU management page.](#)

Step 2 Click **Favorites** in the left menu bar, and then click **Hosts** in the top title bar to access the Hosts page.

Step 3 Click **Delete** in the line of the associated PDU.

Last Page Tool Hosts INFO Alarms(0) Setup Refresh Auto

Hosts		
Host Name	Host Uri	Operation
2nd-PDU	192.168.0.163	Delete
Save		
Add a New Host:	<input type="text"/> Add	The name string must be in a-z, A-Z, 0-9, _-+()#@

-End

3.5.2.4 Access an associated PDU link

NOTE

The associated PDU link can be accessed only after the browsing mode is enabled.

To add an associated PDU link, see [Add an associated PDU link.](#)

Step 1 [Log in to the PDU management page.](#)

Step 2 Deselect **Setup** at the upper right corner of the page to enable the browsing mode.

Last Page Tool Hosts INFO Alarms(2) Setup Refresh Auto

Hosts		
Host Name	Host Uri	Operation
test	10.130.226.6	Go To
set	'test	Go To

Step 3 Click **Favorites** in the left menu bar, and then click **Hosts** in the top title bar to access the Hosts page.

Step 4 Click **Go To** in the line of the associated PDU.

-End

3.5.3 INFO page

[Log in to the PDU management page](#), click **Favorites** in the left menu bar, and then click **INFO** in the top title bar to access the INFO page. On this page, you can view system and PDU information, and set information for SNMP (including system name, contact, and location).

NOTE

The information for SNMP can be set only in the setup mode.

Last Page [Tool](#) [Hosts](#) **INFO**
Alarms(0) Setup Auto

System INFO

Product Name	FLEX PDU	
Product Model	FLXTMA116C2	
Product P/N	P-FLXTMA116C2	
Product S/N	EC5BCD500004	
LAN MAC	EC-5B-CD-50-00-05	
Software Version	NET-1.2.1a	
Customize the info below for SNMP NMS		
System Name	<input type="text" value="FlexPDU"/>	System name, example: pdu
System Contact	<input type="text"/>	Contract info
System Location	<input type="text"/>	Where the equipment is used.
<input type="button" value="Save"/>		

PDU INFO

Outlets		
Outlet Count	12	
Socket: IEC 320 C13	1, 2, 3, 4, 5, 6, 7, 8, 9, 10, 11, 12,	Total: 12

3.6 Power page – PDU

3.6.1 View/Set the PDU input

[Log in to the PDU management page](#), click **PDU** in the left menu bar, and then click **PDU** in the top title bar to access the PDU page. On this page, you can view the overall status information of the PDU (including the input phase type, rated current, frequency, accumulated energy) and set the power-on interval and LCD password.

PDU		
Item	Content	Remark
Phase Type	1 Phase	
Rated Current (A)	16	
Frequency (Hz)	50	
ACC. Energy (kWh)	3.2	
Interval of Power On (s)	<input type="text" value="1"/> Save	1 to 60. Interval of Power Down is 1s.
LCDPassword	<input type="text" value="111111"/> Save	password must be 6bit number

The following table describes the parameters on the page.

Parameter	Description
Interval of Power On (s)	Used to set the power-on and power-off interval of outlet. The default value is 1 second, and the value range is 1s to 60s.
LCDPassword	Used to set the LCD password, which must contain six digits. The default LCD password is 111111.

3.6.2 View/Set the input phase

[Log in to the PDU management page](#), click **PDU** in the left menu bar, and then click **Input** in the top title bar to access the Input page. On this page, you can view the status information of the input phase and set the current and voltage alarm thresholds.

The input range for current alarm thresholds is 0 to 16A. For voltage alarm thresholds, the input range is 50 to 500V and the default values are 190V/280V.

Last Page

PDU



Input

INFO

Alarms(0)



Setup

Refresh

Auto

Input		
Item	Content	Remark
Voltage (V)	230.3	
Current (A)	0	
Apparent Power (W)	0	
Active Power (W)	0	
Reactive Power (W)	0	
Factor	0	
Energy (kWh)	40.1	
Rated Power (W)	3520	
Remaining Power (W)	3520	
Low Limit/High Limit (A)	<input type="text" value="0"/> <input type="text" value="16"/>	
Low Limit/High Limit (V)	<input type="text" value="190"/> <input type="text" value="280"/>	Voltage alarm threshold.

History Event Log of Current:

Time	Type	Source	Detail
No logs!			

3.7 Socket page – Outlets

3.7.1 View and set outlets

[Log in to the PDU management page](#), click **Outlets** in the left menu bar, and then click **Outlets** in the top title bar to access the Outlet page. On this page, you can view the information of all outlets and set the current alarm thresholds for outlets.

Last Page [Outlets](#) [Groups](#) [Detail](#) [Setup](#) **Alarms(0)** **Setup** **Auto**

Outlets												
ID	Name	Socket Type	Switch	Operation	Energy (kWh)	Power (W)	Factor	Load (A)	Limits (A)		Detail	
1	Outlet_1	IEC 320 C13		On Off	0	0	0	0	0	10	Save	Detail
2	Outlet_2	IEC 320 C13		On Off	0	0	0	0	0	10	Save	Detail
3	Outlet_3	IEC 320 C13		On Off	0	0	0	0	0	10	Save	Detail
4	Outlet_4	IEC 320 C13		On Off	0	0	0	0	0	10	Save	Detail
5	Outlet_5	IEC 320 C13		On Off	0	0	0	0	0	10	Save	Detail
6	Outlet_6	IEC 320 C13		On Off	0	0	0	0	0	10	Save	Detail
7	Outlet_7	IEC 320 C13		On Off	0	0	0	0	0	10	Save	Detail
8	Outlet_8	IEC 320 C13		On Off	0	0	0	0	0	10	Save	Detail

Parameter	Description
ID	Indicates the label on the outlet panel, which uniquely identifies the code of the outlet in the whole PDU.
Name	Indicates the outlet name set by the user for convenient management.
Socket Type	Indicates the outlet type.
Switch	Indicates the ON/OFF status of the outlet.
Operation	Used to turn on/off outlets. Available only for PDUs that support this function.
Energy (kWh)	Indicates the outlet energy. Available only for PDUs that support this function.
Power	Indicates the active power of outlet. Available only for PDUs that support this function.
Factor	Indicates the outlet power factor. Available only for PDUs that support this function.
Load (A)	Indicates the outlet load current. Available only for PDUs that support this function.

Parameter	Description
Limits (A)	Indicates the outlet load current alarm threshold, ranging from 0 to the rated current of the outlet. Available only for PDUs that support this function.
Detail	Click Detail to view details and history events of an outlet. For details, see View outlet details .

3.7.2 Outlet groups

[Log in to the PDU management page](#), click **Outlets** in the left menu bar, and then click **Groups** in the top title bar to access the Groups page. On this page, you can manage outlets in groups, turn on/off outlets and set current range in a batch, and view current and energy statistics. For details, see [Grouping page - Groups](#).

Last Page
Outlets
Groups
Detail
Setup
Alarms(0)
Setup Refresh Auto

[ALL]
[Group 2]
[Group 3]
[Group 4]
[Group 5]
[Group 6]
[Group 7]
[Group 8]

Outlets of Group

Name	Switch	Operation	Total Load (A)	Total Energy (kWh)	Low Limit (A)	High Limit (A)
ALL	ON(20),OFF(0)	All On All Off	0	0	0 <input type="text"/> 10 <input type="text"/> <input type="button" value="Set All"/>	10 <input type="text"/> <input type="button" value="Set All"/>

NOTE: When you click 'All On' or 'All Off', You need to refresh the page to get the latest PDU status!

Outlets

ID	Name	Socket Type	Switch	Operation	Energy (kWh)	Power (W)	Factor	Load (A)	Limits (A)	Detail
1	Outlet_1	IEC 320 C13		On Off	0	0	0	0	0 <input type="text"/> 10 <input type="text"/> <input type="button" value="Save"/> Default	
2	Outlet_2	IEC 320 C13		On Off	0	0	0	0	0 <input type="text"/> 10 <input type="text"/> <input type="button" value="Save"/> Default	
3	Outlet_3	IEC 320 C13		On Off	0	0	0	0	0 <input type="text"/> 10 <input type="text"/> <input type="button" value="Save"/> Default	
4	Outlet_4	IEC 320 C13		On Off	0	0	0	0	0 <input type="text"/> 10 <input type="text"/> <input type="button" value="Save"/> Default	
5	Outlet_5	IEC 320 C13		On Off	0	0	0	0	0 <input type="text"/> 10 <input type="text"/> <input type="button" value="Save"/> Default	
6	Outlet_6	IEC 320 C13		On Off	0	0	0	0	0 <input type="text"/> 10 <input type="text"/> <input type="button" value="Save"/> Default	

3.7.3 View outlet details

[Log in to the PDU management page](#), click **Outlets** in the left menu bar, and then click **Detail** in the top title bar to access the Detail page. On this page, you can view details and history alarms (including current and fuse alarm history) of an outlet.

[Last Page](#)
[Outlets](#)
[Groups](#)
[Detail](#)
[Setup](#)

[Alarms\(0\)](#)
 Setup
[Refresh](#)
 Auto

<< Prev 1/20 1 Next >>
 Outlets

Outlets											
ID	Name	Socket Type	Switch	Operation	Energy (kWh)	Power (W)	Factor	Load (A)	Limits (A)		Detail
1	Outlet_1	IEC 320 C13		On Off	0	0	0	0	0	0	10
										<input type="text" value="0"/> <input type="text" value="10"/> <input type="button" value="Save"/>	
										Default	

Operation	Switch Status	--		Socket Type Image
<input type="button" value="On"/> <input type="button" value="Off"/>				

History Event Log of Load:

Time	Type	Source	Detail
No logs!			

You can click **Prev** or **Next** to switch between outlet pages, or directly select the outlet ID from the ID drop-down list box to go to the detail page of the specified outlet. To return to the Outlets page, click **Outlets**. For details about the outlet parameters, see [View and set outlets](#).

3.7.4 Set outlet names and communication addresses

[Log in to the PDU management page](#), click **Outlets** in the left menu bar, and then click **Setup** in the top title bar to access the Setup page. On this page, you can set outlet names.

[Last Page](#)
[Outlets](#)
[Groups](#)
[Detail](#)
[Setup](#)

[Alarms\(0\)](#)
 Setup
[Refresh](#)
 Auto

Setup		
Index	Value	Outlet ID
Name	<input type="text" value="Outlet_1"/>	1
Name #2	<input type="text" value="Outlet_2"/>	2
Name #3	<input type="text" value="Outlet_3"/>	3
Name #4	<input type="text" value="Outlet_4"/>	4
Name #5	<input type="text" value="Outlet_5"/>	5
Name #6	<input type="text" value="Outlet_6"/>	6
Name #7	<input type="text" value="Outlet_7"/>	7
Name #8	<input type="text" value="Outlet_8"/>	8
Name #9	<input type="text" value="Outlet_9"/>	9
Name #10	<input type="text" value="Outlet_10"/>	10
Name #11	<input type="text" value="Outlet_11"/>	11
Name #12	<input type="text" value="Outlet_12"/>	12
Name #13	<input type="text" value="Outlet_13"/>	13
Name #14	<input type="text" value="Outlet_14"/>	14
Name #15	<input type="text" value="Outlet_15"/>	15
Name #16	<input type="text" value="Outlet_16"/>	16
Name #17	<input type="text" value="Outlet_17"/>	17
Name #18	<input type="text" value="Outlet_18"/>	18
Name #19	<input type="text" value="Outlet_19"/>	19
Name #20	<input type="text" value="Outlet_20"/>	20

3.8 Sensor page – Sensors

3.8.1 View sensor info and set sensor alarm thresholds

[Log in to the PDU management page](#), click **Sensors** in the left menu bar, and then click **Sensors** in the top title bar to access the Sensors page. On this page, you can view information of all sensors and set temperature and humidity alarm thresholds.

When a sensor alarm occurs, the alarm cell will be displayed in red, as shown in the following figure.

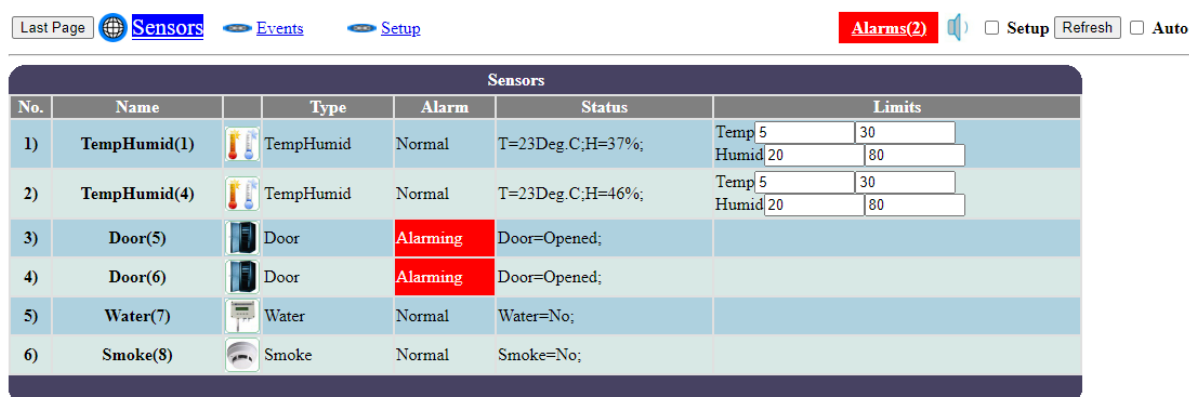

No.	Name	Type	Alarm	Status	Limits
1)	TempHumid(1)	TempHumid	Normal	T=23Deg.C;H=37%;	Temp 5 30 Humid 20 80
2)	TempHumid(4)	TempHumid	Normal	T=23Deg.C;H=46%;	Temp 5 30 Humid 20 80
3)	Door(5)	Door	Alarming	Door=Opened;	
4)	Door(6)	Door	Alarming	Door=Opened;	
5)	Water(7)	Water	Normal	Water=No;	
6)	Smoke(8)	Smoke	Normal	Smoke=No;	

The following table describes some parameters on this page.

Parameter		Description
Status		Displays the current temperature and humidity.
Limits	Temp	Specifies the temperature alarm threshold. The input range is -40°C to +100°C, and the default values are -40°C/+100°C.
	Humid	Specifies the temperature alarm threshold. The input range is 0 to 100%, and the default values are 0/100%.

3.8.2 View sensor events

[Log in to the PDU management page](#), click **Sensors** in the left menu bar, and then click **Events** in the top title bar to access the Events page. On this page, you can view information, alarms, and connection status history of a specific sensor.

When a sensor alarm occurs, the alarm cell will be displayed in red, as shown in the following figure.

[Last Page](#)
[Sensors](#)
[Events](#)
[Setup](#)

Alarms(2)
 Setup

 Auto

<< Prev 1/6 1 Next >>

Events				
No.	Name	Type	Alarm	Status
1)	TempHumid(1)	TempHumid	Normal	T=23Deg.C;H=37%;

History Event Log of Alarm:

Time	Type	Source	Detail
16) 2024-10-25 05:11:56	Normal	/Sensors/Alarm, Name=TempHumid(1)	H=20%;
17) 2024-10-25 05:12:01	Alarming	/Sensors/Alarm, Name=TempHumid(1)	H=19%;
18) 2024-10-25 05:12:09	Normal	/Sensors/Alarm, Name=TempHumid(1)	H=20%;
19) 2024-10-25 05:12:10	Alarming	/Sensors/Alarm, Name=TempHumid(1)	H=19%;
20) 2024-10-25 05:13:04	Normal	/Sensors/Alarm, Name=TempHumid(1)	H=20%;
21) 2024-10-25 05:13:05	Alarming	/Sensors/Alarm, Name=TempHumid(1)	H=19%;
22) 2024-10-25 05:13:14	Normal	/Sensors/Alarm, Name=TempHumid(1)	H=20%;
23) 2024-10-25 05:13:17	Alarming	/Sensors/Alarm, Name=TempHumid(1)	H=19%;
24) 2024-10-25 05:13:30	Normal	/Sensors/Alarm, Name=TempHumid(1)	H=20%;
25) 2024-10-25 05:13:32	Alarming	/Sensors/Alarm, Name=TempHumid(1)	H=19%;

You can click **Prev** or **Next** to switch between sensor pages, or directly select the sensor ID from the ID drop-down list box.

3.8.3 Set sensor parameters

[Log in to the PDU management page](#), click **Sensors** in the left menu bar, and then click **Setup** in the top title bar to access the Setup page. On this page, you can set sensor parameters.

[Last Page](#)
[Sensors](#)
[Events](#)
[Setup](#)

Alarms(2)
 Setup

 Auto

Setup		
Re-scan sensors The "Pulled out" alarms would be reset.	<input type="button" value="Re-scan"/>	
Item	Content	Remark
Temp. Unit	Deg.C	
Wind Unit	m/s	
Name	TempHumid(1)	TempHumid
Name #2	TempHumid(4)	TempHumid
Name #3	Door(5)	Door
Name #4	Door(6)	Door
Name #5	Water(7)	Water
Name #6	Smoke(8)	Smoke

The following table describes the sensor parameters.

Parameter	Description
Re-scan	Used to rescan sensors. Sensors are externally mounted on the sensor port of the PDU, so an alarm will be generated when the sensor is considered to be pulled out. At this time, you can execute this command to rescan all sensors to eliminate the alarm of sensor pull-out.
Temp. Unit	Used to set the temperature unit, including Deg.C and Deg.F .
Wind Unit	Used to set the wind speed unit, including m/s and ft/s .
Name	Used to set sensor names.

3.9 Grouping page – Groups

3.9.1 Group management

[Log in to the PDU management page](#), click **Groups** in the left menu bar, and then click **Groups** in the top title bar to access the Groups page. On this page, you can manage outlets in groups, turn on/off outlets and set current range in batches, and view current and energy statistics.

[Last Page](#) [Groups](#) [Config](#)

[Alarms\(0\)](#) [Setup](#) [Refresh](#) **Auto**

[\[ALL\]](#) [\[Group 2\]](#) [\[Group 3\]](#) [\[Group 4\]](#) [\[Group 5\]](#) [\[Group 6\]](#) [\[Group 7\]](#) [\[Group 8\]](#)

Outlets of Group						
Name	Switch #2	Operation	Total Load (A) #2	Total Energy (kWh) #2	Low Limit (A) #2	High Limit (A) #2
Group 2	ON(3),OFF(0)	<input type="button" value="All On"/> <input type="button" value="All Off"/>	0	0	<input type="text" value="0"/> <input type="button" value="Set All"/>	<input type="text" value="10"/> <input type="button" value="Set All"/>

NOTE: When you click 'All On' or 'All Off', You need to refresh the page to get the latest PDU status!

Outlets											
ID	Name	Socket Type	Switch	Operation	Energy (kWh)	Power (W)	Factor	Load (A)	Limits (A)		Detail
1	Outlet_1	IEC 320 C13		On Off	0	0	0	0	<input type="text" value="0"/> <input type="text" value="10"/> <input type="button" value="Save"/> <input type="button" value="Default"/>		
2	Outlet_2	IEC 320 C13		On Off	0	0	0	0	<input type="text" value="0"/> <input type="text" value="10"/> <input type="button" value="Save"/> <input type="button" value="Default"/>		
3	Outlet_3	IEC 320 C13		On Off	0	0	0	0	<input type="text" value="0"/> <input type="text" value="10"/> <input type="button" value="Save"/> <input type="button" value="Default"/>		

Item	Description
Group filter	<ul style="list-style-type: none"> - ALL: Click to see all outlets. The name cannot be modified. - Group 2 to Group 8: A maximum of seven groups are supported. The group names are default to Group 2 to Group 8 and can be customized.
Outlets of Group	<p>Displays statistics information, and used to perform operations for all outlets in the group.</p> <ul style="list-style-type: none"> - All On/All Off: Used to turn on/off all outlets in the group. - Switch: Displays the number of outlets turned on/off. As shown in the preceding figure, 3 outlets are turned on and 0 outlets are turned off. - Operation: Used to turn on/off all outlets in the group. - Total Load: Indicates the total current of all outlets in the group. - Total Energy: Indicates the total energy of all outlets in the group. - Low Limit/High Limit: Used to set the current range for all outlets in the group, ranging from 0 to the lowest rated current of all outlets in the group.
Outlets	For details, see View and set outlets .

3.9.2 Group configuration

[Log in to the PDU management page](#), click **Groups** in the left menu bar, and then click **Config** in the top title bar to access the Config page. On this page, you can configure outlet groups, including:



- View outlet groups
- Set outlet group names
- Add outlets in groups
- Remove outlets from groups

NOTE

An outlet can be added in only one group (excluding **ALL**). To add an outlet to another group, remove it from its original group first.









3.9.2.1 View outlet groups

[Log in to the PDU management page](#), click **Groups** in the left menu bar, and then click **Config** in the top title bar to access the Config page. Click **View** before a group to see the group information in the table below.

Last Page <> Groups  Alarms(0)  Setup Auto

Groups					
View	ID	Name	Rename	Outlet Detail	Operation
View	1	ALL		20 Outlet(s):All the outlets included!	
View	2	Group 2	<input type="button" value="Set"/>	3 Outlet(s);1,2,3	<input type="button" value="Remove"/>
View	3	Group 3	<input type="button" value="Set"/>	0 Outlet(s):	<input type="button" value="Remove"/>
View	4	Group 4	<input type="button" value="Set"/>	0 Outlet(s):	<input type="button" value="Remove"/>
View	5	Group 5	<input type="button" value="Set"/>	0 Outlet(s):	<input type="button" value="Remove"/>
View	6	Group 6	<input type="button" value="Set"/>	0 Outlet(s):	<input type="button" value="Remove"/>
View	7	Group 7	<input type="button" value="Set"/>	0 Outlet(s):	<input type="button" value="Remove"/>
View	8	Group 8	<input type="button" value="Set"/>	0 Outlet(s):	<input type="button" value="Remove"/>

Members of the group: **Group 2**



Member of outlets					
1		IEC 320 C13	Outlet_1	Unnamed	<input type="button" value="Remove"/>
2		IEC 320 C13	Outlet_2	Unnamed	<input type="button" value="Remove"/>
3		IEC 320 C13	Outlet_3	Unnamed	<input type="button" value="Remove"/>
Other outlets not grouped					
4		IEC 320 C13	Outlet_4	Unnamed	<input type="button" value="Add"/>
5		IEC 320 C13	Outlet_5	Unnamed	<input type="button" value="Add"/>
6		IEC 320 C13	Outlet_6	Unnamed	<input type="button" value="Add"/>
7		IEC 320 C13	Outlet_7	Unnamed	<input type="button" value="Add"/>
8		IEC 320 C13	Outlet_8	Unnamed	<input type="button" value="Add"/>

3.9.2.2 Set outlet group names

Step 1 [Log in to the PDU management page](#).









Step 2 Click **Groups** in the left menu bar, and then click **Config** in the top title bar to access the Config page.

Step 3 Enter a group name in the **Name** box, and click **Set**.

Last Page < Groups  Alarms(0)  Setup Refresh Auto

Groups					
View	ID	Name	Rename	Outlet Detail	Operation
View	1	ALL		20 Outlet(s):All the outlets included!	
View	2	<input type="text" value="Group 2"/>	<input type="button" value="Set"/>	3 Outlet(s);1,2,3	<input type="button" value="Remove"/>
View	3	<input type="text" value="Group 3"/>	<input type="button" value="Set"/>	0 Outlet(s):	<input type="button" value="Remove"/>
View	4	<input type="text" value="Group 4"/>	<input type="button" value="Set"/>	0 Outlet(s):	<input type="button" value="Remove"/>
View	5	<input type="text" value="Group 5"/>	<input type="button" value="Set"/>	0 Outlet(s):	<input type="button" value="Remove"/>
View	6	<input type="text" value="Group 6"/>	<input type="button" value="Set"/>	0 Outlet(s):	<input type="button" value="Remove"/>
View	7	<input type="text" value="Group 7"/>	<input type="button" value="Set"/>	0 Outlet(s):	<input type="button" value="Remove"/>
View	8	<input type="text" value="Group 8"/>	<input type="button" value="Set"/>	0 Outlet(s):	<input type="button" value="Remove"/>

Members of the group: **Group 2**

Member of outlets					
1		IEC 320 C13	Outlet_1	Unnamed	<input type="button" value="Remove"/>
2		IEC 320 C13	Outlet_2	Unnamed	<input type="button" value="Remove"/>
3		IEC 320 C13	Outlet_3	Unnamed	<input type="button" value="Remove"/>
Other outlets not grouped					
4		IEC 320 C13	Outlet_4	Unnamed	<input type="button" value="Add"/>
5		IEC 320 C13	Outlet_5	Unnamed	<input type="button" value="Add"/>
6		IEC 320 C13	Outlet_6	Unnamed	<input type="button" value="Add"/>
7		IEC 320 C13	Outlet_7	Unnamed	<input type="button" value="Add"/>
8		IEC 320 C13	Outlet_8	Unnamed	<input type="button" value="Add"/>

–End

3.9.2.3 Add an outlet in a group

NOTE

An outlet can be added in only one group (excluding **ALL**). To add an outlet to another group, remove it from its original group first.



Step 1 [Log in to the PDU management page.](#)

Step 2 Click **Groups** in the left menu bar, and then click **Config** in the top title bar to access the Config page.

Step 3 Click **View** before a group.









Group 2 is used as an example here.

Step 4 Click **Add** in the **Other outlets not grouped** module.

Last Page [Groups](#)  **Config** Alarms(0)  Setup Auto

Groups					
View	ID	Name	Rename	Outlet Detail	Operation
View	1	ALL		20 Outlet(s):All the outlets included!	
View	2	Group 2	<input type="button" value="Set"/>	3 Outlet(s); 1,2,3	<input type="button" value="Remove"/>
View	3	Group 3	<input type="button" value="Set"/>	0 Outlet(s);	<input type="button" value="Remove"/>
View	4	Group 4	<input type="button" value="Set"/>	0 Outlet(s);	<input type="button" value="Remove"/>
View	5	Group 5	<input type="button" value="Set"/>	0 Outlet(s);	<input type="button" value="Remove"/>
View	6	Group 6	<input type="button" value="Set"/>	0 Outlet(s);	<input type="button" value="Remove"/>
View	7	Group 7	<input type="button" value="Set"/>	0 Outlet(s);	<input type="button" value="Remove"/>
View	8	Group 8	<input type="button" value="Set"/>	0 Outlet(s);	<input type="button" value="Remove"/>

Members of the group: **Group 2**

Member of outlets					
1		IEC 320 C13	Outlet_1	Unnamed	<input type="button" value="Remove"/>
2		IEC 320 C13	Outlet_2	Unnamed	<input type="button" value="Remove"/>
3		IEC 320 C13	Outlet_3	Unnamed	<input type="button" value="Remove"/>
Other outlets not grouped					
4		IEC 320 C13	Outlet_4	Unnamed	<input type="button" value="Add"/>
5		IEC 320 C13	Outlet_5	Unnamed	<input type="button" value="Add"/>
6		IEC 320 C13	Outlet_6	Unnamed	<input type="button" value="Add"/>
7		IEC 320 C13	Outlet_7	Unnamed	<input type="button" value="Add"/>
8		IEC 320 C13	Outlet_8	Unnamed	<input type="button" value="Add"/>

–End

3.9.2.4 Remove an outlet from a group

Step 1 [Log in to the PDU management page.](#)

Step 2 Click **Groups** in the left menu bar, and then click **Config** in the top title bar to access the Config page.

Step 3 Click **View** before a group.

Group 2 is used as an example here.

Step 4 Click **Remove** in the **Member of outlets** module.

NOTE

To remove all outlets in a group, click **Remove** in the **Groups** module.

Groups					
View	ID	Name	Rename	Outlet Detail	Operation
View	1	ALL		20 Outlet(s):All the outlets included!	
View	2	Group 2	<input type="button" value="Set"/>	3 Outlet(s); 1,2,3	<input type="button" value="Remove"/>
View	3	Group 3	<input type="button" value="Set"/>	0 Outlet(s):	<input type="button" value="Remove"/>
View	4	Group 4	<input type="button" value="Set"/>	0 Outlet(s):	<input type="button" value="Remove"/>
View	5	Group 5	<input type="button" value="Set"/>	0 Outlet(s):	<input type="button" value="Remove"/>
View	6	Group 6	<input type="button" value="Set"/>	0 Outlet(s):	<input type="button" value="Remove"/>
View	7	Group 7	<input type="button" value="Set"/>	0 Outlet(s):	<input type="button" value="Remove"/>
View	8	Group 8	<input type="button" value="Set"/>	0 Outlet(s):	<input type="button" value="Remove"/>



Members of the group: **Group 2**

Member of outlets					
1		IEC 320 C13	Outlet_1	Unnamed	<input type="button" value="Remove"/>
2		IEC 320 C13	Outlet_2	Unnamed	<input type="button" value="Remove"/>
3		IEC 320 C13	Outlet_3	Unnamed	<input type="button" value="Remove"/>
Other outlets not grouped					
4		IEC 320 C13	Outlet_4	Unnamed	<input type="button" value="Add"/>
5		IEC 320 C13	Outlet_5	Unnamed	<input type="button" value="Add"/>
6		IEC 320 C13	Outlet_6	Unnamed	<input type="button" value="Add"/>
7		IEC 320 C13	Outlet_7	Unnamed	<input type="button" value="Add"/>
8		IEC 320 C13	Outlet_8	Unnamed	<input type="button" value="Add"/>

-End

3.10 Current alarm page – Alarms

[Log in to the PDU management page](#), click **Alarms** in the left menu bar, and then click **Alarms** in the top title bar to access the Alarm page. On this page, you can see information of current alarms, including alarm occurrence time, source, details, and status. The alarms displayed here cannot be cleared.

Last Page  [Alarms](#) **Alarms(1)**  Setup Auto

Alarms				
No.	Time	Source	Detail	Value(Now)
1)	2021-09-01 15:28:25	/Outlets/Load (A), Name=Outlet_1, ID=1	0, Underflow [1, 10]	0

3.11 Log page– Logs

3.11.1 View/Clear history alarm logs

[Log in to the PDU management page](#), click **Logs** in the left menu bar, and then click **Logs** in the top title bar to access the Logs page. On this page, you can view and clear history alarm logs.

To clear all history alarm logs, click **Clear Log**.

Logs			
Time	Type	Source	Detail
01) 2021-09-01 15:30:12	Normal	/Outlets/Load (A), Name=Outlet_1, ID=1	0
02) 2021-09-01 15:30:16	Alarming	/Outlets/Load (A), Name=Outlet_2, ID=2	0, Underflow [1, 10]
03) 2021-09-01 15:30:28	Normal	/Outlets/Load (A), Name=Outlet_2, ID=2	0

3.11.2 Download system operations logs

[Log in to the PDU management page](#), click **Logs** in the left menu bar, and then click **Events** in the top title bar to access the Events page. On this page, you can download all system operation logs.

[Download](#) Download the event logs.

3.12 System page – System

The system supports network settings, system settings, backup and restoration, user management, upgrade, and system information.

3.12.1 Set network parameters

[Log in to the PDU management page](#), click **Network** under **System** in the left menu bar to access the Network page. In the **Ethernet Settings of LAN** module, you can set network parameters as required.

NOTE

After the IP address is modified, you need to use the new IP address to access the PDU management page.

The screenshot shows the Network configuration page. At the top, there is a navigation bar with 'Network' selected. Below it, the 'Ethernet Settings of LAN' section is visible. It includes fields for 'IP Obtain' (Static), 'IPv6 Address' (fe80::8e1f:64ff:fe8a:e000), 'Subnet prefix length' (64), and 'Default gateway'. Below this is the 'Services' section with checkboxes for HTTP, HTTPS, TELNET, SSH, SNMP, EMAIL, and RADIUS, each with a dropdown menu and a description. At the bottom, there is a red warning message: 'NOTE: Please login again with the new IP address if the IP has been changed!' and an 'Apply Network Settings' button.

The following table describes the parameters on the page.

Parameter	Description
IP Obtain	Used to configure the IPv4 address. To configure a static IPv4 address, select static and click Detail Settings on the right to enter the configuration page, as shown in the following figure. <div data-bbox="552 1619 1406 1848" data-label="Form"> <p>The screenshot shows the Network configuration page. At the top, there is a navigation bar with 'Network' selected. Below it, the 'Ethernet Settings of LAN' section is visible. It includes fields for 'IP Address' (192.168.0.254), 'Subnet Mask' (255.255.255.0), 'Gateway IP' (192.168.0.1), 'Preferred DNS', 'Alternate DNS', and 'LAN MAC' (8C-1F-64-8A-E0-00). There are 'Save' and 'Load Default IP' buttons at the bottom.</p> </div>
IPv6 Address	The IPv6 address is automatically allocated by the system. You can set it based on the IPv6 address rules as required.

Parameter	Description
Subnet prefix length	Specifies the IPv6 subnet prefix length.
Default gateway	Specifies the IPv6 gateway.

The configuration will take effect upon next restart. To have the parameters take effect immediately, click **Apply Network Settings**.

3.12.2 Enable/Disable network services

[Log in to the PDU management page](#), click **Network** under **System** in the left menu bar to access the Network page. In the **Services** module, you can enable/disable network services as required, including HTTP, HTTPS, TELNET, SSH, SNMP, Email, and Radius services.

Last Page [Network](#) [Setup](#) [Profile](#) [Users](#) [Schedule](#) [Upload](#) [ImportCA](#) [INFO](#) [Alarms\(0\)](#) Setup [Refresh](#) Auto

Network

Ethernet Settings of LAN

IP Obtain	Static <input type="text"/>	Detail Settings IP Configure
IPv6 Address	fe80::8e1f:64ff:fe8a:e000 <input type="text"/>	
Subnet prefix length	64 <input type="text"/>	
Default gateway	<input type="text"/>	

Services

HTTP Enable	Enabled <input type="text"/>	WEB server
HTTPS Enable	Disabled <input type="text"/>	WEB server with TLS
TELNET Enable	Enabled <input type="text"/>	Command line interface
SSH Enable	Disabled <input type="text"/>	Command line interface with SSL
SNMP Enable	Enabled <input type="text"/>	Detail Settings SNMP for NMS
EMAIL Enable	Disabled <input type="text"/>	Detail Settings Send alarm to Email
RADIUS Enable	Disabled <input type="text"/>	Detail Settings RadiusConfig

Apply Network Settings

NOTE: Please login again with the new IP address if the IP has been changed!

[Apply Network Settings](#)

Set the SNMP service

Enable the SNMP service, and click **Detail Settings** on the right to enter the service configuration page, as shown in the following figure.

Back Alarms(0) Setup Refresh Auto

SNMP Settings		
General Settings		
SNMP Port	161	
Alarm to Snmp Trap	Enabled ▾	
Enabled SNMPv1/v2c	Disabled ▾	
Enabled SNMPv3	Enabled ▾	
Trap Settings		
Trap Manager	<input type="text"/>	Manager #1
Trap Community	<input type="text"/>	Manager #1
Trap Manager #2	<input type="text"/>	Manager #2
Trap Community #2	<input type="text"/>	Manager #2
SNMP v1/v2c Settings		
Read Community	<input type="text" value="public"/>	Default: public
Write Community	<input type="text" value="private"/>	Default: private
SNMP v3: Read And Write User		
USM User	<input type="text" value="readWriteUser"/>	
Security Level	auth, priv	
Access Right	ReadWrite	
Auth Algorithm	HMAC-SHA	
Auth Password	<input type="password" value="*****"/>	8 to 20 Characters or digits
Privacy Algorithm	CBC-DES	
Privacy Password	<input type="password" value="*****"/>	8 to 20 Characters or digits
Context Name	<input type="text"/>	
SNMP v3: Read Only User		
USM User #2	<input type="text" value="readOnlyUser"/>	
Security Level #2	auth, priv	
Access Right #2	ReadOnly	
Auth Algorithm #2	HMAC-SHA	
Auth Password #2	<input type="password" value="*****"/>	8 to 20 Characters or digits
Privacy Algorithm #2	CBC-DES	
Privacy Password #2	<input type="password" value="*****"/>	8 to 20 Characters or digits
Context Name #2	<input type="text"/>	
Save Default		

By default, the functions of SNMP v1 and v2c are disabled.

- Default read community: public
- Default write community: private

By default, the functions of SNMP v3 are enabled.

For users **readWriteUser** and **readOnlyUser**, the default authentication password is **authPassword**, and the default encryption password is **privacyPassword**.

Set the Email service

Enable the Email service, and click **Detail Settings** on the right to enter the service configuration page, as shown in the following figure.

Back Alarms(0) Setup Refresh Auto

Email Settings		
Item	Content	Remark
SMTP Server	<input type="text"/>	Example: smtp.123.com
SMTP Port	<input type="text" value="25"/>	Default: 25
Authentication Type	LOGIN ▾	
Sender Email	<input type="text"/>	Example: myemail@123.com
Sender Password	<input type="text"/>	
To Address	<input type="text"/>	Receiver #1
To Address #2	<input type="text"/>	Receiver #2
To Address #3	<input type="text"/>	Receiver #3
To Address #4	<input type="text"/>	Receiver #4

Save Default

The following table describes the parameters on the page.

Parameter	Description
SMTP Server	Email sever.
SMTP Port	Email port number, which cannot be modified.
Authentication Type	Email login mode, which cannot be modified.
Sender Email	Email address of sender.
Sender Password	Password of the sender email.
To Address	Email address to receive emails. A maximum of four receiver email addresses can be set.

Set the Radius service

Enable the Radius service, and click **Detail Settings** on the right to enter the service configuration page, as shown in the following figure.

Back Alarms(0) Setup Refresh Auto

Radius Settings		
Item	Content	Remark
Radius Auth Server	<input type="text" value="0.0.0.0"/>	Example: 10.10.10.10
Radius Auth Port	<input type="text" value="1812"/>	Default: 1812
Radius Auth Secret	<input type="text" value="testing123"/>	Example: testing123

Save Default

The following table describes the parameters on the page.

Parameter	Description
Radius Auth Server	Radius authentication server.

Parameter	Description
Radius Auth Port	Radius authentication protocol port.
Radius Auth Secret	Radius authentication server password.

3.12.3 System settings

[Log in to the PDU management page](#), click **Setup** under **System** in the left menu bar to access the Setup page. On this page, you can perform the following settings:

- Alarm output settings
- Webpage and display settings
- System time and communication time settings

Last Page [Network](#) [Setup](#) [Profile](#) [Users](#) [Schedule](#) [Upload](#) [ImportCA](#) [INFO](#) [Alarms\(0\)](#) Setup Auto

Setup

Alarm Output

Enabled Beep	<input type="button" value="Disabled"/>	
Enabled Relay	<input type="button" value="Enabled"/>	
Alarm to Snmp Trap	<input type="button" value="Enabled"/>	
Snmp Query Timeout (s)	<input type="text" value="0"/>	0: Don't send timeout trap
Keep Alive Trap Cycle (s)	<input type="text" value="30"/>	1 - 60000
Alarm To Email	<input type="button" value="Enabled"/>	

Web Page & LCD

Web Auto Refresh Time (s)	<input type="text" value="3"/>	1 - 60000
Web Life Time (s)	<input type="text" value="180"/>	1 - 60000
LCD Life Time (s)	<input type="text" value="60"/>	0 - 60000
LCD Rotation	<input type="button" value="Normal"/>	

System

System Time	<input type="text" value="2021-08-10 14:50:33"/>	<input type="button" value="Load Computer Time"/> Format: 2000-01-02 12:34:56
Modbus Address	<input type="text" value="1"/>	Address range: 1 to 255

The following table describes the parameters on this page.

Parameter	Description	
Alarm Output	Enabled Beep	Used to enable or disable the buzzer.
	Enabled Relay	Optional hardware function. Used to connect to an audible-visual alarm device for quick alarm location.
	Alarm to Snmp Trap	Specifies whether to send SNMP Trap.
	Snmp Query Timeout (s)	SNMP heartbeat packet. If an SNMP data packet is not received within the set time period, an SNMP heartbeat packet will be sent. When set to 0, no heartbeat packet will be sent.

Parameter		Description
	Keep Alive Trap Cycle (s)	Specifies the interval for sending SNMP heartbeat packets.
	Alarm to Email	Used to enable or disable alarm emails.
Web page	Web Auto Refresh Time (s)	Available when Auto in the upper right corner of the page is selected.
	Web Life Time (s)	If no actions are taken during this time period, the login will be automatically exited.
	LCD Life Time (s)	Specifies the automatic turn-off time for display backlight. When set to 0, the backlight stays on constantly.
	LCD Rotation	Specifies the display direction.
System	System time	The system time supports both manual and automatic input: <ul style="list-style-type: none"> - Manual input: Fill in according to the format on the right. - Automatic input: Click Load Computer Time.
	Modbus Address	Specifies the communication address of the PDU for serial communication.
	NTP Setting	Used to synchronize the network time. <div data-bbox="657 1361 1489 1496" data-label="Image"> </div> <ul style="list-style-type: none"> - NTP Time Server: NTP network time server - Time offset: time zone - Sync: used to synchronize the network time immediately

3.12.4 Backup and Restore

[Log in to the PDU management page](#), click **Profile** under **System** in the left menu bar to access the Profile page.

Last Page < Network < Setup < **Profile** < Users < Schedule < Upload < ImportCA < INFO Alarms(0) < Setup Refresh Auto

Profile			
Factory Settings			
Restore Factory Settings		NOTE: The current settings would be lost after restored!	
History Settings			
Profile #1	2000-01-01 00:01:08	Restore from profile	Backup to profile
Profile #2	2000-01-01 00:01:08	Restore from profile	Backup to profile
Profile #3	2000-01-01 00:01:08	Restore from profile	Backup to profile

On this page, you can:

- Restore to factory settings: Click **Restore Factory Settings** to restore all settings to default. Note that all current settings will be lost after this operation. Settings backup in advance is recommended.
- Back up settings: In the **History Settings** module, you can click **Backup to profile** in a data line to save the current settings in a profile.

NOTE

Three backup files are provided by default. You can back up settings in these files, or restore the settings to those backed up in the files. The middle column displays the backup time.

- Restore to backup settings: In the **History Settings** module, you can click **Restore from profile** in a data line to restore settings to the backup settings. Note that all current settings will be lost after this operation. Settings backup in advance is recommended.

3.12.5 User settings

[Log in to the PDU management page](#), click **Users** under **System** in the left menu bar to access the Users page. On this page, you can add, modify, and delete users.

Last Page < Network < Setup < Profile < **Users** < Schedule < Upload < ImportCA < INFO Alarms(0) < Setup Refresh Auto

Users		
User Name	User Group	Operation
admin	ReadWrite	Delete Modify
Add a New User:	Username <input type="text"/> Password <input type="password"/> <input type="button" value="Add"/>	The name string must be in a-z, A-Z, 0-9, _-+()#@

3.12.5.1 Add a user

Step 1 [Log in to the PDU management page](#).

Step 2 Click **Users** under **System** in the left menu bar to access the Users page.

Step 3 Enter a username and password after **Add a New User**, and click **Add**.

test is named for example.

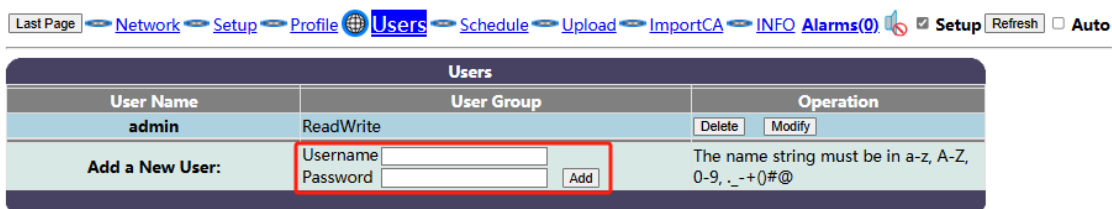

Step 4 Click **Modify** in the line of **test**.

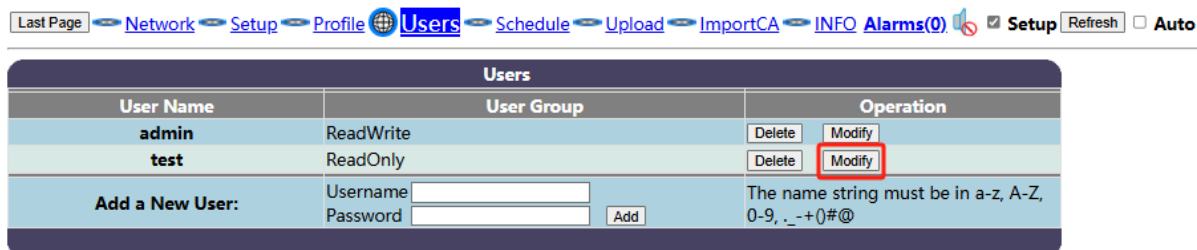

Step 5 Set the user group as required, and click **Save**.

NOTE

ReadWrite: Administrator used to read status and settings, and write settings

ReadOnly: General user used to read state and settings only

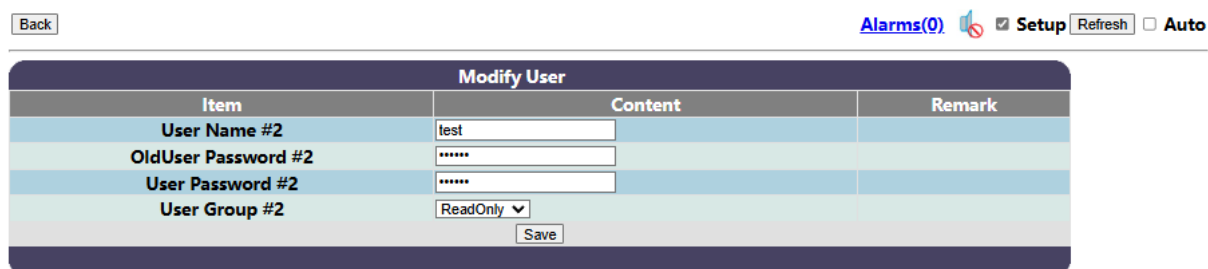

-End

3.12.5.2 Modify a user

Step 1 [Log in to the PDU management page.](#)

Step 2 Click **Users** under **System** in the left menu bar to access the Users page.

Step 3 Click **Modify** in the line of the user to be modified.

User **test** is used for an example.

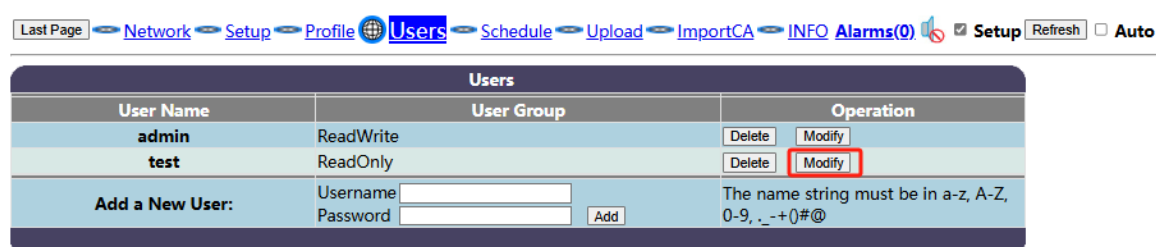

Step 4 Modify the password and user group as required, and click **Save**.

NOTE

ReadWrite: Administrator used to read status and settings, and write settings

ReadOnly: General user used to read state and settings only

Back Alarms(0) Setup Refresh Auto

Modify User		
Item	Content	Remark
User Name #2	test	
OldUser Password #2	*****	
User Password #2	*****	
User Group #2	ReadOnly	

Save

–End

3.12.5.3 Delete a user

NOTE

Administrators can delete all users. However, at least one administrator must be left for the system. If only one administrator exists in the system, this administrator cannot be deleted.

Step 1 [Log in to the PDU management page.](#)

Step 2 Click **Users** under **System** in the left menu bar to access the Users page.

Step 3 Click **Delete** in the line of the user to be deleted.

User **test** is used for an example.

Last Page Network Setup Profile **Users** Schedule Upload ImportCA INFO Alarms(0) Setup Refresh Auto

Users		
User Name	User Group	Operation
admin	ReadWrite	Delete Modify
test	ReadOnly	Delete Modify
Add a New User:		
Username	<input type="text"/>	The name string must be in a-z, A-Z, 0-9, _-+()#@
Password	<input type="password"/>	

Add

–End

3.12.6 Schedule settings

[Log in to the PDU management page](#), click **System** in the left menu bar, and then click **Schedule** in the top title bar to access the Schedule page. On this page, you can perform PDU ON/OFF schedule settings.

NOTE

A maximum of eight schedules can be set.

3.12.6.1 Add a schedule

Step 1 [Log in to the PDU management page.](#)

Step 2 Click **System** in the left menu bar, and then click **Schedule** in the top title bar to access the Schedule page.

Step 3 Enter a schedule name after **Add a New Schedule**, and click **Add**.

test is named for example.

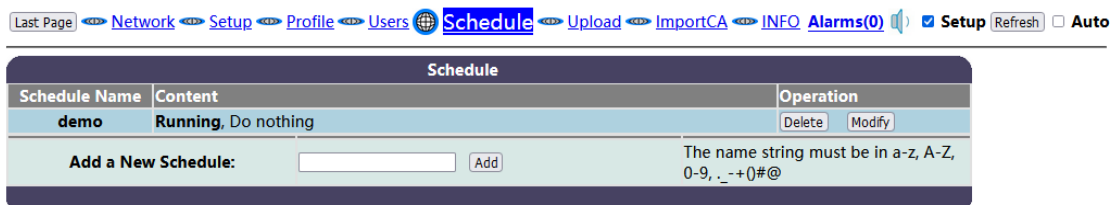

Step 4 Click **Modify** in the line of **test**.

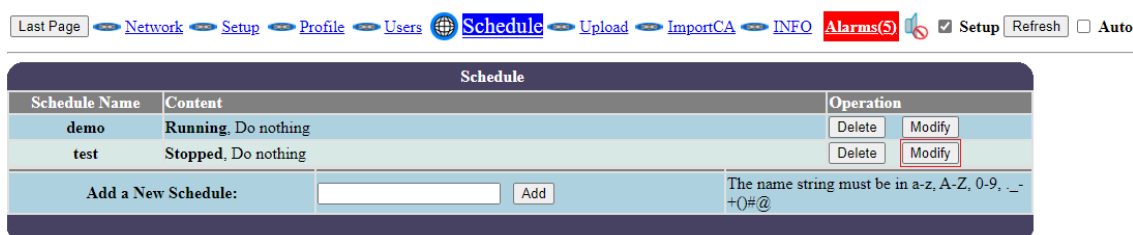

Step 5 Set parameters as required, and click **Save**.

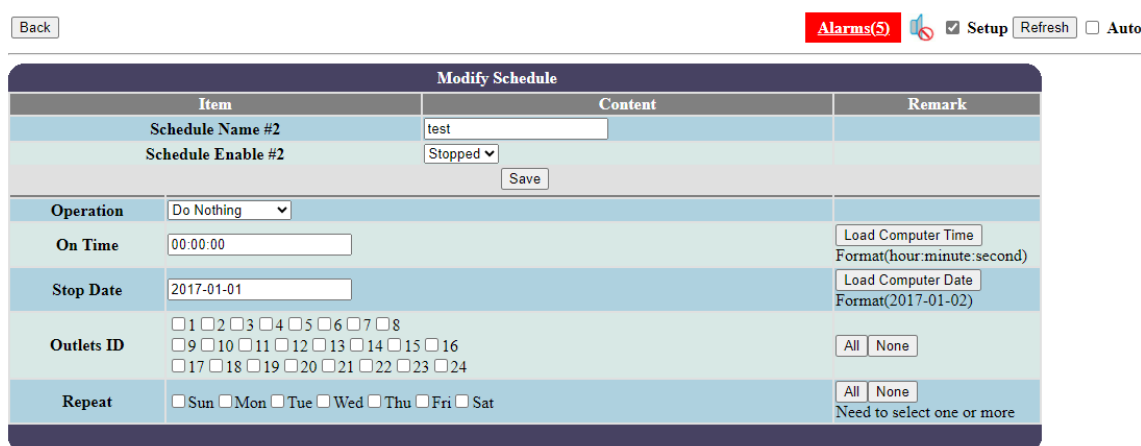

The following table describes the parameters on this page.

Parameter	Description
Schedule Enable	Used to enable or disable the current schedule.
Operation	Select schedule operations as required.
On Time	Specifies the time for schedule operations.
Stop Date	Specifies the date on which the schedule ends.
Outlets ID	Specifies the outlets for which the schedule is performed.

Parameter	Description
Repeat	Specifies the days on which the schedule is performed. At least one day must be selected.

–End

3.12.6.2 Modify a schedule

Step 1 [Log in to the PDU management page.](#)

Step 2 Click **System** in the left menu bar, and then click **Schedule** in the top title bar to access the Schedule page.

Step 3 Click **Modify** in the line of the schedule to be modified.

test is used for example.

Schedule Name	Content	Operation
demo	Running, Do nothing	Delete Modify
test	Stopped, Do nothing	Delete Modify

Add a New Schedule: Add

The name string must be in a-z, A-Z, 0-9, ., _ +()#@

Step 4 Set parameters as required, and click **Save**.

Item	Content	Remark
Schedule Name #2	test	
Schedule Enable #2	Stopped	
Operation	Do Nothing	
On Time	00:00:00	Load Computer Time Format(hour:minute:second)
Stop Date	2017-01-01	Load Computer Date Format(2017-01-02)
Outlets ID	<input type="checkbox"/> 1 <input type="checkbox"/> 2 <input type="checkbox"/> 3 <input type="checkbox"/> 4 <input type="checkbox"/> 5 <input type="checkbox"/> 6 <input type="checkbox"/> 7 <input type="checkbox"/> 8 <input type="checkbox"/> 9 <input type="checkbox"/> 10 <input type="checkbox"/> 11 <input type="checkbox"/> 12 <input type="checkbox"/> 13 <input type="checkbox"/> 14 <input type="checkbox"/> 15 <input type="checkbox"/> 16 <input type="checkbox"/> 17 <input type="checkbox"/> 18 <input type="checkbox"/> 19 <input type="checkbox"/> 20 <input type="checkbox"/> 21 <input type="checkbox"/> 22 <input type="checkbox"/> 23 <input type="checkbox"/> 24	All None
Repeat	<input type="checkbox"/> Sun <input type="checkbox"/> Mon <input type="checkbox"/> Tue <input type="checkbox"/> Wed <input type="checkbox"/> Thu <input type="checkbox"/> Fri <input type="checkbox"/> Sat	All None Need to select one or more

For parameter description, see [Add a schedule.](#)

–End

3.12.6.3 Delete a schedule

Step 1 [Log in to the PDU management page.](#)

Step 2 Click **System** in the left menu bar, and then click **Schedule** in the top title bar to access the Schedule page.

Step 3 Click **Delete** in the line of the schedule to be modified.

test is used for example.

Schedule Name	Content	Operation
demo	Running, Do nothing	Delete Modify
test	Stopped, Do nothing	Delete Modify
Add a New Schedule:		The name string must be in a-z, A-Z, 0-9, . _ - +()#@

–End

3.12.7 Upgrade

Step 1 [Log in to the PDU management page.](#)

Step 2 Click **System** in the left menu bar, and then click **Upload** in the top title bar to access the Upload page.

Step 3 Click **Choose File**, and select the upgrade file.

NOTE

To obtain the upgrade file, contact our service personnel.

The upgrade file is an application firmware upgrade package suffixed with **.enc** (binary file), such as **net-power.version.bin.tar.enc**. The system will be restarted automatically after the file is uploaded.

Other types of files cannot be recognized and processed.

Step 4 Click **Upload**.

–End

3.12.8 Import a CA certificate

NOTE

The newly imported CA certificate will take effect upon next HTTPS connection. System restarting is not required.

Step 1 [Log in to the PDU management page.](#)

Step 2 Click **System** in the left menu bar, and then click **ImportCA** in the top title bar to access the ImportCA page.

Step 3 Click **Choose File**, and select the certificate files.

NOTE

Users need to apply for the CA certificate from relevant organizations. The CA certificate contains three types of documents, all of which must be uploaded.

Step 4 Enter passwords, and click **Submit**.

NOTE

The password is required. For the certificate with a password, enter its password. For the certificate without a password, enter two strings of similar digits.

–End

3.12.9 View/Modify system information

[Log in to the PDU management page](#), click **System** in the left menu bar, and then click **INFO** in the top title bar to access the INFO page. On this page, you can view system information and set product information (including system name, system contact, and system location) for SNMP.

NOTE

To set product information for SNMP, the setup mode must be enabled.

System INFO	
Product Name	FLEX PDU
Product Model	FLXTMA116C2
Product P/N	P-FLXTMA116C2
Product S/N	EC5BCD500004
LAN MAC	EC-5B-CD-50-00-05
Software Version	NET-1.2.1a
Customize the info below for SNMP NMS	
System Name	<input type="text" value="FlexPDU"/> System name, example: pdu
System Contact	<input type="text"/> Contract info
System Location	<input type="text"/> Where the equipment is used.
<input type="button" value="Save"/>	

4 Use the PDU LCD panel

The following figure shows the PDU LCD panel.

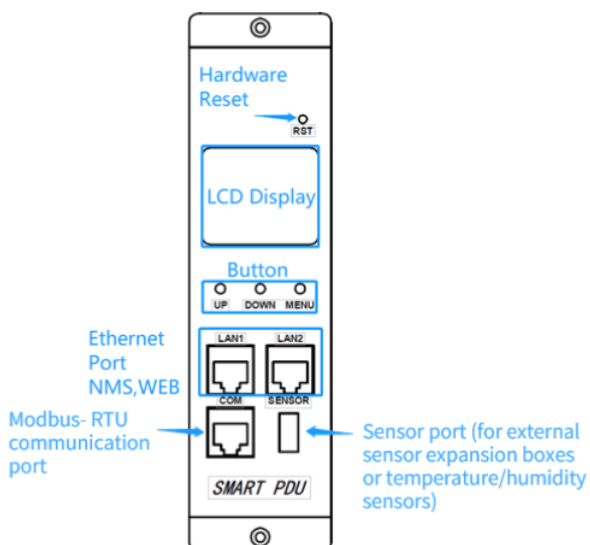

Users can perform operations using the PDU LCD panel. The following figure shows the menu structure of the LCD panel.

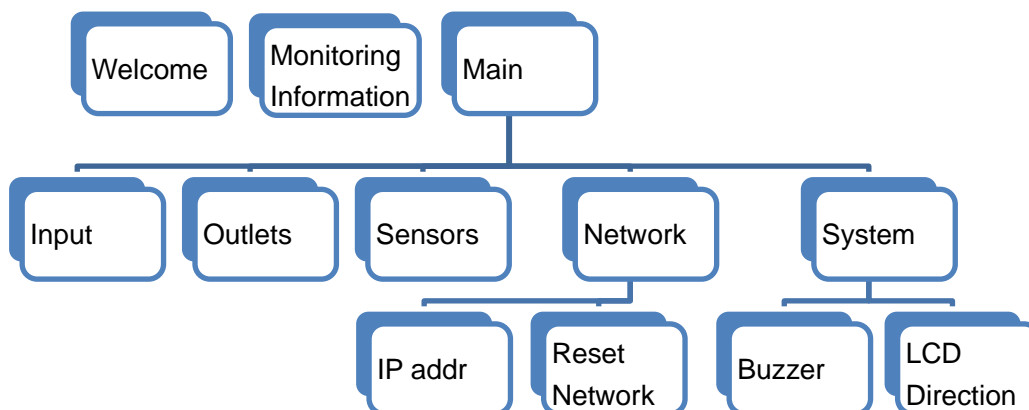

4.1 Welcome page and monitoring information page

After the PDU is powered on, the Welcome page is displayed by default, as shown in the following figure.

FLEX PDU IP Address: 192.168.0.254 Modbus Addr:1 Ver:KEN-1.0.0

The Welcome page displays:

- PDU's IP address: Used to connect the computer to the PDU through the network port
- Modbus RTU communication address: Used to connect to the PDU through serial communication
- Software version

On this page, press the **UP** or **DOWN** button to enter the monitoring information page, as shown in the following figure.

230.0 V 0.00 A 0 W 0.0 kWh
No Alarm

The monitoring information page displays the input voltage, current, active power, energy, and alarm of the PDU. On this page, press the **UP** or **DOWN** button to enter the Welcome page.

4.2 Menu

After the PDU is powered on, press the **MENU** button and enter the LCD password to access the main menu, as shown in the following figure. The LCD password is **111111** by default and can be changed by following [LCDPassword](#).

```

Plesse Enter
Password

0 * * * * *

Up/Down: Change
Menu: Next

```

The following figure shows the main menu. The digit in the parentheses indicates the quantity of the item.

```

Main
1. Inputs (1)
2. Outlets (8)
3. Sensors (0)
4. Network
5. System
6. Back

```

On this page, press the **UP** or **DOWN** button to select a menu item, and then press the **MENU** button to enter the page. If nothing is selected, the page returns to the monitoring information page. After entering the submenu, select **Back** and then press **MENU** or directly press **MENU** when no menu is selected to return to the main menu.

Level-2 menu	Level-3 menu	Description
Input <pre> Input 230.0 V 0.00 A 0 W 0.0 kWh PF: 0.000 </pre>	/	Displays the total input monitoring value. For three-phase PDUs, the monitoring values of each phase are displayed on separate pages.
Output <pre> B1-1 01/08 1. 0.00 A 2. 0 W 3. 0.0 kWh 4. PF: 0.000 5. State: On </pre>	/	Displays the outlet status. Press UP or DOWN to view the status of other outlets.
Sensor <pre> No Sensors </pre>	/	Displays the sensor status. Press UP or DOWN to view the status of other sensors.

Level-2 menu	Level-3 menu	Description
Network <div style="border: 1px solid black; padding: 5px;"> Network 1. IP addr 2. Reset Network 3. Back </div>	IP address <div style="border: 1px solid black; padding: 5px;"> IPv4 Addr: 192.168.0.254 IPv6 Addr: fe80::8e1f:64ff:fe8a:e000 </div>	Displays the IPv4 and IPv6 addresses.
	Reset network <div style="border: 1px solid black; padding: 5px;"> >>>Modify Load Default Network: DO Nothing * Apply Default 【OK】 </div>	Used to restore factory settings, including the username, password, and IP address, and enable HTTP.
System <div style="border: 1px solid black; padding: 5px;"> System 1. Buzzer (On) 2. LCD (Normal) 3. Back </div>	Buzzer	Used to enable/disable the buzzer. Select Buzzer and press MENU to change the ON/OFF status. <ul style="list-style-type: none"> - On: Enable the buzzer. - Off: Disable the buzzer.
	LCD	Used to select the LCD direction. Select LCD and press MENU to change the Normal/Reverse status.

5 Use the command line to manage the PDU

The PDU uses Telnet protocol (unencrypted) and SSH protocol (encryption protocol) to perform command line management function.

5.1 Connect to Telnet

Step 1 Use a network cable to connect the LAN port of PDU to your computer, or use a router for connection.

NOTE

Set network parameters of your computer to access the PDU. If the PDU and your computer are located in the same LAN, set the IP address of your computer in the same network segment with the IP address of the PDU; otherwise, use a correct router or network bridge to connect the PDU.

Step 2 Enable the Telnet service of the PDU.

Log in to the management page of the PDU, access the Network page, set **TELNET Enable** to **Enabled**, and click **Apply Network Settings**. For details, see [Enable/Disable network services](#).

Services		
HTTP Enable	Enabled ▾	WEB server
HTTPS Enable	Disabled ▾	WEB server with TLS
TELNET Enable	Enabled ▾	Command line interface
SSH Enable	Disabled ▾	Command line interface with SSL

Step 3 Run the command line terminal on your computer.

The available software includes SecureCRT, Putty, and FinalShell. SecureCRT is used for example here with the following version.



Step 4 Set connection parameters.

1. Enter the IP address of the PDU (**192.168.0.254** for example), and select the Telnet protocol and set the default port 23.

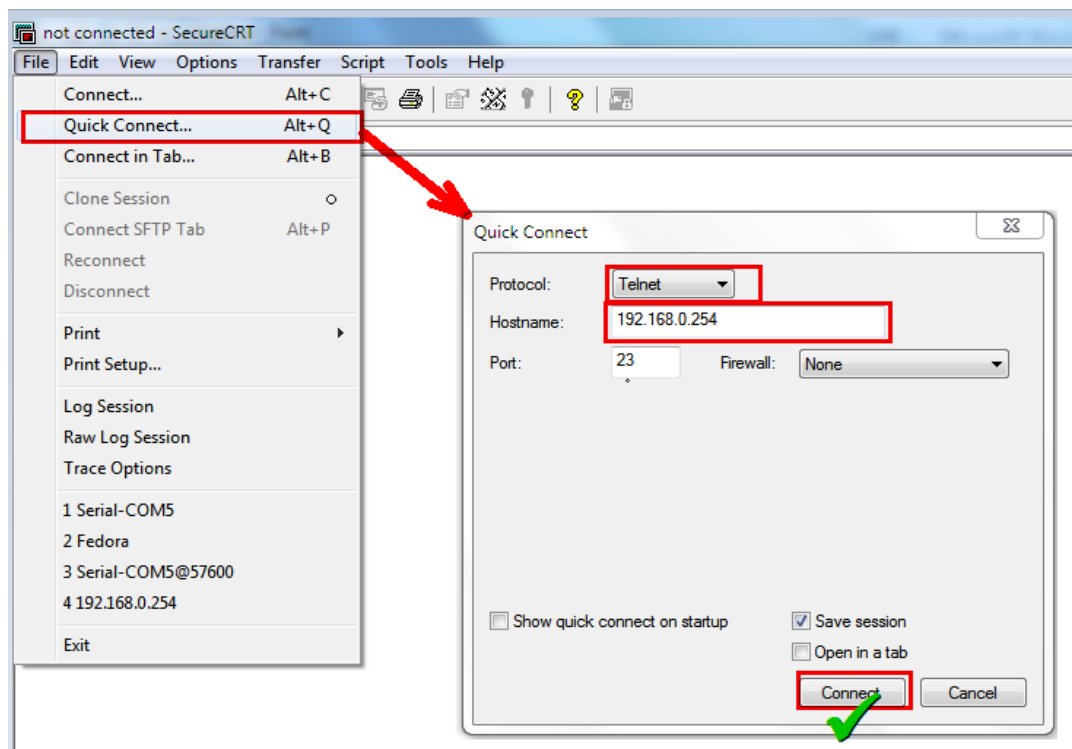

2. Click **Connect**. The **pdu login** prompt is displayed.

```
| 192.168.0.254 (2)
pdu login:
```

Step 5 Log in to the Telnet terminal of the PDU.

Enter the default username (**admin**) and password (**admin**) and press **Enter** to log in. The operation description buttons and commands are displayed, as shown in the following figure.

```
| 192.168.0.254 (2)
pdu login: admin
Password:
### welcome to the command line interface of 'pdu'.
### Press CTRL+D or ESC and then ENTER to cancel current line input.
### List of commands: help/find/gets/list/sync/set/get/exit, etc.
[pdu]
```

NOTE

if no command is input for a long time (about 2 minutes), the terminal will automatically exit.

–End

5.2 Connect to SSH

The method for connecting to the PDU through SSH is almost similar to that through [Telnet](#), while the steps for enabling the SSH service (step 2) and setting connection parameters (step 4) are different.

- Enabling the SSH service of PDU: Log in to the management page of the PDU, access the Network page, set **SSH Enable** to **Enabled**, and click **Apply Network Settings**. For details, see [Enable/Disable network services](#).

Services		
HTTP Enable	Enabled ▾	WEB server
HTTPS Enable	Disabled ▾	WEB server with TLS
TELNET Enable	Enabled ▾	Command line interface
SSH Enable	Disabled ▾	Command line interface with SSL

- Setting connection parameters: Select the SSH2 protocol and default port 22.

Click **Connect**. The following results may occur.

Connection result	Description
	<p>After successful connection, the Enter Secure Shell Password dialog box is displayed.</p> <p>The default username is sshd and default password is 123456.</p> <p>You can select Save password to save the account password.</p>

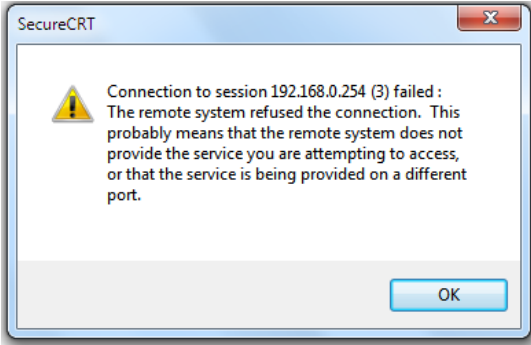
Connection result	Description
 A screenshot of a Windows-style error dialog box titled "SecureCRT". It features a yellow warning triangle icon on the left. The text inside the dialog reads: "Connection to session 192.168.0.254 (3) failed : The remote system refused the connection. This probably means that the remote system does not provide the service you are attempting to access, or that the service is being provided on a different port." At the bottom right of the dialog is a blue "OK" button.	<p>If the connection fails, an error prompt will be displayed. Check whether the firewall settings are correct and whether the communication port is occupied or disabled, and try connection again.</p>

After successful connection, the **pdu login** prompt will be displayed.

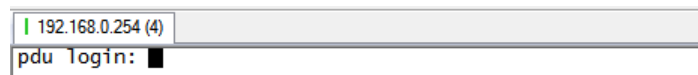

Enter the username and password (same with Telnet) to log in to the PDU.

5.3 Regular instruction for command line

- Input is not case sensitive (except username and password).
- The **DELETE/UP/DOWN/LEFT/RIGHT/HOME/END** keys cannot be used in the command line terminal. If you have used the keys, the current input will be cancelled.
- The **TAB** key can be used to recall history commands. A maximum of eight history commands can be recorded.
- **Object** indicates the management object. These objects are sorted by serial number. The object name and object serial number function similarly for input. Generally, all commands are operated based on the objects.
- To query command description, carry out the **help** command. For details, see [Help command](#).
- To find an object, carry out the **find** command.
- Administrators can read and write objects, and read-only users can view objects only.

5.4 Command instructions

5.4.1 Help command

```
[pdu] help
Help to command:

    [set]  object values #set value to a single object
    [get]  object        #get value of a single object
    gets/g [range]      #get values of objects
    sync/s [range]      #sync objects from other applications
    list/l [range]      #list properties of objects
    list/l object       #list detail properties of a single object
    find/f string       #find the objects which name partial match the
'string'

    hist/h              #show the history commands
    help/?             #show help messages
    exit/x             #exit this application

*** Expression of object ***
softVer                #using name, 'softVer' is an example
softVer.0              #using name with element index
12                     #using identifier number, '12.0' is the same with '12'
12.3                   #using identifier number with element index
.                      #dot punctuation present the last object used

*** Expression of range of objects ***
softVer 34             #using name and number, [softVer, 34]
12 34                  #using numbers only, [12, 34]
12                     #the same as [12,12]

*** Examples ***
find usern             #find object *usern*, we can find 'userName'
list 12 34            #list objects from 12 to 34
get softVer           #get value of object 'softVer'
softVer               #the same as above
.                     #get the last object
set addUser Jack myPw #set object with 2 values
addUser Jack          #set object 'addUser' to value 'Jack'
set userName.2 Rose   #set the 2nd element of object 'userName'
set . Angel           #set the last object to 'Angel'

*** Navigation and notes ***
The read only user has not right to set most objects.
The DELETE/UP/DOWN/LEFT/RIGHT/HOME/END keys are not used here.
Press CTRL+D or ESC or BACKSPACE then ENTER to cancel current line input.
Press TABs first then ENTER to call out the history command (Total 8 items).
Application would quit automatically if more than 120 seconds without any
user input.
```

The following table describes some related commands.

Command	Description
[set] [get]	Indicates that you do not need to enter a command. If it is followed by only one object, it means that the get command is executed. If it is followed by two or more objects, it means that the set command is used.
gets/g	Indicates the gets command, which can be abbreviated as g .
[range]	Indicates the object range. For example, 10 20 (with a space in the middle) indicates objects 10 to 20.

5.4.2 Find and view object attributes

Step 1 Use the **find** command to find the object.

soft is used as an example to query the software version. Object 57 with a similar name is found.

```
[pdu] f soft

NO.  Object Name
+=== +=====
057) SoftVer
```

Step 2 Use the **list** command to list object attributes.

```
[pdu] list 57
Object properties
  NO.      :057 Number of object
  Name     :SoftVer Name of object
  Description :Software Version Description of object
  Elements  :1 (Array member has only one member)
  Data Type :String Type of object : character string
  Access   :Read Only Reading attribute of object, which is
read-only here
  Unit     : Unit of object
  Length   :[0, 10], The length of the object , which is character
string here, so the length can be 0 to 10 characters
```

–End

5.4.3 Read object data

You can use the **gets** or **get** command to read the information. Results of the two commands differs with output formats. The **gets** command can obtain a range of data.

```
[pdu] gets OutletSwitch

NO.  Object Name          Index Values
+=== +=====+
100) OutletSwitch      [ 0] ON
                        [ 1] OFF
                        [ 2] ON
                        [ 3] ON
                        [ 4] ON
                        [ 5] ON
                        [ 6] ON
                        [ 7] ON
```

The query result indicates that the setting is successful.

-End

5.4.5 Synchronize object attributes

When the object attributes are modified, use the **sync** command to update object data.

```
[pdu] sync
Sync properties of
objects.....
177 objects are synchronized OK and 0 are failed.
```

5.4.6 Use object names and serial numbers

Objects can be represented with names or serial numbers. To obtain the object names and serial numbers, see [Instructions for PDU management objects](#). The following figure shows an example.

```
[pdu] f outletswitch

NO.  Object Name
+=== +=====+
100) OutletSwitch  # The object number is 100, and object name is "OutletSwitch"
[pdu] get outletswitch.1 # get the state of No. 1 (the second) switch, which is
"OFF"
OFF
[pdu] get 100.1  get the state of # No.1 (the second) switch, which is "OFF" - which
is replaced with object number, which has the same effect.
OFF
```

5.4.7 Use a dot to indicate the last used object

```
[pdu] get outletswitch.1  get the state of # No.1 (the second) switch, which is "OFF"
OFF
[pdu] set outletswitch.1 1  #set to state of "ON(1)"
### OK!  #setting is successful
[pdu] get outletswitch.1 # set to "ON" state successfully
ON
[pdu] set . 0  # Use a dot to indicate the current object to set it to OFF state.
### OK!
[pdu] get outletswitch.1  # the previous object has been set to OFF state.
OFF
```

5.5 Instructions for PDU management objects

Use the **list** command without entering any more objects, all objects can be listed.

When the page is full, the prompt is as follows. Select "All" to display all the contents.

```
-- Show more [Y<ENTER>/N<SPACE>/A(All)?]a
```

```
[pdu] list
Sync properties of objects...Ok
216 objects are synchronized OK and 0 are failed.
```

NO.	Object Name	Count	Type	Access	
000)	Pduc	[1]	Integer	Read/Write	Note: Quantity of all objects
005)	AddUser	[1]	String	Read/Write	Note: User management
006)	DeleteUser	[1]	String	Read/Write	
007)	ModifyUserName	[1]	String	Read/Write	
008)	ModifyUserPW	[1]	String	Read/Write	
009)	ModifyUserGroup	[1]	String	Read/Write	
010)	UserName	[1]	String	Read/Write	
011)	UserPassword	[1]	String	Read/Write	
012)	UserGroup	[1]	String	Read/Write	
013)	UserCount	[1]	Integer	Read Only	Note: SNMP management
022)	SnmpReadCommunity	[1]	String	Read/Write	
023)	SnmpWriteCommunity	[1]	String	Read/Write	
024)	SnmpTrapManagers	[4]	String	Read/Write	
025)	SnmpTrapCommunities	[4]	String	Read/Write	
026)	SnmpV1Enabled	[1]	EnumText	Read/Write	
027)	SnmpV2Enabled	[1]	EnumText	Read/Write	
028)	SnmpV3Enabled	[1]	EnumText	Read/Write	
029)	SnmpPortNumber	[1]	Integer	Read Only	
030)	SnmpUsmUser	[2]	String	Read/Write	
031)	SnmpSecurityLevel	[2]	EnumText	Read Only	
032)	SnmpAccessRight	[2]	EnumText	Read Only	
033)	SnmpAuthAlgo	[2]	EnumText	Read/Write	
034)	SnmpAuthPassword	[2]	String	Read/Write	
035)	SnmpPrivAlgo	[2]	EnumText	Read/Write	
036)	SnmpPrivPassword	[2]	String	Read/Write	
037)	SnmpContextName	[2]	String	Read Only	
038)	SnmpEngineID	[2]	String	Read Only	Note: Serial port communication Modbus
040)	ModbusAddr	[1]	Integer	Read/Write	Note: Backup settings
044)	BackupConf	[3]	String	Read/Write	

```

045) RestoreConf          [ 3] String    Read/Write
046) LoadFactoryConf     [ 1] EnumText   Read/Write
+=== +===== +===== +===== +=====Note: Alarm management

047) AlarmClear          [ 1] String    Read/Write
048) AlarmCount          [ 1] Integer   Read Only
049) BeepEnable          [ 1] EnumText   Read/Write
050) RelayEnable         [ 1] EnumText   Read/Write
051) EventCode           [ 1] Integer   Read Only
052) EventTime           [ 1] String    Read Only
053) EventLevel          [ 1] EnumText   Read Only
054) EventDetail         [ 1] String    Read Only
055) SourceType          [ 1] String    Read Only
056) SourceId            [ 1] String    Read Only
+=== +===== +===== +===== +=====Note: Product
Information
057) SoftVer             [ 1] String    Read Only
058) ProdName            [ 1] String    Read Only
059) ProdModel           [ 1] String    Read Only
060) ProdPN              [ 1] String    Read Only
061) ProdsN              [ 1] String    Read Only
062) ProdMAC             [ 1] String    Read Only
063) SystemName          [ 1] String    Read/Write
064) SystemContact       [ 1] String    Read/Write
065) SystemLocation      [ 1] String    Read/Write
+=== +===== +===== +===== +=====Note: Input power supply
management
066) PowerFrequency      [ 1] Integer   Read Only
067) PowerAccEnergy      [ 1] Float     Read Only
068) PowerConnectAlarm   [ 1] EnumText   Read Only
069) PowerPhaseVolt      [ 1] Float     Read Only
070) PowerPhaseLoad      [ 1] Float     Read Only
071) PowerActivePower    [ 1] Float     Read Only
072) ReactivePower       [ 1] Float     Read Only
073) ApparentPower       [ 1] Float     Read Only
074) RatedPower          [ 1] Float     Read Only
075) RemainingPower      [ 1] Float     Read Only
076) PowerFactor         [ 1] Float     Read Only
077) PowerPhaseEnergy    [ 1] Float     Read Only
078) PowerInvertJoined   [ 1] EnumText   Read Only
079) PowerLLimit         [ 1] Float     Read/Write
080) PowerLoadLowAlarm   [ 1] EnumText   Read Only
081) PowerHLimit        [ 1] Float     Read/Write
082) PowerLoadHighAlarm  [ 1] EnumText   Read Only
083) VoltageLLimit      [ 1] Float     Read/Write
084) VoltageLowAlarm     [ 1] EnumText   Read Only
085) VoltageHLimit      [ 1] Float     Read/Write

```

```

086) VoltageHighAlarm      [ 1] EnumText  Read Only
087) BreakerName          [ 1] String     Read/Write
088) BreakerAlarm         [ 1] EnumText  Read Only
089) PowerOnInterval      [ 1] Integer   Read/Write
090) OptionName           [ 4] String     Read Only
091) OptionDescr          [ 4] String     Read Only
092) RatedTotalLoad       [ 1] Integer   Read Only
093) PowerPhaseNumber     [ 1] EnumText  Read Only
095) OutletTotalCount     [ 1] Integer   Read Only
096) TotalAddress         [ 1] String     Read/Write
097) SocketType           [ 48] EnumText  Read Only
098) SocketID             [ 48] String     Read/Write
+=== +===== +===== +===== +===== Note: Outlets
management
099) OutletFuse           [ 24] EnumText  Read Only
100) OutletSwitch         [ 24] EnumText  Read/Write
101) OutletHLimit        [ 24] Float     Read/Write
102) OutletLLimit        [ 24] Float     Read/Write
103) OutletLoad           [ 24] Float     Read Only
104) OutletName           [ 24] String     Read/Write
105) OutletConnectAlarm  [ 24] EnumText  Read Only
106) OutletEnergy         [ 24] Float     Read Only
107) OutletPower          [ 24] Float     Read Only
108) OutletPf             [ 24] Float     Read Only
109) OutletDescr          [ 24] String     Read/Write
110) OutletMoveUp        [ 1] Integer   Read/Write
111) OutletMoveDown      [ 1] Integer   Read/Write
+=== +===== +===== +===== +===== Note: Sensor management
112) SensorName           [ 0] String     Read/Write
113) SensorType           [ 0] EnumText  Read Only
114) SensorAddress        [ 0] Integer   Read Only
115) SensorAlarm          [ 0] EnumText  Read Only
116) SensorAlarmEn       [ 0] EnumText  Read/Write
117) SensorStatus         [ 0] String     Read Only
118) SensorTemLLimit     [ 0] Float     Read/Write
119) SensorTemHLimit     [ 0] Float     Read/Write
120) SensorHumLLimit     [ 0] Float     Read/Write
121) SensorHumHLimit     [ 0] Float     Read/Write
122) SensorWindLLimit    [ 0] Float     Read/Write
123) SensorWindHLimit    [ 0] Float     Read/Write
124) SensorWindScale     [ 0] Float     Read/Write
125) TemUnitType          [ 1] EnumText  Read/Write
126) WindUnitType         [ 1] EnumText  Read/Write
127) RescanSensor         [ 1] EnumText  Read/Write
+=== +===== +===== +===== +===== Note: Branch management
128) BranchHLimit        [ 1] Float     Read/Write
129) BranchLoad           [ 1] Float     Read Only

```

130)	PowerBranchVolt	[1]	Float	Read Only
131)	BranchEnergy	[1]	Float	Read Only
132)	BranchActivePower	[1]	Float	Read Only
133)	BranchPowerFactor	[1]	Float	Read Only
134)	BranchConnectAlarm	[1]	EnumText	Read Only
+=== +===== +==== +===== +=====Note: Network parameter				
135)	IpAddr	[1]	String	Read/Write
136)	IpMask	[1]	String	Read/Write
137)	IpGate	[1]	String	Read/Write
138)	IpDns1	[1]	String	Read/Write
139)	IpDns2	[1]	String	Read/Write
140)	IpObtain	[1]	EnumText	Read/Write
146)	HttpEn	[1]	EnumText	Read/Write
147)	HttpsEn	[1]	EnumText	Read/Write
148)	TelnetEn	[1]	EnumText	Read/Write
149)	SshEn	[1]	EnumText	Read/Write
150)	SnmpEn	[1]	EnumText	Read/Write
153)	ResetNetwork	[1]	EnumText	Read/Write
154)	ApplyNetwork	[1]	EnumText	Read/Write
+=== +===== +==== +===== +=====Note: WiFi management				
155)	WifiAddr	[1]	String	Read/Write
156)	WifiMask	[1]	String	Read/Write
157)	WifiGate	[1]	String	Read/Write
158)	WifiDns1	[1]	String	Read/Write
159)	WifiDns2	[1]	String	Read/Write
160)	WifiObtain	[1]	EnumText	Read/Write
161)	WifiSSID	[1]	String	Read/Write
+=== +===== +==== +===== +=====Note: Email sending management				
163)	SmtServer	[1]	String	Read/Write
164)	SmtPort	[1]	Integer	Read/Write
165)	SenderEmail	[1]	String	Read/Write
166)	SenderPassword	[1]	String	Read/Write
167)	SenderAuthType	[1]	EnumText	Read/Write
168)	ToAddress	[4]	String	Read/Write
+=== +===== +==== +===== +===== Note: Radius				
169)	RadiusAuthServer	[1]	String	Read/Write
170)	RadiusAuthPort	[1]	Integer	Read/Write
171)	RadiusAuthSecret	[1]	String	Read/Write
+=== +===== +==== +===== +=====Note: Outlet grouping management				
172)	GroupClear	[8]	EnumText	Read/Write
173)	GroupName	[8]	String	Read/Write
174)	AddGroup	[8]	Integer	Read/Write
175)	RemoveGroup	[8]	Integer	Read/Write
176)	GroupCount	[8]	Integer	Read Only
177)	GroupSwitch	[8]	String	Read/Write

178)	GroupLoad	[8]	Float	Read Only
179)	GroupEnergy	[8]	Float	Read Only
180)	GroupLLimit	[8]	Float	Read/Write
181)	GroupHLimit	[8]	Float	Read/Write
+=== +===== +===== +=====				Note: Main PDU management
183)	AddHost	[1]	String	Read/Write
184)	DeleteHost	[1]	String	Read/Write
185)	ModifyHostName	[1]	String	Read/Write
186)	ModifyHostUri	[1]	String	Read/Write
187)	HostName	[0]	String	Read/Write
188)	HostUri	[0]	String	Read/Write
189)	HostCount	[1]	Integer	Read Only
+=== +===== +===== +=====				Note: Removable outlet management
190)	AddUnit	[1]	String	Read/Write
191)	DeleteUnit	[1]	String	Read/Write
192)	ModifyUnitAddr	[1]	String	Read/Write
193)	ModifyUnitName	[1]	String	Read/Write
194)	UnitAddr	[1]	String	Read/Write
195)	UnitName	[1]	String	Read/Write
196)	UnitCount	[1]	Integer	Read Only
+=== +===== +===== +=====				Note: Communication management
197)	Qos	[34]	String	Read Only
198)	QosClear	[34]	EnumText	Read/Write
+=== +===== +===== +=====				Note: Miscellanea
199)	AlarmToSnmpTrap	[1]	EnumText	Read/Write
200)	SnmpQueryTimeout	[1]	Integer	Read/Write
201)	TrapKeepAliveCycle	[1]	Integer	Read/Write
202)	AlarmToEmail	[1]	EnumText	Read/Write
203)	WebAutoRefreshTime	[1]	Integer	Read/Write
204)	WebPageLifeTime	[1]	Integer	Read/Write
205)	LcdLanguage	[1]	EnumText	Read/Write
206)	LcdRotation	[1]	EnumText	Read/Write
207)	LcdLifeTime	[1]	Integer	Read/Write
208)	Time	[1]	String	Read/Write
209)	TimeServer	[1]	String	Read/Write
210)	TimeZone	[1]	EnumText	Read/Write
211)	NtpSync	[1]	Integer	Read/Write
212)	SyncTime	[1]	String	Read Only
213)	Reboot	[1]	EnumText	Read/Write
214)	Restart	[1]	EnumText	Read/Write
215)	Capw	[1]	String	Read/Write
216)	Rootpw	[1]	String	Read/Write

6 Use SNMP to manage the PDU

The PDU supports the SNMP v1, v2c, and v3.

Through MIB files, PDUs can be connected to the third-party SNMP network management system (NMS), for example, Solarwinds, WhatsUp, CiscoWorks, and HP OpenView.

The MIB browser is used as an example to show the management interface function of PDU and how to view and set management objects of the PDU through SNMP.

6.1 Connect to SNMP

Step 1 Use a network cable to connect the LAN port of PDU to your computer, or use a router for connection.

NOTE

Set network parameters of your computer to access the PDU. If the PDU and your computer are located in the same LAN, set the IP address of your computer in the same network segment with the IP address of the PDU; otherwise, use a correct router or network bridge to connect the PDU.

Step 2 Enable the SNMP service of PDU.

1. Log in to the PDU management page, access the Network page, and set **SNMP Enable** to **Enabled**.

Services		
HTTP Enable	Enabled ▾	WEB server
HTTPS Enable	Disabled ▾	WEB server with TLS
TELNET Enable	Enabled ▾	Command line interface
SSH Enable	Enabled ▾	Command line interface with SSL
SNMP Enable	Enabled ▾	Detail Settings SNMP for NMS

2. Click **Detail Settings** in the line of **SNMP Enable**. Enable corresponding SNMP version and Trap function. Set SNMP parameters for the PDU, and click **Save**.

For different network applications, set SNMP parameters accordingly. For details, see [Enable/Disable network services](#).

SNMP Settings		
General Settings		
SNMP Port	161	
Alarm to Snmp Trap	Enabled ▼	
Enabled SNMPv1/v2c	Disabled ▼	
Enabled SNMPv3	Enabled ▼	
Trap Settings		
Trap Manager	<input type="text"/>	Manager #1
Trap Community	<input type="text"/>	Manager #1
Trap Manager #2	<input type="text"/>	Manager #2
Trap Community #2	<input type="text"/>	Manager #2
SNMP v1/v2c Settings		
Read Community	public	Default: public
Write Community	private	Default: private
SNMP v3: Read And Write User		
USM User	readWriteUser	
Security Level	auth, priv	
Access Right	ReadWrite	
Auth Algorithm	HMAC-SHA	
Auth Password	*****	8 to 20 Characters or digits
Privacy Algorithm	CBC-DES	
Privacy Password	*****	8 to 20 Characters or digits
Context Name		
SNMP v3: Read Only User		
USM User #2	readOnlyUser	
Security Level #2	auth, priv	
Access Right #2	ReadOnly	
Auth Algorithm #2	HMAC-SHA	
Auth Password #2	*****	8 to 20 Characters or digits
Privacy Algorithm #2	CBC-DES	
Privacy Password #2	*****	8 to 20 Characters or digits
Context Name #2		
<input type="button" value="Save"/> <input type="button" value="Default"/>		

- General Settings
 - Alarm to Snmp Trap: Used to enable/disable the function of sending alarm Trap to the network. The network management IP address can be set in the **Trap Settings** module.
 - Enabled SNMP v1/v2c/v3: Used to enable/disable the SNMP version. Settings for v1/v2c can be performed in the **SNMP v1/v2c Settings**. Settings for v3 can be performed in the **SNMP v3: Read And Write User** module. By default, two security users are provided.

Username	Description
readWriteUser	Read and write
readOnlyUser	Read-only

Only encrypted passwords can be set. Other access parameters cannot be added and modified. The passwords must be set with at least eight characters.

3. Click **Back**, and then click **Apply Network Settings**.

Step 3 Open the MIB browser on your computer.

Use SNMP to manage the PDU

Available software includes iReasoning MIB Browser and ManageEngine MibBrowser. iReasoning MIB Browser with the following version is used for example here.



Step 4 Upload the PDU's MIB file to the MIB Browser.

The MIB file **NET-POWER-PDUATS-MIB.txt** is used for example.

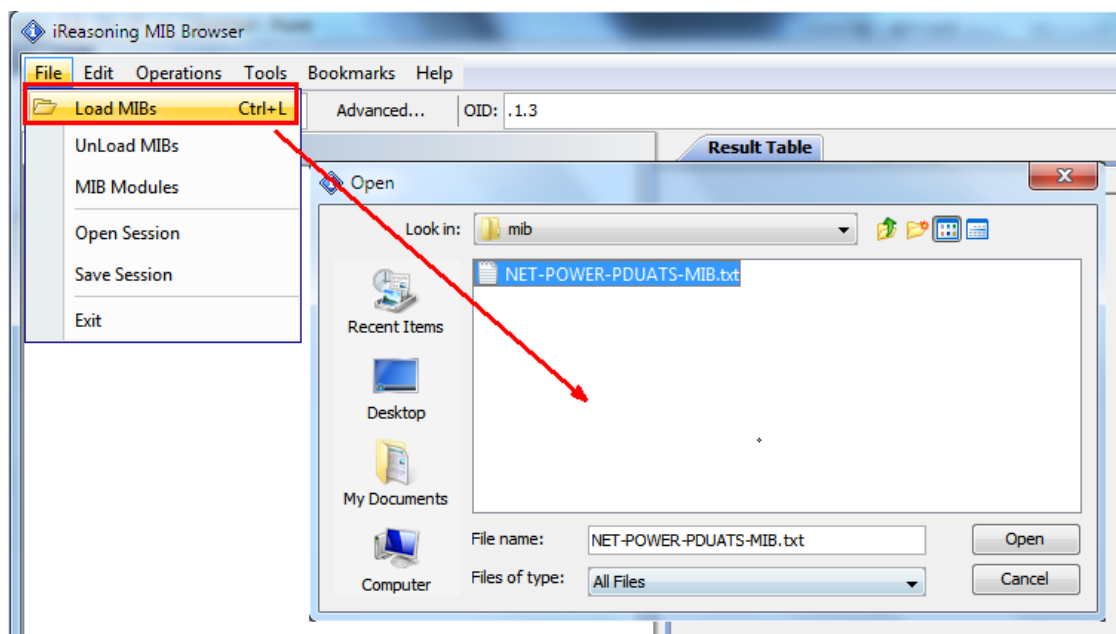

-End

6.2 Set connection parameters

Step 1 In the MIB browser, enter the PDU's IP address (**192.168.0.254** for example) in the address bar, and click **Advanced...** to access connection settings.

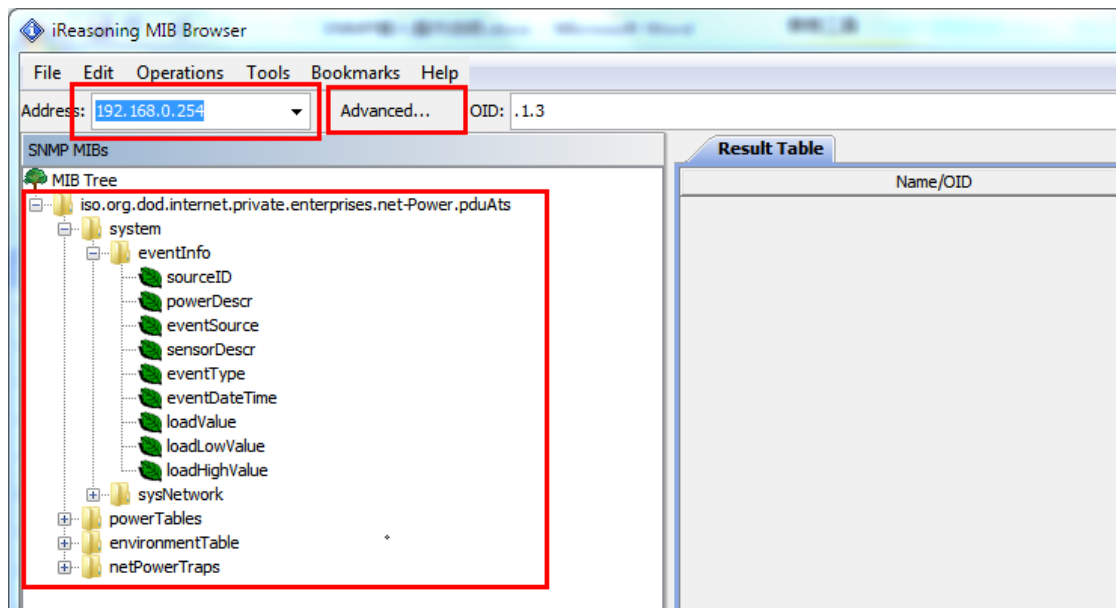

Step 2 Select the SNMP version, and set parameters as required.

- Set **SNMP Version** to **1** or **2** to set connection parameters of SNMP v1 or v2c. Default community information is as follows.

Default read community: Read Community	public
Default write community: Write Community	private

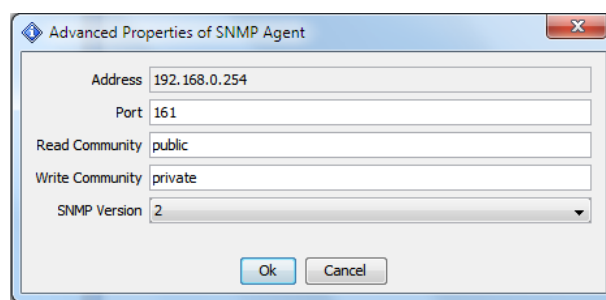

- Set **SNMP Version** to **3** to set connection parameters of SNMP v3. Set parameters according to the following figure, including **USM User**, **Security Level**, **Auth Algorithm**, and **Auth Password**. For user **readWriteUser**, the default authentication password is **authPassword**, and the default encryption password is **privacyPassword**.

Advanced Properties of SNMP Agent

Address: 192.168.0.141
Port: 161
Read Community: *****
Write Community: *****
SNMP Version: 3

SNMPv3

USM User: readWriteUser ← **readWriteUser**
Security Level: auth, priv
Auth Algorithm: SHA
Auth Password: ***** ← **authPassword**
Privacy Algorithm: AES
Privacy Password: ***** ← **privacyPassword**
Context Name:
Engine ID:
Localized Auth Key:
Localized Priv Key:

Ok Cancel

-End

6.3 Example: Read and set management objects

The management object (OID: Object Identifier) configurations vary with PDUs, therefore the corresponding MIB files are different. One type of PDU is used as an example here to show how to read the PDU's IP address and outlet current and set outlet switches.

6.3.1 Read the IP address

Locate the IP address object **ipAddress**. Double-click it to send a read command. If the read result is shown in the right window, the IP address is read successfully.

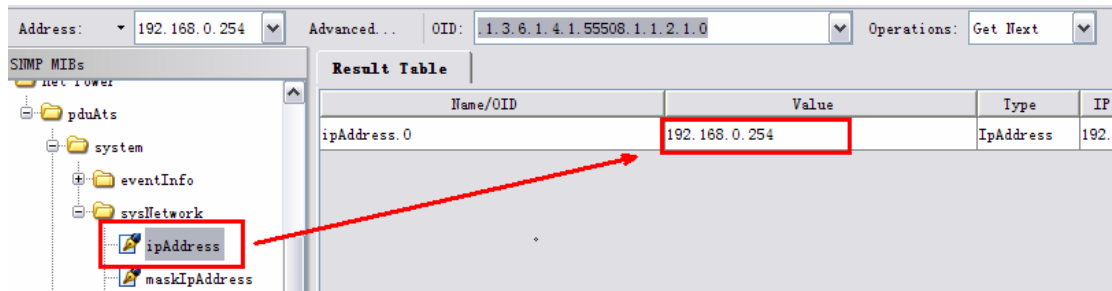

If the connection fails or the SNMP parameters do not match, a read error prompt will be displayed within 10 seconds.

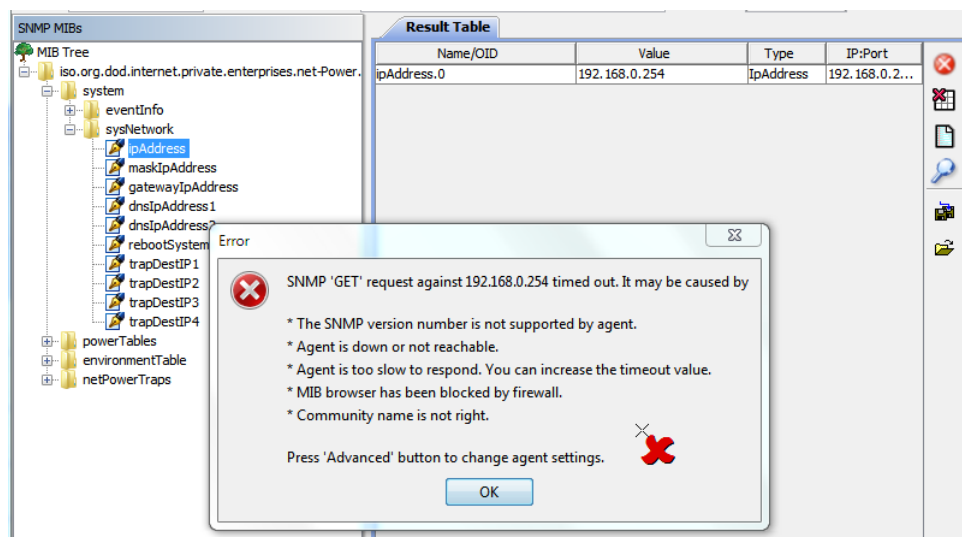

If a read error occurs, perform the following operations:

- Use a network cable to connect the PDU to the network to check whether the network connection is normal.
- Check whether the settings of Read community and Write community are consistent with those on the PDU.
- Check whether the SNMP port number 161 is occupied.

6.3.2 Read outlet current

Select an outlet under the **powerTables** directory, the OID will be displayed in the **OID** textbox on the right.

p1OutletLoad under the **powerTables/power1OutletTable** directory is used for example here.

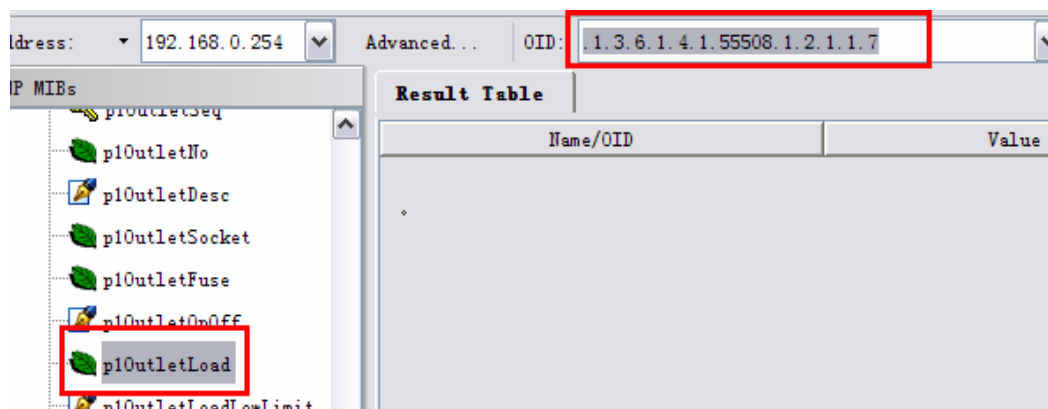

The OID is a table element, therefore the corresponding serial number must be entered for accessing the outlet. By default, **0** indicates the first object and **1** indicates the second object. For example, to access the second outlet, add the serial number **.1** in the textbox. Then, select **Get** for **Operations**, and click **Go** to obtain the current attributes of outlet 1.

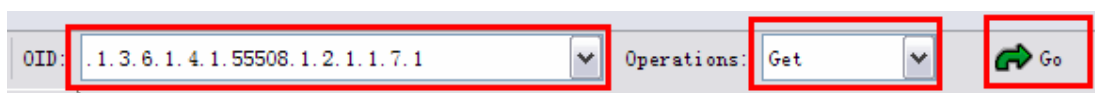

6.3.3 Set outlet switches

Select an outlet OID (**p1OutletOnOff** for example). Read the outlet status by referring to [Read outlet current](#). The read result is **off(0)**.

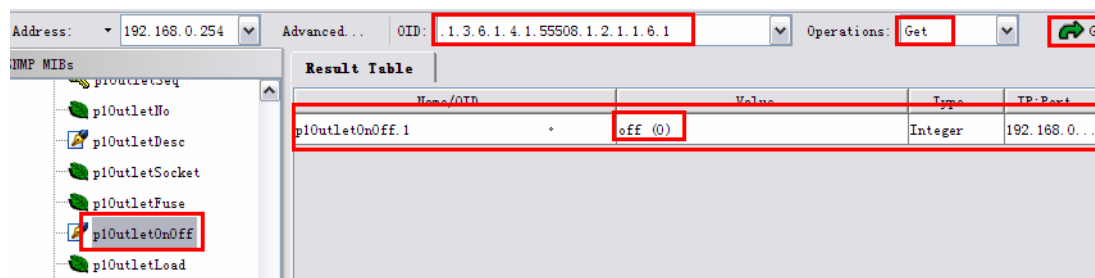

In the result table, right-click the status information of the outlet switch, and select **Set** in the short-cut menu.

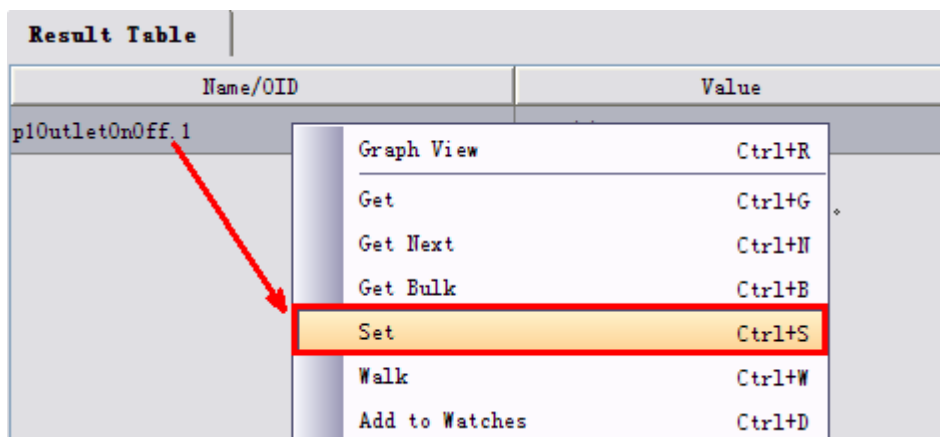

Enter **1** (on) for **Value**, and click **OK**.

SNMP SET

OID: .1.3.6.1.4.1.55508.1.2.1.1.6.1

Data Type: Integer

Value: {none(-1), off(0), on(1)}

Buttons: Ok, Cancel

SNMP SET

OID: .1.3.6.1.4.1.55508.1.2.1.1.6.1

Data Type: Integer

Value: 1

Buttons: [Green Checkmark], Cancel

A success message is displayed.

SET succeeded

SET succeeded

Button: OK

Obtain the outlet status again. Now the switch status is displayed as **on(1)**.

Result Table			
Name/OID ▲	Value ▲	Type	IP:Port
p1OutletOnOff.1	off (0)	Integer	192.168.0.254:161
p1OutletOnOff.1	on (1)	Integer	192.168.0.254:161

7 Use the serial port terminal to manage the PDU

The PDU supports the Modbus protocol based on RS485 bus standard and conforms to the GB/T 19582-2008 standard.

7.1 Physical port

The serial communication port is adapted with standard RS485. Asynchronous Information transmission mode is adopted (one start bit, eight data bits, one stop bit, no verification). Data transfer rate is 9600 bit/s.

Lines of the communication port COM are defined as follows:

	Line No.	Color	Function
	1	Orange and white	NC
	2	Orange	NC
	3	Green and white	NC
	4	Blue	RS485-A
	5	Blue and white	RS485-B
	6	Green	NC
	7	Brown and white	NC
	8	Brown	GND

7.2 Obtain PDU's communication address

To obtain the PDU communication address:

- Method 1: Log in to the PDU management page, and obtain the Modbus address from **/System/Setup**. For details, see [System settings](#).

The screenshot shows the 'Setup' page of the PDU management interface. The page is divided into several sections: 'Alarm Output', 'Web Page & LCD', and 'System'. The 'Modbus Address' field is highlighted with a red box.

Setup		
Alarm Output		
Enabled Beep	Disabled	
Enabled Relay	Enabled	
Alarm to Snmp Trap	Enabled	
Snmp Query Timeout (s)	0	0: Don't send timeout trap
Keep Alive Trap Cycle (s)	30	1 - 60000
Alarm To Email	Enabled	
Web Page & LCD		
Web Auto Refresh Time (s)	3	1 - 60000
Web Life Time (s)	180	1 - 60000
LCD Life Time (s)	60	0 - 60000
LCD Rotation	Normal	
Save		
System		
System Time	2021-08-10 15:16:59	Load Computer Time
Modbus Address	1	Format: 2000-01-02 12:34:56
		Address range: 1 to 255
Save		
NTP Setting		

- Method 2: Obtain the Modbus address from the Welcome page of the PDU LCD panel.

```

FLEX
PDU
IP Address:
192.168.0.254
Modbus Addr:1
Ver:KEN-1.0.0
    
```

7.3 Modbus parameter addresses

Modbus RTU is a standard communication protocol. Based on RS485 bus transmission, users can read data using the Modbus address table. Modbus Poll can be used.

NOTE

Unless stated, the following data are decimal numbers.

Serial No.	Items	Scope	Default	Unit	Modbus Address	Attribute	Real parameter value (Conversion formula)	Number of bytes	Remarks
I. Rated information and metering parameters: 03H function code reading									
1	Manufacturer	Use the string form	\	\	0-3	Read	=Register	8	
2	Model	For example: HVPDU63-2-32(01)	\	\	4-19	Read	=Register	32	Reserved
3	Current hardware version	A-Z	\	\	20	Read	=Register	2	
4	Current software version	100-999	\	\	21	Read	=Register	2	
5	Communication protocol version	0x100-0x999	\	\	22-23	Read	H_Register: large version L_Register: small version	4	
6	Software compilation time	YYYYMMDD character string	\	\	24-27	Read	=Register	8	
7	Rated Voltage	220/380	220/380	V	28	Read	=Register	2	Used for judging one or three-phase PDU
8	Rated Current	100	16/32/63	A	29	Read	=Register	2	
9	Rated Frequency	50	50	Hz	30	Read	=Register	2	

Serial No.	Items	Scope	Default	Unit	Modbus Address	Attribute	Real parameter value (Conversion formula)	Number of bytes	Remarks
10	Numbers of output	48	\	\	31	Read	=Register	2	
11	Switch Function of output	0-1	\	\	32	Read	0: No; 1: Yes	2	
12	Current Measuring Function of output	0-1	\	\	33	Read	0: No; 1: Yes	2	
13	Electrical Degree Measuring Function of output	0-1	\	\	34	Read	0: No; 1: Yes	2	Include Active Power, Power Factor of Output
14	Voltage Value (One Phase)	0-350	\	V	35	Read	=Register	2	
15	Current Value (One Phase)	0-700	\	A	36	Read	=Register/10	2	
16	Active Power (One Phase)	0-65535	\	W	37	Read	=Register	2	
17	Reactive Power (One Phase)	0-65535	\	W	38	Read	=Register	2	
18	Power Factor (One Phase)	0-1000	\	\	39	Read	=Register/1000	2	
19	General Active Electrical Degree	0-9999999	\	kWh	40-41	Read	=Register_L/10 + Register_H*65536/10	4	
20	Frequency	4500-6500	\	Hz	42	Read	=Register/100	2	
21	L1 Voltage Value (Three- Phase)	0-350	\	V	43	Read	=Register	2	

Serial No.	Items	Scope	Default	Unit	Modbus Address	Attribute	Real parameter value (Conversion formula)	Number of bytes	Remarks
22	L2 Voltage Value (Three- Phase)	0-350	\	V	44	Read	=Register	2	
23	L3 Voltage Value (Three- Phase)	0-350	\	V	45	Read	=Register	2	
24	L1 Current Value (Three- Phase)	0-700	\	A	46	Read	=Register/10	2	
25	L2 Current Value (Three- Phase)	0-700	\	A	47	Read	=Register/10	2	
26	L3 Current Value (Three- Phase)	0-700	\	A	48	Read	=Register/10	2	
27	L1 Active Power (Three- Phase)	0-65535	\	W	49	Read	=Register	2	
28	L2 Active Power (Three- Phase)	0-65535	\	W	50	Read	=Register	2	
29	L3 Active Power (Three- Phase)	0-65535	\	W	51	Read	=Register	2	
30	L1 Reactive Power (Three- Phase)	0-65535	\	W	52	Read	=Register	2	
31	L2 Reactive Power (Three- Phase)	0-65535	\	W	53	Read	=Register	2	
32	L3 Reactive Power(Three- Phase)	0-65535	\	W	54	Read	=Register	2	
33	L1 Power Factor(Three- Phase)	0-1000	\	\	55	Read	=Register/1000	2	

Serial No.	Items	Scope	Default	Unit	Modbus Address	Attribute	Real parameter value (Conversion formula)	Number of bytes	Remarks
34	L2 Power Factor (Three- Phase)	0-1000	\	\	56	Read	=Register/1000	2	
35	L3 Power Factor (Three- Phase)	0-1000	\	\	57	Read	=Register/1000	2	
36	1 Current of output	0-700	\	A	58	Read	=Register/10	2	
...	\	A	
83	48 Current of output	0-700	\	A	105	Read	=Register/10	2	
84	1 Electrical Energy of output	0-9999999	\	kWh	106-107	Read	=Register_L/10 + Register_H*65536/10	4	
...	\	kWh	
131	48 Electrical Energy of output	0-9999999	\	kWh	200-201	Read	=Register_L/10 + Register_H*65536/10	4	
132	1 Active Power of output	0-65535	\	W	202	Read	=Register	2	
...	\	W	
179	48 Active Power of output	0-65535	\	W	249	Read	=Register	2	
180	1 Power Factor of output	0-1000	\	\	250	Read	=Register/1000	2	

Serial No.	Items	Scope	Default	Unit	Modbus Address	Attribute	Real parameter value (Conversion formula)	Number of bytes	Remarks
...	\	\	
227	48 Power Factor of output	0-1000	\	\	297	Read	=Register/1000	2	

II. Environmental Parameters: 03H Function code to read, 10H Function code to write

1	Temperature Value 1	0-140	\	°C	500	Read	=Register-40	2	0xFFFF means that it is not installed
2	Humidity Value 1	0-100	\	%	501	Read	=Register	2	0xFFFF means that it is not installed
3	Temperature Value 2	0-140	\	°C	502	Read	=Register-40	2	0xFFFF means that it is not installed
4	Humidity Value 2	0-100	\	%	503	Read	=Register	2	0xFFFF means that it is not installed
5	Temperature Value 3	0-140	\	°C	504	Read	=Register-40	2	0xFFFF means that it is not installed
6	Humidity Value 3	0-100	\	%	505	Read	=Register	2	0xFFFF means that it is not installed
7	Temperature Value 4	0-140	\	°C	506	Read	=Register-40	2	0xFFFF means that it is not installed

Serial No.	Items	Scope	Default	Unit	Modbus Address	Attribute	Real parameter value (Conversion formula)	Number of bytes	Remarks
8	Humidity Value 4	0-100	\	%	507	Read	=Register	2	0xFFFF means that it is not installed
9	Temperature Value 5	0-140	\	°C	508	Read	=Register-40	2	0xFFFF means that it is not installed
10	Humidity Value 5	0-100	\	%	509	Read	=Register	2	0xFFFF means that it is not installed
11	Temperature Value 6	0-140	\	°C	510	Read	=Register-40	2	0xFFFF means that it is not installed
12	Humidity Value 6	0-100	\	%	511	Read	=Register	2	0xFFFF means that it is not installed
13	Temperature Value 7	0-140	\	°C	512	Read	=Register-40	2	0xFFFF means that it is not installed
14	Humidity Value 7	0-100	\	%	513	Read	=Register	2	0xFFFF means that it is not installed
15	Temperature Value 8	0-140	\	°C	514	Read	=Register-40	2	0xFFFF means that it is not installed
16	Humidity Value 8	0-100	\	%	515	Read	=Register	2	0xFFFF means that it is not installed

Serial No.	Items	Scope	Default	Unit	Modbus Address	Attribute	Real parameter value (Conversion formula)	Number of bytes	Remarks
17	Wind Speed Value	0-255	\	m/s	516	Read	=Register/10	2	0xFFFF means that it is not installed

III. Configuration Parameters: 03H Function code to read, 10H Function code to write

1	Communication Address	1-255	1	\	1000	Read and Write	=Register	2	
2	Buzzer Switch	0-1	1	\	1001	Read and Write	0: Close; 1: Start	2	Restart to restore defaults
3	Alarm Dry-Contact Switch	0-1	1	\	1002	Read and Write	0: Close; 1: Start	2	Restart to restore defaults
4	Current Upper Limit alarm set value (One-Phase)	0-700	160/320	A	1003	Read and Write	=Register/10	2	Upper Limit value is larger than that of Lower Limit
5	Current Lower Limit alarm set value (One-Phase)	0-700	0	A	1004	Read and Write	=Register/10	2	Upper Limit value is larger than that of Lower Limit.
6	L1 Current Upper Limit alarm set value (Three-Phase)	0-700	160/320	A	1005	Read and Write	=Register/10	2	Upper Limit value is larger than that of Lower Limit.
7	L1 Current Lower Limit alarm set value (Three-Phase)	0-700	0	A	1006	Read and Write	=Register/10	2	Upper Limit value is larger than that of Lower Limit.

Serial No.	Items	Scope	Default	Unit	Modbus Address	Attribute	Real parameter value (Conversion formula)	Number of bytes	Remarks
8	L2 Current Upper Limit alarm set value (Three-Phase)	0-700	160/320	A	1007	Read and Write	=Register/10	2	Upper Limit value is larger than that of Lower Limit.
9	L2 Current Lower Limit alarm set value (Three-Phase)	0-700	0	A	1008	Read and Write	=Register/10	2	Upper Limit value is larger than that of Lower Limit.
10	L3 Current Upper Limit alarm set value (Three-Phase)	0-700	160/320	A	1009	Read and Write	=Register/10	2	Upper Limit value is larger than that of Lower Limit.
11	L3 Current Lower Limit alarm set value (Three-Phase)	0-700	0	A	1010	Read and Write	=Register/10	2	Upper Limit value is larger than that of Lower Limit.
12	Output 1 Current Upper Limit alarm set value	0-400	160	A	1011	Read and Write	=Register/10	2	Upper Limit value is larger than that of Lower Limit.
13	Output 1 Current Lower Limit alarm set value	0-400	0	A	1012	Read and Write	=Register/10	2	Upper Limit value is larger than that of Lower Limit.
...	Read and Write

Serial No.	Items	Scope	Default	Unit	Modbus Address	Attribute	Real parameter value (Conversion formula)	Number of bytes	Remarks
106	Output 48 Current Upper Limit alarm set value	0-400	160	A	1105	Read and Write	=Register/10	2	Upper Limit value is larger than that of Lower Limit.
107	Output 48 Current Lower Limit alarm set value	0-400	0	A	1106	Read and Write	=Register/10	2	Upper Limit value is larger than that of Lower Limit.
108	Temperature 1 Current Upper Limit alarm set value	0-140	140	°C	1107	Read and Write	=Register-40	2	Upper Limit value is larger than that of Lower Limit.
109	Temperature 1 Current Down Limit alarm set value	0-140	0	°C	1108	Read and Write	=Register-40	2	Upper Limit value is larger than that of Lower Limit.
...	Read and Write
122	Temperature 8 Current Upper Limit alarm set value	0-140	140	°C	1121	Read and Write	=Register-40	2	Upper Limit value is larger than that of Lower Limit.
123	Temperature 8 Current Down Limit alarm set value	0-140	0	°C	1122	Read and Write	=Register-40	2	Upper Limit value is larger than that of Lower Limit.

Serial No.	Items	Scope	Default	Unit	Modbus Address	Attribute	Real parameter value (Conversion formula)	Number of bytes	Remarks
124	Humidity 1 Current Upper Limit alarm set value	0-100	100	%	1123	Read and Write	=Register	2	Upper Limit value is larger than that of Lower Limit.
125	Humidity 1 Current Lower Limit alarm set value	0-100	0	%	1124	Read and Write	=Register	2	Upper Limit value is larger than that of Lower Limit.
...	Read and Write
138	Humidity 8 Current Upper Limit alarm set value	0-100	100	%	1137	Read and Write	=Register	2	Upper Limit value is larger than that of Lower Limit.
139	Humidity 8 Current Lower Limit alarm set value	0-100	0	%	1138	Read and Write	=Register	2	Upper Limit value is larger than that of Lower Limit.
140	Wind Speed Current Upper Limit alarm set value	0-255	250	m/s	1139	Read and Write	=Register/10	2	Upper Limit value is larger than that of Lower Limit.
141	Wind Speed Current Lower Limit alarm set value	0-255	250	m/s	1140	Read and Write	=Register/10	2	Upper Limit value is larger than that of Lower Limit.

VI. Alarm: 01H Function code to read

Serial No.	Items	Scope	Default	Unit	Modbus Address	Attribute	Real parameter value (Conversion formula)	Number of bytes	Remarks
1	General Alarm	\	\	\	2000	Read	0. No Alarm; 1: Alarm	1bit	
2	One-phase Over-current alarm (One-Phase)	\	\	\	2001	Read	0. No Alarm; 1: Alarm	1bit	
3	One-phase under-current alarm (One-Phase)	\	\	\	2002	Read	0. No Alarm; 1: Alarm	1bit	
4	Circuit Breaker Opened alarm	\	\	\	2003	Read	0. No Alarm; 1: Alarm	1bit	
5	L1 Over-current alarm (Three-Phase)	\	\	\	2004	Read	0. No Alarm; 1: Alarm	1bit	
6	L2 Over-current alarm (Three-Phase)	\	\	\	2005	Read	0. No Alarm; 1: Alarm	1bit	
7	L3 Over-current alarm (Three-Phase)	\	\	\	2006	Read	0. No Alarm; 1: Alarm	1bit	
8	L1 Under-current alarm (Three-Phase)	\	\	\	2007	Read	0. No Alarm; 1: Alarm	1bit	
9	L2 Under-current alarm (Three-Phase)	\	\	\	2008	Read	0. No Alarm ; 1: Alarm	1bit	

Serial No.	Items	Scope	Default	Unit	Modbus Address	Attribute	Real parameter value (Conversion formula)	Number of bytes	Remarks
10	L3 Under-current alarm (Three -Phase)	\	\	\	2009	Read	0. No Alarm; 1: Alarm	1bit	
11	Output 1 Over-current alarm	\	\	\	2010	Read	0. No Alarm; 1: Alarm	1bit	
12	Output 1 Under-current alarm	\	\	\	2011	Read	0. No Alarm; 1: Alarm	1bit	
...	...	\	\	\	
105	Output 48 Over-current alarm	\	\	\	2104	Read	0. No Alarm ; 1: Alarm	1bit	
106	Output 48 Under-current alarm	\	\	\	2105	Read	0. No Alarm ; 1: Alarm	1bit	
107	Output 1 with fault	\	\	\	2106	Read	0. No Alarm ; 1: Alarm	1bit	
...	...	\	\	\	
154	Output 48 with fault	\	\	\	2153	Read	0. No Alarm ; 1: Alarm	1bit	
155	Too high Temperature 1 alarm	\	\	\	2154	Read	0. No Alarm ; 1: Alarm	1bit	

Serial No.	Items	Scope	Default	Unit	Modbus Address	Attribute	Real parameter value (Conversion formula)	Number of bytes	Remarks
156	Too low Temperature 1 alarm				2155				
...	...	\	\	\	
169	Too high Temperature 8 alarm	\	\	\	2168	Read	0. No Alarm ; 1: Alarm	1bit	
170	Too low Temperature 8 alarm				2169				
171	Too high Humidity 1 alarm				2170				
172	Too Low Humidity 1 alarm	\	\	\	2171	Read	0. No Alarm ; 1: Alarm	1bit	
...	...	\	\	\	
185	Too high Humidity 8 alarm				2184				
186	Too low Humidity 8 alarm	\	\	\	2185	Read	0. No Alarm ; 1: Alarm	1bit	
187	Door Controller 1 alarm	\	\	\	2186	Read	0. No Alarm ; 1: Alarm	1bit	
...	...	\	\	\	
194	Door Controller 8 alarm	\	\	\	2193	Read	0. No Alarm ; 1: Alarm	1bit	

Serial No.	Items	Scope	Default	Unit	Modbus Address	Attribute	Real parameter value (Conversion formula)	Number of bytes	Remarks
195	Infrared 1 alarm	\	\	\	2194	Read	0. No Alarm ; 1: Alarm	1bit	
...	...	\	\	\	
202	Infrared 8 alarm	\	\	\	2201	Read	0. No Alarm ; 1: Alarm	1bit	
203	Water Logging 1 alarm	\	\	\	2202	Read	0. No Alarm ; 1: Alarm	1bit	
...	...	\	\	\	
210	Water Logging 8 alarm	\	\	\	2209	Read	0. No Alarm ; 1: Alarm	1bit	
211	Smoke 1 alarm	\	\	\	2210	Read	0. No Alarm ; 1: Alarm	1bit	
...	...	\	\	\	
218	Smoke 8 alarm	\	\	\	2217	Read	0. No Alarm ; 1: Alarm	1bit	
219	Too high Wind Speed Alarm				2218				
220	Too Low Wind Speed Alarm	\	\	\	2219	Read	0. No Alarm ; 1: Alarm	1bit	

V. The number of control: 03H Function code to read, 10H Function code to write

1	1st branch output on/off control	\	\	\	3000	Read	0: Cannot be controlled; 1: on; 2: off	2	Writing 0 means invalid; when the parameter
---	----------------------------------	---	---	---	------	------	--	---	---

Use the serial port terminal to manage the PDU

Serial No.	Items	Scope	Default	Unit	Modbus Address	Attribute	Real parameter value (Conversion formula)	Number of bytes	Remarks
2	2nd branch output on/off control	\	\	\	3001	Read	0: Cannot be controlled; 1: on; 2: off	2	value is 0, there is no writing or registration action.
3	3rd branch output on/off control	\	\	\	3002	Read	0: Cannot be controlled; 1: on; 2: off	2	
...	...	\	\	\	...	Read	
48	48th branch output on/off control	\	\	\	3047	Read	0: Cannot be controlled; 1: on; 2: off	2	

VI. Restore Factory Defaults 10H Function code to write

1	Restore Factory Defaults	0x55AA	\	\	4000	Write	=Register	2	
---	--------------------------	--------	---	---	------	-------	-----------	---	--

Appendix Acronyms and abbreviations

Abbreviation/Acronym	Full Form
HTTPS	Hypertext Transfer Protocol Secure
NTP	network time protocol
PDU	power distribution unit
SNMP	Simple Network Management Protocol