



# Hardware Reference Guide

## OMEN 35L Gaming Desktop PC

### **SUMMARY**

This guide provides information about components, power management, security, backing up, and more.

## Legal information

© Copyright 2024 HP Development Company, L.P.

AMD is a trademarks of Advanced Micro Devices, Inc. Intel is a trademark of Intel Corporation or its subsidiaries in the U.S. and/or other countries. Microsoft and Windows are either registered trademarks or trademarks of Microsoft Corporation in the United States and/or other countries. USB Type-C and USB-C are registered trademarks of USB Implementers Forum.

The information contained herein is subject to change without notice. The only warranties for HP products and services are set forth in the express warranty statements accompanying such products and services. Nothing herein should be construed as constituting an additional warranty. HP shall not be liable for technical or editorial errors or omissions contained herein.

First Edition: July 2024

Document Part Number: P01281-001

### Product Notice

This guide describes features that are common to most models. Some features may not be available on your computer.

Not all features are available in all editions or versions of Windows. Systems may require upgraded and/or separately purchased hardware, drivers, software or BIOS update to take full advantage of Windows functionality. Windows is automatically updated, which is always enabled. High-speed internet and Microsoft account required. ISP fees may apply and additional requirements may apply over time for updates. See <http://www.windows.com>.

**If your product ships with Windows in S Mode:** Windows in S Mode works exclusively with apps from the Microsoft Store within Windows. Certain default settings, features, and apps cannot be changed. Some accessories and apps that are compatible with Windows may not work (including some antivirus, PDF writers, driver utilities, and accessibility apps), and performance may vary, even if you switch out of S Mode. If you switch to Windows, you cannot switch back to S Mode. Learn more at [Windows.com/SmodeFAQ](https://www.windows.com/SmodeFAQ).

To access the latest user guides, go to <http://www.hp.com/support>, and follow the instructions to find your product. Then select **Manuals**.

### Software terms





By installing, copying, downloading, or otherwise using any software product preinstalled on this computer, you agree to be bound by the terms of the HP End User License Agreement (EULA). If you do not accept these license terms, your sole remedy is to return the entire unused product (hardware and software) within 14 days for a full refund subject to the refund policy of your seller.

For any further information or to request a full refund of the price of the computer, please contact your seller.

---

# About this guide

This guide provides basic information for using and upgrading this product.

- 
-  **WARNING!** Indicates a hazardous situation that, if not avoided, **could** result in serious injury or death.
  -  **CAUTION:** Indicates a hazardous situation that, if not avoided, **could** result in minor or moderate injury.
  -  **IMPORTANT:** Indicates information considered important but not hazard-related (for example, messages related to property damage). Warns the user that failure to follow a procedure exactly as described could result in loss of data or in damage to hardware or software. Also contains essential information to explain a concept or to complete a task.
  -  **NOTE:** Contains additional information to emphasize or supplement important points of the main text.
  -  **TIP:** Provides helpful hints for completing a task.
-

---

# Table of contents

<b>1 Computer features</b> .....	<b>1</b>
Top components .....	1
Rear components.....	2
<b>2 Hardware setup</b> .....	<b>3</b>
Warnings and cautions.....	3
Preparation for disassembly.....	3
Component identification.....	4
System board layouts.....	5
Computer feet.....	8
Left access panel.....	9
Replacing or installing DIMMs.....	10
Solid-state drive.....	13
WLAN module.....	16
Right access panel.....	18
Hard drive.....	19
Power supply, modular.....	22
Power supply, nonmodular.....	23
Graphics card.....	24
Front bezel.....	30
Front dust filter.....	31
Bottom dust filter.....	32
RGB lighting board.....	33
Front fans.....	35
Rear fan.....	38
Top fans.....	41
Cable cover.....	45
120 mm × 120 mm heat sink (air cooler) adapter bracket.....	46
92 mm heat sink fan (air cooler).....	47
120 mm × 120 mm heat sink fan (air cooler) (fan only).....	49
120 mm × 120 mm heat sink (air cooler) (entire assembly).....	51
Liquid cooler.....	53
Processor.....	59
Top I/O module.....	60

System board.....	63
Wireless antennas and cables.....	65
<b>3 Computer operating guidelines, routine care, and shipping preparation .....</b>	<b>69</b>
Operating guidelines and routine care .....	69
Cleaning your computer .....	69
Removing dirt and debris from your computer.....	70
Cleaning your computer with a disinfectant.....	70
Shipping preparation .....	71
<b>4 Electrostatic discharge.....</b>	<b>72</b>
<b>5 Accessibility .....</b>	<b>73</b>
HP and accessibility.....	73
Finding the technology tools you need.....	73
The HP commitment.....	73
International Association of Accessibility Professionals (IAAP).....	74
Finding the best assistive technology.....	74
Assessing your needs .....	74
Accessibility for HP products.....	74
Standards and legislation .....	75
Standards.....	75
Mandate 376 - EN 301 549 .....	75
Web Content Accessibility Guidelines (WCAG).....	75
Legislation and regulations.....	76
Useful accessibility resources and links .....	76
Organizations .....	76
Educational institutions .....	76
Other disability resources .....	77
HP links.....	77
Contacting support.....	77
<b>Index.....</b>	<b>78</b>

# 1 Computer features

This chapter provides you with an overview of your computer's features.







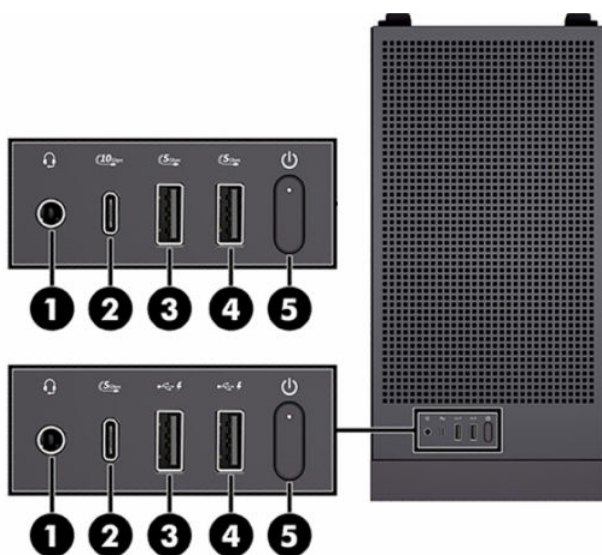

## Top components

To identify the top components, use this illustration and table.

Refer to the illustration that matches your computer.

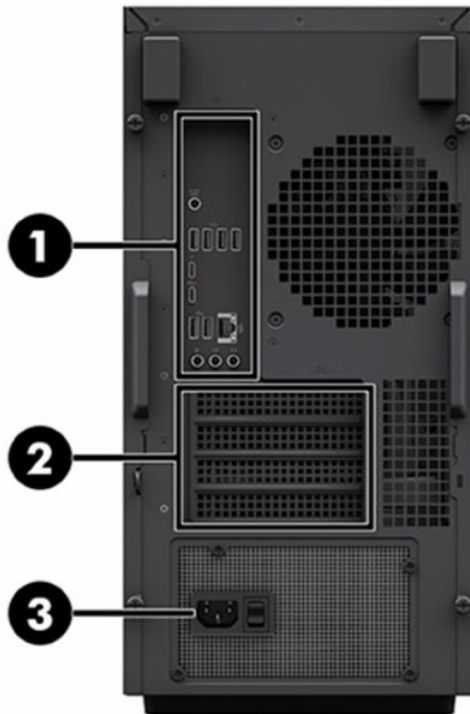

**Table 1-1** Identifying the front panel components

Top components	
1	 Audio-out (headphone)/Audio-in (microphone) combo jack
2	 USB 5 Gbps port - or -  USB 10 Gbps port
3	 USB port - or -  USB 5 Gbps port
4	 USB port - or -  USB 5 Gbps port
5	 Power button

## Rear components

To identify the rear components, use this illustration and table.



**Table 1-2** Identifying the rear components

Rear components			
1	System board I/O area*	3	Power connector**
2	Expansion card slots (4)		

\*System board I/O components might vary.

\*\*Power supply appearance might vary.

---

## 2 Hardware setup

This chapter provides removal and replacement procedures for commonly replaced parts.

### Warnings and cautions

Before performing upgrades, be sure to carefully read all of the applicable instructions, cautions, and warnings.

---

 **WARNING!** To reduce the risk of personal injury from electric shock, hot surfaces, or fire:

- Unplug the power cord from the AC outlet and allow the internal system components to cool before you touch them.
- Do not disable the power cord grounding plug. The grounding plug is an important safety feature.
- Plug the power cord into a grounded (earthed) outlet that is easily accessible at all times.

To reduce the risk of serious injury, read the *Safety & Comfort Guide*. It describes proper workstation setup and provides guidelines for posture and work habits that increase your comfort and decrease your risk of injury. It also provides electrical and mechanical safety information. The Safety & Comfort Guide is located on the HP website at <http://www.hp.com/ergo>.

 **WARNING!** The inside of the computer includes electric and moving parts.

Disconnect power to the equipment before removing the access panel.

Replace and secure the access panel before re-energizing the equipment.

---

 **IMPORTANT:** Static electricity can damage the electrical components of the computer or optional equipment. Before beginning the following procedures, be sure that you are discharged of static electricity by briefly touching a grounded metal object. See [Electrostatic discharge on page 33 on page 72](#) for more information.

---

### Preparation for disassembly

Use this information to properly prepare to disassemble and reassemble the computer.

1. Remove all removable media, such as a USB flash drive, from the computer.
2. Turn off the computer. If you are unsure whether the computer is off or in Hibernation, turn the computer on, and then shut it down through the operating system.

---

 **IMPORTANT:** Turn off the computer before disconnecting any cables.

Regardless of the power state, voltage is always present on the system board as long as the system is plugged into an active AC outlet. In some systems, the cooling fan is on even when the computer is in the Standby or Suspend modes. Always disconnect the power cord before servicing a unit.

---

- Unplug the power cord from the AC outlet and disconnect any external devices.

**IMPORTANT:** When the computer is plugged into an AC power source, voltage is always applied to the system board. To prevent damage to internal components, you must unplug the power cord from the power source before opening the computer.

**CAUTION:** Beware of sharp edges inside the chassis.

**NOTE:** During disassembly, label each cable as you remove it, and note its position and routing. Keep all screws with the removed components.

## Component identification

Use this illustration and table to identify common components.

**NOTE:** Component appearance and configuration might vary.

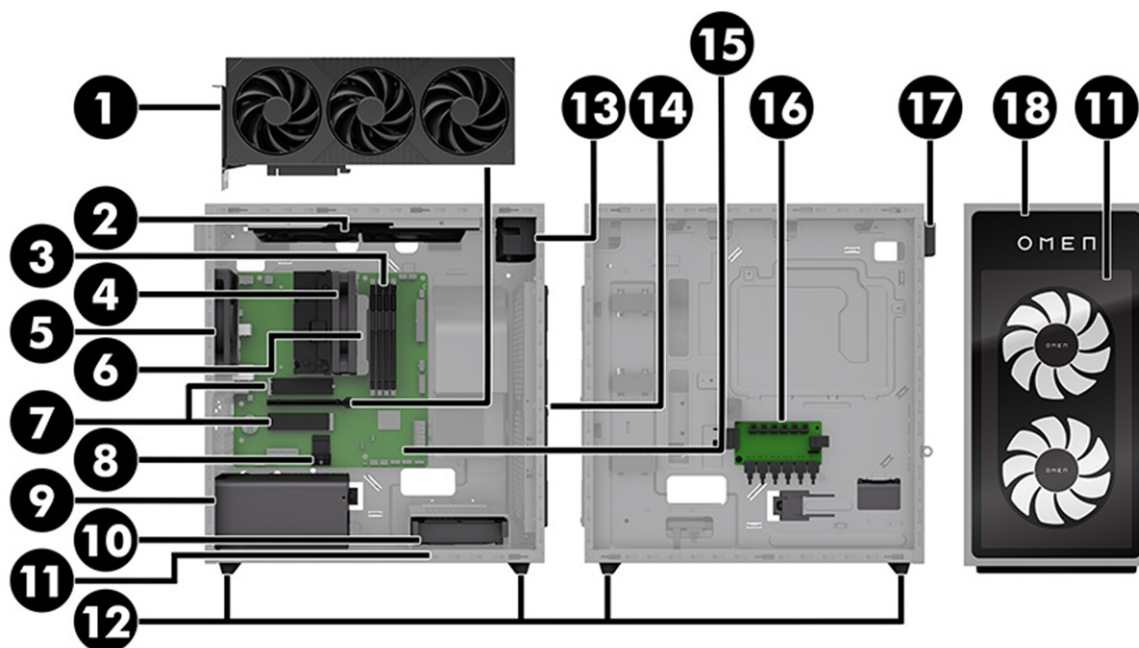

**Table 2-1** Identifying computer components

Computer components			
(1)	Graphics card	(10)	Hard drive (select products only)
(2)	Top fans (number varies by configuration)	(11)	Air filters (bottom and front)
(3)	Memory modules	(12)	Feet
(4)	Processor cooler assembly*	(13)	Top I/O module
(5)	Rear fan	(14)	Front fans
(6)	Processor	(15)	System board
(7)	Solid-state drive (varies by configuration)	(16)	RGB lighting board

**Table 2-1** Identifying computer components (continued)

Computer components			
(8)	WLAN module	(17)	WLAN antenna
(9)	Power supply	(18)	Front bezel (appearance might vary)

\*Options include:

- 92 mm round air cooler
- 2 heat pipe, 120 mm square air cooler
- 4 heat pipe, 120 mm square air cooler
- 240 mm liquid cooler

## System board layouts

To identify the layout of different system boards, use these illustrations and tables.

Refer to the illustration that matches your system board.

### AMD system board

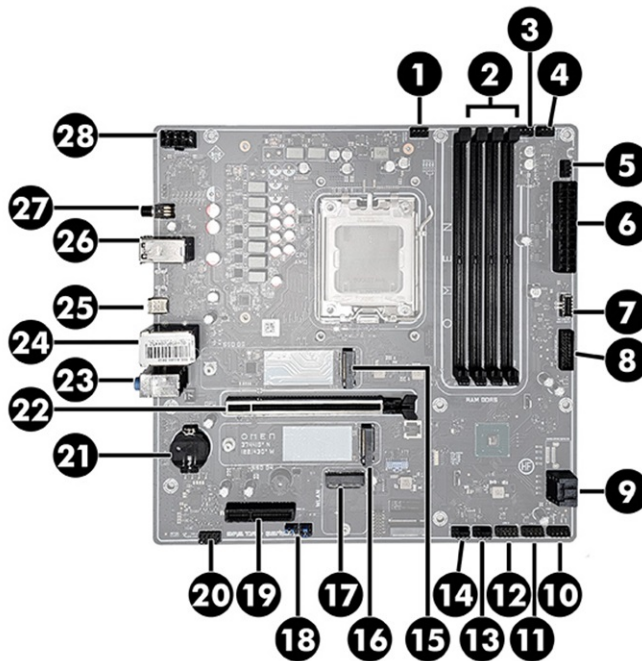

**Table 2-2** Identifying system board components

Top components			
(1)	CPU fan/LCS pump	(15)	SSD Gen4.0
(2)	DDR5 memory slots	(16)	SSD Gen4.0
(3)	Top fan1/LCS fan1	(17)	WLAN socket

**Table 2-2** Identifying system board components (continued)

Top components			
(4)	Top fan2/LCS fan2	(18)	FDO/PSWD/BBR jumper
(5)	Rear fan	(19)	PCIe ×4 slot
(6)	24-pin ATX power connector	(20)	Top I/O audio combo jack
(7)	Top I/O USB Type-C connector	(21)	CMOS/RTC coin battery
(8)	Top I/O USB Type-A connector	(22)	PCIe ×16 slot for graphics card
(9)	SATA connector	(23)	Rear audio jacks
(10)	Top I/O power button and power LED connector	(24)	RJ-45 (network) jack
			USB Type-A 5 Gbps ports (2)
(11)	USB lighting control board	(25)	USB Type-C 10 Gbps port (2)
(12)	USB LCD LCS pump cover	(26)	USB Type-A 2.0 ports (4)
(13)	Front fan1 (upper)	(27)	Clear CMOS button
(14)	Front fan2 (lower)	(28)	8-pin ATX12V power connector

**Intel system board**

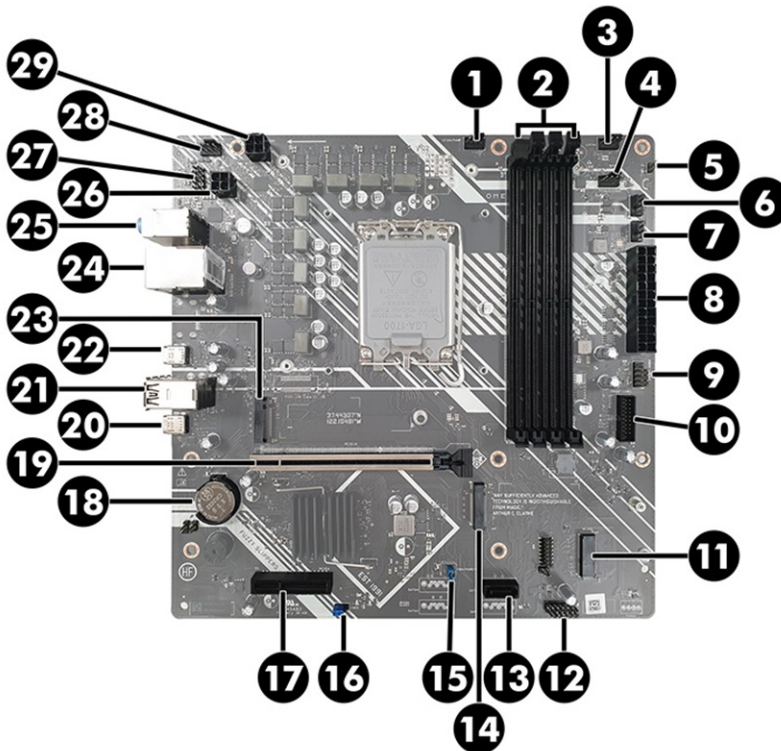

**Table 2-3** Identifying system board components

Top components			
(1)	CPU fan/LCS pump	(16)	Clear CMOS jumper

**Table 2-3 Identifying system board components (continued)**

Top components			
(2)	DDR5 memory slots	(17)	PCIe ×4 slot
(3)	Top fan1/LCS fan1	(18)	CMOS/RTC coin battery
(4)	Top fan2/LCS fan2	(19)	PCIe ×16 slot for graphics card
(5)	Top I/O power button	(20)	USB Type-C 10 Gbps port
(6)	Front fan (upper)	(21)	USB Type-A 5 Gbps ports (2)
			USB Type-A 10 Gbps ports (2)
(7)	Front fan2 (lower)	(22)	USB Type-C 5 Gbps port
(8)	24-pin ATX power connector	(23)	SSD Gen4.0
(9)	USB lighting control board and USB LCD LCS pump cover Y cable	(24)	RJ-45 (network) jack
			USB Type-A 2.0 ports (2)
(10)	Top I/O USB 2.0 Type-C and Type-A connector	(25)	Rear audio jacks
(11)	WLAN connector	(26)	4-pin ATX12V power connector
(12)	Top I/O USB 2.0 Type-A and power LED connector	(27)	Top I/O audio combo connector
(13)	SATA hard drive	(28)	Rear fan
(14)	SSD Gen4.0	(29)	4-pin ATX 12V power connector
(15)	FDO/PSWD/BBR jumper		

**Intel system board**

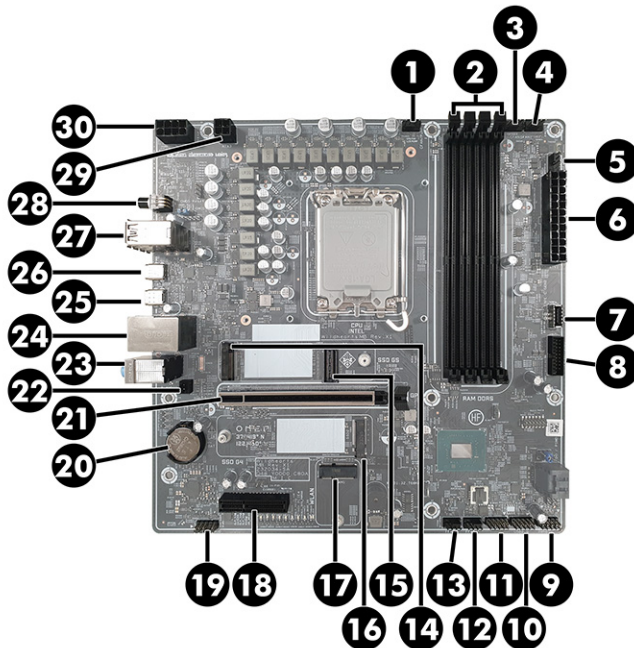

**Table 2-4 Identifying system board components**

Top components	
	(16) SSD Gen 4
(1) CPU fan/LCS pump	(17) WLAN connector
(2) DDR5 memory slots	(17) PCIe x4 slot
(3) Top fan1/LCS fan1	(18) Top I/O combo jack
(4) Top fan2/LCS fan2	(19) CMOS/RTC coin battery
(5) Rear fan	(20) PCIe x16 slot for graphics card
(6) 24-pin ATX power connector	(21) Rear audio jacks
(7) Front fan2 (lower)	(22) RJ-45 and USB Type-A 5 Gbps ports (2)
(8) Top I/O USB Type-C connector	(23) USB Type-C 10 Gbps port
(9) Top I/O USB Type-A connector	(24) Clear CMOS button
(10) USB lighting control board	(25) USB 2.0 Type-A ports (4)
(11) USB LCD LCS pump cover	(26) 8-pin ATX 12V power connector
(12) Front fan1	(27)
(13) Front fan2	(28)
(14) SSD Gen4	(29) 4-pin ATX 12V power connector
(15) SSD Gen4	(30)

## Computer feet

To remove and install the computer feet, use these procedures and illustrations.

1. Prepare the computer for disassembly (see [Preparation for disassembly on page 3](#)).
2. To remove the computer feet:
  - a. Use a flat tool to release the rubber strips (1) from the feet.



- c. Pull the panel **(3)** away from the computer.

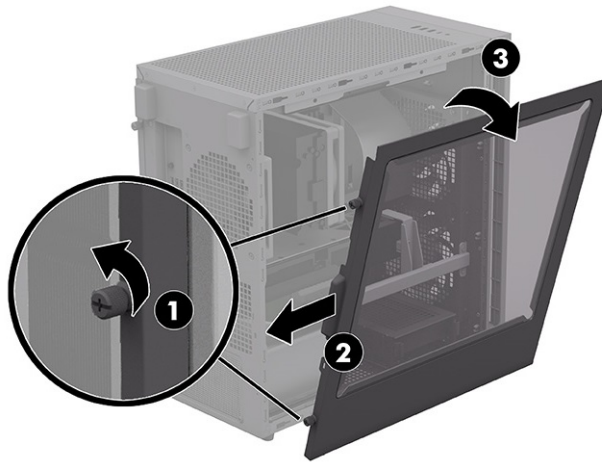

- 3. To install the left access panel:
  - a. Insert the tabs on the bottom of the panel into the groove **(1)** on the bottom of the computer, while making sure the tabs on the bottom of the panel line up with the holes in the chassis.
  - b. Rotate the top of the panel **(2)** onto the computer.
  - c. Slide the panel **(3)** toward the front of the computer, and then tighten the thumbscrews **(4)**.

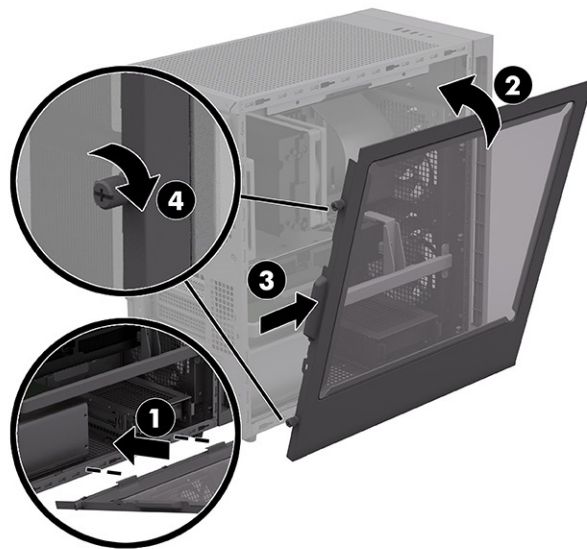

## Replacing or installing DIMMs

The computer uses double data rate 5 synchronous dynamic random access memory (DDR5-SDRAM) dual inline memory modules (DIMMs). There are four memory sockets on the system board that can be populated with up to 64 GB of memory. To replace or install memory modules, use these procedures and illustrations.

For proper system operation, the DIMMs must adhere to the following specifications:

- Kingston FURY DDR5-6000
- UDIMMs
- Industry-standard 288-pin
- Joint Electronic Device Engineering Council (JEDEC) specification

---

 **NOTE:** The system will not operate properly if you install unsupported DIMMs.

---

 **NOTE:** If installing two memory modules, use the DIMM2 and DIMM4 slots for optimal memory tuning.

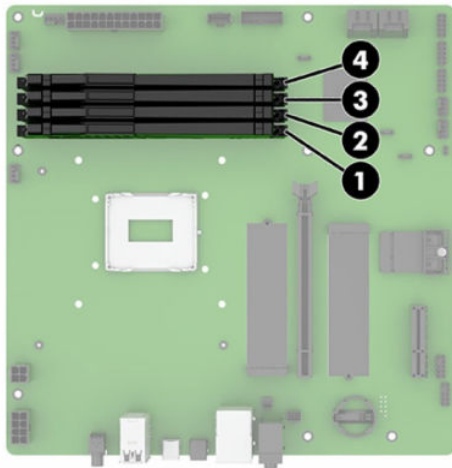

---

 **IMPORTANT:** You must disconnect the power cord and wait approximately 30 seconds for the power to drain before adding or removing memory modules. Regardless of the power state, voltage is always supplied to the memory modules as long as the computer is plugged into an active AC outlet. Adding or removing memory modules while voltage is present can cause irreparable damage to the memory modules or system board.

When handling a memory module, be careful not to touch any of the contacts. Doing so can damage the module.

The memory module sockets have gold-plated metal contacts. When upgrading the memory, use memory modules with gold-plated metal contacts to prevent corrosion, oxidation, or both, resulting from having incompatible metals in contact with each other.

Static electricity can damage the electronic components of the computer or optional cards. Before beginning these procedures, be sure that you are discharged of static electricity by briefly touching a grounded metal object.

---

Remove and install computer memory:

1. Prepare the computer for disassembly (see [Preparation for disassembly on page 3](#)).
2. Remove the left access panel (see [Left access panel on page 9](#)).
3. Position the computer with the system board facing upward.

4. To remove a DIMM, open the outer latch (1), and then use both hands to pull the DIMM (2) out of the socket.

 **NOTE:** Use only the outside latch to release or secure the DIMM.

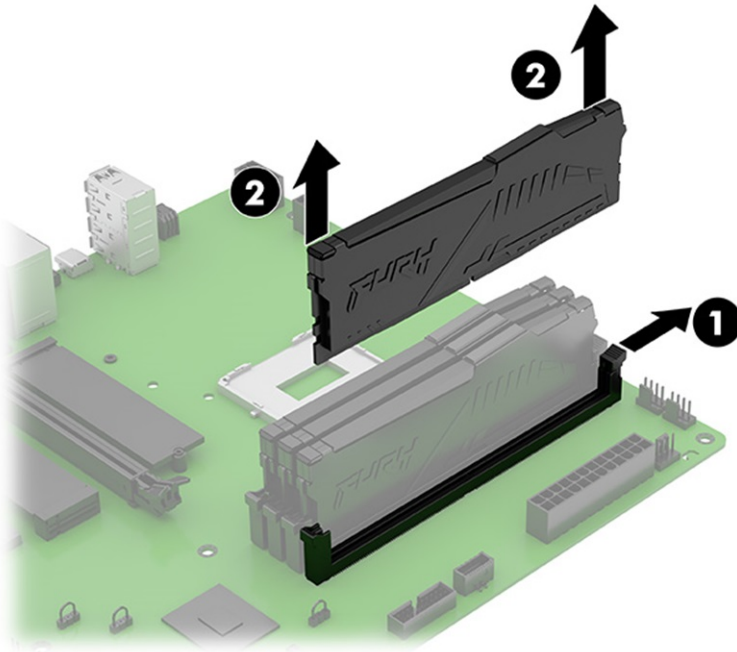

5. To install a DIMM, insert the module (1) into the socket, and then pull the outer latch (2) up to lock the DIMM into place.

 **NOTE:** You can install a memory module in only one way. Match the notch on the module with the tab on the memory socket.

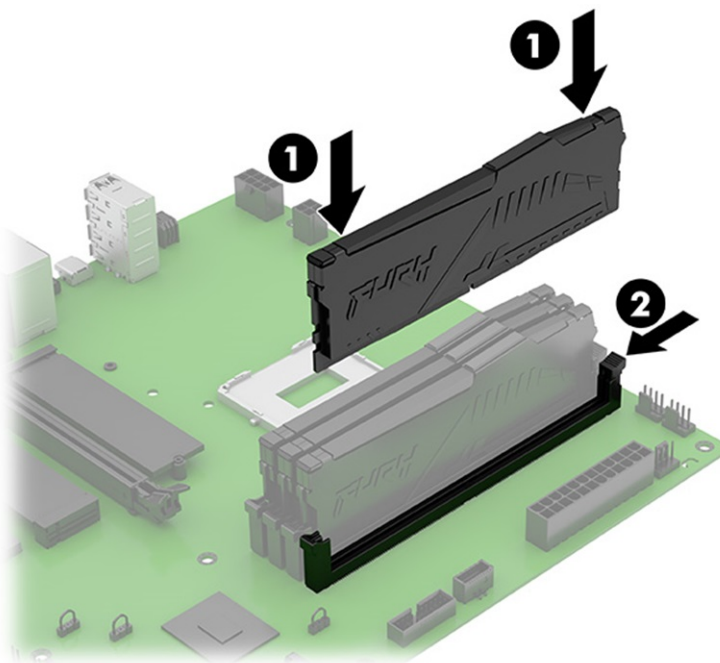

The computer automatically recognizes the new memory.



**NOTE:** The computer takes longer than normal to boot up when you change the memory configuration.

## Solid-state drive

To remove the solid-state drive (SSD), use these procedures and illustrations. Some solid-state drives require use of a heat sink.

1. Prepare the computer for disassembly (see [Preparation for disassembly on page 3](#)).
2. Remove the left access panel (see [Left access panel on page 9](#)).
3. Position the computer with the system board facing upward.

SSDs are installed in the following locations:

(1) SSD

(2) SSD

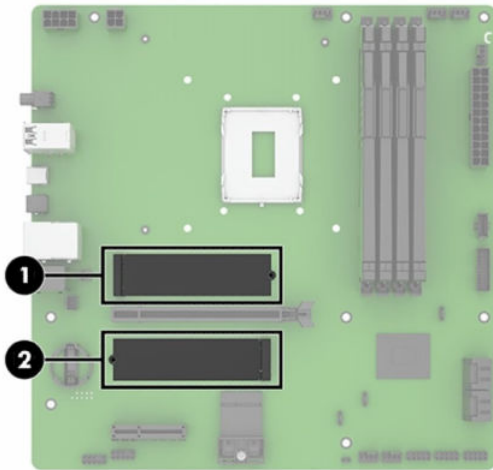

4. To remove an SSD:

- a. (Models without a heat sink) Remove the Phillips screw (1) that secures the drive, and then pull the drive (2) out of the system board connector.

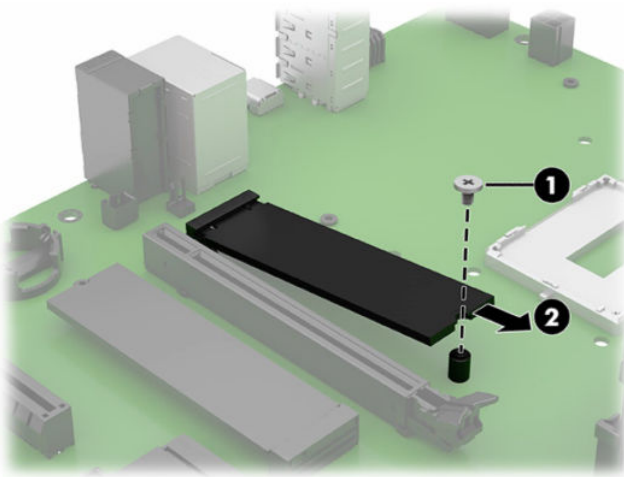

- b. (Models with a heat sink) Remove the Phillips screw (1) that secures the drive, and then pull the drive assembly (2) out of the system board connector.

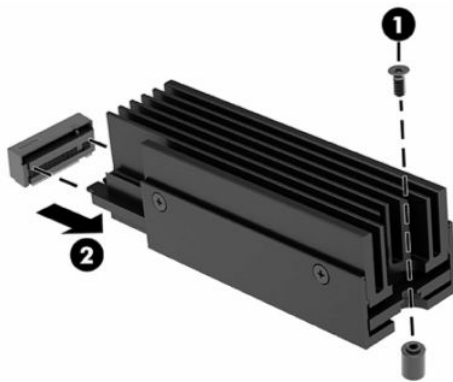

- c. (Models with a heat sink) Remove the four Phillips screws (1), and then remove the heat sink (2) and the SSD (3) from the holder.

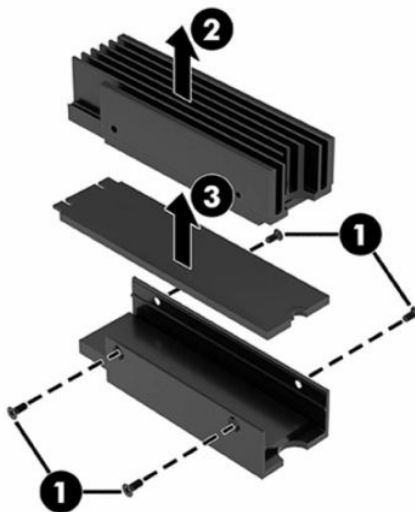

5. To install an SSD:

a. Note the locations of the primary SSD (1) and secondary SSD (2).

 **IMPORTANT:** Thermal pad configuration under SSDs might vary.

Install a thermal pad under the primary SSD only if it does not use a two-part heat sink.

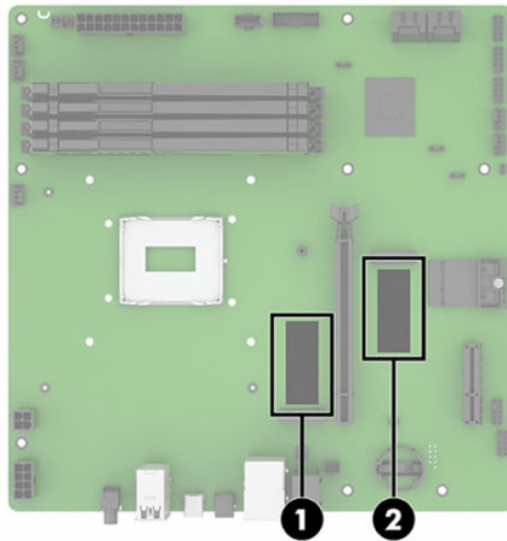

b. (Models without a heat sink) Insert the SSD (1) into the socket, and then install the Phillips screw (2).

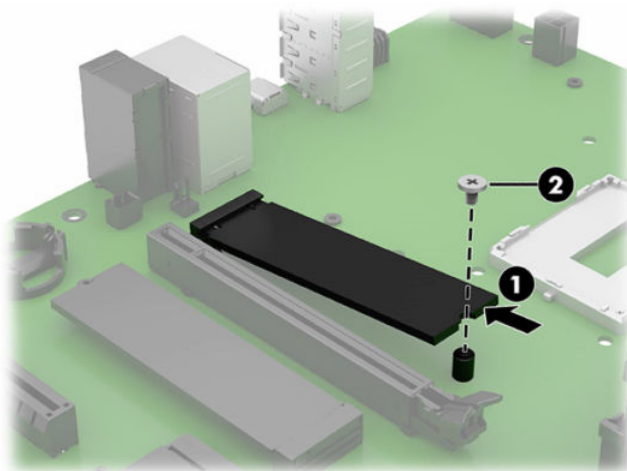

- c. (Models with a heat sink) Insert the SSD (1) and the heat sink (2) into the holder, and then install the four Phillips screws (3). Align the printed circuit board (PCB) of the solid-state drive with the heat sink and holder on the screw side.

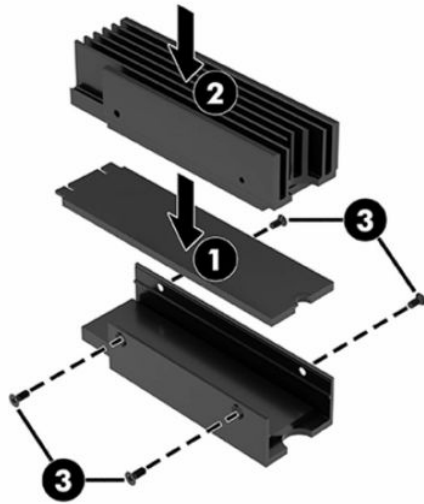

- d. (Models with a heat sink) Insert the drive (1) into the connector, rotate the assembly (2) down into place, and then install the Phillips screw (3).

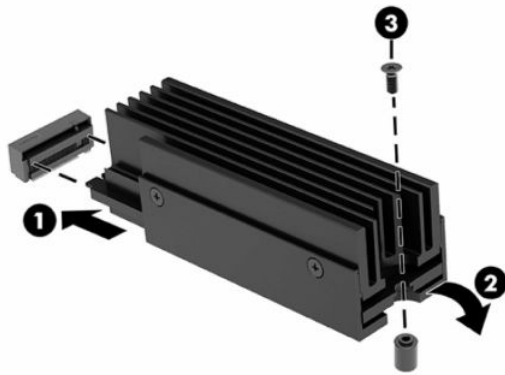

## WLAN module

To remove and install the WLAN module, use these procedures and illustrations.

1. Prepare the computer for disassembly (see [Preparation for disassembly on page 3](#)).
2. Remove the left access panel (see [Left access panel on page 9](#)).
3. Position the computer with the system board facing upward.
4. To remove the WLAN module:
  - a. Remove the Phillips screw (1) that secures the module to the computer.
  - b. Remove the bracket (2) from the module.

- c. Disconnect the antenna cables (3) by pulling them upward and away from the module.

---

 **NOTE:** The coaxial antenna connectors on the WLAN module are small and fragile. To prevent permanent damage to the module and antennas, apply only enough force to pull the antennas up and off the connectors.

---

- d. Pull the module (4) out of the socket.

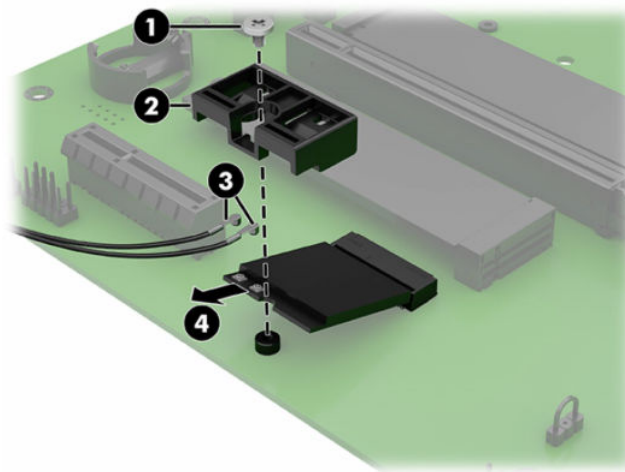

- 5. To install a WLAN module:

- a. Insert the WLAN module (1) into the socket on the system board.
- b. Connect the antenna cables (2) to the module.

---

 **NOTE:** The WLAN antenna cable labeled 1/MAIN connects to the WLAN module Main terminal. The WLAN antenna cable labeled 2/AUX connects to the WLAN module Aux terminal.

---

- c. Place the bracket (3) over the module.
- d. Install the Phillips screw (4) to secure the module to the system board.

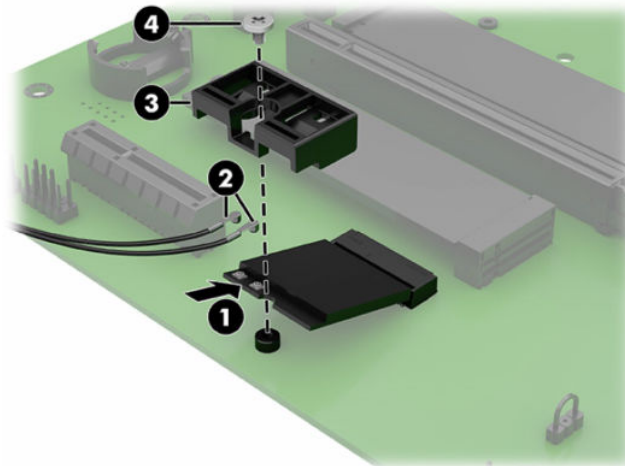

## Right access panel

To remove and install the right access panel, use these procedures and illustrations.

1. Prepare the computer for disassembly (see [Preparation for disassembly on page 3](#)).
2. To remove the right access panel:
  - a. Loosen the two thumbscrews **(1)**.
  - b. Use the handle **(2)** to pull the panel straight back.
  - c. Lift the panel **(3)** away from the computer.

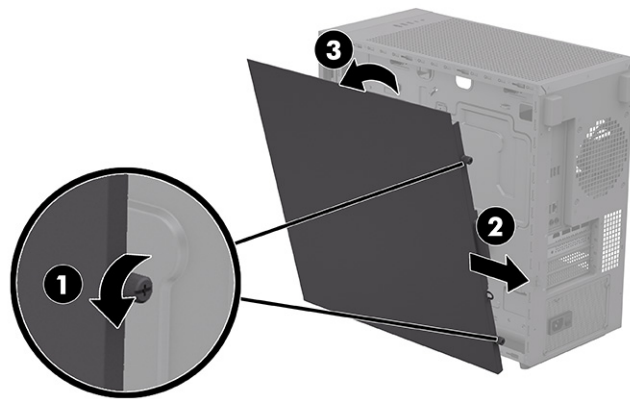

3. To install the right access panel:
  - a. Insert the tabs on the bottom of the panel into the groove **(1)** on the bottom of the computer, while making sure the tabs on the bottom of the panel line up with the holes in the chassis.
  - b. Rotate the top of the panel **(2)** onto the computer.

- c. Slide the panel (3) toward the front of the computer, and then tighten the thumbscrews (4).

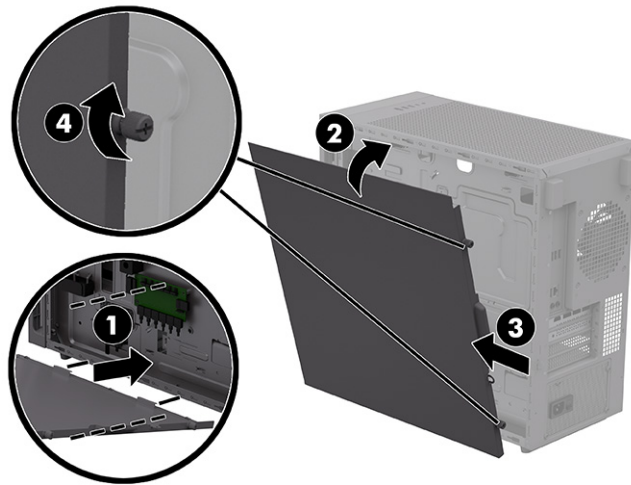

## Hard drive

To remove and install the hard drive, use these procedures and illustrations.

1. Prepare the computer for disassembly (see [Preparation for disassembly on page 3](#)).
2. Remove the left access panel (see [Left access panel on page 9](#)).
3. Remove the right access panel (see [Right access panel on page 18](#)).
4. To remove a hard drive:
  - a. From the right side of the computer, disconnect the power and data cables from the rear of the hard drive.

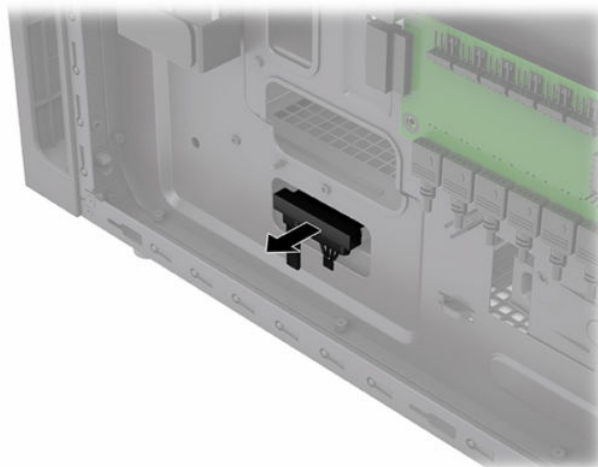

- b. From the left side of the computer, squeeze the hard drive holder tabs (1), and then pull the hard drive assembly (2) out of the hard drive bay.

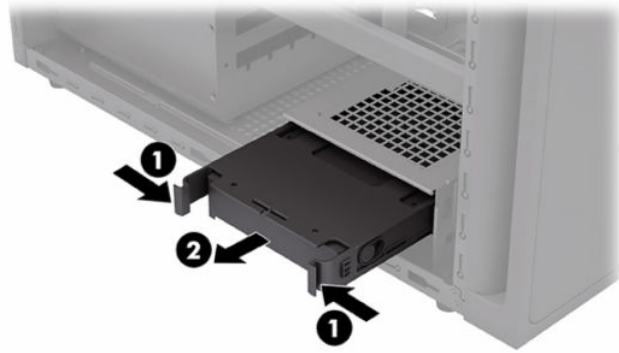

- c. Pull the sides of the hard drive cover (1) outward and away from the hard drive, and then remove the hard drive (2) from the cover.

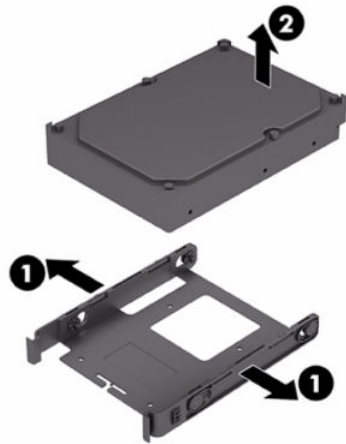

- 5. To install a hard drive:

- a. Pull the sides (1) of the hard drive cover outward, and then insert the hard drive (2) into the cover, making sure the pins in the cover are inserted into the holes (3) on the sides of the hard drive.

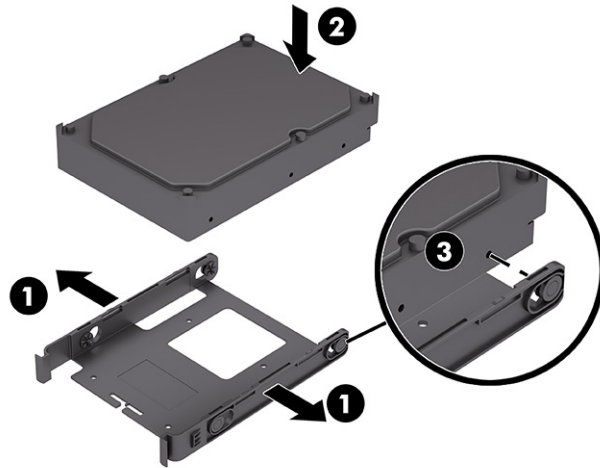

- b. From the left side of the computer, insert the hard drive assembly into the drive bay until it clicks into place.

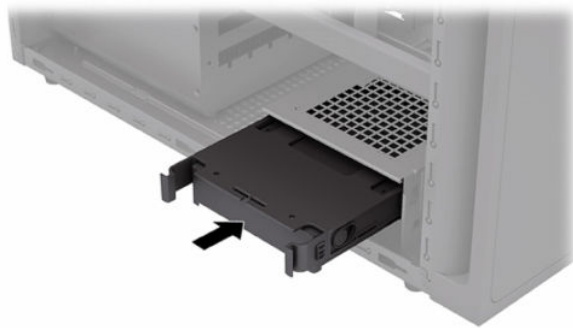

- c. From the right side of the computer, reconnect the power and data cables to the back of the hard drive.

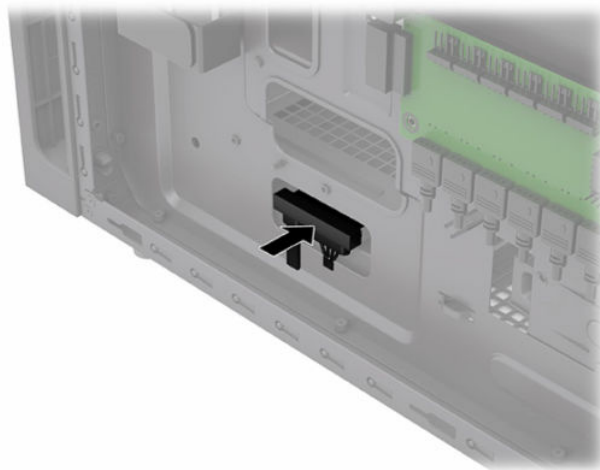

## Power supply, modular

You can disconnect the cables from the back of a modular power supply. To remove and install the modular power supply, use these procedures and illustrations.

1. Prepare the computer for disassembly (see [Preparation for disassembly on page 3](#)).
2. Remove the left access panel (see [Left access panel on page 9](#)).
3. Remove the right access panel (see [Right access panel on page 18](#)).
4. To remove the power supply:
  - a. Disconnect the cables from the back of the power supply (1).
  - b. Remove the four Phillips screws (2) that secure the power supply to the computer.
  - c. Press the power supply release button (3), and then remove the power supply (4).

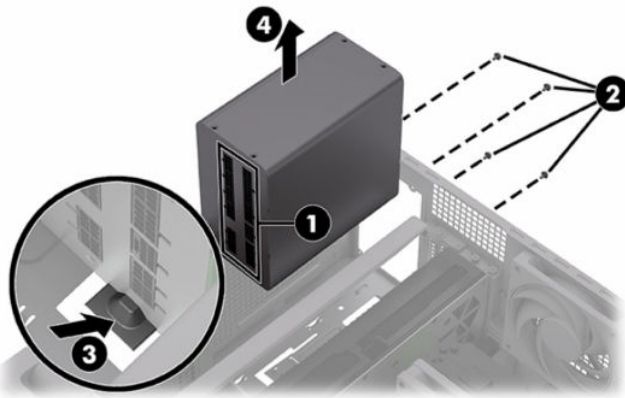

5. To install the power supply:
  - a. Insert the power supply (1) into the computer until it snaps into place.
  - b. Install the four Phillips screws (2) to secure the power supply to the computer.
  - c. Connect the cables (3) to the back of the power supply.

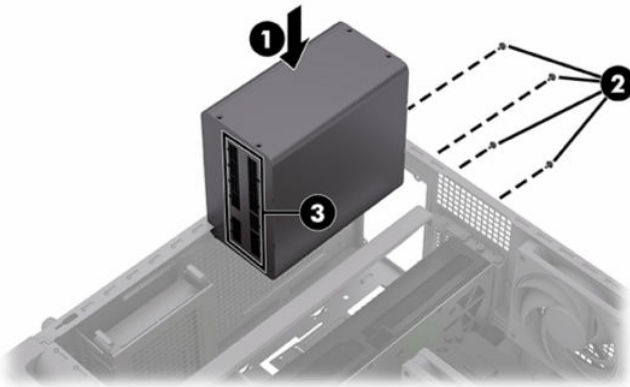

Use the following illustration to determine connector locations on the power supply.

- (1) System board
- (2) PCIe 12VHPWR (for PCIe graphics card)
- (3) SATA
- (4) PCIe/CPU
- (5) SATA

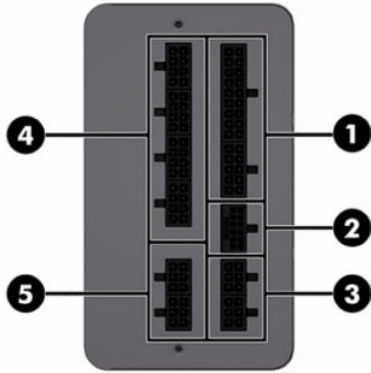

## Power supply, nonmodular

You cannot disconnect the cables from the back of a nonmodular power supply. To remove and install the nonmodular power supply, use these procedures and illustrations.

1. Prepare the computer for disassembly (see [Preparation for disassembly on page 3](#)).
2. Remove the left access panel (see [Left access panel on page 9](#)).
3. To remove the nonmodular supply:
  - a. Disconnect the power supply cables from the system board, graphics card, hard drive (select products only), and RGB lighting board. Connector locations might vary depending on configuration.
  - b. Remove the cables from their routing paths in the computer. Cable routing might vary depending on configuration.
  - c. Remove the four Phillips screws **(1)** that secure the power supply to the computer.

- d. Remove the power supply (2) from the computer.

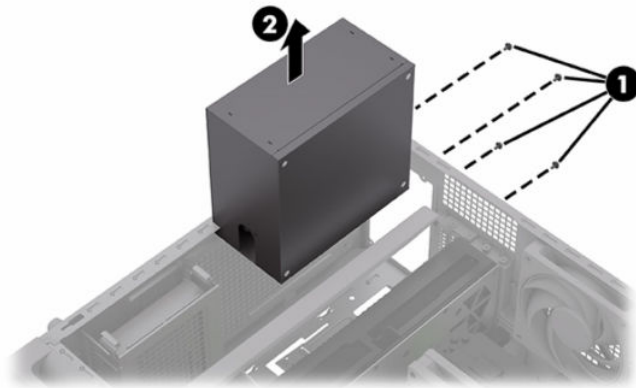

4. To install the power supply:
  - a. Insert the power supply (1) into the computer.
  - b. Install the four Phillips screws (2) to secure the power supply to the computer.

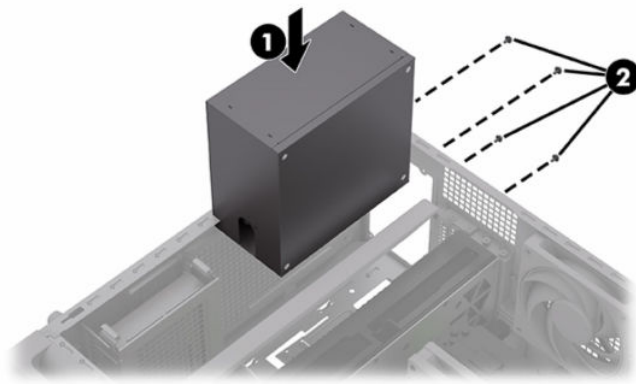

- c. Connect the power cables to the system board, graphics card, hard drive (select products only), and RGB lighting board.

## Graphics card

To install a graphics card, use these procedures and illustrations.

1. Prepare the computer for disassembly (see [Preparation for disassembly on page 3](#)).
2. Remove the left access panel (see [Left access panel on page 9](#)).
3. Position the computer with the system board facing upward.
4. To remove a graphics card that is secured with a bracket:
  - a. (RTX 4080/4090 graphics card bracket) Disconnect the power cable from the card (1).

- b. Remove the four Phillips screws **(2)** from the bracket, and then remove the bracket **(3)** from the computer.

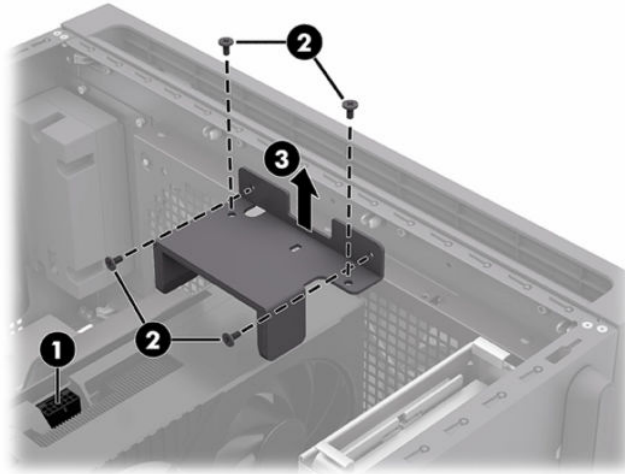

- c. (RTX4070/4070Ti,4060Ti, RX7600/6700 graphics card bracket) Remove the four Phillips screws **(1)** from the bracket, and then remove the bracket **(2)** from the computer.

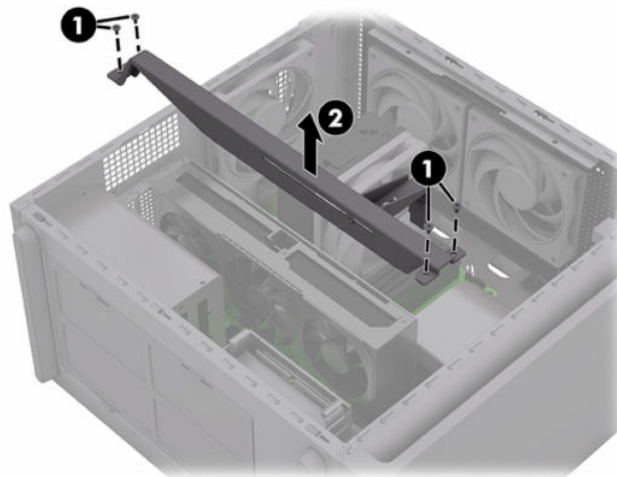

- d. If necessary, disconnect the power cable from the graphics card.
- e. Remove three Phillips screws **(1)** from the back of the graphics card.
- f. Press the push tab **(2)** on the end of the system board socket.

- g. Pull the card **(3)** up and out of the computer.

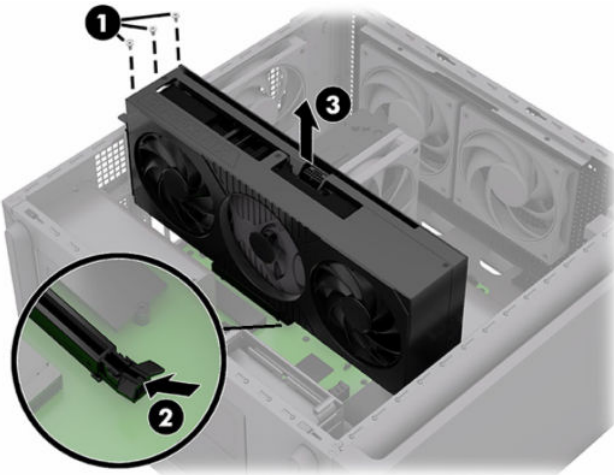

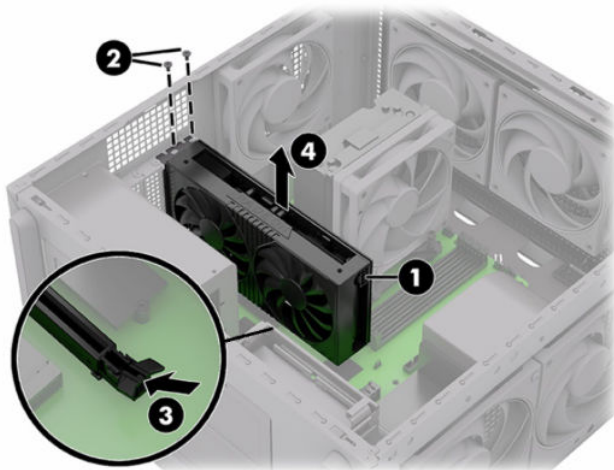

5. To remove a graphics card that is not secured with a bracket:
- a. Disconnect the power cable **(1)** from the graphics card.
  - b. Remove two Phillips screws **(2)** from the back of the graphics card.
  - c. Press the push tab **(3)** on the end of the system board socket.
  - d. Pull the card **(4)** up and out of the computer.

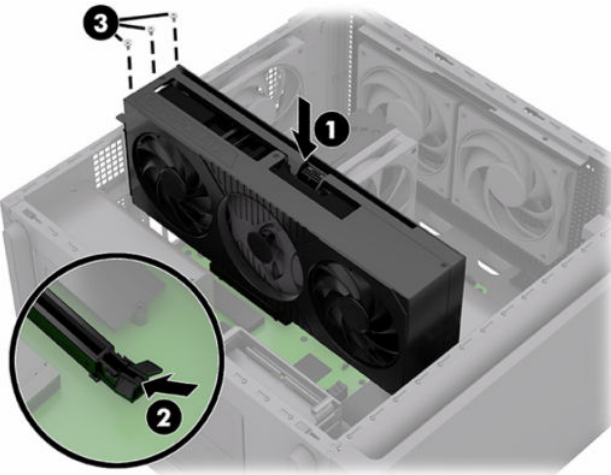

6. To install a graphics card that is secured with a bracket:
- a. Insert the graphics card **(1)** into the socket on the system board.
  - b. Press the card downward to make sure the tab **(2)** on the end of the system board expansion slot pops up and latches the card.

- c. Install three Phillips screws (3) into the back of the graphics card.



 **TIP:** To pop up the tab, press down on the graphics card (1) while using a finger with only the minimum force required to lift the latch (2).

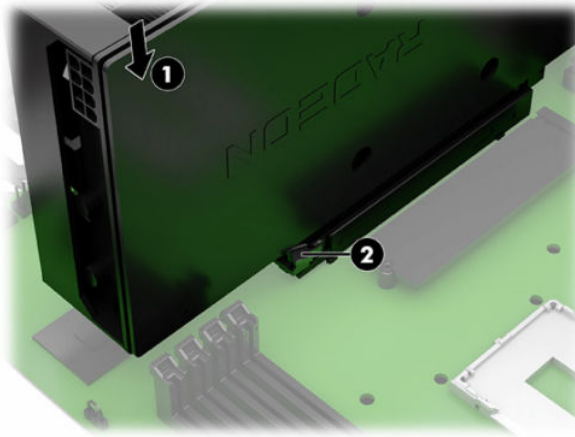

- d. (RTX 4080/4090 graphics card bracket) Position the bracket (1) over the graphics card.
- e. (RTX 4080/4090 graphics card bracket) Install the four Phillips screws (2) into the bracket.

- f. (RTX 4080/4090 graphics card bracket) Connect the power cable to the graphics card **(3)**.

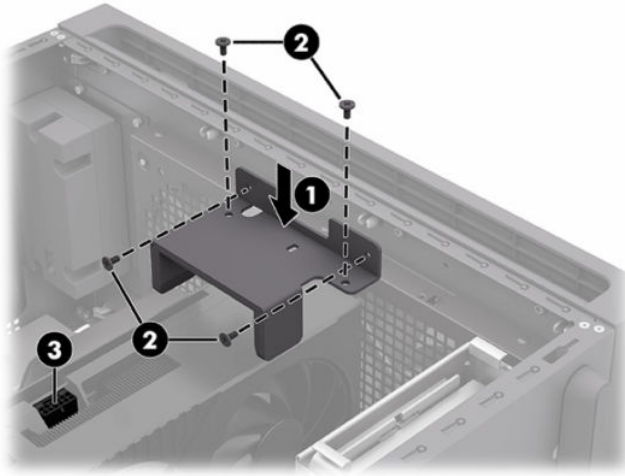

- g. (RTX4070/4070Ti,4060Ti, RX7600/6700 graphics card bracket) Position the bracket **(1)** over the graphics card, and then install four Phillips screws **(2)** into the bracket.

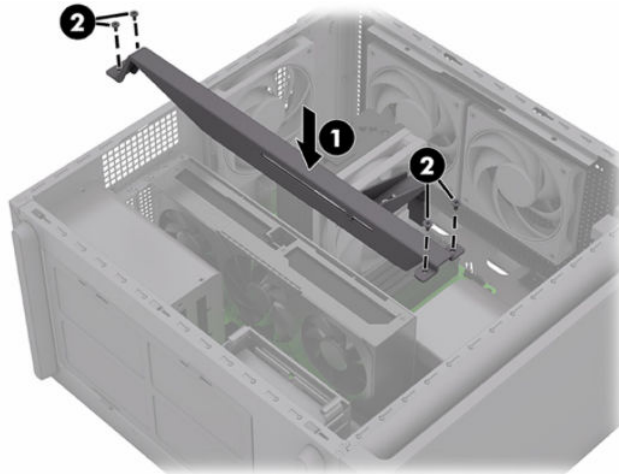

- h. (RTX4070/4070Ti,4060Ti, RX7600/6700 graphics card bracket) To adjust the bracket to fit the width of the card, loosen the screw **(1)** from the bracket, and then slide the bracket **(2)** to the needed width.

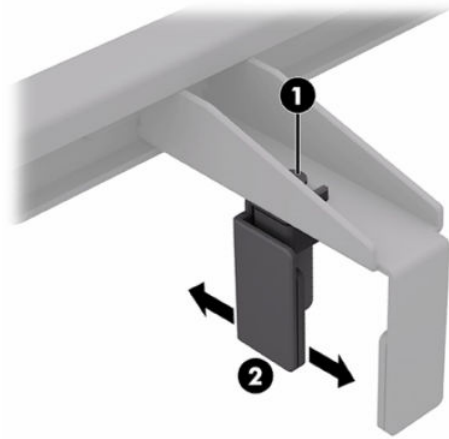

- i. (RTX4070/4070Ti,4060Ti, RX7600/6700 graphics card bracket) To adjust the bracket to fit the length of the card, loosen the screw **(1)** from the bracket, and then slide the bracket **(2)** to the needed length.



Marks on the bracket indicate the suggested positions for graphics card models configured at the factory.

Before moving the computer, fit the adjustable bracket to the original or upgraded graphics card to prevent the bracket from coming loose and damaging the computer.



7. To install a graphics card that is not secured with a bracket:

- a. Insert the graphics card **(1)** into the socket on the system board.
- b. Press the card downward to make sure the tab **(2)** on the end of the system board expansion slot pops up and latches the card.

To pop up the tab, press down on the graphics card while using a finger with only the minimum force required to lift the latch.

- c. Connect the power cable **(3)** to the graphics card.
- d. Install three Phillips screws **(4)** into the back of the graphics card.

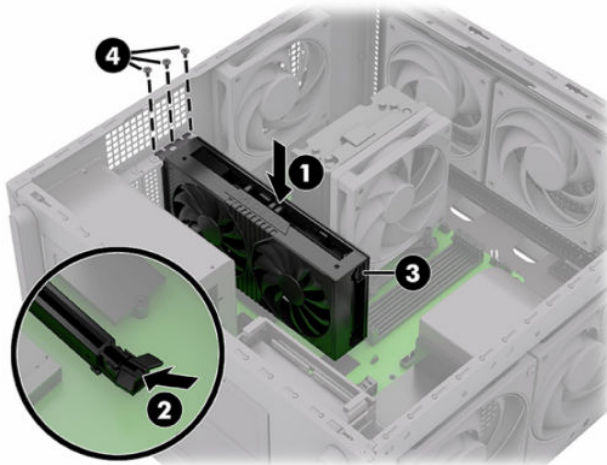

## Front bezel

To remove and install the front bezel, use these procedures and illustrations.

1. Prepare the computer for disassembly (see [Preparation for disassembly on page 3](#)).

2. To remove the front bezel, pull the bottom of the bezel (1) away from the computer, and then pull the bezel (2) away from the computer.



3. To install the front bezel, insert the top of the bezel (1) onto the front of the computer, and then rotate the bottom of the bezel (2) onto the computer until it clicks into place.



## Front dust filter

To remove and install the front dust filter, use these procedures and illustrations.

1. Prepare the computer for disassembly (see [Preparation for disassembly on page 3](#)).
2. Remove the front bezel (see [Front bezel on page 30](#)).

3. To remove the dust filter, press the release tab (1) at the top of the filter, and then rotate the top of the filter (2) out slightly and pull the filter (3) off the computer.

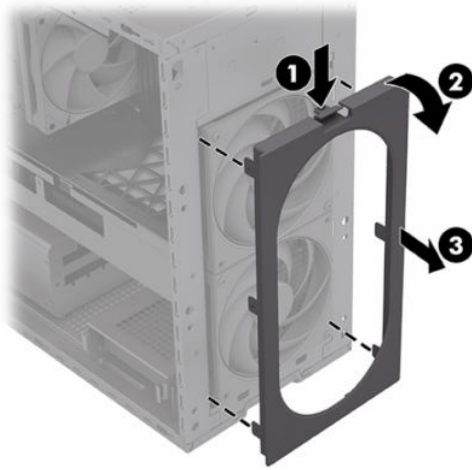

4. To install the dust filter, insert the two tabs at the bottom of the filter (1) into the slots at the bottom of the computer, and then rotate the top of the filter (2) onto the computer until it clicks into place.

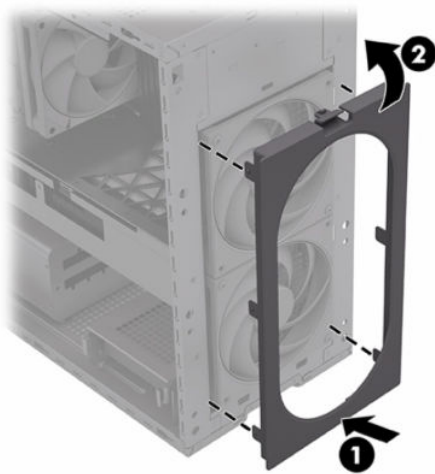

## Bottom dust filter

To remove and install the bottom dust filter, use these procedures and illustrations.

1. Prepare the computer for disassembly (see [Preparation for disassembly on page 3](#)).

2. To remove the bottom dust filter, position the computer upside down. Press the tabs **(1)** toward each other to flex the filter, and then remove the filter **(2)** from the computer.

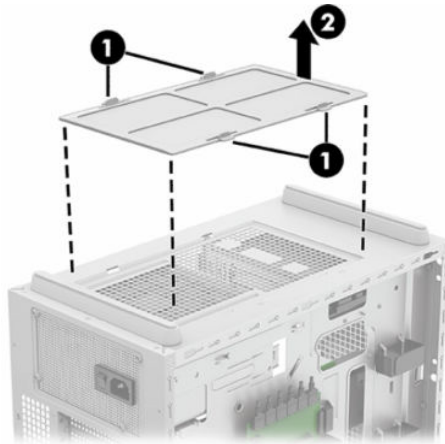

3. To install the bottom dust filter, insert the tabs on the bottom of the filter **(1)** in the slots in the chassis, rotate the filter **(2)** up into place, and then press the tabs **(3)** toward each other to flex the filter enough to insert the top tabs into place.

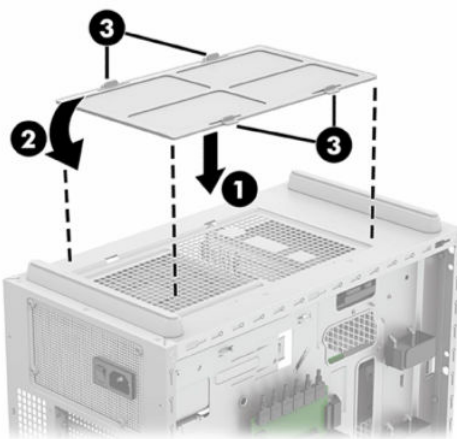

## RGB lighting board

To remove and install the RGB lighting board, use these procedures and illustrations.

The RGB lighting board provides the lighting source connection for all components with RGB lighting. The board is located on the right side of the computer—the opposite side from the system board and other main system components.

The following illustration and table defines the connectors on the RGB board.

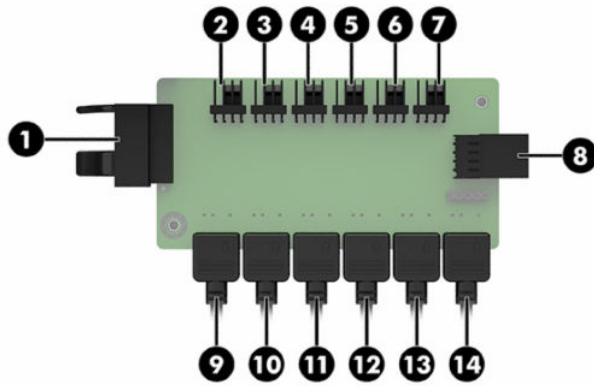

**Table 2-5** RGB lighting board connectors

Connector	
(1) SATA	(8) USB connector to system board
(2) Fan6	(9) Processor (CPU)
(3) Fan5	(10) Front fan 1
(4) Fan4	(11) Front fan 2
(5) Fan3	(12) Top fan 1/liquid cooler fan 1
(6) Fan2	(13) Top fan 2/liquid cooler fan 2
(7) Fan1	(14) Rear fan

 **NOTE:** (9) - (14) are ARGB connectors are either used for configurable factory options or reserved for user upgrade.

(2) - (7) are RGB connectors reserved for user upgrade.

Use the OMEN Gaming Hub from the Microsoft store for lighting control.

1. Prepare the computer for disassembly (see [Preparation for disassembly on page 3](#)).
2. Remove the right access panel (see [Right access panel on page 18](#)).
3. To remove the RGB lighting board:
  - a. Position the computer with the RGB lighting board facing upward.
  - b. Disconnect the cables from the RGB board.
  - c. Remove the two Phillips screws (1) from the board.

- d. Remove the board (2) from the computer.

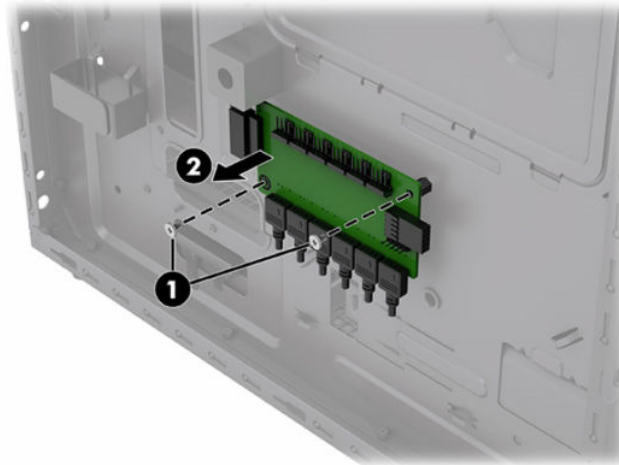

4. To install the RGB lighting board:
  - a. Place the board (1) in the computer.
  - b. Install the two screws (2) that secure the board to the computer.
  - c. Connect the cables to RGB board.

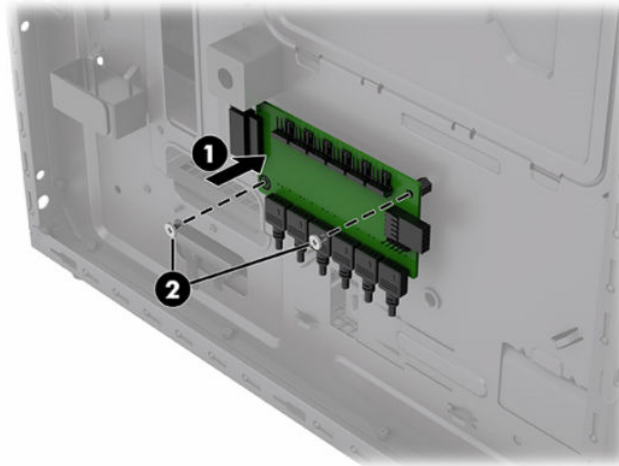

## Front fans

To remove the front fans, use these procedures and illustrations.

1. Prepare the computer for disassembly (see [Preparation for disassembly on page 3](#)).
2. Remove the left access panel (see [Left access panel on page 9](#)).
3. Remove the right access panel (see [Right access panel on page 18](#)).
4. Remove the front bezel (see [Front bezel on page 30](#)).
5. To remove the front fans:

- a. On the left side of the computer, disconnect the fan power cables from the system board.

 **NOTE:** The location of the fan power cable connector can vary depending on the system board configured in the factory.

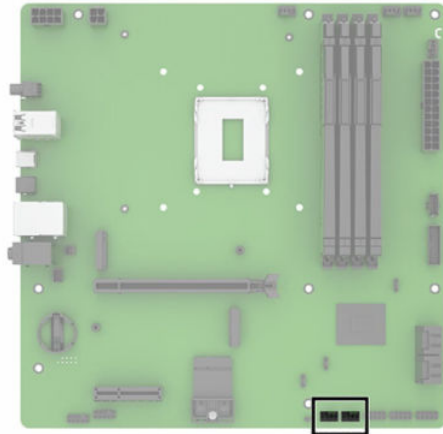

- b. On the right side of the computer, disconnect fan RGB cables **(1)** from the RGB lighting board.
- c. Open the cable ties **(2)**.
- d. Remove the RGB cables and power cables from their routing path **(3)** with other cables routing through the computer.
- e. Pull the power cables through the hole **(4)** in the computer chassis. The power cables route from the left side where they plug into the system board, through the hole, to the right side, and then up to the hole on the right side that leads to the fans on the front of the chassis.

 **NOTE:** Cable routing can vary based on the system board configured at the factory.

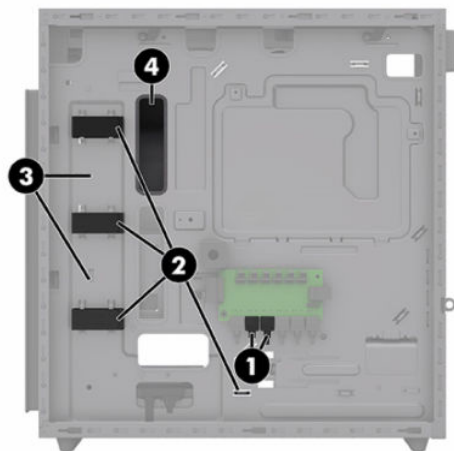

- f. On the front of the computer (under the bezel), remove the four screws **(1)** from the fans.

- g. Remove the fans (2) while pulling the cables out through the hole in the chassis.

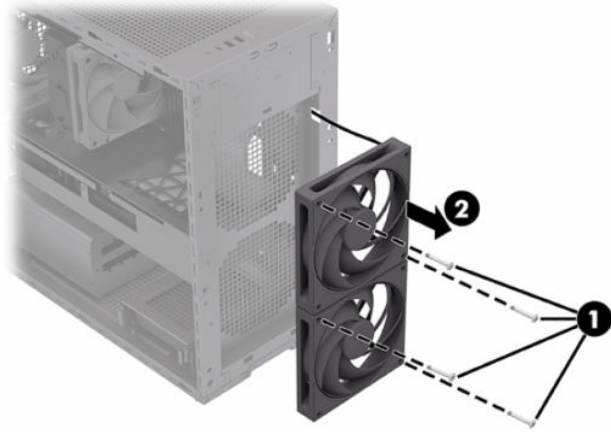

6. To install the front fans:
- a. On the front of the computer, insert the cables through the hole (1) in the chassis.
  - b. Position the fans (2) on the front of the computer.
  - c. Install four screws (3) into the fans.

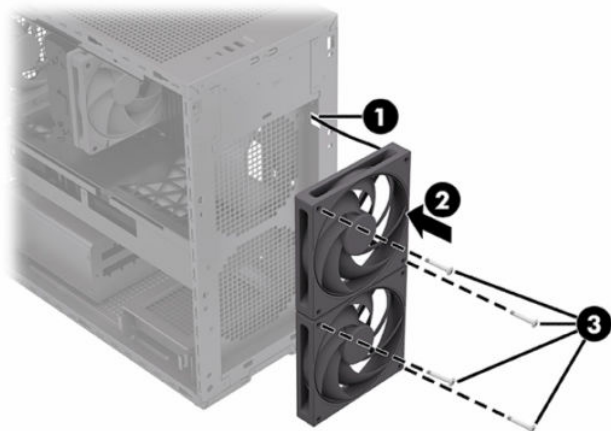

- d. On the right side of the computer, route the power and lighting cables along the cabling path (1) with other cables routing through the computer.
- e. Secure the ties (2).
- f. Plug the lighting cables into the RGB lighting board (3). For RGB lighting board connector designations, see [RGB lighting board on page 33](#).
- g. Route the power cables through the hole (4) in the chassis.

 **NOTE:** Cable routing can vary based on the system board configured at the factory.

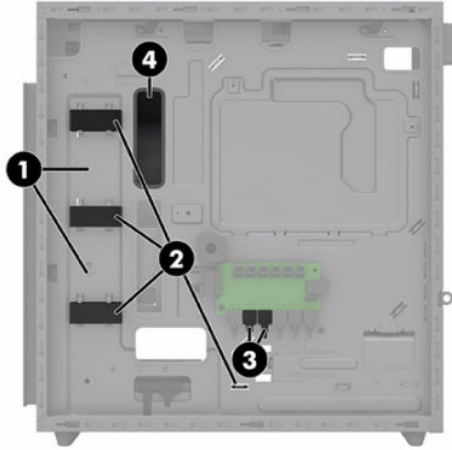

- h. On the left side on the computer, plug the power cables into the system board.

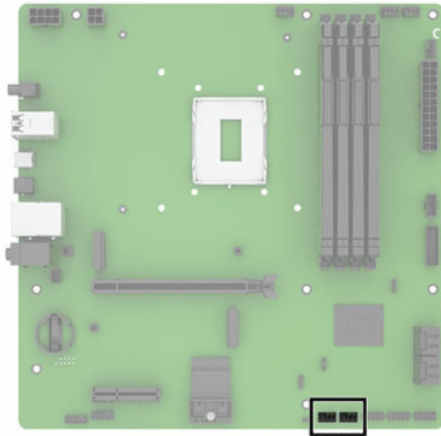

## Rear fan

To remove and install the rear fan, use these procedures and illustrations.

1. Prepare the computer for disassembly (see [Preparation for disassembly on page 3](#)).
2. Remove the left access panel (see [Left access panel on page 9](#)).
3. Remove the right access panel (see [Right access panel on page 18](#)).
4. To remove the rear fan:
  - a. On the left side of the computer, disconnect the fan power cable from the system board.



**NOTE:** The location of the fan power cable connector can vary depending on the system board configured in the factory.

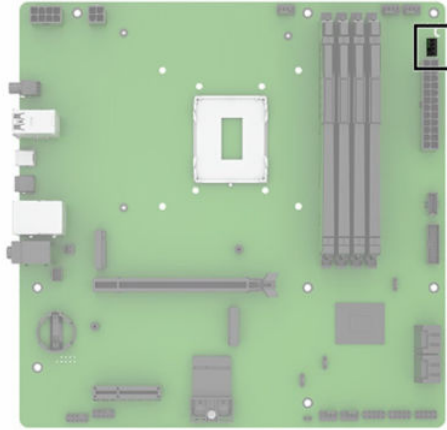

- b. On the right side of the computer, disconnect fan RGB cable **(1)** from the RGB lighting board.
- c. Remove the RGB cable from the cable ties **(2)**.
- d. Push the cable through the hole **(3)** in the computer chassis.
- e. Remove the power cable from the cable tie **(4)**.
- f. Push the power cable through the hole **(5)** in the chassis.

 **NOTE:** Cable routing can vary based on the system board configured at the factory.

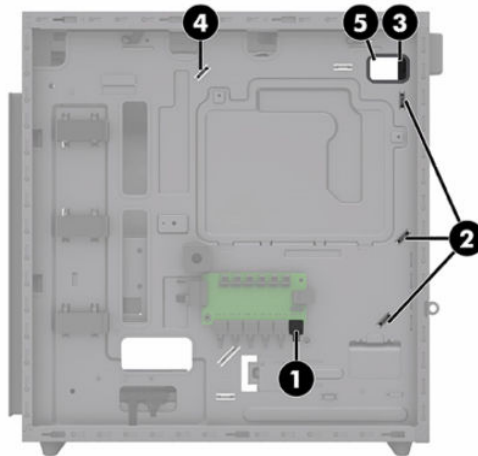

- g. On the rear of the computer, remove the four Phillips screws **(1)** from the fan.

- h. Remove the fan (2).

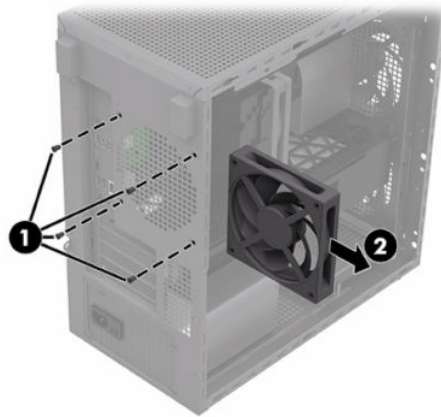

5. To install the rear fans:

- a. Position the fan (1) on the inside rear of the computer.
- b. Install four Phillips screws (2).

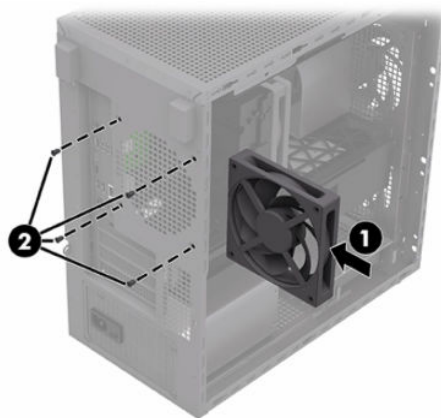

- c. On the right side of the computer, route the power cable through the hole (1) in the chassis.
- d. Route the power cable through the cable tie (2).
- e. Route the RGB cable through the hole (3) in the chassis.
- f. Route the RGB cable through the three cable ties (4).
- g. Plug the lighting cable into the RGB lighting board (5). For RGB lighting board connector designations, see [RGB lighting board on page 33](#).



**NOTE:** Cable routing can vary based on the system board configured at the factory.

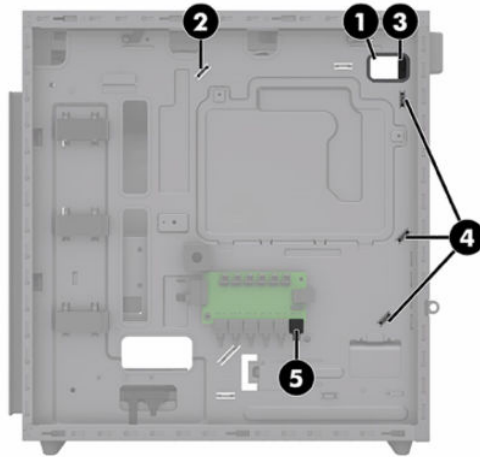

- h. On the left side on the computer, plug the power cable into the system board.

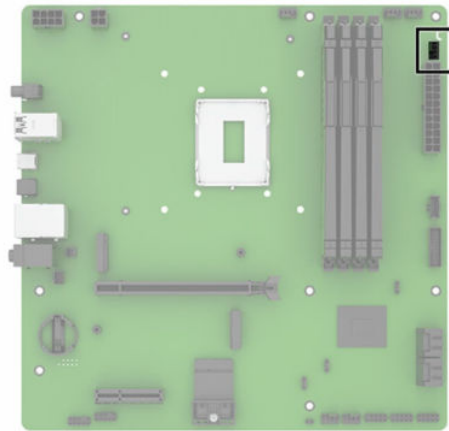

## Top fans

To remove and install the top fans, use these procedures and illustrations.

1. Prepare the computer for disassembly (see [Preparation for disassembly on page 3](#)).
2. Remove the left access panel (see [Left access panel on page 9](#)).
3. Remove the right access panel (see [Right access panel on page 18](#)).
4. To remove the top fans:
  - a. On the right side of the computer, disconnect the top fan RGB cables **(1)** from the RGB lighting board.
  - b. Remove the RGB cables from the clip and cable tie **(2)**.
  - c. Push the cable through the hole **(3)** in the computer chassis.

- d. Remove the two Phillips screws **(4)** from the back of the bracket.

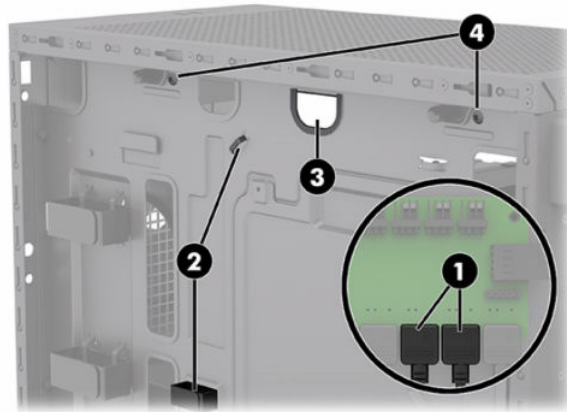

- e. On the left side of the computer, disconnect the top fan cables from the system board **(1)**.
- f. Remove the two Phillips screws **(2)** from the top of the bracket.
- g. Slide the bracket **(3)** toward the rear of the chassis.
- h. Pull the assembly **(4)** into the computer and lift it out to remove it.

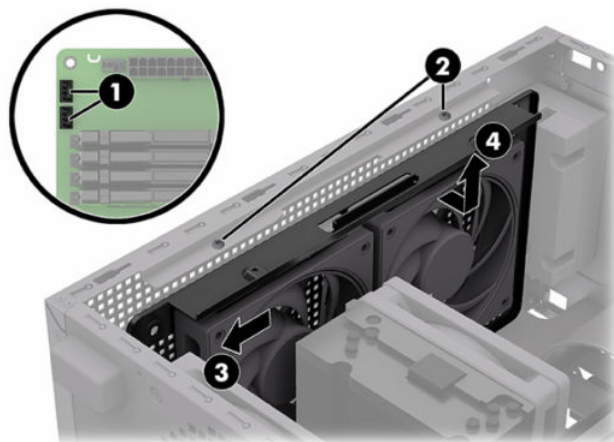

- 5. To remove the fans from the bracket:
  - a. Remove four Phillips screws **(1)** from each fan.

- b. Remove the bracket **(2)** from the fans.

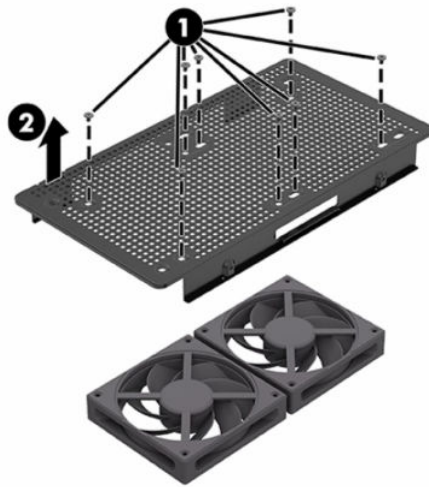

The fan bracket can accommodate two fan sizes as optional upgrades if top fans are not preconfigured:

**(1)** 120 mm fans

**(2)** 140 mm fans

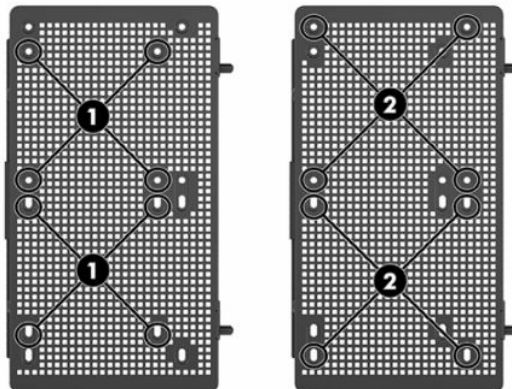

- 6. To install the fans into the bracket:
  - a. Place the bracket **(1)** against the fans.

- b. Install four Phillips screws (2) into each fan.

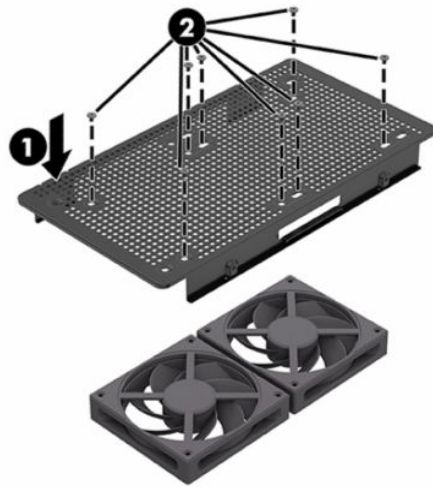

- 7. To install the top fans:
  - a. On the left side of the computer, insert the fan assembly (1) into the computer.
  - b. Slide the assembly (2) toward the front of the chassis and into place.
  - c. Install two Phillips screws (3).
  - d. Connect the power cable to the system board (4).

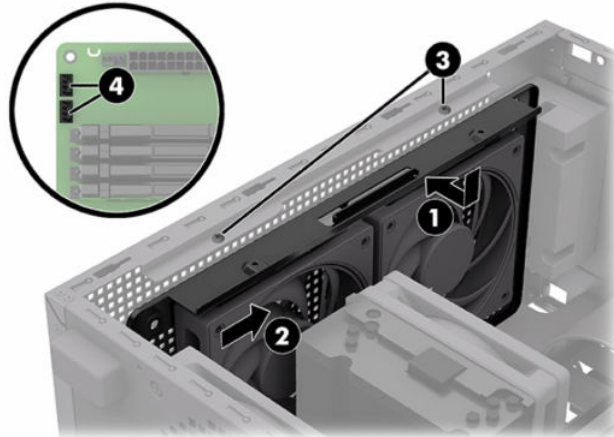

- e. On the right side of the computer, install two screws (1) into the top of the bracket.
- f. Route the RGB cable through the hole (2) in the chassis.
- g. Route the RGB cable through the clip and cable tie (3).

- h. Plug the RGB cable into the RGB lighting board (4). For RGB lighting board connector designations, see [RGB lighting board on page 33](#).

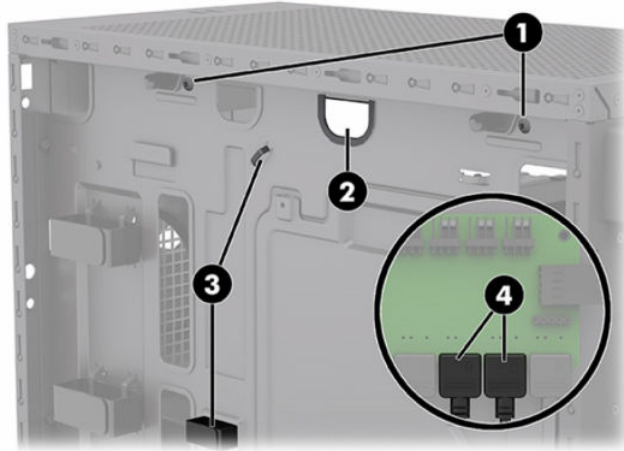

## Cable cover

To remove and install the cable cover, use these procedures and illustrations.

1. Prepare the computer for disassembly (see [Preparation for disassembly on page 3](#)).
2. Remove the left access panel (see [Left access panel on page 9](#)).
3. Position the computer with the system board facing upward.
4. To remove the cable cover:
  - a. Remove two Phillips screws (1) from the cover.
  - b. Lift the flat side of the cover (2) up slightly, and then remove the cover (3) from the computer.

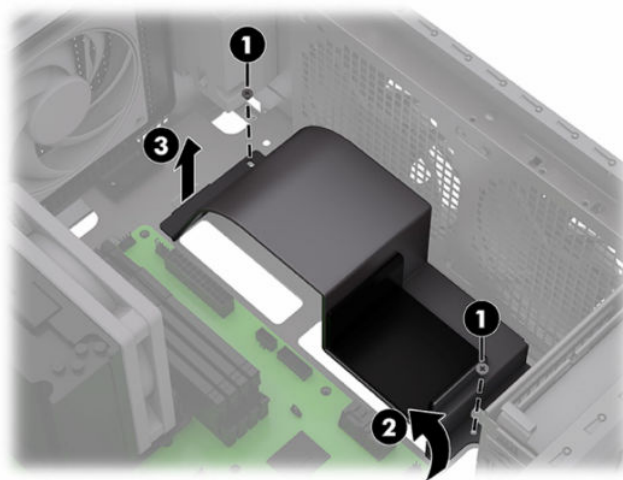

5. To install the cable cover:
  - a. Insert the tab (1) on the side of the cover into the slot in the base of the chassis.

- b. Rotate the cover (2) down into place.
- c. Install two Phillips screws (3) into the cover.

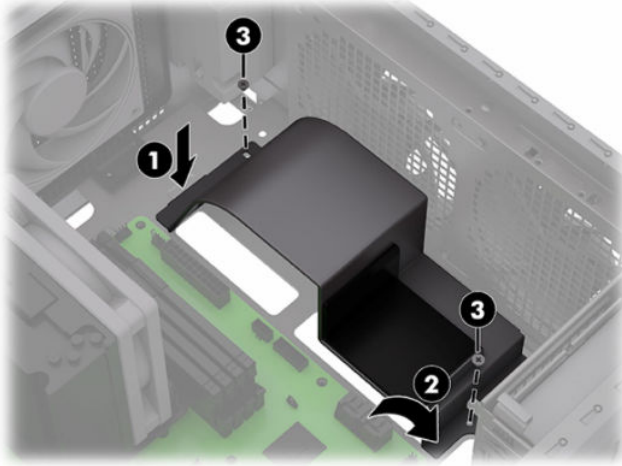

## 120 mm × 120 mm heat sink (air cooler) adapter bracket

A heat sink adapter bracket is used on AMD systems to adapt to an Intel heat sink. To use an AMD heat sink, you must first remove the adapter bracket. To remove and install the heat sink adapter bracket, use these procedures and illustrations.

1. Prepare the computer for disassembly (see [Preparation for disassembly on page 3](#)).
2. Remove the left access panel (see [Left access panel on page 9](#)).
3. Remove the heat sink (see [Liquid cooler on page 53](#)).
4. To remove the heat sink adapter bracket, remove the four Phillips screws (1), and then remove the bracket (2).

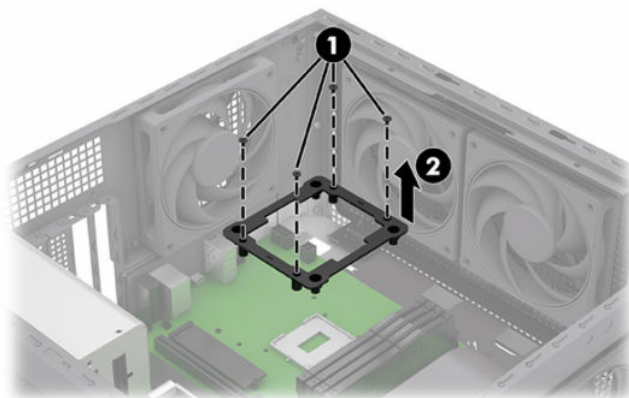

5. To install the heat sink adapter bracket, place the bracket **(1)** onto the system board posts, and then install four Phillips screws **(2)**.

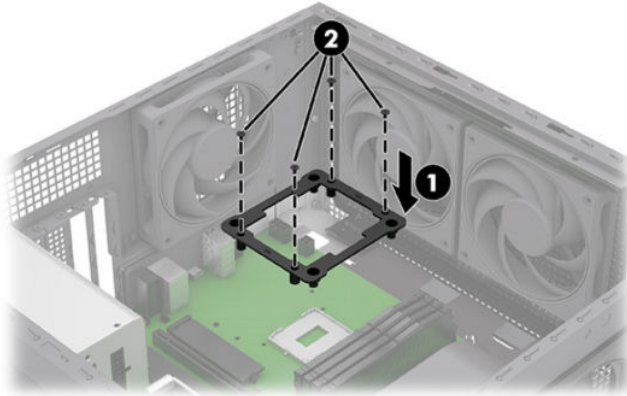

## 92 mm heat sink fan (air cooler)

To remove and install the 92 mm heat sink, use these procedures and illustrations.

1. Prepare the computer for disassembly (see [Preparation for disassembly on page 3](#)).
2. Remove the left access panel (see [Left access panel on page 9](#)).
3. Remove the right access panel (see [Right access panel on page 18](#)).

---

 **NOTE:** The heat sink adapter bracket is not used for Intel system boards when the 92 mm heat sink fan is preconfigured.

---

4. To remove the heat sink:
  - a. On the right side of the computer, disconnect the heat sink fan RGB cable **(1)** from the RGB lighting board.
  - b. Remove the cables from the cable clip and cable tie **(2)**.
  - c. Push the cable through the hole **(3)** in the computer chassis.

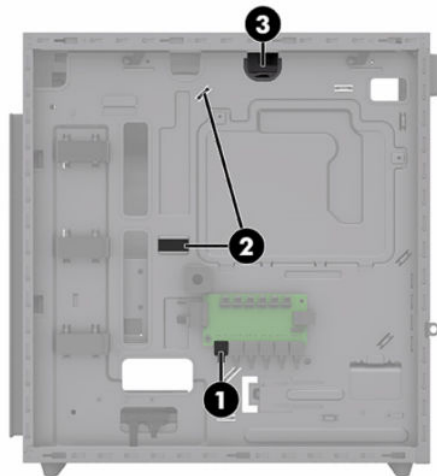

- d. On the left side of the computer, disconnect the heat sink fan cable from the system board **(1)**.
- e. Loosen the four captive Phillips screws **(2)** on the heat sink.
- f. Remove the heat sink assembly **(3)** from the computer.

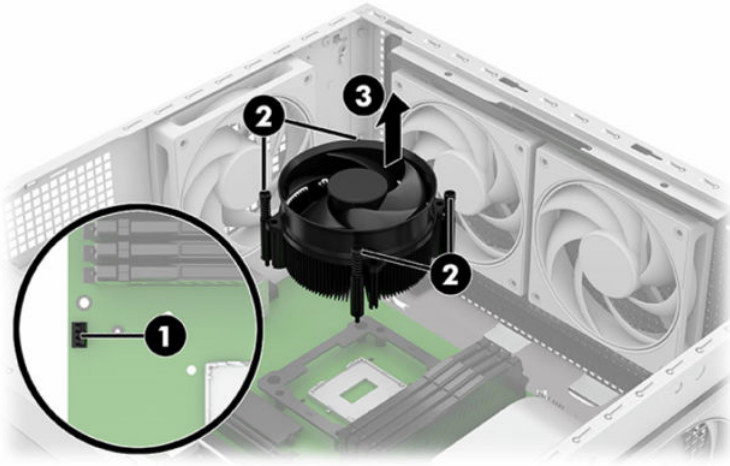

5. To install the heat sink fan:
- a. On the left side of the computer, place the heat sink assembly **(1)** over the processor.
  - b. Tighten the four captive Phillips screws **(2)**.
  - c. Connect the power cable to the system board **(3)**.
  - d. Route the RGB cable through the hole **(4)** in the chassis.

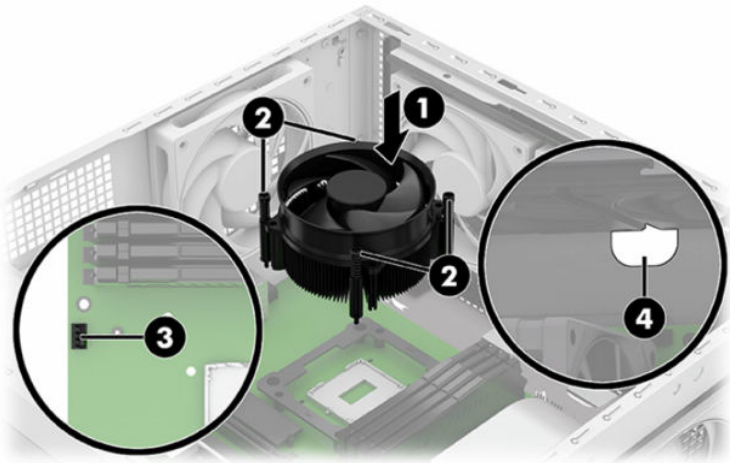

- e. On the right side of the computer, route the RGB cable through the cable clip and cable tie **(1)**.

- f. Plug the RGB cable into the RGB lighting board **(2)**. For RGB lighting board connector designations, see [RGB lighting board on page 33](#).

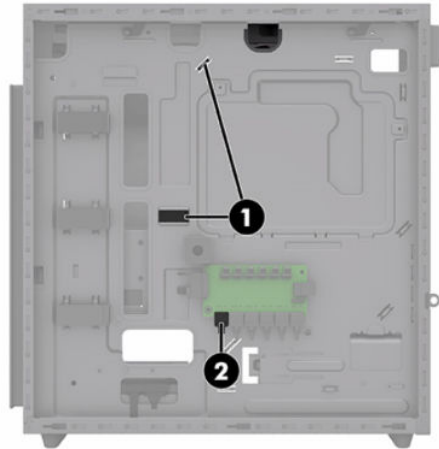

## 120 mm × 120 mm heat sink fan (air cooler) (fan only)

To remove and install the 120 mm heat sink fan, use these procedures and illustrations.

1. Prepare the computer for disassembly (see [Preparation for disassembly on page 3](#)).
2. Remove the left access panel (see [Left access panel on page 9](#)).
3. Remove the right access panel (see [Right access panel on page 18](#)).
4. To remove the heat sink fan:

---

 **NOTE:** The rear and top fans are the functional equivalent to a heat sink fan with a longer fan power cable. The HP service center might use a functional equivalent 120 mm × 120 mm fan with a longer fan power cable for heat sink fan replacement. Route the excess power cable to the right side of the chassis under the cable ties to avoid interference with the heat sink fan blades.

---

- a. On the right side of the computer, disconnect the heat sink fan RGB cable **(1)** from the RGB lighting board.
- b. Remove the cables from the cable clip and cable tie **(2)**.

- c. Push the cable through the hole **(3)** in the computer chassis.

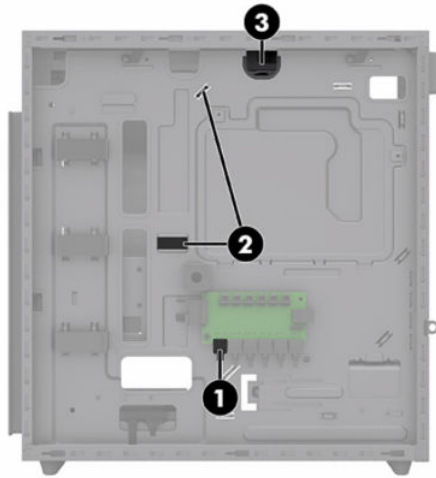

- d. On the left side of the computer, disconnect the heat sink fan cable from the system board **(1)**.
- e. Remove the four Phillips screws **(2)** from the fan.
- f. Remove the fan **(3)** from the heat sink.

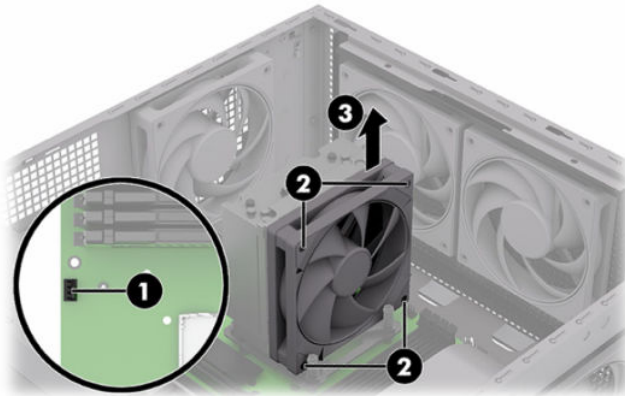

- 5. To install the heat sink fan:
  - a. On the left side of the computer, position the fan **(1)** against the heat sink.
  - b. Install four Phillips screws **(2)** into the fan.
  - c. Connect the power cable to the system board **(3)**.

- d. Route the RGB cable through the hole (4) in the chassis.

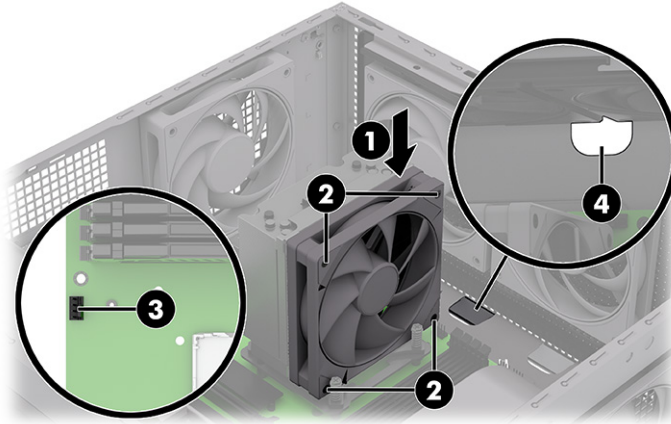

- e. On the right side of the computer, route the RGB cable through the cable clip and cable tie (1).
- f. Plug the RGB cable into the RGB lighting board (2). For RGB lighting board connector designations, see [RGB lighting board on page 33](#).

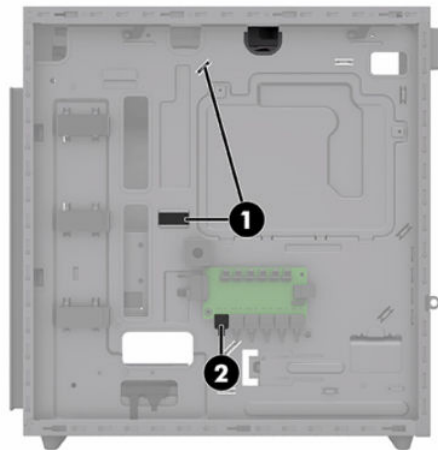

## 120 mm × 120 mm heat sink (air cooler) (entire assembly)

To remove and install the 120 mm heat sink assembly, use these procedures and illustrations.

1. Prepare the computer for disassembly (see [Preparation for disassembly on page 3](#)).
2. Remove the left access panel (see [Left access panel on page 9](#)).
3. Remove the right access panel (see [Right access panel on page 18](#)).
4. To remove the heat sink assembly:

 **NOTE:** The rear and top fans are the functional equivalent to a heat sink fan with a longer fan power cable. The HP service center might use a functional equivalent 120 mm × 120 mm fan with a

longer fan power cable for heat sink fan replacement. Route the excess power cable to the right side of the chassis under the cable ties to avoid interference with the heat sink fan blades.

---

- a. On the right side of the computer, disconnect the heat sink fan RGB cable **(1)** from the RGB lighting board.
- b. Remove the cables from the cable clip and cable tie **(2)**.
- c. Push the fan cable through the hole **(3)** in the computer chassis.

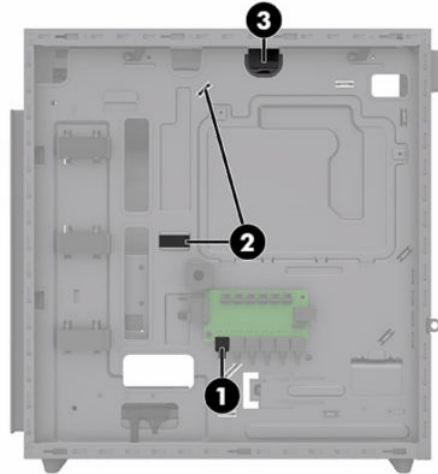

- d. On the left side of the computer, disconnect the heat sink fan cable from the system board **(1)**.
- e. Loosen the four captive Phillips screws **(2)** from the heat sink.
- f. Remove the assembly **(3)** from the computer.

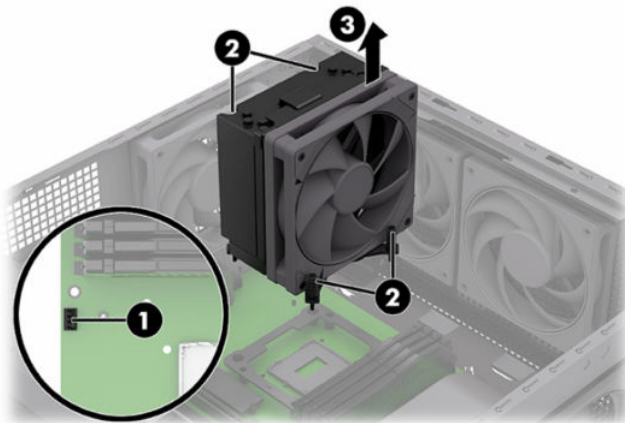

5. To install the heat sink assembly:
  - a. On the left side of the computer, position the assembly **(1)** over the processor.
  - b. Tighten four captive Phillips screws **(2)** on the heat sink.
  - c. Connect the power cable to the system board **(3)**.

- d. Route the fan RGB cable through the hole **(4)** in the chassis.

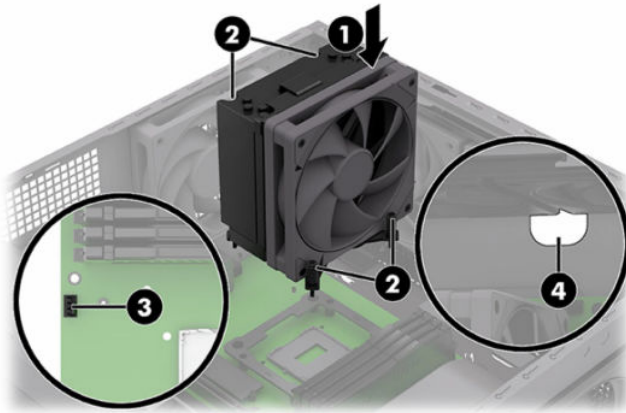

- e. On the right side of the computer, route the RGB cable through the cable clip and cable tie **(1)**.
- f. Plug the RGB cable into the RGB lighting board **(2)**. For RGB lighting board connector designations, see [RGB lighting board on page 33](#).

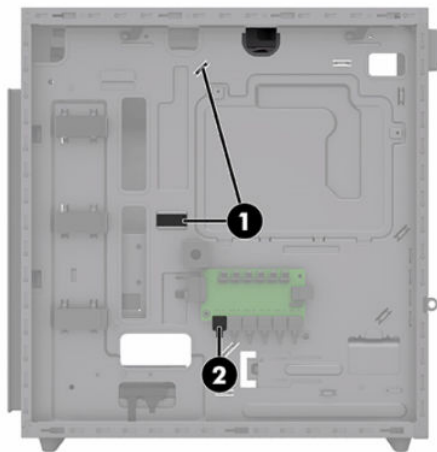

## Liquid cooler

To install the liquid cooler, use these procedures and illustrations.

1. Prepare the computer for disassembly (see [Preparation for disassembly on page 3](#)).
2. Remove the left access panel (see [Left access panel on page 9](#)).
3. Remove the right access panel (see [Right access panel on page 18](#)).

4. Install the backplate specific to the liquid cooler for an Intel system board:

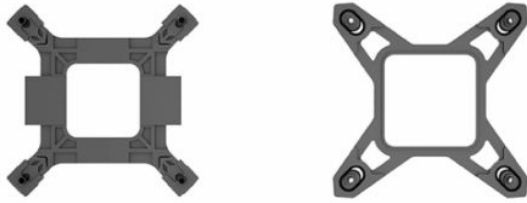

5. If installed, remove the metal back cover by rotating the top of the cover (1) downward, and then lifting the cover (2) out of the computer.

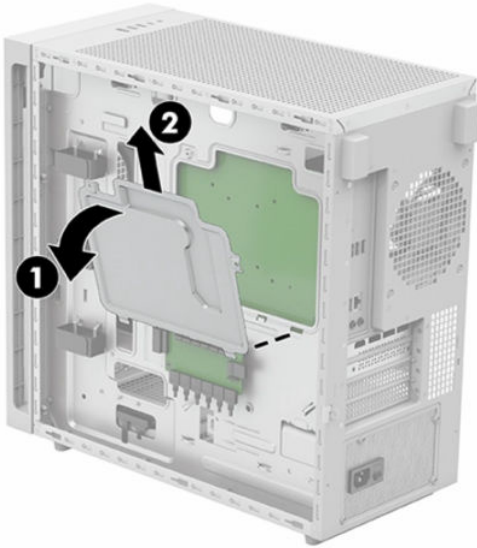

6. On the accessible part of the system board on the right side of the computer, align the backplate with the system board holes, and then press the backplate onto the system board.

 **NOTE:** Backplate appearance can vary.

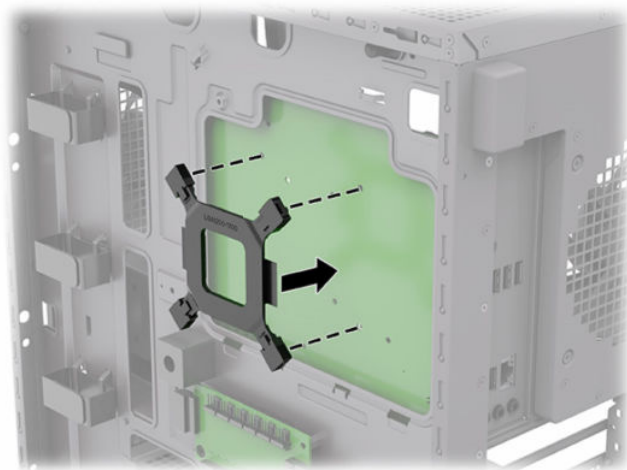

Reference the steps below that match your liquid cool solution.

7. To install an Intel liquid cooler:
  - a. Install the four screw posts (1) on the system board.
  - b. Install the heat sink pump onto the screw posts (2).
  - c. Install the thumbscrews (3) onto the screw posts to secure the heat sink.

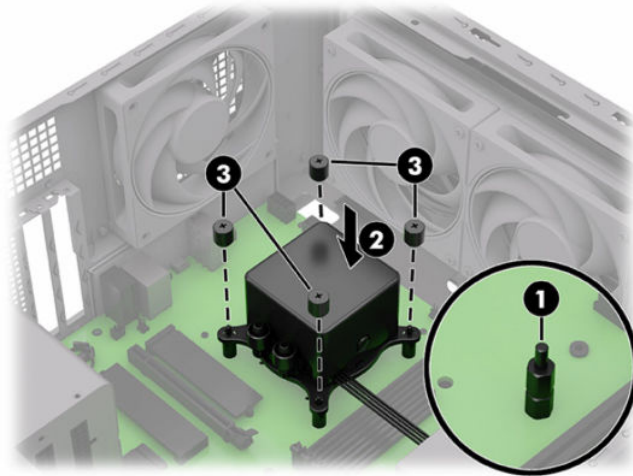

8. To install an AMD liquid cooler (option 1):
  - a. Place the two brackets (1) onto the system board.
  - b. Install two screws (2) into each bracket.

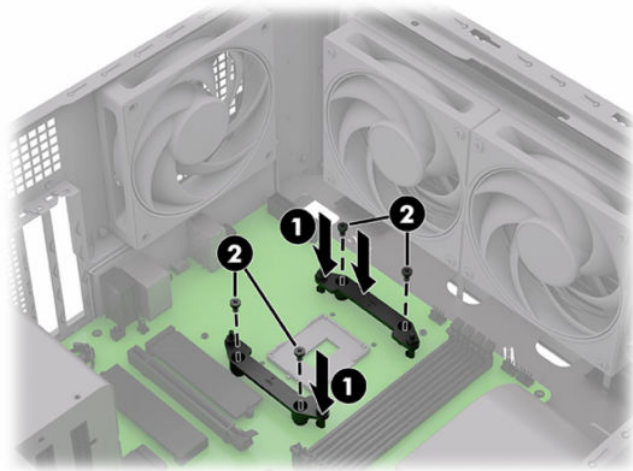

- c. Install the heat sink pump (1) onto the brackets.

- d. Install the thumbscrews (2) to secure the heat sink.

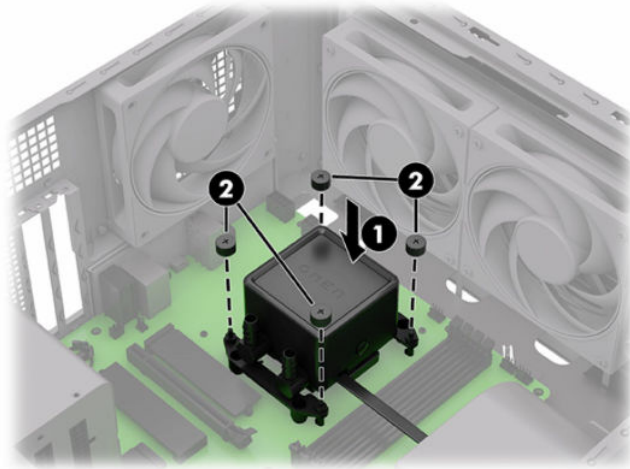

- 9. To install an AMD liquid cooler (option 2):
  - a. Place spacers (1) onto each screw post with the **AM5** marking on the spacers facing up.
  - b. Install the longer side of the screw posts (2) into the spacers.

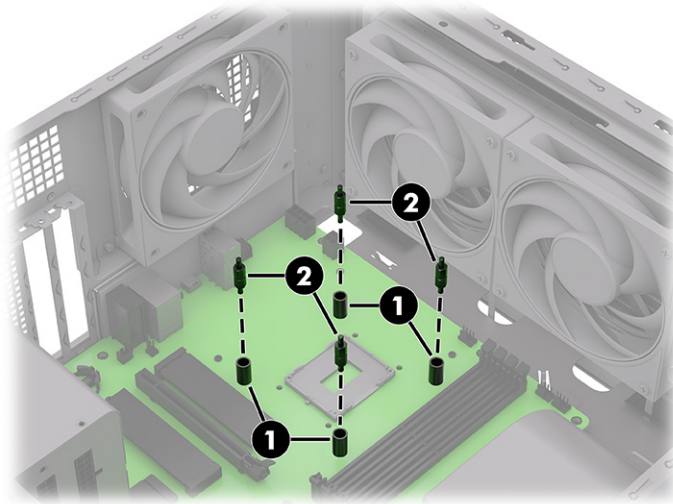

- c. Install the heat sink pump (1) onto the screw posts.

- d. Install four thumbscrews (2) to secure the heat sink.

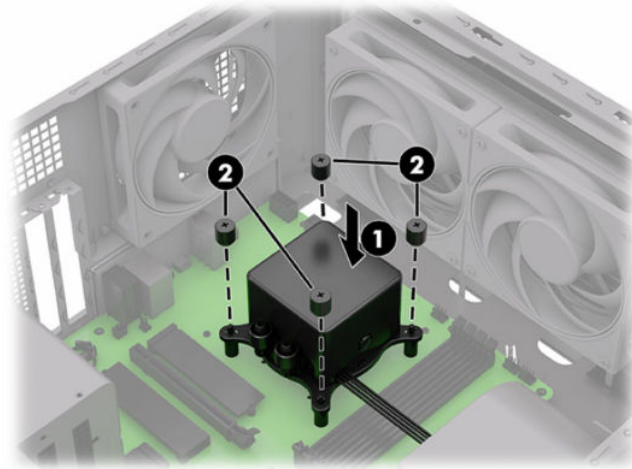

10. After installing the heat sink pump, install the radiator and fan module to the top bracket. The installation steps are the same as the top fans. For installation instructions, see [Top fans on page 41](#).
11. You can upgrade the ARGB heat sink cover with an LCD cover. To remove the cover, disconnect the power cable from the system board (1), press the two release buttons (2), and then lift the cover (3) off the heat sink.

---

 **NOTE:** Cable routing for the heat sink cover is based on whether the cover is ARGB or LCD. The cable for an ARGB cover routes to the RGB lighting board on the right side of the computer. The cable for an LCD cover routes to a USB pin header on the system board on the left side of the computer.

---

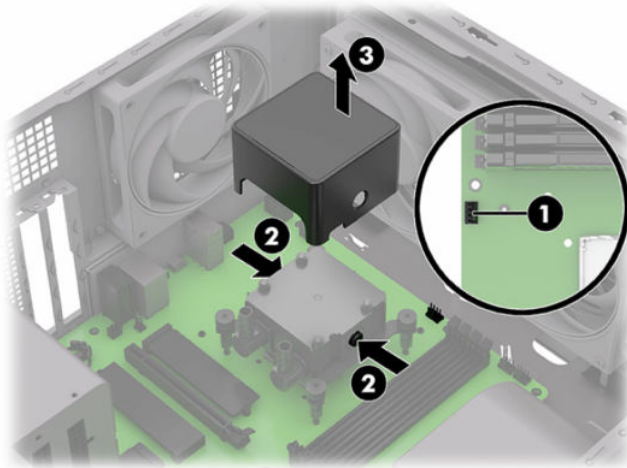

12. On computers configured with a 240 mm liquid cooler or DIY upgrades with an LCD cover and an Intel system board, a Y cable is required because the Intel lacks a reserved USB2 pin header.



The location of the pin header on Intel system boards is as follows:

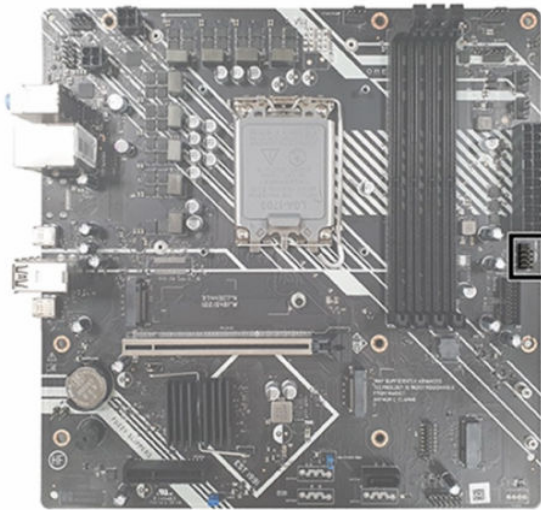

The location of the pin header on AMD system boards is as follows:

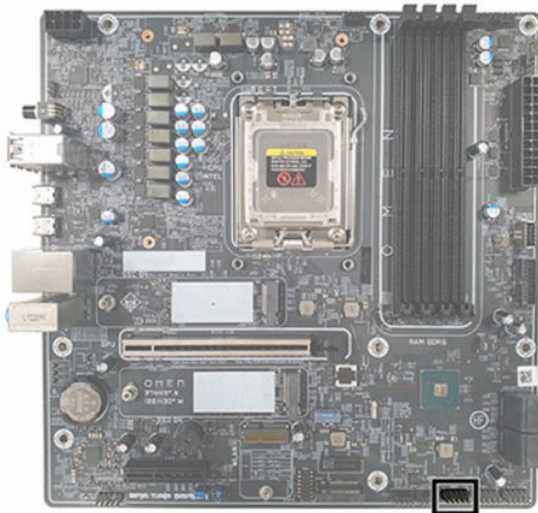

# Processor

To remove and install the processor, use these procedures and illustrations.

1. Prepare the computer for disassembly (see [Preparation for disassembly on page 3](#)).
2. Remove the left access panel (see [Left access panel on page 9](#)).
3. Remove the air or liquid cooler (see [92 mm heat sink fan \(air cooler\) on page 47](#), [120 mm × 120 mm heat sink \(air cooler\) \(entire assembly\) on page 51](#), or [Liquid cooler on page 53](#)).
4. If installed, remove the heat sink adapter bracket (see [120 mm × 120 mm heat sink \(air cooler\) adapter bracket on page 46](#)).
5. To remove the processor:
  - a. Press the retaining arm (1) down and then out to remove it from the hook.
  - b. Lift the retaining arm (2).
  - c. Rotate the processor bracket (3) off the processor.
  - d. Using extreme care, lift the processor (4) out of the computer. Damage to the gold pins underneath the processor can result in system failure and require system board replacement.

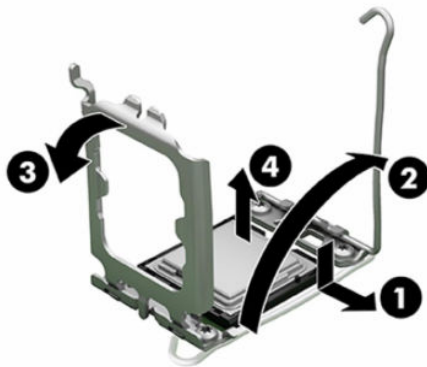

6. To install the processor:
  - a. Orient the processor onto the system board socket, making sure the small triangle marker on the corner of the processor aligns with the marker on the socket, and then using extreme care, place the processor (1) into the socket. Damage to the gold pins underneath the processor can result in system failure and require system board replacement.
  - b. Rotate the bracket (2) over onto the processor.

- c. Rotate the retaining arm **(3)** to clamp the bracket down onto the processor, and then place the arm under the hook.

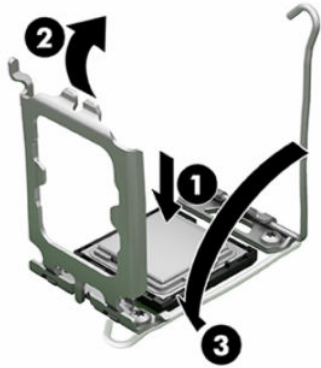

## Top I/O module

To remove and install the top I/O module, use these procedures and illustrations.

1. Prepare the computer for disassembly (see [Preparation for disassembly on page 3](#)).
2. Remove the left access panel (see [Left access panel on page 9](#)).
3. Remove the right access panel (see [Right access panel on page 18](#)).
4. Remove the front bezel (see [Front bezel on page 30](#)).
5. Position the computer with the system board facing upward.
6. To remove the top I/O module:
  - a. On the left side of the computer, disconnect the four top I/O cables from the system board.

 **NOTE:** Connector locations might vary based on factory system board configuration.

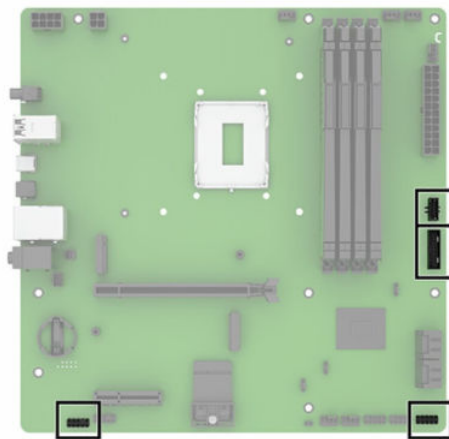

- b. On the right side of the computer, remove the cables from the cable ties **(1)**.

- c. Pull the cables out through the holes (2) in the chassis.

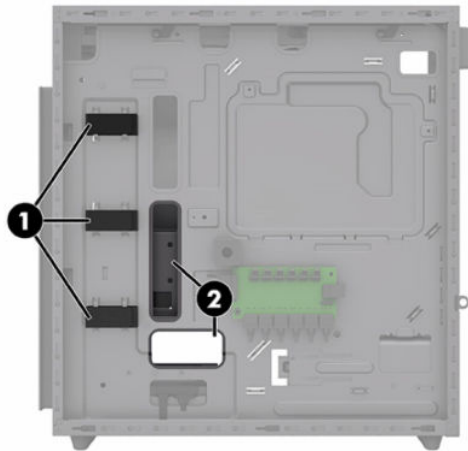

- d. On the front side of the computer, remove the three Phillips screws (1) from the top I/O module.
- e. Push the two latches (2) to release the module.
- f. Remove the top I/O module (3) while pulling the cables (4) through the hole in the chassis..

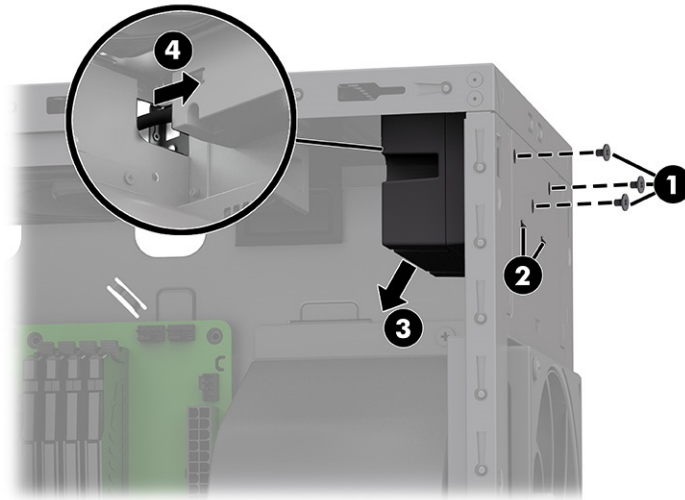

- 7. To install the top I/O module:
  - a. On the front of the computer, route the cables through the hole (1) in the chassis.
  - b. Place the module (2) in the computer.

- c. From the outside of the chassis, install three Phillips screws (3).

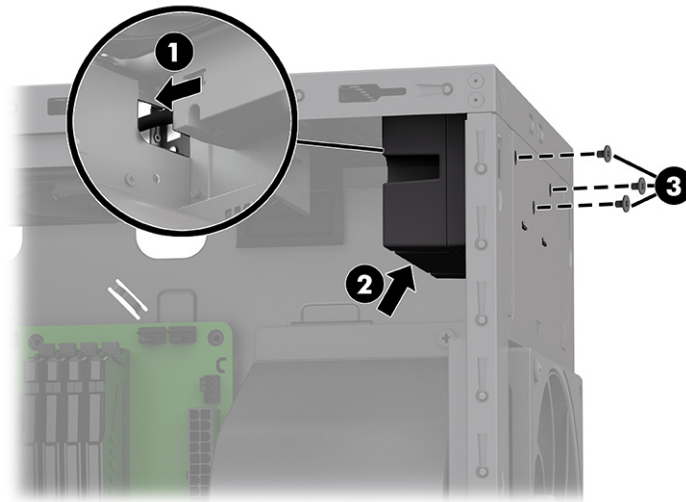

- d. On the right side of the computer, route the cables through the holes (1) in the chassis.
- e. Secure the cables in the cable ties (2).

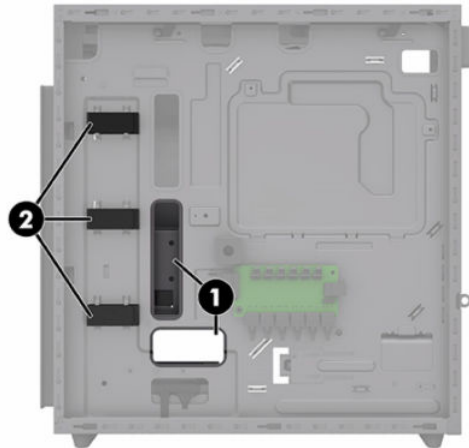

- f. On the left side on the computer, plug the top I/O cables into the system board.

 **NOTE:** Connector locations might vary based on factory system board configuration.

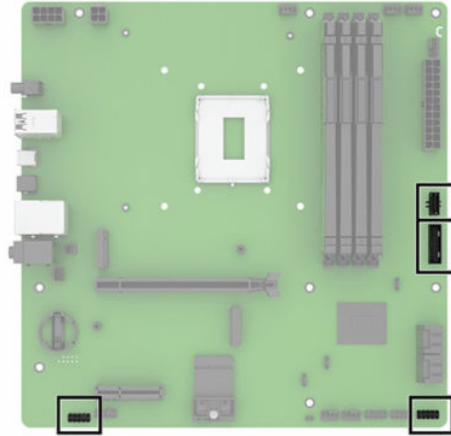

## System board

To remove and install the system board, use these procedures and illustrations.

1. Prepare the computer for disassembly (see [Preparation for disassembly on page 3](#)).
2. Remove the left access panel (see [Left access panel on page 9](#)).
3. Remove the SSD (see [Solid-state drive on page 13](#)).
4. Remove the graphics card (see [Graphics card on page 24](#)).
5. Remove the WLAN module (see [WLAN module on page 16](#)).
6. Remove the air or liquid cooler (see [92 mm heat sink fan \(air cooler\) on page 47](#), [120 mm × 120 mm heat sink \(air cooler\) \(entire assembly\) on page 51](#), or [Liquid cooler on page 53](#)).
7. Position the computer with the system board facing upward.
8. To remove the system board, disconnect the all cables connected to the system board. The following list provides the most common cables:



**NOTE:** System configuration and system board layout can vary depending of product specifications. For detailed system board layouts, see [System board layouts on page 5](#).

- CPU power **(1)**
- Processor fan **(2)**
- Top fan 2 **(3)**
- Top fan 1 **(4)**
- System board power **(5)**
- Top I/O (USB) **(6)**
- Top I/O (USB) **(7)**
- Hard drive **(8)**

- Top I/O (power button and light) (9)
- Liquid cooler LCD cover (10)
- RGB lighting board (11)
- Front fan 1 (12)
- Front fan 2 (13)
- Top I/O (Audio) (14)
- a. Remove the eight Phillips screws (1) from the system board.
- b. Lift the board (2) out of the computer.

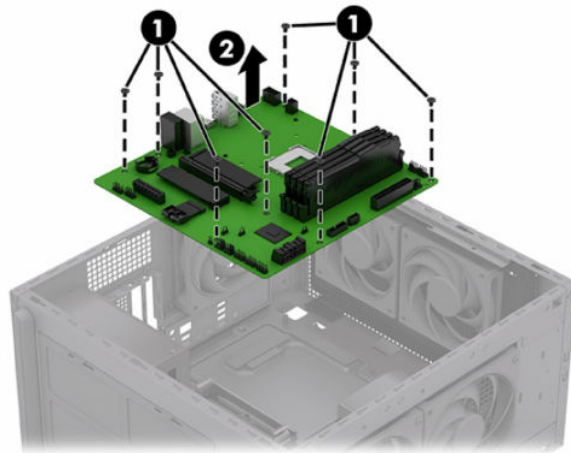

9. To install the system board:

- a. Place the system board (1) into the computer, being sure to align the I/O ports with the back of the computer.
- b. Install eight Phillips screws (2).

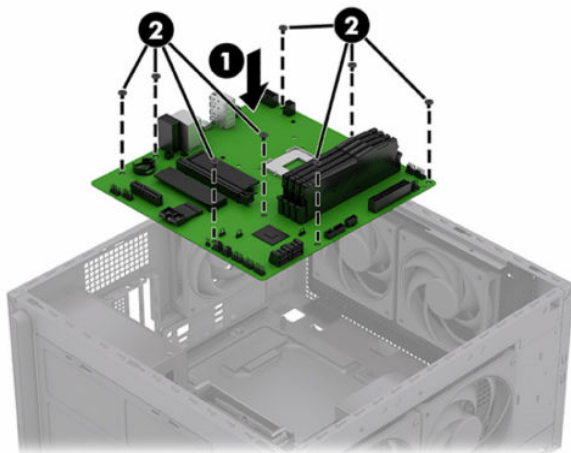

- c. Reconnect all cables.

## Wireless antennas and cables

To remove and install the wireless antennas and cables, use these procedures and illustrations.

1. Prepare the computer for disassembly (see [Preparation for disassembly on page 3](#)).
2. Remove the left access panel (see [Left access panel on page 9](#)).
3. Remove the right access panel (see [Right access panel on page 18](#)).
4. Remove the front bezel (see [Front bezel on page 30](#)).
5. Remove the front fans (see [Front fans on page 35](#)).
6. Remove the air or liquid cooler (see [92 mm heat sink fan \(air cooler\) on page 47](#), [120 mm × 120 mm heat sink \(air cooler\) \(entire assembly\) on page 51](#), or [Liquid cooler on page 53](#)).
7. Position the computer with the system board facing upward.
8. To remove the wireless antennas and cables:
  - a. Disconnect the antenna cables from the WLAN module (see [WLAN module on page 16](#)).
  - b. On the right side of the computer, pull the antenna cables through the small round hole **(1)** that leads to the WLAN module on the opposite side.
  - c. Remove the cables from the cable clips **(2)**.

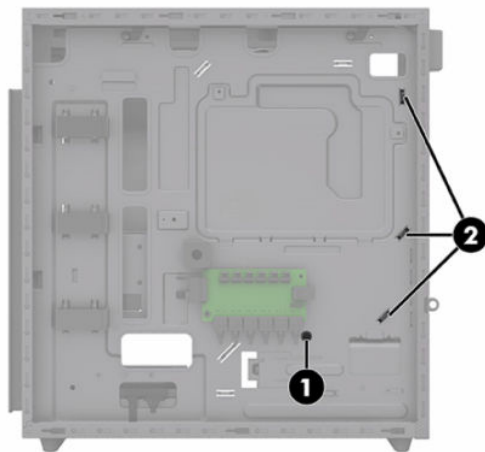

- d. (Left antenna) On the back of the computer, remove the screw **(1)** that secures the left antenna cover to the inside of the computer.
- e. Squeeze the cover **(2)** and rotate it off the computer.

- f. Pull the antenna (3) off the computer and pull the cable through the hole. The antenna is secured with double-sided tape.

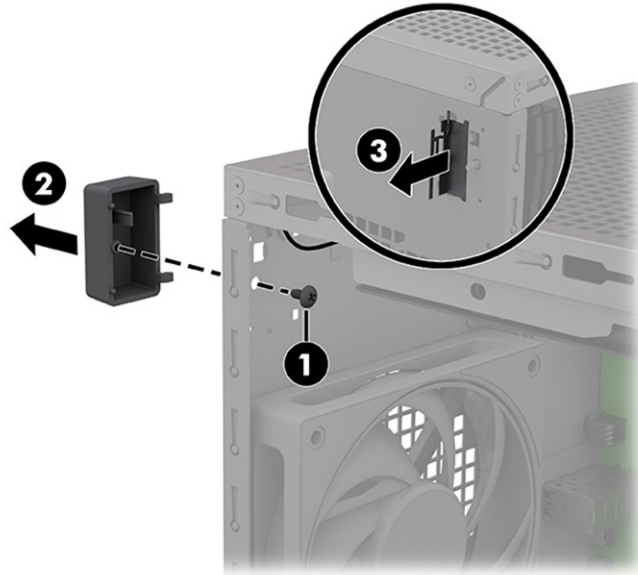

- g. (Right antenna) On the back of the computer, remove the screw (1) from the inside of the computer.
- h. Remove the cover (2) from the computer.
- i. Pull the antenna (3) off the computer and pull the cable through the hole in the chassis. The antenna is secured with double-sided tape.

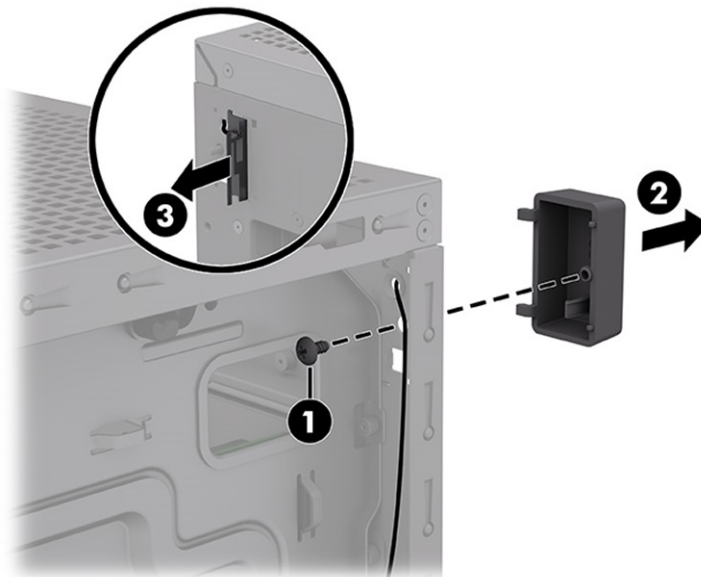

- 9. To install the wireless antennas and cables:
  - a. (Left antenna) On the left side of the computer, insert the left antenna cable through the hole (1) in the back of the chassis.

- b. Install the antenna (2) on the back of the chassis.
- c. Insert the tabs at the top of the antenna cover into the small holes (3) in the chassis, and then rotate the cover (4) into place.
- d. Install the Phillips screw (5).

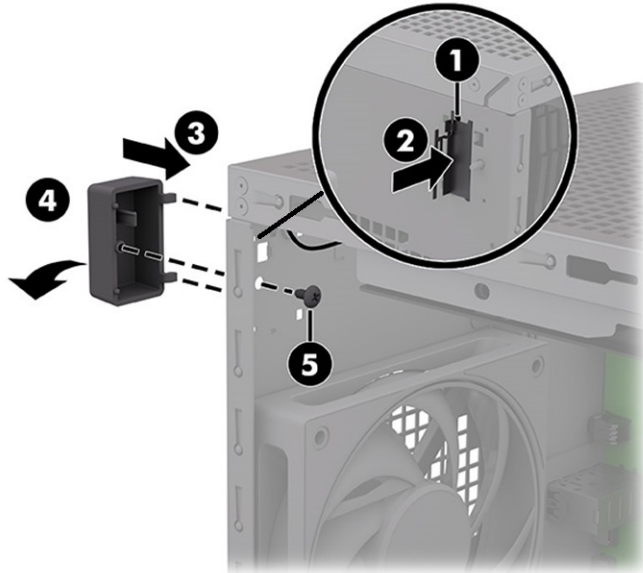

- e. On the right side of the computer, insert the right antenna cable through the hole (1) in the chassis.
- f. Install the antenna (2) on the back of the chassis.
- g. Insert the tabs at the top of the antenna cover into the small holes (3) in the chassis, and then rotate the cover (4) into place.
- h. Install the Phillips screw (5).

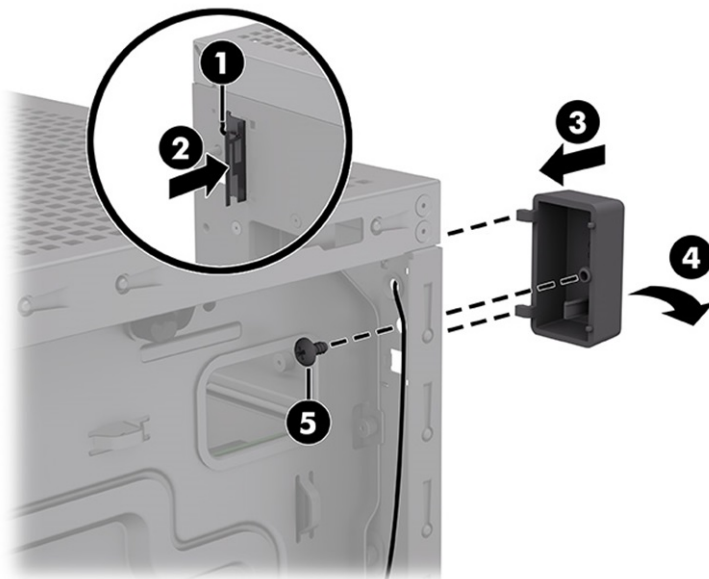

- i. On the right side of the computer, route the antenna cables through the cable ties **(1)**.
- j. Route the antenna cable through the small round hole **(2)** that leads to the WLAN module on the opposite side.

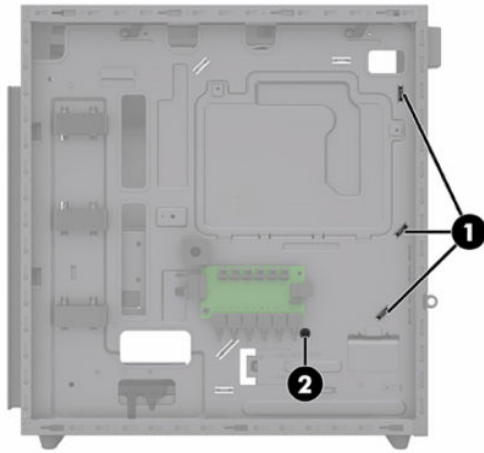

---

## 3 Computer operating guidelines, routine care, and shipping preparation

Follow these guidelines to ensure the best performance and useful life of your computer.

### Operating guidelines and routine care

HP has developed guidelines to help you properly set up and care for the computer and monitor.

- Keep the computer away from excessive moisture, direct sunlight, and extreme heat and cold.
- Operate the computer on a sturdy, level surface. Leave a 10.2 cm (4 inch) clearance on all vented sides of the computer and above the monitor to permit the required airflow.
- Never restrict the airflow into the computer by blocking any vents or air intakes. Do not place the keyboard, with the keyboard feet down, directly against the front of the desktop unit because this also restricts airflow.
- Never operate the computer with the access panel or any of the expansion card slot covers removed.
- Do not stack computers on top of each other or place computers so near each other that they are subject to each other's recirculated or preheated air.
- To operate a computer within a separate enclosure, intake and exhaust ventilation must be provided on the enclosure, and the previous operating guidelines still apply.
- Keep liquids away from the computer and keyboard.
- Never cover the ventilation slots on the monitor with any type of material.
- Install or enable power management functions of the operating system or other software, including sleep states.
- Turn off the computer before you do either of the following tasks:
  - Wipe the exterior of the computer with a soft, damp cloth as needed. Cleaning products might discolor or damage the finish. See [Removing dirt and debris from your computer on page 70](#) for the recommended steps to clean the high-touch, external surfaces on your computer. After you remove the dirt and debris, you can also clean the surfaces with a disinfectant. See [Cleaning your computer with a disinfectant on page 70](#) for guidelines to help prevent the spread of harmful bacteria and viruses.
  - Occasionally clean the air vents on all vented sides of the computer. Lint, dust, and other foreign matter can block the vents and limit the airflow.

### Cleaning your computer

Cleaning your computer regularly removes dirt and debris so that your device continues to operate at its best. Use the following information to safely clean the external surfaces of your computer.

## Removing dirt and debris from your computer

Here are the recommended steps to clean dirt and debris from your computer.

1. Wear disposable gloves made of latex (or nitrile gloves, if you are latex-sensitive) when cleaning the surfaces.
2. Turn off your device and unplug the power cord and other connected external devices. Remove any installed batteries from items such as wireless keyboards.

---

 **CAUTION:** To prevent electric shock or damage to components, never clean a product while it is turned on or plugged in.

---

3. Moisten a microfiber cloth with water. The cloth should be moist, but not dripping wet.

---

 **IMPORTANT:** To avoid damaging the surface, avoid abrasive cloths, towels, and paper towels.

---

4. Wipe the exterior of the product gently with the moistened cloth.

---

 **IMPORTANT:** Keep liquids away from the product. Avoid getting moisture in any openings. If liquid makes its way inside your HP product, it can cause damage to the product. Do not spray liquids directly on the product. Do not use aerosol sprays, solvents, abrasives, or cleaners containing hydrogen peroxide or bleach that might damage the finish.

---

5. Start with the display (if applicable). Wipe carefully in one direction, and move from the top of the display to the bottom. Finish with any flexible cables, like power cord, keyboard cable, and USB cables.
6. Be sure that surfaces have completely air-dried before turning the device on after cleaning.
7. Discard the gloves after each cleaning. Clean your hands immediately after you remove the gloves.

See [Cleaning your computer with a disinfectant on page 70](#) for recommended steps to clean the high-touch, external surfaces on your computer to help prevent the spread of harmful bacteria and viruses.

## Cleaning your computer with a disinfectant

The World Health Organization (WHO) recommends cleaning surfaces, followed by disinfection, as a best practice for preventing the spread of viral respiratory illnesses and harmful bacteria.

After cleaning the external surfaces of your computer using the steps in [Removing dirt and debris from your computer on page 70](#), you might also choose to clean the surfaces with a disinfectant. A disinfectant that is within HP's cleaning guidelines is an alcohol solution consisting of 70% isopropyl alcohol and 30% water. This solution is also known as rubbing alcohol and is sold in most stores.

Follow these steps when disinfecting high-touch, external surfaces on your computer:

1. Wear disposable gloves made of latex (or nitrile gloves, if you are latex-sensitive) when cleaning the surfaces.
2. Turn off your device and unplug the power cord and other connected external devices. Remove any installed batteries from items such as wireless keyboards.

---

 **CAUTION:** To prevent electric shock or damage to components, never clean a product while it is turned on or plugged in.

---

3. Moisten a microfiber cloth with a mixture of 70% isopropyl alcohol and 30% water. The cloth should be moist, but not dripping wet.

---

 **CAUTION:** Do not use any of the following chemicals or any solutions that contain them, including spray-based surface cleaners: bleach, peroxides (including hydrogen peroxide), acetone, ammonia, ethyl alcohol, methylene chloride, or any petroleum-based materials, such as gasoline, paint thinner, benzene, or toluene.

 **IMPORTANT:** To avoid damaging the surface, avoid abrasive cloths, towels, and paper towels.

---

4. Wipe the exterior of the product gently with the moistened cloth.

 **IMPORTANT:** Keep liquids away from the product. Avoid getting moisture in any openings. If liquid makes its way inside your HP product, it can cause damage to the product. Do not spray liquids directly on the product. Do not use aerosol sprays, solvents, abrasives, or cleaners containing hydrogen peroxide or bleach that might damage the finish.

---

5. Start with the display (if applicable). Wipe carefully in one direction, and move from the top of the display to the bottom. Finish with any flexible cables, like power cord, keyboard cable, and USB cables.
6. Be sure that surfaces have completely air-dried before turning the device on after cleaning.
7. Discard the gloves after each cleaning. Clean your hands immediately after you remove the gloves.

## Shipping preparation

If you have to ship your computer, follow these tips to keep your equipment safe.

1. Back up the hard drive files to an external storage device. Be sure that the backup media is not exposed to electrical or magnetic impulses while stored or in transit.

 **NOTE:** The hard drive locks automatically when the system power is turned off.

---

2. Remove and store all removable media.
3. Turn off the computer and external devices.
4. Disconnect the power cord from the AC outlet, and then from the computer.
5. Disconnect the system components and external devices from their power sources and then from the computer.

 **NOTE:** Be sure that all boards are seated properly and secured in the board slots before shipping the computer.

---

6. Pack the system components and external devices in their original packing boxes or similar packaging with sufficient packing material to protect them.

---

## 4 Electrostatic discharge

Electrostatic discharge is the release of static electricity when two objects come into contact—for example, the shock you receive when you walk across the carpet and touch a metal door knob.

A discharge of static electricity from fingers or other electrostatic conductors can damage electronic components.

---

 **IMPORTANT:** To prevent damage to the computer, damage to a drive, or loss of information, observe these precautions:

- If removal or installation instructions direct you to unplug the computer, first be sure that it is properly grounded.
  - Keep components in their electrostatic-safe containers until you are ready to install them.
  - Avoid touching pins, leads, and circuitry. Handle electronic components as little as possible.
  - Use nonmagnetic tools.
  - Before handling components, discharge static electricity by touching an unpainted metal surface.
  - If you remove a component, place it in an electrostatic-safe container.
-

---

## 5 Accessibility

HP's goal is to design, produce, and market products, services, and information that everyone everywhere can use, either on a standalone basis or with appropriate third-party assistive technology (AT) devices or applications.

### HP and accessibility

Because HP works to weave diversity, inclusion, and work/life into the fabric of the company, it is reflected in everything HP does. HP strives to create an inclusive environment focused on connecting people to the power of technology throughout the world.

### Finding the technology tools you need

Technology can unleash your human potential. Assistive technology removes barriers and helps you create independence at home, at work, and in the community. Assistive technology helps increase, maintain, and improve the functional capabilities of electronic and information technology.

For more information, see [Finding the best assistive technology on page 74](#).

### The HP commitment

HP is committed to providing products and services that are accessible for people with disabilities. This commitment supports the company's diversity objectives and helps ensure that the benefits of technology are available to all.

The HP accessibility goal is to design, produce, and market products and services that can be effectively used by everyone, including people with disabilities, either on a standalone basis or with appropriate assistive devices.

To achieve that goal, this Accessibility Policy establishes seven key objectives to guide HP actions. All HP managers and employees are expected to support these objectives and their implementation in accordance with their roles and responsibilities:

- Raise the level of awareness of accessibility issues within HP, and provide employees with the training they need to design, produce, market, and deliver accessible products and services.
- Develop accessibility guidelines for products and services, and hold product development groups accountable for implementing these guidelines where competitively, technically, and economically feasible.
- Involve people with disabilities in the development of accessibility guidelines and in the design and testing of products and services.
- Document accessibility features, and make information about HP products and services publicly available in an accessible form.
- Establish relationships with leading assistive technology and solution providers.
- Support internal and external research and development that improves assistive technology relevant to HP products and services.

- Support and contribute to industry standards and guidelines for accessibility.

## International Association of Accessibility Professionals (IAAP)

IAAP is a not-for-profit association focused on advancing the accessibility profession through networking, education, and certification. The objective is to help accessibility professionals develop and advance their careers and to better enable organizations to integrate accessibility into their products and infrastructure.

As a founding member, HP joined to participate with other organizations to advance the field of accessibility. This commitment supports HP's accessibility goal of designing, producing, and marketing products and services that people with disabilities can effectively use.

IAAP will make the profession strong by globally connecting individuals, students, and organizations to learn from one another. If you are interested in learning more, go to <http://www.accessibilityassociation.org> to join the online community, sign up for newsletters, and learn about membership options.

## Finding the best assistive technology

Everyone, including people with disabilities or age-related limitations, should be able to communicate, express themselves, and connect with the world using technology. HP is committed to increasing accessibility awareness within HP and with our customers and partners.

Whether it's large fonts that are easy on the eyes, voice recognition that lets you give your hands a rest, or any other assistive technology to help with your specific situation—a variety of assistive technologies make HP products easier to use. How do you choose?

## Assessing your needs

Technology can unleash your potential. Assistive technology removes barriers and helps you create independence at home, at work, and in the community. Assistive technology (AT) helps increase, maintain, and improve the functional capabilities of electronic and information technology.

You can choose from many AT products. Your AT assessment should allow you to evaluate several products, answer your questions, and facilitate your selection of the best solution for your situation. You will find that professionals qualified to do AT assessments come from many fields, including those licensed or certified in physical therapy, occupational therapy, speech/language pathology, and other areas of expertise. Others, while not certified or licensed, can also provide evaluation information. You will want to ask about the individual's experience, expertise, and fees to determine if they are appropriate for your needs.

## Accessibility for HP products

These links provide information about accessibility features and assistive technology, if applicable and available in your country or region, that are included in various HP products. These resources will help you select the specific assistive technology features and products most appropriate for your situation.

- HP Aging & Accessibility: Go to <http://www.hp.com>, type **Accessibility** in the search box. Select **Office of Aging and Accessibility**.
- HP computers: For Windows 7, Windows 8, and Windows 10, go to <http://www.hp.com/support>, type **Windows Accessibility Options** in the **Search our knowledge** search box. Select the appropriate operating system in the results.
- HP Shopping, peripherals for HP products: Go to <http://store.hp.com>, select **Shop**, and then select **Monitors or Accessories**.

If you need additional support with the accessibility features on your HP product, see [Contacting support on page 77](#).

Additional links to external partners and suppliers that may provide additional assistance:

- [Microsoft Accessibility information \(Windows 7, Windows 8, Windows 10, Microsoft Office\)](#)
- [Google Products accessibility information \(Android, Chrome, Google Apps\)](#)

## Standards and legislation

Countries worldwide are enacting regulations to improve access to products and services for persons with disabilities. These regulations are historically applicable to telecommunications products and services, PCs and printers with certain communications and video playback features, their associated user documentation, and their customer support.

### Standards

The US Access Board created Section 508 of the Federal Acquisition Regulation (FAR) standards to address access to information and communication technology (ICT) for people with physical, sensory, or cognitive disabilities.

The standards contain technical criteria specific to various types of technologies, as well as performance-based requirements which focus on functional capabilities of covered products. Specific criteria cover software applications and operating systems, web-based information and applications, computers, telecommunications products, video and multimedia, and self-contained closed products.

### Mandate 376 – EN 301 549

The European Union created the EN 301 549 standard within Mandate 376 as an online toolkit for public procurement of ICT products. The standard specifies the accessibility requirements applicable to ICT products and services, with a description of the test procedures and evaluation methodology for each requirement.

### Web Content Accessibility Guidelines (WCAG)

Web Content Accessibility Guidelines (WCAG) from the W3C's Web Accessibility Initiative (WAI) helps web designers and developers create sites that better meet the needs of people with disabilities or age-related limitations.

WCAG advances accessibility across the full range of web content (text, images, audio, and video) and web applications. WCAG can be precisely tested, is easy to understand and use, and allows web developers flexibility for innovation. WCAG 2.0 has also been approved as [ISO/IEC 40500:2012](#).

WCAG specifically addresses barriers to accessing the web experienced by people with visual, auditory, physical, cognitive, and neurological disabilities, and by older web users with accessibility needs. WCAG 2.0 provides characteristics of accessible content:

- **Perceivable** (for instance, by addressing text alternatives for images, captions for audio, adaptability of presentation, and color contrast)
- **Operable** (by addressing keyboard access, color contrast, timing of input, seizure avoidance, and navigability)
- **Understandable** (by addressing readability, predictability, and input assistance)
- **Robust** (for instance, by addressing compatibility with assistive technologies)

## Legislation and regulations

Accessibility of IT and information has become an area of increasing legislative importance.

The [HP policy landscape](#) website provides information about key legislation, regulations, and standards in the following locations:

- United States
- Canada
- Europe
- Australia

## Useful accessibility resources and links

These organizations, institutions, and resources might be good sources of information about disabilities and age-related limitations.



**NOTE:** This is not an exhaustive list. These organizations are provided for informational purposes only. HP assumes no responsibility for information or contacts you encounter on the internet. Listing on this page does not imply endorsement by HP.

## Organizations

These organizations are a few of the many that provide information about disabilities and age-related limitations.

- American Association of People with Disabilities (AAPD)
- The Association of Assistive Technology Act Programs (ATAP)
- Hearing Loss Association of America (HLAA)
- Information Technology Technical Assistance and Training Center (ITTATC)
- Lighthouse International
- National Association of the Deaf
- National Federation of the Blind
- Rehabilitation Engineering & Assistive Technology Society of North America (RESNA)
- Telecommunications for the Deaf and Hard of Hearing, Inc. (TDI)
- W3C Web Accessibility Initiative (WAI)

## Educational institutions

Many educational institutions, including these examples, provide information about disabilities and age-related limitations.

- California State University, Northridge, Center on Disabilities (CSUN)
- University of Wisconsin - Madison, Trace Center

- University of Minnesota computer accommodations program

## Other disability resources

Many resources, including these examples, provide information about disabilities and age-related limitations.

- ADA (Americans with Disabilities Act) Technical Assistance Program
- ILO Global Business and Disability network
- EnableMart
- European Disability Forum
- Job Accommodation Network
- Microsoft Enable

## HP links

These HP-specific links provide information that relates to disabilities and age-related limitations.

[HP comfort and safety guide](#)

[HP public sector sales](#)

## Contacting support

HP offers technical support and assistance with accessibility options for customers with disabilities.



---

**NOTE:** Support is in English only.

---

- Customers who are deaf or hard of hearing who have questions about technical support or accessibility of HP products:
  - Use TRS/VRS/WebCapTel to call (877) 656-7058 Monday through Friday, 6 a.m. to 9 p.m. Mountain Time.
- Customers with other disabilities or age-related limitations who have questions about technical support or accessibility of HP products:
  - Call (888) 259-5707 Monday through Friday, 6 a.m. to 9 p.m. Mountain Time.

---

# Index

## Symbols/Numerics

- 120 mm heat sink
  - removal and replacement 49
- 120 mm heat sink assembly
  - removal and replacement 51
- 92 mm heat sink
  - removal and replacement 47

## A

- access panel
  - removal and replacement 9, 18
- accessibility 73, 74, 76, 77
- accessibility needs
  - assessment 74
- air filter, identifying 4
- assistive technology (AT)
  - finding 74
  - purpose 73
- AT (assistive technology)
  - finding 74
  - purpose 73
- audio-out (headphone)/audio-in (microphone) combo jack, identifying 1

## B

- bottom dust filter
  - removal and replacement 32

## C

- cable cover
  - removal and replacement 45
- caring for your computer 69
- cautions 3
- cleaning your computer 69
  - disinfecting 70
  - removing dirt and debris 70
- computer feet
  - removal and replacement 8
- computer operating guidelines 69
- customer support, accessibility 77

## D

- dust filter
  - removal and replacement 31, 32

## E

- electrostatic discharge 72

## F

- fan
  - removal and replacement 35, 38, 41, 45
- fans
  - removal and replacement 35
- feet
  - removal and replacement 8
- feet, identifying 4
- front bezel
  - removal and replacement 30
- front bezel, identifying 5
- front dust filter
  - removal and replacement 31
- front fans, identifying 4

## G

- graphics card
  - installing 24
- graphics card, identifying 4

## H

- hard drive
  - removal and replacement 19
- hard drive, identifying 4
- hardware setup 3
- heat sink adapter bracket
  - removal and replacement 46
- heat sink assembly, 120 mm
  - removal and replacement 51
- heat sink, 120 mm
  - removal and replacement 49
- heat sink, 92 mm
  - removal and replacement 47
- HP Assistive Policy 73

## I

- installing
  - graphics card 24
  - memory 10
  - power supply, modular 22
  - power supply, nonmodular 23
- International Association of Accessibility Professionals 74

## J

- jacks
  - audio-out (headphone)/audio-in (microphone) combo jack 1

## L

- left access panel
  - removal and replacement 9
- liquid cooler
  - removal and replacement 53

## M

- memory
  - removal and replacement 10
  - socket population 10
  - specifications 10
- memory module
  - installation 10
  - removal and replacement 10
- memory modules, identifying 4

## P

- parts, identifying location 4
- power supply, identifying 5
- power supply, modular
  - installing 22
  - modular power supply 22
  - modular power supply installing 22
- power supply, nonmodular
  - installing 23
  - nonmodular power supply 23
  - nonmodular power supply installing 23
- processor
  - removal and replacement 59

processor cooler, identifying 4

## R

rear components 2

rear fan

removal and replacement 38

rear fan, identifying 4

removal and replacement

120 mm heat sink 49

120 mm heat sink assembly 51

92 mm heat sink 47

access panel 9, 18

bottom dust filter 32

cable cover 45

computer feet 8

dust filter 31, 32

fan 35, 38, 41, 45

feet 8

front bezel 30

front dust filter 31

hard drive 19

heat sink adapter bracket 46

heat sink assembly, 120 mm 51

heat sink, 120 mm 49

heat sink, 92 mm 47

left access panel 9

liquid cooler 53

memory 10

memory modules 10

processor 59

rear fan 38

RGB lighting board 33

right access panel 18

solid-state drive 13

system board 63

top fans 41

top I/O module 60

wireless antennas and

cables 65

WLAN module 16

resources, accessibility 76

RGB lighting board

removal and replacement 33

RGB lighting board, identifying 4

right access panel

removal and replacement 18

## S

Section 508 accessibility

standards 75

shipping preparation 71

solid-state drive

removal and replacement 13

solid-state drive, identifying 4

specifications

memory 10

standards and legislation,

accessibility 75

system board

removal and replacement 63

system board I/O area,

identifying 2

system board, identifying 4

## T

top components 1, 5

top fans

removal and replacement 41

top fans, identifying 4

top I/O module

removal and replacement 60

top I/O module, identifying 4

## V

ventilation guidelines 69

## W

warnings 3

wireless antennas and cables

removal and replacement 65

WLAN antenna, identifying 5

WLAN module

removal and replacement 16

WLAN module, identifying 5