



# Hardware Reference Guide

## **SUMMARY**

This guide provides information about components, network connection, power management, security, backing up, and more.

## Legal information

© Copyright 2025 HP Development Company, L.P.

Intel is a trademark of Intel Corporation or its subsidiaries in the U.S. and/or other countries. Microsoft and Windows are either registered trademarks or trademarks of Microsoft Corporation in the United States and/or other countries. Thunderbolt is a trademark of Intel Corporation or its subsidiaries in the U.S. and/or other countries. USB Type-C, USB-C, and the USB 5 Gbps and USB 10 Gbps port logos are registered trademarks of USB Implementers Forum.

The information contained herein is subject to change without notice. The only warranties for HP products and services are set forth in the express warranty statements accompanying such products and services. Nothing herein should be construed as constituting an additional warranty. HP shall not be liable for technical or editorial errors or omissions contained herein.

First Edition: October 2025

Document Part Number: P67065-001

### Product Notice

This guide describes features that are common to most models. Some features may not be available on your computer.

Not all features are available in all editions or versions of Windows. Systems may require upgraded and/or separately purchased hardware, drivers, software or BIOS update to take full advantage of Windows functionality. Windows is automatically updated, which is always enabled. High-speed internet and Microsoft account required. ISP fees may apply and additional requirements may apply over time for updates. See <http://www.windows.com>.

**If your product ships with Windows in S Mode:** Windows in S Mode works exclusively with apps from the Microsoft Store within Windows. Certain default settings, features, and apps cannot be changed. Some accessories and apps that are compatible with Windows may not work (including some antivirus, PDF writers, driver utilities, and accessibility apps), and performance may vary, even if you switch out of S Mode. If you switch to Windows, you cannot switch back to S Mode. Learn more at [Windows.com/SmodeFAQ](http://Windows.com/SmodeFAQ).

To access the latest user guides, go to <http://www.hp.com/support>, and follow the instructions to find your product. Then select **Manuals**.

### Software terms





By installing, copying, downloading, or otherwise using any software product preinstalled on this computer, you agree to be bound by the terms of the HP End User License Agreement (EULA). If you do not accept these license terms, your sole remedy is to return the entire unused product (hardware and software) within 14 days for a full refund subject to the refund policy of your seller.

For any further information or to request a full refund of the price of the computer, please contact your seller.

---

# About this guide

This guide provides basic information for using and upgrading this product.

- 
-  **WARNING!** Indicates a hazardous situation that, if not avoided, **could** result in serious injury or death.
  -  **CAUTION:** Indicates a hazardous situation that, if not avoided, **could** result in minor or moderate injury.
  -  **IMPORTANT:** Indicates information considered important but not hazard-related (for example, messages related to property damage). Warns the user that failure to follow a procedure exactly as described could result in loss of data or in damage to hardware or software. Also contains essential information to explain a concept or to complete a task.
  -  **NOTE:** Contains additional information to emphasize or supplement important points of the main text.
  -  **TIP:** Provides helpful hints for completing a task.
- 



This product incorporates HDMI® technology.

---

# Table of contents

<b>1 Computer features</b> .....	<b>1</b>
Top components .....	1
Rear panel components .....	1
<b>2 Hardware setup</b> .....	<b>3</b>
Warnings and cautions.....	3
Preparation for disassembly.....	3
System board specification information.....	4
Feet .....	4
Glass access panel.....	5
Memory modules.....	5
WLAN module.....	7
Graphics card .....	8
Front bezel.....	11
Dust filter .....	12
Right access panel.....	12
Hard drive .....	14
RGB lighting board .....	16
Front RGB fans.....	18
Rear fan.....	24
Power supply .....	25
Top I/O module.....	30
Processor .....	34
System board.....	35
CPU backplate .....	36
Cryo chamber.....	38
<b>3 Computer operating guidelines, routine care, and shipping preparation</b> .....	<b>45</b>
Operating guidelines and routine care .....	45
Cleaning your computer .....	45
Removing dirt and debris from your computer.....	46
Cleaning your computer with a disinfectant.....	46
Shipping preparation .....	47
<b>4 Electrostatic discharge</b> .....	<b>48</b>
<b>5 Accessibility</b> .....	<b>49</b>

HP and accessibility.....	49
Finding the technology tools you need.....	49
The HP commitment.....	49
International Association of Accessibility Professionals (IAAP).....	50
Finding the best assistive technology.....	50
Assessing your needs.....	50
Accessibility for HP products.....	50
Standards and legislation.....	51
Standards.....	51
Mandate 376 - EN 301 549.....	51
Web Content Accessibility Guidelines (WCAG).....	51
Legislation and regulations.....	52
Useful accessibility resources and links.....	52
Organizations.....	52
Educational institutions.....	52
Other disability resources.....	53
HP links.....	53
Contacting support.....	53
<b>Index.....</b>	<b>54</b>

# 1 Computer features

This chapter provides you with an overview of your computer's features.



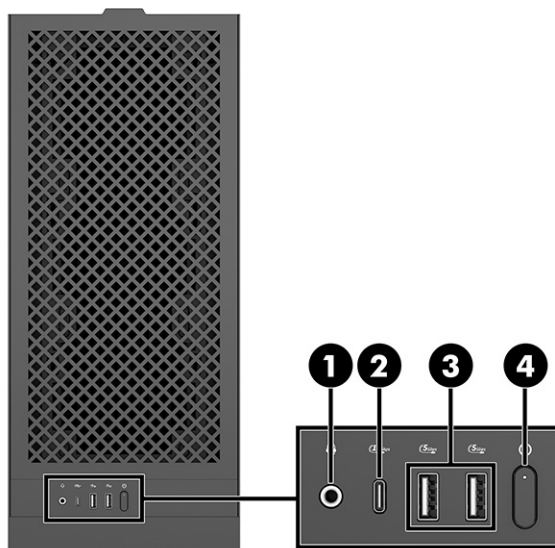

 **IMPORTANT:** Your keyboard might include a Copilot key. Copilot in Windows® (select products only) requires Windows 11. Some features require a neural processing unit (NPU). The timing of feature delivery and availability varies by market and device. You must have a Microsoft account to use the Copilot feature. When the Copilot feature is not available, pressing the Copilot key opens the Bing search engine. See <http://aka.ms/WindowsAIFeatures>.

## Top components

Use this illustration and table to identify the top components.

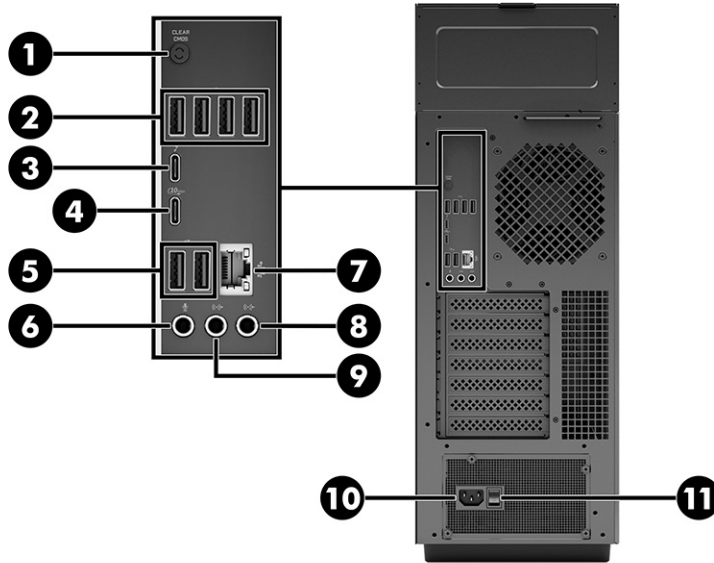

**Table 1-1** Identifying the top components









Top components	
1 	Audio-out (headphone jack)
2 	USB Type-C® 10 Gbps port
3 	USB 5 Gbps ports
4 	Power button and power light

## Rear panel components

Use this illustration and table to identify the rear panel components.



**Table 1-2** Identifying the rear panel components

Rear panel components			
1	Clean CMOS button	7	 RJ-45 (network) jack/status lights
2	 USB ports (4)	8	 Audio-in jack
3	 USB Type-C 10 Gbps port	9	 Audio-out jack for powered audio devices
4	 USB Type-C 10 Gbps port	10	Power connector
5	 USB 5 Gbps ports (2)	11	Power switch
6	 Audio-in (microphone) jack		

---

## 2 Hardware setup

This chapter provides removal and replacement procedures for commonly replaced parts.

### Warnings and cautions

Before performing upgrades, be sure to carefully read all of the applicable instructions, cautions, and warnings.

---

 **WARNING!** To reduce the risk of personal injury from electric shock, hot surfaces, or fire:

- Unplug the power cord from the AC outlet and allow the internal system components to cool before you touch them.
- Do not disable the power cord grounding plug. The grounding plug is an important safety feature.
- Plug the power cord into a grounded (earthed) outlet that is easily accessible at all times.

To reduce the risk of serious injury, read the *Safety & Comfort Guide*. It describes proper workstation setup and provides guidelines for posture and work habits that increase your comfort and decrease your risk of injury. It also provides electrical and mechanical safety information. The Safety & Comfort Guide is located on the HP website at <http://www.hp.com/ergo>.

---

 **WARNING!** The inside of the computer includes electric and moving parts.

Disconnect power to the equipment before removing the access panel.

Replace and secure the access panel before re-energizing the equipment.

---

 **IMPORTANT:** Static electricity can damage the electrical components of the computer or optional equipment. Before beginning the following procedures, be sure that you are discharged of static electricity by briefly touching a grounded metal object. See [Electrostatic discharge on page 33 on page 48](#) for more information.

---

### Preparation for disassembly

Use this information to properly prepare to disassemble and reassemble the computer.

1. Remove all removable media, such as a USB flash drive, from the computer.
2. Turn off the computer. If you are unsure whether the computer is off or in hibernation, turn the computer on, and then shut it down through the operating system.

---

 **IMPORTANT:** Turn off the computer before disconnecting any cables.

Regardless of the power state, voltage is always present on the system board as long as the system is plugged into an active AC outlet. In some systems, the cooling fan is on even when the

computer is in the standby or suspend modes. Always disconnect the power cord before servicing a unit.

3. Unplug the power cord from the AC outlet and disconnect any external devices.

 **IMPORTANT:** When the computer is plugged into an AC power source, voltage is always applied to the system board. To prevent damage to internal components, you must unplug the power cord from the power source before opening the computer.

 **CAUTION:** Beware of sharp edges inside the chassis.

 **NOTE:** During disassembly, label each cable as you remove it, and note its position and routing. Keep all screws with the removed components.

## System board specification information

For system board specification information, refer to online product series specifications.

## Feet

Use this procedure and illustration to remove the feet.

1. Prepare the computer for disassembly (see [Preparation for disassembly on page 3](#)).
2. To remove the feet:
  - a. Peel the rubber strip **(1)** off each foot.
  - b. Remove the two screws **(2)** from each foot.
  - c. Remove the feet **(3)**.

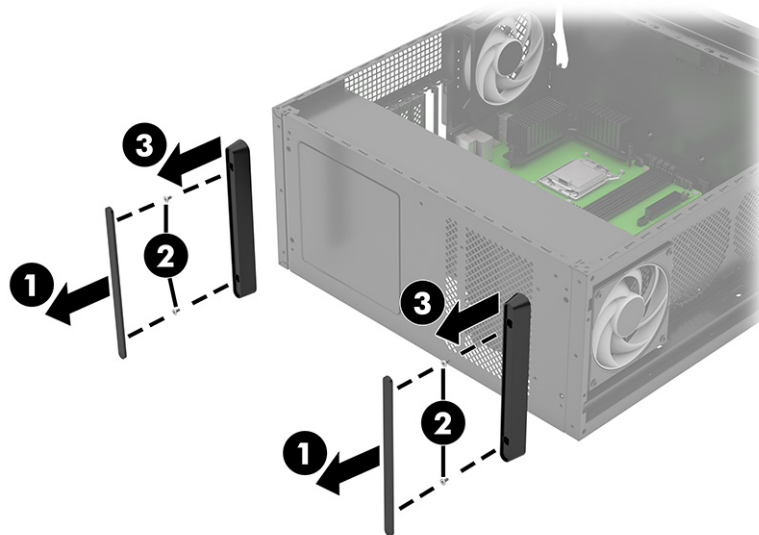

Reverse this procedure to install the feet.

## Glass access panel

Use these procedures and illustrations to remove and install the glass access panel.

 **NOTE:** On select products, the glass access panel might be locked to meet safety regulations. If the access panel is locked, move the lock screw to the unlock position before opening the access panel. After replacing the glass access panel, be sure to move the lock screw to the lock position.

1. Prepare the computer for disassembly (see [Preparation for disassembly on page 3](#)).
2. To remove the glass access panel:
  - a. Press the release button (1).
  - b. After the top of the panel (2) rotates outward, pull it up to remove it.

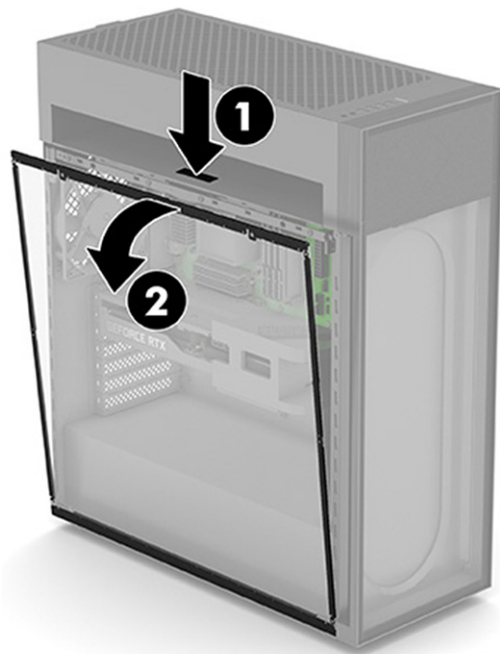

Reverse this procedure to install the glass access panel.

## Memory modules

Use this procedure and illustration to remove the memory modules.

The memory sockets on the system board are populated with at least one preinstalled memory module. To achieve the maximum memory support, you can populate the system board with up to 128 GB of memory configured in a high-performing dual-channel mode.

For proper system operation, the DIMMs must adhere to the following specifications:

- Industry-standard 288-pin
- DDR5-6000 SDRAM DIMM
- Mandatory JEDEC SPD information

The computer supports the following setups:

- 12 Gbit and 16 Gbit non-ECC memory technologies
- Single-rank and double-rank memory modules
- Memory modules constructed with ×8 and ×16 DDR devices; memory modules constructed with ×4 SDRAM are not supported

---

 **NOTE:** Actual data transfer rate is determined by system configuration.

 **NOTE:** When more than one memory slot is populated, symmetric configurations are required for two DIMMs per channel. A mix of different data transfer rates or memory rank mix within the same channel is not allowed.

 **NOTE:** The system does not operate properly if you install unsupported memory modules.

---

Four memory sockets are on the system board, with two sockets per channel. The sockets are labeled DIMM1, DIMM2, DIMM3, and DIMM4. Sockets DIMM1 and DIMM2 operate in memory channel B. Sockets DIMM3 and DIMM4 operate in memory channel A.

The system automatically operates in single-channel mode, dual-channel mode, or flex mode, depending on how the DIMMs are installed.

---

 **IMPORTANT:** You must disconnect the power cord and wait approximately 30 seconds for the power to drain before adding or removing memory modules. Regardless of the power state, voltage is always supplied to the memory modules as long as the computer is plugged into an active AC outlet. Adding or removing memory modules while voltage is present can cause irreparable damage to the memory modules or system board.

The memory module sockets have gold-plated metal contacts. When upgrading the memory, it is important to use memory modules with gold-plated metal contacts to prevent corrosion, oxidation, or both resulting from having incompatible metals in contact with each other.

Static electricity can damage the electronic components of the computer or optional cards. Before beginning these procedures, be sure that you are discharged of static electricity by briefly touching a grounded metal object. For more information, see [Electrostatic discharge information on page 48](#).

When handling a memory module, be careful not to touch any of the contacts. Doing so can damage the module.

---

1. Prepare the computer for disassembly (see [Preparation for disassembly on page 3](#)).
2. Remove the glass access panel (see [Glass access panel on page 5](#)).
3. Open the outside latch **(1)** of the memory module socket, and then remove the memory module **(2)** from the socket.

---

 **NOTE:** Only the outside latch opens. The inside latch is locked in place.

---

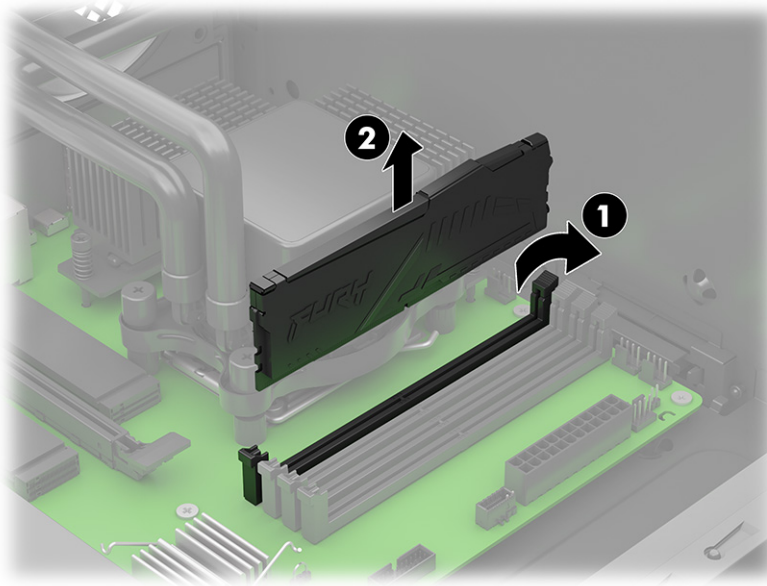

Reverse this procedure to install the memory modules.

## WLAN module

Use these procedures and illustrations to remove the WLAN module.

---

 **IMPORTANT:** To prevent an unresponsive system, replace the wireless module only with a wireless module authorized for use in the computer by the governmental agency that regulates wireless devices in your country or region. If you replace the module and then receive a warning message, remove the module to restore device functionality, and then contact technical support.

---

1. Prepare the computer for disassembly (see [Preparation for disassembly on page 3](#)).
2. Remove the right side access panel (see [Right access panel on page 12](#)).
3. To remove a WLAN module:
  - a. Remove the Phillips screw **(1)**, and then remove the plastic protector **(2)** that covers the antenna connectors.
  - b. Carefully disconnect the two antenna cables **(3)** from the module.
  - c. Pull the module **(4)** out of the socket to remove it.

---

 **NOTE:** The #1 white WLAN antenna cable connects to the WLAN module #1 main terminal. The #2 black WLAN antenna cable connects to the WLAN module #1 aux terminal.

---

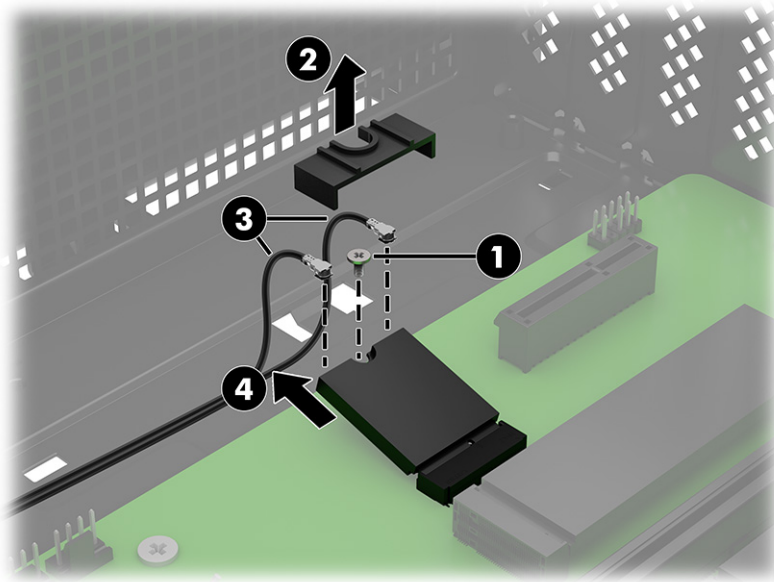

Reverse this procedure to install the WLAN module.

## Graphics card

Use this procedure and illustration to install a graphics card.

1. Prepare the computer for disassembly (see [Preparation for disassembly on page 3](#)).
2. Remove the glass access panel (see [Glass access panel on page 5](#)).
3. Position the computer with the system board facing upward.
4. If the graphics card requires the three-piece bracket, follow these steps:

- a. Place the end bracket (1) onto the graphics card, and then install three screws (2).

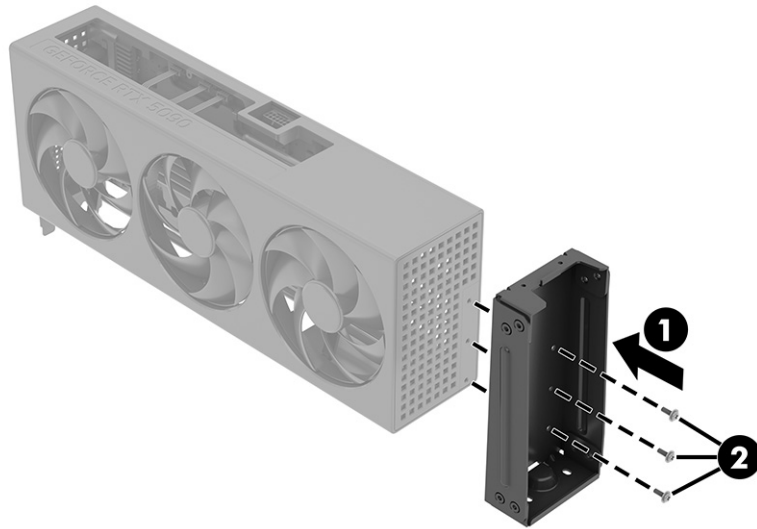

- b. Install the graphics card with bracket assembly (1) into the computer, and then install two screws (2) to secure the bracket.

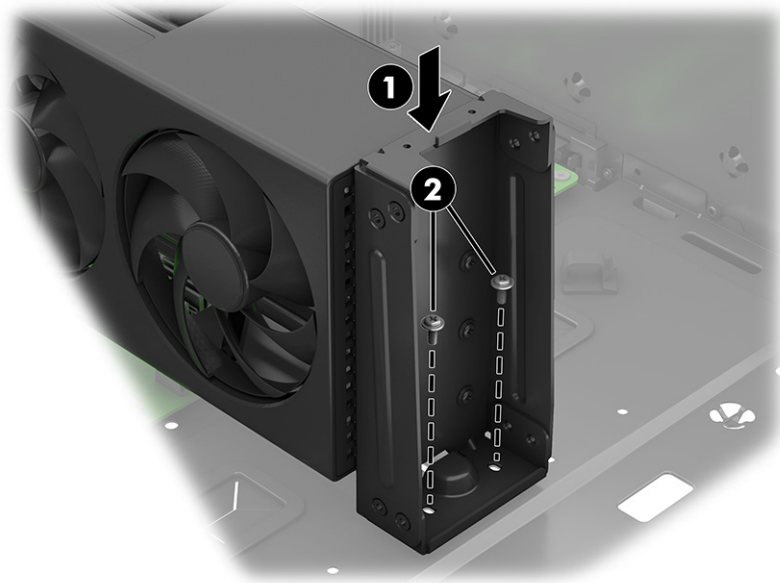

- c. Place the top bracket **(1)** over the graphics card and the outside bracket **(2)** onto the back of the computer, and then install six screws **(3)**.

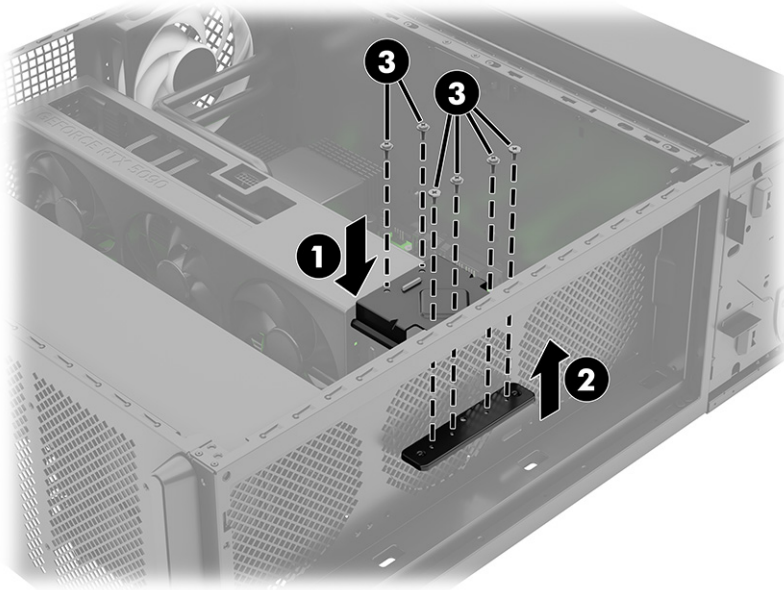

5. If the graphics card does not require a bracket, follow these steps:

 **NOTE:** Screw quantity and power connector location might vary depending on graphics card.

- a. Insert the graphics card **(1)** into the slot until it clicks into place, and then install the screws **(2)**.
- b. Connect the power cable to the connector **(3)** on the graphics card.

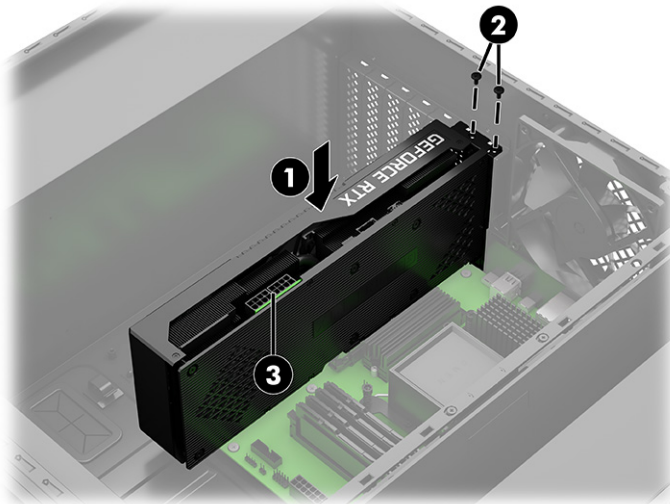

6. If the graphics card requires the one-piece bracket, place the bracket **(1)** over the graphics card, and then install two screws **(2)**.

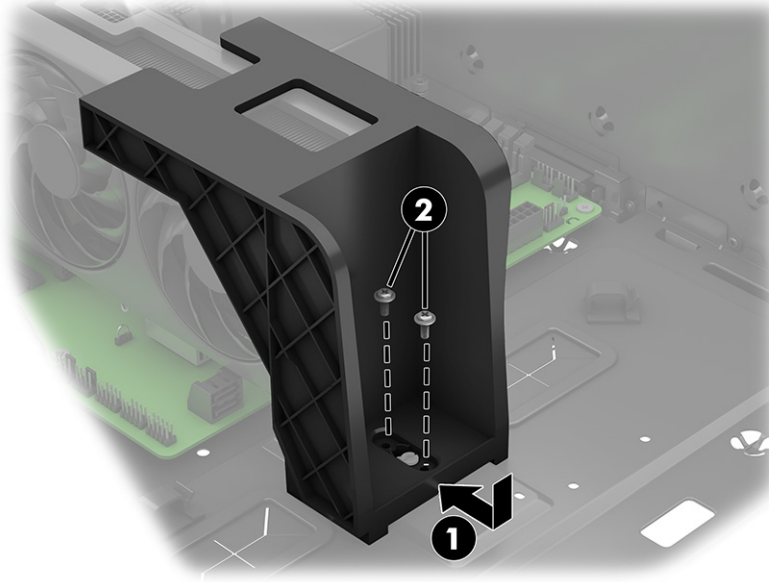

Reverse this procedure to remove the graphics card.

## Front bezel

Use this procedure and illustration to remove the front bezel.

1. Prepare the computer for disassembly (see [Preparation for disassembly on page 3](#)).
2. To remove the front bezel, press the two release buttons **(1)** at the top of each side of the bezel, and then rotate the top of the bezel **(2)** away from the computer to remove it.

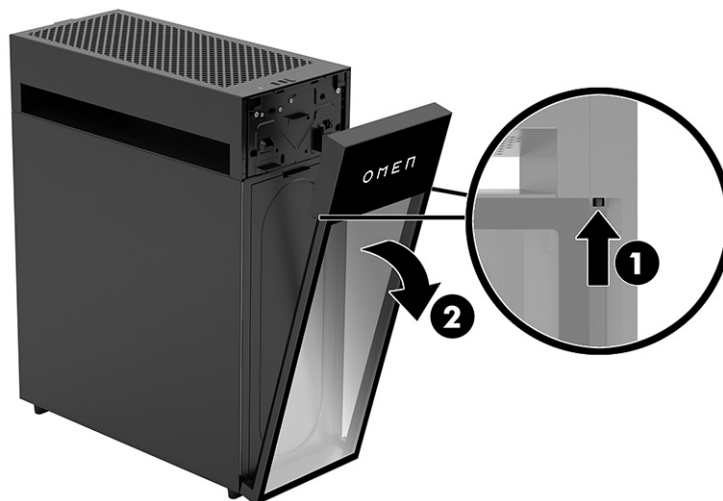

Reverse this procedure to install the front bezel.

## Dust filter

Use this procedure and illustration to remove the dust filter.

 **IMPORTANT:** If your computer has a magnetic dust filter, be sure that the filter is installed. If the filter has been removed, install the filter before using the computer.

1. Prepare the computer for disassembly (see [Preparation for disassembly on page 3](#)).
2. Remove the front bezel (see [Front bezel on page 11](#)).
3. To remove the dust filter, press the release tab **(1)** at the top of the filter, and then rotate the top of the filter **(2)** away from the computer to remove it.

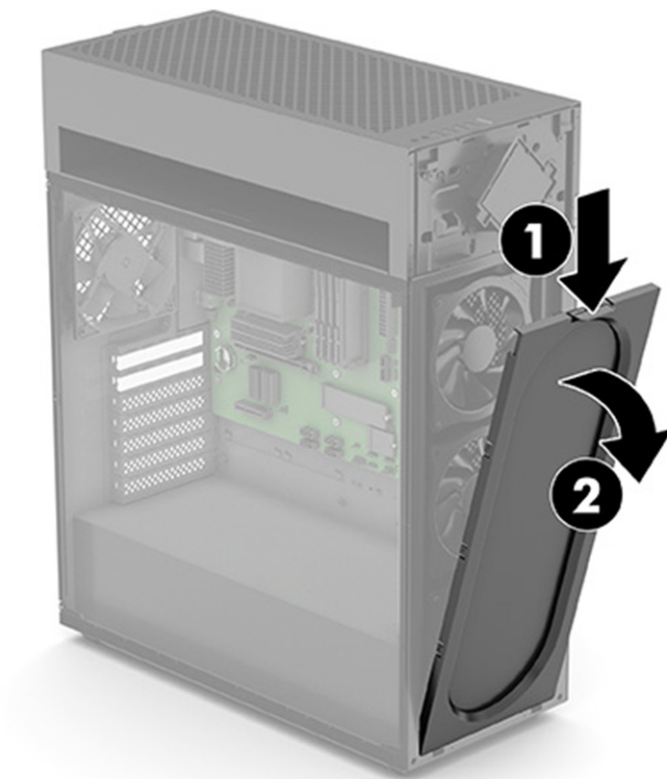

Reverse this procedure to install the dust filter.

## Right access panel

Use these procedures and illustrations to remove and install the right access panel.

1. Prepare the computer for disassembly (see [Preparation for disassembly on page 3](#)).
2. To remove the panel on the right side:
  - a. Press the release button **(1)**. The top of the panel **(2)** rotates outward.

- b. Pull the panel **(3)** up to remove it.

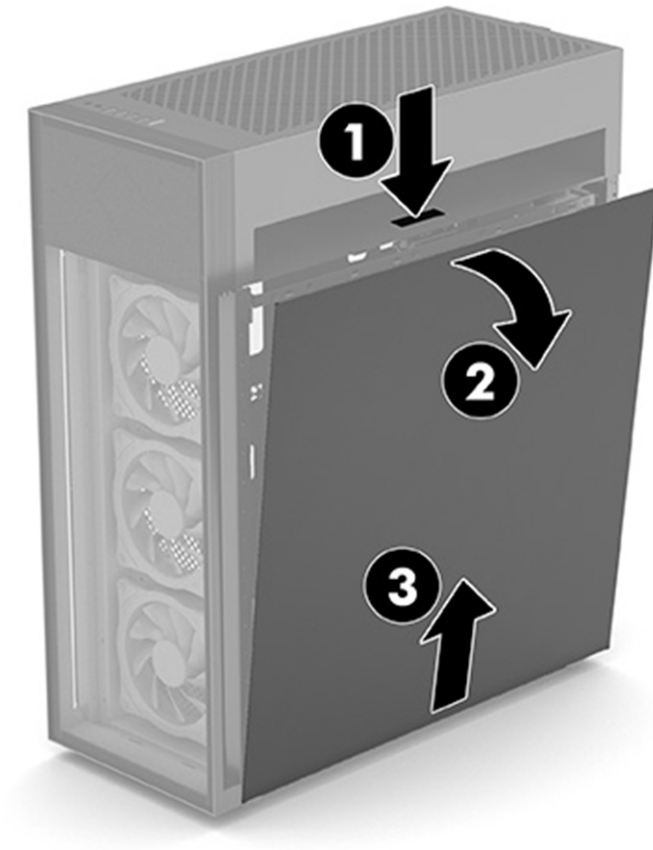

- 3. To install the right access panel:
  - a. Insert the bottom of the panel **(1)** into the groove in the bottom of the computer.





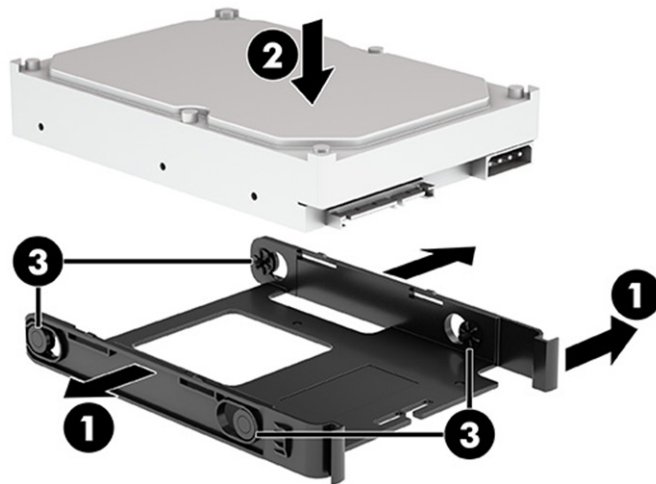

- b. Insert the hard drive assembly (1) into the drive bay until it clicks into place.
- c. Connect the power and data cables (2) into the rear of the hard drive.

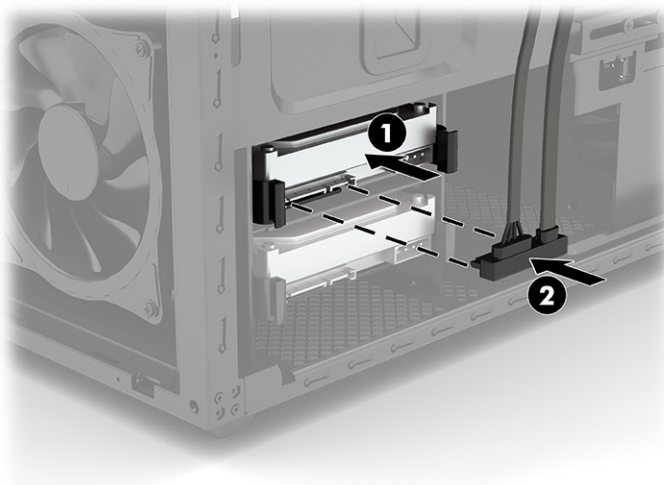

## RGB lighting board

Use this procedure and illustration to remove and install the RGB lighting board.

1. Prepare the computer for disassembly (see [Preparation for disassembly on page 3](#)).
2. Remove the right side access panel (see [Right access panel on page 12](#)).
3. To remove the RGB board:
  - a. Position the computer with the RGB board facing upward.
  - b. Disconnect the cables from the RGB board connectors (1).
  - c. Remove the two Phillips screws (2) from the board.

- d. Remove the board **(3)** from the computer.

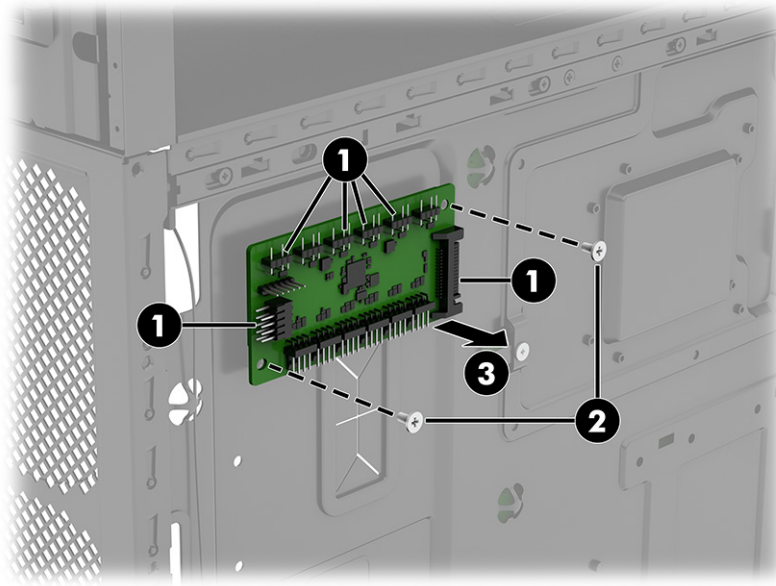

Reverse this procedure to install the RGB lighting board.

Use this illustration to identify RGB board connectors:

- (1):** Rear fan
- (2):** Front fan 3
- (3):** Front fan 2
- (4):** Front fan 1
- (5):** Reserved for ARGB lighting components
- (6):** Reserved for fan power connectors

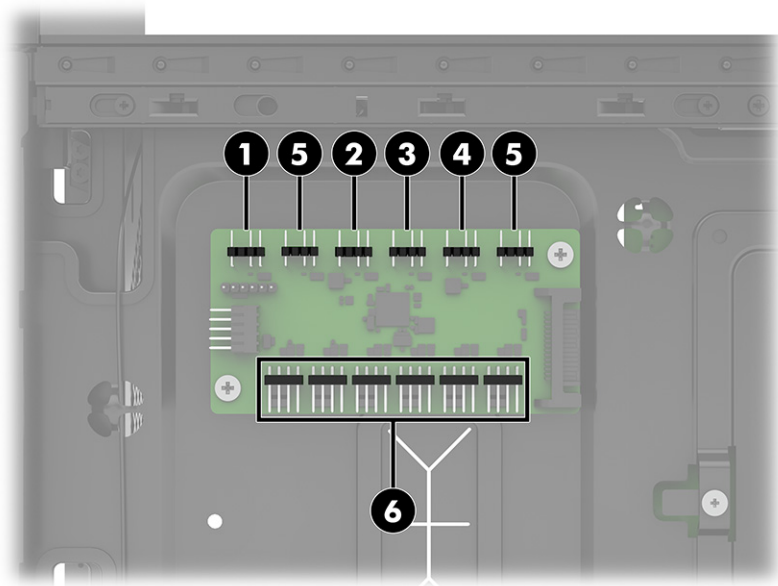

## Front RGB fans

Use these procedures and illustrations to remove and install the front RGB fans.

1. Prepare the computer for disassembly (see [Preparation for disassembly on page 3](#)).
2. Remove the glass access panel (see [Glass access panel on page 5](#)).
3. Remove the front bezel (see [Front bezel on page 11](#)).
4. Remove the right side access panel (see [Right access panel on page 12](#)).
5. Remove the dust filter (see [Dust filter on page 12](#)).
6. To remove the front bottom RGB fan:
  - a. Disconnect the cable from the RGB board **(1)** on the right side of the computer.
  - b. Pull the cable through the hole **(2)** where it routes to the fan on the front of the computer (under the front bezel).
  - c. Disconnect the fan power cable from the system board **(3)** (under the glass access panel).
  - d. Pull the power cable through the hole **(4)** in the side of the computer. The power cable routes from the fan (under the front bezel), to the right side, and then to the system board (under the glass access panel).
  - e. Remove the four screws **(5)** from the outside-front (under the front bezel) that secure the fan to the front of the computer.

- f. Remove the fan **(6)** from the computer.

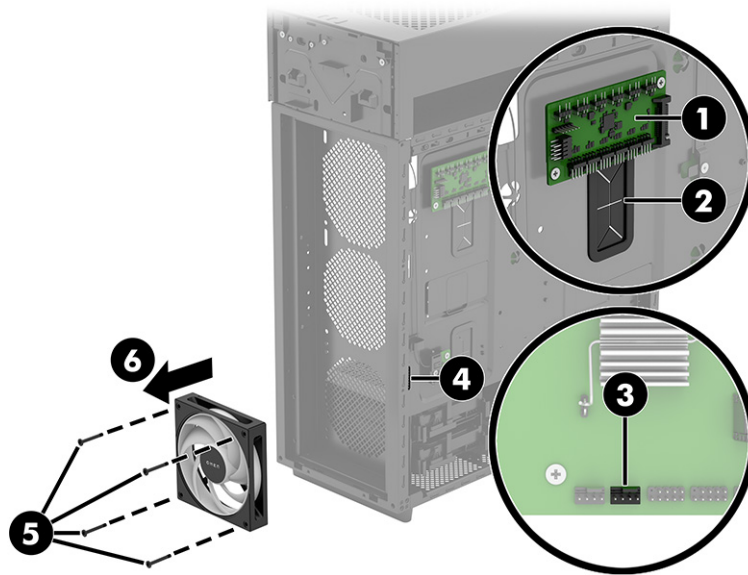

7. To remove the front middle and top RGB fans:

 **NOTE:** The procedure to remove the middle and top fans is the same. The fans connect to different connectors on the RGB board.

- a. Disconnect the cable from the RGB board **(1)** on the right side of the computer.
- b. Pull the cable through the hole **(2)** where it routes to the fan on the front of the computer (under the front bezel).
- c. Disconnect the fan power cable from the system board **(3)** (under the glass access panel).
- d. Pull the power cable through the hole **(4)** in the computer. The power cable routes from the fan (under the front bezel), to the right side, and then to the system board (under the glass access panel).
- e. From the inside-front of the computer, remove the four screws **(5)** that secure the fan to the front of the computer.

- f. Remove the fan **(6)** from the computer.

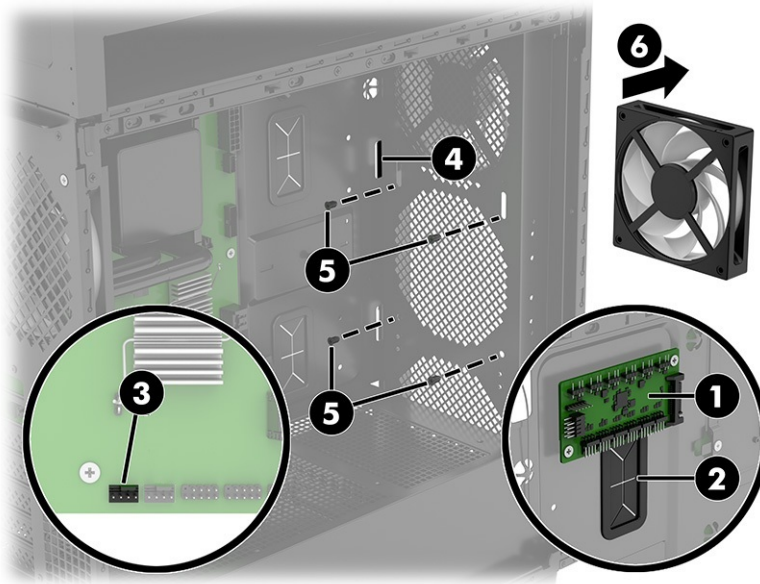

- 8. To install the front bottom RGB fan:
  - a. Position the fan **(1)** on the bottom of the computer (under the front bezel).
  - b. Install the four screws **(2)** from the outside-front that secure the fan to the front of the computer.
  - c. Route the power cable through the hole **(3)** on the right side of the computer and then through the hole to the system board side (under the glass access panel).
  - d. Connect the fan power cable to the system board **(4)**.
  - e. Route the RGB cable through the hole **(5)** on the right side of the computer.

- f. Connect the cable to the RGB board (6). For RGB board connector designations, see [RGB lighting board on page 16](#).

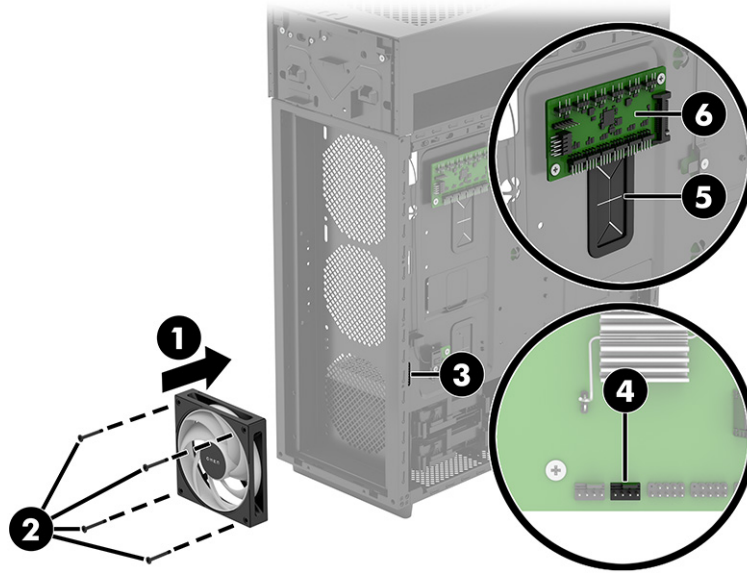

9. To install the middle and top RGB fans:

 **NOTE:** Refer to the illustrations that following this step for more detailed fan cabling information.

- a. Position the fan (1) on the middle of the computer (under the front bezel).
- b. From the inside-front of the computer, install the four screws (2) that secure the fan to the front of the computer.
- c. Route the power cable through the hole (3) on the right side of the computer and then through the hole to the system board side (under the glass access panel).
- d. Connect the fan power cable to the system board (4).
- e. Route the RGB cable through the hole (5) on the right side of the computer.

- f. Connect the cable to the RGB board (6).

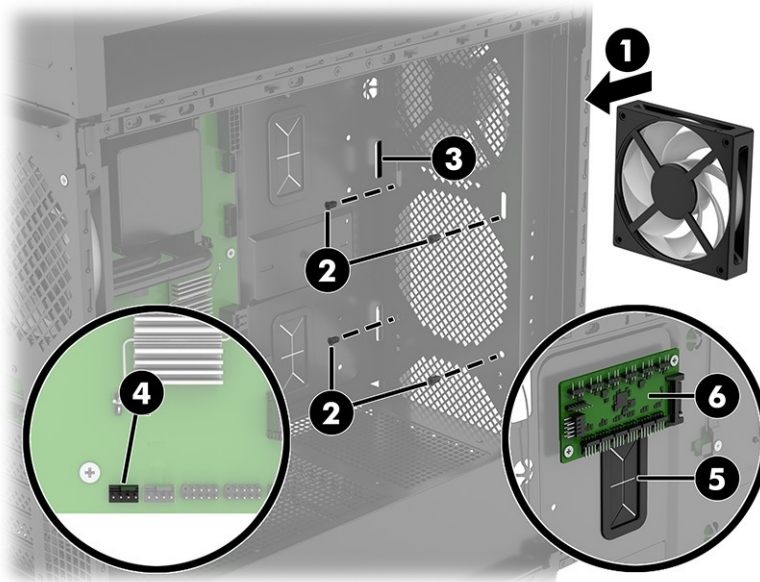

The following illustration shows a simplified view of front fan cabling to the lighting board.

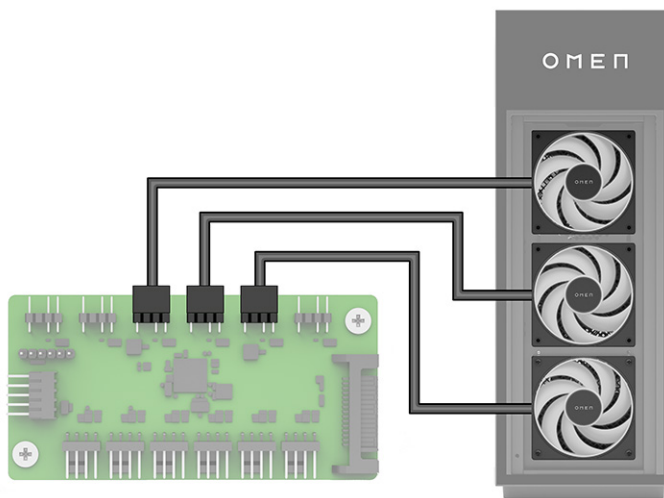

Use the following illustration to determine proper cable routing on the right side of the computer for the fans.

- (1): Rear fan cable (ARGB)
- (2): Rear fan cable (power)
- (3): Front fan 3 cable (power)
- (4): Front fan 2 cable (power)
- (5): Front fan 1 cable (power)

**(6):** Front fan 1 cable (ARGB)

**(7):** Front fan 2 cable (ARGB)

**(8):** Front fan 3 cable (ARGB)

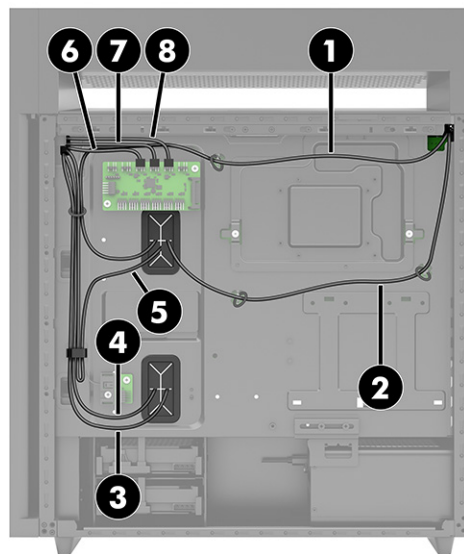

Use the following illustration to determine proper cable routing on the left side of the computer for the fans.

**(1):** Rear fan cable (power)

**(2):** Front fan 3 cable (power)

**(3):** Front fan 2 cable (power)

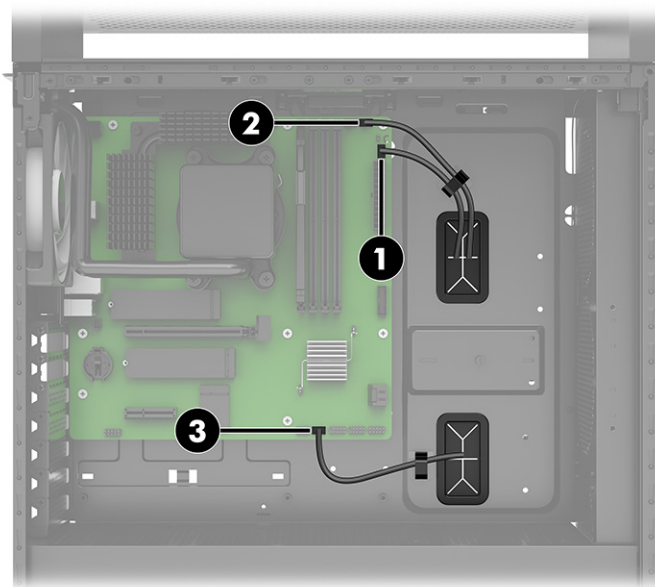

When installing the front fans, be sure to route the fan cables through the holes in the chassis as shown in the following illustration:

- (1) Top fan
- (2) Middle fan
- (3) Bottom fan

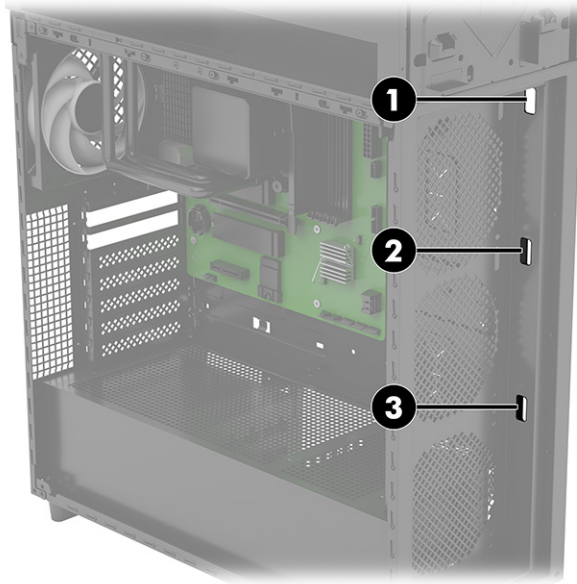

For the correct fan lighting effect, be sure to install the front fans in the correct orientation, as shown in the following illustration.

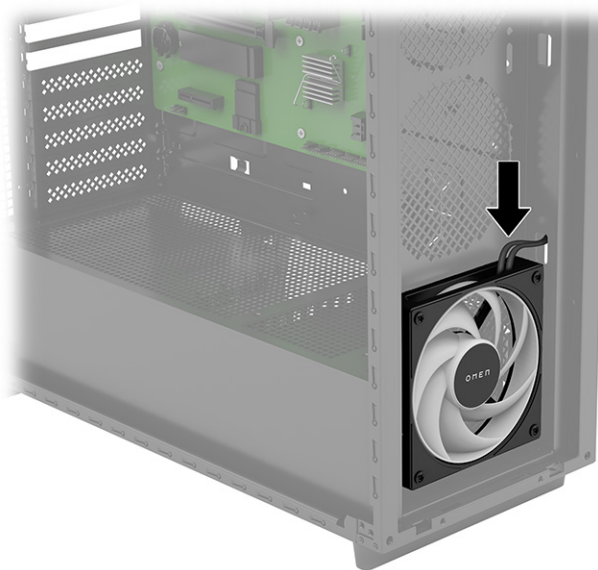

## Rear fan

Use this procedure and illustration to remove the rear fan.

1. Prepare the computer for disassembly (see [Preparation for disassembly on page 3](#)).

2. Remove the glass access panel (see [Glass access panel on page 5](#)).
3. To remove a rear fan:
  - a. Disconnect the fan cable (1) from the lighting board.
  - b. Pull the cable through the hole (2) in the computer chassis.
  - c. Disconnect the power cable from the system board connector (3).
  - d. Remove the four screws (4) from the fan.
  - e. Remove the fan (5).

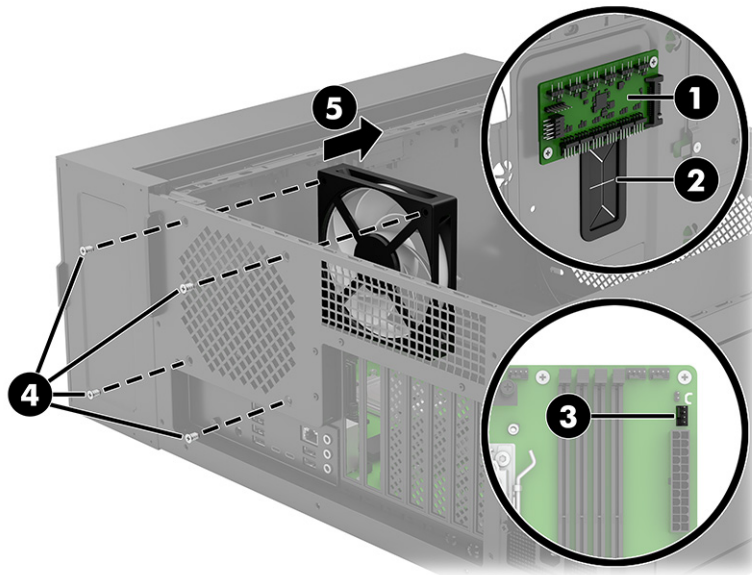

Reverse this procedure to install the rear fan.

## Power supply

Use these procedures and illustrations to install the power supply.

1. Prepare the computer for disassembly (see [Preparation for disassembly on page 3](#)).
2. Remove the glass access panel (see [Glass access panel on page 5](#)).
3. Remove the right side access panel (see [Right access panel on page 12](#)).
4. To install the power supply:
  - a. Insert the power supply (1) into the computer.
  - b. Install four Phillips screws (2) to secure the power supply to the computer.
  - c. Place the bracket (3) on top of the power supply.

- d. Install two Phillips screws (4) to secure the bracket to the power supply.

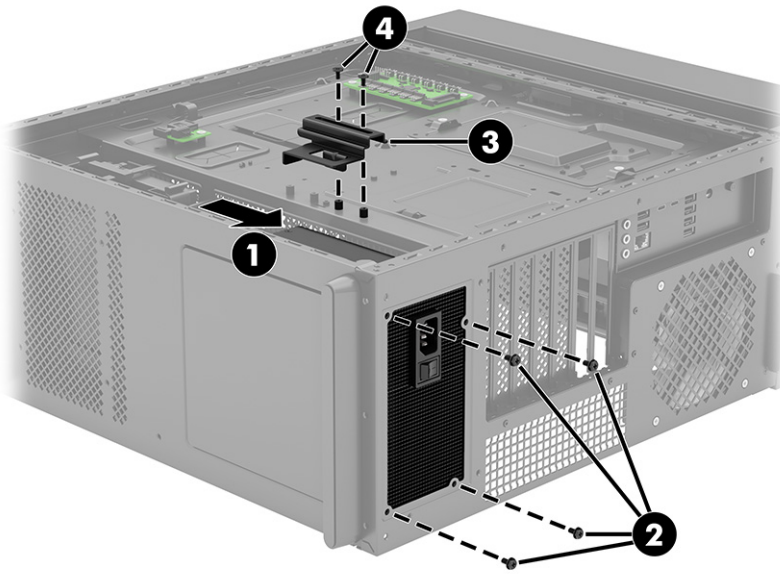

- e. To accommodate power supplies of different sizes, you can adjust the power supply bracket location using any of the available screw holes.

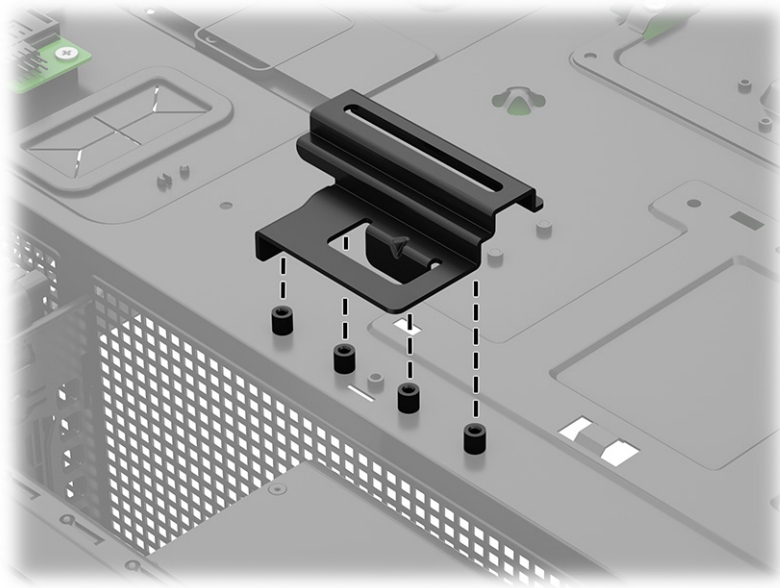

- f. On models with a modular power supply, connect the USB-C cable (1) and install the cable screw (2) to the power supply. Connect the power cable (3).

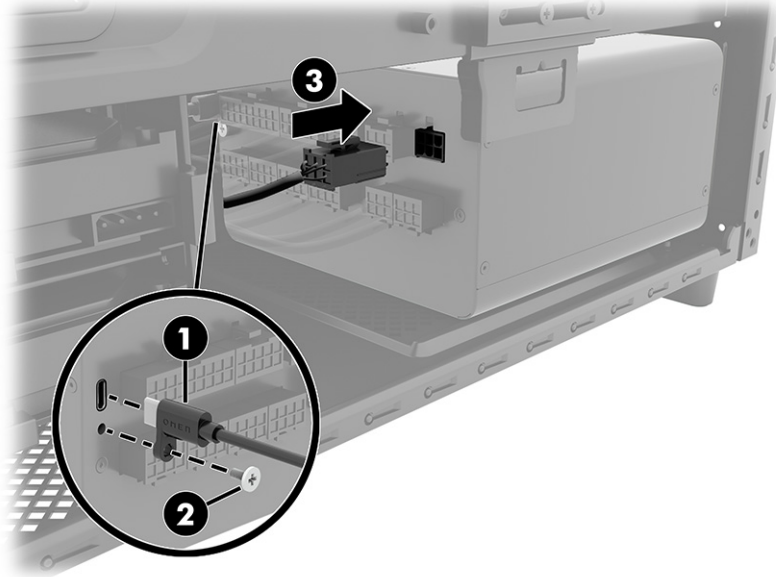

- g. Position the computer with the RGB lighting board facing upward (under the right side access panel).
- h. Push the cables through the holes (1) in the computer that lead to the system board (under the glass access panel).
- i. Connect the power cable to the RGB lighting board (2).
- j. Route the cables through the clips and ties (3).
- k. Connect the power supply cables to any installed hard drives (4).

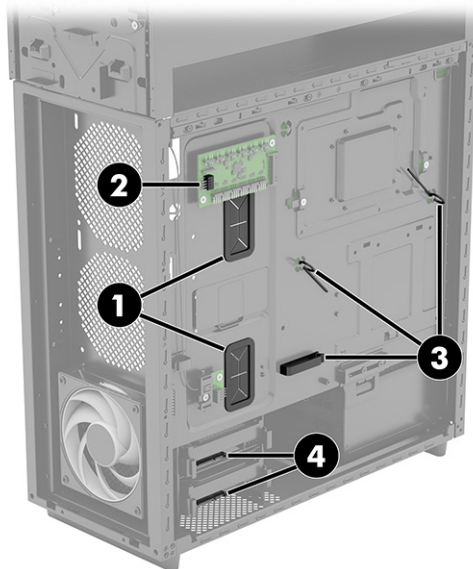

- l. Position the computer with the system board facing upward (under the glass access panel).

- m. Connect the 24-pin power supply cable to the system board connector **(1)**.
- n. Connect the 4-pin power supply cable to the system board connector **(2)**.
- o. Connect the power supply cable to the graphics card connector **(3)**.

 **NOTE:** Connector placement on the system board or graphics card might vary.

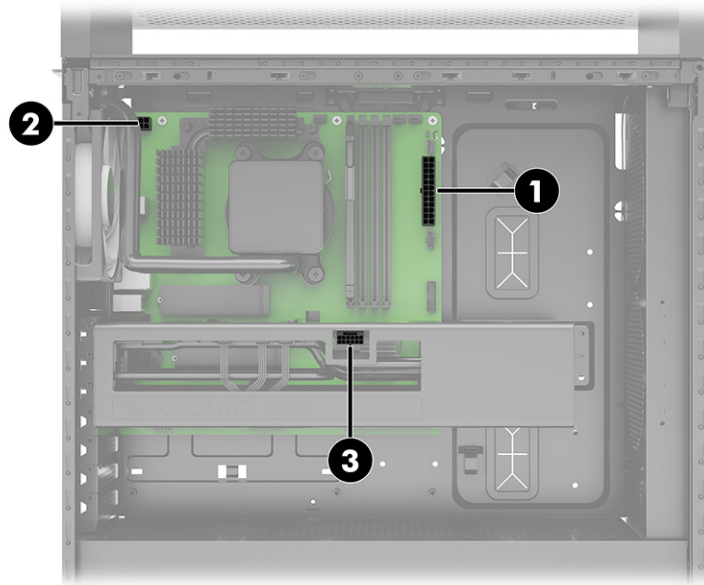

Depending on the power supply, connect power supply cables to the connectors shown in the following illustration:

- (1):** USB extension cable for 1200 W modular power supply (select product only)
- (2):** USB Y cable to lighting board and splitter for LCD cover on CPU liquid cooler

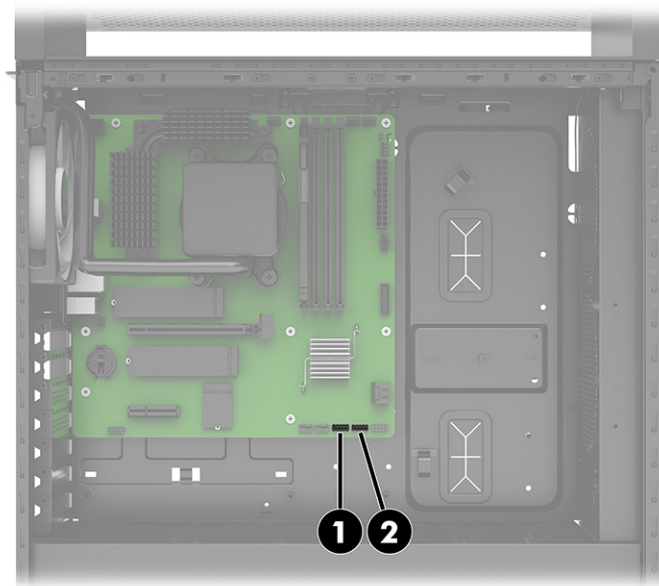

Use the following illustration to determine correct cable routing for power supplies without a USB cable plugged into the power supply:

- (1): USB Y cable to lighting board
- (2): USB cable to LCD cover on CPU liquid cooler

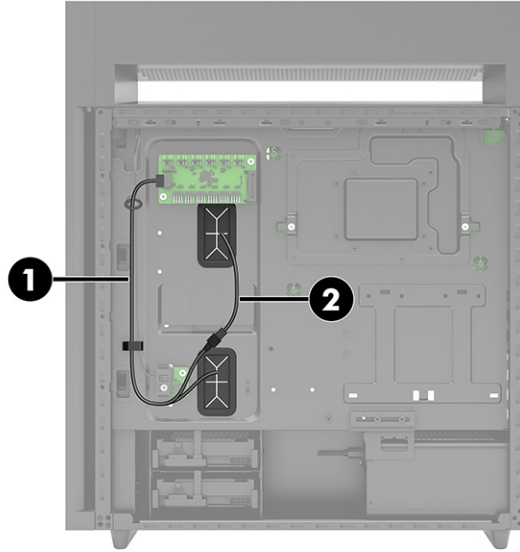

Use the following illustration to determine correct right side cable routing for power supplies with a USB cable plugged into the power supply:

- (1): USB Y cable to lighting board
- (2): USB cable to LCD cover on CPU liquid cooler
- (3): USB extension cable for 1200 W modular power supply (select product only)
- (4): USB-C cable to 1200 W modular power supply (select product only)

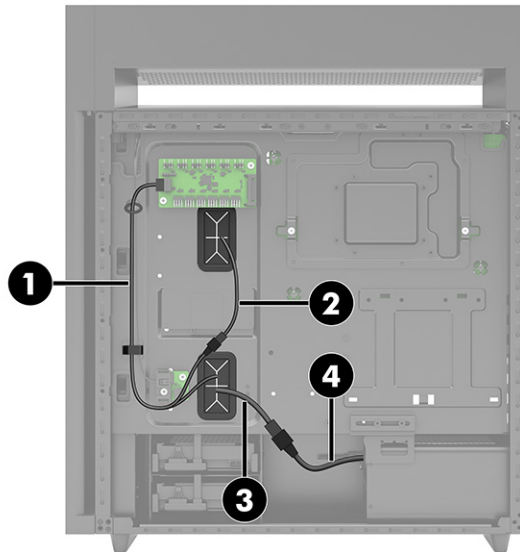

Use the following illustration to determine correct left side cable routing for power supplies with a USB cable plugged into the power supply.

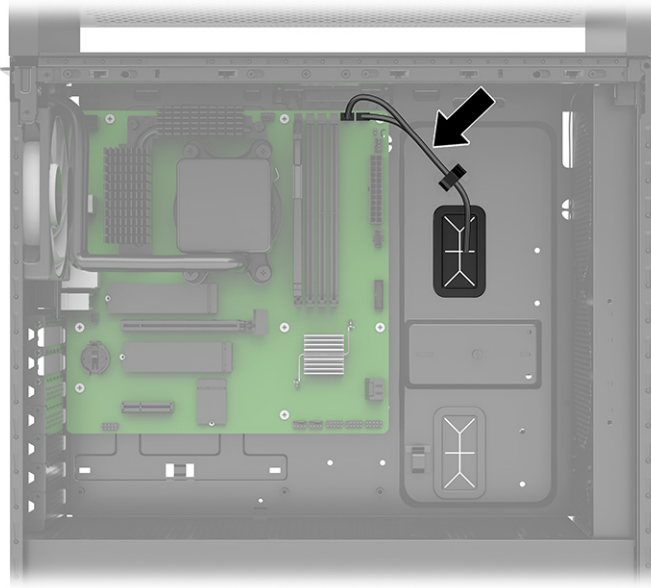

## Top I/O module

Use these procedures and illustrations to remove the top I/O module.

1. Prepare the computer for disassembly (see [Preparation for disassembly on page 3](#)).
2. Remove the right side access panel (see [Right access panel on page 12](#)).
3. To remove a top I/O module:
  - a. Remove the front bezel by pressing the two release buttons **(1)** at the top of each side of the bezel, and then rotate the top of the bezel **(2)** away from the computer to remove it.

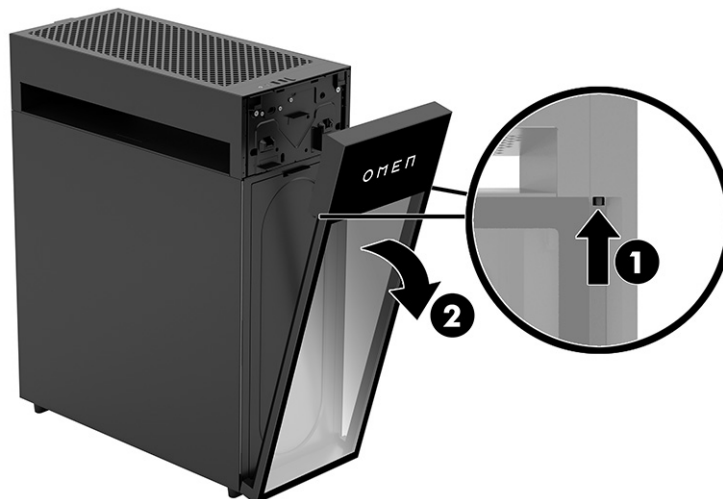

- b. Remove the top cover by lifting it straight up and off the computer.

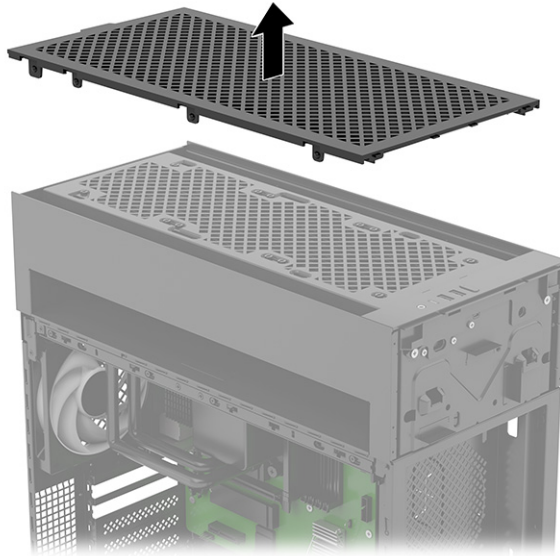

- c. Remove the top I/O bezel by removing the two Phillips screws (1), and then lifting the top I/O bezel (2) off the computer.

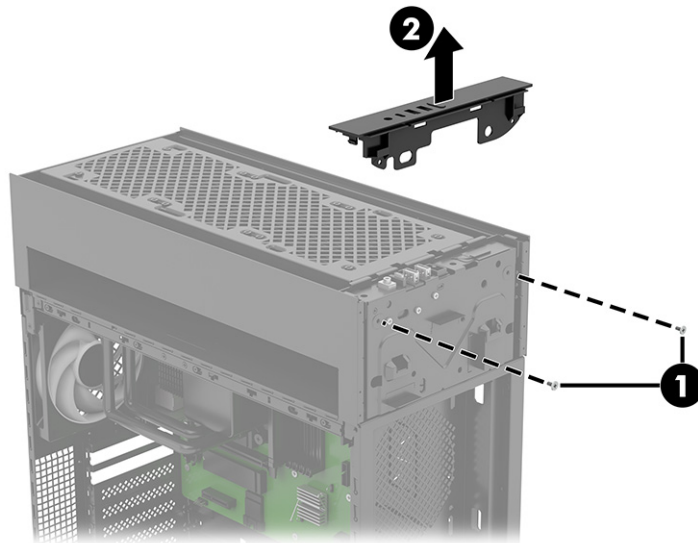

- d. Remove the two screws from the top I/O module.

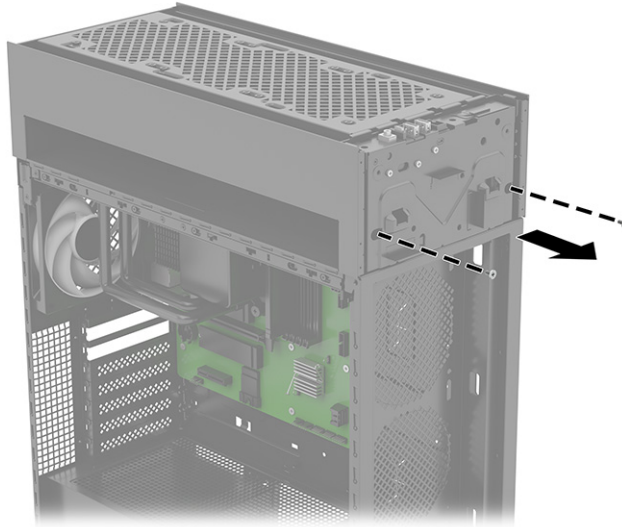

- e. Disconnect the cables from the following system board connectors:

- (1): USB-C cable
- (2): USB-A cable
- (3): Audio cable
- (4): Power button cable
- (5): Antennas from the WLAN module

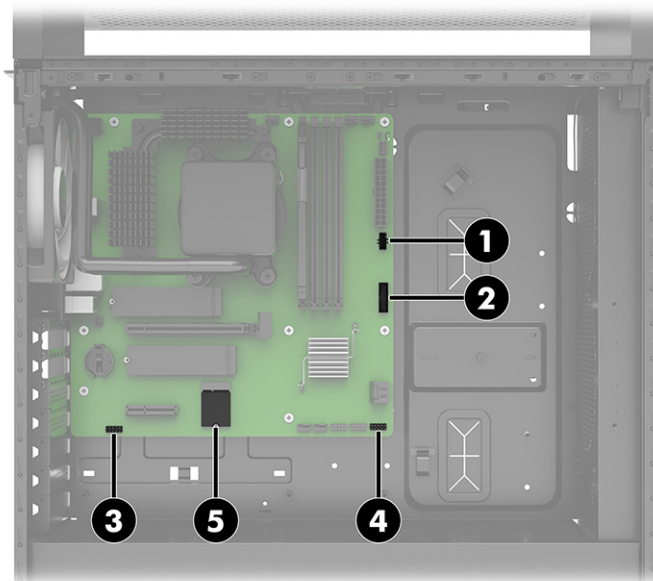

- f. Push the cables through the hole (1) in the chassis, including the WLAN antenna cables (2).

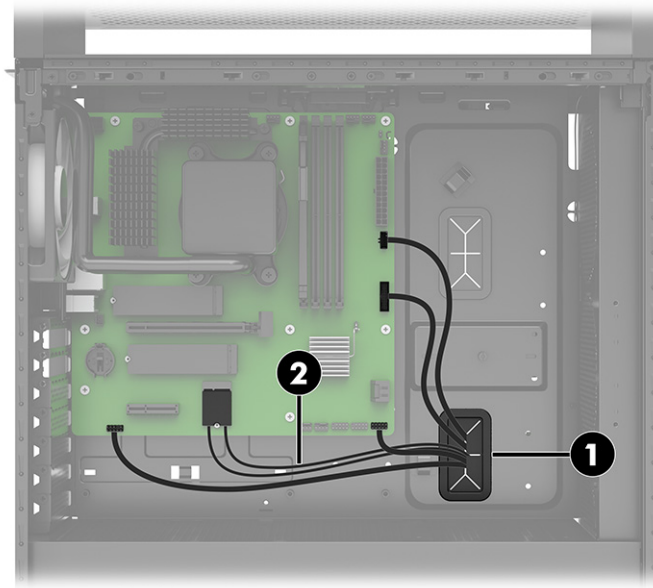

- g. Lift the top I/O module (1) up, and then pull the cables out of the hole (2) in the front of the chassis.

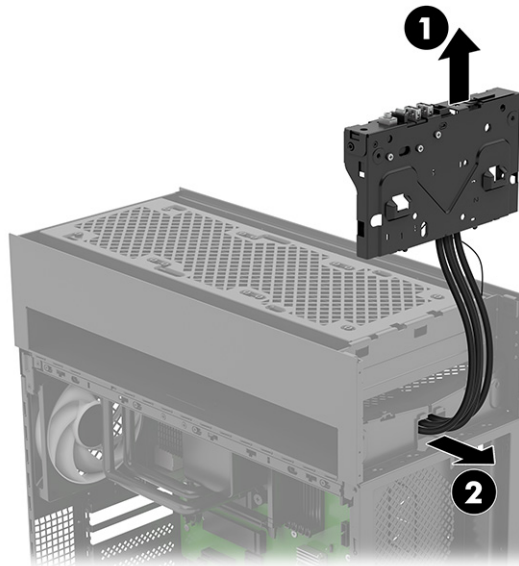

- h. Use a tool to release both antennas from the top I/O module.

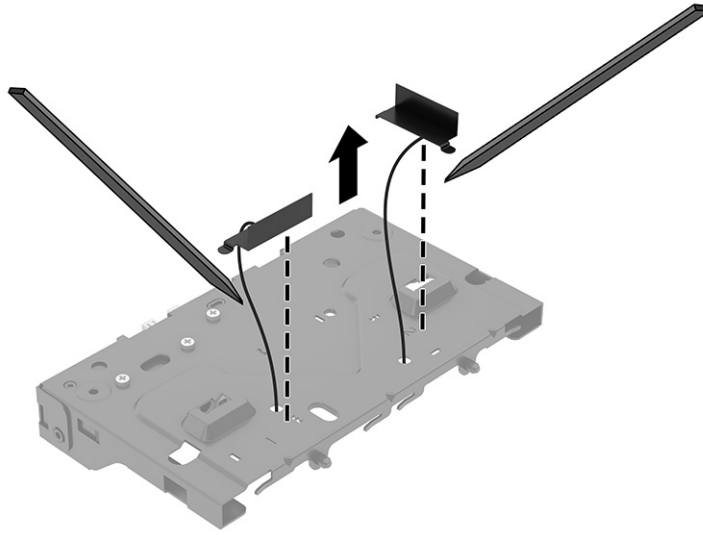

Reverse this procedure to install the top I/O module.

When installing the power button and LED cable, be sure that the + and - symbols on the cables align with the same symbols printed on the system board.

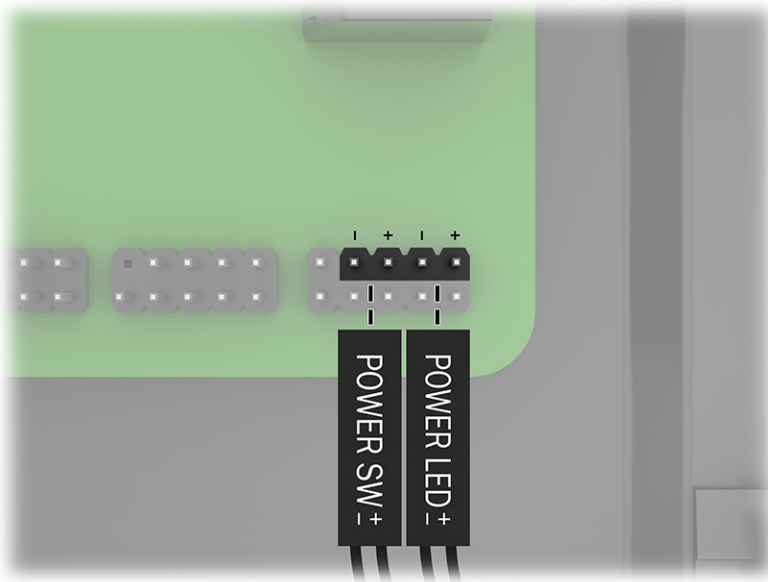

## Processor

Use this procedure and illustration to remove the processor.

1. Prepare the computer for disassembly (see [Preparation for disassembly on page 3](#)).
2. Remove the glass access panel (see [Glass access panel on page 5](#)).

3. To remove a processor:
  - a. Pull the locking lever **(1)** away from the processor, and then rotate the lever **(2)** to its fully open position.
  - b. Raise and rotate the microprocessor retainer **(3)** to its fully open position.
  - c. Carefully lift the processor **(4)** from the socket.

---

 **IMPORTANT:** Do not handle the pins in the processor socket. These pins are fragile, and handling them could cause irreparable damage. If pins are damaged, you might have to replace the system board.

---

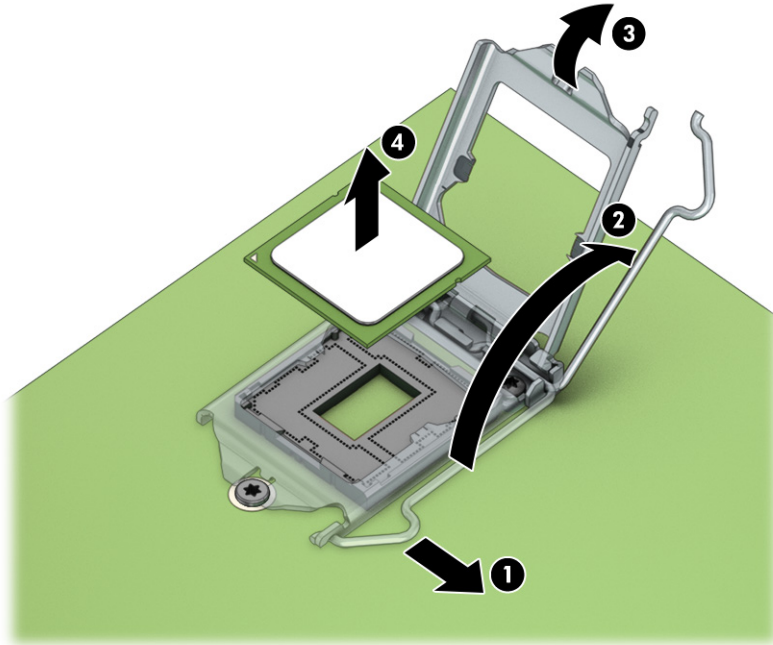

Reverse this procedure to install the processor.

## System board

Use these procedures and illustrations to remove the system board.

1. Prepare the computer for disassembly (see [Preparation for disassembly on page 3](#)).
2. Remove the glass access panel (see [Glass access panel on page 5](#)).
3. Remove all replaceable components from the system board.
4. To remove a system board:

- a. (Select products only) On models with a VRM heat sink, disconnect the VRM heat sink fan cable from the system board connector.

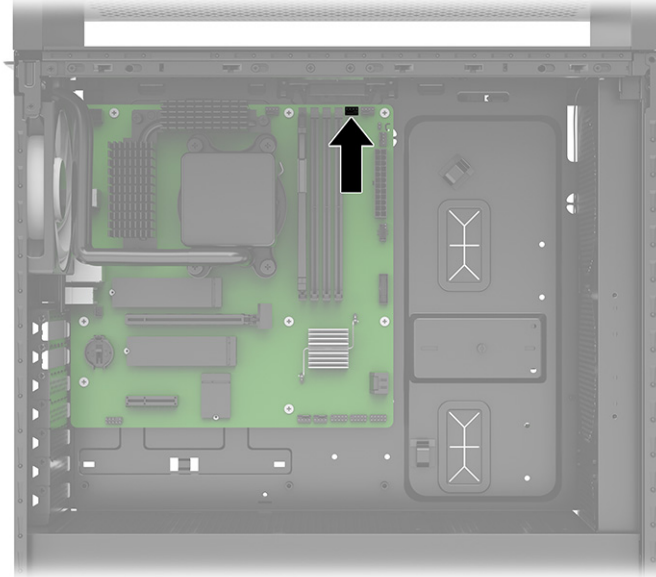

- b. Remove the eight screws (1) from the system board.
- c. Remove the system board (2) from the computer.

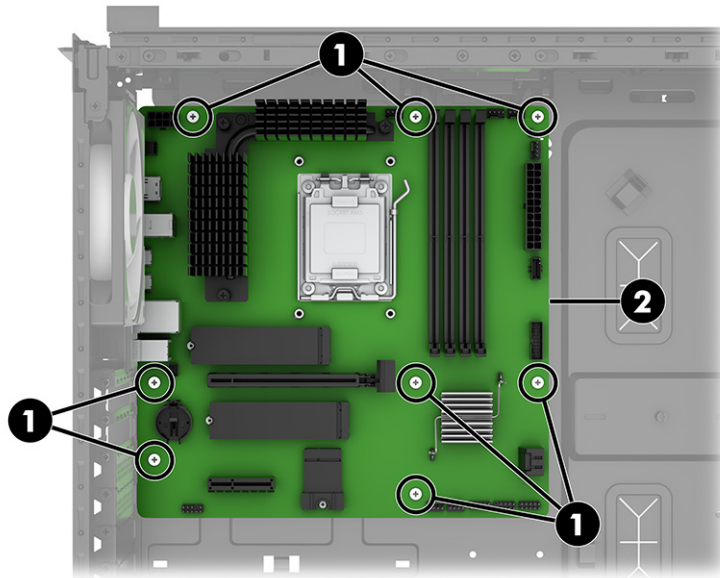

Reverse this procedure to install the system board.

## CPU backplate

Use this procedure and illustration to remove the CPU backplate.

1. Prepare the computer for disassembly (see [Preparation for disassembly on page 3](#)).

2. Remove the right side access panel (see [Right access panel on page 12](#)).
3. To remove a CPU backplate:
  - a. Remove the two screws (1) from the backplate.
  - b. Remove the backplate (2) from the computer.

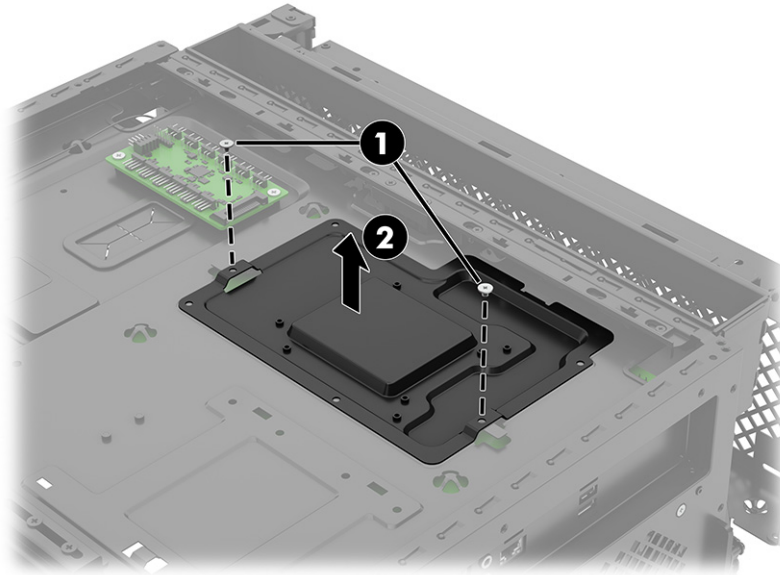

Reverse this procedure to install the CPU backplate.

If you install a different system board, you might need to remove the thermal pads from the backplate if they interfere with the new board.

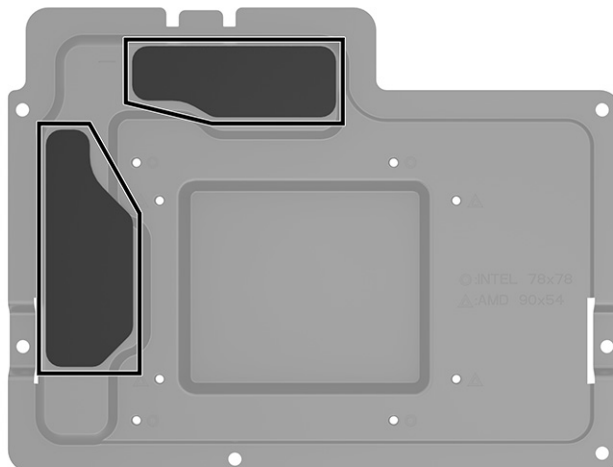

## Cryo chamber

You can install a liquid cooler up to 120 mm × 360 mm in the cryo chamber.

A 120 mm × 360 mm liquid cooler is installed in the location shown in the following illustration.

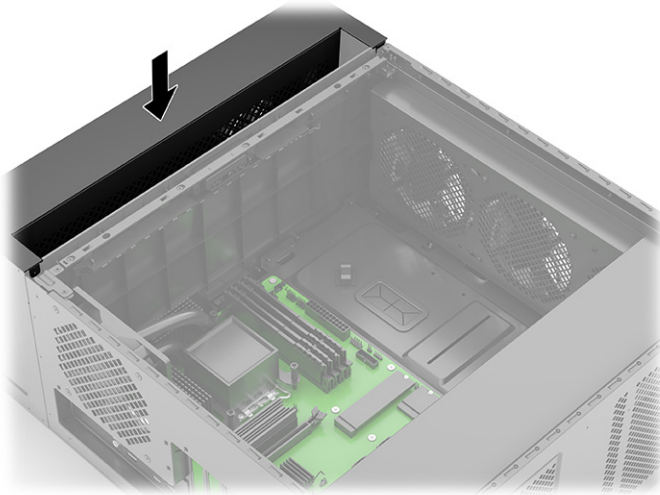

Please note the following considerations when upgrading to this cooling solution:

- To access the screw holes that secure the cooler to the chassis, remove the top cover by lifting it straight up and off the computer. There are up to eight available screw holes to use to secure the cooler.
- You must remove the radiator mounting using the following steps:
  1. Remove the front bezel by pressing the two release buttons (1) at the top of each side of the bezel, and then rotate the top of the bezel (2) away from the computer to remove it.

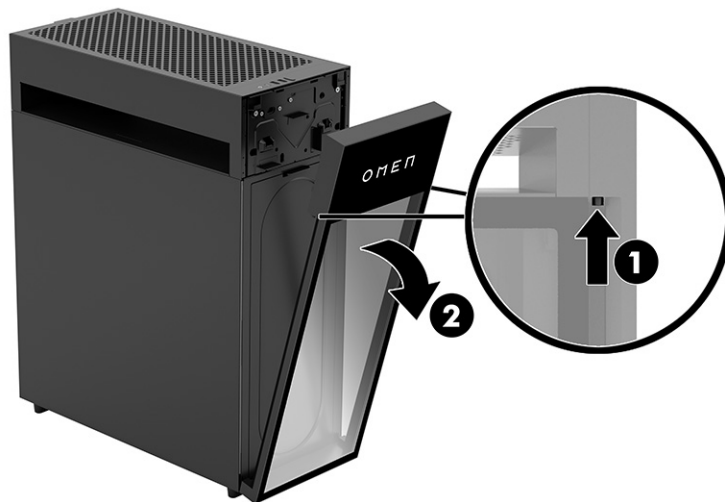

2. Remove the top cover by lifting it straight up and off the computer.

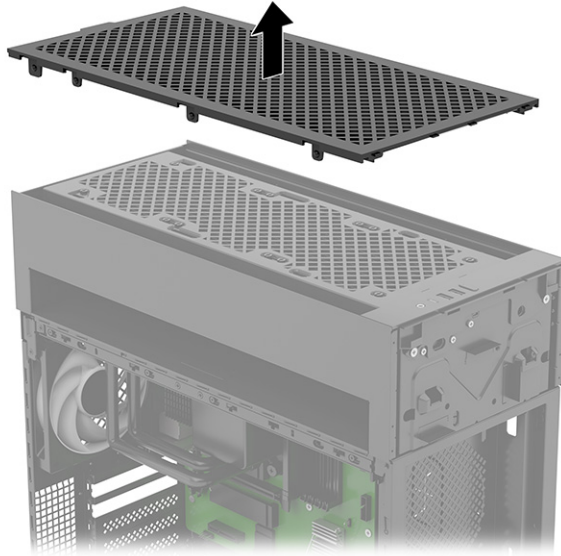

3. Remove the top I/O bezel by removing the two Phillips screws (1), and then lifting the top I/O bezel (2) off the computer.

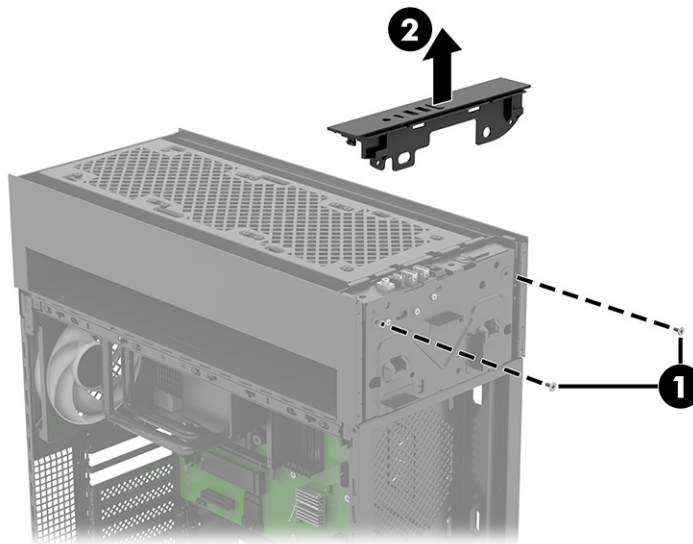

4. Remove the cryo chamber housing by removing the six Phillips screws (1), and then pulling the housing (2) up and off the computer.

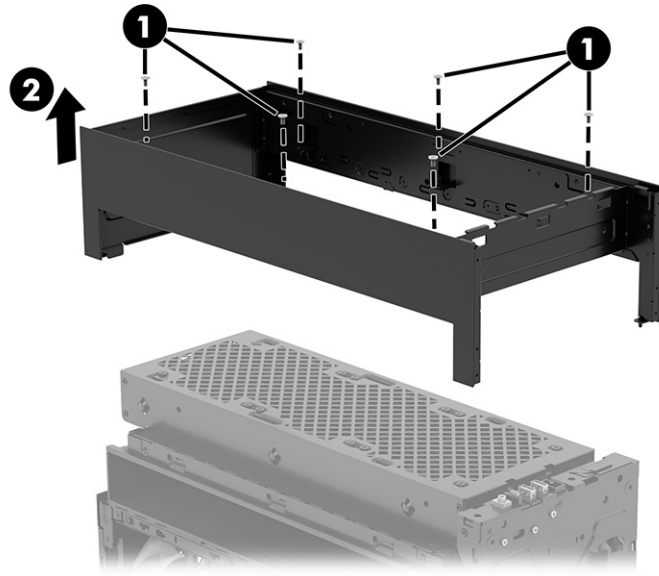

5. Remove two screws (1) and lift the bracket (2) off the computer.

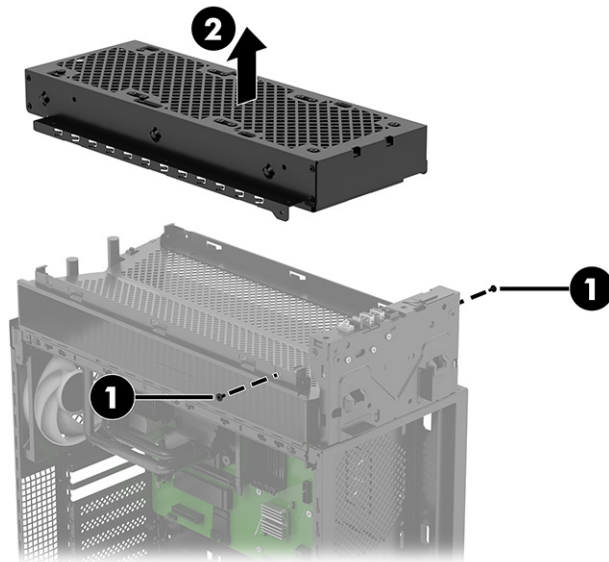

6. To remove the LCD cap, disconnect the power cable from the system board connector.

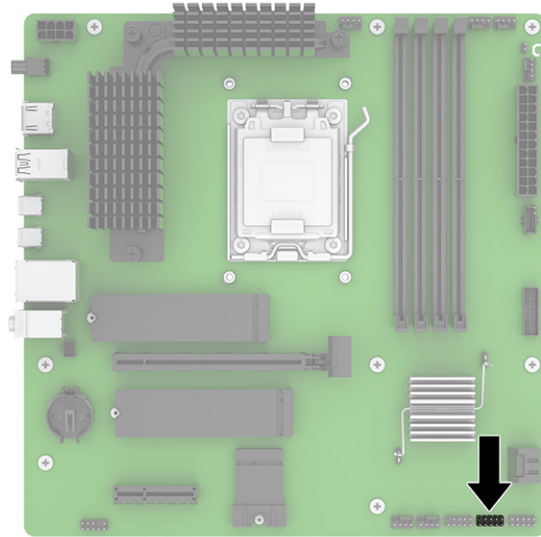

7. Disconnect the signal cable from the Y connector **(1)** on the back of the chassis, and then pull the signal cable through the hole **(2)** in the chassis.

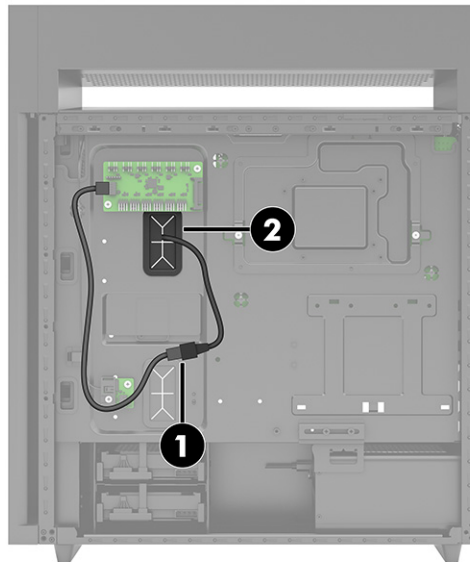

8. Lift the LCD cap off the pump head.

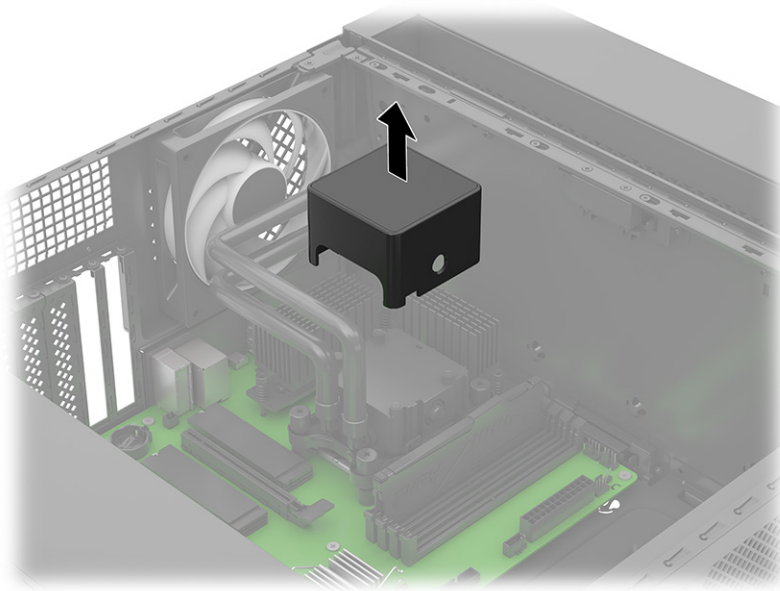

9. To remove the pump head, remove the four screws (1), and then lift the pump head (2) off the processor.

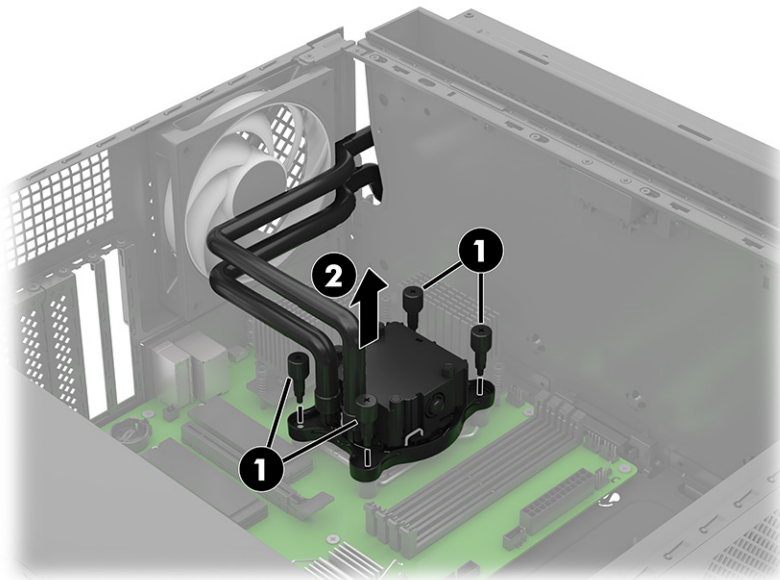

#### Installation notes

- To install the screws for the pump head, install the longer end of the screw (1) into screw cover (2) with AM5 visible at the top of the cover. Install the screw/cover assemblies (3) onto the system board.

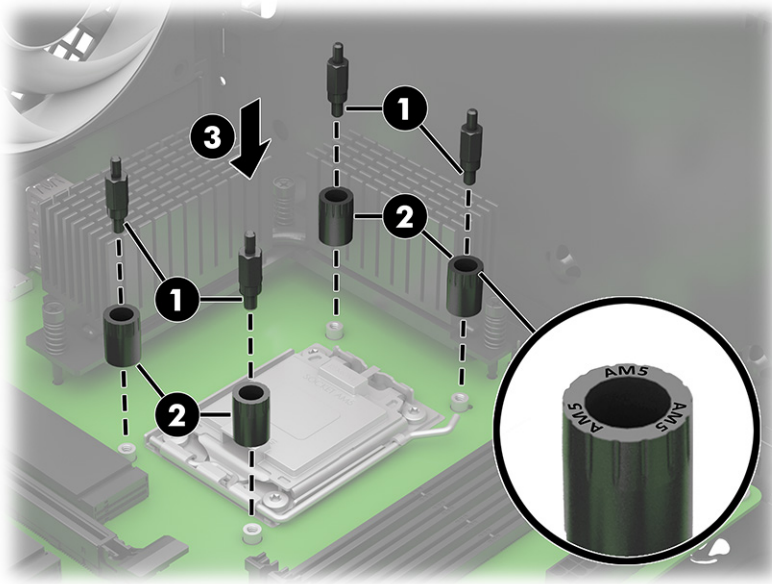

- The cryo chamber houses three fans, and cables (1) from each fan route from the chamber to the back of the computer chassis where the cables all plug into one splitter cable (2), which then routes back through the computer chassis (3) to one connector (4) on the system board.

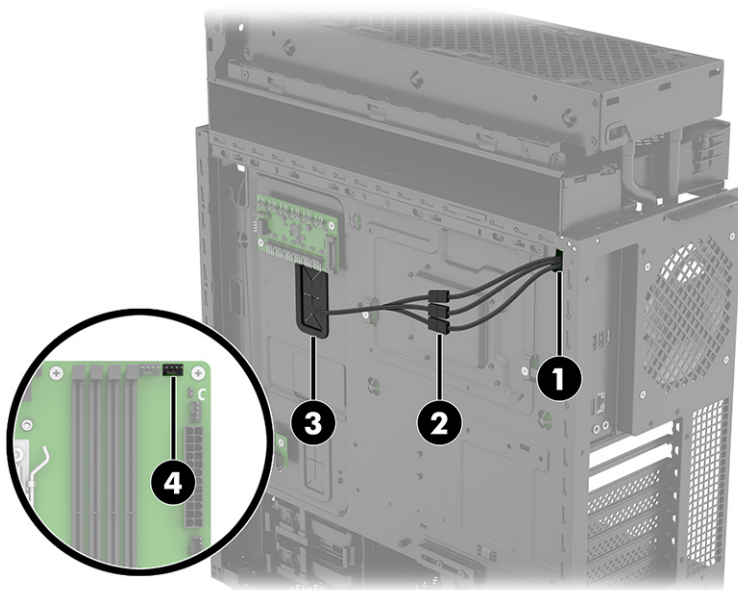

- Liquid cooler tube length can be predefined, or it might be customizable to fit the distance between the processor and the radiator/fan mounting location.
- The mounting pitch differs on computers with Intel® versus AMD processors.
- To route the tubes, fan power, and RGB cables from the cryo chamber to the main chamber, remove the bracket from the left side of the chassis near the fan. To remove the bracket, remove three screws (1), and then remove the bracket (2). The maximum tube diameter is 14 mm. For tubes with a diameter between 14 - 17 mm, confirm that the tubes can be squeezed down to 14 mm so they fit into the cryo chamber tunnel during installation.

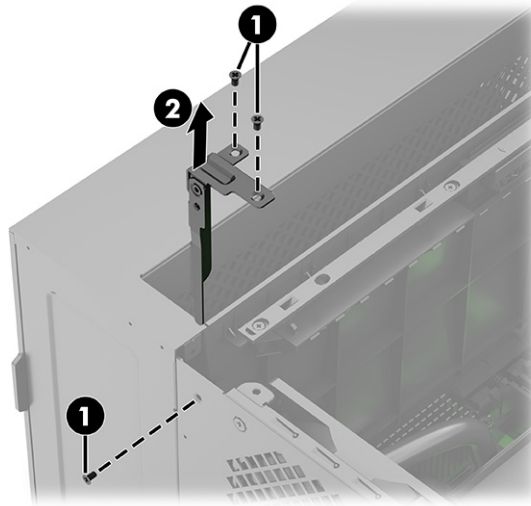

- Depending on your configuration, you might need a fan power bridge or RGB Y cable if you determine you need more fan power headers or RGB lighting pin headers.

---

## 3 Computer operating guidelines, routine care, and shipping preparation

Follow these guidelines to ensure the best performance and useful life of your computer.

### Operating guidelines and routine care

HP has developed guidelines to help you properly set up and care for the computer and monitor.

- Keep the computer away from excessive moisture, direct sunlight, and extreme heat and cold.
- Operate the computer on a sturdy, level surface. Leave a 10.2 cm (4 inch) clearance on all vented sides of the computer and above the monitor to permit the required airflow.
- Never restrict the airflow into the computer by blocking any vents or air intakes. Do not place the keyboard, with the keyboard feet down, directly against the front of the desktop unit because this also restricts airflow.
- Never operate the computer with the access panel or any of the expansion card slot covers removed.
- Do not stack computers on top of each other or place computers so near each other that they are subject to each other's recirculated or preheated air.
- To operate a computer within a separate enclosure, intake and exhaust ventilation must be provided on the enclosure, and the previous operating guidelines still apply.
- Keep liquids away from the computer and keyboard.
- Never cover the ventilation slots on the monitor with any type of material.
- Install or enable power management functions of the operating system or other software, including sleep states.
- Turn off the computer before you do either of the following tasks:
  - Wipe the exterior of the computer with a soft, damp cloth as needed. Cleaning products might discolor or damage the finish. See [Removing dirt and debris from your computer on page 46](#) for the recommended steps to clean the high-touch, external surfaces on your computer. After you remove the dirt and debris, you can also clean the surfaces with a disinfectant. See [Cleaning your computer with a disinfectant on page 46](#) for guidelines to help prevent the spread of harmful bacteria and viruses.
  - Occasionally clean the air vents on all vented sides of the computer. Lint, dust, and other foreign matter can block the vents and limit the airflow.

### Cleaning your computer

Cleaning your computer regularly removes dirt and debris so that your device continues to operate at its best. Use the following information to safely clean the external surfaces of your computer.

## Removing dirt and debris from your computer

Here are the recommended steps to clean dirt and debris from your computer.

1. Wear disposable gloves made of latex (or nitrile gloves, if you are latex-sensitive) when cleaning the surfaces.
2. Turn off your device and unplug the power cord and other connected external devices. Remove any installed batteries from items such as wireless keyboards.

---

 **CAUTION:** To prevent electric shock or damage to components, never clean a product while it is turned on or plugged in.

---

3. Moisten a microfiber cloth with water. The cloth should be moist, but not dripping wet.

---

 **IMPORTANT:** To avoid damaging the surface, avoid abrasive cloths, towels, and paper towels.

---

4. Wipe the exterior of the product gently with the moistened cloth.

---

 **IMPORTANT:** Keep liquids away from the product. Avoid getting moisture in any openings. If liquid makes its way inside your HP product, it can cause damage to the product. Do not spray liquids directly on the product. Do not use aerosol sprays, solvents, abrasives, or cleaners containing hydrogen peroxide or bleach that might damage the finish.

---

5. Start with the display (if applicable). Wipe carefully in one direction, and move from the top of the display to the bottom. Finish with any flexible cables, like power cord, keyboard cable, and USB cables.
6. Be sure that surfaces have completely air-dried before turning the device on after cleaning.
7. Discard the gloves after each cleaning. Clean your hands immediately after you remove the gloves.

See [Cleaning your computer with a disinfectant on page 46](#) for recommended steps to clean the high-touch, external surfaces on your computer to help prevent the spread of harmful bacteria and viruses.

## Cleaning your computer with a disinfectant

The World Health Organization (WHO) recommends cleaning surfaces, followed by disinfection, as a best practice for preventing the spread of viral respiratory illnesses and harmful bacteria.

After cleaning the external surfaces of your computer using the steps in [Removing dirt and debris from your computer on page 46](#), you might also choose to clean the surfaces with a disinfectant. A disinfectant that is within HP's cleaning guidelines is an alcohol solution consisting of 70% isopropyl alcohol and 30% water. This solution is also known as rubbing alcohol and is sold in most stores.

Follow these steps when disinfecting high-touch, external surfaces on your computer:

1. Wear disposable gloves made of latex (or nitrile gloves, if you are latex-sensitive) when cleaning the surfaces.
2. Turn off your device and unplug the power cord and other connected external devices. Remove any installed batteries from items such as wireless keyboards.

---

 **CAUTION:** To prevent electric shock or damage to components, never clean a product while it is turned on or plugged in.

---

3. Moisten a microfiber cloth with a mixture of 70% isopropyl alcohol and 30% water. The cloth should be moist, but not dripping wet.

---

 **CAUTION:** Do not use any of the following chemicals or any solutions that contain them, including spray-based surface cleaners: bleach, peroxides (including hydrogen peroxide), acetone, ammonia, ethyl alcohol, methylene chloride, or any petroleum-based materials, such as gasoline, paint thinner, benzene, or toluene.

 **IMPORTANT:** To avoid damaging the surface, avoid abrasive cloths, towels, and paper towels.

---

4. Wipe the exterior of the product gently with the moistened cloth.

 **IMPORTANT:** Keep liquids away from the product. Avoid getting moisture in any openings. If liquid makes its way inside your HP product, it can cause damage to the product. Do not spray liquids directly on the product. Do not use aerosol sprays, solvents, abrasives, or cleaners containing hydrogen peroxide or bleach that might damage the finish.

---

5. Start with the display (if applicable). Wipe carefully in one direction, and move from the top of the display to the bottom. Finish with any flexible cables, like power cord, keyboard cable, and USB cables.
6. Be sure that surfaces have completely air-dried before turning the device on after cleaning.
7. Discard the gloves after each cleaning. Clean your hands immediately after you remove the gloves.

## Shipping preparation

If you have to ship your computer, follow these tips to keep your equipment safe.

1. Back up the hard drive files to an external storage device. Be sure that the backup media is not exposed to electrical or magnetic impulses while stored or in transit.

 **NOTE:** The hard drive locks automatically when the system power is turned off.

---

2. Remove and store all removable media.
3. Turn off the computer and external devices.
4. Disconnect the power cord from the AC outlet, and then from the computer.
5. Disconnect the system components and external devices from their power sources and then from the computer.

 **NOTE:** Be sure that all boards are seated properly and secured in the board slots before shipping the computer.

---

6. Pack the system components and external devices in their original packing boxes or similar packaging with sufficient packing material to protect them.

---

## 4 Electrostatic discharge

Electrostatic discharge is the release of static electricity when two objects come into contact—for example, the shock you receive when you walk across the carpet and touch a metal door knob.

A discharge of static electricity from fingers or other electrostatic conductors can damage electronic components.

---

 **IMPORTANT:** To prevent damage to the computer, damage to a drive, or loss of information, observe these precautions:

- If removal or installation instructions direct you to unplug the computer, first be sure that it is properly grounded.
  - Keep components in their electrostatic-safe containers until you are ready to install them.
  - Avoid touching pins, leads, and circuitry. Handle electronic components as little as possible.
  - Use nonmagnetic tools.
  - Before handling components, discharge static electricity by touching an unpainted metal surface.
  - If you remove a component, place it in an electrostatic-safe container.
-

---

## 5 Accessibility

HP's goal is to design, produce, and market products, services, and information that everyone everywhere can use, either on a standalone basis or with appropriate third-party assistive technology (AT) devices or applications.

### HP and accessibility

Because HP works to weave diversity, inclusion, and work/life into the fabric of the company, it is reflected in everything HP does. HP strives to create an inclusive environment focused on connecting people to the power of technology throughout the world.

### Finding the technology tools you need

Technology can unleash your human potential. Assistive technology removes barriers and helps you create independence at home, at work, and in the community. Assistive technology helps increase, maintain, and improve the functional capabilities of electronic and information technology.

For more information, see [Finding the best assistive technology on page 50](#).

### The HP commitment

HP is committed to providing products and services that are accessible for people with disabilities. This commitment supports the company's diversity objectives and helps ensure that the benefits of technology are available to all.

The HP accessibility goal is to design, produce, and market products and services that can be effectively used by everyone, including people with disabilities, either on a standalone basis or with appropriate assistive devices.

To achieve that goal, this Accessibility Policy establishes seven key objectives to guide HP actions. All HP managers and employees are expected to support these objectives and their implementation in accordance with their roles and responsibilities:

- Raise the level of awareness of accessibility issues within HP, and provide employees with the training they need to design, produce, market, and deliver accessible products and services.
- Develop accessibility guidelines for products and services, and hold product development groups accountable for implementing these guidelines where competitively, technically, and economically feasible.
- Involve people with disabilities in the development of accessibility guidelines and in the design and testing of products and services.
- Document accessibility features, and make information about HP products and services publicly available in an accessible form.
- Establish relationships with leading assistive technology and solution providers.
- Support internal and external research and development that improves assistive technology relevant to HP products and services.

- Support and contribute to industry standards and guidelines for accessibility.

## International Association of Accessibility Professionals (IAAP)

IAAP is a not-for-profit association focused on advancing the accessibility profession through networking, education, and certification. The objective is to help accessibility professionals develop and advance their careers and to better enable organizations to integrate accessibility into their products and infrastructure.

As a founding member, HP joined to participate with other organizations to advance the field of accessibility. This commitment supports HP's accessibility goal of designing, producing, and marketing products and services that people with disabilities can effectively use.

IAAP will make the profession strong by globally connecting individuals, students, and organizations to learn from one another. If you are interested in learning more, go to <http://www.accessibilityassociation.org> to join the online community, sign up for newsletters, and learn about membership options.

## Finding the best assistive technology

Everyone, including people with disabilities or age-related limitations, should be able to communicate, express themselves, and connect with the world using technology. HP is committed to increasing accessibility awareness within HP and with our customers and partners.

Whether it's large fonts that are easy on the eyes, voice recognition that lets you give your hands a rest, or any other assistive technology (AT) to help with your specific situation—a variety of assistive technologies make HP products easier to use. How do you choose?

## Assessing your needs

Technology can unleash your potential. AT removes barriers and helps you create independence at home, at work, and in the community. AT helps increase, maintain, and improve the functional capabilities of electronic and information technology.

You can choose from many AT products. Your AT assessment should allow you to evaluate several products, answer your questions, and facilitate your selection of the best solution for your situation. You will find that professionals qualified to do AT assessments come from many fields, including those licensed or certified in physical therapy, occupational therapy, speech/language pathology, and other areas of expertise. Others, while not certified or licensed, can also provide evaluation information. You will want to ask about the individual's experience, expertise, and fees to determine if they are appropriate for your needs.

## Accessibility for HP products

These links provide information about accessibility features and assistive technology, if applicable and available in your country or region, that are included in various HP products. These resources will help you select the specific assistive technology features and products most appropriate for your situation.

- HP Aging & Accessibility: Go to <http://www.hp.com>, type **Accessibility** in the search box. Select **Office of Aging and Accessibility**.
- HP computers: For Windows 7, Windows 8, and Windows 10, go to <http://www.hp.com/support>, type **Windows Accessibility Options** in the **Search our knowledge** search box. Select the appropriate operating system in the results.
- HP Shopping, peripherals for HP products: Go to <http://store.hp.com>, select **Shop**, and then select **Monitors** or **Accessories**.

If you need additional support with the accessibility features on your HP product, see [Contacting support on page 53](#).

Additional links to external partners and suppliers that may provide additional assistance:

- [Microsoft Accessibility information \(Windows 7, Windows 8, Windows 10, Microsoft Office\)](#)
- [Google Products accessibility information \(Android, Chrome, Google Apps\)](#)

## Standards and legislation

Countries worldwide are enacting regulations to improve access to products and services for persons with disabilities. These regulations are historically applicable to telecommunications products and services, PCs and printers with certain communications and video playback features, their associated user documentation, and their customer support.

### Standards

The US Access Board created Section 508 of the Federal Acquisition Regulation (FAR) standards to address access to information and communication technology (ICT) for people with physical, sensory, or cognitive disabilities.

The standards contain technical criteria specific to various types of technologies, as well as performance-based requirements which focus on functional capabilities of covered products. Specific criteria cover software applications and operating systems, web-based information and applications, computers, telecommunications products, video and multimedia, and self-contained closed products.

### Mandate 376 – EN 301 549

The European Union created the EN 301 549 standard within Mandate 376 as an online toolkit for public procurement of ICT products. The standard specifies the accessibility requirements applicable to ICT products and services, with a description of the test procedures and evaluation methodology for each requirement.

### Web Content Accessibility Guidelines (WCAG)

Web Content Accessibility Guidelines (WCAG) from the W3C's Web Accessibility Initiative (WAI) helps web designers and developers create sites that better meet the needs of people with disabilities or age-related limitations.

WCAG advances accessibility across the full range of web content (text, images, audio, and video) and web applications. WCAG can be precisely tested, is easy to understand and use, and allows web developers flexibility for innovation. WCAG 2.0 has also been approved as [ISO/IEC 40500:2012](#).

WCAG specifically addresses barriers to accessing the web experienced by people with visual, auditory, physical, cognitive, and neurological disabilities, and by older web users with accessibility needs. WCAG 2.0 provides characteristics of accessible content:

- **Perceivable** (for instance, by addressing text alternatives for images, captions for audio, adaptability of presentation, and color contrast)
- **Operable** (by addressing keyboard access, color contrast, timing of input, seizure avoidance, and navigability)
- **Understandable** (by addressing readability, predictability, and input assistance)
- **Robust** (for instance, by addressing compatibility with assistive technologies)

## Legislation and regulations

Accessibility of IT and information has become an area of increasing legislative importance.

The [HP policy landscape](#) website provides information about key legislation, regulations, and standards in the following locations:

- United States
- Canada
- Europe
- Australia

## Useful accessibility resources and links

These organizations, institutions, and resources might be good sources of information about disabilities and age-related limitations.



---

**NOTE:** This is not an exhaustive list. These organizations are provided for informational purposes only. HP assumes no responsibility for information or contacts you encounter on the internet. Listing on this page does not imply endorsement by HP.

---

## Organizations

These organizations are a few of the many that provide information about disabilities and age-related limitations.

- American Association of People with Disabilities (AAPD)
- The Association of Assistive Technology Act Programs (ATAP)
- Hearing Loss Association of America (HLAA)
- Information Technology Technical Assistance and Training Center (ITTATC)
- Lighthouse International
- National Association of the Deaf
- National Federation of the Blind
- Rehabilitation Engineering & Assistive Technology Society of North America (RESNA)
- Telecommunications for the Deaf and Hard of Hearing, Inc. (TDI)
- W3C Web Accessibility Initiative (WAI)

## Educational institutions

Many educational institutions, including these examples, provide information about disabilities and age-related limitations.

- California State University, Northridge, Center on Disabilities (CSUN)
- University of Wisconsin - Madison, Trace Center

- University of Minnesota computer accommodations program

## Other disability resources

Many resources, including these examples, provide information about disabilities and age-related limitations.

- ADA (Americans with Disabilities Act) Technical Assistance Program
- ILO Global Business and Disability network
- EnableMart
- European Disability Forum
- Job Accommodation Network
- Microsoft Enable

## HP links

These HP-specific links provide information that relates to disabilities and age-related limitations.

[HP comfort and safety guide](#)

[HP public sector sales](#)

## Contacting support

HP offers technical support and assistance with accessibility options for customers with disabilities.



---

**NOTE:** Support is in English only.

---

- Customers who are deaf or hard of hearing who have questions about technical support or accessibility of HP products:
  - Use TRS/VRS/WebCapTel to call (877) 656-7058 Monday through Friday, 6 a.m. to 9 p.m. Mountain Time.
- Customers with other disabilities or age-related limitations who have questions about technical support or accessibility of HP products:
  - Call (888) 259-5707 Monday through Friday, 6 a.m. to 9 p.m. Mountain Time.

---

# Index

- A**
  - access panel
    - removal and replacement 5, 12
  - accessibility 49, 50, 52, 53
  - accessibility needs
    - assessment 50
  - assistive technology (AT)
    - finding 50
    - purpose 49
  - AT (assistive technology)
    - finding 50
    - purpose 49
  - audio-in (microphone) jack,
    - identifying 2
  - audio-out (headphone) jack,
    - identifying 1
- C**
  - caring for your computer 45
  - cautions 3
  - cleaning your computer 45
    - disinfecting 46
    - removing dirt and debris 46
  - Clear CMOS button, identifying 2
  - computer operating
    - guidelines 45
  - connector, power 2
  - CPU backplate
    - removal 36
  - cryo chamber 38
  - customer support,
    - accessibility 53
- D**
  - dust filter
    - removal 12
- E**
  - electrostatic discharge 48
- F**
  - fan
    - removal and replacement 18
  - feet
    - removal 4
- front bezel
  - removal 11
- G**
  - glass access panel
    - removal and replacement 5
  - graphics card
    - installing 8
- H**
  - hard drive
    - removal and replacement 14
  - hardware setup 3
  - HP Assistive Policy 49
- I**
  - installing
    - graphics card 8
    - power supply 25
  - International Association of Accessibility Professionals 50
- J**
  - jacks
    - audio-in (microphone) 2
    - audio-out (headphone) 1
    - network 2
    - RJ-45 (network) 2
- L**
  - lights
    - RJ-45 (network) 2
- M**
  - memory modules
    - removal 5
  - microphone (audio-in) jack,
    - identifying 2
- N**
  - network jack, identifying 2
- P**
  - ports
    - USB 2
  - USB Type-C power connector 2
  - USB Type-C SuperSpeed power connector
    - identifying USB Type-C 2
  - power supply
    - installing 25
  - processor
    - removal 34
- R**
  - rear fan
    - removal 24
  - rear panel components 1
  - removal
    - CPU backplate 36
    - dust filter 12
    - feet 4
    - front bezel 11
    - memory modules 5
    - processor 34
    - rear fan 24
    - system board 35
    - top I/O module 30
    - WLAN module 7
  - removal and replacement
    - access panel 5, 12
    - fan 18
    - glass access panel 5
    - hard drive 14
    - RGB fan 18
    - RGB lighting board 16
    - right access panel 12
  - resources, accessibility 52
  - RGB fans
    - removal and replacement 18
  - RGB lighting board
    - removal and replacement 16
  - right access panel
    - removal and replacement 12
  - RJ-45 (network) jack, identifying 2
  - RJ-45 (network) lights,
    - identifying 2
- S**
  - Section 508 accessibility standards 51

- shipping preparation 47
- standards and legislation,
  - accessibility 51
- system board
  - removal 35
- system board specification
  - information 4

## T

- top components 1
- top I/O module
  - removal 30

## U

- USB port, identifying 2
- USB Type-C port, identifying 2
- USB Type-C power connector,
  - identifying 2

## V

- ventilation guidelines 45

## W

- warnings 3
- WLAN module
  - removal 7