



HPE ProLiant Compute DL380 Gen12 Server User Guide

Part Number: 30-C8D7E7F6-005

Published: February 2026

Edition: 5

HPE ProLiant Compute DL380 Gen12 Server User Guide

Abstract

This document is for the person who installs, administers, and troubleshoots servers and storage systems. Hewlett Packard Enterprise assumes you are qualified in the servicing of computer equipment and trained in recognizing hazards in products with hazardous energy levels.

Part Number: 30-C8D7E7F6-005

Published: February 2026

Edition: 5

© Copyright 2026 Hewlett Packard Enterprise Development LP

Notices

The information provided here is subject to change without notice. Hewlett Packard Enterprise's products and services are covered only by the express warranty statements that come with them. This document does not constitute an additional warranty. Hewlett Packard Enterprise is not responsible for any technical or editorial errors or omissions in this document.

Confidential computer software. You must have a valid license from Hewlett Packard Enterprise to possess, use, or copy the software. In accordance with FAR 12.211 and 12.212, Commercial Computer Software, Computer Software Documentation, and Technical Data for Commercial Items are licensed to the U.S. Government under the vendor's standard commercial license.

Links to third-party websites will take you outside of the Hewlett Packard Enterprise website. Hewlett Packard Enterprise has no control over and is not responsible for the information outside the Hewlett Packard Enterprise website.

Acknowledgments

Intel®, Itanium®, Optane™, Pentium®, Xeon®, Intel Inside®, and the Intel Inside logo are trademarks of Intel Corporation or its subsidiaries.

Microsoft® and Windows® are either registered trademarks or trademarks of Microsoft Corporation in the United States and/or other countries.

Linux® is the registered trademark of Linus Torvalds in the U.S. and other countries.

VMware ESXi™ and VMware vSphere® are registered trademarks or trademarks of VMware, Inc. in the United States and/or other jurisdictions.

Red Hat® Enterprise Linux is a registered trademark of Red Hat, Inc. in the United States and other countries.

microSD® is a trademark or a registered trademark of SD-3D in the United States, other countries of both.

Kensington® is a registered trademark of ACCO Brands.

All third-party marks are property of their respective owners.

Table of contents

Component identification.....	10
Front panel components.....	10
Front panel LEDs and buttons.....	14
Rear panel components.....	17
Rear panel LEDs.....	18
System board components.....	20
System maintenance switch descriptions.....	22
DIMM slot locations.....	23
DIMM label identification.....	23
Drive boxes and numbering.....	25
Fan bay numbering.....	32
Component touchpoints.....	32
HPE Basic Drive LED definitions.....	33
EDSFF SSD LED definitions.....	35
Systems Insight Display LEDs.....	36
Systems Insight Display combined LED descriptions.....	38
HPE NS204i-u Boot Device V2 components.....	41
HPE NS204i-u Boot Device V2 LED definitions	42
Riser board components.....	43
Rear slot numbering.....	47
Heatsink and processor socket components.....	47
Management arm components.....	48
Setup.....	49
HPE Installation Service.....	50
Setting up the server.....	50
Rack warnings and cautions.....	53
Server warnings and cautions.....	55
Electrostatic discharge.....	56
Operations.....	56
iLO service port.....	57
Intel VROC support.....	58
Server UID LED.....	58
Viewing the Server Health Summary.....	59
Monitor setup.....	59

Fan mode behavior.....	60
Supported PCIe form factors.....	61
Accessing the Systems Insight Display.....	62
Trusted Platform Module 2.0.....	64
Trusted Platform Module 2.0 guidelines.....	65
System battery information.....	66
Hardware options.....	66
Hewlett Packard Enterprise product QuickSpecs.....	67
Hardware option installation guidelines.....	67
Pre-installation procedures.....	68
Server data backup.....	68
Power down the server.....	69
Opening and closing the cable management arm.....	70
Extend the server from the rack.....	71
Remove the server from the rack.....	73
Remove the bezel.....	74
Remove the access panel.....	76
Remove the fan cage.....	78
Remove the air baffle or midplane drive cage.....	79
Remove the riser cage.....	82
Post-installation procedures.....	84
Installing the access panel.....	84
Install the fan cage.....	86
Install the air baffle.....	87
Power up the server.....	88
Cooling.....	88
Installing high-performance fans.....	89
Drives.....	91
Drive guidelines.....	91
Installing a hot-plug LFF/SFF SAS, SATA or NVMe drive.....	92
Installing an E3.S drive.....	95
Drive and multipurpose cages.....	97
Installing a front multipurpose cage.....	97
Installing a front 4 EDSFF drive kit.....	100
Installing a front 8SFF drive cage.....	104
Installing a front 2SFF side-by-side drive cage.....	106
Installing a front 2SFF stacked drive cage.....	109
Installing a midplane drive cage.....	114

Installing a rear 2SFF stacked drive cage.....	120
Energy packs.....	126
Minimum firmware versions.....	126
HPE Smart Storage Battery.....	126
HPE Smart Storage Hybrid Capacitor.....	127
Installing a smart storage battery/capacitor.....	127
GPUs.....	129
Installing an accelerator or GPU.....	129
Management.....	135
Installing the Systems Insight Display.....	136
Installing a rear serial port interface.....	139
Media devices.....	140
Installing a universal media bay in the SFF chassis.....	141
Installing a universal media bay in the LFF chassis.....	144
Installing the optical disc drive in the SFF universal media bay.....	146
Installing the optical disc drive in the LFF universal media bay.....	149
Memory.....	152
Memory population information.....	152
DIMM label identification.....	152
DIMM-processor compatibility.....	154
Installing a DIMM.....	154
Networking.....	157
About the front OCP networking enablement kit.....	157
Installing the front OCP enablement kit.....	158
Installing a rear OCP network adapter	169
Installing a PCIe network adapter.....	171
OS boot device.....	175
Installing boot device drives.....	175
Installing the front NS204i-u Boot Device.....	179
Installing the rear NS204i-u boot device.....	187
Power supplies.....	190
Power supply warnings and cautions.....	192
Hot-plug power supply calculations.....	192
Installing an AC power supply.....	193
DC power supply warnings and cautions.....	196
Connecting a DC power cable to a DC power source.....	196
DC power supply wire colors.....	199
Installing a DC power supply.....	199

Processors and heatsinks.....	209
Processor cautions.....	210
Installing a processor or heatsink.....	210
Reconfiguring the system date and time settings.....	220
Connecting the direct liquid cooling kit.....	221
Rack rail and CMA.....	224
Rack mounting interfaces.....	224
Rack rail options.....	225
Rail identification markers.....	225
Installing the rack rails.....	227
Installing the server into the rack.....	233
Installing the rack rail hook-and-loop strap.....	235
Preparing the cable management arm.....	236
Installing the cable management arm.....	237
Risers and riser cages.....	243
Installing expansion boards.....	244
Installing a secondary riser cage.....	247
Installing a tertiary riser cage.....	249
Installing a rear 2 SFF riser cage.....	252
Installing a rear 2LFF riser cage.....	256
Installing primary and secondary risers.....	260
Installing tertiary risers.....	262
Security.....	264
Installing the bezel.....	265
Installing the chassis intrusion detection switch.....	266
Storage controllers.....	267
Installing a type-p storage controller.....	268
Installing a type-o storage controller.....	271
Cabling.....	273
Cabling guidelines.....	274
Cabling diagrams.....	276
EDSFF cabling.....	281
8 SFF box 1 cabling.....	298
8 SFF box 2 cabling.....	313
8 SFF box 3 cabling.....	327
Box 7 cabling.....	341
Front 2 SFF cabling.....	342
Rear 2 SFF cabling.....	351

LFF cabling.....	364
Riser enablement cabling.....	368
Power cabling.....	372
GPU cabling.....	381
NS204i-u boot device cabling.....	383
OCP enablement.....	387
Systems Insight Display cabling.....	396
I/O cabling.....	396
Front power switch cabling.....	400
Serial port cabling.....	401
Configuration resources.....	402
Updating firmware or system ROM.....	403
Configuring the server.....	404
Configuring storage controllers.....	406
Deploying an OS.....	407
Configuring security.....	408
Server management.....	408
Managing Linux-based high performance compute clusters.....	409
Troubleshooting.....	409
NMI functionality.....	410
Front panel LED power fault codes.....	410
Troubleshooting resources.....	411
Safety, warranty, and regulatory information.....	411
Regulatory information.....	411
Notices for Eurasian Economic Union.....	412
Turkey RoHS material content declaration.....	413
Ukraine RoHS material content declaration.....	413
Warranty information.....	413
Specifications.....	413
Server and rackmounting specifications.....	414
Environmental specifications.....	416
Power supply specifications.....	417
HPE 800W Flex Slot Platinum Hot-plug Low Halogen Power Supply.....	418
HPE 1000 W Flex Slot Titanium Hot-plug Power Supply.....	418
HPE 1600 W Flex Slot Platinum Hot-plug Low Halogen Power Supply.....	419
HPE 1600 W Flex Slot -48 VDC Hot-plug Power Supply.....	420
HPE 1800-2200 W Flex Slot Titanium Power Supply.....	421
Operational requirements.....	421

Space and airflow requirements.....	422
Temperature requirements.....	423
Power requirements.....	423
Electrical grounding requirements.....	424
Fan and heatsink requirements	
Support and other resources.....	424
Accessing Hewlett Packard Enterprise Support.....	425
HPE product registration.....	425
Accessing updates.....	426
Customer self repair.....	426
Remote support.....	427
Documentation feedback.....	427

Component identification

Provides an overview of external and internal server features to support hardware installation and servicing.

Subtopics

Front panel components

Front panel LEDs and buttons

Rear panel components

Rear panel LEDs

System board components

Drive boxes and numbering

Fan bay numbering

Component touchpoints

HPE Basic Drive LED definitions

EDSFF SSD LED definitions

Systems Insight Display LEDs

Systems Insight Display combined LED descriptions

HPE NS204i-u Boot Device V2 components

HPE NS204i-u Boot Device V2 LED definitions

Riser board components

Rear slot numbering

Heatsink and processor socket components

Management arm components

Front panel components

SFF front panel components

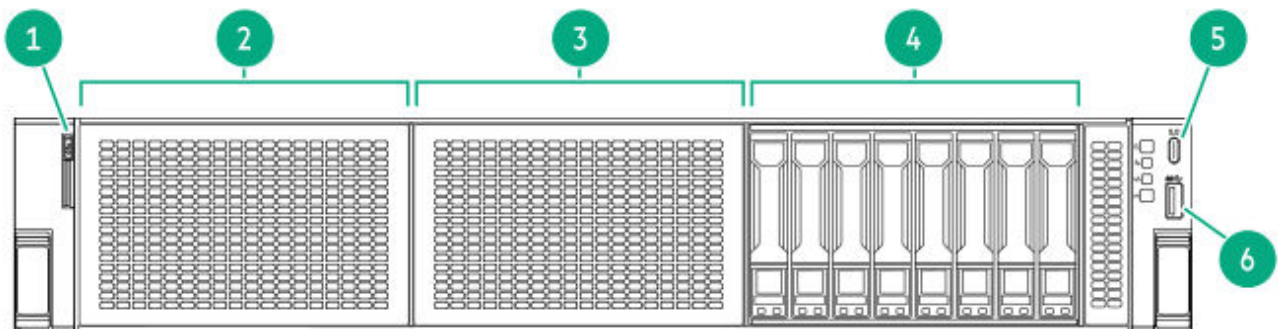

Item	Description
1	Serial number/iLO information pull tab
2	8 SFF drives or universal media bay (optional)
3	8 SFF drives or multipurpose cage (optional)
4	8 SFF drives
5	iLO Service Port
6	USB 3.2 Gen 1 port

SFF media bay components

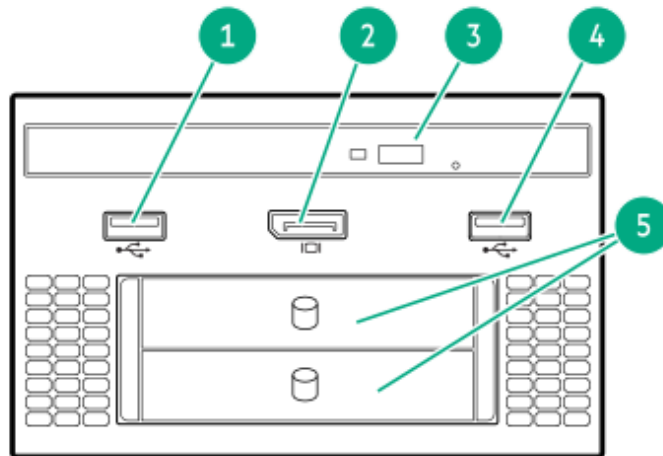

Item	Description
1	USB 2.0 port
2	DisplayPort 1.1a
3	Optical disc drive (optional)
4	USB 2.0 port
5	Front 2 SFF stacked drives (optional)

Multipurpose cage components

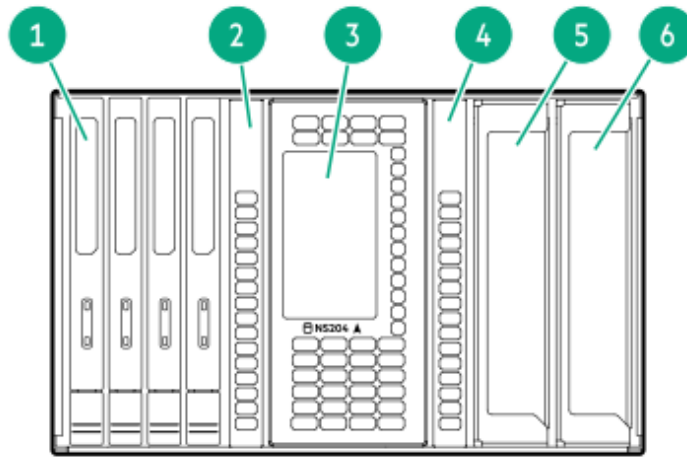

The optional components below are only supported in box 2.

Item	Description
1	EDSFF drives (optional)
2	Filler bay
3	NS204i-u (optional)
4	Filler bay
5	OCP slot box 2 bay 9 (optional)
6	OCP slot box 2 bay 11 (optional)

12 LFF front panel components

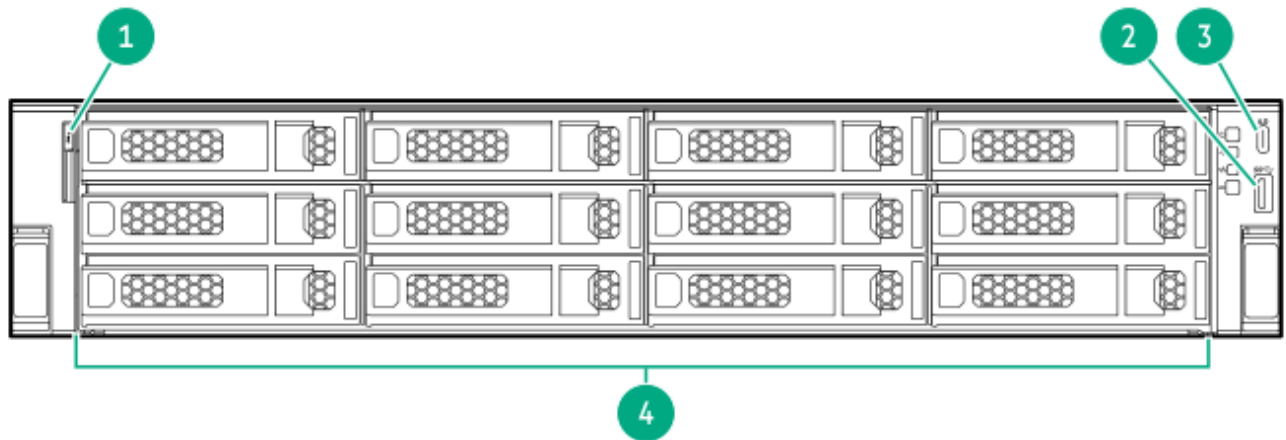

Item	Description
1	Serial number/iLO information pull tab

Item	Description
2	USB 3.2 Gen 1 port
3	iLO Service Port
4	LFF drives

8 LFF front panel components

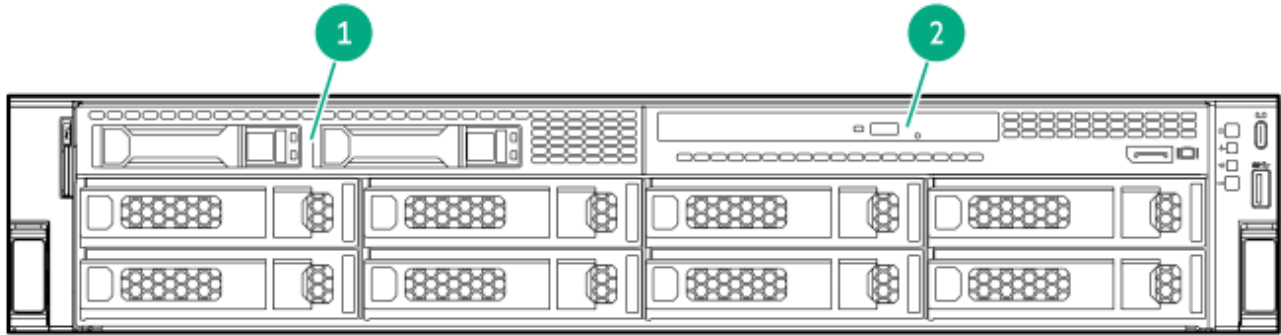

Item	Description
1	2 SFF side by side drives (optional)
2	LFF media bay

LFF media bay components

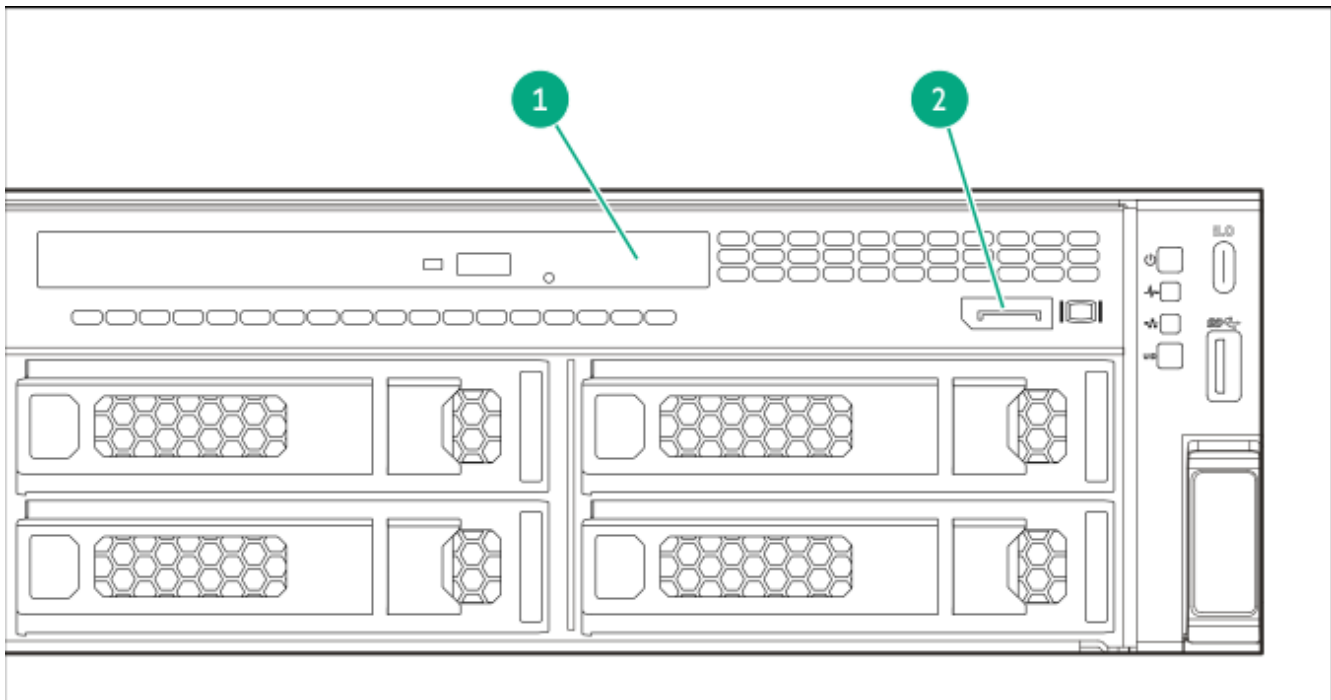

Item	Description
1	Optical disk drive
2	DisplayPort 1.1a

Front panel LEDs and buttons

SFF

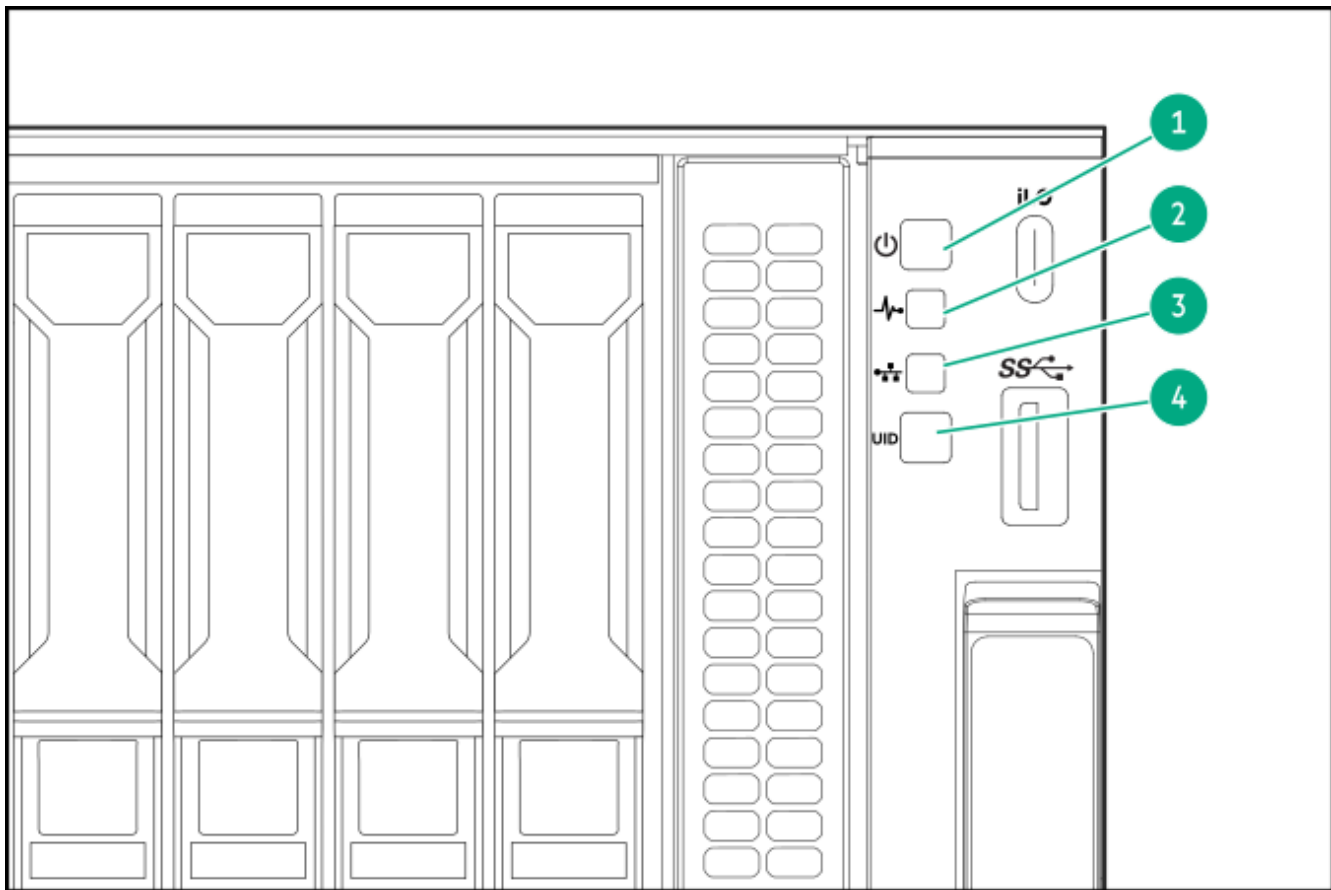

Item	Description	Status
1	Power On/Standby button and system power LED $\frac{1}{-}$	<ul style="list-style-type: none"> • Solid green = System on • Flashing green (1 Hz/cycle per sec) = Performing power on sequence

Item	Description	Status
		<ul style="list-style-type: none"> • Solid amber = System in standby • Off = No power present ²
2	Health LED ¹	<ul style="list-style-type: none"> • Solid green = Normal • Flashing green (1 Hz/cycle per sec) = iLO is rebooting • Flashing amber = System degraded • Flashing red (1 Hz/cycle per sec) = System critical ³
3	NIC status LED ¹	<ul style="list-style-type: none"> • Solid green = Link to network • Flashing green (1 Hz/cycle per sec) = Network active • Off = No network activity
4	UID button/LED ¹	<ul style="list-style-type: none"> • Solid blue = Activated • Flashing blue: <ul style="list-style-type: none"> ◦ 1 Hz/cycle per sec = Remote management or firmware upgrade in progress ◦ 4 Hz/cycle per sec = iLO manual reboot sequence initiated ◦ 8 Hz/cycle per sec = iLO manual reboot sequence in progress ◦ Off = Deactivated

¹ When all four LEDs described in this table flash simultaneously, a power fault has occurred.

² Facility power is not present, the power cord is not attached, no power supplies are installed, power supply failure has occurred, or the power button cable is disconnected.

³ If the health LED indicates a degraded or critical state, review the system IML or use iLO to review the system health status.

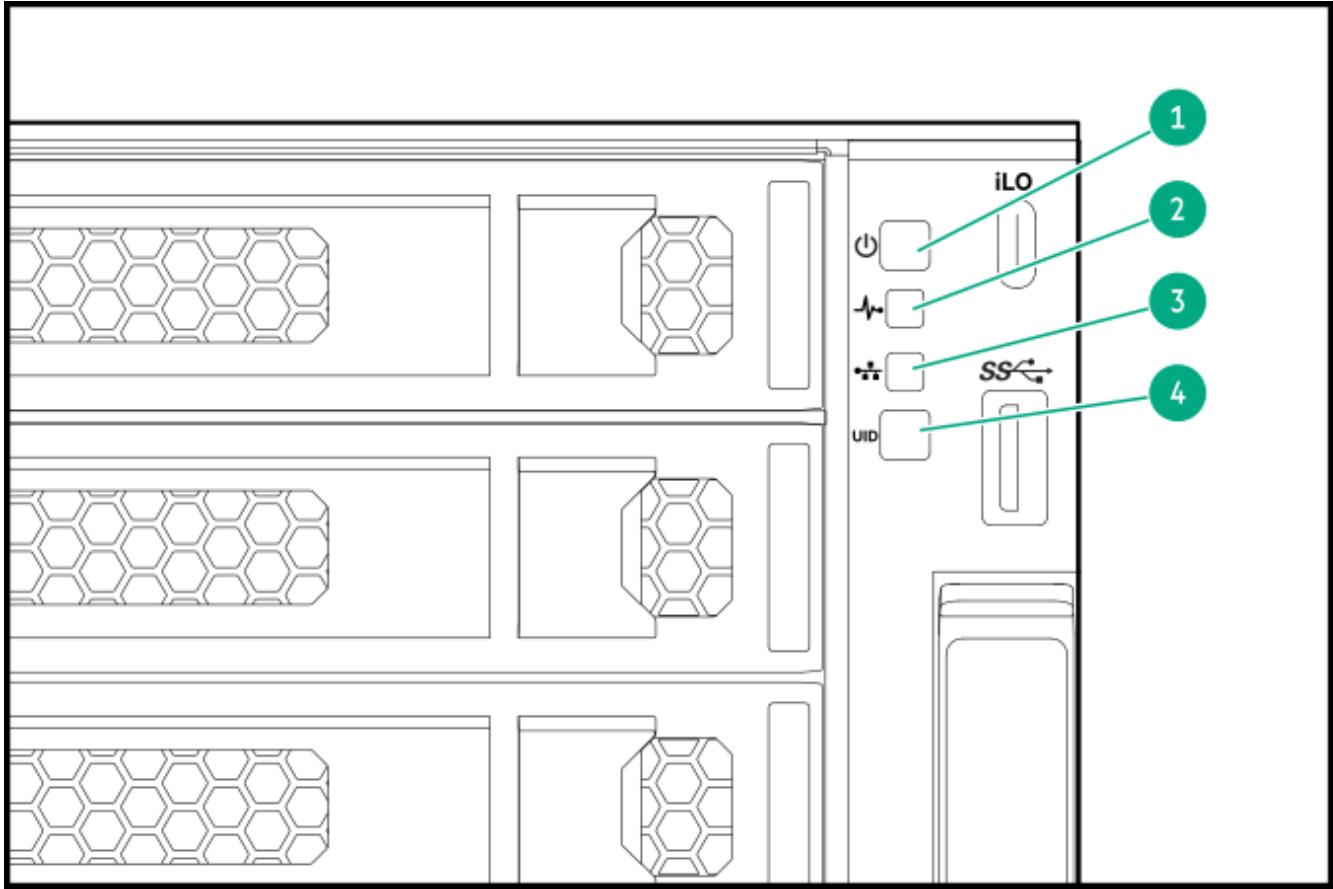

Item	Description	Status
1	Power On/Standby button and system power LED ¹ ₁	<ul style="list-style-type: none"> • Solid green = System on • Flashing green (1 Hz/cycle per sec) = Performing power on sequence • Solid amber = System in standby • Off = No power present ²₂
2	Health LED ¹ ₁	<ul style="list-style-type: none"> • Solid green = Normal • Flashing green (1 Hz/cycle per sec) = iLO is rebooting • Flashing amber = System degraded • Flashing red (1 Hz/cycle per sec) = System critical ³₃
3	NIC status LED ¹ ₁	<ul style="list-style-type: none"> • Solid green = Link to network • Flashing green (1 Hz/cycle per sec) = Network active

Item	Description	Status
		<ul style="list-style-type: none"> • Off = No network activity
4	UID button/LED ¹ / ₂	<ul style="list-style-type: none"> • Solid blue = Activated • Flashing blue: <ul style="list-style-type: none"> ◦ 1 Hz/cycle per sec = Remote management or firmware upgrade in progress ◦ 4 Hz/cycle per sec = iLO manual reboot sequence initiated ◦ 8 Hz/cycle per sec = iLO manual reboot sequence in progress ◦ Off = Deactivated

- ¹ When all four LEDs described in this table flash simultaneously, a power fault has occurred.
- ² Facility power is not present, the power cord is not attached, no power supplies are installed, power supply failure has occurred, or the power button cable is disconnected.
- ³ If the health LED indicates a degraded or critical state, review the system IML or use iLO to review the system health status.

Rear panel components

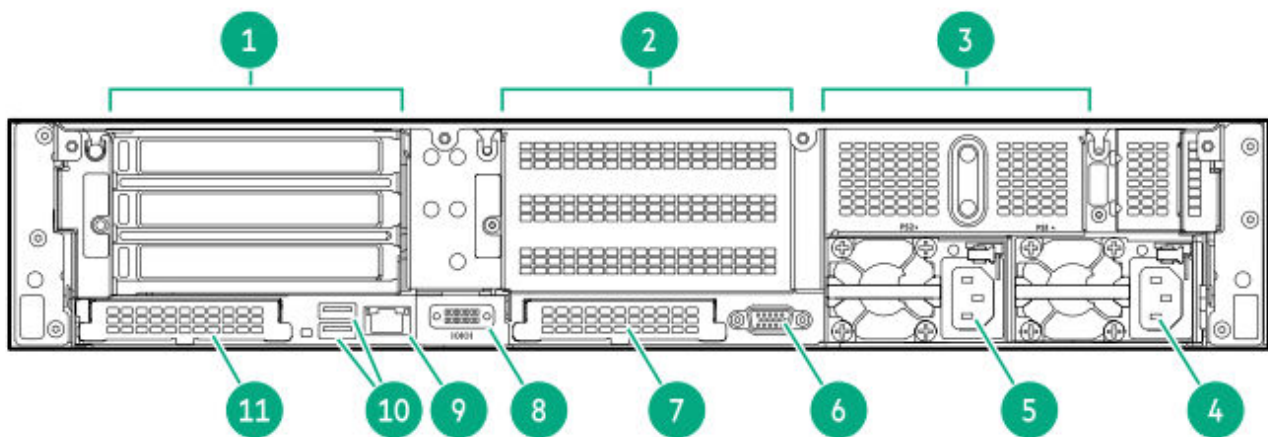

Item	Description
1	Primary riser slots 1–3 (optional drive cage)
2	Secondary riser slots 4–6 (optional drive cage)
3	Tertiary riser slots 7–8 (optional drive cage)
4	Power supply 1 (PS1)
5	Power supply 2 (PS2)
6	Video port (VGA)
7	OCP B
8	Serial port (optional)
9	iLO Management Port
10	USB 3.2 Gen 1 ports
11	OCP A

Rear panel LEDs

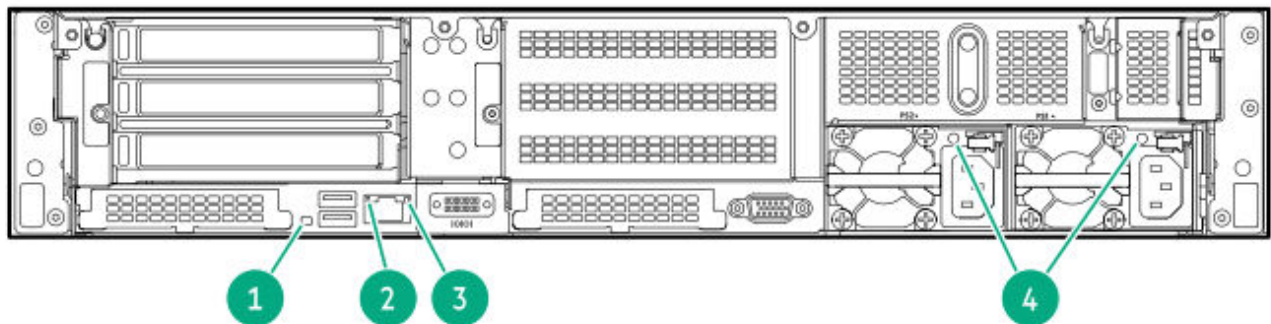

Item	Description	Status
1	UID LED	<ul style="list-style-type: none"> Off = Deactivated Solid blue = Activated Flashing blue = System is being managed remotely
2	Link LED	<ul style="list-style-type: none"> Off = No network link

Item	Description	Status
		<ul style="list-style-type: none">• Green = Network link
3	Status LED	<ul style="list-style-type: none">• Off = No network activity• Solid green = Link to network• Flashing green = Network activity
4	Power supply LED	<ul style="list-style-type: none">• Off = System is off or power supply has failed• Solid green = Normal

System board components

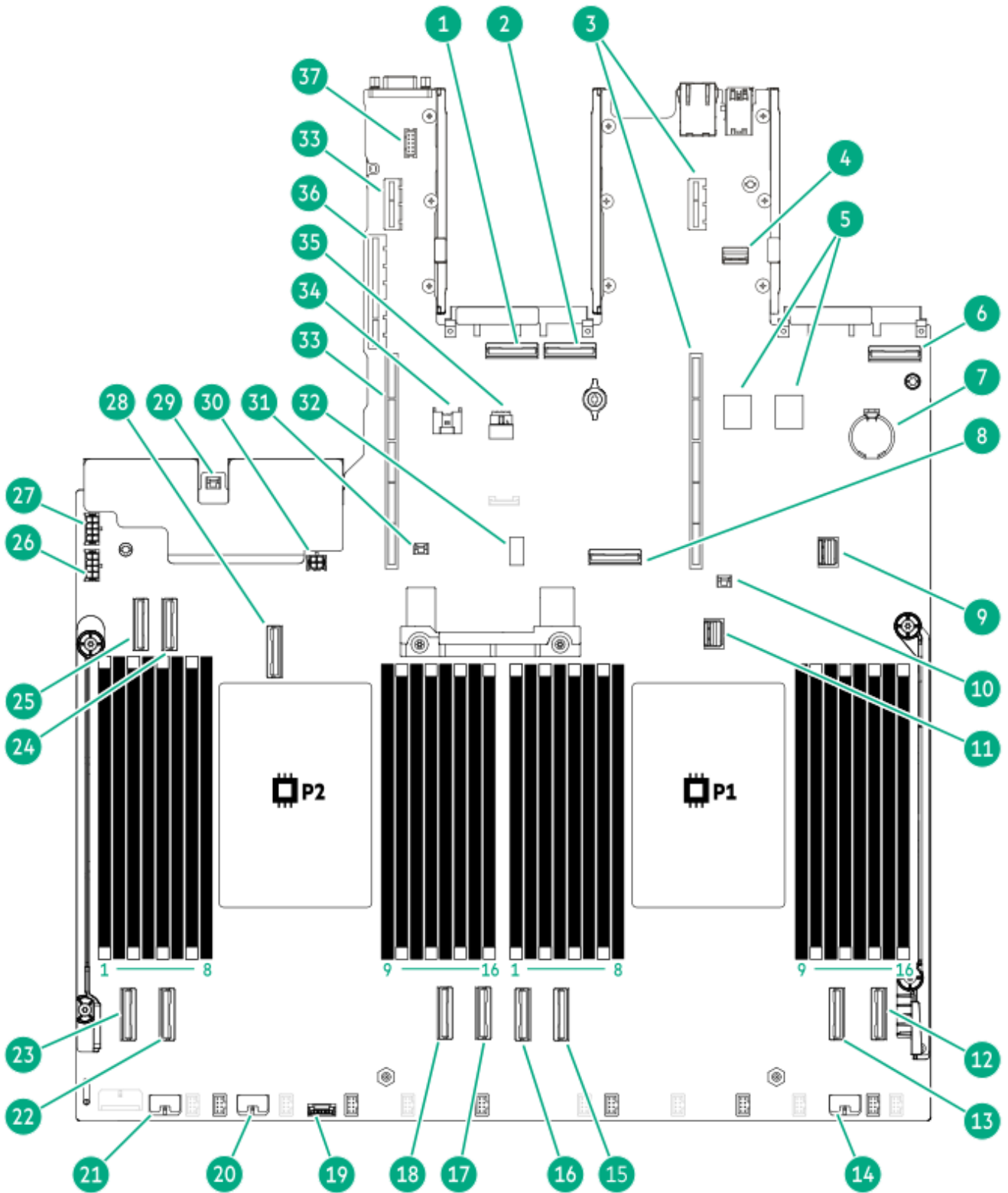

Item	Description
1	OCP B port 1
2	OCP B port 2
3	Primary riser connector
4	Display Port and USB 2.0 port
5	Dual USB 3.2 Gen1 port
6	OSP A port 1
7	System battery
8	MCIO port 12
9	Front I/O connector
10	Storage backup power connector 1
11	NS204i-u signal connector
12	MCIO port 1
13	MCIO port 2
14	Box 3 backplane power connector
15	MCIO port 3
16	MCIO port 4
17	MCIO port 5
18	MCIO port 6
19	Liquid cooling connector
20	Box 2 backplane power connector
21	Box 1 backplane power connector
22	MCIO port 7
23	MCIO port 8
24	MCIO port 10
25	MCIO port 9
26	Backplane power connector
27	Box 6 backplane power connector
28	MCIO port 11
29	Chassis intrusion detection switch connector
30	SmartNIC 4-pin power connector
31	Storage backup power connector 2
32	System maintenance switch

Item	Description
33	Secondary riser connector
34	Energy pack connector
35	NS204i-u power connector
36	Tertiary riser sideband connector
37	Serial port cable connector

Subtopics

[System maintenance switch descriptions](#)

[DIMM slot locations](#)

[DIMM label identification](#)

System maintenance switch descriptions

Position	Default	Function
S1	Off	<ul style="list-style-type: none"> Off—iLO 7 security is enabled. On—iLO 7 security is disabled.
S2	Off	Reserved
S3	Off	Reserved
S4	Off	Reserved
S5	Off	<ul style="list-style-type: none"> Off—Power-on password is enabled. On—Power-on password is disabled.
S6 <u>1</u> , <u>2</u>	Off	<ul style="list-style-type: none"> Off—No function On—Restore default manufacturing settings
S7	Off	Reserved
S8	Off	Reserved
S9	Off	Reserved
S10	Off	Reserved
S11	Off	Reserved

Position	Default	Function
S12	Off	Reserved

- 1 When the system maintenance switch position 6 is set to the On position, the system is prepared to restore all configuration settings to their manufacturing defaults.
- 2 When the system maintenance switch position 6 is set to the On position and Secure Boot is enabled, some configurations cannot be restored. For more information, see [Configuring the server](#).

DIMM slot locations

DIMM slots are numbered sequentially (1 through 16) for each processor.

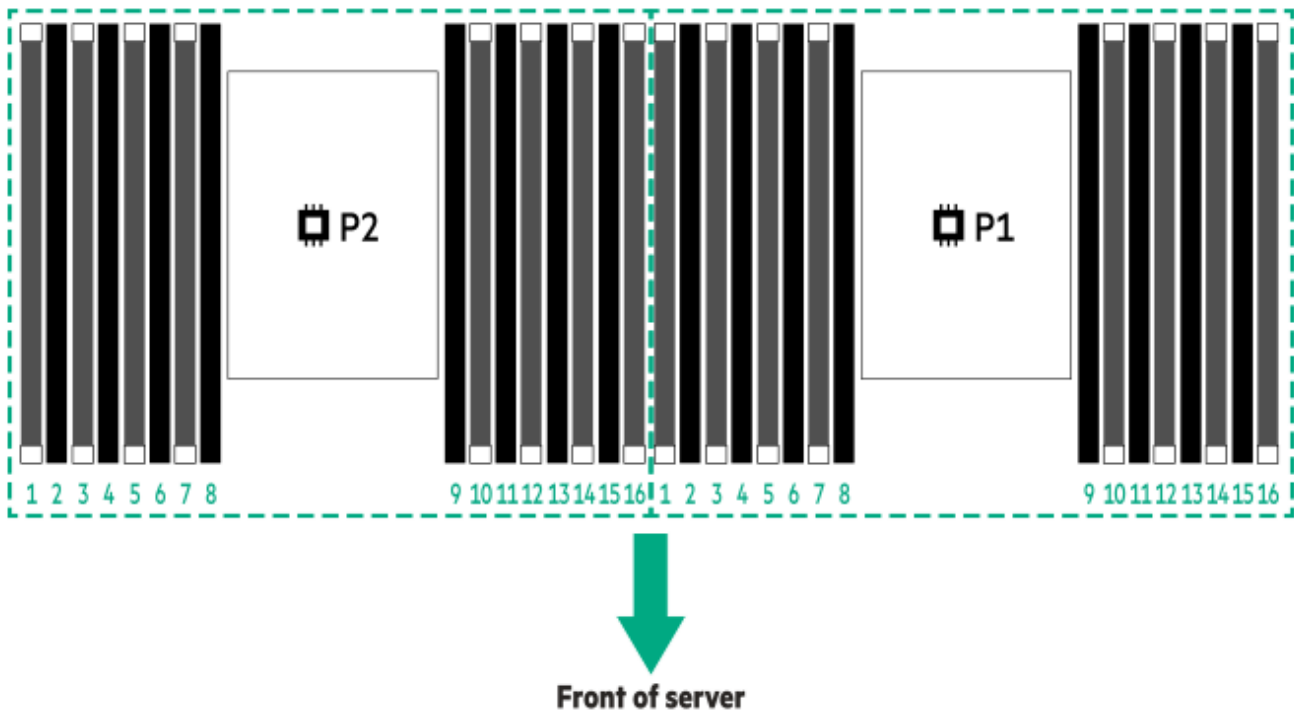

DIMM label identification

The label contains information about the DIMM. For additional information about DIMMs, including:

- Memory speeds and server-specific DIMM population rules
- Product features, specifications, options, configurations, and compatibility

See the website:

<https://www.hpe.com/docs/server-memory>

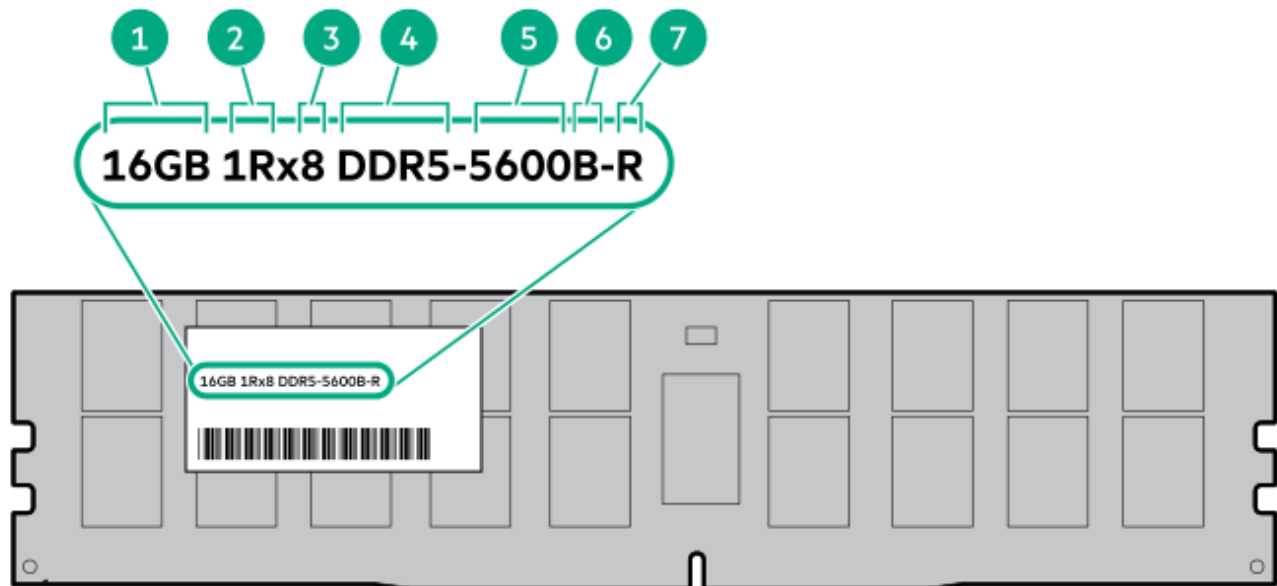

Item	Description	Example
1	Capacity $\frac{1}{-}$	16 GB 32 GB 64 GB 96 GB 128 GB 256 GB
2	Rank	1R—Single rank 2R—Dual rank 4R—Quad rank 8R—Octal rank
3	Data width on DRAM	x4—4-bit x8—8-bit
4	Memory generation	PC5—DDR5
5	Maximum memory speed $\frac{1}{-}$	4800 MT/s

Item	Description	Example
		5600 MT/s 6400 MT/s
6	CAS latency	B—42-42-42 B—50-42-42 (for 128 GB and 256 GB capacities)
7	DIMM type	E—UDIMM (unbuffered with ECC) R—RDIMM (registered)

¹ The maximum memory speed and capacity is a function of the memory type, memory configuration, and processor model.

Drive boxes and numbering

Front SFF drive boxes



Front LFF drive boxes

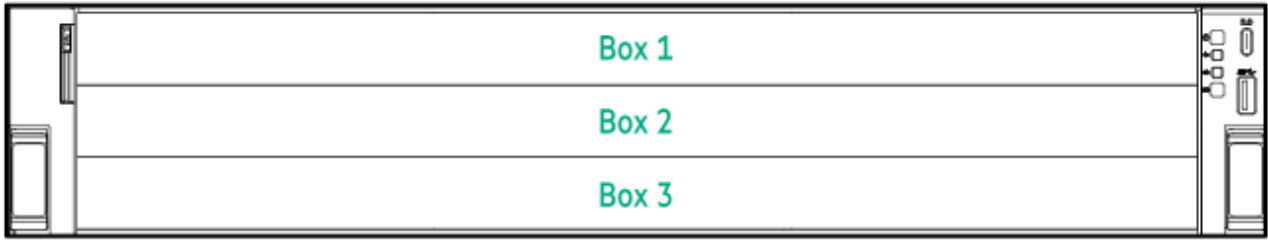

Rear drive boxes



Midplane LFF drive box

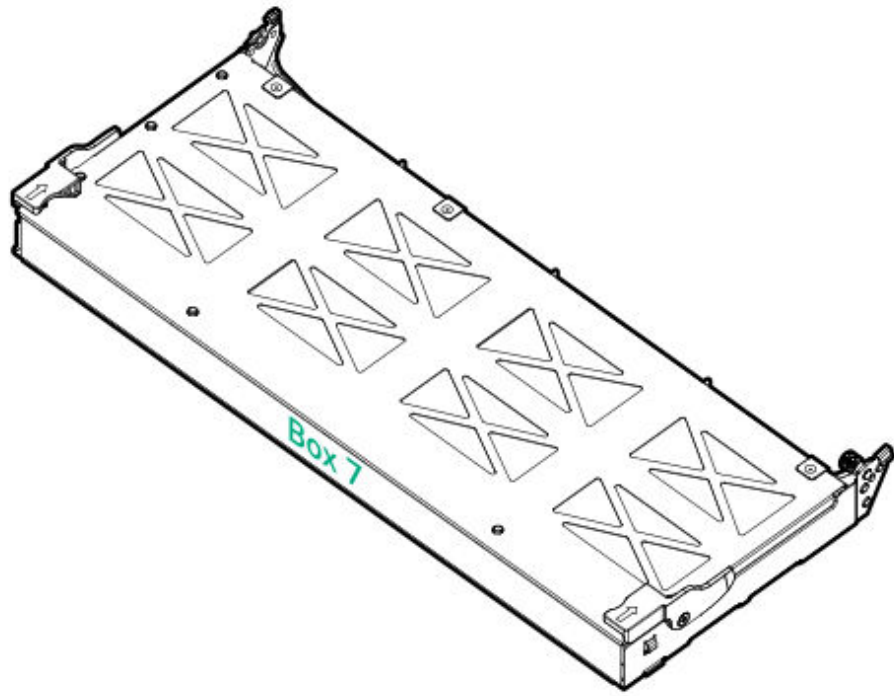

Front EDSFF cages

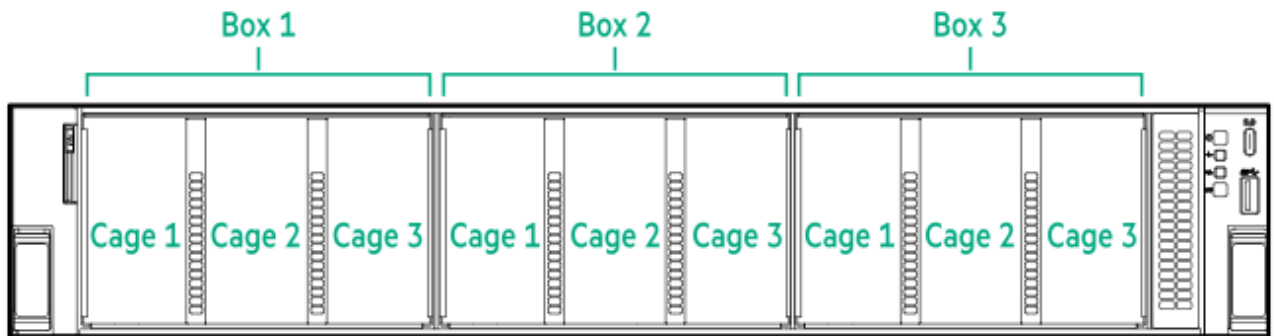

Front EDSFF drives

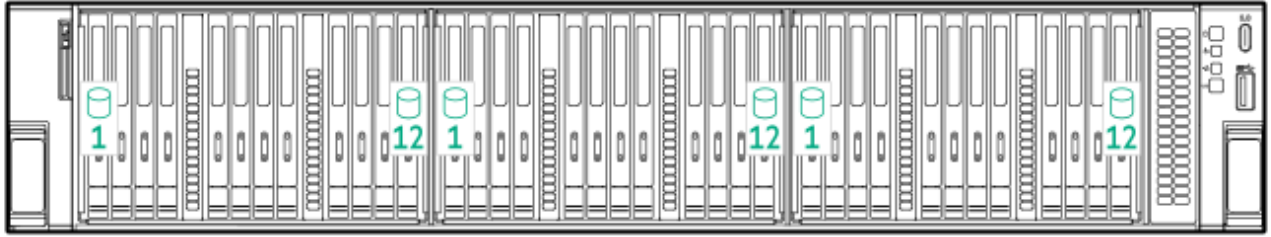

Front EDSFF drives with a multipurpose cage

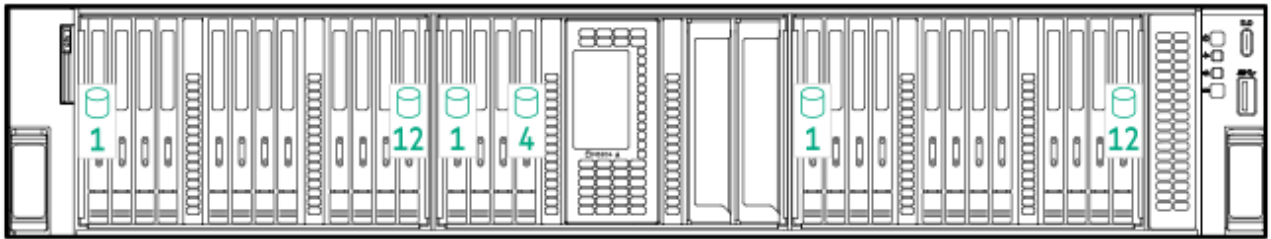

Front SFF drives

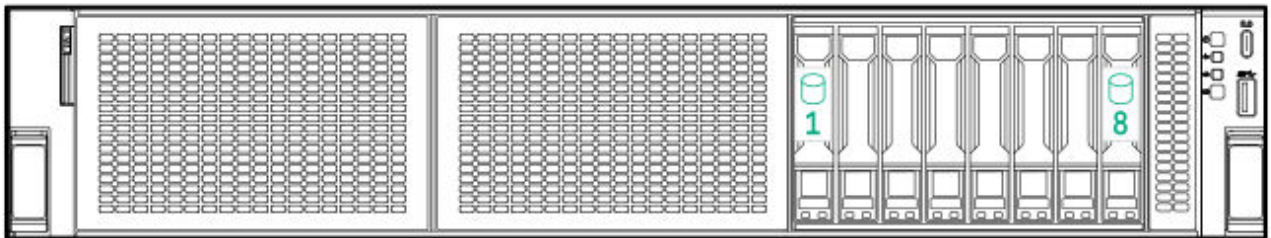

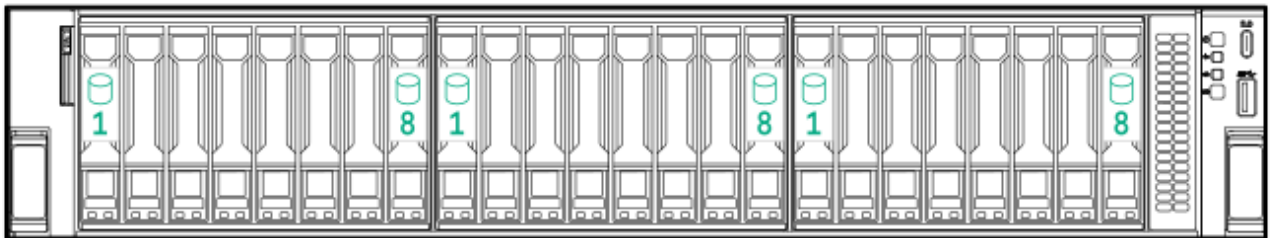
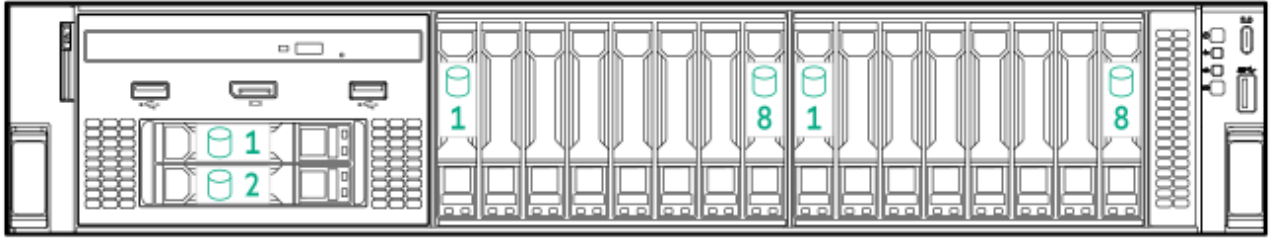

Front SFF drives with a multipurpose cage

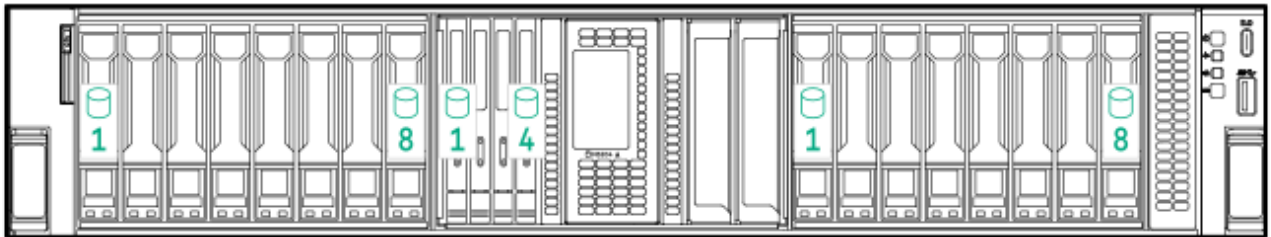

Front LFF drives

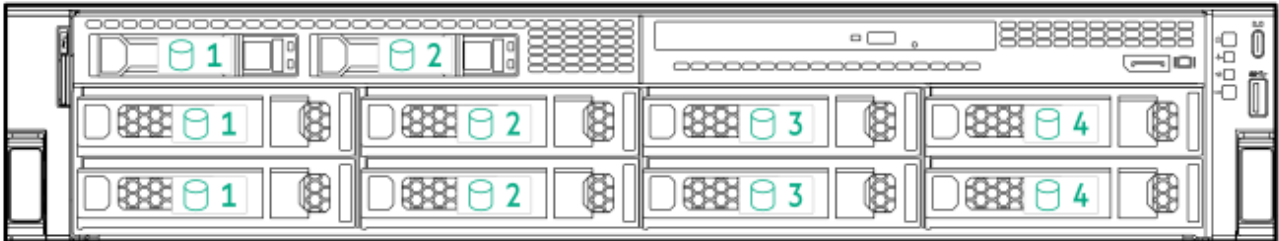
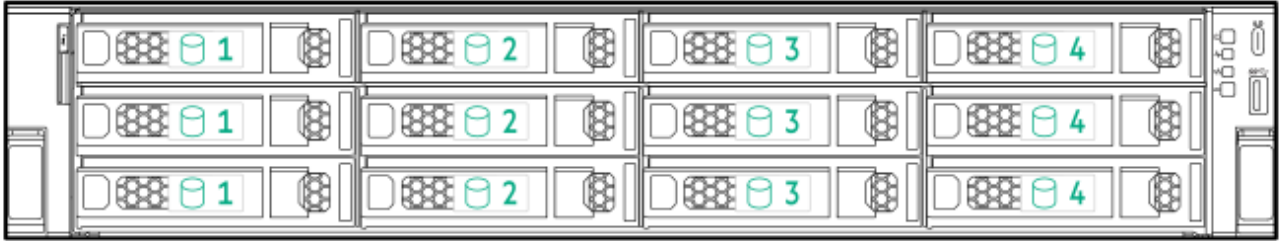

Rear SFF drives

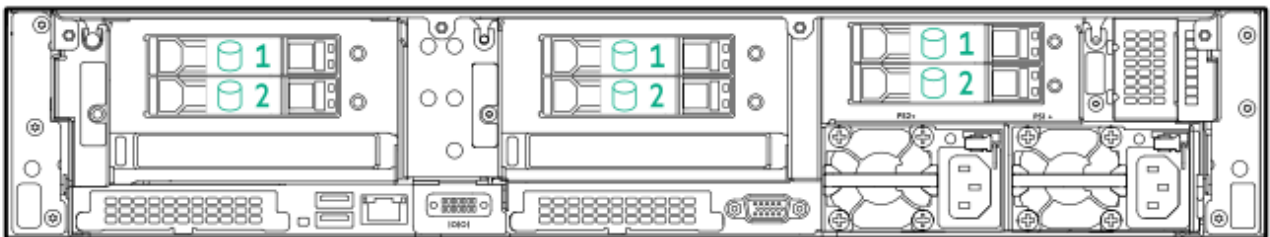

Rear LFF drives

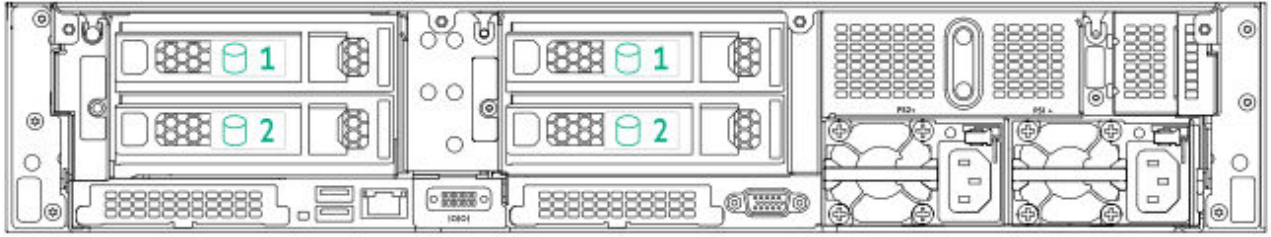

Midplane LFF drives

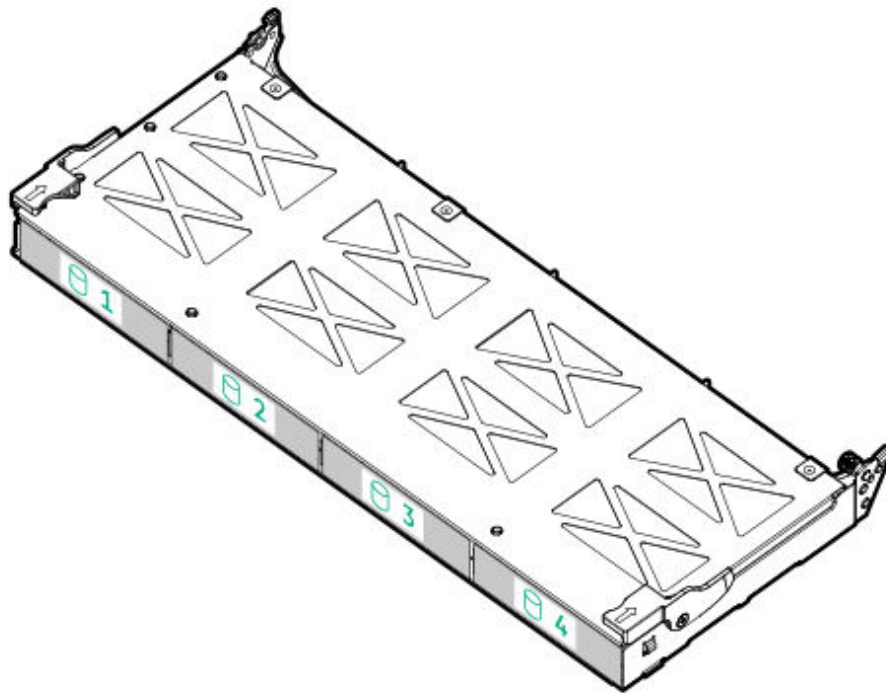

Fan bay numbering

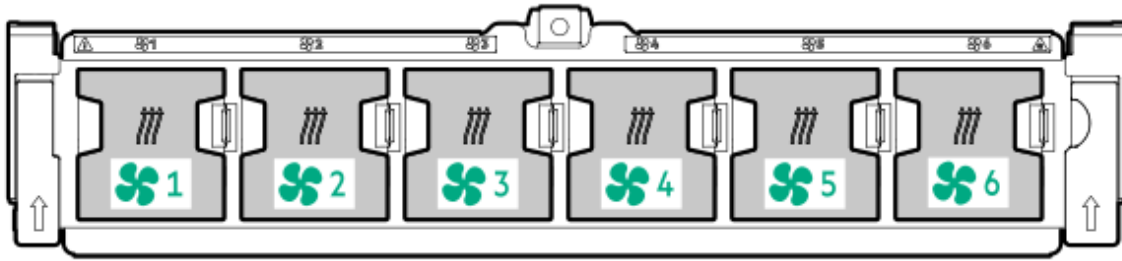

Component touchpoints

Certain components are color-coded. These colors represent the recommended touch areas for a removal process and indicate whether components require a system shutdown before removal.

The following diagrams are examples only.

HPE hot-plug red

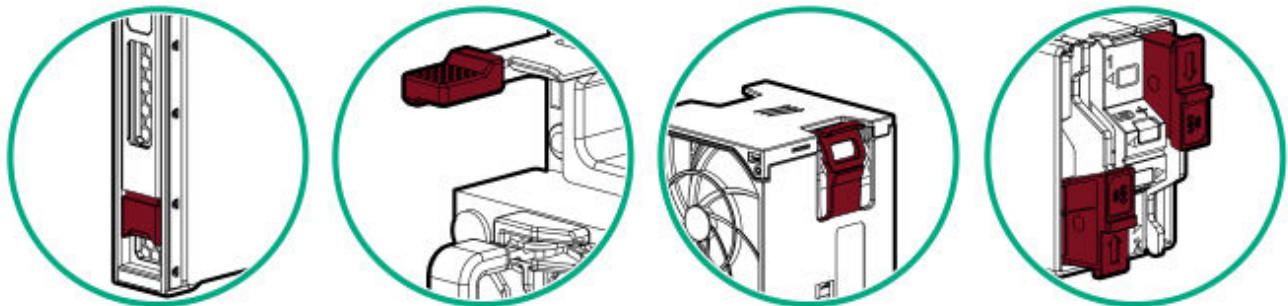

Hot-plug red indicates hot-pluggable components. These components can be removed and installed while the system is running, and doing so will not result in a system shutdown.

Component examples:

- Power supplies in a redundant power configuration
- Hot-plug fans
- Hot-plug drives

- M.2 SSDs in a hot-plug boot device

HPE touchpoint blue

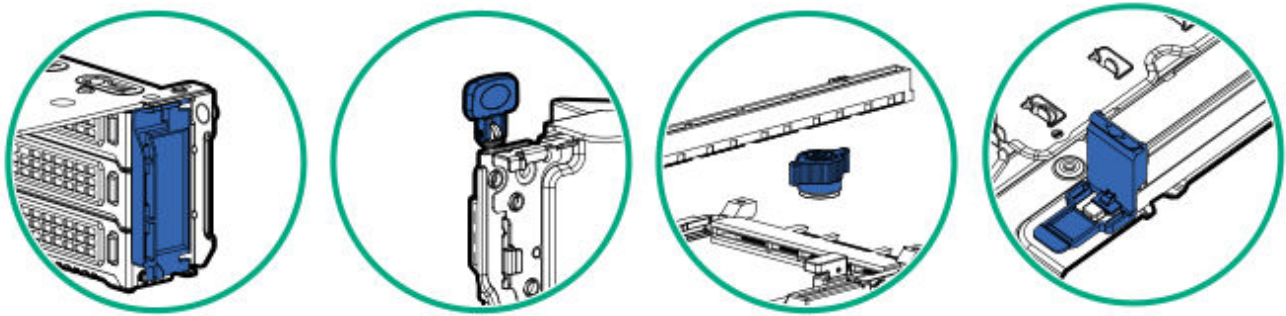

Touchpoint blue indicates cold-pluggable components. These components require a system shutdown. Failure to do so might result in system failure or data loss. Cold-pluggable components might also indicate touchpoints on non-electrical components.

Component examples:

- Storage devices
- Fan cages
- System boards
- Energy packs

HPE Basic Drive LED definitions

The HPE Basic drive carrier has the following LEDs:

- Amber/blue LED—Managed by the drive backplane in conjunction with the storage controller and is used to indicate drive status.
- Green LED—Managed by the drive itself and indicates the drive activity.

LFF drive carrier

The LFF low-profile drive carrier supports hot-plug SAS or SATA.

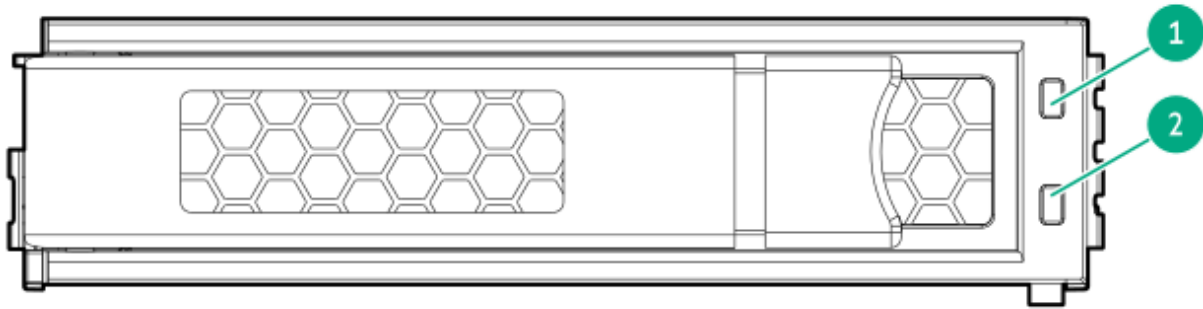

SFF drive carrier

The SFF basic drive carrier supports hot-plug SAS, SATA, or U.3 NVMe.

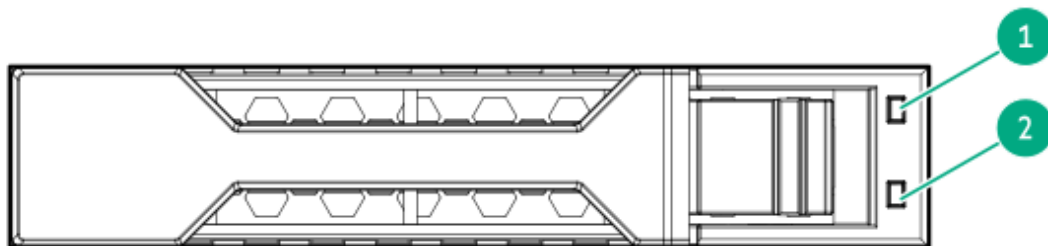

Item	LED	State	Definition
1	Fault/Locate	Solid amber	This drive has failed, is unsupported, or is invalid.
		Solid blue	The drive is operating normally and being identified by a management application.
		Flashing amber/blue (1 flash per second)	The drive has failed, or a predictive failure alert has been received for this drive. The drive has also been identified by a management application.
		Flashing amber (1 flash per second)	A predictive failure alert has been received for this drive. Replace the drive as soon as possible.
		Off	The drive is operating normally and not being identified by a management application.
2	Online/Activity	Solid green	The drive is online and has no activity.

Item	LED	State	Definition
		Flashing green (1 flash per second)	<p>The drive is doing one of the following:</p> <ul style="list-style-type: none"> • Rebuilding or performing a RAID • Performing a stripe size migration • Performing a capacity expansion • Performing a logical drive extension • Erasing • Spare part activation
		Flashing green (4 flashes per second)	The drive is operating normally and has activity.
		Off	The drive is not configured by a RAID controller or is a spare drive.

EDSFF SSD LED definitions

The EDSFF drive carrier has two LEDs:

- Amber/blue LED—Managed by the drive backplane in conjunction with the storage controller and is used to indicate drive status.
- Green LED—Managed by the drive itself and indicates the drive activity.

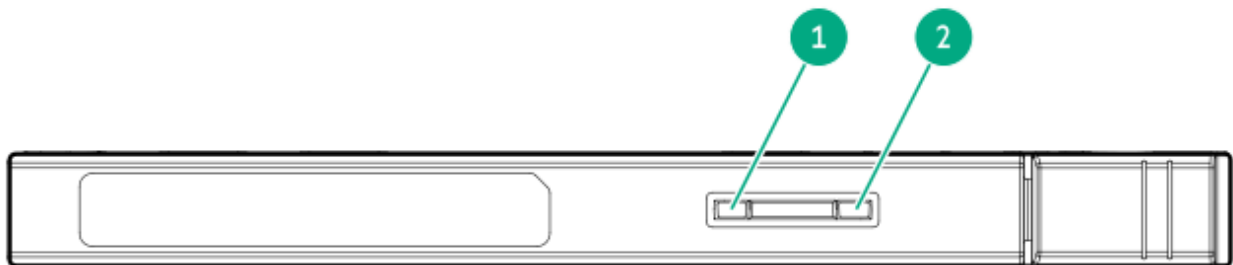

Item	LED	State	Definition
1	Fault/Locate	Solid amber	This drive has failed, is unsupported, or is invalid.

Item	LED	State	Definition
		Solid blue	The drive is operating normally and being identified by a management application.
		Flashing amber/blue (1 flash per second)	The drive has failed, or a predictive failure alert has been received for this drive. The drive has also been identified by a management application.
		Flashing amber (1 flash per second)	A predictive failure alert has been received for this drive. Replace the drive as soon as possible.
		Off	The drive is operating normally and not being identified by a management application.
2	Online/Activity	Solid green	The drive is online and has no activity.
		Flashing green (4 flashes per second)	The drive is operating normally and has activity.
		Off	No power present.

Systems Insight Display LEDs

The Systems Insight Display LEDs represent the system board layout. The display enables diagnosis with the access panel installed.

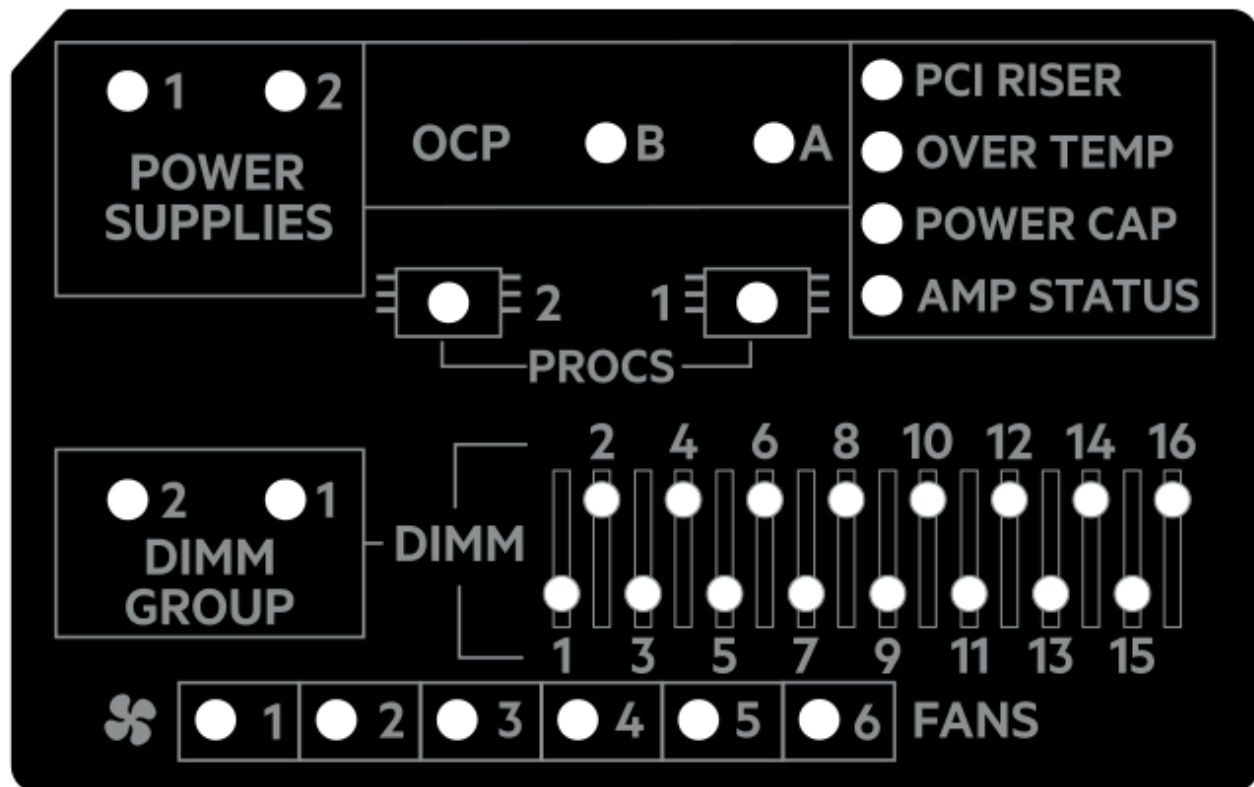

Description

Status

Processor LEDs

Off = Normal

Amber = Failed processor

DIMM LEDs

Off = Normal

Amber = Failed DIMM or configuration issue

DIMM group LEDs

Off = Normal

Amber = Failed DIMM group or configuration issue

Fan LEDs

Off = Normal

Amber = Failed fan or missing fan

NIC LEDs 1

Off = No link to network

Solid green = Network link

Flashing green = Network link with activity

Description	Status
Power supply LEDs	If power is off, the front panel LED is not active. For status, see Rear panel LEDs . Off = Normal Solid amber = Power subsystem degraded, power supply failure, or input power lost.
PCI riser LED	Off = Normal Amber = Incorrectly installed PCI riser cage
Over temp LED	Off = Normal Amber = High system temperature detected
Power cap LED	Off = System is in standby, or no cap is set. Solid green = Power cap applied
AMP ² Status LED	Off = AMP modes disabled Solid green = AMP mode enabled Solid amber = Failover Flashing amber = Invalid configuration

¹ Embedded NIC ports are not equipped on the server. NIC LEDs on the Systems Insight Display will flash based on the network adapter port activity. In the case of a dual-port adapters, only NIC LED 1 and 2 will illuminate to correspond with the activity of the respective network ports.

² To configure Advanced Memory Protection, see the latest [UEFI System Utilities user guide](#).

When the health LED on the front panel illuminates either amber or red, the server is experiencing a health event. For more information on the combination of these LEDs, see [Systems Insight Display combined LED descriptions](#).

Systems Insight Display combined LED descriptions

The combined illumination of the following LEDs indicates a system condition:

- Systems Insight Display LEDs
- System power LED
- Health LED

Systems Insight Display LED and color	Health LED	System power LED	Status
Processor (amber)	Red	Amber	One or more of the following conditions might exist: <ul style="list-style-type: none"> Processor in socket X has failed. Processor X is not installed in the socket. Processor X is unsupported. ROM detects a failed processor during POST.
Processor (amber)	Amber	Green	Processor in socket X is in a pre-failure condition.
DIMM (amber)	Red	Green	One or more DIMMs have failed.
DIMM (amber)	Amber	Green	DIMM in slot X is in a pre-failure condition.
Over temp (amber)	Amber	Green	The Health Driver has detected a cautionary temperature level.
Over temp (amber)	Red	Amber	The server has detected a hardware critical temperature level.
PCI riser (amber)	Red	Green	The PCI riser cage is not seated properly.
Fan (amber)	Amber	Green	One fan has failed or has been removed.
Fan (amber)	Red	Green	Two or more fans have failed or been removed.
Power supply (amber)	Red	Amber	One or more of the following conditions might exist: <ul style="list-style-type: none"> Only one power supply is installed and that power supply is in standby. Power supply fault. System board fault.
Power supply (amber)	Amber	Green	One or more of the following conditions might exist: <ul style="list-style-type: none"> Redundant power supply is installed and only one power supply is functional. AC power cord is not plugged into redundant power supply. Redundant power supply fault.

Systems Insight Display LED and Health LED System power LED Status

Systems Insight Display LED and Health LED	System power LED	Status
		<ul style="list-style-type: none"> Power supply mismatch at POST or power supply mismatch through hot-plugging addition.
Power cap (off)	— Amber	Standby.
Power cap (green)	— Flashing green	Waiting for power.
Power cap (green)	— Green	Power is available.
Power cap (flashing amber)	— Amber	Power is not available.



IMPORTANT

If more than one DIMM slot LED is illuminated, further troubleshooting is required. Test each bank of DIMMs by removing all other DIMMs. Isolate the failed DIMM by replacing each DIMM in a bank with a known working DIMM.

HPE NS204i-u Boot Device V2 components

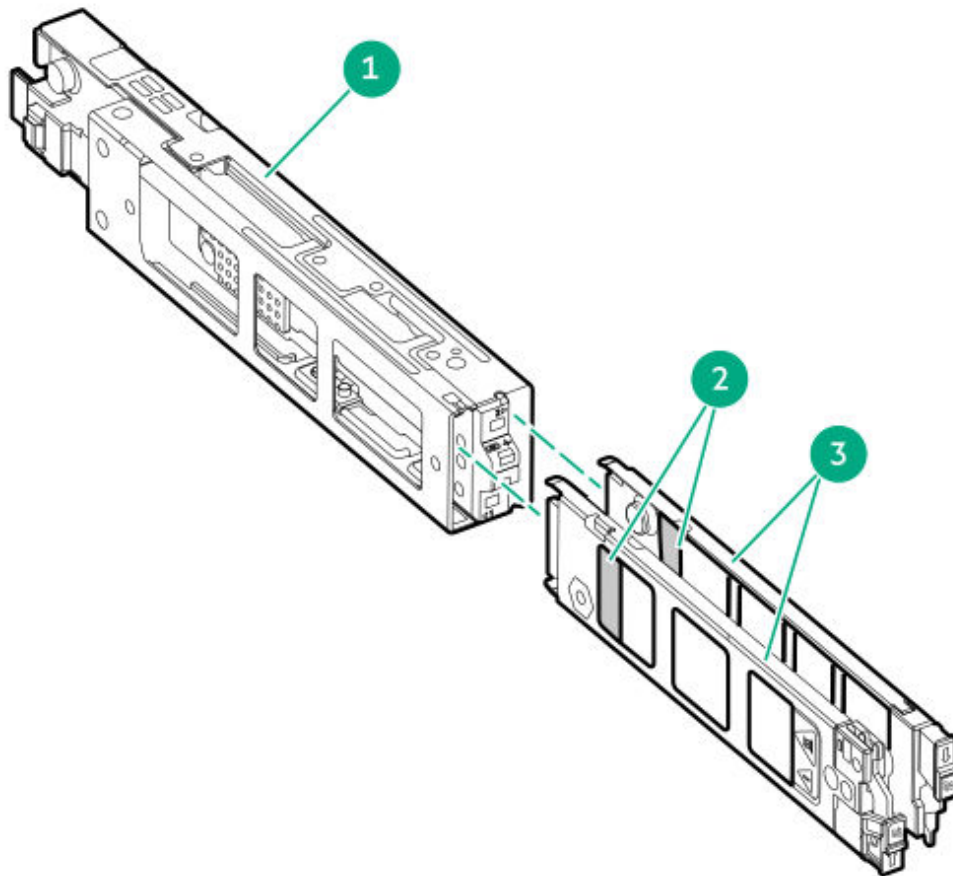

Item	Description
1	Boot device cage
2	M.2 slots
3	Boot device carriers

HPE NS204i-u Boot Device V2 LED definitions

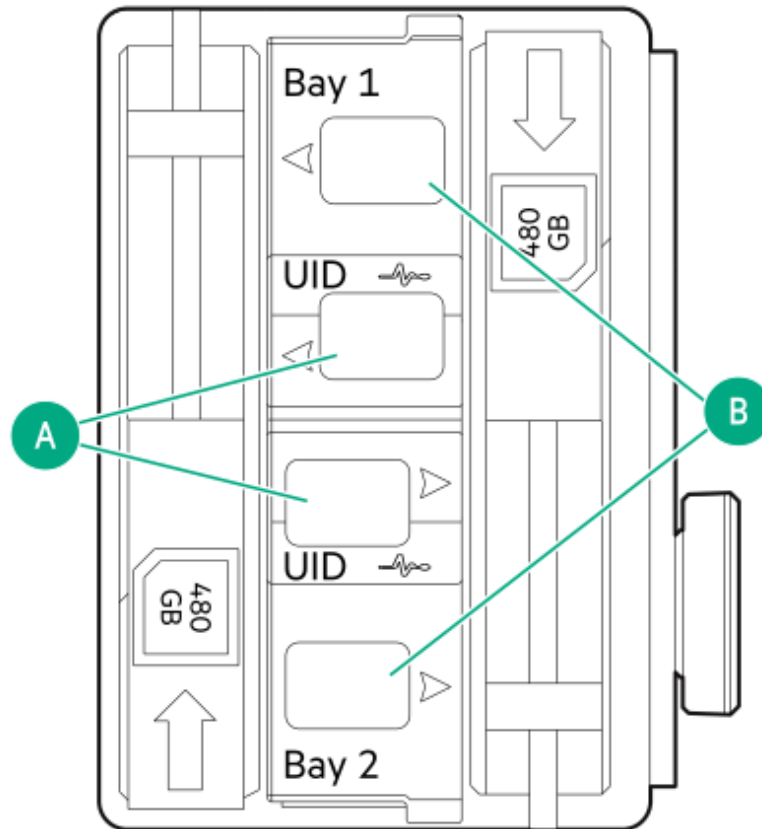

NOTE

The bay number can be found on the SSD carrier handle.

Item	LED	Status	Definition
A	Fault or Locate	Solid amber	Drive has failed, unsupported, or invalid.
		Solid blue	Drive is operating normally.
		Flashing amber or blue (one flash per second)	Drive has failed, or a predictive failure alert is received for the drive.
		Flashing amber (one flash per second)	Drive predictive failure alert is received. Replace the drive as soon as possible.
		Off	Drive is operating normally and is not identified by any application.
B	Online/Activity	Solid green	Drive is online and has no activity.

Item	LED	Status	Definition
		Flashing green (one flash per second)	Drive is doing one of the following: <ul style="list-style-type: none"> Rebuilding or performing a RAID Erasing
		Flashing green (4 flashes per second)	Drive is operating normally and has activity.
		Off	Drive is not configured by a RAID controller.

Riser board components

PCIe5 x16/x16/x16 riser components

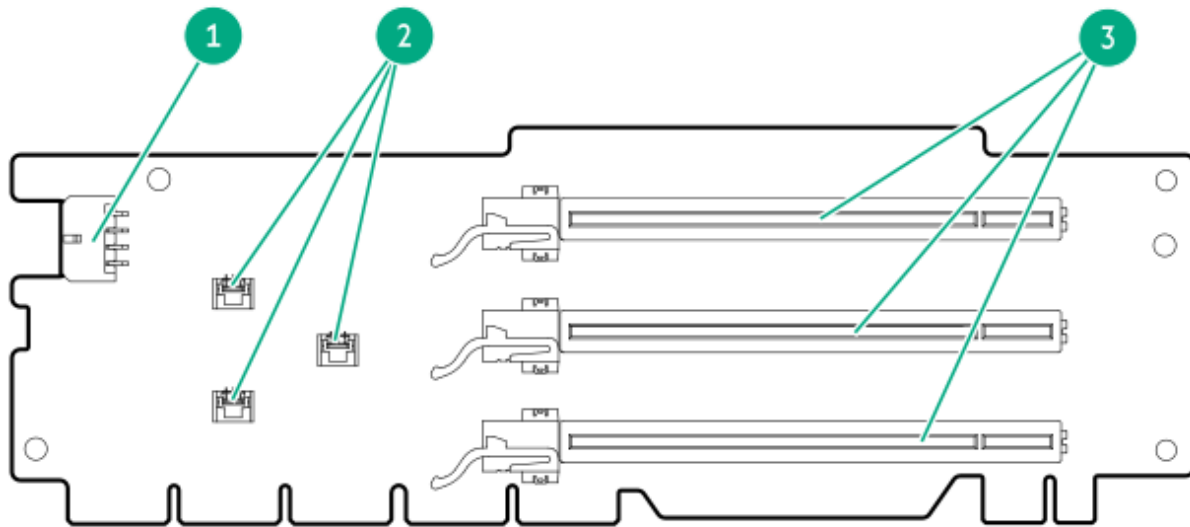

Item	Description
1	8-pin GPU power connector
2	Storage controller voltage back up (VBU) power connectors
3	x16 riser slots

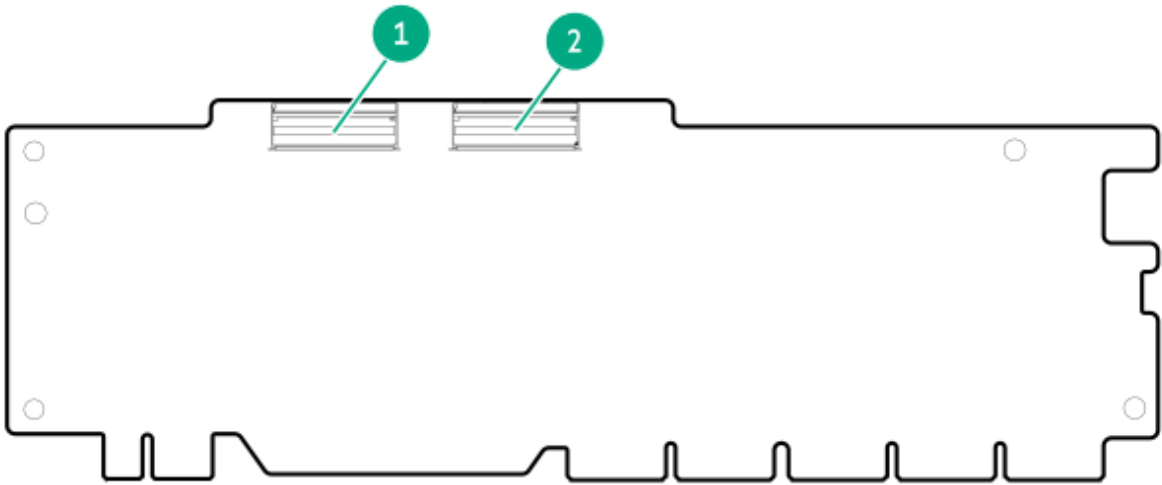

Item	Description
------	-------------

1	LP SlimSAS connector 1
---	------------------------

2	LP SlimSAS connector 2
---	------------------------

PCIe5 x8/x16/x8 riser components

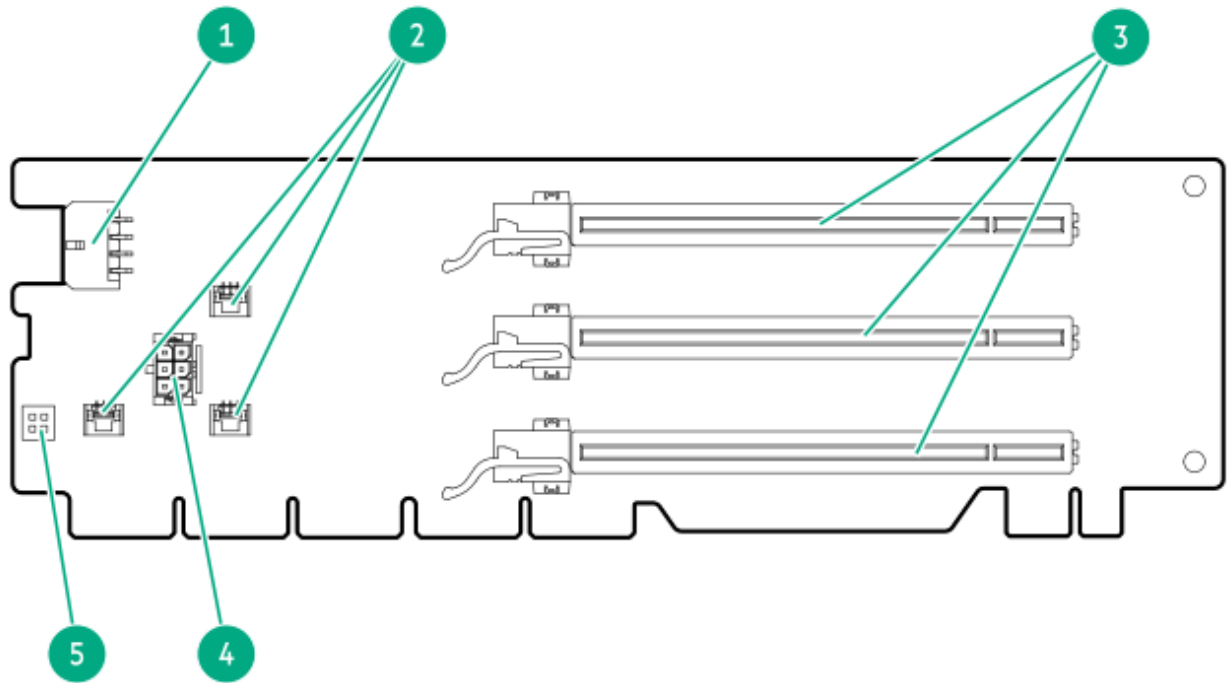

Item	Description
1	8-pin GPU power connector
2	Storage controller voltage back up (VBU) power connectors
3	Slot 1 is x8 Slot 2 is x16 Slot 3 is x8
4	6-pin GPU power connector
5	GPU sideband management connector

PCIe5 x16/x16 tertiary riser components

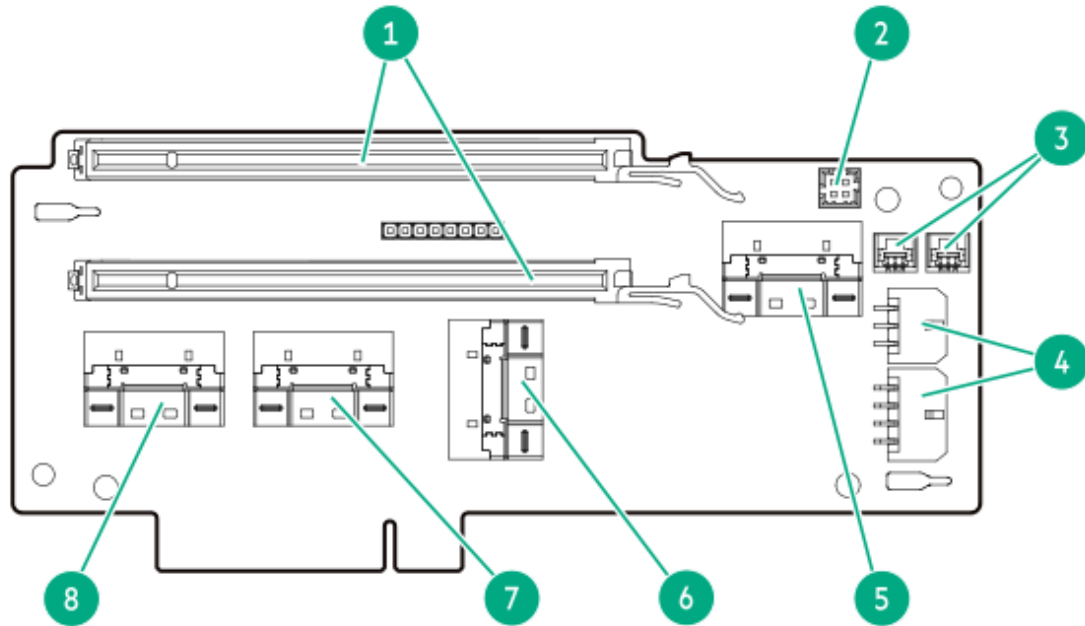

Item	Description
1	PCIe5 x16 (8, 4, 1) slots
2	GPU sideband management connector
3	Storage controller voltage back up (VBU) power connectors
4	6-pin and 8-pin GPU power connector
5	PCIe SlimSAS port 2
6	PCIe SlimSAS port 4
7	PCIe SlimSAS port 3
8	PCIe SlimSAS port 1

Rear slot numbering

All riser slots are PCIe5 and are rated for a maximum power draw of 75 W each.

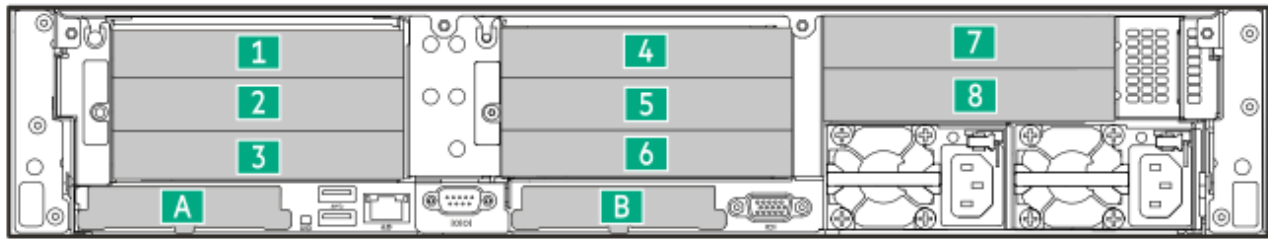

Slot number	Location	Supported form factors
1	Primary riser cage	Full-height, full-length
2		Full-height, half-length
3		Full-height, half-length
4	Secondary riser cage	Full-height, full-length
5		Full-height, half-length
6		Full-height, half-length
7	Tertiary riser cage	Full-height, full-length
8		Full-height, half-length
A	OCP slot A	Standard OCP adapters
B	OCP slot B	Standard OCP adapters

Heatsink and processor socket components

A high-performance heatsink is shown. Your heatsink might look different.

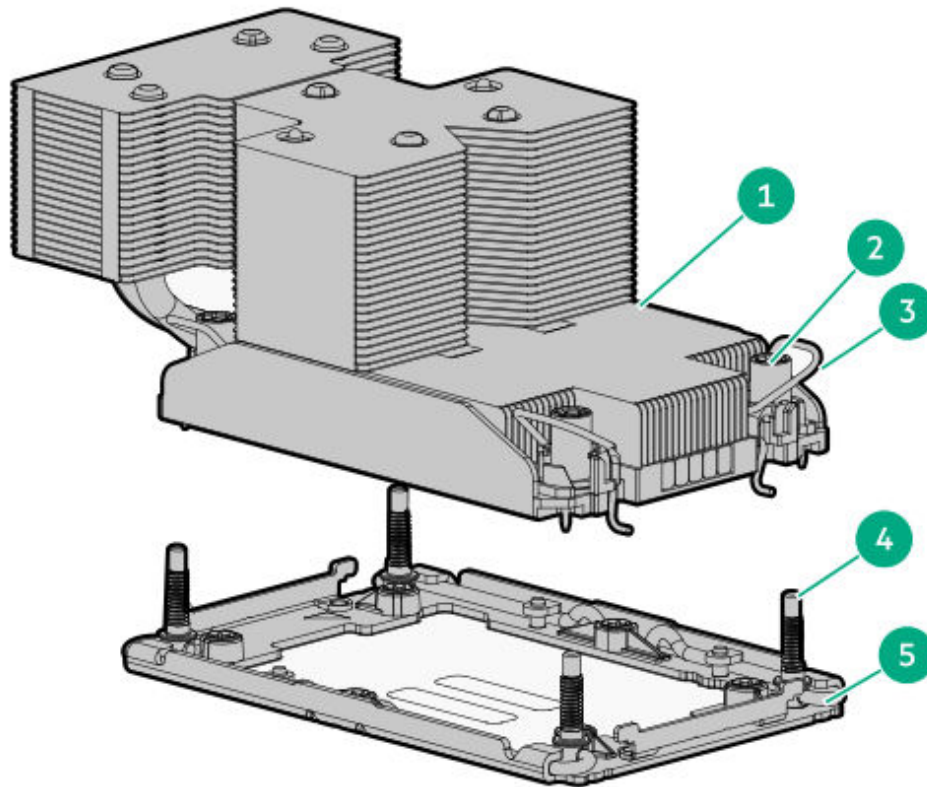

Item	Description
1	Processor-heatsink module ¹ _—
2	Heatsink nuts
3	Heatsink latches
4	Alignment screws
5	Bolster plate

¹_— The module consists of the heatsink, processor, and carrier.

Management arm components

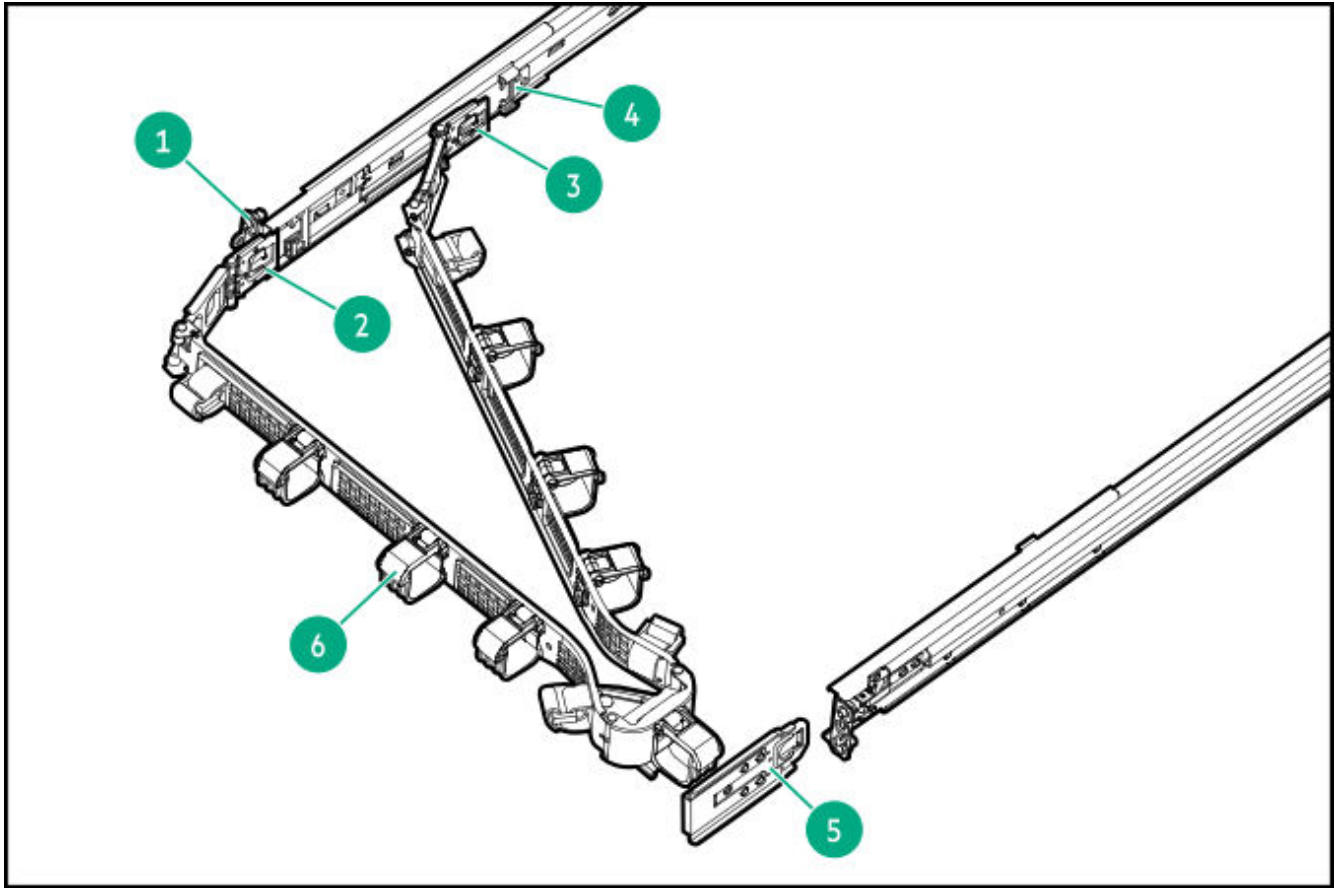

Item	Description
1	Outer rail
2	CMA outer rail bracket
3	CMA inner rail bracket
4	Inner rail
5	CMA elbow bracket
6	Cable basket

Setup

Provides initial setup procedures, operational requirements, and key safety cautions.

Subtopics

HPE Installation Service

Setting up the server

Rack warnings and cautions

Server warnings and cautions

Electrostatic discharge

HPE Installation Service

HPE Installation Service provides basic installation of Hewlett Packard Enterprise branded equipment, software products, as well as HPE-supported products from other vendors that are sold by HPE or by HPE authorized resellers. The Installation Service is part of a suite of HPE deployment services that are designed to give users the peace of mind that comes from knowing that their HPE and HPE-supported products have been installed by an HPE specialist.

The HPE Installation Service provides the following benefits:

- Installation by an HPE authorized technical specialist.
- Verification prior to installation that all service prerequisites are met.
- Delivery of the service at a mutually scheduled time convenient to your organization.
- Allows your IT resources to stay focused on their core tasks and priorities.
- Full coverage during the warranty period for products that require installation by an HPE authorized technical specialist.

For more information on the features, limitations, provisions, and ordering information of the HPE Installation Service, see this Hewlett Packard Enterprise website:

<https://www.hpe.com/support/installation-service>

Setting up the server

Prerequisites

- As a best practice, Hewlett Packard Enterprise recommends installing the latest firmware, drivers, and system software before using the server for the first time. You have these options:
 - HPE Compute Ops Management is an advanced software-as-a-service platform that securely streamlines operations from edge-to-cloud and automates key life cycle tasks through a unified single browser-based interface. For more information on using HPE Compute Ops Management, see **<https://www.hpe.com/info/com-docs>**.

- Use the **Firmware Update** option in Intelligent Provisioning—Intelligent Provisioning is a server deployment tool embedded in HPE ProLiant servers. To access Intelligent Provisioning, during the server boot process, press **F10**. For more information, see the Intelligent Provisioning user guide at <https://www.hpe.com/support/hpeintelligentprovisioning-quicklinks>.
- Download the Service Pack for HPE ProLiant—SPP is a comprehensive system software and firmware update solution that is delivered as a single ISO image. This solution uses Smart Update Manager as the deployment tool.
 - The preferred method for downloading an SPP is by creating an SPP custom download at <https://www.hpe.com/servers/spp/custom>.

This option reduces the size of the SPP by excluding firmware and drivers for OS and server models that are not needed.
 - The SPP is also available for download from the SPP download page at <https://www.hpe.com/servers/spp/download>.

- Verify that your OS or virtualization software is supported:
<https://www.hpe.com/support/Servers-Certification-Matrices>
- This server supports type-o and type-p storage controller options. For storage configuration, use Intel Virtual RAID on CPU (Intel VROC). If you plan to use Intel VROC, [review this important information before setting up the server](#).
- Read the [Operational requirements](#) for the server.
- Read the safety and compliance information:
<https://www.hpe.com/support/safety-compliance-enterpriseproducts>

Procedure

1. Unbox the server and verify the contents:
 - Server
 - Power cord
 - Rackmounting hardware (optional)
 - Documentation

The server does not ship with OS media. All system software and firmware is preloaded on the server.

2. (Optional) [Install the hardware options](#).
3. [Installing the server into the rack](#).
4. Decide how to manage the server:

- Locally: Use a KVM switch or a connect a keyboard, monitor, and mouse.
- Remotely: Connect to the iLO web interface and run a remote console:

a. Verify the following:

- iLO is licensed to use the remote console feature.
If iLO is not licensed, visit the HPE website:

<https://www.hpe.com/info/ilo>

- The iLO management port is connected to a secure network.

b. Using a browser, navigate to the iLO web interface, and then log in.

`https://<iLO hostname or IP address>`

Note the following:

- If a DHCP server assigns the IP address, the IP address appears on the boot screen.
- If a static IP address is assigned, use that IP address.

c. Enter the iLO login name and password, and then click **Log In**.

d. In the navigation tree:

- For iLO 6: Click the **Remote Console & Media** link, and then launch a remote console.
- For iLO 7: Click the **Host > Remote Console**, and then launch a remote console.

5. Press the Power On/Standby button.

For remote management, use the iLO virtual power button.

6. Configure the initial server setup.

7. Set up the storage.

8. Deploy an OS or virtualization software.

9. After the OS is installed, update the drivers.

10. Register the server.

Rack warnings and cautions



WARNING

When all components are removed, the server weighs 25.32 kg (55.81 lb). When all components are installed, the server can weigh up to 29.99 kg (66.11 lb).

Before configuring your rack solution, be sure to check the rack manufacturer weight limits and specifications. Failure to do so can result in physical injury or damage to the equipment and the facility.



WARNING

The server is heavy. To reduce the risk of personal injury or damage to the equipment, do the following:

- Observe local occupational health and safety requirements and guidelines for manual material handling.
- Get help to lift and stabilize the product during installation or removal, especially when the product is not fastened to the rails. The server weighs more than 25.32 kg (55.81 lb), so at least two people must lift the server into the rack together. An additional person may be required to help align the server if the server is installed higher than chest level.
- Use caution when installing the server in or removing the server from the rack.
- Adequately stabilize the rack before extending a component outside the rack. Extend only one component at a time. A rack may become unstable if more than one component is extended.
- Do not stack anything on top of rail-mounted component or use it as a work surface when extended from the rack.



WARNING

To reduce the risk of personal injury or damage to the equipment, be sure that:

- The rack has anti-tip measures in place. Such measures include floor-bolting, anti-tip feet, ballast, or a combination as specified by the rack manufacturer and applicable codes.
- The leveling jacks (feet) are extended to the floor.
- The full weight of the rack rests on the leveling jacks (feet).

Server warnings and cautions



WARNING

To reduce the risk of personal injury, electric shock, or damage to the equipment, disconnect the power cord to remove power from the server. Pressing the Power On/Standby button does not shut off system power completely. Portions of the power supply and some internal circuitry remain active until AC power is removed.



WARNING

To reduce the risk of personal injury from hot surfaces, allow the drives and the internal system components to cool before touching them.



WARNING

To reduce the risk of fire or burns after removing the energy pack:

- Do not disassemble, crush, or puncture the energy pack.
- Do not short external contacts.
- Do not dispose of the energy pack in fire or water.
- Do not expose the energy pack to low air pressure as it might lead to explosion or leakage of flammable liquid or gas.
- Do not expose the energy pack to temperatures higher than 60°C (140°F).

After power is disconnected, battery voltage might still be present for 1s to 160s.



CAUTION

Protect the server from power fluctuations and temporary interruptions with a regulating UPS. This device protects the hardware from damage caused by power surges and voltage spikes and keeps the server in operation during a power failure.



CAUTION

To prevent damage to electrical components, properly ground the server before beginning any installation, removal, or replacement procedure. Improper grounding can cause electrostatic discharge.



CAUTION

To avoid data loss, Hewlett Packard Enterprise recommends that you back up

Electrostatic discharge

Be aware of the precautions you must follow when setting up the system or handling components. A discharge of static electricity from a finger or other conductor may damage system boards or other static-sensitive devices. This type of damage may reduce the life expectancy of the system or component.

To prevent electrostatic damage:

- Avoid hand contact by transporting and storing products in static-safe containers.
- Keep electrostatic-sensitive parts in their containers until they arrive at static-free workstations.
- Place parts on a grounded surface before removing them from their containers.
- Avoid touching pins, leads, or circuitry.
- Always be properly grounded when touching a static-sensitive component or assembly. Use one or more of the following methods when handling or installing electrostatic-sensitive parts:
 - Use a wrist strap connected by a ground cord to a grounded workstation or computer chassis. Wrist straps are flexible straps with a minimum of 1 megohm \pm 10 percent resistance in the ground cords. To provide proper ground, wear the strap snug against the skin.
 - Use heel straps, toe straps, or boot straps at standing workstations. Wear the straps on both feet when standing on conductive floors or dissipating floor mats.
 - Use conductive field service tools.
 - Use a portable field service kit with a folding static-dissipating work mat.

If you do not have any of the suggested equipment for proper grounding, have an authorized reseller install the part.

For more information on static electricity or assistance with product installation, contact an authorized reseller.

Operations

Server features, controls, and behaviors associated with system access and hardware status.

Subtopics

[iLO service port](#)

[Intel VROC support](#)

Server UID LED

Monitor setup

Fan mode behavior

Supported PCIe form factors

Accessing the Systems Insight Display

Trusted Platform Module 2.0

Trusted Platform Module 2.0 guidelines

System battery information

iLO service port

The iLO service port is a USB port with the label **iLO** on the front of the server.

When you have physical access to a server, you can use the iLO service port to:

- Download the Active Health System Log to a supported USB flash drive.

When you use this feature, the connected USB flash drive is not accessible by the host OS.

- Connect a host system (Windows/Mac/Linux laptop or desktop) using either a standard USB Type A-to-Type C cable or USB Type C-to-Type C cable to access the:
 - iLO web interface
 - Remote console
 - iLO RESTful API
 - CLI

When you use the iLO service port:

- Actions are logged in the iLO event log.
- The server UID flashes to indicate the iLO service port status.

You can also retrieve the iLO service port status by using a REST client and the iLO RESTful API.

- You cannot use the iLO service port to boot any device within the server, or the server itself.
- You cannot access the server by connecting to the iLO service port.
- You cannot access the connected device from the server.

For more information about the iLO service port, see the iLO user guide:

<https://www.hpe.com/support/hpeilodocs-quicklinks>

Intel VROC support

Intel Virtual RAID on CPU (Intel VROC) provides enterprise-level hybrid RAID support. Note the following information:

- Intel VROC provides RAID support for direct attached NVMe SSD.
- The Intel VROC driver is required. For the OS-specific driver download, see the following page:
<https://www.hpe.com/support/VROC-installation>
- If you plan to enable Intel VROC for NVMe devices, secure an Intel VROC Hybrid RAID License. For more information on Intel VROC licenses, see the server QuickSpecs:
<https://www.hpe.com/info/quickspecs>
- Intel VROC requires the server boot mode to be set to **UEFI Mode**.
- Intel VROC RAID support is disabled by default. In the pre-OS environment, use UEFI System Utilities to enable Intel VROC and create a VROC RAID volume. These tasks are not supported in Intelligent Provisioning.
- The VROC RAID volume must use drives of the same interface and form factor.
- Intel VROC supports RAID management through the following tools:
 - Non-OS specific: UEFI System Utilities
 - Windows: Intel VROC GUI, Intel VROC CLI
 - Linux: `mdadm` CLI

For more information on Intel VROC features and configuration, see [Configuring storage controllers](#).

Server UID LED

The UID LED can be used to help an on-site technician quickly identify or locate a particular server when it is deployed in a dense rack with other equipment. It can also be used to identify if a remote management, firmware upgrade, or reboot sequence is in progress.

Subtopics

[Viewing the Server Health Summary](#)

Viewing the Server Health Summary

Prerequisites

- An external monitor is connected.
- In the iLO web interface, the **Show Server Health on External Monitor** feature is enabled on the **Access Settings** page.

About this task

If the server does not power on, use the UID button to display the iLO **Server Health Summary** screen on an external monitor. This function works when the server is powered on or off.

For more information, see the iLO troubleshooting guide on the [Hewlett Packard Enterprise website](#).

Procedure

1. Press and release the UID button.



CAUTION

Be sure to press and release the UID button. Pressing the UID button at any time for more than five seconds will initiate a graceful iLO reboot or a hardware iLO reboot. Data loss or NVRAM corruption might occur during a hardware iLO reboot.

The **Server Health Summary** screen displays on the external monitor.

2. Press the UID button again to close the **Server Health Summary** screen.

Monitor setup

Before connecting a monitor, observe the following:

- The server supports both VGA port and DisplayPort 1.1a.
- If you connect two display devices to the server using both the VGA port and DisplayPort, the same image is mirrored on both devices.
- The embedded video controller in the iLO chipset does not support dual display or screen extension mode. To enable dual display, install a compatible graphics card.
- When using HDMI or DVI adapters for the DisplayPort, use an active-type adapter. Passive-type adapters marked with the DP++ symbol are not supported.

- Whenever possible, use the same display connection type. For example, if your monitor only has a VGA port, use the VGA port on the server. Using other adapters or converter cables or dongles might lead to decreased display quality or a lag over the connection.

Fan mode behavior



CAUTION

To avoid damage to server components, fan blanks must be installed in fan bays 1 and 2 in a single-processor configuration.



CAUTION

To avoid damage to the equipment, do not operate the server for extended periods of time if the server does not have the optimal number of fans installed. Although the server might boot, we do not recommend operating the server without the required fans installed and operating.

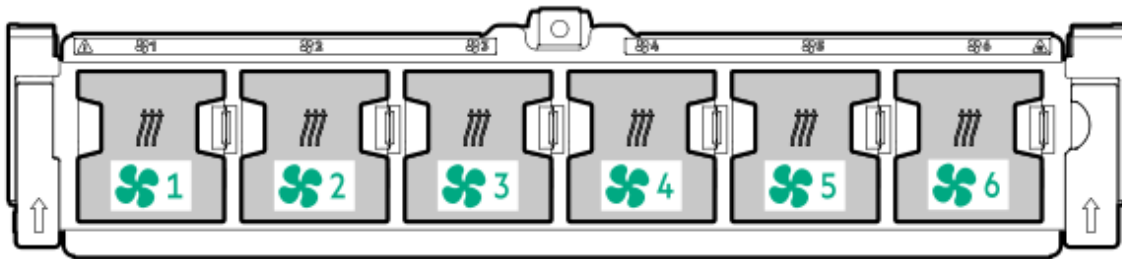

Table 1. Fan configurations

Configuration	Fan bay 1	Fan bay 2	Fan bay 3	Fan bay 4	Fan bay 5	Fan bay 6
Single processor	Fan blank	Fan blank	Fan	Fan	Fan	Fan
Dual processors	Fan	Fan	Fan	Fan	Fan	Fan

For base single-processor configurations, four fans and two blanks are required in specific fan bays for redundancy. A fan failure or missing fan causes a loss of redundancy. A second fan failure or missing fan causes an orderly shutdown of the server.

For dual-processor configurations, six fans are required for redundancy. A fan failure or missing fan causes a loss of redundancy. A second fan failure or missing fan causes an orderly shutdown of the server.

High-performance fans might be necessary certain configurations:

- Optional GPU riser installations
- ASHRAE compliant configurations

For more information, see the [Hewlett Packard Enterprise website](#).

The server supports variable fan speeds. The fans operate at minimum speed until a temperature change requires a fan speed increase to cool the server. The server shuts down during the following temperature-related scenarios:

- At POST and in the OS, iLO 7 performs an orderly shutdown if a cautionary temperature level is detected. If the server hardware detects a critical temperature level before an orderly shutdown occurs, the server performs an immediate shutdown.
- When the Thermal Shutdown feature is disabled in the BIOS/Platform Configuration (RBSU), iLO 7 does not perform an orderly shutdown when a cautionary temperature level is detected. Disabling this feature does not disable the server hardware from performing an immediate shutdown when a critical temperature level is detected.



CAUTION

A thermal event can damage server components when the Thermal Shutdown feature is disabled in the BIOS/Platform Configuration (RBSU).

Supported PCIe form factors

All slots support full-height expansion cards. Use the following information to find supported lengths for each slot.

Primary riser connector

PCIe slot and card length	3-slot riser*	3-slot riser (Optional)
Slot 1 - Full-length/Full-height (FL /FH)	PCIe5 x8 (8, 4, 2, 1)	PCIe5 x16 (16, 8, 4, 2, 1)
Slot 2 - Full-length/Full-height (FL /FH)	PCIe5 x16 (16, 8, 4, 2, 1)	PCIe5 x16 (16, 8, 4, 2, 1)
Slot 3 - Half-length/Full-height (HL /FH)	PCIe5 x8 (8, 4, 2, 1)	PCIe5 x16 (16, 8, 4, 2, 1)

*When a 3 x16 riser kit is installed, all slots support PCIe5 x16 Full Length and Full Height.

Secondary riser connector

PCIe slot and card length	3-slot riser*	3-slot riser (Optional)
Slot 1 - Full-length/Full-height (FL /FH)	PCIe5 x8 (8, 4, 2, 1)	PCIe5 x16 (16, 8, 4, 2, 1)
Slot 2 - Full-length/Full-height (FL /FH)	PCIe5 x16 (16, 8, 4, 2, 1)	PCIe5 x16 (16, 8, 4, 2, 1)
Slot 3 - Half-length/Full-height (H L/FH)	PCIe5 x8 (8, 4, 2, 1)	PCIe5 x16 (16, 8, 4, 2, 1)

*When a 3 x16 riser kit is installed, all slots support PCIe5 x16 Full Length and Full Height.

Tertiary riser connector

PCIe slot and card length	2-slot riser (Optional)
Slot 7 - Full-length/Full-height (FL/FH)	PCIe5 x16 (16, 8, 4, 2, 1)
Slot 8 - Full-length/Full-height (FL/FH)	PCIe5 x8 (8, 4, 2, 1) or PCIe4 x16 (16, 8, 4, 2, 1)

Accessing the Systems Insight Display

About this task

The Systems Insight Display is only supported on SFF models.

Procedure

1. Press and release the panel.

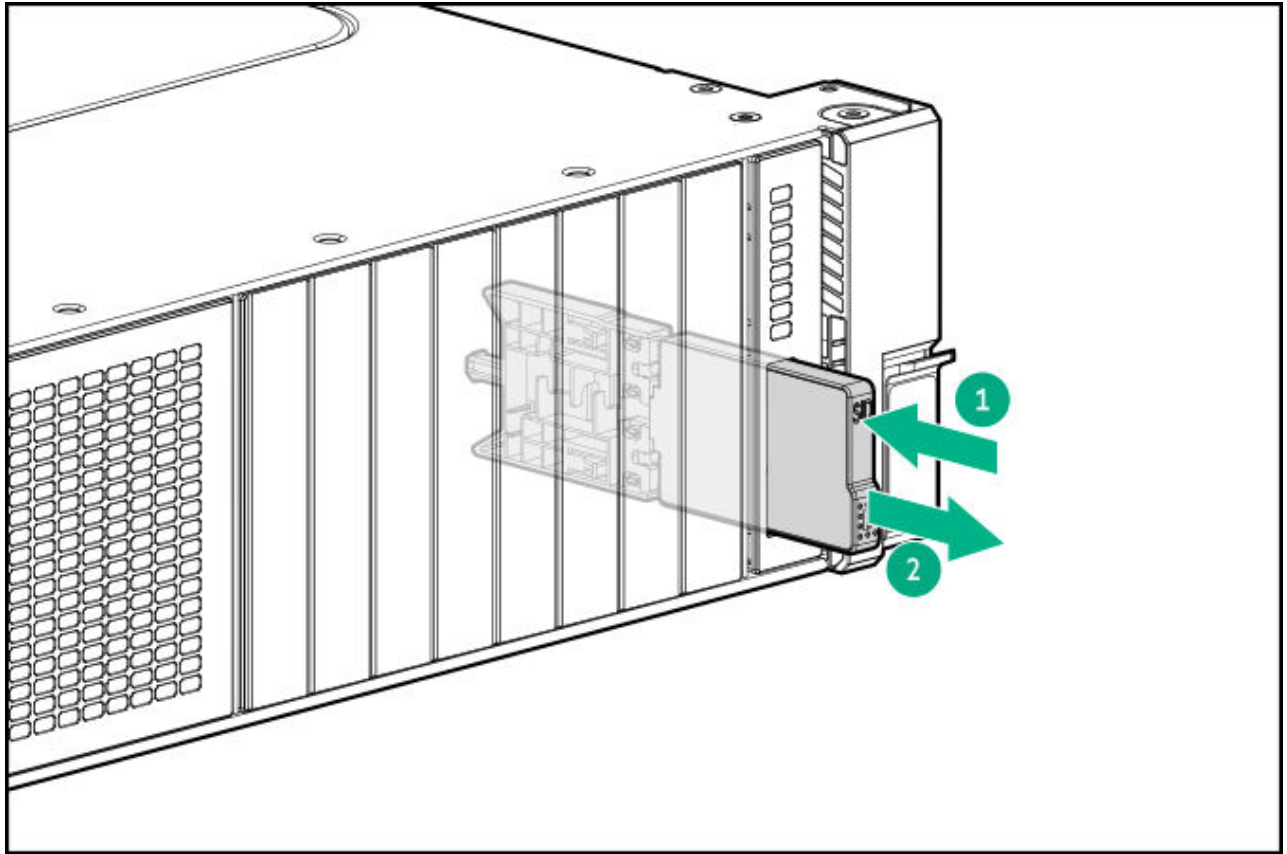

2. After the display fully ejects, rotate the display to view the LEDs.

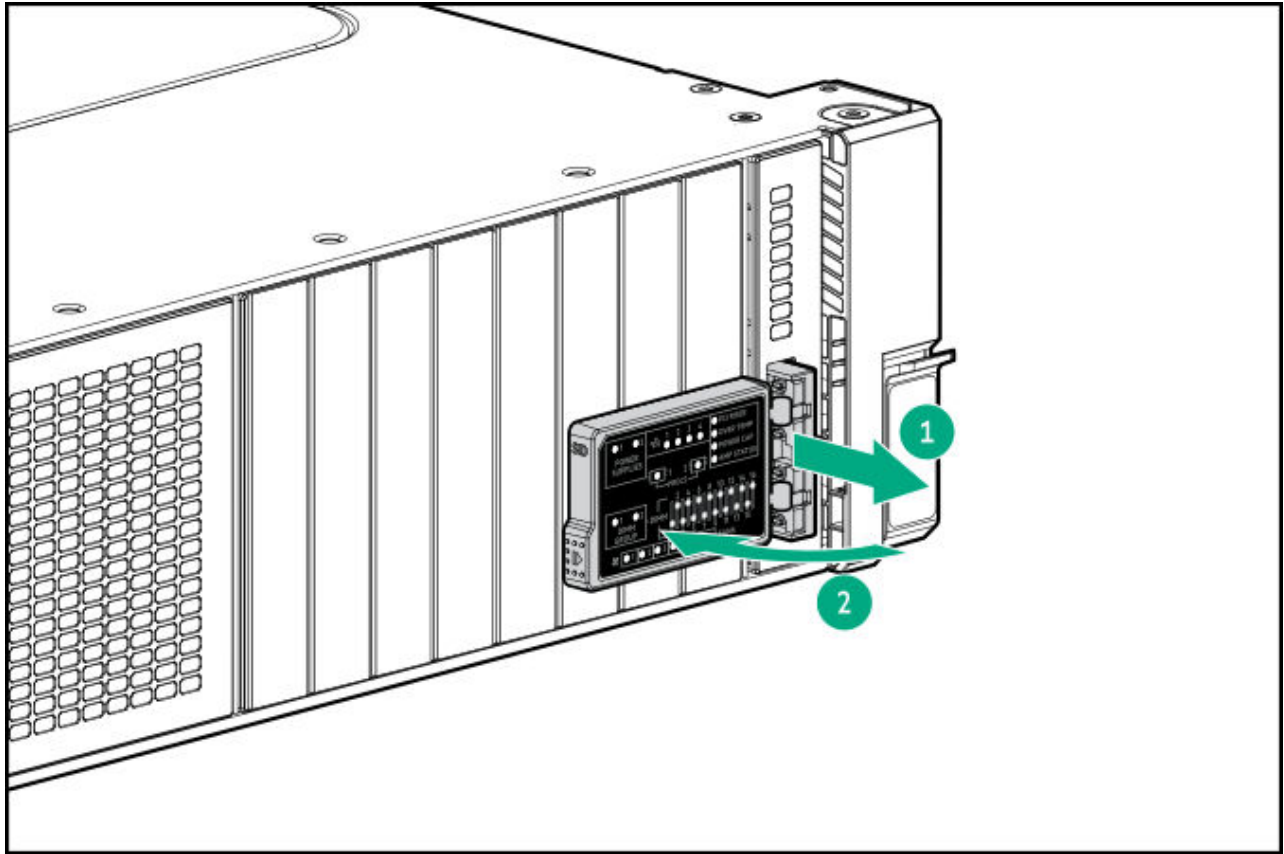

Trusted Platform Module 2.0

The Trusted Platform Module 2.0 (TPM) is:

- Embedded on the system board
- A hardware-based system security feature that securely stores artifacts used to authenticate the platform. These artifacts can include passwords, certificates, and encryption keys
- Supported by specific operating systems such as Microsoft Windows Server 2012 R2 and later

For more information about operating system support, see the product QuickSpecs on the Hewlett Packard Enterprise website (<https://www.hpe.com/info/quickspecs>).

For more information about Microsoft Windows BitLocker Drive Encryption feature, see the Microsoft website (<https://www.microsoft.com>).

Trusted Platform Module 2.0 guidelines



CAUTION

- Always observe the TPM guidelines in this section. Failure to follow these guidelines can cause hardware damage or halt data access.
- If you do not follow procedures for modifying the server and suspending or disabling the TPM in the OS, an OS that is using TPM might lock all data access. This includes updating system or option firmware, replacing hardware such as the system board and drives, and modifying TPM OS settings.
- Changing the TPM mode after installing an OS might cause problems, including loss of data.

- Use the UEFI System Utilities to configure the TPM. From the **System Utilities** screen, select **System Configuration > BIOS/Platform Configuration (RBSU) > Server Security > Trusted Platform Module options**. For more information, see the UEFI user guide:

<https://www.hpe.com/support/hpeuefisystemutilities-quicklinks>

- When using the Microsoft Windows BitLocker Drive Encryption feature, always retain the recovery key or password. The recovery key or password is required to enter Recovery Mode after BitLocker detects a possible compromise of system integrity.
- HPE is not liable for blocked data access caused by improper TPM use. For operating instructions, see the documentation for the encryption technology feature provided by the operating system.

System battery information

The server contains an internal lithium manganese dioxide, a vanadium pentoxide, or an alkaline battery that provides power to the real-time clock.



WARNING

If this battery is not properly handled, a risk of fire or burning exists. To reduce the risk of personal injury:

- Do not attempt to recharge the battery.
- Do not expose the battery to temperatures higher than 60°C (140°F).
- Do not expose the battery to low air pressure as it might lead to explosion or leakage of flammable liquid or gas.
- Do not disassemble, crush, puncture, short external contacts, or dispose of the battery in fire or water.

Hardware options

Provides instructions for installing supported hardware options and required configuration information.

Subtopics

[Hewlett Packard Enterprise product QuickSpecs](#)

[Hardware option installation guidelines](#)

[Pre-installation procedures](#)

[Post-installation procedures](#)

[Cooling](#)

[Drives](#)

[Drive and multipurpose cages](#)

[Energy packs](#)

[GPUs](#)

[Management](#)

[Media devices](#)

[Memory](#)

[Networking](#)

[OS boot device](#)

[Power supplies](#)

[Processors and heatsinks](#)

Rack rail and CMA
Risers and riser cages
Security
Storage controllers

Hewlett Packard Enterprise product QuickSpecs

To learn more about your product, search the Hewlett Packard Enterprise website (<https://www.hpe.com/info/quickspecs>) for the product QuickSpecs:

- Supported options
- Supported configurations
- Component compatibility
- New features
- Specifications
- Part numbers

Hardware option installation guidelines



WARNING

To reduce the risk of personal injury from hot surfaces, allow the drives and the internal system components to cool before touching them.



CAUTION

To avoid data loss, Hewlett Packard Enterprise recommends that you back up all server data before installing or removing a hardware option, or performing a server maintenance or troubleshooting procedure.



CAUTION

To prevent damage to electrical components, properly ground the server before beginning any installation, removal, or replacement procedure. Improper grounding can cause electrostatic discharge.

- Install any hardware options before initializing the server.

- If multiple options are being installed, read the installation instructions for all the hardware options to identify similar steps and streamline the installation process.
- If the hardware option installation involves internal cabling, review the [Cabling guidelines](#).

Pre-installation procedures

Subtopics

Server data backup

Power down the server

Opening and closing the cable management arm

Extend the server from the rack

Remove the server from the rack

Remove the bezel

Remove the access panel

Remove the fan cage

Remove the air baffle or midplane drive cage

Remove the riser cage

Server data backup

To avoid data loss, make sure to back up all server data before installing or removing a hardware option, performing a server maintenance, or a troubleshooting procedure.

Server data in this context refers to information that may be required to return the system to a normal operating environment after completing a hardware maintenance or troubleshooting procedure. This information may include:

- User data files
- User account names and passwords
- Application settings and passwords
- Component drivers and firmware
- TPM recovery key/password
- BIOS configuration settings—Use the backup and restore function in UEFI System Utilities. For more information, see the UEFI user guide (<https://www.hpe.com/support/hpeuefisystemutilities-quicklinks>).

- Custom default system settings
- Security passwords including those required for power-on and BIOS admin access, persistent memory, and Server Configuration Lock (for HPE Trusted Supply Chain servers)
- Server serial number and the product ID
- iLO-related data—Use the iLO backup and restore function. For more information, see the iLO user guide (<https://www.hpe.com/support/hpeilodocs-quicklinks>).
 - iLO license
 - Customer iLO user name, password, and DNS name
 - iLO configuration settings

Power down the server

Before powering down the server for any upgrade or maintenance procedures, perform a backup of critical server data and programs.



IMPORTANT

When the server is in standby mode, auxiliary power is still being provided to the system.

To power down the server, use one of the following methods:

- Press and release the Power On/Standby button.
This method activates a controlled shutdown of applications and the OS before the server enters standby mode. It can also activate a shutdown behavior governed by an OS configuration or policy.
- Press and hold the Power On/Standby button for more than 4 seconds to force the server to enter standby mode.
This method forces the server to enter standby mode without properly exiting applications and the OS. If an application stops responding, you can use this method to force a shutdown.
- Use a virtual power button selection through iLO 7.
This method initiates a controlled remote shutdown of applications and the OS before the server enters standby mode.

Before proceeding, verify that the server is in standby mode by observing that the system power LED is amber.

Opening and closing the cable management arm

About this task



WARNING

Be careful not to pinch your fingers while handling the cable management arm.

Procedure

1. Press the release latch and open the cable management arm.



NOTE

The latch can be released from the inside or outside.

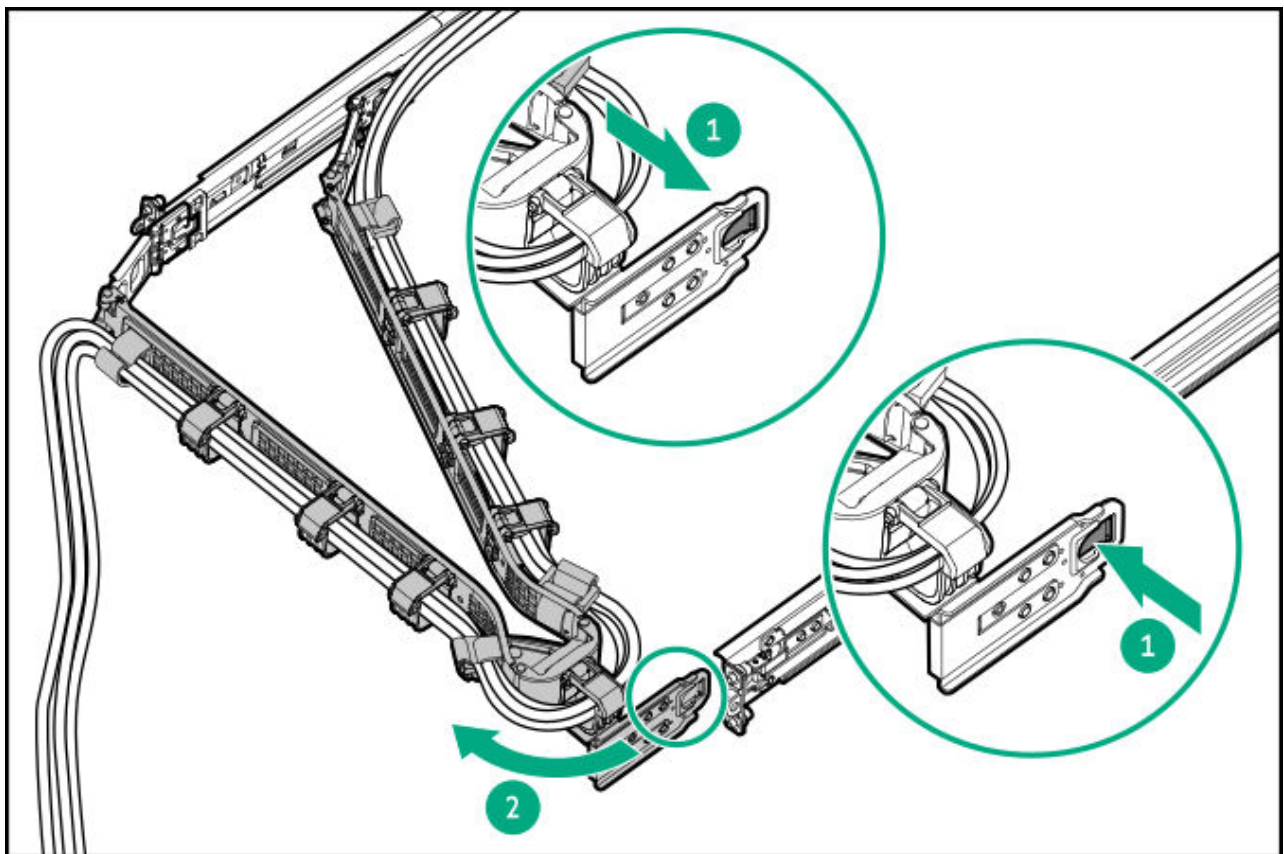

2. To close the cable management arm, align the elbow bracket and install it to the outer rail.

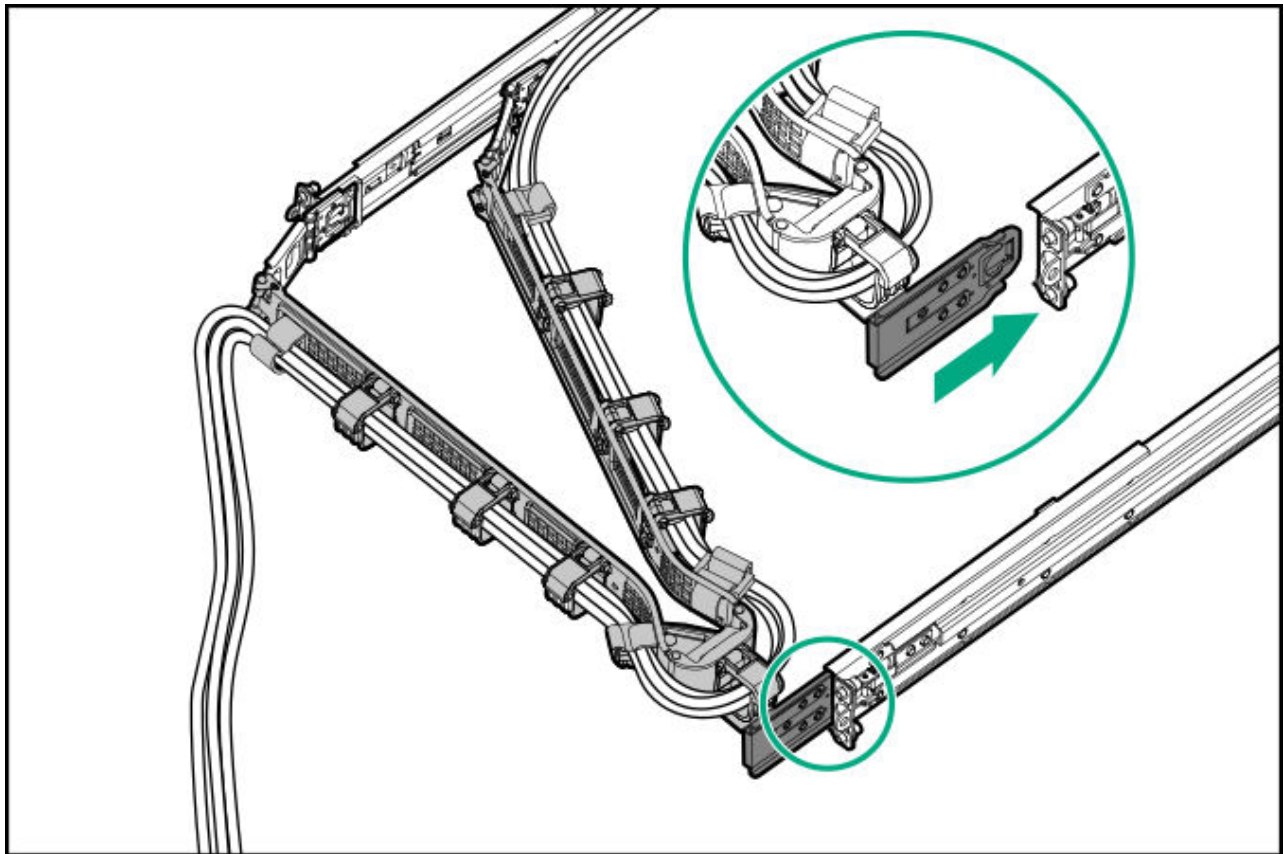

Extend the server from the rack

About this task



WARNING

To reduce the risk of personal injury or equipment damage, be sure that the rack is adequately stabilized before extending anything from the rack.

https://sketchfab.com/models/66332b928e7f49cd81b674563c674c40/embed?ui_infos=0&ui_watermark=0&ui_help=0&ui_vr=0&ui_settings=0&ui_inspector=0&ui_hint=2&ui_color=01a982&ui_theme=dark&autostart=1&camera=0

Procedure

1. Pull down the quick release levers on each side of the server.
2. If needed, use a T-25 Torx screwdriver to loosen the shipping screws.

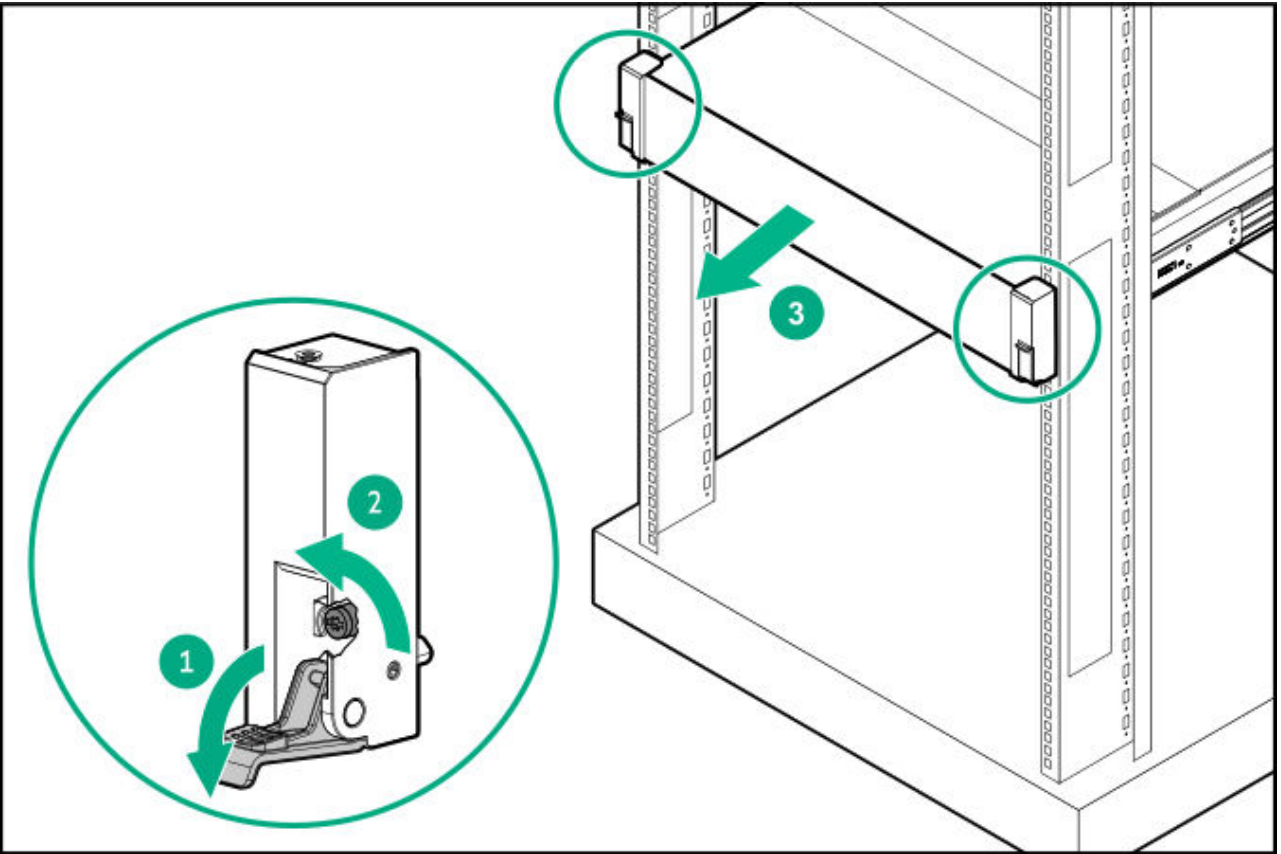

3. Extend the server from the rack.



WARNING

To reduce the risk of personal injury, be careful when pressing the server rail-release latches. The inner rails could pinch your fingers.

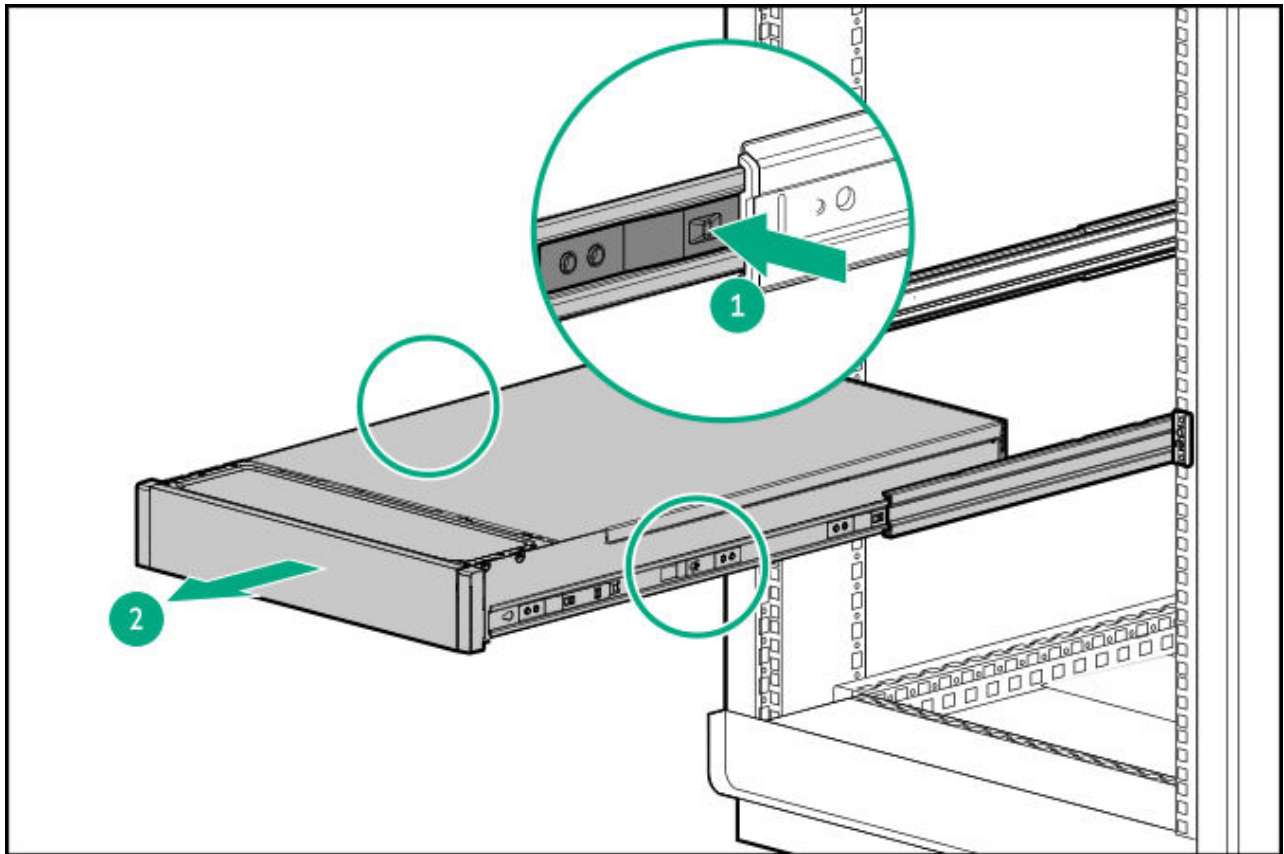

Remove the server from the rack

Prerequisites

- Before you perform this procedure, review the:
 - [Rack warnings and cautions](#)
 - [Server warnings and cautions](#)
- T-25 Torx screwdriver

About this task

https://sketchfab.com/models/2c19c0bf754041f6adc5beef8e87b43d/embed?ui_infos=0&ui_watermark=0&ui_help=0&ui_vr=0&ui_settings=0&ui_inspector=0&ui_hint=2&ui_color=01a982&ui_theme=dark&autostart=1&camera=0

To remove the server:

Procedure

1. Power down the server.
2. Disconnect the rear cabling.
3. Extend the server from the rack.
4. Release the rail latches and remove the server from the rack.

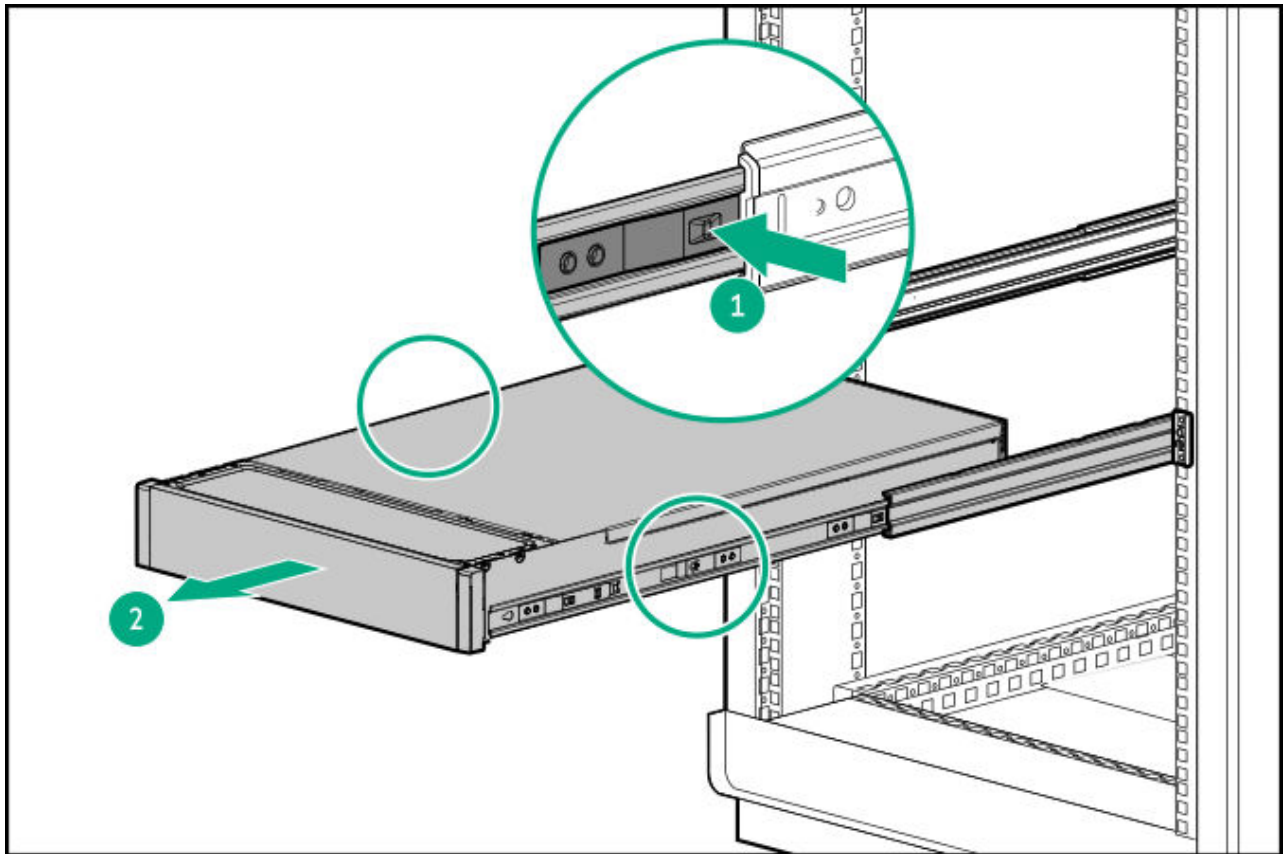

5. Place the server on a sturdy, level surface.

Remove the bezel

Procedure

1. If installed, remove the Kensington security lock.

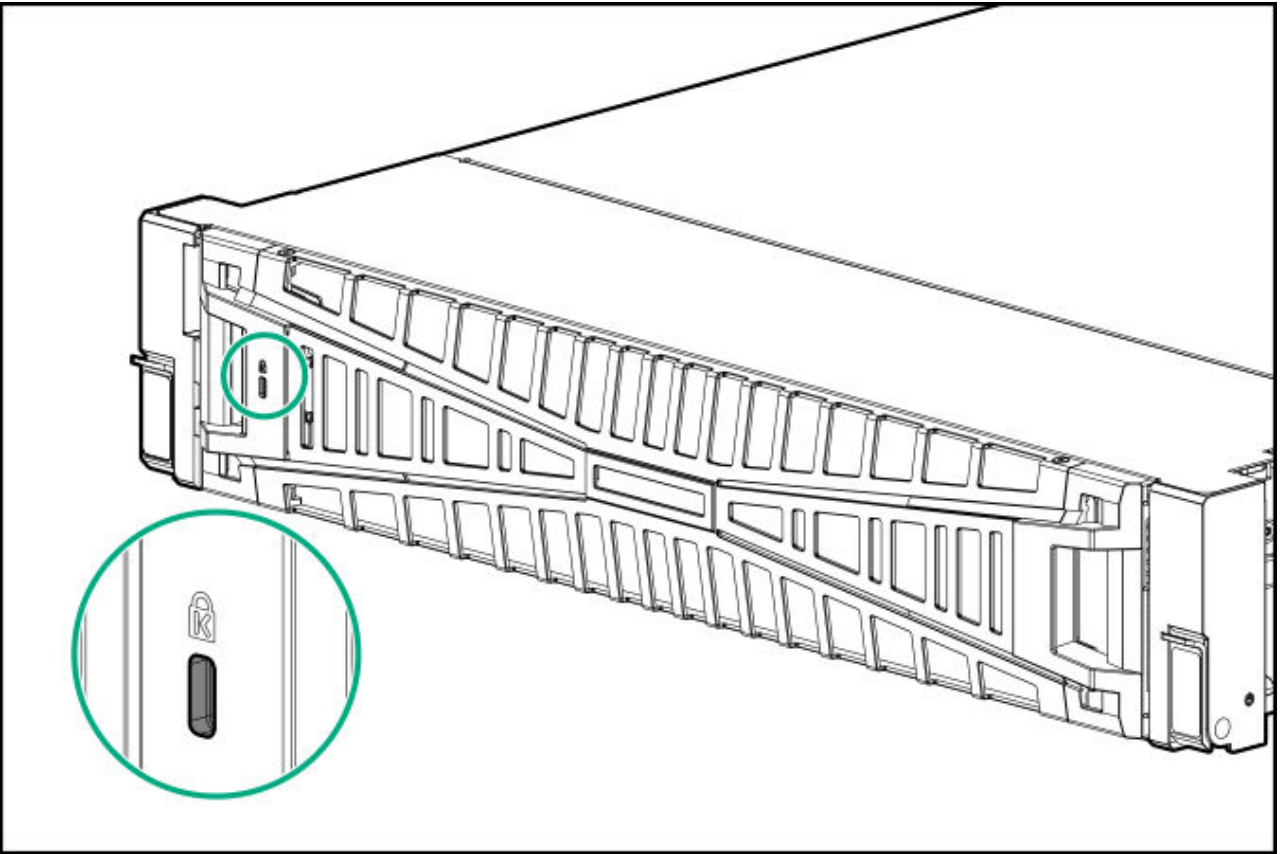

2. Remove the bezel.

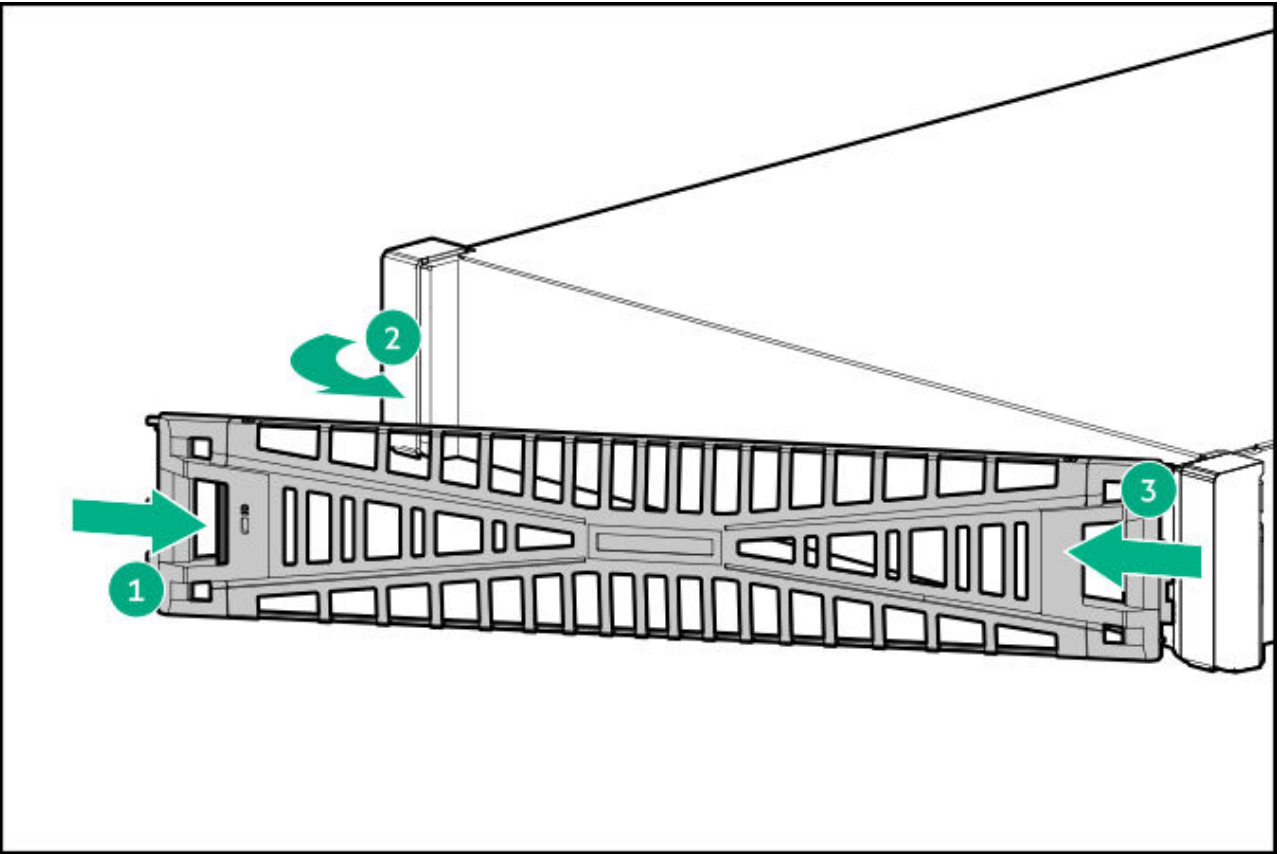

Remove the access panel

Prerequisites

If the access panel is locked, you might need a T-15 Torx screwdriver or small slotted screwdriver to unlock it.

About this task



WARNING

To reduce the risk of personal injury from hot surfaces, allow the drives, power supplies, and internal system components to cool before touching them.



CAUTION

Do not operate the chassis for long periods with the access panel open or removed. Operating the chassis in this manner results in improper airflow and improper cooling that can lead to thermal damage.

Procedure

1. Power down the server.
2. If installed, release the cable management arm.
3. Remove all power:
 - a. Disconnect each power cord from the power source.
 - b. Disconnect each power cord from the server.
4. Do one of the following:
 - Extend the server from the rack.
 - Remove the server from the rack.
5. If the latch is locked, use a T-15 Torx screwdriver or small slotted screwdriver to unlock it. Open the latch, slide the access panel to the rear of the chassis, and remove the access panel.

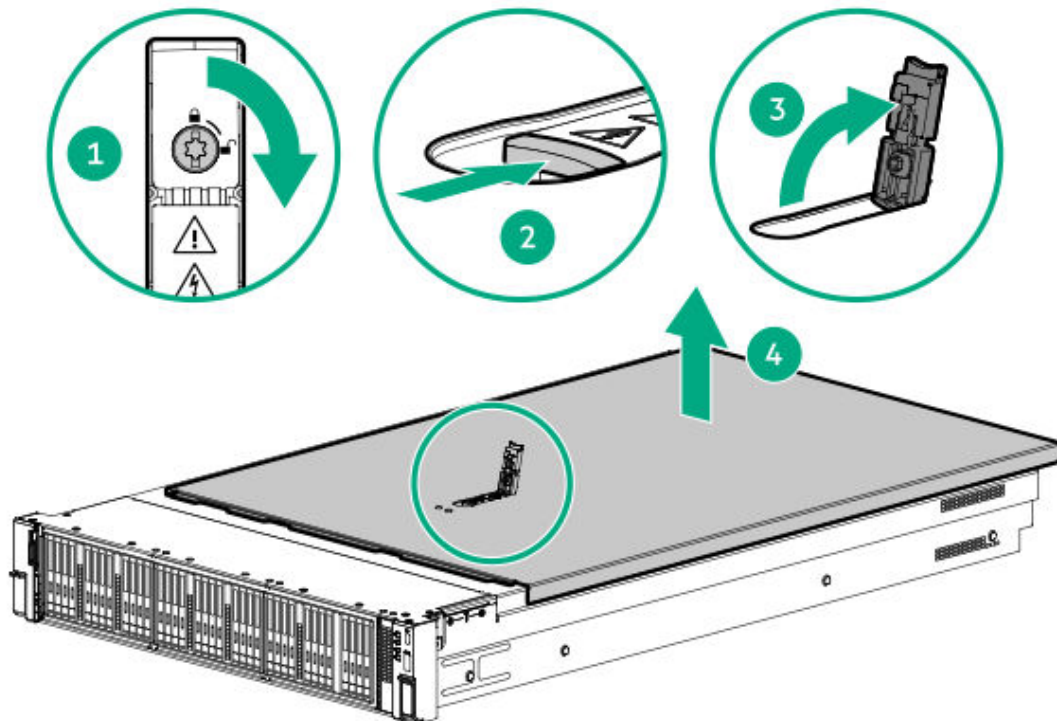

Remove the fan cage

About this task



CAUTION

Do not operate the server for long periods with the access panel open or removed. Operating the server in this manner results in improper airflow and improper cooling that can lead to thermal damage.



IMPORTANT

For optimum cooling, install fans in all primary fan locations.

Procedure

1. Power down the server.
2. Remove all power:
 - Disconnect each power cord from the power source.
 - Disconnect each power cord from the server.
3. Do one of the following:
 - Extend the server from the rack.
 - Remove the server from the rack.
4. Remove the access panel.
5. Remove the fan cage.

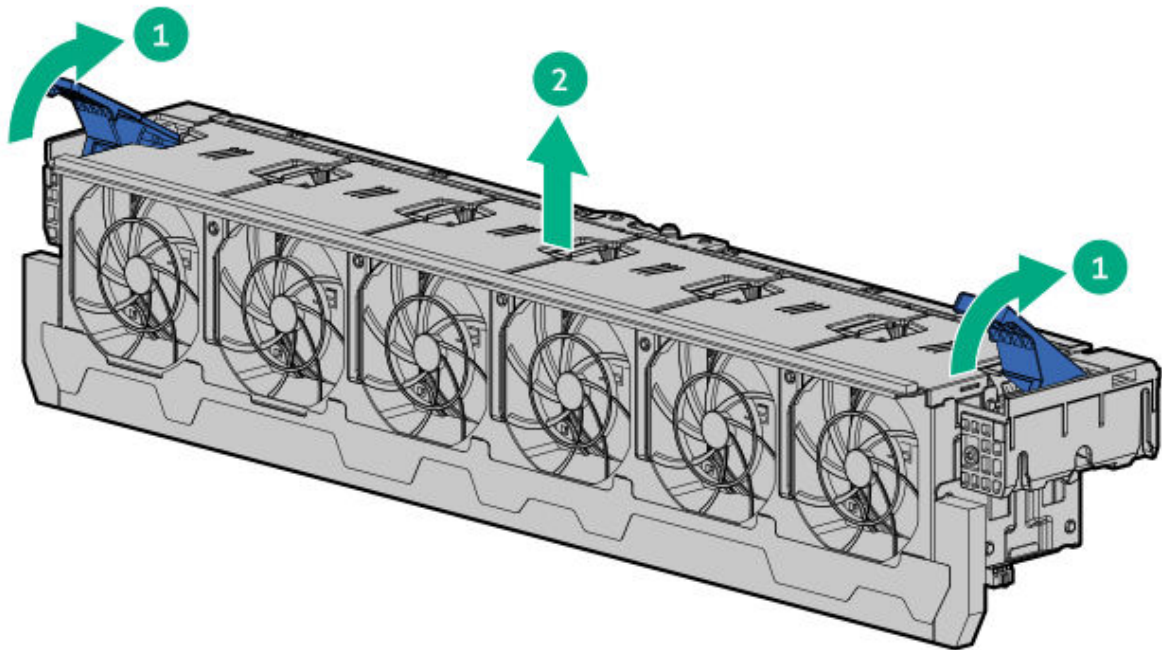

Remove the air baffle or midplane drive cage

About this task



CAUTION

Do not detach the cable that connects the battery pack to the cache module. Detaching the cable causes any unsaved data in the cache module to be lost.



CAUTION

For proper cooling, do not operate the server without the access panel, baffles, expansion slot covers, or blanks installed. If the server supports hot-plug components, minimize the amount of time the access panel is open.

Procedure

1. Power down the server.
2. Remove all power:
 - a. Disconnect each power cord from the power source.
 - b. Disconnect each power cord from the server.
3. Do one of the following:

- Extend the server from the rack.
 - Remove the server from the rack.
4. Remove the access panel.
 5. Do one of the following:
 - Remove the air baffle.

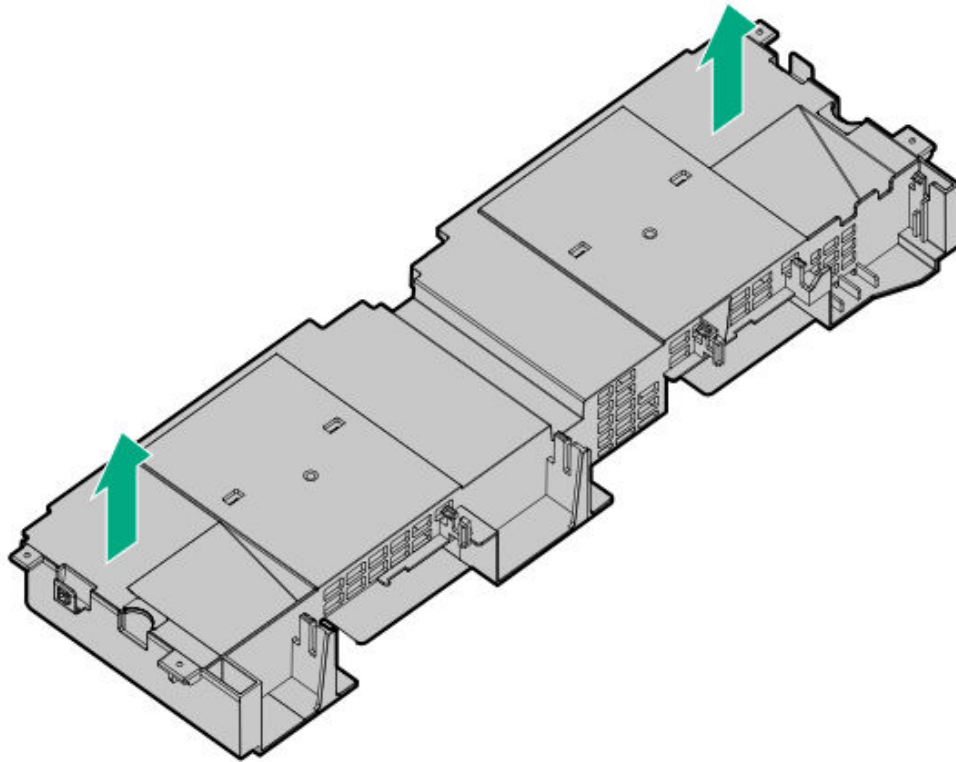

For systems with max-performance heatsinks:

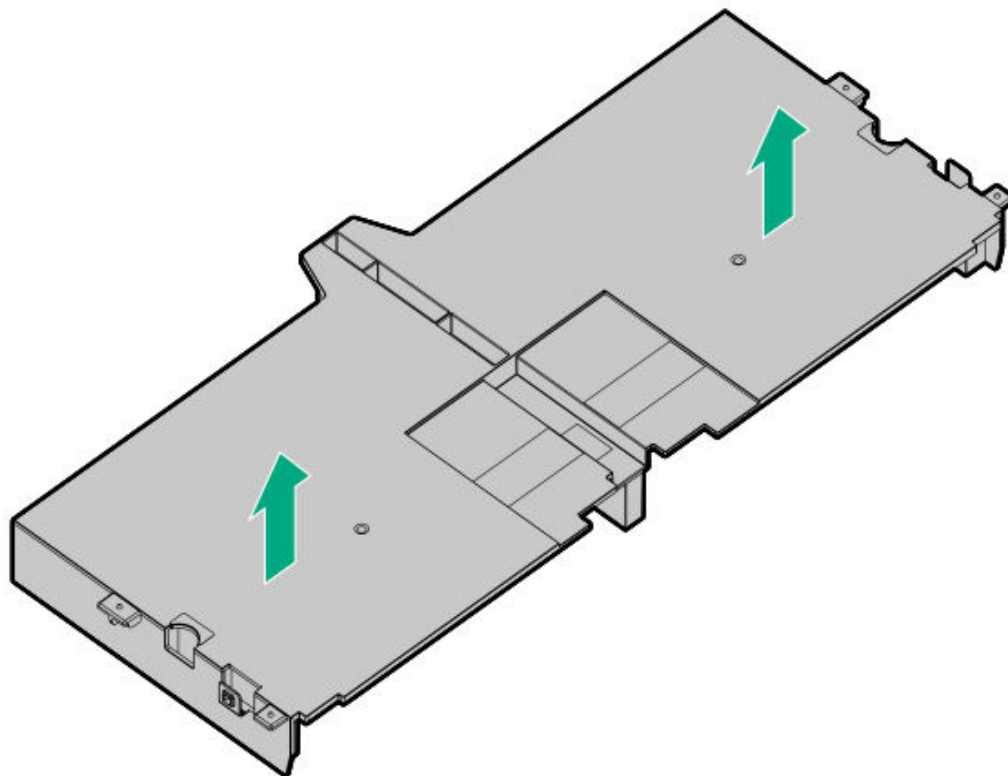

- Remove the midplane drive cage:
 - a. Disconnect all cables.
 - b. Remove all drives.
Be sure to note the location of each drive.
 - c. Remove the drive cage.
A 4LFF version is shown.



CAUTION

Do not drop the drive cage on the system board. Dropping the drive cage on the system board might damage the system or components. Remove all drives and use two hands when installing or removing the drive cage.

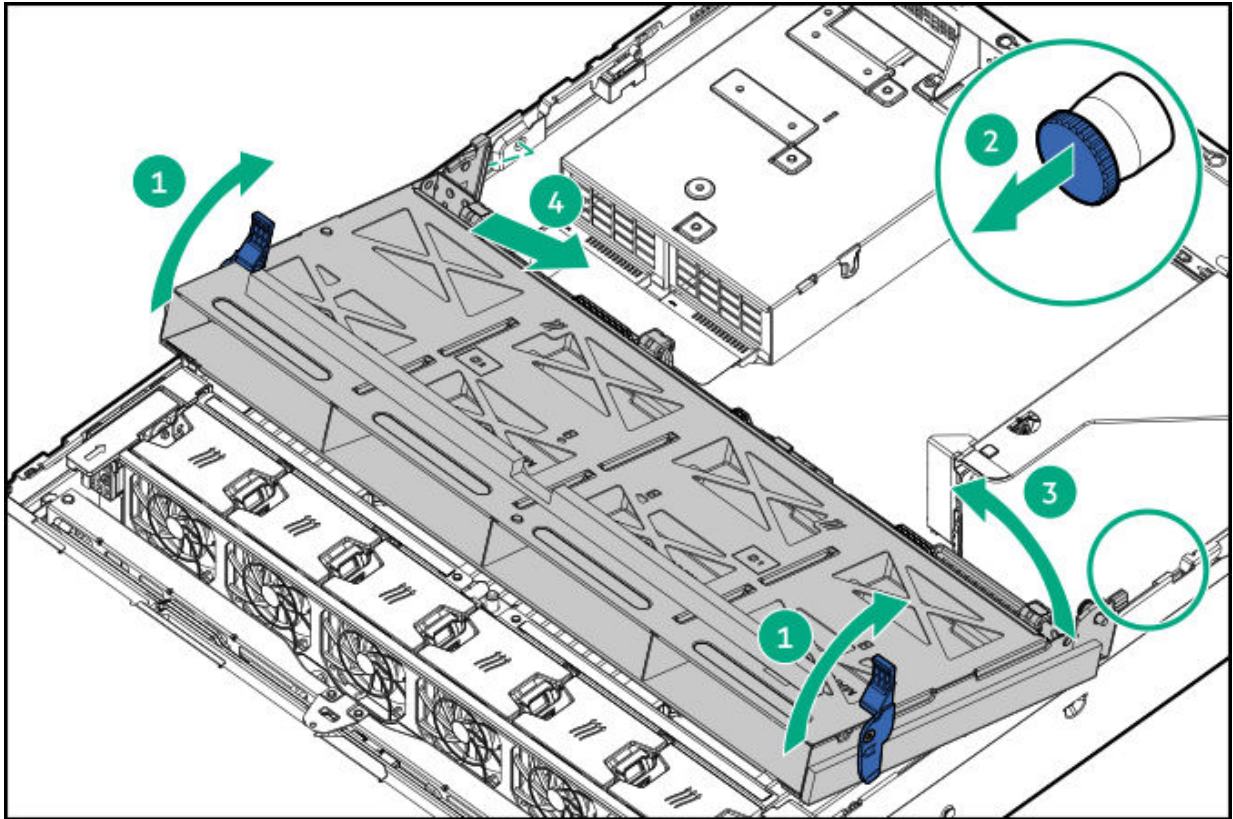

Remove the riser cage

About this task



CAUTION

To prevent damage to the server or expansion boards, power down the server and remove all AC power cords before removing or installing the PCI riser cage.

Procedure

1. Power down the server.
2. Remove all power:
 - a. Disconnect each power cord from the power source.
 - b. Disconnect each power cord from the server.
3. Do one of the following:
 - Extend the server from the rack.

- Remove the server from the rack.
4. Remove the access panel.
 5. Remove the riser cage:
 - Primary and secondary riser cages

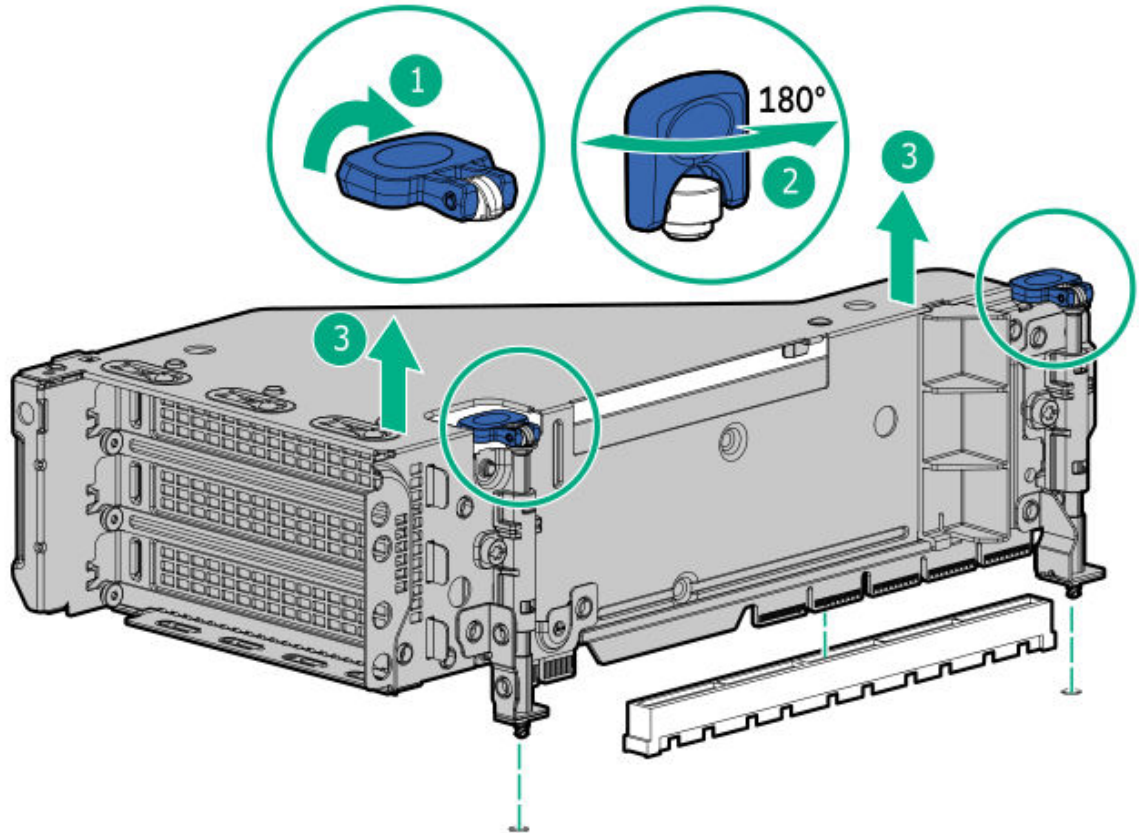

- Tertiary riser cage

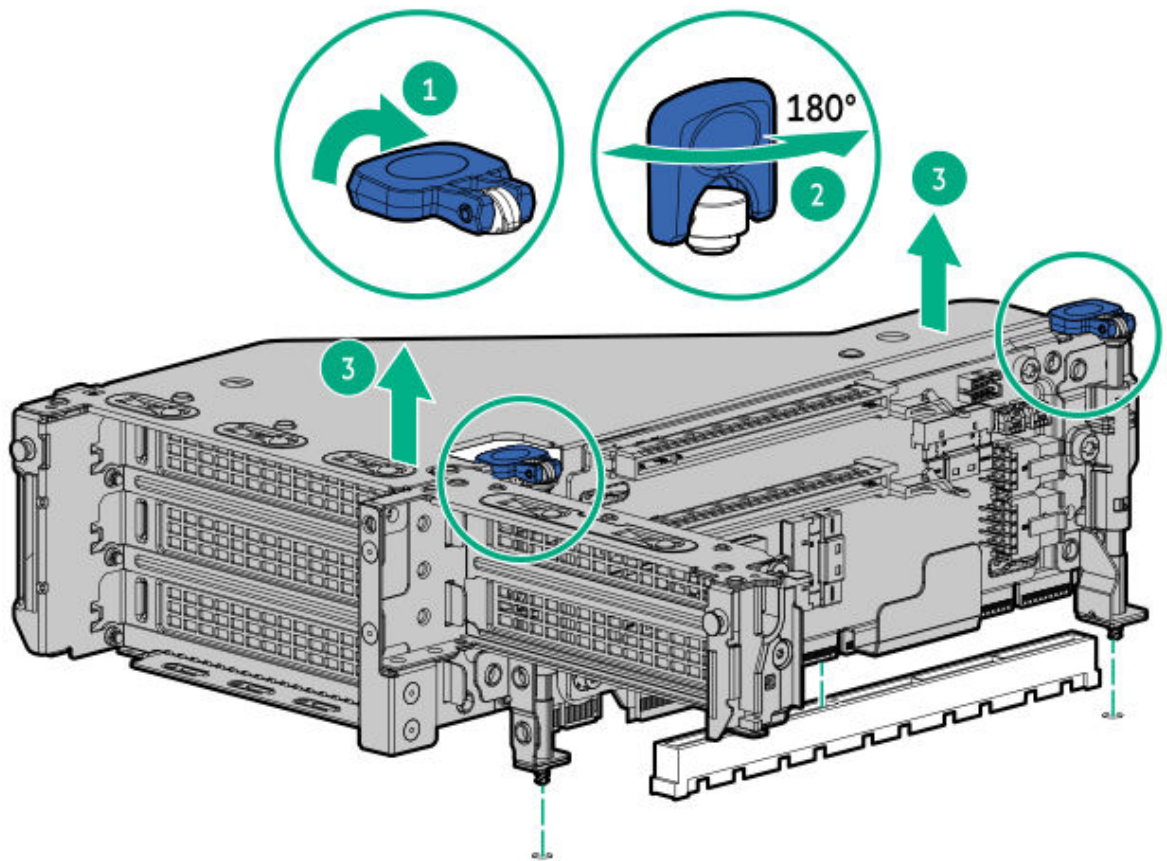

Post-installation procedures

Subtopics

[Installing the access panel](#)

[Install the fan cage](#)

[Install the air baffle](#)

[Power up the server](#)

Installing the access panel

Procedure

1. Place the access panel on top of the server with the latch open.

Allow the panel to extend past the rear of the server approximately 1.25 cm (0.5 in).

2. Push down on the latch.

The access panel slides to a closed position.

3. Tighten the security screw on the latch, if needed.

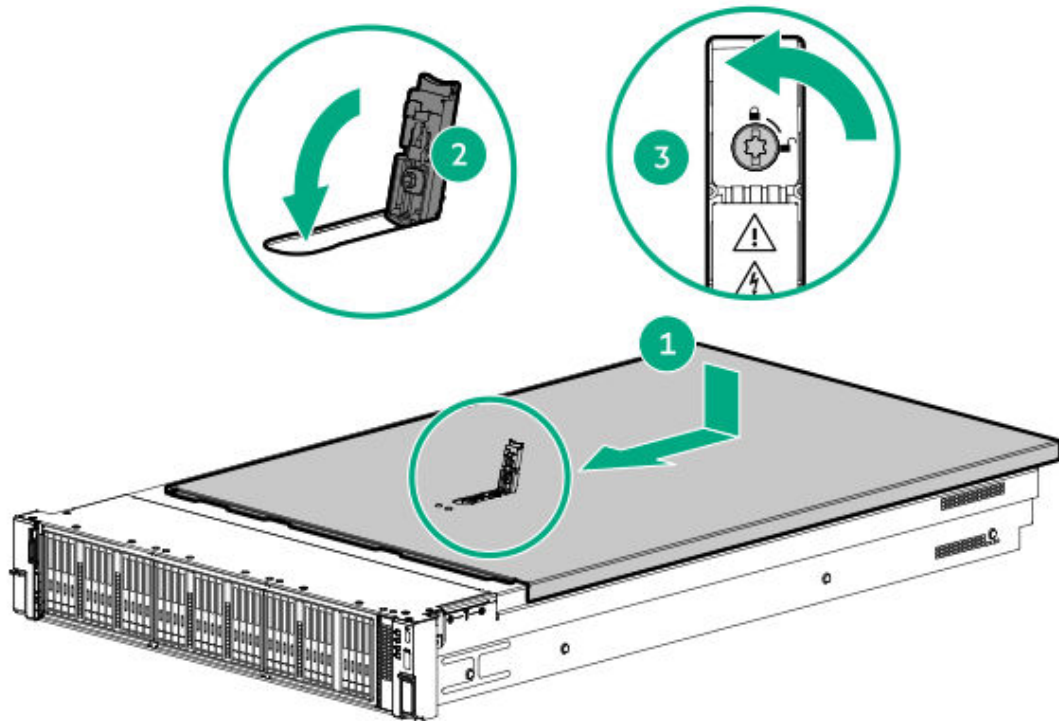

Install the fan cage

About this task



CAUTION

Do not operate the server for long periods with the access panel open or removed. Operating the server in this manner results in improper airflow and improper cooling that can lead to thermal damage.



IMPORTANT

For optimum cooling, install fans in all primary fan locations.

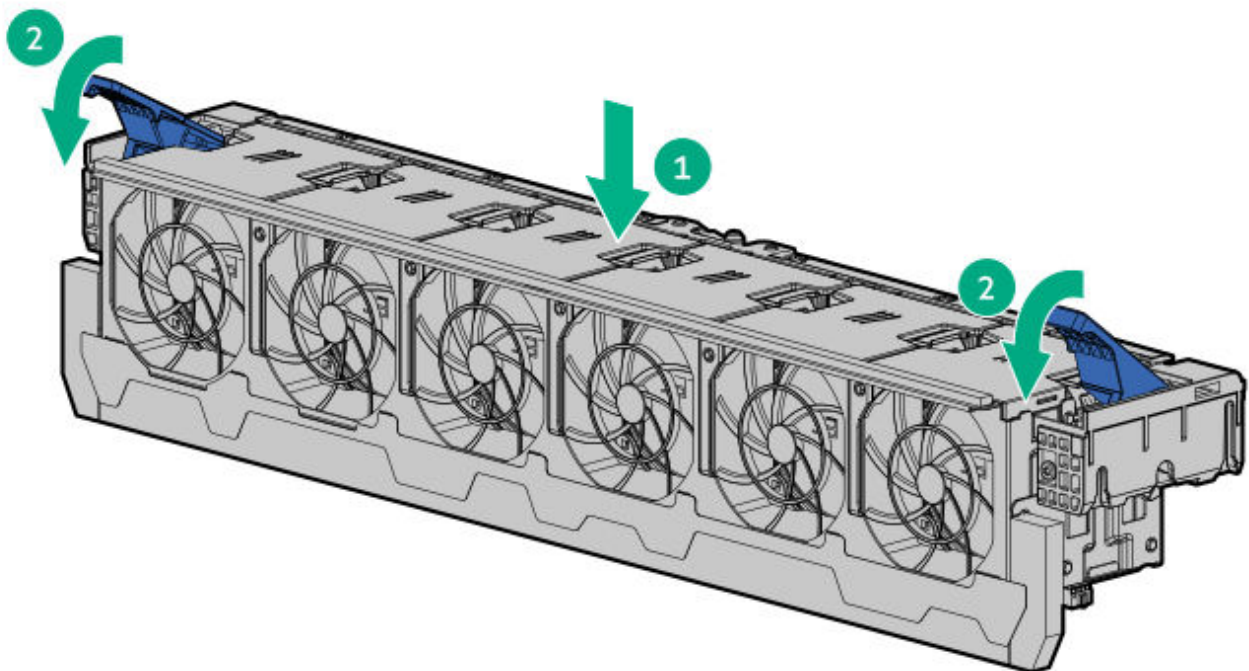

Install the air baffle

Procedure

1. Observe the following alerts.



CAUTION

For proper cooling, do not operate the server without the access panel, baffles, expansion slot covers, or blanks installed. If the server supports hot-plug components, minimize the amount of time the access panel is open.



CAUTION

Do not detach the cable that connects the battery pack to the cache module. Detaching the cable causes any unsaved data in the cache module to be lost.

2. Install the air baffle.

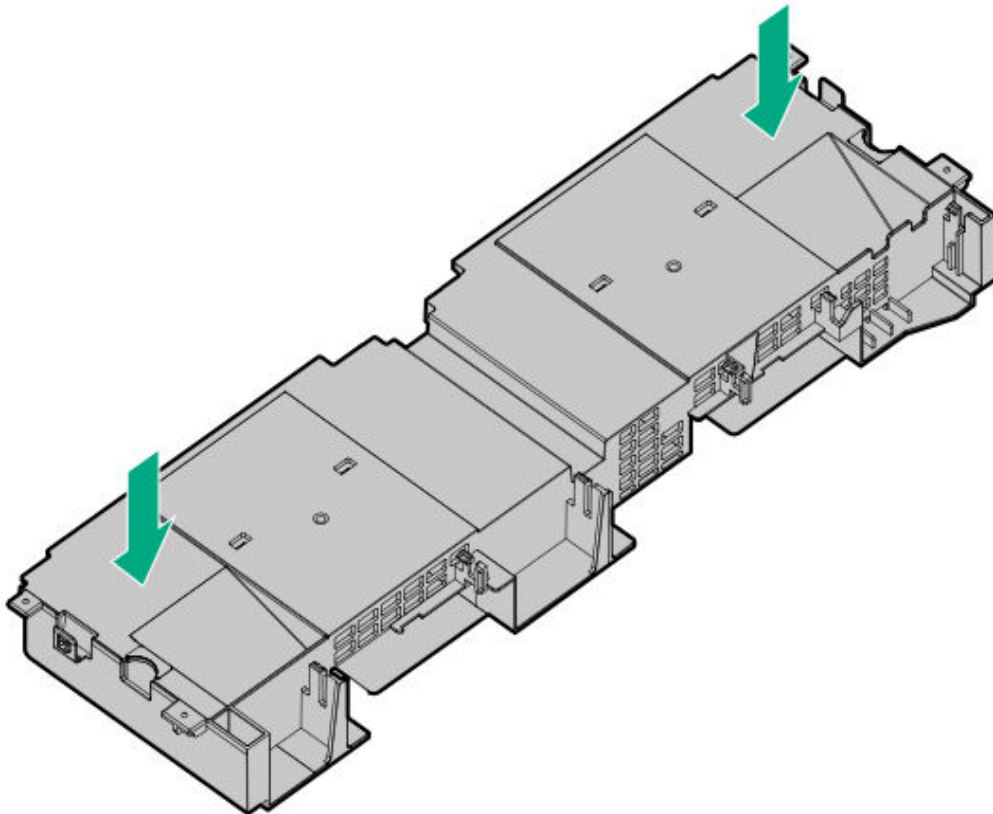

For systems with max-performance heatsinks:

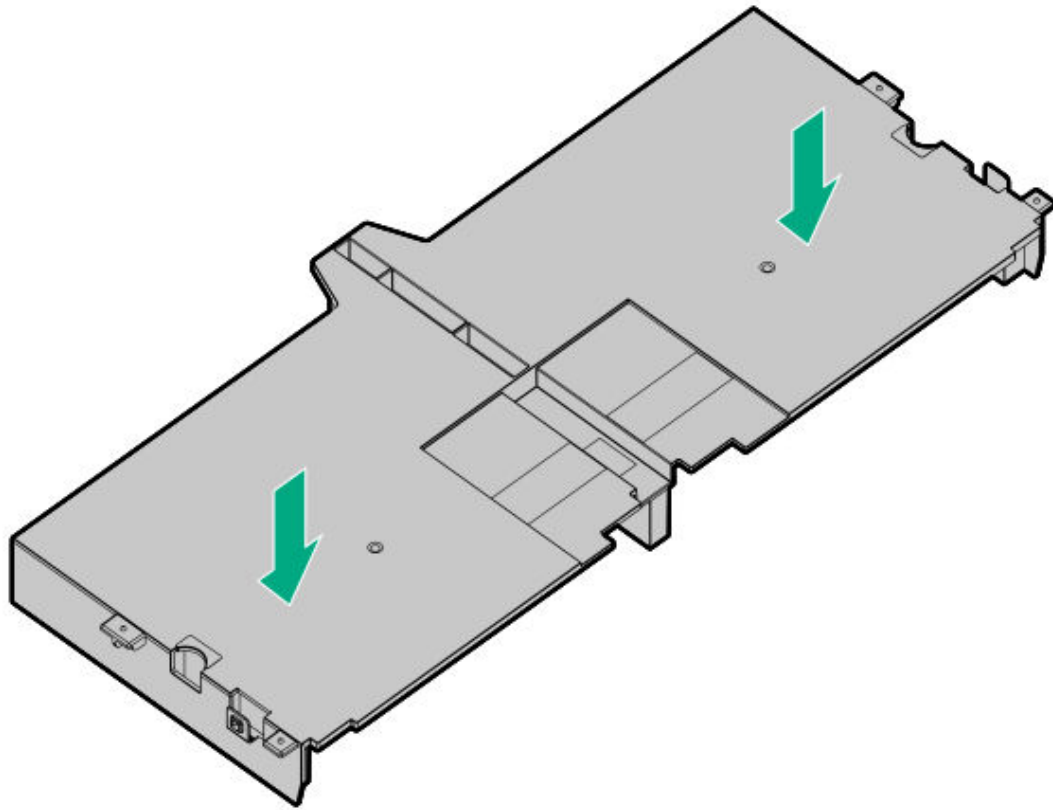

Power up the server

Procedure

- Press the Power On/Standby button.
- Use the virtual power button through iLO 7.

Cooling

Subtopics

Installing high-performance fans

Installing high-performance fans

About this task



CAUTION

Caution: To prevent damage server, ensure that all DIMM latches are closed and locked before installing the fans.



CAUTION

Do not operate the server for long periods with the access panel open or removed. Operating the server in this manner results in improper airflow and improper cooling that can lead to thermal damage.

Procedure

1. Extend the server from the rack.
2. Remove the access panel.
3. If installed, remove all fan blanks.

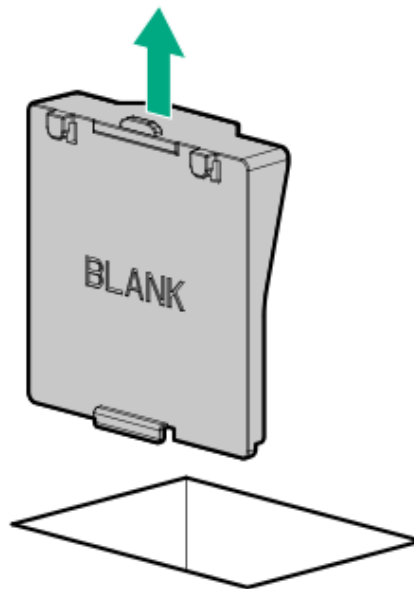

4. Remove all standard fans.



IMPORTANT

Do not mix standard and high performance fans in the same server.

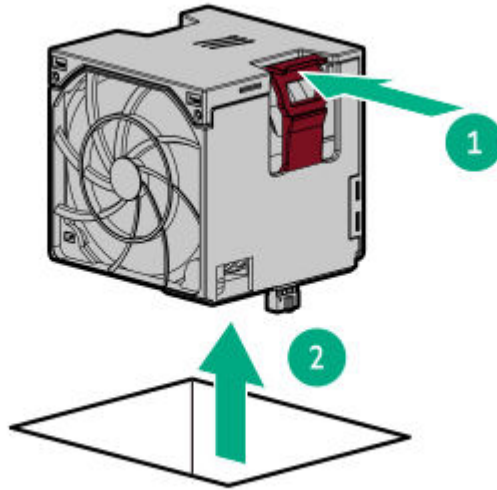

5. Install high-performance fans in all fan bays.

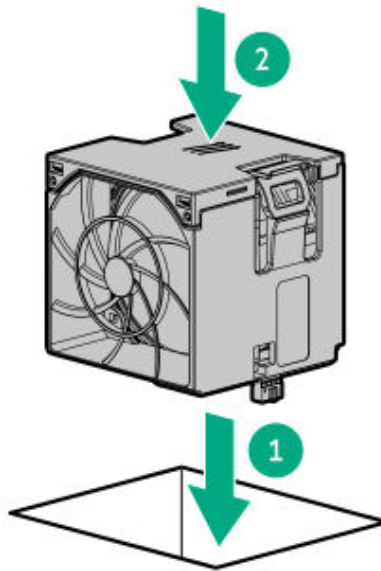

6. Install the access panel.

Results

The installation is complete.

Drives

Subtopics

Drive guidelines

Installing a hot-plug LFF/SFF SAS, SATA or NVMe drive

Installing an E3.S drive

Drive guidelines

Observe the following general guidelines:

- The system automatically sets all drive numbers.
- If only one hard drive is used, install it in the bay with the lowest drive number.
For drive numbering, see [Drive bay numbering](#).
- The NVMe SSD is a PCIe bus device. Devices attached to a PCIe bus cannot be removed without allowing the device and bus to complete and cease the signal/traffic flow.
Do not remove an NVMe SSD from the drive bay while the Do Not Remove button LED is flashing. The Do Not Remove button LED flashes to indicate that the device is still in use. Removal of the NVMe SSD before the device has completed and ceased signal/traffic flow can cause loss of data.
- Drives with the same capacity provide the greatest storage space efficiency when grouped into the same drive array.

Installing a hot-plug LFF/SFF SAS, SATA or NVMe drive

About this task



CAUTION

To maintain proper system cooling, do not operate the server for long period with the access panel open or removed. Operating the server in this manner results in an improper system airflow. For internal hot-plug component procedures, complete the procedure within 60 seconds. Failure to do so can cause the system temperature to increase and trip the safety threshold. When this happens:

- The health LED flashes amber.
- The operating system gracefully shuts down.



CAUTION

A discharge of static electricity from a finger or other conductor might damage system boards or other static-sensitive devices. To prevent damage, observe antistatic precautions.



CAUTION

To prevent improper cooling and thermal damage, do not operate the server unless all bays are populated with either a component or a blank.

Procedure

1. Remove the drive blank.

Retain the blank for future use.

- LFF drive blank

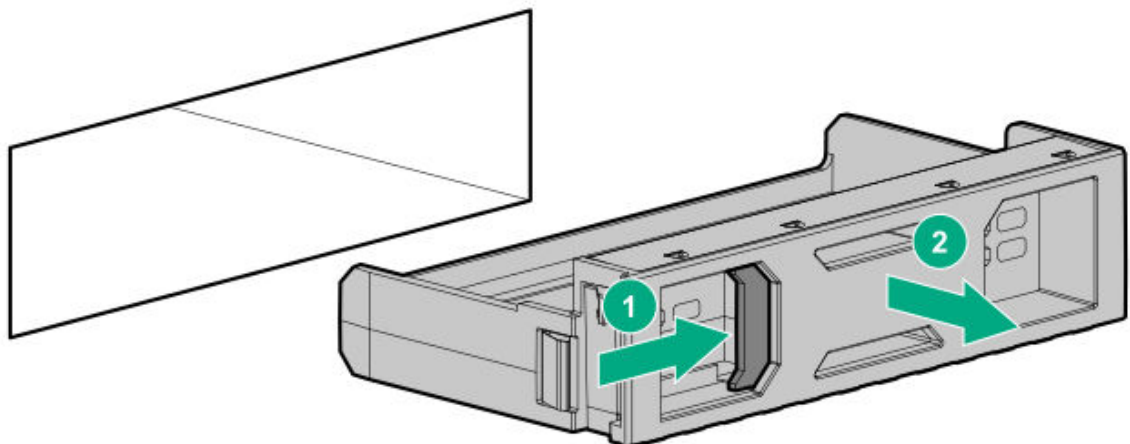

- SFF drive blank

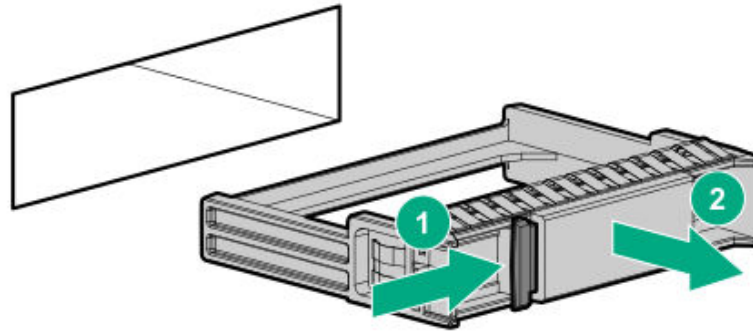

2. Prepare the drive.

- LFF drive

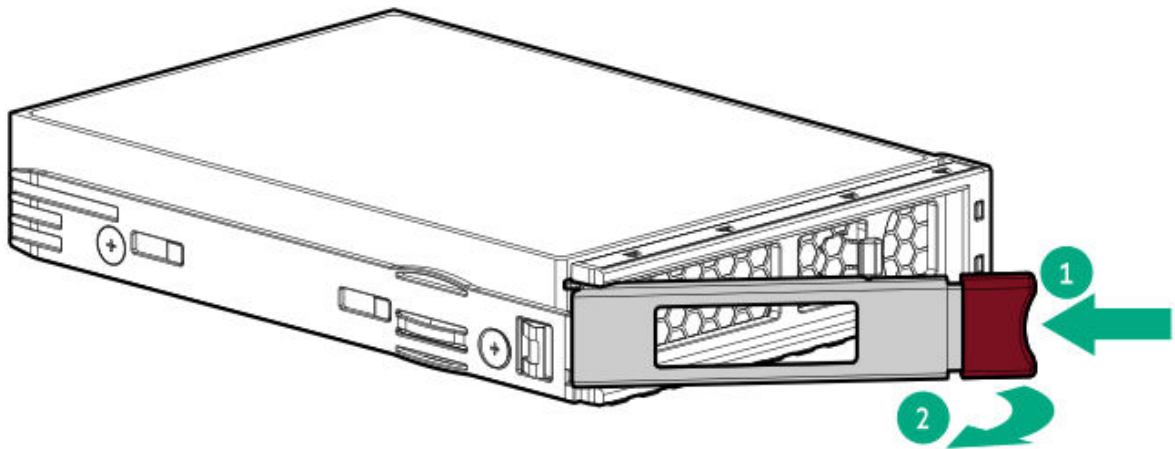

- SFF drive

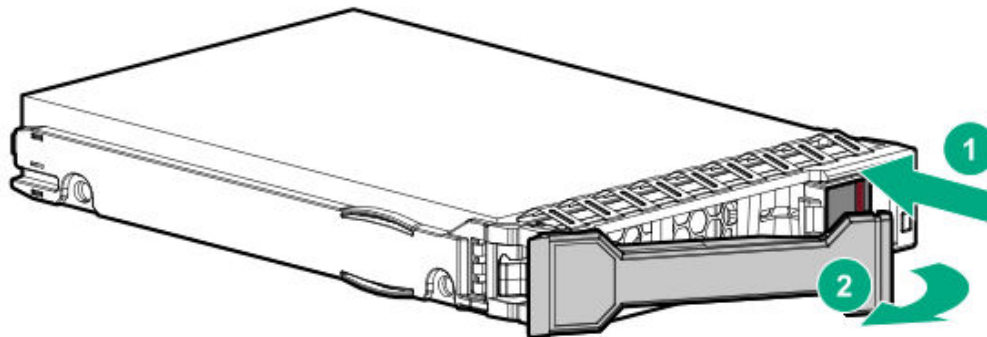

3. Install the drive.

- LFF drive

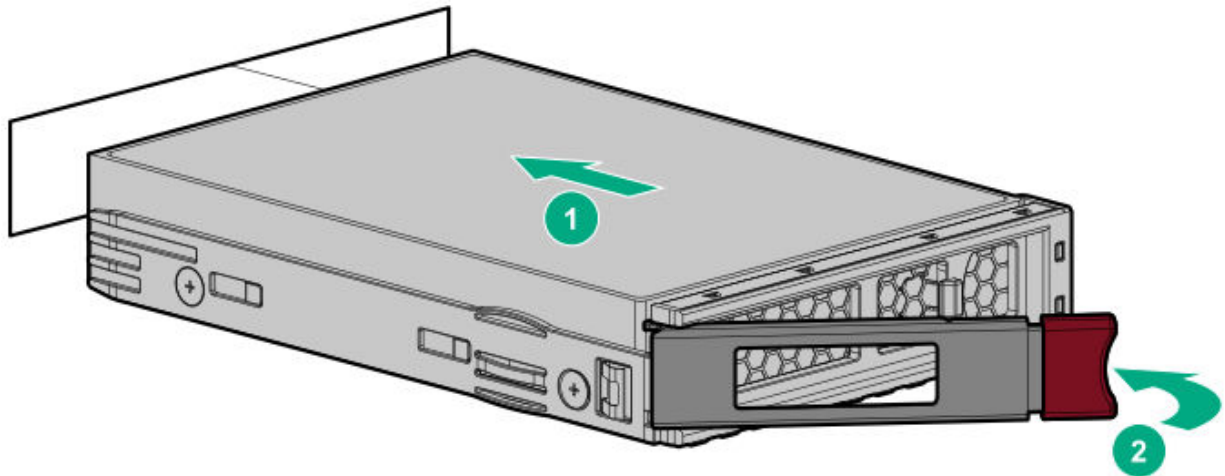

- SFF drive

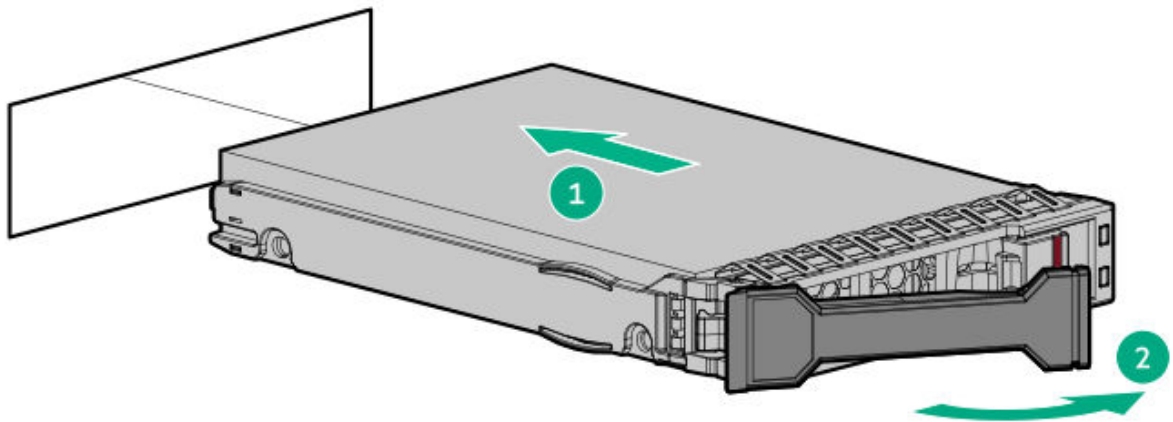

4. Determine the status of the drive from the drive LED definitions.
5. If removed, install the front bezel.
6. Configure the controller.

Results

The installation procedure is complete.

Installing an E3.S drive

About this task



CAUTION

A discharge of static electricity from a finger or other conductor might damage system boards or other static-sensitive devices. To prevent damage, observe antistatic precautions.



CAUTION

To prevent improper cooling and thermal damage, do not operate the server unless all bays are populated with either a component or a blank.

Procedure

1. If installed, remove the front bezel.
2. Observe the drive LED status and determine if the drive can be removed.
3. Remove the drive blank.

Retain the blank for future use.

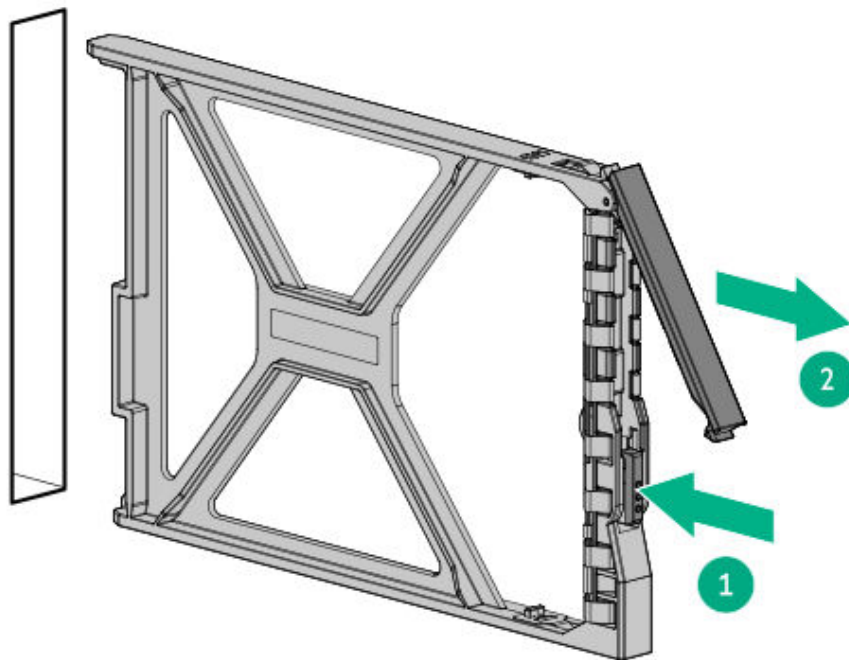

4. Prepare the drive.

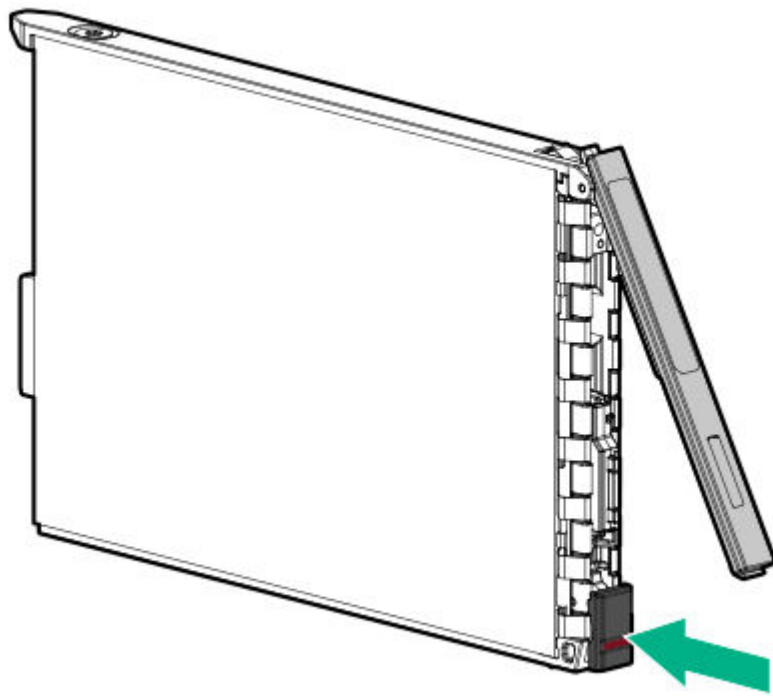

5. Install the drive.

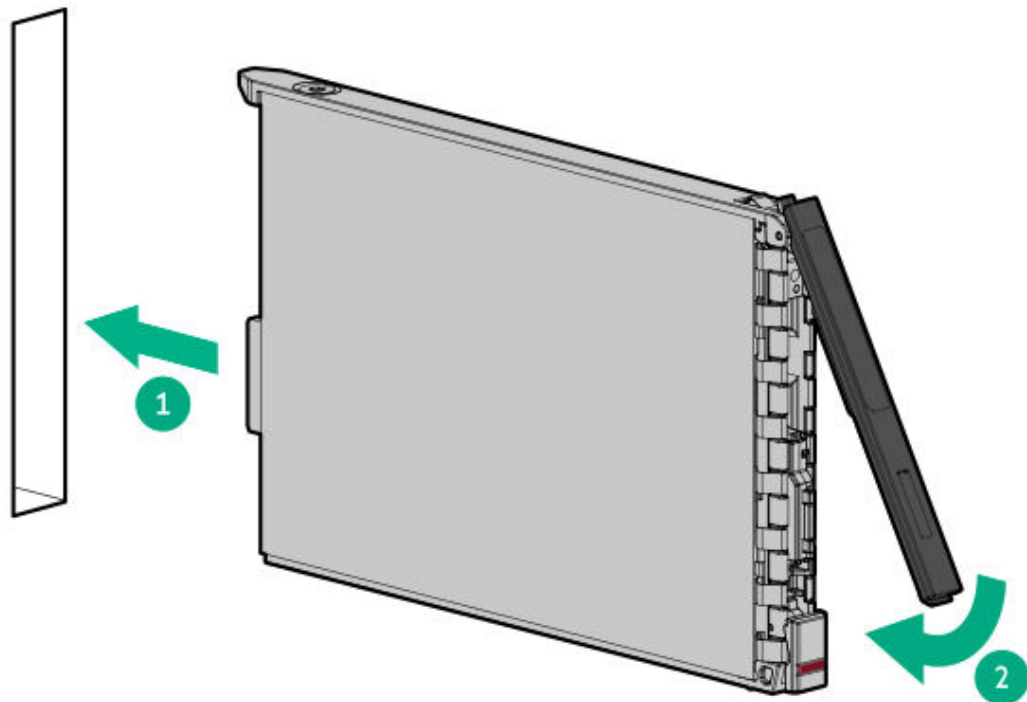

6. [Determine the status of the drive from the drive LED definitions.](#)
7. If removed, [install the front bezel.](#)
8. To configure drive arrays, see the [relevant storage controller guide.](#)

Results

The installation procedure is complete.

Drive and multipurpose cages

Subtopics

[**Installing a front multipurpose cage**](#)

[**Installing a front 4 EDSFF drive kit**](#)

[**Installing a front 8SFF drive cage**](#)

[**Installing a front 2SFF side-by-side drive cage**](#)

[**Installing a front 2SFF stacked drive cage**](#)

[**Installing a midplane drive cage**](#)

[**Installing a rear 2SFF stacked drive cage**](#)

Installing a front multipurpose cage

Prerequisites

Before installing the multipurpose cage:

- You need a T-15 Torx screwdriver.
- If you have any options for the multipurpose cage, be sure to install those options first.

About this task

The multipurpose cage can be installed in any box.

Procedure

1. [Power down the server.](#)
2. Remove all power:

- a. Disconnect each power cord from the power source.
 - b. Disconnect each power cord from the server.
3. Do one of the following:
 - Extend the server from the rack.
 - Remove the server from the rack.
 4. Remove the access panel.
 5. Remove the air baffle.
 6. Remove the fan cage.
 7. Using a T-15 Torx screwdriver, remove the drive cage blank.

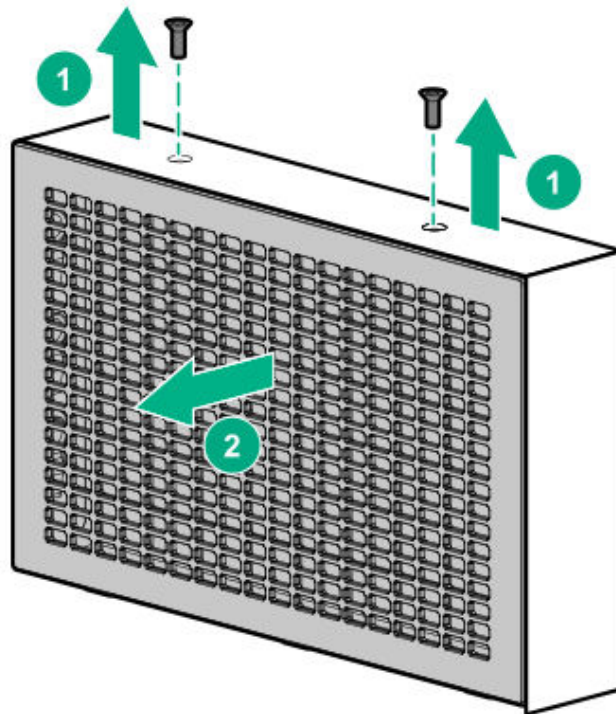

8. Install the multipurpose cage.

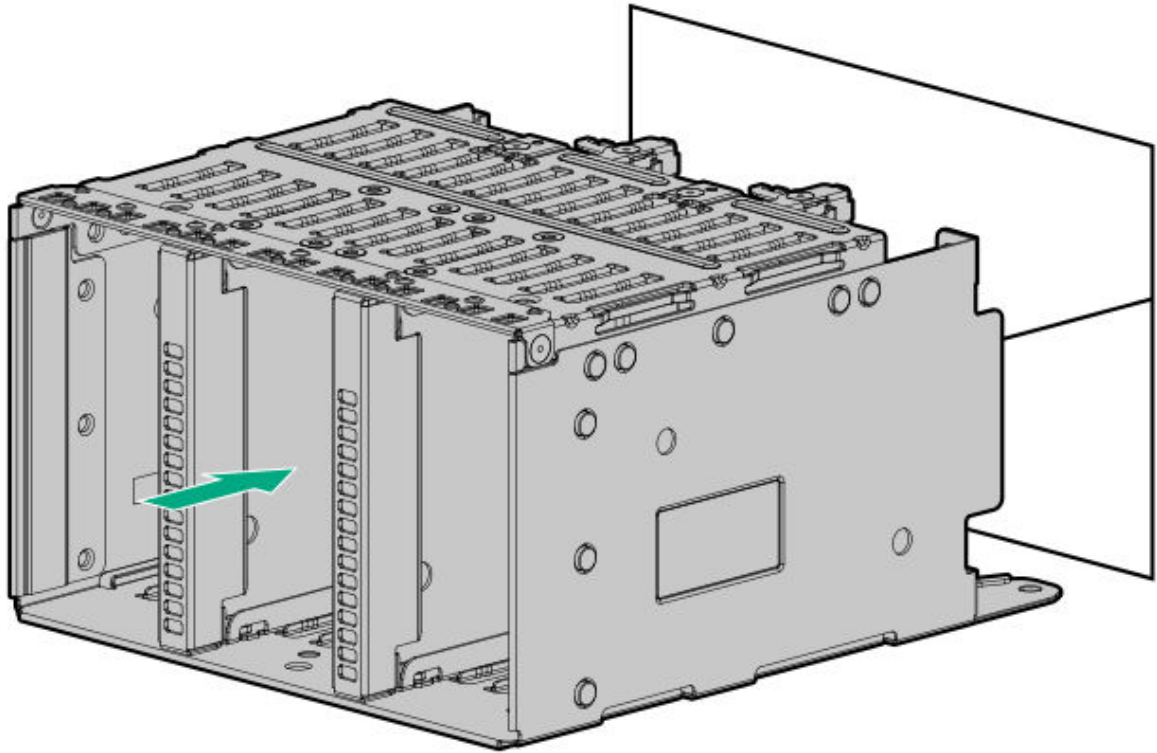

9. Using a T-15 Torx screwdriver, secure the cage.

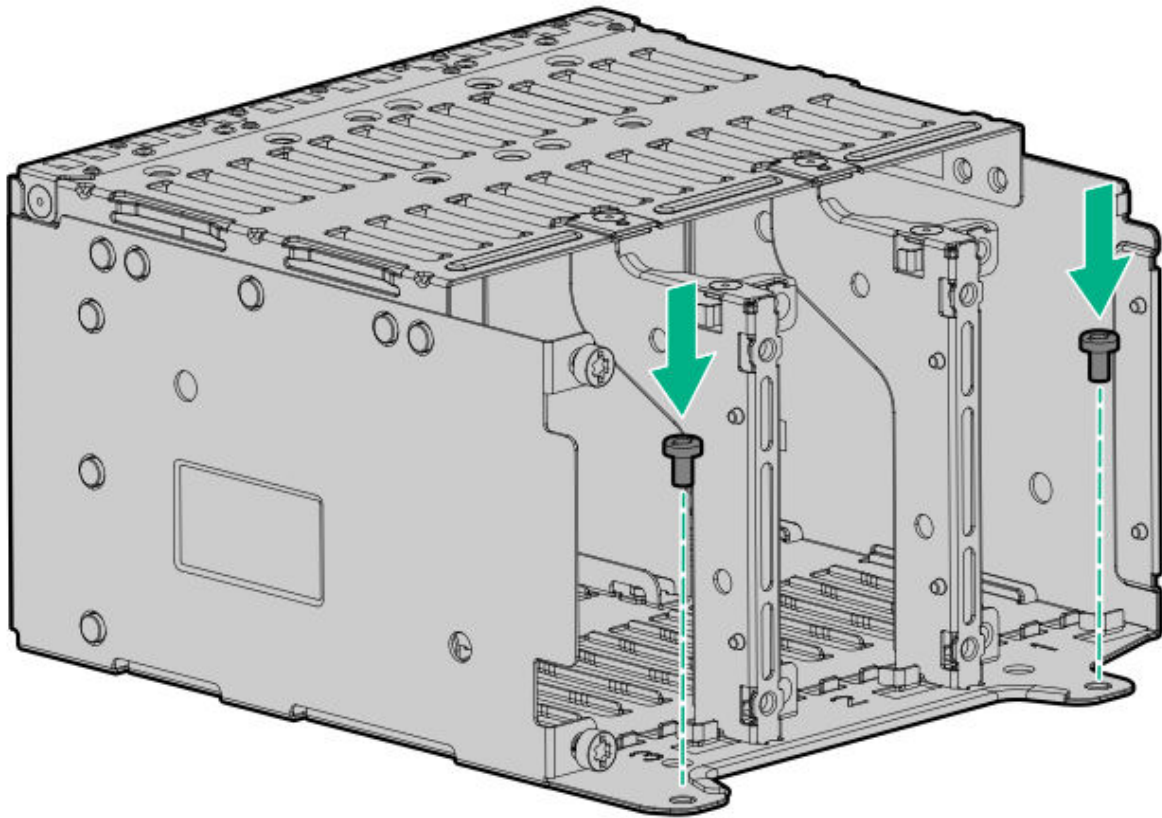

Results

The installation is complete.

Installing a front 4 EDSFF drive kit

Prerequisites

Before you perform this procedure, make sure that you have a T-15 Torx screwdriver or a torque screwdriver with T-15 Torx bit available.

About this task

The kit can be installed in an EDSFF cage or a multipurpose cage:

- If you are installing the kit in a multipurpose cage with a front OCP or NS204i-u option, it must be installed in cage 1.
- If you are installing the kit in an EDSFF cage, it can be installed in any cage.

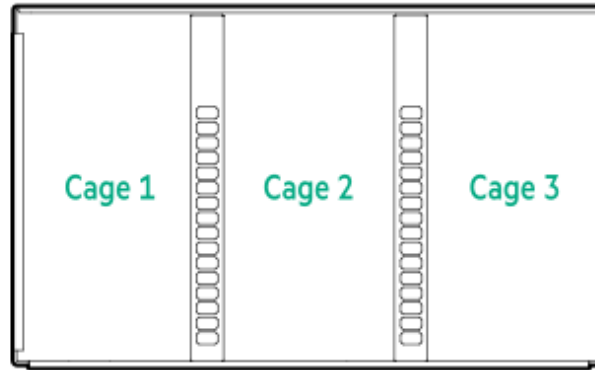

Procedure

1. Power down the server.
2. Remove all power:
 - a. Disconnect each power cord from the power source.
 - b. Disconnect each power cord from the server.
3. Do one of the following:
 - Extend the server from the rack.
 - Remove the server from the rack.
4. Remove the access panel.
5. Remove the air baffle.
6. Remove the fan cage.
7. Decide which cage to install the backplane.
8. On the EDSFF cage, locate the backplane supports.

Each cage has a set of supports. Cage 1 is shown.

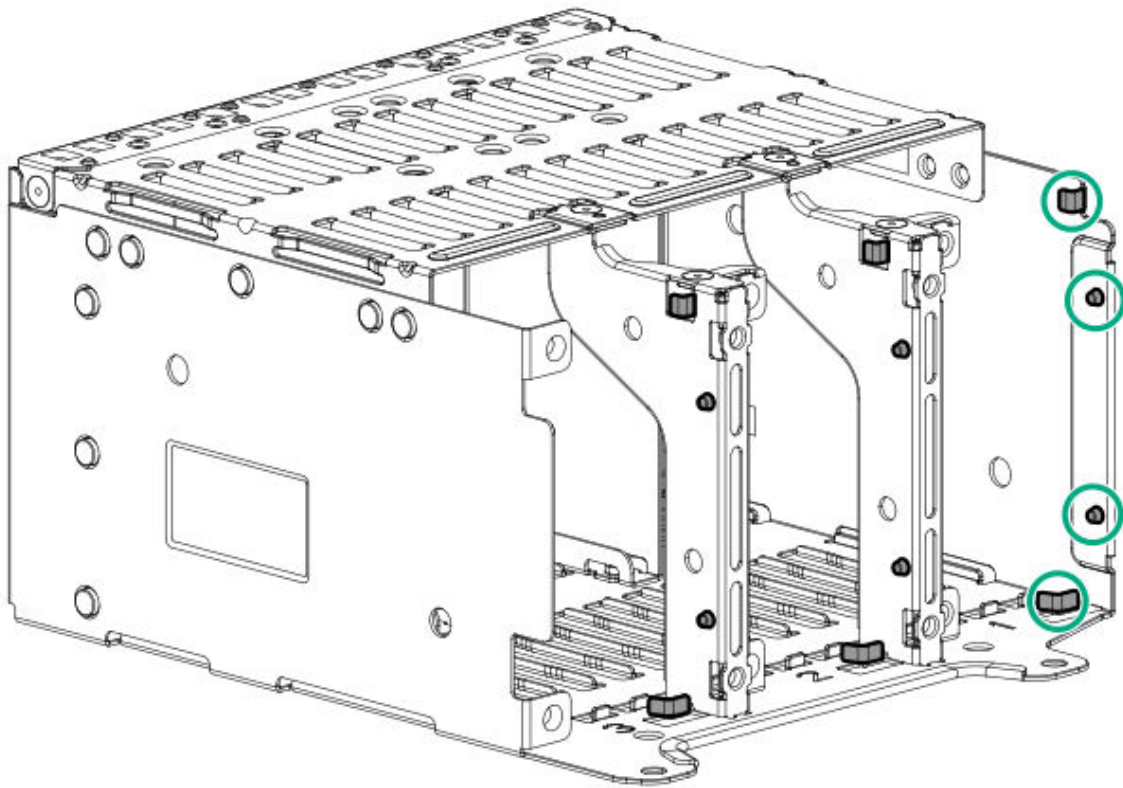

9. Using a T-15 Torx screwdriver, install the backplane.
Be sure to fit the backplane between the supports.

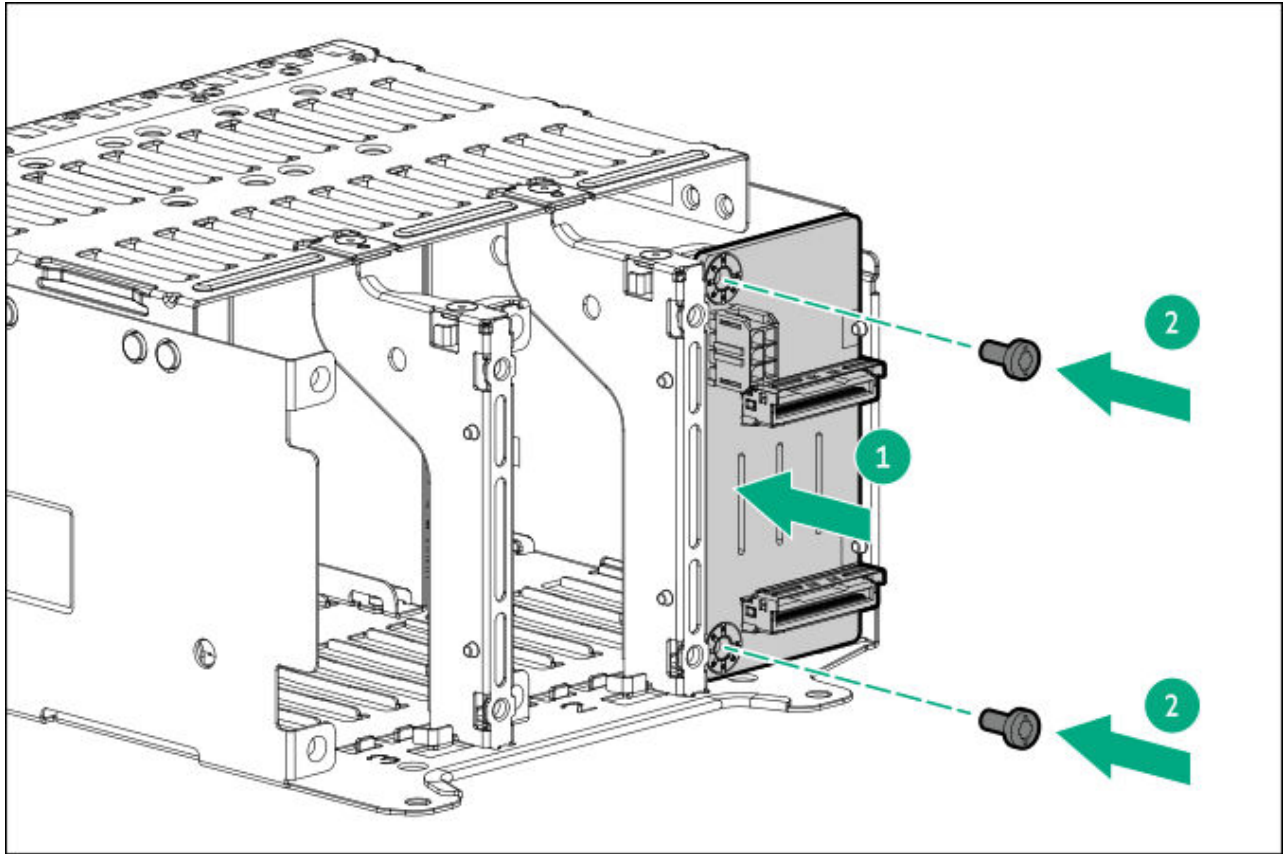

- .0. (Optional) Install additional backplanes, if needed.
- .1. Install the EDSFF cage.
The cage can be installed in boxes 1, 2, or 3.
- .2. Connect the power cable to the drive backplane power connector.
- .3. Connect the data cables from the drive backplane to the controller.
- .4. Install drives or drive blanks.

Results

The installation is complete.

Installing a front 8SFF drive cage

About this task

The drive cage can be installed in any box.



WARNING

To reduce the risk of personal injury from hot surfaces, allow the drives and the internal system components to cool before touching them.



CAUTION

To prevent damage to electrical components, properly ground the server before beginning any installation procedure. Improper grounding can cause ESD.

Procedure

1. Power down the server.
2. Remove all power:
 - a. Disconnect each power cord from the power source.
 - b. Disconnect each power cord from the server.
3. Do one of the following:
 - Extend the server from the rack.
 - Remove the server from the rack.
4. Remove the access panel.
5. Remove the air baffle.
6. Remove the fan cage.
7. Remove the drive cage blank.

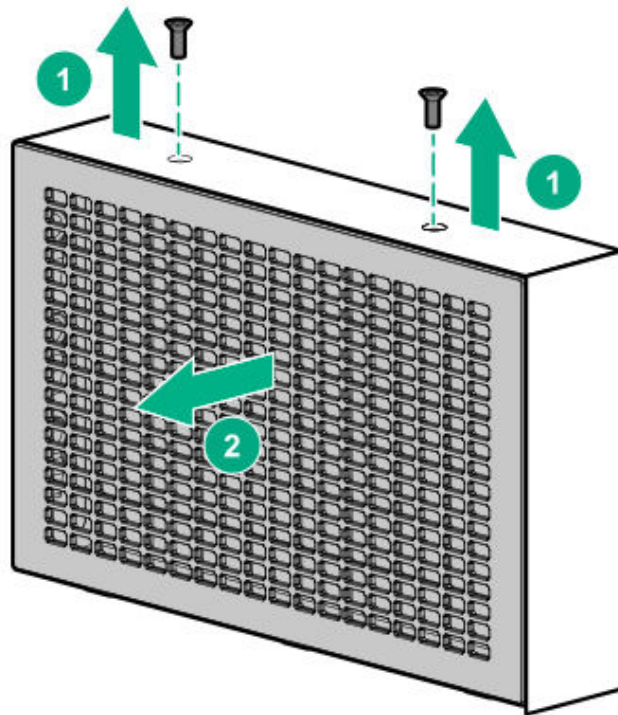

8. Install the drive cage:

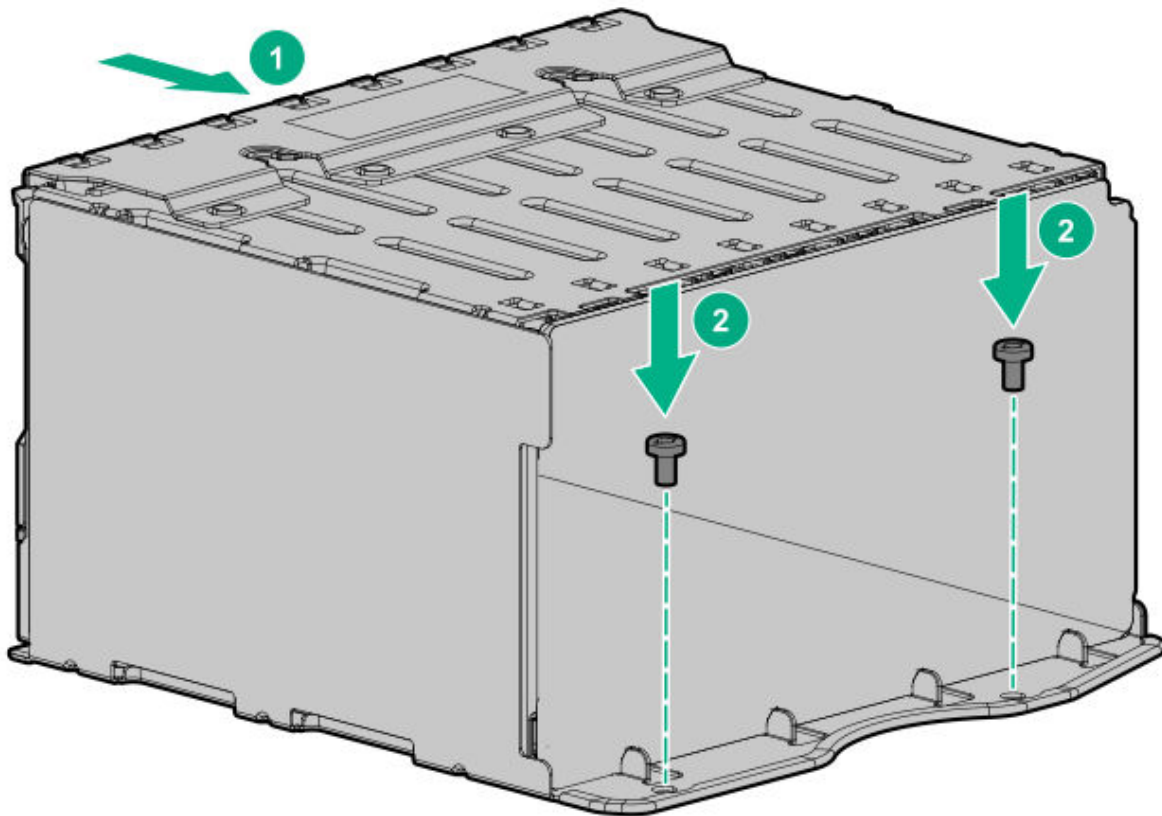

9. [Connect the power cable to the drive backplane power connector.](#)
10. [Connect the data cables from the drive backplane to the NVMe riser.](#)
11. [Install drives](#) or drive blanks.

Results

The installation is complete.

Installing a front 2SFF side-by-side drive cage

About this task



WARNING

To reduce the risk of personal injury from hot surfaces, allow the drives and the internal system components to cool before touching them.



CAUTION

To prevent damage to electrical components, properly ground the server before beginning any installation procedure. Improper grounding can cause ESD.

Procedure

1. [Power down the server.](#)
2. Remove all power:
 - a. Disconnect each power cord from the power source.
 - b. Disconnect each power cord from the server.
3. Do one of the following:
 - [Extend the server from the rack.](#)
 - [Remove the server from the rack.](#)
4. [Remove the access panel.](#)
5. [Remove the air baffle.](#)
6. [Remove the fan cage.](#)
7. Remove the drive cage blank.

8. Remove the support bracket.

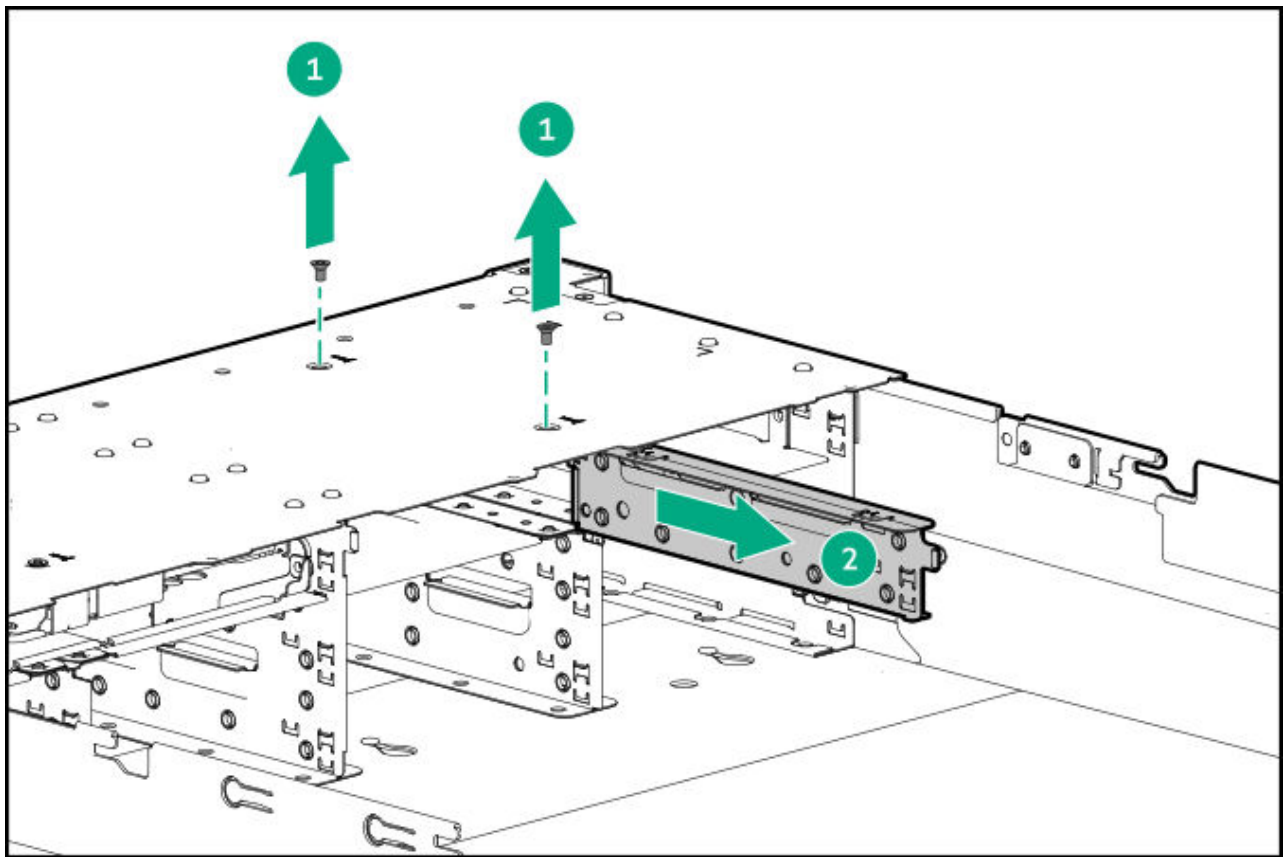

9. Install the drive cage:

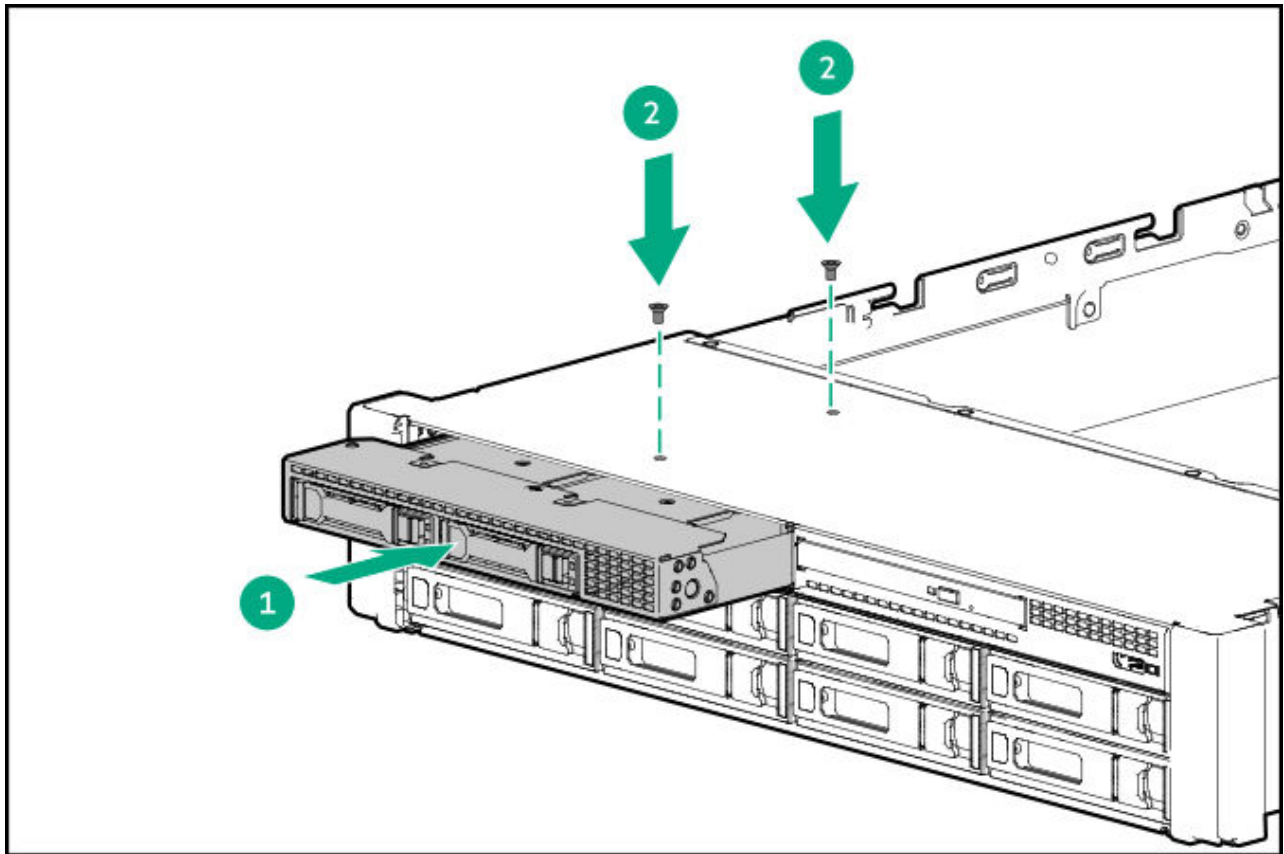

- .0. Connect the power cable to the drive backplane power connector.
- .1. Connect the data cables from the drive backplane to the NVMe riser.
- .2. Install drives or drive blanks.
- .3. Install the access panel.
- .4. Slide the server into the rack.
- .5. Connect each power cord to the server.
- .6. Connect each power cord to the power source.
- .7. Power up the server.

Results

The installation is complete.

Installing a front 2SFF stacked drive cage

Prerequisites

Before you perform this procedure, make sure that you have the following items available:

- T-10 Torx screwdriver
- The components included with the hardware option kit
- This installation requires a universal media bay.

Procedure

1. Power down the server.
2. Remove all power:
 - a. Disconnect each power cord from the power source.
 - b. Disconnect each power cord from the server.
3. Do one of the following:
 - Extend the server from the rack.
 - Remove the server from the rack.
4. Remove the access panel.
5. Remove the drive cage blank.

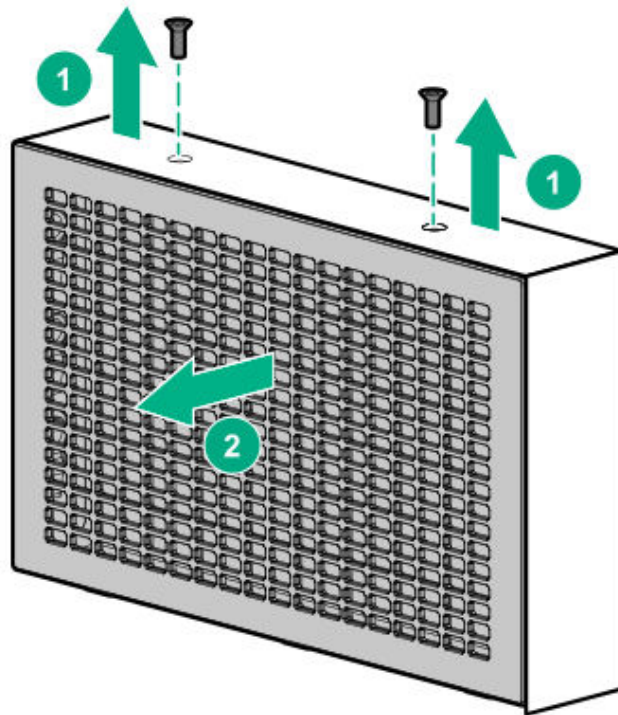

6. Remove the optical disc drive tray from the universal media bay.

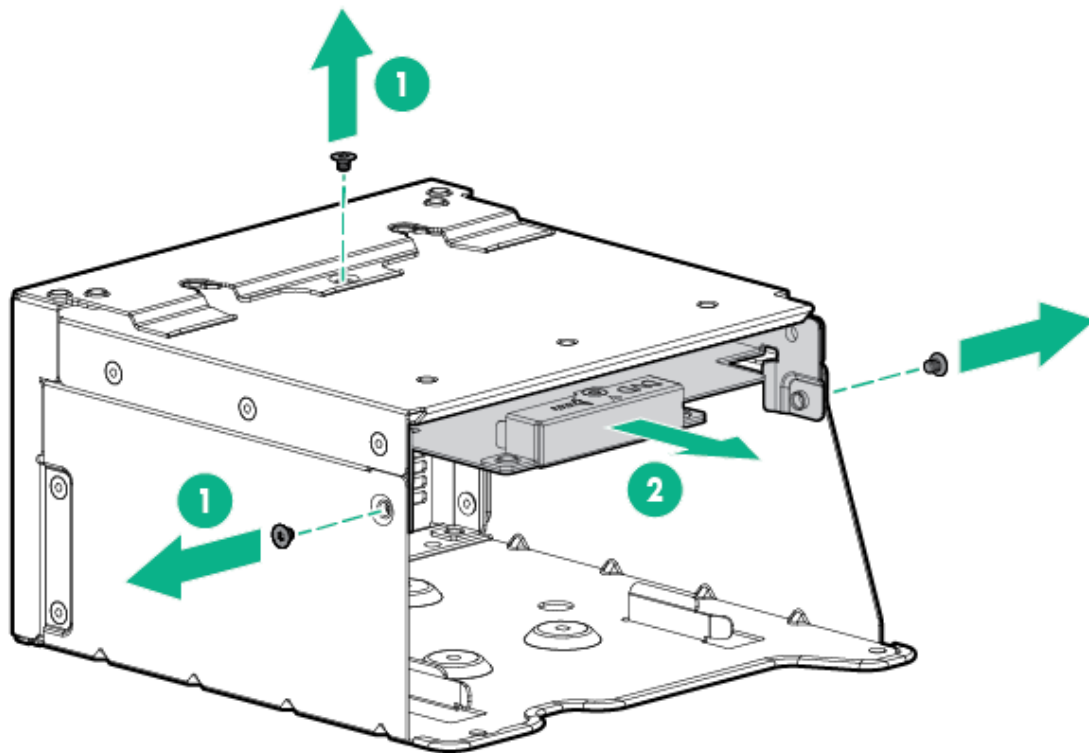

7. Remove the SFF drive blank from the universal media bay.

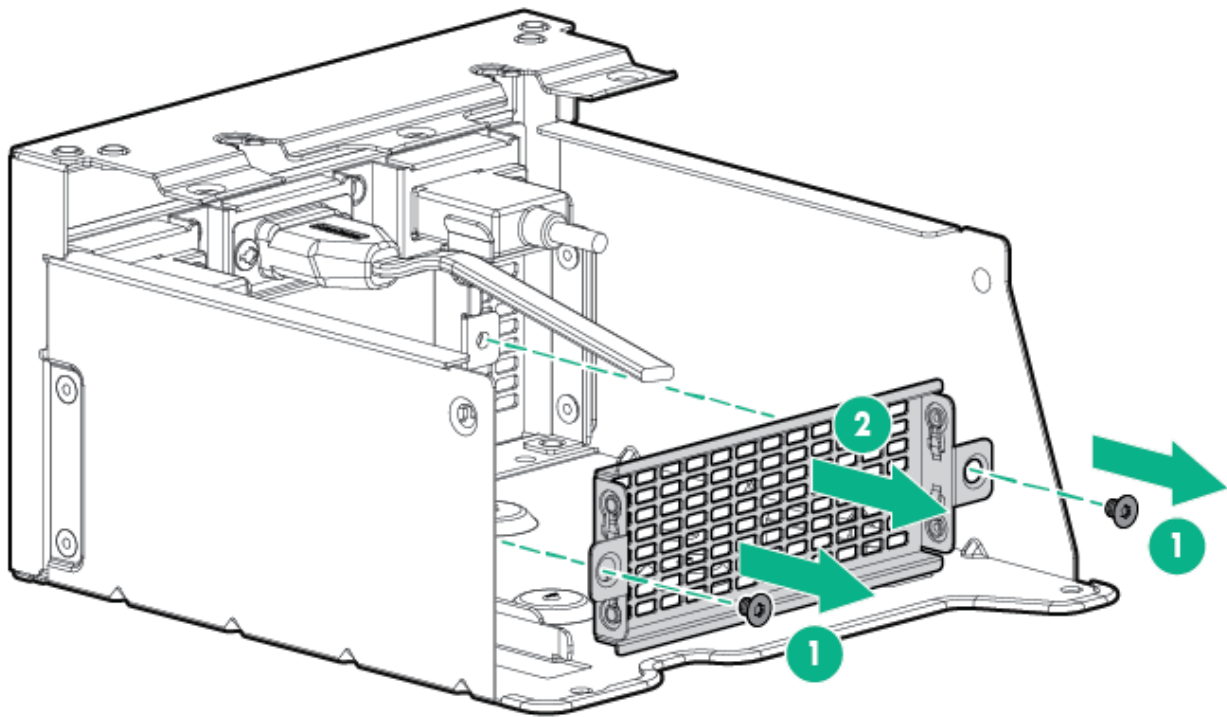

8. Install grommets onto drive cage.

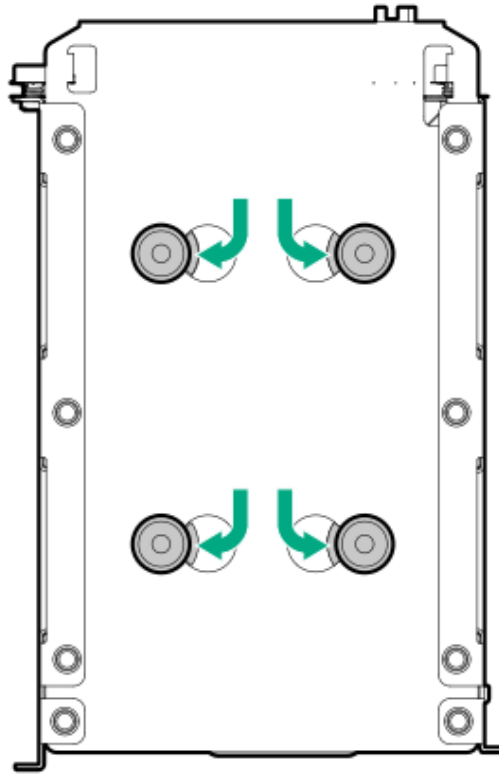

9. Install the drive cage into the universal media bay.

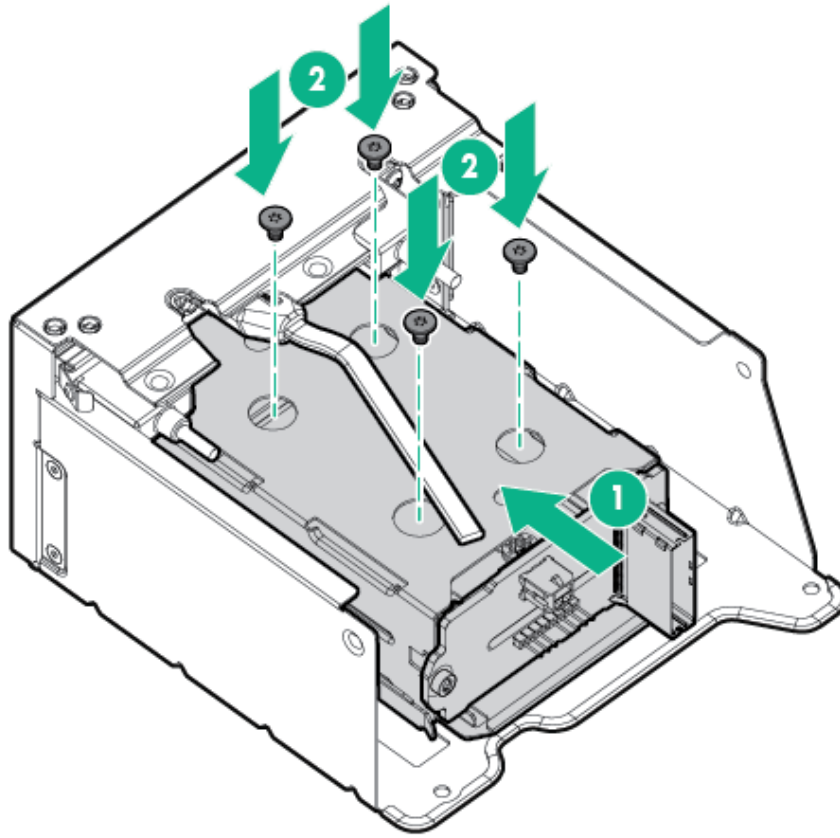

.0. Install the optical disc drive tray.

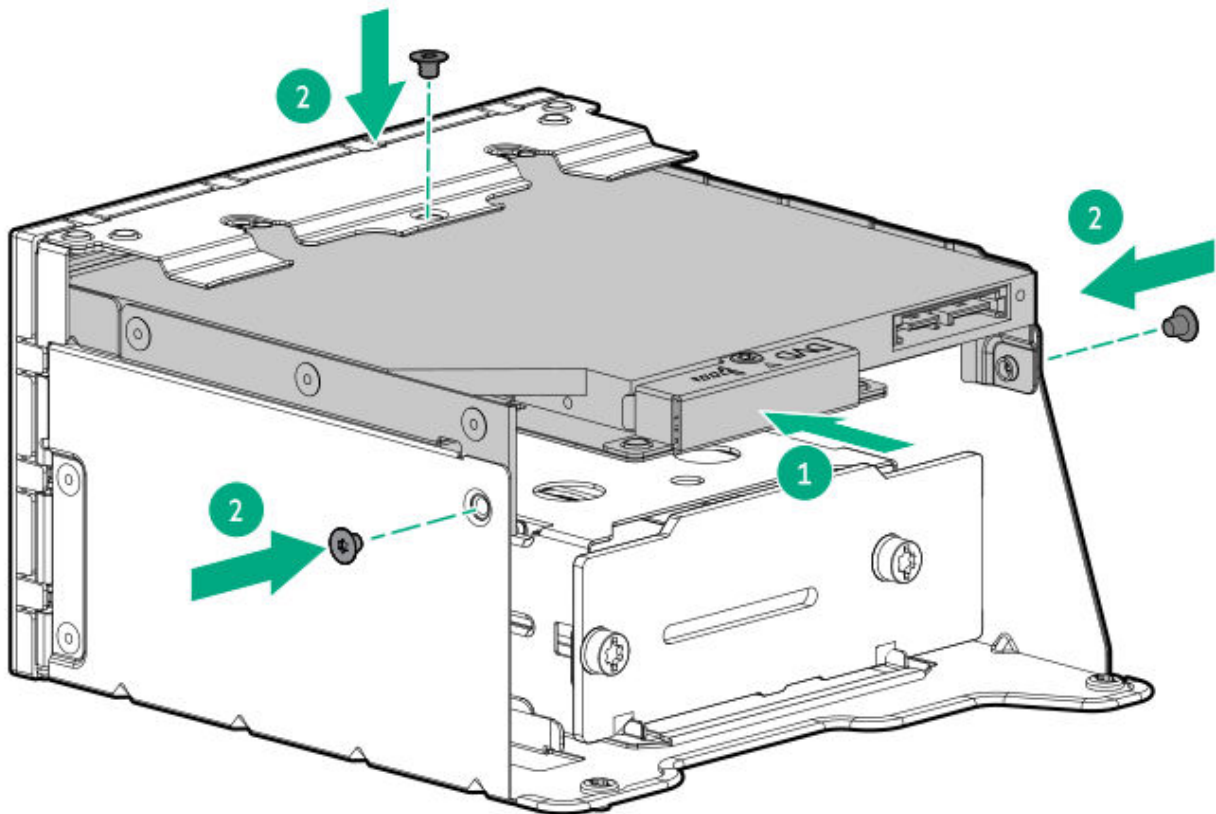

- .1. Install the universal media bay.
- .2. Connect the power and data cables.
- .3. Install the access panel.
- .4. Slide the server into the rack.
- .5. Connect each power cord to the server.
- .6. Connect each power cord to the power source.
- .7. Power up the server.

Installing a midplane drive cage

Prerequisites

Before you perform this procedure, make sure that the components included with the hardware option kit are available.

About this task

- A 1U performance heatsink is required for each processor when installing this option.

Procedure

1. Power down the server.
2. Remove all power:
 - a. Disconnect each power cord from the power source.
 - b. Disconnect each power cord from the server.
3. Do one of the following:
 - Extend the server from the rack.
 - Remove the server from the rack.
4. Remove the access panel.
5. Remove the air baffle.

The air baffle is no longer needed. The drive cage acts as an air baffle for the server.
6. Remove all riser cages.

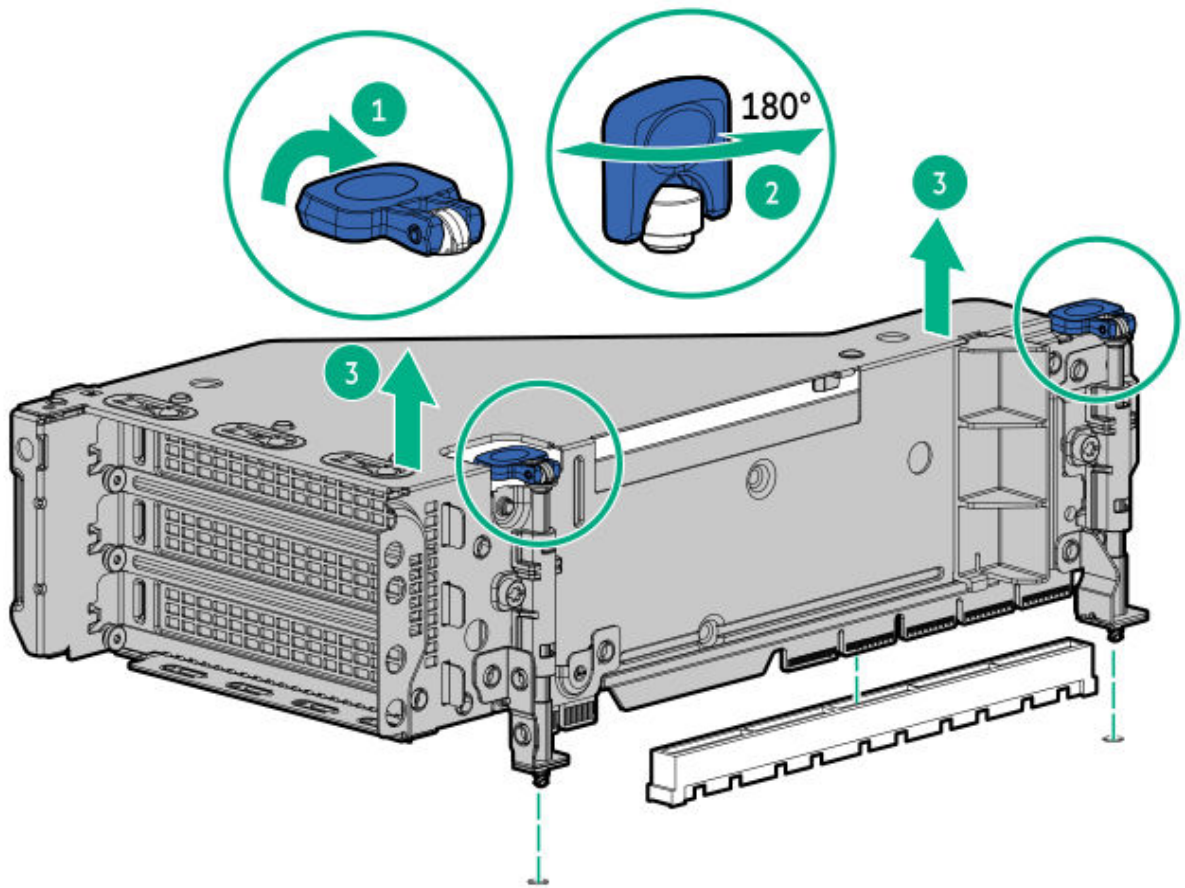

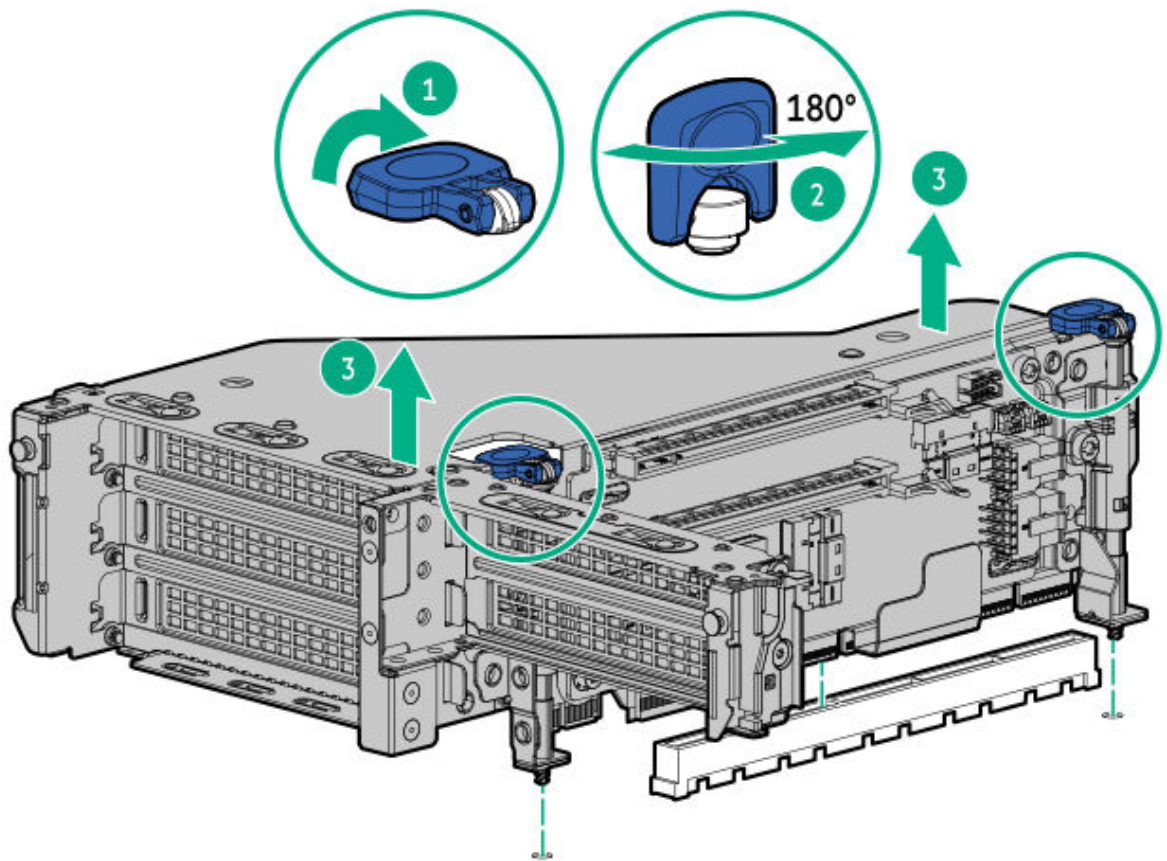

7. Prepare the drive cage for installation by lifting the latches on the drive cage.
8. Install the drive cage:

CAUTION

Do not drop the drive cage on the system board. Dropping the drive cage on the system board might damage the system or components. Remove all drives and use two hands when installing or removing the drive cage.

- a. Locate the alignment pins on the rear of the drive cage.
- b. Align the pin on the rear left of the drive cage to the server and then insert the pin.
- c. Gently lower the opposite side of the drive cage.
- d. Pull the plunger pin on the rear right of the drive cage and then lower the drive cage until the plunger pin engages.

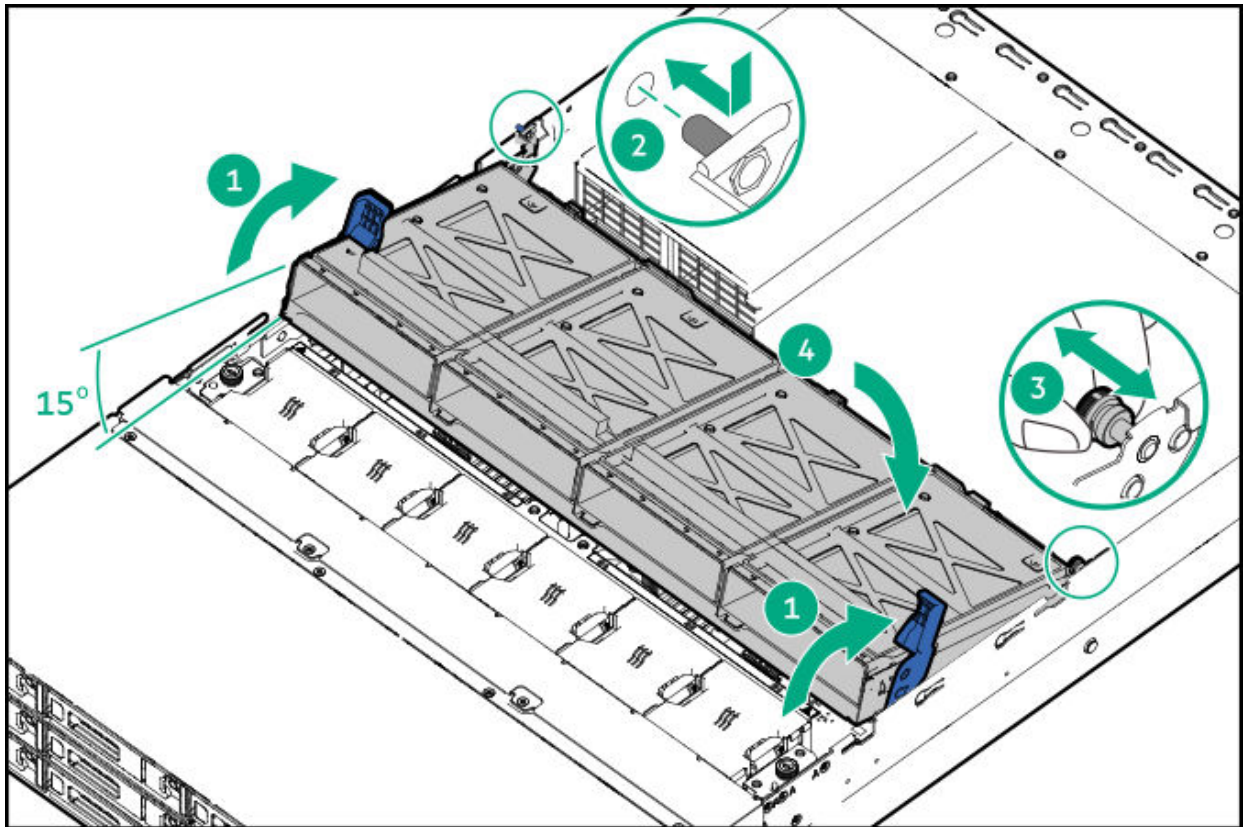

9. Install drives or drive blanks.

10. Push down on the latches to lower the drive cage into place.

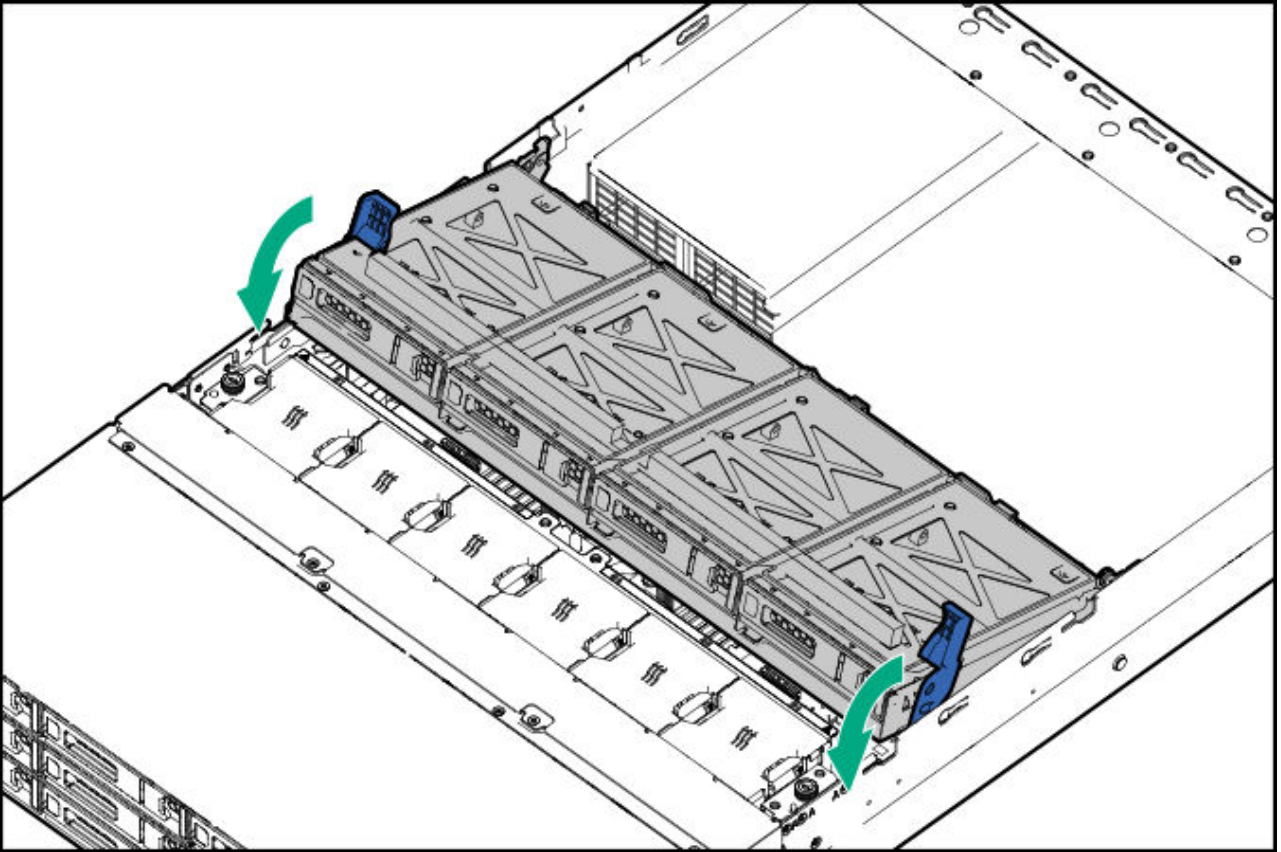

- .1. Connect the power and data cables to the drive backplane.
- .2. Install the riser cages.
- .3. Install the access panel.
- .4. Slide the server into the rack.
- .5. Connect each power cord to the server.
- .6. Connect each power cord to the power source.
- .7. Power up the server.

Results

The installation is complete.

Installing a rear 2SFF stacked drive cage

Prerequisites

Before you perform this procedure, make sure that you have the following items available:

- T-10 Torx screwdriver
- The components included with the hardware option kit
- The front bays are fully populated with 12 LFF or 24 SFF drives
- High-performance fans are installed in all fan bays

Procedure

1. Power down the server.
2. Remove all power:
 - a. Disconnect each power cord from the power source.
 - b. Disconnect each power cord from the server.
3. Do one of the following:
 - Extend the server from the rack.
 - Remove the server from the rack.
4. Remove the access panel.
5. Do one of the following:

- If installed, remove the secondary riser cage.

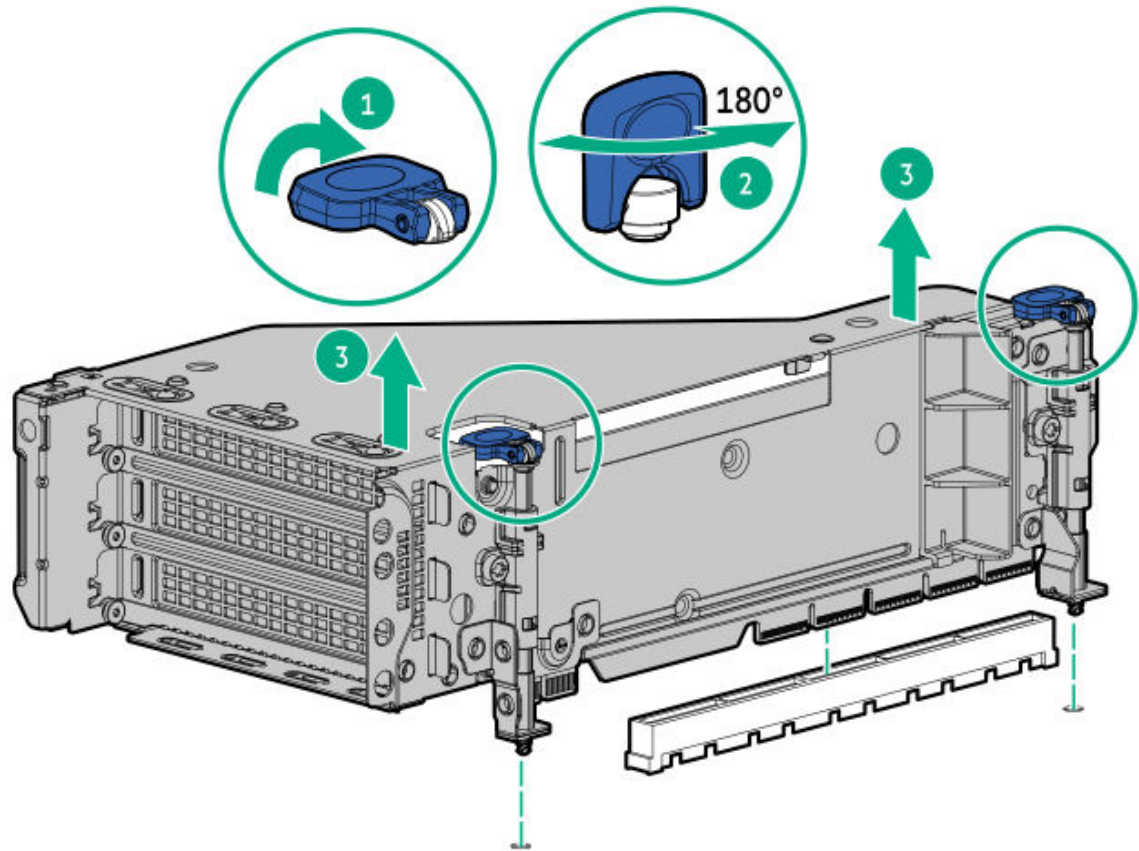

- Remove the secondary wall blank.

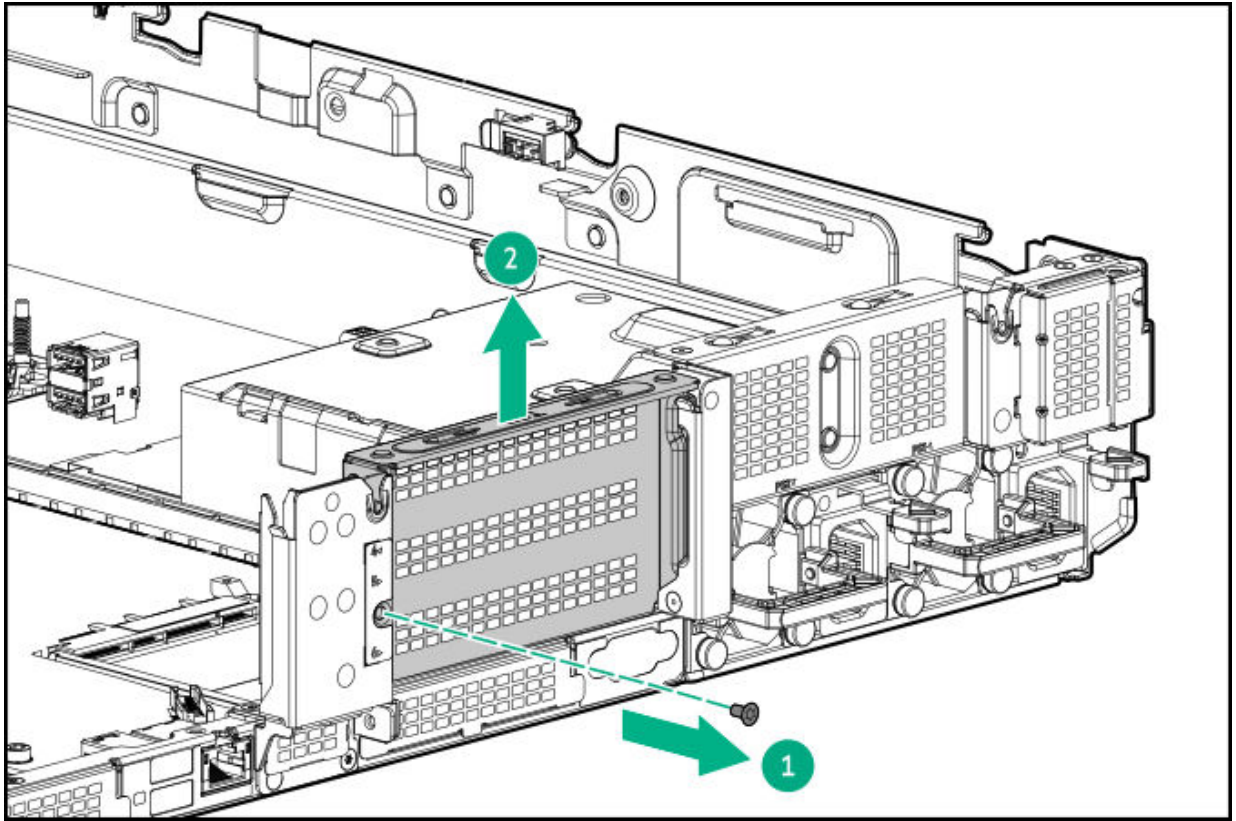

6. Remove the tertiary wall blank.

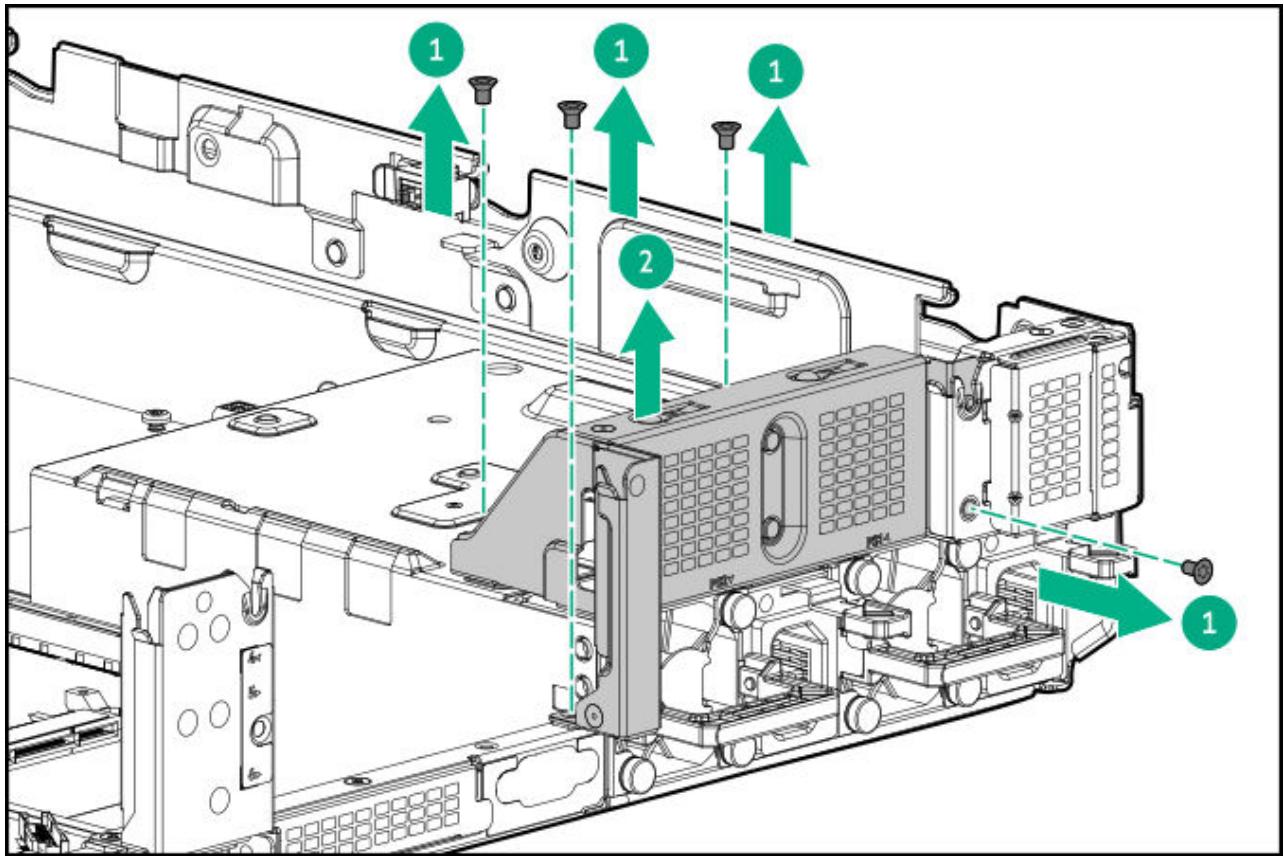

7. Install grommets onto drive cage.

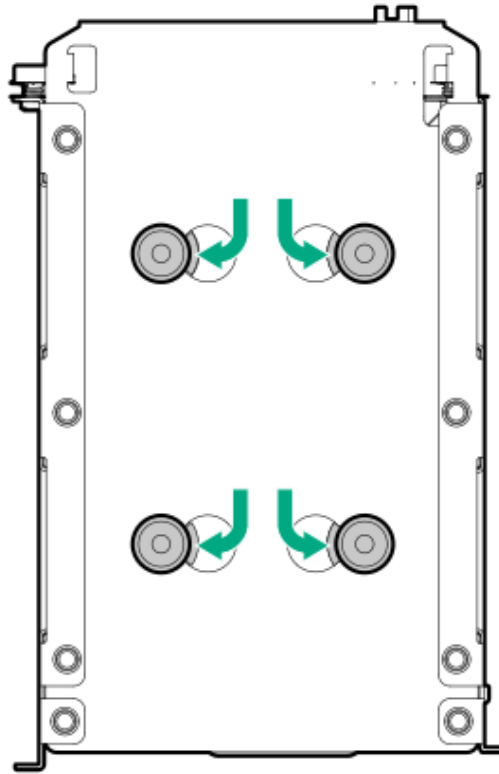

8. Install the drive cage.

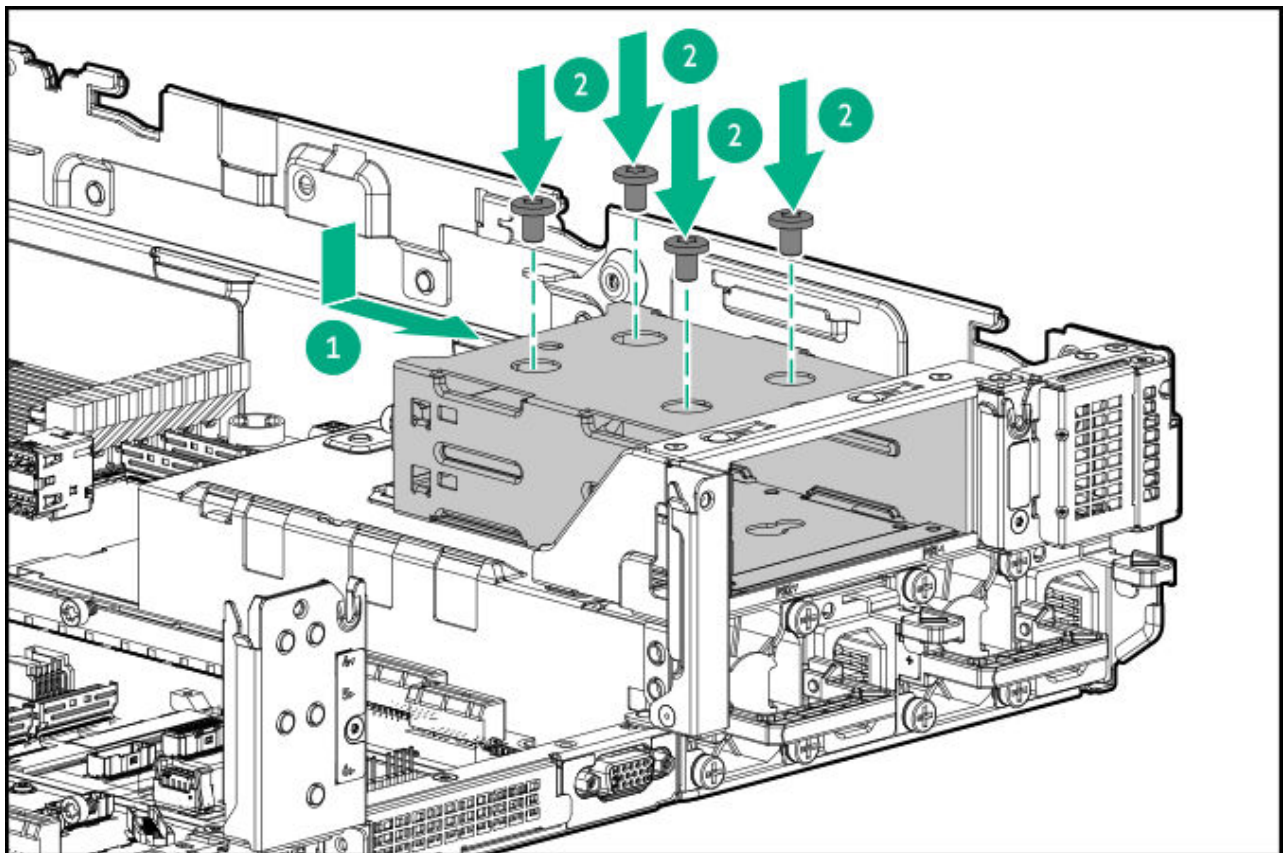
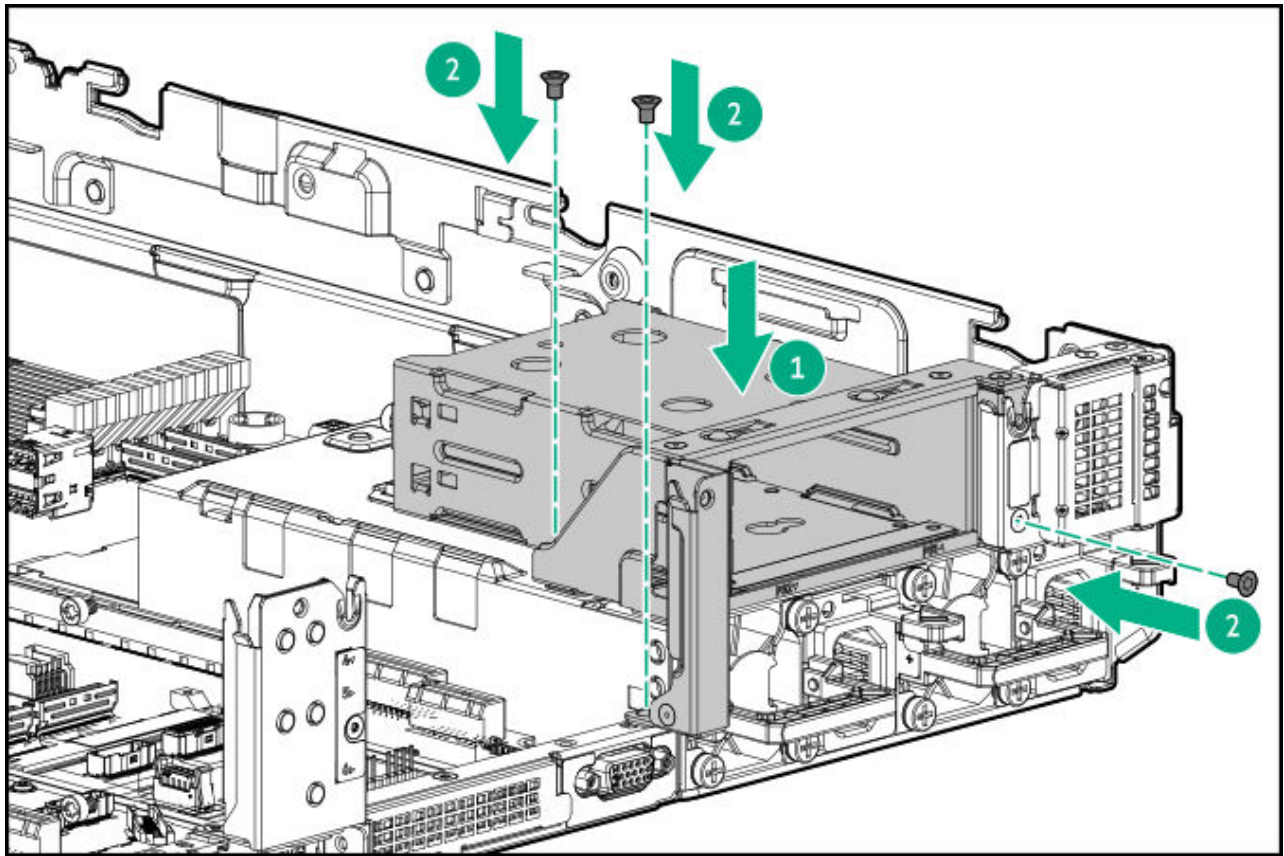

9. [Install drives](#) or drive blanks.
10. Install the secondary rear wall or a secondary riser cage.
11. [Cable the drive backplane](#).
12. [Install the access panel](#).
13. Slide the server into the rack.
14. Connect each power cord to the server.
15. Connect each power cord to the power source.
16. [Power up the server](#).

Energy packs

Subtopics

[Minimum firmware versions](#)

[HPE Smart Storage Battery](#)

[HPE Smart Storage Hybrid Capacitor](#)

[Installing a smart storage battery/capacitor](#)

Minimum firmware versions

Product	Minimum firmware version
Server system ROM	1.20
HPE MR type-o and type-p Gen11 controllers	52.24.3-4948

HPE Smart Storage Battery

A single 96 W battery can support up to 24 devices.

After the battery is installed, it might take up to two hours to charge. Controller features requiring backup power are not re-enabled until the battery is capable of supporting the backup power.

This server supports the 96 W HPE Smart Storage Battery with the 145 mm cable.

For more information, see HPE Smart Storage Batteries and Hybrid Capacitors QuickSpecs:

https://www.hpe.com/psnow/doc/a00028553enw.pdf?jumpid=in_pdp-psnow-qs

HPE Smart Storage Hybrid Capacitor

The capacitor pack can support up to three devices.

This server supports the 12 W or 16 W HPE Smart Storage Hybrid Capacitor with the 145 mm cable.

Before installing the HPE Smart Storage Hybrid Capacitor, verify that the system BIOS meets the minimum firmware requirements to support the capacitor pack.



IMPORTANT

If the system BIOS or controller firmware is older than the minimum recommended firmware versions, the capacitor pack will only support one device.

The capacitor pack is fully charged after the system boots.

For more information, see HPE Smart Storage Batteries and Hybrid Capacitors QuickSpecs:

https://www.hpe.com/psnow/doc/a00028553enw.pdf?jumpid=in_pdp-psnow-qs

Installing a smart storage battery/capacitor

Prerequisites

Be sure you have the components included with the hardware option kit.

Procedure

1. Power down the server.
2. Remove all power:
 - a. Disconnect each power cord from the power source.
 - b. Disconnect each power cord from the server.

3. Do one of the following:
 - a. Extend the server from the rack.
 - b. Remove the server from the rack.
4. Remove the access panel.
5. Install the energy pack.

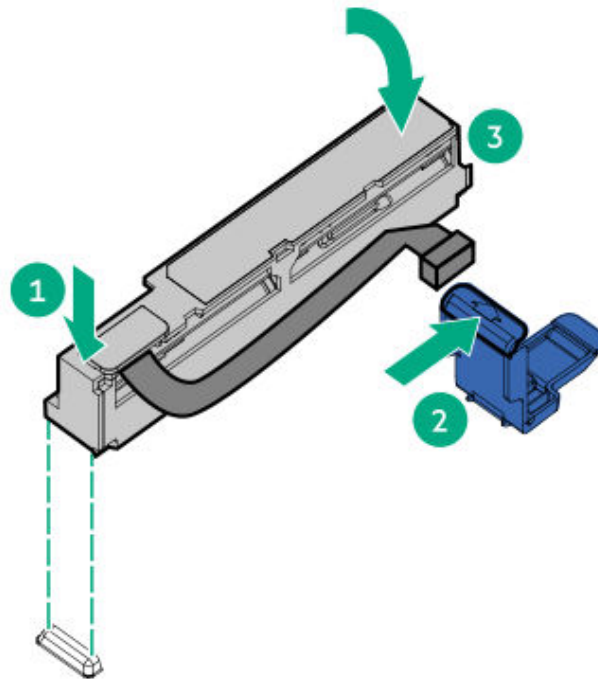

6. If needed, connect the extension cable.
7. Connect the cable to the system board.
8. Install the access panel.
9. Install the server in the rack.
10. Connect each power cord to the server.
11. Connect each power cord to the power source.
12. Power up the server.

Results

The installation is complete.

GPUs

Subtopics

Installing an accelerator or GPU

Installing an accelerator or GPU

Prerequisites

System preparation

To prepare the system, see "[Pre-installation procedures](#)".

Safety and precautions



WARNING

Always observe safety precautions while working with server hardware:

- Wear an ESD strap and work on an ESD-safe surface.
- Power down and unplug equipment before servicing.
- Use proper lifting techniques and assistance for heavy items.
- Allow hot components to cool before handling.
- Watch out for sharp edges and pinch points.

For more information, see "[Safety, warranty, and regulatory information](#)".

Tools and equipment

- T-10 or T-15 Torx screwdriver

About this task

An accelerator or GPU can be installed into the primary, secondary, or tertiary position. This procedure shows an installation in the secondary position.

Procedure

1. Remove the air baffle.

2. Install the appropriate support bracket onto the air baffle.

Install the position that supports your configuration. Primary, secondary, and tertiary positions are shown.

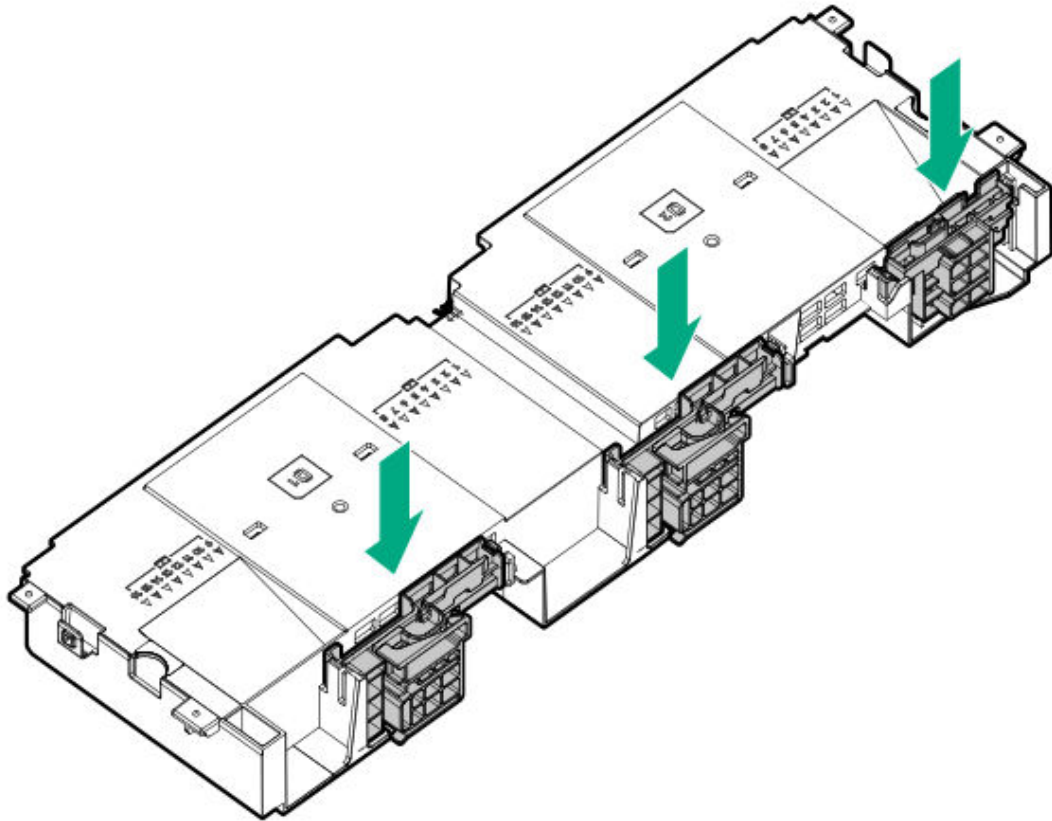

3. Remove the riser cage.

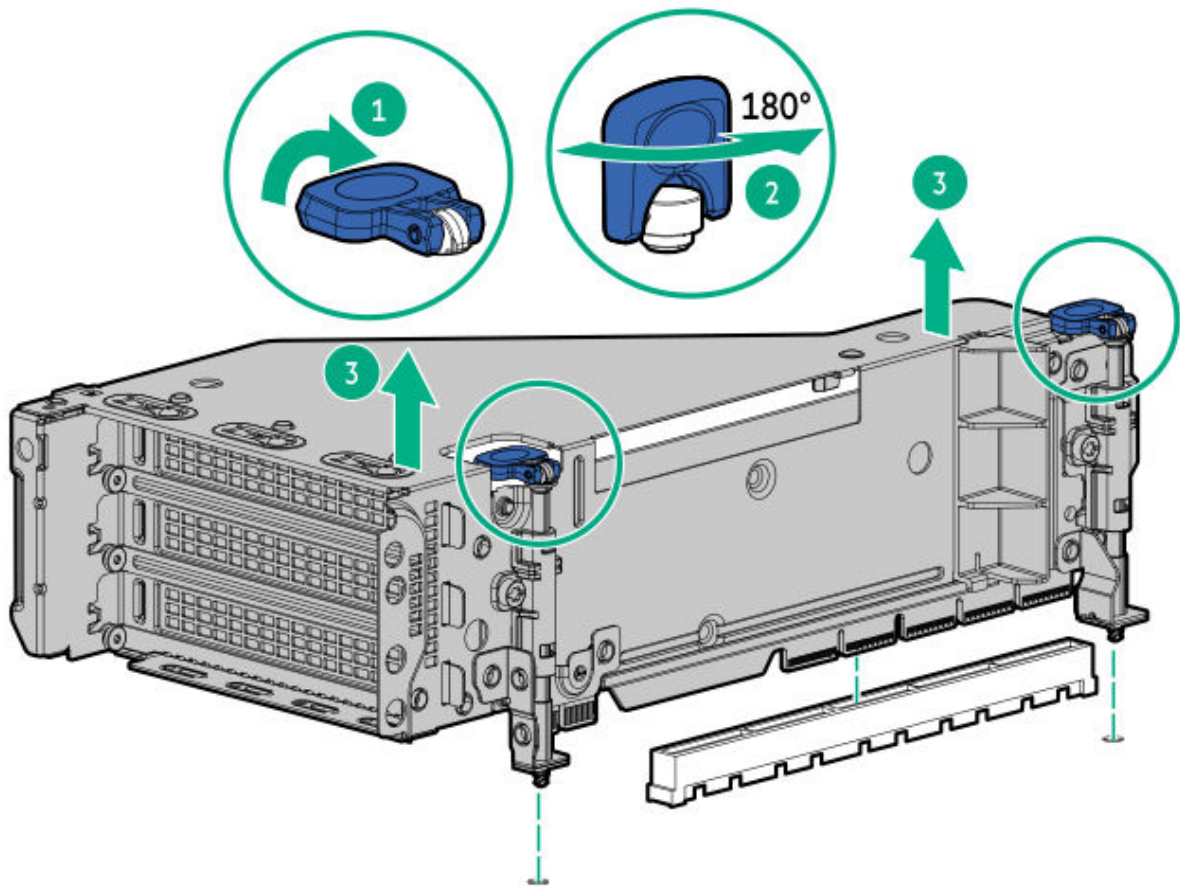

4. Remove the appropriate PCIe blanks from the riser cage.

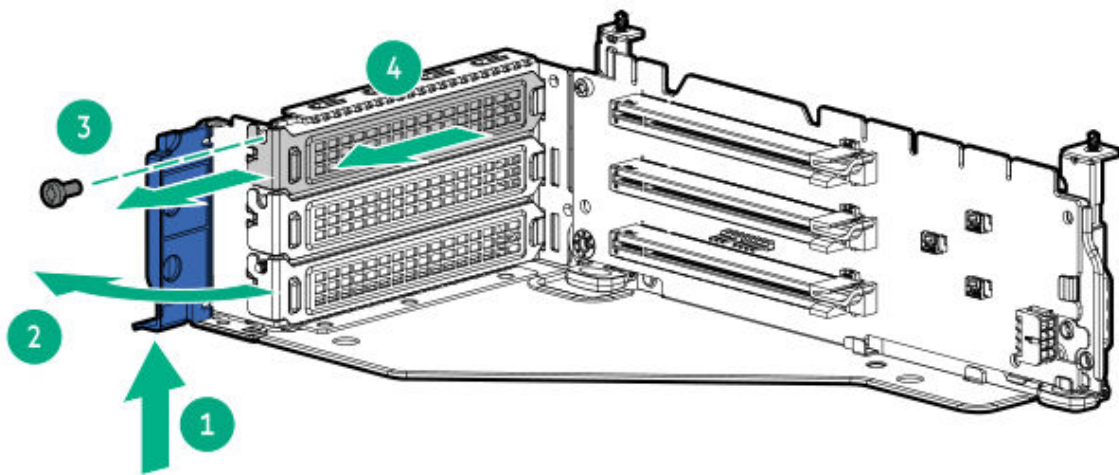

5. Install the GPU extender bracket provided by the manufacturer.

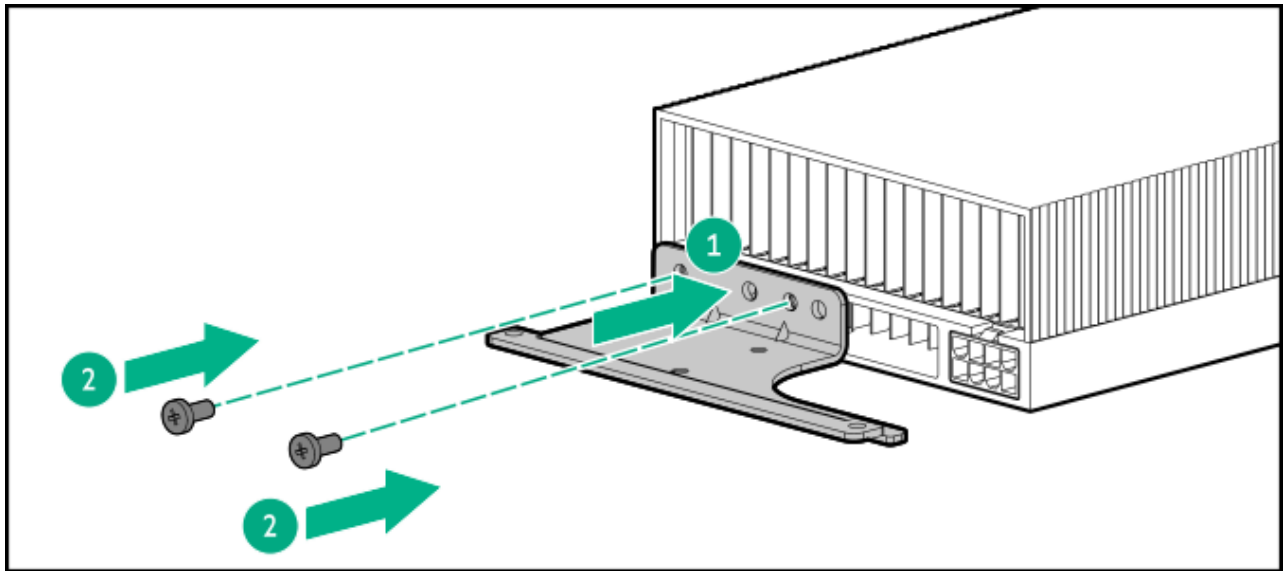

6. Install the GPU into the riser.

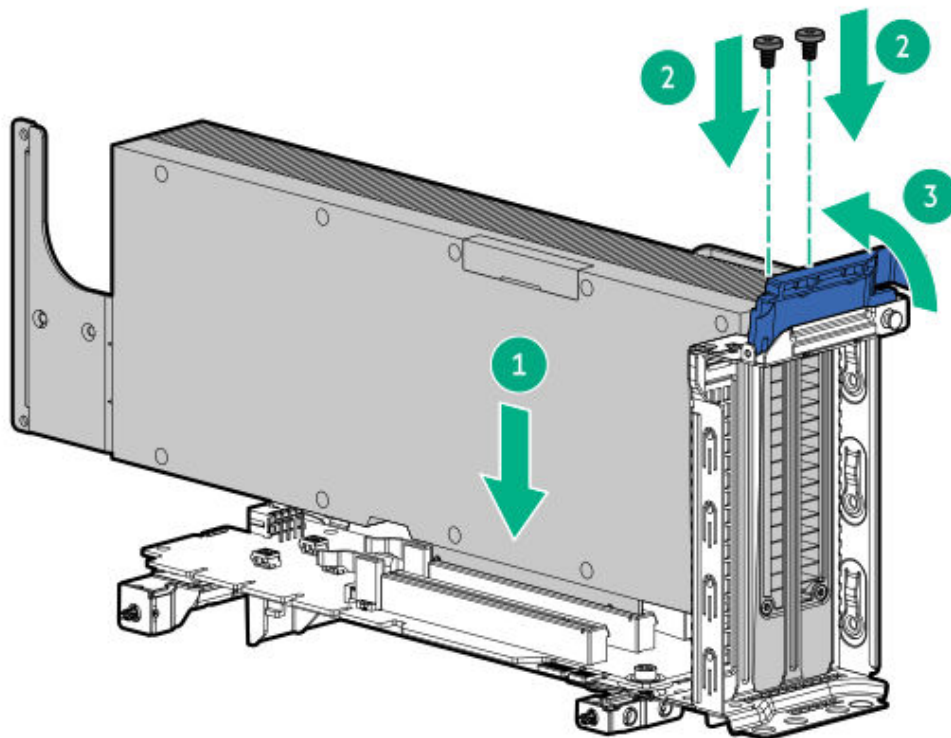

7. Connect the GPU power cables.

6-pin power connectors supply up to 75 W. 8-pin power connectors supply up to 150 W.

If your GPU supports sideband management, connect the sideband management cable to the GPU SB port on the riser.

8. Open the support brackets and install the air baffle.

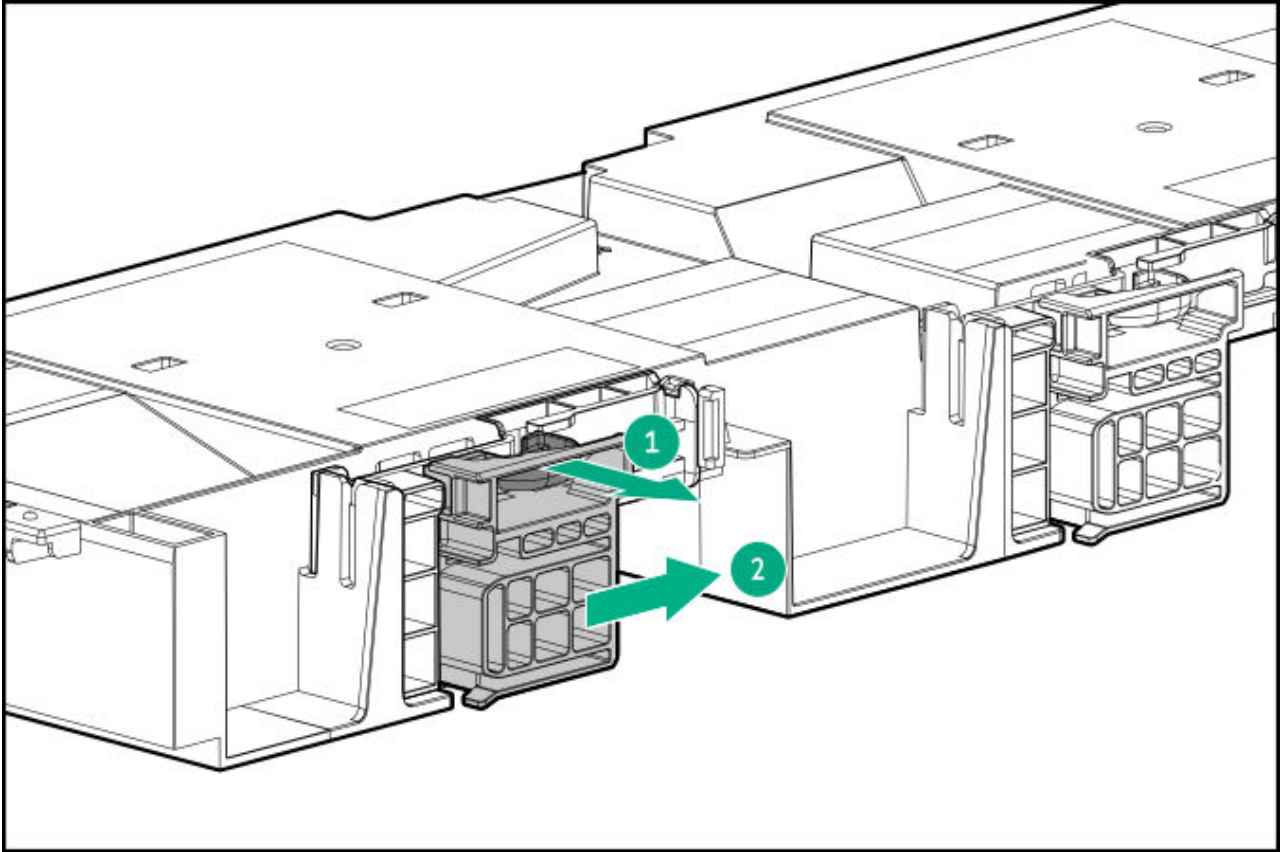

9. Install the riser cage.

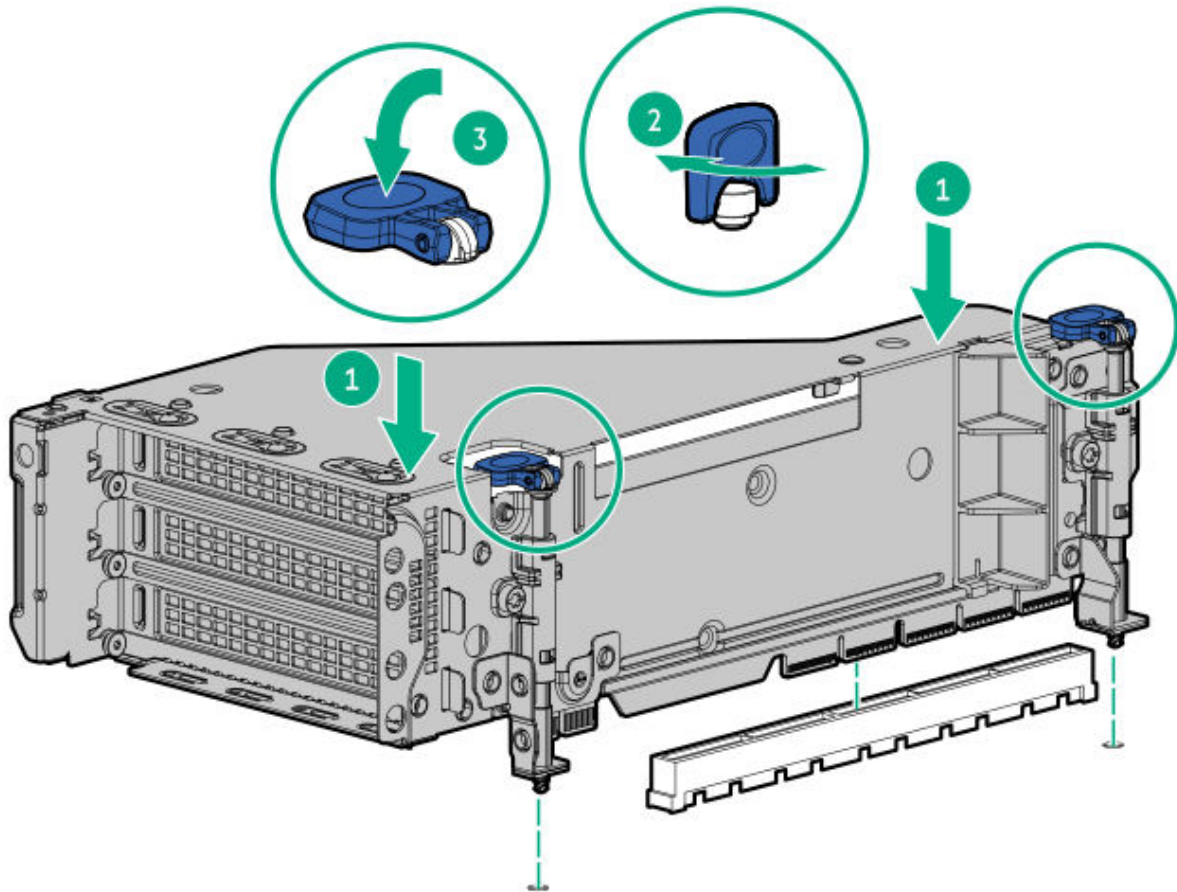

.0. Align the GPU support brackets to the retention clips and lock them into place.

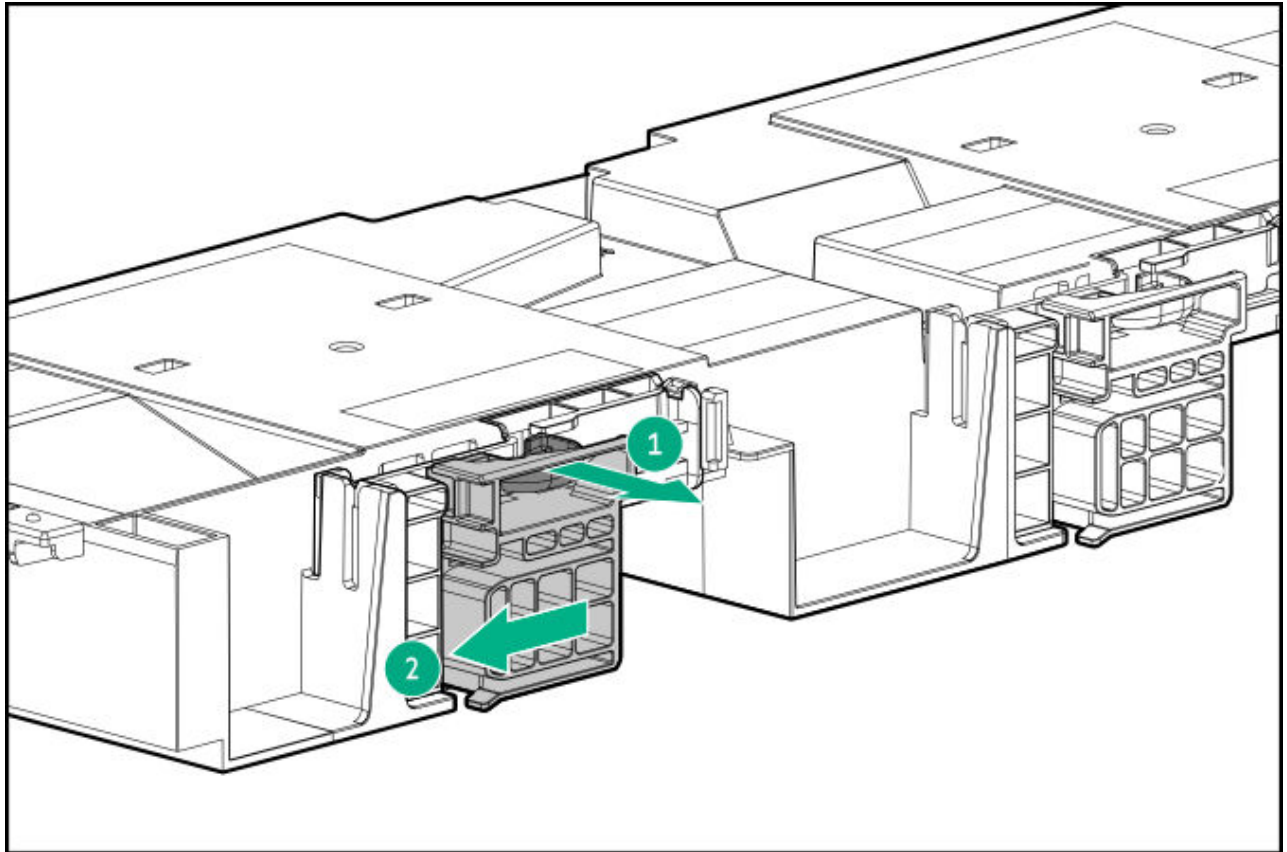

- .1. Install the access panel.
- .2. Slide the server into the rack.
- .3. Connect each power cord to the server.
- .4. Connect each power cord to the power source.
- .5. Power up the server.

Results

The installation is complete.

Management

Subtopics

Installing the Systems Insight Display

Installing a rear serial port interface

Installing the Systems Insight Display

Prerequisites

Before you perform this procedure, make sure that you have the following items available:

- The components included with the hardware option kit
- T-10 Torx screwdriver

About this task

The Systems Insight Display is only supported on SFF models.

Procedure

1. Power down the server.
2. Remove all power:
 - a. Disconnect each power cord from the power source.
 - b. Disconnect each power cord from the server.
3. Do one of the following:
 - Extend the server from the rack.
 - Remove the server from the rack.
4. Remove the access panel.
5. Do one of the following:
 - Remove the air baffle.
 - If installed, remove the midplane drive cage.
6. Remove the fan cage.
7. Using a T-10 driver, remove the power switch module blank. Retain the T-10 screw.

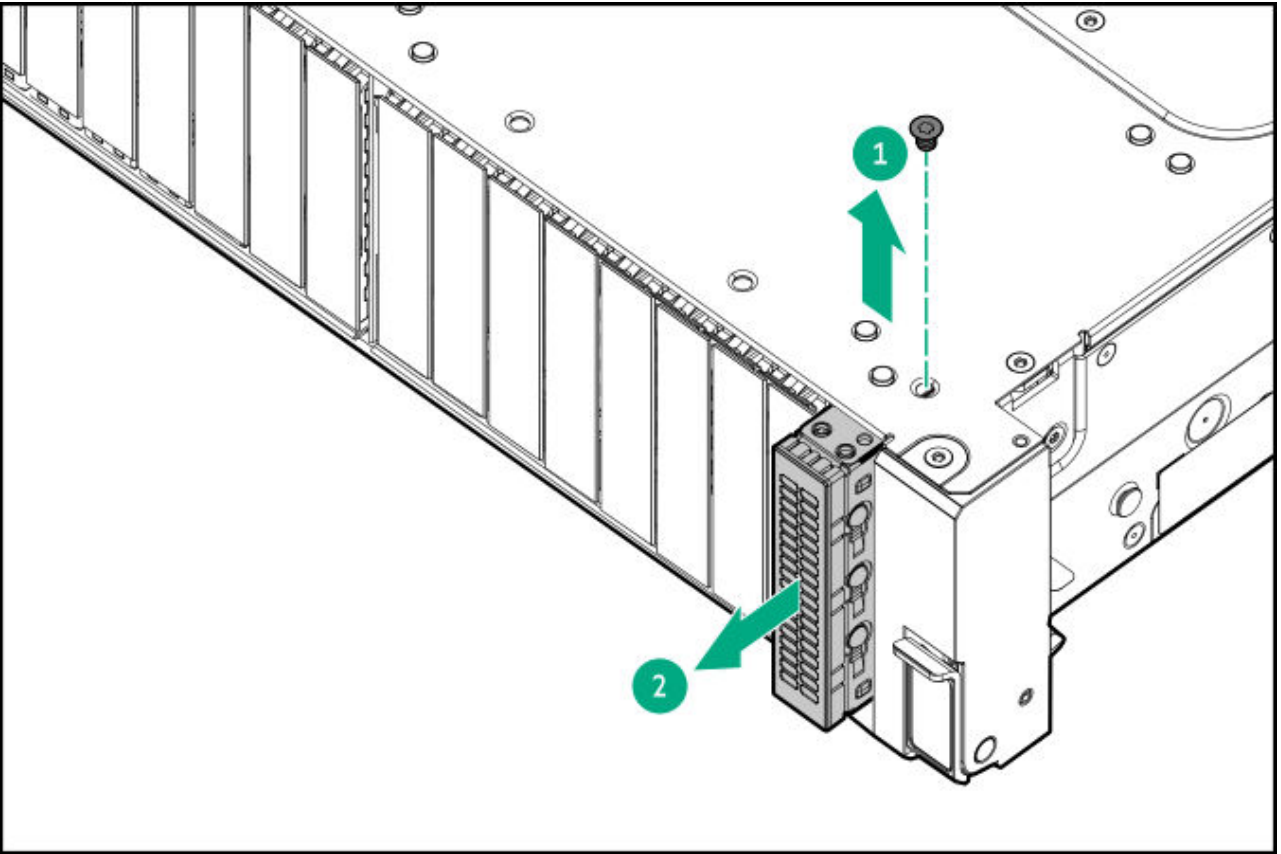

8. Route the SID cable through the opening in the front of the server, and then install the SID module. Secure the module using the T-10 screw.

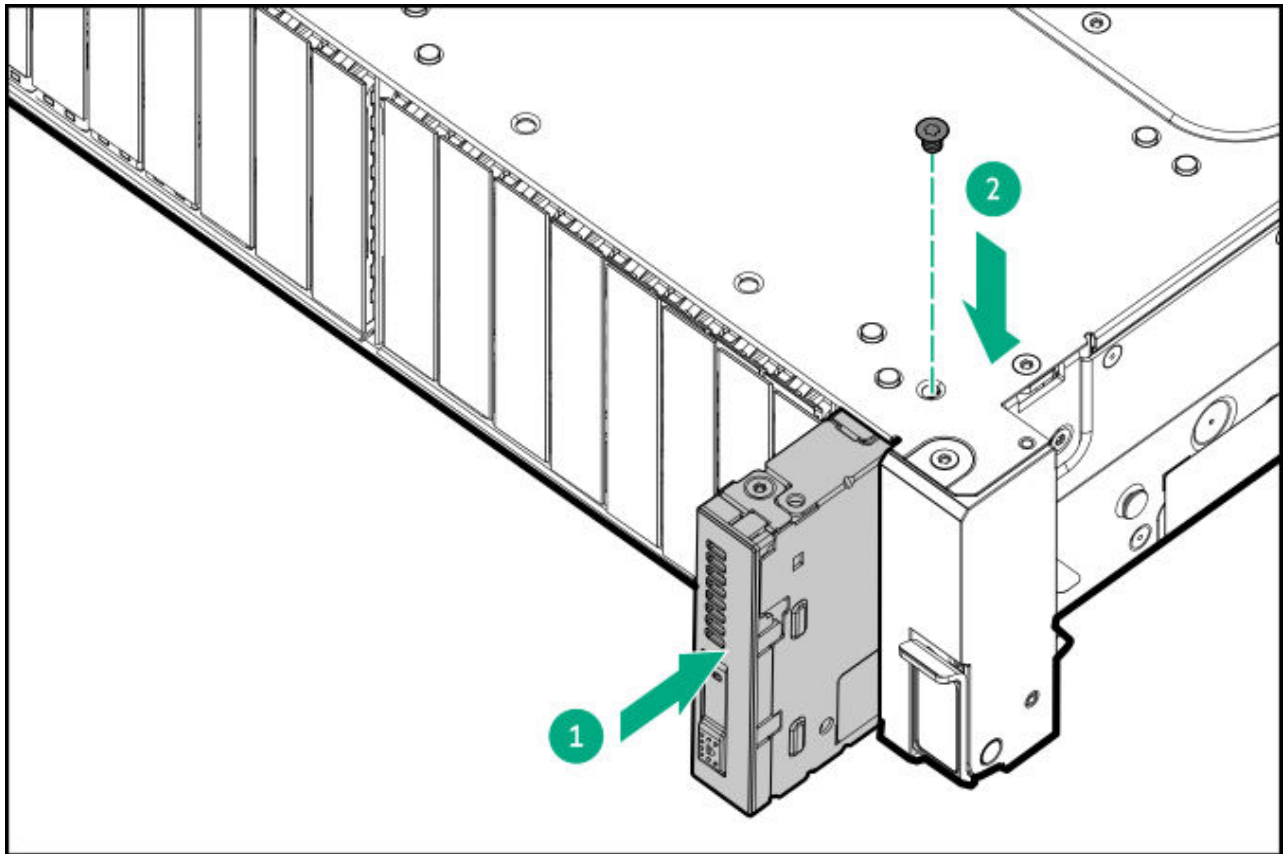

9. Connect the SID module cable to the SID module connector.



CAUTION

When routing cables, make sure that the cables are not in a position where they can be pinched or crimped.

- .0. Install the fan cage.
- .1. Do one of the following:
 - Install the air baffle.
 - Install the midplane drive cage.
- .2. Install the access panel.
- .3. Slide the server into the rack.
- .4. Connect each power cord to the server.
- .5. Connect each power cord to the power source.
- .6. Power up the server.

Results

The installation is complete.

Installing a rear serial port interface

Prerequisites

Before you perform this procedure, make sure that you have the following items available:

The components included with the hardware option kit

Procedure

1. Power down the server.
2. Remove all power:
 - a. Disconnect each power cord from the power source.
 - b. Disconnect each power cord from the server.
3. Do one of the following:
 - Extend the server from the rack.
 - Remove the server from the rack.
4. Remove the access panel.
5. Remove the serial port blank.

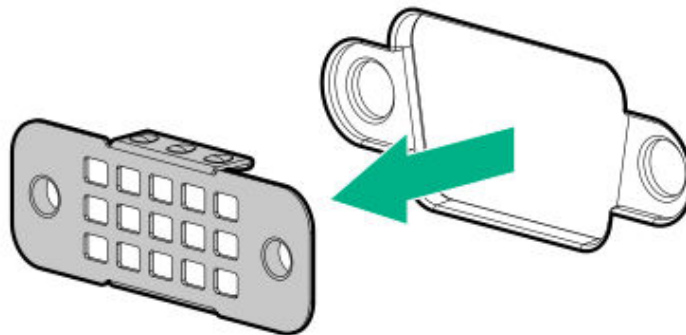

6. Install the serial port interface.

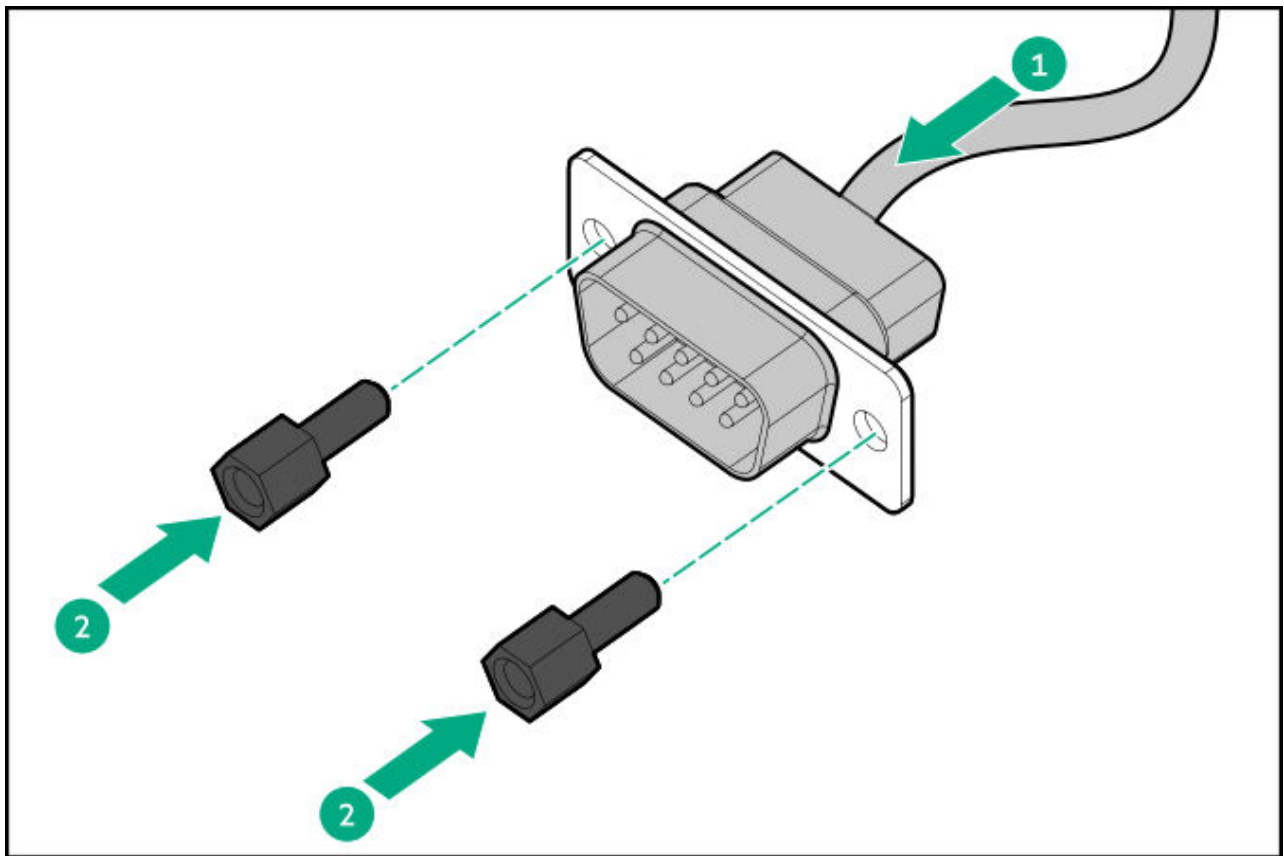

7. Connect the cable to the system board.
8. Install the access panel.
9. Install the server in the rack.
10. Connect each power cord to the server.
11. Connect each power cord to the power source.
12. Power up the server.

Results

The installation is complete.

Media devices

Subtopics

[Installing a universal media bay in the SFF chassis](#)

[Installing a universal media bay in the LFF chassis](#)

[Installing the optical disc drive in the SFF universal media bay](#)

[Installing the optical disc drive in the LFF universal media bay](#)

Installing a universal media bay in the SFF chassis

Prerequisites

Before you perform this procedure, make sure that you have the following items available:

- The components included with the hardware option kit
- T-10 Torx screwdriver

Procedure

1. [Power down the server.](#)
2. Remove all power:
 - a. Disconnect each power cord from the power source.
 - b. Disconnect each power cord from the server.
3. Do one of the following:
 - [Extend the server from the rack.](#)
 - [Remove the server from the rack.](#)
4. [Remove the access panel.](#)
5. [Remove the air baffle.](#)
6. [Remove the fan cage.](#)
7. Remove the bay blank.

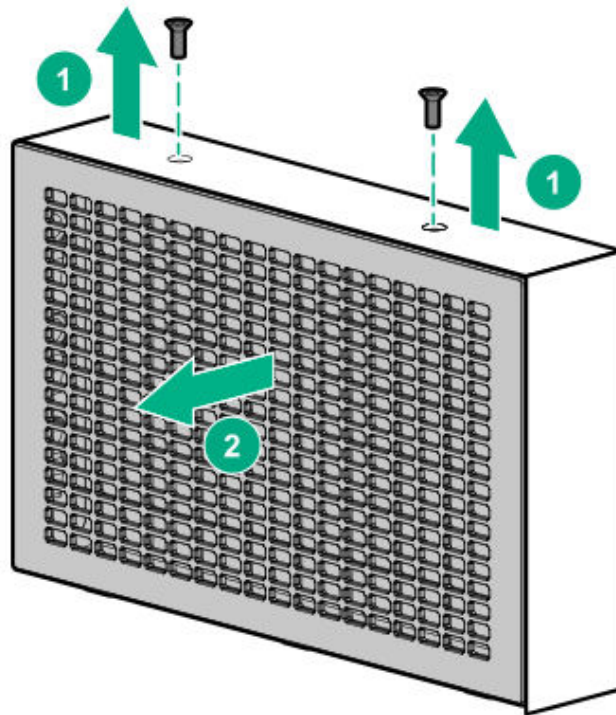

8. Route the USB and video cables through the opening.
9. If installing the front 2SFF stacked drive cage, install the drive cage.
10. Install the universal media bay.

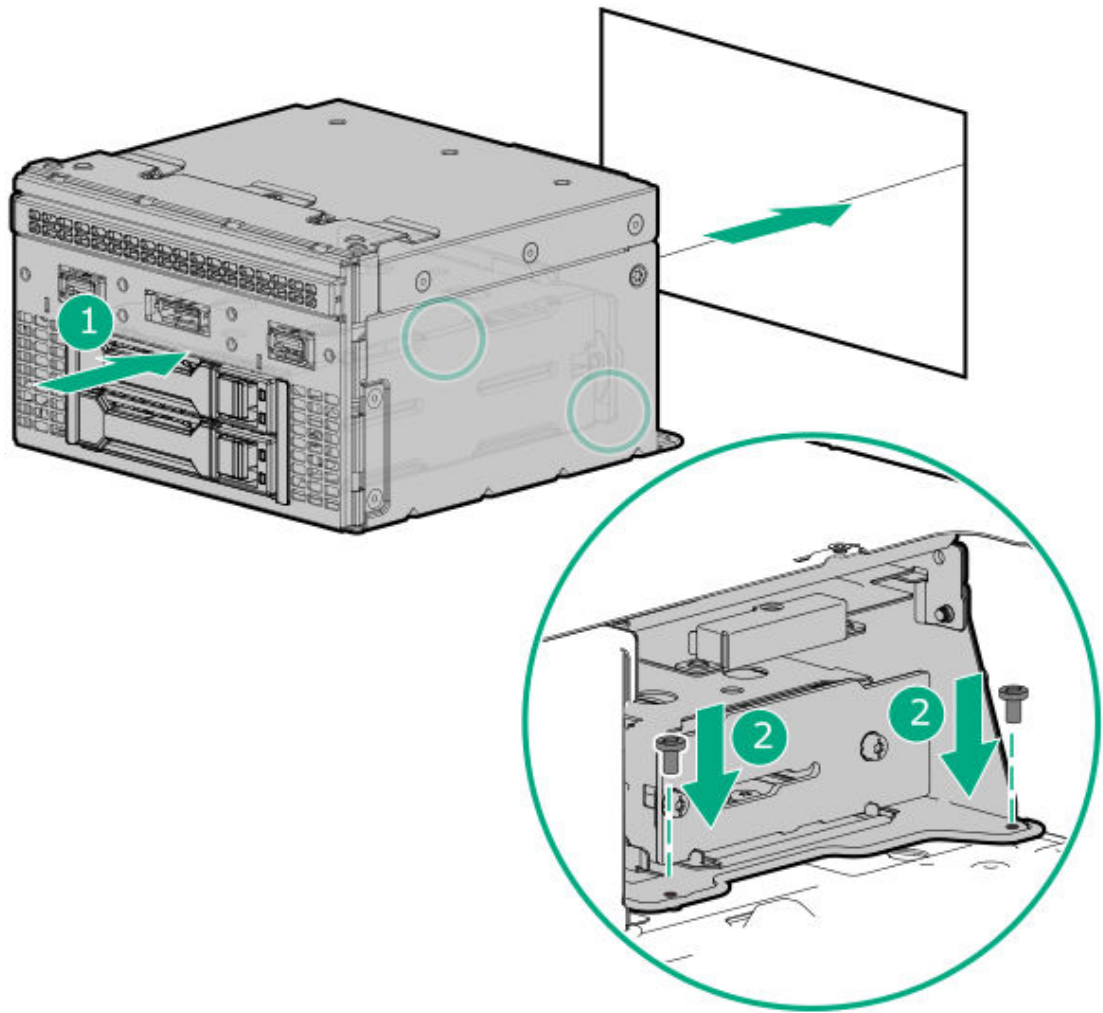

- .1. Connect the cables.
- .2. Install the access panel.
- .3. Slide the server into the rack.
- .4. Connect each power cord to the server.
- .5. Connect each power cord to the power source.
- .6. Power up the server.

Results

The installation is complete.

Installing a universal media bay in the LFF chassis

Prerequisites

Before you perform this procedure, make sure that you have the following items available:

- The components included with the hardware option kit
- T-10 Torx screwdriver

Procedure

1. Power down the server.
2. Remove all power:
 - a. Disconnect each power cord from the power source.
 - b. Disconnect each power cord from the server.
3. Do one of the following:
 - Extend the server from the rack.
 - Remove the server from the rack.
4. Remove the access panel.
5. Remove the air baffle or midplane drive cage.
6. Remove the fan cage.
7. Remove the bay blank.
8. Remove the support bracket.

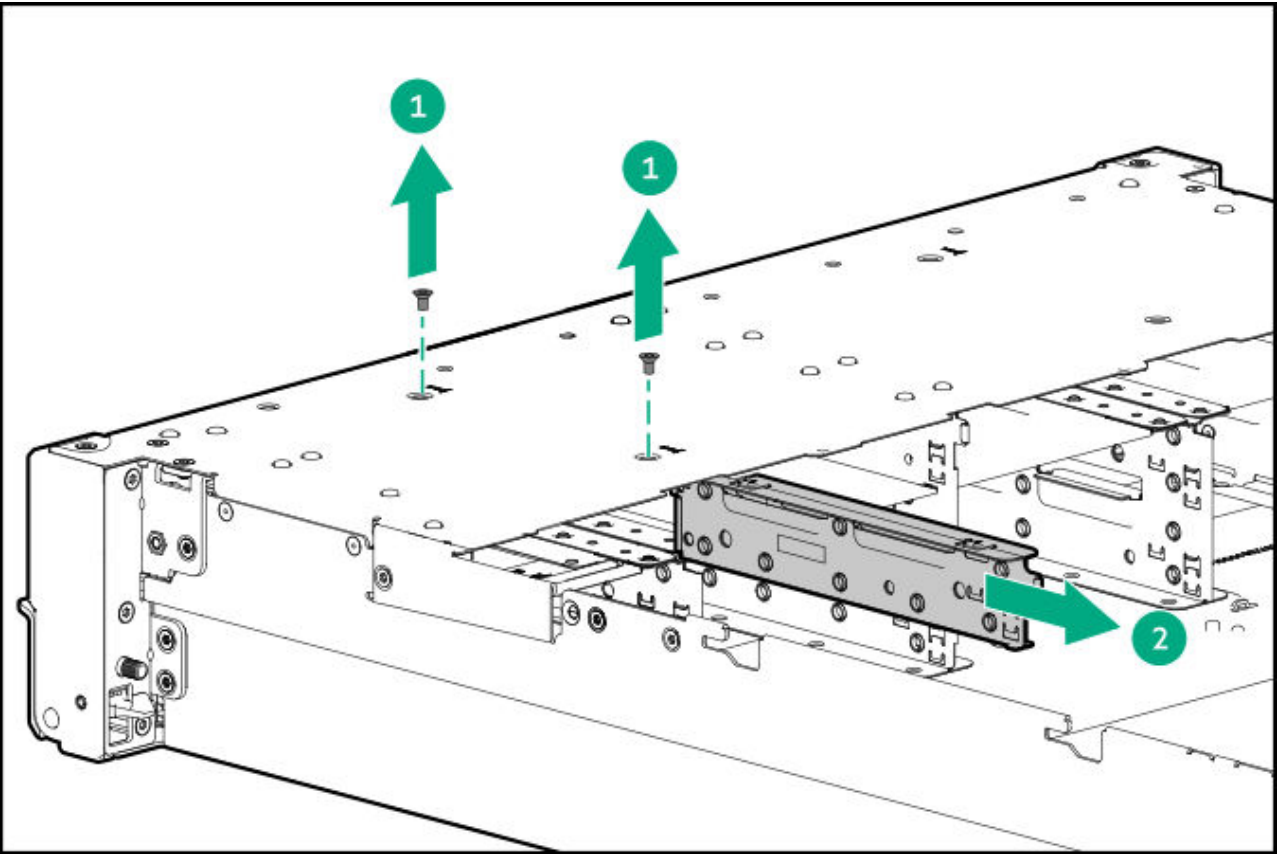

9. Route the cables through the opening.
10. Install the universal media bay.

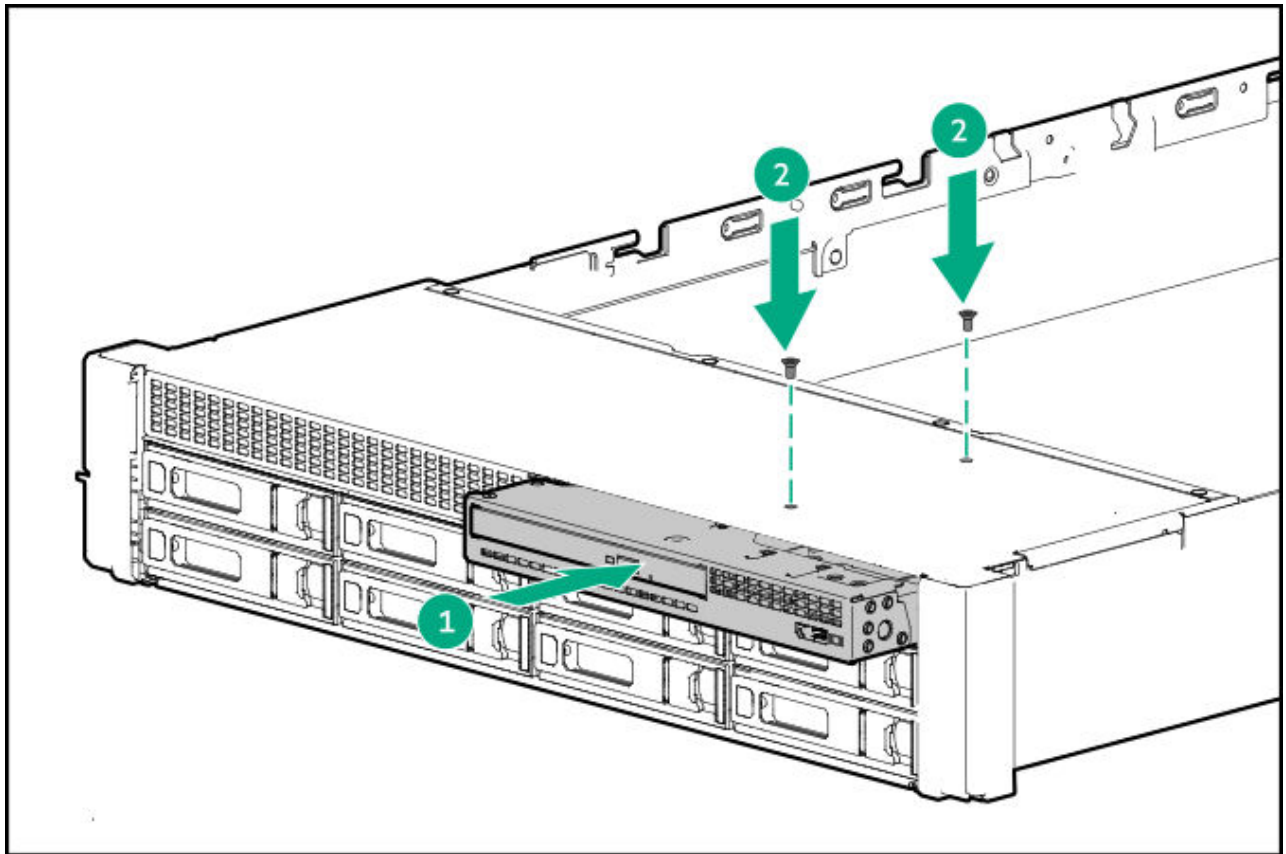

- .1. Connect the cables.
- .2. Install the access panel.
- .3. Slide the server into the rack.
- .4. Connect each power cord to the server.
- .5. Connect each power cord to the power source.
- .6. Power up the server.

Results

The installation is complete.

Installing the optical disc drive in the SFF universal media bay

Prerequisites

Before you perform this procedure, make sure that you have the following items available:

- The components included with the hardware option kit
- T-10 Torx screwdriver
- Phillips No. 1 screwdriver

Procedure

1. Power down the server.
2. Remove all power:
 - a. Disconnect each power cord from the power source.
 - b. Disconnect each power cord from the server.
3. Do one of the following:
 - Extend the server from the rack.
 - Remove the server from the rack.
4. Remove the access panel.
5. Remove the air baffle or midplane drive cage.
6. Remove the fan cage.
7. Remove the optical drive blank from the universal media bay.

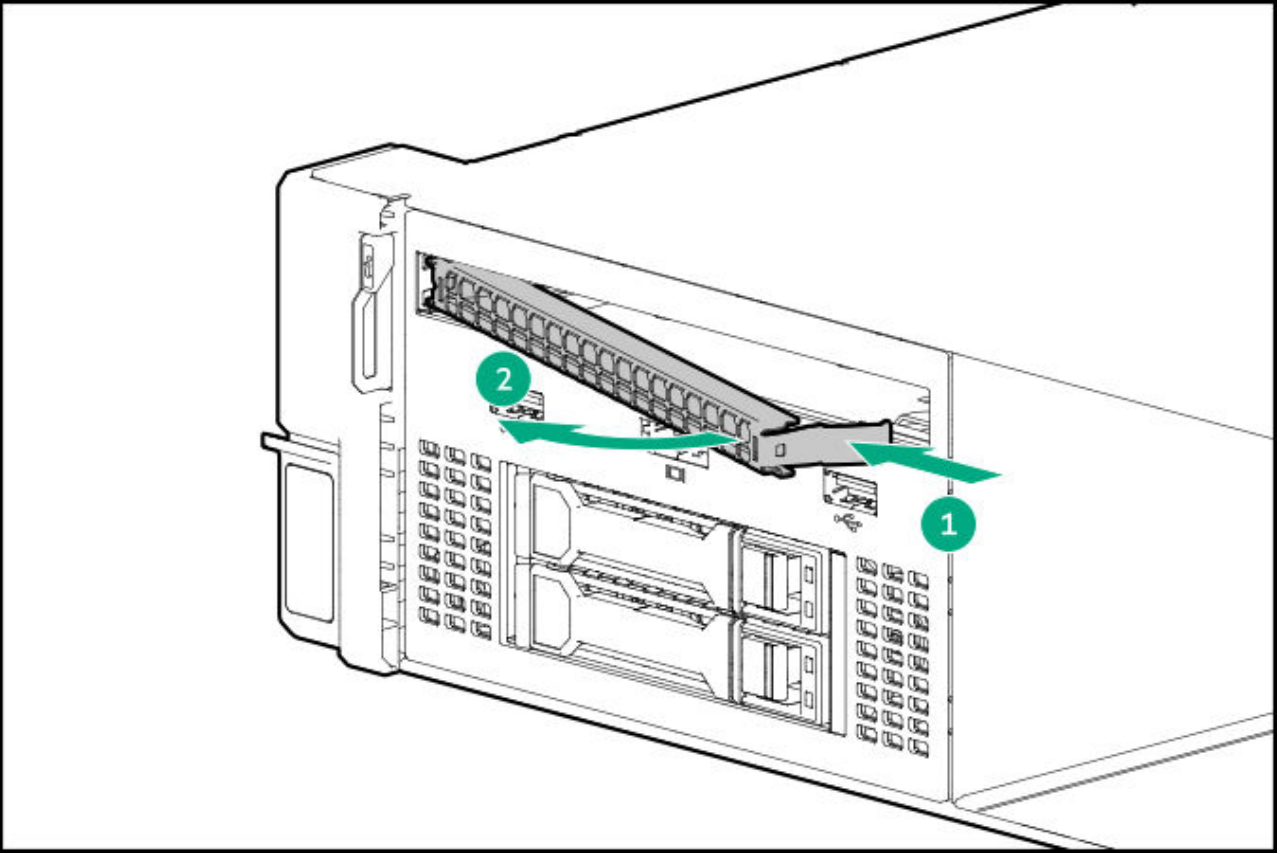

8. Install the optical drive in the universal media bay, and then install the screw.

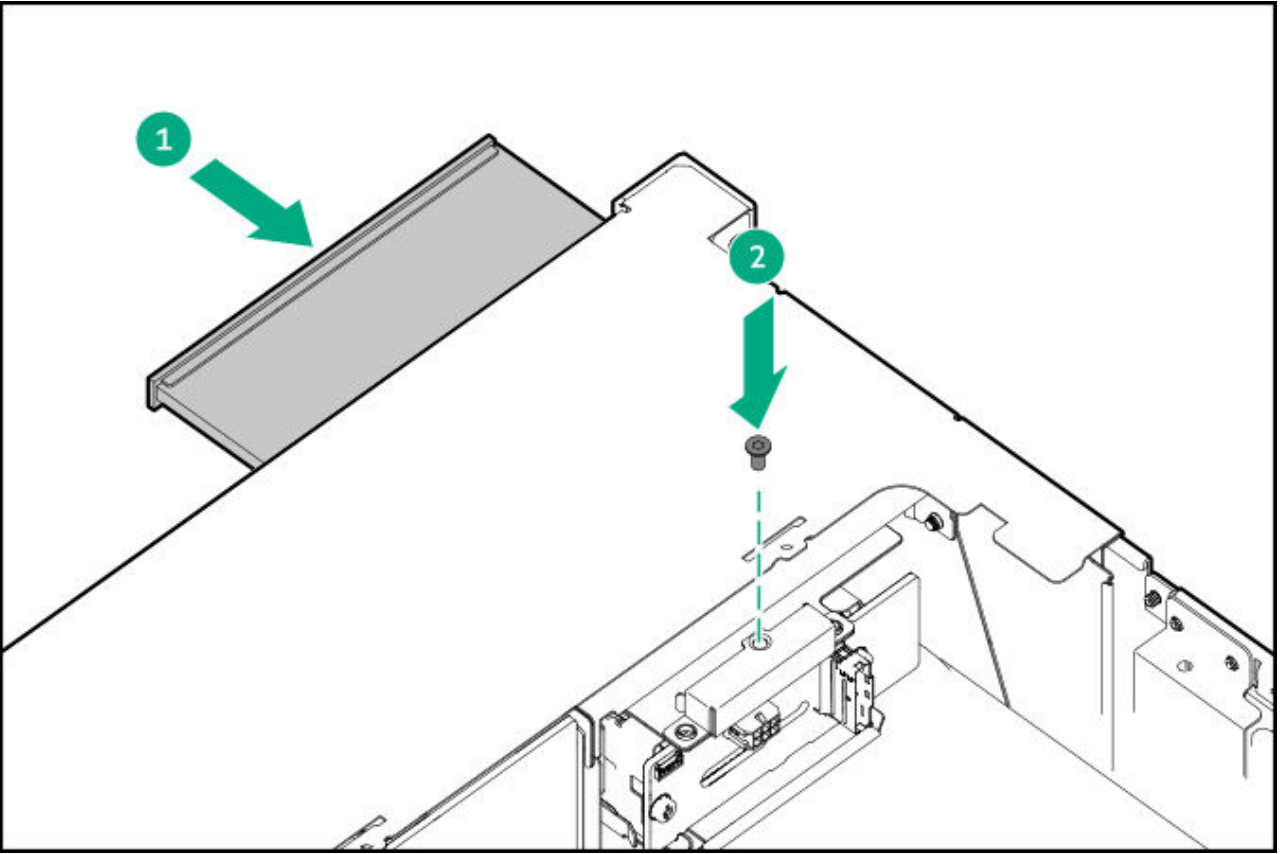

9. Cable the optical disc drive.
- .0. Install the fan cage.
- .1. Install the air baffle or midplane drive cage.
- .2. Install the access panel.
- .3. Slide the server into the rack.
- .4. Connect each power cord to the server.
- .5. Connect each power cord to the power source.
- .6. Power up the server.

Results

The installation procedure is complete.

Installing the optical disc drive in the LFF universal media bay

Prerequisites

Before you perform this procedure, make sure that you have the following items available:

- The components included with the hardware option kit
- T-10 Torx screwdriver
- Phillips No. 1 screwdriver

Procedure

1. Power down the server.
2. Remove all power:
 - a. Disconnect each power cord from the power source.
 - b. Disconnect each power cord from the server.
3. Do one of the following:
 - Extend the server from the rack.
 - Remove the server from the rack.

4. Remove the access panel.
5. Remove the air baffle or midplane drive cage.
6. Remove the fan cage.
7. Remove the optical drive blank from the universal media bay.

Retain the blank for future use.

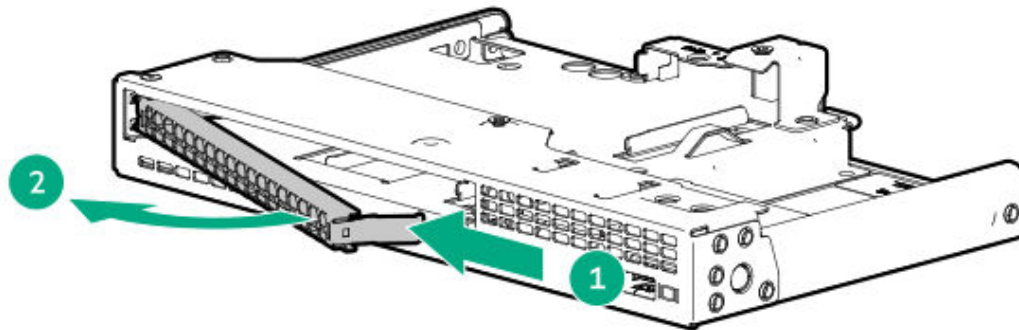

8. Install the optical drive bracket.

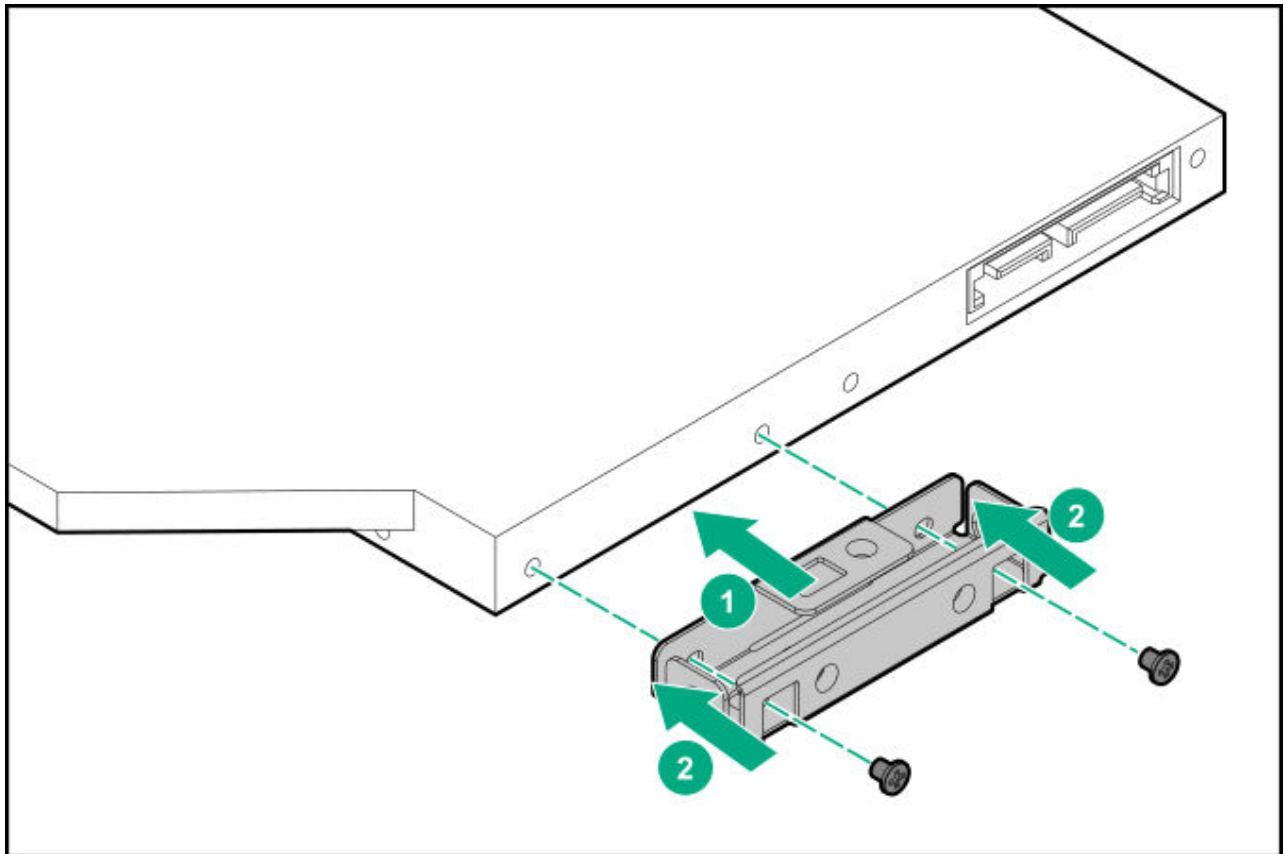

9. Install the optical disc drive.

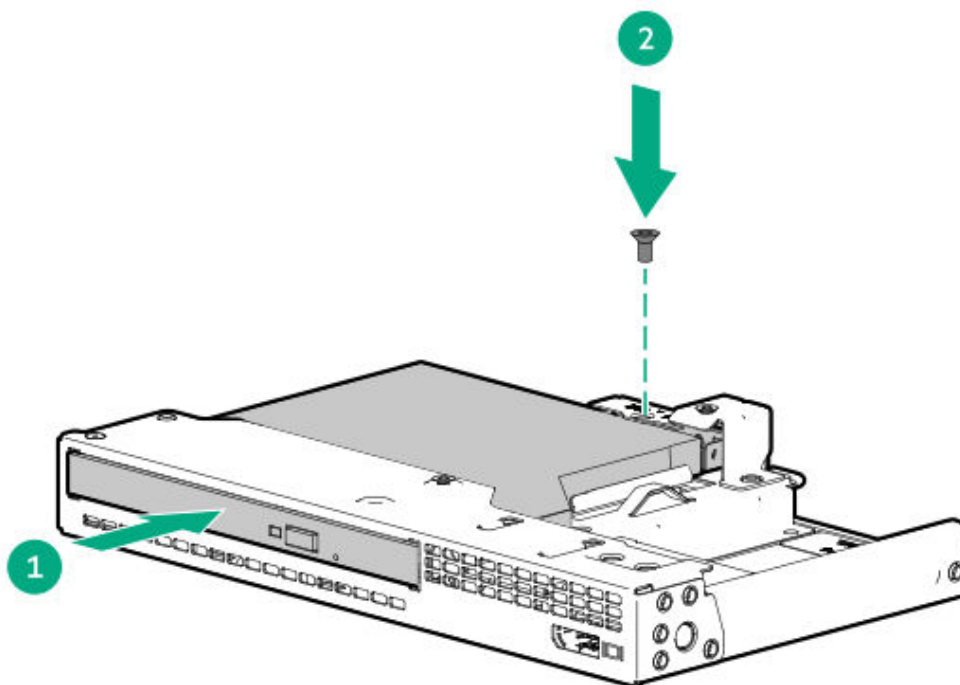

- .0. Install the fan cage.
- .1. Install the air baffle or midplane drive cage.
- .2. Install the access panel.
- .3. Slide the server into the rack.
- .4. Connect each power cord to the server.
- .5. Connect each power cord to the power source.
- .6. Power up the server.

Results

The installation procedure is complete.

Memory

Subtopics

Memory population information

DIMM label identification

DIMM-processor compatibility

Installing a DIMM

Memory population information

For specific memory population information, see the memory population guidelines on the Hewlett Packard Enterprise website (<https://www.hpe.com/docs/server-memory>).

DIMM label identification

To determine DIMM characteristics, see the label attached to the DIMM. The information in this section helps you to use the label to locate specific information about the DIMM.

For more information about product features, specifications, options, configurations, and compatibility, see the HPE DDR5 SmartMemory QuickSpecs:

<https://www.hpe.com/docs/server-memory>

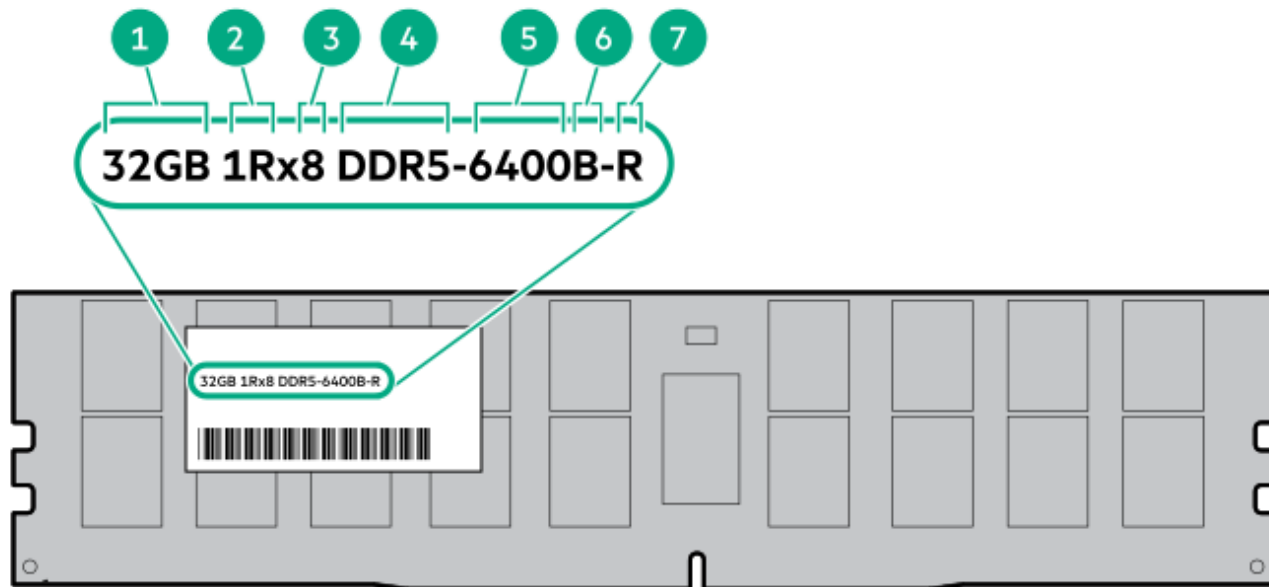

Item	Description	Example
1	Capacity*	16 GB 32 GB 64 GB 96 GB 128 GB 256 GB
2	Rank	1R—Single rank 2R—Dual rank 4R—Quad rank
3	Data width on DRAM	x4—4-bit x8—8-bit
4	Memory generation	PC5—DDR5
5	Maximum memory speed*	6400 MT/s

Item	Description	Example
6	CAS latency	B—42-42-42
7	DIMM type	R—RDIMM (registered)

* The maximum memory speed and capacity is a function of the memory type, memory configuration, and processor model.

DIMM-processor compatibility

Fifth-generation Intel Xeon Scalable processors support DDR5-5600 or 6400 DIMMs.

Do not mix DIMMs. Install only the supported DIMMs in the server.

Installing a DIMM

Prerequisites

Before installing this option, be sure you have the components included with the hardware option kit.

About this task

The server supports up to 32 DIMMs.

Procedure

1. [Power down the server.](#)
2. Remove all power:
 - a. Disconnect each power cord from the power source.
 - b. Disconnect each power cord from the server.
3. Do one of the following:
 - a. [Extend the server from the rack.](#)
 - b. [Remove the server from the rack.](#)
4. [Remove the access panel.](#)

5. Remove the air baffle.
6. Open the DIMM slot latches.

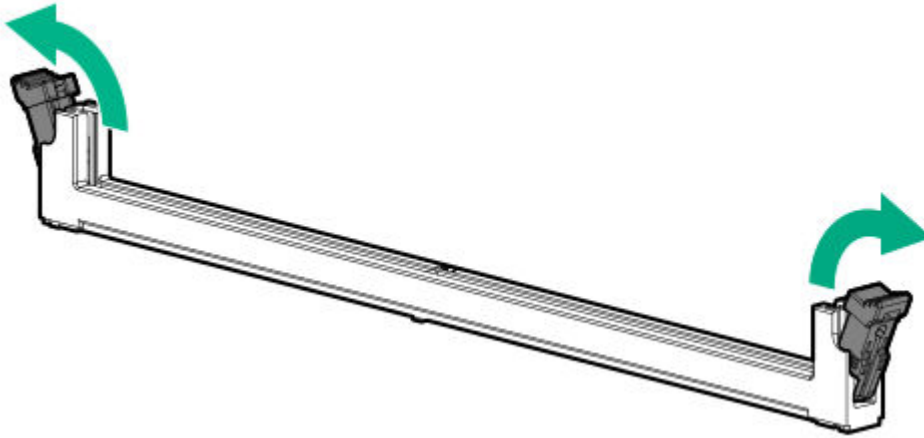

7. Do one of the following:
 - For systems without max-performance heatsinks, install the DIMM.

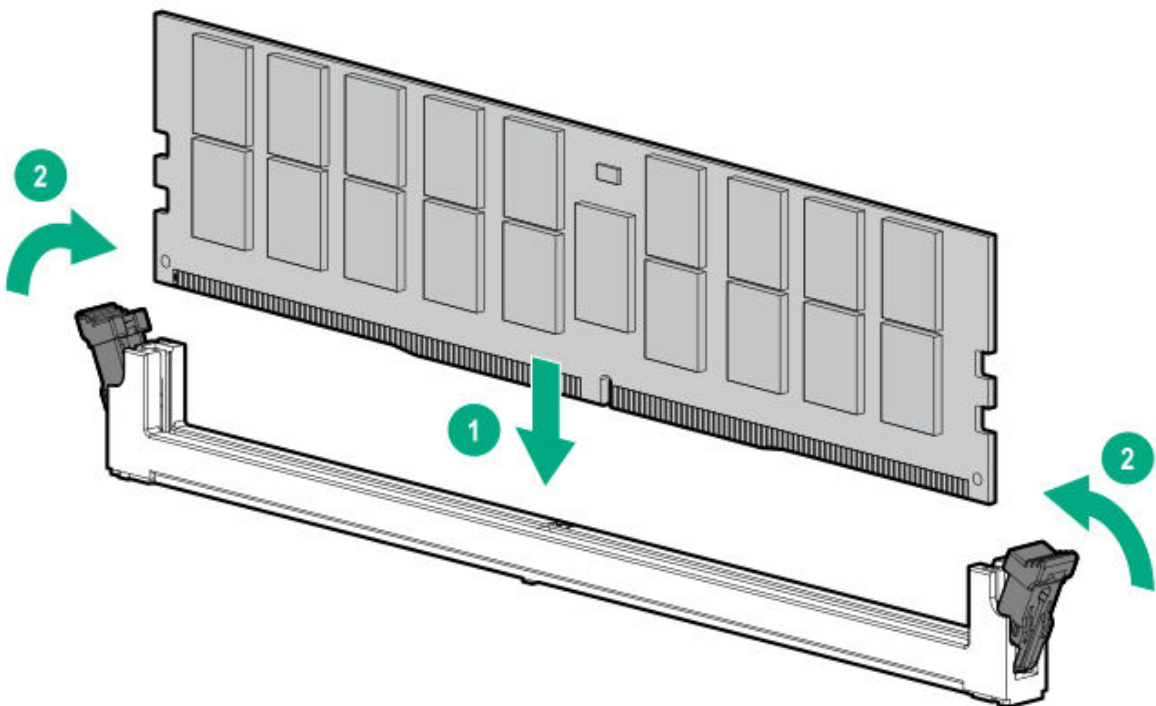

- For systems with max-performance heatsinks, position the DIMM under the heatsink wing and then install the DIMM.



CAUTION

To reduce the risk of personal injury from hot surfaces, allow the heatsink to cool for at least 5 minutes before touching it.

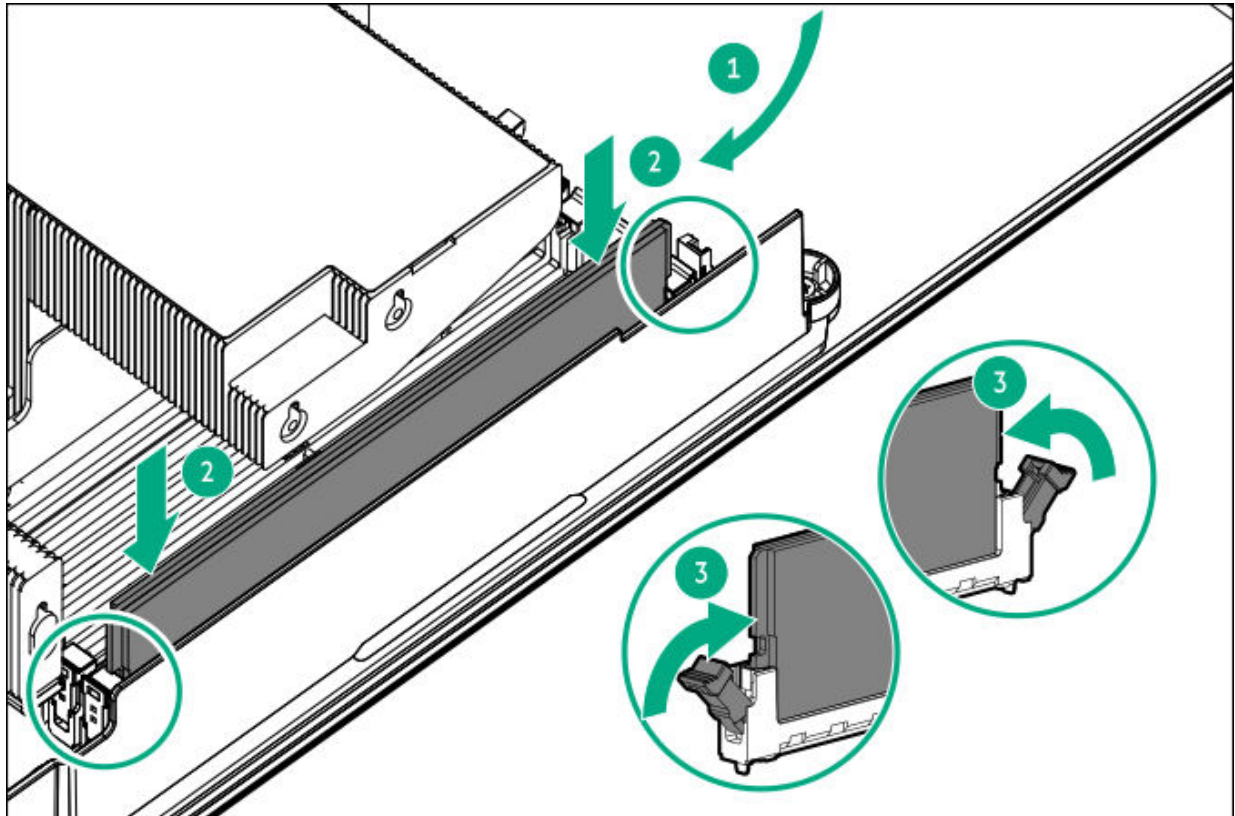

8. Install the air baffle.
9. Install the access panel.
0. Install the server in the rack.
- .1. Connect each power cord to the server.
- .2. Connect each power cord to the power source.
- .3. Power up the server.

Results

To configure the memory mode, use the BIOS/Platform Configuration (RBSU) in the UEFI System Utilities.

For more information about LEDs and troubleshooting failed DIMMs, see "[Systems Insight Display combined LED descriptions](#)."

Networking

Subtopics

[**About the front OCP networking enablement kit**](#)

[**Installing the front OCP enablement kit**](#)

[**Installing a rear OCP network adapter**](#)

[**Installing a PCIe network adapter**](#)

About the front OCP networking enablement kit

The kit uses the following components to transmit and receive signaling from the front OCP slots to the rear OCP slots:

- OCP cage
- PHY board
- Interposer
- Cabling

Observe the following:

- The OCP cage houses the OCP 3.0 NIC adapters.
- The phy board provides signaling from the adapters to the interposer.
- The interposer converts signaling from the phy board to the system board through the rear OCP slot.



Installing the front OCP enablement kit

Prerequisites

Before you perform this procedure, make sure that you have the following items available:

- T-15 Torx screwdriver
- Phillips No. 1 screwdriver
- T-10 Torx screwdriver

About this task



CAUTION

A discharge of static electricity from a finger or other conductor might damage system boards or other static-sensitive devices. To prevent damage, observe antistatic precautions.



CAUTION

To prevent improper cooling and thermal damage, do not operate the server unless all bays are populated with either a component or a blank.

Procedure

Install the front OCP NIC bracket

1. Remove two T-15 screws from the multipurpose cage.

Retain these screws to install the front OCP NIC bracket.

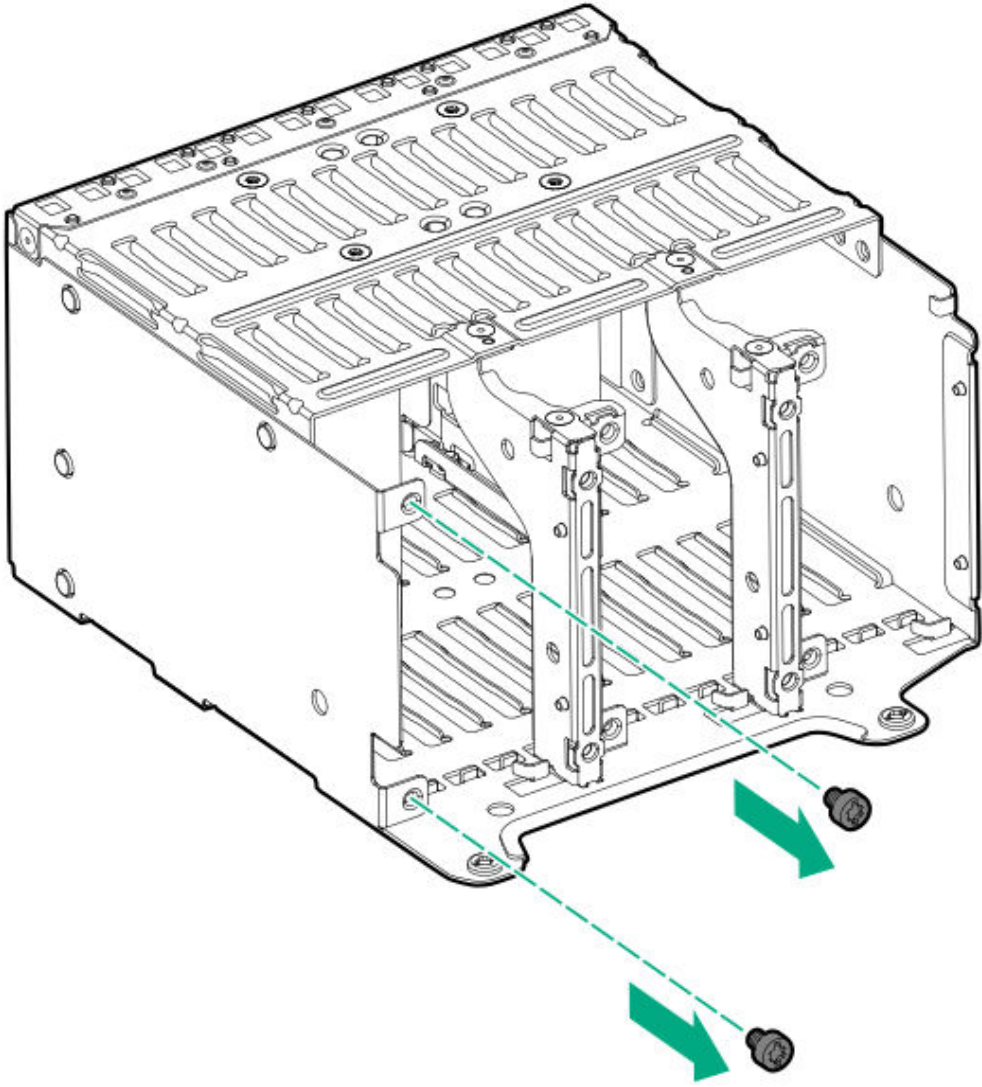

2. Slide the front OCP NIC bracket in the cage, and then secure the bracket with two T-15 screws.

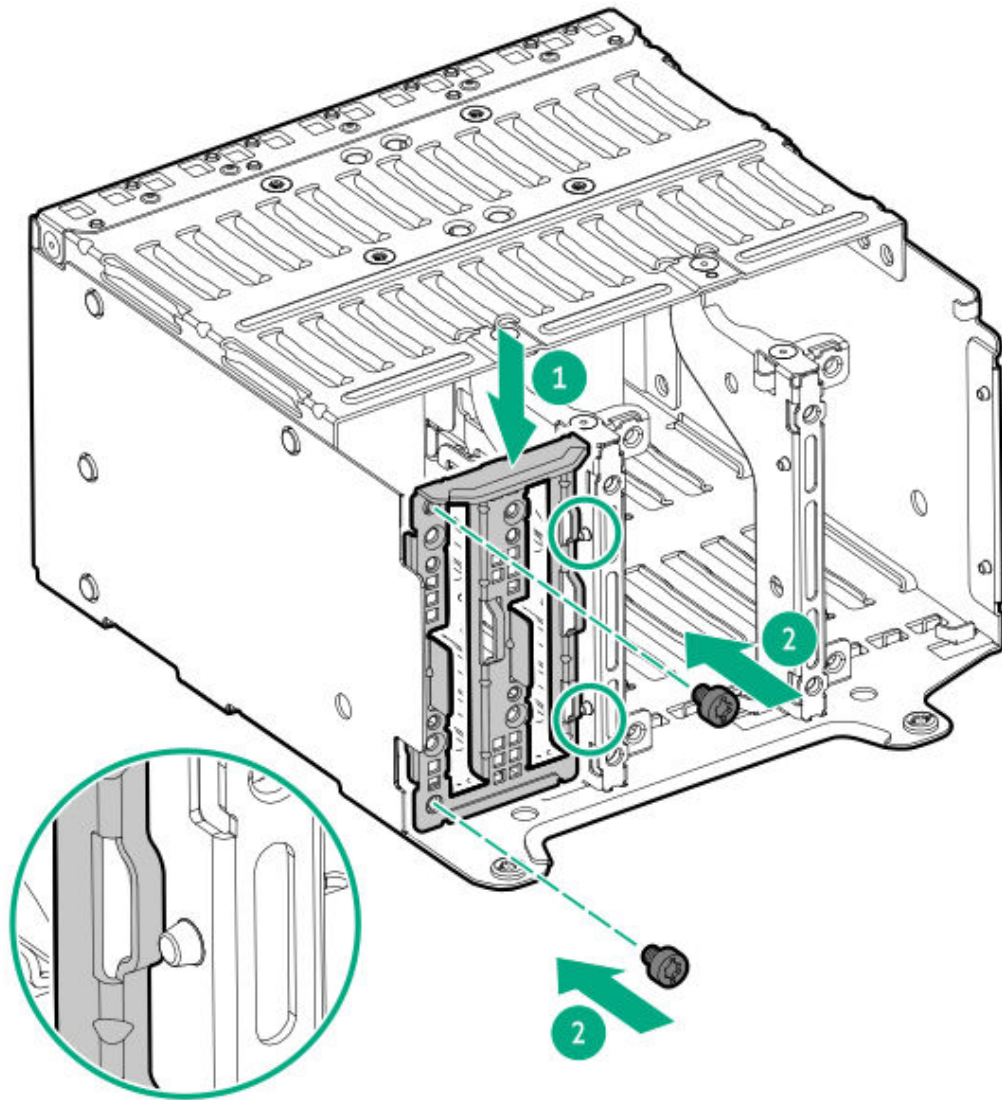

Install the front OCP NIC cable

3. Insert the plastic tabs on the front OCP NIC cable into the notches on the bracket, and then secure the screws on the cable.

Make sure that the plastic tabs are secured in the bracket.

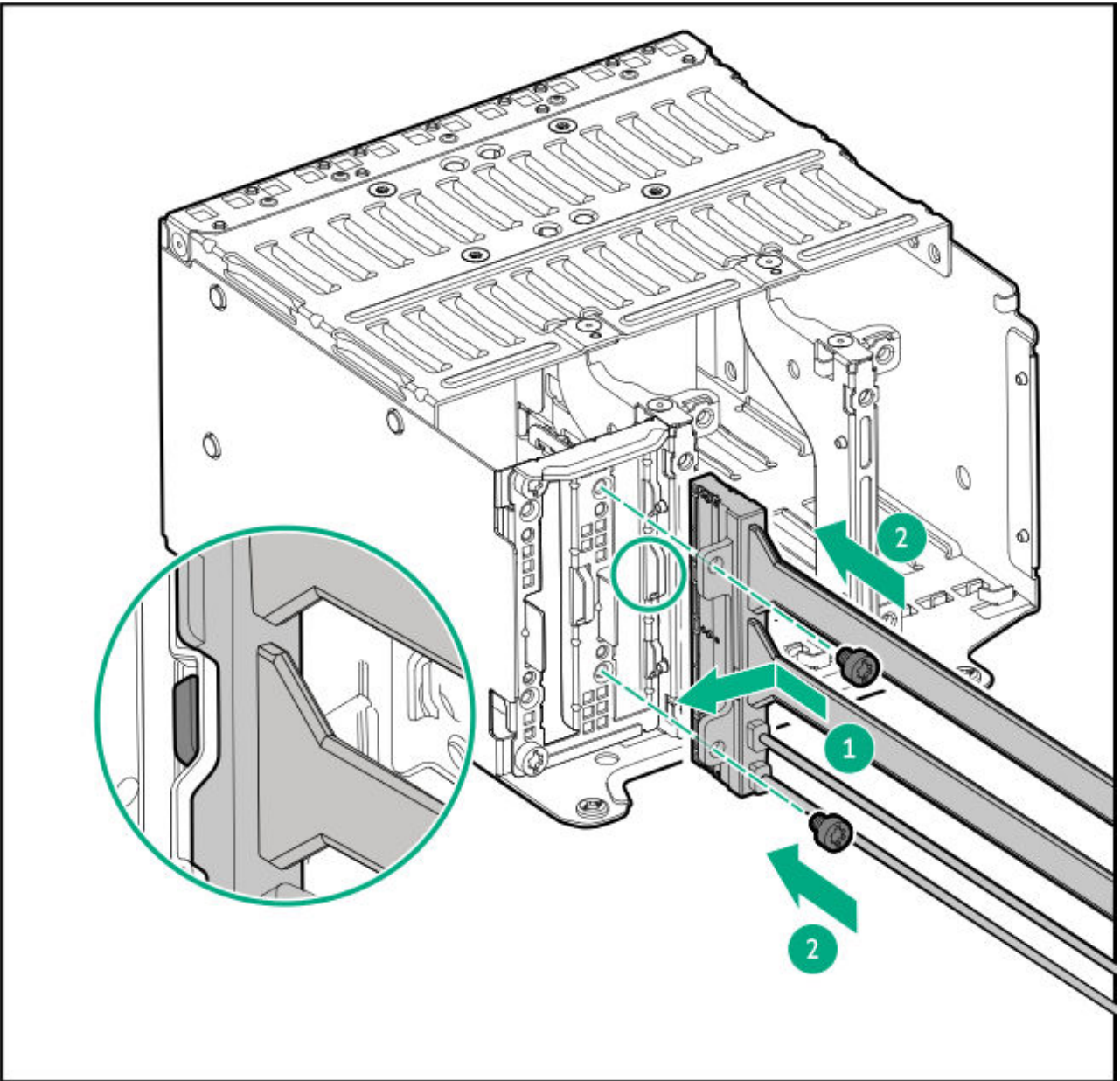

Install the PHY board

4. Install the PHY board on the PHY board bracket.

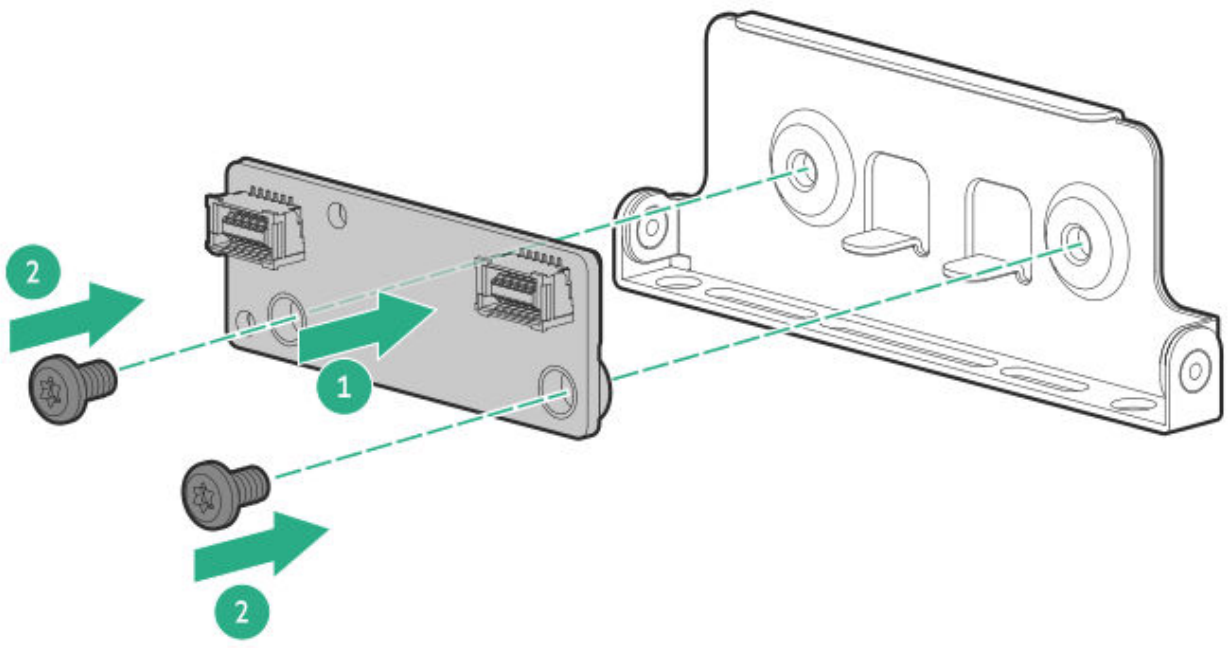

5. Install the PHY board bracket on the multipurpose cage.

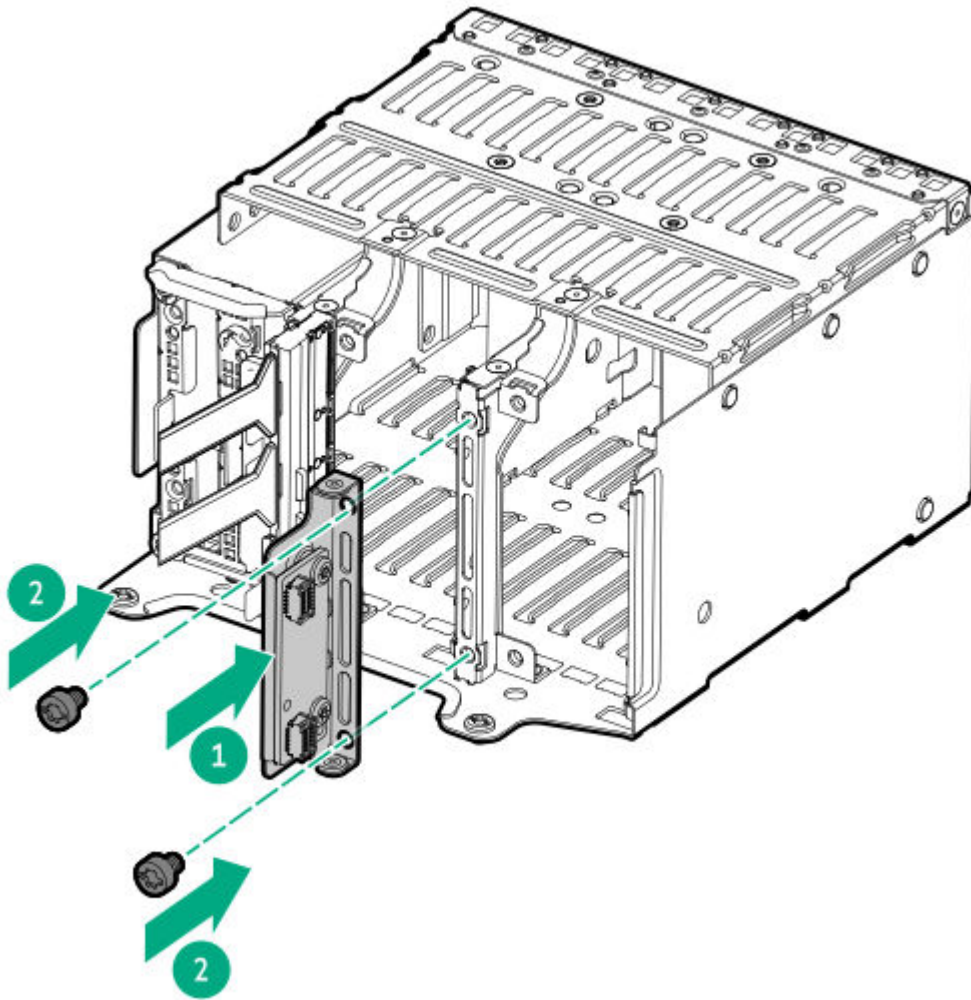

6. Connect the front OCP NIC cable to the PHY board.

Install the OCP NIC carrier and bracket

7. Remove the OCP NIC bracket.

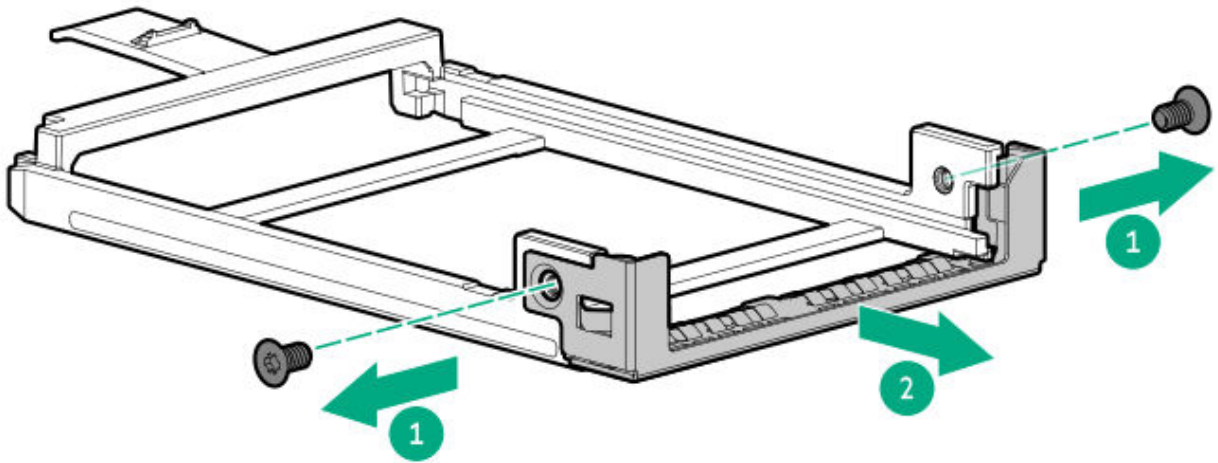

8. Slide the OCP NIC into the OCP NIC carrier.

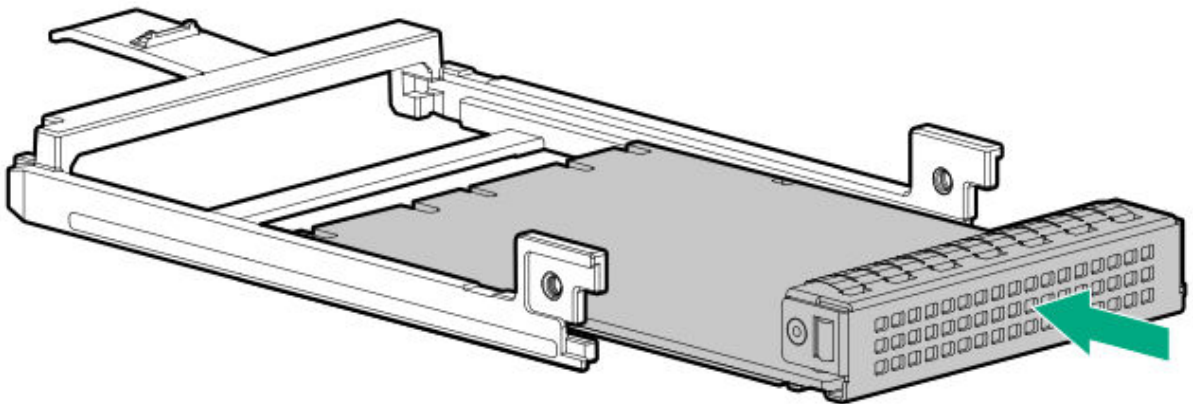

9. Install the OCP NIC bracket.

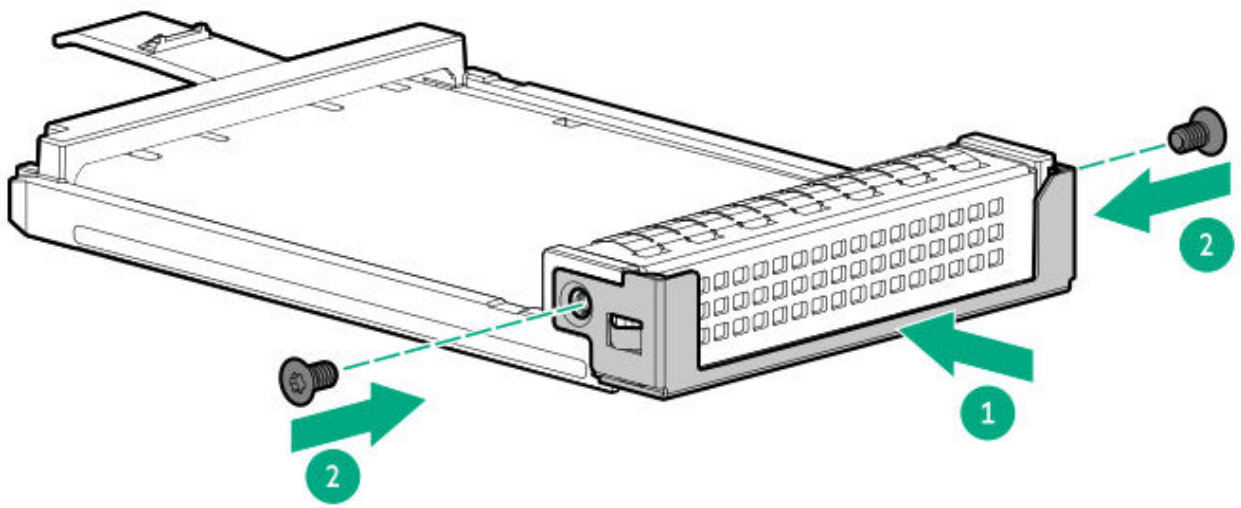

.0. Install the front OCP NIC.

There will be an audible click to indicate that the carrier latch is locked on the bracket.

- Primary front OCP NIC

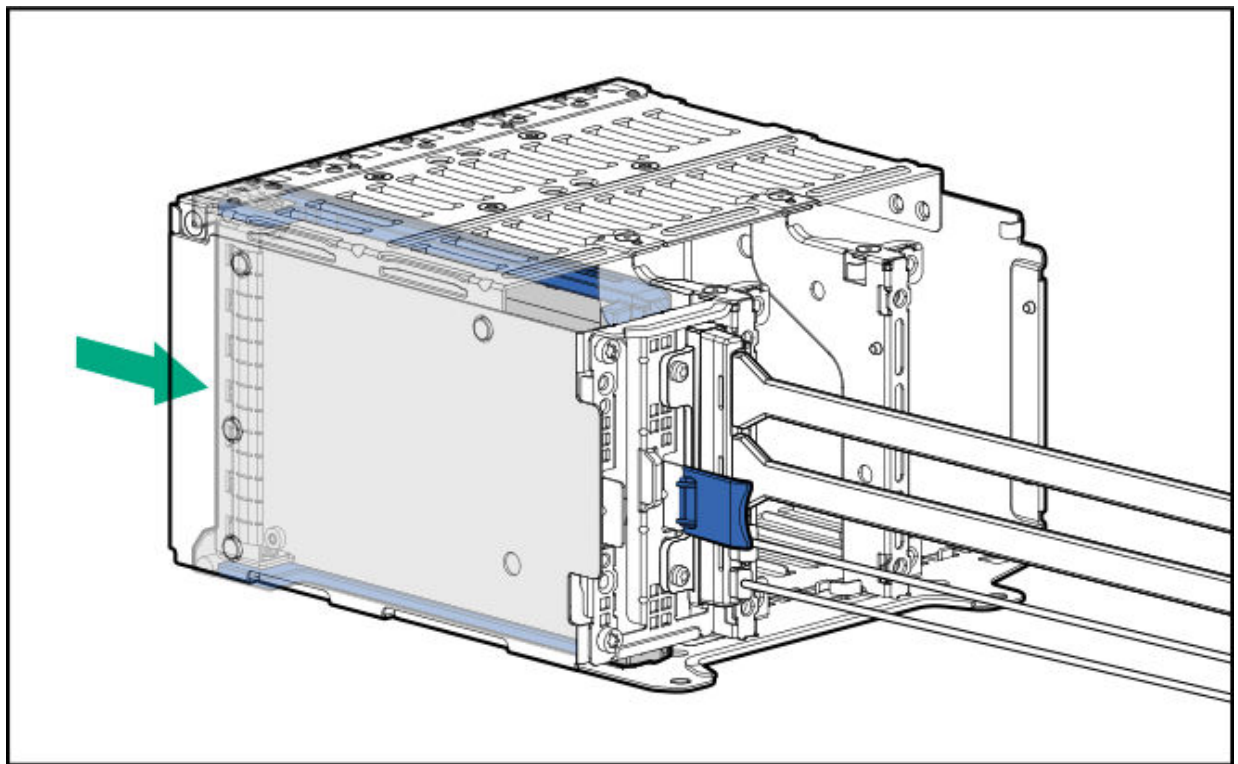

- Secondary front OCP NIC

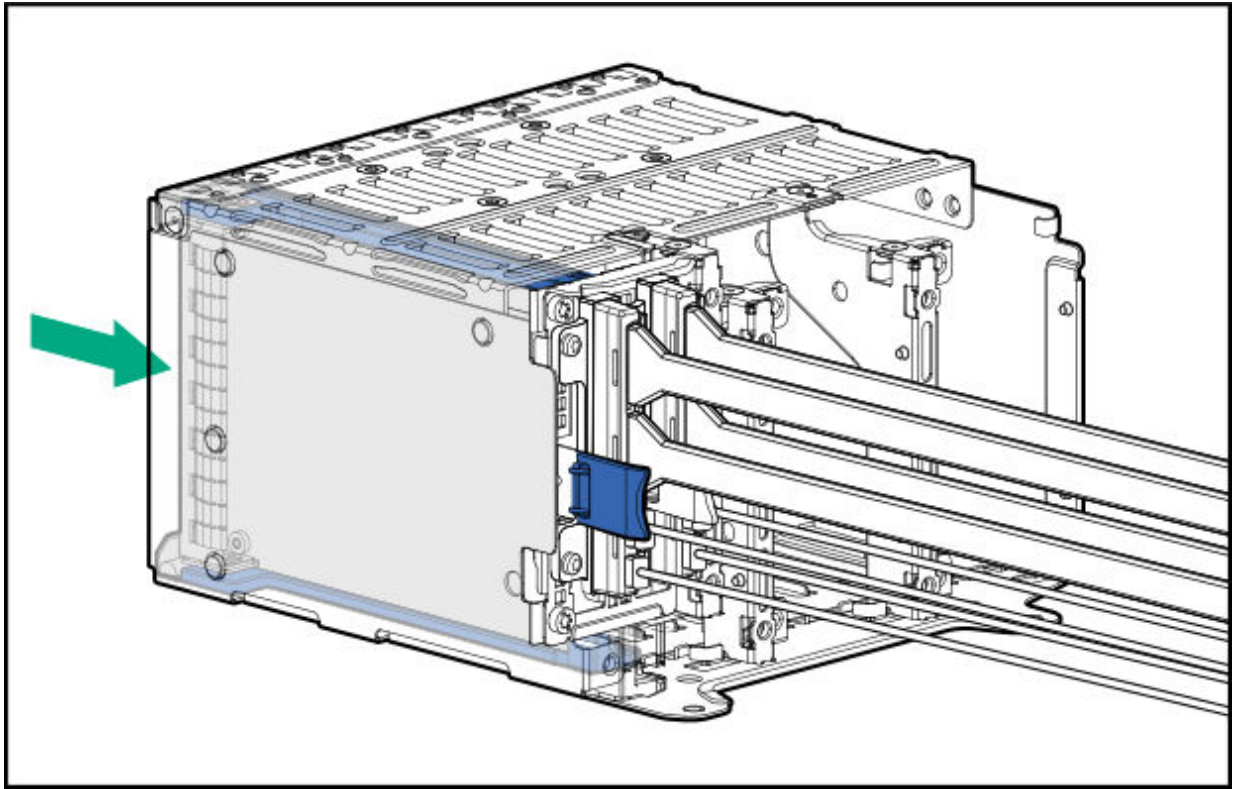

Install the OCP NIC interposer

1. Remove the OCP slot blank.

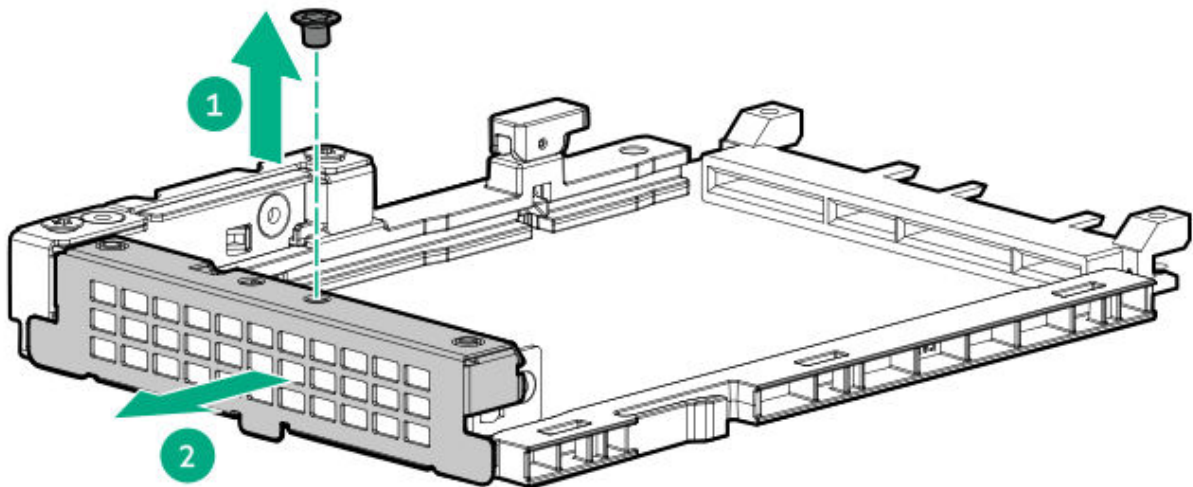

2. Install the OCP NIC interposer:

- a. Rotate the locking pin to the open (vertical) position.

b. Slide the interposer into the slot until it clicks into place.

Make sure that the interposer is seated firmly in the slot.

c. Rotate the locking pin to the close (horizontal) position.

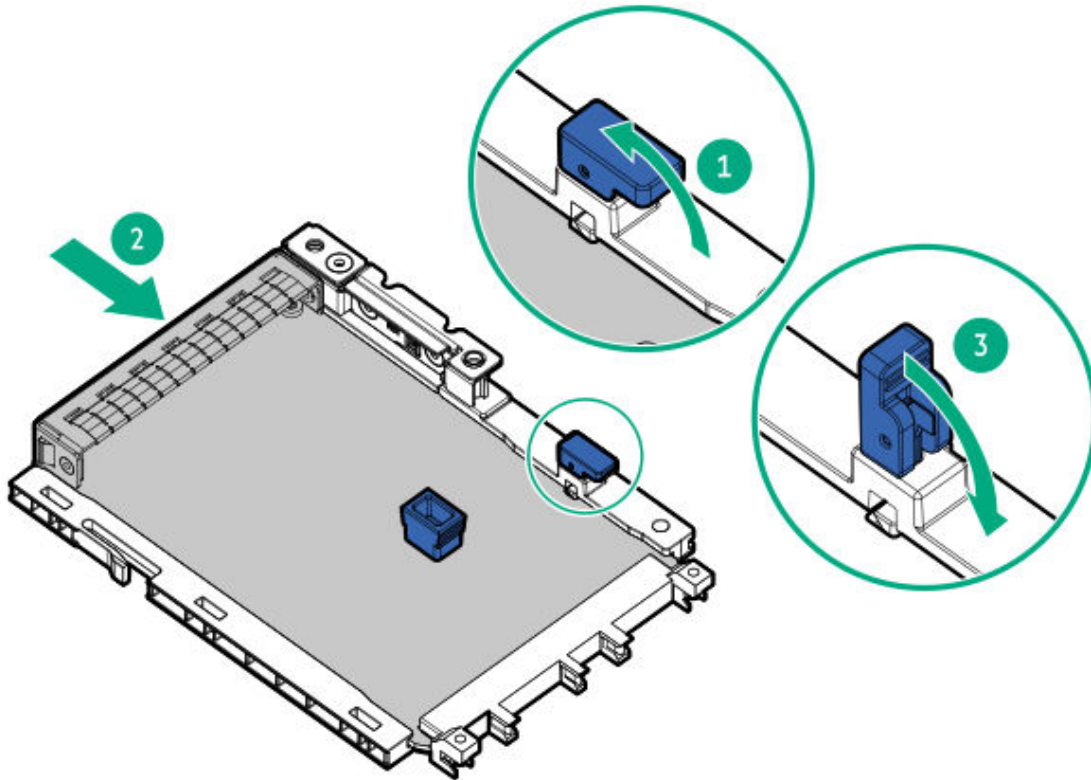

3. Connect the cables to the interposer.

4. Install the fan cage.

5. Install the air baffle.

6. Install the access panel.

7. Install the server into the rack.

8. Connect all peripheral cables to the server.

9. Connect each power cord to the server.

10. Connect each power cord to the power source.

11. Power up the server.

12. Enable the iLO shared NIC port in UEFI System Utilities.

Results

The installation procedure is complete.

Installing a rear OCP network adapter

Prerequisites

Before you begin this procedure, make sure that the components included with the hardware option kit are available.

Procedure

1. Power down the server.
2. Remove all power:
 - a. Disconnect each power cord from the power source.
 - b. Disconnect each power cord from the server.
3. Do one of the following:
 - Extend the server from the rack.
 - Remove the server from the rack.
4. Remove the access panel.
5. Remove the rear wall blank or riser cage.
6. Remove the OCP adapter blank.

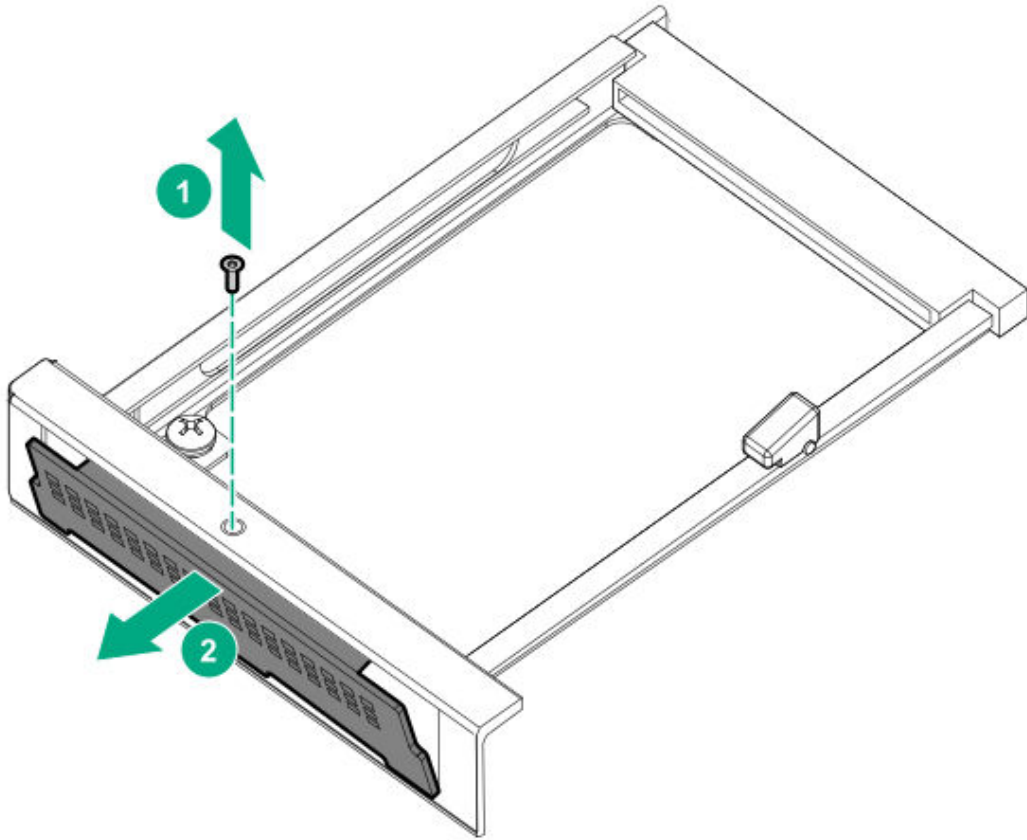

7. Install the network adapter.

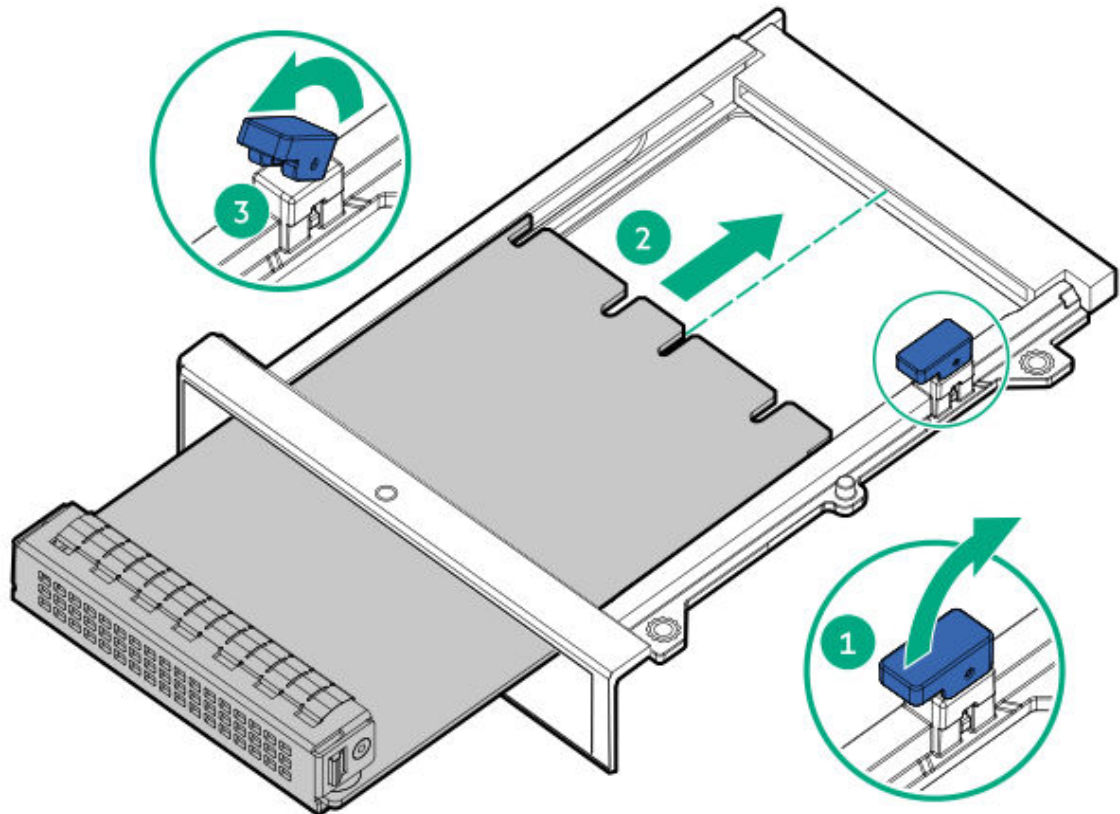

8. Connect the cables.
9. Install the access panel.
0. Slide the server into the rack.
- .1. Connect each power cord to the server.
- .2. Connect each power cord to the power source.
- .3. Power up the server.

Results

The installation is complete.

Installing a PCIe network adapter

Prerequisites

Before you perform this procedure, make sure that you have the following items available:

The components included with the hardware option kit

About this task



WARNING

To reduce the risk of personal injury, electric shock, or damage to the equipment, remove the power cord to remove power from the server. The front panel Power On/Standby button does not shut off system power. Portions of the power supply and some internal circuitry remain active until AC power is removed.



CAUTION

To prevent improper cooling or thermal damage, do not operate the server unless all PCI slots have either an expansion slot cover or an expansion board installed.

To install the component:

Procedure

1. Power down the server.
2. Remove all power:
 - a. Disconnect each power cord from the power source.
 - b. Disconnect each power cord from the server.
3. Do one of the following:
 - Extend the server from the rack.
 - Remove the server from the rack.
4. Remove the access panel.
5. Remove the riser cage.

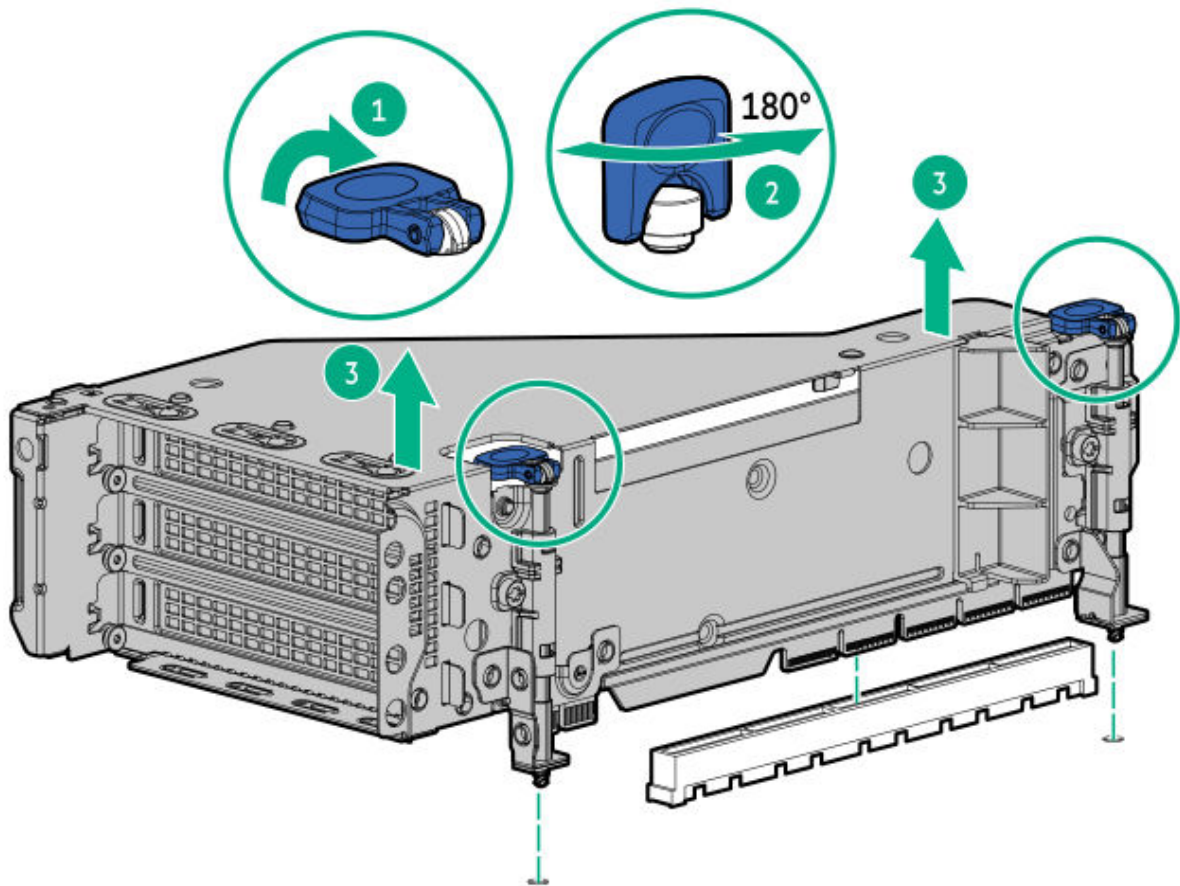

6. Identify and then remove the PCIe blank from the riser cage.

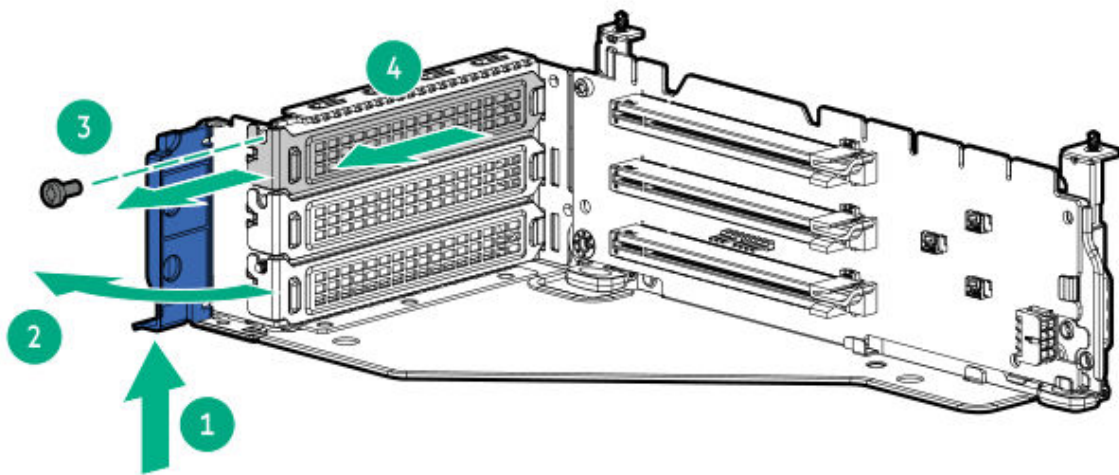

7. Install the expansion board.

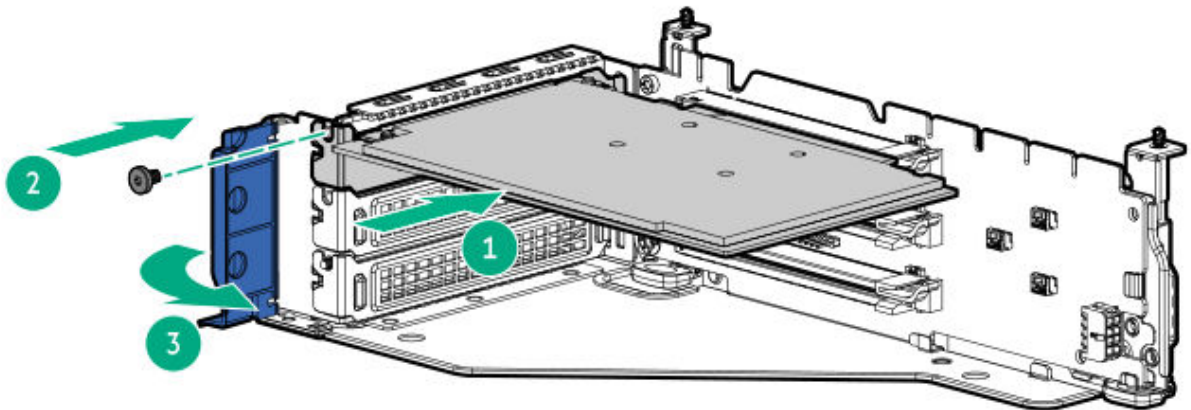

8. Install the riser cage.

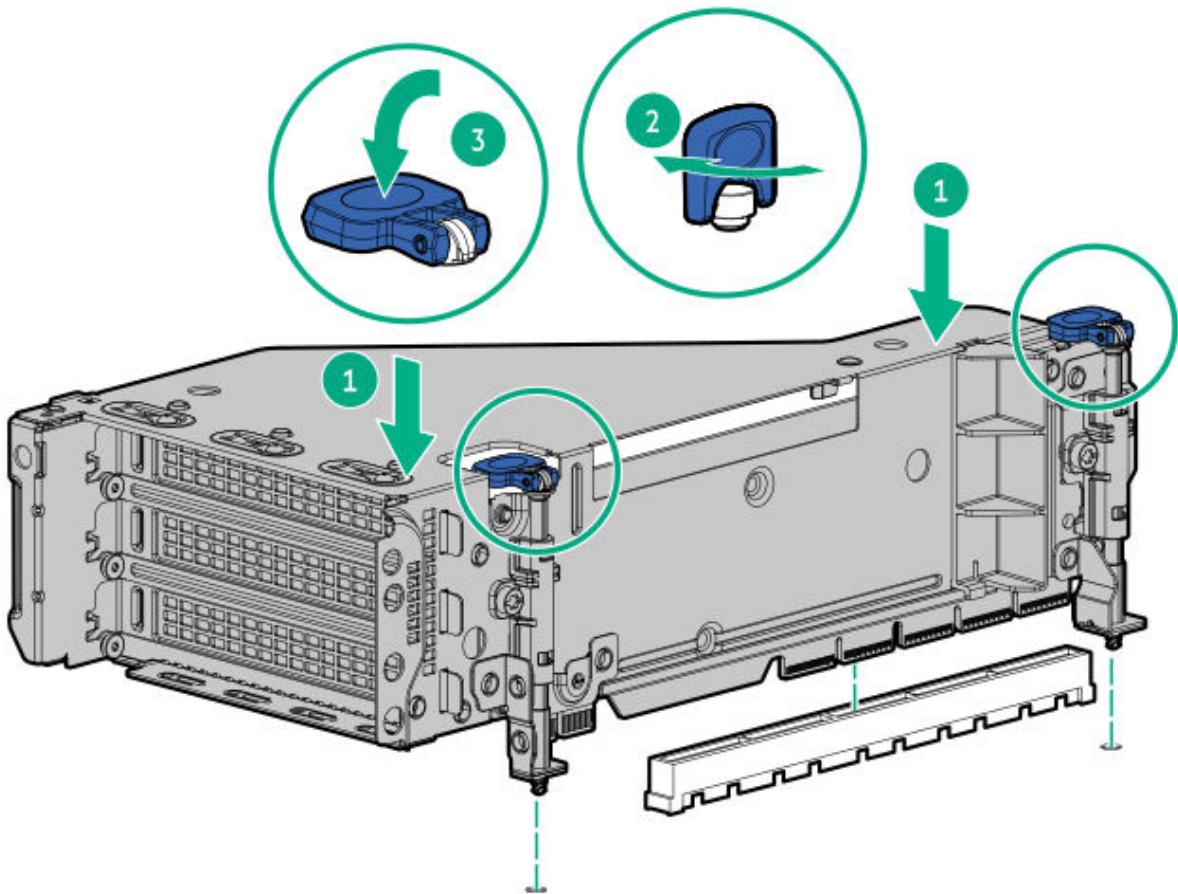

9. Connect the cables.

- .0. Install the access panel.
- .1. Slide the server into the rack.
- .2. Connect each power cord to the server.
- .3. Connect each power cord to the power source.
- .4. Power up the server.

Results

The installation is complete.

OS boot device

Subtopics

Installing boot device drives

Installing the front NS204i-u Boot Device

Installing the rear NS204i-u boot device

Installing boot device drives

Prerequisites

Before you perform this procedure, make sure that you have a Phillips No. 1 screwdriver available.

Procedure

1. Push the button to pull out the carrier.

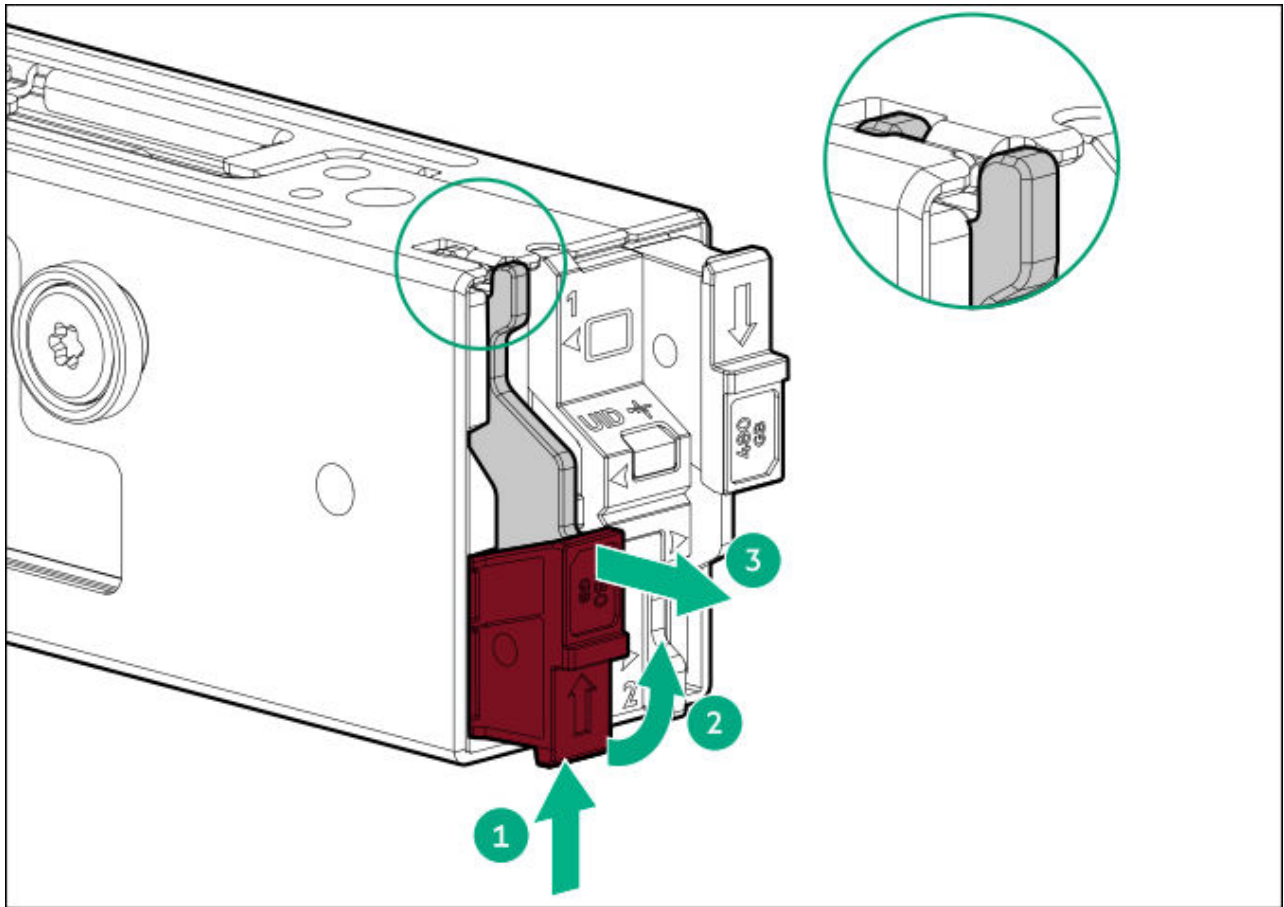

2. Remove the SSD mounting screw.

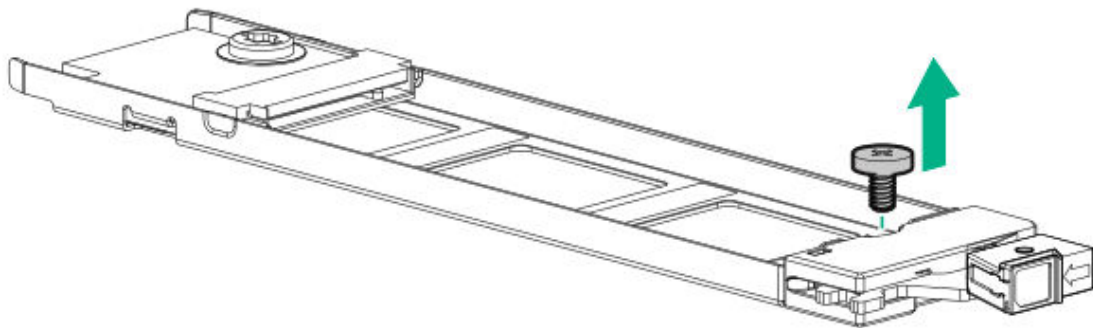

3. Insert the SSD into the M.2 slot at a 45° angle.
4. Carefully press the SSD down to the horizontal position.
5. Install the SSD mounting screw.

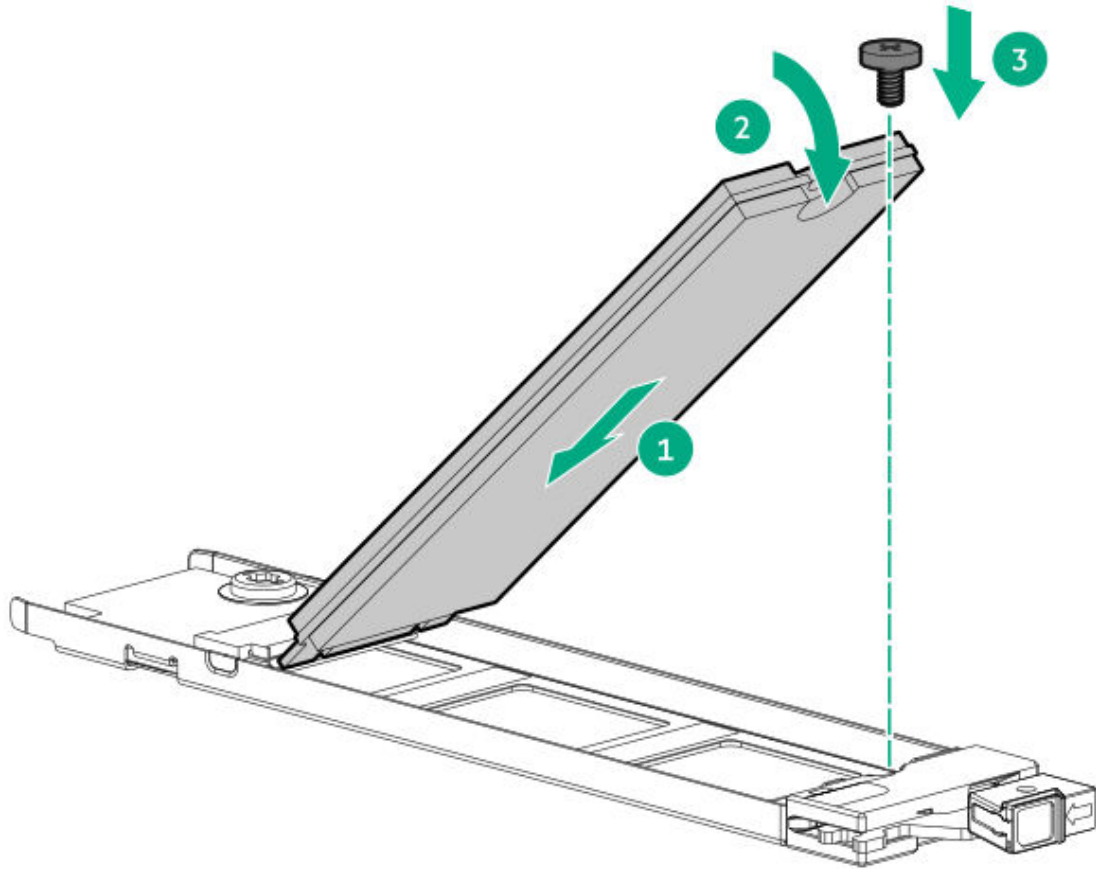

6. If the second M.2 SSD is installed on the carrier assembly, repeat steps 1 and 2.
7. Align and install the drive carrier.

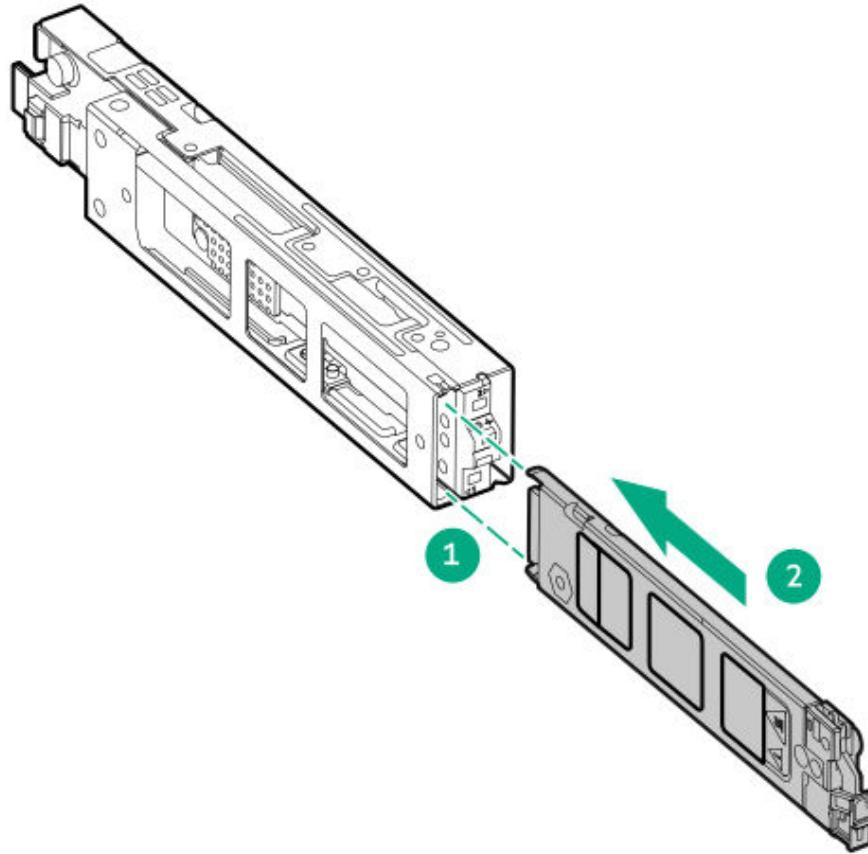

8. Secure the carrier and verify it latches to the device cage.

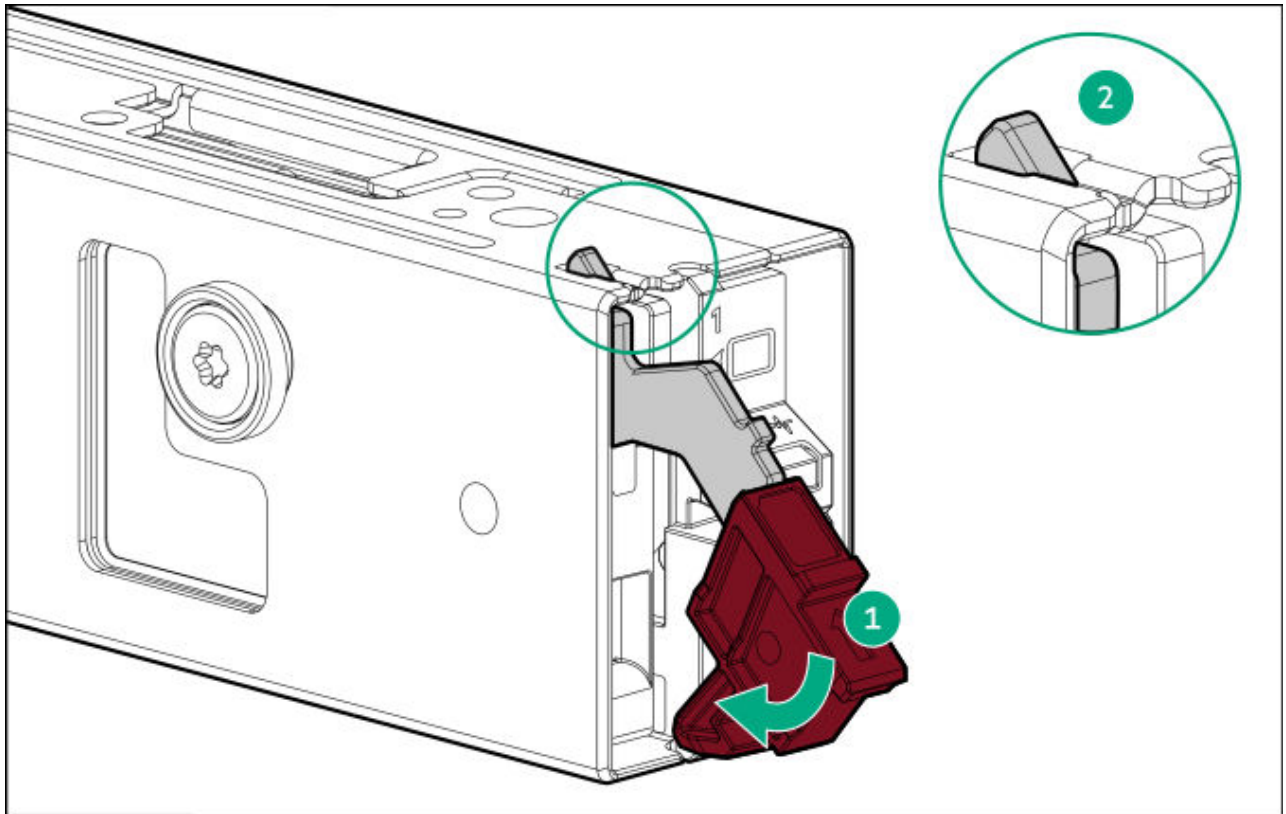

Installing the front NS204i-u Boot Device

Prerequisites

Before installing the boot device:

- You need a T-15 Torx screwdriver or a bit driver with T-15 Torx bit.
- Update all system firmware.
- Install the boot device drives.

About this task

The boot device must be installed in cage 2 of the multipurpose cage.

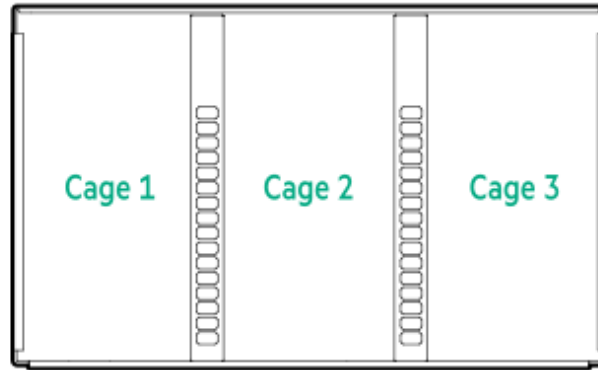

Procedure

1. Power down the server.
2. Remove all power:
 - a. Disconnect each power cord from the power source.
 - b. Disconnect each power cord from the server.
3. Do one of the following:
 - Extend the server from the rack.
 - Remove the server from the rack.
4. Remove the access panel.
5. Remove the air baffle.
6. Remove the fan cage.
7. On the device cage, locate the latch points.

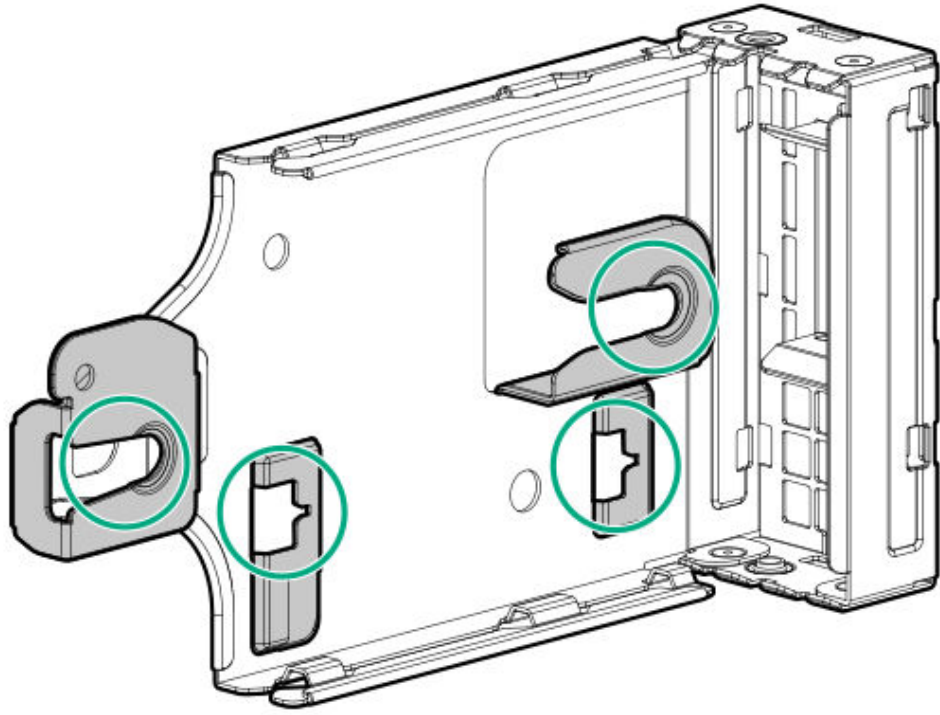

8. Install the air baffle.

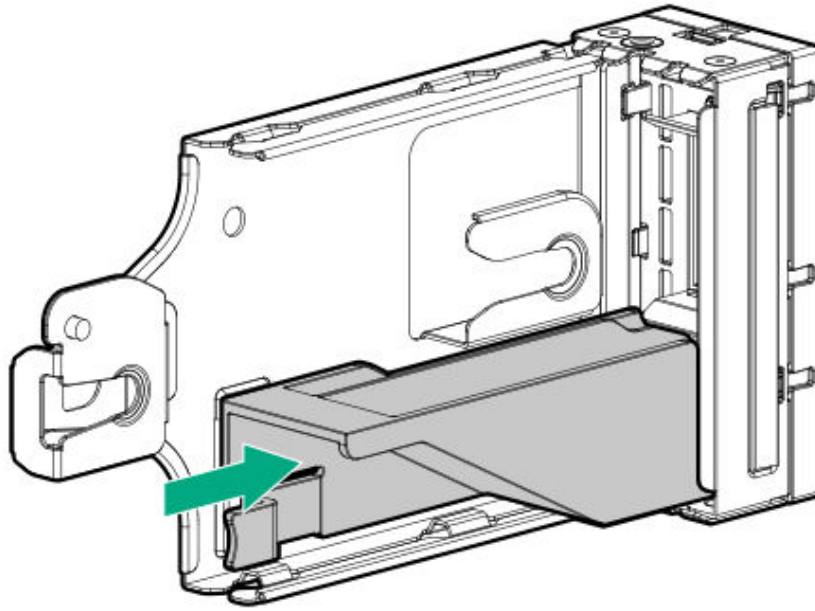

9. Install the boot device cage.

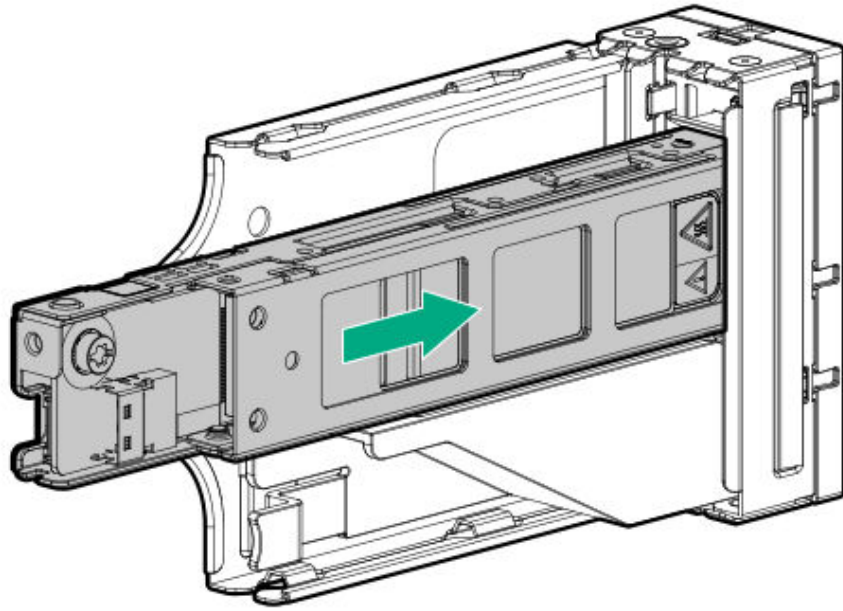

.0. Verify that the device is fully seated and secure it to the cage.

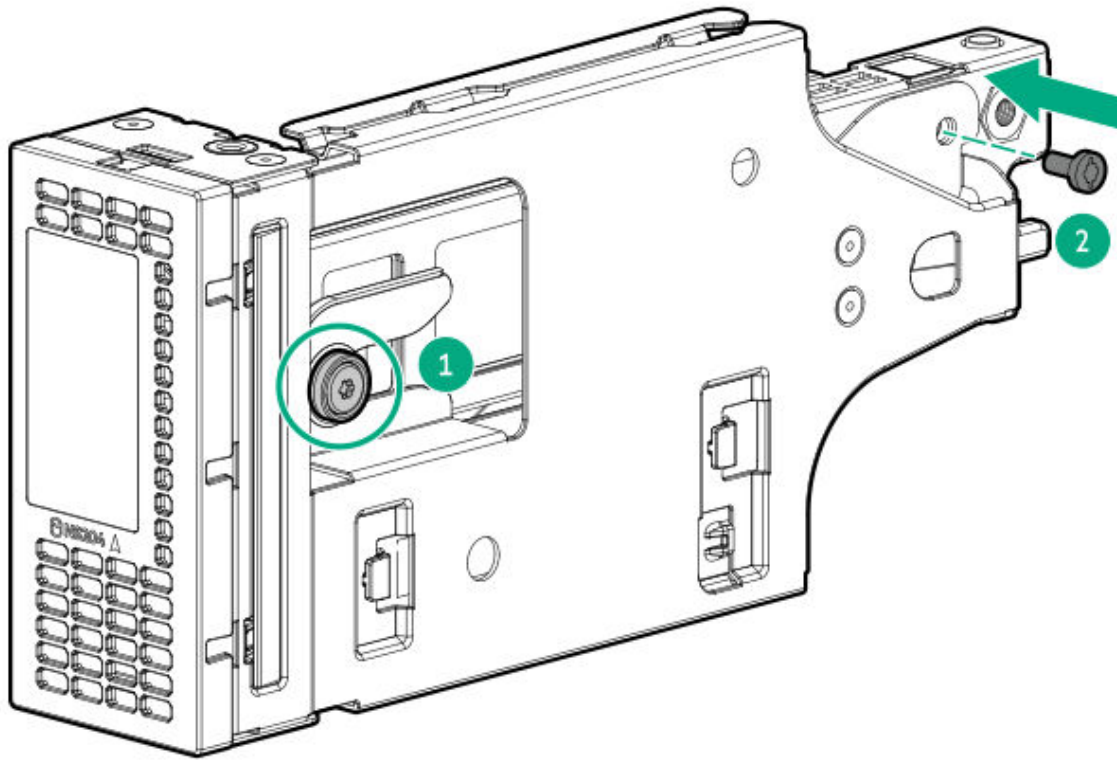

.1. Install the front boot device to the multipurpose cage.

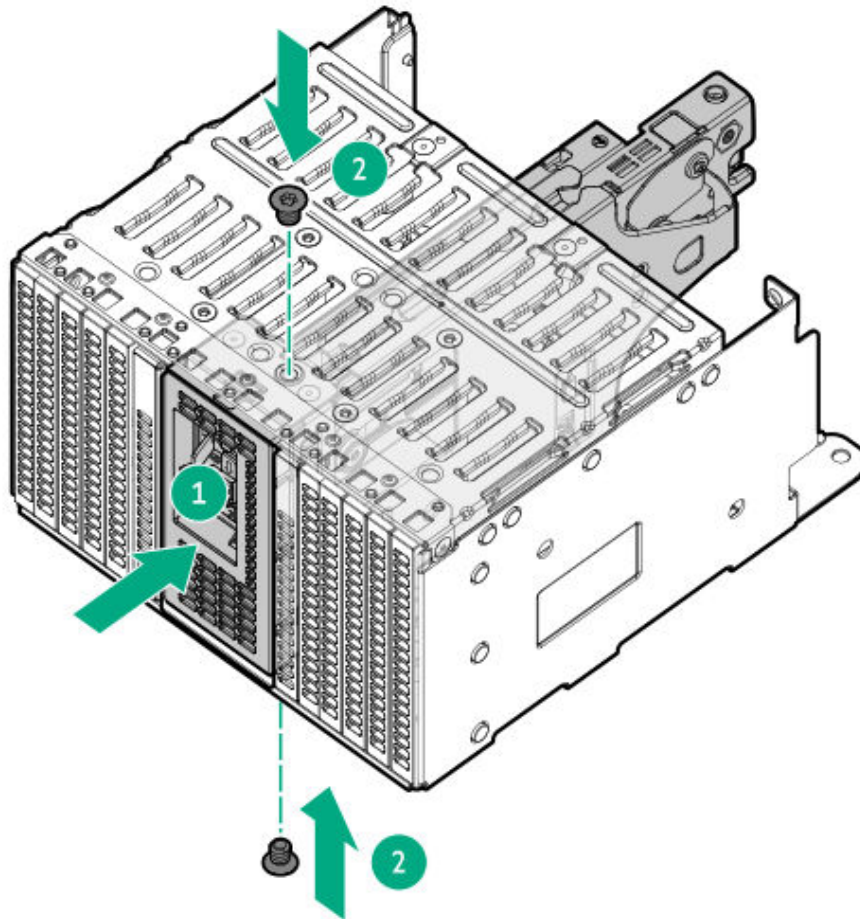

- .2. Install the multipurpose cage.
- .3. Connect the power cable to the connector.

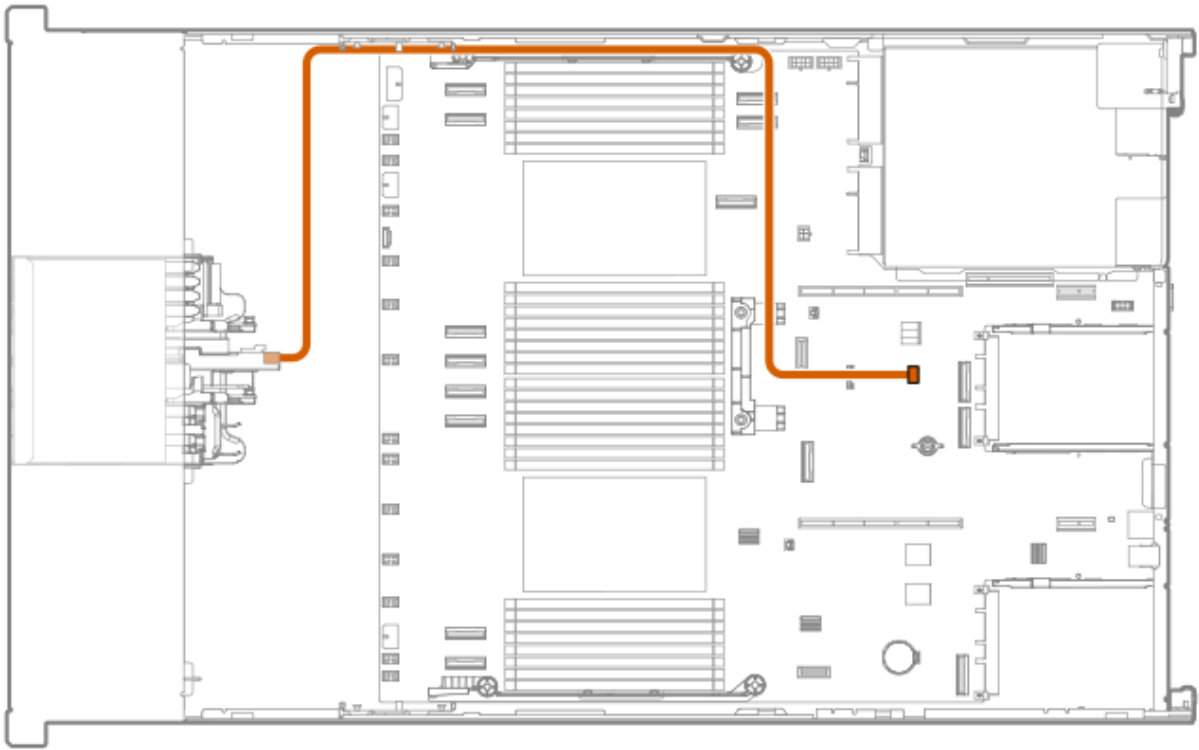

4. Connect the data cable.

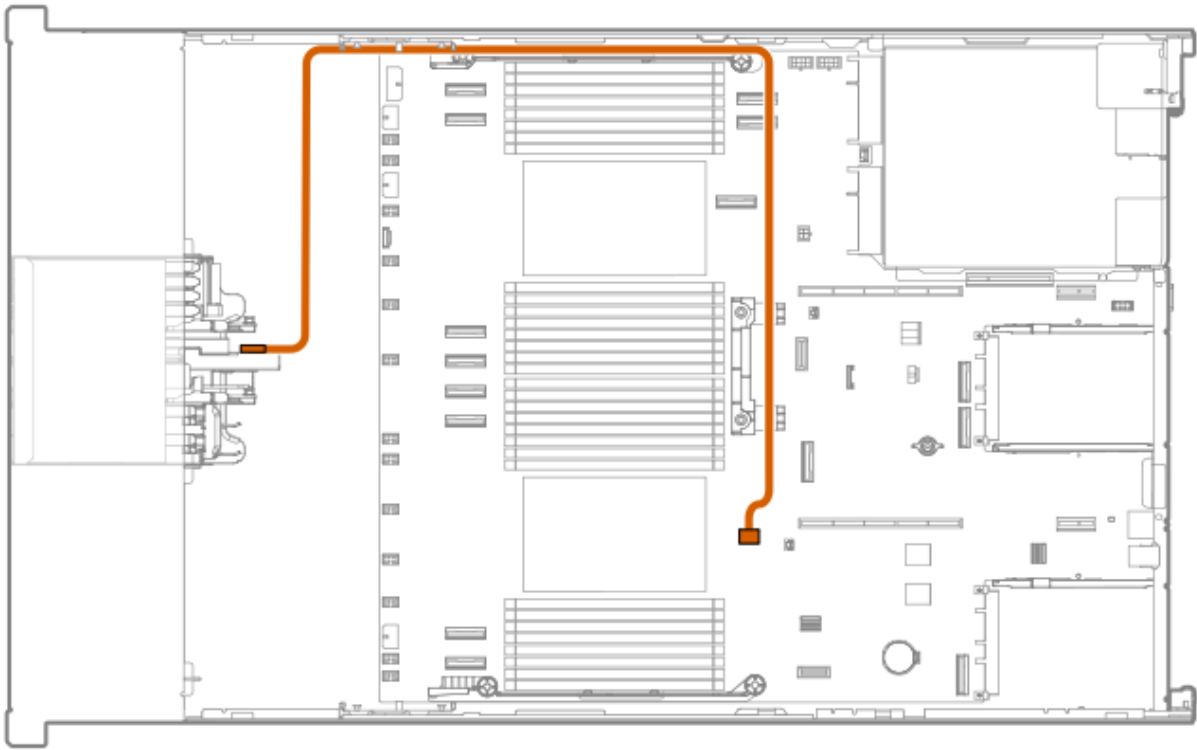

Results

The installation is complete.

Installing the rear NS204i-u boot device

Prerequisites

Before installing the device:

- You need a T-10 Torx screwdriver.
- Update the server with the latest firmware and drivers.

About this task

Note the following:

- The device creates a RAID1 volume during boot. It does not require any configuration.
- Identify the boot device components.

Procedure

1. Power down the server.
2. Remove all power:
 - a. Disconnect each power cord from the power source.
 - b. Disconnect each power cord from the server.
3. Do one of the following:
 - Extend the server from the rack.
 - Remove the server from the rack.
4. Remove the access panel.
5. Install the M.2 drives.
6. Install the mounting bracket.

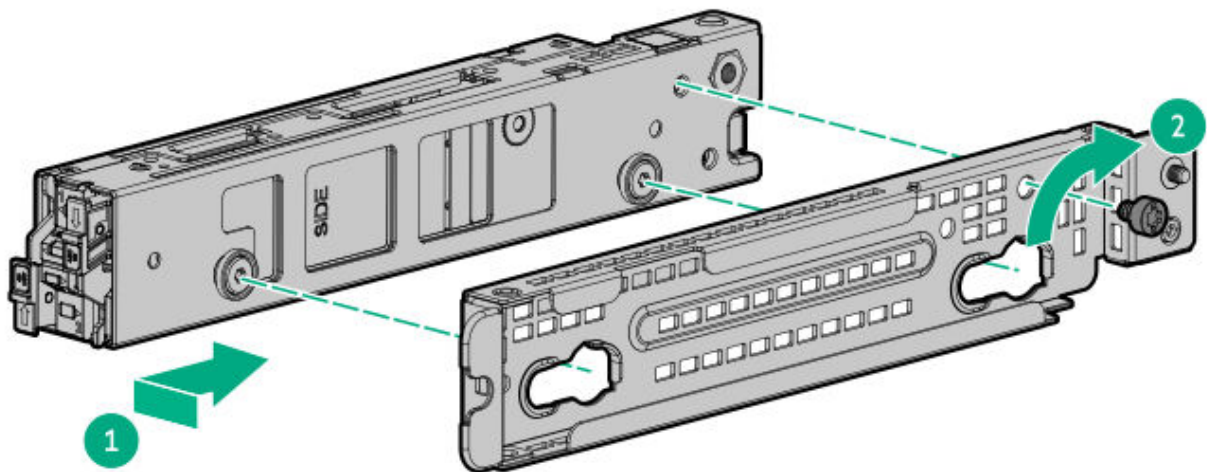

7. Using a T-10 Torx screwdriver, remove the security cover.
If you do not want access to the drives, keep the security cover installed.

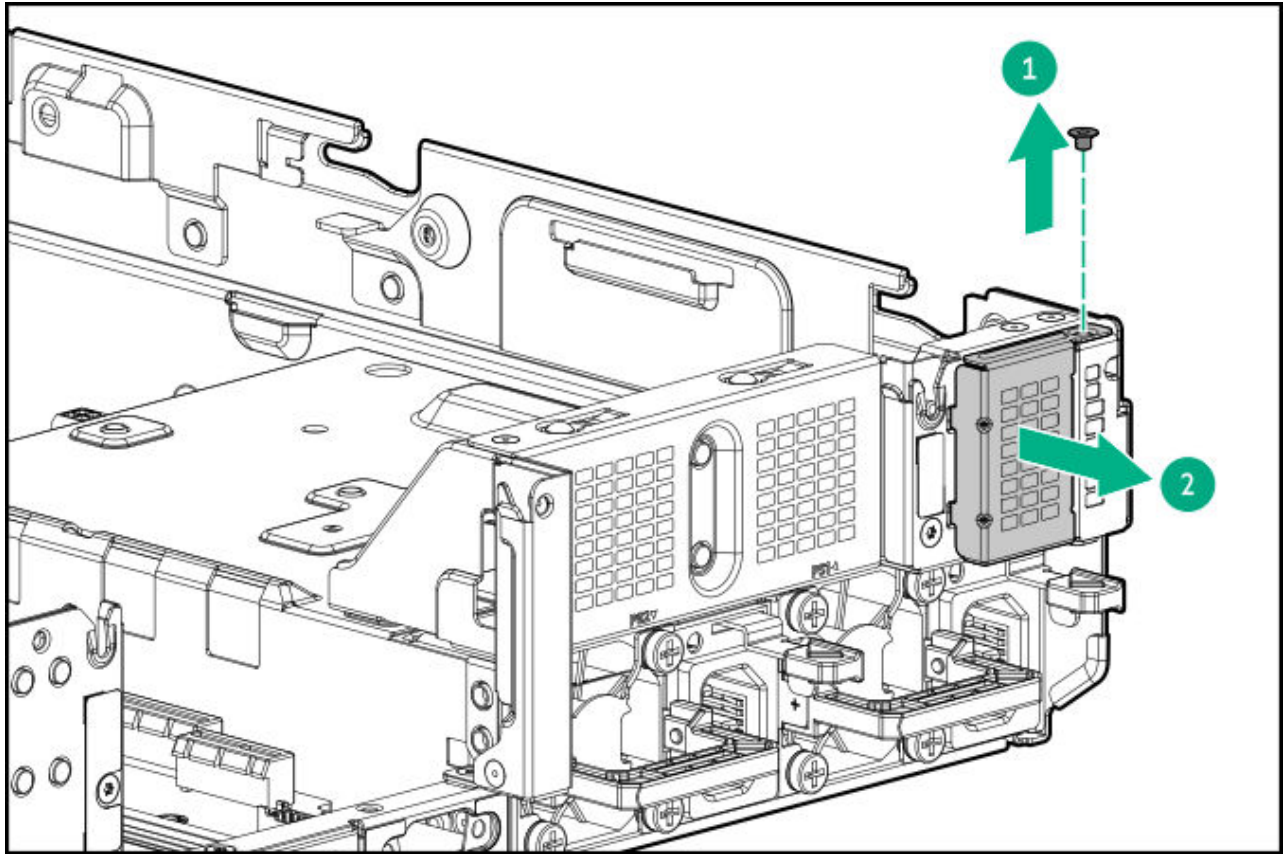

8. Using a T-10 Torx screwdriver, install the boot device.

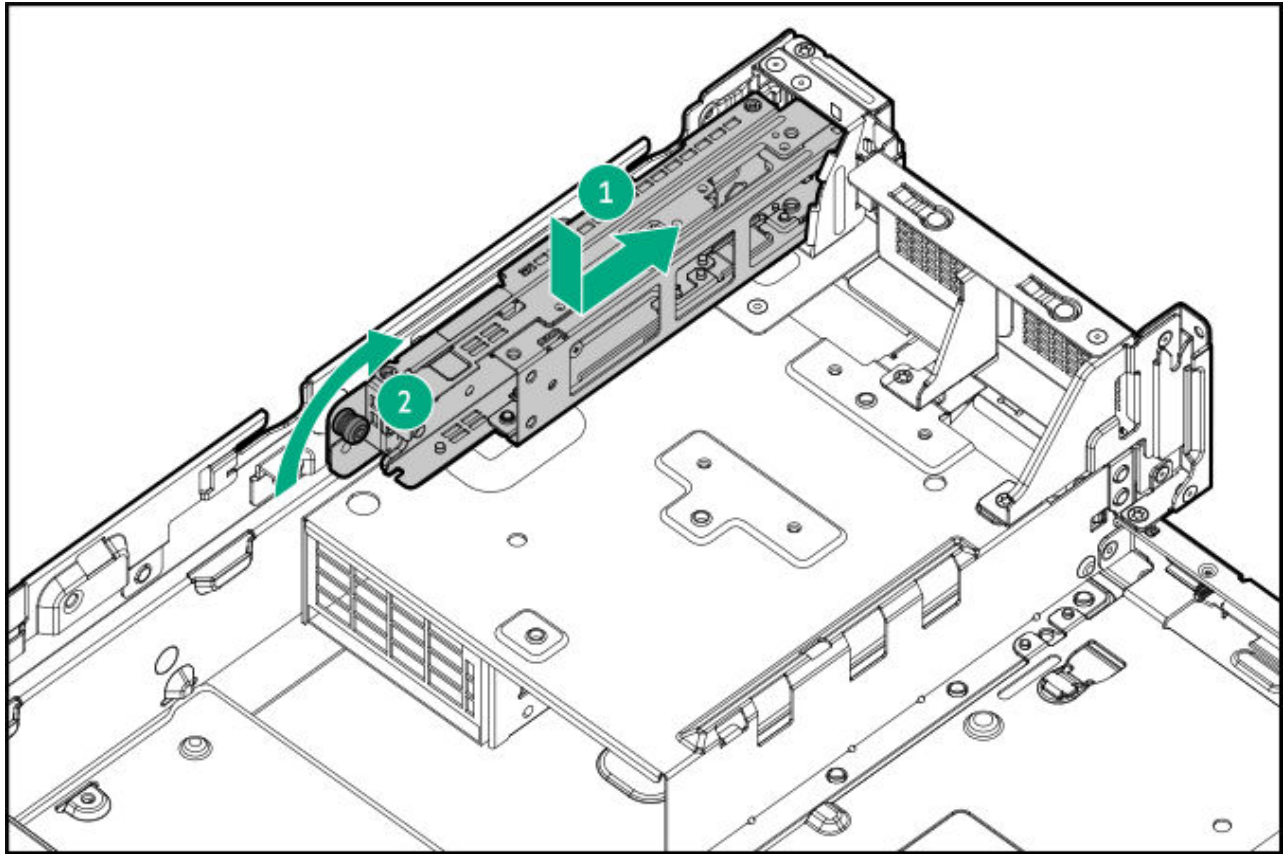

9. Connect the power and signal cables to the boot device.
- .0. Install the access panel.
- .1. Install the server in the rack.
- .2. Connect each power cord to the server.
- .3. Connect each power cord to the power source.
- .4. Power up the server.
- .5. Verify the Online/Activity LEDs on the boot device are solid green.

Results

The installation is complete.

Power supplies

Subtopics

Power supply warnings and cautions

Hot-plug power supply calculations

Installing an AC power supply

DC power supply warnings and cautions

Connecting a DC power cable to a DC power source

DC power supply wire colors

Installing a DC power supply

Power supply warnings and cautions



WARNING

To reduce the risk of electric shock or damage to the equipment:

- Do not disable the power cord grounding plug. The grounding plug is an important safety feature.
- Plug the power cord into a grounded (earthed) electrical outlet that is easily accessible at all times.
- Unplug the power cord from the power supply to disconnect power to the equipment.
- Do not route the power cord where it can be walked on or pinched by items placed against it. Pay particular attention to the plug, electrical outlet, and the point where the cord extends from the server.



WARNING

To reduce the risk of injury from electric shock hazards, do not open power supplies. Refer all maintenance, upgrades, and servicing to qualified personnel.



CAUTION

Mixing different types of power supplies in the same server might:

- Limit or disable some power supply features including support for power redundancy.
- Cause the system to become unstable and might shut down.

To ensure access to all available features, all power supplies in the same server should have the same output and efficiency ratings. Verify that all power supplies have the same part number and label color.

Hot-plug power supply calculations

For hot-plug power supply specifications and calculators to determine electrical and heat loading for the server, see the Hewlett Packard Enterprise Power Advisor website (<https://www.hpe.com/info/poweradvisor/online>).

Installing an AC power supply

Prerequisites

Before installing a power supply option, review the [Power supply warnings and cautions](#).

About this task



WARNING

To reduce the risk of personal injury from hot surfaces, allow the power supply, power supply blank, or dual slot power supply adapter to cool before touching it.



CAUTION

To prevent improper cooling and thermal damage, do not operate the server unless all bays are populated with either a component or a blank.

Procedure

1. Remove the power supply blank.

Retain the blank for future use.

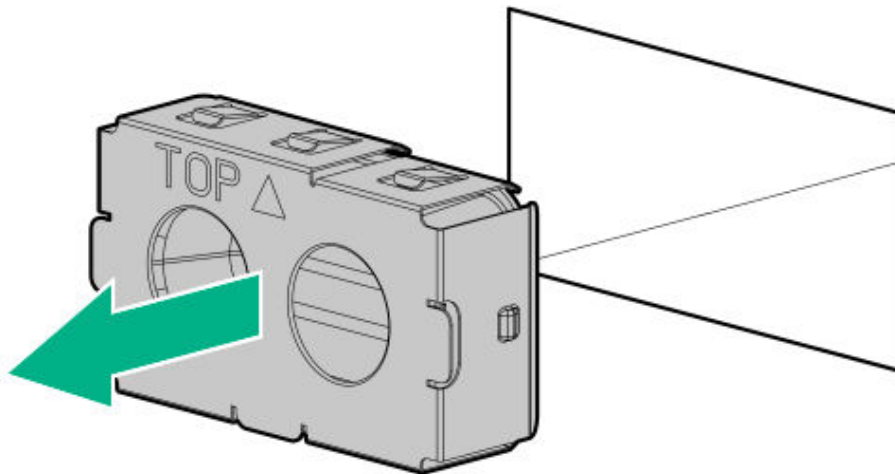

2. Install the power supply.

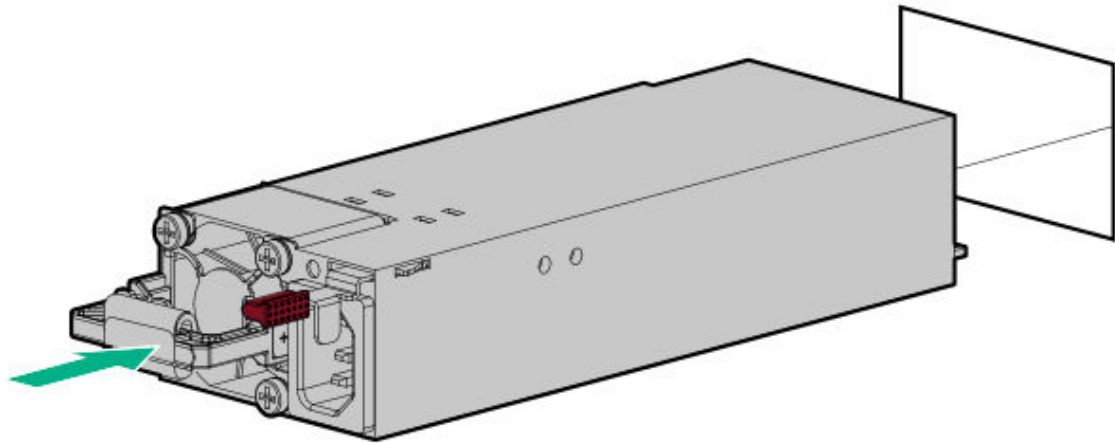

3. Connect the power cord to the power supply.
4. Secure the power cord.



CAUTION

Avoid tight bend radii to prevent damaging the internal wires of a power cord or a server cable. Never bend power cords and server cables tight enough to cause a crease in the sheathing.

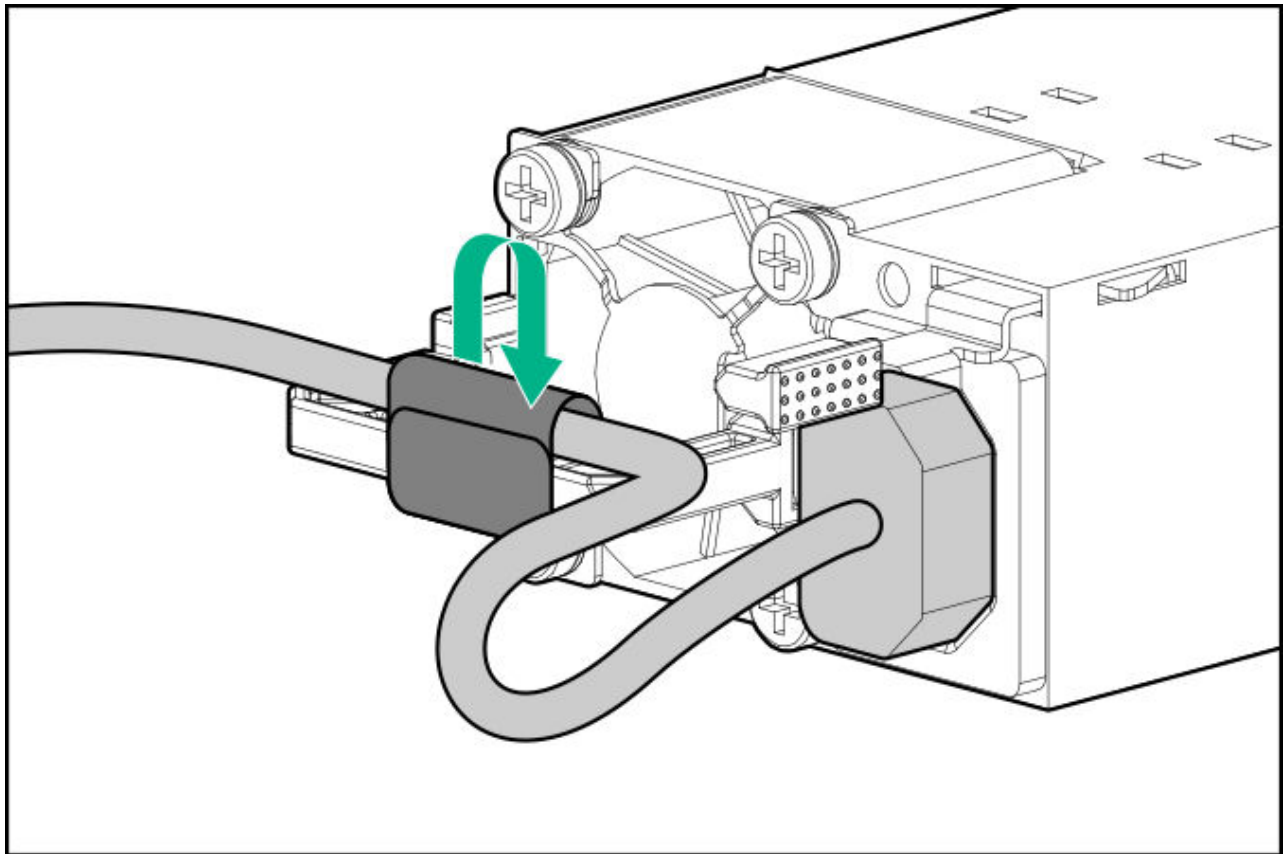

5. Connect the power cords:
 - a. Connect each power cord to the server.
 - b. Connect each power cord to the power source.
6. Make sure that the power supply LED is green.

Results

The installation procedure is complete.

DC power supply warnings and cautions



WARNING

To reduce the risk of electric shock, be sure that the cable grounding kit is properly installed and connected to a suitable protective earth terminal before connecting the power source to the rack.



CAUTION

This equipment is designed to permit the connection of the earthed conductor of the DC supply circuit to the earthing conductor at the equipment. If this connection is made, all the following must be met:

- This equipment must be connected directly to the DC supply system earthing electrode conductor or to a bonding jumper from an earthing terminal bar or bus to which the DC supply system earthing electrode conductor is connected.
- This equipment must be located in the same immediate area (such as adjacent cabinets) as any other equipment that has a connection between the earthed conductor of the same DC supply circuit and the earthing conductor, and also the point of earthing of the DC system. The DC system must be earthed elsewhere.
- The DC supply source is to be located within the same premises as the equipment.
- Switching or disconnecting devices must not be in the earthed circuit conductor between the DC source and the point of connection of the earthing electrode conductor.

Connecting a DC power cable to a DC power source

Prerequisites

Before you perform this procedure, make sure that you have the following items available:

- Electrical wire cutter
- Hand crimp tool

About this task



WARNING

To reduce the risk of electric shock or energy hazards:

- This equipment must be installed by trained service personnel and in accordance with local and regional electric codes and regulations
- Connect the equipment to a reliably grounded secondary circuit source. A secondary circuit has no direct connection to a primary circuit and derives its power from a transformer, converter, or equivalent isolation device.
- The overcurrent protection for the DC source must not exceed 45 A.



WARNING

When installing a DC power supply, the ground wire must be connected before the positive or negative leads.



WARNING

Remove power from the power supply before performing any installation steps or maintenance on the power supply.



CAUTION

The server equipment connects the earthed conductor of the DC supply circuit to the earthing conductor at the equipment. For more information, see the documentation that ships with the power supply.



CAUTION

If a DC connection exists between the earthed conductor of the DC supply circuit and the earthing conductor at the server equipment, the following conditions must be met:

- This equipment must be connected directly to the DC supply system earthing electrode conductor or to a bonding jumper from an earthing terminal bar or bus to which the DC supply system earthing electrode conductor is connected.
- Locate the equipment in the same immediate area (such as adjacent cabinets) as any other equipment that has a connection between the earthed conductor of the same DC supply circuit and the earthing conductor, and also the point of earthing of the DC system. The DC system must be earthed

Procedure

1. Cut the DC power cord ends no shorter than 150.00 cm (59.06 in).



IMPORTANT

The ring terminals must be UL approved and accommodate 6 AWG wires.



IMPORTANT

The minimum nominal thread diameter of a pillar or stud type terminal must be 3.50 mm (0.138 in). The diameter of a screw type terminal must be 5.00 mm (0.197 in).

2. If the power source requires ring tongues, use a crimping tool to install the ring tongues on the power cord wires and ground wire.
3. Stack each same-colored pair of wires and then attach them to the same power source.

For more information, see the documentation that ships with the power supply.

DC power supply wire colors

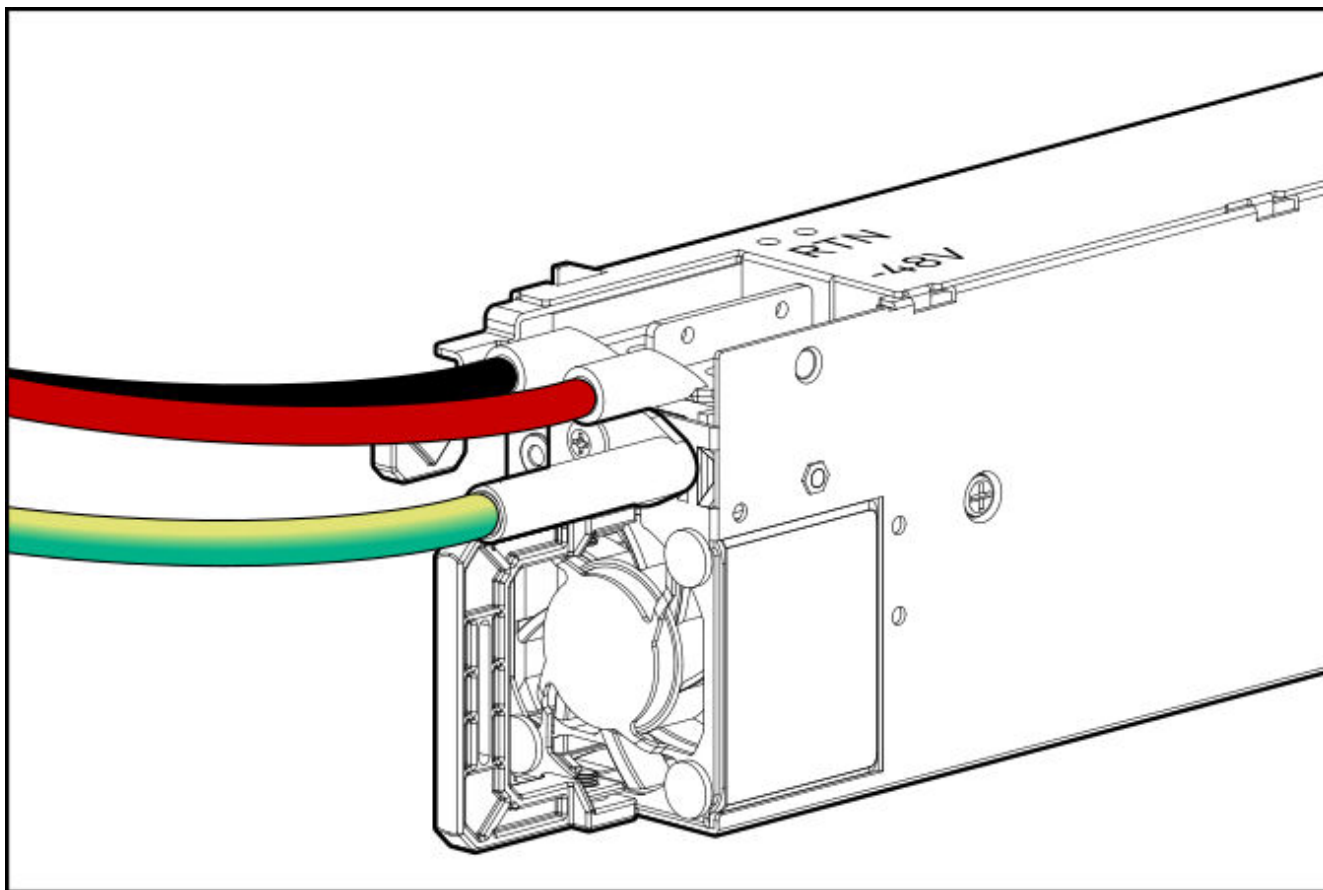

Wire color	Description	Wire slot
Red	Line wire	-48V
Black	Return wire	Return
Green + Yellow	Ground wire	Safety ground

Installing a DC power supply

Prerequisites

- Before installing a power supply, review the following:
 - [Power supply warnings and cautions](#)
 - [DC power supply warnings and cautions](#)

- DC power supply wire colors
- Before you perform this procedure, make sure that you have a Phillips No. 2 screwdriver available.
- Before connecting the power cables, review the following:
 - The optional P36877-B21 HPE lug kit can be purchased from an authorized HPE reseller for use with customer-supplied power cables. (The power cable and lug kit listed below can only be used with the 1600 W -48 VDC power supply.)
 - If you are using an input power cord option, the P22173-B21 HPE 1600 W DC PSU power cable kit can be purchased from an authorized HPE reseller.
 - The DC power supply option kits do not ship with a Power Supply DC cable Kit and may not include a Power Supply Cable Lug kit. The optional DC Cable kit or the optional DC Cable Lug Kit may be purchased directly from Hewlett Packard Enterprise or an authorized HPE reseller. For additional information, see the power supply QuickSpecs at <https://www.hpe.com/info/fsps-qs>.

About this task

If you are not using an input power cord option, the power supply cabling must be made in consultation with a licensed electrician and be compliant with local code.



WARNING

To reduce the risk of electric shock, fire, and damage to the equipment, you must install this product in accordance with the following guidelines:

- The HPE 1600 W Flex Slot -48 VDC hot-plug power supply is intended only for installation in servers located in a restricted access location.
- The HPE 1600 W Flex Slot -48 VDC hot-plug power supply is not intended for direct connection to the DC supply branch circuit. Only connect this power supply to a power distribution unit (PDU) that provides an independent overcurrent-protected output for each DC power supply. Each output overcurrent-protected device in the PDU must be suitable for interrupting fault current available from the DC power source and must be rated no more than 45 A.
- The PDU output must have a shut-off switch or a circuit breaker to disconnect power for each power supply. To completely remove power from the power supply, disconnect power at the PDU. The end product may have multiple power supplies. To remove all power from the product, disconnect the power for each power supply.
- In accordance with applicable national requirements for Information Technology Equipment and Telecommunications Equipment, this power supply only connects to DC power sources that are classified as SELV or TNV. Generally, these requirements are based on the International Standard for Information Technology Equipment, IEC 60950-1/IEC 62368-1. In accordance with local and regional electric codes and regulations, the DC source must have one pole (Neutral/Return) reliably connected to earth ground.
- You must connect the power supply ground screw located on the front of the power supply to a suitable ground (earth) terminal. In accordance with local and regional electric codes and regulations, this terminal must be connected to a suitable building ground (earth) terminal. Do not rely on the rack or cabinet chassis to provide adequate ground (earth) continuity.



WARNING

To reduce the risk of personal injury from hot surfaces, allow the power supply, power supply blank, or dual slot power supply adapter to cool before touching it.

Procedure

1. Remove the protective cover from the power supply.

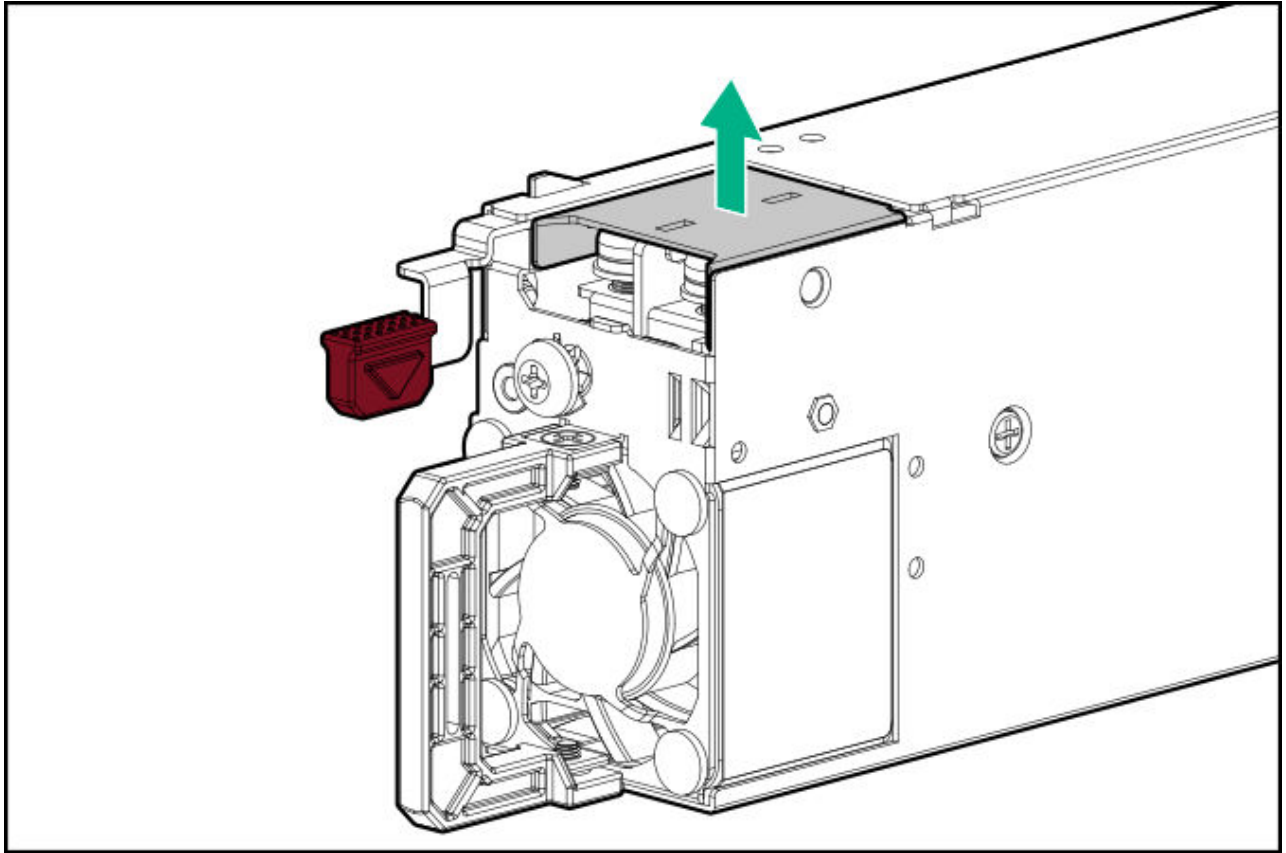

2. Remove the ground wire screw, and then remove the return wire and line wire screws.

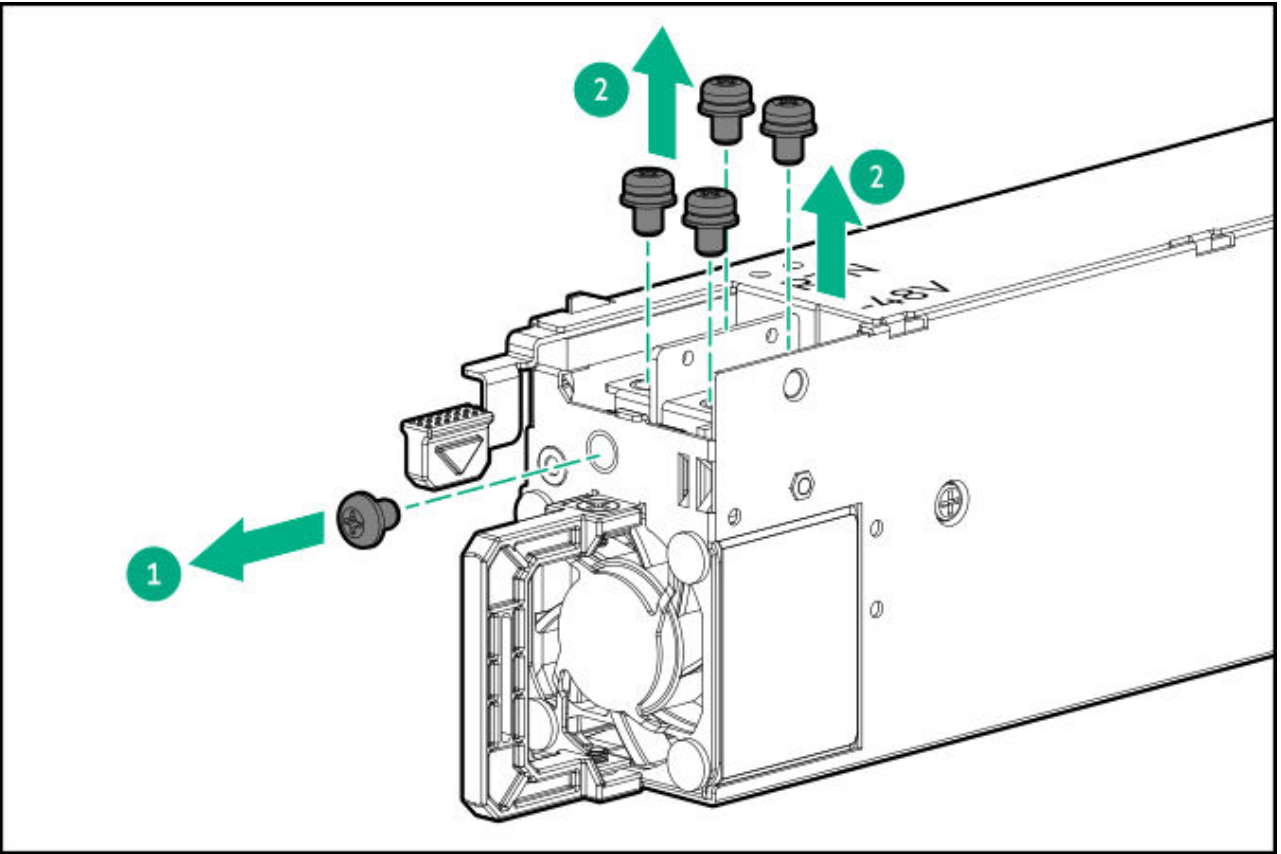

3. Attach the ground wire (green and yellow) to the DC power supply and tighten the screw and washer with 1.47 N-m (13 lbf-in).

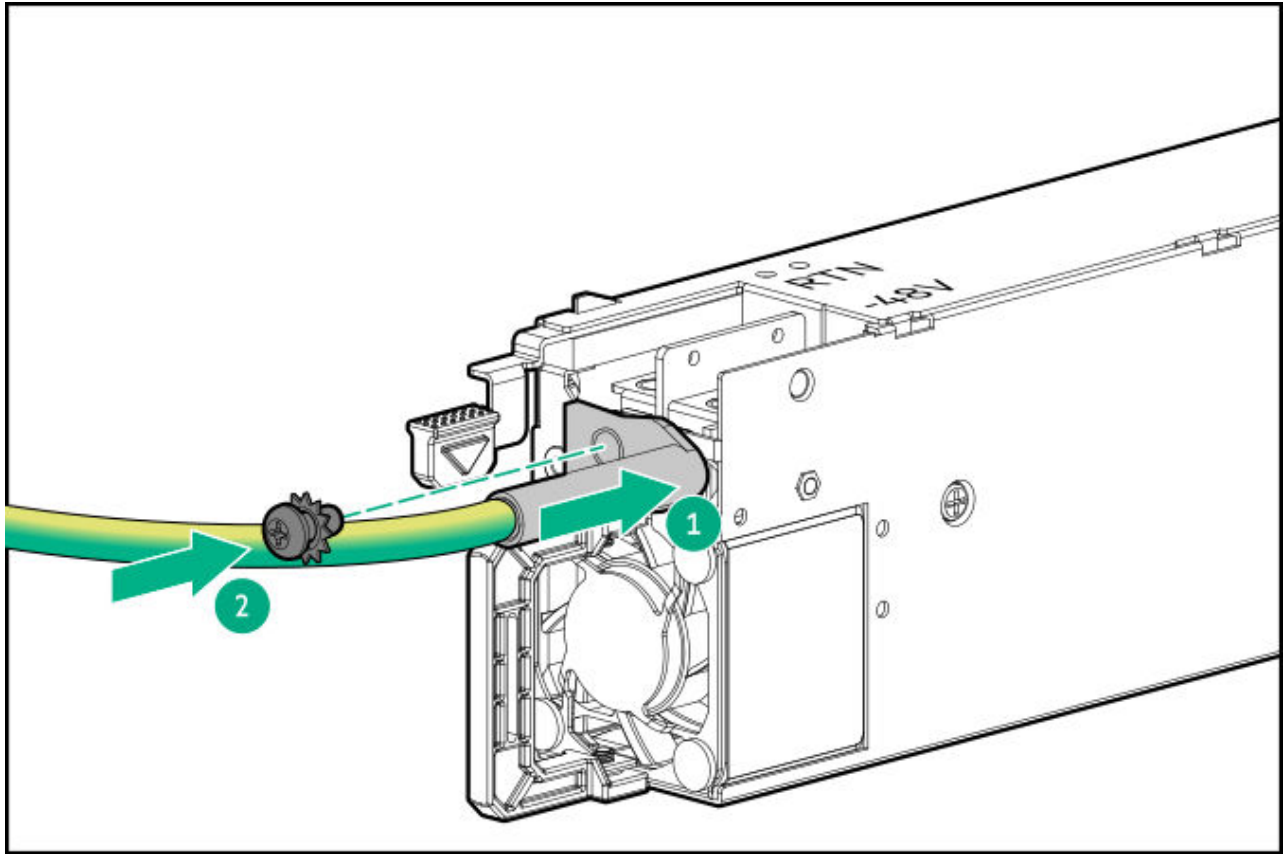

4. Install the return wire (black):

- a. Insert the return wire into the RTN slot on the DC power supply.
- b. Tighten the screw with 0.98 N-m (8.68 lbf-in).

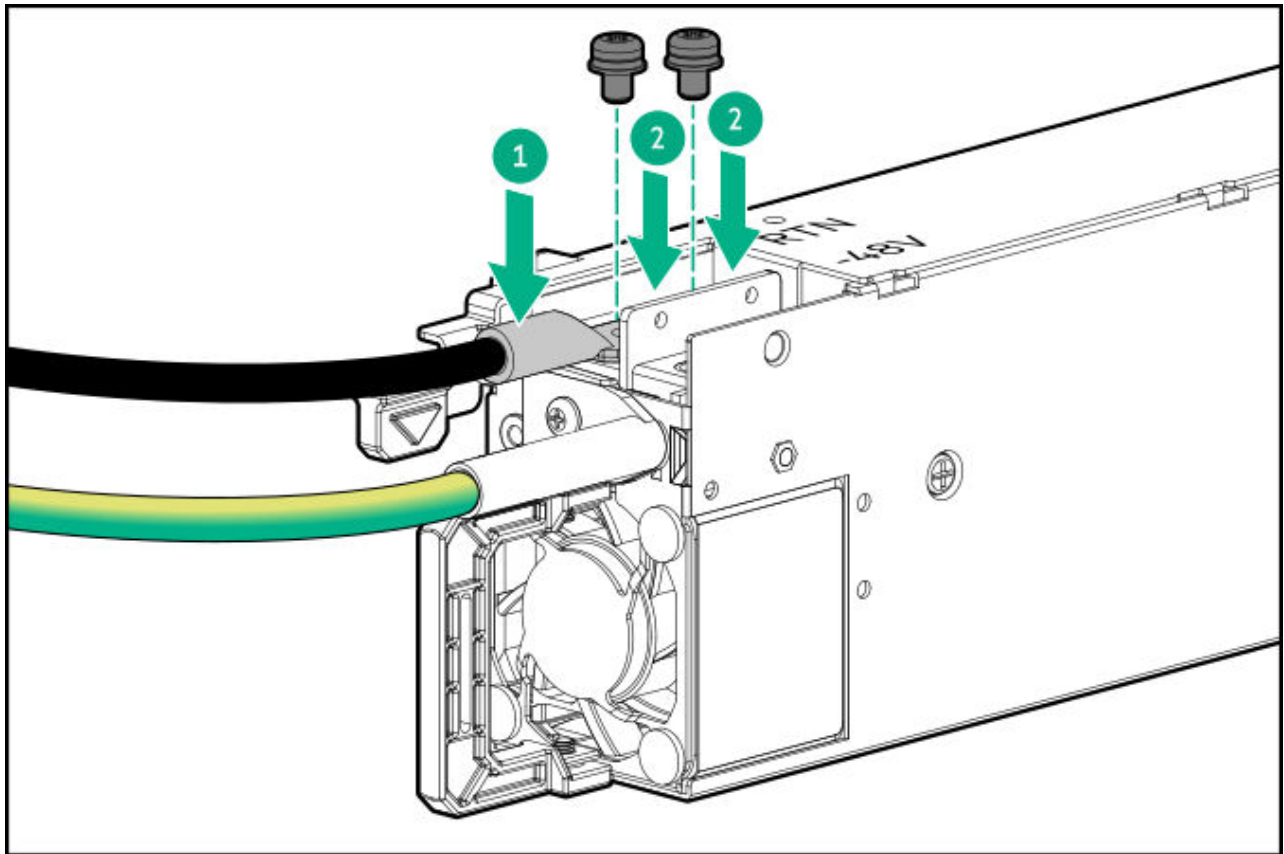

5. Install the line wire (red):

- a. Insert the line wire into the -48V slot on the DC power supply.
- b. Tighten the screw to 0.98 N-m (8.68 lbf-in).

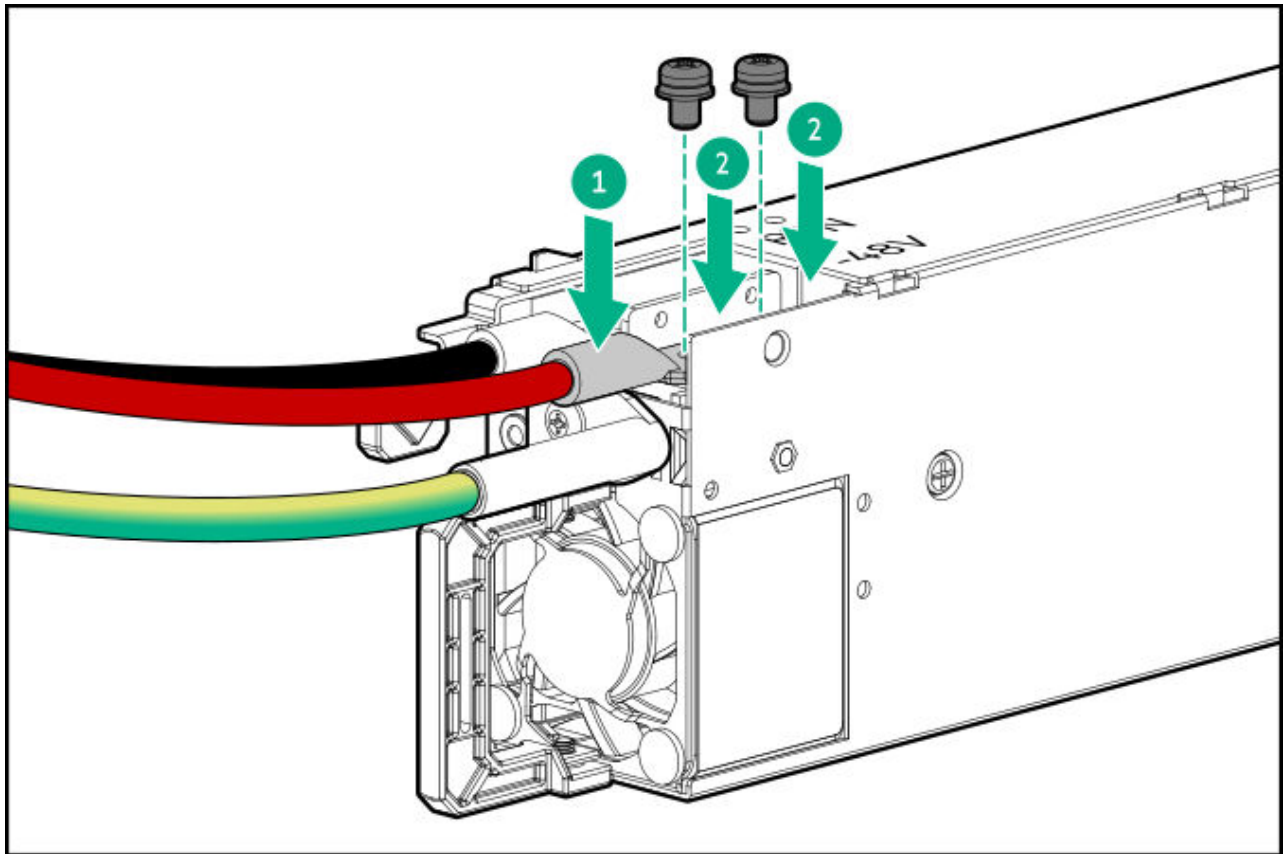

6. Install the protective cover on the DC power supply.

Make sure that the protective cover is locked.

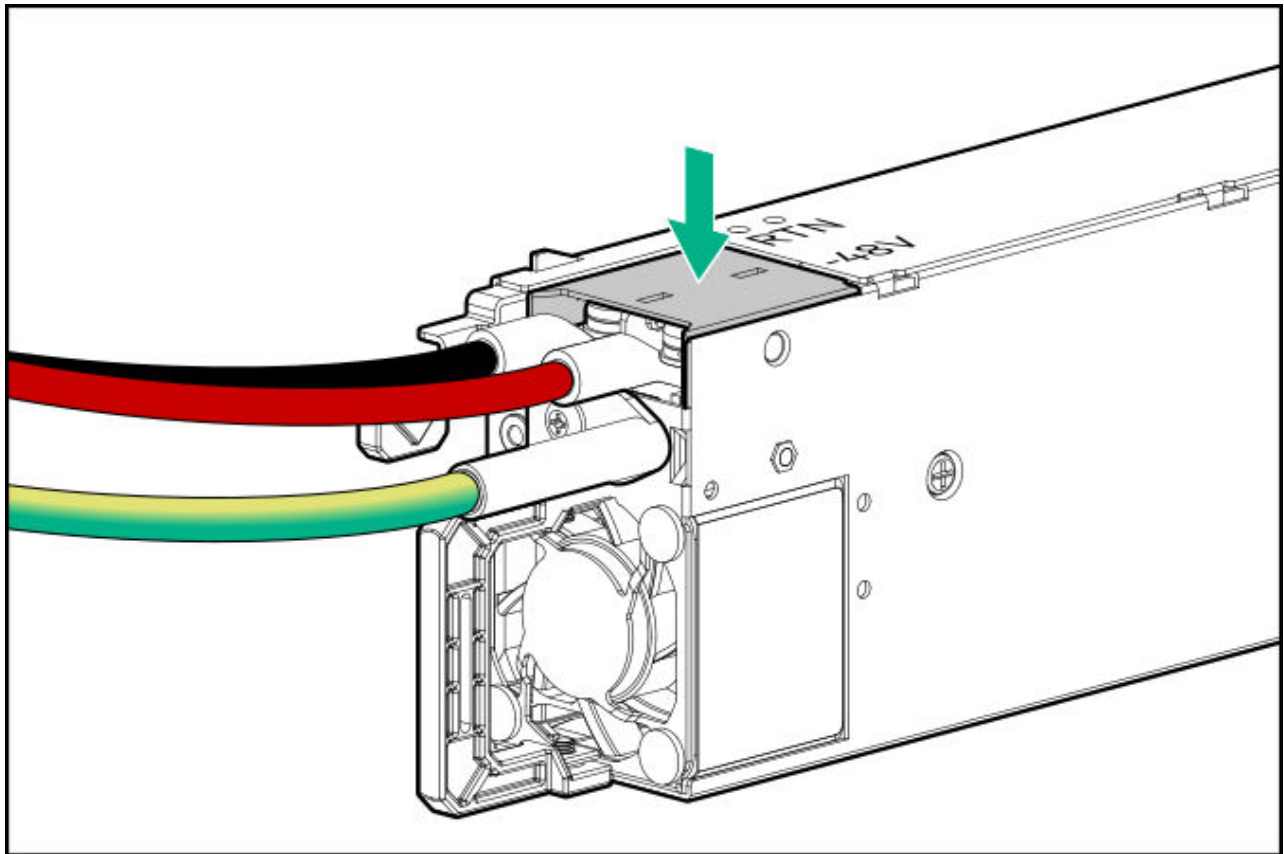

7. Secure the ground, positive return, and negative input wires in the strain relief strap.



CAUTION

Avoid tight bend radii to prevent damaging the internal wires of a power cord or a server cable. Never bend power cords and server cables tight enough to cause a crease in the sheathing.

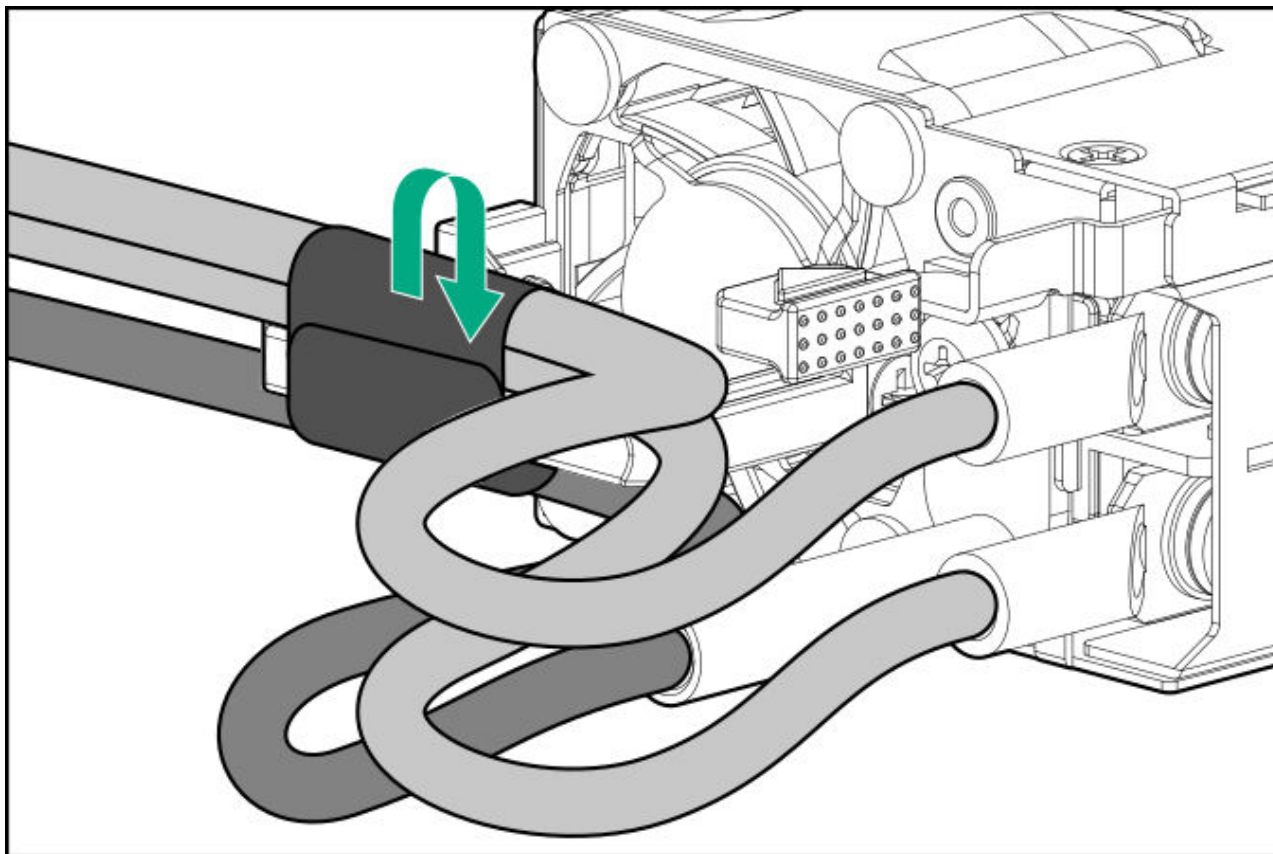

8. If you are installing a power supply in the power supply bay 2, remove the power supply blank.
Retain the blank for future use.

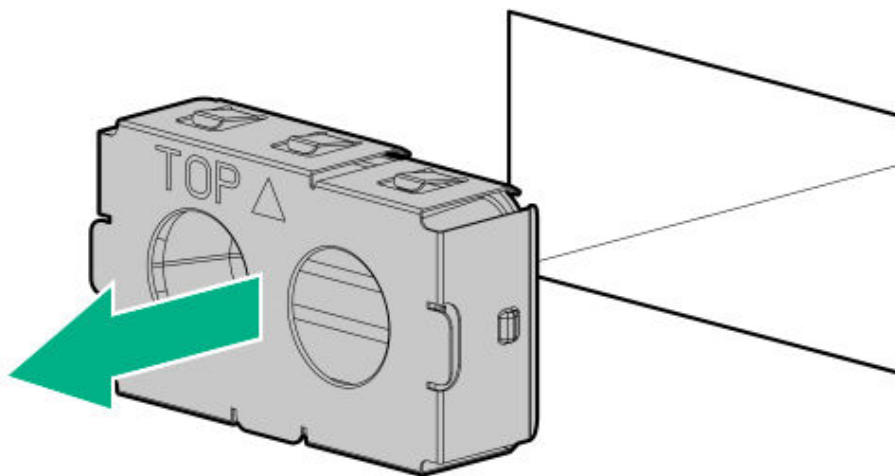

9. Immediately slide the power supply into the bay until it clicks into place.

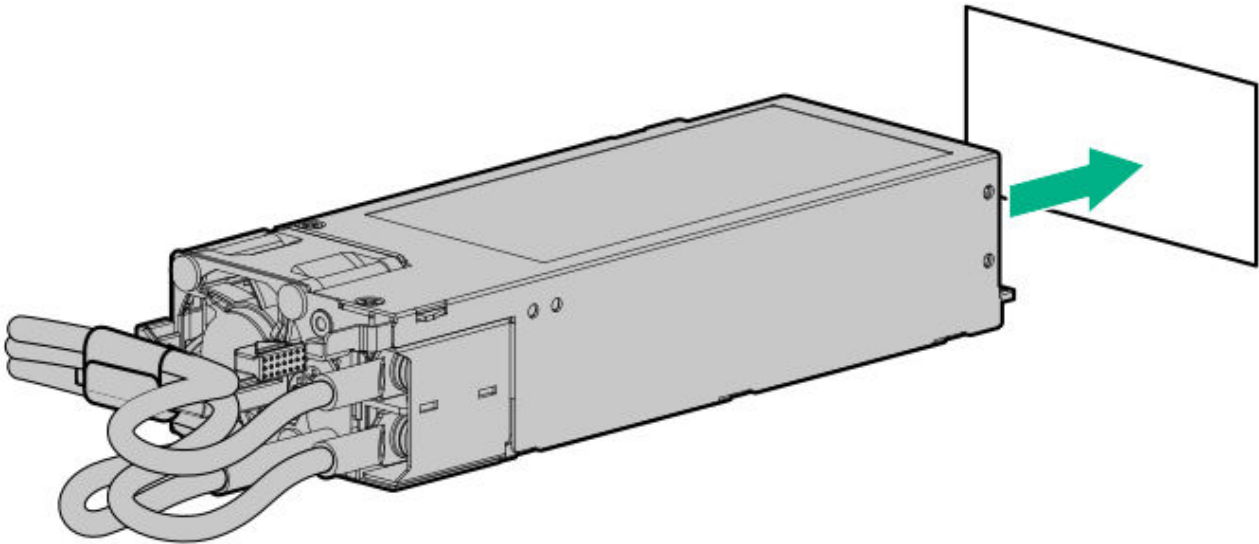

- .0. Make sure the -48 V DC power source is off or the PDU breaker is in the off position, and then connect the power cord to the -48 V DC power source or PDU.
- .1. Turn on the -48 V power source or switch the PDU breaker to the on position to supply -48 V to the power supply.
- .2. Connect a DC power cable to a DC power source.
- .3. Make sure that the power supply LED is green.

Results

The installation procedure is complete.

Processors and heatsinks

Subtopics

Processor cautions

Installing a processor or heatsink

Connecting the direct liquid cooling kit

Processor cautions



CAUTION

To avoid damage to the processor or system board, only authorized personnel should attempt to replace or install the processor in this server.



CAUTION

To prevent possible server malfunction and damage to the equipment, multiprocessor configurations must contain processors with the same part number.



CAUTION

The pins on the processor socket and on the processor are very fragile and easily damaged. To avoid component damage, **do not touch these pins.** Any damage to them might require replacing the system board and/or processor.



IMPORTANT

Processor socket 1 must be populated at all times or the server does not function.



IMPORTANT

If installing a processor with a faster speed, update the system ROM before installing the processor. To download firmware, go to the Hewlett Packard Enterprise Support Center website (<https://www.hpe.com/support/hpesc>).



IMPORTANT

After removing a processor from the system board, the server resets the date and time. For information on reconfiguring these settings, see [Reconfiguring the system date and time settings](#).

Installing a processor or heatsink

Prerequisites

- Identify the heatsink and processor socket components.

- Review the processor cautions.
- Before you perform this procedure, make sure that you have the following items available:
 - T-30 Torx screwdriver
 - Two 1.0 gm (0.5 ml) of thermal grease

About this task

This procedure shows the standard heatsink, but the steps apply to all heatsinks:

- Standard heatsink
- High performance heatsink
- Max performance heatsink
- Low-profile high performance heatsink



CAUTION

To prevent possible server overheating, always populate each socket with a socket cover or blank or a processor and heatsink.

Procedure

1. Power down the server.
2. Remove all power:
 - a. Disconnect each power cord from the power source.
 - b. Disconnect each power cord from the server.
3. Disconnect all peripheral cables from the server.
4. Remove the server from the rack
5. Remove the access panel.
6. Remove the air baffle and any components that block access to the heatsink and processor.
7. Remove the fan cage.
8. Verify that the processor is secure in the carrier.

The processors and carriers are keyed. Different carriers have different tabs in different locations.

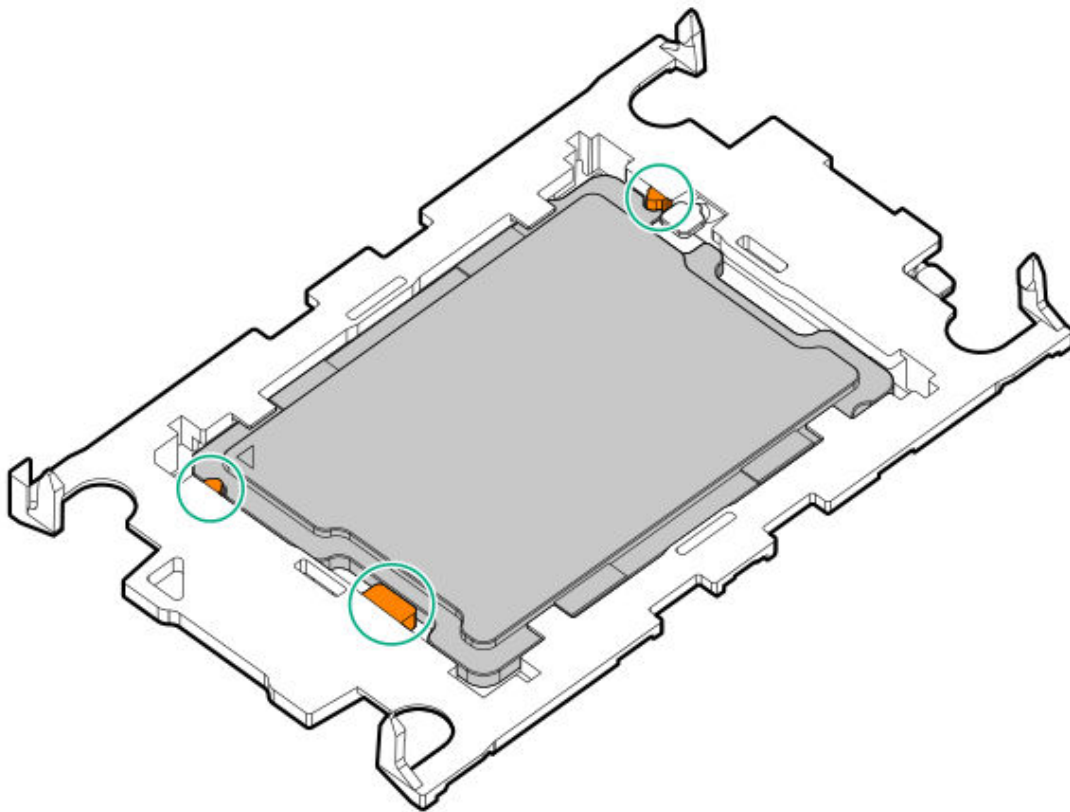

a. Verify that the pin 1 indicators are aligned.

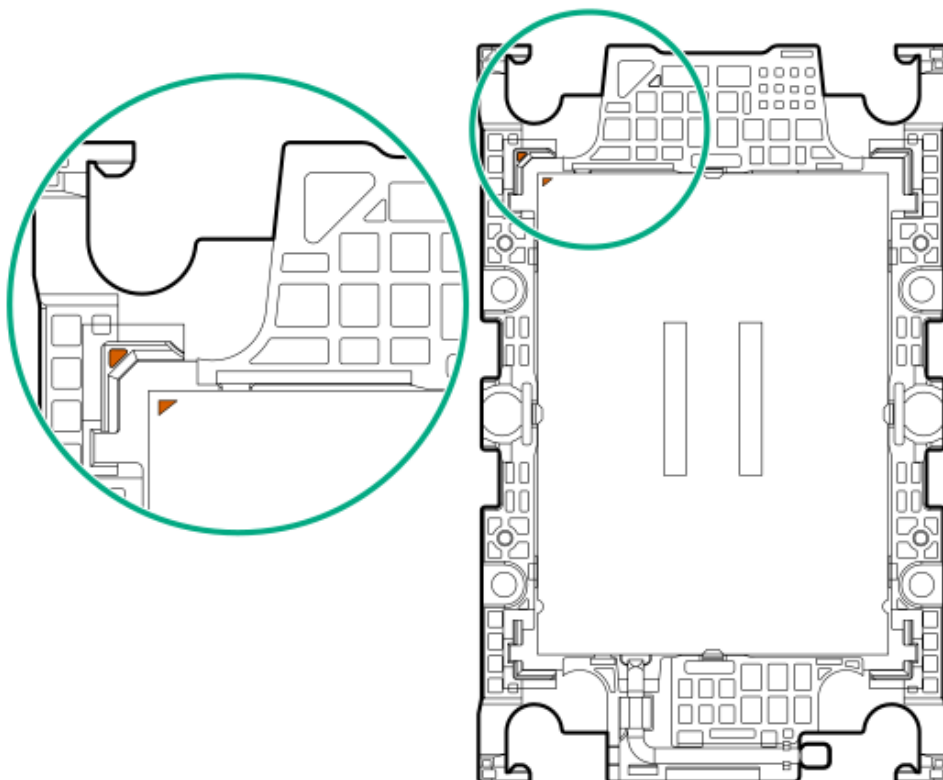

b. Verify that the processor is secured in the carrier.

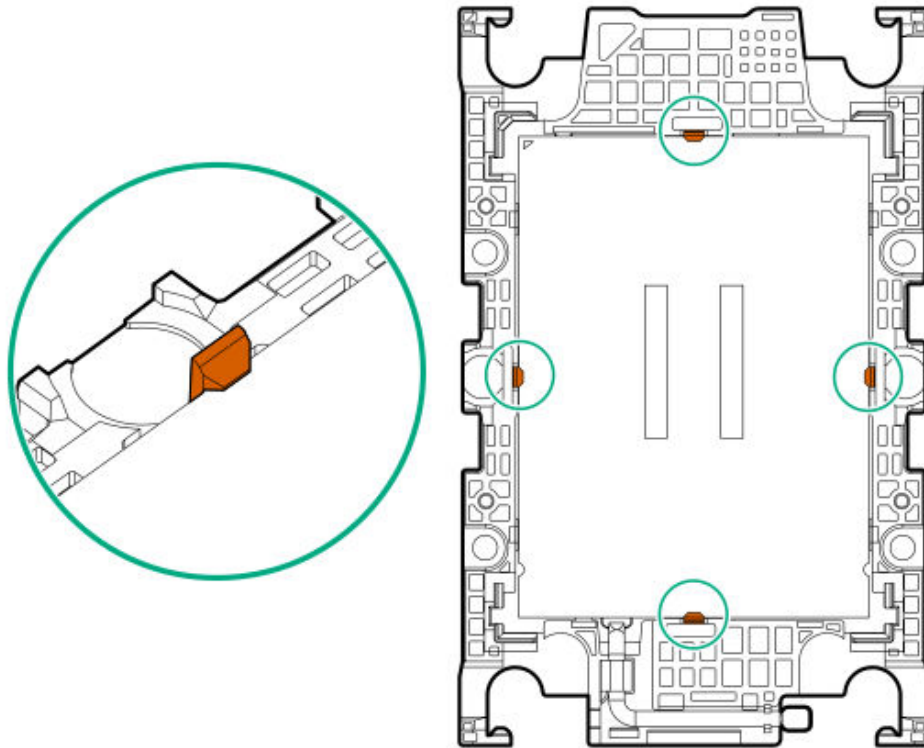

9. Install the carrier to the heatsink.

a. Apply the thermal grease.



CAUTION

To prevent mechanical damage or depositing oil on your hands or other contaminants to the heatsink contact surface, hold the heatsink only by the edge of its base plate. Do not touch the heatsink fins.

- If you are using a new heatsink, remove the protective film from the thermal interface material.

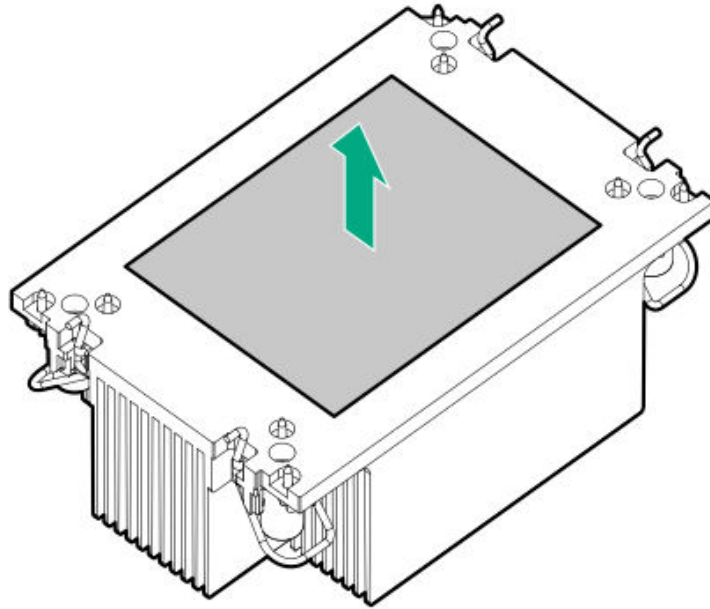

- If you are reusing the same heatsink, verify that the old grease has been cleaned off of the processor. Using the grease syringes, apply grease to the top of the processor.

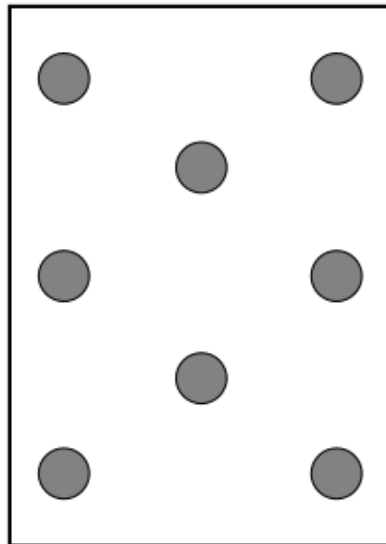

b. Locate the pin 1 indicators on the carrier and heatsink.

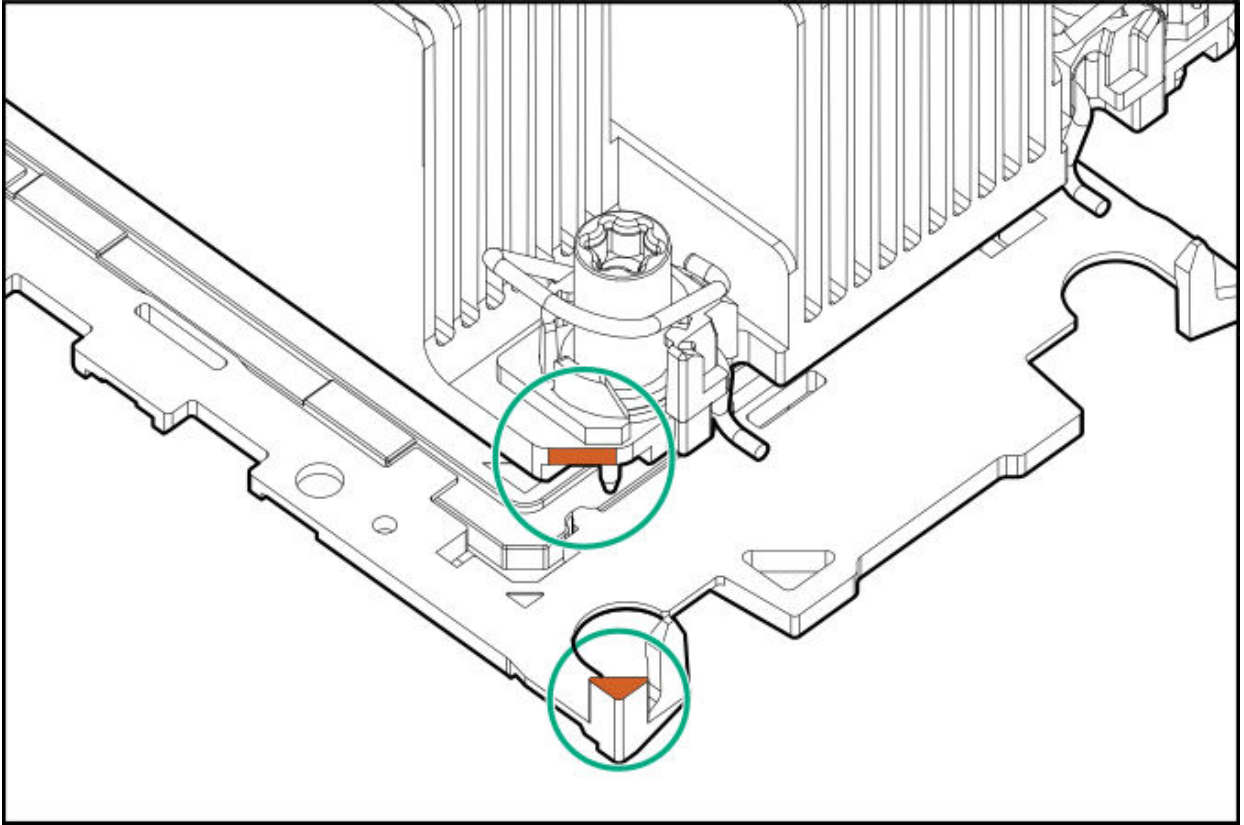

- c. Lower the heatsink on the processor carrier until the carrier latches into place.

There will be an audible click to indicate that the heatsink is properly latched on the processor carrier.

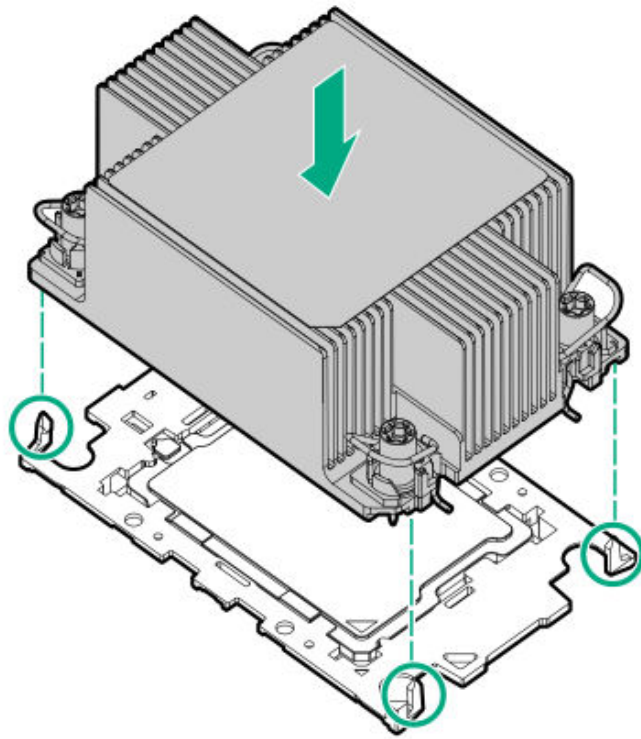

d. Verify that the latches are secured to the heatsink.

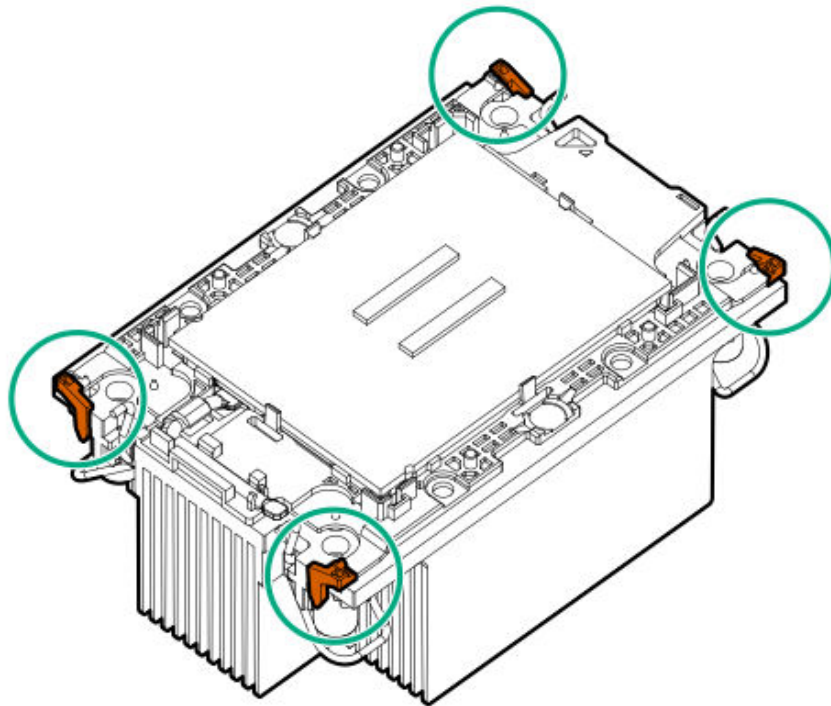

.0. Unlock the anti-tilt wires.

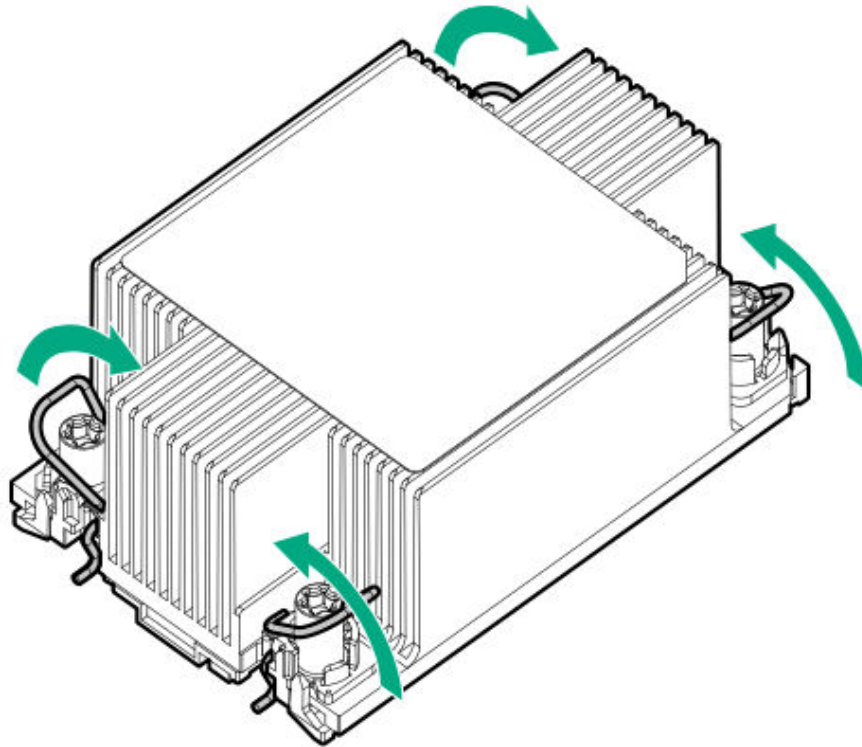

.1.



CAUTION

To prevent thermal failure or component damage, do not move the heatsink once the bottom of its base plate touches the top of the processor. Excessive heatsink movement can cause the thermal grease to smear and become uneven. Voids in the compound can adversely impact the transfer of heat away from the processor.

Install the processor-heatsink module:

- a. Note the **Front of server** text on the heatsink label.
- b. Align the heatsink over the guide posts.

The posts are keyed. The module can only be installed one way.

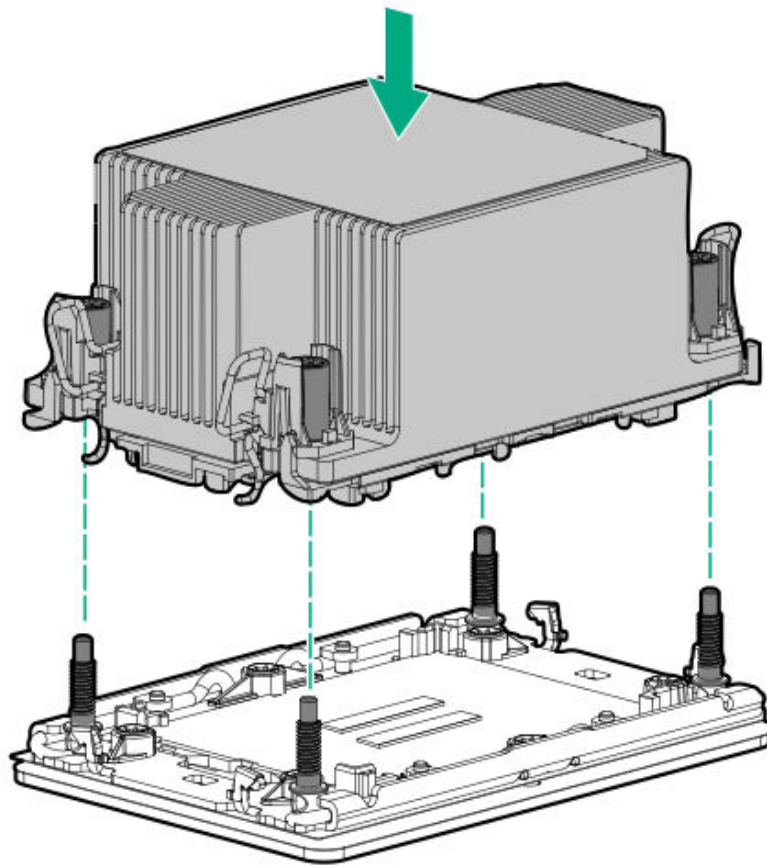

c. Lock the anti-tilt wires.

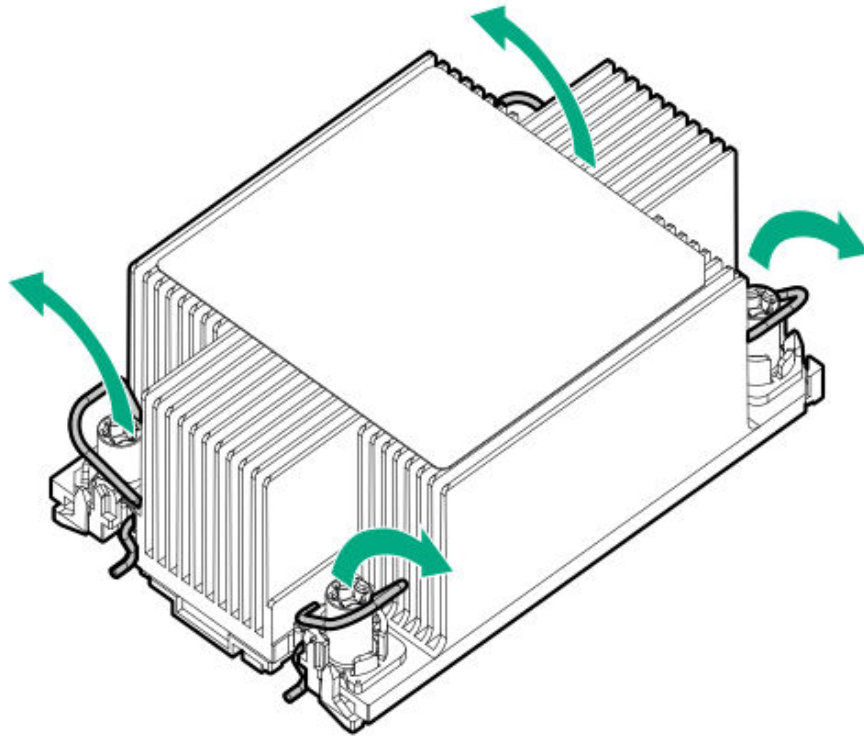

d. Tighten the heatsink screws to **0.9 N-m (8 in-lb) of torque**.

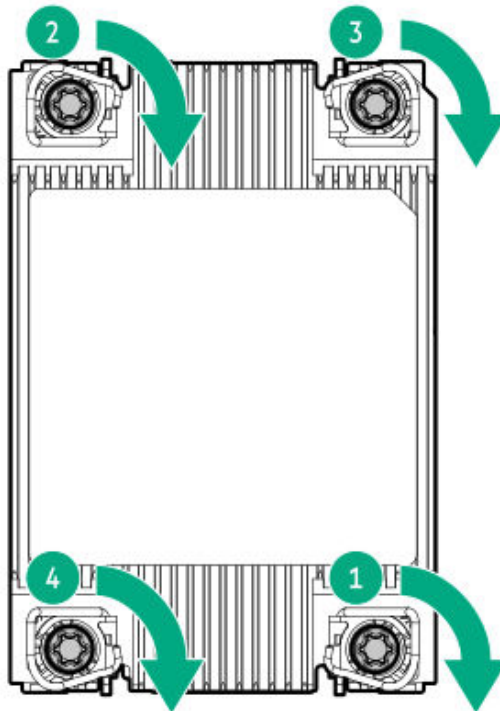

- .2. Install the air baffle and other removed hardware components.
- .3. Install the access panel.
- .4. Install the server into the rack.
- .5. Connect all peripheral cables.
- .6. Connect all power cords.
- .7. Power up the server.
- .8. Configure the system date and time.

Results

The installation procedure is complete.

Subtopics

Reconfiguring the system date and time settings

Reconfiguring the system date and time settings

Procedure

1. Access the UEFI System Utilities. During POST, press **F9**.
2. From the **System Utilities** screen, select **System Configuration > BIOS/Platform Configuration (RBSU) > Date and Time**.
3. Select a setting, and then complete your entry.
 - **Date (mm-dd-yyyy)**—Enter the date in a month-day-year (mm-dd-yyyy) format.
 - **Time (hh:mm:ss)**—Enter the time in a 24-hour format (hh:mm:ss) format.
 - **Hour Format**—Select either a 12- or 24-hours format.
 - **Time Format**
 - **Coordinated Universal Time (UTC)**—Calculates the time stored in the hardware real-time clock (RTC) from the associated **Time Zone** setting.
 - **Local Time**—Removes the use of the **Time Zone** setting. This option is useful for addressing interaction issues in Windows operating systems set in legacy BIOS boot mode.

- **Time Zone**—Select the time zone for the system.
- **Daylight Savings Time**
 - **Enabled**—Adjusts the local time displayed by one hour for Daylight Savings Time.
 - **Disabled**—Does not adjust the local time displayed for Daylight Savings Time.

4. To confirm and save the settings, press **F12**.

The server automatically reboots.

Connecting the direct liquid cooling kit

Prerequisites

You need the DLC hose kit. The hose kit connects the DLC manifold to the processor cold plates.

About this task

For more information about the DLC system, see the **HPE Cray XD Direct Liquid Cooling System Site Preparation, User, and Maintenance Guide**:

<https://www.hpe.com/info/xdDLCguide>

Procedure

1. From the rear of the server, locate the hoses coming from the riser cage or NS204i-u bracket.



NOTE

The image is for identifying possible hose locations. Hoses will only come from the riser cage or the boot device bracket. They will not come from both.

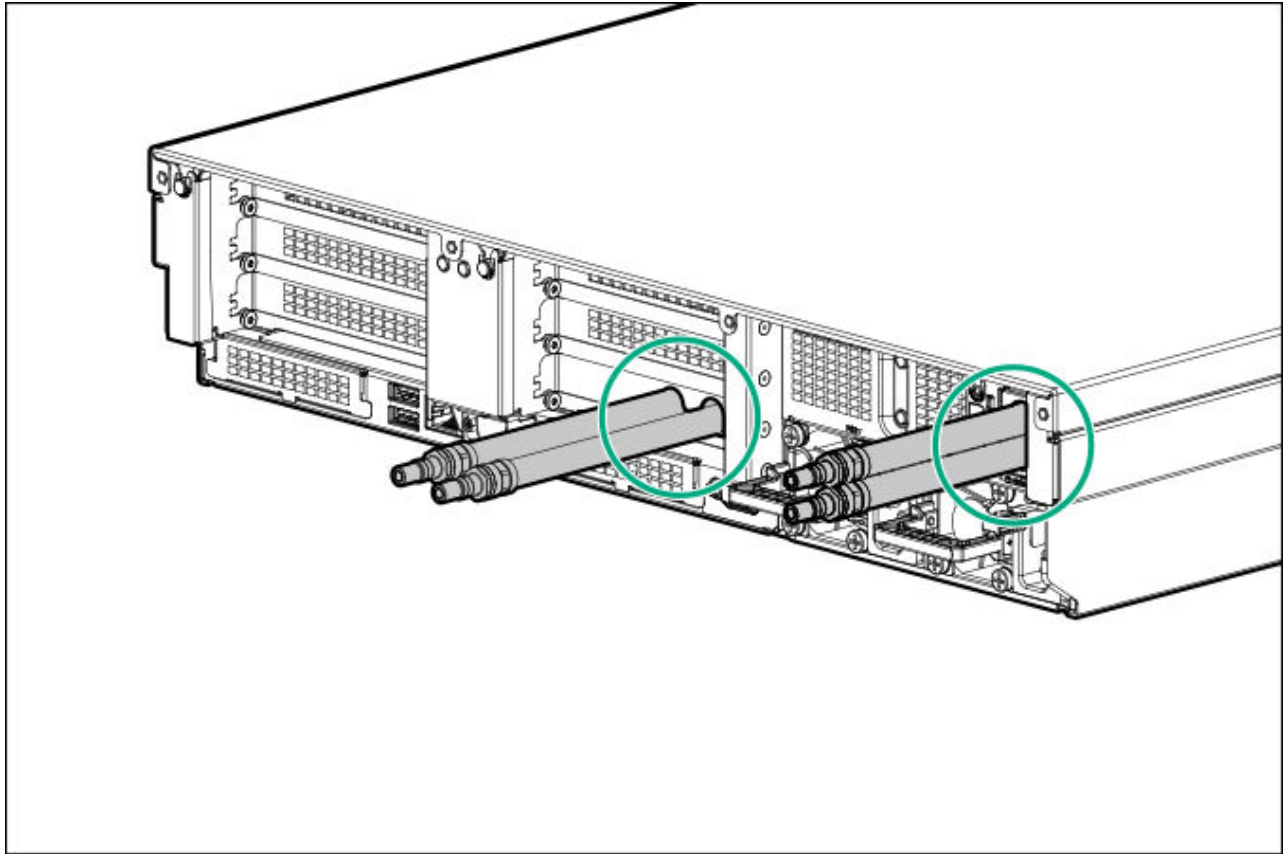

2. Remove the quick connector caps from the hoses.

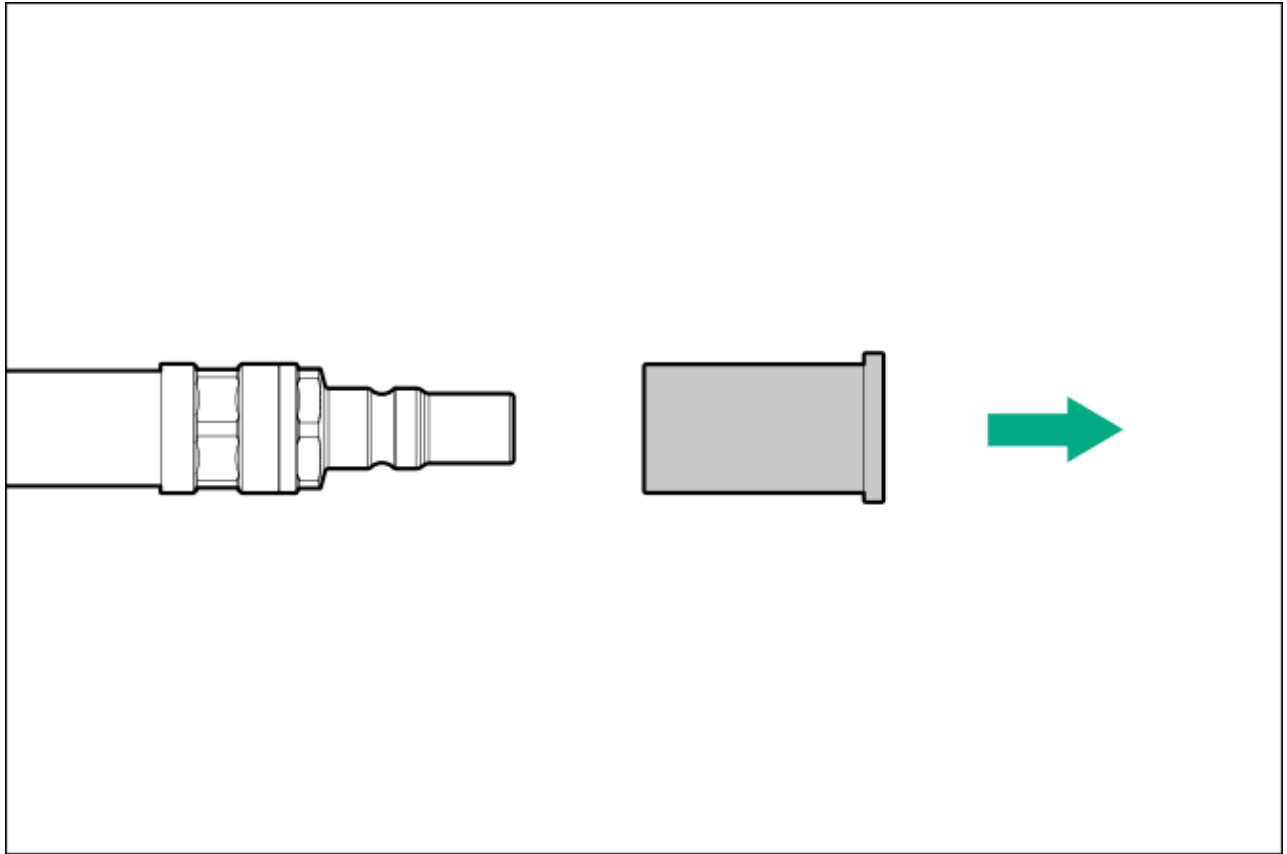

3. Connect the direct liquid cooling kit from the DLC manifold to the server.

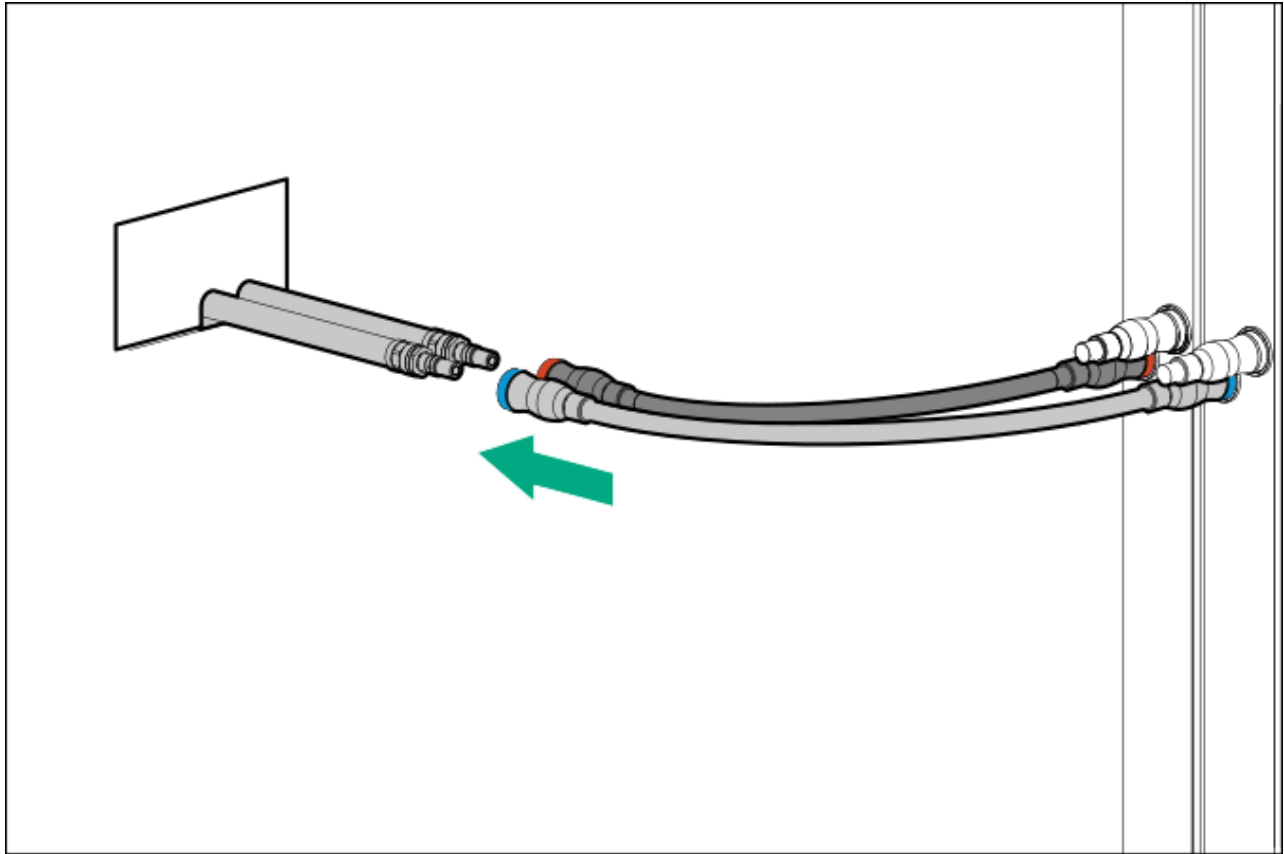

Rack rail and CMA

Subtopics

[Rack mounting interfaces](#)

[Rack rail options](#)

[Rail identification markers](#)

[Installing the rack rails](#)

[Installing the server into the rack](#)

[Installing the rack rail hook-and-loop strap](#)

[Preparing the cable management arm](#)

[Installing the cable management arm](#)

Rack mounting interfaces

The rack rails can be installed in a rack that has the following mounting interfaces:

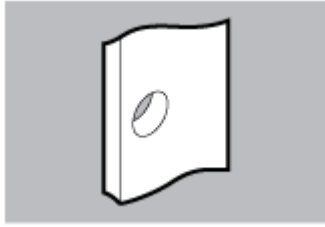

Round-hole

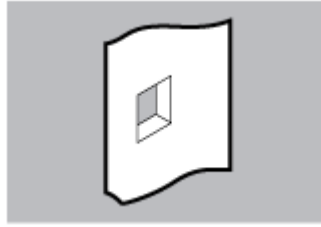

Square-hole

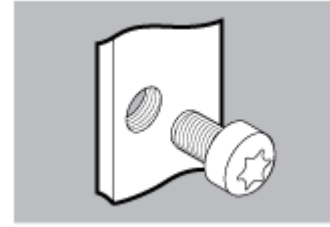

Threaded round-hole

The illustrations used in this procedure show an icon on the upper right corner of the image. This icon indicates the type of mounting interface for which the action illustrated in the image is valid.

Rack rail options

This server supports rack rail #3 for SFF and LFF drive configurations.

Rail identification markers

The rack rail option support is dependent on these two factors:

- The height and weight of the chassis as determined by the front- and rear-end server configurations.
- The depth of the chassis as measured from the edge of the front panel (without the front bezel) to the edge of the rear panel.

To ensure compatibility between the rack rails and the server, verify that the rail number labels on the chassis match the ones stamped on the rails.

- Rail number labels on the chassis

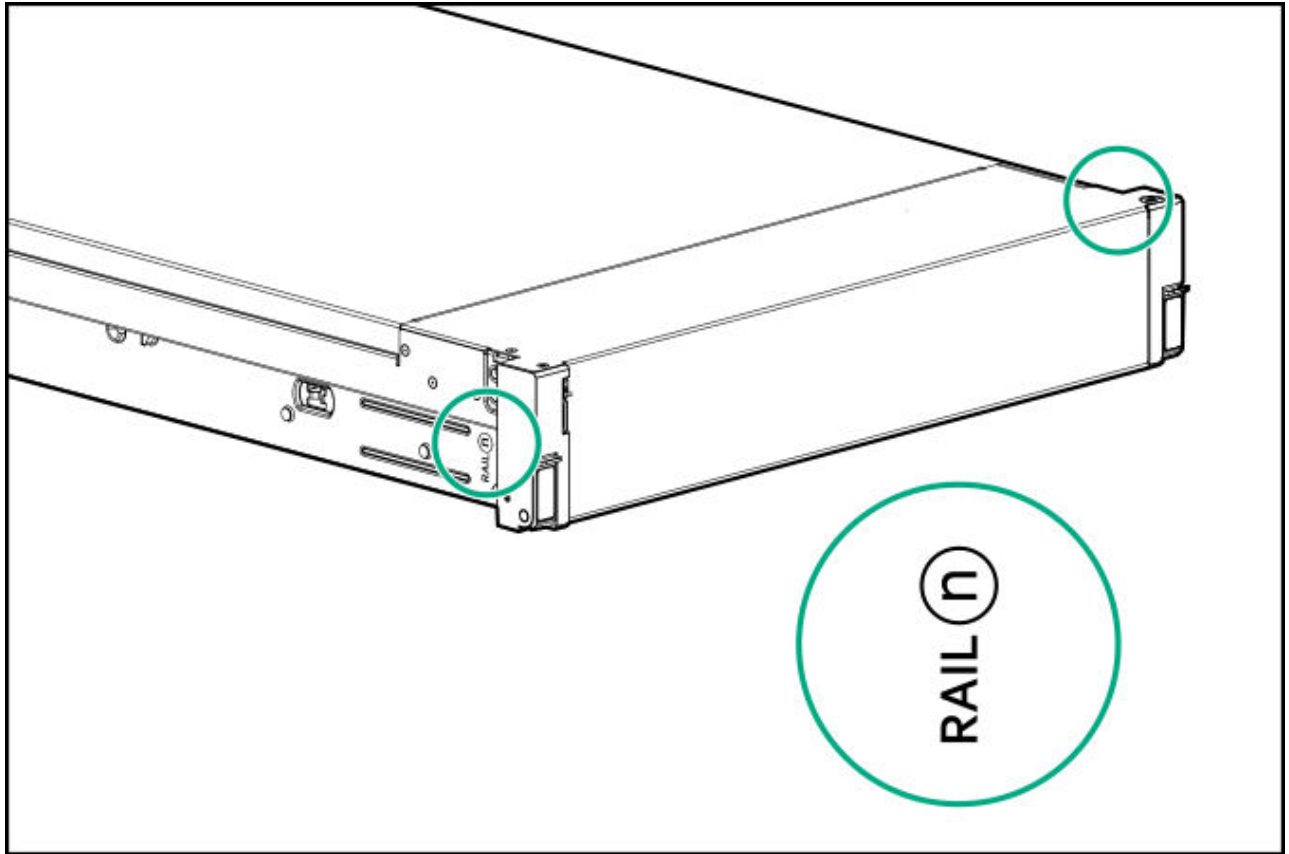

- Rail identifier stamps on the inner rail of the friction rack rail

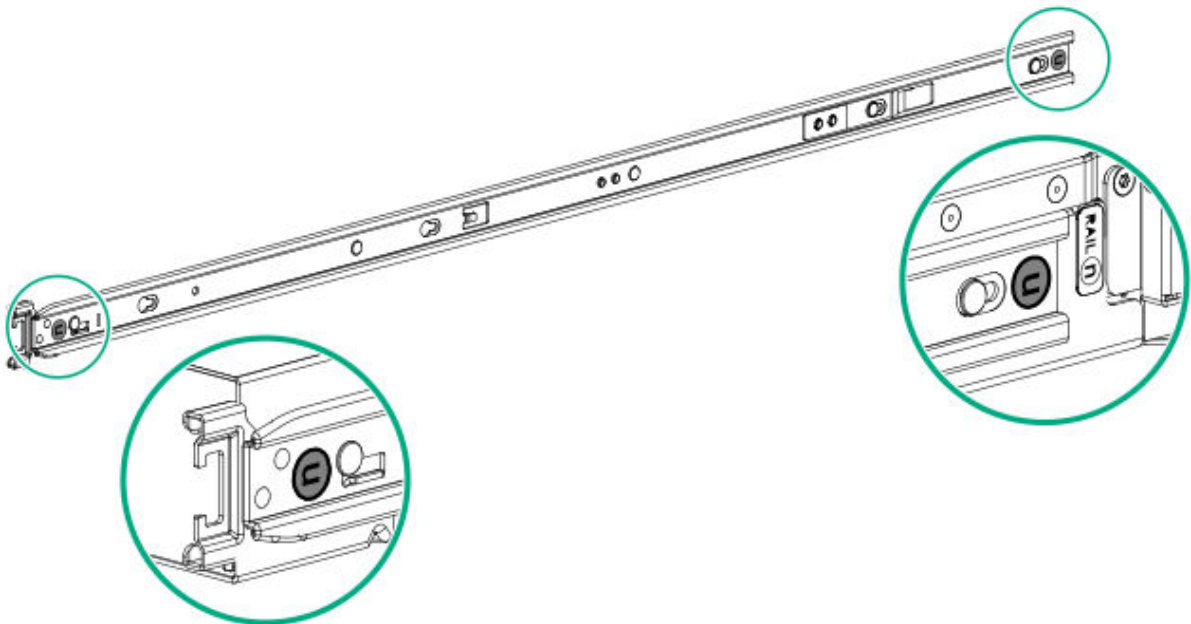

- Rail identifier stamps on the mounting rail of the friction rack rail

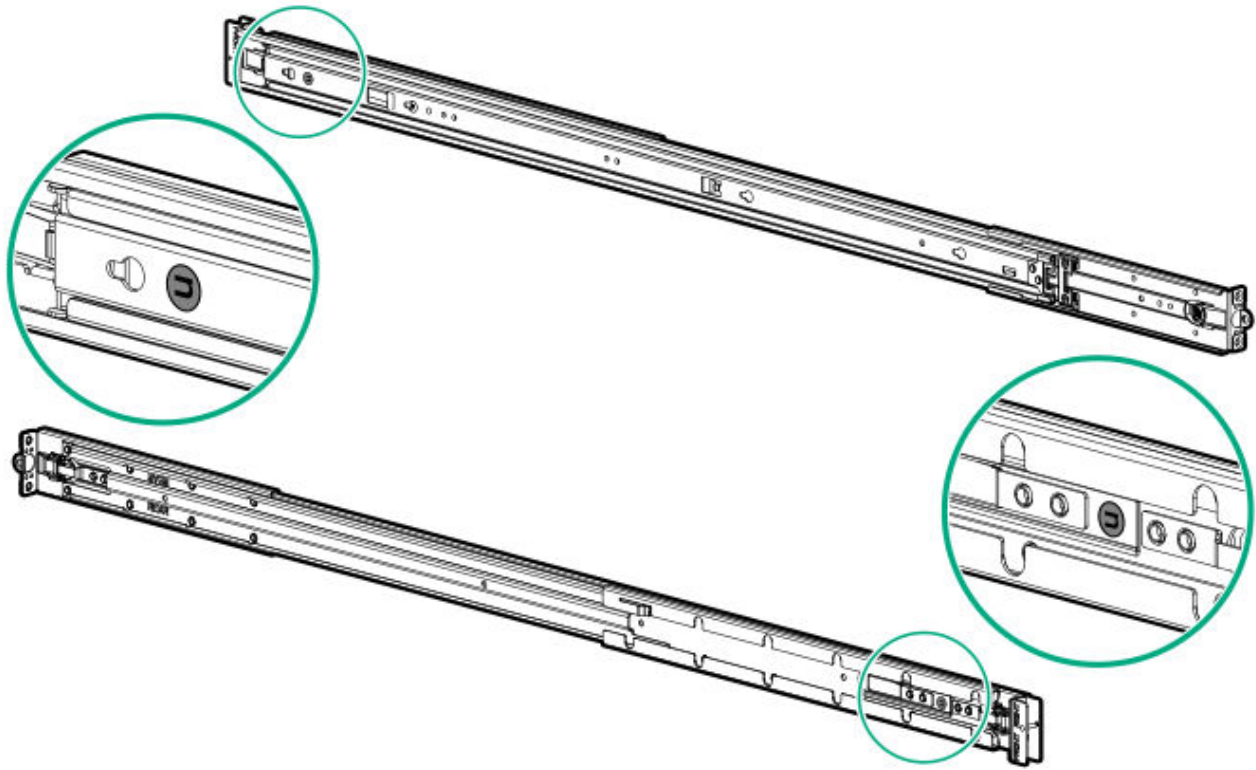

Installing the rack rails

Prerequisites

- Make sure that the rail option is compatible with the server configuration.
- If you are installing the server in a threaded round-hole rack, be sure to have a small slotted screwdriver.

Procedure

1. Install the server rails.

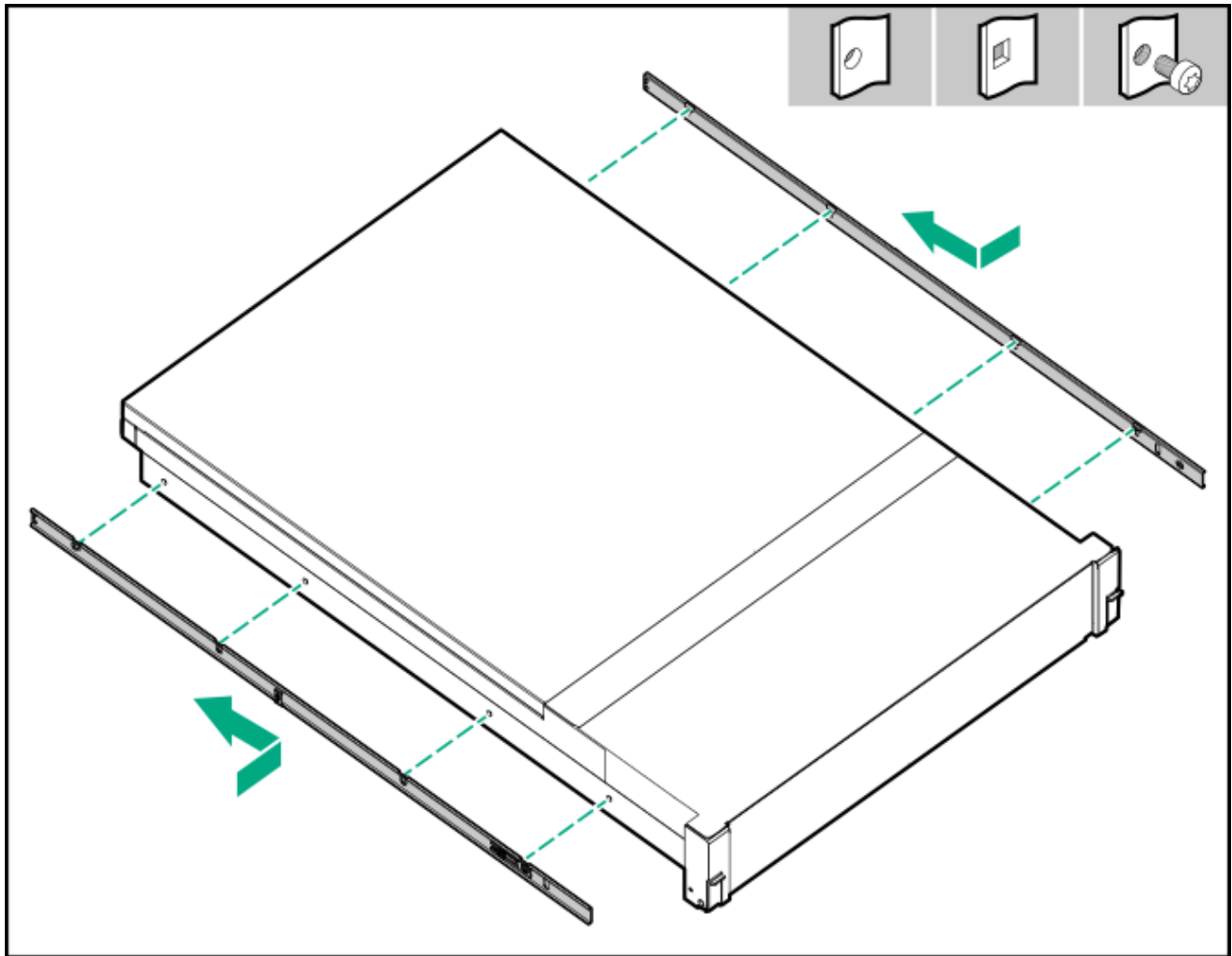

2. Identify the rack rails.

- The front end of the rails is marked as **FRONT LEFT** or **FRONT RIGHT**.
- The other end of the rails is marked as **REAR**.

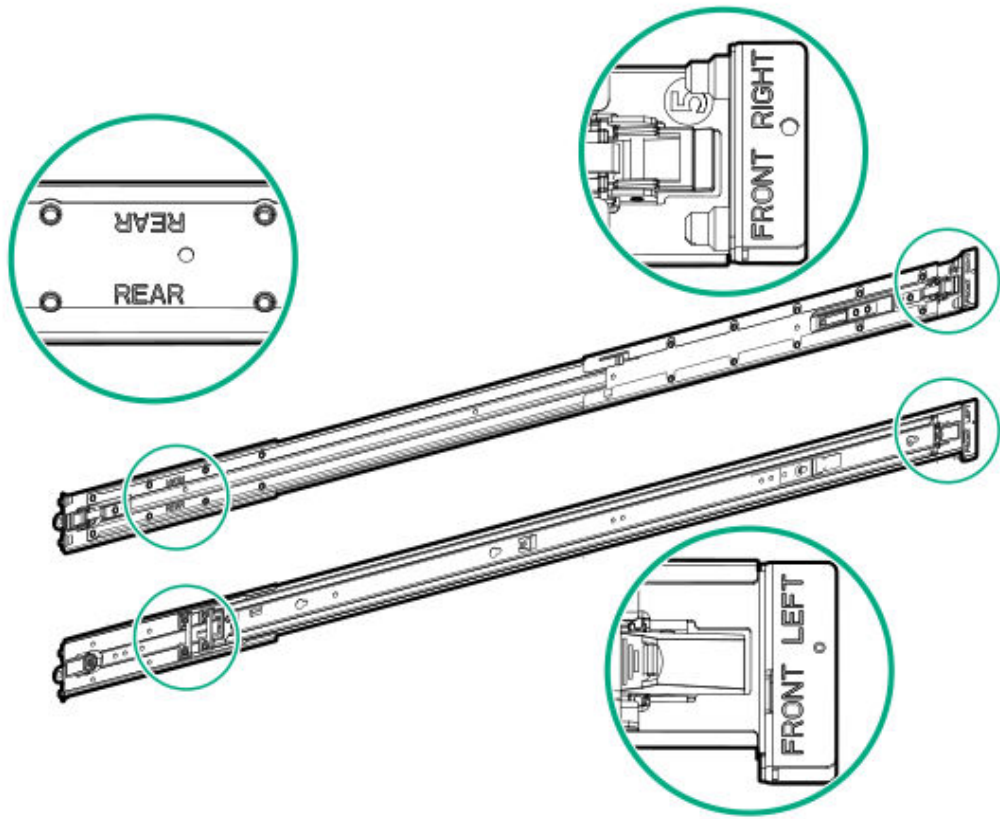

3. Extend the rack rails to align with the depth of the rack.

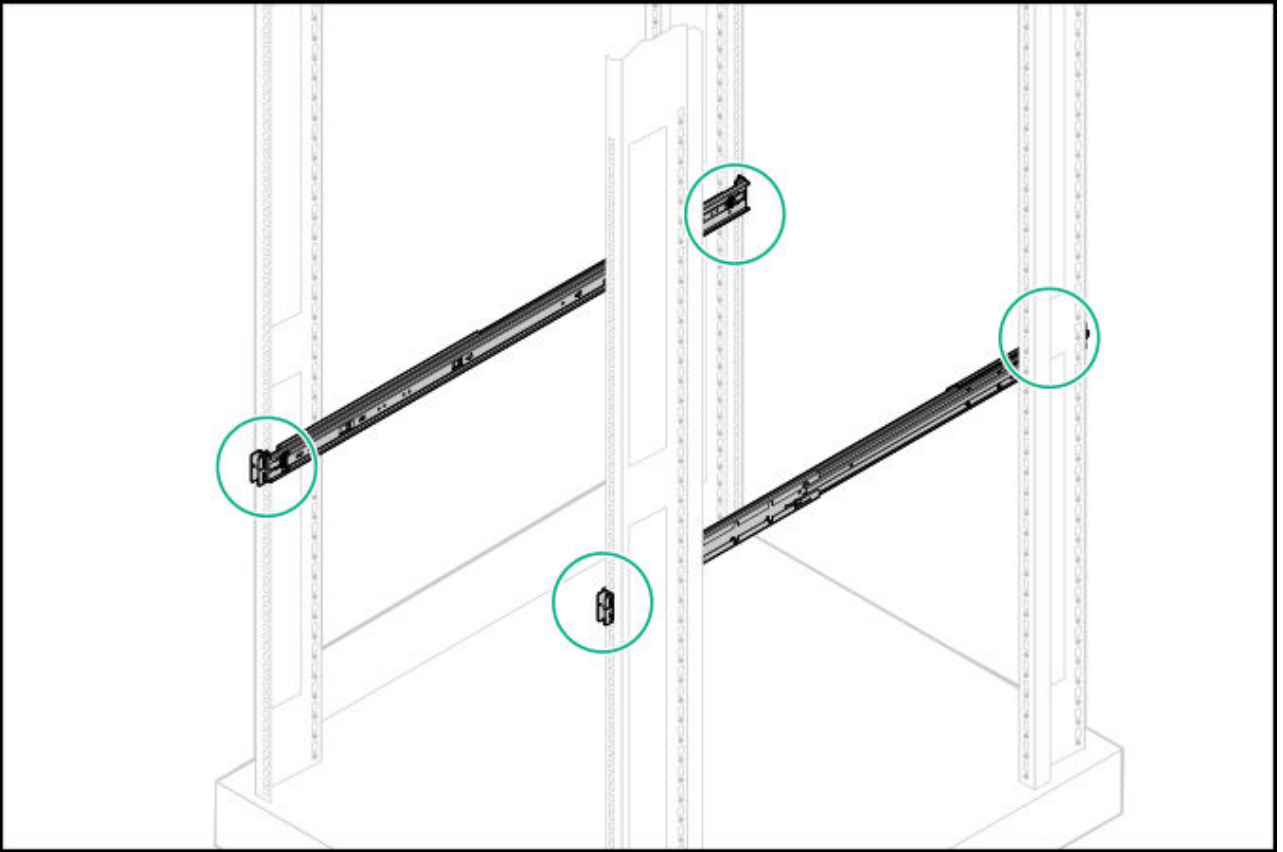

4. Install the rack rails.

- For round-hole or square-hole racks:

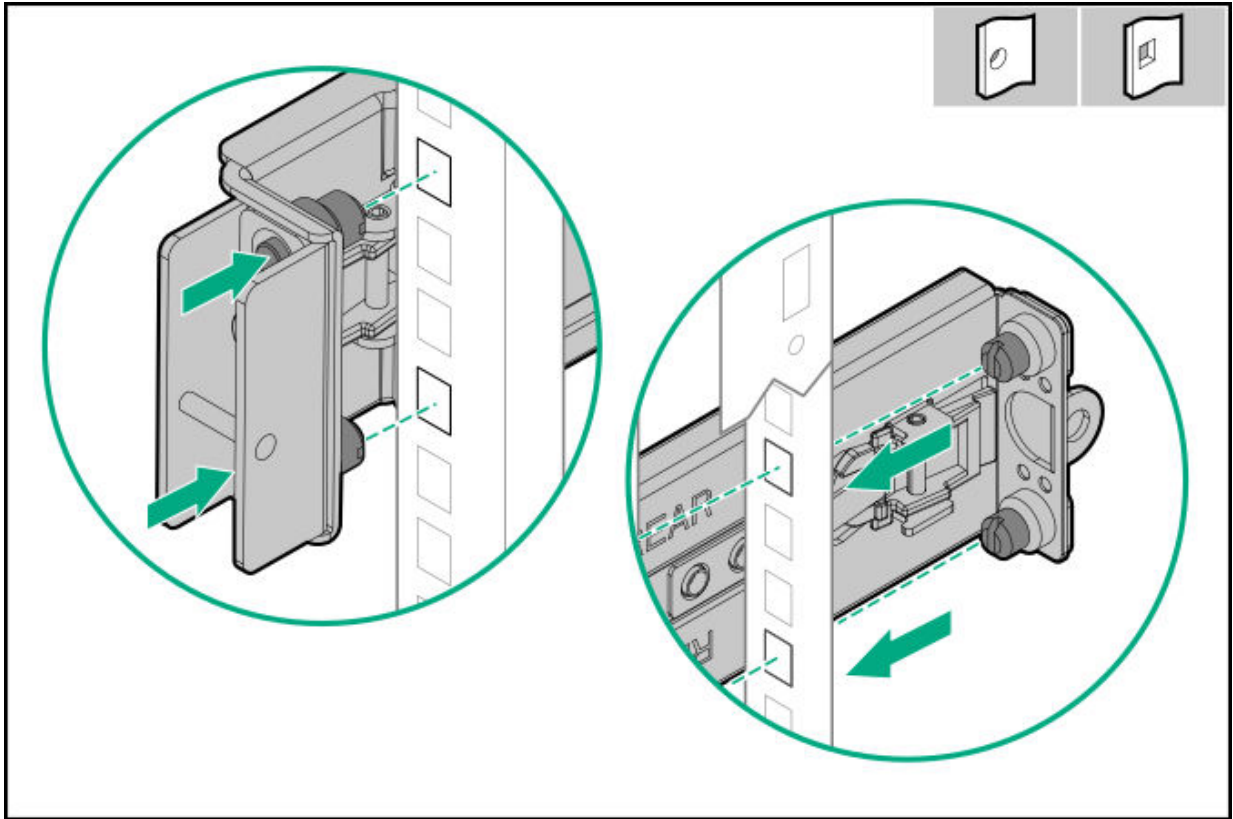

- For threaded round-hole racks:

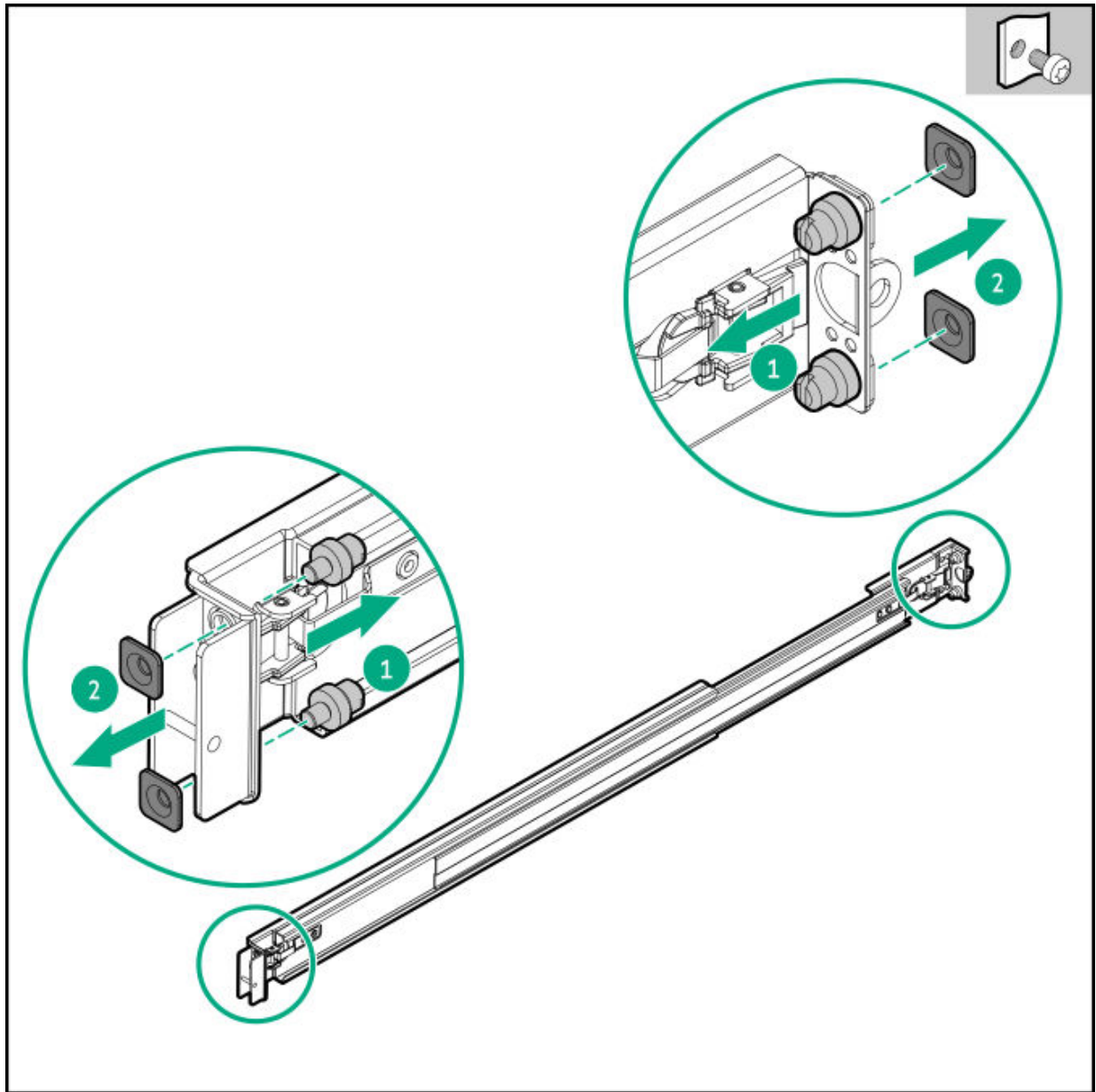

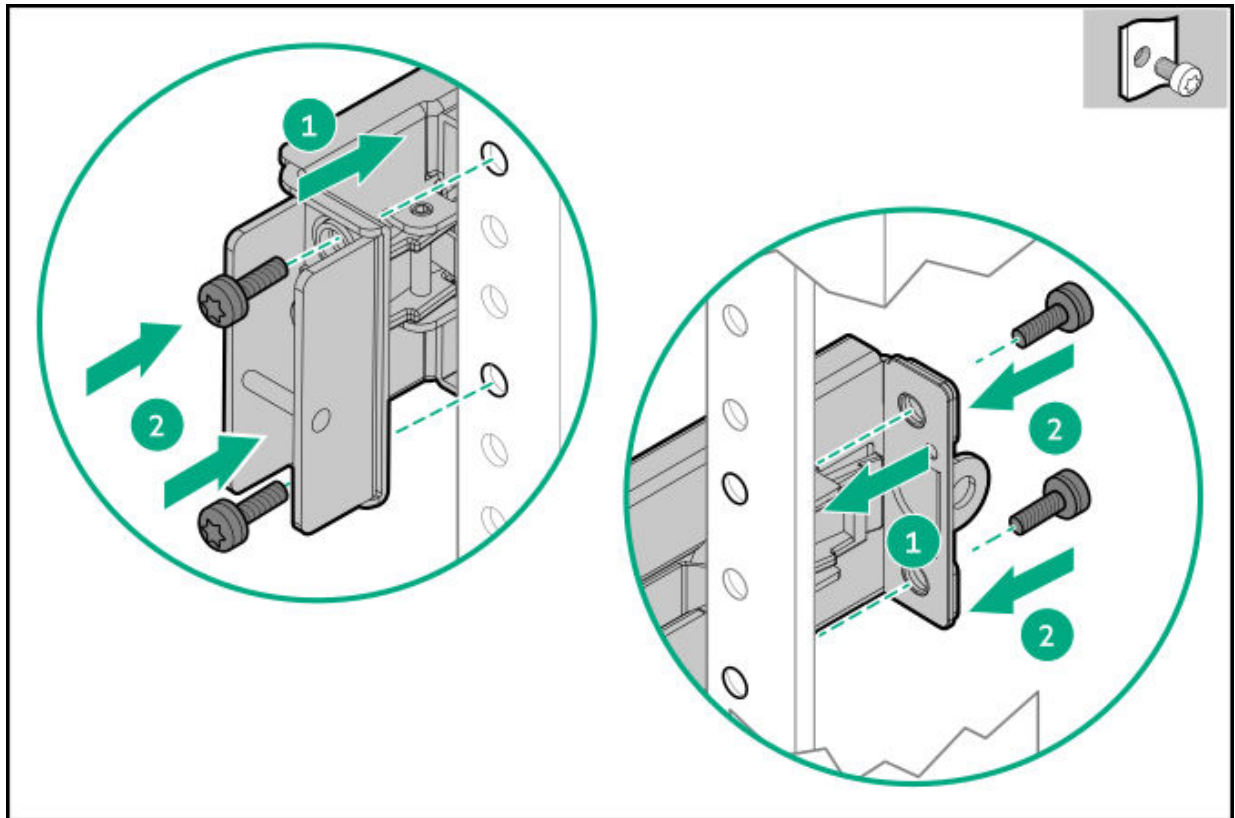

5. Install the server into the rack.

Installing the server into the rack

Prerequisites

- Before you perform this procedure, review the:
 - [Space and airflow requirements](#)
 - [Rack warnings and cautions](#)
 - [Server warnings and cautions](#)
- A fully populated server is heavy. Hewlett Packard Enterprise recommends removing the external chassis components before installing the server into a rack.
- Before you perform this procedure, make sure that you have a T-25 Torx screwdriver available.

Procedure

1. Install the server into the rack.

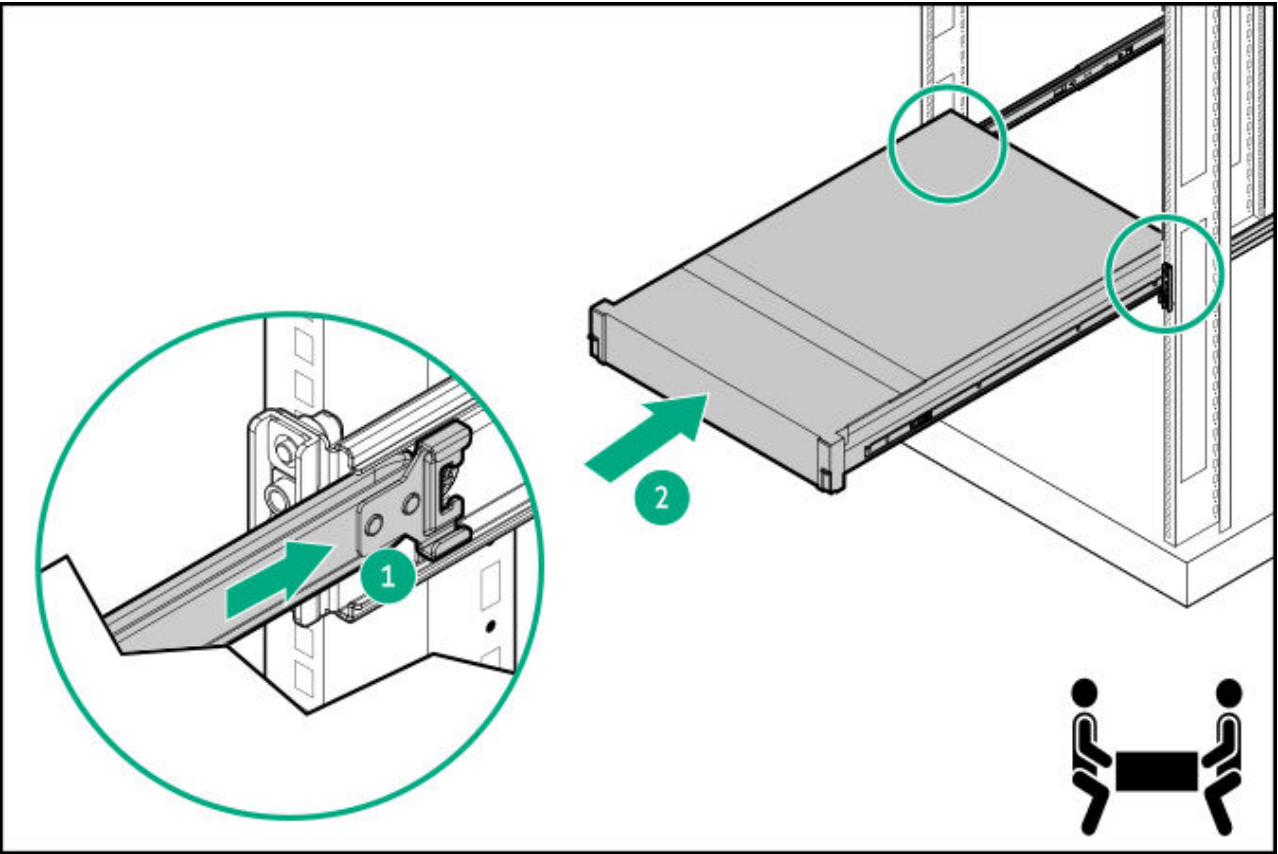

2. Tighten the shipping screws.

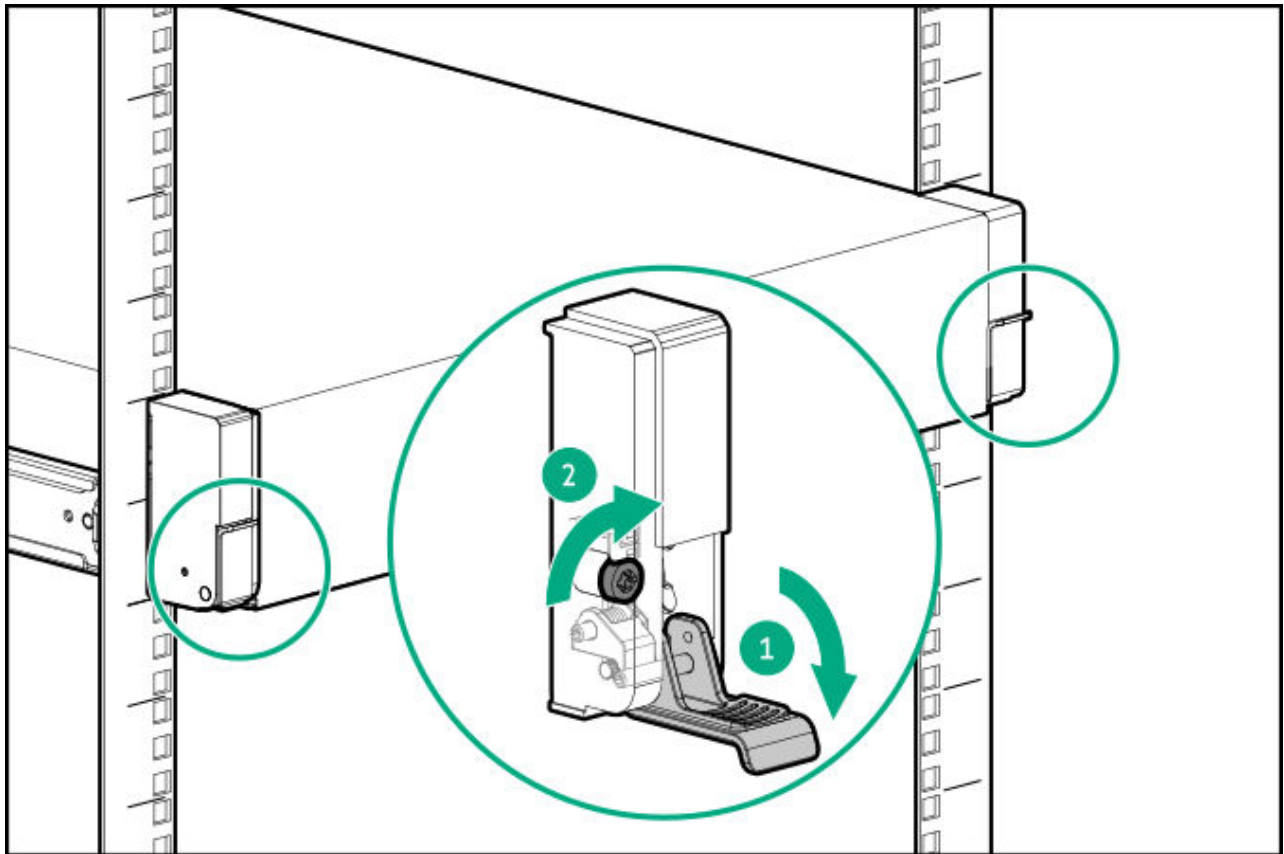

3. Connect all peripheral cables to the server.
4. Connect the power cords:
 - a. Connect each power cord to the server.
 - b. Connect each power cord to the power source.

Installing the rack rail hook-and-loop strap

About this task

The hook-and-loop strap can be installed on either the left or right rail.

Procedure

1. Attach the strap carabiner to the rail.
2. Bundle the cords and cables, and then wrap the strap around the cables.



Results

The installation procedure is complete.

Preparing the cable management arm

About this task

The management arm can be installed to swing out from the left or right side of the rack. Before installing, rotate the elbow bracket according to your configuration.



NOTE

Your bracket might look different than the image below, but the procedure is the same.

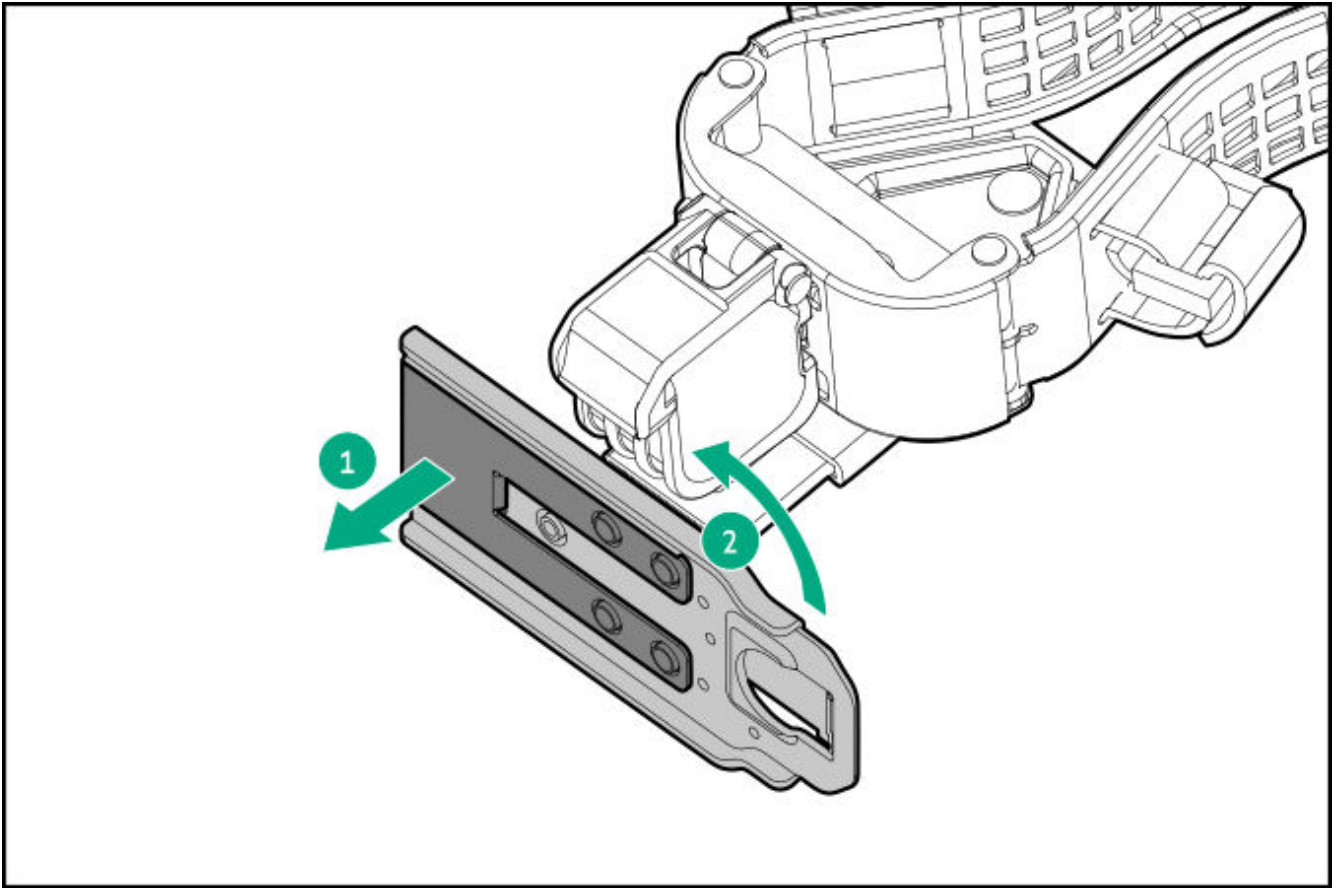

Installing the cable management arm

About this task

Your management arm might look slightly different, but the procedures are the same.

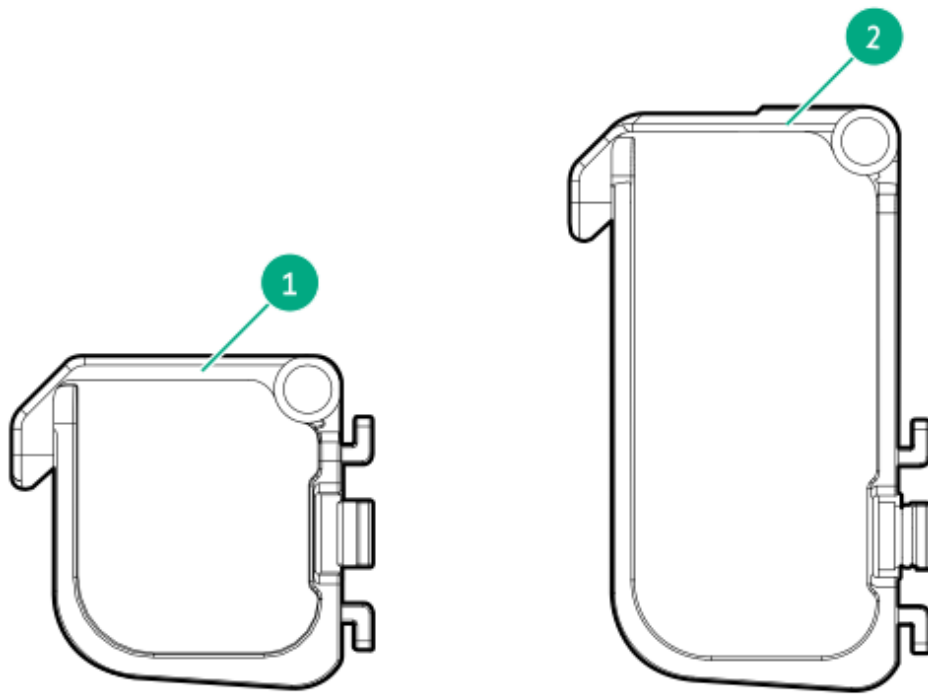

Item	Description
1	1U CMA cable basket
2	2U CMA cable basket

CAUTION
 To reduce the risk of personal injury, be careful when pressing the cable management or rail-release latches. The rails or latches could pinch your fingers.

Procedure

1. Connect any cables and power cords to the rear of the server.
2. Install the CMA brackets to the inner and outer rails.

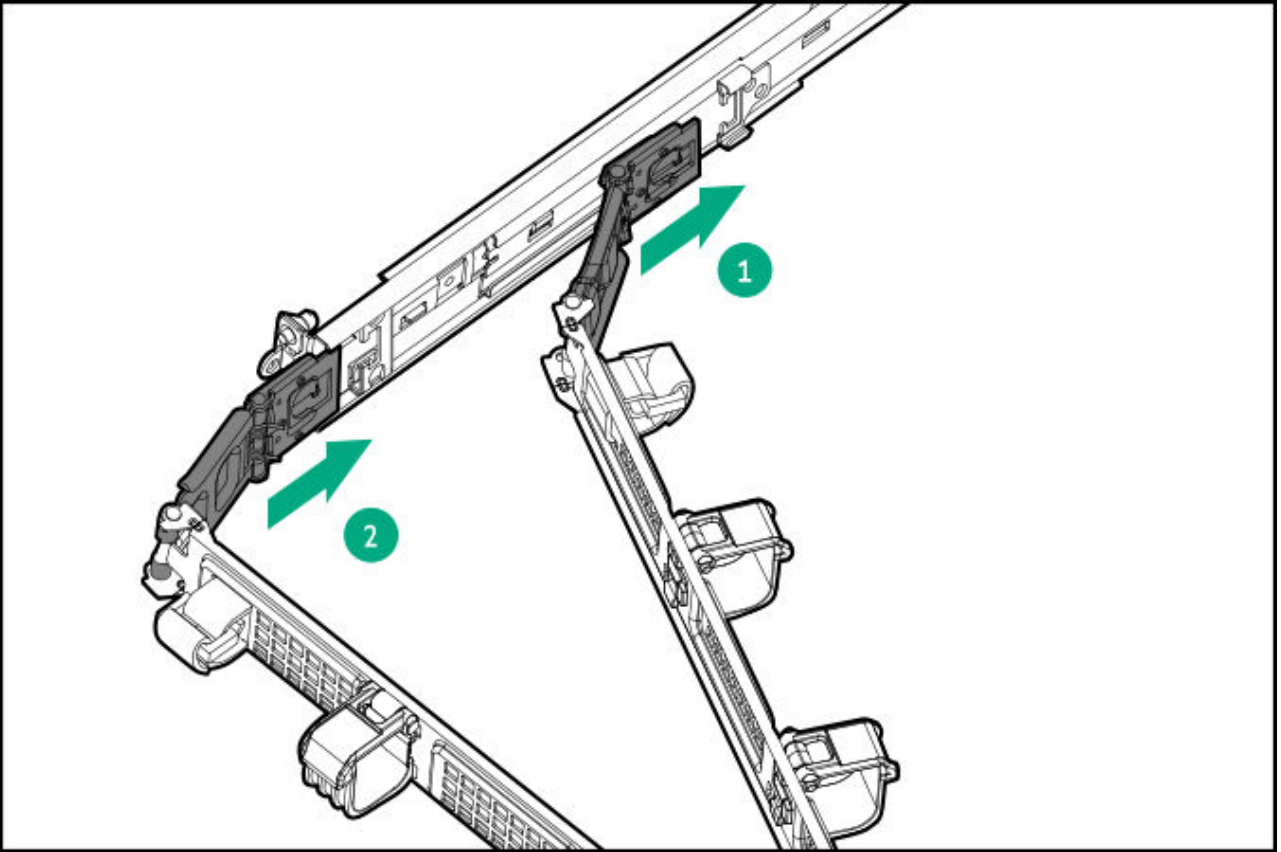

3. Open the straps and cable baskets.

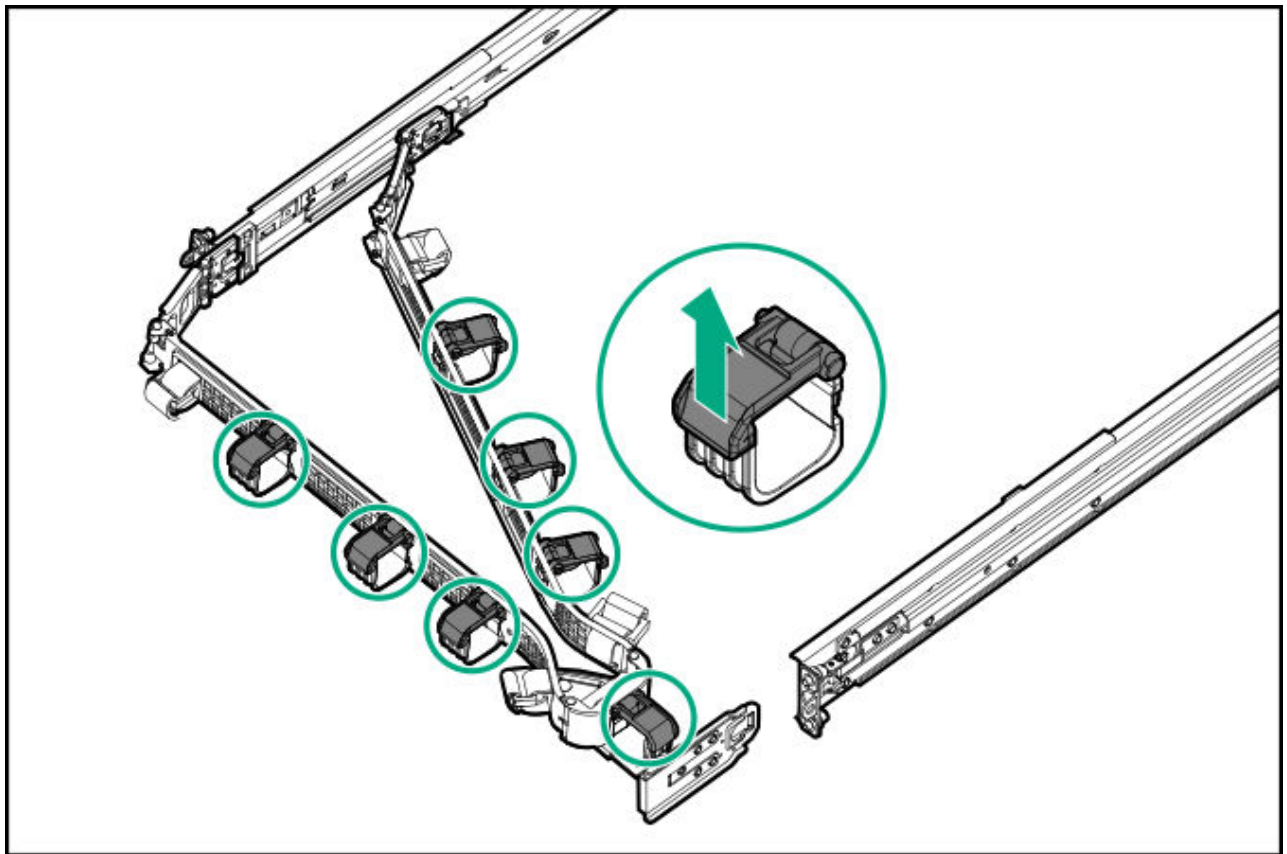
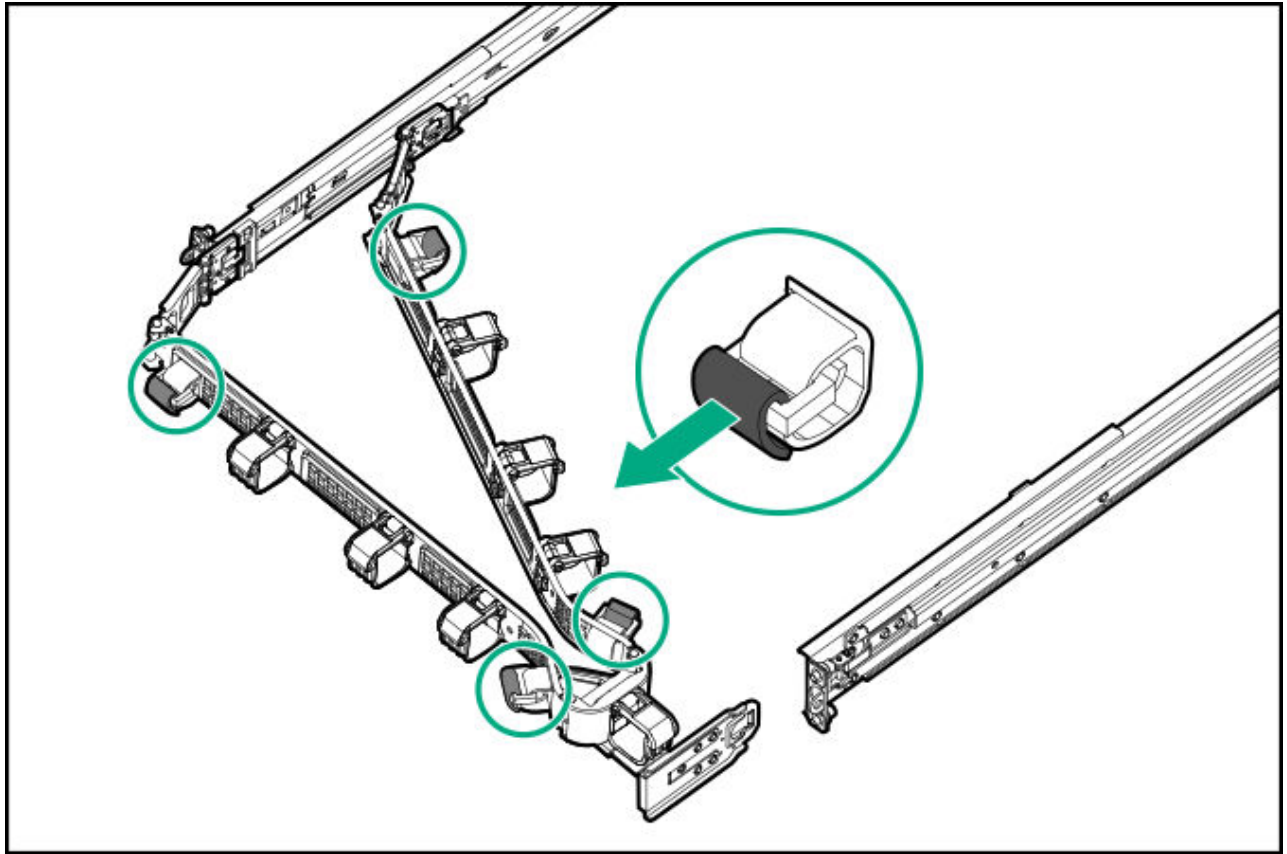

4. Install the cables.

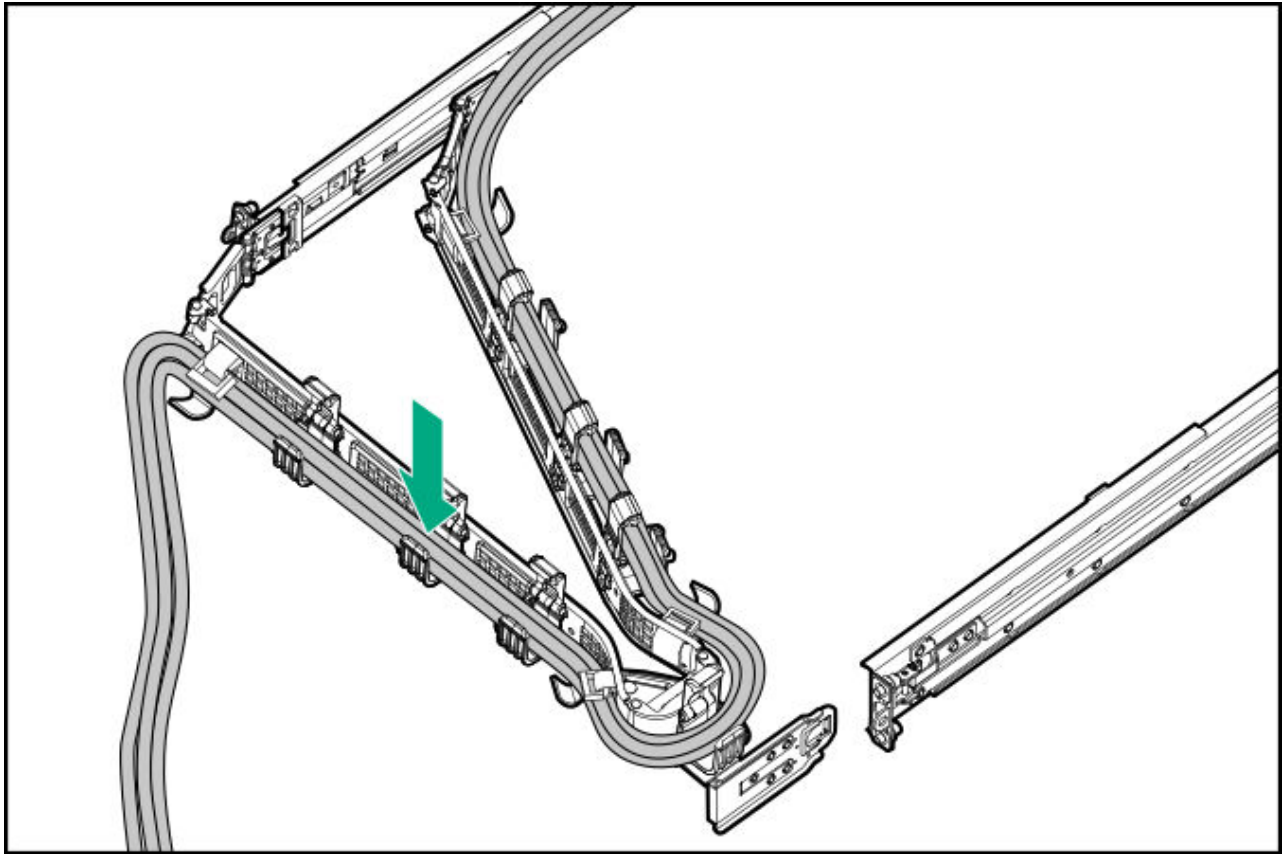

5. Close the baskets and secure the straps.

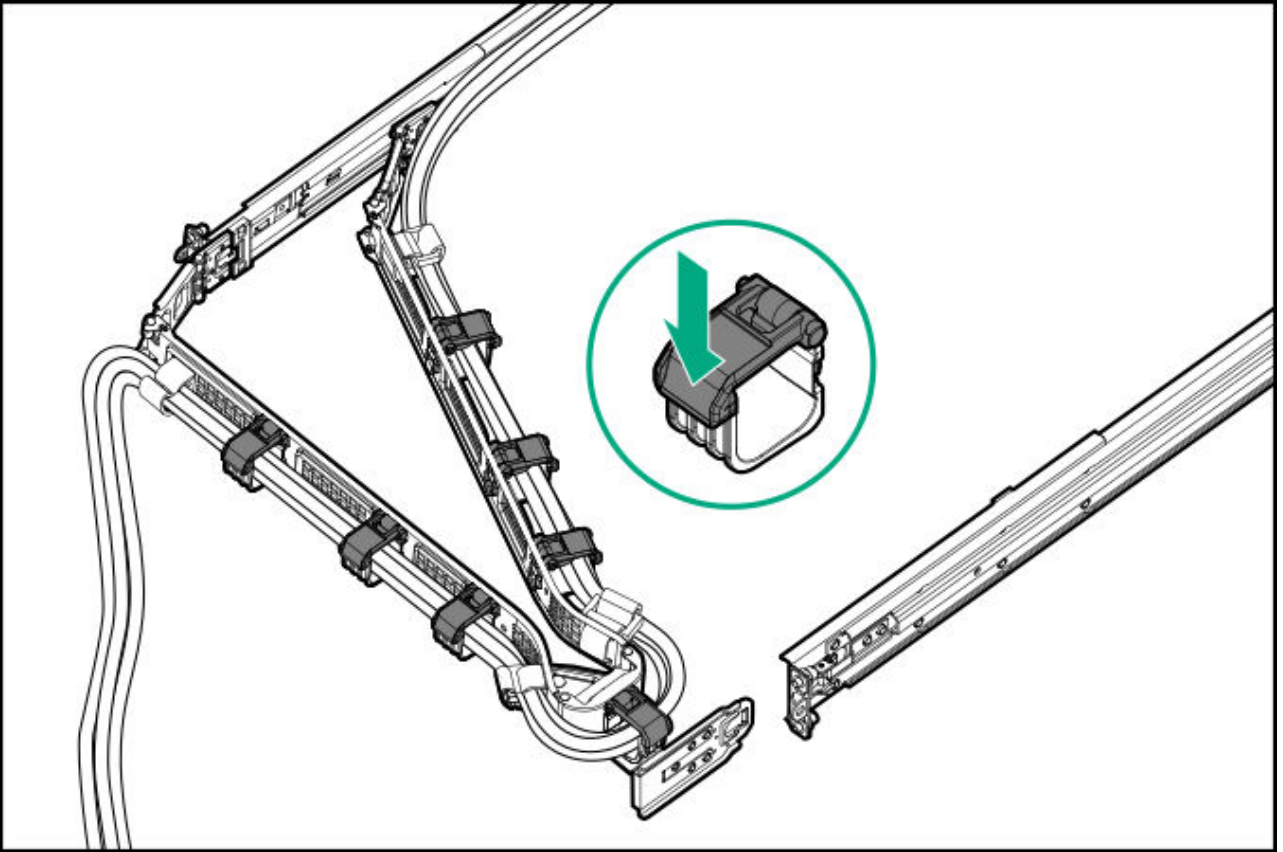

6. Install the elbow bracket to the outer rail.

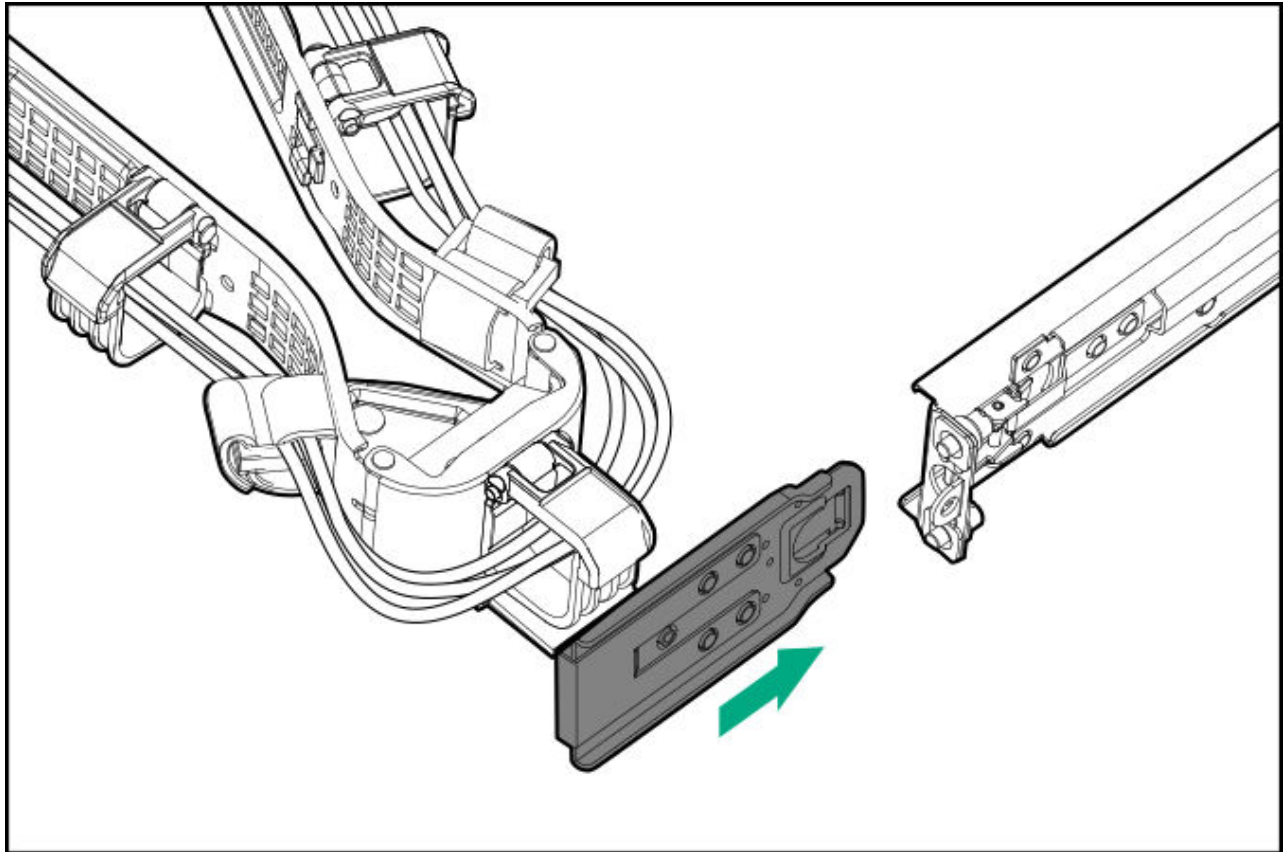

Results

The installation is complete.

Risers and riser cages

Subtopics

[Installing expansion boards](#)

[Installing a secondary riser cage](#)

[Installing a tertiary riser cage](#)

[Installing a rear 2 SFF riser cage](#)

[Installing a rear 2LFF riser cage](#)

[Installing primary and secondary risers](#)

[Installing tertiary risers](#)

Installing expansion boards

Prerequisites

Before you perform this procedure, make sure that you have the following items available:

The components included with the hardware option kit

About this task



WARNING

To reduce the risk of personal injury, electric shock, or damage to the equipment, remove the power cord to remove power from the server. The front panel Power On/Standby button does not shut off system power. Portions of the power supply and some internal circuitry remain active until AC power is removed.



CAUTION

To prevent improper cooling or thermal damage, do not operate the server unless all PCI slots have either an expansion slot cover or an expansion board installed.

To install the component:

Procedure

1. Power down the server.
2. Remove all power:
 - a. Disconnect each power cord from the power source.
 - b. Disconnect each power cord from the server.
3. Do one of the following:
 - Extend the server from the rack.
 - Remove the server from the rack.
4. Remove the access panel.
5. Remove the riser cage.

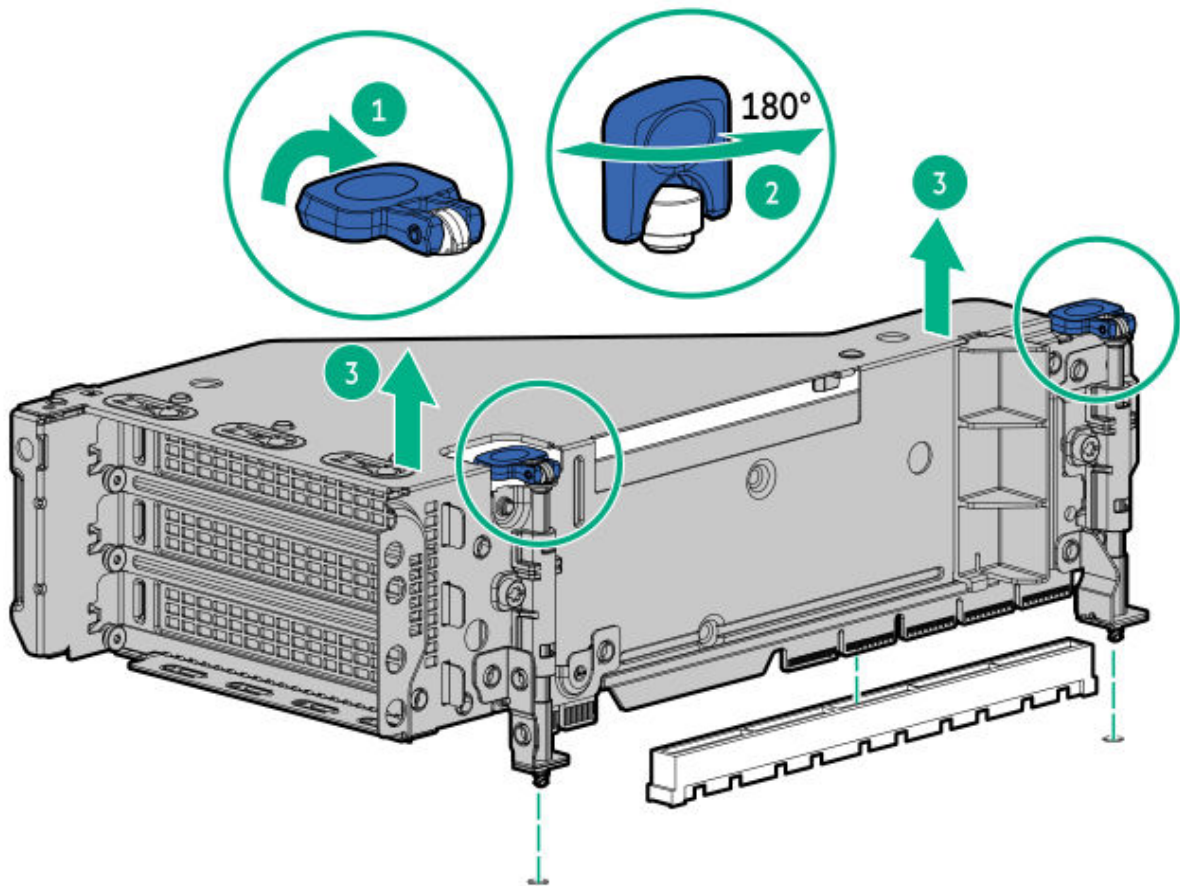

6. Identify and then remove the PCIe blank from the riser cage.

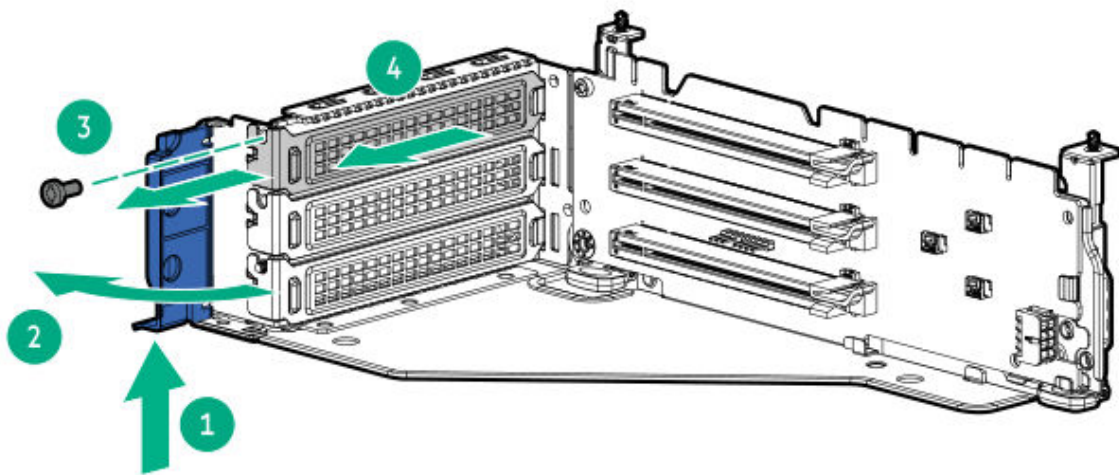

7. Install the expansion board.

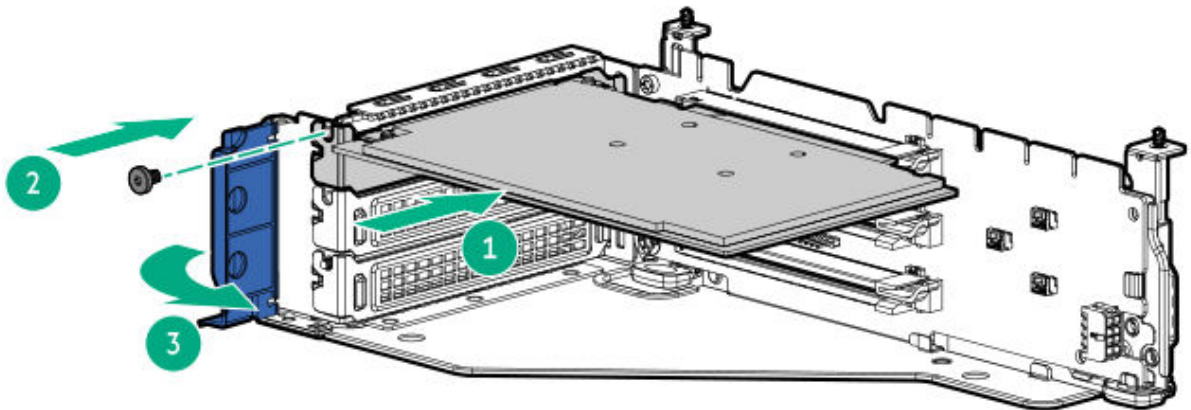

8. Install the riser cage.

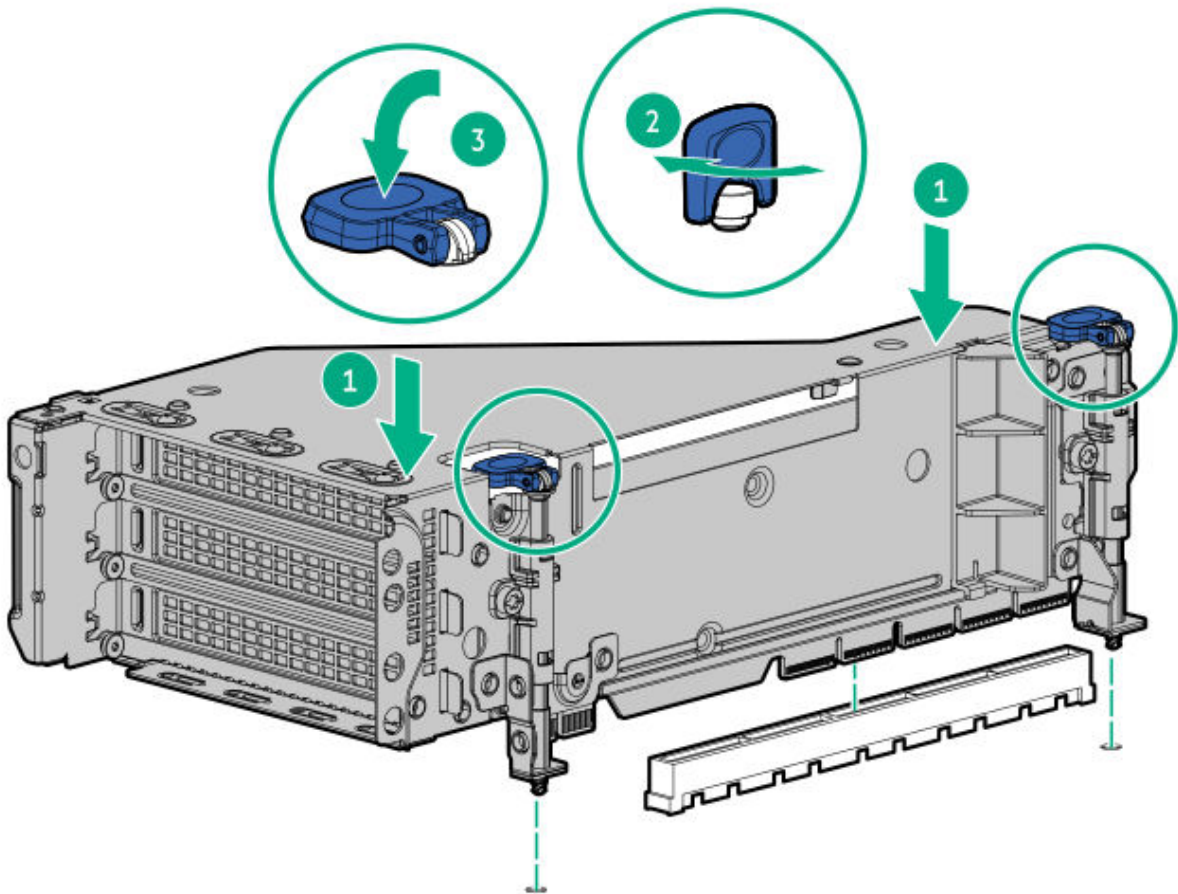

9. Connect the cables.

- .0. Install the access panel.
- .1. Slide the server into the rack.
- .2. Connect each power cord to the server.
- .3. Connect each power cord to the power source.
- .4. Power up the server.

Results

The installation is complete.

Installing a secondary riser cage

Prerequisites

Before you perform this procedure, make sure that you have the following items available:

- The components included with the hardware option kit
- T-10 Torx screwdriver

Procedure

1. Observe the following alert:



CAUTION

To prevent damage to the server or expansion boards, power down the server and remove all AC power cords before removing or installing the PCI riser cage.

2. Power down the server.
3. Remove all power:
 - a. Disconnect each power cord from the power source.
 - b. Disconnect each power cord from the server.
4. Do one of the following:
 - Extend the server from the rack.
 - Remove the server from the rack.

5. Remove the access panel.
6. Remove the rear wall blank.

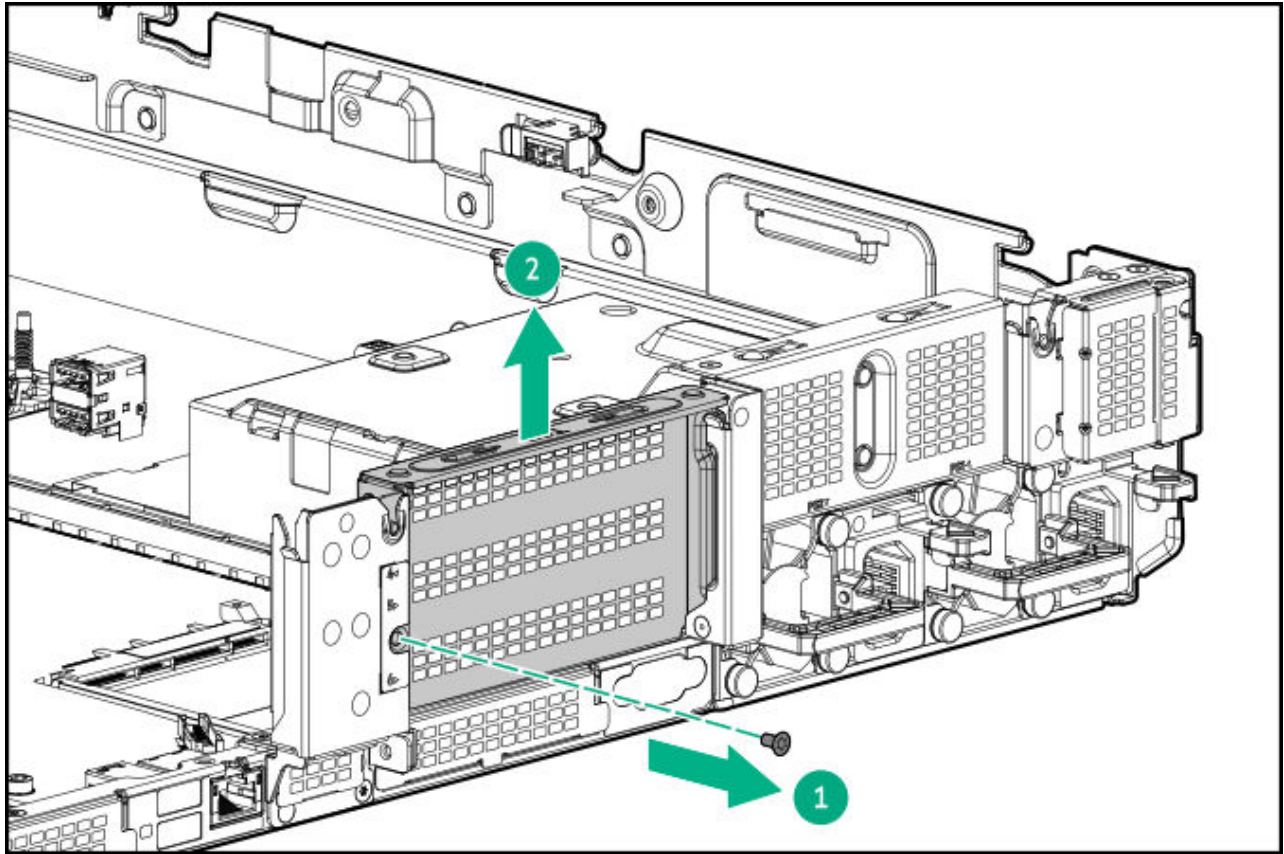

7. Install any expansion boards, if needed.
8. Install the riser cage.

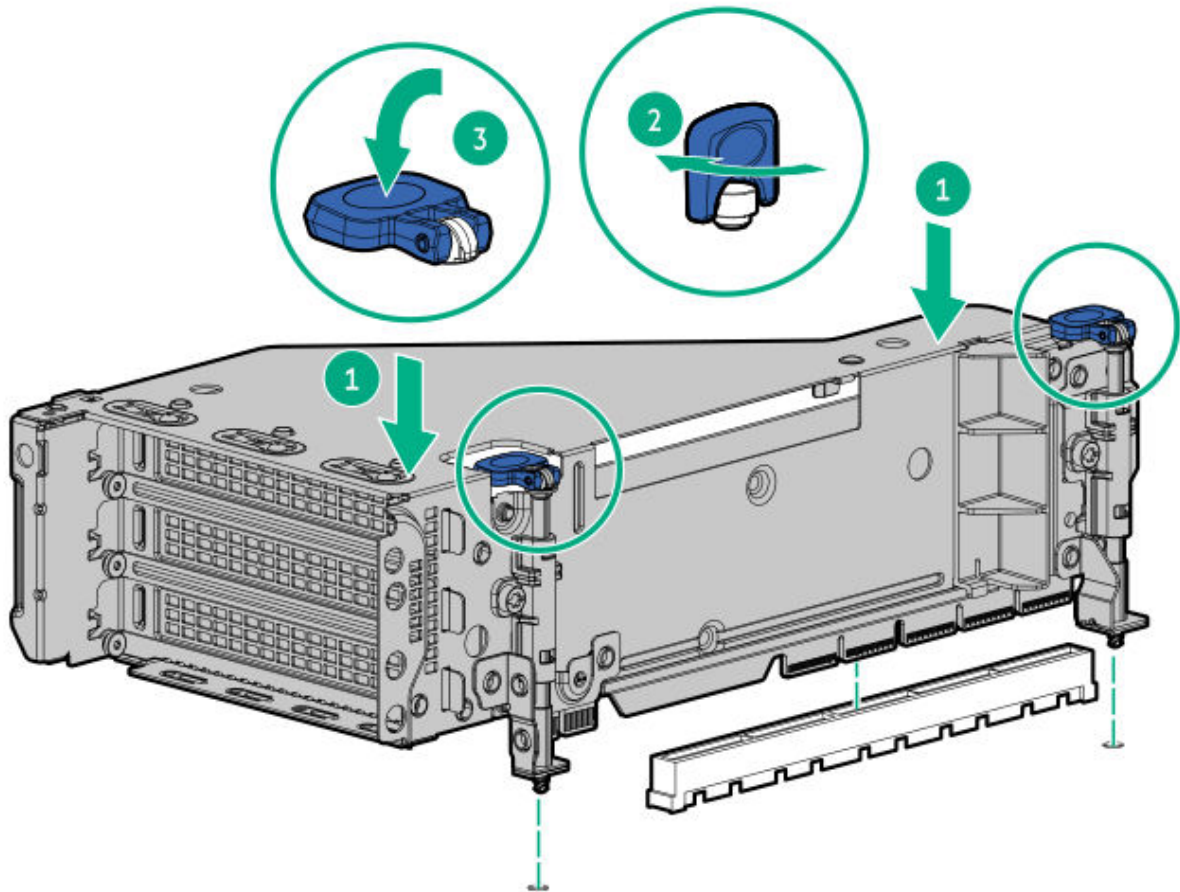

9. Install the access panel.
10. Slide the server into the rack.
11. Connect each power cord to the server.
12. Connect each power cord to the power source.
13. Power up the server.

Results

The installation is complete.

Installing a tertiary riser cage

Prerequisites

Before you perform this procedure, make sure that you have the following items available:

- The components included with the hardware option kit
- T-10 Torx screwdriver

Procedure

1. Observe the following alert.



CAUTION

To prevent damage to the server or expansion boards, power down the server and remove all AC power cords before removing or installing the PCI riser cage.

2. Power down the server.
3. Do one of the following:
 - Disconnect each power cord from the power source.
 - Disconnect each power cord from the server.
4. Do one of the following:
 - Extend the server from the rack.
 - Remove the server from the rack.
5. Remove the access panel.
6. Remove the rear wall blanks.

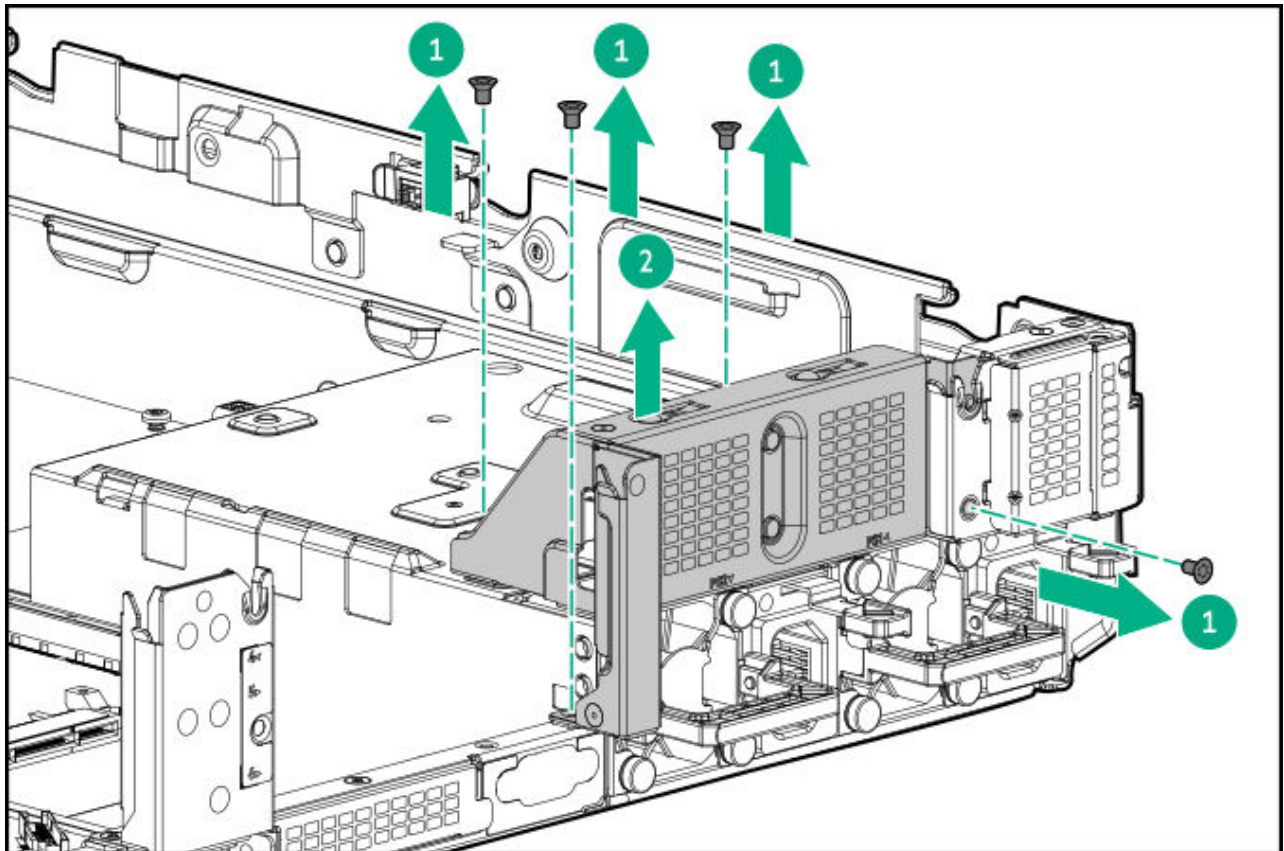
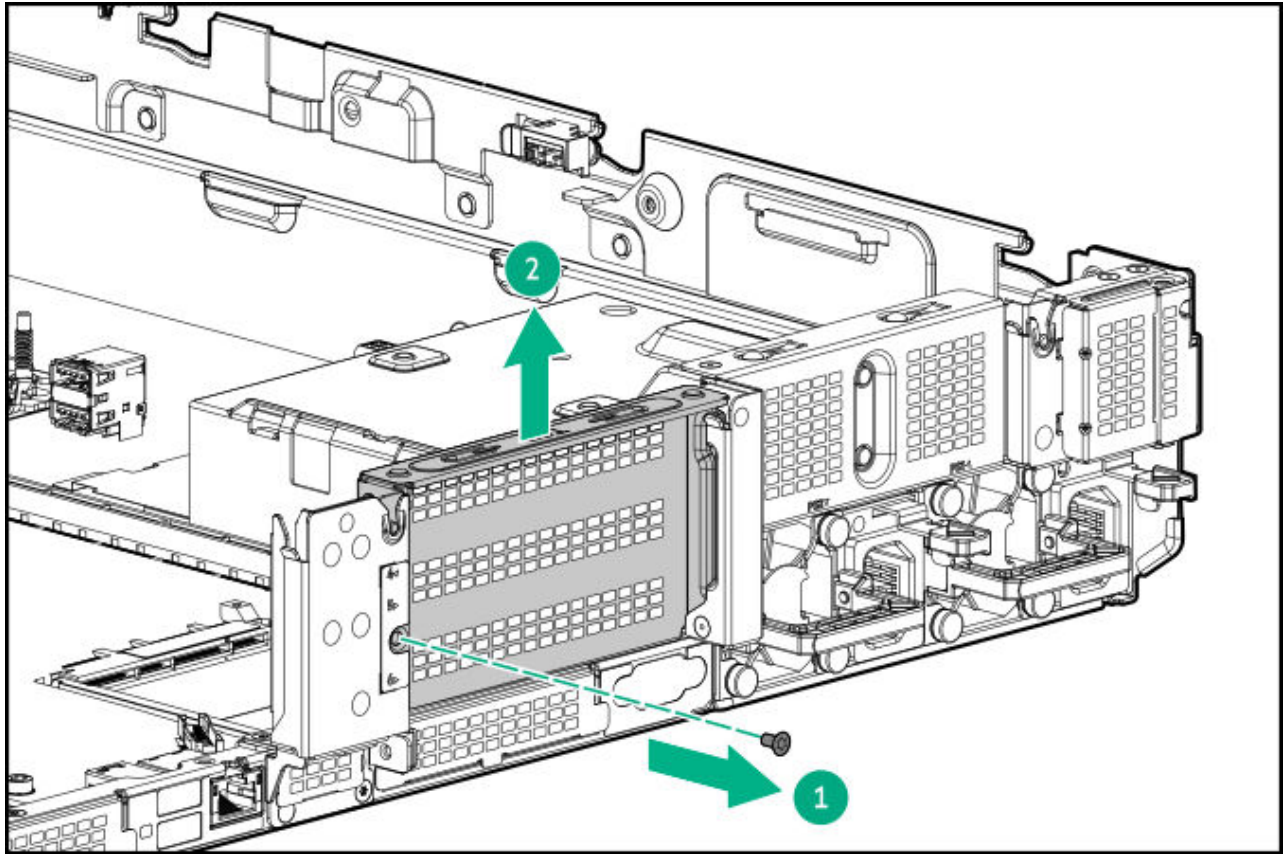

7. Install any expansion boards, if needed
8. Install the tertiary riser cage:

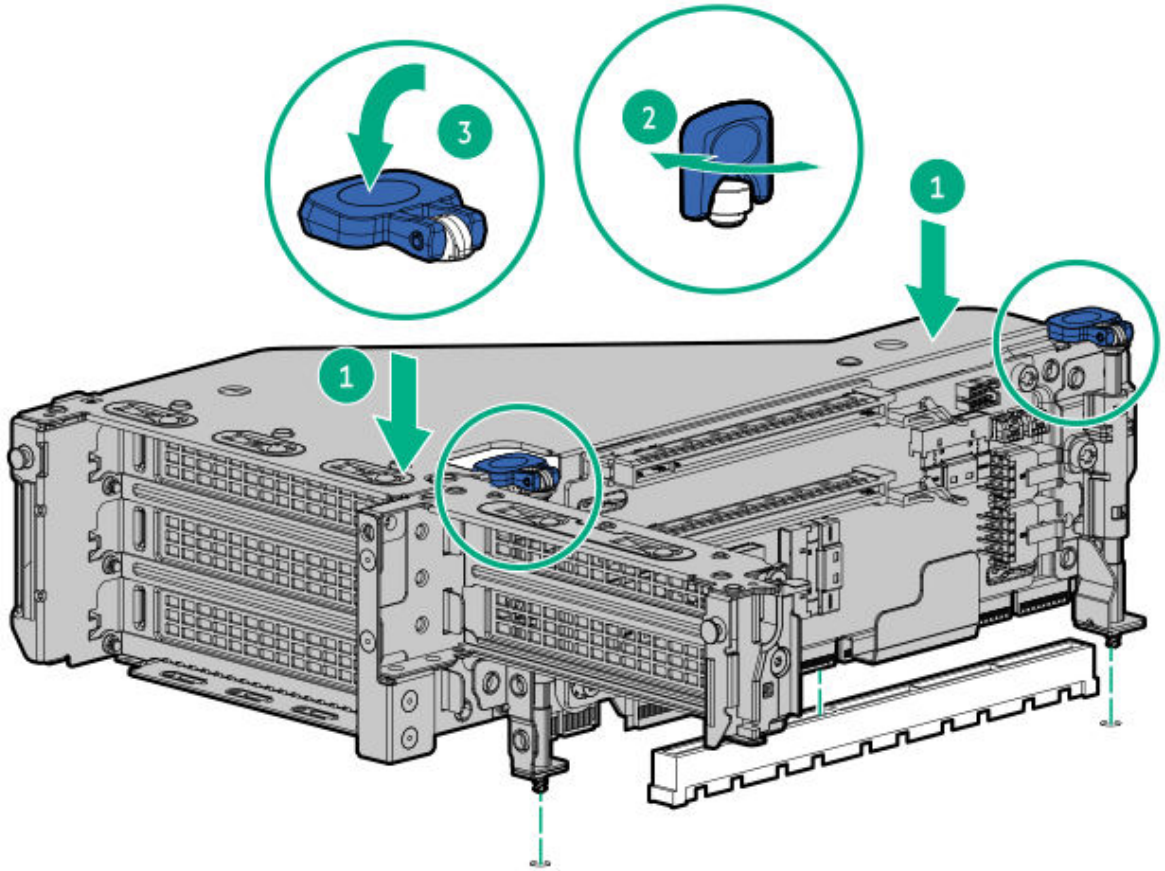

Results

The installation is complete.

Installing a rear 2 SFF riser cage

Prerequisites

Before you perform this procedure, make sure that you have the following items available:

- T-10 Torx screwdriver
- The components included with the hardware option kit

- The front drive bays are fully populated with 12 LFF or 24 SFF drives.
- High-performance fans are installed in all fan bays.

Procedure

1. Power down the server.
2. Remove all power:
 - a. Disconnect each power cord from the power source.
 - b. Disconnect each power cord from the server.
3. Do one of the following:
 - Extend the server from the rack.
 - Remove the server from the rack.
4. Remove the access panel.
5. Do one of the following:
 - For primary bays, remove the riser cage.

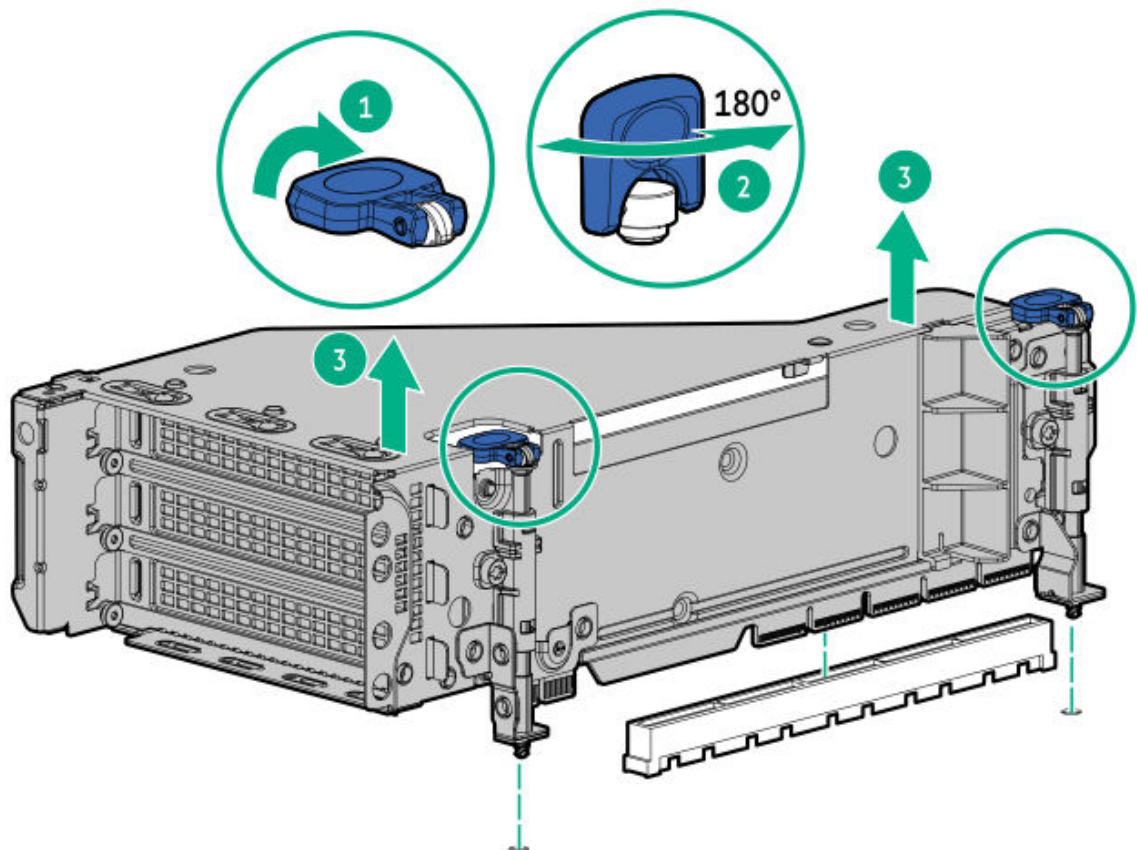

- For secondary bays, remove the rear wall blank.

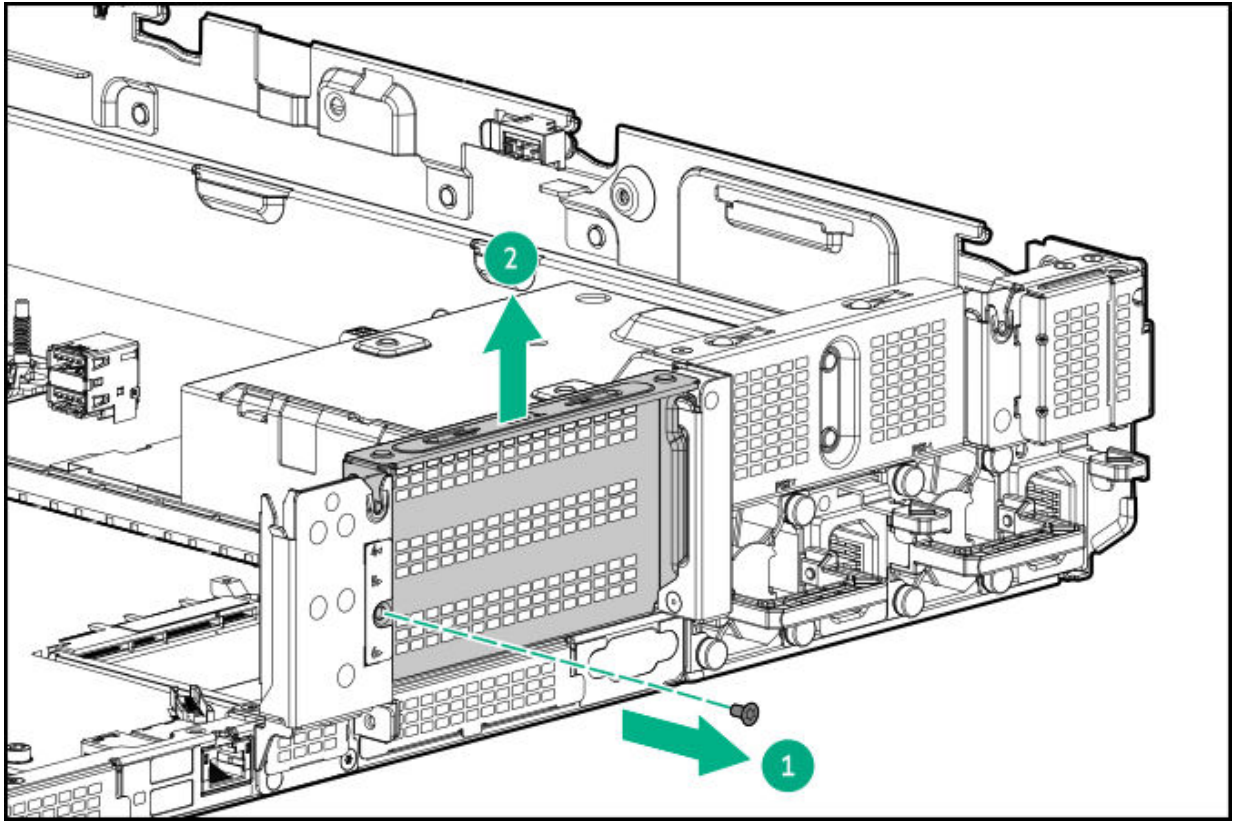

6. Install the drive cage.

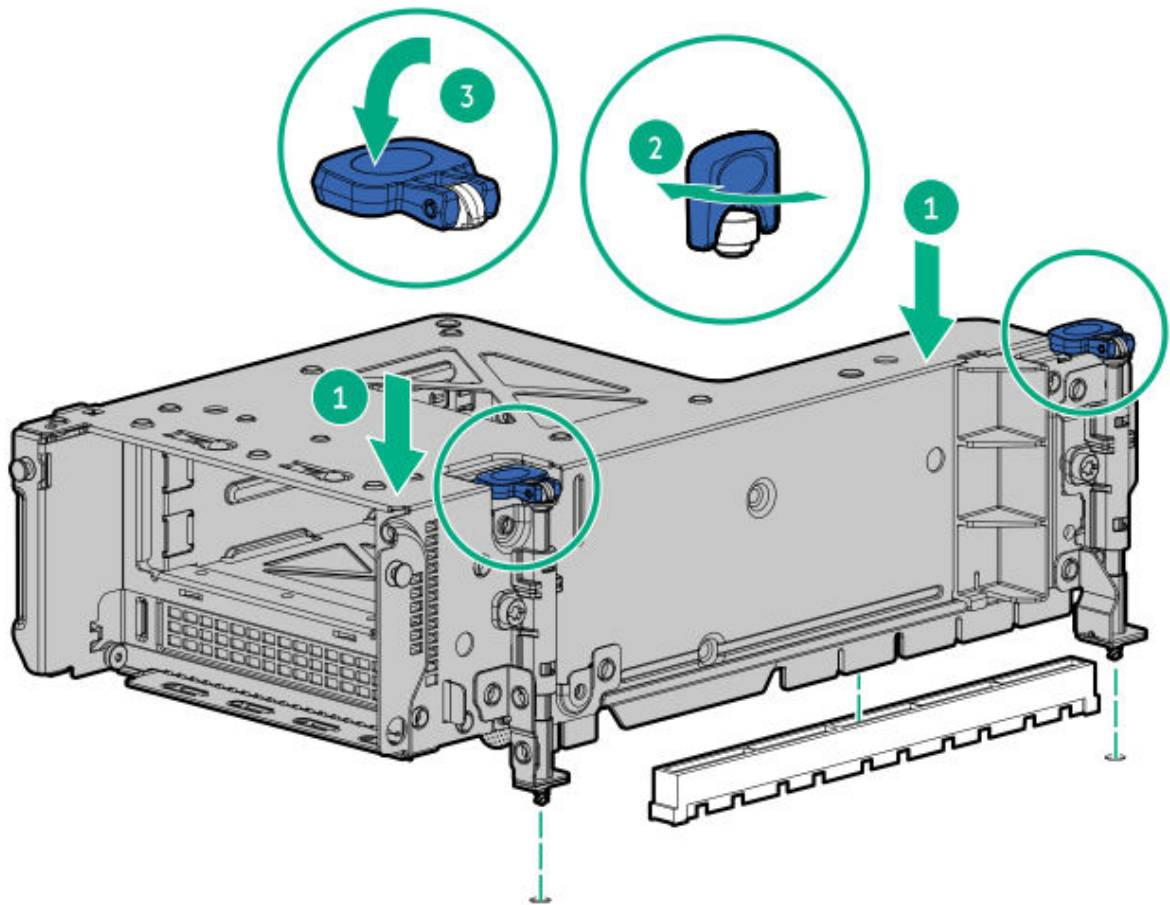

7. Install the drives.
8. Connect the drive backplane cables to the controller.
9. Install the access panel.
0. Slide the server into the rack.
- .1. Connect each power cord to the server.
- .2. Connect each power cord to the power source.
- .3. Power up the server.

Results

The installation is complete.

Installing a rear 2LFF riser cage

Prerequisites

Before you perform this procedure, make sure that you have the following items available:

- T-10 Torx screwdriver
- The components included with the hardware option kit
- The front drive bays are fully populated with 12 LFF or 24 SFF drives.
- High performance fans are installed in all fan bays.

Procedure

1. Power down the server.
2. Remove all power:
 - a. Disconnect each power cord from the power source.
 - b. Disconnect each power cord from the server.
3. Do one of the following:
 - Extend the server from the rack.
 - Remove the server from the rack.
4. Remove the access panel.
5. Do one of the following:
 - For primary bays, remove the riser cage.

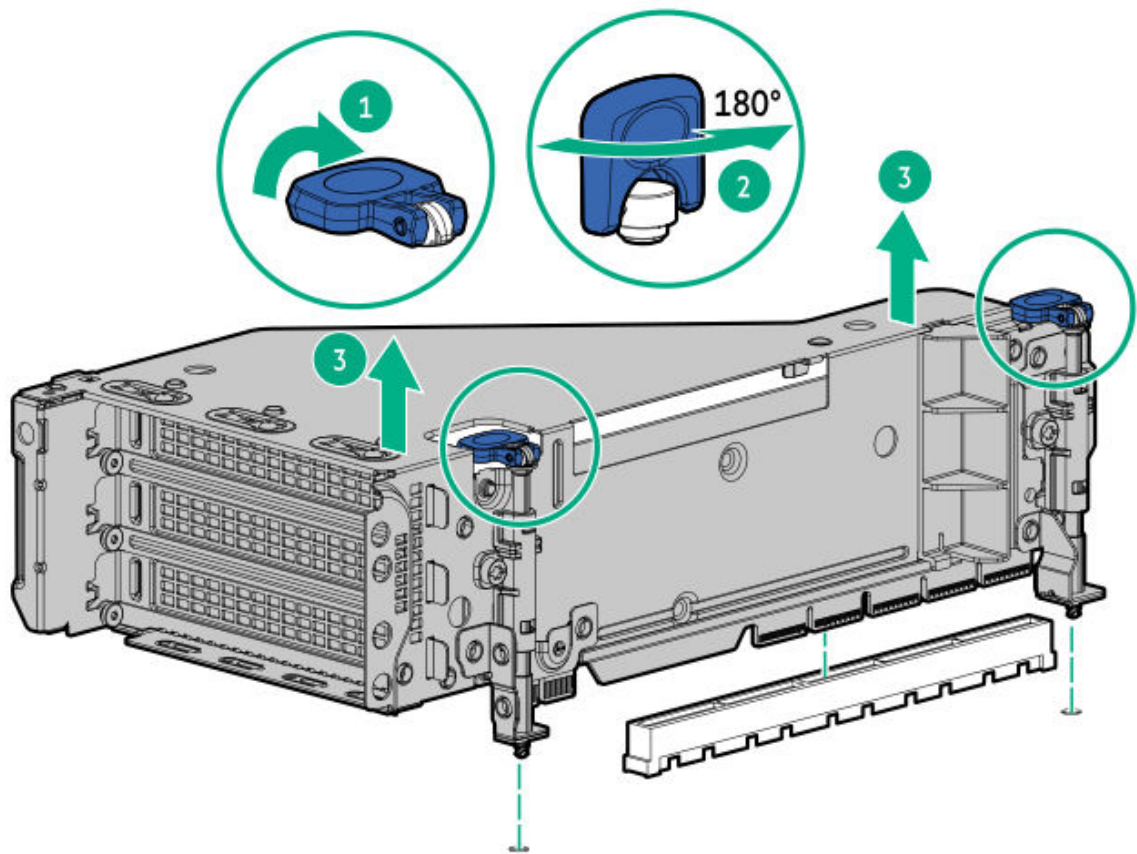

- For secondary riser cages, remove the rear wall blank.

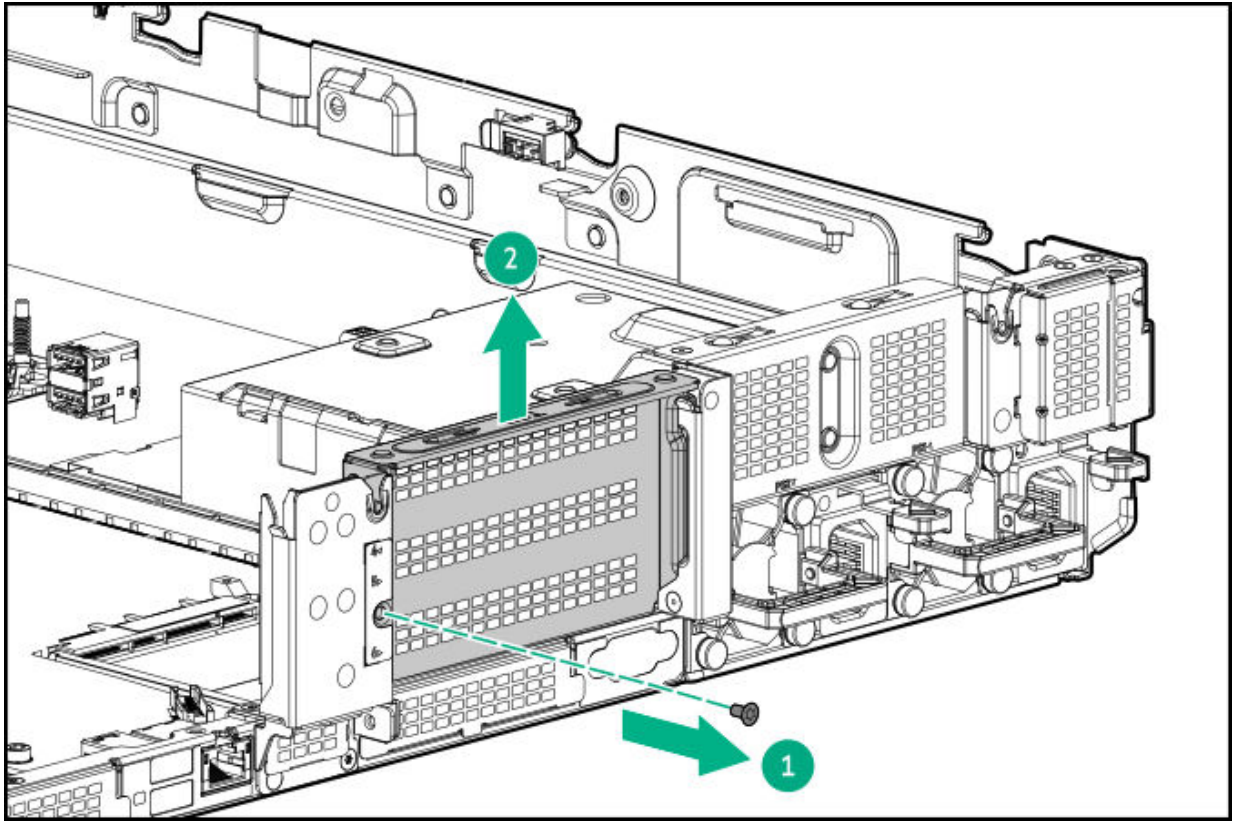

6. Install the drive cage.

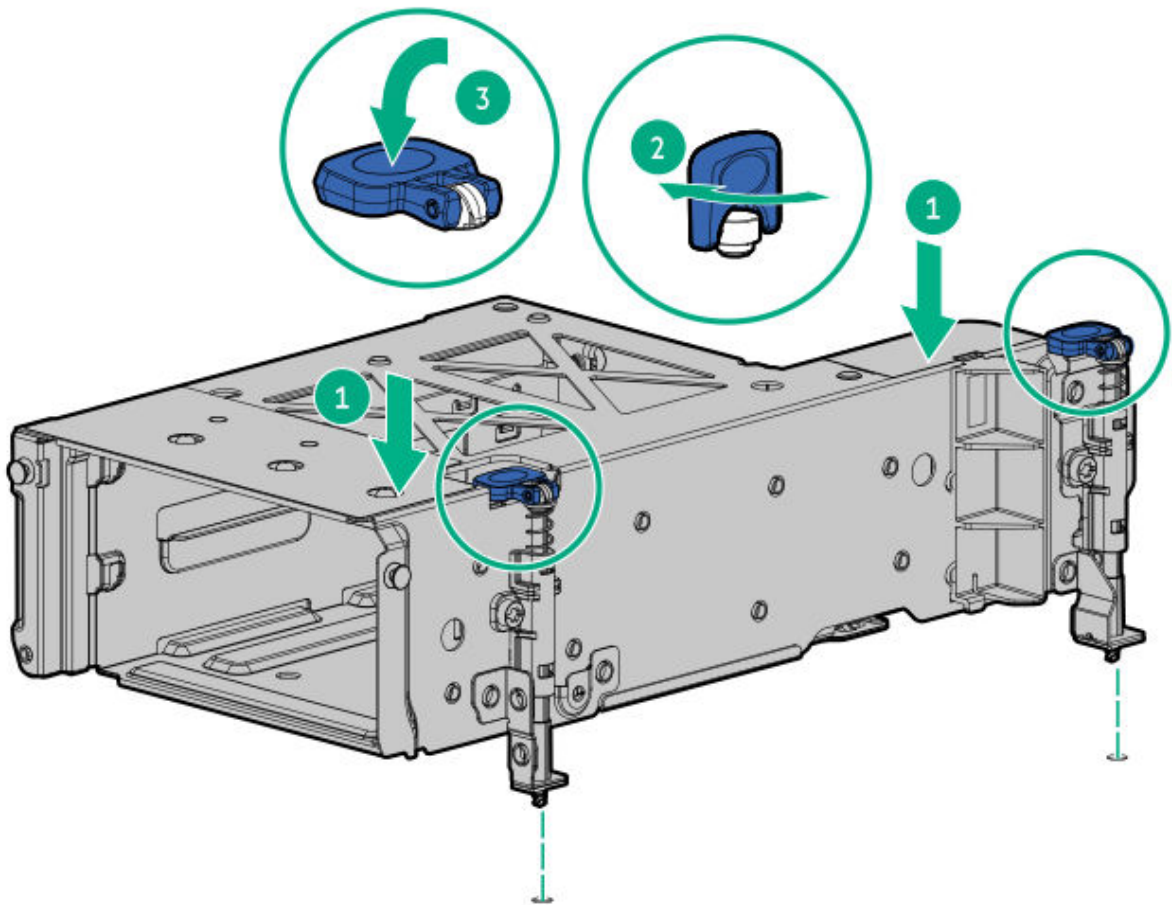

7. Connect the backplane cables.
8. Install the drives.
9. Install the access panel.
0. Return the server to the rack.
- .1. Connect each power cord to the server.
- .2. Connect each power cord to the power source.
- .3. Power up the server.

Results

The installation is complete.

Installing primary and secondary risers

Prerequisites

Before you perform this procedure, make sure that you have the following items available:

- The components included with the hardware option kit
- T-10 Torx screwdriver

Procedure

1. Power down the server.
2. Do one of the following:
 - Disconnect each power cord from the power source.
 - Disconnect each power cord from the server.
3. Do one of the following:
 - Extend the server from the rack.
 - Remove the server from the rack.
4. Remove the access panel.
5. Remove the riser cage.
6. Remove the riser board.

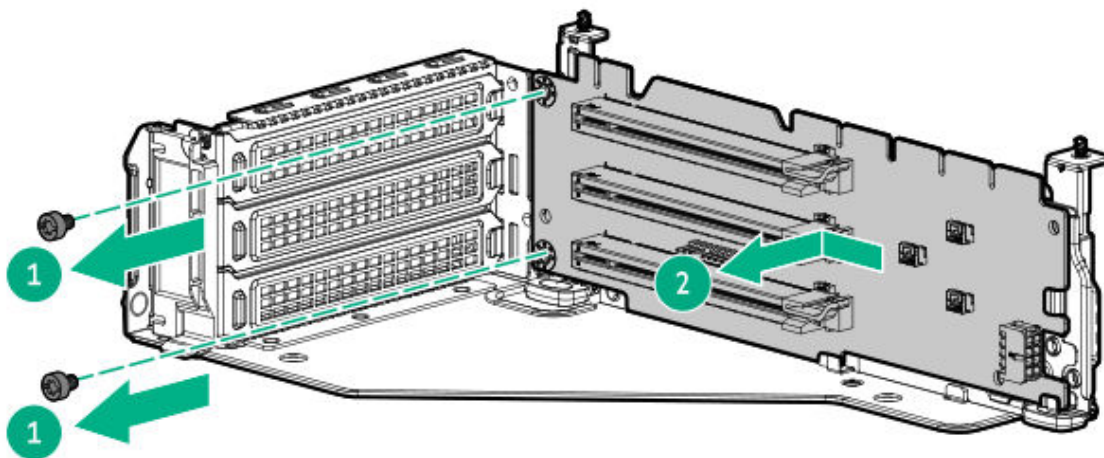

7. Install the riser.

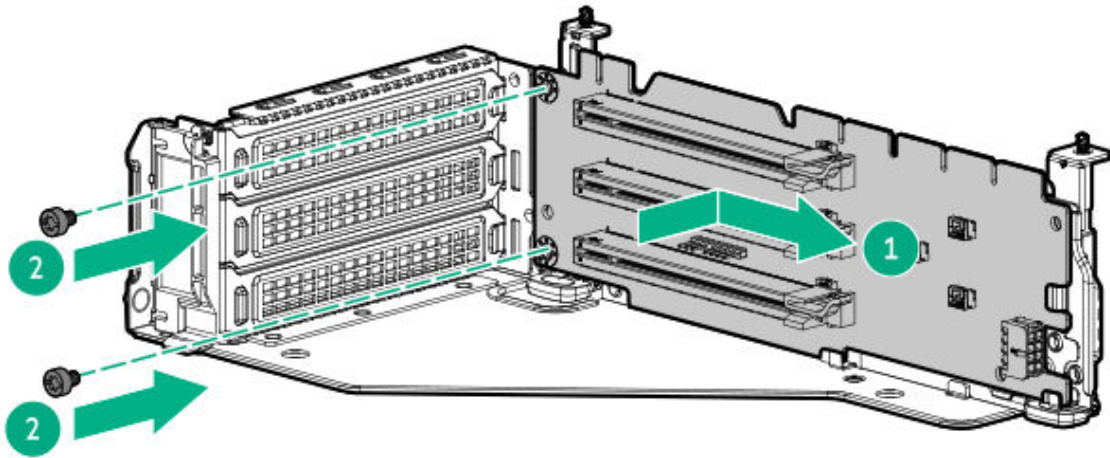

8. If needed, install an expansion board.

9. If needed, connect data cables to the riser or expansion board.

10. Install the riser cage.

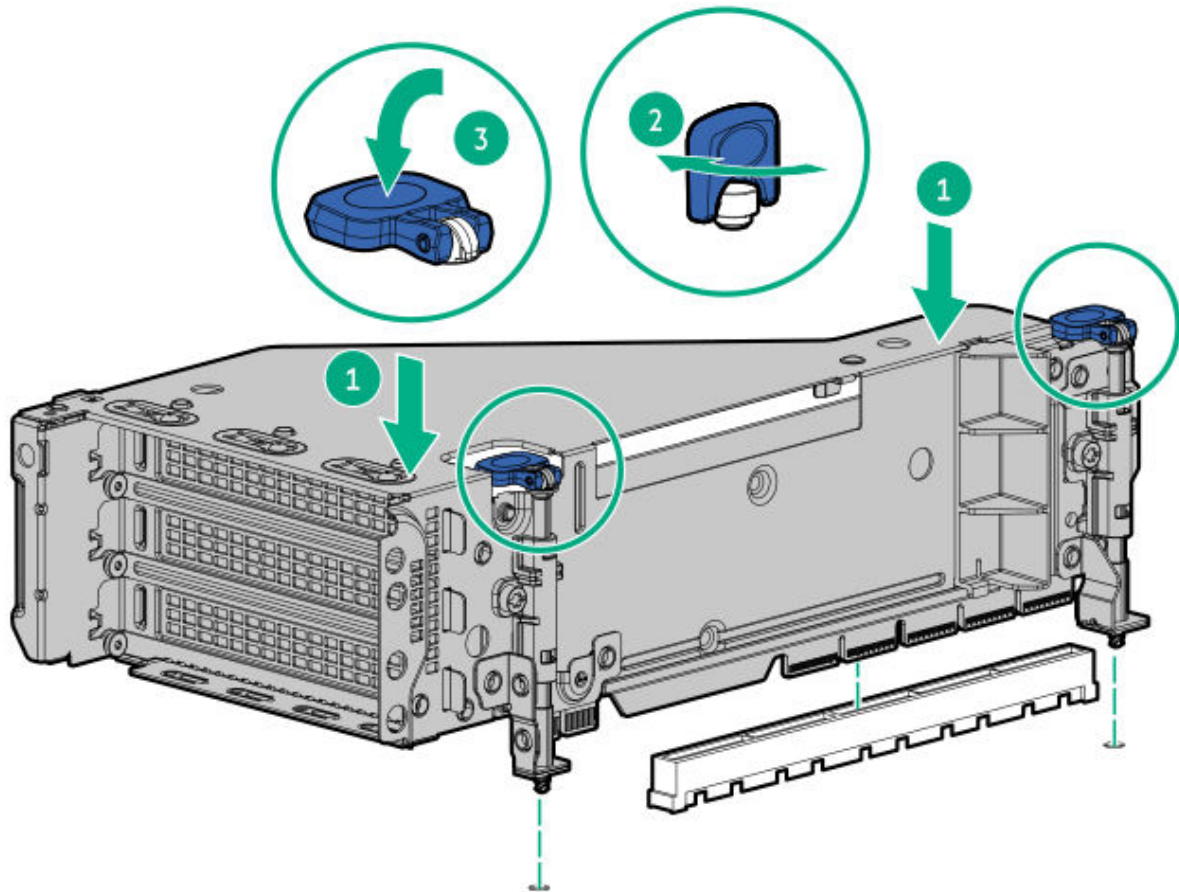

- .1. Install the access panel.
- .2. Slide the server into the rack.
- .3. Connect each power cord to the server.
- .4. Connect each power cord to the power source.
- .5. Power up the server.

Results

The installation is complete.

Installing tertiary risers

Prerequisites

Before you perform this procedure, make sure that you have the following items available:

- The components included with the hardware option kit
- T-10 Torx screwdriver
- A tertiary riser cage is required to install this option.

Procedure

1. Power down the server.
2. Do one of the following:
 - Disconnect each power cord from the power source.
 - Disconnect each power cord from the server.
3. Do one of the following:
 - Extend the server from the rack.
 - Remove the server from the rack.
4. Remove the access panel.
5. Remove the riser cage.
6. Install the riser.

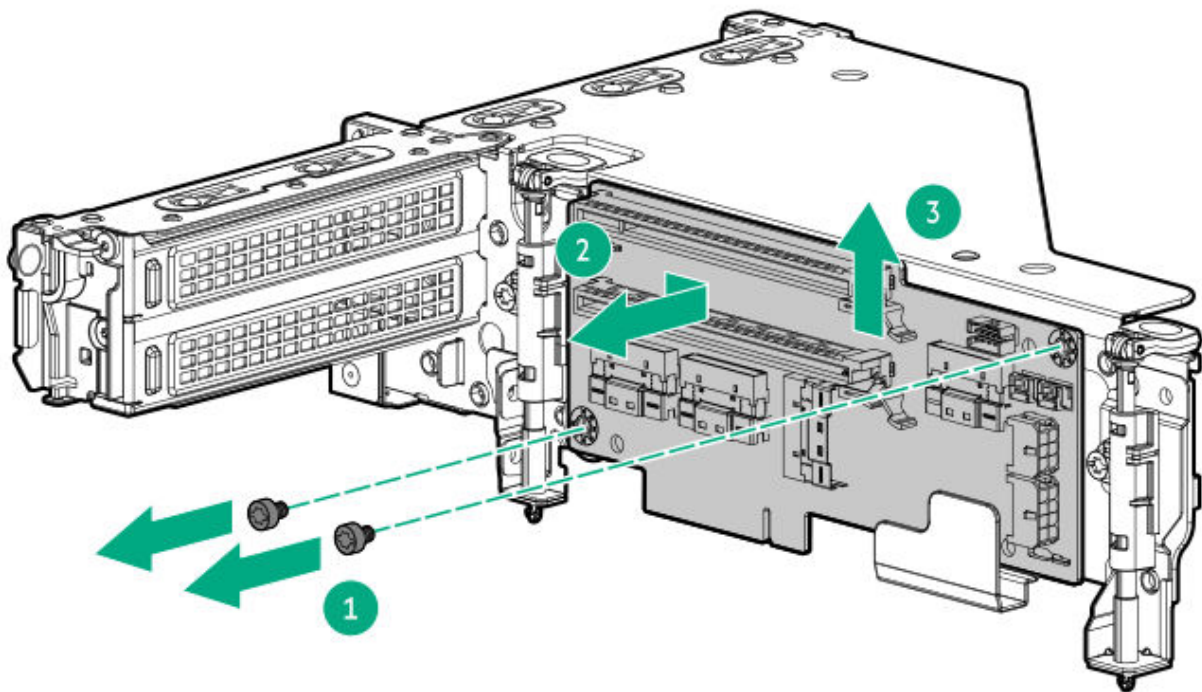

7. If needed, install an expansion board.
8. If needed, connect data cables to the riser or expansion board.
9. Install the tertiary riser cage:

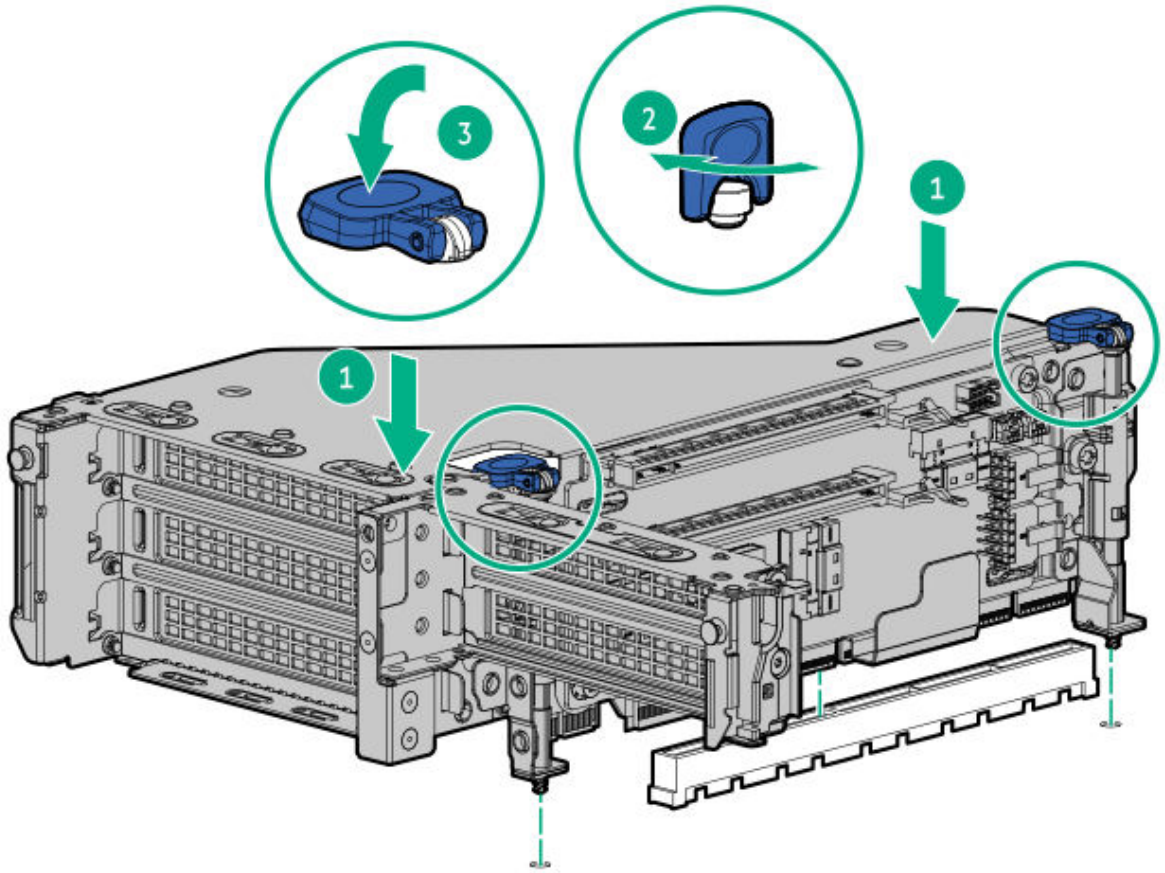

Results

The installation is complete.

Security

Subtopics

[Installing the bezel](#)

[Installing the chassis intrusion detection switch](#)

Installing the bezel

Results

Install the front bezel.

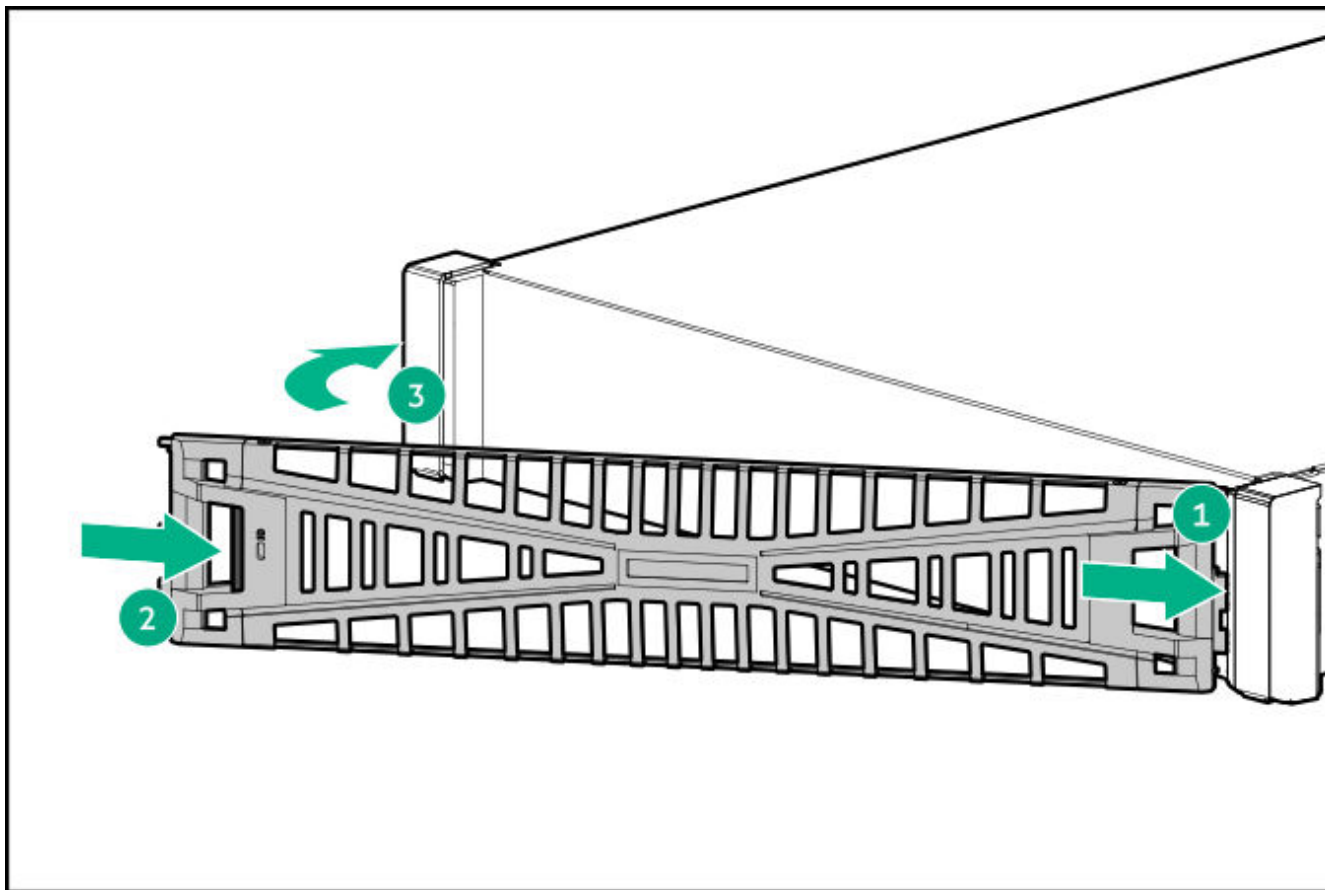

(Optional) Install the bezel lock.

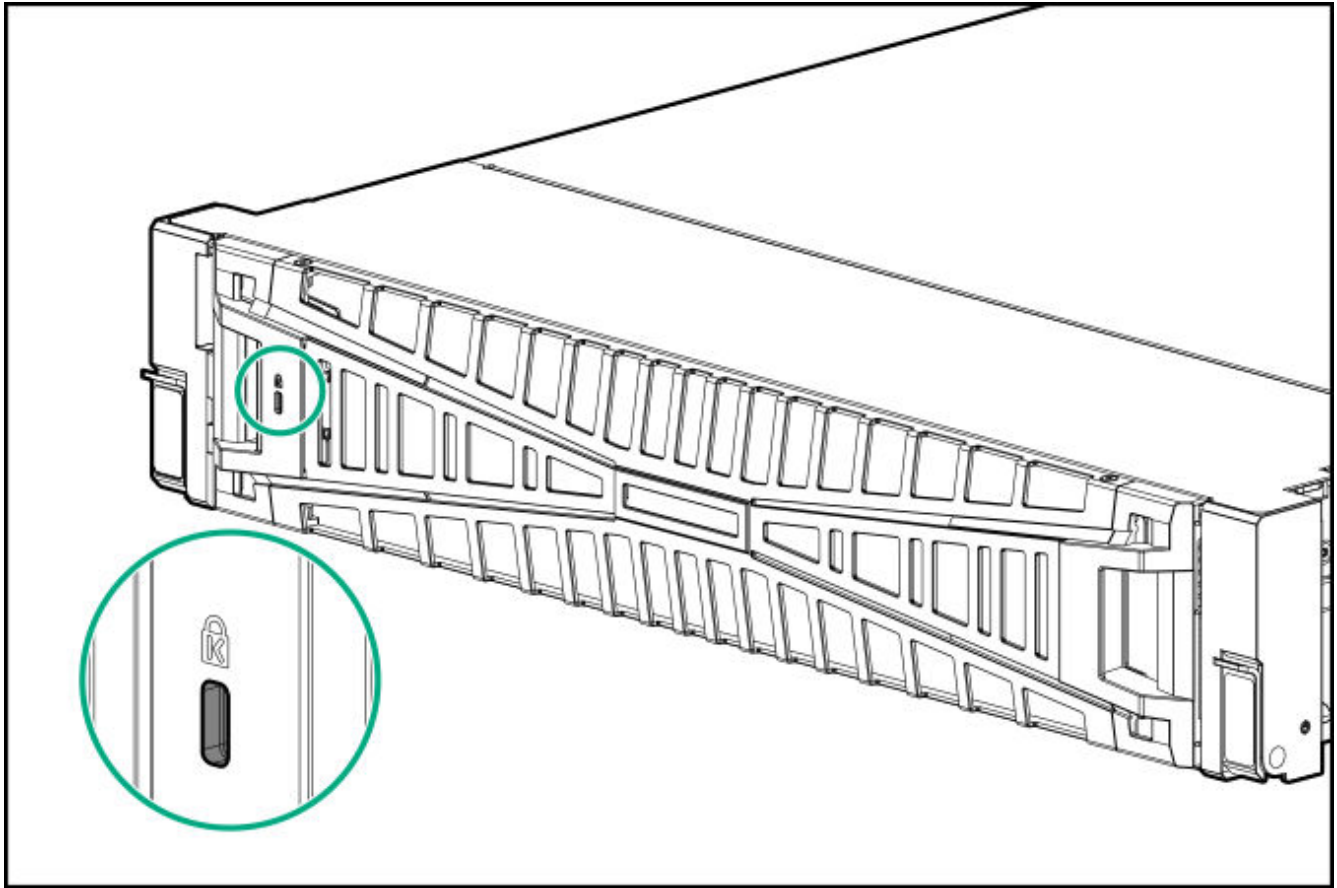

Installing the chassis intrusion detection switch

Prerequisites

Before you perform this procedure, make sure that you have the components included with the hardware option kit.

Procedure

1. Power down the server.
2. Remove all power:
 - a. Disconnect each power cord from the power source.
 - b. Disconnect each power cord from the server.
3. Do one of the following:
 - Extend the server from the rack.

- Remove the server from the rack.
4. Remove the access panel.
 5. Install the chassis intrusion detection switch.

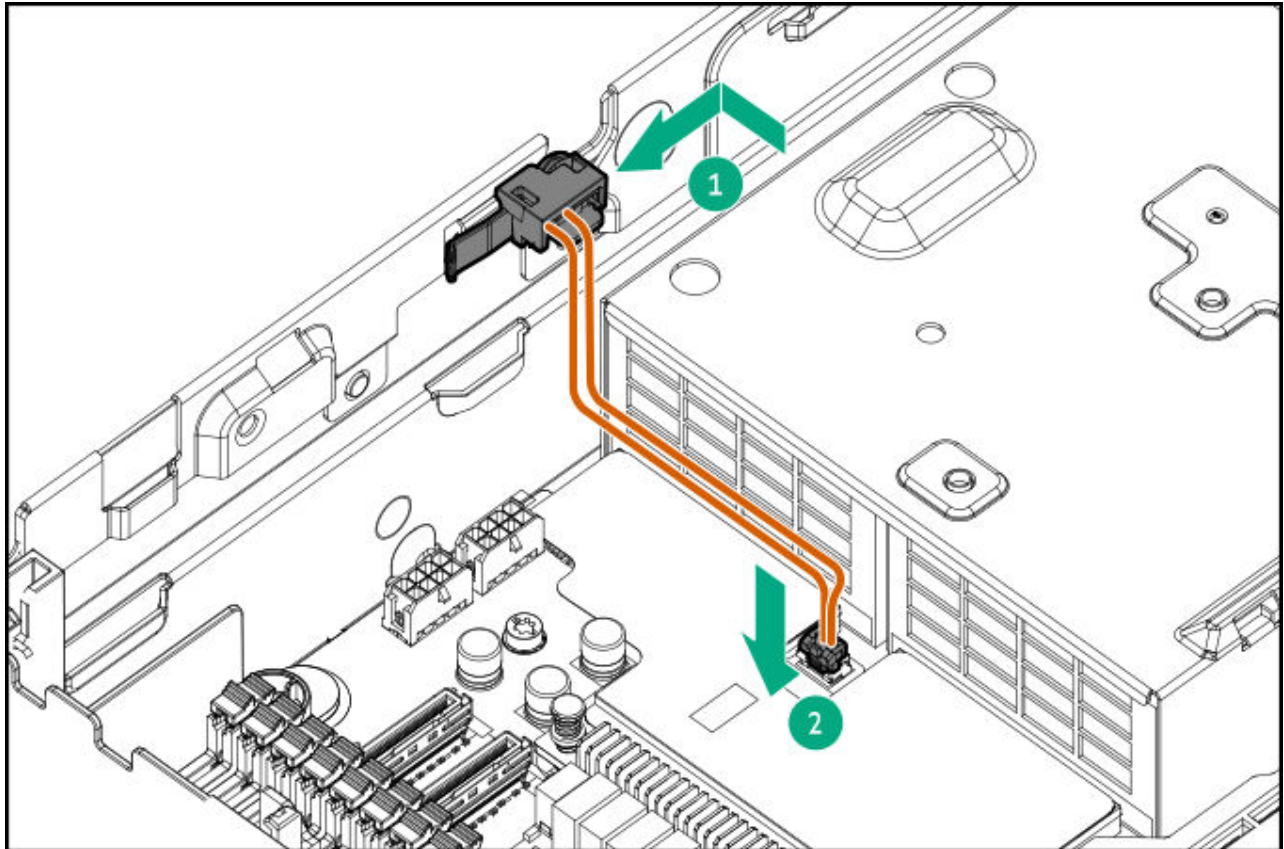

6. Install the access panel.
7. Slide the server into the rack.
8. Connect each power cord to the server.
9. Connect each power cord to the power source.
10. Power up the server.

Storage controllers

Subtopics

Installing a type-p storage controller

Installing a type-p storage controller

Prerequisites

Before you perform this procedure, make sure that you have the following items available:

The components included with the hardware option kit

About this task



WARNING

To reduce the risk of personal injury, electric shock, or damage to the equipment, remove the power cord to remove power from the server. The front panel Power On/Standby button does not shut off system power. Portions of the power supply and some internal circuitry remain active until AC power is removed.



CAUTION

To prevent improper cooling or thermal damage, do not operate the server unless all PCI slots have either an expansion slot cover or an expansion board installed.

To install the component:

Procedure

1. Power down the server.
2. Remove all power:
 - a. Disconnect each power cord from the power source.
 - b. Disconnect each power cord from the server.
3. Do one of the following:
 - Extend the server from the rack.
 - Remove the server from the rack.
4. Remove the access panel.
5. Remove the riser cage.

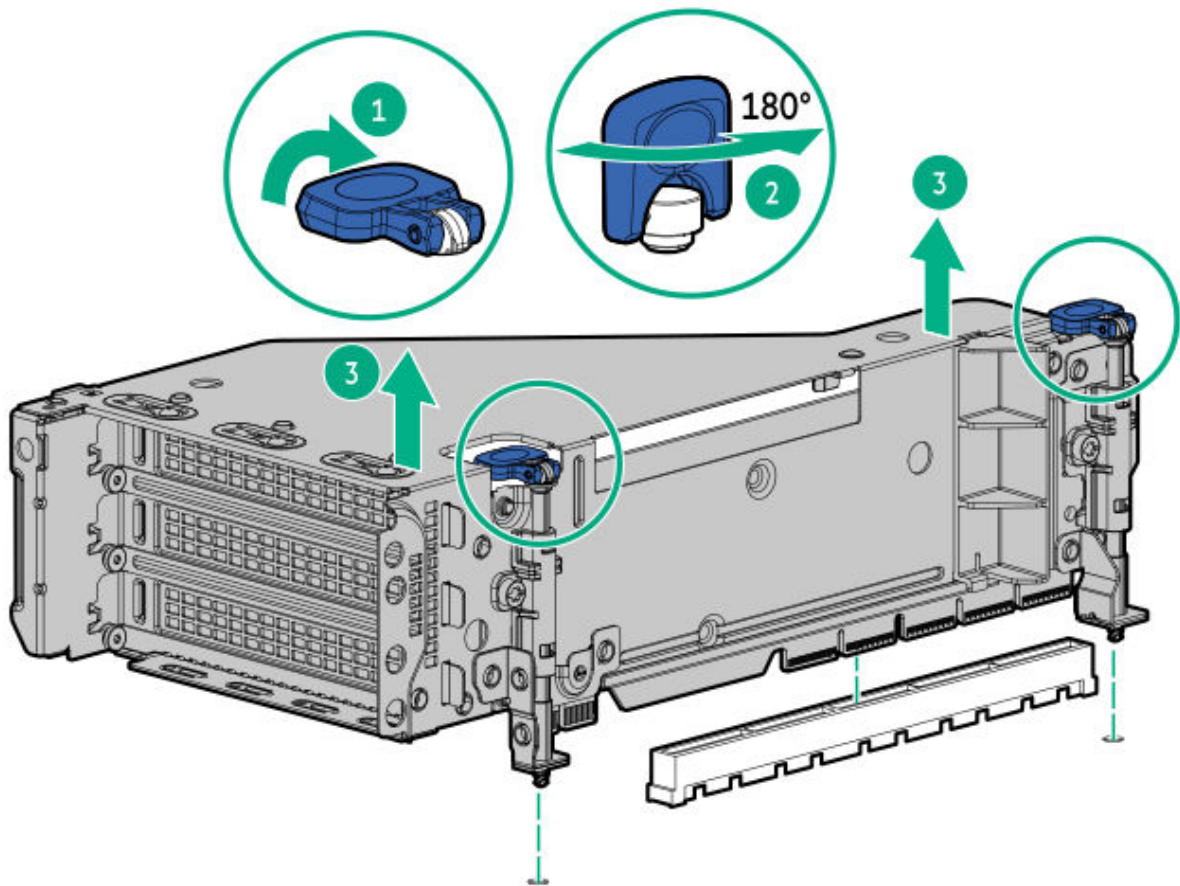

6. Identify and then remove the PCIe blank from the riser cage.

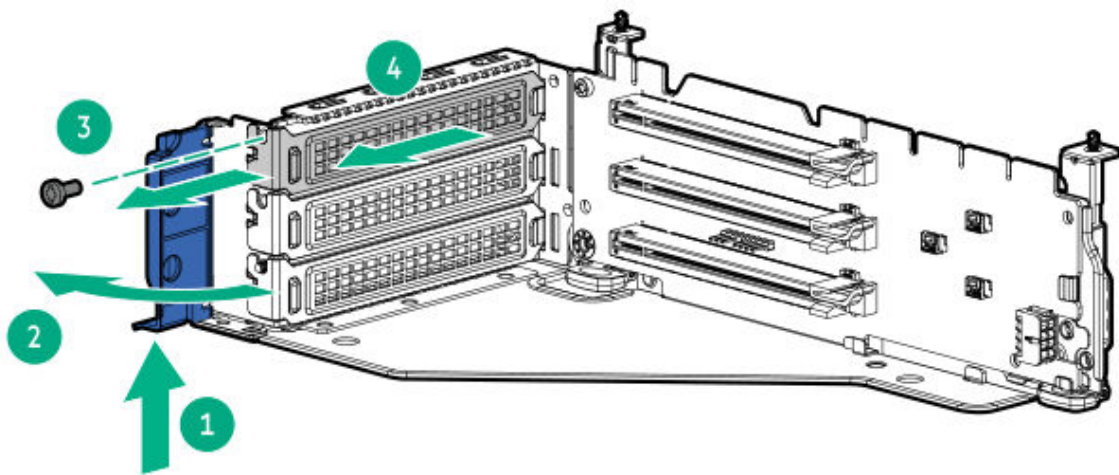

7. Install the expansion board.

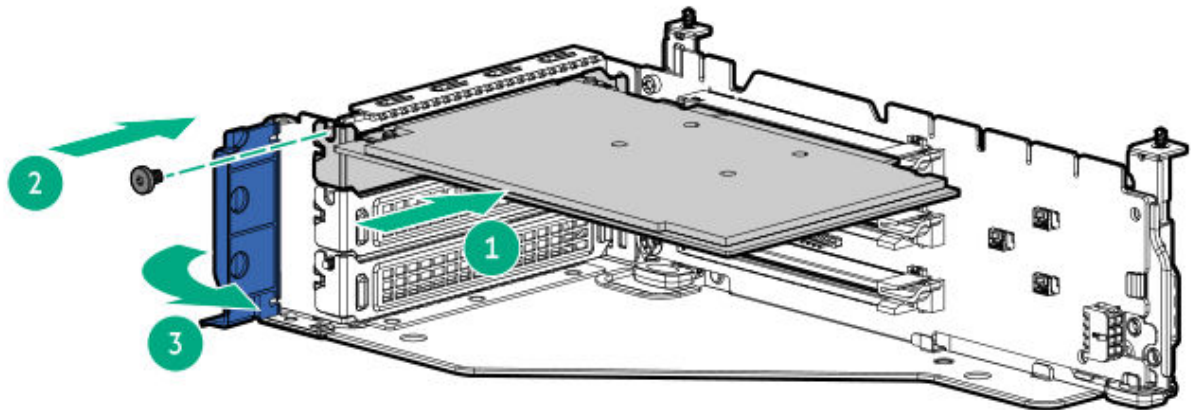

8. If internal cables are required for the expansion board, connect the cables.

9. Install the riser cage.

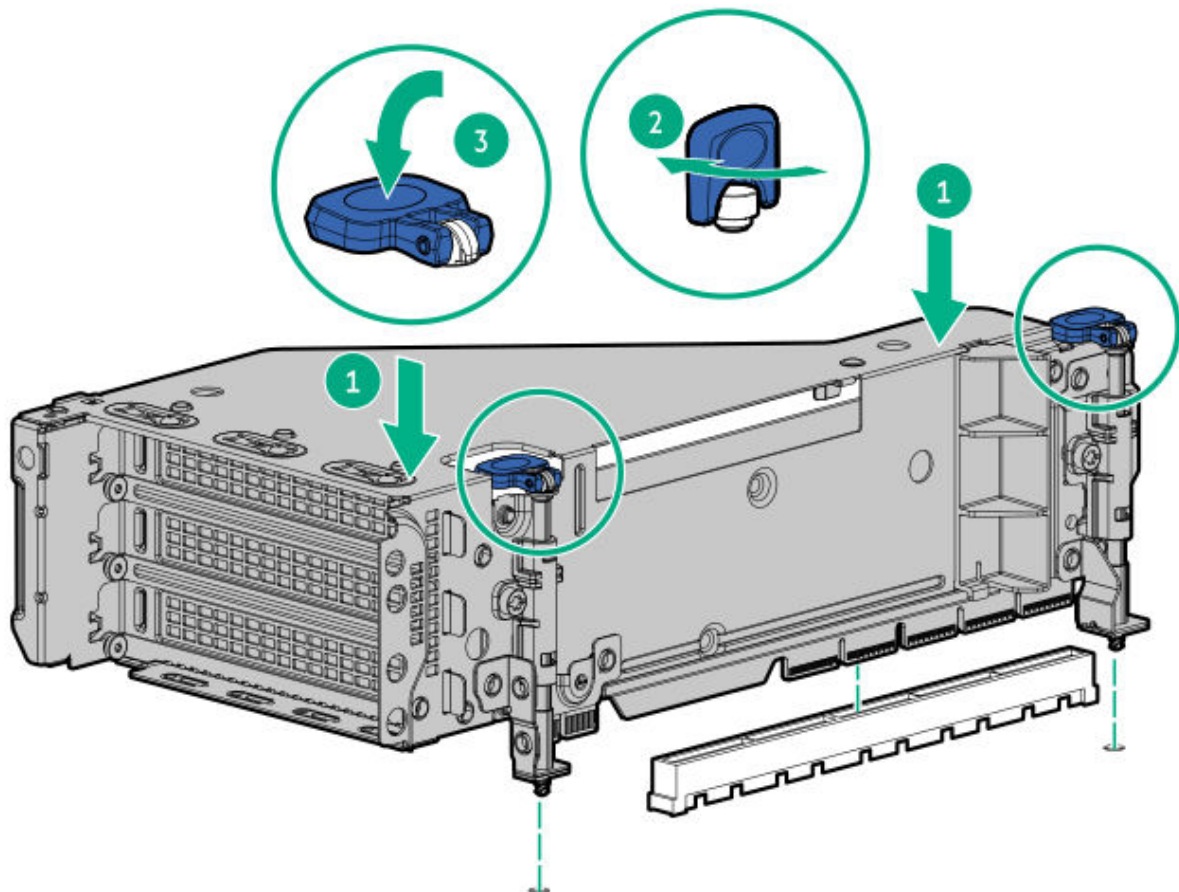

- .0. Connect the cables.
- .1. Install the access panel.
- .2. Slide the server into the rack.
- .3. Connect each power cord to the server.
- .4. Connect each power cord to the power source.
- .5. Power up the server.

Results

The installation is complete.

Installing a type-o storage controller

Prerequisites

Before installing this option, be sure you that have the following:

- The components included with the hardware option kit
- T-10 Torx screwdriver

Procedure

1. Power down the server.
2. Remove all power:
 - a. Disconnect each power cord from the power source.
 - b. Disconnect each power cord from the server.
3. Do one of the following:
 - Extend the server from the rack.
 - Remove the server from the rack.
4. Remove the access panel.
5. Remove the rear wall blank or riser cage.
6. Remove the OCP adapter blank.

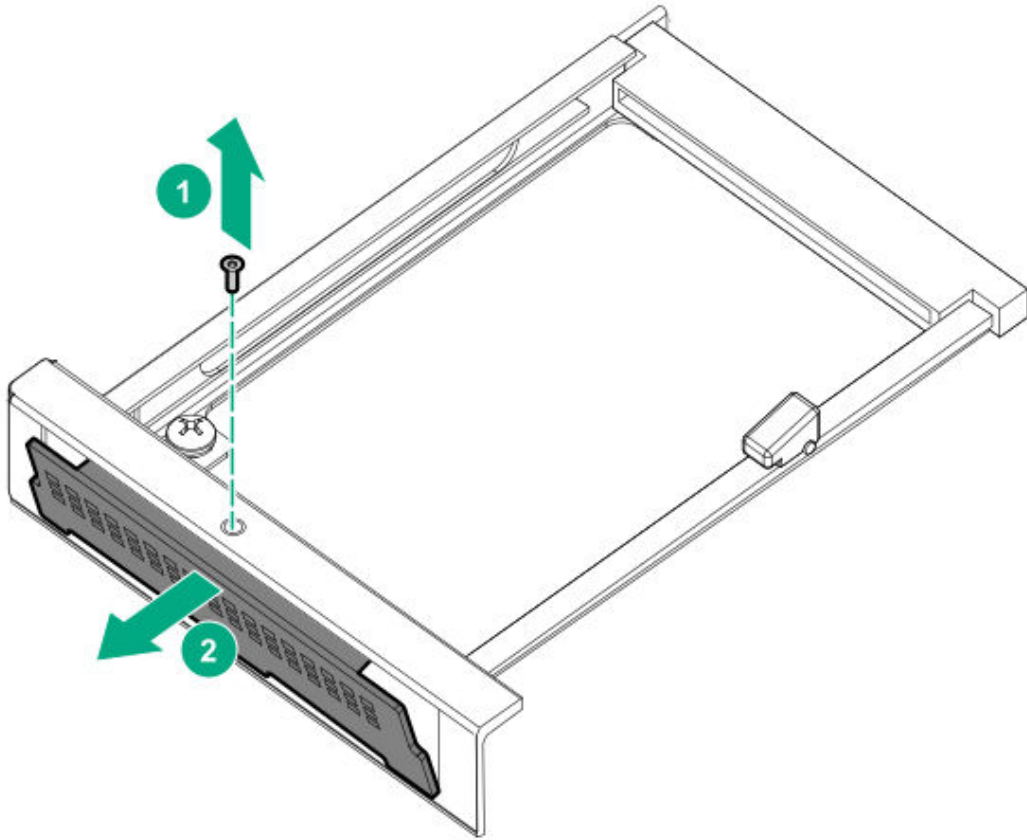

7. Install the storage controller.

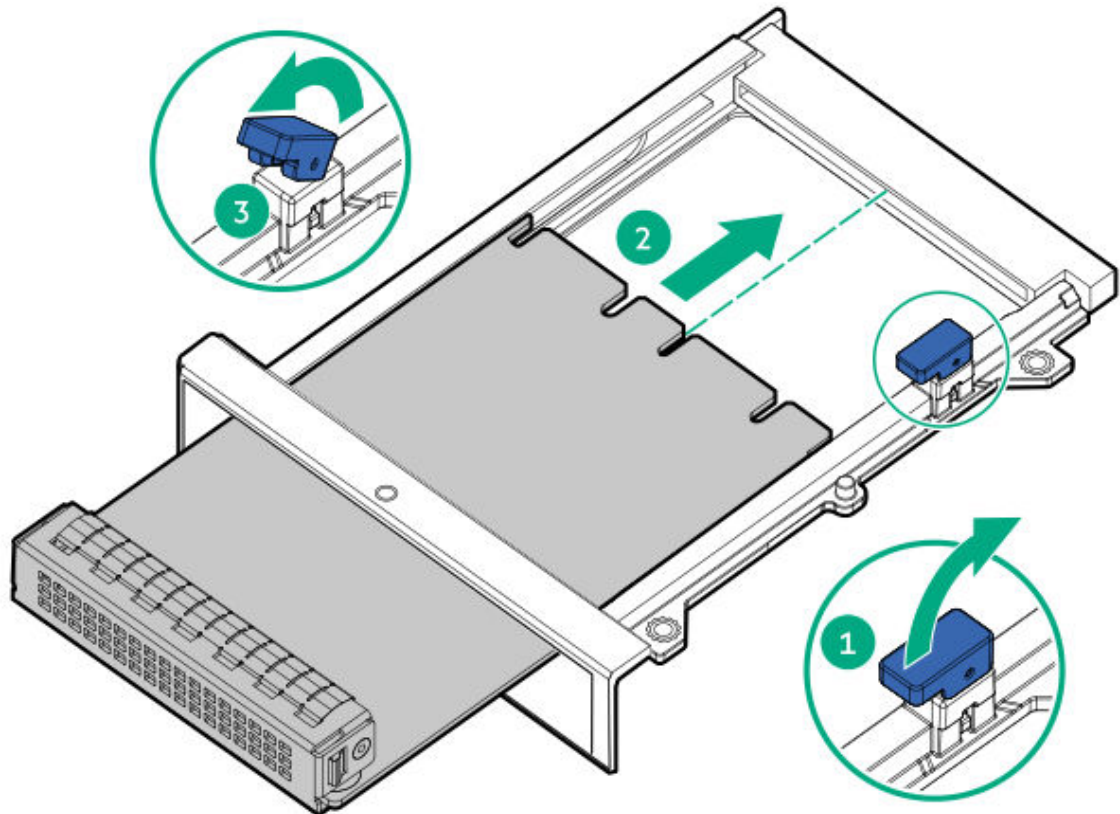

8. Connect the cables.
9. Install the access panel.
0. Slide the server into the rack.
- .1. Connect each power cord to the server.
- .2. Connect each power cord to the power source.
- .3. Power up the server.

Cabling

Subtopics

[Cabling guidelines](#)

[Cabling diagrams](#)

Cabling guidelines

Observe the following:



NOTE

The colors in the cabling diagrams are for illustration purposes only.



CAUTION

To avoid damaging connectors, avoid repeated installation and removal of cables. Excessive handling can shorten the lifespan of the cable.

- For cable option kits, see the product QuickSpecs.
- For cable spare part numbers, see the Illustrated parts catalog in the maintenance and service guide.
- Some diagrams show alphabetical callouts such as A, B, C, etc. These callouts correspond to labels near the connectors on the cable.
- Some cables have more than one connector, such as a Y-cable, but not all connectors are used.
- Observe all guidelines when working with server cables.

Before connecting cables

- Note the port labels on the PCA components. Not all these components are used by all servers:
 - System board ports
 - Drive and power supply backplane ports
 - Expansion board ports (controllers, retimers, adapters, expanders, risers, and similar boards)
- Note the label near each cable connector. This label indicates the destination port for the cable connector.
- Some data cables are prebent. Do not unbend or manipulate the cables.
- To prevent mechanical damage or depositing oil that is present on your hands, and other contamination, do not touch the ends of the connectors.

When connecting cables

- Before connecting a cable to a port, lay the cable in place to verify the length of the cable.
- Use the internal cable management features to properly route and secure the cables.

- Route cables so that they do not contact or rest on cooling components, including heatsinks. Ensure that cable routing does not obstruct airflow to or from heatsinks or ventilation openings
- When routing cables, be sure that the cables are not in a position where they can be pinched or crimped.
- Avoid tight bend radii to prevent damaging the internal wires of a power cord or a server cable. Never bend power cords and server cables tight enough to cause a crease in the sheathing.
- Make sure that the excess length of cables is properly secured to avoid excess bends, interference issues, and airflow restriction.
- Before installing a new component or closing up the server, make sure that all cables are in their appropriate routing position. This cable check prevents component damage and potential signal interference.

When disconnecting cables

- Grip the body of the cable connector. Do not pull on the cable itself because this action can damage the internal wires of the cable or the pins on the port.

- If a cable does not disconnect easily, check for any release latch that must be pressed to disconnect the cable.

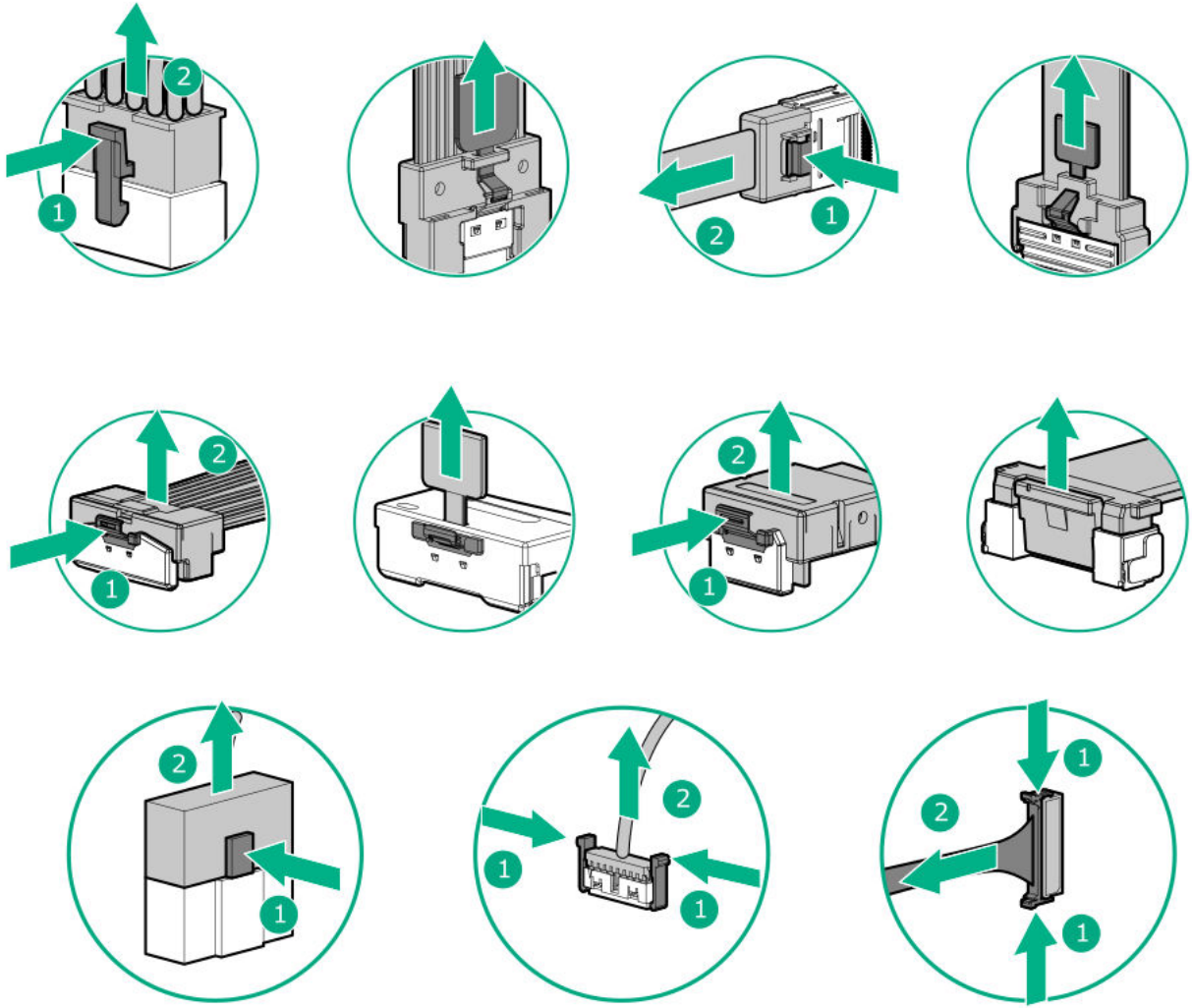

- Remove cables that are no longer being used. Retaining them inside the server can restrict airflow. If you intend to use the removed cables later, label and store them for future use.

Cabling diagrams

Observe the following:

Drive backplanes

Component cabling

Cable part number

EDSFF cabling

[P76139-001](#)

[P76140-001](#)

[P76141-001](#)

[P75317-001](#)

[P76441-001](#)

[P75567-001](#)

[P75369-001](#)

[P75369-001](#)

[P75368-001](#)

[P75908-001](#)

[P76142-001](#)

[P75318-001](#)

[P75569-001](#)

[P75638-001](#)

[P79152-001](#)

[P75318-001](#)

[P75569-001](#)

[P79152-001](#)

8 SFF box 1 cabling

[P74811-001](#)

[P76147-001](#)

[P75367-001](#)

[P75563-001](#)

[P75365-001](#)

[P51545-001](#)

[P51546-001](#)

[P51548-001](#)

[P51547-001](#)

[P74805-001](#)

[P78631-001](#)

8 SFF box 2 cabling

[P76147-001](#)

[P76146-001](#)

Component cabling**Cable part number**

Component cabling	Cable part number
	<u>P76148-001</u>
	<u>P75563-001</u>
	<u>P74805-001</u>
	<u>P51545-001</u>
	<u>P51546-001</u>
	<u>P51547-001</u>
	<u>P22905-001</u>
	<u>P74805-001</u>
8 SFF box 3 cabling	<u>P76146-001</u>
	<u>P75367-001</u>
	<u>P75563-001</u>
	<u>P75365-001</u>
	<u>P75574-001</u>
	<u>P22905-001</u>
	<u>P51545-001</u>
	<u>P51546-001</u>
	<u>P75574-001</u>
	<u>P78631-001</u>
4LFF box 7 cabling	<u>P51560-001</u>
Front 2 SFF cabling	<u>P74811-001</u>
	<u>P22905-001</u>
	<u>P51545-001</u>
Rear 2 SFF cabling	<u>P51554-001</u>
	<u>P14329-001</u>
	<u>P22903-001</u>
	<u>P74818-001</u>
	<u>P51545-001</u>
LFF cabling	<u>P75367-001</u>
	<u>P51559-001</u>
	<u>P51560-001</u>
	<u>P51561-001</u>
Riser enablement cabling	<u>P75362-001</u>
	<u>P76145-001</u>

Component cabling**Cable part number**

P76144-001

Power**Component cabling****Cable part number**

Front EDSFF boxes 1-3	<u>P75227-001</u>
Front 8 SFF boxes 1-3	<u>P75906-001</u>
Front 4 LFF boxes 1-3	<u>P75363-001</u>
Rear boxes 4 and 5	<u>P51574-001</u>
Front 2 SFF side-by-side	<u>P75276-001</u>
Rear/mid boxes 4, 5, and 7	<u>P75364-001</u>
Smart battery	<u>P45618-001</u>

NS204i-u cabling**Component cabling****Cable part number**

Rear NS204i-u data cabling	<u>P72024-001</u>
Rear NS204i-u power cabling	<u>P54089-001</u>
Front NS204i-u data cabling	<u>P74730-001</u>
Front NS204i-u power cabling	<u>P74729-001</u>

OCP cabling**Component cabling****Cable part number**

OCP cabling	<u>P71940-001</u>
	<u>P73927-001</u>
	<u>P74889-001</u>
	<u>P74891-001</u>
	<u>P75370-001</u>
	<u>P74890-001</u>
	<u>P74891-001</u>

Systems Insight Display

Component cabling

Cable part number

Systems Insight Display	P48971-001
-------------------------	----------------------------

I/O cabling

Component cabling

Cable part number

SFF media bay USB	P73776-001
-------------------	----------------------------

SFF media bay DP/USB	P75280-001
----------------------	----------------------------

LFF Display Port	P75279-001
------------------	----------------------------

SFF/LFF ODD	P73776-001
-------------	----------------------------

Front power switch

Component cabling

Cable part number

SFF/LFF front power switch	P71909-001
----------------------------	----------------------------

Serial port cabling

Component cabling

Cable part number

Serial port cable	P45623-001
-------------------	----------------------------

Subtopics

[EDSFF cabling](#)

[8 SFF box 1 cabling](#)

[8 SFF box 2 cabling](#)

[8 SFF box 3 cabling](#)

[Box 7 cabling](#)

[Front 2 SFF cabling](#)

[Rear 2 SFF cabling](#)

[LFF cabling](#)

[Riser enablement cabling](#)

[Power cabling](#)

[GPU cabling](#)

[NS204i-u boot device cabling](#)

[OCP enablement](#)

Systems Insight Display cabling

I/O cabling

Front power switch cabling

Serial port cabling

EDSFF cabling

EDSFF box 1: cage 1

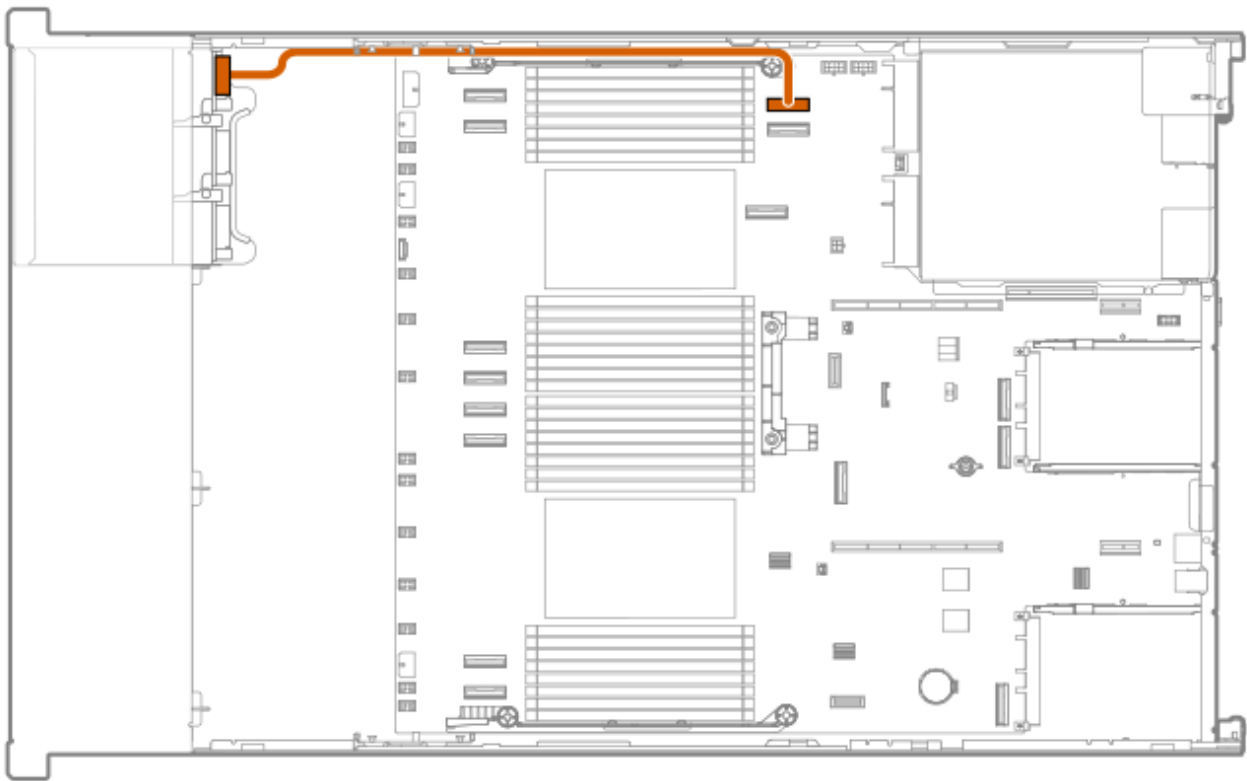

Cable part number	Color	From	To
P76441-001	Orange	Drive backplane	System board

EDSFF box 1 or box 3: cage 1

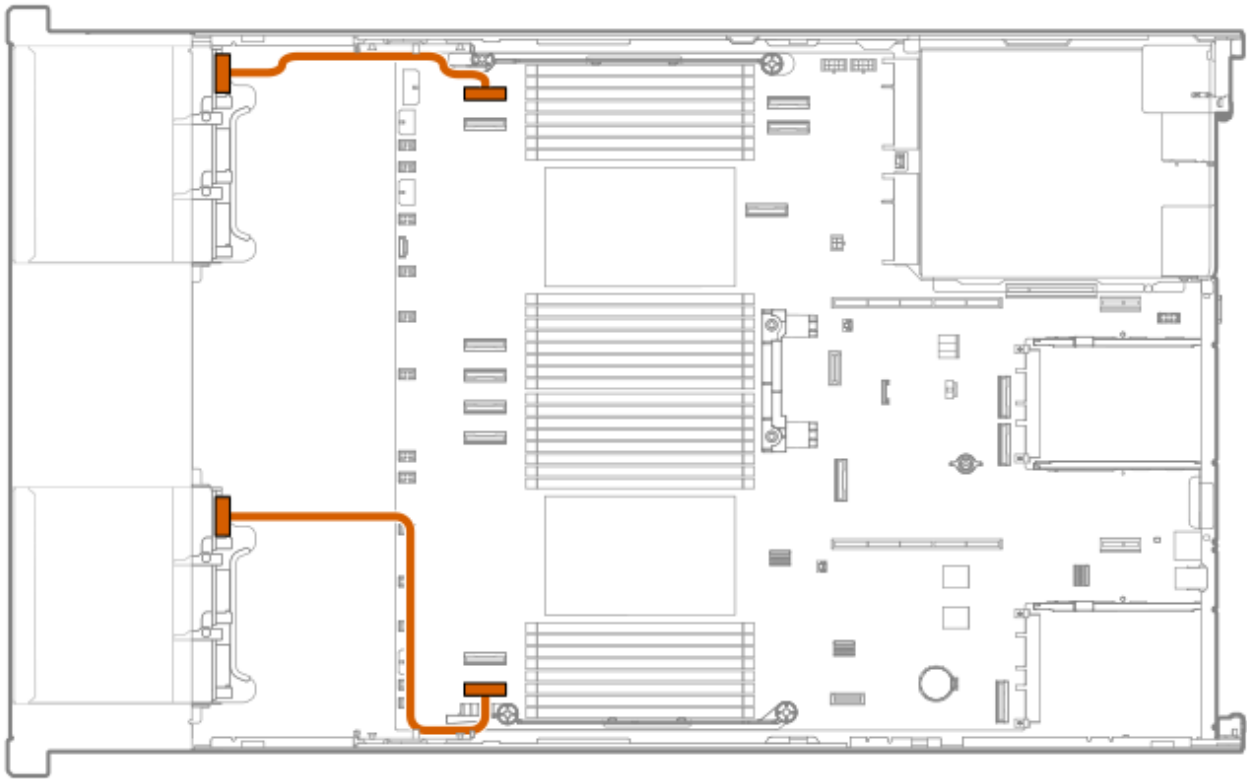

Cable part number	Color	From	To
P75317-001	Orange	Drive backplane	System board

EDSFF box 1: cages 2 or 3 or box 3: cages 1 or 2

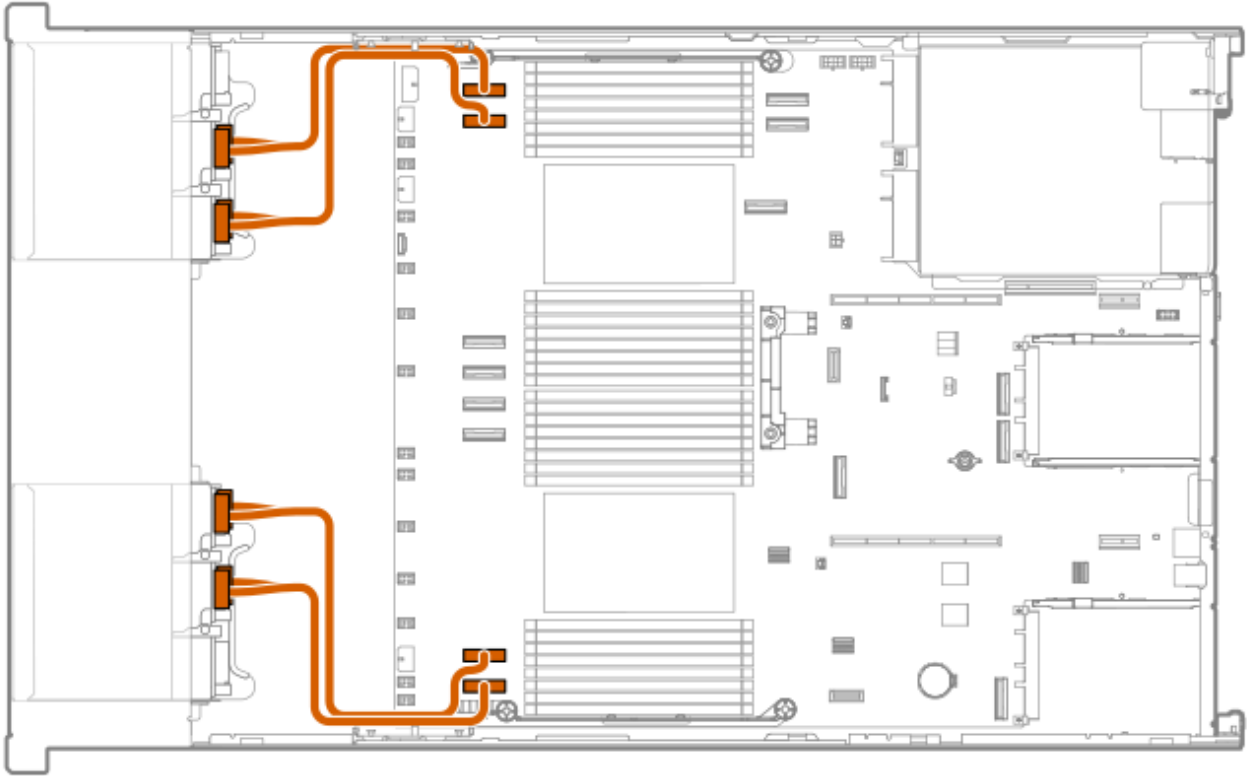

Cable part number	Color	From	To
P75368-001	Orange	Drive backplane	System board

EDSFF box 1: cage 1 or box 3: cage 3

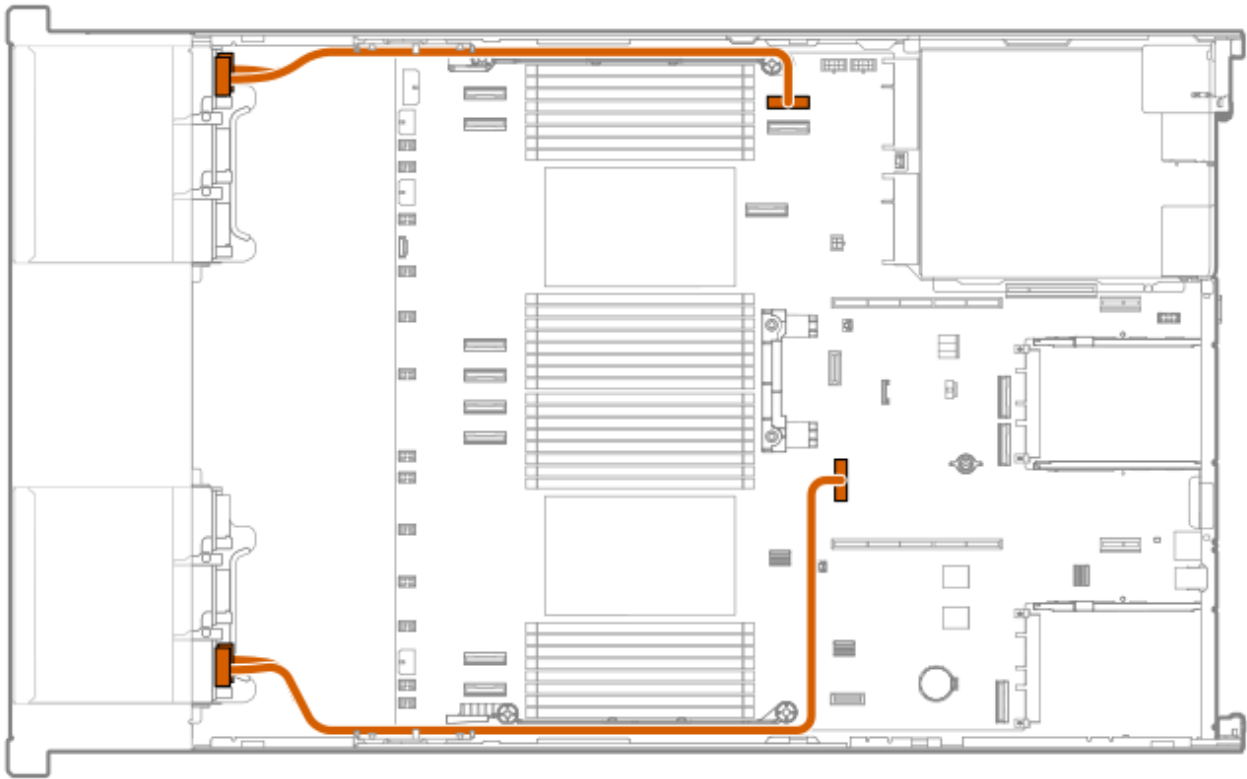

Cable part number	Color	From	To
P75908-001	Orange	Drive backplane	System board

EDSFF box 1 and box 2: PCIe controllers

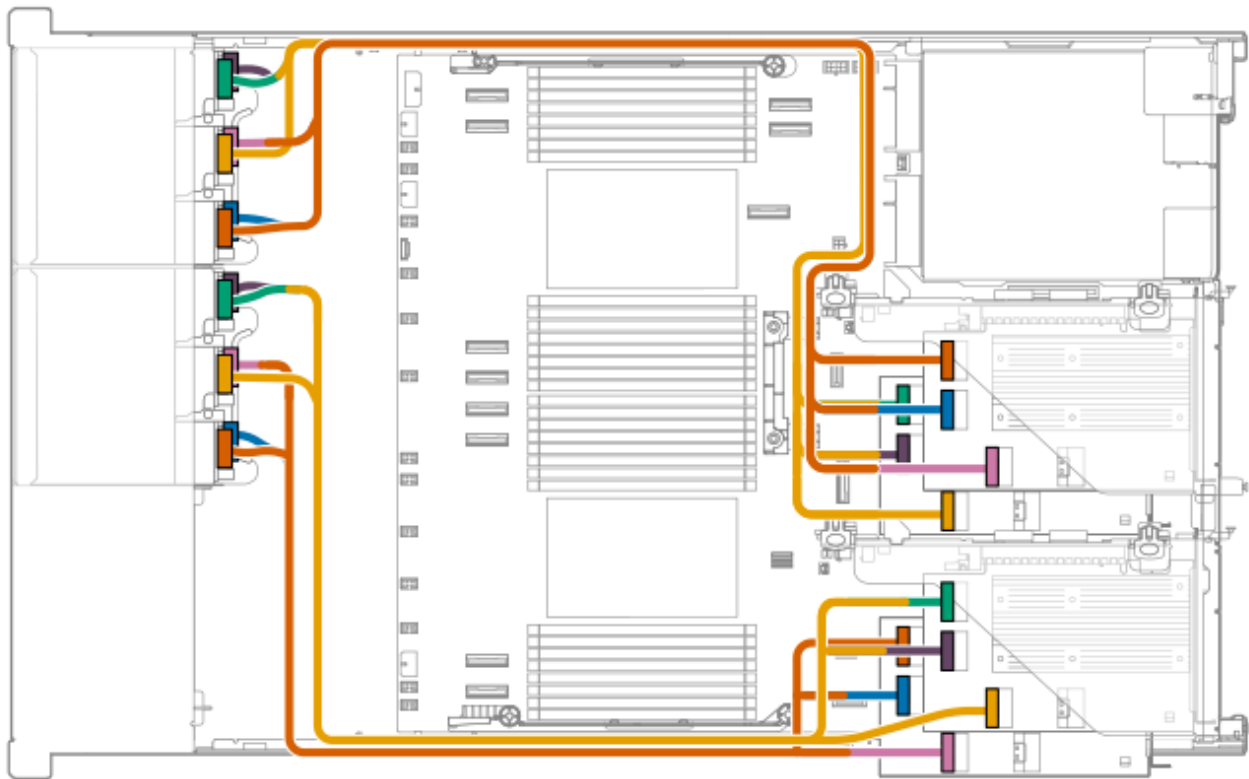

Cable part number	Color	From	To
P75318-001	Green	Cage 1 top port	Bottom controller port 4
	Purple	Cage 1 bottom port	Bottom controller port 3
	Yellow	Cage 2 top port	Bottom controller port 2
P75318-001	Orange	Cage 3 top port	Top controller port 4
	Blue	Cage 3 bottom port	Top controller port 3
	Pink	Cage 2 bottom port	Top controller port 2
P75318-001	Green	Cage 1 top port	Top controller port 4
	Purple	Cage 1 bottom port	Top controller port 3
	Yellow	Cage 2 top port	Top controller port 2
P75318-001	Orange	Cage 3 top port	Bottom controller port 4
	Blue	Cage 3 bottom port	Bottom controller port 3

Cable part number	Color	From	To
	Pink	Cage 2 bottom port	Bottom controller port 2

EDSFF box 1 or box 2: PCIe controllers

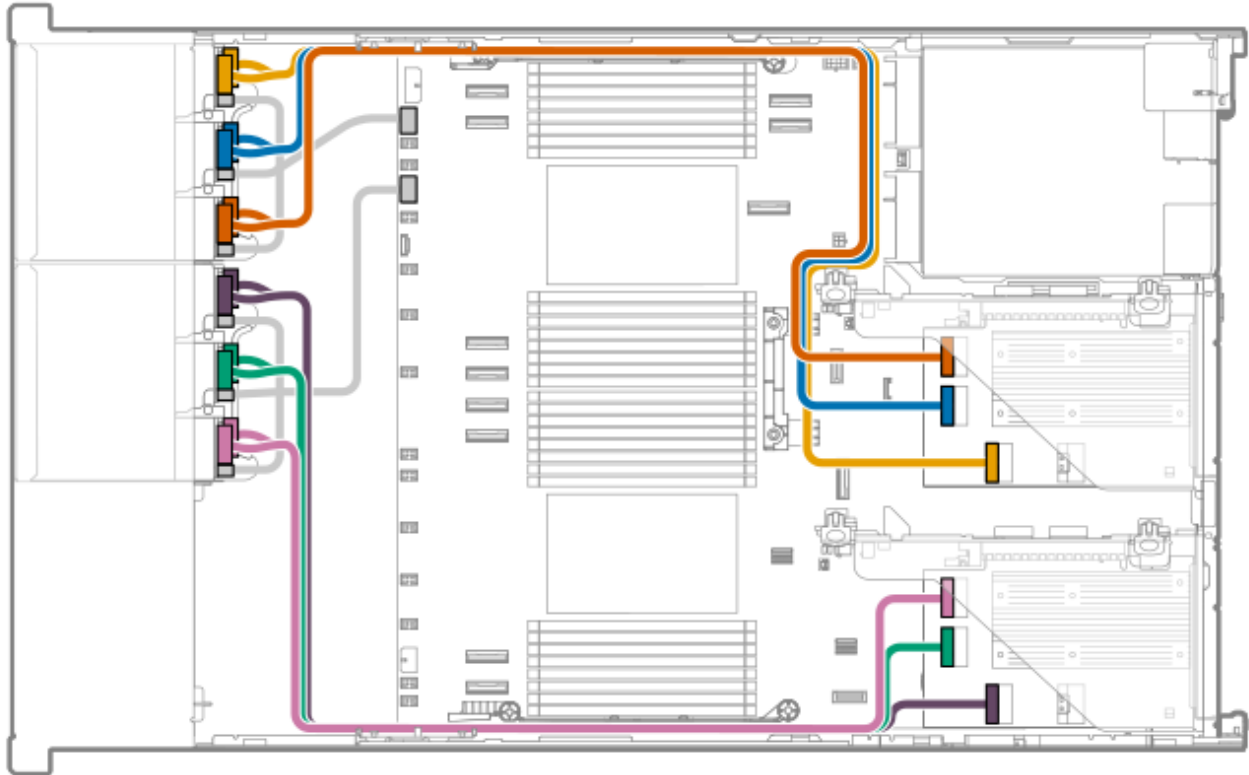

Cable part number	Color	From	To
P79152-001	Orange	Box 1 cage 3	PCIe controller port 4
	Blue	Box 1 cage 2	PCIe controller port 3
	Yellow	Box 1 cage 1	PCIe controller port 2
	Pink	Box 2 cage 3	PCIe controller port 4
	Green	Box 2 cage 2	PCIe controller port 3
	Purple	Box 2 cage 1	PCIe controller port 2

EDSFF box 2:cage 1

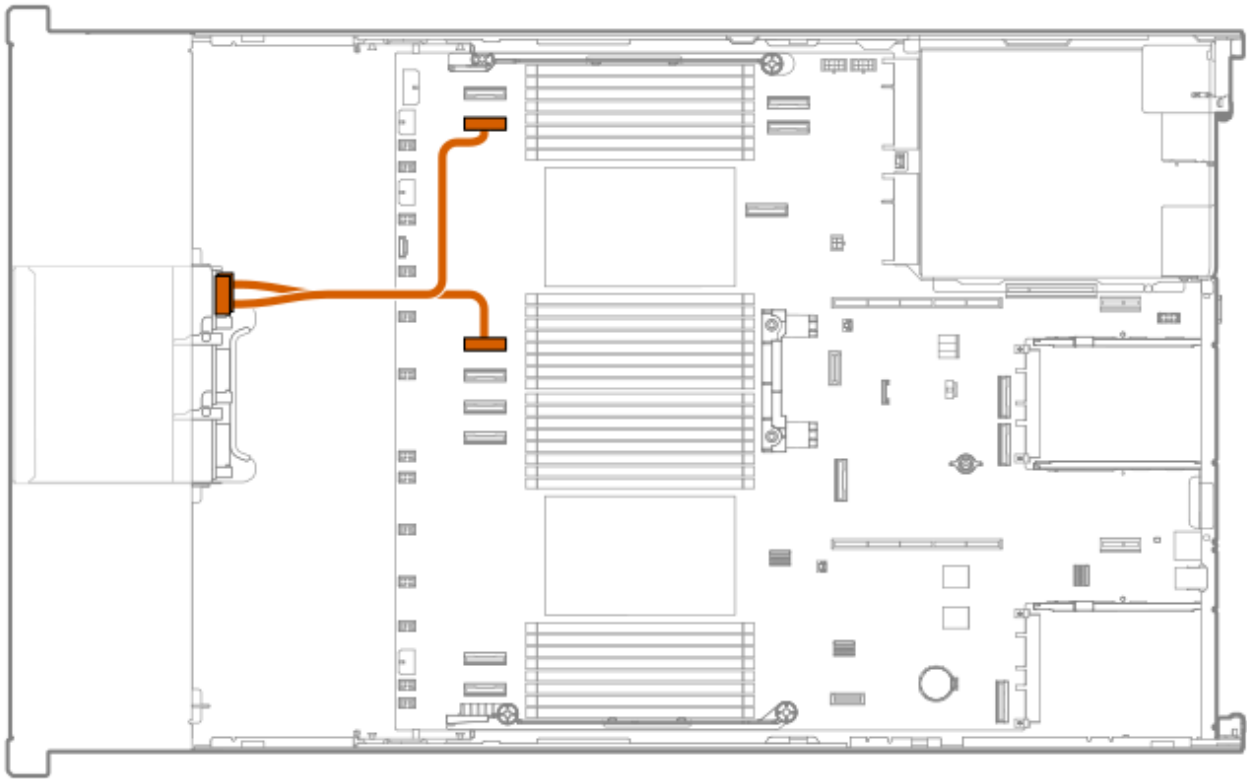

Cable part number	Color	From	To
P76139-001	Orange	Drive backplane	System board

EDSFF box 2: cage 1

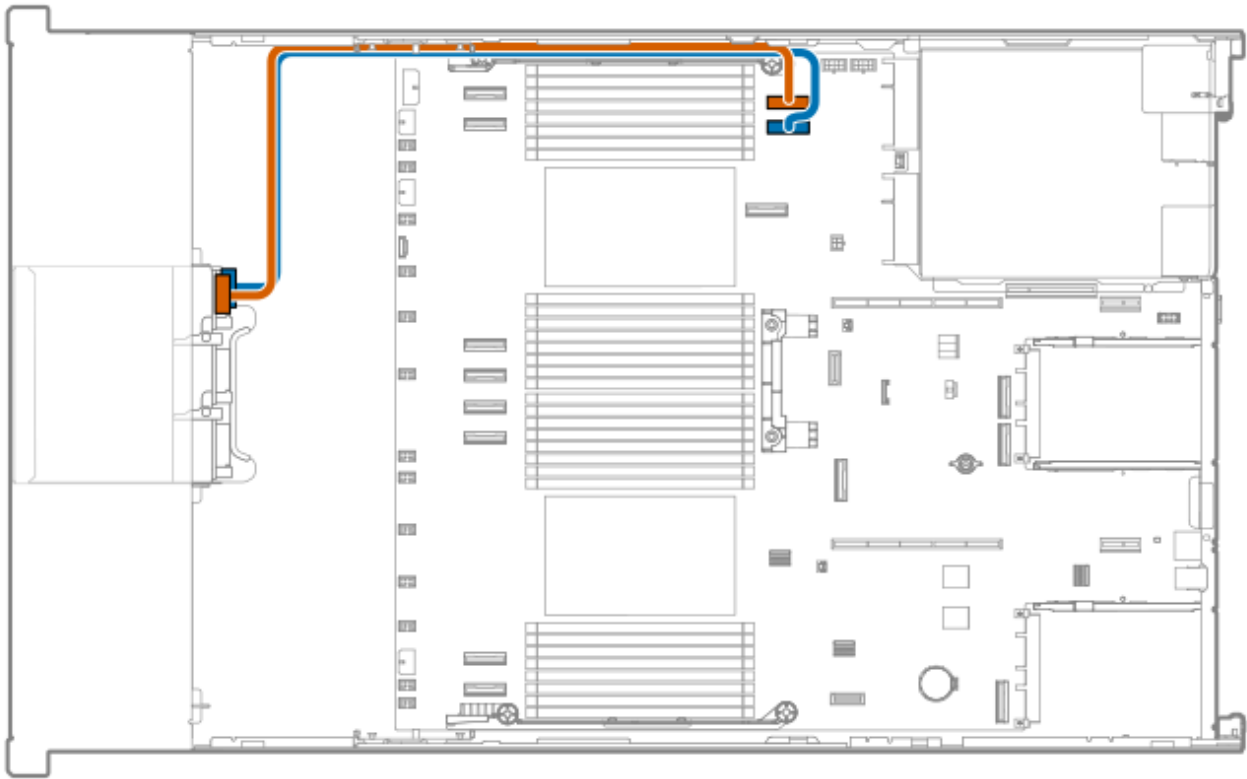

Cable part number	Color	From	To
P76441-001	Orange	Drive backplane	System board
	Blue	Drive backplane	System board

EDSFF box 2: cage 1

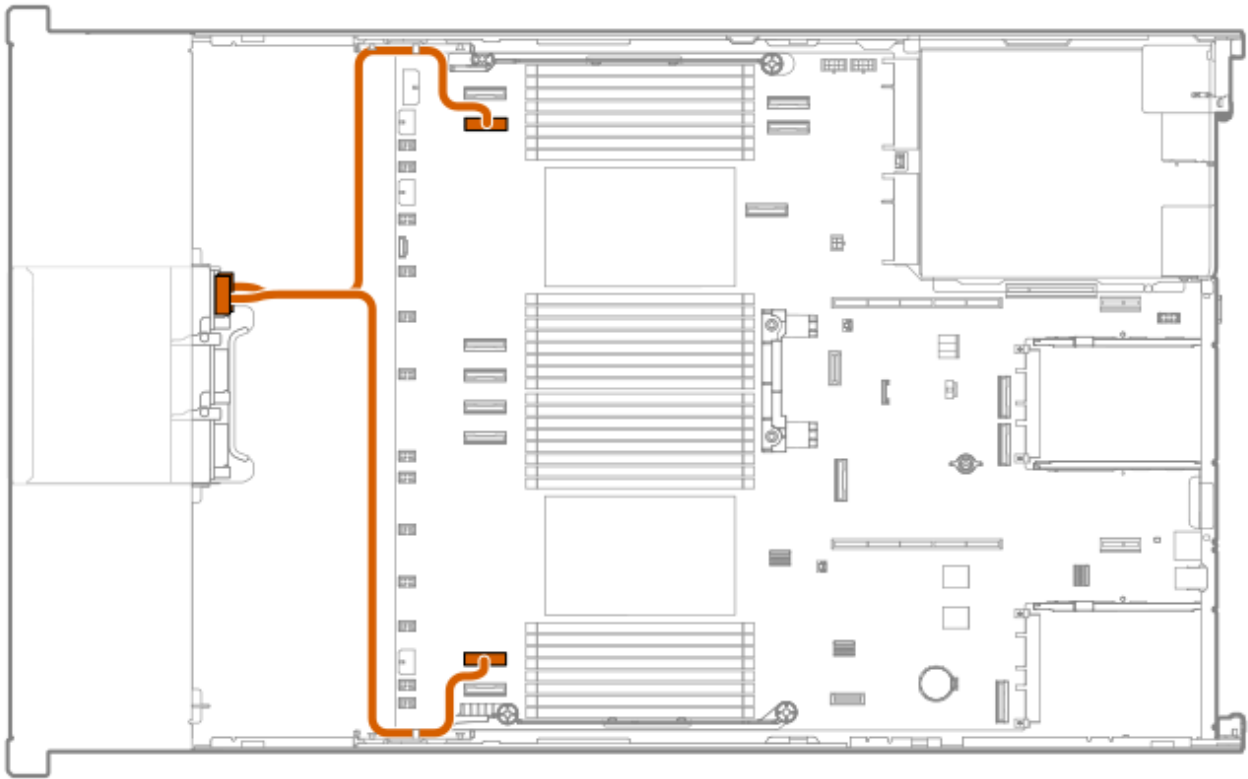

Cable part number	Color	From	To
P76441-001	Orange	Drive backplane	System board

EDSFF box 2: cage 1 or 2

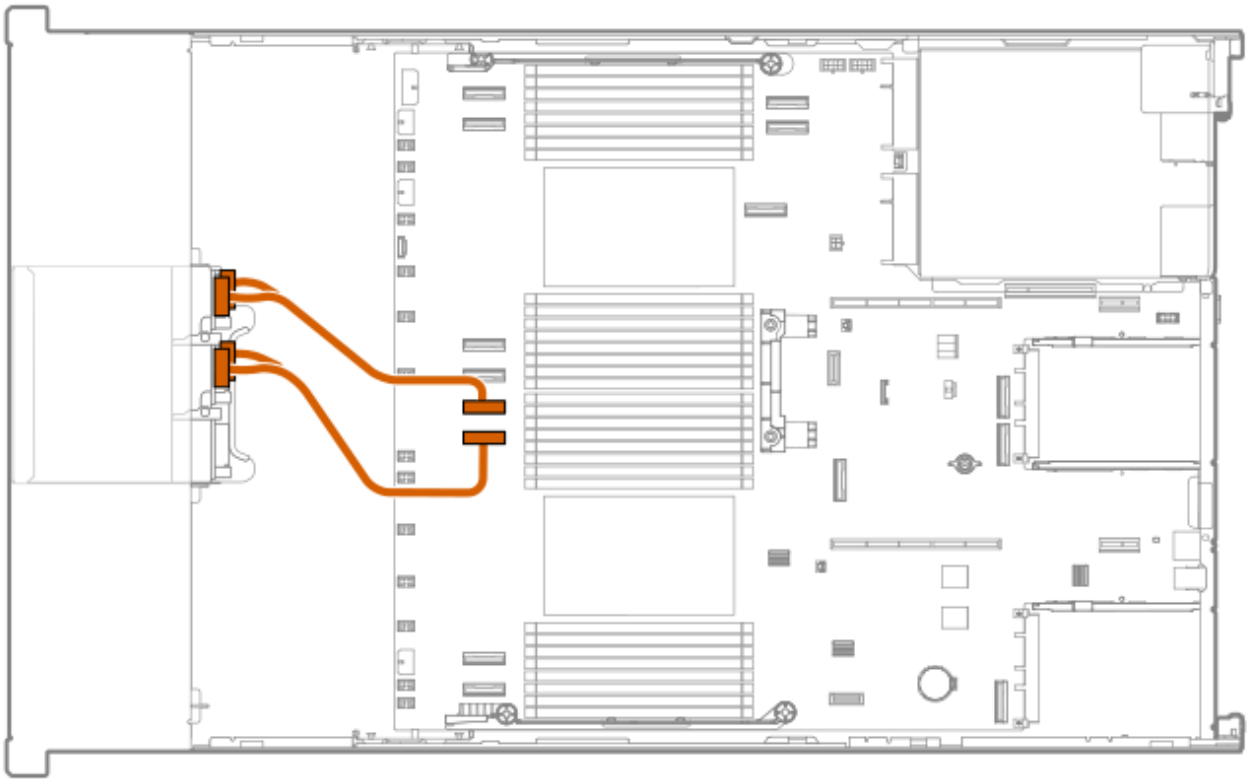

Cable part number	Color	From	To
P75368-001	Orange	Drive backplane	System board

EDSFF box 2: cage 1 or 3

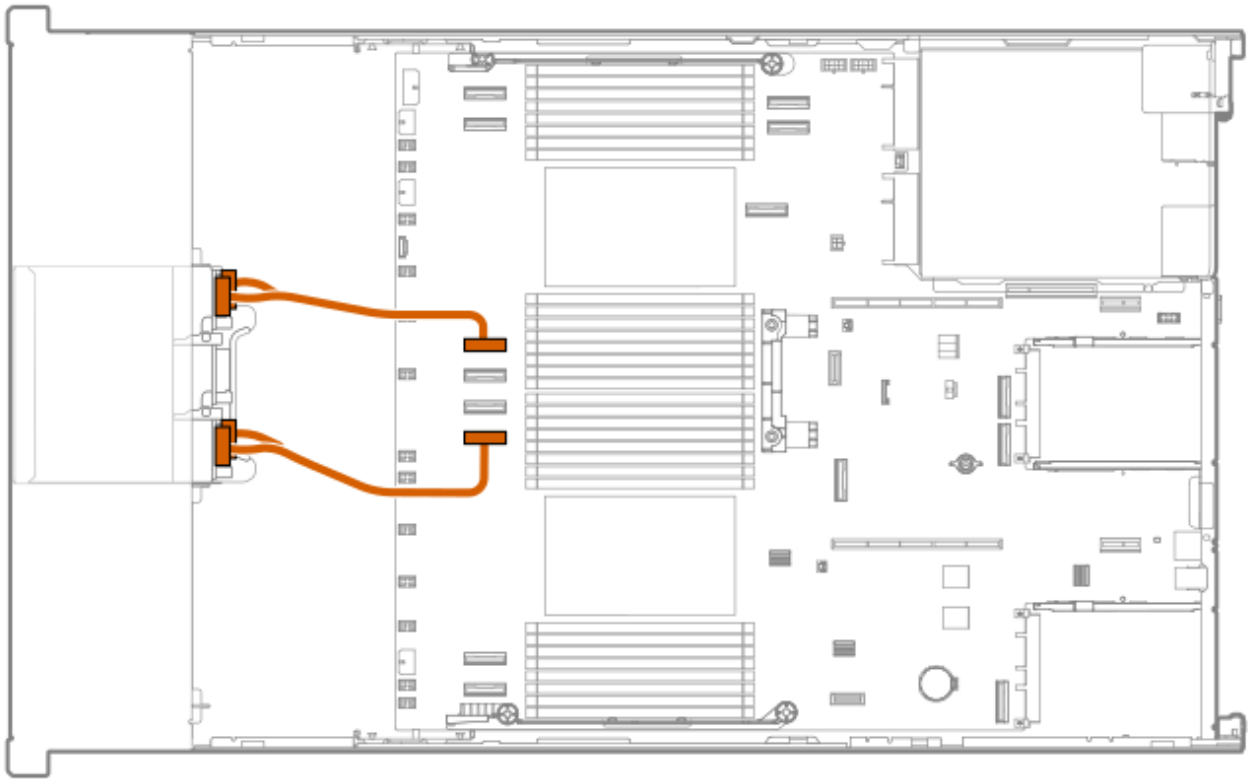

Cable part number	Color	From	To
P75368-001	Orange	Drive backplane	System board

EDSFF box 2: cage 2

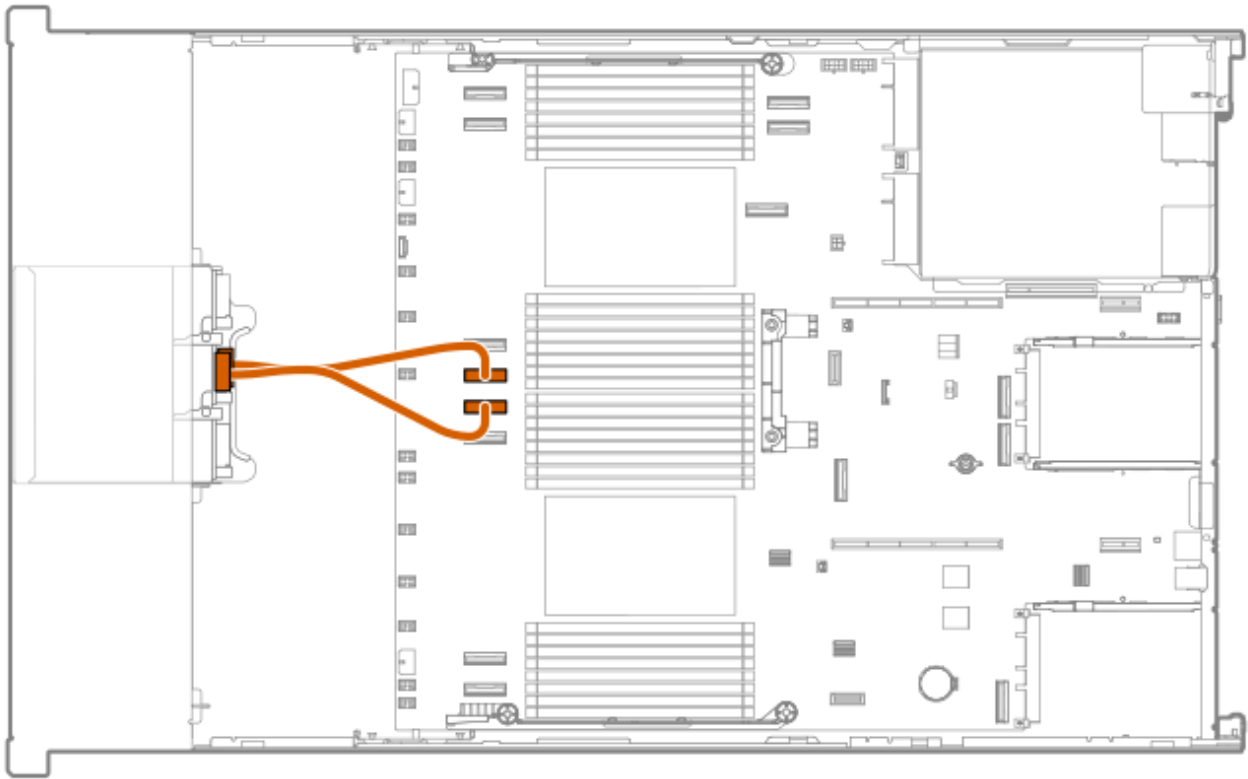

Cable part number	Color	From	To
P76142-001	Orange	Drive backplane	System board

EDSFF box 2: cage 2

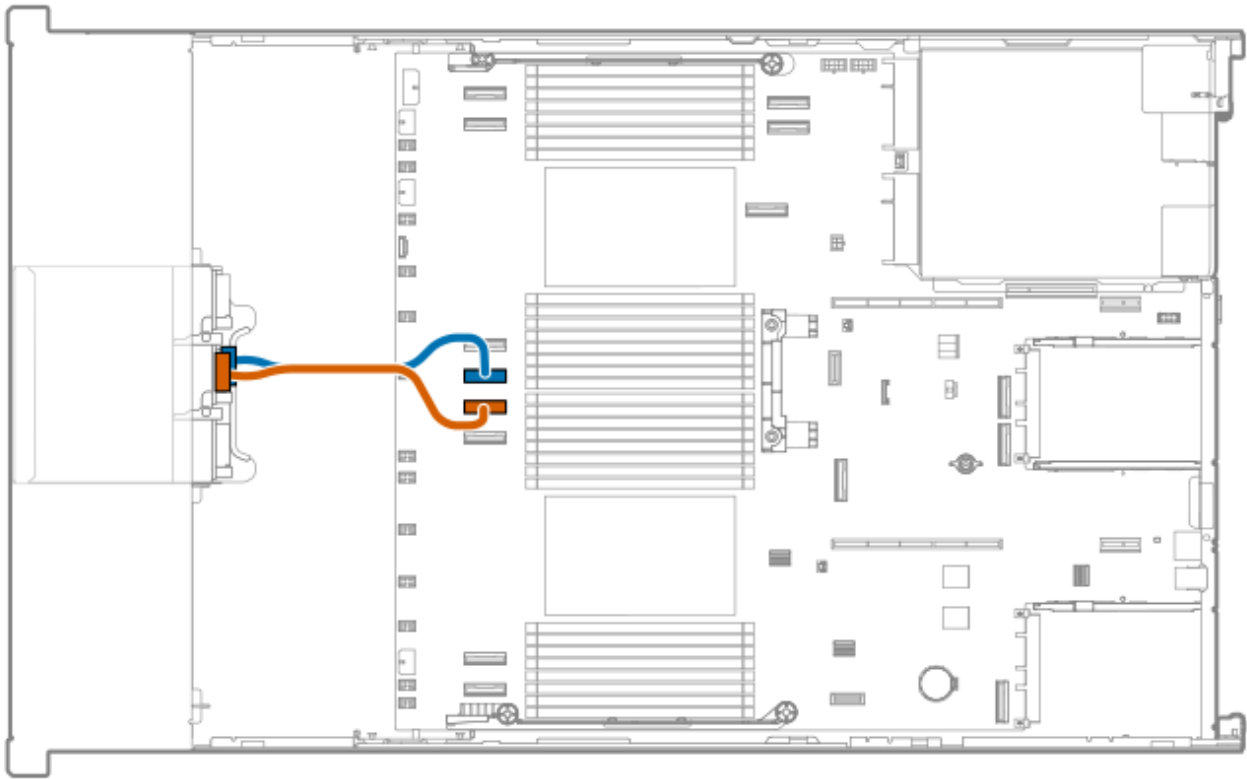

Cable part number	Color	From	To
P76140-001	Orange	Drive backplane	System board
	Blue	Drive backplane	System board

EDSFF box 2: cage 3

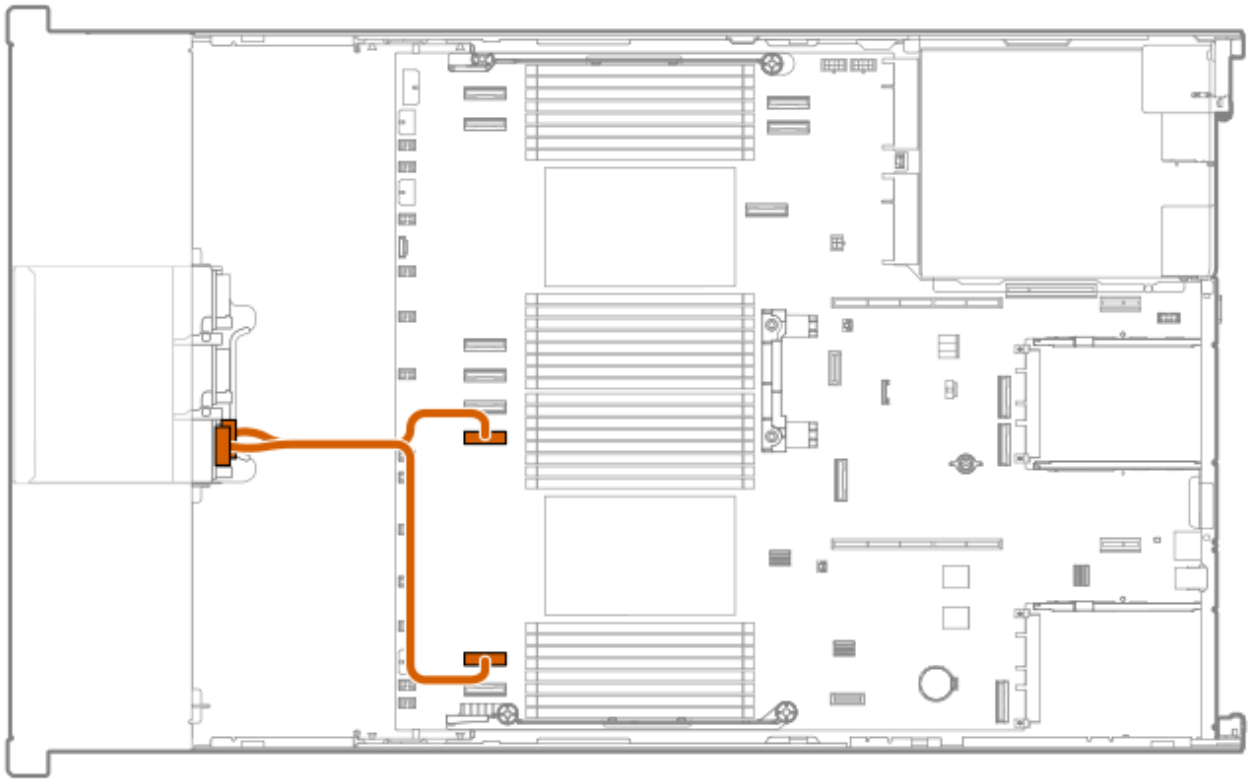

Cable part number	Color	From	To
P76141-001	Orange	Drive backplane	System board

EDSFF box 2: cage 3

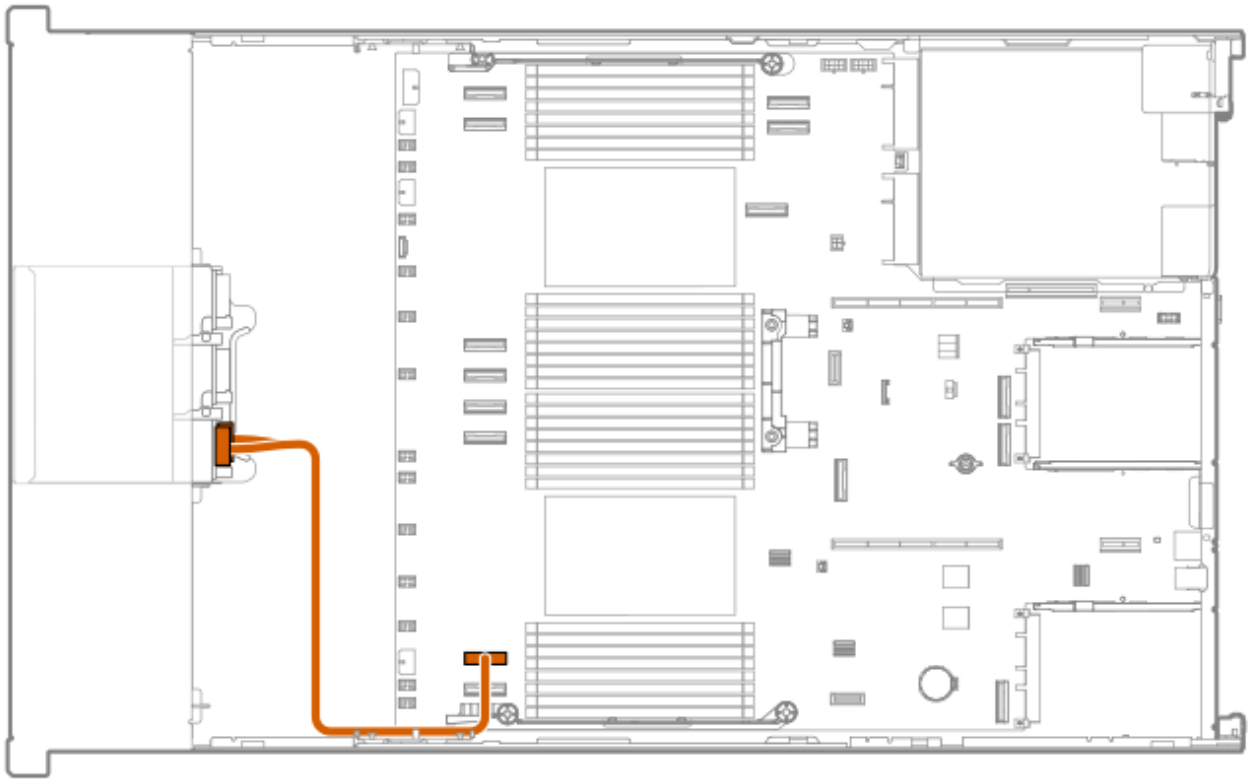

Cable part number	Color	From	To
P75369-001	Orange	Drive backplane	System board

EDSFF box 2: PCIe controllers

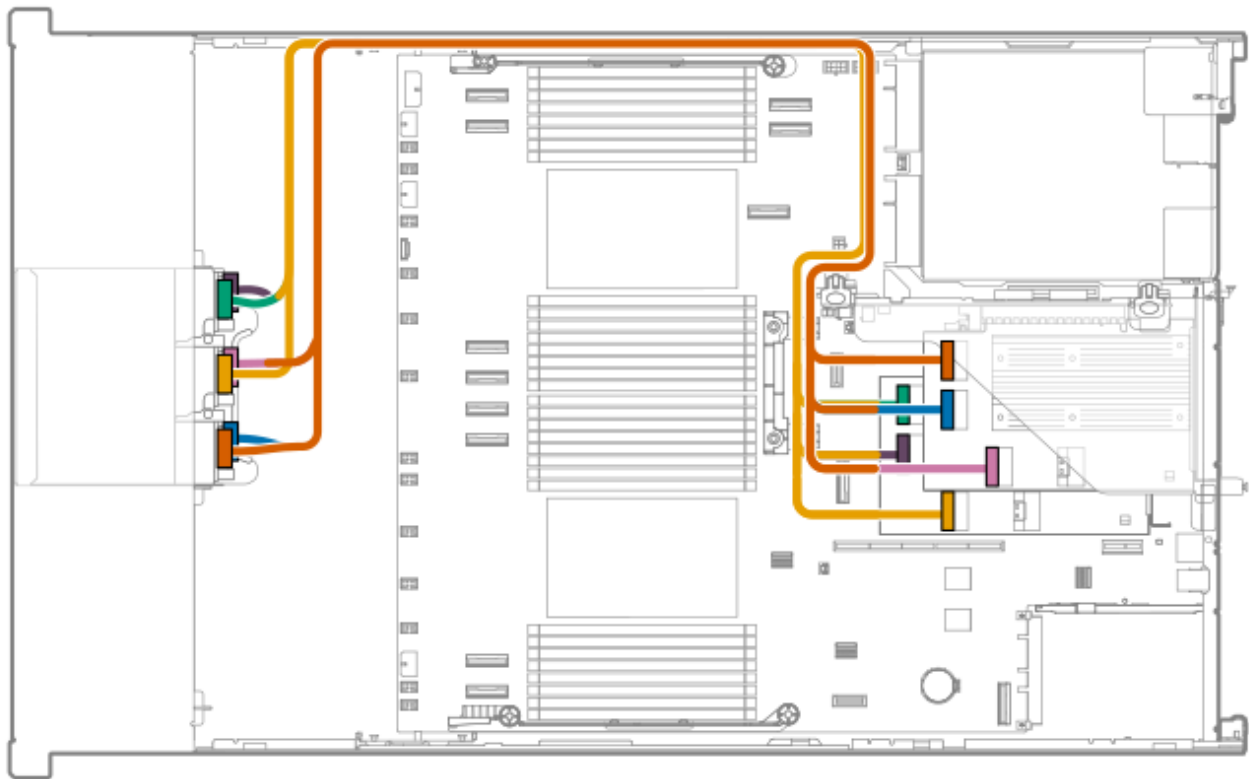

Cable part number	Color	From	To
P75318-001	Orange	Cage 3 top port	Top PCIe controller Port 4
	Yellow	Cage 2 top port	Bottom PCIe controller Port 2
	Green	Cage 1 top port	Bottom PCIe controller Port 4
	Blue	Cage 3 bottom port	Top PCIe controller Port 3
	Pink	Cage 2 bottom port	Top PCIe controller Port 2
	Purple	Cage 1 bottom port	Top PCIe controller Port 3

EDSFF box 3 cages 1, 2, and 3: PCIe controllers



Cable part number	Color	From	To
P75569-001	Yellow	Cage 2 top port	Top MR932i-p Port 2
	Purple	Cage 1 bottom port	Top MR932i-p Port 3
	Green	Cage 1 top port	Top MR932i-p Port 4
P75569-001	Pink	Cage 2 bottom port	Bottom MR932i-p Port 2
	Blue	Cage 3 bottom port	Bottom MR932i-p Port 3
	Orange	Cage 3 top port	Bottom MR932i-p Port 4

EDSFF box 3: cage 1

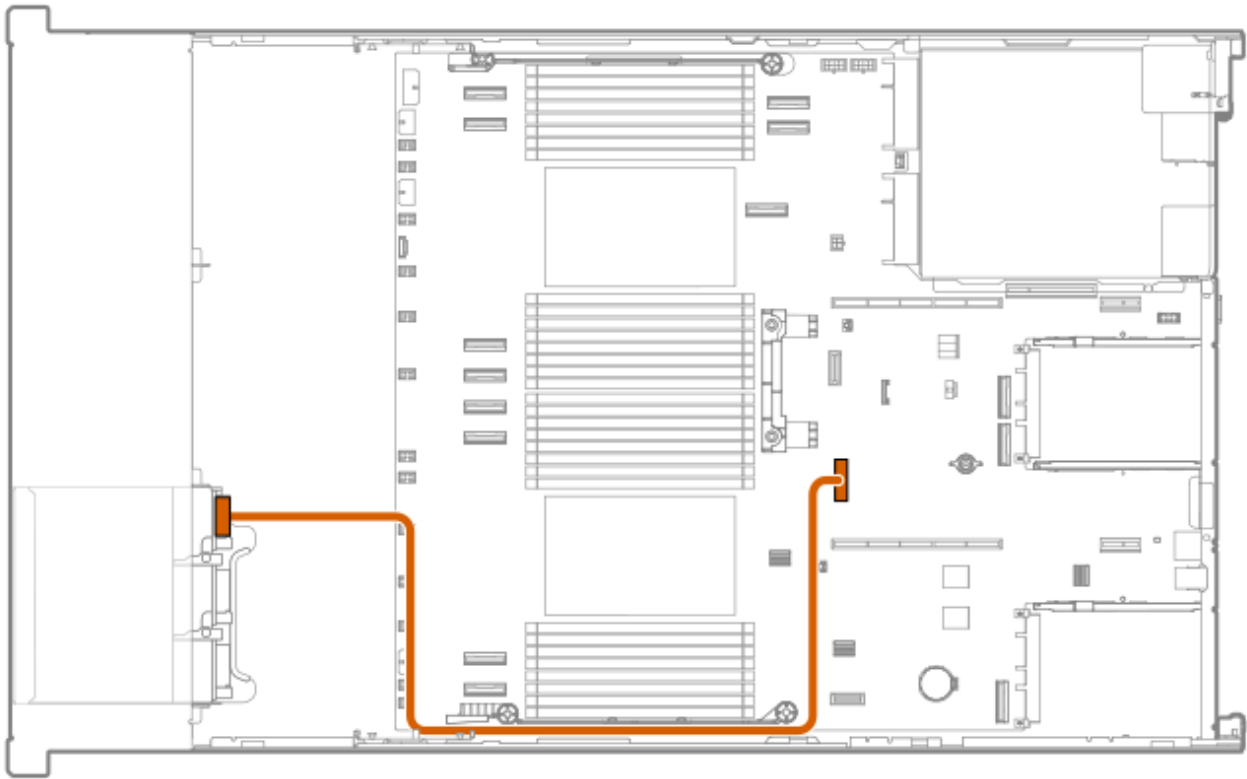

Cable part number	Color	From	To
P75567-001	Orange	Drive backplane	System board

8 SFF box 1 cabling

8 SFF box 1: Secondary PCIe controller

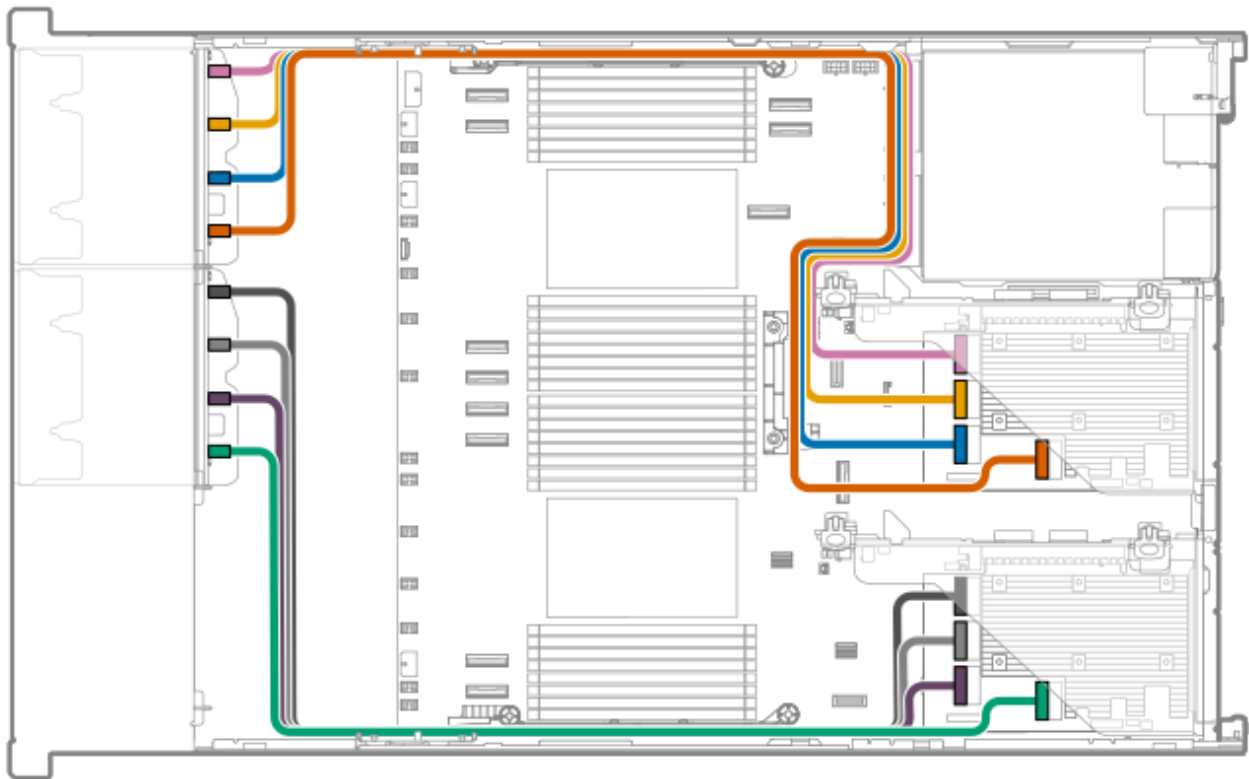

Cable part number	Color	From	To
P74805-001	Pink	Drive backplane Port 1	MR932i-p controller port 4
	Yellow	Drive backplane Port 2	MR932i-p controller port 3
	Blue	Drive backplane Port 3	MR932i-p controller port 2
	Orange	Drive backplane Port 4	MR932i-p controller port 1

8 SFF box 1: Secondary PCIe controller

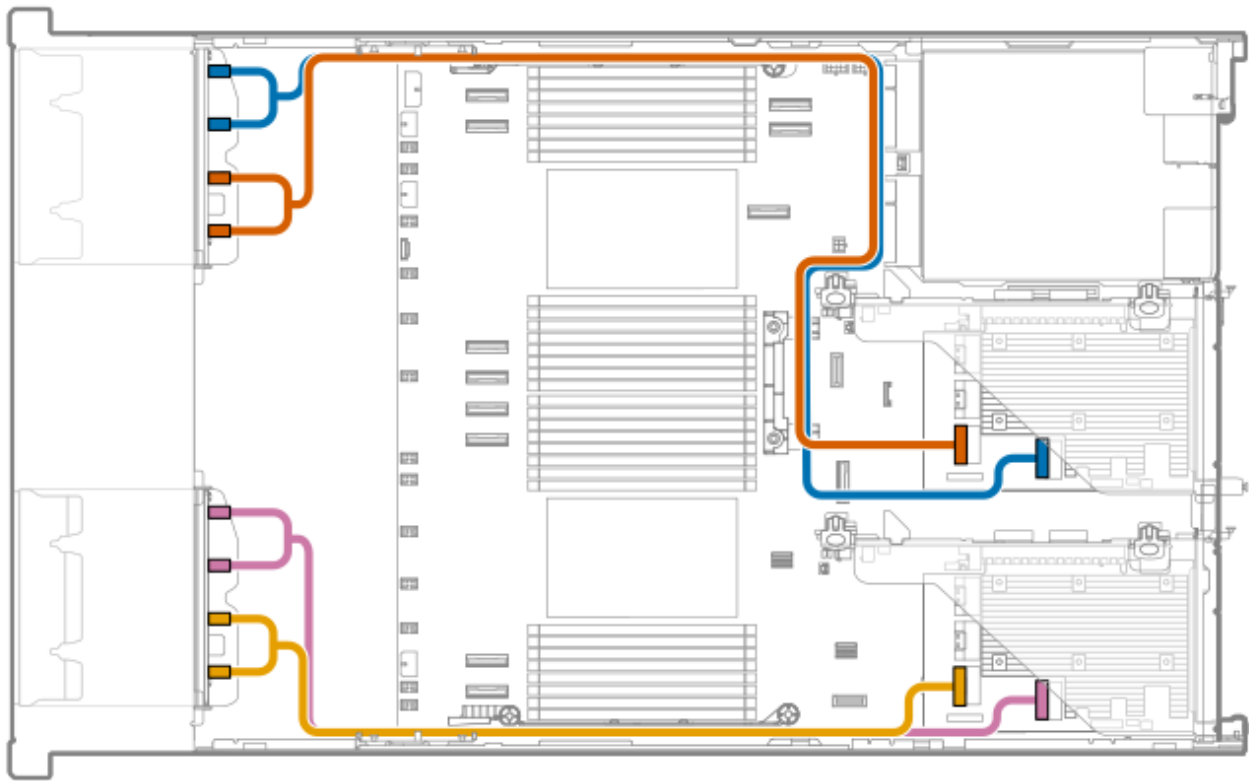

Cable part number	Color	From	To
P78631-001	Blue	Drive backplane Ports 1 and 2	MR932i-p controller port 1
	Orange	Drive backplane Ports 3 and 4	MR932i-p controller port 2

8 SFF box 1: system board



Cable part number	Color	From	To
P74811-001	Orange	Drive backplane	System board

8 SFF box 1: system board

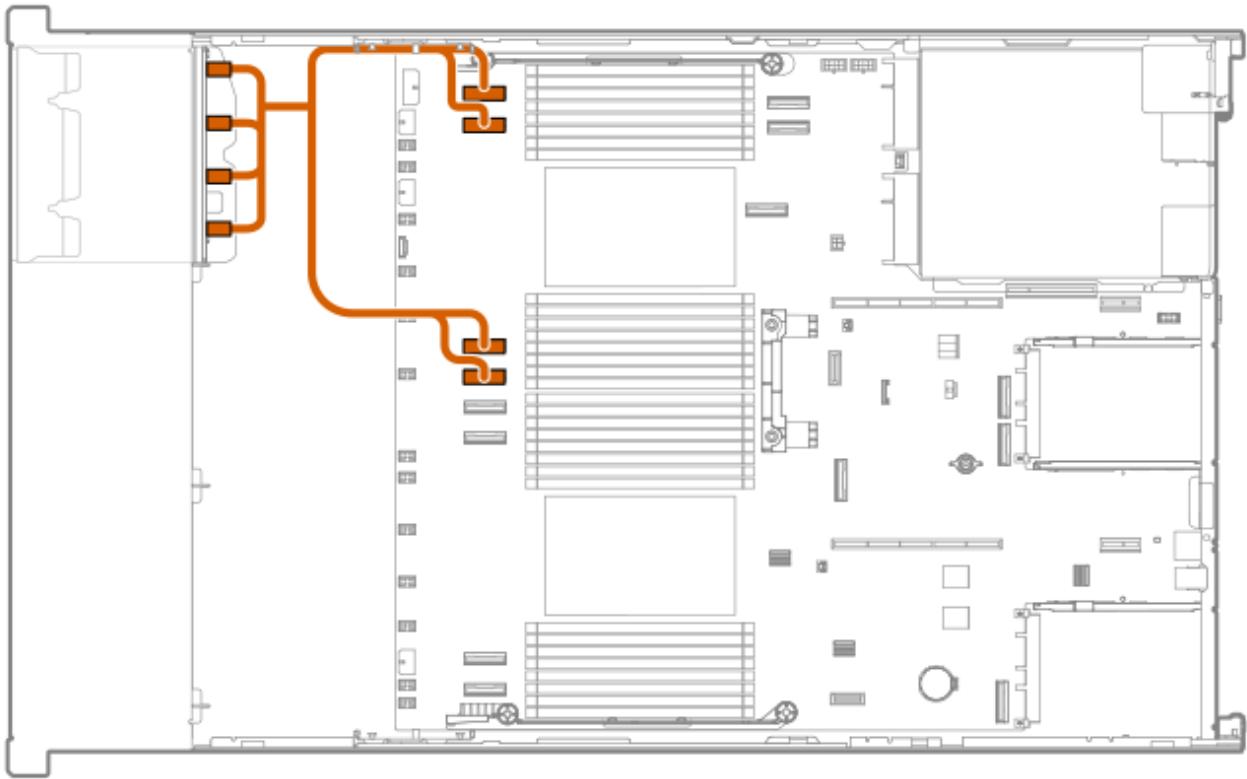

Cable part number	Color	From	To
P76147-001	Orange	Drive backplane	System board

8 SFF box 1: system board

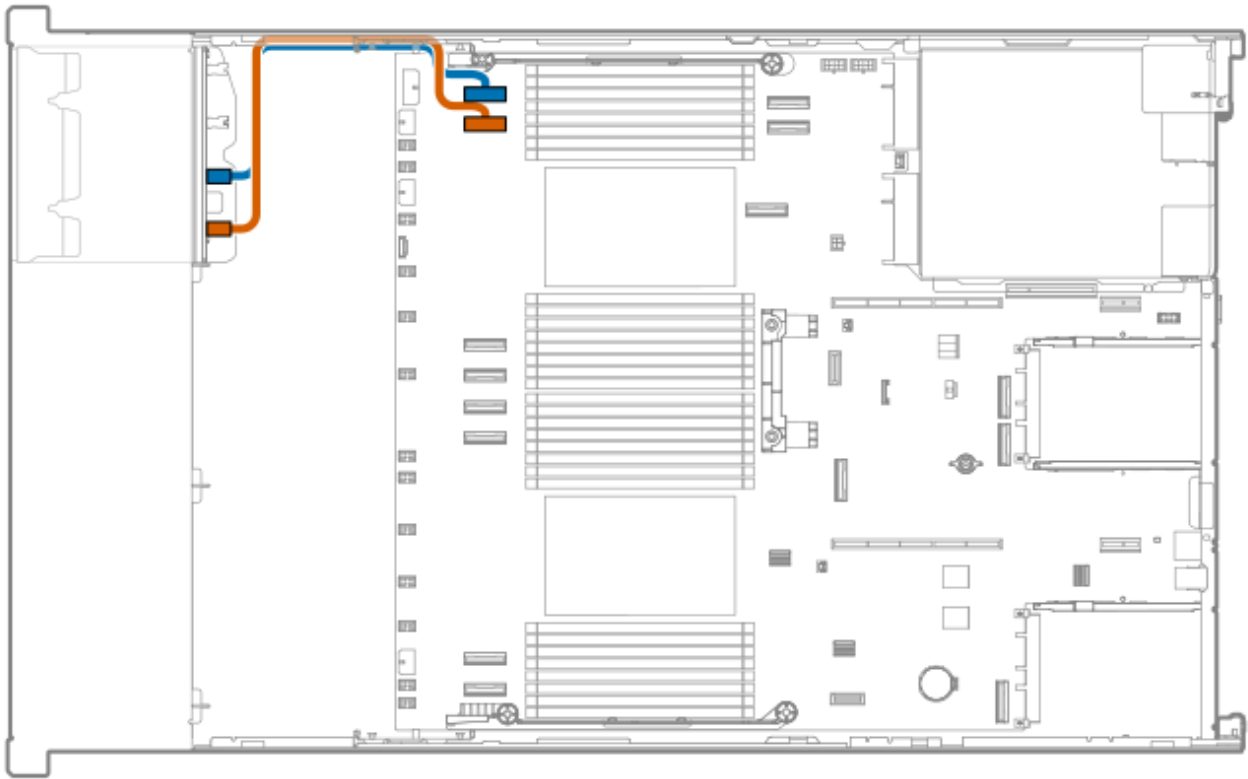

Cable part number	Color	From	To
P75367-001	Orange	Drive backplane	System board

8 SFF box 1: system board

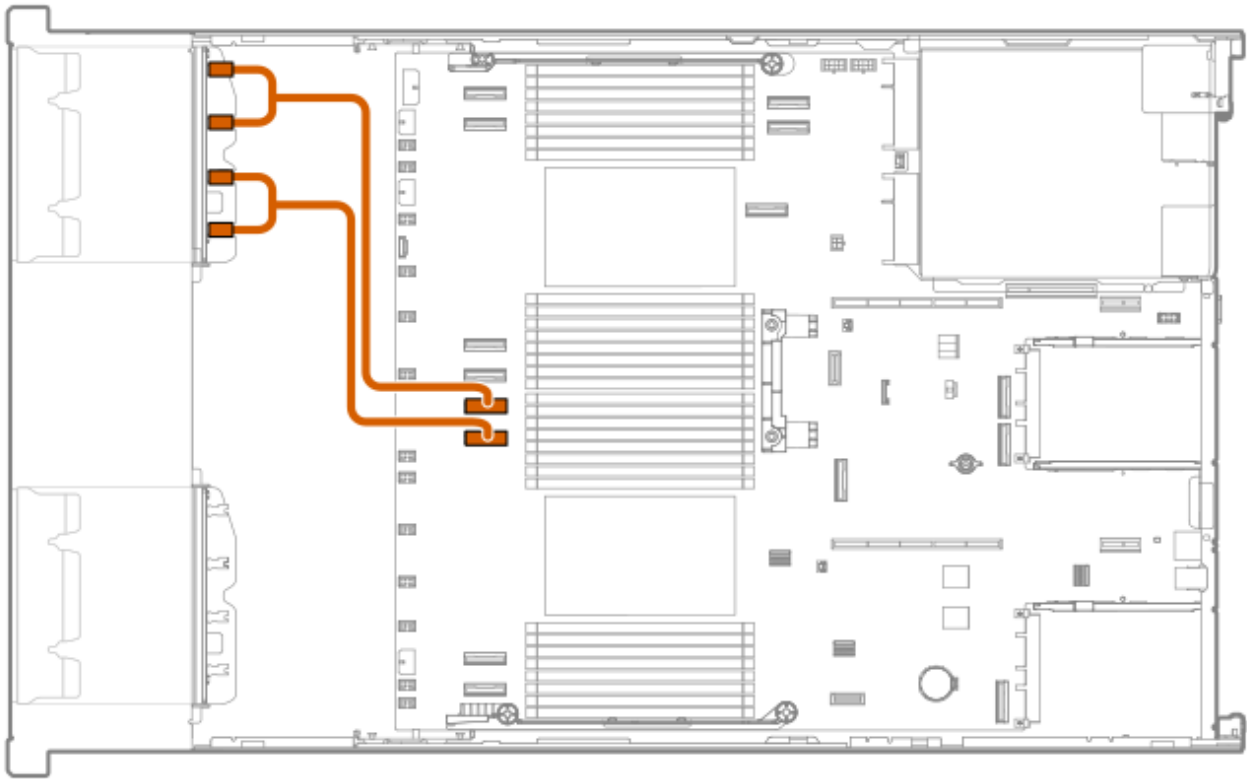

Cable part number	Color	From	To
P75563-001	Orange	Drive backplane	System board

8 SFF box 1: system board

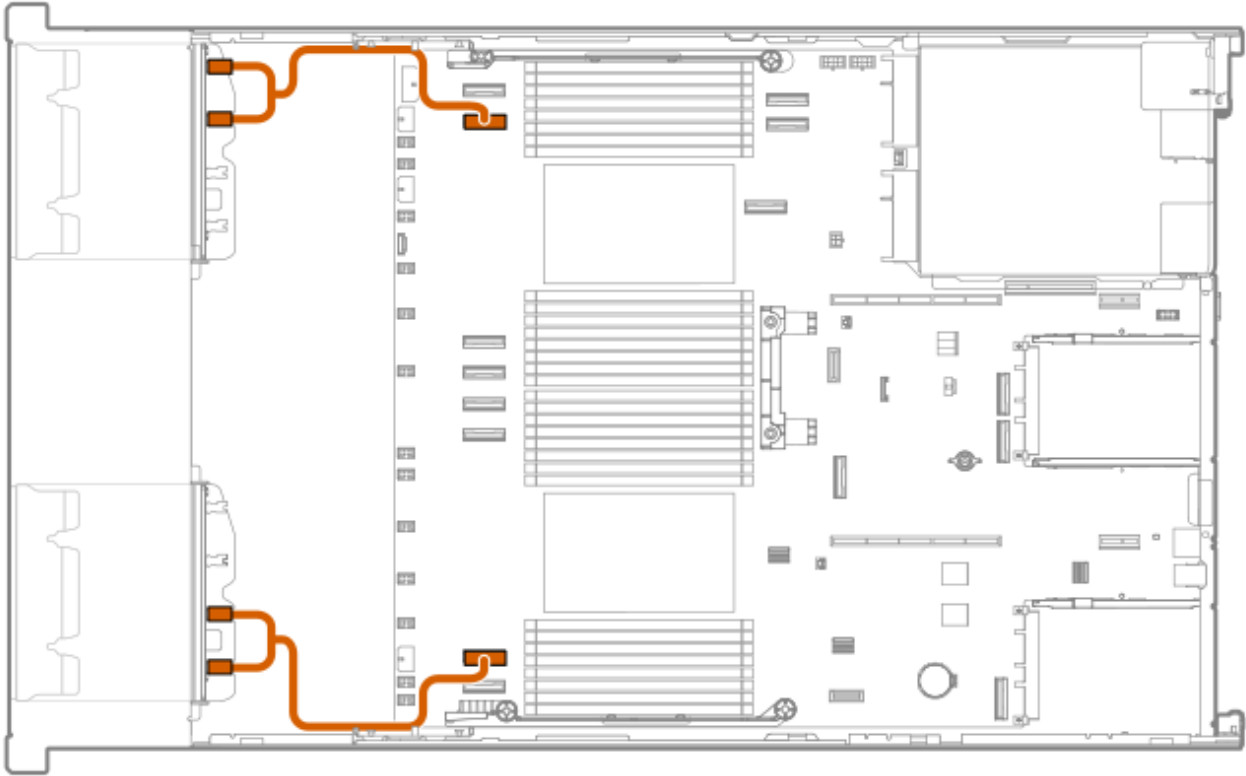

Cable part number	Color	From	To
P75563-001	Orange	Drive backplane	System board

8 SFF box 1: system board

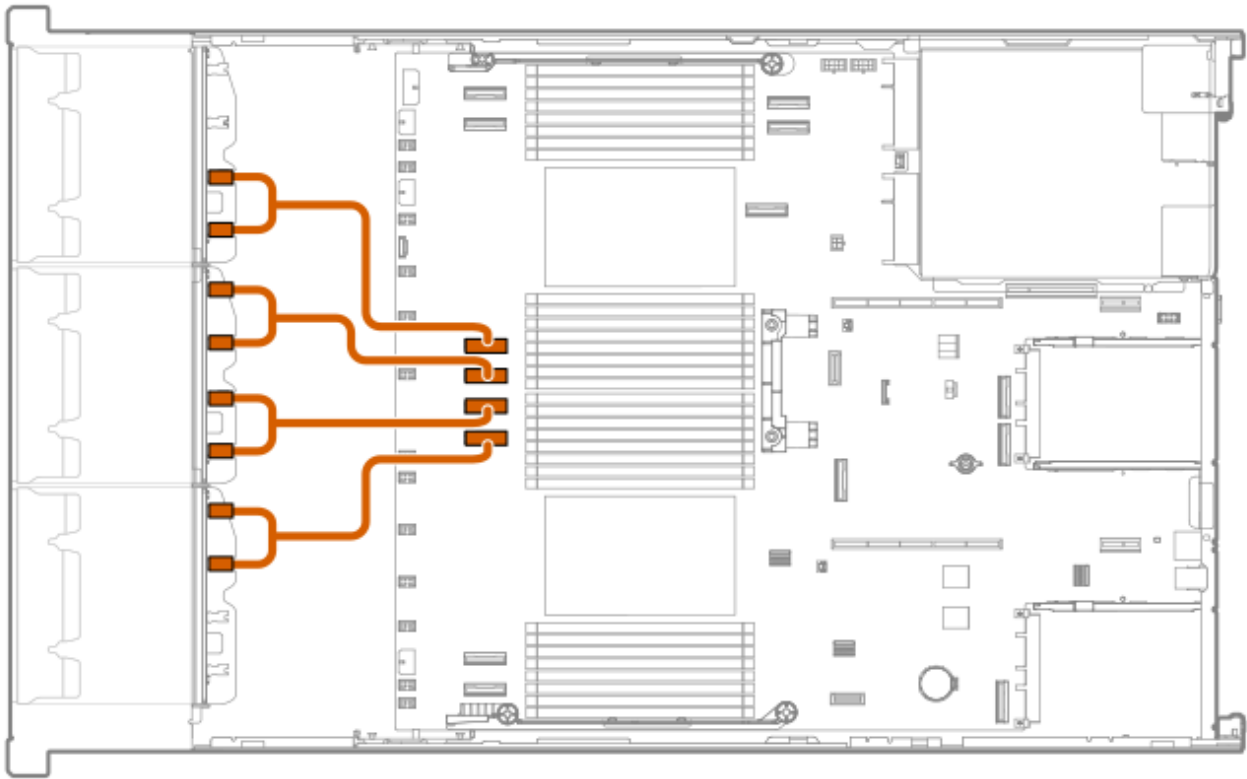

Cable part number	Color	From	To
P75563-001	Orange	Drive backplane	System board

8 SFF box 1: system board

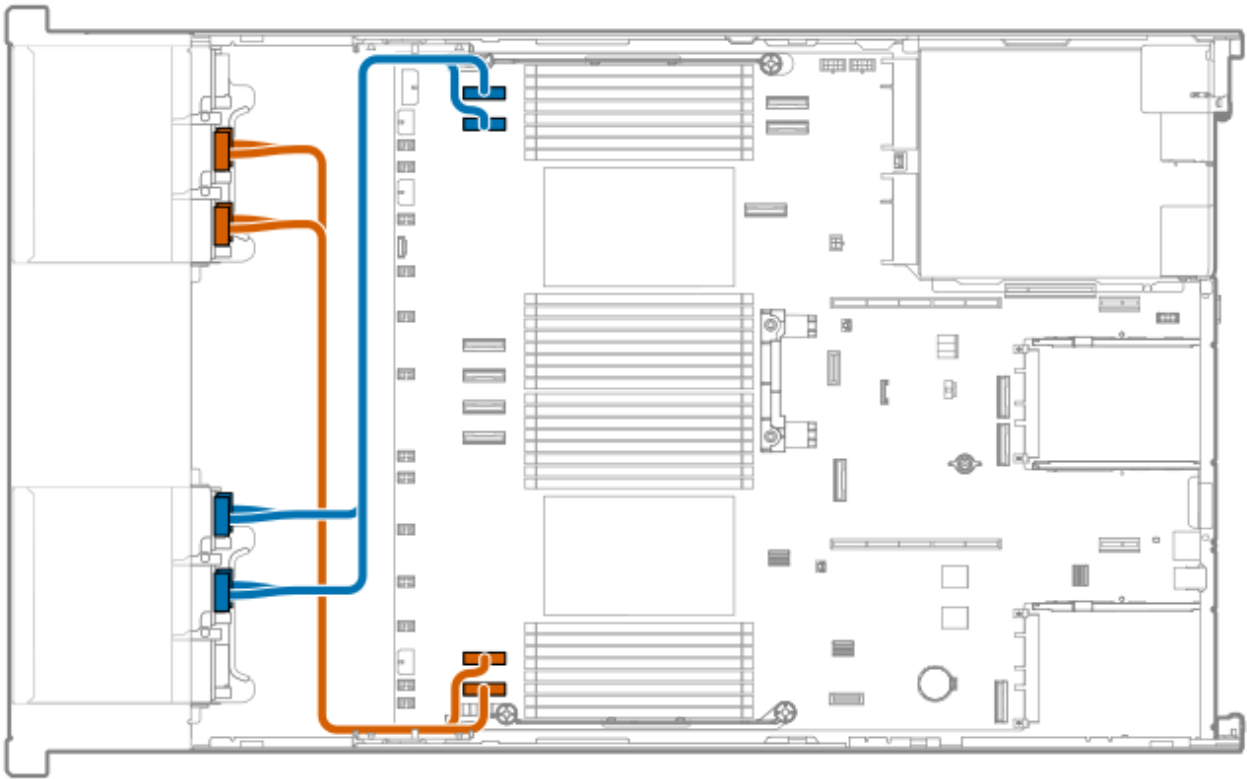

Cable part number	Color	From	To
P75365-001	Orange	Drive backplane	System board

8 SFF box 1: OCP A controller

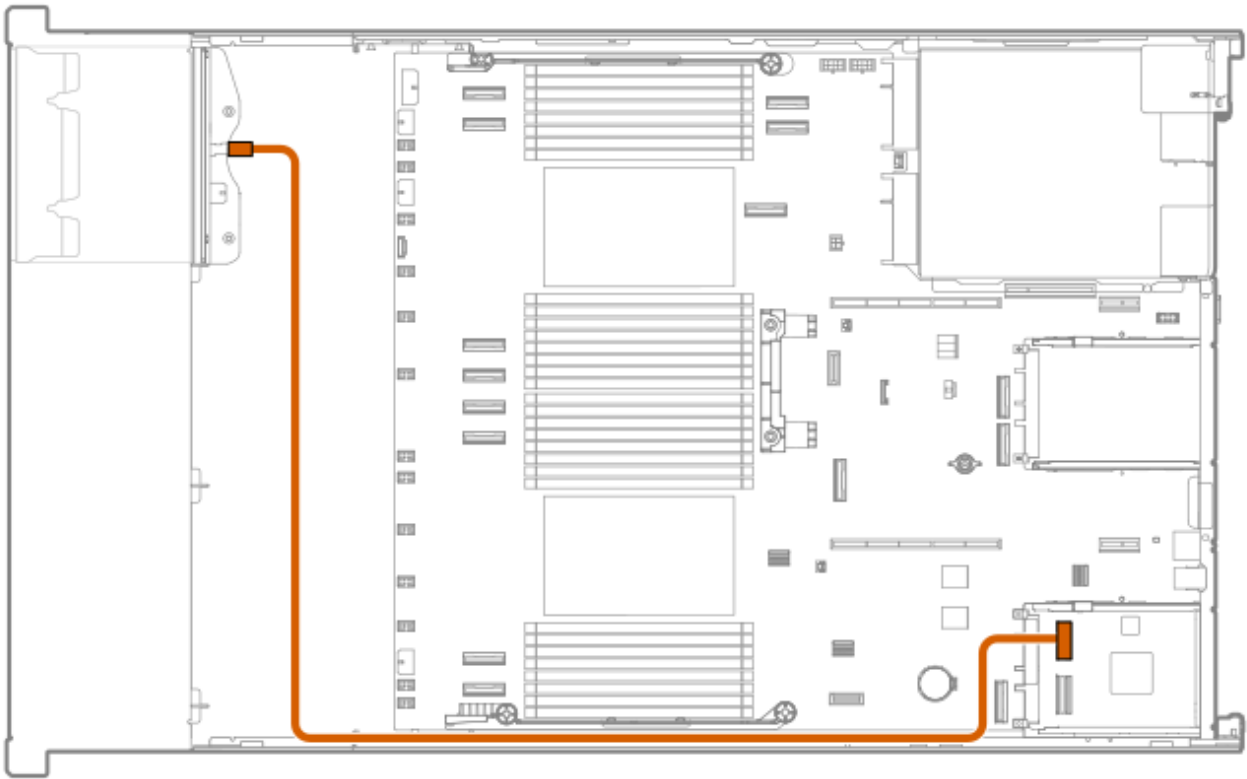

Cable part number	Color	From	To
P51545-001	Orange	Drive backplane	OCP A controller

8 SFF box 1: OCP B controller

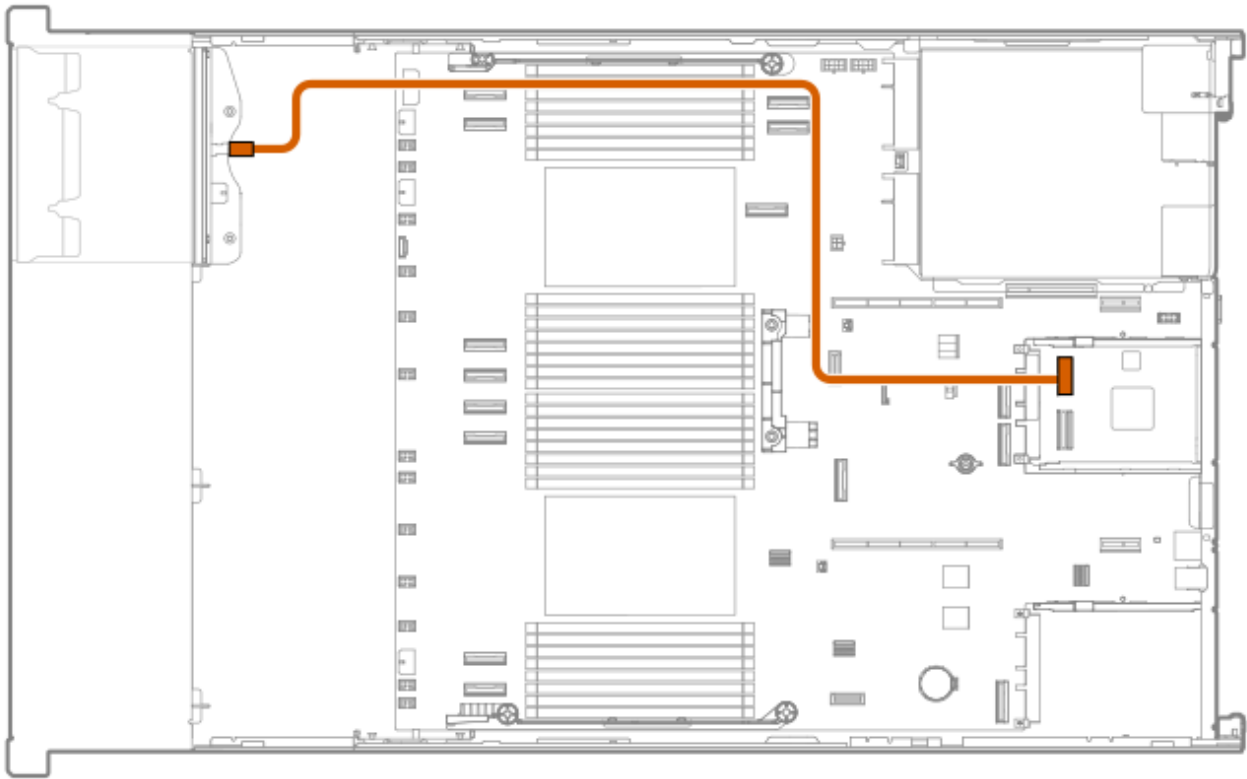

Cable part number	Color	From	To
P51545-001	Orange	Drive backplane	OCP B controller

8 SFF box 1: OCP B controller

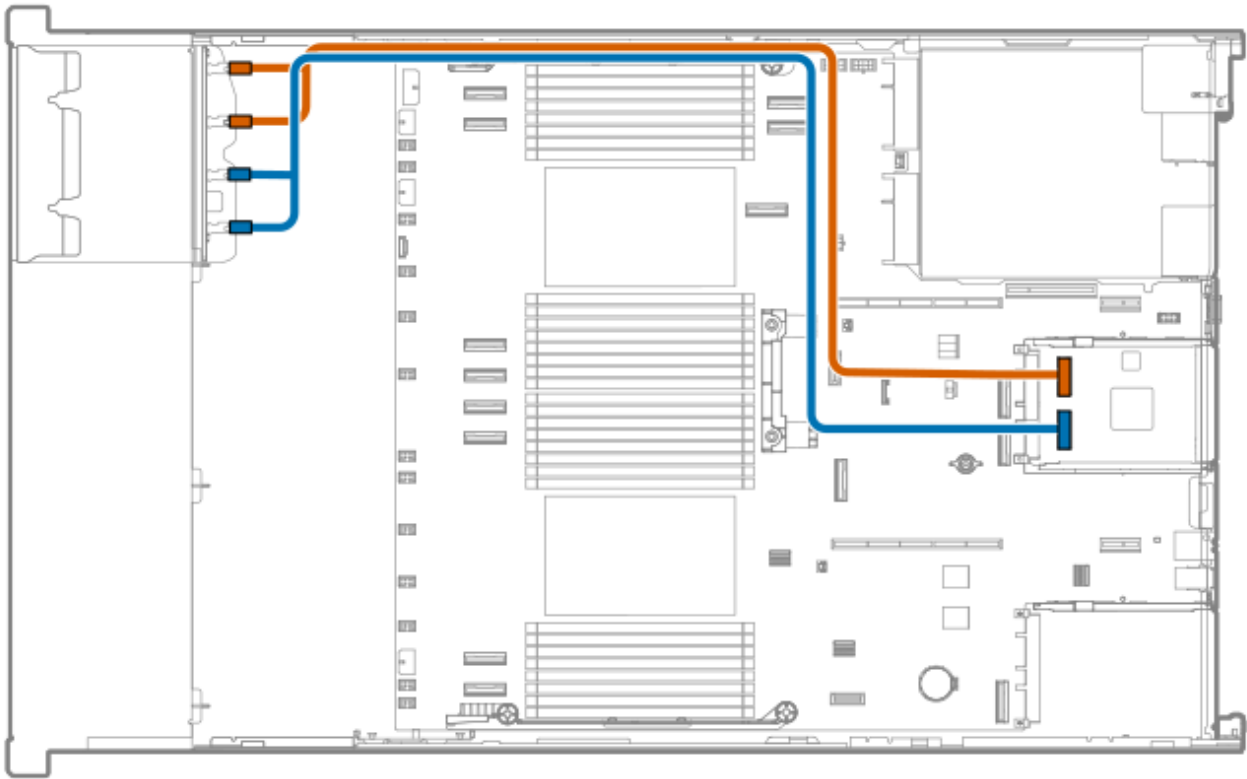

Cable part number	Color	From	To
P51546-001	Orange	Drive backplane	OCP B controller
P51546-001	Blue	Drive backplane	OCP B controller

8 SFF box 1: OCP A controller

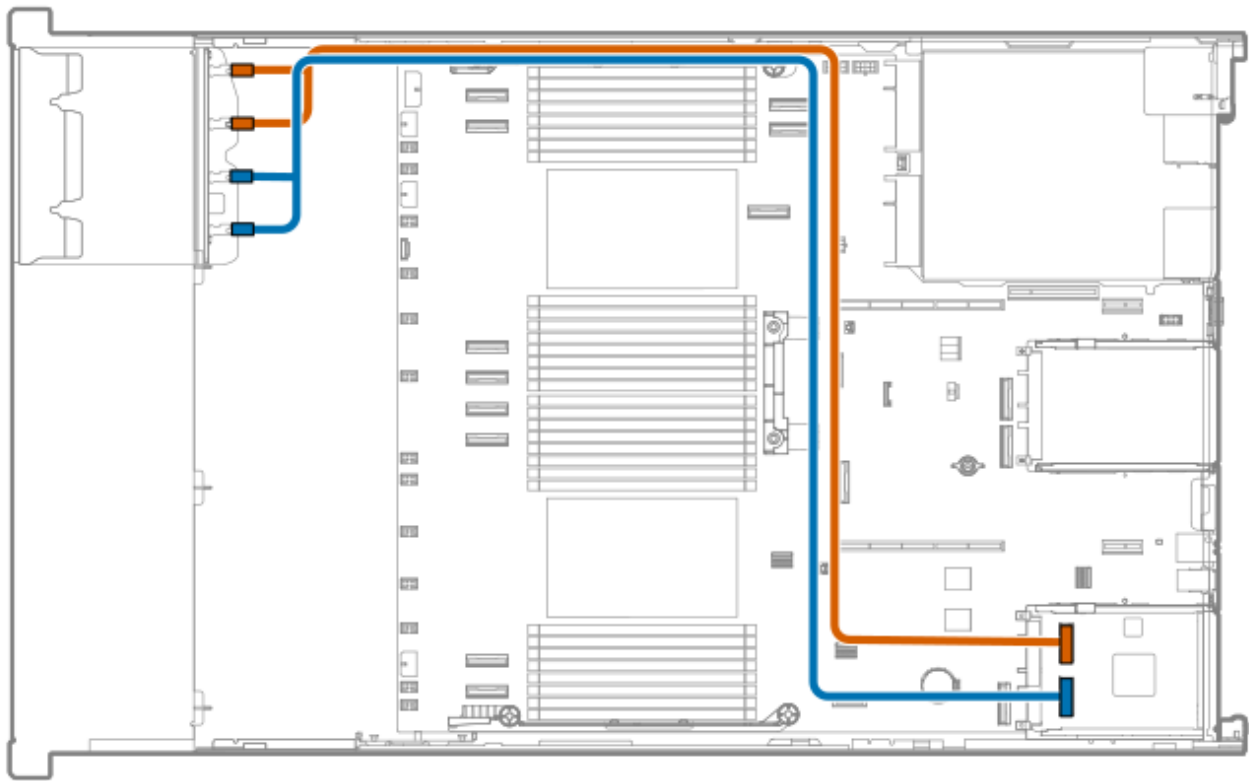

Cable part number	Color	From	To
P51546-001	Orange	Drive backplane	OCP A controller
P51546-001	Blue	Drive backplane	OCP A controller

8 SFF box 1: Secondary PCIe controller

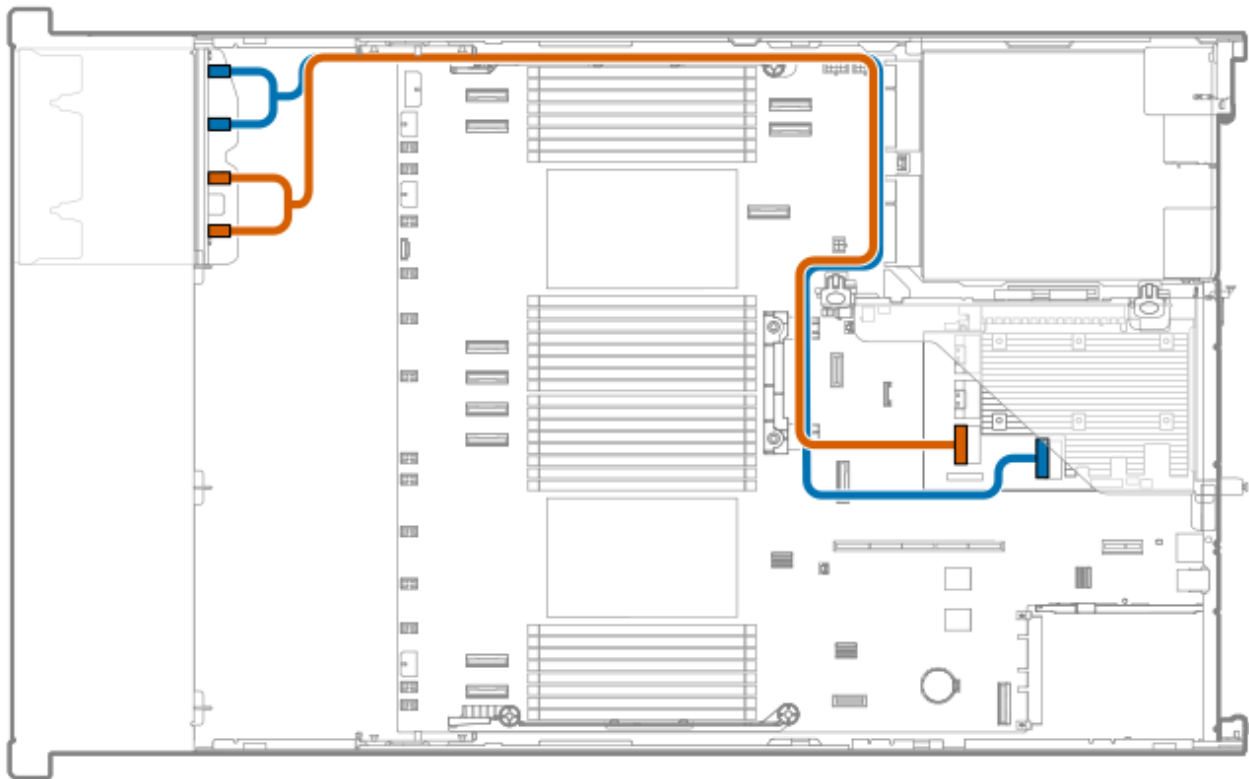

Cable part number	Color	From	To
P51548-001	Orange	Drive backplane	Secondary PCIe controller
P51548-001	Blue	Drive backplane	Secondary PCIe controller

8 SFF box 1: Primary PCIe controller

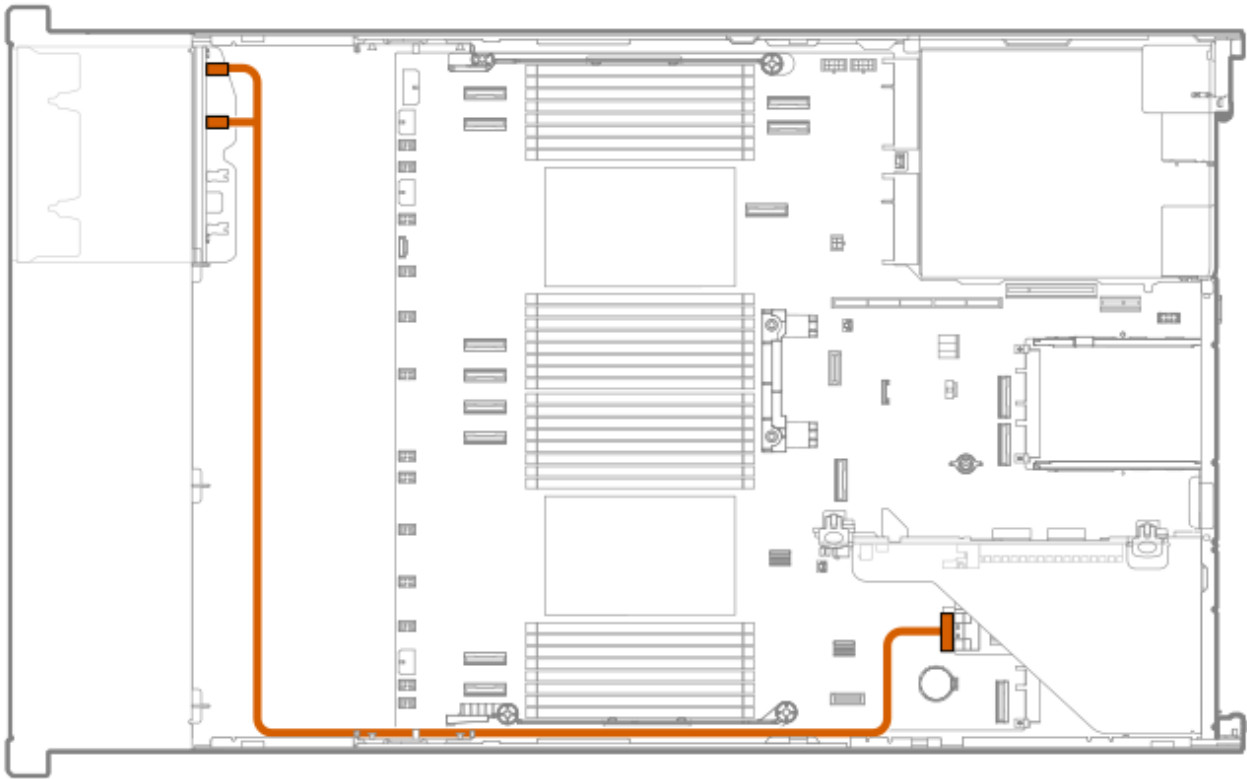

Cable part number	Color	From	To
P51547-001	Orange	Drive backplane	Primary PCIe controller

8 SFF box 2 cabling

8 SFF box 2: PCIe controller

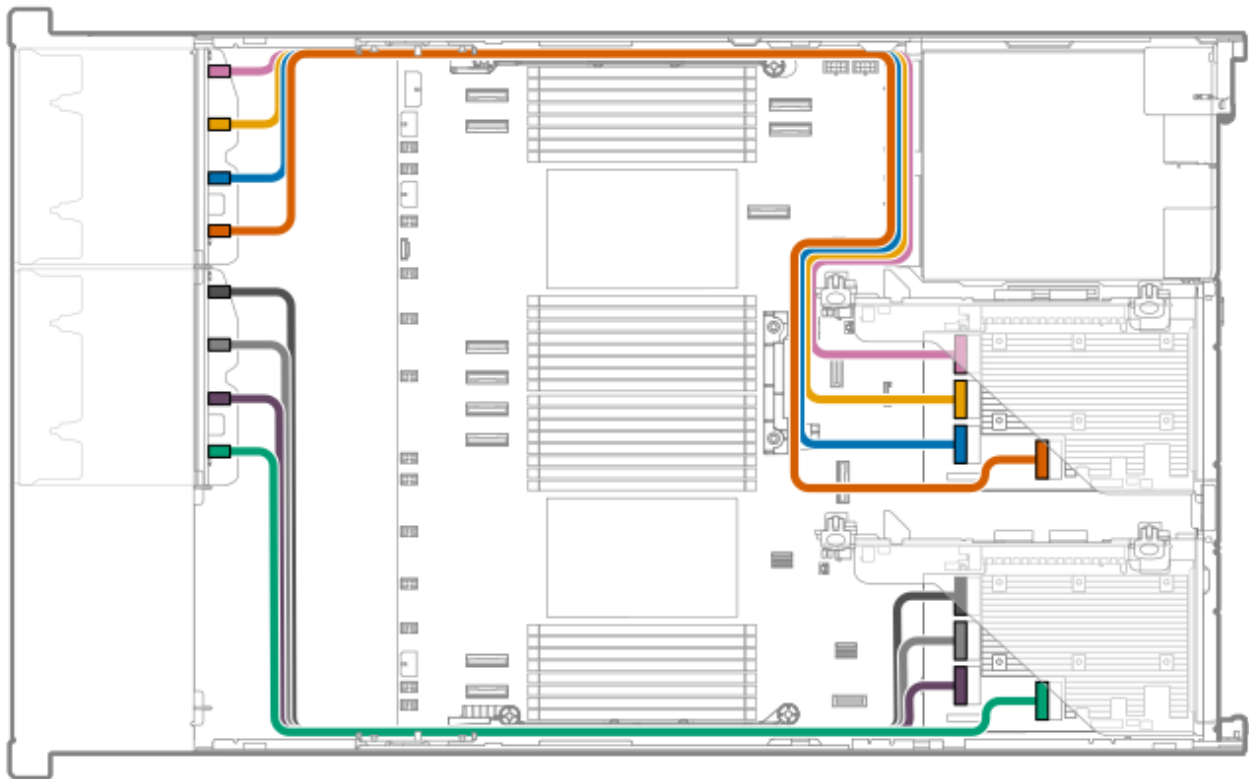

Cable part number	Color	From	To
P74805-001	Dark gray	Drive backplane Port 1	MR932i-p controller port 4
	Light gray	Drive backplane Port 2	MR932i-p controller port 3
	Purple	Drive backplane Port 3	MR932i-p controller port 2
	Green	Drive backplane Port 4	MR932i-p controller port 1

8 SFF box 2: System board

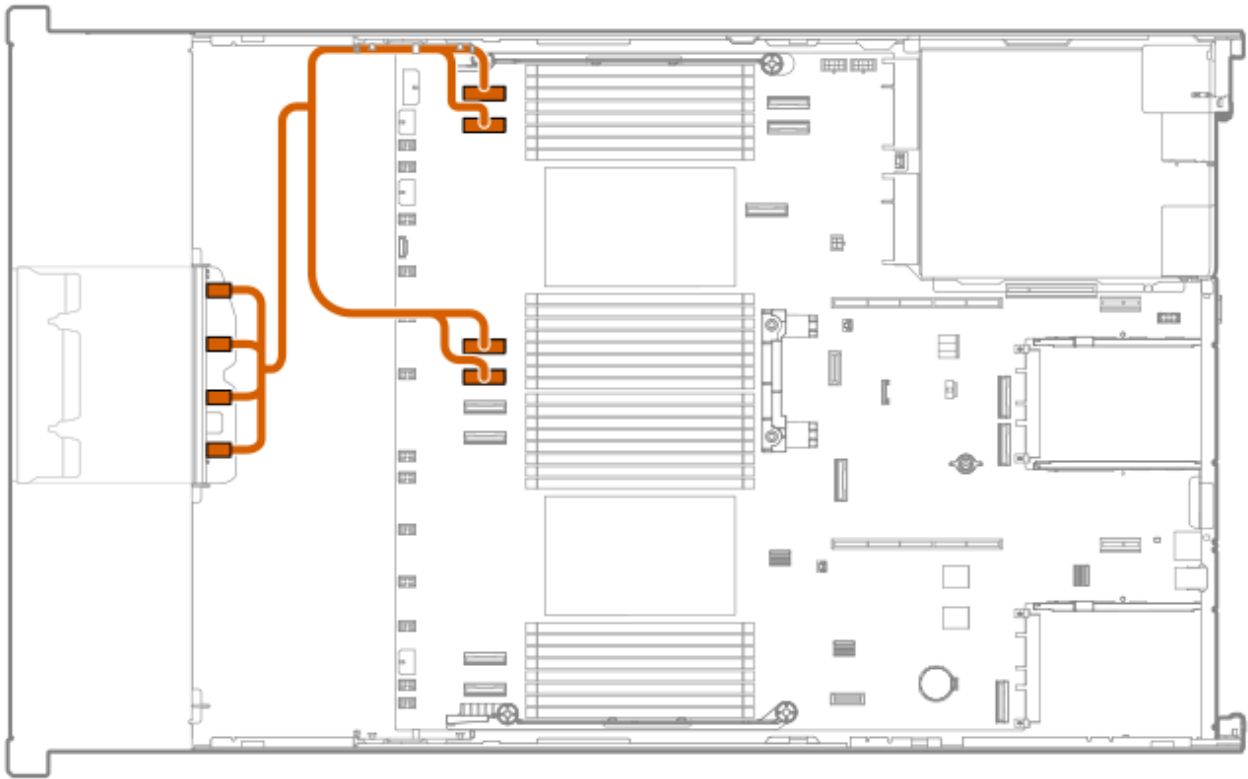

Cable part number	Color	From	To
P76147-001	Orange	Drive backplane	System board

8 SFF box 2: System board

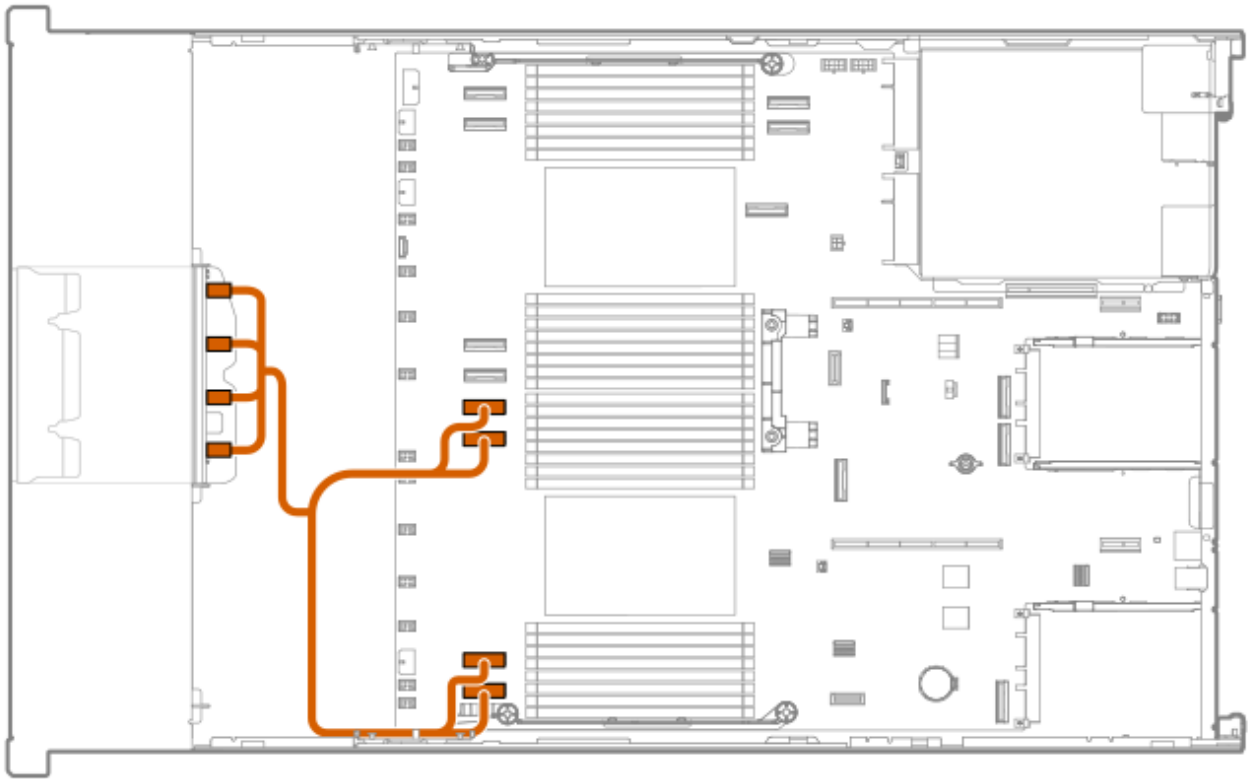

Cable part number	Color	From	To
P76146-001	Orange	Drive backplane	System board

8 SFF box 2: System board

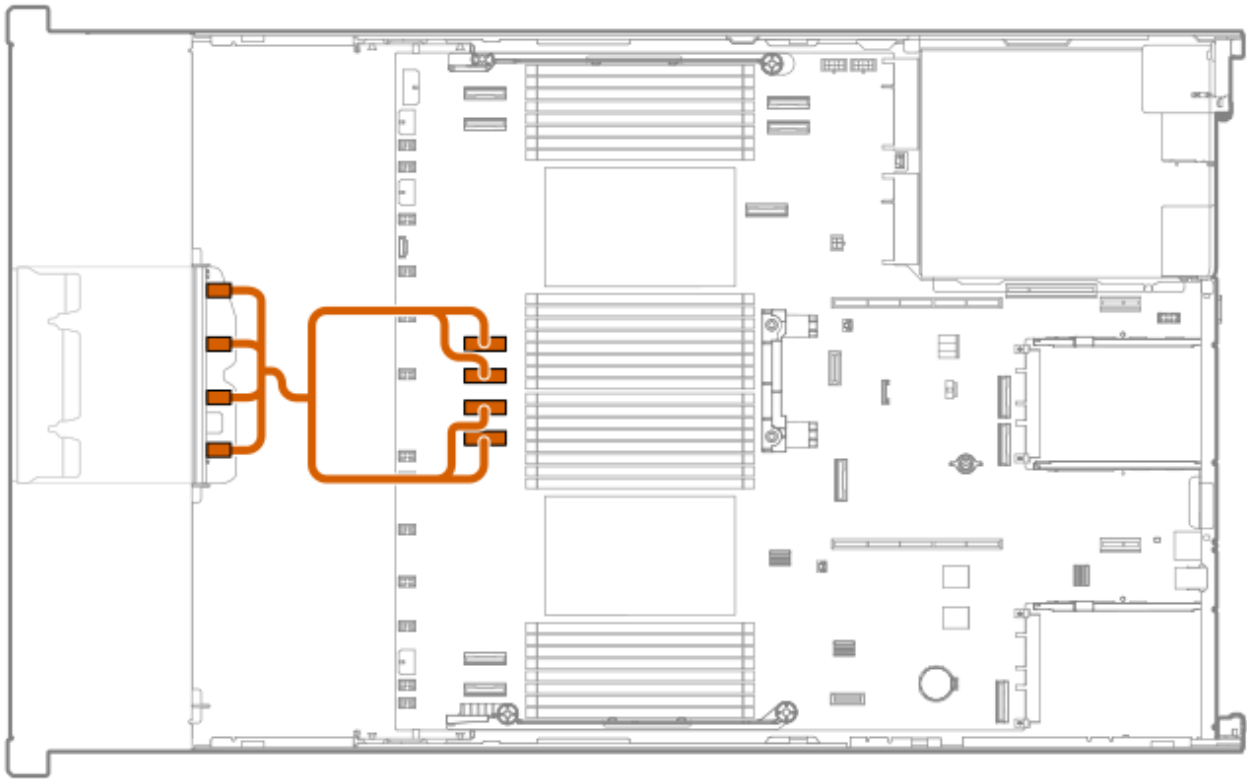

Cable part number	Color	From	To
P76148-001	Orange	Drive backplane	System board

8 SFF box 2: system board

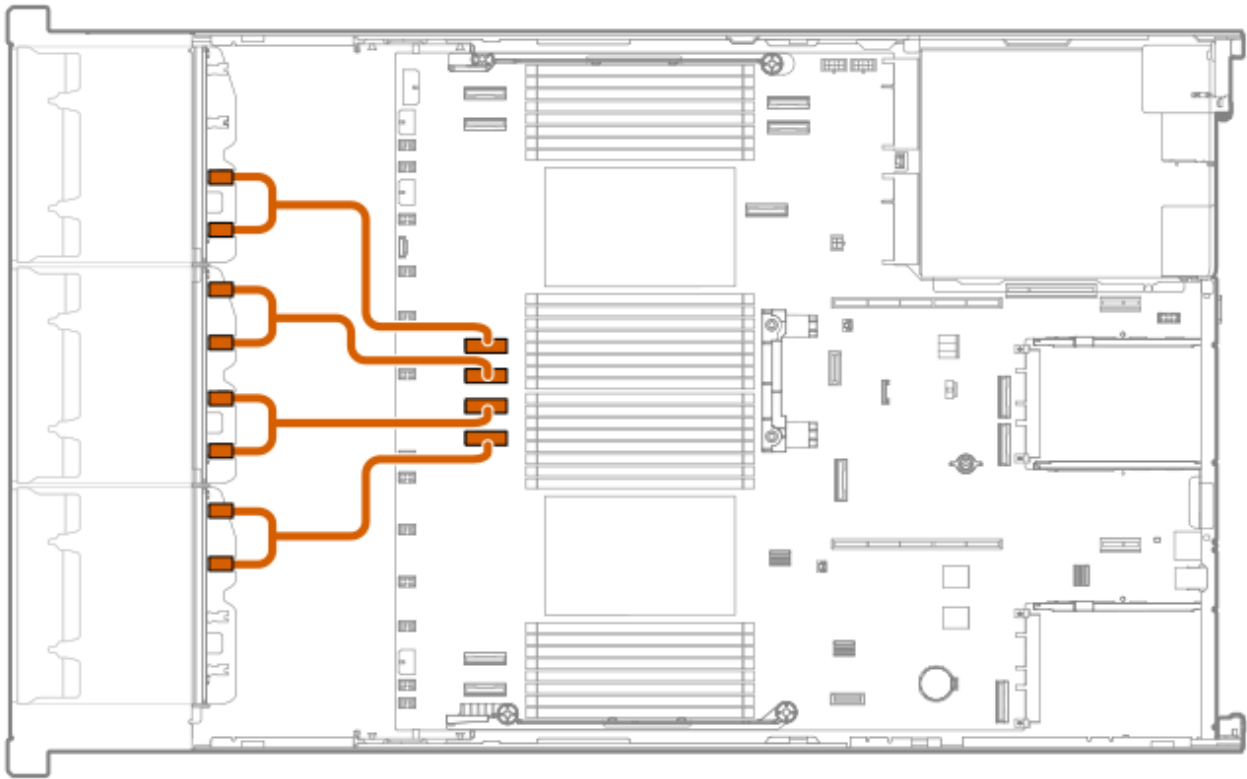

Cable part number	Color	From	To
P75563-001	Orange	Drive backplane	System board

8 SFF box 2: OCP A controller



Cable part number	Color	From	To
P51545-001	Orange	Drive backplane	OCP A controller

8 SFF box 2: OCP B controller

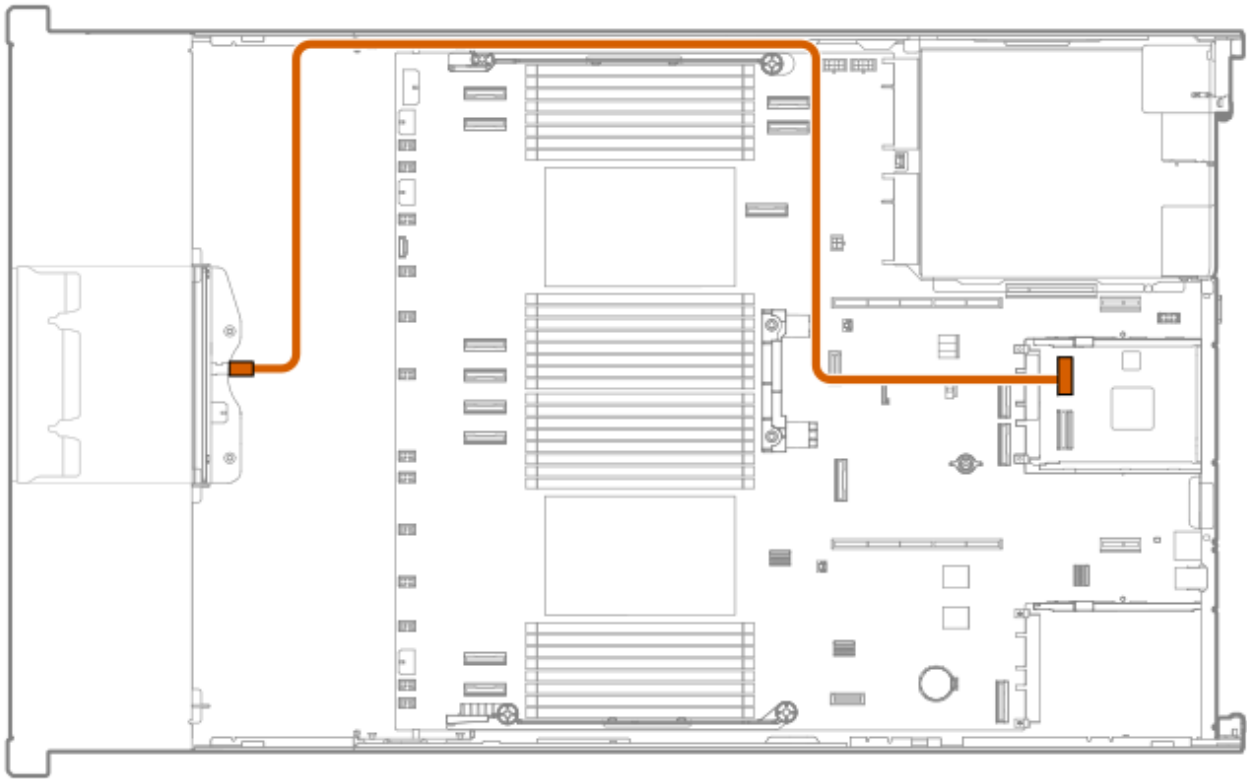

Cable part number	Color	From	To
P51545-001	Orange	Drive backplane	OCP B controller

8 SFF box 2: OCP B controller

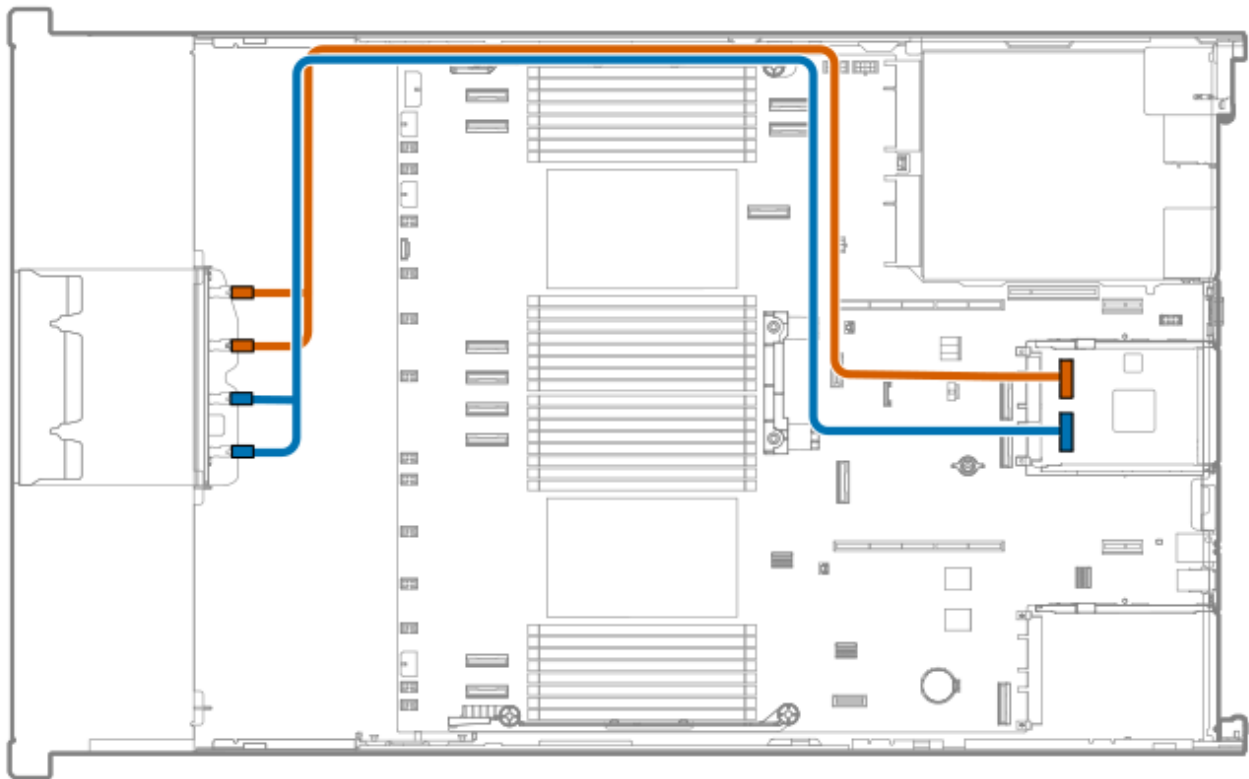

Cable part number	Color	From	To
P51546-001	Orange	Drive backplane	OCP B controller

8 SFF box 2: OCP B controller

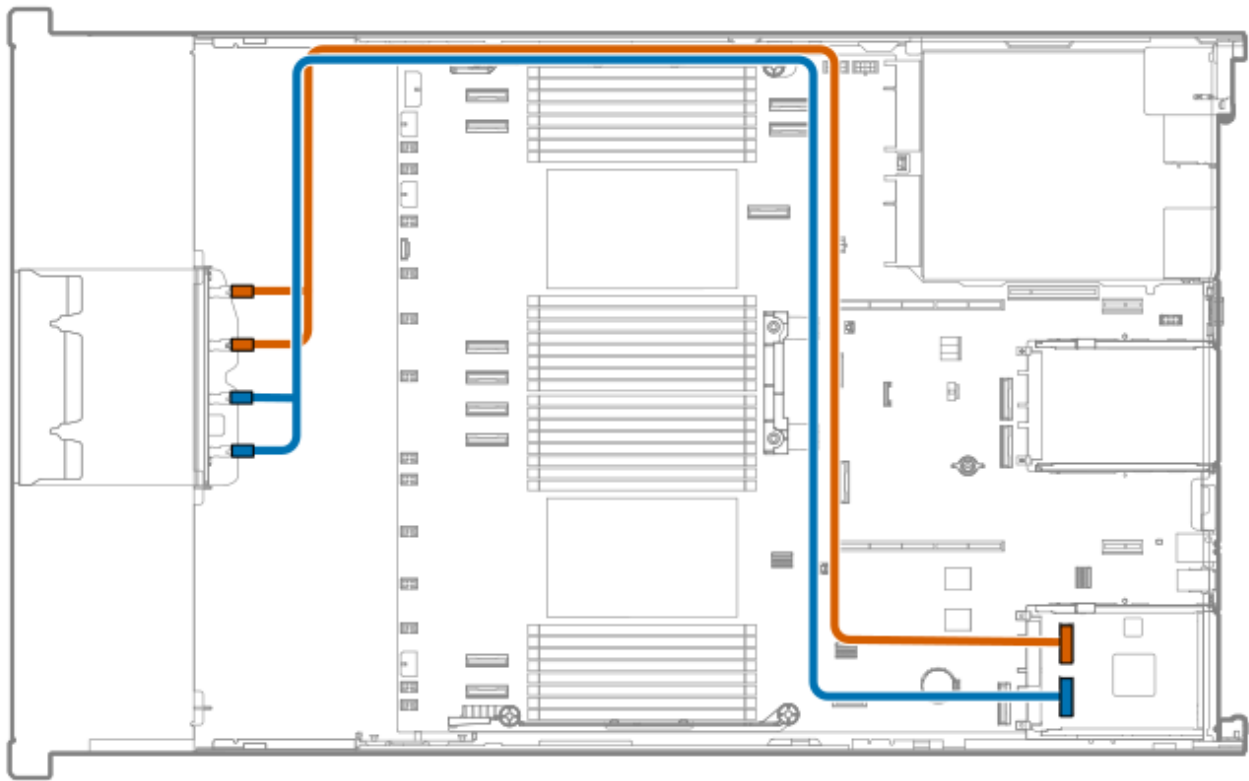

Cable part number	Color	From	To
P51546-001	Orange	Drive backplane	OCP B controller

8 SFF box 2: Primary PCIe controller

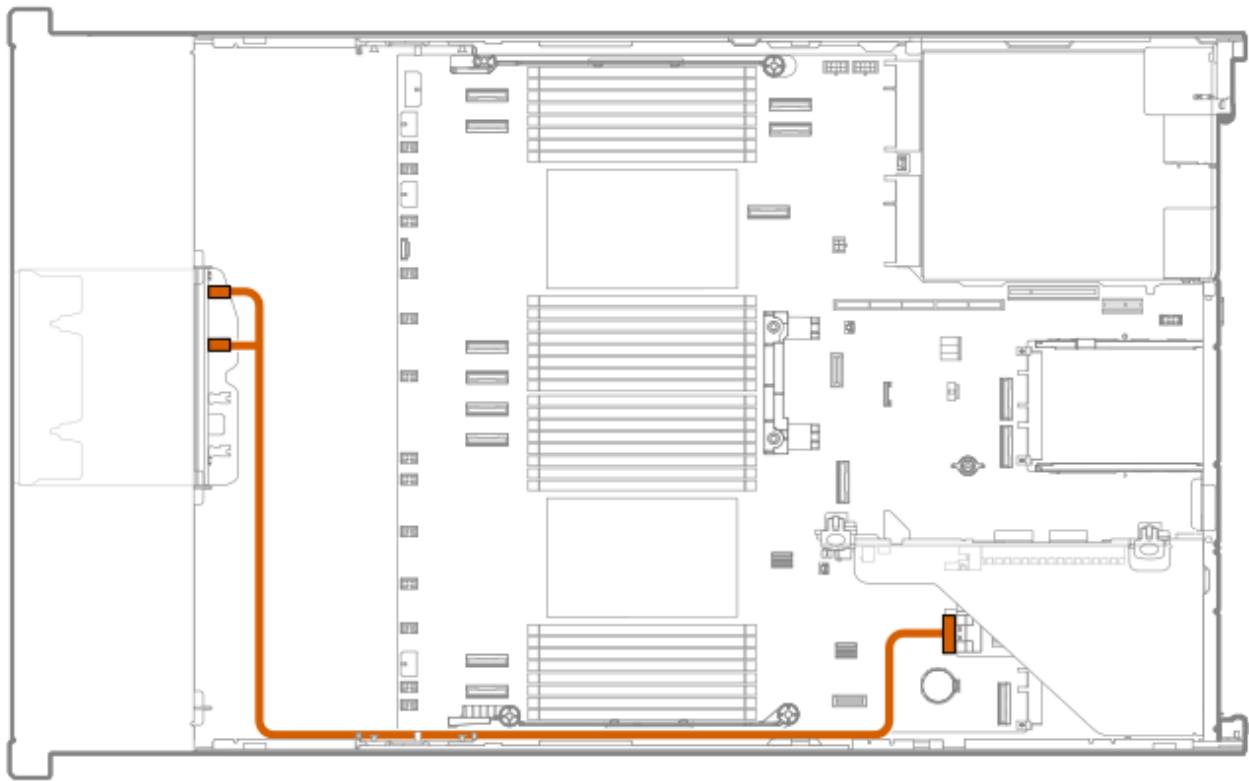

Cable part number	Color	From	To
P51547-001	Orange	Drive backplane	Primary PCIe controller

8 SFF box 2: Primary PCIe controller

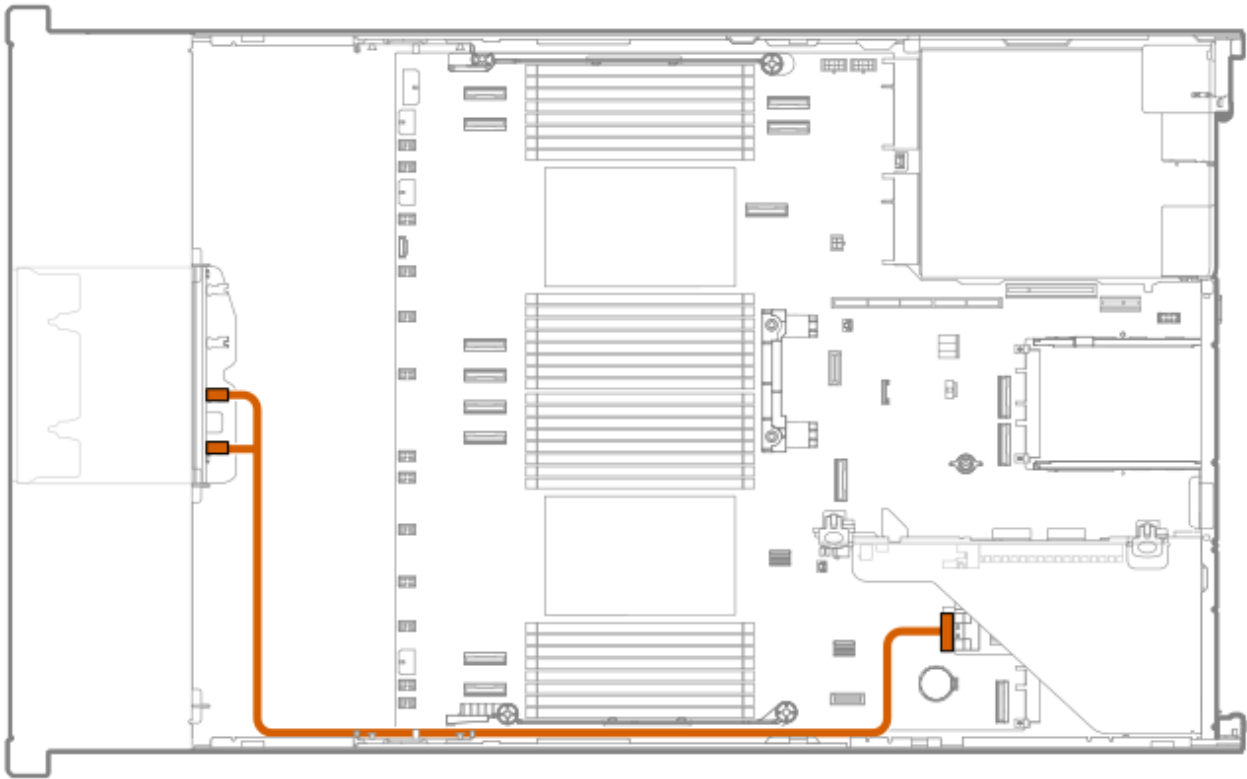

Cable part number	Color	From	To
P51547-001	Orange	Drive backplane	Primary PCIe controller

8 SFF box 2: Secondary PCIe controller

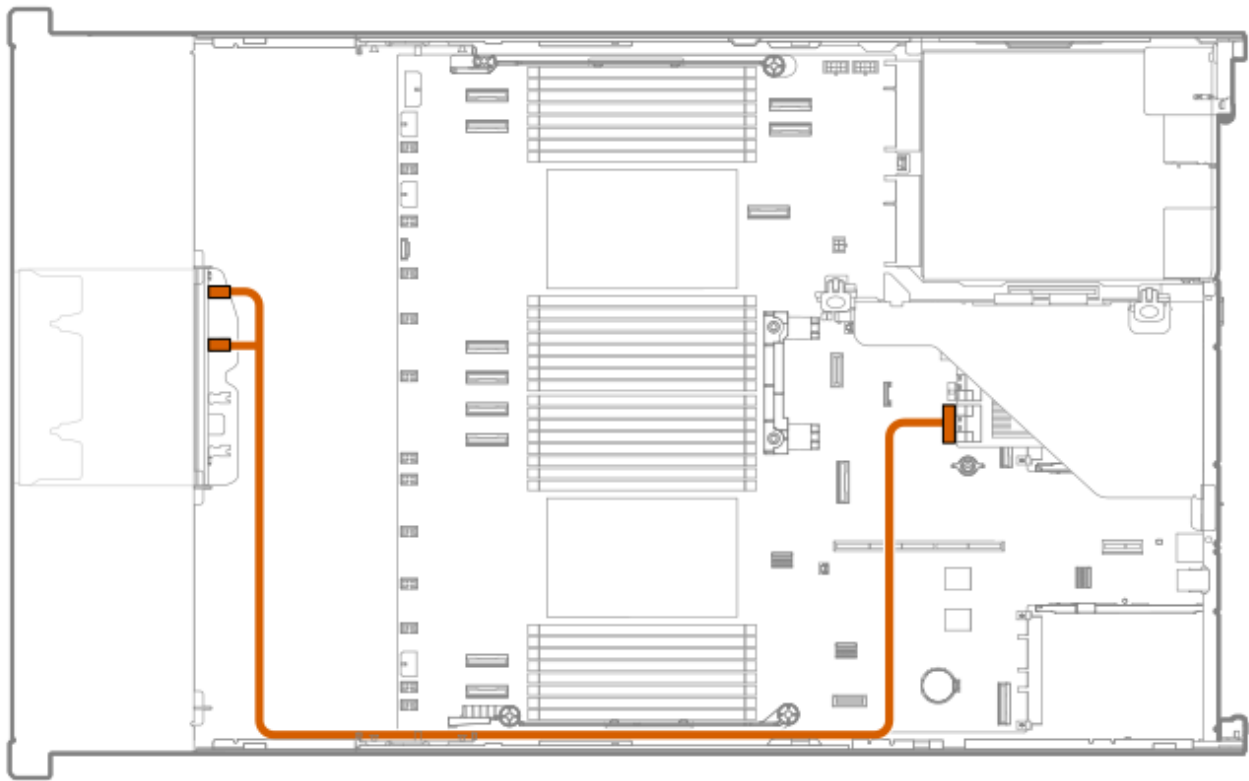

Cable part number	Color	From	To
P51547-001	Orange	Drive backplane	Secondary PCIe controller

8 SFF box 2: Secondary PCIe controller

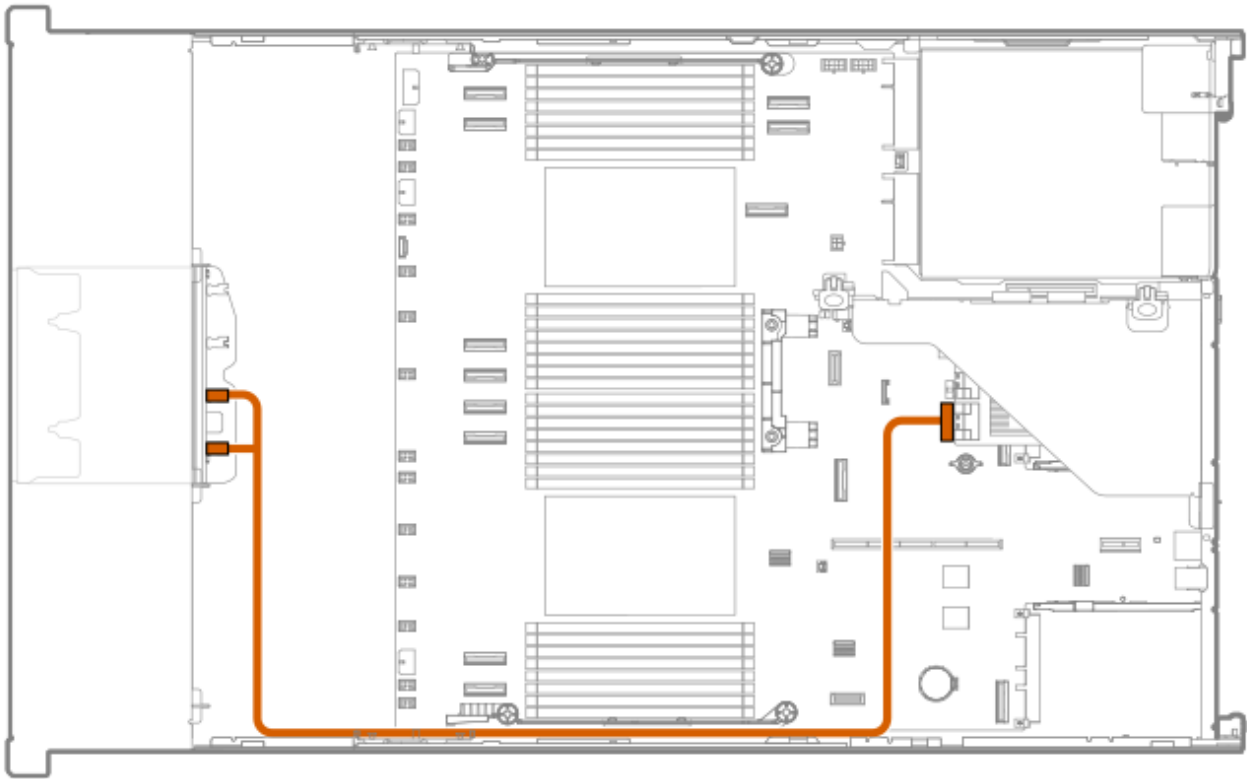

Cable part number	Color	From	To
P51547-001	Orange	Drive backplane	Secondary PCIe controller

8 SFF box 2: Secondary PCIe controller

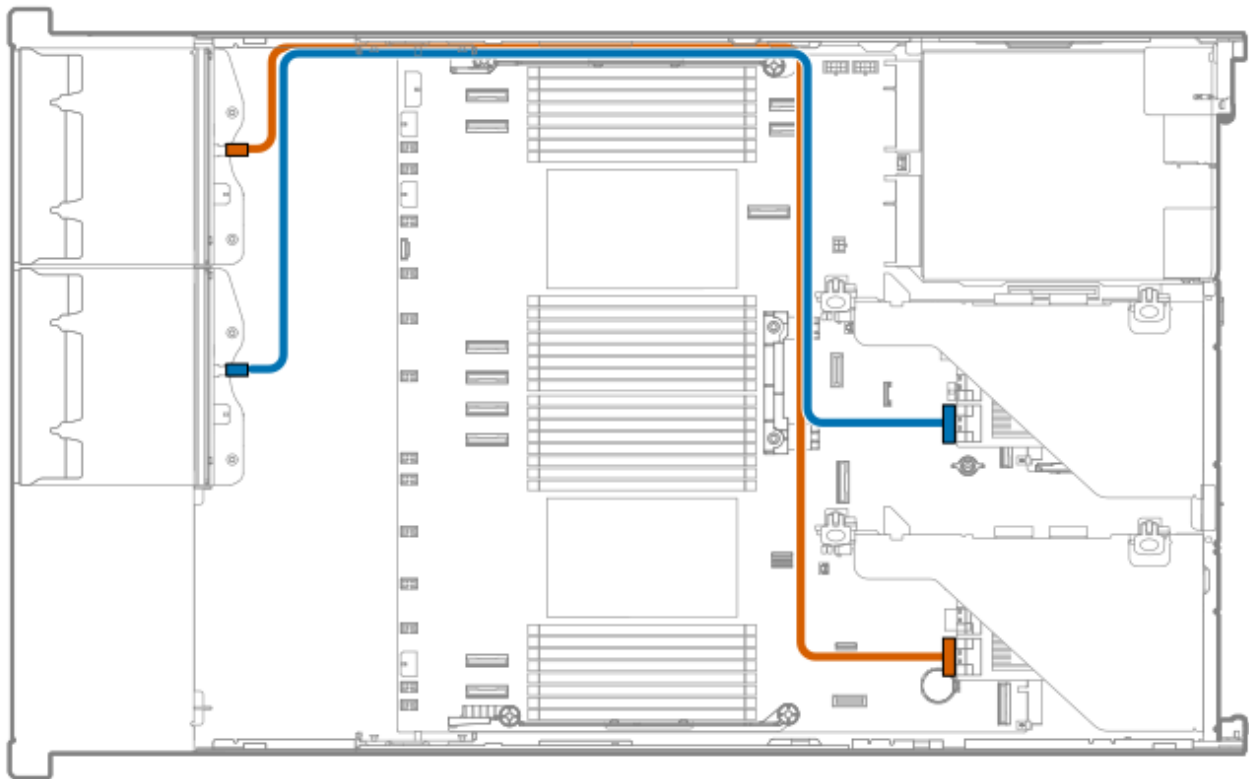

Cable part number	Color	From	To
P22905-001	Orange	Drive backplane	Secondary PCIe controller

8 SFF box 3 cabling

8 SFF box 3: Primary PCIe controller



Cable part number	Color	From	To
P75574-001	Pink	Drive backplane Port 1	MR932i-p controller port 4
	Yellow	Drive backplane Port 2	MR932i-p controller port 3
	Blue	Drive backplane Port 3	MR932i-p controller port 2
	Orange	Drive backplane Port 4	MR932i-p controller port 1

8 SFF box 3: Primary PCIe controller

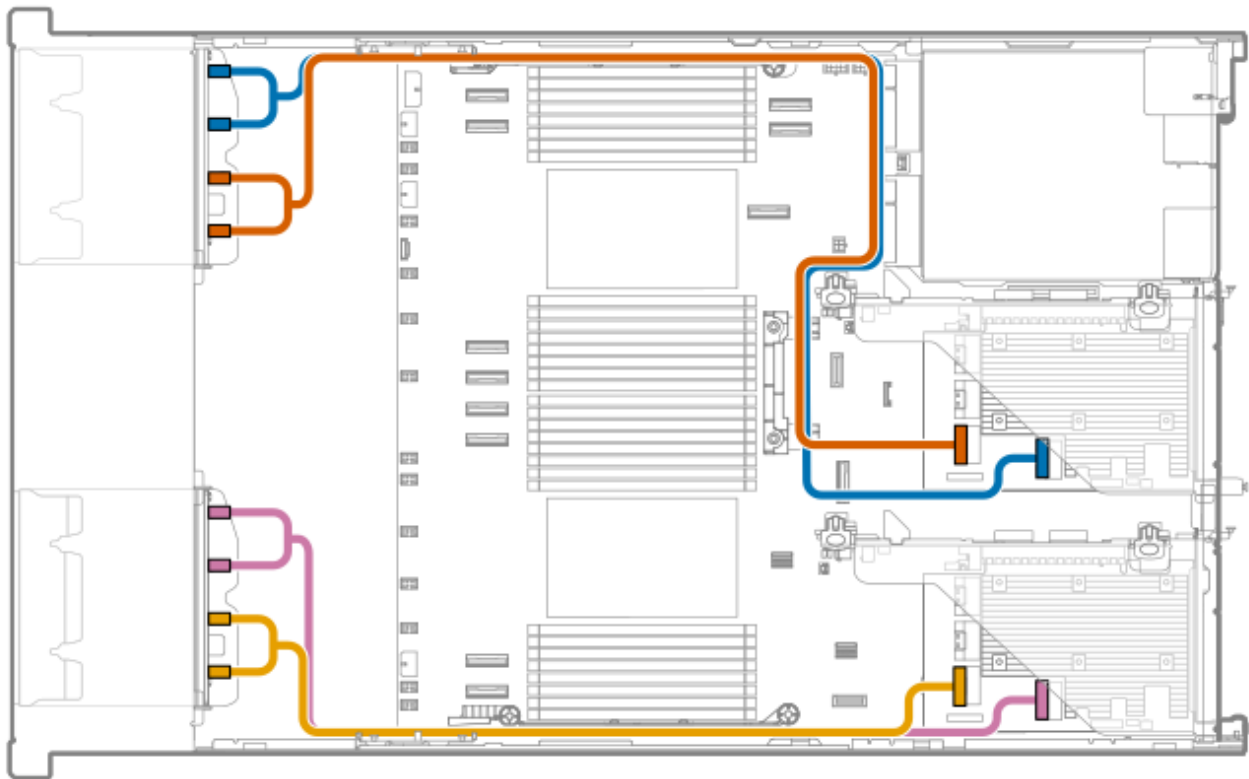

Cable part number	Color	From	To
P78631-001	Pink	Drive backplane Ports 1 and 2	MR932i-p controller port 1
	Yellow	Drive backplane Ports 3 and 4	MR932i-p controller port 2

8 SFF box 3: Primary PCIe controller

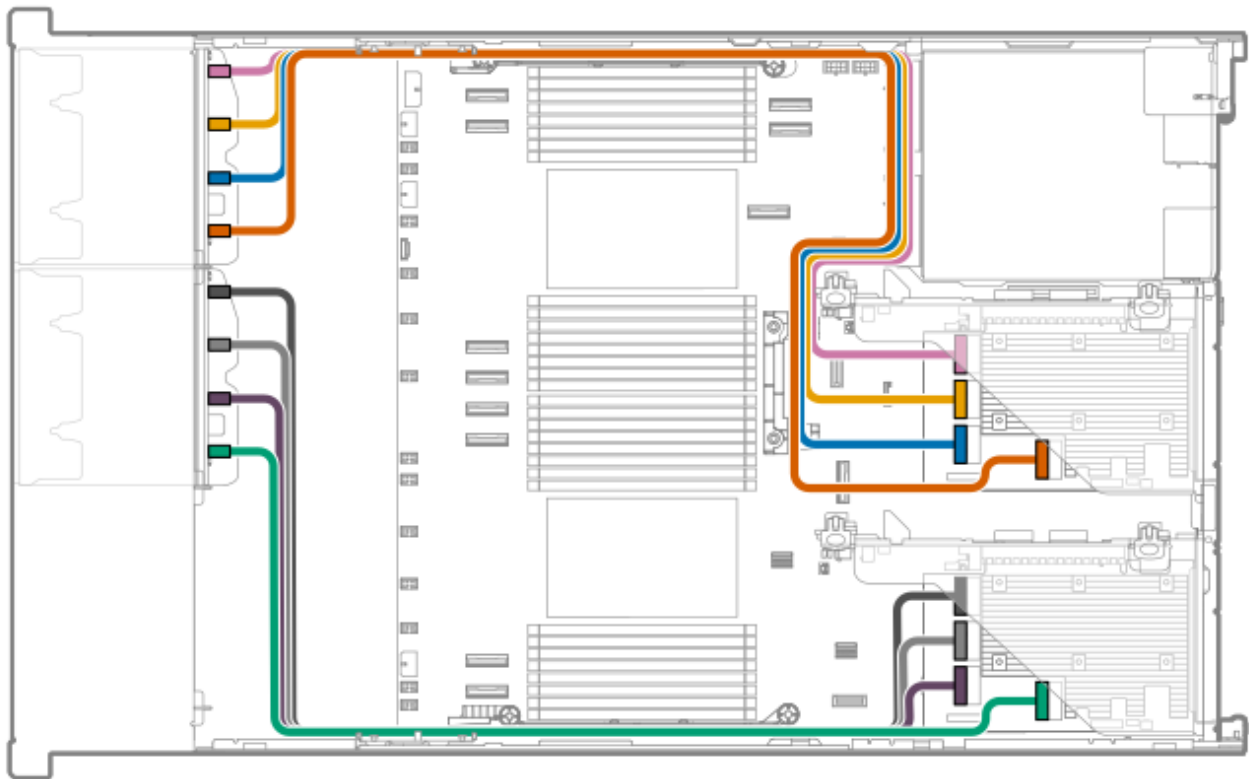

Cable part number	Color	From	To
P74805-001	Dark gray	Drive backplane Port 1	MR932i-p controller port 4
	Light gray	Drive backplane Port 2	MR932i-p controller port 3
	Purple	Drive backplane Port 3	MR932i-p controller port 2
	Green	Drive backplane Port 4	MR932i-p controller port 1

8 SFF box 3: System board

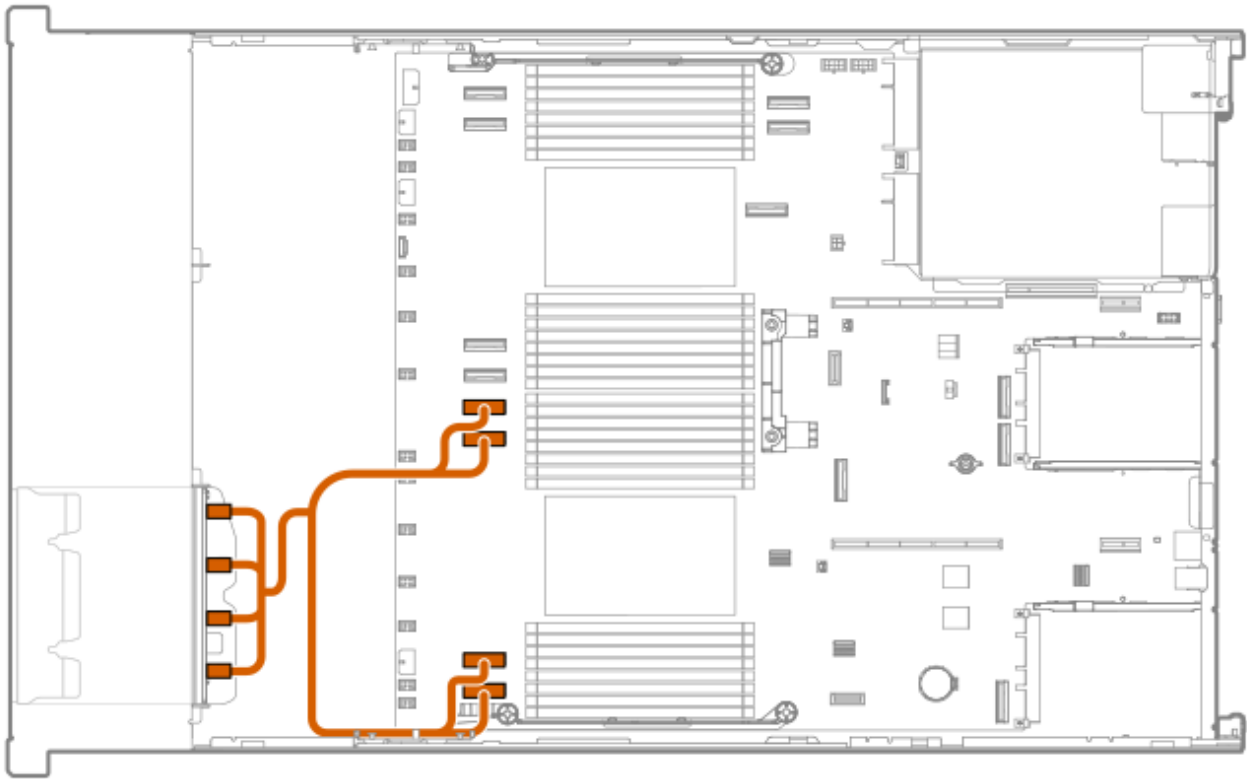

Cable part number	Color	From	To
P76146-001	Orange	Drive backplane	System board

8 SFF box 3: System board

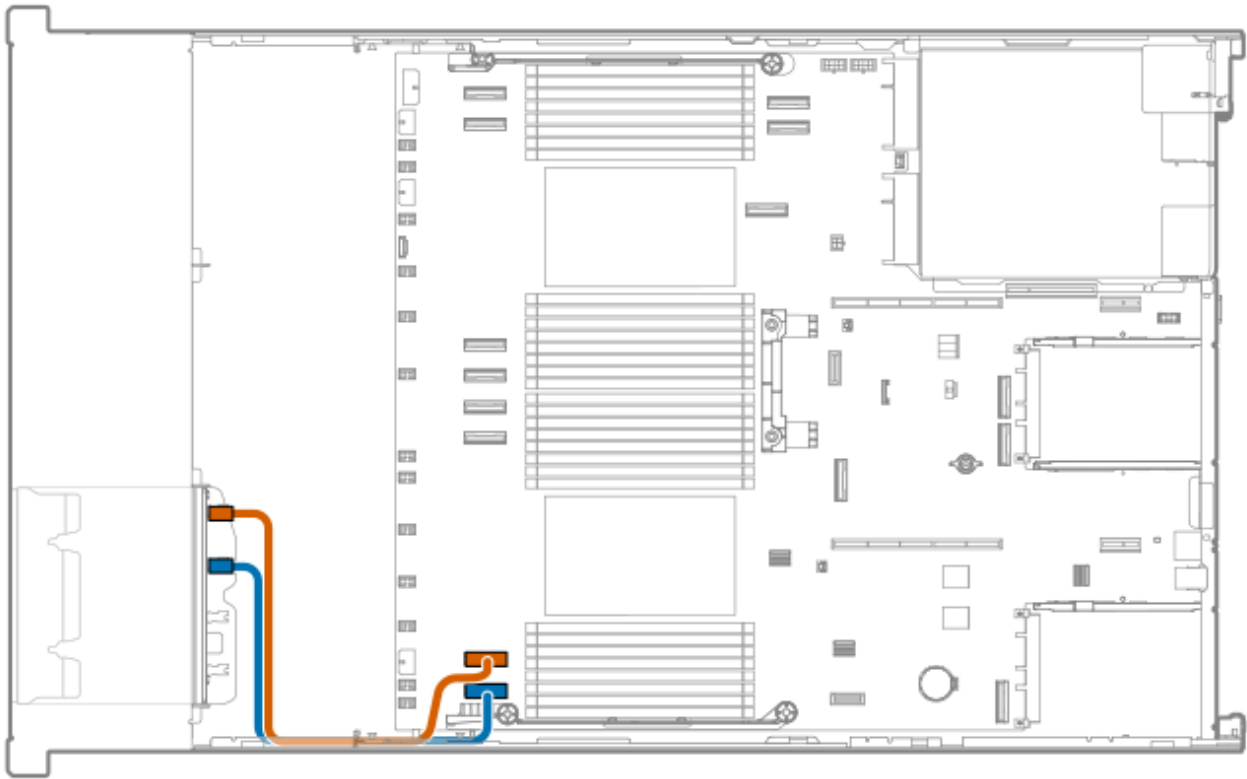

Cable part number	Color	From	To
P75367-001	Orange	Drive backplane	System board
P75367-001	Blue	Drive backplane	System board

8 SFF box 3: system board

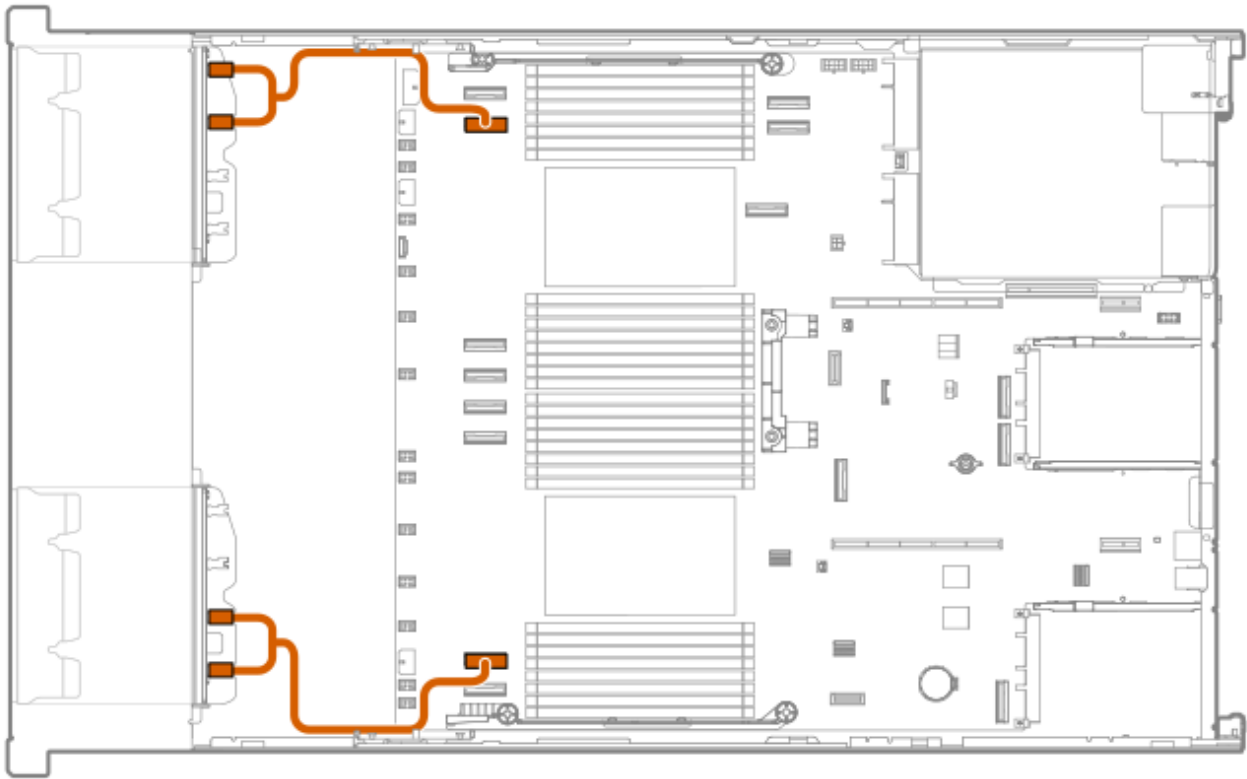

Cable part number	Color	From	To
P75563-001	Orange	Drive backplane	System board

8 SFF box 3: System board

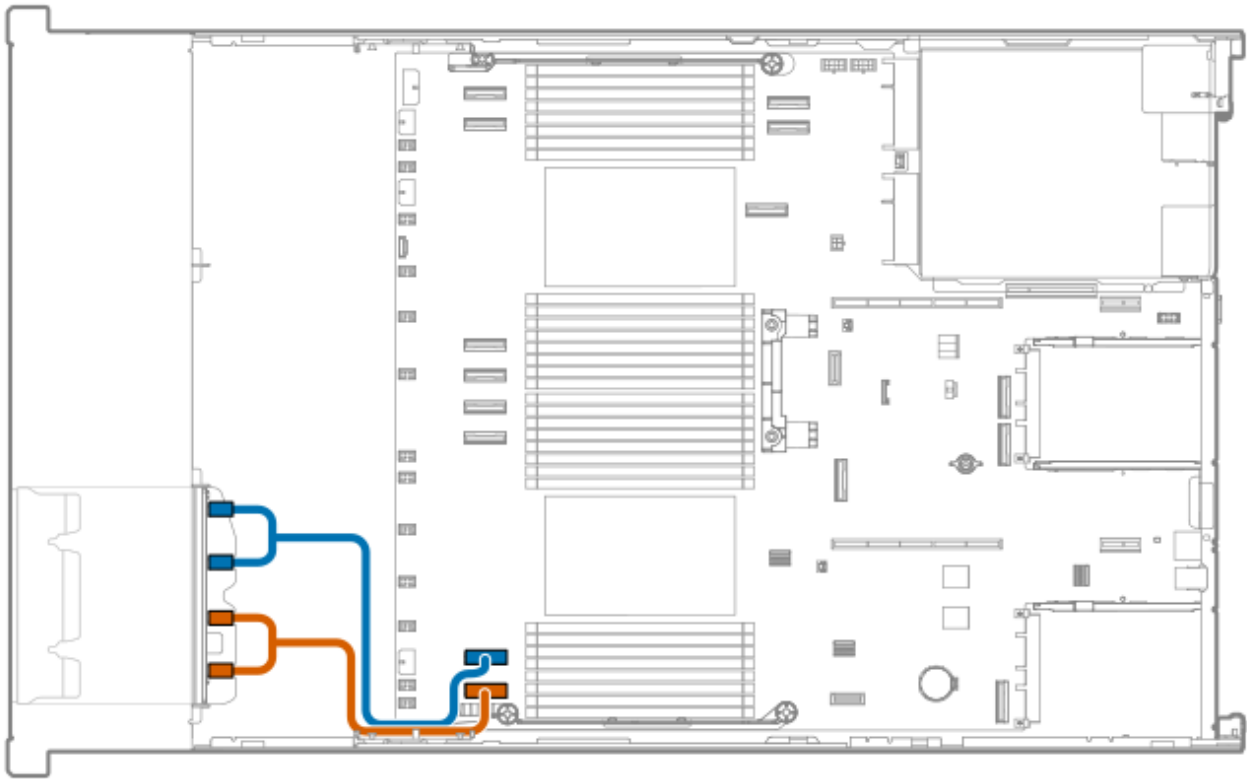

Cable part number	Color	From	To
P75563-001	Orange	Drive backplane	System board
P75563-001	Blue	Drive backplane	System board

8 SFF box 1: system board

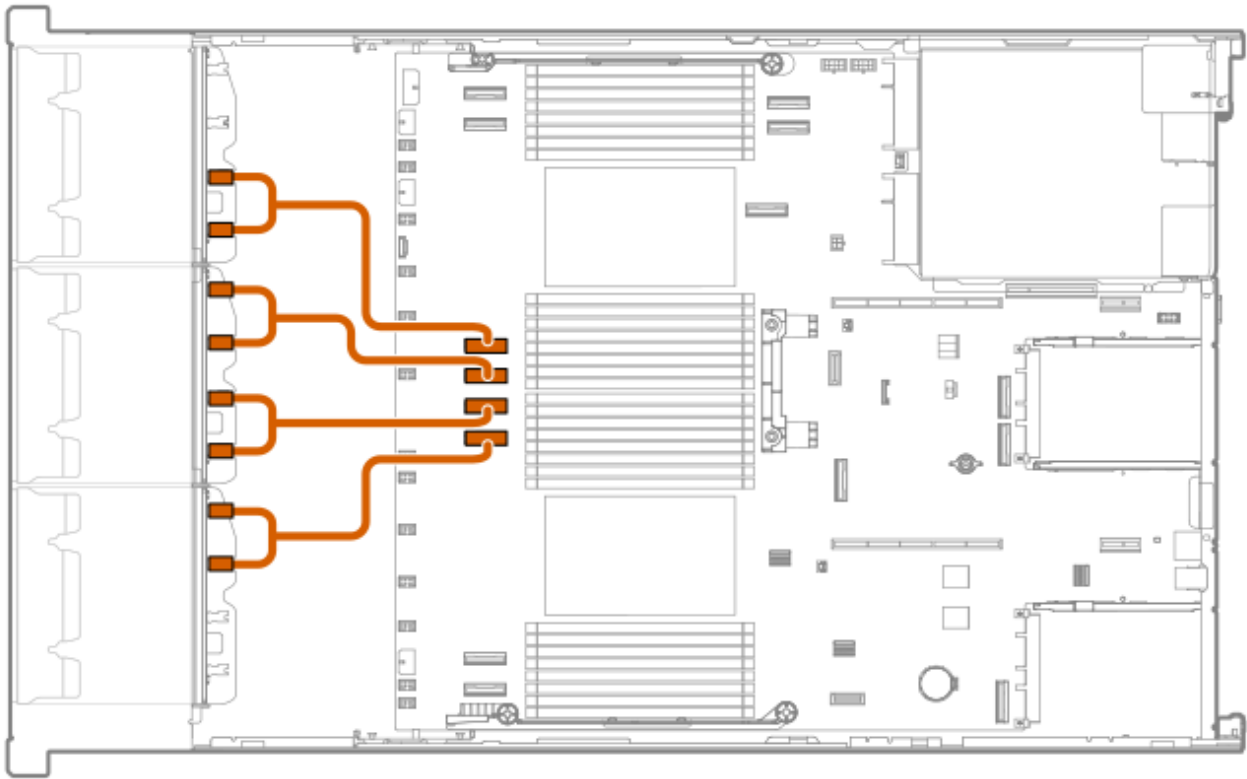

Cable part number	Color	From	To
P75563-001	Orange	Drive backplane	System board

8 SFF box 1: system board

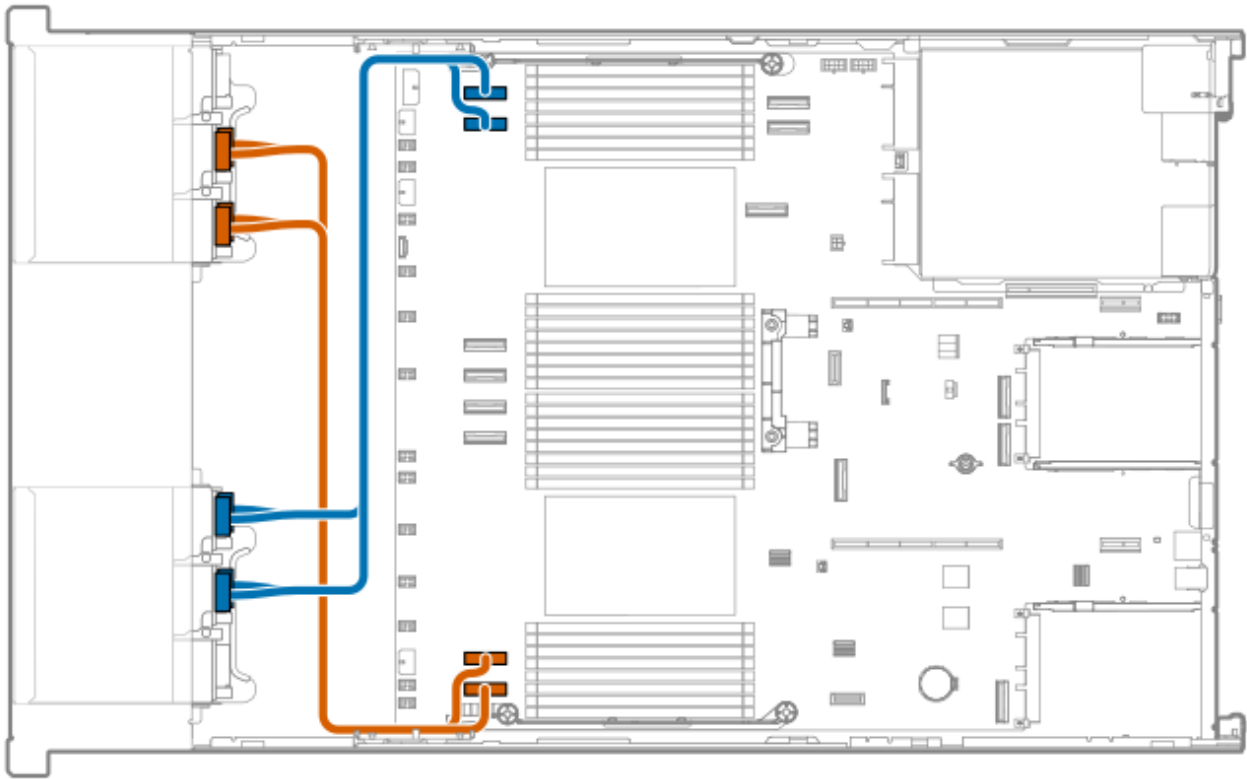

Cable part number	Color	From	To
P75365-001	Orange	Drive backplane	System board
P75365-001	Blue	Drive backplane	System board

8 SFF box 3: Secondary PCIe controller

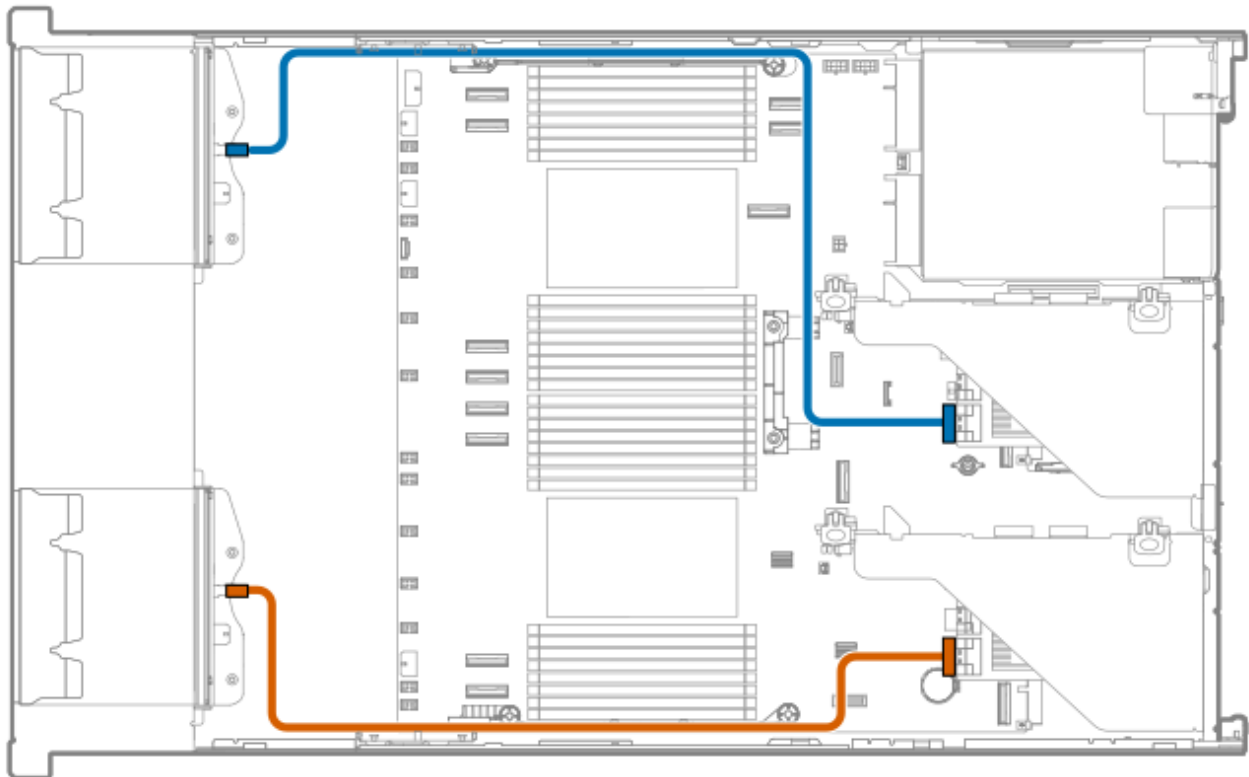

Cable part number	Color	From	To
P22905-001	Orange	Drive backplane	Primary PCIe controller
P22905-001	Blue	Drive backplane	Secondary PCIe controller

8 SFF box 3: Primary PCIe controller



Cable part number	Color	From	To
P51545-001	Orange	Drive backplane	Primary PCIe controller

8 SFF box 3: Secondary PCIe controller

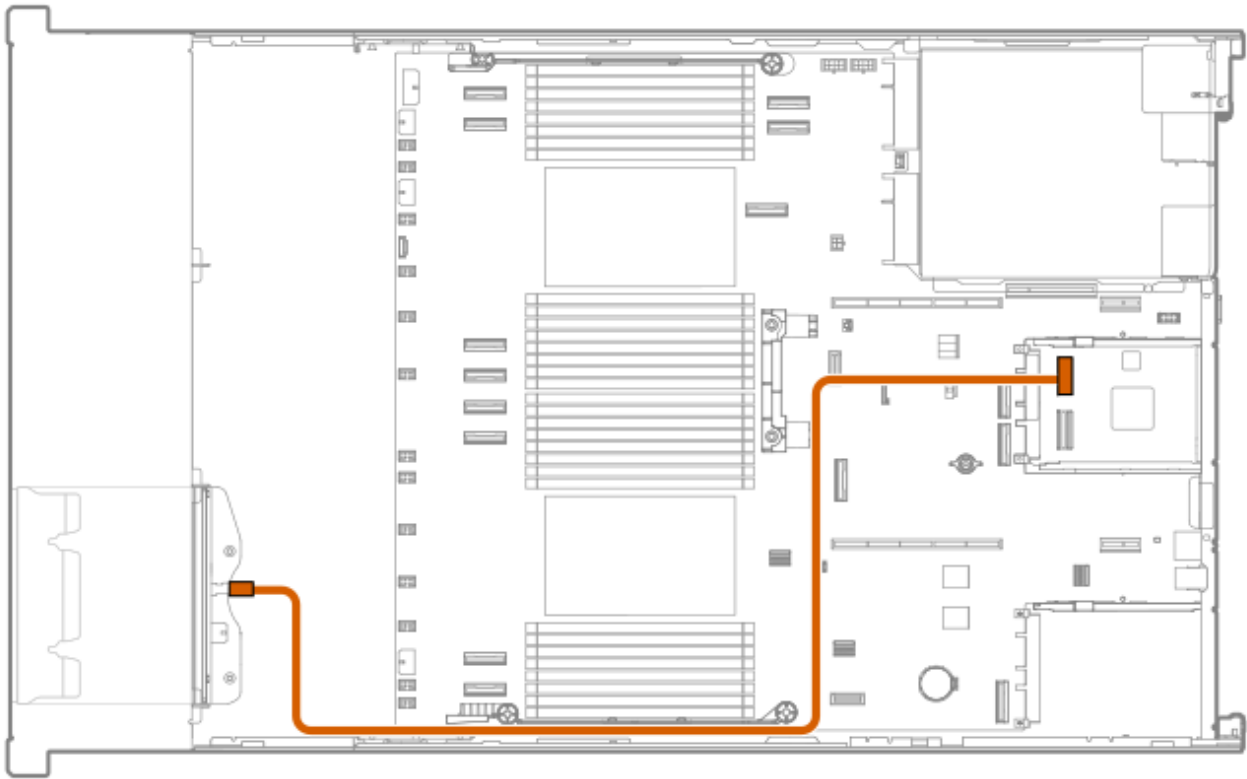

Cable part number	Color	From	To
P51545-001	Orange	Drive backplane	Secondary PCIe controller

8 SFF box 3: OCP B controller

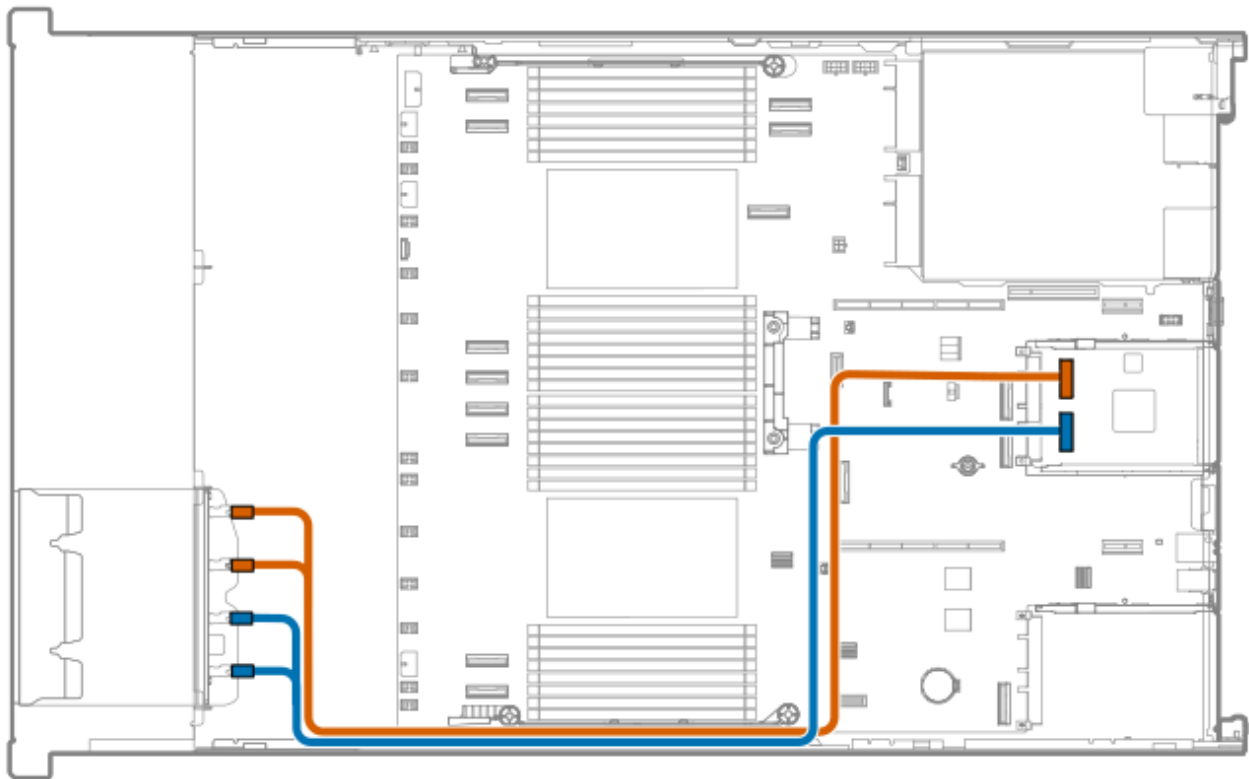

Cable part number	Color	From	To
P51546-001	Orange	Drive backplane	OCP B controller
P51546-001	Blue	Drive backplane	OCP A controller

8 SFF box 3: OCP A controller

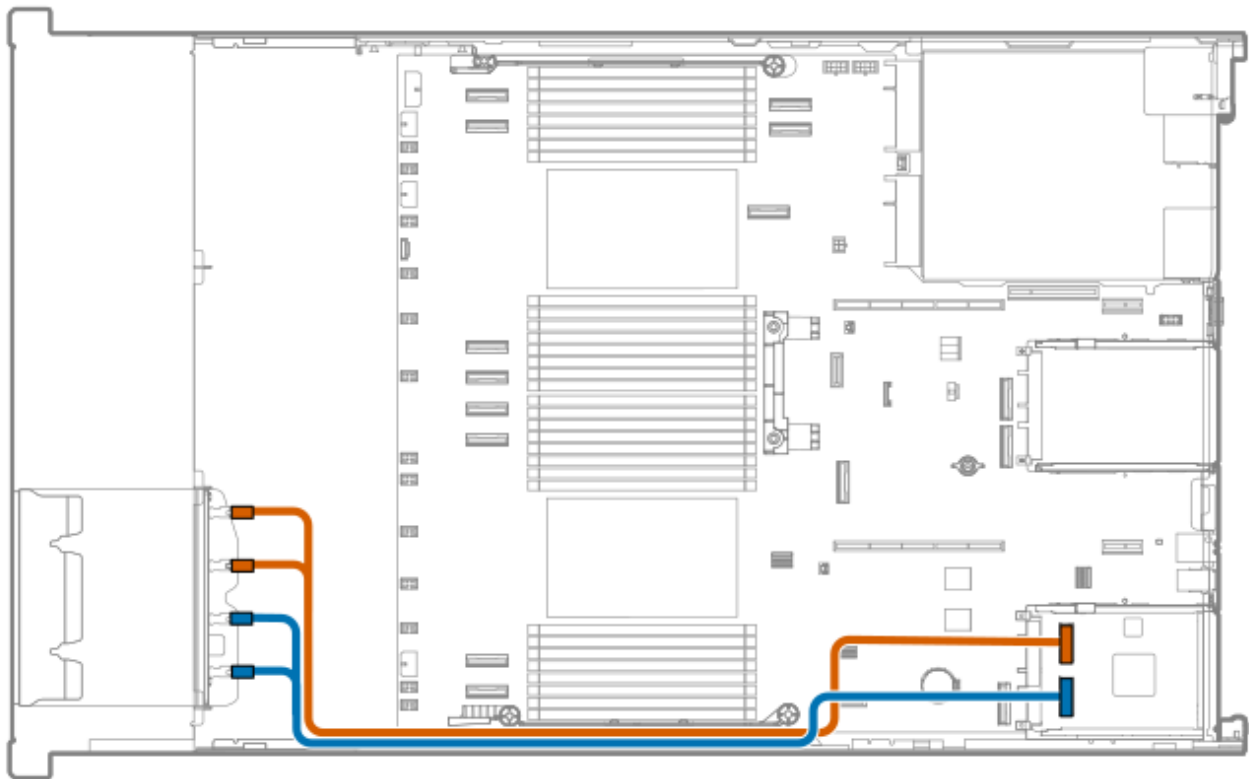

Cable part number	Color	From	To
P51546-001	Orange	Drive backplane	OCP A controller
P51546-001	Blue	Drive backplane	OCP A controller

Box 7 cabling

LFF box 1 and 7: Primary type-o controller

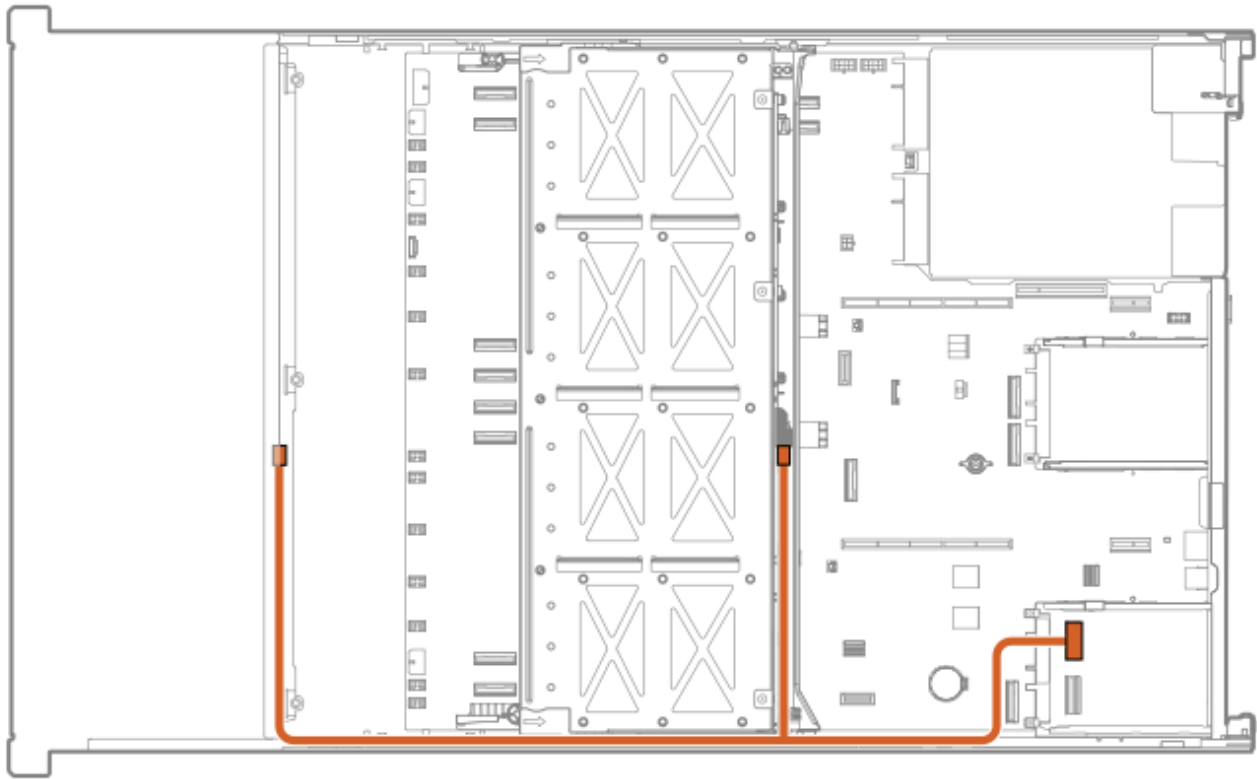

Cable part number	Color	From	To
P51560-001	Orange	LFF box 1 and 7*	Primary type-o controller

*This is a Y-cable and can connect boxes 1 and 7. If there is no box 7, then one end remains loose.

Front 2 SFF cabling

2 SFF stacked box 1: system board

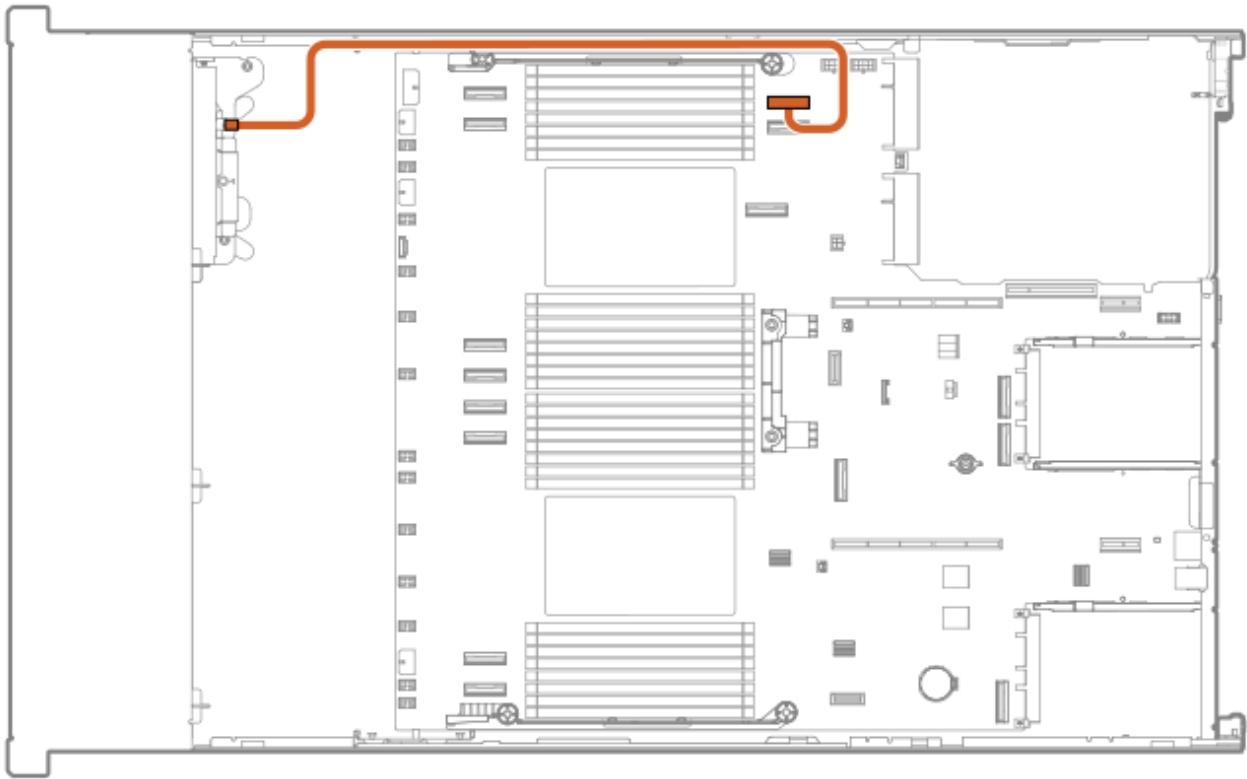

Cable part number	Color	From	To
P74811-001	Orange	Drive backplane	System board

2 SFF stacked box 1: PCIe controller

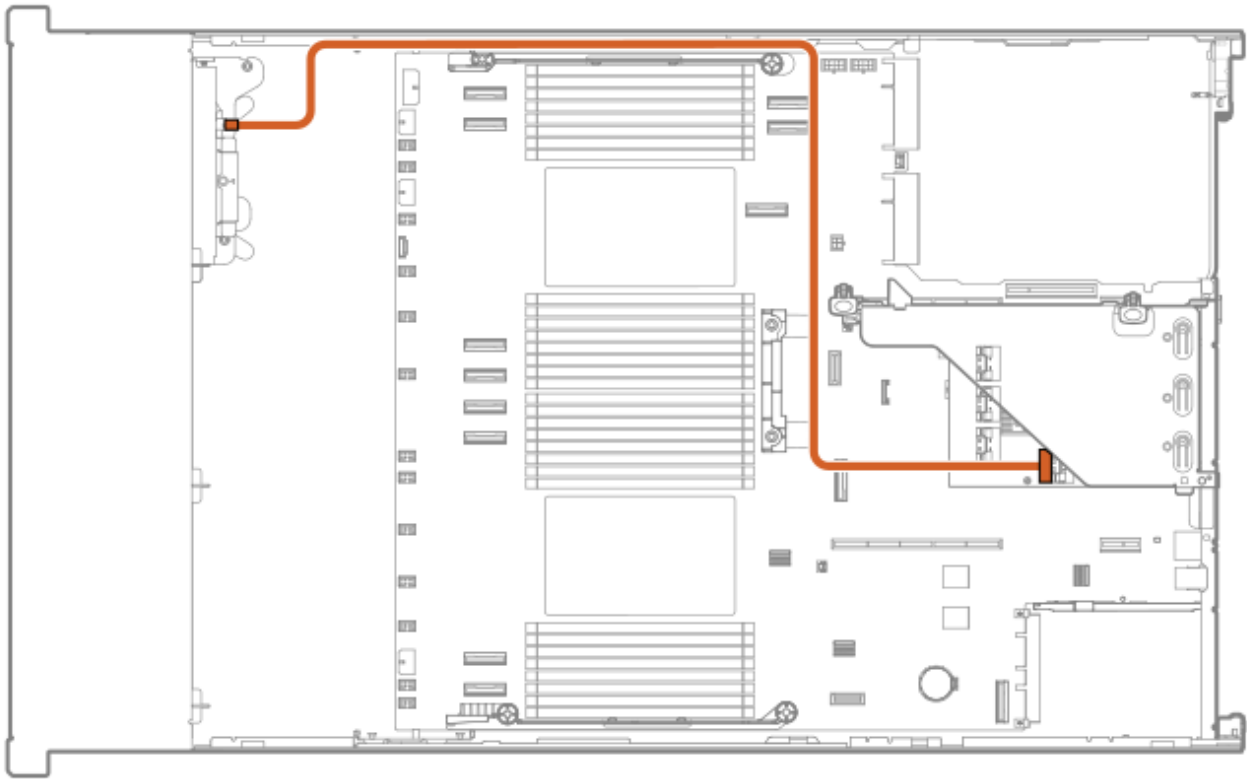

Cable part number	Color	From	To
P22905-001	Orange	Drive backplane	Secondary type-p controller

2 SFF stacked box 1: PCIe controller

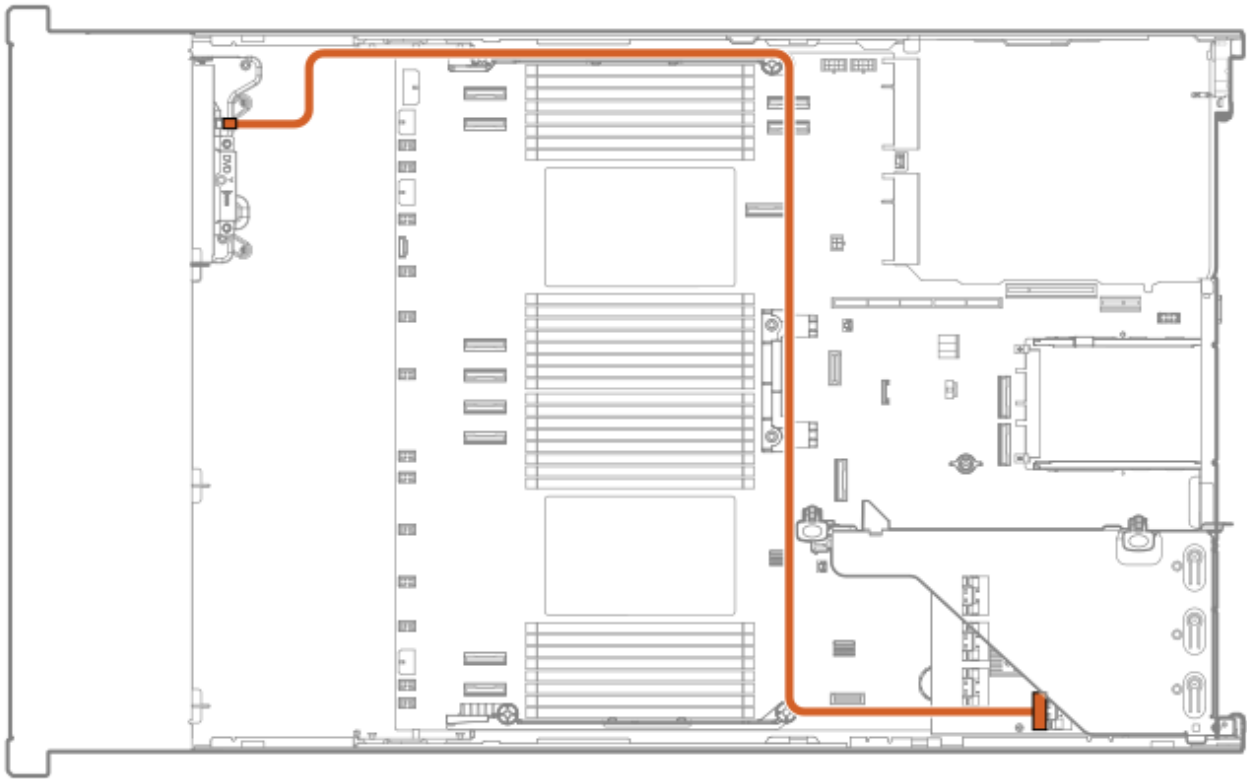

Cable part number	Color	From	To
P22905-001	Orange	Drive backplane	Primary type-p controller

2 SFF stacked box 1: PCIe controller

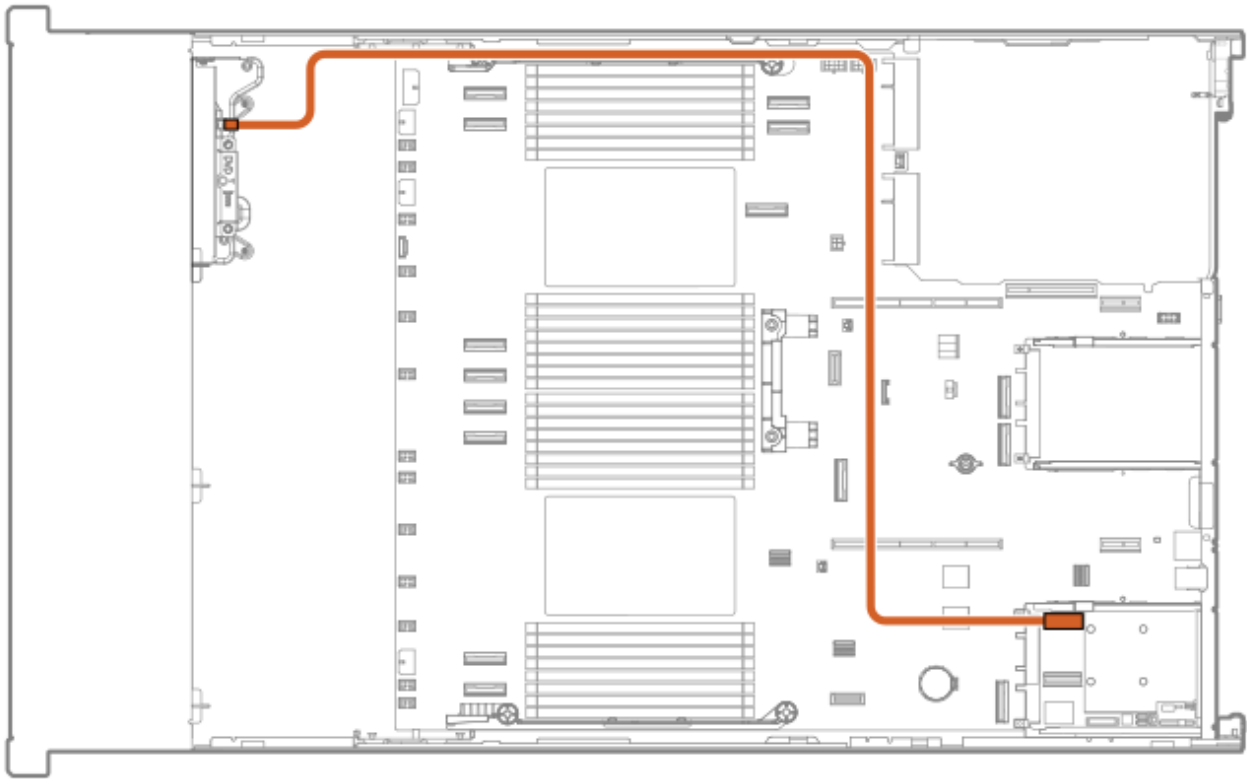

Cable part number	Color	From	To
P51545-001	Orange	Drive backplane	Primary type-o controller

2 SFF stacked box 1: OCP controller

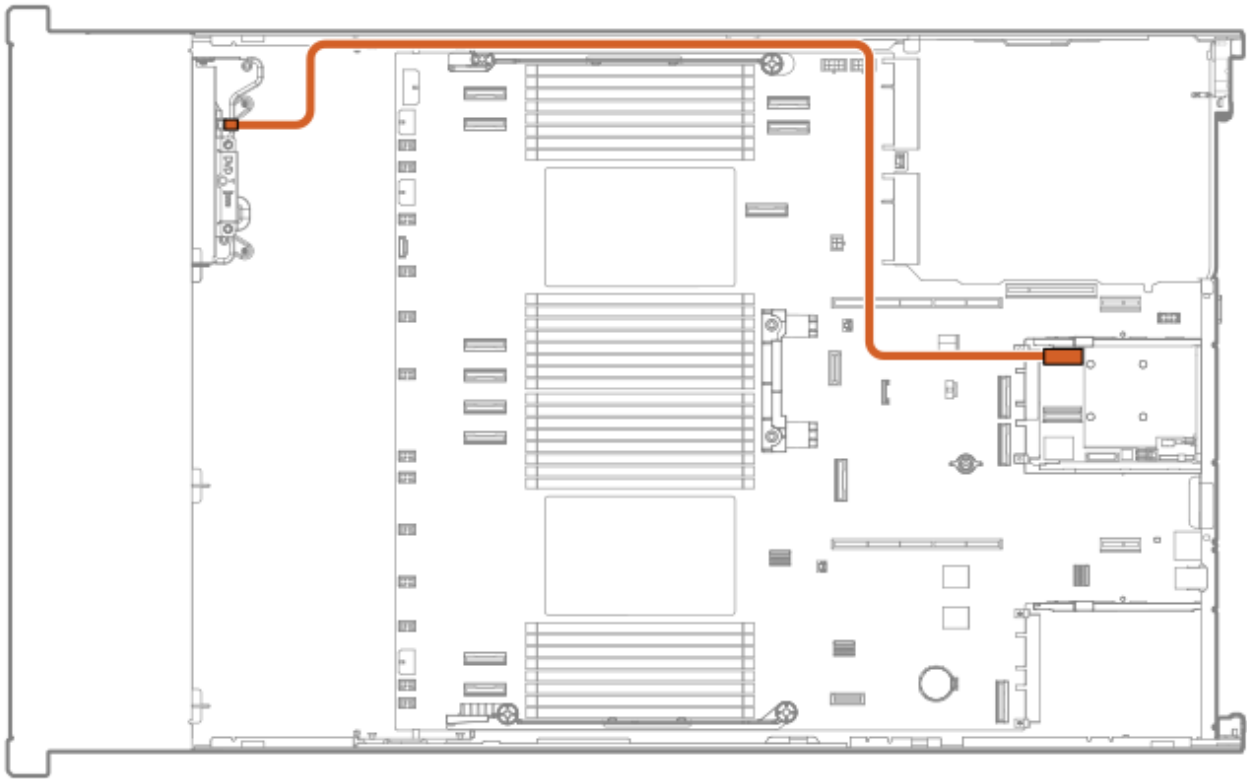

Cable part number	Color	From	To
P51545-001	Orange	Drive backplane	Secondary type-o controller

2 SFF side-by-side box 1: OCP controller

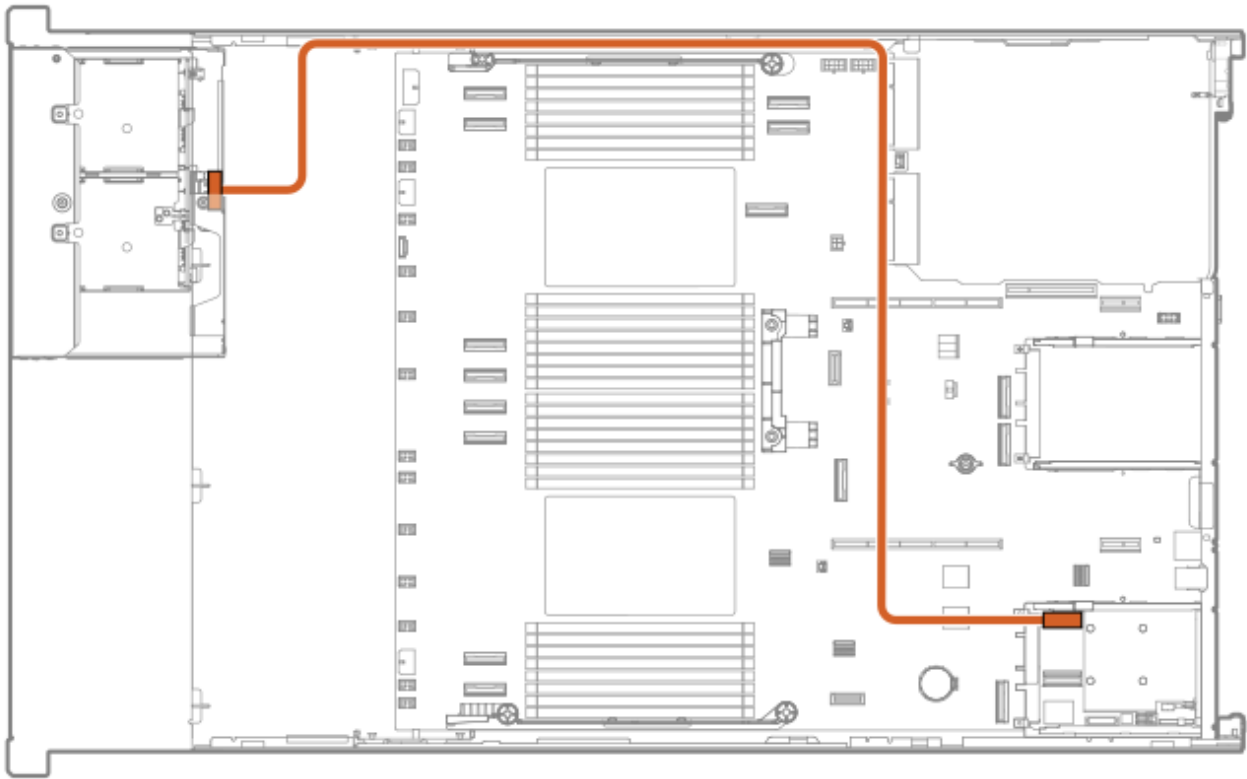

Cable part number	Color	From	To
P51545-001	Orange	Drive backplane	Primary type-o controller

2 SFF side-by-side box 1: OCP controller

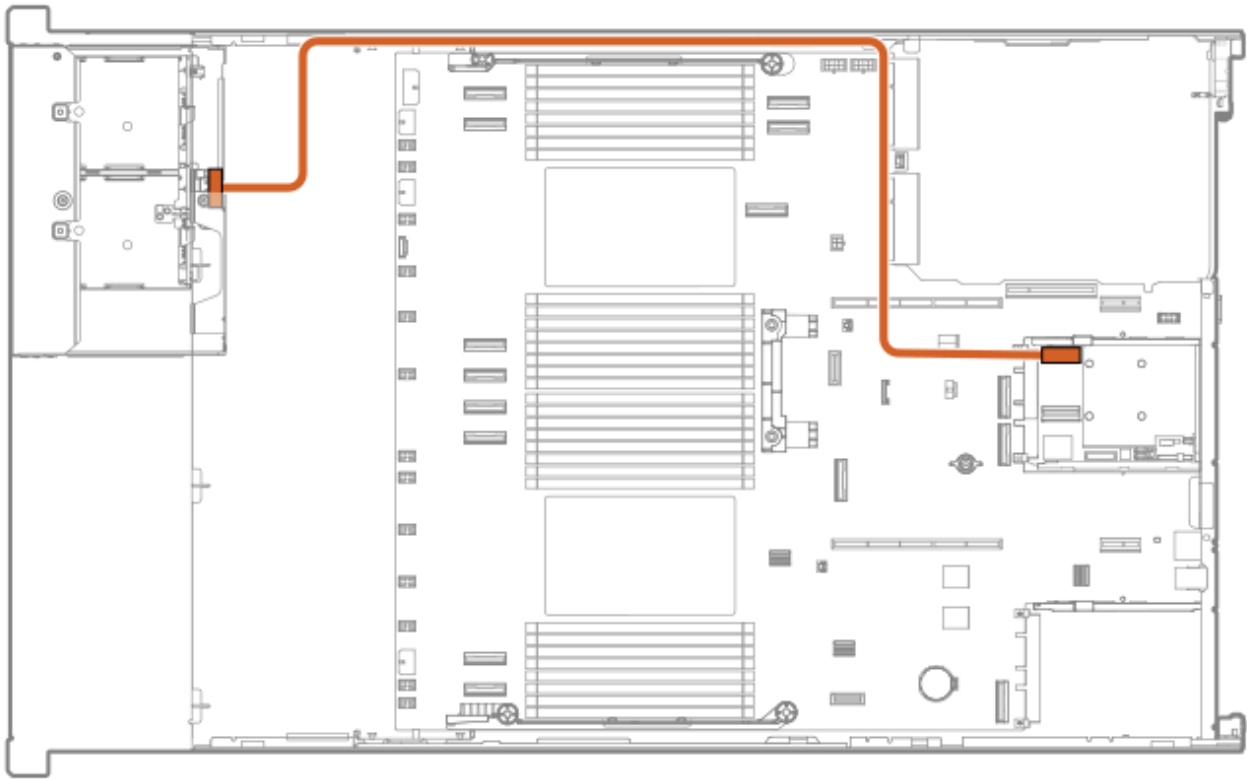

Cable part number	Color	From	To
P51545-001	Orange	Drive backplane	Secondary type-o controller

2 SFF side-by-side box 1: PCIe controller

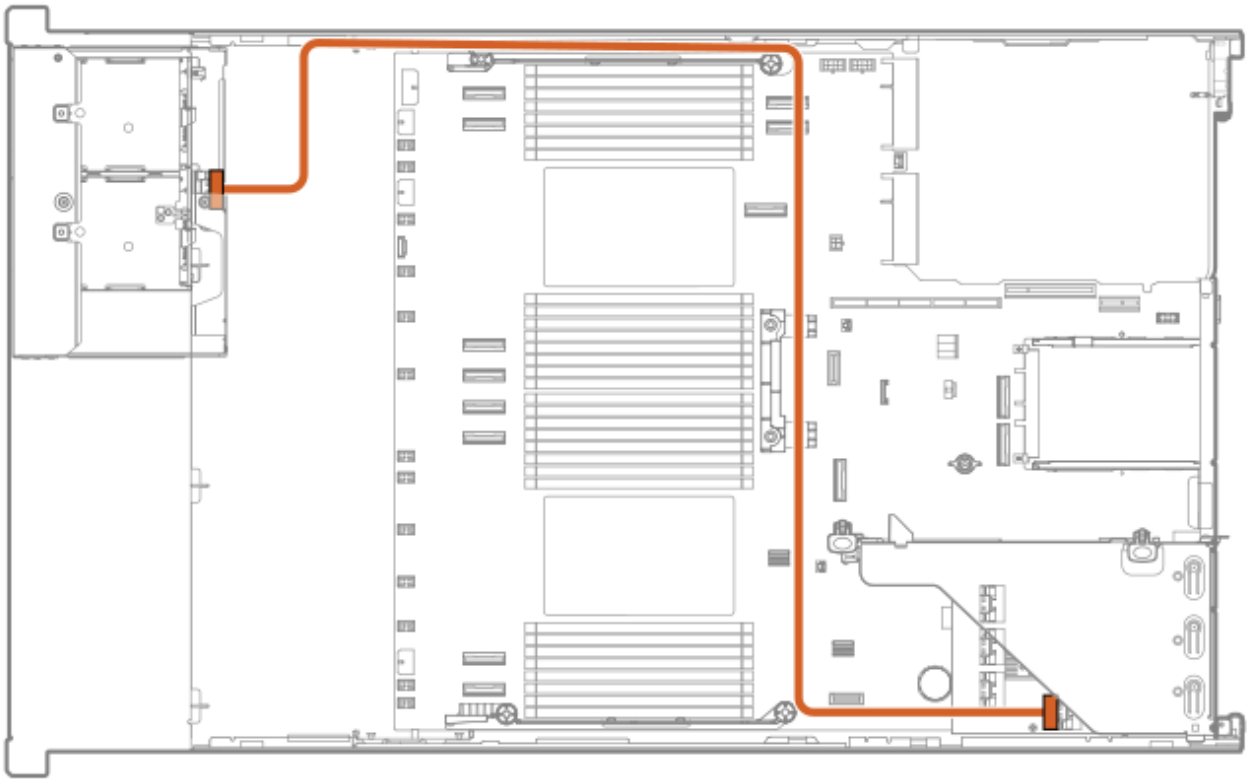

Cable part number	Color	From	To
P22905-001	Orange	Drive backplane	Primary type-p controller

2 SFF side-by-side box 1: PCIe controller

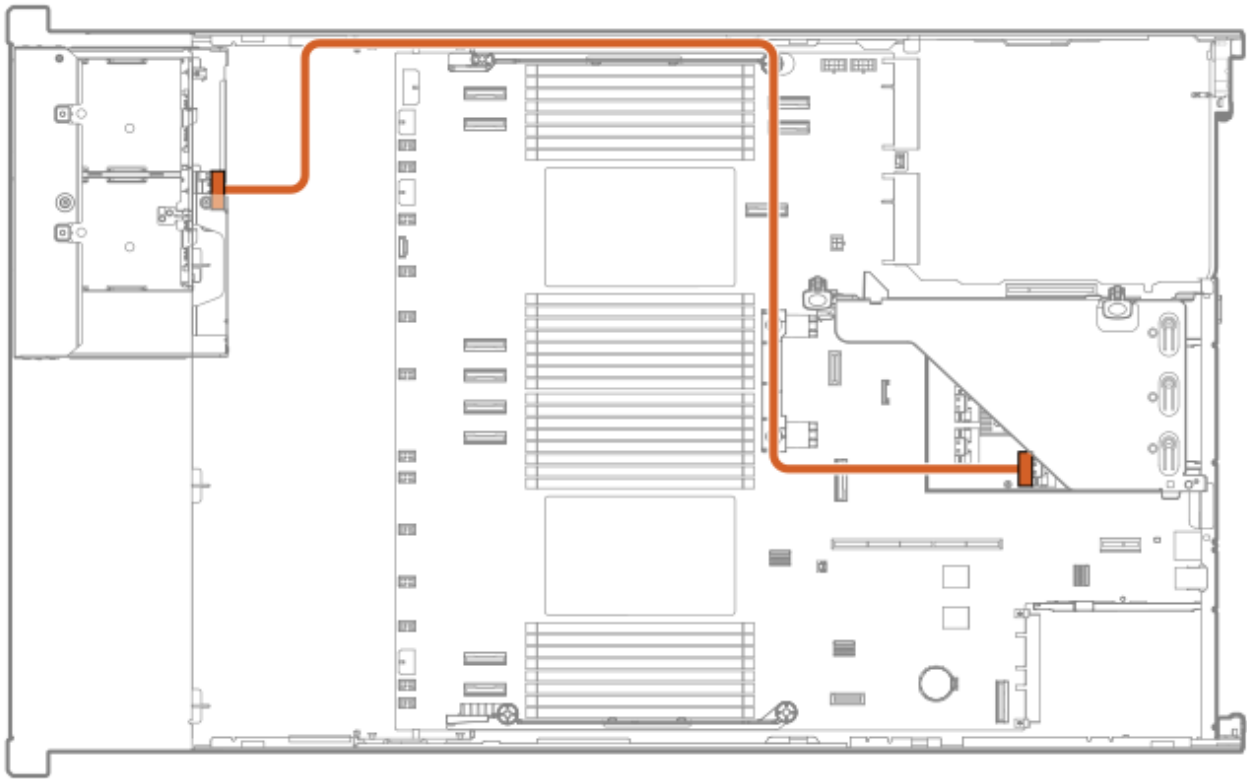

Cable part number	Color	From	To
P22905-001	Orange	Drive backplane	Secondary type-p controller

Rear 2 SFF cabling

2 SFF box 4: Primary type-o controller

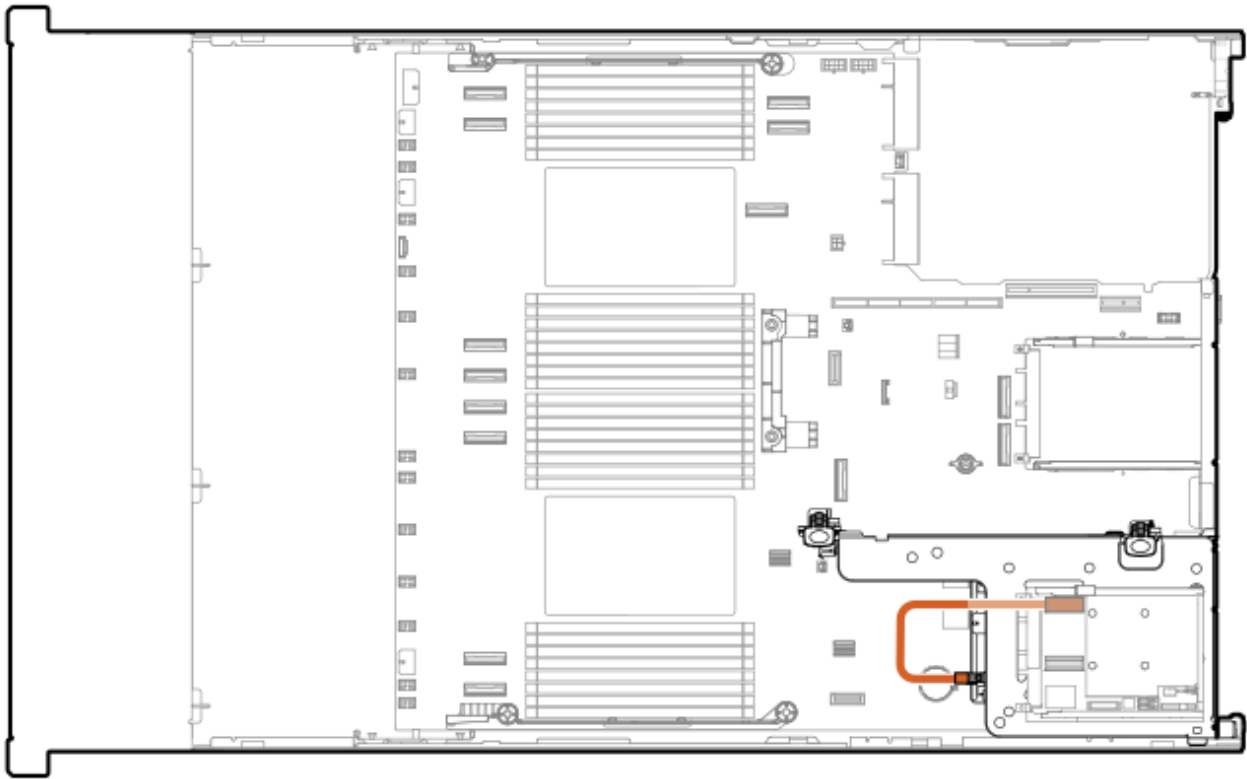

Cable part number	Color	From	To
P51554-001	Orange	Drive backplane	OCP A controller

2 SFF box 4: Secondary type-o controller

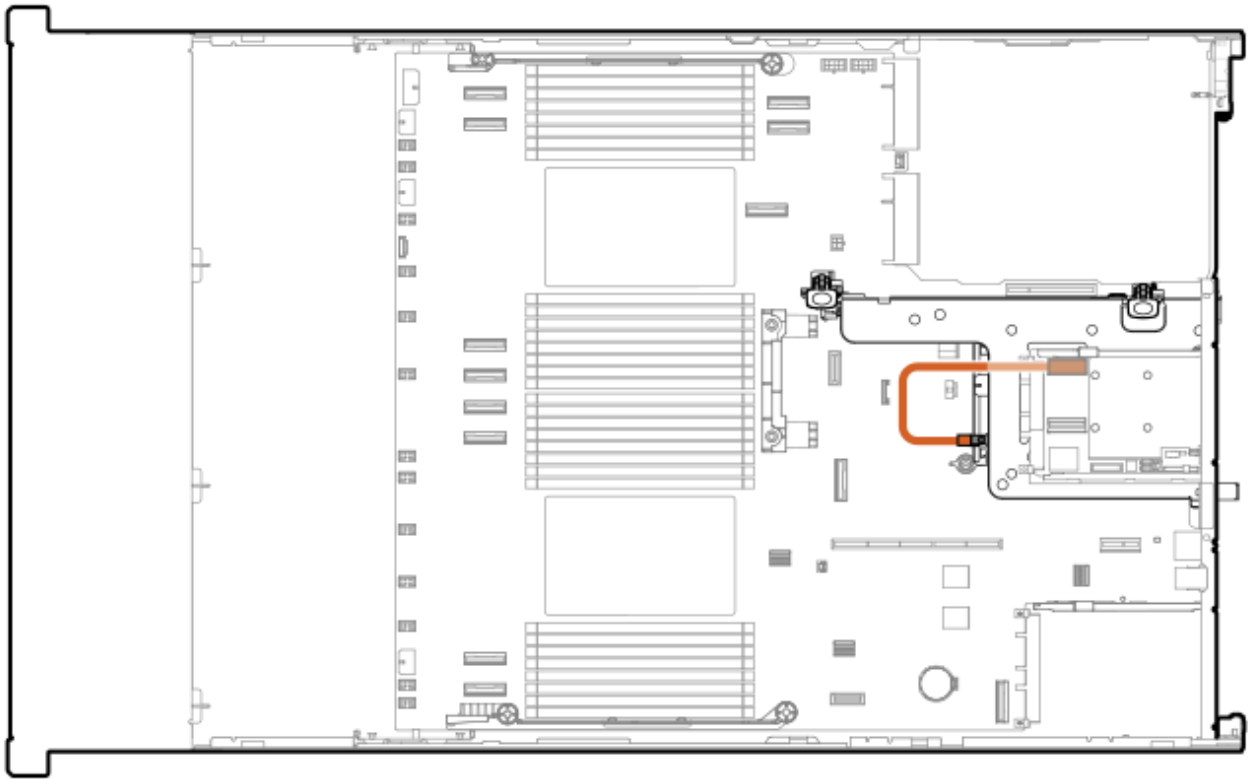

Cable part number	Color	From	To
P51554-001	Orange	Drive backplane	Type-o controller

2 SFF box 4: Secondary type-p controller

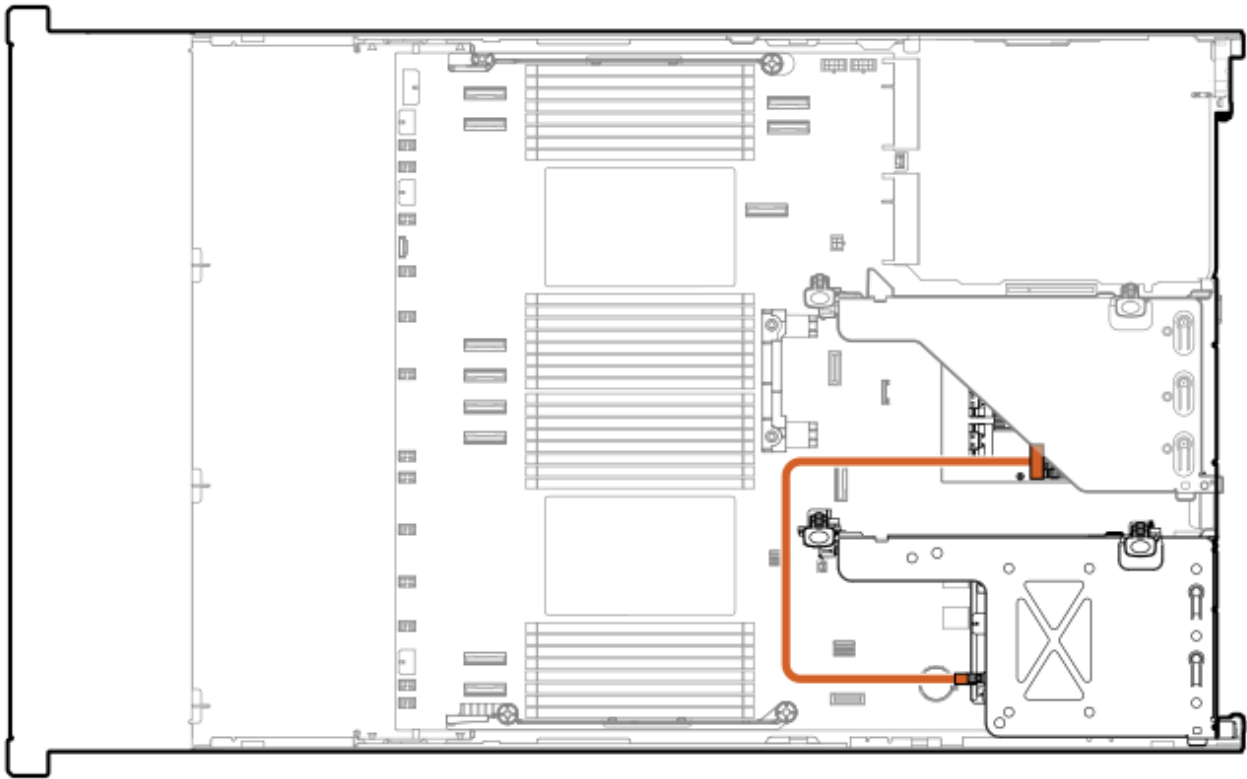

Cable part number	Color	From	To
P14329-001	Orange	Drive backplane	Secondary type-p controller

2 SFF box 4: Tertiary type-p controller

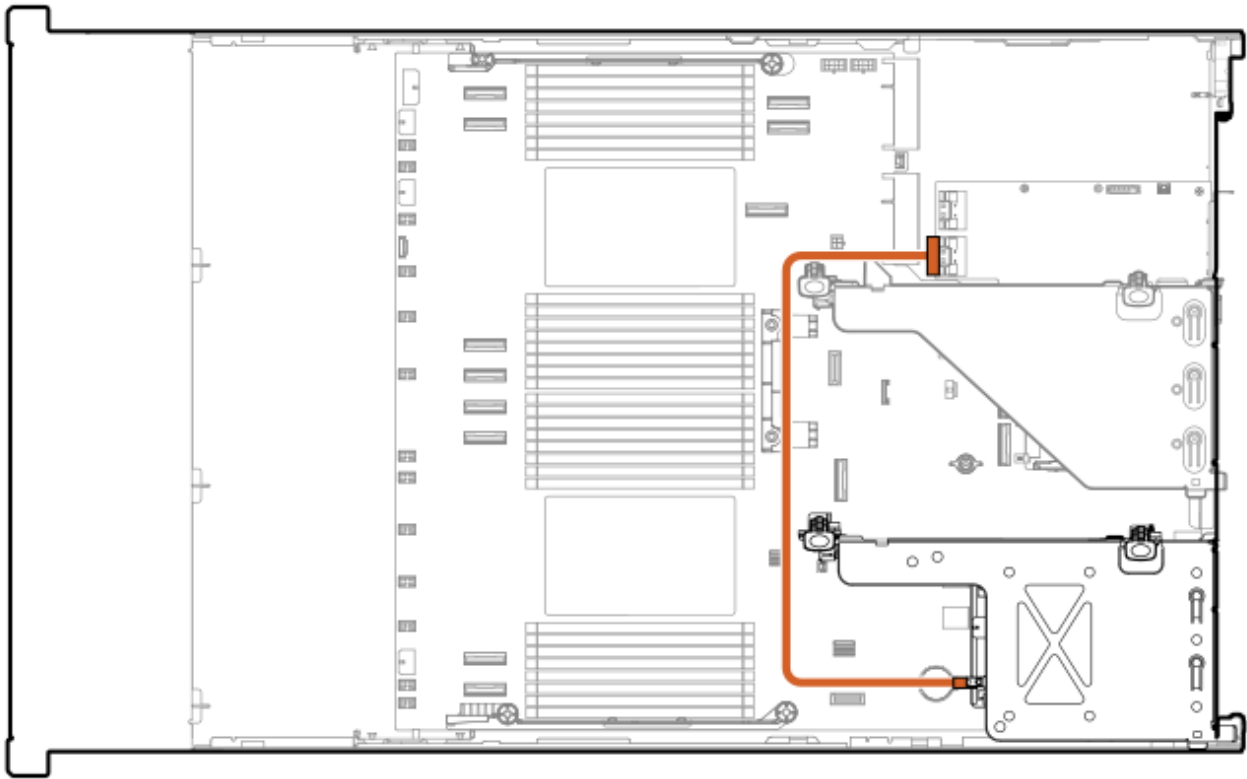

Cable part number	Color	From	To
P22903-001	Orange	Drive backplane	Tertiary type-p controller

2 SFF box 5: Secondary Type-p controller

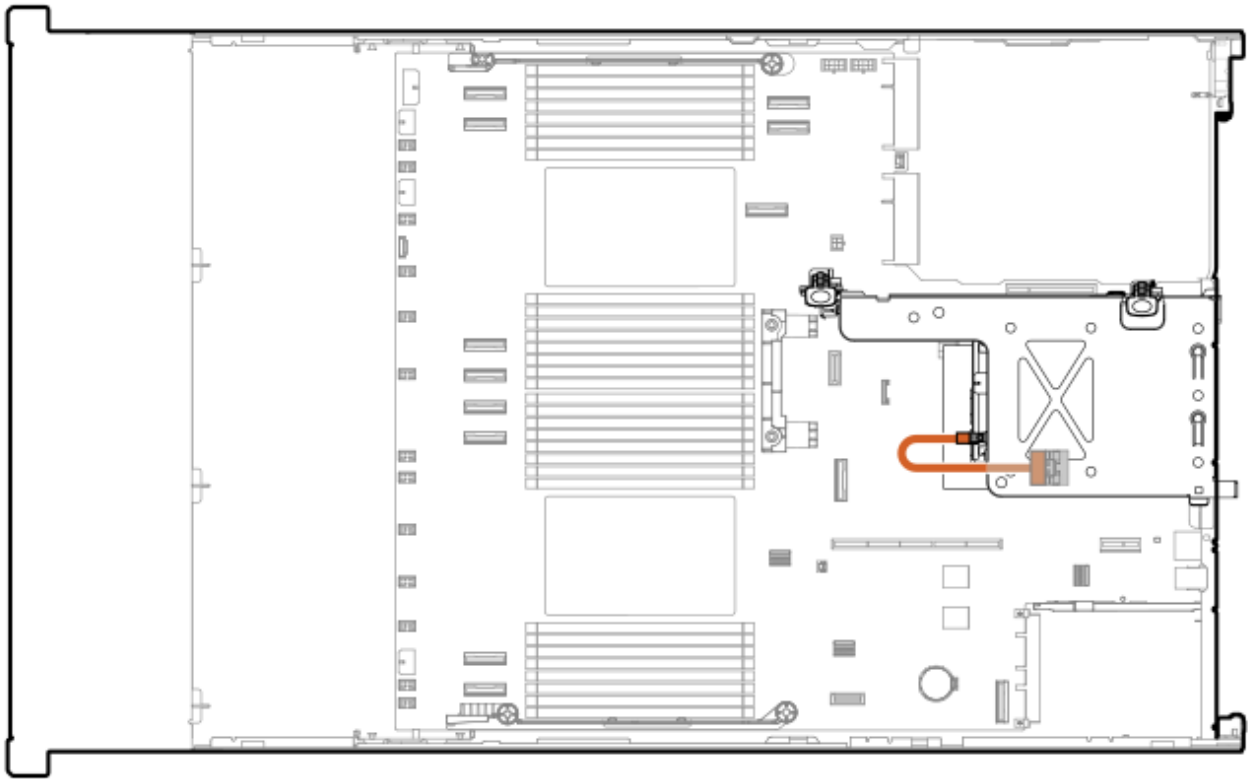

Cable part number	Color	From	To
P14329-001	Orange	Drive backplane	Secondary type-p controller

2 SFF box 5: Primary type-p controller

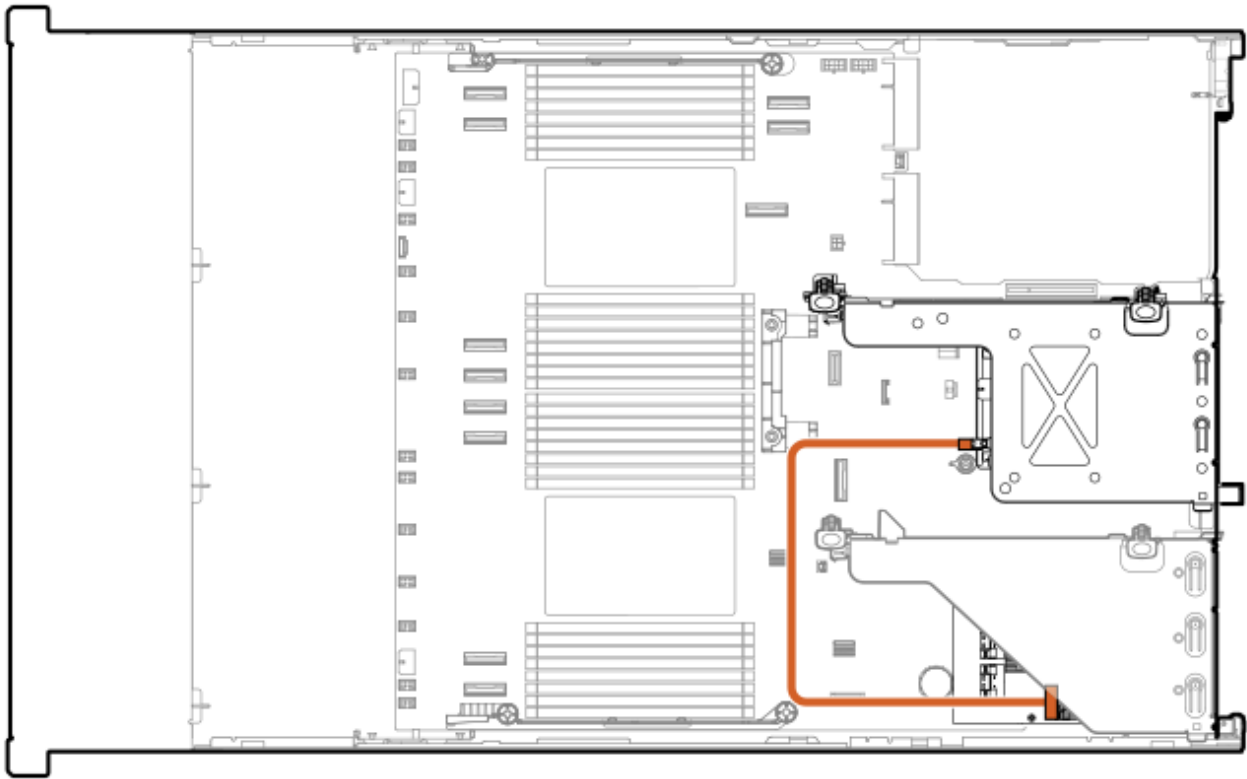

Cable part number	Color	From	To
P22903-001	Orange	Drive backplane	Primary type-p controller

2 SFF box 5: Primary type-p controller

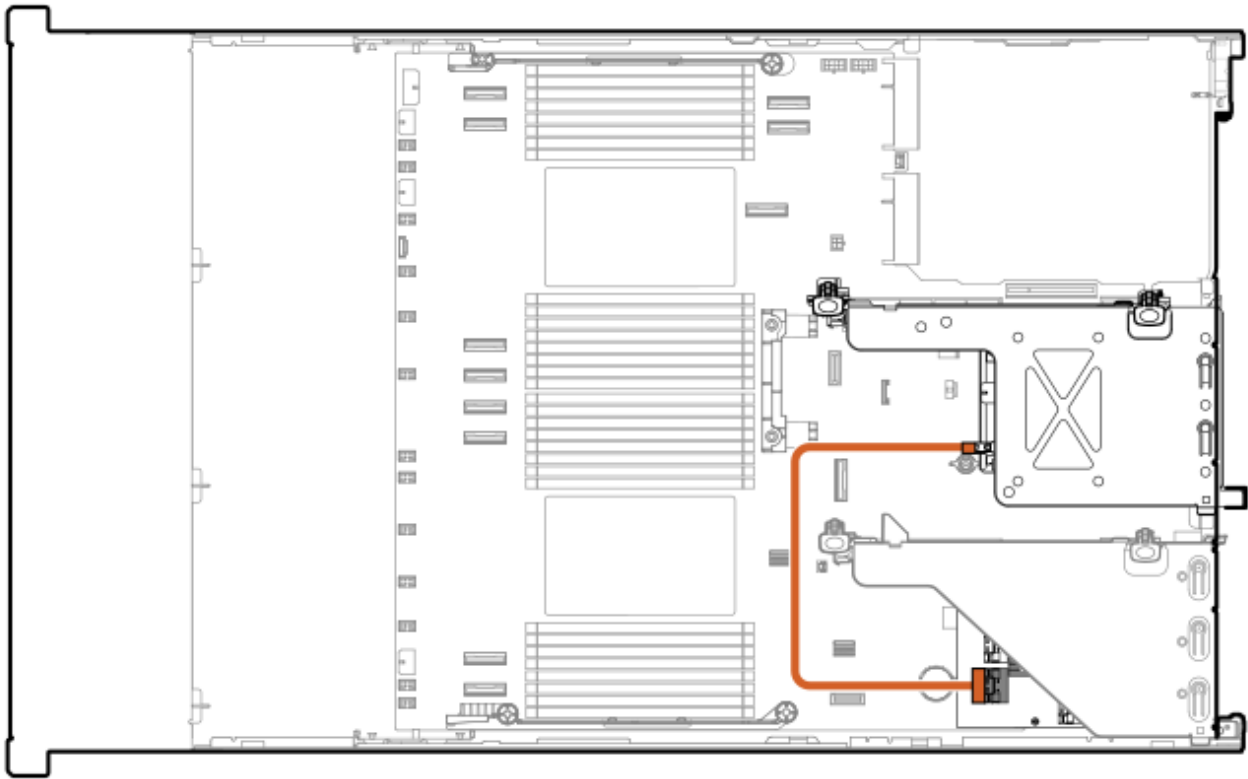

Cable part number	Color	From	To
P14329-001	Orange	Drive backplane	Primary type-p controller

2 SFF box 5: Tertiary type-p controller

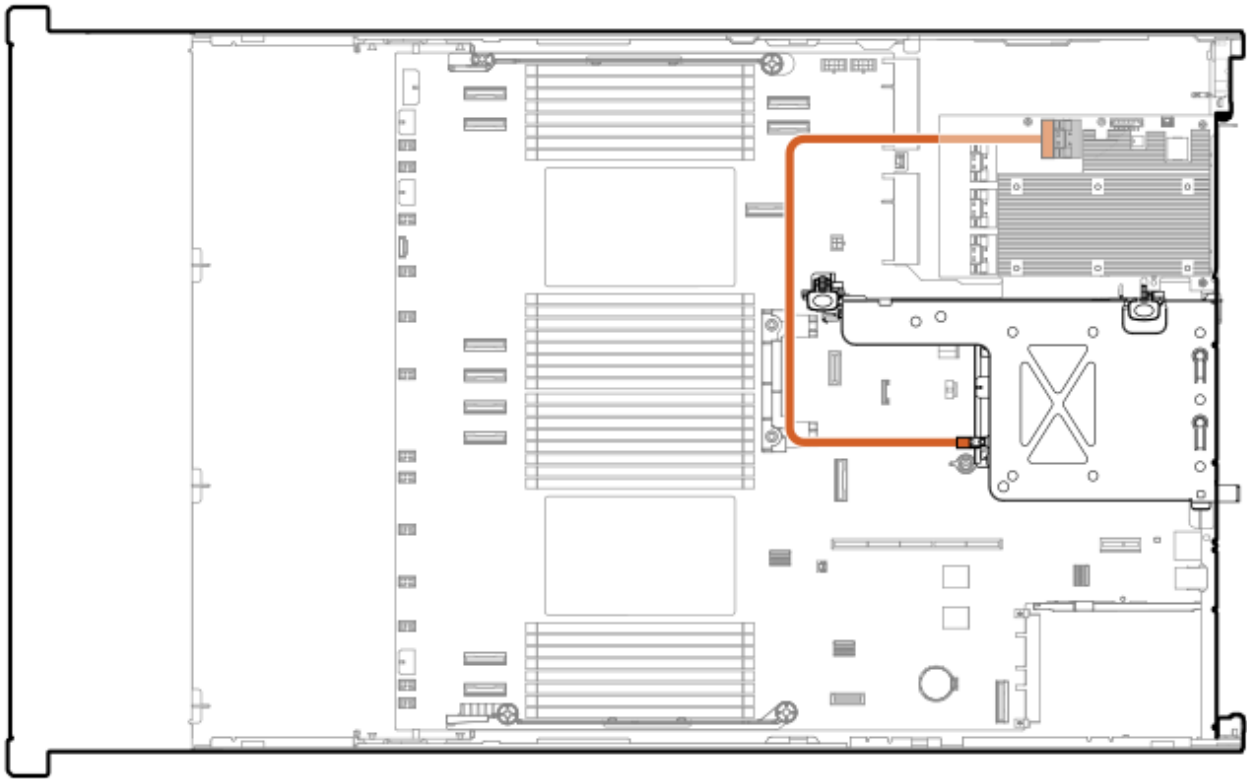

Cable part number	Color	From	To
P22903-001	Orange	Drive backplane	Tertiary type-p controller

2 SFF box 5: Primary type-o controller

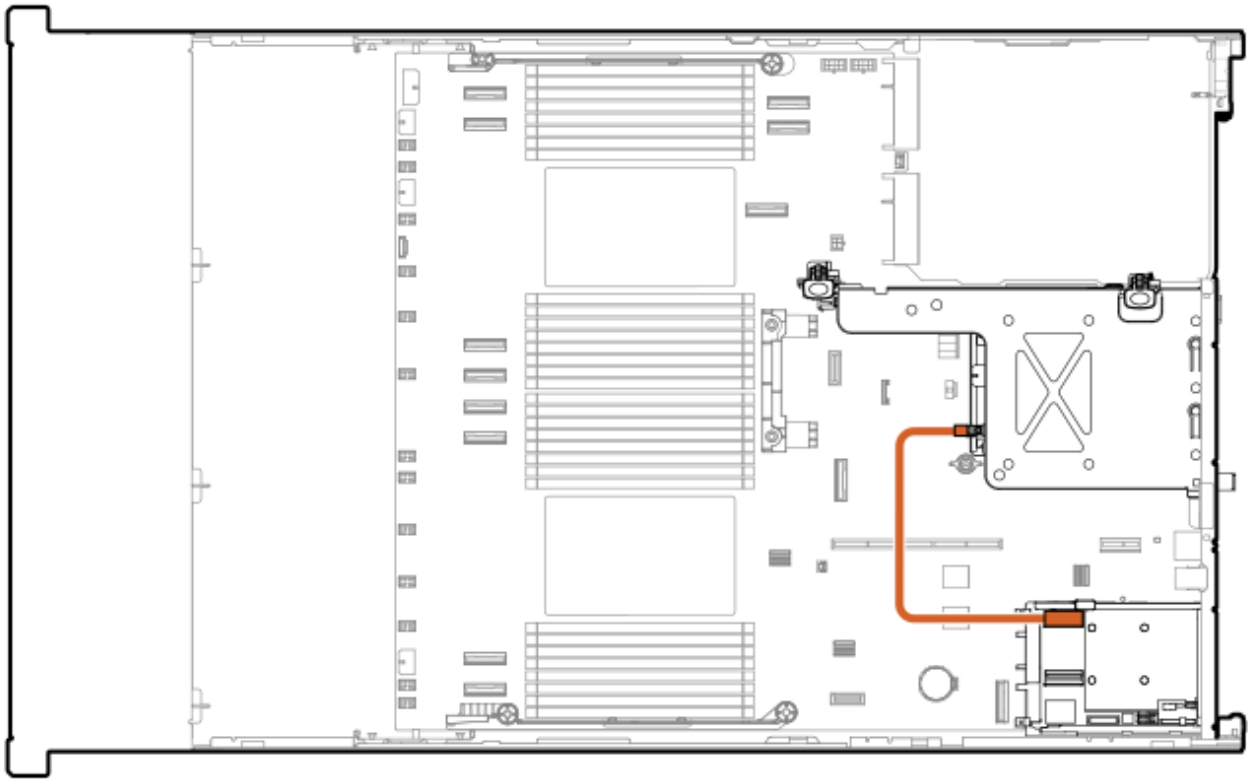

Cable part number	Color	From	To
P51554-001	Orange	Drive backplane	OCP A controller

2 SFF box 6: System board

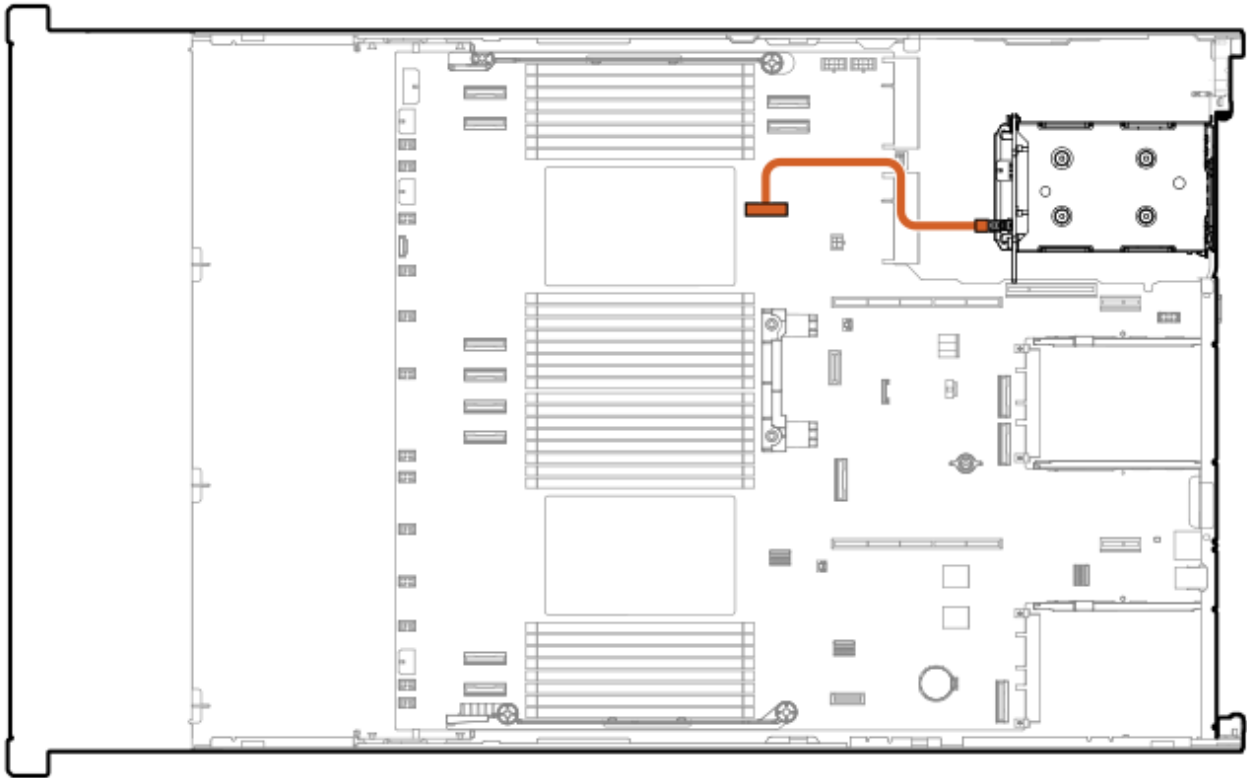

Cable part number	Color	From	To
P74818-001	Orange	Drive backplane	System board

2 SFF box 6: Primary type-p controller

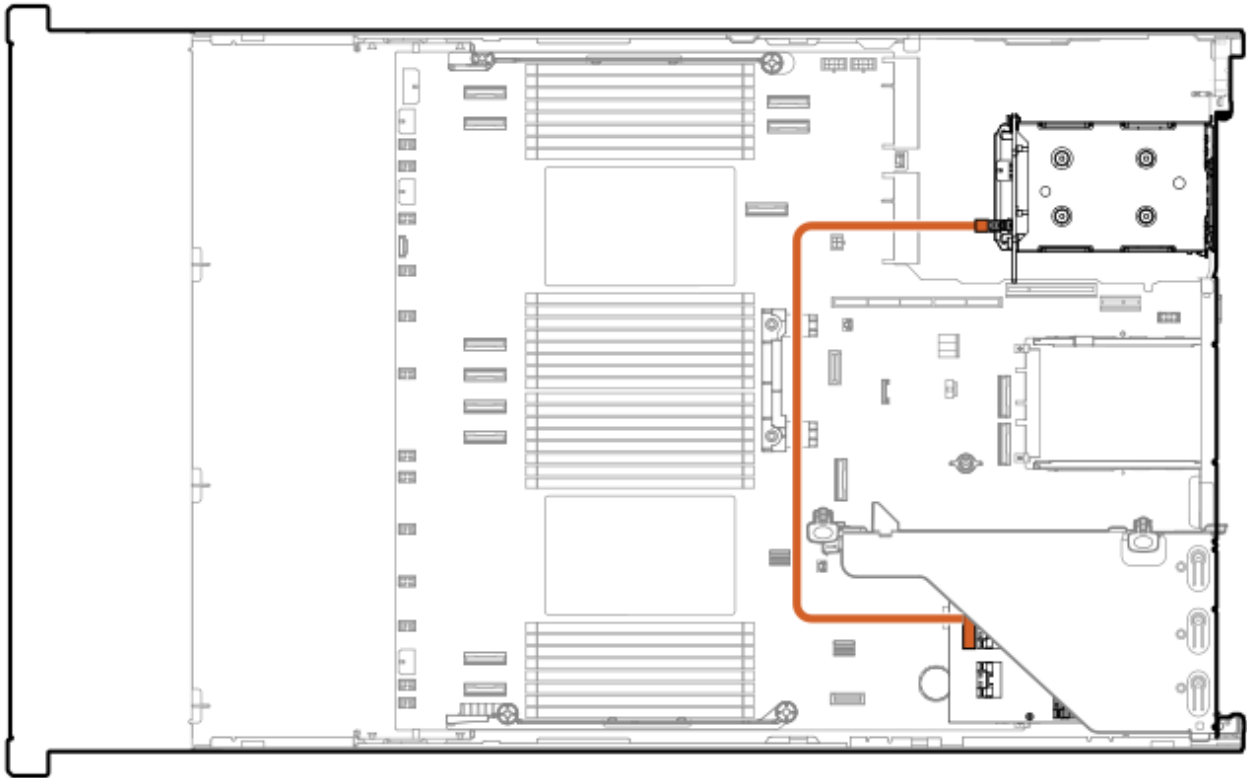

Cable part number	Color	From	To
P51545-001	Orange	Drive backplane	Primary type-p controller

2 SFF box 6: Primary type-p controller

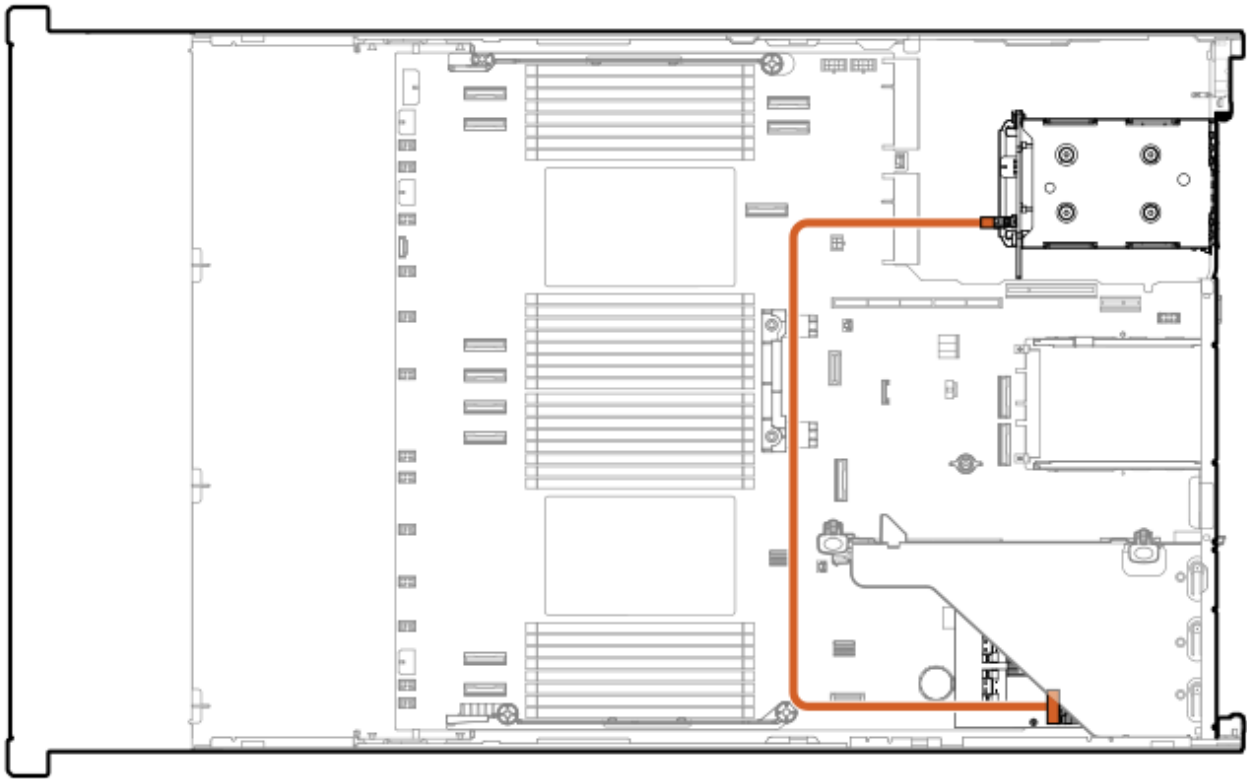

Cable part number	Color	From	To
P22903-001	Orange	Drive backplane	Primary type-p controller

2 SFF box 6: Secondary type-o controller

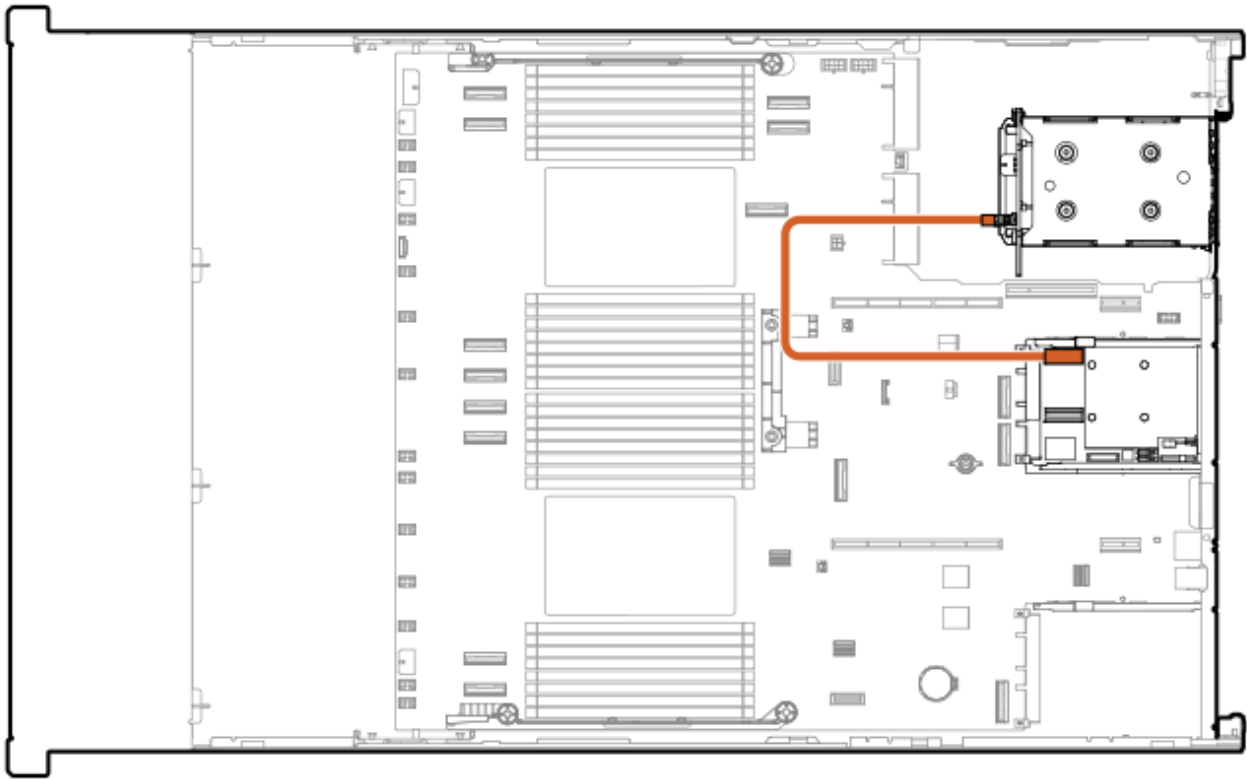

Cable part number	Color	From	To
P51554-001	Orange	Drive backplane	OCP B controller

LFF cabling

LFF box 1 to system board

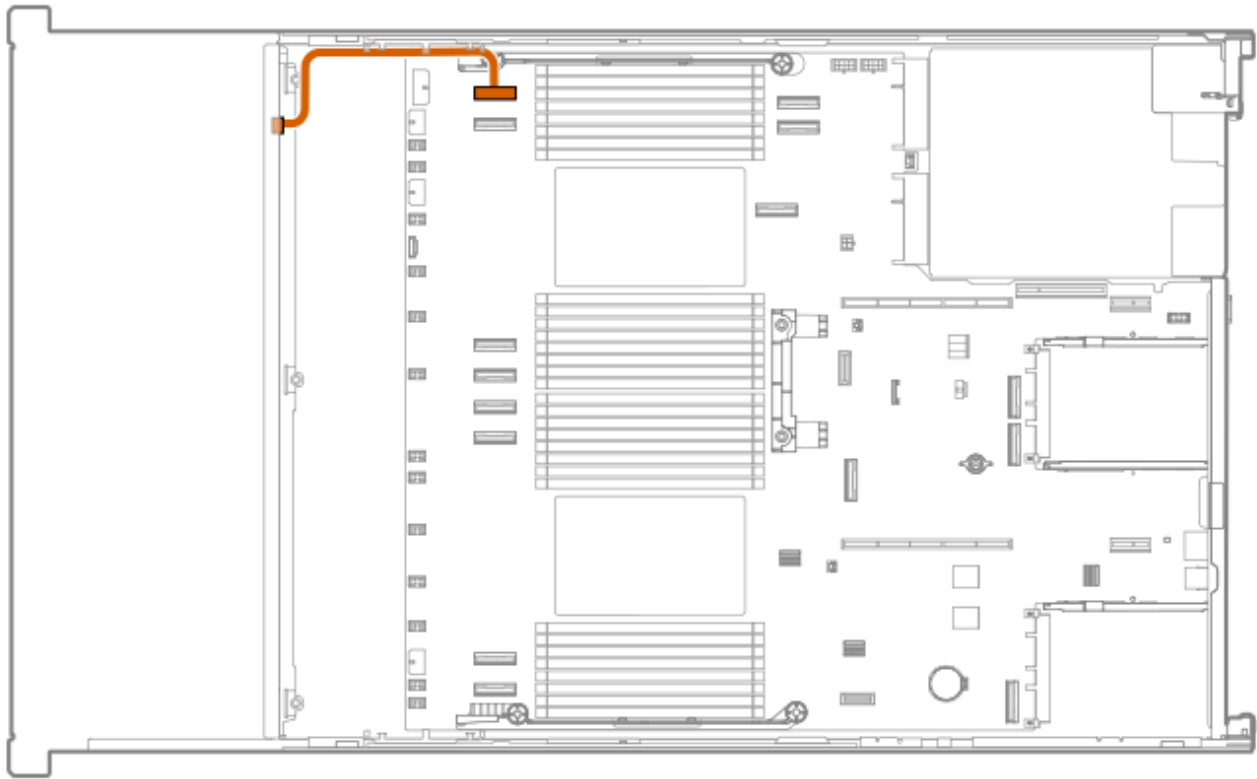

Cable part number	Color	From	To
P75367-001	Orange	Drive backplane	System board

LFF box 2 or 3: Primary type-o controller

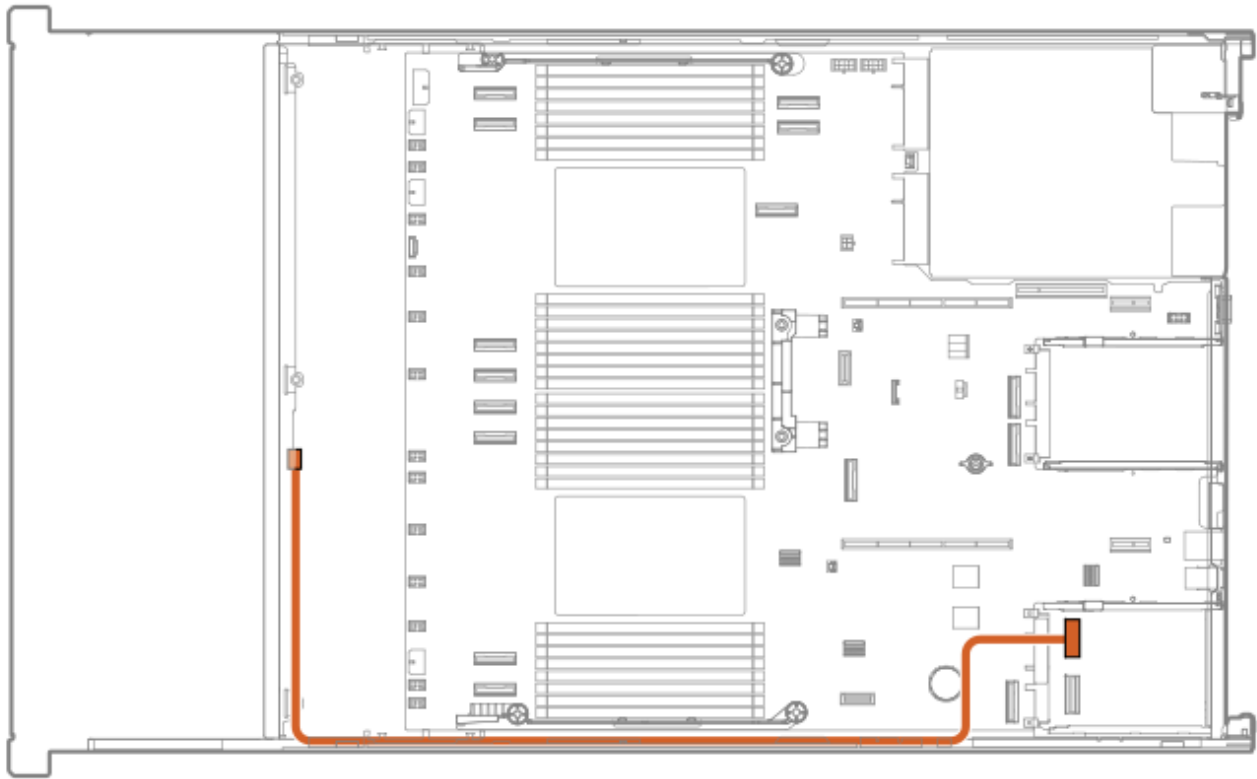

Cable part number	Color	From	To
P51559-001	Orange	LFF box 2 and 3*	Primary type-o controller

*This is a Y-cable and can connect boxes 2 and 3.

LFF box 1 and 7: Primary type-o controller

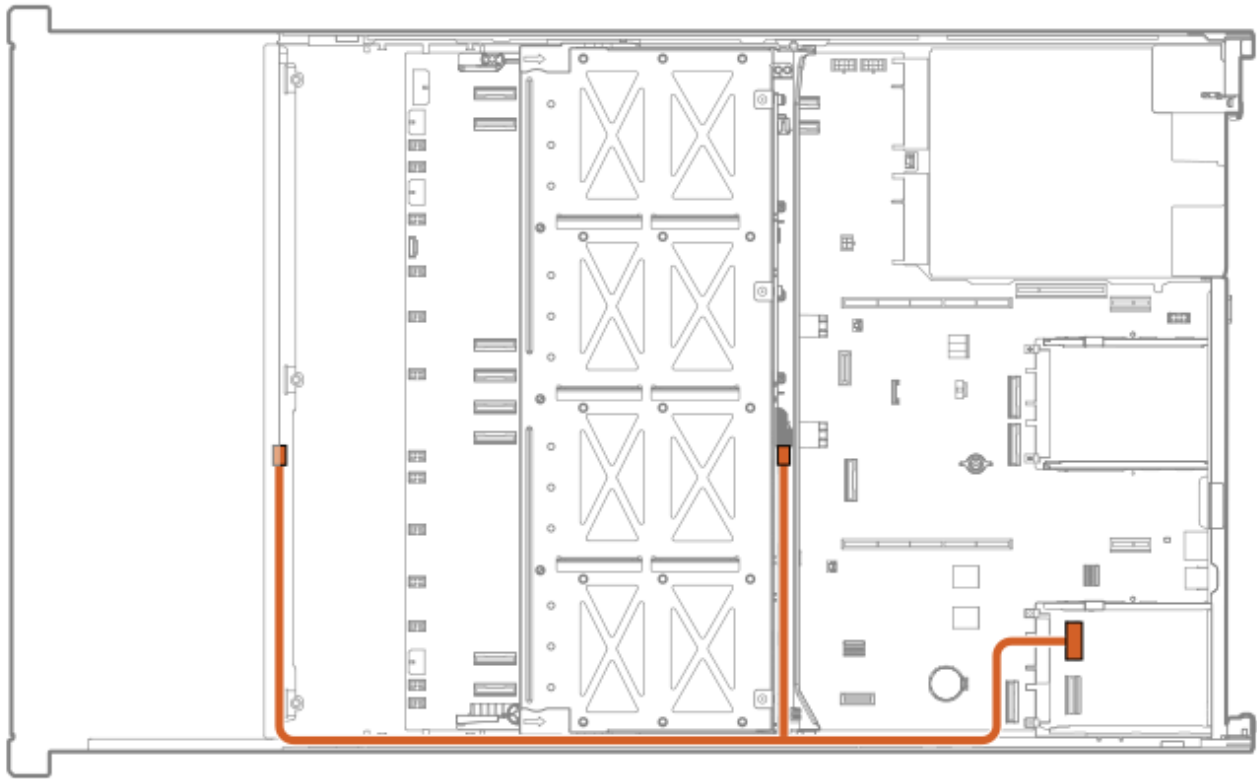

Cable part number	Color	From	To
P51560-001	Orange	LFF box 1 and 7*	Primary type-o controller

*This is a Y-cable and can connect boxes 1 and 7. If there is no box 7, then one end remains loose.

LFF box 4 and 5: Primary type-o controller

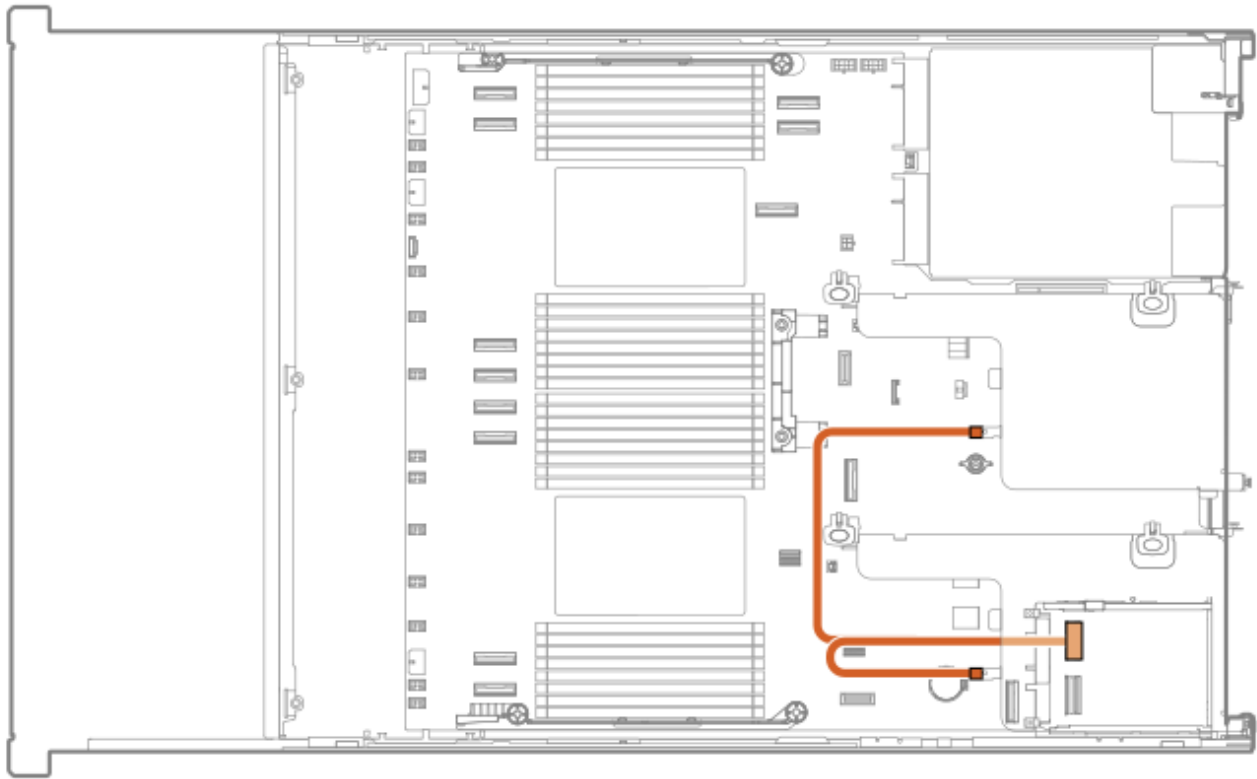

Cable part number	Color	From	To
P51561-001	Orange	LFF box 4 and 5	Primary type-o controller

Riser enablement cabling

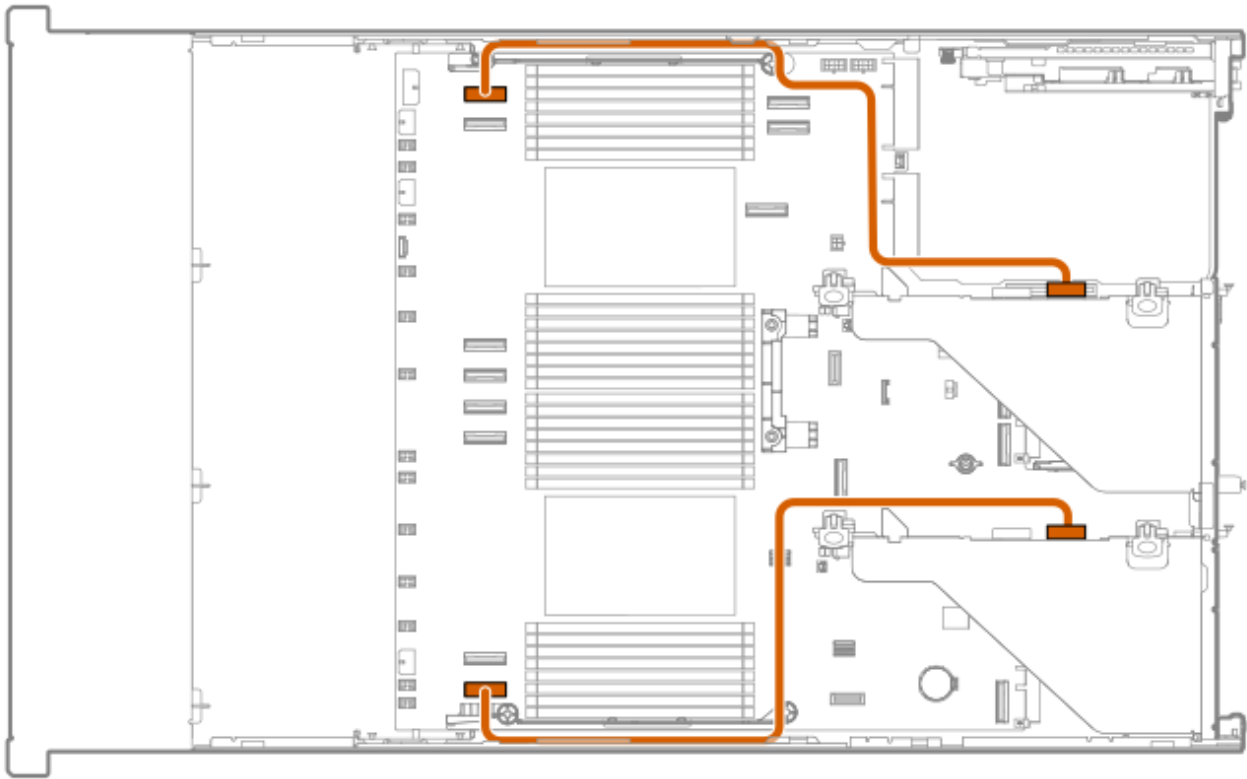

Cable part number	Color	From	To
P75362-001	Orange	Primary and secondary riser	System board

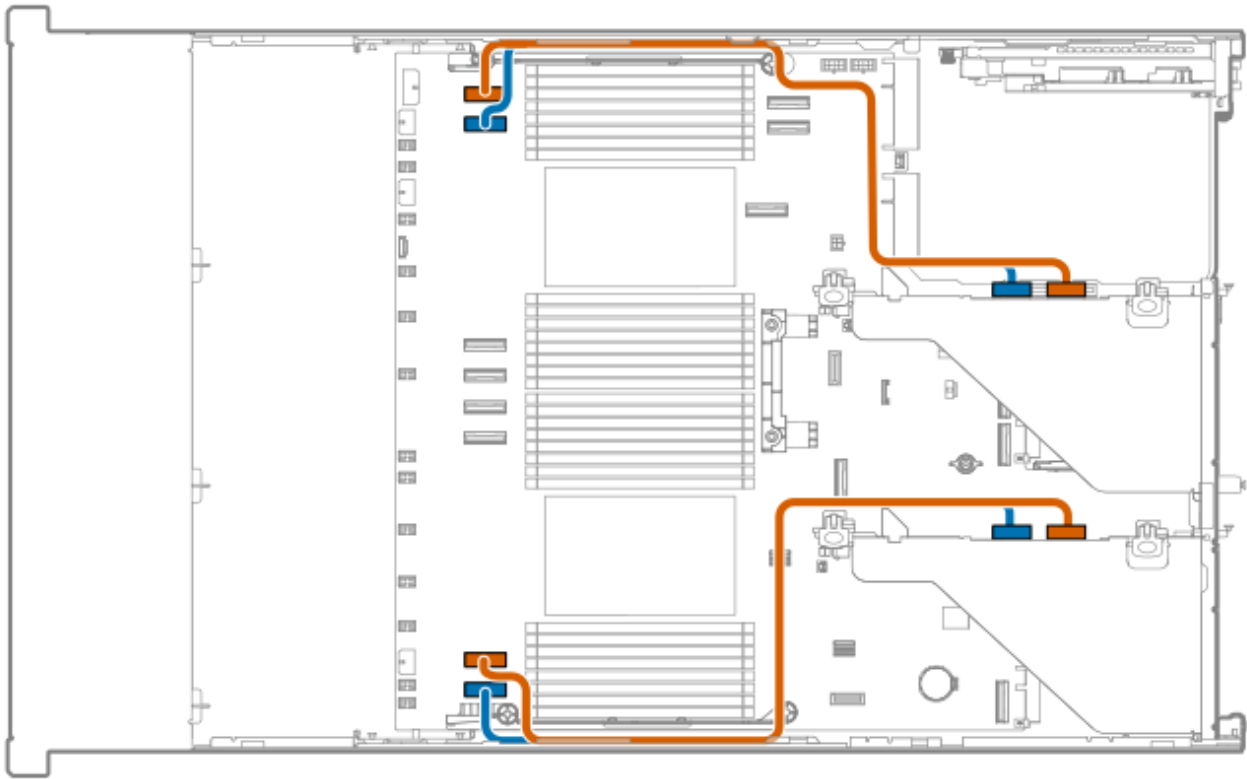

Cable part number	Color	From	To
P75362-001	Orange	Primary and secondary riser	System board
	Blue	Primary and secondary riser	System board

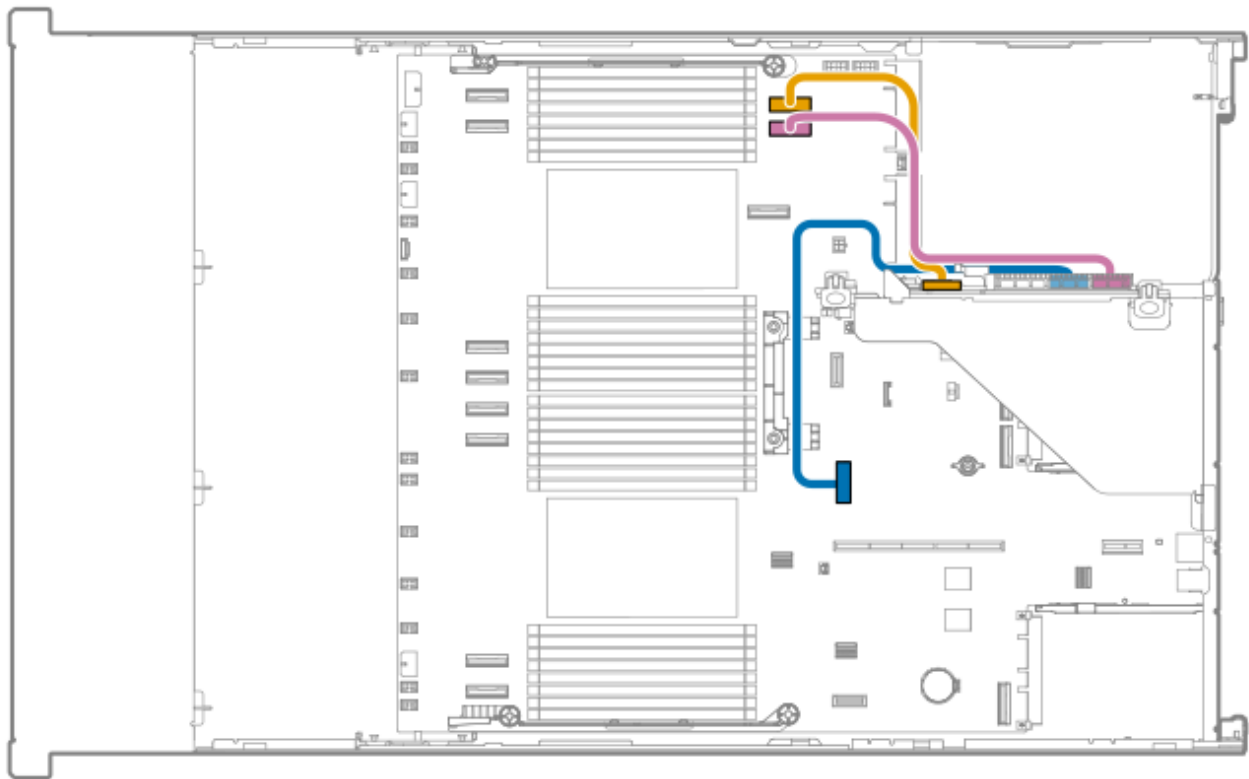

Cable part number	Color	From	To
P76144-001	Yellow	Tertiary riser	System board
	Pink	Tertiary riser	System board
	Blue	Tertiary riser	System board

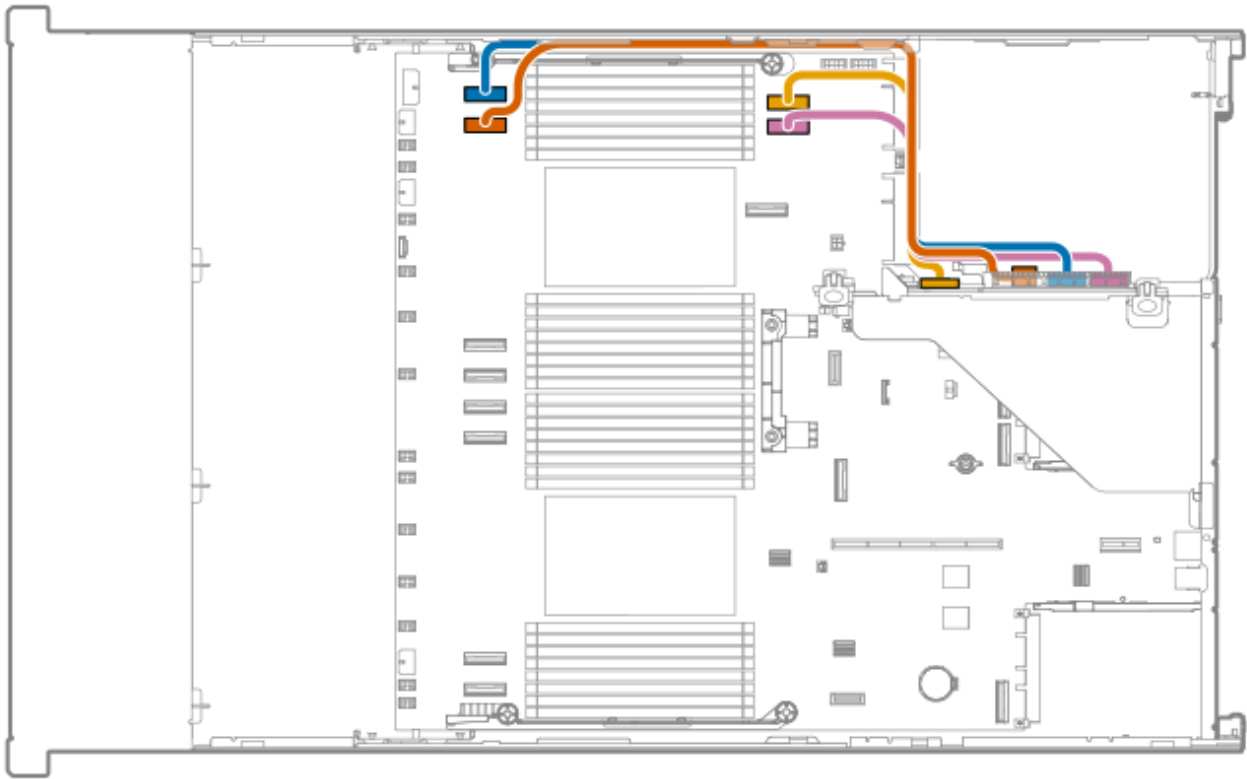

Cable part number	Color	From	To
P76145-001	Yellow	Tertiary riser	System board
	Pink	Tertiary riser	System board
	Blue	Tertiary riser	System board
	Orange	Tertiary riser	System board

Power cabling



CAUTION

Do not install cables into the wrong connector. Connecting the wrong end could damage components. All cables are labeled. Check the connectors and be sure that the labeling matches before connecting them.

4 EDSFF boxes 1, 2, and 3

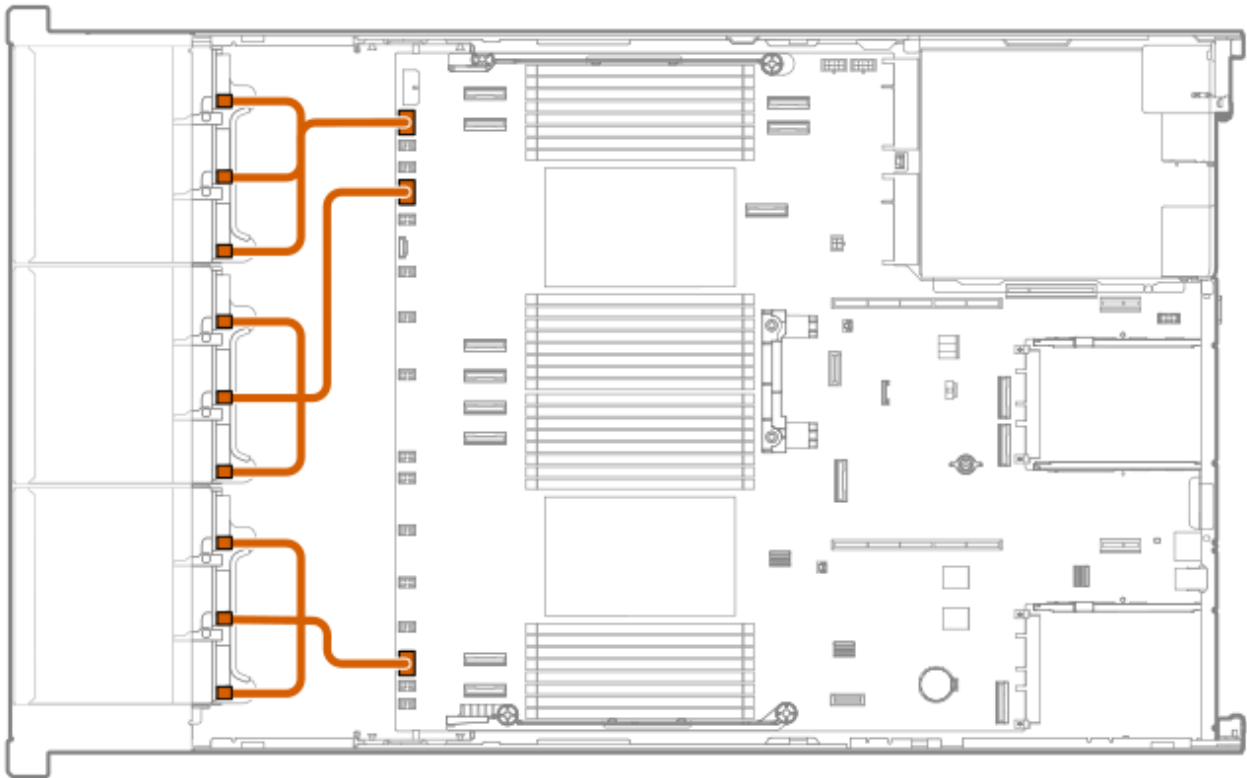

Cable part number	Color	From	To
P75277-001	Orange	Drive backplane	System board

8 SFF boxes 1-3

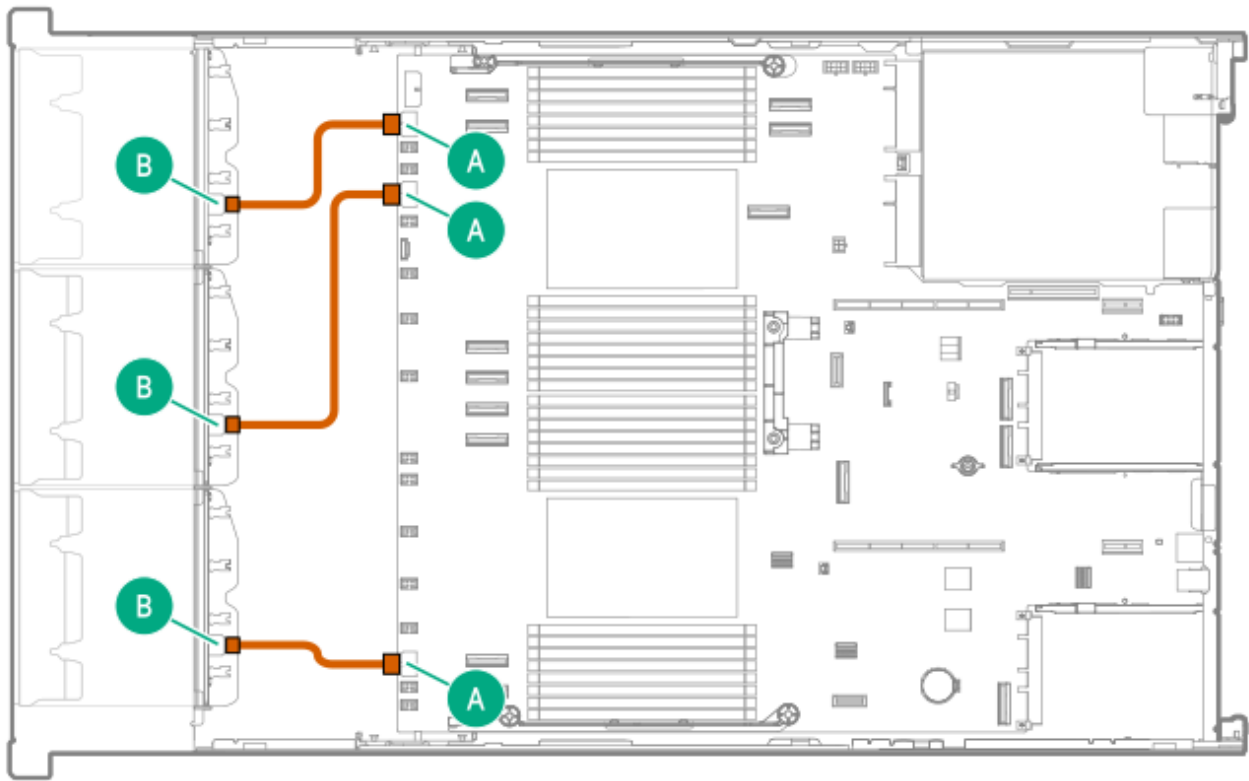

Cable part number	Color	From	To
P75906-001	Orange	8 SFF backplane	System board

4 LFF box 1

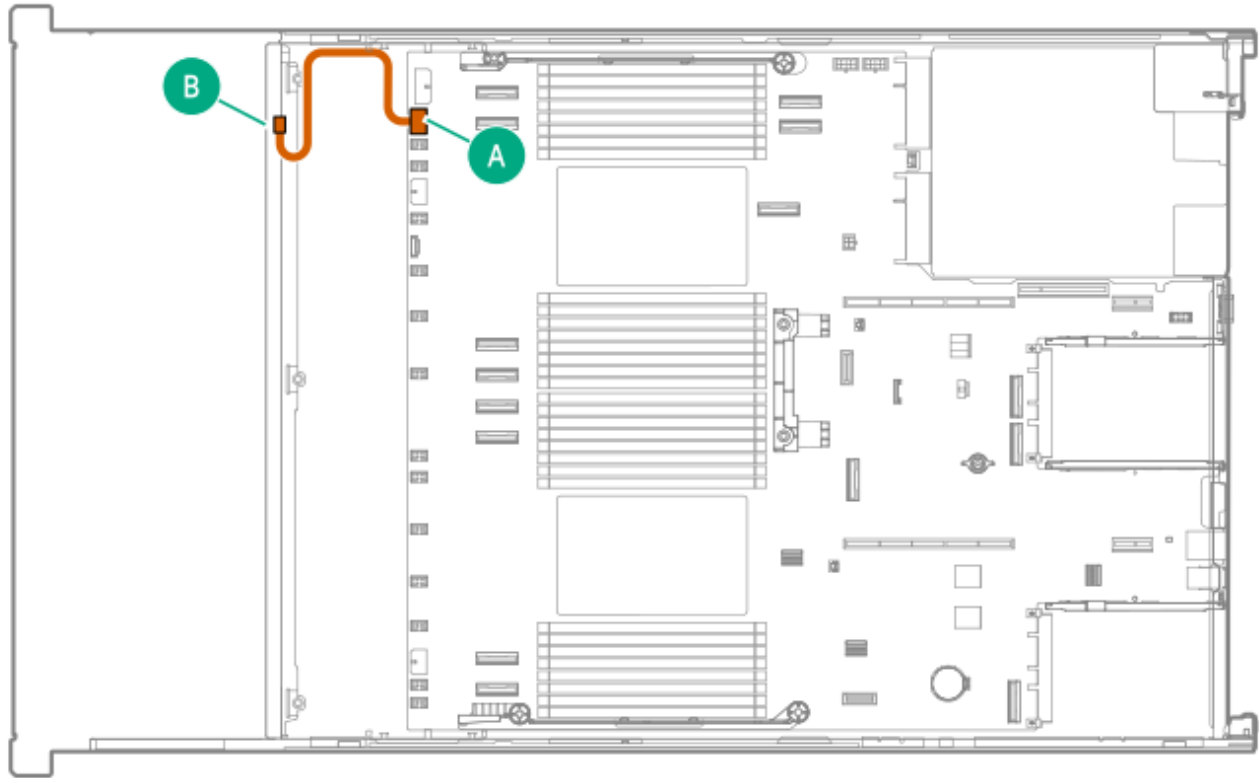

Cable part number	Color	From	To
P75363-001	Orange	4 LFF backplane box 1	System board

4 LFF box 2

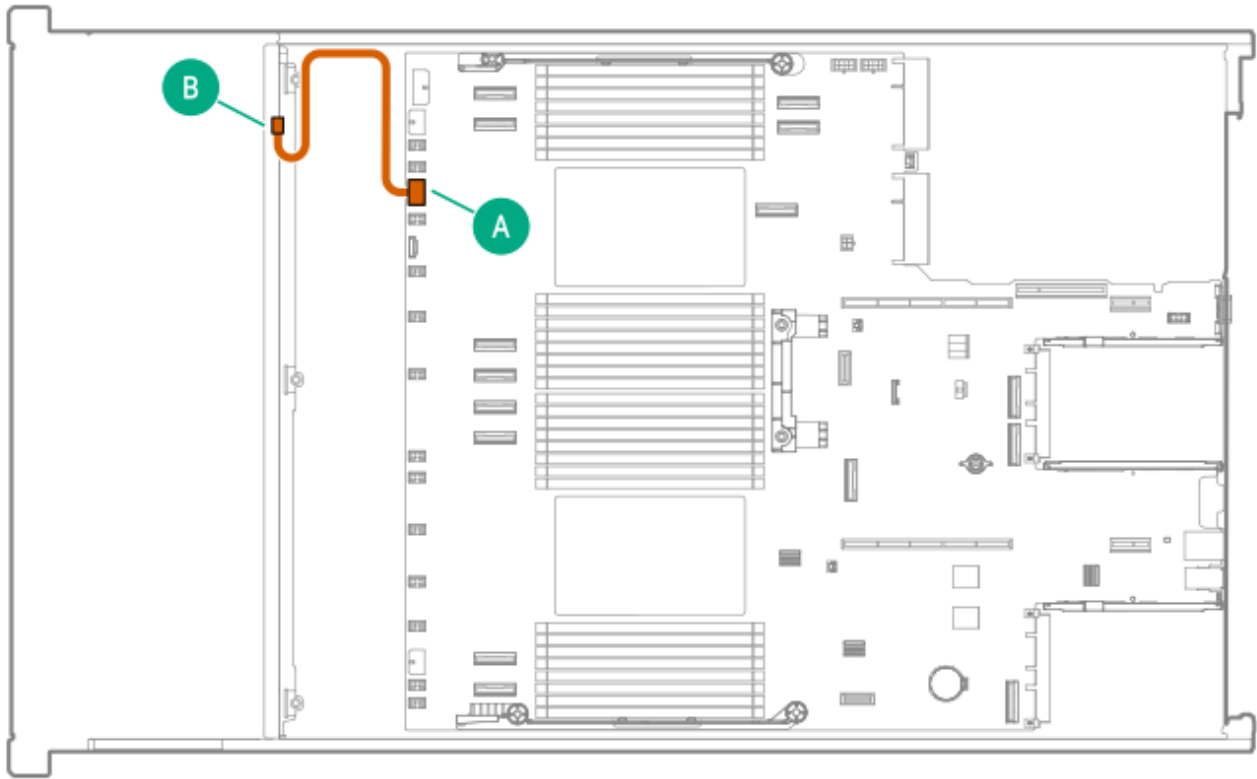

Cable part number	Color	From	To
P75363-001	Orange	4 LFF backplane box 2	System board

4 LFF box 3

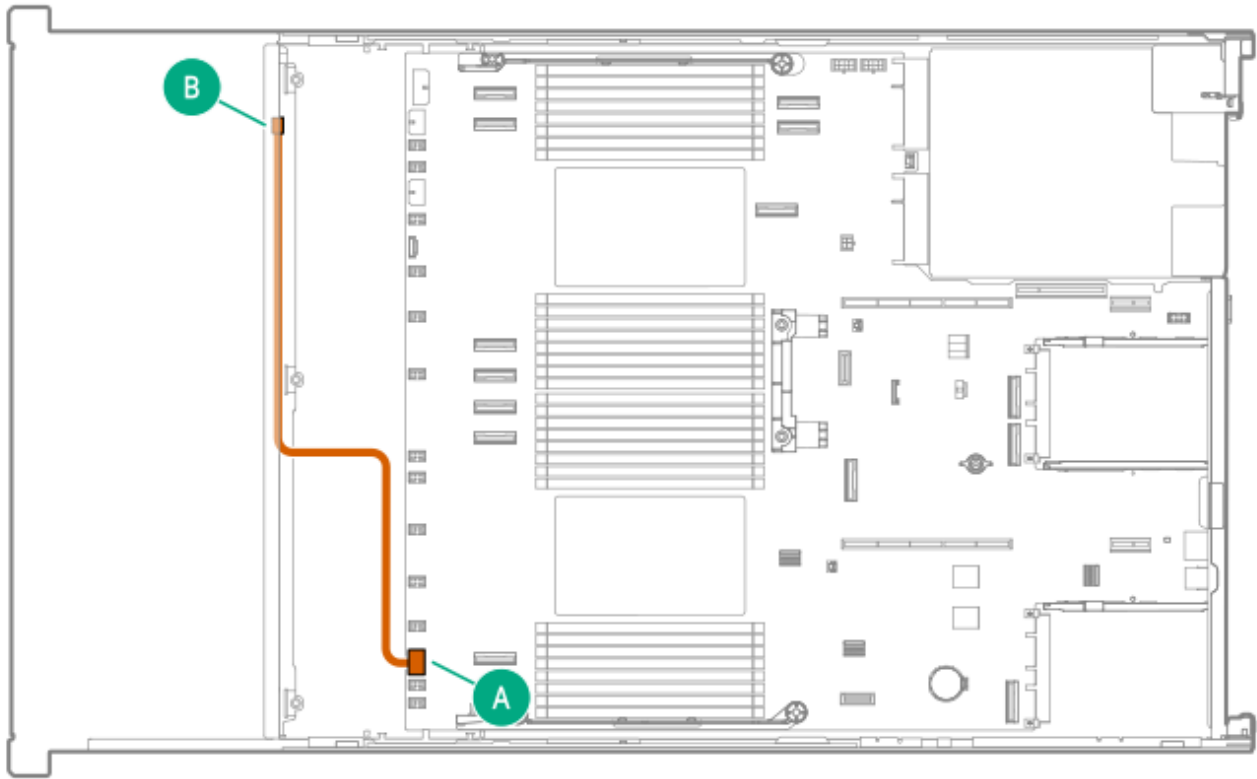

Cable part number	Color	From	To
P75363-001	Orange	4 LFF backplane box 3	System board

2 SFF side-by-side (LFF chassis)

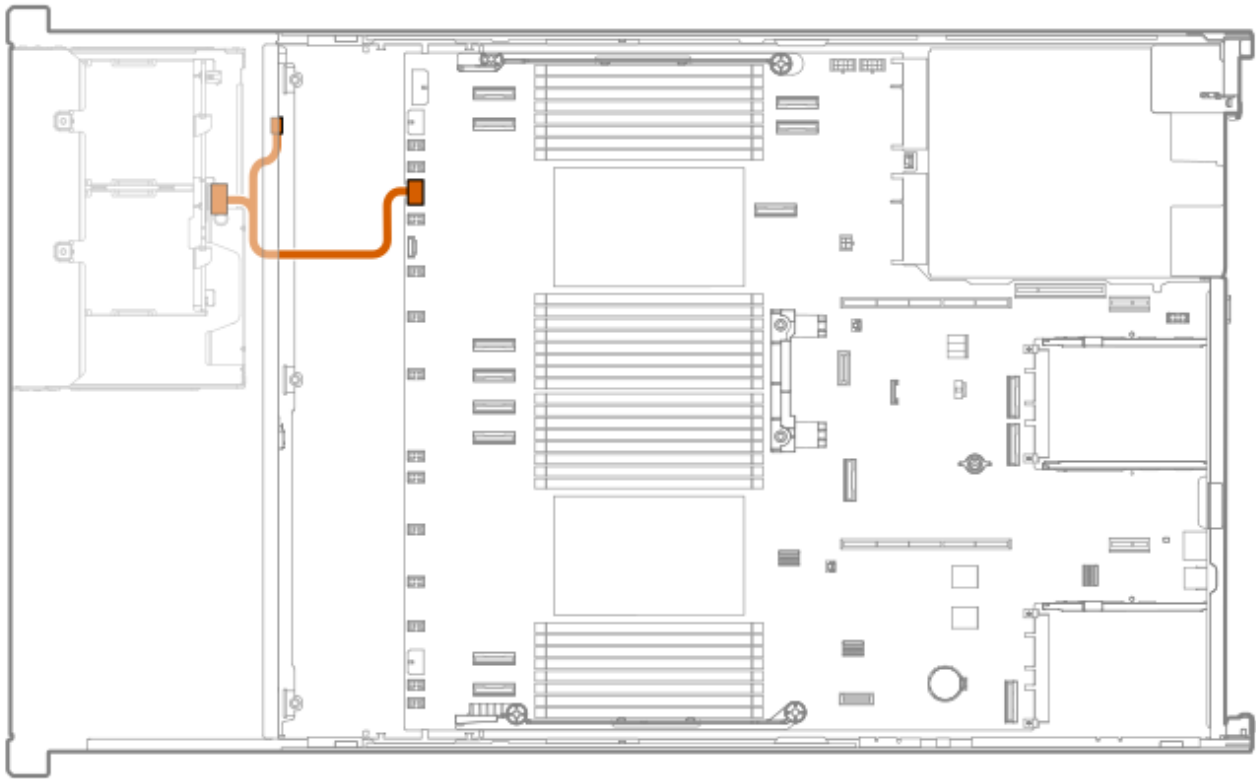

Cable part number	Color	From	To
P75276-001	Orange	Drive backplane	System board

Boxes 4, 5, and 7

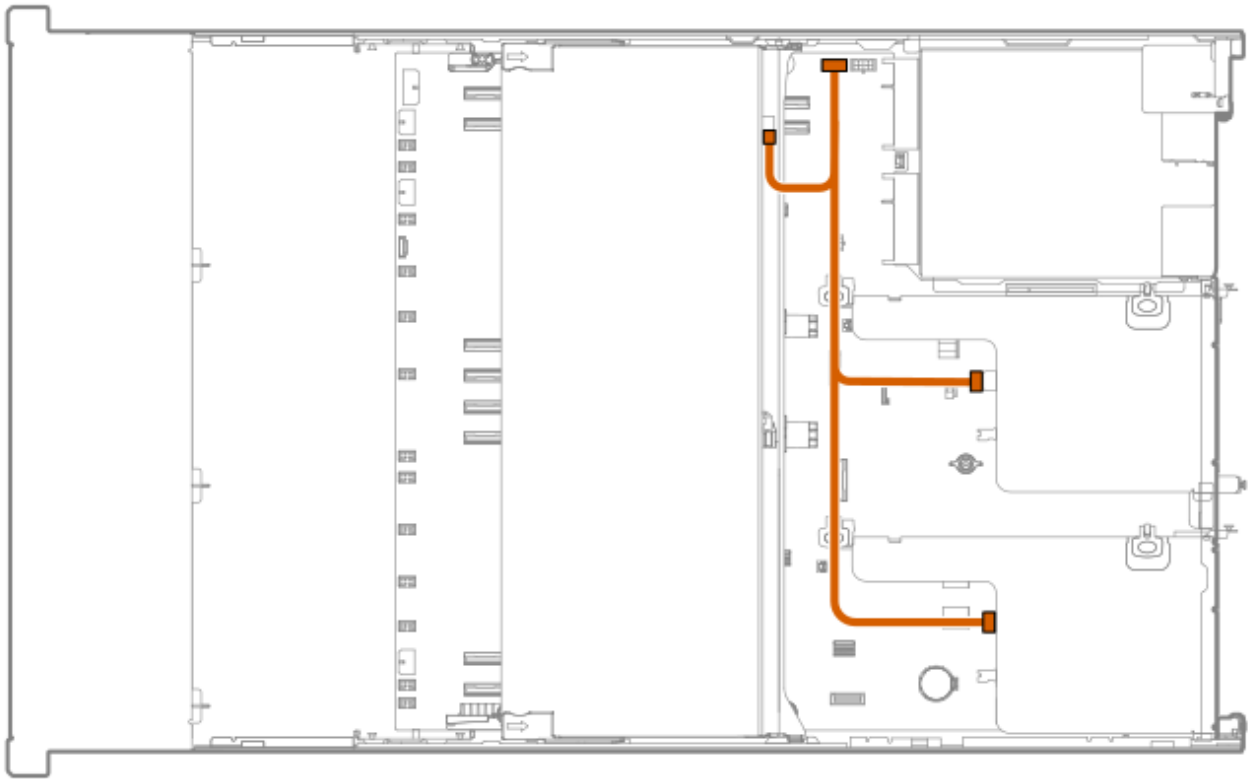

Cable part number	Color	From	To
P75364-001	Orange	Drive backplanes	System board

2 SFF box 4 and 5

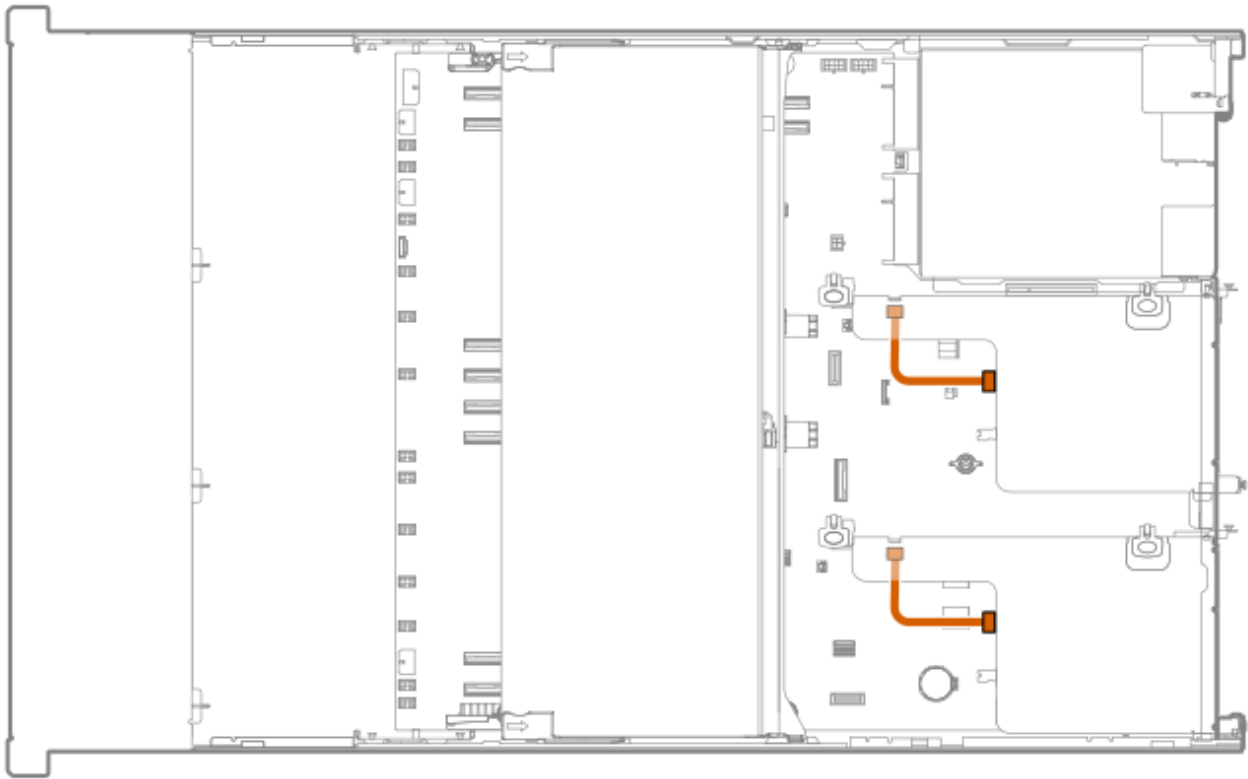

Cable part number	Color	From	To
P51574-001	Orange	Drive backplane	Riser power connector

Smart battery cabling

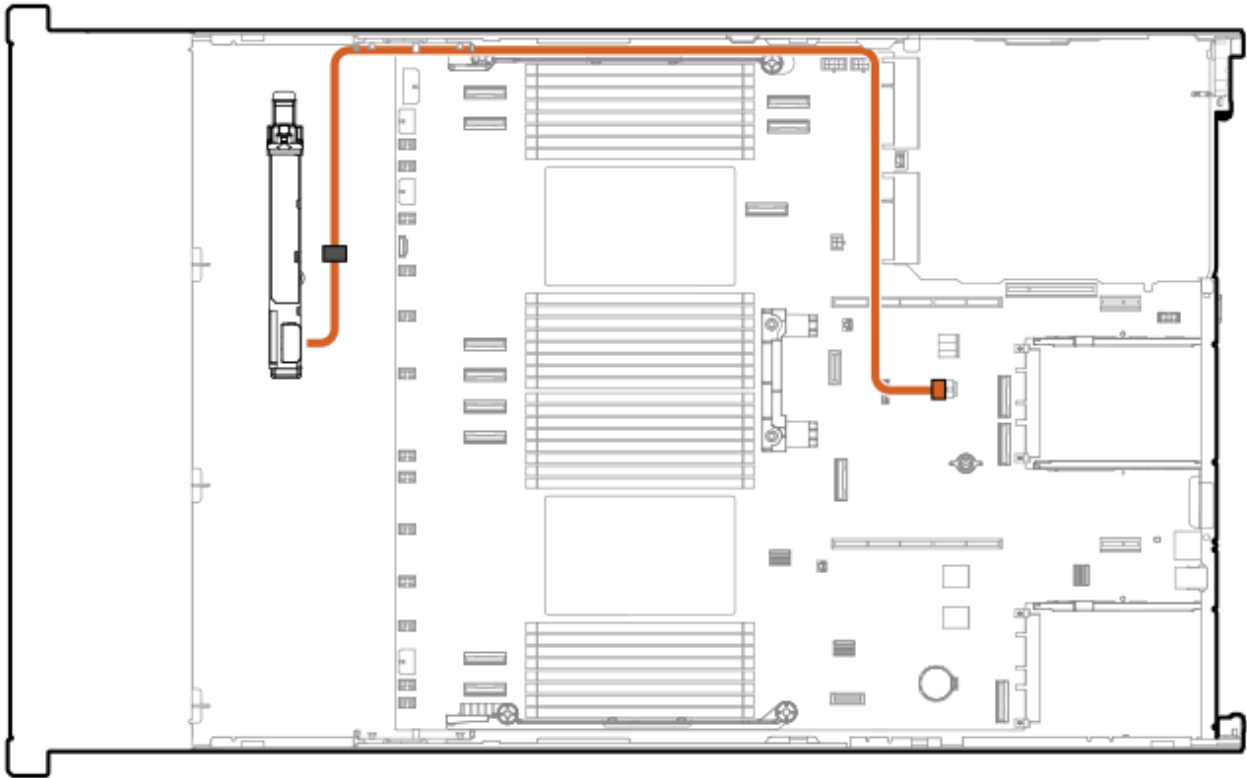

Cable part number	Color	From	To
P45618-001	Orange	Smart battery	System board

GPU cabling

GPU power cabling

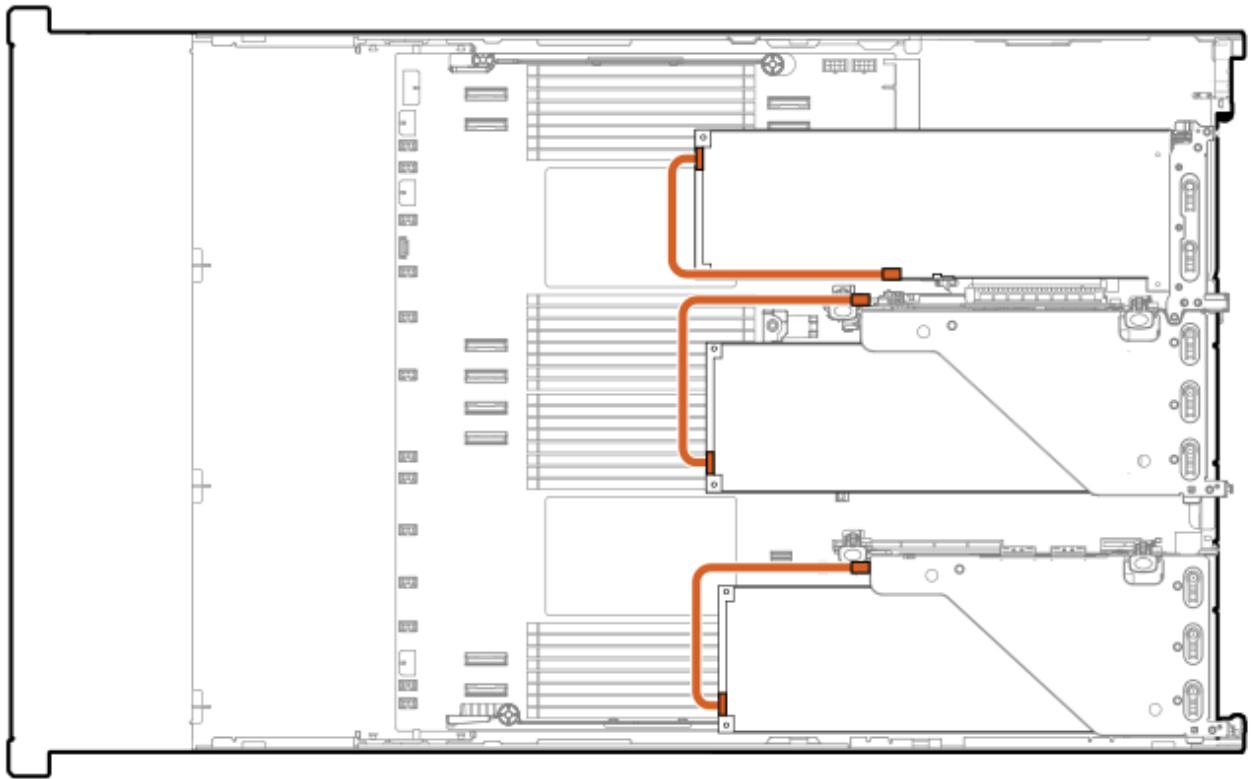

Cable part number	Color	From	To
869820-001 ¹ / _—	Orange	GPU	Riser

¹/_— Option kit: P39102-B21

GPU power + sideband cabling

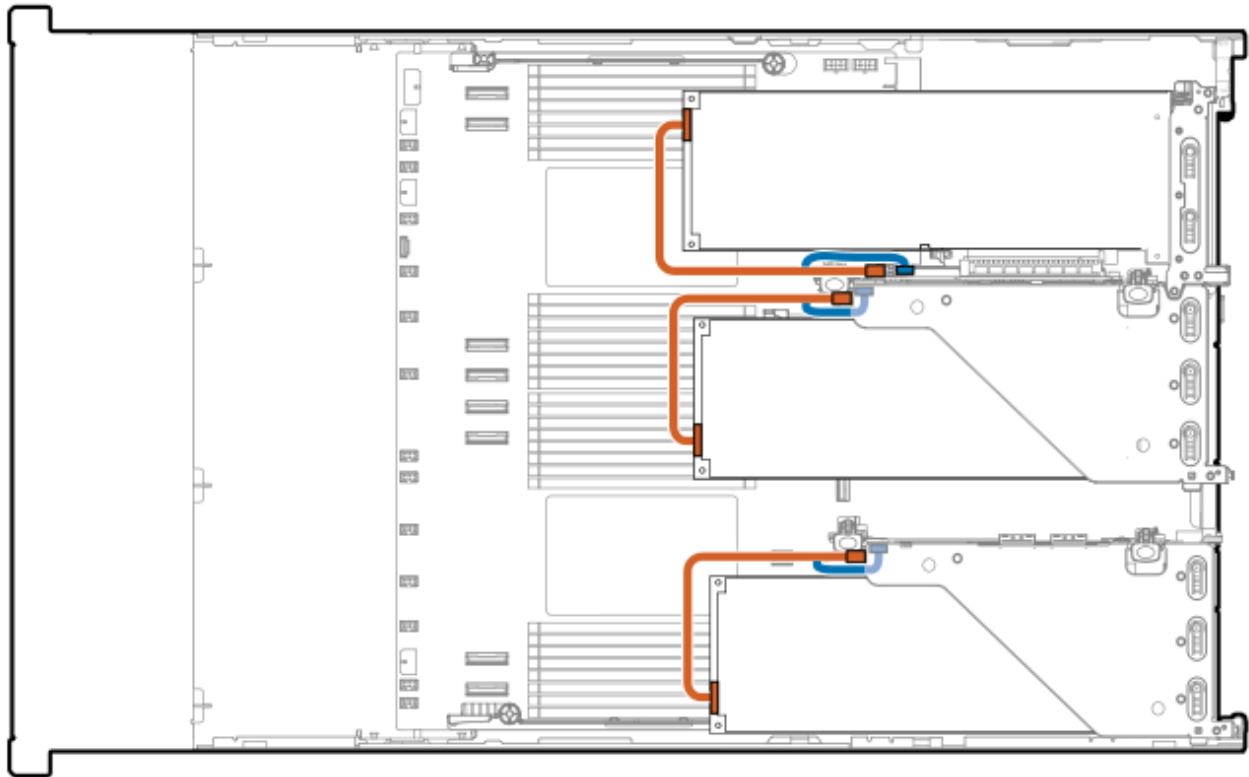

Cable part number	Color	From	To
P58422-001 ¹ / _—	Orange	GPU	Riser

¹/_— Option kit: P56072-B21

NS204i-u boot device cabling

Rear NS204i-u boot device cabling

Figure 1. Data cabling for the rear NS204i-u boot device



Cable part number	Color	From	To
P72024-001	Orange	NS204i-u boot device	System board

Figure 2. Power cabling for the rear NS204i-u boot device

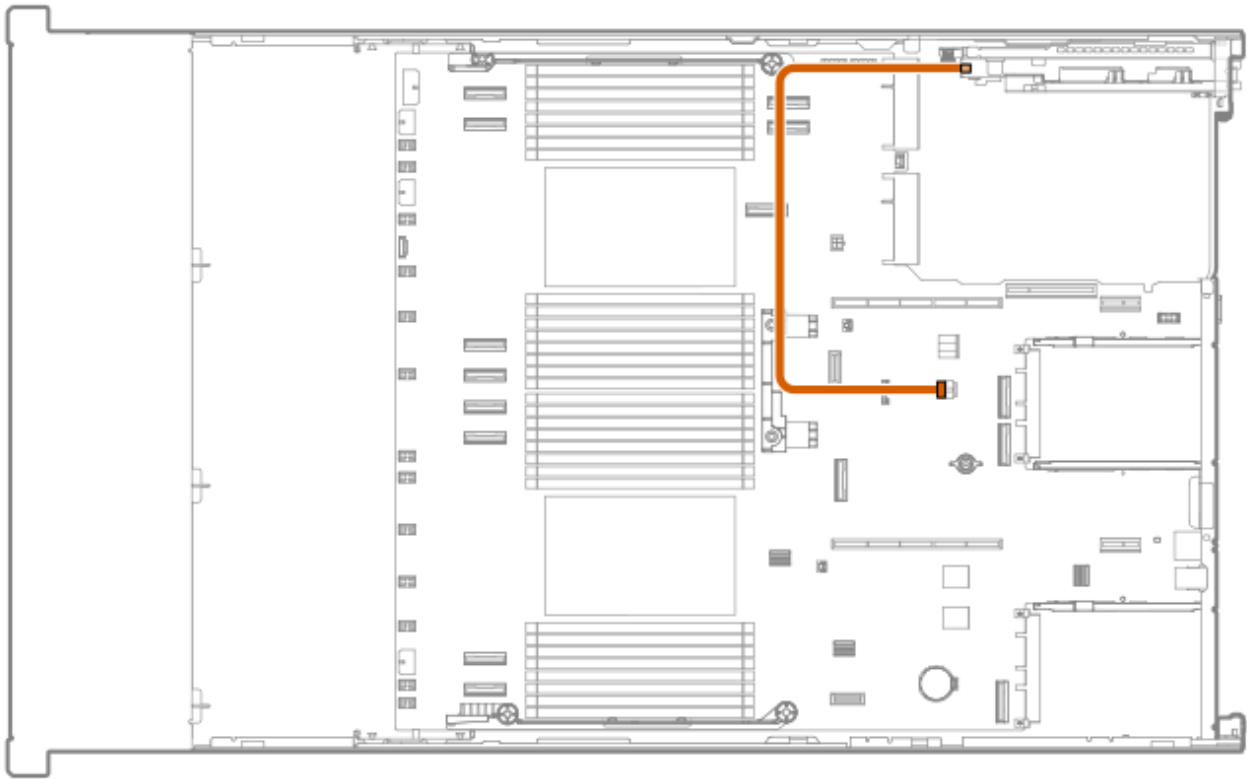

Cable part number	Color	From	To
P54089-001	Orange	NS204i-u boot device	System board

Front NS204i-u boot device cabling

Figure 3. Data cabling for the front NS204i-u boot device

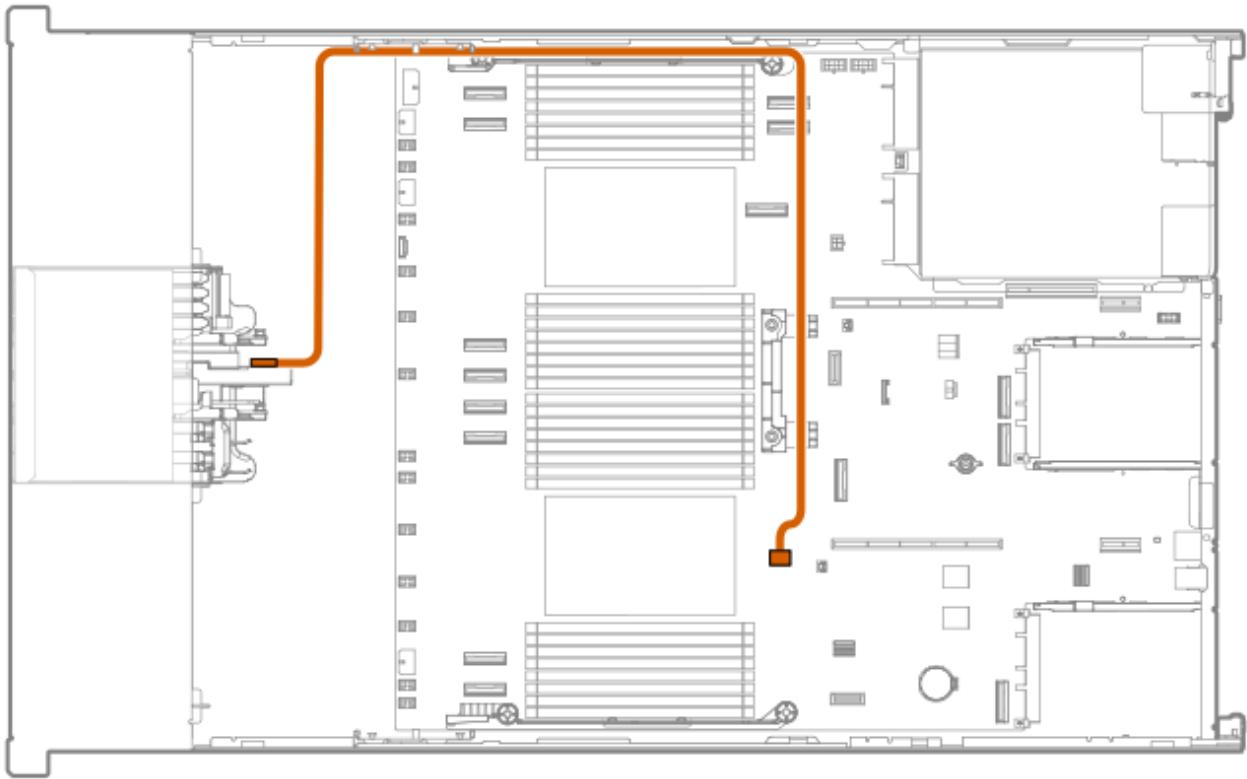

Cable part number	Color	From	To
P74730-001	Orange	NS204i-u boot device	System board

Figure 4. Power cabling for the front NS204i-u boot device

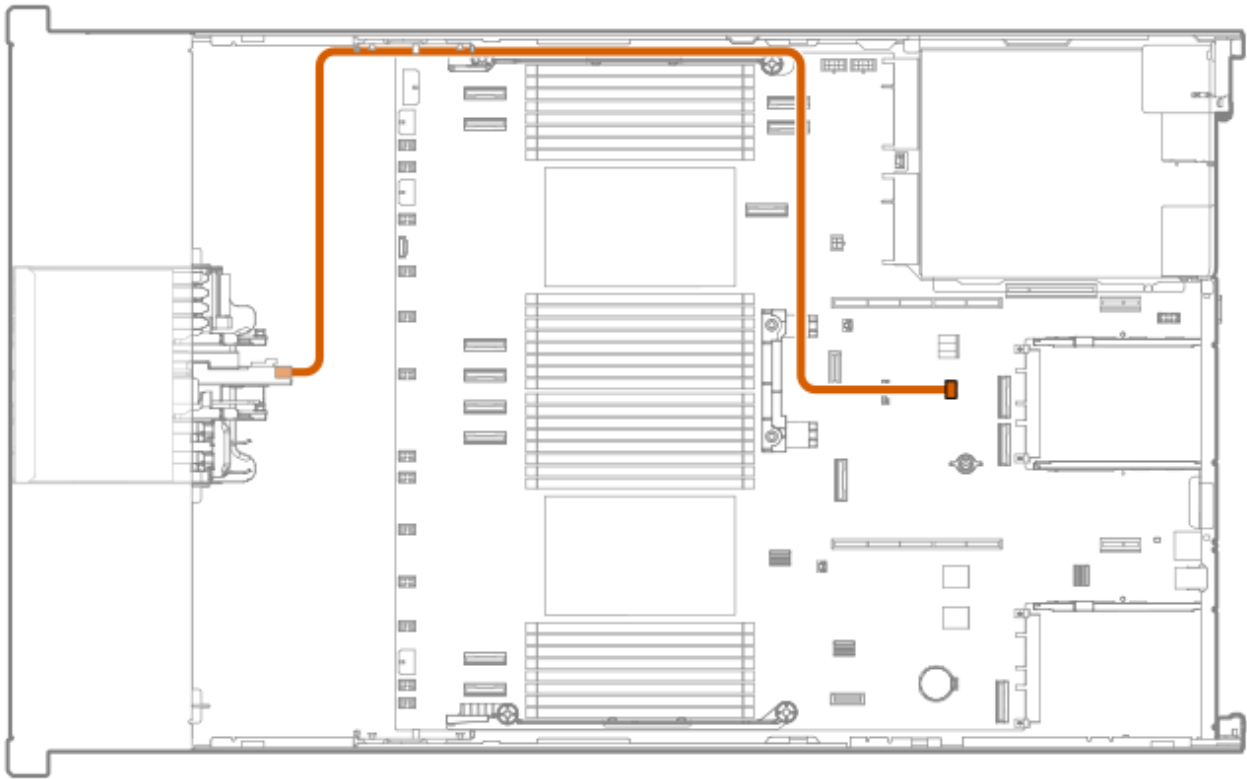

Cable part number	Color	From	To
P74729-001	Orange	NS204i-u boot device	System board

OCP enablement

Front OCP slot 9 enablement

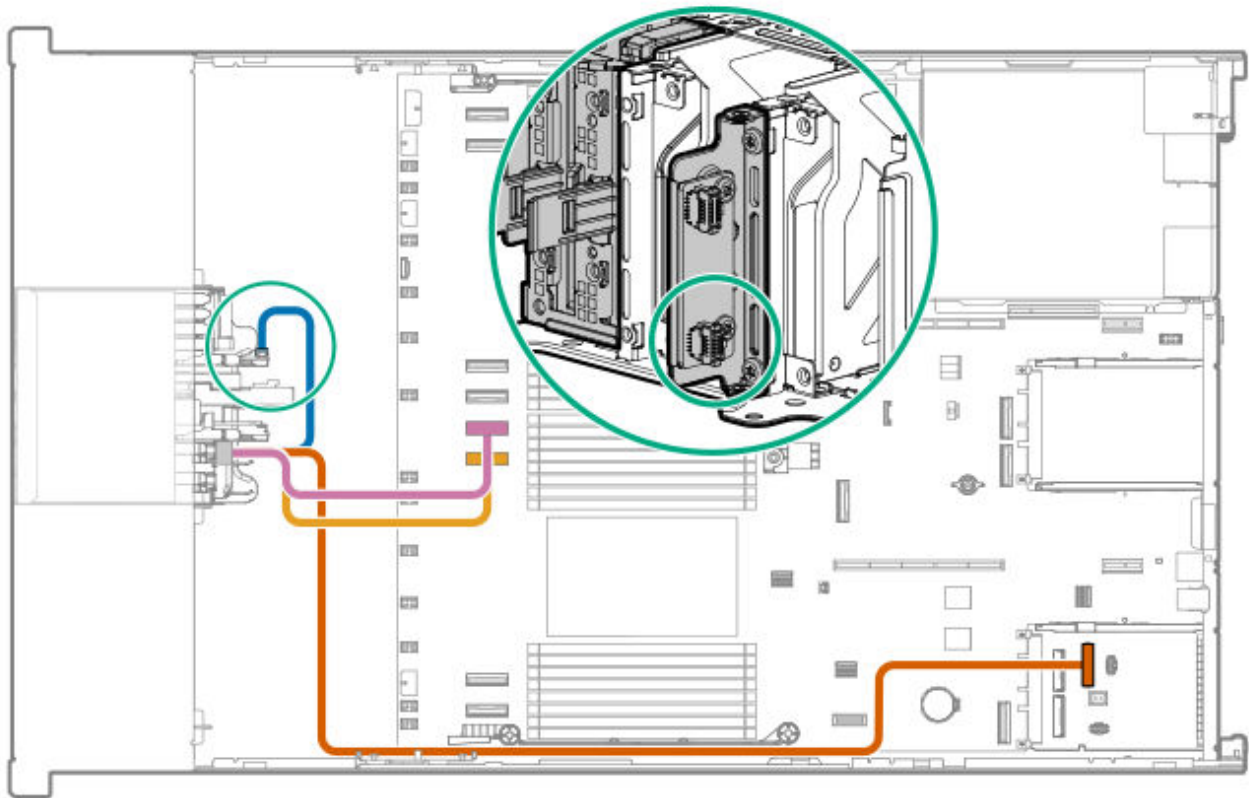

Cable part number	Color	From	To
P71940-001	Pink	OCP cable	System board
	Yellow	OCP cable	System board
	Orange	OCP cable	Interposer (OCP A)
	Blue	OCP cable	Phy board (bottom port)

Front OCP slot 11 enablement

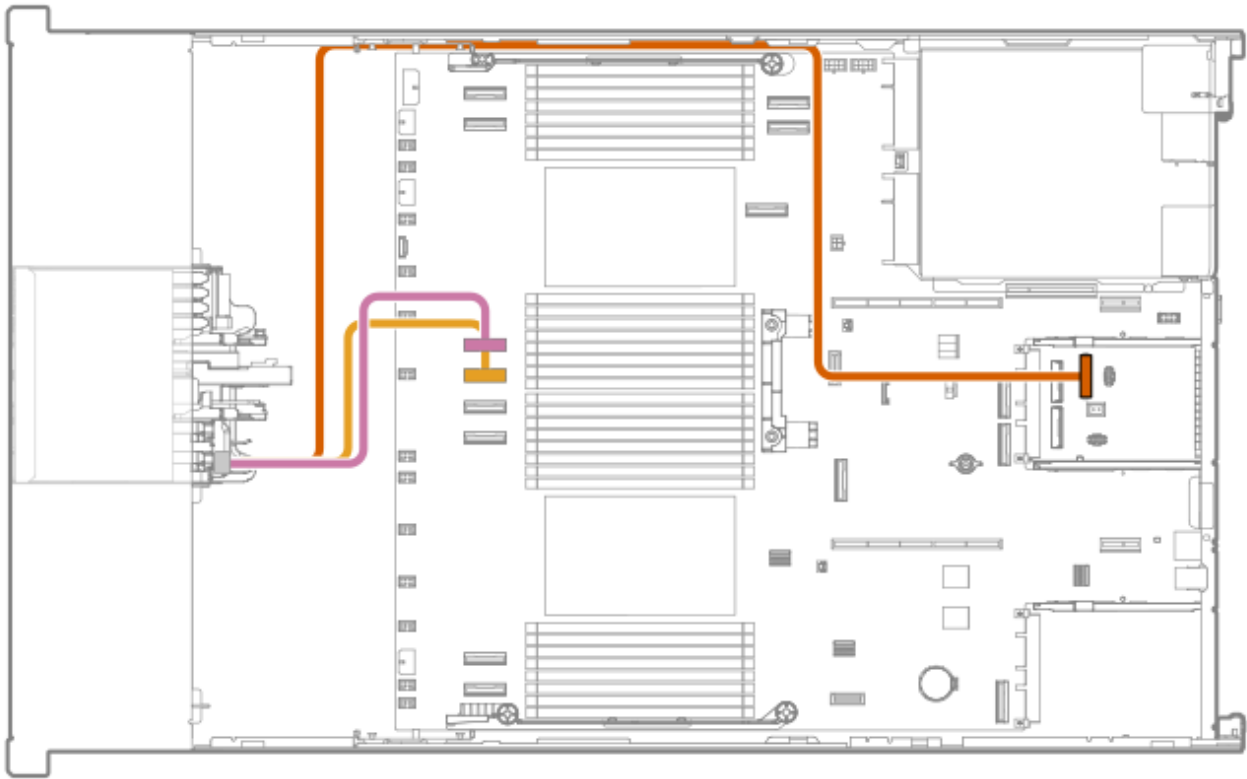

Cable part number	Color	From	To
P71940-001	Pink	OCP cable	System board
	Yellow	OCP cable	System board
	Orange	OCP cable	Interposer (OCP B)

Front OCP Phy board cabling

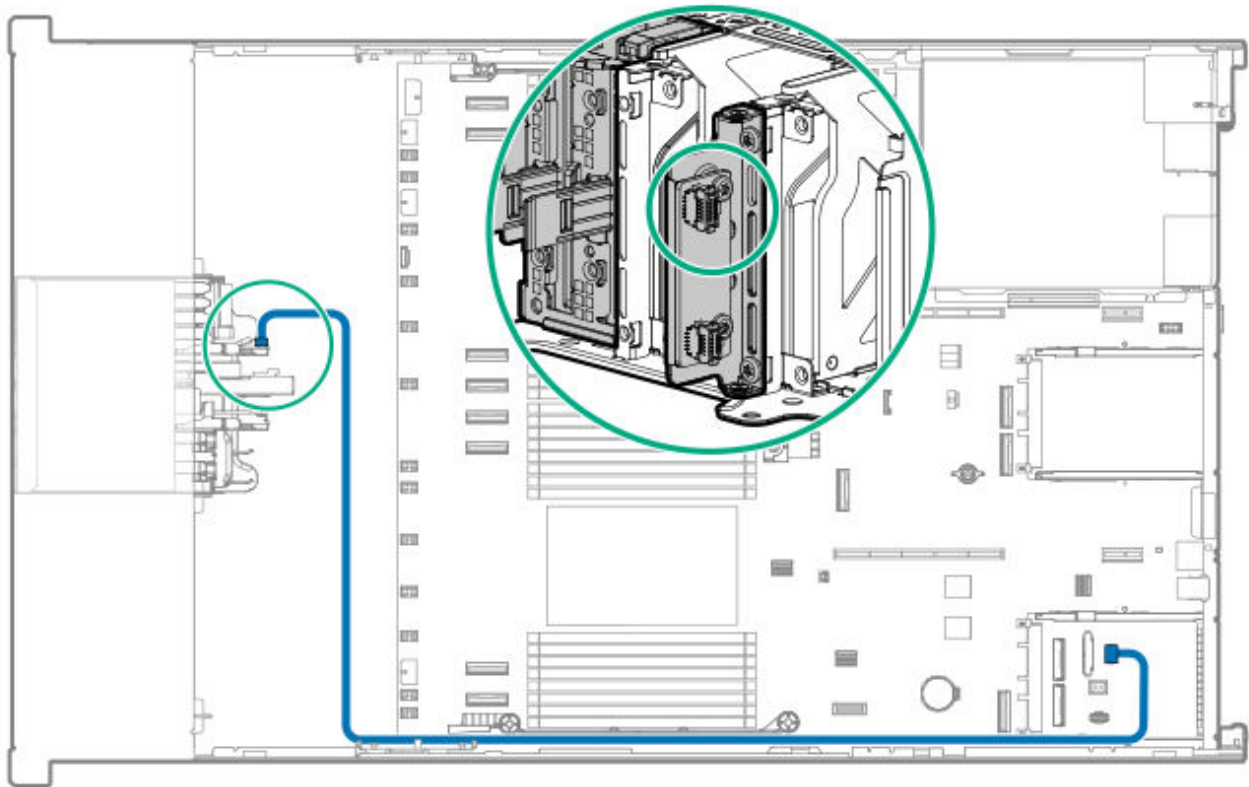

Cable part number	Color	From	To
P73927-001	Blue	Phy board (top port)	Interposer (OCP A)

CPU 1 to OCP B x8 enablement

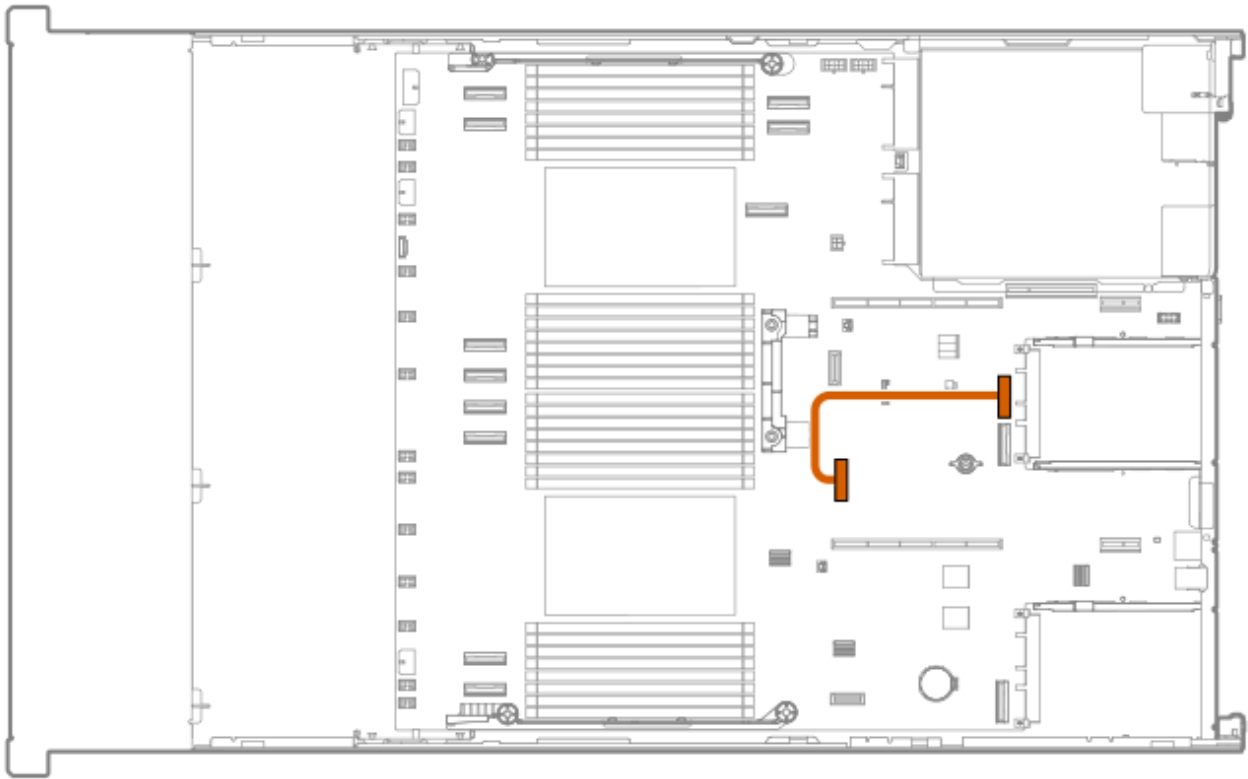

Cable part number	Color	From	To
P74889-001	Orange	OCP slot 15 port 1	Socket 1 MCIO port 1

CPU 2 to OCP B x8 enablement

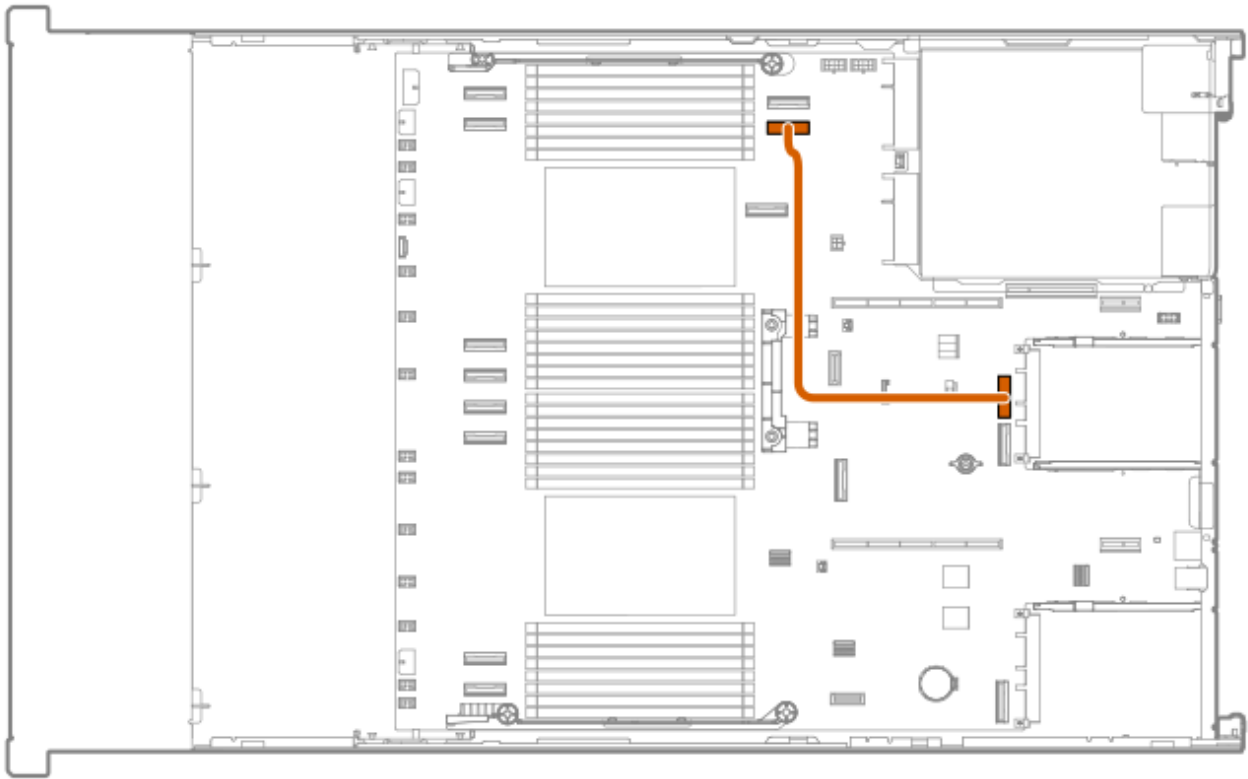

Cable part number	Color	From	To
P74891-001	Orange	OCP slot 15 port 1	Socket 2 MCI/O port 1

CPU 2 to OCP B x16 enablement

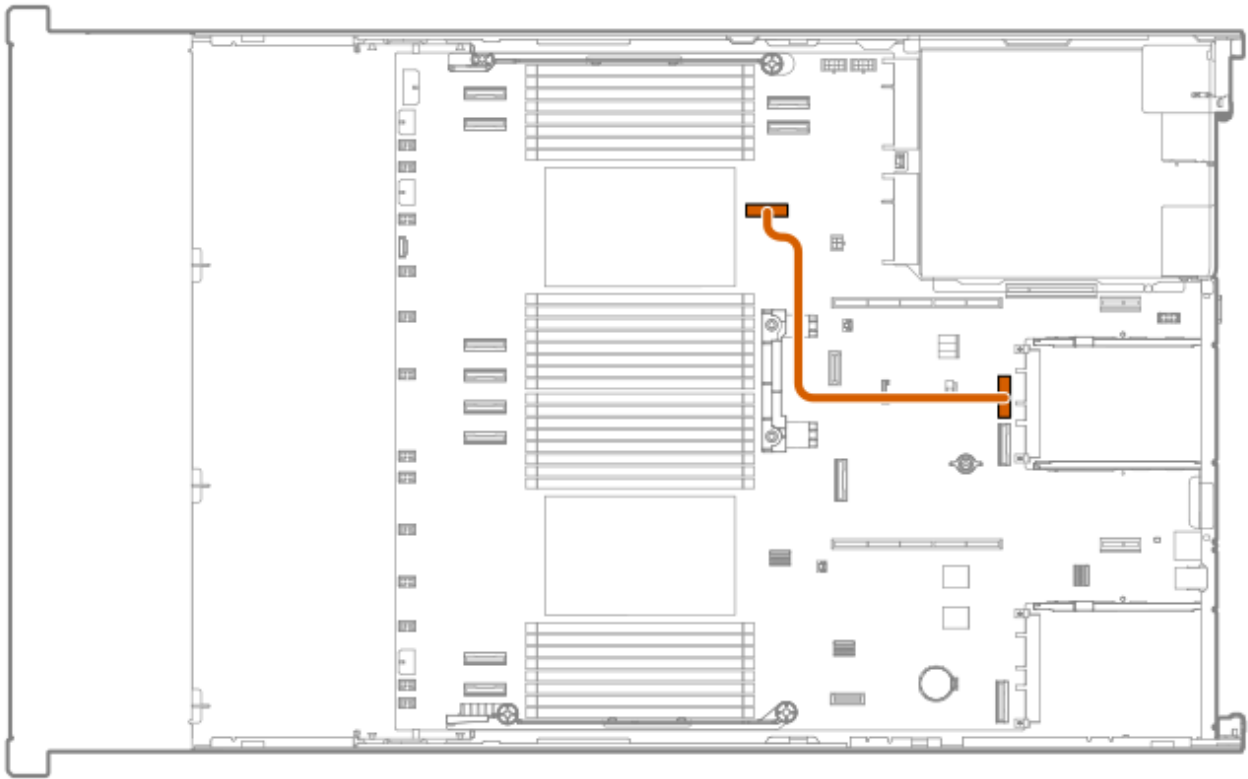

Cable part number	Color	From	To
P75370-001	Orange	OCP slot 15 port 1	Socket 1 MCI/O port 1

OCP A x16 enablement

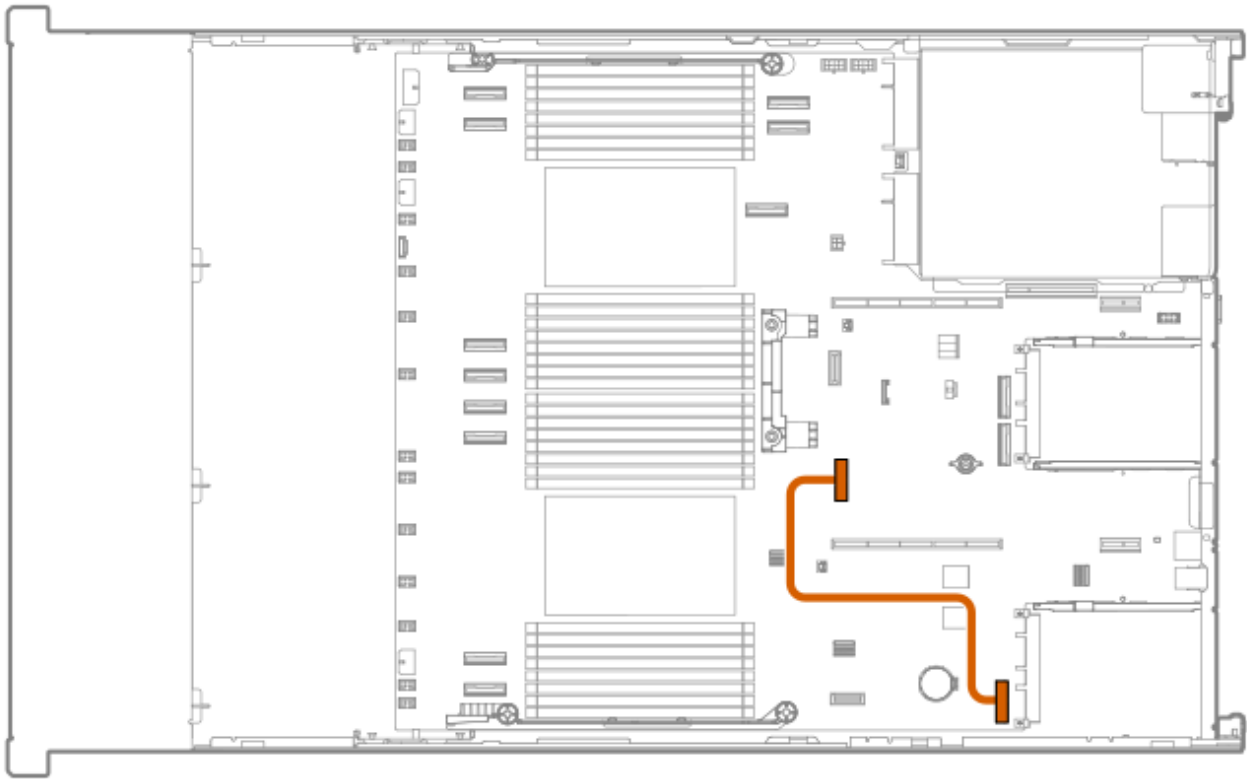

Cable part number	Color	From	To
P74890-001	Orange	OCP slot 14 port 2	Socket 1 MCIO port 1

OCP B x16 enablement

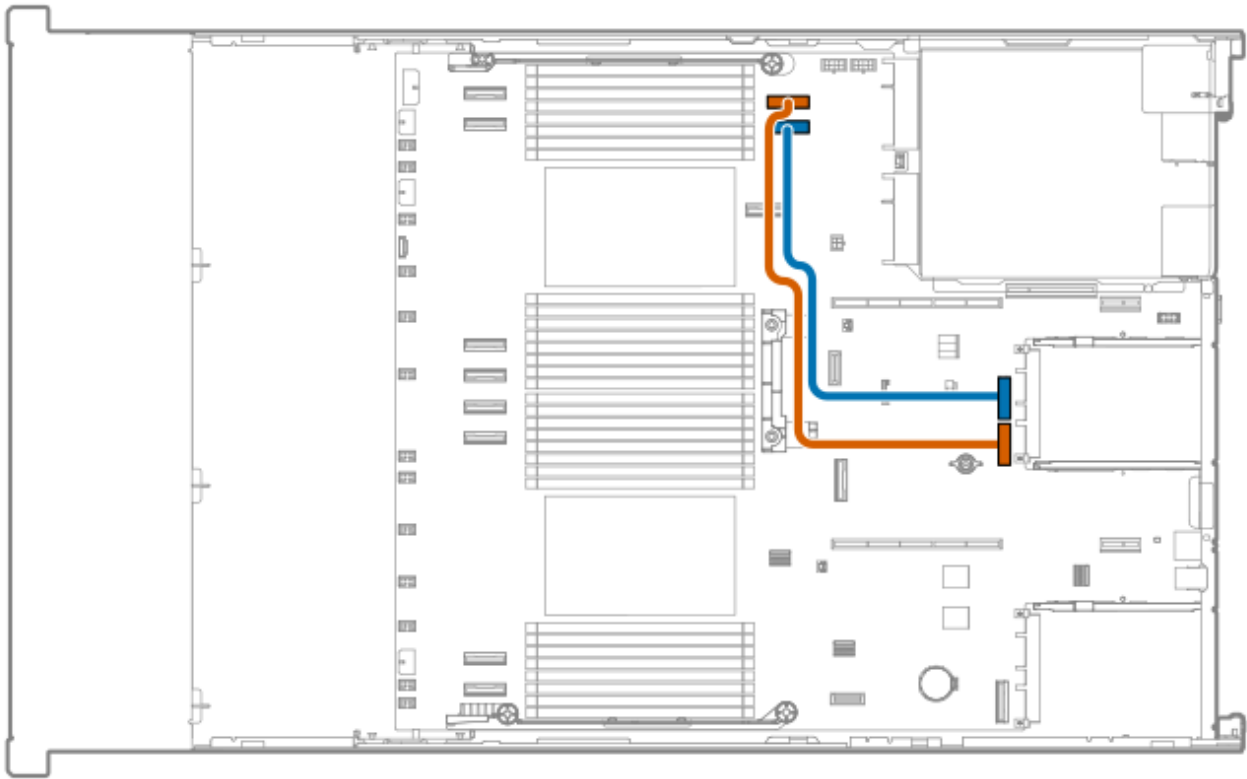

Cable part number	Color	From	To
P74891-001	Orange	OCP slot 15 port 1	Socket 2 MCIO port 1
P74891-001	Blue	OCP slot 15 port 2	Socket 2 MCIO port 2

Systems Insight Display cabling

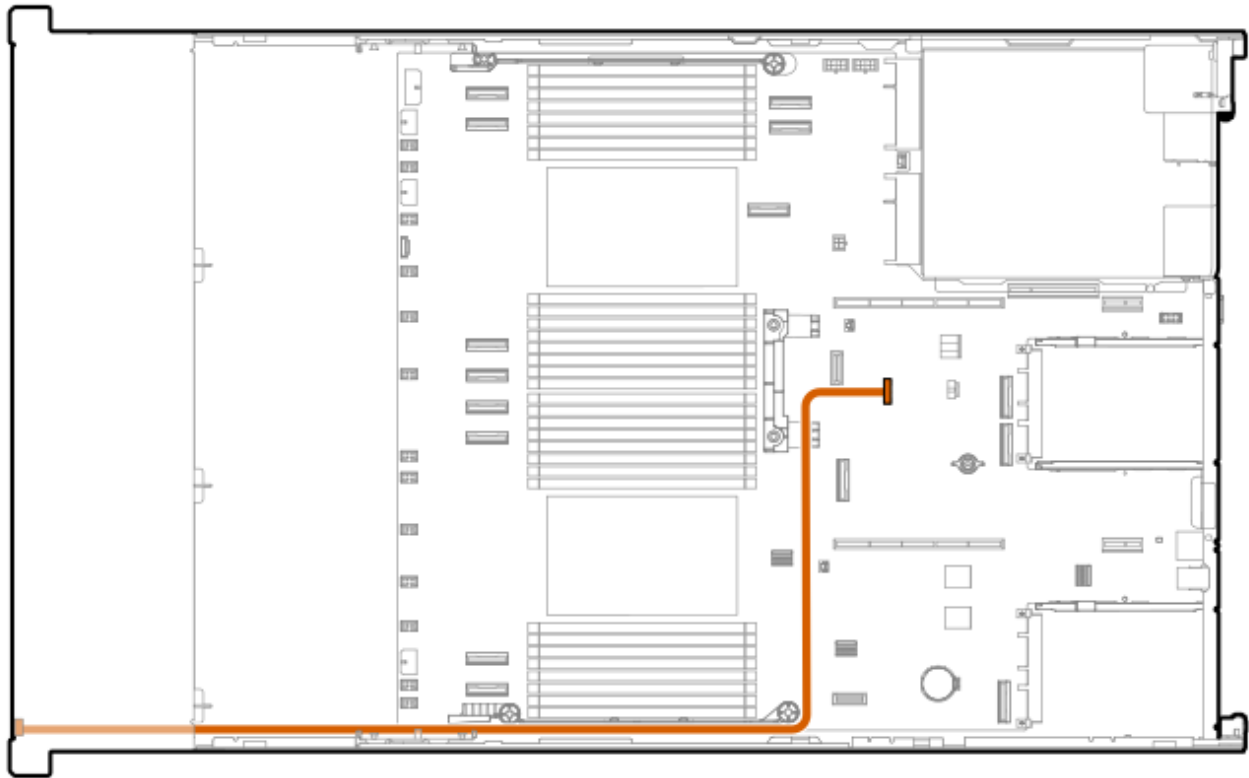

Cable part number	Color	From	To
P48971-001	Orange	Systems Insight Display	System board

I/O cabling

SFF optical disk drive

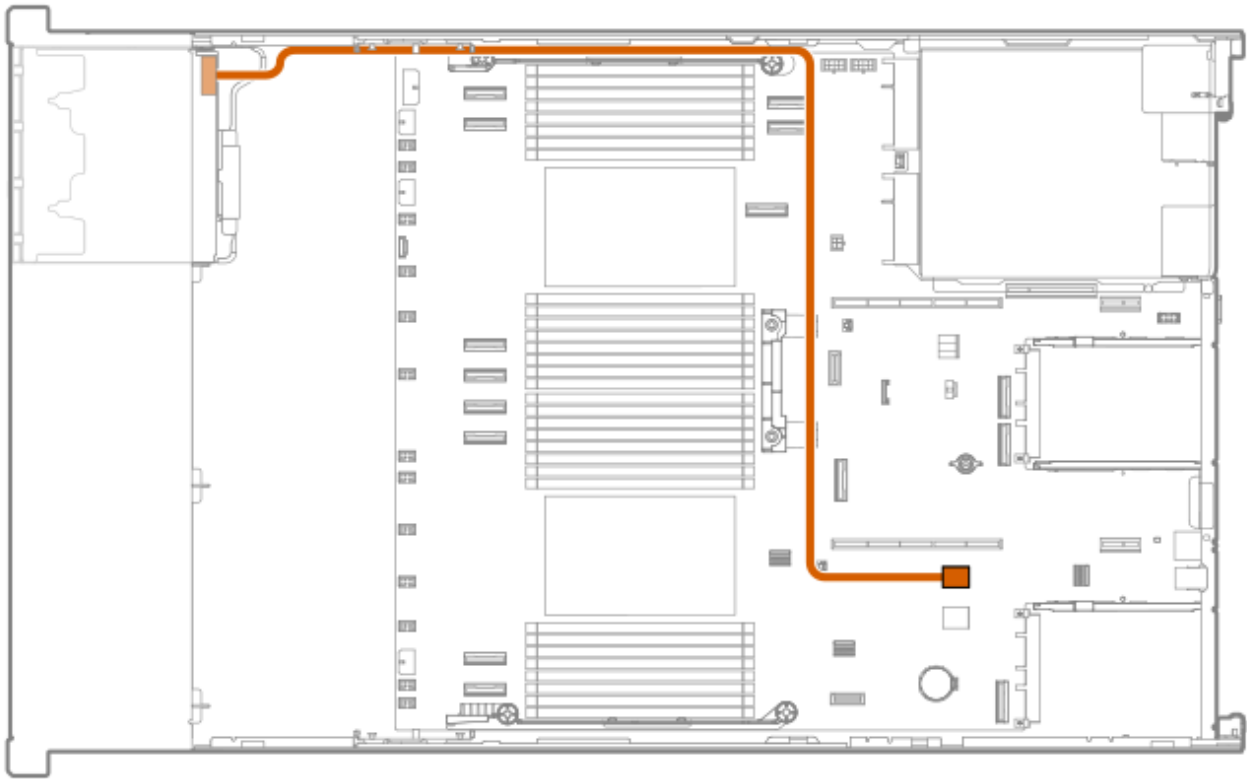

Cable part number	Color	From	To
P73776-001	Orange	SFF ODD	System board

LFF optical disk drive

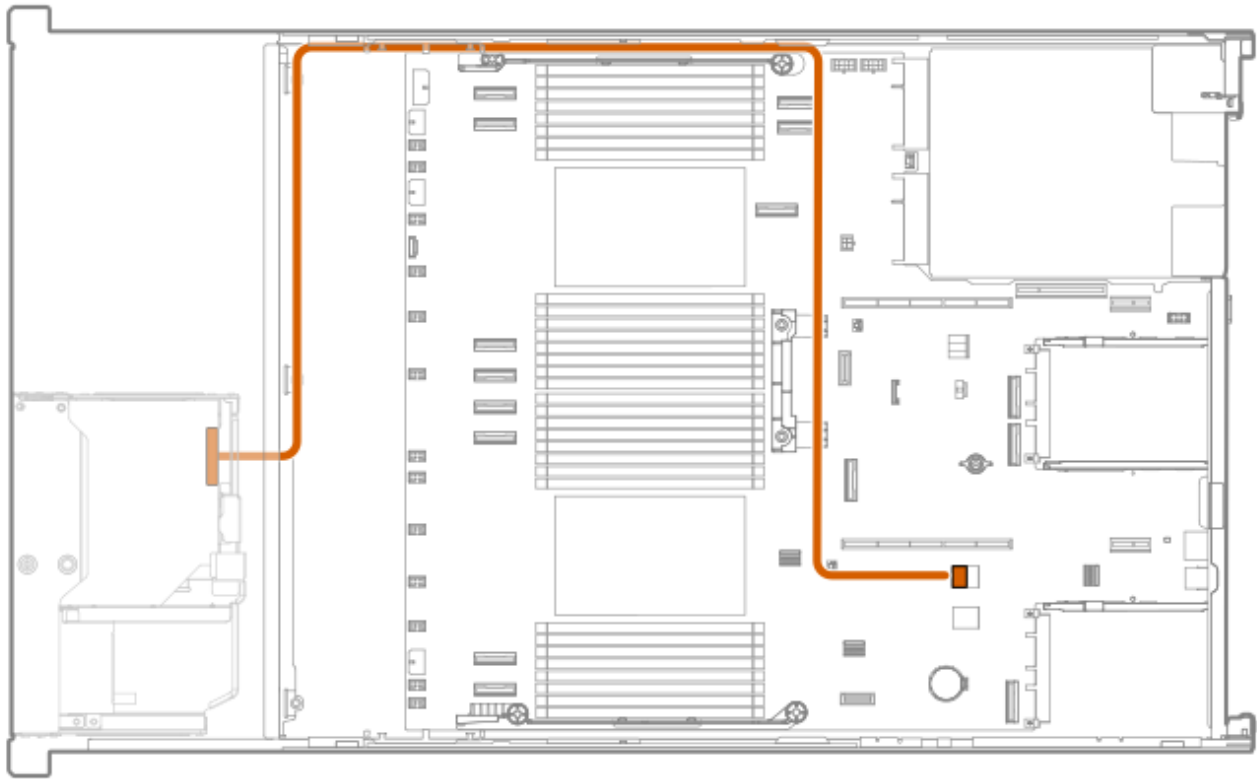

Cable part number	Color	From	To
P73776-001	Orange	LFF ODD	System board

LFF DisplayPort

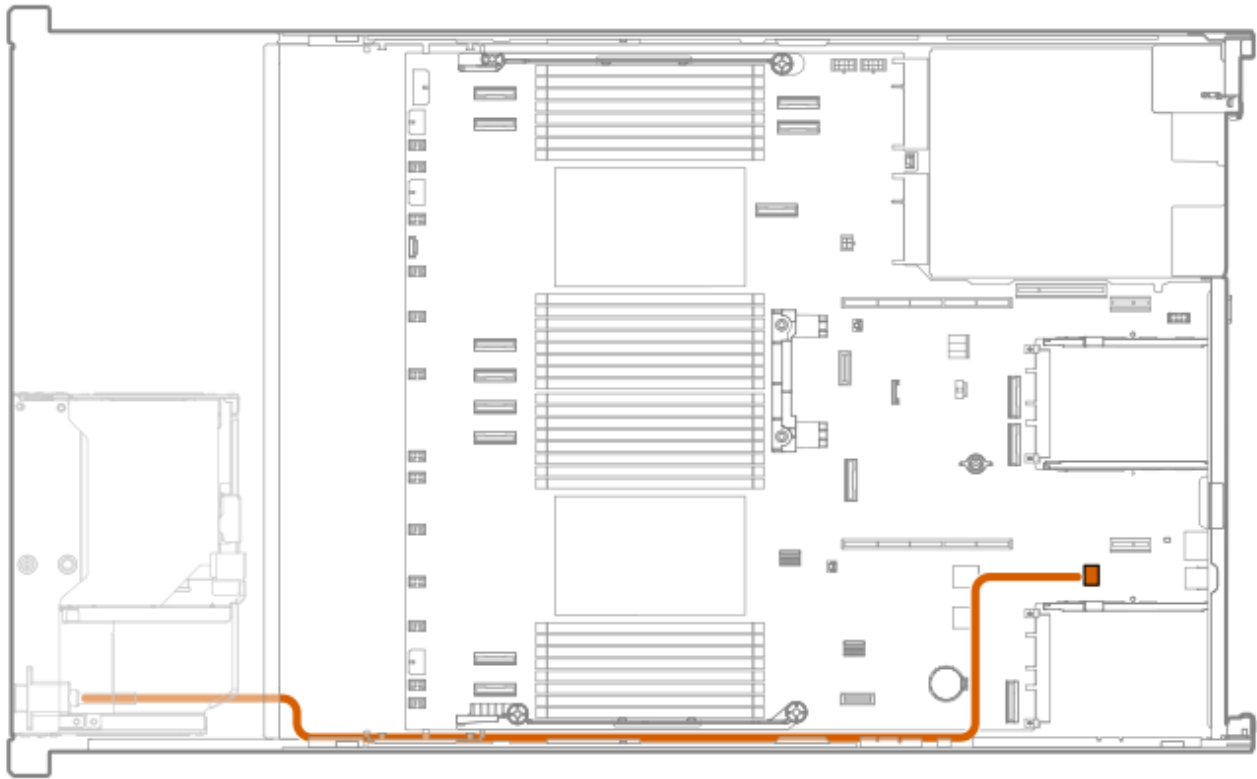

Cable part number	Color	From	To
P75279-001	Orange	Front DisplayPort	System board

SFF UMB DisplayPort/USB cabling

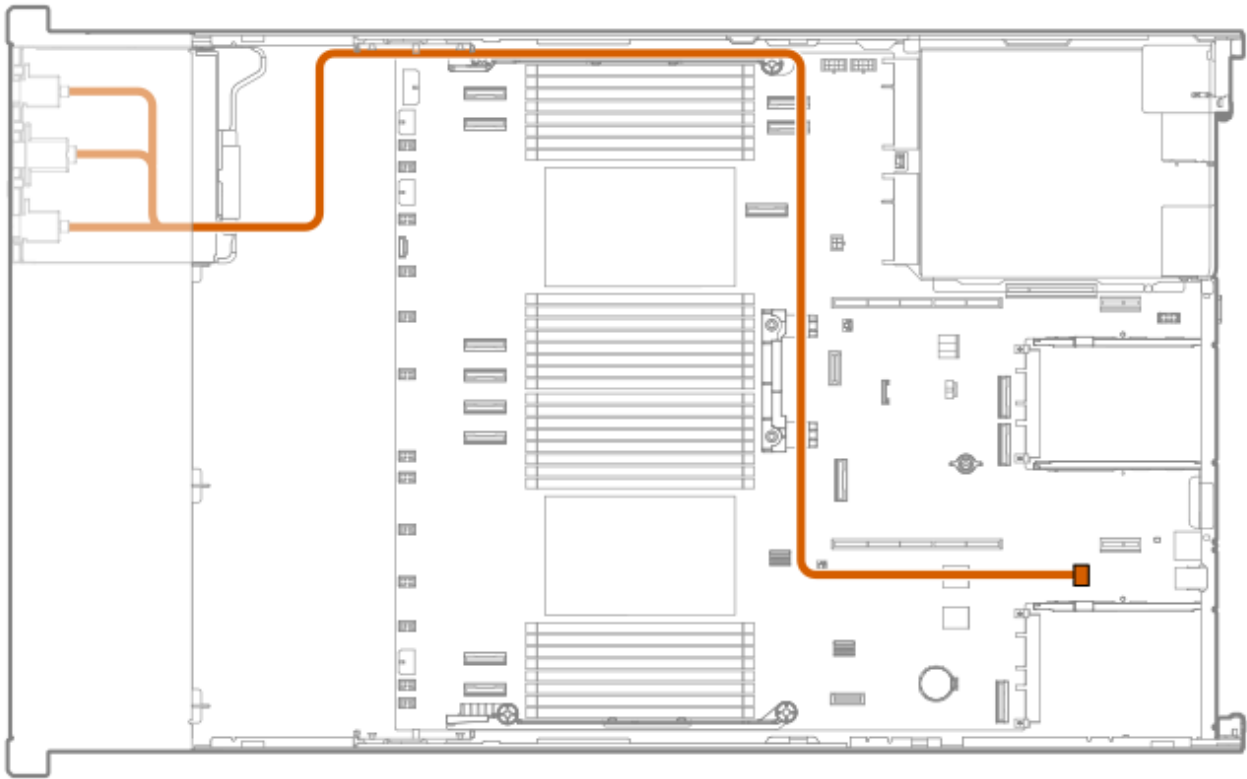

Cable part number	Color	From	To
P75280-001	Orange	Universal media bay	System board

Front power switch cabling

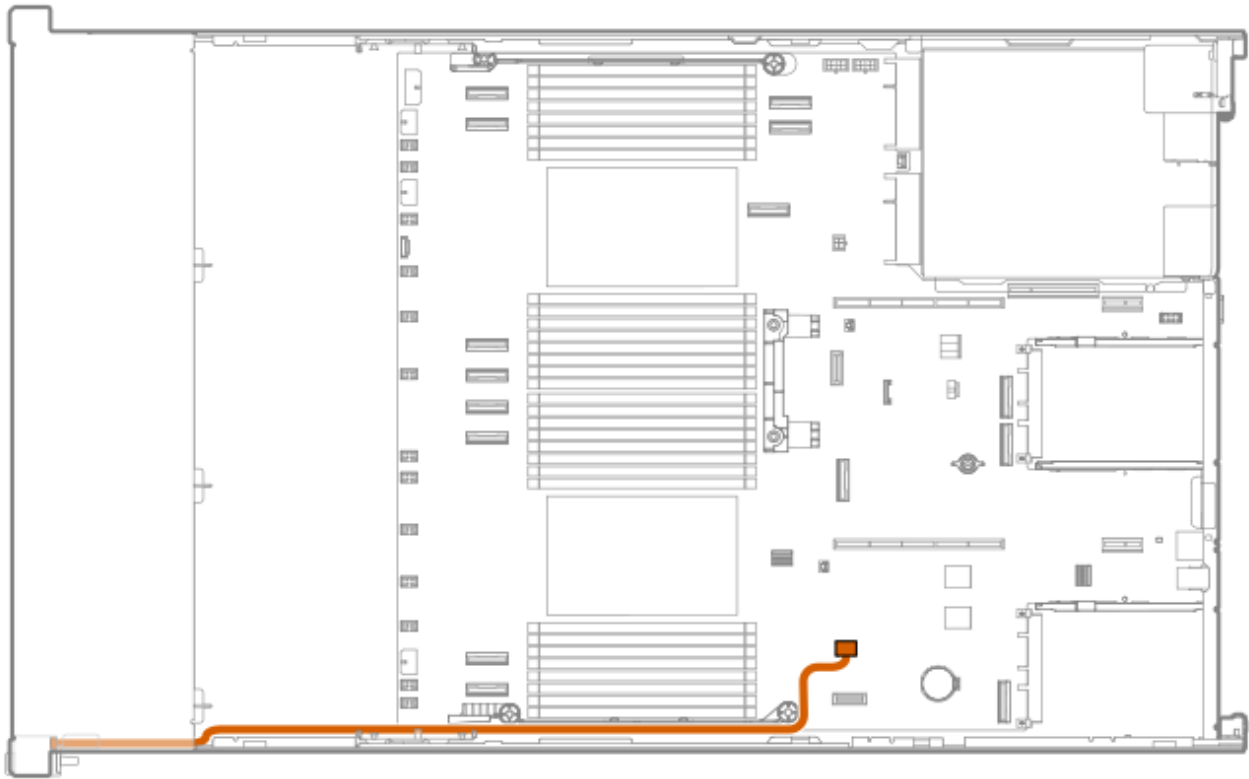

Cable part number	Color	From	To
P71909-002	Orange	Front power switch	System board

Serial port cabling

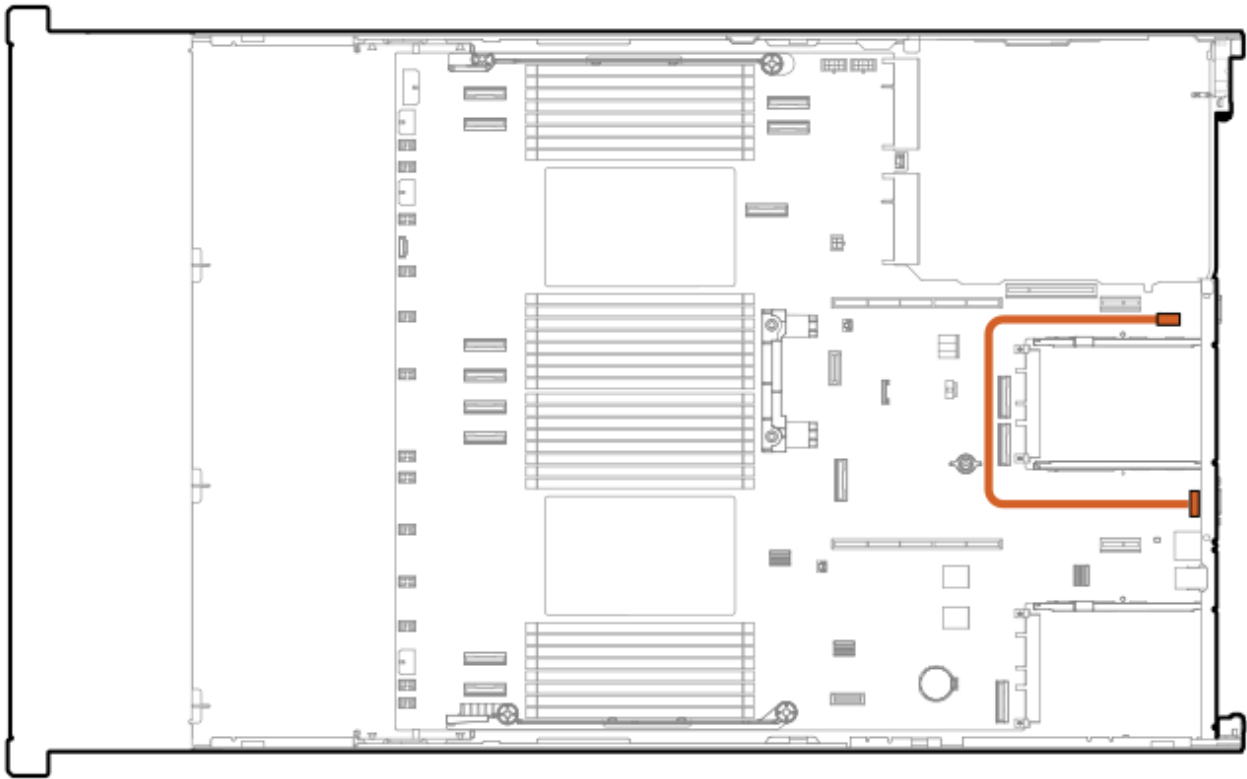

Cable part number	Color	From	To
P45623-001	Orange	Serial port	System board

Configuration resources

Use the following resources to find documentation for configuring and managing your server.

- Some utilities might not apply to your server. For information about server compatibility with the products listed in this chapter, see the product QuickSpecs (<https://www.hpe.com/info/quickspecs>).
- Products ordered from HPE Factory Express might have already been configured with some or all the configurations in this chapter. To determine if any additional setup is required, see your HPE Factory Express order.
- For one-stop access to version-specific software and firmware documentation, including the latest product release notes, see this quick links page:
<https://www.hpe.com/support/hpeproductdocs-quicklinks>

Subtopics

[Updating firmware or system ROM](#)

[Configuring the server](#)

[Configuring storage controllers](#)

[Deploying an OS](#)

[Configuring security](#)

[Server management](#)

[Managing Linux-based high performance compute clusters](#)

Updating firmware or system ROM

To	Use
Download service packs	<ul style="list-style-type: none">Service Pack for HPE ProLiant <u>https://www.hpe.com/servers/spp/download</u>Get an overview of SPP and its ecosystem <u>https://www.hpe.com/support/SPP-overview-views-en</u>
Deploy service packs to a single server	Smart Update Manager <u>https://www.hpe.com/support/hpesmartupdatemanager-quicklinks</u>
Deploy service packs to multiple servers	HPE OneView <u>https://www.hpe.com/support/hpeoneview-quicklinks</u>
Updating iLO or system firmware in a single server	iLO user guide <u>https://www.hpe.com/support/hpeilodocs-quicklinks</u>
<ul style="list-style-type: none">Enable policy-based management of server or server group firmware for distributed server infrastructure	HPE Compute Ops Management <u>https://www.hpe.com/support/hpe-gl-com-quicklinks</u>

To	Use
	<ul style="list-style-type: none"> • Monitor server compliance with a configured firmware baseline • Receive automatic iLO firmware updates • Receive baseline update alerts

Configuring the server

To configure	Use
Single server (GUI)	<ul style="list-style-type: none"> • Intelligent Provisioning https://www.hpe.com/support/hpeintelligentprovisioning-quicklinks • iLO remote console or web interface https://www.hpe.com/support/hpeilodocs-quicklinks • UEFI System Utilities https://www.hpe.com/support/hpeuefisystemutilities-quicklinks • HPE Compute Ops Management https://www.hpe.com/support/hpe-gl-com-quicklinks
Single server (scripting)	<ul style="list-style-type: none"> • RESTful Interface Tool https://www.hpe.com/support/restfulinterface/docs • Python iLO Redfish Library (python-ilo-rest-library) https://github.com/HewlettPackard/python-ilo-rest-library

To configure

Use

- Scripting Tools for Windows Powershell
<https://www.hpe.com/info/powershell/docs>
- iLO RESTful API
<https://servermanagementportal.ext.hpe.com/>
- HPE Compute Ops Management API
<https://developer.greenlake.hpe.com/>

Multiple servers (either UI or scripting)

- HPE OneView ¹
<https://www.hpe.com/support/hpeoneview-quicklinks>
- HPE Compute Ops Management
<https://www.hpe.com/support/hpe-gl-com-quicklinks>
 - **Server settings:** Define server-specific parameters such as firmware baselines, and then apply them to server groups.
 - **Server groups:** Organize servers into custom-defined sets with associated server settings, and then apply group-specific policies to create a consistent configuration across the servers in the group.

¹ For servers running HPE OneView, do not use another tool, such as iLO, to delete or change certain settings. For more information about using HPE OneView and iLO to manage the same server, see the iLO user guide at <https://www.hpe.com/support/hpeilodocs-quicklinks>.

Configuring storage controllers

Controller type	Documentation
HPE MR controller user guides	<ul style="list-style-type: none">• HPE MR Gen11 Controller User Guide https://hpe.com/support/MR-Gen11-UG<ul style="list-style-type: none">◦ MR Gen11 controller configuration: https://www.hpe.com/support/MR-Gen11-configuration◦ MR Gen11 controller RAID creation: https://www.hpe.com/support/MR-Gen11-RAID-creation
HPE MR controller configuration guides	<ul style="list-style-type: none">• HPE MR Storage Administrator User Guide https://www.hpe.com/support/MRSA• HPE StorCLI User Guide https://www.hpe.com/support/StorCLI• HPE StorCLI2 User Guide https://www.hpe.com/support/StorCLI2
Intel VROC for HPE Gen12	<ul style="list-style-type: none">• Intel Virtual RAID on CPU for HPE User Guide https://www.hpe.com/support/VROC-UG• Intel VROC NVMe RAID quick installation: https://www.hpe.com/support/VROC-NVMe-RAID-installation <p>OS-specific configuration guides:</p> <ul style="list-style-type: none">• Intel Virtual RAID on CPU (Intel VROC) for Windows User Guide https://docs.graidtech.com/vroc/User_Guides/000094004_Intel_Virtual_RAID_on_CPU_Intel_VROC_User_Guide_for_Windows/

Controller type

Documentation

- Intel Virtual RAID on CPU (Intel VROC) for Linux User Guide

https://docs.graidtech.com/vroc/User_Guides/000094694_Intel_Virtual_RAID_on_CPU_Intel_VROC_User_Guide_for_Linux/

- Intel Volume Management Device Driver for VMware ESXi User Guide

https://docs.graidtech.com/vroc/User_Guides/000094787_Intel_Virtual_RAID_on_CPU_Intel_VROC_User_Guide_for_VMware_ESXi/

Deploying an OS

For a list of supported operating systems, see the HPE Servers Support & Certification Matrices:

<https://www.hpe.com/support/Servers-Certification-Matrices>

To

See

Deploy an OS using HPE Compute Ops Management

HPE Compute Ops Management User Guide

<https://www.hpe.com/support/hpe-gl-com-quicklinks>

Deploy an OS using Intelligent Provisioning

Intelligent Provisioning user guide

<https://www.hpe.com/support/hpeintelligentprovisioning-quicklinks>

Deploy an OS using iLO virtual media

iLO user guide

<https://www.hpe.com/support/hpeilodocs-quicklinks>

Configure the server to boot from a PXE server

UEFI System Utilities User Guide for HPE Compute servers

<https://www.hpe.com/support/UEFIGen12-UG-en>

Configure the server to boot from a SAN

HPE Boot from SAN Configuration Guide

To

See

<https://www.hpe.com/info/boot-from-san-config-guide>

Configuring security

To

See

Implement server security best practices.

- HPE Compute Security Reference Guide

<https://www.hpe.com/info/server-security-reference-en>

- HPE iLO 7 Security Technology Brief

<https://www.hpe.com/support/ilo7-security-en>

Configure and use the Server Configuration Lock feature on HPE Trusted Supply Chain servers and other servers that have the Server Configuration Lock feature enabled.

Server Configuration Lock User Guide for HPE ProLiant servers and HPE Synergy

<https://www.hpe.com/info/server-config-lock-UG-en>

Server management

To monitor

See

Single server

HPE iLO

<https://www.hpe.com/support/hpeilodocs-quicklinks>

Multiple servers

HPE OneView

To monitor	See
	https://www.hpe.com/support/hpeoneview-quicklinks
Single or multiple servers	HPE Compute Ops Management https://www.hpe.com/support/hpe-gl-com-quicklinks

Managing Linux-based high performance compute clusters

To	Use
Provision, manage, and monitor clusters.	HPE Performance Cluster Manager https://www.hpe.com/support/hpcm_manuals
Optimize your applications.	HPE Performance Analysis Tools https://www.hpe.com/info/perftools
Optimize software library for low latency and high bandwidth, both on-node and off-node, for point-to-point and collective communications.	HPE Cray Programming Environment User Guide https://www.hpe.com/info/cray-pe-user-guides

Troubleshooting

Subtopics

[NMI functionality](#)

[Front panel LED power fault codes](#)

[Troubleshooting resources](#)

NMI functionality

An NMI crash dump enables administrators to create crash dump files when a system is not responding to traditional debugging methods.

An analysis of the crash dump log is an essential part of diagnosing reliability problems, such as hanging operating systems, device drivers, and applications. Many crashes freeze a system, and the only available action for administrators is to cycle the system power. Resetting the system erases any information that could support problem analysis, but the NMI feature preserves that information by performing a memory dump before a hard reset.

To force the OS to initiate the NMI handler and generate a crash dump log, the administrator can use the iLO Generate NMI feature.

Front panel LED power fault codes

The following table provides a list of power fault codes, and the subsystems that are affected. Not all power faults are used by all servers.

Subsystem	LED behavior
System board	1 flash
Processor	2 flashes
Memory	3 flashes
Riser board PCIe slots	4 flashes
OCP adapter	5 flashes
Storage controller	6 flashes
System board PCIe slots	7 flashes
Power backplane	8 flashes
Storage backplane	9 flashes
Power supply	10 flashes
PCIe expansion cards installed in riser board	11 flashes
Chassis	12 flashes
GPU card	13 flashes

Troubleshooting resources

If you need help troubleshooting, see the latest articles for your server.

<https://www.hpe.com/info/dl380gen12-ts>

Safety, warranty, and regulatory information

Subtopics

[Regulatory information](#)

[Warranty information](#)

Regulatory information

To view the regulatory information for your product, view the Safety and Compliance Information for Server, Storage, Power, Networking, and Rack Products, available at the Hewlett Packard Enterprise Support Center:

<https://www.hpe.com/support/Safety-Compliance-EnterpriseProducts>

Additional regulatory information

Hewlett Packard Enterprise is committed to providing our customers with information about the chemical substances in our products as needed to comply with legal requirements such as REACH (Regulation EC No 1907/2006 of the European Parliament and the Council). A chemical information report for this product can be found at:

<https://www.hpe.com/info/reach>

For Hewlett Packard Enterprise product environmental and safety information and compliance data, including RoHS and REACH, see:

<https://www.hpe.com/info/ecodata>

For Hewlett Packard Enterprise environmental information, including company programs, product recycling, and energy efficiency, see:

<https://www.hpe.com/info/environment>

Subtopics

[Notices for Eurasian Economic Union](#)

[Turkey RoHS material content declaration](#)

Notices for Eurasian Economic Union



Manufacturer and Local Representative Information

Manufacturer information:

Hewlett Packard Enterprise Company, 1701 E Mossy Oaks Road, Spring, TX 77389 U.S.

Local representative information Russian:

- **Russia**
ООО "Хьюлетт Паккард Энтерпрайз", Российская Федерация, 125171, г. Москва, Ленинградское шоссе, 16А, стр.3, Телефон: +7 499 403 4248 Факс: +7 499 403 4677
- **Kazakhstan**
ТОО «Хьюлетт-Паккард (К)», Республика Казахстан, 050040, г. Алматы, Бостандыкский район, проспект Аль-Фараби, 77/7, Телефон/факс: + 7 727 355 35 50

Local representative information Kazakh:

- **Russia**
ЖШС "Хьюлетт Паккард Энтерпрайз", Ресей Федерациясы, 125171, Мәскеу, Ленинград тас жолы, 16А блок 3, Телефон: +7 499 403 4248 Факс: +7 499 403 4677
- **Kazakhstan**
ЖШС «Хьюлетт-Паккард (К)», Қазақстан Республикасы, 050040, Алматы қ., Бостандық ауданы, Әл-Фараби даңғылы, 77/7, Телефон/факс: +7 727 355 35 50

Manufacturing date:

The manufacturing date is defined by the serial number.

CCSYWWZZZZ (product serial number format)

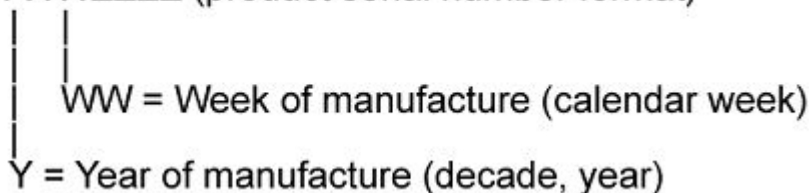

If you need help identifying the manufacturing date, contact tre@hpe.com.

Turkey RoHS material content declaration

Türkiye Cumhuriyeti: AEEE Yönetmeliğine Uygundur

Ukraine RoHS material content declaration

Обладнання відповідає вимогам Технічного регламенту щодо обмеження використання деяких небезпечних речовин в електричному та електронному обладнанні, затвердженого постановою Кабінету Міністрів України від 3 грудня 2008 № 1057

Warranty information

To view the warranty information for your product, see the [warranty check tool](#).

Specifications

Provides environmental, mechanical, and power supply specifications for the server.

Subtopics

[Server and rackmounting specifications](#)

[Environmental specifications](#)

[Power supply specifications](#)

[Operational requirements](#)

Server and rackmounting specifications

Server dimensions

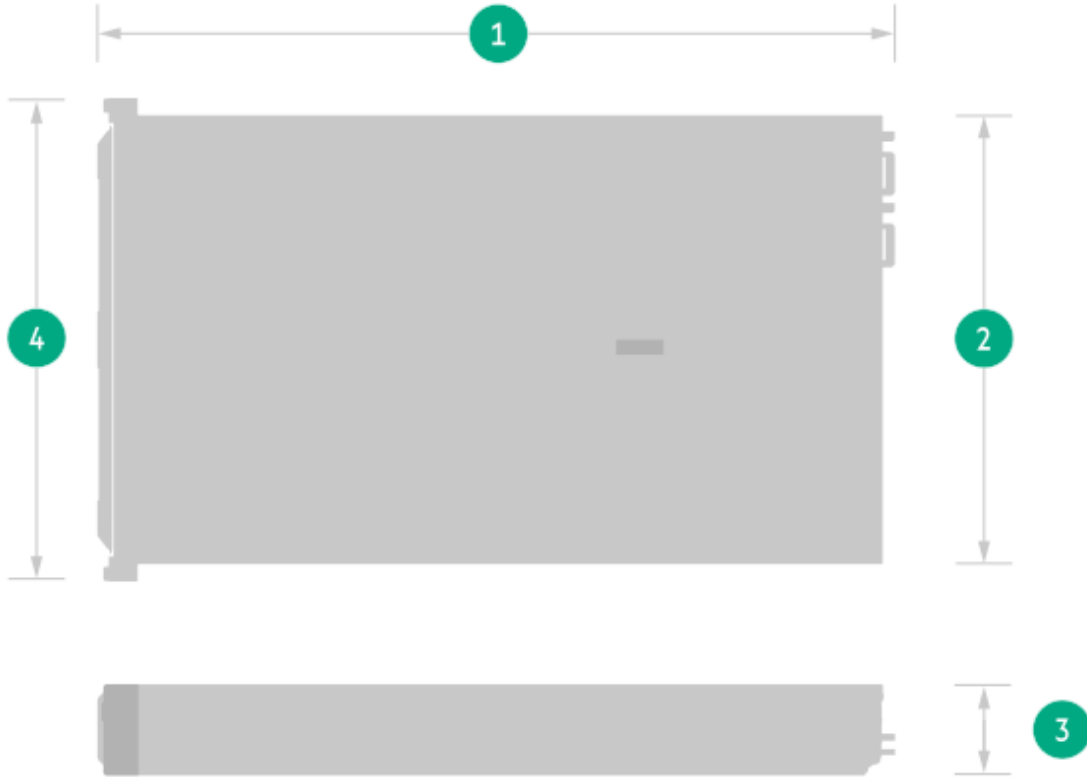

Item	Description	Dimension
1	Depth*	SFF 80.11 cm (31.54 in) LFF 80.66 cm (31.76 in)
2	Width	Chassis 44.80 cm (17.64 in)
3	Height	8.75 cm (3.44 in)
4	Width	Ear-to-ear 48.62 cm (19.14 in)

*The frontmost and rearmost features of the server depend on the options installed, such as front or rear I/Os, bezels, PSUs, or DLC kits.

Rackmounting dimensions



Item	Description	Dimension
1	Front EIA mounting post to frontmost server feature	4.45 cm (1.75 in)
2	Front EIA mounting post to server rear I/O	SFF 72.79 cm (28.66 in) LFF 73.34 cm (28.87 in)
3	Server rear I/O to rearmost CMA feature	SFF 17.65 cm (6.95 in) LFF 17.10 cm (6.73 in)
4	Rail mount range (min to max)*	60.96 cm - 91.81 cm (24 in - 36 in)**
5	Depth of front rail mount	1.57 cm (.62 in)

*The range between the front and rear posts of the rack

**The minimum overall length of the rail kit is 78.76 cm (31.00 in).

Server weight

Specification	Value
Weight, SFF minimum	18.00 kg (39.68 lbs)
Weight, SFF maximum	33.00 kg (72.75 lbs)
Weight, LFF minimum	23.00 kg (50.70 lbs)
Weight, LFF maximum	37.00 kg (81.57 lbs)

Environmental specifications

Specifications	Value
Temperature range	—
Operating	10°C to 35°C (50°F to 95°F)
Nonoperating	Air-cooled systems: -30°C to 60°C (-22°F to 140°F) Liquid-cooled systems (DLC, CLLC): -10°C to 60°C (14°F to 140°F) CAUTION: To prevent freezing the coolant and damaging the liquid cooling module, do not keep the liquid-cooled systems below -10°C (14°F).
Relative humidity (noncondensing)	—
Operating	8% to 90% 28°C (82.4°F) maximum wet bulb temperature, noncondensing
Nonoperating	5% to 95% 38.7°C (101.7°F) maximum wet bulb temperature, noncondensing
Altitude	—
Operating	3050 m (10,000 ft) This value may be limited by the type and number of options installed. Maximum allowable altitude change rate is 457 m/min (1,500 ft/min).
Nonoperating	9144 m (30,000 ft) Maximum allowable altitude change rate is 457 m/min (1,500 ft/min).

Standard operating support

10° to 35°C (50° to 95°F) at sea level with an altitude derating of 1.0°C per every 305 m (1.8°F per every 1,000 ft) above sea level to a maximum of 3,050 m (10,000 ft), no direct sustained sunlight. Maximum rate of change is 20°C/hr (36°F/hr). The upper limit and rate of change might be limited by the type and number of options installed.

System performance under standard operating support might be reduced if operating above 30°C (86°F) or with a faulty fan installed.

Extended ambient operating support

For approved hardware configurations, the supported system inlet range is extended to be:

- 5° to 10°C (41° to 50°F) and 35° to 40°C (95° to 104°F) at sea level with an altitude derating of 1.0°C per every 175 m (1.8°F per every 574 ft) above 900 m (2,953 ft) to a maximum of 3050 m (10,000 ft).
- 40°C to 45°C (104°F to 113°F) at sea level with an altitude derating of 1.0°C per every 125 m (1.8°F per every 410 ft) above 900 m (2953 ft) to a maximum of 3,050 m (10,000 ft).

The approved hardware configurations for this system are listed in the Extended Ambient Temperature Guidelines for Gen12 Servers:

<https://www.hpe.com/support/ASHRAEGen12>

Power supply specifications

Depending on the installed options and the regional location where the server was purchased, the server can be configured with one of the following power supplies. For detailed power supply specifications, see the QuickSpecs on the [Hewlett Packard Enterprise website](#).

Subtopics

[**HPE 800W Flex Slot Platinum Hot-plug Low Halogen Power Supply**](#)

[**HPE 1000 W Flex Slot Titanium Hot-plug Power Supply**](#)

[**HPE 1600 W Flex Slot Platinum Hot-plug Low Halogen Power Supply**](#)

[**HPE 1600 W Flex Slot -48 VDC Hot-plug Power Supply**](#)

[**HPE 1800-2200 W Flex Slot Titanium Power Supply**](#)

HPE 800W Flex Slot Platinum Hot-plug Low Halogen Power Supply

Specification	Value
Input requirements	—
Rated input voltage	100 VAC to 240 VAC 240 VDC for China only
Rated input frequency	50 Hz to 60 Hz
Rated input current	9.4 A at 100 VAC 4.5 A at 200 VAC
Maximum rated input power	899 W at 100 VAC 867 W at 200 VAC
BTUs per hour	3067 at 100 VAC 2958 at 200 VAC
Power supply output	—
Rated steady-state power	800 W at 200 VAC to 240 VAC input 800 W at 240 VDC input
Maximum peak power	800 W at 100 VAC to 240 VAC input

For detailed power supply specifications, see the QuickSpecs on the [Hewlett Packard Enterprise website](#).

HPE 1000 W Flex Slot Titanium Hot-plug Power Supply

Specification	Value
Input requirements	—
Rated input voltage	100 VAC to 127 VAC 200 VAC to 240 VAC 240 VDC for China

Specification	Value
Rated input frequency	50 Hz to 60 Hz
Rated input current	11.3 A at 100 VAC 6.1 A at 200 VAC
Maximum rated input power	1130 W at 100 VAC 1090 W at 200 VAC
BTUs per hour	3764 at 100 VAC 3629 at 200 VAC
Power supply output	—
Rated steady-state power	1000 W at 100 VAC to 127 VAC 1000 W at 200 VAC to 240 VAC input
Maximum peak power	1000 W at 100 VAC to 127 VAC 1000 W at 200 VAC to 240 VAC

HPE 1600 W Flex Slot Platinum Hot-plug Low Halogen Power Supply

Specification	Value
Input requirements	—
Rated input voltage	200 VAC to 240 VAC 240 VDC for China only
Rated input frequency	50 Hz to 60 Hz
Rated input current	8.7 A at 200 VAC 7.2 A at 240 VAC
Maximum rated input power	1734 W at 200 VAC 1725 W at 240 VAC
BTUs per hour	5918 at 200 VAC 5884 at 240 VAC

Specification	Value
Power supply output	—
Rated steady-state power	1600 W at 200 VAC to 240 VAC input 1600 W at 240 VDC input
Maximum peak power	1600 W for 1 ms (turbo mode) at 200 VAC to 240 VAC input

HPE 1600 W Flex Slot -48 VDC Hot-plug Power Supply

Specification	Value
Input requirements	—
Rated input voltage	-40 VDC to -72 VDC
Rated input frequency	DC
Nominal input current	45 A DC at -40 VDC input 36.6 A DC at -48 VDC input 24.4 A DC at -72 VDC input
Maximum Rated Input Wattage Rating	1798 W at -40 VDC input 1758 W at -48 VDC input 1755 W at -72 VDC input
BTUs per hour	6026 at -40 VDC input 6000 at -48 VDC input 5989 at -72 VDC input
Power supply output	—
Rated steady-state power	1600 W at -40 VDC to -72 VDC
Maximum peak power	1600 W at -40 VDC to -72 VDC

HPE 1800-2200 W Flex Slot Titanium Power Supply

Specification	Value
Input requirements	—
Rated input voltage	200 VAC to 240 VAC 240 VDC for China only
Rated input frequency	50 Hz to 60 Hz
Rated input current	10 A at 200 VAC 10 A at 240 VAC 10 A at 240 VDC for China only
Maximum rated input power	1946 W at 200 VAC 2375 W at 240 VAC 2375 W at 240 VDC for China only
BTUs per hour	6497 at 200 VAC 7962 at 240 VAC
Power supply output	—
Rated steady-state power	1800 W at 200 VAC 2200 W at 240 VAC
Maximum peak power	2200 W for 1 ms (turbo mode) at 200 VAC to 240 VAC input

Operational requirements

When preparing and planning the installation, observe the following operational requirements:

- [Space and airflow requirements](#)
- [Temperature requirements](#)
- [Power requirements](#)
- [Electrical grounding requirements](#)

For environmental requirements, see [Environmental specifications](#).

Subtopics

[Space and airflow requirements](#)

[Temperature requirements](#)

[Power requirements](#)

[Electrical grounding requirements](#)

Space and airflow requirements

To allow for servicing and adequate airflow, observe the following space and airflow requirements when installing the server in an indoor commercial rack:

- 63.50 cm (25.00 in) in front of the rack
- 76.20 cm (30.00 in) behind the rack
- 121.90 cm (48.00 in) from the back of the rack to the back of another rack or row of racks

Observe the following:

- Servers draw in cool air through the front of the rack and expel warm air through the rear. The front and rear rack doors must be adequately ventilated to allow ambient air to enter the cabinet. The rear door must be adequately ventilated to allow the warm air to escape from the cabinet.



CAUTION

To prevent improper cooling and damage to the equipment, do not block the ventilation openings.



CAUTION

When the vertical space in the rack is not filled by a server or rack component, the gaps between the components can cause changes in airflow through the rack and around the servers. Cover all gaps with blanking panels to maintain proper airflow. Using a rack without blanking panels results in improper cooling which can lead to thermal damage.

- If a third-party rack is used, observe the following additional requirements to ensure adequate airflow and prevent damage to the equipment:

- Front and rear doors—If the 42U rack includes closing front and rear doors, you must allow 5,350 sq cm (830 sq in) of holes evenly distributed from top to bottom to permit adequate airflow (equivalent to the required 64 percent open area for ventilation).
- Side—The clearance between the installed rack component and the side panels of the rack must be a minimum of 7.00 cm (2.75 in).

Temperature requirements

To ensure continued safe and reliable equipment operation, install or position the system in a well-ventilated, climate-controlled environment.

The maximum recommended ambient operating temperature (TMRA) for most server products is 35°C (95°F). The temperature in the room where the rack is located must not exceed 35°C (95°F).



CAUTION

To reduce the risk of damage to the equipment when installing third-party options:

- Do not permit optional equipment to impede airflow around the server or to increase the internal rack temperature beyond the maximum allowable limits.
- Do not exceed the manufacturer's TMRA.

Power requirements

Installation of this equipment must comply with local and regional electrical regulations governing the installation of information technology equipment by licensed electricians. This equipment is designed to operate in installations covered by NFPA 70, 1999 Edition (National Electric Code) and NFPA-75, 1992

(code for Protection of Electronic Computer/Data Processing Equipment). For electrical power ratings on options, refer to the product rating label or the user documentation supplied with that option.



WARNING

To reduce the risk of personal injury, fire, or damage to the equipment, do not overload the AC supply branch circuit that provides power to the rack. Consult the electrical authority having jurisdiction over wiring and installation requirements of your facility.



CAUTION

Protect the server from power fluctuations and temporary interruptions with a regulating uninterruptible power supply. This device protects the hardware from damage caused by power surges and voltage spikes and keeps the system in operation during a power failure.

Electrical grounding requirements

The server must be grounded properly for proper operation and safety. In the United States, you must install the equipment in accordance with NFPA 70, National Electric Code Article 250, as well as any local and regional building codes. In Canada, you must install the equipment in accordance with Canadian Standards Association, CSA C22.1, Canadian Electrical Code. In all other countries, you must install the equipment in accordance with any regional or national electrical wiring codes, such as the International Electrotechnical Commission (IEC) Code 364, parts 1 through 7. Furthermore, you must be sure that all power distribution devices used in the installation, such as branch wiring and receptacles, are listed or certified grounding-type devices.

Because of the high ground-leakage currents associated with multiple servers connected to the same power source, Hewlett Packard Enterprise recommends the use of a PDU that is either permanently wired to the building's branch circuit or includes a nondetachable cord that is wired to an industrial-style plug. NEMA locking-style plugs or those complying with IEC 60309 are considered suitable for this purpose. Using common power outlet strips for the server is not recommended.

Support and other resources

Subtopics

[**Accessing Hewlett Packard Enterprise Support**](#)

[**HPE product registration**](#)

[**Accessing updates**](#)

[**Customer self repair**](#)

[**Remote support**](#)

Accessing Hewlett Packard Enterprise Support

- For live assistance, go to the Contact Hewlett Packard Enterprise Worldwide website:

<https://www.hpe.com/info/assistance>

- To access documentation and support services, go to the Hewlett Packard Enterprise Support Center website:

<https://www.hpe.com/support/hpesc>

Information to collect

- Technical support registration number (if applicable)
- Product name, model or version, and serial number
- Operating system name and version
- Firmware version
- Error messages
- Product-specific reports and logs
- Add-on products or components
- Third-party products or components

HPE product registration

To gain the full benefits of the Hewlett Packard Enterprise Support Center and your purchased support services, add your contracts and products to your account on the HPESC.

- When you add your contracts and products, you receive enhanced personalization, workspace alerts, insights through the dashboards, and easier management of your environment.
- You will also receive recommendations and tailored product knowledge to self-solve any issues, as well as streamlined case creation for faster time to resolution when you must create a case.

To learn how to add your contracts and products, see **<https://www.hpe.com/info/add-products-contracts>**.

Accessing updates

- Some software products provide a mechanism for accessing software updates through the product interface. Review your product documentation to identify the recommended software update method.
- To download product updates:

Hewlett Packard Enterprise Support Center

<https://www.hpe.com/support/hpesc>

My HPE Software Center

<https://www.hpe.com/software/hpesoftwarecenter>

- To subscribe to eNewsletters and alerts:

<https://www.hpe.com/support/e-updates>

- To view and update your entitlements, and to link your contracts and warranties with your profile, go to the Hewlett Packard Enterprise Support Center **More Information on Access to Support Materials** page:

<https://www.hpe.com/support/AccessToSupportMaterials>



IMPORTANT

Access to some updates might require product entitlement when accessed through the Hewlett Packard Enterprise Support Center. You must have an HPE Account set up with relevant entitlements.

Customer self repair

Hewlett Packard Enterprise customer self repair (CSR) programs allow you to repair your product. If a CSR part needs to be replaced, it will be shipped directly to you so that you can install it at your convenience. Some parts do not qualify for CSR.

For more information about CSR, contact your local service provider.

Remote support

Remote support is available with supported devices as part of your warranty or contractual support agreement. It provides intelligent event diagnosis, and automatic, secure submission of hardware event notifications to Hewlett Packard Enterprise, which initiates a fast and accurate resolution based on the service level of your product. Hewlett Packard Enterprise strongly recommends that you register your device for remote support.

If your product includes additional remote support details, use search to locate that information.

HPE Get Connected

<https://www.hpe.com/services/getconnected>

HPE Tech Care Service

<https://www.hpe.com/services/techcare>

HPE Complete Care Service

<https://www.hpe.com/services/completecure>

Documentation feedback

Hewlett Packard Enterprise is committed to providing documentation that meets your needs. To help us improve the documentation, click the **Feedback** button on the page of an opened document on the Hewlett Packard Enterprise Support Center portal (<https://www.hpe.com/support/hpesc>). Use this feature to send any errors, suggestions, or comments. This process captures all document information.