



# ThinkSystem ST650 V3 User Guide



**Machine Type: 7D7A, 7D7B**

**Note**

Before using this information and the product it supports, be sure to read and understand the safety information and the safety instructions, which are available at: [https://pubs.lenovo.com/safety\\_documentation/](https://pubs.lenovo.com/safety_documentation/)

In addition, be sure that you are familiar with the terms and conditions of the Lenovo warranty for your server, which can be found at: <http://datacentersupport.lenovo.com/warrantylookup>

**Twenty-fourth Edition (November 2025)**

**© Copyright Lenovo 2023, 2025.**

LIMITED AND RESTRICTED RIGHTS NOTICE: If data or software is delivered pursuant to a General Services Administration (GSA) contract, use, reproduction, or disclosure is subject to restrictions set forth in Contract No. GS-35F-05925.

---

# Contents

<b>Contents</b> . . . . .	<b>i</b>
---------------------------	----------

<b>Safety</b> . . . . .	<b>v</b>
-------------------------	----------

Safety inspection checklist . . . . .	vi
---------------------------------------	----

<b>Chapter 1. Introduction</b> . . . . .	<b>1</b>
--	----------

Features . . . . .	1
--------------------	---

Tech Tips . . . . .	3
---------------------	---

Security advisories . . . . .	3
-------------------------------	---

Specifications . . . . .	4
--------------------------	---

Technical specifications . . . . .	5
------------------------------------	---

Mechanical specifications . . . . .	11
-------------------------------------	----

Environmental specifications . . . . .	12
--	----

Management options . . . . .	15
------------------------------	----

<b>Chapter 2. Server components</b> . . . . .	<b>19</b>
---	-----------

Front view . . . . .	19
----------------------	----

Rear view . . . . .	23
---------------------	----

Side view . . . . .	25
---------------------	----

System board layout . . . . .	26
-------------------------------	----

System board connectors . . . . .	26
-----------------------------------	----

System board switches . . . . .	28
---------------------------------	----

Server locks . . . . .	30
------------------------	----

System LEDs and diagnostics display . . . . .	31
---	----

<b>Chapter 3. Parts list</b> . . . . .	<b>33</b>
--	-----------

Power cords . . . . .	36
-----------------------	----

<b>Chapter 4. Unboxing and setup</b> . . . . .	<b>37</b>
--	-----------

Server package contents . . . . .	37
-----------------------------------	----

Identify the server and access the Lenovo XClarity Controller . . . . .	37
--	----

Server setup checklist . . . . .	39
----------------------------------	----

<b>Chapter 5. Hardware replacement procedures</b> . . . . .	<b>41</b>
---	-----------

Installation Guidelines . . . . .	41
-----------------------------------	----

Safety inspection checklist . . . . .	42
---------------------------------------	----

System reliability guidelines . . . . .	43
---	----

Handling static-sensitive devices . . . . .	44
---	----

Memory module installation rules and order . . . . .	45
--	----

DRAM DIMM installation order . . . . .	47
--	----

Power on and power off the server . . . . .	52
---	----

Power on the server . . . . .	52
-------------------------------	----

Power off the server . . . . .	53
--------------------------------	----

Server replacement . . . . .	54
------------------------------	----

Remove the server from the rack . . . . .	54
---	----

Install the server to the rack . . . . .	59
--	----

2.5-inch drive backplane replacement . . . . .	64
--	----

Remove a 2.5-inch drive backplane . . . . .	64
---	----

Install a 2.5-inch drive backplane . . . . .	65
--	----

3.5-inch drive backplane replacement . . . . .	67
--	----

Remove a 3.5-inch drive backplane . . . . .	67
---	----

Install a 3.5-inch drive backplane . . . . .	69
--	----

A2/L4 GPU air duct replacement . . . . .	71
--	----

Remove an A2/L4 GPU air duct . . . . .	71
--	----

Install an A2/L4 GPU air duct . . . . .	72
---	----

Air baffle replacement . . . . .	74
----------------------------------	----

Remove the air baffle . . . . .	74
---------------------------------	----

Install an air baffle . . . . .	75
---------------------------------	----

CMOS battery (CR2032) replacement . . . . .	77
---	----

Remove the CMOS battery (CR2032) . . . . .	77
--	----

Install a CMOS battery (CR2032) . . . . .	79
---	----

Drive replacement . . . . .	81
-----------------------------	----

Remove a hot-swap drive . . . . .	81
-----------------------------------	----

Install a hot-swap drive . . . . .	84
------------------------------------	----

Expansion drive cage replacement . . . . .	86
--	----

Remove the expansion drive cage . . . . .	86
---	----

Install an expansion drive cage . . . . .	88
---	----

Fan and fan cage assembly replacement . . . . .	89
---	----

Remove a fan module . . . . .	89
-------------------------------	----

Remove the fan cage assembly . . . . .	91
--	----

Install the fan cage assembly . . . . .	92
---	----

Install a fan module . . . . .	94
--------------------------------	----

Flash power module replacement . . . . .	100
--	-----

Remove a flash power module . . . . .	100
---------------------------------------	-----

Install a flash power module . . . . .	102
--	-----

Foot stands replacement . . . . .	104
-----------------------------------	-----

Remove the foot stands . . . . .	104
----------------------------------	-----

Install the foot stands . . . . .	106
-----------------------------------	-----

Front bezel replacement . . . . .	107
-----------------------------------	-----

Remove the front bezel . . . . .	107
----------------------------------	-----

Install a front bezel . . . . .	108
---------------------------------	-----

Front I/O module replacement . . . . .	110
--	-----

Remove the front I/O module . . . . .	110
---------------------------------------	-----

Install a front I/O module . . . . .	111
--------------------------------------	-----

FL GPU filler replacement . . . . .	113
-------------------------------------	-----

Remove a FL GPU filler . . . . .	113
----------------------------------	-----

Install a FL GPU filler . . . . .	114
-----------------------------------	-----

Internal CFF HBA/RAID adapter replacement . . . . .	116
---	-----

Remove an internal CFF adapter . . . . .	116
--	-----

Install an internal CFF adapter . . . . .	118
---	-----

Intrusion switch replacement . . . . .	120
--	-----

Remove the intrusion switch . . . . .	121
---------------------------------------	-----

Install an intrusion switch . . . . .	122
M.2 drive and M.2 boot adapter replacement . . . . .	124
Remove an M.2 drive . . . . .	124
Remove an M.2 boot adapter. . . . .	125
Install an M.2 boot adapter . . . . .	127
Adjust the retainer on an M.2 boot adapter . . . . .	129
Install an M.2 drive . . . . .	131
Memory module replacement . . . . .	133
Remove a memory module . . . . .	133
Install a memory module . . . . .	136
MicroSD card replacement . . . . .	139
Remove the MicroSD card . . . . .	139
Install a MicroSD card . . . . .	141
GPU adapter link bridge (NVLink bridge) replacement . . . . .	143
Remove a GPU adapter link bridge (NVLink bridge) . . . . .	143
Install a GPU adapter link bridge (NVLink bridge) . . . . .	145
Optical drive cage replacement. . . . .	147
Remove the optical drive cage . . . . .	147
Install an optical drive cage . . . . .	148
Optical drive or tape drive replacement . . . . .	149
Remove an optical drive or a tape drive. . . . .	149
Install an optical drive or a tape drive. . . . .	153
Remove a 5.25-inch drive bay adapter assembly . . . . .	156
Install a 5.25-inch drive bay adapter assembly . . . . .	159
FL PCIe adapter holder replacement. . . . .	162
Remove a FL PCIe adapter holder . . . . .	162
Install a FL PCIe adapter holder . . . . .	164
PCIe adapter replacement. . . . .	165
Remove a HL PCIe adapter . . . . .	165
Install a HL PCIe adapter . . . . .	167
Remove a FL GPU adapter . . . . .	173
Install a FL GPU adapter . . . . .	175
Power distribution board replacement . . . . .	178
Remove the power distribution board cover . . . . .	178
Remove the power distribution board . . . . .	180
Install a power distribution board . . . . .	183
Install a power distribution board cover. . . . .	185
Power supply unit replacement. . . . .	187
Remove a power supply unit . . . . .	187
Install a power supply unit . . . . .	190
Processor and heat sink replacement (trained technician only) . . . . .	194
Remove a processor and heat sink (trained technician only) . . . . .	194
Separate the processor from carrier and heat sink (trained technician only) . . . . .	199

Install a processor and heat sink (trained technician only) . . . . .	201
Security door replacement . . . . .	207
Remove the security door . . . . .	207
Install the security door . . . . .	208
System board assembly replacement (trained technician only) . . . . .	209
Remove the Firmware and RoT Security Module . . . . .	209
Install the Firmware and RoT Security Module . . . . .	211
Remove the system board (trained technician only) . . . . .	216
Install a system board (trained technician only) . . . . .	221
Update the Vital Product Data (VPD) . . . . .	224
Enable UEFI Secure Boot . . . . .	225
T4 filler replacement . . . . .	226
Remove a T4 filler . . . . .	226
Install a T4 filler . . . . .	228
Server cover replacement . . . . .	230
Remove the server cover . . . . .	230
Install a server cover . . . . .	231
Complete the parts replacement . . . . .	233

## Chapter 6. Internal cable routing . . .235

Identifying connectors . . . . .	236
System-board connectors . . . . .	236
Power distribution board connectors. . . . .	237
Internal CFF RAID adapter connectors . . . . .	238
Drive backplane connectors . . . . .	239
3.5-inch drive cable routing . . . . .	241
SAS/SATA combinations . . . . .	244
Pure NVMe combinations . . . . .	251
Mixed combinations . . . . .	254
2.5-inch drive cable routing . . . . .	278
SAS/SATA combinations . . . . .	281
Pure NVMe combinations . . . . .	293
Mixed combinations . . . . .	296
GPU cable routing . . . . .	311
Front I/O module cable routing . . . . .	313
Power distribution board cable routing. . . . .	314
M.2 boot adapter cable routing. . . . .	314
Optical/tape drives . . . . .	317

## Chapter 7. System configuration . . .319

Set the network connection for the Lenovo XClarity Controller . . . . .	319
Set USB port for Lenovo XClarity Controller connection. . . . .	319
Update the firmware . . . . .	320
Configure the firmware . . . . .	324

Memory module configuration . . . . .	325
Enable Software Guard Extensions (SGX). . . . .	325
RAID configuration . . . . .	325
Deploy the operating system. . . . .	326
Back up the server configuration . . . . .	327
Enable Intel® On Demand . . . . .	328
Enable Intel® On Demand Troubleshooting . . . . .	337

**Chapter 8. Problem determination . . . . . 339**

Event logs . . . . .	339
Troubleshooting by system LEDs and diagnostics display . . . . .	341
Drive LEDs . . . . .	341
Front operator panel LEDs . . . . .	341
Rear system LEDs . . . . .	343
Power supply LEDs . . . . .	345
Firmware and RoT security module LEDs . . . . .	346
System board LEDs . . . . .	348
XCC system management port (10/100/1000 Mbps RJ-45) LEDs . . . . .	349
External Diagnostics Handset . . . . .	349
General problem determination procedures . . . . .	355
Resolving suspected power problems . . . . .	356
Resolving suspected Ethernet controller problems . . . . .	356
Troubleshooting by symptom . . . . .	357
Fan problems . . . . .	357
Intermittent problems. . . . .	358
Keyboard, mouse, KVM switch or USB-device problems . . . . .	359
Memory problems . . . . .	360
Monitor and video problems . . . . .	361

Network problems . . . . .	363
Observable problems. . . . .	363
Optional-device problems . . . . .	366
Performance problems . . . . .	367
Power on and power off problems. . . . .	368
Power problems. . . . .	369
Serial-device problems . . . . .	369
Software problems. . . . .	370
Storage drive problems . . . . .	370

**Appendix A. Hardware disassembling for recycle . . . . . 373**

Disassemble the server for chassis recycle . . . . .	373
--	-----

**Appendix B. Getting help and technical assistance . . . . . 375**

Before you call . . . . .	375
Collecting service data . . . . .	376
Contacting Support . . . . .	377

**Appendix C. Documents and supports . . . . . 379**

Documents download . . . . .	379
Support websites . . . . .	379

**Appendix D. Notices. . . . . 381**

Trademarks . . . . .	382
Important notes. . . . .	382
Electronic emission notices . . . . .	382
Taiwan Region BSMI RoHS declaration . . . . .	383
Taiwan Region import and export contact information . . . . .	383
China Energy Label (CEL) . . . . .	383



---

## Safety

Before installing this product, read the Safety Information.

قبل تركيب هذا المنتج، يجب قراءة الملاحظات الأمنية

Antes de instalar este produto, leia as Informações de Segurança.

在安装本产品之前，请仔细阅读 Safety Information（安全信息）。

安裝本產品之前，請先閱讀「安全資訊」。

Prije instalacije ovog produkta obavezno pročitajte Sigurnosne Upute.

Před instalací tohoto produktu si přečtěte příručku bezpečnostních instrukcí.

Læs sikkerhedsforskrifterne, før du installerer dette produkt.

Lees voordat u dit product installeert eerst de veiligheidsvoorschriften.

Ennen kuin asennat tämän tuotteen, lue turvaohjeet kohdasta Safety Information.

Avant d'installer ce produit, lisez les consignes de sécurité.

Vor der Installation dieses Produkts die Sicherheitshinweise lesen.

Πριν εγκαταστήσετε το προϊόν αυτό, διαβάστε τις πληροφορίες ασφάλειας (safety information).

לפני שתתקינו מוצר זה, קראו את הוראות הבטיחות.

A termék telepítése előtt olvassa el a Biztonsági előírásokat!

Prima di installare questo prodotto, leggere le Informazioni sulla Sicurezza.

製品の設置の前に、安全情報をお読みください。

본 제품을 설치하기 전에 안전 정보를 읽으십시오.

Пред да се инсталира овој продукт, прочитајте информацијата за безбедност.

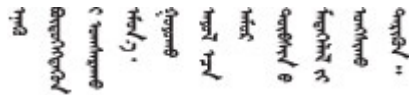

Les sikkerhetsinformasjonen (Safety Information) før du installerer dette produktet.

Przed zainstalowaniem tego produktu, należy zapoznać się z książką "Informacje dotyczące bezpieczeństwa" (Safety Information).

Antes de instalar este produto, leia as Informações sobre Segurança.

Перед установкой продукта прочтите инструкции по технике безопасности.

Pred inštaláciou tohto zariadenia si pečítajte Bezpečnostné predpisy.

Pred namestitvijo tega proizvoda preberite Varnostne informacije.

Antes de instalar este producto, lea la información de seguridad.

Läs säkerhetsinformationen innan du installerar den här produkten.

ཐོན་ཇུས་འདི་བདེ་སྤྱད་མ་བྱས་གོང་། སྐྱོར་གྱི་ཡིད་གཟབ་  
བྱ་འདྲ་མིན་ཡོད་པའི་འོད་སྟེར་བལྟ་དགོས།

Bu ürünü kurmadan önce güvenlik bilgilerini okuyun.

مەزكۇر مەھسۇلاتنى ئورنىتىشتىن بۇرۇن بىخەتەرلىك ئۇچۇرلىرىنى ئوقۇپ چىقىڭ.

Youq mwngz yungh canjbinj neix gaxgonq, itdingh aeu doeg aen  
canjbinj soengq cungj vahgangj ancien siusik.

---

## Safety inspection checklist

Use the information in this section to identify potentially unsafe conditions with your server. As each machine was designed and built, required safety items were installed to protect users and service technicians from injury.

**Note:** This device is not intended for use in the direct field of view at visual display workplaces. To avoid incommoding reflections at visual display workplaces, this device must not be placed in the direct field of view.

### CAUTION:

**This equipment must be installed or serviced by trained personnel, as defined by the NEC, IEC 62368-1 & IEC 60950-1, the standard for Safety of Electronic Equipment within the Field of Audio/Video, Information Technology and Communication Technology. Lenovo assumes you are qualified in the servicing of equipment and trained in recognizing hazards energy levels in products. Access to the equipment is by the use of a tool, lock and key, or other means of security, and is controlled by the authority responsible for the location.**

**Important:** Electrical grounding of the server is required for operator safety and correct system function. Proper grounding of the electrical outlet can be verified by a certified electrician.

Use the following checklist to verify that there are no potentially unsafe conditions:

1. Make sure that the power is off and the power cord is disconnected.
2. Check the power cord.
  - Make sure that the third-wire ground connector is in good condition. Use a meter to measure third-wire ground continuity for 0.1 ohm or less between the external ground pin and the frame ground.
  - Make sure that the power cord is the correct type.

To view the power cords that are available for the server:

- a. Go to:

<http://dcsc.lenovo.com/#/>

- b. Click **Preconfigured Model** or **Configure to order**.
  - c. Enter the machine type and model for your server to display the configurator page.
  - d. Click **Power → Power Cables** to see all line cords.
- Make sure that the insulation is not frayed or worn.
3. Check for any obvious non-Lenovo alterations. Use good judgment as to the safety of any non-Lenovo alterations.
4. Check inside the server for any obvious unsafe conditions, such as metal filings, contamination, water or other liquid, or signs of fire or smoke damage.
5. Check for worn, frayed, or pinched cables.
6. Make sure that the power-supply cover fasteners (screws or rivets) have not been removed or tampered with.



---

## Chapter 1. Introduction

The ThinkSystem ST650 V3 server (Types 7D7A and 7D7B) is a 4U tower server designed for performance and expansion for various IT workloads. With the modular design, the server is flexible to be customized for maximum storage capacity or high storage density with selectable input/output options and tiered system management.

**Note:** In Chinese Mainland, the ThinkSystem ST650 V3 model name is not used. Instead, it is branded as the ThinkSystem ST658 V3.



---

## Features

Performance, ease of use, reliability, and expansion capabilities were key considerations in the design of the server. These design features make it possible for you to customize the system hardware to meet your needs today and provide flexible expansion capabilities for the future.

Your server implements the following features and technologies:

- **Features on Demand**

If a Features on Demand feature is integrated in the server or in an optional device that is installed in the server, you can purchase an activation key to activate the feature. For information about Features on Demand, see:

<https://fod.lenovo.com/lkms>

- **Lenovo XClarity Controller (XCC)**

The server supports Lenovo XClarity Controller 2 (XCC2). For additional information about Lenovo XClarity Controller 2 (XCC2), refer to <https://pubs.lenovo.com/lxcc-overview/>.

With different versions, the Lenovo XClarity Controller is the common management controller for Lenovo ThinkSystem server hardware. The Lenovo XClarity Controller consolidates multiple management functions in a single chip on the server system board (system board assembly). Some of the features that are unique to the Lenovo XClarity Controller are enhanced performance, higher-resolution remote video, and expanded security options.

- **UEFI-compliant server firmware**

Lenovo ThinkSystem firmware is Unified Extensible Firmware Interface (UEFI) compliant. UEFI replaces BIOS and defines a standard interface between the operating system, platform firmware, and external devices.

Lenovo ThinkSystem servers are capable of booting UEFI-compliant operating systems, BIOS-based operating systems, and BIOS-based adapters as well as UEFI-compliant adapters.

**Note:** The server does not support Disk Operating System (DOS).

- **Active Memory**

The Active Memory feature improves the reliability of memory through memory mirroring. Memory mirroring mode replicates and stores data on two pairs of DIMMs within two channels simultaneously. If a failure occurs, the memory controller switches from the primary pair of memory DIMMs to the backup pair of DIMMs.

- **Large system-memory capacity**

The server supports synchronous dynamic random-access memory (SDRAM) registered dual inline memory modules (DIMMs) with error correcting code (ECC). For more information about the specific types and maximum amount of memory, see [“Technical specifications” on page 5](#).

- **Integrated network support**

The server comes with an integrated 1-port Gigabit Ethernet controller with RJ-45 connector, which supports connection to a 1000 Mbps network.

- **Large data-storage capacity and hot-swap capability**

Some server models support a maximum of thirty-two 2.5-inch hot-swap drives or sixteen 3.5-inch hot-swap drives.

With the hot-swap feature, hard disk drives can be added, removed, or replaced without turning off the server.

- **Lightpath Diagnostics**

Lightpath Diagnostics provides LEDs to help you diagnose problems. For more information about the Lightpath Diagnostics, see [“System LEDs and diagnostics display” on page 31](#).

- **Mobile access to Lenovo Service Information website**

The server provides a QR code on the system service label, which is on the inside of the server cover, that you can scan the QR code with a mobile device and a QR code reader application to get quick access to the Lenovo Service Information website. The Lenovo Service Information web site provides additional information for parts installation, replacement videos, and error codes for server support.

- **Active Energy Manager**

Lenovo XClarity Energy Manager is a power and temperature management solution for data centers. You can monitor and manage the power consumption and temperature of Converged, NeXtScale, System x, and ThinkServer servers, and improve energy efficiency using Lenovo XClarity Energy Manager.

- **Redundant networking connection**

The Lenovo XClarity Controller provides failover capability to a redundant Ethernet connection with the applicable application installed. If a problem occurs with the primary Ethernet connection, all Ethernet traffic that is associated with the primary connection is automatically switched to the optional redundant Ethernet connection. If the applicable device drivers are installed, this switching occurs without data loss and without user intervention.

- **Redundant cooling and power capabilities**

The server supports up to four hot-swap fans and two hot-swap power supplies. The redundant cooling by the dual rotor fans in the server enables continued operation if one of the fans fails.

- **ThinkSystem RAID support**

The ThinkSystem RAID adapter provides hardware redundant array of independent disks (RAID) support to create configurations. The standard RAID adapter provides RAID levels 0 and 1. An optional RAID adapter is available for purchase.

---

## Tech Tips

Lenovo continually updates the support website with the latest tips and techniques that you can use to solve issues that your server might encounter. These Tech Tips (also called retain tips or service bulletins) provide procedures to work around issues or solve problems related to the operation of your server.

To find the Tech Tips available for your server:

1. Go to <http://datacentersupport.lenovo.com> and navigate to the support page for your server.
2. Click on **How To's** from the navigation pane.
3. Click **Article Type** → **Solution** from the drop-down menu.

Follow the on-screen instructions to choose the category for the problem that you are having.

---

## Security advisories

Lenovo is committed to developing products and services that adhere to the highest security standards in order to protect our customers and their data. When potential vulnerabilities are reported, it is the responsibility of the Lenovo Product Security Incident Response Team (PSIRT) to investigate and provide information to our customers so they may put mitigation plans in place as we work toward providing solutions.

The list of current advisories is available at the following site:

[https://datacentersupport.lenovo.com/product\\_security/home](https://datacentersupport.lenovo.com/product_security/home)

## Specifications

Summary of the features and specifications of the server. Depending on the model, some features might not be available, or some specifications might not apply.

Refer to the below table for specifications categories and the content of each category.

Specification category	Technical specifications	Mechanical specifications	Environmental specifications
Content	<ul style="list-style-type: none"> <li>• “Processor” on page 5</li> <li>• “Memory” on page 5</li> <li>• “M.2 Drive” on page 6</li> <li>• “Storage expansion” on page 6</li> <li>• “Expansion slots” on page 7</li> <li>• “Graphics processing units (GPU)” on page 7</li> <li>• “Integrated functions and I/O connectors” on page 7</li> <li>• “Network” on page 8</li> <li>• “Rear button” on page 8</li> <li>• “Storage controller” on page 9</li> <li>• “System fan” on page 10</li> <li>• “Electrical input” on page 10</li> <li>• “Minimal configuration for debugging” on page 11</li> <li>• “Operating systems” on page 11</li> </ul>	<ul style="list-style-type: none"> <li>• Dimension</li> <li>• Weight</li> </ul>	<ul style="list-style-type: none"> <li>• “Acoustical noise emissions” on page 12</li> <li>• “Ambient temperature management” on page 13</li> <li>• “Environment” on page 14</li> </ul>

## Technical specifications

Summary of the technical specifications of server. Depending on the model, some features might not be available, or some specifications might not apply.

### Processor

Processor
<p>This server supports up to two Intel® Xeon® series multi-core processors, with integrated memory controller and Ultra Path Interconnect (UPI).</p> <ul style="list-style-type: none"><li>• Designed for LGA 4677 sockets</li><li>• Scalable up to 32 cores per socket</li><li>• Supports up to 3 UPI links at 16 GTS</li><li>• Supports TDP up to 250W</li></ul> <p>For a list of supported processors, see <a href="https://serverproven.lenovo.com">https://serverproven.lenovo.com</a>.</p>

### Memory

Memory
<p><b>Important:</b> See “<a href="#">Memory module installation rules and order</a>” on page 45 for detailed information about memory configuration and setup.</p> <ul style="list-style-type: none"><li>• Minimum memory: 16 GB</li><li>• Maximum memory:<ul style="list-style-type: none"><li>– RDIMM: 2 TB</li><li>– 3DS RDIMM: 4 TB</li></ul></li><li>• Memory module types:<ul style="list-style-type: none"><li>– Double-data-rate 5 (TruDDR5) 4800 MHz and 5600 MHz registered DIMM (RDIMM) or 3DS RDIMM</li></ul><p><b>Note:</b> 4800 MHz memory is only supported with 4th Gen Intel Xeon Scalable processors. 5600 MHz memory is only supported with 5th Gen Intel Xeon Scalable processors.</p></li><li>• Capacity:<ul style="list-style-type: none"><li>– RDIMM: 16 GB, 32 GB, 48 GB, 64 GB, 96 GB and 128 GB</li><li>– 3DS RDIMM: 128 GB</li><li>– Performance+ RDIMM: 32 GB, 64 GB</li></ul></li><li>• Speed<p><b>Note:</b> Operating speed depends on processor model and UEFI settings.</p><ul style="list-style-type: none"><li>– 4800 MHz RDIMMs:<ul style="list-style-type: none"><li>– 1 DIMM per channel: 4800 MT/s</li><li>– 2 DIMM per channel: 4400 MT/s</li></ul></li><li>– 5600 MHz RDIMMs:<ul style="list-style-type: none"><li>– 1 DIMM per channel: 5600 MT/s</li><li>– 2 DIMM per channel:<ul style="list-style-type: none"><li>• 4400 MT/s</li><li>• Performance+ RDIMM: 4800 MT/s</li></ul></li></ul></li></ul></li><li>• Slots: 32 DIMM slots</li></ul> <p>For a list of supported memory modules, see <a href="https://serverproven.lenovo.com">https://serverproven.lenovo.com</a>.</p>

## M.2 Drive

M.2 Drive
<p>The server supports up to two M.2 SATA/NVMe drives of the following drive form factors:</p> <ul style="list-style-type: none"><li>• 42 mm (2242)</li><li>• 60 mm (2260)</li><li>• 80 mm (2280)</li><li>• 110 mm (22110)</li></ul> <p>The server supports the following M.2 drive capacity:</p> <ul style="list-style-type: none"><li>• 128 GB</li><li>• 240 GB</li><li>• 480 GB</li><li>• 960 GB</li></ul> <p><b>Note:</b> All M.2 drives installed in the server must be the same type and capacity.</p> <p>For a list of supported M.2 drives, see <a href="https://serverproven.lenovo.com">https://serverproven.lenovo.com</a>.</p>

## Storage expansion

Storage expansion
<p>The server supports the following storage configurations:</p> <ul style="list-style-type: none"><li>• 2.5-inch hot-swap drive configurations<ul style="list-style-type: none"><li>– Up to thirty-two 2.5-inch SAS/SATA drives</li><li>– Up to twenty-four 2.5-inch NVMe drives</li><li>– Up to twenty-four 2.5-inch SAS/SATA drives and eight 2.5-inch NVMe drives</li></ul></li><li>• 3.5-inch hot-swap drive configurations<ul style="list-style-type: none"><li>– Up to sixteen 3.5-inch SAS/SATA/NVMe drives</li><li>– Up to twelve 3.5-inch SAS/SATA drives and four 3.5-inch NVMe drives</li></ul></li><li>• One optical drive bay supports one of the following:<ul style="list-style-type: none"><li>– One optical disk drive (ODD)</li><li>– One tape drive (RDX or LTO)</li></ul></li></ul> <p><b>Notes:</b></p> <ul style="list-style-type: none"><li>• See “<a href="#">Technical rules for system fans</a>” on page 95 for detailed information about the storage limitations in different server configurations.</li><li>• When an LTO tape drive is to be installed, one of the following HBA should be installed:<ul style="list-style-type: none"><li>– ThinkSystem 440-8i SAS/SATA PCIe 12Gb HBA</li><li>– ThinkSystem 4350-8i SAS/SATA 12Gb HBA</li></ul></li></ul> <p>For a list of supported drives, see <a href="https://serverproven.lenovo.com">https://serverproven.lenovo.com</a>.</p>

## Expansion slots

Expansion slots
<p>Nine PCIe expansion slots are available:</p> <ul style="list-style-type: none"><li>• Slot 1: PCIe Gen 5 x16, 75W, FH/FL</li><li>• Slot 2: PCIe Gen 5 x8 (open end), 75W, FH/FL</li><li>• Slot 3: PCIe Gen 5 x16, 75W, FH/FL</li><li>• Slot 4: PCIe Gen 5 x8 (open end), 75W, FH/FL</li><li>• Slot 5: PCIe Gen 5 x16, 75W, FH/FL</li><li>• Slot 6: PCIe Gen 4 x8 (open end), 75W, FH/FL</li><li>• Slot 7: PCIe Gen 4 x16, 75W, FH/FL</li><li>• Slot 8: PCIe Gen 4 x8 (open end), 75W, FH/FL</li><li>• Slot 9: PCIe Gen 4 x8 (open end), 75W, FH/HL</li></ul>
<p><b>Notes:</b></p> <ul style="list-style-type: none"><li>• Slots 2, 4, 6, 8, and 9 in ThinkSystem ST650 V3 are open-end design, which means that these slots can accept adapters with a longer edge connector than the physical length of the slot connector. For example, if a x16 adapter is installed in the x8 slot 2 of the server, half of the edge connector will not be connected to the slot. The adapter will still function, but the performance will be impacted.</li><li>• See “<a href="#">Install a HL PCIe adapter</a>” on page 167 for detailed information about the technical rules of PCIe slots.</li><li>• For more information about the supported PCIe adapters, see <a href="https://serverproven.lenovo.com">https://serverproven.lenovo.com</a>.</li></ul>

## Graphics processing unit (GPU)

Graphics processing unit (GPU)
<p>The server supports the following GPU configurations:</p> <ul style="list-style-type: none"><li>• With one processor installed:<ul style="list-style-type: none"><li>– Up to two double-width GPUs</li><li>– Up to four single-width GPUs</li></ul></li><li>• With two processors installed:<ul style="list-style-type: none"><li>– Up to four double-width GPUs</li><li>– Up to eight single-width GPUs</li></ul></li></ul>
<p><b>Notes:</b></p> <ul style="list-style-type: none"><li>• See “<a href="#">GPU installation rules</a>” on page 171 for detailed information about the technical rules for GPU installation.</li><li>• For a list of supported GPU adapters, see <a href="https://serverproven.lenovo.com">https://serverproven.lenovo.com</a>.</li></ul>

## Integrated functions and I/O connectors

Integrated functions and I/O connectors
<ul style="list-style-type: none"><li>• Lenovo XClarity Controller (XCC), which provides service processor control and monitoring functions, video controller, and remote keyboard, video, mouse, and remote drive capabilities.<ul style="list-style-type: none"><li>– The server supports Lenovo XClarity Controller 2 (XCC2). For additional information about Lenovo XClarity Controller 2 (XCC2), refer to <a href="https://pubs.lenovo.com/lxcc-overview/">https://pubs.lenovo.com/lxcc-overview/</a>.</li></ul></li><li>• Front panel<ul style="list-style-type: none"><li>– One USB 2.0 connector with Lenovo XClarity Controller 2 management</li><li>– One USB 3.2 Gen1 (5 Gbps) connector</li></ul></li><li>• Rear panel<ul style="list-style-type: none"><li>– One External LCD diagnostics handset connector</li><li>– Four USB 3.2 Gen1 (5 Gbps) connectors</li><li>– Two 10GbE connectors</li><li>– One VGA connector</li><li>– One serial-port-module slot</li><li>– One XClarity Controller 2 network connector (RJ-45 Ethernet connector)</li></ul></li></ul>

## Network

Network
<ul style="list-style-type: none"><li>• Two 10GbE connectors</li><li>• One XClarity Controller 2 network connector (RJ-45 Ethernet connector)</li></ul>

## Rear button

Rear button
NMI button

## Storage controller

### Storage controller

#### Internal adapters / HBA

- ThinkSystem RAID 940-16i 8GB Flash PCIe Gen4 12Gb Internal Adapter (CFF)
- ThinkSystem 440-16i SAS/SATA PCIe Gen4 12Gb Internal HBA (CFF)
- ThinkSystem RAID 9350-16i 4GB Flash PCIe 12Gb Internal Adapter
- ThinkSystem RAID 9350-8i 2GB Flash PCIe 12Gb Internal Adapter
- ThinkSystem RAID 5350-8i PCIe 12Gb Internal Adapter

#### HBA

- ThinkSystem 440-16i SAS/SATA PCIe Gen4 12Gb HBA
- ThinkSystem 4450-16i SAS/SATA/NVMe PCIe Gen4 24Gb HBA
- ThinkSystem 4350-16i SAS/SATA 12Gb HBA
- ThinkSystem 440-8i SAS/SATA PCIe Gen4 12Gb HBA
- ThinkSystem 4350-8i SAS/SATA 12Gb HBA
- ThinkSystem 440-16e SAS/SATA PCIe Gen4 12Gb HBA
- ThinkSystem 440-8e SAS/SATA PCIe Gen4 12Gb HBA

#### RAID adapters

- RAID level 0, 1, 10
  - ThinkSystem RAID 540-8i PCIe Gen4 12Gb Adapter
  - ThinkSystem RAID 540-16i PCIe Gen4 12Gb Adapter
- RAID level 0, 1, 10, 5
  - ThinkSystem RAID 5350-8i PCIe 12Gb Adapter
  - ThinkSystem RAID 5450-16i PCIe Gen4 24Gb Adapter
- RAID level 0, 1, 10, 5, 6
  - ThinkSystem RAID 940-8i 4GB Flash PCIe Gen4 12Gb Adapter (with flash power module)
  - ThinkSystem RAID 940-8i 8GB Flash PCIe Gen4 12Gb Adapter (with flash power module)
  - ThinkSystem RAID 940-16i 4GB Flash PCIe Gen4 12Gb Adapter (with flash power module)
  - ThinkSystem RAID 940-16i 8GB Flash PCIe Gen4 12Gb Adapter (with flash power module)
  - ThinkSystem RAID 940-32i 8GB Flash PCIe Gen4 12Gb Adapter (with flash power module)
- RAID level 0, 1, 10, 5, 6, 1 Triple, 10 Triple
  - ThinkSystem RAID 9350-8i 2GB Flash PCIe 12Gb Adapter (with flash power module)
  - ThinkSystem RAID 9350-16i 4GB Flash PCIe 12Gb Adapter (with flash power module)
  - ThinkSystem RAID 9450-8i 4GB Flash PCIe Gen4 24Gb Adapter (with flash power module)
  - ThinkSystem RAID 9450-16i 8GB Flash PCIe Gen4 24Gb Adapter (with flash power module)

#### Software RAID

- On Board SATA Software RAID
- Intel VROC NVMe RAID
  - Intel VROC Standard: requires an activation key and supports RAID levels 0,1, and 10
  - Intel VROC Premium: requires an activation key and supports RAID levels 0, 1, 5, and 10.
  - Bootable RAID: requires an activation key and supports RAID level 1 only.

For more information about acquiring and installing the activation key, see <https://fod.lenovo.com/lkms>

## Storage controller

### Notes:

- See [“Install a HL PCIe adapter” on page 167](#) for detailed information about the technical rules of PCIe slots.
- For more information about the supported HBA/RAID adapters, see [Lenovo ThinkSystem RAID Adapter and HBA Reference](#).

## System fan

### System fan

The server supports up to four hot-swap fans:

- 9238 single-rotor hot-swap fans
- 9256 dual-rotor hot-swap fans

### Notes:

- Single-rotor hot-swap fans cannot be mixed with dual-rotor hot-swap fans.
- When the system is powered off but still plugged in to AC power, the fan in slot 4 may continue to spin at a much lower speed. This is the system design to provide proper cooling.
- See [“Technical rules for system fans” on page 95](#) for detailed information about the technical rules for fan installation.

## Electrical input

### Electrical input

This server supports up to two units of CFF V4 power supplies with 1+1 redundancy. Following is the list of supported types:

- 750-watt Platinum
- 1100-watt Platinum
- 1100-watt Titanium
- 1800-watt Platinum
- 1800-watt Titanium
- 2600-watt Titanium

### Notes:

- 100V+ is only allowed on the following:
  - 750-watt Platinum
  - 1100-watt Platinum
- 200V+ is allowed only with the following power supplies:
  - 750-watt Platinum
  - 1100-watt Platinum
  - 1100-watt Titanium
  - 1800-watt Platinum
  - 1800-watt Titanium
  - 2600-watt Titanium

**Important:** All power supplies to be installed must be with the same power rating, wattage or level.

### CAUTION:

- **240 V DC input (input range: 180-300 V DC) is only supported in Chinese Mainland.**
- **Power supplies with 240 V DC input do not support hot-plugging power cord function. To remove the power cord, make sure to have turned off the server or disconnect the dc power sources at the breaker panel.**
- **In order for the ThinkSystem products to operate error free in both a DC or AC electrical environment, a TN-S earthing system which complies to 60364-1 IEC 2005 standard has to be present or installed.**

## Minimal configuration for debugging

Minimal configuration for debugging
<ul style="list-style-type: none"><li>• System board</li><li>• Firmware and RoT security module (installed on the system board)</li><li>• One processor in processor socket 1 (processor TDP smaller than 200 watts)</li><li>• One DRAM DIMM in DIMM slot 10</li><li>• One power supply unit in PSU slot 1</li><li>• One drive with RAID adapter and backplane (if OS is needed for debugging)</li><li>• Three single rotor fans in fan slots 1, 2, and 4, and one fan filler in fan slot 3</li></ul>

## Operating systems

Operating systems
Supported and certified operating systems: <ul style="list-style-type: none"><li>• Microsoft Windows Server</li><li>• VMware ESXi</li><li>• Red Hat Enterprise Linux</li><li>• SUSE Linux Enterprise Server</li></ul> References: <ul style="list-style-type: none"><li>• Complete list of available operating systems: <a href="https://lenovopress.lenovo.com/osig">https://lenovopress.lenovo.com/osig</a>.</li><li>• OS deployment instructions, see “Deploy the operating system” on page 326.</li></ul>

## Mechanical specifications

Summary of the mechanical specifications of server. Depending on the model, some features might not be available, or some specifications might not apply.

Dimension
4U server <ul style="list-style-type: none"><li>• Height:<ul style="list-style-type: none"><li>– Without foot stand: 448 mm (17.64 inches)</li><li>– With foot stand: 461.4 mm (18.17 inches)</li></ul></li><li>• Width:<ul style="list-style-type: none"><li>– Without foot stand: 174.2 mm (6.86 inches)</li><li>– With foot stand: 247.4 mm (9.74 inches)</li></ul></li><li>• Depth:<ul style="list-style-type: none"><li>– Without security door: 710.8 mm (27.98 inches)</li><li>– With security door: 733.8 mm (28.89 inches)</li></ul></li></ul>

Weight
<ul style="list-style-type: none"><li>• 2.5-inch drive configuration<ul style="list-style-type: none"><li>– Maximum: 40.21 kg (88.647 lb)</li></ul></li><li>• 3.5-inch drive configuration<ul style="list-style-type: none"><li>– Maximum: 42.735 kg (94.214 lb)</li></ul></li></ul>

## Environmental specifications

Summary of the environmental specifications of server. Depending on the model, some features might not be available, or some specifications might not apply.

### Acoustical noise emissions

Acoustical noise emissions
<p>The server has the following acoustic noise emissions declaration:</p> <ul style="list-style-type: none"><li>• Sound power level (<math>L_{WA,d}</math>)<ul style="list-style-type: none"><li>– Idling:<ul style="list-style-type: none"><li>– Min: 5.2 Bel</li><li>– Typical: 5.8 Bel</li><li>– GPU: 6.4 Bel</li><li>– Storage: 6.4 Bel</li></ul></li><li>– Operating:<ul style="list-style-type: none"><li>– Min: 5.2 Bel</li><li>– Typical: 5.8 Bel</li><li>– GPU: 7.6 Bel</li><li>– Storage: 7.2 Bel</li></ul></li></ul></li><li>• Sound pressure level (<math>L_{pAm}</math>):<ul style="list-style-type: none"><li>– Idling:<ul style="list-style-type: none"><li>– Min: 37 dBA</li><li>– Typical: 41 dBA</li><li>– GPU: 48 dBA</li><li>– Storage: 48 dBA</li></ul></li><li>– Operating:<ul style="list-style-type: none"><li>– Min: 37 dBA</li><li>– Typical: 41 dBA</li><li>– GPU: 59 dBA</li><li>– Storage: 56 dBA</li></ul></li></ul></li></ul> <p><b>Notes:</b></p> <ul style="list-style-type: none"><li>• These sound levels were measured in controlled acoustical environments according to procedures specified by ISO7779 and are reported in accordance with ISO 9296.</li><li>• The declared acoustic sound levels are based on the following configurations, which may change depending on configuration/conditions:<ul style="list-style-type: none"><li>– Minimum configuration: 1x 125W CPU, 4x 16GB RDIMM, 4x 3.5" SAS HDD, SW RAID, 2x onboard 10GB LAN ports, 1x 750W PSU</li><li>– Typical configuration: 2x 150W CPU, 4x 32GB RDIMM, 8x 3.5" SAS HDD, RAID 940-8i, 2x onboard 10GB LAN ports, 2x 750W PSU</li><li>– GPU rich configuration: 2x 150W CPU, 32x 64GB RDIMM, 8x 3.5" SAS HDD, 1xRAID 940-8i, 2x onboard 10GB LAN ports, 8x NVIDIA A2 GPU, 2x 1800W PSU</li><li>– Storage rich configuration: 2x 195W CPU, 32x 64GB RDIMM, 32x 2.5" SAS HDD, 2x RAID 940-16i, 2x onboard 10GB LAN ports, 2x 1800W PSU</li></ul></li><li>• Government regulations (such as those prescribed by OSHA or European Community Directives) may govern noise level exposure in the workplace and may apply to you and your server installation. The actual sound pressure levels in your installation depend upon a variety of factors, including the number of racks in the installation; the size, materials, and configuration of the room; the noise levels from other equipment; the room ambient temperature, and employee's location in relation to the equipment. Further, compliance with such government regulations depends on a variety of additional factors, including the duration of employees' exposure and whether employees wear hearing protection. Lenovo recommends that you consult with qualified experts in this field to determine whether you are in compliance with the applicable regulations.</li></ul>

## Ambient temperature management

### Ambient temperature management

#### Important:

When the ambient temperature is greater than supported temperature, the server will shut down. The server will not power on again until the ambient temperature is back to within the supported temperature range.

Adjust ambient temperature when specific components are installed.

- Keep the ambient temperature to **45°C** or lower when one or more of the following components are installed.
  - Processors with up to 125-watts TDP
  - Thirty-two RDIMMs with capacity smaller than 32 GB
  - Up to two drive backplanes (Only SATA SSD drives are supported)
  - PCIe adapters:<sup>\*1</sup>
    - ThinkSystem Broadcom 5719 1Gb 4-Port RJ45 PCIe Ethernet Adapter
    - ThinkSystem Intel I350-T4 1Gb 4-Port RJ45 PCIe Ethernet Adapter
- Keep the ambient temperature to **40°C** or lower when one or more of the following components are installed.
  - Processors with up to 150-watts TDP
  - Thirty-two RDIMMs with capacity smaller than 32 GB
  - Up to two drive backplanes (Only SATA SSD and SATA HDD drives are supported)
  - PCIe adapters:<sup>\*1</sup>
    - ThinkSystem Broadcom 5719 1Gb 4-Port RJ45 PCIe Ethernet Adapter
    - ThinkSystem Intel I350-T4 1Gb 4-Port RJ45 PCIe Ethernet Adapter
- Keep the ambient temperature to **35°C** or lower when one or more of the following components are installed.
  - Processors with up to 195-watts TDP
  - Thirty-two registered RDIMMs with capacity smaller than 64 GB
  - Up to four drive backplanes
  - ODD/Tape drives (depending on the server model)
  - PCIe adapters:<sup>\*1</sup>
    - Retimers
    - HBA/RAID adapters
    - Ethernet adapters
    - NIC adapters
- Keep the ambient temperature to **30°C** or lower in either of the following scenarios.

- Processors with up to 250-watts TDP
- Thirty-two registered RDIMMs with capacity smaller than 128 GB
- Up to two drive backplanes
- ODD/Tape drives (depending on the server model)
- PCIe adapters:<sup>\*1</sup>
  - Retimers
  - HBA/RAID adapters
  - Ethernet adapters
  - NIC adapters
- GPU adapters<sup>\*1</sup>

- Processors with up to 195-watts TDP
- Thirty-two registered RDIMMs with capacity smaller than 64 GB
- Up to four drive backplanes
- ODD/Tape drives (depending on the server model)
- PCIe adapters:<sup>\*1</sup>
  - Retimers
  - HBA/RAID adapters
  - Ethernet adapters
  - NIC adapters
- A2/L4 GPU adapters<sup>\*1</sup>

- Keep the ambient temperature to **25°C** or lower in either of the following scenarios.

- Processors with up to 250-watts TDP
- Thirty-two registered RDIMMs with capacity smaller than 128 GB
- Up to two drive backplanes
- ODD/Tape drives (depending on the server model)
- PCIe adapters:<sup>\*1</sup>
  - Retimers
  - HBA/RAID adapters

- Processors with up to 250-watts TDP
- Thirty-two registered RDIMMs with capacity smaller than 64 GB
- Up to four drive backplanes
- ODD/Tape drives (depending on the server model)
- PCIe adapters:<sup>\*1</sup>
  - Retimers
  - HBA/RAID adapters

## Ambient temperature management

- |  |  |
|--|--|
| <ul style="list-style-type: none"><li>- Ethernet adapters</li><li>- NIC adapters</li><li>- GPU adapters*<sup>1</sup></li></ul> | <ul style="list-style-type: none"><li>- Ethernet adapters</li><li>- NIC adapters</li><li>- A2/L4 GPU adapters*<sup>1</sup></li></ul> |
|--|--|

### Notes:

- \* For more information about the supported PCIe adapters and GPU adapters, see <https://serverproven.lenovo.com>.
- See “[Technical rules for system fans](#)” on page 95 for detailed information about the storage limitations in different server configurations.

## Environment

### Environment

ThinkSystem ST650 V3 complies with ASHRAE Class A2 specifications. Depending on the hardware configuration, some models comply with ASHRAE Class A3 and Class A4 specifications. System performance may be impacted when operating temperature is outside ASHRAE A2 specification.

- Air temperature:
  - Operating
    - ASHRAE Class A2: 10°C to 35°C (50°F to 95°F); the maximum ambient temperature decreases by 1°C for every 300 m (984 ft) increase in altitude above 900 m (2,953 ft).
    - ASHRAE Class A3: 5°C to 40°C (41°F to 104°F); the maximum ambient temperature decreases by 1°C for every 175 m (574 ft) increase in altitude above 900 m (2,953 ft).
    - ASHRAE Class A4: 5°C to 45°C (41°F to 113°F); the maximum ambient temperature decreases by 1°C for every 125 m (410 ft) increase in altitude above 900 m (2,953 ft).
  - Server off: 5°C to 45°C (41°F to 113°F)
  - Shipment/storage: -40°C to 60°C (-40°F to 140°F)
- Maximum altitude: 3,050 m (10,000 ft)
- Relative Humidity (non-condensing):
  - Operating
    - ASHRAE Class A2: 8% to 80%; maximum dew point: 21°C (70°F)
    - ASHRAE Class A3: 8% to 85%; maximum dew point: 24°C (75°F)
    - ASHRAE Class A4: 8% to 90%; maximum dew point: 24°C (75°F)
  - Shipment/storage: 8% to 90%
- Particulate contamination

**Attention:** Airborne particulates and reactive gases acting alone or in combination with other environmental factors such as humidity or temperature might pose a risk to the server. For information about the limits for particulates and gases, see “[Particulate contamination](#)” on page 14.

**Note:** The server is designed for standard data center environment and recommended to be placed in industrial data center.

## Particulate contamination

**Attention:** Airborne particulates (including metal flakes or particles) and reactive gases acting alone or in combination with other environmental factors such as humidity or temperature might pose a risk to the device that is described in this document.

Risks that are posed by the presence of excessive particulate levels or concentrations of harmful gases include damage that might cause the device to malfunction or cease functioning altogether. This specification sets forth limits for particulates and gases that are intended to avoid such damage. The limits must not be viewed or used as definitive limits, because numerous other factors, such as temperature or moisture content of the air, can influence the impact of particulates or environmental corrosives and gaseous contaminant transfer. In the absence of specific limits that are set forth in this document, you must implement practices that maintain particulate and gas levels that are consistent with the protection of human health and safety. If Lenovo determines that the levels of particulates or gases in your environment have

caused damage to the device, Lenovo may condition provision of repair or replacement of devices or parts on implementation of appropriate remedial measures to mitigate such environmental contamination. Implementation of such remedial measures is a customer responsibility.

Table 1. Limits for particulates and gases

Contaminant	Limits
Reactive gases	Severity level G1 as per ANSI/ISA 71.04-1985 <sup>1</sup> : <ul style="list-style-type: none"> <li>• The copper reactivity level shall be less than 200 Angstroms per month (<math>\text{\AA}/\text{month} \approx 0.0035 \mu\text{g}/\text{cm}^2\text{-hour}</math> weight gain).<sup>2</sup></li> <li>• The silver reactivity level shall be less than 200 Angstroms per month (<math>\text{\AA}/\text{month} \approx 0.0035 \mu\text{g}/\text{cm}^2\text{-hour}</math> weight gain).<sup>3</sup></li> <li>• The reactive monitoring of gaseous corrosivity must be conducted approximately 5 cm (2 in.) in front of the rack on the air inlet side at one-quarter and three-quarter frame height off the floor or where the air velocity is much higher.</li> </ul>
Airborne particulates	Data centers must meet the cleanliness level of ISO 14644-1 class 8.  For data centers without airside economizer, the ISO 14644-1 class 8 cleanliness might be met by choosing one of the following filtration methods: <ul style="list-style-type: none"> <li>• The room air might be continuously filtered with MERV 8 filters.</li> <li>• Air entering a data center might be filtered with MERV 11 or preferably MERV 13 filters.</li> </ul> For data centers with airside economizers, the choice of filters to achieve ISO class 8 cleanliness depends on the specific conditions present at that data center. <ul style="list-style-type: none"> <li>• The deliquescent relative humidity of the particulate contamination should be more than 60% RH.<sup>4</sup></li> <li>• Data centers must be free of zinc whiskers.<sup>5</sup></li> </ul>
<p><sup>1</sup> ANSI/ISA-71.04-1985. <i>Environmental conditions for process measurement and control systems: Airborne contaminants</i>. Instrument Society of America, Research Triangle Park, North Carolina, U.S.A.</p> <p><sup>2</sup> The derivation of the equivalence between the rate of copper corrosion growth in the thickness of the corrosion product in <math>\text{\AA}/\text{month}</math> and the rate of weight gain assumes that <math>\text{Cu}_2\text{S}</math> and <math>\text{Cu}_2\text{O}</math> grow in equal proportions.</p> <p><sup>3</sup> The derivation of the equivalence between the rate of silver corrosion growth in the thickness of the corrosion product in <math>\text{\AA}/\text{month}</math> and the rate of weight gain assumes that <math>\text{Ag}_2\text{S}</math> is the only corrosion product.</p> <p><sup>4</sup> The deliquescent relative humidity of particulate contamination is the relative humidity at which the dust absorbs enough water to become wet and promote ionic conduction.</p> <p><sup>5</sup> Surface debris is randomly collected from 10 areas of the data center on a 1.5 cm diameter disk of sticky electrically conductive tape on a metal stub. If examination of the sticky tape in a scanning electron microscope reveals no zinc whiskers, the data center is considered free of zinc whiskers.</p>	

## Management options

The XClarity portfolio and other system management options described in this section are available to help you manage the servers more conveniently and efficiently.

## Overview

Options	Description
Lenovo XClarity Controller	<p>Baseboard management controller (BMC)</p> <p>Consolidates the service processor functionality, Super I/O, video controller, and remote presence capabilities into a single chip on the server system board (system board assembly).</p> <p><b>Interface</b></p> <ul style="list-style-type: none"> <li>• CLI application</li> <li>• Web GUI interface</li> <li>• Mobile application</li> <li>• Redfish API</li> </ul> <p><b>Usage and downloads</b></p> <p><a href="https://pubs.lenovo.com/lxcc-overview/">https://pubs.lenovo.com/lxcc-overview/</a></p>
Lenovo XCC Logger Utility	<p>Application that reports the XCC events to local OS system log.</p> <p><b>Interface</b></p> <ul style="list-style-type: none"> <li>• CLI application</li> </ul> <p><b>Usage and downloads</b></p> <ul style="list-style-type: none"> <li>• <a href="https://pubs.lenovo.com/lxcc-logger-linux/">https://pubs.lenovo.com/lxcc-logger-linux/</a></li> <li>• <a href="https://pubs.lenovo.com/lxcc-logger-windows/">https://pubs.lenovo.com/lxcc-logger-windows/</a></li> </ul>
Lenovo XClarity Administrator	<p>Centralized interface for multi-server management.</p> <p><b>Interface</b></p> <ul style="list-style-type: none"> <li>• Web GUI interface</li> <li>• Mobile application</li> <li>• REST API</li> </ul> <p><b>Usage and downloads</b></p> <p><a href="https://pubs.lenovo.com/lxca/">https://pubs.lenovo.com/lxca/</a></p>
Lenovo XClarity Essentials toolset	<p>Portable and light toolset for server configuration, data collection, and firmware updates. Suitable both for single-server or multi-server management contexts.</p> <p><b>Interface</b></p> <ul style="list-style-type: none"> <li>• <b>OneCLI</b>: CLI application</li> <li>• <b>Bootable Media Creator</b>: CLI application, GUI application</li> <li>• <b>UpdateXpress</b>: GUI application</li> </ul> <p><b>Usage and downloads</b></p> <p><a href="https://pubs.lenovo.com/lxce-overview/">https://pubs.lenovo.com/lxce-overview/</a></p>

Options	Description
Lenovo XClarity Provisioning Manager	<p>UEFI-based embedded GUI tool on a single server that can simplify management tasks.</p> <p><b>Interface</b></p> <ul style="list-style-type: none"> <li>• Web interface (BMC remote access)</li> <li>• GUI application</li> </ul> <p><b>Usage and downloads</b></p> <p><a href="https://pubs.lenovo.com/lxpm-overview/">https://pubs.lenovo.com/lxpm-overview/</a></p> <p><b>Important:</b> Lenovo XClarity Provisioning Manager (LXPM) supported version varies by product. All versions of Lenovo XClarity Provisioning Manager are referred to as Lenovo XClarity Provisioning Manager and LXPM in this document, unless specified otherwise. To see the LXPM version supported by your server, go to <a href="https://pubs.lenovo.com/lxpm-overview/">https://pubs.lenovo.com/lxpm-overview/</a>.</p>
Lenovo XClarity Integrator	<p>Series of applications that integrate the management and monitoring functionalities of the Lenovo physical servers with the software used in a certain deployment infrastructure, such as VMware vCenter, Microsoft Admin Center, or Microsoft System Center while delivering additional workload resiliency.</p> <p><b>Interface</b></p> <ul style="list-style-type: none"> <li>• GUI application</li> </ul> <p><b>Usage and downloads</b></p> <p><a href="https://pubs.lenovo.com/lxci-overview/">https://pubs.lenovo.com/lxci-overview/</a></p>
Lenovo XClarity Energy Manager	<p>Application that can manage and monitor server power and temperature.</p> <p><b>Interface</b></p> <ul style="list-style-type: none"> <li>• Web GUI Interface</li> </ul> <p><b>Usage and downloads</b></p> <p><a href="https://datacentersupport.lenovo.com/solutions/Invo-lxem">https://datacentersupport.lenovo.com/solutions/Invo-lxem</a></p>
Lenovo Capacity Planner	<p>Application that supports power consumption planning for a server or rack.</p> <p><b>Interface</b></p> <ul style="list-style-type: none"> <li>• Web GUI Interface</li> </ul> <p><b>Usage and downloads</b></p> <p><a href="https://datacentersupport.lenovo.com/solutions/Invo-lcp">https://datacentersupport.lenovo.com/solutions/Invo-lcp</a></p>

## Functions

Options		Functions							
		Multi-system mgmt	OS deployment	System configuration	Firmware updates <sup>1</sup>	Event/alert monitoring	Inventory/logs	Power mgmt	Power planning
Lenovo XClarity Controller				√	√ <sup>2</sup>	√	√ <sup>4</sup>		
Lenovo XCC Logger Utility						√			
Lenovo XClarity Administrator		√	√	√	√ <sup>2</sup>	√	√ <sup>4</sup>		
Lenovo XClarity Essentials toolset	OneCLI	√		√	√ <sup>2</sup>	√	√		
	Bootable Media Creator			√	√ <sup>2</sup>		√ <sup>4</sup>		
	UpdateXpress			√	√ <sup>2</sup>				
Lenovo XClarity Provisioning Manager			√	√	√ <sup>3</sup>		√ <sup>5</sup>		
Lenovo XClarity Integrator		√		√	√	√	√	√ <sup>6</sup>	
Lenovo XClarity Energy Manager		√				√		√	
Lenovo Capacity Planner									√ <sup>7</sup>

### Notes:

1. Most options can be updated through the Lenovo tools. Some options, such as GPU firmware or Omni-Path firmware require the use of supplier tools.
2. The server UEFI settings for option ROM must be set to **Auto** or **UEFI** to update firmware using Lenovo XClarity Administrator, Lenovo XClarity Essentials, or Lenovo XClarity Controller.
3. Firmware updates are limited to Lenovo XClarity Provisioning Manager, Lenovo XClarity Controller, and UEFI updates only. Firmware updates for optional devices, such as adapters, are not supported.
4. The server UEFI settings for option ROM must be set to **Auto** or **UEFI** for detailed adapter card information, such as model name and firmware levels, to be displayed in Lenovo XClarity Administrator, Lenovo XClarity Controller, or Lenovo XClarity Essentials.
5. Limited inventory.
6. Power management function is supported only by Lenovo XClarity Integrator for VMware vCenter.
7. It is highly recommended that you check the power summary data for your server using Lenovo Capacity Planner before purchasing any new parts.

---

## Chapter 2. Server components

This section contains information about each of the components associated with the server.

---

### Front view

This section contains information about the controls, LEDs, and connectors on the front of the server.

**Notes:** The front view of the server varies by models based on drive-bay configurations:

- “Server models with twelve 3.5-inch drive bays” on page 20
- “Server models with sixteen 3.5-inch drive bays” on page 21
- “Server models with thirty-two 2.5-inch drive bays” on page 22
- These different models have the same front I/O module. The connectors on this front I/O module are shown below. For the front operator panel LEDs on the front I/O module, see “Front operator panel LEDs” on page 341.

### Connectors on the front I/O module

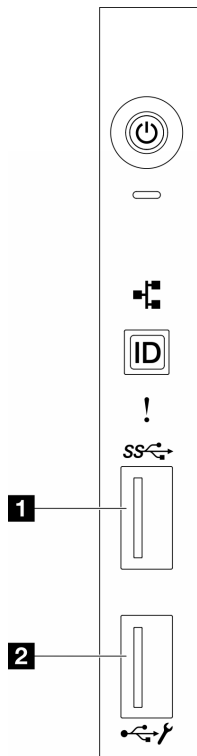

Figure 1. Connectors on the front I/O module

Table 2. Connectors on the front I/O module

<b>1</b> Front USB 3.1 Gen 1 connector	<b>2</b> USB 2.0 connector with Lenovo XClarity Controller management
--	---

## Server models with twelve 3.5-inch drive bays

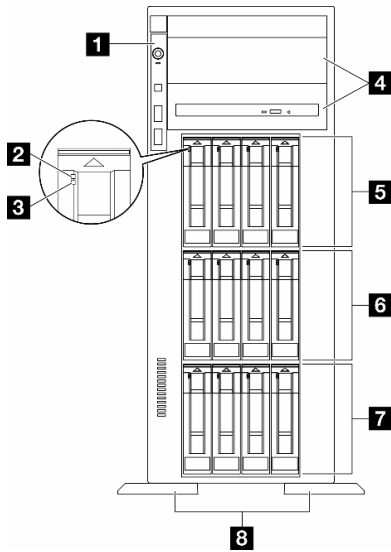

Figure 2. Front view of server models with twelve 3.5-inch drive bays

Table 3. Components on server models with twelve 3.5-inch drive bays

<b>1</b> Front I/O module	<b>5</b> 3.5-inch drive bays 8-11
<b>2</b> Drive activity LED (green)	<b>6</b> 3.5-inch drive bays 4-7
<b>3</b> Drive status LED (yellow)	<b>7</b> 3.5-inch drive bays 0-3
<b>4</b> Optical-drive bays 1-2	<b>8</b> Foot stands

### **1** Front I/O module

For information about the front operator panel LEDs on this front I/O module, see [“Front operator panel LEDs” on page 341](#).

### **2** **3** Drive activity LED (green) and Drive status LED (yellow)

For information about Drive LEDs, see [“Drive LEDs” on page 341](#).

### **4** Optical-drive bays 1-2

Depending on the model, the server might come with an optical drive installed in the lower 5.25-inch optical-drive bay. The upper 5.25-inch optical-drive bay is for a secondary optical drive or a tape drive. Some models have a secondary optical drive or a tape drive installed.

### **5** **6** **7** 3.5-inch drive bays

The drive bays are used to install 3.5-inch drives. When you install drives, follow the order of the drive bay numbers. The EMI integrity and cooling of the server are protected by having all drive bays occupied. The vacant drive bays must be occupied by drive bay fillers or drive fillers.

**Note:** For 3.5-inch drive bay models that support NVMe drives, up to twelve NVMe drives can be stalled in bays 0-3, 4-7, and 8-11.

### **8** Foot stands

For tower form factor models, the foot stands help the server stand steadily.

### Server models with sixteen 3.5-inch drive bays

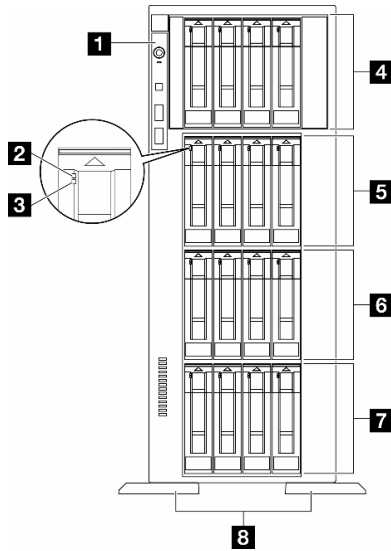

Figure 3. Front view of server models with sixteen 3.5-inch drive bays

Table 4. Components on server models with sixteen 3.5-inch drive bays

<b>1</b> Front I/O module	<b>5</b> 3.5-inch drive bays 8-11
<b>2</b> Drive activity LED (green)	<b>6</b> 3.5-inch drive bays 4-7
<b>3</b> Drive status LED (yellow)	<b>7</b> 3.5-inch drive bays 0-3
<b>4</b> 3.5-inch drive bays 12-15	<b>8</b> Foot stands

#### **1** Front I/O module

For information about the front operator panel LEDs on this front I/O module, see [“Front operator panel LEDs” on page 341](#).

#### **2 3** Drive activity LED (green) and Drive status LED (yellow)

For information about Drive LEDs, see [“Drive LEDs” on page 341](#).

#### **4 5 6 7** 3.5-inch drive bays

The drive bays are used to install 3.5-inch drives. When you install drives, follow the order of the drive bay numbers. The EMI integrity and cooling of the server are protected by having all drive bays occupied. The vacant drive bays must be occupied by drive bay fillers or drive fillers.

**Note:** For 3.5-inch drive bay models that support NVMe drives, up to sixteen NVMe drives can be installed in bays 0-3, 4-7, 8-11, and 12-15.

#### **8** Foot stands

For tower form factor models, the foot stands help the server stand steadily.

## Server models with thirty-two 2.5-inch drive bays

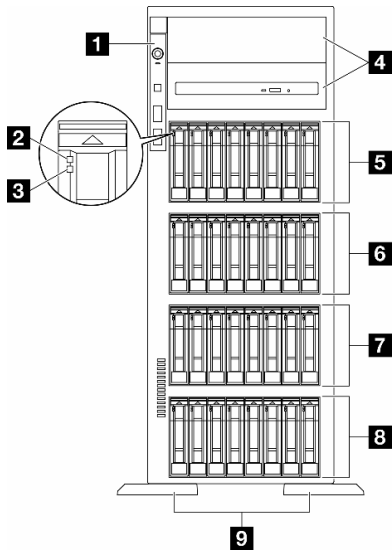

Figure 4. Front view of server models with thirty-two 2.5-inch drive bays

Table 5. Components on server models with thirty-two 2.5-inch drive bays

<b>1</b> Front I/O module	<b>6</b> 2.5-inch drive bays 16-23
<b>2</b> Drive activity LED (green)	<b>7</b> 2.5-inch drive bays 8-15
<b>3</b> Drive status LED (yellow)	<b>8</b> 2.5-inch drive bays 0-7
<b>4</b> Optical-drive bays 1-2	<b>9</b> Foot stands
<b>5</b> 2.5-inch drive bays 24-31	

### **1** Front I/O module

For information about the front operator panel LEDs on this front I/O module, see [“Front operator panel LEDs” on page 341](#).

### **2 3** Drive activity LED (green) and Drive status LED (yellow)

For information about Drive LEDs, see [“Drive LEDs” on page 341](#).

### **4** Optical-drive bays 1-2

Depending on the model, the server might come with an optical drive installed in the lower 5.25-inch optical-drive bay. The upper 5.25-inch optical-drive bay is for a secondary optical drive or a tape drive. Some models have a secondary optical drive or a tape drive installed.

### **5 6 7 8** 2.5-inch drive bays

The drive bays are used to install 2.5-inch drives. When you install drives, follow the order of the drive bay numbers. The EMI integrity and cooling of the server are protected by having all drive bays occupied. The vacant drive bays must be occupied by drive bay fillers or drive fillers.

**Note:** For 2.5-inch drive bay models that support NVMe drives, up to twenty-four NVMe drives can be installed in in bays 0-7, 8-15, and 16-23.

## 9 Foot stands

For tower form factor models, the foot stands help the server stand steadily.

## Rear view

The rear of the server provides access to several components, including the power supplies, PCIe adapters, serial port, and Ethernet port.

### Components on the rear view

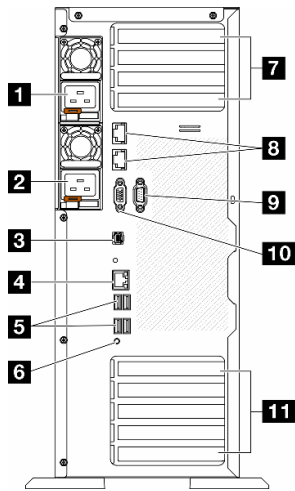

Figure 5. Rear view

Table 6. Components on the rear view

<b>1</b> Power supply unit 1	<b>7</b> PCIe slots 1-4 (top to bottom)
<b>2</b> Power supply unit 2 (optional)	<b>8</b> 10GbE connectors (2)
<b>3</b> External Diagnostics Handset connector	<b>9</b> Serial-port-module slot
<b>4</b> XClarity Controller network connector	<b>10</b> VGA connector
<b>5</b> Four USB 3.1 Gen 1 connectors (4)	<b>11</b> PCIe slots 5-9 (top to bottom)
<b>6</b> NMI button	

**Note:** Listed in this section are the components that can be seen in the rear view. For detailed information about the LEDs for these components, see [“Rear system LEDs” on page 343](#).

### 1 2 Power supply units

Install power supply units to these bays, connect them to power cords. Make sure the power cords are connected properly. Following are the power supplies supported by this system:

- 750-watt Platinum
- 1100-watt Platinum
- 1100-watt Titanium
- 1800-watt Platinum

- 1800-watt Titanium
- 2600-watt Titanium

**Notes:**

- 100V+ is only allowed on the following:
  - 750-watt Platinum
  - 1100-watt Platinum
- 200V+ is allowed only with the following power supplies:
  - 750-watt Platinum
  - 1100-watt Platinum
  - 1100-watt Titanium
  - 1800-watt Platinum
  - 1800-watt Titanium
  - 2600-watt Titanium

On each power supply, there are three status LEDs near the power cord connector. For more details, see [“Power supply LEDs” on page 345](#).

**3 External Diagnostics Handset connector**

Connect the External Diagnostics Handset here. For more details, see [“External Diagnostics Handset” on page 349](#).

**4 XClarity Controller network connector**

Used to attach an Ethernet cable to manage the system using XClarity Controller. For more details, see [“XCC system management port \(10/100/1000 Mbps RJ-45\) LEDs” on page 349](#).

**5 USB 3.1 Gen 1 connectors**

Used to attach a device that requires a USB 2.0 or 3.2 Gen 1 connection, such as a keyboard, a mouse, or a USB flash drive.

**6 NMI button**

Press this button to force a non-maskable interrupt (NMI) to the processor. You might have to use a pen or the end of a straightened paper clip to press the button. You can also use it to force a blue-screen memory dump. Use this button only when you are directed to do so by Lenovo Support.

**7 PCIe slots 1-4 (top to bottom)**

Install PCIe adapters into these slots.

**8 10GbE connector**

This connector is used to attach a 10Gb Ethernet cable. Each 10GbE connector has two status LEDs to help identify the Ethernet connectivity and activity. For more information, see [“Rear system LEDs” on page 343](#).

**9 Serial-port-module slot**

Connect a 9-pin serial device to this connector. The serial port is shared with the XCC. The XCC can take control of the shared serial port to redirect serial traffic, using Serial over LAN (SOL).

**10 VGA connector**

Used to attach a VGA-compatible video device, such as a VGA monitor.

**11 PCIe slots 5-9 (top to bottom)**

Install PCIe adapters into these slots.

## Side view

Follow the instructions in this section to locate the components from the side of the server.

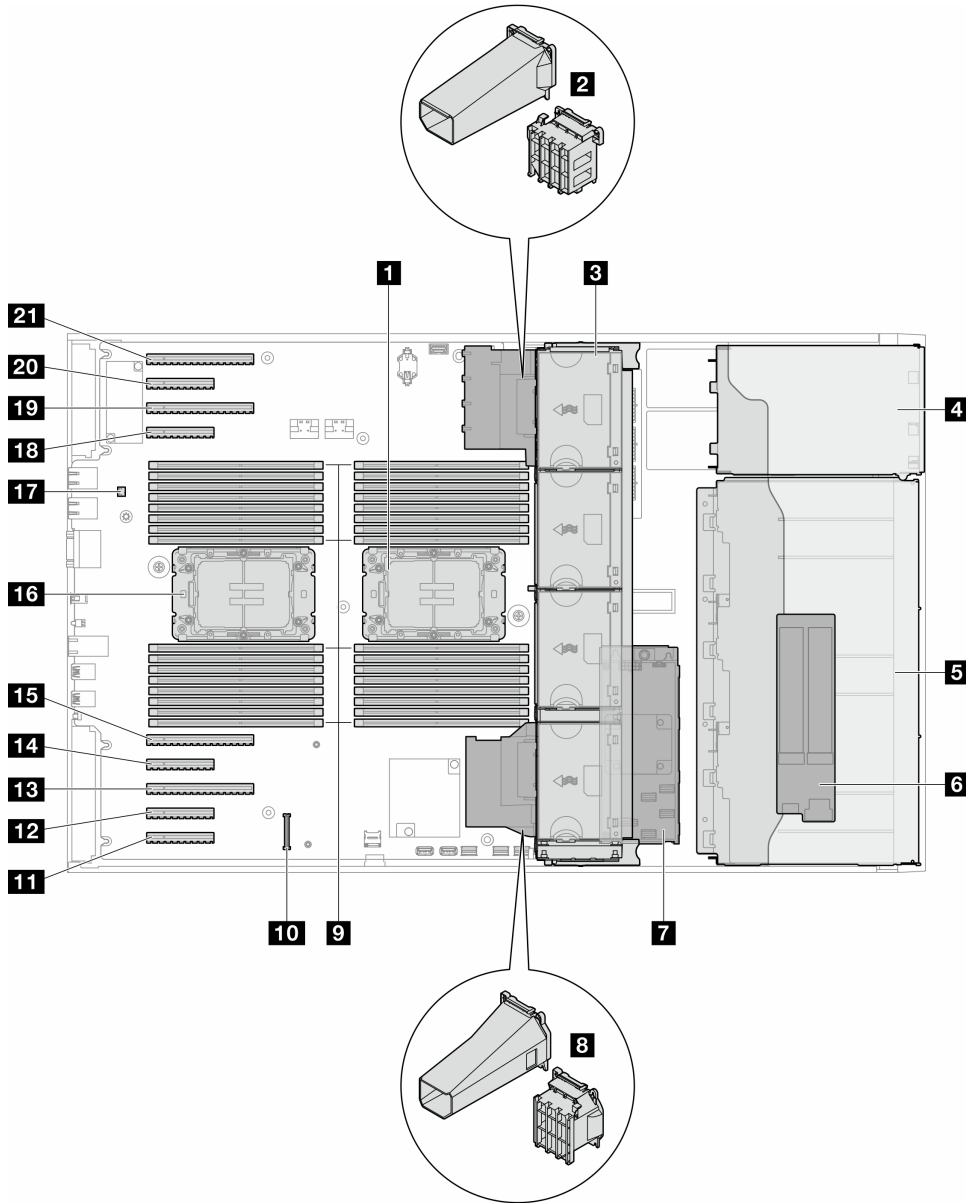

Figure 6. Side view of the ST650 V3

Table 7. Components on the side view of the ST650 V3

<b>1</b> Processor 2 and heat sink	<b>12</b> PCIe slot 8
<b>2</b> PCIe adapter holder or A2/L4 GPU air duct, upper <sup>1</sup>	<b>13</b> PCIe slot 7
<b>3</b> Fan 4, fan 3, fan 2, fan 1 (top to bottom)	<b>14</b> PCIe slot 6
<b>4</b> Drive bay for ODD drive cage, tape drive cage, or expansion drive cage	<b>15</b> PCIe slot 5

Table 7. Components on the side view of the ST650 V3 (continued)

<b>5</b> 3.5-inch or 2.5-inch drive cages <sup>1</sup>	<b>16</b> Processor 1 and heat sink
<b>6</b> M.2 adapter	<b>17</b> Intrusion switch
<b>7</b> Internal CFF RAID	<b>18</b> PCIe slot 4
<b>8</b> PCIe adapter holder or A2/L4 GPU air duct, lower <sup>1</sup>	<b>19</b> PCIe slot 3
<b>9</b> Memory module slots	<b>20</b> PCIe slot 2
<b>10</b> Firmware and RoT security module connector	<b>21</b> PCIe slot 1
<b>11</b> PCIe slot 9	

**Note:** <sup>1</sup> The illustration shows the location of certain parts. Some parts may not be supported at the same time within certain configuration(s).

---

## System board layout

The illustrations in this section provide information about the connectors, switches, and jumpers that are available on the system board.

For more information about the LEDs that are available on the system board, see [“System board LEDs” on page 348](#).

## System board connectors

The following illustration shows the internal connectors on the system board.

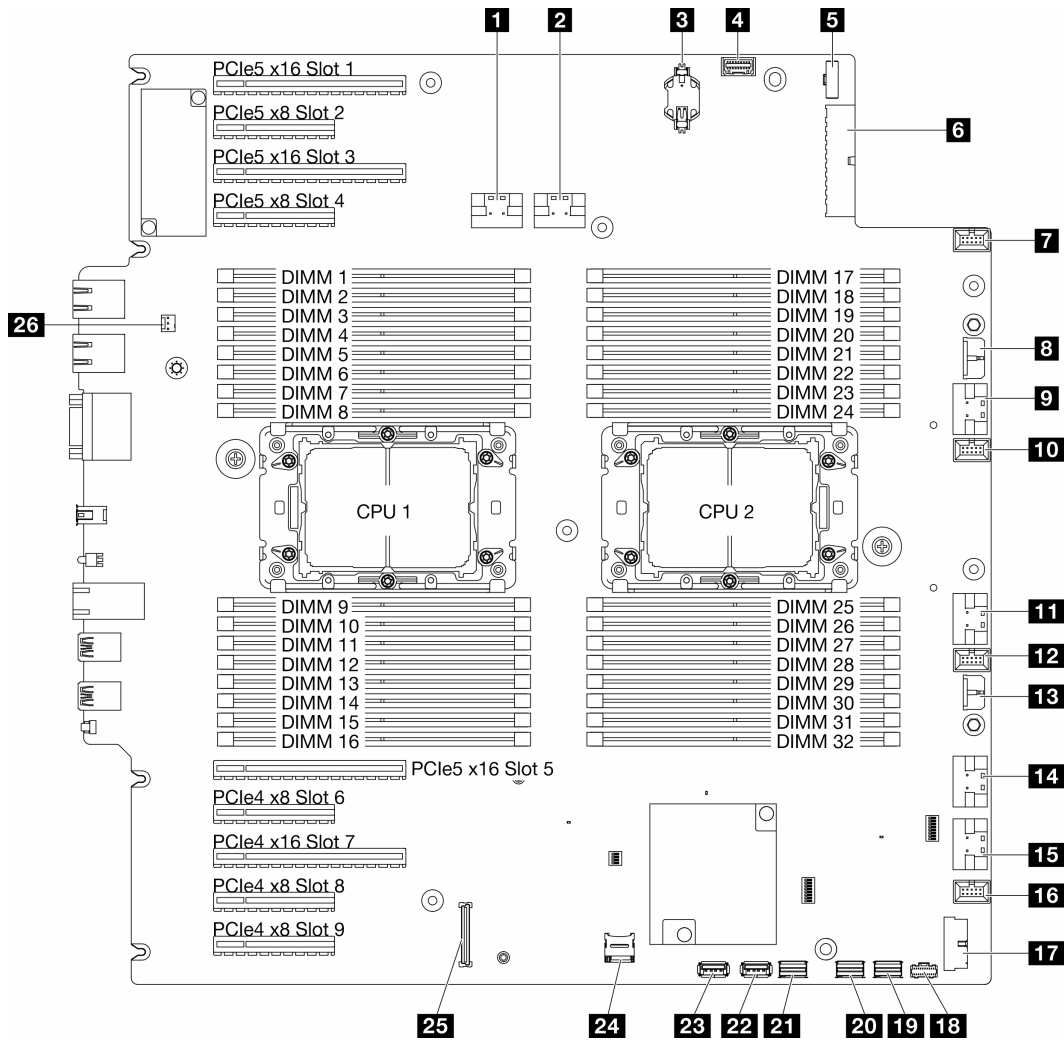

Figure 7. System board connectors

Table 8. System board connectors

<b>1</b> PCIe 1 connector	<b>14</b> PCIe 5 connector
<b>2</b> PCIe 2 connector	<b>15</b> PCIe 6 connector
<b>3</b> CMOS battery (CR2032)	<b>16</b> Fan 1 connector
<b>4</b> Front-operator-panel connector <sup>1</sup>	<b>17</b> Front USB connector <sup>1</sup>
<b>5</b> Power distribution board signal connector	<b>18</b> M.2 power connector
<b>6</b> System board power 1 connector	<b>19</b> M.2 signal connector
<b>7</b> Fan 4 connector	<b>20</b> SATA 4-7 connector
<b>8</b> CFF RAID power connector	<b>21</b> SATA 0-3 connector
<b>9</b> PCIe 3 connector	<b>22</b> Internal USB 2 connector
<b>10</b> Fan 3 connector	<b>23</b> Internal USB 1 connector
<b>11</b> PCIe 4 connector	<b>24</b> MicroSD card

Table 8. System board connectors (continued)

<b>12</b> Fan 2 connector	<b>25</b> Firmware and RoT security module connector
<b>13</b> System board power 2 connector	<b>26</b> Intrusion switch connector

**Note:** <sup>1</sup> Front I/O module cables should be connected to these connectors.

## System board switches

The following illustrations show the location of the switches on the server.

### Locations of system board switches

**Note:** If there is a clear protective sticker on the top of the switch blocks, you must remove and discard it to access the switches.

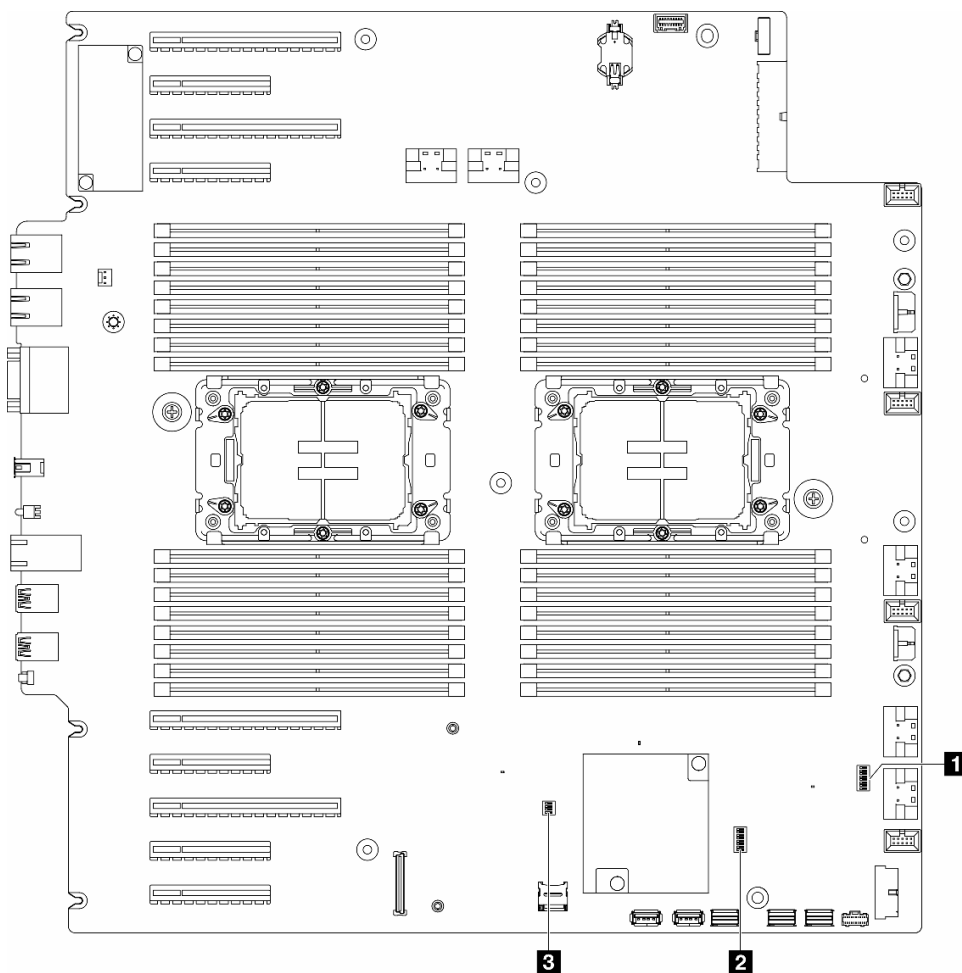

Figure 8. System-board switches

### Important:

1. Before you change any switch settings or move any jumpers, turn off the server; then, disconnect all power cords and external cables. Review the following information:
  - [https://pubs.lenovo.com/safety\\_documentation/](https://pubs.lenovo.com/safety_documentation/)
  - “Installation Guidelines” on page 41

- [“Handling static-sensitive devices” on page 44](#)
  - [“Power off the server” on page 53](#)
2. Any system-board switch or jumper block that is not shown in the illustrations in this document are reserved.

Table 9. **System board switches**

<b>1</b> <a href="#">Table 11 “SW7 switch block” on page 29</a>	<b>3</b> <a href="#">Table 12 “SW9 switch block” on page 30</a>
<b>2</b> <a href="#">Table 10 “SW6 switch block” on page 29</a>	

### SW6 switch block

The following table describes the functions of the SW6 switch block on the system board.

Table 10. **System board SW6 switch block description**

Switch number	Default position	Description	Definition
1	Off	ME security override	Changing this switch to the On position disables ME Security checks.
2	Off	Real time clock (RTC) reset	Changing this switch to the On position resets the RTC. A momentary toggle is all that is required. To avoid excessive CMOS battery drain, do not leave this switch in the On position.
3	Off	Password clear	Changing this switch to the On position overrides the power-on password.
4	Off	ME recovery	Changing this switch to the On position boots ME to recovery
5	Off	Reserved	This switch is reserved for development purpose only. Keep this switch in the Off position.
6	Off	Reserved	This switch is reserved for development purpose only. Keep this switch in the Off position.
7	Off	Reserved	This switch is reserved for development purpose only. Keep this switch in the Off position.
8	Off	Reserved	This switch is reserved for development purpose only. Keep this switch in the Off position.

### SW7 switch block

The following table describes the functions of the SW7 switch block on the system board.

Table 11. **System board SW7 switch block description**

Switch number	Default position	Description	Definition
1	Off	BMC boot primary	Off: XCC boots from upper half of flash region. On: XCC boots from lower half of flash region.
2	Off	XCC force update	Changing this switch to the On position forces XCC to boot from kernel code only.

Table 11. System board SW7 switch block description (continued)

Switch number	Default position	Description	Definition
3	Off	Power permission override	Changing this switch to the On position ignores Power Permission and allows the system to power-on.
4	Off	Force XCC reset	Changing this switch to the On position forces XCC reset.
5	Off	Serial select	Changing this switch to the On position accesses the BMC via the serial port.

### SW9 switch block

The following table describes the functions of the SW9 switch block on the system board.

Table 12. System board SW9 switch block description

Switch number	Default position	Description	Definition
1	Off	Force FPGA reset	Changing this switch to the On position forces FPGA to reset.
2	Off	Force BMC CPU reset	Changing this switch to the On position forces the BMC and CPU to reset.
3	Off	Reserved	This switch is reserved for development purpose only. Keep this switch in the Off position.
4	Off	Reserved	This switch is reserved for development purpose only. Keep this switch in the Off position.

## Server locks

Locking the server cover prevents unauthorized access to the inside of your server and access to the installed drives.

### Server cover and security door lock

The server cover and security door lock prevents unauthorized access to the inside of your server and the installed drives in the drive cage. You can remove the key attached on the rear of the server and use it to unlock or lock the server cover and the security door of the server.

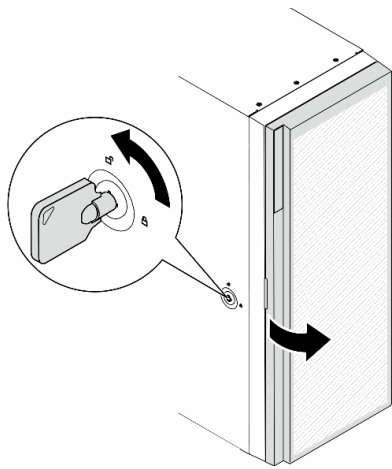

Figure 9. Server cover and security door lock

---

## System LEDs and diagnostics display

See the following section for information on available system LEDs and diagnostics display.

For more information, refer to [“Troubleshooting by system LEDs and diagnostics display”](#) on page 341.



## Chapter 3. Parts list

Identify each of the components that is available for your server with the parts list.

For more information about ordering parts:

1. Go to <http://datacentersupport.lenovo.com> and navigate to the support page for your server.
2. Click **Parts**.
3. Enter the serial number to view a listing of parts for your server.

It is highly recommended that you check the power summary data for your server using Lenovo Capacity Planner before purchasing any new parts.

**Note:** Depending on the model, your server might look slightly different from the illustration.

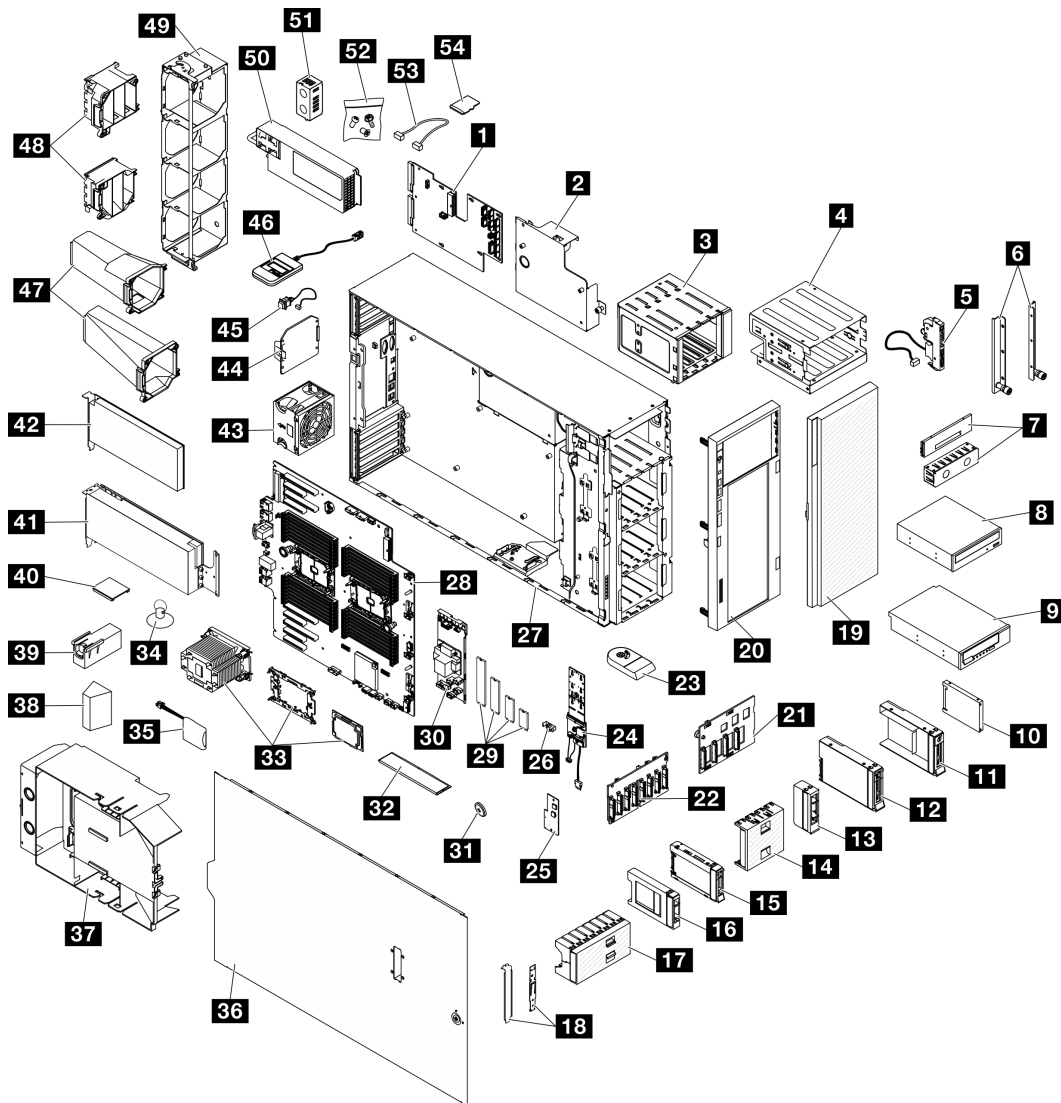

Figure 10. Server components

The parts listed in the following table are identified as one of the following:

- **T1:** Tier 1 customer replaceable unit (CRU). Replacement of Tier 1 CRUs is your responsibility. If Lenovo installs a Tier 1 CRU at your request with no service agreement, you will be charged for the installation.
- **T2:** Tier 2 customer replaceable unit (CRU). You may install a Tier 2 CRU yourself or request Lenovo to install it, at no additional charge, under the type of warranty service that is designated for your server.
- **F:** Field replaceable unit (FRU). FRUs must be installed only by trained service technicians.
- **C:** Consumable and Structural parts. Purchase and replacement of consumable and structural parts (components, such as a filler or bezel) is your responsibility. If Lenovo acquires or installs a structural component at your request, you will be charged for the service.

Table 13. Parts listing

Index	Description	Type
For more information about ordering the parts shown in <a href="#">Figure 10 “Server components” on page 33</a> :		
<a href="http://datacentersupport.lenovo.com/products/servers/thinksystem/st650v3/7d7a/parts">http://datacentersupport.lenovo.com/products/servers/thinksystem/st650v3/7d7a/parts</a>		
It is highly recommended that you check the power summary data for your server using Lenovo Capacity Planner before purchasing any new parts.		
<b>1</b>	Power distribution board	F
<b>2</b>	Power distribution board cover	T1
<b>3</b>	Expansion drive cage	T1
<b>4</b>	Optical drive cage and 5.25-inch drive bay adapter	T1
<b>5</b>	Front I/O module	T1
<b>6</b>	EIA brackets	T1
<b>7</b>	Tape/Optical drive filler cover and tape/optical drive filler	C
<b>8</b>	5.25-inch optical disk drive	T1
<b>9</b>	5.25-inch LTO/RDX tape drive	T1
<b>10</b>	2.5-inch drive	T1
<b>11</b>	3.5-inch drive tray with 2.5-inch to 3.5-inch drive adapter	T1
<b>12</b>	3.5-inch hot-swap drive	T1
<b>13</b>	3.5-inch storage drive filler (single bay)	C
<b>14</b>	3.5-inch storage drive filler (four bays)	C
<b>15</b>	2.5-inch hot-swap drive	T1
<b>16</b>	2.5-inch storage drive filler (single bay)	C
<b>17</b>	2.5-inch storage drive filler (eight bays)	C
<b>18</b>	Bracket kit (drive retainer and PCIe bracket)	T1
<b>19</b>	Security door	T1
<b>20</b>	Front bezel	T1
<b>21</b>	3.5-inch hot-swap drive backplane	T1
<b>22</b>	2.5-inch hot-swap drive backplane	T1

Table 13. Parts listing (continued)

Index	Description	Type
23	Foot stand	C
24	M.2 boot adapter	T1
25	Firmware and RoT security module	F
26	M.2 retainer clip	T1
27	Chassis	F
28	System board	F
29	M.2 drive	T1
30	Internal CFF RAID adapter	T1
31	CMOS battery (CR2032)	C
32	Memory module	T1
33	PHM module (processor, heat sink, and carrier)	F
34	Suction cup (for NVlink bridge)	C
35	Flash power module	T1
36	Server cover	T1
37	Air baffle	T1
38	T4 filler	T1
39	Full-length GPU filler	T1
40	NVLink bridge	T1
41	Full-length GPU adapter	T1
42	PCIe adapter	T1
43	Fan module	T1
44	Fan filler	C
45	Intrusion switch	T1
46	External Diagnostics Handset	T1
47	A2/L4 GPU air ducts	T1
48	Full-length PCIe adapter holder	T1
49	Fan cage	T1
50	Power supply unit	T1
51	PSU filler	C
52	Screw kit	T1
53	Cables	T1
54	MicroSD card	T1

---

## Power cords

Several power cords are available, depending on the country and region where the server is installed.

To view the power cords that are available for the server:

1. Go to:

<http://dcsc.lenovo.com/#/>

2. Click **Preconfigured Model** or **Configure to order**.

3. Enter the machine type and model for your server to display the configurator page.

4. Click **Power** → **Power Cables** to see all line cords.

### Notes:

- For your safety, a power cord with a grounded attachment plug is provided to use with this product. To avoid electrical shock, always use the power cord and plug with a properly grounded outlet.
- Power cords for this product that are used in the United States and Canada are listed by Underwriter's Laboratories (UL) and certified by the Canadian Standards Association (CSA).
- For units intended to be operated at 115 volts: Use a UL-listed and CSA-certified cord set consisting of a minimum 18 AWG, Type SVT or SJT, three-conductor cord, a maximum of 15 feet in length and a parallel blade, grounding-type attachment plug rated 15 amperes, 125 volts.
- For units intended to be operated at 230 volts (U.S. use): Use a UL-listed and CSA-certified cord set consisting of a minimum 18 AWG, Type SVT or SJT, three-conductor cord, a maximum of 15 feet in length and a tandem blade, grounding-type attachment plug rated 15 amperes, 250 volts.
- For units intended to be operated at 230 volts (outside the U.S.): Use a cord set with a grounding-type attachment plug. The cord set should have the appropriate safety approvals for the country in which the equipment will be installed.
- Power cords for a specific country or region are usually available only in that country or region.

---

## Chapter 4. Unboxing and setup

Information in this section assists you on unboxing and setting up the server. When unboxing the server, check if the items in the package are correct, and learn where to find information of server serial number and Lenovo XClarity Controller access. Make sure to follow the instructions in [“Server setup checklist” on page 39](#) when setting up the server.

---

### Server package contents

When you receive your server, verify that the shipment contains everything that you expected to receive.

The server package includes the following items:

- Server
- Rail installation kit\*. Installation guide is provided in the package.
- Material box, including items such as power cords\*, accessory kit, and printed documents.

#### Notes:

- Some of the items listed are available on select models only.
- Items marked with asterisk(\*) are optional.

If any item is missing or damaged, contact your place of purchase. Ensure that you retain your proof of purchase and packing material. They might be required to receive warranty service.

---

### Identify the server and access the Lenovo XClarity Controller

This section contains instruction on how to identify your server and where to find the Lenovo XClarity Controller access information.

#### Identifying your server

When you contact Lenovo for help, the machine type, model, and serial number information help support technicians to identify your server and provide faster service.

The illustration below shows the location of the ID label which contains the model number, machine type, and serial number of the server. You can also add other system information labels to the front of the server in the customer label spaces.

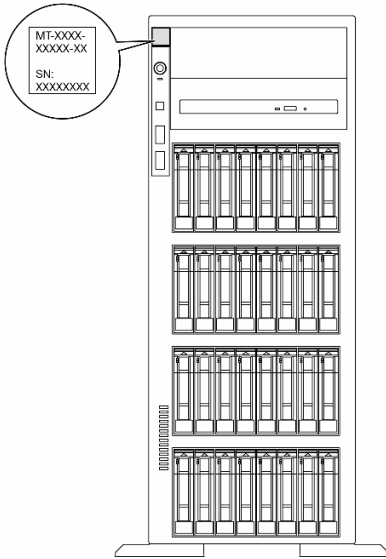

Figure 11. Location of the ID label

### Lenovo XClarity Controller network access label

In addition, the Lenovo XClarity Controller network access label is attached to the front bezel, with MAC address accessible with a pull.

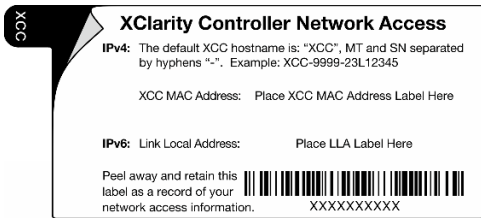

Figure 12. Lenovo XClarity Controller network access label on the pull-out information tab

### Service information QR code

On the surface of the server cover, there is a quick response (QR) code that provides mobile access to service information. You can scan the QR code with a mobile device using a QR code reader application and get quick access to the Service Information web page. The Service Information web page provides additional information for parts installation and replacement videos, and error codes for solution support.

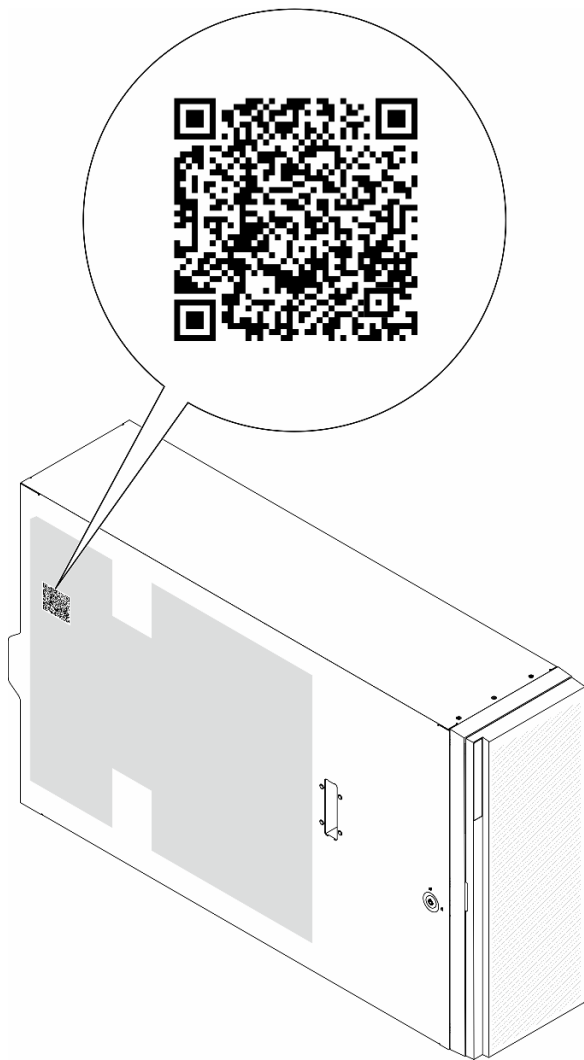

Figure 13. Service information QR code

---

## Server setup checklist

Use the server setup checklist to ensure that you have performed all tasks that are required to set up your server.

The server setup procedure varies depending on the configuration of the server when it was delivered. In some cases, the server is fully configured and you just need to connect the server to the network and an AC power source, and then you can power on the server. In other cases, the server needs to have hardware options installed, requires hardware and firmware configuration, and requires an operating system to be installed.

The following steps describe the general procedure for setting up a server.

### Setup the server hardware

Complete the following procedures to setup the server hardware.

1. Unpack the server package. See [“Server package contents” on page 37](#).
2. Install any required hardware or server options. See the related topics in [Chapter 5 “Hardware replacement procedures” on page 41](#).

3. If necessary, install the rail to a standard rack cabinet. Follow the instruction in *Rail Installation Guide* that comes with the rail installation kit.
4. If necessary, install the server into a standard rack cabinet. See [“Install the server to the rack” on page 59](#).
5. Connect all external cables to the server. See [Chapter 2 “Server components” on page 19](#) for connectors locations.

Typically, you will need to connect the following cables:

- Connect server to the power source
  - Connect server to the data network
  - Connect the server to the storage device
  - Connect the server to the management network
6. Power on the server.

Power button location and power LED are specified in:

- [Chapter 2 “Server components” on page 19](#)
- [“Troubleshooting by system LEDs and diagnostics display” on page 341](#)

The server can be turned on (power LED on) in any of the following ways:

- Press the power button.
- The server can restart automatically after a power interruption.
- The server can respond to remote power-on requests sent to the Lenovo XClarity Controller.

**Note:** You can access the management processor interface to configure the system without powering on the server. Whenever the server is connected to power, the management processor interface is available. For details about accessing the management server processor, see “Opening and Using the XClarity Controller Web Interface” section in the XCC documentation compatible with your server at <https://pubs.lenovo.com/lxcc-overview/>.

7. Validate the server. Make sure that the power LED, Ethernet connector LED, and network LED are lit with green light, which means the server hardware was set up successfully.

See [“System LEDs and diagnostics display” on page 31](#) for more information on the LED indications.

## Configure the system

Complete the following procedures to configure the system. For detailed instructions, refer to [Chapter 7 “System configuration” on page 319](#).

1. Set the network connection for the Lenovo XClarity Controller to the management network.
2. Update the firmware for the server, if necessary.
3. Configure the firmware for the server.

The following information is available for RAID configuration:

- <https://lenovopress.lenovo.com/lp0578-lenovo-raid-introduction>
  - <https://lenovopress.lenovo.com/lp0579-lenovo-raid-management-tools-and-resources>
4. Install the operating system.
  5. Back up the server configuration.
  6. Install the applications and programs for which the server is intended to be used.

---

## Chapter 5. Hardware replacement procedures

This section provides installation and removal procedures for all serviceable system components. Each component replacement procedure references any tasks that need to be performed to gain access to the component being replaced.

---

### Installation Guidelines

Before installing components in your server, read the installation guidelines.

Before installing optional devices, read the following notices carefully:

**Attention:** Prevent exposure to static electricity, which might lead to system halt and loss of data, by keeping static-sensitive components in their static-protective packages until installation, and handling these devices with an electrostatic-discharge wrist strap or other grounding system.

- Read the safety information and guidelines to ensure your safety at work:
  - A complete list of safety information for all products is available at:  
[https://pubs.lenovo.com/safety\\_documentation/](https://pubs.lenovo.com/safety_documentation/)
  - The following guidelines are available as well: “[Handling static-sensitive devices](#)” on page 44.
- Make sure the components you are installing are supported by your server.
  - For a list of supported optional components for the server, see <https://serverproven.lenovo.com>.
  - For the option package contents, see <https://serveroption.lenovo.com/>.
- For more information about ordering parts:
  1. Go to <http://datacentersupport.lenovo.com> and navigate to the support page for your server.
  2. Click **Parts**.
  3. Enter the serial number to view a listing of parts for your server.
- When you install a new server, download and apply the latest firmware. This will help ensure that any known issues are addressed, and that your server is ready to work with optimal performance. Go to <https://datacentersupport.lenovo.com/tw/en/products/servers/thinksystem/st650v3/7d7a/downloads/driver-list/> to download firmware updates for your server.

**Important:** Some cluster solutions require specific code levels or coordinated code updates. If the component is part of a cluster solution, verify the latest Best Recipe code level menu for cluster supported firmware and driver before you update the code.

- If you replace a part, such as an adapter, that contains firmware, you might also need to update the firmware for that part. For more information about updating firmware, see “[Update the firmware](#)” on page 320.
- It is good practice to make sure that the server is working correctly before you install an optional component.
- Keep the working area clean, and place removed components on a flat and smooth surface that does not shake or tilt.
- Do not attempt to lift an object that might be too heavy for you. If you have to lift a heavy object, read the following precautions carefully:
  - Make sure that you can stand steadily without slipping.
  - Distribute the weight of the object equally between your feet.

- Use a slow lifting force. Never move suddenly or twist when you lift a heavy object.
- To avoid straining the muscles in your back, lift by standing or by pushing up with your leg muscles.
- Back up all important data before you make changes related to the disk drives.
- Have a small flat-blade screwdriver, a small Phillips screwdriver, and a T8 torx screwdriver available.
- To view the error LEDs on the system board (system board assembly) and internal components, leave the power on.
- You do not have to turn off the server to remove or install hot-swap power supplies, hot swap fans, or hot-plug USB devices. However, you must turn off the server before you perform any steps that involve removing or installing adapter cables, and you must disconnect the power source from the server before you perform any steps that involve removing or installing a riser card.
- When replacing power supply units or fans, make sure to refer to redundancy rules for these components.
- Blue on a component indicates touch points, where you can grip to remove a component from or install it in the server, open or close a latch, and so on.
- Except PSU, orange on a component or a orange on or near a component indicates that the component can be hot-swapped if the server and operating system support hot-swap capability, which means that you can remove or install the component while the server is still running. (Orange can also indicate touch points on hot-swap components.) See the instructions for removing or installing a specific hot-swap component for any additional procedures that you might have to perform before you remove or install the component.
- PSU with a release tab is a hot-swap PSU.
- The red strip on the drives, adjacent to the release latch, indicates that the drive can be hot-swapped if the server and operating system support hot-swap capability. This means that you can remove or install the drive while the server is still running.

**Note:** See the system specific instructions for removing or installing a hot-swap drive for any additional procedures that you might need to perform before you remove or install the drive.

- After finishing working on the server, make sure you reinstall all safety shields, guards, labels, and ground wires.

## Safety inspection checklist

Use the information in this section to identify potentially unsafe conditions with your server. As each machine was designed and built, required safety items were installed to protect users and service technicians from injury.

**Note:** This device is not intended for use in the direct field of view at visual display workplaces. To avoid incommoding reflections at visual display workplaces, this device must not be placed in the direct field of view.

### CAUTION:

**This equipment must be installed or serviced by trained personnel, as defined by the NEC, IEC 62368-1 & IEC 60950-1, the standard for Safety of Electronic Equipment within the Field of Audio/Video, Information Technology and Communication Technology. Lenovo assumes you are qualified in the servicing of equipment and trained in recognizing hazards energy levels in products. Access to the equipment is by the use of a tool, lock and key, or other means of security, and is controlled by the authority responsible for the location.**

**Important:** Electrical grounding of the server is required for operator safety and correct system function. Proper grounding of the electrical outlet can be verified by a certified electrician.

Use the following checklist to verify that there are no potentially unsafe conditions:

1. Make sure that the power is off and the power cord is disconnected.
2. Check the power cord.
  - Make sure that the third-wire ground connector is in good condition. Use a meter to measure third-wire ground continuity for 0.1 ohm or less between the external ground pin and the frame ground.
  - Make sure that the power cord is the correct type.To view the power cords that are available for the server:
  - a. Go to:
    - <http://dcsc.lenovo.com/#/>
  - b. Click **Preconfigured Model** or **Configure to order**.
  - c. Enter the machine type and model for your server to display the configurator page.
  - d. Click **Power** → **Power Cables** to see all line cords.
- Make sure that the insulation is not frayed or worn.
3. Check for any obvious non-Lenovo alterations. Use good judgment as to the safety of any non-Lenovo alterations.
4. Check inside the server for any obvious unsafe conditions, such as metal filings, contamination, water or other liquid, or signs of fire or smoke damage.
5. Check for worn, frayed, or pinched cables.
6. Make sure that the power-supply cover fasteners (screws or rivets) have not been removed or tampered with.

## System reliability guidelines

Review the system reliability guidelines to ensure proper system cooling and reliability.

Make sure the following requirements are met:

- When the server comes with redundant power, a power supply must be installed in each power-supply bay.
- Adequate space around the server must be spared to allow server cooling system to work properly. Leave approximately 50 mm (2.0 in.) of open space around the front and rear of the server. Do not place any object in front of the fans.
- For proper cooling and airflow, refit the server cover before you turn the power on. Do not operate the server for more than 30 minutes with the server cover removed, for it might damage server components.
- Cabling instructions that come with optional components must be followed.
- A failed fan must be replaced within 48 hours after malfunction.
- A removed hot-swap fan must be replaced within 30 seconds after removal.
- A removed hot-swap drive must be replaced within two minutes after removal.
- A removed hot-swap power supply must be replaced within two minutes after removal.
- Every air baffle that comes with the server must be installed when the server starts (some servers might come with more than one air baffle). Operating the server with a missing air baffle might damage the processor.
- All processor sockets must contain either a socket cover or a processor with heat sink.
- When more than one processor is installed, fan population rules for each server must be strictly followed.

## Handling static-sensitive devices

Review these guidelines before you handle static-sensitive devices to reduce the possibility of damage from electrostatic discharge.

**Attention:** Prevent exposure to static electricity, which might lead to system halt and loss of data, by keeping static-sensitive components in their static-protective packages until installation, and handling these devices with an electrostatic-discharge wrist strap or other grounding system.

- Limit your movement to prevent building up static electricity around you.
- Take additional care when handling devices during cold weather, for heating would reduce indoor humidity and increase static electricity.
- Always use an electrostatic-discharge wrist strap or other grounding system, particularly when working inside the server with the power on.
- While the device is still in its static-protective package, touch it to an unpainted metal surface on the outside of the server for at least two seconds. This drains static electricity from the package and from your body.
- Remove the device from the package and install it directly into the server without putting it down. If it is necessary to put the device down, put it back into the static-protective package. Never place the device on the server or on any metal surface.
- When handling a device, carefully hold it by the edges or the frame.
- Do not touch solder joints, pins, or exposed circuitry.
- Keep the device from others' reach to prevent possible damages.

---

## Memory module installation rules and order

Memory modules must be installed in a specific order based on the memory configuration that you implement and the number of processors and memory modules installed in the server.

### Supported memory types

For information on the types of memory module supported by this server, see “Memory” section in [“Technical specifications” on page 5](#).

Information about optimizing memory performance and configuring memory is available at the Lenovo Press website:

<https://lenovopress.lenovo.com/servers/options/memory>

In addition, you can take advantage of a memory configurator, which is available at the following site:

[https://dcsc.lenovo.com/#/memory\\_configuration](https://dcsc.lenovo.com/#/memory_configuration)

Shown below is the specific information about the installation rules and order of memory modules required in ThinkSystem ST650 V3 based on the system configuration and memory mode.

## Memory modules and processors layout

The memory-channel configuration table below shows the relationship between the processors, memory controllers, memory channels, and memory module slot numbers.

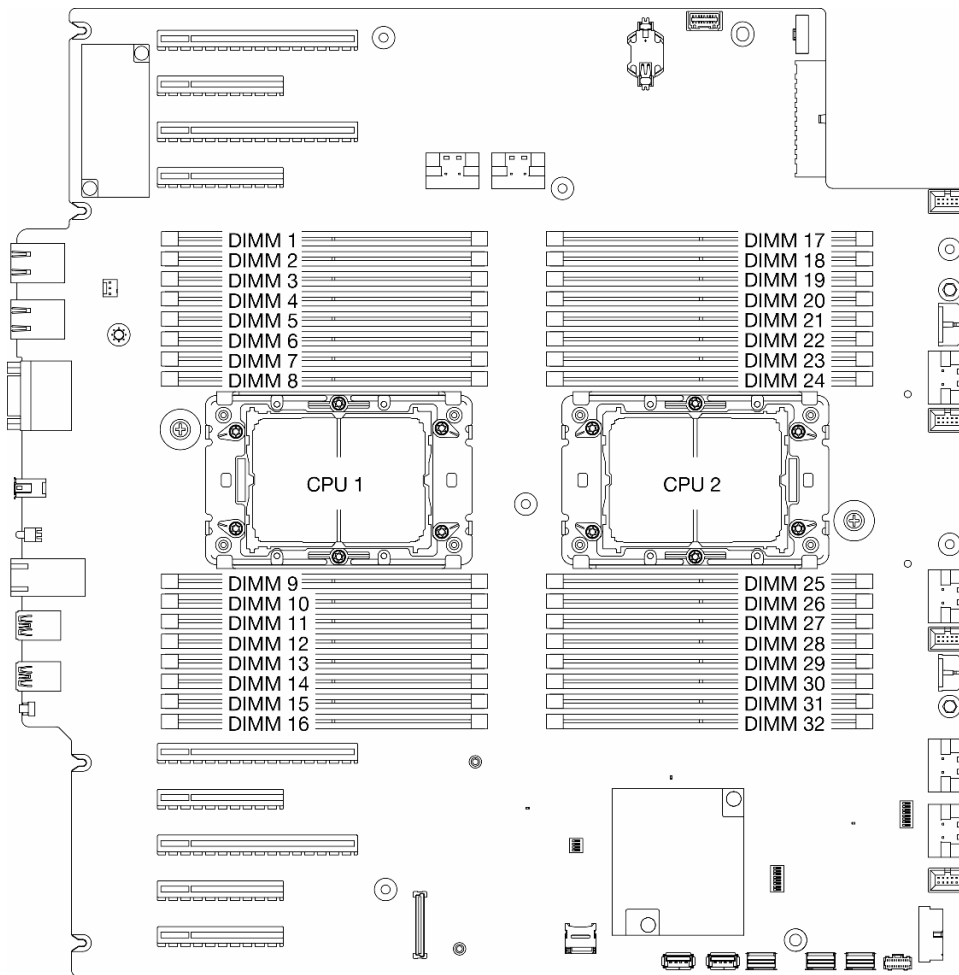

Figure 14. Memory modules and processors layout

Table 14. Memory slot and channel identification

Processor	CPU 1															
	CH1 (7/H)		CH0 (6/G)		CH1 (5/F)		CH0 (4/E)		CH0 (0/A)		CH1 (1/B)		CH0 (2/C)		CH1 (3/D)	
Slot No.	0	1	0	1	0	1	0	1	1	0	1	0	1	0	1	0
DIMM No.	1	2	3	4	5	6	7	8	9	10	11	12	13	14	15	16
Processor	CPU 2															
	CH1 (7/H)		CH0 (6/G)		CH1 (5/F)		CH0 (4/E)		CH0 (0/A)		CH1 (1/B)		CH0 (2/C)		CH1 (3/D)	
Slot No.	0	1	0	1	0	1	0	1	1	0	1	0	1	0	1	0

Table 14. Memory slot and channel identification (continued)

Processor	CPU 2															
Channel	CH1 (7/H)		CH0 (6/G)		CH1 (5/F)		CH0 (4/E)		CH0 (0/A)		CH1 (1/B)		CH0 (2/C)		CH1 (3/D)	
DIMM No.	32	31	30	29	28	27	26	25	24	23	22	21	20	19	18	17

**Notes:**

- Slot No.: DIMM slot number in each memory channel. Each memory channel has two DIMM slots: slot 0 (farthest from the processor) and slot 1 (closest to the processor).
- DIMM No.: DIMM slot number on the system board. Each processor has 16 DIMM slots.

**Memory module installation guideline**

- The following memory configurations and population sequences are supported on ThinkSystem ST650 V3:
  - [“DRAM DIMM installation order” on page 47](#) (RDIMMs or 3DS RDIMMs)
- At least one DIMM is required for each processor. Install at least eight DIMMs per processor for good performance.
- When a DIMM is replaced, the server provides automatic DIMM enablement capability without requiring you to use the Setup Utility to enable the new DIMM manually.

**DRAM DIMM installation order**

Follow the instructions in this section to install DRAM DIMMs properly.

**Independent memory mode**

In independent memory mode, memory channels can be populated with DIMMs in any order. All channels for each processor can be populated in any order with no matching requirements. Independent memory mode provides the highest level of memory performance but lacks failover protection. The DIMM installation order for the independent memory mode varies based on the number of processors and memory modules installed in the server.

**Memory module installation order in independent mode**

Follow the rules below when installing memory modules in independent mode:

- All memory modules must be DDR5 memory modules.
- At least one DDR5 DIMM is required per installed processor.
- All DDR5 DIMM must operate at the same speed in the same system.
- Memory population must be identical between processors.
- Memory modules from different vendors are supported.
- In each memory channel, populate the slot farthest from the processor (slot 0) first.
- x8 DIMMs and x4 DIMMs cannot be mixed in a system.
- All memory modules to be installed must be of the same type.
  - 9x4 RDIMM cannot be mixed with non-9x4 RDIMMs in a system.
  - 3DS RDIMM cannot be mixed with non-3DS RDIMMs in a system.
- All memory modules in a system must have the same number of ranks, except for the conditions below:
  - Single-ranked RDIMMS can be mixed with dual-rank RDIMMs when there are 16 DIMMs populated for each processor (i.e., either 16 or 32 DIMMs in total).

**Note:** System hang on POST may occur on a server operation in this configuration. In this case, contact Lenovo service to replace the failed DIMM for proper operation.

- See [“Independent memory mode with mixing ranks”](#) on page 50 for more information on the installation sequence when installing memory modules with different ranks.
- 4800 MHz memory is only supported with 4th Gen Intel Xeon Scalable processors. 5600 MHz memory is only supported with 5th Gen Intel Xeon Scalable processors.
- Mixing 16Gbit-based (16 GB/32 GB/64 GB/128 GB), 24Gbit-based (48 GB/96 GB), 32Gbit-based (128 GB) memory module is not allowed in a system.
- Before installing 24 Gb DRAM RDIMMs to a system with 4th Gen Intel Xeon processors, make sure to update the UEFI firmware to the latest version first, then remove all existing 16 Gb DRAM RDIMMs.

### With one processor

Table 15. Independent memory mode with one processor

Processor 1																
Total DIMMs	1	2	3	4	5	6	7	8	9	10	11	12	13	14	15	16
<b>1</b> DIMM <sup>6,7</sup>										10						
<b>2</b> DIMMs <sup>1,4,5,6,7</sup>			3							10						
<b>4</b> DIMMs <sup>1,4,5,6,7</sup>			3				7			10				14		
<b>6</b> DIMMs <sup>1,6,7</sup>			3		5		7			10				14		16
<b>8</b> DIMMs <sup>1,2</sup>	1		3		5		7			10		12		14		16
<b>12</b> DIMMs <sup>1,5,6,7</sup>	1		3	4	5		7	8	9	10		12	13	14		16
<b>16</b> DIMMs <sup>1,2,3,5,7</sup>	1	2	3	4	5	6	7	8	9	10	11	12	13	14	15	16

### Notes:

1. Sub NUMA Clustering (SNC2) feature can only be enabled when DIMMs are populated in this specified sequence. The SNC2 feature can be enabled via UEFI.
2. DIMM configurations that support Software Guard Extensions (SGX), see [“Enable Software Guard Extensions \(SGX\)”](#) on page 325 to enable this feature.
3. In ThinkSystem ST650 V3, rank mixing is supported between single-rank and dual-rank RDIMMs when there are 16 DIMMs populated for each processor. See [“Independent memory mode with mixing ranks”](#) on page 50 for more information on the installation sequence when installing memory modules with different ranks.
4. This configuration does not support 24Gbit (96 GB) DIMMs (for 5th Gen Intel processors).
5. This configuration does not support 24Gbit (48 GB) DIMMs (for 5th Gen Intel processors).
6. This configuration does not support 24Gbit (96 GB) DIMMs (for 4th Gen Intel processors)
7. This configuration does not support 24Gbit (48 GB) DIMMs (for 4th Gen Intel processors)

**With two processors**

Table 16. Independent mode with two processors

Processor 1																
Total DIMMs	1	2	3	4	5	6	7	8	9	10	11	12	13	14	15	16
2 DIMMs <sup>1</sup>										10						
4 DIMMs <sup>1</sup>			3							10						
8 DIMMs <sup>1,2</sup>			3				7			10				14		
12 DIMMs <sup>1</sup>			3		5		7			10				14		16
16 DIMMs <sup>1,2</sup>	1		3		5		7			10		12		14		16
24 DIMMs	1		3	4	5		7	8	9	10		12	13	14		16
32 DIMMs <sup>1,2</sup>	1	2	3	4	5	6	7	8	9	10	11	12	13	14	15	16
Processor 2																
Total DIMMs	32	31	30	29	28	27	26	25	24	23	22	21	20	19	18	17
2 DIMMs <sup>1,6,7</sup>										23						
4 DIMMs <sup>1,4,5,6,7</sup>			30							23						
8 DIMMs <sup>1,2,4,5,6,7</sup>			30				26			23				19		
12 DIMMs <sup>1,6,7</sup>			30		28		26			23				19		17
16 DIMMs <sup>1</sup>	32		30		28		26			23		21		19		17
24 DIMMs <sup>5,6,7</sup>	32		30	29	28		26	25	24	23		21	20	19		17
32 DIMMs <sup>1,2,3,5,7</sup>	32	31	30	29	28	27	26	25	24	23	22	21	20	19	18	17

**Notes:**

1. Sub NUMA Clustering (SNC2) feature can only be enabled when DIMMs are populated in this specified sequence. The SNC2 feature can be enabled via UEFI.

2. DIMM configurations that support Software Guard Extensions (SGX), see [“Enable Software Guard Extensions \(SGX\)” on page 325](#) to enable this feature.
3. In ThinkSystem ST650 V3, rank mixing is supported between single-rank and dual-rank RDIMMs when there are 16 DIMMs populated for each processor. See [“Independent memory mode with mixing ranks” on page 50](#) for more information on the installation sequence when installing memory modules with different ranks.
4. This configuration does not support 24Gbit (96 GB) DIMMs (for 5th Gen Intel processors).
5. This configuration does not support 24Gbit (48 GB) DIMMs (for 5th Gen Intel processors).
6. This configuration does not support 24Gbit (96 GB) DIMMs (for 4th Gen Intel processors)
7. This configuration does not support 24Gbit (48 GB) DIMMs (for 4th Gen Intel processors)

### Independent memory mode with mixing ranks

Follow the memory module installation sequence in this section when installing memory modules with different ranks in independent memory mode.

- Single-ranked RDIMMS can be mixed with dual-rank RDIMMs when there are 16 DIMMs populated for each processor (i.e., either 16 or 32 DIMMs in total).
- If a memory channel has two DIMMs with different ranks, populate the DIMM with the higher number of rank in slot 0 (farthest from the processor) first.

### With one processor

When installing DIMMs with different ranks with only one processor (Processor 1) installed, follow the sequence below and install higher rank DIMMs first; then, install the lower rank DIMMs into the remaining slots.

Table 17. Mixed-Rank DIMM slot installation sequence with one processor

Processor 1																
Total DIMMs	1	2	3	4	5	6	7	8	9	10	11	12	13	14	15	16
8 Dual-rank DIMMs	D <sup>2</sup>		D <sup>2</sup>		D <sup>2</sup>		D <sup>2</sup>			D <sup>2</sup>		D <sup>2</sup>		D <sup>2</sup>		D <sup>2</sup>
8 Single-rank DIMMs		S <sup>1</sup>		S <sup>1</sup>		S <sup>1</sup>		S <sup>1</sup>	S <sup>1</sup>		S <sup>1</sup>		S <sup>1</sup>		S <sup>1</sup>	

### Notes:

1. S: Single-rank RDIMM
2. D: Dual-rank RDIMM

### With two processors

When installing DIMMs with different ranks with two processors installed, follow the sequence below and install higher rank DIMMs first; then, install the lower rank DIMMs into the remaining slots.

Table 18. Mixed-Rank DIMM slot installation sequence with two processors

Processor 1																
Total DIMMs	1	2	3	4	5	6	7	8	9	10	11	12	13	14	15	16
16 Dual-rank DIMMs	D <sup>2</sup>		D <sup>2</sup>		D <sup>2</sup>		D <sup>2</sup>			D <sup>2</sup>		D <sup>2</sup>		D <sup>2</sup>		D <sup>2</sup>
16 Single-rank DIMMs		S <sup>1</sup>		S <sup>1</sup>		S <sup>1</sup>		S <sup>1</sup>	S <sup>1</sup>		S <sup>1</sup>		S <sup>1</sup>		S <sup>1</sup>	
Processor 2																
Total DIMMs	32	31	30	29	28	27	26	25	24	23	22	21	20	19	18	17
16 Dual-rank DIMMs	D <sup>2</sup>		D <sup>2</sup>		D <sup>2</sup>		D <sup>2</sup>			D <sup>2</sup>		D <sup>2</sup>		D <sup>2</sup>		D <sup>2</sup>
16 Single-rank DIMMs		S <sup>1</sup>		S <sup>1</sup>		S <sup>1</sup>		S <sup>1</sup>	S <sup>1</sup>		S <sup>1</sup>		S <sup>1</sup>		S <sup>1</sup>	

**Notes:**

1. S: Single-rank RDIMM
2. D: Dual-rank RDIMM

**Memory mirroring mode**

Memory-mirroring mode provides full memory redundancy while reducing the total system memory capacity in half. Memory channels are grouped in pairs with each channel receiving the same data. If a failure occurs, the memory controller switches from the DIMMs on the primary channel to the DIMMs on the backup channel. The DIMM installation order for memory mirroring varies based on the number of processors and DIMMs installed in the server.

**Attention:** Memory mirroring guidelines for :

- Mirroring can be configured across two channels within M2M/iMC complex.
- The total DDR5 memory size of the primary and secondary channels must be the same.
- 9x4 RDIMMs (Value RDIMM) do not support mirroring mode
- Each DIMM must be identical in size and architecture.
- DIMMs on each memory channel must be of equal density.
- If two memory channels have DIMMs, mirroring occurs across two DIMMs (channels 0/1 will both contain the primary/secondary memory caches).
- If three memory channels have DIMMs, mirroring occurs across all three DIMMs (channels 0/1, channels 1/2, and channels 2/0 will all contain primary/secondary memory caches).
- Partial Memory Mirroring is a sub-function of memory mirroring. It requires following the memory installation order of memory mirroring mode.

Channels	Channel 0				Channel 1			
Slots	Slot 1		Slot 0		Slot 1		Slot 0	
Identical DDR5 DIMM installation required								
Identical DDR5 DIMM installation required for full channel mirroring	Y	Y	Y	Y	Y	Y	Y	Y

### Mirror memory mode with one processor

Table 19. Mirror mode with one processor

Total DIMMs	Processor 1																Total DIMMs
	1	2	3	4	5	6	7	8	9	10	11	12	13	14	15	16	
8 <sup>1</sup>	1		3		5		7			10		12		14		16	8*
16 <sup>1,2</sup>	1	2	3	4	5	6	7	8	9	10	11	12	13	14	15	16	16*

#### Notes:

1. Sub NUMA Clustering (SNC2) feature can only be enabled when DIMMs are populated in this specified sequence. The SNC2 feature can be enabled via UEFI.
2. This configuration does not support 24Gbit (48 GB) DIMMs (for 5th Gen Intel processors).

### Mirror memory mode with two processors

Table 20. Mirror mode with two processors (Processor 1)

Total DIMMs	Processor 1																Total DIMMs
	1	2	3	4	5	6	7	8	9	10	11	12	13	14	15	16	
16 <sup>1</sup>	1		3		5		7			10		12		14		16	16*
32 <sup>1</sup>	1	2	3	4	5	6	7	8	9	10	11	12	13	14	15	16	32*

Table 21. Mirror mode with two processors (Processor 2)

Total DIMMs	Processor 2																Total DIMMs
	32	31	30	29	28	27	26	25	24	23	22	21	20	19	18	17	
16 <sup>1</sup>	32		30		28		26			23		21		19		17	16*
32 <sup>1,2</sup>	32	31	30	29	28	27	26	25	24	23	22	21	20	19	18	17	32*

#### Notes:

1. Sub NUMA Clustering (SNC2) feature can only be enabled when DIMMs are populated in this specified sequence. The SNC2 feature can be enabled via UEFI.
2. This configuration does not support 24Gbit (48 GB) DIMMs (for 5th Gen Intel processors).

## Power on and power off the server

Follow the instructions in this section to power on and power off the server.

### Power on the server

After the server performs a short self-test (power status LED flashes quickly) when connected to input power, it enters a standby state (power status LED flashes once per second).

Power button location and power LED are specified in:

- [Chapter 2 “Server components” on page 19](#)
- [“Troubleshooting by system LEDs and diagnostics display” on page 341](#)

The server can be turned on (power LED on) in any of the following ways:

- Press the power button.
- The server can restart automatically after a power interruption.
- The server can respond to remote power-on requests sent to the Lenovo XClarity Controller.

For information about powering off the server, see [“Power off the server” on page 53](#).

## Power off the server

The server remains in a standby state when it is connected to a power source, allowing the Lenovo XClarity Controller to respond to remote power-on requests. To remove all power from the server (power status LED off), make sure all power cables are disconnected.

Power button location and power LED are specified in:

- [Chapter 2 “Server components” on page 19](#)
- [“Troubleshooting by system LEDs and diagnostics display” on page 341](#)

To place the server in a standby state (power status LED flashes once per second):

**Note:** The Lenovo XClarity Controller can place the server in a standby state as an automatic response to a critical system failure.

- Start an orderly shutdown using the operating system (if supported by the operating system).
- Press the power button to start an orderly shutdown (if supported by the operating system).
- Press and hold the power button for more than 4 seconds to force a shutdown.

### Important:

- When in a standby state, the server can respond to remote power-on requests sent to the Lenovo XClarity Controller. For information about powering on the server, see [“Power on the server” on page 52](#).
- When the ambient temperature is greater than supported temperature, the server will shut down. The server will not power on again until the ambient temperature is back to within the supported temperature range.
- When the system is powered off but still plugged in to AC power, the fan in slot 4 may continue to spin at a much lower speed. This is the system design to provide proper cooling.

---

## Server replacement

Follow the instructions in this section to remove the server from and install it onto the rack, as well as to remove and install the tower-to-rack conversion kit.

**Note:** The ThinkSystem ST650 V3 server is designed to support both tower and rack form factors. The chapter includes both steps of removing and installing the tower-to-rack conversion kit from and to the server, and steps of removing and installing the rack-form server from and to the rack.

### Remove the server from the rack

Follow the instructions in this section to remove the server from the rails of the rack and, optionally, remove the tower-to-rack conversion kit.

#### S002



#### **CAUTION:**

The power-control button on the device and the power switch on the power supply do not turn off the electrical current supplied to the device. The device also might have more than one power cord. To remove all electrical current from the device, ensure that all power cords are disconnected from the power source.

#### R006



#### **CAUTION:**

Do not place any object on top of a rack-mounted device unless that rack-mounted device is intended for use as a shelf.

### About this task

#### **Attention:**

- Read [“Installation Guidelines” on page 41](#) and [“Safety inspection checklist” on page 42](#) to ensure that you work safely.
- Power off the server and disconnect all power cords for this task. See [“Power off the server” on page 53](#).

### Procedure

Step 1. Loosen the captive screws.

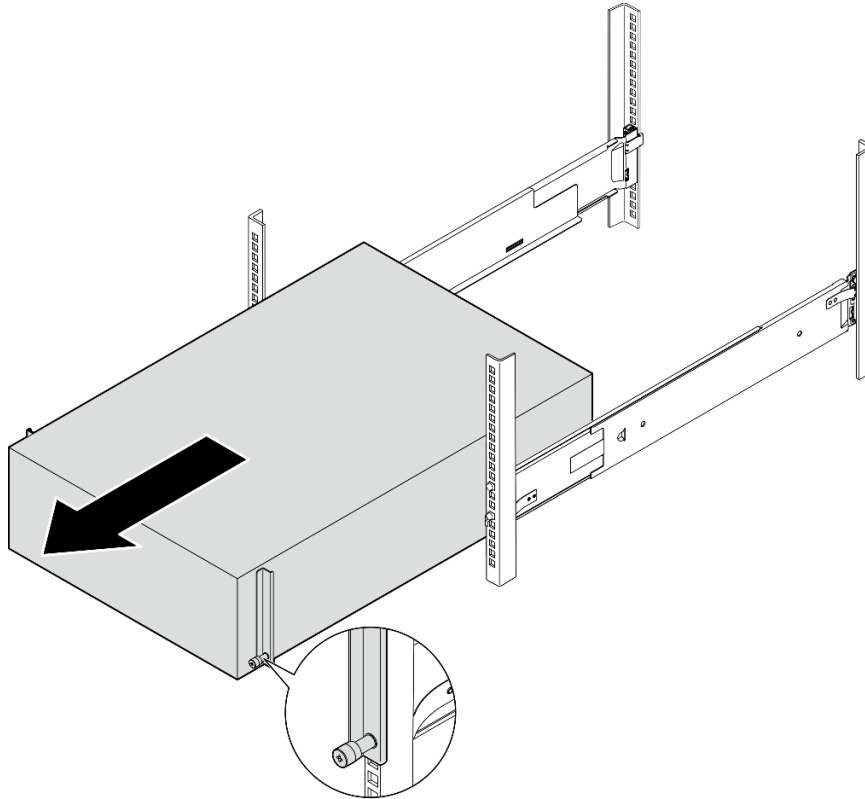

**CAUTION:**  
Drop hazard.



**CAUTION:**  
For tower server removal, use safe practices when lifting.

*Figure 15. Removal of the tower server from the rails*

- Step 2. Slightly pull the chassis out of the rack; then, carefully remove it from the rails gripping the server at sides and adjusting hands as needed.
- Step 3. Carefully lay the server on a flat, static-protective surface.
- Step 4. (Optional) If necessary, remove the tower-to-rack conversion kit (the EIA brackets) from the chassis.
  - a. Lay the server on its side.
  - b. Loosen the three screws at sides to remove the right EIA bracket.

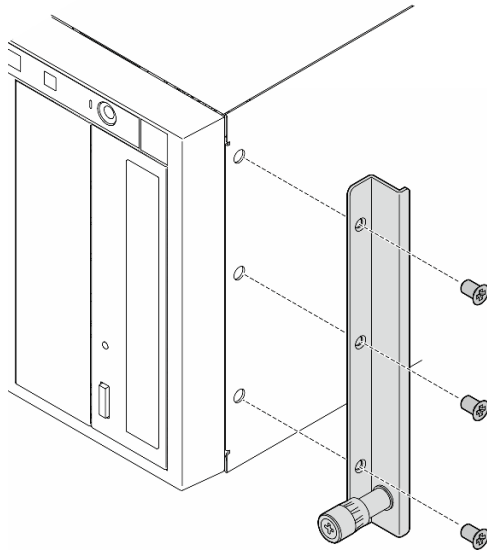

Figure 16. Removal of the right EIA bracket

- c. Use a screwdriver to remove the three screws that secure the left EIA bracket; then, remove the left EIA bracket.

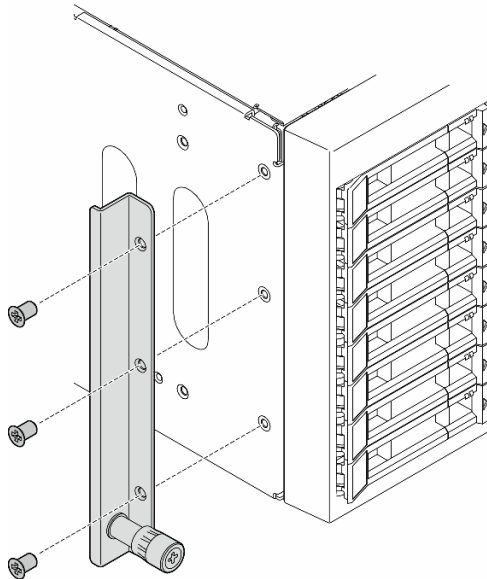
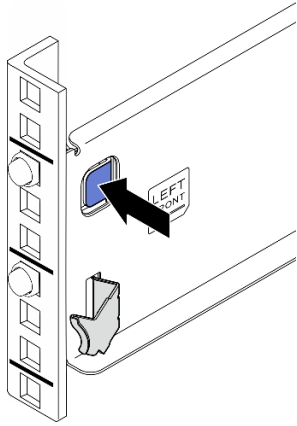

Figure 17. Removal of the left EIA bracket

Step 5. (Optional) If necessary, remove the rails from the rack.

**Note:** For tower server installation, the edges on the rails or the friction caused by the installation might scratch or damage the chassis coating. Applying rail and latch covers can help reduce scratching when installing the server into a rack.

- a. Press and hold the blue button on the front end of the rail to release the front latch gripping the rack flange; then, slightly push the rail towards the rear until the pins disengage from the holes in the EIA flange.



*Figure 18. Releasing rail from front mounting flange*

- b. Hold the rail with one hand and pull the rear latch with your other hand to release the rail from the rear mounting flange; then, remove the rail from the rack.

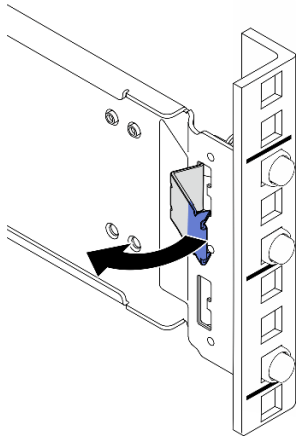

*Figure 19. Releasing rail from rear mounting flange*

- c. Repeat the previous two steps on the other rail to remove it from the rack.

Step 6. (Optional) If necessary, remove the latch covers and rail cover strips from the rails.

- a. Remove the left latch cover from the front latch of the left rail.

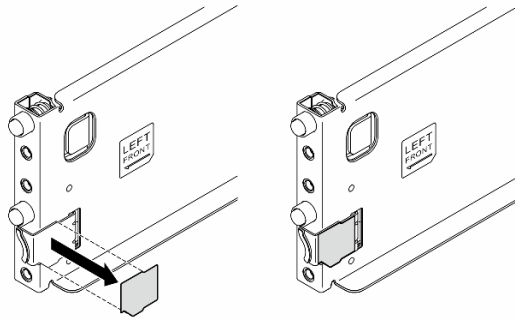

Figure 20. Removal of the left latch cover

- b. Remove the rail cover strip from the bottom surface of the left rail.

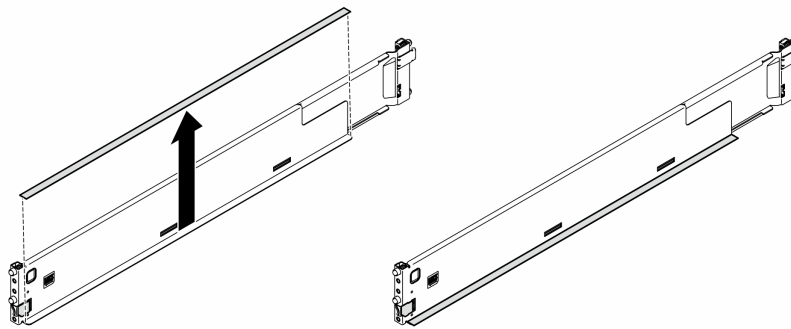

Figure 21. Removal of the left rail cover strip

- c. Repeat the previous two steps for the right rail.

### After this task is completed

1. Carefully lay the server on a flat, static-protective surface.
2. If you are instructed to return the component or optional device, follow all packaging instructions, and use any packaging materials for shipping that are supplied to you.
3. To convert the server to the tower form factor, install the foot stands. See [“Install the foot stands” on page 106](#).

## Install the server to the rack

Follow the instructions in this section to install the tower-to-rack conversion kit to the server, if necessary, and then the server to the rails on the rack.

### About this task

#### S002

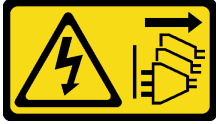

#### **CAUTION:**

The power-control button on the device and the power switch on the power supply do not turn off the electrical current supplied to the device. The device also might have more than one power cord. To remove all electrical current from the device, ensure that all power cords are disconnected from the power source.

#### **Attention:**

- Read [“Installation Guidelines” on page 41](#) and [“Safety inspection checklist” on page 42](#) to ensure that you work safely.
- Power off the server and disconnect all power cords for this task. See [“Power off the server” on page 53](#).
- Prevent exposure to static electricity, which might lead to system halt and loss of data, by keeping static-sensitive components in their static-protective packages until installation, and handling these devices with an electrostatic-discharge wrist strap or other grounding system.

Step 1. If necessary, install the tower-to-rack conversion kit, including the EIA brackets and the rail and latch covers.

**Note:** For tower server installation, the edges on the rails or the friction caused by the installation might scratch or damage the chassis coating. Applying rail and latch covers can help reduce scratching when installing the server into a rack.

- a. Align the holes in the right EIA bracket with the corresponding holes on the top of the chassis; then, install the three screws to secure the right EIA bracket

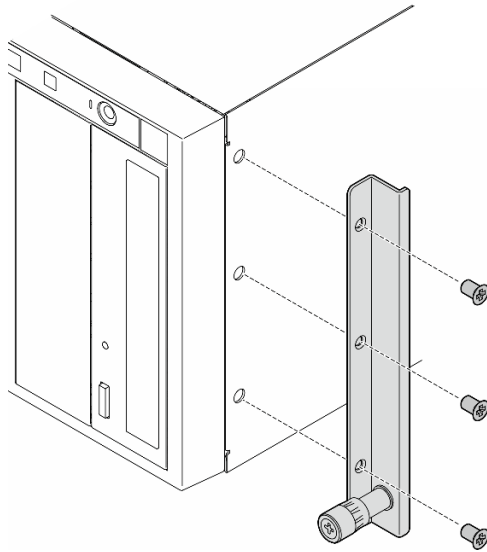

Figure 22. Installation of the right EIA bracket

- b. Align the holes in the left EIA bracket with the corresponding holes on the bottom of the chassis; then, install the three screws to secure the left EIA bracket.

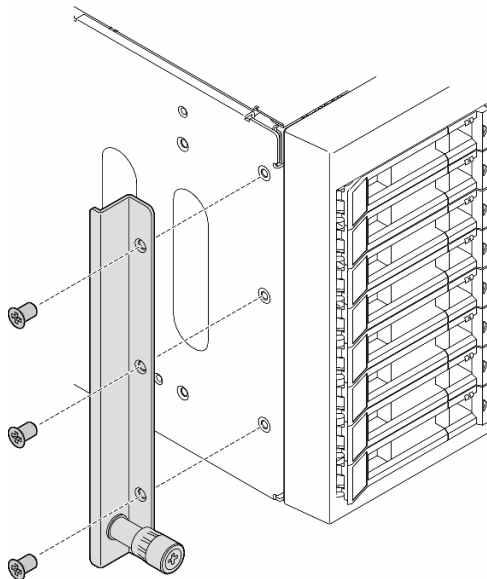

Figure 23. Installation of the left EIA bracket

- c. Peel off the wrapping plastic and apply the left latch cover to the front latch of the left rail.

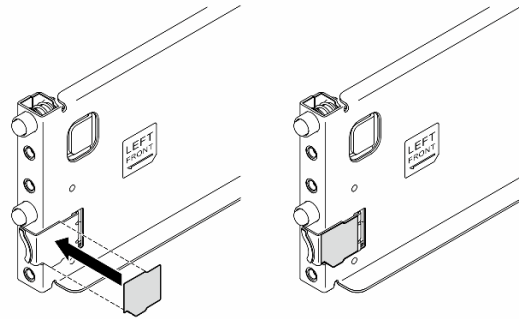

Figure 24. Applying the left latch cover

- d. Peel off the wrapping plastic and apply one rail cover strip to the bottom surface of the left rail.

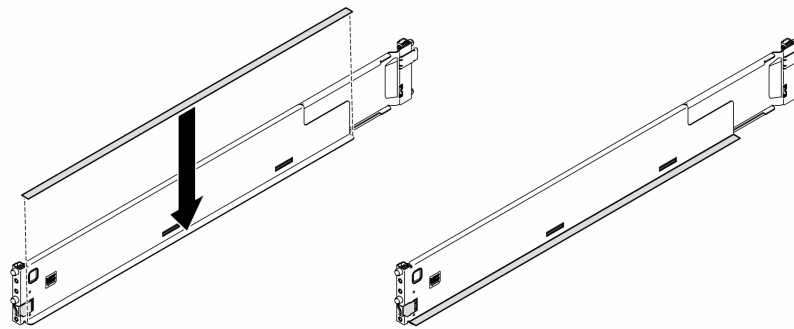

Figure 25. Applying the left rail cover strip

- e. Repeat the previous two steps for the right rail.

Step 2. If necessary, install the rails to the rack.

- a. Grab the rear end of one rail and compress it to the minimal length.

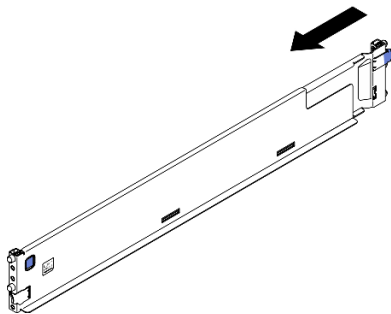

Figure 26. Shorten the rail

- b. Align the rear end of the rail with the holes in the rear EIA flanges; then, push the rail until the latch clicks into place around the edge of the EIA flange.

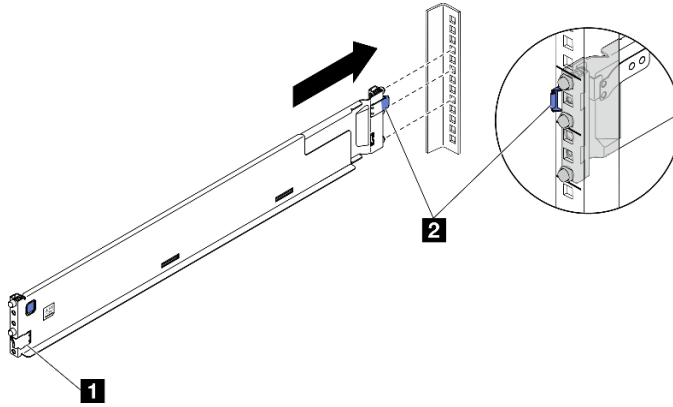

Figure 27. Installation of the rear end of the rail

1 Front latch	2 Rear latch
---------------	--------------

- c. Install the front end of the rail.
1. 1 Pull the rail towards the front.
  2. 2 Press and hold the blue button to open the front latch.
  3. 3 Align the pins on the front end of the rail with the holes in the front EIA flange and pull the rail forward; then, release the blue button so the latch catches over the EIA flange.

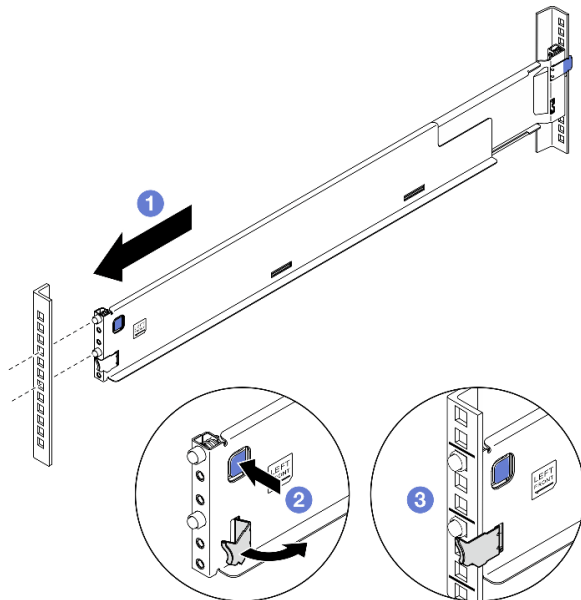
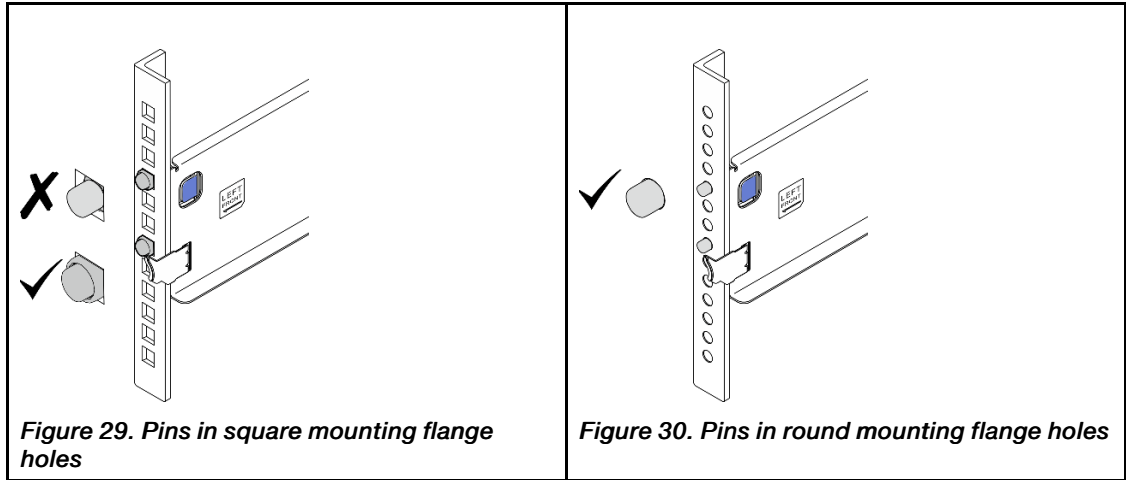

Figure 28. Installation of the front end of the rail

**Note:** To make sure the rails are secured to square hole racks, examine the pins to see if the collars are fully in the mounting flange holes. If not, gently shake the rails until all the collars are visible in the mounting flange holes. Examine both ends to make sure the rails are secured.

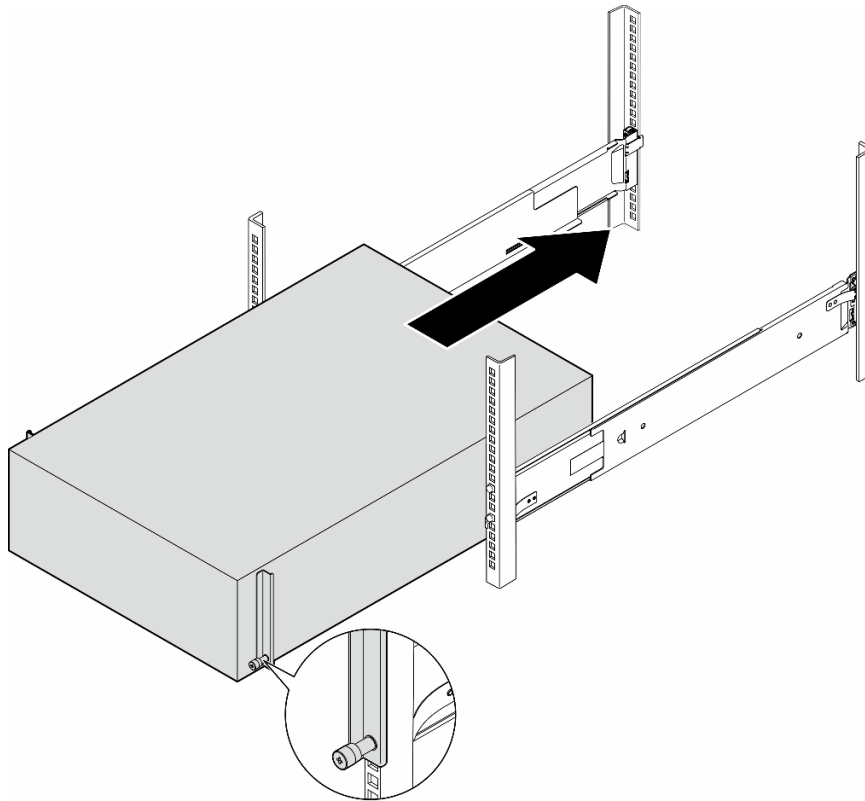

**Figure 29. Pins in square mounting flange holes**

**Figure 30. Pins in round mounting flange holes**

d. Repeat the previous three steps on the other rail.

Step 3. Align and place the chassis onto the rails mounted in the rack; then, slide it into the rack.



**Figure 31. Installation of the server into the rails**



**CAUTION:**  
For tower server installation, use safe practices when lifting.

Step 4. Secure the captive screws.

Step 5. Reinstall all the server components that have been removed.

## After this task is completed

1. Reconnect the power cords and any cables that were removed.
2. Power on the server and any peripheral devices. See [“Power on the server” on page 52](#).
3. Update the server configuration. See [“Complete the parts replacement” on page 233](#).

---

## 2.5-inch drive backplane replacement

Follow the instructions in this section to remove or install a 2.5-inch drive backplane.

**Note:** This topic applies only to server models with 2.5-inch drive backplanes installed.

### Remove a 2.5-inch drive backplane

Follow the instructions in this section to remove a 2.5-inch drive backplane.

#### About this task

##### S002



#### **CAUTION:**

The power-control button on the device and the power switch on the power supply do not turn off the electrical current supplied to the device. The device also might have more than one power cord. To remove all electrical current from the device, ensure that all power cords are disconnected from the power source.

#### **Attention:**

- Read [“Installation Guidelines” on page 41](#) and [“Safety inspection checklist” on page 42](#) to ensure that you work safely.
- Power off the server and disconnect all power cords for this task. See [“Power off the server” on page 53](#).
- Prevent exposure to static electricity, which might lead to system halt and loss of data, by keeping static-sensitive components in their static-protective packages until installation, and handling these devices with an electrostatic-discharge wrist strap or other grounding system.
- If the server is in a rack, remove it from the rack.
- If foot stands are installed on the server, pivot them inwards and lay the server on its side for easier operation.

#### **Procedure**

Step 1. Make preparations for this task.

- a. Remove all installed drives and drive bay fillers (if any) from the drive bays. See [“Remove a hot-swap drive” on page 81](#).
- b. Remove the server cover. See [“Remove the server cover” on page 230](#).

Step 2. Disconnect all cables from the backplane.

Step 3. Remove the backplane.

- a. ① Lift the release tabs to disengage the backplane.
- b. ② Pivot the backplane slightly backward to release it from two pins on the chassis.
- c. ③ Remove the backplane from the drive cage.

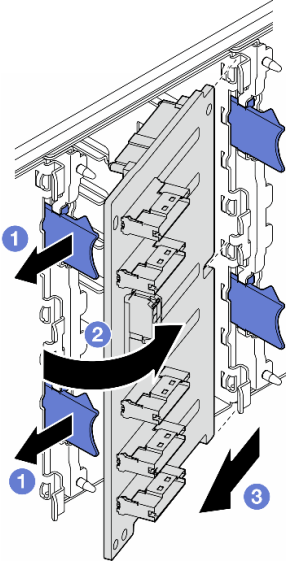

Figure 32. Removal of a 2.5-inch drive backplane

### After this task is completed

1. Install the replacement unit(s), if necessary. See “[Install a 2.5-inch drive backplane](#)” on page 65.
2. If you are instructed to return the component or optional device, follow all packaging instructions, and use any packaging materials for shipping that are supplied to you.

### Demo video

[Watch the procedure on YouTube](#)

## Install a 2.5-inch drive backplane

Follow the instructions in this section to install a 2.5-inch hot-swap drive backplane.

### About this task

**S002**



**CAUTION:**

**The power-control button on the device and the power switch on the power supply do not turn off the electrical current supplied to the device. The device also might have more than one power cord. To remove all electrical current from the device, ensure that all power cords are disconnected from the power source.**

**Attention:**

- Read [“Installation Guidelines” on page 41](#) and [“Safety inspection checklist” on page 42](#) to ensure that you work safely.
- Power off the server and disconnect all power cords for this task. See [“Power off the server” on page 53](#).
- Prevent exposure to static electricity, which might lead to system halt and loss of data, by keeping static-sensitive components in their static-protective packages until installation, and handling these devices with an electrostatic-discharge wrist strap or other grounding system.

**Notes:**

- The server supports up to four 2.5-inch hot-swap drive backplanes.
- See [“Technical rules for system fans” on page 95](#) for detailed information about the storage limitations in different server configurations.
- Before installing the drive backplane:
  1. Determine the location of the backplanes to be installed. Backplanes are installed in the following order:
    - The installation priority of different backplane types is: NVMe > AnyBay > SAS/SATA.
    - The installation order of SAS/SATA backplanes is Backplane 1 > Backplane 2 > Backplane 3 > Backplane 4, from bottom to top when viewed from the front of the server.
    - The installation order of NVMe backplanes is Backplane 4 > Backplane 3 > Backplane 2, from top to bottom when viewed from the front of the server.

**Note:** Depending on models, the server supports up to three 2.5-inch NVMe backplanes.

- The server supports up to one AnyBay backplane. The location of the AnyBay backplane follows the rules below:
  - Install the AnyBay backplane to the first available drive cage counted from top when viewed from the front of the server.
    - When one AnyBay backplane mixes with SAS/SATA backplanes, install the AnyBay backplane as Backplane 4.
    - When one AnyBay backplane mixes with NVMe backplanes, install the NVMe backplanes first, and then install the AnyBay backplane to the first available drive cage counted from top when viewed from the front of the server.

**Procedure**

Step 1. Determine the slot for the backplane to be installed in. See [“2.5-inch drive cable routing” on page 278](#).

Step 2. Install the backplane.

- a. ① Insert the backplane into the backplane slot with an angle as shown.
- b. ② Pivot the backplane carefully toward the drive cage until it is secured by the release tabs.

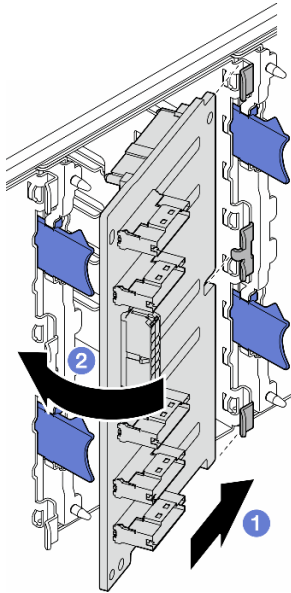

Figure 33. Installation of a 2.5-inch drive backplane

### After you finish

- Connect the cables to the backplane. See [“2.5-inch drive cable routing”](#) on page 278.
- Install all the drives and drive bay fillers (if any) into the drive bays. See [“Install a hot-swap drive”](#) on page 84.
- Complete the parts replacement. See [“Complete the parts replacement”](#) on page 233.

### Demo video

[Watch the procedure on YouTube](#)

---

## 3.5-inch drive backplane replacement

Follow the instructions in this section to remove or install a 3.5-inch drive backplane.

**Note:** This topic applies only to server models with 3.5-inch drive backplanes installed.

### Remove a 3.5-inch drive backplane

Follow the instructions in this section to remove a 3.5-inch drive backplane.

### About this task

**S002**



**CAUTION:**

The power-control button on the device and the power switch on the power supply do not turn off the electrical current supplied to the device. The device also might have more than one power cord. To remove all electrical current from the device, ensure that all power cords are disconnected from the power source.

**Attention:**

- Read [“Installation Guidelines” on page 41](#) and [“Safety inspection checklist” on page 42](#) to ensure that you work safely.
- Power off the server and disconnect all power cords for this task. See [“Power off the server” on page 53](#).
- Prevent exposure to static electricity, which might lead to system halt and loss of data, by keeping static-sensitive components in their static-protective packages until installation, and handling these devices with an electrostatic-discharge wrist strap or other grounding system.
- If the server is in a rack, remove it from the rack.
- If foot stands are installed on the server, pivot them inwards and lay the server on its side for easier operation.

**Procedure**

Step 1. Make preparations for this task.

- a. Remove all installed drives and drive bay fillers (if any) from the drive bays. See [“Remove a hot-swap drive” on page 81](#).
- b. Remove the server cover. See [“Remove the server cover” on page 230](#).

Step 2. Disconnect all cables from the backplane.

Step 3. Remove the backplane.

- a. ① Pull out the blue plunger that secures the backplane.
- b. ② Adjust the backplane to disengage it from the drive cage; then, remove the backplane from the drive cage.

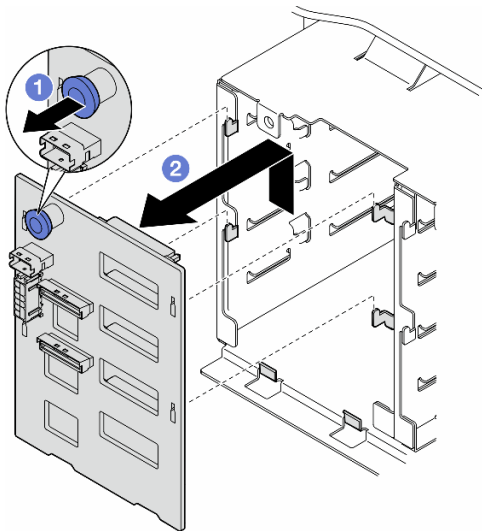

Figure 34. Removal of a 3.5-inch drive backplane

**After this task is completed**

1. Install the replacement unit(s), if necessary. See [“Install a 3.5-inch drive backplane” on page 69](#).

2. If you are instructed to return the component or optional device, follow all packaging instructions, and use any packaging materials for shipping that are supplied to you.

## Demo video

[Watch the procedure on YouTube](#)

## Install a 3.5-inch drive backplane

Follow the instructions in this section to install a 3.5-inch drive backplane.

### About this task

#### S002



#### **CAUTION:**

The power-control button on the device and the power switch on the power supply do not turn off the electrical current supplied to the device. The device also might have more than one power cord. To remove all electrical current from the device, ensure that all power cords are disconnected from the power source.

#### **Attention:**

- Read [“Installation Guidelines” on page 41](#) and [“Safety inspection checklist” on page 42](#) to ensure that you work safely.
- Power off the server and disconnect all power cords for this task. See [“Power off the server” on page 53](#).
- Prevent exposure to static electricity, which might lead to system halt and loss of data, by keeping static-sensitive components in their static-protective packages until installation, and handling these devices with an electrostatic-discharge wrist strap or other grounding system.

#### **Notes:**

- The server supports up to four 3.5-inch hot-swap drive backplanes.
- See [“Technical rules for system fans” on page 95](#) for detailed information about the storage limitations in different server configurations.
- Before installing a drive backplane:
  1. Determine the location of the backplanes to be installed. Backplanes are installed in the following order:
    - The installation priority of different backplane types : NVMe > AnyBay > SAS/SATA.
    - The installation order of SAS/SATA backplanes is Backplane 1 > Backplane 2 > Backplane 3 > Backplane 4, from bottom to top when viewed from the front of the server.
    - The installation order of NVMe backplanes is Backplane 4 > Backplane 3 > Backplane 2 > Backplane 1, from top to bottom when viewed from the front of the server.

**Note:** When an ODD/tape drive is installed, the first NVMe backplane is to be installed as Backplane 3.

- The server supports up to one AnyBay backplane. The location of the AnyBay backplane follows the rules below:

- Install the AnyBay backplane to the first available drive cage counted from top when viewed from the front of the server.
  - When one AnyBay backplane mixes with SAS/SATA backplanes, and there's no ODD/tape drive installed, install the AnyBay backplane as Backplane 4.
  - When one AnyBay backplane mixes with SAS/SATA backplanes, and there's an ODD/tape drive installed, install the AnyBay backplane as Backplane 3.
  - When one AnyBay backplane mixes with NVMe backplanes, install the NVMe backplanes first, and then install the AnyBay backplane to the first available drive cage counted from top when viewed from the front of the server.

## Procedure

Step 1. Determine the slot for the backplane to be installed in. See [“3.5-inch drive cable routing” on page 241](#).

Step 2. Install the backplane.

- a. Align the four tabs on the drive cage with the slots on the 3.5-inch drive backplane; then, insert the tabs into the corresponding slots.
- b. Slide the backplane as shown until it is seated in position in the drive cage.

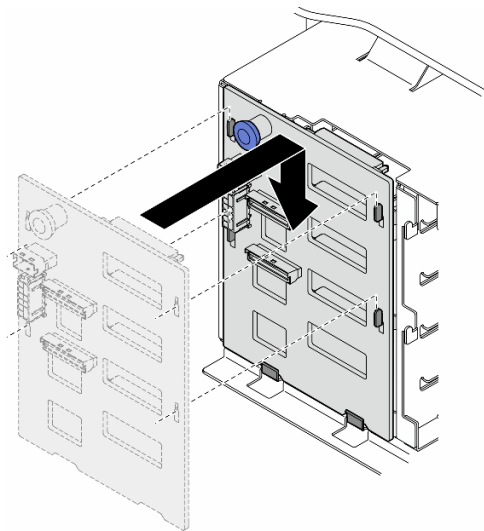

Figure 35. Installation of a 3.5-inch drive backplane

## After you finish

1. Connect the cables to the backplane. See [“3.5-inch drive cable routing” on page 241](#).
2. Install all the drives and drive bay fillers (if any) into the drive bays. See [“Install a hot-swap drive” on page 84](#).
3. Reinstall the server cover. See [“Install a server cover” on page 231](#).
4. Complete the parts replacement. See [“Complete the parts replacement” on page 233](#).

## Demo video

[Watch the procedure on YouTube](#)

---

## A2/L4 GPU air duct replacement

Follow the instructions in this section to remove or install an A2/L4 GPU air duct.

### Remove an A2/L4 GPU air duct

Follow the instructions in this section to remove an A2/L4 GPU air duct.

#### About this task

##### S002

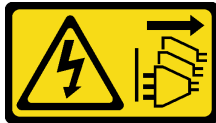

#### **CAUTION:**

The power-control button on the device and the power switch on the power supply do not turn off the electrical current supplied to the device. The device also might have more than one power cord. To remove all electrical current from the device, ensure that all power cords are disconnected from the power source.

#### **Attention:**

- Read [“Installation Guidelines” on page 41](#) and [“Safety inspection checklist” on page 42](#) to ensure that you work safely.
- Power off the server and disconnect all power cords for this task. See [“Power off the server” on page 53](#).
- Prevent exposure to static electricity, which might lead to system halt and loss of data, by keeping static-sensitive components in their static-protective packages until installation, and handling these devices with an electrostatic-discharge wrist strap or other grounding system.
- If the server is in a rack, remove it from the rack.
- If foot stands are installed on the server, pivot them inwards and lay the server on its side for easier operation.

#### **Procedure**

Step 1. Make preparations for this task.

- a. Remove the server cover. See [“Remove the server cover” on page 230](#).
- b. If necessary, remove all flash power modules. See [“Remove a flash power module” on page 100](#).
- c. Remove the air baffle. See [“Remove the air baffle” on page 74](#).
- d. (Optional) If necessary, remove the fans and fan cage. See [“Remove a fan module” on page 89](#) and [“Remove the fan cage assembly” on page 91](#).

**Attention:** All fan modules must be removed from the fan cage when handling the fan cage assembly.

**Note:** This step is optional. Do this step if the removal or installation of the A2/L4 GPU air duct (s) or FL PCIe adapter holder(s) cannot be proceeded smoothly within the chassis.

Step 2. Press and hold the tab to release the air duct from the fan cage; then, remove the air duct from the fan cage.

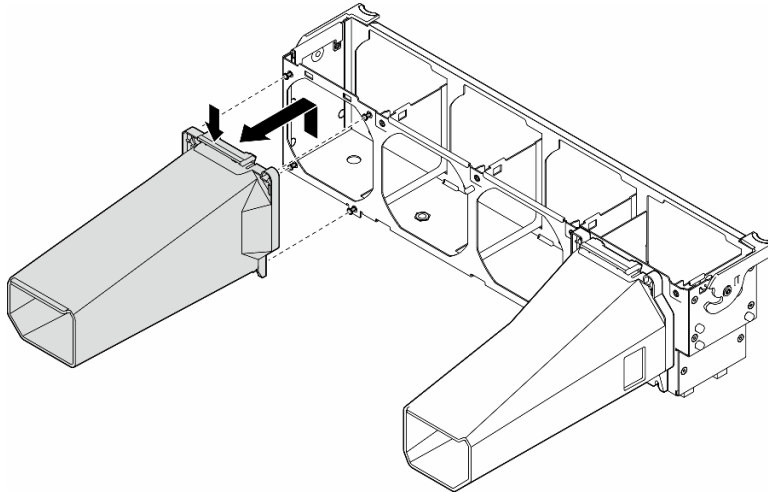

Figure 36. Removal of the A2/L4 GPU air duct

4

### After this task is completed

1. Install the replacement unit(s), if necessary. See “[Install an A2/L4 GPU air duct](#)” on page 72.
2. If you are instructed to return the component or optional device, follow all packaging instructions, and use any packaging materials for shipping that are supplied to you.

### Demo video

[Watch the procedure on YouTube](#)

[https://www.youtube.com/watch?v=sVWdHL\\_6PEE](https://www.youtube.com/watch?v=sVWdHL_6PEE)

### Install an A2/L4 GPU air duct

Follow the instructions in this section to install an A2/L4 GPU air duct.

### About this task

#### S002



#### **CAUTION:**

The power-control button on the device and the power switch on the power supply do not turn off the electrical current supplied to the device. The device also might have more than one power cord. To remove all electrical current from the device, ensure that all power cords are disconnected from the power source.

#### **Attention:**

- Read “[Installation Guidelines](#)” on page 41 and “[Safety inspection checklist](#)” on page 42 to ensure that you work safely.

- Power off the server and disconnect all power cords for this task. See [“Power off the server” on page 53](#).
- Prevent exposure to static electricity, which might lead to system halt and loss of data, by keeping static-sensitive components in their static-protective packages until installation, and handling these devices with an electrostatic-discharge wrist strap or other grounding system.
- When one or more **A2/L4 GPUs** are installed between PCIe slots 1 and 4 or between PCIe slots 5 and 8, one or two **A2/L4 GPU air ducts** are required to be installed on the fan cage at the same side as the installed A2/L4 GPU for proper cooling and airflow.

See [“GPU installation rules” on page 171](#) for detailed information about the technical rules for GPU installation.

## Procedure

Step 1. Make preparations for this task.

- Install all half-length PCIe adapters. See [“Install a HL PCIe adapter” on page 167](#).

Step 2. Align the air duct with the studs on the fan cage at the same side as the installed A2/L4 GPU(s).

### Attention:

- The studs on the fan cage are positioned differently to align the corresponding A2/L4 GPU air duct(s).

Step 3. Insert the air duct onto the fan cage until it snaps into position.

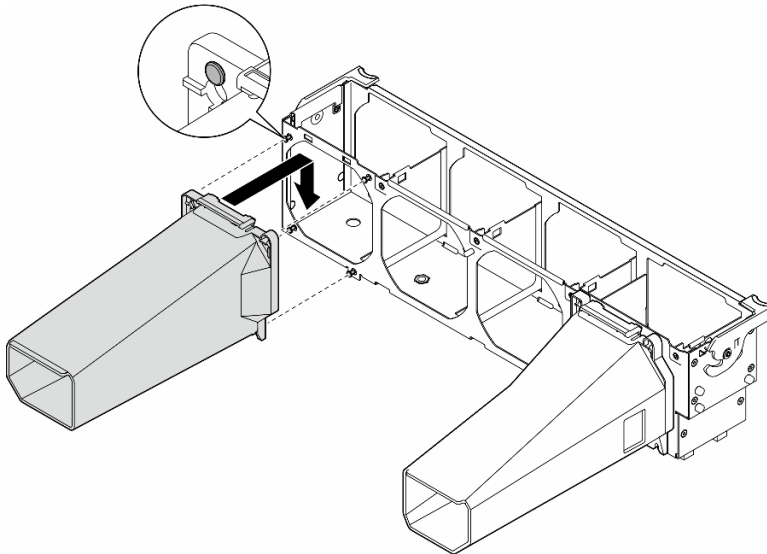

Figure 37. A2/L4 GPU air duct installation

## After this task is completed

1. If the fan cage and fans are not installed in the chassis, reinstall them. See [“Install the fan cage assembly” on page 92](#) and [“Install a fan module” on page 94](#).
2. Reinstall the air baffle. See [“Install an air baffle” on page 75](#).
3. Reinstall all the flash power modules, if necessary. See [“Install a flash power module” on page 102](#).
4. Reinstall the server cover. See [“Install a server cover” on page 231](#).
5. Complete the parts replacement. See [“Complete the parts replacement” on page 233](#).

## Demo video

[Watch the procedure on YouTube](#)

<https://www.youtube.com/watch?v=YN40HxTMDWE>

---

## Air baffle replacement

Follow the instructions in this section to remove or install the air baffle.

### Remove the air baffle

Follow the instructions in this section to remove an air baffle.

#### About this task

##### S033



##### **CAUTION:**

**Hazardous energy present. Voltages with hazardous energy might cause heating when shorted with metal, which might result in spattered metal, burns, or both.**

##### S017



##### **CAUTION:**

**Hazardous moving fan blades nearby. Keep fingers and other body parts away.**

##### **Attention:**

- Read [“Installation Guidelines” on page 41](#) and [“Safety inspection checklist” on page 42](#) to ensure that you work safely.
- Power off the server and disconnect all power cords for this task. See [“Power off the server” on page 53](#).
- Prevent exposure to static electricity, which might lead to system halt and loss of data, by keeping static-sensitive components in their static-protective packages until installation, and handling these devices with an electrostatic-discharge wrist strap or other grounding system.
- If the server is in a rack, remove it from the rack.
- If foot stands are installed on the server, pivot them inwards and lay the server on its side for easier operation.

### Procedure

Step 1. Make preparations for this task.

- a. Remove the server cover. See [“Remove the server cover” on page 230](#).
- b. If necessary, remove all flash power modules. See [“Remove a flash power module” on page 100](#).

Step 2. Lift the air baffle up to remove it from the server; then, set it aside.

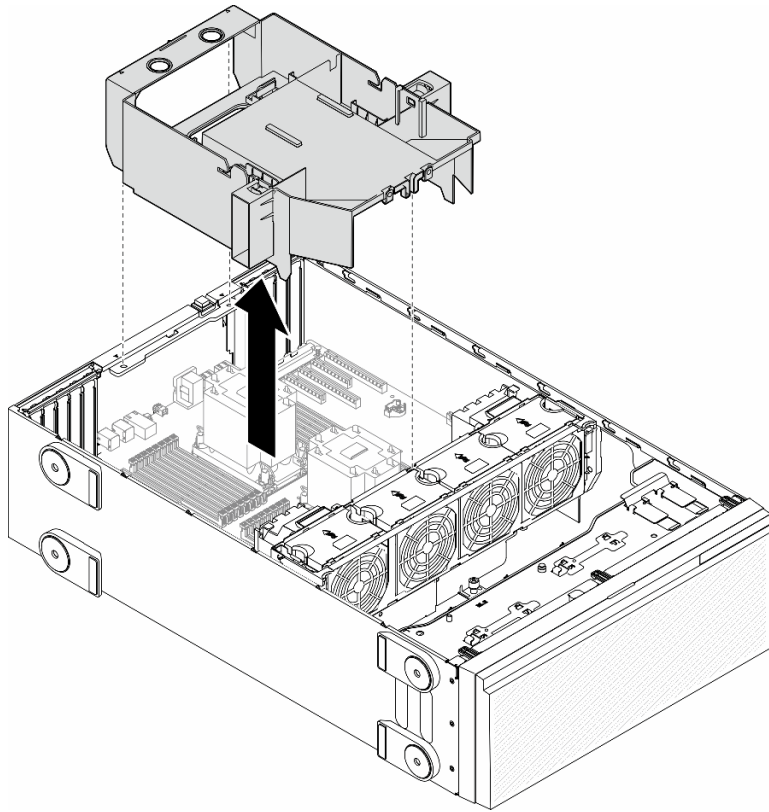

Figure 38. Removal of an air baffle

**Attention:** For proper cooling and airflow, reinstall the air baffle before you turn on the server. Operating the server with the air baffle removed might damage server components.

### After this task is completed

1. Install a replacement unit. See [“Install an air baffle” on page 75](#).
2. If you are instructed to return the component or optional device, follow all packaging instructions, and use any packaging materials for shipping that are supplied to you.

### Demo video

[Watch the procedure on YouTube](#)

<https://www.youtube.com/watch?v=pEOpYo83Ins>

### Install an air baffle

Follow the instructions in this section to install an air baffle.

### About this task

**S033**



**CAUTION:**

**Hazardous energy present. Voltages with hazardous energy might cause heating when shorted with metal, which might result in spattered metal, burns, or both.**

**S017**



**CAUTION:**

**Hazardous moving fan blades nearby. Keep fingers and other body parts away.**

**Attention:**

- Read [“Installation Guidelines” on page 41](#) and [“Safety inspection checklist” on page 42](#) to ensure that you work safely.
- Power off the server and disconnect all power cords for this task. See [“Power off the server” on page 53](#).
- Prevent exposure to static electricity, which might lead to system halt and loss of data, by keeping static-sensitive components in their static-protective packages until installation, and handling these devices with an electrostatic-discharge wrist strap or other grounding system.

**Procedure**

Step 1. Make preparations for this task.

- a. Make sure that all cables inside the server have been properly routed so that they do not interfere with the air baffle. See [Chapter 6 “Internal cable routing” on page 235](#).

Step 2. Align the tabs on the air baffle with the corresponding slots on the rear of the chassis and the fan cage; then, lower the air baffle into the chassis and press it down until it is securely seated.

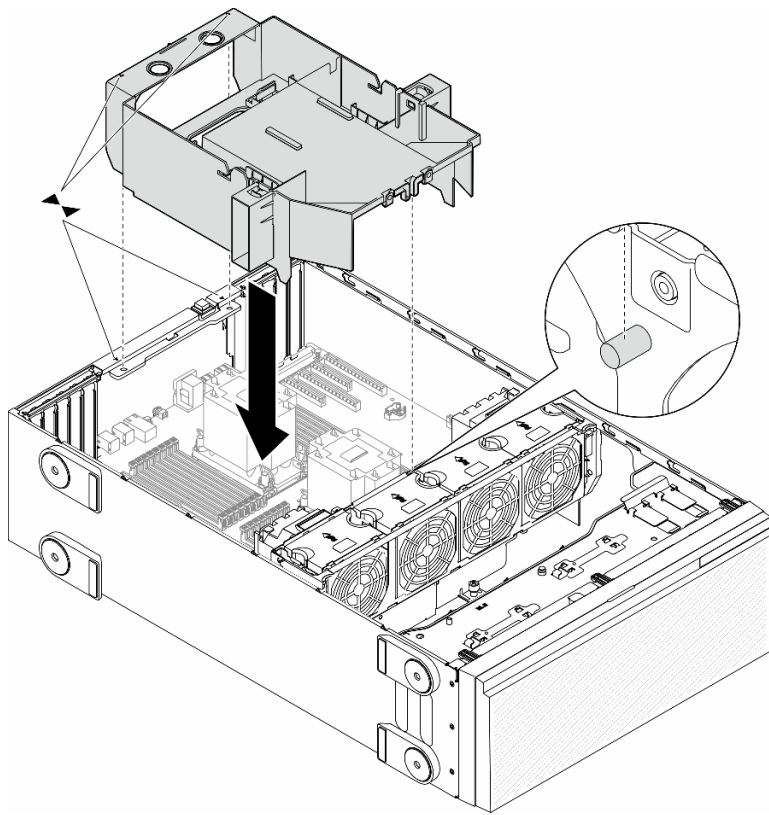

Figure 39. Installation of an air baffle

### After you finish

1. Reinstall all the flash power modules, if necessary. See “Install a flash power module” on page 102.
2. Complete the parts replacement. See “Complete the parts replacement” on page 233.

### Demo video

[Watch the procedure on YouTube](#)

<https://www.youtube.com/watch?v=o4K3y5AUv9c>

---

## CMOS battery (CR2032) replacement

Follow the instructions in this section to remove or install a CMOS battery (CR2032).

### Remove the CMOS battery (CR2032)

Follow the instructions in this section to remove a CMOS battery (CR2032).

### About this task

**S002**



**CAUTION:**

The power-control button on the device and the power switch on the power supply do not turn off the electrical current supplied to the device. The device also might have more than one power cord. To remove all electrical current from the device, ensure that all power cords are disconnected from the power source.

**S004**



**CAUTION:**

When replacing the lithium battery, use only Lenovo specified part number or an equivalent type of battery recommended by the manufacturer. If your system has a module containing a lithium battery, replace it only with the same module type made by the same manufacturer. The battery contains lithium and can explode if not properly used, handled, or disposed of.

*Do not:*

- Throw or immerse into water
- Heat to more than 100°C (212°F)
- Repair or disassemble

Dispose of the battery as required by local ordinances or regulations.

**S005**



**CAUTION:**

The battery is a lithium ion battery. To avoid possible explosion, do not burn the battery. Exchange it only with the approved part. Recycle or discard the battery as instructed by local regulations.

**Attention:**

- Read [“Installation Guidelines” on page 41](#) and [“Safety inspection checklist” on page 42](#) to ensure that you work safely.
- Power off the server and disconnect all power cords for this task. See [“Power off the server” on page 53](#).
- Prevent exposure to static electricity, which might lead to system halt and loss of data, by keeping static-sensitive components in their static-protective packages until installation, and handling these devices with an electrostatic-discharge wrist strap or other grounding system.
- If the server is in a rack, remove it from the rack.
- If foot stands are installed on the server, pivot them inwards and lay the server on its side for easier operation.

## Procedure

Step 1. Make preparations for this task.

- a. Remove the server cover. See “Remove the server cover” on page 230.
- b. If necessary, remove all flash power modules. See “Remove a flash power module” on page 100.
- c. Remove the air baffle. See “Remove the air baffle” on page 74.
- d. Remove the A2/L4 GPU air duct, if any. See “Remove an A2/L4 GPU air duct” on page 71.
- e. Disconnect cables for PCIe adapter or full-length GPU adapter.
- f. Remove all the PCIe adapters. See “Remove a HL PCIe adapter” on page 165.
- g. Remove all the full-length GPU adapters, if any. See “Remove a FL GPU adapter” on page 173.

Step 2. Locate the CMOS battery on the system board. See “System board connectors” on page 26.

Step 3. Remove the CMOS battery.

- a. ① Press on the nub on the side of the CMOS battery.
- b. ② Pivot the battery away from the socket to remove it.

**Attention:** Do not apply excessive force on the CMOS battery. Failing to remove the CMOS battery properly might damage the socket on the system board. Any damage to the socket might require replacing the system board.

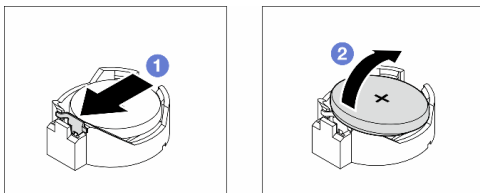

Figure 40. Removal of a CMOS battery

## After this task is completed

1. Install a replacement unit. See “Install a CMOS battery (CR2032)” on page 79.
2. Dispose the component with compliance to local regulations.

## Demo video

[Watch the procedure on YouTube](#)

<https://www.youtube.com/watch?v=mRcZwuv4s88>

## Install a CMOS battery (CR2032)

Follow the instructions in this section to install a CMOS battery (CR2032).

## About this task

**S002**



**CAUTION:**

The power-control button on the device and the power switch on the power supply do not turn off the electrical current supplied to the device. The device also might have more than one power cord. To remove all electrical current from the device, ensure that all power cords are disconnected from the power source.

**S004**



**CAUTION:**

When replacing the lithium battery, use only Lenovo specified part number or an equivalent type of battery recommended by the manufacturer. If your system has a module containing a lithium battery, replace it only with the same module type made by the same manufacturer. The battery contains lithium and can explode if not properly used, handled, or disposed of.

*Do not:*

- Throw or immerse into water
- Heat to more than 100°C (212°F)
- Repair or disassemble

Dispose of the battery as required by local ordinances or regulations.

**S005**



**CAUTION:**

The battery is a lithium ion battery. To avoid possible explosion, do not burn the battery. Exchange it only with the approved part. Recycle or discard the battery as instructed by local regulations.

**Attention:**

- Read [“Installation Guidelines” on page 41](#) and [“Safety inspection checklist” on page 42](#) to ensure that you work safely.
- Power off the server and disconnect all power cords for this task. See [“Power off the server” on page 53](#).
- Prevent exposure to static electricity, which might lead to system halt and loss of data, by keeping static-sensitive components in their static-protective packages until installation, and handling these devices with an electrostatic-discharge wrist strap or other grounding system.

Consider the following when replacing the CMOS battery in the server:

- When replacing the CMOS battery, it is a must to replace another CMOS battery of the same type from the same manufacturer.

- After replacing the CMOS battery, make sure to reconfigure the server and reset system date and time.
- Lenovo has designed this product with safety in mind. The lithium battery must be handled correctly to avoid possible danger. When install the CMOS battery, adhere to the following instructions.
- If the original lithium battery is replaced with a heavy-metal battery or a battery with heavy-metal components, be aware of the following environmental consideration. Batteries and accumulators that contain heavy metals must not be disposed of with normal domestic waste. They will be taken back free of charge by the manufacturer, distributor, or representative, to be recycled or disposed of in a proper manner.

## Procedure

Step 1. Locate the CMOS battery slot on the system board. See [“System board connectors”](#) on page 26.

Step 2. Install a CMOS battery.

- 1 Place the CMOS battery on top of the socket with the positive (+) symbol facing up.
- 2 Push the battery into the socket until it clicks into place.

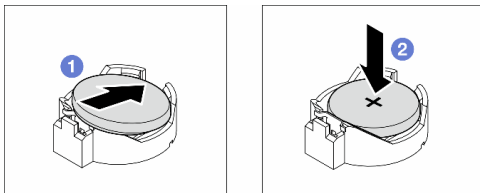

Figure 41. Installation of a CMOS battery

## After you finish

1. Reinstall all the PCIe adapters, if necessary. See [“Install a HL PCIe adapter”](#) on page 167.
2. Reinstall all the full-length GPU adapters, if necessary. See [“Install a FL GPU adapter”](#) on page 175.
3. Reconnect all the cables that were removed. See [Chapter 6 “Internal cable routing”](#) on page 235.
4. Reinstall the A2 GPU air duct, if necessary. See [“Install an A2/L4 GPU air duct”](#) on page 72.
5. Reinstall the air baffle. See [“Install an air baffle”](#) on page 75.
6. Reinstall all the flash power modules, if necessary. See [“Install a flash power module”](#) on page 102.
7. Reinstall the server cover. See [“Install a server cover”](#) on page 231.
8. Complete the parts replacement. See [“Complete the parts replacement”](#) on page 233.
9. Reset date, time, and all the passwords.

## Demo video

[Watch the procedure on YouTube](#)

<https://www.youtube.com/watch?v=EvVNY8DMEUK>

---

## Drive replacement

Follow the instructions in this section to remove or install drives.

### Remove a hot-swap drive

Follow the instructions in this section to remove a hot-swap drive or drive tray from a drive and, if necessary, remove 2.5-inch drive from a 3.5-inch drive tray.

## About this task

### S033



#### **CAUTION:**

**Hazardous energy present. Voltages with hazardous energy might cause heating when shorted with metal, which might result in spattered metal, burns, or both.**

#### **Attention:**

- Read [“Installation Guidelines” on page 41](#) and [“Safety inspection checklist” on page 42](#) to ensure that you work safely.
- Prevent exposure to static electricity, which might lead to system halt and loss of data, by keeping static-sensitive components in their static-protective packages until installation, and handling these devices with an electrostatic-discharge wrist strap or other grounding system.
- To make sure that there is adequate system cooling, do not operate the solution for more than two minutes without either a drive or a filler installed in each bay.
- If one or more NVMe solid-state drives are to be removed, it is recommended to disable them beforehand via the operating system.
- Before removing or making changes to drives, drive controllers (including controllers that are integrated on the system board), drive backplanes or drive cables, back up all important data that is stored on drives.
- Before removing any component of a RAID array (drive, RAID card, etc.), back up all RAID configuration information.

**Note:** Make sure that the drive bay fillers are available in case needed after the removal of drives.

## **Procedure**

Step 1. Use the key to unlock the server cover; then, open the security door.

Step 2. Locate the drive or drive tray to be removed.

Step 3. Remove the hot-swap drive.

- a. ① Slide the release latch to open the tray handle.
- b. ② The tray handle opens automatically.
- c. ③ Pull the tray handle and carefully slide the drive out of the drive bay.

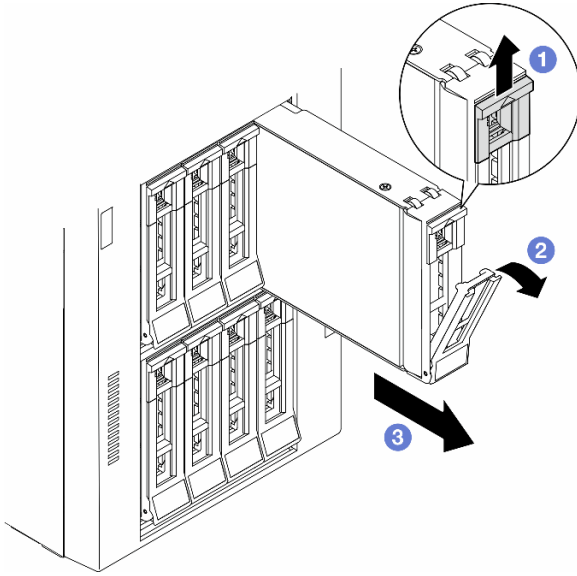

Figure 42. Opening the tray handle

- Step 4. (Optional) If necessary, remove a 2.5-inch drive from a 3.5-inch drive tray.
- a. Remove the five screws that secure the 2.5-inch drive and the drive adapter; then, remove the 2.5-inch drive and the drive adapter from the tray.

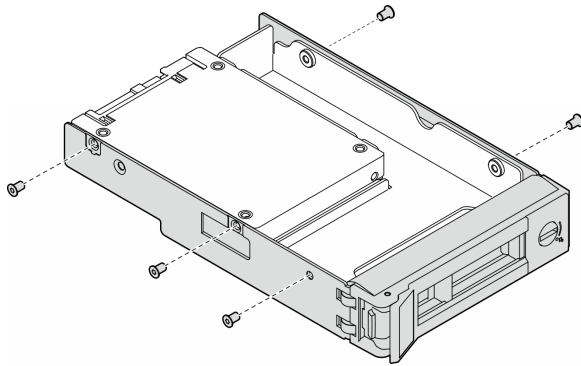

Figure 43. Removal of the screws that secure the 2.5-inch drive and the drive adapter

- b. Remove the two screws that secure the 2.5-inch drive; then, remove the drive from the drive adapter.

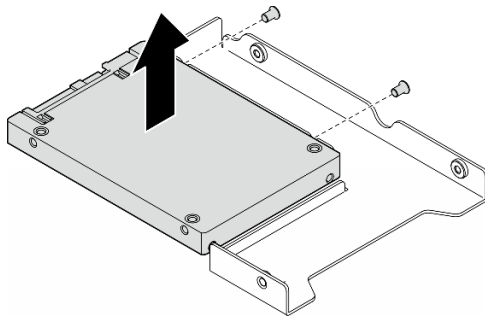

Figure 44. Removal of a 2.5-inch drive from the drive adapter

## After this task is completed

1. Install a replacement unit or filler, see [“Install a hot-swap drive” on page 84](#).
2. If you are instructed to return the component or optional device, follow all packaging instructions, and use any packaging materials for shipping that are supplied to you.

## Demo video

[Watch the procedure on YouTube](#)

<https://www.youtube.com/watch?v=428zOf8EHZI>

## Install a hot-swap drive

Follow the instructions in this section to install a hot-swap drive into a drive bay and, if necessary, install a 2.5-inch drive into a 3.5-inch drive tray and then a 3.5-inch drive bay.

## About this task

### S033



### **CAUTION:**

**Hazardous energy present. Voltages with hazardous energy might cause heating when shorted with metal, which might result in spattered metal, burns, or both.**

### **Attention:**

- Read [“Installation Guidelines” on page 41](#) and [“Safety inspection checklist” on page 42](#) to ensure that you work safely.
- Prevent exposure to static electricity, which might lead to system halt and loss of data, by keeping static-sensitive components in their static-protective packages until installation, and handling these devices with an electrostatic-discharge wrist strap or other grounding system.
- To make sure that there is adequate system cooling, do not operate the solution for more than two minutes without either a drive or a filler installed in each bay.
- If one or more NVMe solid-state drives are to be removed, it is recommended to disable them beforehand via the operating system.
- Before removing or making changes to drives, drive controllers (including controllers that are integrated on the system board), drive backplanes or drive cables, back up all important data that is stored on drives.
- Before removing any component of a RAID array (drive, RAID card, etc.), back up all RAID configuration information.

**Notes:** The following notes describe the type of drives that the server supports and other information that to be considered when installing a drive.

- Locate the documentation that comes with the drive and follow those instructions in addition to the instructions in this chapter.
- The electromagnetic interference (EMI) integrity and cooling of the solution are protected by having all bays and PCI and PCIe slots covered or occupied. When you install a drive, PCI, or PCIe adapter, save the EMC shield and filler panel from the bay or PCI or PCIe adapter slot cover in the event that you later remove the device.

- For a complete list of supported optional devices for the server, see: <https://serverproven.lenovo.com>
- The server supports the installation of 2.5-inch SSDs into a 3.5 inch drive bay through the use of a 3.5-inch drive tray. Refer to the optional part of the procedure.
- The drive bays are numbered in installation ordering (starting from number “0”). Follow this sequential order of the drive bays when installing a drive. To locate the drive bays in the server, see .
- For hard disk drives with different capacities, install the drive in accordance with the sequential order of the drive bays as well as from the lowest capacity to the highest capacity.
- The drives in a single RAID array must be the same type, same size, and same capacity.

## Procedure

Step 1. If the drive bay has a drive filler installed, remove it. Keep the drive filler in a safe place for future use.

Step 2. (Optional) If necessary, install a 2.5-inch drive into a 3.5-inch drive tray.

- Position the 2.5-inch drive into the 2.5-inch to 3.5-inch drive adapter.
- Align the two screw holes in the drive with the corresponding holes in the drive adapter; then, install the two screws to secure the drive into the drive adapter.

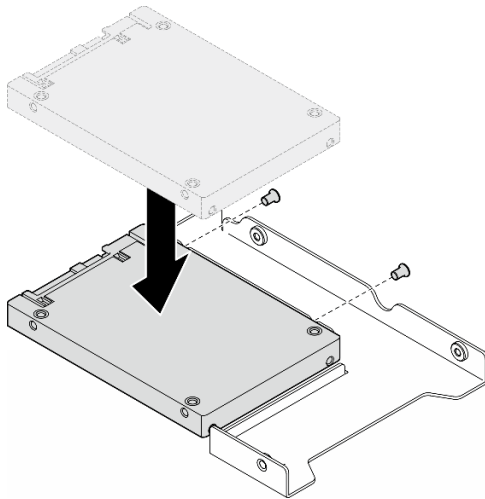

Figure 45. Installation of a 2.5-inch drive into a drive adapter

- Position the drive adapter with the drive into the 3.5-inch drive tray. Align the screw holes in the drive adapter and the drive with the corresponding holes in the tray; then, install the five screws to secure the drive adapter and the drive into the tray.

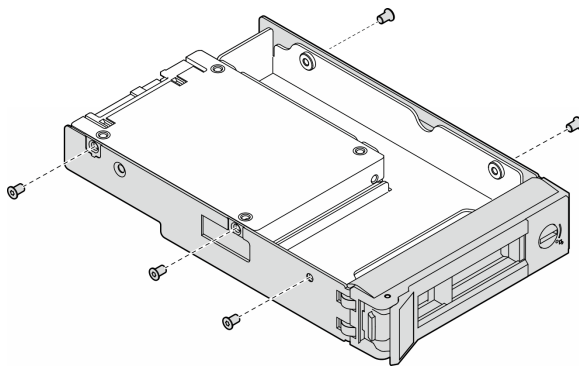

Figure 46. Installation of the screws that secure a 2.5-inch drive and a drive adapter

- Step 3. Slide the drive or drive tray into the drive bay from the front until it snaps into position; then, close the handle completely.
- 1 Ensure that the tray handle is in the open position. Slide the drive into the drive bay until it snaps into position.
  - 2 Close the tray handle to lock the drive in place.

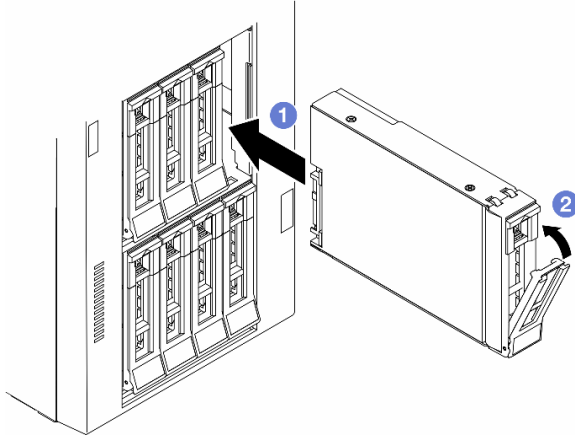

Figure 47. Installation of a hot-swap drive

## After you finish

1. Check the drive status LED to verify that the drive is operating correctly.
  - If the yellow drive status LED of a drive is lit continuously, that drive is faulty and must be replaced.
  - If the green drive activity LED is flashing, the drive is being accessed.
2. If the server is configured for RAID operation through a ThinkSystem RAID adapter, you might have to reconfigure your disk arrays after you install drives. See the ThinkSystem RAID adapter documentation for additional information about RAID operation and complete instructions for using ThinkSystem RAID adapter.
3. If any of the drive bays are left empty, fill them with drive bay fillers.

## Demo video

[Watch the procedure on YouTube](#)

<https://www.youtube.com/watch?v=F0Fd3SPoWVs>

---

## Expansion drive cage replacement

Follow the instructions in this section to remove or install an expansion drive cage.

**Note:** This section applies only to server models with an expansion drive cage installed.

## Remove the expansion drive cage

Follow the instructions in this section to remove an expansion drive cage.

## About this task

### S002

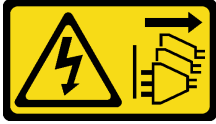

### CAUTION:

The power-control button on the device and the power switch on the power supply do not turn off the electrical current supplied to the device. The device also might have more than one power cord. To remove all electrical current from the device, ensure that all power cords are disconnected from the power source.

### Attention:

- Read [“Installation Guidelines” on page 41](#) and [“Safety inspection checklist” on page 42](#) to ensure that you work safely.
- Power off the server and disconnect all power cords for this task. See [“Power off the server” on page 53](#).
- Prevent exposure to static electricity, which might lead to system halt and loss of data, by keeping static-sensitive components in their static-protective packages until installation, and handling these devices with an electrostatic-discharge wrist strap or other grounding system.
- If the server is in a rack, remove it from the rack.

### Procedure

Step 1. Make preparations for this task.

- a. Remove the server cover. See [“Remove the server cover” on page 230](#).
- b. Remove the security door. See [“Remove the security door” on page 207](#).
- c. Remove the front bezel. See [“Remove the front bezel” on page 107](#).
- d. Remove all installed drives and drive bay fillers (if any) from the drive bays. See [“Remove a hot-swap drive” on page 81](#).

Step 2. Disconnect all cables from the backplane.

Step 3. Remove the expansion drive cage.

- a. ① Lift and hold the blue retention tab.
- b. ② Meanwhile, carefully pull the expansion drive cage until it is completely out of the bay.

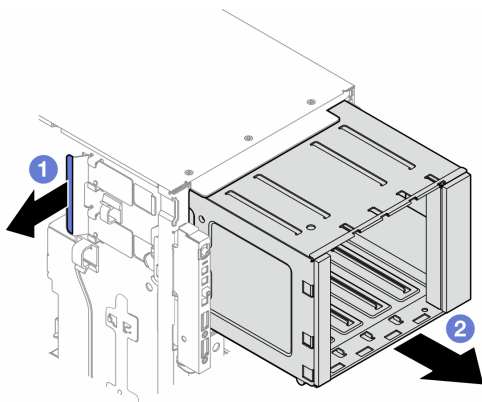

Figure 48. Removal of an expansion drive cage

### After this task is completed

1. Install the replacement unit(s), if necessary. See [“Install an expansion drive cage” on page 88](#) or [“Install an optical drive cage” on page 148](#).
2. If you are instructed to return the component or optional device, follow all packaging instructions, and use any packaging materials for shipping that are supplied to you.

## Demo video

[Watch the procedure on YouTube](#)

<https://www.youtube.com/watch?v=N31qj7ILSDE>

## Install an expansion drive cage

Follow the instructions in this section to install an expansion drive cage.

### About this task

#### S002



#### **CAUTION:**

The power-control button on the device and the power switch on the power supply do not turn off the electrical current supplied to the device. The device also might have more than one power cord. To remove all electrical current from the device, ensure that all power cords are disconnected from the power source.

#### **Attention:**

- Read [“Installation Guidelines” on page 41](#) and [“Safety inspection checklist” on page 42](#) to ensure that you work safely.
- Power off the server and disconnect all power cords for this task. See [“Power off the server” on page 53](#).
- Prevent exposure to static electricity, which might lead to system halt and loss of data, by keeping static-sensitive components in their static-protective packages until installation, and handling these devices with an electrostatic-discharge wrist strap or other grounding system.

## Procedure

- Step 1. ① Lift and hold the blue retention tab.
- Step 2. ② Meanwhile, carefully push the expansion drive cage into the bay until it snaps into position.

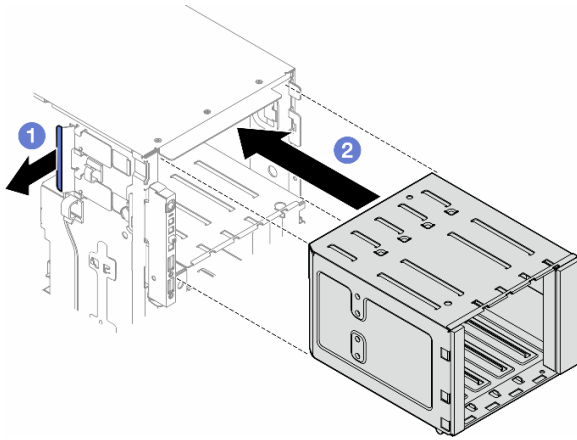

Figure 49. Installation of an expansion drive cage

### After you finish

1. Connect the cables to the backplane. See “3.5-inch drive cable routing” on page 241 .
2. Install all the drives and drive bay fillers (if any) into the drive bays. See “Install a hot-swap drive” on page 84.
3. Reinstall the front bezel. See “Install a front bezel” on page 108.
4. Reinstall the security door. See “Install the security door” on page 208.
5. Complete the parts replacement. See “Complete the parts replacement” on page 233.

### Demo video

Watch the procedure on YouTube

[https://www.youtube.com/watch?v=y\\_o1pfeCSak](https://www.youtube.com/watch?v=y_o1pfeCSak)

---

## Fan and fan cage assembly replacement

Follow the instructions in this section to remove or install a hot-swap fan module and fan cage assembly.

### Remove a fan module

Follow the instructions in this section to remove a fan module.

#### About this task

**S017**



**CAUTION:**  
Hazardous moving fan blades nearby. Keep fingers and other body parts away.

**S033**



**CAUTION:**

**Hazardous energy present. Voltages with hazardous energy might cause heating when shorted with metal, which might result in spattered metal, burns, or both.**

**Attention:**

- Read [“Installation Guidelines” on page 41](#) and [“Safety inspection checklist” on page 42](#) to ensure that you work safely.
- Prevent exposure to static electricity, which might lead to system halt and loss of data, by keeping static-sensitive components in their static-protective packages until installation, and handling these devices with an electrostatic-discharge wrist strap or other grounding system.
- If the server is in a rack, remove it from the rack.
- If foot stands are installed on the server, pivot them inwards and lay the server on its side for easier operation.

**Procedure**

Step 1. Make preparations for this task.

- a. Remove the server cover. See [“Remove the server cover” on page 230](#).

Step 2. Remove the fan module.

- a. ① Squeeze and hold on the pinch points on the top of the fan module.
- b. ② Lift the fan module out of the fan cage.

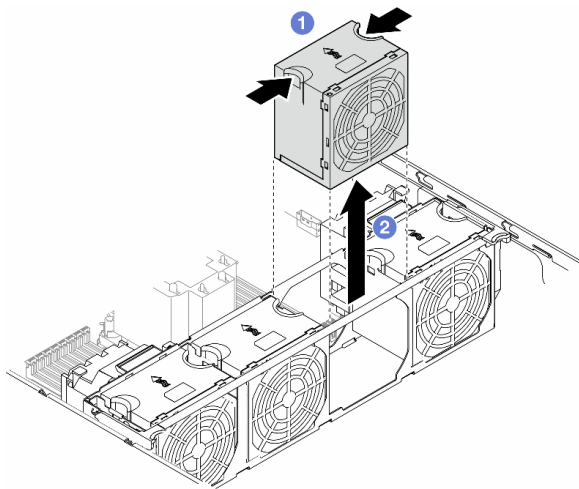

*Figure 50. Removal of a fan module*

**After this task is completed**

- 1. Install a replacement unit. See [“Install a fan module” on page 94](#).

**Attention:** With power on, complete the replacement within 30 seconds to ensure proper operation.

- 2. If you are instructed to return the component or optional device, follow all packaging instructions, and use any packaging materials for shipping that are supplied to you.

## Demo video

Watch the procedure on YouTube

<https://www.youtube.com/watch?v=iNKN4vtVVFE>

## Remove the fan cage assembly

Follow the instructions in this section to remove the fan cage assembly.

### About this task

#### S002

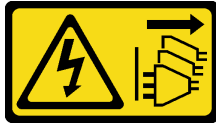

#### **CAUTION:**

The power-control button on the device and the power switch on the power supply do not turn off the electrical current supplied to the device. The device also might have more than one power cord. To remove all electrical current from the device, ensure that all power cords are disconnected from the power source.

#### **Attention:**

- Read “[Installation Guidelines](#)” on page 41 and “[Safety inspection checklist](#)” on page 42 to ensure that you work safely.
- Power off the server and disconnect all power cords for this task. See “[Power off the server](#)” on page 53.
- Prevent exposure to static electricity, which might lead to system halt and loss of data, by keeping static-sensitive components in their static-protective packages until installation, and handling these devices with an electrostatic-discharge wrist strap or other grounding system.
- If the server is in a rack, remove it from the rack.
- If foot stands are installed on the server, pivot them inwards and lay the server on its side for easier operation.

**Note:** Depending on the specific configuration, the component might look different from the illustrations in this section.

## Procedure

Step 1. Make preparations for this task.

- a. Remove the server cover. See “[Remove the server cover](#)” on page 230.
- b. If necessary, remove all flash power modules. See “[Remove a flash power module](#)” on page 100.
- c. Remove the air baffle. See “[Remove the air baffle](#)” on page 74.
- d. Remove all the full-length GPU adapters, if any. See “[Remove a FL GPU adapter](#)” on page 173.
- e. Remove all the fan modules and fan filler. See “[Remove a fan module](#)” on page 89.

**Attention:** All fan modules must be removed from the fan cage when handling the fan cage assembly.

- f. If necessary, remove the PCIe adapter holder(s) or A2/L4 GPU air duct(s) from the fan cage (see “[Remove a FL PCIe adapter holder](#)” on page 162 and “[Remove an A2/L4 GPU air duct](#)” on page 71).

Step 2. Remove the fan cage assembly.

- a. ① Lift up the fan cage release latches to disengage the fan cage from the chassis.
- b. ② Lift the fan cage from the chassis.

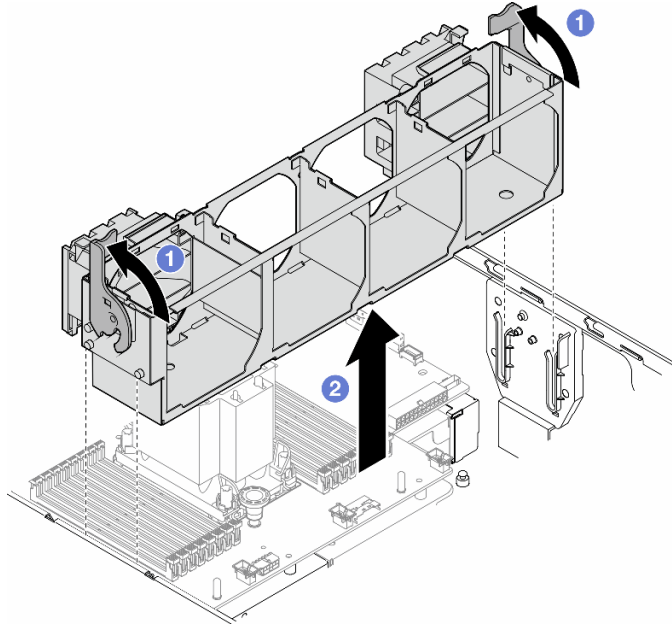

Figure 51. Removal of a fan cage assembly

### After this task is completed

1. Install a replacement unit. See “[Install the fan cage assembly](#)” on page 92.
2. If you are instructed to return the component or optional device, follow all packaging instructions, and use any packaging materials for shipping that are supplied to you.

### Demo video

[Watch the procedure on YouTube](#)

<https://www.youtube.com/watch?v=iNKN4vtVFE>

### Install the fan cage assembly

Follow the instructions in this section to install a fan cage assembly.

### About this task

**S002**

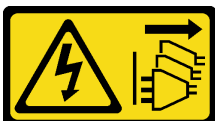

**CAUTION:**

The power-control button on the device and the power switch on the power supply do not turn off the electrical current supplied to the device. The device also might have more than one power cord. To remove all electrical current from the device, ensure that all power cords are disconnected from the power source.

**Attention:**

- Read [“Installation Guidelines” on page 41](#) and [“Safety inspection checklist” on page 42](#) to ensure that you work safely.
- Power off the server and disconnect all power cords for this task. See [“Power off the server” on page 53](#).
- Prevent exposure to static electricity, which might lead to system halt and loss of data, by keeping static-sensitive components in their static-protective packages until installation, and handling these devices with an electrostatic-discharge wrist strap or other grounding system.
- All fan modules must be removed from the fan cage when handling the fan cage assembly.

**Note:** Depending on the specific configuration, the component might look different from the illustrations in this section.

**Procedure**

Step 1. Make preparations for this task.

- a. If necessary, install the FL PCIe adapter holder(s) or A2/L4 GPU air duct(s) to the fan cage depending on the specific configuration (see [“Install a FL PCIe adapter holder” on page 164](#) and [“Install an A2/L4 GPU air duct” on page 72](#)).

**Note:** This step is optional. Do this step if the removal or installation of the A2/L4 GPU air duct (s) or FL PCIe adapter holder(s) cannot be proceeded smoothly within the chassis.

Step 2. Install the fan cage.

- a. ① Align the fan cage assembly with the slots on both sides of the server, and lower it into the server.
- b. ② Push the fan cage release latches all the way down.

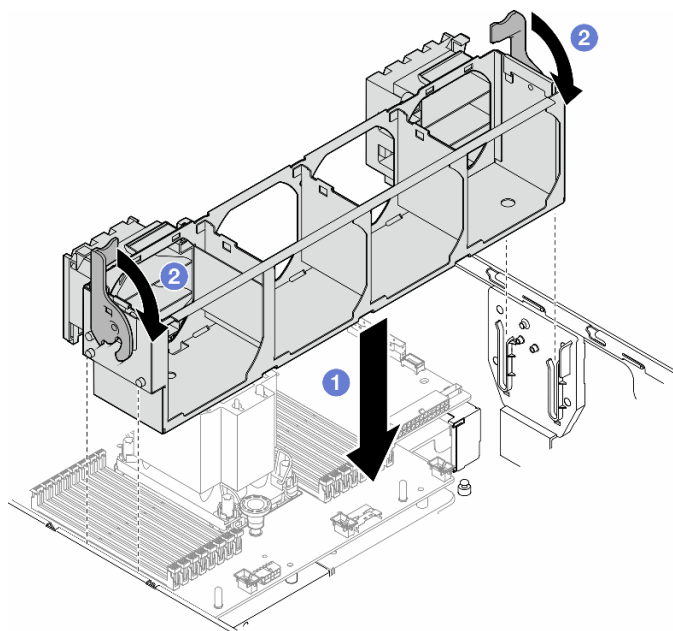

Figure 52. Installation of a fan cage assembly

## After you finish

1. Reinstall all the fan modules (and fan filler, if necessary). See “Install a fan module” on page 94.
2. Install the required A2/L4 GPU air ducts or FL PCIe adapter holders. See “Install an A2/L4 GPU air duct” on page 72 and “Install a FL PCIe adapter holder” on page 164.
3. Reinstall all the full-length GPU adapters, if necessary. See “Install a FL GPU adapter” on page 175.
4. Reinstall the air baffle. See “Install an air baffle” on page 75.
5. Reinstall all the flash power modules, if necessary. See “Install a flash power module” on page 102.
6. Reinstall the server cover. See “Install a server cover” on page 231.
7. Complete the parts replacement. See “Complete the parts replacement” on page 233.

## Demo video

[Watch the procedure on YouTube](#)

<https://www.youtube.com/watch?v=yqx18vUenU>

## Install a fan module

Follow the instructions in this section to install a fan module.

## About this task

**S017**



**CAUTION:**

**Hazardous moving fan blades nearby. Keep fingers and other body parts away.**

**S033**



**CAUTION:**

**Hazardous energy present. Voltages with hazardous energy might cause heating when shorted with metal, which might result in spattered metal, burns, or both.**

**Attention:**

- Read [“Installation Guidelines” on page 41](#) and [“Safety inspection checklist” on page 42](#) to ensure that you work safely.
- Prevent exposure to static electricity, which might lead to system halt and loss of data, by keeping static-sensitive components in their static-protective packages until installation, and handling these devices with an electrostatic-discharge wrist strap or other grounding system.

**Notes:**

- Depending on the specific type, the fan module might look different from the illustration in this section.
- To install one or more new fan modules, follow the technical rules listed below:
  - [“Technical rules for system fans” on page 95](#)
  - [“Fan configuration with one processor ” on page 96](#)
  - [“Fan configuration with two processors” on page 98](#)
- To replace an existing fan module, skip to the procedure of installation: [“Installation procedure of a fan module” on page 99](#)

**Technical rules for system fans**

Fans must be installed in a specific order based on the configuration of the server.

ThinkSystem ST650 V3 supports two types of fans:

- Single rotor 9238 hot-swap fans
- Dual rotor 9256 hot-swap fans

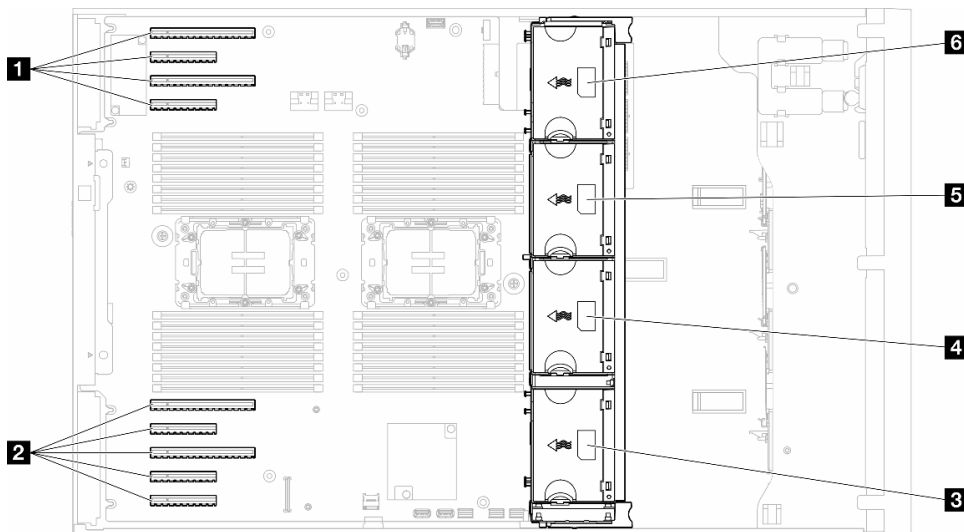

Figure 53. Fan slot locations

Table 22. Locations of PCIe slots and fan slots

<b>1</b> PCIe slot 1-4	<b>4</b> Fan slot 2
<b>2</b> PCIe slot 5-9	<b>5</b> Fan slot 3
<b>3</b> Fan slot 1	<b>6</b> Fan slot 4

**Notes:**

- Single-rotor hot-swap fans cannot be mixed with dual-rotor hot-swap fans.
- When the system is powered off but still plugged in to AC power, the fan in slot 4 may continue to spin at a much lower speed. This is the system design to provide proper cooling.

**One processor**

When only one processor is installed, PCIe slots 1 to 4 and 9 are supported. For more details about the rules of PCIe slots with one processor, see [“PCIe installation rules with one processor” on page 169](#).

For more details about PCIe installation rules with one processor, see [“PCIe installation rules with one processor” on page 169](#).

Table 23. Fan configuration with one processor

Fan configuration	Description
<ul style="list-style-type: none"> <li>• <b>Three single rotor fans in fan slots 1, 2, and 4.</b></li> <li>• One fan filler in fan slot 3.</li> </ul>	<ol style="list-style-type: none"> <li>1. Supports one CPU with TDP less than 200 watts.</li> <li>2. Supports RDIMMs with capacity (each DIMM) ≤ 64 GB.</li> <li>3. GPU adapters are not supported.</li> <li>4. Supports up to sixteen 2.5-inch SAS/SATA drives (two 2.5-inch SAS/SATA drive backplanes).</li> <li>5. Supports up to eight 3.5-inch SAS/SATA drives (two 3.5-in SAS/SATA backplanes).</li> <li>6. Fan redundancy is not supported.</li> </ol>
<ul style="list-style-type: none"> <li>• <b>Three dual rotor fans in fan slots 1, 2, and 4.</b></li> <li>• One fan filler in fan slot 3.</li> </ul>	<ol style="list-style-type: none"> <li>1. All CPU SKUs are supported.</li> <li>2. Supports RDIMMs with capacity (each DIMM) ≤ 128 GB.</li> <li>3. Supports either of the following GPU adapters: <ul style="list-style-type: none"> <li>• up to four single-width GPUs of the same type.</li> <li>• up to two double-width GPUs of the same type.</li> </ul> </li> <li>4. Supports up to sixteen 2.5-inch SAS/SATA drives (two 2.5-inch SAS/SATA drive backplanes).</li> <li>5. Supports up to eight 3.5-inch SAS/SATA drives (two 3.5-in SAS/SATA backplanes).</li> <li>6. Supports ThinkSystem M.2 SATA/NVMe 2-Bay Enablement Kit.</li> <li>7. Supports ThinkSystem M.2 NVMe 2-Bay RAID Enablement Kit</li> <li>8. Supports fan redundancy.</li> </ol>
<p><b>Four single rotor fans</b> in fan slots 1, 2, 3, and 4.</p>	<ol style="list-style-type: none"> <li>1. Supports one CPU with TDP less than 200 watts.</li> <li>2. Supports RDIMMs with capacity (each DIMM) ≤ 64 GB.</li> <li>3. GPU adapters are not supported.</li> <li>4. Supports up to thirty-two 2.5-inch SAS/SATA drives (four 2.5-inch SAS/SATA drive backplanes).</li> <li>5. Supports up to sixteen 3.5-inch SAS/SATA drives (four 3.5-inch SAS/SATA drive backplanes).</li> <li>6. Fan redundancy is not supported.</li> </ol>
<ul style="list-style-type: none"> <li>• <b>Four dual rotor fans</b> in fan slots 1, 2, 3, and 4.</li> <li>• All CPU SKUs</li> <li>• RDIMMs with capacity (each DIMM) ≤ 64 GB</li> </ul>	<ol style="list-style-type: none"> <li>1. GPU adapters are not supported.</li> <li>2. Supports up to thirty-two 2.5-inch SAS/SATA/NVMe drives (four 2.5-inch SAS/SATA or Anybay drive backplanes).</li> <li>3. Supports up to sixteen 3.5-inch SAS/SATA/NVMe drives (four 3.5-inch SAS/SATA or Anybay drive backplanes)</li> <li>4. Supports ThinkSystem M.2 SATA/NVMe 2-Bay Enablement Kit.</li> <li>5. Supports ThinkSystem M.2 NVMe 2-Bay RAID Enablement Kit</li> <li>6. Supports fan redundancy.</li> </ol>

Table 23. Fan configuration with one processor (continued)

Fan configuration	Description
<ul style="list-style-type: none"> <li>• <b>Four dual rotor fans</b> in fan slots 1, 2, 3, and 4.</li> <li>• All CPU SKUs</li> <li>• RDIMMs with capacity (each DIMM) ≤ 128 GB</li> </ul>	<ol style="list-style-type: none"> <li>1. Supports either of the following GPU adapters:               <ul style="list-style-type: none"> <li>• up to four single-width GPUs of the same type.</li> <li>• up to two double-width GPUs of the same type.</li> </ul> </li> <li>2. Supports up to sixteen 2.5-inch SAS/SATA/NVMe drives (two 2.5-inch SAS/SATA or Anybay drive backplanes).</li> <li>3. Supports up to eight 3.5-inch SAS/SATA/NVMe drives (two 3.5-inch SAS/SATA or Anybay drive backplanes).</li> <li>4. Supports ThinkSystem M.2 SATA/NVMe 2-Bay Enablement Kit.</li> <li>5. Supports ThinkSystem M.2 NVMe 2-Bay RAID Enablement Kit</li> <li>6. Supports fan redundancy.</li> </ol>
<ul style="list-style-type: none"> <li>• <b>Four dual rotor fans</b> in fan slots 1, 2, 3, and 4.</li> <li>• CPU with TDP less than 200 watts</li> <li>• RDIMMs with capacity (each DIMM) ≤ 64 GB</li> </ul>	<ol style="list-style-type: none"> <li>1. Supports up to four A2 or L4 GPUs.</li> <li>2. Supports up to thirty-two 2.5-inch SAS/SATA/NVMe drives (four 2.5-inch SAS/SATA or Anybay drive backplanes).</li> <li>3. Supports up to sixteen 3.5-inch SAS/SATA/NVMe drives (four 3.5-inch SAS/SATA or Anybay drive backplanes).</li> <li>4. Supports ThinkSystem M.2 SATA/NVMe 2-Bay Enablement Kit.</li> <li>5. Supports ThinkSystem M.2 NVMe 2-Bay RAID Enablement Kit</li> <li>6. Supports fan redundancy.</li> </ol>

## Two processors

For more details about PCIe installation rules with two processors, see [“PCIe installation rules with two processors” on page 170](#).

Table 24. Fan configuration with two processors

Fan configuration	Description
<p><b>Four single rotor fans</b> in fan slot 1, 2, 3, and 4.</p>	<ol style="list-style-type: none"> <li>1. Supports <b>two CPUs</b> with TDP less than 200 watts.</li> <li>2. Supports RDIMMs with capacity (each DIMM) <math>\leq</math> 64 GB.</li> <li>3. GPU adapters are not supported.</li> <li>4. Supports up to thirty-two 2.5-inch SAS/SATA drives (four 2.5-inch SAS/SATA drive backplanes).</li> <li>5. Supports up to sixteen 3.5-inch SAS/SATA drives (four 3.5-inch SAS/SATA drive backplanes).</li> <li>6. Fan redundancy is not supported.</li> </ol> <p>Fan redundancy is not supported.</p>
<ul style="list-style-type: none"> <li>• <b>Four dual rotor fans</b> in fan slots 1, 2, 3, and 4.</li> <li>• RDIMMs with capacity (each DIMM) <math>\leq</math> 64 GB</li> <li>• Two CPUs with TDP less than 200 watts</li> </ul>	<ol style="list-style-type: none"> <li>1. Supports up to eight A2 or L4 GPUs.</li> <li>2. Supports up to thirty-two 2.5-inch SAS/SATA/NVMe drives (four 2.5-inch SAS/SATA or Anybay drive backplanes).</li> <li>3. Supports up to sixteen 3.5-inch SAS/SATA/NVMe drives (four 3.5-inch SAS/SATA or Anybay drive backplanes).</li> <li>4. Supports ThinkSystem M.2 SATA/NVMe 2-Bay Enablement Kit.</li> <li>5. Supports ThinkSystem M.2 NVMe 2-Bay RAID Enablement Kit</li> <li>6. Supports fan redundancy.</li> </ol>
<ul style="list-style-type: none"> <li>• <b>Four dual rotor fans</b> in fan slots 1, 2, 3, and 4.</li> <li>• All CPU SKUs for the two CPUs</li> <li>• RDIMMs with capacity (each DIMM) <math>\leq</math> 128 GB</li> </ul>	<ol style="list-style-type: none"> <li>1. Supports GPU adapters listed below: <ul style="list-style-type: none"> <li>• up to eight single-width GPUs.</li> <li>• up to four double-width GPUs.</li> <li>• up to four single-width GPUs and two double-width GPUs.</li> <li>• ThinkSystem ST650 V3 does not support mixing GPUs between PCIe slots 1 and 4 or between slots 5 and 8. <ul style="list-style-type: none"> <li>– When a GPU is installed between PCIe slots 1 and 4, only the same type of GPUs can be installed in other slots between 1 and 4.</li> <li>– When a GPU is installed between PCIe slots 5 and 8, only the same type of GPUs can be installed in other slots between 5 and 8.</li> </ul> </li> <li>• See <a href="#">“GPU installation rules” on page 171</a> for more details of the technical rules for GPU installation.</li> </ul> </li> <li>2. Supports up to sixteen 2.5-inch SAS/SATA/NVMe drives (two 2.5-inch SAS/SATA or Anybay drive backplanes).</li> <li>3. Supports up to eight 3.5-inch SAS/SATA/NVMe drives (two 3.5-inch SAS/SATA or Anybay drive backplanes).</li> <li>4. Supports ThinkSystem M.2 SATA/NVMe 2-Bay Enablement Kit.</li> <li>5. Supports ThinkSystem M.2 NVMe 2-Bay RAID Enablement Kit</li> <li>6. Supports fan redundancy.</li> </ol>

## Installation Procedure

Follow the instructions in this section to install a fan module.

**Note:** Depending on the specific configuration, the component might look different from the illustrations in this section.

## Procedure

- Step 1. Locate the slot in the fan cage to install the fan module.
- Step 2. Align the fan module over the fan slot in the fan cage.
- Step 3. Push the fan module into the fan cage until it snaps into position .

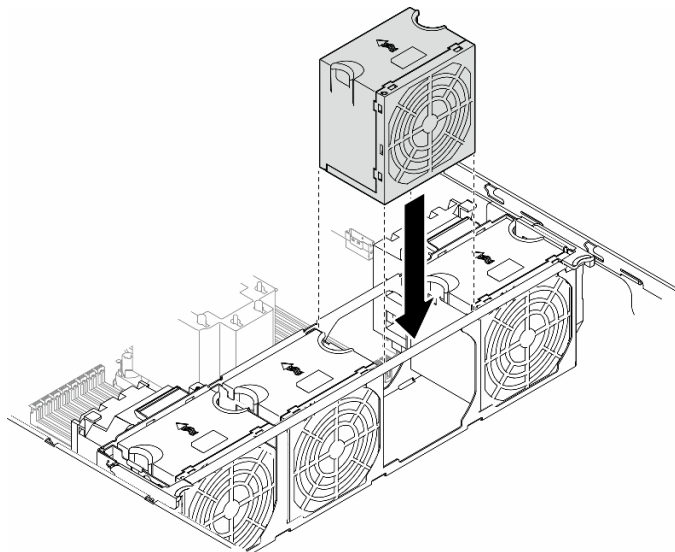

Figure 54. Installation of a fan module

## After this task is completed

1. Reinstall the server cover. See [“Install a server cover”](#) on page 231.
2. Complete the parts replacement. See [“Complete the parts replacement”](#) on page 233.

## Demo video

[Watch the procedure on YouTube](#)

<https://www.youtube.com/watch?v=yrqxI8vUenU>

---

## Flash power module replacement

Follow the instructions in this section to remove or install a flash power module.

The flash power module protects the cache memory on the installed RAID adapters. Flash power modules can be purchased from Lenovo.

For a list of supported options, see: <https://serverproven.lenovo.com>

## Remove a flash power module

Follow the instructions in this section to remove a flash power module.

## About this task

**S002**



**CAUTION:**

The power-control button on the device and the power switch on the power supply do not turn off the electrical current supplied to the device. The device also might have more than one power cord. To remove all electrical current from the device, ensure that all power cords are disconnected from the power source.

**Attention:**

- Read “Installation Guidelines” on page 41 and “Safety inspection checklist” on page 42 to ensure that you work safely.
- Power off the server and disconnect all power cords for this task. See “Power off the server” on page 53.
- Prevent exposure to static electricity, which might lead to system halt and loss of data, by keeping static-sensitive components in their static-protective packages until installation, and handling these devices with an electrostatic-discharge wrist strap or other grounding system.
- If the server is in a rack, remove it from the rack.
- If foot stands are installed on the server, pivot them inwards and lay the server on its side for easier operation.

Locate the flash power module slots on the air baffle.

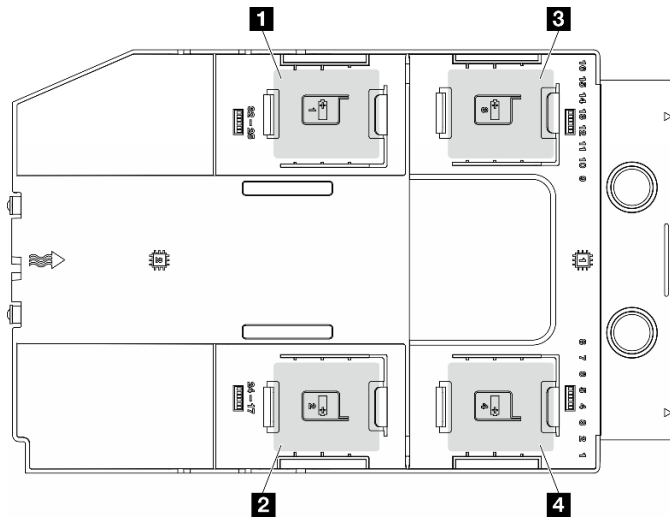

Figure 55. Location of the flash power module slots

Table 25. Flash power module slot location on air baffle

<b>1</b> Flash power module slot 1	<b>3</b> Flash power module slot 3
<b>2</b> Flash power module slot 2	<b>4</b> Flash power module slot 4

**Procedure**

Step 1. Make preparations for this task.

- a. Remove the server cover. See “Remove the server cover” on page 230.

- Step 2. Remove the flash power module.
- 1 Gently press the retaining clip as shown.
  - 2 Lift the flash power module from the holder.

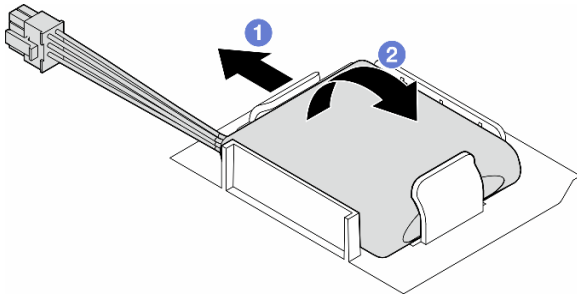

Figure 56. Removal of a flash power module

- Step 3. Disconnect the flash power module cable from the RAID adapter.

### After this task is completed

1. Install a replacement unit. See “Install a flash power module” on page 102.
2. If you are instructed to return the component or optional device, follow all packaging instructions, and use any packaging materials for shipping that are supplied to you.

### Demo video

[Watch the procedure on YouTube](#)

<https://www.youtube.com/watch?v=v9GWmcucRJg>

## Install a flash power module

Follow the instructions in this section to install a flash power module.

### About this task

#### S002



#### **CAUTION:**

The power-control button on the device and the power switch on the power supply do not turn off the electrical current supplied to the device. The device also might have more than one power cord. To remove all electrical current from the device, ensure that all power cords are disconnected from the power source.

#### **Attention:**

- Read “Installation Guidelines” on page 41 and “Safety inspection checklist” on page 42 to ensure that you work safely.
- Power off the server and disconnect all power cords for this task. See “Power off the server” on page 53.

- Prevent exposure to static electricity, which might lead to system halt and loss of data, by keeping static-sensitive components in their static-protective packages until installation, and handling these devices with an electrostatic-discharge wrist strap or other grounding system.

Locate the flash power module slots on the air baffle.

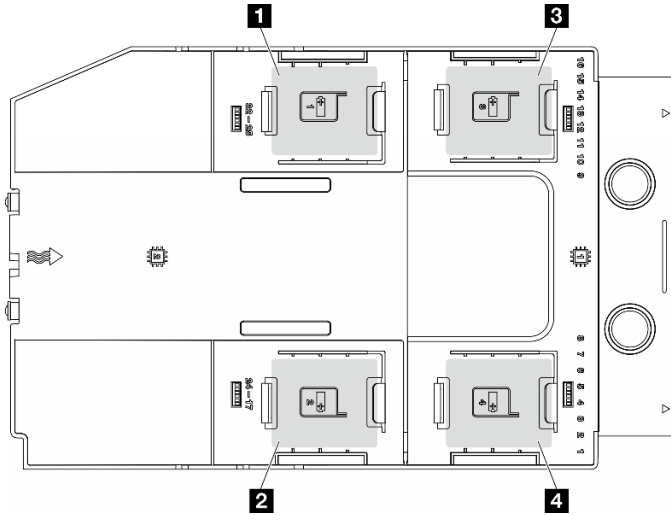

Figure 57. Location of the flash power module slots

Table 26. Flash power module slot location on air baffle

<b>1</b> Flash power module slot 1	<b>3</b> Flash power module slot 3
<b>2</b> Flash power module slot 2	<b>4</b> Flash power module slot 4

## Procedure

Step 1. Make preparations for this task.

- a. Installed the air baffle. See [“Install an air baffle” on page 75](#).

Step 2. Route the flash power module cable and connect it to the RAID adapter.

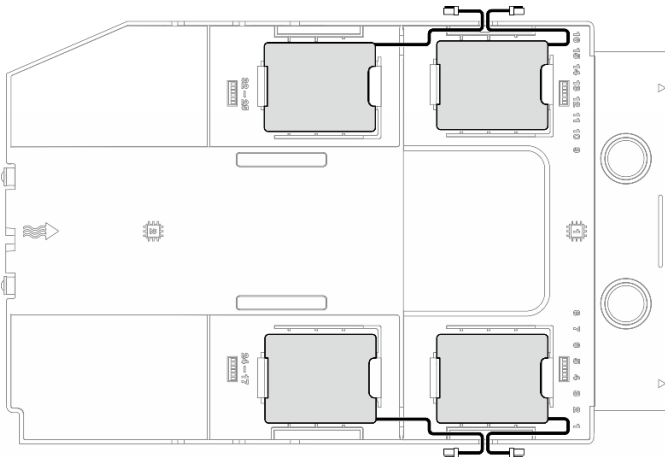

Figure 58. Flash power module cable routing

Step 3. Install the flash power module.

- a. ① Note the orientation of the flash power module; then, gently insert one side of the flash power module into the retaining clip as shown.
- b. ② Press the flash power module down on the other side until it snaps into place.

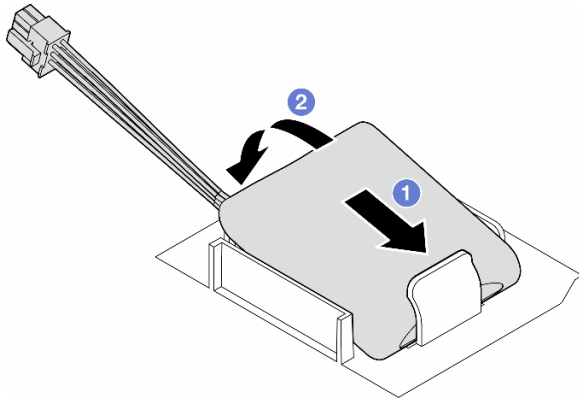

Figure 59. Installation of a flash power module

### After you finish

1. Reinstall the server cover. See “Install a server cover” on page 231.
2. Complete the parts replacement. See “Complete the parts replacement” on page 233.

### Demo video

[Watch the procedure on YouTube](#)

<https://www.youtube.com/watch?v=N3BWqwcUMsg>

---

## Foot stands replacement

Follow the instructions in this section to remove or install foot stands.

**Note:** This section applies only to server models with foot stands installed.

### Remove the foot stands

Follow the instructions in this section to remove foot stands.

### About this task

**S033**



#### **CAUTION:**

**Hazardous energy present. Voltages with hazardous energy might cause heating when shorted with metal, which might result in spattered metal, burns, or both.**

**Attention:**

- Read [“Installation Guidelines” on page 41](#) and [“Safety inspection checklist” on page 42](#) to ensure that you work safely.
- Prevent exposure to static electricity, which might lead to system halt and loss of data, by keeping static-sensitive components in their static-protective packages until installation, and handling these devices with an electrostatic-discharge wrist strap or other grounding system.

**Procedure**

Step 1. For each foot stand, rotate the foot stand inwards; then, lay the server on its side.

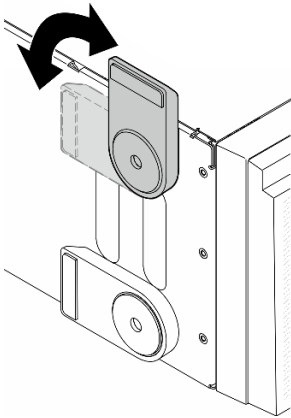

Figure 60. Foot stand adjustment

Step 2. For each foot stand, loosen the screw that secures the foot stand; then, remove the foot stand from the chassis.

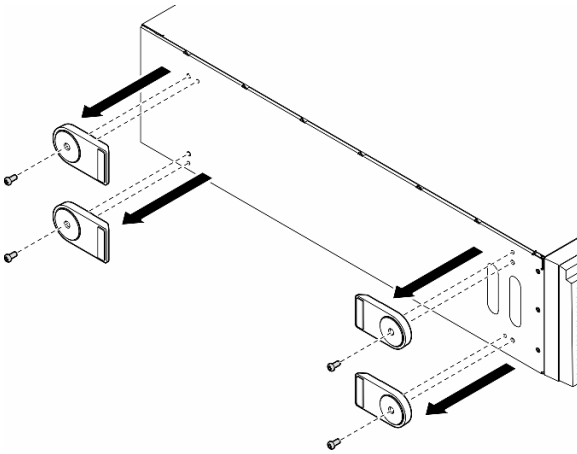

Figure 61. Removal of foot stands

**After this task is completed**

1. Install the replacement unit(s), if necessary. See [“Install the foot stands” on page 106](#).
2. If you are instructed to return the component or optional device, follow all packaging instructions, and use any packaging materials for shipping that are supplied to you.

## Demo video

Watch the procedure on YouTube

<https://www.youtube.com/watch?v=Xo349QxCQxw>

## Install the foot stands

Follow the instructions in this section to install foot stands.

### About this task

#### **S033**



#### **CAUTION:**

**Hazardous energy present. Voltages with hazardous energy might cause heating when shorted with metal, which might result in spattered metal, burns, or both.**

#### **Attention:**

- Read “[Installation Guidelines](#)” on page 41 and “[Safety inspection checklist](#)” on page 42 to ensure that you work safely.
- Prevent exposure to static electricity, which might lead to system halt and loss of data, by keeping static-sensitive components in their static-protective packages until installation, and handling these devices with an electrostatic-discharge wrist strap or other grounding system.

### Procedure

Step 1. For each foot stand, carefully align the pin and screw hole on the foot stand with the corresponding hole on the chassis; then, tighten a screw to secure the foot stand.

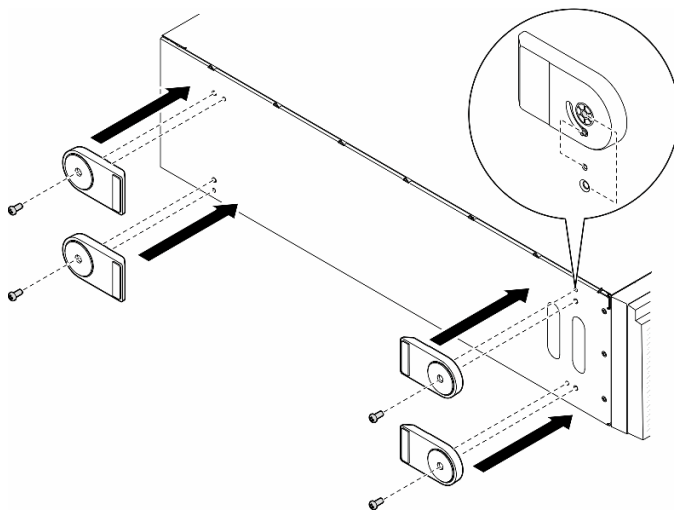

*Figure 62. Installation of foot stands*

Step 2. For each foot stand, rotate the foot stand outwards.

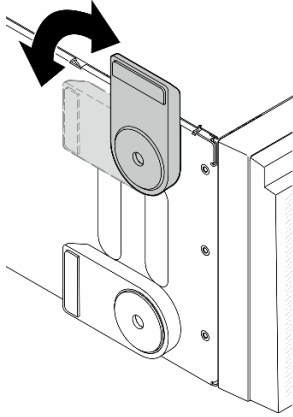

Figure 63. Foot stand adjustment

**Important:** To help the server stand steadily, make sure that the foot stands are rotated outward.

### After this task is completed

Complete the parts replacement. See [“Complete the parts replacement” on page 233](#).

### Demo video

[Watch the procedure on YouTube](#)

<https://www.youtube.com/watch?v=o3-OJNAE9KQ>

---

## Front bezel replacement

Follow the instructions in this section to remove or install a front bezel.

### Remove the front bezel

Follow the instructions in this section to remove a front bezel.

### About this task

#### S033



#### **CAUTION:**

**Hazardous energy present. Voltages with hazardous energy might cause heating when shorted with metal, which might result in spattered metal, burns, or both.**

#### **Attention:**

- Read [“Installation Guidelines” on page 41](#) and [“Safety inspection checklist” on page 42](#) to ensure that you work safely.

- Prevent exposure to static electricity, which might lead to system halt and loss of data, by keeping static-sensitive components in their static-protective packages until installation, and handling these devices with an electrostatic-discharge wrist strap or other grounding system.
- If the server is in a rack, remove it from the rack.
- If foot stands are installed on the server, pivot them inwards and lay the server on its side for easier operation.

## Procedure

Step 1. Make preparations for this task.

- Remove the server cover. See [“Remove the server cover” on page 230](#).
- Remove the security door. See [“Remove the security door” on page 207](#).

Step 2. Remove the front bezel.

- 1 Lift the three plastic tabs to release the left side of the bezel from the chassis.
- 2 Pivot the bezel as shown to remove it from the chassis.

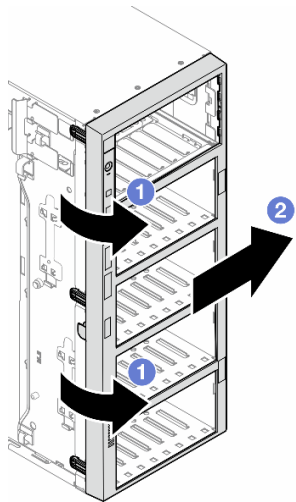

Figure 64. Removal of a front bezel

## After this task is completed

1. Install the replacement unit(s), if necessary. See [“Install a front bezel” on page 108](#).
2. If you are instructed to return the component or optional device, follow all packaging instructions, and use any packaging materials for shipping that are supplied to you.

## Demo video

[Watch the procedure on YouTube](#)

<https://www.youtube.com/watch?v=3wg3FAPqT-w>

## Install a front bezel

Follow the instructions in this section to install a front bezel.

## About this task

## S033



### CAUTION:

**Hazardous energy present. Voltages with hazardous energy might cause heating when shorted with metal, which might result in spattered metal, burns, or both.**

### Attention:

- Read “[Installation Guidelines](#)” on page 41 and “[Safety inspection checklist](#)” on page 42 to ensure that you work safely.
- Prevent exposure to static electricity, which might lead to system halt and loss of data, by keeping static-sensitive components in their static-protective packages until installation, and handling these devices with an electrostatic-discharge wrist strap or other grounding system.

### Procedure

- Step 1. ① Align the three plastic tabs on the right side of the front bezel with the corresponding holes in the chassis; then, install the right side of the bezel into place.
- Step 2. ② Pivot the front bezel inward until the left side snaps into position.

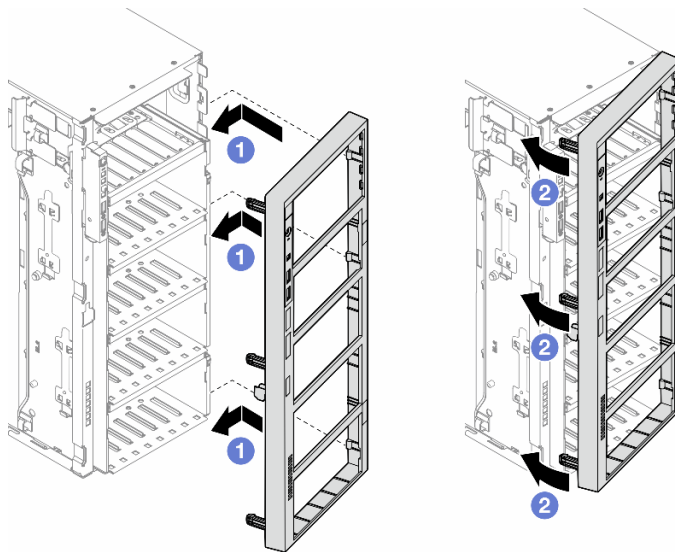

Figure 65. Installation of a front bezel

### After this task is completed

1. Reinstall the server cover. See “[Install a server cover](#)” on page 231.
2. Reinstall the security door. See “[Install the security door](#)” on page 208.
3. Complete the parts replacement. See “[Complete the parts replacement](#)” on page 233.

### Demo video

[Watch the procedure on YouTube](#)

---

## Front I/O module replacement

Follow the instructions in this section to remove or install a front I/O module.

### Remove the front I/O module

Follow the instructions in this section to remove the front I/O module.

#### About this task

##### S002



#### CAUTION:

The power-control button on the device and the power switch on the power supply do not turn off the electrical current supplied to the device. The device also might have more than one power cord. To remove all electrical current from the device, ensure that all power cords are disconnected from the power source.

#### Attention:

- Read [“Installation Guidelines” on page 41](#) and [“Safety inspection checklist” on page 42](#) to ensure that you work safely.
- Power off the server and disconnect all power cords for this task. See [“Power off the server” on page 53](#).
- Prevent exposure to static electricity, which might lead to system halt and loss of data, by keeping static-sensitive components in their static-protective packages until installation, and handling these devices with an electrostatic-discharge wrist strap or other grounding system.
- If the server is in a rack, remove it from the rack.

### Procedure

Step 1. Make preparations for this task.

- a. Remove the security door. See [“Remove the security door” on page 207](#).
- b. Remove the front bezel. See [“Remove the front bezel” on page 107](#).
- c. If foot stands are installed on the server, pivot them inwards and lay the server on its side for easier operation.
- d. Remove the server cover. See [“Remove the server cover” on page 230](#).
- e. If necessary, remove all flash power modules. See [“Remove a flash power module” on page 100](#).
- f. Remove the air baffle. See [“Remove the air baffle” on page 74](#).
- g. Remove all the full-length GPU adapters, if any. See [“Remove a FL GPU adapter” on page 173](#).
- h. Remove all the fan modules and fan filler. See [“Remove a fan module” on page 89](#).

**Attention:** All fan modules must be removed from the fan cage when handling the fan cage assembly.

- i. Remove the fan cage assembly. See “[Remove the fan cage assembly](#)” on page 91.

Step 2. Locate the front I/O module and disconnect the cables from the system board; then, remove the cable from the cable clips. See “[Front I/O module cable routing](#)” on page 313.

**Attention:** To avoid damaging the system board, make sure to follow the instructions in [Chapter 6 “Internal cable routing”](#) on page 235 when disconnecting cables from the system board.

Step 3. Remove the front I/O module.

- a. ① Press the release tab in the direction as shown.
- b. ② Pull the front I/O module outwards; then, pull the cables out to completely remove the front I/O module from the chassis.

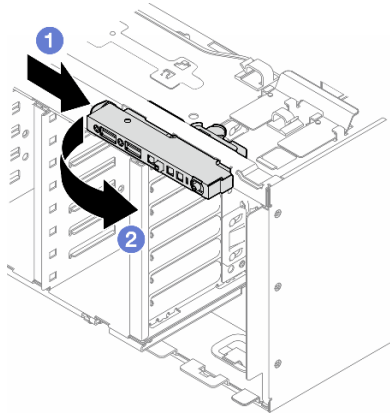

Figure 66. Removal of the front I/O module

### After this task is completed

1. Install a replacement unit. See “[Install a front I/O module](#)” on page 111.
2. If you are instructed to return the component or optional device, follow all packaging instructions, and use any packaging materials for shipping that are supplied to you.

### Demo video

[Watch the procedure on YouTube](#)

<https://www.youtube.com/watch?v=DItZWoBKtw>

### Install a front I/O module

Follow the instructions in this section to install a front I/O module.

### About this task

**S002**



**CAUTION:**

The power-control button on the device and the power switch on the power supply do not turn off the electrical current supplied to the device. The device also might have more than one power cord. To remove all electrical current from the device, ensure that all power cords are disconnected from the power source.

**Attention:**

- Read [“Installation Guidelines” on page 41](#) and [“Safety inspection checklist” on page 42](#) to ensure that you work safely.
- Power off the server and disconnect all power cords for this task. See [“Power off the server” on page 53](#).
- Prevent exposure to static electricity, which might lead to system halt and loss of data, by keeping static-sensitive components in their static-protective packages until installation, and handling these devices with an electrostatic-discharge wrist strap or other grounding system.

**Procedure**

Step 1. Route the cables of the front I/O module through the corresponding hole in the chassis.

Step 2. Install the front I/O module.

- a. 1 Align the tab on the top side of the front I/O module with the side of the corresponding hole in the chassis.
- b. 2 Push in the front I/O module until it snaps into position.

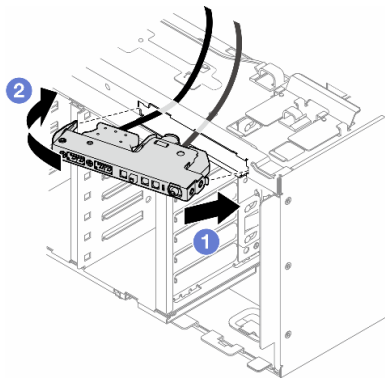

Figure 67. Installation of a front I/O module

Step 3. Carefully route the cable from the secured front I/O module along the cable clips; then, connect the cables to the corresponding connectors on the system board. See [“Front I/O module cable routing” on page 313](#).

**After this task is completed**

1. Reinstall all the PCIe adapters, if necessary. See [“Install a HL PCIe adapter” on page 167](#).

**Attention:** All fan modules must be removed from the fan cage when handling the fan cage assembly.

2. Reinstall the fan cage assembly. See [“Install the fan cage assembly” on page 92](#).
3. Reinstall all the fan modules (and fan filler, if necessary). See [“Install a fan module” on page 94](#).
4. Reinstall all the full-length GPU adapters, if necessary. See [“Install a FL GPU adapter” on page 175](#).
5. Reinstall the air baffle. See [“Install an air baffle” on page 75](#).
6. Reinstall all the flash power modules, if necessary. See [“Install a flash power module” on page 102](#).
7. Reinstall the server cover. See [“Install a server cover” on page 231](#).

8. Reinstall the front bezel. See “[Install a front bezel](#)” on page 108.
9. Reinstall the security door. See “[Install the security door](#)” on page 208.
10. Complete the parts replacement. See “[Complete the parts replacement](#)” on page 233.

## Demo video

[Watch the procedure on YouTube](#)

<https://www.youtube.com/watch?v=nH4tUIEvIKQ>

---

## FL GPU filler replacement

Follow the instructions in this section to remove or install a full-length GPU filler.

### Remove a FL GPU filler

Follow the instructions in this section to remove a full-length GPU filler.

#### About this task

##### S033



#### CAUTION:

**Hazardous energy present. Voltages with hazardous energy might cause heating when shorted with metal, which might result in spattered metal, burns, or both.**

##### S017



#### CAUTION:

**Hazardous moving fan blades nearby. Keep fingers and other body parts away.**

#### Attention:

- Read “[Installation Guidelines](#)” on page 41 and “[Safety inspection checklist](#)” on page 42 to ensure that you work safely.
- Prevent exposure to static electricity, which might lead to system halt and loss of data, by keeping static-sensitive components in their static-protective packages until installation, and handling these devices with an electrostatic-discharge wrist strap or other grounding system.
- If the server is in a rack, remove it from the rack.
- If foot stands are installed on the server, pivot them inwards and lay the server on its side for easier operation.

## Procedure

- Step 1. Make preparations for this task.
- Remove the server cover. See “[Remove the server cover](#)” on page 230.
- Step 2. Press and hold on the latch to release and remove the FL GPU filler from the air baffle.

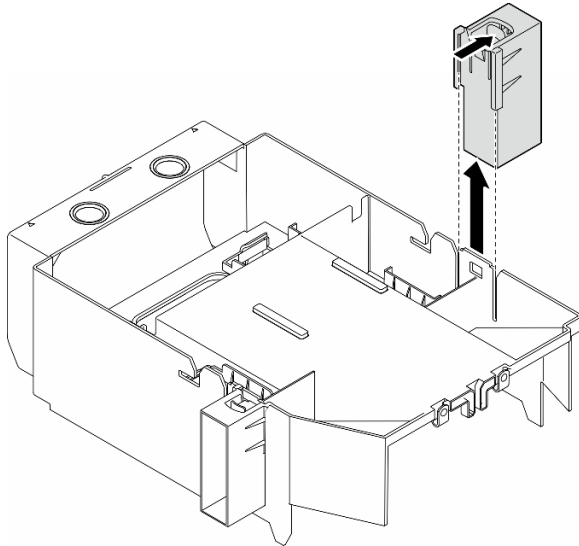

Figure 68. Removal of a FL GPU filler

### After this task is completed

- Install the replacement unit(s), if necessary. See “[Install a FL GPU filler](#)” on page 114.
- If you are instructed to return the component or optional device, follow all packaging instructions, and use any packaging materials for shipping that are supplied to you.

### Demo video

[Watch the procedure on YouTube](#)

<https://www.youtube.com/watch?v=QMKBLpYinJ8>

### Install a FL GPU filler

Follow the instructions in this section to install a full-length GPU filler.

### About this task

#### S033



#### **CAUTION:**

**Hazardous energy present. Voltages with hazardous energy might cause heating when shorted with metal, which might result in spattered metal, burns, or both.**

#### S017



**CAUTION:**

**Hazardous moving fan blades nearby. Keep fingers and other body parts away.**

**Attention:**

- Read [“Installation Guidelines” on page 41](#) and [“Safety inspection checklist” on page 42](#) to ensure that you work safely.
- Prevent exposure to static electricity, which might lead to system halt and loss of data, by keeping static-sensitive components in their static-protective packages until installation, and handling these devices with an electrostatic-discharge wrist strap or other grounding system.

**Notes:**

- When there is only one FL GPU installed between PCIe slots 1 and 4 or between slots 5 and 8, one or two **FL GPU fillers** are required to be installed on the air baffle on the same side of the FL GPU for proper cooling and airflow.
- One or two **FL PCIe adapter holders** are required to have been installed corresponding to the PCIe slot(s) for the FL GPU adapter(s) to be installed.

See [“GPU installation rules” on page 171](#) for detailed information about the technical rules for GPU installation.

**Procedure**

- Step 1. Make preparations for this task.
  - a. If necessary, install the air baffle. See [“Install an air baffle” on page 75](#).
- Step 2. Align the FL GPU filler with the corresponding slot on the air baffle.
- Step 3. Insert the GPU filler onto the air baffle until it snaps into position

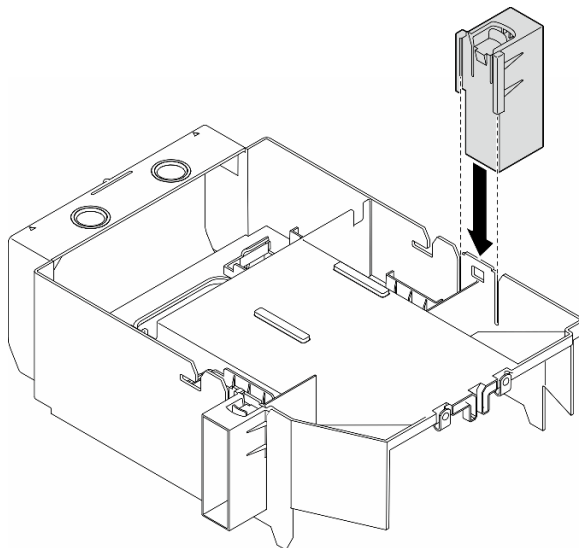

*Figure 69. FL GPU filler installation*

**After this task is completed**

1. Reinstall the server cover. See [“Install a server cover”](#) on page 231.
2. Complete the parts replacement. See [“Complete the parts replacement”](#) on page 233.

## Demo video

[Watch the procedure on YouTube](#)

<https://www.youtube.com/watch?v=0UddsU83YVs>

---

## Internal CFF HBA/RAID adapter replacement

Follow the instructions in this section to remove or install an internal CFF HBA, RAID adapter, or RAID expander adapter.

### Remove an internal CFF adapter

Follow the instructions in this section to remove an internal CFF HBA, RAID adapter, or RAID expander adapter.

### About this task

#### S002



#### **CAUTION:**

The power-control button on the device and the power switch on the power supply do not turn off the electrical current supplied to the device. The device also might have more than one power cord. To remove all electrical current from the device, ensure that all power cords are disconnected from the power source.

#### **Attention:**

- Read [“Installation Guidelines”](#) on page 41 and [“Safety inspection checklist”](#) on page 42 to ensure that you work safely.
- Power off the server and disconnect all power cords for this task. See [“Power off the server”](#) on page 53.
- Prevent exposure to static electricity, which might lead to system halt and loss of data, by keeping static-sensitive components in their static-protective packages until installation, and handling these devices with an electrostatic-discharge wrist strap or other grounding system.
- If the server is in a rack, remove it from the rack.
- If foot stands are installed on the server, pivot them inwards and lay the server on its side for easier operation.

Location of the internal CFF adapter.

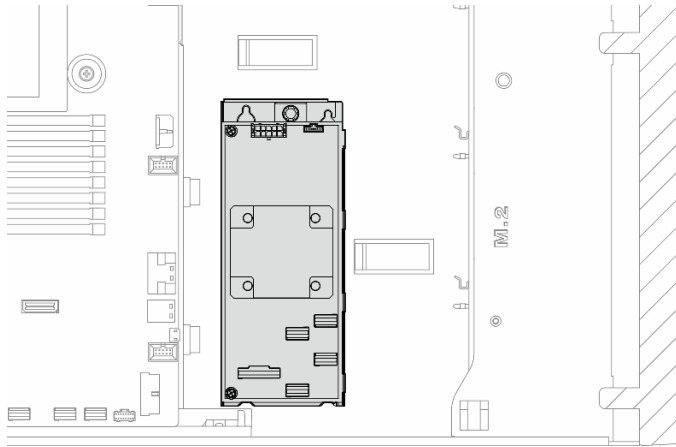

Figure 70. Location of the internal CFF adapter

## Procedure

Step 1. Make preparations for this task.

- a. Remove the server cover. See [“Remove the server cover”](#) on page 230.
- b. If necessary, remove all flash power modules. See [“Remove a flash power module”](#) on page 100.
- c. Remove the air baffle. See [“Remove the air baffle”](#) on page 74.
- d. Remove all the full-length GPU adapters, if any. See [“Remove a FL GPU adapter”](#) on page 173.
- e. If necessary, remove the A2/L4 GPU air duct(s) or FL PCIe adapter holder(s) installed on the fan cage. See [“Remove an A2/L4 GPU air duct”](#) on page 71 or [“Remove a FL PCIe adapter holder”](#) on page 162.
- f. Remove all the fan modules and fan filler. See [“Remove a fan module”](#) on page 89.

**Attention:** All fan modules must be removed from the fan cage when handling the fan cage assembly.

- g. Remove the fan cage assembly. See [“Remove the fan cage assembly”](#) on page 91.

Step 2. Disconnect all the cables from the CFF adapter.

Step 3. Lift the release pin.

Step 4. Slightly slide the CFF adapter toward the pin and carefully lift it out of the chassis.

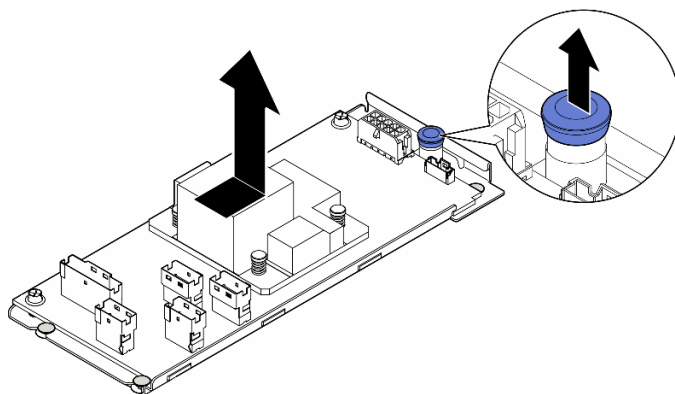

Figure 71. Removal of the internal CFF adapter

Step 5. If necessary, loosen the two screws on the CFF adapter to separate it from its tray.

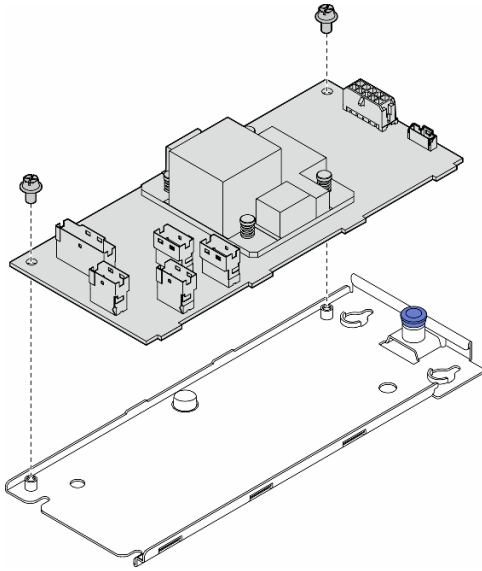

Figure 72. Removal of the internal CFF adapter from its tray

### After this task is completed

1. Install a replacement unit. See [“Install an internal CFF adapter” on page 118](#).
2. If you are instructed to return the component or optional device, follow all packaging instructions, and use any packaging materials for shipping that are supplied to you.

### Demo video

[Watch the procedure on YouTube](#)

<https://www.youtube.com/watch?v=mYJncZI1puk>

### Install an internal CFF adapter

Follow the instructions in this section to install an internal CFF HBA, RAID adapter, or RAID expander adapter.

### About this task

#### S002



#### **CAUTION:**

The power-control button on the device and the power switch on the power supply do not turn off the electrical current supplied to the device. The device also might have more than one power cord. To remove all electrical current from the device, ensure that all power cords are disconnected from the power source.

#### **Attention:**

- Read “[Installation Guidelines](#)” on page 41 and “[Safety inspection checklist](#)” on page 42 to ensure that you work safely.
- Power off the server and disconnect all power cords for this task. See “[Power off the server](#)” on page 53.
- Prevent exposure to static electricity, which might lead to system halt and loss of data, by keeping static-sensitive components in their static-protective packages until installation, and handling these devices with an electrostatic-discharge wrist strap or other grounding system.

Location of the internal CFF adapter.

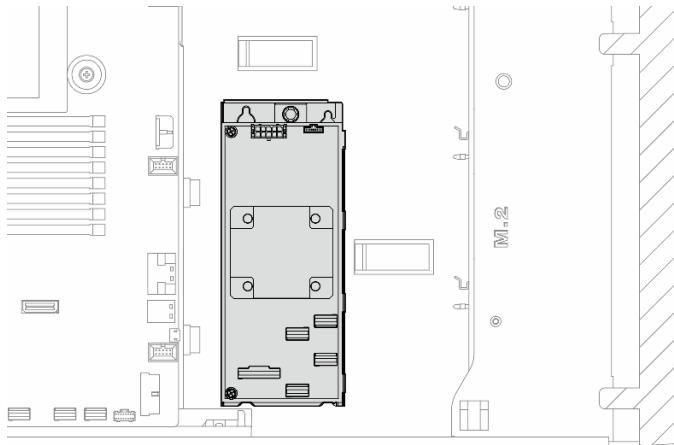

Figure 73. Location of the internal CFF adapter

## Procedure

- Step 1. Align the holes on the CFF adapter with the holes on the adapter tray and put down the CFF adapter onto the tray; then, tighten the screws to secure the CFF adapter.

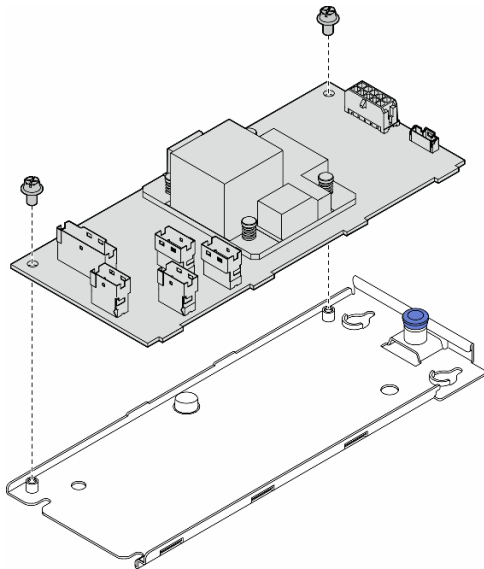

Figure 74. Installation of the internal CFF adapter on its tray

- Step 2. Align the notches on the tray with the pins on the chassis; then, place the CFF adapter down and slide it to one side to secure it to the chassis.

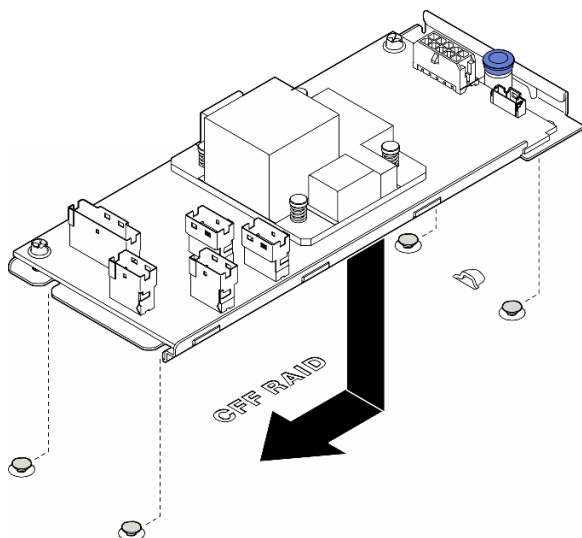

Figure 75. Installation of the internal CFF adapter

Step 3. Close the release pin to secure the CFF adapter into position.

Step 4. Refer to the server configuration and connect the cables to the CFF adapter. See [“3.5-inch drive cable routing” on page 241](#) or [“2.5-inch drive cable routing” on page 278](#).

### After this task is completed

1. Reinstall the fan cage assembly. See [“Install the fan cage assembly” on page 92](#).

**Attention:** All fan modules must be removed from the fan cage when handling the fan cage assembly.

2. Reinstall all the fan modules (and fan filler, if necessary). See [“Install a fan module” on page 94](#).

3. Install the required A2/L4 GPU air ducts or FL PCIe adapter holders. See [“Install an A2/L4 GPU air duct” on page 72](#) and [“Install a FL PCIe adapter holder” on page 164](#).

4. Reinstall all the full-length GPU adapters, if necessary. See [“Install a FL GPU adapter” on page 175](#).

5. Reconnect all the cables that were removed. See [Chapter 6 “Internal cable routing” on page 235](#).

6. Reinstall the air baffle. See [“Install an air baffle” on page 75](#).

7. Reinstall all the flash power modules, if necessary. See [“Install a flash power module” on page 102](#).

8. Reinstall the server cover. See [“Install a server cover” on page 231](#).

9. Complete the parts replacement. See [“Complete the parts replacement” on page 233](#).

### Demo video

[Watch the procedure on YouTube](#)

<https://www.youtube.com/watch?v=8u6-SdXP994>

---

## Intrusion switch replacement

Follow the instructions in this section to remove or install the intrusion switch. The intrusion switch informs you that the server cover is not properly installed or closed by creating an event in the system event log (SEL).

## Remove the intrusion switch

Follow the instructions in this section to remove an intrusion switch.

### About this task

#### S002

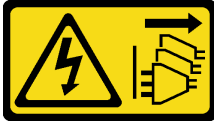

#### **CAUTION:**

The power-control button on the device and the power switch on the power supply do not turn off the electrical current supplied to the device. The device also might have more than one power cord. To remove all electrical current from the device, ensure that all power cords are disconnected from the power source.

#### **Attention:**

- Read [“Installation Guidelines” on page 41](#) and [“Safety inspection checklist” on page 42](#) to ensure that you work safely.
- Power off the server and disconnect all power cords for this task. See [“Power off the server” on page 53](#).
- Prevent exposure to static electricity, which might lead to system halt and loss of data, by keeping static-sensitive components in their static-protective packages until installation, and handling these devices with an electrostatic-discharge wrist strap or other grounding system.
- If the server is in a rack, remove it from the rack.
- If foot stands are installed on the server, pivot them inwards and lay the server on its side for easier operation.

### Procedure

Step 1. Make preparations for this task.

- a. Remove the server cover. See [“Remove the server cover” on page 230](#).
- b. If necessary, remove all flash power modules. See [“Remove a flash power module” on page 100](#).
- c. Remove the air baffle. See [“Remove the air baffle” on page 74](#).

Step 2. Disconnect the intrusion switch cable from the system board.

Step 3. Press the two intrusion switch pinch tabs towards each other; then, carefully pull out the intrusion switch to remove it from the frame.

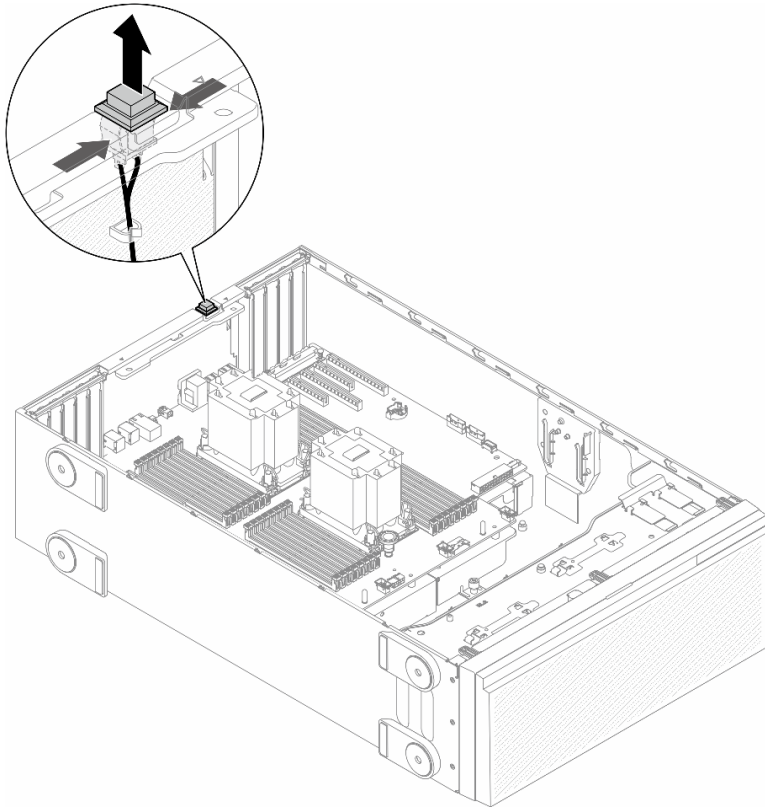

Figure 76. Removal of an intrusion switch

### After this task is completed

1. Install a replacement unit. See “Install an intrusion switch” on page 122.
2. If you are instructed to return the component or optional device, follow all packaging instructions, and use any packaging materials for shipping that are supplied to you.

### Demo video

[Watch the procedure on YouTube](#)

<https://www.youtube.com/watch?v=G0STTuJzBT4>

### Install an intrusion switch

Follow the instructions in this section to install an intrusion switch.

### About this task

**S002**



**CAUTION:**

The power-control button on the device and the power switch on the power supply do not turn off the electrical current supplied to the device. The device also might have more than one power cord. To remove all electrical current from the device, ensure that all power cords are disconnected from the power source.

**Attention:**

- Read [“Installation Guidelines” on page 41](#) and [“Safety inspection checklist” on page 42](#) to ensure that you work safely.
- Power off the server and disconnect all power cords for this task. See [“Power off the server” on page 53](#).
- Prevent exposure to static electricity, which might lead to system halt and loss of data, by keeping static-sensitive components in their static-protective packages until installation, and handling these devices with an electrostatic-discharge wrist strap or other grounding system.

**Procedure**

Step 1. Insert the cable of the new intrusion switch and then the tab on the intrusion switch frame into the corresponding hole in the chassis. Then, push the intrusion switch in until it is securely seated.

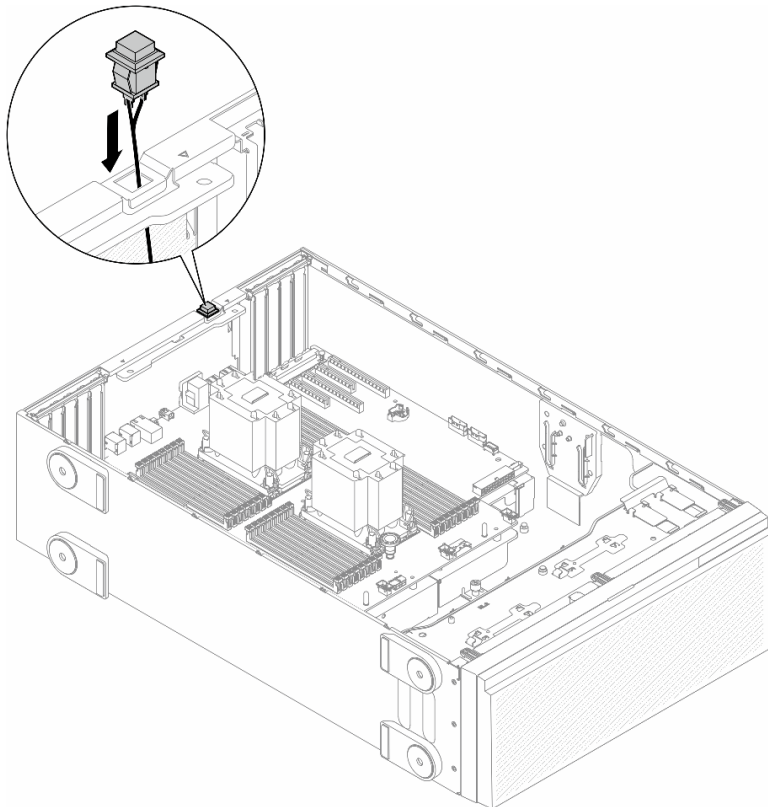

*Figure 77. Installation of an intrusion switch*

Step 2. Connect the intrusion switch cable to the system board. See [“System board connectors” on page 26](#).

**After this task is completed**

1. Reinstall the air baffle. See [“Install an air baffle” on page 75](#).
2. Reinstall all the flash power modules, if necessary. See [“Install a flash power module” on page 102](#).
3. Reinstall the server cover. See [“Install a server cover” on page 231](#).

4. Complete the parts replacement. See [“Complete the parts replacement” on page 233](#).

## Demo video

[Watch the procedure on YouTube](#)

<https://www.youtube.com/watch?v=6C5aEVdMW4Q>

---

## M.2 drive and M.2 boot adapter replacement

Follow the instruction in this section to remove or install an M.2 drive and the M.2 boot adapter.

### Remove an M.2 drive

Follow the instructions in this section to remove an M.2 drive.

### About this task

#### S002



#### CAUTION:

**The power-control button on the device and the power switch on the power supply do not turn off the electrical current supplied to the device. The device also might have more than one power cord. To remove all electrical current from the device, ensure that all power cords are disconnected from the power source.**

#### Attention:

- Read [“Installation Guidelines” on page 41](#) and [“Safety inspection checklist” on page 42](#) to ensure that you work safely.
- Power off the server and disconnect all power cords for this task. See [“Power off the server” on page 53](#).
- Prevent exposure to static electricity, which might lead to system halt and loss of data, by keeping static-sensitive components in their static-protective packages until installation, and handling these devices with an electrostatic-discharge wrist strap or other grounding system.
- If the server is in a rack, remove it from the rack.
- If foot stands are installed on the server, pivot them inwards and lay the server on its side for easier operation.

### Procedure

Step 1. Make preparations for this task.

- a. Remove the server cover. See [“Remove the server cover” on page 230](#).

Step 2. Remove an M.2 drive.

- a. ① Pinch and hold on the M.2 drive retainer clips.
- b. ② Slide the retainer backward to loosen the M.2 drive from the M.2 boot adapter.
- c. ③ Pivot the rear side of the M.2 drive away from the M.2 boot adapter.
- d. ④ Pull the M.2 drive away from the slot at an angle of approximately 30 degrees

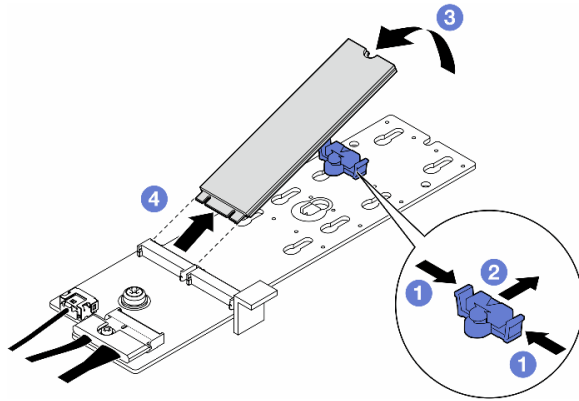

Figure 78. Removal of an M.2 drive

### After this task is completed

1. If necessary, proceed to remove the M.2 boot adapter. See “Remove an M.2 boot adapter” on page 125.
2. Install the replacement unit(s), if necessary. See “Install an M.2 drive” on page 131.
3. If you are instructed to return the component or optional device, follow all packaging instructions, and use any packaging materials for shipping that are supplied to you.

### Demo video

[Watch the procedure on YouTube](#)

[https://www.youtube.com/watch?v=Xj\\_v82Uqhs8](https://www.youtube.com/watch?v=Xj_v82Uqhs8)

### Remove an M.2 boot adapter

Follow the instructions in this section to remove an M.2 boot adapter.

### About this task

#### S002



#### CAUTION:

The power-control button on the device and the power switch on the power supply do not turn off the electrical current supplied to the device. The device also might have more than one power cord. To remove all electrical current from the device, ensure that all power cords are disconnected from the power source.

#### Attention:

- Read “Installation Guidelines” on page 41 and “Safety inspection checklist” on page 42 to ensure that you work safely.
- Power off the server and disconnect all power cords for this task. See “Power off the server” on page 53.

- Prevent exposure to static electricity, which might lead to system halt and loss of data, by keeping static-sensitive components in their static-protective packages until installation, and handling these devices with an electrostatic-discharge wrist strap or other grounding system.
- If the server is in a rack, remove it from the rack.
- If foot stands are installed on the server, pivot them inwards and lay the server on its side for easier operation.

## Procedure

Step 1. Make preparations for this task.

- Remove the server cover. See [“Remove the server cover” on page 230](#).
- Remove all M.2 drives from the M.2 boot adapter. See [“Remove an M.2 drive” on page 124](#).

Step 2. Disconnect all the cables from the M.2 boot adapter.

- Loosen the screw on the signal cable.
- Tilt the connector and remove it.
- Remove the power cable.

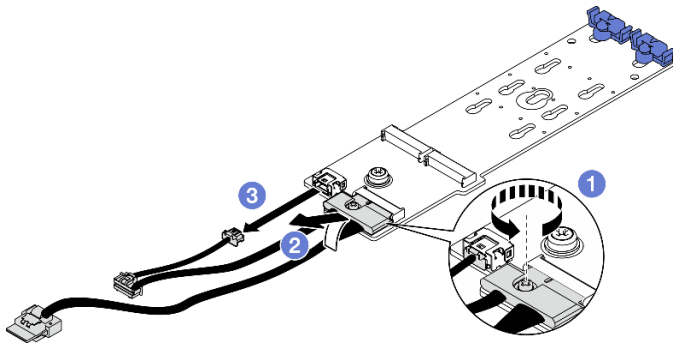

Figure 79. Disconnecting M.2 cables from ThinkSystem M.2 SATA/NVMe 2-Bay Enablement Kit or ThinkSystem M.2 NVMe 2-Bay RAID Enablement Kit

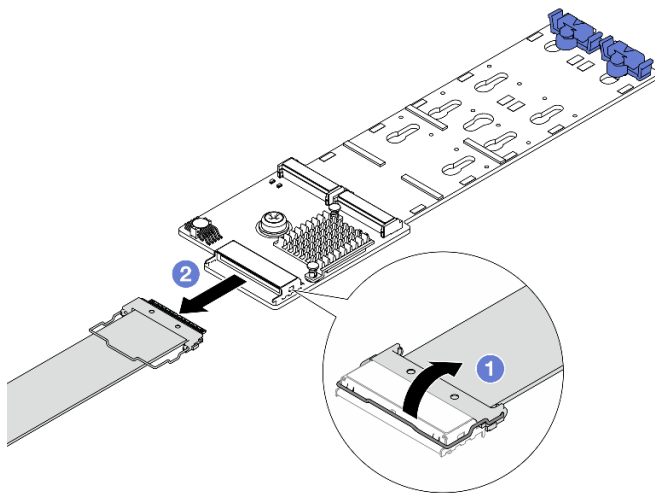

Figure 80. Disconnecting M.2 cables from ThinkSystem M.2 RAID B540i-2i SATA/NVMe Enablement Kit

- Unhook the wire bail on the cable from the connector.
- Disconnect the cable from the M.2 boot adapter.

Step 3. Remove the M.2 boot adapter.

- a. ① Loosen the screw that secures the M.2 boot adapter to the chassis.
- b. ② Slightly slide the M.2 boot adapter towards the side of the M.2 screw hole; then, carefully lift the M.2 adapter away from the rear pin.

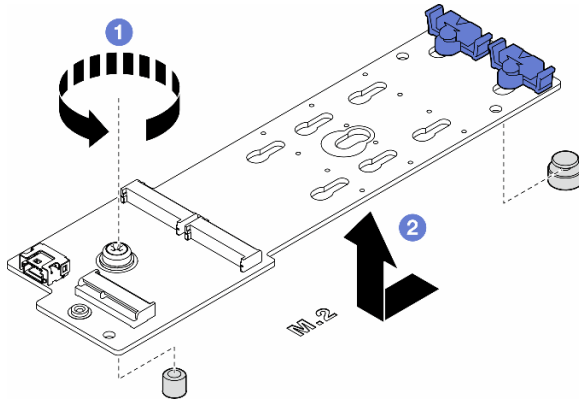

Figure 81. Removal of the M.2 boot adapter

### After this task is completed

1. Install a replacement unit. See “Install an M.2 boot adapter” on page 127.
2. If you are instructed to return the component or optional device, follow all packaging instructions, and use any packaging materials for shipping that are supplied to you.

### Demo video

[Watch the procedure on YouTube](#)

<https://www.youtube.com/watch?v=piQJWa1ImjU>

### Install an M.2 boot adapter

Follow the instructions in this section to install an M.2 boot adapter.

### About this task

**S002**



#### CAUTION:

The power-control button on the device and the power switch on the power supply do not turn off the electrical current supplied to the device. The device also might have more than one power cord. To remove all electrical current from the device, ensure that all power cords are disconnected from the power source.

#### Attention:

- Read “[Installation Guidelines](#)” on page 41 and “[Safety inspection checklist](#)” on page 42 to ensure that you work safely.
- Power off the server and disconnect all power cords for this task. See “[Power off the server](#)” on page 53.
- Prevent exposure to static electricity, which might lead to system halt and loss of data, by keeping static-sensitive components in their static-protective packages until installation, and handling these devices with an electrostatic-discharge wrist strap or other grounding system.
- When the ThinkSystem M.2 SATA/NVMe 2-Bay Enablement Kit is installed, the M.2 drives are managed by Intel VROC/VMD/SATA RAID and do not support hot-swap or LED features.

## Procedure

Step 1. Install the M.2 boot adapter.

- 1 Insert the M.2 boot adapter towards the rear pin.
- 2 Tighten the screw that secures the M.2 boot adapter to the chassis.

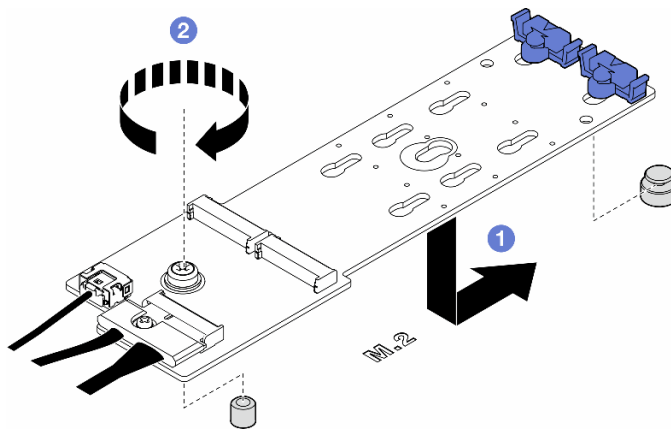

Figure 82. Installation of an M.2 boot adapter

Step 2. Connect the cables to the M.2 boot adapter.

- 1 Tilt the connector at an angle of 20 degrees or lower, and insert it until its bottom surface reaches the ramp.
- 1 Press the connector down flat.
- 1 Tighten the screw on the signal cable.
- 2 Connect the power cable.

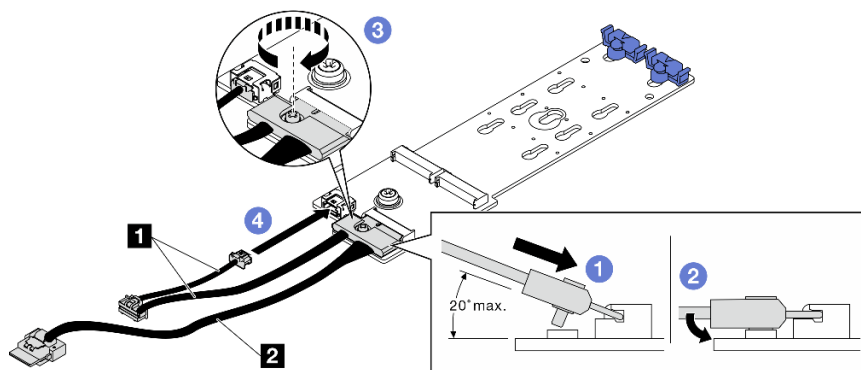

Figure 83. Connecting M.2 cables to ThinkSystem M.2 SATA/NVMe 2-Bay Enablement Kit or ThinkSystem M.2 NVMe 2-Bay RAID Enablement Kit

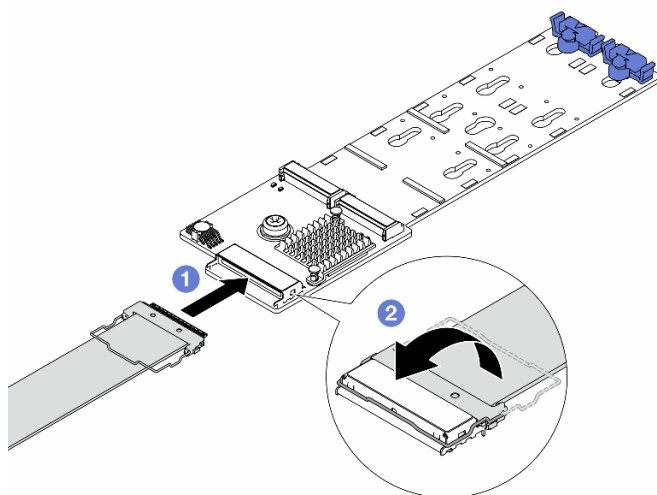

Figure 84. Connecting M.2 cables to ThinkSystem M.2 RAID B540i-2i SATA/NVMe Enablement Kit

- a. ① Connect the M.2 cable to the M.2 boot adapter.
- b. ② Rotate the latch on the cable as illustrated, and press the latch down until it clicks into place.

Step 3. Connect the power cable and the signal cable to the system board. See [“M.2 boot adapter cable routing”](#) on page 314.

### After this task is completed

1. Reinstall the server cover. See [“Install a server cover”](#) on page 231.
2. Complete the parts replacement. See [“Complete the parts replacement”](#) on page 233.

### Demo video

[Watch the procedure on YouTube](#)

<https://www.youtube.com/watch?v=jX-e7mnCnwY>

### Adjust the retainer on an M.2 boot adapter

Follow the instructions in this section to adjust the retainers on an M.2 boot adapter.

## About this task

### S002



#### CAUTION:

The power-control button on the device and the power switch on the power supply do not turn off the electrical current supplied to the device. The device also might have more than one power cord. To remove all electrical current from the device, ensure that all power cords are disconnected from the power source.

#### Attention:

- Read [“Installation Guidelines” on page 41](#) and [“Safety inspection checklist” on page 42](#) to ensure that you work safely.
- Power off the server and disconnect all power cords for this task. See [“Power off the server” on page 53](#).
- Prevent exposure to static electricity, which might lead to system halt and loss of data, by keeping static-sensitive components in their static-protective packages until installation, and handling these devices with an electrostatic-discharge wrist strap or other grounding system.

**Note:** The M.2 boot adapter might look different from the illustrations in this section, but the adjustment method is the same.

## Procedure

Step 1. Make preparations for this task.

- a. Locate the correct keyhole for the retainer according to the size of the M.2 drive.

Step 2. Adjust a retainer on the M.2 boot adapter.

- a. ① Pinch both sides of the retainer.
- b. ② Slide the retainer towards the wider opening of the keyhole.
- c. ③ Remove the retainer out of the keyhole.
- d. ④ Insert the retainer into the keyhole to be installed.
- e. ⑤ Pinch both sides of the retainer.
- f. ⑥ Slide the retainer towards the narrower opening of the keyhole until it is seated in place.

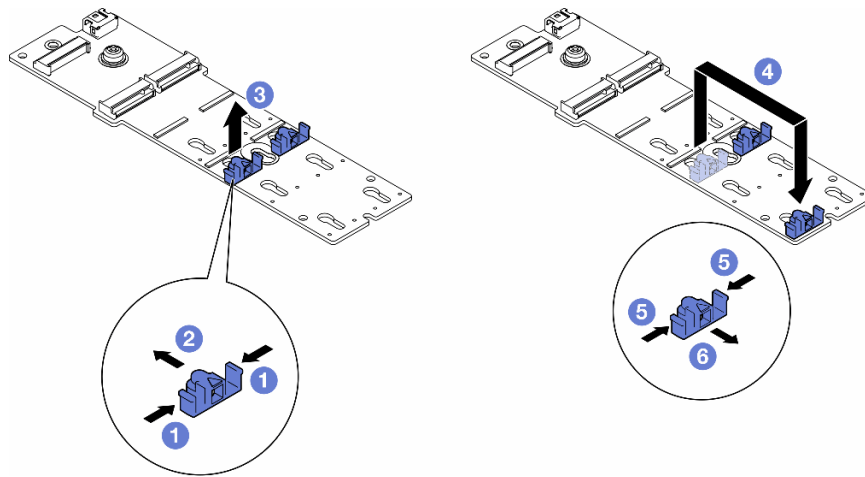

Figure 85. Adjustment of the M.2 retainer

## Demo video

Watch the procedure on YouTube

<https://www.youtube.com/watch?v=tl-S-e1hcH8>

## Install an M.2 drive

Follow the instructions in this section to install an M.2 drive onto an M.2 boot adapter.

### About this task

#### S002



#### CAUTION:

The power-control button on the device and the power switch on the power supply do not turn off the electrical current supplied to the device. The device also might have more than one power cord. To remove all electrical current from the device, ensure that all power cords are disconnected from the power source.

#### Attention:

- Read “Installation Guidelines” on page 41 and “Safety inspection checklist” on page 42 to ensure that you work safely.
- Power off the server and disconnect all power cords for this task. See “Power off the server” on page 53.
- Prevent exposure to static electricity, which might lead to system halt and loss of data, by keeping static-sensitive components in their static-protective packages until installation, and handling these devices with an electrostatic-discharge wrist strap or other grounding system.

Locate the M.2 drive slot on the M.2 boot adapter.

**Note:** Some M.2 adapters support two identical M.2 drives. Install the M.2 drive in slot 0 first.

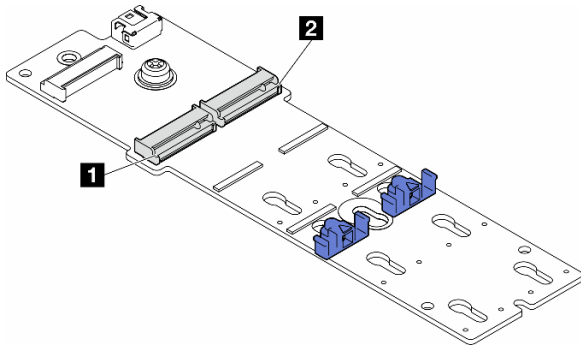

Figure 86. M.2 drive slots on an M.2 adapter

Table 27. M.2 drive slot locations on M.2 boot adapter

1 M.2 boot adapter slot 0	2 M.2 boot adapter slot 1
---------------------------	---------------------------

## Procedure

Step 1. Make preparations for this task.

- a. Adjust the retainers on the M.2 boot adapter to accommodate the M.2 drive to be stalled. See [“Adjust the retainer on an M.2 boot adapter” on page 129.](#)

Step 2. Install an M.2 drive.

- a. 1 Insert the M.2 drive into the slot at an angle of approximately 30 degrees .
- b. 2 Pivot the M.2 drive down until the notch at the end of the M.2 drive catches on the lip of the retainer.
- c. 3 Slide the retainer towards the M.2 drive to secure.

**Note:** The M.2 drive might look different from the illustrations in this section

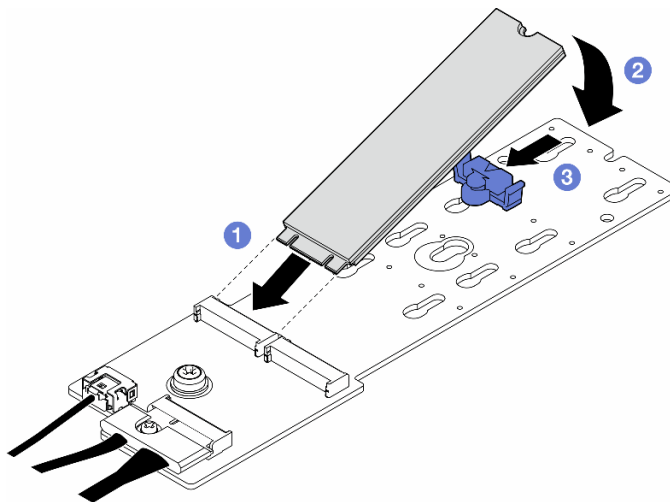

Figure 87. Installation of an M.2 drive

## After this task is completed

1. Reinstall the server cover. See [“Install a server cover” on page 231.](#)
2. Complete the parts replacement. See [“Complete the parts replacement” on page 233.](#)

## Demo video

Watch the procedure on YouTube

<https://www.youtube.com/watch?v=tl-S-e1hcH8>

---

## Memory module replacement

Follow the instructions in this section to remove or install a memory module.

### Remove a memory module

Follow the instructions in this section to remove a memory module.

### About this task

#### S002



#### **CAUTION:**

The power-control button on the device and the power switch on the power supply do not turn off the electrical current supplied to the device. The device also might have more than one power cord. To remove all electrical current from the device, ensure that all power cords are disconnected from the power source.

#### **Attention:**

- Read “Installation Guidelines” on page 41 and “Safety inspection checklist” on page 42 to ensure that you work safely.
- Power off the server and disconnect all power cords for this task. See “Power off the server” on page 53.
- If the server is in a rack, remove it from the rack.
- If foot stands are installed on the server, pivot them inwards and lay the server on its side for easier operation.
- Make sure to remove or install memory module 20 seconds after disconnecting power cords from the system. It allows the system to be completely discharged of electricity and safe for handling memory module.
- Memory modules are sensitive to static discharge and require special handling. Refer to the standard guidelines for “Handling static-sensitive devices” on page 44:
  - Always wear an electrostatic-discharge strap when removing or installing memory modules. Electrostatic-discharge gloves can also be used.
  - Never hold two or more memory modules together so that they do not touch each other. Do not stack memory modules directly on top of each other during storage.
  - Never touch the gold memory module connector contacts or allow these contacts to touch the outside of the memory module connector housing.
  - Handle memory modules with care: never bend, twist, or drop a memory module.
  - Do not use any metal tools (such as jigs or clamps) to handle the memory modules, because the rigid metals may damage the memory modules.
  - Do not insert memory modules while holding packages or passive components, which can cause package cracks or detachment of passive components by the high insertion force.

**Important:** Remove or install memory modules for one processor at a time.

## Procedure

**Attention:** Make sure to remove or install memory module 20 seconds after disconnecting power cords from the system. It allows the system to be completely discharged of electricity and safe for handling memory module.

Step 1. Make preparations for this task.

- a. Remove the server cover. See [“Remove the server cover” on page 230](#).
- b. If necessary, remove all flash power modules. See [“Remove a flash power module” on page 100](#).
- c. Remove the air baffle. See [“Remove the air baffle” on page 74](#).
- d. If necessary, remove the installed A2/L4 GPU air duct(s), FL PCIe adapter holder, or FL GPU adapter(s) (see [“Remove an A2/L4 GPU air duct” on page 71](#), [“Remove a FL PCIe adapter holder” on page 162](#), or [“Remove a FL GPU adapter” on page 173](#)).

**Note:** This step is optional. Do this step if the removal or installation of the DIMM cannot be proceeded smoothly with the A2/L4 GPU air duct(s), FL PCIe adapter holder(s), or FL GPU adapter(s) installed in place.

- e. Locate the memory module slots and determine which memory module is to be removed from the server.

**Important:** Remove or install memory modules for one processor at a time.

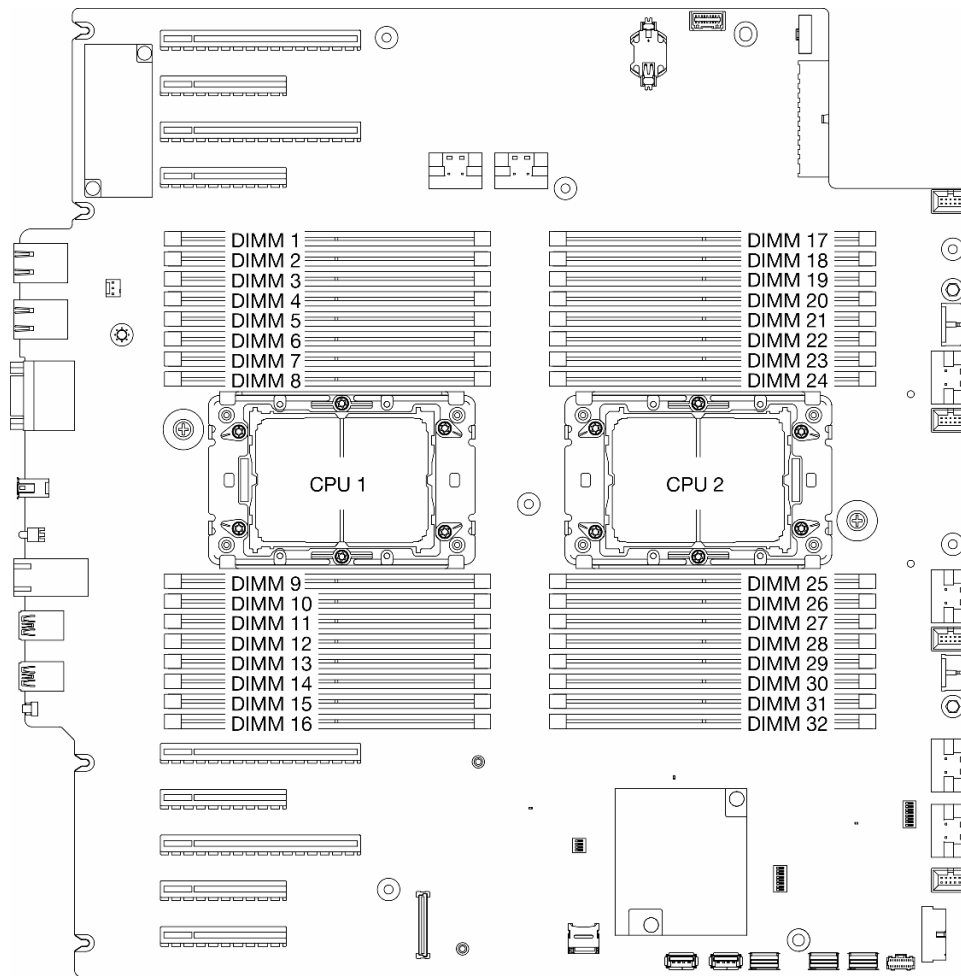

Figure 88. Memory modules and processors layout

Step 2. Remove the memory module from the slot.

**Attention:** To avoid breaking the retaining clips or damaging the memory module slots, handle the clips gently.

- a. ① Open the retaining clip at each end of the memory module slot.
- b. ② Hold both ends of the memory module and carefully lift it out of the slot.

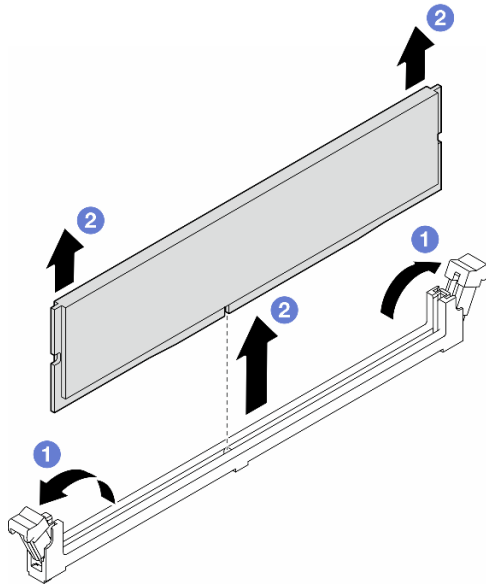

Figure 89. Removal of a memory module

### After this task is completed

- Install a replacement unit. See “[Install a memory module](#)” on page 136.
- If you are instructed to return the component or optional device, follow all packaging instructions, and use any packaging materials for shipping that are supplied to you.

### Demo video

[Watch the procedure on YouTube](#)

<https://www.youtube.com/watch?v=YscdJ1N6-Ts>

### Install a memory module

Follow the instructions in this section to install a memory module.

### About this task

**S002**



#### CAUTION:

The power-control button on the device and the power switch on the power supply do not turn off the electrical current supplied to the device. The device also might have more than one power cord. To remove all electrical current from the device, ensure that all power cords are disconnected from the power source.

#### Attention:

- Read “[Installation Guidelines](#)” on page 41 and “[Safety inspection checklist](#)” on page 42 to ensure that you work safely.

- Make sure to remove or install memory module 20 seconds after disconnecting power cords from the system. It allows the system to be completely discharged of electricity and safe for handling memory module.
- Make sure to adopt one of the supported configurations listed in “[Memory module installation rules and order](#)” on page 45.
- Memory modules are sensitive to static discharge and require special handling. Refer to the standard guidelines for “[Handling static-sensitive devices](#)” on page 44:
  - Always wear an electrostatic-discharge strap when removing or installing memory modules. Electrostatic-discharge gloves can also be used.
  - Never hold two or more memory modules together so that they do not touch each other. Do not stack memory modules directly on top of each other during storage.
  - Never touch the gold memory module connector contacts or allow these contacts to touch the outside of the memory module connector housing.
  - Handle memory modules with care: never bend, twist, or drop a memory module.
  - Do not use any metal tools (such as jigs or clamps) to handle the memory modules, because the rigid metals may damage the memory modules.
  - Do not insert memory modules while holding packages or passive components, which can cause package cracks or detachment of passive components by the high insertion force.

**Important:**

- Remove or install memory modules for one processor at a time.
- Before installing 24 Gb DRAM RDIMMs to a system with 4th Gen Intel Xeon processors, make sure to update the UEFI firmware to the latest version first, then remove all existing 16 Gb DRAM RDIMMs.

**Firmware and driver download:** You might need to update the firmware or driver after replacing a component.

- Go to <https://datacentersupport.lenovo.com/tw/en/products/servers/thinksystem/st650v3/7d7a/downloads/driver-list/> to see the latest firmware and driver updates for your server.
- Go to “[Update the firmware](#)” on page 320 for more information on firmware updating tools.

**Procedure**

**Attention:** Make sure to remove or install memory module 20 seconds after disconnecting power cords from the system. It allows the system to be completely discharged of electricity and safe for handling memory module.

Step 1. Make preparations for this task.

- a. Touch the static-protective package that contains the memory module to any unpainted surface on the outside of the server. Then, take the memory module out of the package and place it on a static-protective surface.
- b. Locate the required memory module slot on the system board.

**Important:**

- Remove or install memory modules for one processor at a time.
- Make sure to observe the installation rules and sequence order in “[Memory module installation rules and order](#)” on page 45.

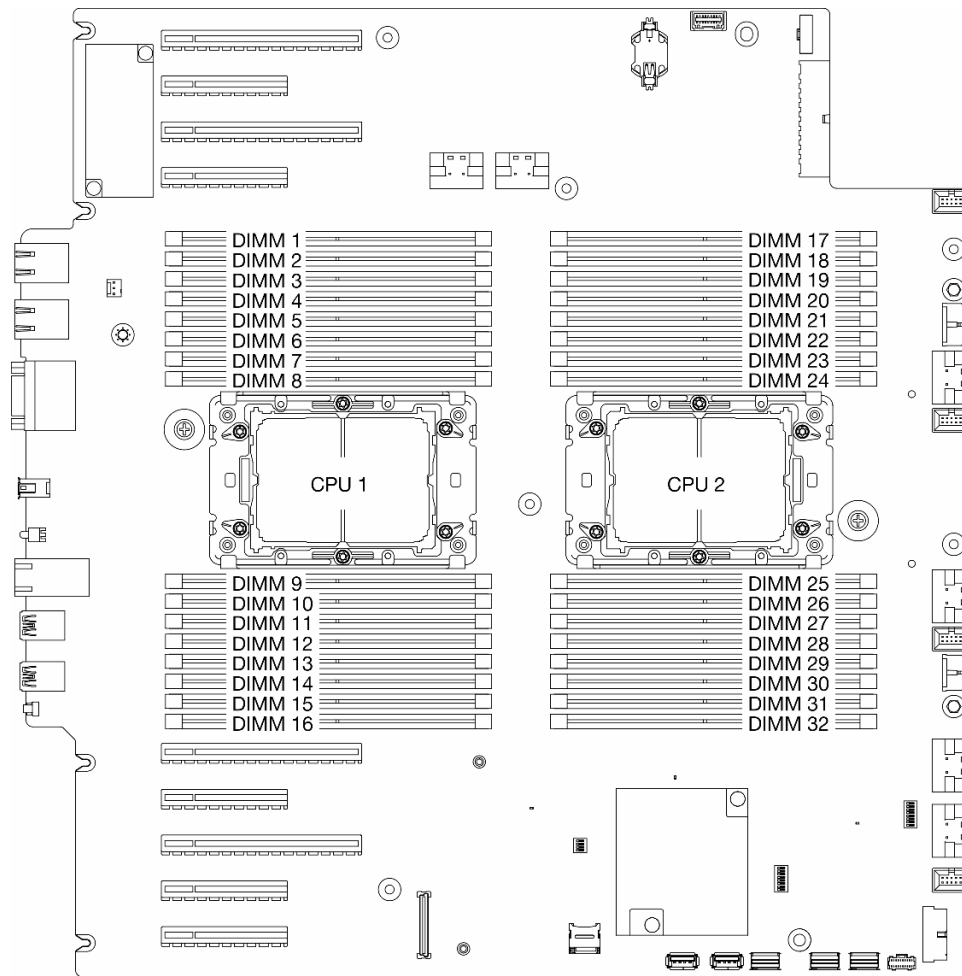

Figure 90. Memory modules and processors layout

Step 2. Install the memory module into the slot.

- a. ① Open the retaining clip at each end of the memory module slot.

**Attention:** To avoid breaking the retaining clips or damaging the memory module slots, handle the clips gently.

- b. ② Align the memory module with the slot, and gently place the memory module on the slot with both hands.
- c. ③ Firmly press both ends of the memory module straight down into the slot until the retaining clips snap into the locked position.

**Note:** If there is a gap between the memory module and the retaining clips, the memory module has not been correctly inserted. In this case, open the retaining clips, remove the memory module, and then reinsert it.

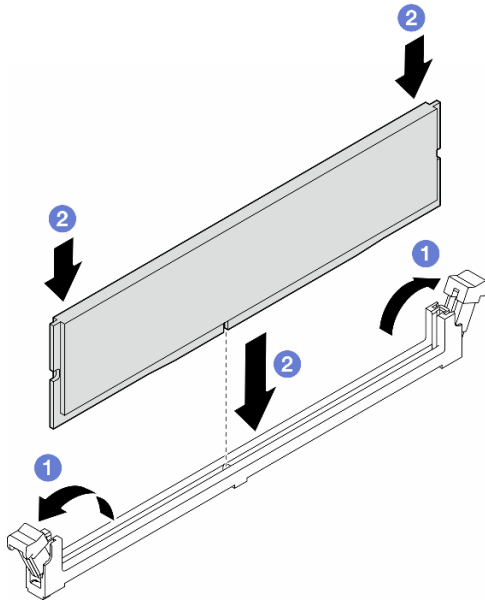

Figure 91. Installation of a memory module

### After you finish

1. If an A2/L4 GPU air duct, FL PCIe adapter holder, or FL GPU adapter have been removed because of the DIMM replacement, reinstalled them (see “Install an A2/L4 GPU air duct” on page 72, “Install a FL PCIe adapter holder” on page 164, or “Install a FL GPU adapter” on page 175).
2. Reinstall the air baffle. See “Install an air baffle” on page 75.
3. Reinstall all the flash power modules, if necessary. See “Install a flash power module” on page 102.
4. Reinstall the server cover. See “Install a server cover” on page 231.
5. Complete the parts replacement. See “Complete the parts replacement” on page 233.

### Demo video

[Watch the procedure on YouTube](#)

[https://www.youtube.com/watch?v=n\\_P-kwOXIXI](https://www.youtube.com/watch?v=n_P-kwOXIXI)

---

## MicroSD card replacement

Follow instructions in this section to remove or install a MicroSD card from or to the system board.

### Remove the MicroSD card

Follow instructions in this section to remove the MicroSD card.

### About this task

**S002**

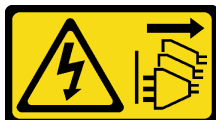

**CAUTION:**

The power-control button on the device and the power switch on the power supply do not turn off the electrical current supplied to the device. The device also might have more than one power cord. To remove all electrical current from the device, ensure that all power cords are disconnected from the power source.

**Attention:**

- Read [“Installation Guidelines” on page 41](#) and [“Safety inspection checklist” on page 42](#) to ensure that you work safely.
- Power off the server and disconnect all power cords for this task. See [“Power off the server” on page 53](#).
- Prevent exposure to static electricity, which might lead to system halt and loss of data, by keeping static-sensitive components in their static-protective packages until installation, and handling these devices with an electrostatic-discharge wrist strap or other grounding system.
- If the server is in a rack, remove it from the rack.
- If foot stands are installed on the server, pivot them inwards and lay the server on its side for easier operation.

**Procedure**

Step 1. Make preparations for this task.

- a. Remove the server cover. See [“Remove the server cover” on page 230](#).
- b. If necessary, remove all flash power modules. See [“Remove a flash power module” on page 100](#).
- c. Remove the air baffle. See [“Remove the air baffle” on page 74](#).
- d. If there are HL PCIe adapter(s) or FL GPU adapter(s) installed between PCIe slots 5 to 9, disconnect the cables and remove these adapters. See [“Remove a HL PCIe adapter” on page 165](#) or [“Remove a FL GPU adapter” on page 173](#).
- e. If an A2/L4 GPU air duct is installed on the side of PCIe slots 5 to 9, remove it. See [“Remove an A2/L4 GPU air duct” on page 71](#).
- f. Locate the MicroSD card socket on the system board (see [“System board connectors” on page 26](#)).

Step 2. Remove the MicroSD card.

- a. ① Slide the socket lid to the open position.
- b. ② Lift open the socket lid.
- c. ③ Remove the MicroSD card from the socket.

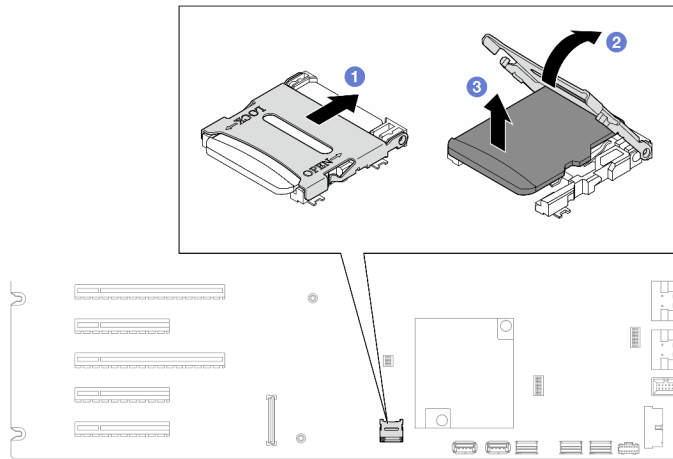

Figure 92. Removal of a MicroSD card

### After this task is completed

- Install a replacement unit. See “Install a MicroSD card” on page 141.
- If you are instructed to return the component or optional device, follow all packaging instructions, and use any packaging materials for shipping that are supplied to you.

### Demo video

Watch the procedure on YouTube

<https://www.youtube.com/watch?v=RBrcks4OP0Q>

### Install a MicroSD card

Follow instructions in this section to install a micro SD card.

### About this task

#### S002



#### **CAUTION:**

The power-control button on the device and the power switch on the power supply do not turn off the electrical current supplied to the device. The device also might have more than one power cord. To remove all electrical current from the device, ensure that all power cords are disconnected from the power source.

#### **Attention:**

- Read “Installation Guidelines” on page 41 and “Safety inspection checklist” on page 42 to ensure that you work safely.

- Power off the server and disconnect all power cords for this task. See [“Power off the server” on page 53](#).
- Prevent exposure to static electricity, which might lead to system halt and loss of data, by keeping static-sensitive components in their static-protective packages until installation, and handling these devices with an electrostatic-discharge wrist strap or other grounding system.

## Procedure

Step 1. Make preparations for this task.

- Locate the MicroSD card socket on the system board (see [“System board connectors” on page 26](#)).

Step 2. Install the MicroSD card.

- 1 Place the MicroSD card into the socket.
- 2 Close the socket lid.
- 3 Slide the socket lid to the lock position.

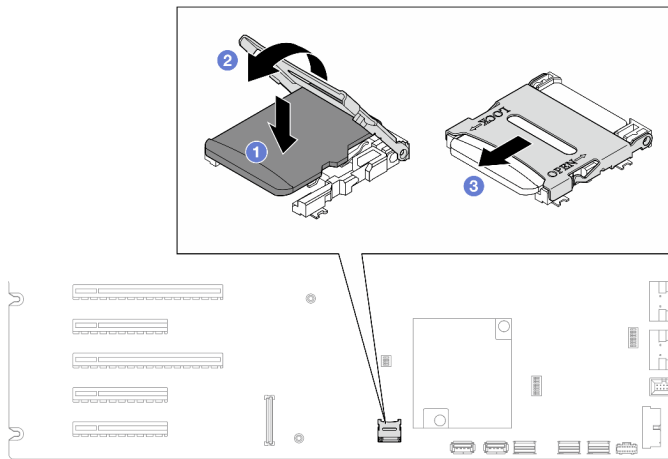

Figure 93. Installation of a MicroSD card

## After this task is completed

- Reinstalled the HL PCIe adapters and FL GPU adapters that were removed for the replacement of the MicroSD card. See [“Install a HL PCIe adapter” on page 167](#) and [“Install a FL GPU adapter” on page 175](#).
- Reinstalled the A2/L4 GPU air duct that was removed for the replacement of the MicroSD card. See [“Install an A2/L4 GPU air duct” on page 72](#).
- Reconnect all the cables that were removed. See [Chapter 6 “Internal cable routing” on page 235](#).
- Reinstall the air baffle. See [“Install an air baffle” on page 75](#).
- Reinstall all the flash power modules, if necessary. See [“Install a flash power module” on page 102](#).
- Reinstall the server cover. See [“Install a server cover” on page 231](#).
- Complete the parts replacement. See [“Complete the parts replacement” on page 233](#).

## Demo video

[Watch the procedure on YouTube](#)

<https://www.youtube.com/watch?v=4pSc-N5f1lo>

---

## GPU adapter link bridge (NVLink bridge) replacement

Follow the instructions in this section to remove or install a GPU adapter link bridge (NVLink bridge).

### Remove a GPU adapter link bridge (NVLink bridge)

Follow the instructions in this section to remove a GPU adapter link bridge (NVLink bridge).

#### About this task

**Important:** Make sure to have a suction cup available to properly remove the NVLink bridge.

#### S002



#### **CAUTION:**

The power-control button on the device and the power switch on the power supply do not turn off the electrical current supplied to the device. The device also might have more than one power cord. To remove all electrical current from the device, ensure that all power cords are disconnected from the power source.

#### **Attention:**

- Read [“Installation Guidelines” on page 41](#) and [“Safety inspection checklist” on page 42](#) to ensure that you work safely.
- Power off the server and disconnect all power cords for this task. See [“Power off the server” on page 53](#).
- Prevent exposure to static electricity, which might lead to system halt and loss of data, by keeping static-sensitive components in their static-protective packages until installation, and handling these devices with an electrostatic-discharge wrist strap or other grounding system.
- If the server is in a rack, remove it from the rack.
- If foot stands are installed on the server, pivot them inwards and lay the server on its side for easier operation.

#### **Procedure**

Step 1. Make preparations for this task.

- a. Remove the server cover. See [“Remove the server cover” on page 230](#).
- b. If necessary, remove all flash power modules. See [“Remove a flash power module” on page 100](#).
- c. Remove the air baffle, if necessary. See [“Remove the air baffle” on page 74](#).

Step 2. Press the suction cup against the NVLink bridge until it adheres; then, pull up the suction cup to remove the NVLink bridge from the GPUs.

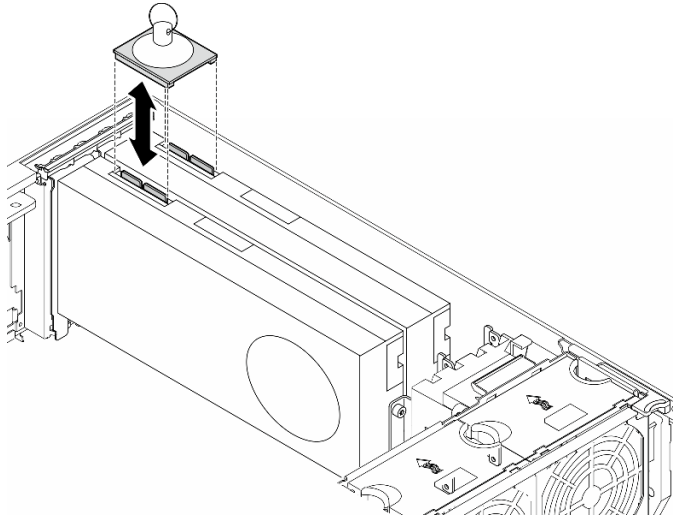

Figure 94. Removal of an NVLink bridge

Step 3. Install the NVLink covers.

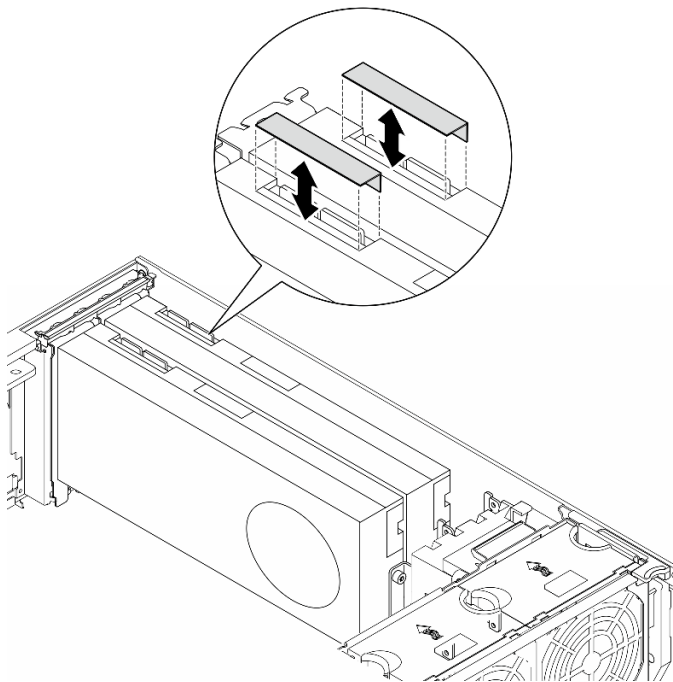

Figure 95. Installation of the NVLink covers

### After this task is completed

1. Install the replacement unit(s), if necessary. See [“Install a GPU adapter link bridge \(NVLink bridge\)” on page 145](#).
2. If you are instructed to return the component or optional device, follow all packaging instructions, and use any packaging materials for shipping that are supplied to you.

### Demo video

[Watch the procedure on YouTube](#)

<https://www.youtube.com/watch?v=dh-IHjQu6zw>

## Install a GPU adapter link bridge (NVLink bridge)

Follow the instructions in this section to install a GPU adapter link bridge (NVLink bridge).

### About this task

#### S002

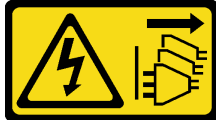

#### **CAUTION:**

The power-control button on the device and the power switch on the power supply do not turn off the electrical current supplied to the device. The device also might have more than one power cord. To remove all electrical current from the device, ensure that all power cords are disconnected from the power source.

#### **Attention:**

- Read “[Installation Guidelines](#)” on page 41 and “[Safety inspection checklist](#)” on page 42 to ensure that you work safely.
- Power off the server and disconnect all power cords for this task. See “[Power off the server](#)” on page 53.
- Prevent exposure to static electricity, which might lead to system halt and loss of data, by keeping static-sensitive components in their static-protective packages until installation, and handling these devices with an electrostatic-discharge wrist strap or other grounding system.

### Procedure

Step 1. Remove the NVLink covers.

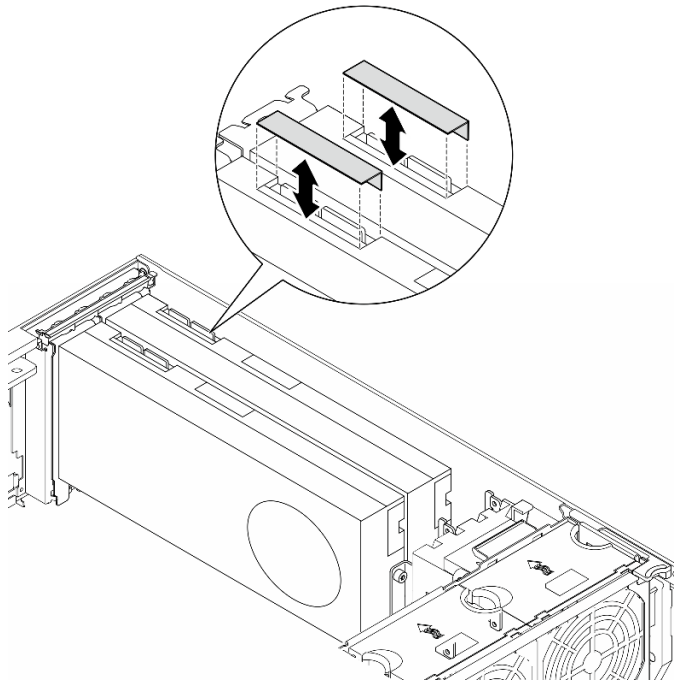

Figure 96. Removal of the NVLink covers

Step 2. Note the orientation of the NVLink bridge; then, install the NVLink bridge as shown.

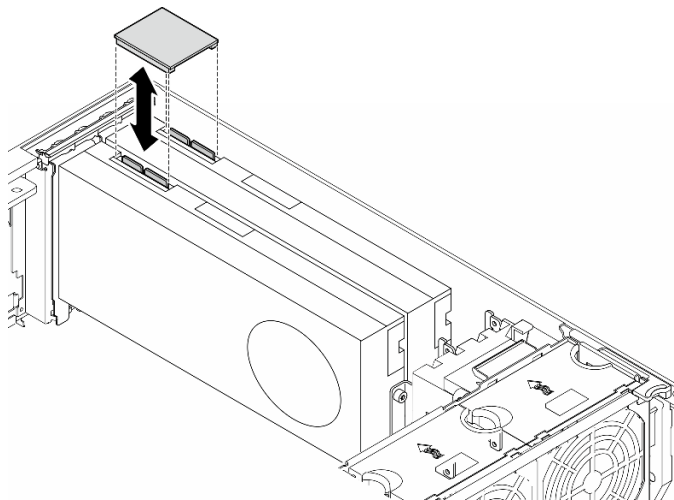

Figure 97. Installation of an NVLink bridge

### After this task is completed

1. Reinstall the air baffle, if necessary. See [“Install an air baffle” on page 75](#).
2. Reinstall all the flash power modules, if necessary. See [“Install a flash power module” on page 102](#).
3. Reinstall the server cover. See [“Install a server cover” on page 231](#).
4. Complete the parts replacement. See [“Complete the parts replacement” on page 233](#).

### Demo video

[Watch the procedure on YouTube](#)

<https://www.youtube.com/watch?v=jnS53K0Z1yo>

---

## Optical drive cage replacement

Follow the instructions in this section to remove or install an optical drive cage.

**Note:** This section applies only to server models with an optical drive cage installed.

### Remove the optical drive cage

Follow the instructions in this section to remove an optical drive cage.

#### About this task

**S002**



#### CAUTION:

The power-control button on the device and the power switch on the power supply do not turn off the electrical current supplied to the device. The device also might have more than one power cord. To remove all electrical current from the device, ensure that all power cords are disconnected from the power source.

#### Attention:

- Read [“Installation Guidelines” on page 41](#) and [“Safety inspection checklist” on page 42](#) to ensure that you work safely.
- Power off the server and disconnect all power cords for this task. See [“Power off the server” on page 53](#).
- Prevent exposure to static electricity, which might lead to system halt and loss of data, by keeping static-sensitive components in their static-protective packages until installation, and handling these devices with an electrostatic-discharge wrist strap or other grounding system.
- If the server is in a rack, remove it from the rack.

#### Procedure

Step 1. Make preparations for this task.

- a. Remove the server cover. See [“Remove the server cover” on page 230](#).
- b. Remove the security door. See [“Remove the security door” on page 207](#).
- c. Remove the front bezel. See [“Remove the front bezel” on page 107](#).
- d. Remove all the installed optical drives, tape drives, and fillers (if any) from the optical drive cage. See [“Remove an optical drive or a tape drive” on page 149](#) and [“Remove a 5.25-inch drive bay adapter assembly” on page 156](#).

Step 2. Remove the optical drive cage.

- a. ① Lift and hold the blue retention tab.
- b. ② Meanwhile, carefully pull the optical drive cage until it is completely out of the bay.

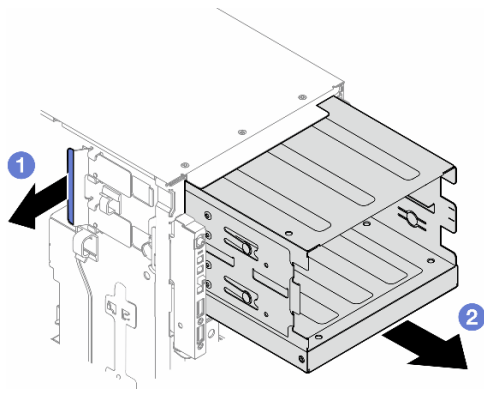

Figure 98. Removal of an optical drive cage

### After this task is completed

- Install a replacement unit. See “Install an expansion drive cage” on page 88 or “Install an optical drive cage” on page 148.
- If you are instructed to return the component or optional device, follow all packaging instructions, and use any packaging materials for shipping that are supplied to you.

### Demo video

[Watch the procedure on YouTube](#)

<https://www.youtube.com/watch?v=N31qj7ILSDE>

### Install an optical drive cage

Follow the instructions in this section to install an optical drive cage.

### About this task

#### S002



#### **CAUTION:**

The power-control button on the device and the power switch on the power supply do not turn off the electrical current supplied to the device. The device also might have more than one power cord. To remove all electrical current from the device, ensure that all power cords are disconnected from the power source.

#### **Attention:**

- Read “Installation Guidelines” on page 41 and “Safety inspection checklist” on page 42 to ensure that you work safely.
- Power off the server and disconnect all power cords for this task. See “Power off the server” on page 53.
- Prevent exposure to static electricity, which might lead to system halt and loss of data, by keeping static-sensitive components in their static-protective packages until installation, and handling these devices with an electrostatic-discharge wrist strap or other grounding system.

## Procedure

Step 1. Install the optical drive cage.

- a. ① Lift and hold the blue retention tab.
- b. ② Meanwhile, carefully push the optical drive cage into the bay until it snaps into position.

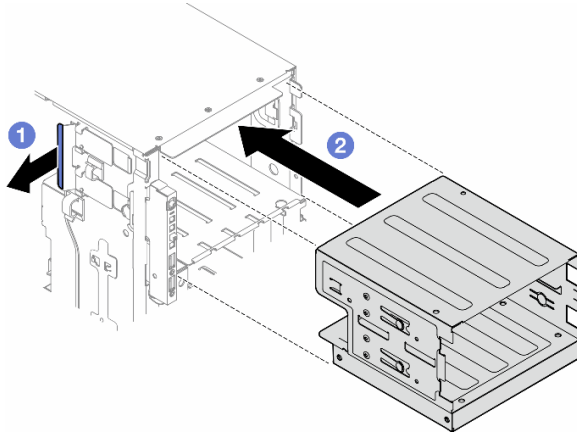

Figure 99. Installation of an optical drive cage

## After this task is completed

1. Install all the optical drives, tape drives, and fillers (if any) into the optical drive cage. See “[Install an optical drive or a tape drive](#)” on page 153 and “[Install a 5.25-inch drive bay adapter assembly](#)” on page 159.
2. Reinstall the front bezel. See “[Install a front bezel](#)” on page 108.
3. Reinstall the security door. See “[Install the security door](#)” on page 208.
4. Complete the parts replacement. See “[Complete the parts replacement](#)” on page 233.

## Demo video

[Watch the procedure on YouTube](#)

[https://www.youtube.com/watch?v=y\\_o1pfeCSak](https://www.youtube.com/watch?v=y_o1pfeCSak)

---

## Optical drive or tape drive replacement

Follow the instructions in this section to remove or install an optical drive or tape drive.

**Note:** This section applies only to server models with an optical drive or a tape drive installed.

### Remove an optical drive or a tape drive

Follow the instructions in this section to remove an optical drive or a tape drive.

### About this task

## S002

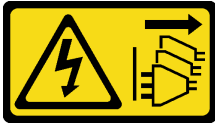

### CAUTION:

The power-control button on the device and the power switch on the power supply do not turn off the electrical current supplied to the device. The device also might have more than one power cord. To remove all electrical current from the device, ensure that all power cords are disconnected from the power source.

## S006



### CAUTION:

When laser products (such as CD-ROMs, DVD drives, fiber optic devices, or transmitters) are installed, note the following:

- Do not remove the covers. Removing the covers of the laser product could result in exposure to hazardous laser radiation. There are no serviceable parts inside the device.
- Use of controls or adjustments or performance of procedures other than those specified herein might result in hazardous radiation exposure.

**Note:** This section only applies to server models that come with an optical or tape drive. For those that come with a 5.25-inch drive bay adapter, see [“Remove a 5.25-inch drive bay adapter assembly” on page 156](#).

### Attention:

- Read [“Installation Guidelines” on page 41](#) and [“Safety inspection checklist” on page 42](#) to ensure that you work safely.
- Power off the server and disconnect all power cords for this task. See [“Power off the server” on page 53](#).
- Prevent exposure to static electricity, which might lead to system halt and loss of data, by keeping static-sensitive components in their static-protective packages until installation, and handling these devices with an electrostatic-discharge wrist strap or other grounding system.
- If the server is in a rack, remove it from the rack.

**Note:** The following illustrations are based on the scenario of removing an optical drive. The procedure is similar to that of removing a tape drive.

## Procedure

Step 1. Make preparations for this task.

- a. Remove the server cover. See [“Remove the server cover” on page 230](#).
- b. Remove the security door. See [“Remove the security door” on page 207](#).
- c. Remove the front bezel. See [“Remove the front bezel” on page 107](#).

Step 2. Disconnect every cable from the rear of the optical drive or tape drive assembly.

Step 3. Remove the optical drive or tape drive.

- a.  Press and hold the release tab.

- b. **2** At the same time, carefully pull the optical drive or tape drive assembly to remove it out of the chassis.

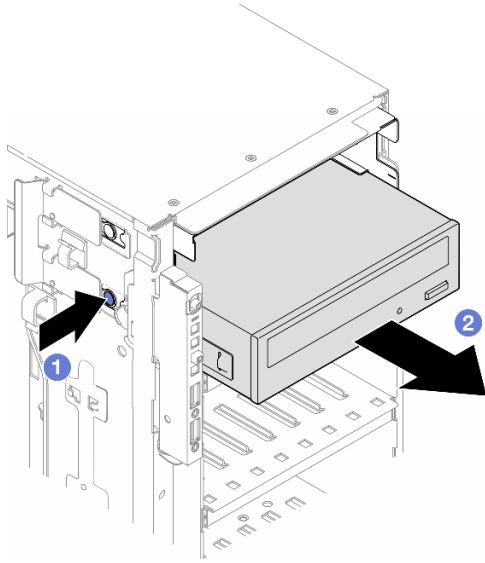

Figure 100. Removal of an optical drive

### After this task is completed

1. Install a replacement unit. See [“Install an optical drive or a tape drive” on page 153](#). To install a filler, follow the steps below:
  - a. Insert the filler to the vacant drive bay.

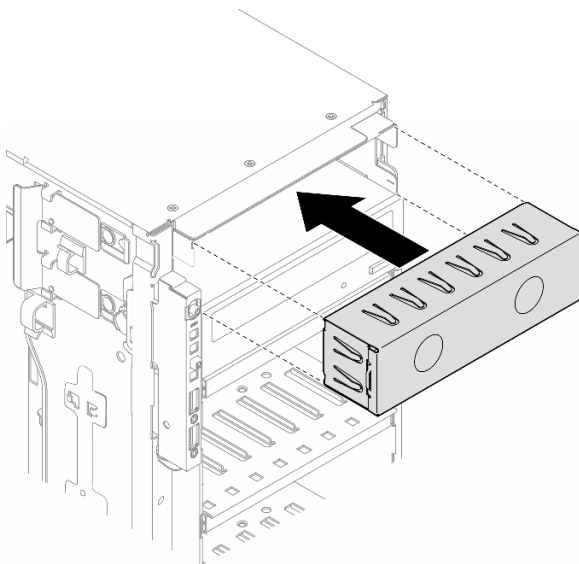

Figure 101. Installation of a drive bay filler

- b. Install the cover of the drive bay filler to the front bezel; then, install the front bezel to the chassis. See [“Install a front bezel” on page 108](#).

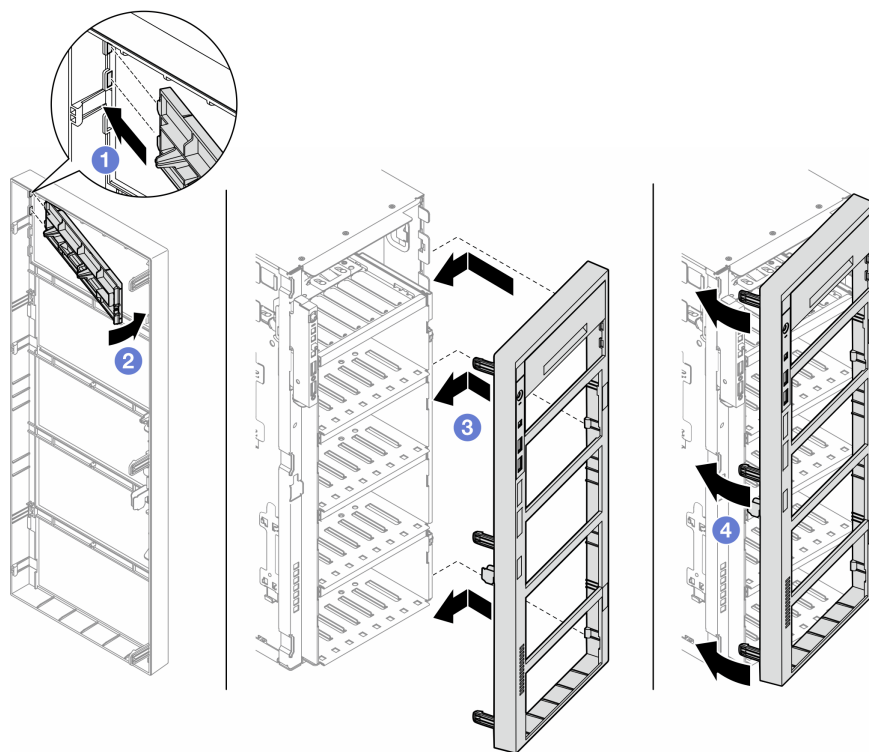

Figure 102. Installation of a drive bay filler cover and then a front bezel

2. Remove the retainer from the removed optical drive or tape drive; then, install this retainer to the chassis.

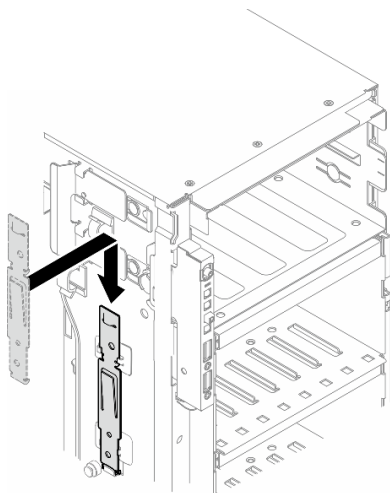

Figure 103. Installation of a drive retainer

3. If you are instructed to return the component or optional device, follow all packaging instructions, and use any packaging materials for shipping that are supplied to you.

## Demo video

[Watch the procedure on YouTube](#)

<https://www.youtube.com/watch?v=jkdcwLIFMMk>

## Install an optical drive or a tape drive

Follow the instructions in this section to install an optical drive or a tape drive.

### About this task

#### S002



#### **CAUTION:**

The power-control button on the device and the power switch on the power supply do not turn off the electrical current supplied to the device. The device also might have more than one power cord. To remove all electrical current from the device, ensure that all power cords are disconnected from the power source.

#### S006



#### **CAUTION:**

When laser products (such as CD-ROMs, DVD drives, fiber optic devices, or transmitters) are installed, note the following:

- Do not remove the covers. Removing the covers of the laser product could result in exposure to hazardous laser radiation. There are no serviceable parts inside the device.
- Use of controls or adjustments or performance of procedures other than those specified herein might result in hazardous radiation exposure.

#### **Attention:**

- Read [“Installation Guidelines” on page 41](#) and [“Safety inspection checklist” on page 42](#) to ensure that you work safely.
- Power off the server and disconnect all power cords for this task. See [“Power off the server” on page 53](#).
- Prevent exposure to static electricity, which might lead to system halt and loss of data, by keeping static-sensitive components in their static-protective packages until installation, and handling these devices with an electrostatic-discharge wrist strap or other grounding system.

**Note:** The following illustrations are based on the scenario that you install an optical drive. The procedure is similar for installing a tape drive.

### Procedure

- Step 1. If necessary, remove the cover of the drive bay filler from the front bezel.
  - 1 Push the tab on the front bezel to release the cover of the drive bay filler.
  - 2 Remove the cover of the drive bay filler as shown.

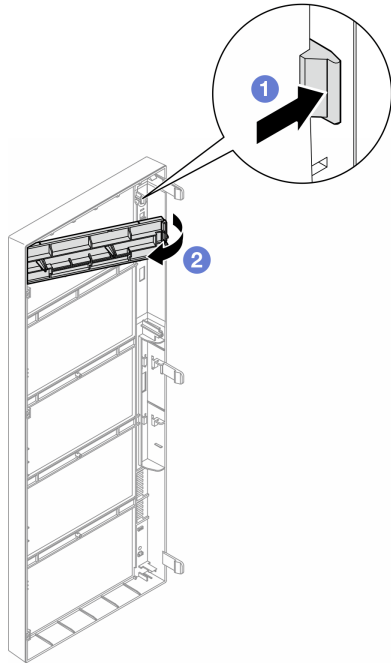

Figure 104. Removal of a drive bay filler cover

Step 2. If necessary, remove the drive bay filler out of the chassis.

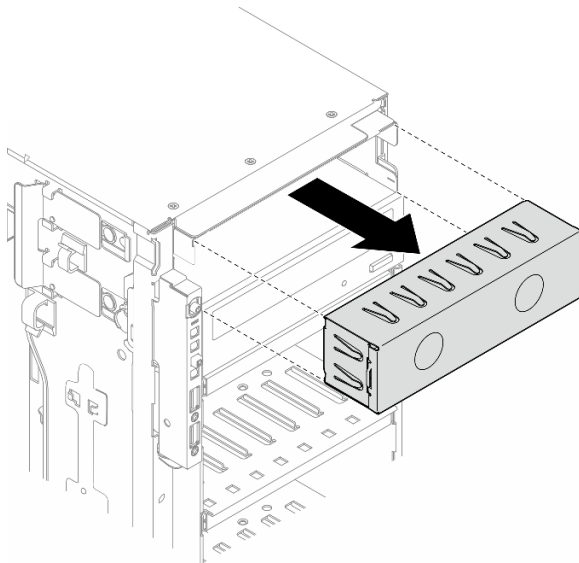

Figure 105. Removal of a drive bay filler

Step 3. Remove the retainer from the chassis.

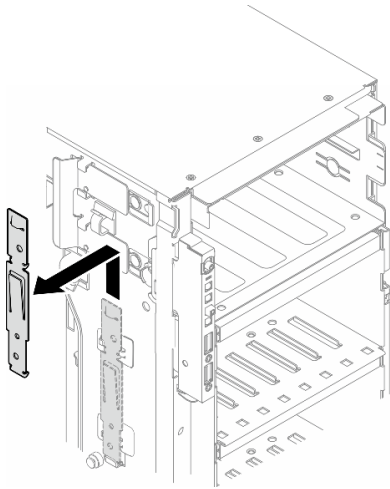

Figure 106. Removal of a drive retainer

Step 4. Install the retainer only to the left side of the optical drive or tape drive.

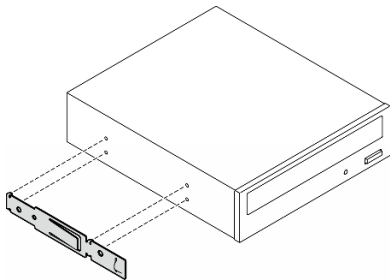

Figure 107. Installation of an optical drive retainer

Step 5. Hold the optical drive or tape drive in the correct orientation; then, slide it into the drive bay until it snaps into position.

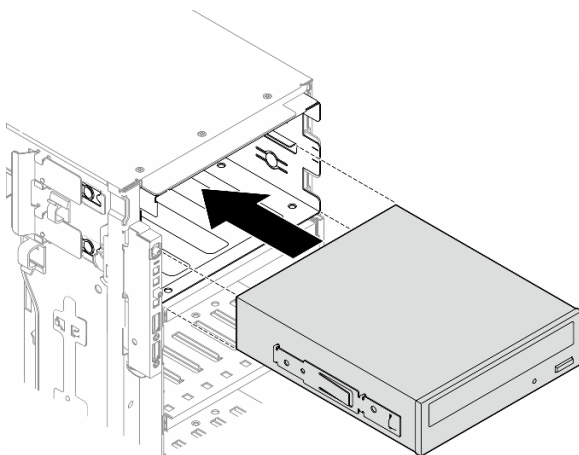

Figure 108. Installation of an optical drive

Step 6. Connect the power cable and signal cable to the rear of the optical drive or tape drive assembly. See [“Optical/tape drives” on page 317](#).

## After you finish

1. Reinstall the front bezel. See [“Install a front bezel”](#) on page 108.
2. Reinstall the security door. See [“Install the security door”](#) on page 208.
3. Reinstall the server cover. See [“Install a server cover”](#) on page 231.
4. Complete the parts replacement. See [“Complete the parts replacement”](#) on page 233.

## Demo video

[Watch the procedure on YouTube](#)

<https://www.youtube.com/watch?v=ZArzxMtPFnU>

## Remove a 5.25-inch drive bay adapter assembly

Follow the instructions in this section to remove a 5.25-inch drive bay adapter assembly.

### About this task

#### S002

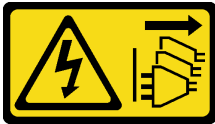

#### **CAUTION:**

The power-control button on the device and the power switch on the power supply do not turn off the electrical current supplied to the device. The device also might have more than one power cord. To remove all electrical current from the device, ensure that all power cords are disconnected from the power source.

#### S006



#### **CAUTION:**

When laser products (such as CD-ROMs, DVD drives, fiber optic devices, or transmitters) are installed, note the following:

- Do not remove the covers. Removing the covers of the laser product could result in exposure to hazardous laser radiation. There are no serviceable parts inside the device.
- Use of controls or adjustments or performance of procedures other than those specified herein might result in hazardous radiation exposure.

**Note:** This section only applies to server models that come with a 5.25-inch drive bay adapter. For those that come with an optical or tape drive, see [“Remove an optical drive or a tape drive”](#) on page 149.

#### **Attention:**

- Read [“Installation Guidelines”](#) on page 41 and [“Safety inspection checklist”](#) on page 42 to ensure that you work safely.

- Power off the server and disconnect all power cords for this task. See [“Power off the server” on page 53](#).
- Prevent exposure to static electricity, which might lead to system halt and loss of data, by keeping static-sensitive components in their static-protective packages until installation, and handling these devices with an electrostatic-discharge wrist strap or other grounding system.
- If the server is in a rack, remove it from the rack.

## Procedure

Step 1. Make preparations for this task.

- Remove the server cover. See [“Remove the server cover” on page 230](#).
- Remove the security door. See [“Remove the security door” on page 207](#).
- Remove the front bezel. See [“Remove the front bezel” on page 107](#).

Step 2. Disconnect every cable from the 5.25-inch drive bay adapter assembly.

Step 3. Remove the 5.25-inch drive bay adapter assembly.

- 1 Press and hold the release tab.
- 2 At the same time, carefully pull the 5.25-inch drive bay adapter assembly to remove it out of the chassis.

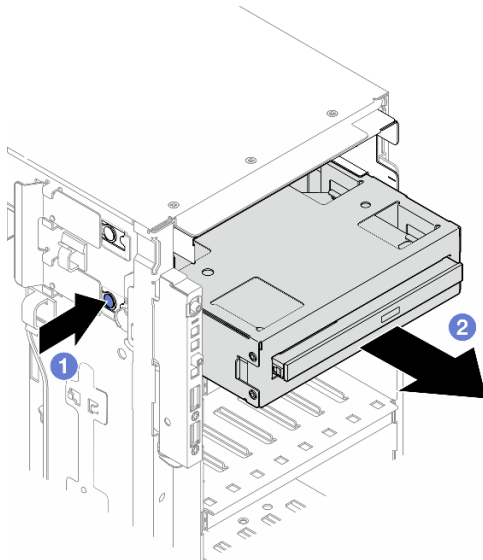

Figure 109. Removal of a 5.25-inch drive bay adapter assembly

Step 4. Remove the slim optical drive out from the adapter.

- 1 Remove the two screws that secure the slim optical drive.
- 2 Slide the slim optical drive out from the adapter.

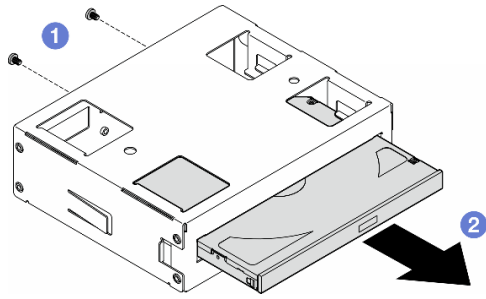

Figure 110. Removal of a slim optical drive from its drive bay adapter

### After this task is completed

1. Install a replacement unit. See [“Install a 5.25-inch drive bay adapter assembly” on page 159](#). To install a filler, follow the steps below:
  - a. Insert the filler to the vacant drive bay.

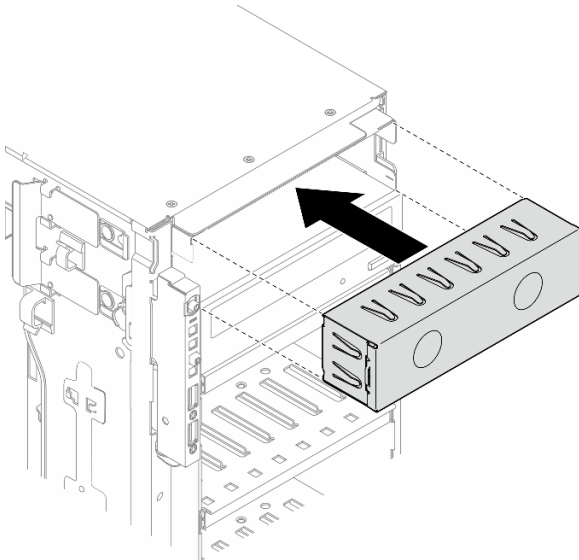

Figure 111. Installation of a drive bay filler

- b. Install the cover of the drive bay filler to the front bezel; then, install the front bezel to the chassis. See [“Install a front bezel” on page 108](#).

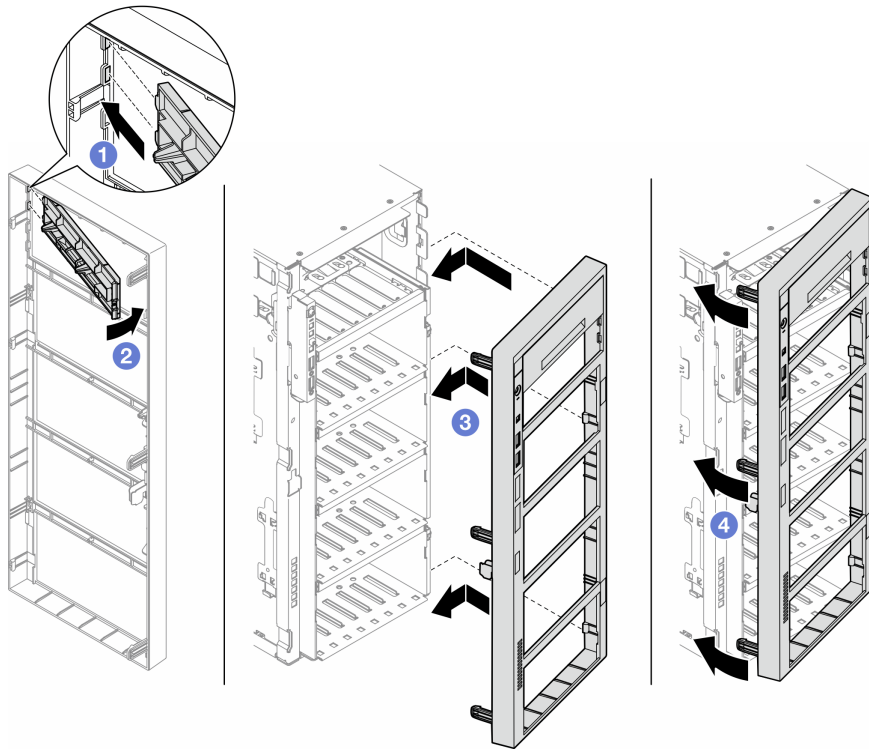

Figure 112. Installation of a drive bay filler cover and then a front bezel

2. If you are instructed to return the component or optional device, follow all packaging instructions, and use any packaging materials for shipping that are supplied to you.

## Demo video

Watch the procedure on YouTube

<https://www.youtube.com/watch?v=jkdcwLIFMMk>

## Install a 5.25-inch drive bay adapter assembly

Follow the instructions in this section to install a 5.25-inch drive bay adapter assembly.

### About this task

**S002**



#### CAUTION:

The power-control button on the device and the power switch on the power supply do not turn off the electrical current supplied to the device. The device also might have more than one power cord. To remove all electrical current from the device, ensure that all power cords are disconnected from the power source.

## S006



### CAUTION:

When laser products (such as CD-ROMs, DVD drives, fiber optic devices, or transmitters) are installed, note the following:

- Do not remove the covers. Removing the covers of the laser product could result in exposure to hazardous laser radiation. There are no serviceable parts inside the device.
- Use of controls or adjustments or performance of procedures other than those specified herein might result in hazardous radiation exposure.

### Attention:

- Read “[Installation Guidelines](#)” on page 41 and “[Safety inspection checklist](#)” on page 42 to ensure that you work safely.
- Power off the server and disconnect all power cords for this task. See “[Power off the server](#)” on page 53.
- Prevent exposure to static electricity, which might lead to system halt and loss of data, by keeping static-sensitive components in their static-protective packages until installation, and handling these devices with an electrostatic-discharge wrist strap or other grounding system.

## Procedure

- Step 1. If applicable, remove the cover of the drive bay filler from the front bezel.
- 1 Push the tab on the front bezel to release the cover of the drive bay filler.
  - 2 Remove the cover of the drive bay filler as shown.

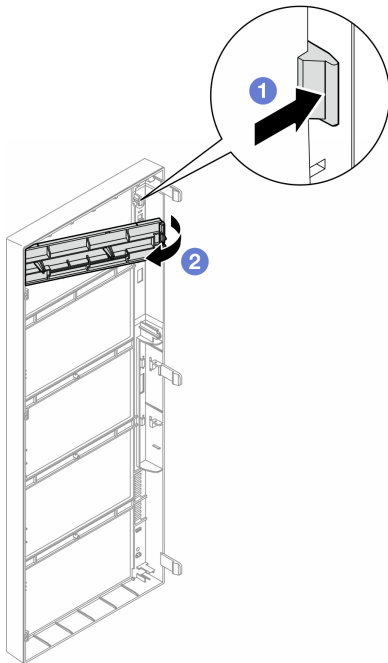

Figure 113. Removal of a drive bay filler cover

Step 2. If applicable, remove the drive bay filler.

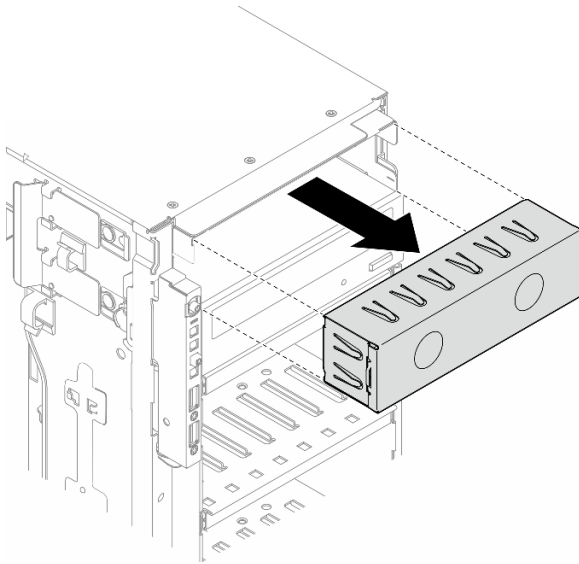

Figure 114. Removal of a drive bay filler

- Step 3. Install the slim optical drive into the adapter.
- a. 1 Slide the slim optical drive into the adapter.
  - b. 2 Secure the slim optical drive with two screws.

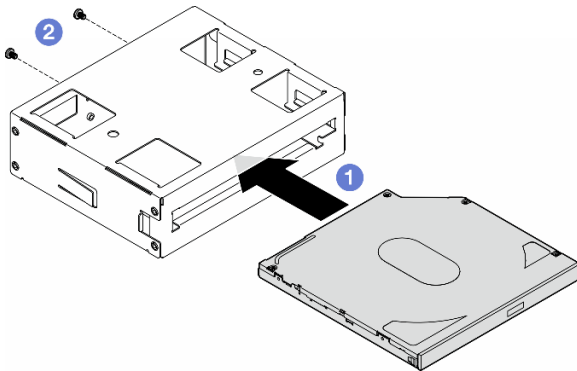

Figure 115. Installation of a slim optical drive into the drive bay adapter

Step 4. Hold the 5.25-inch drive bay adapter assembly in the correct orientation; then, slide it into the drive bay until it snaps into position.

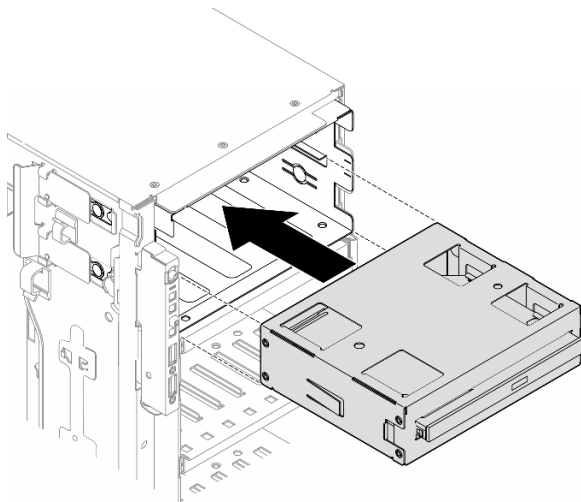

Figure 116. Installation of an optical drive assembly

- Step 5. Connect the power cable and signal cable to the rear of the 5.25-inch drive bay adapter assembly. For more information about the cable routing. See [“Optical/tape drives” on page 317](#).

---

## FL PCIe adapter holder replacement

Follow the instructions in this section to remove or install a FL PCIe adapter holder, which helps to hold a full-length PCIe adapter.

### Remove a FL PCIe adapter holder

Follow the instructions in this section to remove a FL PCIe adapter holder.

#### About this task

##### S002



#### **CAUTION:**

The power-control button on the device and the power switch on the power supply do not turn off the electrical current supplied to the device. The device also might have more than one power cord. To remove all electrical current from the device, ensure that all power cords are disconnected from the power source.

#### **Attention:**

- Read [“Installation Guidelines” on page 41](#) and [“Safety inspection checklist” on page 42](#) to ensure that you work safely.
- Power off the server and disconnect all power cords for this task. See [“Power off the server” on page 53](#).
- Prevent exposure to static electricity, which might lead to system halt and loss of data, by keeping static-sensitive components in their static-protective packages until installation, and handling these devices with an electrostatic-discharge wrist strap or other grounding system.
- If the server is in a rack, remove it from the rack.

- If foot stands are installed on the server, pivot them inwards and lay the server on its side for easier operation.

## Procedure

Step 1. Make preparations for this task.

- a. Remove the server cover. See “[Remove the server cover](#)” on page 230.
- b. If necessary, remove all flash power modules. See “[Remove a flash power module](#)” on page 100.
- c. Remove the air baffle. See “[Remove the air baffle](#)” on page 74.
- d. Remove all the full-length GPU adapters, if any. See “[Remove a FL GPU adapter](#)” on page 173.
- e. (Optional) If necessary, remove the fans and fan cage. See “[Remove a fan module](#)” on page 89 and “[Remove the fan cage assembly](#)” on page 91.

**Attention:** All fan modules must be removed from the fan cage when handling the fan cage assembly.

**Note:** This step is optional. Do this step if the removal or installation of the A2/L4 GPU air duct (s) or FL PCIe adapter holder(s) cannot be proceeded smoothly within the chassis.

Step 2. Press and hold on the tab to release the PCIe adapter holder from the fan cage; then, remove the PCIe adapter holder in the direction as shown.

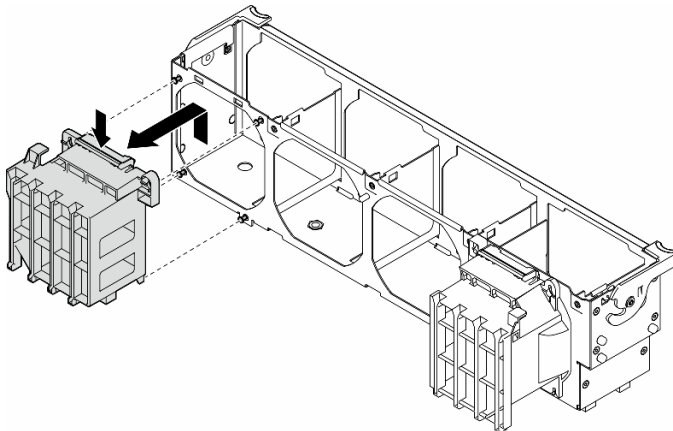

Figure 117. Removal of a PCIe adapter holder

## After this task is completed

1. Install the replacement unit(s), if necessary. See “[Install a FL PCIe adapter holder](#)” on page 164.
2. If you are instructed to return the component or optional device, follow all packaging instructions, and use any packaging materials for shipping that are supplied to you.

## Demo video

[Watch the procedure on YouTube](#)

<https://www.youtube.com/watch?v=MoPn3MgjZfY>

## Install a FL PCIe adapter holder

Follow the instructions in this section to install a FL PCIe adapter holder.

### About this task

#### S002

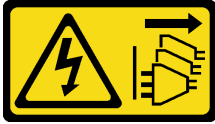

#### **CAUTION:**

The power-control button on the device and the power switch on the power supply do not turn off the electrical current supplied to the device. The device also might have more than one power cord. To remove all electrical current from the device, ensure that all power cords are disconnected from the power source.

#### **Attention:**

- Read [“Installation Guidelines” on page 41](#) and [“Safety inspection checklist” on page 42](#) to ensure that you work safely.
- Power off the server and disconnect all power cords for this task. See [“Power off the server” on page 53](#).
- Prevent exposure to static electricity, which might lead to system halt and loss of data, by keeping static-sensitive components in their static-protective packages until installation, and handling these devices with an electrostatic-discharge wrist strap or other grounding system.

#### **Notes:**

- When there is only one FL GPU installed between PCIe slots 1 and 4 or between slots 5 and 8, one or two **FL GPU fillers** are required to be installed on the air baffle on the same side of the FL GPU for proper cooling and airflow.
- One or two **FL PCIe adapter holders** are required to have been installed corresponding to the PCIe slot(s) for the FL GPU adapter(s) to be installed.

See [“GPU installation rules” on page 171](#) for detailed information about the technical rules for GPU installation.

### Procedure

Step 1. Align the FL PCIe adapter holder with the studs on the fan cage at the same side as the installed FL GPU adapter(s).

**Note:** The studs on the fan cage are positioned differently to align the corresponding FL PCIe adapter holders.

Step 2. Insert the holder onto the fan cage until it snaps into position.

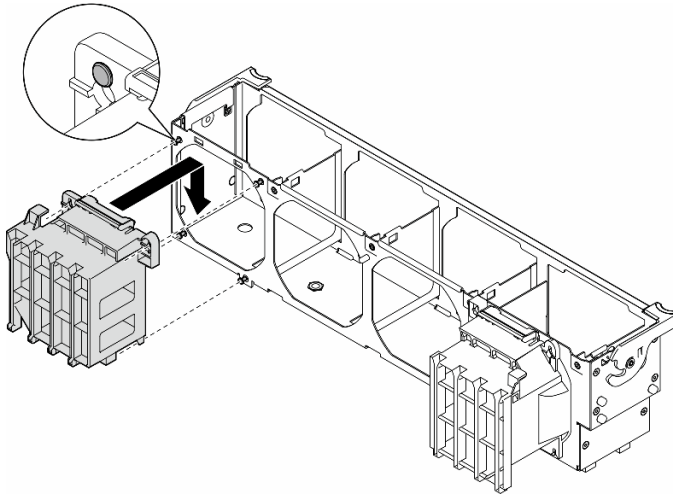

Figure 118. Installation of a FL PCIe adapter holder

### After this task is completed

1. If the fan cage and fans are not installed in the chassis, reinstall them. See “[Install the fan cage assembly](#)” on page 92 and “[Install a fan module](#)” on page 94.
2. Install the FL GPU adapter(s). See “[Install a FL GPU adapter](#)” on page 175.
3. Reinstall the air baffle. See “[Install an air baffle](#)” on page 75.
4. Reinstall all the flash power modules, if necessary. See “[Install a flash power module](#)” on page 102.
5. Reinstall the server cover. See “[Install a server cover](#)” on page 231.
6. Complete the parts replacement. See “[Complete the parts replacement](#)” on page 233.

### Demo video

[Watch the procedure on YouTube](#)

<https://www.youtube.com/watch?v=RmpBW2QYkok>

---

## PCIe adapter replacement

Follow the instructions in this section to remove or install a PCIe adapter, half-length and full-length.

ThinkSystem ST650 V3 comes with nine PCIe slots. Depending on the needs, a PCIe adapter can be installed for the corresponding function or be removed if necessary. The PCIe adapter can be an Ethernet adapter, a host bus adapter (HBA), a RAID adapter, a graphics (GPU) adapter (full-length or half-length), or any other supported PCIe adapters. PCIe adapters vary by type, but the installation and removal procedures are the same except for the full-length GPU adapters, of which the replacement is explained in a section separate from other PCIe adapters.

### Notes:

- For a list of the supported PCIe adapters, see <https://serverproven.lenovo.com>.

## Remove a HL PCIe adapter

Follow the instructions in this section to remove a half-length (HL) PCIe adapter.

## About this task

### S002



#### CAUTION:

The power-control button on the device and the power switch on the power supply do not turn off the electrical current supplied to the device. The device also might have more than one power cord. To remove all electrical current from the device, ensure that all power cords are disconnected from the power source.

#### Attention:

- Read [“Installation Guidelines” on page 41](#) and [“Safety inspection checklist” on page 42](#) to ensure that you work safely.
- Power off the server and disconnect all power cords for this task. See [“Power off the server” on page 53](#).
- Prevent exposure to static electricity, which might lead to system halt and loss of data, by keeping static-sensitive components in their static-protective packages until installation, and handling these devices with an electrostatic-discharge wrist strap or other grounding system.
- If the server is in a rack, remove it from the rack.
- If foot stands are installed on the server, pivot them inwards and lay the server on its side for easier operation.

#### Notes:

- Depending on the specific type, the PCIe adapter might look different from the illustration in this topic.
- Use any documentation that comes with the PCIe adapter and follow those instructions in addition to the instructions in this topic.

## Procedure

Step 1. Make preparations for this task.

- a. Remove the server cover. See [“Remove the server cover” on page 230](#).
- b. If necessary, remove all flash power modules. See [“Remove a flash power module” on page 100](#).
- c. Remove the air baffle. See [“Remove the air baffle” on page 74](#).
- d. Locate the PCIe adapter to be removed. If there is an A2/L4 GPU air duct installed on the same side, remove the A2/L4 GPU air duct. See [“Remove an A2/L4 GPU air duct” on page 71](#).

Step 2. Depending on the type of PCIe adapter, disconnect all cables from the PCIe adapter, the system board, or the drive backplane if necessary.

**Attention:** To avoid damaging the system board, make sure to follow the instructions in [Chapter 6 “Internal cable routing” on page 235](#) when disconnecting cables from the system board.

Step 3. Remove the PCIe adapter.

- a. ① Open the PCIe adapter retainer.
- b. ② Remove the screw that secures the PCIe adapter.
- c. ③ Hold the edges of the PCIe adapter and carefully pull it out of the slot.

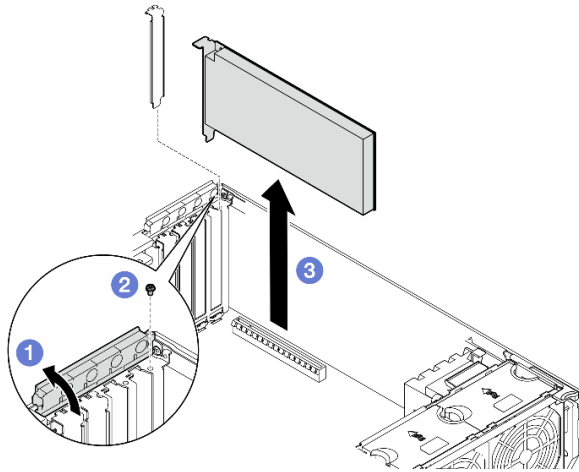

Figure 119. Removal of a PCIe adapter

### After this task is completed

1. Install the replacement unit(s), if necessary. See “[Install a HL PCIe adapter](#)” on page 167. Otherwise, install a bracket to cover the vacancy and close the PCIe adapter retainer.
2. If you are instructed to return the component or optional device, follow all packaging instructions, and use any packaging materials for shipping that are supplied to you.

### Demo video

[Watch the procedure on YouTube](#)

<https://www.youtube.com/watch?v=bN3b1P4bN0U>

### Install a HL PCIe adapter

Follow the instructions in this section to install a half-length (HL) PCIe adapter.

### About this task

#### S002



#### **CAUTION:**

The power-control button on the device and the power switch on the power supply do not turn off the electrical current supplied to the device. The device also might have more than one power cord. To remove all electrical current from the device, ensure that all power cords are disconnected from the power source.

#### **Attention:**

- Read “[Installation Guidelines](#)” on page 41 and “[Safety inspection checklist](#)” on page 42 to ensure that you work safely.
- Power off the server and disconnect all power cords for this task. See “[Power off the server](#)” on page 53.

- Prevent exposure to static electricity, which might lead to system halt and loss of data, by keeping static-sensitive components in their static-protective packages until installation, and handling these devices with an electrostatic-discharge wrist strap or other grounding system.

**Notes:**

- Depending on the specific type, the PCIe adapter might look different from the illustration in this section.
- Use any documentation that comes with the PCIe adapter and follow those instructions in addition to the instructions in this topic.
- Nine PCIe slots are available in this server. To install one or more **new PCIe adapters**, follow the below-listed rules and priority for PCIe slots:
  - [“PCIe installation rules with one processor” on page 169](#)
  - [“PCIe installation rules with two processors” on page 170](#)
  - [“GPU installation rules” on page 171](#)
  - To replace an existing PCIe adapter, skip to the procedure of installation: [Figure 120 “Installation procedure of a HL PCIe adapter” on page 172](#)
- For the location of each of the PCIe slots and related connectors on the system board, see [“System board connectors” on page 26](#).
- For the installation procedure of a full-length GPU adapter, see [“Install a FL GPU adapter” on page 175](#).

## PCIe installation rules with one processor

### Rules and priority for PCIe slots with one processor

When only one processor is installed, PCIe slots 1 to 4 and 9 are supported.

Listed by priority:

1. **Double-width, FH/FL GPU:**<sup>1</sup> Slot 1 >> 3
2. **Retimer:** Slot 1 >> 3
3. **ThinkSystem Broadcom 57508 100GbE QSFP56 2-port PCIe 4 Ethernet Adapter:** Slot 1 >> 3
4. **Single-width, HH/HL GPU:**<sup>2</sup>
  - ThinkSystem NVIDIA A2 Passive GPU: Slot 2 >> 4 >> 1 >> 3
  - ThinkSystem NVIDIA L4 Passive GPU: Slot 1 >> 3 >> 2 >> 4
5. **ThinkSystem RAID 940-32i 8GB Flash PCIe Gen4 12Gb Adapter: Slot 9** only
6. **Other external RAID/HBA adapters:** Slot 9 >> 1 >> 2 >> 3 >> 4
  - Follow the principles of priority listed below:
    - x450 (Gen 4) >> x40 (Gen 4) >> x350 (Gen 3)
    - For example:
      - ThinkSystem RAID 9450-16i 8GB Flash PCIe Gen4 24Gb Adapter >> ThinkSystem RAID 940-16i 8GB Flash PCIe Gen4 12Gb Adapter
      - ThinkSystem RAID 540-16i PCIe Gen4 12Gb Adapter >> ThinkSystem RAID 9350-8i 2GB Flash PCIe 12Gb Adapter
    - For models with the same number of digits, the one with the higher number should be installed before those with the lower.
      - For example:
        - ThinkSystem RAID 940-16i 8GB Flash PCIe Gen4 12Gb Adapter >> ThinkSystem RAID 540-16i PCIe Gen4 12Gb Adapter
        - ThinkSystem RAID 9450-16i 8GB Flash PCIe Gen4 24Gb Adapter >> ThinkSystem RAID 5450-16i PCIe Gen4 24Gb Adapter
      - 32i >> 16i >> 8i
        - For example:
          - ThinkSystem RAID 940-16i 4GB Flash PCIe Gen4 12Gb Adapter >> ThinkSystem RAID 940-8i 4GB Flash PCIe Gen4 12Gb Adapter
        - For RAID adapters or HBAs of the same model, install first the ones with higher capacity.
          - For example:
            - ThinkSystem RAID 940-16i 8GB Flash PCIe Gen4 12Gb Adapter >> ThinkSystem RAID 940-16i 4GB Flash PCIe Gen4 12Gb Adapter
      - RAID/HBA adapters belong to different generation (Gen 3 or Gen 4) are not allowed to be mixed in the same system.
      - Mixing of RAID/HBA X350/X450 adapters and RAID/HBA X40 adapters in the same system is not allowed.
    - 7. Other Ethernet adapters: Slot 9 >> 2 >> 3 >> 4
    - 8. Other external RAID adapters, HBAs, and Ethernet adapters of lower priority: Slot 9 >> 1 >> 2 >> 3 >> 4

## PCIe installation rules with two processors

### Rules and priority for PCIe slots with two processors

With two processor installed, all 9 PCIe slots are supported.

Listed by priority:

1. **Double-width, FH/FL GPU:<sup>1</sup>** Slot 1 >> 3 >> 7 >> 5
2. **Retimer:** Slot 7 >> 5 >> 1 >> 3
3. **ThinkSystem Broadcom 57508 100GbE QSFP56 2-port PCIe 4 Ethernet Adapter:** Slot 1 >> 3 >> 7 >> 5
4. **Single-width, HH/HL GPU:<sup>2</sup>**
  - ThinkSystem NVIDIA A2 Passive GPU: Slot 2 >> 4 >> 7 >> 5 >> 1 >> 3 >> 6 >> 8
  - ThinkSystem NVIDIA L4 Passive GPU: Slot 1 >> 3 >> 7 >> 5 >> 2 >> 4 >> 6 >> 8
5. **ThinkSystem RAID 940-32i 8GB Flash PCIe Gen4 12Gb Adapter:** Slot 9 >> 5 >> 6 >> 7 >> 8
6. **External RAID/HBA adapters:** Slot 9 >> 1 >> 2 >> 3 >> 4 >> 5 >> 6 >> 7 >> 8

**Note:** For **ThinkSystem RAID X450-8i/16i PCIe Gen4 adapter:** Slot 9 >> 1 >> 2 >> 3 >> 4 >> 6 >> 7 >> 8

- Follow the principles of priority listed below for installation:
    - x450 (Gen 4) >> x40 (Gen 4) >> x350 (Gen 3)
      - For example:  
ThinkSystem RAID 9450-16i 8GB Flash PCIe Gen4 24Gb Adapter >> ThinkSystem RAID 940-16i 8GB Flash PCIe Gen4 12Gb Adapter  
ThinkSystem RAID 540-16i PCIe Gen4 12Gb Adapter >> ThinkSystem RAID 9350-8i 2GB Flash PCIe 12Gb Adapter
    - For models with the same number of digits, the one with the higher number should be installed before those with the lower.
      - For example:  
ThinkSystem RAID 940-16i 8GB Flash PCIe Gen4 12Gb Adapter >> ThinkSystem RAID 540-16i PCIe Gen4 12Gb Adapter  
ThinkSystem RAID 9450-16i 8GB Flash PCIe Gen4 24Gb Adapter >> ThinkSystem RAID 5450-16i PCIe Gen4 24Gb Adapter
    - 32i >> 16i >> 8i
      - For example:  
ThinkSystem RAID 940-16i 4GB Flash PCIe Gen4 12Gb Adapter >> ThinkSystem RAID 940-8i 4GB Flash PCIe Gen4 12Gb Adapter
    - For RAID adapters or HBAs of the same model, install first the ones with higher capacity.
      - For example:  
ThinkSystem RAID 940-16i 8GB Flash PCIe Gen4 12Gb Adapter >> ThinkSystem RAID 940-16i 4GB Flash PCIe Gen4 12Gb Adapter
  - RAID/HBA adapters belong to different generation (Gen 3 or Gen 4) are not allowed to be mixed in the same system.
  - Mixing of RAID/HBA X350/X450 adapters and RAID/HBA X40 adapters in the same system is not allowed.
7. Other Ethernet adapters: Slot 9 >> 2 >> 3 >> 4 >> 6 >> 7 >> 8
  8. Other external RAID adapters, HBAs, and Ethernet adapters of lower priority: Slot 9 >> 1 >> 2 >> 3 >> 4 >> 5 >> 6 >> 7 >> 8

## GPU installation rules

### GPU installation rules

1. The installation of a **full-length double-width GPU adapter** should follow the rules specified below:
  - Follow the installation sequence: slot 1 >> 3 >> 7 >> 5
  - One or two **FL PCIe adapter holders** are required to have been installed corresponding to the PCIe slot(s) for the FL GPU adapter(s) to be installed. See “[FL PCIe adapter holder replacement](#)” on page 162 for the installation and removal of a PCIe adapter holder.
  - When a FL DW GPU adapter is installed in PCIe slot 1, only the same type of GPU can be installed in slot 3; different types of FL DW GPUs can be installed in slot 7 and then slot 5.
  - When there is only one FL GPU installed between PCIe slots 1 and 4 or between slots 5 and 8, one or two **FL GPU fillers** are required to be installed on the air baffle on the same side of the FL GPU for proper cooling and airflow.
  - See “[FL GPU filler replacement](#)” on page 113 for the installation and removal of a FL GPU filler.
2. The installation of a **ThinkSystem NVIDIA A2/L4 GPU adapter** should follow the rules specified below:
  - When a ThinkSystem NVIDIA A2/L4 GPU is installed—
    - **between PCIe slots 1 and 4:** the other slots between slots 1 and 4 only support low-profile PCIe adapters
    - **between PCIe slots 5 and 8:** the other slots between slots 5 and 8 only support low-profile PCIe adapters
  - When one or more **A2/L4 GPUs** are installed between PCIe slots 1 and 4 or between PCIe slots 5 and 8, one or two **A2/L4 GPU air ducts** are required to be installed on the fan cage at the same side as the installed A2/L4 GPU for proper cooling and airflow. See “[A2/L4 GPU air duct replacement](#)” on page 71 for the installation and removal of an A2/L4 GPU air duct.
  - A **T4 filler** is required to be installed onto the server cover for proper cooling and airflow when one or more A2/L4 GPU adapters are installed. See “[T4 filler replacement](#)” on page 226 for the installation and removal of a T4 filler.
3. Active GPUs can be installed in PCIe slots 1, 3, 5, and 7; ThinkSystem NVIDIA A2/L4 GPUs can be installed in PCIe slots 1 to 8.
4. ThinkSystem ST650 V3 does not support mixing GPUs between PCIe slots 1 and 4 or between slots 5 and 8.
  - When a GPU is installed between PCIe slots 1 and 4, only the same type of GPUs can be installed in other slots between 1 and 4.
  - When a GPU is installed between PCIe slots 5 and 8, only the same type of GPUs can be installed in other slots between 5 and 8.
5. When GPUs (NVIDIA RTX A6000/A4500/A2/L4) are installed between PCIe slots 1 and 4, these slots do not support any RAID adapter, HBA, or Retimer.
6. When GPUs (NVIDIA RTX A6000/A4500/A2/L4) are installed between PCIe slots 5 and 8, these slots do not support any RAID adapter, HBA, or Retimer.
7. To prevent potential thermal issues, change the **Misc** setting in the BIOS from **Option3** (default value) to **Option1** if the following two conditions are met:
  - The server is equipped with a GPU adapter.
  - The UEFI firmware version is ESE122T or later.

For the method of changing the **Misc** setting, see <https://support.lenovo.com/us/en/solutions/TT1832>.

## Installation procedure

- Step 1. Locate the applicable PCIe slot based on the above-noted rules.
- Step 2. If a bracket has been installed in the PCIe slot, remove it. Store the bracket for the PCIe slot in case it should be needed later.

Step 3. For the 9450-8i, 5450-16i, 9450-16i, and 4450-16i PCIe adapters, make sure to install x8 or x16 PCIe slot holder onto the PCIe connector. **x8 PCIe slot holder**

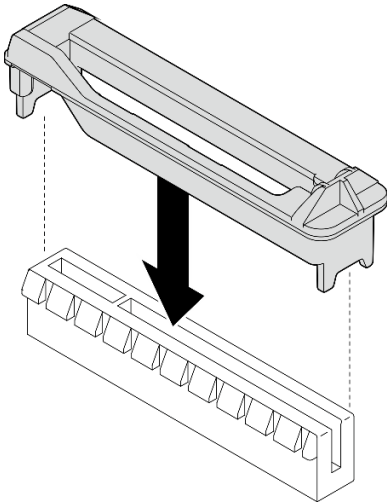

Figure 120. x8 PCIe slot holder

#### **x16 PCIe slot holder**

- a. ① Hold the latch on the plastic filler; then, remove the plastic filler from the PCIe slot holder.
- b. ② Align the PCIe slot holder with the PCIe connector on the system board; then, install the PCIe slot holder onto the PCIe connector.

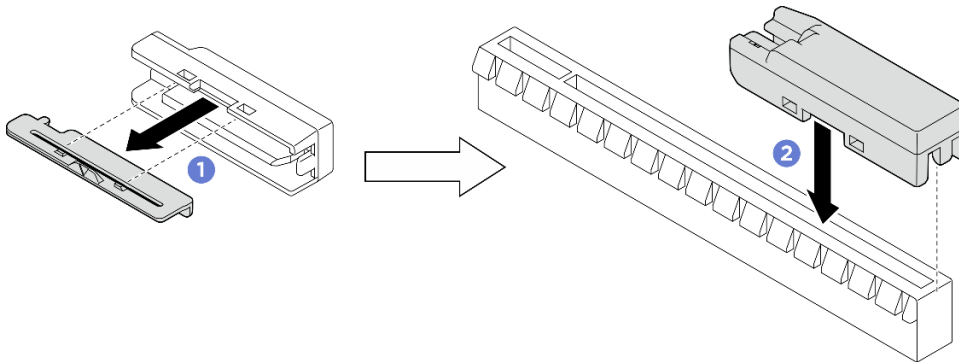

Figure 121. x16 PCIe slot holder

Step 4. Install the PCIe adapter.

#### **Notes:**

- Make sure that the PCIe adapter retainer is in the open position.
- a. ① Align the PCIe adapter to the PCIe slot; then, gently press both ends of the PCIe adapter until it is securely seated in the PCIe slot.
- b. ② Tighten the screw to secure the PCIe adapter.
- c. ③ Close the PCIe adapter retainer.

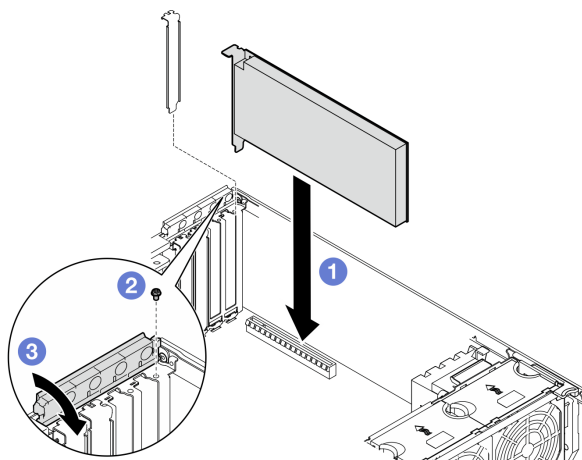

Figure 122. Installation of a HL PCIe adapter

## After you finish

1. Connect all required cables to the PCIe adapter. See [Chapter 6 “Internal cable routing” on page 235](#).
2. If the fan cage and fans are not installed in the chassis, reinstall them. See [“Install the fan cage assembly” on page 92](#) and [“Install a fan module” on page 94](#).
3. If one or more **A2/L4 GPU adapters** are installed, install one or two A2/L4 GPU air ducts to the corresponding slot on the fan cage, and install a T4 filler to the server cover. See [“Install an A2/L4 GPU air duct” on page 72](#) and [“Install a T4 filler” on page 228](#).
4. Reinstall the air baffle. See [“Install an air baffle” on page 75](#).
5. Reinstall all the flash power modules, if necessary. See [“Install a flash power module” on page 102](#).
6. Reinstall the server cover. See [“Install a server cover” on page 231](#).
7. Complete the parts replacement. See [“Complete the parts replacement” on page 233](#).

## Demo video

[Watch the procedure on YouTube](#)

[https://www.youtube.com/watch?v=SUMuKS\\_UGic](https://www.youtube.com/watch?v=SUMuKS_UGic)

## Remove a FL GPU adapter

Follow the instructions in this section to remove a full-length (FL) GPU adapter.

### About this task

#### S002



#### **CAUTION:**

The power-control button on the device and the power switch on the power supply do not turn off the electrical current supplied to the device. The device also might have more than one power cord. To

**remove all electrical current from the device, ensure that all power cords are disconnected from the power source.**

**Attention:**

- Read [“Installation Guidelines” on page 41](#) and [“Safety inspection checklist” on page 42](#) to ensure that you work safely.
- Power off the server and disconnect all power cords for this task. See [“Power off the server” on page 53](#).
- Prevent exposure to static electricity, which might lead to system halt and loss of data, by keeping static-sensitive components in their static-protective packages until installation, and handling these devices with an electrostatic-discharge wrist strap or other grounding system.
- If the server is in a rack, remove it from the rack.
- If foot stands are installed on the server, pivot them inwards and lay the server on its side for easier operation.

**Notes:**

- Depending on the specific type, the full-length GPU adapter might look different from the illustration in this topic.
- Use any documentation that comes with the full-length GPU adapter and follow those instructions in addition to the instructions in this topic.

**Procedure**

Step 1. Make preparations for this task.

- a. Remove the server cover. See [“Remove the server cover” on page 230](#).
- b. If necessary, remove all flash power modules. See [“Remove a flash power module” on page 100](#).
- c. Remove the air baffle. See [“Remove the air baffle” on page 74](#).
- d. If necessary, remove the NVLink bridge from the top of the FL GPU adapters. See [“Remove a GPU adapter link bridge \(NVLink bridge\)” on page 143](#).

Step 2. Locate the full-length GPU adapter to be removed.

Step 3. Remove the FL GPU adapter.

- a. ① Open the PCIe adapter retainer.
- b. ② Remove the screw that secures the full-length GPU adapter.
- c. ③ Hold the edges of the FL GPU adapter and carefully pull it out of the PCIe slot.
- d. ④ Disconnect the power cable from the FL GPU adapter.

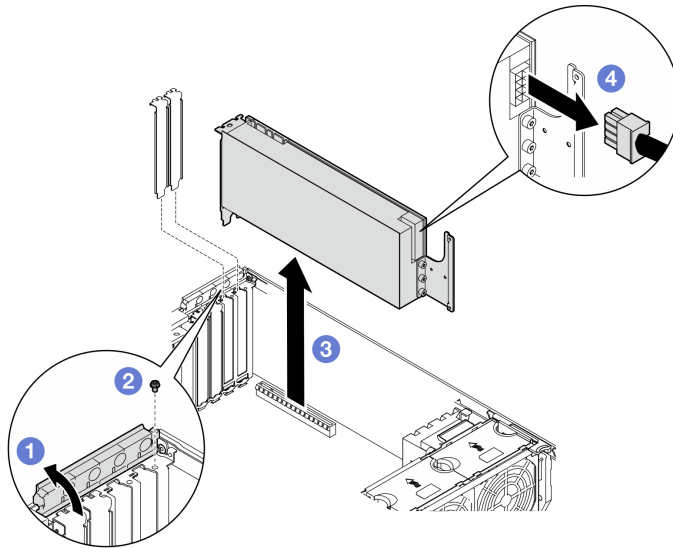

Figure 123. Removal of a FL GPU adapter

### After this task is completed

1. Install the replacement unit(s), if necessary. See “Install a FL GPU adapter” on page 175. Otherwise, install a bracket to cover the vacancy and close the PCIe adapter retainer.
2. If necessary, remove the GPU power cable from the chassis.
  - a. Remove all the fan modules and fan filler. See “Remove a fan module” on page 89.
 

**Attention:** All fan modules must be removed from the fan cage when handling the fan cage assembly.
  - b. Remove the fan cage assembly. See “Remove the fan cage assembly” on page 91.
  - c. Remove the FL GPU power cable from the chassis.
  - d. Reinstall the fan cage assembly. See “Install the fan cage assembly” on page 92.
  - e. Reinstall all the fan modules (and fan filler, if necessary). See “Install a fan module” on page 94.
3. If you are instructed to return the component or optional device, follow all packaging instructions, and use any packaging materials for shipping that are supplied to you.

### Demo video

Watch the procedure on YouTube

[https://www.youtube.com/watch?v=ftV8SzXe\\_WI](https://www.youtube.com/watch?v=ftV8SzXe_WI)

### Install a FL GPU adapter

Follow the instructions in this section to install a full-length (FL) GPU adapter.

### About this task

**S002**

**CAUTION:**

The power-control button on the device and the power switch on the power supply do not turn off the electrical current supplied to the device. The device also might have more than one power cord. To remove all electrical current from the device, ensure that all power cords are disconnected from the power source.

**Attention:**

- Read “[Installation Guidelines](#)” on page 41 and “[Safety inspection checklist](#)” on page 42 to ensure that you work safely.
- Power off the server and disconnect all power cords for this task. See “[Power off the server](#)” on page 53.
- Prevent exposure to static electricity, which might lead to system halt and loss of data, by keeping static-sensitive components in their static-protective packages until installation, and handling these devices with an electrostatic-discharge wrist strap or other grounding system.

**Notes:**

- Depending on the specific type, the full-length GPU adapter might look different from the illustration in this topic.
- Use any documentation that comes with the full-length GPU adapter and follow those instructions in addition to the instructions in this topic.
- To prevent potential thermal issues, change the **Misc** setting in the BIOS from **Option3** (default value) to **Option1** if the following two conditions are met:
  - The server is equipped with a GPU adapter.
  - The UEFI firmware version is ESE122T or later.

For the method of changing the **Misc** setting, see <https://support.lenovo.com/us/en/solutions/TT1832>.

**Attention:**

- Follow the installation sequence: slot 1 >> 3 >> 7 >> 5
- Make sure to follow the installation rules and sequence detailed in “[with one processor](#)” on page 169, “[with two processors](#)” on page 170, and “[GPU installation rules](#)” on page 171.
- One or two **FL PCIe adapter holders** are required to have been installed corresponding to the PCIe slot(s) for the FL GPU adapter(s) to be installed. See “[GPU installation rules](#)” on page 171.
- When there is only one FL GPU installed between PCIe slots 1 and 4 or between slots 5 and 8, one or two **FL GPU fillers** are required to be installed on the air baffle on the same side of the FL GPU for proper cooling and airflow.

**Procedure**

Step 1. Make preparations for this task.

- a. Locate the applicable PCIe slot to install the FL GPU adapter. See “[Expansion slots](#)” on page 7 and “[GPU installation rules](#)” on page 171.
- b. Make sure that a FL PCIe adapter holder has been installed corresponding to the corresponding PCIe slot. See “[Install a FL PCIe adapter holder](#)” on page 164.

Step 2. If necessary, route the power cable for the FL GPU adapter.

- a. Remove all the fan modules and fan filler. See “[Remove a fan module](#)” on page 89.

**Attention:** All fan modules must be removed from the fan cage when handling the fan cage assembly.

- b. Remove the fan cage assembly. See [“Remove the fan cage assembly” on page 91](#).
- c. Connect the power cable to the power distribution board; then, route the power cable and secure it under the clip. See [“GPU cable routing” on page 311](#).
- d. Reinstall the fan cage assembly. See [“Install the fan cage assembly” on page 92](#).
- e. Reinstall all the fan modules (and fan filler, if necessary). See [“Install a fan module” on page 94](#).

Step 3. If a bracket has been installed in the PCIe slot, remove it. Store the bracket for the PCIe slot in case it should be needed later.

Step 4. Install the FL GPU adapter.

**Note:** Make sure the PCIe adapter retainer is in the opened position.

- a. ① Connect the power cable to the FL GPU adapter.
- b. ② Align the FL GPU adapter to the FL PCIe adapter holder and the PCIe slot; then, gently press both ends of the FL GPU adapter until it is securely seated in the PCIe slot.
- c. ③ Tighten the screw to secure the GPU adapter.
- d. ④ Close the PCIe adapter retainer.

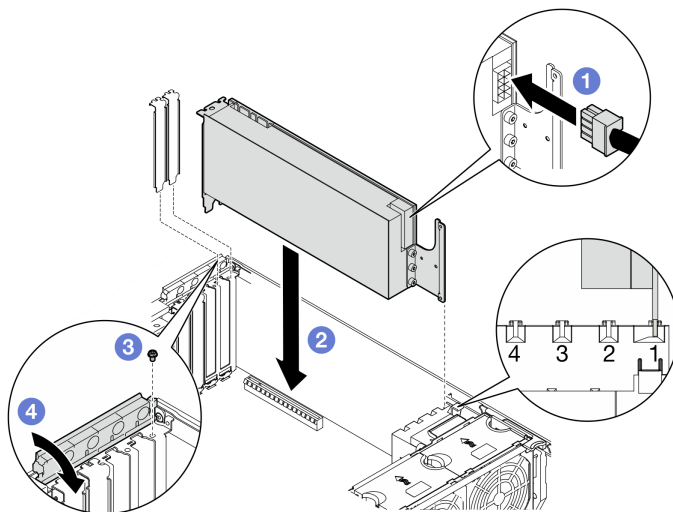

Figure 124. Installation of a FL GPU adapter

## After you finish

1. For proper cooling and airflow, install a FL GPU filler as necessary. See [“Install a FL GPU filler” on page 114](#).

**Note:** When there is only one FL GPU installed between PCIe slots 1 and 4 or between slots 5 and 8, one or two **FL GPU fillers** are required to be installed on the air baffle on the same side of the FL GPU for proper cooling and airflow.

2. Reinstall the air baffle. See [“Install an air baffle” on page 75](#).
3. Reinstall all the flash power modules, if necessary. See [“Install a flash power module” on page 102](#).
4. Reinstall the server cover. See [“Install a server cover” on page 231](#).
5. Complete the parts replacement. See [“Complete the parts replacement” on page 233](#).

## Demo video

Watch the procedure on YouTube

<https://www.youtube.com/watch?v=57-pympRuNA>

---

## Power distribution board replacement

Follow the instructions in this section to remove or install a power distribution board.

### Remove the power distribution board cover

Follow the instructions in this section to remove a power distribution board cover.

#### About this task

##### S002



#### CAUTION:

The power-control button on the device and the power switch on the power supply do not turn off the electrical current supplied to the device. The device also might have more than one power cord. To remove all electrical current from the device, ensure that all power cords are disconnected from the power source.

#### Attention:

- Read [“Installation Guidelines” on page 41](#) and [“Safety inspection checklist” on page 42](#) to ensure that you work safely.

#### Procedure

Step 1. Make preparations for this task.

- Record all system configuration information, such as Lenovo XClarity Controller IP addresses, vital product data, and the machine type, model number, serial number, Universally Unique Identifier, and asset tag of the server.
- Save the system configuration to an external device with Lenovo XClarity Essentials.
- Power off the server and disconnect all power cords for this task. See [“Power off the server” on page 53](#).
- Prevent exposure to static electricity, which might lead to system halt and loss of data, by keeping static-sensitive components in their static-protective packages until installation, and handling these devices with an electrostatic-discharge wrist strap or other grounding system.
- Remove the redundant power supply unit. See [“Remove a power supply unit” on page 187](#).
- If the server is in a rack, remove it from the rack.
- If foot stands are installed on the server, pivot them inwards and lay the server on its side for easier operation.
- Remove the server cover. See [“Remove the server cover” on page 230](#).
- If necessary, remove all flash power modules. See [“Remove a flash power module” on page 100](#).

- j. Remove the air baffle. See [“Remove the air baffle” on page 74](#).
- k. Disconnect cables for PCIe adapter or full-length GPU adapter.
- l. Remove all the full-length GPU adapters, if any. See [“Remove a FL GPU adapter” on page 173](#).
- m. If necessary, remove the A2/L4 GPU air duct(s) or FL PCIe adapter holder(s) installed on the fan cage. See [“Remove an A2/L4 GPU air duct” on page 71](#) or [“Remove a FL PCIe adapter holder” on page 162](#).
- n. Remove all the fan modules and fan filler. See [“Remove a fan module” on page 89](#).
 

**Attention:** All fan modules must be removed from the fan cage when handling the fan cage assembly.
- o. Remove the fan cage assembly. See [“Remove the fan cage assembly” on page 91](#).
- p. Remove the internal CFF HBA/RAID adapter. See [“Remove an internal CFF adapter” on page 116](#).
- q. Remove the RoT module. See [“Remove the Firmware and RoT Security Module” on page 209](#).
- r. Remove all the PCIe adapters, if any. See [“Remove a HL PCIe adapter” on page 165](#).
- s. Disconnect the intrusion switch cable from the system board, or remove the intrusion switch, if necessary. See [“Remove the intrusion switch” on page 121](#).
- t. If necessary, remove the CMOS battery. See [“Remove the CMOS battery \(CR2032\)” on page 77](#).
- u. If necessary, remove the MicroSD card. See [“Remove the MicroSD card” on page 139](#).
- v. Label the slot number on each memory module; then, remove all the memory modules from the system board and set them aside on a static-protective surface for reinstallation. See [“Remove a memory module” on page 133](#).
- w. Remove the processor and the heat sink. See [“Remove a processor and heat sink \(trained technician only\)” on page 194](#).
- x. Make note of where the cables are connected to the system board; then, disconnect all the cables.

**Note:** Disengage all latches, cable clips, release tabs, or locks on cable connectors beforehand. Failing to release them before removing the cables will damage the cable connectors on the system board. Any damage to the cable connectors may require replacing the system board.

- y. Remove the system board. See [“Remove the system board \(trained technician only\)” on page 216](#).

Step 2. Remove the power distribution board cover.

- a. ① Loosen the captive screw.
- b. ② Push the power distribution board cover toward the captive screw; then lift it up to remove.

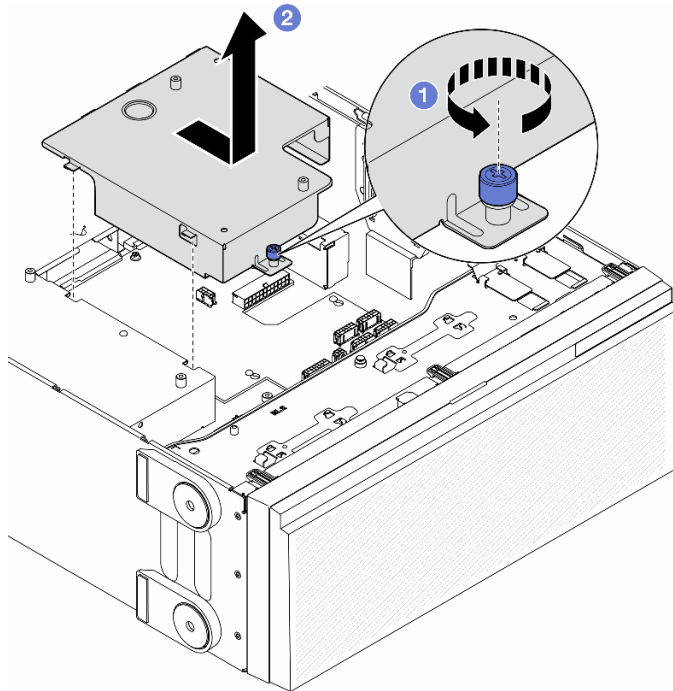

Figure 125. Removal of a power distribution board cover

### After this task is completed

1. Install a replacement unit. See “[Install a power distribution board cover](#)” on page 185.
2. If you are instructed to return the component or optional device, follow all packaging instructions, and use any packaging materials for shipping that are supplied to you.

### Demo video

[Watch the procedure on YouTube](#)

<https://www.youtube.com/watch?v=eBeC41HIXWQ>

### Remove the power distribution board

Follow the instructions in this section to remove a power distribution board.

### About this task

**S002**



#### CAUTION:

The power-control button on the device and the power switch on the power supply do not turn off the electrical current supplied to the device. The device also might have more than one power cord. To remove all electrical current from the device, ensure that all power cords are disconnected from the power source.

**Attention:**

- Read [“Installation Guidelines” on page 41](#) and [“Safety inspection checklist” on page 42](#) to ensure that you work safely.

**Procedure**

Step 1. Make preparations for this task.

- a. Record all system configuration information, such as Lenovo XClarity Controller IP addresses, vital product data, and the machine type, model number, serial number, Universally Unique Identifier, and asset tag of the server.
- b. Save the system configuration to an external device with Lenovo XClarity Essentials.
- c. Power off the server and disconnect all power cords for this task. See [“Power off the server” on page 53](#).
- d. Prevent exposure to static electricity, which might lead to system halt and loss of data, by keeping static-sensitive components in their static-protective packages until installation, and handling these devices with an electrostatic-discharge wrist strap or other grounding system.
- e. Remove the redundant power supply unit. See [“Remove a power supply unit” on page 187](#).
- f. If the server is in a rack, remove it from the rack.
- g. If foot stands are installed on the server, pivot them inwards and lay the server on its side for easier operation.
- h. Remove the server cover. See [“Remove the server cover” on page 230](#).
- i. If necessary, remove all flash power modules. See [“Remove a flash power module” on page 100](#).
- j. Remove the air baffle. See [“Remove the air baffle” on page 74](#).
- k. Disconnect cables for PCIe adapter or full-length GPU adapter.
- l. Remove all the full-length GPU adapters, if any. See [“Remove a FL GPU adapter” on page 173](#).
- m. If necessary, remove the A2/L4 GPU air duct(s) or FL PCIe adapter holder(s) installed on the fan cage. See [“Remove an A2/L4 GPU air duct” on page 71](#) or [“Remove a FL PCIe adapter holder” on page 162](#).
- n. Remove all the fan modules and fan filler. See [“Remove a fan module” on page 89](#).

**Attention:** All fan modules must be removed from the fan cage when handling the fan cage assembly.

- o. Remove the fan cage assembly. See [“Remove the fan cage assembly” on page 91](#).
- p. Remove the internal CFF HBA/RAID adapter. See [“Remove an internal CFF adapter” on page 116](#).
- q. Remove the RoT module. See [“Remove the Firmware and RoT Security Module” on page 209](#).
- r. Remove all the PCIe adapters, if any. See [“Remove a HL PCIe adapter” on page 165](#).
- s. Disconnect the intrusion switch cable from the system board, or remove the intrusion switch, if necessary. See [“Remove the intrusion switch” on page 121](#).
- t. If necessary, remove the CMOS battery. See [“Remove the CMOS battery \(CR2032\)” on page 77](#).
- u. If necessary, remove the MicroSD card. See [“Remove the MicroSD card” on page 139](#).
- v. Label the slot number on each memory module; then, remove all the memory modules from the system board and set them aside on a static-protective surface for reinstallation. See [“Remove a memory module” on page 133](#). See [“Remove a memory module” on page 133](#).

- w. Remove the processor and the heat sink. See [“Remove a processor and heat sink \(trained technician only\)” on page 194.](#)
- x. Make note of where the cables are connected to the system board; then, disconnect all the cables.

**Note:** Disengage all latches, cable clips, release tabs, or locks on cable connectors beforehand. Failing to release them before removing the cables will damage the cable connectors on the system board. Any damage to the cable connectors may require replacing the system board.

- y. Remove the system board. See [“Remove the system board \(trained technician only\)” on page 216.](#)
- z. Remove the power distribution board cover. See [“Remove the power distribution board cover” on page 178.](#)

Step 2. Disconnect all the cables from the power distribution board.

Step 3. Remove the power distribution board.

- a. ① Remove the three screws that secure the power distribution board to the chassis.
- b. ② Slide the power distribution board towards the rear of the server to release it from the chassis; then, carefully hold edges of the power distribution board and lift it out of the chassis.

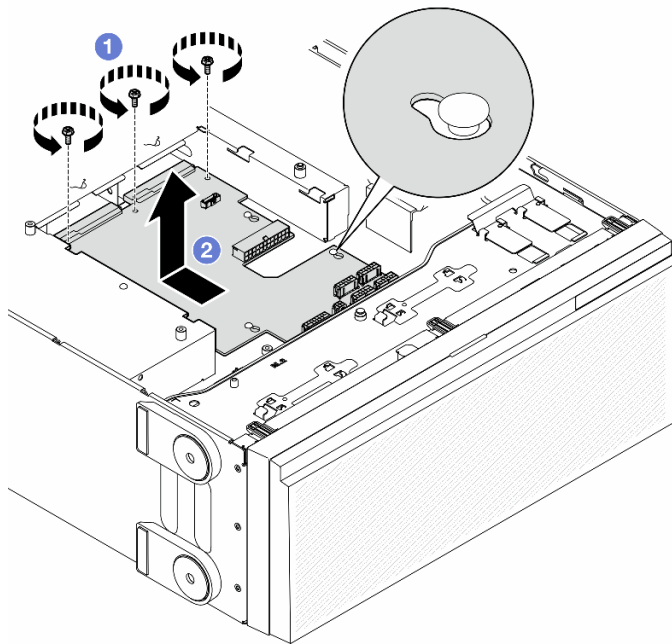

Figure 126. Removal of the power distribution board

### After this task is completed

- Install a replacement unit. See [“Install a power distribution board” on page 183.](#)
- If you are instructed to return the component or optional device, follow all packaging instructions, and use any packaging materials for shipping that are supplied to you.

### Demo video

[Watch the procedure on YouTube](#)

<https://www.youtube.com/watch?v=eBeC41HIXWQ>

## Install a power distribution board

Follow the instructions in this section to install a power distribution board.

### About this task

**S002**

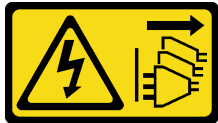

#### CAUTION:

The power-control button on the device and the power switch on the power supply do not turn off the electrical current supplied to the device. The device also might have more than one power cord. To remove all electrical current from the device, ensure that all power cords are disconnected from the power source.

#### Attention:

- Read “[Installation Guidelines](#)” on page 41 and “[Safety inspection checklist](#)” on page 42 to ensure that you work safely.
- Power off the server and disconnect all power cords for this task. See “[Power off the server](#)” on page 53.
- Prevent exposure to static electricity, which might lead to system halt and loss of data, by keeping static-sensitive components in their static-protective packages until installation, and handling these devices with an electrostatic-discharge wrist strap or other grounding system.

### Procedure

Step 1. Install the power distribution board.

- 1 Carefully hold the edges of the power distribution board and position it to the chassis. Ensure that the tabs on the chassis are inserted into the corresponding holes in the power distribution board; then, slide the power distribution board towards the front of the server.
- 2 Tighten the three screws to secure the power distribution board to the chassis.

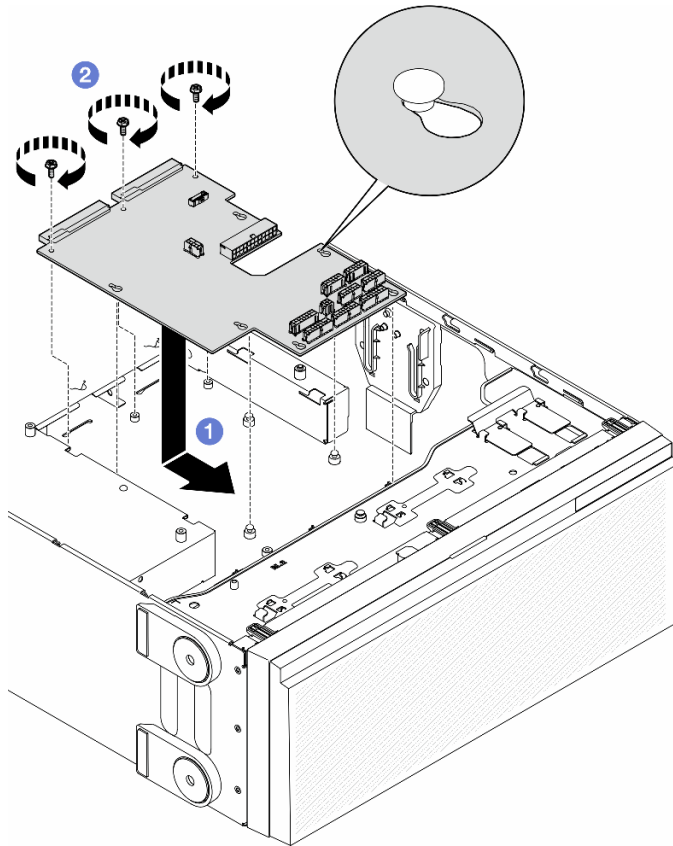

Figure 127. Installation of a power distribution board

Step 2. Connect the cables to the power distribution board signal connector and main power connector on the power distribution board. See [Chapter 6 “Internal cable routing” on page 235](#).

### After this task is completed

1. Reinstall the power distribution board cover. See [“Install a power distribution board cover” on page 185](#).
2. Reinstall the system board. See [“Install a system board \(trained technician only\)” on page 221](#).
3. Connect the power distribution board cables to the system board. See [“Power distribution board cable routing” on page 314](#).
4. Reinstall the processor and the heat sink. See [“Install a processor and heat sink \(trained technician only\)” on page 201](#).
5. Reinstall all the memory modules. See [“Install a memory module” on page 136](#).
6. Reinstall the CMOS battery. See [“Install a CMOS battery \(CR2032\)” on page 79](#).
7. Reinstall the intrusion switch or reconnect the intrusion switch cable to the system board. See [“Install an intrusion switch” on page 122](#).
8. Reinstall the internal CFF HBA/RAID adapter. See [“Install an internal CFF adapter” on page 118](#).
9. Reinstall the MicroSD card. See [“Install a MicroSD card” on page 141](#).
10. Reinstall the RoT module. See [“Install the Firmware and RoT Security Module” on page 211](#).
11. Reinstall all the PCIe adapters. See [“Install a HL PCIe adapter” on page 167](#).
12. Reinstall the fan cage assembly. See [“Install the fan cage assembly” on page 92](#).

**Attention:** All fan modules must be removed from the fan cage when handling the fan cage assembly.

13. Reinstall all the fan modules (and fan filler, if necessary). See “Install a fan module” on page 94.
14. Install the required A2/L4 GPU air ducts or FL PCIe adapter holders. See “Install an A2/L4 GPU air duct” on page 72 and “Install a FL PCIe adapter holder” on page 164.

Reinstall all the full-length GPU adapters, if necessary. See “Install a FL GPU adapter” on page 175.

15. Reconnect all the cables that were removed. See Chapter 6 “Internal cable routing” on page 235.
16. Reinstall the air baffle. See “Install an air baffle” on page 75.
17. Reinstall all the flash power modules, if necessary. See “Install a flash power module” on page 102.
18. Reinstall the server cover. See “Install a server cover” on page 231.
19. Reinstall the redundant power supply unit. See “Install a power supply unit” on page 190.
20. Complete the parts replacement. See “Complete the parts replacement” on page 233.
21. Update the vital product data (VPD). See “Update the Vital Product Data (VPD)” on page 224.

Machine type number and serial number can be found on the ID label, see “Identify the server and access the Lenovo XClarity Controller” on page 37.

22. If hiding TPM or updating TPM firmware is needed, see “Hide/observe TPM” on page 215 or “Update the TPM firmware” on page 216.
23. Optionally, enable Secure Boot. See “Enable UEFI Secure Boot” on page 225.

## Demo video

[Watch the procedure on YouTube](#)

<https://www.youtube.com/watch?v=ULNPixRUKyg>

## Install a power distribution board cover

Follow the instructions in this section to install a power distribution board cover.

### About this task

#### S002



#### **CAUTION:**

**The power-control button on the device and the power switch on the power supply do not turn off the electrical current supplied to the device. The device also might have more than one power cord. To remove all electrical current from the device, ensure that all power cords are disconnected from the power source.**

#### **Attention:**

- Read “Installation Guidelines” on page 41 and “Safety inspection checklist” on page 42 to ensure that you work safely.
- Power off the server and disconnect all power cords for this task. See “Power off the server” on page 53.
- Prevent exposure to static electricity, which might lead to system halt and loss of data, by keeping static-sensitive components in their static-protective packages until installation, and handling these devices with an electrostatic-discharge wrist strap or other grounding system.

## Procedure

- Step 1. ① Insert the power distribution board cover into place as shown.
- Step 2. ② Tighten the captive screw to secure the power distribution board cover.

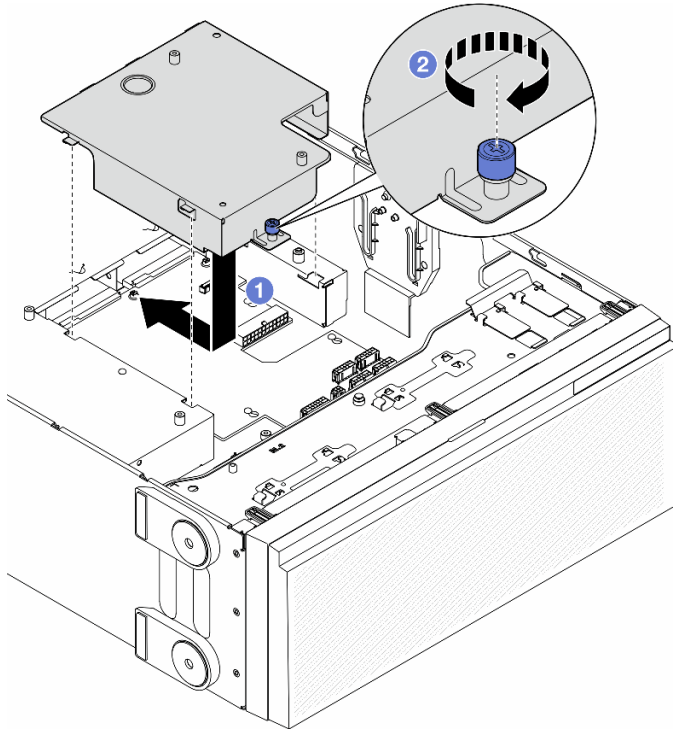

Figure 128. Installation of a power distribution board cover

## After this task is completed

1. Reinstall the system board. See [“Install a system board \(trained technician only\)”](#) on page 221.
2. Connect the power distribution board cables to the system board. See [“Power distribution board cable routing”](#) on page 314.
3. Reinstall the processor and the heat sink. See [“Install a processor and heat sink \(trained technician only\)”](#) on page 201.
4. Reinstall all the memory modules. See [“Install a memory module”](#) on page 136.
5. Reinstall the CMOS battery. See [“Install a CMOS battery \(CR2032\)”](#) on page 79.
6. Reinstall the intrusion switch or reconnect the intrusion switch cable to the system board. See [“Install an intrusion switch”](#) on page 122.
7. Reinstall the internal CFF HBA/RAID adapter. See [“Install an internal CFF adapter”](#) on page 118.
8. Reinstall the MicroSD card. See [“Install a MicroSD card”](#) on page 141.
9. Reinstall the RoT module. See [“Install the Firmware and RoT Security Module”](#) on page 211.
10. Reinstall all the PCIe adapters. See [“Install a HL PCIe adapter”](#) on page 167.
11. Reinstall the fan cage assembly. See [“Install the fan cage assembly”](#) on page 92.

**Attention:** All fan modules must be removed from the fan cage when handling the fan cage assembly.

12. Reinstall all the fan modules (and fan filler, if necessary). See [“Install a fan module”](#) on page 94.
13. Install the required A2/L4 GPU air ducts or FL PCIe adapter holders. See [“Install an A2/L4 GPU air duct”](#) on page 72 and [“Install a FL PCIe adapter holder”](#) on page 164.

- Reinstall all the full-length GPU adapters, if necessary. See “Install a FL GPU adapter” on page 175.
14. Reconnect all the cables that were removed. See Chapter 6 “Internal cable routing” on page 235.
  15. Reinstall the air baffle. See “Install an air baffle” on page 75.
  16. Reinstall all the flash power modules, if necessary. See “Install a flash power module” on page 102.
  17. Reinstall the server cover. See “Install a server cover” on page 231.
  18. Reinstall the redundant power supply unit. See “Install a power supply unit” on page 190.
  19. Complete the parts replacement. See “Complete the parts replacement” on page 233.
  20. Update the vital product data (VPD). See “Update the Vital Product Data (VPD)” on page 224.

Machine type number and serial number can be found on the ID label, see “Identify the server and access the Lenovo XClarity Controller” on page 37.

21. If hiding TPM or updating TPM firmware is needed, see “Hide/observe TPM” on page 215 or “Update the TPM firmware” on page 216.
22. Optionally, enable Secure Boot. See “Enable UEFI Secure Boot” on page 225.

## Demo video

Watch the procedure on YouTube

<https://www.youtube.com/watch?v=ULNPixRUKyg>

---

## Power supply unit replacement

Follow the instructions in this section to remove or install a redundant power supply unit.

### Remove a power supply unit

Follow the instructions in this section to remove a power supply unit.

#### About this task

##### S001



**Electrical current from power, telephone, and communication cables is hazardous.  
To avoid a shock hazard:**

- Connect all power cords to a properly wired and grounded electrical outlet/source.
- Connect any equipment that will be attached to this product to properly wired outlets/sources.
- When possible, use one hand only to connect or disconnect signal cables.
- Never turn on any equipment when there is evidence of fire, water, or structural damage.
- The device might have more than one power cord, to remove all electrical current from the device, ensure that all power cords are disconnected from the power source.

## S002

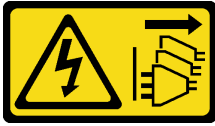

### **CAUTION:**

The power-control button on the device and the power switch on the power supply do not turn off the electrical current supplied to the device. The device also might have more than one power cord. To remove all electrical current from the device, ensure that all power cords are disconnected from the power source.

## S033



### **CAUTION:**

Hazardous energy present. Voltages with hazardous energy might cause heating when shorted with metal, which might result in spattered metal, burns, or both.

## S035



### **CAUTION:**

Never remove the cover on a power supply or any part that has this label attached. Hazardous voltage, current, and energy levels are present inside any component that has this label attached. There are no serviceable parts inside these components. If you suspect a problem with one of these parts, contact a service technician.

### **Attention:**

- Read [“Installation Guidelines” on page 41](#) and [“Safety inspection checklist” on page 42](#) to ensure that you work safely.
- Prevent exposure to static electricity, which might lead to system halt and loss of data, by keeping static-sensitive components in their static-protective packages until installation, and handling these devices with an electrostatic-discharge wrist strap or other grounding system.

The following tips describe the information that must be considered for the removal of a power supply with dc input.

### **CAUTION:**

1. 240 V dc input (input range: 180-300 V dc) is **ONLY** supported in Chinese Mainland.
2. Power supplies with 240 V dc are not hot-swappable. To remove the power cord, ensure you have turned off the server or disconnected the dc power sources at the breaker panel.
3. In order for the ThinkSystem products to operate error free in both a DC or AC electrical environment, a TN-S earthing system which complies to 60364-1 IEC 2005 standard has to be present or installed.

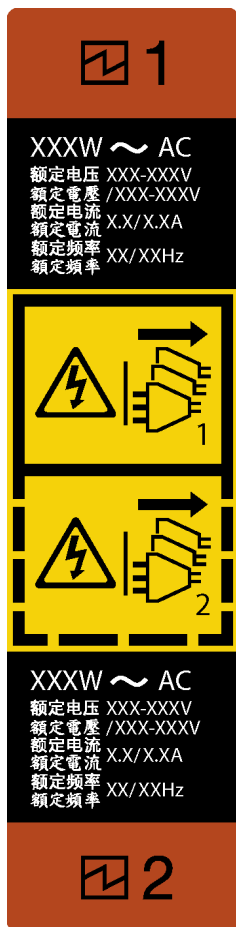

Figure 129. Power supply unit label

**Attention:** This type of power supply unit is hot-swap only when two power supplies are installed for redundancy. If only one power supply unit is installed, you must power off the server first before removing the power supply.



在直流输入状态下，若电源供应器插座不支持热插拔功能，请务必不要对设备电源线进行热插拔，此操作可能导致设备损坏及数据丢失。因错误执行热插拔导致的设备故障或损坏，不属于保修范围。

NEVER CONNECT AND DISCONNECT THE POWER SUPPLY CABLE AND EQUIPMENT WHILE YOUR EQUIPMENT IS POWERED ON WITH DC SUPPLY (hot-plugging). Otherwise the equipment and result in data loss may be damaged, the damages and losses result from incorrect operation of the equipment will not be covered by the manufacturers' warranty.

## Procedure

- Step 1. Locate the power supply unit on the rear of the server; then, disconnect the power cord from the power supply unit.
- Step 2. Remove the power supply unit.
  - a. ① Press and hold the release tab in the direction as shown.

- b. ② At the same time, carefully pull the handle to slide the power supply unit out of the chassis.

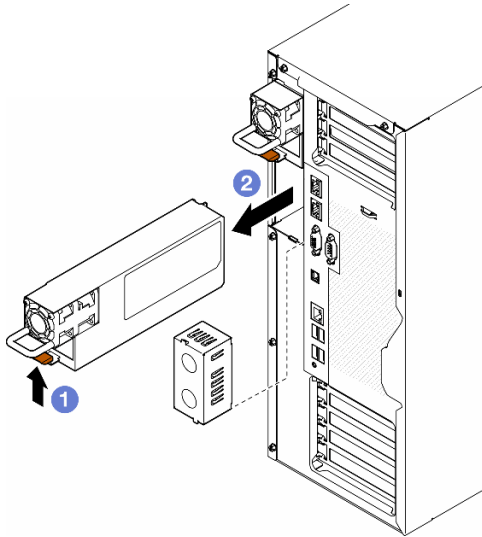

Figure 130. Removal of a power supply unit or PSU filler

### After this task is completed

1. Install a replacement unit or filler, see “[Install a power supply unit](#)” on page 190.

**Important:** To ensure proper cooling during normal server operation, both of the power supply bays must be occupied either with a power supply unit or a PSU filler.

2. If you are instructed to return the component or optional device, follow all packaging instructions, and use any packaging materials for shipping that are supplied to you.

### Demo video

[Watch the procedure on YouTube](#)

<https://www.youtube.com/watch?v=PW6NwqSRmRQ>

### Install a power supply unit

Follow the instructions in this section to install a power supply unit.

### About this task

**S001**



 **DANGER**

Electrical current from power, telephone, and communication cables is hazardous.  
To avoid a shock hazard:

- Connect all power cords to a properly wired and grounded electrical outlet/source.
- Connect any equipment that will be attached to this product to properly wired outlets/sources.
- When possible, use one hand only to connect or disconnect signal cables.
- Never turn on any equipment when there is evidence of fire, water, or structural damage.
- The device might have more than one power cord, to remove all electrical current from the device, ensure that all power cords are disconnected from the power source.

**S002**



**CAUTION:**

The power-control button on the device and the power switch on the power supply do not turn off the electrical current supplied to the device. The device also might have more than one power cord. To remove all electrical current from the device, ensure that all power cords are disconnected from the power source.

**S033**



**CAUTION:**

Hazardous energy present. Voltages with hazardous energy might cause heating when shorted with metal, which might result in spattered metal, burns, or both.

**S035**



**CAUTION:**

Never remove the cover on a power supply or any part that has this label attached. Hazardous voltage, current, and energy levels are present inside any component that has this label attached. There are no serviceable parts inside these components. If you suspect a problem with one of these parts, contact a service technician.

**Attention:**

- Read [“Installation Guidelines” on page 41](#) and [“Safety inspection checklist” on page 42](#) to ensure that you work safely.

- Prevent exposure to static electricity, which might lead to system halt and loss of data, by keeping static-sensitive components in their static-protective packages until installation, and handling these devices with an electrostatic-discharge wrist strap or other grounding system.

The following tips describe the type of power supply unit that the server supports and other information to be consider when installing a power supply unit:

- The standard shipping has only one power supply unit installed in the server. For redundancy and hot-swap support, installing an additional power supply unit is a must. Certain customized models might be shipped with two power supplies installed.
- Ensure that the devices to be installed are supported. For a list of supported optional devices for the server, go to: <https://serverproven.lenovo.com>

**CAUTION:**

- 1. 240 V dc input (input range: 180-300 V dc) is ONLY supported in Chinese Mainland.**
- 2. Power supplies with 240 V dc are not hot-swappable. To remove the power cord, ensure you have turned off the server or disconnected the dc power sources at the breaker panel.**
- 3. In order for the ThinkSystem products to operate error free in both a DC or AC electrical environment, a TN-S earthing system which complies to 60364-1 IEC 2005 standard has to be present or installed.**

**Notes:**

- Ensure that the two power supply units installed on the server have the same wattage.
- When replacing the existing power supply unit with a new power supply unit of different wattage, attach the power information label that comes with this option onto the existing label near the power supply unit.

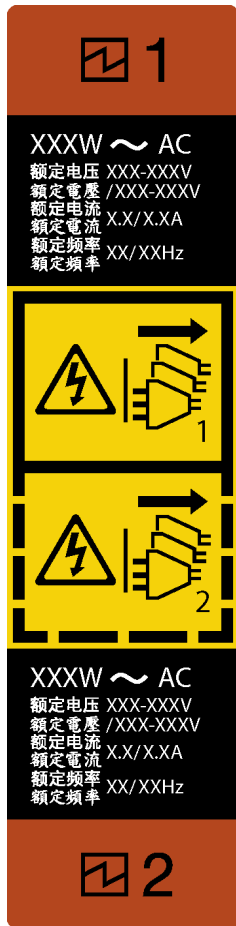

Figure 131. Power supply unit label



在直流输入状态下，若电源供应器插座不支持热插拔功能，请务必不要对设备电源线进行热插拔，此操作可能导致设备损坏及数据丢失。因错误执行热插拔导致的设备故障或损坏，不属于保修范围。

NEVER CONNECT AND DISCONNECT THE POWER SUPPLY CABLE AND EQUIPMENT WHILE YOUR EQUIPMENT IS POWERED ON WITH DC SUPPLY (hot-plugging). Otherwise the equipment and result in data loss may be damaged, the damages and losses result from incorrect operation of the equipment will not be covered by the manufacturers' warranty.

## Procedure

Step 1. Remove a power-supply-bay filler, if any.

**Important:** To ensure proper cooling during normal server operation, both of the power supply bays must be occupied. This means that each bay must have a power supply unit installed; or one has a power supply unit installed and the other has a power-supply filler installed.

Step 2. Note the orientation of the power supply unit; then, slide it into the chassis until it snaps into position.

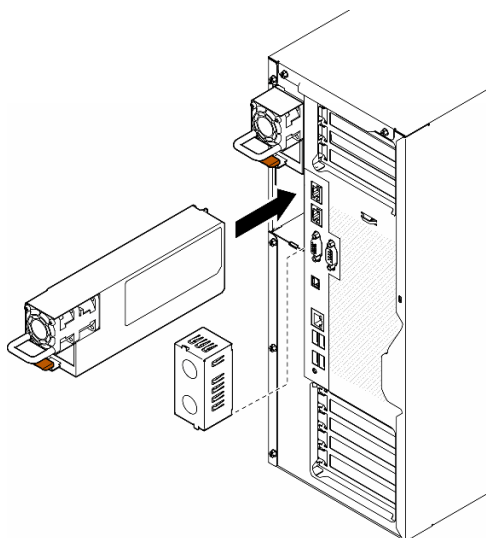

Figure 132. Installation of a power supply unit or PSU filler

### After this task is completed

1. Connect the power cable to the power supply and a properly grounded electrical outlet.
2. Pull the handle to ensure the power supply unit is properly installed.
3. If the server is powered off, power on the server. Ensure that both the power input LED and the power output LED on the power supply are lit, indicating that the power supply is operating properly.
4. Complete the parts replacement. See [“Complete the parts replacement” on page 233](#).

### Demo video

[Watch the procedure on YouTube](#)

<https://www.youtube.com/watch?v=yD1uVB3x-0Y>

---

## Processor and heat sink replacement (trained technician only)

Follow the instruction in this section to replace an assembled processor and heat sink, known as a processor-heat-sink module (PHM), a processor, or a heat sink.

**Attention:** Before reusing a processor or heat sink, make sure you use Lenovo proven alcohol cleaning pad and thermal grease.

**Important:** The processor in your server can throttle in response to thermal conditions, temporarily lowering its speed to reduce heat output. In instances where a few processor cores are throttled for an extremely short time period (100 ms or less), the only indication might be an entry in the operating system event log with no corresponding entry in the system XCC event log. If this situation occurs, the event can be ignored and processor replacement is not required.

## Remove a processor and heat sink (trained technician only)

Follow the instructions in this section to remove an assembled processor and heat sink, known as a processor-heat-sink module (PHM). This task requires a Torx T30 driver. This procedure must be executed by a trained technician.

**Important:** This task must be operated by trained technicians.

## About this task

### S002



#### **CAUTION:**

The power-control button on the device and the power switch on the power supply do not turn off the electrical current supplied to the device. The device also might have more than one power cord. To remove all electrical current from the device, ensure that all power cords are disconnected from the power source.

#### **Attention:**

- Read [“Installation Guidelines” on page 41](#) and [“Safety inspection checklist” on page 42](#) to ensure that you work safely.
- Power off the server and disconnect all power cords for this task. See [“Power off the server” on page 53](#).
- Prevent exposure to static electricity, which might lead to system halt and loss of data, by keeping static-sensitive components in their static-protective packages until installation, and handling these devices with an electrostatic-discharge wrist strap or other grounding system.
- If the server is in a rack, remove it from the rack.
- If foot stands are installed on the server, pivot them inwards and lay the server on its side for easier operation.
- Each processor socket must always contain a cover or a PHM. When removing or installing a PHM, protect the empty processor sockets with a cover.
- Do not touch the processor socket or processor contacts. Processor-socket contacts are very fragile and easily damaged. Contaminants on the processor contacts, such as oil from your skin, can cause connection failures.
- Do not allow the thermal grease on the processor or heat sink to come in contact with anything. Contact with any surface can compromise the thermal grease, rendering it ineffective. Thermal grease can damage components, such as the electrical connectors in the processor socket.

Remove and install only one PHM at a time. If the system board supports multiple processors, install the PHMs starting with the first processor socket.

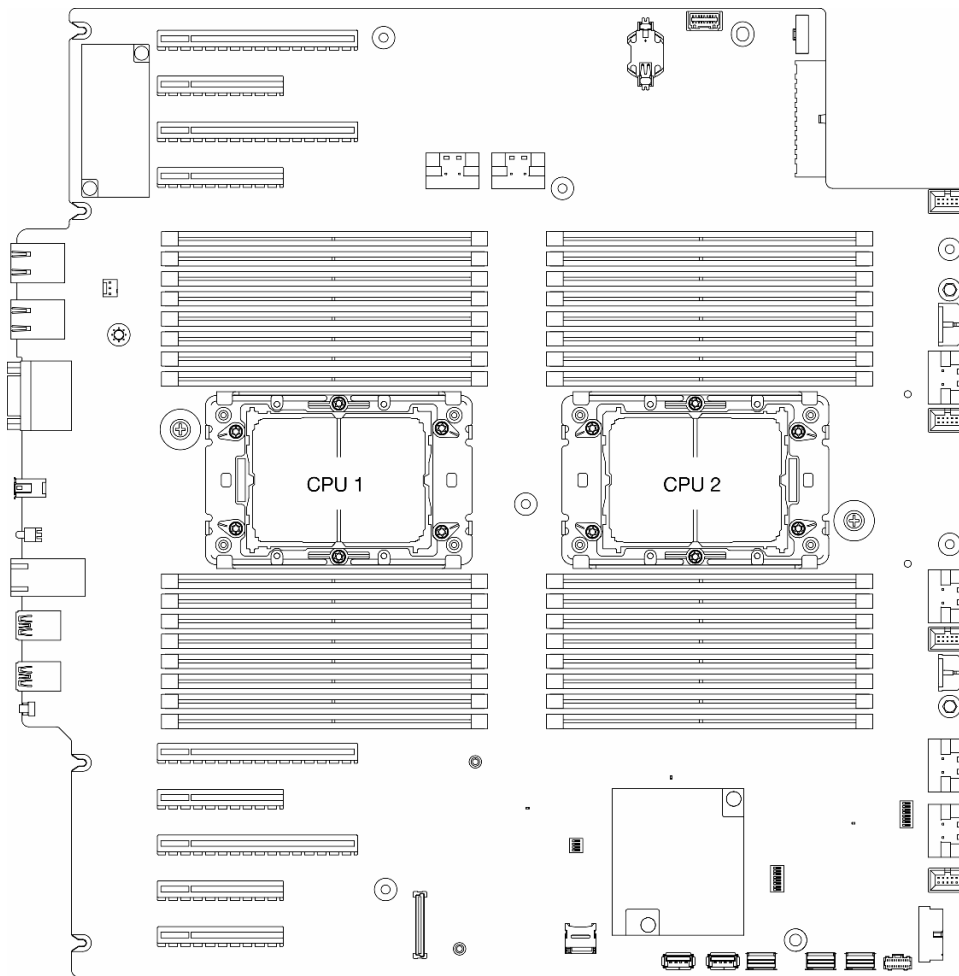

Figure 133. Processor locations on the system board

**Note:** The heat sink, processor, and processor carrier might look different from the illustrations in this section.

The following illustration shows the components of the PHM.

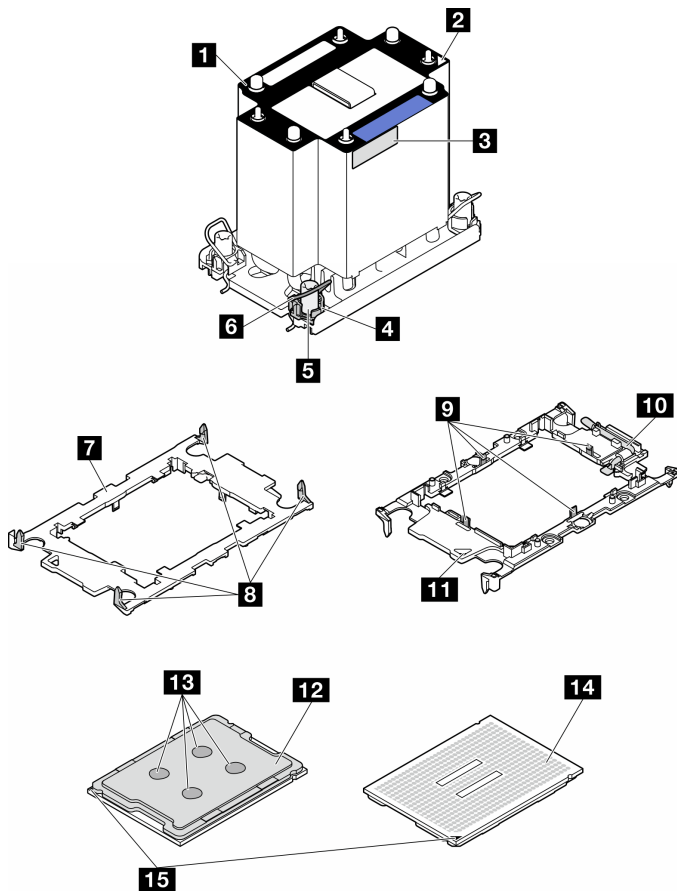

Figure 134. PHM components

<b>1</b> Heat sink	<b>9</b> Clips to secure processor in carrier
<b>2</b> Heat sink triangular mark	<b>10</b> Carrier triangular mark
<b>3</b> Processor identification label	<b>11</b> Processor ejector handle
<b>4</b> Nut and wire bail retainer	<b>12</b> Processor heat spreader
<b>5</b> Torx T30 nut	<b>13</b> Thermal grease
<b>6</b> Anti-tilt wire bail	<b>14</b> Processor contacts
<b>7</b> Processor carrier	<b>15</b> Processor triangular mark
<b>8</b> Clips to secure carrier to heat sink	

## Procedure

Step 1. Make preparations for this task.

- a. Remove the redundant power supply unit. See [“Remove a power supply unit”](#) on page 187.
- b. Remove the server cover. See [“Remove the server cover”](#) on page 230.
- c. If necessary, remove all flash power modules. See [“Remove a flash power module”](#) on page 100.
- d. Remove the air baffle. See [“Remove the air baffle”](#) on page 74.

Step 2. Remove the PHM from the system board.

- a. ① Fully loosen the Torx T30 nuts on the PHM *in the removal sequence shown* on the heat-sink label.
- b. ② Pivot the anti-tilt wire bails inward.
- c. ③ Carefully lift the PHM from the processor socket. If the PHM cannot be fully lifted out of the socket, further loosen the Torx T30 nuts and try lifting the PHM again.

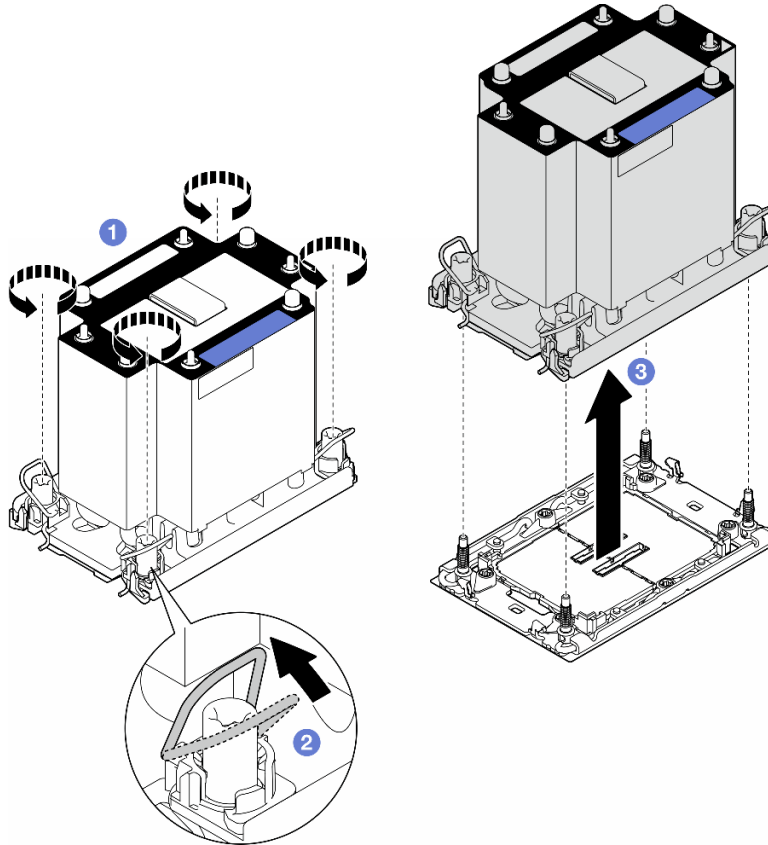

Figure 135. Removal of a PHM

### After this task is completed

- Each processor socket must always contain a cover or a PHM. When removing or installing a PHM, protect the empty processor sockets with a cover.
- If the PHM is removed as part of the system board replacement, set the PHM aside.
- To reuse the processor or heat sink, separate the processor from its retainer. See “[Separate the processor from carrier and heat sink \(trained technician only\)](#)” on page 199.
- If you are instructed to return the component or optional device, follow all packaging instructions, and use any packaging materials for shipping that are supplied to you.

### Demo video

[Watch the procedure on YouTube](#)

<https://www.youtube.com/watch?v=ibXKZF0K0gk>

## Separate the processor from carrier and heat sink (trained technician only)

Follow the instructions in this section to separate a processor and its carrier from an assembled processor and heat sink, known as a processor-heat-sink module (PHM). This procedure must be executed by a trained technician.

**Important:** This task must be operated by trained technicians.

### About this task

#### S002

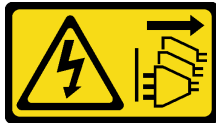

#### **CAUTION:**

**The power-control button on the device and the power switch on the power supply do not turn off the electrical current supplied to the device. The device also might have more than one power cord. To remove all electrical current from the device, ensure that all power cords are disconnected from the power source.**

#### **Attention:**

- Read [“Installation Guidelines” on page 41](#) and [“Safety inspection checklist” on page 42](#) to ensure that you work safely.
- Power off the server and disconnect all power cords for this task. See [“Power off the server” on page 53](#).
- Prevent exposure to static electricity, which might lead to system halt and loss of data, by keeping static-sensitive components in their static-protective packages until installation, and handling these devices with an electrostatic-discharge wrist strap or other grounding system.
- Do not touch the processor contacts. Contaminants on the processor contacts, such as oil from your skin, can cause connection failures.
- Do not allow the thermal grease on the processor or heat sink to come in contact with anything. Contact with any surface can compromise the thermal grease, rendering it ineffective. Thermal grease can damage components, such as the electrical connectors in the processor socket.

**Note:** The heat sink, processor, and processor carrier might look different from the illustrations in this section.

### Procedure

- Step 1. Separate the processor from the heat sink and carrier.
  - 1 Lift the handle to release the processor from the carrier.
  - 2 Hold the processor by its edges; then, lift the processor from the heat sink and carrier.
  - 3 Without putting the processor down, wipe the thermal grease from the top of the processor with an alcohol cleaning pad; then, place the processor on a static protective surface with the processor-contact side up.

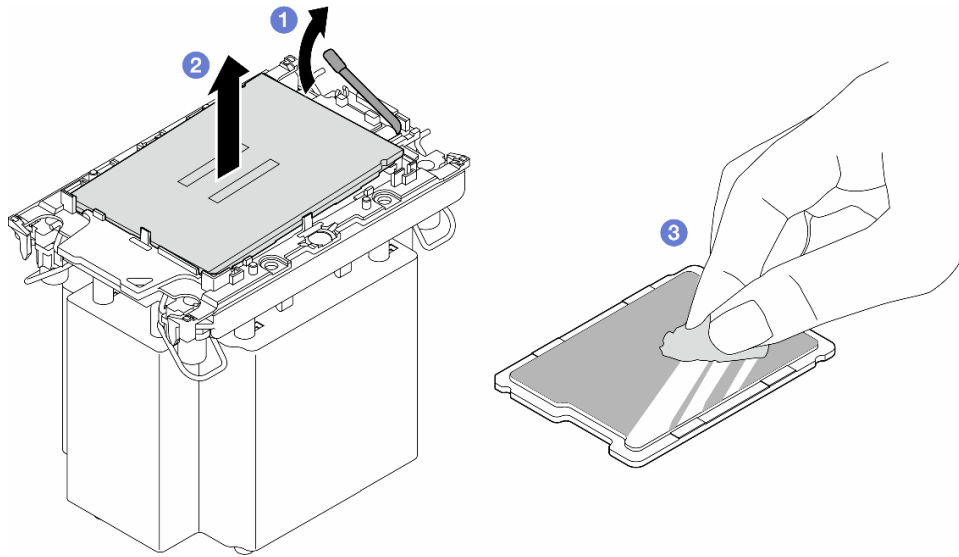

Figure 136. Separation of a processor from the heat sink and carrier

**Note:** Do not touch the contacts on the processor.

Step 2. Separate the processor carrier from the heat sink.

- a. ① Release the retaining clips from the heat sink.
- b. ② Lift the carrier from the heat sink.
- c. ③ Wipe the thermal grease from the bottom of the heat sink with an alcohol cleaning pad.

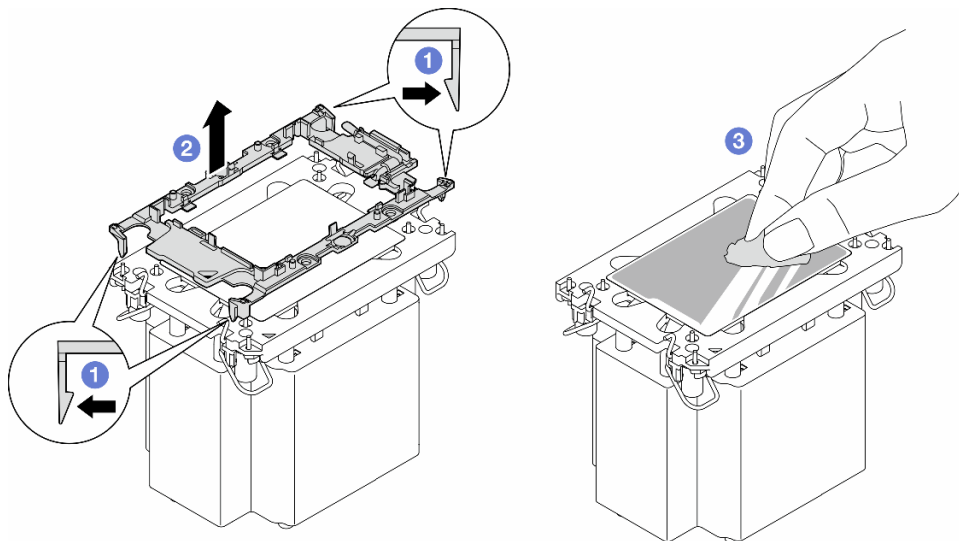

Figure 137. Separation of a processor carrier from the heat sink

**Note:** The processor carrier will be discarded and replaced with a new one.

### After this task is completed

1. Install the replacement unit(s), if necessary. See [“Install a processor and heat sink \(trained technician only\)” on page 201.](#)

2. If you are instructed to return the component or optional device, follow all packaging instructions, and use any packaging materials for shipping that are supplied to you.

## Demo video

[Watch the procedure on YouTube](#)

<https://www.youtube.com/watch?v=ibXKZF0K0gk>

## Install a processor and heat sink (trained technician only)

Follow the instructions in this section to install an assembled processor and heat sink, known as a processor-heat-sink module (PHM). This task requires a Torx T30 driver. This procedure must be executed by a trained technician.

**Important:** This task must be operated by trained technicians.

## About this task

### S002



#### **CAUTION:**

The power-control button on the device and the power switch on the power supply do not turn off the electrical current supplied to the device. The device also might have more than one power cord. To remove all electrical current from the device, ensure that all power cords are disconnected from the power source.

#### **Attention:**

- Read “[Installation Guidelines](#)” on page 41 and “[Safety inspection checklist](#)” on page 42 to ensure that you work safely.
- Power off the server and disconnect all power cords for this task. See “[Power off the server](#)” on page 53.
- Prevent exposure to static electricity, which might lead to system halt and loss of data, by keeping static-sensitive components in their static-protective packages until installation, and handling these devices with an electrostatic-discharge wrist strap or other grounding system.
- Each processor socket must always contain a cover or a PHM. When removing or installing a PHM, protect the empty processor sockets with a cover.
- Do not touch the processor socket or processor contacts. Processor-socket contacts are very fragile and easily damaged. Contaminants on the processor contacts, such as oil from your skin, can cause connection failures.
- Do not allow the thermal grease on the processor or heat sink to come in contact with anything. Contact with any surface can compromise the thermal grease, rendering it ineffective. Thermal grease can damage components, such as the electrical connectors in the processor socket.
- Remove and install only one PHM at a time. If the system board supports multiple processors, install the PHMs starting with the first processor socket.

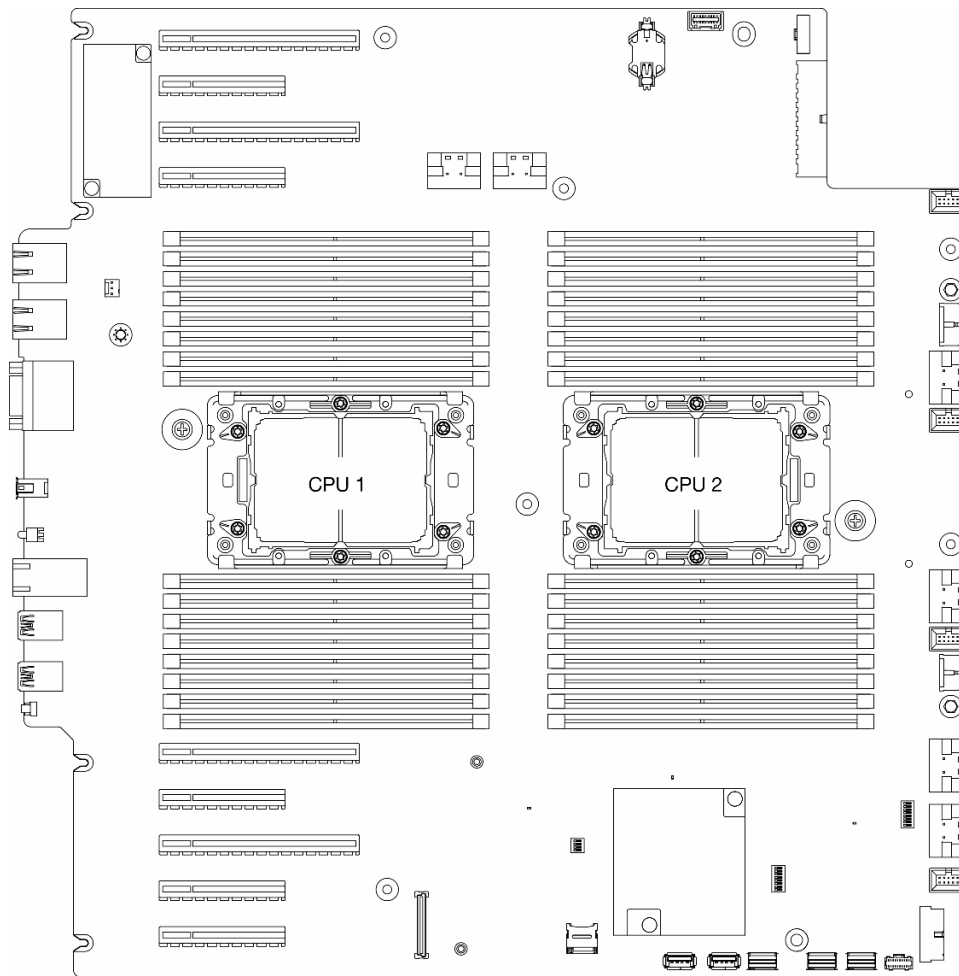

Figure 138. Processor locations on the system board

**Notes:**

- The heat sink, processor, and processor carrier might look different from the illustrations in this section.
- PHMs are keyed for the socket where they can be installed and for their orientation in the socket.
- See <https://serverproven.lenovo.com> for a list of processors supported for your server. All processors on the system board must have the same speed, number of cores, and frequency.
- Before you install a new PHM or replacement processor, update your system firmware to the latest level. See “Update the firmware” on page 320.

The following illustration shows the components of the PHM.

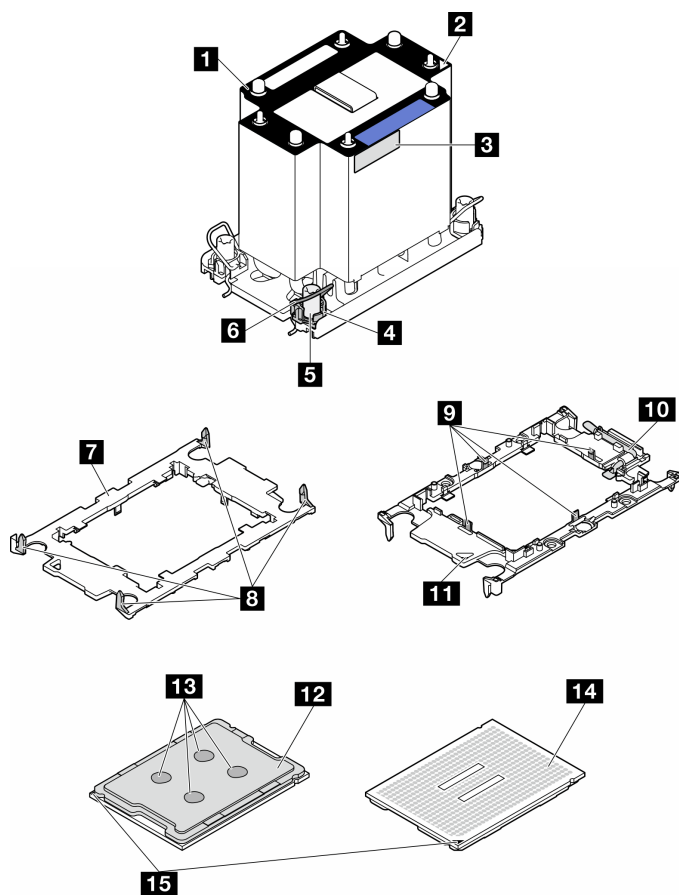

Figure 139. PHM components

<b>1</b> Heat sink	<b>9</b> Clips to secure processor in carrier
<b>2</b> Heat sink triangular mark	<b>10</b> Carrier triangular mark
<b>3</b> Processor identification label	<b>11</b> Processor ejector handle
<b>4</b> Nut and wire bail retainer	<b>12</b> Processor heat spreader
<b>5</b> Torx T30 nut	<b>13</b> Thermal grease
<b>6</b> Anti-tilt wire bail	<b>14</b> Processor contacts
<b>7</b> Processor carrier	<b>15</b> Processor triangular mark
<b>8</b> Clips to secure carrier to heat sink	

**Firmware and driver download:** You might need to update the firmware or driver after replacing a component.

- Go to <https://datacentersupport.lenovo.com/tw/en/products/servers/thinksystem/st650v3/7d7a/downloads/driver-list/> to see the latest firmware and driver updates for your server.
- Go to “Update the firmware” on page 320 for more information on firmware updating tools.

## Procedure

Step 1. When replacing a processor and reusing the heat sink:

- a. Remove the processor identification label from the heat sink and replace it with the new label that comes with the replacement processor.
- b. If there is any old thermal grease on the heat sink, wipe the thermal grease from the bottom of the heat sink with an alcohol cleaning pad.

Step 2. When replacing a heat sink and reusing the processor.

- a. Remove the processor identification label from the old heat sink and place it on the new heat sink in the same location. The label is on the side of the heat sink closest to the triangular alignment mark.

**Note:** When unable to remove the label and place it on the new heat sink, or if the label is damaged during transfer, write the processor serial number from the processor identification label on the new heat sink in the same location as the label would be placed using a permanent marker.

- b. Install processor in the new carrier.

**Note:** Replacement heat sinks come with both gray and black processor carriers. Make sure to use the carrier with the same color as the one discarded earlier.

1. ① Make sure the handle on the carrier is in the closed position.
2. ② Align the processor on the new carrier so that the triangular marks align; then, insert the marked end of the processor into the carrier.
3. ③ Hold the inserted end of the processor in place; then, pivot the unmarked end of the carrier down and away from the processor.
4. ④ Press the processor and secure the unmarked end under the clip on the carrier.
5. ⑤ Carefully pivot the sides of the carrier down and away from the processor.
6. ⑥ Press the processor and secure the sides under the clips on the carrier.

**Note:** To prevent the processor from falling out of the carrier, keep the processor-contact side up and hold the processor-carrier assembly by the sides of the carrier.

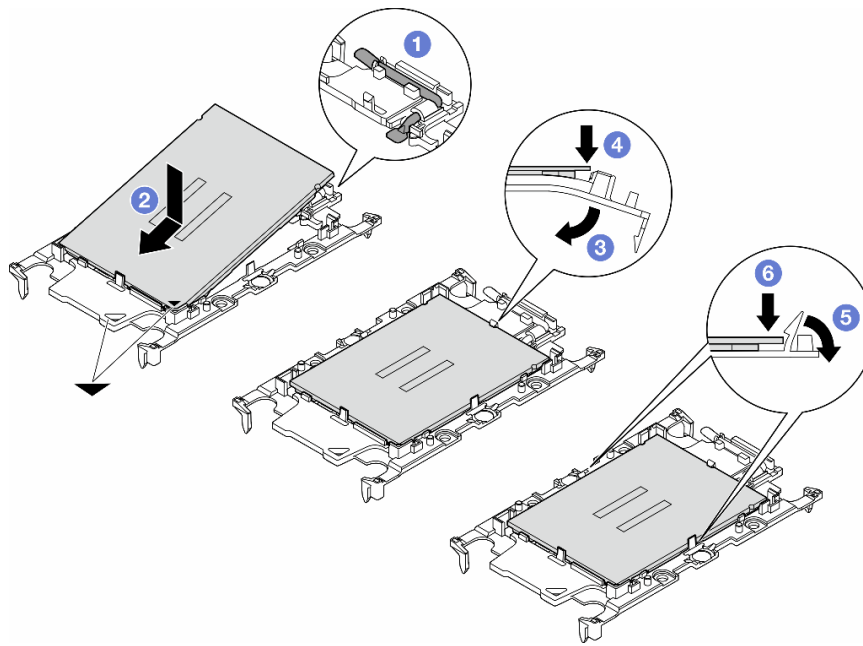

Figure 140. Installation of a processor carrier

Step 3. Apply thermal grease.

- a. Carefully place the processor and carrier in the shipping tray with the processor-contact side down. Make sure the triangular mark on the carrier is aligned with the triangular mark in the shipping tray.
- b. If there is any old thermal grease on the processor, gently wipe the top of the processor with an alcohol cleaning pad.

**Note:** Make sure the alcohol has fully evaporated before applying new thermal grease.

- c. Apply the thermal grease on the top of the processor with syringe by forming four uniformly spaced dots, while each dot consists of about 0.1 ml of thermal grease.

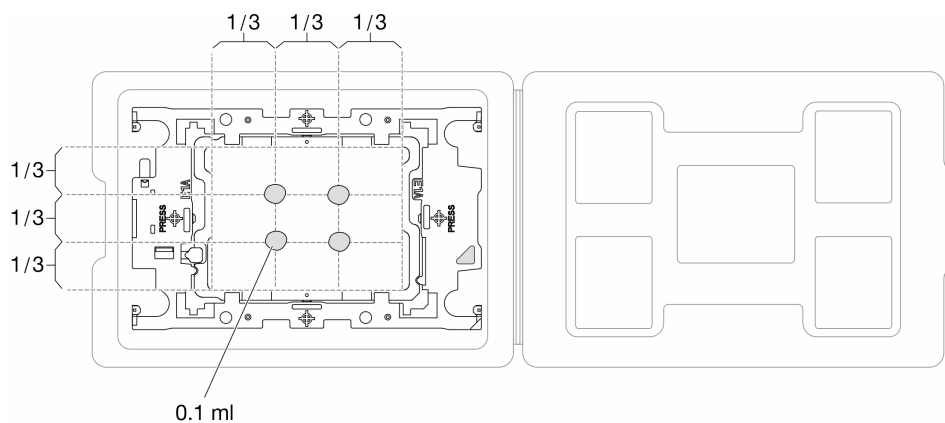

Figure 141. Thermal grease application with processor in shipping tray

Step 4. Assemble the processor and heat sink.

- a. Align the triangular mark on the heat sink label with the triangular mark on the processor carrier and processor.
- b. Install the heat sink onto the processor-carrier.
- c. Press the carrier into place until the clips at all four corners engage.

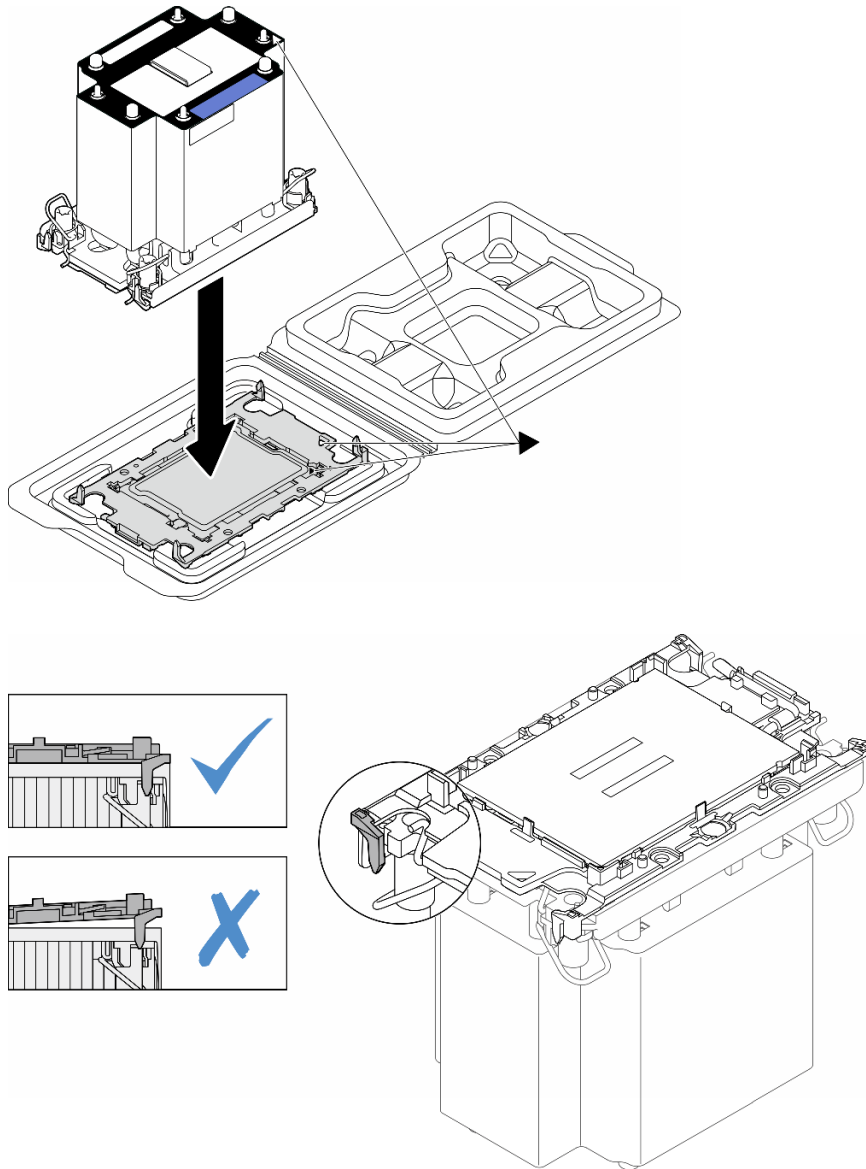

Figure 142. Assembling the PHM with processor in shipping tray

- Step 5. Install the processor-heat-sink module into the system board socket.
- a. ① Rotate the anti-tilt wire bails inward.
  - b. ② Align the triangular mark and four Torx T30 nuts on the PHM with the triangular mark and threaded posts of the processor socket; then, insert the PHM into the processor socket.
  - c. ③ Rotate the anti-tilt wire bails outward until they engage with the hooks in the socket.
  - d. ④ Fully tighten the Torx T30 nuts *in the installation sequence shown* on the heat-sink label. Tighten the screws until they stop; then, visually inspect to make sure that there is no gap

between the screw shoulder beneath the heat sink and the processor socket. (For reference, the torque required for the fasteners to fully tighten is 1.1 newton-meters, 10 inch-pounds).

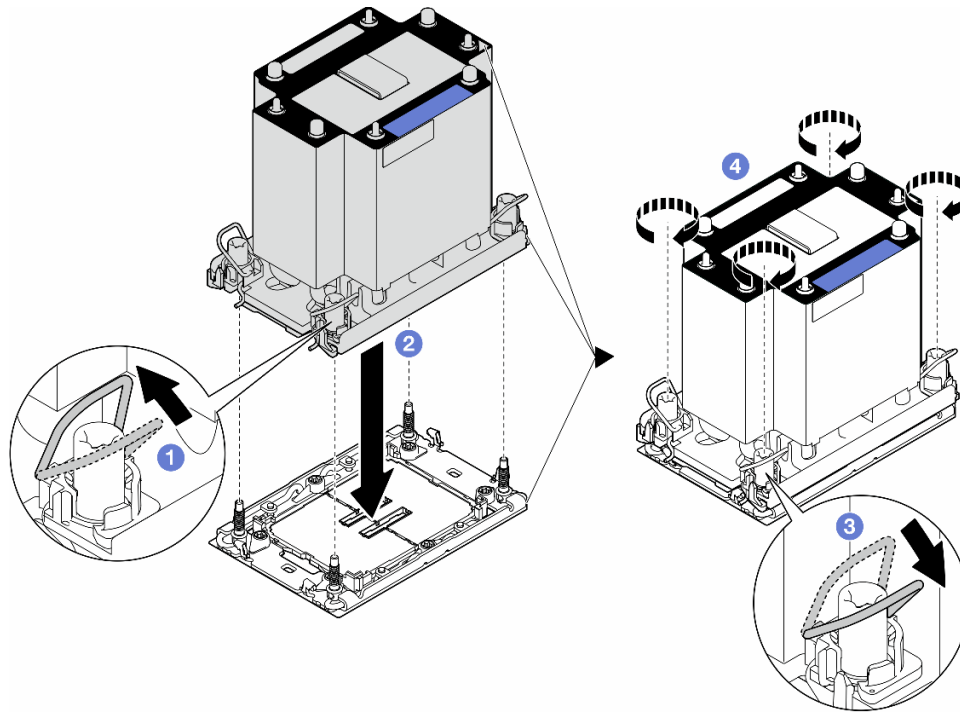

Figure 143. Installing a standard PHM

### After this task is completed

1. Reinstall the air baffle. See “Install an air baffle” on page 75.
2. Reinstall all the flash power modules, if necessary. See “Install a flash power module” on page 102.
3. Reinstall the server cover. See “Install a server cover” on page 231.
4. Reinstall the redundant power supply unit. See “Install a power supply unit” on page 190.
5. Complete the parts replacement. See “Complete the parts replacement” on page 233.

### Demo video

[Watch the procedure on YouTube](#)

[https://www.youtube.com/watch?v=vACSnj6Gj\\_M](https://www.youtube.com/watch?v=vACSnj6Gj_M)

---

## Security door replacement

Follow the instructions in this section to remove or install a security door.

**Note:** This section applies only to server models with a security door installed.

### Remove the security door

Follow the instructions in this section to remove the security door.

### About this task

**Attention:**

- Read “[Installation Guidelines](#)” on page 41 and “[Safety inspection checklist](#)” on page 42 to ensure that you work safely.
- Prevent exposure to static electricity, which might lead to system halt and loss of data, by keeping static-sensitive components in their static-protective packages until installation, and handling these devices with an electrostatic-discharge wrist strap or other grounding system.

**Procedure**

Step 1. ① Use the key attached to the rear of the server to unlock the cover.

Step 2. ② Open the security door.

Step 3. ③ Lift the security door slightly upwards until it is completely removed from the chassis.

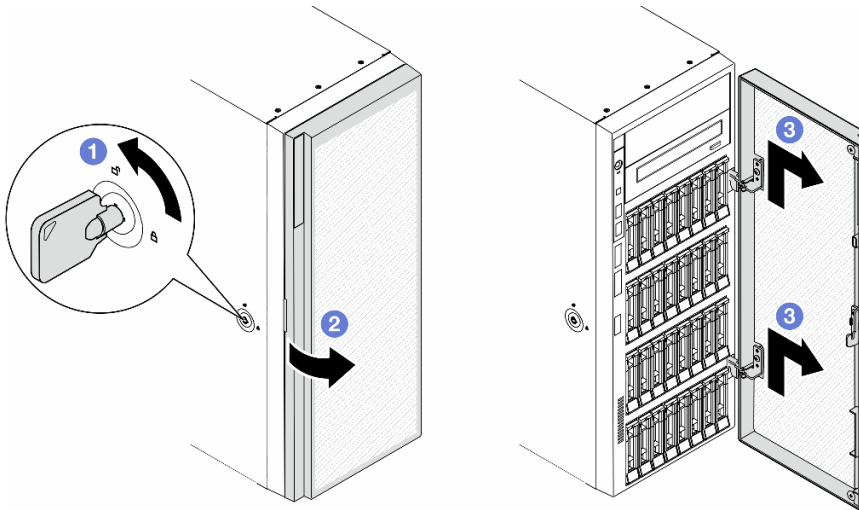

Figure 144. Removal of the security door

**After this task is completed**

1. Install a replacement unit. See “[Install the security door](#)” on page 208.
2. If you are instructed to return the component or optional device, follow all packaging instructions, and use any packaging materials for shipping that are supplied to you.

**Demo video**

[Watch the procedure on YouTube](#)

<https://www.youtube.com/watch?v=SUJ9jHhUQkQ>

**Install the security door**

Follow the instructions in this section to install the security door.

**About this task****Attention:**

- Read “[Installation Guidelines](#)” on page 41 and “[Safety inspection checklist](#)” on page 42 to ensure that you work safely.

- Prevent exposure to static electricity, which might lead to system halt and loss of data, by keeping static-sensitive components in their static-protective packages until installation, and handling these devices with an electrostatic-discharge wrist strap or other grounding system.

## Procedure

- Step 1. ① Align the two hooks on the security door with the corresponding holes on the front bezel; then, push the security door inwards and place it down until it is secured in place.
- Step 2. ② Close the security door.
- Step 3. ③ Use the key attached to the rear of the server to lock the server cover.

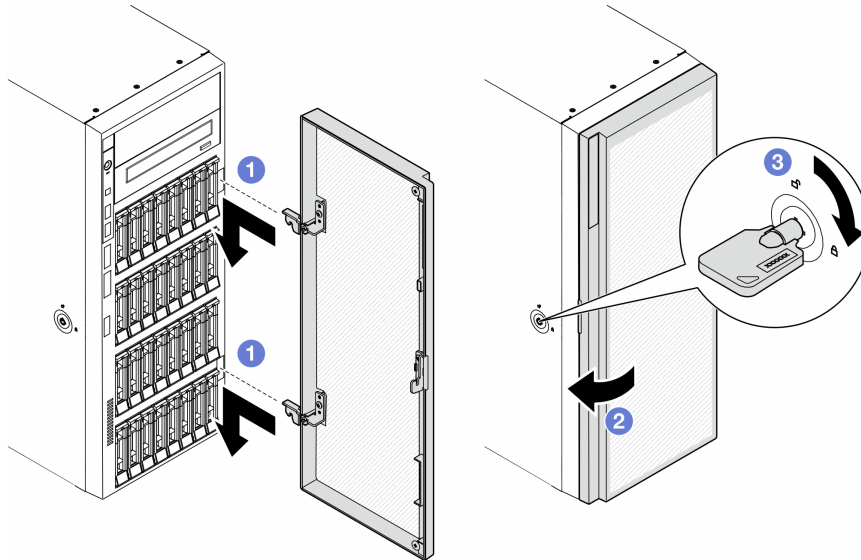

Figure 145. Installation of the security door

## After this task is completed

Complete the parts replacement. See “[Complete the parts replacement](#)” on page 233.

## Demo video

[Watch the procedure on YouTube](#)

<https://www.youtube.com/watch?v=hUTIBeWNsp8>

---

## System board assembly replacement (trained technician only)

Follow the instructions in this section to remove or install a system board.

**Important:** This task must be operated by trained technicians.

## Remove the Firmware and RoT Security Module

Follow the instructions in this section to remove the ThinkSystem V3 Firmware and Root of Trust Security Module (firmware and RoT security module).

## About this task

**Attention:**

- Read “[Installation Guidelines](#)” on page 41 and “[Safety inspection checklist](#)” on page 42 to ensure that you work safely.
- Prevent exposure to static electricity, which might lead to system halt and loss of data, by keeping static-sensitive components in their static-protective packages until installation, and handling these devices with an electrostatic-discharge wrist strap or other grounding system.

**Procedure**

Step 1. Make preparations for this task.

- a. Perform OneCLI commands or XCC actions to back up the UEFI and XCC settings. See [https://pubs.lenovo.com/lxce-onecli/config\\_backup](https://pubs.lenovo.com/lxce-onecli/config_backup) or [https://pubs.lenovo.com/xcc2/NN1ia\\_c\\_backupthexcc.html](https://pubs.lenovo.com/xcc2/NN1ia_c_backupthexcc.html).
- b. Power off the server and disconnect all power cords for this task. See “[Power off the server](#)” on page 53.
- c. If the server is in a rack, remove it from the rack.
- d. If foot stands are installed on the server, pivot them inwards and lay the server on its side for easier operation.
- e. Remove the server cover. See “[Remove the server cover](#)” on page 230.
- f. If necessary, remove all flash power modules. See “[Remove a flash power module](#)” on page 100.
- g. Remove the air baffle. See “[Remove the air baffle](#)” on page 74.
- h. If there are HL PCIe adapter(s) or FL GPU adapter(s) installed between PCIe slots 5 to 9, disconnect the cables and remove these adapters. See “[Remove a HL PCIe adapter](#)” on page 165 or “[Remove a FL GPU adapter](#)” on page 173.
- i. If an A2/L4 GPU air duct is installed on the side of PCIe slots 5 to 9, remove it. See “[Remove an A2/L4 GPU air duct](#)” on page 71.

Step 2. Loosen the two screws of the firmware and RoT security module; then, lift the RoT module from the chassis.

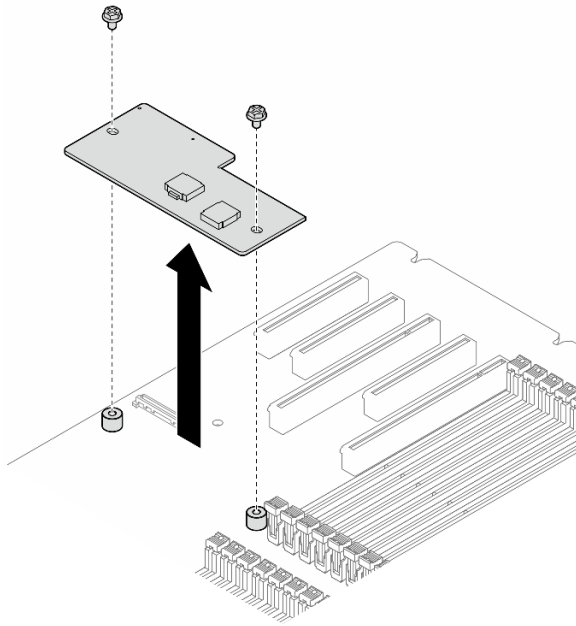

Figure 146. Removal of the firmware and RoT security module

### After this task is completed

1. Install the replacement unit(s), if necessary. See “[Install the Firmware and RoT Security Module](#)” on page 211.
2. If you are instructed to return the component or optional device, follow all packaging instructions, and use any packaging materials for shipping that are supplied to you.

### Demo video

[Watch the procedure on YouTube](#)

<https://www.youtube.com/watch?v=DjNJqPCel10>

## Install the Firmware and RoT Security Module

Follow the instructions in this section to install the ThinkSystem V3 Firmware and Root of Trust Security Module (firmware and RoT security module).

### About this task

#### Important:

- This task must be operated by trained technicians that are certified by Lenovo Service. Do not attempt to remove or install the part without proper training and qualification.
- (Lenovo trained technicians only) After replacing the Firmware and RoT Security Module, update the UEFI, XCC and LXPM firmware to the specific version supported by the server. For detailed information on how to update the firmware, see <https://support.lenovo.com/us/en/solutions/TT3485>.

#### Attention:

- Read “[Installation Guidelines](#)” on page 41 and “[Safety inspection checklist](#)” on page 42 to ensure that you work safely.
- Power off the server and disconnect all power cords for this task. See “[Power off the server](#)” on page 53.

- Prevent exposure to static electricity, which might lead to system halt and loss of data, by keeping static-sensitive components in their static-protective packages until installation, and handling these devices with an electrostatic-discharge wrist strap or other grounding system.
- If the server is in a rack, remove it from the rack.
- If foot stands are installed on the server, pivot them inwards and lay the server on its side for easier operation.

## Procedure

Step 1. Make preparations for this task.

- Touch the static-protective package that contains the new part to any unpainted surface on the outside of the server. Then, take the new part out of the package and place it on a static-protective surface.

Step 2. Place the firmware and RoT security module evenly on the system board; then, align and tighten the two screws with corresponding nuts to secure.

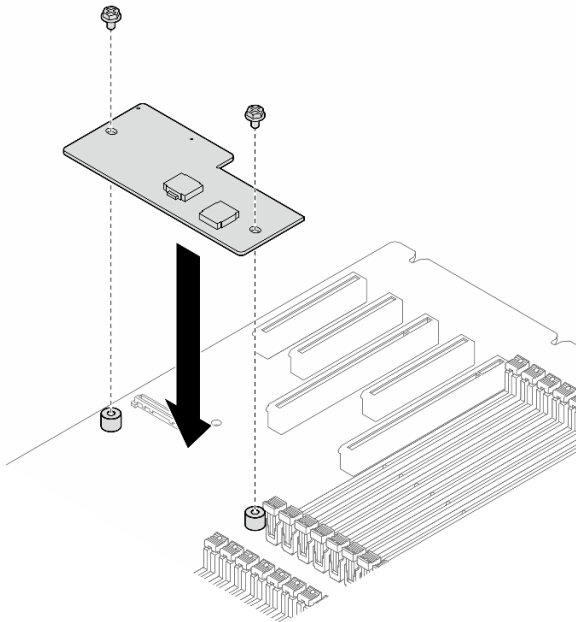

Figure 147. Installation of the firmware and RoT security module

Step 3. Connect cables to the system board. See [“System board connectors” on page 26](#).

## After this task is completed

1. Reinstalled the HL PCIe adapters and FL GPU adapters that were removed for the replacement of the firmware and RoT security module. See [“Install a HL PCIe adapter” on page 167](#) and [“Install a FL GPU adapter” on page 175](#).
2. Reinstalled the A2/L4 GPU air duct that was removed for the replacement of the firmware and RoT security module. See [“Install an A2/L4 GPU air duct” on page 72](#).
3. Reconnect all the cables that were removed. See [Chapter 6 “Internal cable routing” on page 235](#).
4. Reinstall the air baffle. See [“Install an air baffle” on page 75](#).
5. Reinstall all the flash power modules, if necessary. See [“Install a flash power module” on page 102](#).
6. Reinstall the server cover. See [“Install a server cover” on page 231](#).

7. Complete the parts replacement. See “[Complete the parts replacement](#)” on page 233.
8. Update the UEFI, XCC, and LXPM firmware to the specific version supported by the server. See <https://support.lenovo.com/us/en/solutions/TT3485> (Lenovo service technicians only).
9. Perform OneCLI commands or XCC actions to restore the UEFI and XCC settings. See [https://pubs.lenovo.com/lxce-onecli/onecli\\_r\\_restore\\_command](https://pubs.lenovo.com/lxce-onecli/onecli_r_restore_command) or [https://pubs.lenovo.com/xcc2/NN1ia\\_c\\_restorethexcc.html](https://pubs.lenovo.com/xcc2/NN1ia_c_restorethexcc.html).
10. If there is a software (SW) key, for example, XCC FoD key, installed in the system, inject the key again to ensure that the key functions properly. See [Using Lenovo Features on Demand](#).
11. Set the TPM policy. See “[Enable TPM](#)” on page 213.
12. Optionally, do the following if needed:
  - Hide TPM. See “[Hide/observe TPM](#)” on page 215.
  - Update the TPM firmware. See “[Update the TPM firmware](#)” on page 216.
  - Enable UEFI Secure Boot. See “[Enable UEFI Secure Boot](#)” on page 225.

## Demo video

[Watch the procedure on YouTube](#)

<https://www.youtube.com/watch?v=ZkH0PExgDOo>

## Enable TPM

The server supports Trusted Platform Module (TPM), Version 1.2 or Version 2.0.

**Note:** For customers in Chinese Mainland, integrated TPM is not supported. However, customers in Chinese Mainland can install a Trusted Cryptographic Module (TCM) adapter or a TPM adapter (sometimes called a daughter card).

When a system board is replaced, you must make sure that the TPM policy is set correctly.

### CAUTION:

**Take special care when setting the TPM policy. If it is not set correctly, the system board can become unusable.**

### Set the TPM policy

By default, a replacement system board is shipped with the TPM policy set to **undefined**. You must modify this setting to match the setting that was in place for the system board that is being replaced.

There are two methods available to set the TPM policy:

- From Lenovo XClarity Provisioning Manager

To set the TPM policy from Lenovo XClarity Provisioning Manager:

1. Start the server and press the key specified in the on-screen instructions to display the Lenovo XClarity Provisioning Manager interface. (For more information, see the “Startup” section in the LXPM documentation compatible with your server at <https://pubs.lenovo.com/lxpm-overview/>.)
2. If the power-on Administrator password is required, enter the password.
3. From the System Summary page, click **Update VPD**.
4. Set the policy to one of the following settings.
  - **NationZ TPM 2.0 enabled - China only.** Customers in the Chinese Mainland should choose this setting if a NationZ TPM 2.0 adapter is installed.

- **TPM enabled - ROW.** Customers outside of the Chinese Mainland should choose this setting.
- **Permanently disabled.** Customers in the Chinese Mainland should use this setting if no TPM adapter is installed.

**Note:** Although the setting **undefined** is available as a policy setting, it should not be used.

- From Lenovo XClarity Essentials OneCLI

**Note:** Please note that a Local IPMI user and password must be setup in Lenovo XClarity Controller for remote accessing to the target system.

To set the TPM policy from Lenovo XClarity Essentials OneCLI:

1. Read TpmTcmPolicyLock to check whether the TPM\_TCM\_POLICY has been locked:  
`OneCli.exe config show IMM.TpmTcmPolicyLock --override --bmc <userid>:<password>@<ip_address>`

**Note:** The IMM.TpmTcmPolicyLock value must be 'Disabled', which means TPM\_TCM\_POLICY is NOT locked and changes to the TPM\_TCM\_POLICY are permitted. If the return code is 'Enabled' then no changes to the policy are permitted. The planar may still be used if the desired setting is correct for the system being replaced.

2. Configure the TPM\_TCM\_POLICY into XCC:
  - For customers in Chinese Mainland with no TPM, or customers that require to disable TPM:  
`OneCli.exe config set IMM.TpmTcmPolicy "NeitherTpmNorTcm" --override --bmc <userid>:<password>@<ip_address>`
  - For customers in Chinese Mainland that require to enable TPM:  
`OneCli.exe config set IMM.TpmTcmPolicy "NationZTPM20Only" --override --bmc <userid>:<password>@<ip_address>`
  - For customers outside Chinese Mainland that require to enable TPM:  
`OneCli.exe config set IMM.TpmTcmPolicy "TpmOnly" --override --bmc <userid>:<password>@<ip_address>`
3. Issue reset command to reset system:  
`OneCli.exe misc ospower reboot --bmc <userid>:<password>@<ip_address>`
4. Read back the value to check whether the change has been accepted:  
`OneCli.exe config show IMM.TpmTcmPolicy --override --bmc <userid>:<password>@<ip_address>`

**Notes:**

- If the read back value is matched it means the TPM\_TCM\_POLICY has been set correctly.

imm.TpmTcmPolicy is defined as below:

- Value 0 use string "Undefined", which means UNDEFINED policy.
- Value 1 use string "NeitherTpmNorTcm", which means TPM\_PERM\_DISABLED.
- Value 2 use string "TpmOnly", which means TPM\_ALLOWED.
- Value 4 use string "NationZTPM20Only", which means NationZ\_TPM20\_ALLOWED.
- Below 4 steps must also be used to 'lock' the TPM\_TCM\_POLICY when using OneCli/ASU commands:

5. Read TpmTcmPolicyLock to check whether the TPM\_TCM\_POLICY has been locked, command as below:  
`OneCli.exe config show IMM.TpmTcmPolicyLock --override --bmc <userid>:<password>@<ip_address>`

The value must be 'Disabled', it means TPM\_TCM\_POLICY is NOT locked and must be set.

6. Lock the TPM\_TCM\_POLICY:  
`OneCli.exe config set IMM.TpmTcmPolicyLock "Enabled" --override --bmc <userid>:<password>@<ip_address>`
7. Issue reset command to reset system, command as below:  
`OneCli.exe misc ospower reboot --bmc <userid>:<password>@<ip_address>`

During the reset, UEFI will read the value from `imm.TpmTcmPolicyLock`, if the value is 'Enabled' and the `imm.TpmTcmPolicy` value is valid, UEFI will lock the `TPM_TCM_POLICY` setting.

**Note:** The valid values for `imm.TpmTcmPolicy` include 'NeitherTpmNorTcm', 'TpmOnly', and 'NationZTPM20Only'.

If the `imm.TpmTcmPolicyLock` is set as 'Enabled' but `imm.TpmTcmPolicy` value is invalid, UEFI will reject the 'lock' request and change `imm.TpmTcmPolicyLock` back to 'Disabled'.

8. Read back the value to check whether the 'Lock' is accepted or rejected. Command as below:  
`OneCli.exe config show IMM.TpmTcmPolicy --override --bmc <userid>:<password>@<ip_address>`

**Note:** If the read back value is changed from 'Disabled' to 'Enabled' that means the `TPM_TCM_POLICY` has been locked successfully. There is no method to unlock a policy once it has been set other than replacing system board.

`imm.TpmTcmPolicyLock` is defined as below:

Value 1 uses string "Enabled" , which means lock the policy. Other values are not accepted.

## Hide/observe TPM

TPM is enabled by default to encrypt data transfer for system operation. Optionally, you can disable TPM using Unified Extensible Firmware Interface (UEFI) or Lenovo XClarity Essentials OneCLI.

### Using UEFI

For details, see "Hide TPM from OS" in *UEFI User Guide* at <https://pubs.lenovo.com/uefi-overview/>.

### Using Lenovo XClarity Essentials OneCLI

To disable TPM, do the following:

1. Download and install Lenovo XClarity Essentials OneCLI.

To download Lenovo XClarity Essentials OneCLI, go to the following site:

<https://datacentersupport.lenovo.com/solutions/HT116433>

2. Run the following command:

```
OneCli.exe config set TrustedComputingGroup.HideTPMfromOS "Yes" -bmc <userid>:<password>@<ip_address>
```

where:

- `<userid>:<password>` are the credentials used to access the BMC (Lenovo XClarity Controller interface) of your server. The default user ID is `USERID`, and the default password is `PASSWORD` (zero, not an uppercase o)
- `<ip_address>` is the IP address of the BMC.

Example:

```
D:\onecli>OneCli.exe config set UEFI.TrustedComputingGroup_TPMDevice "Disabled" --bmc USERID:PASSWORD@10.245.38.64
[Is]Certificate check finished [100%][=====]>]
Start to connect BMC at 10.245.38.64 to apply config set
Invoking SET command ...
UEFI.TrustedComputingGroup_TPMDevice=Disabled
Changes completed successfully, but these changes will not take effect until next reboot.
Succeed.
```

3. Reboot the system.

If you want to enable TPM again, run the following command and reboot the system:

```
OneCli.exe config set TrustedComputingGroup.HideTPMfromOS "No" -bmc <userid>:<password>@<ip_address>
```

Example:

```
D:\onecli>OneCli.exe config set UEFI.TrustedComputingGroup_TPMDevice "Enabled" --bmc USERID:PASSWORD@10.245.38.64
[Is]Certificate check finished [100%] [=====>]
Start to connect BMC at 10.245.38.64 to apply config set
Invoking SET command ...
UEFI.TrustedComputingGroup_TPMDevice=Enabled
Changes completed successfully, but these changes will not take effect until next reboot.
Succeed.
```

## Update the TPM firmware

Optionally, you can update the TPM firmware using Lenovo XClarity Essentials OneCLI.

**Note:** TPM firmware update is irreversible. After update, the TPM firmware cannot be downgraded to earlier versions.

### TPM firmware version

Follow the procedure below to see the TPM firmware version:

From Lenovo XClarity Provisioning Manager

1. Start the server and press the key specified in the on-screen instructions to display the Lenovo XClarity Provisioning Manager interface. (For more information, see the “Startup” section in the LXPM documentation compatible with your server at <https://pubs.lenovo.com/lxpm-overview/>.)
2. If the power-on Administrator password is required, enter the password.
3. From the UEFI Setup page, click **System Settings → Security → Trusted Platform Module → TPM 2.0 → TPM Firmware Version**.

### Update the TPM firmware

To update the TPM firmware, do the following:

1. Download and install Lenovo XClarity Essentials OneCLI.

To download Lenovo XClarity Essentials OneCLI, go to the following site:

<https://datacentersupport.lenovo.com/solutions/HT116433>

2. Run the following command:

```
OneCli.exe config set TrustedComputingGroup.DeviceOperation "Update to TPM 2.0 firmware version <x.x.x.x>" --bmc
<userid>:<password>@<ip_address>
```

where:

- <x.x.x.x> is the target TPM version.  
e.g. TPM 2.0 (7.2.1.0) -> TPM 2.0 (7.2.2.0):

```
OneCli.exe config set TrustedComputingGroup.DeviceOperation "Update to TPM 2.0 firmware version 7.2.2.0" --bmc
<userid>:<password>@<ip_address>
```

- <userid>:<password> are the credentials used to access the BMC (Lenovo XClarity Controller interface) of your server. The default user ID is USERID, and the default password is PASSWORD (zero, not an uppercase o).
- <ip\_address> is the IP address of the BMC.

## Remove the system board (trained technician only)

Follow the instructions in this section to remove a system board.

**Important:** This task must be operated by trained technicians.

## About this task

### S002



#### **CAUTION:**

The power-control button on the device and the power switch on the power supply do not turn off the electrical current supplied to the device. The device also might have more than one power cord. To remove all electrical current from the device, ensure that all power cords are disconnected from the power source.

#### **Attention:**

- Read [“Installation Guidelines” on page 41](#) and [“Safety inspection checklist” on page 42](#) to ensure that you work safely.

## Procedure

Step 1. Make preparations for this task.

- Record all system configuration information, such as Lenovo XClarity Controller IP addresses, vital product data, and the machine type, model number, serial number, Universally Unique Identifier, and asset tag of the server.
- Save the system configuration to an external device with Lenovo XClarity Essentials.
- Power off the server and disconnect all power cords for this task. See [“Power off the server” on page 53](#).
- Prevent exposure to static electricity, which might lead to system halt and loss of data, by keeping static-sensitive components in their static-protective packages until installation, and handling these devices with an electrostatic-discharge wrist strap or other grounding system.
- If the server is in a rack, remove it from the rack.
- If foot stands are installed on the server, pivot them inwards and lay the server on its side for easier operation.
- Remove the server cover. See [“Remove the server cover” on page 230](#).
- If necessary, remove all flash power modules. See [“Remove a flash power module” on page 100](#).
- Remove the air baffle. See [“Remove the air baffle” on page 74](#).
- Disconnect cables for PCIe adapter or full-length GPU adapter.
- Remove all the full-length GPU adapters, if any. See [“Remove a FL GPU adapter” on page 173](#).
- If necessary, remove the A2/L4 GPU air duct(s) or FL PCIe adapter holder(s) installed on the fan cage. See [“Remove an A2/L4 GPU air duct” on page 71](#) or [“Remove a FL PCIe adapter holder” on page 162](#).
- Remove all the fan modules and fan filler. See [“Remove a fan module” on page 89](#).  
**Attention:** All fan modules must be removed from the fan cage when handling the fan cage assembly.
- Remove the fan cage assembly. See [“Remove the fan cage assembly” on page 91](#).

- o. Remove the internal CFF HBA/RAID adapter. See [“Remove an internal CFF adapter” on page 116.](#)
- p. Remove the RoT module. See [“Remove the Firmware and RoT Security Module” on page 209.](#)
- q. Remove all the PCIe adapters. See [“Remove a HL PCIe adapter” on page 165.](#)
- r. Disconnect the intrusion switch cable from the system board, or remove the intrusion switch if necessary. See [“Remove the intrusion switch” on page 121.](#)
- s. If necessary, remove the CMOS battery. See [“Remove the CMOS battery \(CR2032\)” on page 77.](#)
- t. If necessary, remove the MicroSD card. See [“Remove the MicroSD card” on page 139.](#)
- u. Label the slot number on each memory module; then, remove all the memory modules from the system board and set them aside on a static-protective surface for reinstallation. See [“Remove a memory module” on page 133.](#)
- v. Remove the processor and the heat sink. See [“Remove a processor and heat sink \(trained technician only\)” on page 194.](#)
- w. Make note of where the cables are connected to the system board; then, disconnect all the cables.

**Note:** Disengage all latches, cable clips, release tabs, or locks on cable connectors beforehand. Failing to release them before removing the cables will damage the cable connectors on the system board. Any damage to the cable connectors may require replacing the system board.

Step 2. Remove the nine screws that secure the system board.

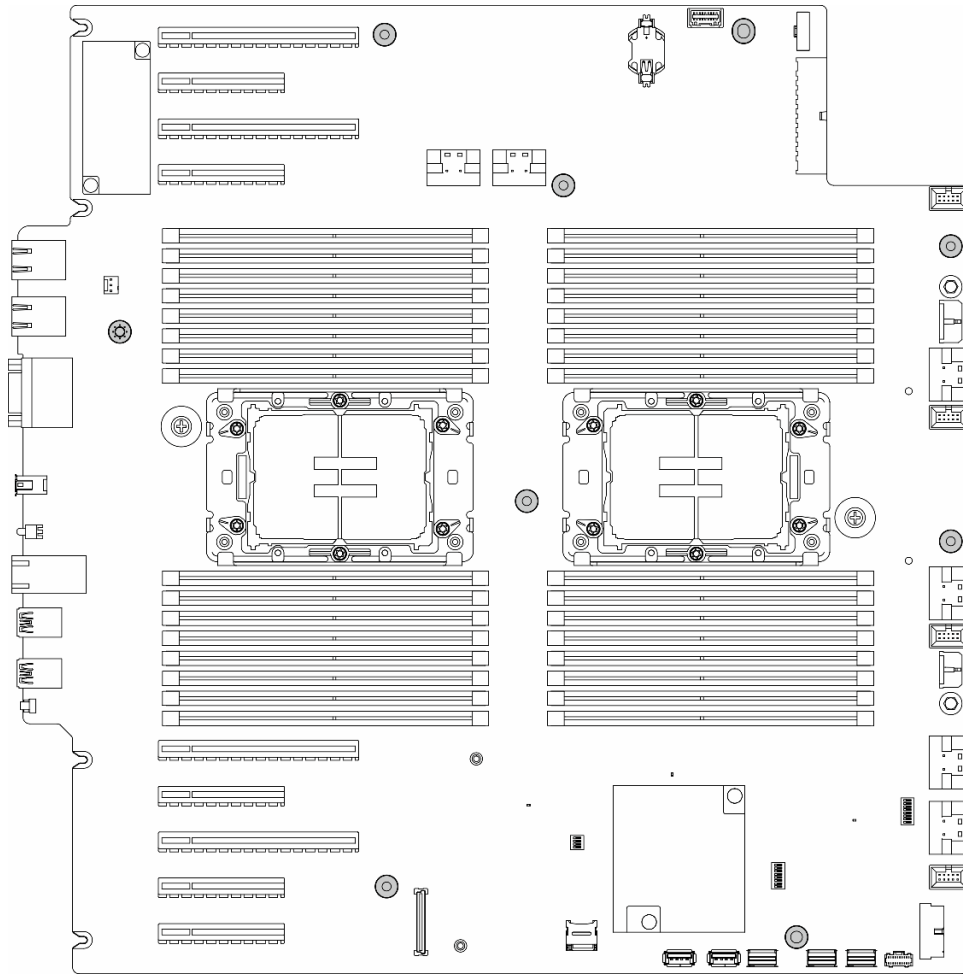

Figure 148. Removal of the system board screws

- Step 3. Move the system board towards the front of the server. Make sure that the rear connectors on the system board are disengaged from the corresponding holes in the rear panel.

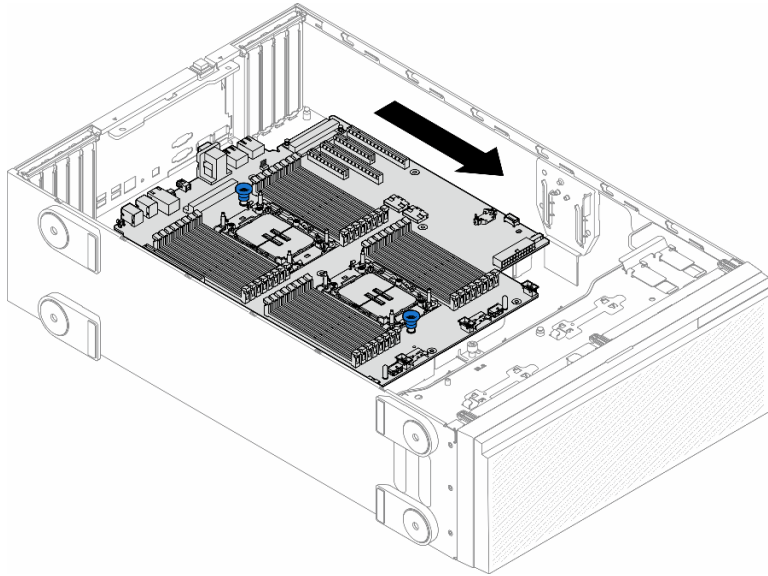

Figure 149. Disengaging the system board from chassis

Step 4. Hold the plungers and remove the system board in the direction as shown.

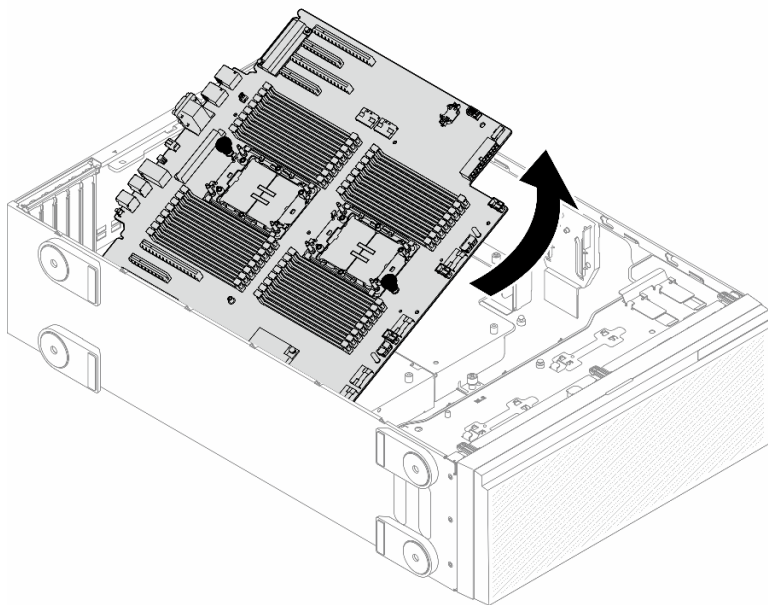

Figure 150. Removal of a system board

Step 5. Place the old system board on a clean, flat, and static-protective surface.

### After this task is completed

- Install a system board. See [“Install a system board \(trained technician only\)” on page 221](#).
- If you are instructed to return the component or optional device, follow all packaging instructions, and use any packaging materials for shipping that are supplied to you.

**Important:** Before returning the system board, make sure that you install the processor socket dust covers from the new system board. To replace a processor socket dust cover:

1. Take a dust cover from the processor socket assembly on the new system board and orient it correctly above the processor socket assembly on the removed system board.
2. Gently press down the dust cover legs to the processor socket assembly, pressing on the edges to avoid damage to the socket pins. You might hear a click on the dust cover is securely attached.
3. **Make sure** that the dust cover is securely attached to the processor socket assembly.

## Demo video

[Watch the procedure on YouTube](#)

<https://www.youtube.com/watch?v=XwCR5oVyHB0>

## Install a system board (trained technician only)

Follow the instructions in this section to install a system board.

**Important:** This task must be operated by trained technicians.

### About this task

#### S002



#### **CAUTION:**

The power-control button on the device and the power switch on the power supply do not turn off the electrical current supplied to the device. The device also might have more than one power cord. To remove all electrical current from the device, ensure that all power cords are disconnected from the power source.

#### **Attention:**

- Read “[Installation Guidelines](#)” on page 41 and “[Safety inspection checklist](#)” on page 42 to ensure that you work safely.
- Power off the server and disconnect all power cords for this task. See “[Power off the server](#)” on page 53.
- Prevent exposure to static electricity, which might lead to system halt and loss of data, by keeping static-sensitive components in their static-protective packages until installation, and handling these devices with an electrostatic-discharge wrist strap or other grounding system.

### Procedure

Step 1. Hold the system board by the plungers and gently lower the system board into the chassis as shown.

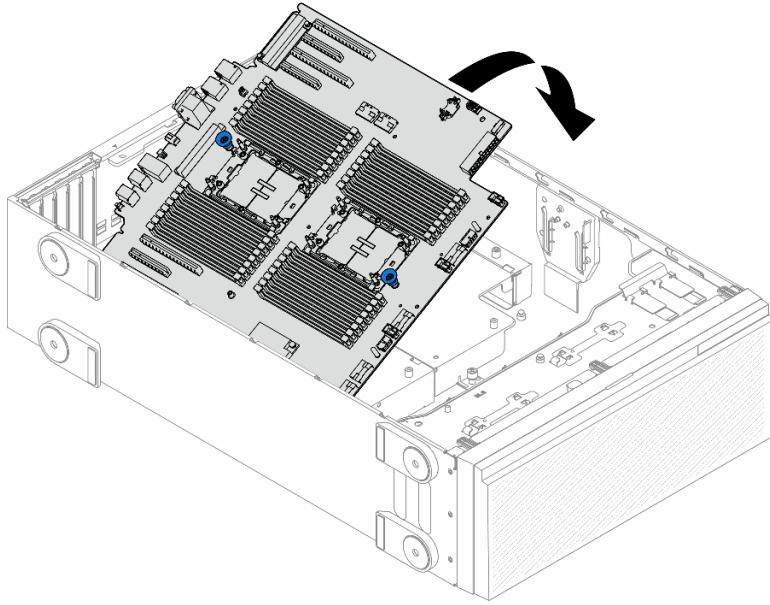

*Figure 151. Installation of a system board*

- Step 2. Move the system board towards the rear of the server. Make sure that the rear connectors on the new system board are inserted into the corresponding holes in the rear panel.

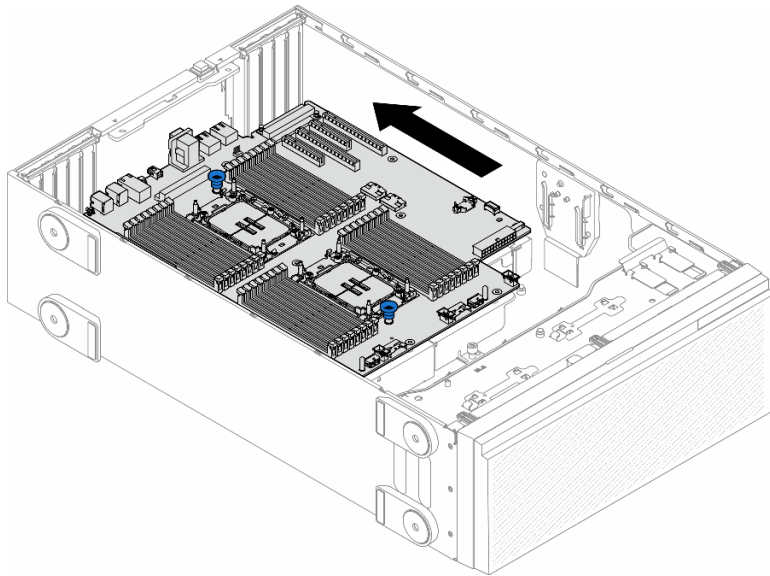

*Figure 152. Engaging the system board to chassis*

- Step 3. Tighten the nine screws to secure the system board in place.

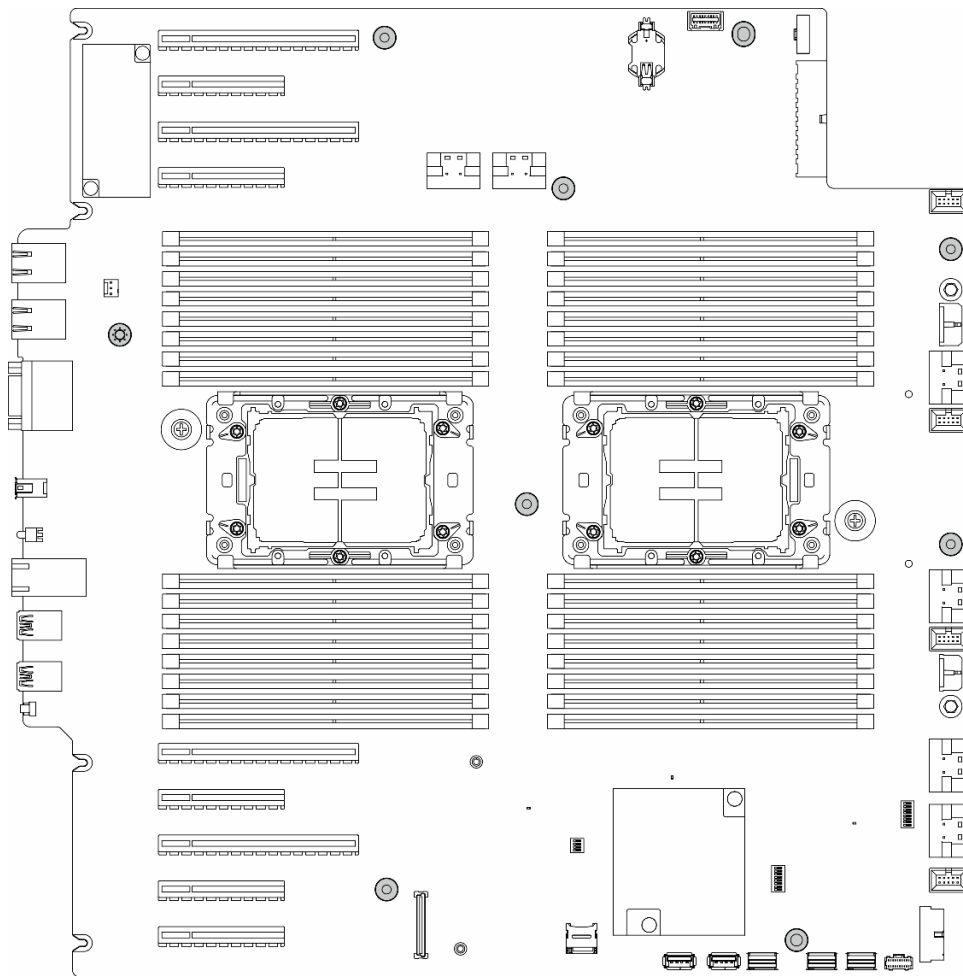

Figure 153. Installation of system board screws

### After this task is completed

1. Reinstall the processor and the heat sink. See [“Install a processor and heat sink \(trained technician only\)” on page 201](#).
2. Reinstall all the memory modules. See [“Install a memory module” on page 136](#).
3. Reinstall the CMOS battery. See [“Install a CMOS battery \(CR2032\)” on page 79](#).
4. Reinstall the intrusion switch or reconnect the intrusion switch cable to the system board. See [“Install an intrusion switch” on page 122](#).
5. Reinstall the internal CFF HBA/RAID adapter. See [“Install an internal CFF adapter” on page 118](#).
6. Reinstall the MicroSD card. See [“Install a MicroSD card” on page 141](#).
7. Reinstall the RoT module. See [“Install the Firmware and RoT Security Module” on page 211](#).
8. Reinstall all the PCIe adapters. See [“Install a HL PCIe adapter” on page 167](#).
9. Reinstall the fan cage assembly. See [“Install the fan cage assembly” on page 92](#).

**Attention:** All fan modules must be removed from the fan cage when handling the fan cage assembly.

10. Reinstall all the fan modules (and fan filler, if necessary). See [“Install a fan module” on page 94](#).
11. Install the required A2/L4 GPU air ducts or FL PCIe adapter holders. See [“Install an A2/L4 GPU air duct” on page 72](#) and [“Install a FL PCIe adapter holder” on page 164](#).

12. Reinstall all the full-length GPU adapters, if necessary. See [“Install a FL GPU adapter” on page 175](#).
13. Reconnect all the cables that were removed. See [Chapter 6 “Internal cable routing” on page 235](#).
14. Reinstall the air baffle. See [“Install an air baffle” on page 75](#).
15. Reinstall all the flash power modules, if necessary. See [“Install a flash power module” on page 102](#).
16. Reinstall the server cover. See [“Install a server cover” on page 231](#).
17. Complete the parts replacement. See [“Complete the parts replacement” on page 233](#).
18. Update the vital product data (VPD). See [“Update the Vital Product Data \(VPD\)” on page 224](#).

Machine type number and serial number can be found on the ID label, see [“Identify the server and access the Lenovo XClarity Controller” on page 37](#).

19. If hiding TPM or updating TPM firmware is needed, see [“Hide/observe TPM” on page 215](#) or [“Update the TPM firmware” on page 216](#).
20. Optionally, enable Secure Boot. See [“Enable UEFI Secure Boot” on page 225](#).

## Demo video

[Watch the procedure on YouTube](#)

<https://www.youtube.com/watch?v=4sxdGI4WnuQ>

## Update the Vital Product Data (VPD)

Use this topic to update the Vital Product Data (VPD).

- **(Required)** Machine type
- **(Required)** Serial number
- **(Required)** System model
- (Optional) Asset tag
- (Optional) UUID

### Recommended tools:

- Lenovo XClarity Provisioning Manager
- Lenovo XClarity Essentials OneCLI commands

### Using Lenovo XClarity Provisioning Manager

#### Steps:

1. Start the server and press the key according to the on-screen instructions. The Lenovo XClarity Provisioning Manager interface is displayed by default.
2. Click  on the top right corner of the Lenovo XClarity Provisioning Manager main interface.
3. Click **Update VPD**; then, follow on-screen instructions to update the VPD.

### Using Lenovo XClarity Essentials OneCLI commands

- Updating **machine type**  
`onecli config set SYSTEM_PROD_DATA.SysInfoProdName <m/t_model> [access_method]`
- Updating **serial number**  
`onecli config set SYSTEM_PROD_DATA.SysInfoSerialNum <s/n> [access_method]`
- Updating **system model**

```
onecli config set SYSTEM_PROD_DATA.SysInfoProdIdentifier <system model> [access_method]
```

- Updating **asset tag**  
onecli config set SYSTEM\_PROD\_DATA.SysEncloseAssetTag <asset\_tag> [access\_method]
- Updating **UUID**  
onecli config createuuid SYSTEM\_PROD\_DATA.SysInfoUUID [access\_method]

Variable	Description
<m/t_model>	The server machine type and model number. Type xxxxyyyyyy, where xxxx is the machine type and yyyyyy is the server model number.
<s/n>	The serial number on the server. Type zzzzzzzz (length 8-10 characters), where zzzzzzzz is the serial number.
<system model>	The system model on the server. Type system yyyyyyyyyy, where yyyyyyyy is the product identifier.
<asset_tag>	The server asset tag number. Type aaaaaaaaaaaaaaaaaaaaaaaaaaaaaa, where aaaaaaaaaaaaaaaaaaaaaaaaaaaaaa is the asset tag number.
[access_method]	<p>The access method that you select to access the target server.</p> <ul style="list-style-type: none"> <li>• Online KCS (unauthenticated and user restricted): You can directly delete [access_method] from the command.</li> <li>• Online authenticated LAN: In this case, specify below LAN account information at the end of the OneCLI command: --bmc-username &lt;user_id&gt; --bmc-password &lt;password&gt;</li> <li>• Remote WAN/LAN: In this case, specify below XCC account information and IP address at the end of the OneCLI command: --bmc &lt;bmc_user_id&gt;:&lt;bmc_password&gt;@&lt;bmc_external_IP&gt;</li> </ul> <p><b>Notes:</b></p> <ul style="list-style-type: none"> <li>- &lt;bmc_user_id&gt; The BMC account name (1 of 12 accounts). The default value is USERID.</li> <li>- &lt;bmc_password&gt; The BMC account password (1 of 12 accounts).</li> </ul>

## Enable UEFI Secure Boot

Optionally, you can enable UEFI Secure Boot.

There are two methods available to enable UEFI Secure Boot:

- From Lenovo XClarity Provisioning Manager

To enable UEFI Secure Boot from Lenovo XClarity Provisioning Manager:

1. Start the server and press the key specified in the on-screen instructions to display the Lenovo XClarity Provisioning Manager interface. (For more information, see the “Startup” section in the LXPM documentation compatible with your server at <https://pubs.lenovo.com/lxpm-overview/>.)
2. If the power-on Administrator password is required, enter the password.

3. From the UEFI Setup page, click **System Settings** → **Security** → **Secure Boot Configuration** → **Secure Boot Setting**.
4. Enable Secure Boot and save the settings.

**Note:** If disabling UEFI secure boot is needed, select Disable in step 4.

- From Lenovo XClarity Essentials OneCLI

To enable UEFI Secure Boot from Lenovo XClarity Essentials OneCLI:

1. Download and install Lenovo XClarity Essentials OneCLI.

To download Lenovo XClarity Essentials OneCLI, go to the following site:

<https://datacentersupport.lenovo.com/solutions/HT116433>

2. Run the following command to enable Secure Boot:

```
OneCli.exe config set UEFI.SecureBootConfiguration_SecureBootSetting Enabled --bmc  
<userid>:<password>@<ip_address>
```

where:

- *<userid>:<password>* are the credentials used to access the BMC (Lenovo XClarity Controller interface) of your server. The default user ID is USERID, and the default password is PASSWORD (zero, not an uppercase o)
- *<ip\_address>* is the IP address of the BMC.

For more information about the Lenovo XClarity Essentials OneCLI `set` command, see:

[https://pubs.lenovo.com/lxce-onecli/onecli\\_r\\_set\\_command](https://pubs.lenovo.com/lxce-onecli/onecli_r_set_command)

**Note:** If disabling UEFI secure boot is needed, run the following command:

```
OneCli.exe config set UEFI.SecureBootConfiguration_SecureBootSetting Disabled --bmc <userid>:<password>@<ip_<br>address>
```

---

## T4 filler replacement

Follow the instructions in this section to remove or install a T4 filler.

### Remove a T4 filler

Follow the instructions in this section to remove a T4 filler.

#### About this task

**S017**



**CAUTION:**

**Hazardous moving fan blades nearby. Keep fingers and other body parts away.**

**S033**



**CAUTION:**

**Hazardous energy present. Voltages with hazardous energy might cause heating when shorted with metal, which might result in spattered metal, burns, or both.**

**Attention:**

- Read [“Installation Guidelines” on page 41](#) and [“Safety inspection checklist” on page 42](#) to ensure that you work safely.
- Prevent exposure to static electricity, which might lead to system halt and loss of data, by keeping static-sensitive components in their static-protective packages until installation, and handling these devices with an electrostatic-discharge wrist strap or other grounding system.
- If the server is in a rack, remove it from the rack.
- If foot stands are installed on the server, pivot them inwards and lay the server on its side for easier operation.

**Note:**

**Procedure**

- Step 1. Remove the server cover. See [“Remove the server cover” on page 230](#).
- Step 2. Turn the server cover over and locate the T4 filler you want to remove.
- Step 3. Remove the T4 filler.

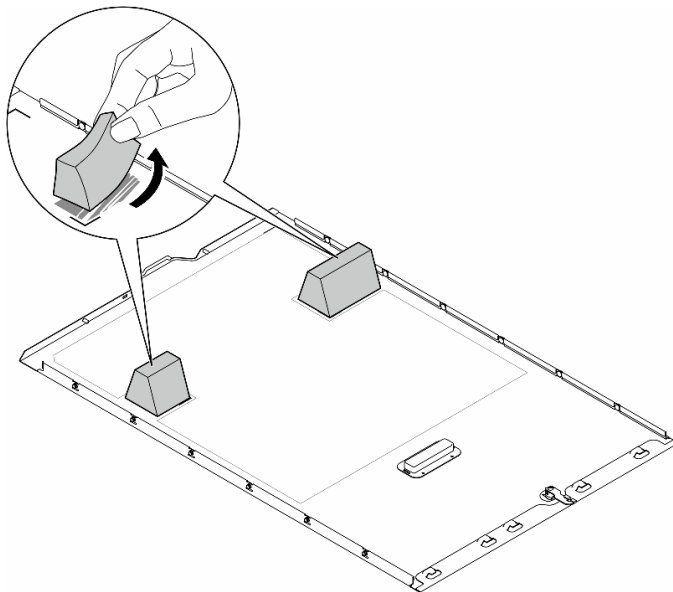

*Figure 154. Removal of a T4 filler*

**After this task is completed**

1. Install the replacement unit(s), if necessary. See [“Install a T4 filler” on page 228](#).
2. If you are instructed to return the component or optional device, follow all packaging instructions, and use any packaging materials for shipping that are supplied to you.

## Demo video

## Install a T4 filler

Follow the instructions in this section to install a T4 filler.

### About this task

#### S017



**CAUTION:**

**Hazardous moving fan blades nearby. Keep fingers and other body parts away.**

#### S033



**CAUTION:**

**Hazardous energy present. Voltages with hazardous energy might cause heating when shorted with metal, which might result in spattered metal, burns, or both.**

**Attention:**

- Read [“Installation Guidelines” on page 41](#) and [“Safety inspection checklist” on page 42](#) to ensure that you work safely.
- Prevent exposure to static electricity, which might lead to system halt and loss of data, by keeping static-sensitive components in their static-protective packages until installation, and handling these devices with an electrostatic-discharge wrist strap or other grounding system.

**Note:** A **T4 filler** is required to be installed onto the server cover for proper cooling and airflow when one or more A2/L4 GPU adapters are installed. See [“GPU installation rules” on page 171](#) for detailed information about the technical rules for GPU installation.

## Procedure

- Step 1. Locate the corresponding location on the bottom of the server cover for the applicable PCIe slot.
- Step 2. Wipe the surface with an alcohol cleaning pad.

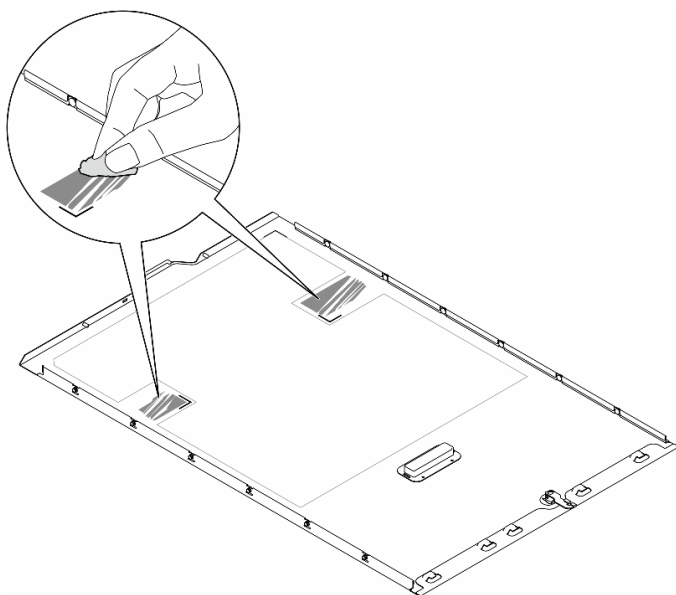

Figure 155. Cleaning surface

Step 3. Peel away the plastic and apply the T4 filler. Make sure the T4 filler is aligned to the **1** corner mark.

**Note:** Make sure the alcohol has fully evaporated before applying the new T4 filler.

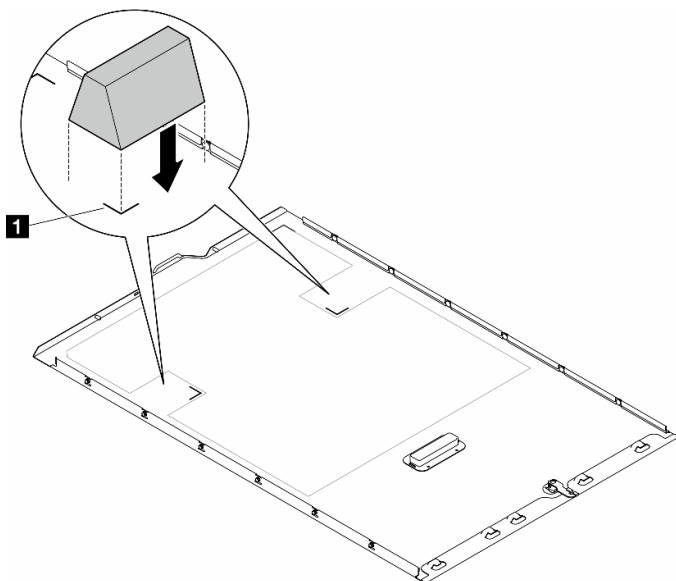

Figure 156. Installation of a T4 filler

### After you finish

1. Reinstall the server cover. See [“Install a server cover” on page 231](#).
2. Complete the parts replacement. See [“Complete the parts replacement” on page 233](#).

### Demo video

---

## Server cover replacement

Follow the instructions in this section to remove or install a server cover.

### Remove the server cover

Follow the instructions in this section to remove a server cover.

#### About this task

##### S014



**CAUTION:**

**Hazardous voltage, current, and energy levels might be present. Only a qualified service technician is authorized to remove the covers where the label is attached.**

##### S017



**CAUTION:**

**Hazardous moving fan blades nearby. Keep fingers and other body parts away.**

##### S033



**CAUTION:**

**Hazardous energy present. Voltages with hazardous energy might cause heating when shorted with metal, which might result in spattered metal, burns, or both.**

**Attention:**

- Read [“Installation Guidelines” on page 41](#) and [“Safety inspection checklist” on page 42](#) to ensure that you work safely..
- Prevent exposure to static electricity, which might lead to system halt and loss of data, by keeping static-sensitive components in their static-protective packages until installation, and handling these devices with an electrostatic-discharge wrist strap or other grounding system.
- If the server is in a rack, remove it from the rack.

**Attention:** For proper cooling, always install the server cover before powering on the server. Operating the server without the cover properly installed might result in server component damage.

### Procedure

Step 1. Remove the server cover.

- a. ① Use the key attached to the rear of the server to unlock the cover lock.
- b. ② Slide the server cover towards the rear of the server until the server cover is disengaged from the chassis. Then, lift the server cover off the chassis and place it on a flat clean surface.

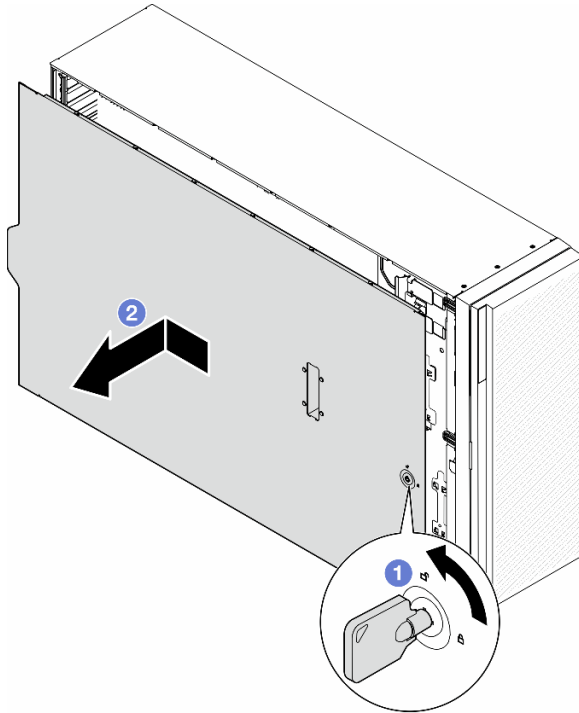

Figure 157. Removal of the server cover

### After this task is completed

1. Install a replacement unit. See “[Install a server cover](#)” on page 231.
2. If you are instructed to return the component or optional device, follow all packaging instructions, and use any packaging materials for shipping that are supplied to you.

### Demo video

[Watch the procedure on YouTube](#)

<https://www.youtube.com/watch?v=yANB4GEjuoM>

### Install a server cover

Follow the instructions in this section to install a server cover.

### About this task

**S014**



**CAUTION:**

Hazardous voltage, current, and energy levels might be present. Only a qualified service technician is authorized to remove the covers where the label is attached.

**S017****CAUTION:**

Hazardous moving fan blades nearby. Keep fingers and other body parts away.

**S033****CAUTION:**

Hazardous energy present. Voltages with hazardous energy might cause heating when shorted with metal, which might result in spattered metal, burns, or both.

**Attention:**

- Read Read [“Installation Guidelines” on page 41](#) and [“Safety inspection checklist” on page 42](#) to ensure that you work safely.
- Prevent exposure to static electricity, which might lead to system halt and loss of data, by keeping static-sensitive components in their static-protective packages until installation, and handling these devices with an electrostatic-discharge wrist strap or other grounding system.
- Ensure that all adapters and other components are installed and seated correctly and that you have not left loose tools or parts inside the server.
- Ensure that all internal cables are correctly routed. See [Chapter 6 “Internal cable routing” on page 235](#).
- When installing a new server cover, attach the service label to the inside of the new server cover first if necessary.

**Note:** A new server cover comes without a service label attached. If you need a service label, order it together with the new server cover. The service label is free of charge.

**Procedure**

Step 1. Install the server cover.

- 1 Lower the server cover onto the chassis until all tabs on both sides of the server cover engage with the chassis. Then, slide the server cover towards the front of the chassis until the server cover stops and the front edge of the cover aligns with the edge of the front bezel.
- 2 Use the key to lock the cover.

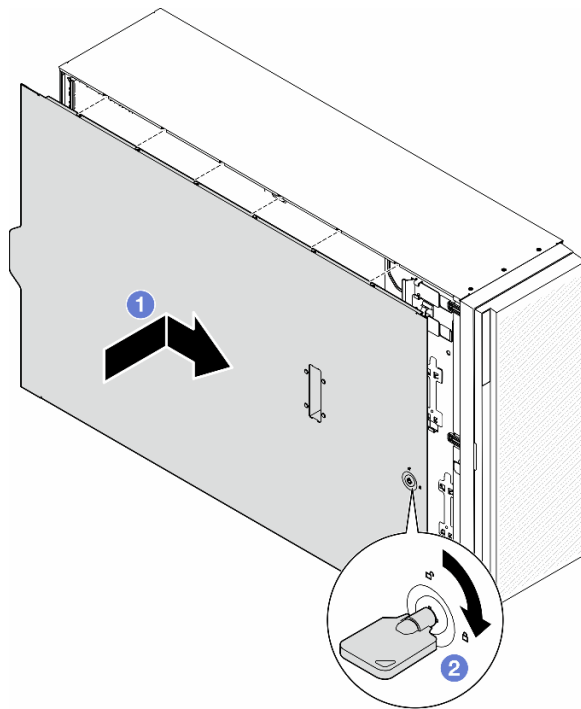

Figure 158. Installation of a server cover

**Note:** Before you slide the cover forward, ensure that all the tabs of the cover engage the chassis correctly. If all the tabs do not engage the chassis correctly, it will be very difficult to remove the cover later.

## After this task is completed

Complete the parts replacement. See [“Complete the parts replacement” on page 233](#).

## Demo video

[Watch the procedure on YouTube](#)

<https://www.youtube.com/watch?v=DB33ttJ9Gw4>

---

## Complete the parts replacement

Follow the instructions in this section to complete the parts replacement.

To complete the parts replacement, follow the steps below:

1. Ensure that all components have been reassembled correctly and that no tools or loose screws are left inside your server.
2. Properly route and secure the cables in the server. Refer to the cable connecting and routing information for each component.
3. If the air baffle has been removed, reinstall it. See [“Install an air baffle” on page 75](#).
4. If the server cover has been removed, reinstall it. See [“Install a server cover” on page 231](#).

**Attention:** For proper cooling and airflow, reinstall the air baffle before you turn on the server. Operating the server with the air baffle removed might damage server components.

5. If necessary, install the server to the rack. See “[Install the server to the rack](#)” on page 59.
6. Reconnect the power cords and any cables that were removed.
7. Power on the server and any peripheral devices. See “[Power on the server](#)” on page 52.
8. Update the server configuration.
  - Download and install the latest device drivers: <http://datacentersupport.lenovo.com>.
  - Update the system firmware. See “[Update the firmware](#)” on page 320.
  - Update the UEFI configuration. See <https://pubs.lenovo.com/uefi-overview/>.
  - Reconfigure the disk arrays if you have installed or removed a hot-swap drive or a RAID adapter. See <https://pubs.lenovo.com/lxpm-overview/> for the LXPM documentation compatible with your server.

## Chapter 6. Internal cable routing

See this section to do cable routing for specific components.

**Attention:** Disengage all latches, release tabs, or locks on cable connectors when disconnecting cables from the system board. Failing to release them before removing the cables will damage the cable sockets on the system board, which are fragile. Strictly observe the following instructions to avoid damaging cable sockets on the system board. Any damage to the cable sockets might require replacing the system board.

- Connect cable connectors vertically or horizontally in alignment with the orientations of the corresponding cable sockets, avoiding any tilt.
- To disconnect cables from the system board, do as follows:
  1. Press and hold all latches, release tabs, or locks on cable connectors to release the cable connectors.
  2. Remove the cable connectors vertically or horizontally in alignment with the orientations of the corresponding cable sockets, avoiding any tilt.

**Note:** The cable connectors might look different from those in the illustration, but the removal procedure is the same.

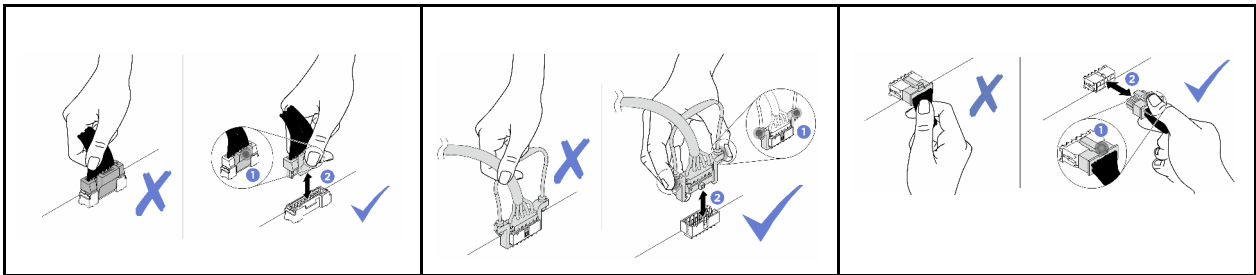

## Identifying connectors

See this section to locate and identify the connectors on the electric boards.

## System-board connectors

See this topic to locate the connectors on the system board.

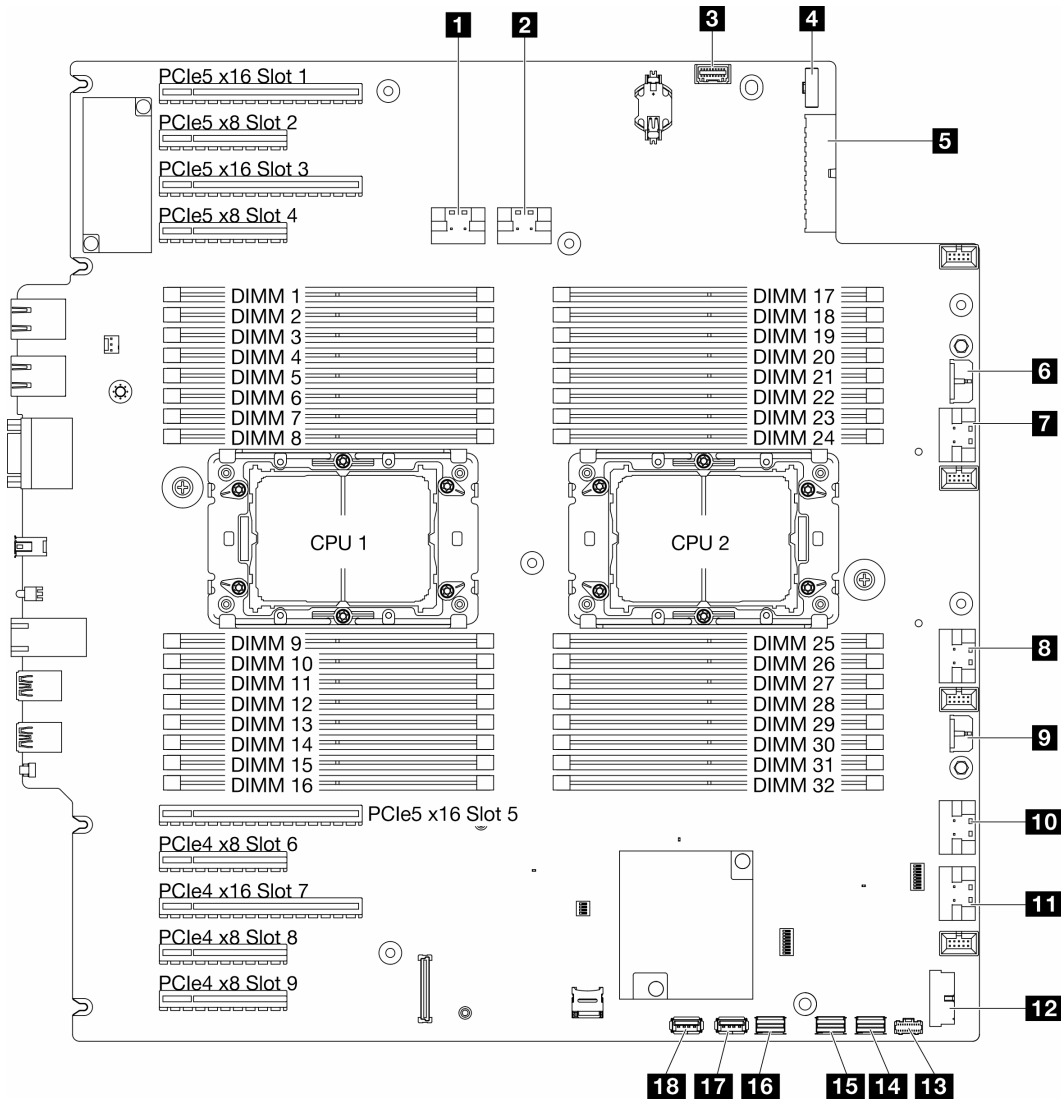

Figure 159. System-board connectors

Table 28. System-board connectors

<b>1</b> PCIe 1 connector	<b>10</b> PCIe 5 connector
<b>2</b> PCIe 2 connector	<b>11</b> PCIe 6 connector
<b>3</b> Front-operator-panel connector	<b>12</b> Front USB connector
<b>4</b> Power sideband connector	<b>13</b> M.2 power connector
<b>5</b> System board power 1 connector	<b>14</b> M.2 signal connector

Table 28. System-board connectors (continued)

<b>6</b> CFF RAID connector	<b>15</b> SATA 4-7 connector
<b>7</b> PCIe 3 connector	<b>16</b> SATA 0-3 connector
<b>8</b> PCIe 4 connector	<b>17</b> Internal USB 2 connector
<b>9</b> System board power 2 connector	<b>18</b> Internal USB 1 connector

## Power distribution board connectors

See this section to locate the connectors on the power distribution board.

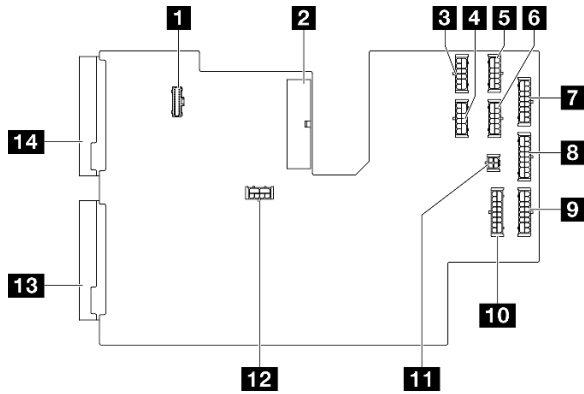

Figure 160. Connectors on the power distribution board

<b>1</b> PDB sideband connector	<b>8</b> BP3 power connector
<b>2</b> Main power connector 1	<b>9</b> BP2 power connector
<b>3</b> GPU 1 power connector	<b>10</b> BP1 power connector
<b>4</b> GPU 2 power connector	<b>11</b> ODD power connector
<b>5</b> GPU 3 power connector	<b>12</b> Main power connector 2
<b>6</b> GPU 4 power connector	<b>13</b> PSU2 power connector
<b>7</b> BP4 power connector	<b>14</b> PSU1 power connector

## Internal CFF RAID adapter connectors

See this topic to locate the connectors on the internal CFF RAID adapter.

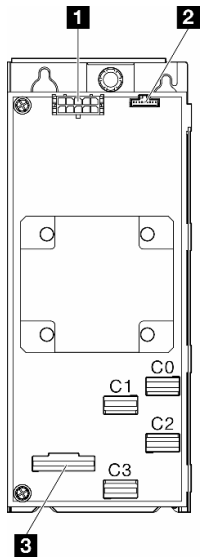

Figure 161. Connectors on the internal CFF RAID adapter

<b>1</b> Power connector	<b>3</b> Signal connector
<b>2</b> Sideband connector	

## Drive backplane connectors

Use the section to identify the drive backplane.

### 3.5-inch drive backplanes

See this topic to locate the connectors on 3.5-inch drive backplanes.

#### 3.5-inch SAS/SATA 4-bay backplane

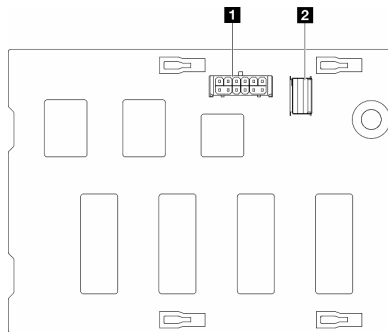

- 1** Power connector
- 2** SAS/SATA connector

Figure 162. 3.5-inch SAS/SATA 4-bay backplane connectors

#### 3.5-inch SAS/SATA/NVMe and NVMe 4-bay backplane

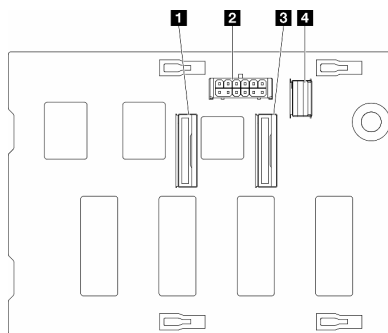

- 1** NVMe 2-3 connector
- 2** Power connector
- 3** NVMe 0-1 connector
- 4** SAS/SATA connector

Figure 163. 3.5-inch SAS/SATA/NVMe and NVMe 4-bay backplane connectors

## 2.5-inch drive backplanes

See this topic to locate the connectors on 2.5-inch drive backplanes.

### 2.5-inch SAS/SATA 8-bay backplane

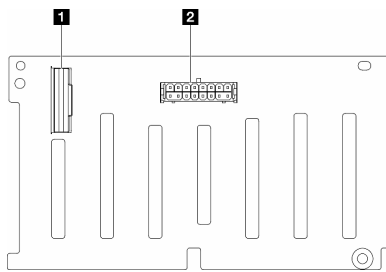

- 1** SAS/SATA connector
- 2** Power connector

Figure 164. 2.5-inch SAS/SATA 8-bay backplane connectors

### 2.5-inch SAS/SATA/NVMe and NVMe 8-bay backplane

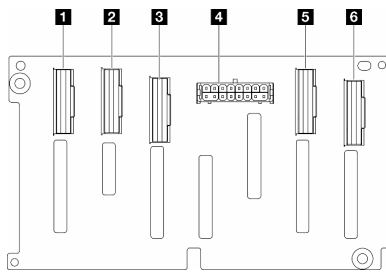

- 1** NVMe 6-7 connector
- 2** NVMe 4-5 connector
- 3** SAS/SATA connector
- 4** Power connector
- 5** NVMe 2-3 connector
- 6** NVMe 0-1 connector

Figure 165. 2.5-inch SAS/SATA/NVMe and NVMe 8-bay backplane connectors

## 3.5-inch drive cable routing

See this topic to learn how to do cable routing for server models with 3.5-inch drive backplanes.

Complete the following routing for power cables corresponding to the backplanes that are installed in the system.

Table 29. Power cable routing - 3.5-inch drive backplanes

From (backplane) to power distribution board		Length
<b>4</b> BP4	BP4 power connector	160 mm
<b>3</b> BP3	BP3 power connector	355 mm
<b>2</b> BP2	BP2 power connector	455 mm
<b>1</b> BP1	BP1 power connector	455 mm

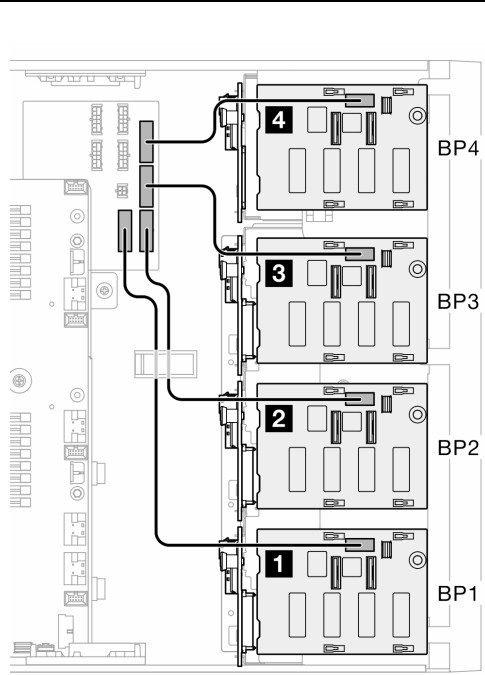

Then, proceed to the table of combinations that correspond to the system configuration:

- [“Pure SAS/SATA combinations” on page 242](#)
- [“Pure NVMe combinations” on page 242](#)
- [“Mixed combinations” on page 243](#)

**Notes:** \* Depending on the configurations, the server might come with either the **3.5-inch BP4** or the **ODD/Tape drive cage**.

1. For server models with the 3.5-inch BP4, there is no ODD/Tape drive cage.
2. For server models with the ODD/Tape drive cage, there is no 3.5-inch BP4.

See [“Front view” on page 19](#) for different sever models.

## Pure SAS/SATA combinations

Table 30. Pure SAS/SATA cable routing combinations for 3.5-inch drives

BP1	BP12	BP123	BP1234 (without ODD/Tape drives) <sup>*1</sup>	
(ODD/ Tape drives) <sup>*2</sup>	(ODD/ Tape drives) <sup>*2</sup>	(ODD/ Tape drives) <sup>*2</sup>	SAS/ SATA	<b>BP4</b> (or ODD/Tape drive cage)
		SAS/ SATA	SAS/ SATA	<b>BP3</b>
	SAS/ SATA	SAS/ SATA	SAS/ SATA	<b>BP2</b>
SAS/ SATA	SAS/ SATA	SAS/ SATA	SAS/ SATA	<b>BP1</b>
<ul style="list-style-type: none"> <li>• “HW 8i/16i(BP1)” on page 244</li> <li>• “HW 8i/16i (BP12)” on page 245</li> <li>• “SW RAID (BP1/BP12)” on page 245</li> </ul>		<ul style="list-style-type: none"> <li>• “HW 8i (BP123)” on page 246</li> <li>• “HW 8i (BP1234)” on page 247</li> <li>• “HW 16i (BP123)” on page 248</li> <li>• “HW 16i (BP1234)” on page 249</li> <li>• “CFF (BP123/BP1234)” on page 250</li> </ul>		

## Pure NVMe combinations

Table 31. Pure NVMe cable routing combinations for 3.5-inch drives

BP4 (without ODD/Tape drives) <sup>*1</sup>	BP3	BP34 (without ODD/Tape drives) <sup>*1</sup>	BP23	BP234 (without ODD/Tape drives) <sup>*1</sup>	BP123	BP1234 (without ODD/Tape drives) <sup>*1</sup>	
NVMe	(ODD/ Tape drives) <sup>*2</sup>	NVMe	(ODD/ Tape drives) <sup>*2</sup>	NVMe	(ODD/ Tape drives) <sup>*2</sup>	NVMe	<b>BP4</b> (or ODD/ Tape drive cage)
	NVMe	NVMe	NVMe	NVMe	NVMe	NVMe	<b>BP3</b>
			NVMe	NVMe	NVMe	NVMe	<b>BP2</b>
					NVMe	NVMe	<b>BP1</b>
<ul style="list-style-type: none"> <li>• “VROC (BP4)” on page 251</li> <li>• “VROC (BP3)” on page 252</li> <li>• “VROC (BP34)” on page 252</li> </ul>			<ul style="list-style-type: none"> <li>• “VROC (BP23/BP234)” on page 253</li> <li>• “VROC (BP123/BP1234)” on page 254</li> </ul>				

## Mixed combinations

Table 32. Mixed cable routing combinations for 3.5-inch drives

BP124 (without ODD/Tape drives)*1	BP123	BP124 (without ODD/Tape drives)*1	BP123	BP1234 (without ODD/Tape drives)*1	BP1234 (without ODD/Tape drives)*1	BP1234 (without ODD/Tape drives)*1	
NVMe	(ODD/ Tape drives)*2	SAS/ SATA/ NVMe	(ODD/ Tape drives)*2	NVMe	SAS/ SATA/ NVMe	NVMe	<b>BP4</b> (or ODD/ Tape drive cage)
	NVMe		SAS/ SATA/ NVMe	SAS/ SATA	SAS/ SATA	NVMe	<b>BP3</b>
SAS/ SATA	SAS/ SATA	SAS/ SATA	SAS/ SATA	SAS/ SATA	SAS/ SATA	NVMe	<b>BP2</b>
SAS/ SATA	SAS/ SATA	SAS/ SATA	SAS/ SATA	SAS/ SATA	SAS/ SATA	SAS/ SATA/ NVMe	<b>BP1</b>
<ul style="list-style-type: none"> <li>• “OSW (BP12); VROC (BP4)” on page 255</li> <li>• “OSW (BP12); VROC (BP3)” on page 256</li> <li>• “8i (BP12); VROC (BP3)” on page 257</li> <li>• “8i (BP12); VROC (BP4)” on page 258</li> </ul>		<ul style="list-style-type: none"> <li>• “8i (BP123); VROC (BP3)” on page 259</li> <li>• “8i (BP124); VROC (BP4)” on page 262</li> <li>• “16i (BP123); VROC (BP3)” on page 266</li> <li>• “16i (BP124); VROC (BP4)” on page 268</li> <li>• “CFF (BP124); VROC (BP4)” on page 274</li> <li>• “CFF (BP123); VROC (BP3)” on page 275</li> </ul>		<ul style="list-style-type: none"> <li>• “8i (BP123); VROC (BP4)” on page 260</li> <li>• “8i (BP1234) VROC (BP4)” on page 263</li> <li>• “16i (BP123); VROC (BP4)” on page 270</li> <li>• “16i (BP1234); VROC (BP4)” on page 272</li> <li>• “CFF (BP123); VROC (BP4)” on page 276</li> <li>• “CFF (BP1234); VROC (BP4)” on page 277</li> </ul>		<ul style="list-style-type: none"> <li>• “8i (BP1); VROC (BP234)” on page 265</li> </ul>	

## SAS/SATA combinations

See this topic to locate the combination with SAS/SATA backplanes.

### Notes:

- Secure unused end of Y-cable under the cable clip.

## BP1/BP12

### HW 8i/16i(BP1)

Table 33. 3.5-inch drive cable routing - HW RAID 8i/16i (BP1)

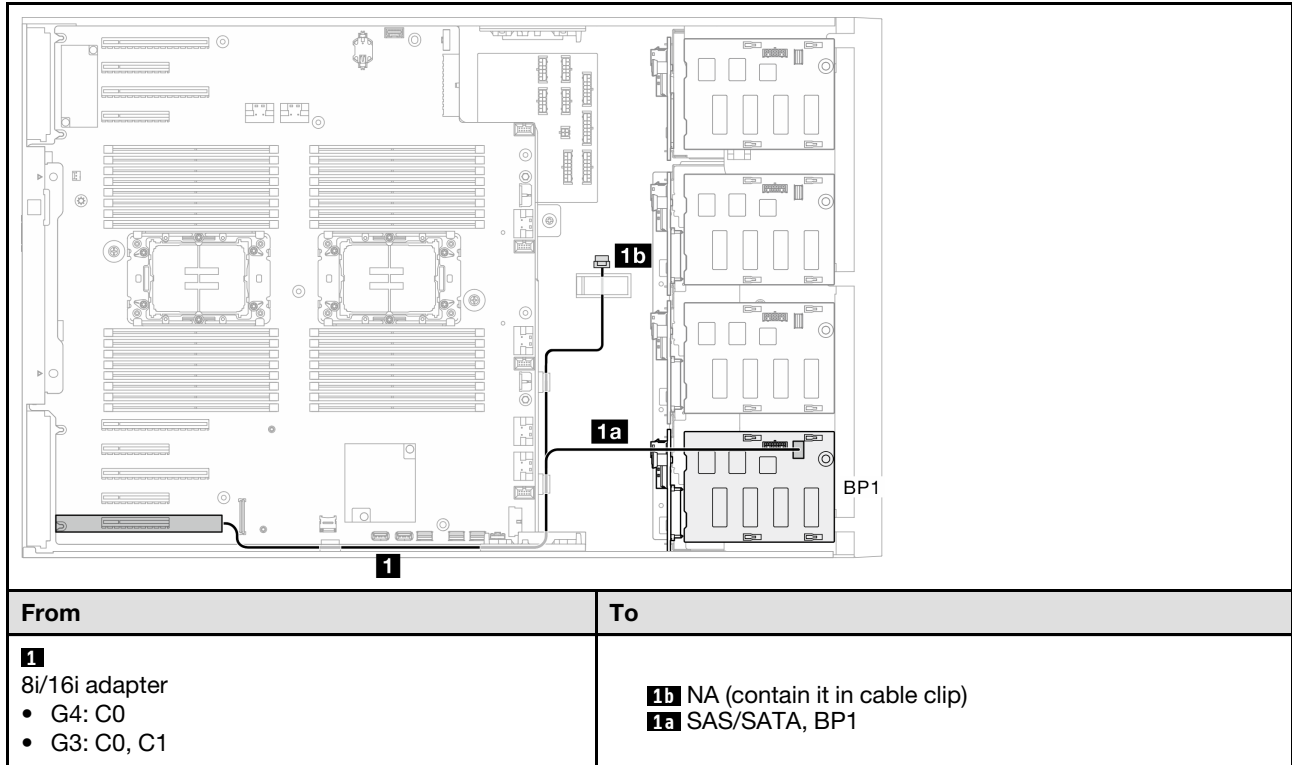

## HW 8i/16i (BP12)

Table 34. 3.5-inch drive cable routing - HW RAID 8i/16i (BP12)

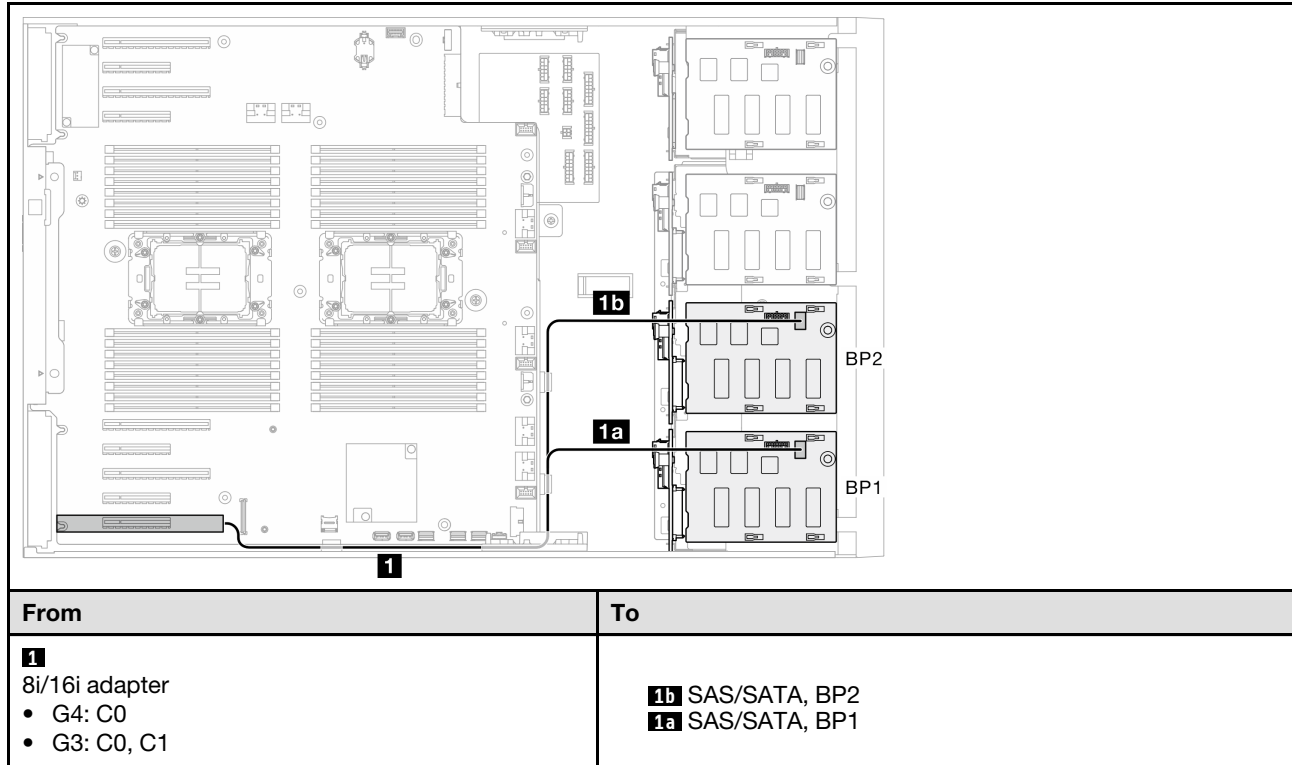

## SW RAID (BP1/BP12)

Table 35. 3.5-inch drive cable routing - Onboard SW RAID (BP1/BP12)

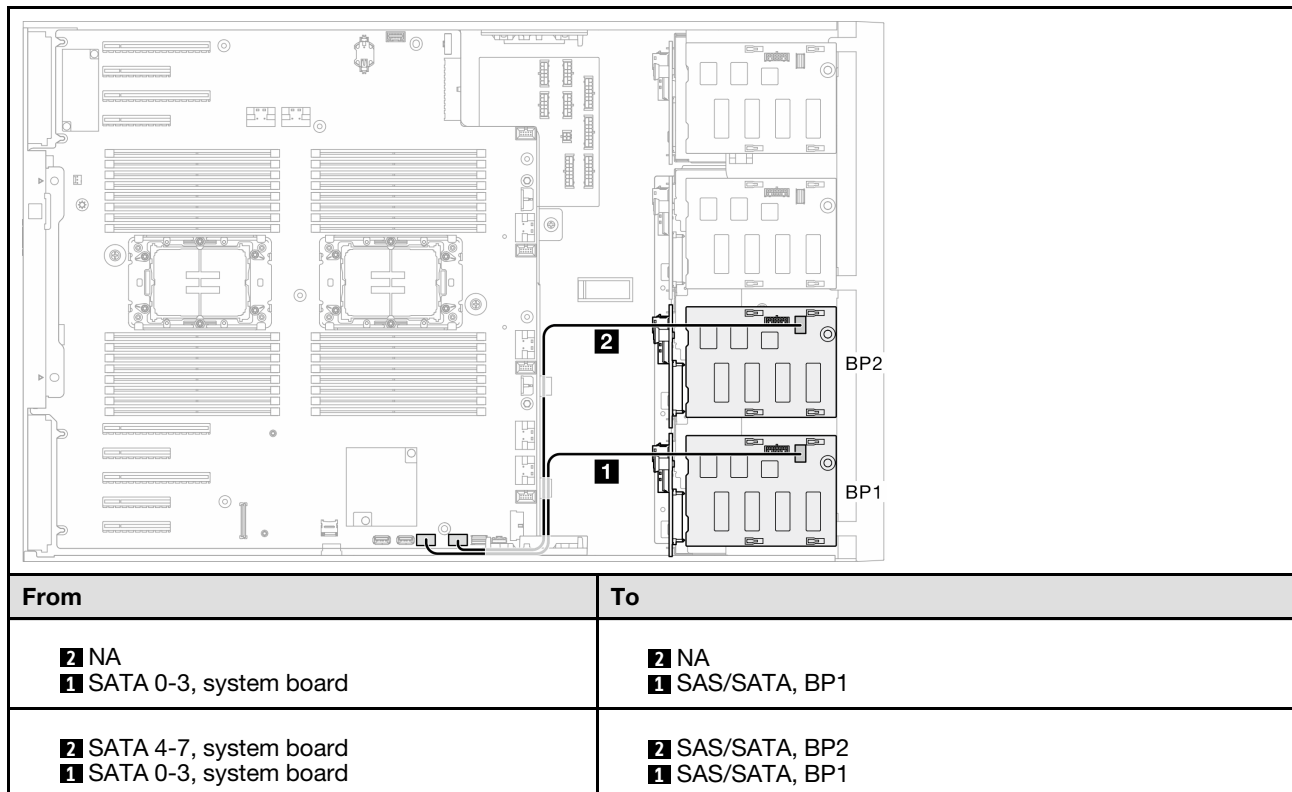

# BP123/BP1234

## HW 8i (BP123)

Table 36. 3.5-inch drive cable routing - HW RAID 8i (BP123)

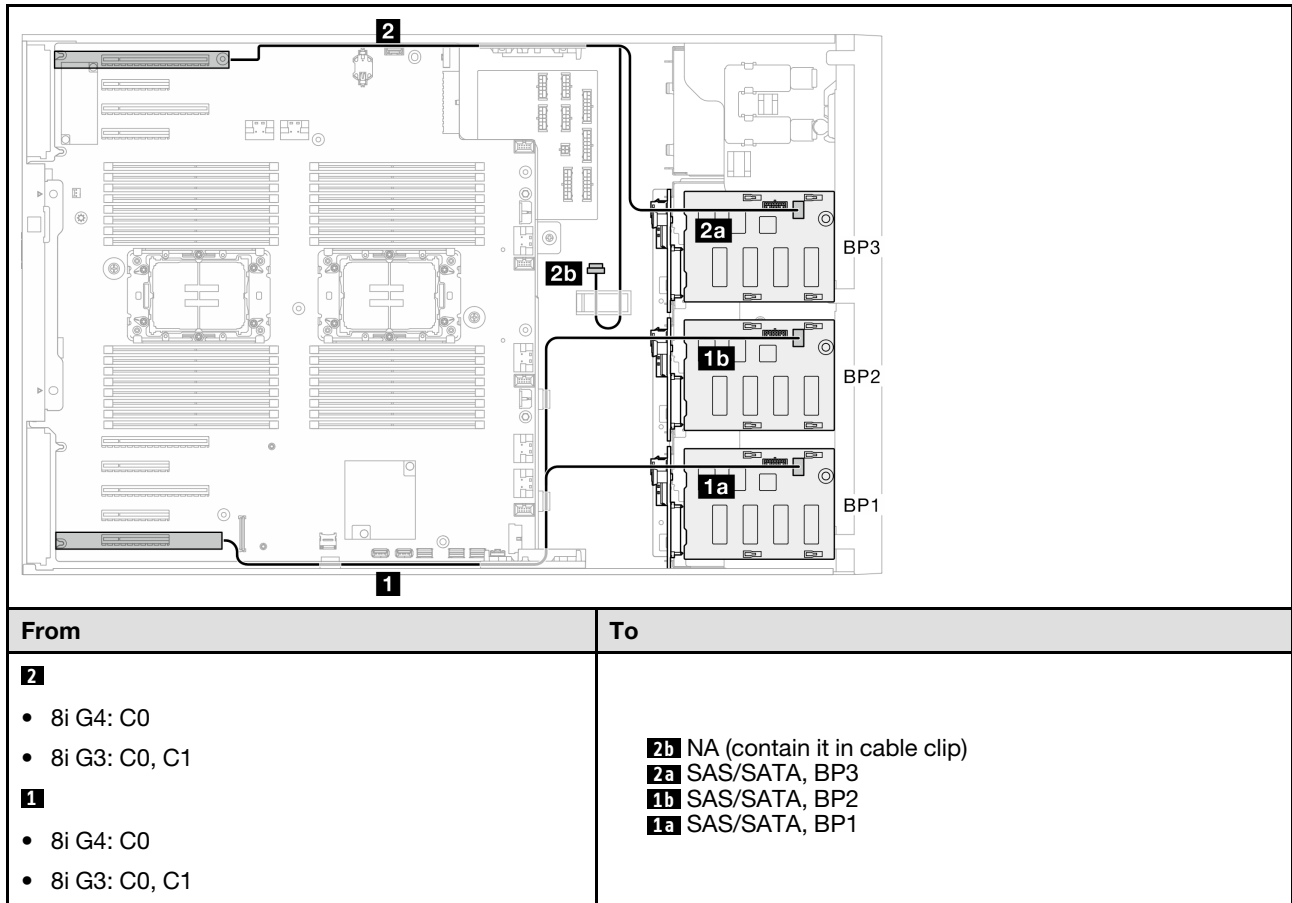

## HW 8i (BP1234)

Table 37. 3.5-inch drive cable routing - HW RAID 8i (BP1234)

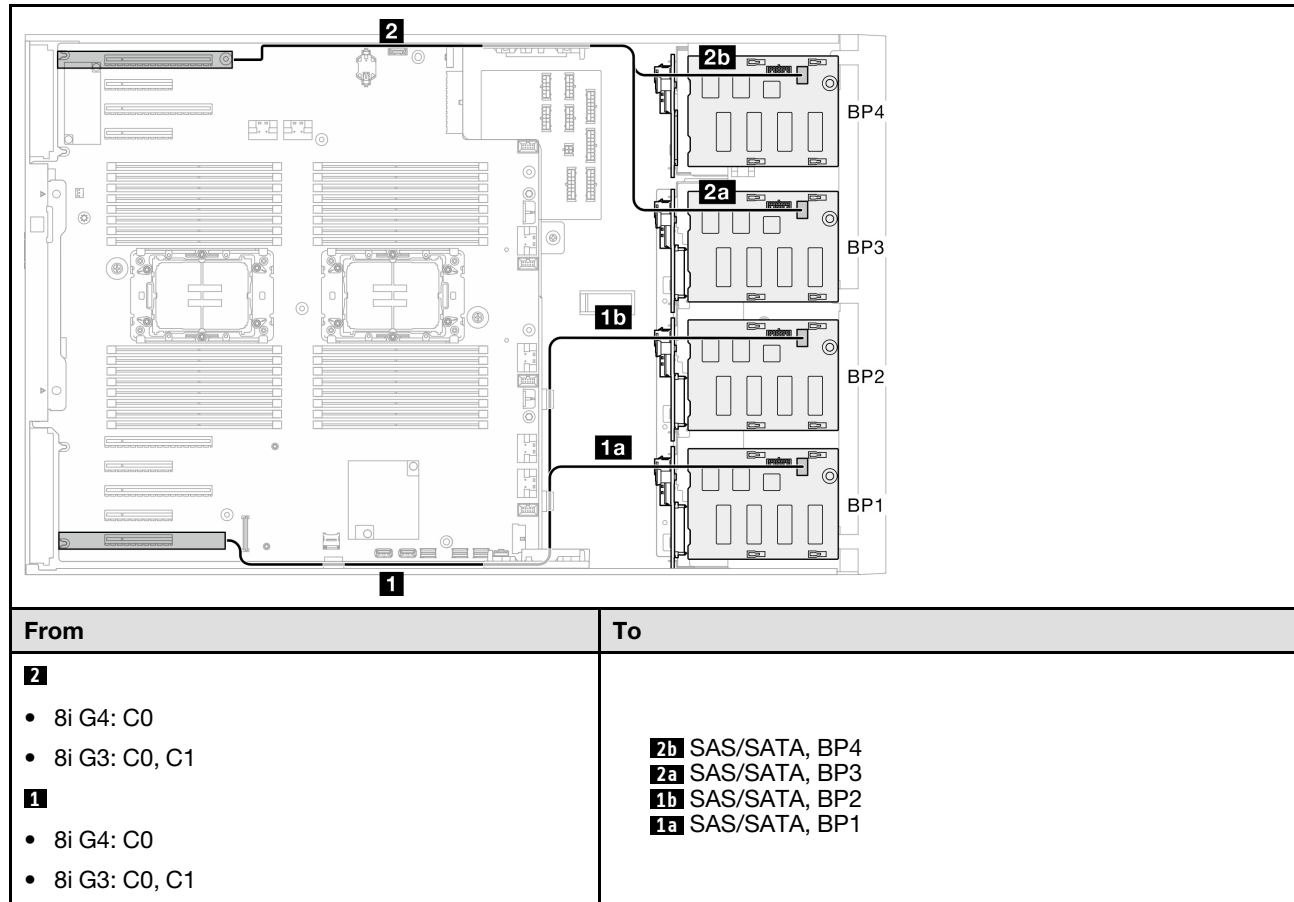

## HW 16i (BP123)

Table 38. 3.5-inch drive cable routing - HW RAID 16i (BP123)

From	To
<p><b>2</b></p> <ul style="list-style-type: none"> <li>• 16i G4: C1</li> <li>• 16i G3: C2, C3</li> </ul> <p><b>1</b></p> <ul style="list-style-type: none"> <li>• 16i G4: C0</li> <li>• 16i G3: C0, C1</li> </ul>	<p><b>2b</b> NA (contain it in cable clip)</p> <p><b>2a</b> SAS/SATA, BP3</p> <p><b>1b</b> SAS/SATA, BP2</p> <p><b>1a</b> SAS/SATA, BP1</p>

## HW 16i (BP1234)

Table 39. 3.5-inch drive cable routing - HW RAID 16i (BP1234)

From	To
<p><b>2</b></p> <ul style="list-style-type: none"> <li>• 16i G4: C1</li> <li>• 16i G3: C2, C3</li> </ul> <p><b>1</b></p> <ul style="list-style-type: none"> <li>• 16i G4: C0</li> <li>• 16i G3: C0, C1</li> </ul>	<p><b>2b</b> SAS/SATA, BP4</p> <p><b>2a</b> SAS/SATA, BP3</p> <p><b>1b</b> SAS/SATA, BP2</p> <p><b>1a</b> SAS/SATA, BP1</p>

## CFF (BP123/BP1234)

Table 40. 3.5-inch drive cable routing - Internal CFF RAID (BP123/BP1234)

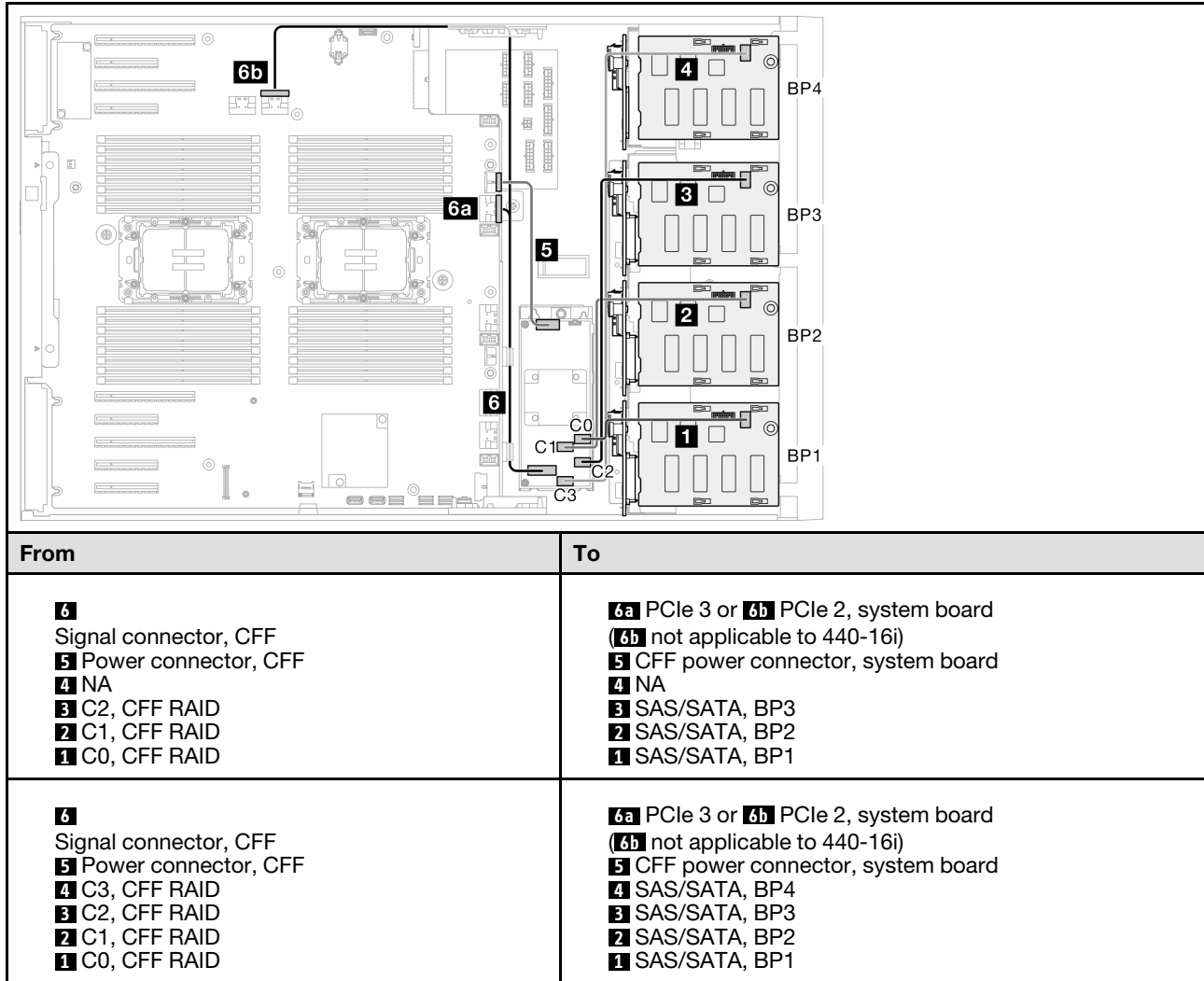

## Pure NVMe combinations

See this topic to locate the combination with NVMe drive backplanes.

### BP4/BP3/BP34

#### VROC (BP4)

Table 41. 3.5-inch drive cable routing - VROC (BP4)

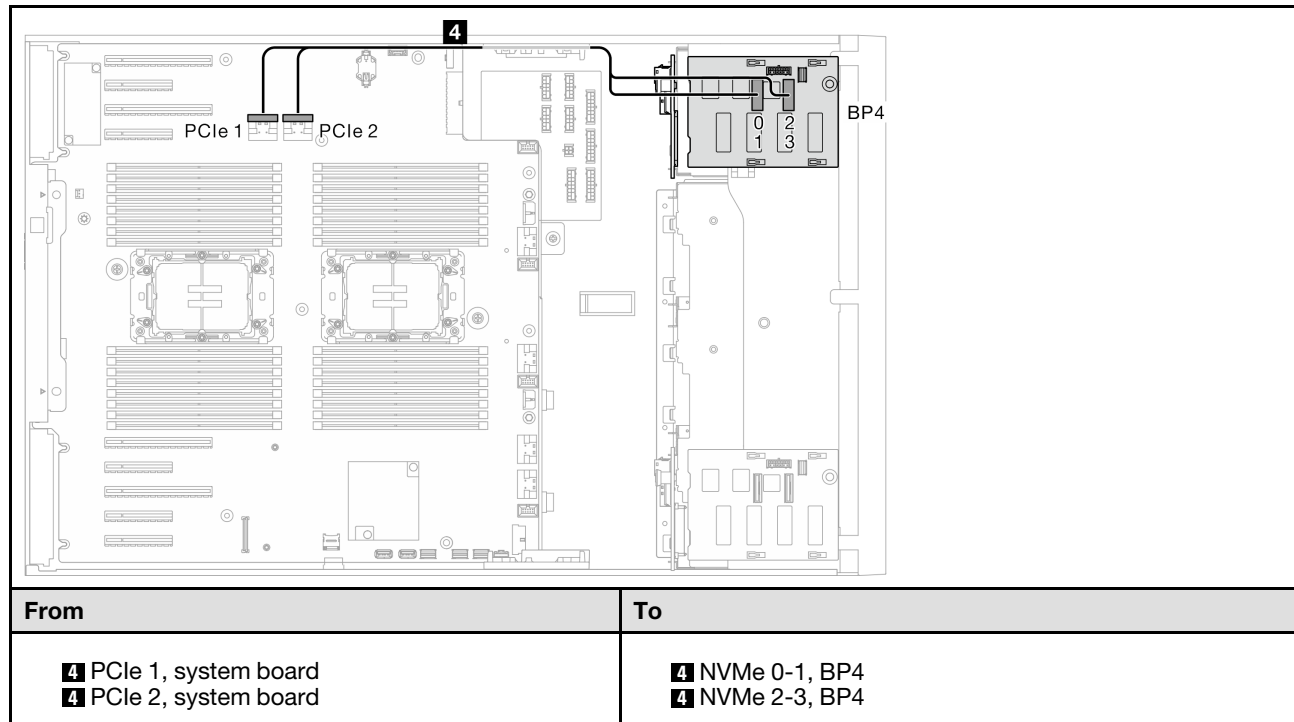

## VROC (BP3)

Table 42. 3.5-inch drive cable routing - VROC (BP3)

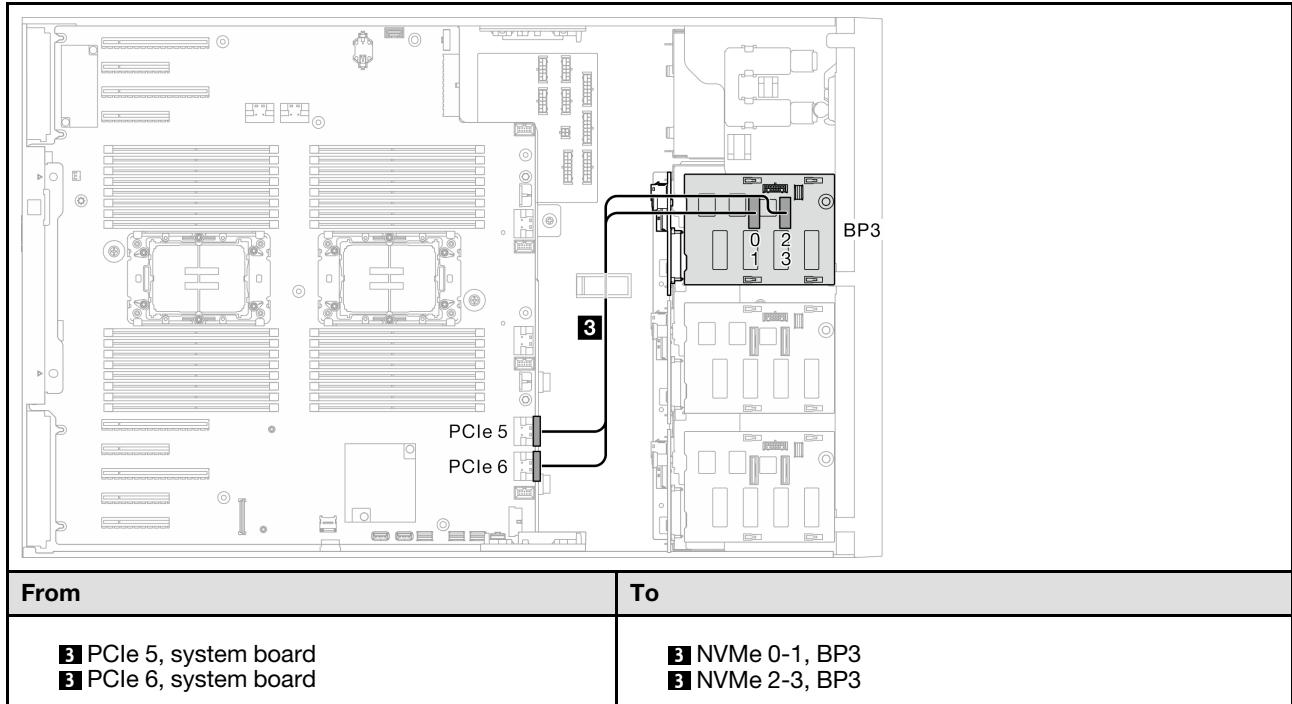

## VROC (BP34)

Table 43. 3.5-inch drive cable routing - VROC (BP34)

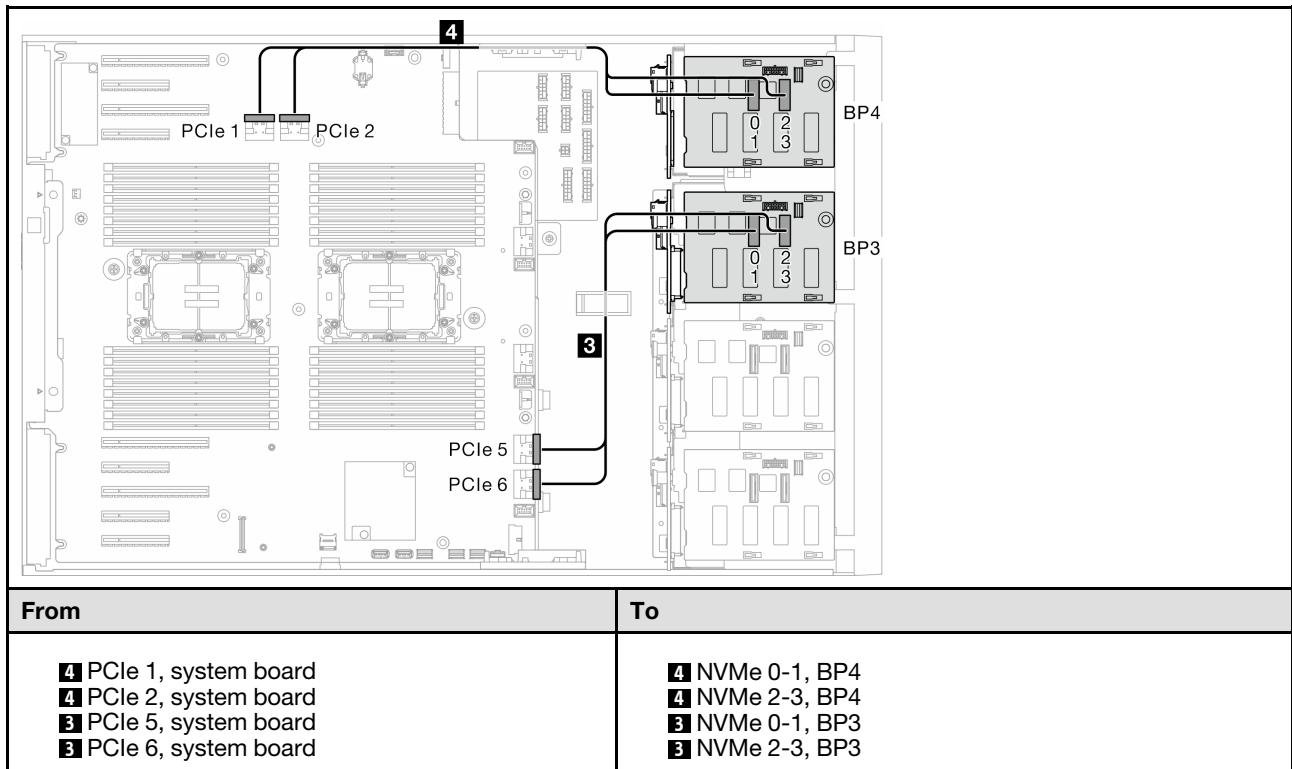

# BP23/BP234/BP123/BP1234

## VROC (BP23/BP234)

Table 44. 3.5-inch drive cable routing - VROC (BP23/BP234)

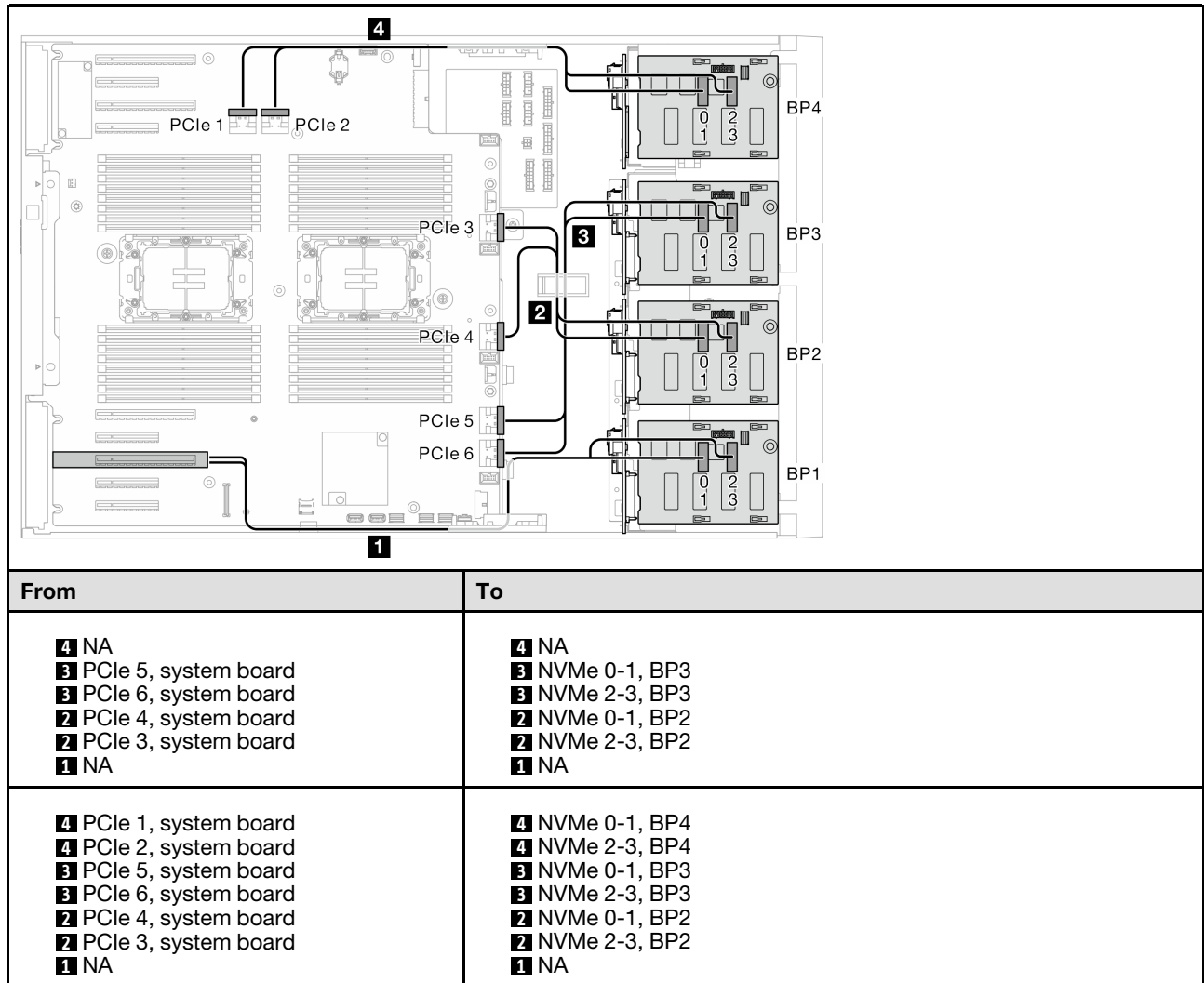

## VROC (BP123/BP1234)

Table 45. 3.5-inch drive cable routing - VROC (BP123/BP1234)

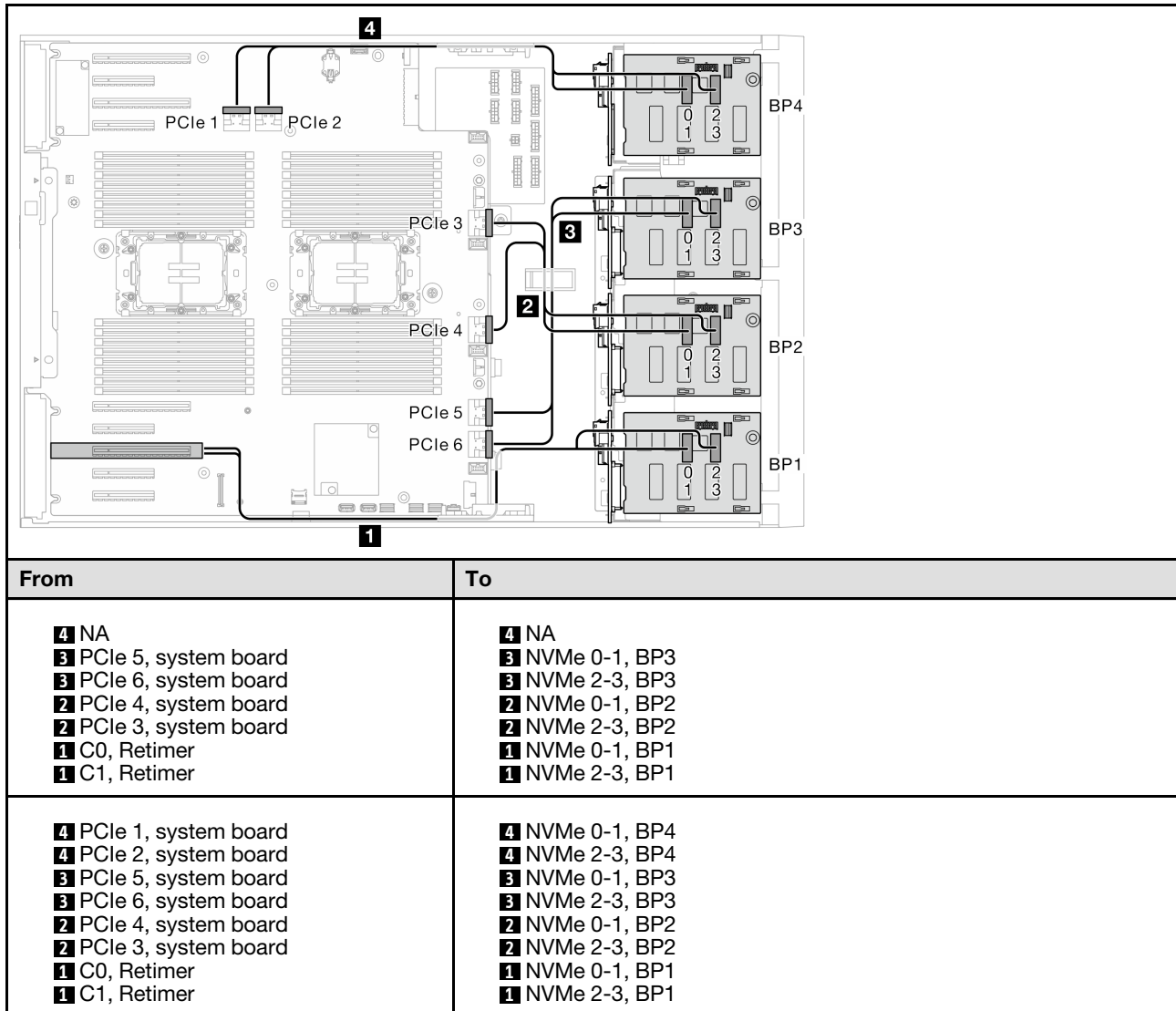

## Mixed combinations

See this topic to locate the combination with SAS/SATA and AnyBay backplanes.

### Notes:

- Secure unused end of Y-cable under the cable clip.

## Onboard SW RAID and VROC combinations

**OBSW (BP12); VROC (BP4)**

Table 46. 3.5-inch drive cable routing - OBSW (BP12); VROC (BP4)

From	To	Backplanes
<p><b>4</b> PCIe 1, system board  <b>4</b> PCIe 2, system board</p>	<p><b>4</b> NVMe 0-1, BP4  <b>4</b> NVMe 2-3, BP4</p>	<p><b>BP4: NVMe</b>                      BP3: empty                      BP2: SAS/SATA                      BP1: SAS/SATA</p>
From	To	Backplanes
<p><b>2</b> SATA 4-7, system board  <b>1</b> SATA 0-3, system board</p>	<p><b>2</b> SAS/SATA, BP2  <b>1</b> SAS/SATA, BP1</p>	<p>BP4: NVMe                      BP3: empty  <b>BP2: SAS/SATA</b>  <b>BP1: SAS/SATA</b></p>

**OBSW (BP12); VROC (BP3)**

Table 47. 3.5-inch drive cable routing - OBSW (BP12); VROC (BP3)

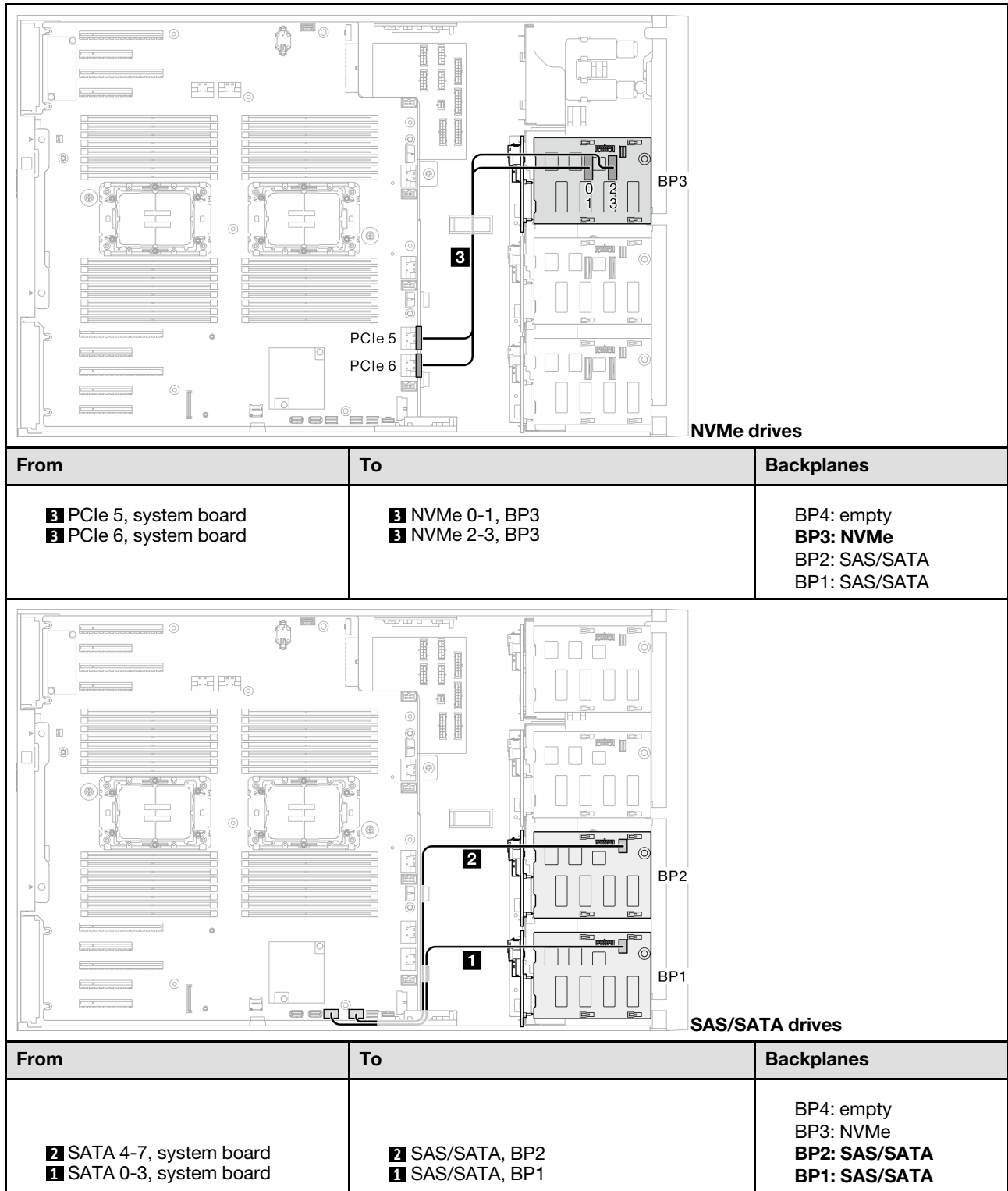

## 8i and VROC combinations

### 8i (BP12); VROC (BP3)

Table 48. 3.5-inch drive cable routing - 8i (BP12); VROC (BP3)

From	To	Backplanes
<p><b>3</b> PCIe 5, system board</p> <p><b>3</b> PCIe 6, system board</p>	<p><b>3</b> NVMe 0-1, BP3</p> <p><b>3</b> NVMe 2-3, BP3</p>	<p>BP4: empty</p> <p><b>BP3: NVMe</b></p> <p>BP2: SAS/SATA</p> <p>BP1: SAS/SATA</p>
From	To	Backplanes
<p><b>1</b></p> <ul style="list-style-type: none"> <li>• 8i G4: C0</li> <li>• 8i G3: C0, C1</li> </ul>	<p><b>1b</b> SAS/SATA, BP2</p> <p><b>1a</b> SAS/SATA, BP1</p>	<p>BP4: empty</p> <p>BP3: NVMe</p> <p><b>BP2: SAS/SATA</b></p> <p><b>BP1: SAS/SATA</b></p>

## 8i (BP12); VROC (BP4)

Table 49. 3.5-inch drive cable routing - 8i (BP12); VROC (BP4)

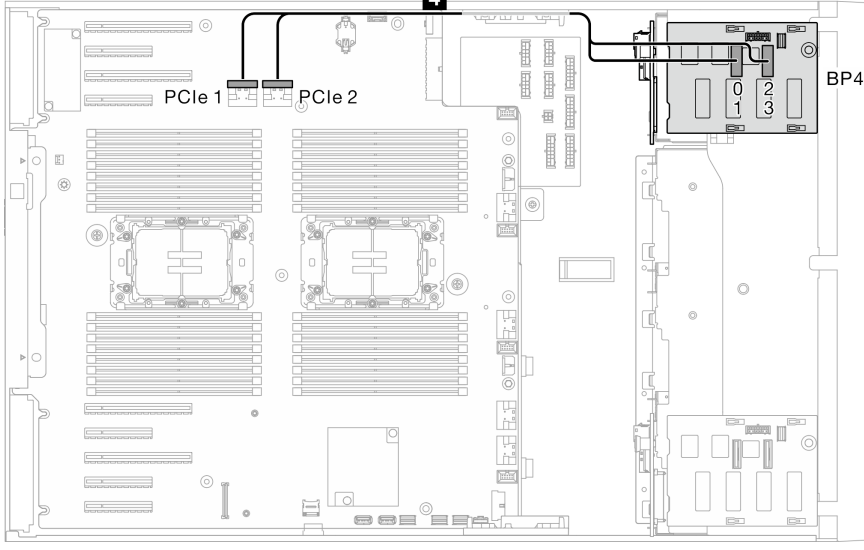
		
From	To	Backplanes
<p><b>4</b> PCIe 1, system board</p> <p><b>4</b> PCIe 2, system board</p>	<p><b>4</b> NVMe 0-1, BP4</p> <p><b>4</b> NVMe 2-3, BP4</p>	<p><b>BP4: NVMe</b></p> <p>BP3: empty</p> <p>BP2: SAS/SATA</p> <p>BP1: SAS/SATA</p>
		
From	To	Backplanes
<p><b>1</b></p> <ul style="list-style-type: none"> <li>8i G4: C0</li> <li>8i G3: C0, C1</li> </ul>	<p><b>1b</b> SAS/SATA, BP2</p> <p><b>1a</b> SAS/SATA, BP1</p>	<p>BP4: NVMe</p> <p>BP3: empty</p> <p><b>BP2: SAS/SATA</b></p> <p><b>BP1: SAS/SATA</b></p>

## 8i (BP123); VROC (BP3)

Table 50. 3.5-inch drive cable routing - 8i (BP123); VROC (BP3)

From	To	Backplanes
<ul style="list-style-type: none"> <li><b>3</b> PCIe 5, system board</li> <li><b>3</b> PCIe 6, system board</li> </ul>	<ul style="list-style-type: none"> <li><b>3</b> NVMe 0-1, BP3</li> <li><b>3</b> NVMe 2-3, BP3</li> </ul>	BP4: empty <b>BP3: SAS/SATA/NVMe</b> BP2: SAS/SATA BP1: SAS/SATA
From	To	Backplanes
<ul style="list-style-type: none"> <li><b>2</b> <ul style="list-style-type: none"> <li>• 8i G4: C0</li> <li>• 8i G3: C0, C1</li> </ul> </li> <li><b>1</b> <ul style="list-style-type: none"> <li>• 8i G4: C0</li> <li>• 8i G3: C0, C1</li> </ul> </li> </ul>	<ul style="list-style-type: none"> <li><b>2b</b> NA (contain it in cable clip)</li> <li><b>2a</b> SAS/SATA, BP3</li> <li><b>1b</b> SAS/SATA, BP2</li> <li><b>1a</b> SAS/SATA, BP1</li> </ul>	BP4: empty <b>BP3: SAS/SATA/NVMe</b> <b>BP2: SAS/SATA</b> <b>BP1: SAS/SATA</b>

**8i (BP123); VROC (BP4)**

Table 51. 3.5-inch drive cable routing - 8i (BP123); VROC (BP4)

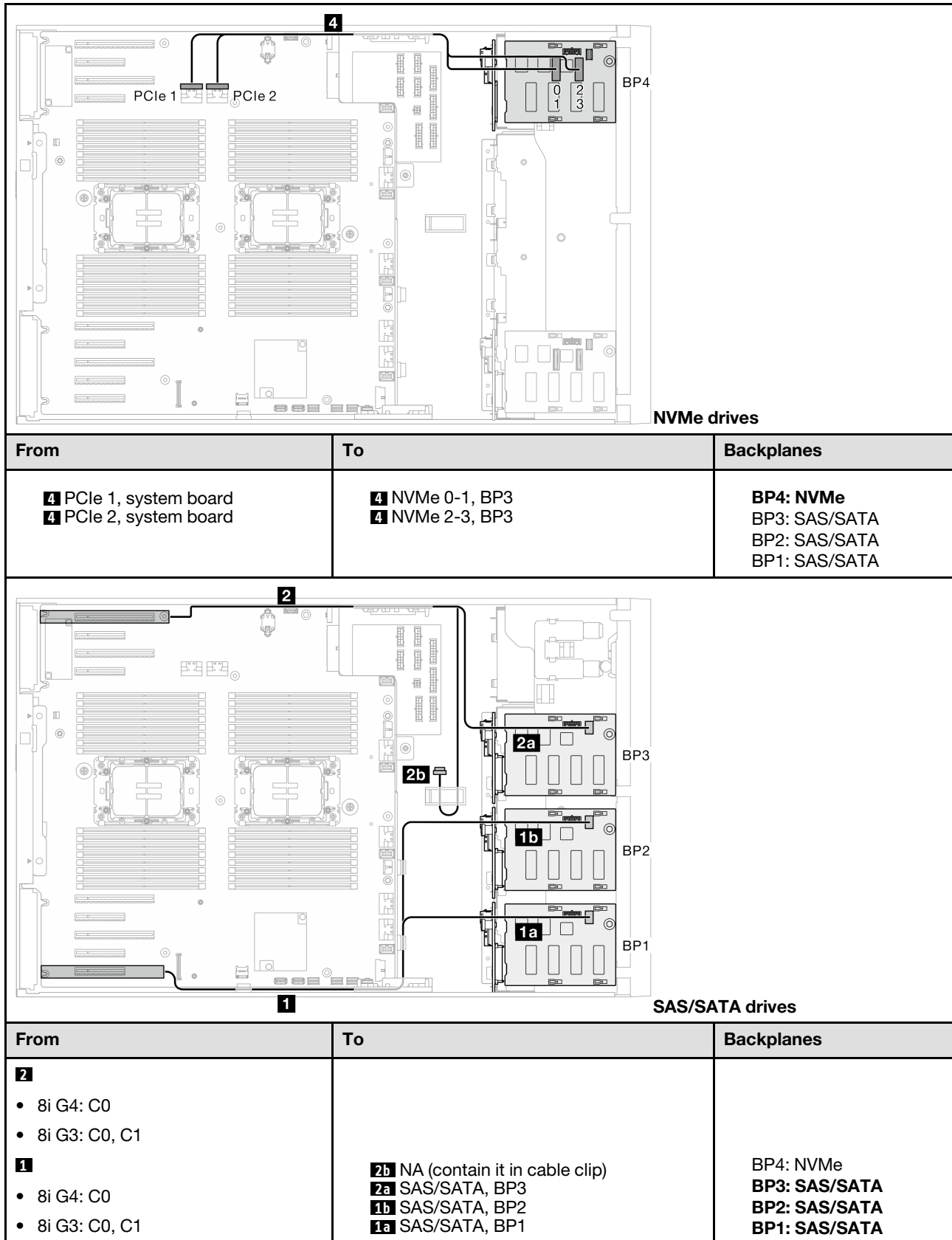



## 8i (BP124); VROC (BP4)

Table 52. 3.5-inch drive cable routing - 8i (BP124); VROC (BP4)

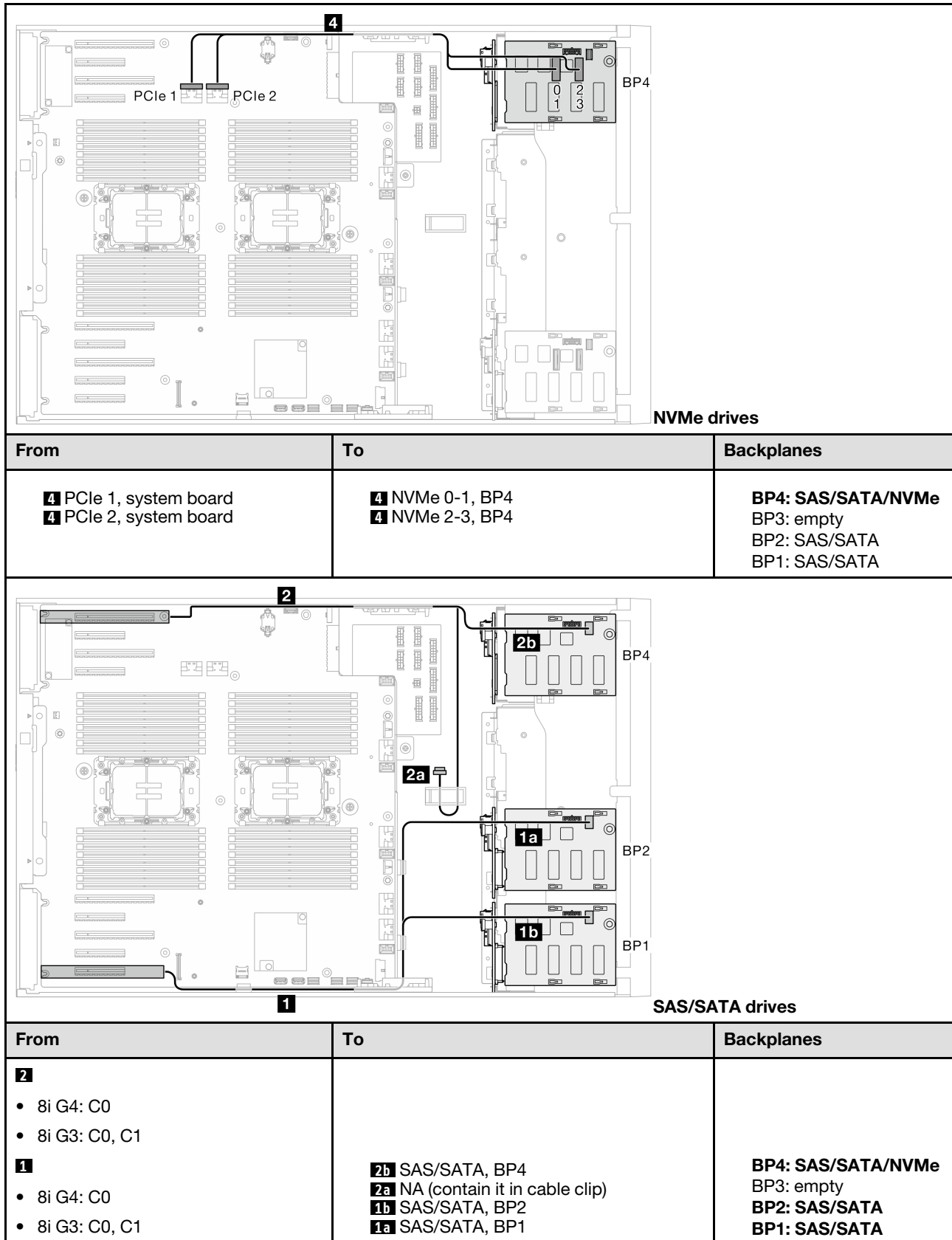

## 8i (BP1234) VROC (BP4)

Table 53. 3.5-inch drive cable routing - 8i (BP1234); VROC (BP4)

<p style="text-align: right;"><b>NVMe drives</b></p>		
From	To	Backplanes
<p><b>4</b> PCIe 1, system board</p> <p><b>4</b> PCIe 2, system board</p>	<p><b>4</b> NVMe 0-1, BP4</p> <p><b>4</b> NVMe 2-3, BP4</p>	<p><b>BP4: SAS/SATA/NVMe</b></p> <p>BP3: SAS/SATA</p> <p>BP2: SAS/SATA</p> <p>BP1: SAS/SATA</p>
<p style="text-align: right;"><b>SAS/SATA drives</b></p>		
From	To	Backplanes
<p><b>2</b></p> <ul style="list-style-type: none"> <li>• 8i G4: C0</li> <li>• 8i G3: C0, C1</li> </ul> <p><b>1</b></p> <ul style="list-style-type: none"> <li>• 8i G4: C0</li> <li>• 8i G3: C0, C1</li> </ul>	<p><b>2b</b> SAS/SATA, BP4</p> <p><b>2a</b> SAS/SATA, BP3</p> <p><b>1b</b> SAS/SATA, BP2</p> <p><b>1a</b> SAS/SATA, BP1</p>	<p><b>BP4: SAS/SATA/NVMe</b></p> <p><b>BP3: SAS/SATA</b></p> <p><b>BP2: SAS/SATA</b></p> <p><b>BP1: SAS/SATA</b></p>



## 8i (BP1); VROC (BP234)

Table 54. 3.5-inch drive cable routing - 8i (BP1); VROC (BP234)

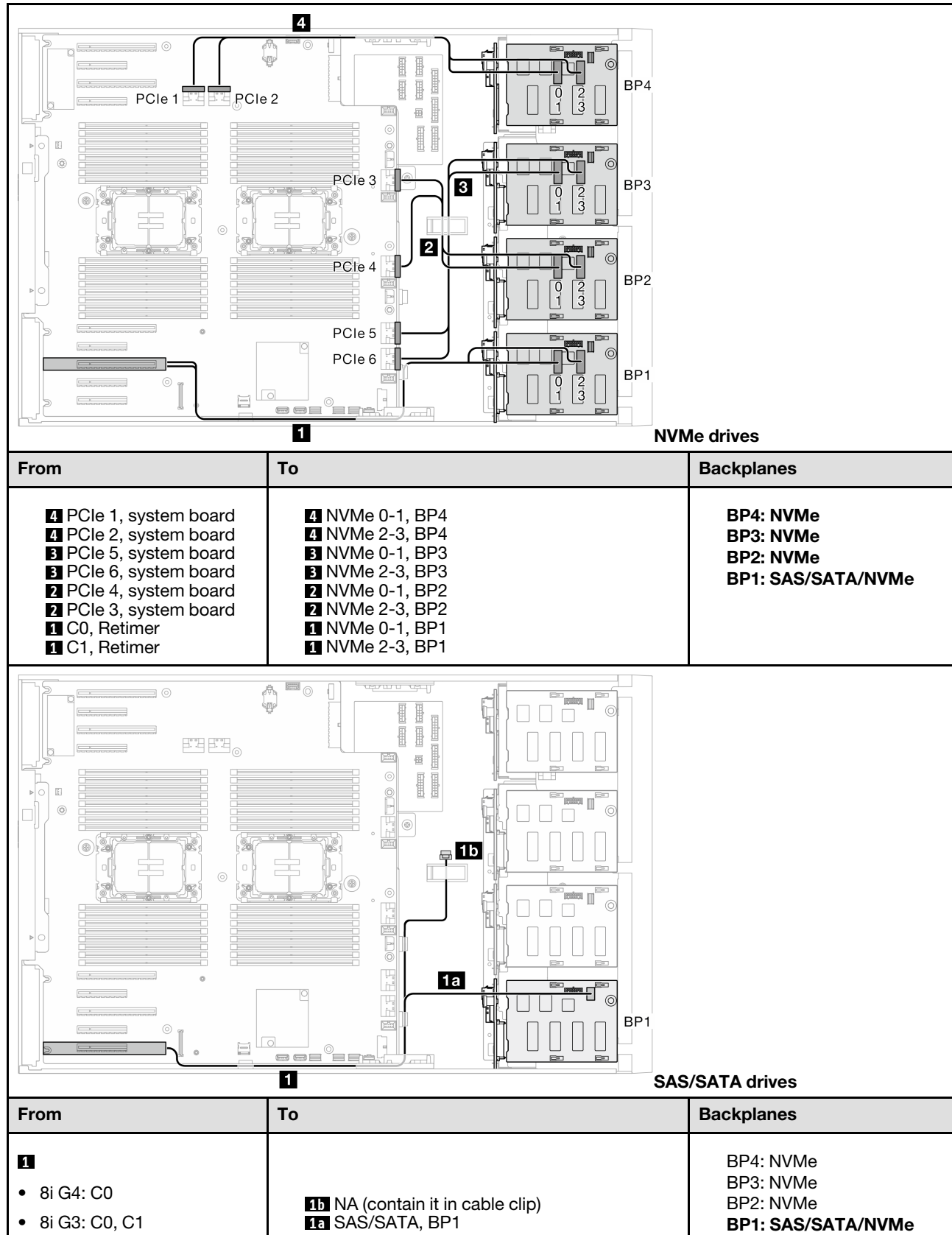

## 16i and VROC combinations

### 16i (BP123); VROC (BP3)

Table 55. 3.5-inch drive cable routing - 16i (BP123); VROC (BP3)

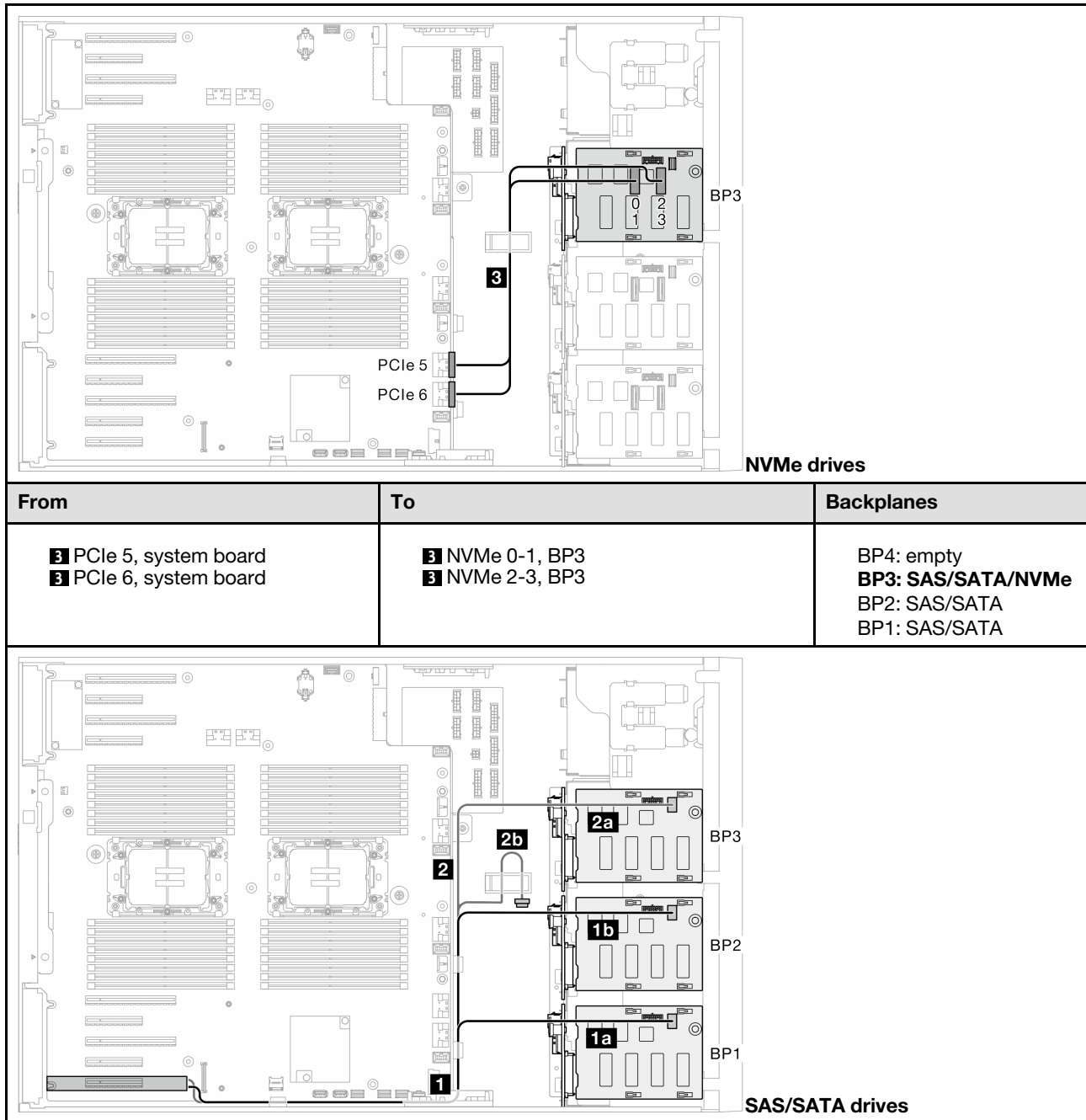

Table 55. 3.5-inch drive cable routing - 16i (BP123); VROC (BP3) (continued)

From	To	Backplanes
<p><b>2</b></p> <ul style="list-style-type: none"> <li>• 16i G4: C1</li> <li>• 16i G3: C2, C3</li> </ul> <p><b>1</b></p> <ul style="list-style-type: none"> <li>• 16i G4: C0</li> <li>• 16i G3: C0, C1</li> </ul>	<p><b>2b</b> NA (contain it in cable clip)</p> <p><b>2a</b> SAS/SATA, BP3</p> <p><b>1b</b> SAS/SATA, BP2</p> <p><b>1a</b> SAS/SATA, BP1</p>	<p>BP4: empty</p> <p><b>BP3: SAS/SATA/NVMe</b></p> <p><b>BP2: SAS/SATA</b></p> <p><b>BP1: SAS/SATA</b></p>

## 16i (BP124); VROC (BP4)

Table 56. 3.5-inch drive cable routing - 16i (BP124); VROC (BP4)

From	To	Backplanes
<p><b>4</b> PCIe 1, system board</p> <p><b>4</b> PCIe 2, system board</p>	<p><b>4</b> NVMe 0-1, BP4</p> <p><b>4</b> NVMe 2-3, BP4</p>	<p><b>BP4: SAS/SATA/NVMe</b></p> <p>BP3: empty</p> <p>BP2: SAS/SATA</p> <p>BP1: SAS/SATA</p>
From	To	Backplanes
<p><b>2</b></p> <ul style="list-style-type: none"> <li>• 16i G4: C1</li> <li>• 16i G3: C2, C3</li> </ul> <p><b>1</b></p> <ul style="list-style-type: none"> <li>• 16i G4: C0</li> <li>• 16i G3: C0, C1</li> </ul>	<p><b>2b</b> SAS/SATA, BP4</p> <p><b>2a</b> NA (contain it in cable clip)</p> <p><b>1b</b> SAS/SATA, BP2</p> <p><b>1a</b> SAS/SATA, BP1</p>	<p><b>BP4: SAS/SATA/NVMe</b></p> <p>BP3: empty</p> <p><b>BP2: SAS/SATA</b></p> <p><b>BP1: SAS/SATA</b></p>



**16i (BP123); VROC (BP4)**

Table 57. 3.5-inch drive cable routing - 16i (BP123); VROC (BP4)

<p style="text-align: right;"><b>NVMe drives</b></p>		
From	To	Backplanes
<p><b>4</b> PCIe 1, system board</p> <p><b>4</b> PCIe 2, system board</p>	<p><b>4</b> NVMe 0-1, BP4</p> <p><b>4</b> NVMe 2-3, BP4</p>	<p><b>BP4: NVMe</b></p> <p>BP3: SAS/SATA</p> <p>BP2: SAS/SATA</p> <p>BP1: SAS/SATA</p>
<p style="text-align: right;"><b>SAS/SATA drives</b></p>		
From	To	Backplanes
<p><b>2</b></p> <ul style="list-style-type: none"> <li>• 16i G4: C1</li> <li>• 16i G3: C2, C3</li> </ul> <p><b>1</b></p> <ul style="list-style-type: none"> <li>• 16i G4: C0</li> <li>• 16i G3: C0, C1</li> </ul>	<p><b>2b</b> NA (contain it in cable clip)</p> <p><b>2a</b> SAS/SATA, BP3</p> <p><b>1b</b> SAS/SATA, BP2</p> <p><b>1a</b> SAS/SATA, BP1</p>	<p>BP4: NVMe</p> <p><b>BP3: SAS/SATA</b></p> <p><b>BP2: SAS/SATA</b></p> <p><b>BP1: SAS/SATA</b></p>



## 16i (BP1234); VROC (BP4)

Table 58. 3.5-inch drive cable routing - 16i (BP1234); VROC (BP4)

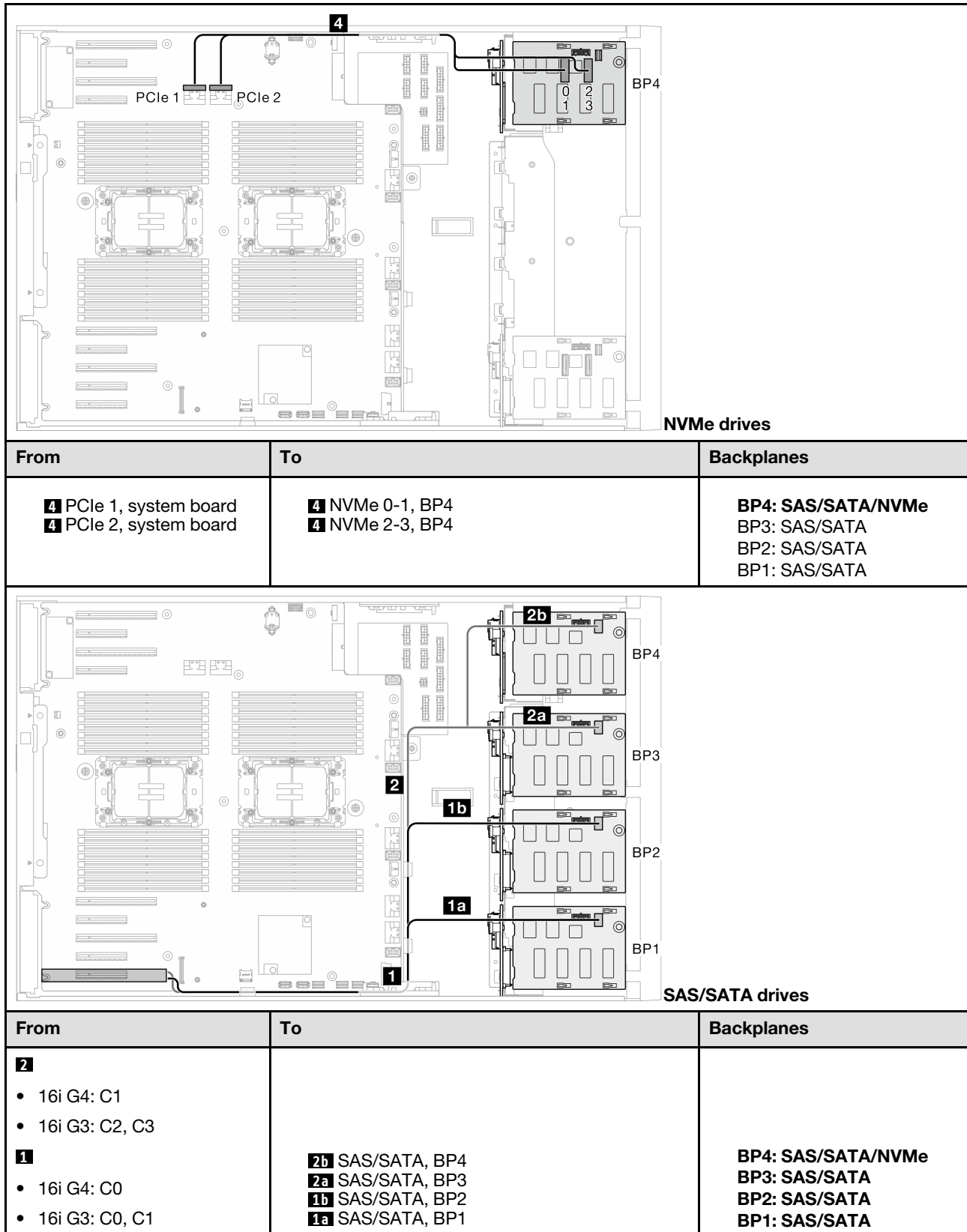

**Internal CFF and VROC combinations**

**CFF (BP124); VROC (BP4)**

Table 59. 3.5-inch drive cable routing - CFF (BP124); VROC (BP4)

<p style="text-align: right;"><b>NVMe drives</b></p>		
From	To	Backplanes
<p><b>4</b> PCIe 1, system board  <b>4</b> PCIe 2, system board</p>	<p><b>4</b> NVMe 0-1, BP4  <b>4</b> NVMe 2-3, BP4</p>	<p><b>BP4: SAS/SATA/NVMe</b>                      BP3: empty                      BP2: SAS/SATA                      BP1: SAS/SATA</p>
<p style="text-align: right;"><b>SAS/SATA drives</b></p>		
From	To	Backplanes
<p><b>6</b> Signal connector, CFF  <b>5</b> Power connector, CFF  <b>4</b> C3, CFF RAID  <b>3</b> NA  <b>2</b> C1, CFF RAID  <b>1</b> C0, CFF RAID</p>	<p><b>6</b> PCIe 3, system board  <b>5</b> CFF power connector, system board  <b>4</b> SAS/SATA, BP4  <b>3</b> NA  <b>2</b> SAS/SATA, BP2  <b>1</b> SAS/SATA, BP1</p>	<p><b>BP4: SAS/SATA/NVMe</b>                      BP3: empty                      BP2: SAS/SATA                      BP1: SAS/SATA</p>

**CFF (BP123); VROC (BP3)**

Table 60. 3.5-inch drive cable routing - CFF (BP123); VROC (BP3)

From	To	Backplanes
<ul style="list-style-type: none"> <li><b>3</b> PCIe 5, system board</li> <li><b>3</b> PCIe 6, system board</li> </ul>	<ul style="list-style-type: none"> <li><b>3</b> NVMe 0-1, BP3</li> <li><b>3</b> NVMe 2-3, BP3</li> </ul>	BP4: empty <b>BP3: SAS/SATA/NVMe</b> BP2: SAS/SATA BP1: SAS/SATA
From	To	Backplanes
<ul style="list-style-type: none"> <li><b>6</b> Signal connector, CFF</li> <li><b>5</b> Power connector, CFF</li> <li><b>4</b> NA</li> <li><b>3</b> C2, CFF RAID</li> <li><b>2</b> C1, CFF RAID</li> <li><b>1</b> C0, CFF RAID</li> </ul>	<ul style="list-style-type: none"> <li><b>6a</b> PCIe 3 or <b>6b</b> PCIe 2, system board (<b>6b</b> not applicable to 440-16i)</li> <li><b>5</b> CFF power connector, system board</li> <li><b>4</b> NA</li> <li><b>3</b> SAS/SATA, BP3</li> <li><b>2</b> SAS/SATA, BP2</li> <li><b>1</b> SAS/SATA, BP1</li> </ul>	BP4: empty <b>BP3: SAS/SATA/NVMe</b> <b>BP2: SAS/SATA</b> <b>BP1: SAS/SATA</b>

**CFF (BP123); VROC (BP4)**

Table 61. 3.5-inch drive cable routing - CFF (BP123); VROC (BP4)

<p style="text-align: right;"><b>NVMe drives</b></p>		
From	To	Backplanes
<ul style="list-style-type: none"> <li><b>4</b> PCIe 1, system board</li> <li><b>4</b> PCIe 2, system board</li> </ul>	<ul style="list-style-type: none"> <li><b>4</b> NVMe 0-1, BP4</li> <li><b>4</b> NVMe 2-3, BP4</li> </ul>	<ul style="list-style-type: none"> <li><b>BP4: SAS/SATA/NVMe</b></li> <li>BP3: SAS/SATA</li> <li>BP2: SAS/SATA</li> <li>BP1: SAS/SATA</li> </ul>
<p style="text-align: right;"><b>SAS/SATA drives</b></p>		
From	To	Backplanes
<ul style="list-style-type: none"> <li><b>6</b> Signal connector, CFF</li> <li><b>5</b> Power connector, CFF</li> <li><b>4</b> NA</li> <li><b>3</b> C2, CFF RAID</li> <li><b>2</b> C1, CFF RAID</li> <li><b>1</b> C0, CFF RAID</li> </ul>	<ul style="list-style-type: none"> <li><b>6</b> PCIe 3, system board</li> <li><b>5</b> CFF power connector, system board</li> <li><b>4</b> NA</li> <li><b>3</b> SAS/SATA, BP3</li> <li><b>2</b> SAS/SATA, BP2</li> <li><b>1</b> SAS/SATA, BP1</li> </ul>	<ul style="list-style-type: none"> <li>BP4: NVMe</li> <li><b>BP3: SAS/SATA</b></li> <li><b>BP2: SAS/SATA</b></li> <li><b>BP1: SAS/SATA</b></li> </ul>

**CFF (BP1234); VROC (BP4)**

Table 62. 3.5-inch drive cable routing - CFF (BP1234); VROC (BP4)

<p style="text-align: right;"><b>NVMe drives</b></p>		
From	To	Backplanes
<p><b>4</b> PCIe 1, system board  <b>4</b> PCIe 2, system board</p>	<p><b>4</b> NVMe 0-1, BP4  <b>4</b> NVMe 2-3, BP4</p>	<p><b>BP4: SAS/SATA/NVMe</b>  <b>BP3: SAS/SATA</b>  <b>BP2: SAS/SATA</b>  <b>BP1: SAS/SATA</b></p>
<p style="text-align: right;"><b>SAS/SATA drives</b></p>		
From	To	Backplanes
<p><b>6</b> Signal connector, CFF  <b>5</b> Power connector, CFF  <b>4</b> C3, CFF RAID  <b>3</b> C2, CFF RAID  <b>2</b> C1, CFF RAID  <b>1</b> C0, CFF RAID</p>	<p><b>6</b> PCIe 3, system board  <b>5</b> CFF power connector, system board  <b>4</b> SAS/SATA, BP4  <b>3</b> SAS/SATA, BP3  <b>2</b> SAS/SATA, BP2  <b>1</b> SAS/SATA, BP1</p>	<p><b>BP4: SAS/SATA/NVMe</b>  <b>BP3: SAS/SATA</b>  <b>BP2: SAS/SATA</b>  <b>BP1: SAS/SATA</b></p>

## 2.5-inch drive cable routing

See this topic to learn how to do cable routing for server models with 2.5-inch drive backplanes.

Complete the following routing for power cables corresponding to the backplanes that are installed in the system.

Table 63. Power cable routing - 2.5-inch drive backplanes

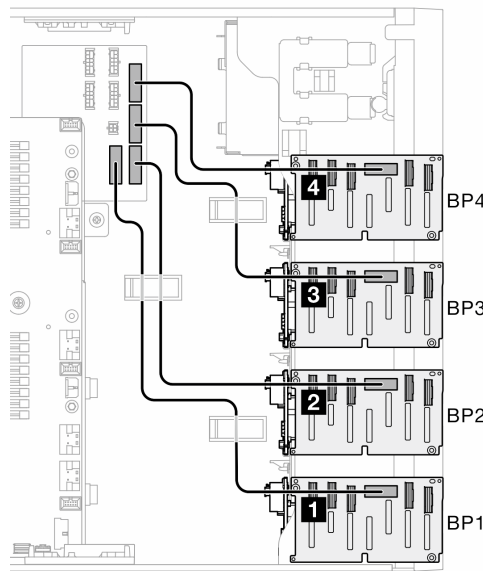
	From (backplane) to power distribution board		Length
	<b>4</b> BP4	BP4 power connector	355mm
<b>3</b> BP3	BP3 power connector		
<b>2</b> BP2	BP2 power connector	455mm	
<b>1</b> BP1	BP1 power connector		

Then, proceed to the table of combinations that correspond to the system configuration:

- [“Pure SAS/SATA combinations” on page 279](#)
- [“Pure NVMe combinations” on page 279](#)
- [“Mixed combinations” on page 280](#)

**Note:** Depending on models, the server supports up to three 2.5-inch NVMe backplanes.

### Pure SAS/SATA combinations

Table 64. Pure SAS/SATA cable routing combinations for 2.5-inch drives

BP1	BP12	BP123	BP1234	
			SAS/ SATA	BP4
		SAS/ SATA	SAS/ SATA	BP3
	SAS/ SATA	SAS/ SATA	SAS/ SATA	BP2
SAS/ SATA	SAS/ SATA	SAS/ SATA	SAS/ SATA	BP1
<ul style="list-style-type: none"> <li>• “SW RAID (BP1)” on page 281</li> <li>• “HW 8i/16i (BP1)” on page 282</li> <li>• “HW 8i; 8i (BP12)” on page 283</li> <li>• “HW 16i (BP12)” on page 284</li> <li>• “CFF (BP1/BP12)” on page 285</li> </ul>		<ul style="list-style-type: none"> <li>• “HW 16i; 8i; (BP123)” on page 286</li> <li>• “HW 8i; 8i; 8i (BP123)” on page 287</li> <li>• “HW 16i; 16i (BP1234)” on page 289</li> <li>• “HW 16i; 8i; 8i (BP123/BP1234)” on page 290</li> <li>• “HW 32i (BP123/BP1234)” on page 291</li> <li>• “HW 16i; CFF (BP1234)” on page 292</li> </ul>		

### Pure NVMe combinations

Table 65. Pure NVMe cable routing combinations for 2.5-inch drives

BP4	BP34	BP234	
NVMe	NVMe	NVMe	BP4
	NVMe	NVMe	BP3
		NVMe	BP2
			BP1
<ul style="list-style-type: none"> <li>• “VROC (BP4)” on page 293</li> </ul>	<ul style="list-style-type: none"> <li>• “VROC (BP34)” on page 294</li> </ul>	<ul style="list-style-type: none"> <li>• “VROC (BP234)” on page 295</li> </ul>	

## Mixed combinations

Table 66. Mixed cable routing combinations for 2.5-inch drives

BP1	BP4	BP12	BP34	BP14	BP234	BP124	BP1234	
	SAS/ SATA/ NVMe		NVMe	SAS/ SATA/ NVMe	NVMe	SAS/ SATA/ NVMe	SAS/ SATA/ NVMe	BP4
			SAS/ SATA/ NVMe		NVMe		SAS/ SATA	BP3
		SAS/ SATA/ NVMe			SAS/ SATA/ NVMe	SAS/ SATA	SAS/ SATA	BP2
SAS/ SATA/ NVMe		SAS/ SATA/ NVMe		SAS/ SATA		SAS/ SATA	SAS/ SATA	BP1
<ul style="list-style-type: none"> <li>“8i (tri-mode)” on page 296</li> </ul>	<ul style="list-style-type: none"> <li>“8i (BP4); VROC (BP4)” on page 297</li> </ul>	<ul style="list-style-type: none"> <li>“16i (tri-mode)” on page 298</li> </ul>	<ul style="list-style-type: none"> <li>“8i (BP3); VROC (BP34)” on page 299</li> </ul>	<ul style="list-style-type: none"> <li>“8i (BP1); 8i (BP4); VROC (BP4)” on page 300</li> <li>“16i (BP14); VROC (BP4)” on page 301</li> </ul>	<ul style="list-style-type: none"> <li>“8i (BP2); VROC (B-P234)” on page 302</li> </ul>	<ul style="list-style-type: none"> <li>“16i (BP12); 8i (BP4); VROC (BP4)” on page 303</li> <li>“8i (BP124); VROC (BP4)” on page 304</li> <li>“32i (BP124); VROC (BP4)” on page 305</li> </ul>	<ul style="list-style-type: none"> <li>“16i (BP12); 8i (BP34); VROC (BP4)” on page 306</li> <li>“16i (BP12); 16i (BP34); VROC (BP4)” on page 307</li> <li>“32i (B-P1234); VROC (BP4)” on page 309</li> <li>“16i (BP12); CFF (BP34); VROC (BP4)” on page 310</li> </ul>	

## SAS/SATA combinations

See this topic to locate the combination with SAS/SATA backplanes.

### BP1/BP12

#### SW RAID (BP1)

Table 67. 2.5-inch drive cable routing - Onboard SW RAID (BP1)

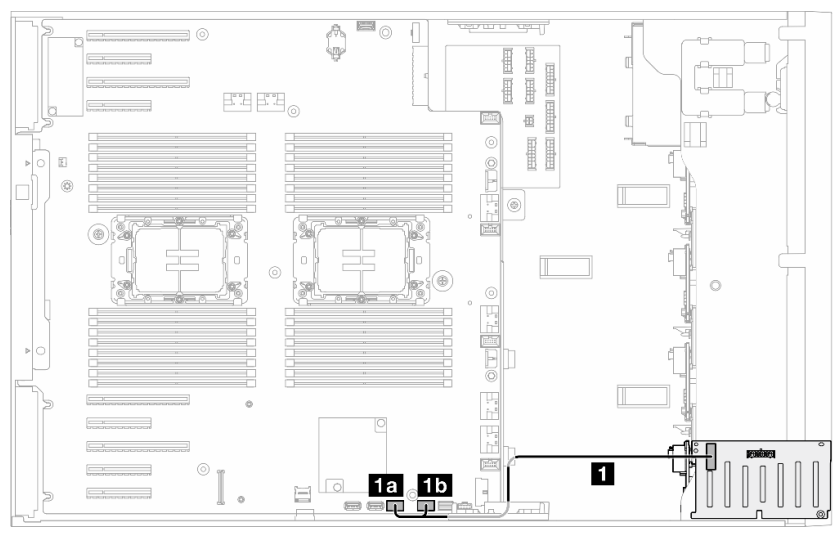

From	To
<b>1a</b> SATA 0-3, system board <b>1b</b> SATA 4-7, system board	<b>1</b> SAS/SATA, BP1

## HW 8i/16i (BP1)

Table 68. 2.5-inch drive cable routing - HW RAID 8i/16i (BP1)

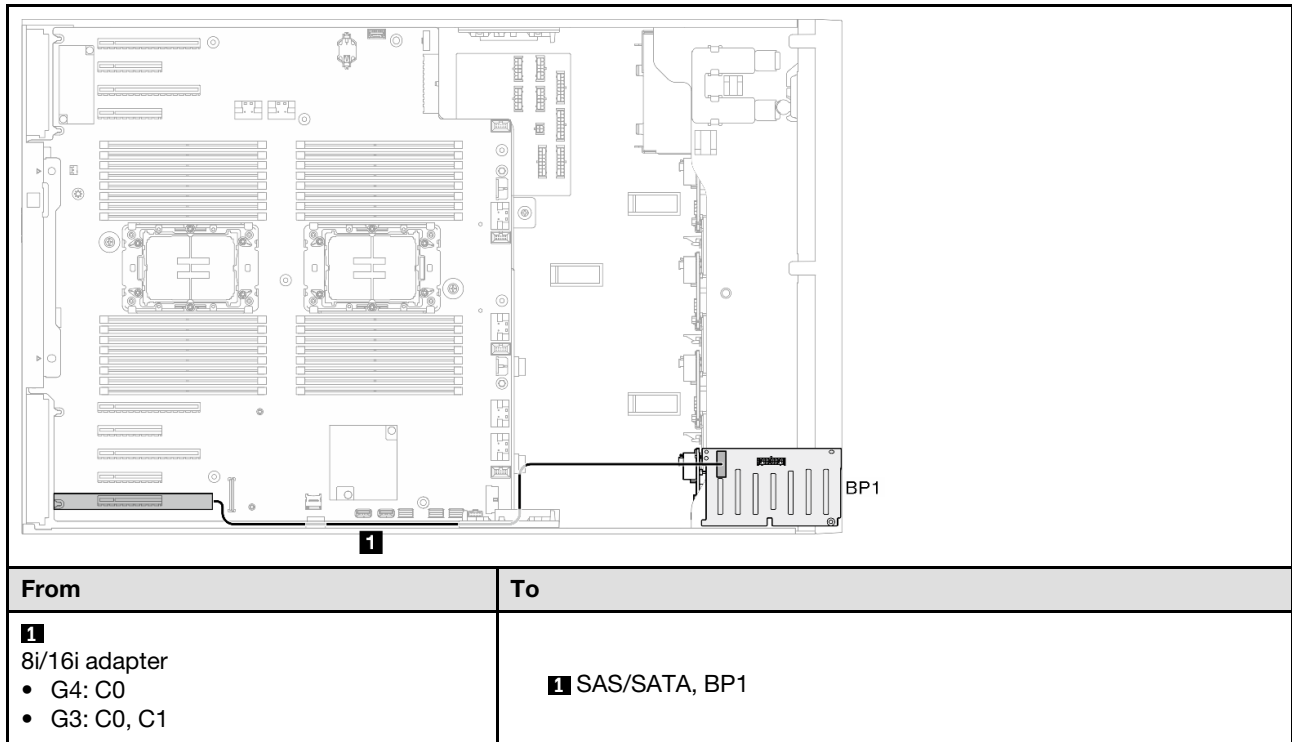

## HW 8i; 8i (BP12)

Table 69. 2.5-inch drive cable routing - HW RAID 8i; 8i (BP12)

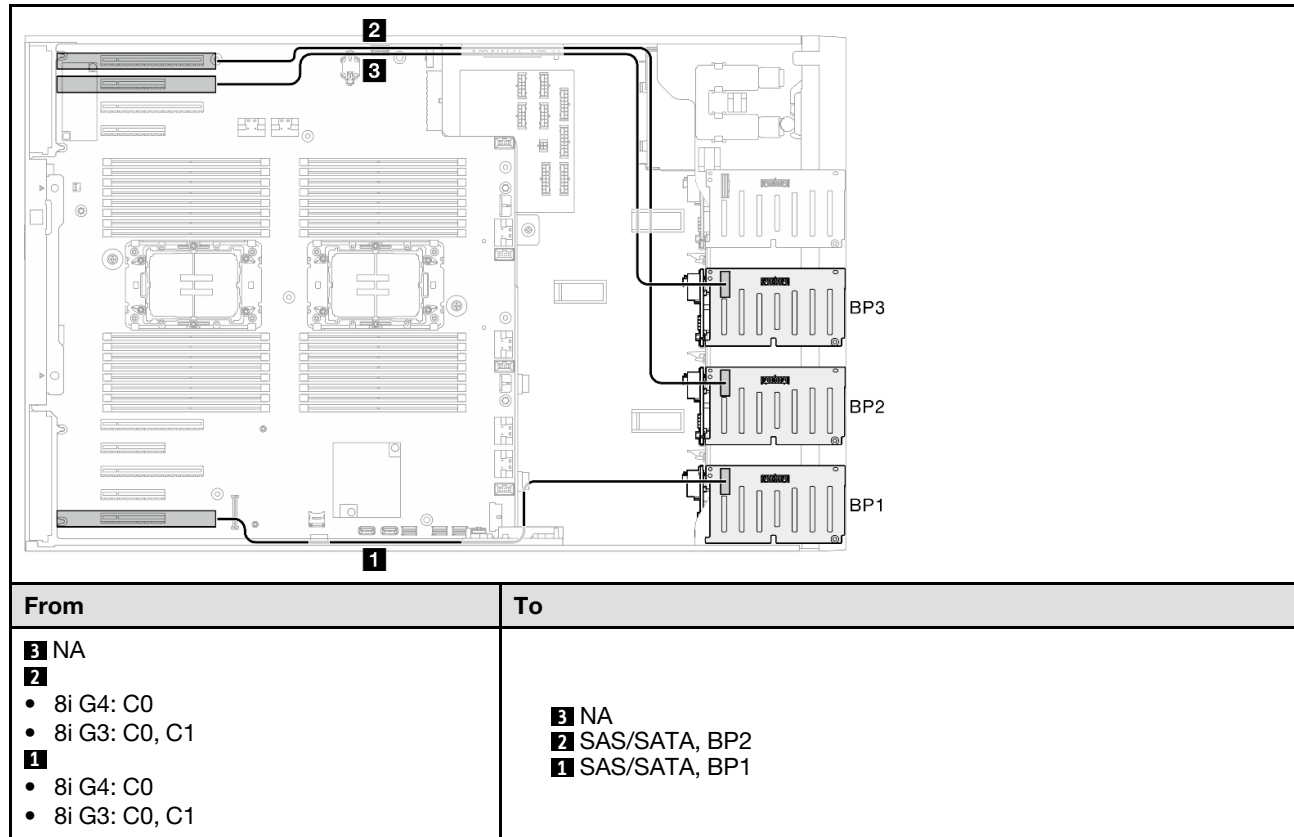

## HW 16i (BP12)

Table 70. 2.5-inch drive cable routing - HW RAID 16i (BP12)

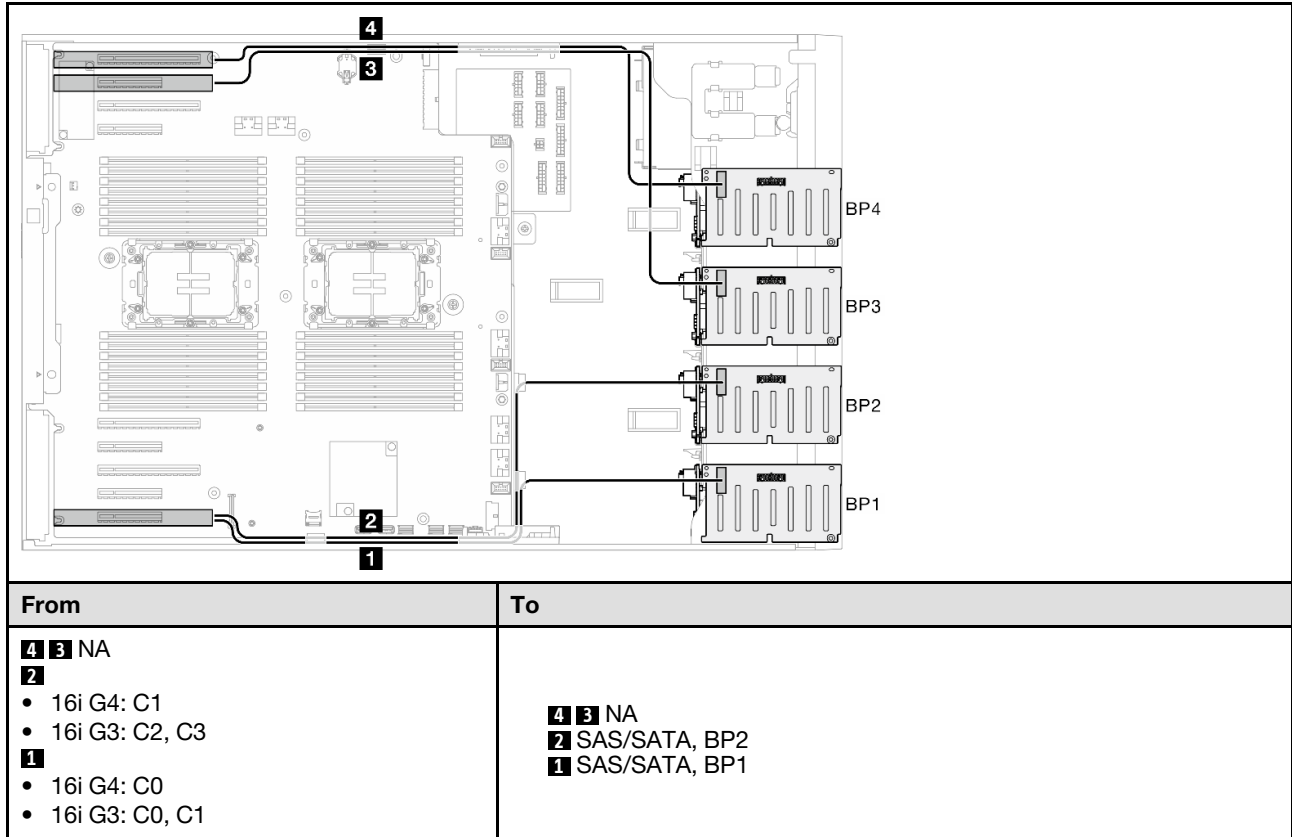

## CFF (BP1/BP12)

Table 71. 2.5-inch drive cable routing - Internal CFF RAID (BP1/BP12)

From	To
<p><b>4</b> Signal connector, CFF</p> <p><b>3</b> Power connector, CFF</p> <p><b>2</b> NA</p> <p><b>1</b> C0 &amp; C1, CFF RAID</p>	<p><b>4a</b> PCIe 3 or <b>4b</b> PCIe 2, system board (<b>4b</b> not applicable to 440-16i)</p> <p><b>3</b> CFF power connector, system board</p> <p><b>2</b> NA</p> <p><b>1</b> SAS/SATA, BP1</p>
<p><b>4</b> Signal connector, CFF</p> <p><b>3</b> Power connector, CFF</p> <p><b>2</b> C2 &amp; C3, CFF RAID</p> <p><b>1</b> C0 &amp; C1, CFF RAID</p>	<p><b>4a</b> PCIe 3 or <b>4b</b> PCIe 2, system board (<b>4b</b> not applicable to 440-16i)</p> <p><b>3</b> CFF power connector, system board</p> <p><b>2</b> SAS/SATA, BP2</p> <p><b>1</b> SAS/SATA, BP1</p>

# BP123/BP1234

## HW 16i; 8i; (BP123)

Table 72. 2.5-inch drive cable routing - HW RAID 16i; 8i;(BP123)

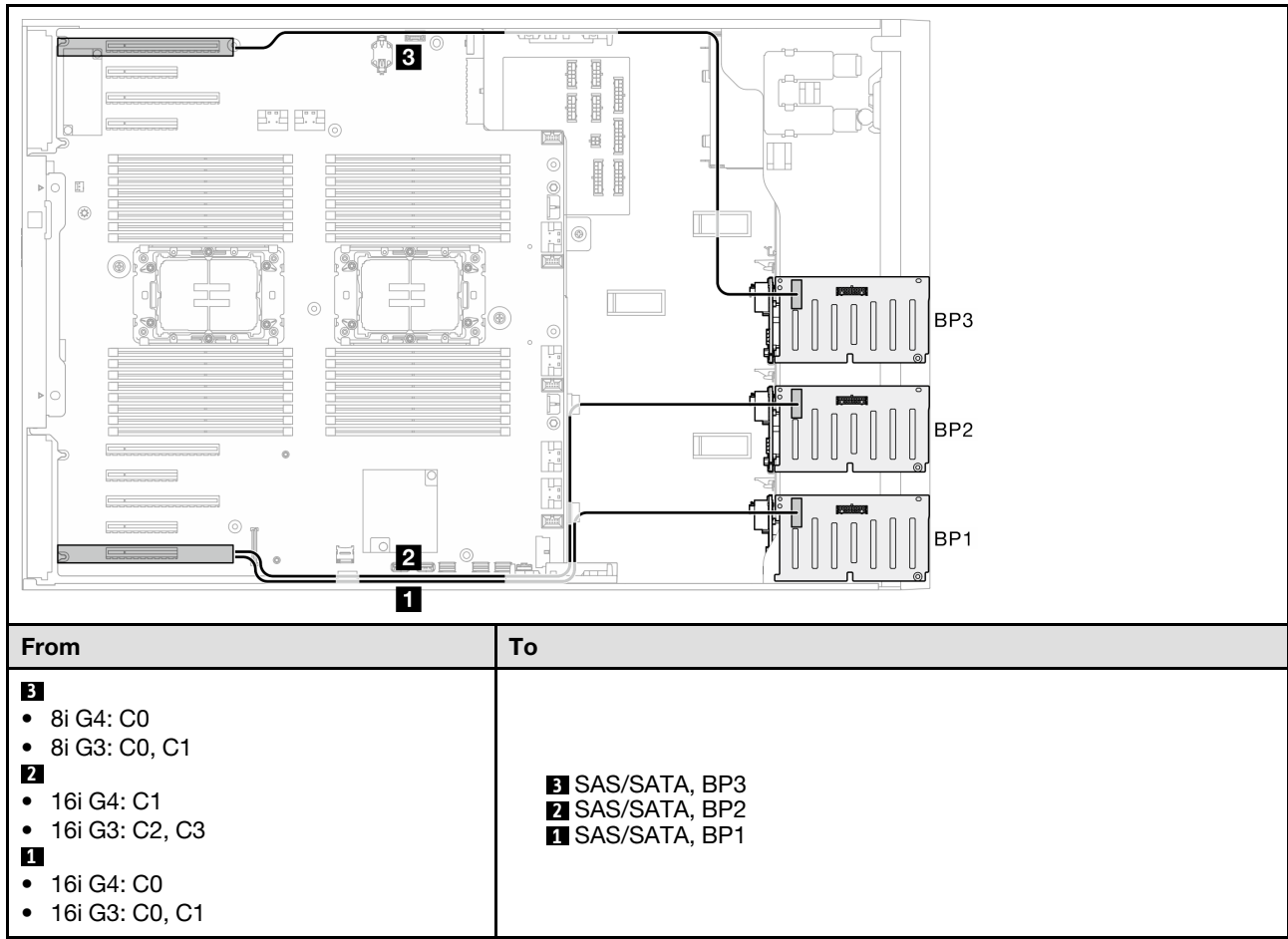

## HW 8i; 8i; 8i (BP123)

Table 73. 2.5-inch drive cable routing - HW RAID 8i; 8i; 8i (BP123)

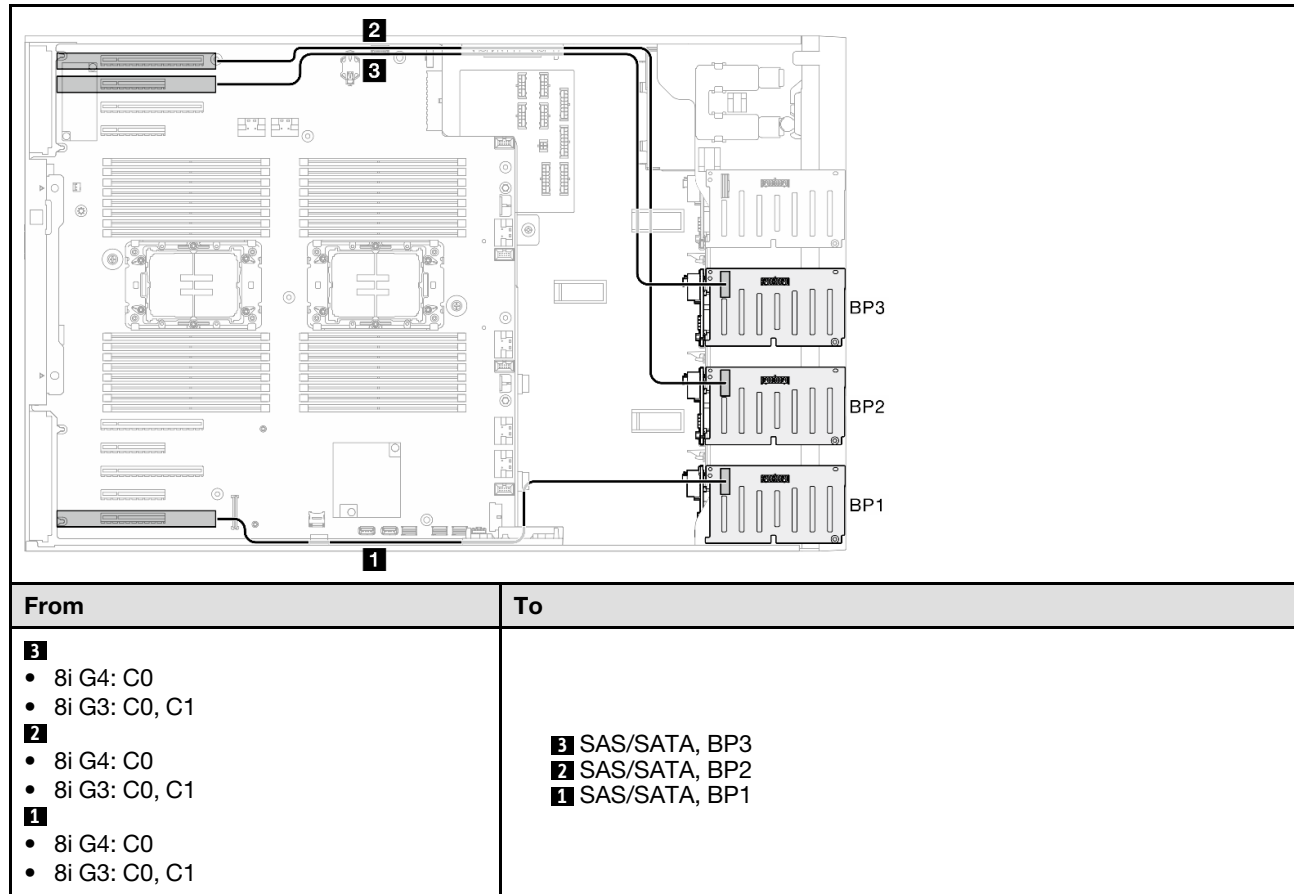



## HW 16i; 16i (BP1234)

Table 74. 2.5-inch drive cable routing - HW RAID 16i; 16i

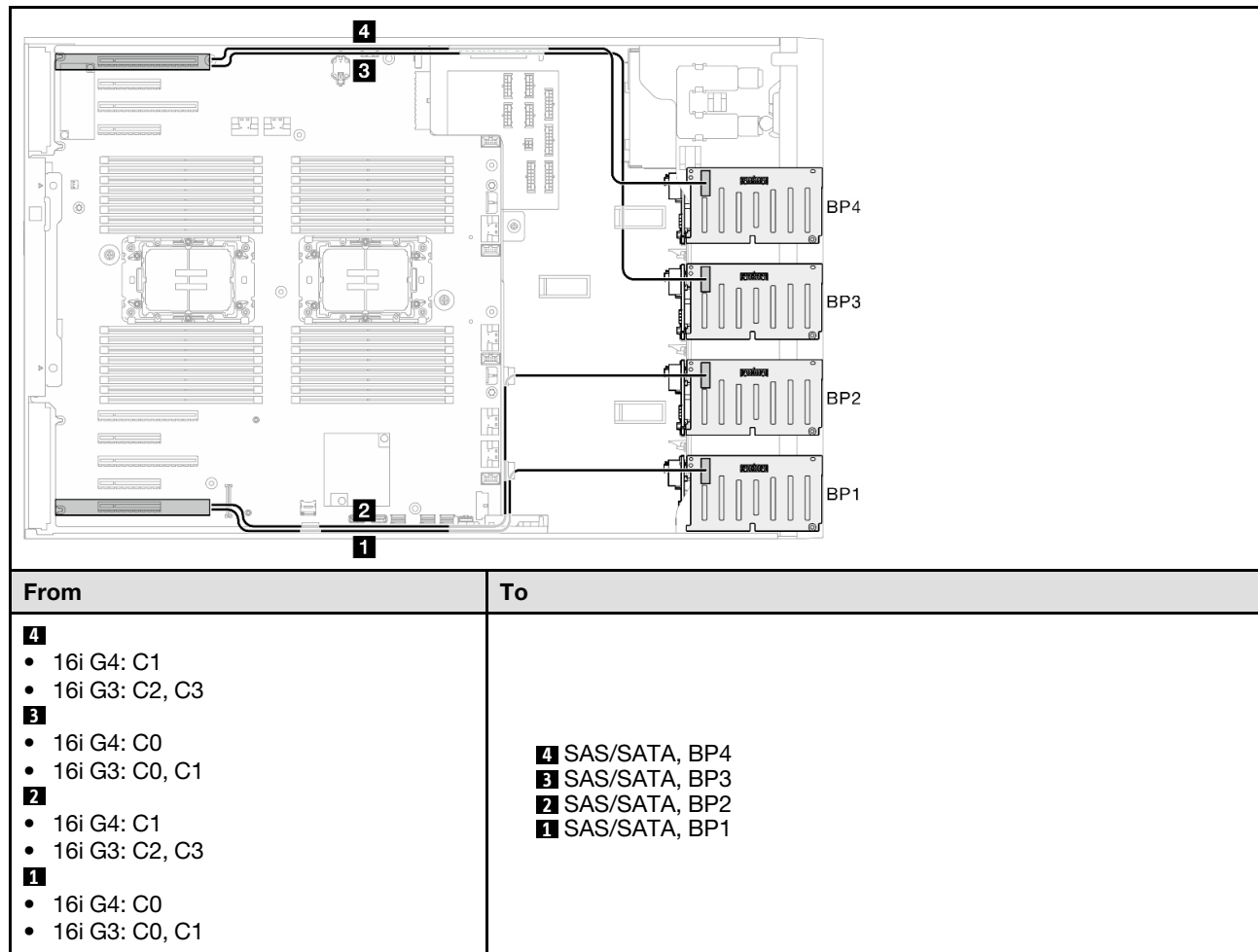

**HW 16i; 8i; 8i (BP123/BP1234)**

*Table 75. 2.5-inch drive cable routing - HW RAID 16i; 8i; 8i (BP123/BP1234)*

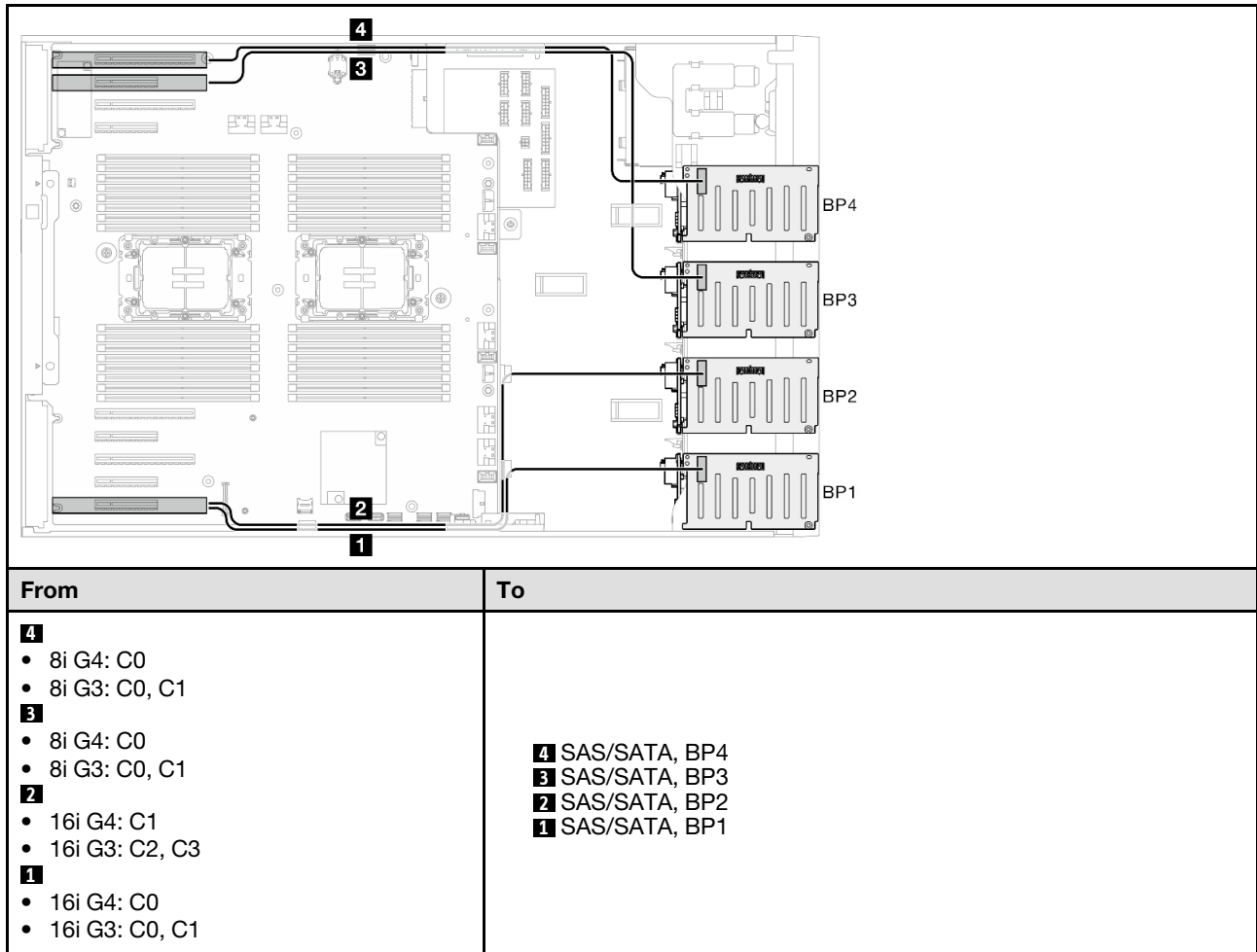

## HW 32i (BP123/BP1234)

Table 76. 2.5-inch drive cable routing - HW RAID 32i (BP123/BP1234)

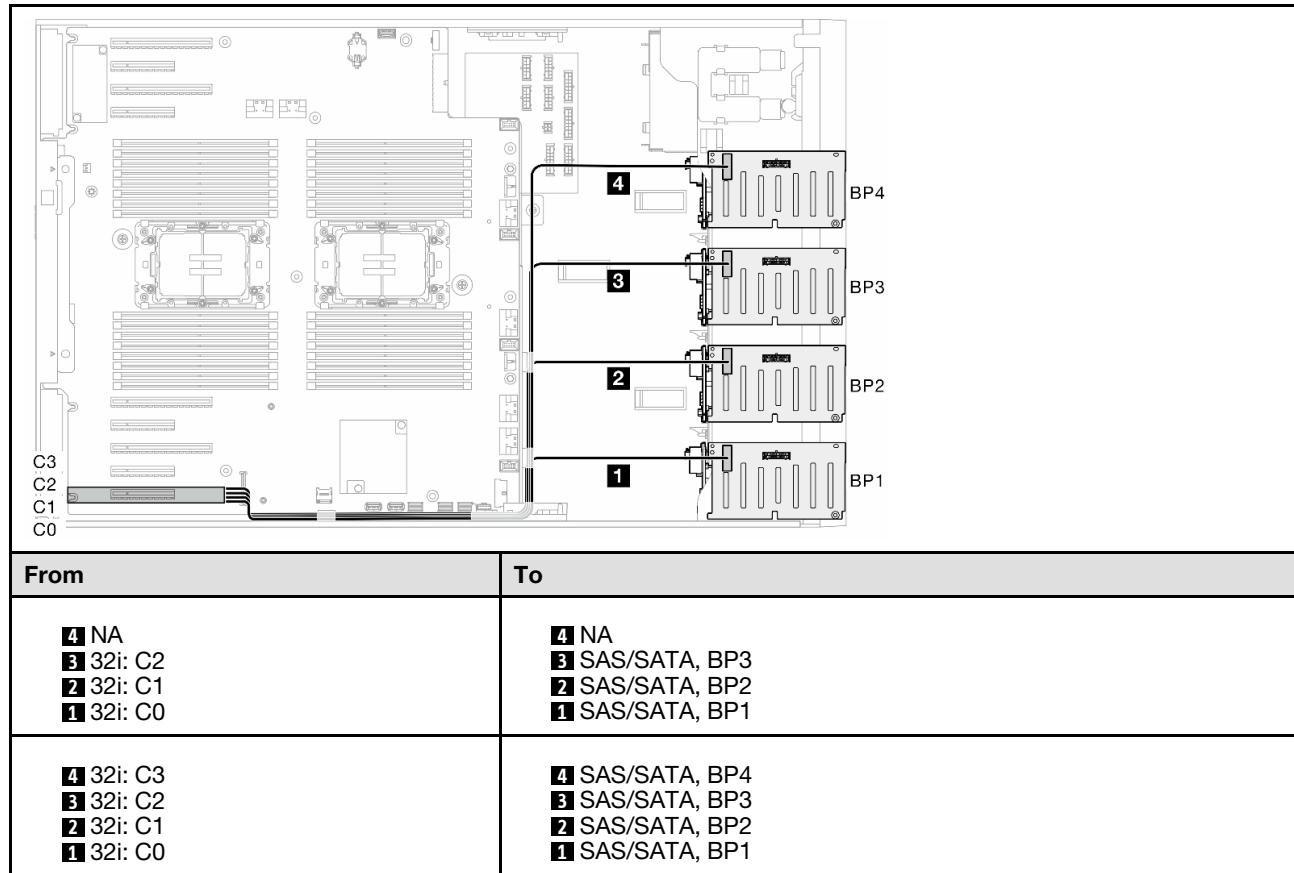

## HW 16i; CFF (BP1234)

Table 77. 2.5-inch drive cable routing - HW RAID 16i; Internal CFF RAID (BP1234)

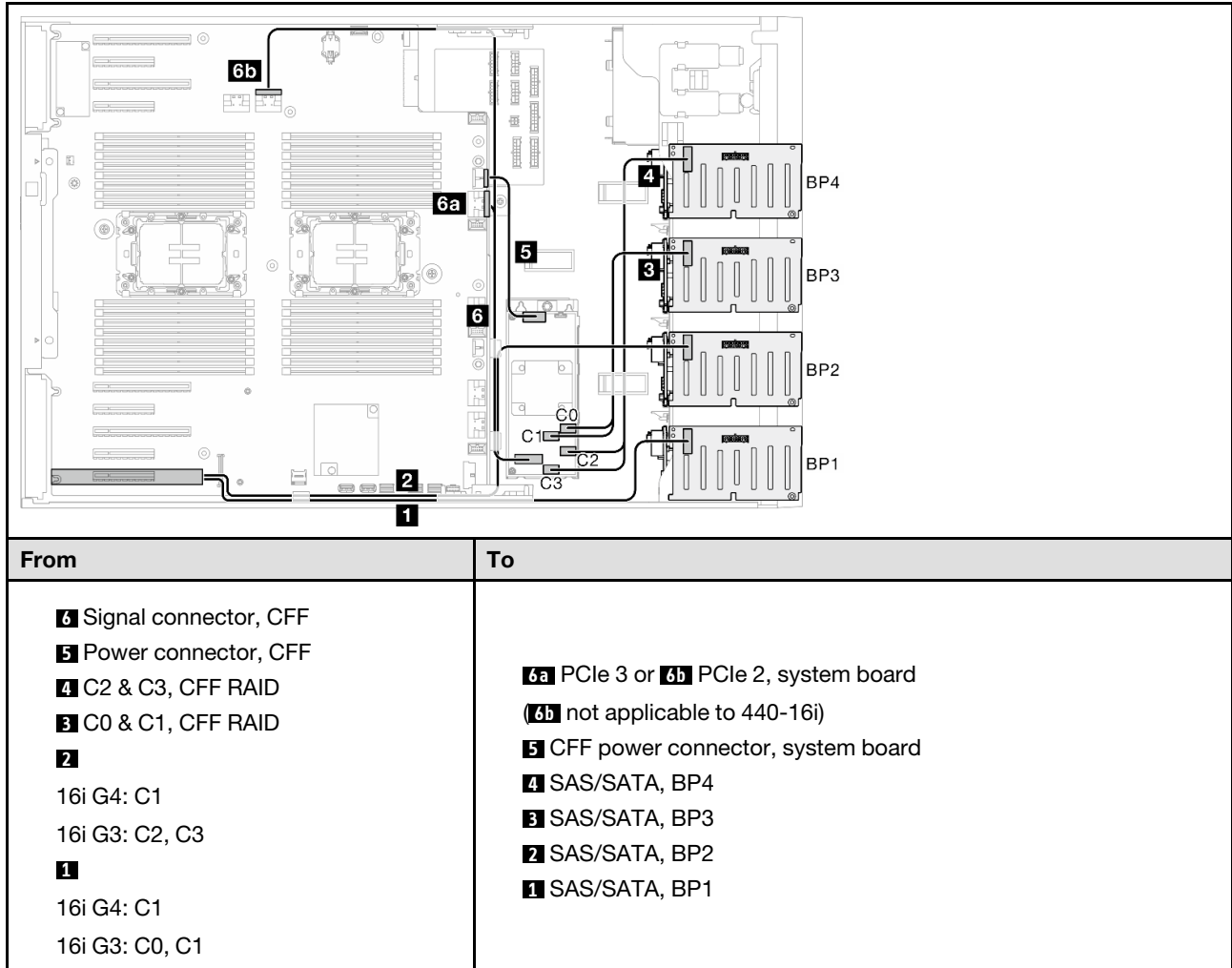

## Pure NVMe combinations

See this topic to locate the combination with NVMe drive backplanes.

### BP4

#### VROC (BP4)

Table 78. 2.5-inch drive cable routing - VROC (BP4)

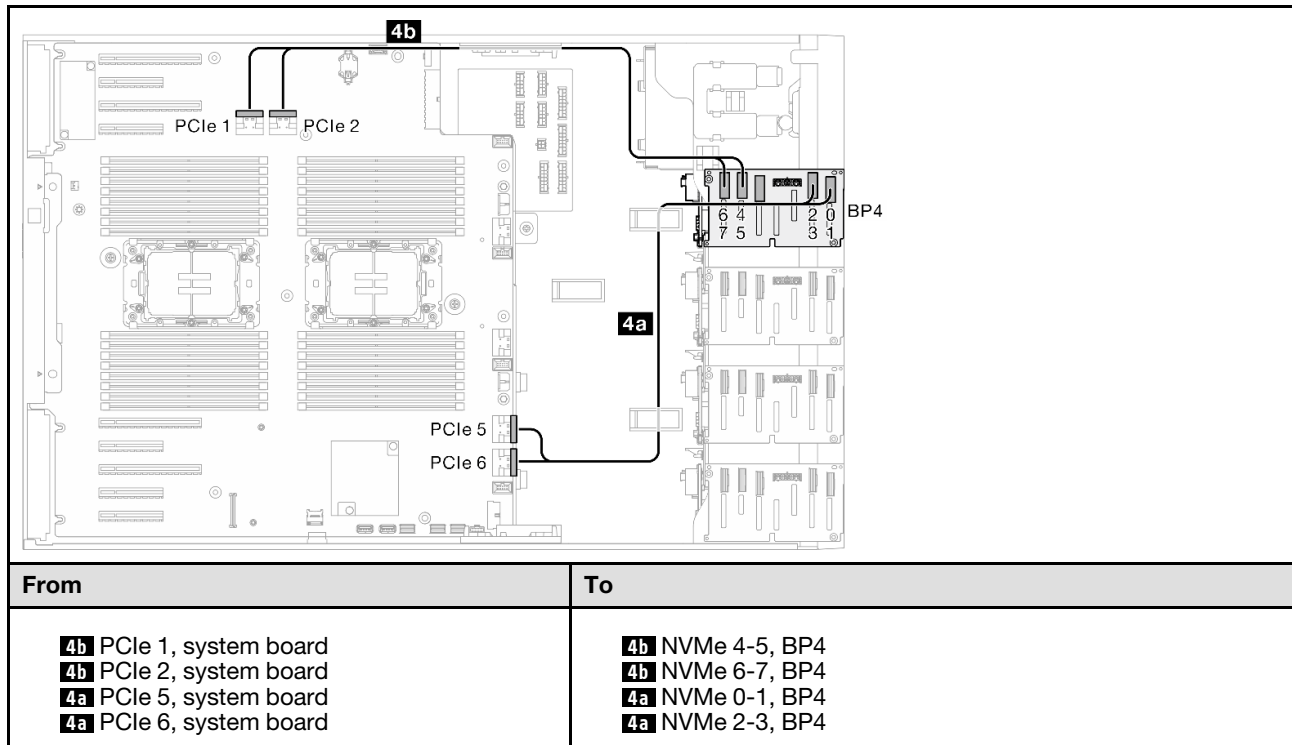

# BP34

## VROC (BP34)

Table 79. 2.5-inch drive cable routing - VROC (BP34)

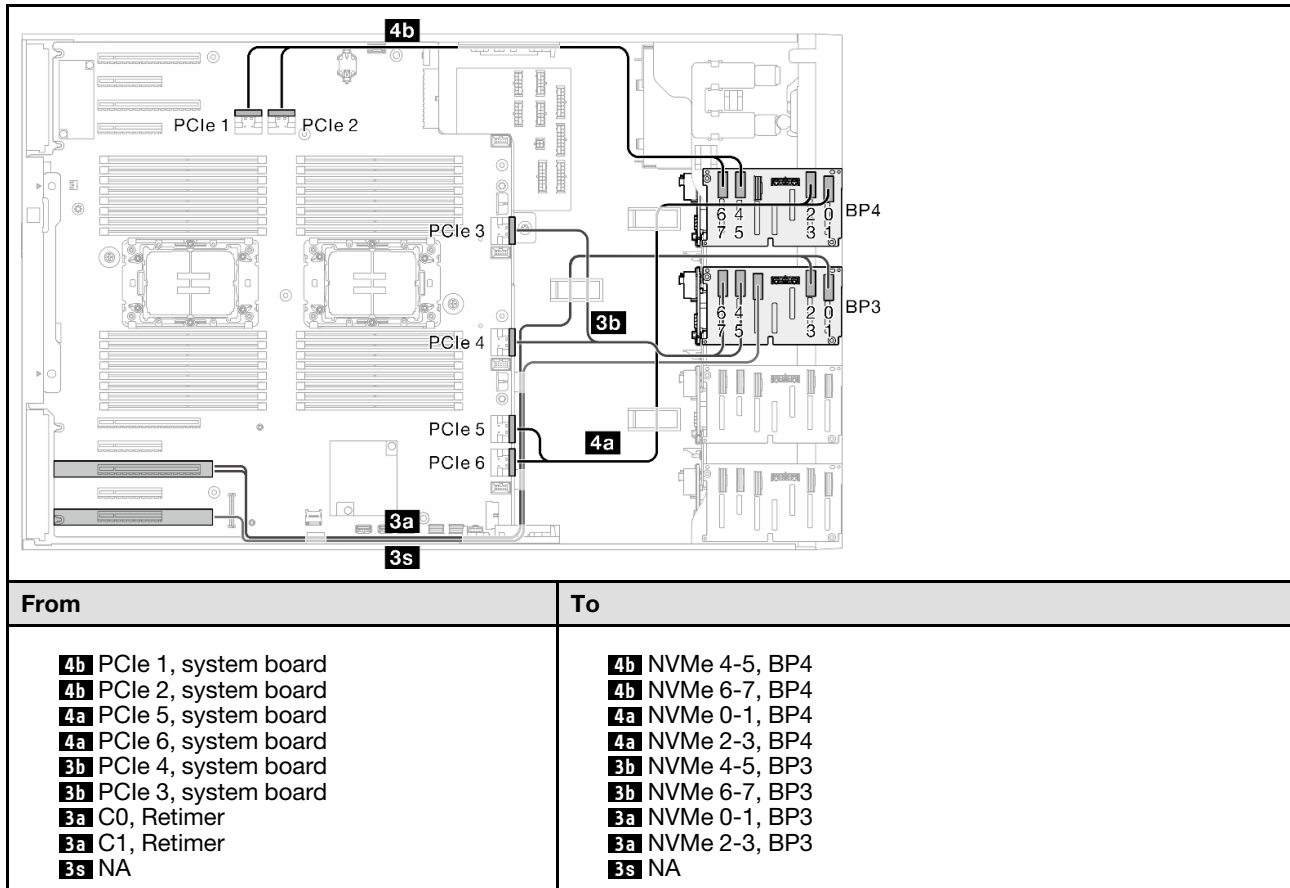

# BP234

## VROC (BP234)

Table 80. 2.5-inch drive cable routing - VROC (BP234)

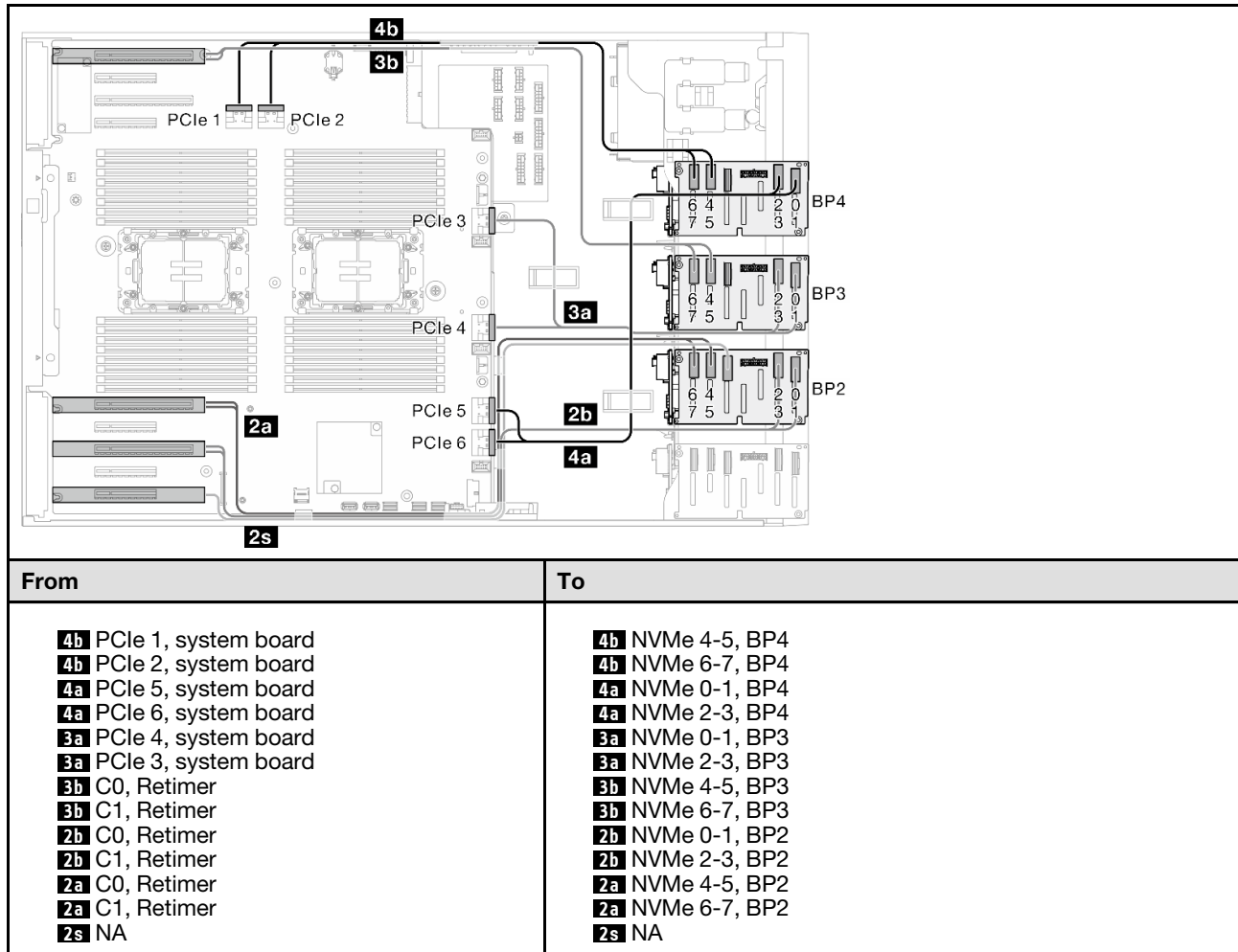

## Mixed combinations

See this topic to locate the combination with SAS/SATA and AnyBay drive backplanes.

### BP1

#### 8i (tri-mode)

Table 81. 2.5-inch drive cable routing - 8i (tri-mode)

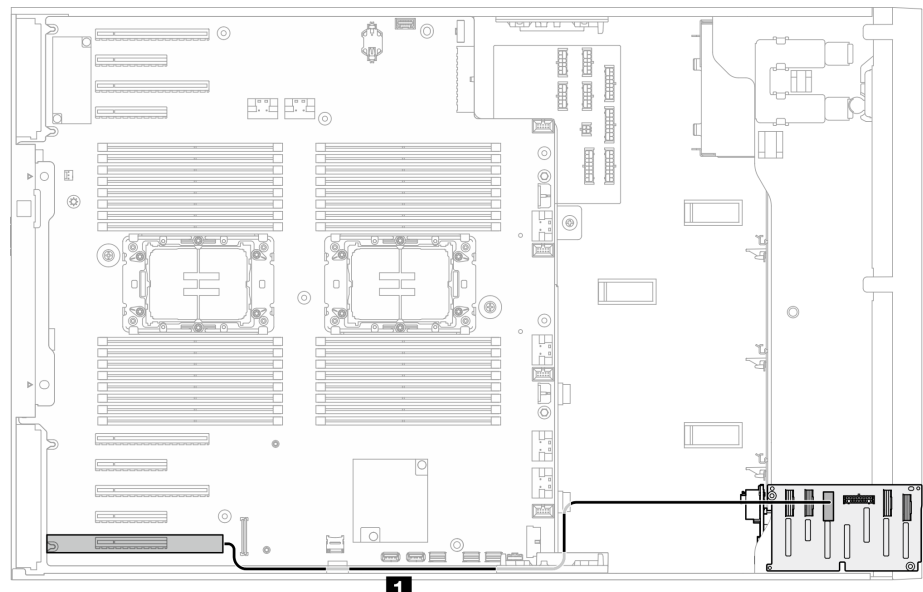

From	To	Backplanes
<b>1</b> 8i G4: C0	<b>1</b> SAS/SATA, BP1	BP1: SAS/SATA/NVMe

## BP4

### 8i (BP4); VROC (BP4)

Table 82. 2.5-inch drive cable routing - 8i (BP4); VROC (BP4)

From	To	Backplanes
<p><b>4b</b> PCIe 1, system board</p> <p><b>4b</b> PCIe 2, system board</p> <p><b>4a</b> PCIe 5, system board</p> <p><b>4a</b> PCIe 6, system board</p> <p><b>4s</b></p> <p>8i G4: C0</p> <p>8i G3: C0, C1</p>	<p><b>4b</b> NVMe 4-5, BP4</p> <p><b>4b</b> NVMe 6-7, BP4</p> <p><b>4a</b> NVMe 0-1, BP4</p> <p><b>4a</b> NVMe 2-3, BP4</p> <p><b>4s</b> SAS/SATA, BP4</p>	<p><b>BP4: SAS/SATA/NVMe</b></p> <p>BP3: empty</p> <p>BP2: empty</p> <p>BP1: empty</p>

## BP12

### 16i (tri-mode)

Table 83. 2.5-inch drive cable routing - 16i (tri-mode)

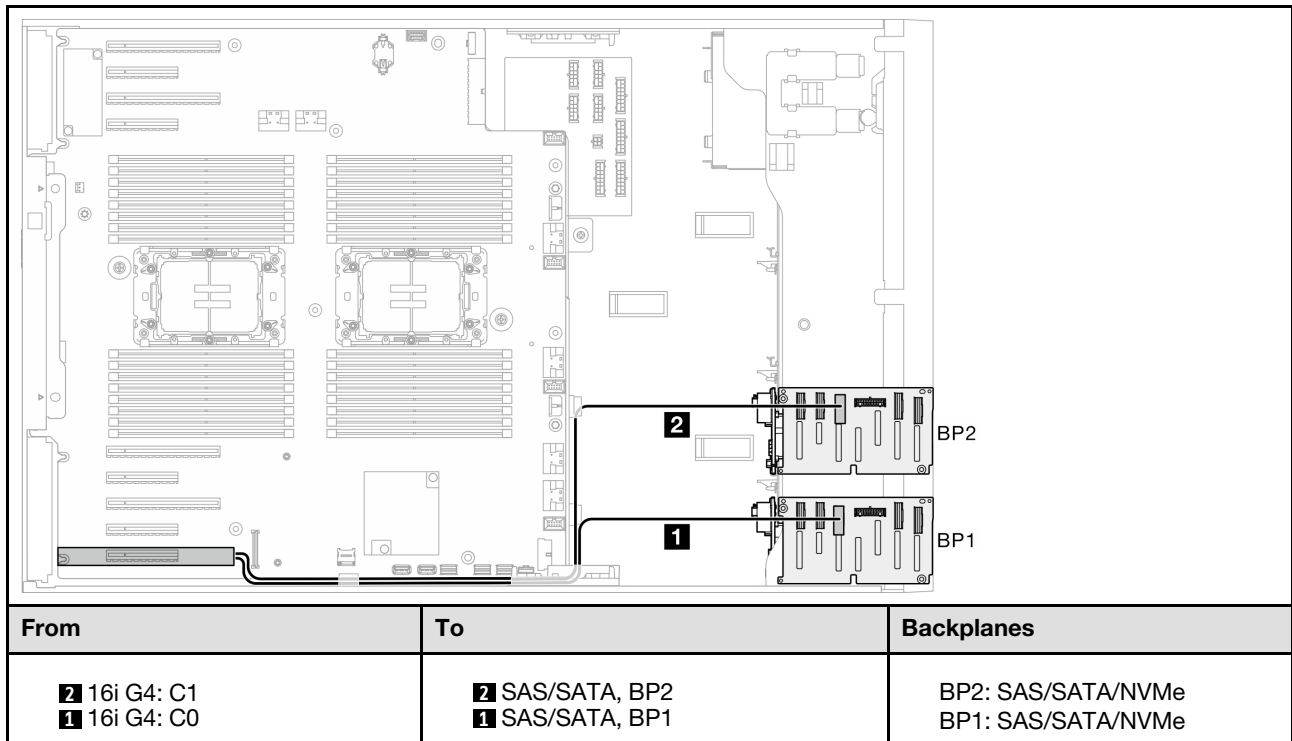

## BP34

### 8i (BP3); VROC (BP34)

Table 84. 2.5-inch drive cable routing - 8i (BP3); VROC (BP34)

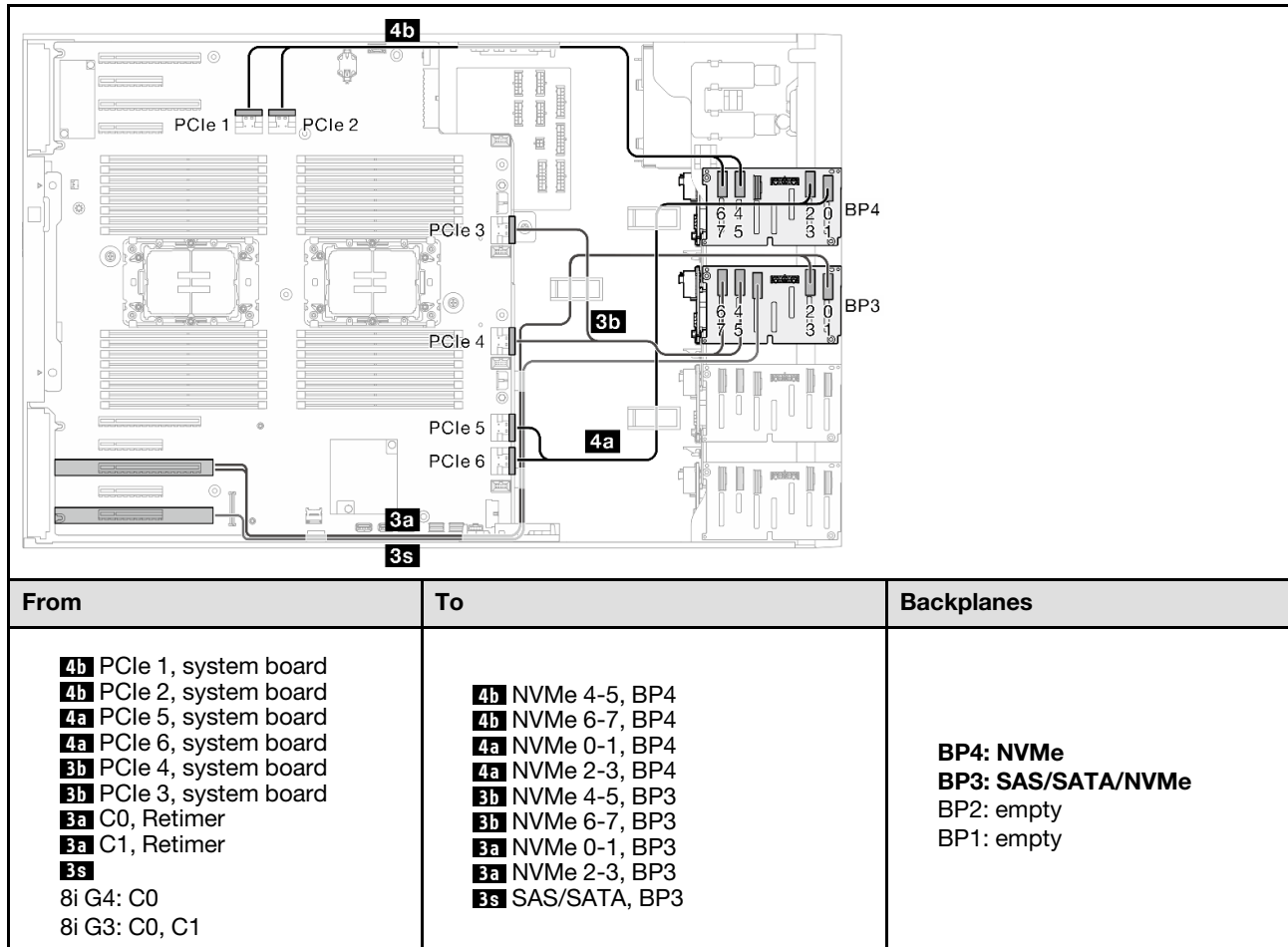

# BP14

8i (BP1); 8i (BP4); VROC (BP4)

Table 85. 2.5-inch drive cable routing - 8i (BP1); 8i (BP4); VROC (BP4)

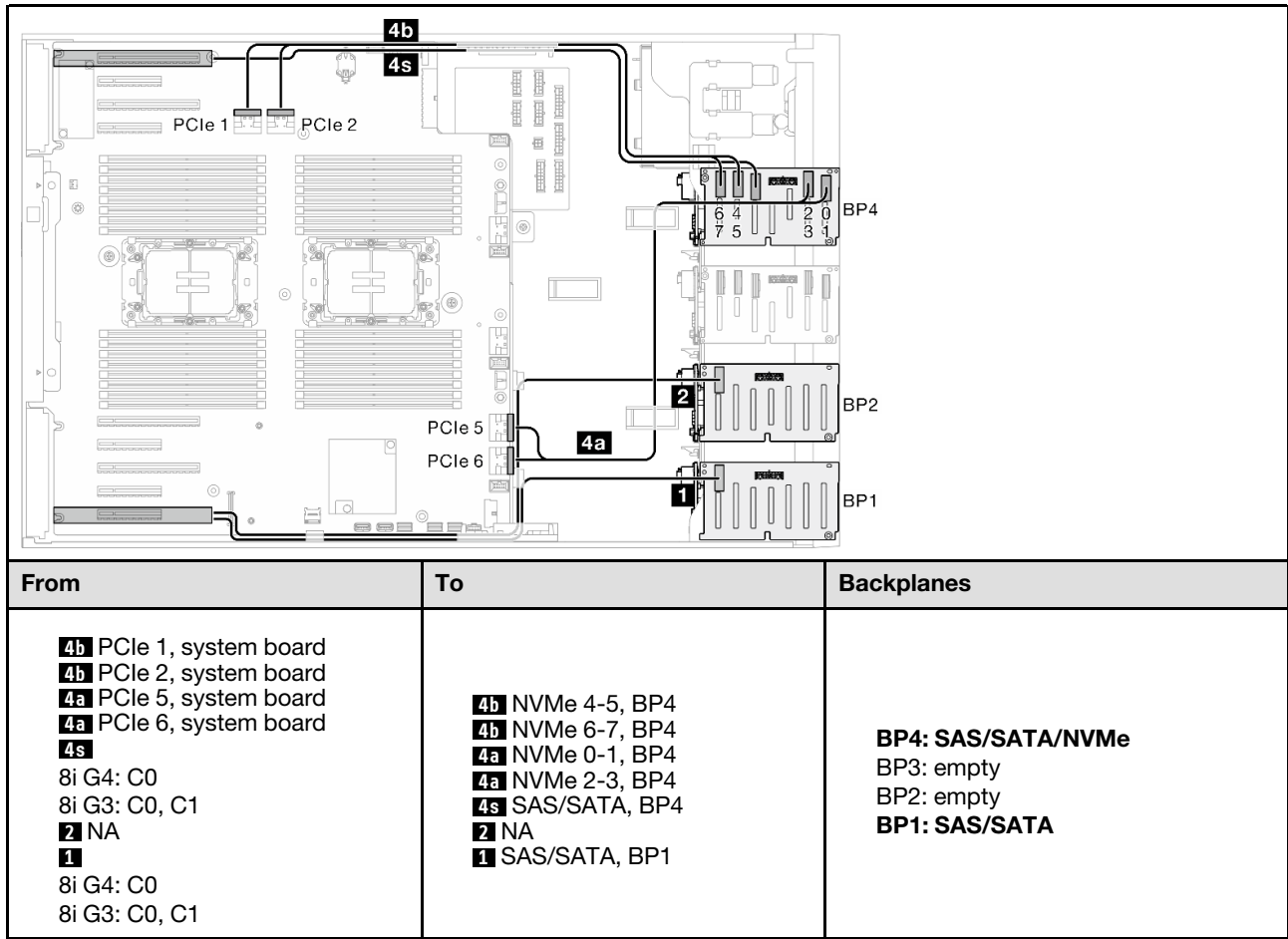

**16i (BP14); VROC (BP4)**

Table 86. 2.5-inch drive cable routing - 16i (BP14); VROC (BP4)

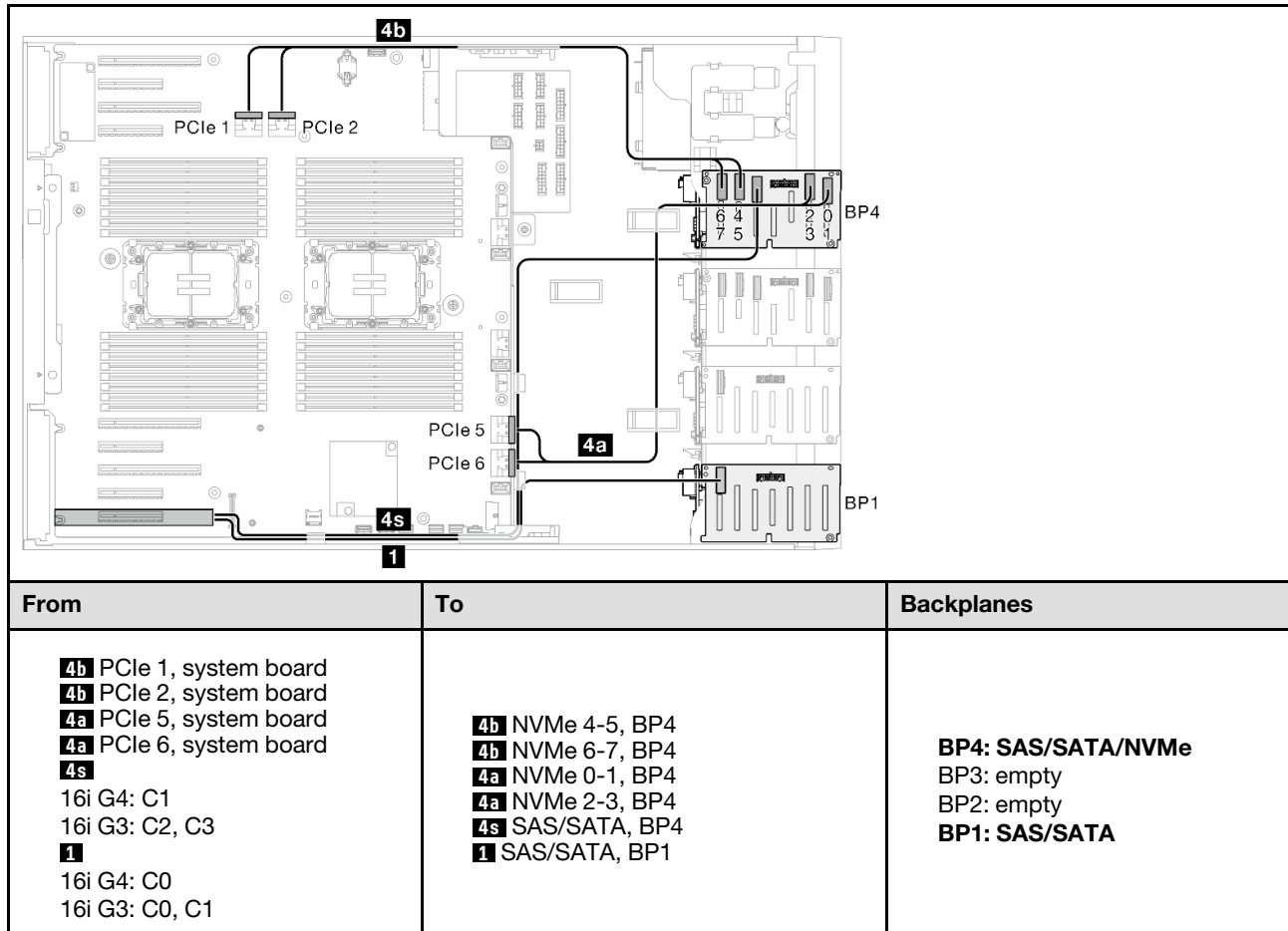

# BP234

## 8i (BP2); VROC (BP234)

Table 87. 2.5-inch drive cable routing - 8i (BP2); VROC (BP234)

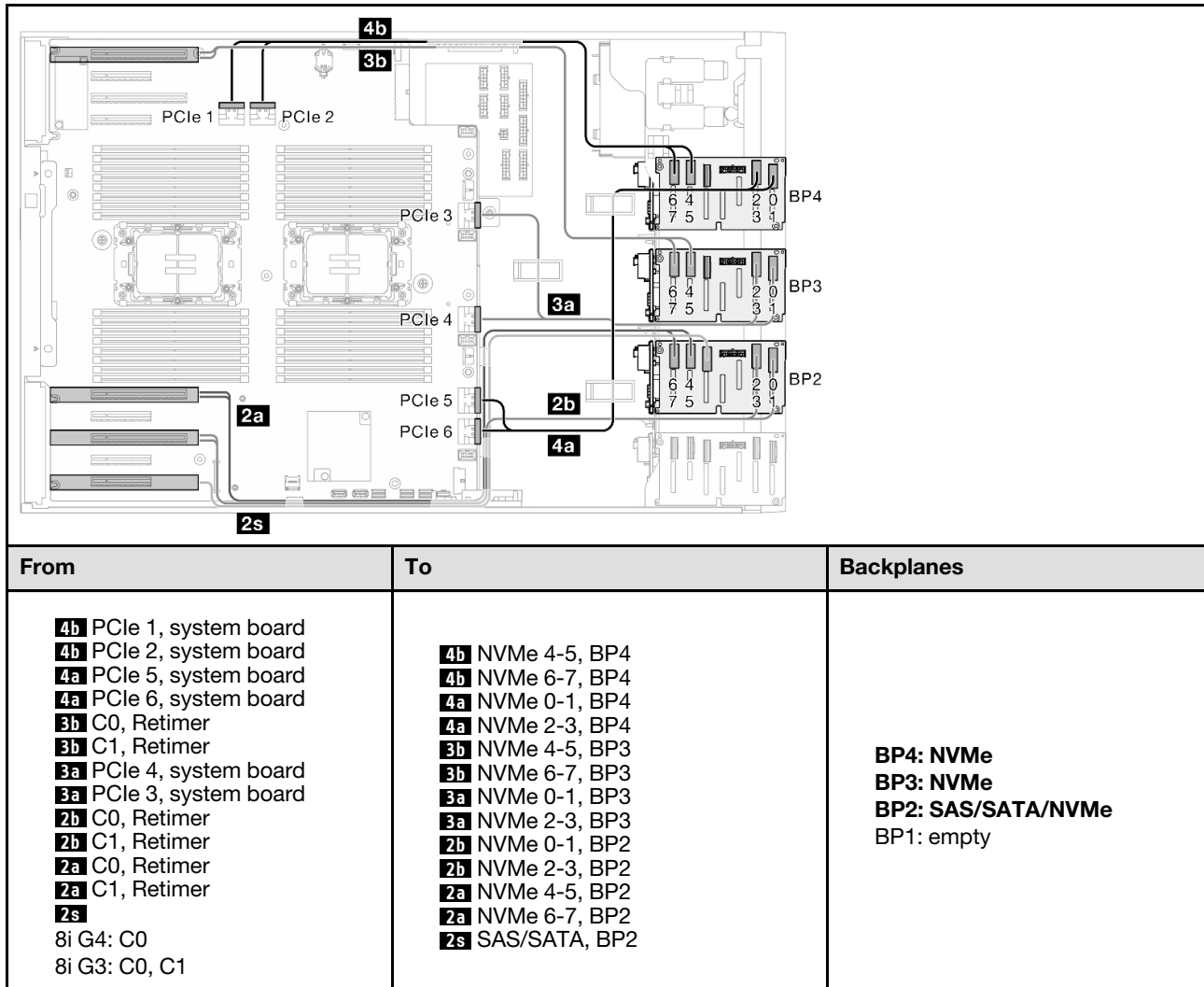

# BP124

16i (BP12); 8i (BP4); VROC (BP4)

Table 88. 2.5-inch drive cable routing - 16i (BP12); 8i (BP4); VROC (BP4)

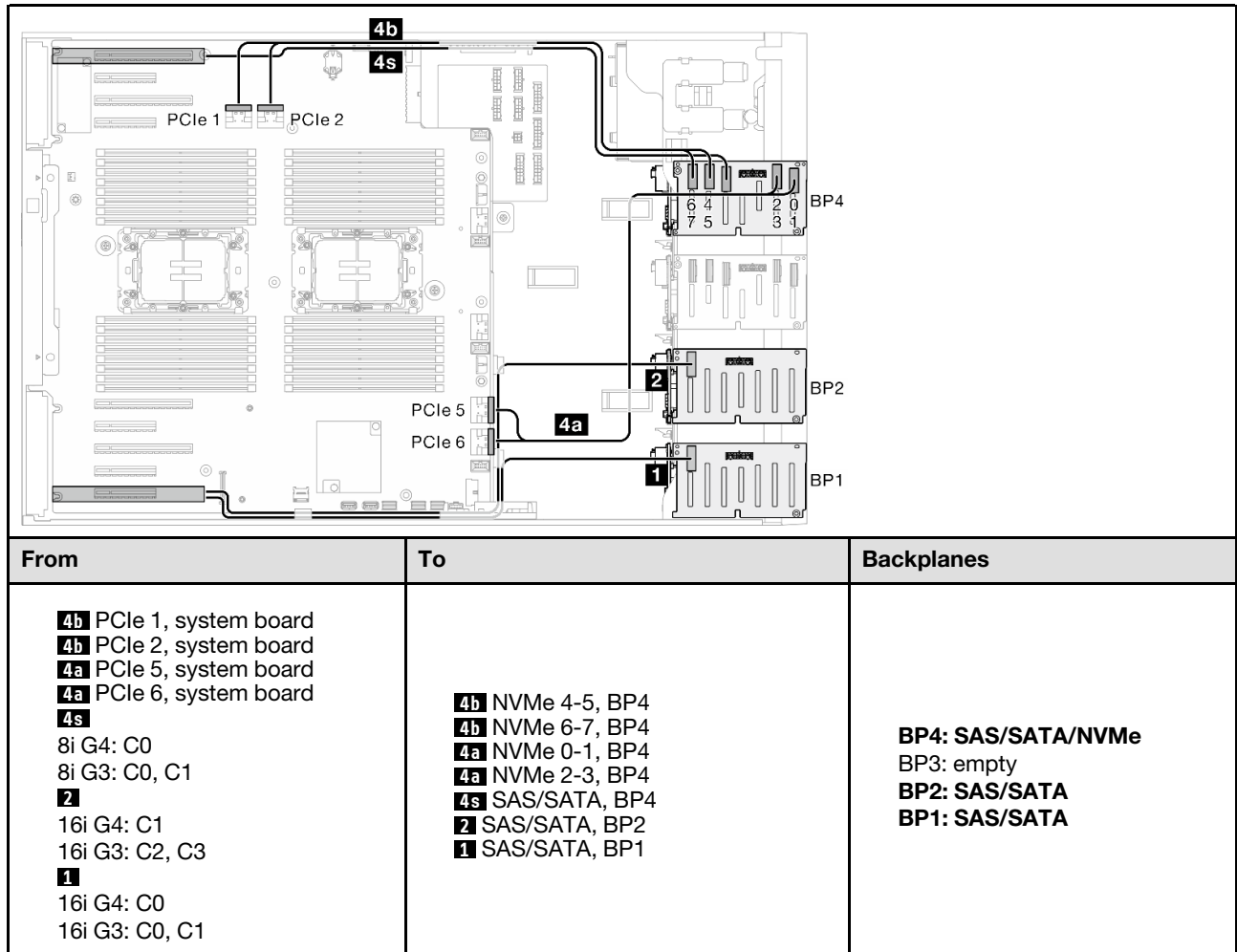

## 8i (BP124); VROC (BP4)

Table 89. 2.5-inch drive cable routing - 8i (BP124); VROC (BP4)

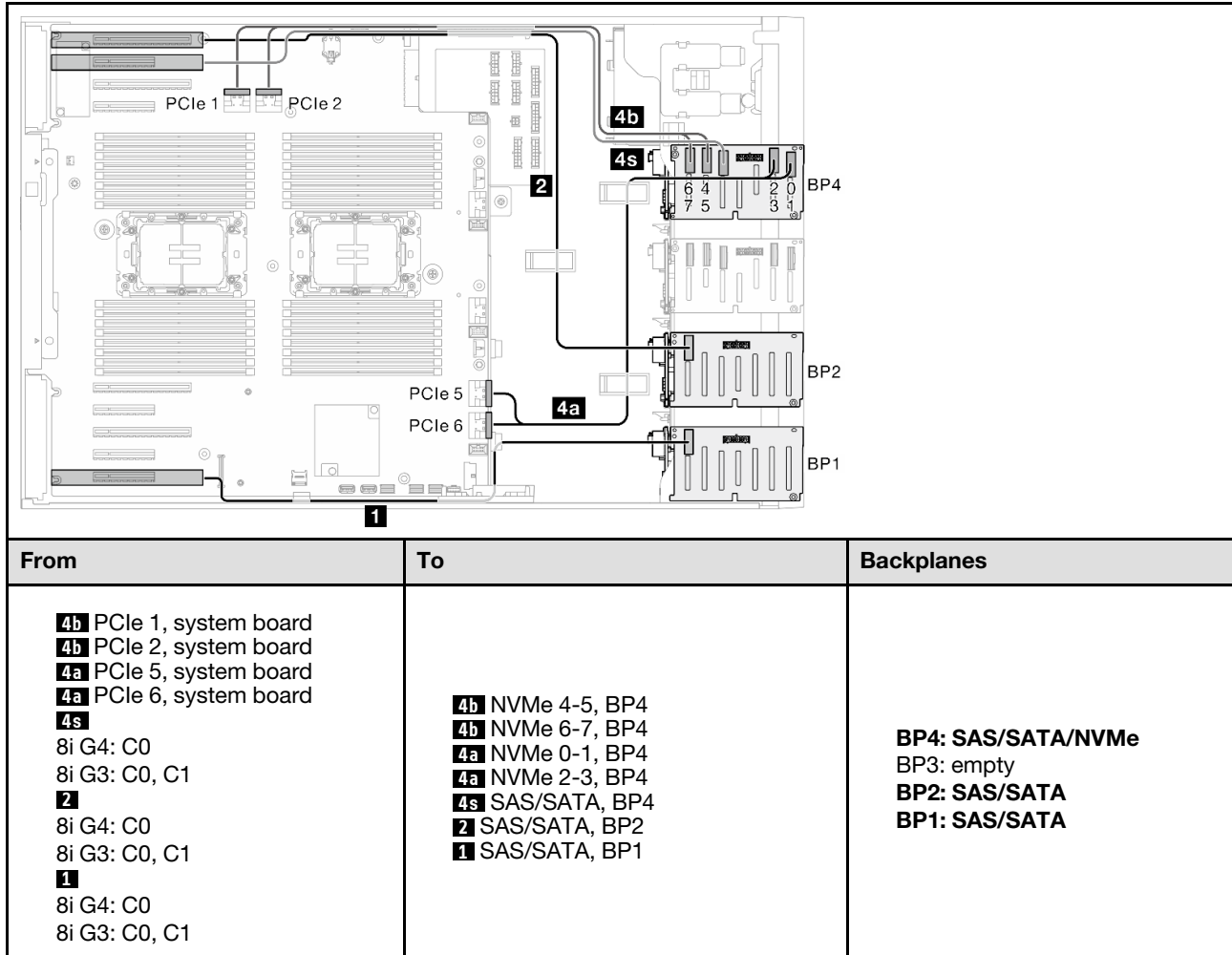

### 32i (BP124); VROC (BP4)

Table 90. 2.5-inch drive cable routing - 32i (BP124); VROC (BP4)

<p style="text-align: right;"><b>NVMe drives</b></p>		
From	To	Backplanes
<p><b>4b</b> PCIe 1, system board</p> <p><b>4b</b> PCIe 2, system board</p> <p><b>4a</b> PCIe 5, system board</p> <p><b>4a</b> PCIe 6, system board</p>	<p><b>4b</b> NVMe 4-5, BP4</p> <p><b>4b</b> NVMe 6-7, BP4</p> <p><b>4a</b> NVMe 0-1, BP4</p> <p><b>4a</b> NVMe 2-3, BP4</p>	<p><b>BP4: SAS/SATA/NVMe</b></p> <p>BP3: empty</p> <p>BP2: SAS/SATA</p> <p>BP1: SAS/SATA</p>
<p style="text-align: right;"><b>SAS/SATA drives</b></p>		
From	To	Backplanes
<p><b>4</b> 32i: C3</p> <p><b>3</b> NA</p> <p><b>2</b> 32i: C1</p> <p><b>1</b> 32i: C0</p>	<p><b>4</b> SAS/SATA, BP4</p> <p><b>3</b> NA</p> <p><b>2</b> SAS/SATA, BP2</p> <p><b>1</b> SAS/SATA, BP1</p>	<p><b>BP4: SAS/SATA/NVMe</b></p> <p>BP3: empty</p> <p><b>BP2: SAS/SATA</b></p> <p><b>BP1: SAS/SATA</b></p>

# BP1234

16i (BP12); 8i (BP34); VROC (BP4)

Table 91. 2.5-inch drive cable routing - 16i (BP12); 8i (BP34); VROC (BP4)

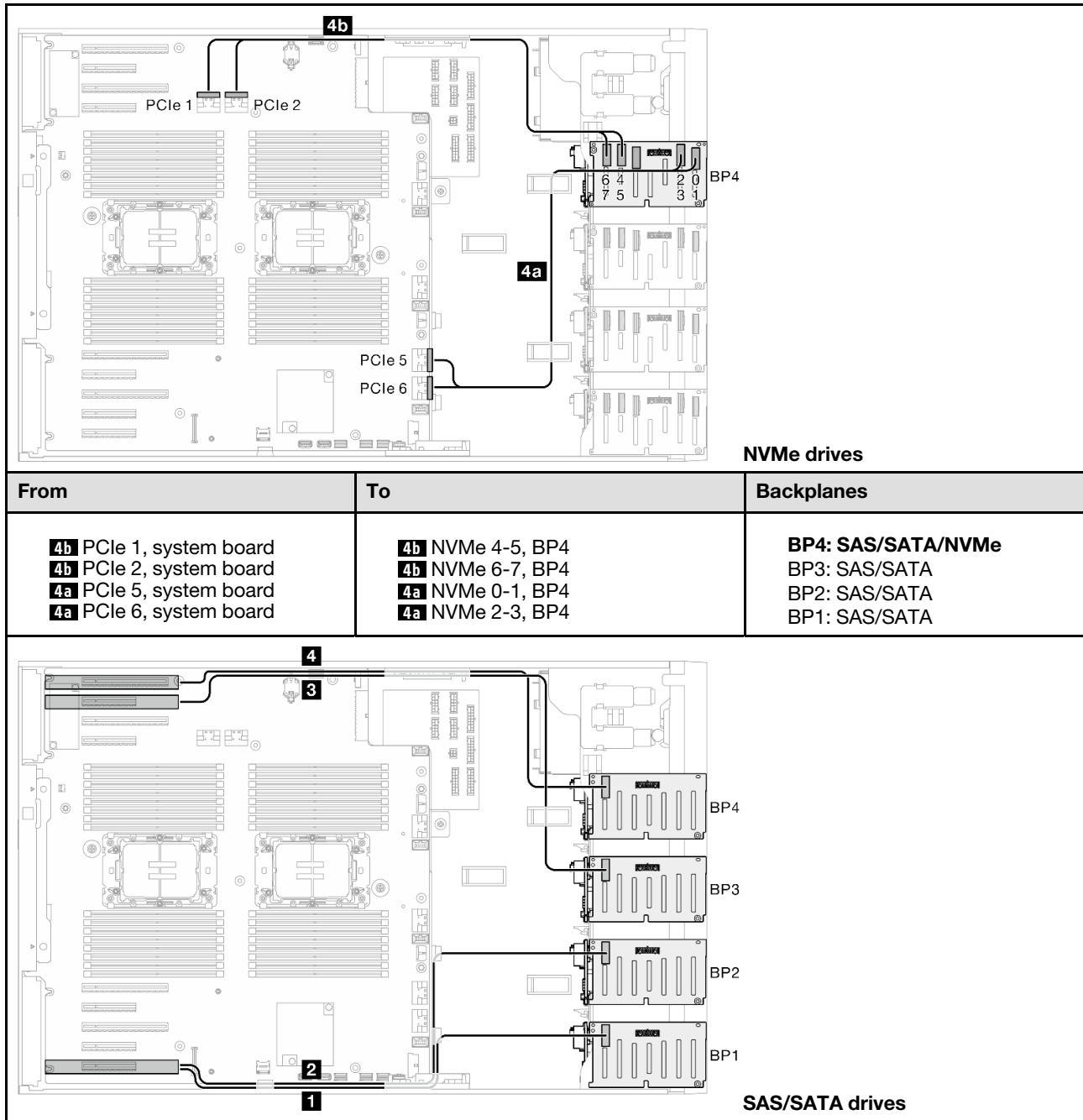

Table 91. 2.5-inch drive cable routing - 16i (BP12); 8i (BP34); VROC (BP4) (continued)

From	To	Backplanes
<p><b>4</b></p> <ul style="list-style-type: none"> <li>8i G4: C0</li> <li>8i G3: C0, C1</li> </ul> <p><b>3</b></p> <ul style="list-style-type: none"> <li>8i G4: C0</li> <li>8i G3: C0, C1</li> </ul> <p><b>2</b></p> <ul style="list-style-type: none"> <li>16i G4: C1</li> <li>16i G3: C2, C3</li> </ul> <p><b>1</b></p> <ul style="list-style-type: none"> <li>16i G4: C0</li> <li>16i G3: C0, C1</li> </ul>	<p><b>4</b> SAS/SATA, BP4</p> <p><b>3</b> SAS/SATA, BP3</p> <p><b>2</b> SAS/SATA, BP2</p> <p><b>1</b> SAS/SATA, BP1</p>	<p><b>BP4: SAS/SATA/NVMe</b></p> <p><b>BP3: SAS/SATA</b></p> <p><b>BP2: SAS/SATA</b></p> <p><b>BP1: SAS/SATA</b></p>

**16i (BP12); 16i (BP34); VROC (BP4)**

Table 92. 2.5-inch drive cable routing - 16i (BP12); 16i (BP34); VROC (BP4)

<p>The diagram shows a top-down view of a server system board. On the left, there are two PCIe slots labeled PCIe 1 and PCIe 2. Below them are PCIe 5 and PCIe 6. On the right, there is a backplane labeled BP4 with eight NVMe drive slots numbered 0 through 7. Cable routing paths are shown: path 4b connects PCIe 1 and 2 to NVMe slots 4-5 and 6-7; path 4a connects PCIe 5 and 6 to NVMe slots 0-1 and 2-3.</p>		
		<b>NVMe drives</b>
From	To	Backplanes
<p><b>4b</b> PCIe 1, system board</p> <p><b>4b</b> PCIe 2, system board</p> <p><b>4a</b> PCIe 5, system board</p> <p><b>4a</b> PCIe 6, system board</p>	<p><b>4b</b> NVMe 4-5, BP4</p> <p><b>4b</b> NVMe 6-7, BP4</p> <p><b>4a</b> NVMe 0-1, BP4</p> <p><b>4a</b> NVMe 2-3, BP4</p>	<p><b>BP4: SAS/SATA/NVMe</b></p> <p><b>BP3: SAS/SATA</b></p> <p><b>BP2: SAS/SATA</b></p> <p><b>BP1: SAS/SATA</b></p>

Table 92. 2.5-inch drive cable routing - 16i (BP12); 16i (BP34); VROC (BP4) (continued)

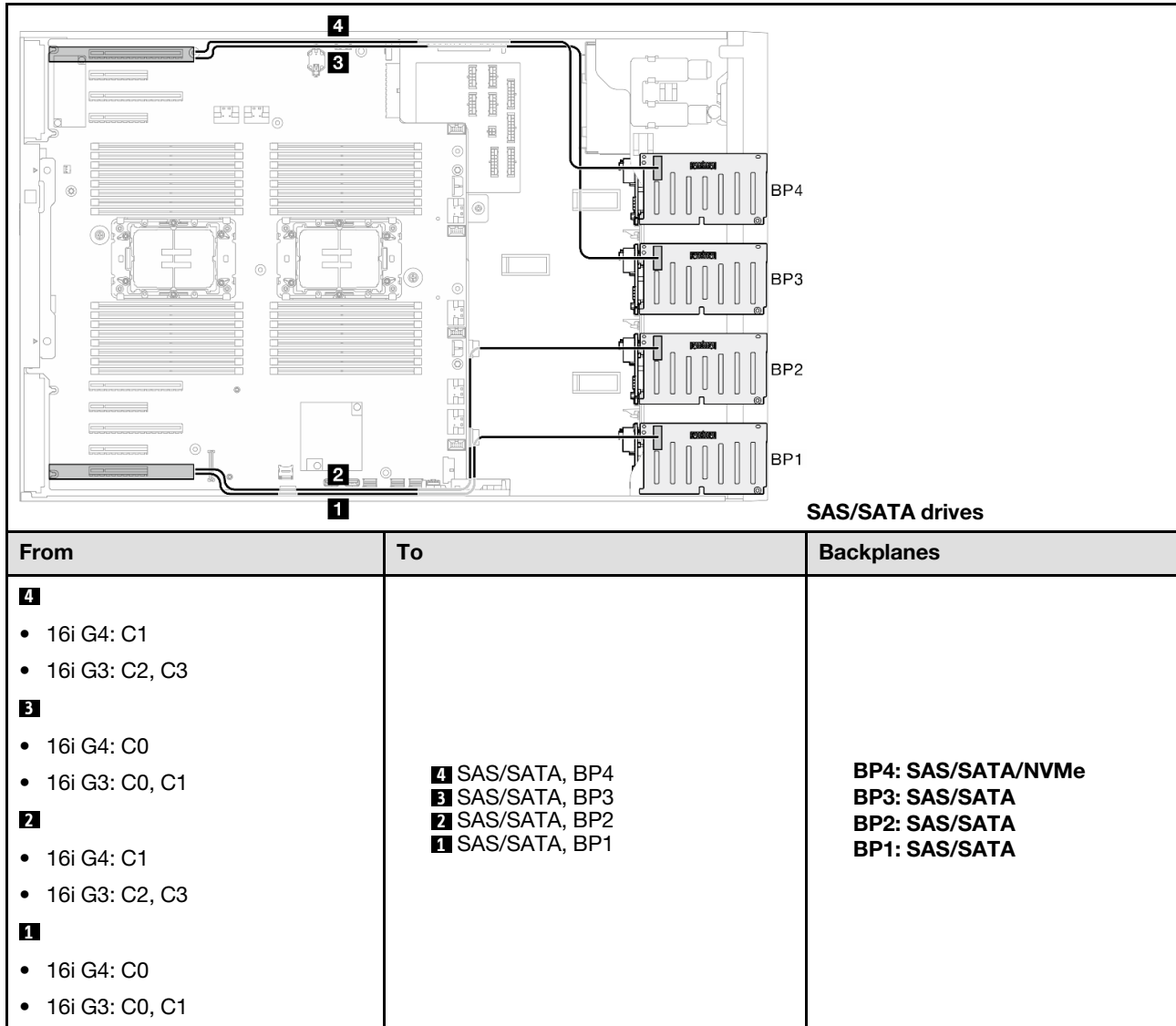

### 32i (BP1234); VROC (BP4)

Table 93. 2.5-inch drive cable routing - 32i (BP1234); VROC (BP4)

<b>NVMe drives</b>		
From	To	Backplanes
<ul style="list-style-type: none"> <li><b>4b</b> PCIe 1, system board</li> <li><b>4b</b> PCIe 2, system board</li> <li><b>4a</b> PCIe 5, system board</li> <li><b>4a</b> PCIe 6, system board</li> </ul>	<ul style="list-style-type: none"> <li><b>4b</b> NVMe 4-5, BP4</li> <li><b>4b</b> NVMe 6-7, BP4</li> <li><b>4a</b> NVMe 0-1, BP4</li> <li><b>4a</b> NVMe 2-3, BP4</li> </ul>	<ul style="list-style-type: none"> <li><b>BP4: SAS/SATA/NVMe</b></li> <li><b>BP3: SAS/SATA</b></li> <li><b>BP2: SAS/SATA</b></li> <li><b>BP1: SAS/SATA</b></li> </ul>
<b>SAS/SATA drives</b>		
From	To	Backplanes
<ul style="list-style-type: none"> <li><b>4</b> 32i: C3</li> <li><b>3</b> 32i: C2</li> <li><b>2</b> 32i: C1</li> <li><b>1</b> 32i: C0</li> </ul>	<ul style="list-style-type: none"> <li><b>4</b> SAS/SATA, BP4</li> <li><b>3</b> SAS/SATA, BP3</li> <li><b>2</b> SAS/SATA, BP2</li> <li><b>1</b> SAS/SATA, BP1</li> </ul>	<ul style="list-style-type: none"> <li><b>BP4: SAS/SATA/NVMe</b></li> <li><b>BP3: SAS/SATA</b></li> <li><b>BP2: SAS/SATA</b></li> <li><b>BP1: SAS/SATA</b></li> </ul>

**16i (BP12); CFF (BP34); VROC (BP4)**

Table 94. 2.5-inch drive cable routing - 16i (BP12); CFF (BP34); VROC (BP4)

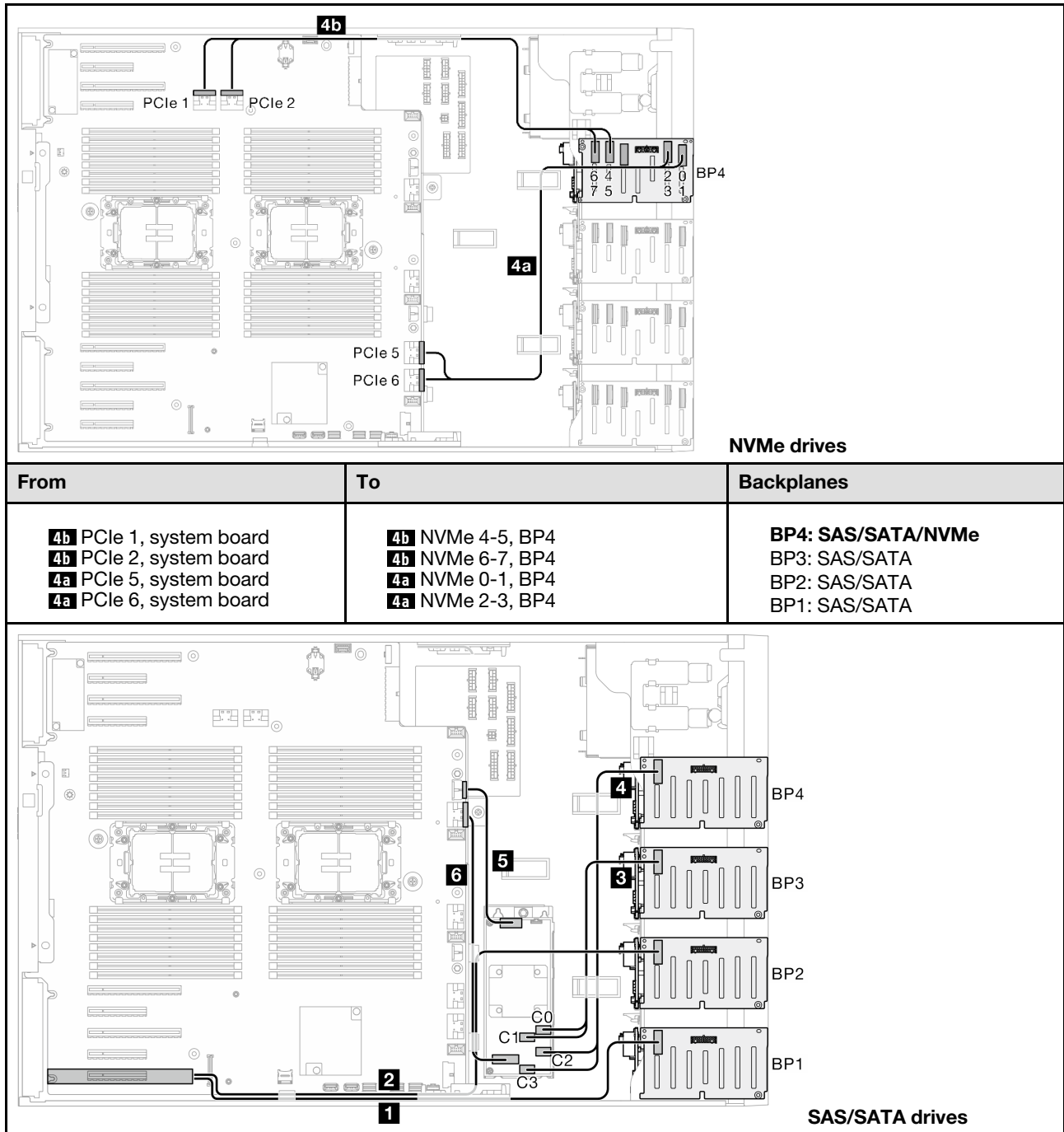

Table 94. 2.5-inch drive cable routing - 16i (BP12); CFF (BP34); VROC (BP4) (continued)

From	To	Backplanes
<b>6</b> Signal connector, CFF <b>5</b> Power connector, CFF <b>4</b> C2 & C3, CFF RAID <b>3</b> C0 & C1, CFF RAID <b>2</b> 16i G4: C1 16i G3: C2, C3 <b>1</b> 16i G4: C0 16i G3: C0, C1	<b>6</b> PCIe 3, system board <b>5</b> CFF power connector, system board <b>4</b> SAS/SATA, BP4 <b>3</b> SAS/SATA, BP3 <b>2</b> SAS/SATA, BP2 <b>1</b> SAS/SATA, BP1	<b>BP4: SAS/SATA/NVMe</b> <b>BP3: SAS/SATA</b> <b>BP2: SAS/SATA</b> <b>BP1: SAS/SATA</b>

## GPU cable routing

Use this section to understand the cable routing for the GPU.

**Important:** If the label on the GPU power cable shows connector information different from the illustration and table in this section, follow the instructions here.

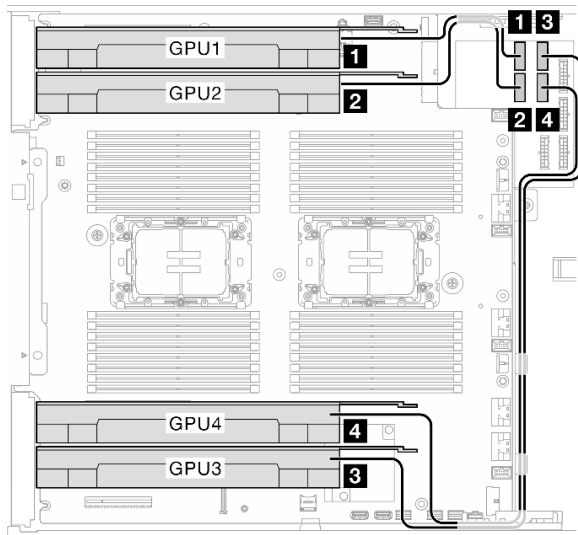

Figure 166. Cable routing for GPU

From Power connector	To power distribution board	Cable length
<b>1</b> GPU 1 (PCIe slot 1)	GPU 1 power connector	320 mm
<b>2</b> GPU 2 (PCIe slot 3)	GPU 2 power connector	320 mm
<b>3</b> GPU 3 (PCIe slot 7)	GPU 3 power connector	660 mm

From Power connector	To power distribution board	Cable length
4 GPU 4 (PCIe slot 5)	GPU 4 power connector	660 mm
<p><b>Notes:</b></p> <ul style="list-style-type: none"> <li>• Depending on the GPU model, the information provided in the label of the GPU power cable might not match the connectors on the power distribution board.</li> <li>• Make sure to follow the instructions in this table and illustration when connecting the GPU power cables: <ul style="list-style-type: none"> <li>– For GPU 1 and GPU 2, use the shorter cables (320 mm).</li> <li>– For GPU 3 and GPU 4, use the longer cables (660 mm).</li> <li>– If the label on the GPU power cable shows connector information different from the illustration and table in this section, follow the instructions here.</li> </ul> </li> </ul>		

## Front I/O module cable routing

Follow the instructions in this section to route the cables for the front I/O module.

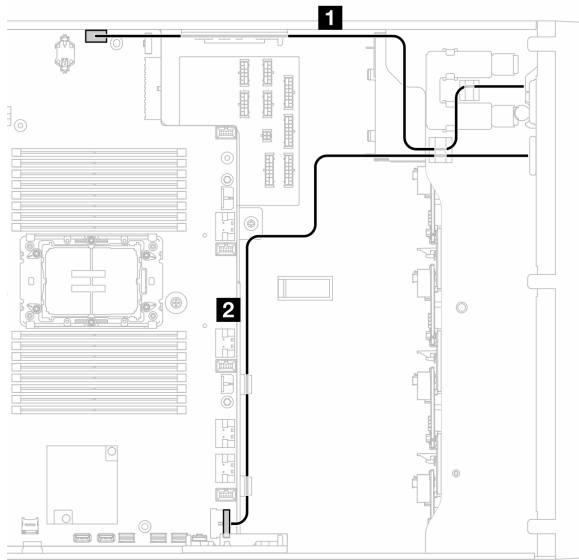

Figure 167. Cable routing for the front I/O module

From	To system board
Front I/O module	1 Front-operator-panel connector
	2 Front USB connector

---

## Power distribution board cable routing

See this topic to learn how to do cable routing for power distribution board.

Figure 168. Cable routing for power distribution board

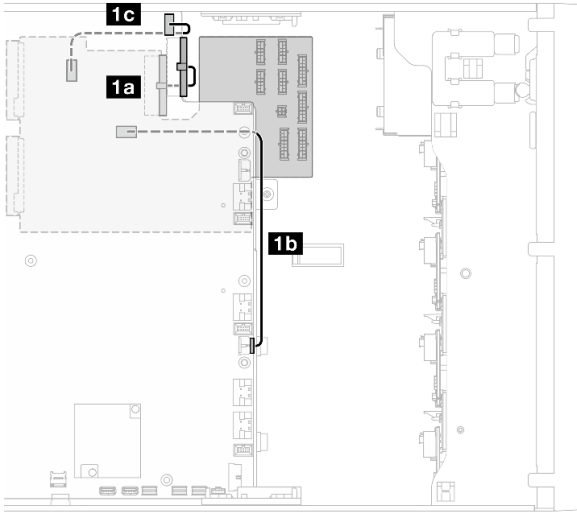

Category	From	To (system board)
Power distribution board	<b>1a</b> PDB main power connector 1	System board power 1 connector
	<b>1b</b> PDB main power connector 2	System board power 2 connector
	<b>1c</b> PDB sideband connector	Power sideband connector

---

## M.2 boot adapter cable routing

See this topic to learn how to do cable routing for M.2 boot adapter.

## ThinkSystem M.2 SATA/NVMe 2-Bay Enablement Kit

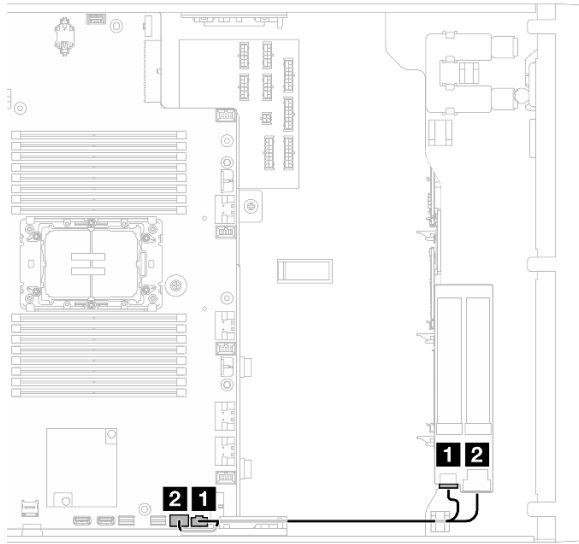

Figure 169. ThinkSystem M.2 SATA/NVMe 2-Bay Enablement Kit cable routing

From (M.2 boot adapter)	To (system board)
<b>1</b> M.2 power connector	M.2 power connector
<b>2</b> M.2 signal connector	M.2 signal connector

## ThinkSystem M.2 NVMe 2-Bay RAID Enablement Kit

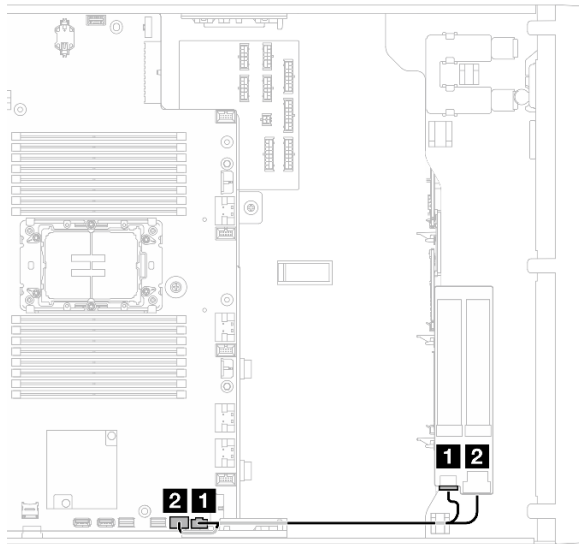

Figure 170. ThinkSystem M.2 NVMe 2-Bay RAID Enablement Kit cable routing

From (M.2 boot adapter)	To (system board)
<b>1</b> M.2 power connector	M.2 power connector
<b>2</b> M.2 signal connector	M.2 signal connector

**ThinkSystem M.2 RAID B540i-2i SATA/NVMe Enablement Kit**

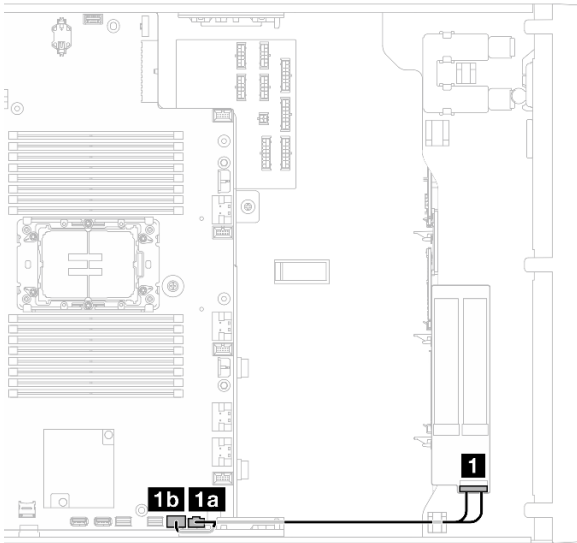

Figure 171. ThinkSystem M.2 RAID B540i-2i SATA/NVMe Enablement Kit cable routing

From (M.2 boot adapter)	To (system board)
<b>1</b> M.2 power and signal connector	<b>1a</b> M.2 power connector
	<b>1b</b> M.2 signal connector

---

## Optical/tape drives

Use this section to understand the cable routing for optical/tape drives.

- “Optical drive” on page 317
- “SAS/USB tape drive” on page 318

### Optical drive

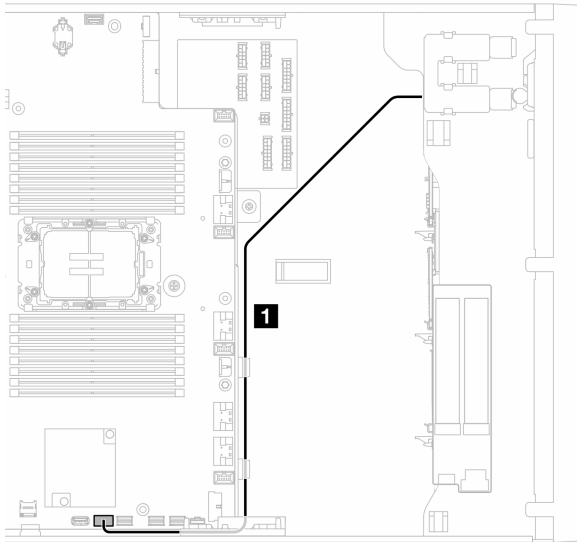

Figure 172. Cable routing for optical drive

From Optical drive	To system board
<b>1</b> Signal + Power connector	Internal USB 2 connector

## SAS/USB tape drive

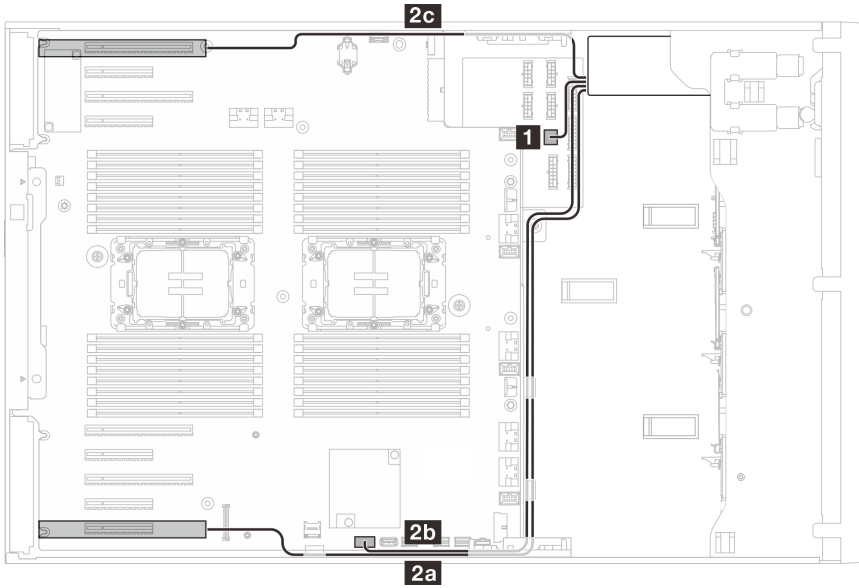

Figure 173. Cable routing for SAS/USB tape drive

From tape drive	To
<b>1</b> Power connector	Power distribution board: ODD power connector
<b>2</b> Signal connector	<b>2c</b> RAID/HBA adapter (Slot 1 to 4) <b>2b</b> Internal USB connector <b>2a</b> RAID/HBA adapter (Slot 5 to 9)

---

## Chapter 7. System configuration

Complete these procedures to configure your system.

---

### Set the network connection for the Lenovo XClarity Controller

Before you can access the Lenovo XClarity Controller over your network, you need to specify how Lenovo XClarity Controller will connect to the network. Depending on how the network connection is implemented, you might need to specify a static IP address as well.

The following methods are available to set the network connection for the Lenovo XClarity Controller if you are not using DHCP:

- If a monitor is attached to the server, you can use Lenovo XClarity Provisioning Manager to set the network connection.

Complete the following steps to connect the Lenovo XClarity Controller to the network using the Lenovo XClarity Provisioning Manager.

1. Start the server.
2. Press the key specified in the on-screen instructions to display the Lenovo XClarity Provisioning Manager interface. (For more information, see the “Startup” section in the LXPM documentation compatible with your server at <https://pubs.lenovo.com/lxpm-overview/>.)
3. Go to **LXPM → UEFI Setup → BMC Settings** to specify how the Lenovo XClarity Controller will connect to the network.
  - If you choose a static IP connection, make sure that you specify an IPv4 or IPv6 address that is available on the network.
  - If you choose a DHCP connection, make sure that the MAC address for the server has been configured in the DHCP server.
4. Click **OK** to apply the setting and wait for two to three minutes.
5. Use an IPv4 or IPv6 address to connect Lenovo XClarity Controller.

**Important:** The Lenovo XClarity Controller is set initially with a user name of USERID and password of PASSWORD (with a zero, not the letter O). This default user setting has Supervisor access. It is required to change this user name and password during your initial configuration for enhanced security.

---

### Set USB port for Lenovo XClarity Controller connection

Before you can access the Lenovo XClarity Controller through the USB port, you need to configure the USB port for Lenovo XClarity Controller connection.

#### Server support

To see if your server supports accessing Lenovo XClarity Controller through the USB port, check one of the following:

- Refer to [Chapter 2 “Server components” on page 19](#).



- If there is a wrench icon on the USB port of your server, you can set the management USB port to connect to Lenovo XClarity Controller. It is also the only USB port that supports USB automation update of the system I/O board (or firmware and RoT security module).

### Setting the USB port for Lenovo XClarity Controller connection

You can switch the USB port between normal and Lenovo XClarity Controller management operation by performing one of the following steps.

- Hold the ID button for at least 3 seconds until its LED flashes slowly (once every couple of seconds). See [Chapter 2 “Server components” on page 19](#) for ID button location.
- From the Lenovo XClarity Controller management controller CLI, run the `usbfp` command. For information about using the Lenovo XClarity Controller CLI, see the “Command-line interface” section in the XCC documentation compatible with your server at <https://pubs.lenovo.com/lxcc-overview/>.
- From the Lenovo XClarity Controller management controller web interface, click **BMC Configuration → Network → USB Management Port Assignment**. For information about Lenovo XClarity Controller web interface functions, see the “Description of XClarity Controller functions on web interface” section in the XCC documentation compatible with your server at <https://pubs.lenovo.com/lxcc-overview/>.

### Checking USB port current setting

You can also check the current setting of the USB port using the Lenovo XClarity Controller management controller CLI (`usbfp` command) or the Lenovo XClarity Controller management controller web interface (**BMC Configuration → Network → USB Management Port Assignment**). See the “Command-line interface” and “Description of XClarity Controller functions on web interface” sections in the XCC documentation compatible with your server at <https://pubs.lenovo.com/lxcc-overview/>.

---

## Update the firmware

Several options are available to update the firmware for the server.

You can use the tools listed here to update the most current firmware for your server and the devices that are installed in the server.

- Best practices related to updating firmware is available at the following site:
  - <https://lenovopress.lenovo.com/lp0656-lenovo-thinksystem-firmware-and-driver-update-best-practices>
- The latest firmware can be found at the following site:
  - <https://datacentersupport.lenovo.com/tw/en/products/servers/thinksystem/st650v3/7d7a/downloads/driver-list/>
- You can subscribe to product notification to stay up to date on firmware updates:
  - <https://datacentersupport.lenovo.com/solutions/ht509500>

### Update Bundles (Service Packs)

Lenovo typically releases firmware in bundles called Update Bundles (Service Packs). To ensure that all of the firmware updates are compatible, you should update all firmware at the same time. If you are updating firmware for both the Lenovo XClarity Controller and UEFI, update the firmware for Lenovo XClarity Controller first.

## Update method terminology

- **In-band update.** The installation or update is performed using a tool or application within an operating system that is executing on the server's core CPU.
- **Out-of-band update.** The installation or update is performed by the Lenovo XClarity Controller collecting the update and then directing the update to the target subsystem or device. Out-of-band updates have no dependency on an operating system executing on the core CPU. However, most out-of-band operations do require the server to be in the S0 (Working) power state.
- **On-Target update.** The installation or update is initiated from an installed operating system executing on the target server itself.
- **Off-Target update.** The installation or update is initiated from a computing device interacting directly with the server's Lenovo XClarity Controller.
- **Update Bundles (Service Packs).** Update Bundles (Service Packs) are bundled updates designed and tested to provide the interdependent level of functionality, performance, and compatibility. Update Bundles (Service Packs) are server machine-type specific and are built (with firmware and device driver updates) to support specific Windows Server, Red Hat Enterprise Linux (RHEL) and SUSE Linux Enterprise Server (SLES) operating system distributions. Machine-type-specific firmware-only Update Bundles (Service Packs) are also available.

## Firmware updating tools

See the following table to determine the best Lenovo tool to use for installing and setting up the firmware:

Tool	Update Methods Supported	Core System Firmware Updates	I/O Devices Firmware Updates	Drive Firmware Updates	Graphical user interface	Command line interface	Supports Update Bundles (Service Packs)
<b>Lenovo XClarity Provisioning Manager (LXPM)</b>	In-band <sup>2</sup> On-Target	√			√		
<b>Lenovo XClarity Controller (XCC)</b>	In-band <sup>4</sup> Out-of-band Off-Target	√	Selected I/O devices	√ <sup>3</sup>	√		√
<b>Lenovo XClarity Essentials OneCLI (OneCLI)</b>	In-band Out-of-band On-Target Off-Target	√	All I/O devices	√ <sup>3</sup>		√	√
<b>Lenovo XClarity Essentials UpdateXpress (LXCE)</b>	In-band Out-of-band On-Target Off-Target	√	All I/O devices		√		√

Tool	Update Methods Supported	Core System Firmware Updates	I/O Devices Firmware Updates	Drive Firmware Updates	Graphical user interface	Command line interface	Supports Update Bundles (Service Packs)
<b>Lenovo XClarity Essentials Bootable Media Creator (BoMC)</b>	In-band Out-of-band Off-Target	√	All I/O devices		√ (BoMC application)	√ (BoMC application)	√
<b>Lenovo XClarity Administrator (LXCA)</b>	In-band <sup>1</sup> Out-of-band <sup>2</sup> Off-Target	√	All I/O devices	√	√		√
<b>Lenovo XClarity Integrator (LXCI) for VMware vCenter</b>	Out-of-band Off-Target	√	Selected I/O devices		√		
<b>Lenovo XClarity Integrator (LXCI) for Microsoft Windows Admin Center</b>	In-band Out-of-band On-Target Off-Target	√	All I/O devices		√		√

**Notes:**

1. For I/O firmware updates.
2. For BMC and UEFI firmware updates.
3. Drive firmware update is only supported by the tools and methods below:
  - XCC Bare Metal Update (BMU): In-band, and requires system reboot.
  - Lenovo XClarity Essentials OneCLI:
    - For OneCLI version earlier than 5.0.0:
      - For drives supported by ThinkSystem V2 and V3 products (legacy drives): In-band, and does not require system reboot.
      - For drives supported only by ThinkSystem V3 products (new drives): Staging to XCC and complete the update with XCC BMU (In-band, and requires system reboot.).
    - For OneCLI 5.0.0 and later versions: In-band, and does not require system reboot.
4. Bare Metal Update (BMU) only.

• **Lenovo XClarity Provisioning Manager**

From Lenovo XClarity Provisioning Manager, you can update the Lenovo XClarity Controller firmware, the UEFI firmware, and the Lenovo XClarity Provisioning Manager software.

**Note:** By default, the Lenovo XClarity Provisioning Manager Graphical User Interface is displayed when you start the server and press the key specified in the on-screen instructions. If you have changed that default to be the text-based system setup, you can bring up the Graphical User Interface from the text-based system setup interface.

For additional information about using Lenovo XClarity Provisioning Manager to update firmware, see:

“Firmware Update” section in the LXPM documentation compatible with your server at <https://pubs.lenovo.com/lxpm-overview/>

- **Lenovo XClarity Controller**

If you need to install a specific update, you can use the Lenovo XClarity Controller interface for a specific server.

**Notes:**

- To perform an in-band update through Windows or Linux, the operating system driver must be installed and the Ethernet-over-USB (sometimes called LAN over USB) interface must be enabled.

For additional information about configuring Ethernet over USB, see:

“Configuring Ethernet over USB” section in the XCC documentation version compatible with your server at <https://pubs.lenovo.com/lxcc-overview/>

- If you update firmware through the Lenovo XClarity Controller, make sure that you have downloaded and installed the latest device drivers for the operating system that is running on the server.

For additional information about using Lenovo XClarity Controller to update firmware, see:

“Updating Server Firmware” section in the XCC documentation compatible with your server at <https://pubs.lenovo.com/lxcc-overview/>

- **Lenovo XClarity Essentials OneCLI**

Lenovo XClarity Essentials OneCLI is a collection of command line applications that can be used to manage Lenovo servers. Its update application can be used to update firmware and device drivers for your servers. The update can be performed within the host operating system of the server (in-band) or remotely through the BMC of the server (out-of-band).

For additional information about using Lenovo XClarity Essentials OneCLI to update firmware, see:

[https://pubs.lenovo.com/lxce-onecli/onecli\\_c\\_update](https://pubs.lenovo.com/lxce-onecli/onecli_c_update)

- **Lenovo XClarity Essentials UpdateXpress**

Lenovo XClarity Essentials UpdateXpress provides most of OneCLI update functions through a graphical user interface (GUI). It can be used to acquire and deploy Update Bundles (Service Packs) update packages and individual updates. Update Bundles (Service Packs) contain firmware and device driver updates for Microsoft Windows and for Linux.

You can obtain Lenovo XClarity Essentials UpdateXpress from the following location:

<https://datacentersupport.lenovo.com/solutions/Invo-xpress>

- **Lenovo XClarity Essentials Bootable Media Creator**

You can use Lenovo XClarity Essentials Bootable Media Creator to create bootable media that is suitable for firmware updates, VPD updates, inventory and FFDC collection, advanced system configuration, FoD Keys management, secure erase, RAID configuration, and diagnostics on supported servers.

You can obtain Lenovo XClarity Essentials BoMC from the following location:

<https://datacentersupport.lenovo.com/solutions/Invo-bomc>

- **Lenovo XClarity Administrator**

If you are managing multiple servers using the Lenovo XClarity Administrator, you can update firmware for all managed servers through that interface. Firmware management is simplified by assigning firmware-compliance policies to managed endpoints. When you create and assign a compliance policy to managed

endpoints, Lenovo XClarity Administrator monitors changes to the inventory for those endpoints and flags any endpoints that are out of compliance.

For additional information about using Lenovo XClarity Administrator to update firmware, see:

[https://pubs.lenovo.com/lxca/update\\_fw](https://pubs.lenovo.com/lxca/update_fw)

- **Lenovo XClarity Integrator offerings**

Lenovo XClarity Integrator offerings can integrate management features of Lenovo XClarity Administrator and your server with software used in a certain deployment infrastructure, such as VMware vCenter, Microsoft Admin Center, or Microsoft System Center.

For additional information about using Lenovo XClarity Integrator to update firmware, see:

<https://pubs.lenovo.com/lxci-overview/>

---

## Configure the firmware

Several options are available to install and set up the firmware for the server.

**Note:** UEFI **Legacy Mode** is not supported by ThinkSystem V4 products.

- **Lenovo XClarity Provisioning Manager (LXPM)**

From Lenovo XClarity Provisioning Manager, you can configure the UEFI settings for your server.

**Notes:** The Lenovo XClarity Provisioning Manager provides a Graphical User Interface to configure a server. The text-based interface to system configuration (the Setup Utility) is also available. From Lenovo XClarity Provisioning Manager, you can choose to restart the server and access the text-based interface. In addition, you can choose to make the text-based interface the default interface that is displayed when you start LXPM. To do this, go to **Lenovo XClarity Provisioning Manager → UEFI Setup → System Settings → <F1>Start Control → Text Setup**. To start the server with Graphic User Interface, select **Auto** or **Tool Suite**.

See the following documentations for more information:

- Search for the LXPM documentation version compatible with your server at <https://pubs.lenovo.com/lxpm-overview/>
- *UEFI User Guide* at <https://pubs.lenovo.com/uefi-overview/>

- **Lenovo XClarity Essentials OneCLI**

You can use the config application and commands to view the current system configuration settings and make changes to Lenovo XClarity Controller and UEFI. The saved configuration information can be used to replicate or restore other systems.

For information about configuring the server using Lenovo XClarity Essentials OneCLI, see:

[https://pubs.lenovo.com/lxce-onecli/onecli\\_c\\_settings\\_info\\_commands](https://pubs.lenovo.com/lxce-onecli/onecli_c_settings_info_commands)

- **Lenovo XClarity Administrator**

You can quickly provision and pre-provision all of your servers using a consistent configuration. Configuration settings (such as local storage, I/O adapters, boot settings, firmware, ports, and Lenovo XClarity Controller and UEFI settings) are saved as a server pattern that can be applied to one or more managed servers. When the server patterns are updated, the changes are automatically deployed to the applied servers.

Specific details about configuring the server using Lenovo XClarity Administrator are available at:

[https://pubs.lenovo.com/lxca/server\\_configuring](https://pubs.lenovo.com/lxca/server_configuring)

- **Lenovo XClarity Controller**

You can configure the management processor for the server through the Lenovo XClarity Controller Web interface, the command-line interface, or Redfish API.

For information about configuring the server using Lenovo XClarity Controller, see:

“Configuring the Server” section in the XCC documentation compatible with your server at <https://pubs.lenovo.com/lxcc-overview/>

---

## Memory module configuration

Memory performance depends on several variables, such as memory mode, memory speed, memory ranks, memory population and processor.

Information about optimizing memory performance and configuring memory is available at the Lenovo Press website:

<https://lenovopress.lenovo.com/servers/options/memory>

In addition, you can take advantage of a memory configurator, which is available at the following site:

[https://dcsc.lenovo.com/#/memory\\_configuration](https://dcsc.lenovo.com/#/memory_configuration)

---

## Enable Software Guard Extensions (SGX)

Intel® Software Guard Extensions (Intel® SGX) operates under the assumption that the security perimeter includes only the internals of the CPU package, and leaves the DRAM untrusted.

Complete the following steps to enable SGX.

- Step 1. **Make sure** to refer to “[Memory module installation rules and order](#)” on page 45, which specifies whether your server supports SGX and lists the memory module population sequence for SGX configuration. (DIMM configuration must be at least 8 DIMMs per socket to support SGX.)
- Step 2. Restart the system. Before the operating system starts up, press the key specified in the on-screen instructions to enter the Setup Utility. (For more information, see the “Startup” section in the LXPM documentation compatible with your server at <https://pubs.lenovo.com/lxpm-overview/>.)
- Step 3. Go to **System settings** → **Processors** → **Total Memory Encryption (TME)** and enable the option.
- Step 4. Save the changes, then go to **System settings** → **Processors** → **SW Guard Extension (SGX)** and enable the option.

---

## RAID configuration

Using a Redundant Array of Independent Disks (RAID) to store data remains one of the most common and cost-efficient methods to increase server’s storage performance, availability, and capacity.

RAID increases performance by allowing multiple drives to process I/O requests simultaneously. RAID can also prevent data loss in case of a drive failure by reconstructing (or rebuilding) the missing data from the failed drive using the data from the remaining drives.

RAID array (also known as RAID drive group) is a group of multiple physical drives that uses a certain common method to distribute data across the drives. A virtual drive (also known as virtual disk or logical drive) is a partition in the drive group that is made up of contiguous data segments on the drives. Virtual drive

is presented up to the host operating system as a physical disk that can be partitioned to create OS logical drives or volumes.

An introduction to RAID is available at the following Lenovo Press website:

<https://lenovopress.lenovo.com/lp0578-lenovo-raid-introduction>

Detailed information about RAID management tools and resources is available at the following Lenovo Press website:

<https://lenovopress.lenovo.com/lp0579-lenovo-raid-management-tools-and-resources>

## Intel VROC

### Enabling Intel VROC

Before setting up RAID for NVMe drives, follow the below steps to enable VROC:

1. Restart the system. Before the operating system starts up, press the key specified in the on-screen instructions to enter the Setup Utility. (For more information, see the “Startup” section in the LXPM documentation compatible with your server at [https://pubs.lenovo.com/lxpm-overview/.](https://pubs.lenovo.com/lxpm-overview/))
2. Go to **System settings** → **Devices and I/O Ports** → **Intel® VMD technology** → **Enable/Disable Intel® VMD** and enable the option.
3. Save the changes and reboot the system.

### Intel VROC configurations

Intel offers various VROC configurations with different RAID level and SSD support. See the following for more details.

#### Notes:

- Supported RAID levels varies by model. For the RAID level supported by ST650 V3, see [Technical specifications](#).
- For more information about acquiring and installing the activation key, see <https://fod.lenovo.com/lkms>.
- When the ThinkSystem M.2 SATA/NVMe 2-Bay Enablement Kit is installed, the M.2 drives are managed by Intel VROC/VMD/SATA RAID and do not support hot-swap or LED features.

Intel VROC configurations for PCIe NVMe SSDs	Requirements
Intel VROC Standard	<ul style="list-style-type: none"><li>• Supports RAID levels 0, 1, and 10</li><li>• Requires an activation key</li></ul>
Intel VROC Premium	<ul style="list-style-type: none"><li>• Supports RAID levels 0, 1, 5, and 10</li><li>• Requires an activation key</li></ul>
Bootable RAID	<ul style="list-style-type: none"><li>• RAID 1 only</li><li>• Requires an activation key</li></ul>
Intel VROC configurations for SATA SSDs	Requirements
Intel VROC SATA RAID	<ul style="list-style-type: none"><li>• Supports RAID level 0, 1, 5, and 10.</li></ul>

---

## Deploy the operating system

Several options are available to deploy an operating system on the server.

## Available operating systems

- Microsoft Windows Server
- VMware ESXi
- Red Hat Enterprise Linux
- SUSE Linux Enterprise Server

Complete list of available operating systems: <https://lenovopress.lenovo.com/osig>.

## Tool-based deployment

- **Multi-server**

Available tools:

- Lenovo XClarity Administrator

[https://pubs.lenovo.com/lxca/compute\\_node\\_image\\_deployment](https://pubs.lenovo.com/lxca/compute_node_image_deployment)

- **Single-server**

Available tools:

- Lenovo XClarity Provisioning Manager

“OS Installation” section in the LXPM documentation compatible with your server at <https://pubs.lenovo.com/lxpm-overview/>

## Manual deployment

If you cannot access the above tools, follow the instructions below, download the corresponding *OS Installation Guide*, and deploy the operating system manually by referring to the guide.

1. Go to <https://datacentersupport.lenovo.com/solutions/server-os>.
2. Select an operating system from the navigation pane and click **Resources**.
3. Locate the “OS Install Guides” area and click the installation instructions. Then, follow the instructions to complete the operation system deployment task.

---

## Back up the server configuration

After setting up the server or making changes to the configuration, it is a good practice to make a complete backup of the server configuration.

Make sure that you create backups for the following server components:

- **Management processor**

You can back up the management processor configuration through the Lenovo XClarity Controller interface. For details about backing up the management processor configuration, see:

“Backing up the BMC configuration” section in the XCC documentation compatible with your server at <https://pubs.lenovo.com/lxcc-overview/>.

Alternatively, you can use the `backup` command from Lenovo XClarity Essentials OneCLI to create a backup of all configuration settings. For more information about the `backup` command, see:

[https://pubs.lenovo.com/lxce-onecli/config\\_backup](https://pubs.lenovo.com/lxce-onecli/config_backup)

- **Operating system**

Use your backup methods to back up the operating system and user data for the server.

---

## Enable Intel® On Demand

A processor is equipped with various computing capabilities. Basic capabilities are available at the initial processor installation, while others remain inactivated. As development environment and tasks evolve, computing demands may accelerate and require leverage of the previously inactivated processor capabilities. In such cases, user can select desired processor capabilities and activate them through Intel On Demand feature—a feature that allows user to customize processor capabilities according to environment and tasks at hand. The following section specifies system hardware and software requirement, Intel On Demand enabling and transferring procedures, and list of processor capabilities.

This documentation includes the following sections:

- “Supported processor” on page 328
- “Installation tool” on page 328
- Procedures for “Enabling Intel On Demand Features” on page 329
- Procedures for “Transferring Intel On Demand Features” on page 330
- XCC and LXCE OneCLI instructions for:
  - “Reading PPIN” on page 330
  - “Installing Intel On Demand to processor” on page 332
  - “Acquiring and uploading Intel On Demand State Report” on page 333
  - “Checking the Intel On Demand features installed in a processor” on page 335

**Note:** Depending on the model, the XCC Web GUI layout may be slightly different from the illustrations in this document.

### Supported processor

Intel On Demand is only supported by Intel On Demand capable processors. For more information on Intel On Demand capable processors supported by ST650 V3, see <https://lenovopress.lenovo.com/lp1604-thinksystem-st630-v3-server>.

**Note:** All processors in a system must be installed with identical Intel On Demand feature.

### Installation tool

Intel On Demand can be installed via Lenovo XClarity Controller (XCC) and Lenovo XClarity Essentials OneCLI (LXCE OneCLI). After confirming that your processor supports Intel On Demand, you also need to make sure the XCC and LXCE OneCLI installed in your system supports installing Intel On Demand.

1. Check if Lenovo XClarity Controller (XCC) supports installing Intel On Demand (two methods provided):

- **Via XCC WebGUI**

Go to **BMC Configuration → License**, if there is a section named **On Demand Capabilities for Intel CPU** in the page, it indicates that current XCC supports installing Intel On Demand, otherwise you need to update XCC firmware to the latest version to ensure it supports installing Intel On Demand.

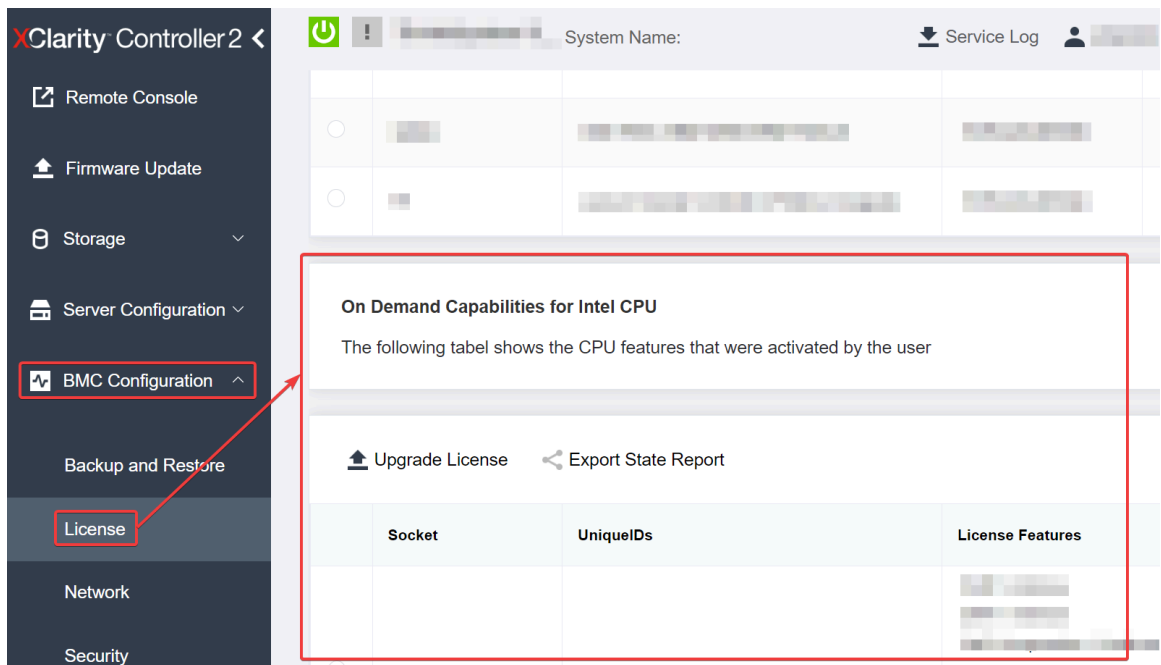

Figure 174. On Demand Capabilities for Intel CPU in XCC Web GUI

- **Via XCC REST API**

- Use the **GET** method with the following Request URL:  
GET [https://bmc\\_ip/redfish/v1/LicenseService/Licenses/](https://bmc_ip/redfish/v1/LicenseService/Licenses/)
- In the response JSON object, the Members field includes the API such as `/redfish/v1/LicenseService/Licenses/CPUX_OnDemandCapability`, where X is the CPU numbering, it indicates that current XCC supports installing Intel On Demand, otherwise you need to update XCC firmware to the latest version to ensure it supports installing Intel On Demand.

For example:

```
"Members": [
  {
    "@odata.id": "/redfish/v1/LicenseService/Licenses/CPU1_OnDemandCapability"
  },
  {
    "@odata.id": "/redfish/v1/LicenseService/Licenses/CPU2_OnDemandCapability"
  }
]
```

- Check if LXCE OneCLI supports installing Intel On Demand

- LXCE OneCLI version must be at 4.2.0 or above.

### Enabling Intel On Demand Features

- Select the Intel On Demand features that meets your workload needs, see [“Intel On Demand Features” on page 336](#).
- After completing ordering the features, you will receive Authorization Code via e-mail.
- PPIN is a mandatory information for enabling the features. Read the PPIN of the processor that is to be installed with the features. See [“Reading PPIN” on page 330](#).
- Go to <https://fod.lenovo.com/kms> and input the Authorization Code to acquire the Activation Key.
- In the website, input Machine Type, Machine serial number, and PPIN.
- The website will generate the Activation Key. Download the Activation Key.

7. Install the features to the processor with the Activation Key via XCC or LXCE OneCLI. See [“Installing Intel On Demand to processor” on page 332](#).

**Note:** If more than one Activation Keys are acquired, it is mandatory to install them in the sequential order they were acquired. For example, start with installing the first acquired key, and proceed with the second acquired key, and so on.

8. AC cycle the server.
9. (Optional) Upload Intel On Demand State Report. See [“Acquiring and uploading Intel On Demand State Report” on page 333](#).

The State Report represents the current configuration state of the Intel On Demand capable processors. Lenovo accepts State Reports from customers to calibrate the current state of the Intel On Demand capable processors.

10. To see the features installed in a processor, see [“Checking the Intel On Demand features installed in a processor” on page 335](#).

For reference, see [https://pubs.lenovo.com/lenovo\\_fod](https://pubs.lenovo.com/lenovo_fod).

### Transferring Intel On Demand Features

After replacing a processor, you may need to transfer the features from the defective processor to the new processor. Complete the following steps to transfer features to new processor.

1. Before removing the defective processor from the system, read the PPIN of the defective processor. See [“Reading PPIN” on page 330](#).
2. After installing the new processor, read the PPIN of the new processor. See [“Reading PPIN” on page 330](#).
3. Go to <https://fod.lenovo.com/lkms> and input the PPIN of the defective processor. (Input PPIN in the UID section.)
4. Select the features to be transferred.
5. Input the PPIN of the new processor.
6. The website will generate the new Activation Key. Download the new Activation Key. See [“Installing Intel On Demand to processor” on page 332](#).
7. Install the features to the new processor with the new Activation Key via XCC or LXCE OneCLI.
8. AC cycle the server.
9. (Optional) Upload Intel On Demand State Report. See [“Acquiring and uploading Intel On Demand State Report” on page 333](#).

The State Report represents the current configuration state of the Intel On Demand capable processors. Lenovo accepts State Reports from customers to calibrate the current state of the Intel On Demand capable processors.

10. To see the features installed in a processor, see [“Checking the Intel On Demand features installed in a processor” on page 335](#).

For reference, see [https://pubs.lenovo.com/lenovo\\_fod](https://pubs.lenovo.com/lenovo_fod).

### Reading PPIN

Protected Processor Inventory Number, or PPIN, is a mandatory information for enabling Intel On Demand. PPIN can be read via XCC Web GUI, XCC REST API, and LXCE OneCLI. See the following for more information.

### Reading PPIN via XCC Web GUI

Open XCC Web GUI, go to **Inventory page** → **CPU tab** → **Expand** → **PPIN**

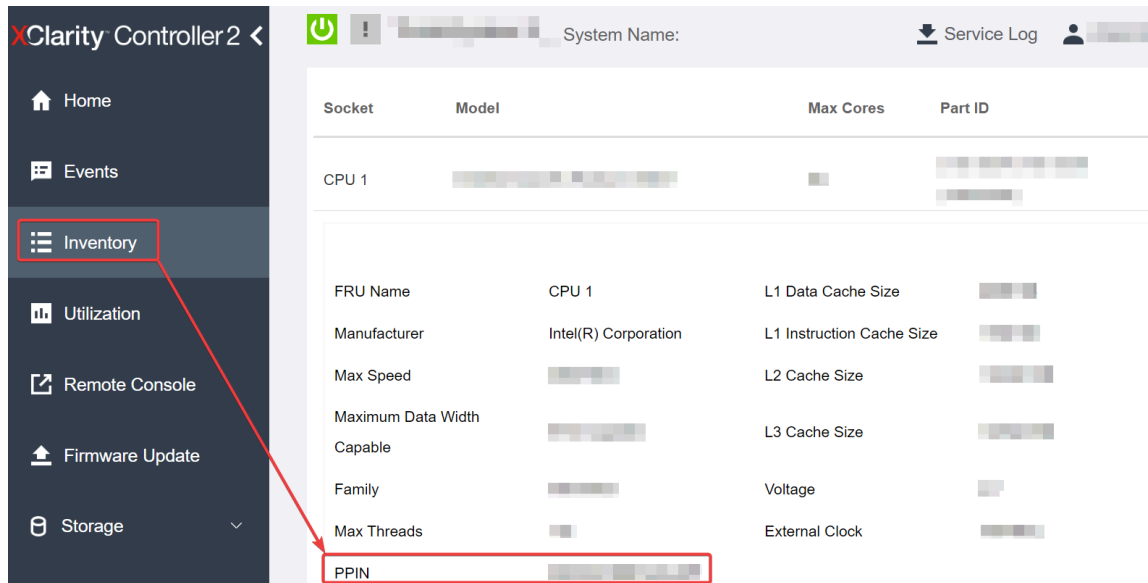

Figure 175. Reading PPIN via XCC Web GUI

### Reading PPIN via XCC REST API

1. Use the **GET** method with the following Request URL:

GET [https://bmc\\_ip/redfish/v1/Systems/1/Processors](https://bmc_ip/redfish/v1/Systems/1/Processors)

For example:

GET [https://bmc\\_ip/redfish/v1/Systems/1/Processors](https://bmc_ip/redfish/v1/Systems/1/Processors)

2. In the response JSON object, the Members field shows reference link to an element of processor resource.

For example:

```
"Members":[
  {
    @odata.id: "/redfish/v1/Systems/1/Processors/1"
  },
  {
    @odata.id: "/redfish/v1/Systems/1/Processors/2"
  }
],
```

3. Select the processor you need to read the PPIN from. Use the **GET** method with the following Request URL, where x is the CPU numbering:

GET [https://bmc\\_ip/redfish/v1/Systems/1/Processors/x](https://bmc_ip/redfish/v1/Systems/1/Processors/x)

For example, to read Processor 1 PPIN, see the following:

GET [https://bmc\\_ip/redfish/v1/Systems/1/Processors/1](https://bmc_ip/redfish/v1/Systems/1/Processors/1)

4. In the response JSON object, the ProcessorId field shows the ProtectedIdentificationNumber field, which is the PPIN info of the requested CPU.

For example:

```
"ProcessorId":{
  "ProtectedIdentificationNumber":"1234567890xxxxyy"
},
```

### Reading PPIN via LXCE OneCLI

Input the following command:

```
OneCli.exe fod showppin -b XCC_USER:XCC_PASSWORD@XCC_HOST
```

The output shows PPIN information. For example:

```
Machine Type: 7D75
Serial Number: 7D75012345
FoD PPIN result:
```

```
=====
| Socket ID | PPIN |
| Processor 1 | 1234567890xxxyyy |
| Processor 2 | 9876543210zzzyyy |
=====
```

## Installing Intel On Demand to processor

Install Intel On Demand features to the processor with the Activation Key downloaded from the <https://fod.lenovo.com/lkms> via XCC Web GUI, XCC REST API or LXCE OneCLI.

### Use XCC Web GUI to install Intel On Demand

1. Open XCC Web GUI, go to **BMC Configuration → License → On Demand Capabilities for Intel CPU → Upgrade License → Browse → Import** to upload the Activation Key

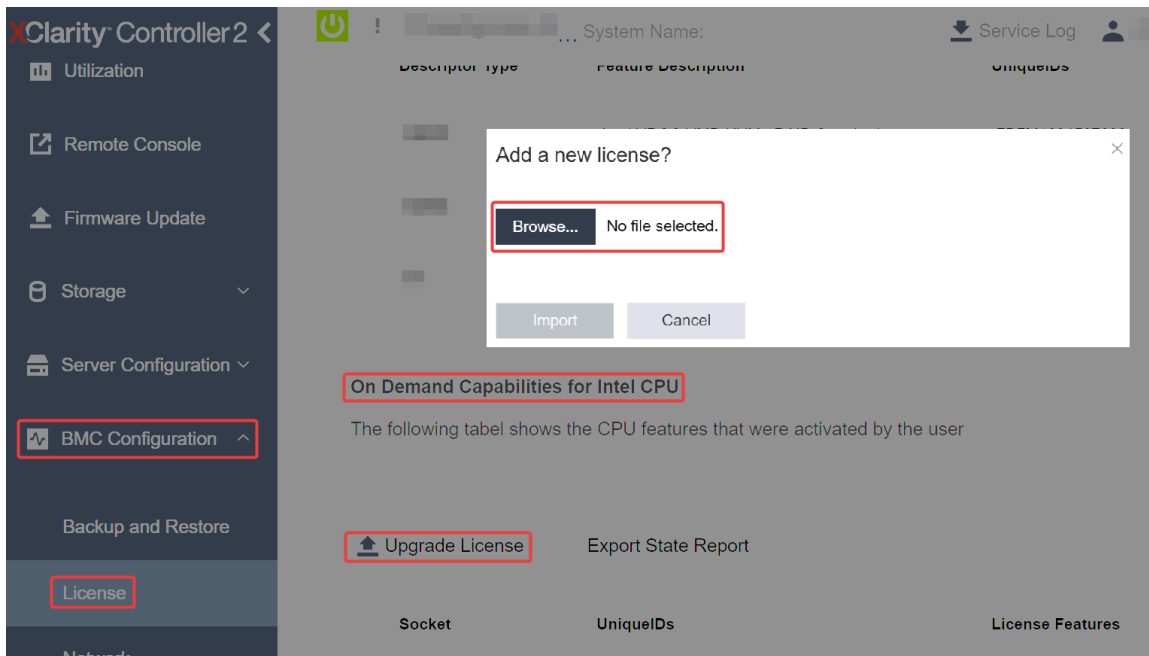

Figure 176. Uploading Activation Key via XCC Web GUI

2. If the installation is successful, the Web GUI will show a pop-up window with the message “License key upgraded successfully. The features will be activated on the processor after system power cycle”.

Otherwise, see “[Enable Intel® On Demand Troubleshooting](#)” on page 337.

### Use XCC REST API to install Intel On Demand

1. Use the **POST** method with the following Request URL:  
POST [https://bmc\\_ip/redfish/v1/LicenseService/Licenses](https://bmc_ip/redfish/v1/LicenseService/Licenses)
2. Transfer Activation Key to base64 string at first and fill it into the LicenseString field as POST data.

```
{
  "LicenseString": ""
}
```

3. If the installation is successful, XCC REST API show the message “License key upgraded successfully. The features will be activated on the processor after system power cycle”.

Otherwise, see “[Enable Intel® On Demand Troubleshooting](#)” on page 337.

### Use LXCE OneCLI to install Intel On Demand

Input the following command, where <key\_file> specifies the Activation Key:

```
OneCli.exe fod install --keyfile <key_file>
```

If successfully installed, the response will show:

```
Successfully install key
```

Call Lenovo support if the response shows the following:

```
Failed to install key
```

### Acquiring and uploading Intel On Demand State Report

After completing enabling or transferring Intel On Demand, acquire and upload the State Report via XCC Web GUI, XCC REST API, and LXCE OneCLI. See the following for more information.

### Use XCC Web GUI to upload State Report

1. Open XCC Web GUI, go to **BMC Configuration** → **License** → **On Demand Capabilities for Intel CPU** → **Choose CPU** → **Export State Report**

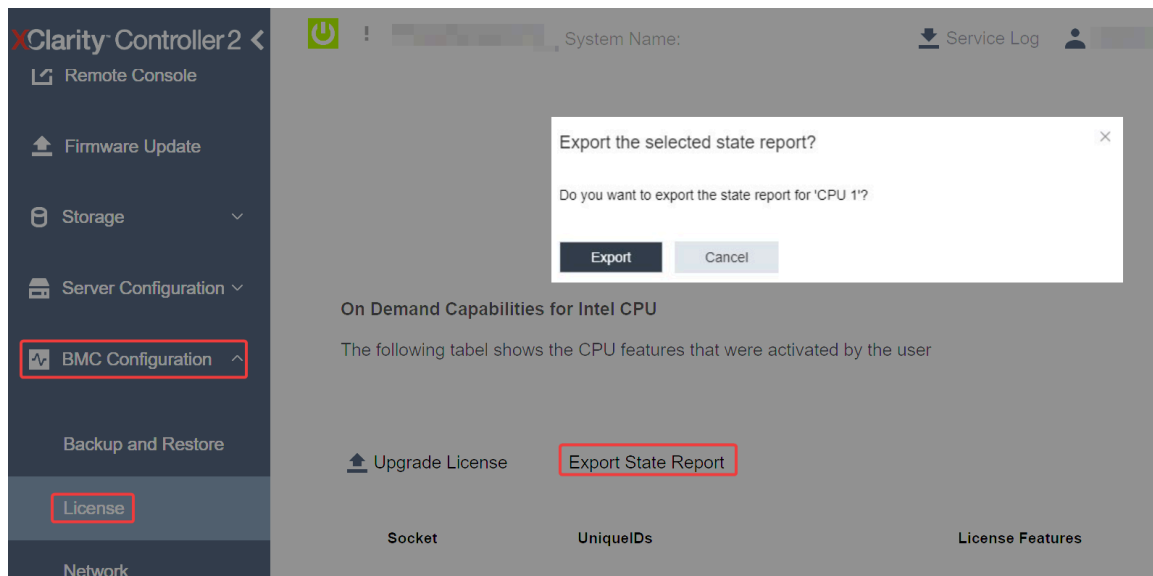

Figure 177. Export State Report via XCC Web GUI

2. Upload State Report via “On Demand Feedback” section in <https://fod.lenovo.com/lkms>.

### Use XCC REST API to upload State Report

1. Use the **GET** method with the following Request URL to retrieve CPU State Report API, where X is the CPU numbering:
 

```
GET https://bmc_ip/redfish/v1/LicenseService/Licenses/CPUX_OnDemandCapability
```

 For example, to retrieve CPU 1 State Report API, see the following:
 

```
GET https://bmc_ip/redfish/v1/LicenseService/Licenses/CPU1_OnDemandCapability
```
2. In the response JSON object, the response of the target field of the `LenovoLicense.ExportStateReport` field is the CPU State Report API, where X is the CPU numbering:

```

"Actions": {
  "Oem": {
    "#LenovoLicense.ExportStateReport": {
      "title": "ExportStateReport",
      "target": "/redfish/v1/LicenseService/Licenses/CPUX_OnDemandCapability/Actions/Oem/LenovoLicense.ExportStateReport"
    }
  }
},

```

In the following example, the response of the target field is the CPU 1 State Report API. Copy the CPU 1 State Report API.

```

"Actions": {
  "Oem": {
    "#LenovoLicense.ExportStateReport": {
      "title": "ExportStateReport",
      "target": "/redfish/v1/LicenseService/Licenses/CPU1_OnDemandCapability/Actions/Oem/LenovoLicense.ExportStateReport"
    }
  }
},

```

### 3. Retrieve the State Report.

- a. Use the **POST** method with the following Request URL with CPU State Report API to retrieve the State Report, where X is the CPU numbering:

POST [https://bmc\\_ip/redfish/v1/LicenseService/Licenses/CPUX\\_OnDemandCapability/Actions/Oem/LenovoLicense.ExportStateReport](https://bmc_ip/redfish/v1/LicenseService/Licenses/CPUX_OnDemandCapability/Actions/Oem/LenovoLicense.ExportStateReport)

For example, to retrieve CPU 1 State Report, see the following:

POST [https://bmc\\_ip/redfish/v1/LicenseService/Licenses/CPU1\\_OnDemandCapability/Actions/Oem/LenovoLicense.ExportStateReport](https://bmc_ip/redfish/v1/LicenseService/Licenses/CPU1_OnDemandCapability/Actions/Oem/LenovoLicense.ExportStateReport)

- b. Use an empty JSON object as POST data. When using API tool such as Postman, fill an empty JSON object in **Body** → **Raw** → **JSON**, fill a NULL object '{}' in a JSON file.

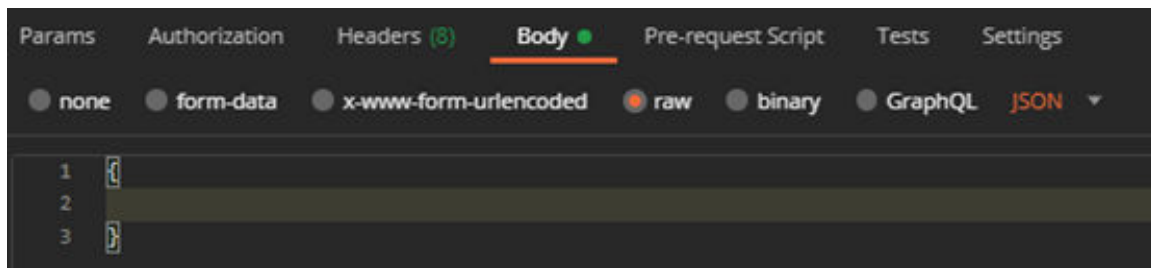

4. In the response, retrieve the State Report in the stateReports field.

```

{
  "stateReports": [
    {
      "syntaxVersion": "1.0",
      "timestamp": "",
      "objectId": "",
      "hardwareComponentData": [
        {
          "hardwareId": {
            "type": "PPIN",
            "value": ""
          },
          "stateCertificate": {
            "pendingCapabilityActivationPayloadCount": ,
            "value": ""
          },
          "hardwareType": "CPU"
        }
      ]
    }
  ]
}

```

```

    }
  ]
}

```

5. Upload State Report via “On Demand Feedback” section in <https://fod.lenovo.com/lkms>.

### Use LXCE OneCLI to upload State Report

1. Acquire State Report with the following command:  
`OneCli.exe fod exportreport -b XCC_USER:XCC_PASSWORD@XCC_HOST`
2. Upload State Report with the following command:  
`OneCli.exe fod uploadreport --file CPU1_xxxxxx_StateReport.json --kmsid KMS_USER:KMS_PASSWORD`  
 Where:

CPU1\_xxxxxx\_StateReport.json is the file name downloaded from the **fod exportreport** command in Step 1.

KMS\_USER and KMS\_PASSWORD are your ID and password on the <https://fod.lenovo.com/lkms>.

### Checking the Intel On Demand features installed in a processor

You can check the Intel On Demand features installed in a processor via XCC Web GUI, XCC REST API, and LXCE OneCLI. See the following for more information.

**Note:** If the processor has not been installed with any license, it would not appear in the **On Demand Capabilities for Intel CPU** section in XCC Web GUI.

### Use XCC Web GUI to check the Intel On Demand features installed in a processor

Go to **BMC Configuration** → **License** → **On Demand Capabilities for Intel CPU** → **Choose CPU** → **License Features**, where the installed features are listed.

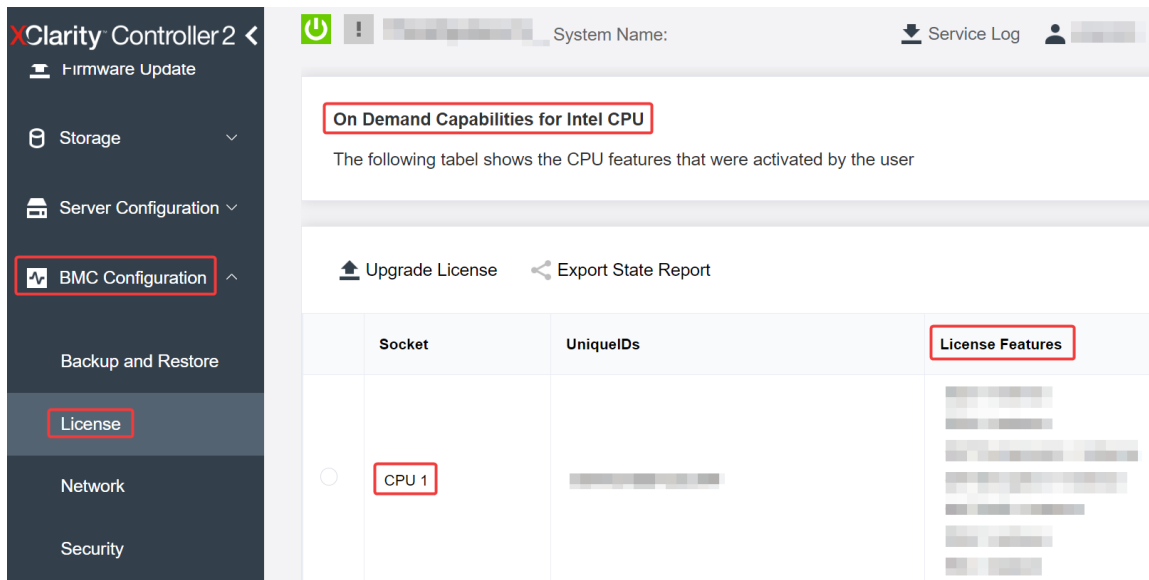

Figure 178. Checking the Intel On Demand features installed in a processor in XCC Web GUI

### Use XCC REST API to check the Intel On Demand features installed in a processor

1. Use the **GET** method with the following Request URL to retrieve Intel On Demand features installed on CPU X, where X is the CPU numbering:  
`GET https://bmc_ip/redfish/v1/LicenseService/Licenses/CPUX_OnDemandCapability`  
 For example, to retrieve Intel On Demand features installed on CPU 1, see the following:

GET https://bmc\_ip/redfish/v1/LicenseService/Licenses/CPU1\_OnDemandCapability

2. In the response JSON object, the FeatureList field contains the Intel On Demand features installed in this processor.

```
"Dem": {
  "Lenovo": {
    "FeatureList": []
    "@odata.type": ""
  }
},
```

### Use LXCE OneCLI to check the Intel On Demand features installed in a processor

1. Check installed features with the following command:  
OneCli.exe fod report -b XCC\_USER:XCC\_PASSWORD@XCC\_HOST
2. The output shows all license, including Intel On Demand features. For example:

```
FoD Reports result:
=====
| Feature | Key | Status | Description | User | Expired |
| Type | ID | | Feature List | Reminding | Date |
=====
| N/A | CPU1_OnDemandCapability | StandbyOffline | DSA 4 instances, | N/A | N/A |
| | | | IAA 4 instances | | |
=====
| N/A | CPU2_OnDemandCapability | Enabled | DSA 4 instances, | N/A | N/A |
| | | | IAA 4 instances | | |
=====
| 004a | XCC2_Platinum | Enabled | Lenovo XClarity Controller 2 | N/A | N/A |
| | | | Platinum Upgrade | | |
=====
Succeed.
```

### Intel On Demand Features

Intel On Demand features are listed below. Supported features vary by product, for more information, see <https://lenovopress.lenovo.com/lp1604-thinksystem-st630-v3-server>.

#### Features

- **Intel Quick Assist Technology (Intel QAT)<sup>1</sup>**

Intel® QAT which helps free up processor cores by offloading encryption, decryption, and compression so systems can serve a larger number of clients or use less power. With Intel QAT, 4th gen Intel Xeon Scalable processors are the highest performance CPUs that can compress and encrypt in a single data flow.

- **Intel Dynamic Load Balancer (Intel DLB)<sup>2</sup>**

Intel DLB is a hardware managed system of queues and arbiters connecting producers and consumers. It is a PCI device envisaged to live in the server CPU uncore and can interact with software running on cores, and potentially with other devices.

- **Intel Data Streaming Accelerator (Intel DSA)<sup>1</sup>**

Intel DSA drives high performance for storage, networking, and data-intensive workloads by improving streaming data movement and transformation operations. Designed to offload the most common data movement tasks that cause overhead in data center-scale deployments, Intel DSA helps speed up data movement across the CPU, memory, caches, all attached memory, storage, and network devices.

- **Intel In Memory Accelerator (Intel IAA)<sup>1</sup>**

Intel IAA helps run database and analytics workloads faster, with potentially greater power efficiency. This built-in accelerator increases query throughput and decreases the memory footprint for in-memory database and big data analytics workloads. Intel IAA is ideal for in-memory databases, and source databases.

- **Intel Software Guard Extensions (Intel SGX) 512 GB<sup>3</sup>**

Intel® SGX offers hardware-based memory encryption that isolates specific application code and data in memory. Intel SGX allows user-level code to allocate private regions of memory, called enclaves, which are designed to be protected from processes running at higher privilege levels.

References

- <sup>1</sup>*Achieve Performance Advantage with Intel oneAPI, AI Tools, and 4th Gen Intel® Xeon® Scalable Processors Featuring Built-in Accelerator Engines*, (n.d.). Intel. <https://www.intel.com/content/www/us/en/developer/articles/technical/performance-advantage-with-xeon-and-oneapi-tools.html>
- <sup>2</sup>*Intel® Dynamic Load Balancer*, (2023, May 23) Intel. <https://www.intel.com/content/www/us/en/download/686372/intel-dynamic-load-balancer.html>
- <sup>3</sup>*Intel® Software Guard Extensions (Intel® SGX)*, (n.d.) Intel. <https://www.intel.com/content/www/us/en/architecture-and-technology/software-guard-extensions.html>

## Enable Intel® On Demand Troubleshooting

Refer to the table below for Intel On Demand installation error messages and user actions.

Table 95. Intel On Demand installation messages and user actions

Message	User Action
License key upgraded successfully. The features will be activated on the processor after system power cycle.	You can activate Intel On Demand after performing one system power cycle.
The activation key format is invalid	Check if you have uploaded the correct Activation Key file. If the error persists, contact Lenovo support.
Invalid processor PPIN in Activation key	Contact Lenovo support.
The license was installed in the processor already	You have already installed this activation key. Check if the activation key you uploaded is correct.
Not enough NMRAM space in the processor	Contact Lenovo support.
Internal error	Contact Lenovo support.
Cold reset needed before next provisioning	If you want to continue installing an activation key, perform a system power cycle at first.
Unable to provision LAC due to FEH error	Contact Lenovo support.
Unable to import license in shutdown state, please try again after power on.	Power on the system before installing Intel On Demand.
Unable to import license due to On Demand Capabilities information is in progress. Please try again later.	If you want to continue installing an activation key, try again later.



---

## Chapter 8. Problem determination

Use the information in this section to isolate and resolve issues that you might encounter while using your server.

Lenovo servers can be configured to automatically notify Lenovo Support if certain events are generated. You can configure automatic notification, also known as Call Home, from management applications, such as the Lenovo XClarity Administrator. If you configure automatic problem notification, Lenovo Support is automatically alerted whenever a server encounters a potentially significant event.

To isolate a problem, you should typically begin with the event log of the application that is managing the server:

- If you are managing the server from the Lenovo XClarity Administrator, begin with the Lenovo XClarity Administrator event log.
- If you are using some other management application, begin with the Lenovo XClarity Controller event log.

### Web resources

- **Tech tips**

Lenovo continually updates the support website with the latest tips and techniques that you can use to solve issues that your server might encounter. These Tech Tips (also called retain tips or service bulletins) provide procedures to work around issues or solve problems related to the operation of your server.

To find the Tech Tips available for your server:

1. Go to <http://datacentersupport.lenovo.com> and navigate to the support page for your server.
2. Click on **How To's** from the navigation pane.
3. Click **Article Type** → **Solution** from the drop-down menu.

Follow the on-screen instructions to choose the category for the problem that you are having.

- **Lenovo Data Center Forum**

- Check [https://forums.lenovo.com/t5/Datacenter-Systems/ct-p/sv\\_eg](https://forums.lenovo.com/t5/Datacenter-Systems/ct-p/sv_eg) to see if someone else has encountered a similar problem.

---

## Event logs

An *alert* is a message or other indication that signals an event or an impending event. Alerts are generated by the Lenovo XClarity Controller or by UEFI in the servers. These alerts are stored in the Lenovo XClarity Controller Event Log. If the server is managed by the Chassis Management Module 2 or by the Lenovo XClarity Administrator, alerts are automatically forwarded to those management applications.

**Note:** For a listing of events, including user actions that might need to be performed to recover from an event, see the *Messages and Codes Reference*, which is available at [https://pubs.lenovo.com/st650-v3/pdf\\_files](https://pubs.lenovo.com/st650-v3/pdf_files).

### Lenovo XClarity Administrator event log

If you are using Lenovo XClarity Administrator to manage server, network, and storage hardware, you can view the events from all managed devices through the XClarity Administrator.

## Logs

The Event log provides a history of hardware and management conditions that have been detected.

Show:

All Event Sources

All Dates

Severity	Serviceability	Date and Time	System	Event	System Type	Source ID
Warning	Support	Jan 30, 2017, 7:48:07 AM	Chassis114:...	Node Node 08 device	Chassis	Jan 30, 20
Warning	Support	Jan 30, 2017, 7:48:07 AM	Chassis114:...	Node Node 02 device	Chassis	Jan 30, 20
Warning	User	Jan 30, 2017, 7:48:07 AM	Chassis114:...	I/O module IO Module	Chassis	Jan 30, 20
Warning	User	Jan 30, 2017, 7:48:07 AM	Chassis114:...	Node Node 08 incom	Chassis	Jan 30, 20

Figure 179. Lenovo XClarity Administrator event log

For more information about working with events from XClarity Administrator, see:

[https://pubs.lenovo.com/lxca/events\\_vieweventlog](https://pubs.lenovo.com/lxca/events_vieweventlog)

### Lenovo XClarity Controller event log

The Lenovo XClarity Controller monitors the physical state of the server and its components using sensors that measure internal physical variables such as temperature, power-supply voltages, fan speeds, and component status. The Lenovo XClarity Controller provides various interfaces to systems management software and to system administrators and users to enable remote management and control of a server.

The Lenovo XClarity Controller monitors all components of the server and posts events in the Lenovo XClarity Controller event log.

ThinkSystem System name: XCC0023579PK

Event Log Audit Log Maintenance History

Customize Table Clear Logs Refresh

Type: All Source All Date

Severity	Source	Event ID	Message	Date
	System	0X4000000E00000000	Remote login successful. Login ID: userid from webguis at IP address: 10.104.194.180.	27 Jul 2015, 08:11:04 AM
	System	0X4000000E00000000	Remote login successful. Login ID: userid from webguis at IP address: 10.104.194.180.	27 Jul 2015, 08:11:04 AM
	System	0X4000000E00000000	Remote login successful. Login ID: userid from webguis at IP address: 10.104.194.180.	27 Jul 2015, 08:11:04 AM
	System	0X4000000E00000000	Remote login successful. Login ID: userid from webguis at IP address: 10.104.194.180.	27 Jul 2015, 08:11:04 AM

Figure 180. Lenovo XClarity Controller event log

For more information about accessing the Lenovo XClarity Controller event log, see:

“Viewing Event Logs” section in the XCC documentation compatible with your server at <https://pubs.lenovo.com/lxcc-overview/>

---

## Troubleshooting by system LEDs and diagnostics display

See the following section for information on available system LEDs and diagnostics display.

### Drive LEDs

This topic provides information on drive LEDs.

The following table describes the problems that are indicated by drive activity LED and drive status LED.

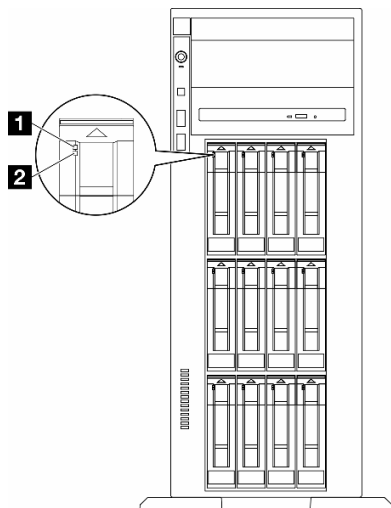

Figure 181. Drive LEDs

LED	Description
<b>1</b> Drive activity LED (green)	Each hot-swap drive comes with an activity LED. When this LED is flashing, it indicates that the drive is in use.
<b>2</b> Drive status LED (yellow)	The drive status LED indicates the following status: <ul style="list-style-type: none"><li>• The LED is lit: the drive has failed.</li><li>• The LED is flashing slowly (once per second): the drive is being rebuilt.</li><li>• The LED is flashing rapidly (three times per second): the drive is being identified.</li></ul>

### Front operator panel LEDs

This section contains information about the front operator panel LEDs.

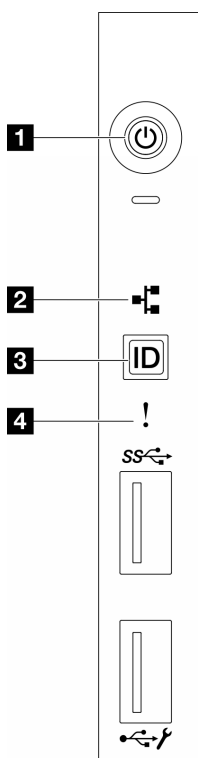

Figure 182. Front operator panel LEDs

Table 96. Front operator panel LEDs

<b>1</b> “Power button with power status LED (green)” on page 342	<b>3</b> “System ID button with system ID LED (blue)” on page 343
<b>2</b> “Network activity LED (green)” on page 342	<b>4</b> “System Error LED (yellow)” on page 343

### **1** Power button with power status LED (green)

You can press the power button to power on the server when you finish setting up the server. You also can hold the power button for several seconds to power off the server if you cannot shut down the server from the operating system. The states of the power LED are as follows:

Status	Color	Description
Off	None	No power supply is properly installed, or the LED itself has failed.
Flashing rapidly (four times per second)	Green	The server is turned off and is not ready to be turned on. The power button is disabled. This will last approximately 5 to 10 seconds.
Flashing slowly (once per second)	Green	The server is turned off and is ready to be turned on. You can press the power button to turn on the server.
Lit	Green	The server is turned on.

### **2** Network activity LED (green)

The network activity LED helps you identify the network connectivity and activity.

Status	Color	Description
On	Green	The server is connected to a network.
Blinking	Green	The network is connected and active.
Off	None	The server is disconnected from the network.

### 3 System ID button with system ID LED (blue)

Use this system ID button and the blue system ID LED to visually locate the server. Each time you press the system ID button, the state of the system ID LED changes. The LED can be changed to on, blinking, or off. You can also use the Lenovo XClarity Controller or a remote management program to change the state of the system ID LED to assist in visually locating the server among other servers.

### 4 System Error LED (yellow)

The system error LED helps you to determine if there are any system errors.

Status	Color	Description	Action
On	Yellow	<p>An error has been detected on the server. Causes might include one or more of the following errors:</p> <ul style="list-style-type: none"> <li>• The temperature of the server reached the non-critical temperature threshold.</li> <li>• The voltage of the server reached the non-critical voltage threshold.</li> <li>• A fan has been detected to be running at low speed.</li> <li>• The power supply has a critical error.</li> <li>• The power supply is not connected to the power.</li> </ul>	Check the Event log to determine the exact cause of the error.
Off	None	The server is off or the server is on and is working correctly.	None.

## Rear system LEDs

The illustration in this section shows the LEDs on the rear of the server.

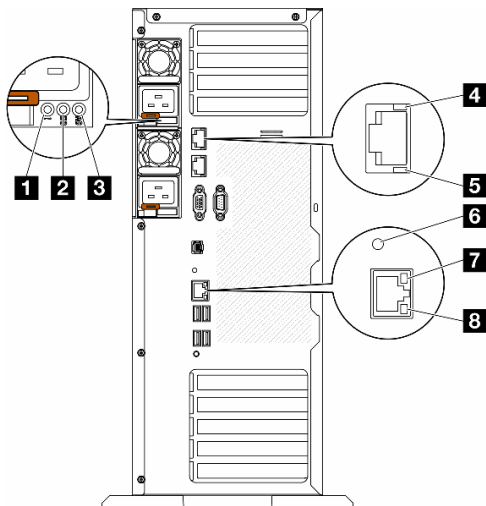

Figure 183. Rear system LEDs of the server

Table 97. LEDs on the rear of the server

<b>1</b> Power supply error LED (yellow)	<b>5</b> 10GbE activity LED (green)
<b>2</b> DC power LED (green)	<b>6</b> System ID LED (blue)
<b>3</b> AC power LED (green)	<b>7</b> Ethernet link LED (green)
<b>4</b> 10GbE link LED (green)	<b>8</b> Ethernet activity LED (green)

#### **1 Power supply error LED (yellow)**

When the power-supply error LED is lit, it indicates that the power supply has failed.

#### **2 DC power LED (green)**

Each hot-swap power supply comes with a dc power LED and an ac power LED. When the dc power LED is lit, it indicates that the power supply is supplying adequate dc power to the system. During normal operation, both the ac and dc power LEDs are lit.

#### **3 AC power LED (green)**

Each hot-swap power supply comes with an ac power LED and a dc power LED. When the ac power LED is lit, it indicates that sufficient power is being supplied to the power supply through the power cord. During normal operation, both the ac and dc power LEDs are lit.

For more details about the power supply LEDs, see [“Power supply LEDs” on page 345](#).

#### **4 10GbE link LED (green) 5 10GbE activity LED (green)**

Each 10Gb ethernet connector has two status LEDs.

Ethernet status LED	Color	Status	Description
4 Ethernet link LED	Green	On	Network link is established.
	None	Off	Network link is disconnected.
5 Ethernet activity LED	Green	Blinking	Network link is connected and active.
	None	Off	The server is disconnected from a LAN.

### 6 System ID LED (blue)

Use this blue system ID LED to visually locate the server. A system ID LED is also located on the front of the server. Each time you press the system ID button on the front panel, the state of both the system ID LEDs changes. The LEDs can be changed to on, blinking, or off. You can also use the Lenovo XClarity Controller or a remote management program to change the state of the system ID LEDs to assist in visually locating the server among other servers.

If the XClarity Controller USB connector is set to have both the USB 2.0 function and XClarity Controller management function, you can press the system ID button for three seconds to switch between the two functions.

### 7 Ethernet link LED (green) 8 Ethernet activity LED (green)

Each network connector has two status LEDs.

Ethernet status LED	Color	Status	Description
7 Ethernet link LED	Green	On	Network link is established.
	None	Off	Network link is disconnected.
8 Ethernet activity LED	Green	Blinking	Network link is connected and active.
	None	Off	The server is disconnected from a LAN.

## Power supply LEDs

This topic provides information about various power supply LED status and corresponding action suggestions.

The following minimum configuration is required for the server to start:

- System board
- Firmware and RoT security module (installed on the system board)
- One processor in processor socket 1 (processor TDP smaller than 200 watts)
- One DRAM DIMM in DIMM slot 10
- One power supply unit in PSU slot 1
- One drive with RAID adapter and backplane (if OS is needed for debugging)
- Three single rotor fans in fan slots 1, 2, and 4, and one fan filler in fan slot 3

The following table describes the problems that are indicated by various combinations of the power-supply LEDs and the power-on LED on the front operator panel and suggested actions to correct the detected problems.

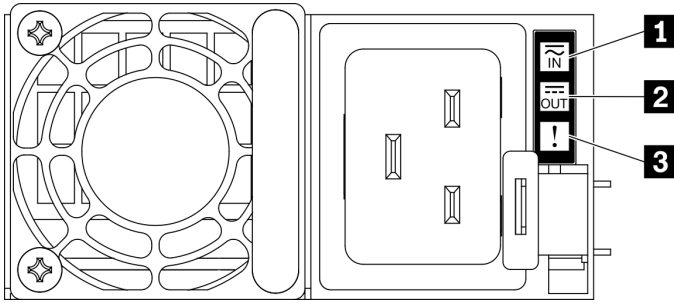

Figure 184. Power supply LEDs

LED	Description
<b>1</b> Input status	<p>The input status LED can be in one of the following states:</p> <ul style="list-style-type: none"> <li>• Off: The power supply is disconnected from the AC power source.</li> <li>• Green: The power supply is connected to the AC power source.</li> </ul>
<b>2</b> Output status	<p>The output status LED can be in one of the following states:</p> <ul style="list-style-type: none"> <li>• Off: The server is powered off, or the power supply is not working properly. If the server is powered on but the output status LED is off, replace the power supply.</li> <li>• Slow blinking green (about one flash every two seconds): The power supply is in cold redundancy active mode.</li> <li>• Fast blinking green (about 2 flashes each second): The power supply is in cold redundancy sleep mode.</li> <li>• Green: The server is on and the power supply is working normally.</li> </ul> <p>Zero-output mode can be disabled via Setup utility or Lenovo XClarity Controller web interface. If you disable zero-output mode, both power supplies will be in the active state.</p> <ul style="list-style-type: none"> <li>• Start the Setup utility, go to <b>System Settings → Power → Zero Output</b> and select <b>Disable</b>. If you disable zero-output mode, both power supplies will be in the active state.</li> <li>• Log in to the Lenovo XClarity Controller web interface, choose <b>Server Configuration → Power Policy</b>, disable <b>Zero Output Mode</b>, and then click <b>Apply</b>.</li> </ul>
<b>3</b> Fault LED	<ul style="list-style-type: none"> <li>• Off: The power supply is working normally</li> <li>• Amber: The power supply may have failed. Dump the FFDC log from the system and contact Lenovo back end support team for PSU data log reviewing.</li> </ul>

## Firmware and RoT security module LEDs

The following illustration shows the light-emitting diodes (LEDs) on the ThinkSystem V3 Firmware and Root of Trust Security Module (Firmware and RoT security module).

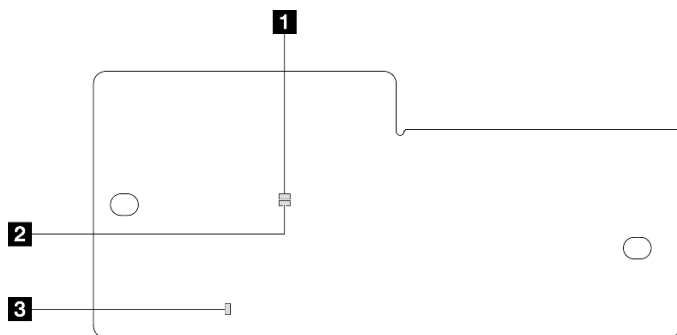

Figure 185. LEDs on the firmware and RoT security module

<b>1</b> AP0 LED (Green)	<b>2</b> AP1 LED (Green)	<b>3</b> Fatal Error LED (Amber)
--------------------------	--------------------------	----------------------------------

Table 98. LEDs description

Scenario	AP0 LED	AP1 LED	Fatal Error LED	FPGA heart-beat LED	XCC heart-beat LED	Actions
RoT security module fatal firmware failure	Off	Off	On	N/A	N/A	Replace the firmware and RoT security module.
	Blink	N/A	On	N/A	N/A	Replace the firmware and RoT security module.
No system power (FPGA heartbeat LED off)	Off	Off	Off	Off	Off	If the AC power is on, but the system board assembly does not have power, then: <ol style="list-style-type: none"> <li>1. Check the power supply unit (PSU) or power distribution board (PDB) if any. If the PSU or PDB has any error, replace it.</li> <li>2. If the PSU or PDB is good, do the following:               <ol style="list-style-type: none"> <li>a. Replace the system I/O board.</li> <li>b. Replace the processor board.</li> </ol> </li> </ol>
XCC firmware recoverable error	Blink	N/A	Off	N/A	N/A	Information only. No action is required.
XCC firmware is recovered from error	Blink	N/A	Off	N/A	N/A	Information only. No action is required.
UEFI firmware authentication failure	N/A	Blink	Off	N/A	N/A	Information only. No action is required.
UEFI firmware is recovered from authentication failure	N/A	On	Off	N/A	N/A	Information only. No action is required.
System is OK (FPGA heartbeat LED is On)	On	On	Off	On	Blink (1 Hz)	Information only. No action is required.

**Note:** For locations of the FPGA LED and XCC heartbeat LED, see “System board LEDs” on page 348.

## System board LEDs

The illustration in this section shows the LEDs on the system board.

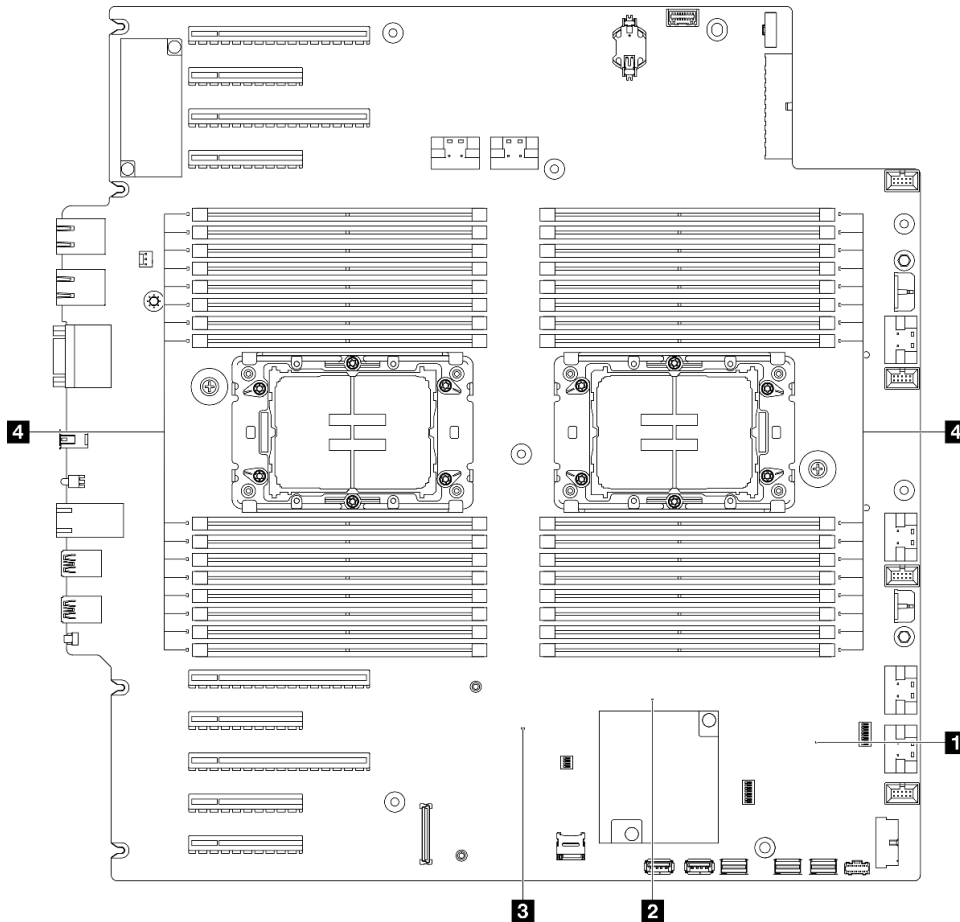

Figure 186. System board LEDs

- **1 FPGA heartbeat LED (green) behavior:**
  - Blinking:** FPGA is working normally..
  - On or off:** FPGA is not working.
- **2 ME heartbeat LED (green) behavior:**
  - Blinking:** PCH ME is functioning.
  - On or Off:** PCH ME is malfunctioning.
- **3 XCC heartbeat LED (green) behavior:**
  - Blinking rapidly:** XCC is at the initial phase.
  - Blinking (about one flash per second):** XCC is working normally.
  - Off or always on:** XCC is not working or is working abnormally.
- **4 DIMM error LEDs (amber) behavior:**
  - On:** an error has occurred to the DIMM the LED represents.

## XCC system management port (10/100/1000 Mbps RJ-45) LEDs

This topic provides information on LEDs of XCC system management port (10/100/1000 Mbps RJ-45).

The following table describes the problems that are indicated by LEDs on XCC system management port (10/100/1000 Mbps RJ-45).

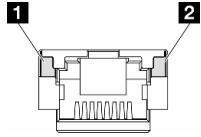

Figure 187. XCC system management port (10/100/1000 Mbps RJ-45) LEDs

LED	Description
<b>1</b> XCC system management port (10/100/1000 Mbps RJ-45) link LED	Use this green LED to distinguish the network connectivity status: <ul style="list-style-type: none"><li>• Off: The network link is disconnected.</li><li>• Green: The network link is established.</li></ul>
<b>2</b> XCC system management port (10/100/1000 Mbps RJ-45) activity LED	Use this green LED to distinguish the network activity status: <ul style="list-style-type: none"><li>• Off: The server is disconnected from a LAN.</li><li>• Green: The network is connected and active.</li></ul>

## External Diagnostics Handset

The External Diagnostics Handset is an external device that is connected to the server with a cable, and it allows quick access to system information such as errors, system status, firmware, network, and health information.

## Location of the External Diagnostics Handset

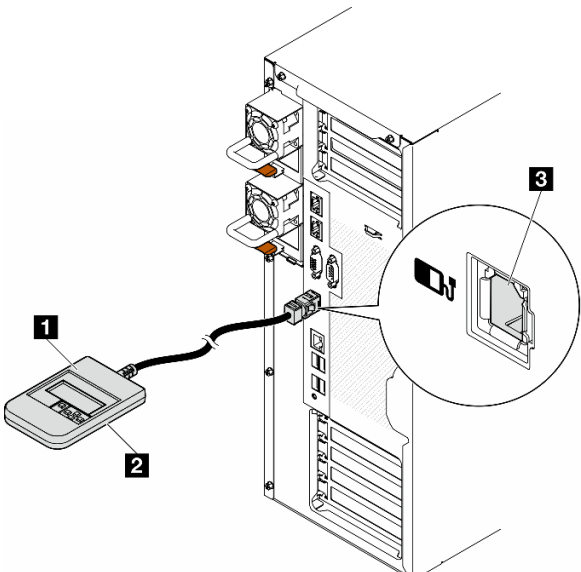
Location	Callouts
<p>The External Diagnostics Handset is connected to the server with an external cable.</p> 	<p><b>1</b> External Diagnostics Handset</p> <p><b>2</b> Magnetic bottom With this component, the diagnostic handset can be attached to the top or side of the rack with hands spared for service tasks.</p> <p><b>3</b> External Diagnostics Handset connector This connector is located on the front of the server, and is used to connect an External Diagnostics Handset.</p>

**Note:** When unplugging the External Diagnostics Handset, see the following instructions:

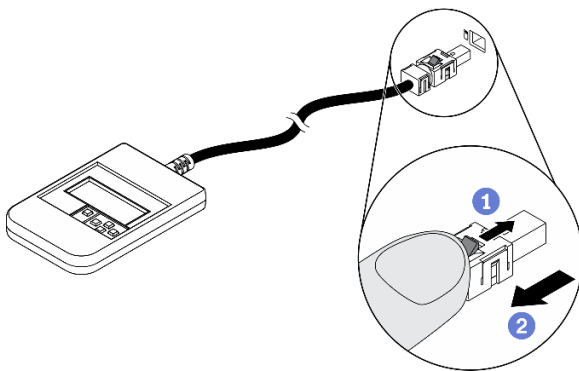

- 1** Press the plastic clip on the plug forward.
- 2** Hold the clip and remove the cable from the connector.

## Display panel overview

The diagnostics device consists of an LCD display and 5 navigation buttons.



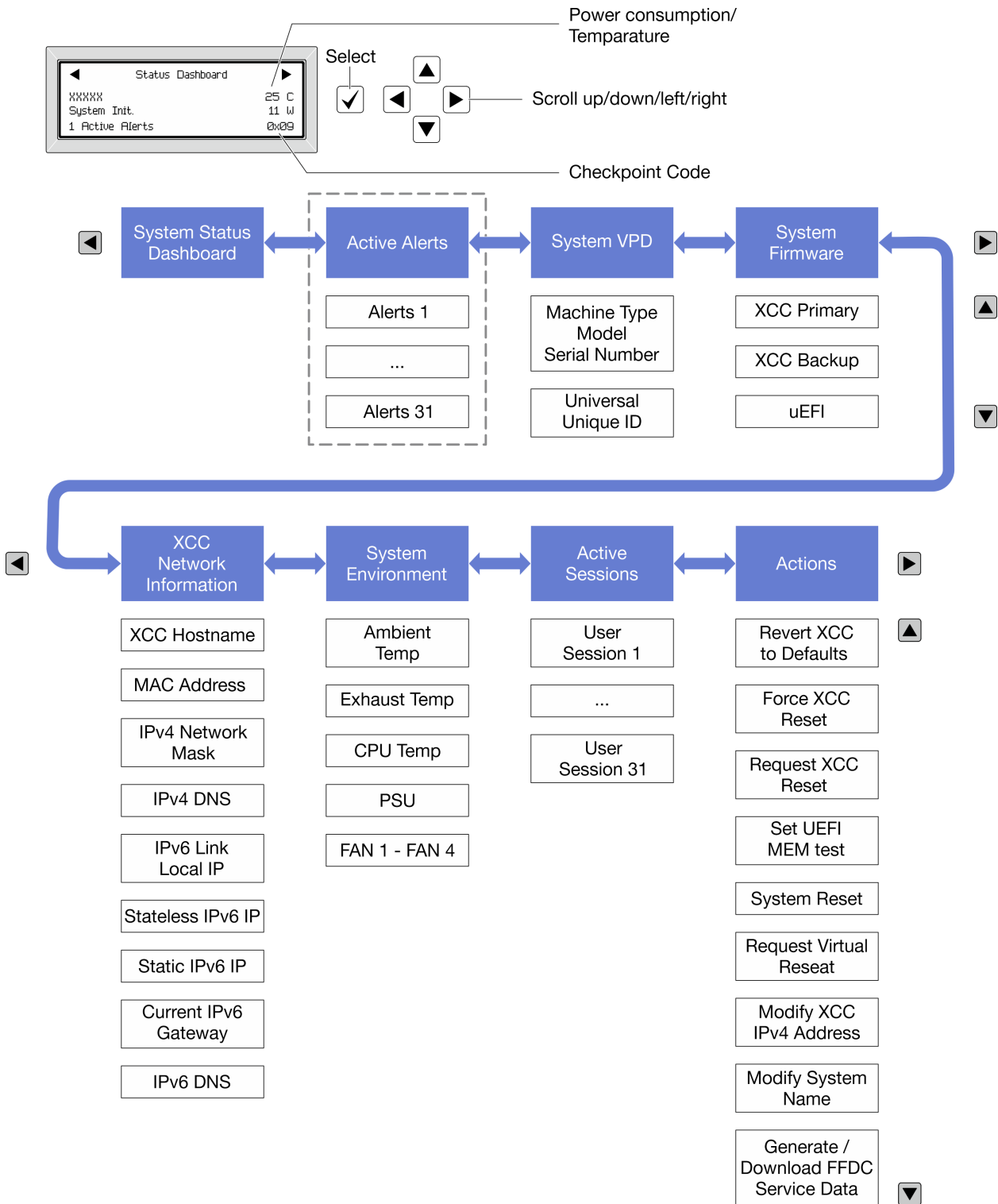

**Full menu list**

Following is the list of available options. Switch between an option and the subordinate information entries with the select button, and switch among options or information entries with the scroll buttons.

Depending on the model, the options and entries on the LCD display might be different.

## Home Menu (System Status Dashboard)

Home Menu	Example
<ul style="list-style-type: none"> <li>1 System name</li> <li>2 System status</li> <li>3 Active alert quantity</li> <li>4 Temperature</li> <li>5 Power consumption</li> <li>6 Checkpoint code</li> </ul>	<p>The screenshot shows a 'Status Dashboard' with the following information:         <ul style="list-style-type: none"> <li>1: System name (xxxxxx)</li> <li>2: System status (System Init.)</li> <li>3: Active alert quantity (1 Active Alerts)</li> <li>4: Temperature (25 C)</li> <li>5: Power consumption (11 W)</li> <li>6: Checkpoint code (0x09)</li> </ul> </p>

## Active Alerts

Sub Menu	Example
Home screen: Active error quantity <b>Note:</b> The “Active Alerts” menu displays only the quantity of active errors. If no errors occur, the “Active Alerts” menu will not be available during navigation.	1 Active Alerts
Details screen: <ul style="list-style-type: none"> <li>• Error message ID (Type: Error/Warning/Information)</li> <li>• Occurrence time</li> <li>• Possible sources of the error</li> </ul>	Active Alerts: 1 Press ▼ to view alert details FQXSPPU009N(Error) 04/07/2020 02:37:39 PM CPU 1 Status: Configuration Error

## System VPD Information

Sub Menu	Example
<ul style="list-style-type: none"> <li>• Machine type and serial number</li> <li>• Universal Unique ID (UUID)</li> </ul>	Machine Type: xxxx Serial Num: xxxxxx Universal Unique ID: xxxxxxxxxxxxxxxxxxxxxxxxxxxxxxxx

## System Firmware

Sub Menu	Example
XCC Primary <ul style="list-style-type: none"> <li>Firmware level (status)</li> <li>Build ID</li> <li>Version number</li> <li>Release date</li> </ul>	XCC Primary (Active) Build: DVI399T Version: 4.07 Date: 2020-04-07
XCC Backup <ul style="list-style-type: none"> <li>Firmware level (status)</li> <li>Build ID</li> <li>Version number</li> <li>Release date</li> </ul>	XCC Backup (Active) Build: D8BT05I Version: 1.00 Date: 2019-12-30
UEFI <ul style="list-style-type: none"> <li>Firmware level (status)</li> <li>Build ID</li> <li>Version number</li> <li>Release date</li> </ul>	UEFI (Inactive) Build: D0E101P Version: 1.00 Date: 2019-12-26

## XCC Network Information

Sub Menu	Example
<ul style="list-style-type: none"> <li>XCC hostname</li> <li>MAC address</li> <li>IPv4 Network Mask</li> <li>IPv4 DNS</li> <li>IPv6 Link Local IP</li> <li>Stateless IPv6 IP</li> <li>Static IPv6 IP</li> <li>Current IPv6 Gateway</li> <li>IPv6 DNS</li> </ul> <p><b>Note:</b> Only the MAC address that is currently in use is displayed (extension or shared).</p>	XCC Network Information XCC Hostname: XCC-xxxx-SN MAC Address: xx:xx:xx:xx:xx:xx IPv4 IP: xx.xx.xx.xx IPv4 Network Mask: x.x.x.x IPv4 Default Gateway: x.x.x.x

## System Environmental Information

Sub Menu	Example
<ul style="list-style-type: none"> <li>• Ambient temperature</li> <li>• Exhaust temperature</li> <li>• CPU temperature</li> <li>• PSU status</li> <li>• Spinning speed of fans by RPM</li> </ul>	Ambient Temp: 24 C Exhaust Temp: 30 C CPU1 Temp: 50 C PSU1: Vin= 213 w Inlet= 26 C FAN1 Front: 21000 RPM FAN2 Front: 21000 RPM FAN3 Front: 21000 RPM FAN4 Front: 21000 RPM

## Active Sessions

Sub Menu	Example
Quantity of active sessions	Active User Sessions: 1

## Actions

Sub Menu	Example
Several quick actions are available: <ul style="list-style-type: none"> <li>• Revert XCC to Defaults</li> <li>• Force XCC Reset</li> <li>• Request XCC Reset</li> <li>• Set UEFI Memory Test</li> <li>• Request Virtual Reseat</li> <li>• Modify XCC Static IPv4 Address/Net mask/Gateway</li> <li>• Modify System Name</li> <li>• Generate/Download FFDC Service Data</li> </ul>	Request XCC Reset? This will request the BMC to reboot itself. Hold √ for 3 seconds

---

## General problem determination procedures

Use the information in this section to resolve problems if the event log does not contain specific errors or the server is inoperative.

If you are not sure about the cause of a problem and the power supplies are working correctly, complete the following steps to attempt to resolve the problem:

1. Power off the server.
2. Make sure that the server is cabled correctly.
3. Remove or disconnect the following devices if applicable, one at a time, until you find the failure. Power on and configure the server each time you remove or disconnect a device.
  - Any external devices.
  - Surge-suppressor device (on the server).
  - Printer, mouse, and non-Lenovo devices.
  - Each adapter.

- Hard disk drives.
- Memory modules until you reach the minimal configuration for debugging that is supported for the server.

To determine the minimal configuration for your server, see “Minimal configuration for debugging” in [“Technical specifications” on page 5](#).

#### 4. Power on the server.

If the problem is solved when you remove an adapter from the server, but the problem recurs when you install the same adapter again, suspect the adapter. If the problem recurs when you replace the adapter with a different one, try a different PCIe slot.

If the problem appears to be a networking problem and the server passes all system tests, suspect a network cabling problem that is external to the server.

## Resolving suspected power problems

Power problems can be difficult to solve. For example, a short circuit can exist anywhere on any of the power distribution buses. Usually, a short circuit will cause the power subsystem to shut down because of an overcurrent condition.

Complete the following steps to diagnose and resolve a suspected power problem.

Step 1. Check the event log and resolve any errors related to the power.

**Note:** Start with the event log of the application that is managing the server. For more information about event logs, see [“Event logs” on page 339](#).

Step 2. Check for short circuits, for example, if a loose screw is causing a short circuit on a circuit board.

Step 3. Remove the adapters and disconnect the cables and power cords to all internal and external devices until the server is at the minimal configuration for debugging that is required for the server to start. To determine the minimal configuration for your server, see “Minimal configuration for debugging” in [“Technical specifications” on page 5](#).

Step 4. Reconnect all AC power cords and turn on the server. If the server starts successfully, reseal the adapters and devices one at a time until the problem is isolated.

If the server does not start from the minimal configuration, replace the components in the minimal configuration one at a time until the problem is isolated.

## Resolving suspected Ethernet controller problems

The method that you use to test the Ethernet controller depends on which operating system you are using. See the operating-system documentation for information about Ethernet controllers, and see the Ethernet controller device-driver readme file.

Complete the following steps to attempt to resolve suspected problems with the Ethernet controller.

Step 1. Make sure that the correct device drivers, which come with the server are installed and that they are at the latest level.

Step 2. Make sure that the Ethernet cable is installed correctly.

- The cable must be securely attached at all connections. If the cable is attached but the problem remains, try a different cable.
- Make sure that the cable rating is applicable for the network speed selected. For example, an SFP+ cable is only suitable for 10G operation. An SFP25 cable is needed for 25G operation. Likewise for Base-T operation, a CAT5 cable is required for 1G Base-T operation while a CAT6 cable is required for 10G Base-T operation.

- Step 3. Set both the adapter port and the switch port to auto-negotiation. If auto-negotiation is not supported on one of the ports, try configuring both ports manually to match each other.
- Step 4. Check the Ethernet controller LEDs on the server. These LEDs indicate whether there is a problem with the connector, cable, or hub.

Although some adapters may vary, when installed vertically the adapter link LED is typically on the left of the port and the activity LED is typically on the right.

The server front panel LED is described in [“Troubleshooting by system LEDs and diagnostics display” on page 341](#).

- The Ethernet link status LED is lit when the Ethernet controller receives a link indication from the switch. If the LED is off, there might be a defective connector or cable or a problem with the switch.
  - The Ethernet transmit/receive activity LED is lit when the Ethernet controller sends or receives data over the Ethernet network. If the Ethernet transmit/receive activity is off, make sure that the hub and network are operating and that the correct device drivers are installed.
- Step 5. Check the Network activity LED on the server. The Network activity LED is lit when data is active on the Ethernet network. If the Network activity LED is off, make sure that the hub and network are operating and that the correct device drivers are installed.

Network activity LED location is specified in [“Troubleshooting by system LEDs and diagnostics display” on page 341](#).

- Step 6. Check for operating-system-specific causes of the problem, and also make sure that the operating system drivers are installed correctly.
- Step 7. Make sure that the device drivers on the client and server are using the same protocol.

If the Ethernet controller still cannot connect to the network but the hardware appears to be working, the network administrator must investigate other possible causes of the error.

---

## Troubleshooting by symptom

Follow the instructions in this section to find solutions to problems that have identifiable symptoms.

To use the symptom-based troubleshooting information in this section, complete the following steps:

1. Check the event log of the application that is managing the server and follow the suggested actions to resolve any event codes.
  - If you are managing the server from the Lenovo XClarity Administrator, begin with the Lenovo XClarity Administrator event log.
  - If you are using some other management application, begin with the Lenovo XClarity Controller event log.

For more information about event logs (see [“Event logs” on page 339](#)).

2. Review this section to find the symptoms that you are experiencing and follow the suggested actions to resolve the issue.
3. If the problem persists, contact support (see [“Contacting Support” on page 377](#)).

## Fan problems

See this section to resolve issues related the to fans.

### **Abnormally high RPM (revolutions per minute)**

Complete the following steps until the problem is solved.

1. Check to see if the system inlet perforation or heatsinks are clogged.
2. Make sure that all air baffles are correctly installed in the server.
3. Check the thermal grease on the processor, and make sure it i's not contaminated.

### **Intermittent problems**

Use this information to solve intermittent problems.

- “Intermittent external device problems” on page 358
- “Intermittent KVM problems” on page 358
- “Intermittent unexpected reboots” on page 358

### **Intermittent external device problems**

Complete the following steps until the problem is solved.

1. Update the UEFI and XCC firmware to the latest versions.
2. Make sure that the correct device drivers are installed. See the manufacturer's website for documentation.
3. For a USB device:
  - a. Make sure that the device is configured correctly.

Restart the server and press the key according to the on-screen instructions to display the LXPM system setup interface. (For more information, see the “Startup” section in the LXPM documentation compatible with your server at <https://pubs.lenovo.com/lxpm-overview/>.) Then, click **System Settings** → **Devices and I/O Ports** → **USB Configuration**.

- b. Connect the device to another port. If using a USB hub, remove the hub and connect the device directly to the server. Make sure that the device is configured correctly for the port.

### **Intermittent KVM problems**

Complete the following steps until the problem is solved.

#### **Video problems:**

1. Make sure that all cables and the console breakout cable are properly connected and secure.
2. Make sure that the monitor is working properly by testing it on another server.
3. Test the console breakout cable on a working server to ensure that it is operating properly. Replace the console breakout cable if it is defective.

#### **Keyboard problems:**

Make sure that all cables and the console breakout cable are properly connected and secure.

#### **Mouse problems:**

Make sure that all cables and the console breakout cable are properly connected and secure.

### **Intermittent unexpected reboots**

**Note:** Some uncorrectable errors require that the server reboot so that it can disable a device, such as a memory DIMM or a processor to allow the machine to boot up properly.

1. If the reset occurs during POST and the POST watchdog timer is enabled, make sure that sufficient time is allowed in the watchdog timeout value (POST Watchdog Timer).

To check the POST watchdog time, restart the server and press the key according to the on-screen instructions to display the LXPM system setup interface. (For more information, see the “Startup” section in the LXPM documentation compatible with your server at <https://pubs.lenovo.com/lxpm-overview/>.) Then, click **BMC Settings → POST Watchdog Timer**.

2. If the reset occurs after the operating system starts, do one of the followings:
  - Enter the operating system when the system operates normally and set up operating system kernel dump process (Windows and Linux base operating systems will be using different method). Enter the UEFI setup menus and disable the feature, or disable it with the following OneCli command.  
`OneCli.exe config set SystemRecovery.RebootSystemOnNMI Disable --bmc XCC_USER:XCC_PASSWORD@XCC_IPAddress`
  - Disable any automatic server restart (ASR) utilities, such as the Automatic Server Restart IPMI Application for Windows, or any ASR devices that are installed.
3. See the management controller event log to check for an event code that indicates a reboot. See “[Event logs](#)” on page 339 for information about viewing the event log. If you are using Linux base operating system, then capture all logs back to Lenovo support for further investigation.

## Keyboard, mouse, KVM switch or USB-device problems

Follow the instructions in this section to solve problems related to a keyboard, mouse, KVM switch or USB-device problems.

- “[All or some keys on the keyboard do not work](#)” on page 359
- “[Mouse does not work](#)” on page 359
- “[KVM switch problems](#)” on page 359
- “[USB-device does not work](#)” on page 360

### All or some keys on the keyboard do not work

1. Make sure that:
  - The keyboard cable is securely connected.
  - The server and the monitor are turned on.
2. If you are using a USB keyboard, run the Setup utility and enable keyboardless operation.
3. If you are using a USB keyboard and it is connected to a USB hub, disconnect the keyboard from the hub and connect it directly to the server.
4. Replace the keyboard.

### Mouse does not work

1. Make sure that:
  - The mouse cable is securely connected to the server.
  - The mouse device drivers are installed correctly.
  - The server and the monitor are turned on.
  - The mouse option is enabled in the Setup utility.
2. If you are using a USB mouse and it is connected to a USB hub, disconnect the mouse from the hub and connect it directly to the server.
3. Replace the mouse.

### KVM switch problems

1. Make sure that the KVM switch is supported by your server.

2. Make sure that the KVM switch is powered on correctly.
3. If the keyboard, mouse or monitor can be operated normally with direct connection to the server, then replace the KVM switch.

### **USB-device does not work**

1. Make sure that:
  - The correct USB device driver is installed.
  - The operating system supports USB devices.
2. Make sure that the USB configuration options are set correctly in system setup.

Restart the server and press the key according to the on-screen instructions to display the LXPM system setup interface. (For more information, see the “Startup” section in the LXPM documentation compatible with your server at <https://pubs.lenovo.com/lxpm-overview/>.) Then, click **System Settings → Devices and I/O Ports → USB Configuration**.

3. If you are using a USB hub, disconnect the USB device from the hub and connect it directly to the server.

## **Memory problems**

See this section to resolve issues related to memory.

### **Common memory problems**

- [“Multiple memory modules in a channel identified as failing” on page 360](#)
- [“Displayed system memory is less than installed physical memory” on page 360](#)
- [“Invalid memory population detected” on page 361](#)

### **Multiple memory modules in a channel identified as failing**

**Note:** Each time you install or remove a memory module, you must disconnect the server from the power source; then, wait 10 seconds before restarting the server.

Complete the following procedure to solve the problem.

1. Reseat the memory modules; then, restart the server.
2. Remove the highest-numbered memory module of those that are identified and replace it with an identical known good memory module; then, restart the server. Repeat as necessary. If the failures continue after all identified memory modules are replaced, go to step 4.
3. Return the removed memory modules, one at a time, to their original connectors, restarting the server after each memory module, until a memory module fails. Replace each failing memory module with an identical known good memory module, restarting the server after each memory module replacement. Repeat step 3 until you have tested all removed memory modules.
4. Replace the highest-numbered memory module of those identified; then, restart the server. Repeat as necessary.
5. Reverse the memory modules between the channels (of the same processor), and then restart the server. If the problem is related to a memory module, replace the failing memory module.
6. (Trained technician only) Install the failing memory module into a memory module connector for processor 2 (if installed) to verify that the problem is not the processor or the memory module connector.
7. (Trained technician only) Replace the system board (system board assembly).

### **Displayed system memory is less than installed physical memory**

Complete the following procedure to solve the problem.

**Note:** Each time you install or remove a memory module, you must disconnect the server from the power source; then, wait 10 seconds before restarting the server.

1. Make sure that:

- No error LEDs are lit. See “[Troubleshooting by system LEDs and diagnostics display](#)” on page 341.
- No memory module error LEDs are lit on the system board (system board assembly).
- Memory mirrored channel does not account for the discrepancy.
- The memory modules are seated correctly.
- You have installed the correct type of memory module (see “[Memory module installation rules and order](#)” on page 45 for requirements).
- After changing or replacing a memory module, memory configuration is updated accordingly in the Setup Utility.
- All banks of memory are enabled. The server might have automatically disabled a memory bank when it detected a problem, or a memory bank might have been manually disabled.
- There is no memory mismatch when the server is at the minimum memory configuration.

2. Reseat the memory modules, and then restart the server.

3. Check the POST error log:

- If a memory module was disabled by a systems-management interrupt (SMI), replace the memory module.
- If a memory module was disabled by the user or by POST, reseat the memory module; then, run the Setup Utility and enable the memory module.

4. Run memory diagnostics. When you start a solution and press the key according to the on-screen instructions, the LXPM interface is displayed by default. (For more information, see the “Startup” section in the LXPM documentation compatible with your server at <https://pubs.lenovo.com/lxpm-overview/>.) You can perform memory diagnostics with this interface. From the Diagnostic page, go to **Run Diagnostic → Memory test**.

5. Reverse the modules between the channels (of the same processor), and then restart the server. If the problem is related to a memory module, replace the failing memory module.

6. Re-enable all memory modules using the Setup Utility, and then restart the server.

7. (Trained technician only) Install the failing memory module into a memory module connector for processor 2 (if installed) to verify that the problem is not the processor or the memory module connector.

8. (Trained technician only) Replace the system board (system board assembly).

### Invalid memory population detected

If this warning message appears, complete the following steps:

Invalid memory population (unsupported DIMM population) detected. Please verify memory configuration is valid.

1. See “[Memory module installation rules and order](#)” on page 45 to make sure the present memory module population sequence is supported.
2. If the present sequence is indeed supported, see if any of the modules is displayed as “disabled” in Setup Utility.
3. Reseat the module that is displayed as “disabled,” and reboot the system.
4. If the problem persists, replace the memory module.

## Monitor and video problems

Follow the instructions in this section to solve problems related to a monitor or video.

- [“Incorrect characters are displayed” on page 362](#)
- [“Screen is blank” on page 362](#)
- [“Screen goes blank when you start some application programs” on page 362](#)
- [“The monitor has screen jitter, or the screen image is wavy, unreadable, rolling, or distorted” on page 362](#)
- [“The wrong characters appear on the screen” on page 363](#)

### **Incorrect characters are displayed**

Complete the following steps:

1. Verify that the language and locality settings are correct for the keyboard and operating system.
2. If the wrong language is displayed, update the server firmware to the latest level. See [“Update the firmware” on page 320](#).

### **Screen is blank**

**Note:** Make sure that the expected boot mode has not been changed from the UEFI to Legacy or vice versa.

1. If the server is attached to a KVM switch, bypass the KVM switch to eliminate it as a possible cause of the problem: connect the monitor cable directly to the correct connector on the rear of the server.
2. If the server is installed with the graphical adapters while turning on the server, the Lenovo logo is displayed on the screen after approximately 3 minutes. This is normal operation while the system loads.
3. Make sure that:
  - The server is turned on and there is power supplied to the server.
  - The monitor cables are connected correctly.
  - The monitor is turned on and the brightness and contrast controls are adjusted correctly.
4. Make sure that the correct server is controlling the monitor, if applicable.
5. Make sure that the video output is not affected by corrupted server firmware; See [“Update the firmware” on page 320](#).
6. If the problem remains, contact Lenovo Support.

### **Screen goes blank when you start some application programs**

1. Make sure that:
  - The application program is not setting a display mode that is higher than the capability of the monitor.
  - You installed the necessary device drivers for the application.

### **The monitor has screen jitter, or the screen image is wavy, unreadable, rolling, or distorted**

1. If the monitor self-tests show that the monitor is working correctly, consider the location of the monitor. Magnetic fields around other devices (such as transformers, appliances, fluorescents, and other monitors) can cause screen jitter or wavy, unreadable, rolling, or distorted screen images. If this happens, turn off the monitor.

**Attention:** Moving a color monitor while it is turned on might cause screen discoloration.

Move the device and the monitor at least 305 mm (12 in.) apart, and turn on the monitor.

#### **Notes:**

- a. To prevent diskette drive read/write errors, make sure that the distance between the monitor and any external diskette drive is at least 76 mm (3 in.).
  - b. Non-Lenovo monitor cables might cause unpredictable problems.
2. Reseat the monitor cable.

3. Replace the components listed in step 2 one at a time, in the order shown, restarting the server each time:
  - a. Monitor cable
  - b. Video adapter (if one is installed)
  - c. Monitor
  - d. (Trained technician only) System board (system board assembly)

### The wrong characters appear on the screen

Complete the following steps until the problem is solved:

1. Verify that the language and locality settings are correct for the keyboard and operating system.
2. If the wrong language is displayed, update the server firmware to the latest level. See [“Update the firmware” on page 320](#).

## Network problems

Follow the instructions in this section to resolve issues related to networking.

### Could not log in using LDAP account with SSL enabled

Complete the following steps until the problem is resolved:

1. Make sure that the license key is valid.
2. Generate a new license key and log in again.

## Observable problems

Use this information to solve observable problems.

- [“Server hangs during the UEFI boot process” on page 363](#)
- [“The server immediately displays the POST Event Viewer when it is turned on” on page 364](#)
- [“Server is unresponsive \(POST is complete and operating system is running\)” on page 364](#)
- [“Server is unresponsive \(POST failed and cannot start System Setup\)” on page 364](#)
- [“Voltage planar fault is displayed in the event log” on page 365](#)
- [“Unusual smell” on page 365](#)
- [“Server seems to be running hot” on page 365](#)
- [“Cannot enter legacy mode after installing a new adapter” on page 365](#)
- [“Cracked parts or cracked chassis” on page 366](#)

### Server hangs during the UEFI boot process

If the system hangs during the UEFI boot process with the message UEFI: DXE INIT on the display, make sure that Option ROMs were not configured with a setting of **Legacy**. You can remotely view the current settings for Option ROMs by running the following command using the Lenovo XClarity Essentials OneCLI:

```
onecli config show EnableDisableAdapterOptionROMSupport --bmc xcc_userid:xcc_password@xcc_ipaddress
```

To recover a system that hangs during the boot process with Legacy Option ROM settings, see the following Tech Tip:

<https://datacentersupport.lenovo.com/solutions/ht506118>

If legacy Option ROMs must be used, do not set slot Option ROMs to **Legacy** on the Devices and I/O Ports menu. Instead, set slot Option ROMs to **Auto** (the default setting), and set the System Boot Mode to **Legacy Mode**. Legacy option ROMs will be invoked shortly before the system boots.

### **The server immediately displays the POST Event Viewer when it is turned on**

Complete the following steps until the problem is solved.

1. Correct any errors that are indicated by the system LEDs and diagnostics display.
2. Make sure that the server supports all the processors and that the processors match in speed and cache size.

You can view processor details from system setup.

To determine if the processor is supported for the server, see <https://serverproven.lenovo.com>.

3. (Trained technician only) Make sure that processor 1 is seated correctly.
4. (Trained technician only) Remove processor 2 and restart the server.
5. Replace the following components one at a time, in the order shown, restarting the server each time:
  - a. (Trained technician only) Processor
  - b. (Trained technician only) System board (system board assembly)

### **Server is unresponsive (POST is complete and operating system is running)**

Complete the following steps until the problem is solved.

- If you are in the same location as the compute node, complete the following steps:
  1. If you are using a KVM connection, make sure that the connection is operating correctly. Otherwise, make sure that the keyboard and mouse are operating correctly.
  2. If possible, log in to the compute node and verify that all applications are running (no applications are hung).
  3. Restart the compute node.
  4. If the problem remains, make sure that any new software has been installed and configured correctly.
  5. Contact your place of purchase of the software or your software provider.
- If you are accessing the compute node from a remote location, complete the following steps:
  1. Make sure that all applications are running (no applications are hung).
  2. Attempt to log out of the system and log back in.
  3. Validate the network access by pinging or running a trace route to the compute node from a command line.
    - a. If you are unable to get a response during a ping test, attempt to ping another compute node in the enclosure to determine whether it is a connection problem or compute node problem.
    - b. Run a trace route to determine where the connection breaks down. Attempt to resolve a connection issue with either the VPN or the point at which the connection breaks down.
  4. Restart the compute node remotely through the management interface.
  5. If the problem remains, verify that any new software has been installed and configured correctly.
  6. Contact your place of purchase of the software or your software provider.

### **Server is unresponsive (POST failed and cannot start System Setup)**

Configuration changes, such as added devices or adapter firmware updates, and firmware or application code problems can cause the server to fail POST (the power-on self-test).

If this occurs, the server responds in either of the following ways:

- The server restarts automatically and attempts POST again.
- The server hangs, and you must manually restart the server for the server to attempt POST again.

After a specified number of consecutive attempts (automatic or manual), the server reverts to the default UEFI configuration and starts System Setup so that you can make the necessary corrections to the configuration and restart the server. If the server is unable to successfully complete POST with the default configuration, there might be a problem with the system board (system board assembly).

You can specify the number of consecutive restart attempts in System Setup. Restart the server and press the key according to the on-screen instructions to display the LXPM system setup interface. (For more information, see the “Startup” section in the LXPM documentation compatible with your server at <https://pubs.lenovo.com/lxpm-overview/>.) Then, click **System Settings** → **Recovery and RAS** → **POST Attempts** → **POST Attempts Limit**. Available options are 3, 6, 9, and disable.

### **Voltage planar fault is displayed in the event log**

Complete the following steps until the problem is solved.

1. Revert the system to the minimum configuration. See “Specifications” on page 4 for the minimally required number of processors and DIMMs.
2. Restart the system.
  - If the system restarts, add each of the removed items one at a time and restart the system each time until the error occurs. Replace the item for which the error occurs.
  - If the system does not restart, suspect the system board (system board assembly).

### **Unusual smell**

Complete the following steps until the problem is solved.

1. An unusual smell might be coming from newly installed equipment.
2. If the problem remains, contact Lenovo Support.

### **Server seems to be running hot**

Complete the following steps until the problem is solved.

Multiple compute nodes or chassis:

1. Make sure that the room temperature is within the specified range (see “Specifications” on page 4).
2. Make sure that the fans are installed correctly.
3. Update the UEFI and XCC to the latest versions.
4. Make sure that the fillers in the server are installed correctly (see Chapter 5 “Hardware replacement procedures” on page 41 for detailed installation procedures).
5. Use the IPMI command to ramp up the fan speed to the full fan speed to see whether the issue can be resolved.

**Note:** The IPMI raw command should only be used by trained technician and each system has its own specific IPMI raw command.

6. Check the management processor event log for rising temperature events. If there are no events, the compute node is running within normal operating temperatures. Note that you can expect some variation in temperature.

### **Cannot enter legacy mode after installing a new adapter**

Complete the following procedure to solve the problem.

1. Go to **UEFI Setup** → **Devices and I/O Ports** → **Set Option ROM Execution Order**.

2. Move the RAID adapter with operation system installed to the top of the list.
3. Select **Save**.
4. Reboot the system and auto boot to operation system.

### **Cracked parts or cracked chassis**

Contact Lenovo Support.

## **Optional-device problems**

Use this information to solve problems related to optional devices.

- [“External USB device is not recognized” on page 366](#)
- [“PCIe adapter is not recognized or is not functioning” on page 366](#)
- [“Insufficient PCIe resources are detected.” on page 367](#)
- [“A Lenovo optional device that was just installed does not work.” on page 367](#)
- [“A Lenovo optional device that worked previously does not work now” on page 367](#)

### **External USB device is not recognized**

Complete the following steps until the problem is resolved:

1. Update the UEFI firmware to the latest version.
2. Make sure that the proper drivers are installed on the compute node. See the product documentation for the USB device for information about device drivers.
3. Use the Setup utility to make sure that the device is configured correctly.
4. If the USB device is plugged into a hub or the console breakout cable, unplug the device and plug it directly into the USB port on the front of the compute node.

### **PCIe adapter is not recognized or is not functioning**

Complete the following steps until the problem is resolved:

1. Update the UEFI firmware to the latest version.
2. Check the event log and resolve any issues related to the device.
3. Validate that the device is supported for the server (see <https://serverproven.lenovo.com>). Make sure that the firmware level on the device is at the latest supported level and update the firmware if applicable.
4. Make sure that the adapter is installed in a correct slot.
5. Make sure that the proper device drivers are installed for the device.
6. Resolve any resource conflicts if running legacy mode (UEFI). Check legacy ROM boot orders and modify the UEFI setting for MM config base.

**Note:** Ensure that you modify the ROM boot order associated with the PCIe adapter to the first execution order.

7. Check <http://datacentersupport.lenovo.com> for any tech tips (also known as retain tips or service bulletins) that might be related to the adapter.
8. Ensure any adapter external connections are correct and that the connectors are not physically damaged.
9. Make sure that the PCIe adapter is installed with the supported operating system.

### **Insufficient PCIe resources are detected.**

If you see an error message stating “Insufficient PCI Resources Detected,” complete the following steps until the problem is resolved:

1. Press Enter to access System Setup Utility.
2. Select **System Settings → Devices and I/O Ports → MM Config Base**; then, modify the setting to increase the device resources. For example, modify 3 GB to 2 GB or modify 2 GB to 1 GB.
3. Save the settings and restart the system.
4. If the error recurs with the highest device resource setting (1GB), shutdown the system and remove some PCIe devices; then, power on the system.
5. If the reboot failed, repeat step 1 to step 4.
6. If the error recurs, press Enter to access System Setup Utility.
7. Select **System Settings → Devices and I/O Ports → PCI 64-Bit Resource Allocation**, then; modify the setting from **Auto** to **Enable**.
8. If the Boot Device does not support MMIO above 4GB for Legacy Boot, use UEFI Boot Mode or remove/disable some PCIe devices.
9. DC cycle the system and ensure the system is enter UEFI boot menu or the operating system; then, capture the FFDC log.
10. Contact Lenovo technical support.

### **A Lenovo optional device that was just installed does not work.**

1. Make sure that:
  - The device is supported for the server (see <https://serverproven.lenovo.com>).
  - You followed the installation instructions that came with the device and the device is installed correctly.
  - You have not loosened any other installed devices or cables.
  - You updated the configuration information in system setup. When you start a server and press the key according to the on-screen instructions to display the Setup Utility. (For more information, see the “Startup” section in the LXPM documentation compatible with your server at <https://pubs.lenovo.com/lxpm-overview/>.) Whenever memory or any other device is changed, you must update the configuration.
2. Reseat the device that you have just installed.
3. Replace the device that you have just installed.
4. Reseat the cable connection and check there is no physical damage to the cable.
5. If there is any cable damage, then replace the cable.

### **A Lenovo optional device that worked previously does not work now**

1. Make sure that all of the cable connections for the device are secure.
2. If the device comes with test instructions, use those instructions to test the device.
3. Reseat the cable connection and check if any physical parts have been damaged.
4. Replace the cable.
5. Reseat the failing device.
6. Replace the failing device.

## **Performance problems**

Follow the instructions in this section to solve performance problems.

- [“Network performance” on page 368](#)
- [“Operating system performance” on page 368](#)

### **Network performance**

Complete the following steps until the problem is solved:

1. Isolate which network is operating slowly (such as storage, data, and management). You might find it helpful to use ping tools or operating-system tools such as task manager or resource manager.
2. Check for traffic congestion on the network.
3. Update the NIC device driver, or the storage device controller device driver.
4. Use the traffic-diagnostic tools that are provided by the IO-module manufacturer.

### **Operating system performance**

Complete the following steps until the problem is solved:

1. If you have recently made changes to the compute node (for example updated device drivers or installed software applications) remove the changes.
2. Check for any networking issues.
3. Check the operating system logs for performance related errors.
4. Check for events related to high temperatures and power issues as the compute node might be throttled to help with cooling. If it is throttled, reduce the workload on the compute node to help improve performance.
5. Check for events related to disabled DIMMs. If you do not have enough memory for the application workload, your operating system will have poor performance.
6. Ensure that the workload is not too high for the configuration.

## **Power on and power off problems**

Use this information to resolve issues when powering on or powering off the server.

- [“The power button does not work \(server does not start\)” on page 368](#)
- [“Server does not power on” on page 369](#)

### **The power button does not work (server does not start)**

**Note:** The power button will not function until approximately 1 to 3 minutes after the server has been connected to ac power to allow time for BMC to initialize.

Complete the following steps until the problem is resolved:

1. Make sure that the power button on the server is working correctly:
  - a. Disconnect the server power cords.
  - b. Reconnect the server power cords.
  - c. Reseat the front operator panel cable, and then repeat steps 1a and 2b.
    - If the server starts, reseat the front operator panel.
    - If the problem remains, replace the front operator panel.
2. Make sure that:
  - The power cords are correctly connected to the server and to a working electrical outlet.
  - The LEDs on the power supply do not indicate a problem.
  - The Power button LED is lit on and is flashing slowly.

- The push force is enough and with button force response.
3. If the power button LED is not lit on or is not flashing correctly, reseal all the power supplies and make sure AC LED on PSU rear side are lit on.
  4. If you have just installed an optional device, remove it, and restart the server.
  5. If the issue is still observed or without power button LED lit on, implement the minimum configuration to check whether any specific components lock the power permission. Replace the each power supply and check the power button function after installing the each one.
  6. If everything is still done and the issue cannot be resolved, collect the failure information with system logs captured to Lenovo support.

### **Server does not power on**

Complete the following steps until the problem is resolved:

1. Check the event log for any events related to the server not powering on.
2. Check for any LEDs that are flashing amber.
3. Check the power LED on the system board (system board assembly).
4. Check if AC power LED is lit on or the amber LED is lit on at the PSU rear side.
5. AC cycle the system.
6. Remove the CMOS battery for at least ten seconds, then, reinstall the CMOS battery.
7. Try to power on the system by IPMI command through XCC or by the power button.
8. Implement the minimum configuration (see [“Technical specifications” on page 5](#)).
9. Reseat all power supplies and make sure that AC LEDs on the PSU rear side are lit.
10. Replace the each power supply and check the power button function after installing the each one.
11. If the issue cannot be resolved by above actions, call service to review the issue symptom and see whether the system board (system board assembly) replacement is necessary.

## **Power problems**

Follow the instructions in this section to resolve issues related to power.

### **System error LED is on and event log "Power supply has lost input" is displayed**

To resolve the problem, ensure that:

1. The power supply is properly connected to a power cord.
2. The power cord is connected to a properly grounded electrical outlet for the server.
3. Make sure that the power supply AC source is stable within the supported range.
4. Swap the power supply to see if the issue follows the power supply, if it follows the power supply, then replace the failing one.
5. Review the event log and see how the problem it is to follow the event log actions to resolved the problems.

## **Serial-device problems**

Use this information to solve problems with serial ports or devices.

- [“Number of displayed serial ports is less than the number of installed serial ports” on page 370](#)
- [“Serial device does not work” on page 370](#)

## Number of displayed serial ports is less than the number of installed serial ports

Complete the following steps until the problem is solved.

1. Make sure that:
  - Each port is assigned a unique address in the Setup utility and none of the serial ports is disabled.
  - The serial-port adapter (if one is present) is seated correctly.
2. Reseat the serial port adapter.
3. Replace the serial port adapter.

## Serial device does not work

1. Make sure that:
  - The device is compatible with the server.
  - The serial port is enabled and is assigned a unique address.
  - The device is connected to the correct connector (see [“System board connectors” on page 26](#)).
2. Reseat the following components:
  - a. Failing serial device.
  - b. Serial cable.
3. Replace the following components:
  - a. Failing serial device.
  - b. Serial cable.
4. (Trained technician only) Replace the system board (system board assembly).

## Software problems

Follow the instructions in this section to solve software problems.

1. To determine whether the problem is caused by the software, make sure that:
  - The server has the minimum memory that is needed to use the software. For memory requirements, see the information that comes with the software.

**Note:** If you have just installed an adapter or memory, the server might have a memory-address conflict.

  - The software is designed to operate on the server.
  - Other software works on the server.
  - The software works on another server.
2. If you receive any error messages while you use the software, see the information that comes with the software for a description of the messages and suggested solutions to the problem.
3. Contact your place of purchase of the software.

## Storage drive problems

Use this information to resolve issues related to the storage drives.

- [“Server cannot recognize a drive” on page 371](#)
- [“Multiple drives fail” on page 371](#)
- [“Multiple drives are offline” on page 372](#)
- [“A replacement drive does not rebuild” on page 372](#)
- [“Green drive activity LED does not represent actual state of associated drive” on page 372](#)

- “Yellow drive status LED does not represent actual state of associated drive” on page 372

### Server cannot recognize a drive

Complete the following steps until the problem is solved.

1. Observe the associated yellow drive status LED. If the LED is lit, it indicates a drive fault.
2. If the status LED is lit, remove the drive from the bay, wait 45 seconds, and reinsert the drive, making sure that the drive assembly connects to the drive backplane.
3. Observe the associated green drive activity LED and the yellow status LED and perform corresponding operations in different situations:
  - If the green activity LED is flashing and the yellow status LED is not lit, the drive is recognized by the controller and is working correctly. Run the diagnostics tests for the drives. When you start a server and press the key according to the on-screen instructions, the LXPM is displayed by default. (For more information, see the “Startup” section in the LXPM documentation compatible with your server at <https://pubs.lenovo.com/lxpm-overview/>.) You can perform drive diagnostics from this interface. From the Diagnostic page, click **Run Diagnostic → Disk Drive Test**.
  - If the green activity LED is flashing and the yellow status LED is flashing slowly, the drive is recognized by the controller and is rebuilding.
  - If neither LED is lit or flashing, check whether the drive backplane is correctly seated. For details, go to step 4.
  - If the green activity LED is flashing and the yellow status LED is lit, replace the drive.
4. Make sure that the drive backplane is correctly seated. When it is correctly seated, the drive assemblies correctly connect to the backplane without bowing or causing movement of the backplane.
5. Reseat the backplane power cable and repeat steps 1 through 3.
6. Reseat the backplane signal cable and repeat steps 1 through 3.
7. Suspect the backplane signal cable or the backplane:
  - Replace the affected backplane signal cable.
  - Replace the affected backplane.
8. Run the diagnostics tests for the drives. When you start a server and press the key according to the on-screen instructions, the LXPM is displayed by default. (For more information, see the “Startup” section in the LXPM documentation compatible with your server at <https://pubs.lenovo.com/lxpm-overview/>.) You can perform drive diagnostics from this interface. From the Diagnostic page, click **Run Diagnostic → Disk Drive Test**.

Based on those tests:

- If the backplane passes the test but the drives are not recognized, replace the backplane signal cable and run the tests again.
- Replace the backplane.
- If the adapter fails the test, disconnect the backplane signal cable from the adapter and run the tests again.
- If the adapter fails the test, replace the adapter.

### Multiple drives fail

Complete the following steps until the problem is solved:

- View the Lenovo XClarity Controller event log for events related to power supplies or vibration issues and resolve those events.
- Make sure that the device drivers and firmware for the drive and server are at the latest level.

**Important:** Some cluster solutions require specific code levels or coordinated code updates. If the device is part of a cluster solution, verify that the latest level of code is supported for the cluster solution before you update the code.

### **Multiple drives are offline**

Complete the following steps until the problem is solved:

- View the Lenovo XClarity Controller event log for events related to power supplies or vibration issues and resolve those events.
- View the storage subsystem log for events related to the storage subsystem and resolve those events.

### **A replacement drive does not rebuild**

Complete the following steps until the problem is solved:

1. Make sure that the drive is recognized by the adapter (the green drive activity LED is flashing).
2. Review the SAS/SATA RAID adapter documentation to determine the correct configuration parameters and settings.

### **Green drive activity LED does not represent actual state of associated drive**

Complete the following steps until the problem is solved:

1. If the green drive activity LED does not flash when the drive is in use, run the diagnostics tests for the drives. When you start a server and press the key according to the on-screen instructions, the LXPM is displayed by default. (For more information, see the “Startup” section in the LXPM documentation compatible with your server at <https://pubs.lenovo.com/lxpm-overview/>.) You can perform drive diagnostics from this interface. From the Diagnostic page, click **Run Diagnostic → Disk Drive Test**
2. If the drive passes the test, replace the backplane.
3. If the drive fails the test, replace the drive.

### **Yellow drive status LED does not represent actual state of associated drive**

Complete the following steps until the problem is solved:

1. Turn off the server.
2. Reseat the SAS/SATA adapter.
3. Reseat the backplane signal cable and backplane power cable.
4. Reseat the drive.
5. Power on the server and observe the activity of the drive LEDs.

---

## Appendix A. Hardware disassembling for recycle

Follow the instructions in this section to recycle components with compliance with local laws or regulations.

---

### Disassemble the server for chassis recycle

Follow the instructions in this section to disassemble the server before recycling the chassis.

#### About this task

##### Attention:

- Read [“Installation Guidelines” on page 41](#) and [“Safety inspection checklist” on page 42](#) to ensure that you work safely.
- Power off the server and disconnect all power cords for this task. See [“Power off the server” on page 53](#).
- Prevent exposure to static electricity, which might lead to system halt and loss of data, by keeping static-sensitive components in their static-protective packages until installation, and handling these devices with an electrostatic-discharge wrist strap or other grounding system.
- If the server is in a rack, remove it from the rack.
- If foot stands are installed on the server, pivot them inwards and lay the server on its side for easier operation.

Step 1. Remove the redundant power supply unit. See [“Remove a power supply unit” on page 187](#).

Step 2. If necessary, remove the EIA brackets. See [“Remove the server from the rack” on page 54](#).

Step 3. Remove all the installed drives and drive fillers. See [“Remove a hot-swap drive” on page 81](#).

Step 4. Remove the server cover. See [“Remove the server cover” on page 230](#).

Step 5. Remove the security door. See [“Remove the security door” on page 207](#).

Step 6. Remove the front bezel. See [“Remove the front bezel” on page 107](#).

Step 7. Remove the front I/O module. See [“Remove the front I/O module” on page 110](#).

Step 8. Remove the optical drives. See [“Remove a 5.25-inch drive bay adapter assembly” on page 156](#) or [“Remove an optical drive or a tape drive” on page 149](#).

Step 9. Remove the expansion drive cage. [“Remove the expansion drive cage” on page 86](#).

Step 10. Remove the optical drive cage. See [“Remove the optical drive cage” on page 147](#).

Step 11. Remove all the T4 fillers. See [“Remove a T4 filler” on page 226](#).

Step 12. Remove all the flash power modules. See If necessary, remove all flash power modules. See [“Remove a flash power module” on page 100](#).

Step 13. If applicable, remove all the GPU fillers. See [“Remove a FL GPU filler” on page 113](#).

Step 14. Remove the air baffle. See [“Remove the air baffle” on page 74](#).

Step 15. If applicable, remove all the NVLink bridges. See [“Remove a GPU adapter link bridge \(NVLink bridge\)” on page 143](#).

Step 16. If applicable, remove all full-length GPU adapters. See [“Remove a FL GPU adapter” on page 173](#).

Step 17. Remove all the PCIe adapters. See [“Remove a HL PCIe adapter” on page 165](#).

Step 18. If applicable, remove all PCIe adapter holders. See [“Remove a FL PCIe adapter holder” on page 162](#).

Step 19. If applicable, remove all A2/L4 GPU air ducts. See [“Remove an A2/L4 GPU air duct” on page 71](#).

- Step 20. Remove the RoT module. See [“Remove the Firmware and RoT Security Module”](#) on page 209.
- Step 21. Remove all the fan modules and fan filler. See [“Remove a fan module”](#) on page 89.
- Step 22. Remove the fan cage assembly. See [“Remove the fan cage assembly”](#) on page 91.
- Step 23. Remove all the drive backplanes. See [“Remove a 2.5-inch drive backplane”](#) on page 64 or [“Remove a 3.5-inch drive backplane”](#) on page 67.
- Step 24. Remove all the M.2 drives from the M.2 boot adapter. See [“Remove an M.2 drive”](#) on page 124
- Step 25. Remove the M.2 boot adapter. See [“Remove an M.2 boot adapter”](#) on page 125.
- Step 26. Remove the internal CFF adapter. See [“Remove an internal CFF adapter”](#) on page 116.
- Step 27. Remove the intrusion switch. See [“Remove the intrusion switch”](#) on page 121.
- Step 28. Remove the CMOS battery (CR2032). See [“Remove the CMOS battery \(CR2032\)”](#) on page 77.
- Step 29. Remove all the memory modules. See [“Remove a memory module”](#) on page 133.
- Step 30. Remove all the PHMs. See [“Remove a processor and heat sink \(trained technician only\)”](#) on page 194.
- Step 31. Remove the system board. See [“Remove the system board \(trained technician only\)”](#) on page 216.
- Step 32. Remove the power distribution board cover. See [“Remove the power distribution board cover”](#) on page 178.
- Step 33. Remove the power distribution board. See [“Remove the power distribution board”](#) on page 180.
- Step 34. If applicable, remove the foot stands. See [“Remove the foot stands”](#) on page 104.

After disassembling the server, recycle the unit in compliance with local regulations.

---

## Appendix B. Getting help and technical assistance

If you need help, service, or technical assistance or just want more information about Lenovo products, you will find a wide variety of sources available from Lenovo to assist you.

On the World Wide Web, up-to-date information about Lenovo systems, optional devices, services, and support are available at:

<http://datacentersupport.lenovo.com>

**Note:** IBM is Lenovo's preferred service provider for ThinkSystem.

---

### Before you call

Before you call, there are several steps that you can take to try and solve the problem yourself. If you decide that you do need to call for assistance, gather the information that will be needed by the service technician to more quickly resolve your problem.

#### Attempt to resolve the problem yourself

You can solve many problems without outside assistance by following the troubleshooting procedures that Lenovo provides in the online help or in the Lenovo product documentation. The online help also describes the diagnostic tests that you can perform. The documentation for most systems, operating systems, and programs contains troubleshooting procedures and explanations of error messages and error codes. If you suspect a software problem, see the documentation for the operating system or program.

You can find the product documentation for your ThinkSystem products at the following location:

<https://pubs.lenovo.com/>

You can take these steps to try to solve the problem yourself:

- Check all cables to make sure that they are connected.
- Check the power switches to make sure that the system and any optional devices are turned on.
- Check for updated software, firmware, and operating-system device drivers for your Lenovo product. (See the following links) The Lenovo Warranty terms and conditions state that you, the owner of the Lenovo product, are responsible for maintaining and updating all software and firmware for the product (unless it is covered by an additional maintenance contract). Your service technician will request that you upgrade your software and firmware if the problem has a documented solution within a software upgrade.
  - Drivers and software downloads
    - <https://datacentersupport.lenovo.com/tw/en/products/servers/thinksystem/st650v3/7d7a/downloads/driver-list/>
  - Operating system support center
    - <https://datacentersupport.lenovo.com/solutions/server-os>
  - Operating system installing instructions
    - <https://pubs.lenovo.com/thinksystem#os-installation>
- If you have installed new hardware or software in your environment, check <https://serverproven.lenovo.com> to make sure that the hardware and software are supported by your product.
- Refer to [Chapter 8 “Problem determination” on page 339](#) for instructions on isolating and solving issues.

- Go to <http://datacentersupport.lenovo.com> and check for information to help you solve the problem.

To find the Tech Tips available for your server:

1. Go to <http://datacentersupport.lenovo.com> and navigate to the support page for your server.
2. Click on **How To's** from the navigation pane.
3. Click **Article Type** → **Solution** from the drop-down menu.

Follow the on-screen instructions to choose the category for the problem that you are having.

- Check Lenovo Data Center Forum at [https://forums.lenovo.com/t5/Datacenter-Systems/ct-p/sv\\_eg](https://forums.lenovo.com/t5/Datacenter-Systems/ct-p/sv_eg) to see if someone else has encountered a similar problem.

### Gathering information needed to call Support

If you require warranty service for your Lenovo product, the service technicians will be able to assist you more efficiently if you prepare the appropriate information before you call. You can also go to <http://datacentersupport.lenovo.com/warrantylookup> for more information about your product warranty.

Gather the following information to provide to the service technician. This data will help the service technician quickly provide a solution to your problem and ensure that you receive the level of service for which you might have contracted.

- Hardware and Software Maintenance agreement contract numbers, if applicable
- Machine type number (Lenovo 4-digit machine identifier). Machine type number can be found on the ID label, see “[Identify the server and access the Lenovo XClarity Controller](#)” on page 37.
- Model number
- Serial number
- Current system UEFI and firmware levels
- Other pertinent information such as error messages and logs

As an alternative to calling Lenovo Support, you can go to <https://support.lenovo.com/servicerequest> to submit an Electronic Service Request. Submitting an Electronic Service Request will start the process of determining a solution to your problem by making the pertinent information available to the service technicians. The Lenovo service technicians can start working on your solution as soon as you have completed and submitted an Electronic Service Request.

---

## Collecting service data

To clearly identify the root cause of a server issue or at the request of Lenovo Support, you might need collect service data that can be used for further analysis. Service data includes information such as event logs and hardware inventory.

Service data can be collected through the following tools:

- **Lenovo XClarity Provisioning Manager**

Use the Collect Service Data function of Lenovo XClarity Provisioning Manager to collect system service data. You can collect existing system log data or run a new diagnostic to collect new data.

- **Lenovo XClarity Controller**

You can use the Lenovo XClarity Controller web interface or the CLI to collect service data for the server. The file can be saved and sent to Lenovo Support.

- For more information about using the web interface to collect service data, see the “Backing up the BMC configuration” section in the XCC documentation compatible with your server at <https://pubs.lenovo.com/lxcc-overview/>.

- For more information about using the CLI to collect service data, see the “XCC `ffdc` command” section in the XCC documentation compatible with your server at <https://pubs.lenovo.com/lxcc-overview/>.

- **Lenovo XClarity Administrator**

Lenovo XClarity Administrator can be set up to collect and send diagnostic files automatically to Lenovo Support when certain serviceable events occur in Lenovo XClarity Administrator and the managed endpoints. You can choose to send diagnostic files to Lenovo Support using Call Home or to another service provider using SFTP. You can also manually collect diagnostic files, open a problem record, and send diagnostic files to the Lenovo Support.

You can find more information about setting up automatic problem notification within the Lenovo XClarity Administrator at [https://pubs.lenovo.com/lxca/admin\\_setupcallhome](https://pubs.lenovo.com/lxca/admin_setupcallhome).

- **Lenovo XClarity Essentials OneCLI**

Lenovo XClarity Essentials OneCLI has inventory application to collect service data. It can run both in-band and out-of-band. When running in-band within the host operating system on the server, OneCLI can collect information about the operating system, such as the operating system event log, in addition to the hardware service data.

To obtain service data, you can run the `getinfor` command. For more information about running the `getinfor`, see [https://pubs.lenovo.com/lxce-onecli/onecli\\_r\\_getinfor\\_command](https://pubs.lenovo.com/lxce-onecli/onecli_r_getinfor_command).

---

## Contacting Support

You can contact Support to obtain help for your issue.

You can receive hardware service through a Lenovo Authorized Service Provider. To locate a service provider authorized by Lenovo to provide warranty service, go to <https://datacentersupport.lenovo.com/serviceprovider> and use filter searching for different countries. For Lenovo support telephone numbers, see <https://datacentersupport.lenovo.com/supportphonenumberlist> for your region support details.



---

## Appendix C. Documents and supports

This section provides handy documents, driver and firmware downloads, and support resources.

---

### Documents download

This section provides introduction and download link for handy documents.

#### Documents

Download the following product documentations at:

[https://pubs.lenovo.com/st650-v3/pdf\\_files](https://pubs.lenovo.com/st650-v3/pdf_files)

- **Rail Installation Guides**
  - Rail installation in a rack
- **User Guide**
  - Complete overview, system configuration, hardware components replacing, and troubleshooting.  
Selected chapters from *User Guide*:
    - **System Configuration Guide** : Server overview, components identification, system LEDs and diagnostics display, product unboxing, setting up and configuring the server.
    - **Hardware Maintenance Guide** : Installing hardware components, cable routing, and troubleshooting.
- **Messages and Codes Reference**
  - XClarity Controller, LXPM, and uEFI events
- **UEFI Manual**
  - UEFI setting introduction

---

### Support websites

This section provides driver and firmware downloads and support resources.

#### Support and downloads

- Drivers and Software download website for ThinkSystem ST650 V3
  - <https://datacentersupport.lenovo.com/tw/en/products/servers/thinksystem/st650v3/7d7a/downloads/driver-list/>
- Lenovo Data Center Forum
  - [https://forums.lenovo.com/t5/Datacenter-Systems/ct-p/sv\\_eg](https://forums.lenovo.com/t5/Datacenter-Systems/ct-p/sv_eg)
- Lenovo Data Center Support for ThinkSystem ST650 V3
  - <https://datacentersupport.lenovo.com/products/servers/thinksystem/st650v3/7d7a>
- Lenovo License Information Documents
  - <https://datacentersupport.lenovo.com/documents/Invo-eula>
- Lenovo Press website (Product Guides/Datasheets/White papers)
  - <https://lenovopress.lenovo.com/>

- Lenovo Privacy Statement
  - <https://www.lenovo.com/privacy>
- Lenovo Product Security Advisories
  - [https://datacentersupport.lenovo.com/product\\_security/home](https://datacentersupport.lenovo.com/product_security/home)
- Lenovo Product Warranty Plans
  - <http://datacentersupport.lenovo.com/warrantylookup>
- Lenovo Server Operating Systems Support Center website
  - <https://datacentersupport.lenovo.com/solutions/server-os>
- Lenovo ServerProven website (Options compatibility lookup)
  - <https://serverproven.lenovo.com>
- Operating System Installation Instructions
  - <https://pubs.lenovo.com/thinksystem#os-installation>
- Submit an eTicket (service request)
  - <https://support.lenovo.com/servicerequest>
- Subscribe to Lenovo Data Center Group product notifications (Stay up to date on firmware updates)
  - <https://datacentersupport.lenovo.com/solutions/ht509500>

---

## Appendix D. Notices

Lenovo may not offer the products, services, or features discussed in this document in all countries. Consult your local Lenovo representative for information on the products and services currently available in your area.

Any reference to a Lenovo product, program, or service is not intended to state or imply that only that Lenovo product, program, or service may be used. Any functionally equivalent product, program, or service that does not infringe any Lenovo intellectual property right may be used instead. However, it is the user's responsibility to evaluate and verify the operation of any other product, program, or service.

Lenovo may have patents or pending patent applications covering subject matter described in this document. The furnishing of this document is not an offer and does not provide a license under any patents or patent applications. You can send inquiries in writing to the following:

*Lenovo (United States), Inc.  
8001 Development Drive  
Morrisville, NC 27560  
U.S.A.  
Attention: Lenovo Director of Licensing*

LENOVO PROVIDES THIS PUBLICATION "AS IS" WITHOUT WARRANTY OF ANY KIND, EITHER EXPRESS OR IMPLIED, INCLUDING, BUT NOT LIMITED TO, THE IMPLIED WARRANTIES OF NON-INFRINGEMENT, MERCHANTABILITY OR FITNESS FOR A PARTICULAR PURPOSE. Some jurisdictions do not allow disclaimer of express or implied warranties in certain transactions, therefore, this statement may not apply to you.

This information could include technical inaccuracies or typographical errors. Changes are periodically made to the information herein; these changes will be incorporated in new editions of the publication. Lenovo may make improvements and/or changes in the product(s) and/or the program(s) described in this publication at any time without notice.

The products described in this document are not intended for use in implantation or other life support applications where malfunction may result in injury or death to persons. The information contained in this document does not affect or change Lenovo product specifications or warranties. Nothing in this document shall operate as an express or implied license or indemnity under the intellectual property rights of Lenovo or third parties. All information contained in this document was obtained in specific environments and is presented as an illustration. The result obtained in other operating environments may vary.

Lenovo may use or distribute any of the information you supply in any way it believes appropriate without incurring any obligation to you.

Any references in this publication to non-Lenovo Web sites are provided for convenience only and do not in any manner serve as an endorsement of those Web sites. The materials at those Web sites are not part of the materials for this Lenovo product, and use of those Web sites is at your own risk.

Any performance data contained herein was determined in a controlled environment. Therefore, the result obtained in other operating environments may vary significantly. Some measurements may have been made on development-level systems and there is no guarantee that these measurements will be the same on generally available systems. Furthermore, some measurements may have been estimated through extrapolation. Actual results may vary. Users of this document should verify the applicable data for their specific environment.

---

## Trademarks

LENOVO, THINKSYSTEM, Flex System, System x, NeXtScale System, xArchitecture, ThinkEdge, and Neptune are trademarks of Lenovo.

Intel and Intel Xeon are trademarks of Intel Corporation in the United States, other countries, or both.

Internet Explorer, Microsoft, and Windows are trademarks of the Microsoft group of companies.

Linux is a registered trademark of Linus Torvalds.

All other trademarks are the property of their respective owners. © 2018 Lenovo.

---

## Important notes

Processor speed indicates the internal clock speed of the processor; other factors also affect application performance.

CD or DVD drive speed is the variable read rate. Actual speeds vary and are often less than the possible maximum.

When referring to processor storage, real and virtual storage, or channel volume, KB stands for 1 024 bytes, MB stands for 1 048 576 bytes, and GB stands for 1 073 741 824 bytes.

When referring to hard disk drive capacity or communications volume, MB stands for 1 000 000 bytes, and GB stands for 1 000 000 000 bytes. Total user-accessible capacity can vary depending on operating environments.

Maximum internal hard disk drive capacities assume the replacement of any standard hard disk drives and population of all hard-disk-drive bays with the largest currently supported drives that are available from Lenovo.

Maximum memory might require replacement of the standard memory with an optional memory module.

Each solid-state memory cell has an intrinsic, finite number of write cycles that the cell can incur. Therefore, a solid-state device has a maximum number of write cycles that it can be subjected to, expressed as total bytes written (TBW). A device that has exceeded this limit might fail to respond to system-generated commands or might be incapable of being written to. Lenovo is not responsible for replacement of a device that has exceeded its maximum guaranteed number of program/erase cycles, as documented in the Official Published Specifications for the device.

Lenovo makes no representations or warranties with respect to non-Lenovo products. Support (if any) for the non-Lenovo products is provided by the third party, not Lenovo.

Some software might differ from its retail version (if available) and might not include user manuals or all program functionality.

---

## Electronic emission notices

When you attach a monitor to the equipment, you must use the designated monitor cable and any interference suppression devices that are supplied with the monitor.

Additional electronic emissions notices are available at:

## Taiwan Region BSMI RoHS declaration

單元 Unit	限用物質及其化學符號 Restricted substances and its chemical symbols					
	鉛Lead (Pb)	汞Mercury (Hg)	鎘Cadmium (Cd)	六價鉻 Hexavalent chromium (Cr <sup>6+</sup> )	多溴聯苯 Polybrominated biphenyls (PBB)	多溴二苯醚 Polybrominated diphenyl ethers (PBDE)
機架	○	○	○	○	○	○
外部蓋板	○	○	○	○	○	○
機械組零件	-	○	○	○	○	○
空氣傳動設備	-	○	○	○	○	○
冷卻組零件	-	○	○	○	○	○
內存模組	-	○	○	○	○	○
處理器模組	-	○	○	○	○	○
電纜組零件	-	○	○	○	○	○
電源供應器	-	○	○	○	○	○
儲備設備	-	○	○	○	○	○
印刷電路板	-	○	○	○	○	○
光碟機	-	○	○	○	○	○

備考1. “超出0.1 wt %”及“超出0.01 wt %”係指限用物質之百分比含量超出百分比含量基準值。  
 Note1: “exceeding 0.1wt%” and “exceeding 0.01 wt%” indicate that the percentage content of the restricted substance exceeds the reference percentage value of presence condition.

備考2. “○”係指該項限用物質之百分比含量未超出百分比含量基準值。  
 Note2: “○”indicates that the percentage content of the restricted substance does not exceed the percentage of reference value of presence.

備考3. “-”係指該項限用物質為排除項目。  
 Note3: The “-” indicates that the restricted substance corresponds to the exemption.

0718

## Taiwan Region import and export contact information

Contacts are available for Taiwan Region import and export information.

委製商/進口商名稱: 台灣聯想環球科技股份有限公司  
 進口商地址: 台北市南港區三重路 66 號 8 樓  
 進口商電話: 0800-000-702

## China Energy Label (CEL)

本产品的中国能效标识加施在服务器产品本体上。  
 中国能效标识中的配置类型Type 1、Type 2、Type 3分别对应能效等级1、2、3级的产品配置。同一规格型号下产品配置会有所不同。（此描述仅适用于中国能效范围内的产品）





**Lenovo**