



# INFOCUS QUANTUM LASER USERS GUIDE

REGULATORY MODEL	PRODUCT NAME	LENS TYPE	RESOLUTION
P135	QUANTUM LASER IN1068SL	STANDARD THROW	1080P
P135	QUANTUM LASER IN1069SL	STANDARD THROW	WUXGA



## TABLE OF CONTENTS

<b>1. ABOUT THIS GUIDE.....</b>	<b>3</b>
1.1 DESCRIPTION OF THE USER .....	3
1.2 CONVENTIONS USED IN THIS GUIDE.....	3
1.3 EXPLANATION OF SAFETY WARNINGS .....	3
1.4 RETAINING INSTRUCTIONS .....	3
1.5 OBTAINING DOCUMENTATION AND INFORMATION .....	4
1.6 DOCUMENTATION FEEDBACK.....	4
1.7 SUPPORT AND SERVICE.....	4
<b>2. SAFETY INSTRUCTIONS.....</b>	<b>5</b>
2.1 INTENDED USE STATEMENT.....	6
2.2 SAFETY INFORMATION .....	6
2.3 TRADEMARKS .....	7
2.4 REGULATORY NOTICES.....	7
2.5 DO NOT STARE INTO THE BEAM .....	8
2.6 PRODUCT SAFETY LABELS AND LOCATION.....	9
<b>3. INTRODUCTION .....</b>	<b>10</b>
3.1 PACKAGE OVERVIEW .....	10
3.2 STANDARD ACCESSORIES.....	10
3.3 PRODUCT OVERVIEW.....	10
3.4 CONNECTIONS .....	11
3.5 KEYPAD.....	11
3.6 REMOTE CONTROL .....	12
<b>4. SETUP AND INSTALLATION.....</b>	<b>13</b>
4.1 INSTALLING THE PROJECTOR.....	13
4.2 CONNECTING TO A COMPUTER.....	15
4.3 CONNECTING TO A DVD PLAYER .....	16
4.4 ADJUSTING THE PROJECTOR IMAGE.....	17
4.5 REMOTE SETUP.....	18
<b>5. USING THE PROJECTOR .....</b>	<b>20</b>
5.1 POWERING ON / OFF THE PROJECTOR .....	20
5.2 SELECTING AN INPUT SOURCE .....	21
5.3 MENU NAVIGATION AND FEATURES .....	21
5.4 OSD MENU TREE .....	22
5.5 IMAGE MENU .....	27
5.6 DISPLAY MENU .....	29
5.7 DEVICE SETUP MENU .....	31
5.8 INPUT SETTINGS MENU .....	33
5.9 AUDIO MENU .....	34
5.10 CONTROL (NETWORK) MENU .....	34
5.11 NETWORK CONTROL MENU .....	36
5.12 INFO MENU .....	41
<b>6. ADDITIONAL INFORMATION .....</b>	<b>41</b>
6.1 COMPATIBLE RESOLUTIONS.....	41
6.2 IMAGE SIZE AND PROJECTION DISTANCE .....	46
6.3 PROJECTOR DIMENSIONS AND CEILING MOUNT INSTALLATION .....	49
6.4 RS232 COMMANDS AND PROTOCOL FUNCTION LIST .....	50
6.5 TROUBLESHOOTING .....	58
6.6 WARNING INDICATORS.....	59
6.7 SPECIFICATIONS.....	60
<b>7. CONTACT INFORMATION.....</b>	<b>62</b>

# 1. ABOUT THIS GUIDE

## 1.1 DESCRIPTION OF THE USER

This document is intended for anyone who will install, setup, or use the projector.

## 1.2 CONVENTIONS USED IN THIS GUIDE

The following style conventions are used in this document:

### **Bold**

- Names of product elements, commands, options, and programs.
- Names of interface elements (such windows, dialog boxes, buttons, fields, and menus).
- Interface elements the user selects, clicks, taps, or types.

### *Italic*

- Publication titles.
- Emphasis (for example, a new term).

## 1.3 EXPLANATION OF SAFETY WARNINGS



### **WARNING**

“WARNING” indicates a hazard with a medium to high level of risk which, could result in death or serious injury.



### **ATTENTION**

“ATTENTION” indicates a hazard with a low level of risk which, if not avoided, could result in minor or moderate injury.



### **INFORMATION**

“INFORMATION” Indicates information considered important, but not hazardrelated.

## 1.4 RETAINING INSTRUCTIONS

Keep all safety information and instructions for future reference and pass them on to subsequent users of the product.



### **WARNING**

Ensure that each person who uses the product has read and understood this guide and its safety instructions before using this product. Failure to do so can result in serious injury or death.



### **ATTENTION**

Follow all the instructions. This will avoid fire, explosions, electric shocks, or other hazards that may result in damage to property and/or severe or fatal injuries.



### **INFORMATION**

The manufacturer is not liable for cases of material damage or personal injury caused by incorrect handling or non-compliance with the safety instructions. In such cases, the warranty will be voided.

## 1.5 OBTAINING DOCUMENTATION AND INFORMATION

The latest version of this document can be obtained by visiting:

- <https://infocus.com/product/authentic-ii/>

## 1.6 DOCUMENTATION FEEDBACK

If you are reading product documentation on the internet, any comments can be submitted [Here](#). We appreciate your comments.

## 1.7 SUPPORT AND SERVICE

Please contact the support team in your region for technical and product support. Alternatively, you may contact your local distributor if you are in Asia or Australia.

### AMERICAS

Monday – Friday  
6am – 5pm PST

 +1 877-388-8360

 [support@infocus.com](mailto:support@infocus.com)

 [infocus.com/support](https://infocus.com/support)

### EUROPE, MIDDLE EAST & AFRICA

Monday – Friday  
8am – 5pm CET

 [eusupport@infocus.com](mailto:eusupport@infocus.com)

 [infocus.com/support](https://infocus.com/support)

### ASIA PACIFIC

Monday – Friday  
8am – 5pm ICT

 [apsupport@infocus.com](mailto:apsupport@infocus.com)

 [infocus.com/support](https://infocus.com/support)

## 2. SAFETY INSTRUCTIONS



The lightning flash with arrow head within an equilateral triangle is intended to alert the user to the presence of uninsulated “dangerous voltage” within the product’s enclosure that may be of sufficient magnitude to constitute a risk of electric shock to persons.



The exclamation point within an equilateral triangle is intended to alert the user to the presence of important operating and maintenance (servicing) instructions in the literature accompanying the appliance.



### WARNING

To reduce the risk of fire or electric shock, do not expose this appliance to rain or moisture. Dangerous high voltages are present inside the enclosure. Do not open the cabinet. Refer servicing to qualified personnel only.

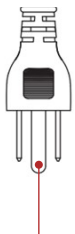

Do not remove



### ATTENTION

This equipment is equipped with a three-pin grounding-type power plug. Do not remove the grounding pin on the power plug. This plug will only fit a grounding type power outlet. This is a safety feature. If you are unable to insert the plug into the outlet, contact an electrician. Do not defeat the purpose of the grounding plug.



### WARNING

Do not remove the earthing pin on the mains plugs. This apparatus is equipped with a three prong earthing type mains plug. This plug will only fit an earthing-type mains socket. This is a safety feature. If you are unable to insert the plug into the mains socket, contact an electrician. Do not defeat the purpose of the earthing plug.

## IMPORTANT SAFETY INSTRUCTION

1. Do not block any ventilation openings. To ensure reliable operation of the projector and to protect from over heating, it is recommended to install the projector in a location that does not block ventilation. As an example, do not place the projector on a crowded coffee table, sofa, bed, etc. Do not put the projector in an enclosure such as a book case or a cabinet that restricts air flow.
2. Do not use the projector near water or moisture. To reduce the risk of fire and/or electric shock, do not expose the projector to rain or moisture.
3. Do not install near heat sources such as radiators, heaters, stoves or any other apparatus such as amplifiers that emit heat.
4. Clean only with dry cloth.
5. Only use attachments/accessories specified by the manufacturer.
6. Do not use the unit if it has been physically damaged or abused. Physical damage/abuse would be (but not limited to):
  - Unit has been dropped.
  - Power supply cord or plug has been damaged.
  - Liquid has been spilled on to the projector.
  - Projector has been exposed to rain or moisture.
  - Something has fallen in the projector or something is loose inside.

Do not attempt to service the unit yourself. Opening or removing covers may expose you to dangerous voltages or other hazards. Please call InFocus before you send the unit for repair.
7. Do not let objects or liquids enter the projector. They may touch dangerous voltage points and short out parts that could result in fire or electric shock.
8. See projector enclosure for safety related markings.
9. The unit should only be repaired by appropriate service personnel.

### 2.1 INTENDED USE STATEMENT

#### Operation Temperature:

- For 0 - 2500 ft, 0°C ~ 40°C
- For 2500 - 5000 ft, 0°C ~ 35°C
- For 5000 - 10000 ft, 0°C ~ 30°C

#### Maximum Humidity:

- Operating: 10%~80% RH (Max.), Non-condensing
- Storage: 5%~90% RH, Non-condensing

The ambient operating environment should be free of airborne smoke, grease, oil and other contaminants that can affect the operation or performance of the projector.

Use of this product in adverse conditions will void the product warranty.

### 2.2 SAFETY INFORMATION

Please read, understand, and follow all safety information contained in these instructions prior to the use of this projector. Retain these instructions for future reference.



#### WARNING

##### To reduce the risk associated with hazardous voltage:

- Do not modify this product in any way.
- Do not attempt to service this projector.
- There are no user-serviceable parts. Service to be performed only by a InFocus authorized service provider using InFocus approved system components.

##### To reduce the risk associated with fire and explosion:

- Do not immerse the projector in any liquid or allow to get wet.

##### To reduce the risks associated with choking:

- Keep all small parts like the remote control battery away from young children and pets.

##### To reduce the risk associated with hazardous voltage, impact, tripping, and intense visible light:

- Do not use this projector around unsupervised children.



#### ATTENTION

##### To reduce the risks associated with hearing loss:

- Be sure to read earphone manufacturer's instructions with respect to volume level.
- User is responsible to set a safe volume level.

##### To reduce the risk associated with explosion, and/or chemicals from a leaking batteries:

- Use with two AAA batteries.
- Orient the battery's plus (+) and minus (-) terminals of the batteries according to the markings found on the remote control.
- Do not leave the batteries in the remote for an extended period of time.
- Do not heat or expose the batteries to fire.
- Do not disassemble, short, or recharge the batteries.
- Do not carry batteries loose in your pocket or purse.
- Avoid eye and skin contact in the event a battery leaks.

##### To reduce the risk associated with environmental contamination:

- Dispose of all system components in accordance with applicable government regulations.

##### To reduce the risks associated with Laser light:

- Do not stare directly into the projector lens.

##### To reduce the risks associated with tripping and falling:

- Position the power cord and data cables so that they are not a tripping hazard.

**INFORMATION**

Do not expose the projector to direct sunlight in a closed space such as a vehicle.

**SAVE THESE INSTRUCTIONS****ATTENTION**

Use of controls or adjustments or performance of procedures other than those specified herein may result in hazardous radiation exposure.

**2.3 TRADEMARKS**

InFocus and the InFocus logo are trademarks of InFocus Corporation.

Adobe and the Adobe logo are either registered trademarks or trademarks of Adobe Systems Incorporated in the United States and/or other countries.

Microsoft, PowerPoint, and Excel are registered trademarks of Microsoft Corporation.

All other trademarks or registered trademarks are property of their respective companies.

**2.4 REGULATORY NOTICES****FCC STATEMENT - CLASS B**

This equipment generates, uses and can radiate radio frequency energy, and if not installed and used in accordance with the instruction manual may cause interference to radio communications. It has been tested and found to comply with the limits for a Class "B" computing device pursuant to Subpart B of Part 15 of the FCC Rules, which are designed to provide reasonable protection against such interference when operated in a residential installation. However, there is no guarantee that interference will not occur in a particular installation. If this equipment does cause harmful interference to radio or television reception, which can be determined by turning the equipment off and on, the user is encouraged to try to correct the interference by one or more of the following measures:

- Reorient or relocate the receiving antenna.
- Increase the separation between the equipment and receiver.
- Connect the equipment into an outlet on a circuit different from that to which the receiver is connected.
- Consult the dealer or an experienced radio/TV technician for help.

**Notice**

This Class B digital apparatus complies with Canadian ICES-003.

Cet appareil numérique de la classe B est conforme à la norme NMB-003 du Canada.

**INDUSTRY CANADA REGULATORY INFORMATION**

Operation is subject to the following two conditions:

1. this device may not cause interference,  
and
2. this device must accept any interference, including interference that may cause undesired operation of the device.

The user is cautioned that this device should be used only as specified within this manual to meet RF exposure requirements. Use of this device in a manner inconsistent with this manual could lead to excessive RF exposure conditions.

**INSTRUCTIONS TO USERS:** This equipment complies with the requirements of FCC equipment provided that the following conditions are met. If the cables include a EMI ferrite core, attach the ferrite core end of the cable to the projector. Use the cables which are included with the projector or specified.

**Note**

Changes or modifications not expressly approved by the party responsible for compliance could void the user's authority to operate the equipment.

**Complies with IDA Standards DA103121**

## CE STATEMENT

**Electromagnetic Compatibility Statement:** Meets 2014/30/EU Directive

**Low Voltage Directive:** Meets 2014/35/EU Directive

### WEEE Statement

The following information is only for EU-member States:

The mark shown below is in compliance with Waste Electrical and Electronic Equipment Directive 2012/19/EU (WEEE). The mark indicates the requirement NOT to dispose of the equipment as unsorted municipal waste, but use the return and collection systems according to local law.



## UKCA COMPLIANCE STATEMENT

Electromagnetic Compatibility Regulations 2016

Electrical Equipment (Safety) Regulations 2016

The Restriction of the Use of Certain Hazardous Substances in Electrical and Electronic Equipment Regulations 2012  
 Manufacturer, Importer and Authorised Representative in accordance with national directives

## 2.5 DO NOT STARE INTO THE BEAM

- This product is classified as CLASS 1 LASER PRODUCT - RISK GROUP 2 of IEC60825-1: 2014 and also complies with 21 CFR 1040.10 and 1040.11 as a Risk Group 2, LIP (Laser Illuminated Projector) as defined in IEC 6247:1:Ed. 1.0.
- For more information, see Laser Notice No. 57, dated May 8, 2019.
- Additional instructions to supervise children, no staring, and not use optical aids.
- Notice is given to supervise children and to never allow them to stare into the projector beam at any distance from the projector.
- Notice is given to use caution when using the remote control for starting the projector while in front of the projection lens.
- Notice is given to the user to avoid the use of optical aids such as binoculars or telescopes inside the beam.
- When turning on the projector, make sure no one within projection range is looking at the lens.
- Keep any items (magnifying glass etc.) out of the light path of the projector. The light path being projected from the lens is extensive, therefore any kind of abnormal objects that can redirect light coming out of the lens, can cause an unpredictable outcome such as a fire or injury to the eyes.
- Any operation or adjustment not specifically instructed by the user's guide creates the risk of hazardous laser radiation exposure.
- Do not open or disassemble the projector as this may cause damage by the exposure of laser radiation.
- Do not stare into beam when the projector is on. The bright light may result in permanent eye damage.
- Without following the control, adjustment or operation procedure may cause damage by the exposure of laser radiation.

### Do not stare into beam, RG2

As with any bright source, do not stare into the direct beam, RG2 IEC 62471-5:2015.



### CAUTION! Hot Surface, Do not touch.



- Do not place your hands, face, or other objects in front of the projector lens while the projector is operating. Doing so can cause the object to get extremely hot, and possibly resulting in a fire or damage due to the heat emitted from the light output. Things placed in front of the lens may overheat and burn or start a fire.
- Do not spray flammable gas to get rid of the dust and dirt that accumulated in the lens.
- Doing so could cause a fire.

## 2.6 PRODUCT SAFETY LABELS AND LOCATION

### Light Beam Related Safety Labels and Location

LABEL NAME	LABEL IMAGE	LABEL LOCATION
Specification Label		
<p><b>Note</b> Spec label varies by region (for reference only).</p>		
Warning Label		
Warning Label		
Safety Label		

## 3. INTRODUCTION

### 3.1 PACKAGE OVERVIEW

Carefully unpack and verify that you have the items listed below under standard accessories. Some of the items under optional accessories may not be available depending on the model, specification and your region of purchase. Please check with your place of purchase. Some accessories may vary from region to region. The warranty card is only supplied in some specific regions. Please consult your dealer for detailed information.

### 3.2 STANDARD ACCESSORIES

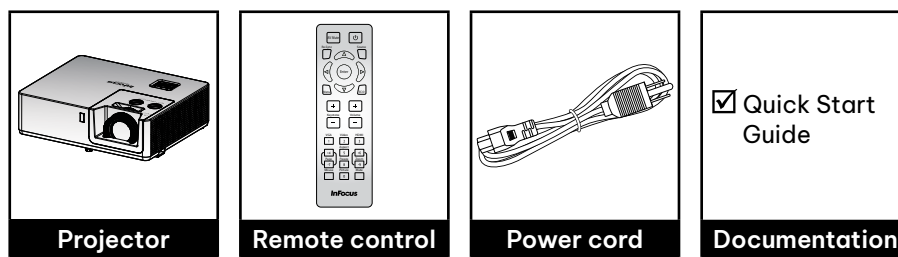

### 3.3 PRODUCT OVERVIEW

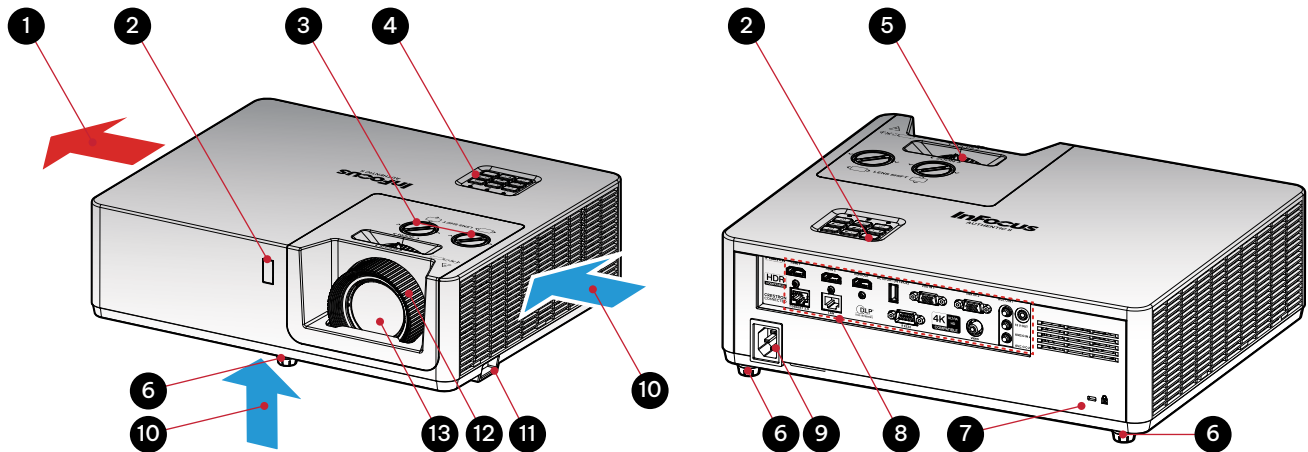

- Note**
- Do not block projector intake and exhaust vents.
  - When operating the projector in an enclosed space, allow at least 30 cm clearance around the intake and exhaust vents.

REFERENCE	DESCRIPTION	REFERENCE	DESCRIPTION
1	Ventilation (outlet)	8	Input / Output
2	IR Receivers	9	Power Socket
3	Lens Shift Ring	10	Ventilation (inlet)
4	Keypad	11	Security Bar
5	Zoom Ring	12	Focus Ring
6	Tilt - Adjustment Feet	13	Lens
7	Kensington™ Lock Port		

### 3.4 CONNECTIONS

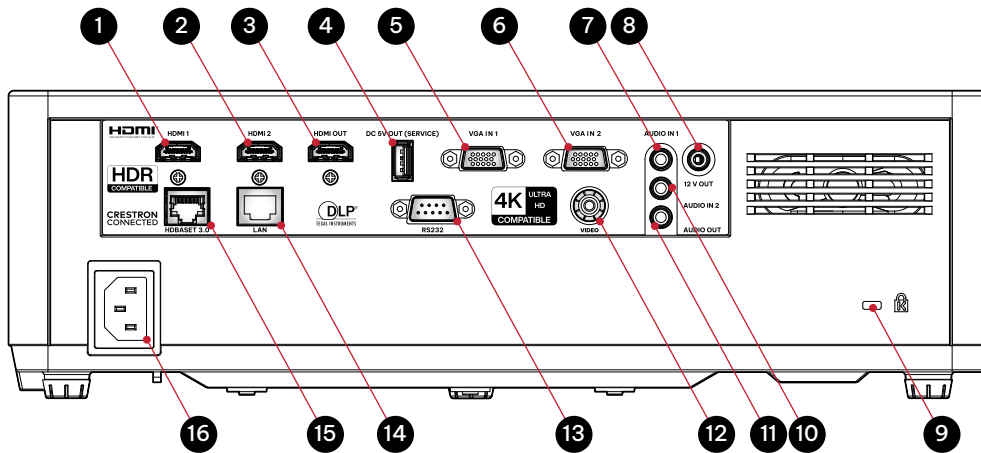

REFERENCE	DESCRIPTION
1	HDMI IN 1 Connector
2	HDMI IN 2 Connector
3	HDMI OUT Connector
4	USB Power Out (DC 5V) Connector
5	VGA IN 1 Connector
6	VGA IN 2 Connector
7	AUDIO IN 1 Connector
8	12V OUT Connector

REFERENCE	DESCRIPTION
9	Kensington™ Lock Port
10	AUDIO IN 2 Connector
11	AUDIO OUT Connector
12	VIDEO Connector
13	RS232 Connector
14	RJ45 Connector
15	HDBaseT Connector
16	Power Socket

### 3.5 KEYPAD

REFERENCE	DESCRIPTION
1	Power LED
2	Lamp LED
3	Temperature LED
4	Keystone correction
5	Information
6	Re-Sync
7	Enter
8	Menu
9	Four Directional Select Keys
10	Source
11	Power

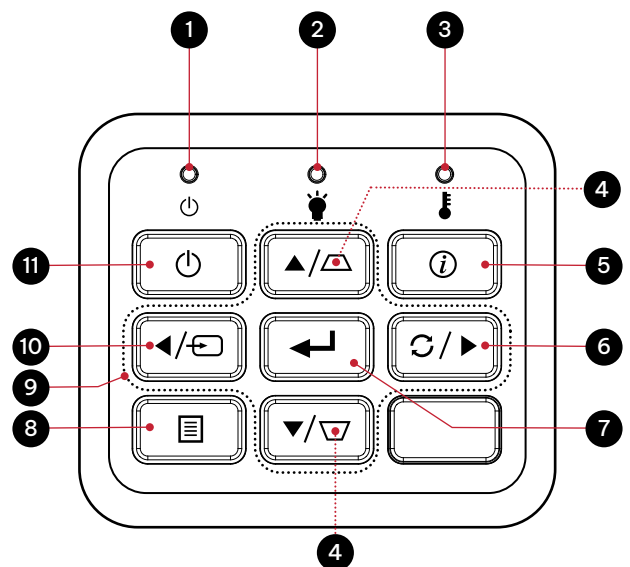

## 3.6 REMOTE CONTROL

REFERENCE	DESCRIPTION
1	IR LED
2	Power
3	Source
4	Enter
5	ECO
6	Volume
7	Aspect
8	HDMI – Press once for HDMI 1 and twice for HDMI 2
9	Zoom
10	Mute
11	Freeze
12	Picture
13	Mouse
14	Page
15	VGA
16	Video
17	Keystone correction
18	Menu
19	Directional keys
20	Re-sync
21	AV Mute

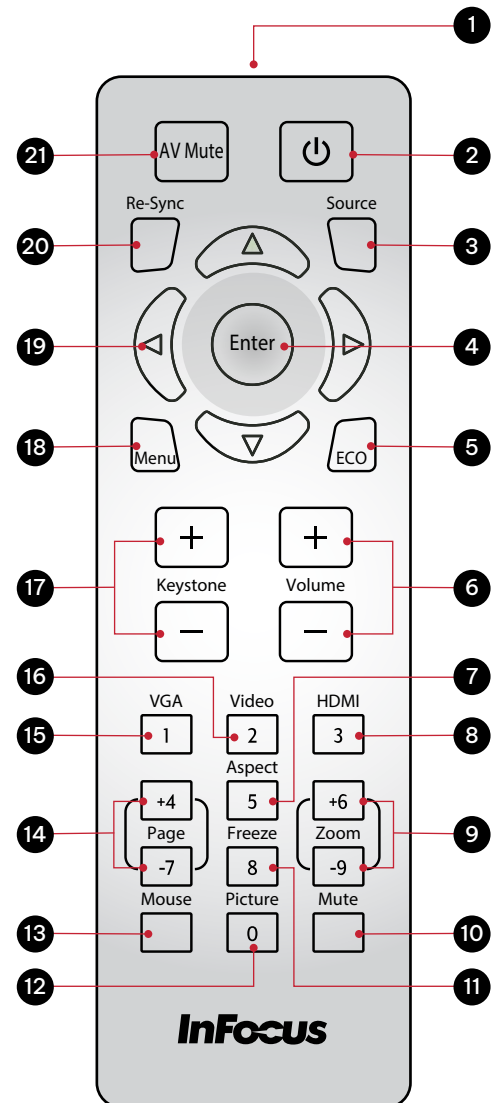

**Note** Some keys may have no function for models that do not support these features.

## 4. SETUP AND INSTALLATION

### 4.1 INSTALLING THE PROJECTOR

Your projector is designed to be installed in one of four possible positions. Your room layout or personal preference will dictate which installation location you select. Take into consideration the size and position of your screen, the location of a suitable power outlet, as well as the location and distance between the projector and the rest of your equipment.

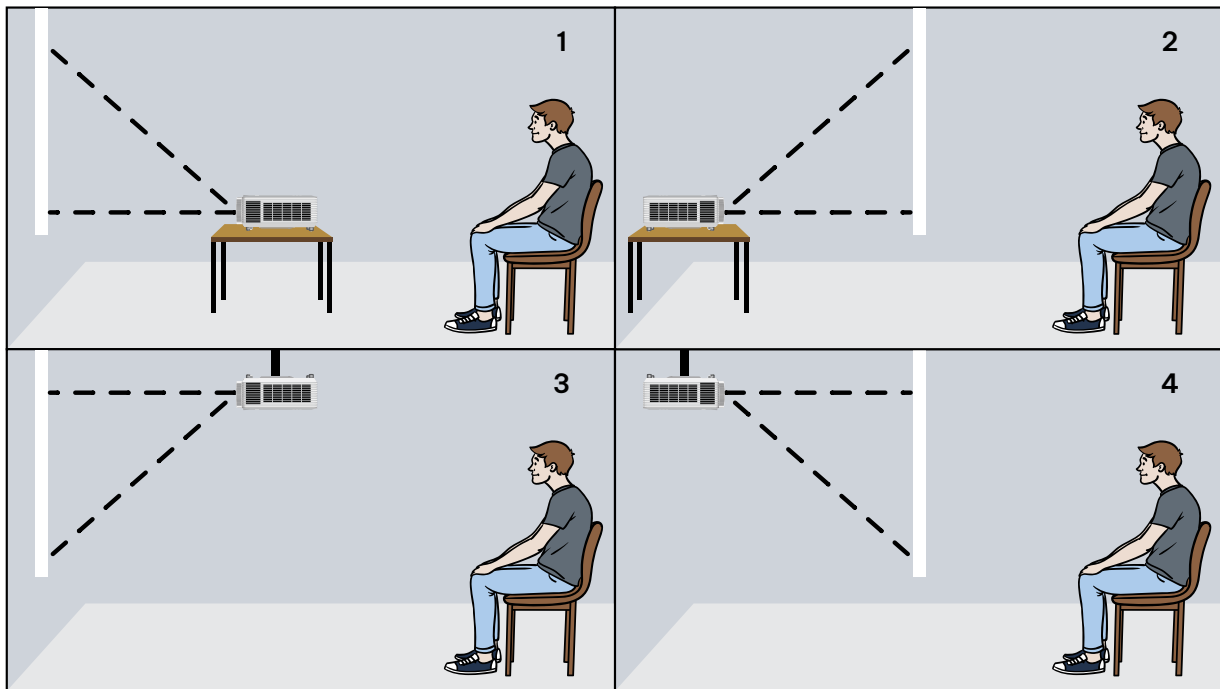

1. Table mounted front projection
2. Table mounted rear projection
3. Ceiling mounted front projection
4. Ceiling mounted rear projection

Projector should be placed flat on a surface and 90 degrees / perpendicular to the screen.

- How to determine projector location for a given screen size, please refer to distance table on pages [46-48](#).
- How to determine screen size for a given distance, please refer to distance table on pages [46-48](#).

**Note** The further away the projector is placed from the screen the projected image size increases and vertical offset also increases proportionally.



#### INFORMATION

Do not operate the projector in any orientation other than table top or ceiling mount. The projector should be horizontal and not tilted either forwards/backwards or left/right. Any other orientation will invalidate the warranty and may shorten the lifetime of the projector light source or the projector itself. For non-standard installation advice please contact InFocus.

### PROJECTOR INSTALLATION NOTICE

- Place the projector in a horizontal position. **The tilt angle of the projector should not exceed 15 degrees, however, portrait installation is allowed.** The projector should not be installed in any way other than the desktop and ceiling mount, otherwise laser life could decrease dramatically, and may lead to other **unpredictable damage.**

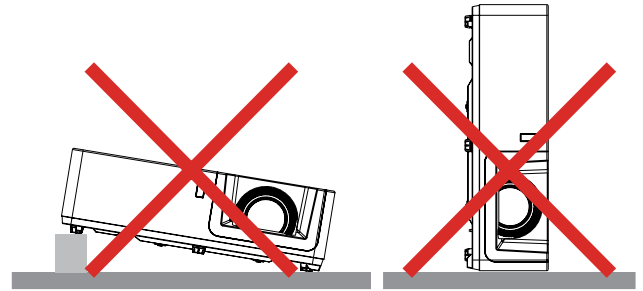

- When the projector is installed in 360° / portrait upright position, make sure the intake and exhaust vents are unobstructed and there is at least 30cm clearance around the vents.

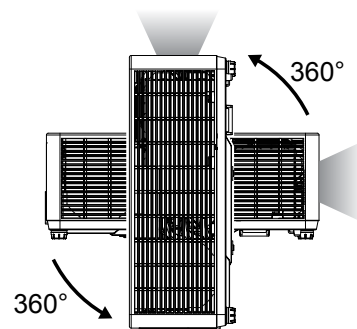

- Allow at least 30cm clearance around the intake and exhaust vents.

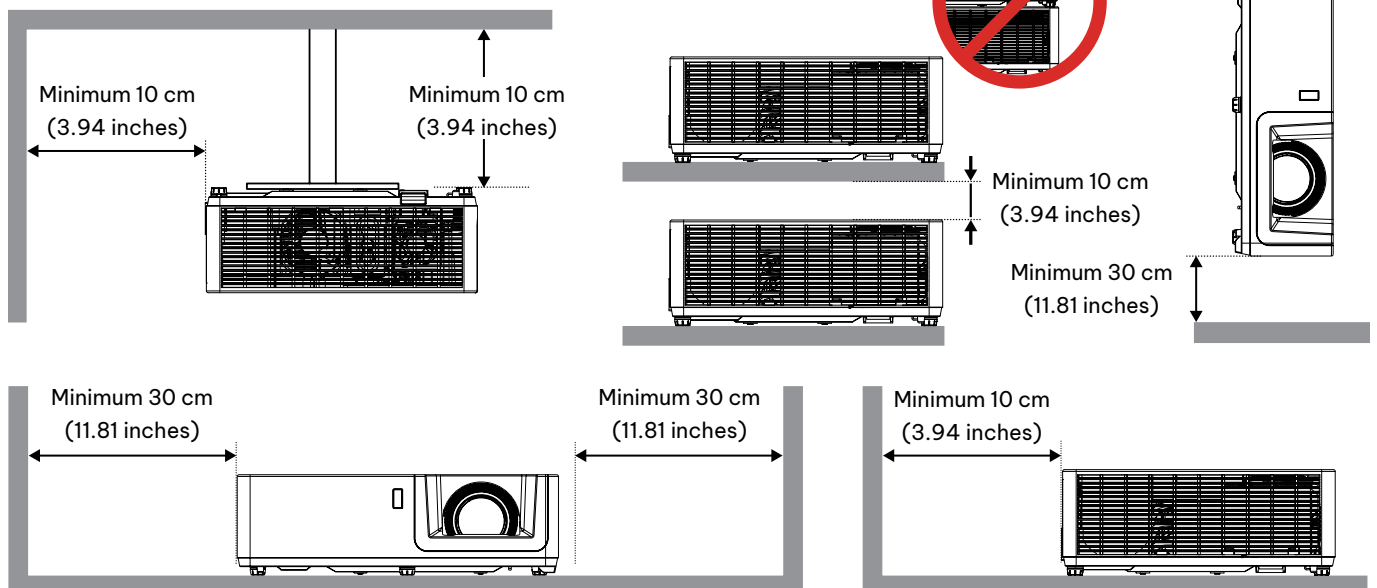

- Ensure that the intake vents do not recycle hot air from the exhaust vent.
- When operating the projector in an enclosed space, ensure that the surrounding air temperature within the enclosure does not exceed operation temperature while the projector is running, and the air intake and exhaust vents are unobstructed.
- All enclosures should pass a certified thermal evaluation to ensure that the projector does not recycle exhaust air, as this may cause the device to shutdown even if the enclosure temperature is within the acceptable operation temperature range.

## 4.2 CONNECTING TO A COMPUTER

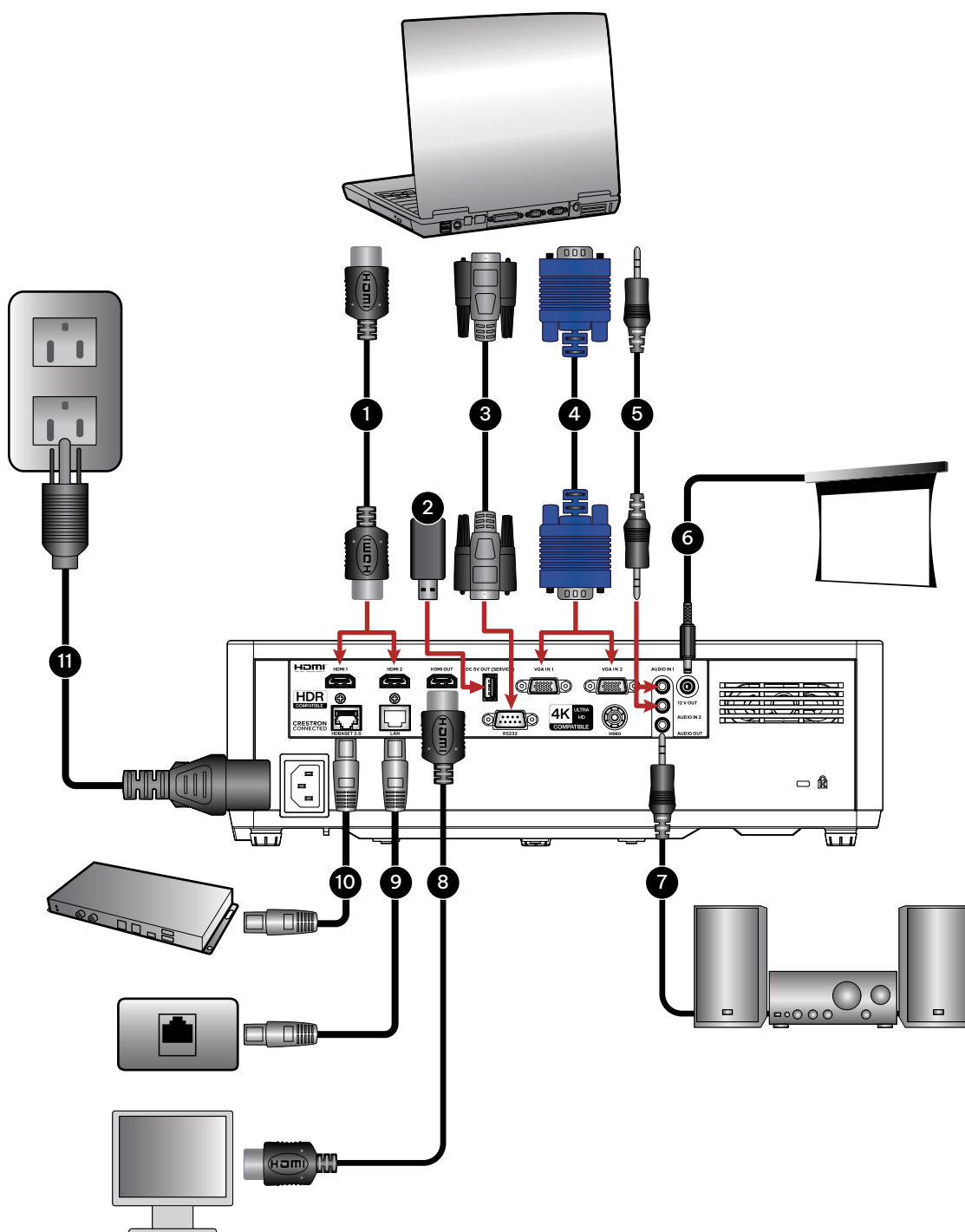

REFERENCE	DESCRIPTION
1	HDMI In Cable
2	USB Disk Drive
3	RS232 Cable
4	VGA In Cable
5	Audio In Cable
6	12V DC Jack

REFERENCE	DESCRIPTION
7	Audio Out Cable
8	HDMI Out Cable
9	RJ45 Cable
10	RJ45 Cable (Cat5 Cable)
11	Power Cable

### 4.3 CONNECTING TO A DVD PLAYER

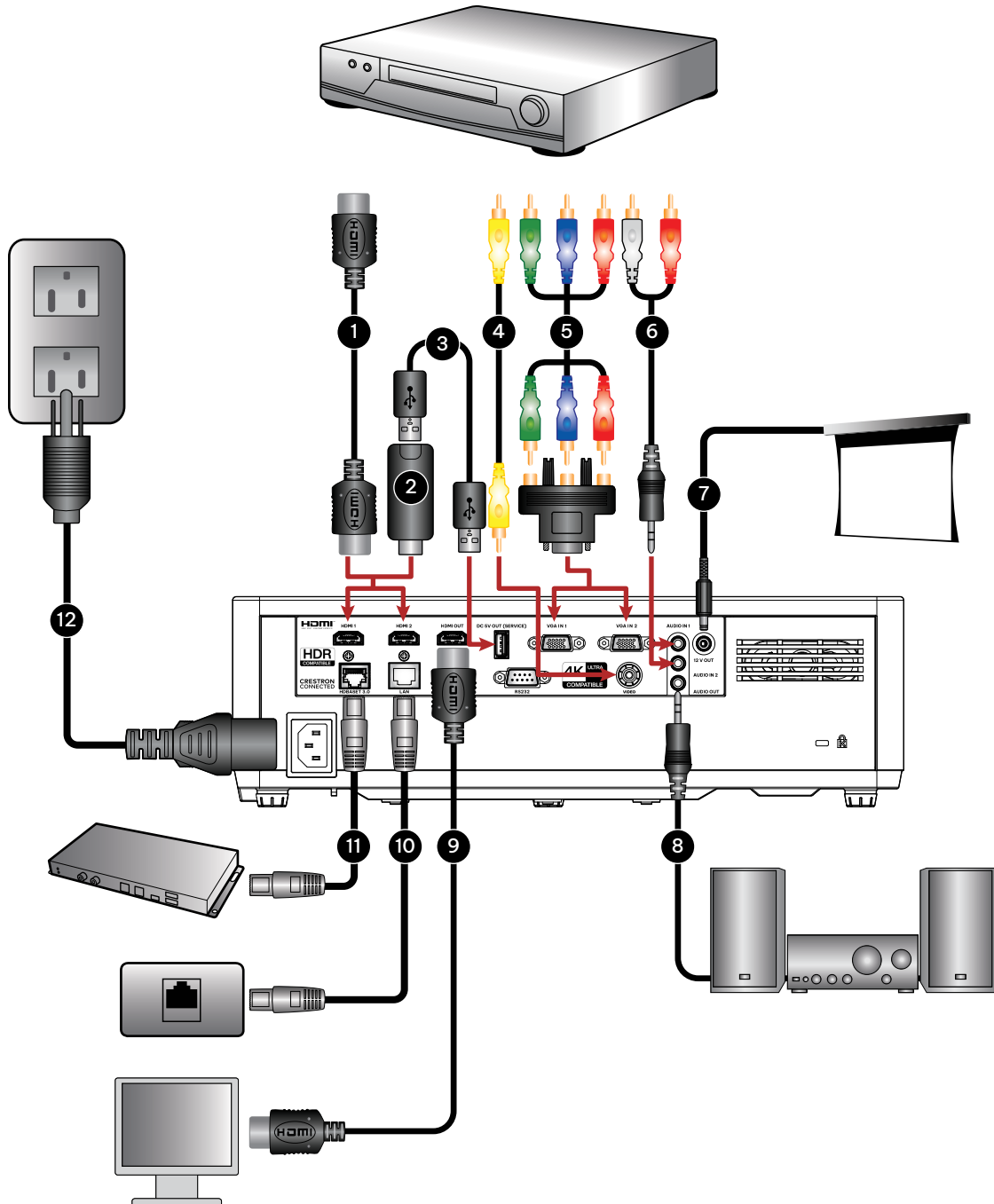

REFERENCE	DESCRIPTION	REFERENCE	DESCRIPTION
1	HDMI Cable	7	12V DC Jack
2	HDMI Dongle	8	Audio Out Cable
3	USB Power Cable	9	HDMI Cable
4	Video Cable	10	RJ45 Cable
5	RCA Component Cable	11	RJ45 Cable (Cat5 Cable)
6	Audio In Cable	12	Power Cable

## 4.4 ADJUSTING THE PROJECTOR IMAGE

### IMAGE HEIGHT

The projector is equipped with elevator feet for adjusting the image height.

1. Locate the adjustable foot you wish to adjust on the underside of the projector.
2. Rotate the adjustable foot clockwise or counterclockwise to raise or lower the projector.

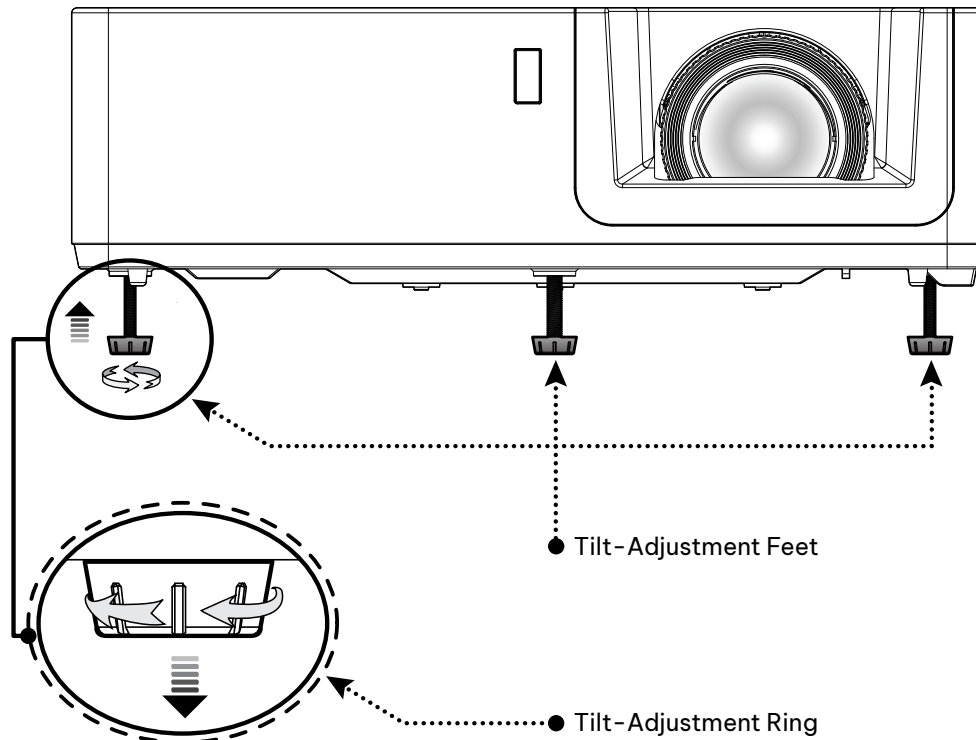

### ZOOM, FOCUS, AND LENS SHIFT

- To adjust the image size, turn the zoom ring clockwise or counterclockwise to increase or decrease the projected image size.
- To adjust the focus, turn the focus ring clockwise or counterclockwise until the image is sharp and legible.
- To adjust the image position, turn the lens shift ring clockwise or counterclockwise to adjust the position of the projected image vertically or horizontally.

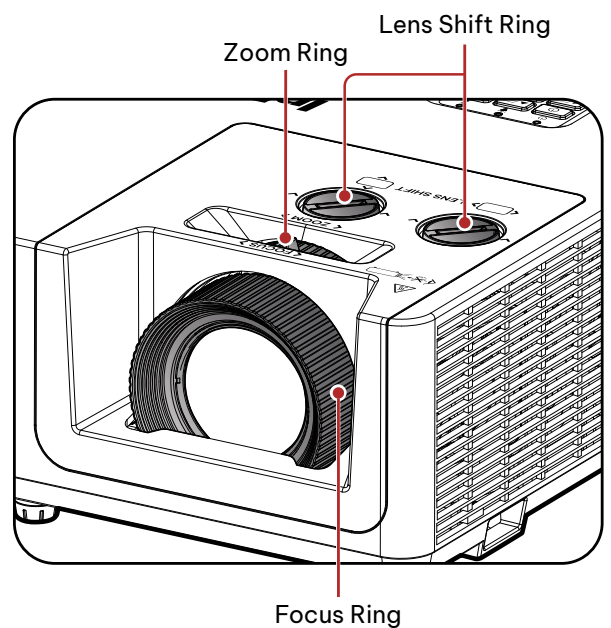

**Note** Ensure that the projection screen is within the required distance from the projector. Please refer to “Image size and projection distance” for more information.

### 4.5 REMOTE SETUP

#### INSTALLING / REPLACING THE BATTERIES

Two AAA size batteries are required. (Not included)

1. Push the clip to release the battery cover.

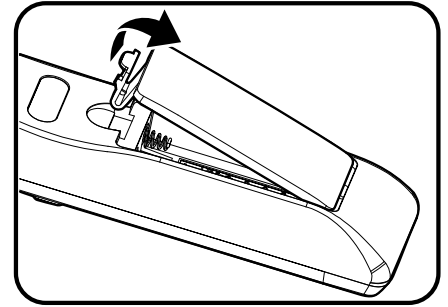

2. Install new batteries (AAA/R03). Ensure that you have the batteries' polarity (+/-) aligned correctly.

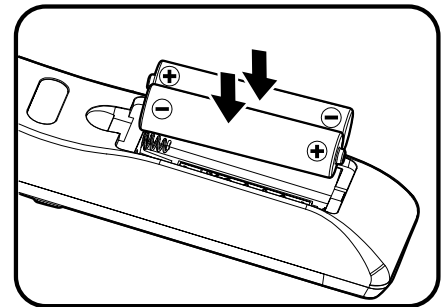

3. Replace back cover on the remote control and press down until it clicks in to place.

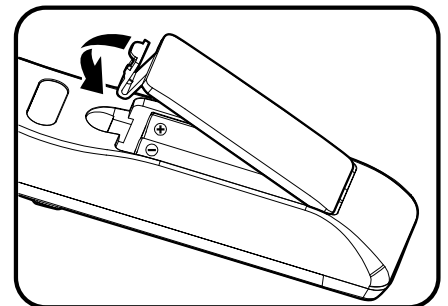

**Note** Do not mix different types of batteries or new and old batteries.



#### ATTENTION

To ensure safe operation, please observe the following precautions:

- Use AAA/R03 type batteries.
- Avoid contact with water or liquid.
- Do not expose the remote control to moisture or heat.
- Do not drop the remote control.
- If the batteries have leaked in the remote control, carefully wipe the case clean and install new batteries.
- There is a risk of explosion if the batteries are replaced with the wrong type.
- Dispose of used batteries according to the instructions.
- Remove the batteries from the remote control when not using for extended periods.
- The remote control may fail to operate if the infrared remote sensor is exposed to bright sunlight or fluorescent lighting.

## EFFECTIVE RANGE

Infra-Red (IR) remote control sensor is located in front and on top of the projector. Ensure to hold the remote control at an angle within 30° perpendicular to the projector's IR remote control sensors to function correctly. The distance between the remote control and the sensor should not be longer than 6 meters (~19 feet).

**Note** When pointing the remote control directly (0 degrees angle) on the IR sensor, the distance between the remote control and the sensor should not be longer than 8 meters (~26 feet).

- Make sure that there are no obstacles between the remote control and the IR sensor on the projector that might obstruct the infra-red beam.
- Make sure the IR transmitter of the remote control is not being illuminated by sunlight or fluorescent lamps directly.
- Keep the remote control more than 2 meters away from fluorescent lamps or it may not function.
- When you aim at the screen the effective distance is 5 meters or less from the remote to the screen then back to the projector. The range will be different based on the reflectivity of the screen.

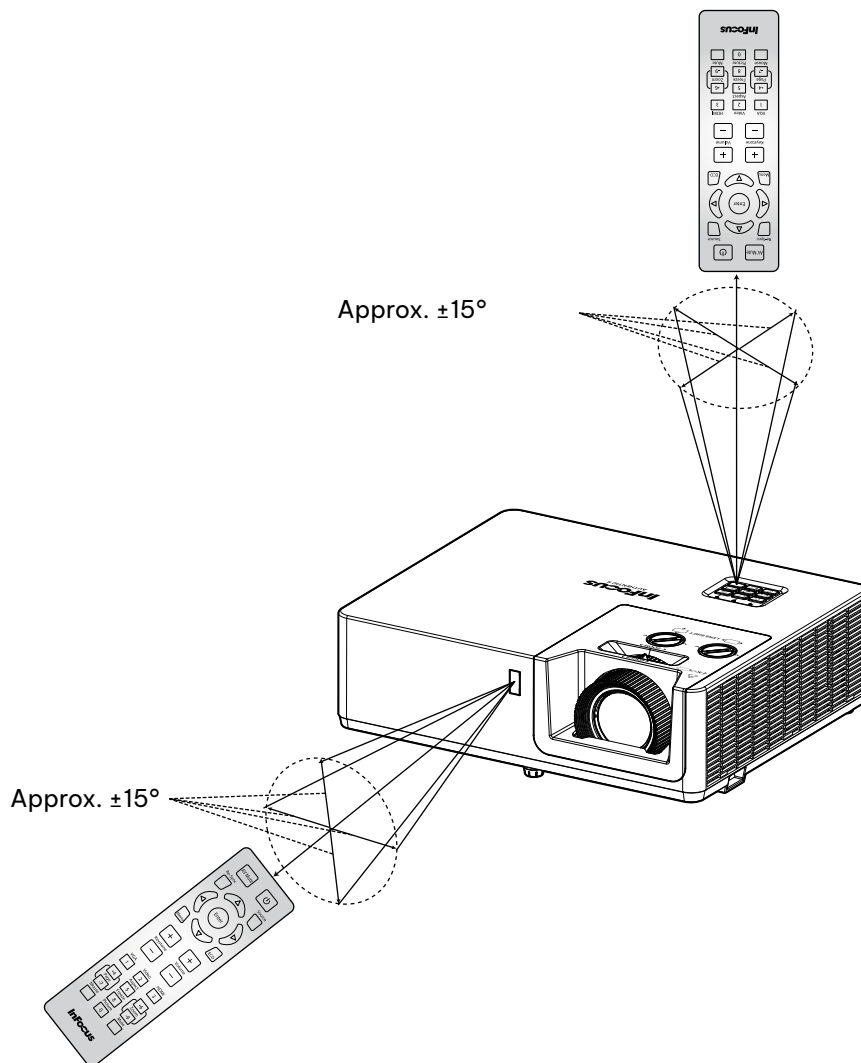

## 5. USING THE PROJECTOR

### 5.1 POWERING ON / OFF THE PROJECTOR

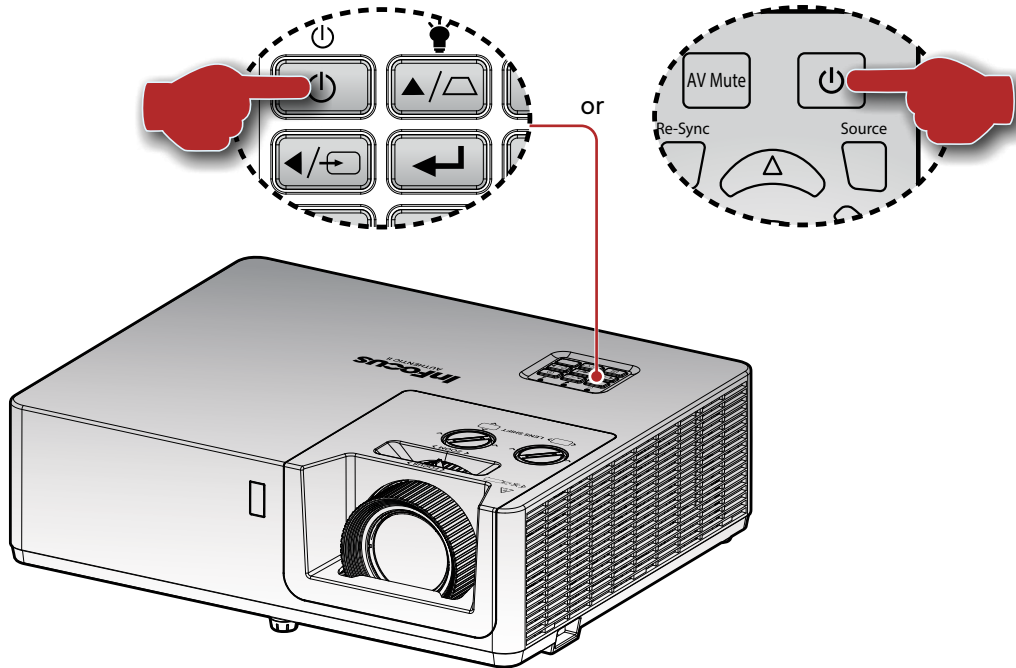

#### POWERING ON



1. Securely connect the signal/source cables. Then connect the power lead to the adaptor and the adaptor to the projector. When connected, the Power LED will turn red.
2. Turn on the projector by pressing the  button on the projector keypad or remote control.
3. A start up screen will display in approximately 10 seconds and the Power LED will turn blue.

**Note** The first time the projector is turned on, you will be prompted to select the preferred language, projection orientation, and other settings.

#### POWERING OFF

1. Turn off the projector by pressing the  button on the projector keypad or remote control.
2. The following message will be displayed:



3. Press the  button again to confirm, otherwise the message will disappear after 10 seconds. When you press the  button for the second time, the projector will shut down.
4. When the Power turns solid red, this indicates the projector has entered standby mode. If you wish to turn the projector back on, you must wait until the cooling cycle has finished and the projector has entered standby mode. When the projector is in standby mode, simply press the  button again to turn on the projector.
5. Disconnect the power lead from the electrical outlet and the projector.

**Note** It is not recommended that the projector is turned on immediately, right after a power off procedure.

## 5.2 SELECTING AN INPUT SOURCE

Turn on the connected source such as a computer, Blu-Ray player, HDBaseT etc. Press the button on the keypad or the **Source** button on the remote control.

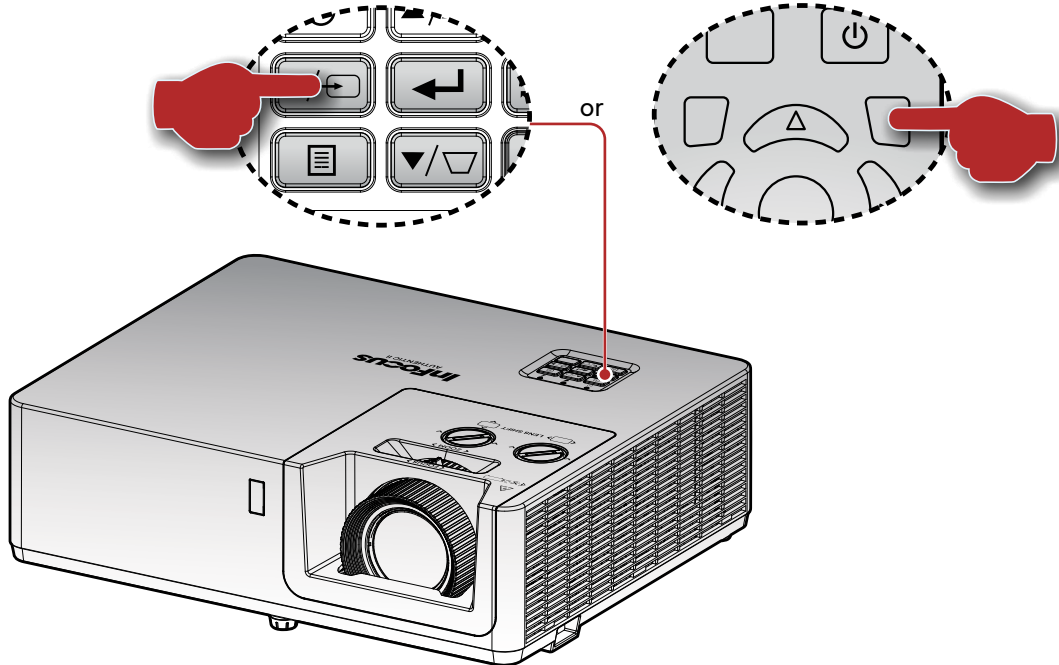

## 5.3 MENU NAVIGATION AND FEATURES

The projector has multilingual on screen display menus that allow you to make image adjustments and change a variety of settings.



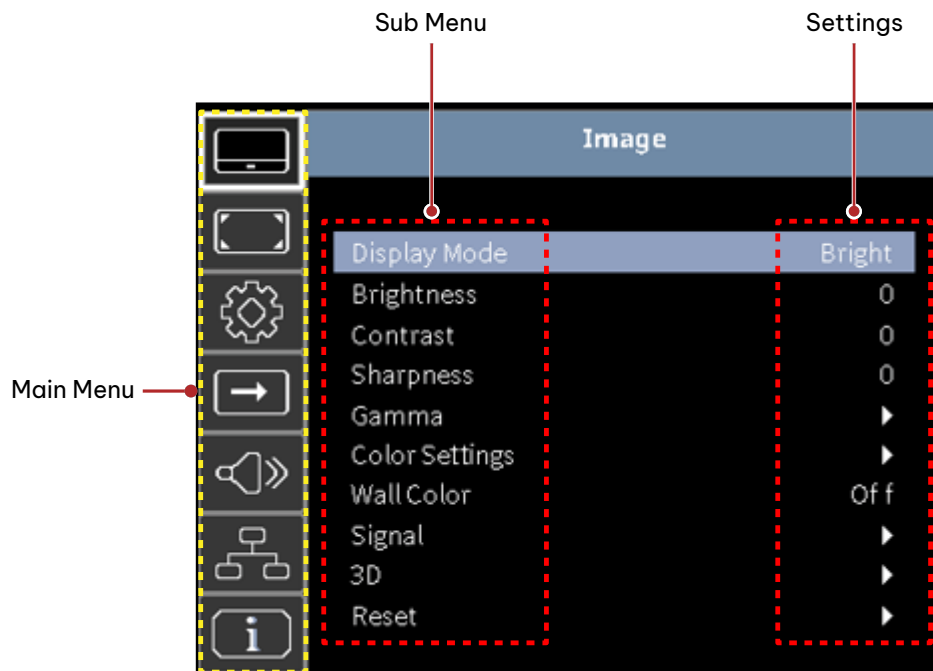



1. To open the OSD menu, press the button on the projector keypad or the **Menu** button on the remote control.
2. When OSD is displayed, use keys to select any item in the main menu. While making a selection on a particular page, press the button on the projector keypad or the **Enter** button on the remote control to enter the sub menu.
3. Use keys to select the desired item in the sub menu and then press the or **Enter** button to view further settings. Adjust the settings by using keys.
4. Select the next item to be adjusted in the sub menu and adjust as described above.
5. Press press the or **Enter** button to confirm, and the screen will return to the main menu.
6. To exit, press the or **Menu** button again. The OSD menu will close and the projector will automatically save the new settings.



## 5.4 OSD MENU TREE

Main Menu	Sub Menu	Sub Menu 2	Sub Menu 3	Values
Image	Display Mode			Presentation
				Bright
				HDR SIM.
				Cinema
				Game
				sRGB
				DICOM SIM.
				User
	Brightness			-50 ~ 50
	Contrast			-50 ~ 50
	Sharpness			1 ~ 15
	Gamma			Film
				Video
				Graphics
				Standard (2.2)
				1.8
	Color Settings	Color		
Tint				-50 ~ 50
BrilliantColor™				1 ~ 10

Main Menu	Sub Menu	Sub Menu 2	Sub Menu 3	Values	
Image	Color Settings	Color Temperature		Warm	
				Standard	
				Cool	
				Cold	
		Color Matching	Color	White, Red, Green, Blue, Cyan, Magenta, Yellow	
			Hue	-50 ~ 50	
			Saturation	-50 ~ 50	
			Gain	-50 ~ 50	
			Reset	No / Yes	
		Color Space	Non-HDMI		Auto
					RGB
					YUV
			HDMI		Auto
					RGB (0~255)
					RGB (16~235)
				YUV	
	Wall Color			Off	
				Blackboard	
				Light Yellow	
				Light Green	
				Light Blue	
				Pink	
				Gray	
	Signal		Automatic	Off/On	
			Frequency	-10 ~ 10	
			Phase	0 ~ 31	
			H. Position	-5 ~ 5	
			V. Position	-5 ~ 5	
	3D	3D Mode		Off	
				DLP-Link	
		3D → 2D		3D	
				L	
			R		
3D Format			Auto		
			SBS		
			Top and Bottom		
			Frame Sequential		
		3D Sync Invert	Off / On		
	Reset	No / Yes			
Reset			No / Yes		

Main Menu	Sub Menu	Sub Menu 2	Sub Menu 3	Values	
Display	Brightness Mode	Dynamic Black		Off / On	
		Eco.			
		Power		Power = 100% / 95% / 90% / 85% / 80% / 75% / 70% / 65% / 60% / 55% / 50%	
	Aspect Ratio				Auto
					4:3
					16:9
					16:10
					21:9
					Native
	Geometric Correction	Auto Keystone			Off / On
		V Keystone			-30 ~ 30
		H Keystone			-30 ~ 30
		Four Corner Adjustment			
		Reset			No / Yes
Edge Mask				0 ~ 10	
Zoom				-5~25	
Image Shift	H 			-100 ~ 100	
	V 			-100 ~ 100	
Reset				No / Yes	
Device Setup	Test Pattern			Green Grid/ White / Test Card / Off	
	Projection			Front  / Rear  / Ceiling-Top  / Rear-Top 	
	Language				English
					Deutsch
					Français
					Italiano
					Español
					Português
					Polski
					Nederlands
					Svenska
					Norsk
					Dansk
					Suomi
					ελληνικά
					繁體中文
					简体中文
			日本語		
			한국어		
			Русский		
			Magyar		
			Čeština		

Main Menu	Sub Menu	Sub Menu 2	Sub Menu 3	Values	
Device Setup	Language			عربي	
				ไทย	
				Türkçe	
				فارسی	
				Tiếng Việt	
				Bahasa Indonesia	
				Română	
	Menu Settings	Menu Location			Top-Left <input type="checkbox"/>
					Top-Right <input type="checkbox"/>
					Center <input type="checkbox"/>
					Bottom-Left <input type="checkbox"/>
					Bottom-Right <input type="checkbox"/>
		Menu Timer			Off
					5 sec
				10 sec	
	High Altitude			Off / On	
	Power Settings	Direct Power On			Off / On
		Signal Power On			Off / On
		Auto Power Off (min.)			0 ~ 180 (5 min increments)
		Power Mode (Standby)			Eco. / Active / ErP Off
		12V Trigger			Off / On
	Security	Security			Off / On
		Security Timer	Month		Off / On
			Day		0 ~ 12
			Hour		0 ~ 30
	Change Password			0 ~ 24	
	Logo			Default / Neutral	
	Background Color				None
					Blue
					Red
				Green	
				Gray	
				Logo	
Closed Captioning				Off / CC1 / CC2	
Reset to Default				No / Yes	
Input Settings	Auto Source			Off / On	
	HDMI Out			HDMI 1 / HDMI 2	
	HDMI CEC Settings	HDMI CEC		Off / On	
	Reset			No / Yes	
Audio	Volume			0 - 10	
	Mute			Off / On	

Main Menu	Sub Menu	Sub Menu 2	Sub Menu 3	Values	
Audio	Audio Input	HDMI 1		Audio 1 / Audio 2 / Default	
		HDMI 2		Audio 1 / Audio 2 / Default	
		VGA IN 1		Audio 1 / Audio 2	
		VGA IN 2		Audio 1 / Audio 2	
		VIDEO		Audio 1 / Audio 2	
		HDBaseT		Audio 1 / Audio 2 / Default	
	Reset			No / Yes	
Control (Network)	LAN	Network Status		Disconnect/Connected	
		MAC Address		AA : BB : CC : DD : EE : FF	
		DHCP		Off / On	
		IP Address		xxx.xxx.xxx.xxx	
		Subnet Mask		xxx.xxx.xxx.xxx	
		Gateway		xxx.xxx.xxx.xxx	
		DNS		xxx.xxx.xxx.xxx	
		Reset			
	Control	Crestron		Off / On	
		Extron		Off / On	
		PJ Link		Off / On	
		AMX Device Discovery		Off / On	
		Telnet		Off / On	
		HTTP		Off / On	
	HDBaseT Control	Ethernet		Off / On	
		RS232		Off / On	
	Reset			No / Yes	
	Info	Serial Number			
		Source Info.			ie.HDMI1, 1920x1200, 0.00Hz
Display Mode					
Color Info.				ie. 12bit,	
				BT.2020 HDR	
				YUV	
Power Mode (Standby)				Eco. / Active / ErP Off	
Light Source Hours				SSI models	
Brightness Mode					
IP Address					
Network Status					
FW Version		DDP			Cxx
		MCU			Cxx
		LAN			Cxx
	HDBaseT			Hxxxxxxx	

**Note** Functions vary depending on model definition.

## 5.5 IMAGE MENU

### PICTURE MODE

There are many factory presets optimized for various types of images.

- **Presentation:** This mode is suitable for showing in front of public in connection to the PC.
- **Bright:** Maximum brightness from any source.
- **Vivid:** Selecting this mode balances colour saturation and brightness for a brighter display. Choose this mode for setups with ambient lighting, or where brighter images/presentations are necessary.
- **HDR SIM.:** Decodes and displays High Dynamic Range (HDR) content for the deepest blacks, brightest whites, and vivid cinematic color using REC.2020 color gamut.
- This mode will be automatically enabled (and HDR/HLG Content is sent to projector – 4K UHD Blu-ray, 1080p/4K UHD HDR Games, 4K UHD Streaming Video).
- **Cinema:** Provides the best colors for watching movies.
- **Game:** Optimises your projector for maximum contrast and vivid colours allowing you to see shadow detail when playing video games.
- **sRGB:** Standardized accurate color.
- **DICOM SIM.:** Suitable for displaying monochrome medical images, such as X-rays and MRIs.
- **User:** Saved user's settings.
- **3D:** To experience 3D you need DLP-Link 3D glasses and video source capable of sending 3D content.

**Note** To experience the 3D effect, you will need to have compatible DLP Link 3D glasses. See 3D section for more information.

### BRIGHTNESS

Adjust the brightness of the image.

### CONTRAST

The contrast controls the degree of difference between the lightest and darkest parts of the picture.

### SHARPNESS

Adjust the sharpness of a video source.

### GAMMA

Set up gamma curve type. After the initial setup and fine tuning is completed, utilize the Gamma Adjustment steps to optimize your image output.

- **Film:** For home theater.
- **Video:** For video or TV source.
- **Graphics:** For PC / Photo source.
- **Standard (2.2):** For standardized setting.
- **1.8 / 2.0 / 2.2 / 2.4 / 2.6:** For specific PC / Photo source.

**Note** These options are only available if the 3D mode function is disabled, the **Wall Color** setting is not set to **Blackboard**, and the **Picture Mode** setting is not set to **HDR SIM.**

### COLOR SETTINGS

#### Color

Adjust a video image from black and white to fully saturated color.

#### Tint

Adjust the color balance of red and green.

#### BrilliantColor™

This adjustable item utilizes a new color-processing algorithm and enhancements to enable higher brightness while providing true, more vibrant colors in picture.

### Color Temperature

Select a color temperature from Warm, Standard, Cool, or Cold.

### Color Matching

Select the following options:

- **Color:** Adjust the red, green, blue, cyan, yellow, magenta, and white level of the image. Hue: Adjust the color balance of red and green.
- **Saturation:** Adjust a video image from black and white to fully saturated color.
- **Gain:** Adjust the brightness (gain) of an image.
- **Reset:** Return the factory default settings for color adjustment.

### Color Space

Select an appropriate color matrix type from the following: Auto, RGB (0-255), RGB (16-235), and YUV.

**Note** For non-HDMI input, select an appropriate color matrix type from the following: AUTO, RGB, or YUV.

## WALL COLOR

Designed to adjust the colors of the projected image when projecting on to a wall without a screen. Each mode has been fine-tuned by our expert colour team to ensure superior color performance.

There are several predefined modes that you can choose from to suit the colour of your wall. Select between off, blackboard, light yellow, light green, light blue, pink, and grey.

Note: For accurate color reproduction, we recommend using a screen.

## SIGNAL

Adjust the signal synchronization settings for VGA/Component sources.

- **Automatic:** Configure automatically the signal (the frequency and phase items are grayed out). If automatic is disabled, the frequency and phase items will appear for tuning and saving the settings.
- **Frequency:** Change the display data frequency to match the frequency of your computer's graphic card. Use this function only if the image appears to flicker vertically.
- **Phase:** Synchronize the signal timing of the display with the graphic card. If the image appears to be unstable or flickers, use this function to correct it.
- **H. Position:** Adjust the horizontal position of the image.
- **V. Position:** Adjust the vertical position of the image.

## 3D

- Note**
- This projector is a full 3D projector with DLP-Link 3D solution.
  - Please ensure that 3D glasses are in use for DLP-Link 3D content before enjoying your video.
  - This projector supports frame sequential (page-flip) 3D via HDMI1/HDMI2/HDMI3 ports.
  - To reach the best performance, resolution 1920x1080 is recommended, please note that 4K (3840x2160) resolution is not supported in 3D mode.

### 3D Mode

Use this option to disable or enable the 3D function.

- **Off:** Select "Off" to turn off 3D mode.
- **DLP-Link:** Select "DLP-Link" to turn on 3D mode and use optimized settings for DLP 3D Glasses.

### 3D → 2D

Use this option to specify how the 3D content should appear on the screen.

- **3D:** Display 3D signal.
- **L:** Display the left frame of 3D content. **R:** Display the right frame of 3D content.

### 3D Format

Use this option to select the appropriate 3D format content.

- **Auto:** When a 3D identification signal is detected, the 3D format is selected automatically. **SBS:** Display 3D signal in "Side-by-Side" format.
- **Top and Bottom:** Display 3D signal in "Top and Bottom" format.
- **Frame Sequential:** Display 3D signal in "Frame Sequential" format.

**3D Sync Invert**

Use this option to enable/disable the 3D sync invert function.

**Reset**

Return the factory default setting for 3D settings.

- **No:** Select to cancel Reset.
- **Yes:** Select to return the factory default settings for 3D.

**RESET**

Return the factory default settings for image settings.

**5.6 DISPLAY MENU**

**BRIGHTNESS MODE**

Adjust the brightness mode settings.

- **Dynamic Black:** Automatically adjusts the brightness based on the source signal for optimum contrast performance.
- **Eco:** Minimum power consumption.
- **Power:** Select the power percentage to adjust the overall brightness.

**ASPECT RATIO**

Select the aspect ratio of the displayed image between the following options:

- **Auto:** Automatically selects the appropriate display format.
- **4:3:** This format is for 4:3 input sources.
- **16:9:** This format is for 16:9 input sources, like HDTV and DVD enhanced for Wide screen TV. **16:10:** This format is for 16:10 input sources
- **21:9:** This format is for 21:9 input source, like HDTV and DVD enhanced for Wide screen TV. **Native:** This format displays the original image without any scaling.

**1080P SCALING TABLE**

<b>4x3</b>	Scale to 1440x1080.
<b>16x9</b>	Scale to 1920x1080.
<b>Native mode</b>	<ul style="list-style-type: none"> <li>• 1:1 mapping centered.</li> <li>• No scaling will be made; the image is displayed with the resolution based on input source.</li> </ul>
<b>Auto</b>	<ul style="list-style-type: none"> <li>• If source is 4:3, the screen type will be scaled to 1440 x1080.</li> <li>• If source is 16:9, the screen type will be scaled to 1920x1080.</li> <li>• If source is 16:10, the screen type will be scaled to 1920x1200 and cut 1920x1080 area to display.</li> </ul>

## 1080P AUTO MAPPING RULE

Auto	Input resolution		Auto/Scale	
	H-resolution	V-resolution	1920	1200
4:3	640	480	1440	1080
	800	600	1440	1080
	1024	768	1440	1080
	1280	1024	1440	1080
	1400	1050	1440	1080
	1600	1200	1440	1080
Wide Laptop	1280	720	1920	1080
	1280	768	1800	1080
	1280	800	1728	1080
SDTV	720	576	1350	1080
	720	480	1620	1080
HDTV	1280	720	1920	1080
	1920	1080	1920	1080

## WUXGA SCALING TABLE

<b>4x3</b>	Scale to 1600x1200.
<b>16x9</b>	Scale to 1920x1080.
<b>16x10</b>	Scale to 1920x1200.
<b>Native mode</b>	<ul style="list-style-type: none"> <li>• 1:1 mapping centered.</li> <li>• No scaling will be made; the image is displayed with the resolution based on input source.</li> </ul>
<b>Auto</b>	<ul style="list-style-type: none"> <li>• If source is 4:3, the screen type will be scaled to 1600 x1200.</li> <li>• If source is 16:9, the screen type will be scaled to 1920x1080.</li> <li>• If source is 16:10, the screen type will be scaled to 1920x1200.</li> </ul>

## WUXGA AUTO MAPPING RULE

Auto	Input resolution		Auto/Scale	
	H-resolution	V-resolution	1920	1200
4:3	640	480	1600	1200
	800	600	1600	1200
	1024	768	1600	1200
	1280	1024	1600	1200
	1400	1050	1600	1200
	1600	1200	1600	1200
Wide Laptop	1280	720	1920	1080
	1280	768	1920	1200
	1280	800	1920	1200
SDTV	720	576	1500	1200
	720	480	1800	1200
HDTV	1280	720	1920	1080
	1920	1080	1920	1080

## GEOMETRIC CORRECTION

### **Auto Keystone**

Correct keystone digitally to fit the projected image on the area on which you are projecting.

### **V Keystone**

Adjust image distortion vertically and make a squarer image. Vertical keystone is used to correct a keystone image shape in which the top and bottom are slanted to one of the sides. This is intended for use with vertically on-axis applications.

### **H Keystone**

Adjust image distortion horizontally and make a squarer image. Horizontal keystone is used to correct a keystone image shape in which the left and right borders of the image are unequal in length. This is intended for use with horizontally on-axis applications.

### **Four Corner Adjustment**

This setting allows the projected image to be adjusted from each corner to make a square image when the projection surface is not level.

### **Reset**

Return the factory default setting for geometric correction settings.

## EDGE MASK

Use this function to remove the video encoding noise on the edge of video source.

## ZOOM

Use to reduce or magnify an image on the projection screen. Digital Zoom is not the same as optical zoom and can result in degradation of image quality.

**Note** Zoom settings are retained on power cycle of the projector.

## IMAGE SHIFT

Adjust the projected image position horizontally (H) or vertically (V).

## RESET

Return the factory default settings for display settings.

## 5.7 DEVICE SETUP MENU

### TEST PATTERN

Select the test pattern from green grid, white, test card, or disable this function (off).

### PROJECTION ORIENTATION

Select the preferred projection between front, rear, ceiling-top, and rear-top.

### LANGUAGE

Select the multilingual OSD menu.

### MENU SETTINGS

#### **Menu Location**

Select the menu location on the display screen.

### Menu Timer

Set the duration where the OSD menu stays visible on the screen.

### HIGH ALTITUDE

When “On” is selected, the fans will spin faster. This feature is useful in high altitude areas where the air is thin.

### POWER SETTINGS

#### Direct Power On

Choose “On” to activate Direct Power mode. The projector will automatically power on when AC power is supplied, without pressing the “Power” key on the projector keypad or on the remote control.

#### Signal Power On

Choose “On” to activate Signal Power mode. The projector will automatically power on when a signal is detected, without pressing the “Power” key on the projector Keypad or on the remote control.

**Note** This function is applicable that plug in HDMI and VGA sources.

#### Auto Power Off (min.)

Sets the countdown timer interval. The countdown timer will start, when there is no signal being sent to the projector. The projector will automatically power off when the countdown has finished (in minutes).

#### Power Mode (Standby)

Set the power mode setting.

- **Eco:** In extreme power-saving mode, standby power consumption is less than 0.5 watts. LAN and HDBaseT are disabled.
- **Active:** Normal Standby,
  - LAN On, HDBaseT On: standby power consumption is less than 7 watts. The system will automatically disable LAN and HDBaseT after 20 minutes of inactivity, regardless of usage
  - LAN On, HDBaseT Off: standby power consumption is less than 2 watts. The system will automatically disable LAN after 20 minutes of inactivity, regardless of usage.
- **ErP Off:**
  - LAN On, HDBaseT On: the system maintains a standby power consumption of less than 7 watts, and these functions operate without a 20-minute time limit.
  - LAN On, HDBaseT Off: the system maintains a standby power consumption of less than 2 watts, and LAN function operate without a 20-minute time limit.

### 12V TRIGGER

Use this function to enable or disable the trigger.

**Note** 3.5mm mini jack that outputs 12V 500mA (max.) for relay system control.

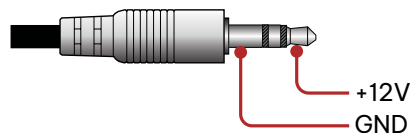

- **On:** Choose “On” to enable the trigger.
- **Off:** Choose “Off” to disable the trigger.

### SECURITY

#### Security

Enable this function to prompt for a password before using the projector.

- **On:** Choose “On” to use security verification when the turning on the projector.
- **Off:** Choose “Off” to be able to switch on the projector without password verification.

**Note** The default password is 1234.

**Security Timer**

Select the time (Month/Day/Hour) function to set the number of hours the projector can be used. Once this time has elapsed you will be requested to enter your password again.

**Change Password**

Use to set or modify the password that is prompted when turning the projector on.

**LOGO**

Use this function to set the desired startup screen. If changes are made, they will take effect the next time the projector is powered on.

- **Default:** The default startup screen.
- **Neutral:** Same as the “Background Color” setting.

**BACKGROUND COLOR**

Use this function to display a blue, red, green, gray, logo, or none when no signal is available.

**Note** If the background color is set to “None”, then the background color is black.

**CLOSED CAPTIONING**

Closed Captioning is a text version of the program sound or other information displayed on the screen. If the input signal contains closed captions, you can turn on the feature and watch the channels. The available options include “Off”, “CC1”, and “CC2”.

**RESET TO DEFAULT**

Return all settings to factory default settings.

**5.8 INPUT SETTINGS MENU**

**AUTO SOURCE**

Choose this option to let the projector automatically find an available input source.

**HDMI OUT**

Set the HDMI output to HDMI 1 or HDMI 2.

**HDMI CEC SETTINGS**

**Note** When you connect HDMI CEC-compatible devices to the projector with HDMI cables, you can control them on the same power on or power off status using the HDMI Link control feature in the projector’s OSD. This lets one device or multiple devices in a group power on or power off via HDMI Link Feature in a typical configuration, your DVD player may be connected to the projector through an amplifier or home theater system.

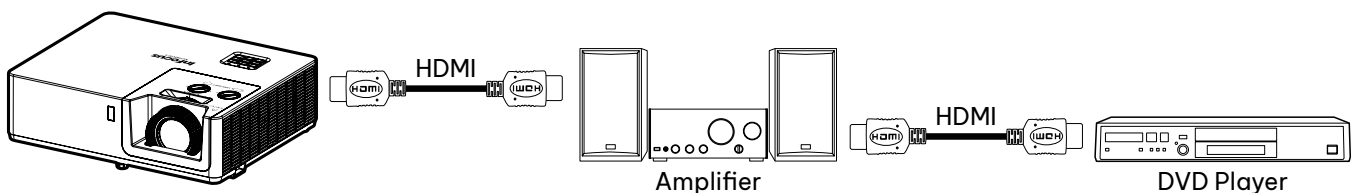

**HDMI CEC**

HDMI CEC-compatible devices connected to the projector via HDMI enable synchronized power state management through the projector’s OSD HDMI CEC control, allowing for grouped power on/off.

**RESET**

Return the factory default settings for input settings.

### 5.9 AUDIO MENU

#### VOLUME

Adjust the volume level.

#### MUTE

Use this option to temporarily turn off the sound.

- Off: Choose “Off” to turn mute off.
- On: Choose “On” to turn mute on.

**Note** “Mute” function affects both internal and external speaker volume.

#### AUDIO INPUT

Select the audio input port for the video sources as follows:

- **HDMI 1:** Audio 1, Audio 2, or Default.
- **HDMI 2:** Audio 1, Audio 2, or Default.
- **VGA IN 1:** Audio 1 or Audio 2.
- **VGA IN 2:** Audio 1 or Audio 2.
- **VIDEO:** Audio 1 or Audio 2.
- **HDBaseT:** Audio 1, Audio 2, or Default.

#### RESET

Return the factory default settings for audio settings.

### 5.10 CONTROL (NETWORK) MENU

#### LAN

Configure the projector’s network settings.

##### **Network Status**

Display the network connection status. (Read only)

##### **MAC Address**

Display the MAC address. (Read only)

##### **DHCP**

Turn on DHCP to automatically acquire IP address, subnet mask, gateway, and DNS.

##### **IP Address**

Assign the projector’s IP address.

##### **Subnet Mask**

Assign the projector’s subnet mask.

##### **Gateway**

Assign the projector’s gateway.

##### **DNS**

Assign the projector’s DNS.

##### **Reset**

Reset the network settings to default factory values.

## CONTROL

This projector can be controlled remotely by a computer or other external devices through the wired network connection. It allows the user to control one or more projectors from a remote control center, such as powering the projector on or off, and adjusting the image brightness or contrast.

Use the Control submenu to select a control device for the projector.

### Crestron

Control the projector with Crestron controller and related software. (Port: 41794)

For more information, please visit <http://www.crestron.com>.

### Extron

Control the projector with Extron devices. (Port: 2023)

For more information, please visit <http://www.extron.com>.

### PJ Link

Control the projector with PJLink v2.0 commands. (Port: 4352)

For more information, please visit <http://pjlink.jbmia.or.jp/english>.

### AMX Device Discovery

Control the projector with AMX devices. (Port: 9131)

For more information, please visit <http://www.amx.com>.

### Telnet

Control the projector using RS232 commands through Telnet connection. (Port: 23)

For more information, refer to “RS232 by Telnet Function” on page 49.

### HTTP

Control the projector with web browser. (Port: 80)

For more information, refer to “How to use web browser to control your projector” on page 45.

**Note**

- Crestron is a registered trademark of Crestron Electronics, Inc. of the United States.
- Extron is a registered trademark of Extron Electronics, Inc. of the United States.
- AMX is a registered trademark of AMX LLC of the United States.
- PJLink applied for trademark and logo registration in Japan, the United States of America, and other countries by JBMIA.
- For more information about the various types of external devices which can be connected to the LAN / RJ45 port and remotely control the projector, as well as the supported commands for these external devices, please contact the Support-Service directly.

## HDBASET CONTROL

### Ethernet (LAN, Local Area Network)

CONTROL PORT		
Control	Crestron	Port 41794
	Extron	Port 2023
	PJ Link	Port 4352
	AMX Device Discovery	Port 9131
	Telnet	Port 23
	HTTP	Port 80

### RS232 (Recommended Standard 232)

Users can control projectors via RS232 cable connections for functions like “Power On / Power Off / Input Select HDMI1 / Input Select HDMI 2”.

COMMUNICATION PROTOCOL	
Baud rate	9600 bps
Data length	8 bits
Parity	No parity
Stop bit	One bit

COMMUNICATION PROTOCOL	
X on/off	None
Communication procedure	Full duplex

### Reset

Reset the network settings to default factory values.

## 5.11 NETWORK CONTROL MENU

This projector can be controlled remotely by a computer or other external devices through the wired network connection. It allows the user to control one or more projectors from a remote control center, such as powering the projector on or off, and adjusting the image brightness or contrast.

Use the Control submenu to select a control device for the projector.

### Crestron

Control the projector with Crestron controller and related software. (Port: 41794)

For more information, please visit <http://www.crestron.com>.

## SETUP NETWORK CONTROL

### LAN RJ45 function

For simplicity and ease of operation, the projector provides diverse networking and remote management features. The LAN / RJ45 function of the projector through a network, such as remotely manage: Power On / Off, brightness, and contrast settings. Also, you can view the projector status information, such as: Video- Source, Sound-Mute, etc.

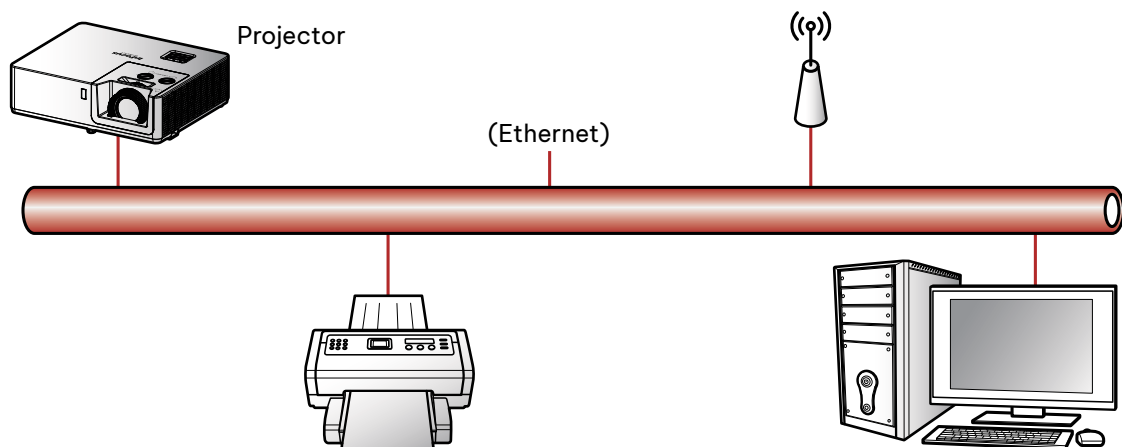

### Wired LAN terminal functionalities

This projector can be controlled by using a PC (laptop) or other external device via LAN / RJ45 port and compatible with Crestron / Extron / AMX (Device -Discovery) / PJLink.

- Crestron is a registered trademark of Crestron Electronics, Inc. of the United States.
- Extron is a registered trademark of Extron Electronics, Inc. of the United States.
- AMX is a registered trademark of AMX LLC of the United States.
- PJLink applied for trademark and logo registration in Japan, the United States of America, and other countries by JBMIA.

The projector is supported by the specified commands of the Crestron Electronics controller and related software, for example RoomView®.

<http://www.crestron.com/>

This projector is compliant to support Extron device(s) for reference.

<http://www.extron.com/>

This projector is supported by AMX (Device Discovery).

<http://www.amx.com/>

This projector supports all commands of PJLink Class 2.

<http://pjlink.jbmia.or.jp/english/>

For more detailed information about the various types of external devices which can be connected to the LAN / RJ45 port and remote control the projector, as well as the supported commands for these external devices, please contact the Support-Service directly.

**How to use web browser to control your projector**

1. Connect the projector to an active network port using the RJ45 port on the back of the projector.
2. Select “Control (Network) → LAN → DHCP”.
3. Select “On”.
4. Press “Enter”.
5. Select “Control (Network) → LAN → IP Address” to view the projector’s IP address.
6. Open a web browser.
7. Type the projector’s IP address and then type the user name and password. The default user name and password is “admin” (without quotation marks).
8. Click “Login”. The projector’s configuration page appears.

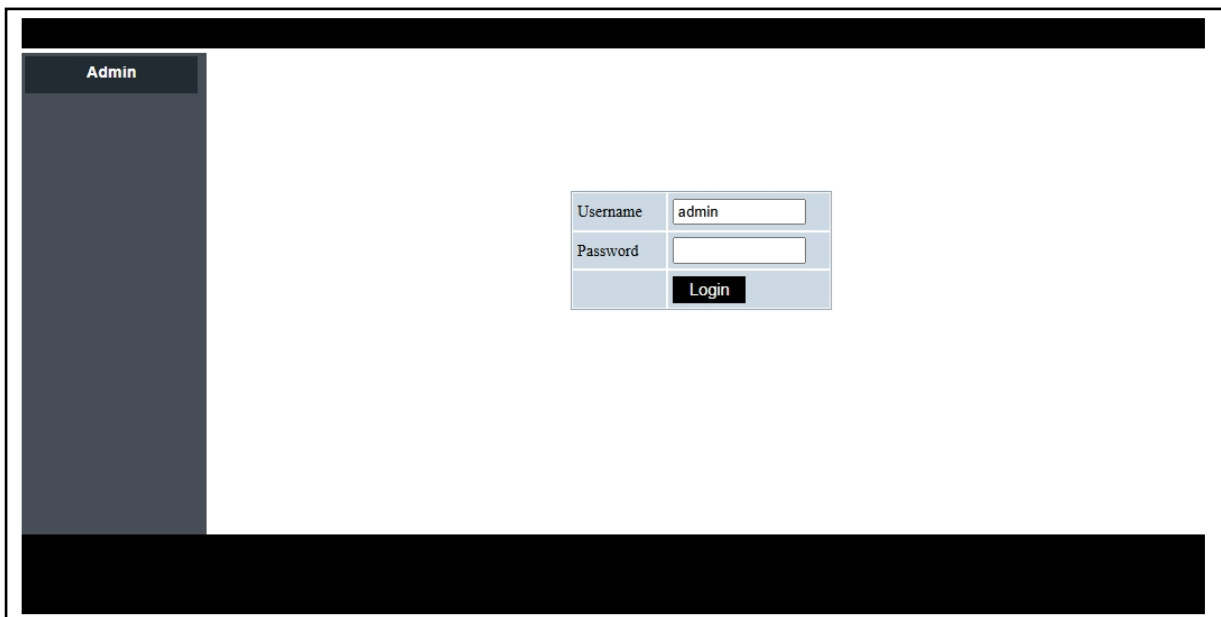
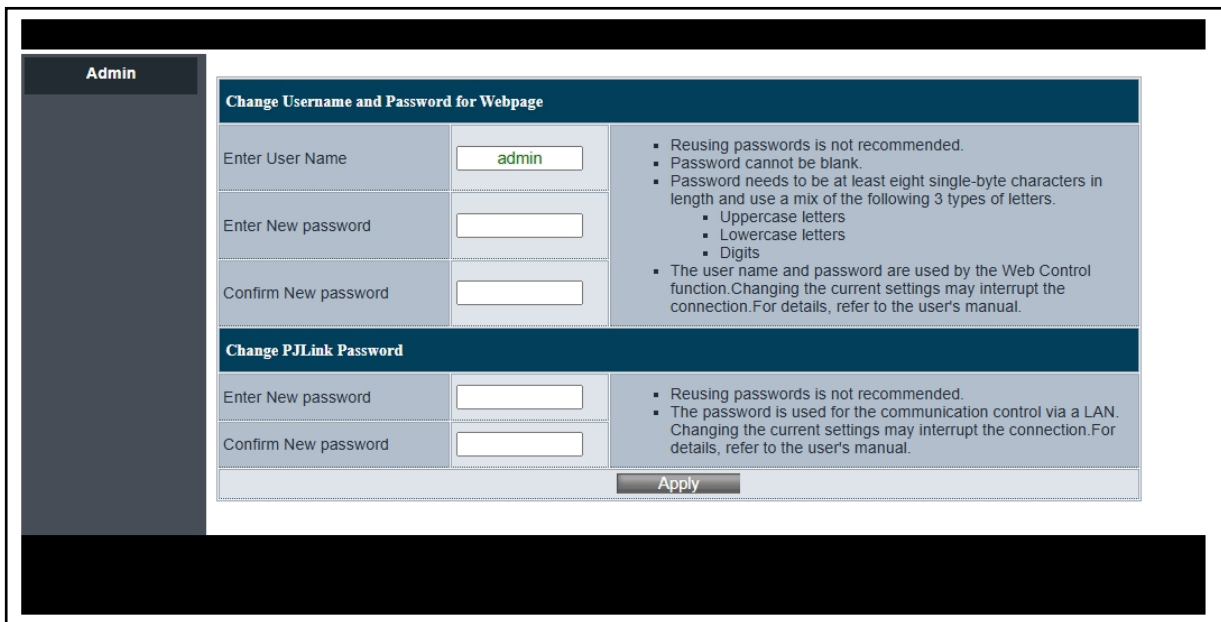

Logout

**Admin > System Status**

System Status	
General Setup	
Projector Control	
Network Setup	
Alert Setup	
Crestron	
Reset to Default	
Reboot System	

<b>Model Name</b>	InFocus PJ
<b>Projector Name</b>	InFocus PJ
<b>FW Version</b>	
System	B01
LAN	B01
<b>LAN Status</b>	
IP Address	192.168.0.100
Subnet Mask	255.255.255.0
Default Gateway	192.168.0.254
MAC Address	00:50:41:C0:39:39

Logout

**Admin > General Setup**

System Status	Projector Name <input type="text" value="InFocus PJ"/> <span>Apply</span>	
General Setup	<b>Change Username and password for Webpage</b>	
Projector Control	Enter Username <input type="text" value="admin"/>	<ul style="list-style-type: none"> <li>▪ Reusing passwords is not recommended.</li> <li>▪ Password cannot be blank.</li> <li>▪ Password needs to be at least eight single-byte characters in length and use a mix of the following 3 types of letters.             <ul style="list-style-type: none"> <li>▪ Uppercase letters</li> <li>▪ Lowercase letters</li> <li>▪ Digits</li> </ul> </li> <li>▪ The user name and password are used by the Web Control function. Changing the current settings may interrupt the connection. For details, refer to the user's manual.</li> </ul>
Network Setup	Enter Old password <input type="text"/>	
Alert Setup	Enter New password <input type="text"/>	
Crestron	Confirm New password <input type="text"/>	
Reset to Default	<span>Apply</span>	
Reboot System	<b>PJLink Setting</b>	
	PJLink Password <input type="radio"/> Enable <input checked="" type="radio"/> Disable	<ul style="list-style-type: none"> <li>▪ Reusing passwords is not recommended.</li> <li>▪ The password is used for the communication control via a LAN. Changing the current settings may interrupt the connection. For details, refer to the user's manual.</li> </ul>
	Current Password <input type="text"/>	
	New Password <input type="text"/>	
	Comfirm Password <input type="text"/>	
	<span>Apply</span>	

[Logout](#)

**Admin > Projector Control**

<ul style="list-style-type: none"> <li>System Status</li> <li>General Setup</li> <li><b>Projector Control</b></li> <li>Network Setup</li> <li>Alert Setup</li> <li>Crestron</li> <li>Reset to Default</li> <li>Reboot System</li> </ul>	<div style="display: flex; justify-content: space-between;"> <div style="width: 45%;"> <div style="display: flex; justify-content: space-between; margin-bottom: 5px;"> <span>Power On</span> <span>Power Off</span> </div> <div style="display: flex; justify-content: space-between; margin-bottom: 5px;"> <span>Resync</span> <span>Next Source</span> </div> <div style="display: flex; justify-content: space-between; margin-bottom: 5px;"> <span>Auto Source</span> </div> <div style="display: flex; justify-content: space-between; margin-bottom: 5px;"> <span>AV Mute</span> </div> <div style="display: flex; justify-content: space-between; margin-bottom: 5px;"> <span>Freeze</span> </div> <div style="display: flex; justify-content: space-between; margin-bottom: 5px;"> <span>3D Format</span> <span>Auto</span> </div> <div style="display: flex; justify-content: space-between; margin-bottom: 5px;"> <span>3D L/R Invert</span> </div> </div> <div style="width: 45%;"> <div style="display: flex; justify-content: space-between; margin-bottom: 5px;"> <span>Input</span> <span>HDMI1</span> </div> <div style="display: flex; justify-content: space-between; margin-bottom: 5px;"> <span>Brightness</span> <span>- 0 +</span> </div> <div style="display: flex; justify-content: space-between; margin-bottom: 5px;"> <span>Contrast</span> <span>- 0 +</span> </div> <div style="display: flex; justify-content: space-between; margin-bottom: 5px;"> <span>Sharpness</span> <span>- 10 +</span> </div> <div style="display: flex; justify-content: space-between; margin-bottom: 5px;"> <span>Display Mode</span> <span>Cinema</span> </div> </div> </div>	<div style="display: flex; justify-content: space-between; margin-bottom: 5px;"> <span>Audio</span> </div> <div style="display: flex; justify-content: space-between; margin-bottom: 5px;"> <span>Volume</span> <span>- 5 +</span> </div> <div style="display: flex; justify-content: space-between; margin-bottom: 5px;"> <span>Auto Shutdown (Min.)</span> <span>- 15 +</span> </div> <div style="display: flex; justify-content: space-between; margin-bottom: 5px;"> <span>Brightness Mode</span> <span>Power</span> </div> <div style="display: flex; justify-content: space-between; margin-bottom: 5px;"> <span>Aspect Ratio</span> <span>Auto</span> </div>
---	--	---

[Logout](#)

**Admin > Network Setup**

<ul style="list-style-type: none"> <li>System Status</li> <li>General Setup</li> <li>Projector Control</li> <li><b>Network Setup</b></li> <li>Alert Setup</li> <li>Crestron</li> <li>Reset to Default</li> <li>Reboot System</li> </ul>	<div style="display: flex; justify-content: space-between; margin-bottom: 5px;"> <span>IP Setup</span> <span>DHCP <input type="radio"/> On <input checked="" type="radio"/> Off</span> </div> <table border="1" style="width: 100%; border-collapse: collapse;"> <tr> <td style="width: 30%;">IP Address</td> <td style="width: 10%;">192</td> <td style="width: 10%;">168</td> <td style="width: 10%;">0</td> <td style="width: 10%;">100</td> </tr> <tr> <td>Subnet Mask</td> <td>255</td> <td>255</td> <td>255</td> <td>0</td> </tr> <tr> <td>Default Gateway</td> <td>192</td> <td>168</td> <td>0</td> <td>254</td> </tr> <tr> <td>DNS Server</td> <td>192</td> <td>168</td> <td>0</td> <td>51</td> </tr> </table> <div style="text-align: center; margin-top: 5px;"> <span>Apply</span> </div>	IP Address	192	168	0	100	Subnet Mask	255	255	255	0	Default Gateway	192	168	0	254	DNS Server	192	168	0	51
IP Address	192	168	0	100																	
Subnet Mask	255	255	255	0																	
Default Gateway	192	168	0	254																	
DNS Server	192	168	0	51																	

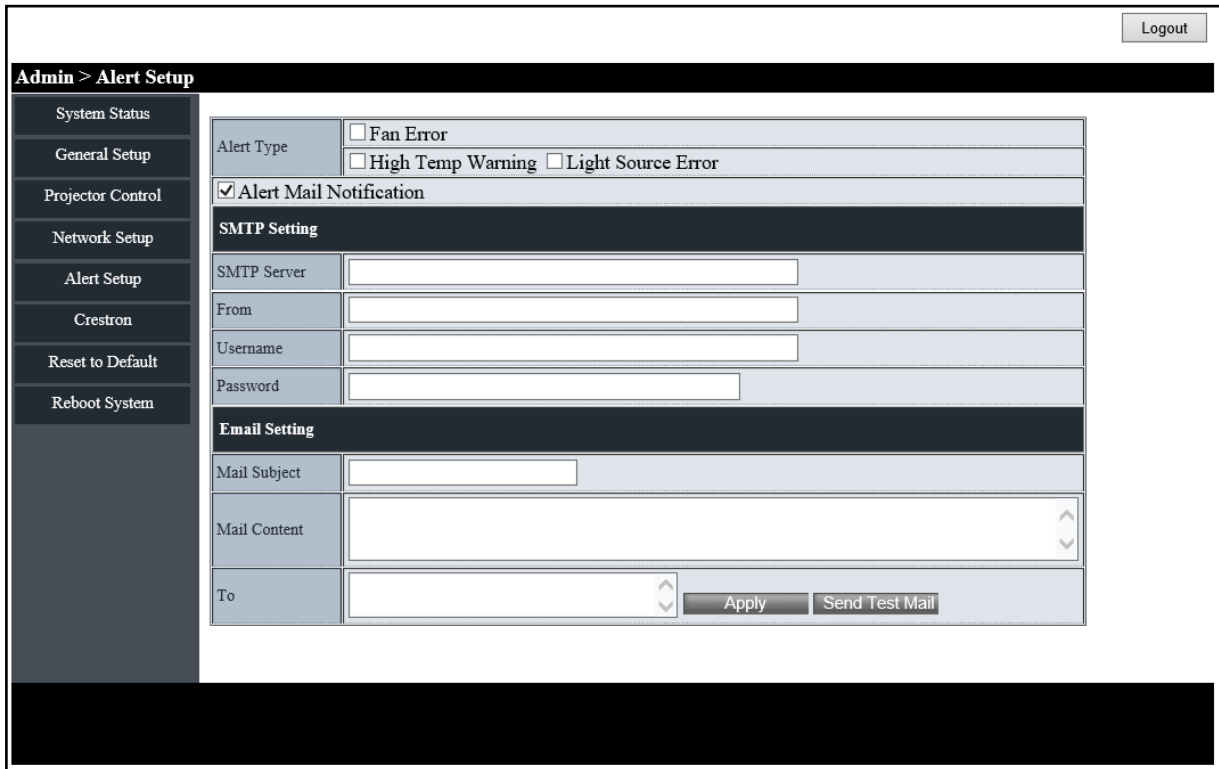

## RS232 by Telnet Function

As an alternative method of control, this projector has RS232 command control by TELNET for LAN / RJ45 interface.

### Quick Start-Guide for “RS232 by Telnet”

- Check and get the IP address on OSD of the projector.
- Make sure that the PC / laptop can access the web-page of the projector.
- Make sure that “Windows Firewall” setting is set to disabled in case of “TELNET” function filtering out by PC / laptop.

1. Click on **Search**  and then enter “cmd” as a search word. Press the “Enter” key.

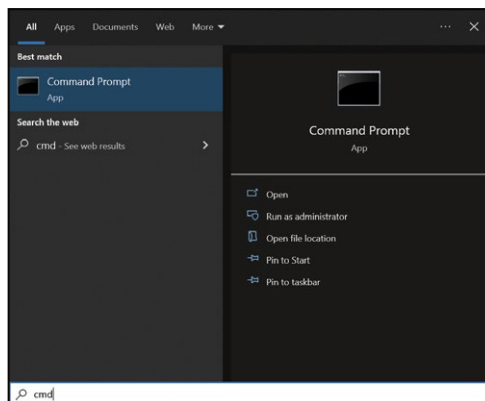

2. Open the Command Prompt app.
3. Input the command format as follows:
  - telnet ttt.xxx.yyy.zzz 23 (“Enter” key pressed)
  - (ttt.xxx.yyy.zzz: IP-Address of the projector)
4. If Telnet-Connection ready, and user can have RS232 command input, then press the “Enter” key and Telnet connection should be ready for RS232 command control.

**Specification for “RS232 by TELNET”:**

1. Telnet: TCP.
2. Telnet port: 23 (for further details, please contact the Optoma service team).
3. Telnet utility: Windows “TELNET.exe” (console mode).
4. To end the Telnet session, just close the Command Prompt app window.
5. Windows Telnet utility directly after TELNET connection ready.
  - Limitation 1 for Telnet-Control: There cannot be more than 50 bytes for successive network payload for Telnet-Control application.
  - Limitation 2 for Telnet-Control: There cannot be more than 26 bytes for successive RS232 command for Telnet-Control.
  - Limitation 3 for Telnet-Control: Minimum delay for next command must be more than 200 (ms).

**5.12 INFO MENU**

View the projector information as listed below:

- Serial Number Source Info.
- Display Mode
- Color Info.
- Power Mode (Standby) Light Source Hours Brightness Mode
- IP Address
- Network Status
- FW Version

**6. ADDITIONAL INFORMATION**

**6.1 COMPATIBLE RESOLUTIONS**

**Input Signal for HDMI**

1080p		
Signal	Resolution	Refresh Rate (Hz)
VGA	640 X 480	60/67/72/75
SVGA	800 X 600	56/60/72/75
XGA	1024 X 768	60(*2)/70/75/120(*2)
	1152 X 870	75
SDTV(480I)	720 X 480	60
SDTV(480P)	720 X 480	60
SDTV(576I)	720 X 576	50
SDTV(576P)	720 X 576	50
HDTV(720p)	1280 X 720	60(*2)/120(*2)
WXGA	1280 X 800	60/120(*2)
WXGA	1366 X 768	60
SXGA	1280 X 1024	60/75/85
UXGA	1600 X 1200	60
HDTV(1080I)	1920 X 1080	50/60
HDTV(1080p)	1920 X 1080	24/25/30/50/60/120
WUXGA	1920 X 1200(*1)	60
UHD(2160p)	3840 X 2160	24/25/30/50(*3)/60(*3)
4K2K(2160p)	4096 X 2160	24/25(*3)/30(*3)/50(*3)/60(*3)

WUXGA		
Signal	Resolution	Refresh Rate (Hz)
VGA	640 X 480	60/67/72/75
SVGA	800 X 600	56/60/72/75
XGA	1024 X 768	60(*2)/70/75/120(*2)
	1152 X 870	75
SDTV(480I)	720 X 480	60
SDTV(480P)	720 X 480	60
SDTV(576I)	720 X 576	50
SDTV(576P)	720 X 576	50
HDTV(720p)	1280 X 720	60(*2)/120(*2)
WXGA	1280 X 800	60/120(*2)
WXGA	1366 X 768	60
SXGA	1280 X 1024	60/75/85
UXGA	1600 X 1200	60
HDTV(1080I)	1920 X 1080	50/60
HDTV(1080p)	1920 X 1080	24/25/30/50/60/120
WUXGA	1920 X 1200(*1)	60
UHD(2160p)	3840 X 2160	24/25/30/50(*3)/60(*3)
4K2K(2160p)	4096 X 2160	24/25(*3)/30(*3)/50(*3)/60(*3)

**Note** (\*1) 1920 x 1200 @60Hz only support RB (reduced blanking).  
 (\*2) 3D timing for True 3D projector (optional).

### 3D Timing

WUXGA				
INPUT RESOLUTIONS	INPUT	INPUT TIMING		
		HDMI 3D Input (with 3D InfoFrame information)	1280 x 720P @50Hz	Top-and-Bottom
1280 x 720P @60Hz			Top-and-Bottom	
1280 x 720P @50Hz			Frame packing	
1280 x 720P @60Hz			Frame packing	
1920 x 1080i @50 Hz			Side-by-Side (Half)	
1920 x 1080i @60 Hz			Side-by-Side (Half)	
1920 x 1080P @24 Hz			Top-and-Bottom	
1920 x 1080P @24 Hz			Frame packing	
HDMI 3D Input (without 3D InfoFrame information)		1920 x 1080i @50Hz	Side-by-Side (Half)	SBS mode is on
		1920 x 1080i @60Hz		
		1280 x 720P @50Hz		
		1280 x 720P @60Hz	Top-and-Bottom	TAB mode is on
		1920 x 1080i @50Hz		
		1920 x 1080i @60Hz		
1280 x 720P @50Hz				
1280 x 720P @60Hz				
480i	HQFS (3D format is Frame sequential)			

1080p				
INPUT RESOLUTIONS	INPUT	INPUT TIMING		
	HDMI 3D Input (with 3D InfoFrame information)	1280 x 720P @50Hz	Top-and-Bottom	
		1280 x 720P @60Hz	Top-and-Bottom	
		1280 x 720P @50Hz	Frame packing	
		1280 x 720P @60Hz	Frame packing	
		1920 x 1080i @50 Hz	Side-by-Side (Half)	
		1920 x 1080i @60 Hz	Side-by-Side (Half)	
		1920 x 1080P @24 Hz	Top-and-Bottom	
		1920 x 1080P @24 Hz	Frame packing	
	HDMI 3D Input (without 3D InfoFrame information)	1920 x 1080i @50Hz	Side-by-Side (Half)	SBS mode is on
		1920 x 1080i @60Hz		
		1280 x 720P @50Hz		
		1280 x 720P @60Hz		
		1920 x 1080i @50Hz	Top-and-Bottom	TAB mode is on
		1920 x 1080i @60Hz		
1280 x 720P @50Hz				
1280 x 720P @60Hz				
480i	HQFS (3D format is Frame sequential)			

- Note**
- If 3D input is 1080p@24Hz, the DMD should replay with integral multiple with 3D mode.
  - 1080i@25Hz and 720p@50Hz will run in 100Hz; other 3D timing will run in 120Hz.
  - 1080P@24Hz will run 144Hz (XGA, WXGA, 1080p) / 96Hz (WUXGA).
  - For **Triple Flash 3D** mode support - DDP442x is limited to 1920x1080 input 3D sources due to ASIC buffer memory limitation. This means **WUXGA@24Hz** is not supported in **Triple Flash** mode (144Hz output rate), it can be processed in **Double Flash** mode (96Hz output rate) or the WUXGA input image can be cropped to 1080p before enabling 3D processing.

## Digital compatibility

1080p													
HDMI 1 / HDMI 2													
B0/Established Timing			B0/Standard Timing			B0/Detail Timing			B1/Video Mode			B1/Detail Timing	
Resolution	V [Hz]	H [Hz]	Resolution	V [Hz]	Aspect ratio	Resolution	V [Hz]	VIC	Resolution	V [Hz]	Resolution	V [Hz]	
720x400	70.0	31.5	1280x720	60.0	16:9	1920x1080	60.0	1	640x480P 4:3	60.0	1920 X 1080	60.0	
640x480	60.0	31.5	1280x800	60.0	16:10			2	720x480p 4:3	60.0	1366 x 768	60.0	
640x480	66.6 (67)	34.9	1280x1024	60.0	5:4			3	720x480p 16:9	60.0			
640x480	72.0	37.9	1600x1200	60.0	4:3			4	1280x720p 16:9	60.0			
640x480	75.0	37.5	1920x1200	60.0	16:10			5	1920x1080i 16:9	60.0			
800x600	56.0	35.1	1024x768	120.0	4:3			6	720(1440)x480i 4:3	60.0			
800x600	60.0	37.9	1280x720	120.0	16:9			7	720(1440)x480i 16:9	60.0			
800x600	72.0	48.1	1280x800	120.0	16:10			16	1920x1080p 16:9	60.0			
800x600	75.0	46.9						17	720x576p 4:3	50.0			
1024x768	60.0	48.4						18	720x576p 16:9	50.0			
1024x768	70.0	56.5						19	1280x720p 16:9	50.0			
1024x768	75.0	60.0						20	1920x1080i 16:9	50.0			
1280x1024	75.0	80.0						21	720(1440)x576i 4:3	50.0			
1152x870	75.0	67.5						22	720(1440)x576i 16:9	50.0			
								31	1920x1080p 16:9	50.0			
								32	1920x1080p 16:9	24.0			
								33	1920x1080p 16:9	25.0			
								34	1920x1080p 16:9	30.0			
								93	3840 x 2160p 16:9	24.0			
								94	3840 x 2160p 16:9	25.0			
								95	3840 x 2160p 16:9	30.0			
								96	3840 x 2160p 6:9	50.0	YCbCr 4:2:0		
								97	3840 x 2160p 16:9	60.0	YCbCr 4:2:0		
								98	4096 x 2160p 256:135	24.0			
								99	4096 x 2160p 256:135	25.0			
								100	4096 x 2160p 256:135	30.0			
								101	4096 x 2160p 256:135	50.0	YCbCr 4:2:0		
								102	4096 x 2160p 256:135	60.0	YCbCr 4:2:0		

1080p									
VGA In									
B0/Established Timing			B0/Standard Timing			B0/Detail Timing		B1/Detail Timing	
Resolution	V [Hz]	H [Hz]	Resolution	V [Hz]	Aspect ratio	Resolution	V [Hz]	Resolution	V [Hz]
720x400	70.0	31.5	1024x768	120.0	4:3	1920x1080	60.0	1366 x 768	60.0
640x480	60.0	31.5	1280x720	60.0	16:9			1920 x 1080	60.0
640x480	66.6 (67)	34.9	1280x720	120.0	16:9				
640x480	72.0	37.9	1280x800	60.0	16:10				
640x480	75.0	37.5	1280x1024	60.0	5:4				
800x600	56.0	35.1	1440x900	60.0	16:10				
800x600	60.0	37.9	1400x1050	60.0	4:3				
800x600	72.0	48.1	1600x1200	60.0	4:3				
800x600	75.0	46.9							
1024x768	60.0	48.4							
1024x768	70.0	56.5							
1024x768	75.0	60.0							
1280x1024	75.0	80.0							
1152x870	75.0	67.5							

WUXGA													
HDMI 1 / HDMI 2													
B0/Established Timing			B0/Standard Timing			B0/Detail Timing			B1/Video Mode			B1/Detail Timing	
Resolution	V [Hz]	H [Hz]	Resolution	V [Hz]	Aspect ratio	Resolution	V [Hz]	VIC	Resolution	V [Hz]	Resolution	V [Hz]	
720x400	70.0	31.5	1280X720	60.0	16:9	1920X1200	60.0	1	640X480P 4:3	60.0	1920 X 1080	60.0	
640x480	60.0	31.5	1280x800	60.0	16:10			2	720x480p 4:3	60.0	1366 x 768	60.0	
640x480	66.6 (67)	34.9	1280x1024	60.0	5:4			3	720x480p 16:9	60.0			
640x480	72.0	37.9	1600x1200	60.0	4:3			4	1280x720p 16:9	60.0			
640x480	75.0	37.5	1920x1200	60.0	16:10			5	1920x1080i 16:9	60.0			
800x600	56.0	35.1	1024x768	120.0	4:3			6	720(1440)x480i 4:3	60.0			
800x600	60.0	37.9	1280x720	120.0	16:9			7	720(1440)x480i 16:9	60.0			
800x600	72.0	48.1	1280x800	120.0	16:10			16	1920x1080p 16:9	60.0			
800x600	75.0	46.9						17	720x576p 4:3	50.0			
1024x768	60.0	48.4						18	720x576p 16:9	50.0			
1024x768	70.0	56.5						19	1280x720p 16:9	50.0			
1024x768	75.0	60.0						20	1920x1080i 16:9	50.0			
1280x1024	75.0	80.0						21	720(1440)x576i 4:3	50.0			
1152x870	75.0	67.5						22	720(1440)x576i 16:9	50.0			
								31	1920x1080p 16:9	50.0			
								32	1920x1080p 16:9	24.0			
								33	1920x1080p 16:9	25.0			
								34	1920x1080p 16:9	30.0			
								93	3840 x 2160p 16:9	24.0			
								94	3840 x 2160p 16:9	25.0			
								95	3840 x 2160p 16:9	30.0			
								96	3840 x 2160p 6:9	50.0	YCbCr 4:2:0		
								97	3840 x 2160p 16:9	60.0	YCbCr 4:2:0		
								98	4096 x 2160p 256:135	24.0			
								99	4096 x 2160p 256:135	25.0			
								100	4096 x 2160p 256:135	30.0			
								101	4096 x 2160p 256:135	50.0	YCbCr 4:2:0		
								102	4096 x 2160p 256:135	60.0	YCbCr 4:2:0		

WUXGA									
VGA In									
B0/Established Timing			B0/Standard Timing			B0/Detail Timing		B1/Detail Timing	
Resolution	V [Hz]	H [Hz]	Resolution	V [Hz]	Aspect ratio	Resolution	V [Hz]	Resolution	V [Hz]
720x400	70.0	31.5	1024x768	120.0	4:3	1920x1200	60.0	1366 x 768	60.0
640x480	60.0	31.5	1280x720	60.0	16:9			1920 x 1080	60.0
640x480	66.6 (67)	34.9	1280x720	120.0	16:9				
640x480	72.0	37.9	1280x800	60.0	16:10				
640x480	75.0	37.5	1280x1024	60.0	5:4				
800x600	56.0	35.1	1440x900	60.0	16:10				
800x600	60.0	37.9	1400x1050	60.0	4:3				
800x600	72.0	48.1	1600x1200	60.0	4:3				
800x600	75.0	46.9							
1024x768	60.0	48.4							
1024x768	70.0	56.5							
1024x768	75.0	60.0							
1280x1024	75.0	80.0							
1152x870	75.0	67.5							

## 6.2 IMAGE SIZE AND PROJECTION DISTANCE

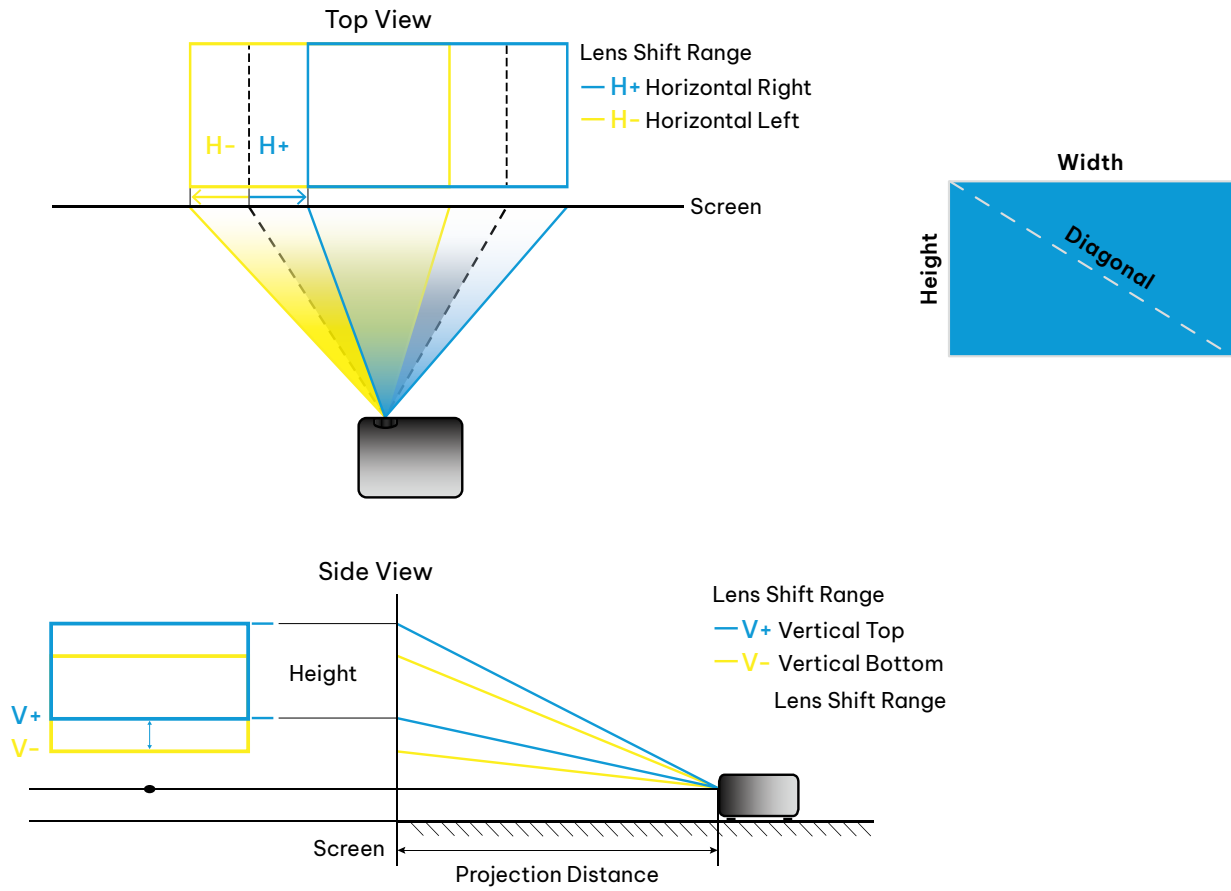

1080P

DESIRED IMAGE SIZE						PROJECTION DISTANCE (C)			
Diagonal		Width		Height		Wide		Tele	
m	inch	m	inch	m	inch	m	feet	m	feet
0.76	30	0.66	26.15	0.37	14.71	/	/	1.28	4.18
1.02	40	0.89	34.86	0.50	19.61	/	/	1.70	5.58
1.27	50	1.11	43.58	0.62	24.51	1.33	4.36	2.26	7.41
1.52	60	1.33	52.29	0.75	29.42	1.59	5.23	2.71	8.89
1.78	70	1.55	61.01	0.87	34.32	1.86	6.10	3.16	10.37
2.03	80	1.77	69.73	1.00	39.22	2.13	6.97	3.61	11.85
2.29	90	1.99	78.44	1.12	44.12	2.39	7.84	4.06	13.34
2.54	100	2.21	87.16	1.25	49.03	2.66	8.72	4.52	14.82
2.87	113	2.50	98.49	1.41	55.40	3.00	9.85	5.10	16.74
3.81	150	3.32	130.74	1.87	73.54	3.98	13.07	6.77	22.23
4.57	180	3.98	156.88	2.24	88.25	4.78	15.69	8.13	26.67
5.08	200	4.43	174.32	2.49	98.05	5.31	17.43	/	/
6.35	250	5.53	217.89	3.11	122.57	6.64	21.79	/	/
7.62	300	6.64	261.47	3.74	147.08	7.97	26.15	/	/

DESIRED IMAGE SIZE (Diagonal) inch	LENS SHIFT RANGE (WIDE)				
	Vertical Image Shift			Horizontal Image Shift	
	Vertical + (Max) (A), cm	Vertical - (Min) (B), cm	Vertical Shift Range cm	Horizontal + (Right), cm	Horizontal - (Left), cm
30	47.07	39.60	7.47	6.64	6.64
40	62.76	52.80	9.96	8.86	8.86
50	78.45	66.00	12.45	11.07	11.07
60	94.14	79.20	14.94	13.28	13.28
70	109.83	92.40	17.43	15.50	15.50
80	125.52	105.60	19.92	17.71	17.71
90	141.21	118.80	22.41	19.92	19.92
100	156.90	132.00	24.91	22.14	22.14
113	177.30	149.16	28.14	25.02	25.02
150	235.35	198.00	37.36	33.21	33.21
180	282.43	237.60	44.83	39.85	39.85
200	313.81	264.00	49.81	44.28	44.28
250	392.26	329.99	62.26	55.35	55.35
300	470.71	395.99	74.72	66.41	66.41

## WUXGA

DESIRED IMAGE SIZE						PROJECTION DISTANCE (C)			
Diagonal		Width		Height		Wide		Tele	
m	inch	m	inch	m	inch	m	feet	m	feet
0.76	30	0.65	25.44	0.40	15.90	/	/	1.32	4.32
1.02	40	0.86	33.92	0.54	21.20	/	/	1.76	5.77
1.27	50	1.08	42.40	0.67	26.50	1.29	4.24	2.20	7.21
1.52	60	1.29	50.88	0.81	31.80	1.55	5.09	2.64	8.65
1.78	70	1.51	59.36	0.94	37.10	1.81	5.94	3.08	10.09
2.08	82	1.77	69.54	1.10	43.46	2.12	6.95	3.60	11.82
2.29	90	1.94	76.32	1.21	47.70	2.33	7.63	3.95	12.97
2.54	100	2.15	84.80	1.35	53.00	2.58	8.48	4.39	14.42
2.95	116	2.50	98.37	1.56	61.48	3.00	9.84	5.10	16.72
3.81	150	3.23	127.20	2.02	79.50	3.88	12.72	6.59	21.62
4.57	180	3.88	152.64	2.42	95.40	4.65	15.26	7.91	25.95
5.08	200	4.31	169.60	2.69	106.00	5.17	16.96	/	/
6.35	250	5.38	212.00	3.37	132.50	6.46	21.20	/	/
7.62	300	6.46	254.40	4.04	159.00	7.75	25.44	/	/

DESIRED IMAGE SIZE (Diagonal) inch	LENS SHIFT RANGE (WIDE)				
	Vertical Image Shift			Horizontal Image Shift	
	Vertical + (Max) (A), cm	Vertical - (Min) (B), cm	Vertical Shift Range cm	Horizontal + (Right), cm	Horizontal - (Left), cm
30	48.46	40.39	8.08	6.46	6.46
40	64.62	53.85	10.77	8.62	8.62
50	80.77	67.31	13.46	10.77	10.77
60	96.93	80.77	16.15	12.92	12.92
70	113.08	94.23	18.85	15.08	15.08
82	132.47	110.39	22.08	17.66	17.66
90	145.39	121.16	24.23	19.39	19.39
100	161.54	134.62	26.92	21.54	21.54
116	187.39	156.16	31.23	24.99	24.99
150	242.32	201.93	40.39	32.31	32.31
180	290.78	242.32	48.46	38.77	38.77
200	323.09	269.24	53.85	43.08	43.08
250	403.86	336.55	67.31	53.85	53.85
300	484.63	403.86	80.77	64.62	64.62

### 6.3 PROJECTOR DIMENSIONS AND CEILING MOUNT INSTALLATION

To prevent damage to your projector, please use only approved InFocus ceiling mounts:

<https://www.infocus.com/accessories/mounts>

If you wish to use a third party ceiling mount kit, please ensure the screws used to attach a mount to the projector meet the following specifications:

- Screw type: M4\*3 pcs
- Minimum screw length: 10mm

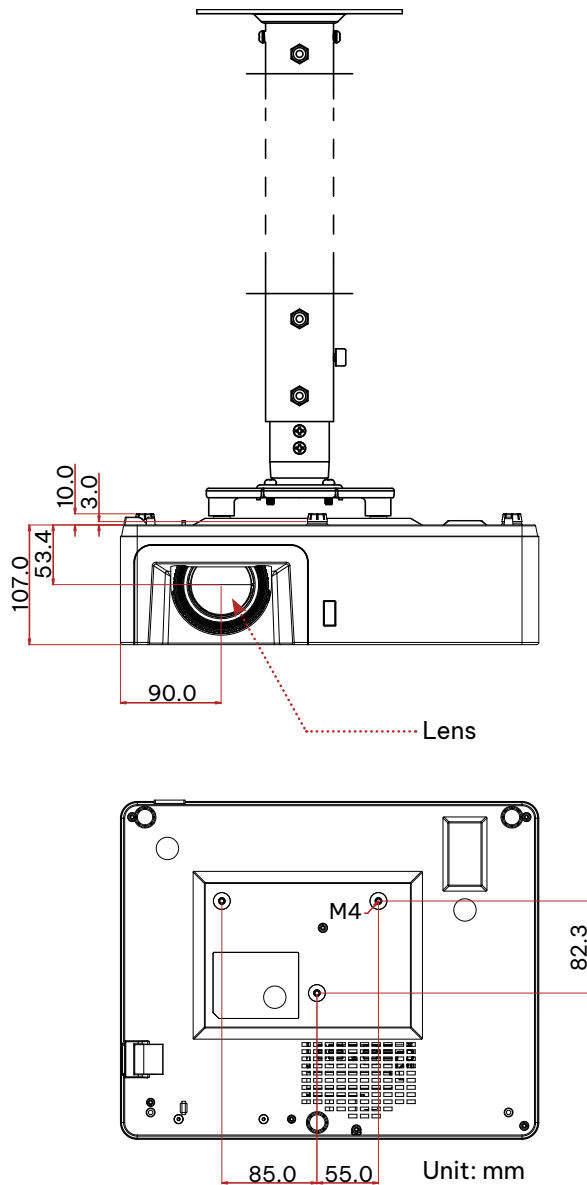

**Note** Please note that damage resulting from incorrect installation will void the warrant



**WARNING**

- Screw size will vary depending on the thickness of the mounting plate.
- Be sure to keep at least 10 cm gap between the ceiling and the bottom of the projector. Avoid installing the projector near a heat source.

## 6.4 RS232 COMMANDS AND PROTOCOL FUNCTION LIST

### RS232 PIN ASSIGNMENTS

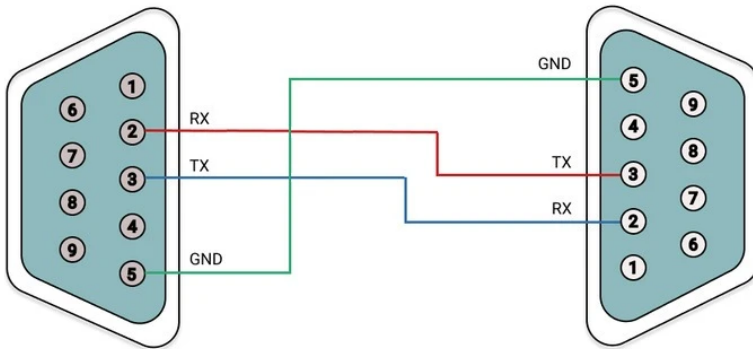

PIN	SIGNAL	SIGNAL FUNCTION
1	DCD	Data Carrier Detect
2	RxD	Receive Data
3	TxD	Transmit Data
	DTR	Data Terminal Ready
5	GND	Ground (Signal)
6	DSR	Data Set Ready
7	RTS	Request to Send
8	CTS	Clear to Send
9	RI	Ring Indicator

### RS232 SETTING

Baud Rate: 9600

Data Bits: 8

Parity: None

Stop Bits: 1

Flow Control: None

UART16550 FIFO: Disable

Projector Return (Pass): P

Projector Return (Fail): F XX= 00-99 (Projector's ID), XX= 00 is for all projectors

**Note**

- There is a <CR> after all ASCII commands
- 0D is the HEX code for <CR> in ASCII code

### SEND TO PROJECTOR

INDEX	COMMAND SET		FUNCTION	VALUE/RANGE
	ASCII Code	HEX Code		
S001	~XX00 1	7E 30 30 30 30 20 31 0D	Power	On
	~XX00 0	7E 30 30 30 30 20 30 0D		Off (0/2 for backward compatible)
S002	~XX00 1 ~nnnn	7E 30 30 30 30 20 31 20 a 0D	Power ON with Password ~nnnn	nnnn = Password ~0000 (a=7E 30 30 30 30) ~9999 (a=7E 39 39 39 39)
	~XX01 1	7E 30 30 30 31 20 31 0D	Resync	
S004	~XX02 1	7E 30 30 30 32 20 31 0D	AV Mute	On
	~XX02 0	7E 30 30 30 32 20 30 0D		Off (0/2 for backward compatible)
S005	~XX03 1	7E 30 30 30 33 20 31 0D	Mute	On
	~XX03 0	7E 30 30 30 33 20 30 0D		Off (0/2 for backward compatible)

INDEX	COMMAND SET		FUNCTION	VALUE/RANGE
	ASCII Code	HEX Code		
S006	~XX04 1	7E 30 30 30 34 20 31 0D	Freeze	
	~XX04 0	7E 30 30 30 34 20 30 0D	Unfreeze	(0/2 for backward compatible)
S007	~XX05 1	7E 30 30 30 35 20 31 0D	Zoom Plus	
S008	~XX06 1	7E 30 30 30 36 20 31 0D	Zoom Minus	
S010	~XX12 5	7E 30 30 31 32 20 35 0D	Direct Source Commands	VGA
	~XX12 6	7E 30 30 31 32 20 36 0D		VGA 2
	~XX12 10	7E 30 30 31 32 20 31 30 0D		Video
	~XX12 1	7E 30 30 31 32 20 31 0D		HDMI (HDMI 1)
	~XX12 15	7E 30 30 31 32 20 31 35 0D		HDMI 2
	~XX12 21	7E 30 30 31 32 20 32 31 0D		HDBaseT
S011	~XX20 1	7E 30 30 32 30 20 31 0D	Picture Mode	Presentation
	~XX20 2	7E 30 30 32 30 20 32 0D		Bright
	~XX20 3	7E 30 30 32 30 20 33 0D		Movie (Cinema)
	~XX20 4	7E 30 30 32 30 20 34 0D		sRGB
	~XX20 13	7E 30 30 32 30 20 31 33 0D		DICOM SIM.
	~XX20 5	7E 30 30 32 30 20 35 0D		User
	~XX20 9	7E 30 30 32 30 20 39 0D		3D
	~XX20 12	7E 30 30 32 30 20 31 32 0D		Game(Football)
~XX20 22	7E 30 30 32 30 20 32 32 0D	HDR SIM.		
S012	~XX21 n	7E 30 30 32 31 20 a 0D	Brightness	n = -50 (a=2D 35 30) ~ 50 (a=35 30)
S013	~XX22 n	7E 30 30 32 32 20 a 0D	Contrast	n = -50 (a=2D 35 30) ~ 50 (a=35 30)
S014	~XX23 n	7E 30 30 32 33 20 a 0D	Sharpness	n = 1 (a=31) ~ 15 (a=31 35)
S021	~XX34 n	7E 30 30 33 34 20 a 0D	BrilliantColor™	n = 1 (a=30) ~ 10 (a=31 30)
S022	~XX35 1	7E 30 30 33 35 20 31 0D	Gamma	Film
	~XX35 2	7E 30 30 33 35 20 32 0D		Video
	~XX35 3	7E 30 30 33 35 20 33 0D		Graphics
	~XX35 4	7E 30 30 33 35 20 34 0D		Standard (2.2)
	~XX35 5	7E 30 30 33 35 20 35 0D		1.8
	~XX35 6	7E 30 30 33 35 20 36 0D		2.0
	~XX35 12	7E 30 30 33 35 20 31 32 0D		2.4
	~XX35 8	7E 30 30 33 35 20 38 0D		2.6
S023	~XX36 1	7E 30 30 33 36 20 34 0D	Colour Temp.	Warm
	~XX36 2	7E 30 30 33 36 20 31 0D		Medium (Standard)
	~XX36 4	7E 30 30 33 36 20 32 0D		Cool
	~XX36 3	7E 30 30 33 36 20 33 0D		Cold
S024	~XX37 1	7E 30 30 33 37 20 31 0D	Colour Space	Auto
	~XX37 2	7E 30 30 33 37 20 32 0D		RGB \ RGB(0-255)
	~XX37 3	7E 30 30 33 37 20 33 0D		YUV
	~XX37 4	7E 30 30 33 37 20 34 0D		RGB (16 – 235)
S025	~XX44 n	7E 30 30 34 34 20 a 0D	Tint	n = -50 (a=2D 35 30) ~ 50 (a=35 30)
S026	~XX45 n	7E 30 30 34 35 20 a 0D	Colour (Saturation)	n = -50 (a=2D 35 30) ~ 50 (a=35 30)
S027	~XX46 1	7E 30 30 34 36 20 31 0D	Brightness	Brightness -
	~XX46 2	7E 30 30 34 36 20 32 0D		Brightness +
S028	~XX47 1	7E 30 30 34 37 20 31 0D	Contrast	Contrast -
	~XX47 2	7E 30 30 34 37 20 32 0D		Contrast +
S029	~XX59 1	7E 30 30 35 39 20 31 0D	Four corners	top-left (right+)
	~XX59 2	7E 30 30 35 39 20 32 0D		top-left (left+)
	~XX59 3	7E 30 30 35 39 20 33 0D		top-left (up +)

INDEX	COMMAND SET		FUNCTION	VALUE/RANGE
	ASCII Code	HEX Code		
S029	~XX59 4	7E 30 30 35 39 20 34 0D	Four corners	top-left (down +)
	~XX59 5	7E 30 30 35 39 20 35 0D		top right (right +)
	~XX59 6	7E 30 30 35 39 20 36 0D		top right (left +)
	~XX59 7	7E 30 30 35 39 20 37 0D		top right (up +)
	~XX59 8	7E 30 30 35 39 20 38 0D		top right (down +)
	~XX59 9	7E 30 30 35 39 20 39 0D		Bottom-left (right+)
	~XX59 10	7E 30 30 35 39 20 31 30 0D		Bottom-left(left+)
	~XX59 11	7E 30 30 35 39 20 31 31 0D		Bottom-left(Up+)
	~XX59 12	7E 30 30 35 39 20 31 32 0D		Bottom-left(down+)
	~XX59 13	7E 30 30 35 39 20 31 33 0D		Bottom-right (right+)
	~XX59 14	7E 30 30 35 39 20 31 34 0D		Bottom-right(left+)
	~XX59 15	7E 30 30 35 39 20 31 35 0D		Bottom-right(Up+)
	~XX59 16	7E 30 30 35 39 20 31 36 0D		Bottom-right(down+)
	S030	~XX60 1		7E 30 30 36 30 20 31 0D
~XX60 2		7E 30 30 36 30 20 32 0D	16:9	
~XX60 3		7E 30 30 36 30 20 33 0D	16:10	
~XX60 6		7E 30 30 36 30 20 36 0D	Native	
~XX60 7		7E 30 30 36 30 20 37 0D	Auto	
~XX60 16		7E 30 30 36 30 20 31 36 0D	21:9	
S031	~XX61 n	7E 30 30 36 31 20 a 0D	Edge mask	n = 0 (a=30) ~ 10 (a=31 30)
S032	~XX62 n	7E 30 30 36 32 20 a 0D	Zoom	n = -5 (a=2D 35) ~ 25 (a=32 35)
S033	~XX63 n	7E 30 30 36 33 20 a 0D	H Image Shift	n = -100 (a=2D 31 30 30) ~ 100 (a= 31 30 30)
S034	~XX64 n	7E 30 30 36 34 20 a 0D	V Image Shift	n = -100 (a=2D 31 30 30) ~ 100 (a= 31 30 30)
S035	~XX65 n	7E 30 30 36 35 20 a 0D	H Keystone	n = -30 (a=2D 33 30) ~ 30 (a=33 30)
S036	~XX66 n	7E 30 30 36 36 20 a 0D	V Keystone	RT: n = -40 (a=2D 34 30) ~ 40 (a=34 30) ST: n = -20 (a=2D 32 30) ~ 20 (a=32 30) n = -30 (a=2D 33 30) ~ 30 (a=33 30) (for INL2156,58,59)
S037	~XX69 1	7E 30 30 36 39 20 31 0D	Auto Keystone	On
	~XX69 0	7E 30 30 36 39 20 30 0D		Off (0/2 for backward compatible)
S038	~XX70 1	7E 30 30 37 30 20 31 0D	Language	English
	~XX70 2	7E 30 30 37 30 20 32 0D		Deutsch
	~XX70 3	7E 30 30 37 30 20 33 0D		Français
	~XX70 4	7E 30 30 37 30 20 34 0D		Italiana
	~XX70 5	7E 30 30 37 30 20 35 0D		Español
	~XX70 6	7E 30 30 37 30 20 36 0D		Português
	~XX70 7	7E 30 30 37 30 20 37 0D		Polski
	~XX70 8	7E 30 30 37 30 20 38 0D		Nederlands
	~XX70 9	7E 30 30 37 30 20 39 0D		Svenska
	~XX70 11	7E 30 30 37 30 20 31 31 0D		Suomi
	~XX70 12	7E 30 30 37 30 20 31 32 0D		ελληνικά
	~XX70 13	7E 30 30 37 30 20 31 33 0D		繁體中文
	~XX70 14	7E 30 30 37 30 20 31 34 0D		简体中文
	~XX70 15	7E 30 30 37 30 20 31 35 0D		日本語
	~XX70 16	7E 30 30 37 30 20 31 36 0D		한국어
	~XX70 17	7E 30 30 37 30 20 31 37 0D		Русский
	~XX70 18	7E 30 30 37 30 20 31 38 0D		Magyar
	~XX70 19	7E 30 30 37 30 20 31 39 0D		Čeština

INDEX	COMMAND SET		FUNCTION	VALUE/RANGE
	ASCII Code	HEX Code		
S038	~XX70 20	7E 30 30 37 30 20 32 30 0D	Language	عربي
	~XX70 21	7E 30 30 37 30 20 32 31 0D		ไทย
	~XX70 22	7E 30 30 37 30 20 32 32 0D		Türkçe
	~XX70 23	7E 30 30 37 30 20 32 33 0D		فارسی
	~XX70 25	7E 30 30 37 30 20 32 35 0D		Tiếng Việt
	~XX70 26	7E 30 30 37 30 20 32 36 0D		Bahasa Indonesia
	~XX70 27	7E 30 30 37 30 20 32 37 0D		Română
	~XX70 32	7E 30 30 37 30 20 33 32 0D		Norsk
	~XX70 33	7E 30 30 37 30 20 33 33 0D		Dansk
S039	~XX71 1	7E 30 30 37 31 20 31 0D	Projection	Front
	~XX71 2	7E 30 30 37 31 20 32 0D		Rear
	~XX71 3	7E 30 30 37 31 20 33 0D		Front-Ceiling
	~XX71 4	7E 30 30 37 31 20 34 0D		Rear-Ceiling
S040	~XX72 1	7E 30 30 37 32 20 31 0D	Menu Location	Top Left
	~XX72 2	7E 30 30 37 32 20 32 0D		Top Right
	~XX72 3	7E 30 30 37 32 20 33 0D		Centre
	~XX72 4	7E 30 30 37 32 20 34 0D		Bottom Left
	~XX72 5	7E 30 30 37 32 20 35 0D		Bottom Right
S041	~XX73 n	7E 30 30 37 33 20 a 0D	Signal Frequency	n = -5 (a=2D 35) ~ 5 (a=35) By signal
S042	~XX74 n	7E 30 30 37 34 20 a 0D	Signal Phase	n = 0 (a=30) ~ 63 (a=36 33) By signal
S043	~XX75 n	7E 30 30 37 35 20 a 0D	Signal H. Position	n = -5 (a=2D 35) ~ 5 (a=35) By timing
S044	~XX76 n	7E 30 30 37 36 20 a 0D	Signal V. Position	n = -5 (a=2D 35) ~ 5 (a=35) By timing
S045	~XX77 ~n	7E 30 30 37 37 20 aabbcc 0D	Security Security Timer Month/Day/Hour	n = mm/dd/hh mm= 00 (aa=30 30) ~ 12 (aa=31 32) dd = 00 (bb=30 30) ~ 30 (bb=33 30) hh= 00 (cc=30 30) ~ 24 (cc=32 34)
S046	~XX78 1 ~nnnn	7E 30 30 37 38 20 31 20 a 0D	Security	On with password ~nnnn = ~0000 (a= 7E 30 30 30 30) ~9999 (a=7E 39 39 39 39)
	~XX78 0 ~nnnn	7E 30 30 37 38 20 30 20 a 0D		Off (0/2 for backward compatible) with password ~nnnn = ~0000 (a= 7E 30 30 30 30) ~9999 (a=7E 39 39 39 39)
S048	~XX80 1	7E 30 30 38 30 20 31 0D	Mute	On
	~XX80 0	7E 30 30 38 30 20 30 0D		Off (0/2 for backward compatible)
S049	~XX81 n	7E 30 30 38 31 20 a 0D	Volume (Audio)	n = 0 (a=30) ~ 10 (a=31 30)
S050	~XX82 1	7E 30 30 38 32 20 31 0D	Logo	Default
	~XX82 3	7E 30 30 38 32 20 33 0D		Neutral
S052	~XX88 0	7E 30 30 38 38 20 30 0D	Closed Captioning	Off
	~XX88 1	7E 30 30 38 38 20 31 0D		CC1
	~XX88 2	7E 30 30 38 38 20 32 0D		CC2
S054	~XX91 1	7E 30 30 39 31 20 31 0D	Signal Automatic	On
	~XX91 0	7E 30 30 39 31 20 30 0D		Off
S055	~XX101 1	7E 30 30 31 30 31 20 31 0D	High Altitude	On
	~XX101 0	7E 30 30 31 30 31 20 30 0D		Off (0/2 for backward compatible)
S058	~XX104 0	7E 30 30 31 30 34 20 30 0D	Background Color	None
	~XX104 1	7E 30 30 31 30 34 20 31 0D		Blue
	~XX104 3	7E 30 30 31 30 34 20 33 0D		Red
	~XX104 4	7E 30 30 31 30 34 20 34 0D		Green
	~XX104 6	7E 30 30 31 30 34 20 36 0D		Gray
	~XX104 7	7E 30 30 31 30 34 20 37 0D		Logo

INDEX	COMMAND SET		FUNCTION	VALUE/RANGE
	ASCII Code	HEX Code		
S059	~XX105 1	7E 30 30 31 30 35 20 31 0D	Direct Power On	On
	~XX105 0	7E 30 30 31 30 35 20 30 0D		Off (0/2 for backward compatible)
S060	~XX106 n	7E 30 30 31 30 36 20 a 0D	Auto Power Off (min) (5 minutes for each step)	n = 0 (a=30) ~ 180 (a=31 38 30)
S065	~XX112 1	7E 30 30 31 31 32 20 31 0D	Reset to Default Yes (P.S When security is off)	Yes with no password (Security is Off)
S066	~XX112 1 ~nnnn	7E 30 30 31 31 32 20 31 0D	Reset to Default Yes (P.S When security is On/Off)	Yes with no password (Security is Off)
S067	~XX113 1	7E 30 30 31 31 33 20 31 0D	Signal Power On	On
	~XX113 0	7E 30 30 31 31 33 20 30 0D		Off (0/2 for backward compatible)
S068	~XX114 1	7E 30 30 31 31 34 20 31 0D	Power Mode (Standby)	Active
	~XX114 0	7E 30 30 31 31 34 20 30 0D		Eco. (<0.5W)
	~XX114 2	7E 30 30 31 31 34 20 32 0D		ErP Off
S070	~XX140 10	7E 30 30 31 34 30 20 31 30 0D	IR Function	Up
	~XX140 11	7E 30 30 31 34 30 20 31 31 0D		Left
	~XX140 12	7E 30 30 31 34 30 20 31 32 0D		Enter (for Projection MENU)
	~XX140 13	7E 30 30 31 34 30 20 31 33 0D		Right
	~XX140 14	7E 30 30 31 34 30 20 31 34 0D		Down
	~XX140 15	7E 30 30 31 34 30 20 31 35 0D		Keystone +
	~XX140 16	7E 30 30 31 34 30 20 31 36 0D		Keystone -
	~XX140 17	7E 30 30 31 34 30 20 31 37 0D		Volume -
	~XX140 18	7E 30 30 31 34 30 20 31 38 0D		Volume +
	~XX140 19	7E 30 30 31 34 30 20 31 39 0D		Brightness
	~XX140 20	7E 30 30 31 34 30 20 32 30 0D		Menu
	~XX140 21	7E 30 30 31 34 30 20 32 31 0D		Zoom
	~XX140 28	7E 30 30 31 34 30 20 32 38 0D		Contrast
	~XX140 47	7E 30 30 31 34 30 20 34 37 0D		Source
S071	~XX195 0	7E 30 30 31 39 35 20 30 0D	Test Pattern	Off
	~XX195 2	7E 30 30 31 39 35 20 32 0D		White
	~XX195 3	7E 30 30 31 39 35 20 33 0D		Grid (Green)
	~XX195 9	7E 30 30 31 39 35 20 39 0D		Test Card
S077	~XX230 0	7E 30 30 32 33 30 20 30 0D	3D Mode	Off
	~XX230 1	7E 30 30 32 33 30 20 31 0D		DLP-Link
S078	~XX231 0	7E 30 30 32 33 31 20 30 0D	3D Sync Invert	Off
	~XX231 1	7E 30 30 32 33 31 20 31 0D		On
S079	~XX313 1	7E 30 30 33 31 33 20 31 0D	Information Menu	On
	~XX313 0	7E 30 30 33 31 33 20 30 0D		Off (0/2 for backward compatible)
S083	~XX327 n	7E 30 30 33 32 37 20 a 0D	Colour Setting Red Hue	n = -50 (a=2D 35 30) ~ 50 (a=35 30)
S084	~XX328 n	7E 30 30 33 32 38 20 a 0D	Colour Setting Green Hue	n = -50 (a=2D 35 30) ~ 50 (a=35 30)
S085	~XX329 n	7E 30 30 33 32 39 20 a 0D	Colour Setting Blue Hue	n = -50 (a=2D 35 30) ~ 50 (a=35 30)
S086	~XX330 n	7E 30 30 33 33 30 20 a 0D	Colour Setting Cyan Hue	n = -50 (a=2D 35 30) ~ 50 (a=35 30)
S087	~XX331 n	7E 30 30 33 33 31 20 a 0D	Colour Setting Yellow Hue	n = -50 (a=2D 35 30) ~ 50 (a=35 30)
S088	~XX332 n	7E 30 30 33 33 32 20 a 0D	Colour Setting Magenta Hue	n = -50 (a=2D 35 30) ~ 50 (a=35 30)
S089	~XX333 n	7E 30 30 33 33 33 20 a 0D	Colour Setting Red Stutation	n = -50 (a=2D 35 30) ~ 50 (a=35 30)
S090	~XX334 n	7E 30 30 33 33 34 20 a 0D	Colour Setting Green Stutation	n = -50 (a=2D 35 30) ~ 50 (a=35 30)
S091	~XX335 n	7E 30 30 33 33 35 20 a 0D	Colour Setting Blue Stutation	n = -50 (a=2D 35 30) ~ 50 (a=35 30)
S092	~XX336 n	7E 30 30 33 33 36 20 a 0D	Colour Setting Cyan Stutation	n = -50 (a=2D 35 30) ~ 50 (a=35 30)
S093	~XX337 n	7E 30 30 33 33 37 20 a 0D	Colour Setting Yellow Stutation	n = -50 (a=2D 35 30) ~ 50 (a=35 30)

INDEX	COMMAND SET		FUNCTION	VALUE/RANGE
	ASCII Code	HEX Code		
S094	~XX338 n	7E 30 30 33 33 38 20 a 0D	Colour Setting Magenta Stutation	n = -50 (a=2D 35 30) ~ 50 (a=35 30)
S095	~XX339 n	7E 30 30 33 33 39 20 a 0D	Colour Setting Red Gain	n = -50 (a=2D 35 30) ~ 50 (a=35 30)
S096	~XX340 n	7E 30 30 33 34 30 20 a 0D	Colour Setting Green Gain	n = -50 (a=2D 35 30) ~ 50 (a=35 30)
S097	~XX341 n	7E 30 30 33 34 31 20 a 0D	Colour Setting Blue Gain	n = -50 (a=2D 35 30) ~ 50 (a=35 30)
S098	~XX342 n	7E 30 30 33 34 32 20 a 0D	Colour Setting Cyan Gain	n = -50 (a=2D 35 30) ~ 50 (a=35 30)
S099	~XX343 n	7E 30 30 33 34 33 20 a 0D	Colour Setting Yellow Gain	n = -50 (a=2D 35 30) ~ 50 (a=35 30)
S100	~XX344 n	7E 30 30 33 34 34 20 a 0D	Colour Setting Magenta Gain	n = -50 (a=2D 35 30) ~ 50 (a=35 30)
S101	~XX345 n	7E 30 30 33 34 35 20 a 0D	Colour Setting White Red	n = -50 (a=2D 35 30) ~ 50 (a=35 30)
S102	~XX346 n	7E 30 30 33 34 36 20 a 0D	Colour Setting White Green	n = -50 (a=2D 35 30) ~ 50 (a=35 30)
S103	~XX347 n	7E 30 30 33 34 37 20 a 0D	Colour Setting White Blue	n = -50 (a=2D 35 30) ~ 50 (a=35 30)
S105	~XX400 0	7E 30 30 34 30 30 20 30 0D	3D→2D	3D
	~XX400 1	7E 30 30 34 30 30 20 31 0D		L
	~XX400 2	7E 30 30 34 30 30 20 32 0D		R
S106	~XX405 0	7E 30 30 34 30 35 20 30 0D	3D Format	Auto
	~XX405 1	7E 30 30 34 30 35 20 31 0D		SBS
	~XX405 2	7E 30 30 34 30 35 20 32 0D		Top and Bottom
	~XX405 3	7E 30 30 34 30 35 20 33 0D		Frame Sequential
S107	~XX506 0	7E 30 30 35 30 36 20 30 0D	Wall Colour	Whiteboard
	~XX506 1	7E 30 30 35 30 36 20 31 0D		Blackboard
	~XX506 2	7E 30 30 35 30 36 20 32 0D		Light Yellow
	~XX506 3	7E 30 30 35 30 36 20 33 0D		Light Green
	~XX506 4	7E 30 30 35 30 36 20 34 0D		Light Blue
	~XX506 5	7E 30 30 35 30 36 20 35 0D		Pink
	~XX506 6	7E 30 30 35 30 36 20 36 0D		Gray
S108	~XX511 0	7E 30 30 35 31 31 20 30 0D	HDMI Link(CEC)	Off (0/2 for backward compatible)
	~XX511 1	7E 30 30 35 31 31 20 31 0D		On
S109	~XX563 0	7E 30 30 35 36 33 20 30 0D	Auto Source	Off (0/2 for backward compatible)
	~XX563 1	7E 30 30 35 36 33 20 31 0D		On

SEND FROM PROJECTOR AUTOMATICALLY

INDEX	COMMAND SET		FUNCTION	VALUE/RANGE
	ASCII Code	HEX Code		
A001	N/A	N/A	Projector Information a=0, Standby a=1, Warming a=2, Cooling a=3, Out of Range a=4, Lamp Fail a=6, Fan Lock a=7, Over Temperature a=8, Lamp Hours Running Out	INFOa

READ FROM PROJECTOR

INDEX	COMMAND SET		FUNCTION	VALUE/RANGE
	ASCII Code	HEX Code		
R001	~XX87 1	7E 30 30 38 37 20 31 0D	LAN Settings /Net- work State	Oka (a=0 Disconnected a=1 Connected)
R002	~XX87 3	7E 30 30 38 37 20 33 0D	LAN Settings /IP Ad- dress	Okaaa_bbb_ccc_ddd
R003	~XX108 1	7E 30 30 31 30 38 20 31 0D	Lamp Hours aaaaa=(5 digits) Total Lamp Hours	Okaaaaa

INDEX	COMMAND SET		FUNCTION	VALUE/RANGE
	ASCII Code	HEX Code		
R004	~XX121 1	7E 30 30 31 32 31 20 31 0D	Input Source Com- mands a=0, None a=7, HDMI (HDMI 1) a=2, VGA a=3, VGA 2 a=5, Video a=8, HDMI 2 a=16, HDBaseT	Oka
R005	~XX122 1	7E 30 30 31 32 32 20 31 0D	Software Version aaaa=Software Version	Okaaaa
R006	~XX123 1	7E 30 30 31 32 33 20 31 0D	Display Mode a=0, None a=1, Presentation a=2, Bright a=3, Movie (Cinema) a=4, sRGB a=5, User a=9, 3D a=12, Game a=13, DICOM SIM. a=22, HDR SIM	Oka
R007	~XX124 1	7E 30 30 31 32 34 20 31 0D	Power State a=0, Off a=1, On	Oka
R008	~XX125 1	7E 30 30 31 32 35 20 31 0D	Brightness aaa=-50 ~+50	Okaaa
R009	~XX126 1	7E 30 30 31 32 36 20 31 0D	Contrast aaa=-50 ~+50	Okaaa
R010	~XX127 1	7E 30 30 31 32 37 20 31 0D	Aspect Ratio aa=0, None aa=1, 4:3 aa=2, 16:9 aa=3, 16:10 aa=6, Native aa=7, Auto aa=16, 21:9	Okaa
R011	~XX128 1	7E 30 30 31 32 38 20 31 0D	Color Temperature a=1, Warm a=2, Medium (Standard) a=3, Cold a=4, Cool	Oka
R012	~XX129 1	7E 30 30 31 32 39 20 31 0D	Projection Mode a=0, Front a=1, Rear a=2, Front-Ceiling a=3, Rear-Ceiling	Oka
R013	~XX150 1	7E 30 30 31 35 30 20 31 0D	Information a=Power Status a=0, Power Off a=1, Power On bbbb=Lamp Hours cc=Input Source cc=00, None cc=02, VGA cc=03, VGA 2 cc=05, Video cc=07, HDMI 1 cc=08, HDMI 2 cc=16, HDBaseT dddd=Software Version ee=Display Mode ee=00, None ee=01, Presentation ee=02, Bright ee=03, Movie (Cin- ema) ee=04, sRGB ee=05, User ee=09, 3D ee=12, Game ee=13, DICOM SIM. ee=22, HDR SIM.	Okabbbbccddddee

INDEX	COMMAND SET		FUNCTION	VALUE/RANGE
	ASCII Code	HEX Code		
R014	~XX150 4	7E 30 30 31 35 30 20 34 0D	Resolution a=string (e.g. Ok1920x1080)	Ok
R015	~XX150 16	7E 30 30 31 35 30 20 31 36 0D	Standby Power Mode a=0, Eco. a=1, Active a=2, ErP Off	Ok
R016	~XX150 19	7E 30 30 31 35 30 20 31 39 0D	Refresh rate a=string (e.g. Ok60Hz)	Ok
R017	~XX151 1	7E 30 30 31 35 31 20 31 0D	Model Name a=1, SVGA a=2, XGA a=3, WXGA a=4, 1080p a=5, WUXGA	Ok
R018	~XX321 1	7E 30 30 33 32 31 20 31 0D	Filter Usage Hours aaaa=00000~99999	Okaaaa
R019	~XX352 1	7E 30 30 33 35 32 20 31 0D	System Temperature aaa=000~999	Okaaa
R020	~XX353 1	7E 30 30 33 35 33 20 31 0D	Serial Number a=string	Ok
R021	~XX355 1	7E 30 30 33 35 35 20 31 0D	AV Mute a=0, Off a=1, On	Ok
R022	~XX356 1	7E 30 30 33 35 36 20 31 0D	Mute a=0, Off a=1, On	Ok
R023	~XX543 1	7E 30 30 35 34 33 20 31 0D	H Image Shift aaaa=-100~+100	Okaaaa
R024	~XX543 2	7E 30 30 35 34 33 20 32 0D	V Image Shift aaaa=-100~+100	Okaaaa
R025	~XX543 3	7E 30 30 35 34 33 20 33 0D	V Keystone aaa=-40~+40	Okaaa
R026	~XX543 4	7E 30 30 35 34 33 20 34 0D	H Keystone aaa=-40~+40	Okaaa
R027	~XX555 1	7E 30 30 35 35 35 20 31 0D	LAN MAC Address	Ok###:###:###:###:###:##
R028	~XX558 1	7E 30 30 35 35 38 20 31 0D	Projector ID aa=00~99	Okaa

- Note**
- ~xx112 1 ~nnnn (nnnn = password) When security is on, you need to add password after command or it will return F.
  - When the projector show other OSD, user key the command “~XX313 0 7E 30 30 33 31 33 20 30 0D Information menu Off (0/2 for backward compatible)” then it will return F.

## 6.5 TROUBLESHOOTING

If you experience a problem with your projector, please refer to the following information. If a problem persists, please contact your local reseller or service center.

### IMAGE PROBLEMS

-  **No image appears on screen**

  - Ensure all the cables and power connections are correctly and securely connected as described in the “Installation” section.
  - Ensure the pins of connectors are not crooked or broken.
  - Ensure the “Mute” or “AV Mute” features are not turned on.
  
-  **Image is out of focus**

  - Turn the focus ring clockwise or counterclockwise until the image is sharp and legible. (Please see page 19).
  - Make sure the projection screen is between the required distances from the projector. (Please refer to “Image size and projection distance” section).
  
-  **The image is stretched when displaying 16:9 DVD title**

  - Ensure all the cables and power connections are correctly and securely connected as described in the When playing anamorphic sources or 16:9 sources the projector will display the best image in 16:9 format.
  - If you play 4:3 format DVD title, please change the format as 4:3 in projector OSD.
  - Please setup the display format as 16:9 (wide) aspect ratio type on your DVD player.
  
-  **Image is too small or too large**

  - Turn the zoom ring clockwise or counterclockwise to increase or decrease the projected image size. (Please see page 19).
  - Move the projector closer to or further from the screen.
  - Press “Menu” on the projector panel, go to “Display → Aspect Ratio”. Try the different settings.
  
-  **Image has slanted sides**

  - If possible, reposition the projector so that it is centered on the screen and below the bottom of the screen.
  - Adjust the vertical or horizontal keystone until the image appears rectangular.
  
-  **Image is reversed**

  - Select “Device Setup → Projection” from the OSD and adjust the projection mode.

### OTHER PROBLEMS

-  **The projector stops responding to all controls**

  - If possible, turn off the projector, then unplug the power cord and wait at least 20 seconds before reconnecting power.

### REMOTE CONTROL PROBLEMS

-  **If the remote control does not work**

  - Check the operating angle of the remote control is within  $\pm 30^\circ$  to the IR receiver on the projector.
  - Make sure there are not any obstructions between the remote control and the projector.
  - Move to within 6 m (19 ft) of the projector.
  - Make sure there are no fluorescent light sources shining on the IR receivers.
  - Make sure batteries are inserted correctly.
  - Replace batteries if they are exhausted.

## 6.6 WARNING INDICATORS

When the warning indicators (see below) light up or flash, the projector will automatically shutdown:

- “Lamp” LED indicator is lit red and if “Power” indicator flashes red.
- “Temp” LED indicator is lit red and if “Power” indicator flashes red. This indicates the projector has overheated. Under normal conditions, the project can be switched back on.
- “Temp” LED indicator flashes red and if “Power” indicator flashes red.

Unplug the power cord from the projector, wait for 30 seconds and try again. If the warning indicators light up or flash please contact your nearest service center for assistance.

### LED LIGHTNING MESSAGES

MESSAGE	POWER LED		TEMP LED	LAMP LED
	(Red)	(White)	(Red)	(Red)
Standby State (Input power cord)	Steady light	-	-	-
Power on (Warming)	-	Flashing (0.5 sec off, 0.5 sec light)	-	-
Power on & Lamp	-	Steady light	-	-
Power off (Cooling)	-	Flashing (0.5 sec off, 0.5 sec light)	-	-
Quick Resume (100 secs)	-	Back to Red steady light when cooling fan turns off	-	-
Lamp failure	Flashing	-	-	Steady light
Fan failure	Flashing	-	Flashing	-
Overheat (over temperature)	Flashing	-	Steady light	-

- Power off:



- Temperature warning:

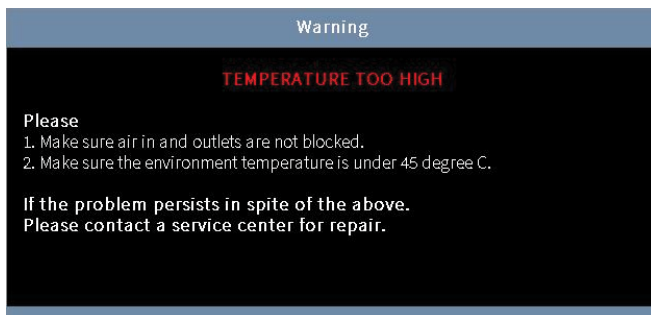

## 6.7 SPECIFICATIONS

	IN1068SL	IN1069SL
<b>IMAGE</b>		
Projection Technology	Texas Instruments DLP®	
Panel Size	0.65" DMD	0.67" DMD
Native Resolution	1080p	WUXGA
Pixels	1920×1080	1920×1200
Aspect Ratio	16:9	16:10
Contrast Ratio	2,000,000 : 1 (Dynamic)	
Brightness (Lumens)	7,000	
Light Source	Quantum Laser	
Light Source Life Maximum Hours	30,000	
Maximum Supported Resolution	4K UHD (3840 x 2160)	
Horizontal Sync. Range (KHz)	15 ~ 135	
Vertical Sync. Range (Hz)	23 ~ 120	
Color Processing	10-bit	
Uniformity (%)	85	
<b>LENS</b>		
Lens	1.7×	
Lens Adjustment	Manual	
Image Offset (%)	120 ± 5	
Throw Ratio	1.20 ~ 2.04	
Focal Length (mm)	17.63 ~ 27.9	
F-Stop	2.3 ~ 3	
Vertical Lens Shift (%)	106 ~ 126	100 ~ 120
Horizontal Lens Shift (%)	20	
Keystone Adjustment	Manual/Automatic	
Horizontal Keystone Correction	± 30°	
Vertical Keystone Correction	± 30°	
Projection Distance (Meters/Feet)	1.28 ~ 7.97 / 4.2 ~ 26.15	1.29 ~ 7.75 / 4.23 ~ 25.43
Min/Max Image Size	30" - 300"	
<b>CONNECTIVITY—INPUTS</b>		
Mini D-sub 15-pin (VGA)	☑ ☑	
Composite Video	☑	
HDBaseT™	☑	
HDMI™ 2.0	☑ ☑	
RJ45 - LAN 10/100	☑	
3.5 mm Stereo Mini Jack	☑ ☑	
USB-A (5V/1.5A)	☑	
<b>CONNECTIVITY—OUTPUTS</b>		
HDMI™	☑	
3.5 mm Stereo Mini Jack	☑	
12V Trigger	☑	

	IN1068SL	IN1069SL
<b>CONNECTIVITY- OTHER</b>		
RS232		☑
<b>POWER</b>		
Power Supply	100 ~ 240 V AC; 50 ~ 60 Hz	
Power Consumption Max (W)	355 (±15%)	
Power Consumption Min. (W)	295 (±15%)	
Power Consumption Network Standby (W)	<0.5	
Power Consumption Standby (W)	<0.5	
<b>GENERAL</b>		
Product Dimensions (L x W x H) (mm / in)	374 x 302 x 107 / 14.8 x 11.9 x 4.2	
Product Weight (Kilograms/Pounds)	6.1 / 13.45	
Fan Noise (dB)	33 ~ 36	
Audio (W)	2 x 15	
Operating Temperature (Celsius/Fahrenheit)	0 ~ 40 / 32 ~ 104	
Operating Humidity (%)	10 ~ 80 (no condensation)	
Max Operating Altitude (meters / feet)	3,048 / 10000	
Storage Temperature (Celsius/Fahrenheit)	-10 ~ 60 / 14 ~ 140	
Storage Humidity (%)	0 ~ 85	
Security	Kensington Security Slot™, PIN Code Lock & Timer	
Safety and Regulatory	cTUVus / FCC / FDA / CB (62368/60825) / EC62471-5 / 3rd/CE/EMC	
Environmental	RoHS Declaration	
OSD Languages	English, Arabic, Chinese (Simplified), Chinese (Traditional), Czech, Dutch, Finnish, French, German, Hungarian, Bahasa Indonesian, Italian, Japanese, Korean, Norwegian/Danish, Polish, Portuguese, Russian, Spanish, Swedish, Thai, Turkish, Vietnamese	
<b>IN THE BOX</b>		
Projector		☑
Simplified Users Guide		☑
HDMI Cable		☑
Regional Power Cord		☑
Remote Control (no Battery)		☑

## 7. CONTACT INFORMATION

### FOR USERS IN THE UNITED STATES AND CANADA

**INFORMATION****US Importer and Local Representative in accordance with FCC regulations**

Maxnerva Technology Services USA LLC  
13190 SW 68th Parkway, Suite 120  
Portland, Oregon 97223.

### FOR USERS IN EUROPEAN UNION

**INFORMATION****EU Importer**

Grand Field Technology Limited  
Room 1001, 10/F, Houston Centre, 63 Mody Road, Tsim Sha Tsui East, Kowloon, Hong Kong.

**EU Authorised Representative**

24hour Solutions B.V.  
Van Nelleweg 1,  
3044 BC, Rotterdam,  
The Netherlands  
info@24hour-ar.com  
www.24hour-ar.com

### FOR USERS IN THE UNITED KINGDOM AND NORTHERN IRELAND

**INFORMATION****Manufacturer**

Maxnerva Technology Services Limited  
Room 1001, 10/F, Houston Centre, 63 Mody Road, Tsim Sha Tsui East, Kowloon, Hong Kong.

**UK Authorised Representative in accordance with UK regulations**

24hour Solutions Ltd.  
15 Beaufort Court  
Admirals Way, Canary Wharf  
London, E14 9XL, UK  
+44 (0)20 457 129 06  
Company ID 13630765

### FOR USERS IN RUSSIA

**INFORMATION****Russian Authorised Representative**

Maxnerva has appointed AUVIX LLC, 129085, c. Moscow, Zvezdny Boulevard, 21, bldg. 1. as the authorised representative in Russia and this product is compliant with TR TC 004/2011, TR TC 020/2011 and TR CU 020/2011 local conformity testing and approvals.

Maxnerva назначил ООО « АУВИКС », 129085, г. Москва, Звездный бульвар, д. 21, стр. 1., в качестве официального представителя в России, и этот продукт соответствует требованиям TR TC 004/2011, TR TC 020/2011 и TR CU 020 /2011г. местные испытания на соответствие и согласования.

ООО « АУВИКС »  
129085, г. Москва, Звездный бульвар, д. 21, стр. 1  
+7 (495) 797-57-75  
info@auvix.ru