

Magellan™ 3410VSi OEM

INTEGRATION GUIDE



Omni-Directional Imaging Scanner

Datalogic S.r.l.

Via S. Vitalino, 13

40012 Calderara di Reno (BO)

Italy

Tel. +39 051 3147011

Fax +39 051 3147205

© 2022 Datalogic S.p.A. and /or its affiliates

All rights reserved. Without limiting the rights under copyright, no part of this documentation may be reproduced, stored in or introduced into a retrieval system, or transmitted in any form or by any means, or for any purpose, without the express written permission of Datalogic S.p.A. and/or its affiliates.

Owners of Datalogic products are hereby granted a non-exclusive, revocable license to reproduce and transmit this documentation for the purchaser's own internal business purposes. Purchaser shall not remove or alter any proprietary notices, including copyright notices, contained in this documentation and shall ensure that all notices appear on any reproductions of the documentation.

Electronic versions of this document may be downloaded from the Datalogic website (www.datalogic.com). If you visit our website and would like to make comments or suggestions about this or other Datalogic publications, please let us know via the "Contact" page.

Disclaimer

Datalogic has taken reasonable measures to provide information in this manual that is complete and accurate, however, Datalogic shall not be liable for technical or editorial errors or omissions contained herein, nor for incidental or consequential damages resulting from the use of this material. Datalogic reserves the right to change any specification at any time without prior notice.

Trademarks

Datalogic and the Datalogic logo are registered trademarks of Datalogic S.p.A. in many countries, including the U.S.A. and the E.U.

Magellan is a trademark of Datalogic S.p.A. or of Datalogic and/or its affiliates, registered in many countries, including the U.S. and the E.U. All other trademarks and brands are property of their respective owners.

Patents

See www.patents.datalogic.com for patent list.

ORIGINAL INSTRUCTIONS

**See the Regulatory Addendum included with your product
for additional regulatory, safety and legal information.**

TABLE OF CONTENTS

CHAPTER 1. INTRODUCTION	1
Overview	1
Reference Documents	1
Unpacking the Scanner	2
Technical Support	2
Website	2
Reseller	2
Scanner Care	2
System Overview	3
Beeper indicators	3
CHAPTER 2. MOUNTING THE SCANNER	4
General Considerations	4
Mounting	4
Mounting the Scanner Standalone	4
Scanner Ventilation	4
Integrating the Scanner to Read at the Proper Distance	5
Design of the Scanner Opening	5
Housing Design	6
Mounting Holes	6
Integrating the Scanner Behind a Window	6
Scanner Clearance for Integration	6
Exit Window Clearance	7
CHAPTER 3. ELECTRICAL INTEGRATION	8
ESD	8
Electrical Interface	8
Supply Voltages	9
POS Host Interface	9
Service Port Interface	9
USB Aux Port Interface	10
MicroSD Card	10
MicroSD Function Summary	10
APPENDIX A. TECHNICAL SPECIFICATIONS	11
Optical and Read Performance Parameters	11
Depth of Field	11
Electrical Parameters	12
Utilities	12
APPENDIX B. MECHANICAL SPECIFICATIONS	13
Physical Characteristics	13
Mounting Template	14

CHAPTER 1

INTRODUCTION

This document provides instruction, mechanical details, and design considerations to integrate the Magellan 3410VSi OEM scanner into equipment-integrated scanning applications.

OVERVIEW

The Magellan™ 3410VSi OEM is designed for retail checkout environments where there is a relatively high number of transactions with a fairly small number of items per transaction. The proprietary imaging technology excels at capturing 1D and 2D bar codes in omni-direction orientation.

A typical system using the scanner consists of a host system such as a price verifier, self checkout, or kiosk. The host system interfaces with the scanner and receives decoded bar code data produced by the scanner. The illumination LEDs in the scanner emit visible light as well as invisible infrared light. When a bar code passes through the scan volume area, light is reflected off the bar code. The scanner collects this reflected light, processes it into a digital signal and decodes it into data that can be used by the host system. The scanner has different operational modes which can be selected via special programming bar codes.

REFERENCE DOCUMENTS

The OEM scanner contains versions of the scan engine, electrical components, software, and configuration programming options as those available on standard Magellan 3410VSi scanner models. This document is meant to give instructions, mechanical details, and design considerations to integrate the OEM scanner model. For information on the Magellan 3410VSi, please refer to the Magellan 3410VSi Product Reference Guide.

Details about configuration settings and programming can be found in the Magellan 3410VSi Product Reference Guide.

UNPACKING THE SCANNER

The scanner is shipped in custom packaging. Carefully open the package, and inspect for the following:

- scanner
- power supply (if ordered)
- interface cable (if ordered)

If any parts are damaged or you need additional hardware, please contact technical support.

TECHNICAL SUPPORT

Website

Datalogic provides several services as well as technical support through its website. Log on to www.datalogic.com.

For quick access, from the home page click on the search icon, and type in the name of the product you're looking for. This allows you access to download Data Sheets, Manuals, Software & Utilities, and Drawings. Hover over the Support & Service menu for access to Services and Technical Support.

Reseller

An excellent source for technical assistance and information is an authorized Datalogic reseller. A reseller is acquainted with specific types of businesses, application software, and computer systems and can provide individualized assistance.

Scanner Care

The scanner contains sensitive components which require special handling. Datalogic may not warrant damage due to improper handling.

- Use standard ESD precautions & policies when handling the 3410VSi OEM scan engine.
- Avoid touching the front window. Fingerprints will degrade the scanner's performance.
- Only clean the scan window when visual inspection reveals dirt or residue. Remove lint or foreign material present with filtered compressed air. Remove fingerprints or other residue using clean, cotton-tipped applicators dipped in isopropyl alcohol, or with soft tissues dipped in high-quality lens or eyeglass cleaner. Do not reuse cotton-tipped applicators or tissues.
- Do not scrub the window.
- Never wipe the window with a dry tissue or applicator.

SYSTEM OVERVIEW

The 3410VSi OEM scanner has several features and interfaces available to the host system. The interface block diagram is shown below. Programmable features can be found in the 3410VSi Product Reference Guide.

Figure 1-1. Scanner block diagram

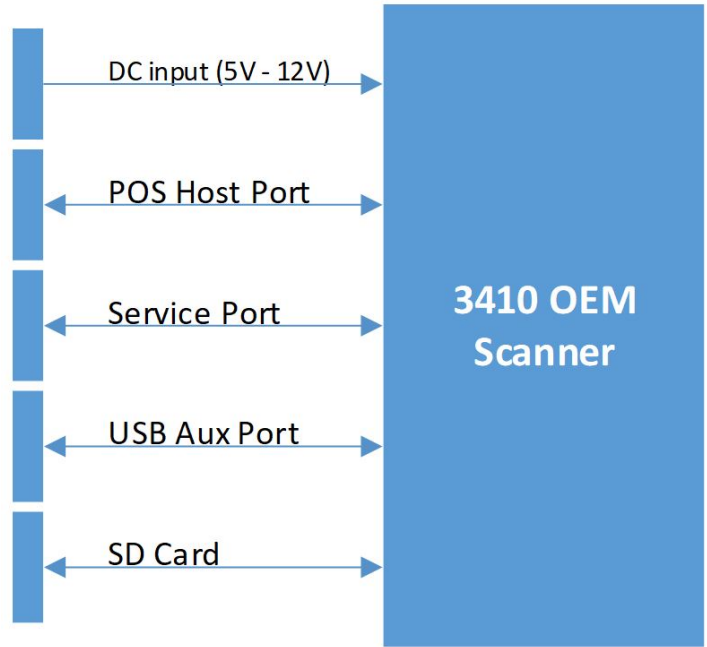

BEEPER INDICATORS

The scanner's beeper sounds to indicate various functions or errors on the scanner. Refer to the 3410VSi Product Reference Guide for a list of these indications. The scanner's functions are programmable, and so may or may not be turned on. For example, certain indications such as the power-up beep can be disabled using programming bar code labels.

CHAPTER 2

MOUNTING THE SCANNER

This section describes how to design the mounting for optimum scanner performance.

GENERAL CONSIDERATIONS

A typical system uses the scanner mounted inside a host enclosure, with an opening for the scanning pattern to exit and read bar codes. The opening should be the size of the scanner window at a minimum, but only exposing as much of the scanner as necessary.

Although the scanner has been designed to be impact-resistant, it is important to consider the effect of the environment on the scanner. In particular, mounting should minimize the possibility of foreign objects coming into contact with the window's surface. Such contact will damage the window over time and reduce the scanner's performance. Consideration should also be given to the clearances needed for the scanner's interface cable (reference the following section).

MOUNTING

System integration is made easy with the OEM scanner's mounting features. Four mounting holes are located on the front of the scanner for use with size M3 screws of your required length. [Appendix B](#) contains mechanical drawings of the scanner including the position of the mounting features.

The scanner can be mounted upside down with no loss in scanning performance, but the illumination will be more visible to the operator.

MOUNTING THE SCANNER STANDALONE

The OEM scanner is not intended for use in a standalone application. This model is intended to be integrated inside a host enclosure. Standard Magellan 3410VSi models should be used when a standalone application is required.

SCANNER VENTILATION

When mounting the scanner inside a secondary enclosure, it is important to have proper ventilation to ensure that the scanner temperature does not exceed the maximum operating temperature as listed in [Appendix A](#). The reliability of the scanner may be compromised if the temperature range is not maintained.

INTEGRATING THE SCANNER TO READ AT THE PROPER DISTANCE

The scanner must be positioned so that the scan volume and illumination light will cover the entire bar code. The scan volume is shown in [Figure 2-1 on page 5](#). The combination of the Scan Volume and the illumination light is called the Field of View. Designing around the scanner Field of View is explained more in the following section.

Figure 2-1. Scanner Volume

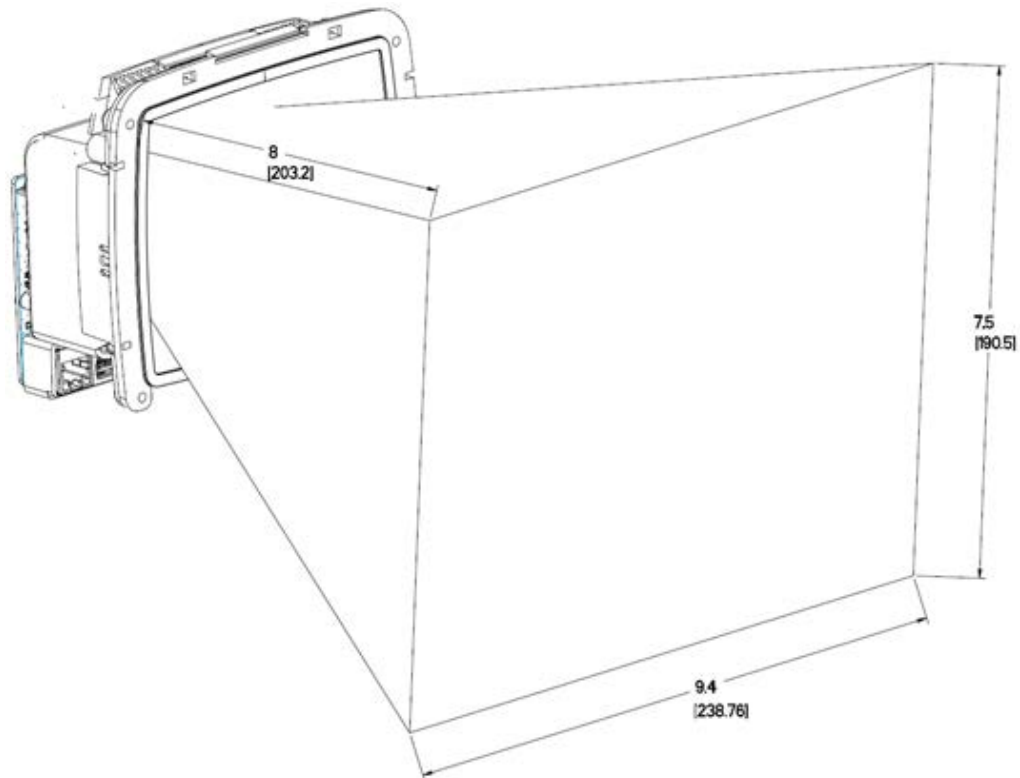

DESIGN OF THE SCANNER OPENING

A typical system uses the scanner mounted inside a host enclosure with an opening for the scanner Field of View to exit the scanner window and read bar codes. If the scanner is flush against the opening, it should be the size of the scanner window at a minimum, but only exposing as much of the front surface of the scanner as necessary. Additional clearance in the opening can also be considered for the speaker opening.

The design and placement of the scanner opening within a host enclosure is critical for optimum system performance. Use the detailed dimensions shown in [Appendix B](#) to design the host enclosure and scanner opening along with the following guidelines.

- The opening must not block any of the outgoing illumination light, described by dimensions of the scanner Field of View.
- Ensure that there are no reflective surfaces around the area of the scanner opening.
- The opening or other parts of the host enclosure must not enter the Field of View in order to allow the bar code image to be captured by the scanner.

HOUSING DESIGN

The enclosure must be designed to prevent internal reflections from illumination and aiming systems into the receiving optics. It is not recommended to place any type of additional window between the scanner and the bar code to be read.

The housing design must provide adequate ESD protection for the scanner. Ideally, static discharge should not be allowed to discharge to the scanner. The preferred method to prevent static discharge is to provide a long discharge path to all circuits. Only the front surface should be exposed in order to read bar codes. This is to protect the rear interface connector area which can be susceptible to static discharge. Interface cables should also not be powered up when inserted into the scanner. It is also recommended that any metal mounting surfaces for the scanner be electrically grounded.

Static discharge (ESD) testing is recommended for the entire system integration to ensure proper ESD protection. Proper ESD protection should be used at the time of installation and servicing of the scanner or the host equipment.

MOUNTING HOLES

There are four mounting holes located on the 4 corners of the window. The recommended size for the screws is 3mm. See "[Mounting Template](#)" on page 14 for a 1:1 template drawing of the mounting holes.

INTEGRATING THE SCANNER BEHIND A WINDOW

It is not recommended to place any type of additional window between the scanner and the bar code to be read. The addition of a host enclosure window will significantly degrade scanner performance. This is due to the additional reflective surfaces that will cause optical interference with the imaging.

SCANNER CLEARANCE FOR INTEGRATION

To avoid damaging the 3410VSi OEM scanner by accidental impact or Electro Static Discharge, maintain 0.38 in clearance between the scanner and any other items in the customer enclosure (except front mounting surface).

EXIT WINDOW CLEARANCE

The opening or other parts of the host enclosure must not enter the Field of View of the scanner. The enclosure wall thickness should not exceed 0.38 in to prevent clipping of the FoV, as shown in Figure 2-2 on page 7.

Figure 2-2. Exit window clearance

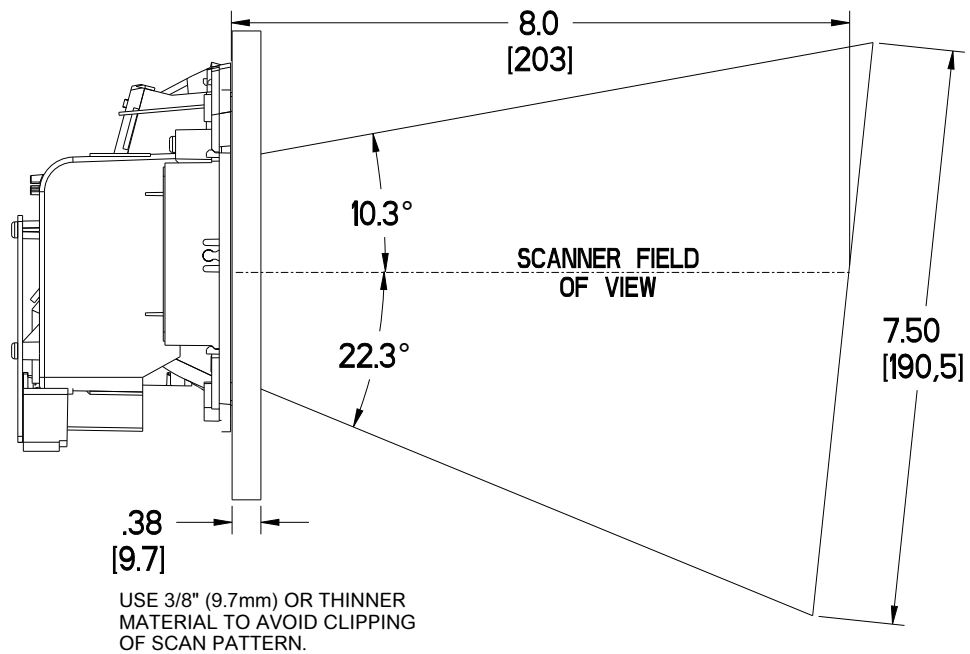

CHAPTER 3

ELECTRICAL INTEGRATION

ESD

The scanner is protected from ESD up to $\pm 2.0\text{KV}$ on the host connector.

During installation, it is recommended to apply standard ESD handling procedures, such as operating in a properly grounded working area using wrist straps.

ELECTRICAL INTERFACE

The scanner can be connected to various interfaces, supporting:

- Bar code data and commands via the host port
- An external handheld scanner interface via the USB AUX port
- A micro-SD card slot for configuration
- A Micro USB port for configuration
- A power jack for DC power input

Figure 3-1. Connector positions

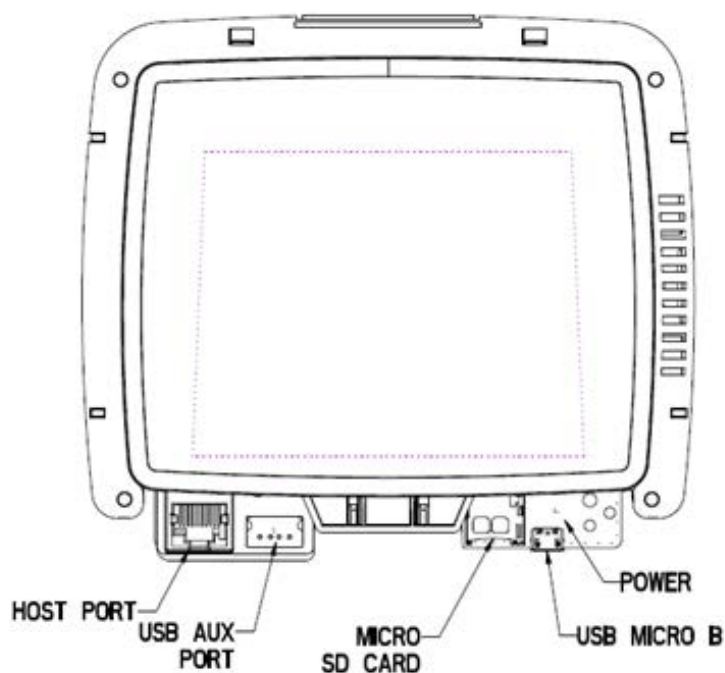

Supply Voltages

NAME	DESCRIPTION
5V-12V DC Input	A dedicated power jack for DC input power. This input must be used when an external handheld scanner is attached to the Aux port. Please use only Datalogic brand power supply.
5V USB Input	5V DC provided by the POS connector when the USB interface is in use. Note that the USB interface will only supply enough power for the 3410 OEM. If an auxiliary device (handheld) is connected, power must be provided via the 5V-12V DC input jack.

POS HOST INTERFACE

The POS host can be set to operate in the following interface protocols

- RS232
- USB OEM
- USB COM
- USB Keyboard

Refer to the Magellan 3410VSi Product Reference Guide for details on how to select these interfaces.

Table 1. POS Host Cable Pinouts

PIN #	RS-232	USB-OEM	USB, USB KEYBOARD, USB COM	NOTES
1		D+	D+	USB Data+
2	CTS			RS232 CTS input
3		D-	D-	USB Data-
4	RTS			RS232 RTS output
5	RXD			RS232 RXD input
6	TXD			RS232 TXD output
7				
8	VIN	VIN/BUS	VIN/BUS	5V DC input - must be limited to 5V
9	GND	GND	GND	Ground
10	ERI	ERI	ERI	External read indicator output

SERVICE PORT INTERFACE

The service port is a high-speed USB device interface adhering to the CDC-ACM USB device class. It is used to configure the scanner. This port uses a Type-B Micro USB connector.

USB AUX PORT INTERFACE

The USB Aux port is a full-speed USB interface adhering to the CDC-ACM USB device class. It is a powered type-A USB connector used to connect a handheld scanner to the OEM scanner.



NOTE: if a handheld scanner is attached to the AUX port, an external 12V power supply is required.

MICROSD CARD

The microSD card interface supports SD-Memory Card Specifications Part 1. Physical Layer Specification; Version 1.01, but the processor MCI can communicate with SDHC Cards. For example, the scanner can perform the functions specified below for the SDA 2.0 specification. Both FAT16 and FAT32 formats are supported. Filenames are limited to the 8.3 file naming format (i.e., FILENAME.EXT), and MUST be capitalized.

MicroSD Function Summary

The following table summarizes various functions of microSD card. Contact Datalogic Technical Support regarding upgrade license for new features.

FUNCTION		IMAGE CAPTURE	EXPORT STATUS	EXPORT CONFIG	LOAD APP	LOAD CONFIG	LOAD CPLD CODE	FEATURE UPGRADE
Direction	Scanner to microSD Card	X	X	X				
	microSD Card to Scanner				X	X	X	X
Initiated by	Scanning a label	X	X					
	AUTO-RUN.DLS file in microSD card		X	X	X	X	X	X

APPENDIX A

TECHNICAL SPECIFICATIONS

OPTICAL AND READ PERFORMANCE PARAMETERS

PARAMETER	SPECIFICATION
Image Capture	Graphic Formats: BMP, JPEG
Imager Sensor	1 MP, 1280 X 800
Scan Rate	30 Frames/second
Read Height	14.0 cm / 5.5 in
Minimum Resolution	5 mil
Minimum Print Contrast Ratio	25%
Reading Angle	Pitch: +/- 65°; Roll (Tilt): 0 - 360°; Skew (Yaw): +/- 75°

DEPTH OF FIELD

Depth of field is dependent upon printing resolution, print contrast, symbol length, scan angle, and ambient light.

PARAMETER		SPECIFICATION
	Codes Size	Depth of Field
1D/Linear Codes	5 mil	0 to 6.4 cm / 0 to 2.5 in
	10 mil	0 to 15.2 cm / 0 to 6.0 in
	13 mil	0 to 20.3 cm / 0 to 8.0 in
2D Codes	6.6 mil	PDF: 0 to 5.1 cm / 0 to 2.0 in
	10 mil	PDF: 0 to 12.7 cm / 0 to 5.0 in
	10 mil	Datamatrix: 0 to 6.4 cm / 0 to 2.5 in
	20 mil	Datamatrix: 0 to 18.0 cm / 0 to 7.0 in

ELECTRICAL PARAMETERS

PARAMETER	SPECIFICATION
Operating Voltage	Input voltage 5 to 12 VDC Note: 12V power can only be applied to the DC input power port
Power Consumption: <ul style="list-style-type: none"> • Maximum • Typical (RMS) • Sleep Mode (RMS) 	2.25W @ 5V; 3.3W @ 12V 1.6W @ 5V; 2.1W @ 12V 0.95W @ 5V; 1.25W @ 12V

UTILITIES

PARAMETER	SPECIFICATION
Scanalyzer	Magellan Scanalyzer configuration software is available for download at www.data-logic.com .
OPOS / JavaPOS	OPOS and JavaPOS utilities are available for download at no charge.

APPENDIX B

MECHANICAL SPECIFICATIONS

PHYSICAL CHARACTERISTICS

PARAMETER	SPECIFICATION
Dimensions	12.7 x 14.4 x 7.8 cm 5 x 5.7 x 3.1 in
Weight	0.3 kg 0.8 lb

Figure B-1. Scanner dimensions

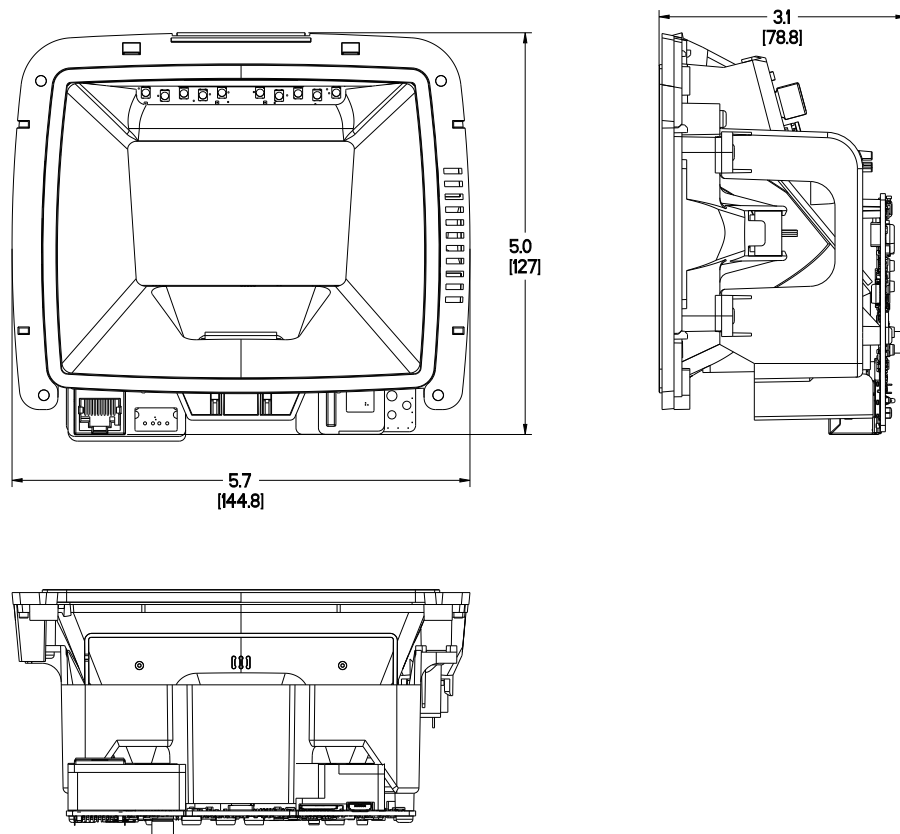

MOUNTING TEMPLATE

The Mounting Template in the following page shows the mounting holes for the scanner.



NOTE: the Mounting Template drawing must be printed actual size to ensure proper dimensions.

**MOUNTING TEMPLATE
PRINT THIS PAGE AT 1:1 SCALE**

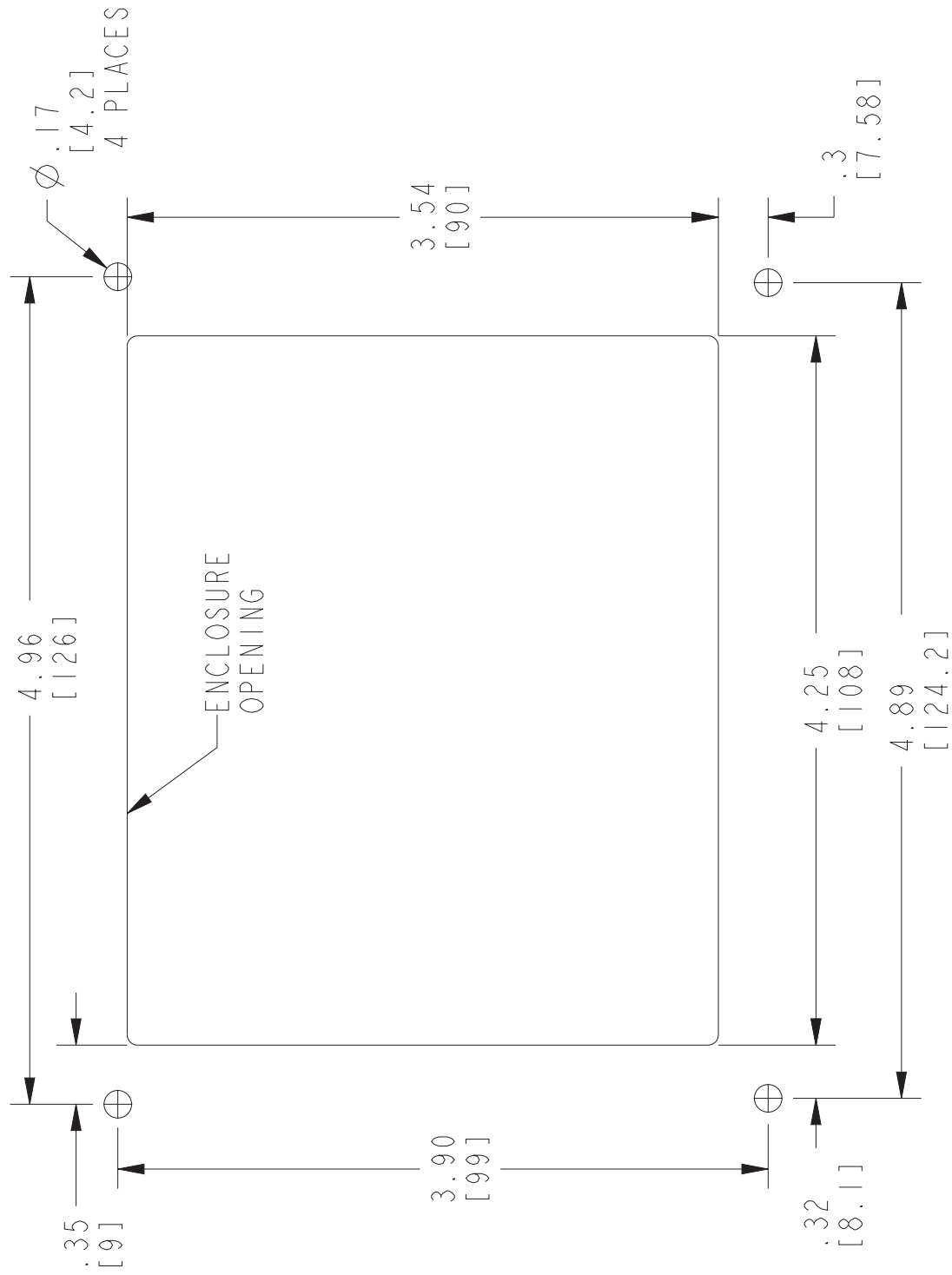

**USE 3/8" (9.5mm) OR THINNER MATERIAL TO AVOID
CLIPPING OF SCAN PATTERN.**

© 2022 Datalogic S.p.A. and /or its affiliates • All rights reserved • Without limiting the rights under copyright, no part of this documentation may be reproduced, stored in or introduced into a retrieval system, or transmitted in any form or by any means, or for any purpose, without the express written permission of Datalogic S.p.A. and/or its affiliates • Datalogic and the Datalogic logo are registered trademarks of Datalogic S.p.A. in many countries, including the U.S. and the E.U.



DATALOGIC
www.datalogic.com

Datalogic S.r.l.

Via S. Vitalino, 13
40012 Calderara di Reno (BO)
Italy
Tel. +39 051 3147011
Fax +39 051 3147205

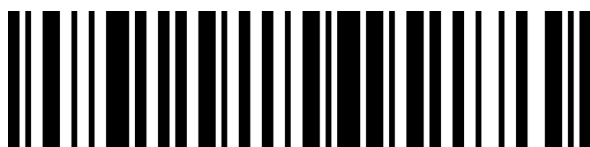

820124200

(Rev A)

May 2022