

# HP Color LaserJet Enterprise MFP 8801

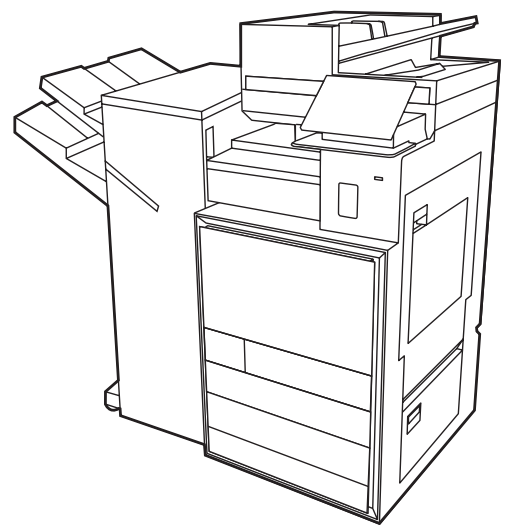

8801dn, 8801z, 8801z+

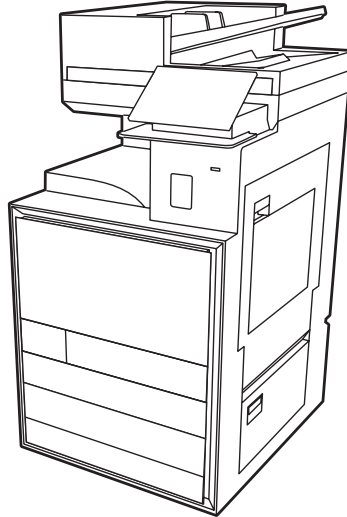
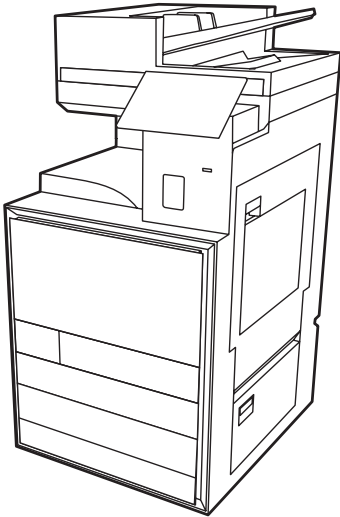

EN

Installation Guide

FR

Guide d'installation

ES

Guía de instalación

PT

Guia de instalação

ES

Lea esto primero



[www.support.hp.com](http://www.support.hp.com)  
[www.hp.com/support/colorlj8801MFP](http://www.hp.com/support/colorlj8801MFP)

1

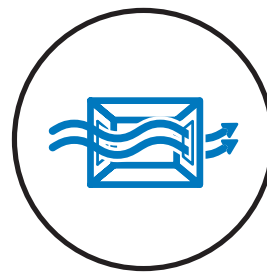
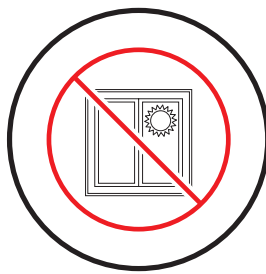
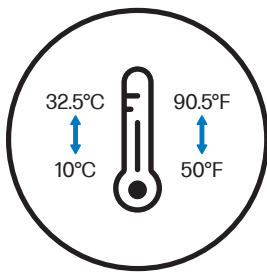

(EN) Select a sturdy, well-ventilated, dust-free area, away from direct sunlight to position the printer.

(FR) Choisissez un support solide et un endroit propre, bien aéré et à l'abri du rayonnement direct du soleil pour placer votre imprimante.

(ES) Busque una superficie sólida en un lugar bien ventilado, sin polvo y alejado de la luz solar directa para colocar la impresora.

(PT) Escolha um local firme, bem ventilado, sem poeira e longe da exposição direta à luz do sol para instalar a impressora.

2

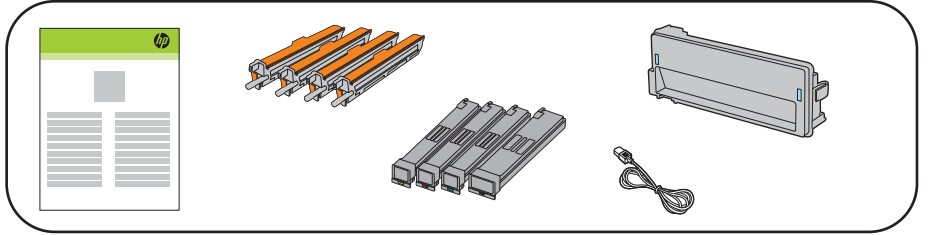
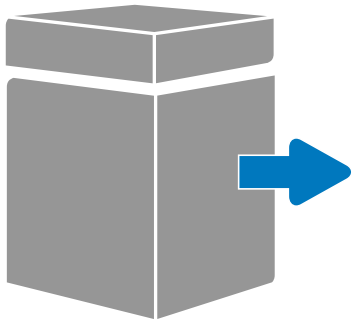

129.08 kg  
284.57 lb

133.02 kg  
293.26 lb

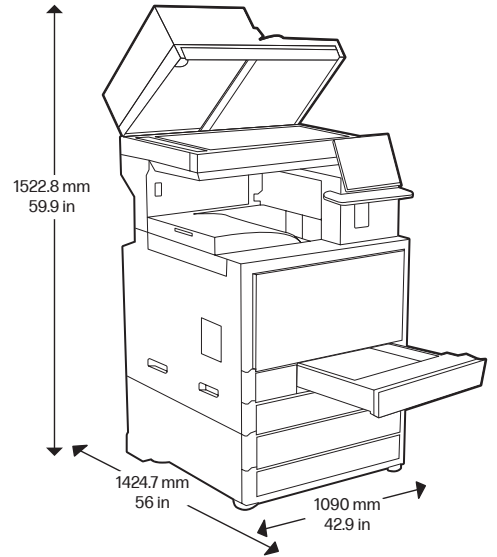
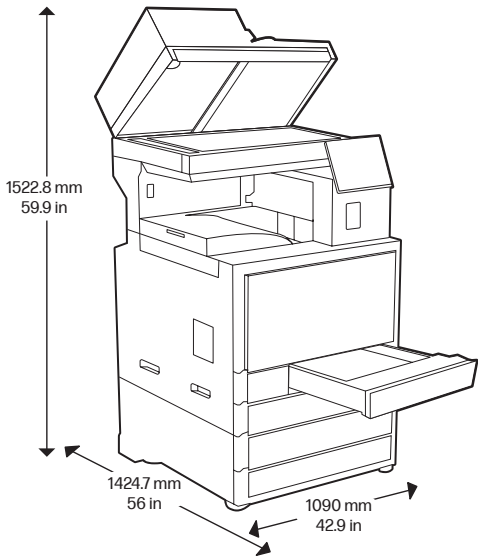

171.3 kg  
377.65 lb

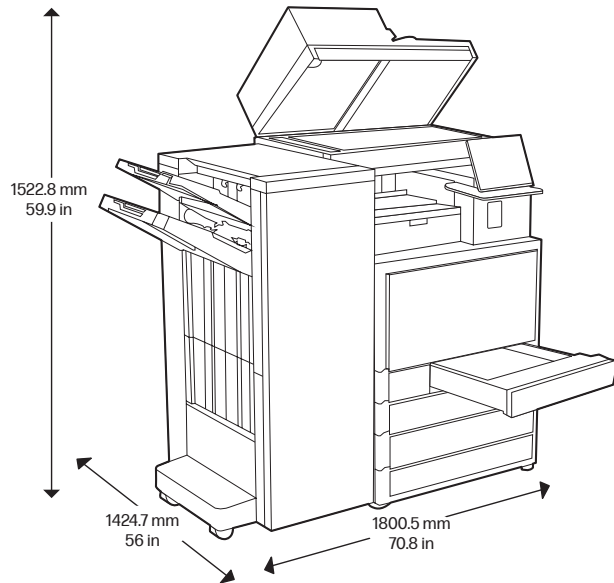

3



3.1

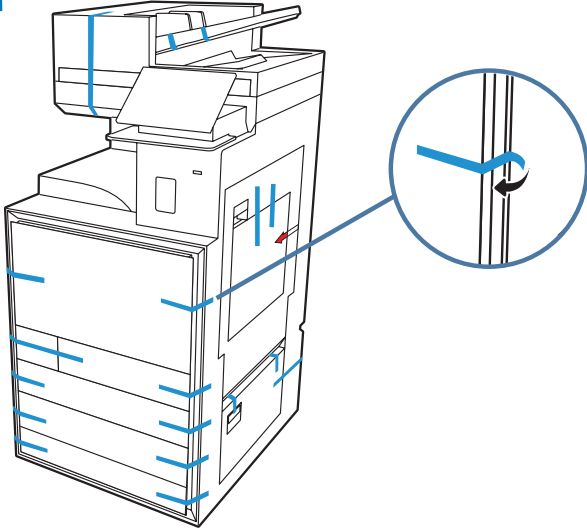

3.2

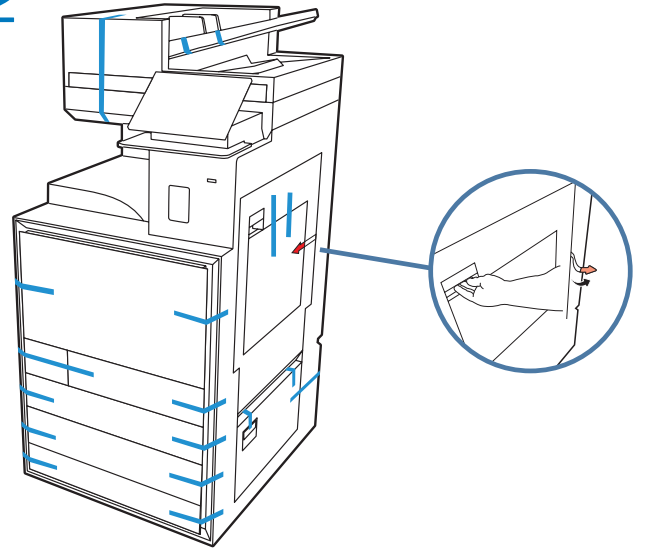

3.3

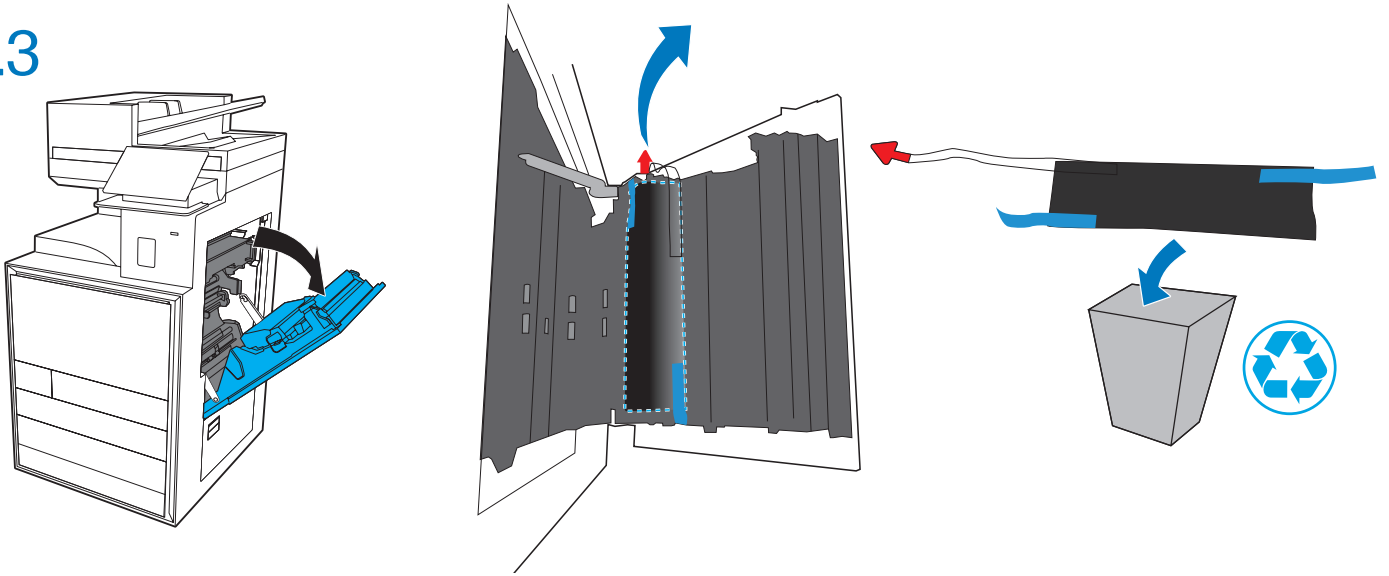

(EN) Remove all tape and packing material.

(ES) Retire todos los precintos y el material de embalaje.

(FR) Retirez tous les rubans adhésifs et les matériaux d'emballage.

(PT) Remova toda a fita e o material da embalagem.

4

4.1

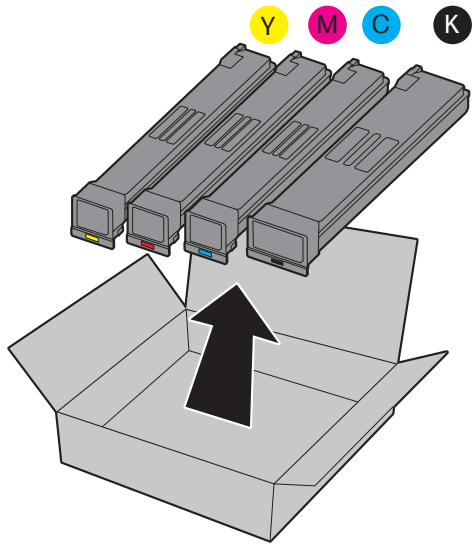

4.2

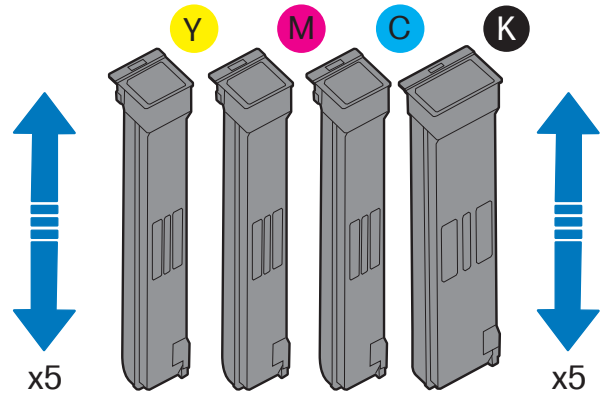

4.3

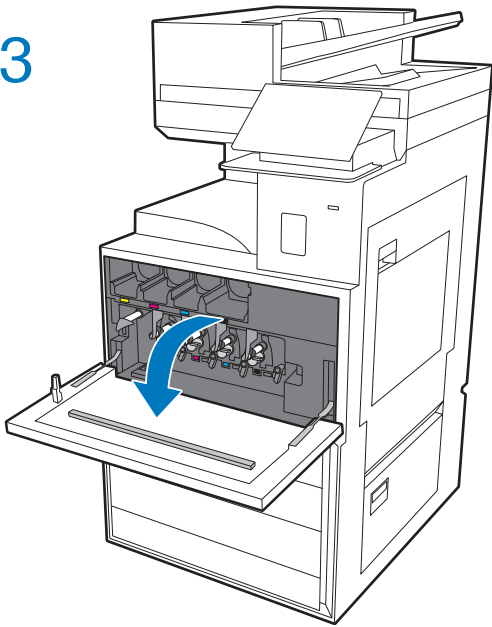

4.4

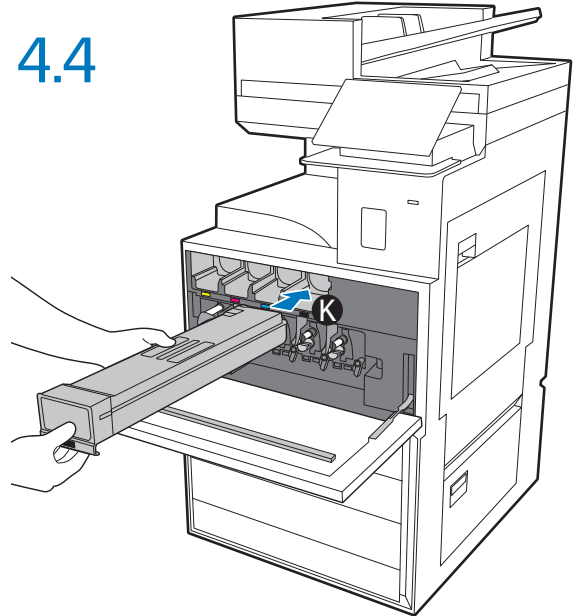

4.5

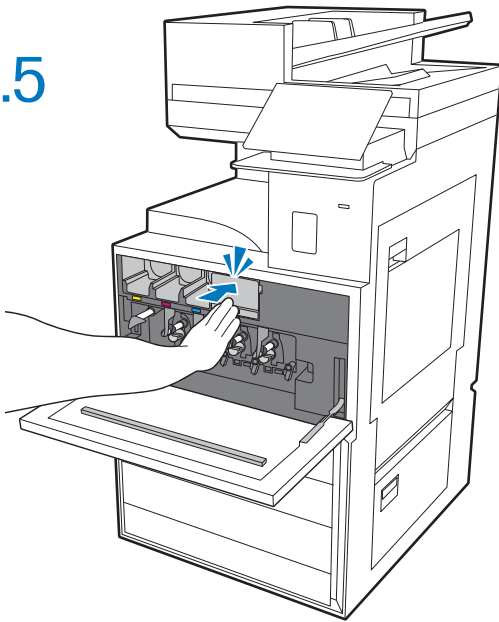

4.6

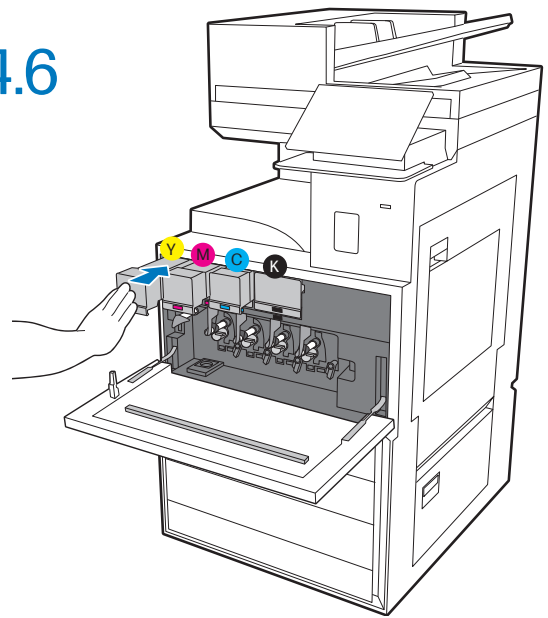

4.7

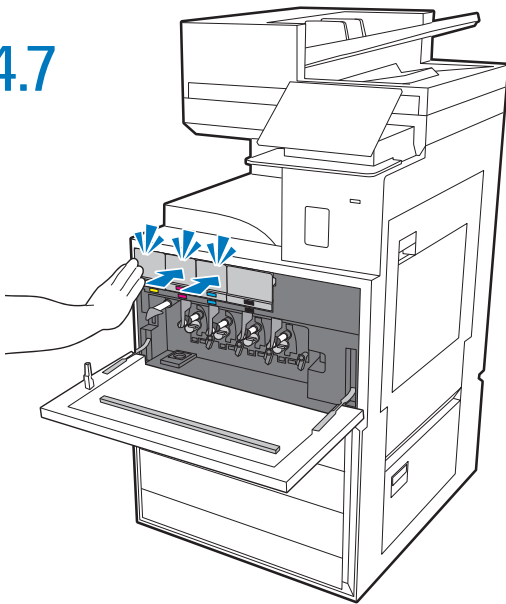

5



5.1

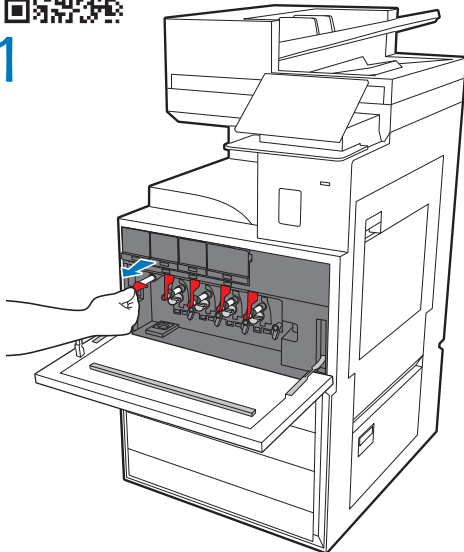

5.2

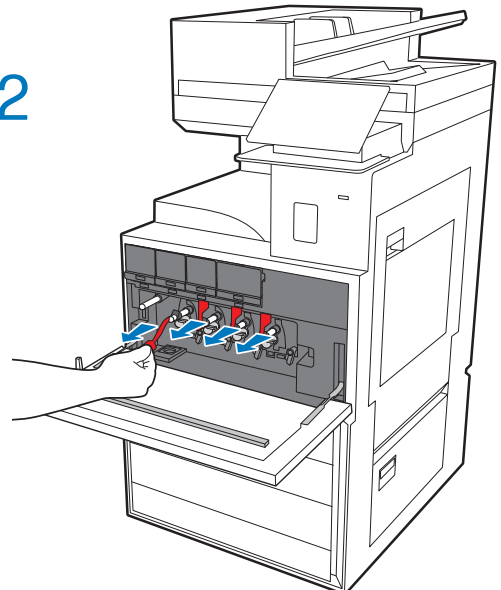
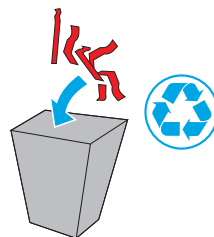

6



Y M C

K

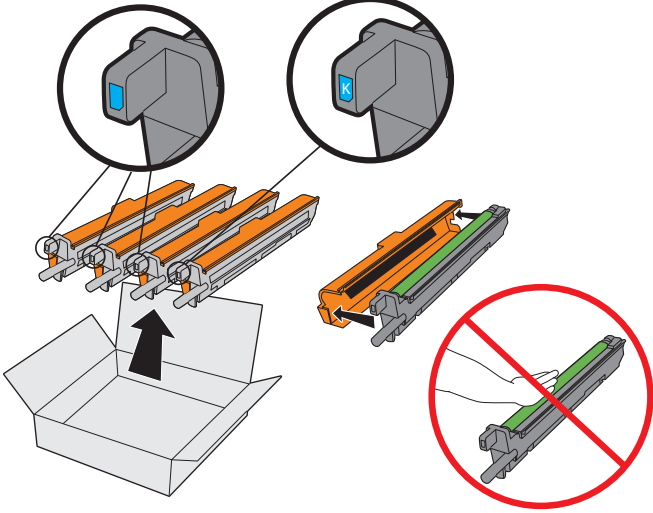

6.1

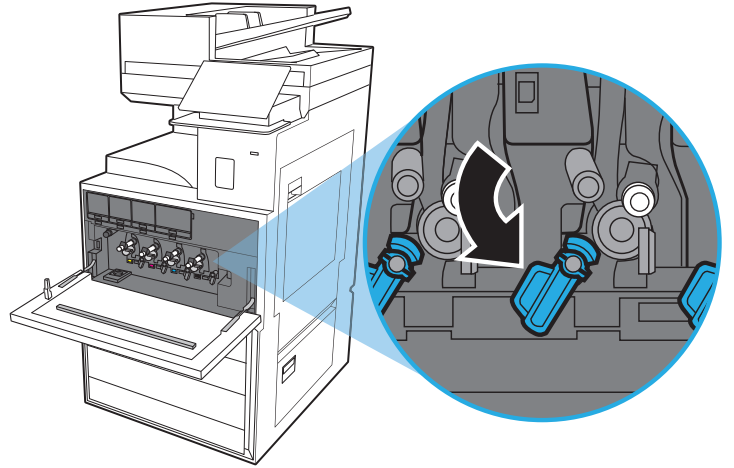

6.2

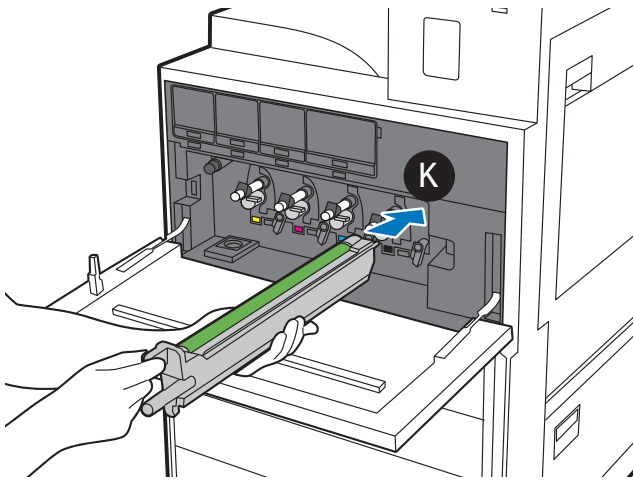

6.3

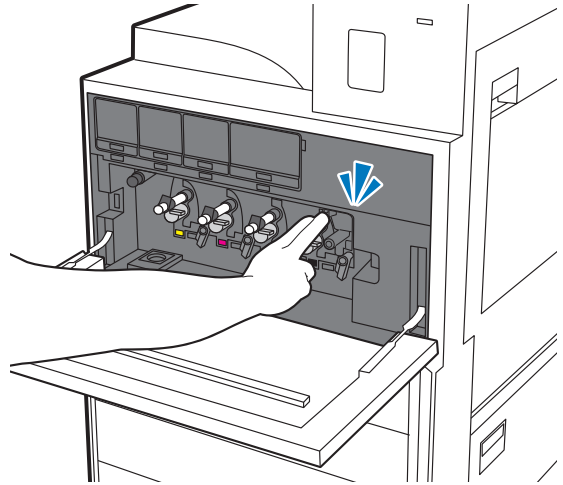

6.4

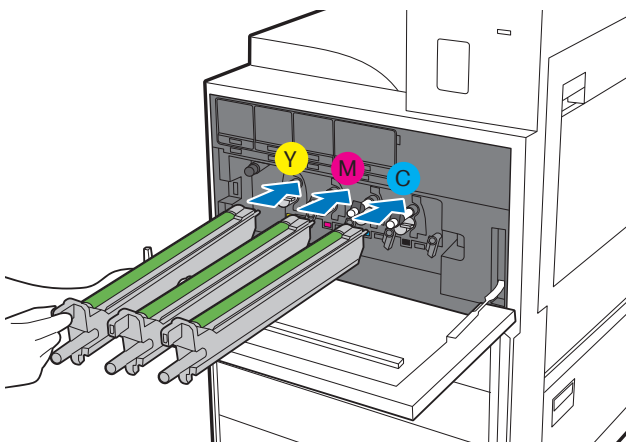

6.5

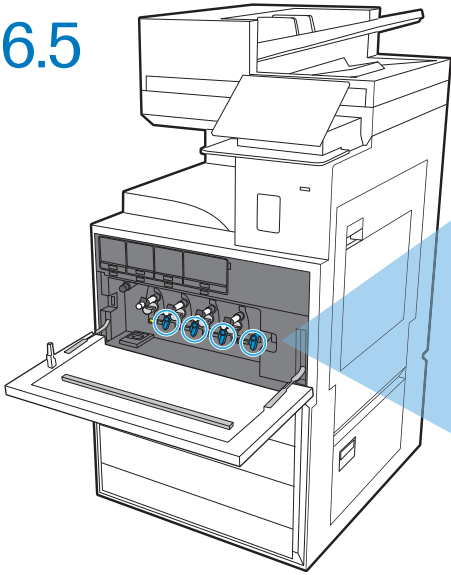

1

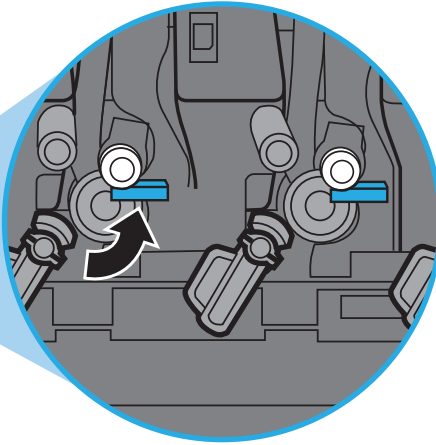

2

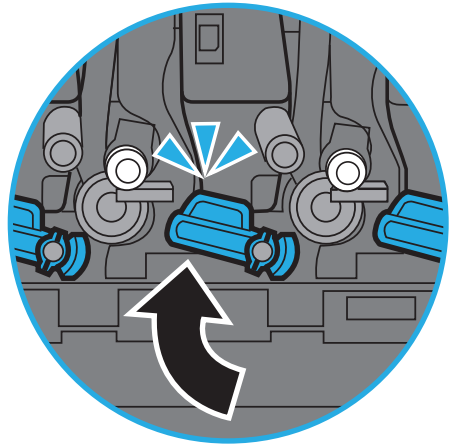

7

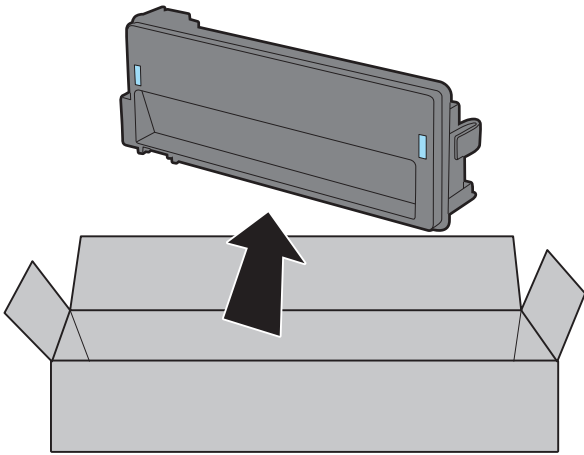

7.1

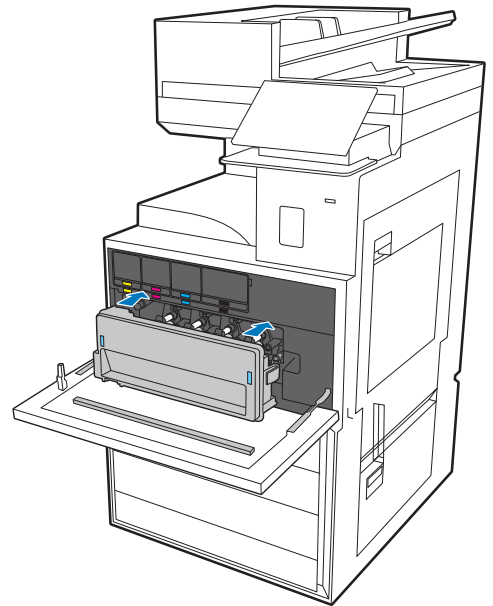

7.2

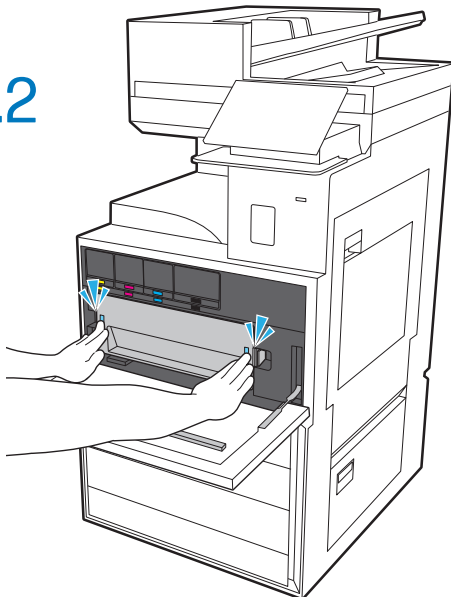

7.3

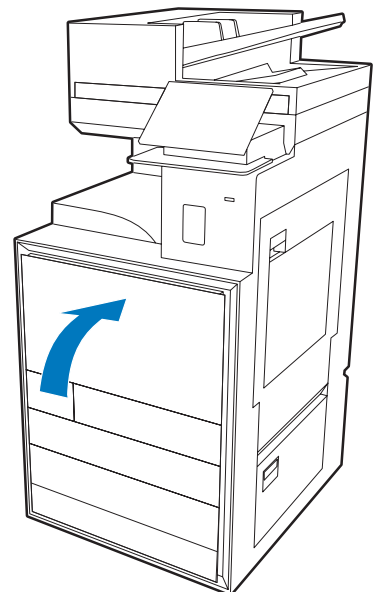

8



8.1

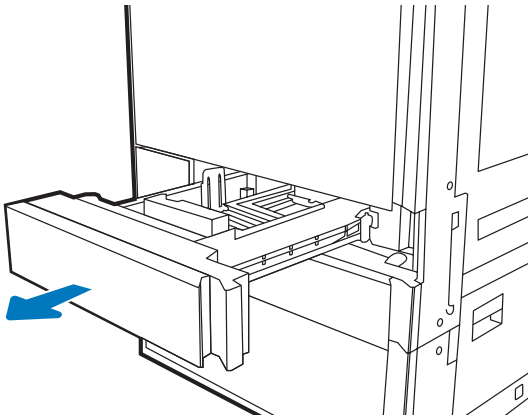

8.2

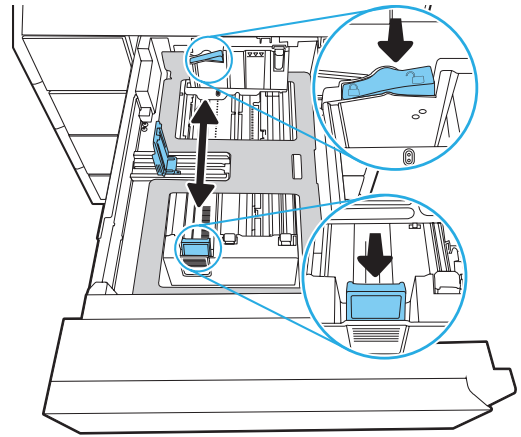

8.3

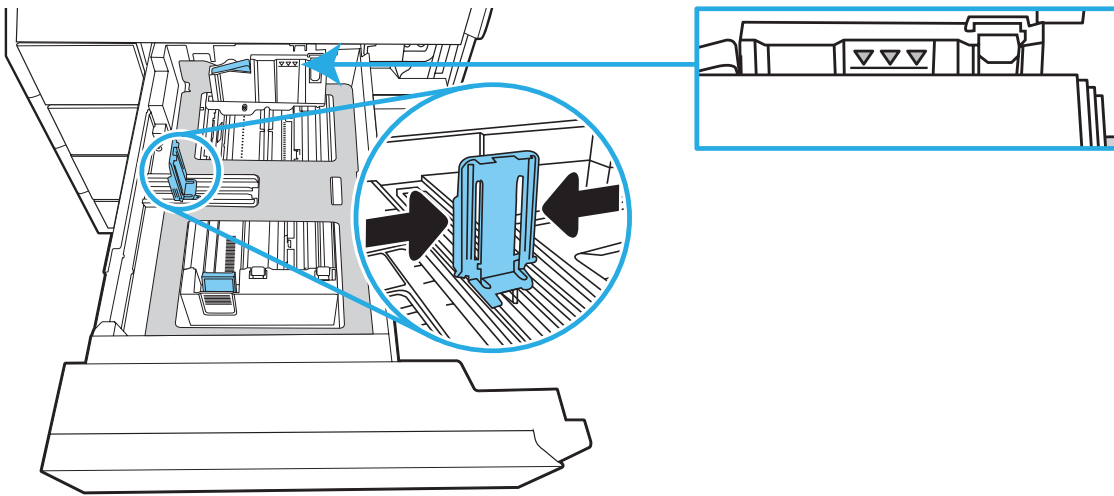

8.4

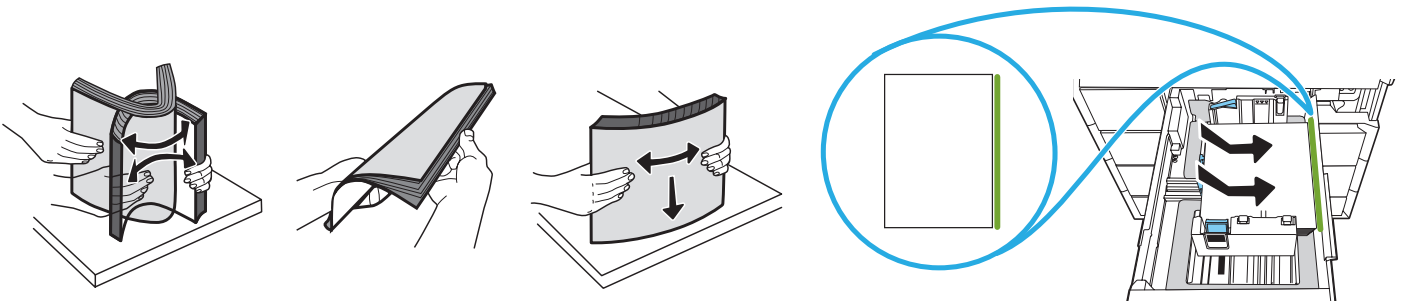

**EN** **CAUTION:** Do not extend more than one paper tray at a time. Do not use paper tray as a step. Keep hands out of paper trays when closing. All trays must be closed when moving the printer.

**FR** **ATTENTION :** N'utilisez pas plus d'un bac à papier à la fois. N'utilisez pas le bac à papier comme marchepied. Écartez vos mains des bacs à papier lors de la fermeture. Lorsque vous déplacez l'imprimante, tous les bacs doivent être fermés.

**ES** **PRECAUCIÓN:** no extienda más de una bandeja para papel cada vez. No utilice la bandeja para papel como apoyo para subirse encima. Mantenga las manos alejadas de las bandejas para papel cuando las cierre. Todas las bandejas deben estar cerradas para mover la impresora.

**PT** **CUIDADO:** Não estenda mais de uma bandeja de papel ao mesmo tempo. Não use a bandeja de papel como um degrau. Afaste suas mãos da bandeja de papel ao fechá-la. Todas as bandejas devem estar fechadas quando transportar a impressora.

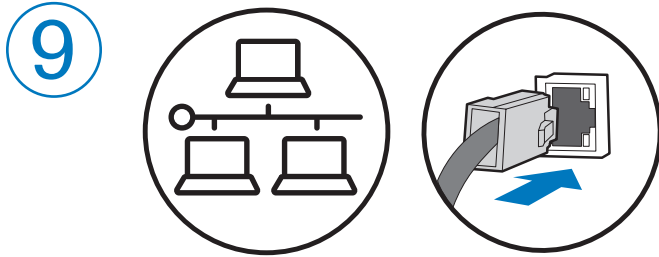

**EN** If you are connecting to a network, connect the network cable now.  
**NOTE:** The cables are not included with the printer.

**FR** Si vous vous connectez à un réseau, branchez le câble réseau maintenant.  
**REMARQUE :** Les câbles ne sont pas fournis avec l'imprimante.

**ES** Si va a conectar la impresora a una red, conecte ahora el cable de red.  
**NOTA:** los cables no se incluyen con la impresora.

**PT** Se você estiver se conectando a uma rede, conecte o cabo de rede agora.  
**NOTA:** Os cabos não são fornecidos com a impressora.

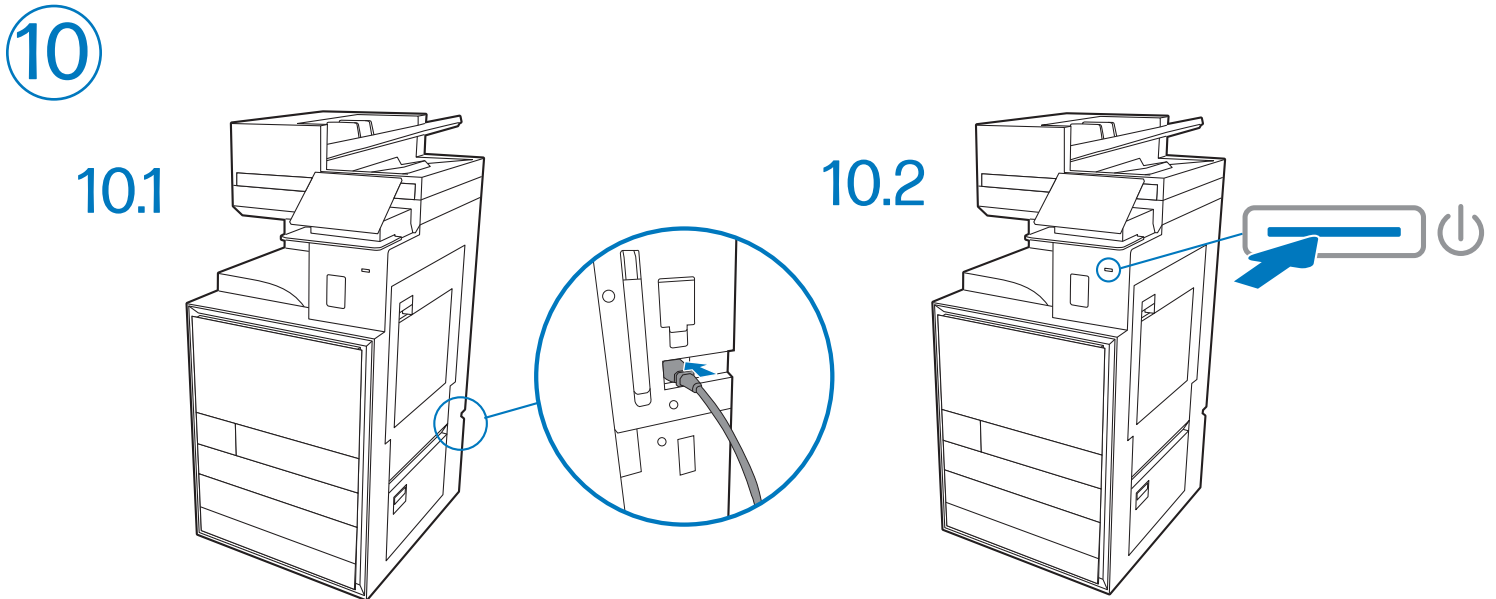

11

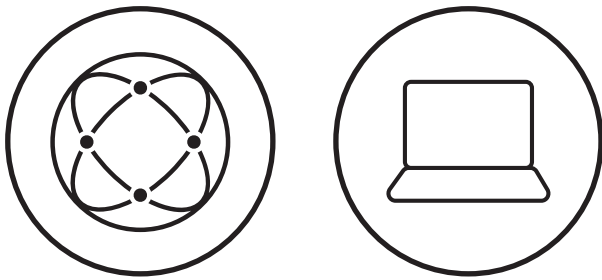

EN

Download from Product Support website (Windows clients and servers)

1. Go to [www.hp.com/support/colorlj8801MFP](http://www.hp.com/support/colorlj8801MFP).
2. Select Software and Drivers.
3. Download the software for your printer model and operating system.

**NOTE:** Windows - Driver - Product Installation Software for clients, Basic Drivers V3 for clients and servers.

4. Launch the installation file by clicking the .exe or .zip file as necessary.

FR

Téléchargement du site Web d'assistance du produit (clients et serveurs Windows)

1. Accédez à [www.hp.com/support/colorlj8801MFP](http://www.hp.com/support/colorlj8801MFP).
2. Sélectionnez Pilotes et logiciels.
3. Téléchargez le logiciel adapté à votre modèle d'imprimante et à votre système d'exploitation.

**REMARQUE :** Windows - Pilote - logiciel d'installation de produits pour les clients, Pilotes de base V3 pour les clients et les serveurs.

4. Lancez le fichier d'installation en cliquant sur le fichier .exe ou .zip le cas échéant.

ES

Descarga desde el sitio web de asistencia del producto (clientes y servidores de Windows)

1. Acceda a [www.hp.com/support/colorlj8801MFP](http://www.hp.com/support/colorlj8801MFP).
2. Seleccione Software y controladores.
3. Descargue el software para su modelo de impresora y sistema operativo.

**NOTA:** Windows - Controlador - Software de instalación del producto para clientes, Controladores básicos V3 para clientes y servidores.

4. Haga clic en el archivo .exe o .zip según sea necesario para iniciar el archivo de instalación.

PT

Faça download no site de Suporte do Produto (clientes e servidores do Windows)

1. Acesse [www.hp.com/support/colorlj8801MFP](http://www.hp.com/support/colorlj8801MFP).
2. Selecione Software e Drivers.
3. Faça o download do software para seu modelo de impressora e sistema operacional.

**NOTA:** Windows - Driver - Software de instalação do produto para clientes, Drivers básicos V3 para clientes e servidores.

4. Inicie o arquivo de instalação clicando no arquivo .exe ou .zip, como necessário.

12



EN

For more information on firmware updates and advanced configuration using the Embedded Web Server, see the User Guide or go to [www.hp.com/support/colorlj8801MFP](http://www.hp.com/support/colorlj8801MFP). Select the Help  button on the printer control panel to access Help topics.

FR

Pour plus d'informations sur les mises à jour du micrologiciel et la configuration avancée à l'aide de l'Embedded Web Server, consultez le guide de l'utilisateur ou rendez-vous sur le site suivant [www.hp.com/support/colorlj8801MFP](http://www.hp.com/support/colorlj8801MFP). Sélectionnez le bouton d'aide  sur le panneau de commandes de l'imprimante pour accéder aux rubriques d'aide.

ES

Para obtener más información sobre las actualizaciones de firmware y la configuración avanzada mediante el Servidor web incorporado, consulte la Guía del usuario o acceda a [www.hp.com/support/colorlj8801MFP](http://www.hp.com/support/colorlj8801MFP). Toque el botón de Ayuda  en el panel de control de la impresora para acceder a los temas de ayuda.

PT

Para mais informações sobre atualizações de firmware e configuração avançada usando o Servidor da Web Integrado, vide o Guia do Usuário ou acesse [www.hp.com/support/colorlj8801MFP](http://www.hp.com/support/colorlj8801MFP). Selecione o botão Ajuda  no painel de controle da impressora para acessar os tópicos da Ajuda.

© Copyright 2025 HP Development Company, L.P.

Reproduction, adaptation or translation without prior written permission is prohibited, except as allowed under the copyright laws.

The information contained herein is subject to change without notice.

The only warranties for HP products and services are set forth in the express warranty statements accompanying such products and services. Nothing herein should be construed as constituting an additional warranty. HP shall not be liable for technical or editorial errors or omissions contained herein.

## Trademark Credits

Microsoft, Windows, and Windows Server are trademarks of the Microsoft Group of companies.

macOS is a trademark of Apple Inc., registered in the U.S. and other countries.

AirPrint and the AirPrint logo are trademarks of Apple Inc.



La reproduction, l'adaptation ou la traduction de ce document sans l'autorisation écrite préalable de HP est interdite, sauf dans des conditions conformes aux lois relatives au copyright.

Les informations contenues dans ce document peuvent être modifiées sans préavis.

Les seules garanties pour les produits et services HP sont décrites dans les déclarations de garantie expresse qui accompagnent ces produits et services. Les informations contenues dans ce document ne constituent en aucun cas une garantie supplémentaire. HP n'est pas responsable des erreurs d'ordre technique ou éditorial ou des omissions contenues dans ce document.

## Crédits concernant les marques

Microsoft, Windows et Windows Server sont des marques commerciales du groupe de sociétés Microsoft.

macOS est une marque commerciale d'Apple Inc. aux États-Unis et dans d'autres pays/régions.

Le nom et le logo AirPrint sont des marques de commerce d'Apple Inc.



9S183-90008

