



Poly Documentation

Contents



1. Overview.....	3
2. Connect and pair.....	6
3. Fit and charge.....	9
4. Load software.....	12
5. Basics.....	13
6. More Features.....	18
7. Troubleshooting.....	19
8. What's in the box.....	22
9. Support.....	24

Overview

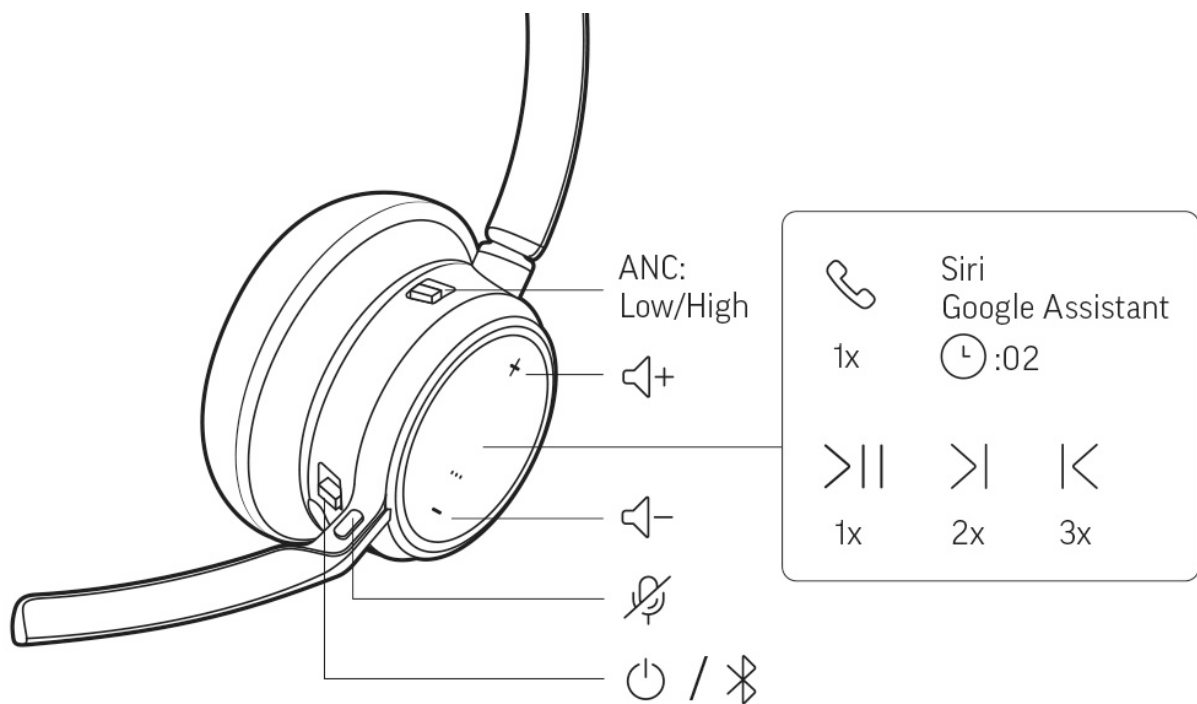
Headset



Icon	Headset control
ANC	Active Noise Cancelling (off/low/high)
🔊+	Volume up
📞	Call button/Press to interact with Microsoft Teams (Teams model only, requires Teams app)
Siri/Google Assistant	Default voice assistant
▶	Play/pause**
▶	Next track**
◀	Previous track**
🔊-	Volume down
🔇	Mute/unmute

Icon	Headset control
	Power on/off
	Bluetooth pairing

Note **Functionality varies by application. May not function with web-based apps.

Be safe

Please read the safety guide for important safety and regulatory information before using your new device.

Charge stand (select models only)

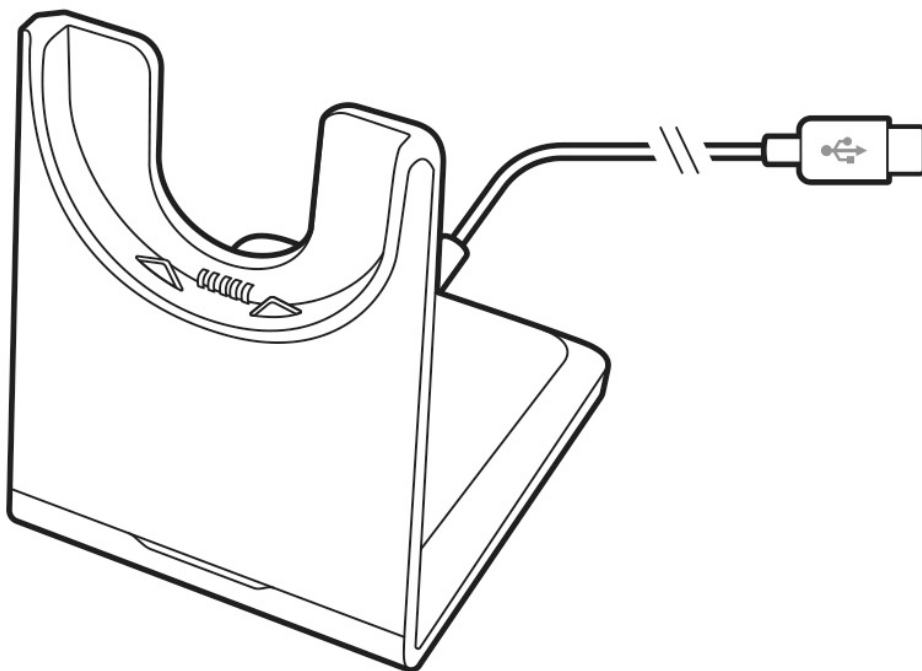

Note The charge stand plugs into a computer or wall charger's USB port.

USB Bluetooth adapter

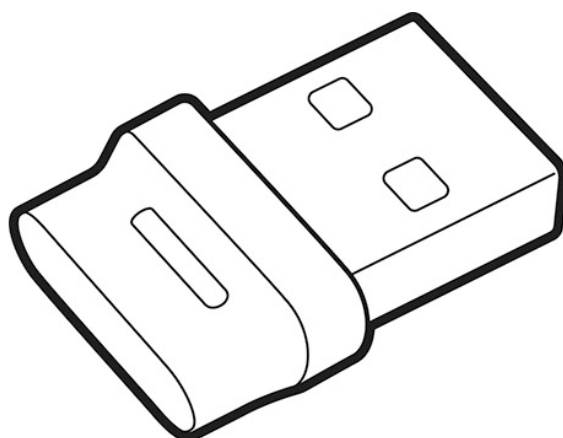

Your high-fidelity Bluetooth USB adapter comes pre-paired to your Poly device. Plug it into your computer to connect to high-fidelity computer audio.

Note Adapter's USB connection and design may vary, but function is the same.

Standard LEDs

USB LEDs	What they mean
Flashing red and blue	Pairing
Solid blue	Device connected
Flashing blue	On a call
Solid red	Mute active
Flashing purple	Streaming media from computer

LEDs when Microsoft Teams* is detected

USB LEDs	What they mean
Flashing red and blue	Pairing
Solid purple	Microsoft Teams connected
Flashing blue	On a call
Solid red	Mute active
Pulsing purple	Microsoft Teams notification

Note *Requires Microsoft Teams desktop application.

Connect and pair

Connect to PC

Your Bluetooth USB adapter provides the best connection, softphone functionality and acoustic sound quality through your headset. The adapter comes pre-paired to your headset.

Task

- 1 Turn on your headset and insert the Bluetooth USB adapter into your laptop or PC.

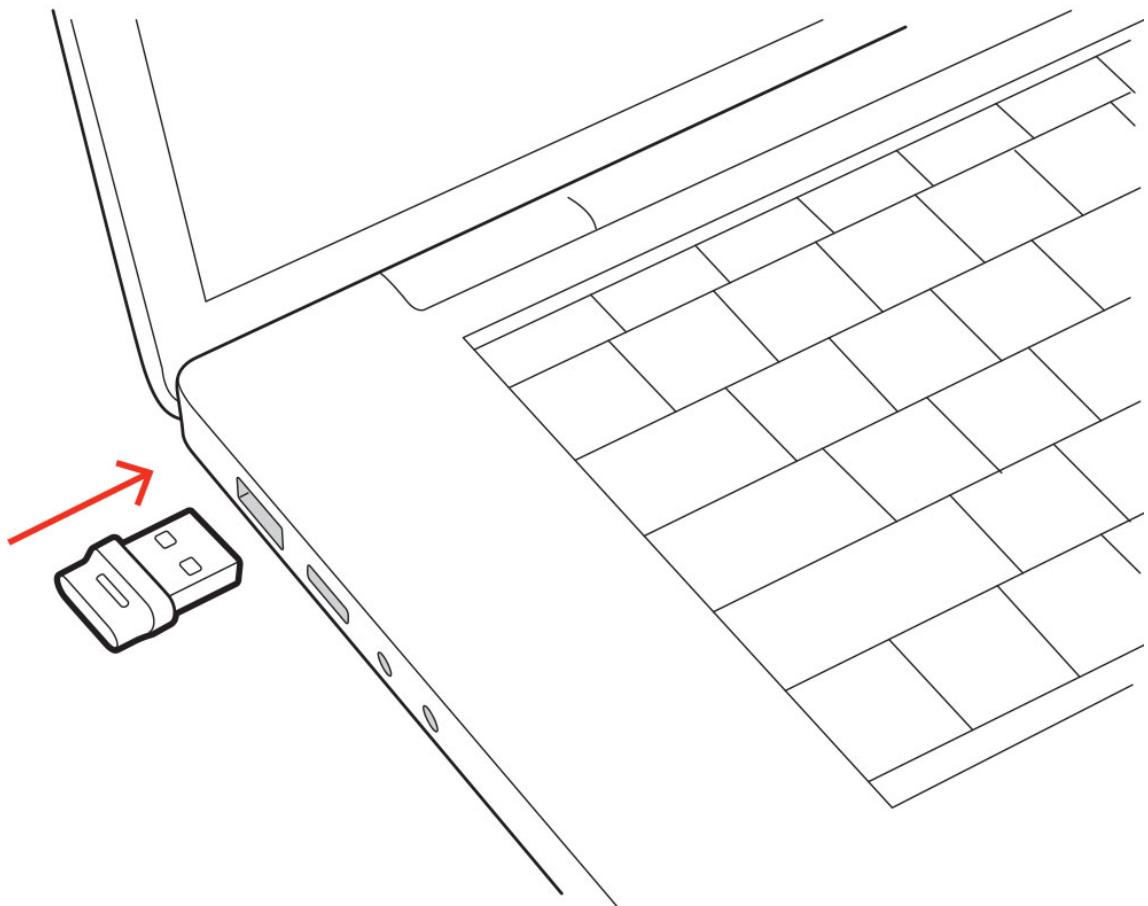

- 2 The USB adapter LED flashes and then turns solid to indicate the headset is connected to the USB adapter. If you are wearing your headset you hear “PC connected” to indicate the connection has been established. When on a call, the LED on the USB adapter flashes blue. When not on a call the LED is solid.
- 3 Load Poly Lens Desktop App by visiting poly.com/lens. This allows you to customize your headset behavior through advanced settings and options.

Configure USB adapter for streaming media

Your high-fidelity Bluetooth USB adapter comes ready to take calls. To stream media, configure your Bluetooth USB adapter.

Windows

- 1 To configure your Bluetooth USB adapter for streaming media in your PC, go to **Start menu > Control Panel > Sound > Playback tab**. Select Poly BT700 set it as the Default Device and click OK.
- 2 To pause music when you place or receive calls, go to **Start menu > Control Panel > Sound > Communications tab** and select the desired parameter.

Mac

- 1 To configure your Bluetooth USB adapter for streaming media on your Mac, go to **System Preferences > Sound**. On both the Input and Output tabs, select **Poly BT700**.

Pair to mobile device

Task

- 1 To put your headset in pair mode, slide and hold the Power  switch away from the off position until you hear "pairing" and the headset LEDs flash red and blue.

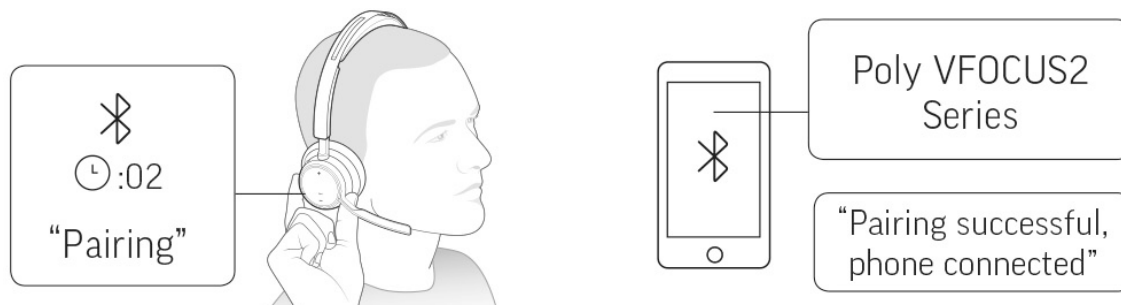

- 2 Activate Bluetooth on your phone and set it to search for new devices.

- iPhone **Settings > Bluetooth > On***
- Android **Settings > Bluetooth On > Scan for devices***

Note *Menus may vary by device.

- 3 Select "Poly VFOCUS2 Series."

Once successfully paired, you hear "pairing successful" and the headset LEDs stop flashing.

Note Your headset can pair with up to 8 devices but only maintain 2 connections simultaneously; this includes the base.

Pair mode

Put your headset in pair mode to connect to a new device or to pair again.

Task

- Slide and hold the headset Power  switch away from the off position until the LEDs flash red and blue.

Pair BT700 USB adapter again

Typically, your USB Bluetooth adapter is pre-paired to your Poly audio device. In the event that your adapter is disconnected or bought separately, you will need to pair the adapter to your Poly device.

Your USB adapter requires Poly Lens Desktop App to pair to a Poly audio device. Download: poly.com/lens.

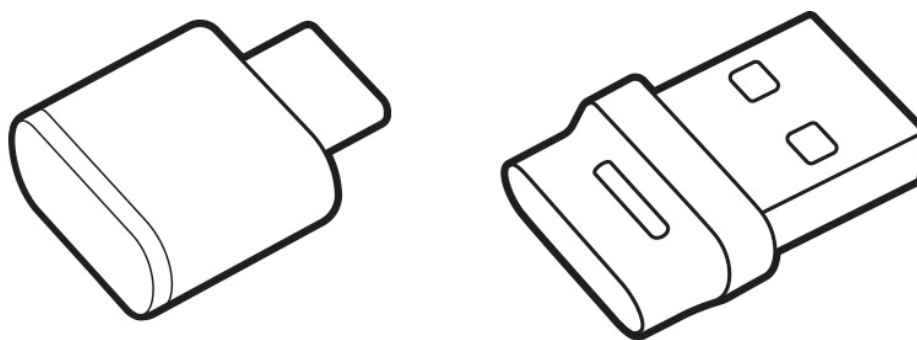

Note Adapter design varies by USB connection.

Task

- 1 Insert the high-fidelity Bluetooth USB adapter into your laptop or computer and wait for your computer to recognize it.
- 2 Put your Poly audio device in pair mode.
- 3 Launch Poly Lens Desktop App and navigate to Poly BT700.
- 4 Put your Bluetooth USB adapter into pair mode by selecting "Pair new device" on the adapter's main page or overflow menu. Your adapter flashes red and blue.

Pairing is successful when you hear "pairing successful" and "PC connected" and the Bluetooth USB adapter LED is solid.

Fit and charge

Wear on the right or left

Task

- To position the microphone on the right or left side, rotate the microphone boom up and over. Bend the boom so it is approximately 2 finger widths from the corner of your mouth.

Note Your headset senses when you change the microphone boom from one side to the other and syncs the audio specific to each side.

- Gently flex the headband wider if the fit is uncomfortable on your ears.

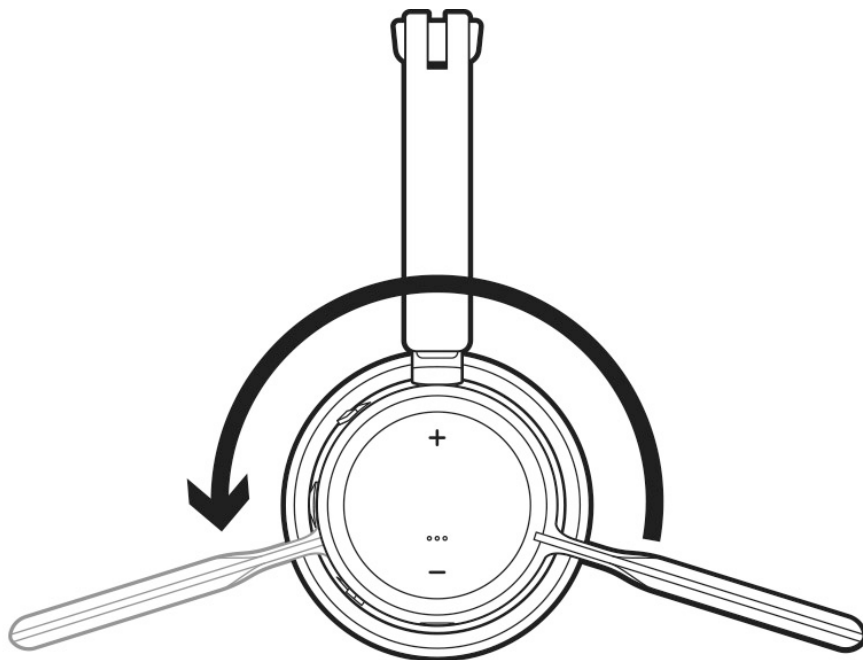

Charge

Task

-
- **Note** The micro USB cable and charge stand (sold separately) plug into a computer or wall charger's USB port.
-

Charge your headset using the micro USB cable or the charge stand (sold separately). The headset LEDs flash when charging. It takes approximately 2 hours to fully charge your headset. The LEDs turn off once charging is complete.

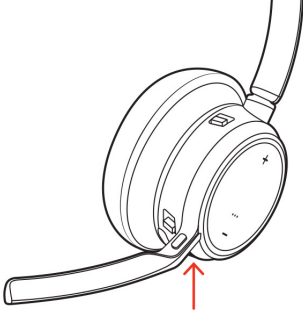
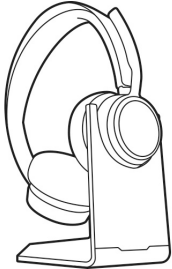
Micro USB cable	Charge stand (sold separately)
	
Headset LEDs	What they mean
Off	Charging complete
•••	Battery high
••	Battery medium
•	Battery low
✱	Battery critical

Check headset battery status

Check your headset battery status:

Task

- With headset inactive, slide and release the Power  switch away from the off position. Listen to the voice alert or observe the headset LEDs.

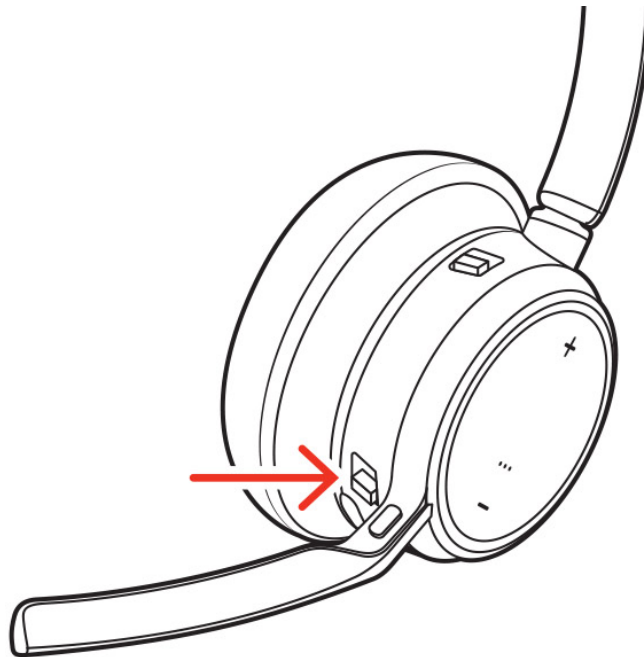

Load software

Download Poly Lens App to get the most out of your device. Some softphones require the installation of Poly software to enable device call control (answer/end and mute) functionality. Download: poly.com/lens.

Task

- Enable features
- Change settings
- Configure call control for softphones
- Update device firmware
- Manage notifications and alerts
- Schedule health and wellness reminders

Update your Poly device

Keep your firmware and software up-to-date to improve performance and add new features to your Poly device.

Update your device using Poly Lens App. Download at poly.com/lens.

Basics

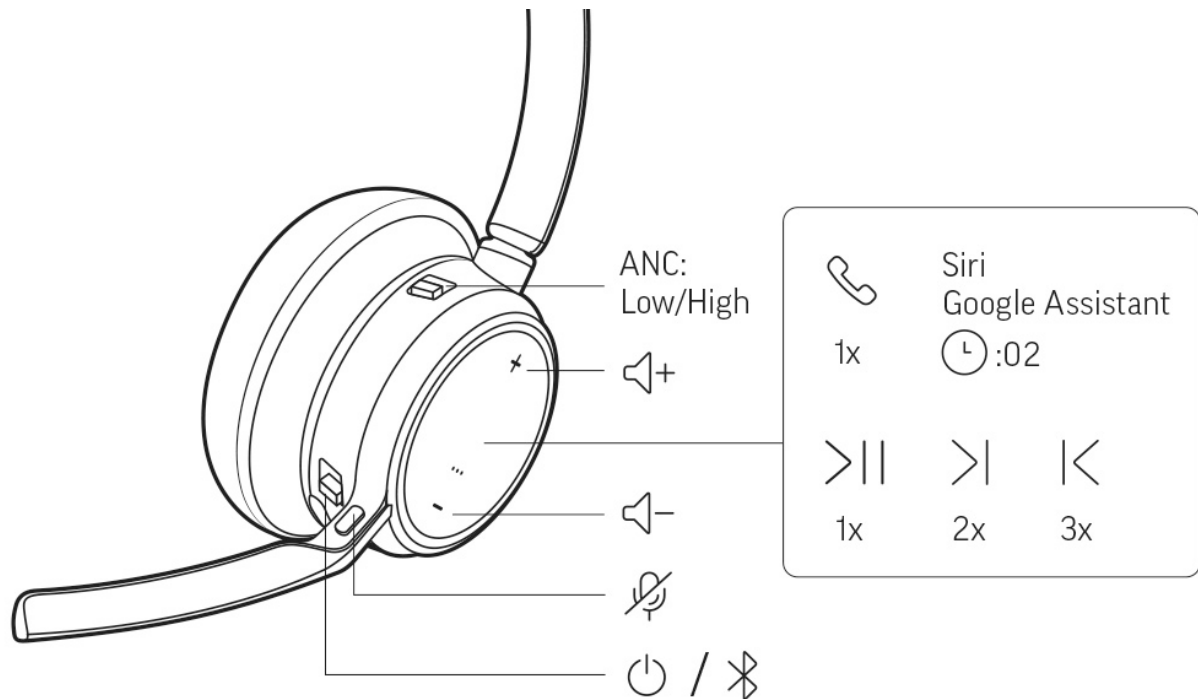

Power on/off

Task

- To turn on the headset, slide the Power  button to reveal green.

Adjust the volume

Task

- Tap the Volume up (+) or down (-) button.

Adjust headset microphone volume (softphone)

Place a test softphone call and adjust softphone volume and PC sound volume accordingly.

Task

-

Adjust voice prompt volume

Task

- To adjust the volume of voice alerts and prompts, toggle the volume switch up (+) or down (-) while not on a call or streaming audio.

Make/Take/End Calls



Answer or end a call

Task

- Tap the Call  button.

Answer a second call

Task

- First, tap the Call button  to end current call, then tap the Call button  again to answer new call.

Mute

Task

- Mute your headset on an active call:
 - Tap the Mute  button
 - Rotate your microphone boom and click it into the up position
 - Take off your headset (requires active smart sensors). Put on your headset to unmute.

Hold a call

Task

- To hold an active call, press the headset Call button for 2 seconds. Press the Call button to resume a held call.

Hold a call

Task

- To hold an active call, press the headset Call button for 2 seconds. Press the Call button to resume a held call.

Switch between calls (flash)

Task

- To switch between calls, press the headset Call button for 2 seconds.

Note Available for softphone calls only. Does not work with mobile calls.

Call back last call (smartphone)

Task

- To dial your last number you dialed, double-tap the Call button.

Answer calls from a second device

It's easy to answer calls from two devices (including softphone).

When on a call, you hear a ringtone notification of the incoming call from the second paired device.

Task

- To answer a second call from the other device, first tap the Call  button to end the current call and tap the Call button again to answer the new call. If you choose to not answer the second call, it will go to voicemail.

Launch Microsoft Teams (Teams model only)

Tap your headset Teams button to quickly open and use the Microsoft Teams desktop app.

Task

- When not on a call, tap your Teams  button to view Microsoft Teams app on your computer.
- When your connected USB adapter LED pulses purple, tap your Teams button to view Teams notifications.

Note Teams model and Teams desktop application required. Teams mobile application is not supported.

ANC

Active Noise Canceling (ANC) reduces external noise and enhances your music and sound quality.

Task

- Slide the ANC switch to choose:
 - Low: recommended for office
 - High: recommended for loud environments

Use sensors

Smart sensors respond when you put on or take off your headset. Customize in Poly Lens App. Below describes default settings.

With active sensors	putting on the headset will:	taking off the headset will:
Mobile/softphone call	answer the call	keep call in headset
Music/media	resume music/media (if playing previous to taking off)*	pause music/media (if playing)*
Mute (activate in Poly Lens App)	unmute if on an active call	mute if on an active call

Note *Functionality varies by application. May not function with web-based apps.

Reset sensors

You may need to reset the sensors if they are not working as expected.



Task

- There are two ways to reset the headset sensors. Choose:

- With your headset powered on, charge your headset on the charge stand for 10 seconds
- Power on your headset while pressing the Mute  button for more than 4 seconds until the LEDs flash purple 4 times, being careful to not touch the earcup padding or allow it to come in contact with surfaces

Disable sensors

Task

- You can disable your headset smart sensors 2 ways:
 - Manage sensors in Poly Lens App
 - Hold both the Mute  and Call  buttons for more than 4 seconds until the LED flashes purple then red. Repeat to reactivate; the LED flashes purple then blue

Note Sensors cannot be disabled while streaming audio.

Play or pause audio

Task

- Tap the Call  button to pause or resume streaming audio.

Note Functionality varies by application. May not function with web-based apps.

Voice assistant (smartphone feature)

Task

- **Siri, Google Assistant, Cortana** Press and hold the Call button for 2 seconds to activate your phone's default voice assistant. Wait for the phone prompt to activate voice dialing, search, and other smartphone voice controls.

More Features

Select language

Task

- You can wirelessly change your headset language using Poly Lens App. Download: poly.com/lens.

Online indicator

Task

- Your headset LED illuminates red to inform others that you are on a call. Manage settings in Poly Lens App.

Corded mode (audio over USB)

If your audio is cutting out during softphone calls, you may be experiencing Bluetooth density problems. Improve audio performance by using density-friendly corded mode.

Task



- 1 Disconnect your Bluetooth USB adapter from your computer
- 2 Connect your headset directly to your computer with the provided 1.5 m USB cable
- 3 Power off your headset to use density-friendly corded mode

Note Your headset battery charges while in corded mode.

Troubleshooting

Table 1. Headset troubleshooting

Issue	Resolution
How do I pair my headset to a mobile device?	See Pair to mobile device .
How do I pair my headset to a computer or laptop?	Plug in the USB Bluetooth adapter to your computer or laptop. The adapter is paired to your headset and connects to computer audio. See Connect to PC .
Why should I use the USB Bluetooth adapter instead of my computer's Bluetooth?	Your USB Bluetooth adapter provides the best connection, softphone functionality and acoustic sound quality through your headset. See Connect to PC , Configure USB adapter for streaming media .
How do I pair my USB Bluetooth adapter to another supported Poly audio device?	Poly Lens Desktop App is required to pair your BT700 USB Bluetooth adapter to another device. Your Bluetooth adapter remembers up to 2 supported Poly audio devices, but connects to only one at a time. See Pair USB adapter again .
Can I connect my headset to a mobile phone and computer at the same time?	Yes, your headset can connect to mobile and PC. Your headset remembers up to 8 devices, but connect to up to 2 devices at a time. That includes the USB Bluetooth adapter.
The headset audio is not working as expected when connected to my computer. <ul data-bbox="245 1480 703 1749" style="list-style-type: none">• During a call, nobody can hear me• During a call, I can't hear anybody• Music is not coming through my headset• When I play music and a call comes in, the music is too loud or doesn't pause	Check the following: <ul data-bbox="791 1447 1374 1727" style="list-style-type: none">• To configure the headset sound on your computer, see Configure USB adapter for streaming media, Load software.• Ensure that only one softphone application is opened at a time.• For best performance, ensure your headset firmware is up-to-date. See Update your Poly device.

Issue	Resolution
<p>My headset call control is not working as expected when on a softphone call.</p>	<p>Check the following:</p> <ul style="list-style-type: none"> • For best performance, ensure your headset firmware is up-to-date. See Update your Poly device. • Ensure that only one softphone application is opened at a time. • If required to enable headset control (answer/end and mute) functionality, ensure you have Poly Lens Desktop App installed. See Load software. • Select your softphone application in Poly Lens Desktop App.
<p>(Teams model only) How do I interact with Microsoft Teams using my headset?</p>	<ul style="list-style-type: none"> • Tap the headset Call  button to quickly open and use Microsoft Teams. See Launch Microsoft Teams (Teams model only). • Set your target softphone by going to Poly Lens Desktop App
<p>(Teams model only) Does my Microsoft Teams-enabled headset work with other softphones?</p>	<p>Yes, while your headset is optimized for Microsoft Teams, it can be configured to use with other supported softphones. Set your target phone by going to Poly Lens Desktop App.</p> <p>When you configure another softphone, the Call  button:</p> <ul style="list-style-type: none"> • doesn't interact with Teams • doesn't go to Teams notifications • will not launch Cortana
<p>I want to customize my headset features.</p>	<p>Customize your device settings with Poly Lens App. Download: poly.com/lens</p>
<p>The headset audio is cutting out during softphone calls.</p>	<p>You may be experiencing Bluetooth density issues. Use density-friendly corded mode. See Corded mode (audio over USB).</p>
<p>I want to use my headset as a USB corded headset with my computer.</p>	<p>Your headset can be used in corded mode. See Corded mode (audio over USB).</p>
<p>Can I use my headset while charging it?</p>	<p>Your headset charges while in corded mode. See Corded mode (audio over USB).</p>
<p>The headset talk time is not accurate.</p>	<p>Deplete your headset battery and then fully charge to reset the accuracy of the talk time prompts.</p>

Issue	Resolution
I don't have enough charge ports for my Bluetooth USB adapter and my optional charge stand.	Try the following: <ul style="list-style-type: none"><li data-bbox="791 387 1337 421">● Plug your charge stand into a wall charger<li data-bbox="791 434 1406 528">● To charge your headset while connected to your computer, use corded mode. See Corded mode (audio over USB).

What's in the box

Contents may vary by product.

Figure 1. Headset

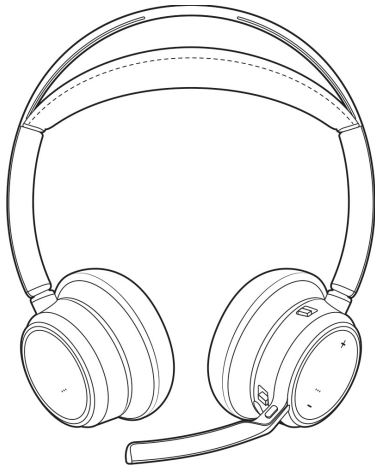

Figure 2. Bluetooth USB Adapter (design may vary)

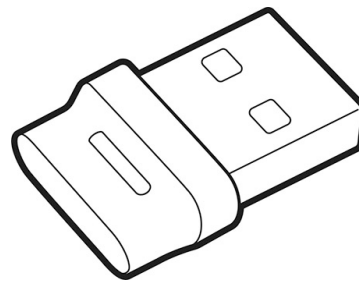

Figure 3. Charge stand (select models only)



Figure 4. Carrying case

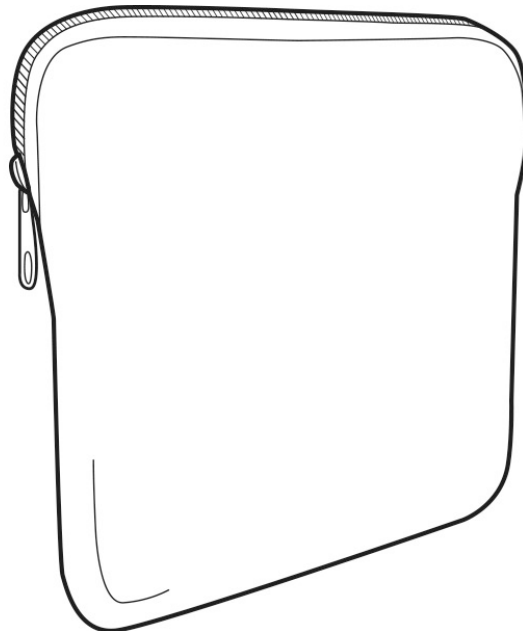

Figure 5. Micro USB cable

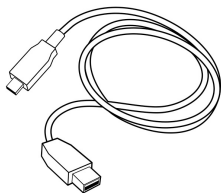
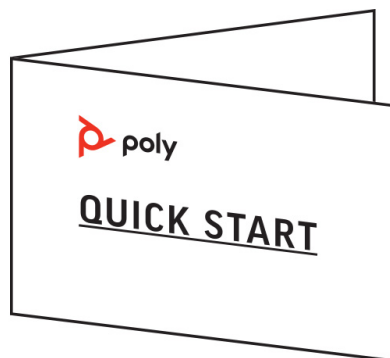

Figure 6. Quick start guide



Support

NEED MORE HELP?

poly.com/support

HP Inc.

1501 Page Mill Road

Palo Alto 94304, U.S.A.

650-857-1501

HP Deutschland GmbH

HP HQ-TRE

71025 Boeblingen, Germany

HP Inc UK Ltd

Regulatory Enquiries, Earley West

300 Thames Valley Park Drive

Reading, RG6 1PT

United Kingdom

© 2023 Poly. Bluetooth is a registered trademark of Bluetooth SIG, Inc. All trademarks are the property of their respective owners.

Model ID: Headset VFOCUS2/VFOCUS2-M, Adapter BT700/BT700C. System: Poly Voyager Focus 2 UC has a VFOCUS2/VFOCUS2-M headset and a BT700/BT700C adapter.