



Digital Projector

# User Manual

LH850ST

VI.00

# Copyright and disclaimer

## Copyright

Copyright 2024 BenQ Corporation. All rights reserved. No part of this publication may be reproduced, transmitted, transcribed, stored in a retrieval system or translated into any language or computer language, in any form or by any means, electronic, mechanical, magnetic, optical, chemical, manual or otherwise, without the prior written permission of BenQ Corporation. All other logos, products, or company names mentioned in this manual may be the registered trademarks or copyrights of their respective companies, and are used for informational purposes only.

## Disclaimer

BenQ Corporation makes no representations or warranties, either expressed or implied, with respect to the contents hereof and specifically disclaims any warranties, merchantability or fitness for any particular purpose. Further, BenQ Corporation reserves the right to revise this publication and to make changes from time to time in the contents hereof without obligation of BenQ Corporation to notify any person of such revision or changes.

This user manual aims to provide the most updated and accurate information to customers, and thus all contents may be modified from time to time without prior notice. Please visit <http://www.benq.com> for the latest version of this manual.

## Statement regarding hyperlinks and third-party websites

BenQ is not responsible for the content of the websites or of similar resources, which are maintained and controlled by third parties, that may be linked from this product. Providing links to those websites or to similar resources does not mean that BenQ makes any warranty or representation to their content by expression or by implication.

Any third party content or service preinstalled in this product is provided "as is". BenQ does not, by expression or by implication, make any warrant to the content or to the services provided by third parties. BenQ does not warrant or guarantee that the content or services provided by third parties are accurate, effective, most up-to-date, legal, or complete. Under no circumstances shall BenQ be liable for the content or services provided by third parties including their negligence. Services provided by third parties may be terminated temporarily or permanently. BenQ does not warrant or guarantee that the any content or services provided by third parties are in good condition at any time, and is not liable for the termination of the said content and services. In addition, BenQ is not involved in any transactions you conduct in the websites or similar resources maintained by third parties.

You should contact the content or service providers for any questions, concerns, or disputes.

## Table of Contents

<b>Copyright and disclaimer .....</b>	<b>2</b>
Copyright.....	2
Disclaimer .....	2
Statement regarding hyperlinks and third-party websites.....	2
<b>Important safety instructions.....</b>	<b>5</b>
General safety instruction.....	5
Notice on laser .....	6
Label instruction .....	7
Laser light instruction .....	8
Prepare for installation.....	8
Focus adjustment .....	8
Cooling notice .....	9
<b>Package contents .....</b>	<b>11</b>
Standard packing items .....	11
<b>Introduction.....</b>	<b>12</b>
Projector exterior view .....	12
Front and upper side view .....	12
Rear view .....	12
Controls and functions.....	13
Control panel.....	13
Control terminal .....	14
Remote control .....	15
<b>Installation .....</b>	<b>18</b>
Evaluate for distance by image size .....	18
Obtaining a preferred projected image size .....	18
Projection dimensions.....	18
Mounting the projector .....	19
Before mounting the projector .....	19
Ceiling/Wall mount installation diagram .....	19
Installing the side filter .....	20
Connection .....	21
Before connecting.....	21
Connecting with AV equipment.....	22
Connecting with computer .....	22
Connecting with LAN.....	23
Connecting audio .....	23
Connecting the Wireless Dongle.....	24
<b>Operations.....</b>	<b>25</b>
Starting up the projector.....	25
Adjusting the projected image.....	26
Adjusting the projection angle.....	26
Fine-tuning the image size and clarity .....	26
Correcting 2D Keystone.....	27
Correcting Corner Fit .....	28
Corner Fit and 2D Keystone Adjustment Notice.....	28

Using the menus .....	29
Securing the projector .....	30
Using a security cable lock.....	30
Utilizing the password function .....	30
Switching input signal.....	32
Shutting down the projector .....	32
<b>Menu operation .....</b>	<b>33</b>
Menu System .....	33
Basic menu.....	33
<b>Advanced menu .....</b>	<b>34</b>
Basic menu.....	37
Advanced menu .....	39
<b>Maintenance .....</b>	<b>48</b>
Care of the projector .....	48
Cleaning the lens.....	48
Cleaning the projector case .....	48
Storing the projector .....	48
Transporting the projector.....	48
Filter maintenance.....	49
Cleaning the filter .....	49
Replacing the side filter .....	50
Indicators.....	51
<b>Troubleshooting .....</b>	<b>52</b>
Troubleshooting.....	52
? The projector does not turn on.....	52
? No picture. ....	52
? Blurred image.....	52
? Remote control does not work.....	52
? The password is incorrect. ....	52
<b>Specifications.....</b>	<b>53</b>
Projector specifications .....	53
Dimensions .....	54
Timing table .....	55
Support video timing for HDMI input.....	55
Support PC timing for HDMI input.....	55
True 3D Video Compatibility table .....	57
RS232 command control .....	58
PJLink.....	65
PJLink protocol .....	65
Control commands.....	65

# Important safety instructions

Your projector is designed and tested to meet the latest standards for safety of information technology equipment. However, to ensure safe use of this product, it is important that you follow the instructions mentioned in this manual and marked on the product.

## General safety instruction

1. Do not look straight at the projector lens during operation. The intense light beam may damage your eyes.
2. Always open the lens shutter or remove the lens cap when the projector light source is on.
3. In some countries, the line voltage is NOT stable. This projector is designed to operate safely within a mains voltage between 100 to 240 volts AC, but could fail if power cuts or surges of  $\pm 10$  volts occur. In areas where the mains voltage may fluctuate or cut out, it is recommended that you connect your projector through a power stabilizer, surge protector or uninterruptible power supply (UPS).
4. Do not block the projection lens with any objects when the projector is under operation as this could cause the objects to become heated and deformed or even cause a fire. To temporarily turn off the light source, press **BLANK** on the remote control.
5. Do not place this product on an unstable cart, stand, or table. The product may fall, sustaining serious damage.
6. Do not attempt to disassemble this projector. There are dangerous high voltages inside which may cause death if you should come into contact with live parts.

Under no circumstances should you ever undo or remove any other covers. Refer servicing only to suitably qualified professional service personnel.

7. Do not place this projector in any of the following environments.
  - Space that is poorly ventilated or confined. Allow at least 50 cm clearance from walls and free flow of air around the projector.
  - Locations where temperatures may become excessively high, such as the inside of a car with all windows rolled up.
  - Locations where excessive humidity, dust, or cigarette smoke may contaminate optical components, shortening the projector's life span and darkening the image.
  - Locations near fire alarms
  - Locations with an ambient temperature above 40°C / 104°F
  - Locations where the altitudes are higher than 3000 m (10000 feet).
8. Do not block the ventilation holes.
  - Do not place this projector on a blanket, bedding or any other soft surface.
  - Do not cover this projector with a cloth or any other item.
  - Do not place inflammables near the projector.

If the ventilation holes are seriously obstructed, overheating inside the projector may result in a fire.

9. Do not step on the projector or place any objects upon it. Besides probable physical damage to the projector, doing so may result in accidents and possible injury.
10. Do not place liquids near or on the projector. Liquids spilled into the projector may cause it to fail. If the projector does become wet, disconnect it from the power supply's wall socket and call BenQ to have the projector serviced.

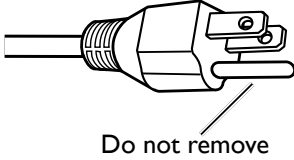

This equipment has a three-pin grounding-type power plug. Do not remove the grounding pin. As a safety feature, this plug will only fit a grounding-type power outlet. If you are unable to fit the plug into the outlet, contact an electrician.

## Notice on laser

Caution – use of controls or adjustments or performance of procedures other than those specified herein may result in hazardous radiation exposure.

Do not point laser or allow laser light to be directed or reflected toward other people or reflective objects.

Direct or scattered light can be hazardous to eyes and skin.

There is a potential hazard of eye exposure to laser radiation if the included instructions are not followed.

Do not allow to look into the projector beam at any distance from the projector. An adult should supervise the children to prevent exposure risks.

Check that there is no one looking at the lens, when using the remote control for starting the projector.

Do not look at the projected light using optical devices(binoculars, telescopes, magnifying glasses, reflectors, etc).

## Label instruction

Below drawing show the label's location.

### 1. Laser warning label

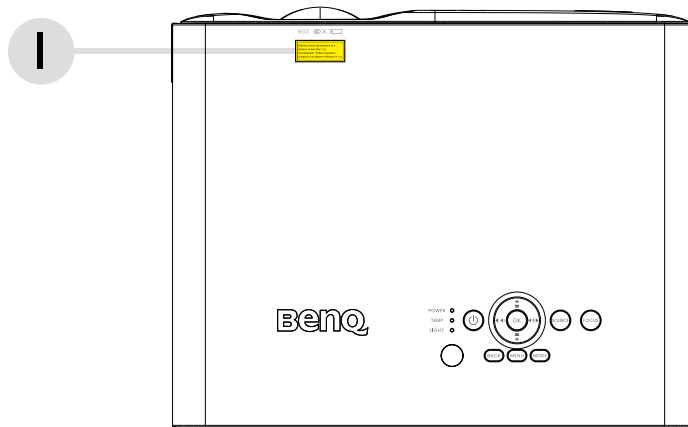

### 2. RG2

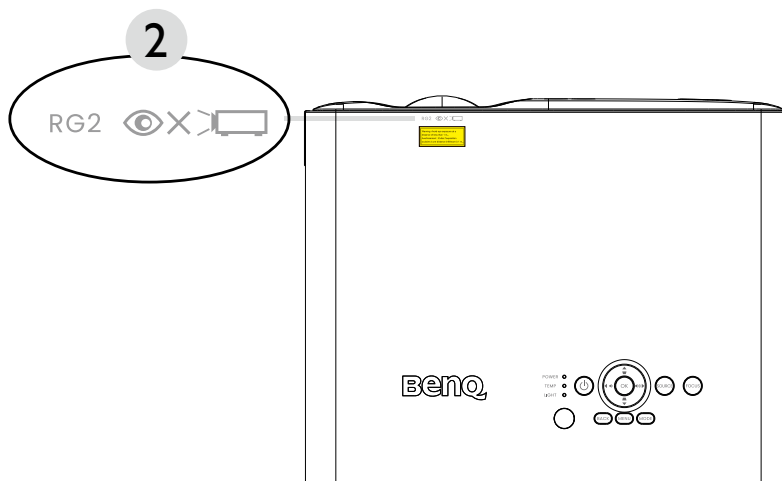

### ! Caution:

As with any bright light source, do not stare into the beam, RG2 IEC 62471-5:2015

**Possibly hazardous optical radiation emitted from this product.**

**Do not stare at operating light source. May be harmful to the eyes.**

## Laser light instruction

Below drawing is the laser aperture location. Be careful not to let the eye see the light directly.

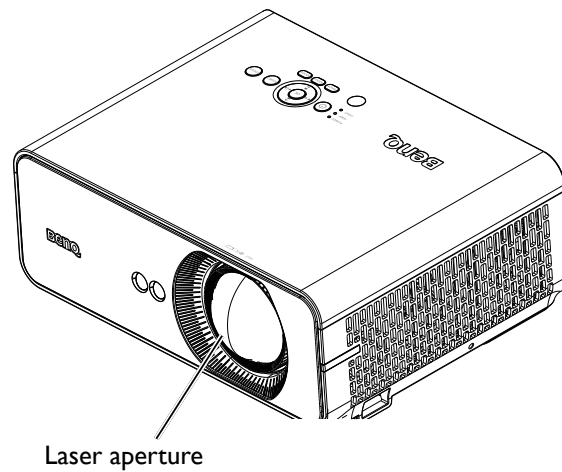

## Prepare for installation

### Focus adjustment

The high clarity projection lens is thermally affected by the light from the light source; thus, the focus is unstable for a short period immediately after the power is turned on. Please wait at least 15 minutes of continuous projection before adjusting the focus. See ["Adjusting the Focus" on page 26.](#)

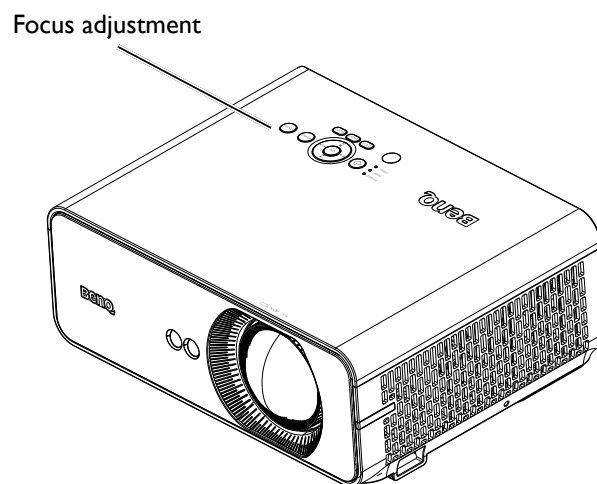



## Cooling notice

Allow at least 50 cm (19.7 inch) for clearance around the exhaust vent. Make sure no objects block air inlet within 50 cm (19.7 inch).

Keep the outlet at least 1 m away from the inlets of other projectors.

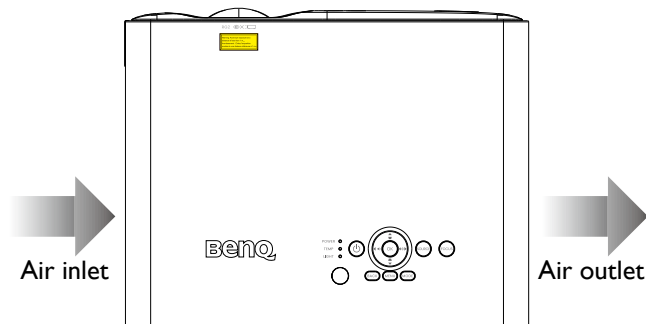

### **!** Caution:

Installation of the projector should be performed carefully. Incomplete or improper installation may cause the projector to fall, resulting in personal injury or property damage.

- Allow at least 50 cm of clearance around the exhaust vent.

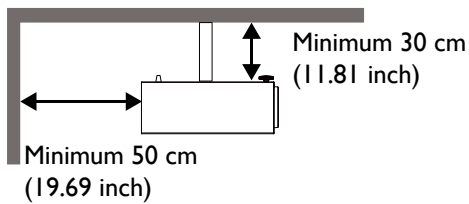
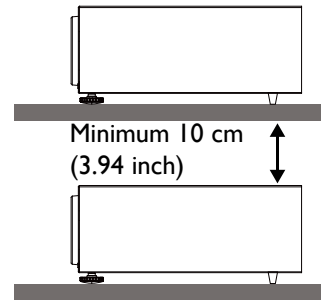
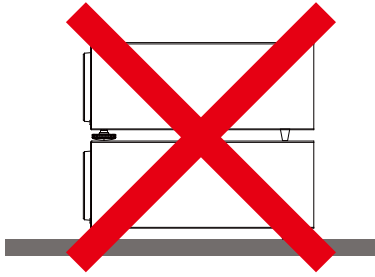
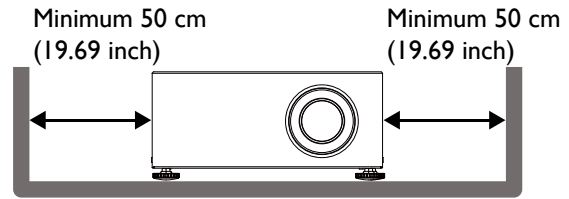
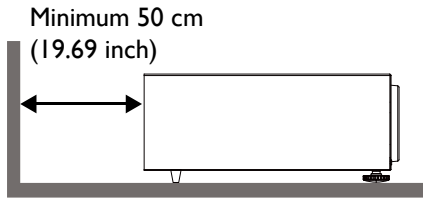

- Ensure that the air intake vents do not recycle hot air from the exhaust vent.
- When operating in an enclosed space, make sure that the surrounding air temperature does not exceed the projector's operating temperature and that the air intake and exhaust vents are unobstructed.
- All enclosures should pass a certified thermal evaluation to ensure that the projector does not recycle exhaust air. Recycling exhaust air may cause the projector to shutdown even if the ambient temperature is within the acceptable operating temperature range.

**! Caution:**

To avoid damaging the DLP chips, never aim a high-power laser beam into the projection lens.

# Package contents

## Standard packing items

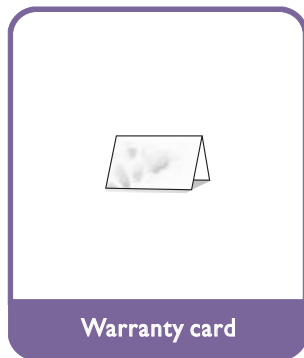
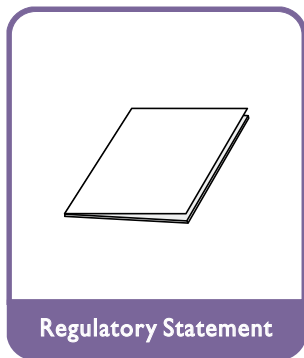
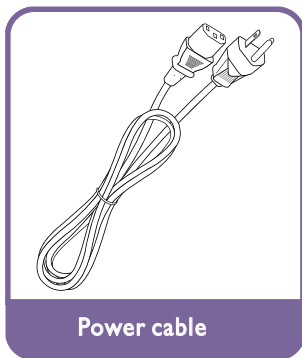
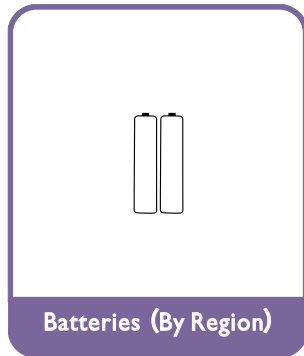

# Introduction

## Projector exterior view

### Front and upper side view

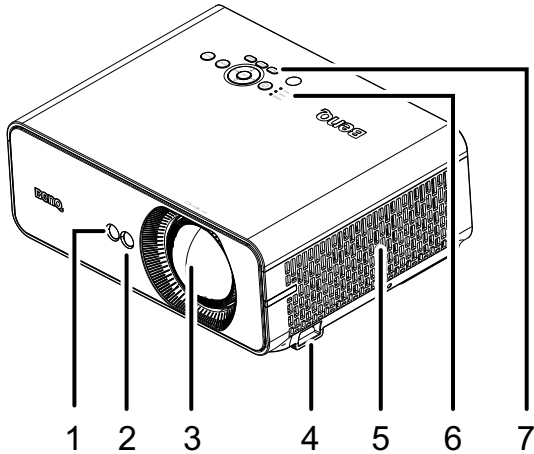

1. Front IR remote sensor
2. Focus adjustment
3. Projection lens
4. Security Bar
5. Vent (air inlet)
6. LED indicator light
7. Control panel

### Rear view

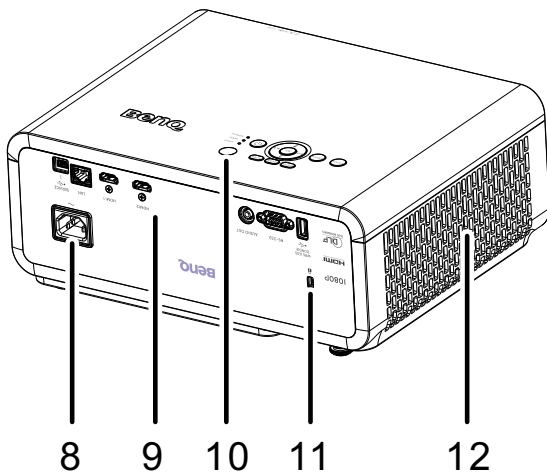

8. AC power cord inlet
9. Control terminals
10. Top IR remote sensor
11. Kensington anti-theft lock slot
12. Vent (air outlet)

## Controls and functions

### Control panel

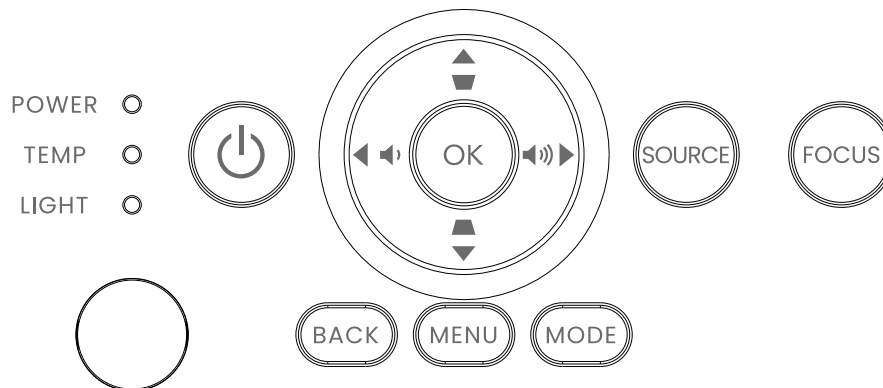

- ⏻ Power**  
 Toggles the projector between standby mode and on. See ["Starting up the projector" on page 25](#) and ["Shutting down the projector" on page 32](#) for details.
- Volume keys ( 🔊 , 🔊 )**  
 Decreases or increases the projector volume.
- Keystone keys ( ▴ , ▾ )**  
 Manually corrects distorted images resulting from an angled projection.
- Arrow keys ( ▲, ▼ , ◀, ▶ )**  
 When the On-Screen Display (OSD) menu is activated, these keys are used as directional arrows to select the desired menu items and to make adjustments. See ["Using the menus" on page 29](#) for details.
- OK**  
 Enacts the selected On-Screen Display (OSD) menu item. See ["Using the menus" on page 29](#) for details.
- SOURCE**  
 Displays the source selection bar.
- FOCUS**  
 Press to focus the image and then displays the adjustment page for manual adjustment.  
 \*Available on compatible projectors only. See ["Focus" on page 43](#) for details.
- BACK**  
 Goes back to previous OSD menu, exits and saves menu settings.
- MENU**  
 Turns on the On-Screen Display (OSD) menu. Goes back to previous OSD menu, exits and saves menu settings. See ["Using the menus" on page 29](#) for details.
- MODE**  
 Selects an available picture setup mode. See ["Using the menus" on page 29](#) for details.

## Control terminal



### WIRELESS DONGLE

Connection to wireless dongle.

### RS-232 IN

Standard 9-pin D-sub interface for connection to PC control system and projector maintenance.

### AUDIO OUT

Connection to a speaker amplifier or headset.

### HDMI 2

Connection to HDMI source.

### HDMI 1

Connection to HDMI source.

### LAN

For connection to RJ45 Ethernet cable to control the projector through a network.

### SERVICE

Support Mini USB type B for service only.

### ! Caution:

Make sure the port is valid before inserting a wired remote controller. The remote controller may be damaged in case of an invalid port, e.g. a wired remote controller is connected to trigger output. For more information about upgrading firmware via Lan, please contact BenQ service.

## Remote control

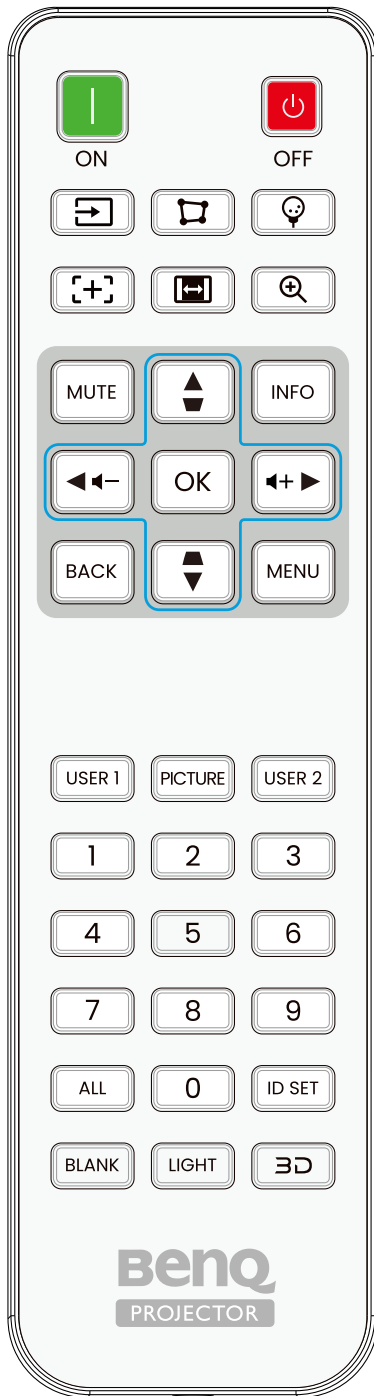

- **ON / OFF**

Toggles the projector between standby mode and on.

- **Source**

Displays the source selection bar.

- **Geometry**

Open 'Geometry' men windows (access to corner fit and warping).

- **Golf Setting**

Open golf setting menu (original Quick Install).

- **Focus**

Press to focus the image and then displays the adjustment page for manual adjustment.

\*Available on compatible projectors only.

- **Screen Fill**

Quick access to screen fill selection list for 16:9/16:10/4:3/1:1.

- **Zoom**

Magnifies or reduces the projected picture size.

- **MUTE**

Toggles projector audio between on and off.

- **KEYSTONE+/KEYSTONE-**

Manually corrects distorted images resulting from an angled projection.

- **VOLUME +/VOLUME -**

Increases/decreases the projector volume.

- **Arrow keys ( ▲ Up, ▼ Down, ◀ Left, ▶ Right )**

When the On-Screen Display (OSD) menu is activated, the arrow keys are used as directional arrows to select the desired menu items and to make adjustments. See "[Using the menus](#)" on page 29 for details.

- **OK**

Selects an available picture setup mode. Activates the selected On-Screen Display (OSD) menu item.

- **INFO.**

Press to display INFORMATION menu.

- **BACK**

Goes back to previous OSD menu.

Close OSD menu when it's in the top level.

- **MENU**

Turns on /off the On-Screen Display (OSD) menu.

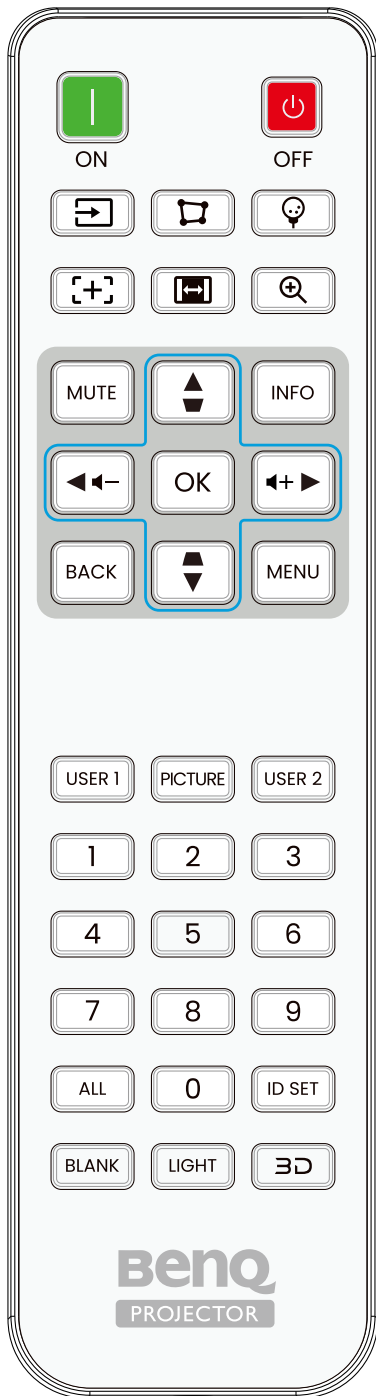

- **USER1**

Apply Picture Mode "User1" Immediately.

- **PCITURE**

Press to display **Picture** menu.

- **USER2**

Apply Picture Mode "User2" Immediately.

- **ID SET**

- Remote control ID SET (set the particular remote code)

Press to set remote ID.

Press **ID SET** for three seconds. The **POWER** indicator on the remote control blinks, then press 01~99 to designate an ID.



**Note:**

The remote control number (Remote control ID) must match the Projector ID Setting number for accurate control.

- Clear Remote ID SET (set remote code to all)

Press **CLEAR** and **ID SET** for five seconds. The **POWER** indicator on the remote control blinks a single instance to reset remote code to all, can control projector no matter projector id setting.

- **Numeric buttons**

Enters numbers in network settings.

Numeric buttons 1, 2, 3, 4 cannot be pressed when asked to enter password.

- **BLANK**

Used to hide the screen picture.

- **LIGHT**

Press to open backlight of remote controller.

- **3D MODE**

Press to display 3D setup menu.



## Remote control effective range

Infra-Red (IR) remote control sensor is located on the front and top of the projector. The remote control must be held at an angle within 30 degrees perpendicular to the projector's IR remote control sensor to function correctly. The distance between the remote control and the sensor should not exceed 8 meters (~ 26 feet).

Make sure that there are no obstacles between the remote control and the IR sensor on the projector that might obstruct the infra-red beam.

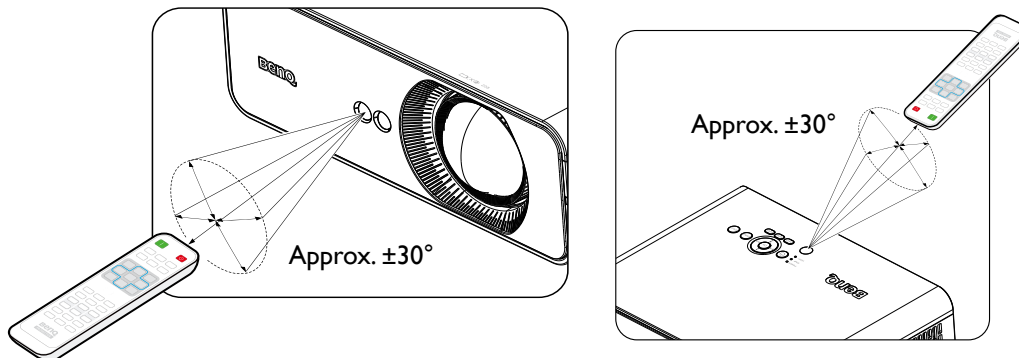

## Replacing the remote control battery

1. To open the battery cover, turn the remote control over to view its back, push on the finger grip on the cover and slide it up in the direction of the arrow as illustrated. The cover will slide off.
2. Remove any existing batteries (if necessary) and install two AA batteries observing the battery polarities as indicated in the base of the battery compartment. Positive (+) goes to positive and negative (-) goes to negative.
3. Refit the cover by aligning it with the base and sliding it back down into position. Stop when it clicks into place.

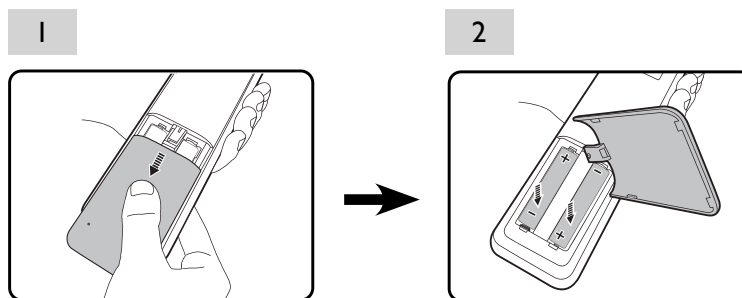

### ! Caution:

- Avoid excessive heat and humidity.
- There may be battery damage if the battery is incorrectly replaced.
- Replace only with the same or equivalent type recommended by the battery manufacturer.
- Dispose of the used battery according to the battery manufacturer's instructions.
- Never throw a battery into a fire. There may be danger of an explosion.
- If the battery is dead or if you will not be using the remote control for a long time, remove the battery to prevent damage to the remote control from possible battery leakage.

# Installation

## Evaluate for distance by image size

### Obtaining a preferred projected image size

The distance from the projector lens to the screen, the zoom setting (if available), and the video format each factors in the projected image size.

### Projection dimensions

Refer to "[Dimensions](#)" on [page 54](#) for the center of lens dimensions of this projector before calculating the appropriate position.

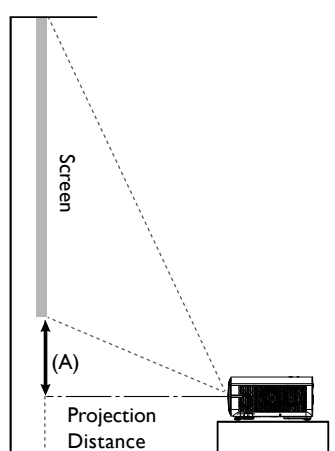

The screen aspect ratio is 16:10 and the projected picture is 16:10.

#### Note:

To optimize the projection quality, we suggest to project images in an area without grayscale.

Image size						OFFSET	Fix	Distance	
Diagonal		Width		Height		Projector Top to Screen Bottom (A)		Center of Cover Glass to Screen (B)	
Inch	mm	Inch	mm	Inch	mm	Inch	mm	Inch	mm
90	2286	78	1992	44	1121	5.29	134.5	39.14	994.2
100	2540	87	2214	49	1245	5.88	149.4	43.49	1104.7
110	2794	96	2435	54	1370	6.47	164.4	47.84	1215.2
120	3048	105	2657	59	1494	7.06	179.3	52.19	1325.6
130	3302	113	2878	64	1619	7.65	194.3	56.54	1436.1
140	3556	122	3099	69	1743	8.24	209.2	60.89	1546.6
150	3810	131	3321	74	1868	8.82	224.1	65.24	1657.0
160	4064	139	3542	78	1992	9.41	239.1	69.59	1767.5
170	4318	148	3763	83	2117	10.00	254.0	73.94	1878.0
180	4572	157	3985	88	2241	10.59	269.0	78.28	1988.4
190	4826	166	4206	93	2366	11.18	283.9	82.63	2098.9
200	5080	174	4428	98	2491	11.77	298.9	86.98	2209.4
210	5334	183	4649	103	2615	12.35	313.8	91.33	2319.8
220	5588	192	4870	108	2740	12.94	328.7	95.68	2430.3

## Note:

- There is 5% tolerance among these numbers due to optical component variations. BenQ recommends that if you intend to permanently install the projector, you should physically test the projection size and distance using the actual projector before you permanently install it, so as to make allowance for this projector's optical characteristics. This will help you determine the exact mounting position so that it best suits your installation location.
- To optimize the projection quality, we suggest to project images in an area without grayscale.

## Mounting the projector

If you intend to mount your projector, we strongly recommend that you use a proper fitting BenQ projector mounting kit and that you ensure it is securely and safely installed.

If you use a non-BenQ brand projector mounting kit, there is a safety risk that the projector may fall down due to an improper attachment through the use of the wrong gauge or length screws.

## Before mounting the projector

- Purchase a BenQ projector mounting kit from the place you purchased your BenQ projector.
- BenQ recommends that you also purchase a separate Kensington lock compatible security cable and attach it securely to both the Kensington lock slot on the projector and the base of the mounting bracket. This will perform the secondary role of restraining the projector should its attachment to the mounting bracket become loose.
- Ask your dealer to install the projector for you. Installing the projector on your own may cause it to fall and result in injury.
- Take necessary procedures to prevent the projector from falling off such as during an earthquake.
- The warranty doesn't cover any product damage caused by mounting the projector with a non-BenQ brand projector mounting kit.
- Consider the surrounding temperature where the projector is ceiling/wall mounted. If a heater is used, the temperature around the ceiling may be higher than expected.
- Read the user manual for the mounting kit about the range of torque. Tightening with torque exceeding the recommended range may cause damage to the projector and subsequently falling off.
- Make sure the power outlet is at an accessible height so that you can easily shut down the projector.

## Ceiling/Wall mount installation diagram

Ceiling/Wall mount screw:

M4, L = 8 mm

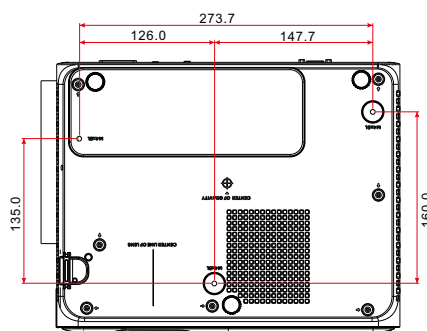

## Installing the side filter

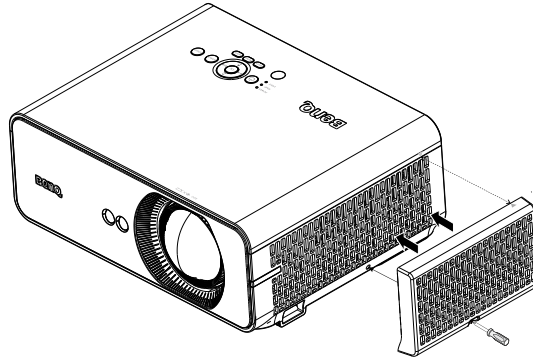

Filter is an optional accessory. After you installing the filter, do the following procedures to start filter timing:

After the startup logo, open the On-Screen Display (OSD) menu. Go to the **SYSTEM:**

**Operation Settings > Filter Settings** menu. Press **ENTER**. The Filter Settings page displays.

Highlight **Filter Timer**. Press ◀▶ to select **On** and press **ENTER**.

See "[Replacing the side filter](#)" on page 50 for details

## Connection

### Before connecting

- Before connecting, carefully read the operating instructions for connecting the external device
- Turn off the power to all devices before connecting cables.
- Take note of the following before connecting cables. Failure to do so may result in malfunctions.
  - Before connecting a cable to the projector or to a device that is connected to the projector, touch any nearby metallic objects to remove any static electricity from your body.
  - Do not use unnecessarily long cables to connect the projector or a device to the projector. Using a longer cable that is wound makes it act like an antenna, making it more susceptible to noise.
  - When connecting cables, connect GND first and then insert the connecting terminal of the connecting device.
- Acquire any connection cables necessary to connect external devices to the system that are not supplied.
- The images on the screen may wobble if the video signal contains too much jitter. In this case, a time base corrector (TBC) must be connected.
- If synchronization signal outputs from computers or video equipment are disrupted due to changes in the video output settings or any other reasons, the colors of projected images may be temporarily disrupted.
- Some computer models are not compatible with the projector.
- Use a cable compensator when you connect devices to the projector with long cables. If a cable compensator is not used, the image may not display properly.

### HDMI

No.	Serial
1	TMDS Data2+
2	TMDS Data2 Shield
3	TMDS Data2-
4	TMDS Data1+
5	TMDS Data1 Shield
6	TMDS Data1-
7	TMDS Data0+
8	TMDS Data0 Shield
9	TMDS Data0-
10	TMDS Clock+

No.	Serial
11	TMDS Clock Shield
12	TMDS Clock-
13	CEC
14	Reserved (N.C. on device)
15	SCL
16	SDA
17	DDC/CEC Ground
18	+5 V Power (max 50 mA)
19	Hot Plug Detect

Even-numbered pins of 2 to 18

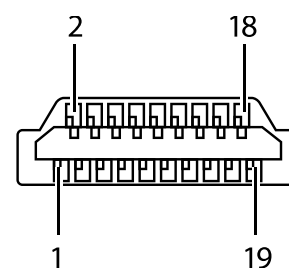

Odd-numbered pins of 1 to 19

## Connecting with AV equipment

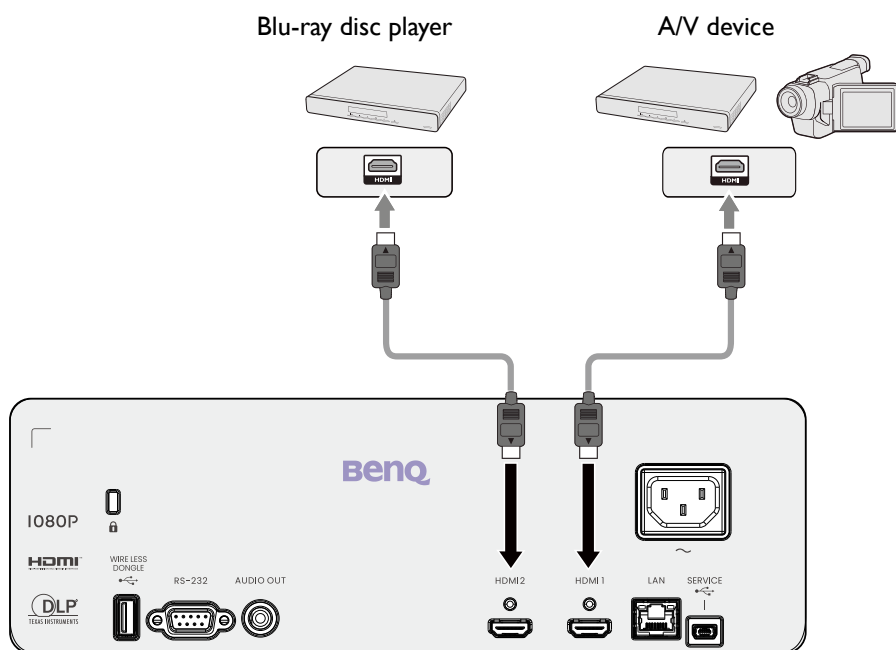

## Connecting with computer

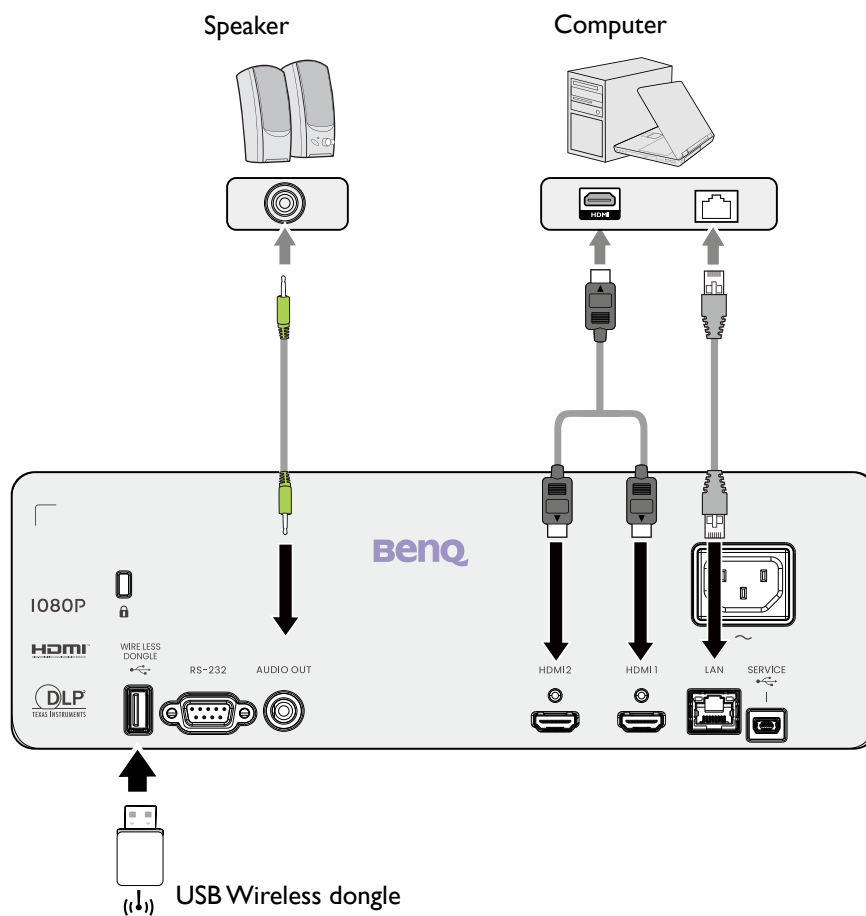

## Connecting with LAN

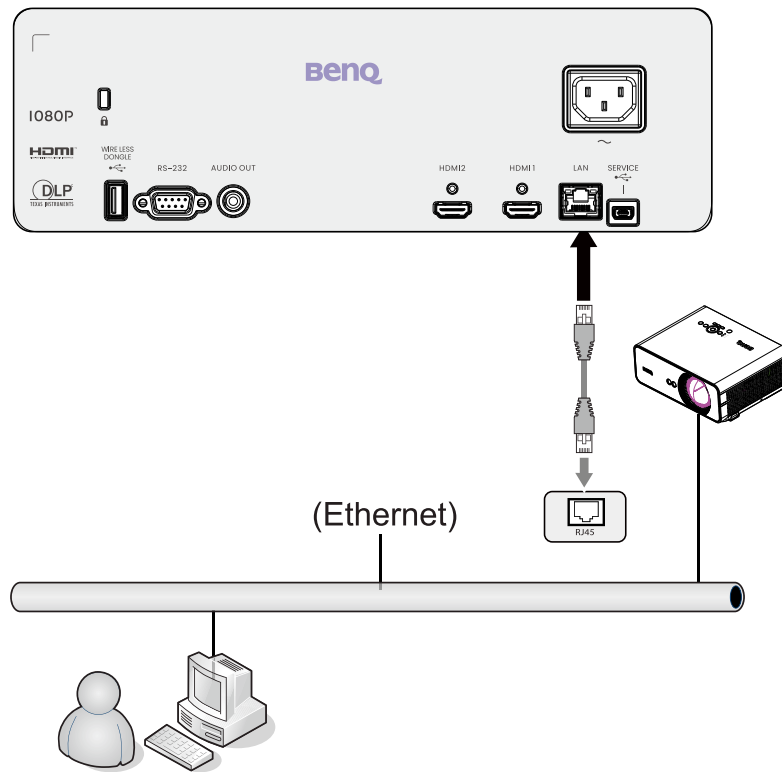

## Connecting audio

The projector has built-in mono speaker(s) which are designed to provide basic audio functionality accompanying data presentations for business purposes only. They are not designed for, nor intended for stereo audio reproduction use as might be expected in home theater or home cinema applications. Any stereo audio input (if provided), is mixed into a common mono audio output through the projector speaker(s).

The built-in speaker(s) will be muted when the AUDIO OUT jack is connected.

### Note:

- The projector is only capable of playing mixed mono audio, even if a stereo audio input is connected.
- If the selected video image is not displayed after the projector is turned on and the correct video source has been selected, check that the video source device is turned on and operating correctly. Also check that the signal cables have been connected correctly.

## Connecting the Wireless Dongle

The projector is equipped with a WIRELESS DONGLE port for the Wireless Dongle (EZC-5201BS) which supports wireless projection between the projector and the following systems: iOS, macOS, Android, Windows.

After inserting the wireless dongle into the WIRELESS DONGLE port, select Wireless Display from the source selection bar. You can follow the on-screen instructions to enable wireless projection.

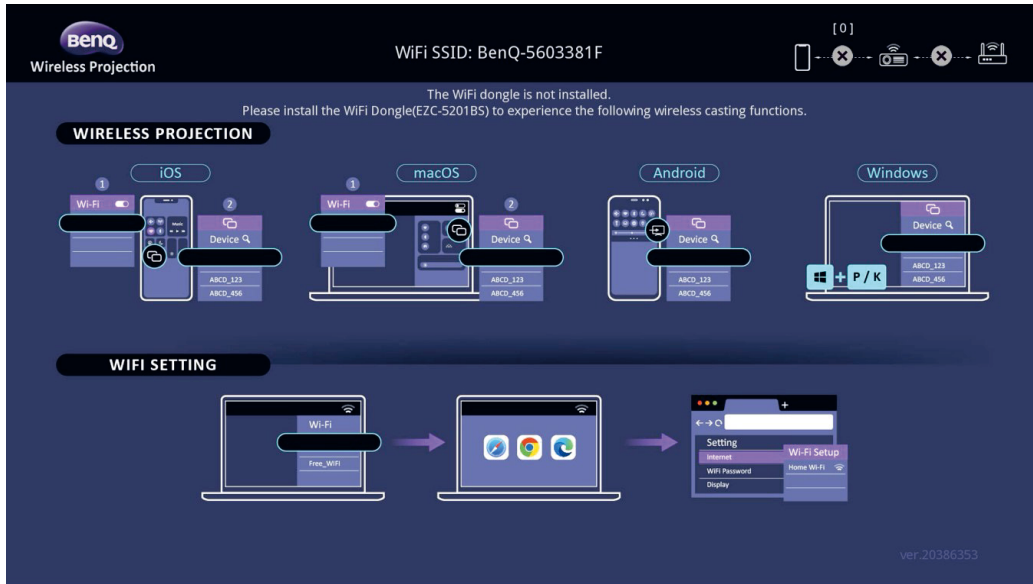

## Performing wireless projection

For different devices, follow the steps below.

- For iOS/macOS devices

1. Select the WiFi network that the projector joined in the WiFi settings on your device.
2. After opening control center, press screen mirroring and choose the projector (BenQ\_XXXXXXXX) to start projection.

- For Android devices

After opening the Quick settings panel, press the Screen Mirroring icon and choose the projector (BenQ\_XXXXXXXX).

- For Windows OS devices

Press the Windows + P / K and choose the projector (BenQ\_XXXXXXXX).

Connecting the projector to the Internet

1. Select the WiFi SSID (BenQ\_XXXXXXXX) of the projector in the WiFi settings on your device.
2. Enter the password from the projected image.
3. Open your web browser and go to the address of the projector (192.168.203.1).
4. Select a WiFi network that you want to join.
5. Enter the password if asked.



# Operations

## Starting up the projector

1. Plug the power cord into the projector and into a wall socket. Turn on the wall socket switch (where fitted). Check that the **POWER indicator light** on the projector lights orange after power has been applied.
2. Press **POWER** button on the projector or  on the remote control to start the projector. The **POWER indicator** flashes green and stays green when the projector is on.
3. The start up procedure takes about 30 seconds. In the later stage of start up, a startup logo is projected.
4. (If necessary) Press Focus to adjust the image clearness.
5. If the projector is activated for the first time, select your OSD language following the on-screen instructions.
6. If you are prompted for a password, press the arrow keys to enter a 6-digit password. See ["Utilizing the password function" on page 30.](#)
7. Switch all of the connected equipment on.
8. The projector will search for input signals. The current input signal being scanned appears. If the projector does not detect a valid signal, the message **"No Signal"** will continue displaying until an input signal is found.
9. You can also press **SOURCE** to select your desired input signal. See ["Switching input signal" on page 32.](#)

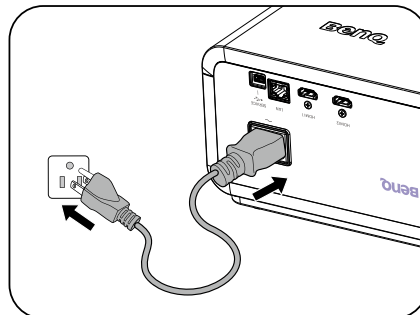

### ! Caution:

Please use the original accessories (e.g. power cord) to avoid possible dangers such as electric shock and fire.

### 📝 Note:

- The Setup Wizard screenshots are for reference only and may differ from the actual design.
- If the frequency/resolution of the input signal exceeds the projector's operating range, you will see the message "Out of Range" displayed on the background screen. Please change to an input signal which is compatible with the projector's resolution or set the input signal to a lower setting. See ["Timing table" on page 55.](#)
- If no signal is detected for 3 minutes, the projector automatically enters saving mode.

## Adjusting the projected image

### Adjusting the projection angle

The projector is equipped with 2 adjuster feet. These adjusters change the image height and projection angle. To adjust the projector:

Screw adjuster foot to fine tune the horizontal angle.

To retract the foot, hold up the projector then slowly lower the projector. Screw the adjuster foot in a reverse direction.

If the projector is not placed on a flat surface or the screen and the projector are not perpendicular to each other, the projected image becomes trapezoidal. To correct this situation, see "[Correcting 2D Keystone](#)" on page 27 for details.

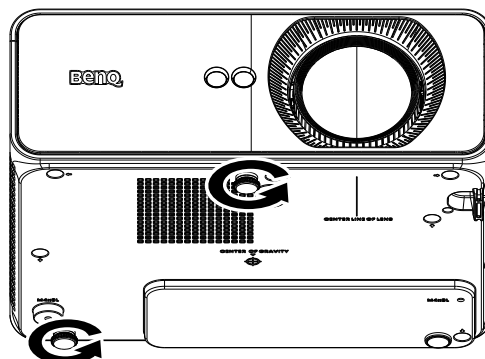

### ! Caution:

- Do not look into the lens while the projector is on. The strong light from the light may cause damage to your eyes.
- Be careful when you press the adjuster button as it is close to the exhaust vent where hot air comes from.

## Fine-tuning the image size and clarity

### Adjusting the Focus

Adjust the focus of the image in one of the following situations:

- During initial setup.
- After moving the projector.
- After adjusting zoom.
- When image is fuzzy and you wish to obtain a clearer image.

To adjust the focus:

1. Press FOCUS on the remote control or projector.
2. Press and hold ◀▶ to adjust the focus.

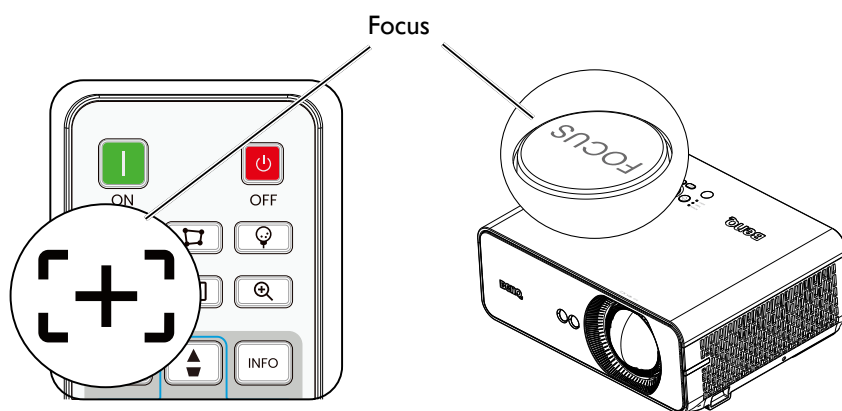

## Correcting 2D Keystone

2D Keystone function enables a wider projector installation area compared to conventional projectors with limited positioning in front of the screen.

To correct this, you will need to manually correct it following one of these steps.

- Using the projector or remote control

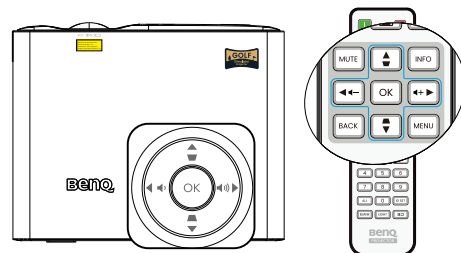

Press / on the projector or remote control to display the 2D Keystone page. Press / to adjust vertical values from -30 to 30. Press / to adjust horizontal values from -30 to 30.

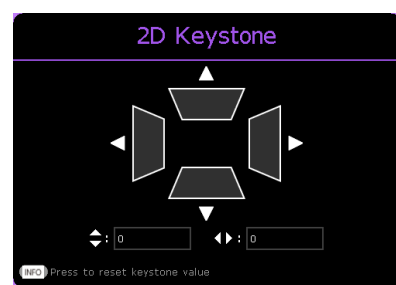

- Using the OSD menu

1. Press **MENU** and then press / until the **Installation** menu is highlighted and press .
2. Press / to highlight **Geometry** and press **OK**. The Geometry Submenu display.
3. Press / to highlight **2D Keystone** and press **OK**. The **2D Keystone** page displays.
4. Press /// to adjust the keystone values.

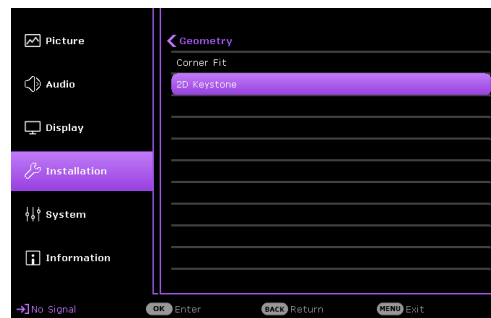

## Correcting Corner Fit

Manually adjust four corners of the image by setting the horizontal and vertical values.

Using the OSD menu

1. Press **MENU** and then press ▲/▼ until the **Installation** menu is highlighted and press ►.
2. Press ▲/▼ to highlight **Geometry** and press **OK**. The Geometry Submenu display.
3. Press ▲/▼ to highlight **Corner Fit** and press **OK**. The **Corner Fit** page displays.

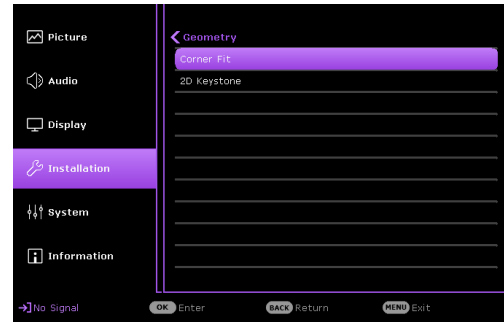

4. Press ▲/▼/◀/▶ to select one of the four corners and press **OK**.

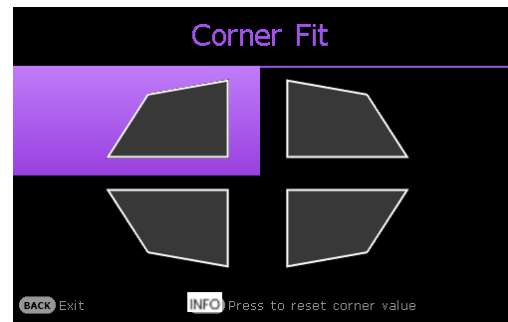

5. Press ◀/▶ to adjust vertical values from 0 to 360.
6. Press ▲/▼ to adjust horizontal values from 0 to 640.

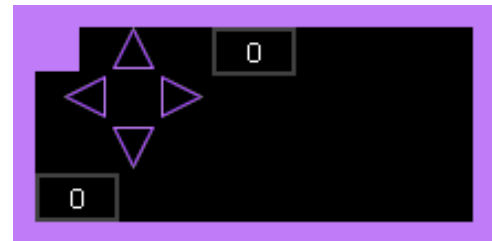

## Corner Fit and 2D Keystone Adjustment Notice

The corner fit function is closely related to the 2D keystone function as both make adjustments to correct picture distortion. Therefore, when correcting picture distortion, both corner fit and 2D keystone functions should be used in conjunction to achieve the best picture shape.

To achieve the best picture shape:

- When installing the projector, align the projector to the screen so they are as perpendicular to each other as possible in order to minimize picture distortion.
- When making corner fit adjustments, if the desired effect cannot be achieved, adjust the 2D keystone value and try again.
- When making 2D keystone adjustments, if the desired effect cannot be achieved, adjust the corner fit value and try again.

## Using the menus

The projector is equipped with 2 types of On-Screen Display (OSD) menus for making various adjustments and settings.

- **Basic** OSD menu: provides primary menu functions. (See "[Basic menu](#)" on page 37)
- **Advanced** OSD menu: provides full menu functions. (See "[Advanced menu](#)" on page 39)

To access the OSD menu, press **MENU** on the projector or remote control.

- Use the arrow keys (**▲/▼/◀/▶**) on the projector or remote control to move through the menu items.
- Use **OK** on the projector or remote control to confirm the selected menu item.

The first time you use the projector (after finishing the initial setup), Basic OSD menu displays.

### Note:

The OSD screenshots below are for reference only, and may differ from the actual design.

Below is the overview of the **Basic** OSD menu.

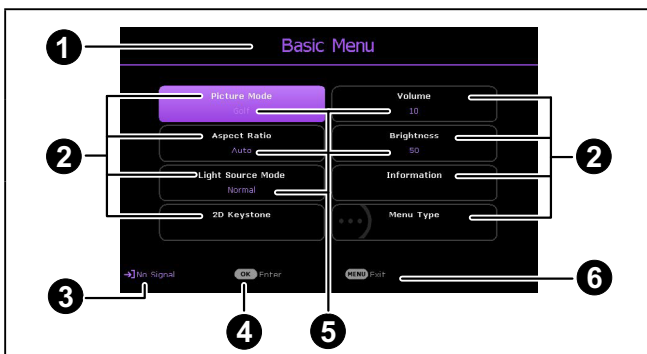
	1	Menu Type	4	Press OK to enter the menu.
	2	Main menu	5	Status
	3	Current input signal	6	Press MENU to go to the previous page or to exit.

If you intend to switch from the **Basic** OSD menu to the **Advanced** OSD menu, follow the instructions below:

1. Go to **Basic Menu > Menu Type**.
2. Press **OK** and press **▲/▼** to select **Advanced**. Next time when you turn on the projector, you may access the **Advanced** OSD menu by pressing **MENU**.

Below is the overview of the **Advanced** OSD menu.

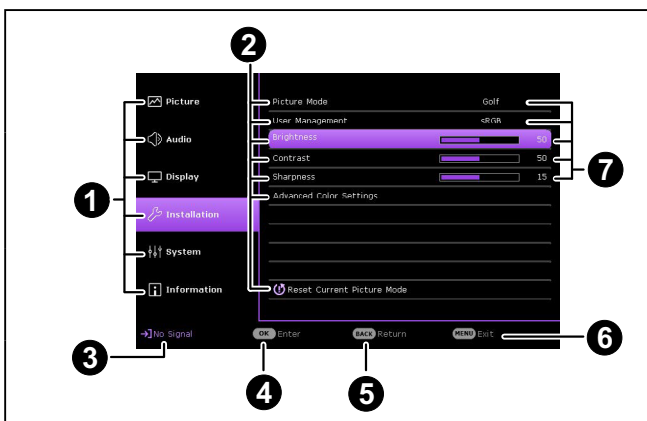
	1	Main menu & Main menu icon	5	Press <b>BACK</b> to go to the previous page.
	2	Sub-menu	6	Press <b>MENU</b> to go to the previous page or to exit.
	3	Current input signal	7	Status
	4	Press OK to enter the menu.		

Likewise, when you wish to switch from the **Advanced** OSD menu to the **Basic** OSD menu, follow the instructions below:

1. Go to **Advanced Menu - System > Menu Settings** and press **OK**.
2. Select **Menu Type** and **OK**.
3. Press **▲/▼** to select **Basic**. Next time when you turn on the projector, you may access the **Basic** OSD menu by pressing **MENU**.

## Securing the projector

### Using a security cable lock

The projector has to be installed in a safe place to prevent theft. Otherwise, purchase a lock, such as a Kensington lock, to secure the projector. You can locate a Kensington lock slot on the left side of the projector. See "[Kensington anti-theft lock slot](#)" on [page 12](#) for details.

A Kensington security cable lock is usually a combination of key(s) and a lock. Refer to the lock's documentation for finding out how to use it.

### Utilizing the password function

#### Setting a password

1. Go to **Advanced Menu - System > Security Settings > Password**. Press **OK**. The **Password** page appears.
2. Highlight **Change Password** and press **OK**.
3. The four arrow keys (▲/▶/▼/◀) respectively represent 4 digits (1, 2, 3, 4). According to the password you desire to set, press the arrow keys to enter six digits for the password.
4. Confirm the new password by re-entering the new password.  
Once the password is set, the OSD menu returns to the **Security Settings** page.
5. To activate the **Power On Lock** function, press ▲/▼ to highlight **Power On Lock** and press **OK**. Press ◀/▶ to select **On**. Input the password again.

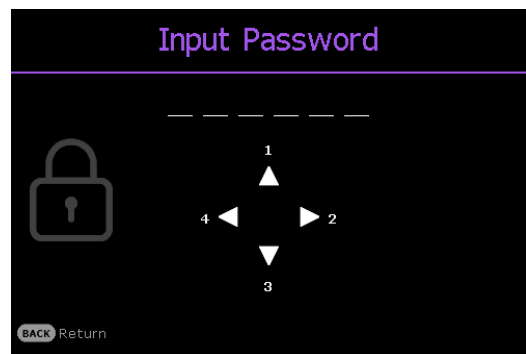

#### ! Caution:

- The digits being input will display as asterisks on-screen. Make a note of your selected password and keep it in a safe place in advance or right after the password is entered so that it is available to you should you ever forget it.
- Once a password has been set and the power on lock is activated, the projector cannot be used unless the correct password is entered every time the projector is started.

#### If you forget the password

If you enter the wrong password, the password error message will appear, and the **Input Current Password** message follows. If you absolutely do not remember the password, you can use the password recall procedure. See "[Entering the password recall procedure](#)" on [page 31](#).

If you enter an incorrect password 5 times in succession, the projector will automatically shut down in a short time.

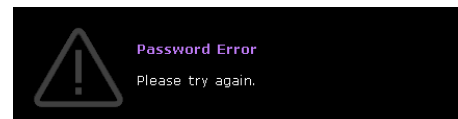

## Entering the password recall procedure

1. Press and hold **OK** for 3 seconds. The projector will display a coded number on the screen.
2. Write down the number and turn off your projector.
3. Seek help from the local BenQ service center to decode the number. You may be required to provide proof of purchase documentation to verify that you are an authorized user of the projector.

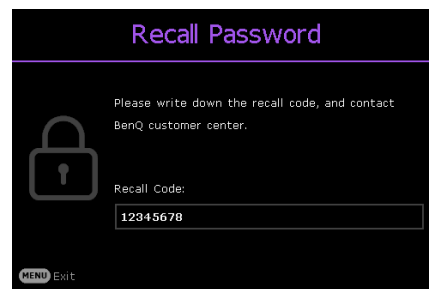

## Changing the password

1. Go to **Advanced Menu - System > Security Settings > Password > Change Password**.
2. Press **OK**. The message “**Input Current Password**” appears.
3. Enter the old password.
  - If the password is correct, another message “**Input New Password**” appears.
  - If the password is incorrect, the password error message will appear, and the message “**Input Current Password**” appears for your retry. You can press **BACK** to cancel the change or try another password.
4. Enter a new password.
5. Confirm the new password by re-entering the new password.

## Disabling the password function

To disable password protection, go to **Advanced Menu - System > Security Settings > Password > Power On Lock** and press **OK**. Press ◀▶ to select **Off**. The message “**Input Current Password**” appears. Enter the current password.

1. If the password is correct, the OSD menu returns to the **Security Settings** page. You will not have to enter the password next time turning on the projector.
2. If the password is incorrect, the password error message will appear, and the message “**Input Current Password**” appears for your retry. You can press **BACK** to cancel the change or try another password.

### **Note:**

Though the password function is disabled, you need to keep the old password in hand should you ever need to re-activate the password function by entering the old password.

## Switching input signal

The projector can be connected to multiple devices at the same time. However, it can only display one full screen at a time. When starting up, the projector automatically searches for the available signals.

Be sure the **Advanced Menu - Display > Auto Source Search** menu is **On** if you want the projector to automatically search for the signals.

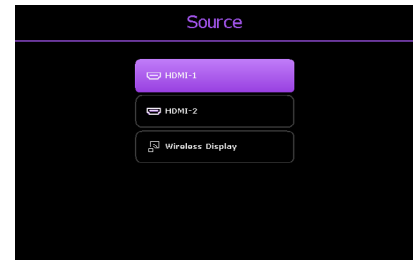

To select the source:



1. Press **SOURCE**. A source selection bar appears.
2. Press **▲/▼** until your desired signal is selected and press **OK**.

Once detected, the selected source information will appear at the corner of the screen for seconds. If there is multiple equipment connected to the projector, repeat steps 1-2 to search for another signal.

### Note:

- The brightness level of the projected image will change accordingly when you switch between different input signals.
- For best display picture results, you should select and use an input signal which outputs at the projector's native resolution. Any other resolutions will be scaled by the projector depending upon the "aspect ratio" setting, which may cause some image distortion or loss of picture clarity. See "Screen Fill" on page 38 for details.

## Shutting down the projector

1. Press **POWER** on the projector or  on the remote control and a confirmation message will appear prompting you. If you don't respond in a few seconds, the message will disappear.
2. Press **POWER** or  a second time. The power indicator flashes orange, the projector shuts down, and the fans will continue to run for approximately 3 seconds to quick cool down the projector.
3. Once the cooling process finishes, the power indicator becomes a steady orange and fans stop. Disconnect the power cord from the power outlet.

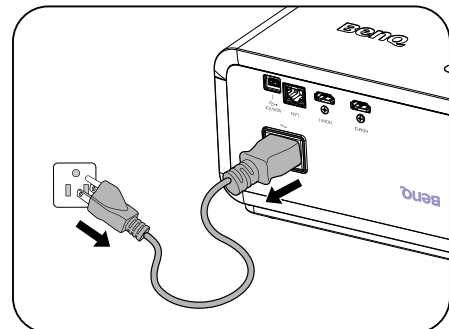



# Menu operation

Please note that the on-screen display (OSD) menus vary according to the signal type selected and the projector model you are using.

The menu items are available when the projector detects at least one valid signal. If there is no equipment connected to the projector or no signal detected, limited menu items are accessible.

## Menu System

### Basic menu

Main menu	Options
Picture Mode	Bright/Simulation/Cinema/Game/sRGB
Screen Fill	16:9/16:10/4:3/1:1
Light Source Mode	Normal/ECO/ SmartEco/Custom
2D Keystone	H: -30~0~30 V: -30~0~30
Volume	0~10~20
Brightness	0~50~100
Information	Native Resolution
	Detected Resolution
	Source
	Picture Mode
	Light Source Mode
	3D Format
	Color System
	Light Source Usage Time
	Projector ID
	Firmware Version
Service Code	
Menu Type	Basic/Advanced

## Advanced menu

Main menu	Submenu	Options		
Picture	Picture Mode	Bright/Simulation/Cinema/Game/sRGB		
	User Management	sRGB/Bright/Simulation/Cinema/Game		
	Brightness	0~50~100		
	Contrast	0~50~100		
	Sharpness	0~15~31		
		Gamma Selection	1.8/2.0/2.1/2.2/2.3/2.4/2.5/2.6/BenQ	
		Color Temperature (Normal/Cool/Warm)		
		R Gain (0~200)		
		Color Temperature Tuning	G Gain (0~200)	
			B Gain (0~200)	
			R Offset (0~511)	
			G Offset (0~511)	
			B Offset (0~511)	
		Advanced Color Settings	R (Hue/Saturation/Gain)	
			G (Hue/Saturation/Gain)	
			B (Hue/Saturation/Gain)	
			Color Management	C (Hue/Saturation/Gain)
				M (Hue/Saturation/Gain)
				Y (Hue/Saturation/Gain)
				W (R Gain/B Gain/G Gain)
		Reset (Reset/Cancel)		
	Brilliant Color	Off/On		
	Light Source Mode	Normal/ECO/SmartEco/Custom		
	Custom Brightness	40%-100%		
	HDR Brightness	-2/-1/0/1/2		
	Noise Reduction	0~31		
	Reset Current Picture Mode	Reset/Cancel		
Audio	Audio Output	Internal Speaker/3.5mm Jack		
	Mute	Off/On		
	Volume	0~10~20		
	Power On/Off Ring Tone	Off/On		
	Reset Audio	Reset/Cancel		



Main menu	Submenu	Options	
	Screen Fill	16:9/16:10/4:3/1:1	
	Auto Source Search	On/Off	
Display	3D	3D Mode	Auto/Top Bottom/Frame Sequential/ Frame Packing/Side-By-Side/Off
		3D Sync Invert	Disable/Invert
		Save 3D Settings	3D Settings 1/3D Settings 2/ 3D Settings 3
		Apply 3D Settings	3D Settings 1/3D Settings 2/ 3D Settings 3/Off
	HDMI Settings	HDMI Format	Auto/Limited/Full
		HDMI Equalizer	HDMI-1/HDMI-2
		HDMI EDID	HDMI-1/HDMI-2
	Reset Display	Reset/Cancel	
	Projector Position	Front/Front Ceiling/Rear/Rear Ceiling	
	Focus	Focus	OK
Manual Focus			
Test Pattern	Off/On		
Geometry	Corner Fit	Top Left (H: 0~640/V: 0~360)	
		Top Right (H: 0~640/V: 0~360)	
		Bottom Left (H: 0~640/V: 0~360)	
Bottom Right (H: 0~640/V: 0~360)			
2D Keystone	H: -30~0~30 V: -30~0~30		
Installation	Digital Zoom	PC: 1.0X~1.2X Video: 1.0X~1.2X	
	Digital Shrink & Shift	0.75x~1.00x	
	Image Resizing	Modes of adjustment (One Side/ Opposite Sides/All 4 sides)	
		Blanking	Top (0~220)
	Bottom (0~220)		
Left (0~125) Right (0~125)			
Reset all Blanking settings (Reset/Cancel)			
Wall Color	Off/Light Yellow/Pink/Light Green/Blue/ Blackboard		
High Altitude Mode	Off/On		
Baud Rate	9600/14400/19200/38400/57600/115200		
Projector ID	Off /01/02/...../99		

Main menu	Submenu	Options
	Language	English/Français/Deutsch/Italiano/Español/ Русский/繁體中文/简体中文/日本語/한국어/ Svenska / Nederlands/Türkçe/Čeština/ Português/ไทย/Polski/Magyar/Hrvatski/ Română/Norsk/Dansk/Български/ Suomi/Bhs Ind/Ελληνικά/العربية/हिंदी/ Tiếng Việt / فارسی
	Background Settings	Background Color <b>Black/Blue/Purple</b> Splash Screen <b>BenQ/Black/Blue</b>
	Menu Settings	Menu Type <b>Basic/Advanced</b> Menu Display Time <b>5 sec/10 sec/20 sec/30 sec/Always</b> Menu Position <b>Center/Top-Left/Top-Right/Bottom-Right/Bottom-Left</b> Reminder Message <b>Off/On</b>
	Light Source Information	Light Source Usage Time Normal Mode ECO Mode SmartECO Mode Custom Mode
	Standby Settings	Standby Mode <b>ECO/Network/Normal</b> Audio Pass Through <b>Off/HDMI-1/HDMI-2</b>
System	Operation Settings	LED Indicator <b>Off/On</b> Power On/Off Settings Direct Power On Signal Power On Auto Power Off Filter Setting Filter Timer Reset Filter Timer Filter Usage Time
	Security Settings	Panel Key Lock <b>Off/On</b> Password Change Password Power On Lock
	Network Settings	Wired LAN Status DHCP IP Address Subnet Mask Default Gateway DNS Server Apply AMX Device Discovery <b>Off/On</b> MAC Address (Wired)
	Factory Default Reset System	Reset/ <b>Cancel</b> Reset/ <b>Cancel</b>

Main menu	Submenu	Options
Information	Native Resolution	
	Detected Resolution	
	Source	
	Picture Mode	
	Light Source Mode	
	3D Format	
	Color System	
	Light Source Usage Time	
	Projector ID	
	Firmware Version	
	Service Code	

## Basic menu

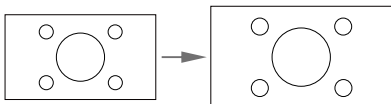
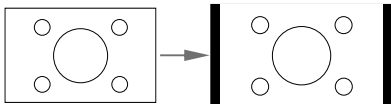
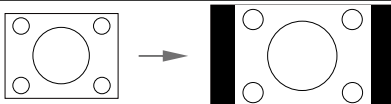
<b>Picture Mode</b>	<p>The projector is preset with several predefined picture modes so that you can choose one to suit your operating environment and input signal picture type.</p> <ul style="list-style-type: none"> <li>• <b>Bright:</b> Maximizes the brightness of the projected image. This mode is suitable for environments where extra-high brightness is required, such as using the projector in well lit rooms.</li> <li>• <b>Simulation:</b> Is designed for use in training environments, providing precise and realistic image reproduction. This mode accurately represents colors, ensuring the best possible blending and seamless visual experience for immersive simulation.</li> <li>• <b>Cinema:</b> Is appropriate for playing video clips under ambient light.</li> <li>• <b>Game:</b> Is designed for playing games, enhances the details of images and vivid color performance and details.</li> <li>• <b>sRGB:</b> Maximizes the purity of RGB colors to provide true-to-life images regardless of brightness setting. It is most suitable for viewing photos taken with an sRGB compatible and properly calibrated camera, and for viewing PC graphic and drawing applications such as AutoCAD.</li> <li>• <b>User 1/User 2:</b> Recalls the settings customized based on the current available picture modes. See "<a href="#">User Management</a>" on page 39.</li> </ul>
---------------------	---

	<p>There are several options to set the image's aspect ratio depending on your input signal source.</p> <ul style="list-style-type: none"> <li>• <b>16:9:</b> Scales an image so that it is displayed in the center of the screen with a 16:9 aspect ratio</li> </ul>	 <p><b>16:9 Picture</b></p>
<b>Screen Fill</b>	<ul style="list-style-type: none"> <li>• <b>16:10:</b> Scales an image so that it is displayed in the center of the screen with a 16:10 aspect ratio</li> </ul>	 <p><b>16:10 picture</b></p>
	<ul style="list-style-type: none"> <li>• <b>4:3:</b> Scales an image so that it is displayed in the center of the screen with a 4:3 aspect ratio</li> </ul>	 <p><b>4:3 picture</b></p>
	<ul style="list-style-type: none"> <li>• <b>1:1:</b> Scales an image so that it is displayed in the center of the screen with a 1:1 aspect ratio.</li> </ul>	 <p><b>1:1 picture</b></p>
<b>Light Source Mode</b>	<ul style="list-style-type: none"> <li>• <b>Normal:</b> Provides full light source brightness.</li> <li>• <b>ECO:</b> Lowers brightness to extend the light source life and decreases the fan noise.</li> <li>• <b>SmartEco:</b> Adjusts the light source power automatically depending on the content brightness level while optimizing display quality.</li> <li>• <b>Custom:</b> Enables the light source brightness adjustment bar so that you can adjust the setting to your liking.</li> </ul>	
<b>2D Keystone</b>	Adjusts the shape of the projected image to ensure straight lines on all four corners. See " <a href="#">Correcting 2D Keystone</a> " on page 27 for details.	
<b>Volume</b>	Adjusts the sound level.	
<b>Brightness</b>	The higher the value, the brighter the image. Adjust this control so the black areas of the image appear just as black and that detail in the dark areas is visible.	
<b>Information</b>	<ul style="list-style-type: none"> <li>• <b>Native Resolution:</b> Shows the native resolution of the projector.</li> <li>• <b>Detected Resolution:</b> Shows the native resolution of the input signal.</li> <li>• <b>Source:</b> Shows the current signal source.</li> <li>• <b>Picture Mode:</b> Shows the selected mode in the Picture menu.</li> <li>• <b>Light Source Mode:</b> Shows the selected mode in the Light Settings menu.</li> <li>• <b>3D Format:</b> Shows the current 3D mode.</li> <li>• <b>Color System:</b> Shows input system format.</li> <li>• <b>Light Source Usage Time:</b> Shows the number of hours the light source has been used.</li> <li>• <b>Projector ID:</b> Adjust a two digit projector ID from 0 through 99.</li> <li>• <b>Firmware Version:</b> Shows the firmware version of your projector.</li> <li>• <b>Service Code:</b> Shows the projector serial number.</li> </ul>	
<b>Menu Type</b>	Switches to the Advanced OSD menu. See " <a href="#">Using the menus</a> " on page 29.	

## Advanced menu

### Picture

<p><b>Picture Mode</b></p>	<p>The projector is preset with several predefined picture modes so that you can choose one to suit your operating environment and input signal picture type.</p> <ul style="list-style-type: none"> <li>• <b>Bright:</b> Maximizes the brightness of the projected image. This mode is suitable for environments where extra-high brightness is required, such as using the projector in well lit rooms.</li> <li>• <b>Simulation:</b> Is designed for use in training environments, providing precise and realistic image reproduction. This mode accurately represents colors, ensuring the best possible blending and seamless visual experience for immersive simulation.</li> <li>• <b>Cinema:</b> Is appropriate for playing video clips under ambient light.</li> <li>• <b>Game:</b> Is designed for playing games, enhances the details of images and vivid color performance and details.</li> <li>• <b>sRGB:</b> Maximizes the purity of RGB colors to provide true-to-life images regardless of brightness setting. It is most suitable for viewing photos taken with an sRGB compatible and properly calibrated camera, and for viewing PC graphic and drawing applications such as AutoCAD.</li> <li>• <b>User 1/User 2:</b> Recalls the settings customized based on the current available picture modes. See "<a href="#">User Management</a>" on page 39.</li> </ul>
<p><b>User Management</b></p>	<p>There are 2 user-definable modes if the current available picture modes are not suitable for your need. You can use one of the picture modes (except the User 1/User 2) as a starting point and customize the settings.</p> <ol style="list-style-type: none"> <li>1. Go to <b>Picture &gt; Picture Mode</b>.</li> <li>2. Press ◀▶ to select <b>User 1</b> or <b>User 2</b>.</li> <li>3. Press ▼ to highlight <b>User Management</b>, and press ◀▶ to select a picture mode that is closest to your need.</li> <li>4. Press ▼ to select a menu item to be changed and adjust the value. The adjustments define the selected user mode.</li> </ol>
<p><b>Brightness</b></p>	<p>The higher the value, the brighter the image. Adjust this control so the black areas of the image appear just as black and that detail in the dark areas is visible.</p>
<p><b>Contrast</b></p>	<p>The higher the value, the greater the contrast. Use this to set the peak white level after you have previously adjusted the Brightness setting to suit your selected input and viewing environment.</p>
<p><b>Sharpness</b></p>	<p>The higher the value, the sharper the picture becomes.</p>

## Advanced Color Settings

**Gamma Selection**

To select a preferred gamma setting, which are defined by gamma tables.

**Color Temperature Tuning**

You can also set a preferred color temperature by adjusting the following options.

- **Color Temperature**

There are several preset color temperature settings available. The available settings may vary according to the signal type selected.

- **Normal:** Maintains normal colorings for white.
- **Cool:** Makes images appear bluish white.
- **Warm:** Makes images appear reddish white.
- **R Gain/G Gain/B Gain:** Adjusts the contrast levels of Red, Green, and Blue.
- **R Offset/G Offset/B Offset:** Adjusts the brightness levels of Red, Green, and Blue

**Color Management**

This function provides seven sets (RGBCMYW) of colors to be adjusted. When you select each color, you can independently adjust its range and saturation according to your preference.

- **Primary Color:** Selects a color from among **R** (Red), **G** (Green), **B** (Blue), **C** (Cyan), **M** (Magenta), **Y** (Yellow), or **W** (White).

- **Hue:** Increase in the range will include colors consisted of more proportions of its two adjacent colors. Please refer to the illustration for how the colors relate to each other.

For example, if you select Red and set its range at 0, only pure red in the projected picture will be selected. Increasing its range will include red close to yellow and red close to magenta.

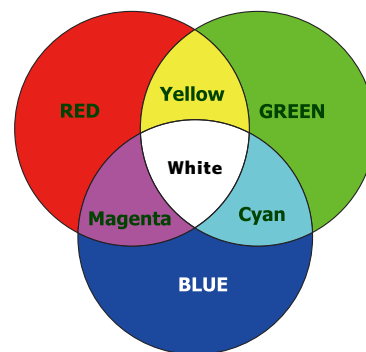

- **Saturation:** Adjusts the values to your preference. Every adjustment made will reflect to the image immediately. For example, if you select Red and set its value at 0, only the saturation of pure red will be affected.



**Saturation** is the amount of that color in a video picture. Lower settings produce less saturated colors; a setting of “0” removes that color from the image entirely. If the saturation is too high, that color will be overpowering and unrealistic.

- **Gain:** Adjusts the values to your preference. The contrast level of the primary color you select will be affected. Every adjustment made will reflect to the image immediately.





<b>Advanced Color Settings</b>	<p><b>Brilliant Color</b> This feature utilizes a new color-processing algorithm and system level enhancements to enable higher brightness while providing truer, more vibrant colors in picture. It enables a greater than 50% brightness increase in mid-tone images, which are common in video and natural scenes, so the projector reproduces images in realistic and true colors. If you prefer images with that quality, select <b>On</b>. When <b>Off</b> is selected, the <b>Color Temperature</b> function is not available.</p>
	<p><b>Light Source Mode</b></p> <ul style="list-style-type: none"> <li>• <b>Normal:</b> Provides full light source brightness.</li> <li>• <b>ECO:</b> Lowers brightness to extend the light source life and decreases the fan noise.</li> <li>• <b>SmartEco:</b> Adjusts the light source power automatically depending on the content brightness level while optimizing display quality.</li> <li>• <b>Custom:</b> Enables the light source brightness adjustment bar so that you can adjust the setting to your liking.</li> </ul>
	<p><b>Custom Brightness</b> Adjust the light power manually.</p>
	<p><b>HDR Brightness</b></p> <ul style="list-style-type: none"> <li>• To select a preferred HDR EOTF (HDR10 and HLG) setting via adjusting HDR EOTF curve, which are defined by HDR tables.</li> <li>• HDR10 and HLG will share the same description of settings but the values of EOTF will be divided in each mode.</li> </ul>
	<p><b>Noise Reduction</b> To reduce electrical image noise. The higher the setting, the less the image noise.</p>
<b>Reset Current Picture Mode</b>	Returns all of the adjustments you've made for the <b>Picture</b> menu to the factory preset values.

## Audio

<b>Audio Output</b>	To select audio outputs from internal or external speakers.
<b>Mute</b>	To enable or disable mute function.
<b>Volume</b>	Adjusts the sound level.
<b>Power On/Off Ring Tone</b>	To enable or disable power on/off ring tone
<b>Reset Audio</b>	To reset audio mode settings to default.

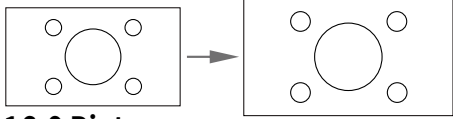
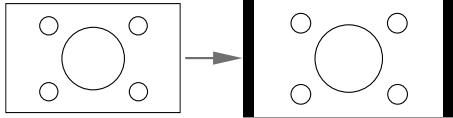
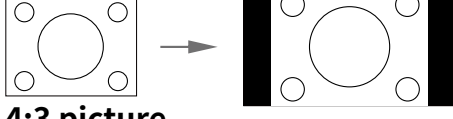

## Display

<p><b>Screen Fill</b></p>	<p>There are several options to set the image's aspect ratio depending on your input signal source.</p>	
	<ul style="list-style-type: none"> <li>• <b>16:9:</b> Scales an image so that it is displayed in the center of the screen with a 16:9 aspect ratio</li> </ul>	 <p><b>16:9 Picture</b></p>
	<ul style="list-style-type: none"> <li>• <b>16:10:</b> Scales an image so that it is displayed in the center of the screen with a 16:10 aspect ratio</li> </ul>	 <p><b>16:10 picture</b></p>
	<ul style="list-style-type: none"> <li>• <b>4:3:</b> Scales an image so that it is displayed in the center of the screen with a 4:3 aspect ratio</li> </ul>	 <p><b>4:3 picture</b></p>
<ul style="list-style-type: none"> <li>• <b>1:1:</b> Scales an image so that it is displayed in the center of the screen with a 1:1 aspect ratio.</li> </ul>	 <p><b>1:1 picture</b></p>	
<p><b>Auto Source Search</b></p>	<p>Allows the projector to automatically search for a signal..</p>	
<p><b>3D</b></p>	<p>This projector features a 3D function which enables you to enjoy the 3D movies, videos, and sporting events in a more realistic way by presenting the depth of the images. You need to wear a pair of 3D glasses to view the 3D images.</p> <ul style="list-style-type: none"> <li>• <b>3D Mode:</b> The default setting is <b>Off</b>. If you want the projector to automatically choose an appropriate 3D format when detecting 3D contents, select <b>Auto</b>. If the projector cannot recognize the 3D format, press <b>▲/▼</b> to choose a 3D mode from among <b>Top Bottom</b>, <b>Frame Sequential</b>, <b>Frame Packing</b> and <b>Side by Side</b>.</li> <li>• <b>When 3D function is activated:</b> <ul style="list-style-type: none"> <li>• The brightness level of the projected image will decrease.</li> <li>• The following settings cannot be adjusted: <b>Picture Mode</b>, <b>Reference Mode</b>.</li> <li>• The <b>Keystone</b> can only be adjusted within limited degrees.</li> </ul> </li> <li>• <b>3D Sync Invert:</b> When you discover the inversion of the image depth, enable this function to correct the problem.</li> <li>• <b>Save 3D Settings:</b> When you have successfully displayed the 3D contents after making the appropriate adjustments, you can enable this function and choose a set of 3D settings to memorize current 3D settings.</li> <li>• <b>Apply 3D Settings:</b> After the 3D settings are saved, you can decide if you would like to apply them by choosing a set of 3D settings that you have saved. Once applied, the projector will automatically play the incoming 3D contents if it matches the 3D settings saved.</li> <li>• <b>Only the set(s) of 3D settings with memorized data is available.</b></li> </ul>	

<b>HDMI Settings</b>	<ul style="list-style-type: none"> <li>• <b>HDMI Format:</b> Selects a suitable color format to optimize display quality.</li> <li>• <b>Auto:</b> Automatically selects a suitable color space and gray level for the incoming HDMI signal.</li> <li>• <b>Limited:</b> Utilizes the Limited range RGB 16-235.</li> <li>• <b>Full:</b> Utilizes the Full range RGB 0-255.</li> <li>• <b>HDMI Equalizer:</b> Adjusts the equalizer gain settings for an HDMI signal. The higher the setting, the stronger the gain value. If there are more than one HDMI port on the projector, select the HDMI port first before adjusting the value.</li> <li>• <b>HDMI EDID:</b> Switch HDMI EDID between HDMI 1.4 or HDMI 2.0 in order to solve compatibility issue with uncertain old players. <ul style="list-style-type: none"> <li>• <b>Enhance:</b> Enhanced mode can switch to HDMI 2.0 EDID</li> <li>• <b>Standard:</b> Standard mode can switch to HDMI 1.4 EDID.</li> </ul> </li> </ul>
<b>Reset Display</b>	Returns all of the adjustments you've made for the <b>Display</b> menu to the factory preset values.

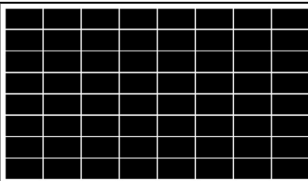
## Installation



<b>Projector Position</b>	The projector can be installed on a ceiling or behind a screen, or with one or more mirrors. The options are Front, Front Ceiling, Rear and Rear Ceiling.	
<b>Focus</b>	<p><b>Focus</b> Press FOCUS on the remote control to adjust the focus of the image. After focus is complete, an adjustment page is displayed to allow user to manually fine-tune the focus by pressing ◀▶ on the remote control.</p> <p><b>Manual Focus</b> Manually adjust the focus by pressing ◀▶ on the remote control.</p>	
<b>Test Pattern</b>	Adjusts the image size and focus and check that the projected image is free from distortion.	
<b>Geometry</b>	<p><b>Corner Fit</b></p> <ul style="list-style-type: none"> <li>• <b>Top Left:</b> To correct the top left corner.</li> <li>• <b>Top Right:</b> To correct the top right corner.</li> <li>• <b>Bottom Left:</b> To correct the bottom left corner.</li> <li>• <b>Bottom Right:</b> To correct the bottom right corner.</li> </ul> <p><b>2D Keystone</b> Adjusts the shape of the projected image to ensure straight lines on all four corners. See "<a href="#">Correcting 2D Keystone</a>" on page 27 for details.</p>	

<b>Image Resizing</b>	<p><b>Digital Zoom</b> Magnifies or reduces the projected image.</p> <ol style="list-style-type: none"> <li>1. After the Zoom bar displays, press ▲ repeatedly to magnify the picture to a desired size.</li> <li>2. To navigate the picture, press <b>OK</b> to switch to the panning mode and press the directional arrows (▲, ▼, ◀, ▶) on the projector or remote control to navigate the picture.</li> <li>3. To reduce size of the picture, press <b>OK</b> to switch back to the zoom in/out function, and press <b>AUTO</b> to restore the picture to its original size. You can also press repeatedly until it is restored to the original size.</li> </ol> <p> The picture can only be navigated after it is magnified. You can further magnify the picture while searching for details.</p>
	<p><b>Digital Shrink &amp; Shift</b> Shrinks and/or shifts the projected image.</p> <ol style="list-style-type: none"> <li>1. After the adjustment bar displays, press ◀▶ repeatedly to shrink or magnify the picture to a desired size.</li> <li>2. Press <b>OK</b> to activate digital shift function.</li> <li>3. After digital shift function is activated, press the directional arrows (▲, ▼, ◀, ▶) to shift the image.</li> <li>4. Press <b>AUTO</b> to restore the picture to its original size.</li> </ol> <p> The picture can only be shifted after it shrank.</p>
	<p><b>Blanking</b></p> <ul style="list-style-type: none"> <li>• <b>Modes of adjustment:</b></li> <li>• <b>Top:</b> To adjust the top blanking area on the projected picture</li> <li>• <b>Bottom:</b> To adjust the bottom blanking area on the projected picture.</li> <li>• <b>Left:</b> To adjust the left blanking area on the projected picture.</li> <li>• <b>Right:</b> To adjust the right blanking area on the projected picture.</li> <li>• <b>Reset all blanking settings:</b> To set up all Blanking settings to default.</li> </ul>
<b>Wall Color</b>	<p>5 common wall colors for users to correct the image color bias reflected by the wall. (Off/Light Yellow/Pink/Light Green/Blue/Blackboard)Corrects the projected picture's color when the projection surface such as a painted wall which may not be white, the Wall Color feature can help correct the projected picture's colors to prevent possible color difference between the source and projected pictures. There are several precalibrated colors to choose from: <b>Light Yellow, Pink, Light Green, Blue</b> and <b>Blackboard</b>.</p>

<b>High Altitude Mode</b>	<p>We recommend you use the <b>High Altitude Mode</b> when your environment is between 1500 m –3000 m above sea level, and ambient temperature is between 0°C–30°C.</p> <p>Operation under "<b>High Altitude Mode</b>" may cause a higher decibel operating noise level because of increased fan speed necessary to improve overall system cooling and performance.</p> <p>If you use this projector under other extreme conditions excluding the above, it may display auto shut-down symptoms, which is designed to protect your projector from over-heating. In cases like this, you should switch to High Altitude mode to solve these symptoms. However, this is not to state that this projector can operate under any and all harsh or extreme conditions.</p> <p> Do not use the High Altitude Mode if your altitude is between 0 m and 1500 m and ambient temperature is between 0°C and 35°C. The projector will be over cooled, if you turn the mode on under such a condition.</p>
<b>Baud Rate</b>	<p>Selects a baud rate that is identical with your computer's so that you can connect the projector using a suitable RS-232 cable and update or download the projector's firmware. This function is intended for qualified service personnel.</p>
<b>Projector ID</b>	<p>Set an ID for projector to match with corresponding remote control</p>

## System

<b>Language</b>	<p>Sets the language for the On-Screen Display (OSD) menus.</p>
<b>Background Settings</b>	<ul style="list-style-type: none"> <li>• <b>Background:</b> Sets the background color for the projector.</li> <li>• <b>Splash Screen:</b> Allows you to select which logo screen will be displayed during projector start-up.</li> </ul>
<b>Menu Settings</b>	<ul style="list-style-type: none"> <li>• <b>Menu Type:</b> Switches to the <b>Basic</b> OSD menu.</li> <li>• <b>Menu Display Time:</b> Sets the length of time the OSD will remain active after your last key press.</li> <li>• <b>Menu Position:</b> Select menu display position.</li> <li>• <b>Reminder Message:</b> Sets the reminder messages on or off.</li> </ul>
<b>Light Source Information</b>	<p>Shows the current light mode.</p>
<b>Standby Settings</b>	<ul style="list-style-type: none"> <li>• <b>Standby Mode</b> <ul style="list-style-type: none"> <li>• <b>ECO:</b> The projector maintains at normal standby mode with less than 0.5W power consumption.</li> <li>• <b>Network:</b> The projector maintains at network standby mode with less than 2W power consumption.</li> <li>• <b>Normal:</b> Allows the projector to provide network, monitor out and audio pass through functions in standby mode.</li> </ul> </li> <li>• <b>Audio Pass Through:</b> The projector can play sound when it is in standby mode and the corresponding jacks are correctly connected to devices. Press ◀▶ to choose the source that you wish to use. See "<a href="#">Connection</a>" on page 20 for how to make the connection.</li> </ul>

<b>Operation Settings</b>	<p><b>LED Indicator</b> You can turn off the LED warning lights. This is to avoid any light disturbance when viewing images in a dark room.</p>
	<p><b>Power On/Off Settings</b></p> <ul style="list-style-type: none"> <li>• <b>Direct Power On:</b> Allows the projector to turn on automatically once the power is fed through the power cord.</li> <li>• <b>Signal Power On:</b> Sets whether to turn the projector directly on without pressing <b>POWER</b> or  <b>ON</b> when the projector is in standby mode and detects a VGA signal or a HDMI signal with 5V power.</li> <li>• <b>Auto Power Off:</b> Allows the projector to turn off automatically if no input signal is detected after a set period of time to prevent unnecessary waste of light source life.</li> </ul>
	<p><b>Filter Setting</b></p> <ul style="list-style-type: none"> <li>• <b>Filter Timer:</b> If user enable filter timer, system will start counting filter usage time and show in 'x hours.'</li> <li>• <b>Reset Filter Timer:</b> If user reset filter timer, the current filter timer 'x hours' will be cleared and shown as '0 hours,' and restart counting.</li> <li>• <b>Filter Usage Time :</b> Shows the number of hours the Filter has been used.</li> </ul>
<b>Security Settings</b>	See " <a href="#">Utilizing the password function</a> " on page 30.
<b>Network Settings</b>	<ul style="list-style-type: none"> <li>• <b>Wired LAN</b></li> <li>• <b>AMX Device Discovery:</b> When this function is <b>On</b>, the projector can be detected by AMX controller.</li> <li>• <b>MAC Address (Wired):</b> Displays the mac address for this projector.</li> </ul>
<b>Factory Default</b>	<p>Returns all settings to the factory preset values.</p> <p> The following settings will still remain: <b>Keystone, Projector Installation, Light Usage Time, High Altitude Mode, Security Settings, Baud Rate, HDMI Equalizer, Digital Shrink &amp; Shift, Filter Usage Time.</b></p>
<b>Reset System</b>	Returns all of the adjustments you've made for the <b>System</b> menu to the factory preset values.

## Information

<b>Information</b>	<ul style="list-style-type: none"><li>• <b>Native Resolution:</b> Shows the native resolution of the projector.</li><li>• <b>Detected Resolution:</b> Shows the native resolution of the input signal.</li><li>• <b>Source:</b> Shows the current signal source.</li><li>• <b>Picture Mode:</b> Shows the selected mode in the Picture menu.</li><li>• <b>Light Source Mode:</b> Shows the selected mode in the Light Settings menu.</li><li>• <b>3D Format:</b> Shows the current 3D mode.</li><li>• <b>Color System:</b> Shows input system format.</li><li>• <b>Light Source Usage Time:</b> Shows the number of hours the light source has been used.</li><li>• <b>Projector ID:</b> Show projector ID. If there's no projector ID, it will be shown as Off.</li><li>• <b>Firmware Version:</b> Shows the firmware version of your projector.</li><li>• <b>Service Code:</b> Shows the projector serial number.</li></ul>
--------------------	---

# Maintenance

## Care of the projector

Your projector needs little maintenance. The only thing you need to do on a regular basis is to keep the lens clean.

Never remove any parts of the projector. Contact your dealer if other parts need replacing.

### Cleaning the lens

Clean the lens whenever you notice dirt or dust on the surface.

- Use a canister of compressed air to remove dust.
- If there is dirt or smears, use lens-cleaning paper or moisten a soft cloth with lens cleaner and gently wipe the lens surface.



Never use any type of abrasive pad, alkaline/acid cleaner, scouring powder, or volatile solvent, such as alcohol, benzene, thinner or insecticide. Using such materials or maintaining prolonged contact with rubber or vinyl materials may result in damage to the projector surface and cabinet material.

### Cleaning the projector case

Before you clean the case, turn the projector off using the proper shutdown procedure as described in ["Shutting down the projector" on page 32](#) and unplug the power cord.

- To remove dirt or dust, wipe the case with a soft, lint-free cloth.
- To remove stubborn dirt or stains, moisten a soft cloth with water and a neutral pH detergent. Then wipe the case.



Never use wax, alcohol, benzene, thinner or other chemical detergents. These can damage the case.

### Storing the projector

If you need to store the projector for an extended time, please follow the instructions below:

- Make sure the temperature and humidity of the storage area are within the recommended range for the projector. Please refer to ["Specifications" on page 53](#) or consult your dealer about the range.
- Retract the adjuster feet.
- Remove the battery from the remote control.
- Pack the projector in its original packing or equivalent.

### Transporting the projector

It is recommended that you ship the projector with its original packing or equivalent. When you carry the projector yourself, please use the original box or a suitable soft carry case.



## Filter maintenance

### Cleaning the filter

The air filter prevents dust from accumulating on the surface of the optical elements inside the projector. If the filter is dirty or clogged, your projector may overheat or degrading the projected image quality.

1. Turn off the projector, and unplug the AC power cord from the AC outlet.
2. Cleaning the filter with a vacuum cleaner.

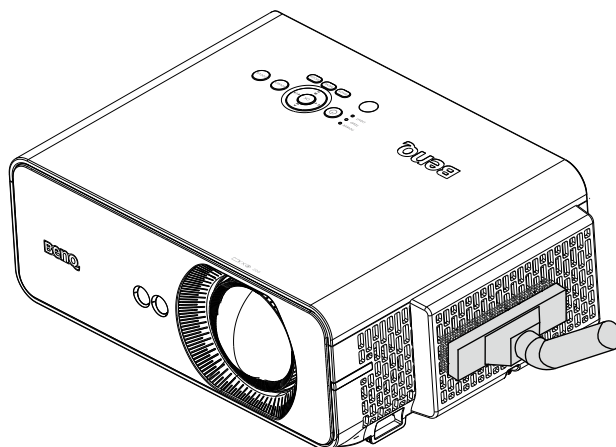

#### **Caution:**

Recommend avoiding dusty or smoky environments when you operate the projector; it may cause poor image quality. If the filter is heavily clogged and unable to clean, replace a new filter.

#### **Note:**

Using a ladder is recommended to access the filter. Do not remove the projector from the wall mount.

## Replacing the side filter

Turn off the projector and unplug the power cord from the outlet. Remove any dust on the projector and around the air vents.

1. Loosen the screw on the filter cover. Remove the filter module from the Projector.
3. Replace a new filter module or replace filter into cover.

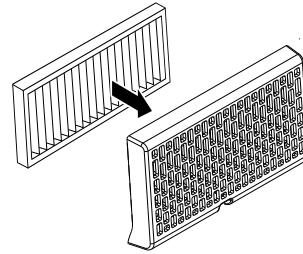
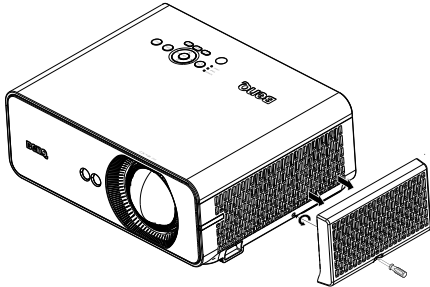

2. Lift the filter from the filter cover. Use a vacuum cleaner to vacuum the cover.
4. Replace the filter module onto the projector and tighten the screws.

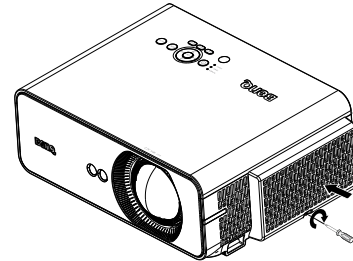
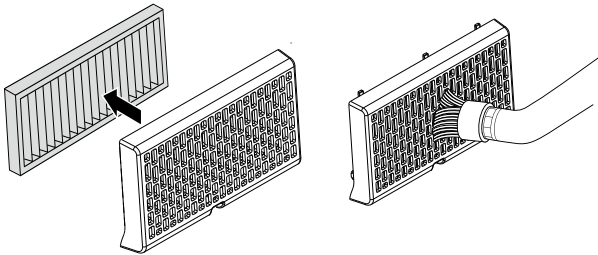

### Note:

- Do not wash the filter with the water or other liquid matter.
- If there is too much dust, the machine may overheat and shut down automatically; It is recommended to replace the Filter regularly according to the Filter Timer reminder.

## Resetting the filter timer

5. After the startup logo, open the On-Screen Display (OSD) menu. Go to the **SYSTEM : Operation Settings > Filter Settings** menu. Press **ENTER**. The Filter Settings page displays. Highlight **Reset Filter Timer**. A warning message displays asking if you want to

reset the filter timer. Highlight **Reset** and press **ENTER**. The filter time will be reset to '0'.

## Indicators

POWER	TEMP	LIGHT	STATUS
System Messages			
<b>O</b>			Stand-by
<b>G</b>			Powering up
<b>G</b>			Normal operation
<b>O</b>			Normal power down cooling
<b>R</b>	<b>R</b>	<b>R</b>	Download
<b>G</b>		<b>R</b>	CW start fail
<b>G</b>		<b>R</b>	Phosphor Wheel start fail
<b>O</b>		<b>R</b>	Case open
<b>O</b>	<b>G</b>		Thermal break sensor error
Burn-In Messages			
<b>G</b>			Burn-in on
<b>G</b>	<b>G</b>	<b>G</b>	Burn-in off
Lamp Error Messages			
		<b>R</b>	Lamp 1 error in normal operation
		<b>R</b>	Lamp is not lit up
Thermal Error Messages			
<b>R</b>	<b>R</b>		Fan 1 error (the actual fan speed is outside the desired speed)
<b>R</b>	<b>R</b>		Fan 2 error (the actual fan speed is outside the desired speed)
<b>R</b>	<b>G</b>		Fan 3 error (the actual fan speed is outside the desired speed)
<b>G</b>	<b>R</b>		Temperature 1 error (over limited temperature)
<b>G</b>	<b>R</b>		Thermal Sensor 1 open error
<b>G</b>	<b>G</b>		Thermal Sensor 1 short error
<b>G</b>	<b>G</b>		Thermal IC #1 I2C Connection error
<b>G</b>	<b>R</b>		Temperature 2 error (over limited temperature)
<b>G</b>	<b>R</b>		Thermal Sensor 2 open error
<b>G</b>	<b>G</b>		Thermal Sensor 2 short error
<b>G</b>	<b>G</b>		Thermal IC #2 I2C Connection error
<b>G</b>	<b>R</b>	<b>R</b>	Temperature 3 error (over limited temperature)
<b>G</b>	<b>R</b>	<b>R</b>	Thermal Sensor 3 open error
<b>G</b>	<b>R</b>	<b>G</b>	Thermal Sensor 3 short error
<b>G</b>	<b>R</b>	<b>G</b>	Thermal IC #3 I2C Connection error

**O** : Static orange

**G** : Static green

**R** : Static red

**O** : Flashing orange (cycle : on 1 sec/off 1 sec)

**G** : Flashing green (cycle : on 1 sec/off 1 sec)

**R** : Flashing red (cycle : on 1 sec/off 1 sec)

# Troubleshooting

## Troubleshooting

### ? The projector does not turn on.

Cause	Remedy
There is no power from the power cable.	Plug the power cord into the AC inlet on the projector, and plug the power cord into the power outlet. If the power outlet has a switch, make sure that it is switched on.
Attempting to turn the projector on again during the cooling process.	Wait until the cooling down process has completed.

### ? No picture.

Cause	Remedy
The video source is not turned on or connected correctly.	Turn the video source on and check that the signal cable is connected correctly.
The projector is not correctly connected to the input signal device.	Check the connection.
The input signal has not been correctly selected.	Select the correct input signal with the <b>SOURCE</b> key on the projector or remote control.

### ? Blurred image.

Cause	Remedy
The projection lens is not correctly focused.	Adjust the focus.
If the focus cannot be used.	Please check whether there is dust on the front cover and clean it. Make sure there is no dust accumulation and then execute focus again. Please avoid using organic solvents when cleaning.
The projector and the screen are not aligned properly.	Adjust the projection angle and direction as well as the height of the unit if necessary.

### ? Remote control does not work.

Cause	Remedy
The battery is out of power.	Replace the battery with new one.
There is an obstacle between the remote control and the projector.	Remove the obstacle.
You are too far away from the projector.	Stand within 7 meters (23 feet) of the projector.

### ? The password is incorrect.

Cause	Remedy
You do not remember the password.	Please see <a href="#">"Entering the password recall procedure"</a> on page 31 for details.

# Specifications

## Projector specifications



All specifications are subject to change without notice.

### Optical

Resolution

LH850ST

1920 x 1080 1080p

Display system

Single-chip DLP™ system

Lens

F = 2.8, f = 7.46 mm

Light source

Laser diodes

### Electrical

Power supply

AC100-240V, 3.0A

50-60 Hz (Automatic)

Power consumption

300W (Max); < 0.5W (Standby); <2W(When the network function in the standby settings is on)

### Mechanical

Weight

11.2 lbs (5.1 Kg)

Dimension

320mm (W) x 130.6 (H) x 255 (D) mm  
(12.60"x5.14"x10.04") (without lens)

### Output terminals

Speaker

10 watt x 1

Audio signal output

PC audio jack x 1

### Control

USB

Type-B mini USB(For Service)

Type-A power supply 1.5A

(Optional for Wireless Dongle)

RS-232 serial control

9 pin x 1 (In)

IR receiver x 2 (Front & Top)

LAN control

RJ45 x 1 (10/100Mbps)

### Input terminals

Digital - HDMI 2.0 x 2

### Environmental Requirements

Temperature

Operating: 0°C–40°C at sea level

Storage: -20°C–60°C at sea level

Relative humidity

Operating: 10%–90% (without condensation)

Storage: 10%–90% (without condensation)

### Transporting

Original packing or equivalent is recommended.

### Repairing

Please visit below website and choose your country to find your service contact window. <http://www.benq.com/welcome>

# Dimensions

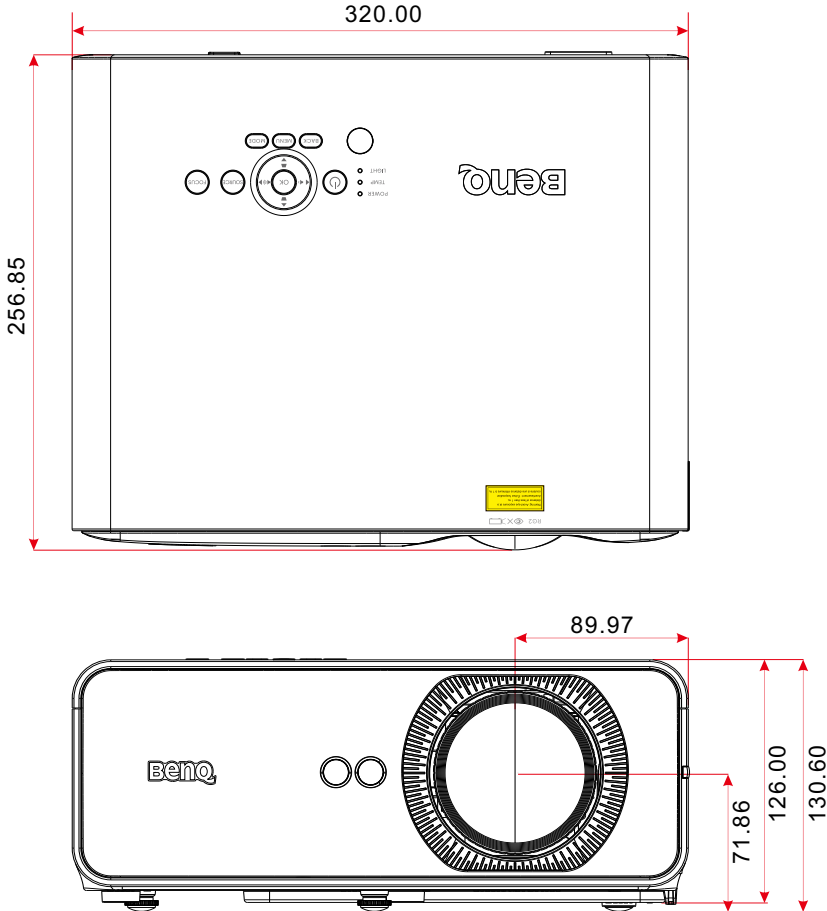

## Timing table

### Support video timing for HDMI input

Timing	Resolution	Horizontal frequency (kHz)	Vertical frequency (Hz)	Dot Clock Frequency (MHz)	3D Field Sequential	3D frame packing	3D over-under	3D side-by-side
480i	720(1440) × 480	15.73	59.94	27	⊙			
480p	720 × 480	31.47	59.94	27	⊙			
576i	720(1440) × 576	15.63	50	27				
576p	720 × 576	31.25	50	27				
720/50p	1280 × 720	37.5	50	74.25		⊙	⊙	⊙
720/60p	1280 × 720	45	60	74.25	⊙	⊙	⊙	⊙
1080/24P	1920 × 1080	27	24	74.25		⊙	⊙	⊙
1080/25P	1920 × 1080	28.13	25	74.25				
1080/30P	1920 × 1080	33.75	30	74.25				
1080/50i	1920 × 1080	28.13	50	74.25				⊙
1080/60i	1920 × 1080	33.75	60	74.25				⊙
1080/50P	1920 × 1080	56.25	50	148.5			⊙	⊙
1080/60P	1920 × 1080	67.5	60	148.5			⊙	⊙
1080/120P	1920 × 1080	135	120	297	⊙			
2160/24P	3840 × 2160	54	24	297				
2160/25P	3840 × 2160	56.25	25	297				
2160/30P	3840 × 2160	67.5	30	297				
2160/50P	3840 × 2160	112.5	50	594				
2160/60P	3840 × 2160	135	60	594				

### Support PC timing for HDMI input

Resolution	Mode	Refresh rate (Hz)	Horizontal frequency (kHz)	Clock (MHz)	3D Field Sequential	3D over-under	3D side-by-side
640 × 480	VGA_60	59.94	31.469	25.175	⊙	⊙	⊙
	VGA_72	72.809	37.861	31.5			
	VGA_75	75	37.5	31.5			
	VGA_85	85.008	43.269	36			
720 × 400	720x400_70	70.087	31.469	28.3221			

Resolution	Mode	Refresh rate (Hz)	Horizontal frequency (kHz)	Clock (MHz)	3D Field Sequential	3D over-under	3D side-by-side
800 x 600	SVGA_60	60.317	37.879	40	⊙	⊙	⊙
	SVGA_72	72.188	48.077	50			
	SVGA_75	75	46.875	49.5			
	SVGA_85	85.061	53.674	56.25			
	SVGA_120 (Reduce Blanking)	119.854	77.425	83	⊙		
1024 x 768	XGA_60	60.004	48.363	65	⊙	⊙	⊙
	XGA_70	70.069	56.476	75			
	XGA_75	75.029	60.023	78.75			
	XGA_85	84.997	68.667	94.5			
	XGA_120 (Reduce Blanking)	119.989	97.551	115.5	⊙		
1152 x 864	1152 x 864_75	75	67.5	108			
1024x576	BenQ Notebook Timing	60	35.82	46.996			
1024x600	BenQ Notebook Timing	64.995	41.467	51.419			
1280x720	1280 x 720_60	60	45	74.25	⊙	⊙	⊙
1280 x 768	1280 x 768_60	59.87	47.776	79.5	⊙	⊙	⊙
1280 x 800	WXGA_60	59.81	49.702	83.5	⊙	⊙	⊙
	WXGA_75	74.934	62.795	106.5			
	WXGA_85	84.88	71.554	122.5			
	WXGA_120 (Reduce Blanking)	119.909	101.563	146.25	⊙		
1280 x 1024	SXGA_60	60.02	63.981	108		⊙	⊙
	SXGA_75	75.025	79.976	135			
	SXGA_85	85.024	91.146	157.5			
1280 x 960	1280 x 960_60	60	60	108		⊙	⊙
	1280 x 960_85	85.002	85.938	148.5			
1360 x 768	1360 x 768_60	60.015	47.712	85.5		⊙	⊙
1440 x 900	WXGA+_60	59.887	55.935	106.5		⊙	⊙
1400X1050	SXGA+_60	59.978	65.317	121.75		⊙	⊙
1600x1200	UXGA	60	75	162		⊙	
1680x1050	1680x1050_60	59.954	65.29	146.25		⊙	⊙
640x480 @67Hz	MACI3	66.667	35	30.24			
832x624 @75Hz	MACI6	74.546	49.722	57.28			
1024x768 @75Hz	MACI9	75.02	60.241	80			
1152x870 @75Hz	MAC21	75.06	68.68	100			



Resolution	Mode	Refresh rate (Hz)	Horizontal frequency (kHz)	Clock (MHz)	3D Field Sequential	3D over-under	3D side-by-side
1920x1080 @60HZ	1920X1080_60 (Reduce Blanking)	60	67.5	148.5	⊙	⊙	⊙
1920x1200 @60HZ	1920X1200_60 (Reduce Blanking)	59.95	74.038	154	⊙	⊙	⊙
"1920x1080 @120Hz"	1920X1080_120	120	135	297			
"1920x1200 @120Hz"	1920X1200_120 (Reduce Blanking)	119.909	152.404	317			
3840x2160	3840X2160_30 (Reduce Blanking)	29.97	65.66	257.404			
3840x2160	3840X2160_60 (Reduce Blanking)	59.94	133.187	522.092			
3840x2160	3840X2160_30	30	67.5	297			
3840x2160	3840X2160_60	60	135	594			

## True 3D Video Compatibility table

Input Resolutions	HDMI I.4a 3D Input	Input timing			
		1280 X 720P @ 50Hz	Top-and-Bottom		
		1280 X 720P @ 60Hz	Top-and-Bottom		
		1280 X 720P @ 50Hz	Frame packing		
		1280 X 720P @ 60Hz	Frame packing		
		1920 X 1080i @50 Hz	Side-by-Side (Half)		
		1920 X 1080i @60 Hz	Side-by-Side (Half)		
		1920 X 1080P @24 Hz	Top-and-Bottom		
		1920 X 1080P @24 Hz	Frame packing		
	HDMI I.3	1920 x 1080i @ 50Hz	Side-by-Side(Half)	SBS mode is on	
		1920 x 1080i @ 60Hz			
		1280 x 720P @50Hz			
		1280 x 720P @60Hz			
		480i	HQFS	3D format is Frame sequential	

\*When testing 3D, please confirm that the glasses must support up to 144Hz

## RS232 command control

Function	Type	Operation	ASCII
Power	Write	Power On	<CR>*pow=on#<CR>
	Write	Power off	<CR>*pow=off#<CR>
	Read	Power Status	<CR>*pow=?#<CR>
Source Selection	Write	COMPUTER/YPbPr	<CR>*sour=RGB#<CR>
	Write	HDMI(MHL)	<CR>*sour=hdmi#<CR>
	Write	HDMI 2(MHL2)	<CR>*sour=hdmi2#<CR>
	Write	Wireless Display	<CR>*sour=wireless#<CR>
	Read	Current source	<CR>*sour=?#<CR>
Audio Control	Write	Mute On	<CR>*mute=on#<CR>
	Write	Mute Off	<CR>*mute=off#<CR>
	Read	Mute Status	<CR>*mute=?#<CR>
	Write	Volume +	<CR>*vol=+#<CR>
	Write	Volume -	<CR>*vol=-#<CR>
	Write	Volume level for customer	<CR>*vol=value#<CR>
	Read	Volume Status	<CR>*vol=?#<CR>
	Write	Mic. Volume +	<CR>*micvol=+#<CR>
	Write	Mic. Volume -	<CR>*micvol=-#<CR>
	Read	Mic. Volume Status	<CR>*micvol=?#<CR>
Audio Source Select	Write	Audio pass Through off	<CR>*audiosour=off#<CR>
	Write	Audio-ComputerI	<CR>*audiosour=RGB#<CR>
	Write	Audio-HDMI	<CR>*audiosour=hdmi#<CR>
	Write	Audio-HDMI2	<CR>*audiosour=hdmi2#<CR>
	Read	Audio pass Status	<CR>*audiosour=?#<CR>
Picture Mode	Write	Presentation	<CR>*appmod=preset#<CR>
	Write	sRGB	<CR>*appmod=srgb#<CR>
	Write	Bright	<CR>*appmod=bright#<CR>
	Write	Game	<CR>*appmod=game#<CR>
	Write	Cinema(Rec.709)	<CR>*appmod=cine#<CR>
	Write	Golf	<CR>*appmod=golf#<CR>
	Write	User1	<CR>*appmod=user1#<CR>
	Write	User2	<CR>*appmod=user2#<CR>
	Write	3D	<CR>*appmod=threed#<CR>
	Write	HDR10	<CR>*appmod=hdr#<CR>
	Write	HLG	<CR>*appmod=hlg#<CR>
	Write	Spreadsheet	<CR>*appmod=spreadsheet#<CR>
	Read	Picture Mode	<CR>*appmod=?#<CR>

Function	Type	Operation	ASCII
Picture Setting	Write	Contrast +	<CR>*con=+#<CR>
	Write	Contrast -	<CR>*con=-#<CR>
	Write	Set Contrast value	<CR>*con=value#<CR>
	Read	Contrast value	<CR>*con=?#<CR>
	Write	Brightness +	<CR>*bri=+#<CR>
	Write	Brightness -	<CR>*bri=-#<CR>
	Write	Set Brightness value	<CR>*bri=value#<CR>
	Read	Brightness value	<CR>*bri=?#<CR>
	Write	Color +	<CR>*color=+#<CR>
	Write	Color -	<CR>*color=-#<CR>
	Write	Set Color value	<CR>*color=value#<CR>
	Read	Color value	<CR>*color=?#<CR>
	Write	Sharpness +	<CR>*sharp=+#<CR>
	Write	Sharpness -	<CR>*sharp=-#<CR>
	Write	Set Sharpness value	<CR>*sharp=value#<CR>
	Read	Sharpness value	<CR>*sharp=?#<CR>
	Write	Color Temperature-Warm	<CR>*ct=warm#<CR>
	Write	Color Temperature-Normal	<CR>*ct=normal#<CR>
	Write	Color Temperature-Cool	<CR>*ct=cool#<CR>
	Read	Color Temperature Status	<CR>*ct=?#<CR>
	Write	Aspect 4:3	<CR>*asp=4:3#<CR>
	Write	Aspect 16:9	<CR>*asp=16:9#<CR>
	Write	Aspect 16:10	<CR>*asp=16:10#<CR>
	Write	Aspect Auto	<CR>*asp=AUTO#<CR>
	Write	Aspect Real	<CR>*asp=REAL#<CR>
	Read	Aspect Status	<CR>*asp=?#<CR>
	Write	Vertical Keystone +	<CR>*vkeystone=+#<CR>
	Write	Vertical Keystone -	<CR>*vkeystone=-#<CR>
	Write	Vertical Keystone value Set	<CR>*vkeystone=value#<CR>
	Read	Vertical Keystone value	<CR>*vkeystone=?#<CR>
	Write	Horizontal Keystone +	<CR>*hkeystone=+#<CR>
	Write	Horizontal Keystone -	<CR>*hkeystone=-#<CR>
Write	Horizontal Keystone value Set	<CR>*hkeystone=value#<CR>	
Read	Horizontal Keystone value	<CR>*hkeystone=?#<CR>	

Function	Type	Operation	ASCII
Picture Setting	Write	4 Corners Top-Left-X Decrease	<CR>*cornerfittlx=-#<CR>
	Write	4 Corners Top-Left-X Increase	<CR>*cornerfittlx=+#<CR>
	Read	4 Corners Top-Left-X Status	<CR>*cornerfittlx=?#<CR>
	Write	4 Corners Top-Left-Y Decrease	<CR>*cornerfittly=-#<CR>
	Write	4 Corners Top-Left-Y Increase	<CR>*cornerfittly=+#<CR>
	Read	4 Corners Top-Left-Y Status	<CR>*cornerfittly=?#<CR>
	Write	4 Corners Top-Right-X Decrease	<CR>*cornerfittrx=-#<CR>
	Write	4 Corners Top-Right-X Increase	<CR>*cornerfittrx=+#<CR>
	Read	4 Corners Top-Right-X Status	<CR>*cornerfittrx=?#<CR>
	Write	4 Corners Top-Right-Y Decrease	<CR>*cornerfittry=-#<CR>
	Write	4 Corners Top-Right-Y Increase	<CR>*cornerfittry=+#<CR>
	Read	4 Corners Top-Right-Y Status	<CR>*cornerfittry=?#<CR>
	Write	4 Corners Bottom-Left-X Decrease	<CR>*cornerfitblx=-#<CR>
	Write	4 Corners Bottom-Left-X Increase	<CR>*cornerfitblx=+#<CR>
	Read	4 Corners Bottom-Left-X Status	<CR>*cornerfitblx=?#<CR>
	Write	4 Corners Bottom-Left-Y Decrease	<CR>*cornerfitbly=-#<CR>
	Write	4 Corners Bottom-Left-Y Increase	<CR>*cornerfitbly=+#<CR>
	Read	4 Corners Bottom-Left-Y Status	<CR>*cornerfitbly=?#<CR>
	Write	4 Corners Bottom-Right-X Decrease	<CR>*cornerfitbrx=-#<CR>
	Write	4 Corners Bottom-Right-X Increase	<CR>*cornerfitbrx=+#<CR>
	Read	4 Corners Bottom-Right-X Status	<CR>*cornerfitbrx=?#<CR>
	Write	4 Corners Bottom-Right-Y Decrease	<CR>*cornerfitbry=-#<CR>
	Write	4 Corners Bottom-Right-Y Increase	<CR>*cornerfitbry=+#<CR>
	Read	4 Corners Bottom-Right-Y Status	<CR>*cornerfitbry=?#<CR>
	Write	Digital Zoom In	<CR>*zoomI#<CR>
	Write	Digital Zoom out	<CR>*zoomO#<CR>
	Write	Auto	<CR>*auto#<CR>
	Write	Brilliant color on	<CR>*BC=on#<CR>
	Write	Brilliant color off	<CR>*BC=off#<CR>
	Read	Brilliant color status	<CR>*BC=?#<CR>
	Write	Reset current picture settings	<CR>*rstcurpicsetting#<CR>
	Write	Reset all picture settings	<CR>*rstallpicsetting#<CR>

Function	Type	Operation	ASCII
Operation Settings	Write	Projector Position-Front Table	<CR>*pp=FT#<CR>
	Write	Projector Position-Rear Table	<CR>*pp=RE#<CR>
	Write	Projector Position-Rear Ceiling	<CR>*pp=RC#<CR>
	Write	Projector Position-Front Ceiling	<CR>*pp=FC#<CR>
	Read	Projector Position Status	<CR>*pp=?#<CR>
	Write	Quick auto search	<CR>*QAS=on#<CR>
	Write	Quick auto search	<CR>*QAS=off#<CR>
	Read	Quick auto search status	<CR>*QAS=?#<CR>
	Write	Menu Position - Center	<CR>*menuposition=center#<CR>
	Write	Menu Position - Top-Left	<CR>*menuposition=tl#<CR>
	Write	Menu Position - Top-Right	<CR>*menuposition=tr#<CR>
	Write	Menu Position - Bottom-Right	<CR>*menuposition=br#<CR>
	Write	Menu Position - Bottom-Left	<CR>*menuposition=bl#<CR>
	Read	Menu Position Status	<CR>*menuposition=?#<CR>
	Write	Direct Power On-on	<CR>*directpower=on#<CR>
	Write	Direct Power On-off	<CR>*directpower=off#<CR>
	Read	Direct Power On-Status	<CR>*directpower=?#<CR>
	Write	Signal Power On-on	<CR>*autopower=on#<CR>
	Write	Signal Power On-off	<CR>*autopower=off#<CR>
	Read	Signal Power On-Status	<CR>*autopower=?#<CR>
Baud Rate	Write	9600	<CR>*baud=9600#<CR>
	Write	14400	<CR>*baud=14400#<CR>
	Write	19200	<CR>*baud=19200#<CR>
	Write	38400	<CR>*baud=38400#<CR>
	Write	57600	<CR>*baud=57600#<CR>
	Write	115200	<CR>*baud=115200#<CR>
	Read	Current Baud Rate	<CR>*baud=?#<CR>
Lamp Control	Write	Normal mode	<CR>*lampm=lnor#<CR>
	Write	Eco mode	<CR>*lampm=eco#<CR>
	Write	SmartEco mode	<CR>*lampm=seco#<CR>
	Write	Custom mode	<CR>*lampm=custom#<CR>
	Read	Lamp Mode Status	<CR>*lampm=?#<CR>
Miscellaneous	Read	Model Name	<CR>*modelName=?#<CR>
	Read	System F/W Version	<CR>*sysfwversion=?#<CR>
	Read	Scaler F/W Version	<CR>*scalerfwversion=?#<CR>
	Read	Lan F/W Version	<CR>*lanfwversion=?#<CR>

Function	Type	Operation	ASCII
Miscellaneous	Read	MCU F/W Version	<CR>*mcfwversion=?#<CR>
	Write	Blank On	<CR>*blank=on#<CR>
	Write	Blank Off	<CR>*blank=off#<CR>
	Read	Blank Status	<CR>*blank=?#<CR>
	Write	Menu On	<CR>*menu=on#<CR>
	Write	Menu Off	<CR>*menu=off#<CR>
	Read	Menu Status	<CR>*menu=?#<CR>
	Write	Up	<CR>*up#<CR>
	Write	Down	<CR>*down#<CR>
	Write	Right	<CR>*right#<CR>
	Write	Left	<CR>*left#<CR>
	Write	Enter	<CR>*enter#<CR>
	Write	Back	<CR>*back#<CR>
	Write	Source Menu On	<CR>*sourmenu=on#<CR>
	Write	Source Menu Off	<CR>*sourmenu=off#<CR>
	Read	Source Menu Status	<CR>*sourmenu=?#<CR>
	Write	3D Auto	<CR>*3d=auto#<CR>
	Write	3D Sync Top Bottom	<CR>*3d=tb#<CR>
	Write	3D Sync Frame Sequential	<CR>*3d=fs#<CR>
	Write	3D Frame packing	<CR>*3d=fp#<CR>
	Write	3D Side by side	<CR>*3d=sbs#<CR>
	Write	3D inverter disable	<CR>*3d=da#<CR>
	Write	3D inverter	<CR>*3d=iv#<CR>
	Read	3D Sync Status	<CR>*3d=?#<CR>
	Read	Mac Address	<CR>*macaddr=?#<CR>
	Write	High Altitude mode on	<CR>*Highaltitude=on#<CR>
	Write	High Altitude mode off	<CR>*Highaltitude=off#<CR>
Read	High Altitude mode status	<CR>*Highaltitude=?#<CR>	
Color Calibration	Write	Set BenQ gamma value	<CR>*gamma=value#<CR>
	Read	Gamma value status	<CR>*gamma=?#<CR>
	Write	Set HDR Brightness value	<CR>*hdrbri=value#<CR>
	Read	Get HDR Brightness value	<CR>*hdrbri=?#<CR>
	Write	Red Gain +	<CR>*RGain=+#<CR>
	Write	Red Gain -	<CR>*RGain=-#<CR>

Function	Type	Operation	ASCII
Color Calibration	Write	Set Red Gain value	<CR>*RGain=value#<CR>
	Read	Get Red Gain value	<CR>*RGain=?#<CR>
	Write	Green Gain +	<CR>*GGain=+#<CR>
	Write	Green Gain -	<CR>*GGain=-#<CR>
	Write	Set Green Gain value	<CR>*GGain=value#<CR>
	Read	Get Green Gain value	<CR>*GGain=?#<CR>
	Write	Blue Gain +	<CR>*BGain=+#<CR>
	Write	Blue Gain -	<CR>*BGain=-#<CR>
	Write	Set Blue Gain value	<CR>*BGain=value#<CR>
	Read	Get Blue Gain value	<CR>*BGain=?#<CR>
	Write	Red Offset +	<CR>*ROffset=+#<CR>
	Write	Red Offset -	<CR>*ROffset=-#<CR>
	Write	Set Red Offset value	<CR>*ROffset=value#<CR>
	Read	Get Red Offset value	<CR>*ROffset=?#<CR>
	Write	Green Offset +	<CR>*GOffset=+#<CR>
	Write	Green Offset -	<CR>*GOffset=-#<CR>
	Write	Set Green Offset value	<CR>*GOffset=value#<CR>
	Read	Get Green Offset value	<CR>*GOffset=?#<CR>
	Write	Blue Offset +	<CR>*BOffset=+#<CR>
	Write	Blue Offset -	<CR>*BOffset=-#<CR>
	Write	Set Blue Offset value	<CR>*BOffset=value#<CR>
	Read	Get Blue Offset value	<CR>*BOffset=?#<CR>
	Write	Primary Color	<CR>*primcr=value#<CR>
	Read	Primary Color Status	<CR>*primcr=?#<CR>
	Write	Hue +	<CR>*hue=+#<CR>
	Write	Hue -	<CR>*hue=-#<CR>
	Write	Set Hue value	<CR>*hue=value#<CR>
	Read	Get Hue value	<CR>*hue=?#<CR>
	Write	Saturation +	<CR>*saturation=+#<CR>
	Write	Saturation -	<CR>*saturation=-#<CR>
	Write	Set Saturation value	<CR>*saturation=value#<CR>
	Read	Get Saturation value	<CR>*saturation=?#<CR>
Write	Gain +	<CR>*gain=+#<CR>	
Write	Gain -	<CR>*gain=-#<CR>	
Write	Set Gain value	<CR>*gain=value#<CR>	
Read	Get Gain value	<CR>*gain=?#<CR>	

Function	Type	Operation	ASCII
Color Calibration	Write	White Red Gain +	<CR>*WRGain=+#<CR>
	Write	White Red Gain -	<CR>*WRGain=-#<CR>
	Write	Set White Red Gain value	<CR>*WRGain=value#<CR>
	Read	Get White Red Gain value	<CR>*WRGain=?#<CR>
	Write	White Green Gain +	<CR>*WGGain=+#<CR>
	Write	White Green Gain -	<CR>*WGGain=-#<CR>
	Write	Set White Green Gain value	<CR>*WGGain=value#<CR>
	Read	Get White Green Gain value	<CR>*WGGain=?#<CR>
	Write	White Blue Gain +	<CR>*WBGain=+#<CR>
	Write	White Blue Gain -	<CR>*WBGain=-#<CR>
	Write	Set White Blue Gain value	<CR>*WBGain=value#<CR>
	Read	Get White Blue Gain value	<CR>*WBGain=?#<CR>
Service	Write	Service mode enable for error report	<CR>*error=enable#<CR>
	Read	Error Code report	<CR>*error=report#<CR>
	Read	FAN 1 speed	<CR>*fan1=?#<CR>
	Read	FAN 2 speed	<CR>*fan2=?#<CR>
	Read	FAN 3 speed	<CR>*fan3=?#<CR>
	Read	Temperature 1	<CR>*tmp1=?#<CR>
	Read	Temperature 2	<CR>*tmp2=?#<CR>
	Read	Temperature 3	<CR>*tmp3=?#<CR>
Filter Commands	Write	Filter timer on	<CR>*fltrtmr=on#<CR>
	Write	Filter timer off	<CR>*fltrtmr =off#<CR>
	Read	Filter timer status	<CR>*fltrtmr =?#<CR>
	Write	Filter timer setup (10 hours/step)	Min: <CR>*fltrtmrstp=10#<CR> Max: <CR>*fltrtmrstp=500#<CR>
	Read	Filter timer setup status	<CR>* fltrtmrstp =?#<CR>
	Write	Filter timer count reset	<CR>* fltrtmrcntrst#<CR>
	Read	Filter timer count status	<CR>* fltrtmrcntrst=?#<CR>
	Auto	Filter change notify	<CR>*fltrchgntfy#<CR>
Installation	Write	Focus	<CR>*focus=auto#<CR>
	Write	Focus +	<CR>*focus=+#<CR>
	Write	Focus -	<CR>*focus=-#<CR>



# PJLink

## PJLink protocol

The network function of this projector support the PJLink class I, and the PJLink protocol can be used to perform projector setting and projector status query operations from a computer.

### Control commands

The following table lists the PJLink protocol commands that can be used to control the projector.

- x characters in table are non-specific characters.

Command	Control Details	Parameter/ Return String	Remark		
POWR	Power supply control	0 1	Standby Power on		
POWR?	Power supply status query	0 1	Standby Power on		
INPT	Input selection	31	HDMI1		
INPT?	Input status query	32	HDMI2		
		33	HDMI3 (Wireless display)		
AVMT	Mute	11	Video mute On		
AVMT?	Mute query	10	Video mute Off		
		21	Audio mute On		
		20	Audio mute Off		
		31	Video & Audio mute On		
		30	Video & Audio mute Off		
ERST?	Error status query	xxxxxx	1st byte	0 = No error is detected 1 = Warning 2 = Error	
			2nd byte		Indicates light source errors, and returns 0 - 2
			3rd byte		Indicates temperature errors, and returns 0 - 2
			4th byte		Return 0
			5th byte		Return 0
			6th byte		Indicates other errors, and returns 0 - 2
LAMP?	Light source status query	xxxxxxxxxxxx	1st number (1-5 digitals): Light source 1 runtime		
INST?	Input selection list query	31 32 33	LH850ST		
NAME?	Projector name query	xxxxx	Returns the name set in [PROJECTOR NAME] of [NETWORK SETUP]		
INFI?	Manufacturer name query	BenQ	Returns manufacturer name		

<b>Command</b>	<b>Control Details</b>	<b>Parameter/ Return String</b>	<b>Remark</b>
INF2?	Model name query	LH850ST	Returns moder name
INF0?	Other information queries	xxxxx	Returns information such as version number
CLASS?	Class information query	I	Returns class for PJLink