



Hewlett Packard
Enterprise

HPE ProLiant DL385 Gen11 Server User Guide

Part Number: 30-507A97B9-006

Published: July 2024

Edition: 6

HPE ProLiant DL385 Gen11 Server User Guide

Abstract

This document is for the person who installs, administers, and troubleshoots servers and storage systems. Hewlett Packard Enterprise assumes you are qualified in the servicing of computer equipment and trained in recognizing hazards in products with hazardous energy levels.

Part Number: 30-507A97B9-006

Published: July 2024

Edition: 6

© Copyright 2022-2024 Hewlett Packard Enterprise Development LP

Notices

The information contained herein is subject to change without notice. The only warranties for Hewlett Packard Enterprise products and services are set forth in the express warranty statements accompanying such products and services. Nothing herein should be construed as constituting an additional warranty. Hewlett Packard Enterprise shall not be liable for technical or editorial errors or omissions contained herein.

Confidential computer software. Valid license from Hewlett Packard Enterprise required for possession, use, or copying. Consistent with FAR 12.211 and 12.212, Commercial Computer Software, Computer Software Documentation, and Technical Data for Commercial Items are licensed to the U.S. Government under vendor's standard commercial license.

Links to third-party websites take you outside the Hewlett Packard Enterprise website. Hewlett Packard Enterprise has no control over and is not responsible for information outside the Hewlett Packard Enterprise website.

Acknowledgments

AMD is a trademark of Advanced Micro Devices, Inc.

Linux® is the registered trademark of Linus Torvalds in the U.S. and other countries.

Microsoft® and Windows® are either registered trademarks or trademarks of Microsoft Corporation in the United States and/or other countries.

VMware® is a registered trademark or trademark of VMware, Inc. and its subsidiaries in the United States and other jurisdictions.

All third-party marks are property of their respective owners.

Table of contents

- Component identification
 - Front panel components
 - iLO Service Port
 - Front panel LEDs and buttons
 - Server UID LED
 - Using the UID button to view the Server Health Summary
 - Front panel LED power fault codes
 - Rear panel components
 - Display device setup
 - Rear panel LEDs
 - System board components
 - System maintenance switch descriptions
 - DIMM label identification
 - DIMM slot numbering
 - Processor and socket components
 - Riser board components
 - PCIe5 slot description
 - PCIe switch board components
 - Accelerator numbering
 - Riser slot numbering
 - Drive bay numbering
 - SFF drive bay numbering
 - LFF drive bay numbering
 - E3.S drive bay numbering
 - Drive backplane naming
 - HPE Basic Drive LED definitions
 - EDSFF SSD LED definitions
 - DSC-25 2-port SFP28 card ports and LEDs
 - Fan numbering
 - Fan and heatsink requirements
 - Trusted Platform Module 2.0
 - Trusted Platform Module 2.0 guidelines
 - BitLocker recovery key/password retention guidelines
 - HPE NS204i-u Boot Device components
 - HPE NS204i-u Boot Device LED definitions
- Setup
 - Initial system installation
 - HPE Installation Service
 - Setting up the server

- Operational requirements
 - Space and airflow requirements
 - Temperature requirements
 - Power requirements
 - Electrical grounding requirements
- Rack warnings and cautions
- Server warnings and cautions
- Electrostatic discharge
- Operations
 - Power up the server
 - Power down the server
 - Open the cable management arm
 - Types of air baffles
 - Remove the air baffle
 - Install the air baffle
 - Extend the server out of the rack
 - Remove the server from the rack
 - Remove the front bezel
 - Remove the access panel
 - Remove the fan cage
 - Remove the LFF drive backplane bracket
 - Remove the midwall bracket
 - Remove the midplane drive cage
 - Remove the rear 4 LFF drive cage
 - Remove the riser cage
 - Install the access panel
 - Install the LFF drive backplane bracket
 - Install the riser cage
 - Install the midwall bracket
 - Install the rear 4 LFF drive cage
 - Install the fan cage
- Hardware options installation
 - Server data backup
 - Hardware option installation guidelines
 - Hewlett Packard Enterprise product QuickSpecs
 - Rack mounting options
 - Rail identification markers
 - Rack mounting interfaces
 - Rack rail options
 - Installing the friction rack rails
 - Installing the ball-bearing rack rails

- Installing the server into the rack: Friction rack rail
- Installing the server into the rack: Ball-bearing rack rail
- Installing the rack rail hook-and-loop strap
- Installing the cable management arm
- Installing the front bezel option
- Universal media bay options
 - Installing the universal media bay in the LFF chassis
 - Installing the universal media bay in the SFF chassis
- Optical drive option
 - Installing the optical disc drive in the LFF universal media bay
 - Installing the optical disc drive in the SFF universal media bay
- Power supply options
 - Power supply warnings and cautions
 - DC power supply warnings and cautions
 - DC power supply wire colors
 - Connecting a DC power cable to a DC power source
 - Installing a DC power supply
 - Installing an AC power supply
 - Installing the power supply cage
- Expansion card options
 - Installing an expansion card
 - Installing the expansion card in the HPE NS204i-u Boot Device riser cage
 - Installing an expansion card on the three-slot riser cage
- Processor and heatsink options
 - Processor cautions
 - Installing a processor heatsink assembly
 - Reconfiguring the system date and time settings
- Drive options
 - Drive installation guidelines
 - Installing a hot-plug LFF/SFF SAS, SATA or NVMe drive
 - Installing a hot-plug SAS, SATA or NVMe drive in the midplane drive cage
 - Installing an E3.S drive
- Drive cage options
 - Installing the front 2 SFF side-by-side drive cage
 - Installing the front 2 SFF stacked drive cage
 - Installing the rear 2 SFF drive cage over the power supplies
 - Installing the front 8 SFF drive cage
 - Installing the front 8 SFF drive cage in the 48 SFF drive configuration
 - Installing the midplane drive cage
 - Installing the 8 E3.S drive cage
- Fan options

- Fan mode behavior
- Installing a high performance fan
- Accelerator options
 - Accelerator installation guidelines
 - Installing an accelerator
- Riser and riser cage options
 - Installing the secondary riser cage
 - Installing a stacking riser
- Memory option
 - HPE SmartMemory speed and population information
 - Installing a DIMM
- OCP NIC 3.0 adapter option
 - OCP slot population rules
 - Installing the OCP NIC 3.0 adapter
- HPE NS204i-u Boot Device option
 - Installing the boot device security cover in a preconfigured server
 - Installing the HPE NS204i-u Boot Device on the secondary low-profile riser cage
 - Installing the HPE NS204i Boot Device on the secondary riser cage
 - Installing the HPE NS204i Boot Device on top of the power supply cage
- Storage controller options
 - Preparing the server for storage controller installation
 - Installing a type-p storage controller in the 4 LFF drive configuration
 - Installing a type-p storage controller in the three-slot riser cage
 - Installing a type-o controller
- Transceiver option
 - Transceiver warnings and cautions
 - Installing a transceiver
- Energy pack options
 - HPE Smart Storage Battery
 - HPE Smart Storage Hybrid Capacitor
 - Installing an energy pack
 - Installing an energy pack in an accelerator-optimized drive configuration
- Serial port option
 - Installing the serial port
- Chassis intrusion detection switch option
 - Installing the chassis intrusion detection switch
- Installing the System Insight Display module
- Internal USB device option
 - Installing an internal USB device
- Cabling
 - Cabling guidelines

- Internal cabling management
- Cabling diagrams
- Storage cabling
 - Drive power cabling
 - Storage controller cabling
 - Front-end drive cabling
 - SFF drive cabling
 - LFF drive cabling
 - E3.S drive cabling
 - Midplane drive cabling
 - Rear-end drive controller cabling
 - SFF drive cabling
 - LFF drive cabling
 - Energy pack cabling
 - Storage controller backup power cabling
- GPU auxiliary power cabling
- Riser cabling
 - Stacking riser cabling
 - GPU riser cabling
- Switch board cabling
- HPE NS204i Boot Device cabling
- System Insight Display cabling
- Chassis intrusion switch cabling
- Universal media bay cabling
- DisplayPort cabling
- Front I/O cabling
- Power distribution board cabling
- Serial port cabling
- Optical drive cabling
- OCP bandwidth upgrade cabling
- XGMI cabling
- Configuration resources
 - Updating firmware or system ROM
 - Configuring the server
 - Configuring storage controllers
 - Managing the HPE NS204i-u Boot Device
 - Deploying an OS
 - Configuring security
 - Optimizing the server
 - Server management
 - Managing Linux-based high performance compute clusters

- Troubleshooting
 - NMI functionality
 - Troubleshooting resources
- System battery replacement
 - System battery information
 - Replace the system battery
- Safety, warranty, and regulatory information
 - Regulatory information
 - Notices for Eurasian Economic Union
 - Turkey RoHS material content declaration
 - Ukraine RoHS material content declaration
 - Warranty information
- Specifications
 - Environmental specifications
 - Mechanical specifications
 - Power supply specifications
 - HPE 800W Flex Slot Platinum Hot-plug Low Halogen Power Supply
 - HPE 1600 W Flex Slot Platinum Hot-plug Low Halogen Power Supply
 - HPE 1600 W Flex Slot -48 VDC Hot-plug Power Supply
- Websites
- Support and other resources
 - Accessing Hewlett Packard Enterprise Support
 - HPE product registration
 - Accessing updates
 - Customer self repair
 - Remote support
 - Documentation feedback

Component identification

Subtopics

[Front panel components](#)

[Front panel LEDs and buttons](#)

[Rear panel components](#)

[Rear panel LEDs](#)

[System board components](#)

[Riser board components](#)

[PCIe5 slot description](#)

[PCIe switch board components](#)

[Accelerator numbering](#)

[Riser slot numbering](#)

[Drive bay numbering](#)

[Drive backplane naming](#)

[HPE Basic Drive LED definitions](#)

[EDSFF SSD LED definitions](#)

[DSC-25 2-port SFP28 card ports and LEDs](#)

[Fan numbering](#)

[Fan and heatsink requirements](#)

[Trusted Platform Module 2.0](#)

[HPE NS204i-u Boot Device components](#)

[HPE NS204i-u Boot Device LED definitions](#)

Front panel components

8 LFF drive configuration



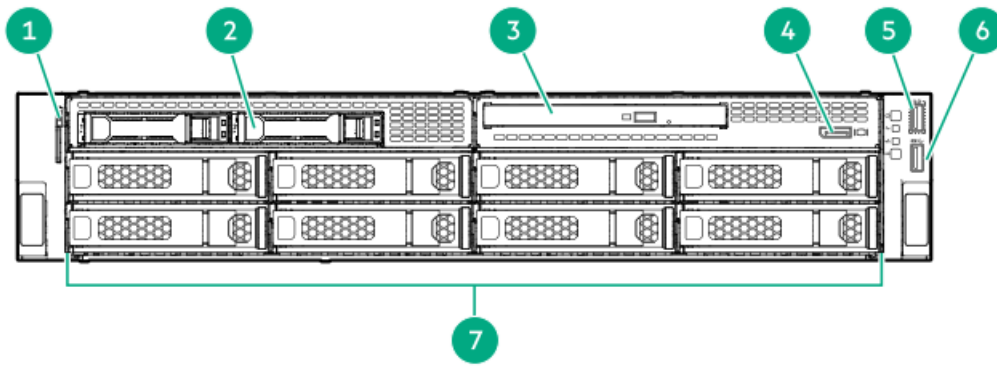

Item	Description
1	Serial number/iLO information pull tab ¹
2	2 SFF side-by-side drives (optional) ²
3	Optical drive (optional)
4	<u>DisplayPort 1.1a</u> (optional)
5	<u>iLO service port</u>
6	USB 3.2 Gen 1 port
7	LFF drives ³

¹ The serial number/iLO information pull tab is double-sided. One side shows the server serial number and the customer asset tag label. The other side shows the default iLO account information.

² The 2 SFF side-by-side drive cage option supports SAS, SATA, or U.3 NVMe drives.

³ The server supports LFF SAS or SATA drives.

12 LFF drive configuration

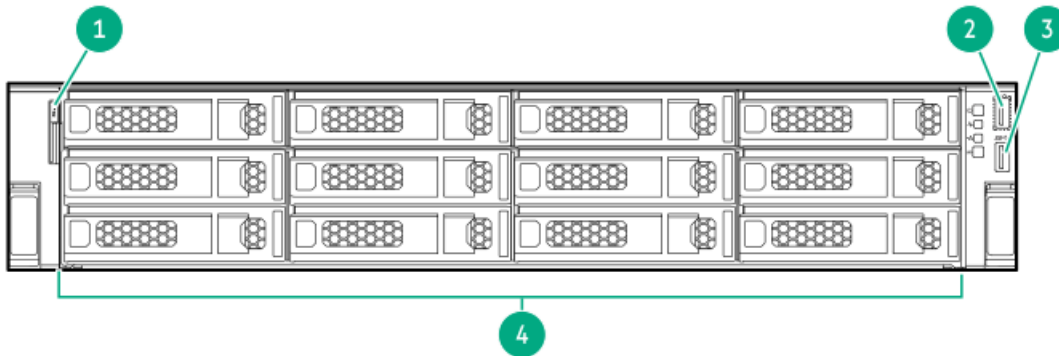

Item	Description
1	Serial number/iLO information pull tab ¹
2	<u>iLO service port</u>
3	USB 3.2 Gen 1 port
4	LFF drives ²

¹ The serial number/iLO information pull tab is double-sided. One side shows the server serial number and the customer asset tag label. The other side shows the default iLO account information.

² The server supports LFF SAS or SATA drives.

16 SFF drive model with options

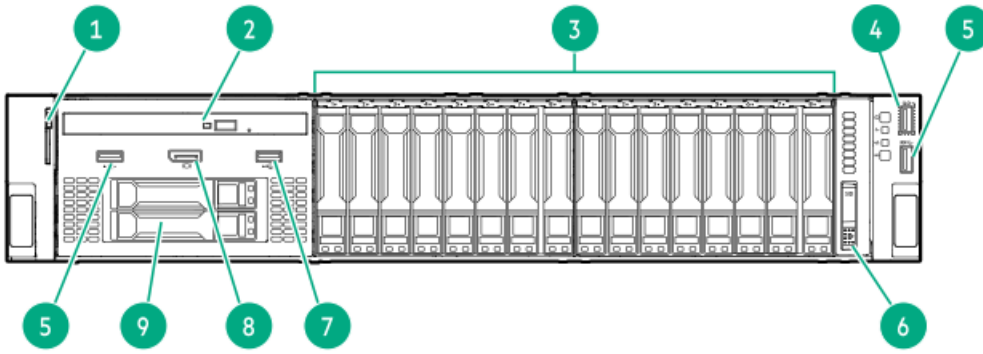

Item	Description
1	Serial number/iLO information pull tab ¹
2	Optical drive (optional)
3	SFF drive bays ²
4	iLO service port
5	USB 3.2 Gen 1 port (optional)
6	System Insight Display (optional)
7	USB 2.0 port
8	DisplayPort 1.1a (optional)
9	Front 2 SFF stacked drives (optional)

¹ The serial number/iLO information pull tab is double-sided. One side shows the server serial number and the customer asset tag label. The other side shows the default iLO account information.

² The 8 SFF drive cage supports the following drive types: SATA, SAS and U.3 NVMe drives.

24 SFF drive configuration

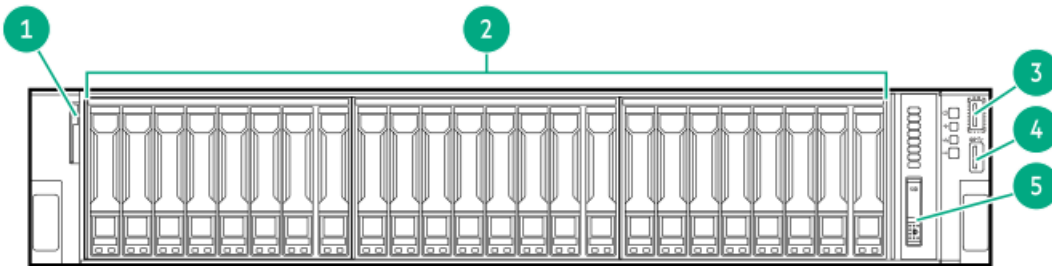

Item	Description
1	Serial number/iLO information pull tab ¹
2	SFF drives ²
3	iLO service port
4	USB 3.2 Gen 1 port
5	System Insight Display (optional)

¹ The serial number/iLO information pull tab is double-sided. One side shows the server serial number and the customer asset tag label. The other side shows the default iLO account information.

² Depending on the [type of drive backplane installed](#), the server supports SFF SAS, SATA, or U.3 NVMe drives.

48 SFF drive configuration

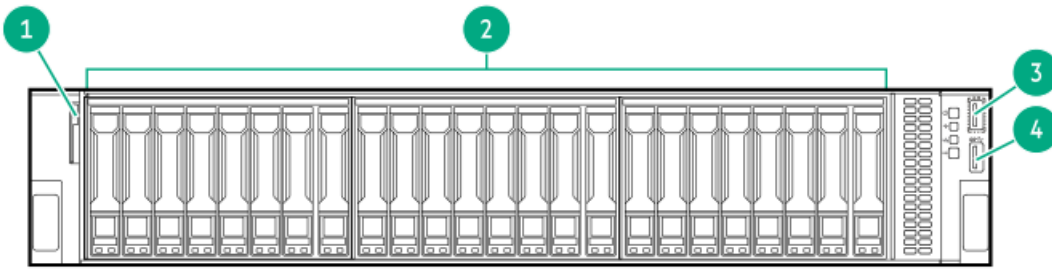

Item	Description
1	Serial number/iLO information pull tab ¹
2	SFF drives ²
3	iLO service port
4	USB 3.2 Gen 1 port

¹ The serial number/iLO information pull tab is double-sided. One side shows the server serial number and the customer asset tag label. The other side shows the default iLO account information.

² Depending on the [type of drive backplane installed](#), the server supports SFF SAS, SATA, or U.3 NVMe drives.

24 E3.S drive configuration

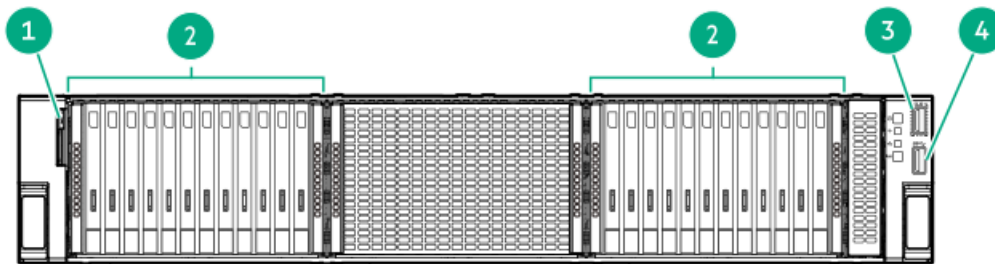

Item	Description
1	Serial number/iLO information pull tab ¹
2	E3.S drives
3	iLO service port
4	USB 3.2 Gen 1 port

¹ The serial number/iLO information pull tab is double-sided. One side shows the server serial number and the customer asset tag label. The other side shows the default iLO account information.

32 E3.S drive configuration



Item	Description
1	Serial number/iLO information pull tab ²
2	E3.S drives
3	<u>iLO service port</u>
4	USB 3.2 Gen 1 port

² The serial number/iLO information pull tab is double-sided. One side shows the server serial number and the customer asset tag label. The other side shows the default iLO account information.

36 E3.S drive configuration

This drive configuration supports a x2 connection.

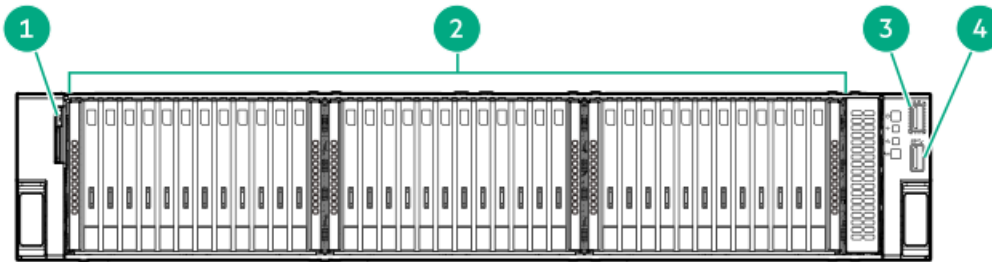

Item	Description
1	Serial number/iLO information pull tab ¹
2	E3.S drives
3	<u>iLO service port</u>
4	USB 3.2 Gen 1 port

¹ The serial number/iLO information pull tab is double-sided. One side shows the server serial number and the customer asset tag label. The other side shows the default iLO account information.

8 SFF drive configuration with two GPU riser cages

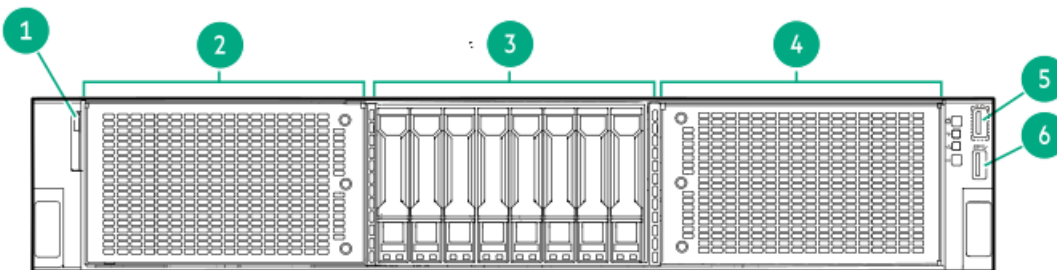

Item	Description
1	Serial number/iLO information pull tab ¹
2	GPU riser cage 1
3	SFF drives ²
4	GPU riser cage 2
5	<u>iLO service port</u>
6	USB 3.2 Gen 1 port

¹ The serial number/iLO information pull tab is double-sided. One side shows the server serial number and the customer asset tag label. The other side shows the default iLO account information.

² The server supports U.3 NVMe drives.

8 E3.S drive configuration with two GPU riser cages

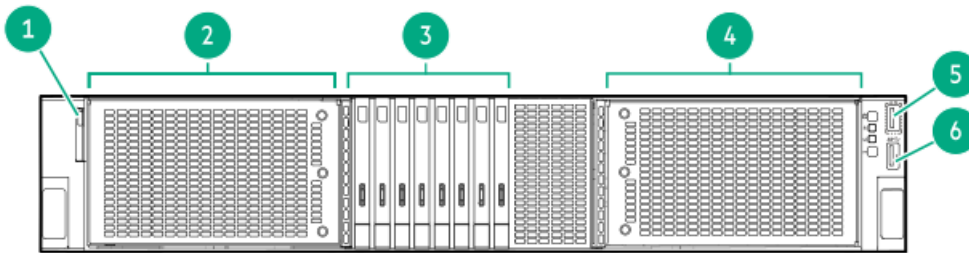

Item	Description
1	Serial number/iLO information pull tab ¹
2	GPU riser cage 1
3	8 E3.S drives
4	GPU riser cage 2
5	<u>iLO service port</u>
6	USB 3.2 Gen 1 port

¹ The serial number/iLO information pull tab is double-sided. One side shows the server serial number and the customer asset tag label. The other side shows the default iLO account information.

12 E3.S drive configuration with two GPU riser cages

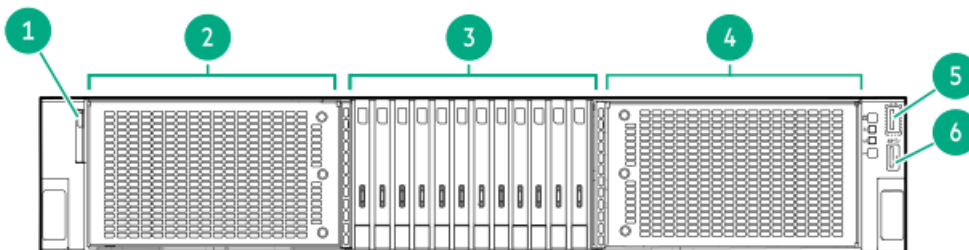

Item	Description
1	Serial number/iLO information pull tab ¹
2	GPU riser cage 1
3	12 E3.S drives
4	GPU riser cage 2
5	<u>iLO service port</u>
6	USB 3.2 Gen 1 port

¹ The serial number/iLO information pull tab is double-sided. One side shows the server serial number and the customer asset tag label. The other side shows the default iLO account information.

Subtopics

iLO Service Port

iLO Service Port

The Service Port is a USB port with the label **iLO** on supported servers and compute modules.

To find out if your server or compute module supports this feature, see the server specifications document at the following website: <https://www.hpe.com/info/quickspecs>.

The Service Port is a USB port with the label **iLO** on the front of the server.

To find out if your server supports this feature, see the server specifications document at the following website: <https://www.hpe.com/info/quickspecs>.

When you have physical access to a server, you can use the Service Port to do the following:

- Download the Active Health System Log to a supported USB flash drive.
 - When you use this feature, the connected USB flash drive is not accessible by the host operating system.
- Connect a client (such as a laptop) with a supported USB to Ethernet adapter to access the following:
 - iLO web interface
 - Remote console
 - iLO RESTful API
 - CLI

When you use the iLO Service Port:

- Actions are logged in the iLO event log.
- The server UID flashes to indicate the Service Port status.
 - You can also retrieve the Service Port status by using a REST client and the iLO RESTful API.
- You cannot use the Service Port to boot any device within the server, or the server itself.
- You cannot access the server by connecting to the Service Port.
- You cannot access the connected device from the server.

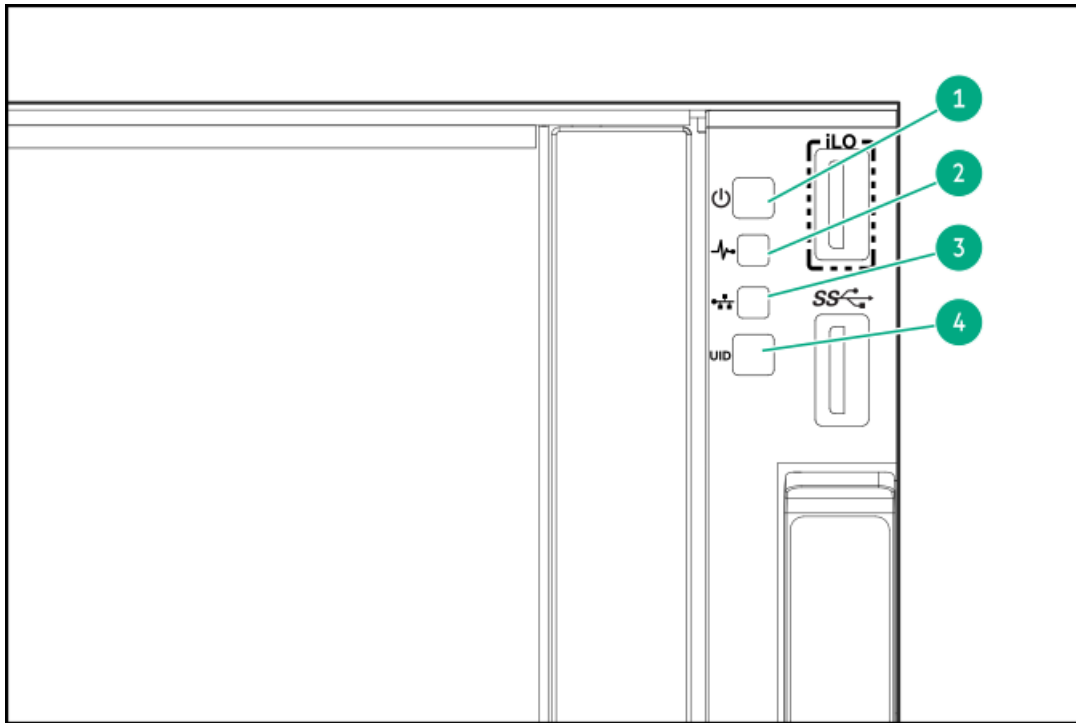

Item	Description	Status	Definition
1	Power On/Standby button and system power LED ¹	Solid green	System on
		Flashing green	Performing power-on sequence
		Solid amber	System in standby
		Off	No power present ²
2	Health LED ¹	Solid green	Normal
		Flashing green	iLO is rebooting
		Flashing amber	System degraded ³
		Flashing red	System critical ³
3	NIC status LED ¹	Solid green	Linked to network
		Flashing green	Network active
		Off	No network activity
4	UID button/LED ¹	Solid blue	Activated
		Flashing blue	<ul style="list-style-type: none"> 1 flash per second—Remote management or firmware upgrade in progress 4 flashes per second—iLO manual reboot sequence initiated 8 flashes per second—iLO manual reboot sequence in progress
		Off	Deactivated



- 1 When all LEDs flash simultaneously, a power fault has occurred. For more information, see [Front panel LED power fault codes](#).
- 2 Facility power is not present, power cord is not attached, no power supplies are installed, power supply failure has occurred, or the front I/O cable is disconnected.
- 3 If the health LED indicates a degraded or critical state, [review the system Integrated Management Log \(IML\) or use HPE iLO to review the system health status](#).

Subtopics

[Server UID LED](#)

[Using the UID button to view the Server Health Summary](#)

[Front panel LED power fault codes](#)

Server UID LED

The UID LED is used to locate a particular server when it is deployed in a dense rack with other equipment. Activating the UID LED helps an on-site technician to quickly identify a server for maintenance tasks.

Using the UID button to view the Server Health Summary

Prerequisites

- An external monitor is connected.
- In the iLO web interface, the Show Server Health on External Monitor feature is enabled on the Access Settings page.

About this task

Use the UID button to display the iLO Server Health Summary screen on an external monitor. This function works when the server is powered on or off. Use this feature for troubleshooting if the server will not start up.

 **CAUTION:** Press and release the UID button. Holding it down at any time for more than five seconds initiates a graceful iLO reboot or a hardware iLO reboot. Data loss or NVRAM corruption might occur during a hardware iLO reboot.

Procedure

1. Press and release the UID button.

The Server Health Summary screen is displayed on the external monitor. For more information, see the iLO troubleshooting guide:

<https://www.hpe.com/support/ilo6>

2. Press the UID button again to close the Server Health Summary screen.

Front panel LED power fault codes

The following table provides a list of power fault codes, and the subsystems that are affected. Not all power faults are used by all servers.



Subsystem	LED behavior
System board	1 flash
Processor	2 flashes
Memory	3 flashes
Riser board PCIe slots	4 flashes
FlexibleLOM	5 flashes
Storage controller	6 flashes
System board PCIe slots	7 flashes
Power backplane	8 flashes
Storage backplane	9 flashes
Power supply	10 flashes
PCIe expansion cards installed in riser board	11 flashes
Chassis	12 flashes
GPU card	13 flashes

Rear panel components

Rear panel components with options

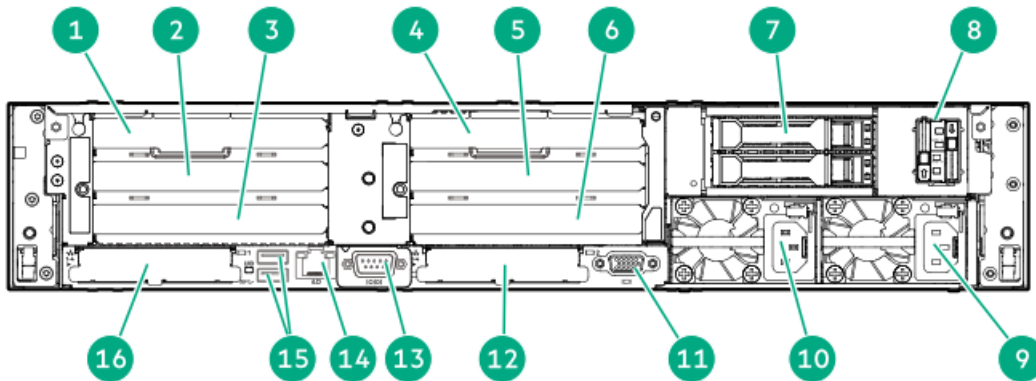

Item	Description
1	Slot 1 PCIe5 x16 stacking riser (optional) ¹
2	Slot 2 PCIe5 x16 stacking riser (optional) ¹
3	Slot 3 PCIe5 x16 base riser ¹
4	Slot 4 PCIe5 x16 stacking riser (optional) ²
5	Slot 5 PCIe5 x16 stacking riser (optional) ²
6	Slot 6 PCIe5 x16 base riser (optional) ²
7	Rear 2 SFF stacked drives (optional)
8	NS204i-u boot device (optional)
9	Flexible Slot power supply 1
10	Flexible Slot power supply 2 (optional)
11	<u>VGA port</u>
12	Slot 22 OCP PCIe5 x8
13	Serial port (optional)
14	iLO management port
15	USB 3.2 Gen 1 ports
16	Slot 21 OCP PCIe5 x8

- ¹ These riser slots are in a primary riser cage.
² These riser slots are in a secondary riser cage.

Rear panel components with the tertiary riser

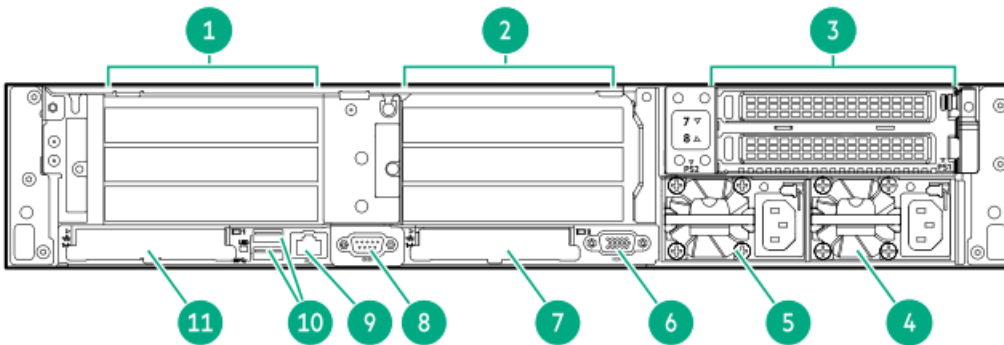

Item	Description
1	1-3 PCIe5 x16 slots (primary riser, slot 1 and 2 are optional)
2	4-6 PCIe5 x16 slots (secondary riser, optional)
3	7-8 PCIe5 x16 slots (tertiary riser, optional)
4	Flexible Slot power supply 1
5	Flexible Slot power supply 2 (optional)
6	<u>VGA port</u>
7	Slot 22 OCP PCIe5 x8
8	Serial port (optional)
9	iLO management port
10	USB 3.2 Gen 1 ports
11	Slot 21 OCP PCIe5 x8

Rear panel components with rear 4 LFF drives

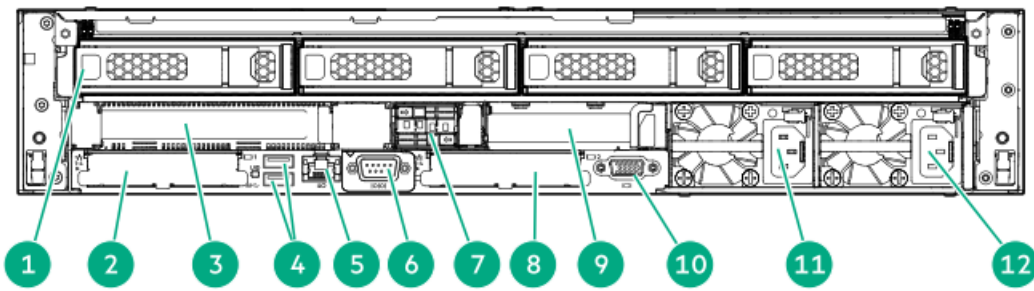

Item	Description
1	LFF drives (optional)
2	Slot 21 OCP PCIe5 x8
3	Slot 3 PCIe5 x16 base riser1 ¹
4	USB 3.2 Gen 1 ports
5	iLO management port
6	Serial port (optional)
7	NS204i-u boot device (optional)
8	Slot 22 OCP PCIe5 x8
9	Slot 6 PCIe5 x16 in low-profile riser (optional) ²
10	VGA port
11	Flexible Slot power supply 2 (optional)
12	Flexible Slot power supply 1

¹ This riser slot is in a primary riser cage.

² This riser slot is in a secondary riser cage.

Rear panel components with four power supplies

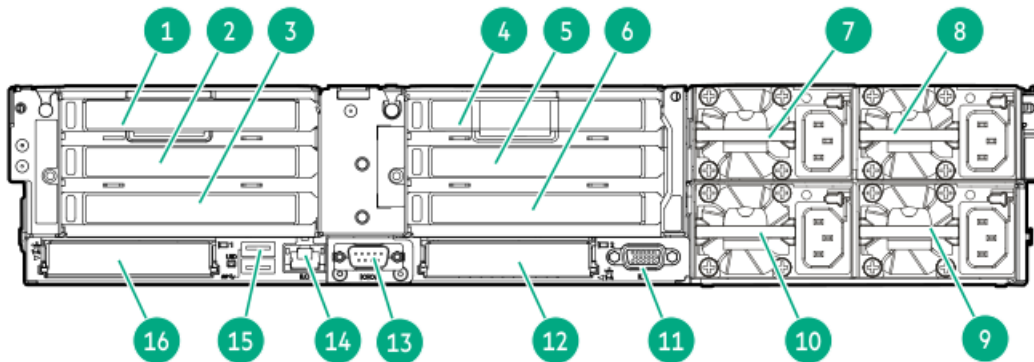

Item	Description
1	Slot 1 PCIe5 x16 stacking riser (optional) ¹
2	Slot 2 PCIe5 x16 stacking riser (optional)
3	Slot 3 PCIe5 x16 base riser
4	Slot 4 PCIe5 x16 stacking riser (optional) ²
5	Slot 5 PCIe5 x16 stacking riser (optional)
6	Slot 6 PCIe5 x16 base riser (optional)
7	Flexible Slot power supply 4 (optional)
8	Flexible Slot power supply 3 (optional)
9	Flexible Slot power supply 1
10	Flexible Slot power supply 2
11	<u>VGA port</u>
12	Slot 22 OCP PCIe5 x8
13	Serial port (optional)
14	iLO management port
15	USB 3.2 Gen 1 ports
16	Slot 21 OCP PCIe5 x8

- ¹ These riser slots are in a primary riser cage.
² These riser slots are in a secondary riser cage.

Subtopics

Display device setup

Display device setup

This server supports both VGA port and Display port 1.1a. Before connecting a display device to this server, review the following information:

- Whenever possible, use the same display connection type. For example, if your PC or monitor only has a VGA output, connect it to the server VGA port. Use of any kind of adapter or converter cable or dongle might lead to decreased display quality or a lag over the connection.
- DisplayPort connection: When connecting an HDMI or DVI display to the DisplayPort, use an active type adapter. Passive type adapter—marked with the DP++ symbol—is not supported.
- Display output modes:
 - If you connect two display devices to the VGA port and DisplayPort, the same image is shown on both devices—screen mirroring mode.
 - The embedded video controller in the iLO 6 chipset does not support dual display or screen extension mode. To enable dual display mode, install a compatible graphics card that supports this feature in the expansion slot.

Rear panel LEDs



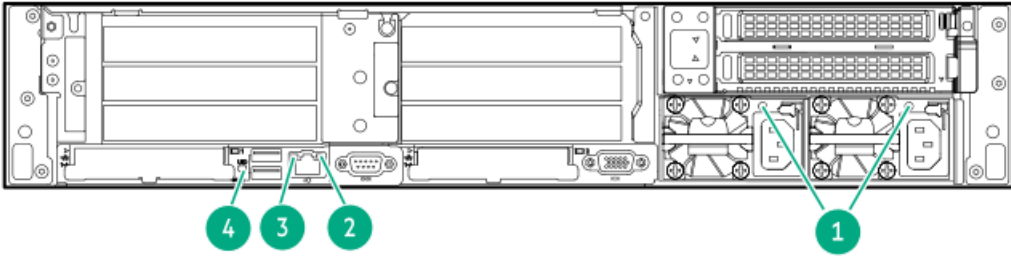

Item	LED	Status	Definition
1	Power supply	Solid green	The power supply is operating normally.
		Off	One or more of the following conditions exists: <ul style="list-style-type: none"> Power is unavailable Power supply failure Power supply is in standby mode Power supply error The front I/O cable is disconnected.
2	iLO status	Solid green	Lined to network
		Flashing green	Network active
		Off	No network activity
3	iLO link	Solid green	Network link
		Off	No network link
4	UID	Solid blue	Activated
		Flashing blue	<ul style="list-style-type: none"> 1 flash per sec—Remote management or firmware upgrade in progress 4 flashes per sec—iLO manual reboot sequence initiated 8 flashes per sec—iLO manual reboot sequence in progress
		Off	Deactivated
		Off	Deactivated

System board components



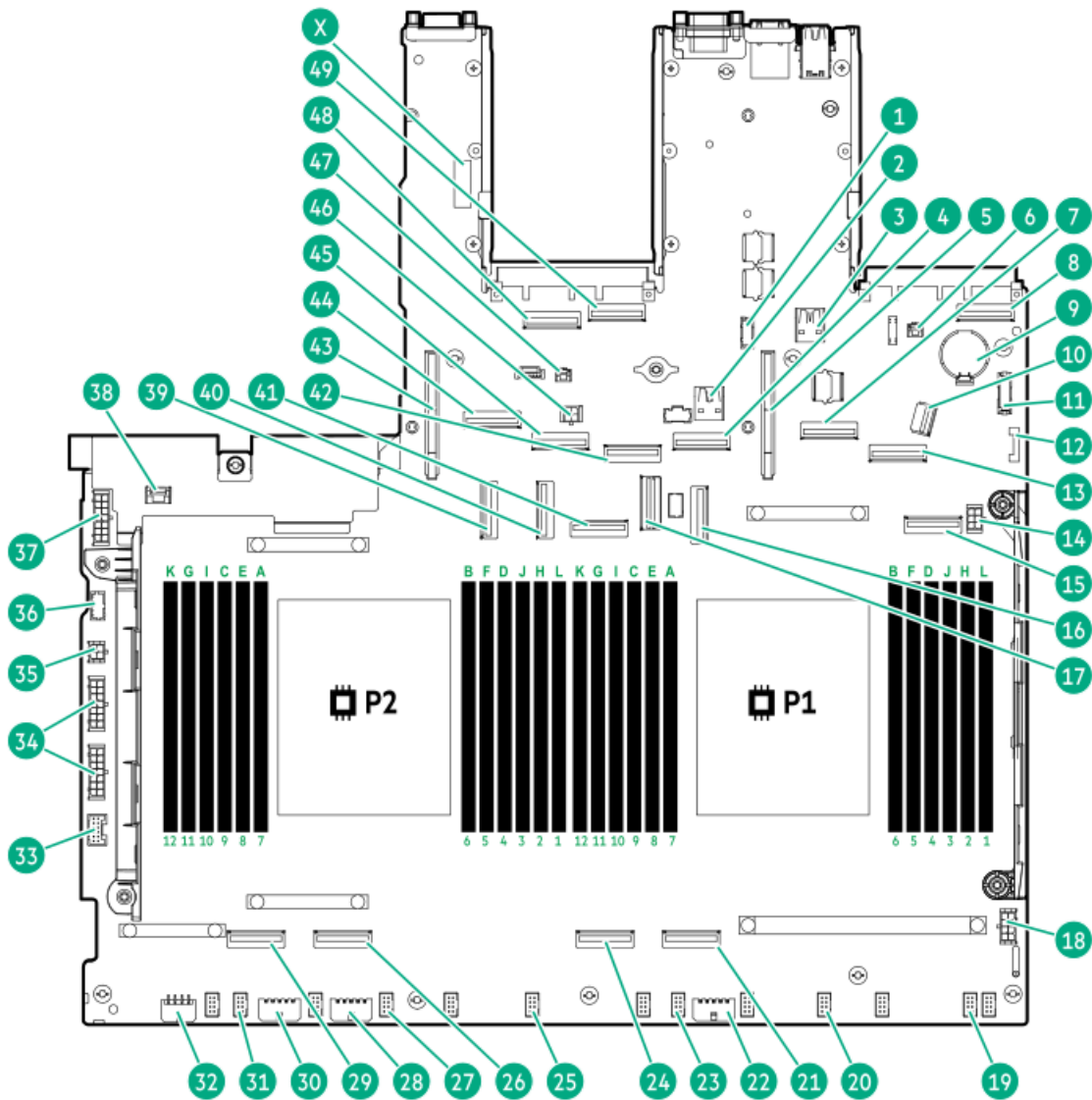

Item	Description
1	Serial port connector
2	Internal USB 3.2 Gen 1 port
3	Internal USB 3.2 Gen 1 port
4	NVMe/SATA port 1A
5	Primary riser connector
6	OCP slot 21 backup power connector
7	NVMe port 7A
8	OCP slot 21 x16 upgrade connector
9	System battery
10	Front I/O connector
11	Front DisplayPort/USB 2.0 connector
12	SID connector
13	NVMe port 6A
14	ODD/2SFF power connector

Item	Description
15	NVMe port 4A
16	NVMe/SATA port 9A
17	NS204i-u signal connector
18	GPU riser power connector
19	Fan connector 6
20	Fan connector 5
21	NVMe port 2A
22	Drive backplane power connector 3
23	Fan connector 4
24	NVMe port 3A
25	Fan connector 3
26	NVMe port 2B
27	Fan connector 2
28	Drive backplane power connector 2
29	NVMe port 3B
30	Drive backplane power connector 1
31	Fan connector 1
32	GPU riser power connector
33	Energy pack connector
34	GPU/Backplane/switch board power connector
35	Free-height riser power connector
36	Free-height riser sideband connector
37	Backplane power connector
38	Chassis intrusion detection switch connector
39	NVMe port 7B
40	NVMe port 6B
41	NVMe port 4B
42	NVMe port 5B
43	Secondary riser connector
44	NVMe/SATA port 9B
45	NVMe/SATA port 8B
46	Smart NIC mode 2 power connector
47	OCP slot 22 backup power connector
48	OCP slot 22 port 1
49	OCP slot 22 port 2
X	System maintenance switch

Subtopics

[System maintenance switch descriptions](#)

[DIMM label identification](#)

[DIMM slot numbering](#)



System maintenance switch descriptions

Position	Default	Function
S1 ¹	Off	<ul style="list-style-type: none">Off—iLO 6 security is enabled.On—iLO 6 security is disabled.
S2	Off	Reserved
S3	Off	Reserved
S4	Off	Reserved
S5 ¹	Off	<ul style="list-style-type: none">Off—Power-on password is enabled.On—Power-on password is disabled.
S6 ^{1, 2, 3}	Off	<ul style="list-style-type: none">Off—No functionOn—Restore default manufacturing settings
S7	Off	Reserved
S8	Off	Reserved
S9	Off	Reserved
S10	Off	Reserved
S11	Off	Reserved
S12	Off	Reserved

- ¹ To access the redundant ROM, set S1, S5, and S6 to On.
- ² When the system maintenance switch position 6 is set to the On position, the system is prepared to restore all configuration settings to their manufacturing defaults.
- ³ When the system maintenance switch position 6 is set to the On position and Secure Boot is enabled, some configurations cannot be restored. For more information, see [Configuring the server](#).

DIMM label identification

To determine DIMM characteristics, see the label attached to the DIMM. The information in this section helps you to use the label to locate specific information about the DIMM.

For more information about product features, specifications, options, configurations, and compatibility, see the [HPE DDR5 SmartMemory QuickSpecs](#):

<https://www.hpe.com/docs/server-memory>



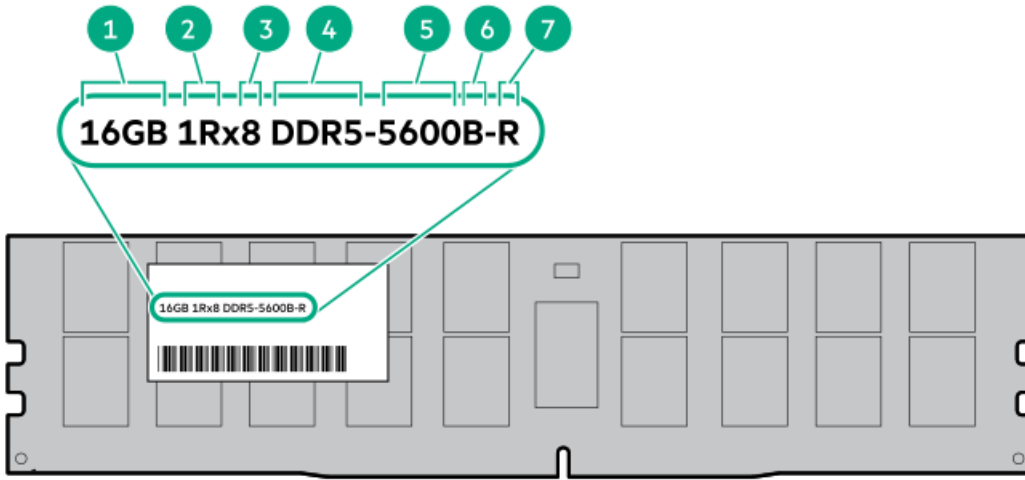

Item	Description	Example
1	Capacity ¹	16 GB 32 GB 64 GB 128 GB 256 GB
2	Rank	1R—Single rank 2R—Dual rank 4R—Quad rank 8R—Octal rank
3	Data width on DRAM	x4—4-bit x8—8-bit
4	Memory generation	PC5—DDR5
5	Maximum memory speed ¹	4800 MT/s 5600 MT/s
6	CAS latency	B—42-42-42 B—50-42-42 (for 128 GB and 256 GB capacities)
7	DIMM type	E—UDIMM (unbuffered with ECC) R—RDIMM (registered)

¹ The maximum memory speed and capacity is a function of the memory type, memory configuration, and processor model.

DIMM slot numbering

The arrow points to the front of the server.

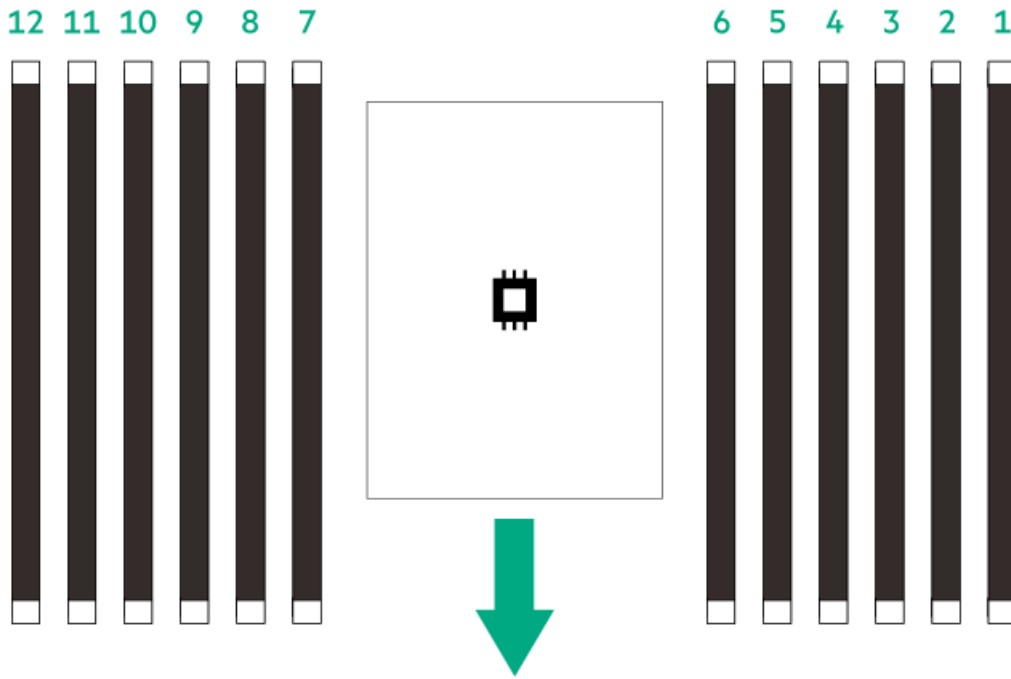

Processor and socket components

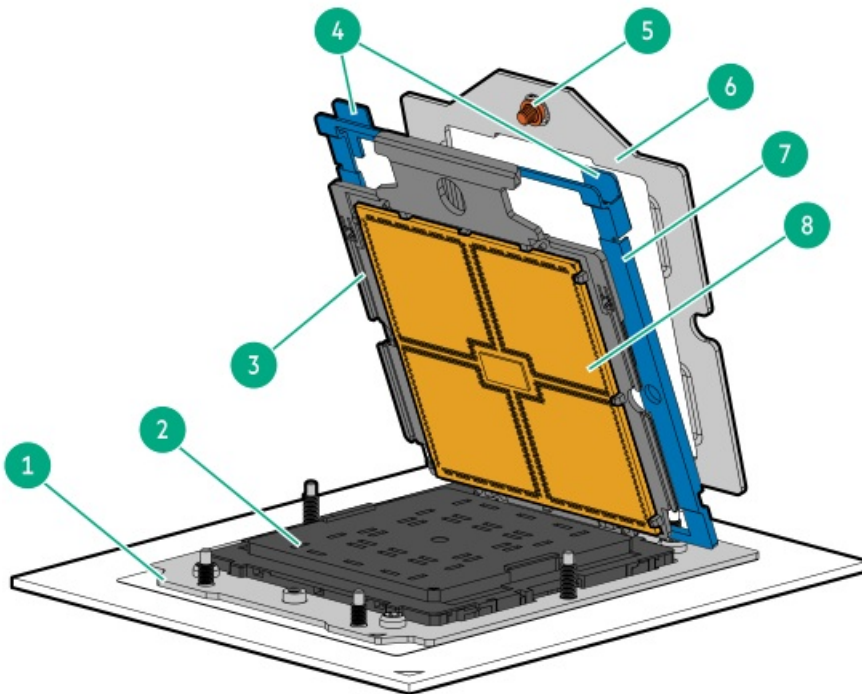

Item	Description
1	Processor socket
2	Pin field cover cap
3	Processor carrier
4	Rail frame lift tabs
5	Retention frame screw (T-20)
6	Retention frame
7	Rail frame
8	Processor

Riser board components

This server support three types of PCIe risers:

- Standard riser—This riser is a board-only riser that is directly installed on the riser connector on the system board. This riser type is used:
 - As a standalone riser in a single-slot riser cage.
 - As the base riser in a three-slot riser cage.
 - As the base riser in a two-slot riser cage.
- Cabled riser—This riser type has its signal cable soldered on the board itself. This riser type is combined with a standard, base riser and another cabled riser in a three-slot riser cage.
- Tertiary riser—This riser type has its signal cable soldered on the board itself. This riser type is combined with a standard, base riser and another cabled riser in a two-slot riser cage.
- GPU riser—This riser type has its signal cable soldered on the board itself. This riser type is combined with another GPU riser in GPU cage.

For clarity, the riser cage and the cables of the cabled risers are not shown in the following images.

Standard riser components

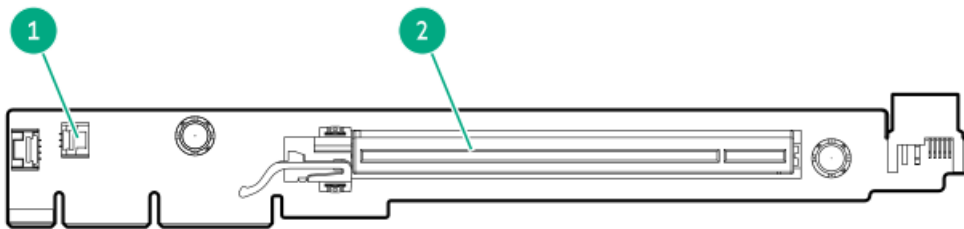

Item	Description
1	Storage controller backup power connector
2	PCIe5 x16 (16, 8, 4, 1) slot

Cabled riser components

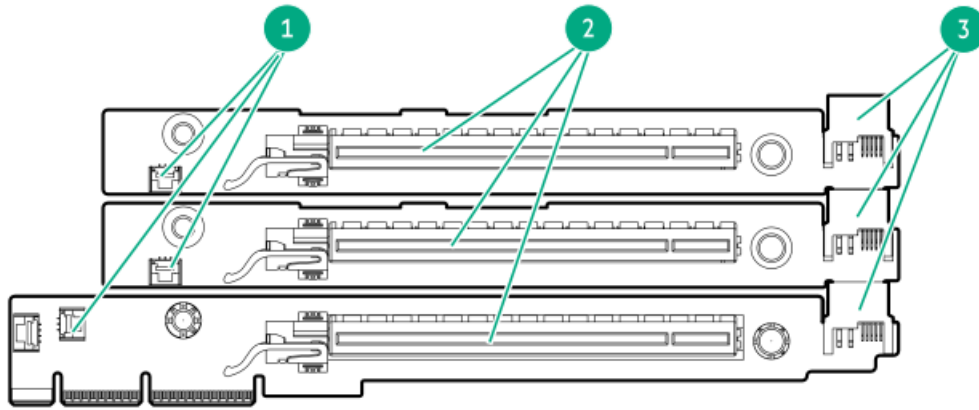

Item	Description
1	Storage controller backup power connectors
2	PCIe5 x16 (16, 8, 4, 1) slots
3	Riser power connectors

Tertiary riser components

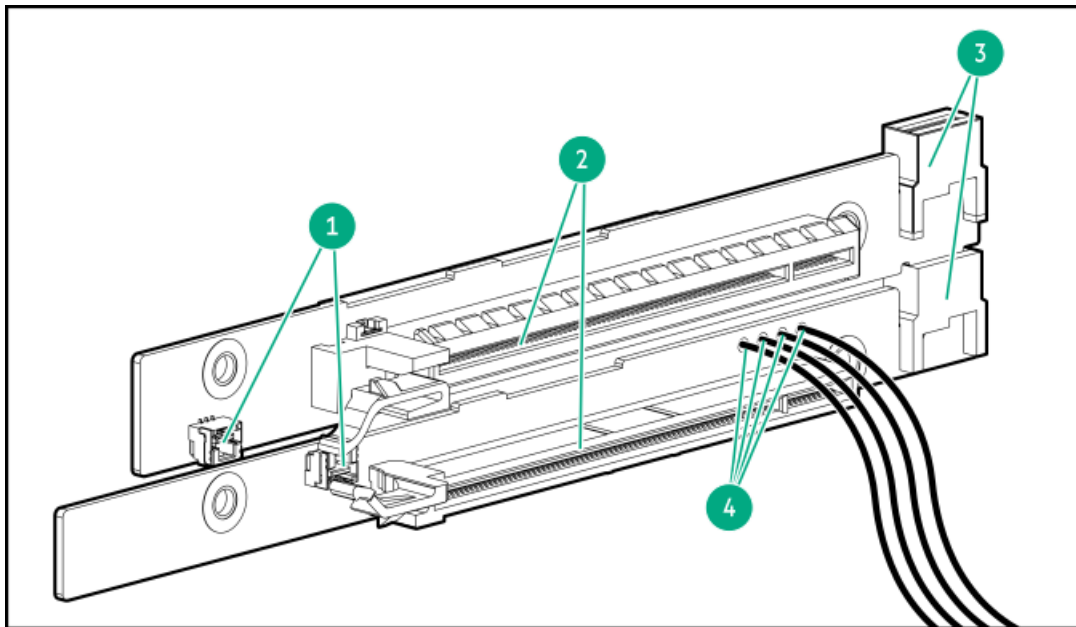

Item	Description
1	Storage controller backup power connector
2	PCIe5 x16 (16, 8, 4, 1) slots
3	Riser board power connector
4	Power cable

GPU riser components



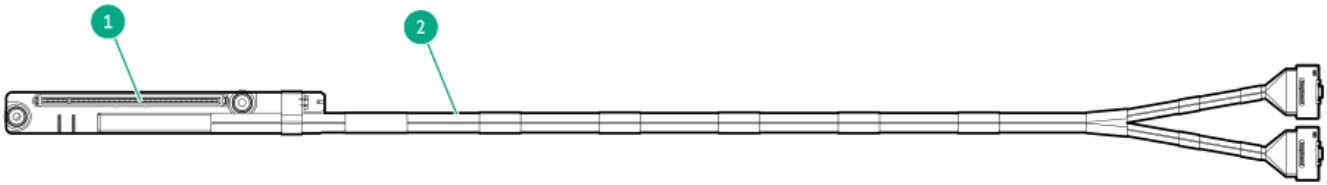

Item	Description
1	PCIe5 x16 (16, 8, 4, 1) slot
2	Signal cable

PCIe5 slot description

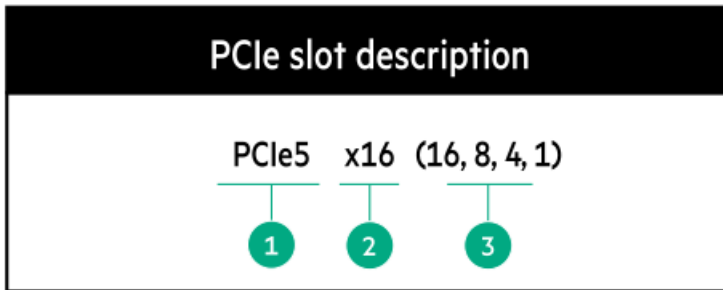

Item	Description	Definition
1	PCI Express version	<p>Each PCIe version corresponds to a specific data transfer rate between the processor and peripheral devices. Generally, a version update corresponds to an increase in transfer rate.</p> <ul style="list-style-type: none"> • PCIe 1.x • PCIe 2.x • PCIe 3.x • PCIe 4.x • PCIe 5.x <p>The PCIe technology is under constant development. For the latest information, see the PCI-SIG website.</p>
2	Physical connector link width	<p>PCIe devices communicate through a logical connection called an interconnect or link. At the physical level, a link is composed of one or more lanes. The number of lanes is written with an x prefix with x16 being the largest size in common use.</p> <ul style="list-style-type: none"> • x1 • x2 • x4 • x8 • x16
3	Negotiable link width	<p>These numbers correspond to the maximum link bandwidth supported by the slot.</p>

PCIe switch board components

Upper switch board

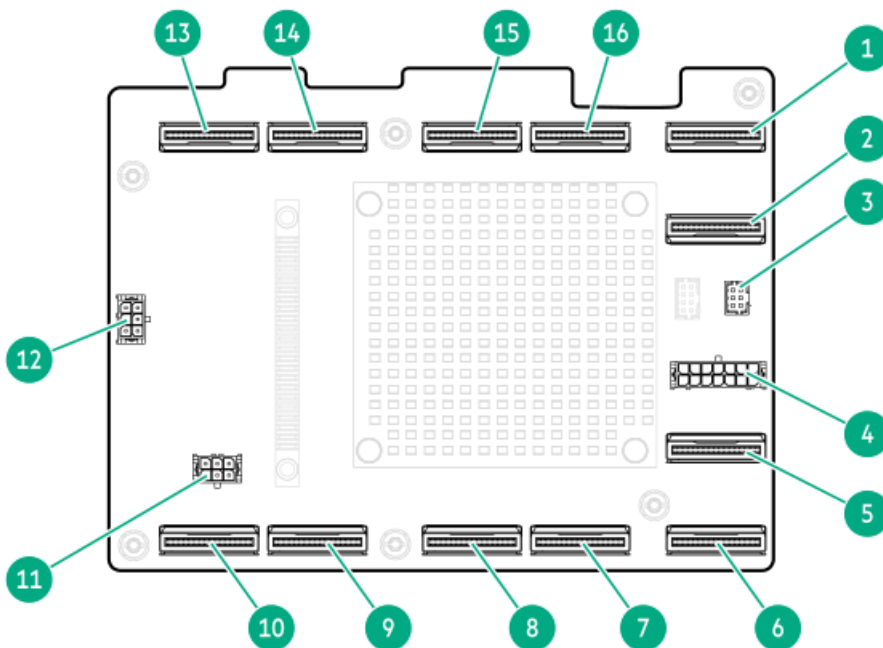

Item	Description	Connect to
1	Upper switch board downstream port 1	NVMe/SATA port 8B
2	Upper switch board downstream port 2	NVMe/SATA port 9B
3	Upper switch board signal extension connector	Lower switch board signal extension connector
4	Upper switch board power connector	Upper switch board power connector (P2) GPU cage 1 accelerator auxiliary power connector (P3)
5	Upper switch board downstream port 3	NVMe/SATA port 1A
6	Upper switch board downstream port 4	NVMe/SATA port 9A
7	GPU riser slot 14 MCIO connector (SEC)	GPU riser slot 14
8	GPU riser slot 14 MCIO connector (PRIM)	
9	GPU riser slot 13 MCIO connector (SEC)	GPU riser slot 13
10	GPU riser slot 13 MCIO connector (PRIM)	
11	GPU riser slot 13 and 14 power connector	GPU riser slot 13 (P2) GPU riser slot 14 (P3)
12	GPU riser slot 9 and 10 power connector	GPU riser slot 9 (P3) GPU riser slot 10 (P2)
13	GPU riser slot 9 MCIO connector (SEC)	GPU riser slot 9
14	GPU riser slot 9 MCIO connector (PRIM)	
15	GPU riser slot 10 MCIO connector (SEC)	GPU riser slot 10
16	GPU riser slot 10 MCIO connector (PRIM)	

Lower switch board



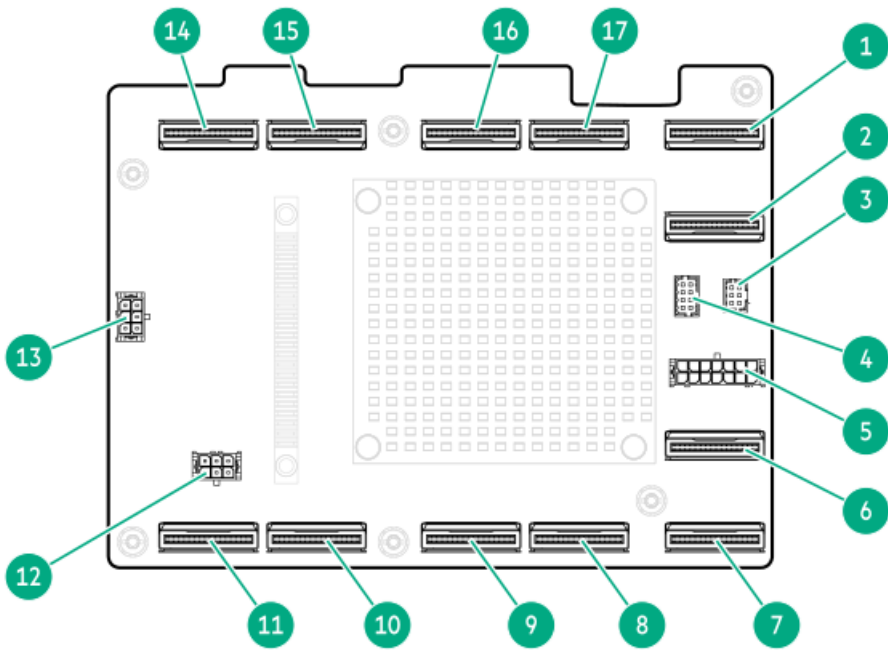

Item	Description	Connect to
1	Lower switch board downstream port 1	NVMe port 6B
2	Lower switch board downstream port 2	NVMe port 7B
3	Lower switch board signal connector	PCIe switch board signal connector on system board
4	Lower switch board signal extension connector	Upper switch board signal extension connector
5	Lower switch board power connector	Lower switch board power connector (P2) GPU cage 2 accelerator auxiliary power connector (P3)
6	Lower switch board downstream port 3	NVMe port 6A
7	Lower switch board downstream port 4	NVMe port 7A
8	GPU riser slot 16 MCIO connector (SEC)	GPU riser slot 16
9	GPU riser slot 16 MCIO connector (PRIM)	
10	GPU riser slot 15 MCIO connector (SEC)	GPU riser slot 15
11	GPU riser slot 15 MCIO connector (PRIM)	
12	GPU riser slot 15 and 16 power connector	GPU riser slot 15 (P2) GPU riser slot 16 (P3)
13	GPU riser slot 11 and 12 power connector	GPU riser slot 11 (P3) GPU riser slot 12 (P2)
14	GPU riser slot 11 MCIO connector (SEC)	GPU riser slot 11
15	GPU riser slot 11 MCIO connector (PRIM)	
16	GPU riser slot 12 MCIO connector (SEC)	GPU riser slot 12
17	GPU riser slot 12 MCIO connector (PRIM)	

Accelerator numbering

4 single-width accelerators

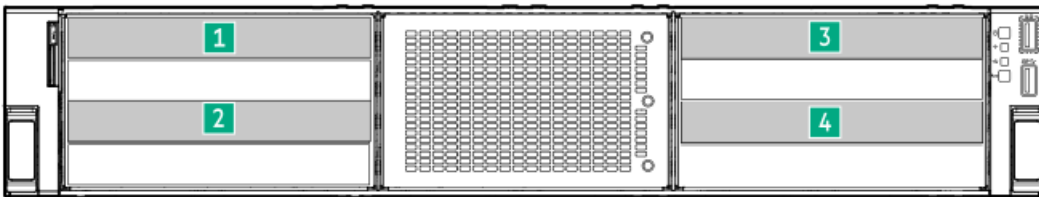

8 single-width accelerators



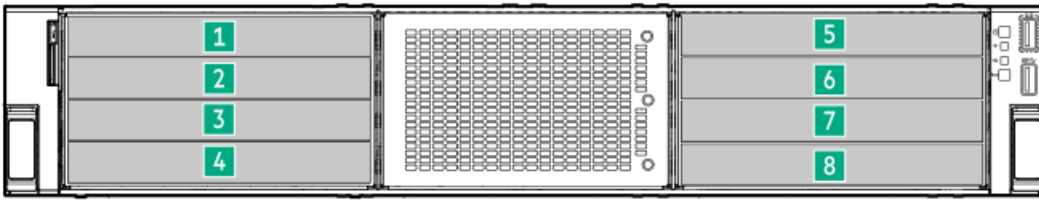

4 double-width accelerators

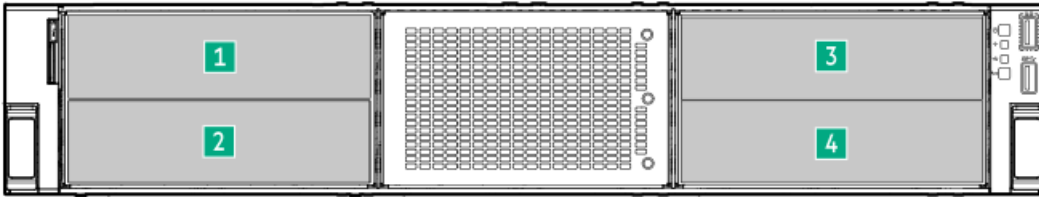

Riser slot numbering



CAUTION:

To maintain proper system cooling, do not install a 100 Gb or faster Ethernet / InfiniBand / NVME-oF adapter in Slot 6.

All riser slots are PCIe5 x16 (16, 8, 4, 1) and are rated for a maximum power draw of 75 W each.

8 single-width accelerator configuration

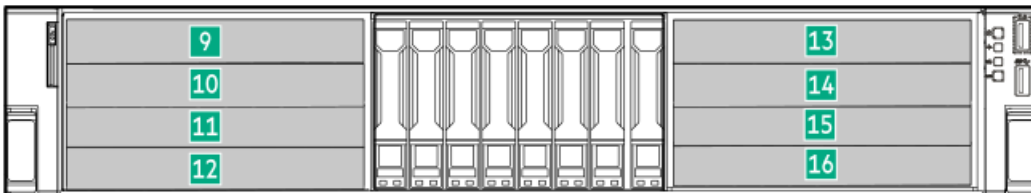

Slot number	Location	Supported form factors
9	GPU cage 1	Single-width, full-height, length ≤ 10.50 inches
10		
11		
12		
13	GPU cage 2	
14		
15		
16		

4 double-width accelerator configuration



Slot number	Location	Supported form factor
9	GPU riser cage 1	Double-width, full-height, length ≤ 10.50 inches
11		
14	GPU riser cage 2	
16		

Two-slot riser configuration without HPE NS204i-u Boot Device

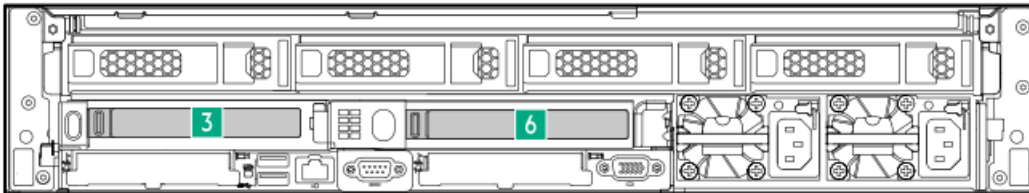

Slot number	Location	Supported form factors
3	Primary riser cage	<ul style="list-style-type: none"> • Full-height, half-length
6	Secondary riser cage	<ul style="list-style-type: none"> • Half-height, half-length (low-profile)

Two-slot riser configuration with HPE NS204i-u Boot Device

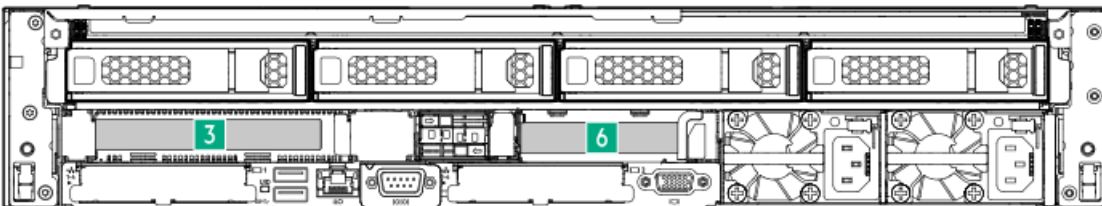

Slot number	Location	Supported form factors
3	Primary riser cage	<ul style="list-style-type: none"> • Full-height, half-length • Half-height, half-length (low-profile)
6	Secondary riser cage	Half-height, half-length (low-profile)

Six-slot riser configuration

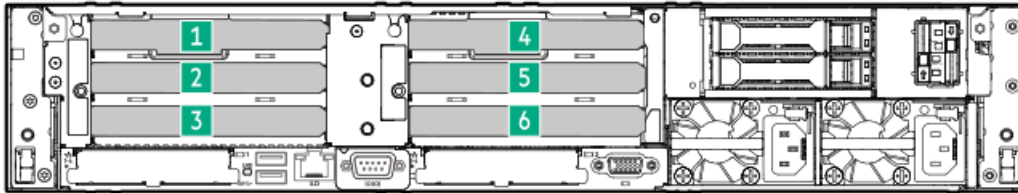

Slot number	Location	Description	Supported form factors
1	Primary riser cage	Stacking riser	<ul style="list-style-type: none"> • Full-height, half-length
2		Stacking	<ul style="list-style-type: none"> • Half-height, half-length (low-profile)
3		Base riser	
4	Secondary riser cage	Stacking riser	
5		Stacking riser	
6		Base riser	

Six-slot riser configuration with the tertiary riser cage

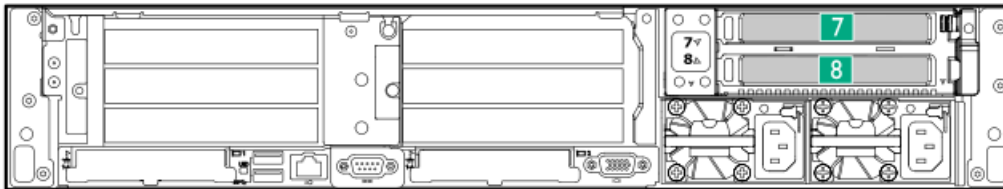

Slot number	Location	Supported form factors
7	Tertiary riser cage	<ul style="list-style-type: none"> • Full-height, half-length
8		<ul style="list-style-type: none"> • Half-height, half-length (low-profile)

Drive bay numbering

Drive bay numbering depends on how the drive backplanes are connected:

- To a controller:
 - Type-o controllers install to OCP slot 21.
 - Type-p controllers install to a PCIe riser.

Subtopics

[SFF drive bay numbering](#)

[LFF drive bay numbering](#)

[E3.S drive bay numbering](#)

SFF drive bay numbering

The following drive backplane options are supported in SFF drive configurations:

- Front-end: 2 SFF, side-by-side (LFF chassis only)
 - 2 SFF 24G x4 U.3 NVMe / SAS UBM3 BC
 - 2 SFF 24G x4 U.3 NVMe / SAS UBM6 BC
- Front- or rear-end: 2 SFF, stacked:
 - - 24G x4 U.3 NVMe / SAS UBM3 BC
 - - 24G x4 U.3 NVMe / SAS UBM6 BC
- Front-end: 8 SFF
 - 8 SFF 24G x1 U.3 NVMe / SAS UBM3 BC
 - 8 SFF 24G x1 U.3 NVMe / SAS UBM6 BC
 - 8 SFF 24G x4 U.3 NVMe / SAS UBM3 BC
 - 8 SFF 24G x4 U.3 NVMe / SAS UBM6 BC
- Midplane: 8 SFF
 - 8 SFF 24G x1 U.3 NVMe / SAS UBM3 BC
 - 8 SFF 24G x4 U.3 NVMe / SAS UBM3 BC

For more information on the drive backplane description, see [Drive backplane naming](#).

Front: 8 LFF + 2 SFF drive bay numbering



Front: 16 SFF + 2 SFF drive bay numbering



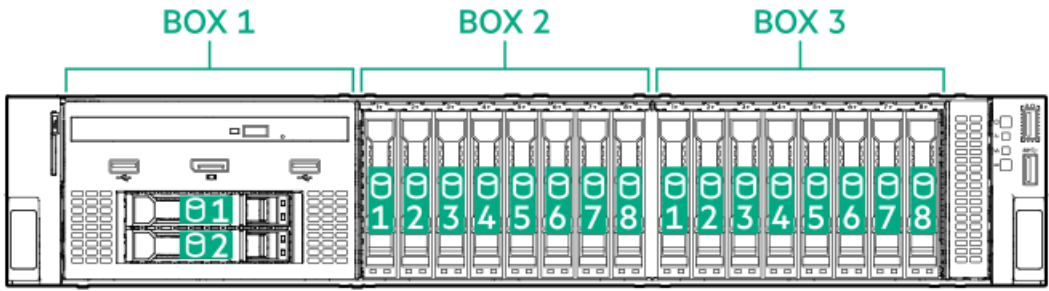

Front: 24 and 48 SFF drive bay numbering

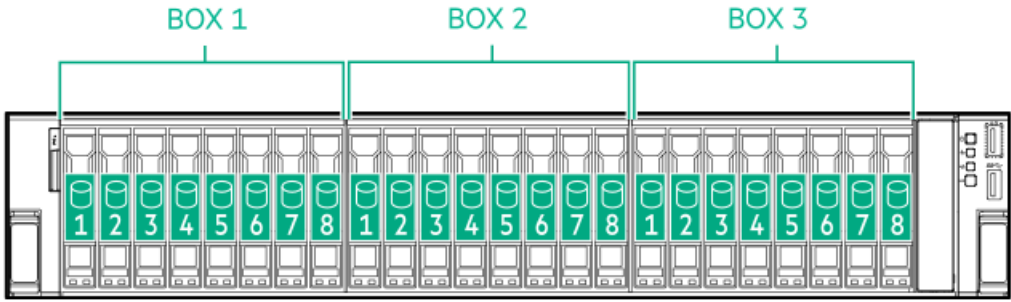

Front: 48 SFF drive bay numbering

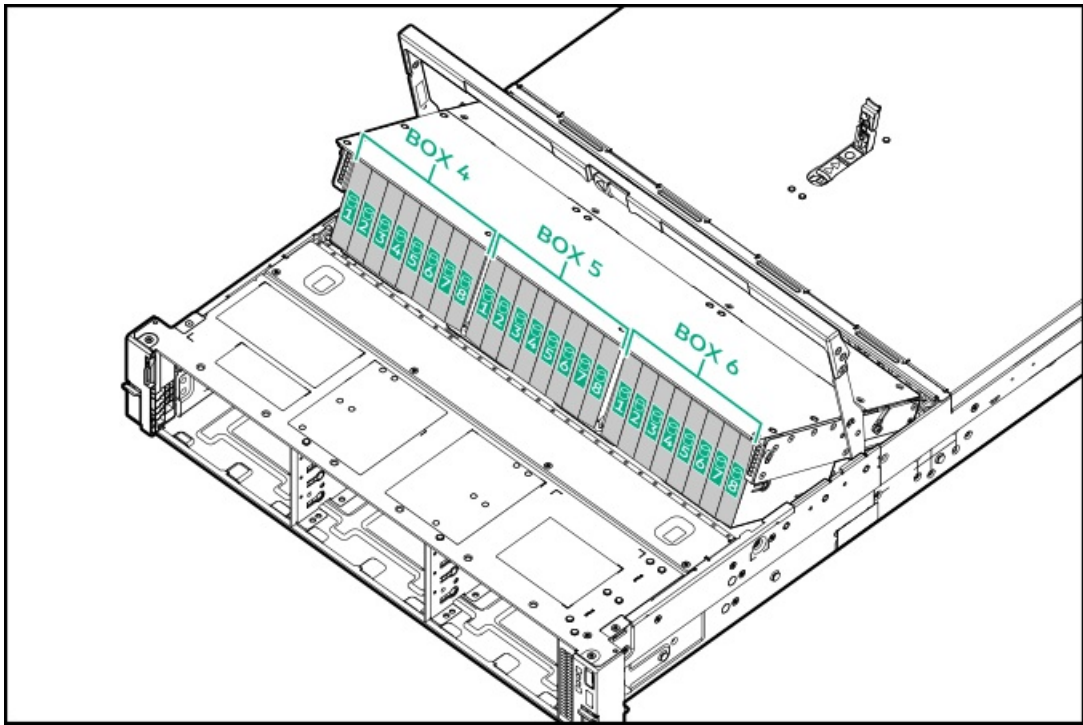

Front: 8 SFF drive bay numbering with two GPU riser cages



BOX 1

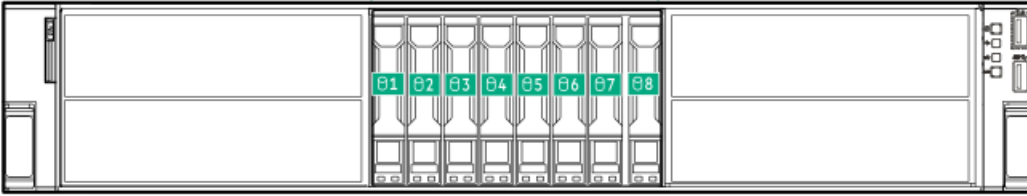

Midplane: 8 SFF drive bay numbering

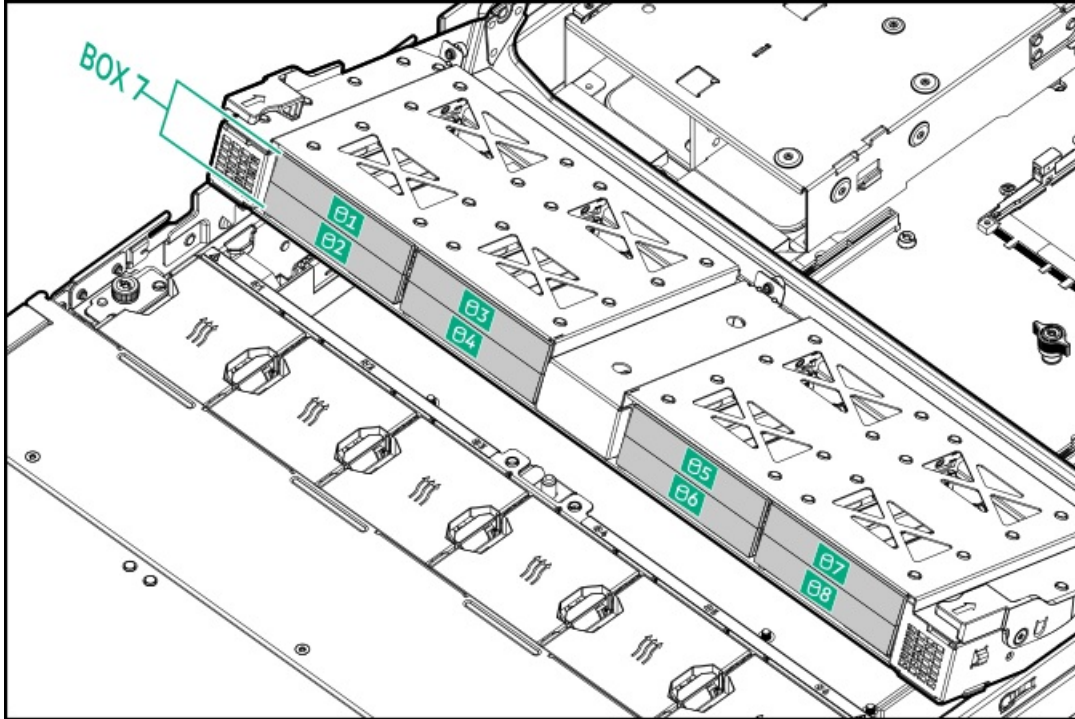

Rear: 2 SFF drive bay numbering

BOX 8

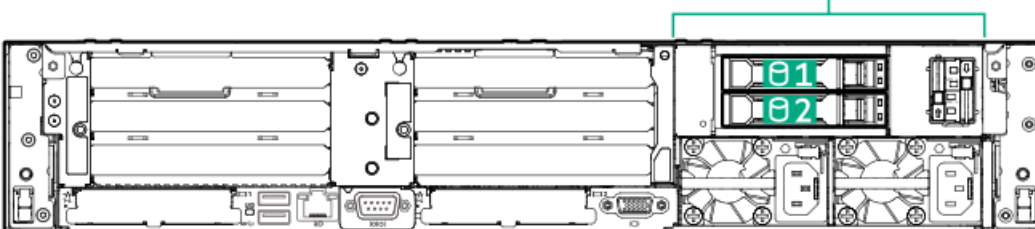

LFF drive bay numbering

The following drive backplane options are supported in LFF drive configurations:

- 4 LFF 12G x1 SAS / SATA UBM2 LP
- 4 LFF 12G x1 SAS / SATA UBM6 LP

For more information on the drive backplane description, see [Drive backplane naming](#).

Front: 12 LFF drive bay numbering



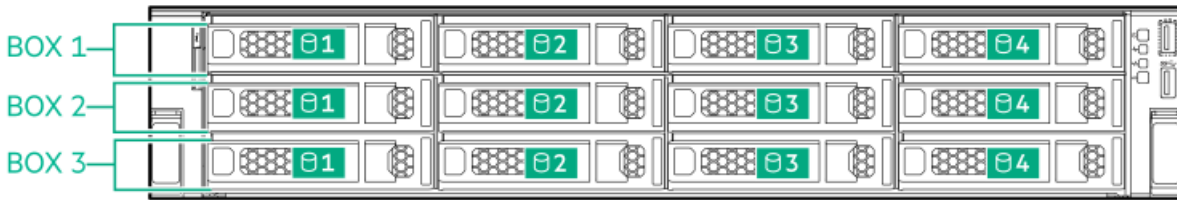

Midplane: 4 LFF drive bay numbering

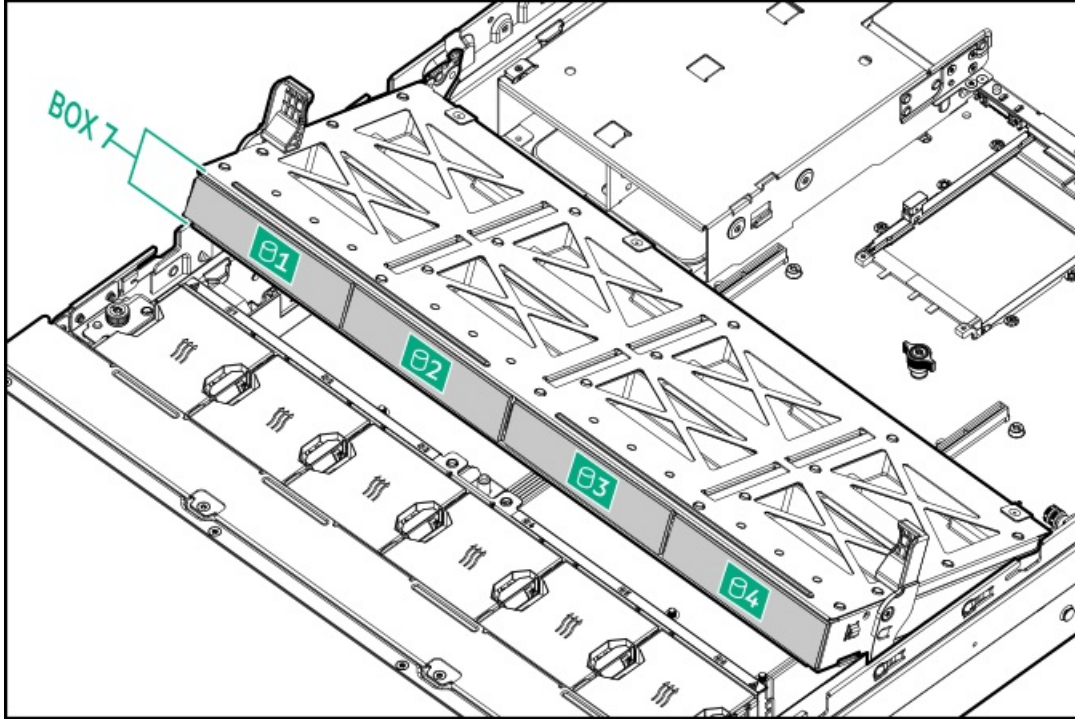

Rear: 4 LFF drive bay numbering

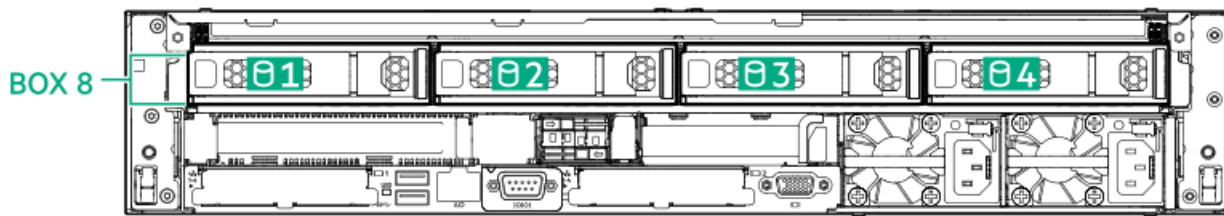

E3.S drive bay numbering

The following drive backplane options are supported in the E3.S drive configurations:

- 12 E3.S 32G x4 UMB5 EC1
- 12 E3.S 32G x4 UMB7 EC1

For more information on the drive backplane description, see [Drive backplane naming](#).

8 E3.S drive bay numbering



BOX 1



12 E3.S drive bay numbering

BOX 1



24 E3.S drive bay numbering

BOX 1

BOX 3

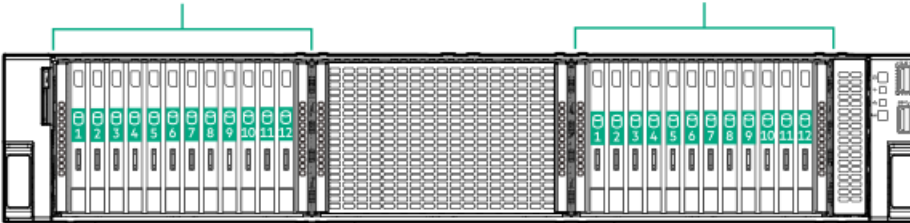

32 E3.S drive bay numbering

BOX 1

BOX 2

BOX 3

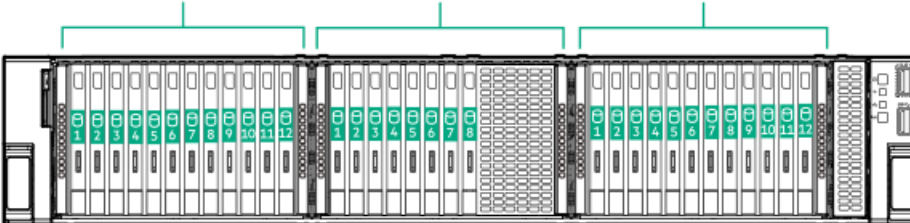

36 E3.S drive bay numbering

BOX 1

BOX 2

BOX 3

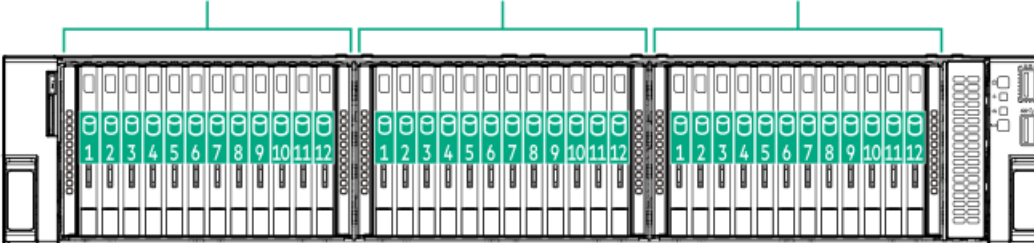

Drive backplane naming

This topic explains the features represented in the drive backplane naming. This naming convention was adopted starting in the HPE Gen11 server release. Your server might not support all the features listed in this topic. For server-specific support information, see the server guides:

- Drive backplane support, see [Drive bay numbering](#).
- Drive backplane cabling, see [Storage cabling](#).

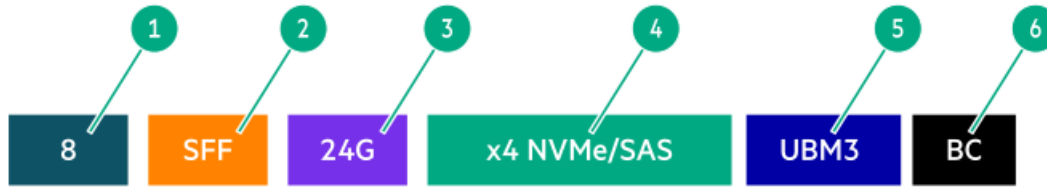

Item	Description	Values
1	Drive bay count	Number of drive bays supported by the backplane.
2	Drive form factor	LFF—Large Form Factor SFF—Small Form Factor E3.S—Enterprise and Datacenter Standard Form Factor (EDSFF)
3	Maximum link rate per lane (GT/s)	12G 16G 24G 32G
4	Port link width and interface	x1 NVMe/SAS—U.3 NVMe, SAS, or SATA ¹ x4 NVMe/SAS—U.3 NVMe, SAS, or SATA ² x4 NVMe—U.2 NVMe ³ x4 NVMe—E3.S
5	Universal backplane manager (UBM) options	UBM2—Segregated SAS/SATA UBM3 or UBM6—Converged UBM4 or UBM6—Segregated U.2 NVMe UBM5 or UBM7—EDSFF
6	Drive carrier type	BC—Basic carrier (SFF) LP—Low-profile carrier (LFF) EC1—E3.S carrier

¹ Tri-mode controller support for x1 U.3 NVMe, SAS, and SATA drives. System board connection supports SATA drives only.

² CPU direct attach or tri-mode controller support for x4 U.3 NVMe, x2 U.3 NVMe, or x1 SAS and SATA drives.

³ CPU direct attach or tri-mode controller support for x4 U.2 NVMe drives.

HPE Basic Drive LED definitions

The HPE Basic drive carrier has the following LEDs:

- Amber/blue LED—Managed by the drive backplane in conjunction with the storage controller and is used to indicate drive status.
- Green LED—Managed by the drive itself and indicates the drive activity.

LFF low-profile drive carrier

The LFF low-profile drive carrier supports hot-plug SAS and SATA drives.

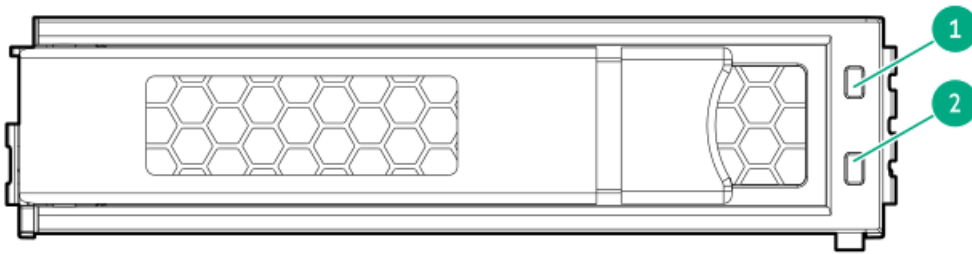

SFF basic drive carrier

The SFF basic drive carrier supports hot-plug SAS, SATA, and U.3 NVMe drives.

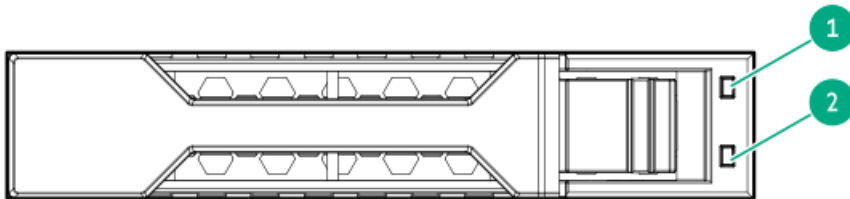

Item	LED	State	Definition
1	Fault/Locate	Solid amber	This drive has failed, is unsupported, or is invalid.
		Solid blue	The drive is operating normally and being identified by a management application.
		Flashing amber/blue (1 flash per second)	The drive has failed, or a predictive failure alert has been received for this drive. The drive has also been identified by a management application.
		Flashing amber (1 flash per second)	A predictive failure alert has been received for this drive. Replace the drive as soon as possible.
		Off	The drive is operating normally and not being identified by a management application.
2	Online/Activity	Solid green	The drive is online and has no activity.
		Flashing green (1 flash per second)	The drive is doing one of the following: <ul style="list-style-type: none"> Rebuilding or performing a RAID Performing a stripe size migration Performing a capacity expansion Performing a logical drive extension Erasing Spare part activation
		Flashing green (4 flashes per second)	The drive is operating normally and has activity.
		Off	The drive is not configured by a RAID controller or is a spare drive.

EDSFF SSD LED definitions

This server supports hot-plug Enterprise and Data Center Standard Form Factor (EDSFF) drives. Specifically, E3.S form factor PCIe5 NVMe SSDs. The EDSFF drive carrier has two LEDs:

- Amber/blue LED—Managed by the drive backplane in conjunction with the storage controller and is used to indicate drive status.
- Green LED—Managed by the drive itself and indicates the drive activity.



Item	LED	State	Definition
1	Fault/Locate	Solid amber	This drive has failed, is unsupported, or is invalid.
		Solid blue	The drive is operating normally and being identified by a management application.
		Flashing amber/blue (1 flash per second)	The drive has failed, or a predictive failure alert has been received for this drive. The drive has also been identified by a management application.
		Flashing amber (1 flash per second)	A predictive failure alert has been received for this drive. Replace the drive as soon as possible.
		Off	The drive is operating normally and not being identified by a management application.
2	Online/Activity	Solid green	The drive is online and has no activity.
		Flashing green (4 flashes per second)	The drive is operating normally and has activity.
		Off	No power present

DSC-25 2-port SFP28 card ports and LEDs

Ports

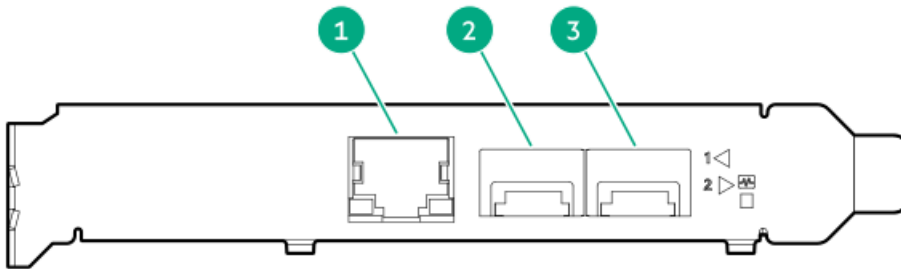

Item	Port	Description
1	Management port	1GbE RJ45
2	Network interface port	10/25G SFP+ based
3	Network interface port	10/25G SFP+ based

LEDs

The HPE for Pensando DSP DSC-25 2p SFP28 card is a dual-port, single-slot, half-height, half-length (HHHL) SFP28 network adapter. It has LEDs for Link (L) and Activity (A) for each port. A half-height bracket is shown in the following illustration with SFP28 ports and LEDs.

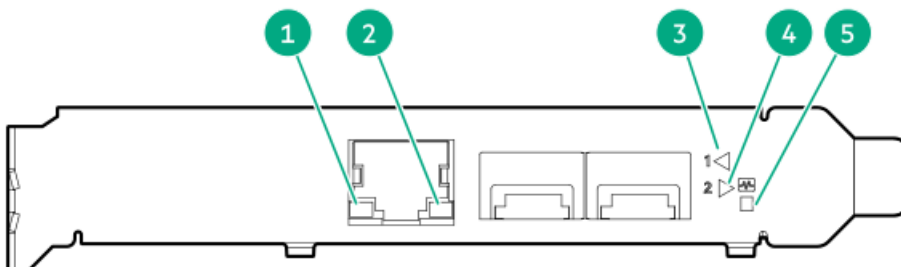

Item	LED	Status	Description
1	Management Port Activity LED	Off	No activity
		Flashing	Passing traffic; flashing frequency indicates traffic intensity
2	Management Port Link LED	Off	A link has not been established
		Solid green	Valid Ethernet link
3	SFP Port 1 Link/Activity LED	Off	A link has not been established
		Solid green	Valid Ethernet link
		Flashing green	Passing traffic; flashing frequency indicates traffic intensity
		Solid amber	Link fault
4	SFP Port 2 Link/Activity LED	Off	A link has not been established
		Solid green	Valid Ethernet link
		Flashing green	Passing traffic; flashing frequency indicates traffic intensity
		Solid amber	Link fault
5	System status LED	Off	System is not powered
		Solid amber	Power is up, software has not booted yet
		Solid green	System is up and fully operational

Fan numbering

To provide sufficient airflow to the system, the server is populated by four fans by default. There are a total of six fans. The fans can either be standard, single-rotor fans or high performance, dual-rotor fans. Mixed fan configuration is not supported.

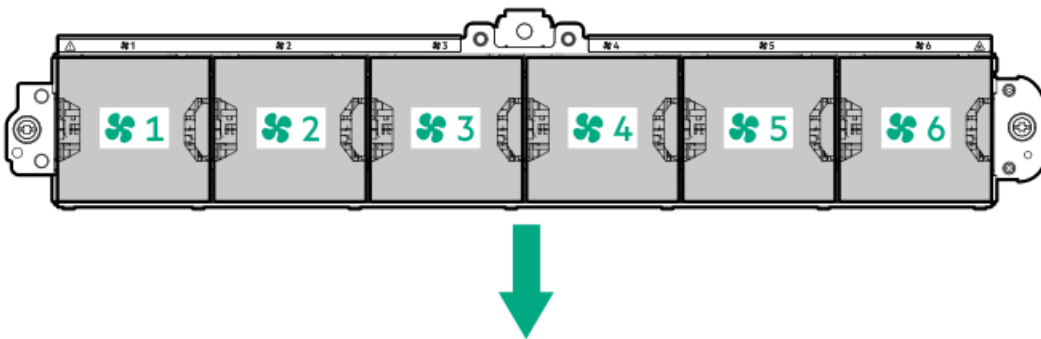

The arrow points to the front of the server.

Fan and heatsink requirements

CAUTION:

To maintain proper system cooling, install the correct fan and heatsink types required for specific hardware configurations.

- Using NVMe drives requires high performance fans.
- The maximum processor support with a midplane cage installed is 300 W.

Configuration	Midplane drive	Rear drive	Fan type	Max processor cTDP	Ambient operating temperature	Heatsink
8 LFF	Not installed	2 SFF or PCIe	Standard	240 W	35°C (95°F)	Standard
			High performance	300 W		High performance
				400 W		Max performance
12 LFF	Not installed	2 SFF or PCIe	High performance	240 W	35°C (95°F)	High performance
				300 W		
				400 W		
	4 LFF drives	4 LFF drives	240 W	35°C (95°F)	Midplane cage	
		2 SFF or PCIe	300 W			
	4 LFF drives	300 W	25°C (77°F)			
8/16 SFF	Not installed	2 SFF or PCIe	Standard	240 W	35°C (95°F)	Standard
			High performance	300 W		High performance
				400 W		Max performance
24 SFF	Not installed	2 SFF or PCIe	High performance	240 W	35°C (95°F)	High performance
				300 W		
				400 W		
	8 SFF drives	≤ 300 W	Midplane cage			
48 SFF	Not installed	2 SFF or PCIe	High performance	240 W	35°C (95°F)	High performance
				300 W		
				400 W		
E3.S	Not installed	2 SFF or PCIe	High performance	240 W	35°C (95°F)	High performance
				300 W		
				400 W		
GPU	Not installed	2 SFF or PCIe	High performance	240 W	35°C (95°F)	High performance
				300 W		
				400 W		

Trusted Platform Module 2.0

The Trusted Platform Module 2.0 (TPM) is a hardware-based system security feature that securely stores artifacts used to authenticate the platform. These artifacts can include passwords, certificates, and encryption keys.

The TPM 2.0 is embedded on the server system board.

The TPM 2.0 is supported with specific operating system support such as Microsoft Windows Server 2012 R2 and later. For more information about operating system support, see the product QuickSpecs on the Hewlett Packard Enterprise website (<https://www.hpe.com/info/quickspecs>). For more information about Microsoft Windows BitLocker Drive Encryption feature, see the Microsoft website (<https://www.microsoft.com>).

Subtopics

[Trusted Platform Module 2.0 guidelines](#)

[BitLocker recovery key/password retention guidelines](#)

Trusted Platform Module 2.0 guidelines

CAUTION:

- Always observe the TPM guidelines in this section. Failure to follow these guidelines can cause hardware damage or halt data access.
- If you do not follow procedures for modifying the server and suspending or disabling the TPM in the OS, an OS that is using TPM might lock all data access. This includes updating system or option firmware, replacing hardware such as the system board and drives, and modifying TPM OS settings.
- Changing the TPM mode after installing an OS might cause problems, including loss of data.

Hewlett Packard Enterprise SPECIAL REMINDER: Before enabling TPM functionality on this system, you must ensure that your intended use of TPM complies with relevant local laws, regulations and policies, and approvals or licenses must be obtained if applicable.

慧与特别提醒：在您启用系统中的TPM功能前，请务必确认您对TPM的使用遵守当地相关法律、法规及政策，并已事先获得所需的一切批准及许可（如适用），因您未获得相应的操作/使用许可而导致的违规问题，皆由您自行承担全部责任，与慧与无涉。

- When the embedded TPM is enabled, the Trusted Platform Module operates in TPM 2.0 mode.
- Use the UEFI System Utilities to configure the TPM. From the System Utilities screen, select System Configuration > BIOS/Platform Configuration (RBSU) > Server Security > Trusted Platform Module options. For more information, see the UEFI user guide: <https://www.hpe.com/support/UEFIgen11-UG-en>
- When using the Microsoft Windows BitLocker Drive Encryption feature, always retain the recovery key or password. The recovery key or password is required to enter Recovery Mode after BitLocker detects a possible compromise of system integrity.
- HPE is not liable for blocked data access caused by improper TPM use. For operating instructions, see the documentation for the encryption technology feature provided by the operating system.

BitLocker recovery key/password retention guidelines

The recovery key/password is generated during BitLocker setup, and can be saved and printed after BitLocker is enabled. When using BitLocker, always retain the recovery key/password. The recovery key/password is required to enter Recovery Mode after BitLocker detects a possible compromise of system integrity.

To help ensure maximum security, observe the following guidelines when retaining the recovery key/password:

- Always store the recovery key/password in multiple locations.

- Always store copies of the recovery key/password away from the server.
- Do not save the recovery key/password on an encrypted drive.

HPE NS204i-u Boot Device components

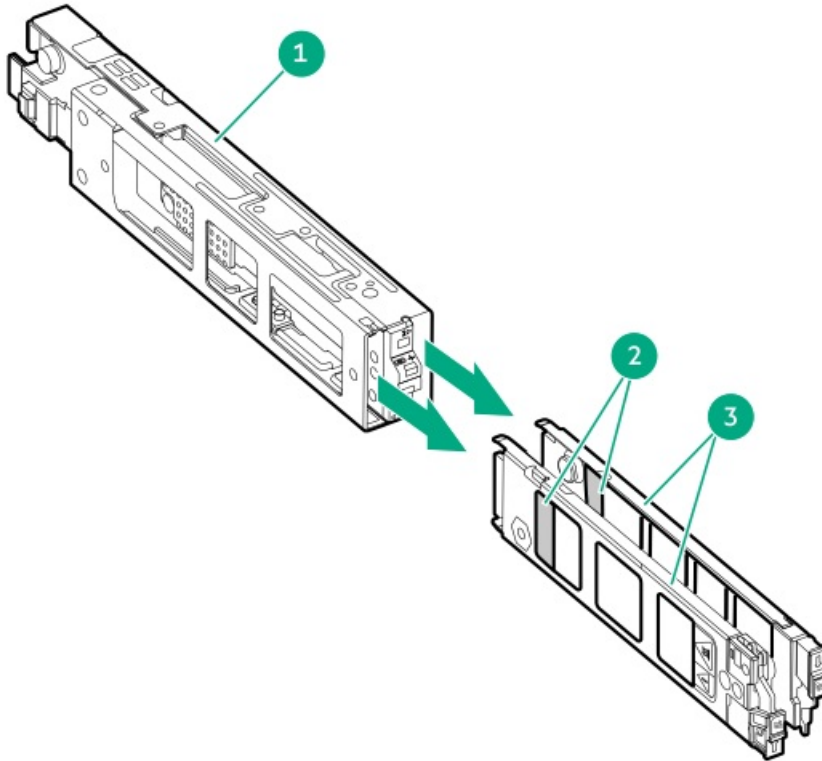

Item	Description
1	Boot device cage
2	M.2 slots
3	Boot device carriers

HPE NS204i-u Boot Device LED definitions

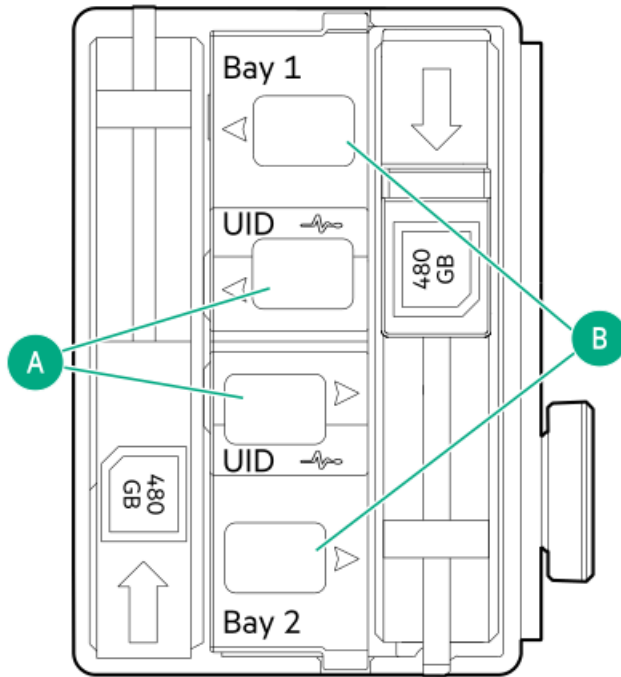

NOTE: The bay number can be found on the SSD carrier handle.

Item	LED	Status	Definition
A	Fault or Locate	Solid amber	Drive has failed, unsupported, or invalid.
		Solid blue	Drive is operating normally.
		Flashing amber or blue (one flash per second)	Drive has failed, or a predictive failure alert is received for the drive.
		Flashing amber (one flash per second)	Drive predictive failure alert is received. Replace the drive as soon as possible.
		Off	Drive is operating normally and is not identified by any application.
B	Online/Activity	Solid green	Drive is online and has no activity.
		Flashing green (one flash per second)	Drive is doing one of the following: <ul style="list-style-type: none"> Rebuilding or performing a RAID Erasing
		Flashing green (4 flashes per second)	Drive is operating normally and has activity.
		Off	Drive is not configured by a RAID controller.

Setup

This chapter describes general operational requirements and safety reminders, as well as the initial setup procedure for the server.

Subtopics

[Initial system installation](#)

[Operational requirements](#)

[Rack warnings and cautions](#)

[Server warnings and cautions](#)

[Electrostatic discharge](#)

Initial system installation

Depending on your technical expertise and the complexity of the product, for the initial system installation, select one of the following options:

- [Ordering the HPE Installation Service](#)
- [Setting up the server](#)

Subtopics

[HPE Installation Service](#)

[Setting up the server](#)

HPE Installation Service

HPE Installation Service provides basic installation of Hewlett Packard Enterprise branded equipment, software products, as well as HPE-supported products from other vendors that are sold by HPE or by HPE authorized resellers. The Installation Service is part of a suite of HPE deployment services that are designed to give users the peace of mind that comes from knowing that their HPE and HPE-supported products have been installed by an HPE specialist.

The HPE Installation Service provides the following benefits:

- Installation by an HPE authorized technical specialist.
- Verification prior to installation that all service prerequisites are met.
- Delivery of the service at a mutually scheduled time convenient to your organization.
- Allows your IT resources to stay focused on their core tasks and priorities.
- Full coverage during the warranty period for products that require installation by an HPE authorized technical specialist.

For more information on the features, limitations, provisions, and ordering information of the HPE Installation Service, see this Hewlett Packard Enterprise website:

<https://www.hpe.com/support/installation-service>

Setting up the server

Prerequisites

Before setting up the server:

- As a best practice, Hewlett Packard Enterprise recommends installing the latest firmware, drivers, and system software before using the server for the first time. You have these options:
 - HPE GreenLake for Compute Ops Management is an advanced software-as-a-service platform that securely streamlines operations from edge-to-cloud and automates key life cycle tasks through a unified single browser-based interface. For more information on using HPE GreenLake for Compute Ops Management, see <https://www.hpe.com/info/com-docs>.

- Use the Firmware Update option in Intelligent Provisioning—Intelligent Provisioning is a server deployment tool embedded in HPE ProLiant servers. To access Intelligent Provisioning, during the server boot process, press **F10**. For more information, see the Intelligent Provisioning user guide at <https://www.hpe.com/info/intelligentprovisioning/docs>.
- Download the Service Pack for ProLiant (SPP)—SPP is a comprehensive system software and firmware update solution that is delivered as a single ISO image. This solution uses Smart Update Manager (SUM) as the deployment tool.
 - The preferred method for downloading an SPP is by creating an SPP custom download at <https://www.hpe.com/servers/spp/custom>.
This option reduces the size of the SPP by excluding firmware and drivers for OS and server models that are not needed.
 - The SPP is also available for download from the SPP download page at <https://www.hpe.com/servers/spp/download>.
- Verify that your OS or virtualization software is supported:
<https://www.hpe.com/support/Servers-Certification-Matrices>
- Read the [operational requirements](#) for the server.
- Read the safety and compliance information on the HPE website:
<https://www.hpe.com/support/safety-compliance-enterpriseproducts>

Procedure

1. Unbox the server and verify the contents:

- Server
- Power cord
- Rack rail hook-and-loop strap
- Rack-mounting hardware (optional)
- Printed setup documentation

The server does not ship with OS media. All system software and firmware is preloaded on the server.

2. (Optional) [Install the hardware options](#).

3. [Install the server into the rack](#).

4. Press the Power On/Standby button.

5. Decide how to manage the server:

- Locally: Use a KVM switch or connect a keyboard, monitor, and mouse.
- Remotely: Connect to the iLO web interface and run a remote console:

a. Verify the following:

- iLO is licensed to use the remote console feature.

If iLO is not licensed, visit the HPE website:

<https://www.hpe.com/info/ilo>

- The iLO management port is connected to a secure network.

b. Using a browser, navigate to the iLO web interface, and then log in.

```
https://<iLO hostname or IP address>
```

Note the following:

- The iLO host name is on the serial number/ iLO information pull tab on the front panel.
- If a DHCP server assigns the IP address, the IP address appears on the boot screen.

- o If a static IP address is assigned, use that IP address.
 - o The default login credentials are on the serial number/ iLO information pull tab on the front panel.
 - c. Enter the iLO login name and password, and then click **Log In**.
 - d. In the navigation tree, click the **Remote Console & Media** link, and then launch a remote console.
6. [Configure the initial server setup](#).
 7. [Set up the storage](#).
 8. [Deploy an OS or virtualization software](#).
 9. After the OS is installed, [update the drivers](#).
 10. [Register the server](#).

Operational requirements

When preparing and planning the installation, observe the following operational requirements:

- [Space and airflow requirements](#)
- [Temperature requirements](#)
- [Power requirements](#)
- [Electrical grounding requirements](#)

For environmental requirements, see [Environmental specifications](#).

Subtopics

[Space and airflow requirements](#)

[Temperature requirements](#)

[Power requirements](#)

[Electrical grounding requirements](#)

Space and airflow requirements

To allow for servicing and adequate airflow, observe the following space and airflow requirements when installing the server in an indoor commercial rack:

- 63.50 cm (25.00 in) in front of the rack
- 76.20 cm (30.00 in) behind the rack
- 121.90 cm (48.00 in) from the back of the rack to the back of another rack or row of racks

Observe the following additional airflow requirements:

- Servers draw in cool air through the front door and expel warm air through the rear door. Therefore, the front and rear rack doors must be adequately ventilated to allow ambient room air to enter the cabinet, and the rear door must be adequately ventilated to allow the warm air to escape from the cabinet.
- To prevent improper cooling and damage to the equipment, do not block the ventilation openings.
- When the vertical space in the rack is not filled by a server or rack component, the gaps between the components cause changes in

airflow through the rack and across the servers. Cover all gaps with blanking panels to maintain proper airflow. Using a rack without blanking panels results in improper cooling which can lead to thermal damage.

- If a third-party rack is used, observe the following additional requirements to ensure adequate airflow and prevent damage to the equipment:
 - Front and rear doors—If the 42U rack includes closing front and rear doors, you must allow 5,350 sq cm (830 sq in) of holes evenly distributed from top to bottom to permit adequate airflow (equivalent to the required 64 percent open area for ventilation).
 - Side—The clearance between the installed rack component and the side panels of the rack must be a minimum of 7.00 cm (2.75 in).

Temperature requirements

To ensure continued safe and reliable equipment operation, install or position the system in a well-ventilated, climate-controlled environment.

The maximum recommended ambient operating temperature (TMRA) for most server products is 35°C (95°F). The temperature in the room where the rack is located must not exceed 35°C (95°F).



CAUTION: To reduce the risk of damage to the equipment when installing third-party options:

- Do not permit optional equipment to impede airflow around the server or to increase the internal rack temperature beyond the maximum allowable limits.
 - Do not exceed the manufacturer's TMRA.
-

Power requirements

Installation of this equipment must comply with local and regional electrical regulations governing the installation of information technology equipment by licensed electricians. This equipment is designed to operate in installations covered by NFPA 70, 1999 Edition (National Electric Code) and NFPA-75, 1992 (code for Protection of Electronic Computer/Data Processing Equipment). For electrical power ratings on options, refer to the product rating label or the user documentation supplied with that option.



WARNING: To reduce the risk of personal injury, fire, or damage to the equipment, do not overload the AC supply branch circuit that provides power to the rack. Consult the electrical authority having jurisdiction over wiring and installation requirements of your facility.



CAUTION: Protect the server from power fluctuations and temporary interruptions with a regulating uninterruptible power supply. This device protects the hardware from damage caused by power surges and voltage spikes and keeps the system in operation during a power failure.

Electrical grounding requirements

The server must be grounded properly for proper operation and safety. In the United States, you must install the equipment in accordance with NFPA 70, National Electric Code Article 250, as well as any local and regional building codes. In Canada, you must install the equipment in accordance with Canadian Standards Association, CSA C22.1, Canadian Electrical Code. In all other countries, you must install the equipment in accordance with any regional or national electrical wiring codes, such as the International Electrotechnical Commission (IEC) Code 364, parts 1 through 7. Furthermore, you must be sure that all power distribution devices used in the installation, such as branch wiring and receptacles, are listed or certified grounding-type devices.

Because of the high ground-leakage currents associated with multiple servers connected to the same power source, Hewlett Packard Enterprise recommends the use of a PDU that is either permanently wired to the building's branch circuit or includes a nondetachable cord that is wired to an industrial-style plug. NEMA locking-style plugs or those complying with IEC 60309 are considered suitable for this purpose. Using common power outlet strips for the server is not recommended.

Rack warnings and cautions



WARNING:

When all components are removed, the server weighs 16.78 kg (36.99 lb). When all components are installed, the server can weigh up to 41.41 kg (91.29 lb).

Before configuring your rack solution, be sure to check the rack manufacturer weight limits and specifications. Failure to do so can result in physical injury or damage to the equipment and the facility.



WARNING:

The server is heavy. To reduce the risk of personal injury or damage to the equipment, do the following:

- Observe local occupational health and safety requirements and guidelines for manual material handling.
 - Get help to lift and stabilize the product during installation or removal, especially when the product is not fastened to the rails. The server weighs more than 16.78 kg (36.99 lb), so at least two people must lift the server into the rack together. An additional person may be required to help align the server if the server is installed higher than chest level.
 - Use caution when installing the server in or removing the server from the rack.
 - Adequately stabilize the rack before extending a component outside the rack. Extend only one component at a time. A rack may become unstable if more than one component is extended.
 - Do not stack anything on top of rail-mounted component or use it as a work surface when extended from the rack.
-



WARNING:

To reduce the risk of personal injury or damage to the equipment, be sure that:

- The rack has anti-tip measures in place. Such measures include floor-bolting, anti-tip feet, ballast, or a combination as specified by the rack manufacturer and applicable codes.
 - The leveling jacks (feet) are extended to the floor.
 - The full weight of the rack rests on the leveling jacks (feet).
 - The stabilizing feet are attached to the rack if it is a single-rack installation.
 - The racks are coupled together in multiple rack installations.
-



WARNING:

To reduce the risk of personal injury or equipment damage when unloading a rack:

- At least two people are needed to safely unload the rack from the pallet. An empty 42U rack can weigh as much as 115 kg (253 lb), can stand more than 2.1 m (7 ft) tall, and might become unstable when being moved on its casters.
 - Never stand in front of the rack when it is rolling down the ramp from the pallet. Always handle the rack from both sides.
-



CAUTION:

Always plan the rack installation so that the heaviest item is on the bottom of the rack. Install the heaviest item first, and continue to populate the rack from the bottom to the top.



CAUTION:

Before installing the server in a rack, be sure to properly scope the limitations of the rack. Before proceeding with the installation, consider the following:

- You must fully understand the static and dynamic load carrying capacity of the rack and be sure that it can accommodate the weight of the server.
 - Be sure sufficient clearance exists for cabling, installation and removal of the server, and movement of the rack doors.
-

Server warnings and cautions



WARNING:

To reduce the risk of personal injury, electric shock, or damage to the equipment, disconnect the power cord to remove power from the server. Pressing the Power On/Standby button does not shut off system power completely. Portions of the power supply and some internal circuitry remain active until AC power is removed.



WARNING: To reduce the risk of personal injury from hot surfaces, allow the drives and the internal system components to cool before touching them.



WARNING:

To reduce the risk of fire or burns after removing the energy pack:

- Do not disassemble, crush, or puncture the energy pack.
- Do not short external contacts.
- Do not dispose of the energy pack in fire or water.
- Do not expose the energy pack to low air pressure as it might lead to explosion or leakage of flammable liquid or gas.
- Do not expose the energy pack to temperatures higher than 60°C (140°F).

After power is disconnected, battery voltage might still be present for 1s to 160s.



CAUTION:

Protect the server from power fluctuations and temporary interruptions with a regulating UPS. This device protects the hardware from damage caused by power surges and voltage spikes and keeps the server in operation during a power failure.



CAUTION:

To prevent damage to electrical components, properly ground the server before beginning any installation, removal, or replacement procedure. Improper grounding can cause [electrostatic discharge](#).



CAUTION:

To avoid data loss, Hewlett Packard Enterprise recommends that you [back up all server data](#) before installing or removing a hardware option, or performing a server maintenance or troubleshooting procedure.



CAUTION: Do not operate the server for long periods with the access panel open or removed. Operating the server in this manner results in improper airflow and improper cooling that can lead to thermal damage.

Electrostatic discharge

Be aware of the precautions you must follow when setting up the system or handling components. A discharge of static electricity from a finger or other conductor may damage system boards or other static-sensitive devices. This type of damage may reduce the life expectancy of the system or component.

To prevent electrostatic damage:

- Avoid hand contact by transporting and storing products in static-safe containers.
- Keep electrostatic-sensitive parts in their containers until they arrive at static-free workstations.
- Place parts on a grounded surface before removing them from their containers.
- Avoid touching pins, leads, or circuitry.

- Always be properly grounded when touching a static-sensitive component or assembly. Use one or more of the following methods when handling or installing electrostatic-sensitive parts:
 - Use a wrist strap connected by a ground cord to a grounded workstation or computer chassis. Wrist straps are flexible straps with a minimum of 1 megohm \pm 10 percent resistance in the ground cords. To provide proper ground, wear the strap snug against the skin.
 - Use heel straps, toe straps, or boot straps at standing workstations. Wear the straps on both feet when standing on conductive floors or dissipating floor mats.
 - Use conductive field service tools.
 - Use a portable field service kit with a folding static-dissipating work mat.

If you do not have any of the suggested equipment for proper grounding, have an authorized reseller install the part.

For more information on static electricity or assistance with product installation, contact an authorized reseller.

Operations

This chapter describes the hardware operations carried out prior to and after installing or removing a hardware component, or performing a server maintenance or troubleshooting procedure. Before performing these hardware operations, review the:

- [Rack warnings and cautions](#)
- [Server warnings and cautions](#)

Subtopics

[Power up the server](#)

[Power down the server](#)

[Open the cable management arm](#)

[Types of air baffles](#)

[Extend the server out of the rack](#)

[Remove the server from the rack](#)

[Remove the front bezel](#)

[Remove the access panel](#)

[Remove the fan cage](#)

[Remove the LFF drive backplane bracket](#)

[Remove the midwall bracket](#)

[Remove the midplane drive cage](#)

[Remove the rear 4 LFF drive cage](#)

[Remove the riser cage](#)

[Install the access panel](#)

[Install the LFF drive backplane bracket](#)

[Install the riser cage](#)

[Install the midwall bracket](#)

[Install the rear 4 LFF drive cage](#)

[Install the fan cage](#)

Power up the server

Procedure

- Press the Power On/Standby button.
- Use the virtual power button through iLO 6.

Power down the server

Before powering down the server for any upgrade or maintenance procedures, [perform a backup of critical server data and programs](#).



IMPORTANT:

When the server is in standby mode, auxiliary power is still being provided to the system.

To power down the server, use one of the following methods:

- Press and release the Power On/Standby button.
This method activates a controlled shutdown of applications and the OS before the server enters standby mode. It can also activate a shutdown behavior governed by an OS configuration or policy.
- Press and hold the Power On/Standby button for more than 4 seconds to force the server to enter standby mode.
This method forces the server to enter standby mode without properly exiting applications and the OS. If an application stops responding, you can use this method to force a shutdown.
- Use a virtual power button selection through iLO 6.
This method initiates a controlled remote shutdown of applications and the OS before the server enters standby mode.

Before proceeding, verify that the server is in standby mode by observing that the system power LED is amber.

Open the cable management arm

Procedure

1. Press and hold the blue **PUSH** button on the retention bracket.
2. Swing the arm away from the rear panel.



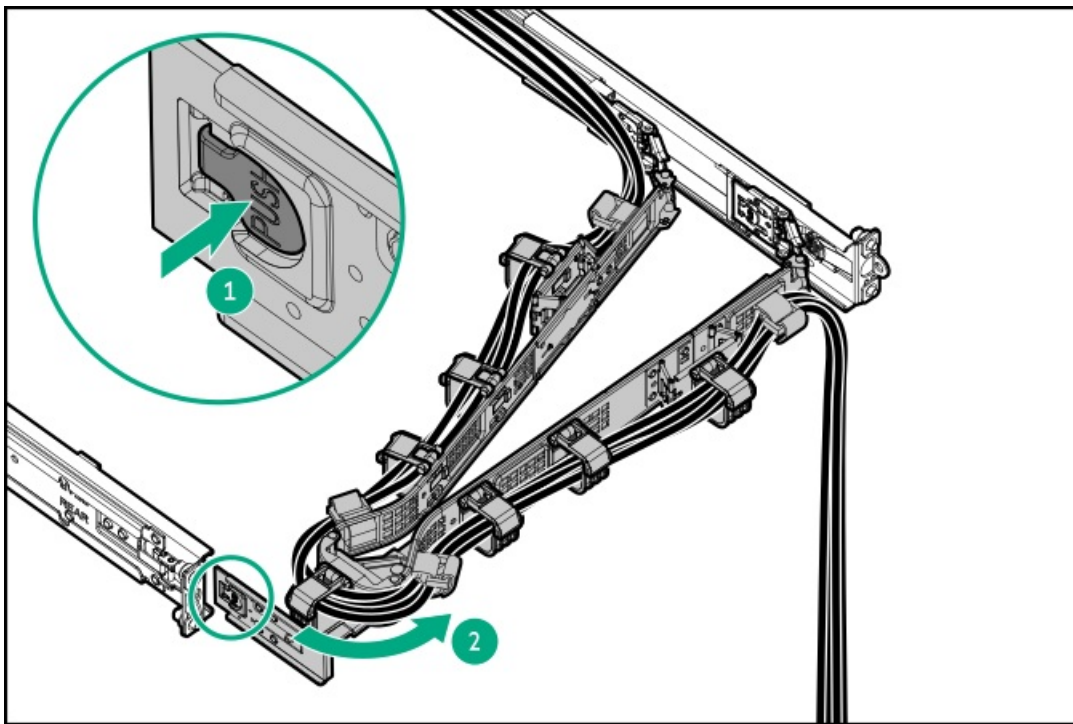

Types of air baffles

The server has a standard and high performance air baffle. Depending on the type of heatsink installed, you will need to install the correct air baffle.

Standard air baffle

Install a standard air baffle with a standard heatsink.

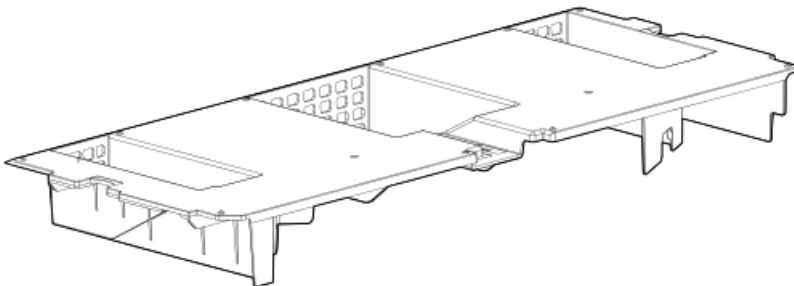

High performance air baffle

Install a high performance air baffle with a performance or high performance heatsink.

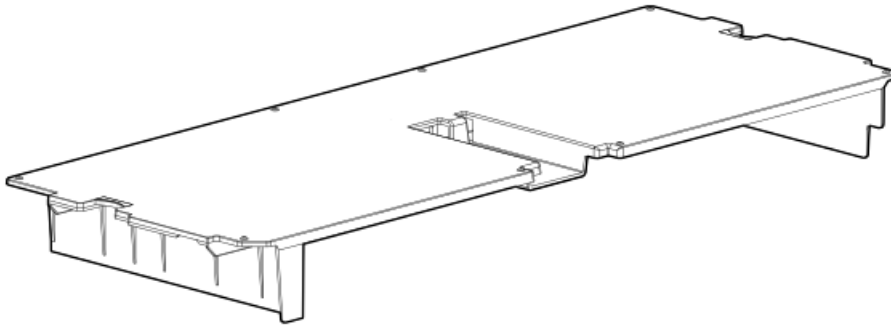

Subtopics

[Remove the air baffle](#)

[Install the air baffle](#)

Remove the air baffle

About this task

Depending on the type of heatsink installed, the server has two types of air baffles: standard and high performance. The removal procedures for both air baffles are the same. The following steps show the removal of a high performance air baffle.

CAUTION: For proper cooling, do not operate the server without the access panel, baffles, expansion slot covers, or blanks installed. If the server supports hot-plug components, minimize the amount of time the access panel is open.

Procedure

1. [Power down the server.](#)
2. If installed, [open the cable management arm.](#)
3. Remove all power:
 - a. Disconnect each power cord from the power source.
 - b. Disconnect each power cord from the server.
4. Do one of the following:
 - a. [Extend the server from the rack.](#)
 - b. [Remove the server from the rack.](#)
5. Disconnect all peripheral cables from the server.
6. [Remove the access panel.](#)
7. Remove the air baffle.

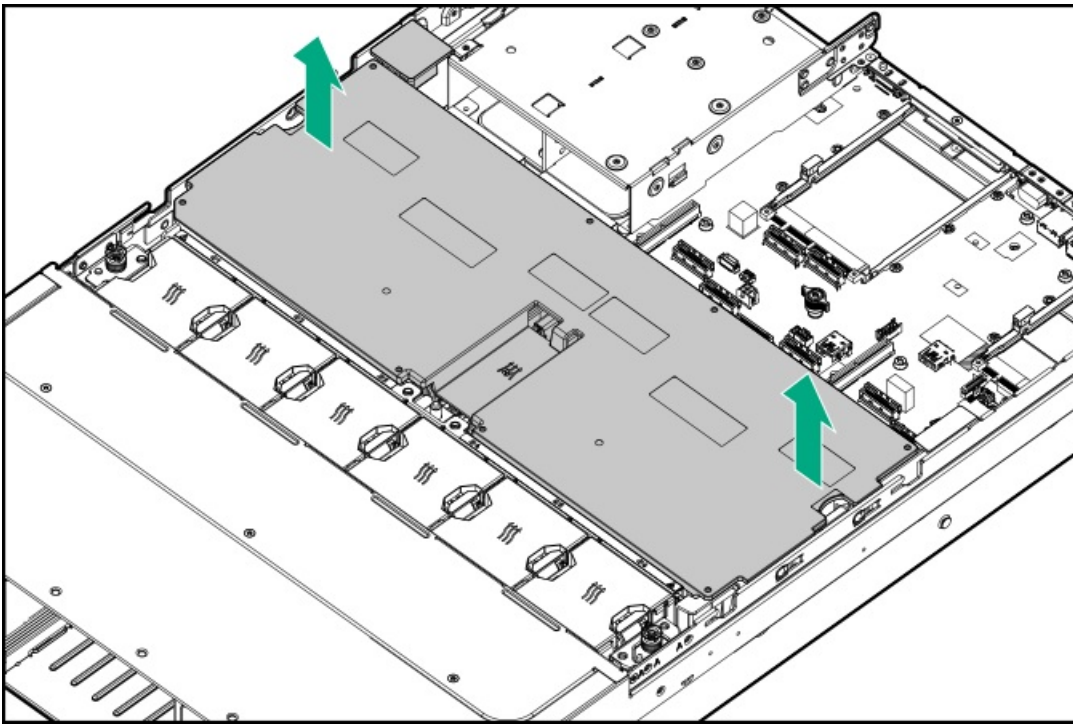

Install the air baffle

About this task

The server has two types of air baffles. The installation procedure for these two air baffles are the same. This procedure shows the installation step for the high performance air baffle.

Procedure

1. If removed, install the cable guards:

- Right cable guard

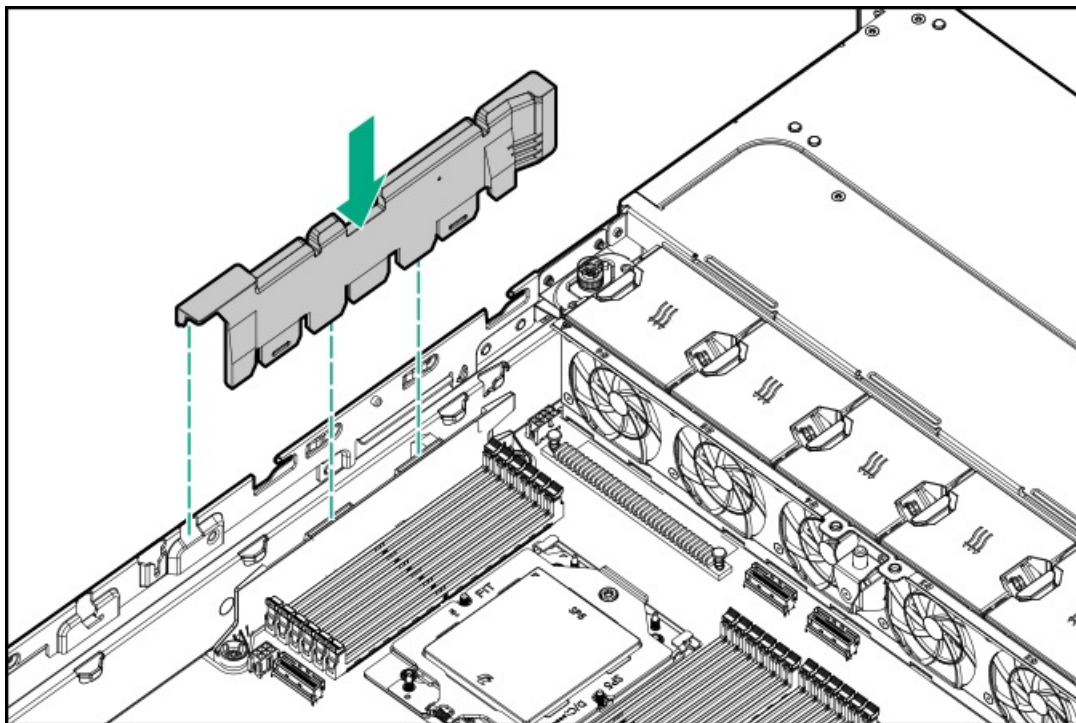

- Left cable guard

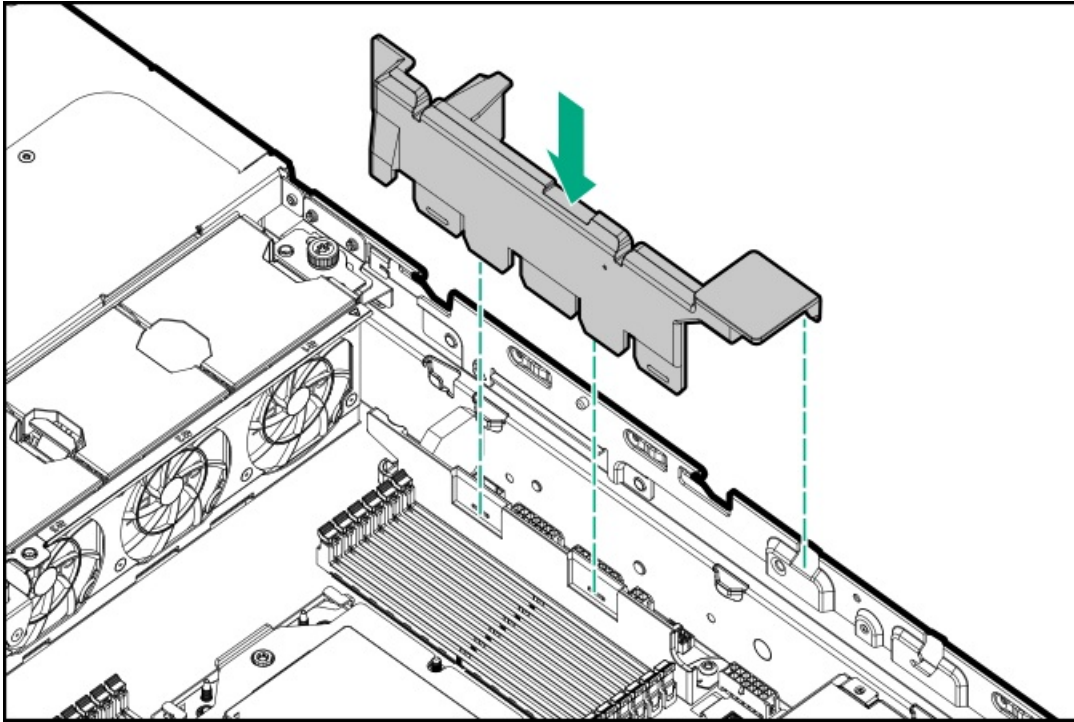

2. Make sure that all internal cables have been properly routed and will not interfere with the air baffle installation.
3. Lower the air baffle into the chassis and make sure that it fits properly into place.

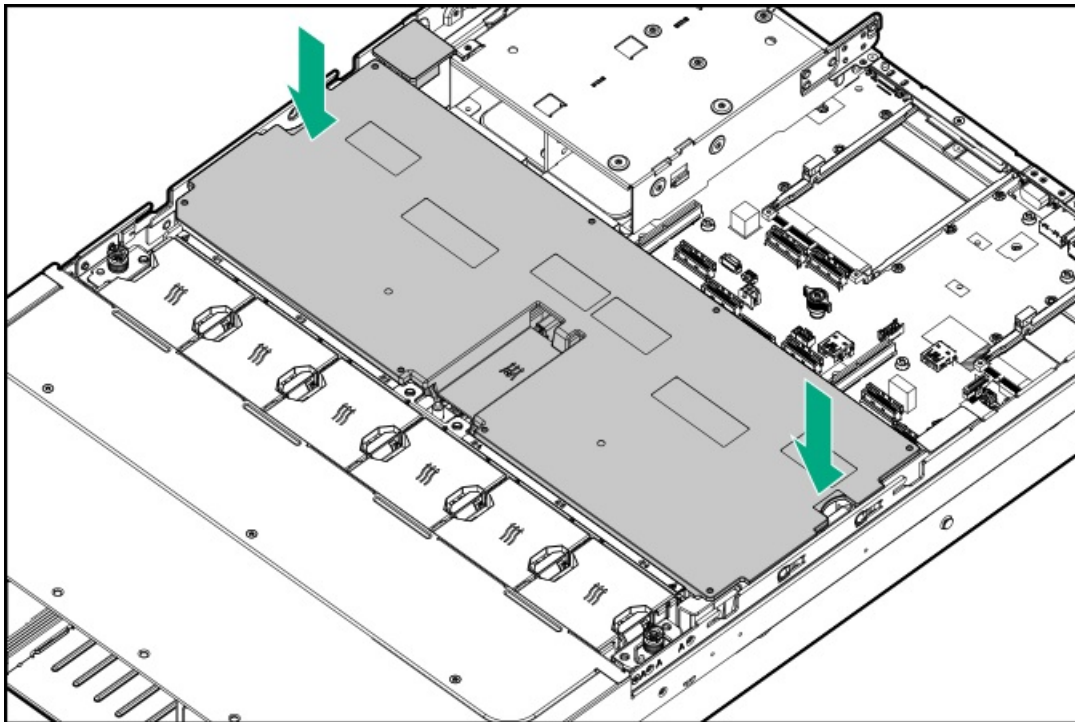

4. Perform the post-installation or maintenance steps required by the procedure that necessitates the removal of the air baffle.

Extend the server out of the rack

Prerequisites



- Before you perform this procedure, review the [Rack warnings and cautions](#).
- T-25 Torx screwdriver—This tool is required if the shipping screws located inside the chassis ears are secured.

About this task



WARNING:

To reduce the risk of personal injury, be careful when pressing the server rail-release latches. The inner rails could pinch your fingers.

Procedure

1. If needed, loosen the shipping screws, and then use the chassis ear latches to slide the server out of the rack until the rail-release latches are engaged.

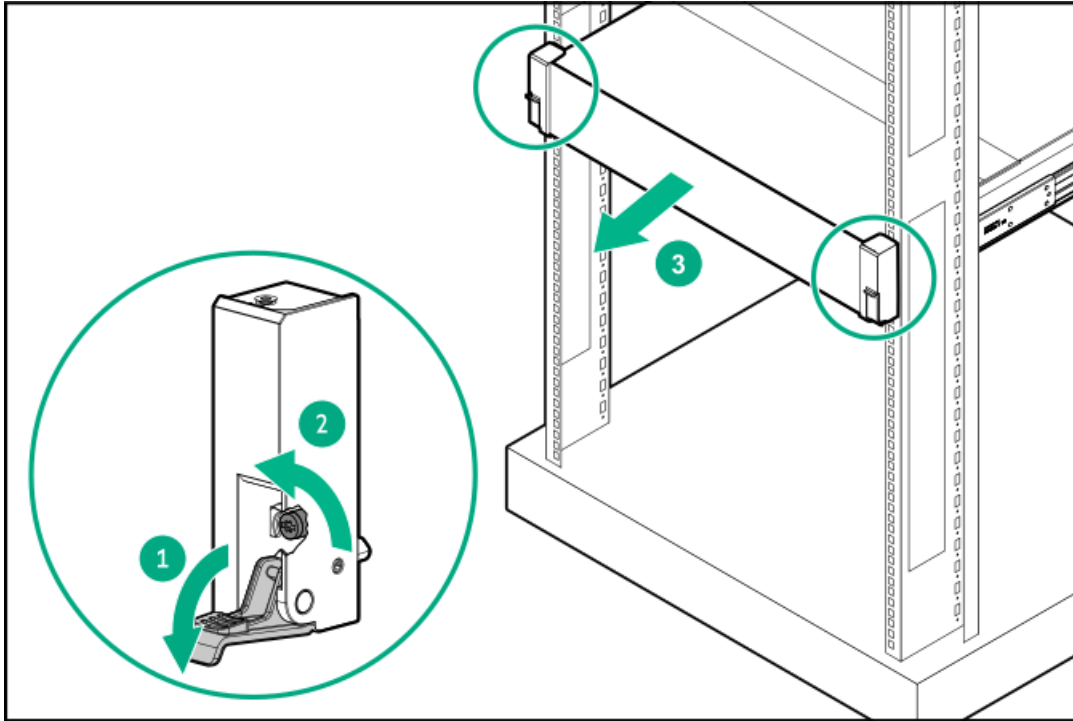

2. Press and hold the rear-end rail-release latches, and then slide the server out of the rack until it is fully extended.



WARNING:

To reduce the risk of personal injury, be careful when pressing the server rail-release latches. The inner rails could pinch your fingers.

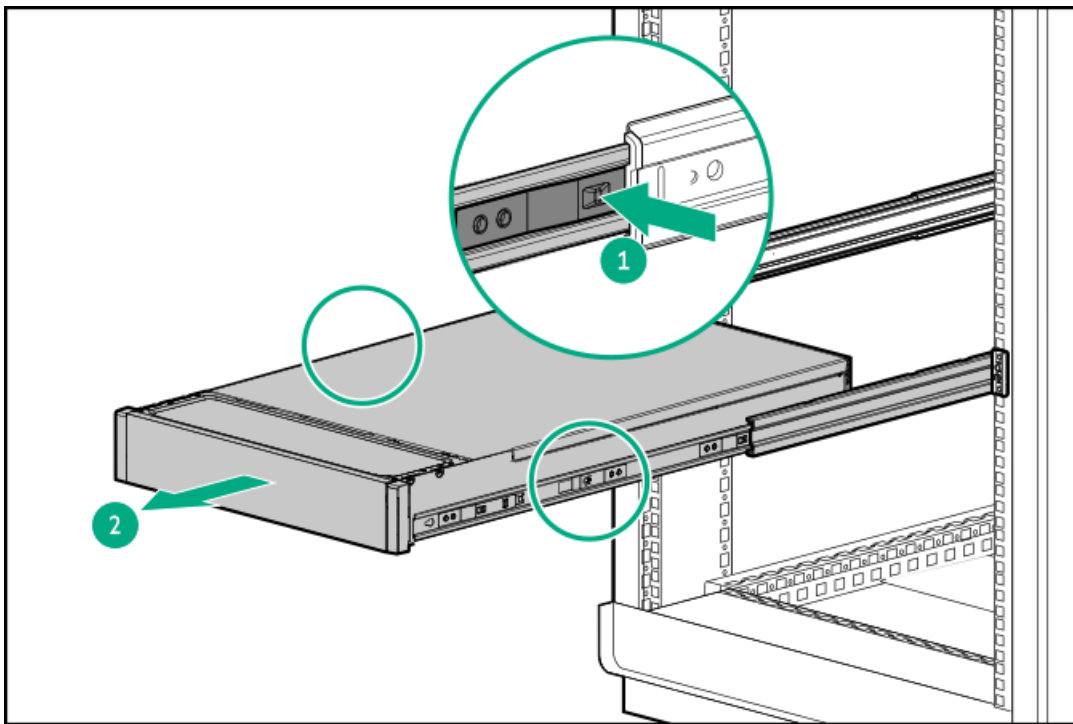

Remove the server from the rack

Prerequisites

- Get help to lift and stabilize the server during removal from the rack. **If the server is installed higher than chest level, an additional two people might be required to help remove the server:** One person to support the server weight, and the other two to slide the server out of the rack.
- Before you perform this procedure, review the:
 - [Rack warnings and cautions](#)
 - [Server warnings and cautions](#)
- A fully populated server is heavy. Hewlett Packard Enterprise recommends removing the external server components before removing the server from the rack.
- T-25 Torx screwdriver—This tool is required if shipping screws located inside the chassis ears are secured.

Procedure

1. [Power down the server.](#)
2. If installed, [open the cable management arm.](#)
3. Remove all power:
 - a. Disconnect each power cord from the power source.
 - b. Disconnect each power cord from the server.
4. Disconnect all peripheral cables from the server.
5. If needed, loosen the shipping screws, and then use the chassis ear latches to slide the server out of the rack until the rail-release latches are engaged.



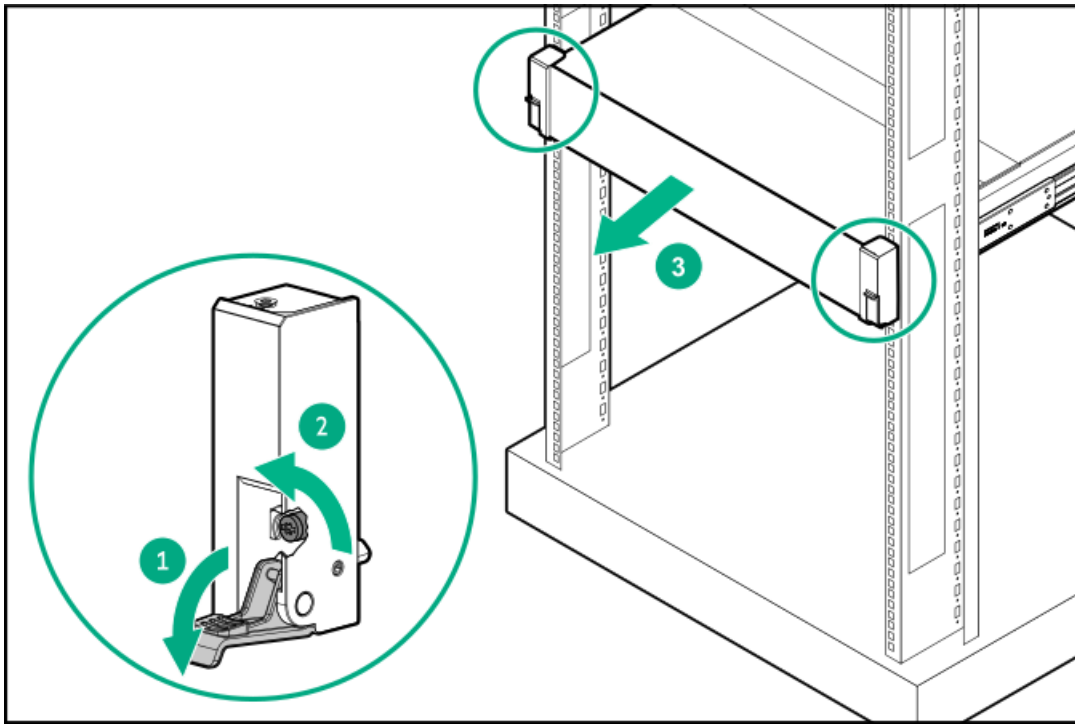

6. Press and hold the rear-end rail-release latches, and then slide the server out of the rack until it is fully extended.



WARNING:

To reduce the risk of personal injury, be careful when pressing the server rail-release latches. The inner rails could pinch your fingers.

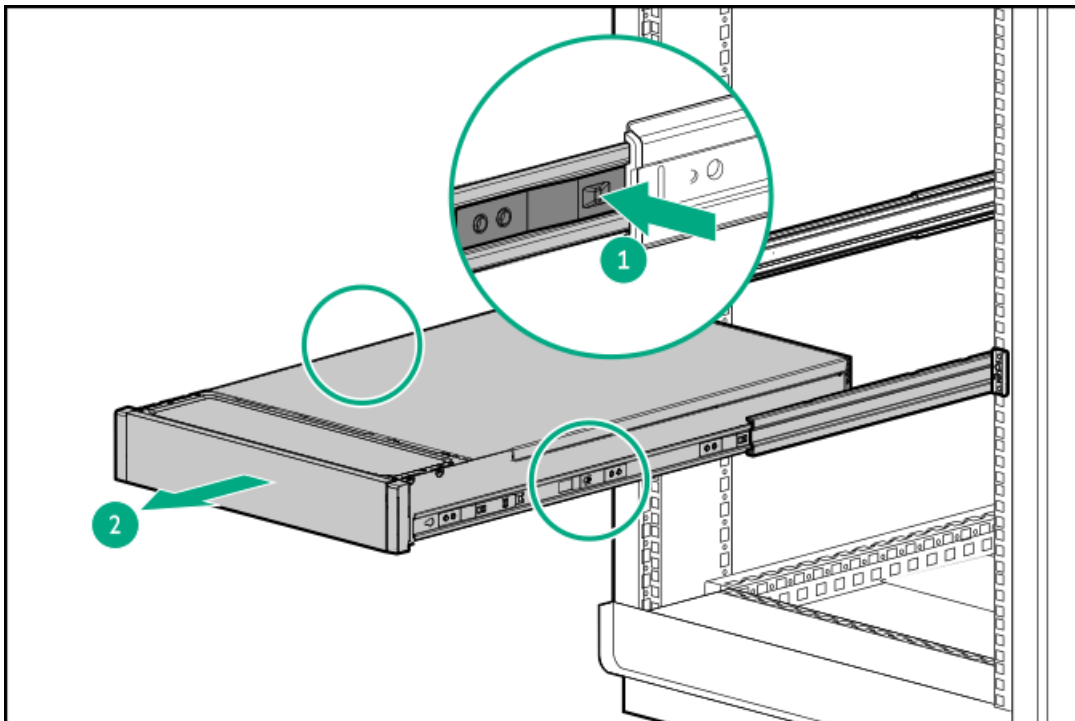

7. Slide the server completely out of the rack.



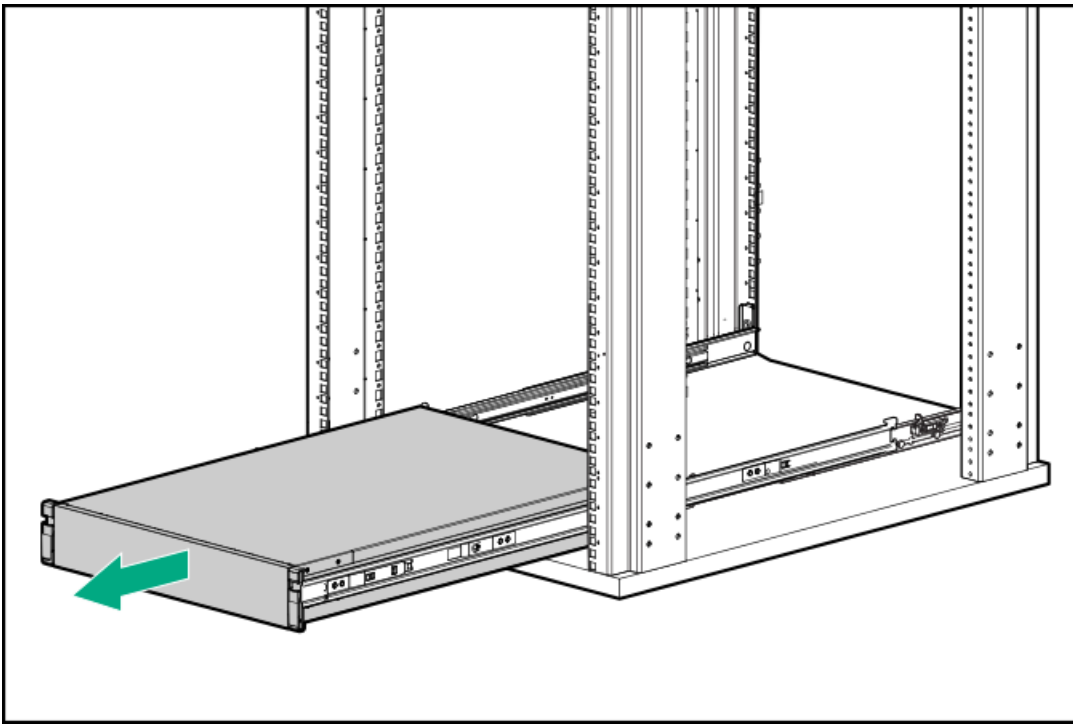

8. Place the server on a flat, level work surface.

Remove the front bezel

Procedure

1. If installed, remove the Kensington security lock.

For more information, see the lock documentation.

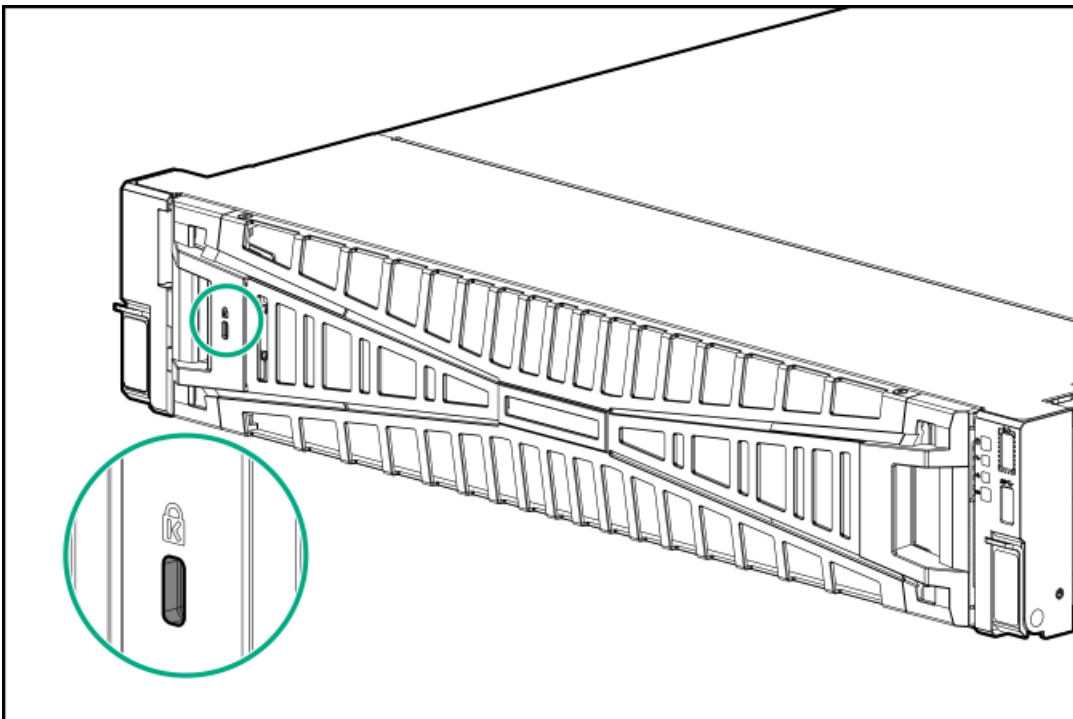

2. Press the bezel release latch, and then pivot the bezel open.



3. Release the right side of the bezel from the front panel.

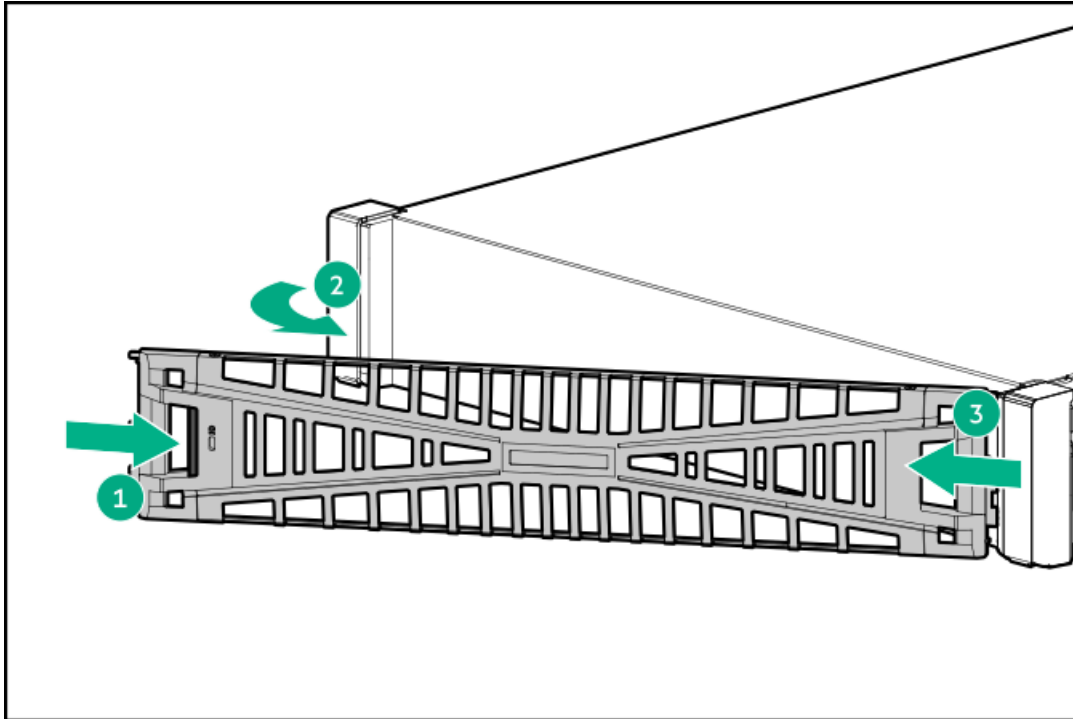

Remove the access panel

About this task

WARNING: To reduce the risk of personal injury from hot surfaces, allow the drives and the internal system components to cool before touching them.

CAUTION:
To prevent damage to electrical components, properly ground the server before beginning any installation, removal, or replacement procedure. Improper grounding can cause [electrostatic discharge](#).

CAUTION: To maintain proper system cooling, do not operate the server for long period with the access panel open or removed. Operating the server in this manner results in an improper system airflow. For internal hot-plug component procedures, complete the procedure within 60 seconds. Failure to do so can cause the system temperature to increase and trip the safety threshold. When this happens:

- The health LED flashes amber.
- The operating system gracefully shuts down.

Procedure

1. Power down the server.
2. If installed, open the cable management arm.
3. Remove all power:
 - a. Disconnect each power cord from the power source.
 - b. Disconnect each power cord from the server.
4. Disconnect all peripheral cables from the server.
5. Do one of the following:

- a. Extend the server from the rack.
 - b. Remove the server from the rack.
6. Remove the access panel:
- a. If necessary, unlock the access panel latch.
 - b. To disengage the access panel from the chassis, press the release button and pull up the latch.
 - c. Lift the access panel.

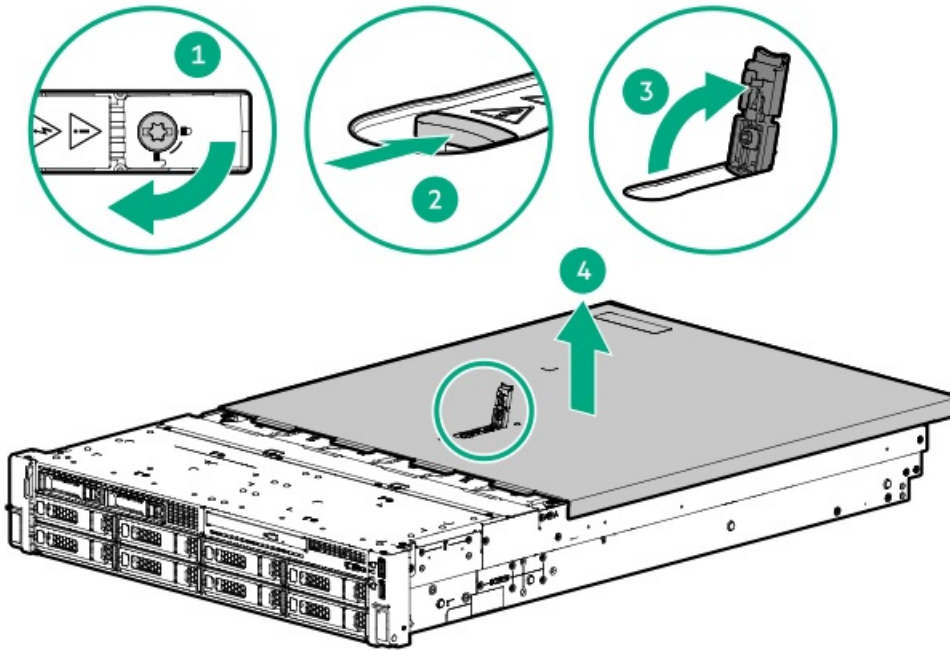

Remove the fan cage

Prerequisites

Before you perform this procedure, make sure that you have a T-15 Torx screwdriver available.

Procedure

1. Power down the server.
2. If installed, open the cable management arm.
3. Remove all power:
 - a. Disconnect each power cord from the power source.
 - b. Disconnect each power cord from the server.
4. Disconnect all peripheral cables from the server.
5. Remove the server from the rack.
6. Place the server on a flat, level work surface.
7. Remove the access panel.
8. Remove all fans:

- a. Press and hold the latch (callout 1).
- b. Lift the fan from the fan cage (callout 2).

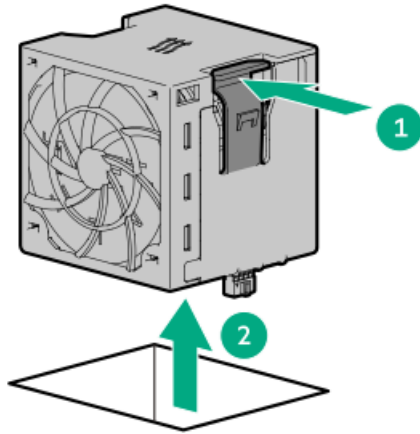

9. Remove the fan cage:
- a. Loosen the captive screws.
 - b. Lift the fan cage away from the chassis.

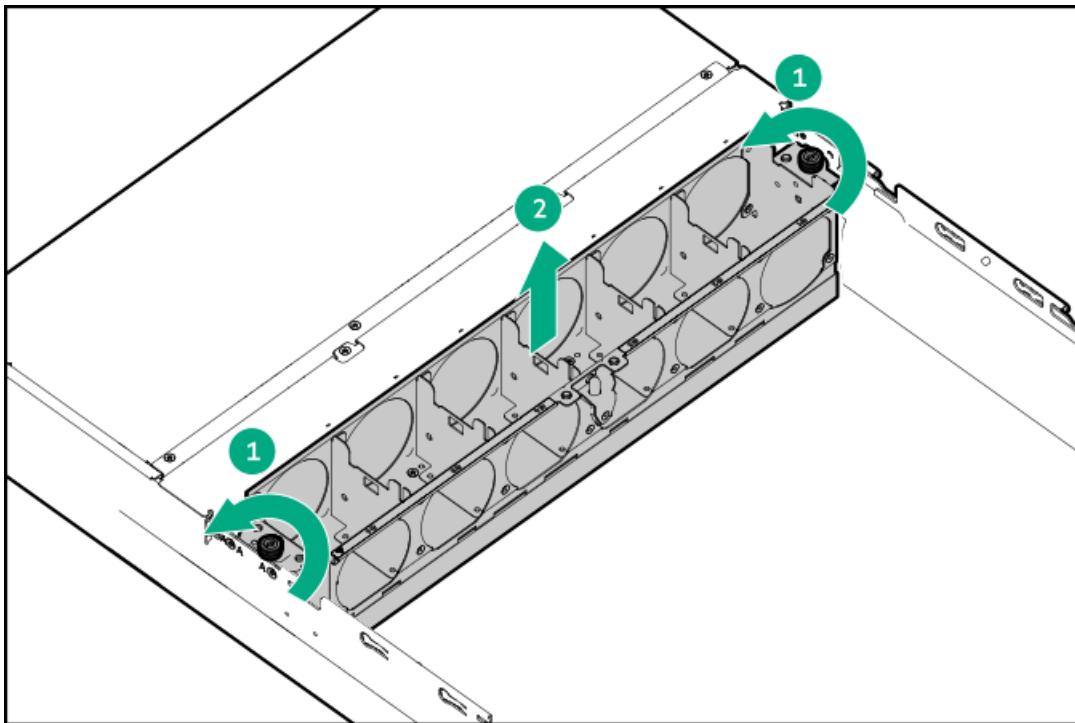

Remove the LFF drive backplane bracket

Prerequisites

Before you perform this procedure, make sure that you have a T-10 Torx screwdriver available.

About this task

The drive backplane bracket is only present in LFF drive configurations.

Procedure



1. Power down the server.
2. If installed, open the cable management arm.
3. Remove all power:
 - a. Disconnect each power cord from the power source.
 - b. Disconnect each power cord from the server.
4. Disconnect all peripheral cables from the server.
5. Remove the server from the rack.
6. Place the server on a flat, level work surface.
7. Remove the access panel.
8. Remove the fan cage.
9. Remove the midwall bracket.
10. Disconnect all cables from the drive backplane.
11. Remove the drive backplane bracket screws.

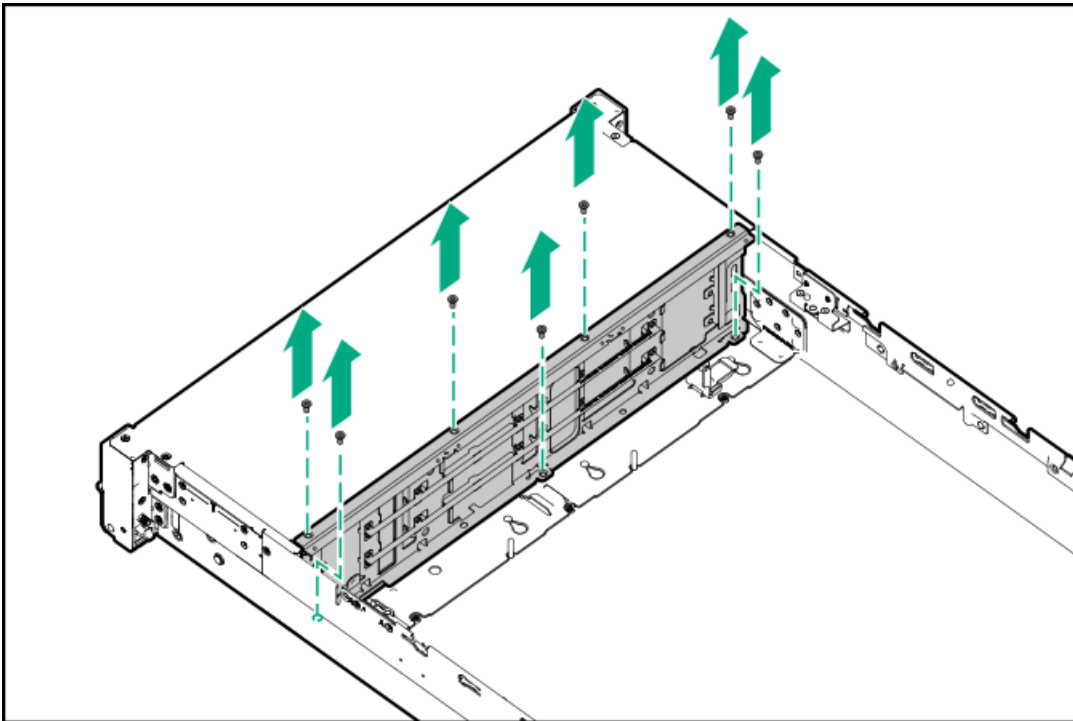

12. Remove the drive backplane bracket from the server.

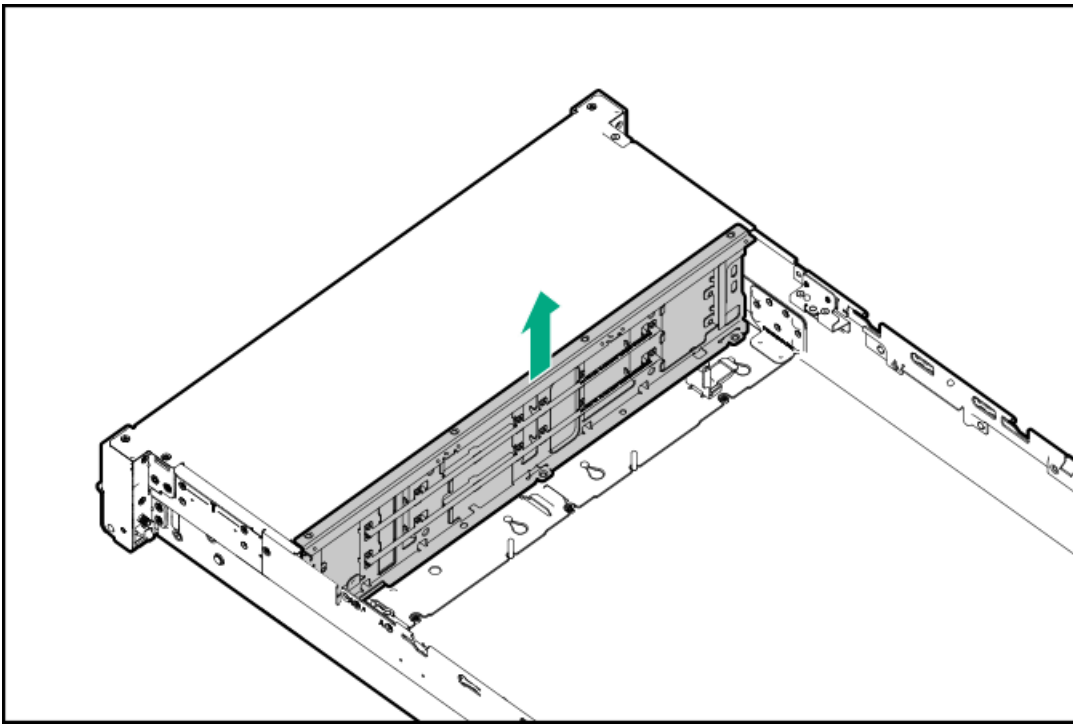

Remove the midwall bracket

Prerequisites

Before you perform this procedure, make sure that you have a T-10 Torx screwdriver available.

Procedure

1. Power down the server.
2. If installed, open the cable management arm.
3. Remove all power:
 - a. Disconnect each power cord from the power source.
 - b. Disconnect each power cord from the server.
4. Disconnect all peripheral cables from the server.
5. Remove the server from the rack.
6. Place the server on a flat, level work surface.
7. Remove the access panel.
8. Do one of the following:
 - Remove the air baffle.
 - Remove the midplane drive cage.
9. Remove the fan cage.
10. Remove the midwall bracket screws.
 - LFF chassis



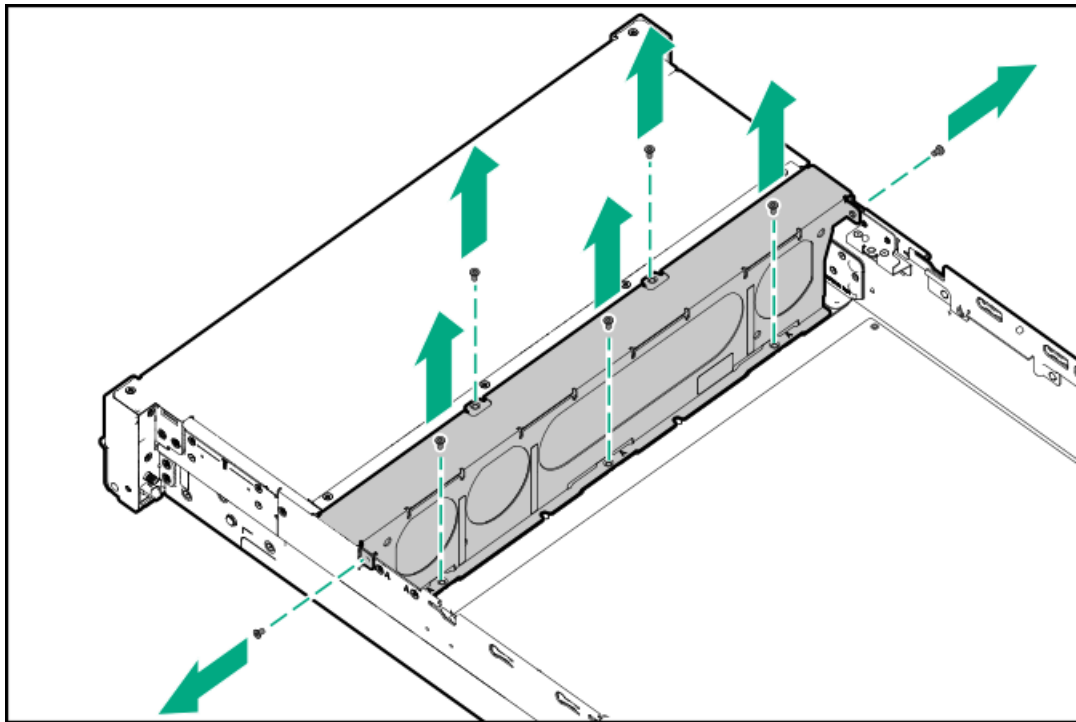

- SFF chassis

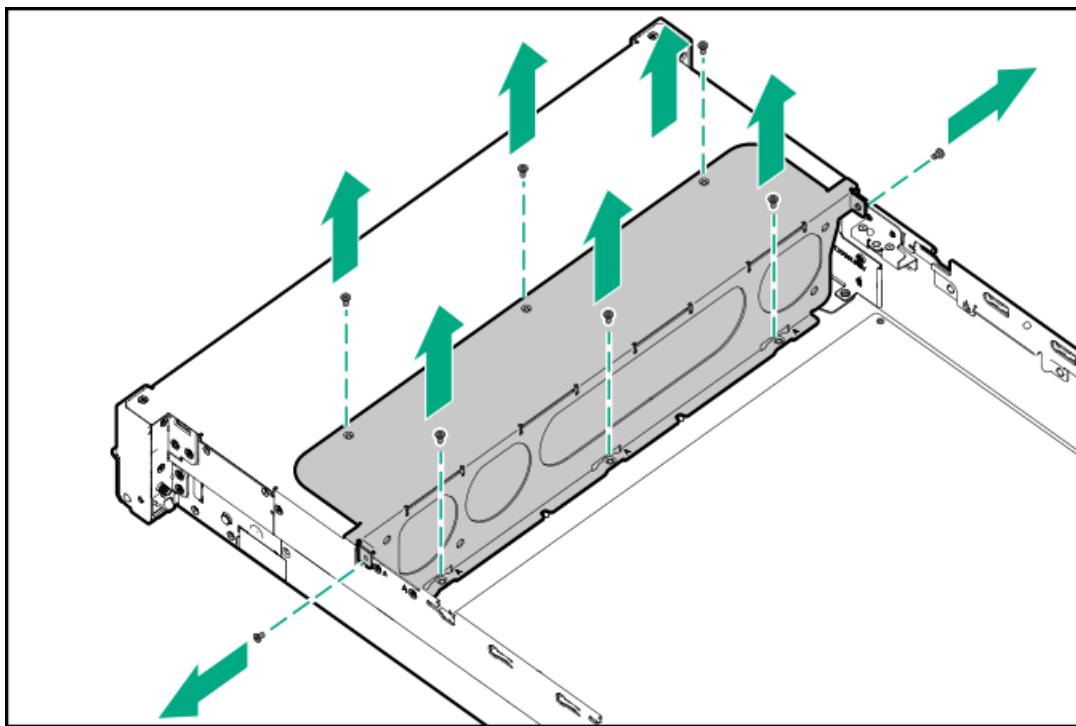

11. Lift the midwall bracket away from the chassis.

- LFF chassis



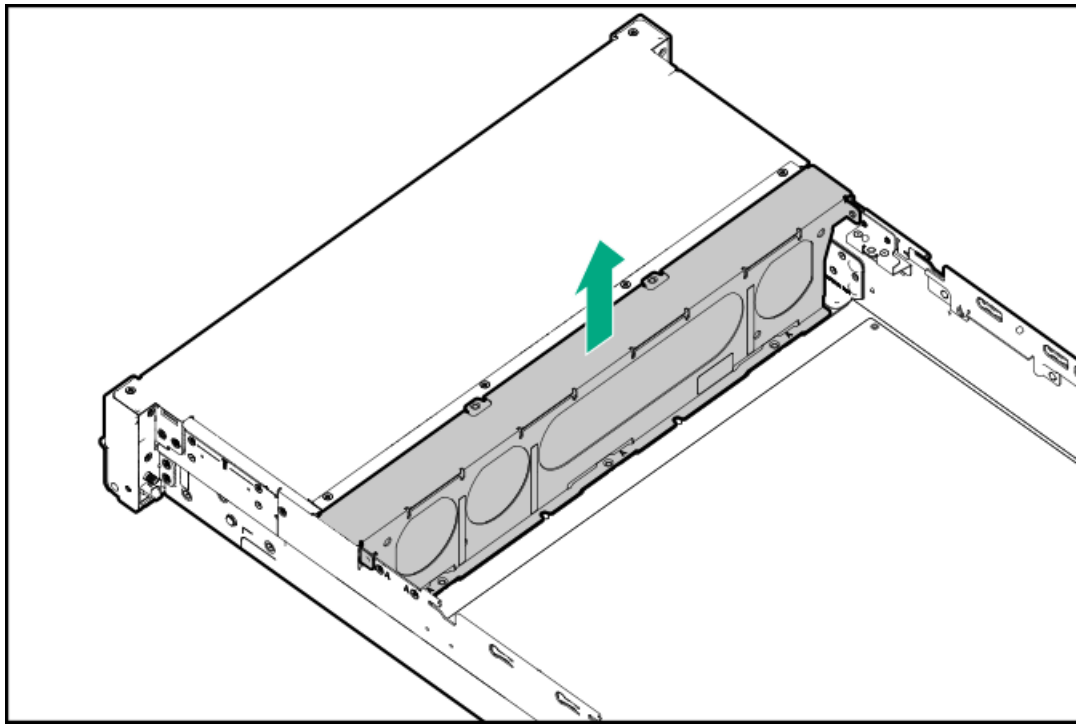

- SFF chassis

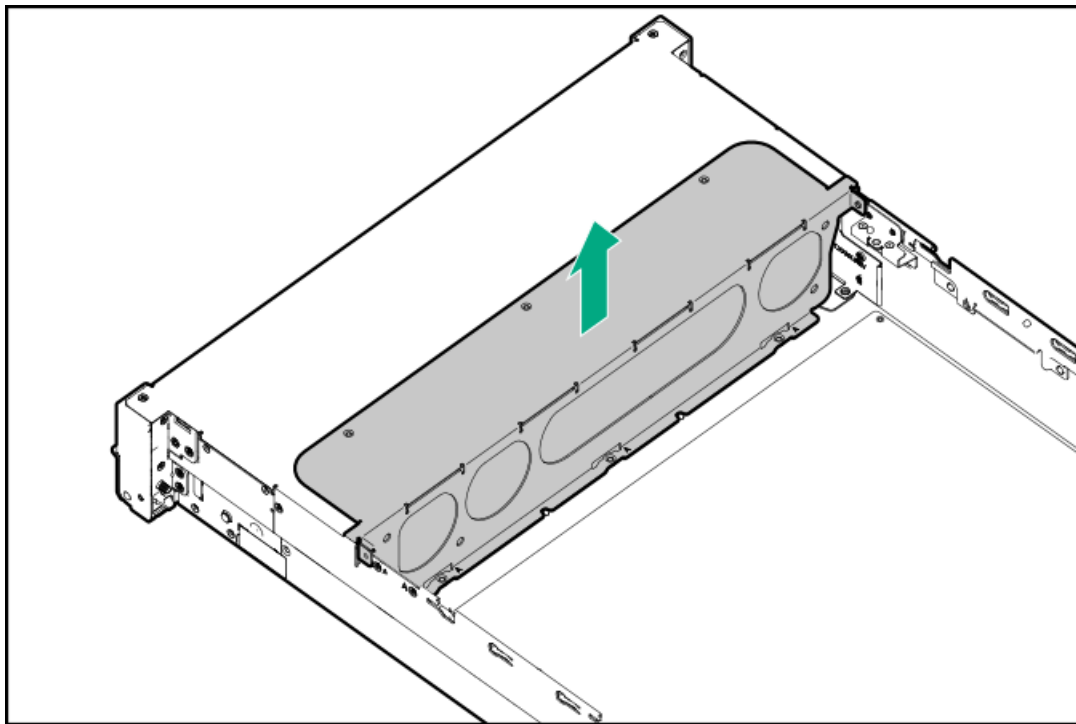

Remove the midplane drive cage

About this task

CAUTION: Do not detach the cable that connects the battery pack to the cache module. Detaching the cable causes any unsaved data in the cache module to be lost.

CAUTION: For proper cooling, do not operate the server without the access panel, baffles, expansion slot covers, or blanks installed. If the server supports hot-plug components, minimize the amount of time the access panel is open.

Procedure

1. Power down the server.
2. If installed, open the cable management arm.
3. Remove all power:
 - a. Disconnect each power cord from the power source.
 - b. Disconnect each power cord from the server.
4. Disconnect all peripheral cables from the server.
5. Remove the server from the rack.
6. Place the server on a flat, level work surface.
7. Remove the access panel.
8. Remove the air baffle.
9. Remove the midplane drive cage:
 - a. Pull the plunger pin on the rear right side of the drive cage.
 - b. Use the drive cage latches to lift the cage out of the server.

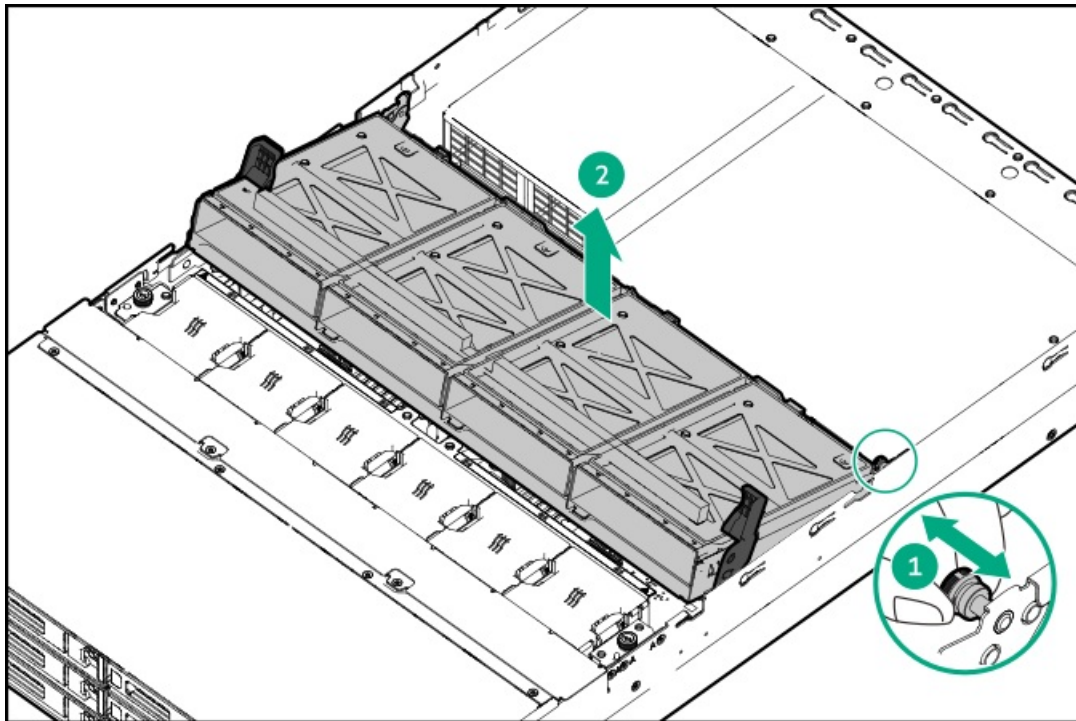

10. Remove the drive.
 - LFF drive

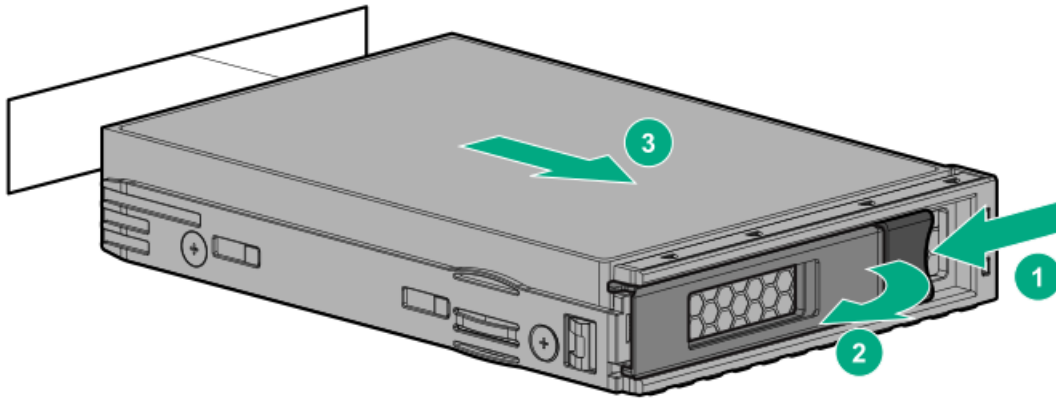

- SFF drive

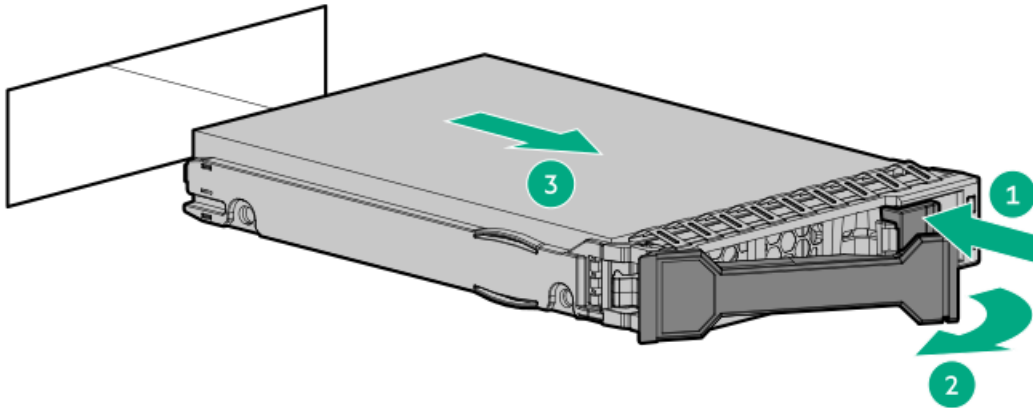

11. Remove the midplane drive cage:

- Pull the plunger pin on the rear right side of the drive cage.
- Use the drive cage latches to lift the cage out of the server.

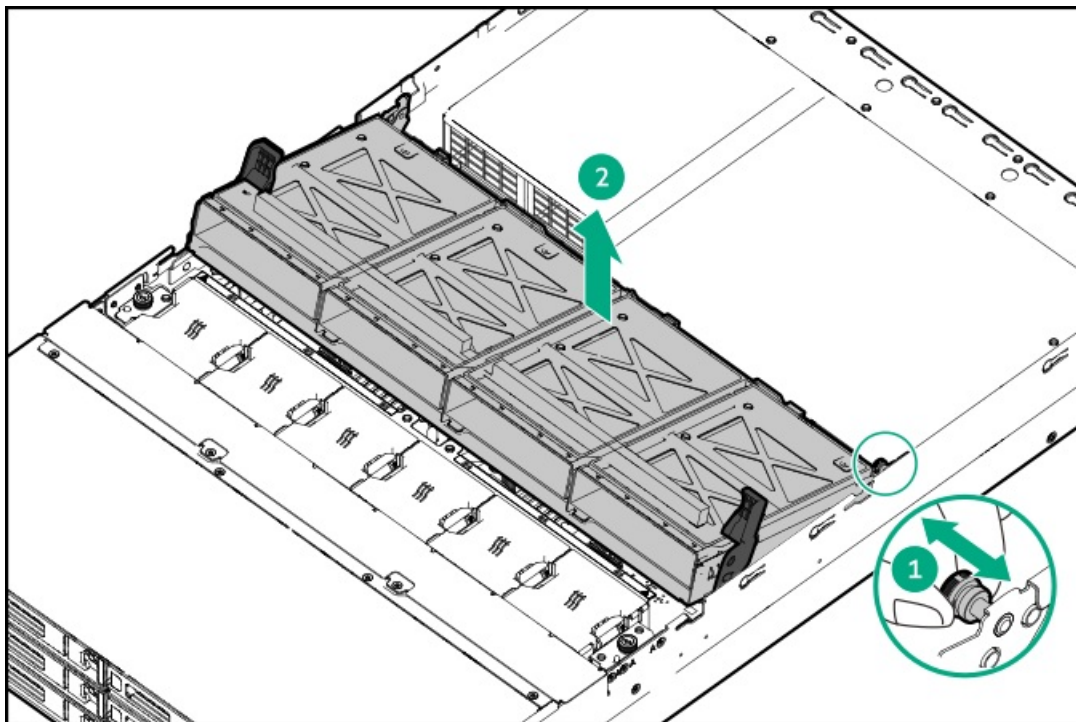

Remove the rear 4 LFF drive cage

Prerequisites

Before you perform this procedure, make sure that you have a T-10 Torx screwdriver available.

About this task

CAUTION: A discharge of static electricity from a finger or other conductor might damage system boards or other static-sensitive devices. To prevent damage, observe [antistatic precautions](#).

CAUTION: To prevent improper cooling and thermal damage, do not operate the server unless all bays are populated with either a component or a blank.

Procedure

1. Remove all drives or drive blanks.

- Drive blank

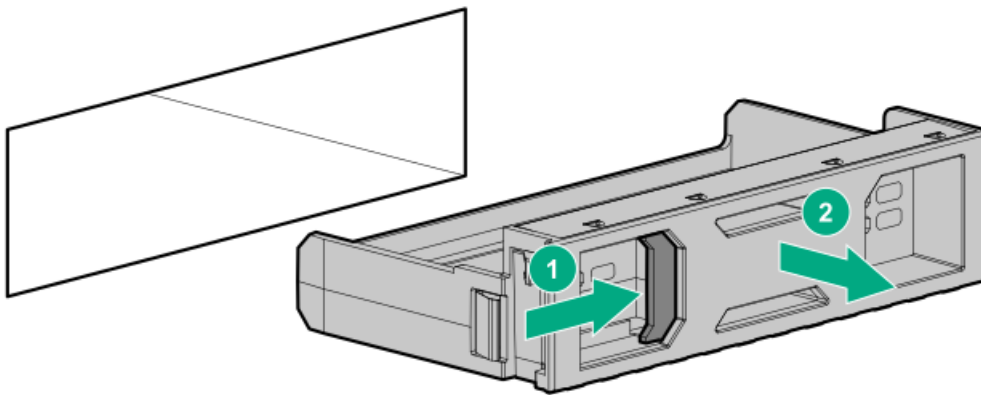

- Drive

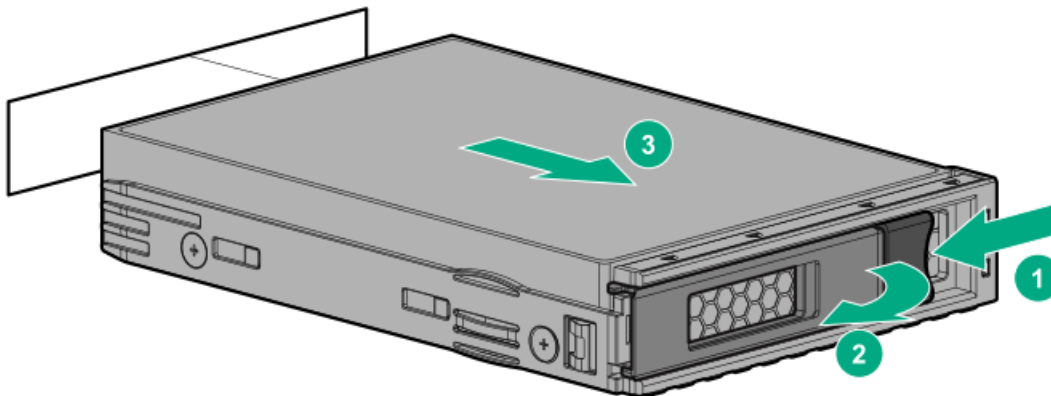

2. [Power down the server](#).

3. If installed, [open the cable management arm](#).

4. Remove all power:

a. Disconnect each power cord from the power source.

b. Disconnect each power cord from the server.

5. Disconnect all peripheral cables from the server.

6. [Remove the server from the rack](#).

7. Place the server on a flat, level work surface.

8. Remove the access panel.
9. Disconnect all cables from the rear 4 LFF drive cage.
10. Remove the rear 4 LFF drive cage:
 - a. Loosen the captive screws, and then pull the rear 4 LFF drive cage into place.
 - b. Lift the rear 4 LFF drive cage.

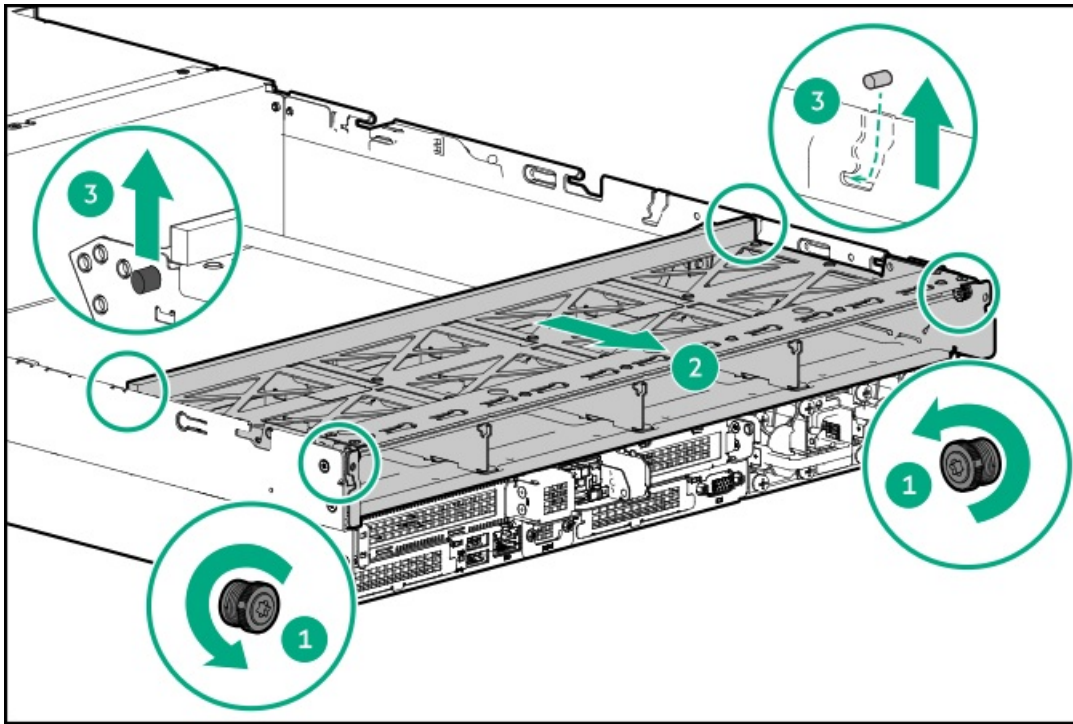

Remove the riser cage

Prerequisites

If removing the three-slot riser cage or tertiary riser cage, make sure that you have a T-15 Torx screwdriver available.

About this task

⚠ WARNING: To reduce the risk of personal injury from hot surfaces, allow the drives and the internal system components to cool before touching them.

Procedure

1. Power down the server.
2. If installed, open the cable management arm.
3. Remove all power:
 - a. Disconnect each power cord from the power source.
 - b. Disconnect each power cord from the server.
4. Disconnect all peripheral cables from the server.
5. Remove the server from the rack.
6. Place the server on a flat, level work surface.

7. Remove the access panel.
8. If an expansion card with internal cables is installed on the riser, disconnect the cables from the card.
9. Remove the one-slot riser cage:
 - a. Release the half-turn spring latch.
 - b. Lift the riser cage off the system board.
 - One-slot primary/secondary riser cage

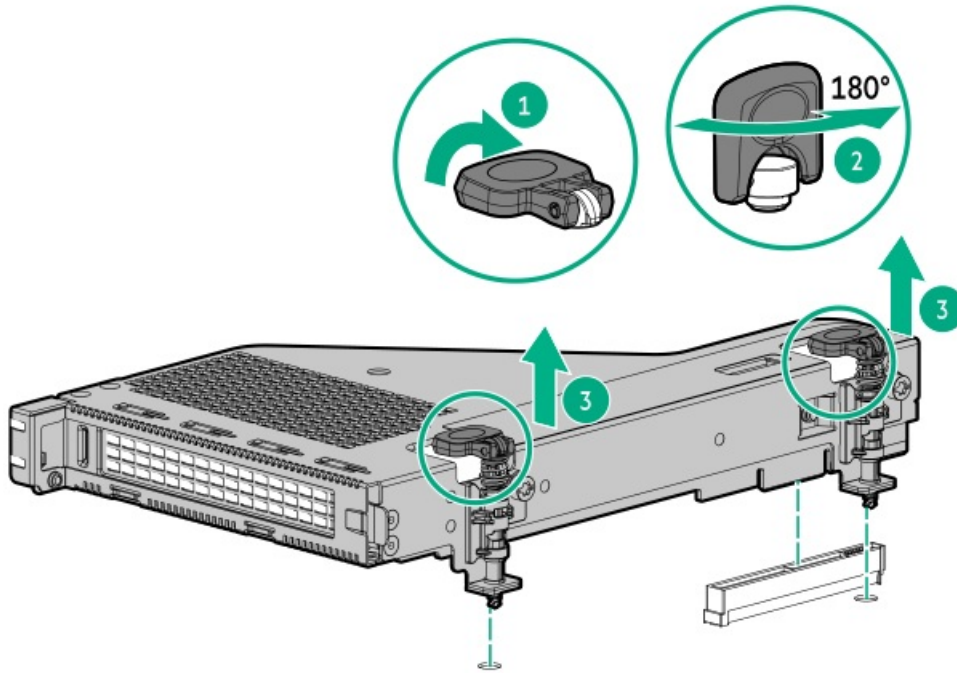

- NS204i-u + secondary low-profile riser cage

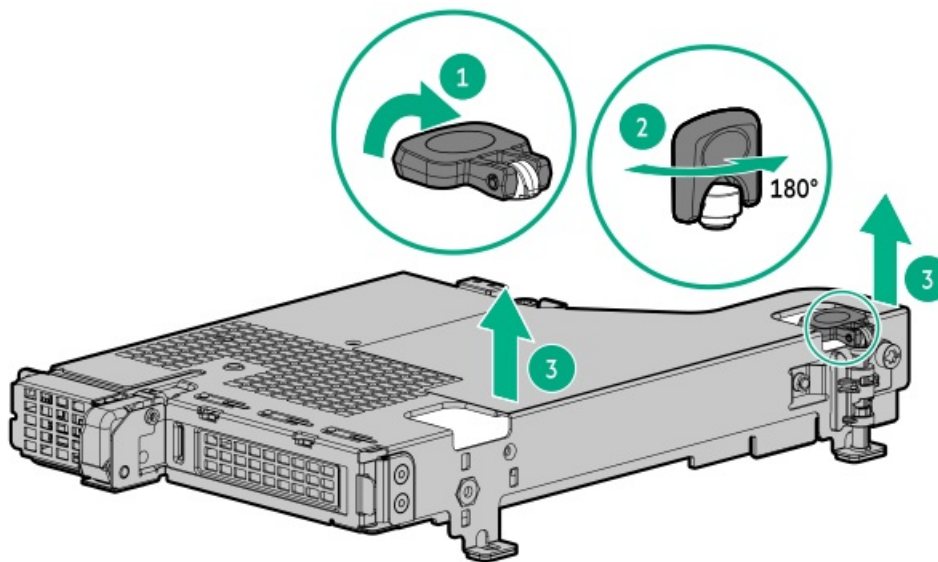

10. Remove the three-slot riser cage:
 - a. Loosen the captive screws.
 - b. Lift the riser cage off the system board.



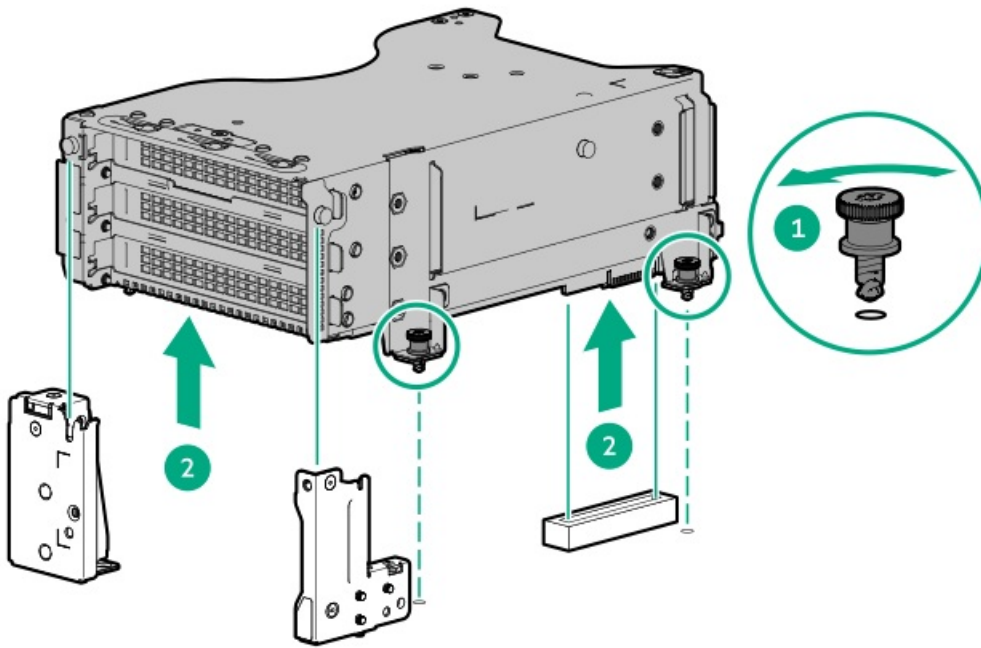

11. Remove the tertiary riser cage:

- a. Loosen the thumbscrews (callout 1).
- b. Lift the riser cage out of the slot (callout 2).

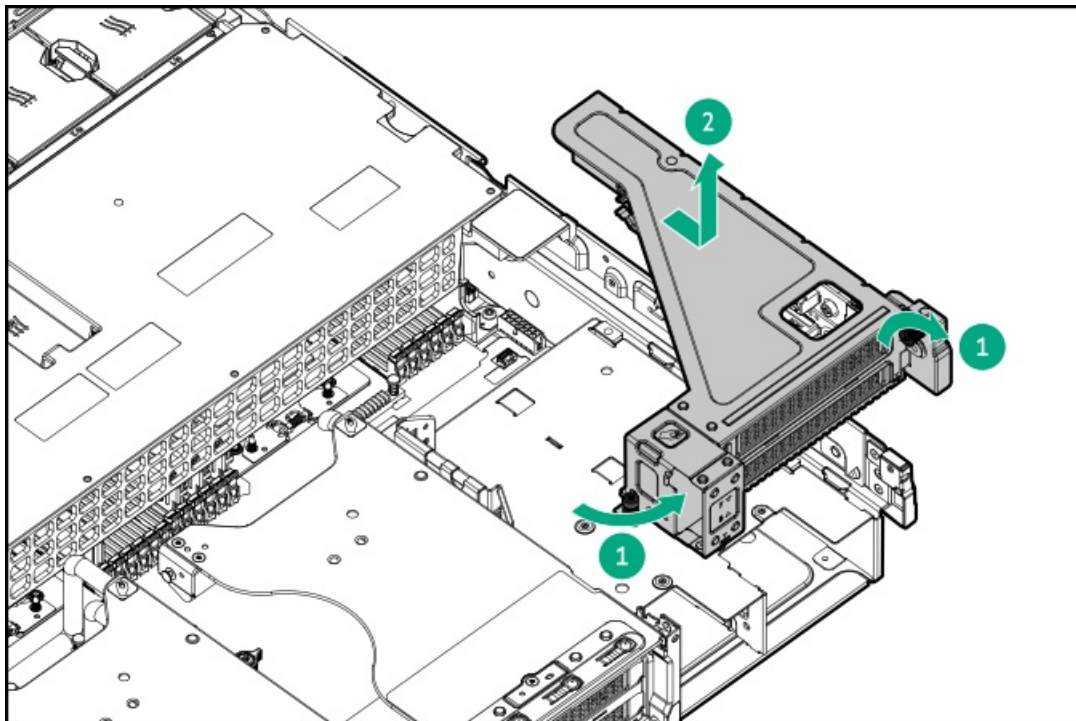

Install the access panel

Prerequisites

Before you perform this procedure, make sure that you have a T-15 Torx screwdriver available.

Procedure



1. With the access panel latch open, insert the guide pin on the chassis through the hole on the bottom side of the latch.
2. Close the access panel latch.
The access panel slides to the closed position.
3. Lock the access panel latch.

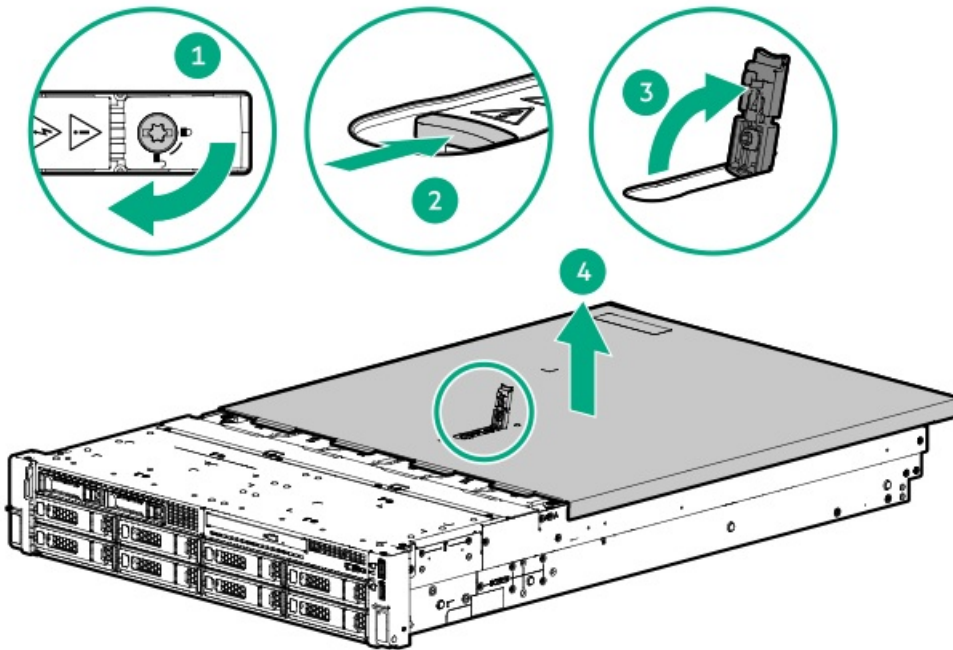

4. Perform the post-installation or maintenance steps required by the procedure that necessitates the removal of the access panel.

Install the LFF drive backplane bracket

Prerequisites

Before you perform this procedure, make sure that you have a T-10 Torx screwdriver available.

About this task

The drive backplane bracket is only present in LFF drive configurations.

Procedure

1. Fit the drive backplane bracket behind the drive cage.

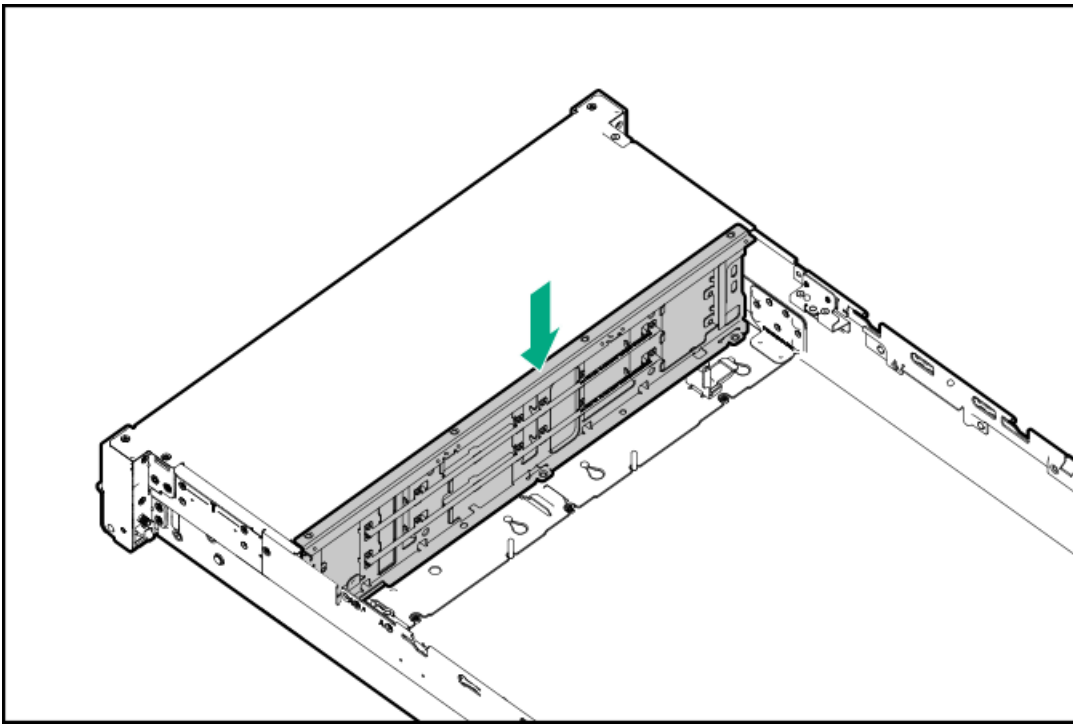

2. Install the drive backplane bracket screws.

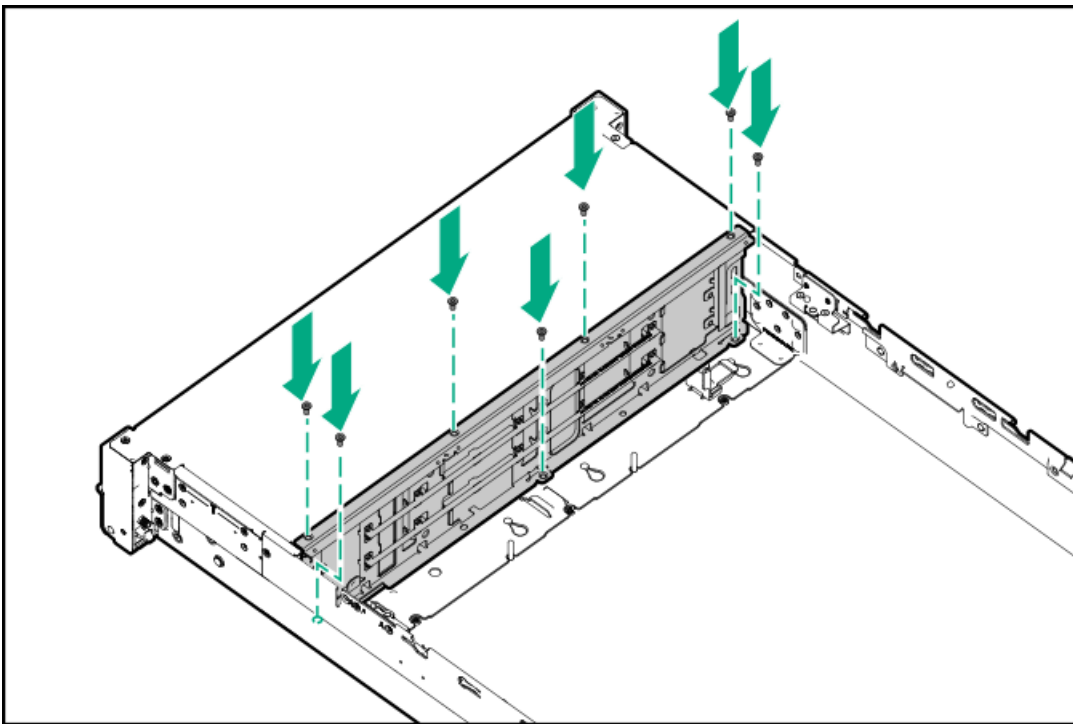

3. Connect all drive backplane cables.
4. Perform the post-installation or maintenance steps required by the procedure that necessitates the removal of the drive backplane bracket.

Install the riser cage

Prerequisites

If installing the three-slot riser cage, make sure you have a T-15 Torx screwdriver available.



If installing the tertiary riser cage, make sure you have a T-10 Torx screwdriver available.

Procedure

1. Install the one-slot riser cage:

- a. Carefully press the riser down on its system board connector.

Make sure that the riser board is firmly seated.

- b. Simultaneously push and rotate the half-turn spring latch to 180°.

- c. Close the spring latch.

- One-slot secondary riser cage

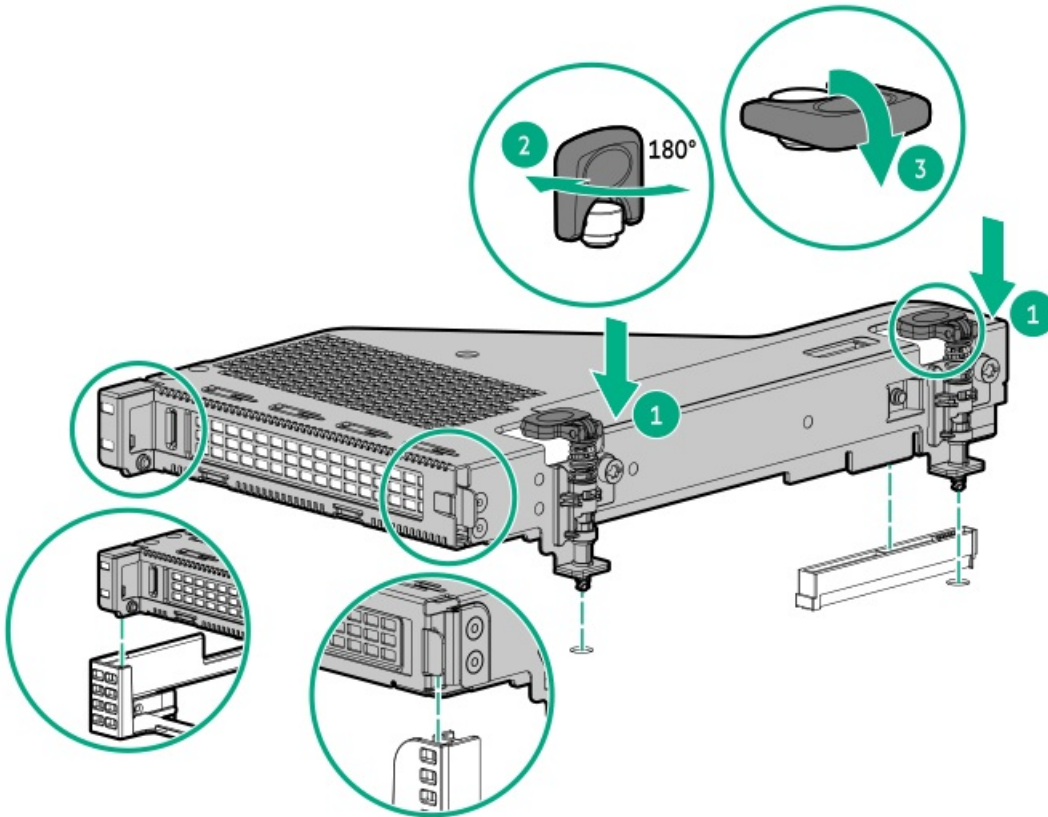

- NS204i-u + secondary low-profile riser cage

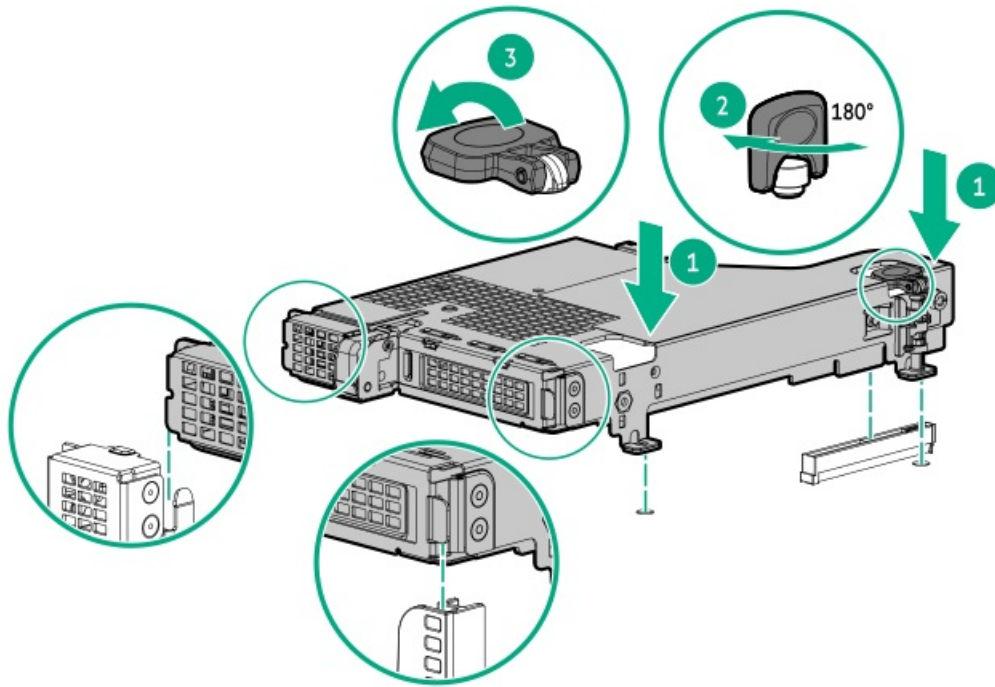

2. Install the three-slot riser cage:

- a. Carefully press the riser down on its system board connector.

Make sure that the riser board is firmly seated.

- b. Tighten the captive screws.

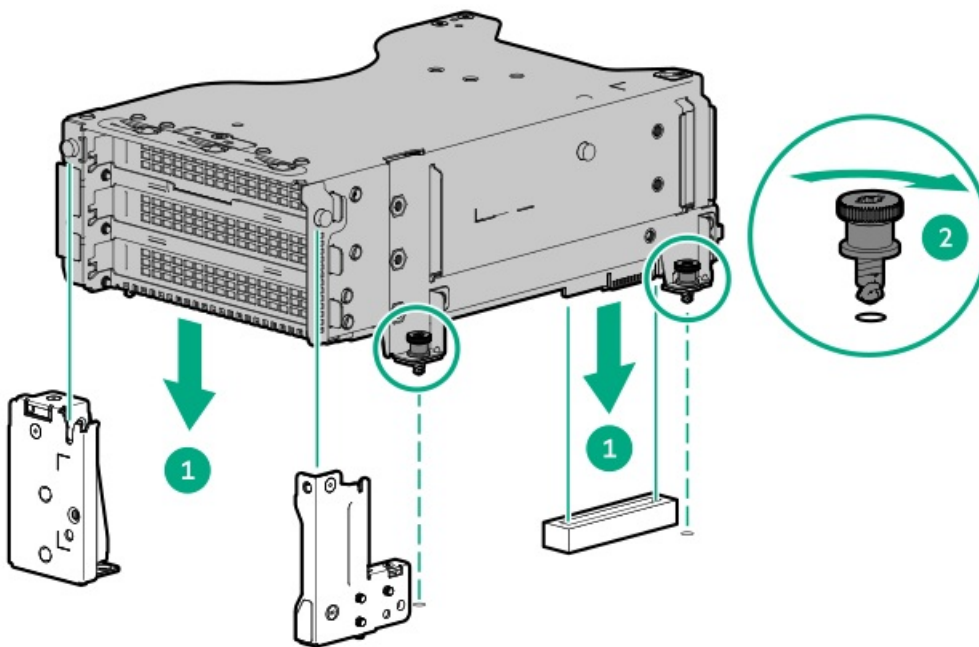

3. Install the tertiary riser cage:

- a. Align the riser to the holes on the server (callout 1).
- b. Carefully slide the riser into the slot (callout 2).
- c. Tighten the thumbscrews (callout 3).



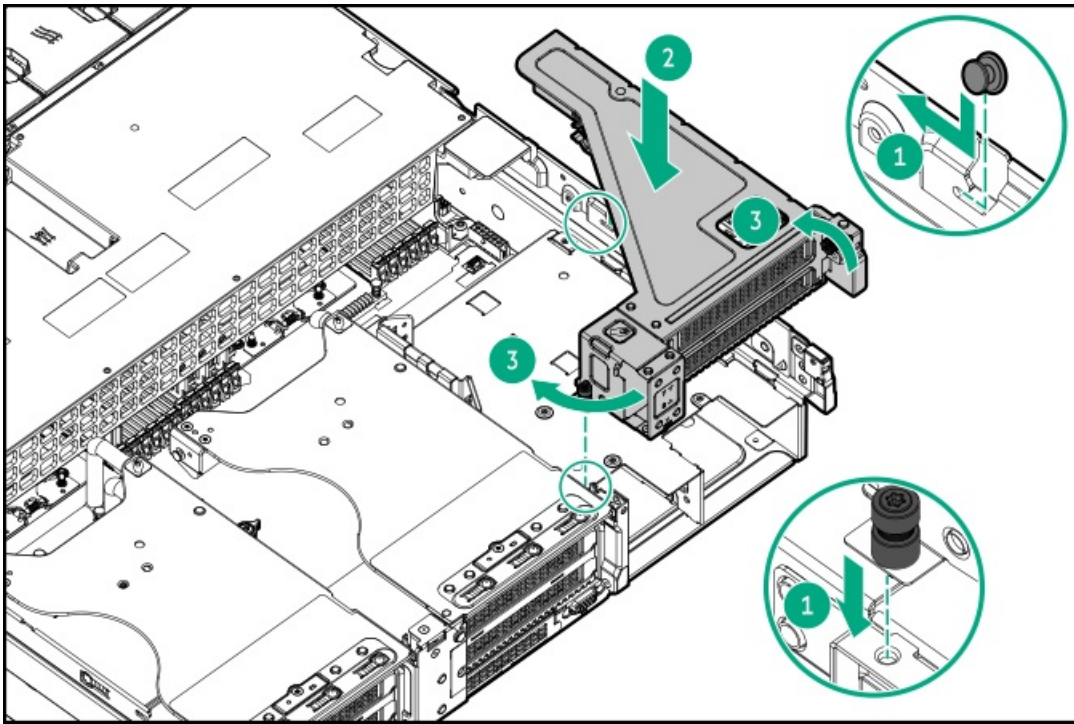

Install the midwall bracket

Prerequisites

Before you perform this procedure, make sure that you have a T-15 Torx screwdriver available.

Procedure

1. Lower the midwall bracket into the chassis.
 - LFF chassis

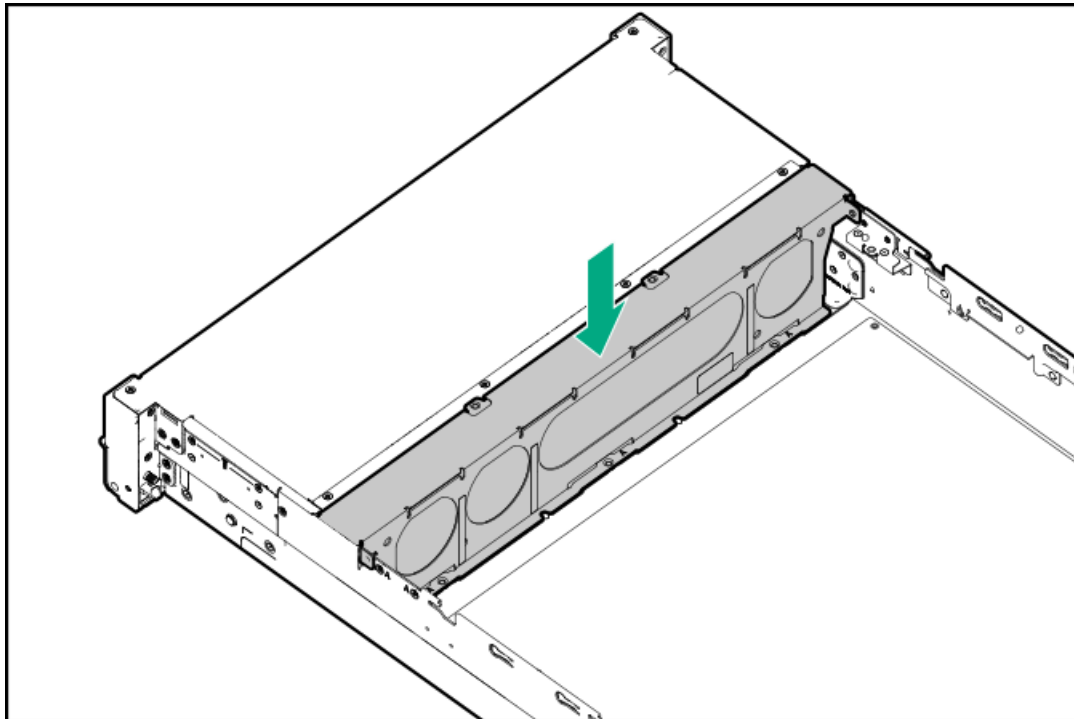

- SFF chassis

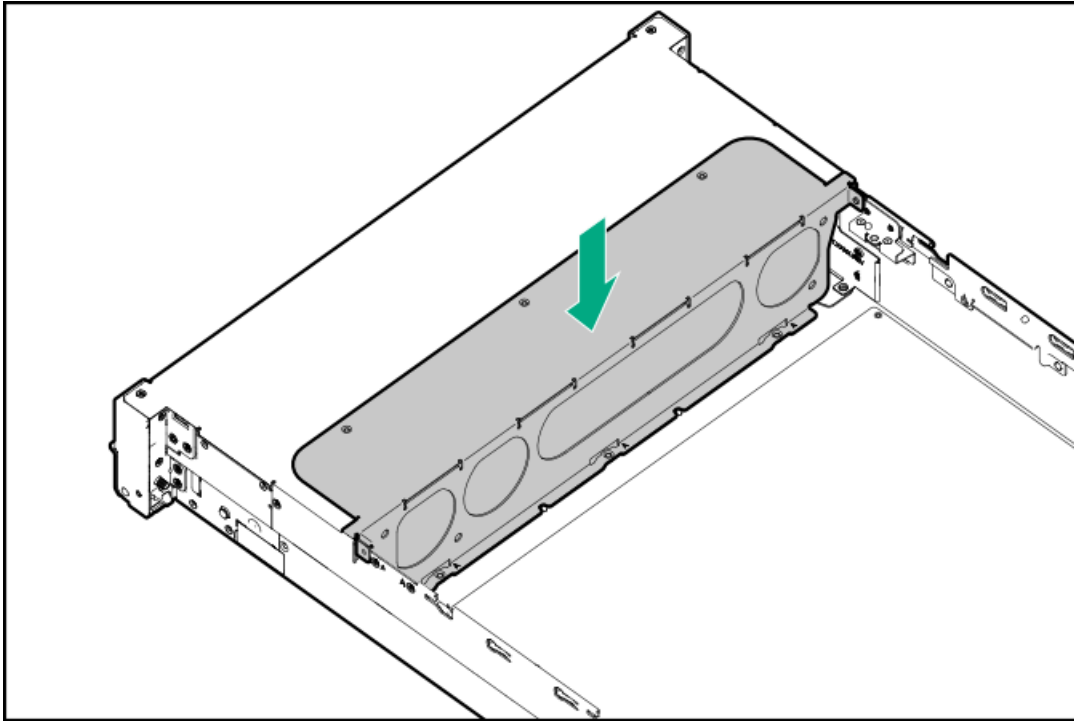

2. Perform the post-installation or maintenance steps required by the procedure that necessitates the removal of the midwall bracket.

Install the rear 4 LFF drive cage

Prerequisites

Before you perform this procedure, make sure that you have a T-10 Torx screwdriver available.

About this task

CAUTION: A discharge of static electricity from a finger or other conductor might damage system boards or other static-sensitive devices. To prevent damage, observe [antistatic precautions](#).

CAUTION: To prevent improper cooling and thermal damage, do not operate the server unless all bays are populated with either a component or a blank.

Procedure

1. Install the rear 4 LFF drive cage:
 - a. Align the pin on the rear left of the drive cage to the server and then insert the pin.
 - b. Lower the rear right of the drive cage to insert the pin into the server.
 - c. Install the rear 4 LFF drive cage into the place, and then tighten the captive screws.

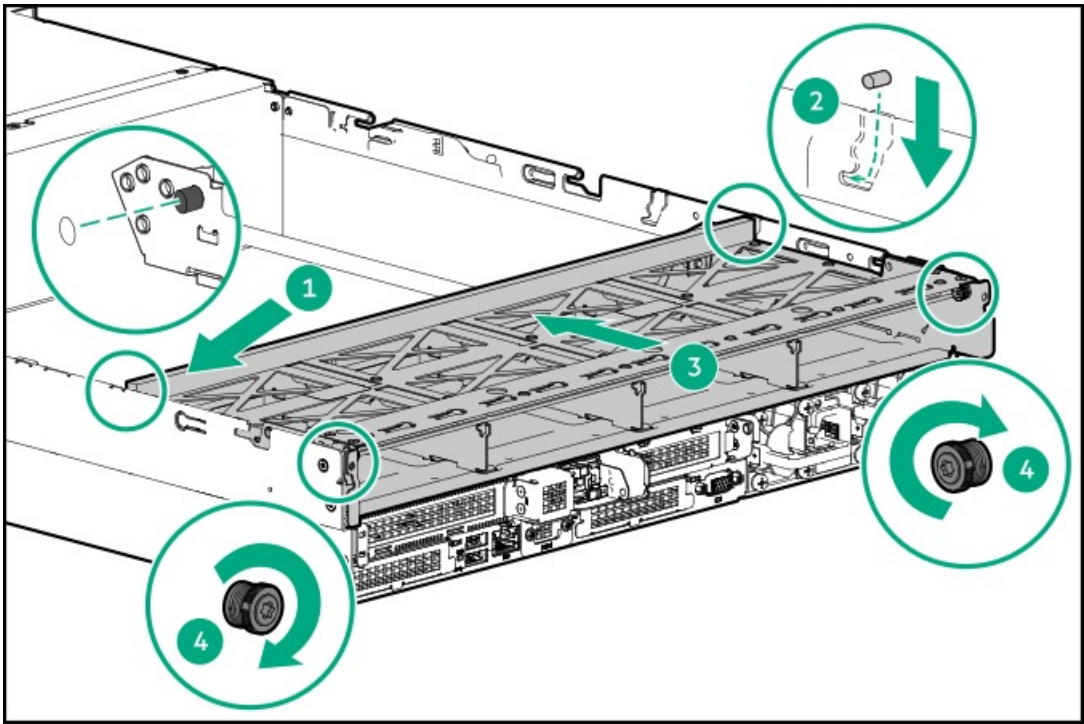

2. Install all drives or drive blanks.

- Drive blank

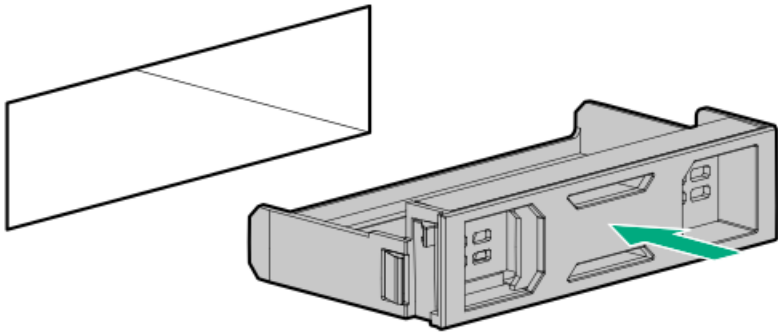

- Drive

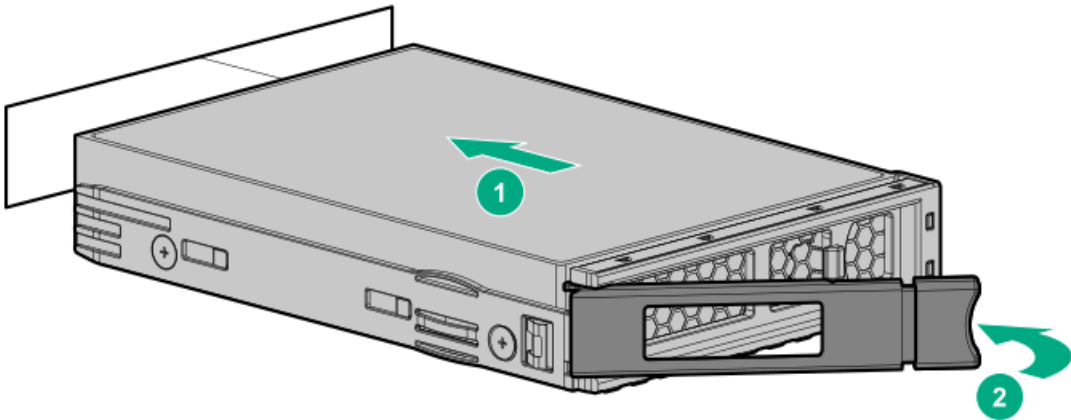

Install the fan cage



Prerequisites

Before you perform this procedure, make sure that you have a T-15 Torx screwdriver available.

Procedure

1. Install the fan cage:
 - a. Lower the fan cage into the chassis.
 - b. Tighten the captive screws.

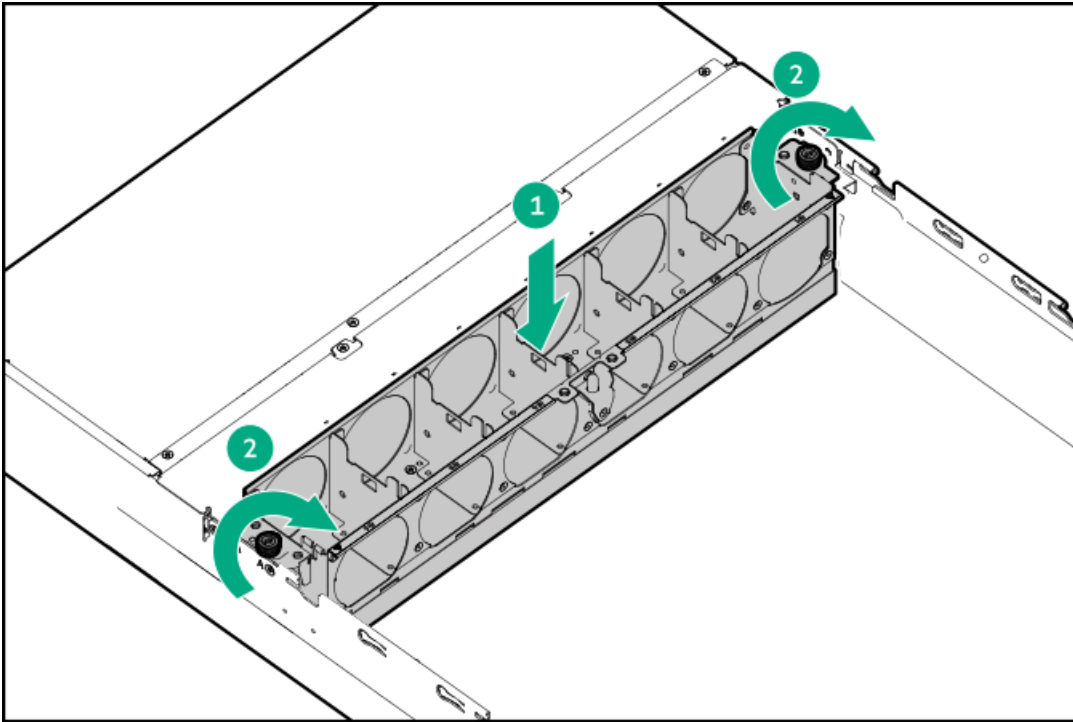

2. Install all fans:
 - a. Lower the fan into the fan bay.
 - b. Press down on the fan to make sure that it is seated firmly in the bay.

A click sound indicates that the fan is properly engaged.

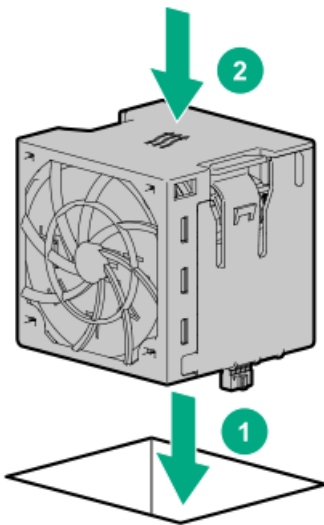

3. Perform the post-installation or maintenance steps required by the procedure that necessitates the removal of the fan cage.

Hardware options installation

This chapter provides instructions for installing supported hardware options. To ensure proper server deployment and operation, Hewlett Packard Enterprise recommends installing only HPE-validated hardware options. To see the list of validated options for this server, see the product QuickSpecs on the HPE ProLiant DL385 Gen11 Server website:

<https://www.hpe.com/info/quickspecs>

To view the warranty for your server and supported options, see [Warranty information](#).

Subtopics

[Server data backup](#)

[Hardware option installation guidelines](#)

[Hewlett Packard Enterprise product QuickSpecs](#)

[Rack mounting options](#)

[Installing the front bezel option](#)

[Universal media bay options](#)

[Optical drive option](#)

[Power supply options](#)

[Expansion card options](#)

[Processor and heatsink options](#)

[Drive options](#)

[Drive cage options](#)

[Fan options](#)

[Accelerator options](#)

[Riser and riser cage options](#)

[Memory option](#)

[OCP NIC 3.0 adapter option](#)

[HPE NS204i-u Boot Device option](#)

[Storage controller options](#)

[Transceiver option](#)

[Energy pack options](#)

[Serial port option](#)

[Chassis intrusion detection switch option](#)

[Installing the System Insight Display module](#)

[Internal USB device option](#)

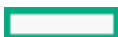

Server data backup

To avoid data loss, make sure to back up all server data before installing or removing a hardware option, performing a server maintenance, or a troubleshooting procedure.

Server data in this context refers to information that may be required to return the system to a normal operating environment after completing a hardware maintenance or troubleshooting procedure. This information may include:

- User data files
- User account names and passwords
- Application settings and passwords
- Component drivers and firmware
- TPM recovery key/password
- BIOS configuration settings—Use the backup and restore function in UEFI System Utilities. For more information, see the UEFI user guide (<https://www.hpe.com/info/UEFI-manuals>).
 - Custom default system settings
 - Security passwords including those required for power-on and BIOS admin access, persistent memory, and Server Configuration Lock (for HPE Trusted Supply Chain servers)
 - Server serial number and the product ID
- iLO-related data—Use the iLO backup and restore function. For more information, see the iLO user guide (<https://www.hpe.com/support/ilo6>).
 - iLO license
 - Customer iLO user name, password, and DNS name
 - iLO configuration settings
- For servers managed by HPE GreenLake for Compute Ops Management, make sure that you have your HPE GreenLake account ID. For more information, see the HPE GreenLake for Compute Ops Management Getting Started Guide :
<https://www.hpe.com/info/com-gsg>

Hardware option installation guidelines



WARNING: To reduce the risk of personal injury from hot surfaces, allow the drives and the internal system components to cool before touching them.



CAUTION:

To avoid data loss, Hewlett Packard Enterprise recommends that you back up all server data before installing or removing a hardware option, or performing a server maintenance or troubleshooting procedure.



CAUTION:

To prevent damage to electrical components, properly ground the server before beginning any installation, removal, or replacement procedure. Improper grounding can cause electrostatic discharge.

- Install any hardware options before initializing the server.
- If multiple options are being installed, read the installation instructions for all the hardware options to identify similar steps and streamline the installation process.
- If the hardware option installation involves internal cabling, review the Cabling guidelines.

Hewlett Packard Enterprise product QuickSpecs

To learn more about your product, search the Hewlett Packard Enterprise website (<https://www.hpe.com/info/quickspecs>) for the product QuickSpecs:

- Supported options
- Supported configurations
- Component compatibility
- New features
- Specifications
- Part numbers

Rack mounting options

Use the quick-deploy, toolless HPE rack rail option to install the server in a standard four-post rack. The rail design supports installation on rack of [different mounting interfaces](#).

For cable management, the rack rail kit might include one or both of the following options:

- [Rack rail hoop-and-loop strap](#)
- [Cable management arm](#)

Subtopics

[Rail identification markers](#)

[Rack mounting interfaces](#)

[Rack rail options](#)

[Installing the server into the rack: Friction rack rail](#)

[Installing the server into the rack: Ball-bearing rack rail](#)

[Installing the rack rail hook-and-loop strap](#)

[Installing the cable management arm](#)

Rail identification markers

The rack rail option support is dependent on these two factors:

- The height and weight of the chassis as determined by the front- and rear-end server configurations.
- The depth of the chassis as measured from the edge of the front panel (without the front bezel) to the edge of the rear panel.

To ensure compatibility between the rack rails and the server, verify that the rail number labels on the chassis match the ones stamped on the rails.

- Rail number labels on the chassis

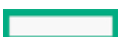

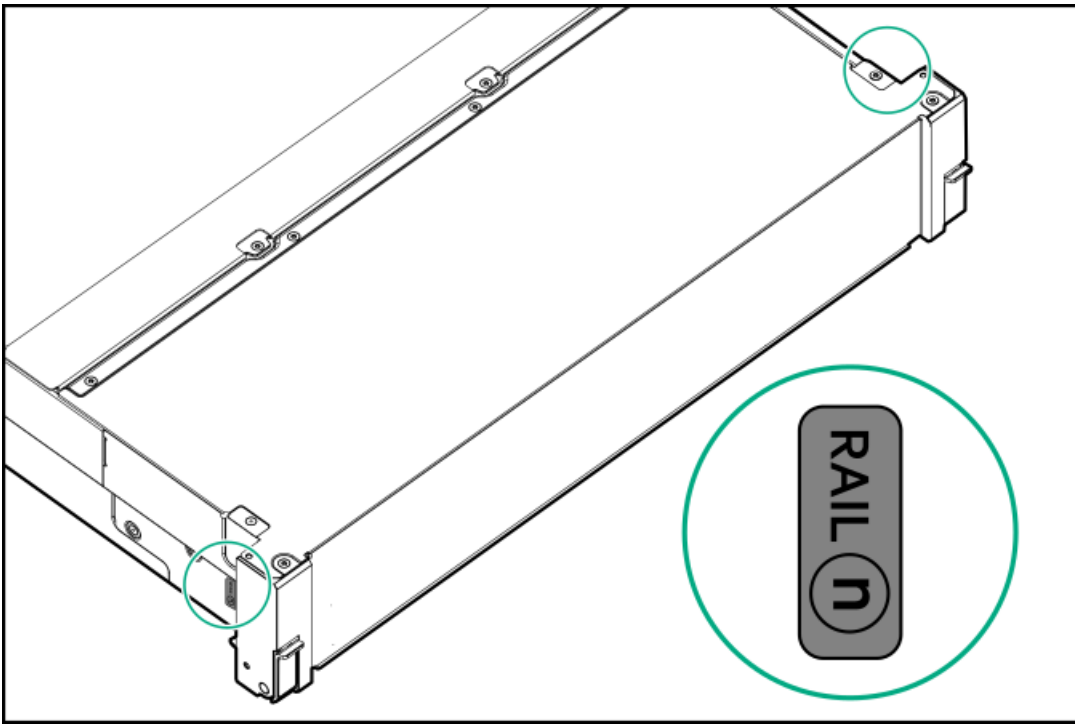

- Rail identifier stamps on the inner rail of the friction rack rail

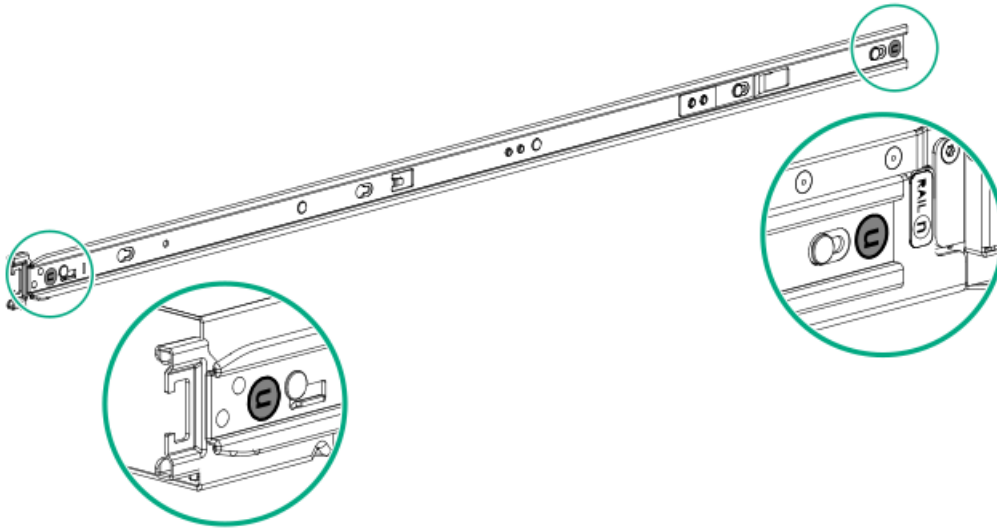

- Rail identifier stamps on the mounting rail of the friction rack rail

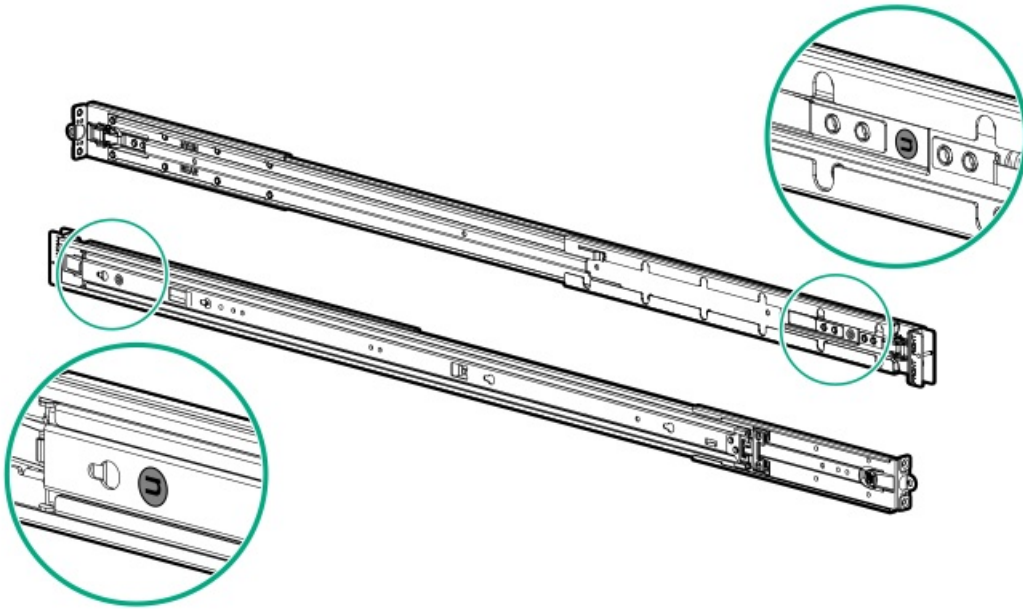

- Rail identifier stamps on the short ball-bearing rail

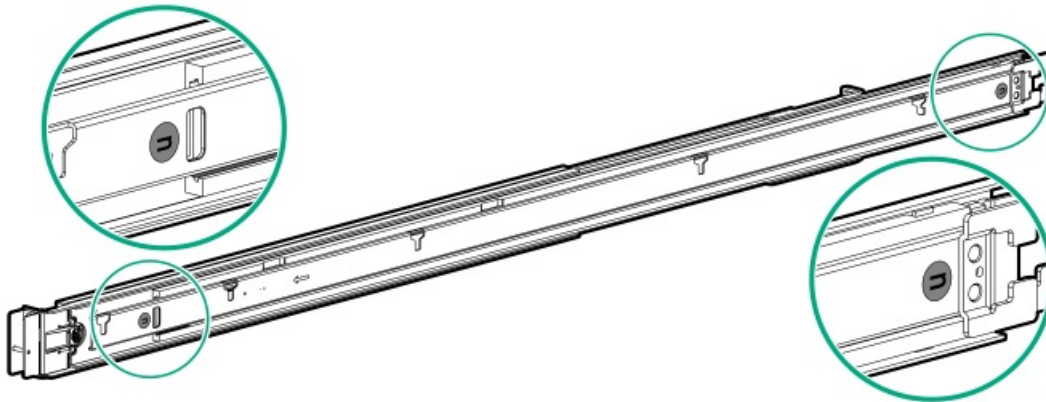

- Rail identifier stamps on the long ball-bearing rail

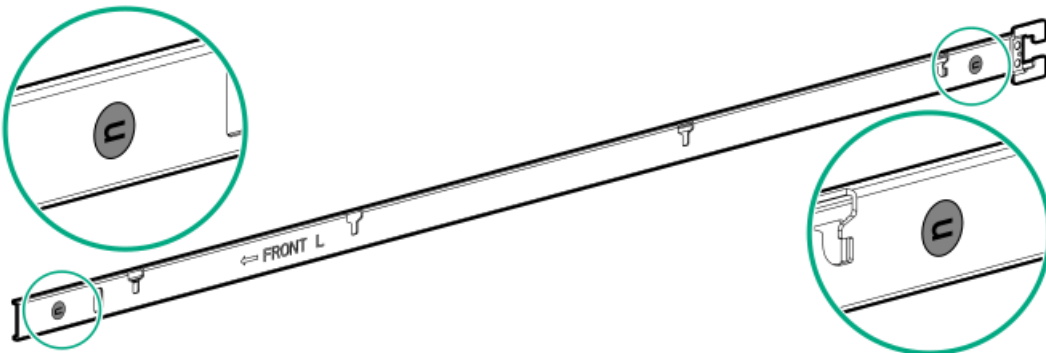

Rack mounting interfaces

The rack rails can be installed in a rack that has the following mounting interfaces:

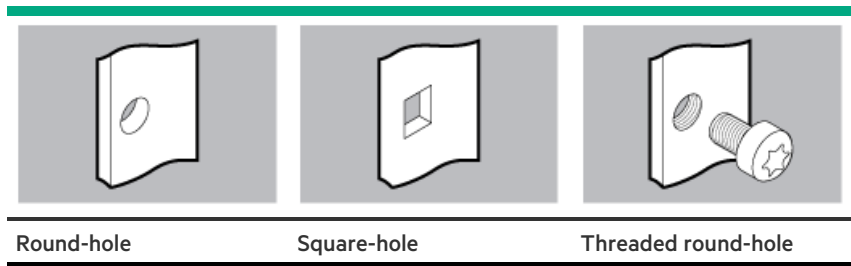

The illustrations used in this procedure show an icon on the upper right corner of the image. This icon indicates the type of mounting interface for which the action illustrated in the image is valid.

Rack rail options

This server supports the following HPE Easy Install friction / ball bearing rack rail options:

Server configuration	Type	Rack rail option	Minimum rail length	Adjustable rail range
SFF, LFF, and E3.S drive	Friction rack rail (stab-in)	Rail option #2 (P52351-B21)	714.32 mm (28.12 in)	609.60 mm to 918.10 mm (24.00 in to 36.15 in)
Accelerator-optimized	Ball bearing rack rail (drop-in)	Rail option #8 (P52345-B21)	808.69 mm (31.84 in)	609.60 mm to 918.10 mm (24.00 in to 36.15 in)
Two-row SFF drive	Ball bearing rack rail (drop-in)	Rail option #10 (P52347-B21)	905.93 mm (35.67 in)	609.60 mm to 918.10 mm (24.00 in to 36.15 in)

Subtopics

[Installing the friction rack rails](#)

[Installing the ball-bearing rack rails](#)

Installing the friction rack rails

Prerequisites

- [Make sure that the rail option is compatible with the server configuration.](#)
- Before you perform this procedure, review the:
 - [Space and airflow requirements](#)
 - [Rack warnings and cautions](#)
 - [Server warnings and cautions](#)
- A fully populated server is heavy. Hewlett Packard Enterprise recommends removing the external chassis components before installing the server into a rack.

- Before you perform this procedure, make sure that you have a small slotted screwdriver—This tool is required if you intend to install the server in a threaded round-hole rack.

Procedure

1. Attach the inner rails to the server:
 - a. Insert the spools on the sides of the server through the keyed slots on the rails.
 - b. Slide the rail towards the rear panel to lock it into place.

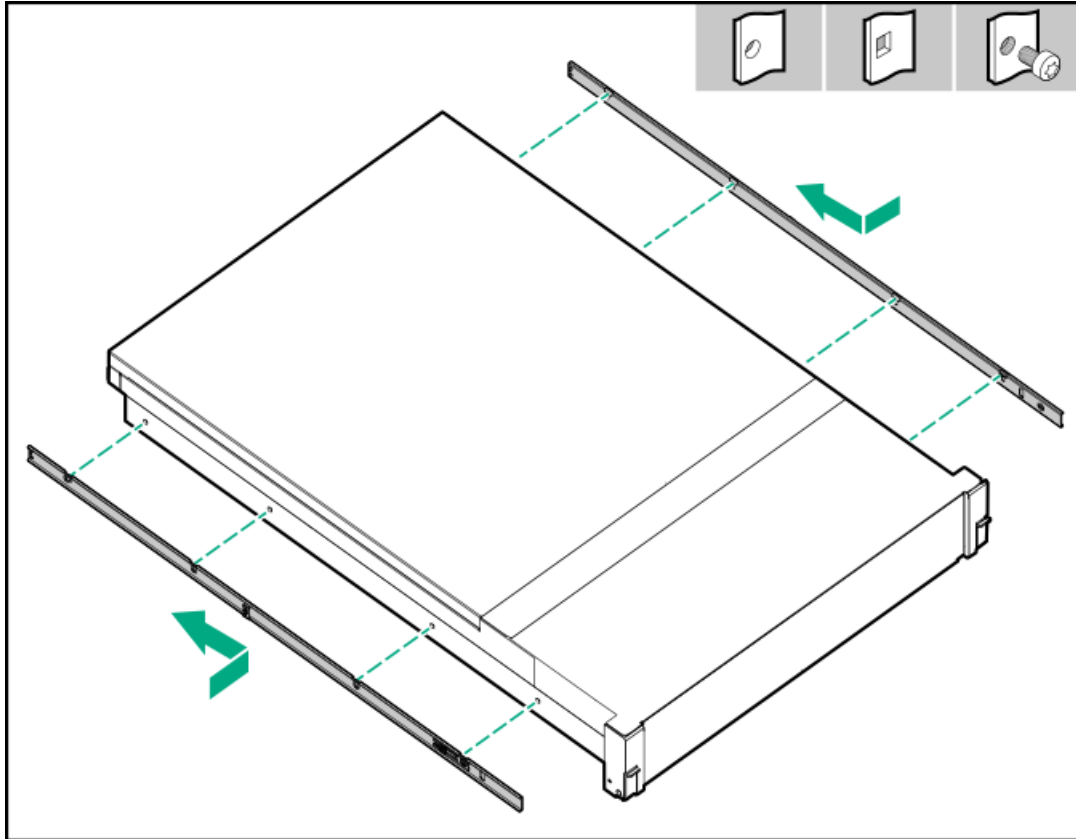

2. Locate the orientation markers on the mounting rails.
 - The front end of the rails is marked as **FRONT LEFT** or **FRONT RIGHT**.
 - The other end of the rails is marked as **REAR**.

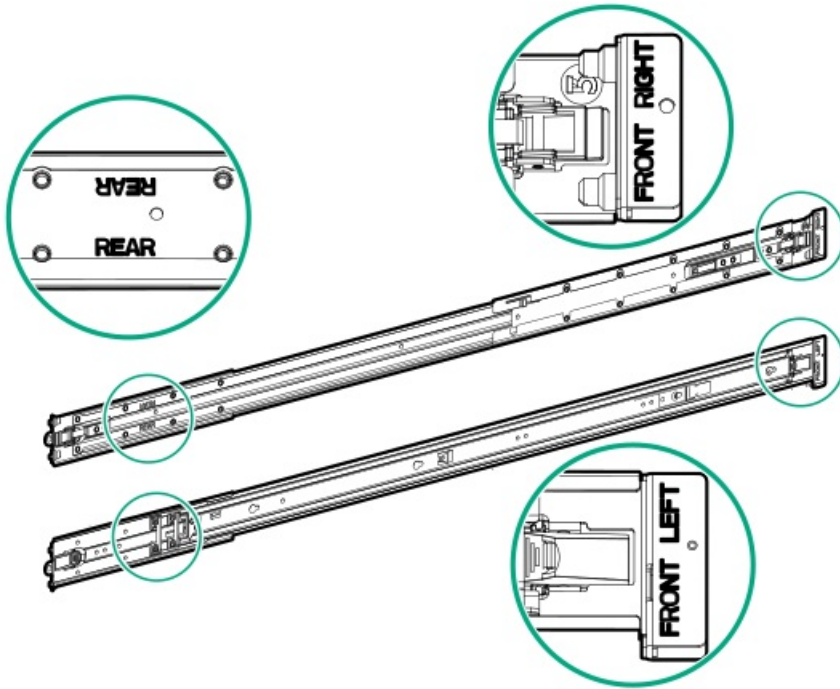

3. Extend the mounting rails to align with the depth of the rack.
4. To install the mounting rails in a round-hole or square-hole rack, insert the pins on the mounting flanges into the rack post holes.

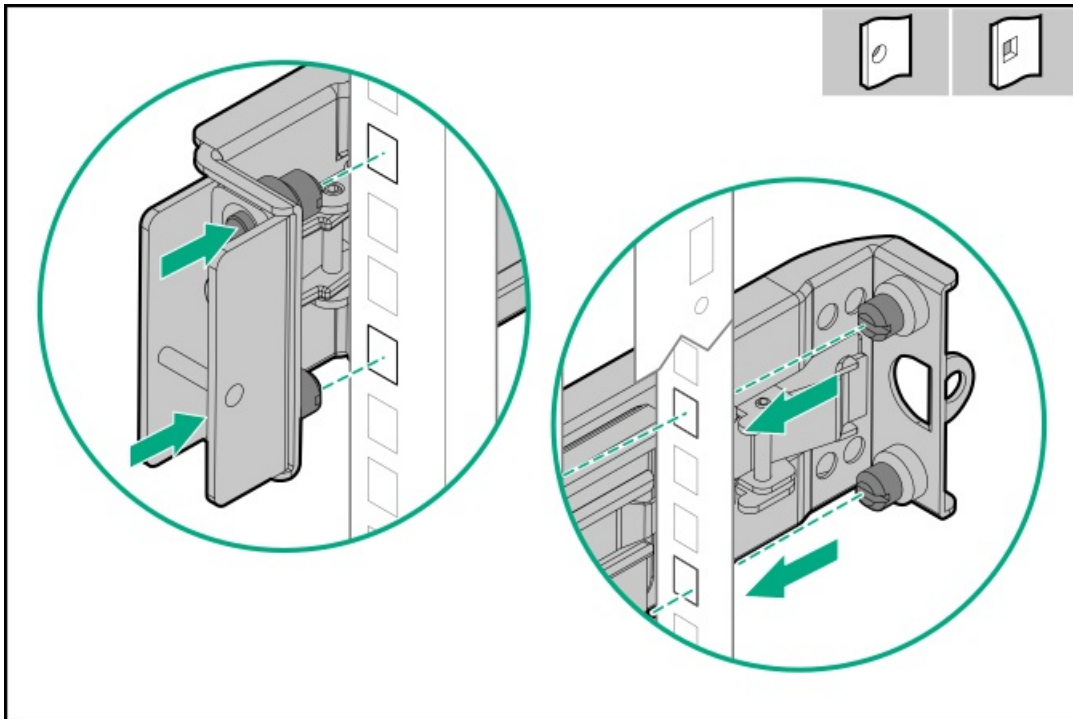

5. To install the mounting rails in a threaded round-hole rack, do the following:
 - a. Remove the pins and washers from the mounting rails.



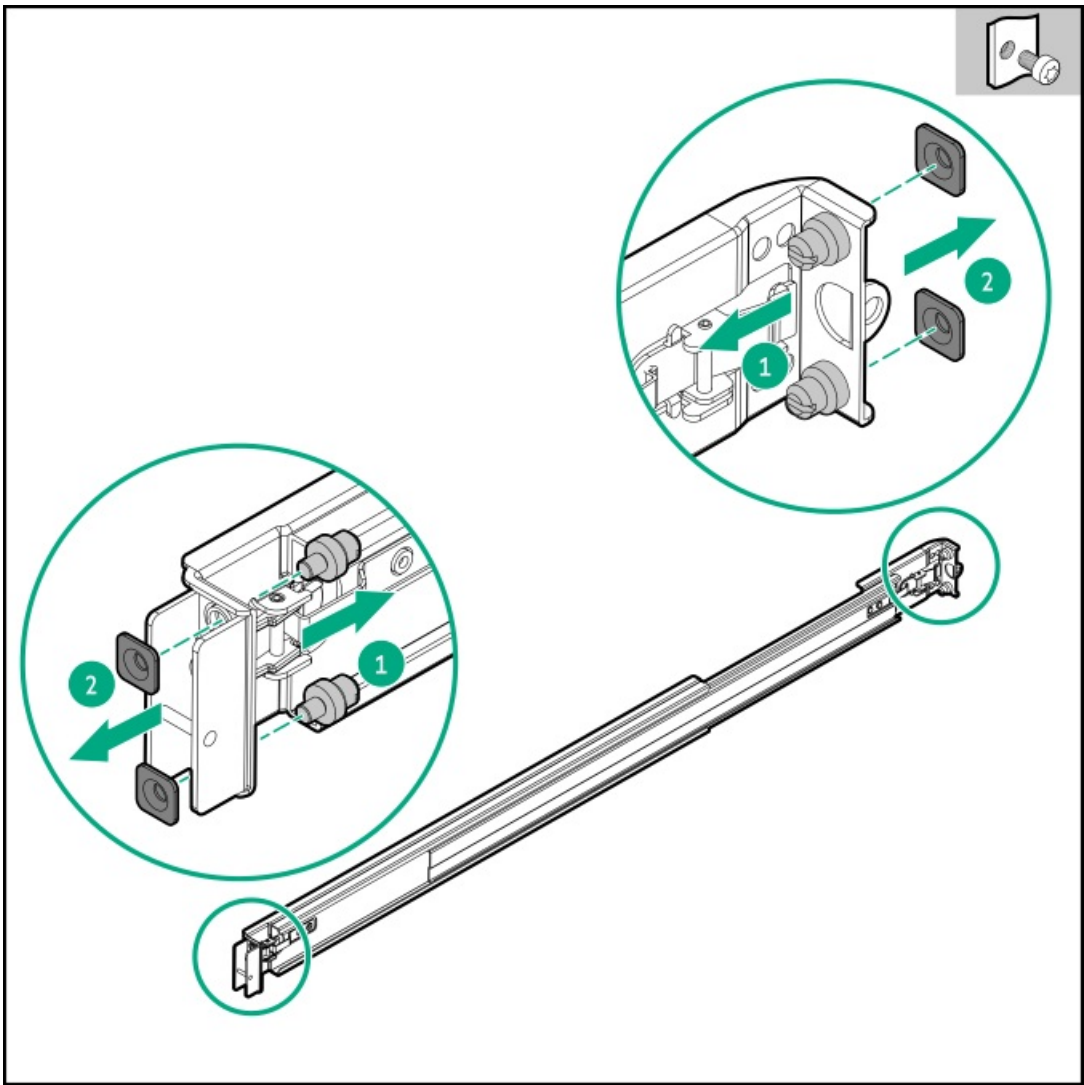

- b. Position the holes on the mounting flanges against the threaded holes on the rack post.
- c. Install the rack mounting screws.

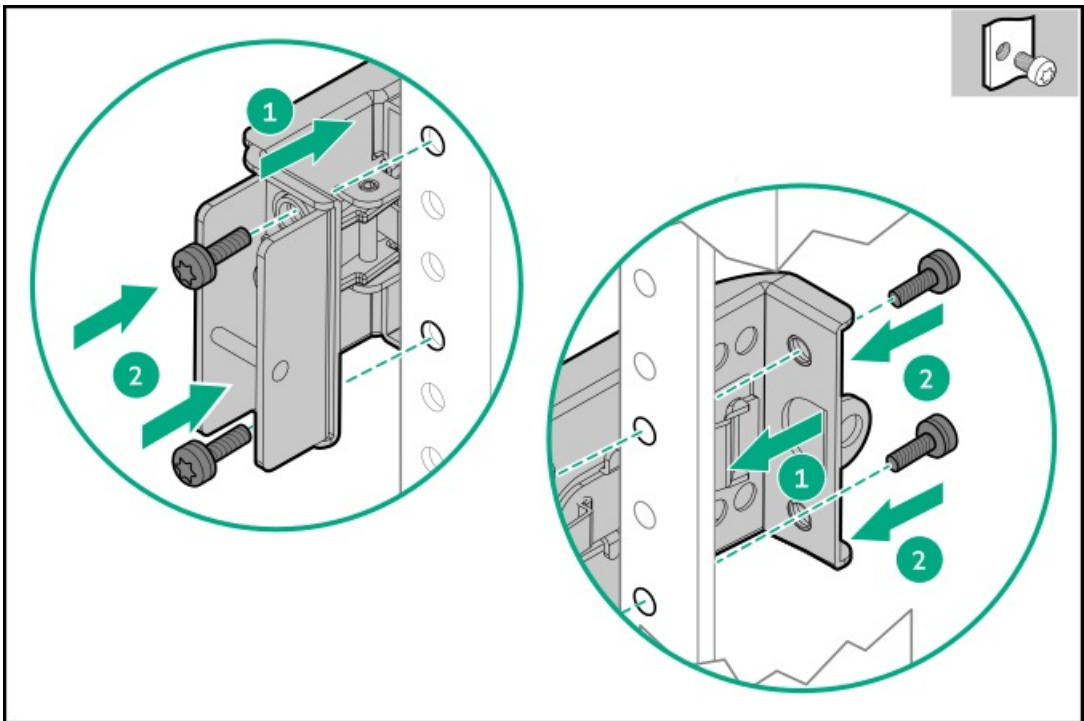

6. Install the server into the rack.

Installing the ball-bearing rack rails

Prerequisites

- Make sure that the rail option is compatible with the server configuration.
- Before you perform this procedure, review the:
 - Space and airflow requirements
 - Rack warnings and cautions
 - Server warnings and cautions
- A fully populated server is heavy. Hewlett Packard Enterprise recommends removing the external chassis components before installing the server into a rack.
- Before you perform this procedure, make sure that you have a small slotted screwdriver—This tool is required if you intend to install the server in a threaded round-hole rack.

Procedure

1. Verify the rail identifiers match on the server and rails.

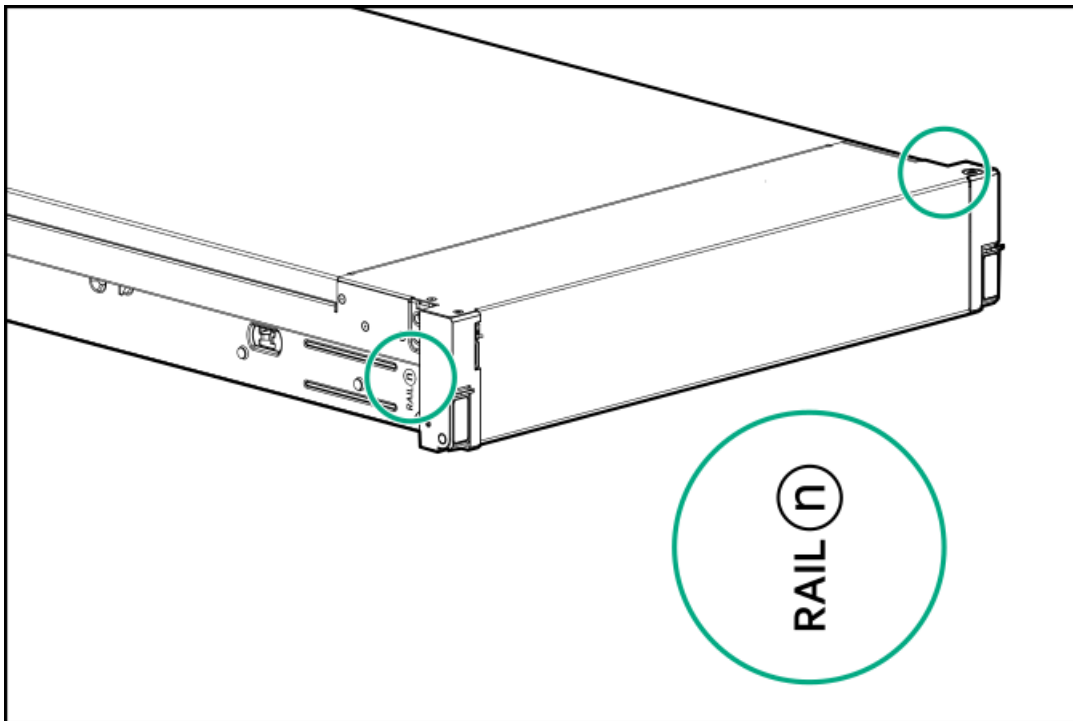

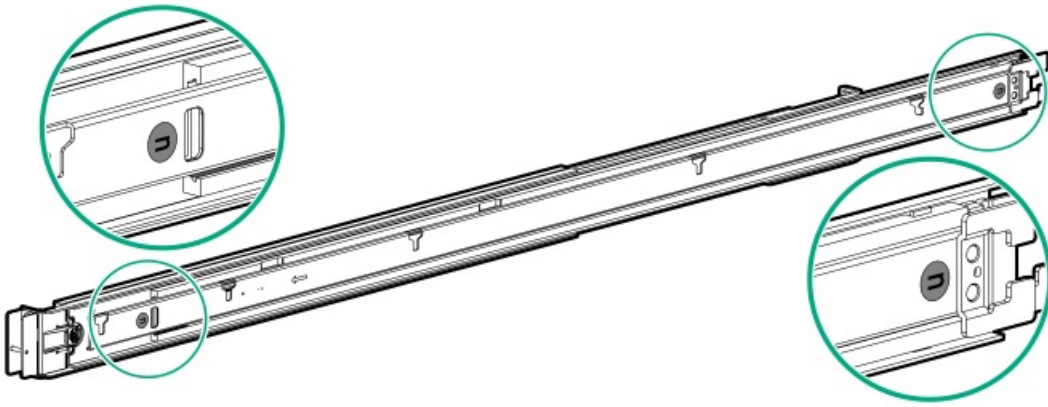

2. Install the rack rails.

- For round and square-hole racks

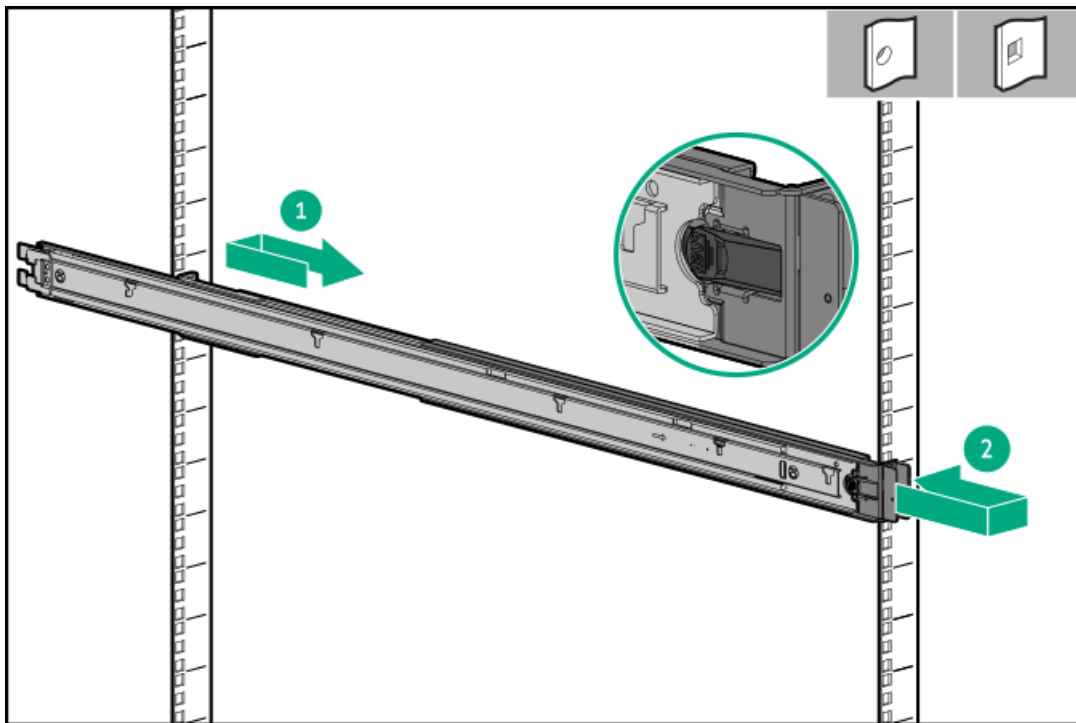

- For threaded-hole racks



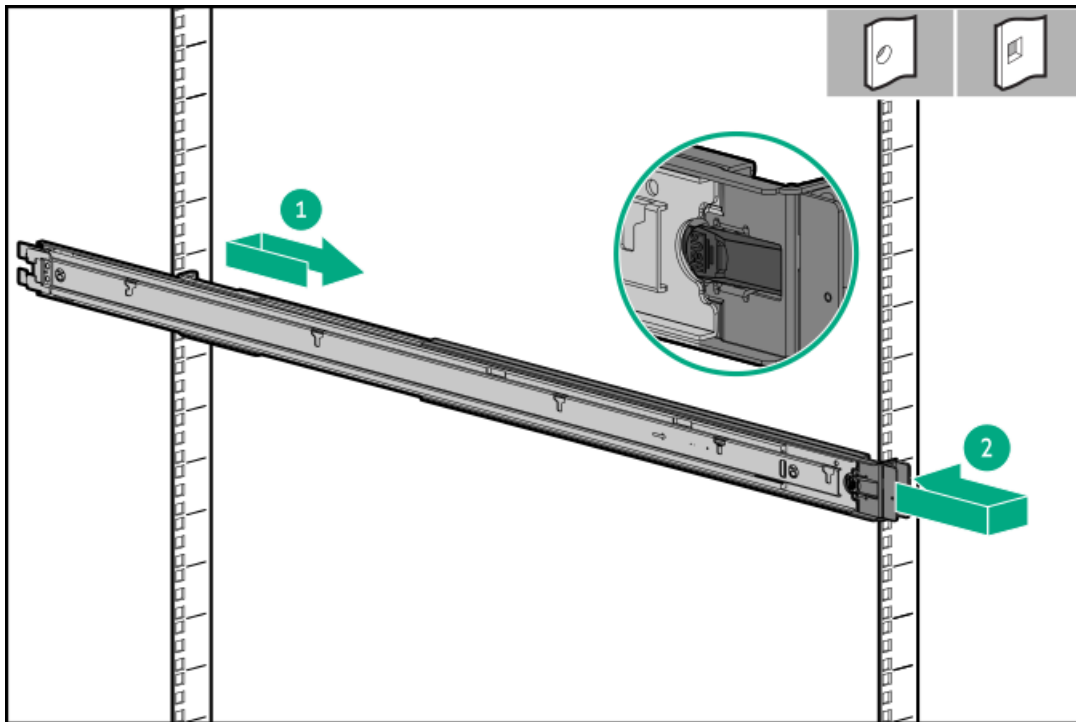
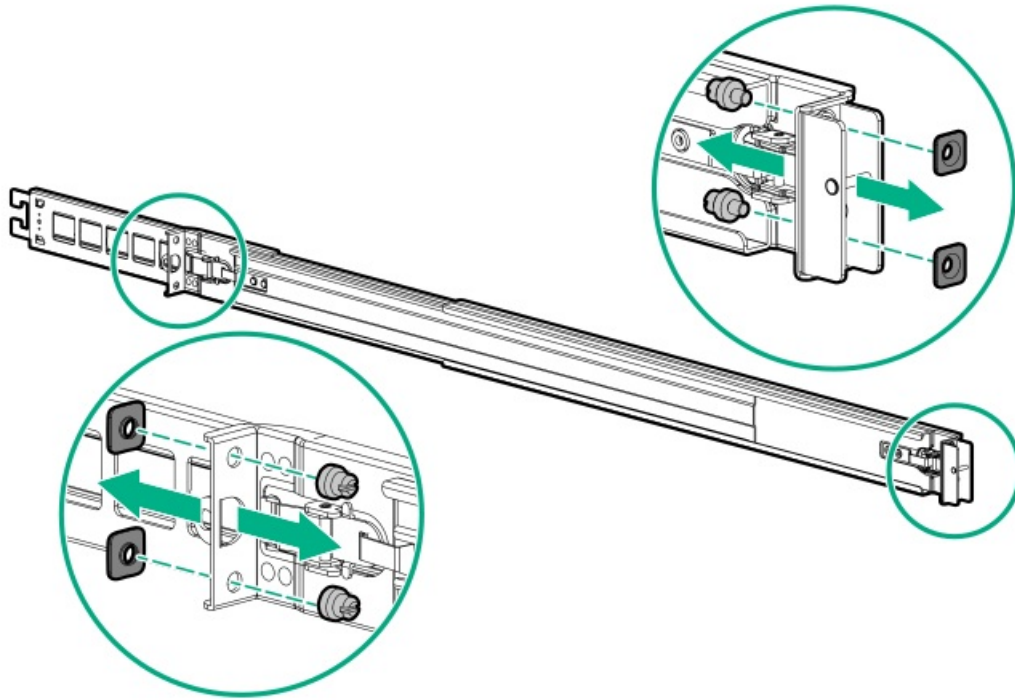

3. Fully extend the rails to the locked position.



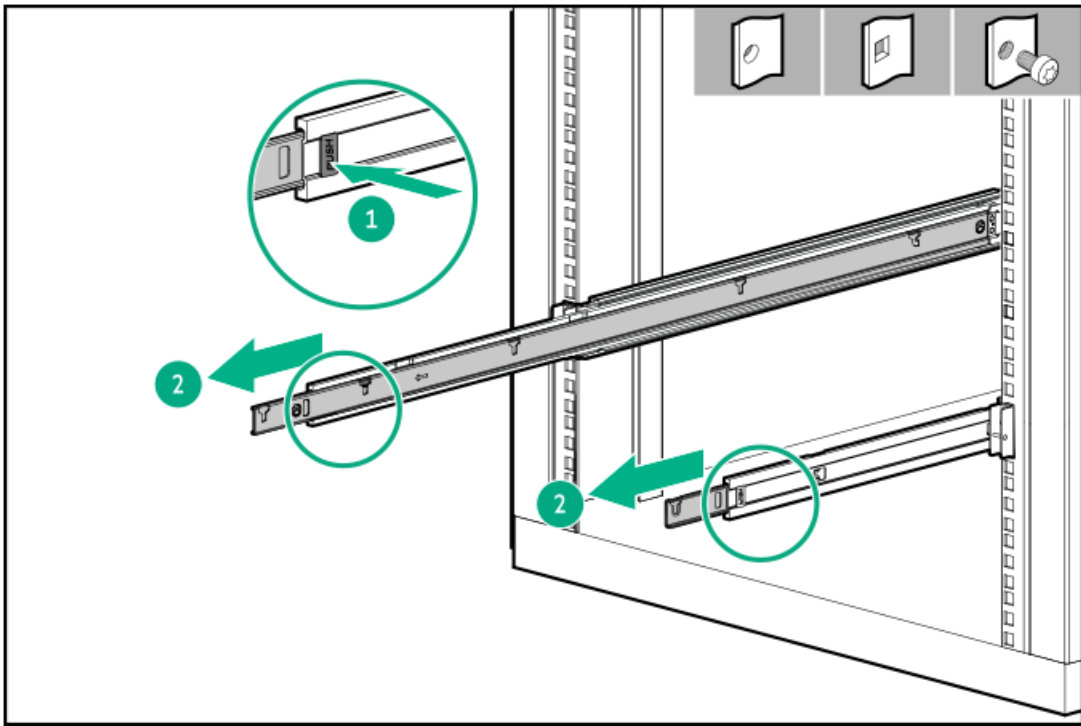

4. Install the server into the rack.

Installing the server into the rack: Friction rack rail

Prerequisites

- Get help to lift and stabilize the server during rack installation. **If the server is installed higher than chest level, an additional two people might be required to help install the server:** One person to support the server weight, and the other two to slide the server into the rack.
- Before you perform this procedure, review the:
 - [Space and airflow requirements](#)
 - [Rack warnings and cautions](#)
 - [Server warnings and cautions](#)
- A fully populated server is heavy. Hewlett Packard Enterprise recommends removing the external chassis components before installing the server into a rack.
- Before you perform this procedure, make sure that you have a T-25 Torx screwdriver available.

Procedure

1. Extend the slide rails out on the mounting rails until they hit the internal stops and lock into place.



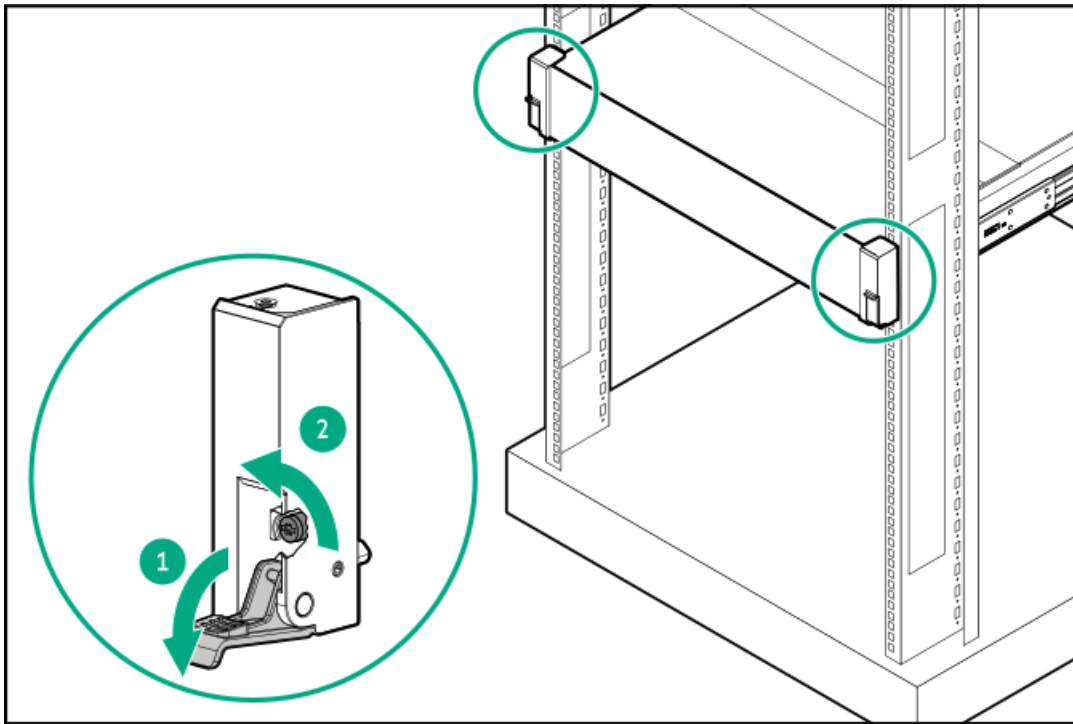

4. Connect all peripheral cables to the server.
5. Connect the power cords:
 - a. Connect each power cord to the server.
 - b. Connect each power cord to the power source.

Installing the server into the rack: Ball-bearing rack rail

Prerequisites

- Get help to lift and stabilize the server during rack installation. **If the server is installed higher than chest level, an additional two people might be required to help install the server:** One person to support the server weight, and the other two to slide the server into the rack.
- Before you perform this procedure, review the:
 - [Space and airflow requirements](#)
 - [Rack warnings and cautions](#)
 - [Server warnings and cautions](#)
- A fully populated server is heavy. Hewlett Packard Enterprise recommends removing the external chassis components before installing the server into a rack.
- Before you perform this procedure, make sure that you have a T-25 Torx screwdriver available.

Procedure

1. Fully extend the rails to the locked position.

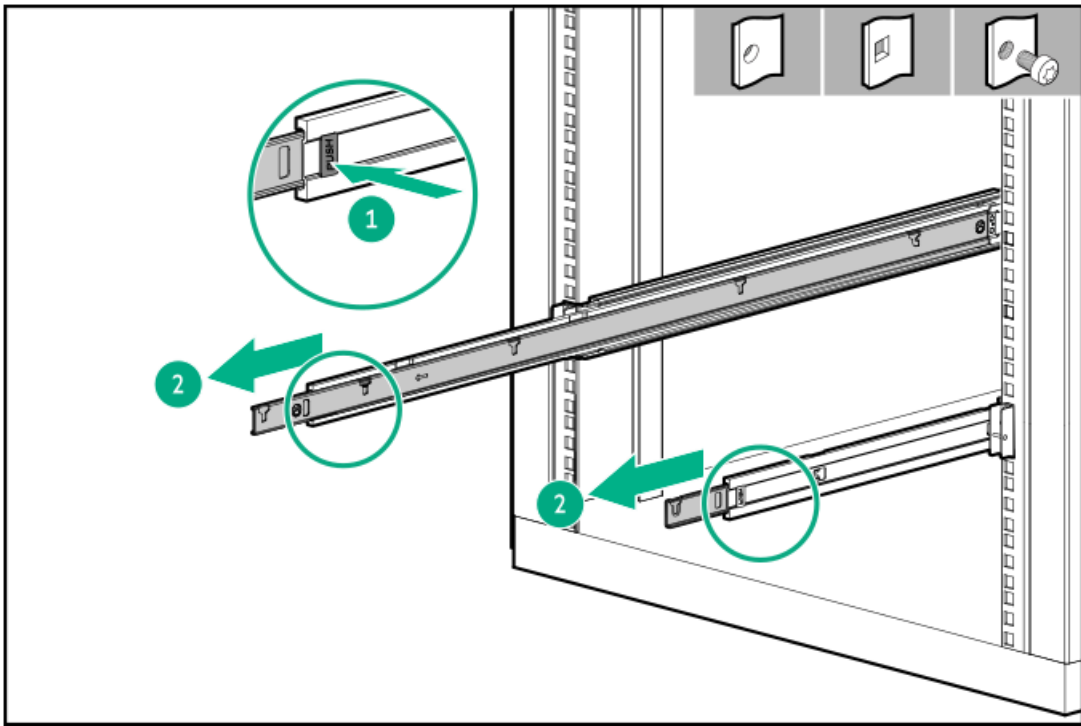

2. Install the server into the rails.

- a. Install the rear of the server into the J-slots.

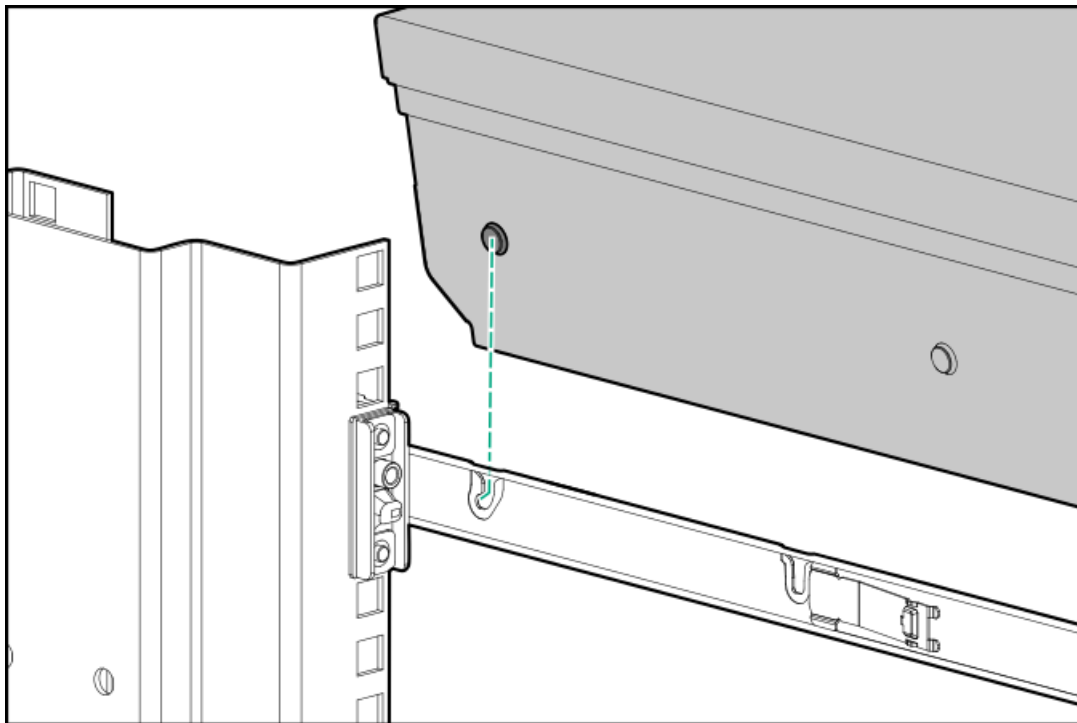

- b. Install each spool to the rail.



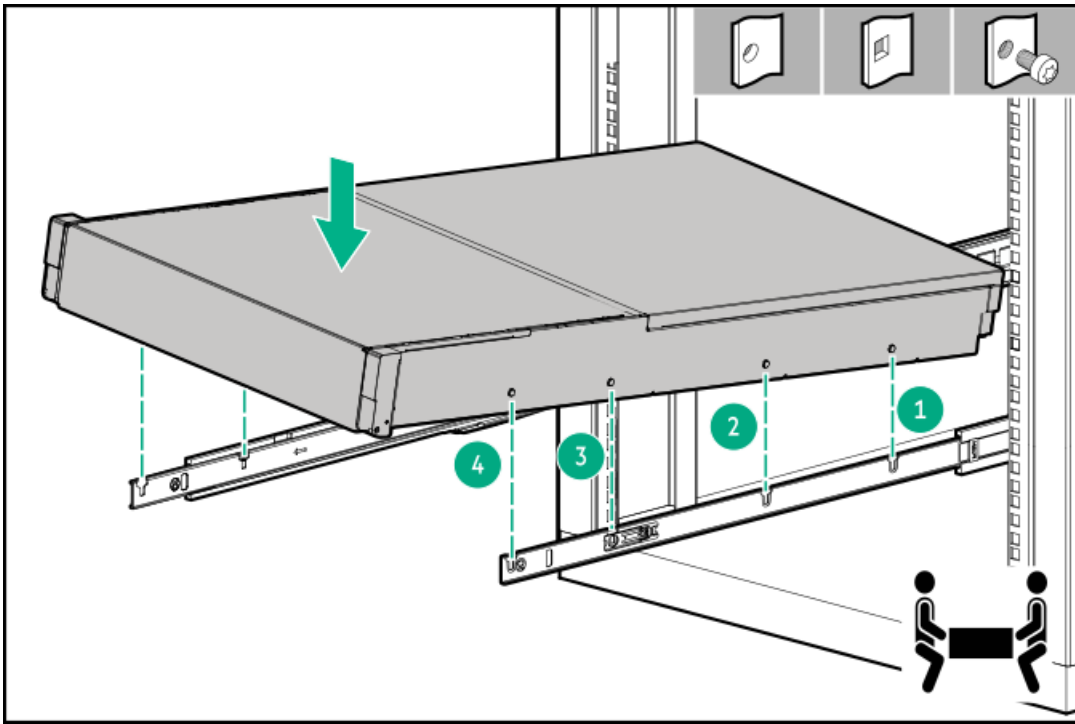

c. Install the front of the server.

Be sure the front spool engages the locking tab.

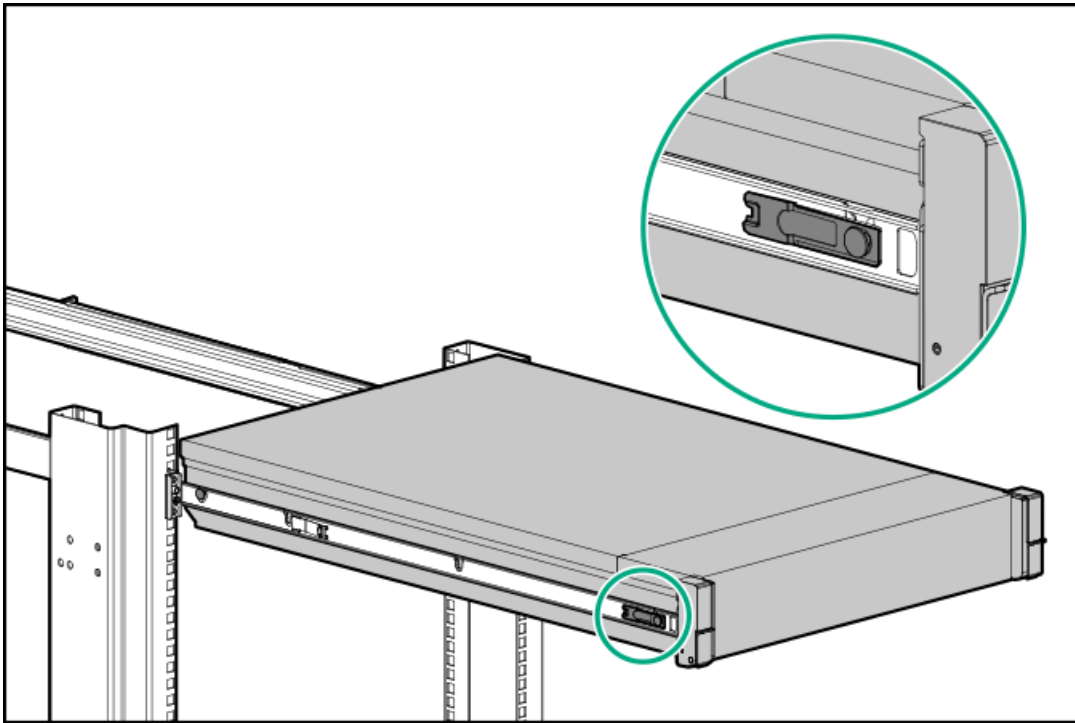

⚠ CAUTION:

To prevent damage to the rack rails when installing the server into the rack, make sure that all spools on the server are firmly seated on the notches on the rails.

3. Install the server into the rack.



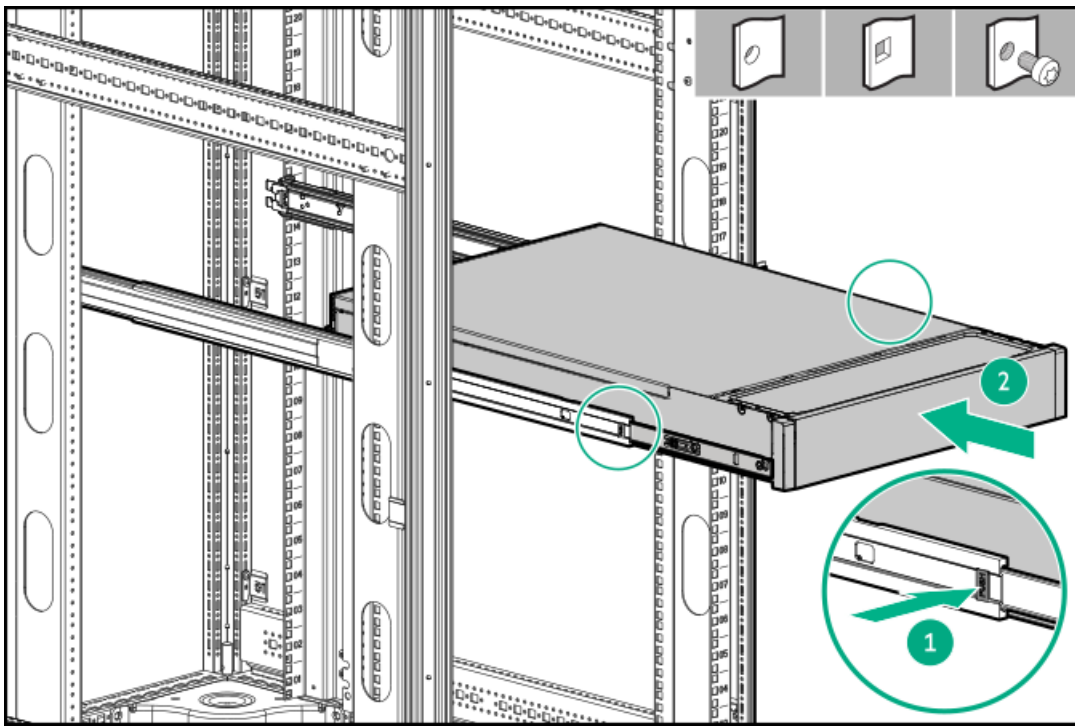

4. Open the chassis ears, and then tighten the shipping screws.

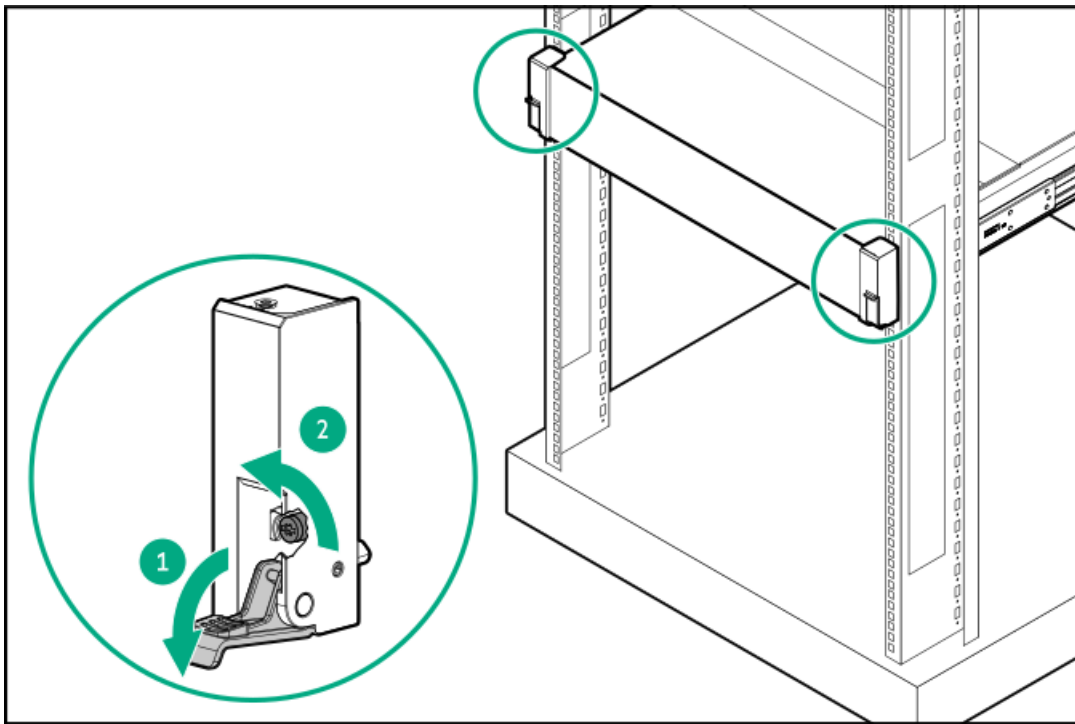

5. Connect all peripheral cables to the server.

6. Connect the power cords:

- a. Connect each power cord to the server.
- b. Connect each power cord to the power source.

Installing the rack rail hook-and-loop strap



About this task

The hook-and-loop strap can be installed on either the left or right rail.

Procedure

1. Attach the strap carabiner to the rail.
2. Bundle the cords and cables, and then wrap the strap around the cables.

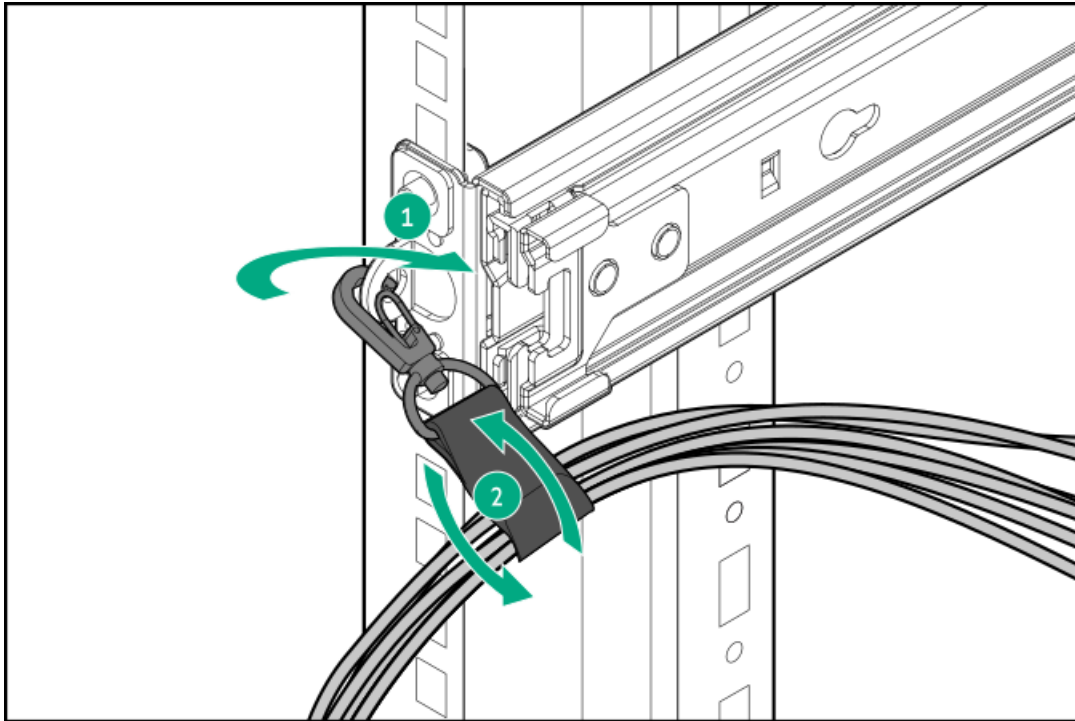

Installing the cable management arm

Prerequisites

- Before you perform this procedure, review the [Rack warnings and cautions](#).
- T-25 Torx screwdriver—This tool is required if the shipping screws located inside the chassis ears need to be loosened or tightened.

About this task

The cable management arm (CMA) allows the server to be fully extended from the rack without the need to power off the system or disconnect any rear panel cables. This CMA is designed for ambidextrous implementation.

For the purpose of this procedure, left and right terminology is from the perspective of a user facing the front of the rack.

CAUTION:

Support the CMA during the removal and replacement procedures. Do not allow the CMA to hang by its own weight during the procedure.

Procedure

1. Connect and secure all peripheral cables and power cords to the rear panel.
2. (Optional) The CMA retention bracket can be rotated to fit a left- or right-hand CMA operation. Press and hold the rotate mechanism (callout 1), and then rotate the bracket 180°(callout 2).

There will be an audible click to indicate that the bracket is locked in its adjusted position.

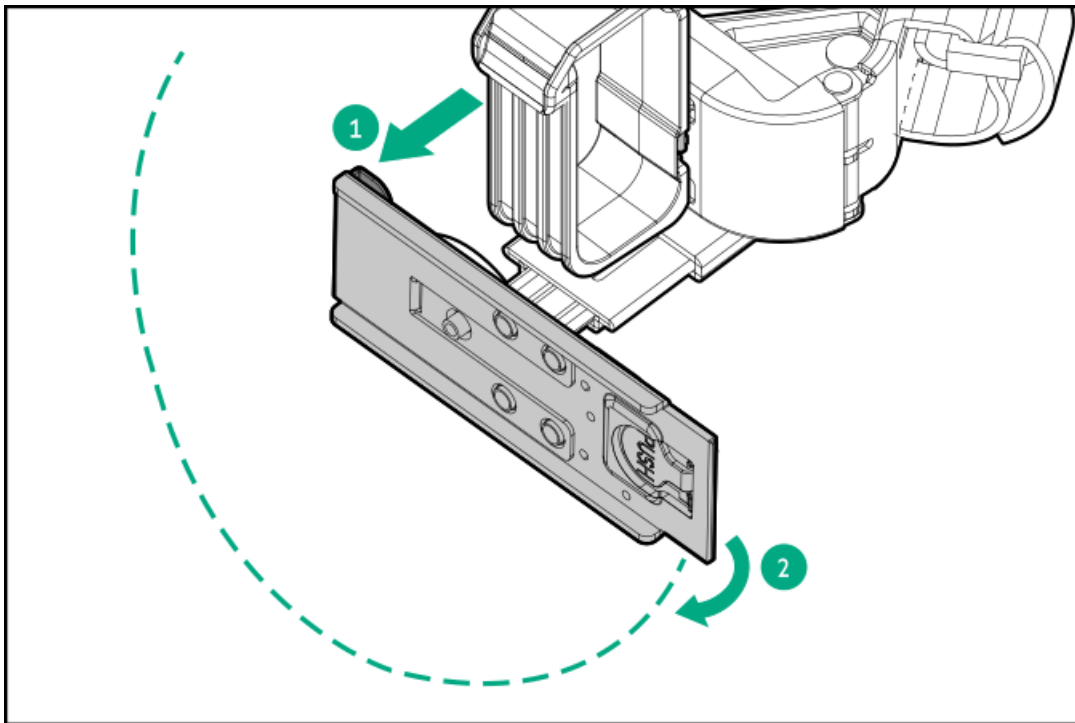
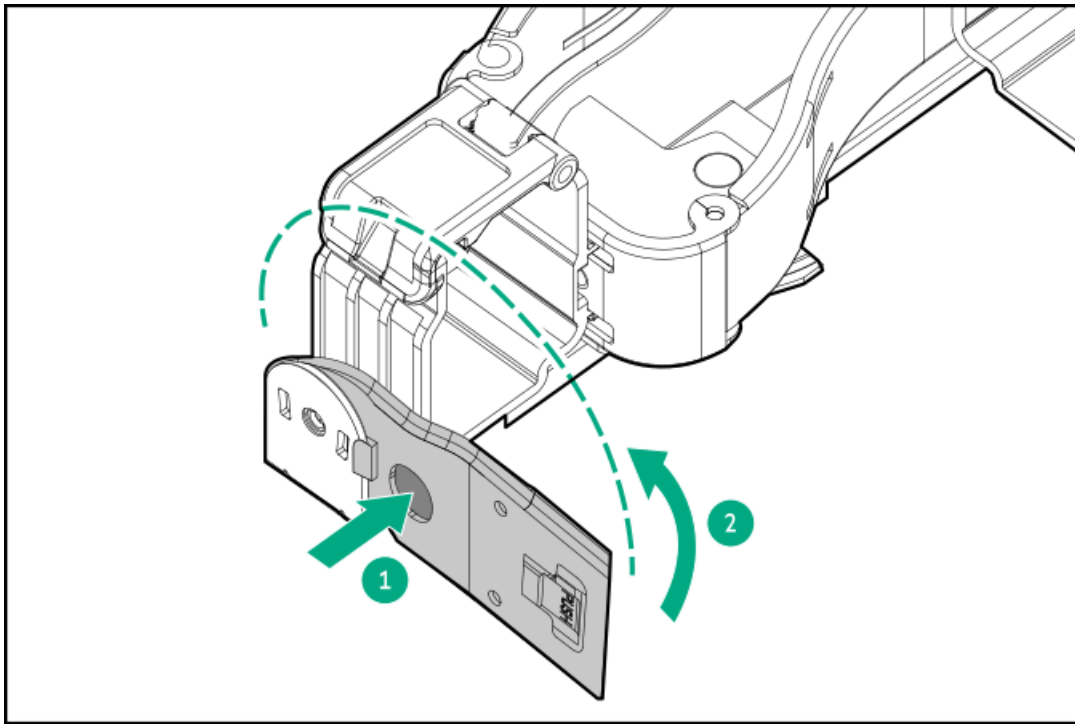

3. Connect the CMA hinged tabs and retention bracket to the rack rails:

- a. Insert the inner tab into the slide rail.
- b. Insert the outer tab into the mounting rail.
- c. Insert the retention bracket into the opposite mounting rail.

There will be an audible click to indicate that the tabs and bracket are locked into place.



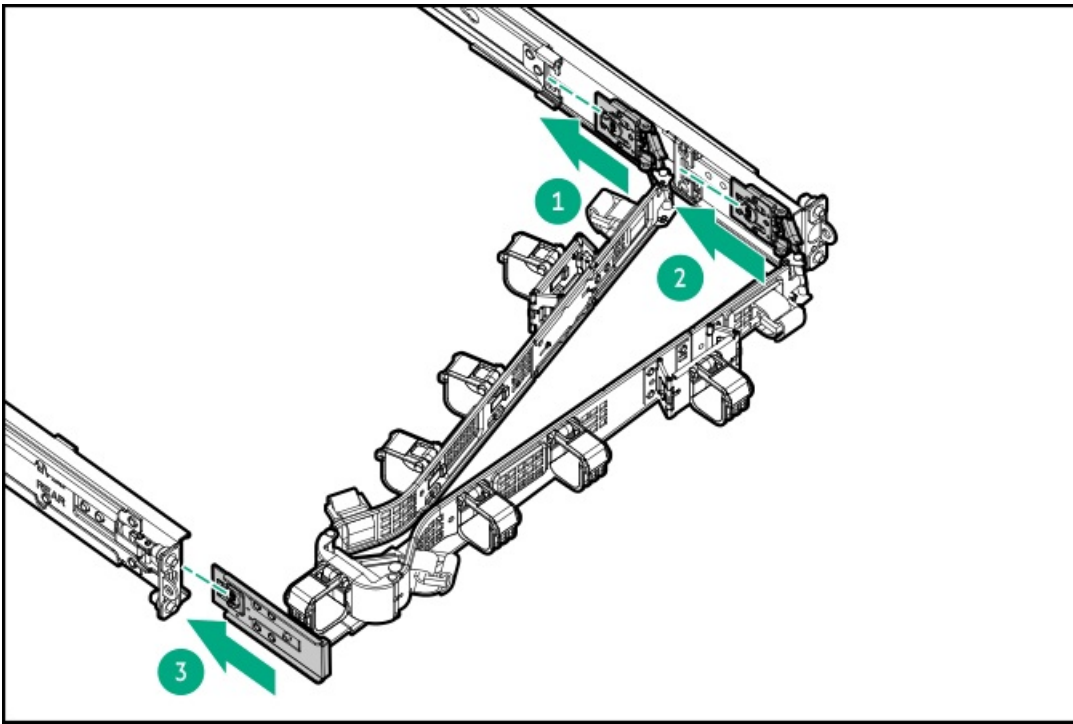

4. Open the cable clamps.

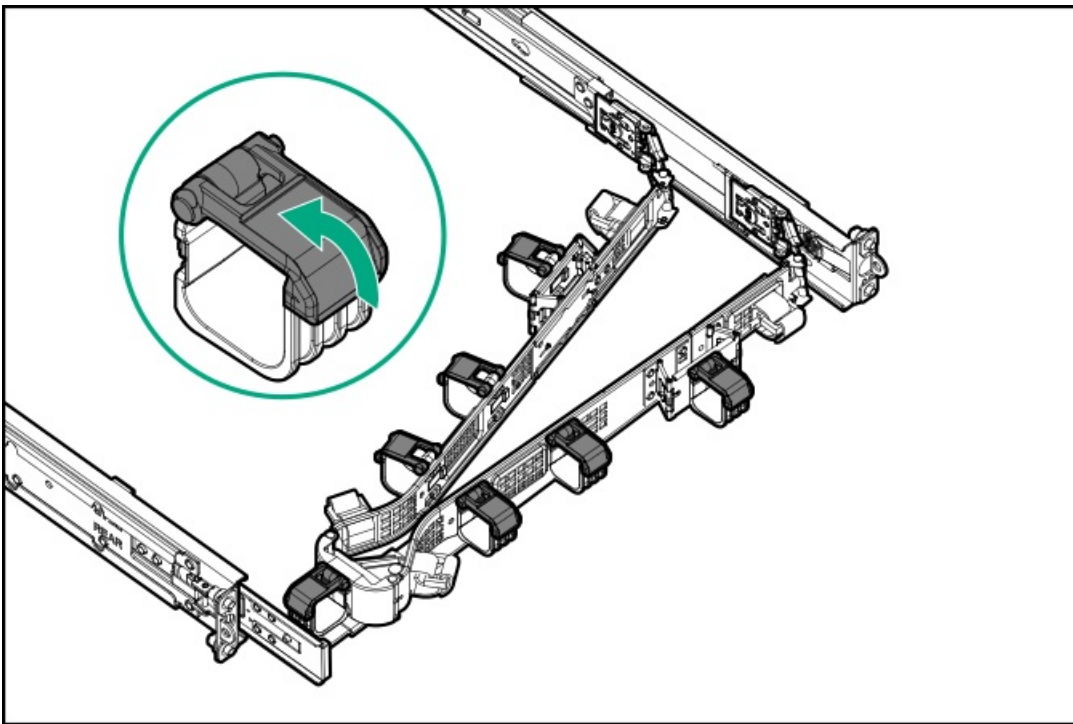

5. (Optional) If your CMA has cable straps for additional cable strain relief, unwrap the straps.



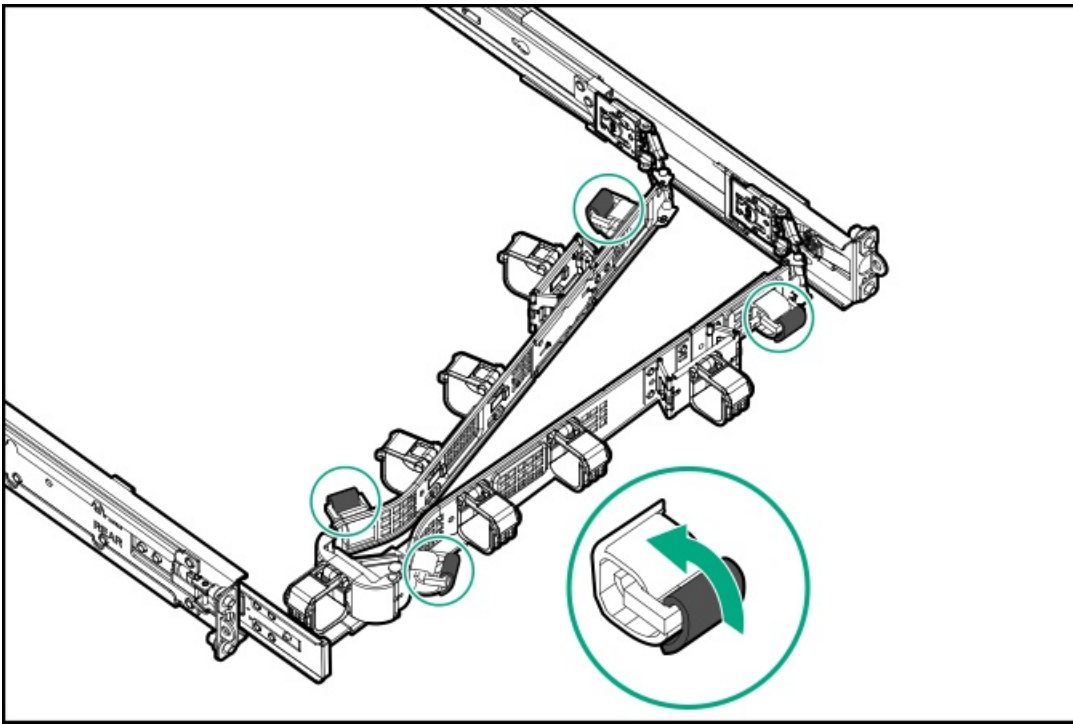

6. **CAUTION:** Employ industry best practices in managing peripheral cables and power cords secured in the CMA. These are some of the more important points:
- Leave enough cable slack between the rear panel and the CMA to allow the full extension of the CMA when the server is extended out of the rack.
 - However, there should be no excess cable slack inside the CMA; this might cause cable binding and could lead to cable damage.
 - Make sure that the cables and power cords do not extend above the top or below the bottom of the server to which they are attached. Otherwise, the cables might snag on other equipment installed in the rack when the server is extended from or returned to the rack.

Route the peripheral cables and power cords through the cable clamps and/or straps.

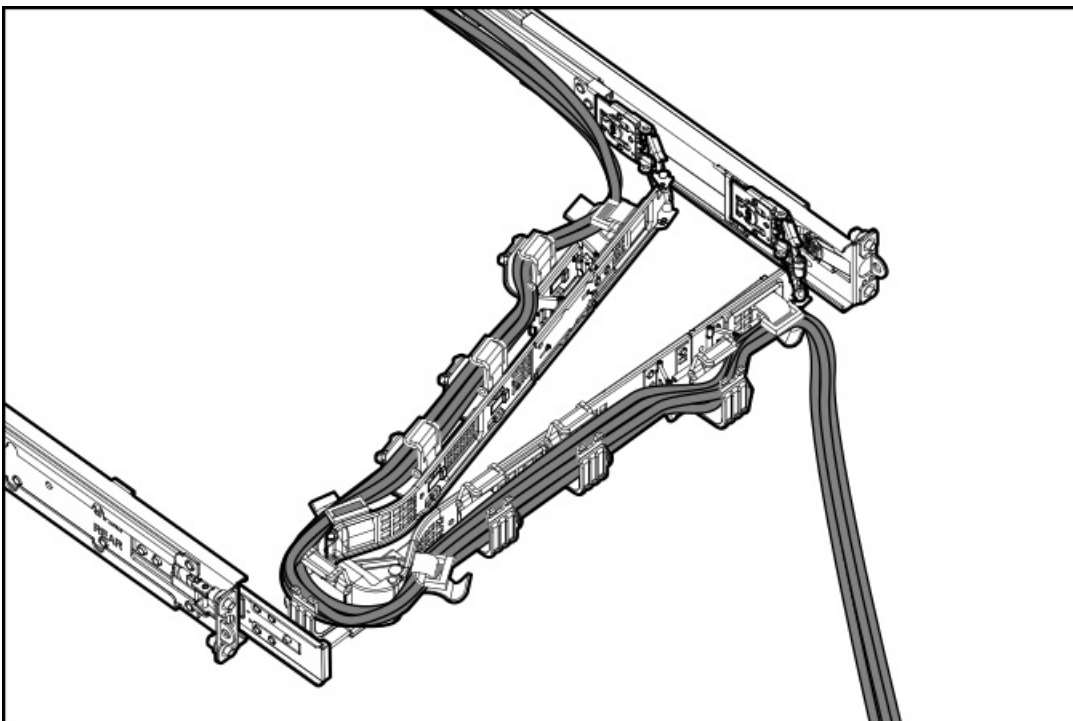

7. Close the cable clamps.

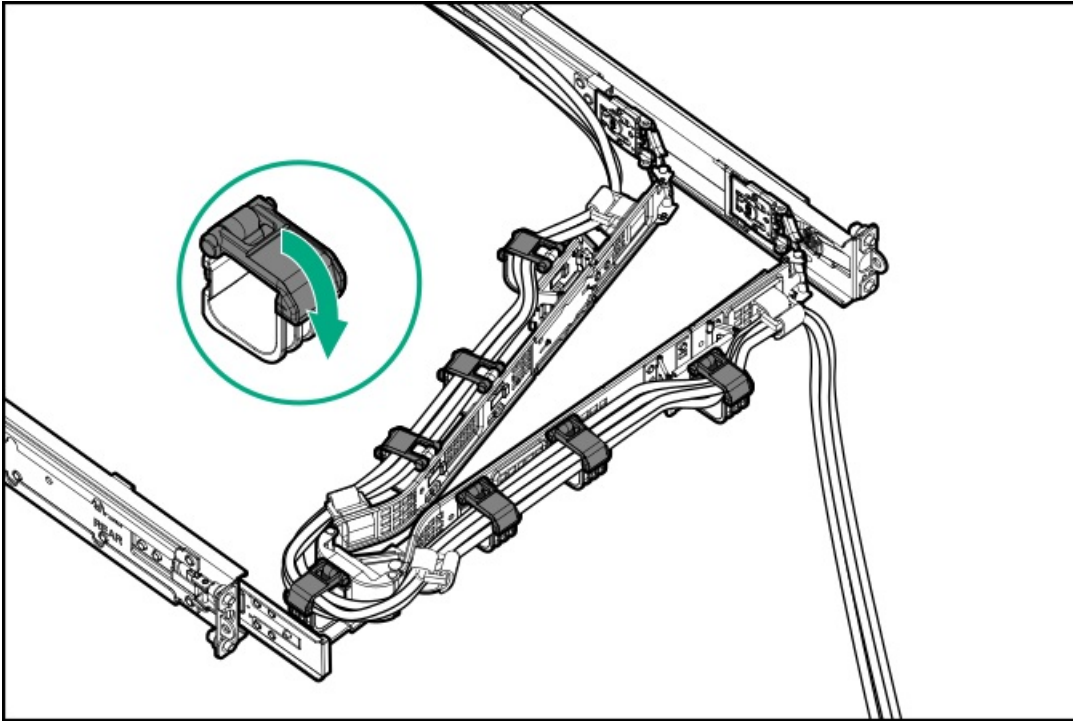

8. (Optional) If your CMA has cable straps, fasten the straps.

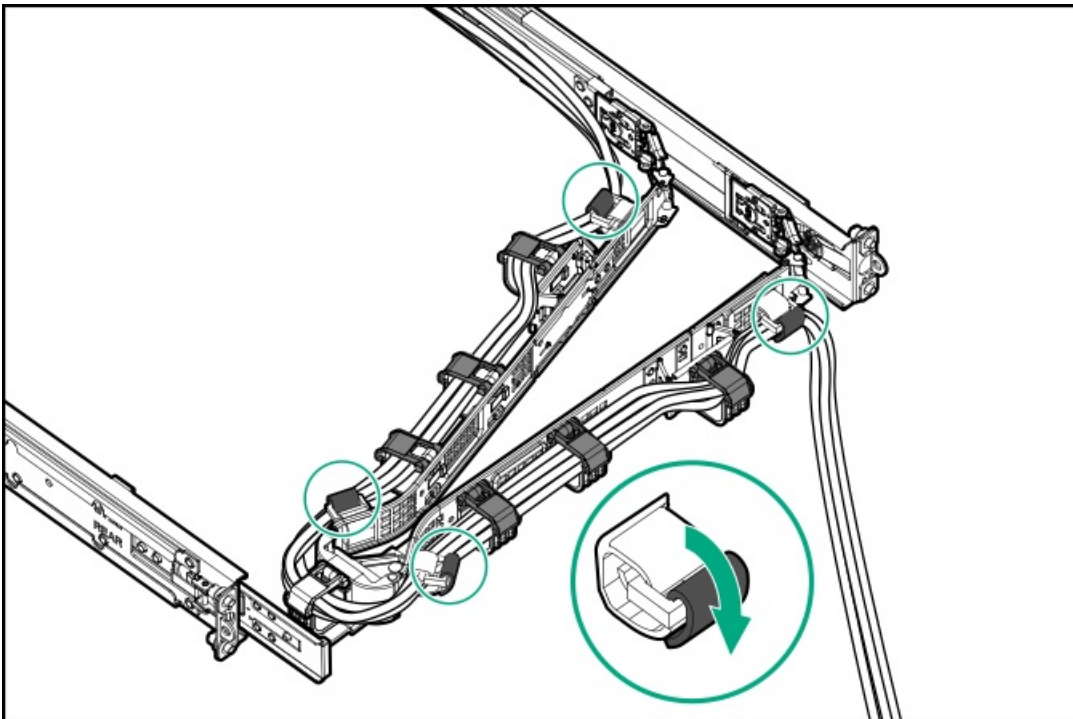

9. Verify the operation of the rack rails:
- Fully extend the chassis out of the rack.
 - Check that there is enough slack in the cables and cords for full extension of the chassis. Make sure that there is no cable binding or crimping.
 - To ensure that the cables and cords are secured properly, slide the chassis in and out of the rack. Make sure that there is no risk of accidental disconnection of the peripheral cables and power cords.
10. Slide the server into the rack until the chassis ears are flushed against the rack posts.



11. (Optional) Open the chassis ear latches, and then tighten the shipping screws.

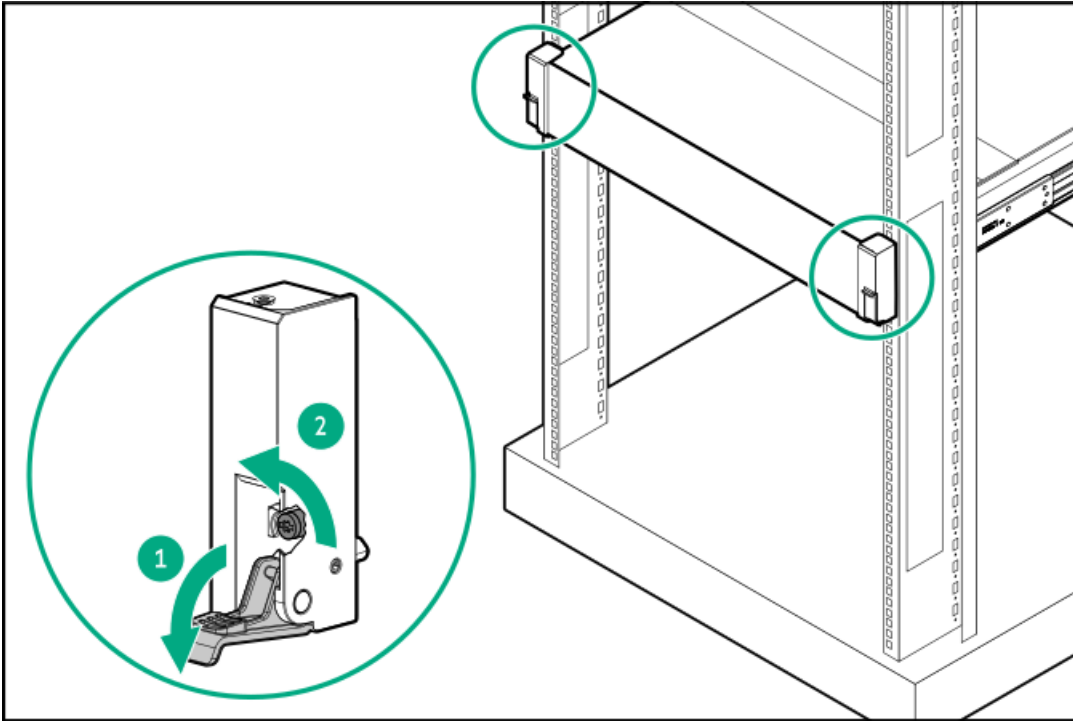

Results

The installation procedure is complete.

Installing the front bezel option

Procedure

1. Attach the front bezel to the right chassis ear.
2. Press and hold the front bezel release latch.
3. Close the front bezel.



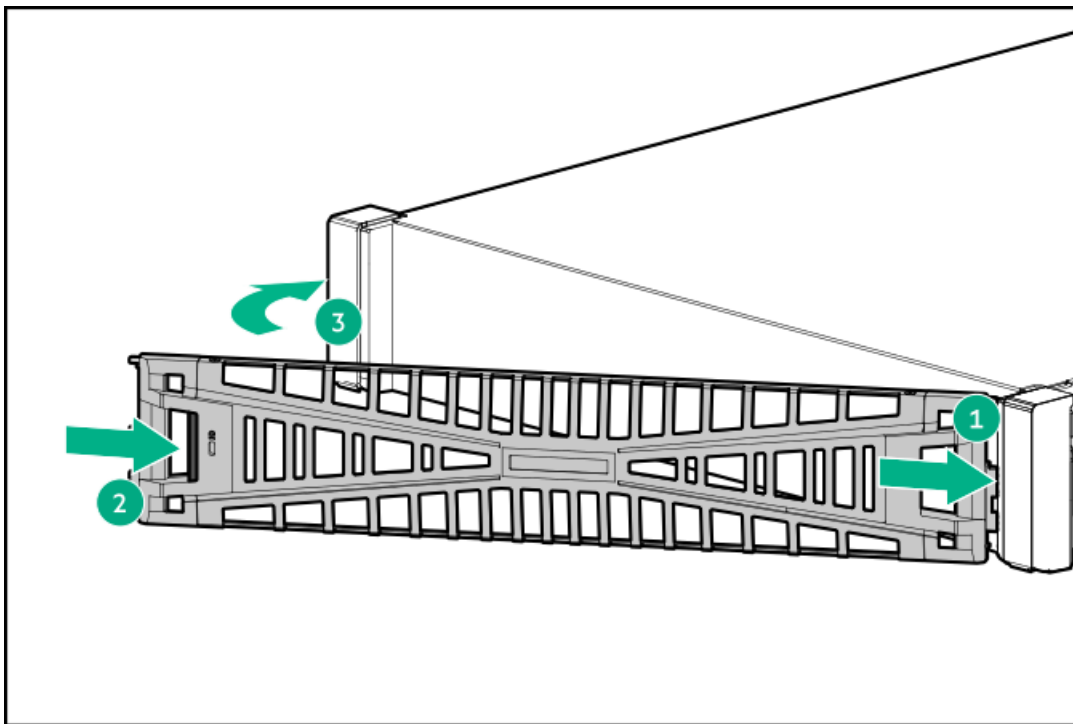

4. (Optional) Install the Kensington security lock.

For more information, see the lock documentation.

Results

The installation procedure is complete.

Universal media bay options

In either LFF or SFF drive configuration, the universal media bay is populated in Box 1.

Subtopics

[Installing the universal media bay in the LFF chassis](#)

[Installing the universal media bay in the SFF chassis](#)

Installing the universal media bay in the LFF chassis

Prerequisites

Before you perform this procedure, make sure that you have the following items available:

- The components included with the hardware option kit
- T-10 Torx screwdriver

About this task

This server supports the universal media bay with an optical drive bay and Display port 1.1a.

Procedure

1. If installed, [remove the front bezel](#).



2. Power down the server.
3. If installed, open the cable management arm.
4. Remove all power:
 - a. Disconnect each power cord from the power source.
 - b. Disconnect each power cord from the server.
5. Disconnect all peripheral cables from the server.
6. Remove the server from the rack.
7. Place the server on a flat, level work surface.
8. Remove the access panel.
9. Do one of the following:
 - Remove the air baffle.
 - Remove the midplane drive cage.
10. Remove the fan cage.
11. Remove the midwall bracket.
12. Remove the LFF drive backplane bracket.

13. **(i) IMPORTANT:**

Retain the removed partitions to revert to the 12 LFF drive configuration.

Remove the right partition:

- a. Remove the partition screws.
- b. Remove the partition.

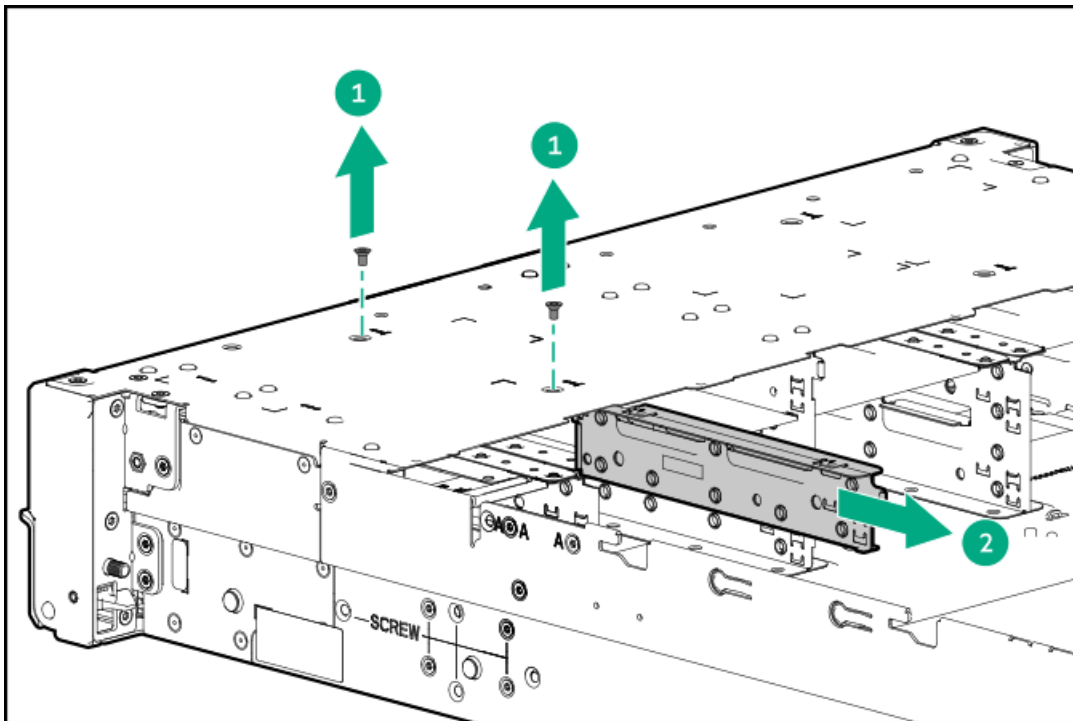

14. (Optional): Install the optical drive into the universal media bay.
15. Install the universal media bay:



- a. Install the universal media bay in the server.
- b. Install the universal media bay screws.

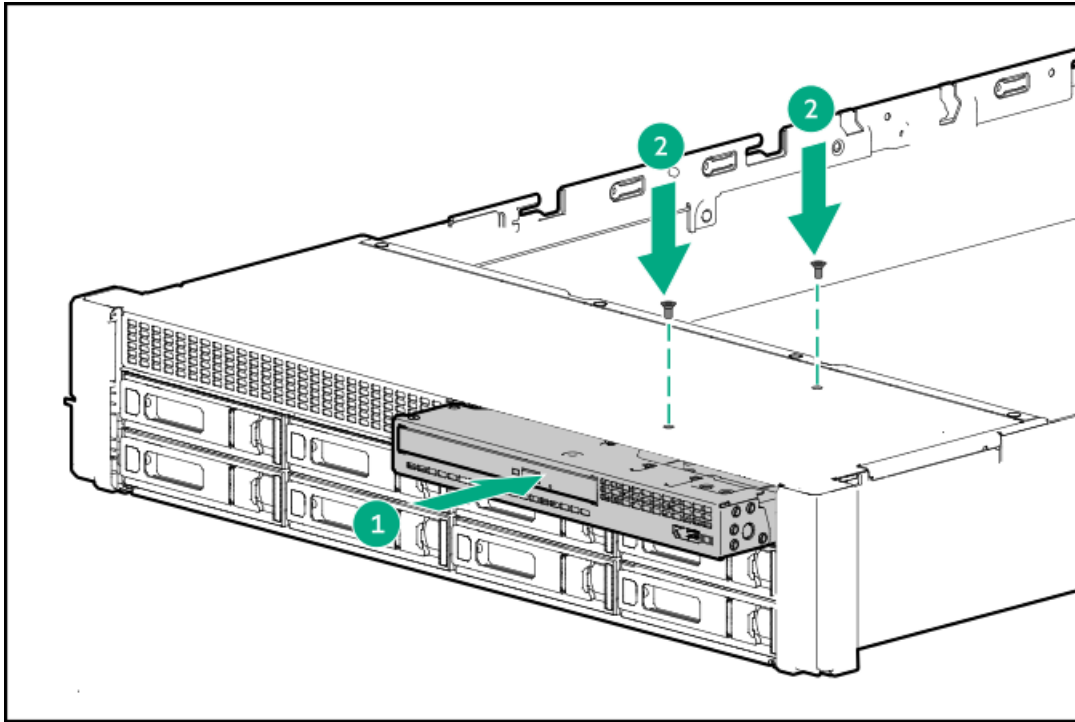

16. Install the LFF drive backplane bracket.
17. Cable the drive backplanes.
18. Install the midwall bracket.
19. Install the fan cage.
20. Do one of the following:
 - Install the air baffle.
 - Install the midplane drive cage.
21. Install the access panel.
22. Install the server into the rack.
23. Install the drives.
24. If removed, install the front bezel.
25. Connect all peripheral cables to the server.
26. Connect the power cords:
 - a. Connect each power cord to the server.
 - b. Connect each power cord to the power source.
27. If installed, close the cable management arm.

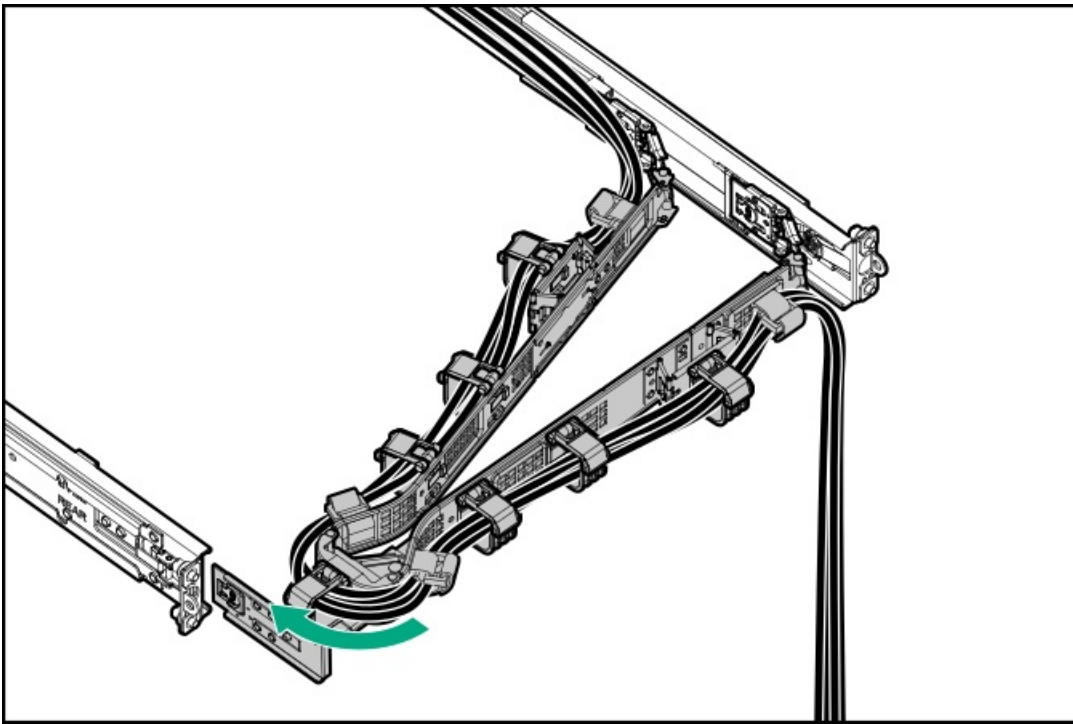

28. Power up the server.
29. If removed, install the front bezel.

Results

The installation procedure is complete.

Installing the universal media bay in the SFF chassis

Prerequisites

Before you perform this procedure, make sure that you have a T-15 Torx screwdriver available.

About this task

This server supports the universal media bay with an optical drive bay, two USB 2.0 ports, Display port 1.1a, and two front SFF stacked drives.

Procedure

1. Power down the server.
2. If installed, open the cable management arm.
3. Remove all power:
 - a. Disconnect each power cord from the power source.
 - b. Disconnect each power cord from the server.
4. Disconnect all peripheral cables from the server.
5. Remove the server from the rack.
6. Place the server on a flat, level work surface.
7. Remove the access panel.
8. Do one of the following:

- Remove the air baffle.
 - Remove the midplane drive cage.
9. Remove the fan cage.
 10. Remove the midwall bracket.
 11. (Optional) Install the front 2 SFF stacked drive cage .
 12. Remove the drive box blank:
 - a. Remove the drive box blank screws.
 - b. Remove the drive box blank.

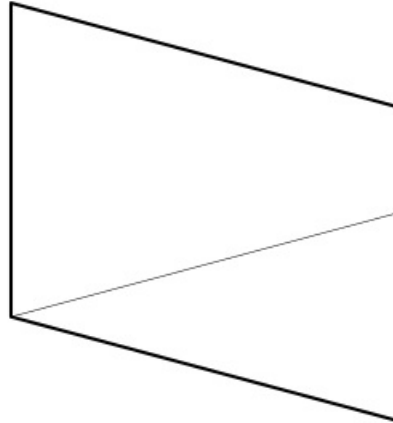
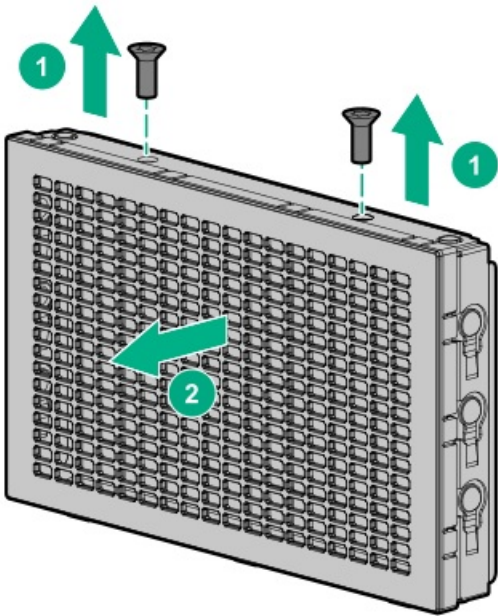

13. Install the universal media bay:
 - a. Install the universal media bay in the server.
 - b. Install the universal media bay screws.

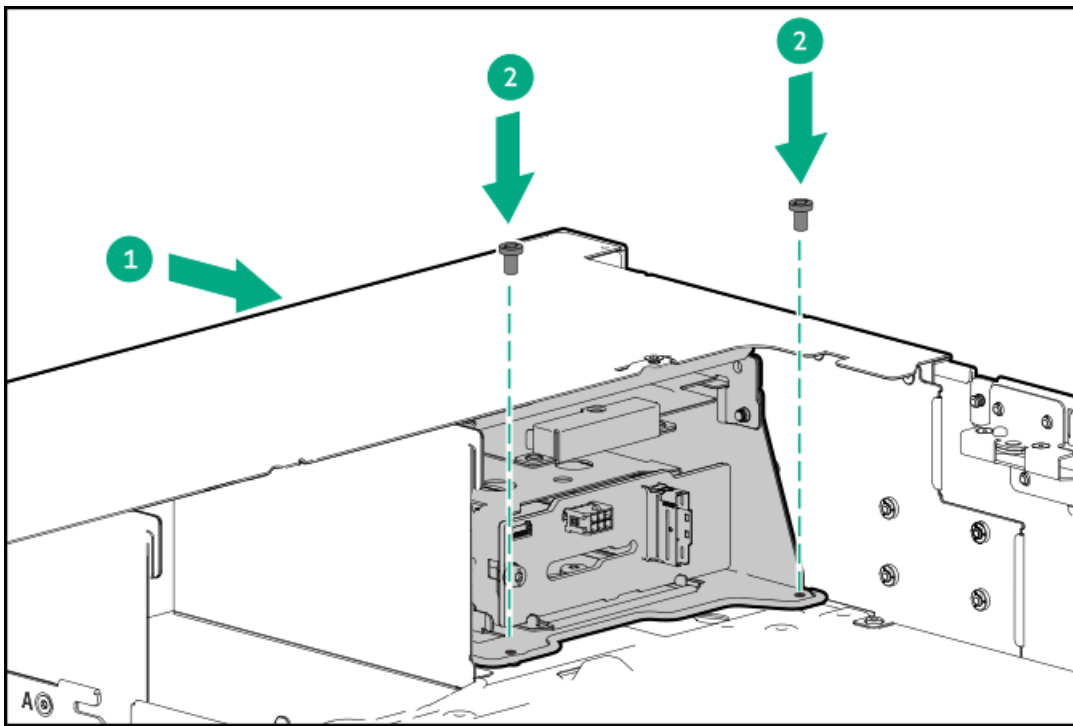

14. Cable the universal media bay.
15. (Optional) Install the optical drive.
16. Install the midwall bracket.
17. Install the fan cage.
18. Do one of the following:
 - Install the air baffle.
 - Install the midplane drive cage.
19. Install the access panel.
20. Install the server into the rack.
21. Connect all peripheral cables to the server.
22. Connect the power cords:
 - a. Connect each power cord to the server.
 - b. Connect each power cord to the power source.
23. If installed, close the cable management arm.



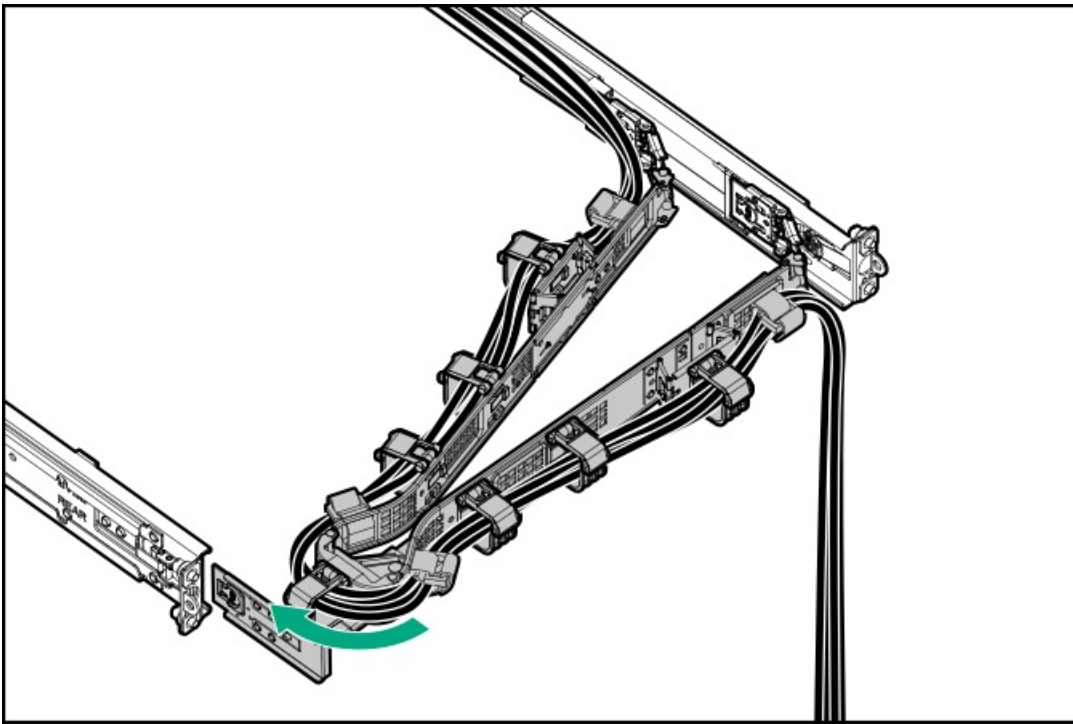

24. [Power up the server.](#)

Results

The installation procedure is complete.

Optical drive option

The server supports a slim-type SATA optical drive.

Subtopics

[Installing the optical disc drive in the LFF universal media bay](#)

[Installing the optical disc drive in the SFF universal media bay](#)

Installing the optical disc drive in the LFF universal media bay

Prerequisites

Before you perform this procedure, make sure that you have the following items available:

- The components included with the hardware option kit
- T-10 Torx screwdriver
- Phillips No. 1 screwdriver

Procedure

Installing the optical drive in the universal media bay

1. Remove the optical drive blank from the universal media bay.

Retain the blank for future use.



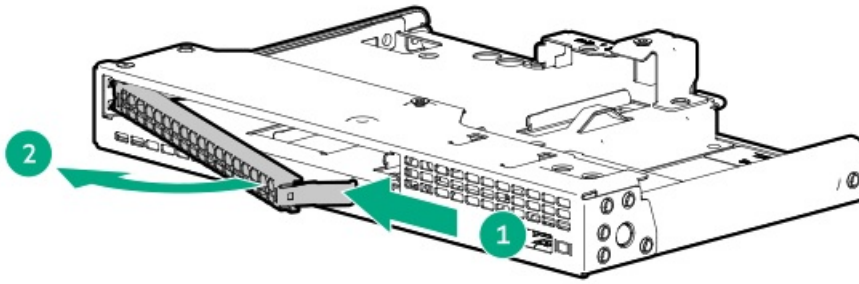

2. Install the optical drive bracket.

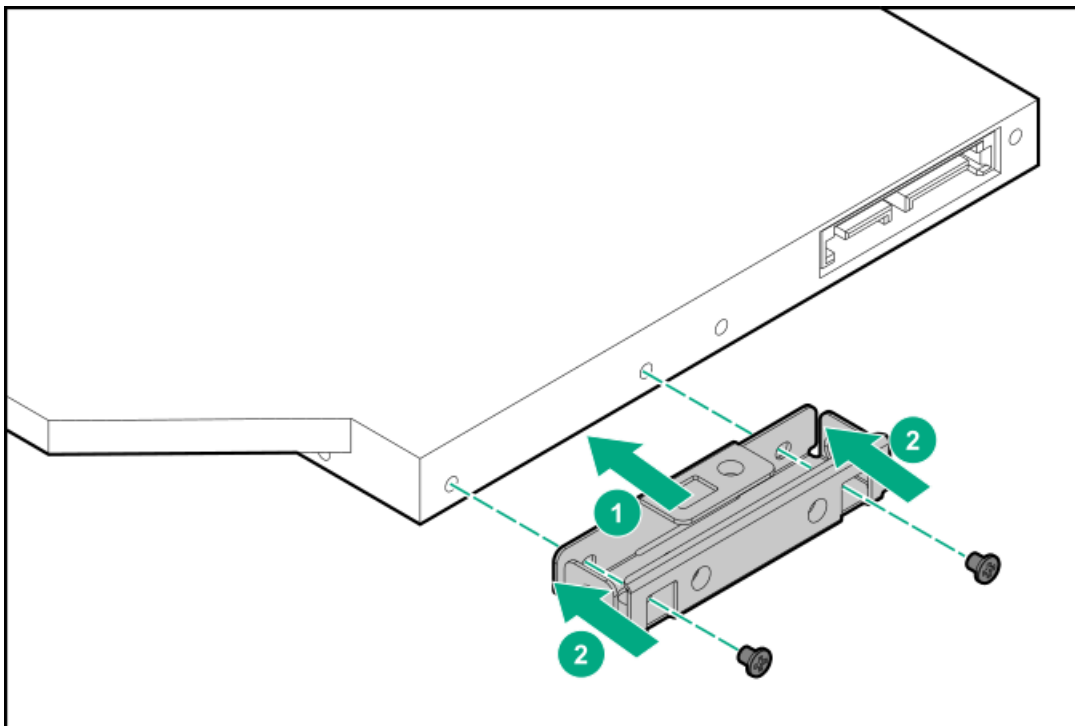

3. Install the optical drive bracket.



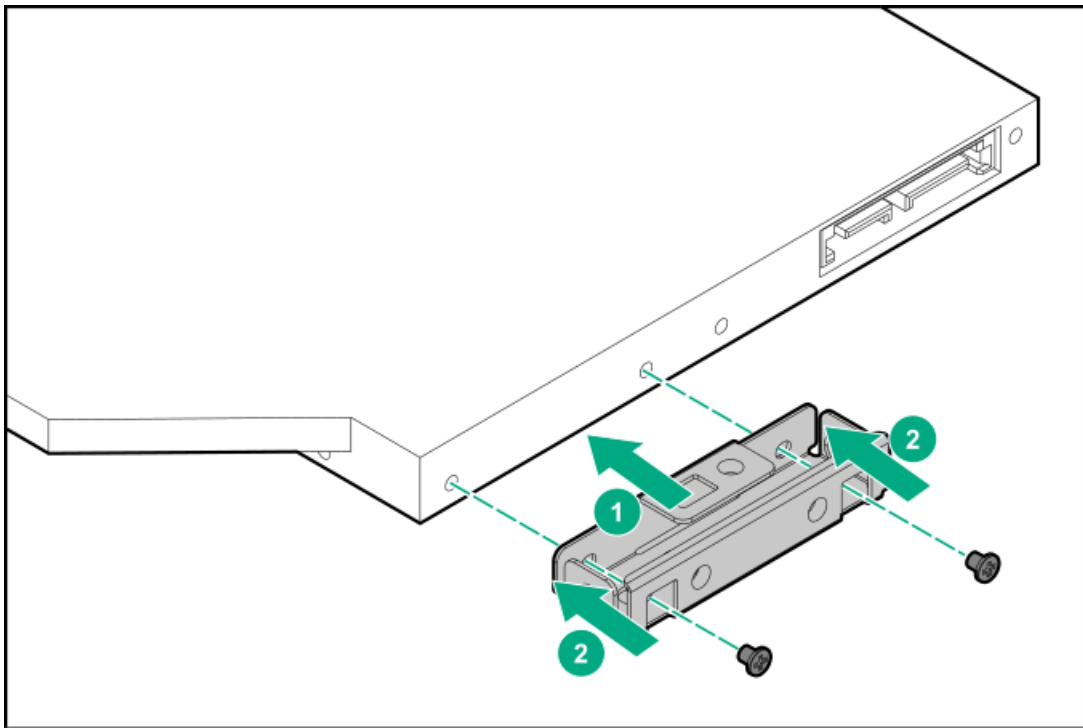

Installing the universal media bay in the server

4. Remove the drive:

- a. Press the latch to open the release lever.
- b. Pull the release lever to disengage the drive from the backplane, and then slide the drive out of the bay.

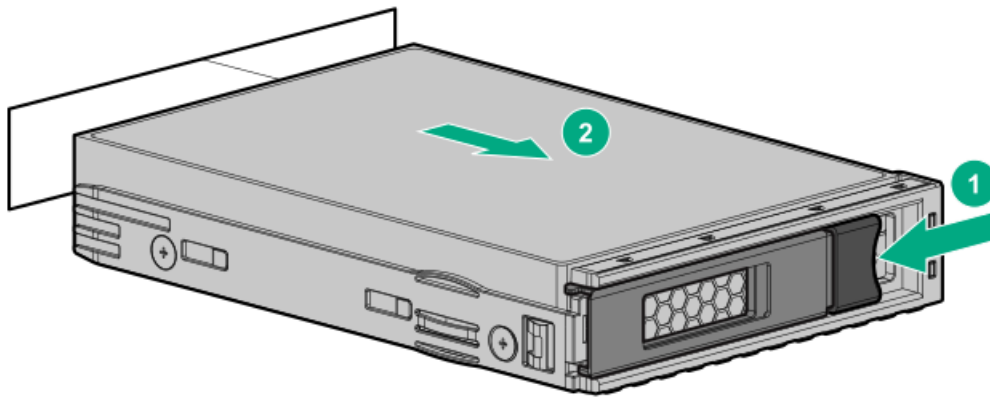

- 5. Power down the server.
- 6. If installed, open the cable management arm.
- 7. Remove all power:
 - a. Disconnect each power cord from the power source.
 - b. Disconnect each power cord from the server.
- 8. Disconnect all peripheral cables from the server.
- 9. Remove the server from the rack.
- 10. Place the server on a flat, level work surface.
- 11. Remove the access panel.
- 12. Do one of the following:



- [Remove the air baffle.](#)
 - [Remove the midplane drive cage.](#)
13. [Remove the midwall bracket.](#)
 14. [Remove the fan cage.](#)
 15. [Remove the LFF drive backplane bracket.](#)

16. **ⓘ IMPORTANT:**

Retain the removed partitions to revert to the 12 LFF drive configuration.

Remove the right partition:

- a. Remove the partition screws.
- b. Remove the partition.

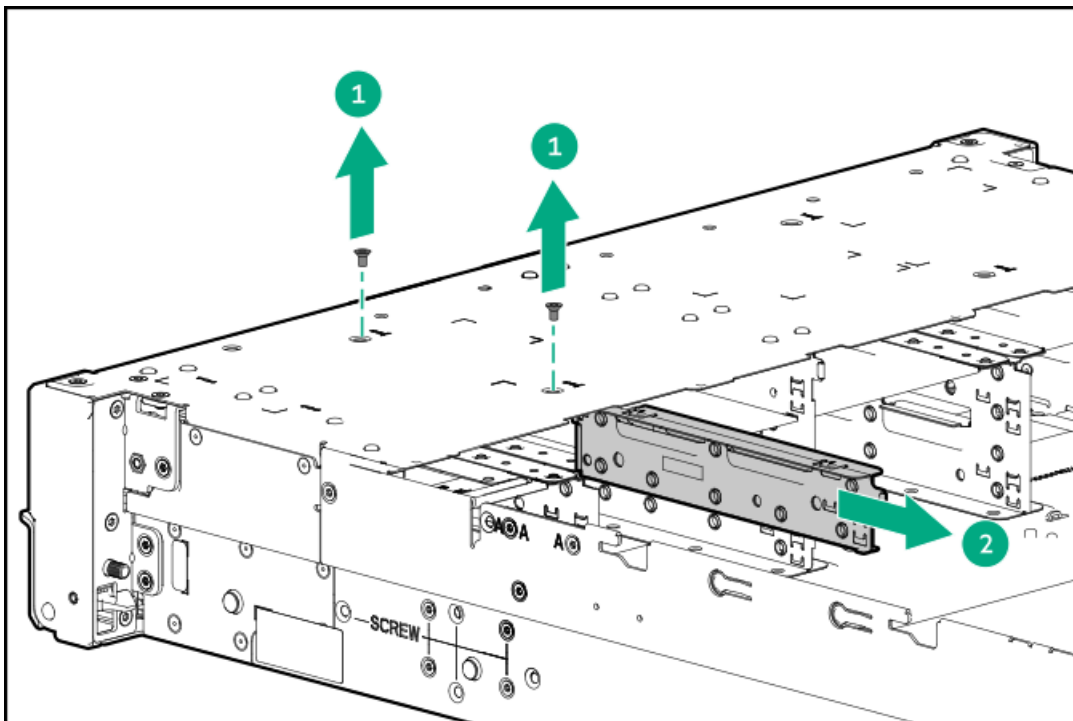

17. [Install the universal media bay.](#)
18. [Cable the optical disc drive.](#)
19. [Install the LFF drive backplane bracket.](#)
20. [Install the fan cage.](#)
21. Do one of the following:
 - [Install the air baffle.](#)
 - [Install the midplane drive cage.](#)
22. [Install the access panel.](#)
23. [Install the server into the rack.](#)
24. Connect all peripheral cables to the server.
25. Connect the power cords:
 - a. Connect each power cord to the server.

b. Connect each power cord to the power source.

26. If installed, close the cable management arm.

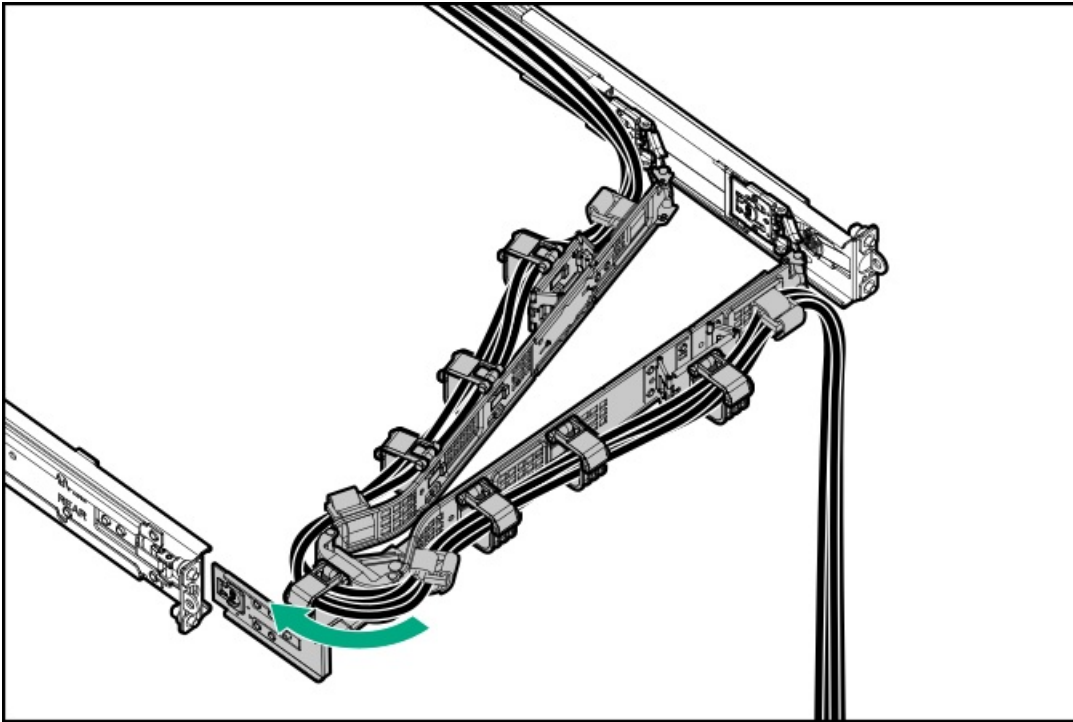

27. Power up the server.

Results

The installation procedure is complete.

Installing the optical disc drive in the SFF universal media bay

Prerequisites

Before you perform this procedure, make sure that you have the following items available:

- The components included with the hardware option kit
- T-10 Torx screwdriver
- Phillips No. 1 screwdriver

Procedure

1. If installed, remove the front bezel.
2. Power down the server.
3. If installed, open the cable management arm.
4. Remove all power:
 - a. Disconnect each power cord from the power source.
 - b. Disconnect each power cord from the server.
5. Disconnect all peripheral cables from the server.
6. Remove the server from the rack.

7. Place the server on a flat, level work surface.
8. Remove the access panel.
9. Do one of the following:
 - Remove the air baffle.
 - Remove the midplane drive cage.
10. Remove the fan cage.
11. Remove the midwall bracket.
12. Install the universal media bay.
13. Remove the optical drive blank from the universal media bay.

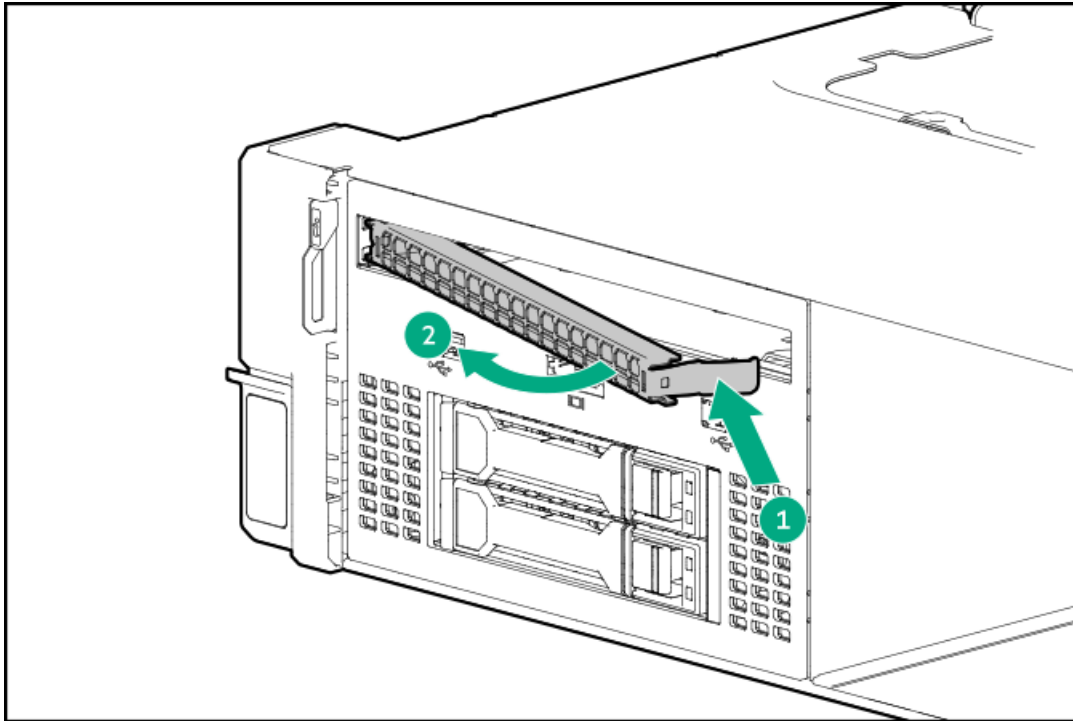

14. Install the optical drive in the universal media bay, and then install the screw.

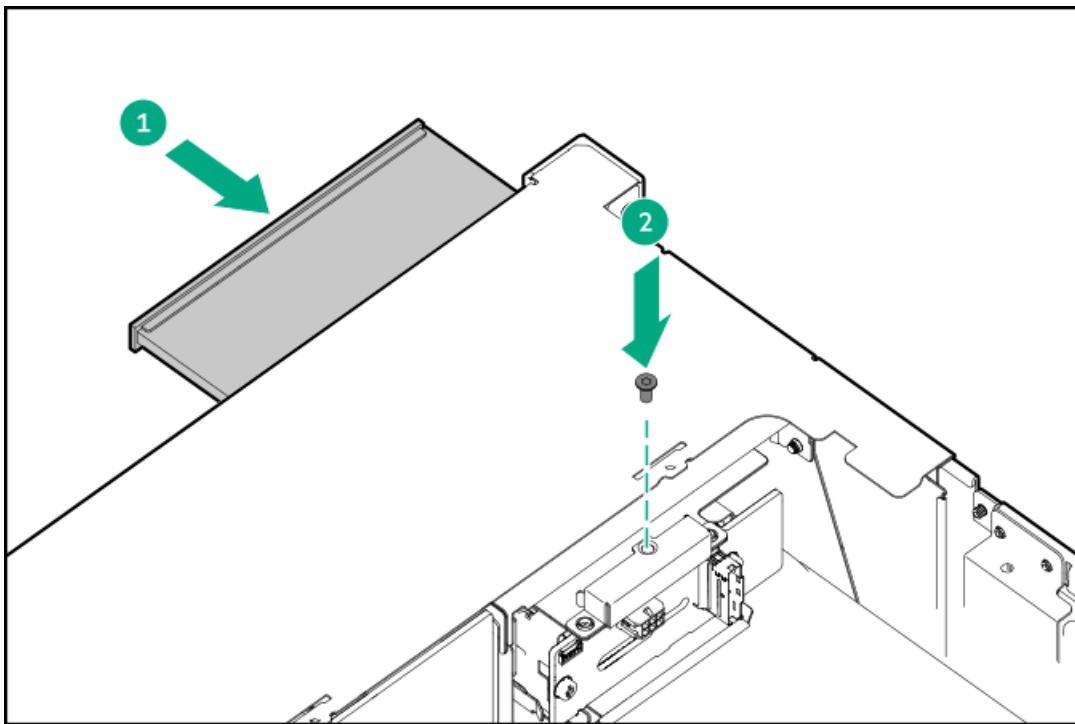

15. Install the midwall bracket.
16. Install the fan cage.
17. Do one of the following:
 - Install the air baffle.
 - Install the midplane drive cage.
18. Install the access panel.
19. Install the server into the rack.
20. Connect all peripheral cables to the server.
21. Connect the power cords:
 - a. Connect each power cord to the server.
 - b. Connect each power cord to the power source.
22. If installed, close the cable management arm.

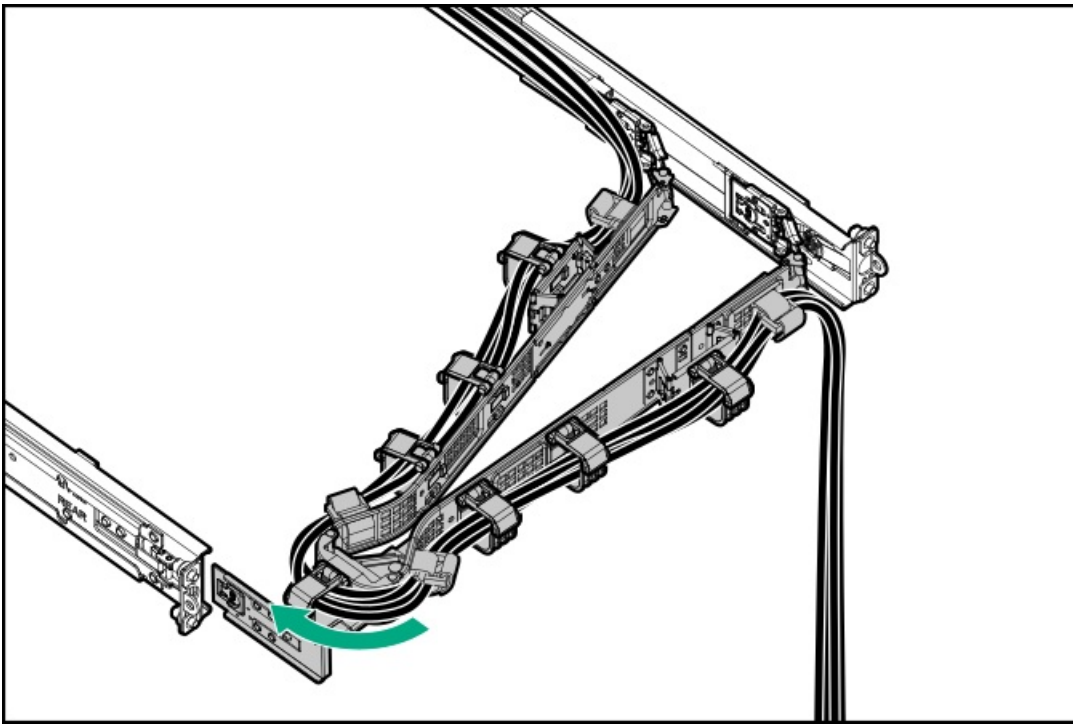

23. [Power up the server.](#)
24. If removed, [install the front bezel.](#)

Results

The installation procedure is complete.

Power supply options

Depending on the installed options and the regional location where the server was purchased, the server can be configured with one of the supported [power supplies](#).

Subtopics

[Power supply warnings and cautions](#)

[DC power supply warnings and cautions](#)

[DC power supply wire colors](#)

[Connecting a DC power cable to a DC power source](#)

[Installing a DC power supply](#)

[Installing an AC power supply](#)

[Installing the power supply cage](#)

Power supply warnings and cautions



**WARNING:**

To reduce the risk of electric shock or damage to the equipment:

- Do not disable the power cord grounding plug. The grounding plug is an important safety feature.
 - Plug the power cord into a grounded (earthed) electrical outlet that is easily accessible at all times.
 - Unplug the power cord from the power supply to disconnect power to the equipment.
 - Do not route the power cord where it can be walked on or pinched by items placed against it. Pay particular attention to the plug, electrical outlet, and the point where the cord extends from the server.
-



WARNING: To reduce the risk of injury from electric shock hazards, do not open power supplies. Refer all maintenance, upgrades, and servicing to qualified personnel.



CAUTION: Mixing different types of power supplies in the same server might:

- Limit or disable some power supply features including support for power redundancy.
- Cause the system to become unstable and might shut down.

To ensure access to all available features, all power supplies in the same server should have the same output and efficiency ratings. Verify that all power supplies have the same part number and label color.

DC power supply warnings and cautions



WARNING: To reduce the risk of electric shock, be sure that the cable grounding kit is properly installed and connected to a suitable protective earth terminal before connecting the power source to the rack.



CAUTION: This equipment is designed to permit the connection of the earthed conductor of the DC supply circuit to the earthing conductor at the equipment. If this connection is made, all the following must be met:

- This equipment must be connected directly to the DC supply system earthing electrode conductor or to a bonding jumper from an earthing terminal bar or bus to which the DC supply system earthing electrode conductor is connected.
 - This equipment must be located in the same immediate area (such as adjacent cabinets) as any other equipment that has a connection between the earthed conductor of the same DC supply circuit and the earthing conductor, and also the point of earthing of the DC system. The DC system must be earthed elsewhere.
 - The DC supply source is to be located within the same premises as the equipment.
 - Switching or disconnecting devices must not be in the earthed circuit conductor between the DC source and the point of connection of the earthing electrode conductor.
-

DC power supply wire colors



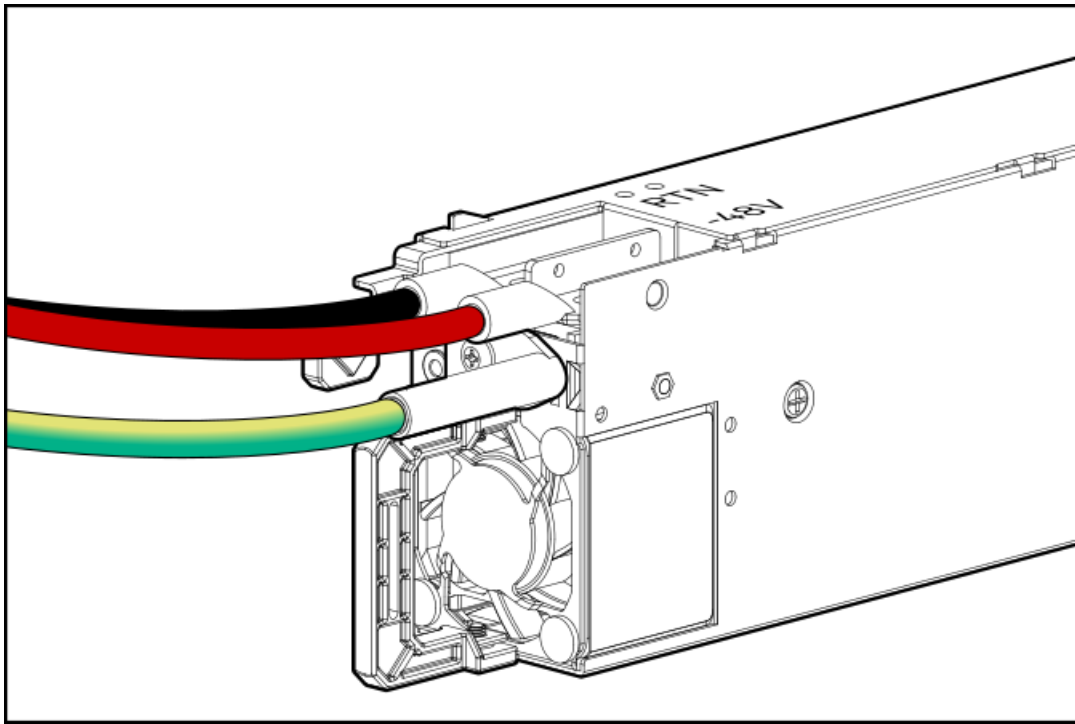

Wire color	Description	Wire slot
Red	Line wire	-48V
Black	Return wire	Return
Green + Yellow	Ground wire	Safety ground

Connecting a DC power cable to a DC power source

Prerequisites

Before you perform this procedure, make sure that you have the following items available:

- Electrical wire cutter
- Hand crimp tool

About this task



WARNING:

To reduce the risk of electric shock or energy hazards:

- This equipment must be installed by trained service personnel and in accordance with local and regional electric codes and regulations
- Connect the equipment to a reliably grounded secondary circuit source. A secondary circuit has no direct connection to a primary circuit and derives its power from a transformer, converter, or equivalent isolation device.
- The overcurrent protection for the DC source must not exceed 45 A.



WARNING:

When installing a DC power supply, the ground wire must be connected before the positive or negative leads.

**WARNING:**

Remove power from the power supply before performing any installation steps or maintenance on the power supply.

**CAUTION:**

The server equipment connects the earthed conductor of the DC supply circuit to the earthing conductor at the equipment. For more information, see the documentation that ships with the power supply.

**CAUTION:**

If a DC connection exists between the earthed conductor of the DC supply circuit and the earthing conductor at the server equipment, the following conditions must be met:

- This equipment must be connected directly to the DC supply system earthing electrode conductor or to a bonding jumper from an earthing terminal bar or bus to which the DC supply system earthing electrode conductor is connected.
- Locate the equipment in the same immediate area (such as adjacent cabinets) as any other equipment that has a connection between the earthed conductor of the same DC supply circuit and the earthing conductor, and also the point of earthing of the DC system. The DC system must be earthed elsewhere.
- The DC supply source is to be located within the same premises as the equipment.
- Switching or disconnecting devices should not be in the earthed circuit conductor between the DC source and the point of connection of the earthing electrode conductor.

Procedure

1. Cut the DC power cord ends no shorter than 150.00 cm (59.06 in).

**IMPORTANT:**

The ring terminals must be UL approved and accommodate 6 AWG wires.

**IMPORTANT:**

The minimum nominal thread diameter of a pillar or stud type terminal must be 3.50 mm (0.138 in). The diameter of a screw type terminal must be 5.00 mm (0.197 in).

2. If the power source requires ring tongues, use a crimping tool to install the ring tongues on the power cord wires and ground wire.
3. Stack each same-colored pair of wires and then attach them to the same power source.

For more information, see the documentation that ships with the power supply.

Installing a DC power supply

Prerequisites

- Before installing a power supply, review the following:
 - [Power supply warnings and cautions](#)
 - [DC power supply warnings and cautions](#)
 - [DC power supply wire colors](#)
- Before you perform this procedure, make sure that you have a Phillips No. 2 screwdriver available.
- Before connecting the power cables, review the following:
 - The optional P36877-B21 HPE lug kit can be purchased from an authorized HPE reseller for use with customer-supplied power

cables. (The power cable and lug kit listed below can only be used with the 1600 W -48 VDC power supply.)

- If you are using an input power cord option, the P22173-B21 HPE 1600 W DC PSU power cable kit can be purchased from an authorized HPE reseller.
- The DC power supply option kits do not ship with a Power Supply DC cable Kit and may not include a Power Supply Cable Lug kit. The optional DC Cable kit or the optional DC Cable Lug Kit may be purchased directly from Hewlett Packard Enterprise or an authorized HPE reseller. For additional information, see the power supply QuickSpecs at <https://www.hpe.com/info/fsps-qs>.

About this task

If you are not using an input power cord option, the power supply cabling must be made in consultation with a licensed electrician and be compliant with local code.



WARNING:

To reduce the risk of electric shock, fire, and damage to the equipment, you must install this product in accordance with the following guidelines:

- The HPE 1600 W Flex Slot -48 VDC hot-plug power supply is intended only for installation in Hewlett Packard Enterprise servers located in a restricted access location.
- The HPE 1600 W Flex Slot -48 VDC hot-plug power supply is not intended for direct connection to the DC supply branch circuit. Only connect this power supply to a power distribution unit (PDU) that provides an independent overcurrent-protected output for each DC power supply. Each output overcurrent-protected device in the PDU must be suitable for interrupting fault current available from the DC power source and must be rated no more than 45 A.
- The PDU output must have a shut-off switch or a circuit breaker to disconnect power for each power supply. To completely remove power from the power supply, disconnect power at the PDU. The end product may have multiple power supplies. To remove all power from the product, disconnect the power for each power supply.
- In accordance with applicable national requirements for Information Technology Equipment and Telecommunications Equipment, this power supply only connects to DC power sources that are classified as SELV or TNV. Generally, these requirements are based on the International Standard for Information Technology Equipment, IEC 60950-1/IEC 62368-1. In accordance with local and regional electric codes and regulations, the DC source must have one pole (Neutral/Return) reliably connected to earth ground.
- You must connect the power supply ground screw located on the front of the power supply to a suitable ground (earth) terminal. In accordance with local and regional electric codes and regulations, this terminal must be connected to a suitable building ground (earth) terminal. Do not rely on the rack or cabinet chassis to provide adequate ground (earth) continuity.



WARNING: To reduce the risk of personal injury from hot surfaces, allow the power supply, power supply blank, or dual slot power supply adapter to cool before touching it.



CAUTION: To prevent improper cooling and thermal damage, do not operate the server unless all bays are populated with either a component or a blank.

Procedure

1. Remove the protective cover from the power supply.

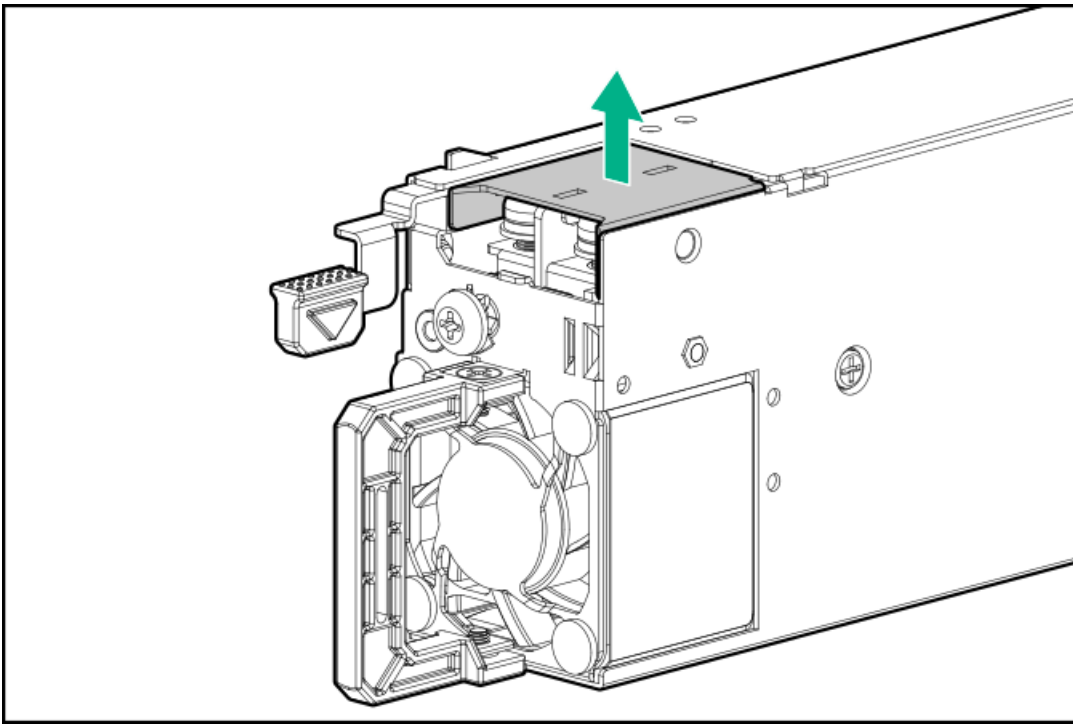

2. Remove the ground wire screw, and then remove the return wire and line wire screws.

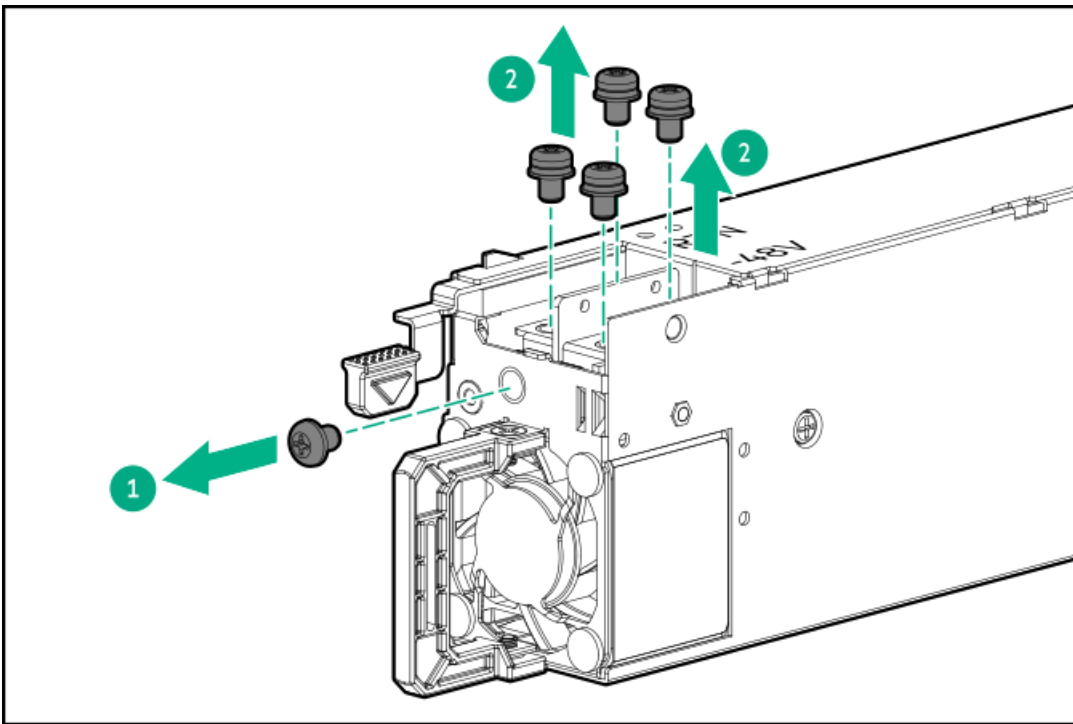

3. Attach the ground wire (green and yellow) to the DC power supply and tighten the screw and washer with 1.47 N-m (13 lbf-in).



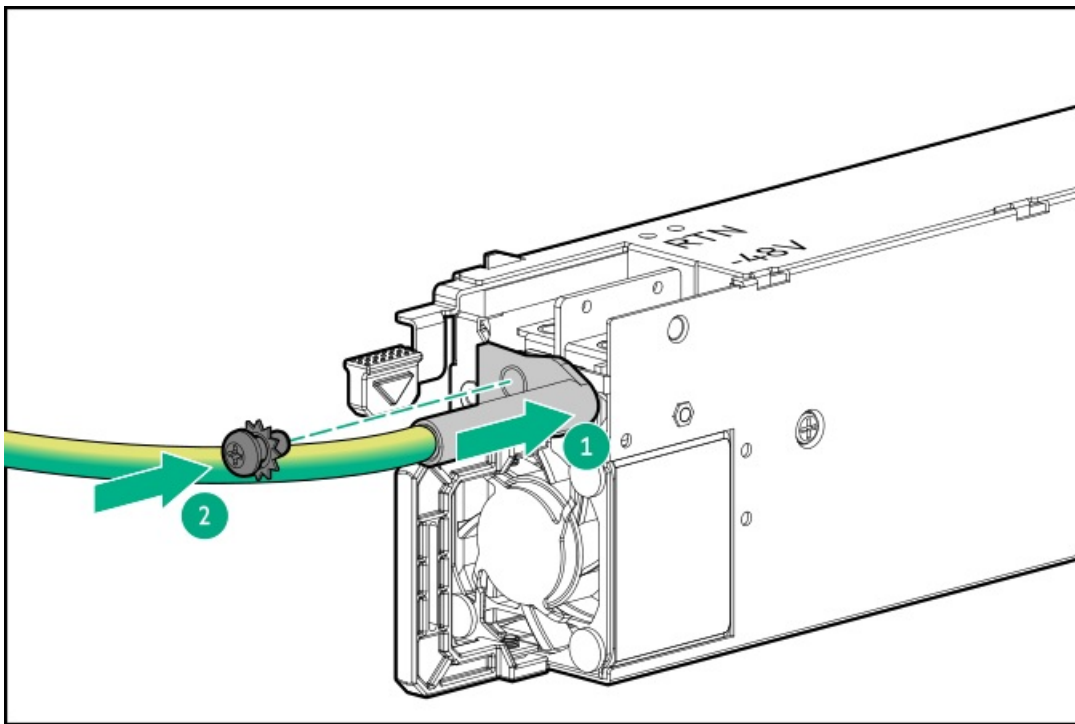

4. Install the return wire (black):

- a. Insert the return wire into the RTN slot on the DC power supply.
- b. Tighten the screw with 0.98 N-m (8.68 lbf-in).

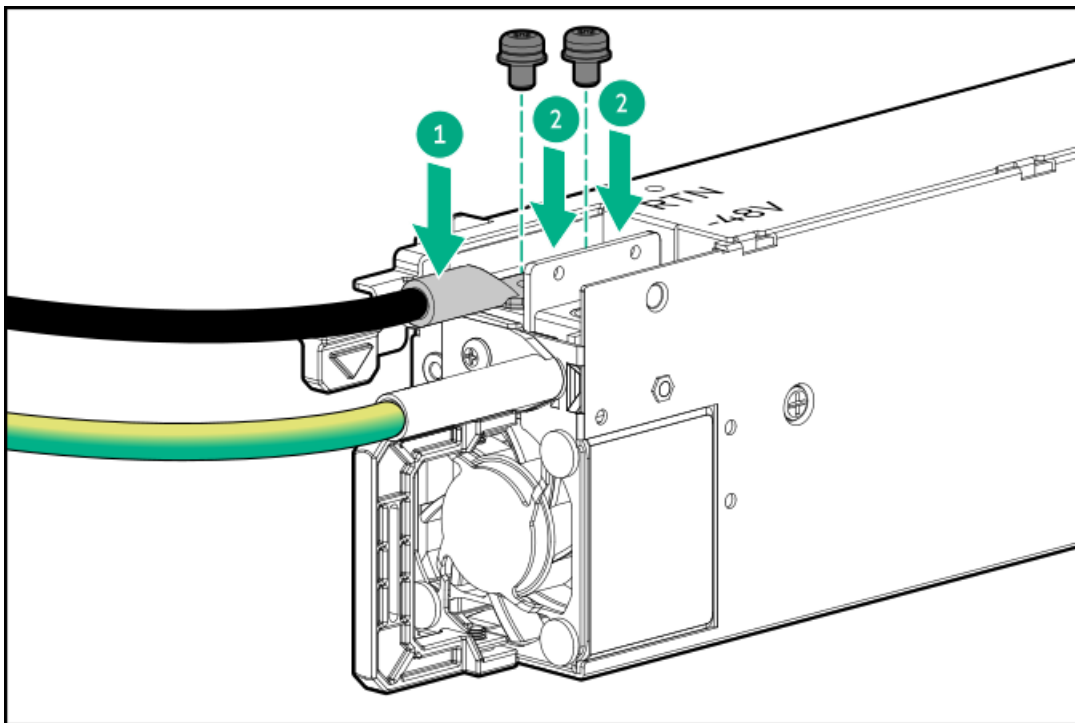

5. Install the line wire (red):

- a. Insert the line wire into the -48V slot on the DC power supply.
- b. Tighten the screw to 0.98 N-m (8.68 lbf-in).



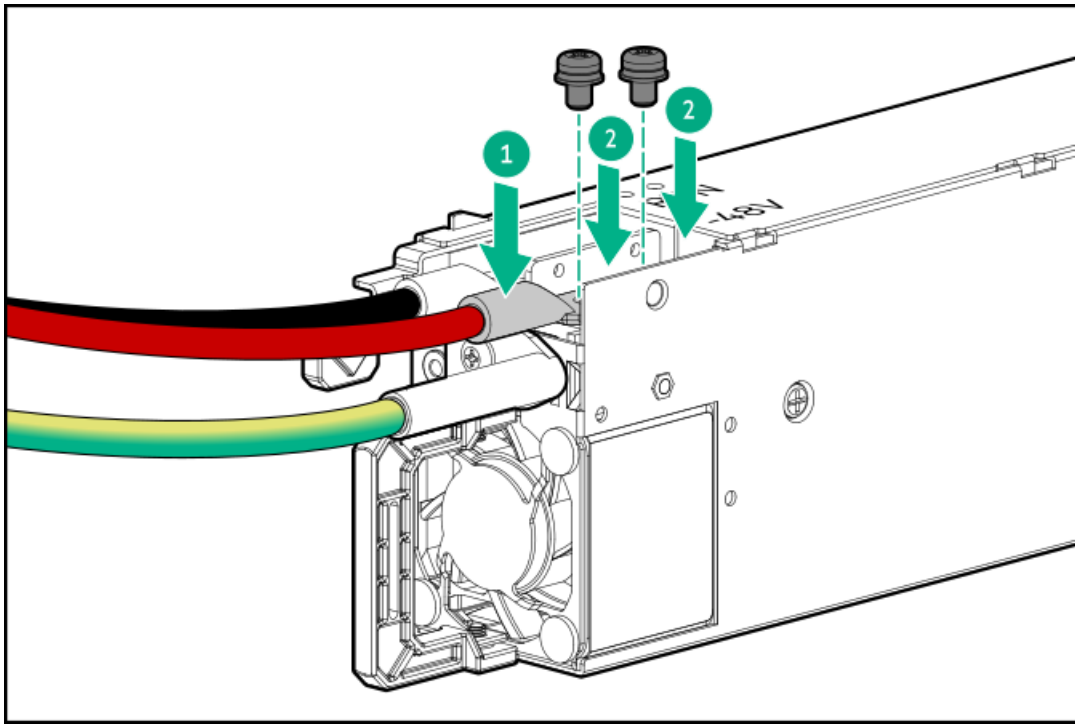

6. Install the protective cover on the DC power supply.

Make sure that the protective cover is locked.

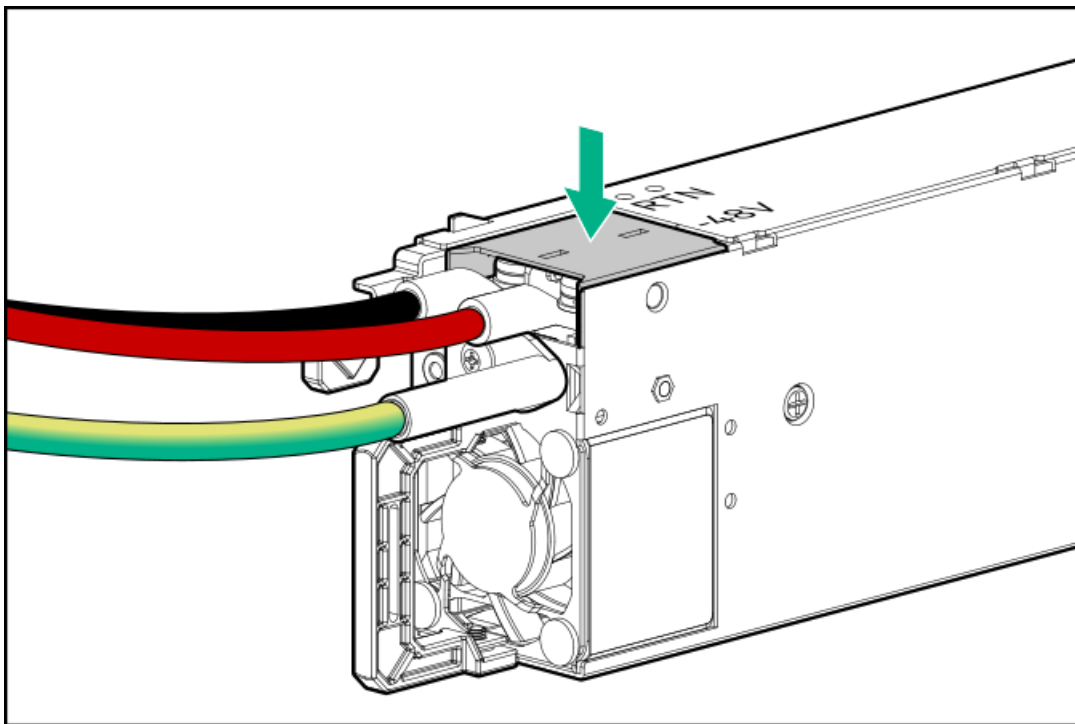

7. Secure the ground, positive return, and negative input wires in the strain relief strap.

CAUTION: Avoid tight bend radii to prevent damaging the internal wires of a power cord or a server cable. Never bend power cords and server cables tight enough to cause a crease in the sheathing.

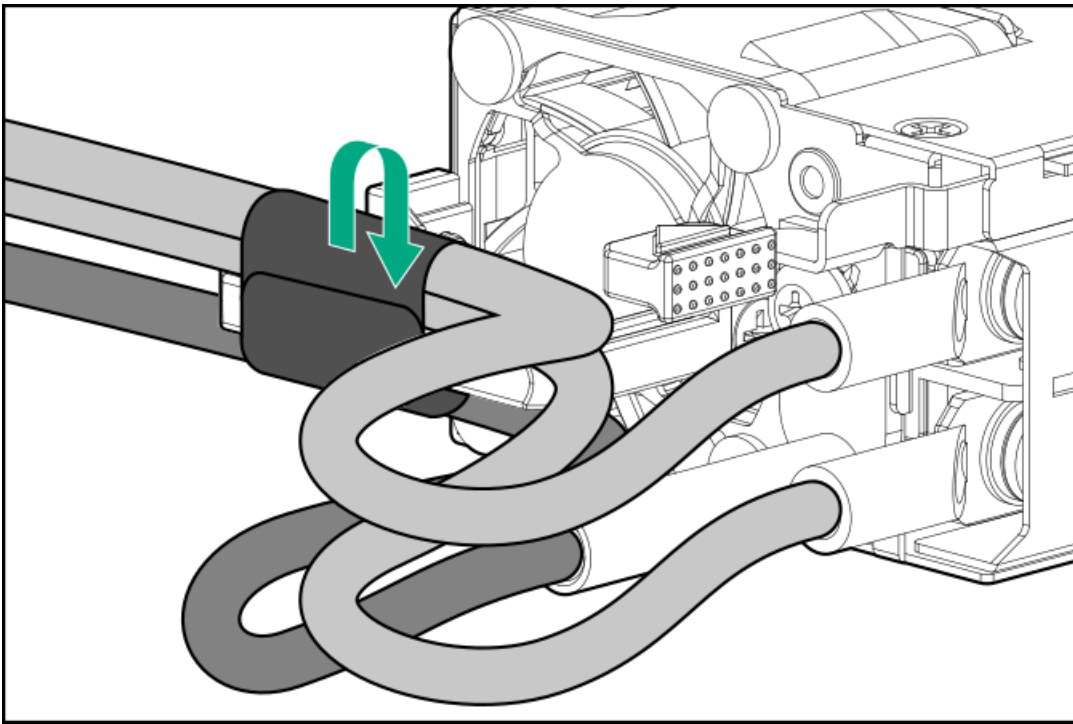

8. If you are installing a power supply in the power supply bay 2, remove the power supply blank.

Retain the blank for future use.

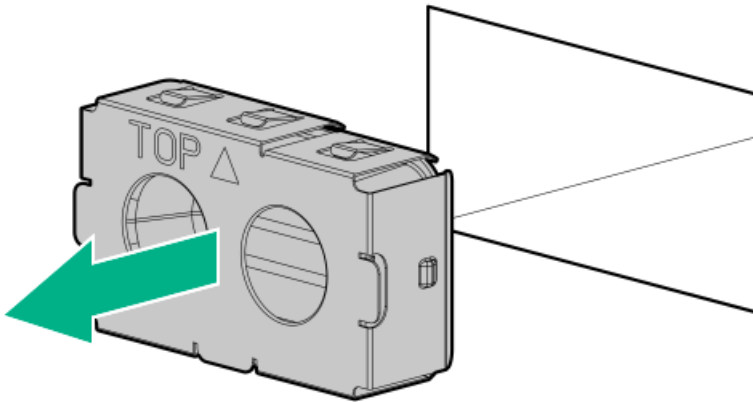

9. Immediately slide the power supply into the bay until it clicks into place.

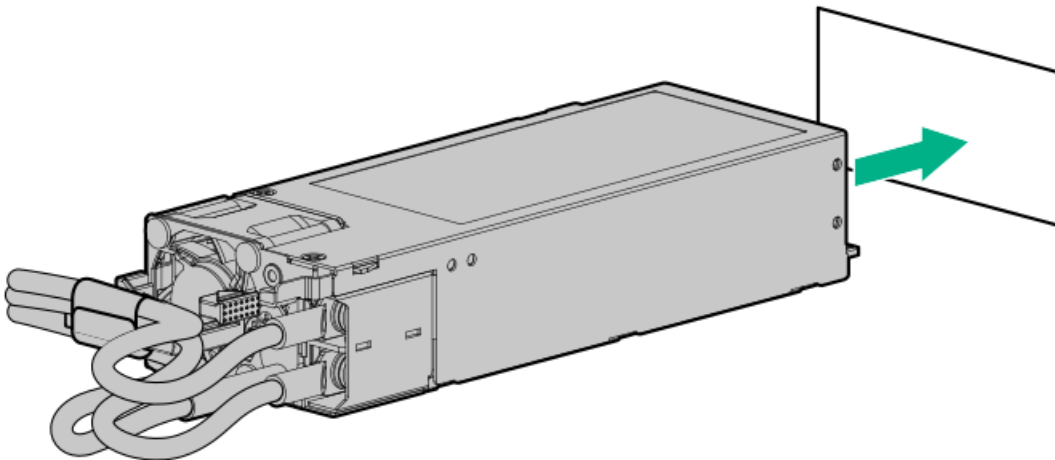

10. Make sure the -48 V DC power source is off or the PDU breaker is in the off position, and then connect the power cord to the -48 V DC power source or PDU.
11. Turn on the -48 V power source or switch the PDU breaker to the on position to supply -48 V to the power supply.
12. Connect a DC power cable to a DC power source.
13. Make sure that the power supply LED is green.

Results

The installation procedure is complete.

Installing an AC power supply

Prerequisites

Before installing a power supply option, review the [Power supply warnings and cautions.](#)

About this task

WARNING: To reduce the risk of personal injury from hot surfaces, allow the power supply, power supply blank, or dual slot power supply adapter to cool before touching it.

CAUTION: To prevent improper cooling and thermal damage, do not operate the server unless all bays are populated with either a component or a blank.

Procedure

1. Remove the power supply blank.

Retain the blank for future use.

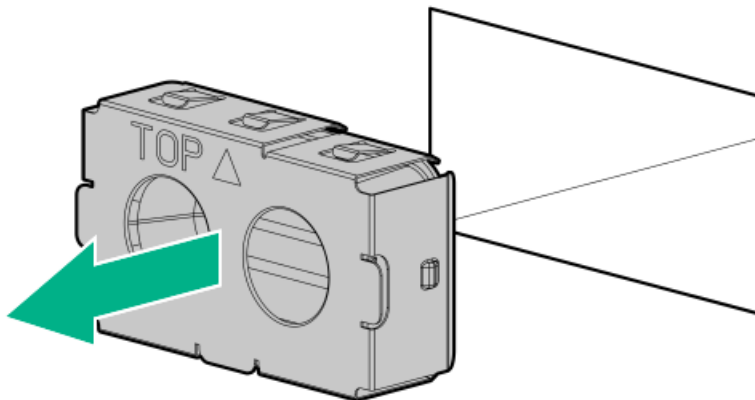

2. Install the power supply.

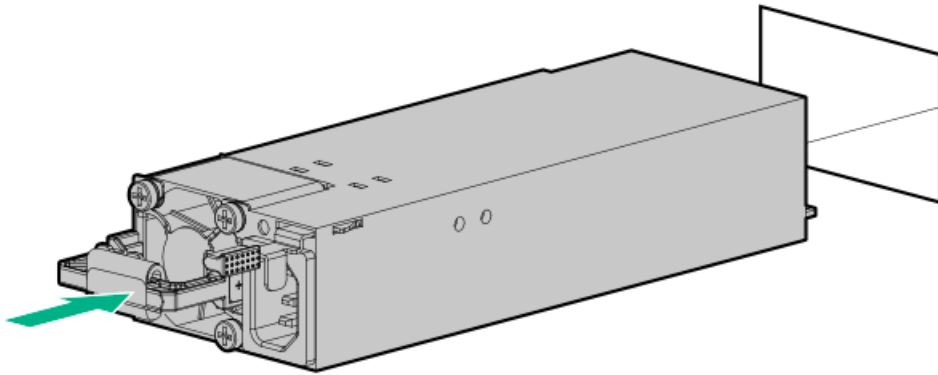

3. Connect the power cord to the power supply.
4. Secure the power cord.

CAUTION: Avoid tight bend radii to prevent damaging the internal wires of a power cord or a server cable. Never bend power cords and server cables tight enough to cause a crease in the sheathing.

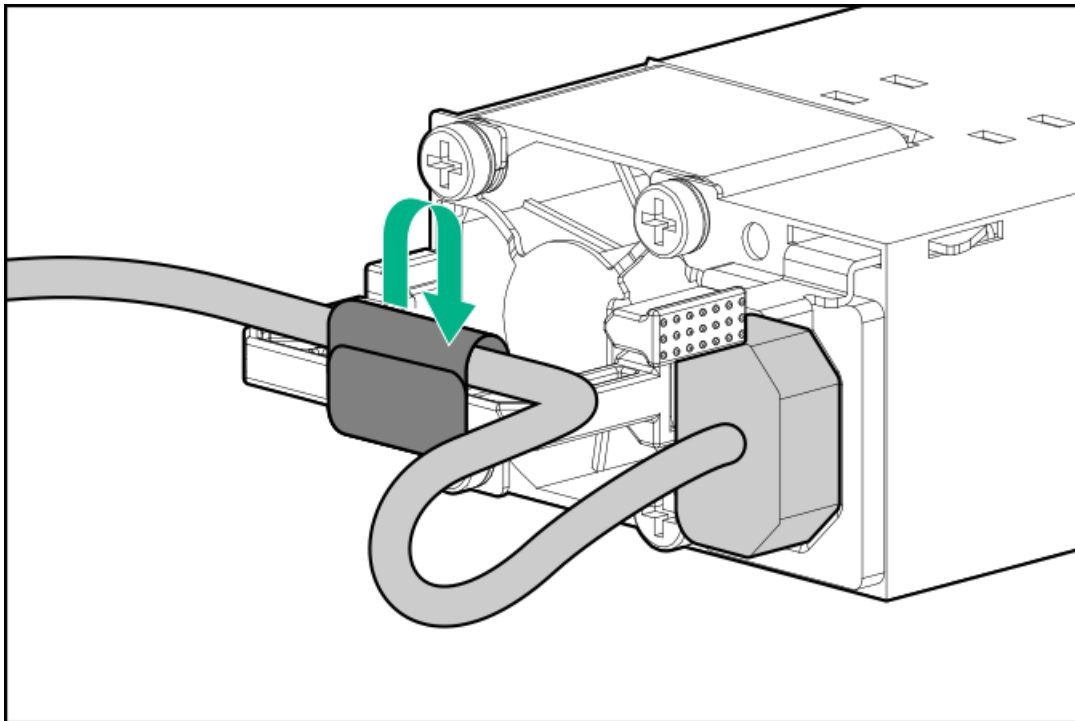

5. Connect the power cords:
 - a. Connect each power cord to the server.
 - b. Connect each power cord to the power source.
6. Make sure that the power supply LED is green.

Results

The installation procedure is complete.

Installing the power supply cage

Prerequisites

Before you perform this procedure, make sure that you have the following items available:

- The components included with the hardware option kit
- T-10 Torx screwdriver

Procedure

1. Power down the server.
2. If installed, open the cable management arm.
3. Remove all power:
 - a. Disconnect each power cord from the power source.
 - b. Disconnect each power cord from the server.
4. Disconnect all peripheral cables from the server.
5. Remove the server from the rack.
6. Place the server on a flat, level work surface.
7. Remove the access panel.
8. Do one of the following:
 - Remove the air baffle.
 - Remove the midplane drive cage.
9. Disconnect all power supply cables from the system board, drive cages, and devices.
10. Remove the security cover.

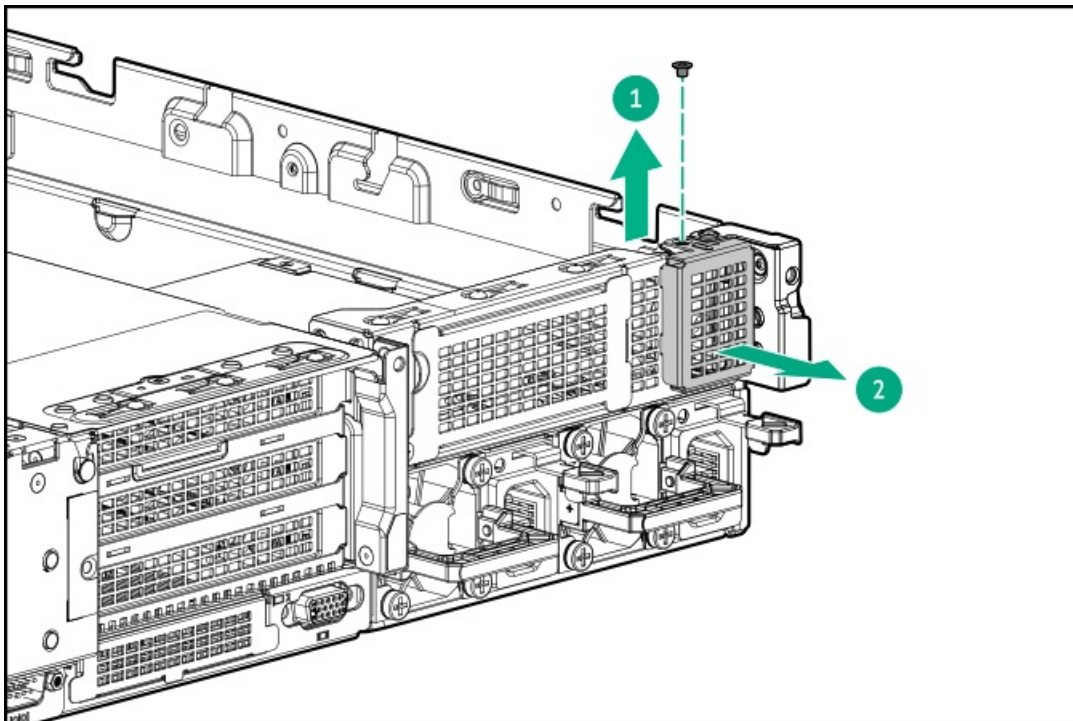

11. Remove the riser blank.



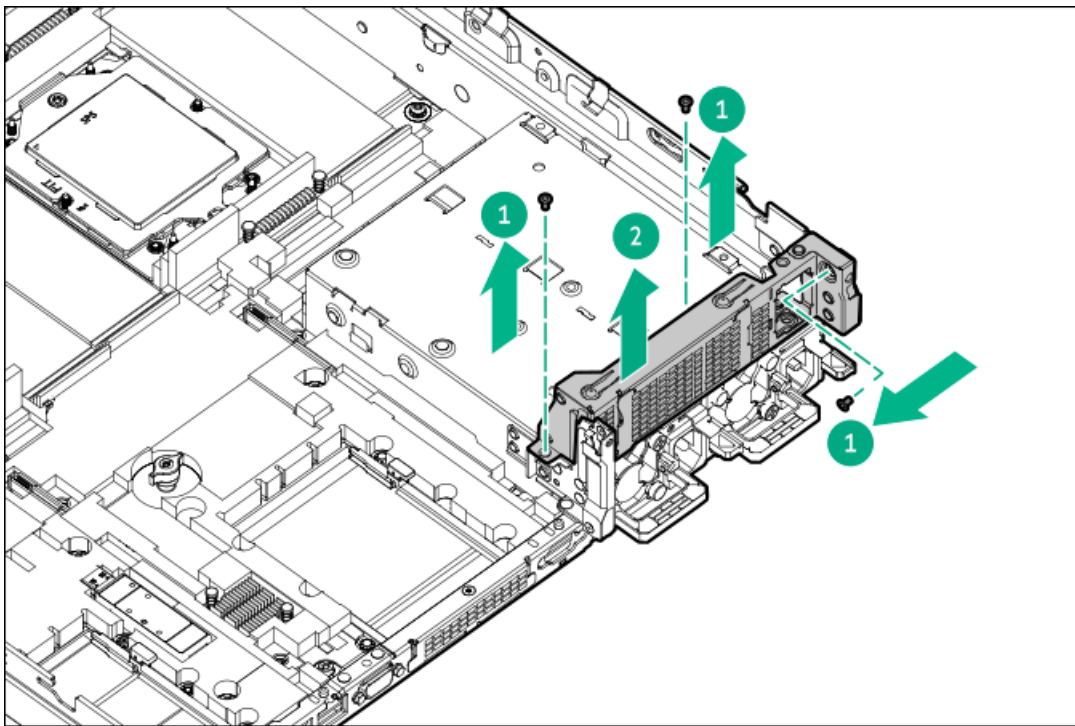

12. Slide the power distribution board onto the power supply cage (callout 1) and tighten the thumbscrew (callout 2).

Make sure that the board is firmly seated in the slot using the latches on the side.

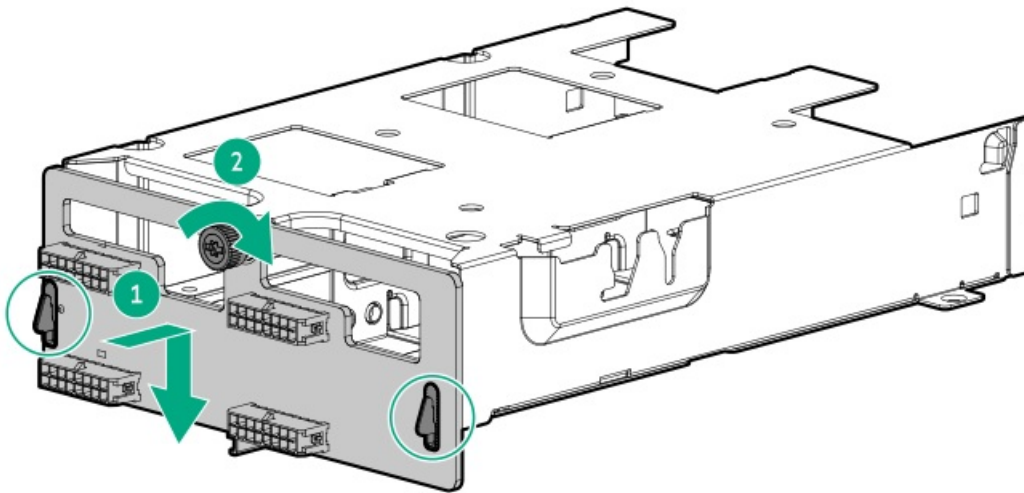

13. Install the power supply cage.
 - a. Lower the power supply cage into the slot (callout 1).
 - b. Install the screws (callout 2).



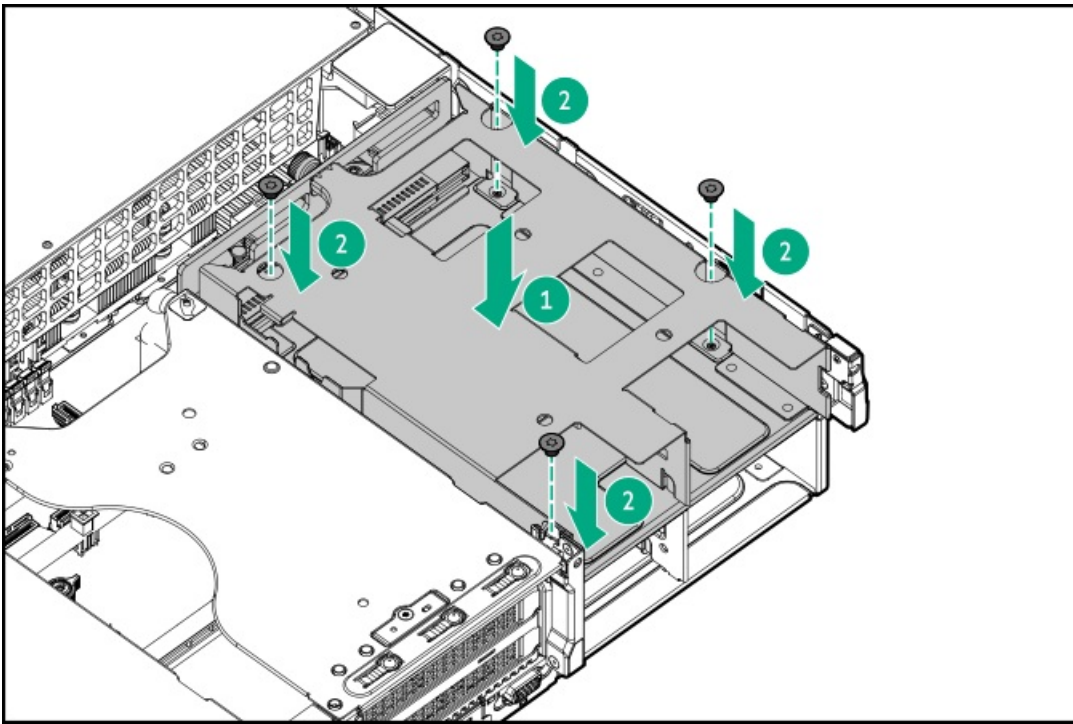

14. Install the power supplies:

- [Install a DC power supply](#)
- [Install an AC power supply](#)

15. Do one of the following:

- [Install the air baffle.](#)
- [Install the midplane drive cage.](#)

16. [Install the access panel.](#)

17. [Install the server into the rack.](#)

18. Connect all peripheral cables to the server.

19. Connect the power cords:

- a. Connect each power cord to the server.
- b. Connect each power cord to the power source.

20. If installed, close the cable management arm.

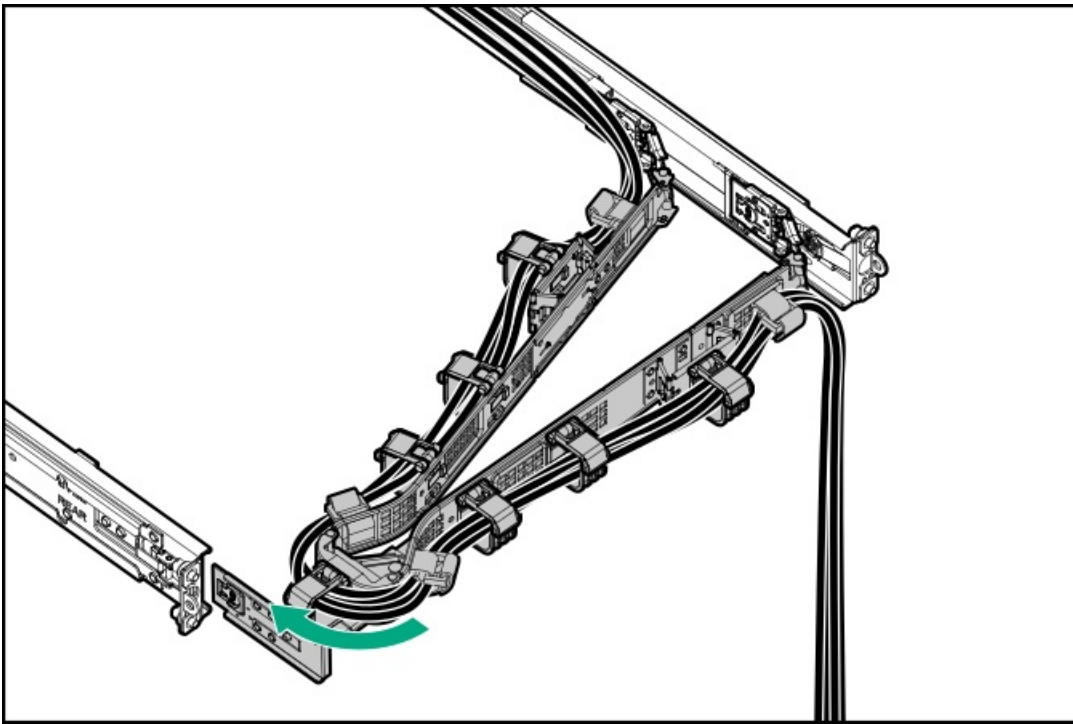

21. Power up the server.

Results

The installation procedure is complete.

Expansion card options

The server supports the installation of full-height, half-length and half-height, half-length (low-profile) PCIe expansion / add-in (AIC) cards such as:

- HPE type-p storage controller
- Ethernet adapter
- HDR InfiniBand adapter
- Fibre channel host bus adapter (FC HBA)
- Accelerator (workload, computational, or graphics accelerator)

For more information on the expansion options validated for this server, see the server QuickSpecs on the Hewlett Packard Enterprise website:

<https://www.hpe.com/info/qs>

Subtopics

[Installing an expansion card](#)

[Installing the expansion card in the HPE NS204i-u Boot Device riser cage](#)

[Installing an expansion card on the three-slot riser cage](#)

Installing an expansion card

Prerequisites

- Before you perform this procedure, make sure that you have the following items available:
 - T-10 Torx screwdriver
 - Phillips No. 1 screwdriver

About this task

This procedure applies to the rear 4 LFF configuration.

CAUTION: A discharge of static electricity from a finger or other conductor might damage system boards or other static-sensitive devices. To prevent damage, observe [antistatic precautions](#).

CAUTION: To prevent improper cooling and thermal damage, do not operate the server unless all PCIe slots have either a riser slot blank or an expansion card installed.

Procedure

1. Power down the server.
2. If installed, open the cable management arm.
3. Remove all power:
 - a. Disconnect each power cord from the power source.
 - b. Disconnect each power cord from the server.
4. Disconnect all peripheral cables from the server.
5. Remove the server from the rack.
6. Remove the riser cage.
7. Identify the riser slot compatible with the expansion card.

8. Remove the riser slot blank.

Retain the screw and blank. The screw will be used to secure the new expansion card.

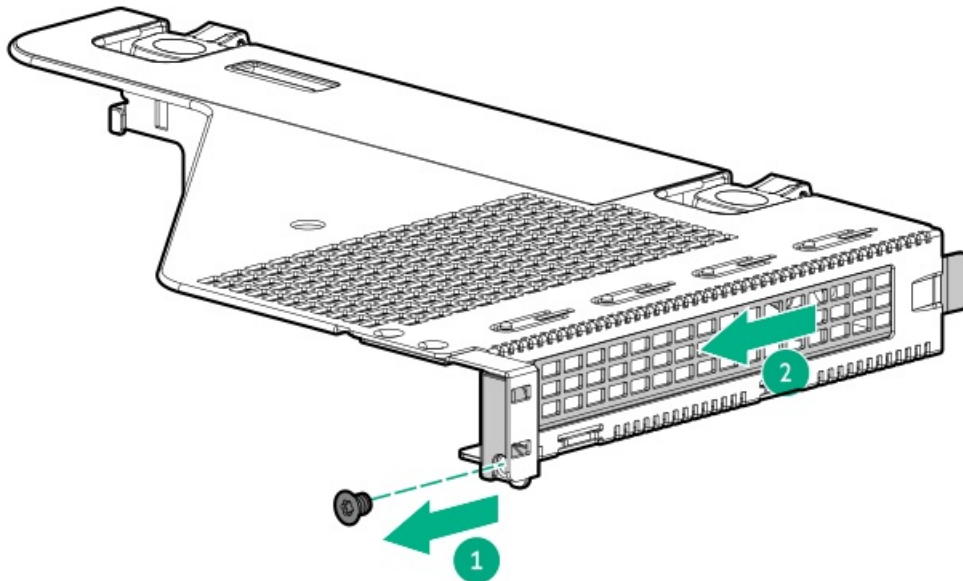

9. Make sure that any switches or jumpers on the expansion card are set properly.

For more information, see the documentation that ships with the expansion card option.

10. Install the expansion card:

Make sure that the expansion card is seated firmly in the slot.

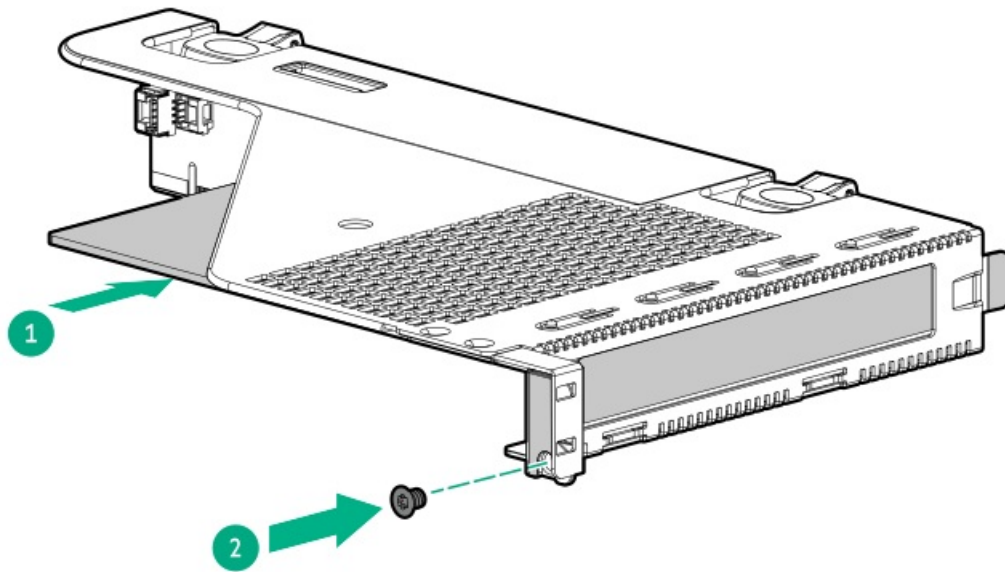

11. Connect all necessary internal cabling to the expansion card.

For more information on these cabling requirements, see the documentation that ships with the option.

12. Install the access panel.
13. Connect all peripheral cables to the server.
14. Connect the power cords:
 - a. Connect each power cord to the server.
 - b. Connect each power cord to the power source.
15. If installed, close the cable management arm.

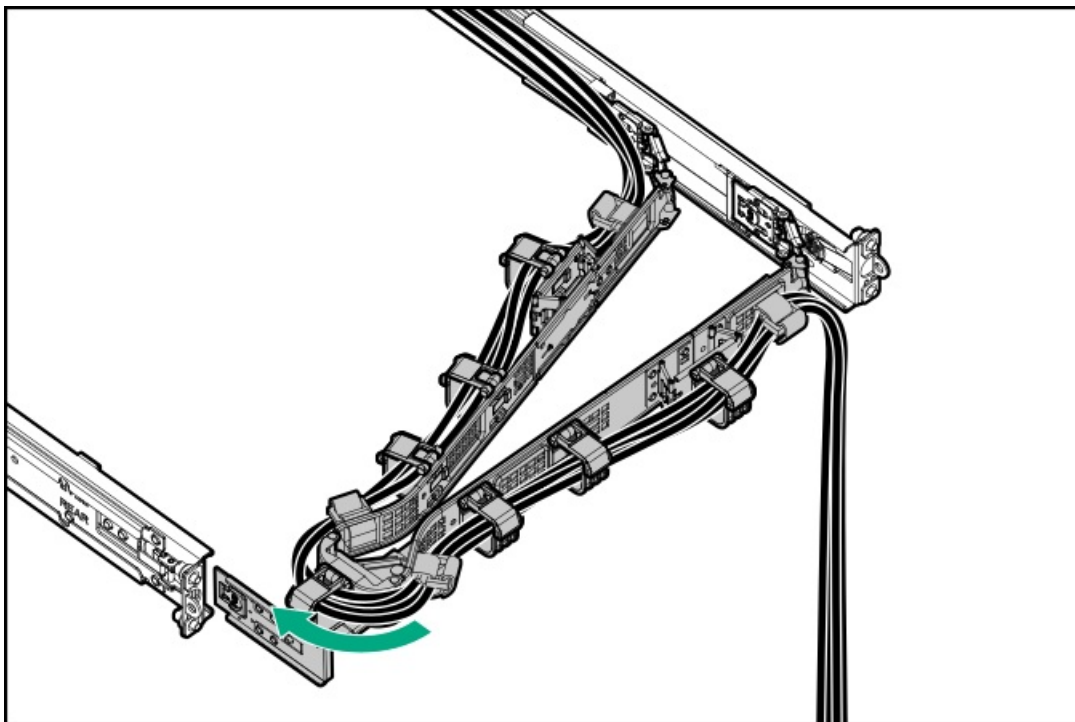

16. Power up the server.



Results

The installation procedure is complete.

Installing the expansion card in the HPE NS204i-u Boot Device riser cage

Prerequisites

Before you perform this procedure, make sure that you have a T-10 Torx screwdriver available.

About this task

 **CAUTION:** A discharge of static electricity from a finger or other conductor might damage system boards or other static-sensitive devices. To prevent damage, observe [antistatic precautions](#).

 **CAUTION:** To prevent improper cooling and thermal damage, do not operate the server unless all PCIe slots have either a riser slot blank or an expansion card installed.

Procedure

1. [Power down the server](#).
2. If installed, [open the cable management arm](#).
3. Remove all power:
 - a. Disconnect each power cord from the power source.
 - b. Disconnect each power cord from the server.
4. Disconnect all peripheral cables from the server.
5. [Remove the server from the rack](#).
6. [Remove the access panel](#).
7. [Remove the riser cage](#).
8. If installing an expansion card on the HPE NS204i-u Boot Device + low-profile riser cage, do the following:
 - a. If installed, remove the full-height bracket from the expansion card.

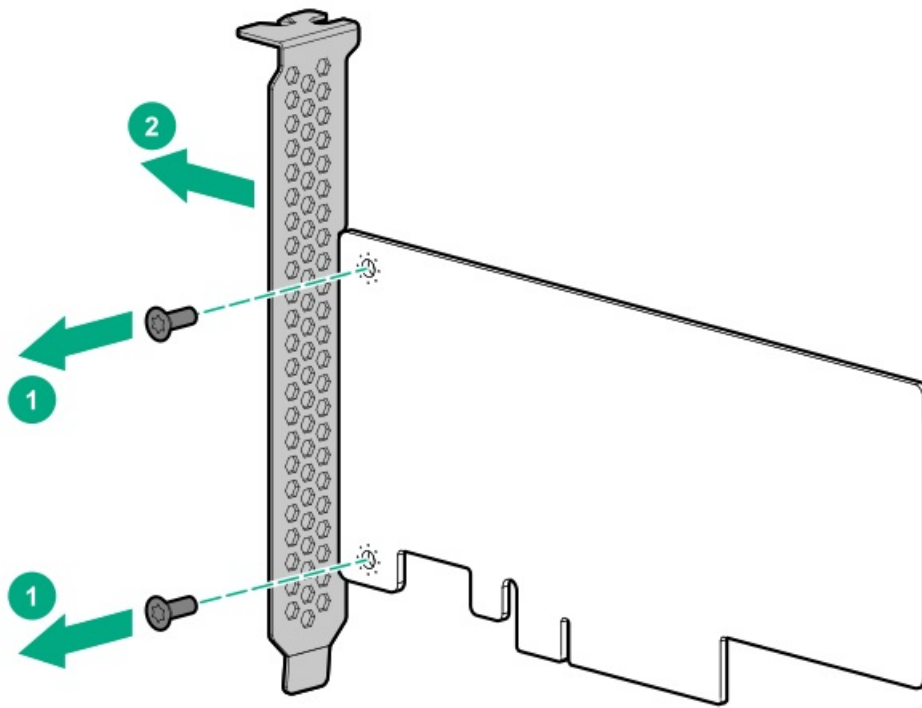

b. Install the low-profile bracket on the expansion card.

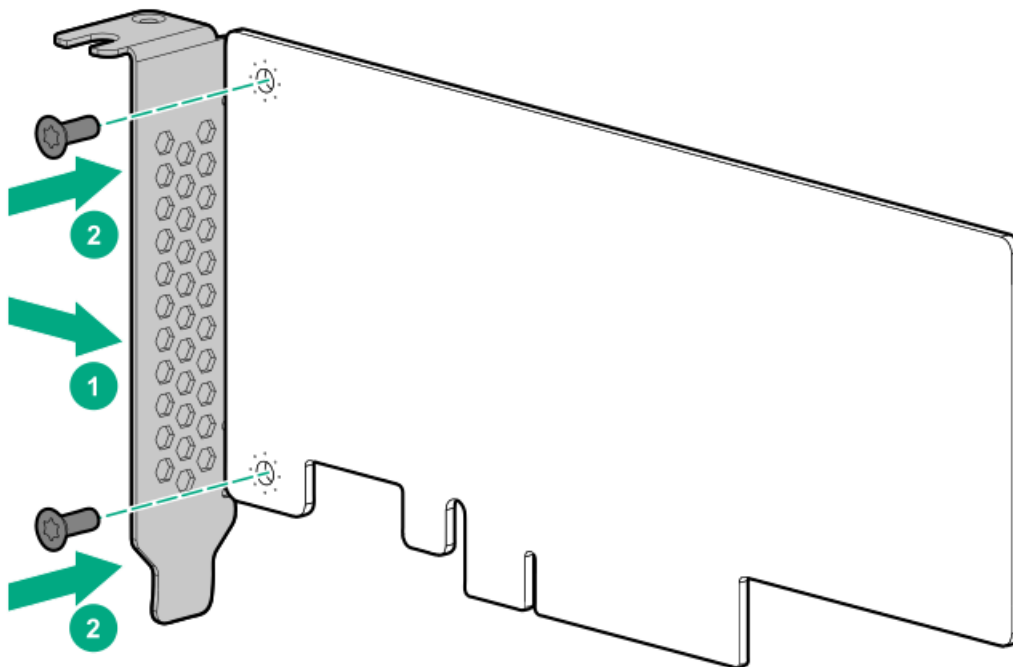

c. Remove the riser slot blank.

Retain the screw and blank for future use.



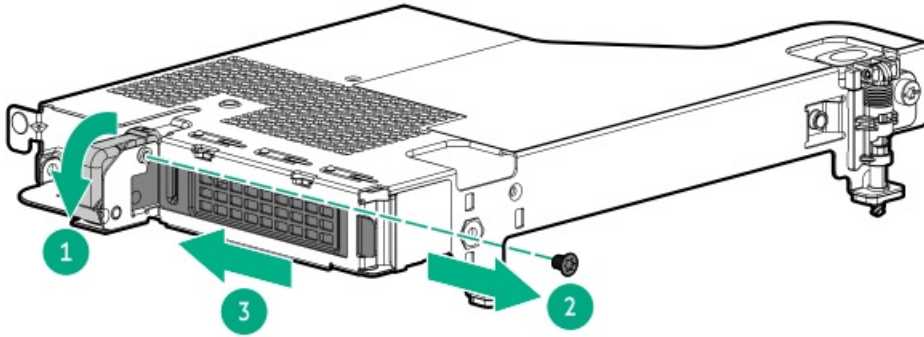

9. Install the expansion card:

- a. Pivot the NS204i-u + secondary low-profile riser cage and the riser slot is facing up.
- b. Install the expansion card (callouts 1 and 2).

Installing the screw is optional. Make sure that the expansion card is seated firmly in the slot.

- c. Close the retention latch (callout 3).

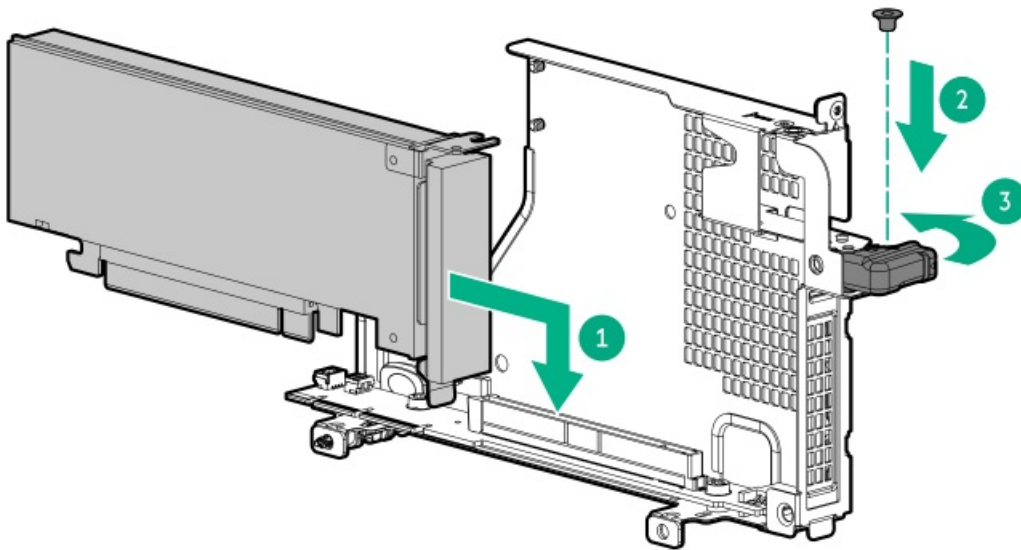

10. Install the riser cage.

11. Install the access panel.

12. Install the server into the rack.

13. Connect all peripheral cables to the server.

14. Connect the power cords:

- a. Connect each power cord to the server.
- b. Connect each power cord to the power source.

15. If installed, close the cable management arm.



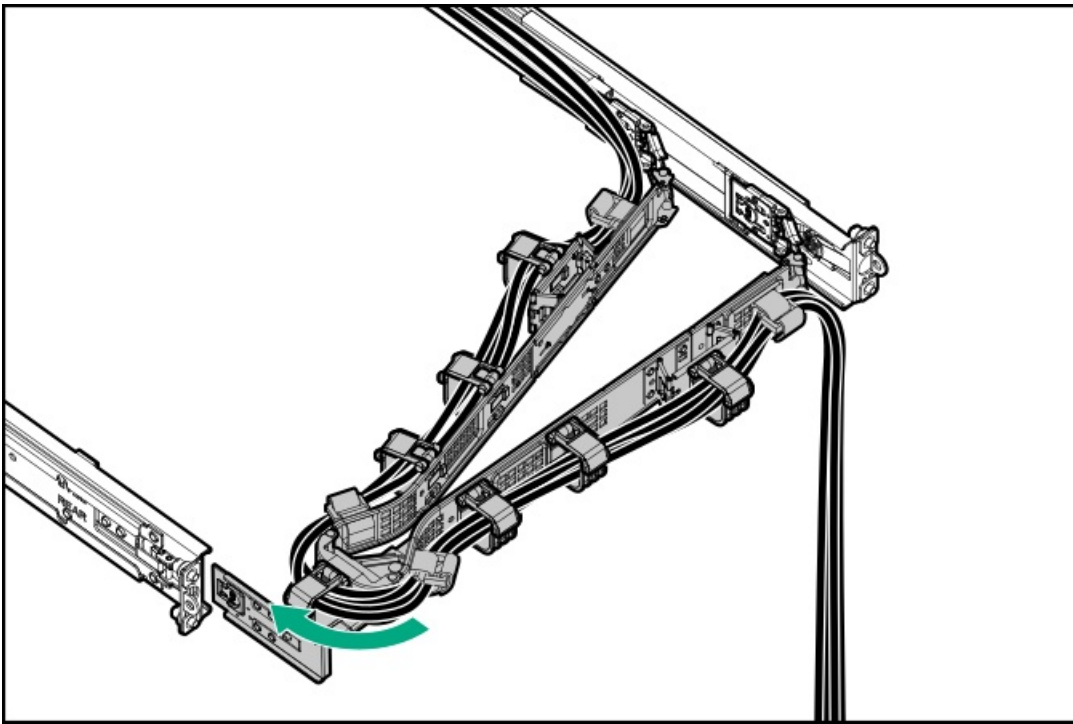

16. Power up the server.

Results

The installation procedure is complete.

Installing an expansion card on the three-slot riser cage

Prerequisites

Before you perform this procedure, make sure that you have a T-10 Torx screwdriver available.

About this task

CAUTION: A discharge of static electricity from a finger or other conductor might damage system boards or other static-sensitive devices. To prevent damage, observe antistatic precautions.

CAUTION: To prevent improper cooling and thermal damage, do not operate the server unless all PCIe slots have either a riser slot blank or an expansion card installed.

Procedure

1. Power down the server.
2. If installed, open the cable management arm.
3. Remove all power:
 - a. Disconnect each power cord from the power source.
 - b. Disconnect each power cord from the server.
4. Disconnect all peripheral cables from the server.
5. Remove the server from the rack.
6. Remove the access panel.
7. Remove the riser cage.

8. (Optional) Install the risers.
9. Install the expansion card:
 - a. Remove the riser slot blank.

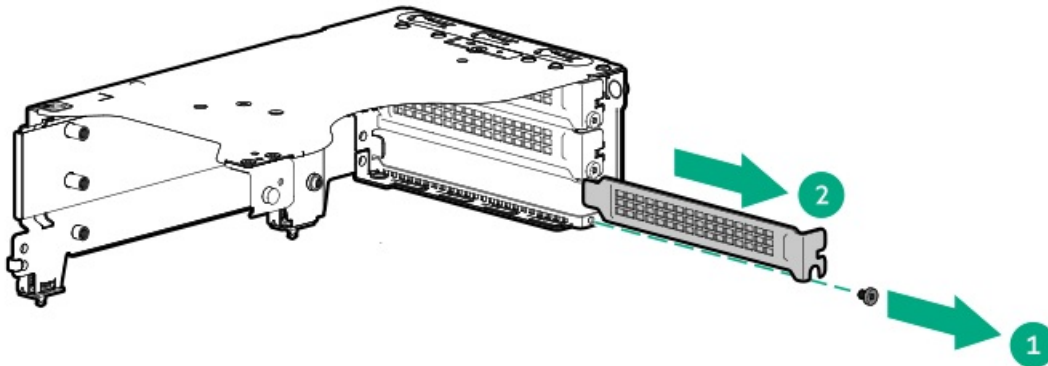

- b. Install the expansion card.

Make sure that the expansion card is seated firmly in the slot.

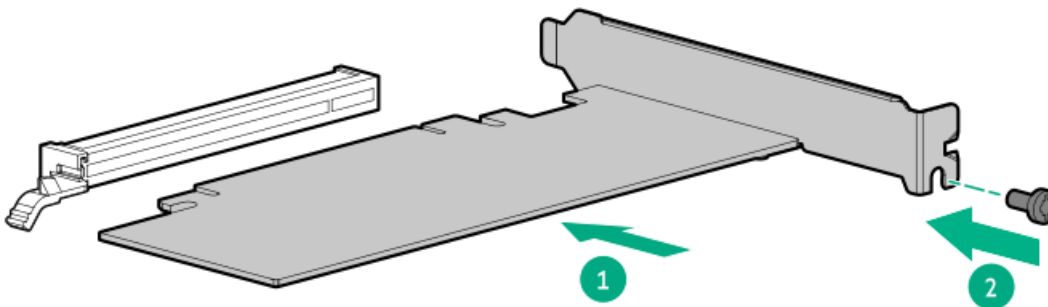

10. Install the riser cage.
11. Install the access panel.
12. Install the server into the rack.
13. Connect all peripheral cables to the server.
14. Connect the power cords:
 - a. Connect each power cord to the server.
 - b. Connect each power cord to the power source.
15. If installed, close the cable management arm.



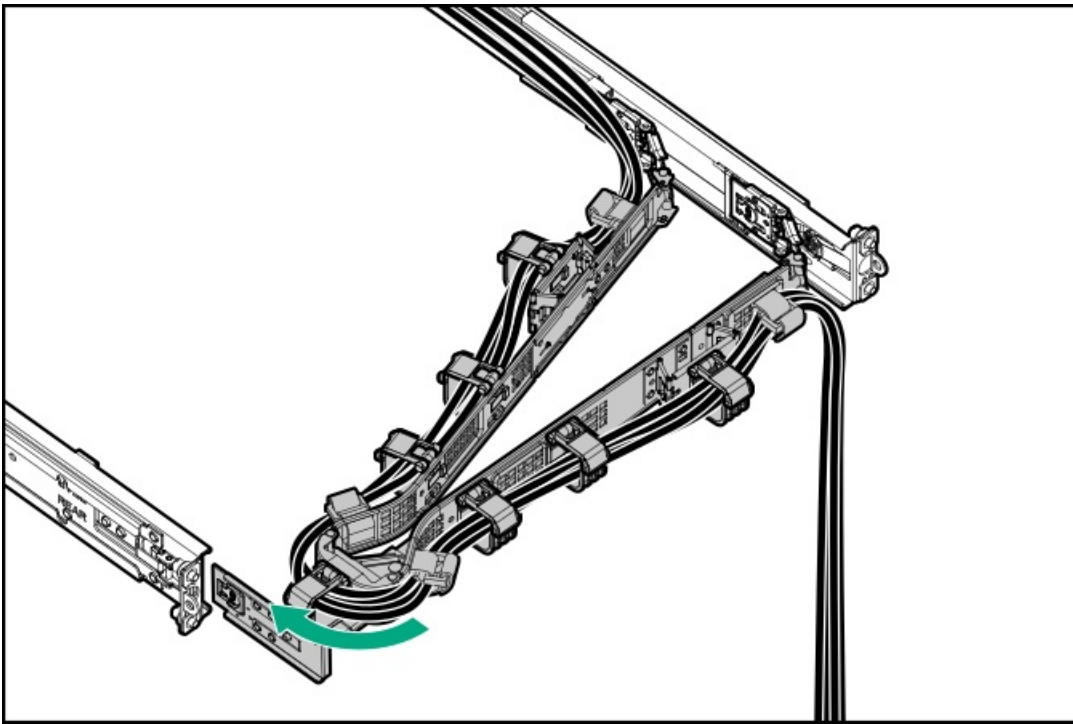

16. [Power up the server.](#)

Results

The installation procedure is complete.

Processor and heatsink options

This server supports the following heatsink options:

- Standard heatsink
- Midplane cage heatsink
- High performance heatsink
- Max performance heatsink

Subtopics

[Processor cautions](#)

[Installing a processor heatsink assembly](#)

[Reconfiguring the system date and time settings](#)

Processor cautions

CAUTION: To avoid damage to the processor or system board, only authorized personnel should attempt to replace or install the processor in this server.

CAUTION: To prevent possible server malfunction and damage to the equipment, multiprocessor configurations must contain processors with the same part number.

CAUTION: The pins on the processor socket and on the processor are very fragile and easily damaged . To avoid component damage, do not touch these pins. Any damage to them might require replacing the system board and/or processor.

IMPORTANT: Processor socket 1 must be populated at all times or the server does not function.

IMPORTANT: If installing a processor with a faster speed, update the system ROM before installing the processor. To download firmware, see [Updating firmware or system ROM](#).

IMPORTANT:
After removing a processor from the system board, the server resets the date and time. For information on reconfiguring these settings, see [Reconfiguring the system date and time settings](#).

Installing a processor heatsink assembly

Prerequisites

Before you perform this procedure, make sure that you have the following items available:

- The components included with the hardware option kit
- T-20 Torx screwdriver
- Two 1.0 gm (0.5 ml) or four 0.5 gm (0.25 ml) of thermal grease
- Alcohol wipe

About this task

CAUTION: To avoid damage to the processor or system board, only authorized personnel should attempt to replace or install the processor in this server.

CAUTION: To prevent possible server malfunction and damage to the equipment, multiprocessor configurations must contain processors with the same part number.

CAUTION: If installing a processor with a faster speed, update the system ROM before installing the processor. To download the firmware and view installation instructions, see the [Hewlett Packard Enterprise Support Center website](#).

CAUTION: THE CONTACTS ARE VERY FRAGILE AND EASILY DAMAGED. To avoid damage to the socket or processor, do not touch the contacts.

Procedure

1. [Power down the server](#).
2. If installed, [open the cable management arm](#).
3. Remove all power:
 - a. Disconnect each power cord from the power source.
 - b. Disconnect each power cord from the server.
4. Disconnect all peripheral cables from the server.
5. [Remove the server from the rack](#).
6. [Remove the access panel](#).
7. [Remove the air baffle](#).

8. Remove the processor:

- a. While holding the sides of the retention frame, loosen the frame screw.

This retention frame is spring-loaded. After the screw is loosened enough, hold the retention frame as it automatically pivots to a vertical position.

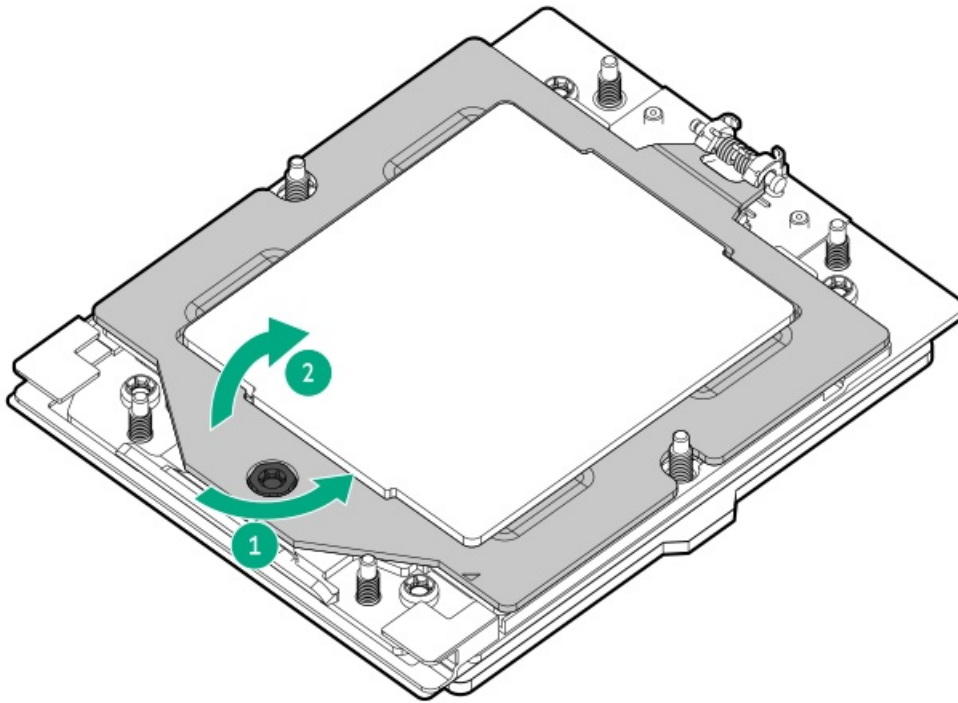

- b. Hold the lift tabs and pivot the rail frame to the vertical position.
- c. Slide the processor out of the rail frame.

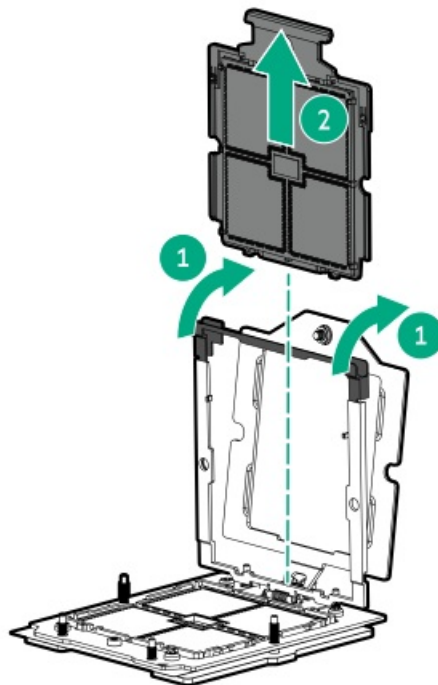

CAUTION:

The pins on the processor socket and on the processor are very fragile and easily damaged. To avoid component damage, do not touch these pins. Any damage to them might require replacing the system board and/or processor.



9. Do not touch the pin field on the socket and the processor contacts.

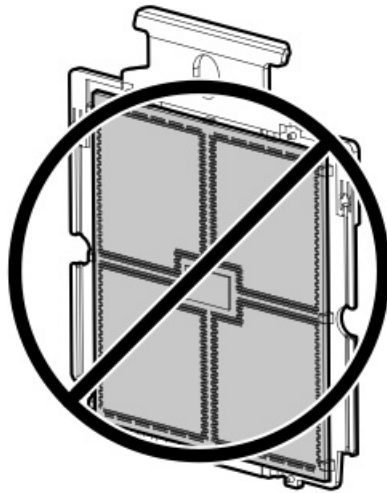
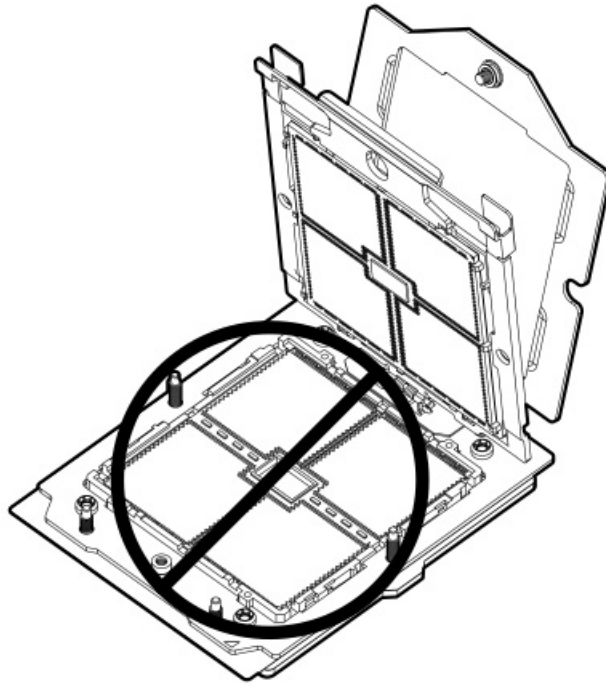

10. Install the processor:
 - a. Hold the processor by its carrier handle.
 - b. Slide the processor into the rail frame until it engages with a click sound.

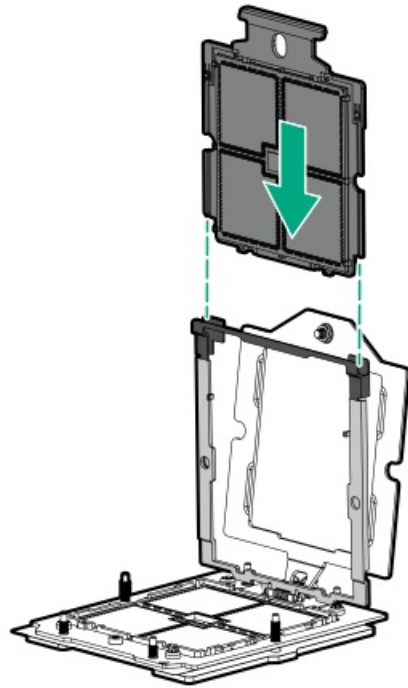

11. Hold the lift tabs and pivot the rail frame to the closed position.

A click sound indicates that the rail frame is properly engaged.

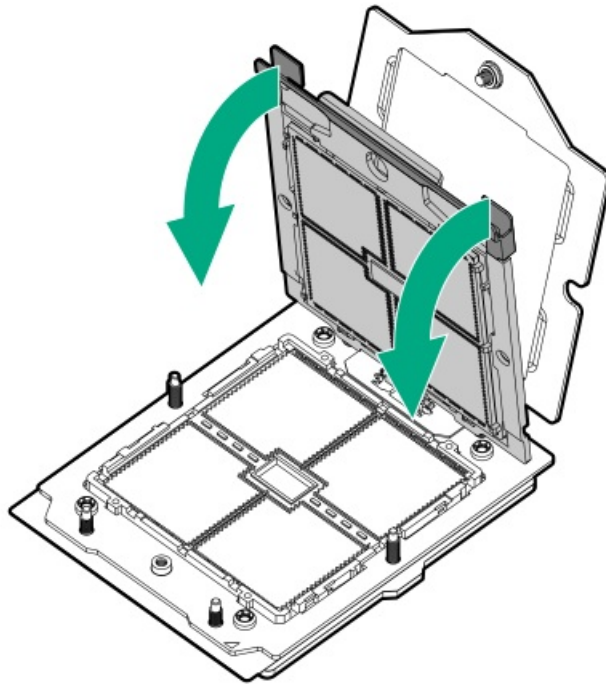

12. Close the retention frame:

- a. When using a torque screwdriver to tighten the retention frame screw, set a torque between 1.24 N-m (11 lbf-in) to 1.47 N-m (13 lbf-in).
- b. Pivot the spring-loaded retention frame downward and hold it down.
- c. Tighten the retention frame screw.



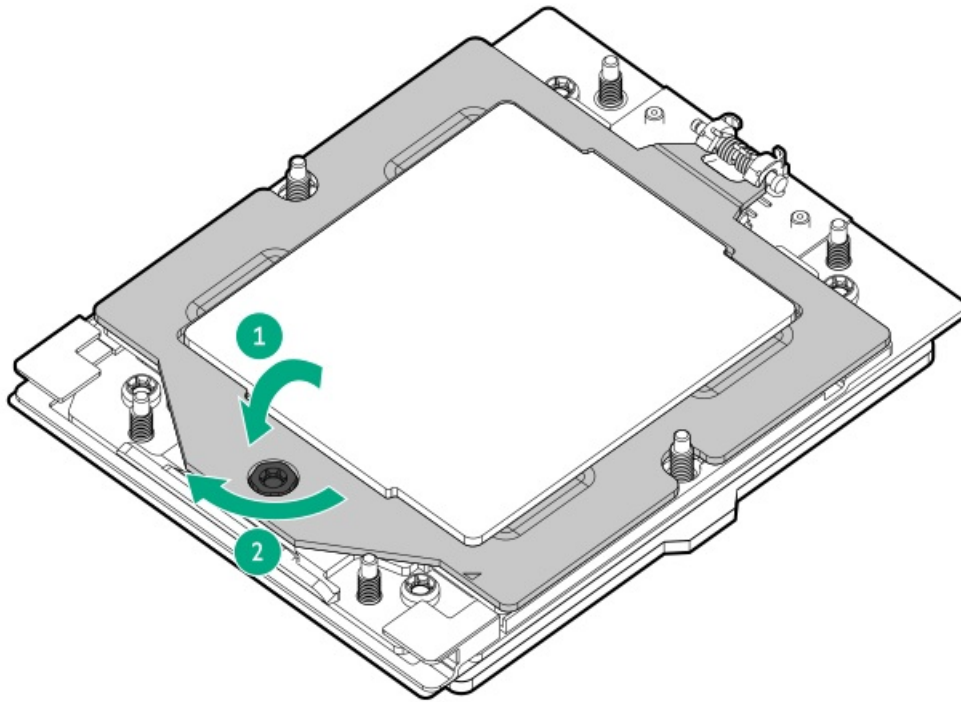

13. Install the heatsink:

CAUTION: To prevent mechanical damage or depositing oil on your hands or other contaminants to the heatsink contact surface, hold the heatsink only by the edge of its base plate. Do not touch the heatsink fins.

CAUTION:

To prevent thermal failure or component damage, do not move the heatsink once the bottom of its base plate touches the top of the processor. Excessive heatsink movement can cause the thermal grease to smear and become uneven. Voids in the compound can adversely impact the transfer of heat away from the processor.

- a. When using a torque screwdriver to tighten the heatsink screws, set a torque between 1.24 N-m (11 lbf-in) to 1.47 N-m (13 lbf-in) .
- b. Note the **Front of server** text on the heatsink label to correctly orient the heatsink over the processor socket.
- c. Position the heatsink on top of the processor, ensuring that it is properly seated before securing the screws.
 - Standard heatsink

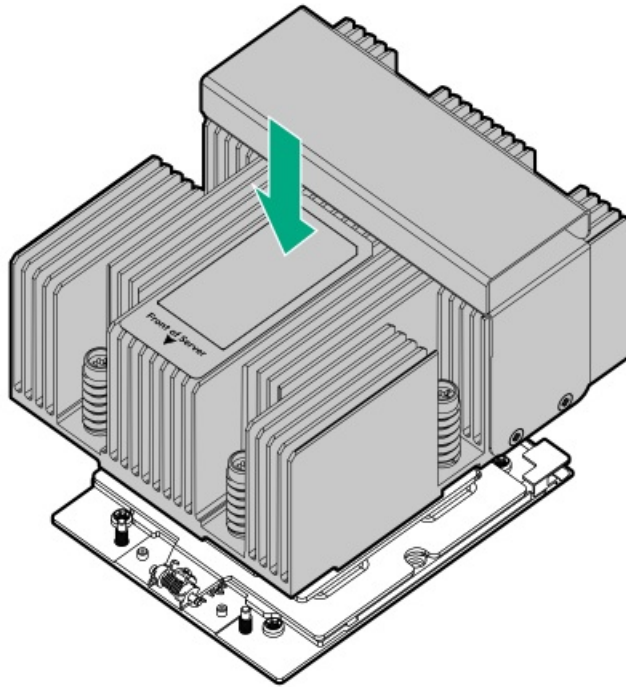

- High performance heatsink

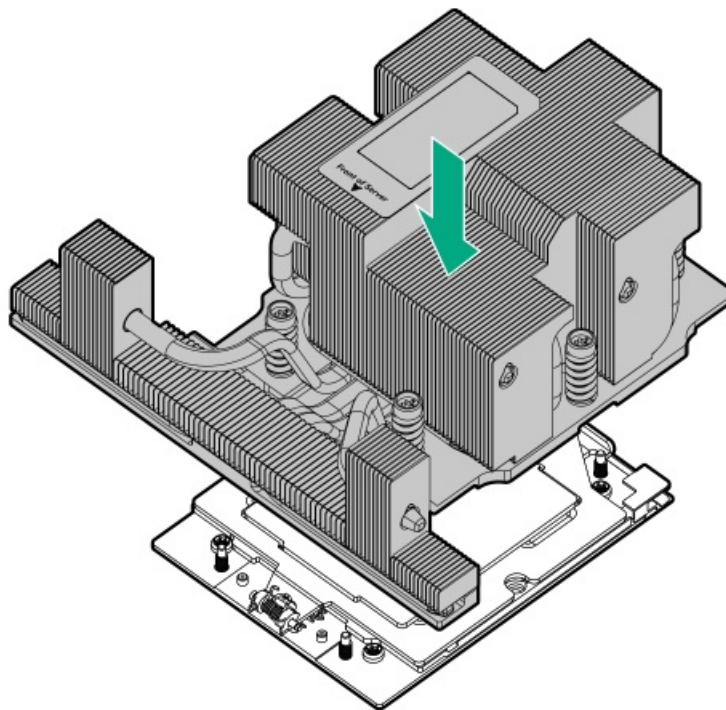

- Max performance heatsink



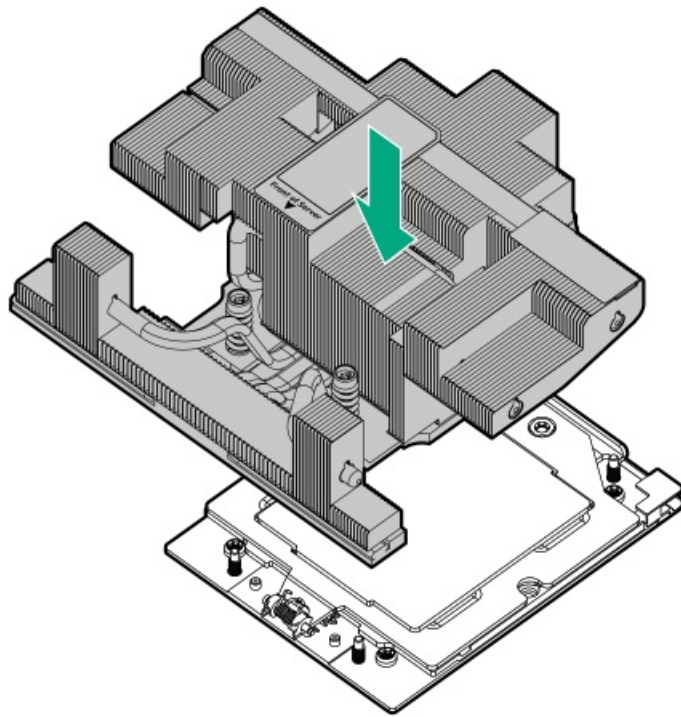

d. Tighten the heatsink screw numbers 1 and 2 (callouts 1 and 2).

- Standard heatsink

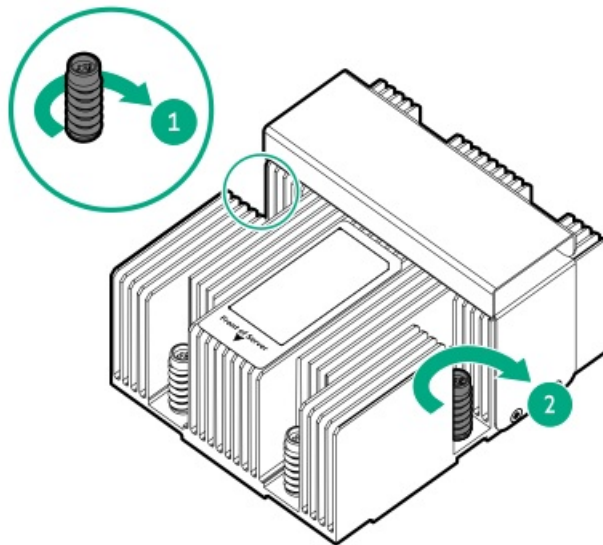

- High performance heatsink



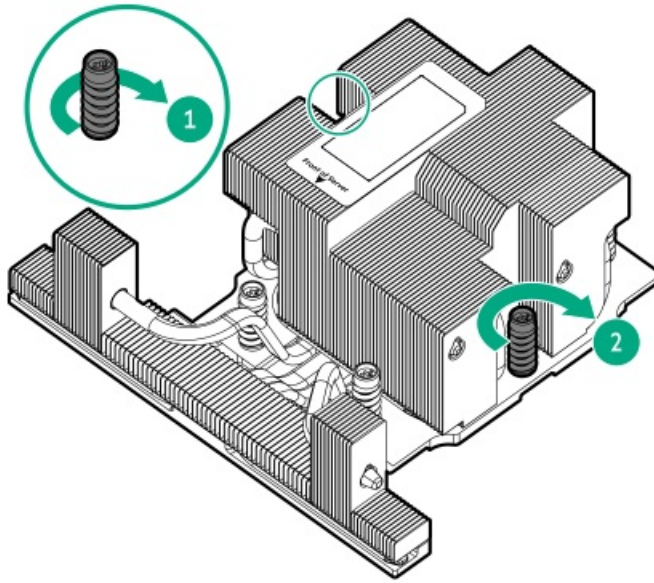

- Max performance heatsink

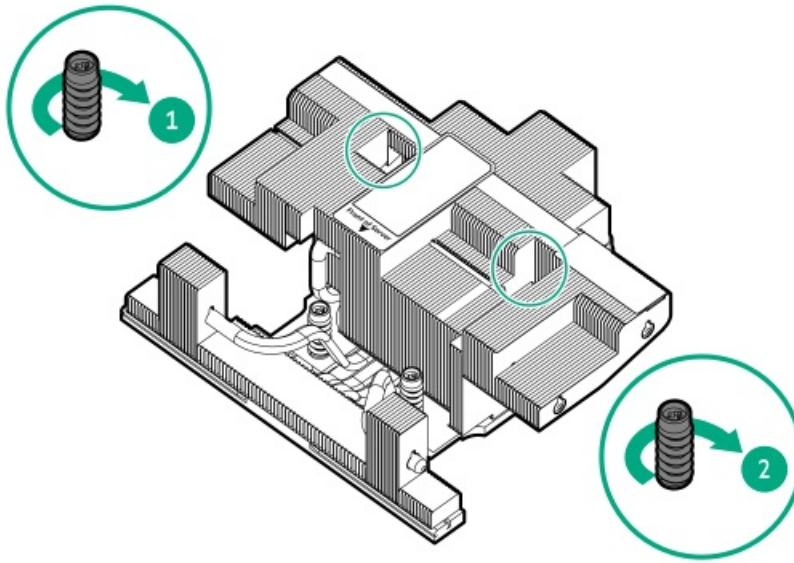

e. Tighten the heatsink screw numbers 3, 4, 5, and 6 in a diagonal manner (callouts 3 to 6).

- Standard heatsink

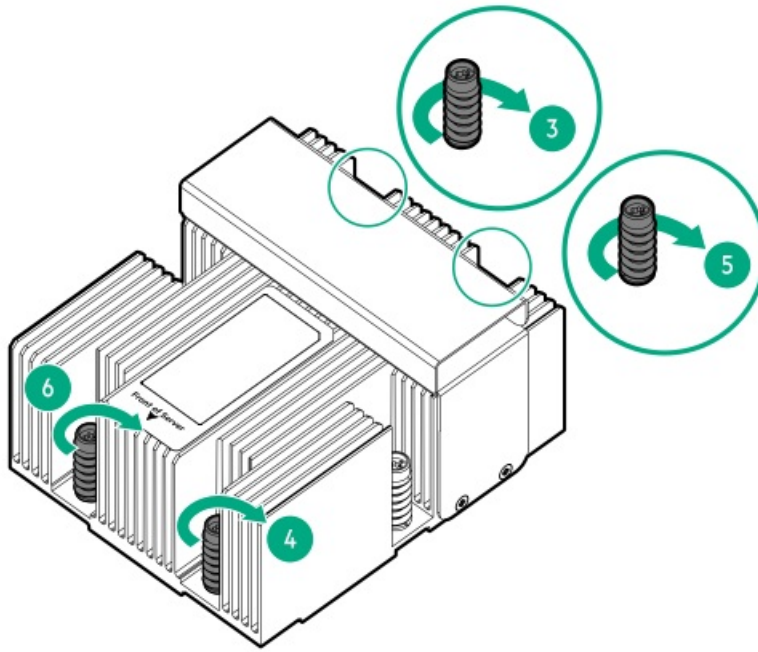

- High performance heatsink

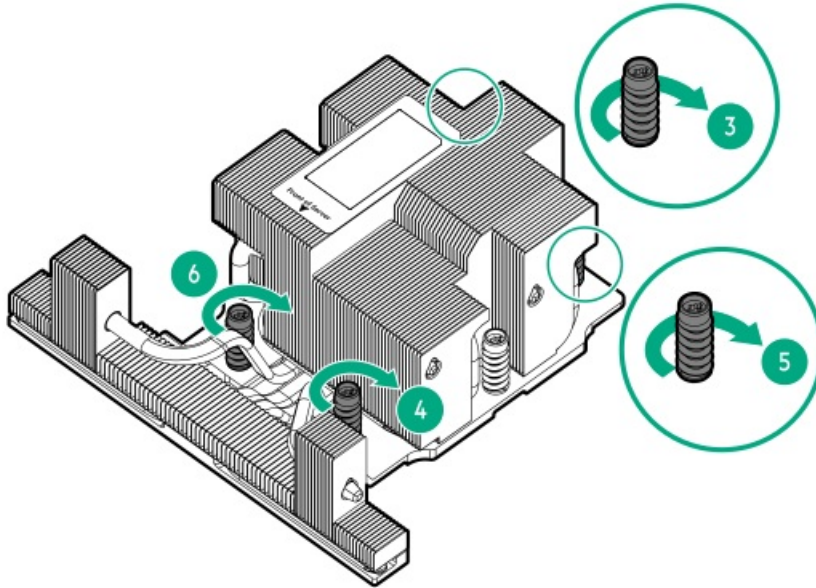

- Max performance heatsink

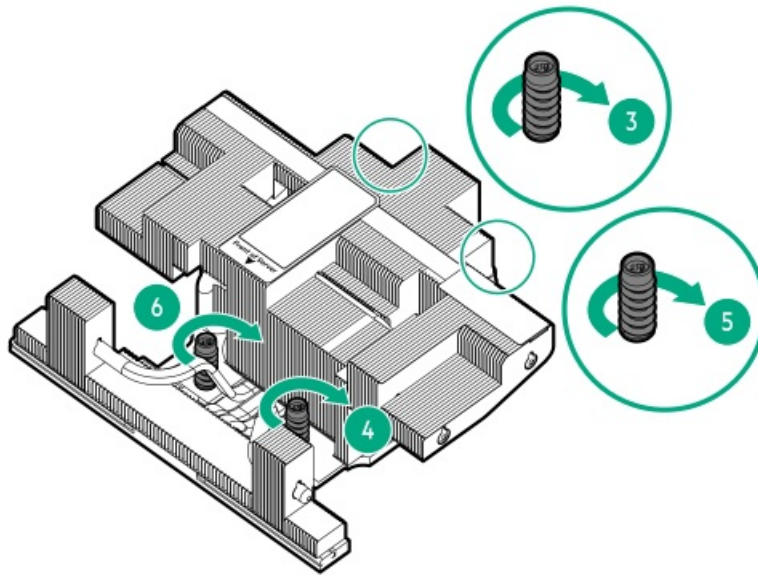

14. Do one of the following:
 - [Install the air baffle.](#)
 - [Install the midplane drive cage.](#)
15. [Install the access panel.](#)
16. [Install the server into the rack.](#)
17. Connect all peripheral cables to the server.
18. Connect the power cords:
 - a. Connect each power cord to the server.
 - b. Connect each power cord to the power source.
19. If installed, close the cable management arm.

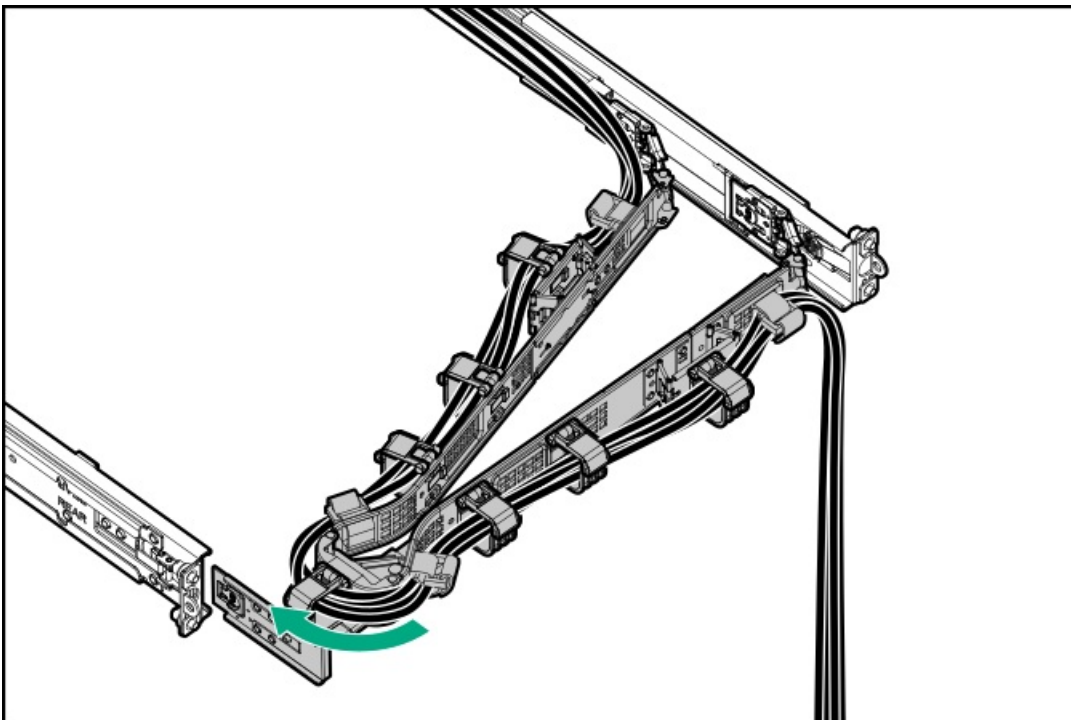

20. [Power up the server.](#)



21. Reconfigure the system date and time settings.

Results

The installation procedure is complete.

Reconfiguring the system date and time settings

Procedure

1. Access the UEFI System Utilities. During POST, press **F9**.
2. From the System Utilities screen, select System Configuration > BIOS/Platform Configuration (RBSU) > Date and Time.
3. Select a setting, and then complete your entry.
 - Date (mm-dd-yyyy)—Enter the date in a month-day-year (mm-dd-yyyy) format.
 - Time (hh:mm:ss)—Enter the time in a 24-hour format (hh:mm:ss) format.
 - Hour Format—Select either a 12- or 24-hours format. (This setting is supported in Gen10 Plus and later servers.)
 - Time Format
 - Coordinated Universal Time (UTC)—Calculates the time stored in the hardware real-time clock (RTC) from the associated Time Zone setting.
 - Local Time—Removes the use of the Time Zone setting. This option is useful for addressing interaction issues in Windows operating systems set in legacy BIOS boot mode.
 - Time Zone—Select the time zone for the system.
 - Daylight Savings Time
 - Enabled—Adjusts the local time displayed by one hour for Daylight Savings Time.
 - Disabled—Does not adjust the local time displayed for Daylight Savings Time.
4. To confirm and save the settings, press **F12**.

The server automatically reboots.

Drive options

Depending on the drive backplane installed, the server supports the following drive types:

- Hot-plug LFF SAS and SATA drives
- Hot-plug SFF SAS, SATA, and U.3 NVMe drives
- Hot-plug E3.S PCIe5 NVMe SSDs

This server has no embedded software RAID support. Direct attached SATA drives operate in AHCI mode.

To support hardware RAID, [install a storage controller option.](#)

Subtopics

[Drive installation guidelines](#)

[Installing a hot-plug LFF/SFF SAS, SATA or NVMe drive](#)

Drive installation guidelines

Observe the following general guidelines:

- The system automatically sets all drive numbers.

 **CAUTION:**

When a server is purchased without any drive installed, some drive bays might be empty while other drive bays might be populated with drive blanks. To maintain proper system cooling, do not operate the server without a drive or a drive blank installed.

- If only one drive is used, install it in the bay with the lowest drive number.
For drive numbering, see [Drive bay numbering](#).
- This server does not support mixed drive types in the same drive box.
- All drives grouped into the same drive array must meet the following criteria:
 - All drives must be either all hard drives or all solid-state drives.
 - All drives must be of the same capacity to provide the greatest storage space efficiency when drives are grouped into the same drive array.

Installing a hot-plug LFF/SFF SAS, SATA or NVMe drive

About this task

 **CAUTION:** To maintain proper system cooling, do not operate the server for long period with the access panel open or removed. Operating the server in this manner results in an improper system airflow. For internal hot-plug component procedures, complete the procedure within 60 seconds. Failure to do so can cause the system temperature to increase and trip the safety threshold. When this happens:

- The health LED flashes amber.
 - The operating system gracefully shuts down.
-

 **CAUTION:** A discharge of static electricity from a finger or other conductor might damage system boards or other static-sensitive devices. To prevent damage, observe [antistatic precautions](#).

 **CAUTION:** To prevent improper cooling and thermal damage, do not operate the server unless all bays are populated with either a component or a blank.

Procedure

1. Remove the drive blank.

Retain the blank for future use.

- LFF drive blank

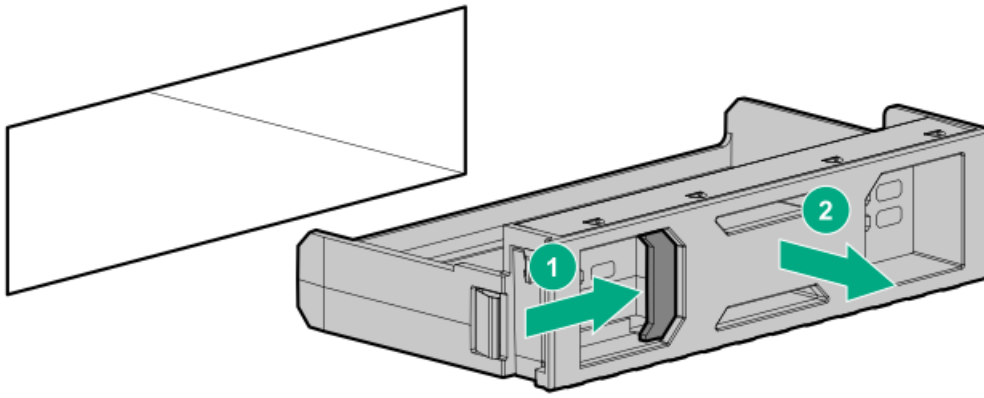

- SFF drive blank

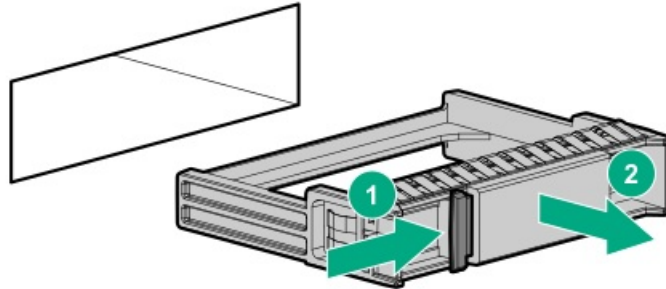

2. Prepare the drive.

- LFF drive

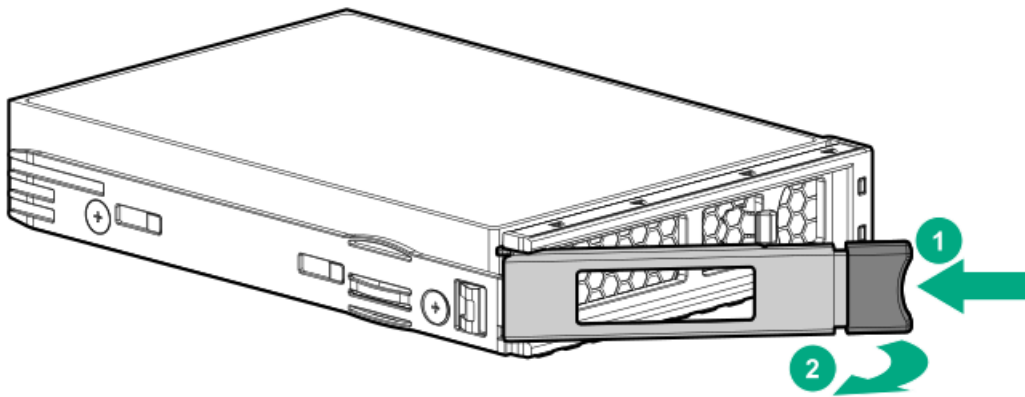

- SFF drive

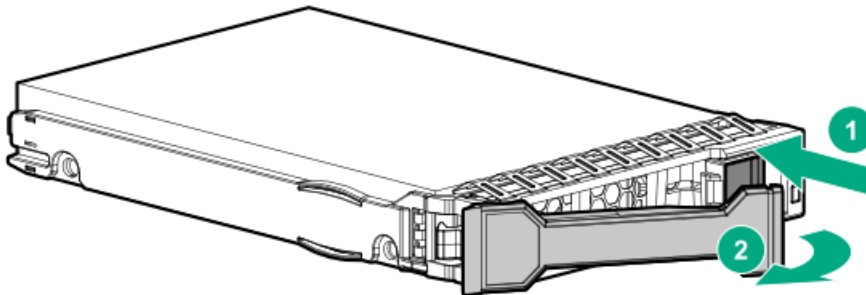

3. Install the drive.

- LFF drive



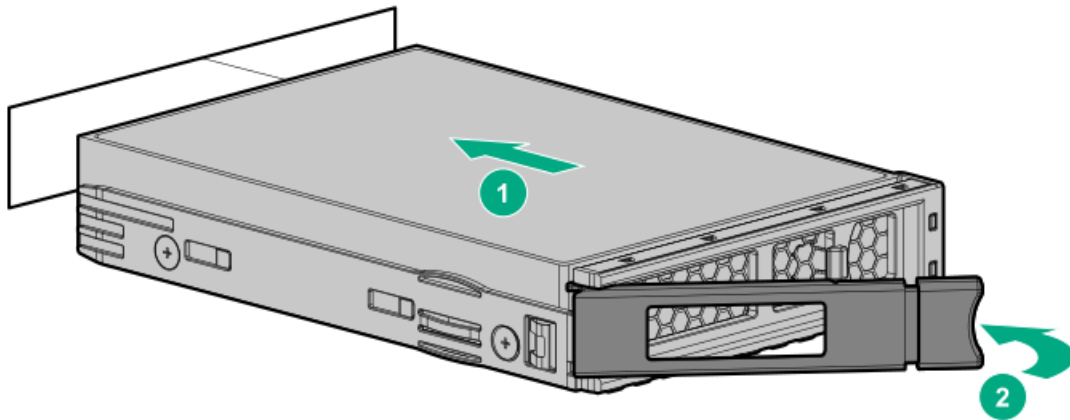

- SFF drive

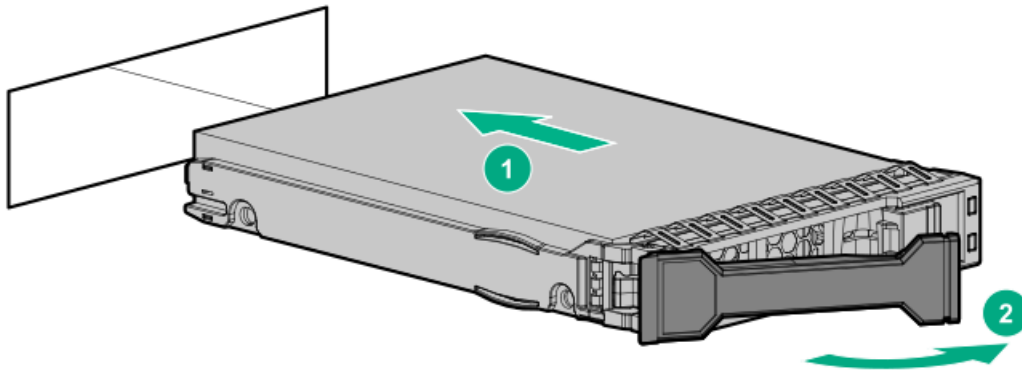

4. Determine the status of the drive from the drive LED definitions.
5. If removed, install the front bezel.
6. Configure the controller.

Results

The installation procedure is complete.

Installing a hot-plug SAS, SATA or NVMe drive in the midplane drive cage

About this task

-
- ⚠ **CAUTION:** To maintain proper system cooling, do not operate the server for long period with the access panel open or removed. Operating the server in this manner results in an improper system airflow. For internal hot-plug component procedures, complete the procedure within 60 seconds. Failure to do so can cause the system temperature to increase and trip the safety threshold. When this happens:
 - The health LED flashes amber.
 - The operating system gracefully shuts down.
-

- ⚠ **CAUTION:** A discharge of static electricity from a finger or other conductor might damage system boards or other static-sensitive devices. To prevent damage, observe antistatic precautions.
-

- ⚠ **CAUTION:** To prevent improper cooling and thermal damage, do not operate the server unless all bays are populated with either a component or a blank.
-

This procedure is the same for both LFF and SFF.

Procedure

1. If installed, open the cable management arm.
2. Extend the server from the rack.
3. Remove the access panel.
4. Lift the latches on the drive cage to keep 15-degree angle between the drive cage and the chassis.

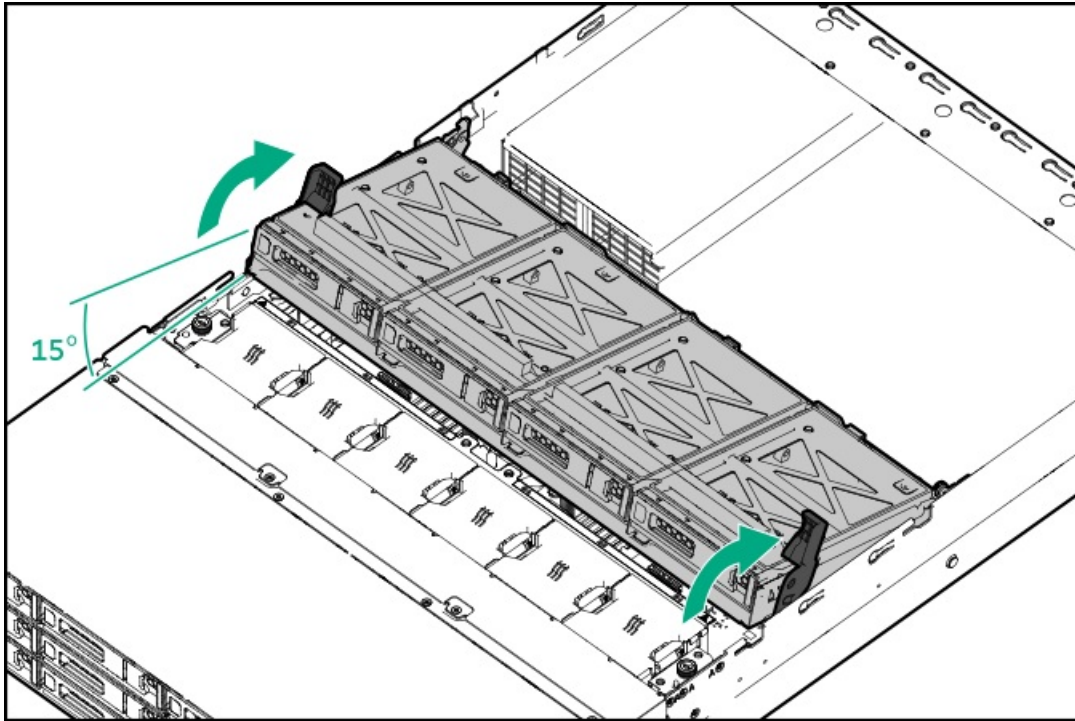

5. Remove the drive blank.

Retain the blank for future use.

- LFF drive blank

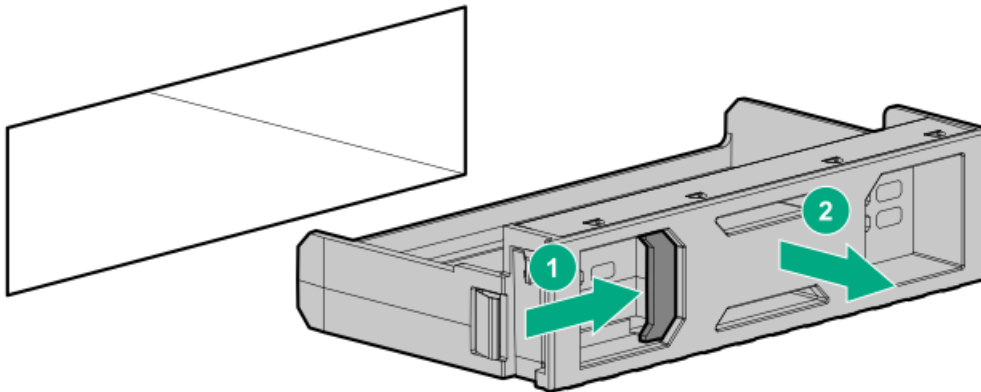

- SFF drive blank

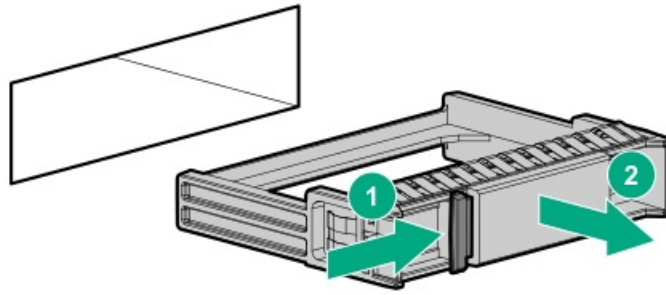

6. Prepare the drive.

- LFF drive

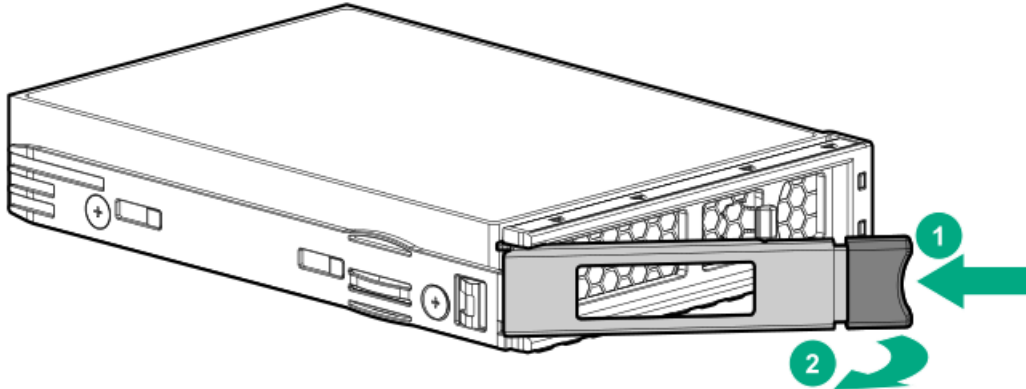

- SFF drive

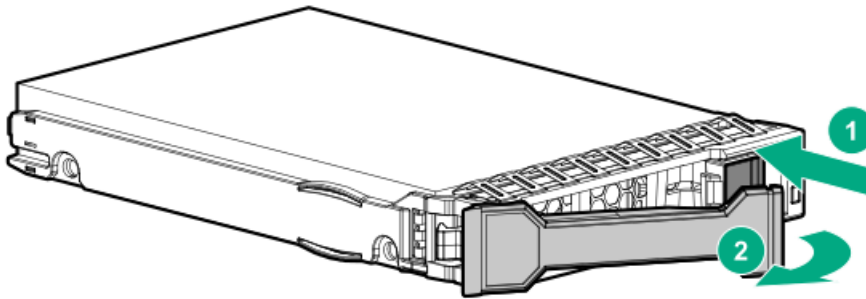

7. Install the drive.

- LFF drive

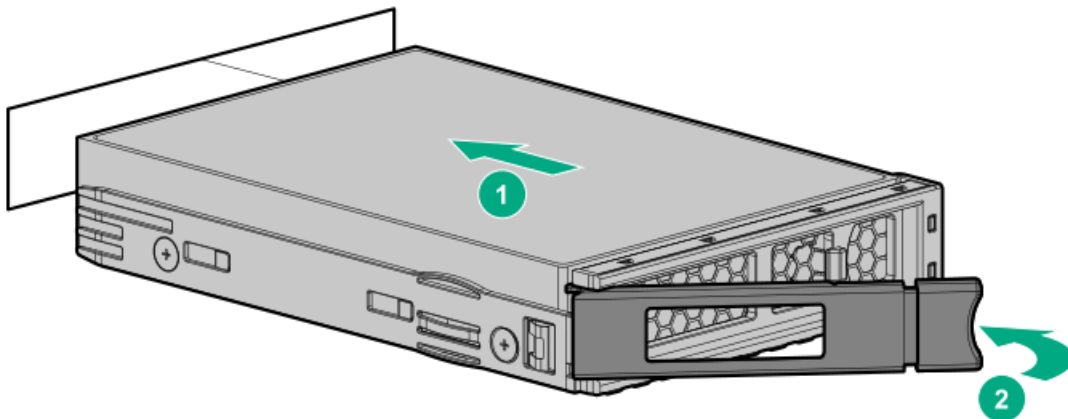

- SFF drive



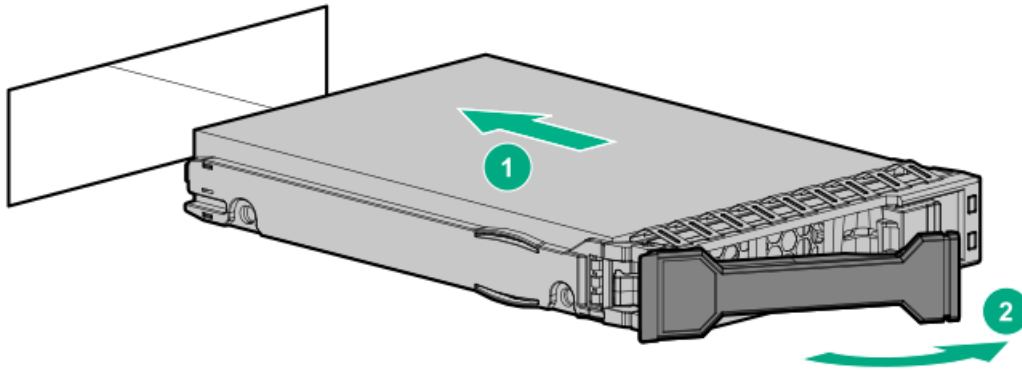

8. Install the access panel.
9. Determine the status of the drive from the drive LED definitions .
10. Configure the controller.

Results

The installation procedure is complete.

Installing an E3.S drive

About this task

CAUTION: A discharge of static electricity from a finger or other conductor might damage system boards or other static-sensitive devices. To prevent damage, observe antistatic precautions.

CAUTION: To prevent improper cooling and thermal damage, do not operate the server unless all bays are populated with either a component or a blank.

Procedure

1. If installed, remove the front bezel.
2. Observe the drive LED status and determine if the drive can be removed.
3. Remove the drive blank.

Retain the blank for future use.

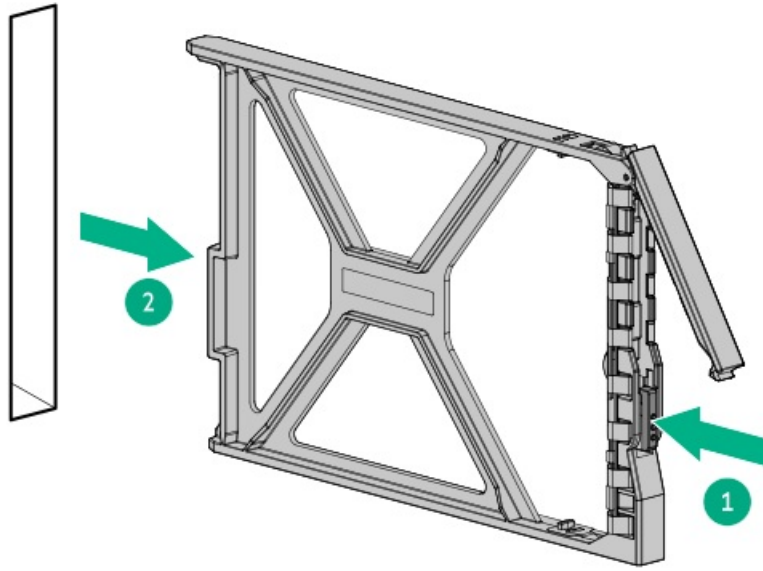

4. Prepare the drive.

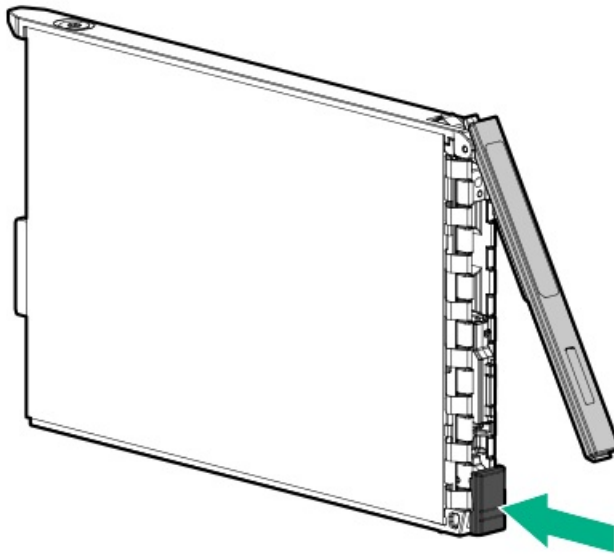

5. Install the drive.



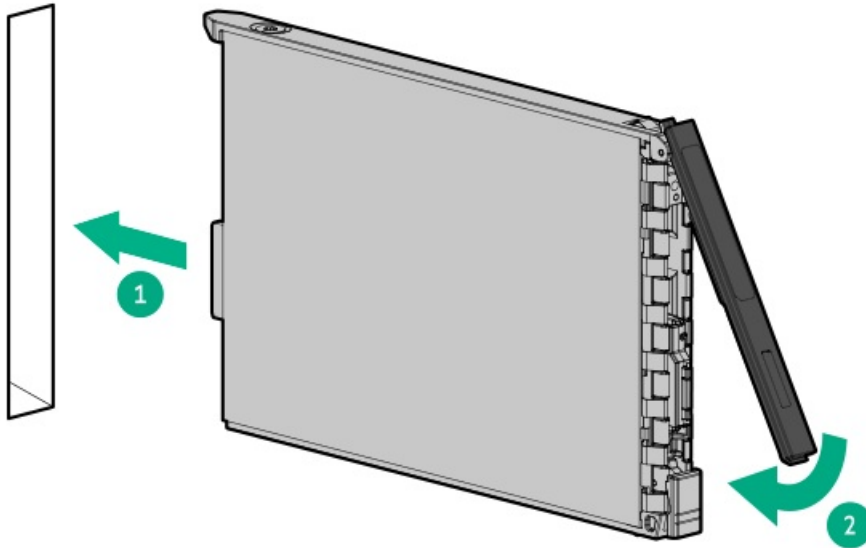

6. Determine the status of the drive from the drive LED definitions .
7. If removed, install the front bezel.
8. To configure drive arrays, see the relevant storage controller guide.

Results

The installation procedure is complete.

Drive cage options

Subtopics

[Installing the front 2 SFF side-by-side drive cage](#)

[Installing the front 2 SFF stacked drive cage](#)

[Installing the rear 2 SFF drive cage over the power supplies](#)

[Installing the front 8 SFF drive cage](#)

[Installing the front 8 SFF drive cage in the 48 SFF drive configuration](#)

[Installing the midplane drive cage](#)

[Installing the 8 E3.S drive cage](#)

Installing the front 2 SFF side-by-side drive cage

Prerequisites

Before you perform this procedure, make sure that you have a T-10 Torx screwdriver available.

Procedure

1. If installed, remove the front bezel.
2. Power down the server.

3. If installed, open the cable management arm.
4. Remove all power:
 - a. Disconnect each power cord from the power source.
 - b. Disconnect each power cord from the server.
5. Disconnect all peripheral cables from the server.
6. Remove the server from the rack.
7. Remove the access panel.
8. Do one of the following:
 - Remove the air baffle.
 - Remove the midplane drive cage.
9. Remove the fan cage.
10. Remove the midwall bracket.
11. Remove the LFF drive backplane bracket.

-
12. **i** **IMPORTANT:**
Retain the removed partitions to revert to the 12 LFF drive configuration.
-

Remove the left partition:

- a. Remove the partition screws.
- b. Remove the partition.

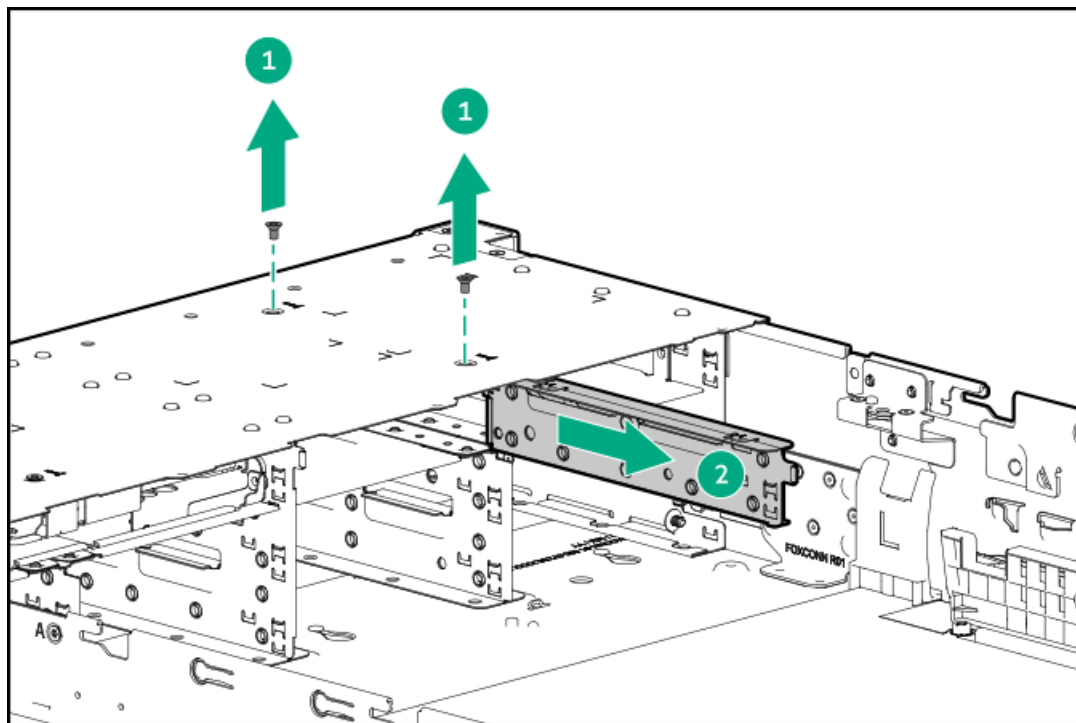

13. Install the front 2 SFF side-by-side drive cage:
 - a. Install the front 2 SFF side-by-side drive cage in the server.
 - b. Install the drive cage screws.

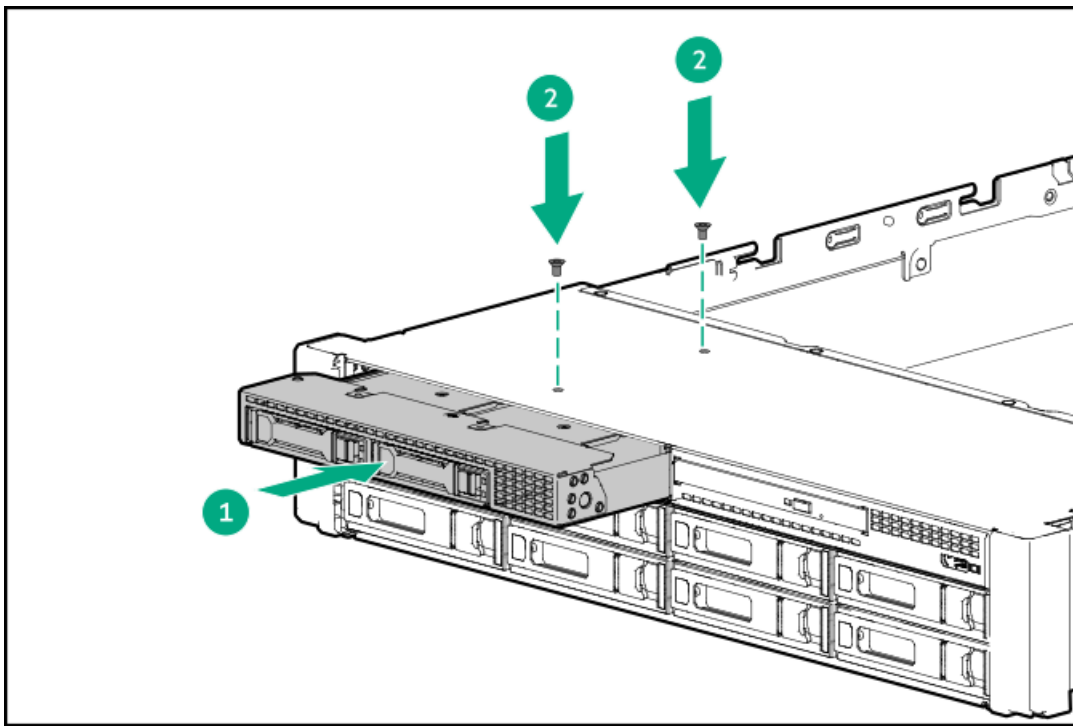

14. Install the LFF drive backplane bracket.
15. Connect the cables to the drive backplane.
16. Install the midwall bracket.
17. Install the fan cage.
18. Do one of the following:
 - Install the air baffle.
 - Install the midplane drive cage.
19. Install the access panel.
20. Install the server into the rack.
21. Connect all peripheral cables to the server.
22. Connect the power cords:
 - a. Connect each power cord to the server.
 - b. Connect each power cord to the power source.
23. If installed, close the cable management arm.



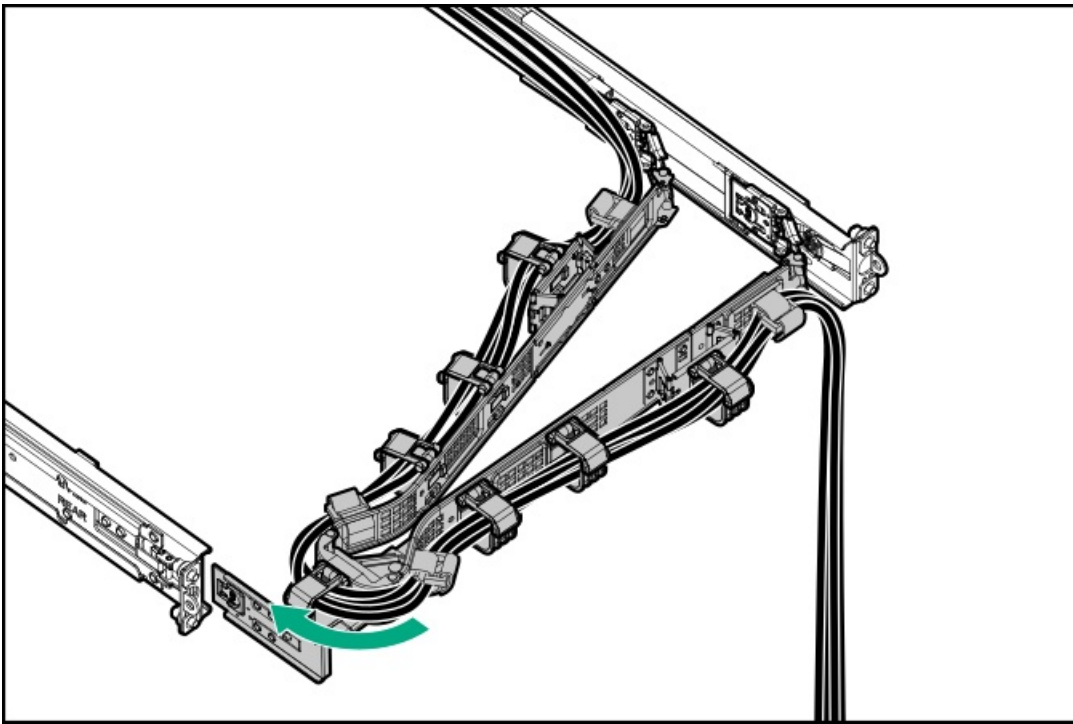

24. Power up the server.
25. If removed, install the front bezel.

Results

The installation procedure is complete.

Installing the front 2 SFF stacked drive cage

Prerequisites

Before you perform this procedure, make sure that you have the following items available:

- T-10 Torx screwdriver
- The components included with the hardware option kit
- This installation requires a universal media bay.

Procedure

Installing the stacked drive cage in the universal media bay

1. Install the grommets onto the underside of the stacked drive cage.



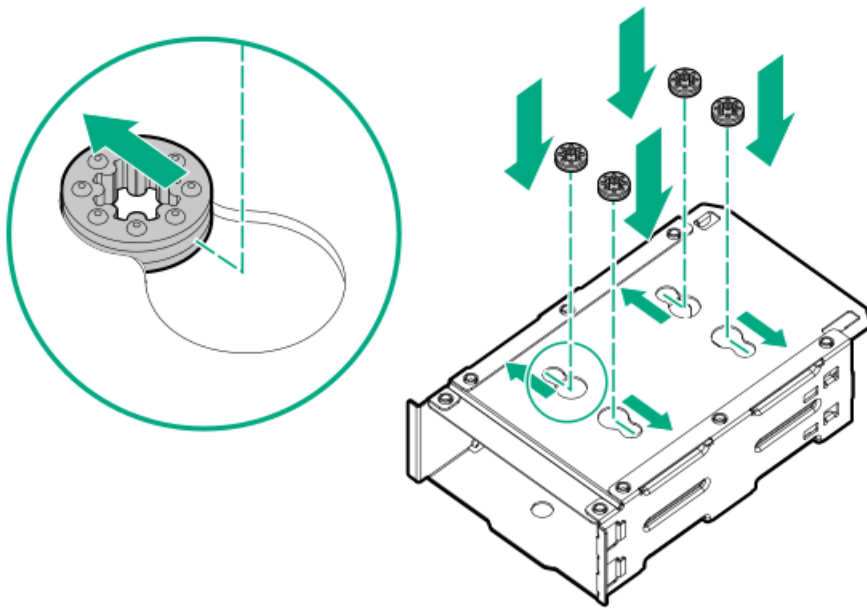

2. Remove the optical drive tray:

- a. Remove the optical drive tray screws.
- b. Remove the optical drive tray from universal media bay.

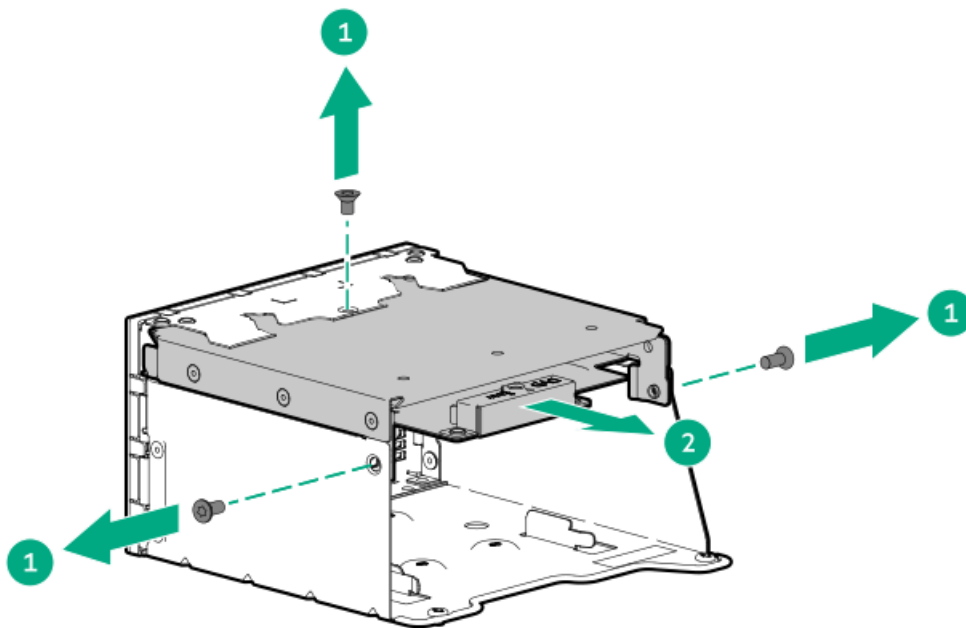

3. Remove the 2 SFF drive blank:

- a. Remove the blank screws.
- b. Remove the drive blank from universal media bay.



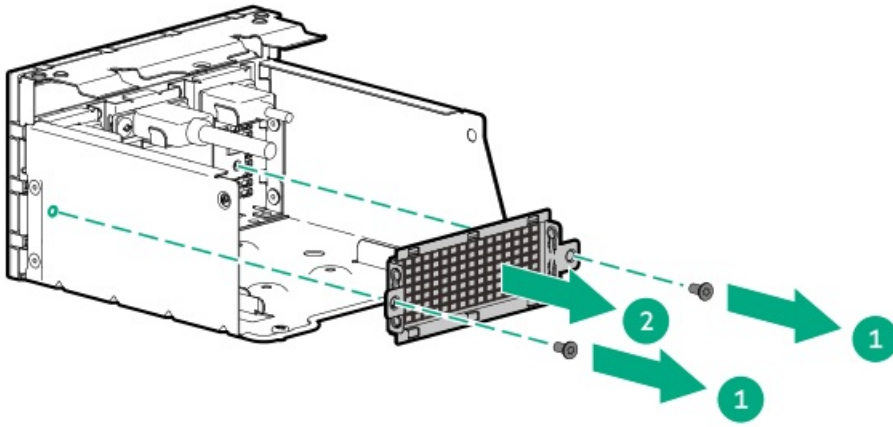

4. Install the front 2 SFF stacked drive cage:

- a. Install the 2 SFF stacked drive cage in the universal media bay.
- b. Install the stacked drive cage screws.

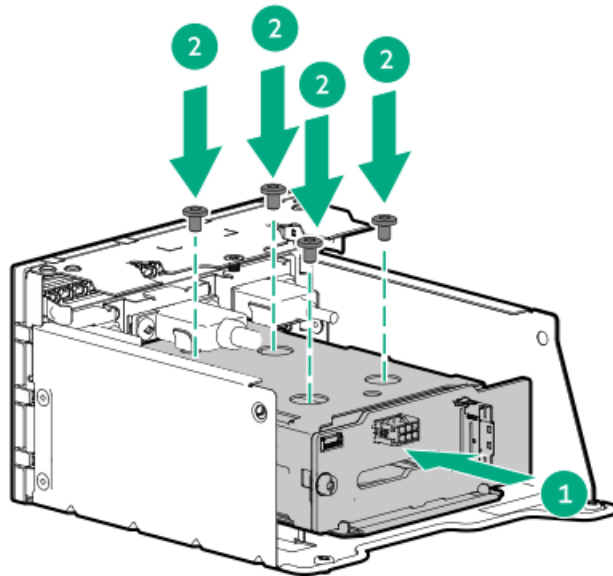

5. Install the optical drive tray:

- a. Install the optical drive bay on the universal media bay.
- b. Install the optical drive bay screws.



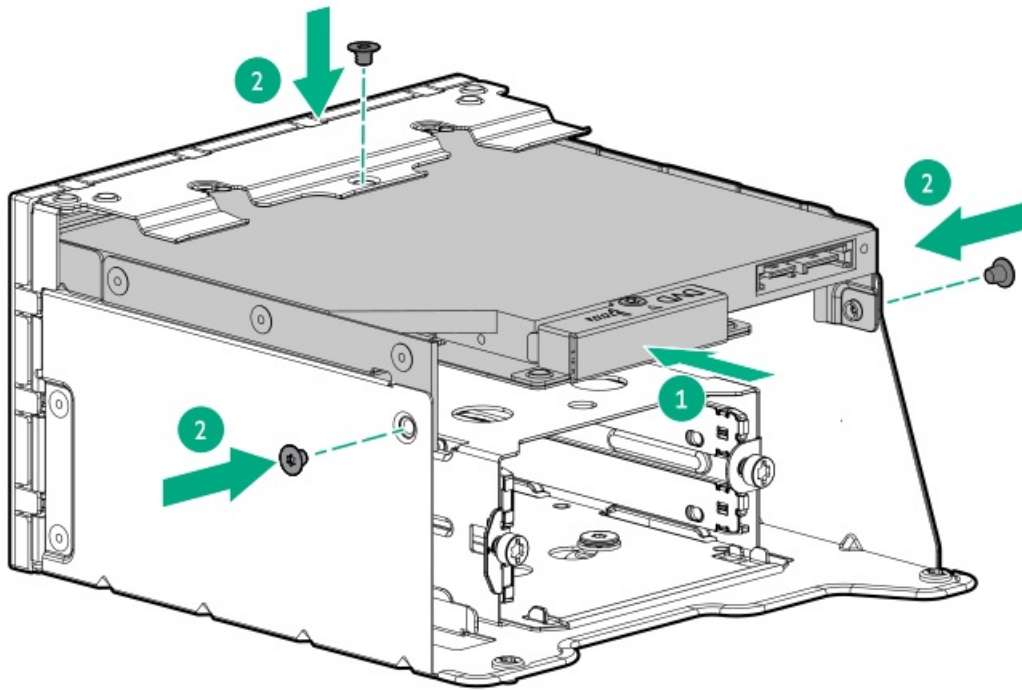

Installing the universal media bay in the server

6. Power down the server.
7. If installed, open the cable management arm.
8. Remove all power:
 - a. Disconnect each power cord from the power source.
 - b. Disconnect each power cord from the server.
9. Disconnect all peripheral cables from the server.
10. Remove the server from the rack.
11. Remove the access panel.
12. Do one of the following:
 - Remove the air baffle.
 - Remove the midplane drive cage.
13. Remove the fan cage.
14. Remove the midwall bracket.
15. Install the universal media bay.
16. Install the midwall bracket.
17. Install the fan cage.
18. Do one of the following:
 - Install the air baffle.
 - Install the midplane drive cage.
19. Install the access panel.
20. Connect all peripheral cables to the server.
21. Connect the power cords:

- a. Connect each power cord to the server.
 - b. Connect each power cord to the power source.
22. If installed, close the cable management arm.

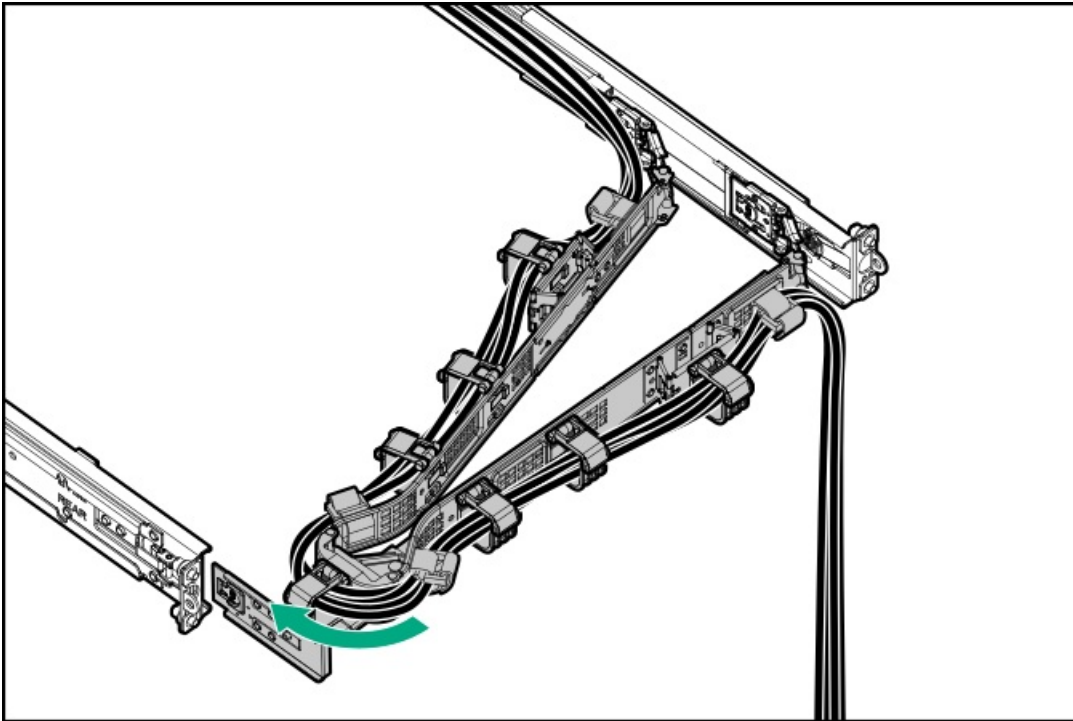

23. Power up the server.

Results

The installation procedure is complete.

Installing the rear 2 SFF drive cage over the power supplies

Prerequisites

Before you perform this procedure, make sure that you have the following items available:

- T-10 Torx screwdriver
- The components included with the hardware option kit

About this task

Both the LFF and SFF chassis support the rear 2 SFF side-by-side drive cage option. This drive cage supports SAS, SATA, and U.3 NVMe drives.

Procedure

1. Power down the server.
2. If installed, open the cable management arm.
3. Remove all power:
 - a. Disconnect each power cord from the power source.
 - b. Disconnect each power cord from the server.
4. Disconnect all peripheral cables from the server.

5. Remove the server from the rack.
6. Remove the access panel.
7. Do one of the following:
 - Remove the air baffle.
 - Remove the midplane drive cage.
8. Install the grommets onto the underside of the stacked drive cage.

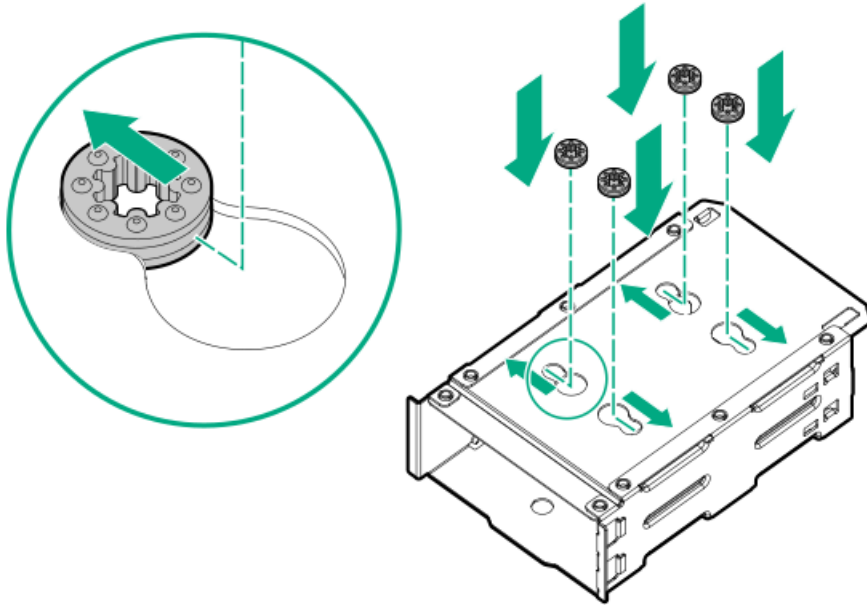

9. Install the rear 2 SFF stacked drive cage:
 - a. Install the 2 SFF stacked drive cage on top of the power supply cage.
 - b. Install the stacked drive cage screws.

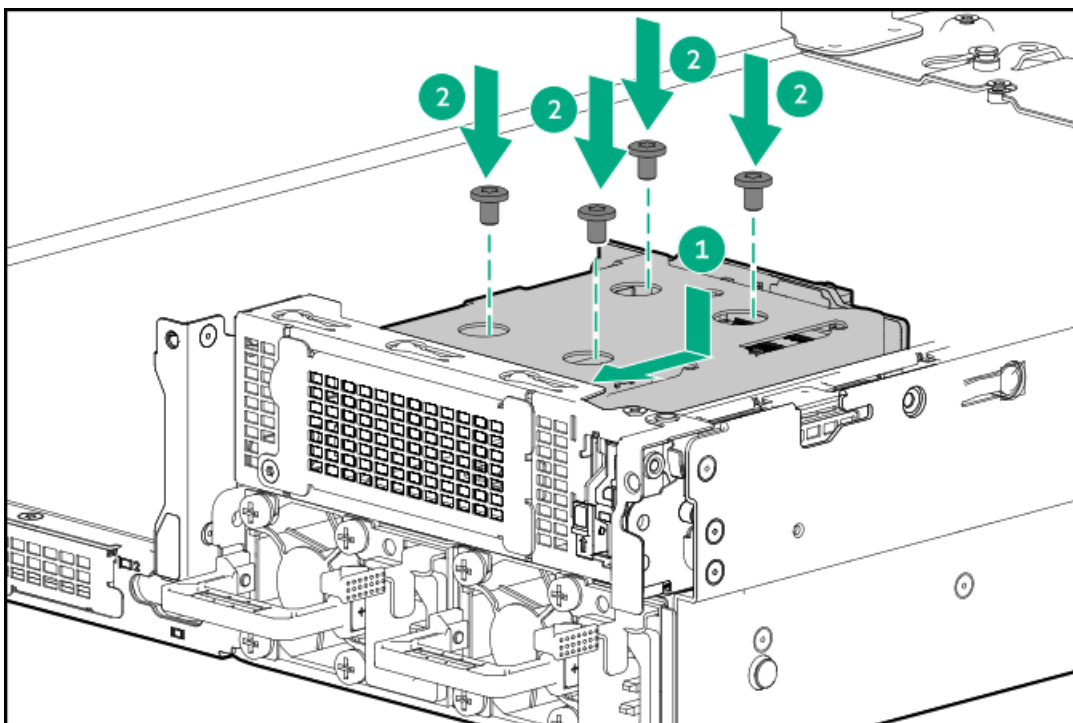

10. Connect the drive power and storage controller cable to the 2 SFF stacked drive backplane.

11. Remove the stacked drive bay blank:

- a. Remove the blank screw.
- b. Remove the blank.

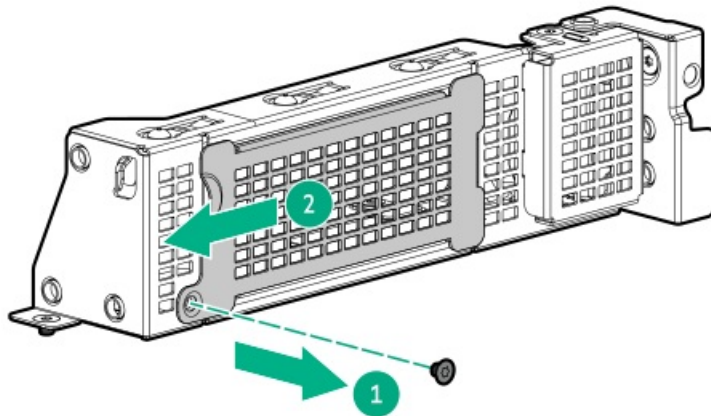

12. Install the drive.

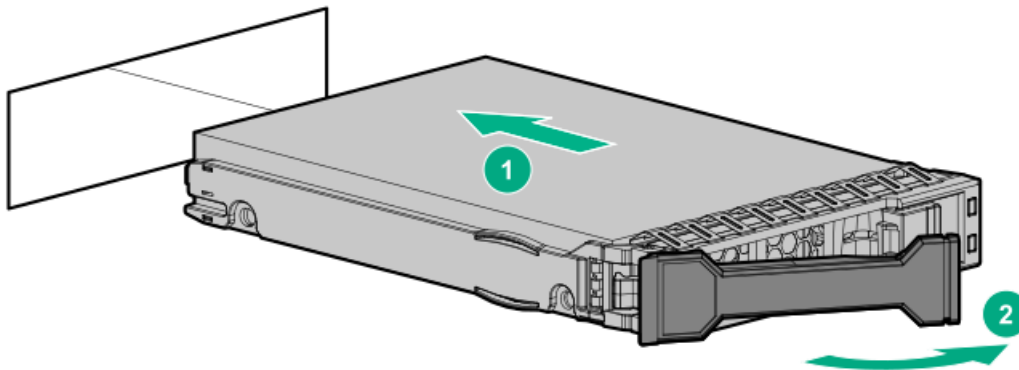

13. Do one of the following:

- [Install the air baffle.](#)
- [Install the midplane drive cage.](#)

14. [Install the access panel.](#)

15. Connect all peripheral cables to the server.

16. Connect the power cords:

- a. Connect each power cord to the server.
- b. Connect each power cord to the power source.

17. If installed, close the cable management arm.



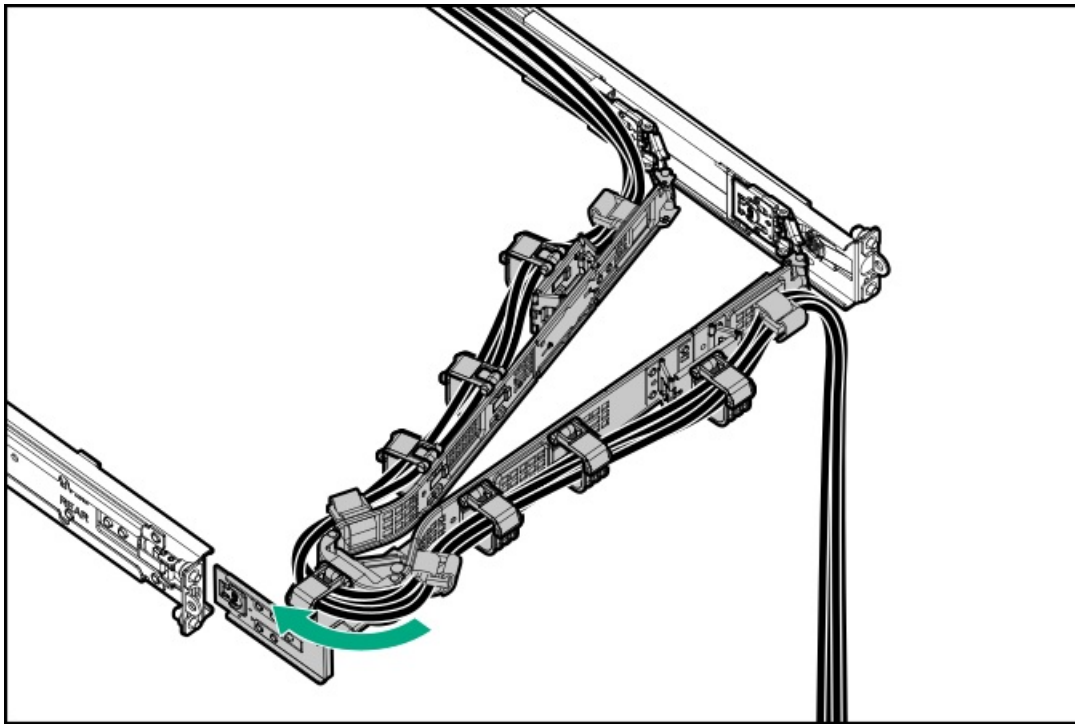

18. Power up the server.

Results

The installation procedure is complete.

Installing the front 8 SFF drive cage

Prerequisites

Before you perform this procedure, make sure that you have the following items available:

- T-10 Torx screwdriver
- The components included with the hardware option kit

Procedure

1. Power down the server.
2. If installed, open the cable management arm.
3. Remove all power:
 - a. Disconnect each power cord from the power source.
 - b. Disconnect each power cord from the server.
4. Disconnect all peripheral cables from the server.
5. Remove the server from the rack.
6. Remove the access panel.
7. Do one of the following:
 - Remove the air baffle.
 - Remove the midplane drive cage.



8. Remove the fan cage.
9. Remove the midwall bracket.
10. Remove the drive box blank:
 - a. Remove the drive box blank screws.
 - b. Remove the drive box blank.

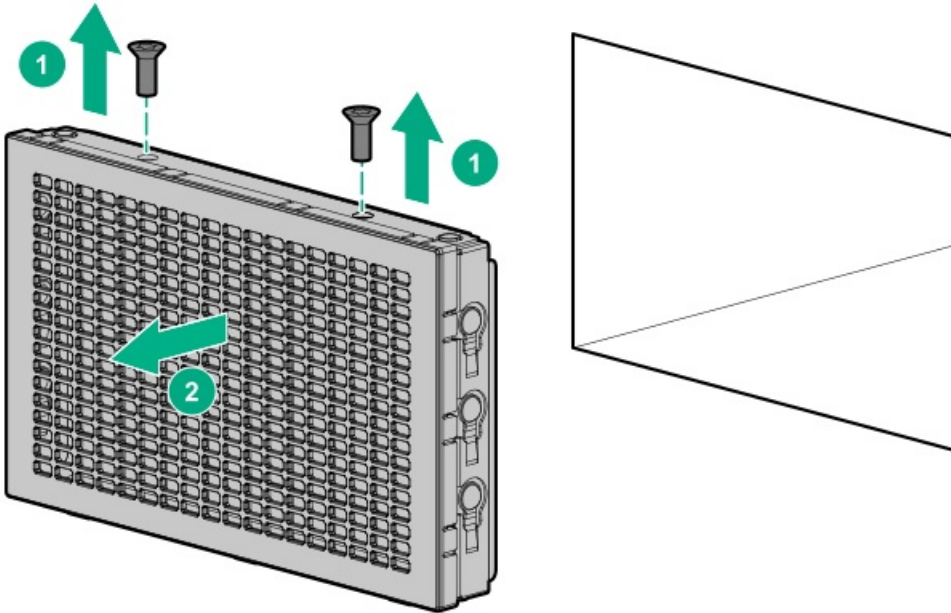

11. Install the 8 SFF drive cage:
 - a. Install the 8 SFF drive cage in the server.
 - b. Install the drive cage screws.

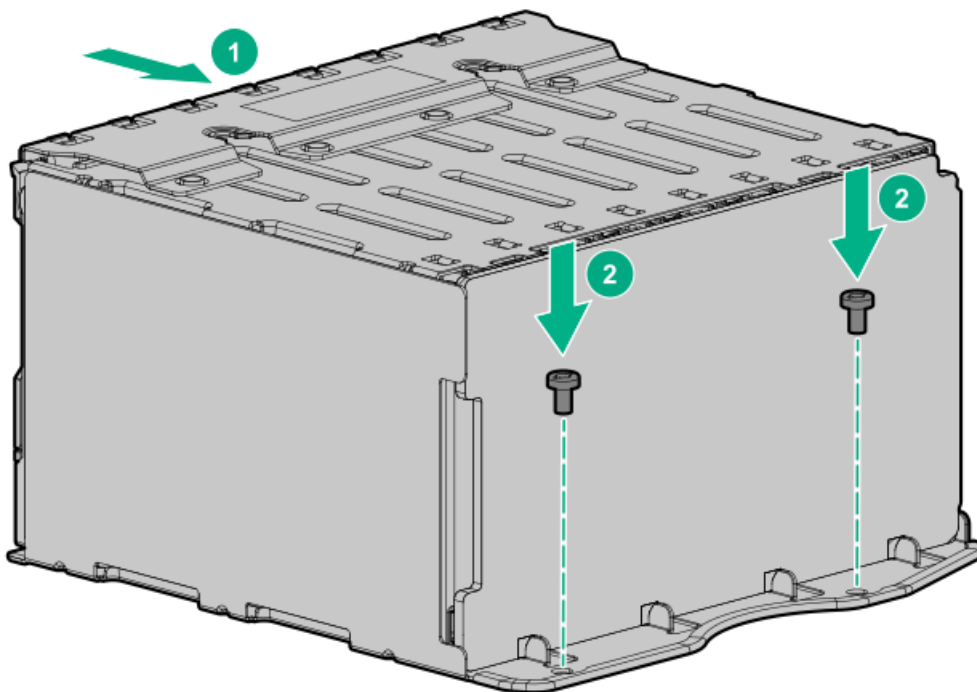

12. Install the midwall bracket.
13. Install the fan cage.



14. Do one of the following:
 - [Install the air baffle.](#)
 - [Install the midplane drive cage.](#)
15. [Install the access panel.](#)
16. [Install the server into the rack.](#)
17. Connect all peripheral cables to the server.
18. Connect the power cords:
 - a. Connect each power cord to the server.
 - b. Connect each power cord to the power source.
19. If installed, close the cable management arm.

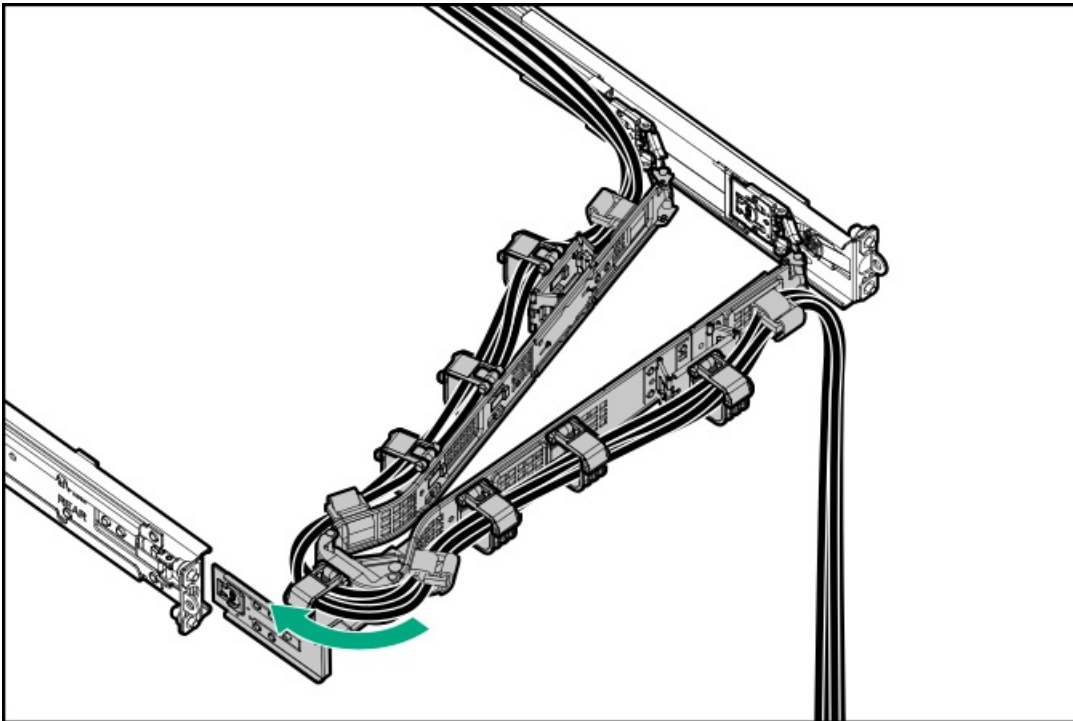

20. [Power up the server.](#)

Results

The installation procedure is complete.

Installing the front 8 SFF drive cage in the 48 SFF drive configuration

Prerequisites

Before you perform this procedure, make sure that you have the following items available:

- T-10 Torx screwdriver
- The components included with the hardware option kit

Procedure

1. If installed, [remove the front bezel.](#)



2. Power down the server.
3. If installed, open the cable management arm.
4. Remove all power:
 - a. Disconnect each power cord from the power source.
 - b. Disconnect each power cord from the server.
5. Disconnect all peripheral cables from the server.
6. Remove the server from the rack.
7. Release the second-row cage:
 - a. Remove the two screws (callout 1).

These screws are shipping screws and do not have to be retained.

 - b. Press and slide the latch to the left (callout 2) and lift the drive cage (callout 3).

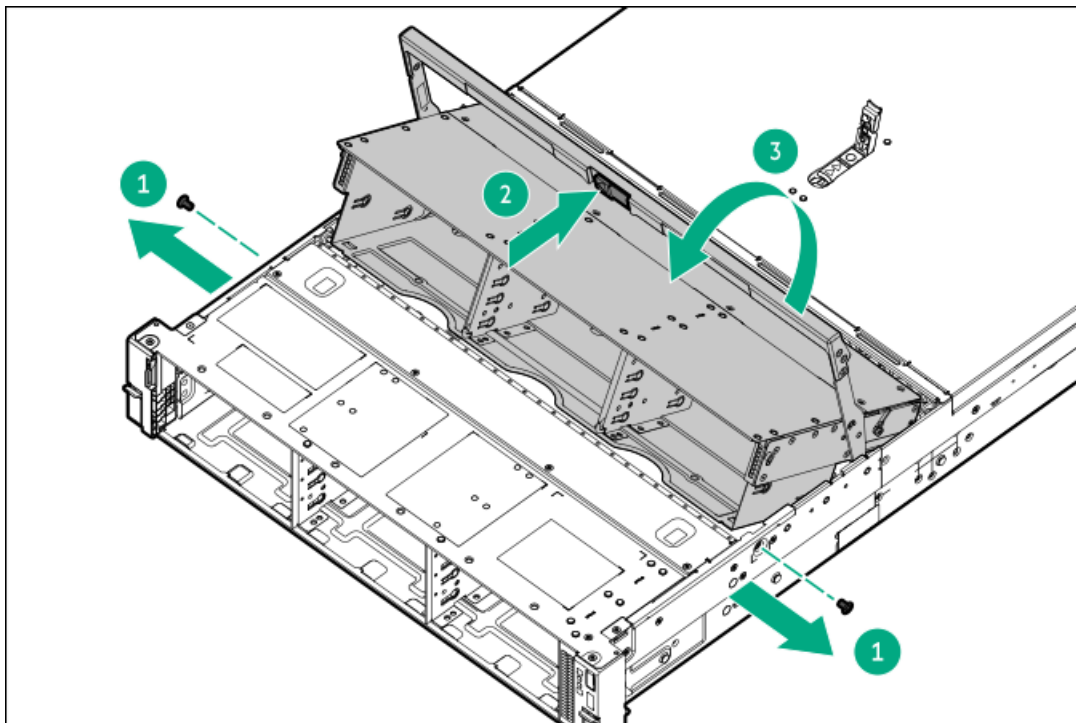

8. Remove the covers.

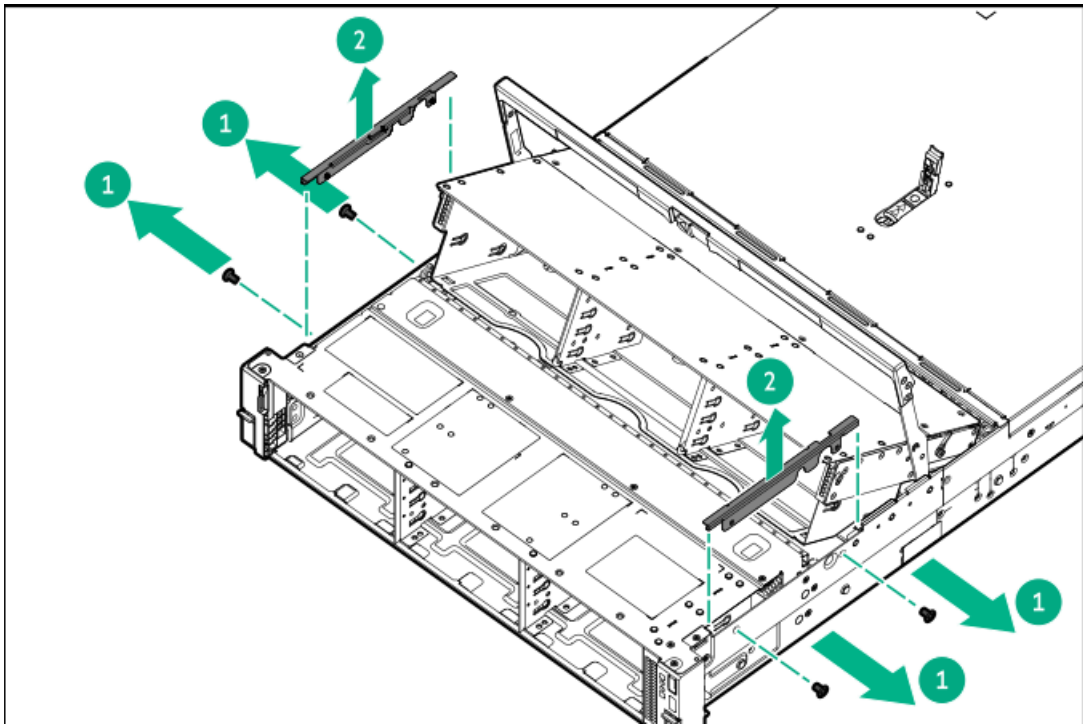

9. Remove the first-row drive backplane cover.

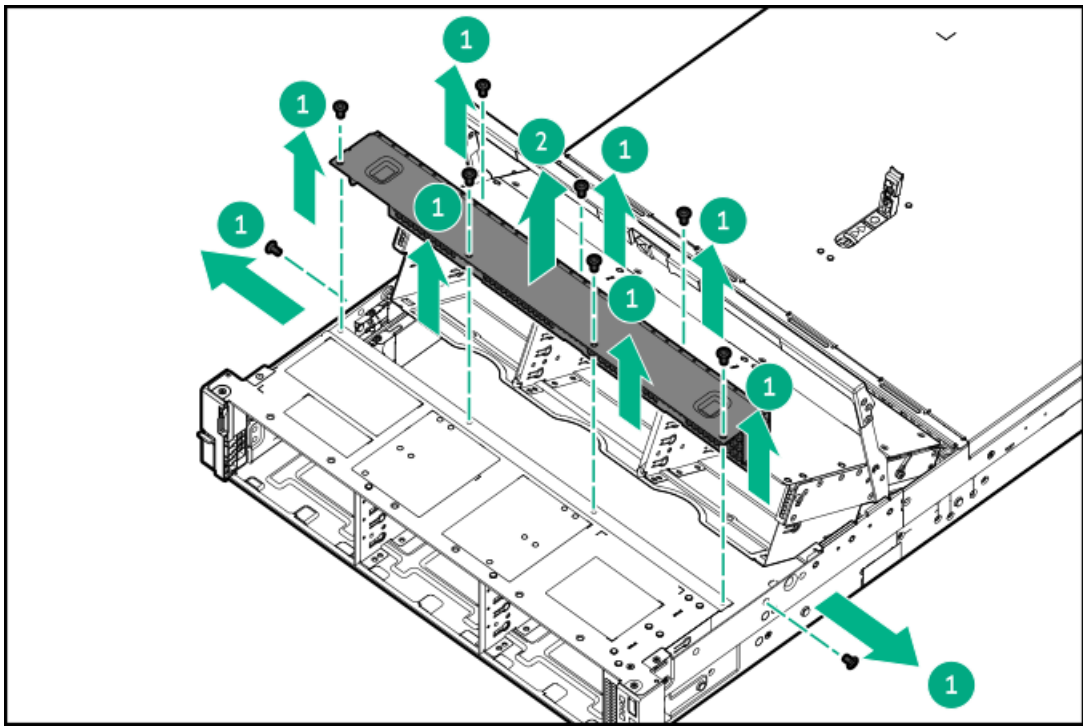

10. Install the 8 SFF drive cage.



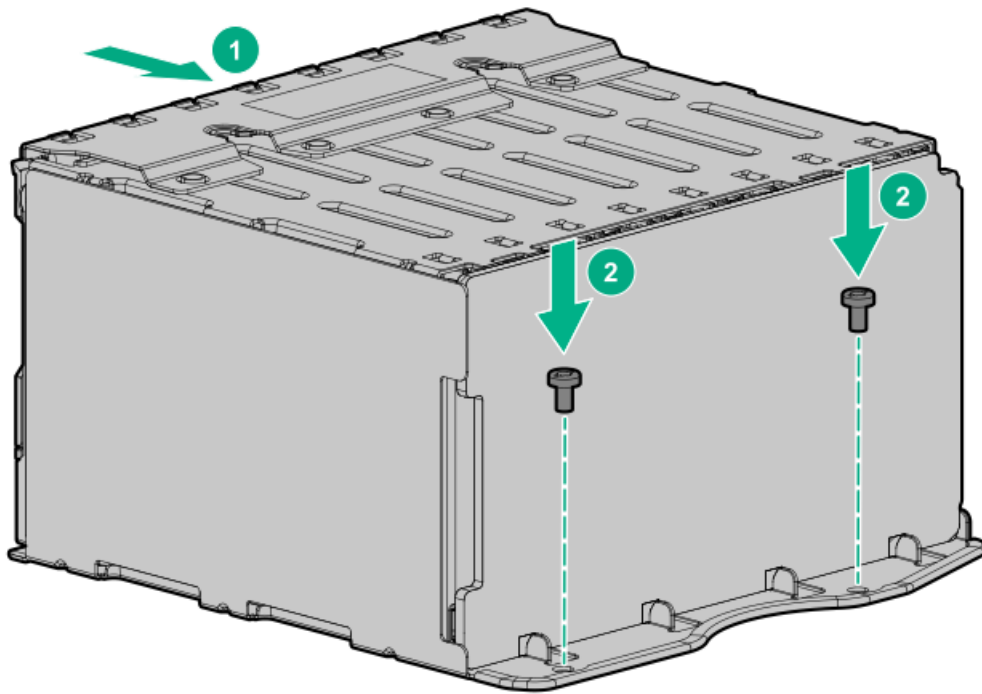

11. Connect the signal and power cable.
12. Install the first-row drive backplane cover.

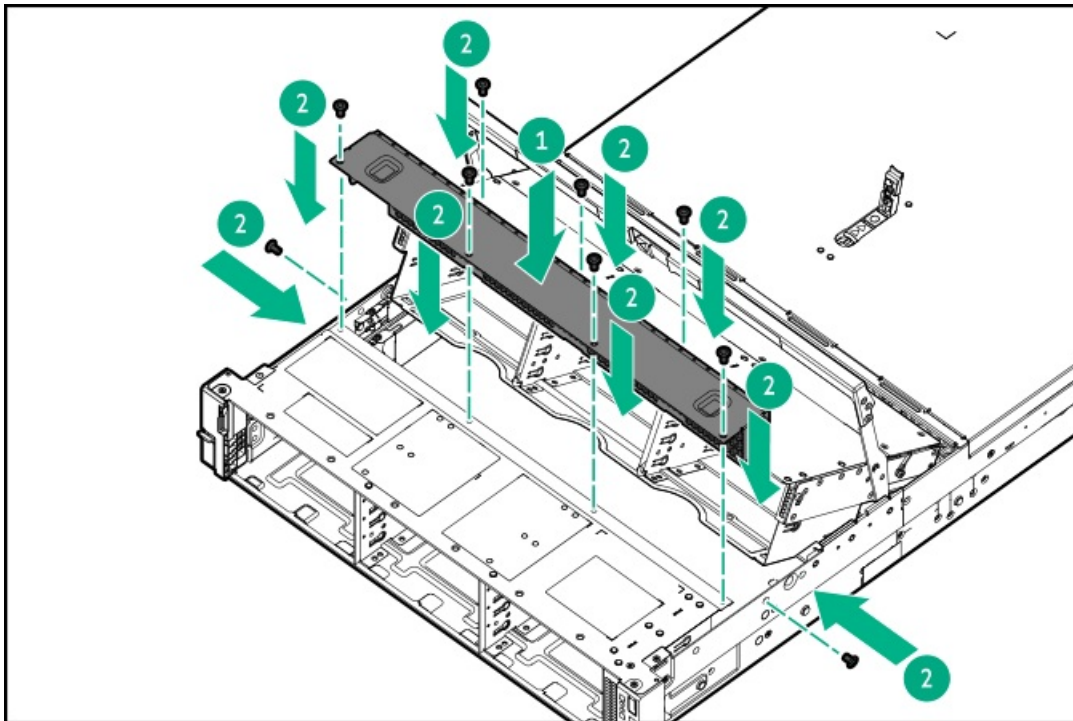

13. Install the covers.



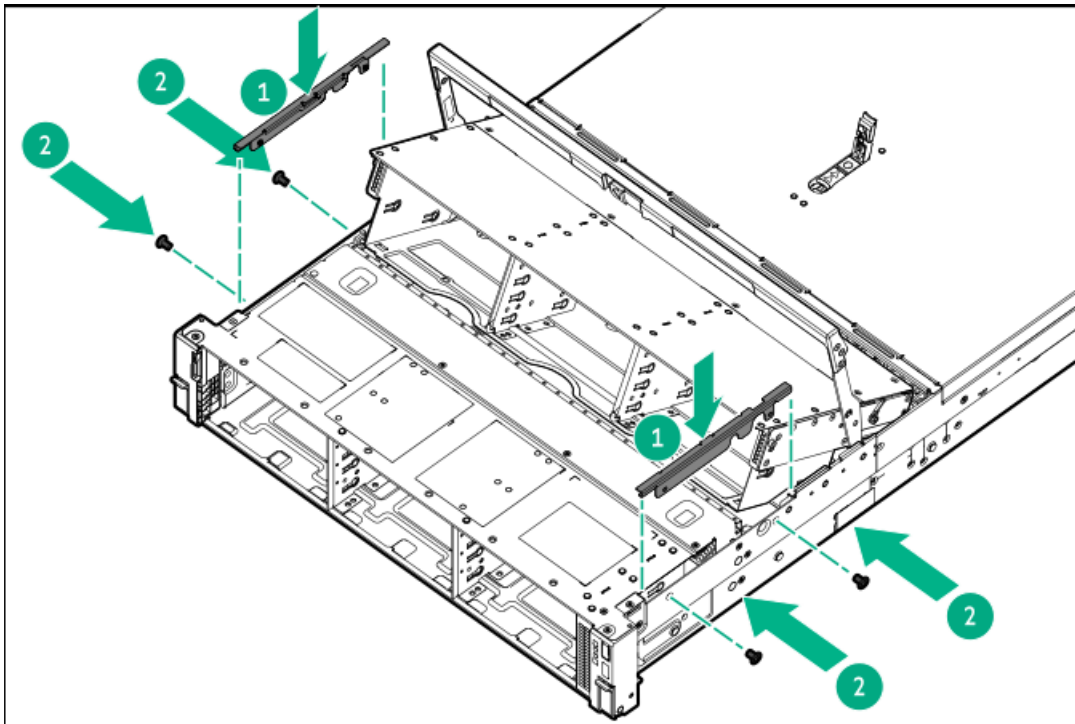

14. To install the drive cage in box 4-6, do the following:

- a. Remove the second-row backplane cover.

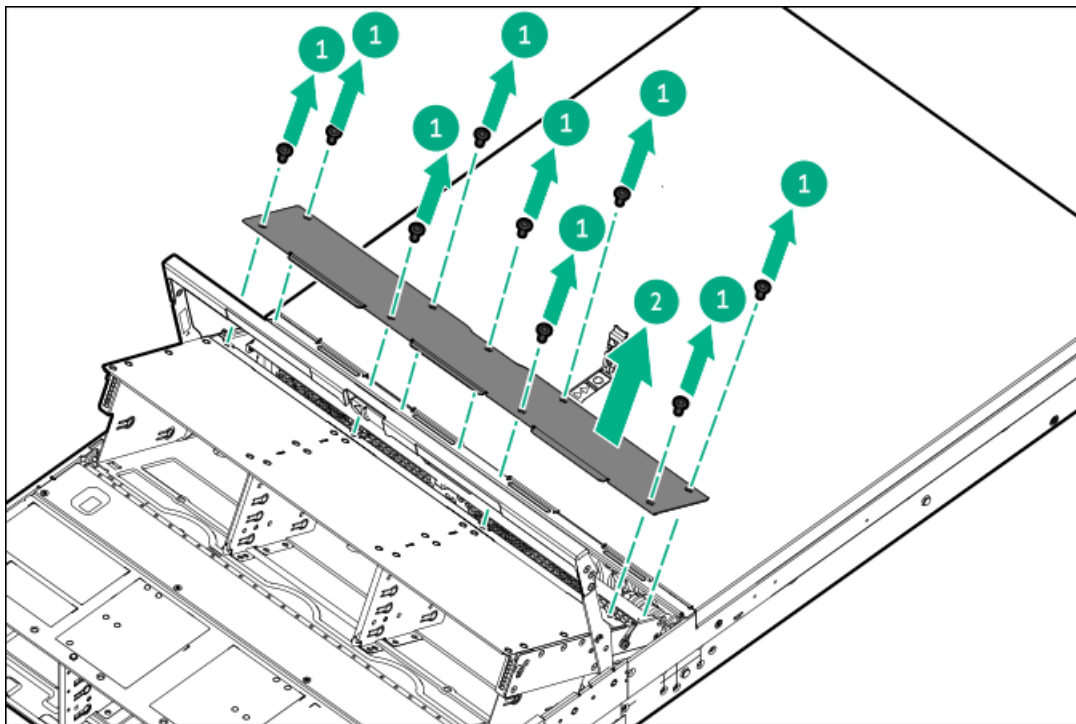

- b. Install the 8 SFF drive cage.



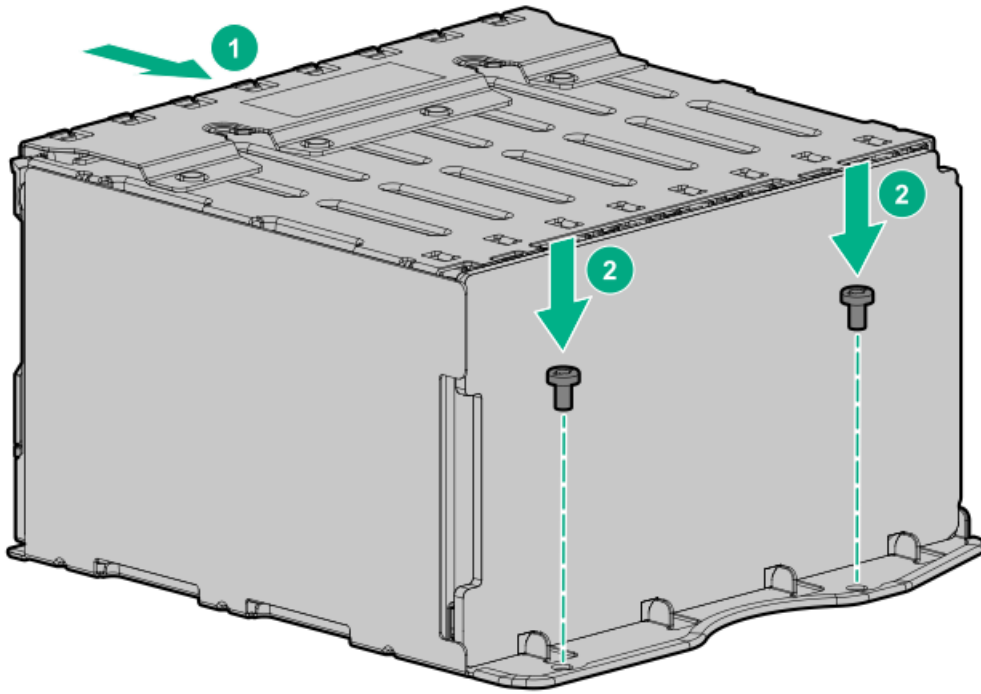

- c. Connect the signal and power cable.
- d. Install the second-row drive backplane cover.

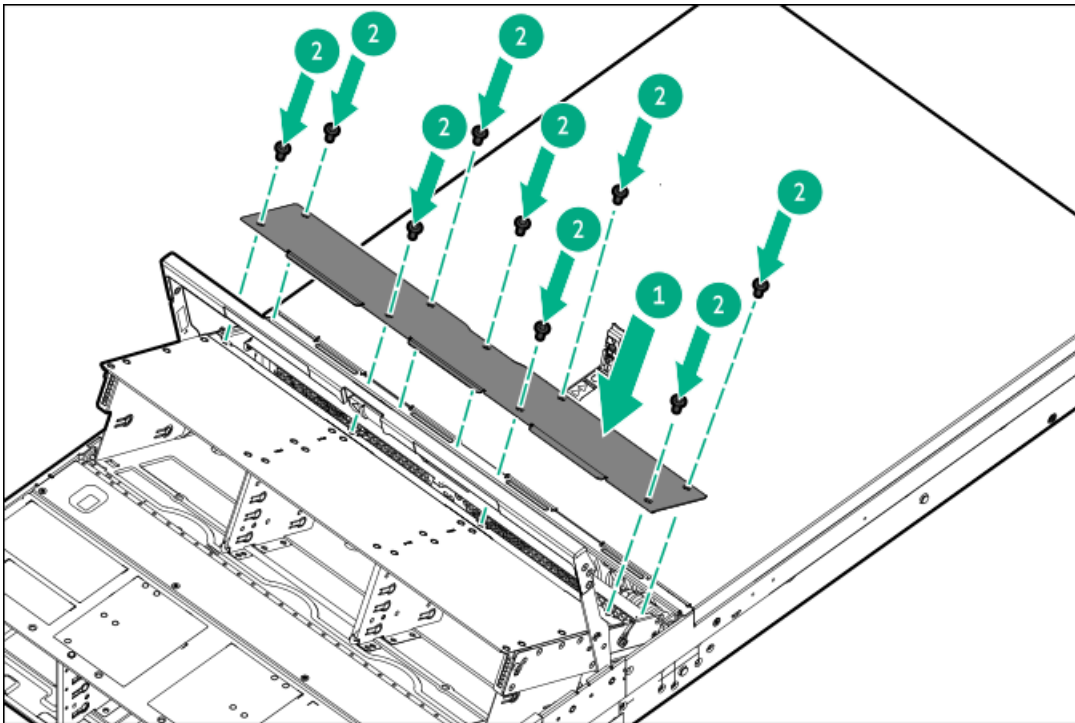

15. Return the second-row drive cage.



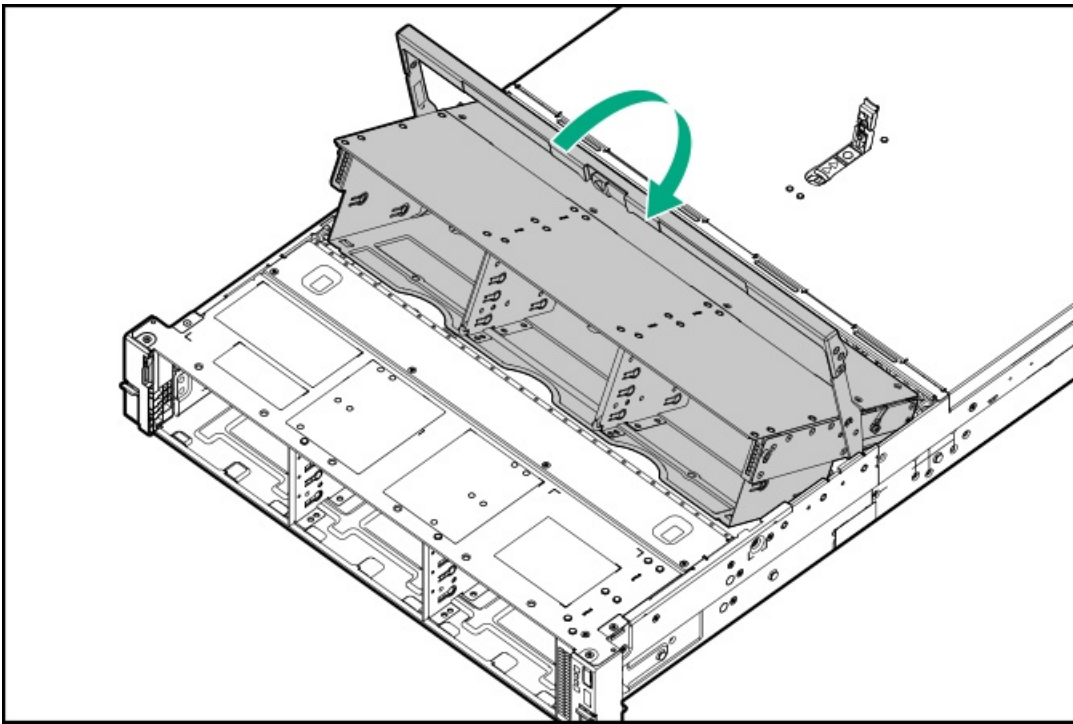

16. Install the server into the rack.
17. Connect all peripheral cables to the server.
18. Connect the power cords:
 - a. Connect each power cord to the server.
 - b. Connect each power cord to the power source.
19. If installed, close the cable management arm.

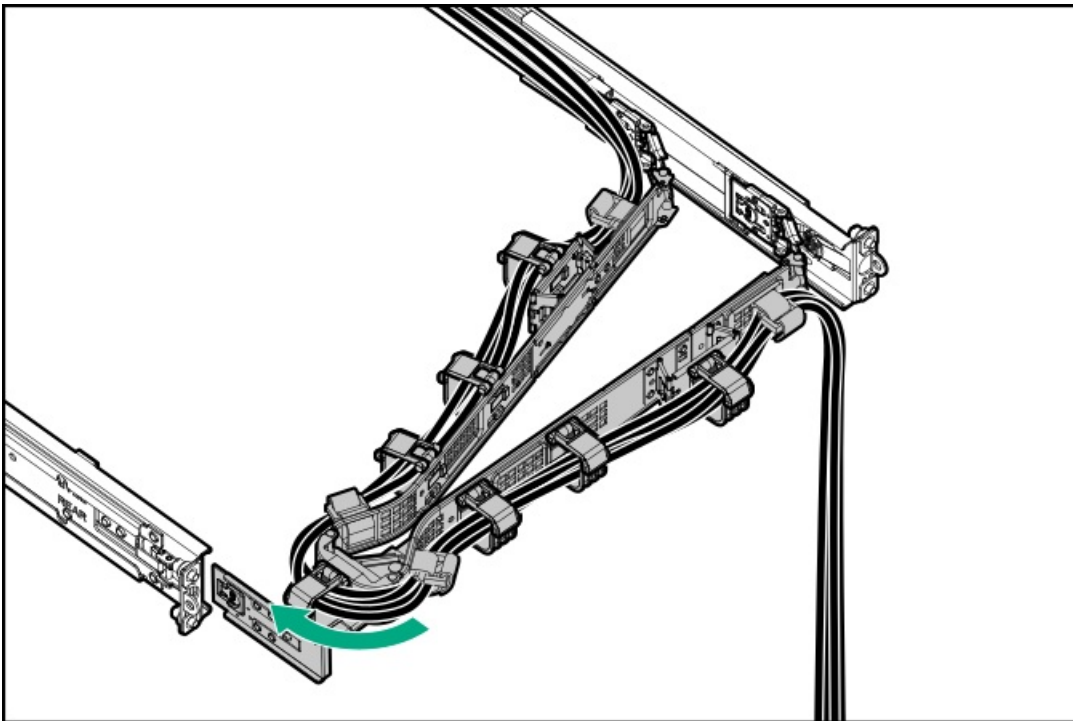

20. Power up the server.
21. If removed, install the front bezel.



Results

The installation procedure is complete.

Installing the midplane drive cage

Prerequisites

- To maintain proper system cooling when a midplane drive cage is installed, the high performance, dual-rotor fans are required.
- Before you perform this procedure, make sure that you have the following items available:
 - The following tools required for installing the midplane cage heatsink:
 - T-20 Torx screwdriver or a torque screwdriver with T-20 drill bit
 - Alcohol wipe

About this task

This server supports either a 4 LFF or an 8 SFF midplane cage option. The drive form factor on the front and midplane drive cages should match: either all LFF or all SFF drives.

- The 4 LFF midplane drive cage supports SAS and SATA drives.
- The 8 SFF midplane drive cage supports SAS, SATA, and U.3 NVMe drives.

 **CAUTION:** A discharge of static electricity from a finger or other conductor might damage system boards or other static-sensitive devices. To prevent damage, observe antistatic precautions.

 **CAUTION:** To prevent improper cooling and thermal damage, do not operate the server unless all bays are populated with either a component or a blank.

Procedure

1. Power down the server.
2. If installed, open the cable management arm.
3. Remove all power:
 - a. Disconnect each power cord from the power source.
 - b. Disconnect each power cord from the server.
4. Disconnect all peripheral cables from the server.
5. Remove the server from the rack.
6. Remove the access panel.
7. Remove the air baffle.

The air baffle is no longer needed. The drive cage acts as an air baffle for the server.

Installing the midplane cage heatsink

8. Allow all internal system components to cool before continuing.
9. Remove the standard heatsink:
 - a. Review the heatsink screw numbering on the heatsink label.
 - b. Loosen the heatsink screw numbers 6, 5, 4, and 3 in a diagonal manner (callouts 1 to 4).

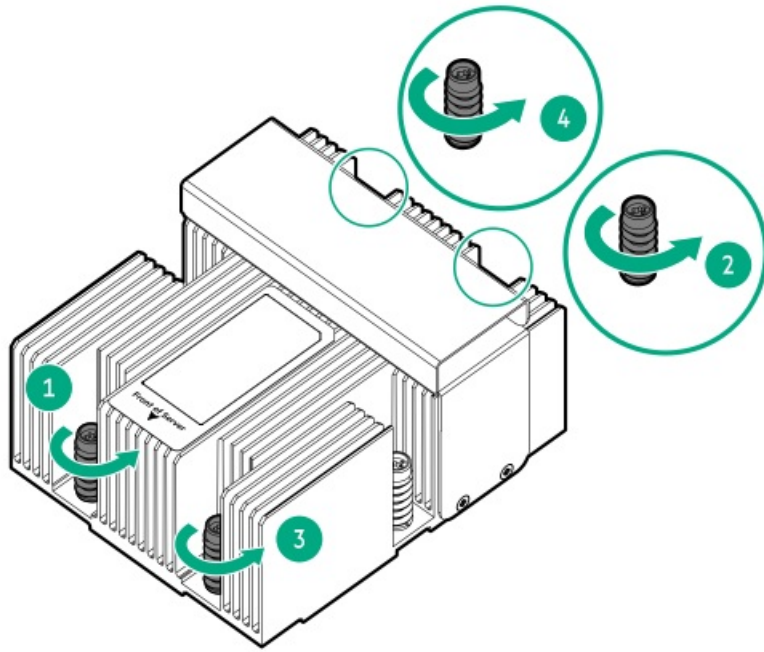

c. Loosen the heatsink screw numbers 2 and 1 (callouts 5 and 6).

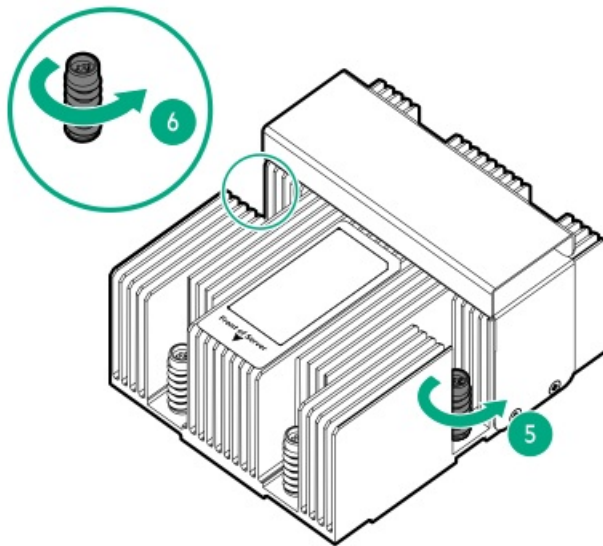

10. Lift the standard heatsink away from the processor socket.



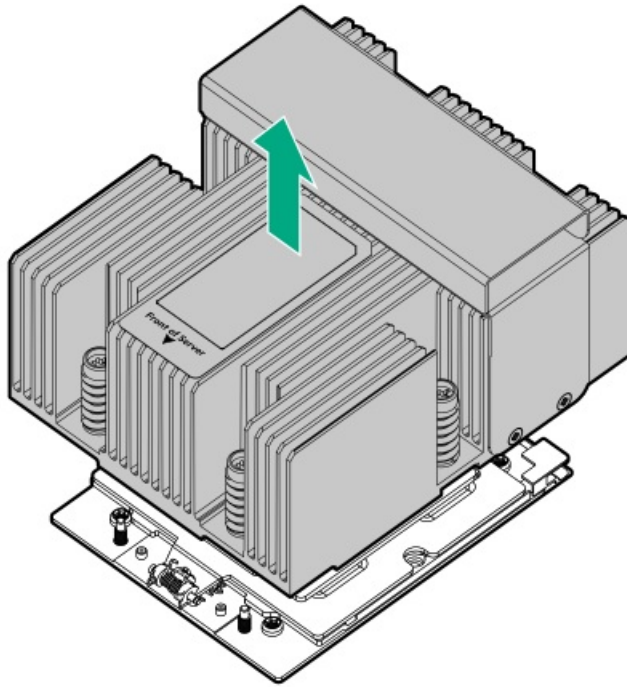

11. Place the heatsink on a flat work surface with its contact side facing up.
12. Use an alcohol wipe to remove the existing thermal grease from the heatsink and processor.
Allow the alcohol to evaporate before continuing.
13. Remove the thermal interface protective cover from the new heatsink.
14. Install the midplane cage heatsink:

CAUTION: To prevent mechanical damage or depositing oil on your hands or other contaminants to the heatsink contact surface, hold the heatsink only by the edge of its base plate. Do not touch the heatsink fins.

CAUTION:

To prevent thermal failure or component damage, do not move the heatsink once the bottom of its base plate touches the top of the processor. Excessive heatsink movement can cause the thermal grease to smear and become uneven. Voids in the compound can adversely impact the transfer of heat away from the processor.

- a. When using a torque screwdriver to tighten the heatsink screws, set a torque between 1.24 N-m (11 lbf-in) to 1.47 N-m (13 lbf-in) .
- b. Note the **Front of server** text on the heatsink label to correctly orient the heatsink over the processor socket.
- c. Position the heatsink on top of the processor, ensuring that it is properly seated before securing the screws.

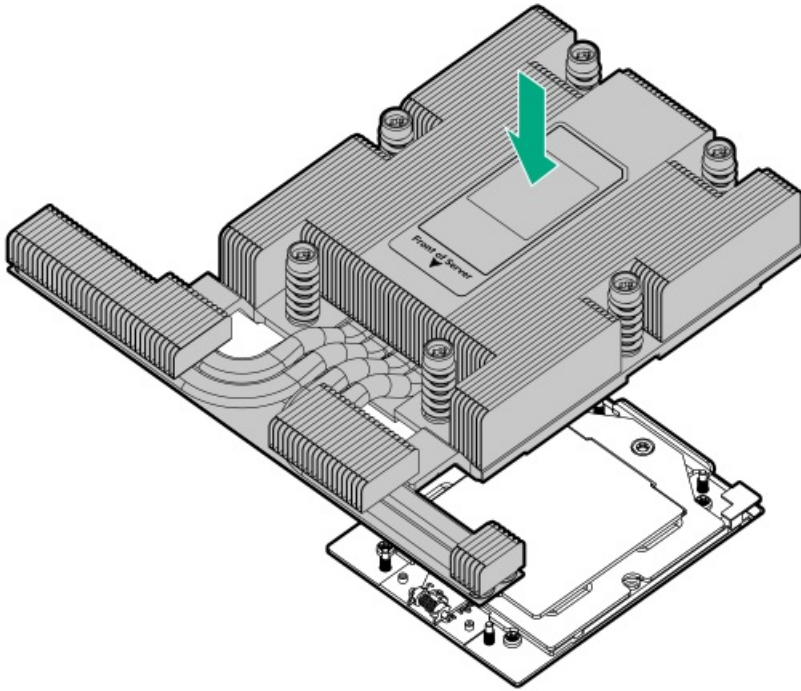

d. Tighten the heatsink screw numbers 1 and 2 (callouts 1 and 2).

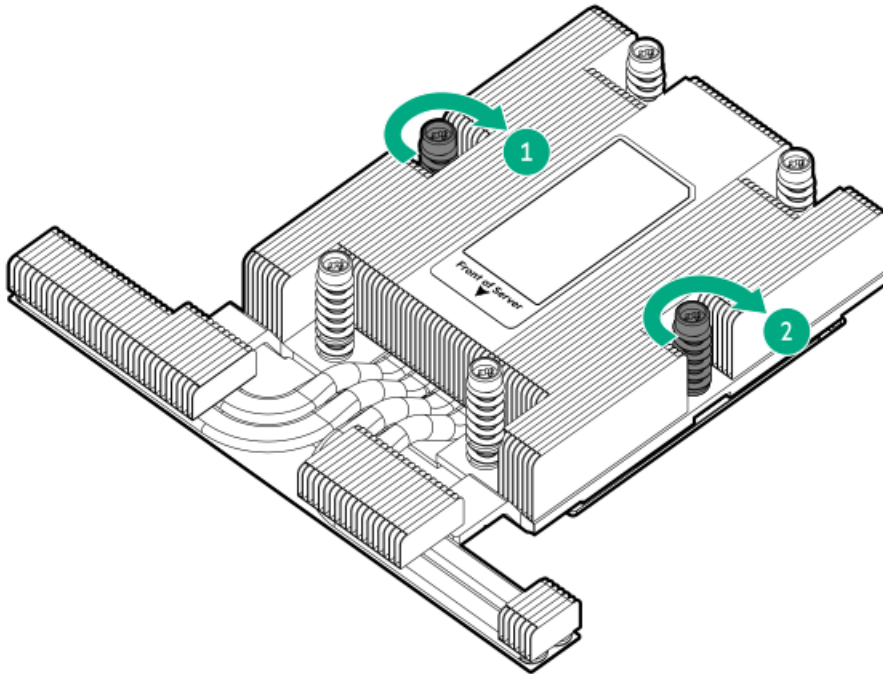

e. Tighten the heatsink screw numbers 3, 4, 5, and 6 in a diagonal manner (callouts 3 to 6).



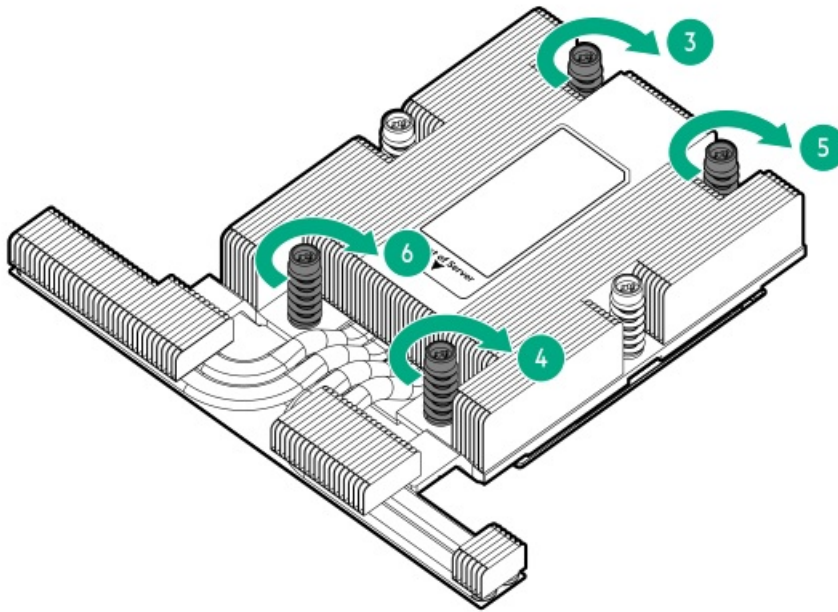

Installing the midplane drive cage

15. Install the midplane drive cage:

- a. Lift the latches on the midplane drive cage.
- b. Align the pin on the rear left of the drive cage to the server and then insert the pin.
- c. Pull the plunger pin on the rear right of the drive cage, and then lower the drive cage until the plunger pin engages.

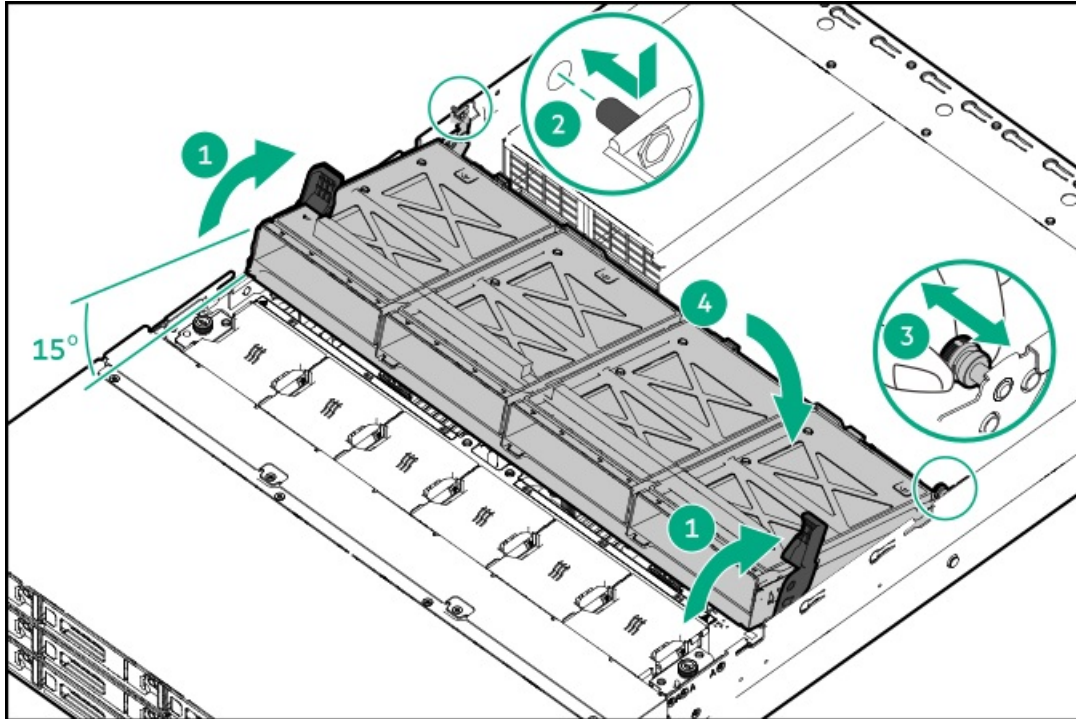

16. Install the drives in the midplane drive cage.

17. Push down on the latches to lower the midplane drive cage into place.



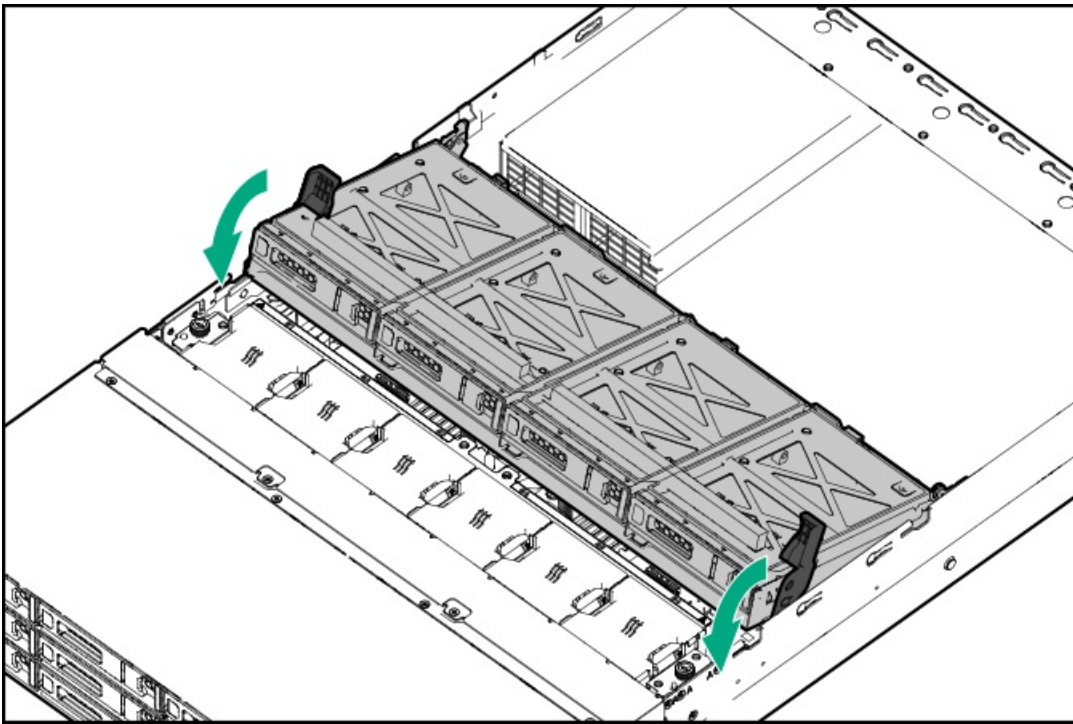

18. Connect the power and data cables to the drive backplane.
19. Cable the midplane drive:
 - Drive power cable
 - Storage controller cable
20. Install the access panel.
21. Install the server into the rack.
22. Connect all peripheral cables to the server.
23. Connect the power cords:
 - a. Connect each power cord to the server.
 - b. Connect each power cord to the power source.
24. If installed, close the cable management arm.

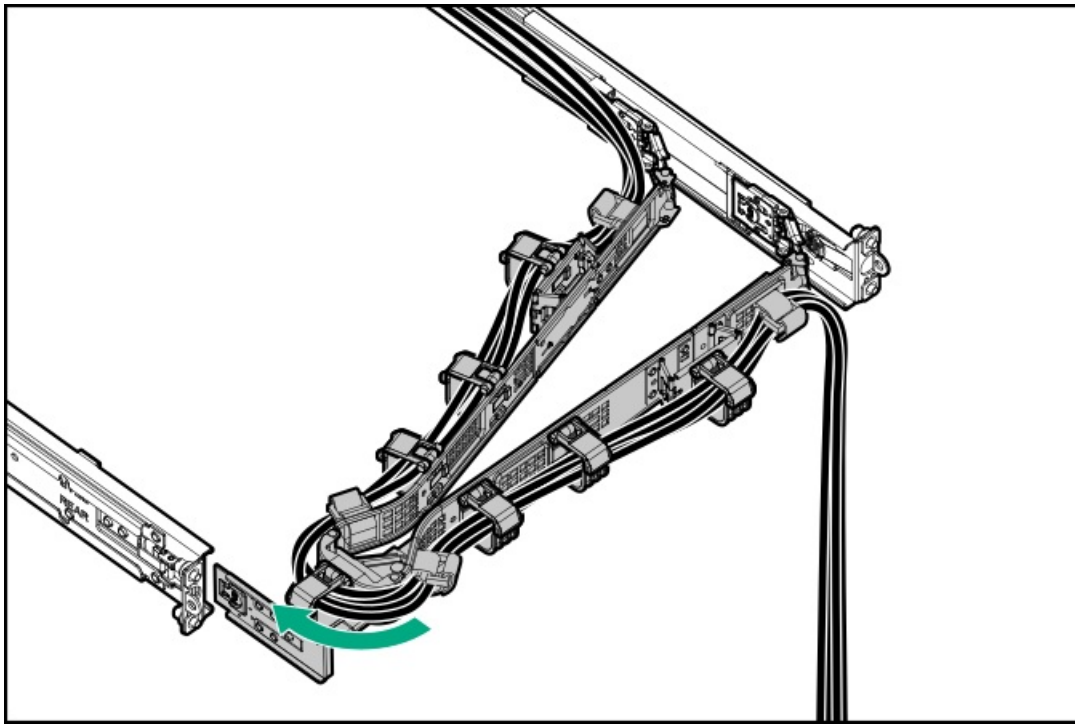

25. Power up the server.

Results

The installation procedure is complete.

Installing the 8 E3.S drive cage

Prerequisites

Before you perform this procedure, make sure that you have the following items available:

- T-10 Torx screwdriver
- T-15 Torx screwdriver

About this task

This server supports several front 8 E3.S drive cage options with different backplanes.

CAUTION: A discharge of static electricity from a finger or other conductor might damage system boards or other static-sensitive devices. To prevent damage, observe antistatic precautions.

CAUTION: To prevent improper cooling and thermal damage, do not operate the server unless all bays are populated with either a component or a blank.

Procedure

1. Back up all server data.
2. If installed, remove the front bezel.
3. Power down the server.
4. Remove all power:
 - a. Disconnect each power cord from the power source.
 - b. Disconnect each power cord from the server.

5. Disconnect all peripheral cables from the server.
6. Do one of the following:
 - a. Extend the server from the rack.
 - b. Remove the server from the rack.
7. Place the server on a flat, level work surface.
8. Remove the access panel.
9. Remove the air baffle.
10. Remove the fan cage.
11. Remove the middle cover:
 - a. Press and hold the release buttons.
 - b. Disengage the cover from the front cage.

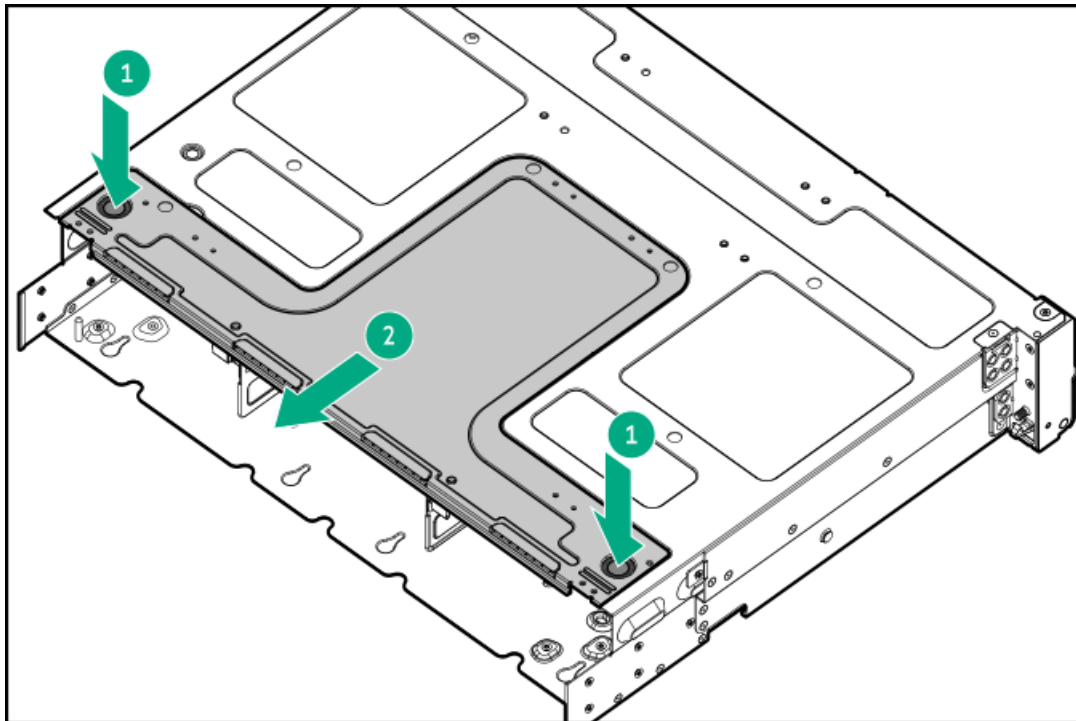

12. Remove the drive box blank:
 - a. Remove the drive box blank screws.
 - b. Remove the drive box blank.

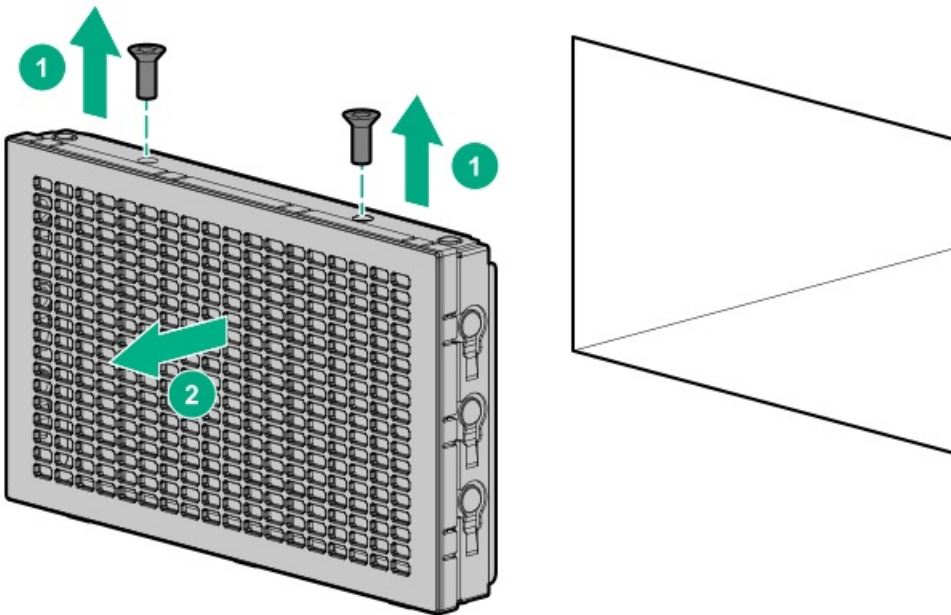

13. Group and route all drive cables through the drive box bay.

14. Install the 8 E3.S drive cage:

- a. Install the 8 E3.S drive cage in the server.
- b. Install the drive cage screws.

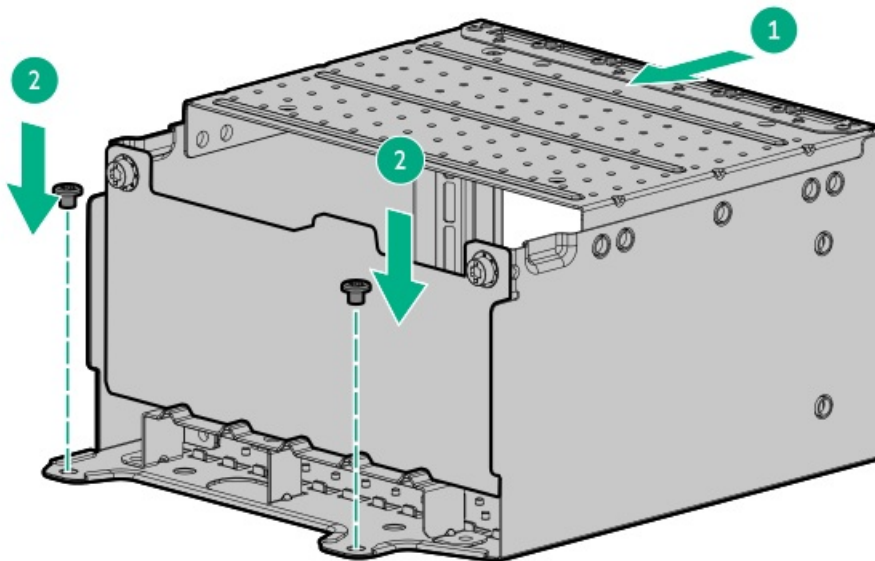

15. Connect the following cables to the 8 E3.S drive backplane and the system board:

- Storage controller cable
- Drive power cable

If the upper PCIe switch board is installed, make sure that the drive cables are routed against the GPU riser cages.

16. Install the middle cover.

A click sound indicates that the cover is properly engaged with the front cage.



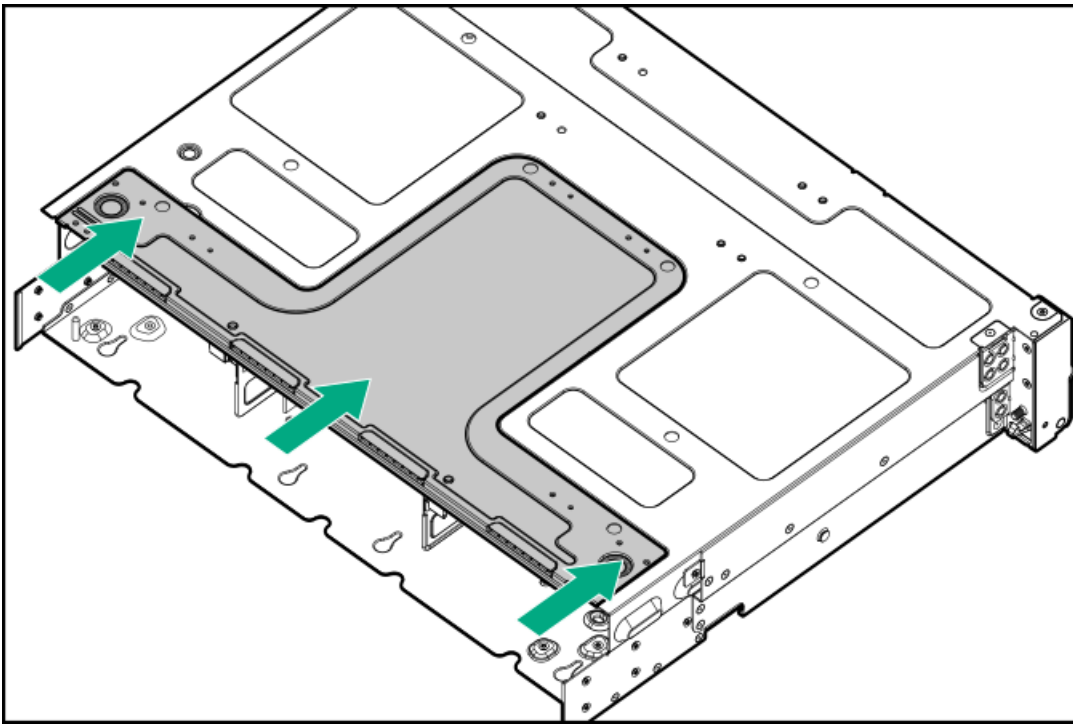

17. [Install the fan cage.](#)
18. Make sure that all the system cables that are secured in the cable guard and routed through the cable channel along the side of the chassis.
19. [Install the air baffle.](#)
20. [Install the access panel.](#)
21. [Install the server into the rack.](#)
22. Connect all peripheral cables to the server.
23. Connect the power cords:
 - a. Connect each power cord to the server.
 - b. Connect each power cord to the power source.
24. [Power up the server.](#)
25. [Installing an E3.S drive.](#)
26. If removed, [install the front bezel.](#)

Results

The installation procedure is complete.

Fan options

CAUTION: To avoid damage to the equipment, do not operate the server for extended periods of time if the server does not have the optimal number of fans installed. Although the server might boot, Hewlett Packard Enterprise does not recommend operating the server without the required fans installed and operating.

To maintain proper system cooling, [install the correct fan and heatsink types required for specific hardware configurations.](#)

Configuration	Fan bay 1	Fan bay 2	Fan bay 3	Fan bay 4	Fan bay 5	Fan bay 6
1 processor SFF configuration	Fan blank	Fan blank	Fan	Fan	Fan	Fan
1 processor 12 LFF and 3 backplane configuration	Fan	Fan	Fan	Fan	Fan	Fan
1 processor 16 SFF and 2 backplane configuration	Fan	Fan	Fan	Fan	Fan	Fan

For a single-processor configuration, excluding 24 SFF, 8 LFF, or 12 LFF configurations, four fans and two blanks are required in specific fan bays for redundancy. A fan failure or missing fan causes a loss of redundancy. A second fan failure or missing fan causes an orderly shutdown of the server.

For a dual-processor configuration or single-processor 24 SFF, 8 LFF, or 12 LFF configurations, six standard (8 LFF) or max performance (24 SFF, 12 LFF) fans are required for redundancy. A fan failure or missing fan causes a loss of redundancy. A second fan failure or missing fan causes an orderly shutdown of the server.

Max performance fans might be necessary in 24 SFF and 12 LFF configurations for the following installations:

- Optional GPU riser installations
- ASHRAE-compliant configurations

For more information, see the [Hewlett Packard Enterprise website](#).

The server supports variable fan speeds. The fans operate at minimum speed until a temperature change requires a fan speed increase to cool the server. The server shuts down during the following temperature-related scenarios:

- At POST and in the OS, iLO 6 performs an orderly shutdown if a cautionary temperature level is detected. If the server hardware detects a critical temperature level before an orderly shutdown occurs, the server performs an immediate shutdown.
- When the Thermal Shutdown feature is disabled in the BIOS/Platform Configuration (RBSU), iLO 6 does not perform an orderly shutdown when a cautionary temperature level is detected. Disabling this feature does not disable the server hardware from performing an immediate shutdown when a critical temperature level is detected.

 **CAUTION:** A thermal event can damage server components when the Thermal Shutdown feature is disabled in the BIOS/Platform Configuration (RBSU).

Subtopics

[Fan mode behavior](#)

[Installing a high performance fan](#)

Fan mode behavior

The fully loaded six fan configuration provides redundant fan support. In redundant fan mode, if a fan fails or is missing:

- The system switches to nonredundant fan mode. The system continues to operate in this mode.
- The system Health LED flashes amber.

If a second fan rotor failure or a missing fan occurs, the OS gracefully shuts down.

Installing a high performance fan

Prerequisites

Review the fan and heatsink requirements for specific hardware configurations.

About this task

CAUTION: To maintain proper system cooling, do not operate the server for long period with the access panel open or removed. Operating the server in this manner results in an improper system airflow. For internal hot-plug component procedures, complete the procedure within 60 seconds. Failure to do so can cause the system temperature to increase and trip the safety threshold. When this happens:

- The health LED flashes amber.
- The operating system gracefully shuts down.

IMPORTANT:

The fan setup can either be standard, single-rotor fans or high performance, dual-rotor fans. Do not mix fan types in the same server.

The installation and removal procedures for the standard and high performance fans are the same.

Procedure

1. If installed, open the cable management arm.
2. Extend the server from the rack.
3. Remove the access panel.
4. Remove the existing fans:
 - a. Press and hold the latch.
 - b. Lift the fan from the fan cage.

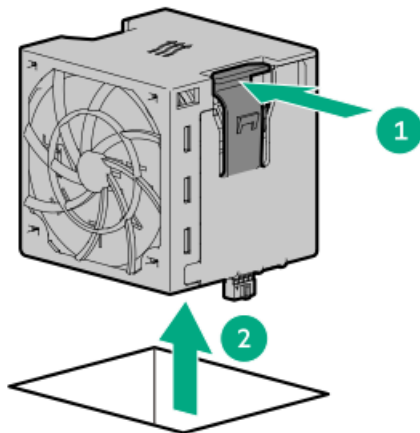

5. Install new fans:
 - a. Lower the fan into the fan bay.
 - b. Press down on the fan to make sure that it is seated firmly in the bay.

A click sound indicates that the fan is properly engaged.

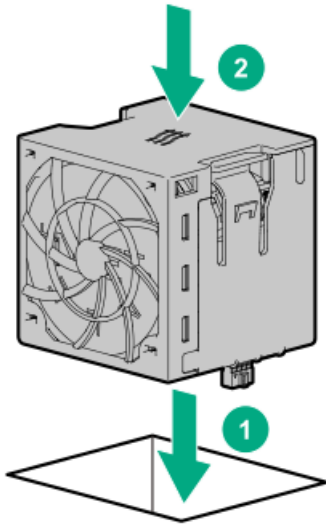

6. Install the access panel.
7. If installed, close the cable management arm.

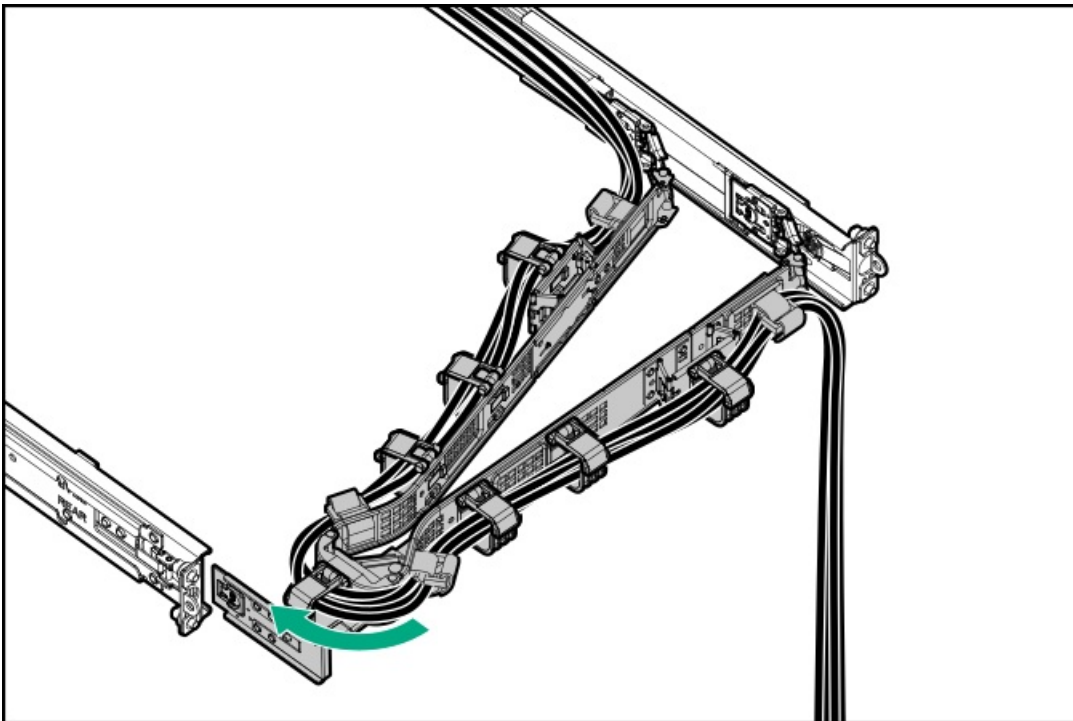

Results

The installation procedure is complete.

Accelerator options

This server supports various accelerator options to meet your computational and graphics workload requirements. For a list of supported accelerator models, see the server QuickSpecs on the Hewlett Packard Enterprise website (<https://www.hpe.com/info/quickspecs>).

Subtopics

[Accelerator installation guidelines](#)

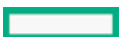

Accelerator installation guidelines

- To support high power accelerators (> TDP 75 W), the CPU 8-pin auxiliary power cable option (P64382-B21) is required.
- To maintain proper system cooling, all six high performance fans are required for accelerator installation.
- The limited operating inlet ambient temperatures required for accelerators vary based on the model and the server drive configuration. For more information, see the server QuickSpecs on the Hewlett Packard Enterprise website (<https://www.hpe.com/info/quickspecs>).

i **IMPORTANT:** Workloads for high performance accelerators with passive cooling can cause the fans to operate at high speeds to maintain optimum system cooling. Hewlett Packard Enterprise does not recommend installing accelerators with passive cooling in or near a site where there is a reasonable expectation for a quiet environment.

Installing an accelerator

Prerequisites

Before you perform this procedure, make sure that you have the following items available:

- Review the [Accelerator installation guidelines](#).
- The components included with the hardware option kit
- T-10 Torx screwdriver
- T-15 Torx screwdriver

Procedure

1. If installed, [remove the front bezel](#).
2. [Power down the server](#).
3. If installed, [open the cable management arm](#).
4. Remove all power:
 - a. Disconnect each power cord from the power source.
 - b. Disconnect each power cord from the server.
5. Disconnect all peripheral cables from the server.
6. [Remove the server from the rack](#).
7. [Remove the access panel](#).
8. [Remove the air baffle](#).
9. Remove the middle cover.

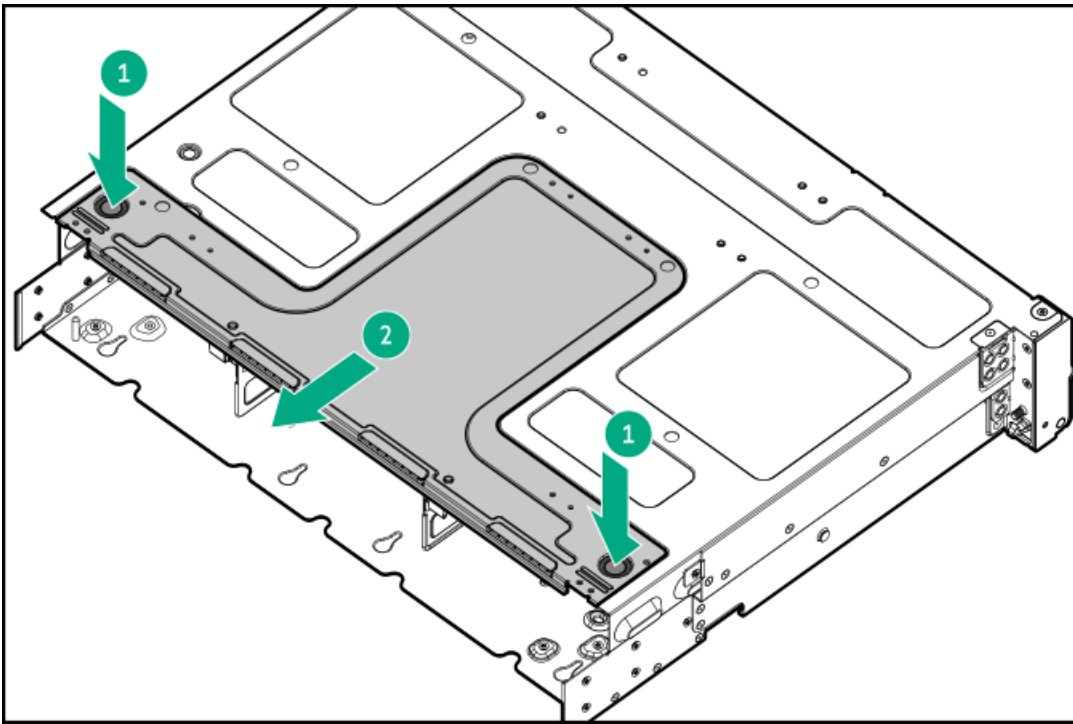

10. Disconnect the GPU riser cables from the system board .

11. Remove a GPU riser cage:

- a. Rotate the locking pin to the open (vertical) position.
- b. Remove the GPU riser cage from the server.

Carefully feed the riser cables through the cable channel.

- GPU riser cage 1

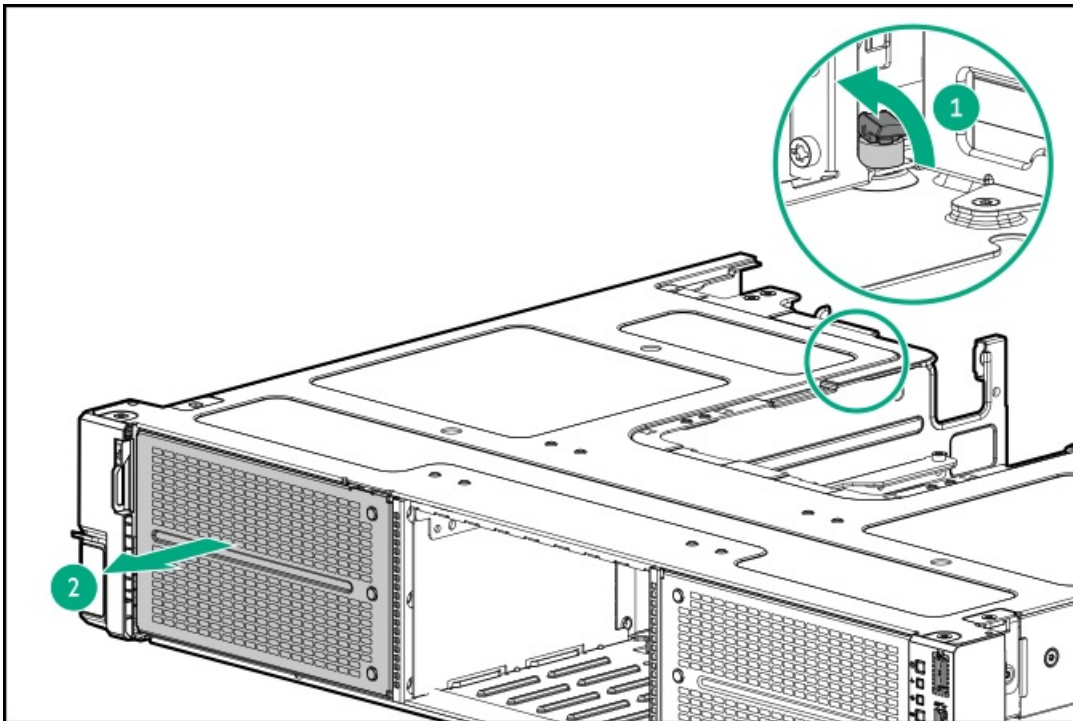

- GPU riser cage 2



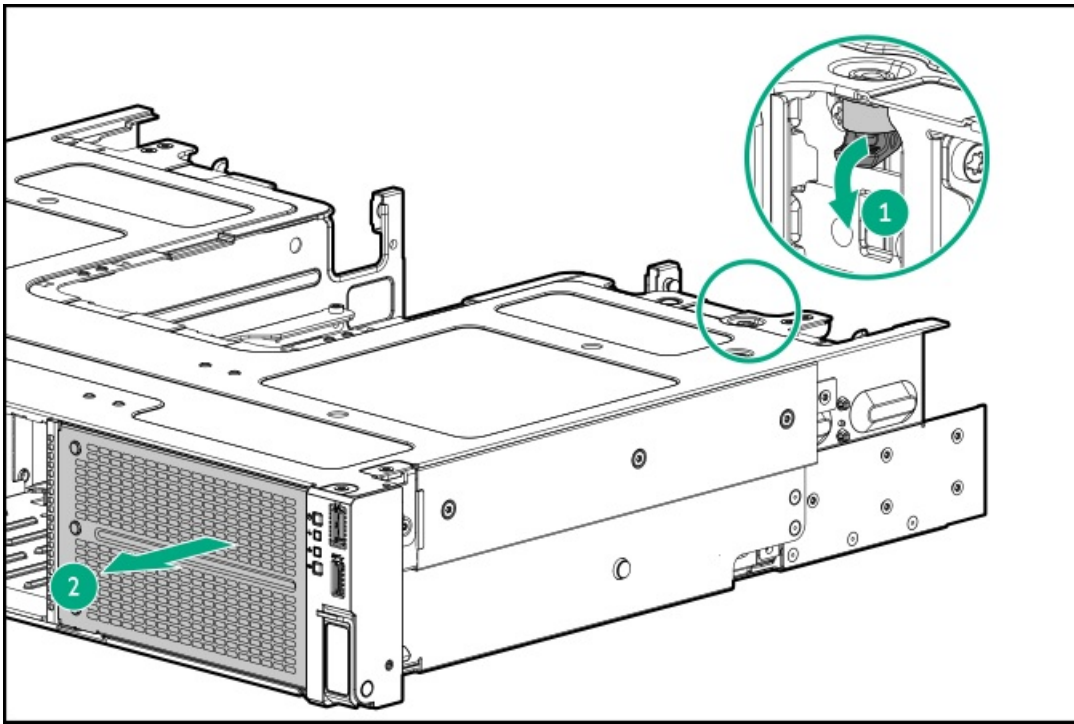

12. Remove the GPU riser cage cover.

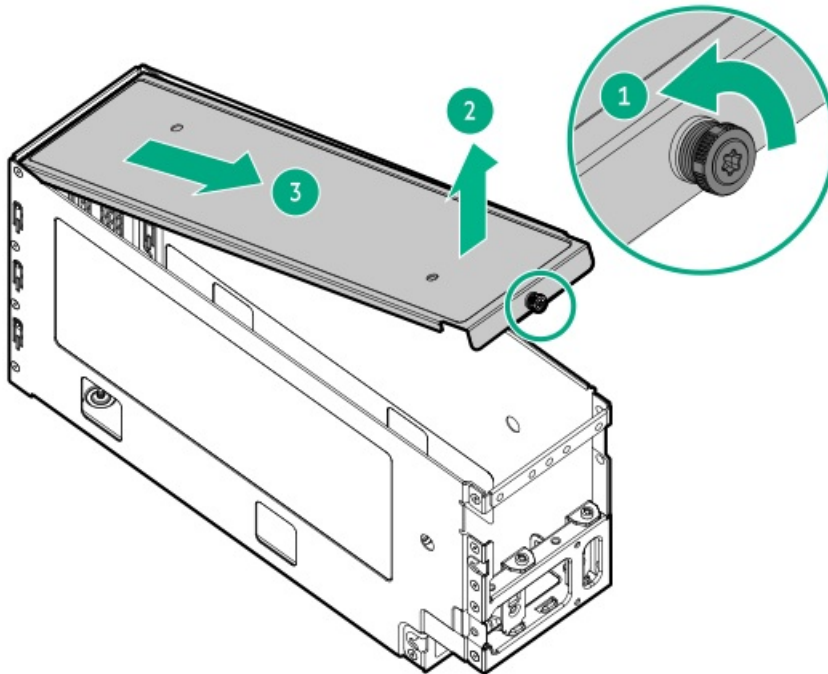

13. If installing a double-width accelerator:

- a. Remove the accelerator support bracket from the GPU riser cage.



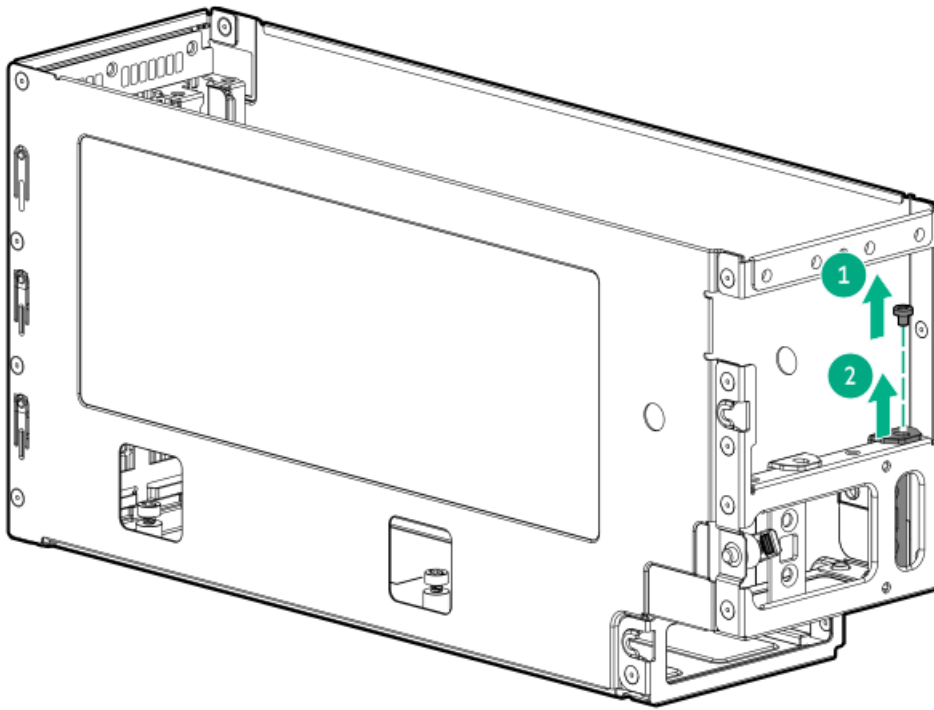

b. Install the support bracket on the double-width accelerator.

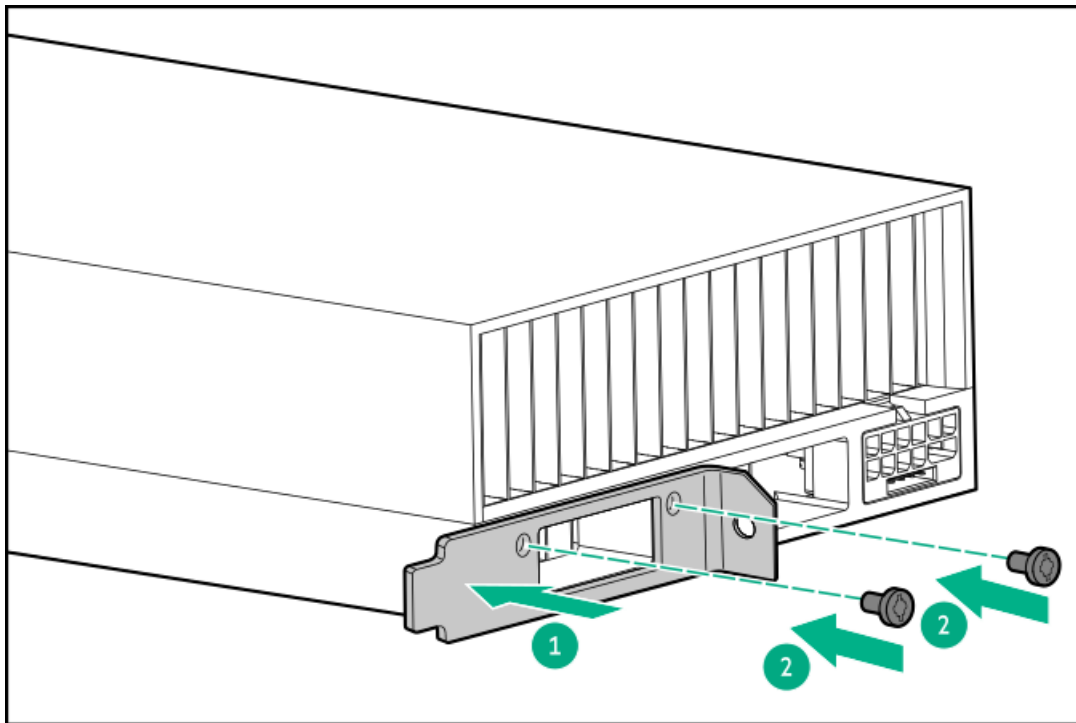

14. Remove the GPU riser slot brackets.

Remove one bracket for single-width accelerators. Remove two blanks for double-width accelerators. Retain the screws. These screws will be used to install the accelerator.



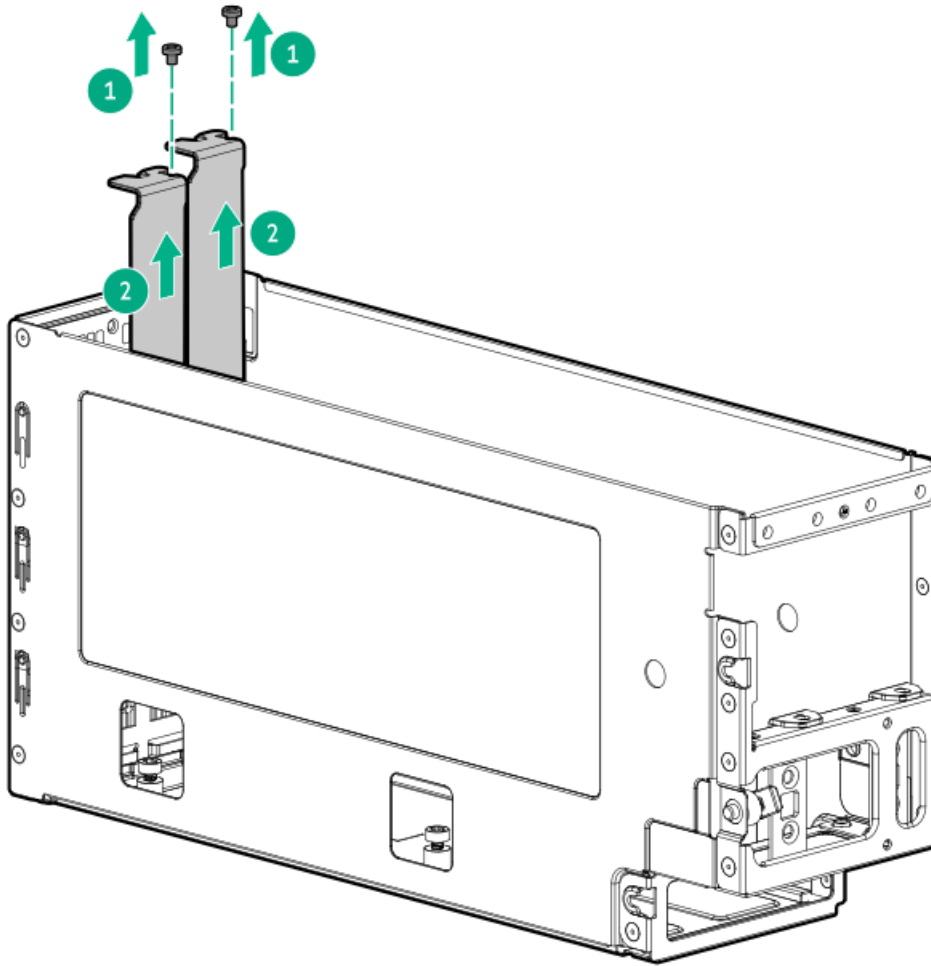

15. Install the accelerator in the GPU riser cage:

- a. Install the accelerator to make sure that it is seated firmly on the GPU riser.

A click sound indicates that the accelerator is properly engaged.

- b. Install the screws.

- Single-width accelerator

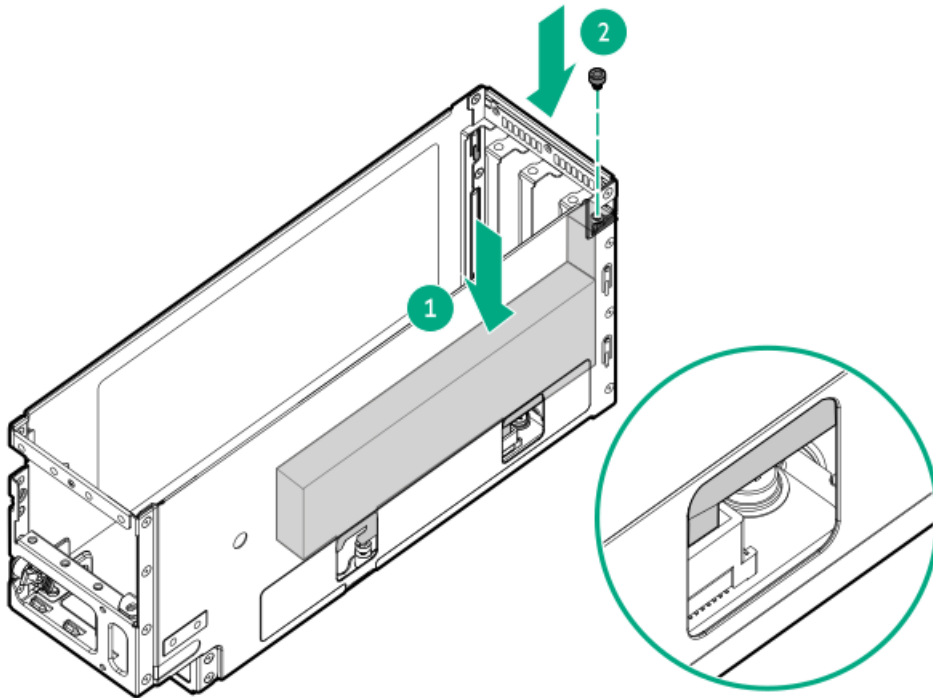

- Double-width accelerator

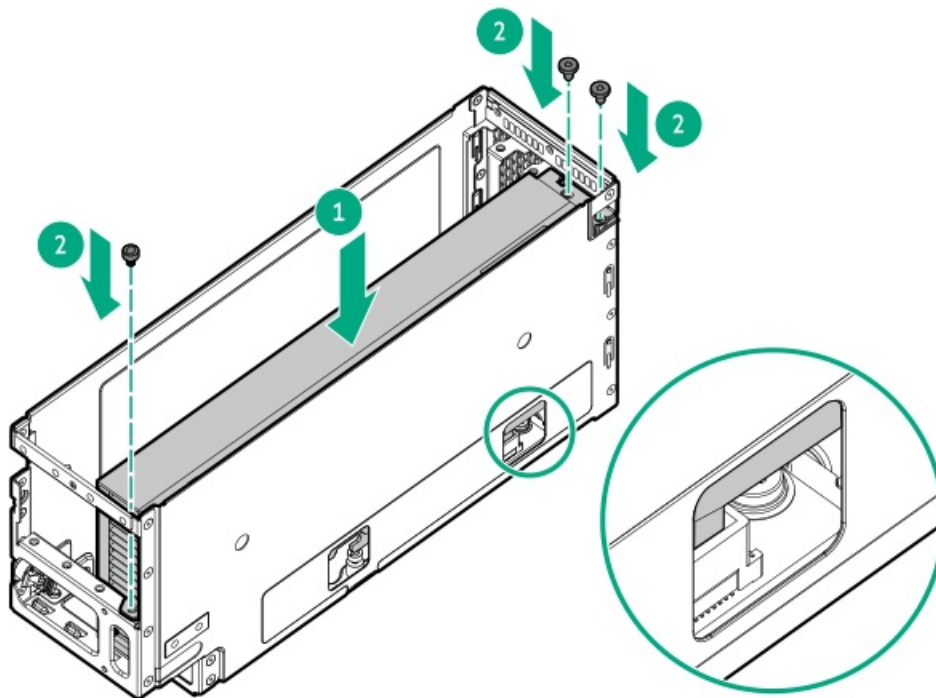

16. Install the GPU riser cage cover.



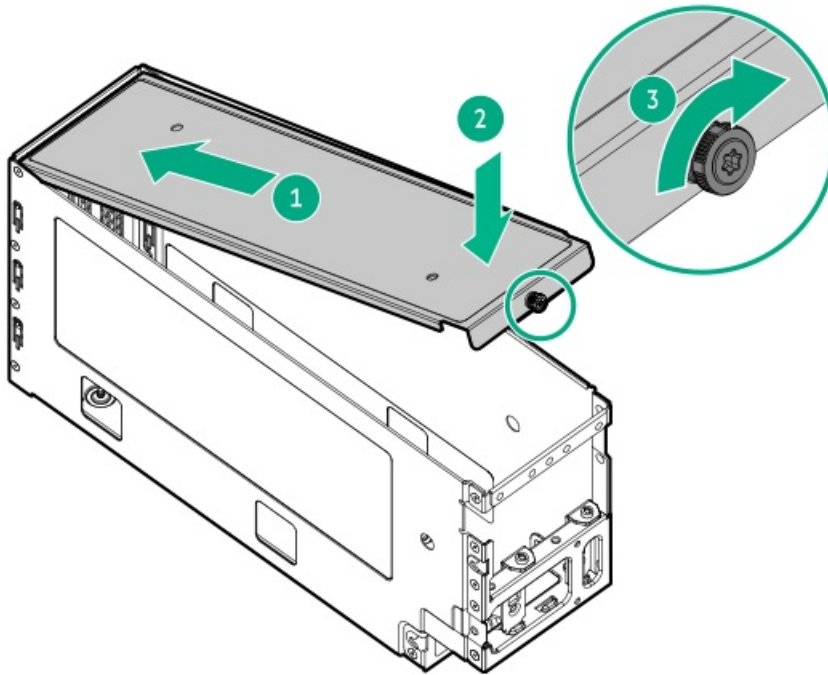

17. Install the GPU riser cage:

- a. Slide the GPU riser cage into the server.

Feed the riser cables through the channel nearest to the chassis wall.

- b. Rotate the locking pin to the close (horizontal) position.

Make sure that the locking pin is locked on the chassis.

- GPU riser cage 1



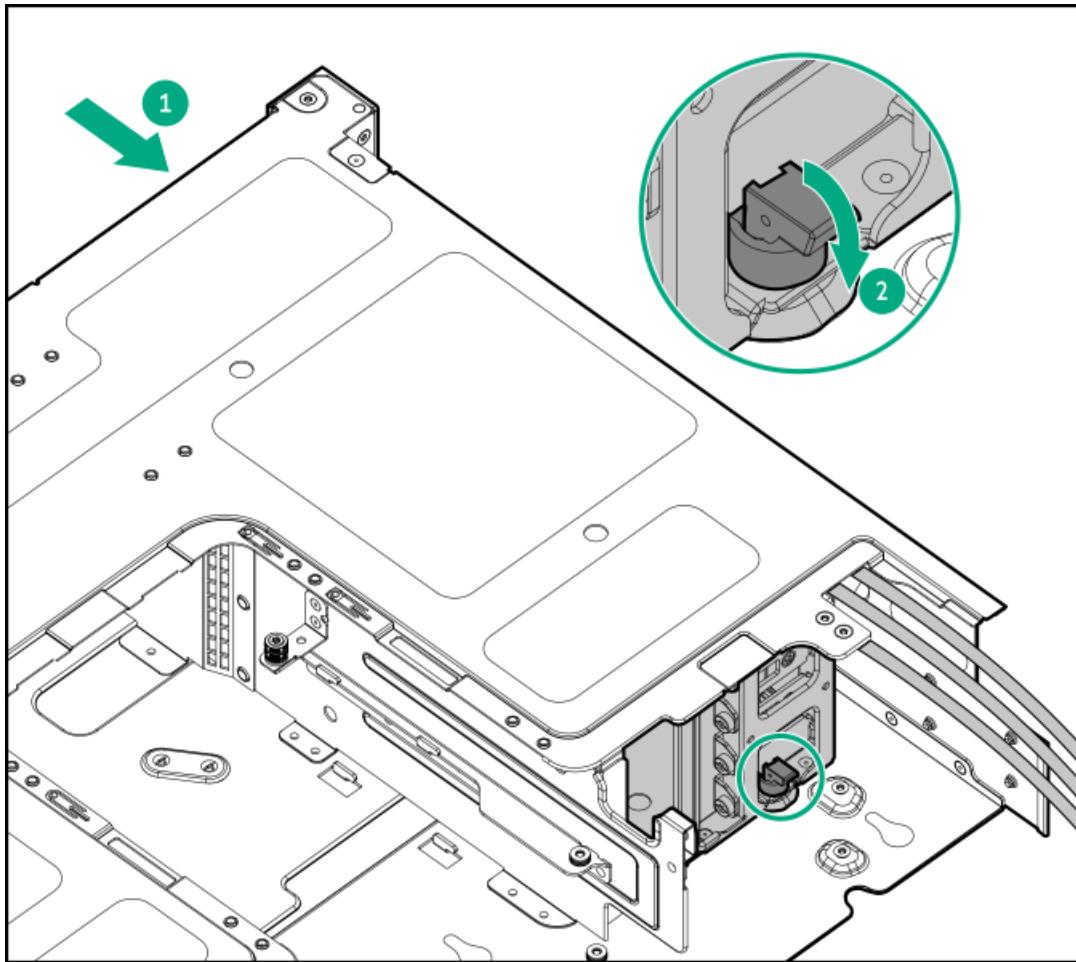

- GPU riser cage 2

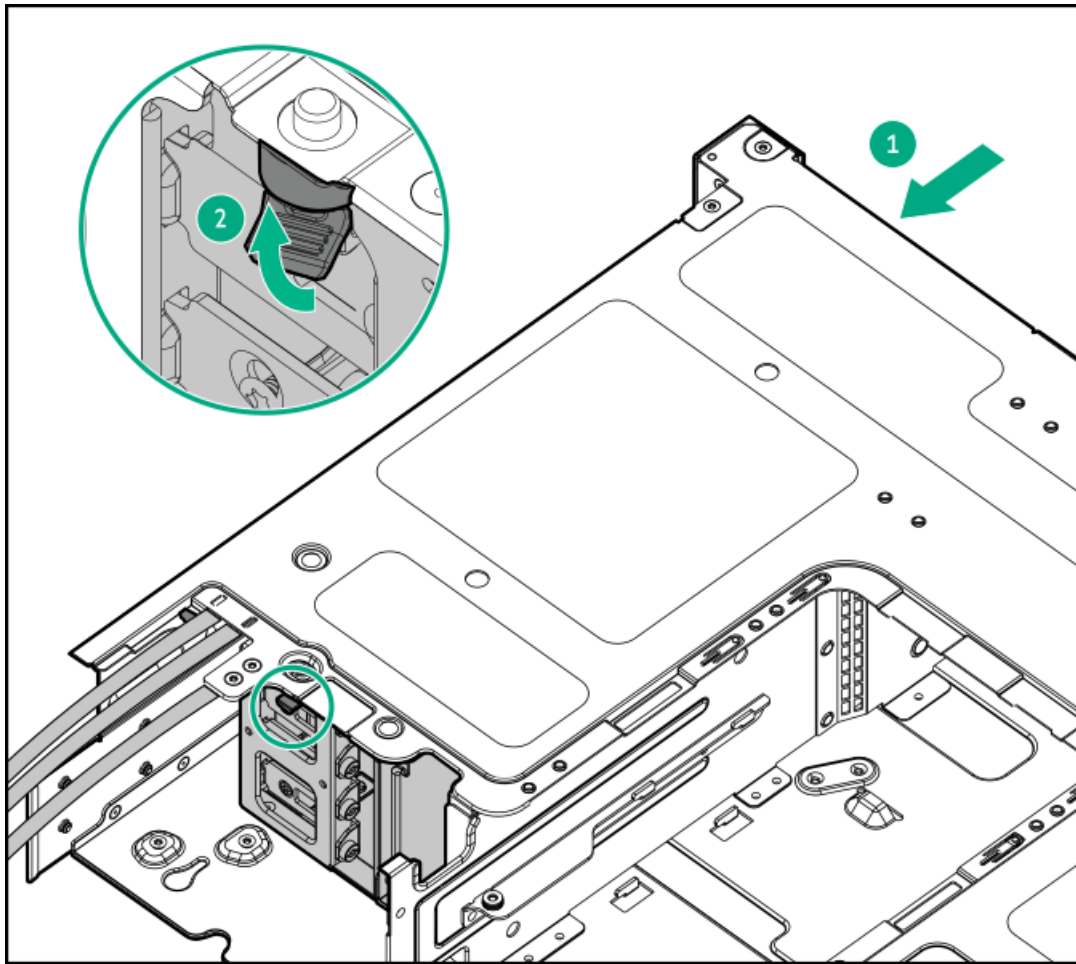

18. Connect the GPU riser cables to the system board.

If the cables are not connected correctly, the system will not power on.

19. If a high power accelerator is installed, connect the accelerator auxiliary power cable.

20. Install the middle cover.

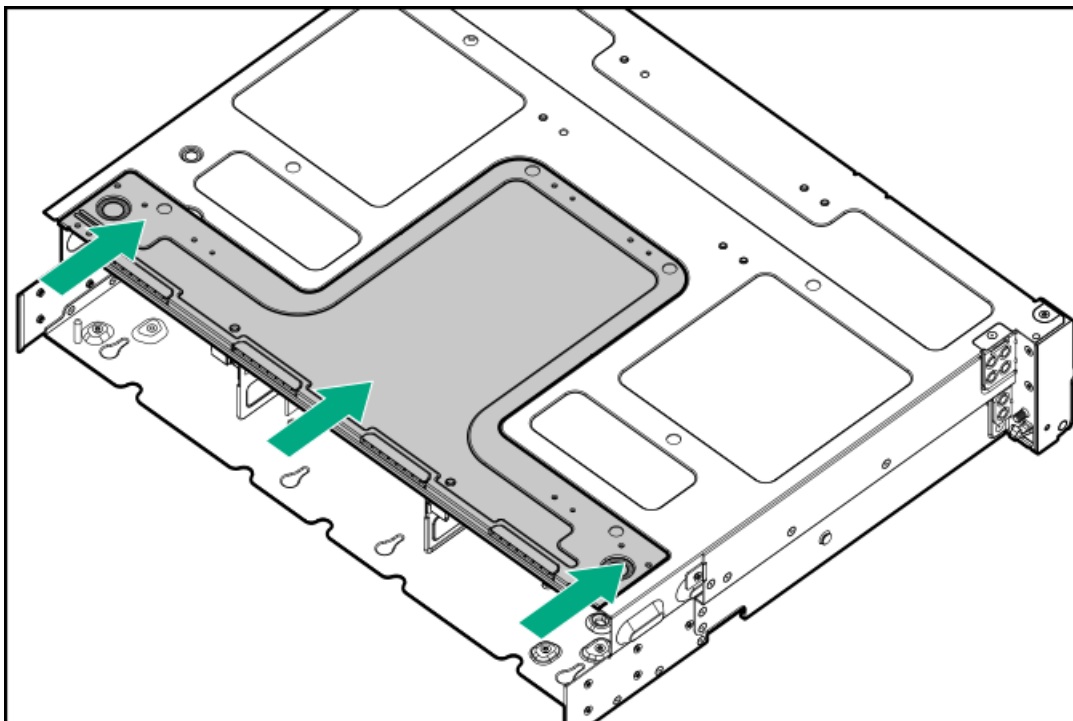

21. [Install the air baffle.](#)
22. [Install the access panel.](#)
23. [Install the server into the rack.](#)
24. Connect all peripheral cables to the server.
25. Connect the power cords:
 - a. Connect each power cord to the server.
 - b. Connect each power cord to the power source.
26. If installed, close the cable management arm.

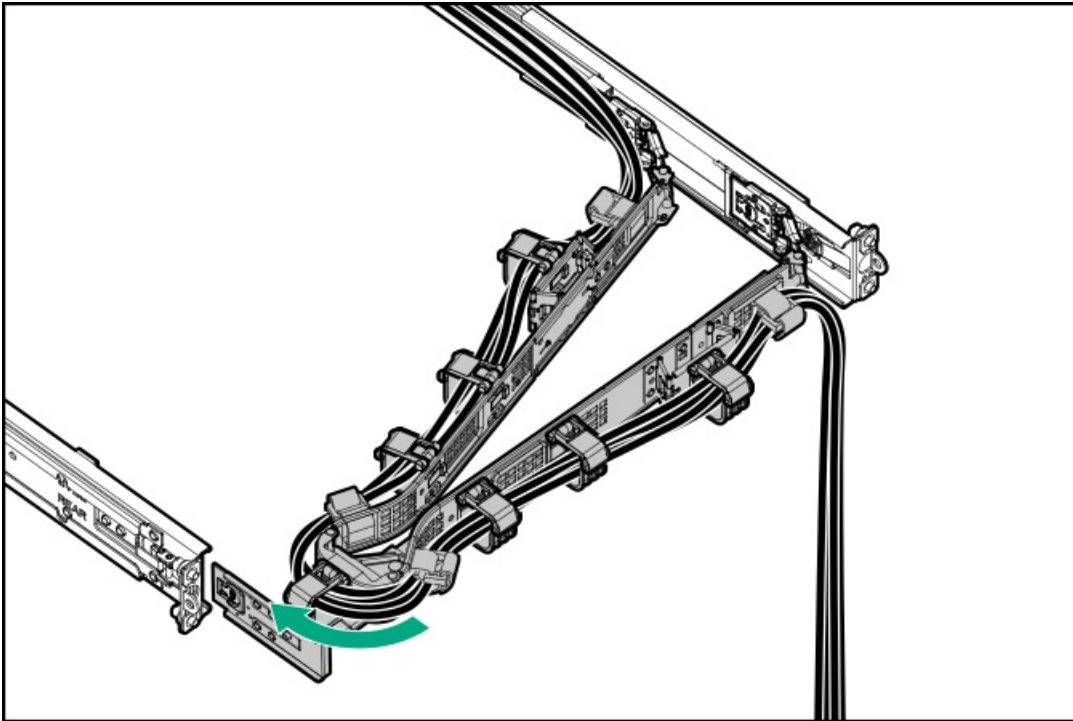

27. [Power up the server.](#)
28. If removed, [install the front bezel.](#)

Results

The installation is complete.

Riser and riser cage options

In the rear 4 LFF drive configuration, the one-slot primary riser cage is default in the server. The server supports the following riser cage options:

- Primary riser cage
- Secondary riser cage
- HPE NS204i Boot Device + secondary low-profile riser cage
- Tertiary riser cage

Subtopics



[Installing the secondary riser cage](#)

[Installing a stacking riser](#)

Installing the secondary riser cage

Prerequisites

Before you perform this procedure, make sure that you have a T-15 Torx screwdriver available.

Procedure

1. [Power down the server.](#)
2. If installed, [open the cable management arm.](#)
3. Remove all power:
 - a. Disconnect each power cord from the power source.
 - b. Disconnect each power cord from the server.
4. Disconnect all peripheral cables from the server.
5. [Remove the server from the rack.](#)
6. [Remove the access panel.](#)
7. Do one of the following:
 - [Remove the air baffle.](#)
 - [Remove the midplane drive cage.](#)
8. [Remove the rear 4 LFF drive cage.](#)
9. (Optional) If installing the NS204i-u + secondary low-profile riser cage, [install the HPE NS204i-u Boot Device.](#)
10. (Optional) [Install an expansion card onto the secondary riser cage.](#)
11. Remove the secondary riser cage blank.



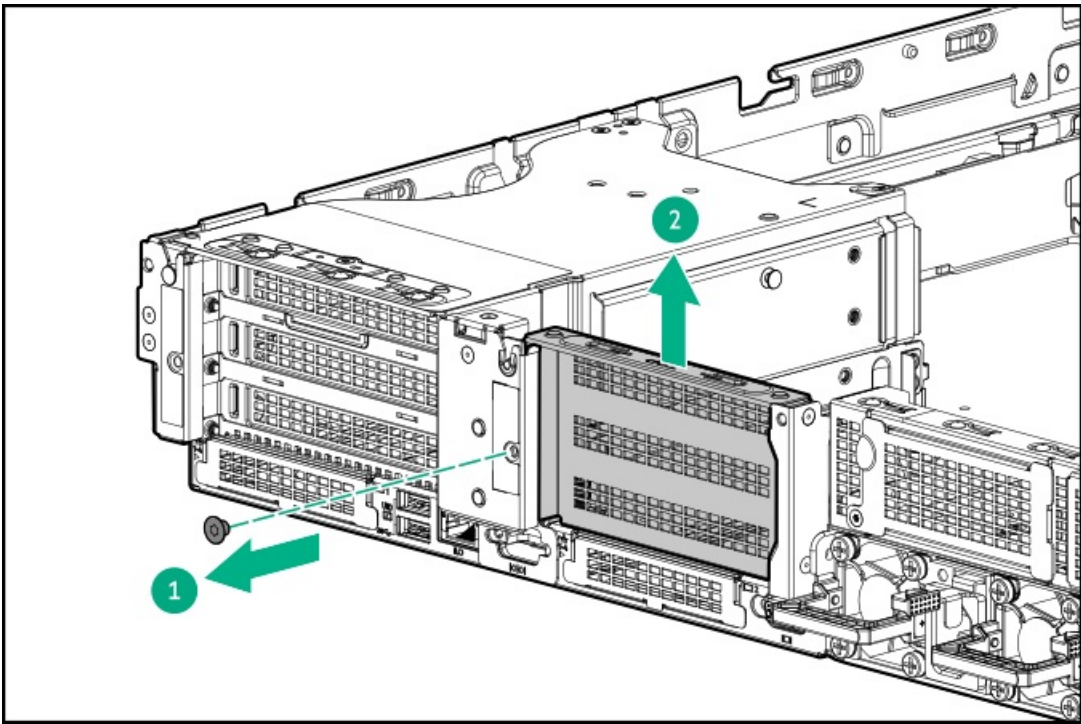

12. Install the riser cage:

- a. Carefully press the riser down on its system board connector.

Make sure that the riser board is firmly seated.

- b. Simultaneously push and rotate the half-turn spring latch to 180°.

- c. Close the spring latch.

- One-slot secondary riser cage

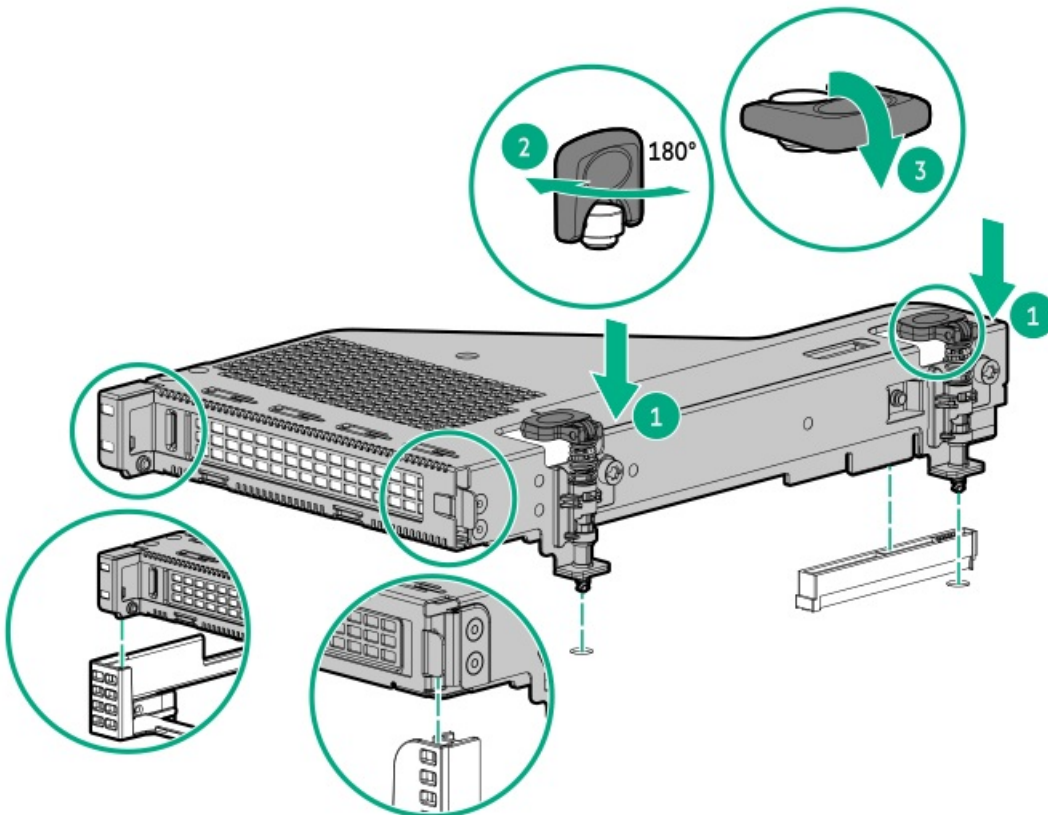

- NS204i-u + secondary low-profile riser cage

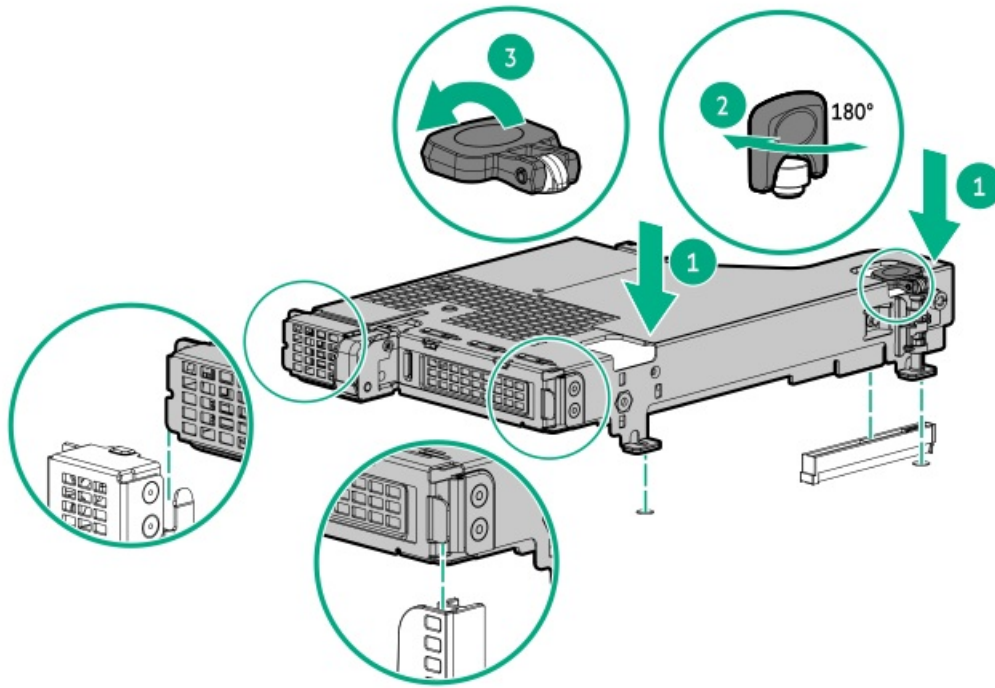

13. To install the three-slot riser cage, do the following:

- Install the bracket onto the side of the power supply cage.

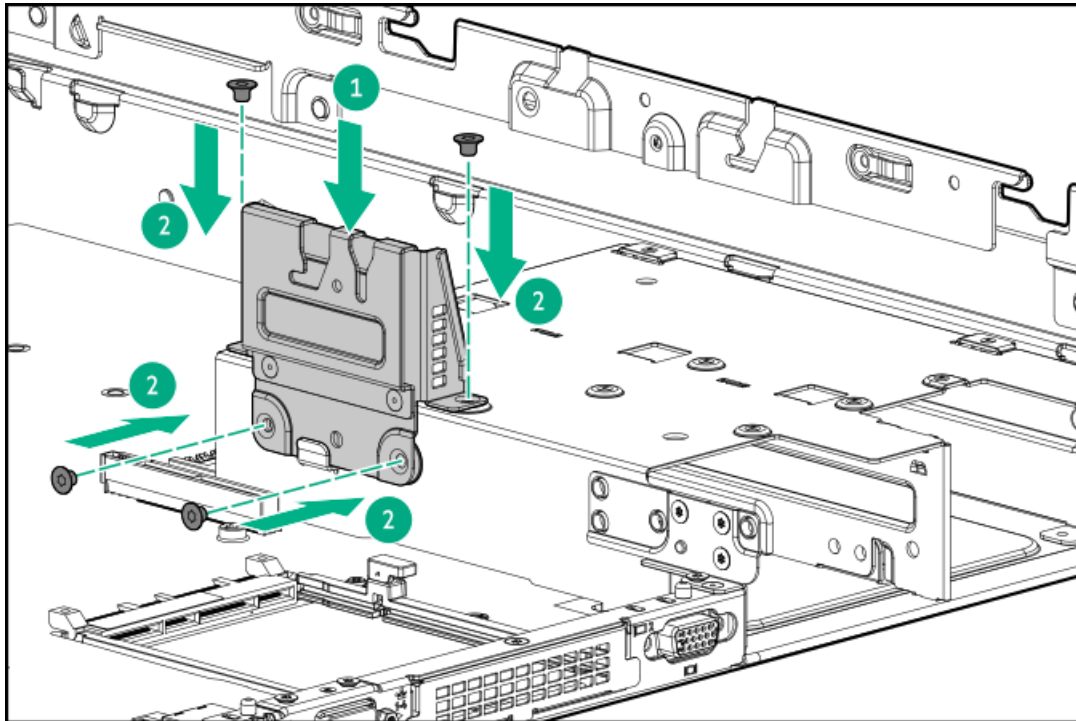

- Align the riser cage pin to the bracket slot.
- Carefully press the riser down on its system board connector (callout 1).

Make sure that the riser board is firmly seated.

- Tighten the captive screws (callout 2).



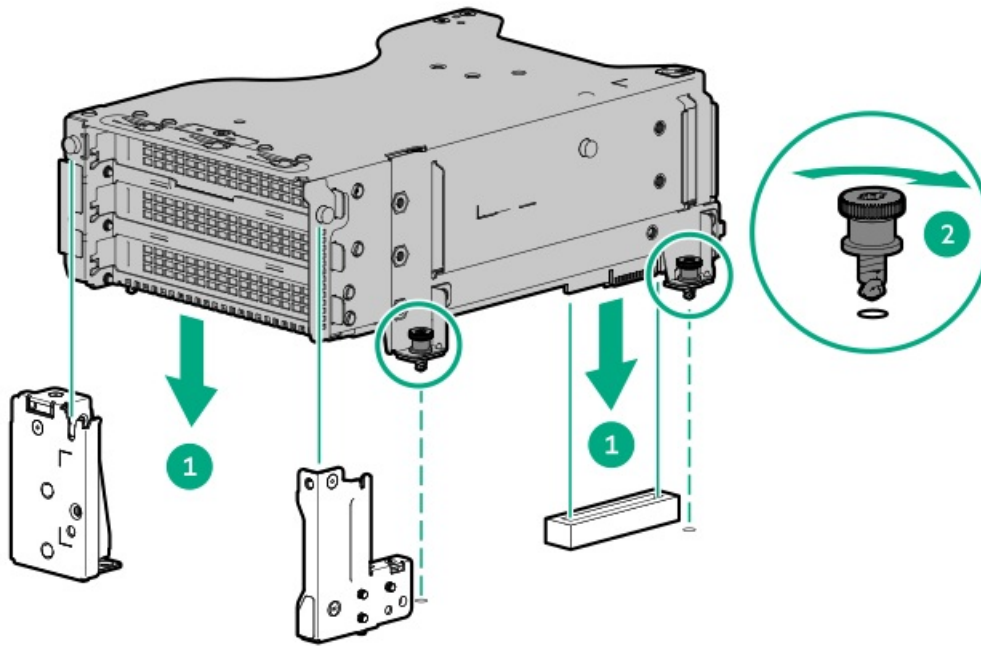

14. (Optional) Connect all necessary internal cabling to the expansion card.

For more information on these cabling requirements, see the documentation that ships with the option.

15. Install the rear 4 LFF drive cage.

16. Do one of the following:

- Install the air baffle.
- Install the midplane drive cage.

17. Install the access panel.

18. Install the server into the rack.

19. Install all drives.

20. Connect all peripheral cables to the server.

21. Connect the power cords:

- a. Connect each power cord to the server.
- b. Connect each power cord to the power source.

22. If installed, close the cable management arm.



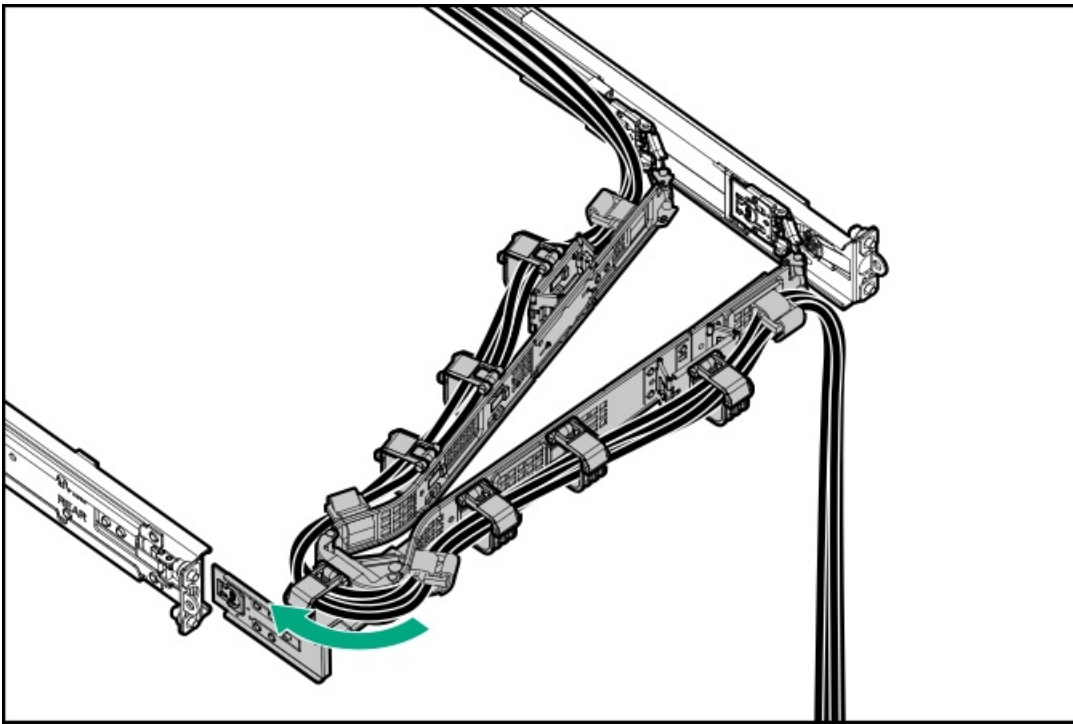

23. Power up the server.

Results

The installation procedure is complete.

Installing a stacking riser

About this task

WARNING: To reduce the risk of personal injury from hot surfaces, allow the drives and the internal system components to cool before touching them.

CAUTION: To prevent damage to electrical components, properly ground the server before beginning any installation procedure. Improper grounding can cause electrostatic discharge.

Before you perform this procedure, make sure that you have a T-15 Torx screwdriver available.

Procedure

1. Power down the server.
2. If installed, open the cable management arm.
3. Remove all power:
 - a. Disconnect each power cord from the power source.
 - b. Disconnect each power cord from the server.
4. Disconnect all peripheral cables from the server.
5. Remove the server from the rack.
6. Remove the access panel.
7. Remove the riser cage.
8. Connect the stacking risers.

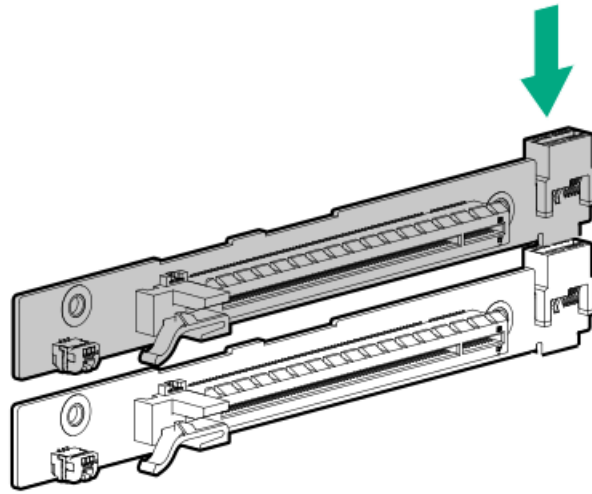

9. Install the risers on the riser cage:
 - a. Install the risers on the riser cage.
 - b. Install the riser screws.

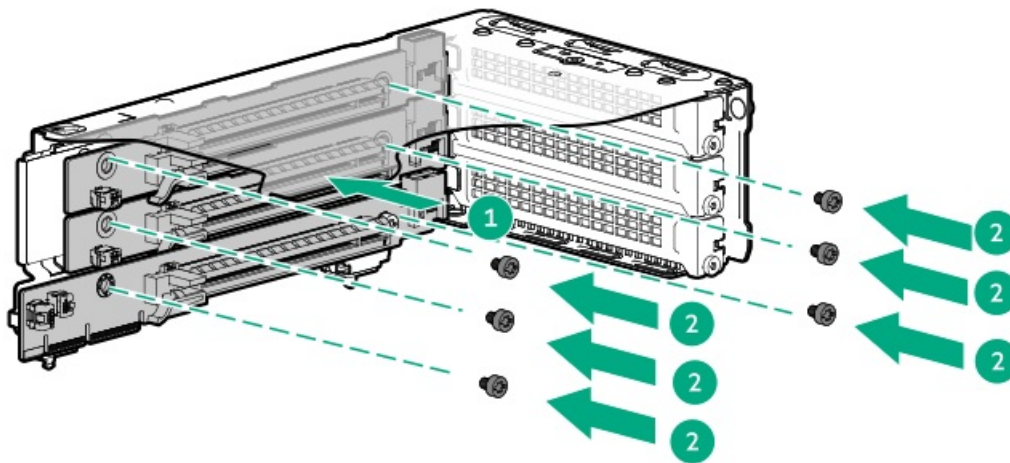

10. Install the riser cage.
11. Install the access panel.
12. Install the server into the rack.
13. Connect all peripheral cables to the server.
14. Connect the power cords:
 - a. Connect each power cord to the server.
 - b. Connect each power cord to the power source.
15. If installed, close the cable management arm.



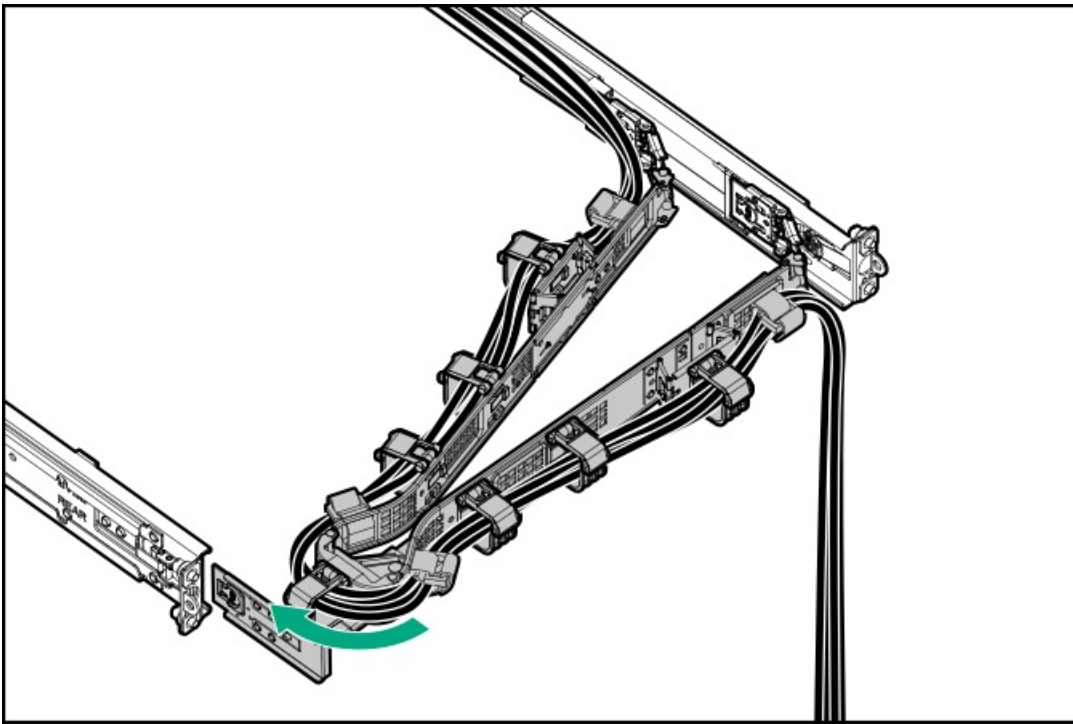

16. Power up the server.

Results

The installation procedure is complete.

Memory option

The server has 12 DIMM slots supporting RDIMM.

The arrow points to the front of the server.

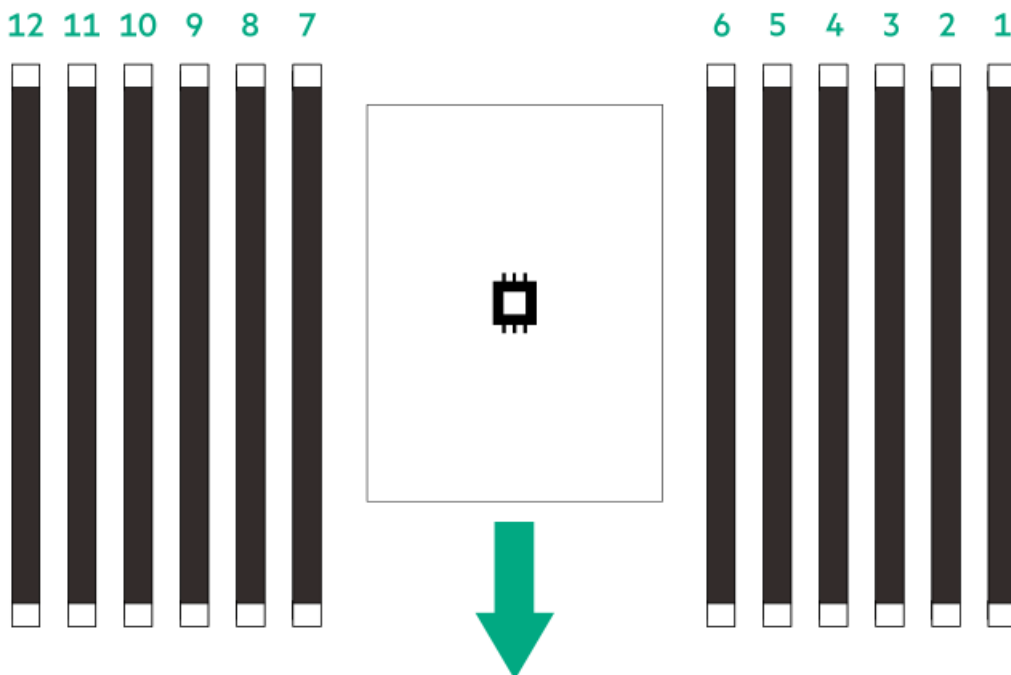

Subtopics

[HPE SmartMemory speed and population information](#)

[Installing a DIMM](#)

HPE SmartMemory speed and population information

For information about memory speed and server-specific DIMM population rules for HPE servers using AMD EPYC 9004 Series Processor, see the relevant memory technical paper in:

<https://www.hpe.com/docs/server-memory>

Installing a DIMM

Prerequisites

If you install a 256 GB or higher capacity DIMM, [the high performance, dual-rotor fans are required](#).

About this task



CAUTION:

Do not install ×4 and ×8 DRAM widths in the same server. All memory installed in the server must be of the same type. Installing different DIMM types can cause the server to halt during BIOS initialization.



CAUTION: A discharge of static electricity from a finger or other conductor might damage system boards or other static-sensitive devices. To prevent damage, observe [antistatic precautions](#).

Procedure

1. [Power down the server](#).
 2. If installed, [open the cable management arm](#).
 3. Remove all power:
 - a. Disconnect each power cord from the power source.
 - b. Disconnect each power cord from the server.
 4. Disconnect all peripheral cables from the server.
 5. [Extend the server from the rack](#).
 6. [Remove the access panel](#).
 7. Do one of the following:
 - [Remove the air baffle](#).
 - [Remove the midplane drive cage](#).
- Installing a DIMM with a max performance heatsink**
8. Install the DIMM:
 - a. Open the DIMM slot latches.
 - b. Carefully slide the DIMM under the max performance heatsink (callout 1).
 - c. Fully press the DIMM into the slot until the latches snap back into place (callout 2).

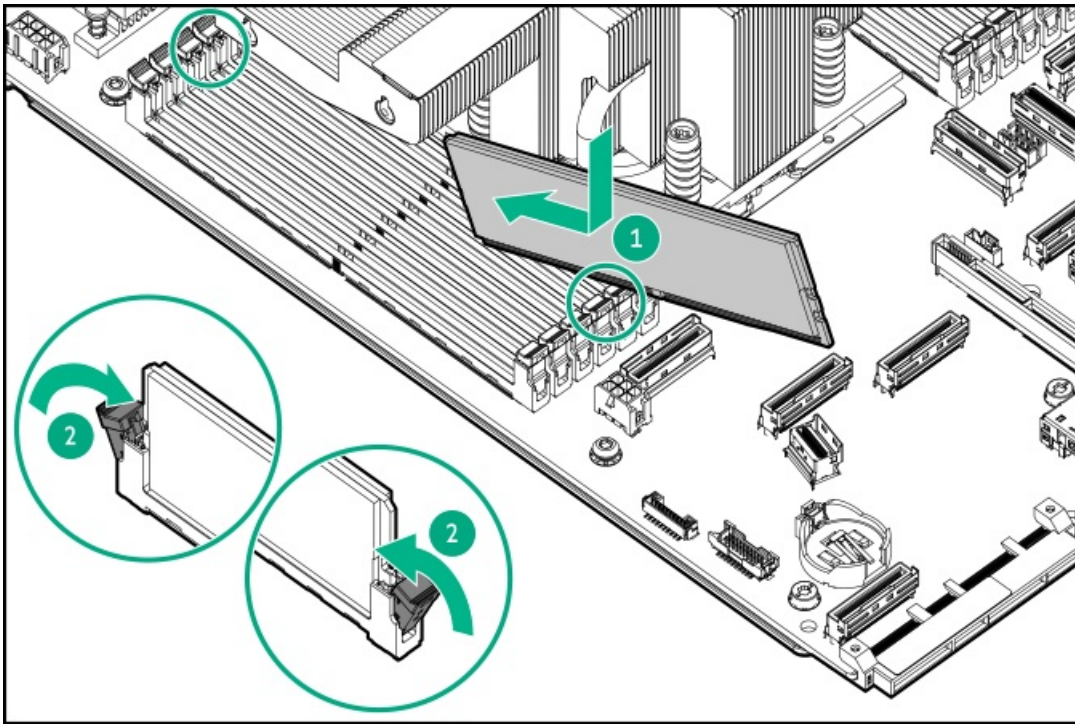

Installing a DIMM with a standard, high performance, or midplane cage heatsink

9. Install the DIMM:

- a. Open the DIMM slot latches.
- b. Align the notch on the bottom edge of the DIMM with the keyed surface of the DIMM slot, and then fully press the DIMM into the slot until the latches snap back into place.

The DIMM slots are structured to ensure proper installation. If you try to insert a DIMM but it does not fit easily into the slot, you might have positioned it incorrectly. Reverse the orientation of the DIMM and insert it again.

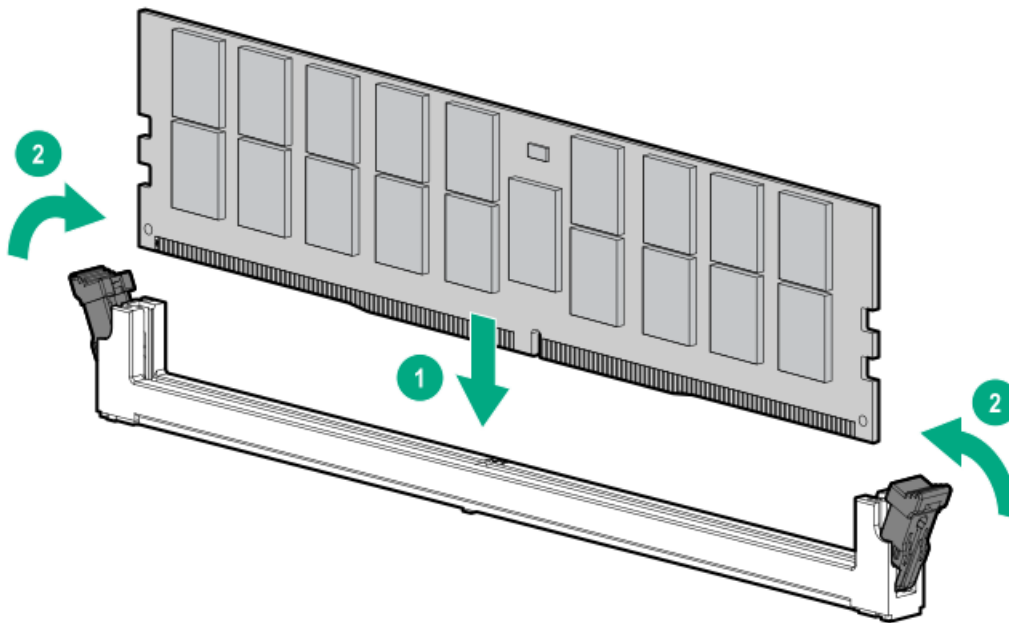

10. Ensure that all DIMM latches are closed.

11. Do one of the following:

- Install the air baffle.

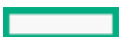

- [Install the midplane drive cage.](#)
12. [Install the access panel.](#)
 13. Connect all peripheral cables to the server.
 14. Connect the power cords:
 - a. Connect each power cord to the server.
 - b. Connect each power cord to the power source.
 15. If installed, close the cable management arm.

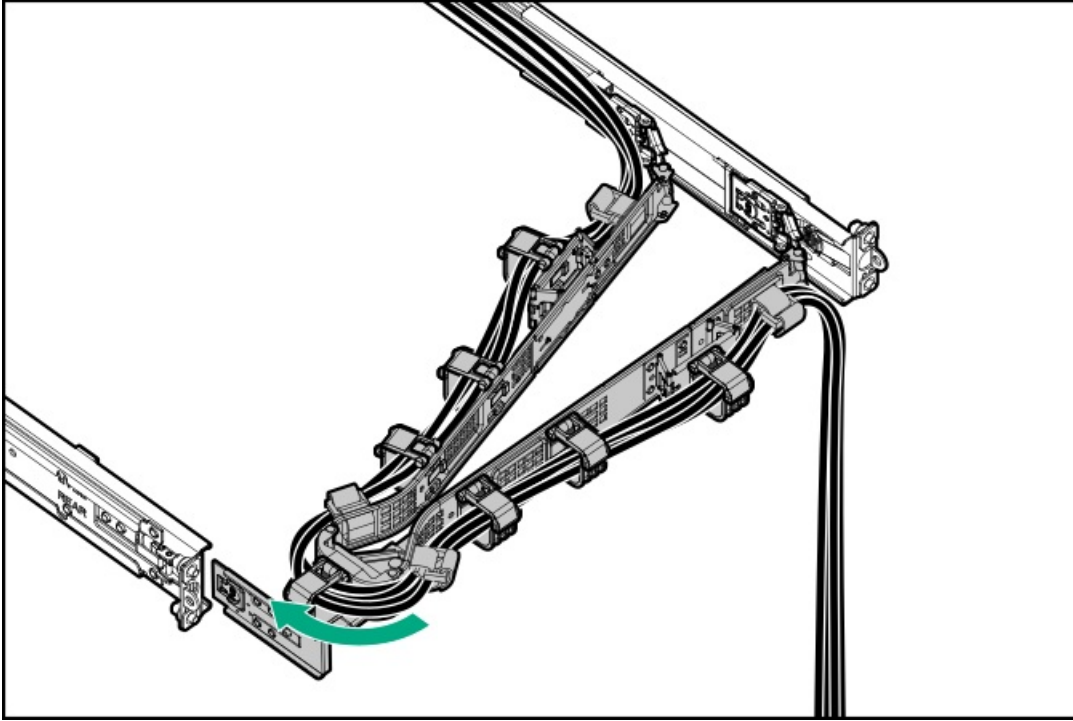

16. [Power up the server.](#)

Results

The installation procedure is complete.

OCP NIC 3.0 adapter option

The server supports SFF dual-port and quad-port OCP NIC 3.0 adapter options with various interfaces and advanced interconnect features for high-bandwidth applications.

Subtopics

[OCP slot population rules](#)

[Installing the OCP NIC 3.0 adapter](#)

OCP slot population rules



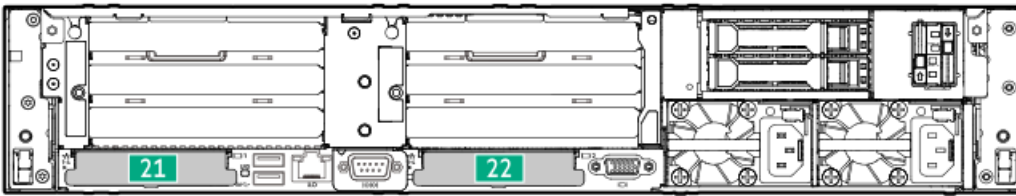

Slot number	Supported hardware components
Slot 21 OCP PCIe5 x8	<ul style="list-style-type: none"> Type-o storage controller OCP NIC 3.0 adapter
Slot 22 OCP PCIe5 x8	OCP NIC 3.0 adapter ¹

¹ When installing the first OCP NIC 3.0 adapter, always install in Slot 22.

Installing the OCP NIC 3.0 adapter

Prerequisites

- Review the [OCP slot population rules](#).
- Before you perform this procedure, make sure that you have a T-10 Torx screwdriver available.

About this task

CAUTION: A discharge of static electricity from a finger or other conductor might damage system boards or other static-sensitive devices. To prevent damage, observe [antistatic precautions](#).

CAUTION: The port blank provides EMI shielding and helps maintain proper thermal status inside the server. Do not operate the server when a port blank is removed without the corresponding I/O port option installed.

Procedure

- [Power down the server](#).
- If installed, [open the cable management arm](#).
- Remove all power:
 - Disconnect each power cord from the power source.
 - Disconnect each power cord from the server.
- Disconnect all peripheral cables from the server.
- [Remove the server from the rack](#).
- [Remove the access panel](#).
- If the server is in the rear 4 LFF drive configuration:
 - [Remove the rear 4 LFF drive cage](#).
 - [Remove the primary riser cage](#).
 - (Optional) If installed, [remove the secondary riser cage](#).

8. If the server has two three-slot riser cages, remove the primary and secondary riser cages.

9. Remove the OCP slot blank:

- a. Remove the blank screw.
- b. Remove the blank.

Retain the screw and blank for future use.

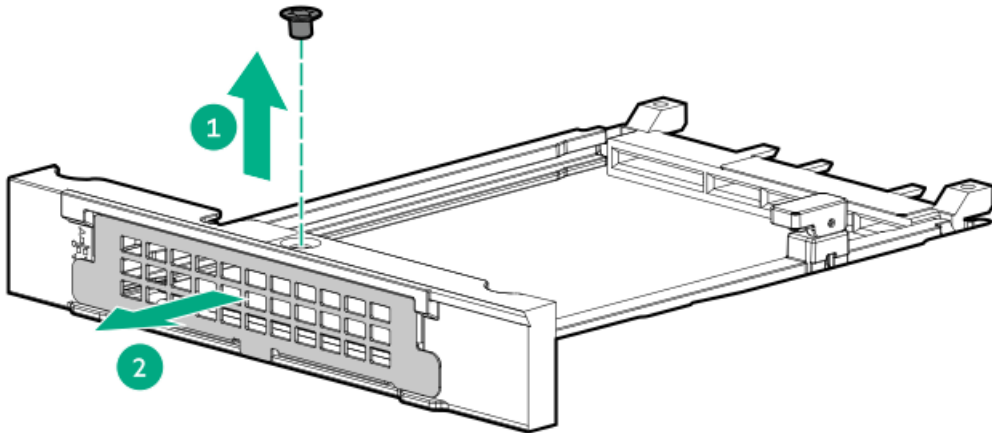

10. Install the OCP NIC 3.0 adapter:

- a. Rotate the locking pin to the open (vertical) position.
- b. Slide the adapter into the bay until it clicks into place.
Make sure that the adapter is seated firmly in the slot.
- c. Rotate the locking pin to the close (horizontal) position.

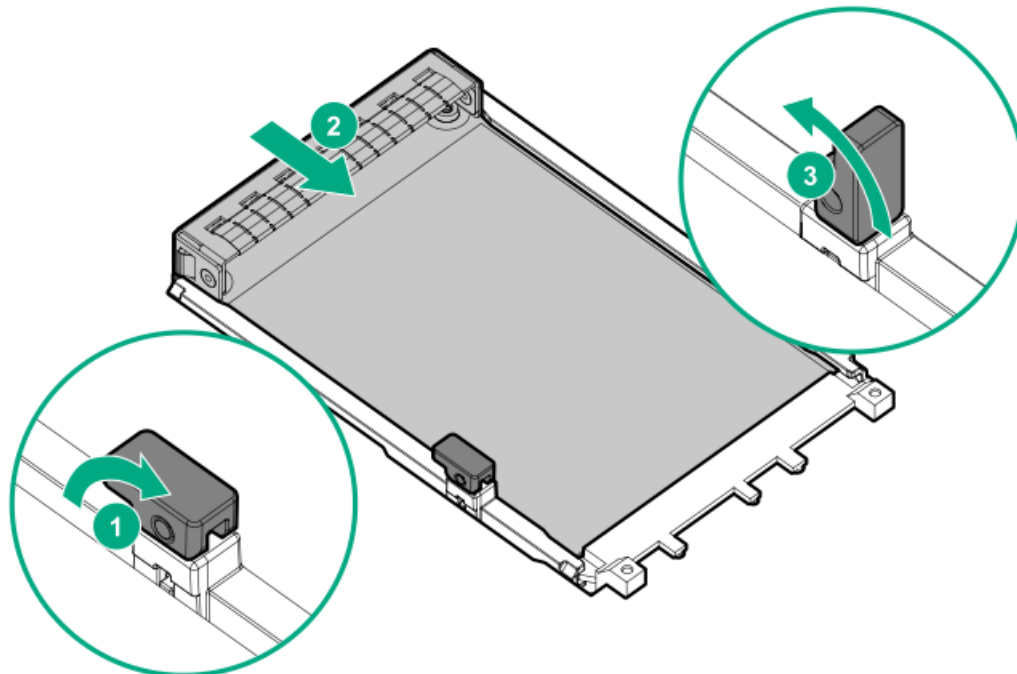

11. If removed, install the following items:



- [Primary riser cage](#)
 - [Secondary riser cage](#)
 - [Rear 4 LFF drive cage](#)
12. [Cable the controller.](#)
 13. Do one of the following:
 - [Install the air baffle.](#)
 - [Install the midplane drive cage.](#)
 14. [Install the access panel.](#)
 15. [Install the server into the rack.](#)
 16. Connect all peripheral cables to the server.
 17. Connect the power cords:
 - a. Connect each power cord to the server.
 - b. Connect each power cord to the power source.
 18. If installed, close the cable management arm.

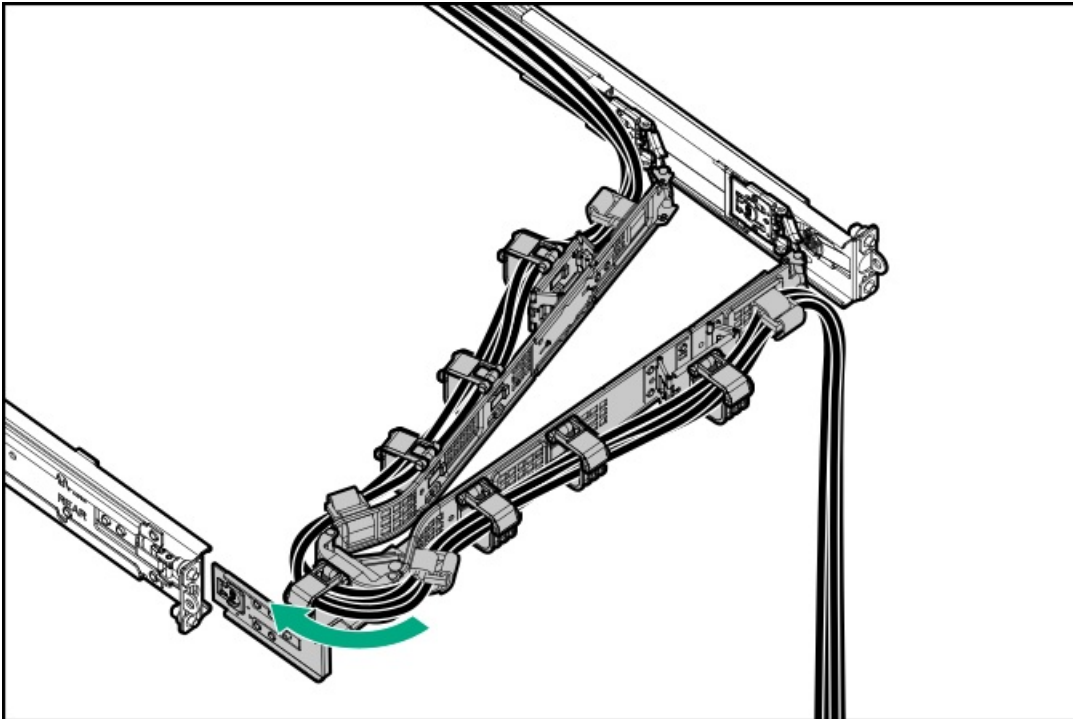

19. [Power up the server.](#)

Results

The installation procedure is complete.

HPE NS204i-u Boot Device option

Note the following information about the HPE NS204i-u Boot Device option:

- The HPE NS204i-u Gen11 NVMe Hot Plug Boot Optimized Storage Device is a custom form factor module that includes two hot-



pluggable 2280 M.2 NVMe SSDs.

- This boot device enables the deployed OS to be mirrored through a dedicated hardware RAID 1.
- The boot device auto-creates a RAID1 volume during boot. This means the boot device does not require further RAID configuration.
- This boot device is compatible with the following native OS:
 - Windows
 - Linux
 - VMware
- This boot device uses native inbox OS NVMe drivers.

Subtopics

[Installing the boot device security cover in a preconfigured server](#)

[Installing the HPE NS204i-u Boot Device on the secondary low-profile riser cage](#)

[Installing the HPE NS204i Boot Device on the secondary riser cage](#)

[Installing the HPE NS204i Boot Device on top of the power supply cage](#)

Installing the boot device security cover in a preconfigured server

Prerequisites

Before you perform this procedure, make sure that you have a T-10 Torx screwdriver available.

About this task

In a preconfigured server that ships with the boot device already installed in the NS204i-u + secondary low-profile riser cage, the accessory bag in the server box includes the security cover for the boot device. If you want to prevent hot-plug access to the SSDs on the boot device, install this security cover.

Procedure

1. [Power down the server.](#)
2. Remove all power:
 - a. Disconnect each power cord from the power source.
 - b. Disconnect each power cord from the server.
3. Disconnect all peripheral cables from the server.
4. Do one of the following:
 - [Extend the server from the rack.](#)
 - [Remove the server from the rack.](#)
5. [Remove the access panel.](#)
6. [Remove the rear 4 LFF drive cage.](#)
7. Remove the NS204i-u + secondary low-profile riser cage:
 - a. Release the half-turn spring latch.
 - b. Lift the riser cage off the system board.

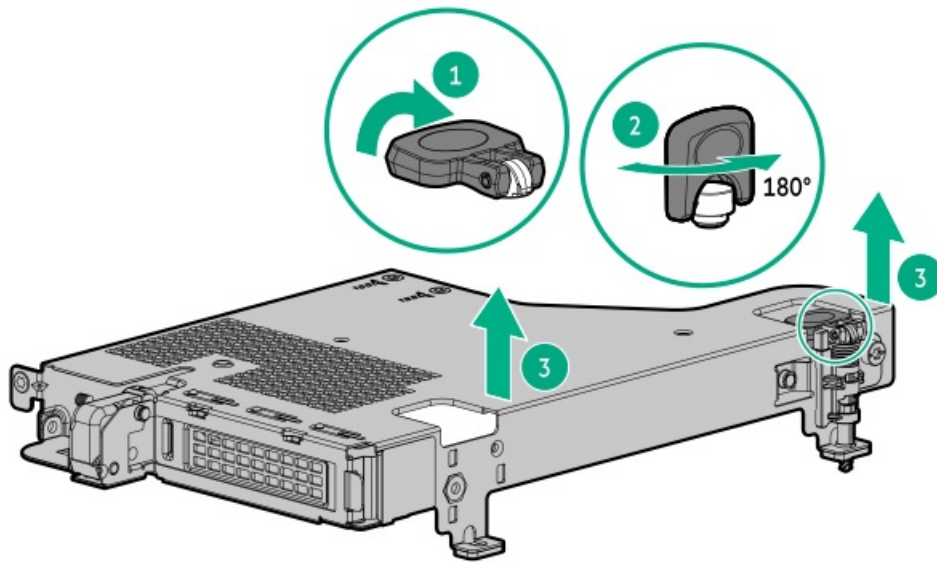

8. Install the security cover for the boot device.

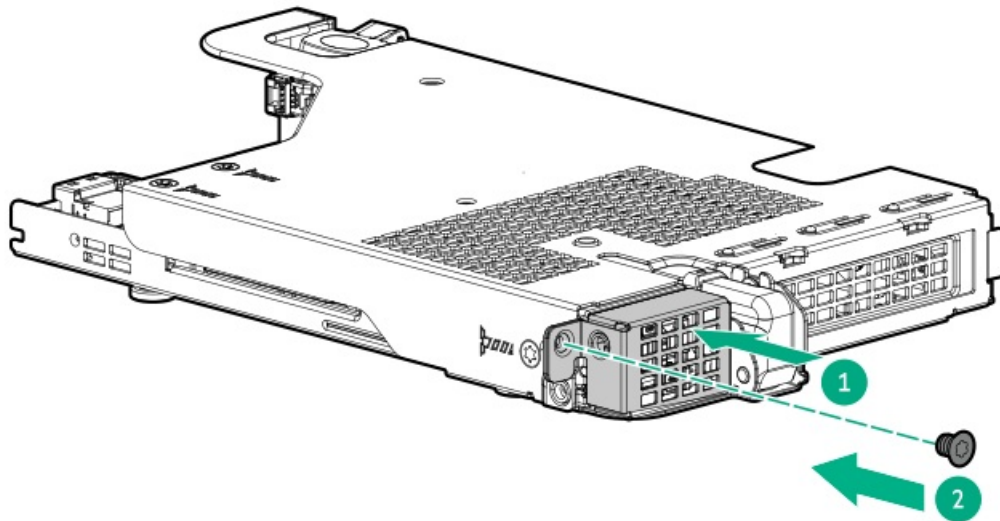

9. Install the NS204i-u + secondary low-profile riser cage:

a. Carefully press the riser down on its system board connector.

Make sure that:

- The riser cage is aligned with the rear chassis.
- The riser board is firmly seated on the system board.

b. Simultaneously push and rotate the half-turn spring latch to 180°.

c. Close the spring latch.



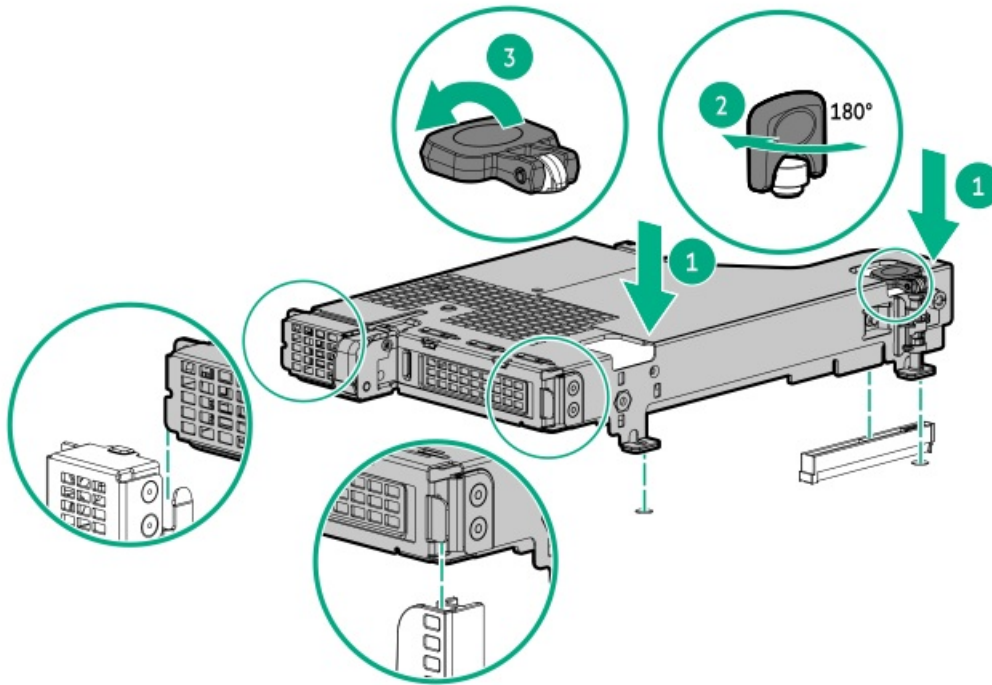

10. Install the rear 4 LFF drive cage.
11. Install the access panel.
12. Install the server into the rack.
13. Connect all peripheral cables to the server.
14. Connect each power cord to the server.
15. Connect each power cord to the power source.
16. Power up the server.

Results

The installation procedure is complete.

Installing the HPE NS204i-u Boot Device on the secondary low-profile riser cage

Prerequisites

- Before beginning installation, make sure that the server is updated with the latest operating system firmware and drivers.
- Identify the HPE NS204i-u Boot Device components.
- Before you perform this procedure, make sure that you have the following items available:
 - T-10 Torx screwdriver
 - Phillips No. 1 screwdriver—This tool is required only if the M.2 SSDs are not preinstalled on the boot device carriers.

About this task

CAUTION: A discharge of static electricity from a finger or other conductor might damage system boards or other static-sensitive devices. To prevent damage, observe antistatic precautions.

Procedure

Installing drives onto the boot device

1. Remove the boot device carrier:

- a. Press and hold the carrier latch.
- b. Pivot the latch to open.
- c. Slide the carrier out from the boot device cage.

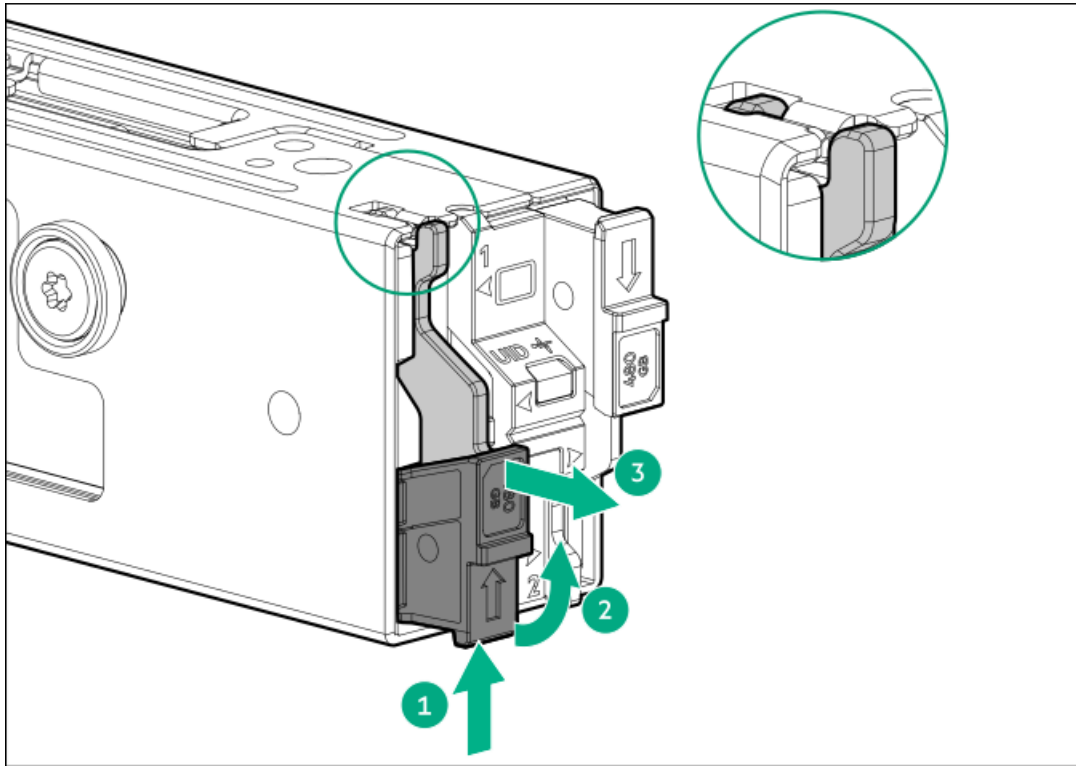

2. Install the SSD on the boot device carrier:

- a. Remove the SSD mounting screw.

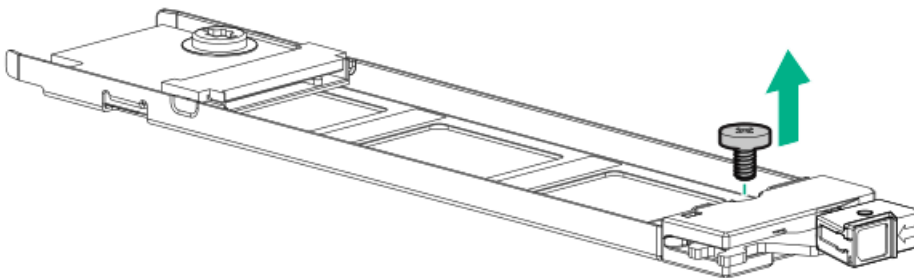

- b. Insert the SSD into the M.2 slot at a 45° angle.
- c. Carefully press the SSD down to the horizontal position.
- d. Install the SSD mounting screw.

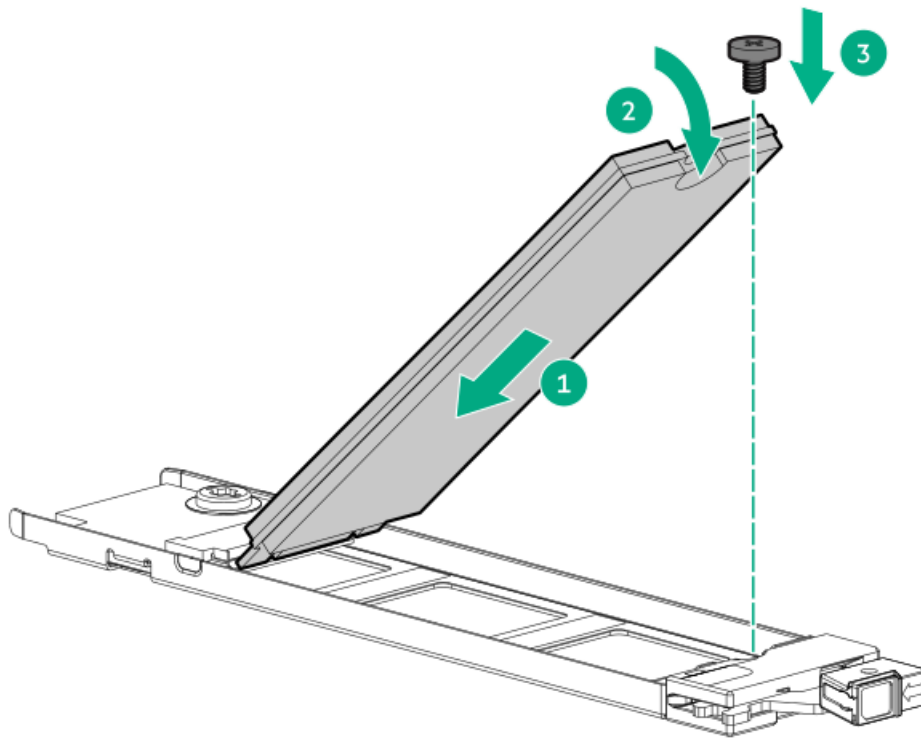

3. Install the boot device carriers:

- a. If closed, pivot the carrier latch to open.
- b. Slide the carrier into the boot device cage.
- c. Pivot the latch to close.

Make sure that the carrier latch is locked on the boot device cage.

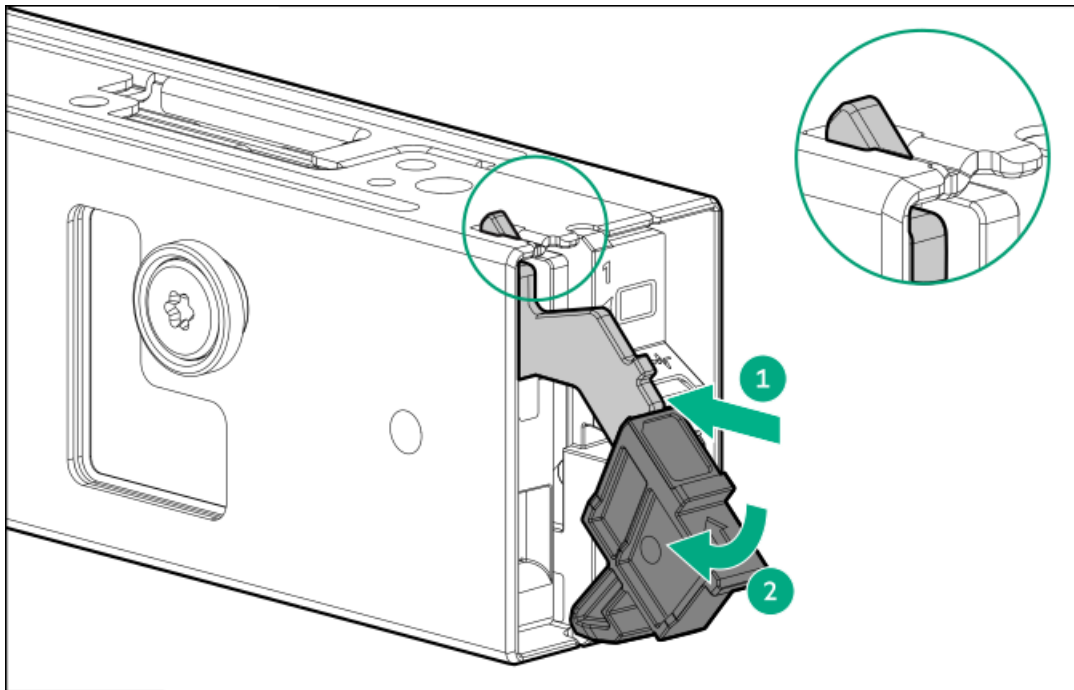

Installing the boot device

- 4. Power down the server.
- 5. If installed, open the cable management arm.
- 6. Remove all power:



- a. Disconnect each power cord from the power source.
- b. Disconnect each power cord from the server.
7. Disconnect all peripheral cables from the server.
8. Remove the server from the rack.
9. Place the server on a flat, level work surface.
10. Remove the access panel.
11. Do one of the following:
 - Remove the air baffle.
 - Remove the midplane drive cage.
12. If you are installing the HPE NS204i-u Boot Device on a one-slot secondary riser cage, remove the rear 4 LFF drive cage.
13. Remove the primary riser cage.
14. Remove the secondary riser slot blank.

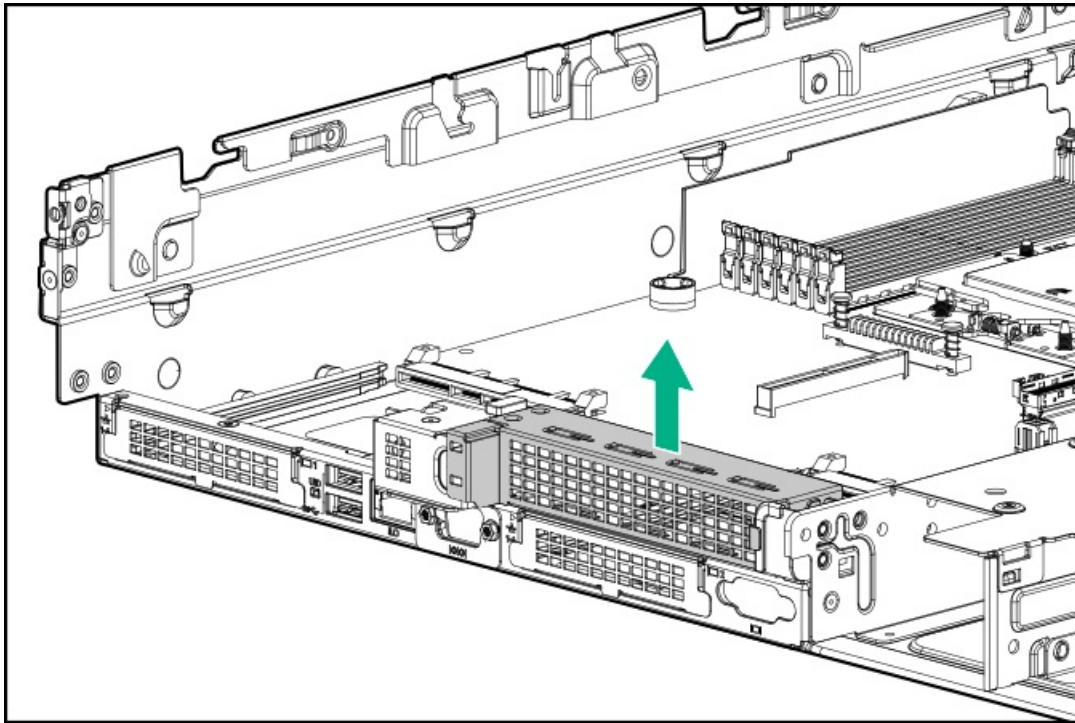

15. Remove the default secondary riser cage bracket.

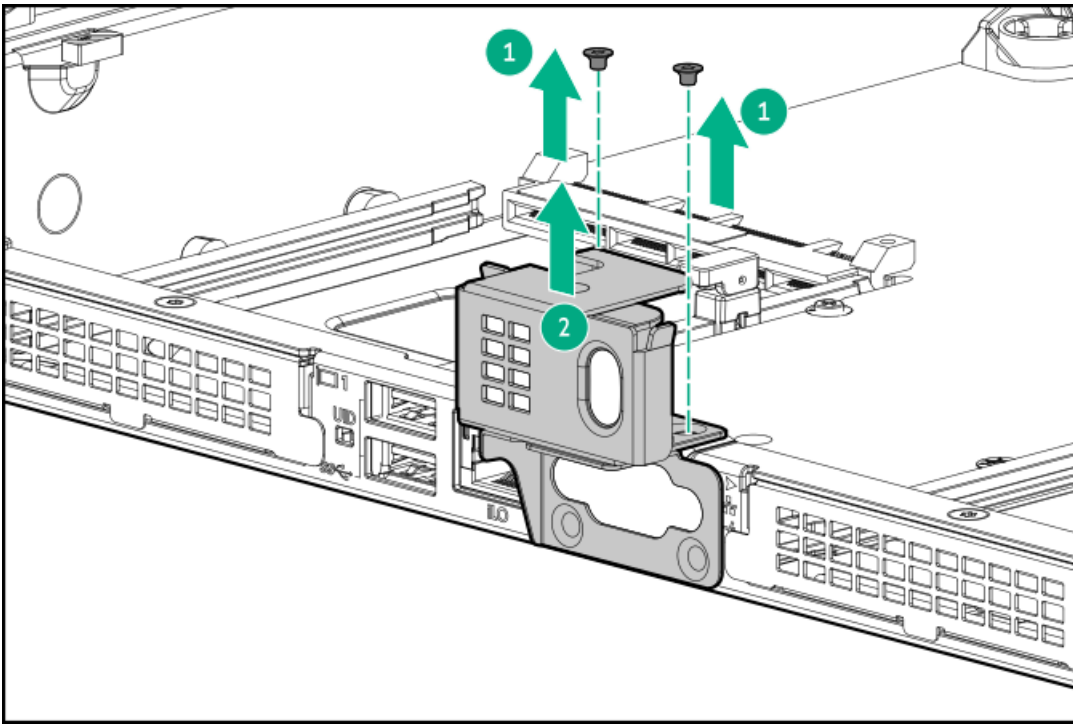

16. Install the NS204i-u + secondary low-profile riser cage bracket.

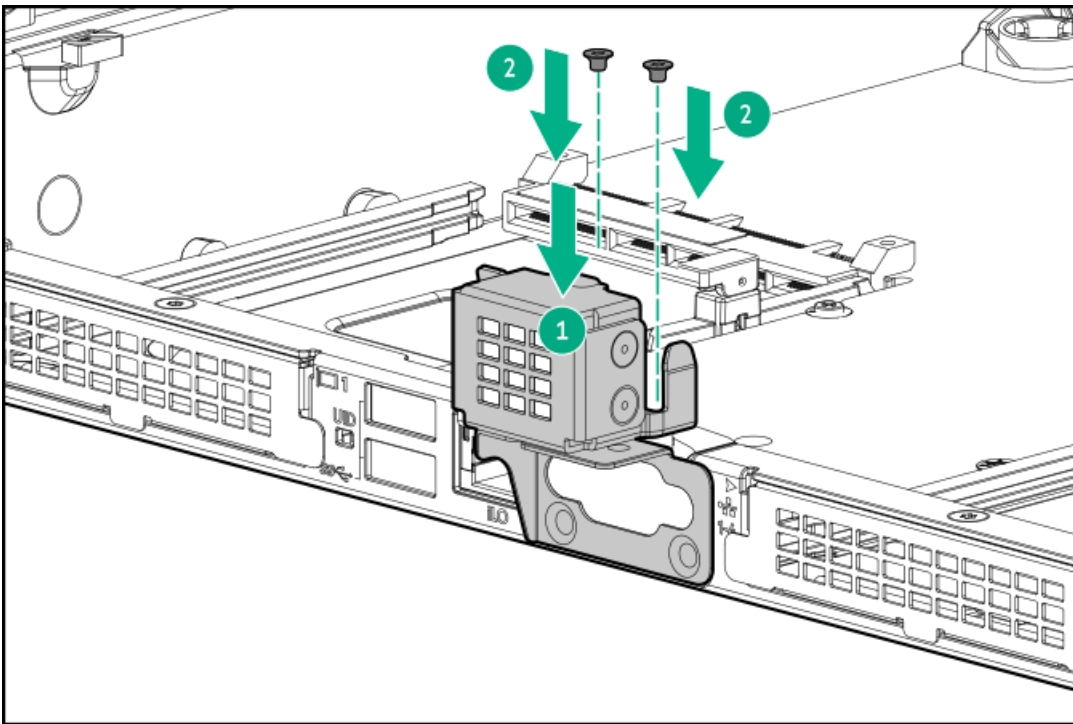

17. Install the boot device in the riser cage:

- a. Position the latch end of the boot device on the rear side of the riser cage.
- b. Install the boot device screws.

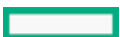

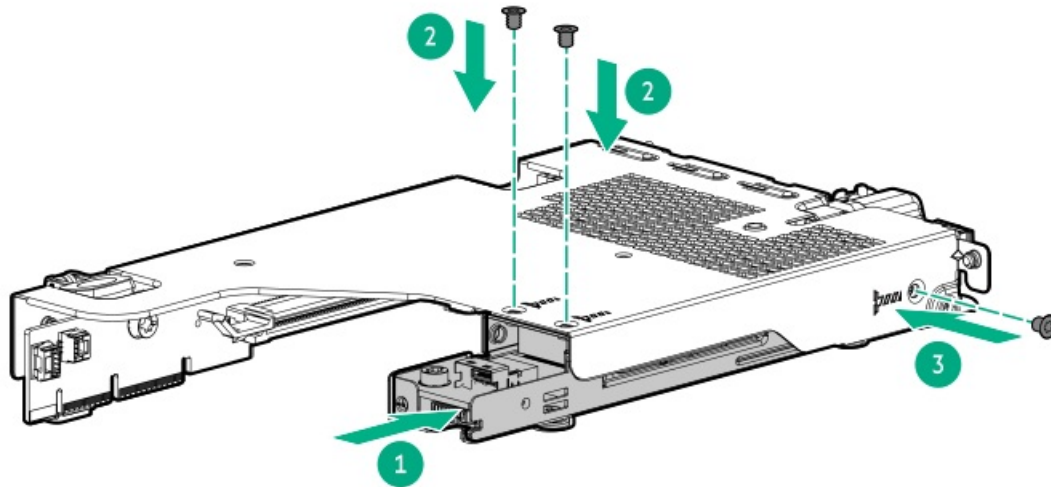

18. Connect the signal and power cables to a boot device.
19. To prevent hot-plug access to the SSDs on the boot device, install the security cover.
After the security cover is installed, the hot-plug feature of the boot device is disabled.

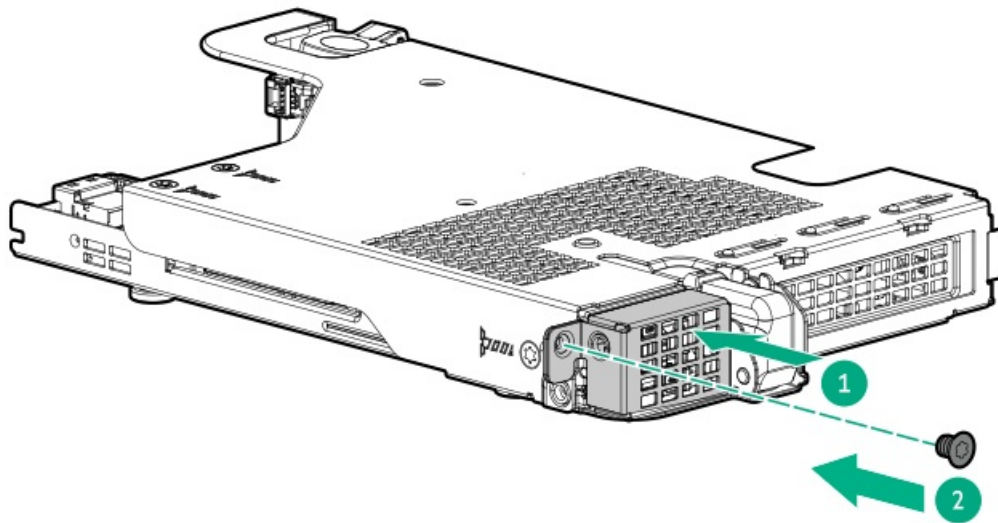

20. Install the NS204i-u + secondary low-profile riser cage.
21. Connect the boot device signal and power cables to the system board.
22. Install the rear 4 LFF drive cage.
23. Do one of the following:
 - Install the air baffle.
 - Install the midplane drive cage.
24. Install the access panel.
25. Install the server into the rack.
26. Connect all peripheral cables to the server.
27. Connect the power cords:
 - a. Connect each power cord to the server.



b. Connect each power cord to the power source.

28. If installed, close the cable management arm.

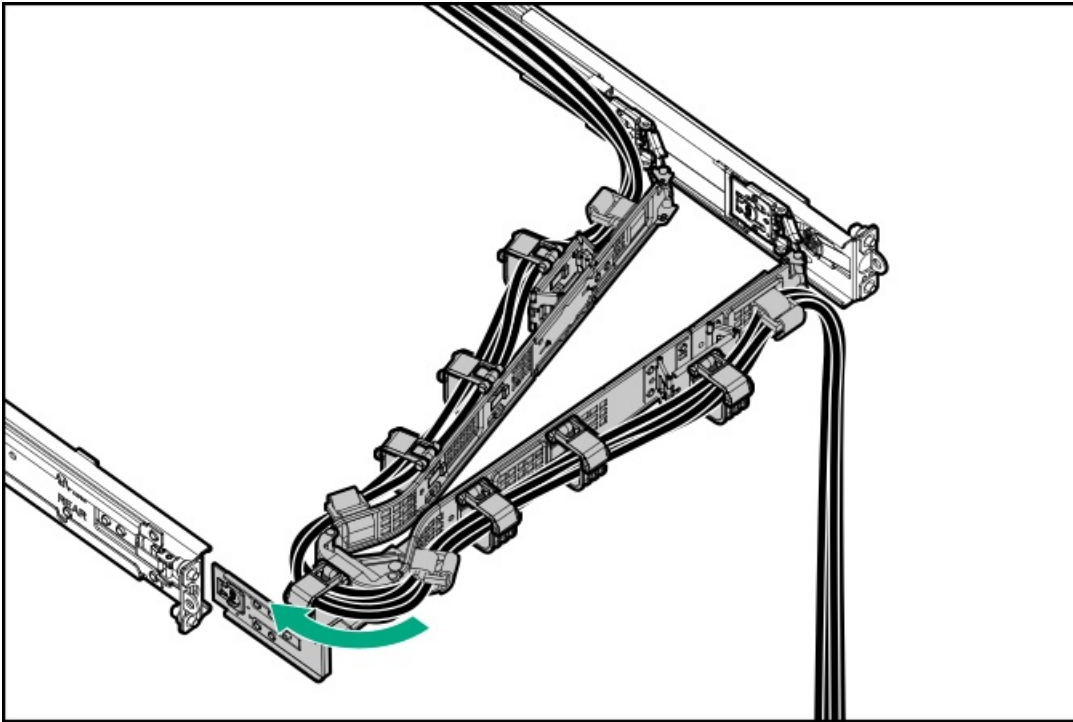

29. Power up the server.

Results

The installation procedure is complete.

Installing the HPE NS204i Boot Device on the secondary riser cage

Prerequisites

- Before beginning installation, make sure that the server is updated with the latest OS firmware and drivers.
- Before you perform this procedure, make sure that you have a T-10 Torx screwdriver available.
- Make sure you [install the power supply cage](#) prior to installing this option.

About this task

This option is supported on the first slot of the secondary riser cage.

CAUTION: A discharge of static electricity from a finger or other conductor might damage system boards or other static-sensitive devices. To prevent damage, observe [antistatic precautions](#).

Procedure

Installing drives onto the boot device

1. Remove the boot device carrier:
 - a. Press and hold the carrier latch.
 - b. Pivot the latch to open.
 - c. Slide the carrier out from the boot device cage.

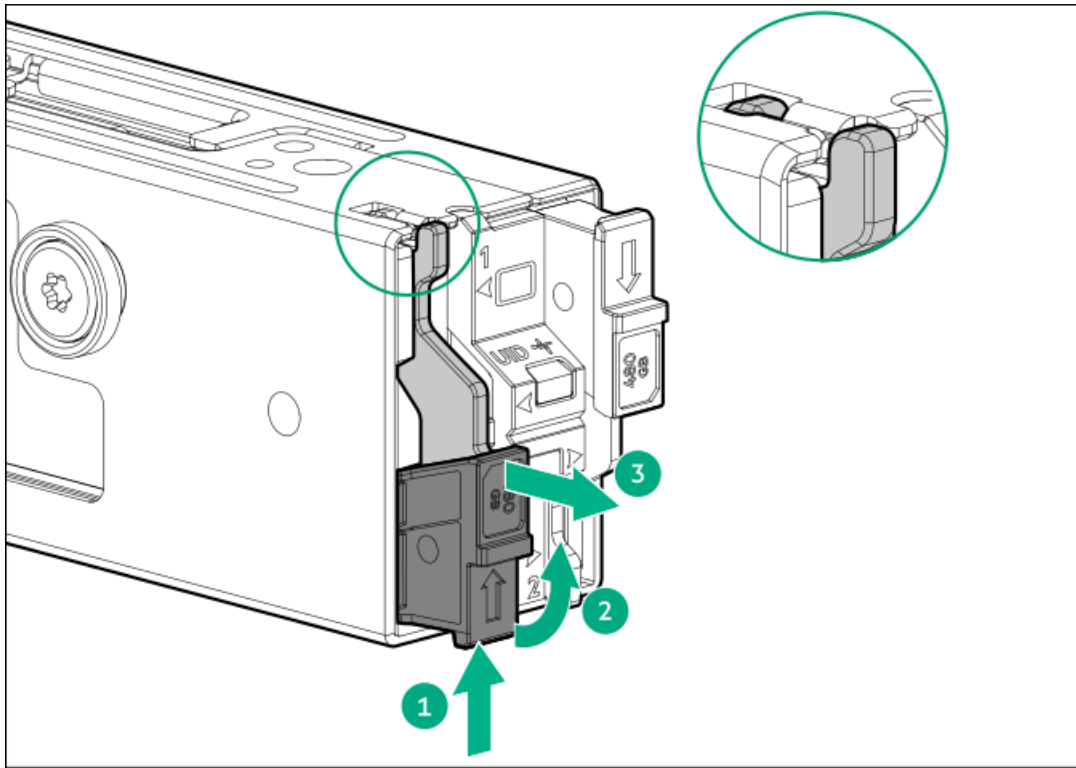

2. Install the SSD on the boot device carrier:

- a. Remove the SSD mounting screw.

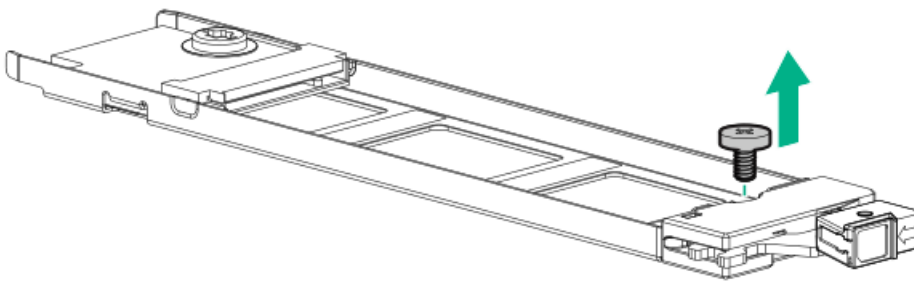

- b. Insert the SSD into the M.2 slot at a 45° angle.
- c. Carefully press the SSD down to the horizontal position.
- d. Install the SSD mounting screw.

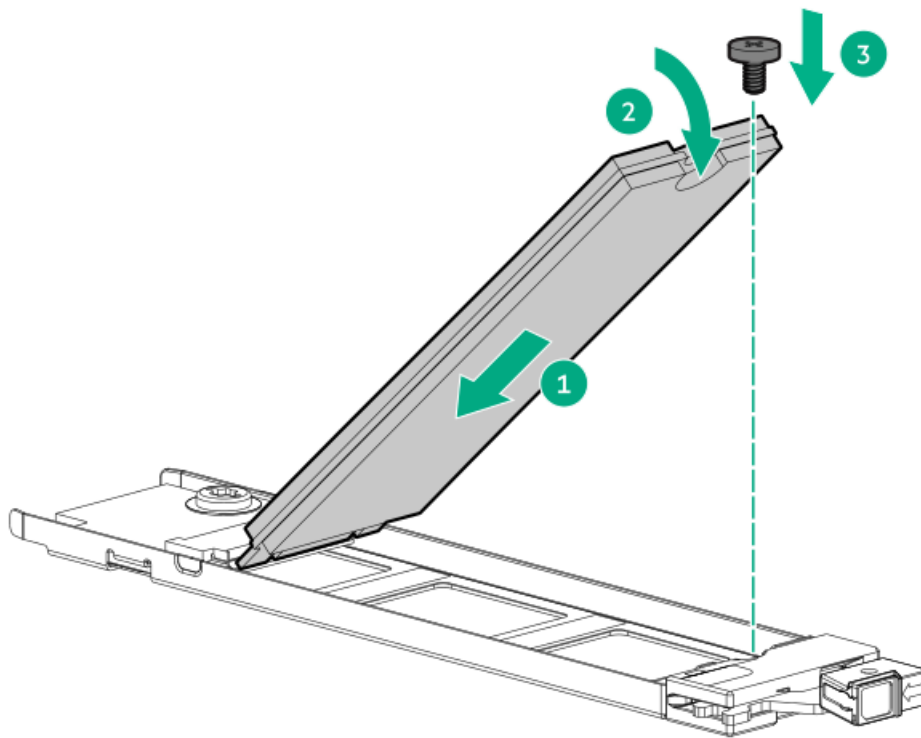

3. Install the boot device carriers:

- a. If closed, pivot the carrier latch to open.
- b. Slide the carrier into the boot device cage.
- c. Pivot the latch to close.

Make sure that the carrier latch is locked on the boot device cage.

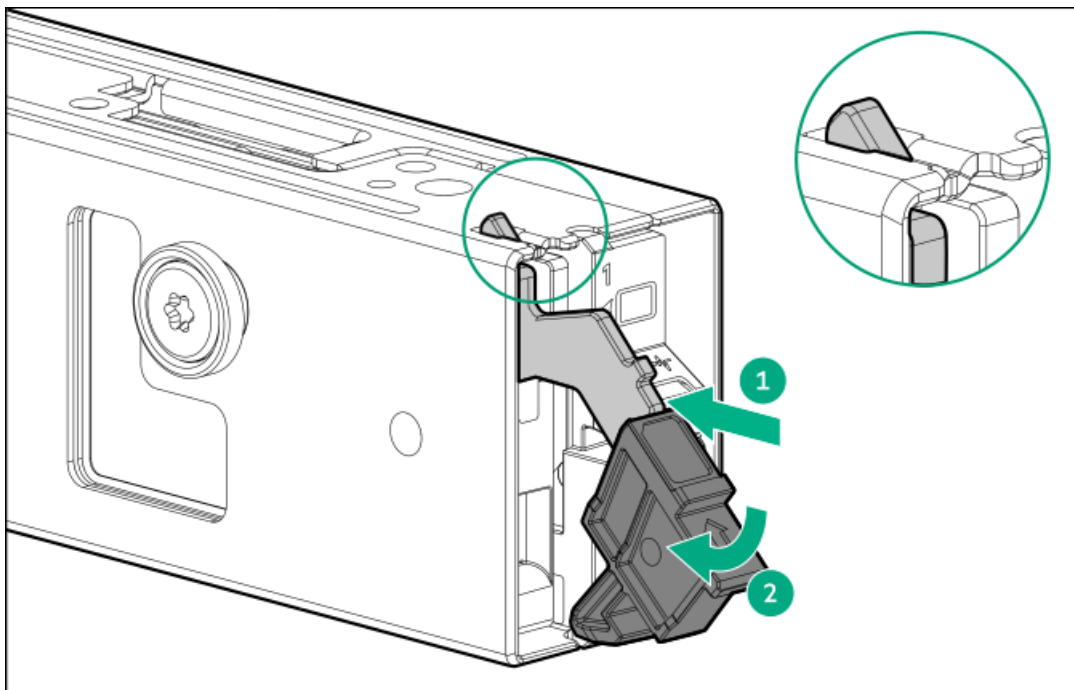

Installing the boot device

- 4. Power down the server.
- 5. If installed, open the cable management arm.
- 6. Remove all power:



- a. Disconnect each power cord from the power source.
 - b. Disconnect each power cord from the server.
7. Disconnect all peripheral cables from the server.
8. Remove the server from the rack.
9. Remove the access panel.
10. Do one of the following:
- Remove the air baffle.
 - Remove the midplane drive cage.
11. Remove the screws and spools from the HPE NS204i Boot Device.

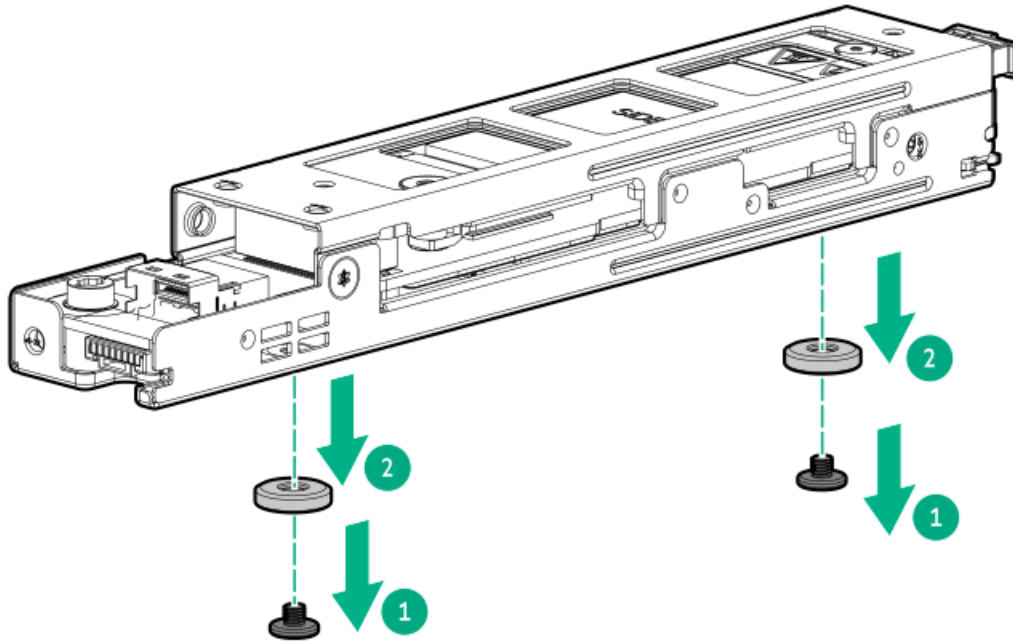

12. Remove the first secondary riser slot blank.

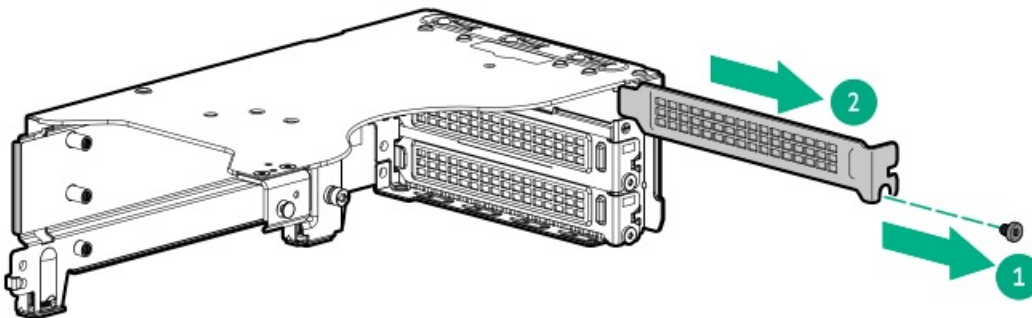

13. Install the HPE NS204i Boot Device onto the bracket:
- a. Slide the HPE NS204i Boot Device onto the bracket (callout 1).
 - b. Install the two screws on the side (callout 2).



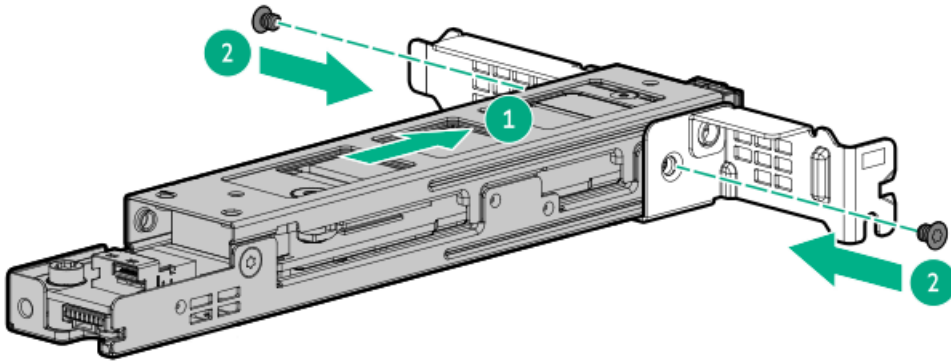

14. Remove the boot device carriers.

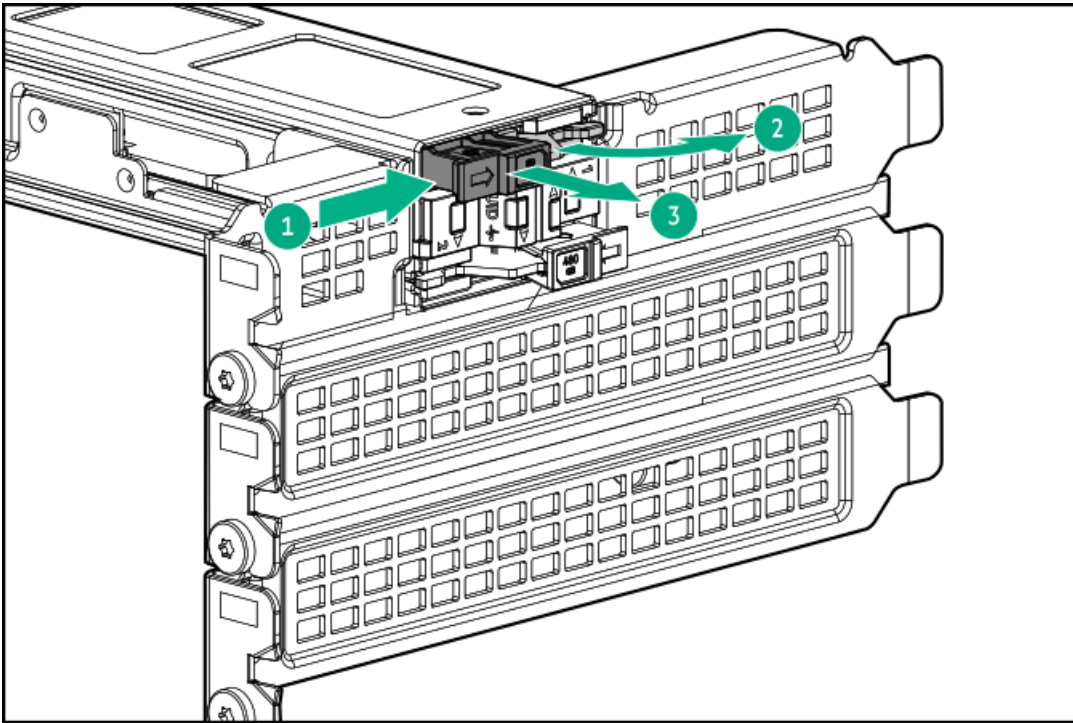

15. Install the HPE NS204i Boot Device:

- a. Install the HPE NS204i Boot Device on the first slot (callout 1).
- b. Install the screws (callout 2).



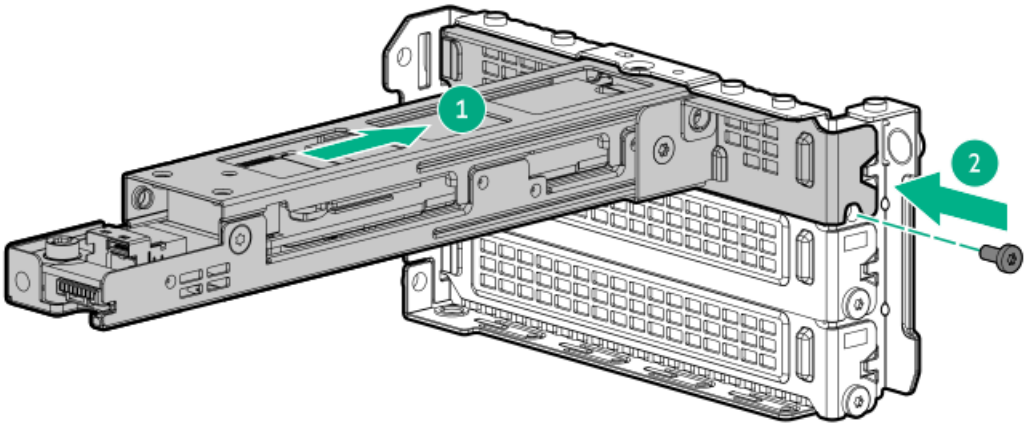

16. Install the screws on the top of the secondary riser cage.

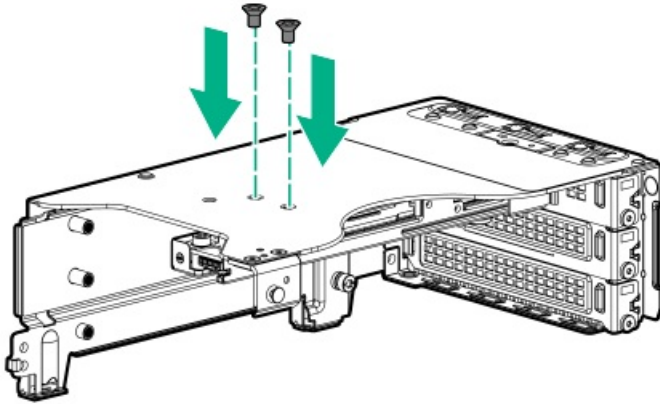

17. Install the boot device carriers.

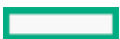

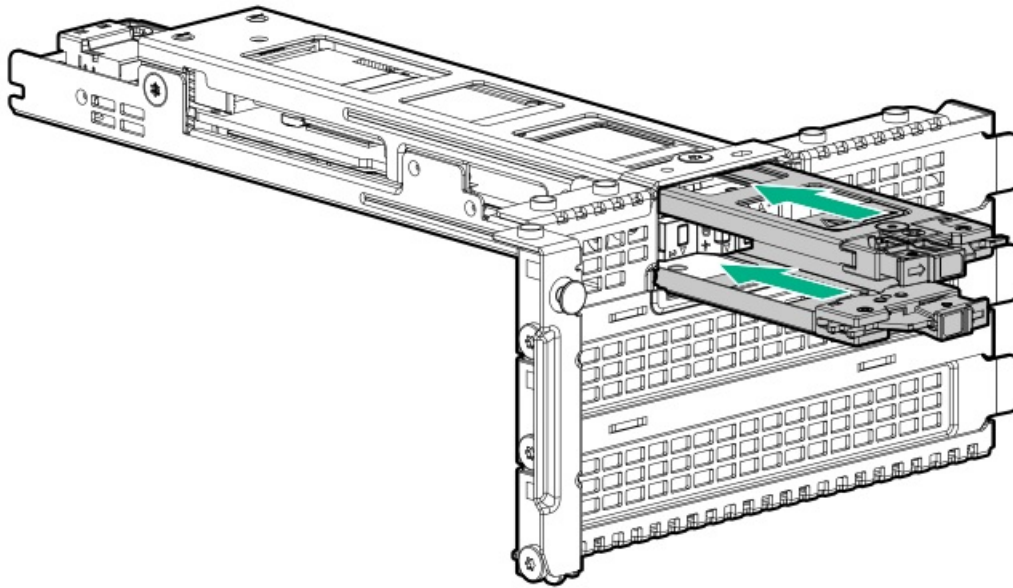

18. Install the secondary riser cage.
19. Connect the signal and power cables to a boot device.
20. Install the access panel.
21. Connect all peripheral cables to the server.
22. Connect the power cords:
 - a. Connect each power cord to the server.
 - b. Connect each power cord to the power source.
23. If installed, close the cable management arm.

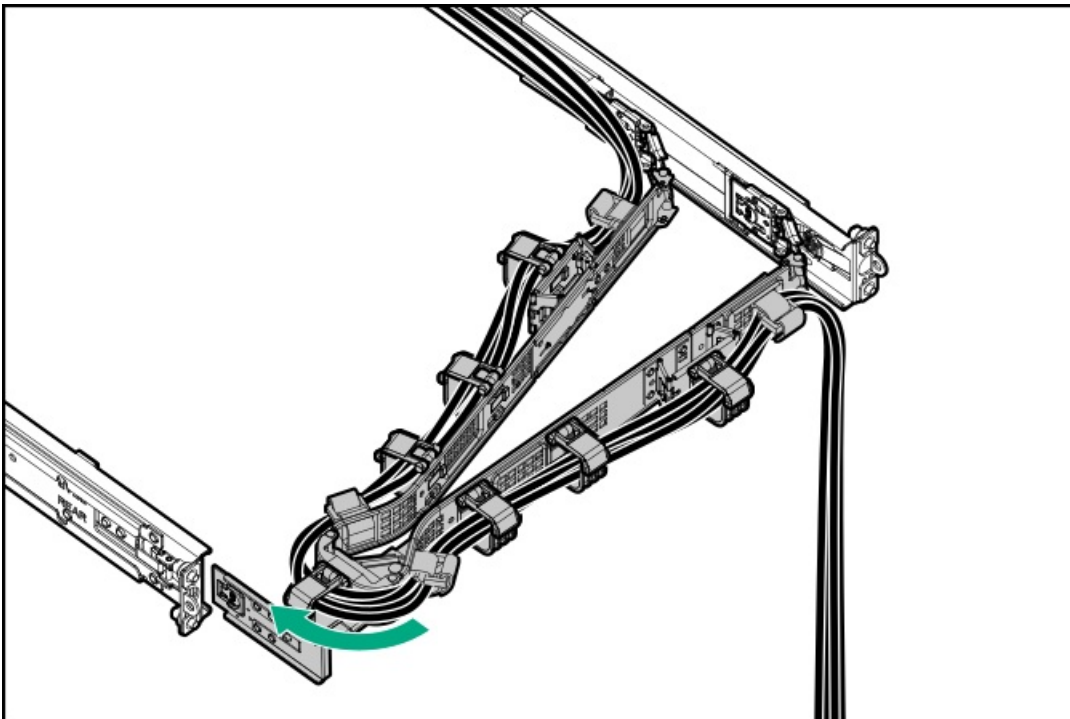

24. Power up the server.



Results

The installation procedure is complete.

Installing the HPE NS204i Boot Device on top of the power supply cage

Prerequisites

- Before beginning installation:
 - Make sure that the server is updated with the latest operating system firmware and drivers.
 - [Identify the HPE NS204i Boot Device components](#)
- Before you perform this procedure, make sure that you have the following items available:
 - T-10 Torx screwdriver
 - T-15 Torx screwdriver
 - Phillips No. 1 screwdriver

Procedure

Installing drives onto the boot device

1. Remove the boot device carrier:
 - a. Press and hold the carrier latch.
 - b. Pivot the latch to open.
 - c. Slide the carrier out from the boot device cage.

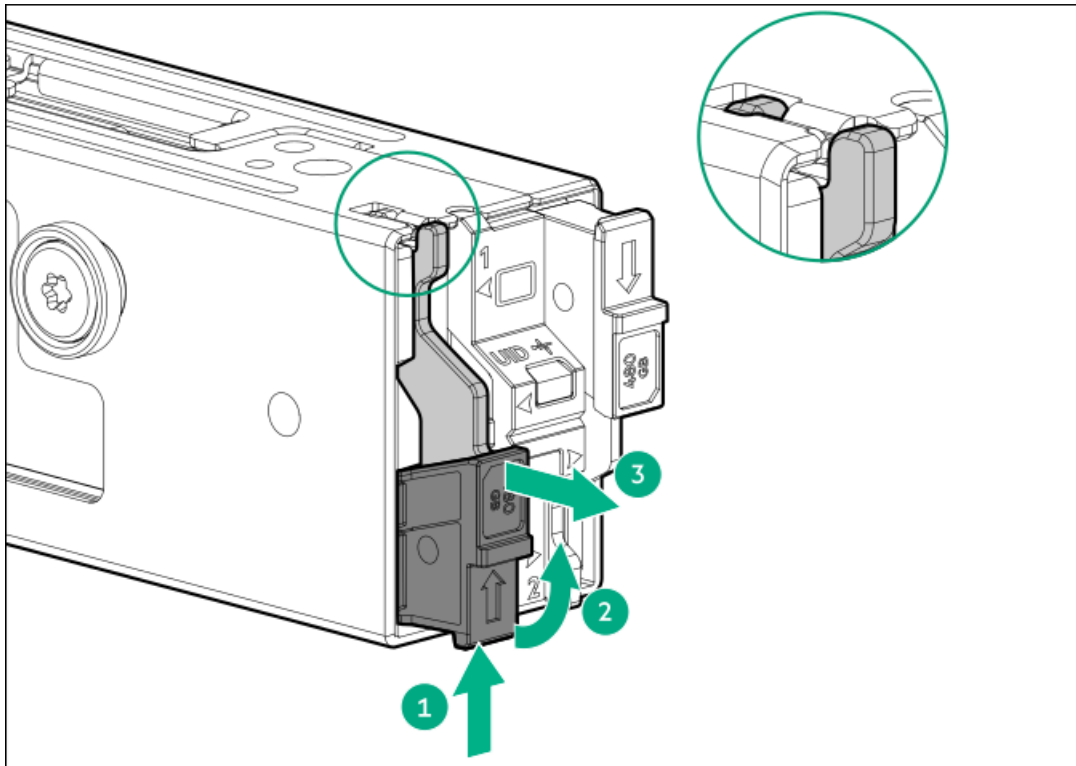

2. Install the SSD on the boot device carrier:
 - a. Remove the SSD mounting screw.

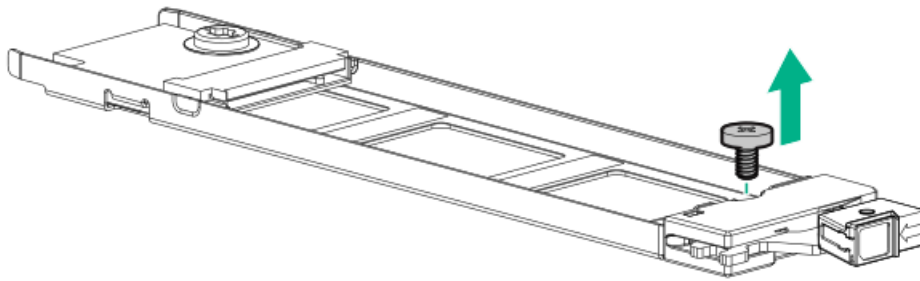

- b. Insert the SSD into the M.2 slot at a 45° angle.
- c. Carefully press the SSD down to the horizontal position.
- d. Install the SSD mounting screw.

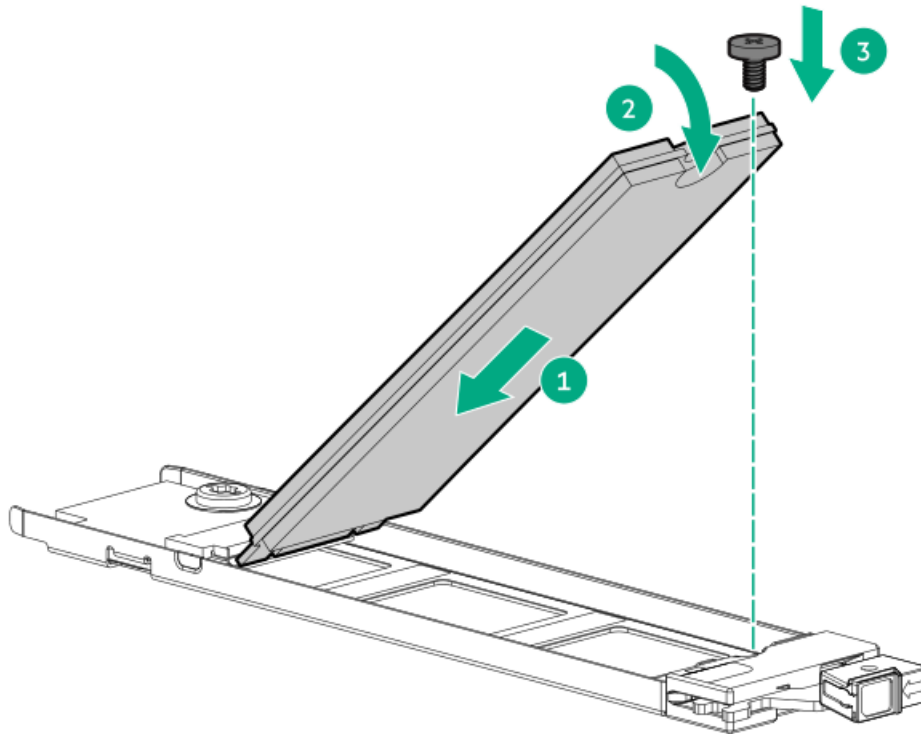

3. Install the boot device carriers:
- a. If closed, pivot the carrier latch to open.
 - b. Slide the carrier into the boot device cage.
 - c. Pivot the latch to close.

Make sure that the carrier latch is locked on the boot device cage.



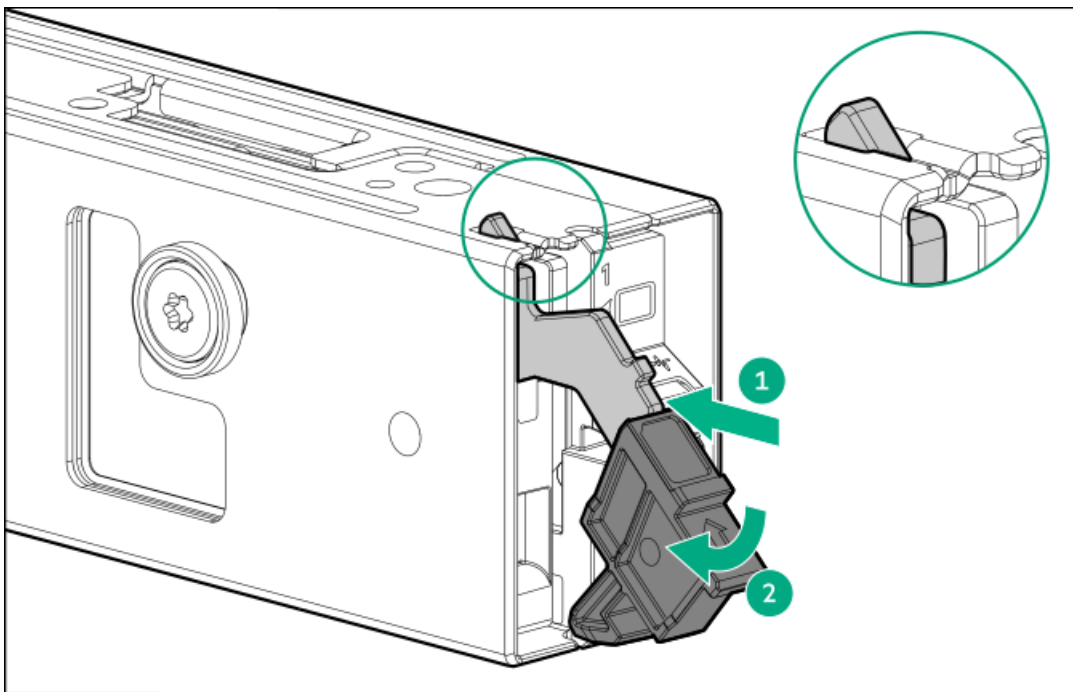

Installing the boot device

4. Power down the server.
5. If installed, open the cable management arm.
6. Remove all power:
 - a. Disconnect each power cord from the power source.
 - b. Disconnect each power cord from the server.
7. Disconnect all peripheral cables from the server.
8. Remove the server from the rack.
9. Remove the access panel.
10. Do one of the following:
 - Remove the air baffle.
 - Remove the midplane drive cage.
11. Connect the signal and power cables to the boot device.
12. Install the boot device bracket:
 - a. Insert the spools on the boot device with the notches on the bracket.
 - b. Install the bracket screw.



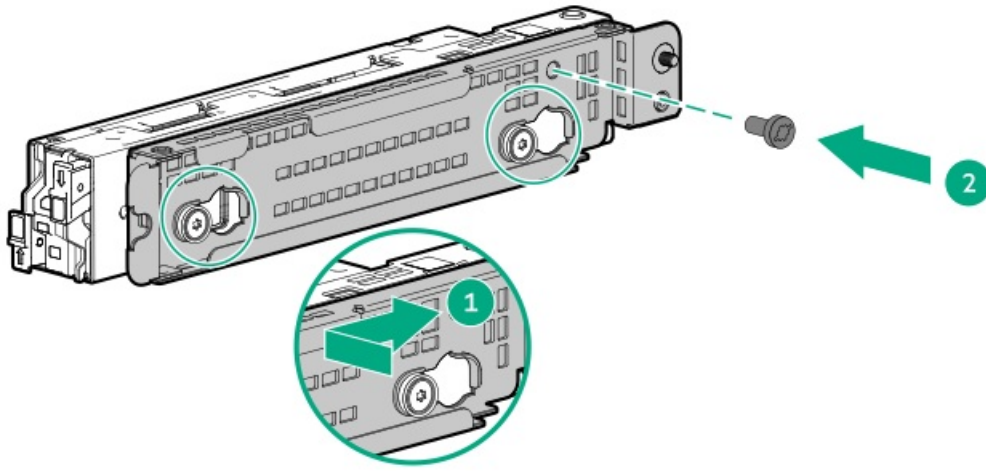

13. Install the boot device on top of the power supply cage:

For clarity, the connected power and signal cables are not shown in the following image.

- a. Position the boot device against the chassis side wall, with the rear end of the device flushed against the wall pin.
- b. Tighten the bracket thumbscrew.

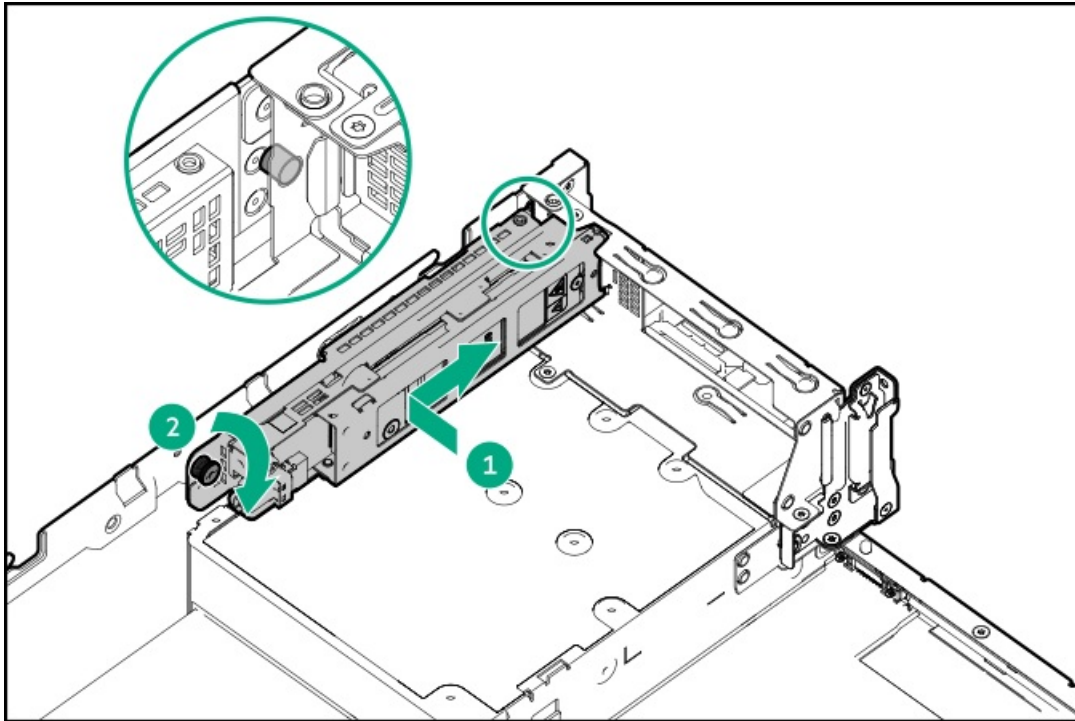

14. Connect the boot device signal and power cables to the system board.

15. To allow hot-plug access to the SSDs on the boot device, remove the security cover.



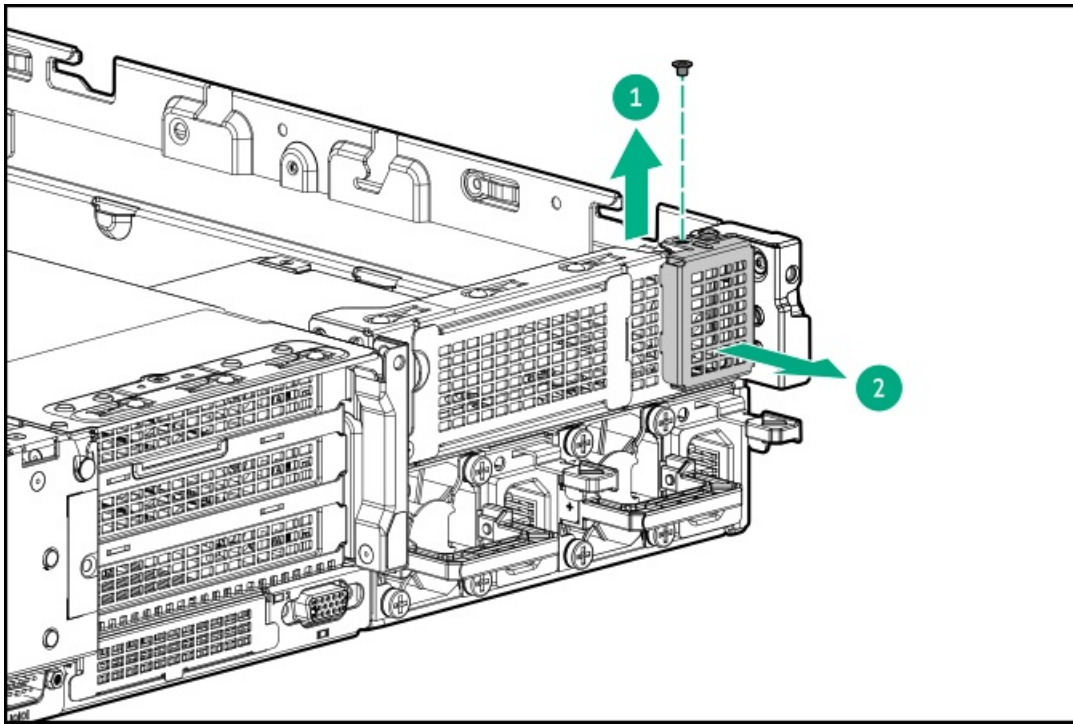

16. Install the rear 2 SFF drive cage.
17. Do one of the following:
 - Install the air baffle.
 - Install the midplane drive cage.
18. Install the access panel.
19. Install the server into the rack.
20. Connect all peripheral cables to the server.
21. Connect the power cords:
 - a. Connect each power cord to the server.
 - b. Connect each power cord to the power source.
22. If installed, close the cable management arm.



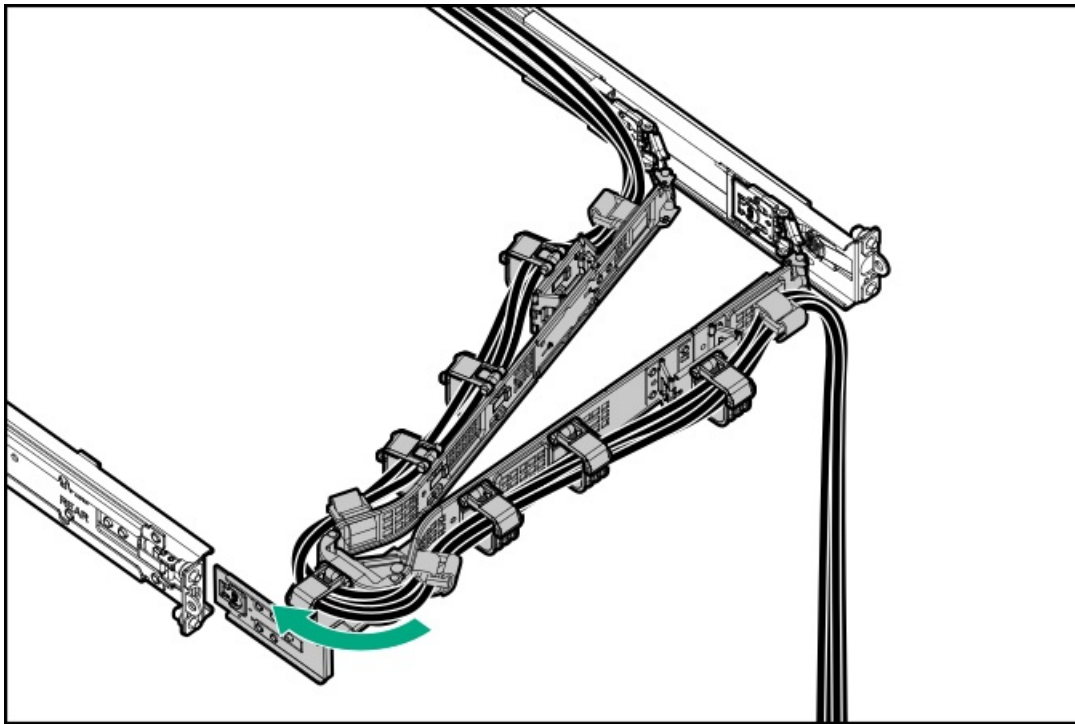

23. Power up the server.

Results

The installation procedure is complete.

Storage controller options

This server has no embedded software RAID support. Direct attached SATA drives operate in AHCI mode.

To support hardware RAID, install a storage controller option:

- HPE MR type-o and type-p Gen11 controllers
- HPE SR type-p Gen11 controllers
- HPE SR type-p Gen10 Plus controllers

When a tri-mode storage controller option is used together with a U.3 drive backplane, the system will support mixed drive configuration.

Subtopics

[Preparing the server for storage controller installation](#)

[Installing a type-p storage controller in the 4 LFF drive configuration](#)

[Installing a type-p storage controller in the three-slot riser cage](#)

[Installing a type-o controller](#)

Preparing the server for storage controller installation

Prerequisites

Before beginning this procedure, download the Service Pack for ProLiant (SPP) from the Hewlett Packard Enterprise website

(<https://www.hpe.com/servers/spp/download>).

Procedure

1. If the server was previously configured:
 - a. Back up data on the system.
 - b. Close all applications.
 - c. Ensure that users are logged off and that all tasks are completed on the server.

 **CAUTION:** In systems that use external data storage, be sure that the server is the first unit to be powered down and the last to be powered back up. Taking this precaution ensures that the system does not erroneously mark the drives as failed when the server is powered up.

2. If the server firmware is not the latest revision, update the firmware.
3. If the new controller is the new boot device, install the controller drivers.

Installing a type-p storage controller in the 4 LFF drive configuration

Prerequisites

- To enable the flash-backed write cache (FBWC) feature of a storage controller option, install an energy pack.

For more information on the controller caching feature, see the controller QuickSpecs on the Hewlett Packard Enterprise website (<https://www.hpe.com/info/qs>).

- Before you perform this procedure, make sure that you have the following items available:
 - Compatible controller cable
 - T-10 Torx screwdriver

About this task

 **CAUTION:** A discharge of static electricity from a finger or other conductor might damage system boards or other static-sensitive devices. To prevent damage, observe antistatic precautions.

Procedure

1. Power down the server.
2. If installed, open the cable management arm.
3. Remove all power:
 - a. Disconnect each power cord from the power source.
 - b. Disconnect each power cord from the server.
4. Disconnect all peripheral cables from the server.
5. Remove the server from the rack.
6. Remove the access panel.
7. Do one of the following:
 - Remove the air baffle.
 - Remove the midplane drive cage.
8. Remove the rear 4 LFF drive cage.

9. Do one of the following:
 - Remove the riser cage
 - Remove the rear riser cage blank.
10. Identify the riser slot compatible with the storage controller.
11. Remove the riser slot blank.

Retain the screw and blank. This screw will be used to secure the new type-p storage controller.

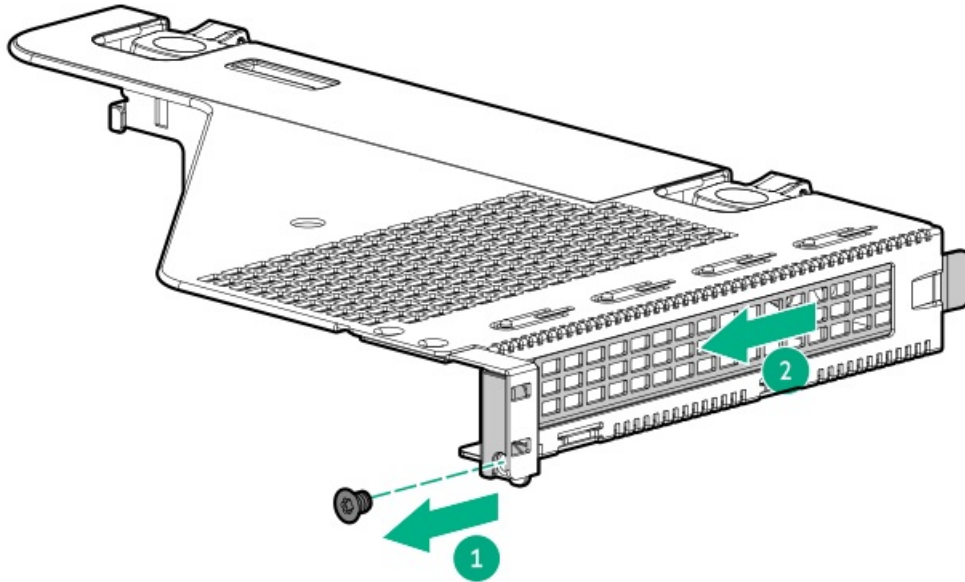

12. Install the type-p storage controller.
Make sure that the controller is seated firmly in the slot.

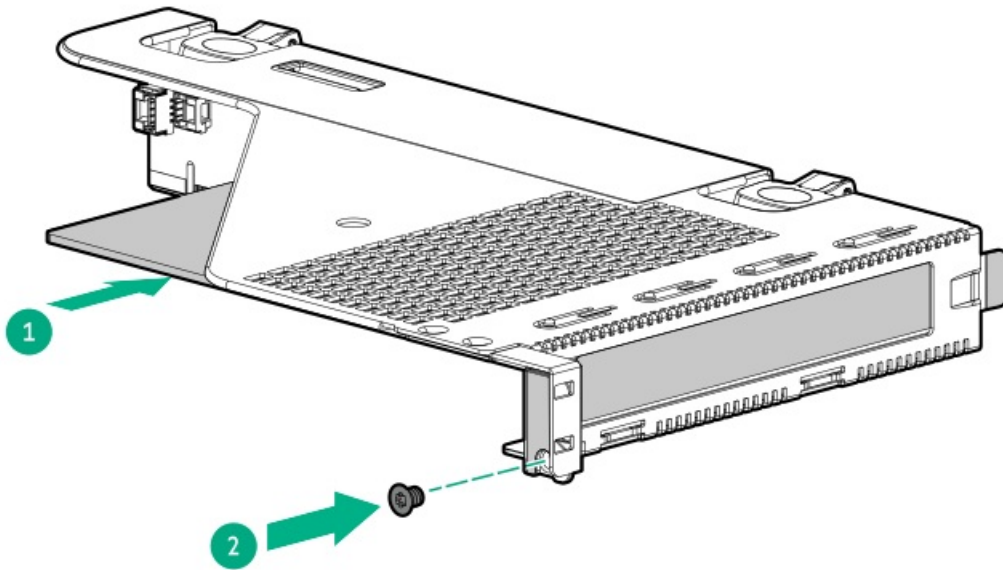

13. Cable the type-p storage controller.
14. (Optional) If the controller cable is not connected to the front drive backplane:
 - a. Remove the fan cage.

- b. Remove the midwall bracket.
- c. Cable the storage controller.
15. If removed, install the following components:
 - a. Install the midwall bracket.
 - b. Install the fan cage.
16. To enable the HPE SR SmartCache or MR CacheCade feature, install an energy pack.
17. Install the rear 4 LFF drive cage.
18. Do one of the following:
 - Install the air baffle.
 - Install the midplane drive cage.
19. Install the access panel.
20. Install the server into the rack.
21. Connect all peripheral cables to the server.
22. Connect the power cords:
 - a. Connect each power cord to the server.
 - b. Connect each power cord to the power source.
23. If installed, close the cable management arm.

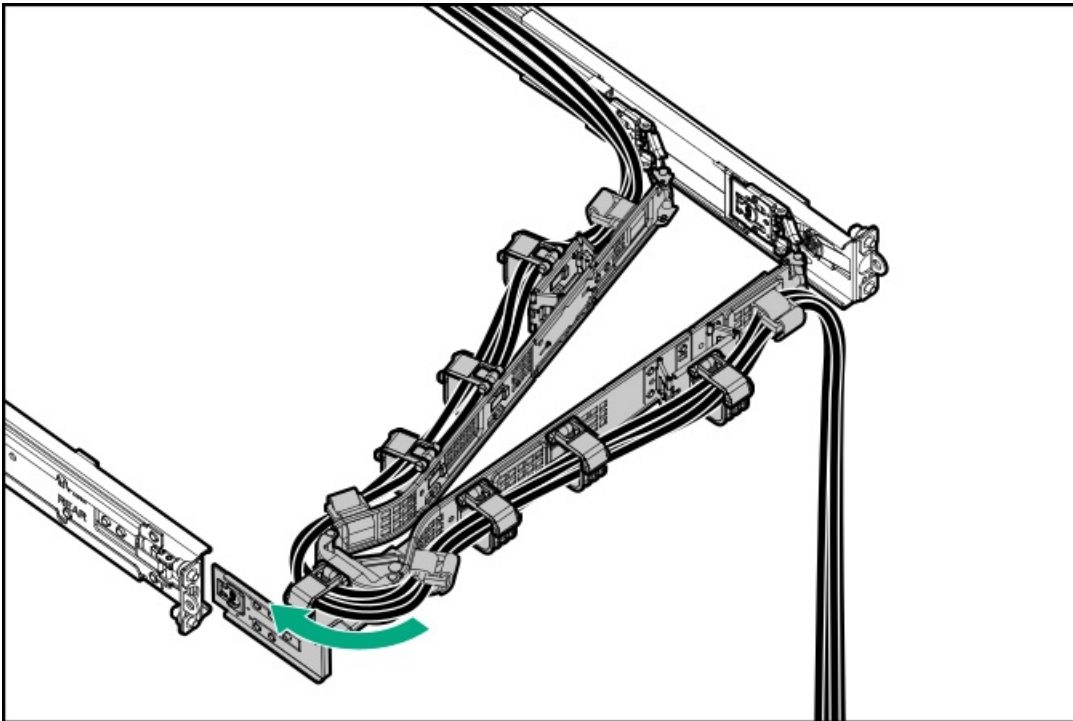

24. Power up the server.
25. Before using the controller for the first time, update the server and controller firmware if they are not the latest revision.

Results

The installation procedure is complete.



Installing a type-p storage controller in the three-slot riser cage

Prerequisites

- To enable the flash-backed write cache (FBWC) feature of a storage controller option, [install an energy pack](#).

For more information on the controller caching feature, see the controller QuickSpecs on the Hewlett Packard Enterprise website (<https://www.hpe.com/info/qs>).

- Before you perform this procedure, make sure that you have the following items available:
 - [Compatible controller cable](#)
 - T-10 Torx screwdriver

About this task



CAUTION: A discharge of static electricity from a finger or other conductor might damage system boards or other static-sensitive devices. To prevent damage, observe [antistatic precautions](#).

Procedure

1. [Power down the server](#).
2. If installed, [open the cable management arm](#).
3. Remove all power:
 - a. Disconnect each power cord from the power source.
 - b. Disconnect each power cord from the server.
4. Disconnect all peripheral cables from the server.
5. [Remove the server from the rack](#).
6. [Remove the access panel](#).
7. Do one of the following:
 - [Remove the air baffle](#).
 - [Remove the midplane drive cage](#).
8. [Remove the riser cage](#).
9. (Optional) [Install the risers](#).
10. Install the type-p controller:
 - a. Remove the riser slot blank.

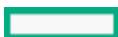

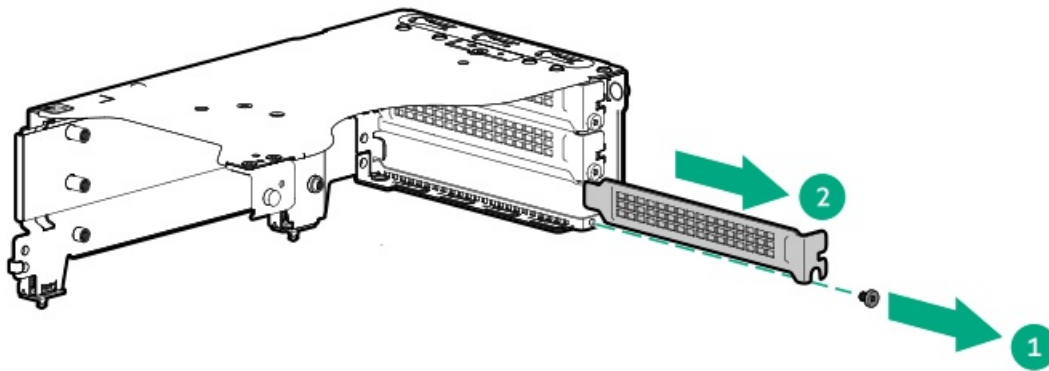

b. Install the storage controller

Make sure that the storage controller is seated firmly in the slot.

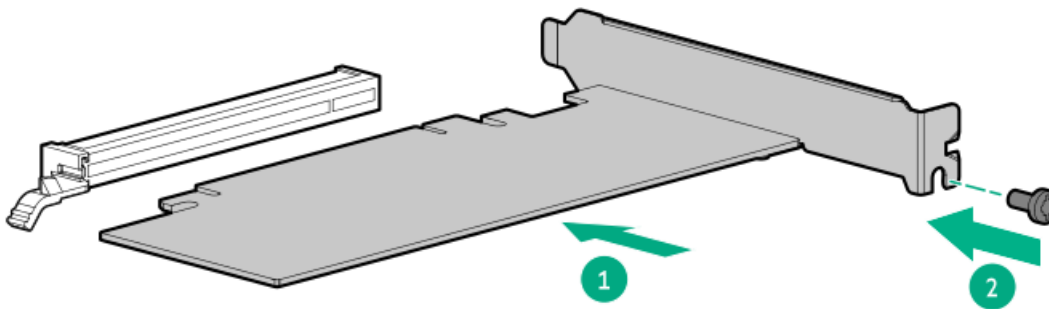

11. [Install the riser cage.](#)
12. [Cable the type-p storage controller.](#)
13. (Optional) If the controller cable is not connected to the front drive backplane:
 - a. [Remove the fan cage.](#)
 - b. [Remove the midwall bracket.](#)
 - c. [Cable the storage controller.](#)
14. If removed, install the following components:
 - a. [Install the midwall bracket.](#)
 - b. [Install the fan cage.](#)
15. To enable the FBWC feature of the storage controller, [install an energy pack.](#)
16. Do one of the following:
 - [Install the air baffle.](#)
 - [Install the midplane drive cage.](#)
17. [Install the access panel.](#)
18. [Install the server into the rack.](#)
19. Connect all peripheral cables to the server.
20. Connect the power cords:



- a. Connect each power cord to the server.
 - b. Connect each power cord to the power source.
21. If installed, close the cable management arm.

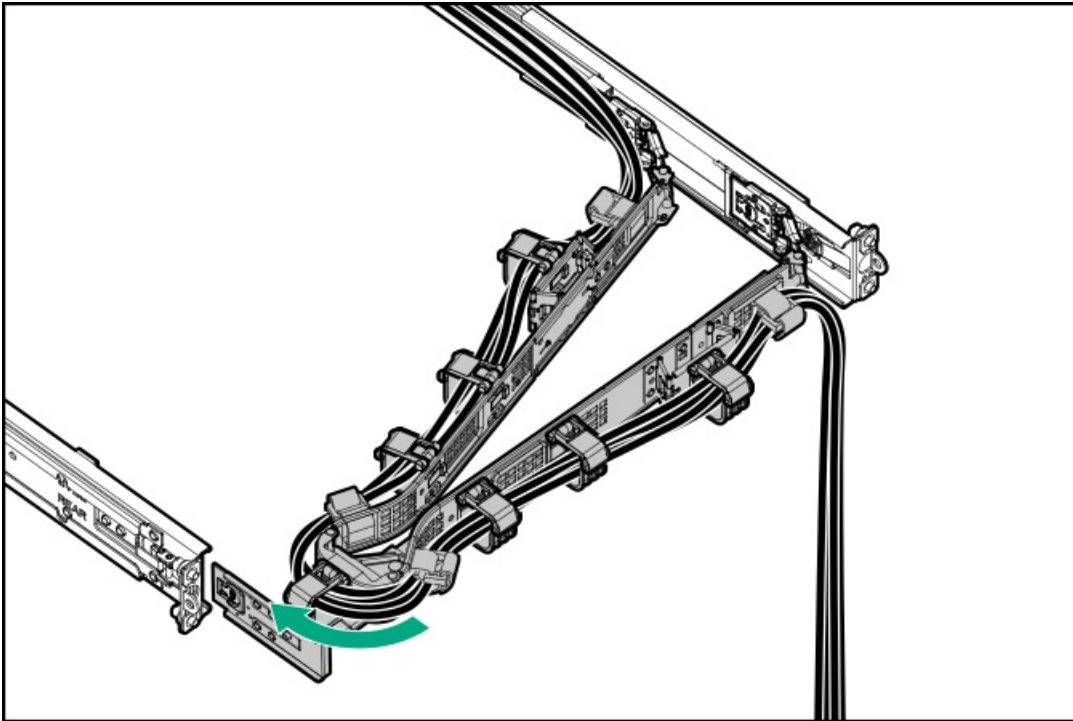

22. Power up the server.
23. Before using the controller for the first time, update the server and controller firmware if they are not the latest revision.

Results

The installation procedure is complete.

Installing a type-o controller

Prerequisites

- The flash-backed write cache (FBWC) feature of some storage controllers requires the installation of an energy pack option. For more information, see the controller QuickSpecs on the Hewlett Packard Enterprise website (<https://www.hpe.com/info/qs>).

Before you perform this procedure, make sure that you have the following items available:

- Compatible controller cable option
- Phillips No. 1 screwdriver

About this task

This server supports type-o storage controller installation in the OCP slot 21.

CAUTION: A discharge of static electricity from a finger or other conductor might damage system boards or other static-sensitive devices. To prevent damage, observe antistatic precautions.

Procedure

1. Power down the server.
2. If installed, open the cable management arm.

3. Remove all power:
 - a. Disconnect each power cord from the power source.
 - b. Disconnect each power cord from the server.
4. Disconnect all peripheral cables from the server.
5. Remove the server from the rack.
6. Remove the access panel.
7. Remove the riser cage.
8. Remove the OCP slot blank:
 - a. Remove the blank screw.
 - b. Remove the blank.

Retain the screw and blank for future use.

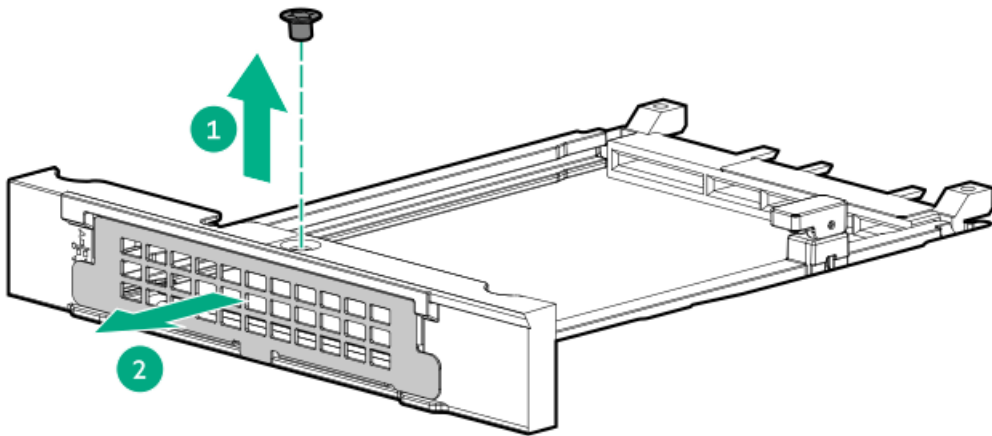

9. Install the type-o storage controller:
 - a. Rotate the locking pin to the open (vertical) position.
 - b. Slide the controller into the bay until it clicks into place.

Make sure that the controller is seated firmly in the slot.
 - c. Rotate the locking pin to the close (horizontal) position.

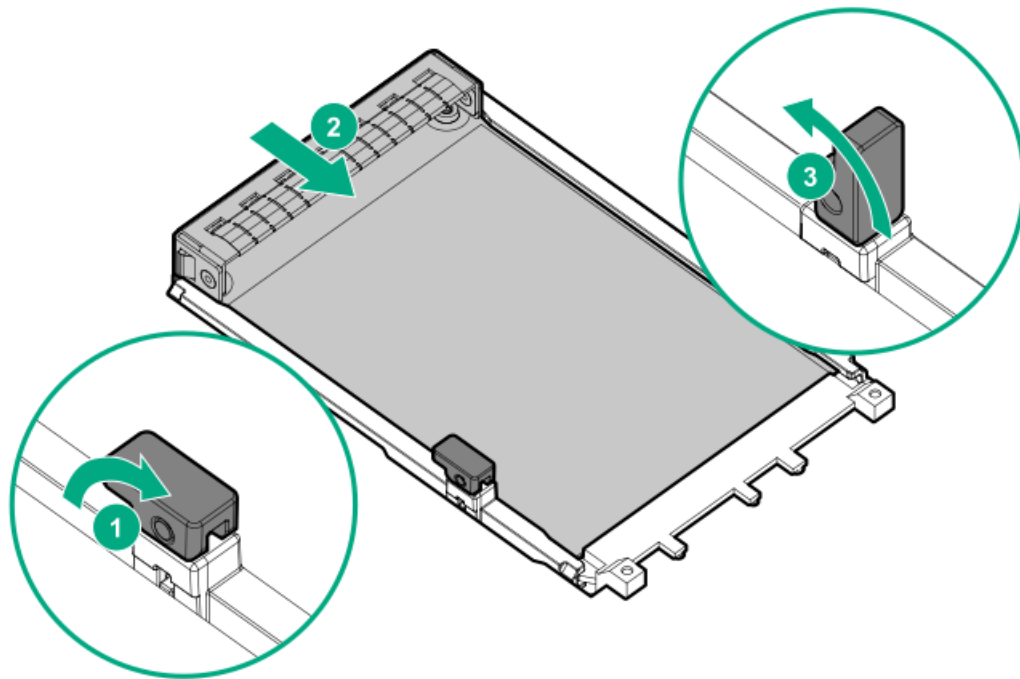

10. Install the access panel.
11. Install the server into the rack.
12. Connect all peripheral cables to the server.
13. Connect the power cords:
 - a. Connect each power cord to the server.
 - b. Connect each power cord to the power source.
14. If installed, close the cable management arm.

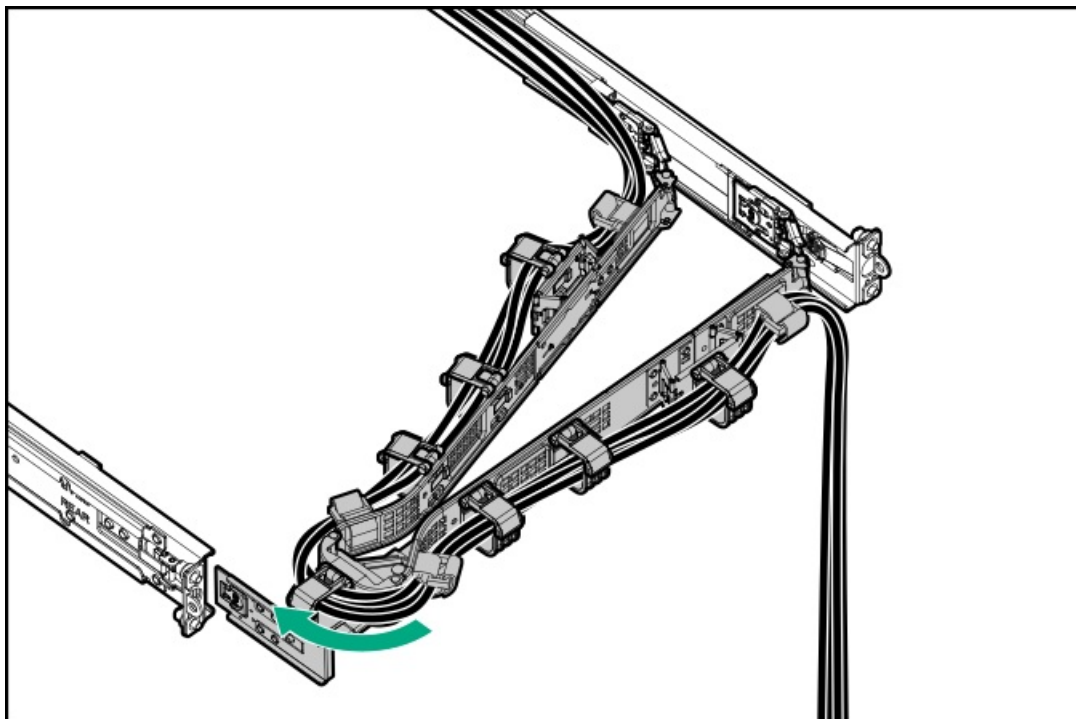

15. Power up the server.

Results



The installation procedure is complete.

Transceiver option

Transceivers serve as the connection between the adapter and the network cable for maintaining high-speed performance.

Subtopics

[Transceiver warnings and cautions](#)

[Installing a transceiver](#)

Transceiver warnings and cautions



WARNING:

Fiber-optic transceivers and fiber-optic cables connected to transceivers emit laser light that can damage your eyes. To avoid eye injuries, avoid direct eye exposure to the beam from the fiber-optic transceiver or into the ends of fiber-optic cables when they are powered-up.



CAUTION:

The presence of dust in transceiver ports can cause poor cable connectivity. To prevent dust from entering, install a dust plug in an unused transceiver port.



CAUTION:

Supported transceivers can be hot-swapped—removed and installed while the server is powered-on. However, to prevent potential damage to the transceiver or the fiber-optic cable, disconnect the cable from the transceiver before hot-swapping it.



CAUTION:

Do not remove and install transceivers more often than is necessary. Doing so can shorten the useful life of the transceiver.



IMPORTANT:

When you replace a transceiver with another of a different type, the server might retain selected port-specific configuration settings that were configured for the replaced transceiver. Be sure to validate or reconfigure port settings as required.

Installing a transceiver

Prerequisites

Before installing a transceiver option, review the following:

- [Transceiver warnings and cautions](#)
- Transceiver documentation for specific operational and cabling requirements

Procedure

1. Hold the transceiver by its sides and gently insert it into the network adapter port until it clicks into place.

Transceivers are keyed so that they can only be inserted in the correct orientation. If the transceiver does not fit easily into the port, you

might have positioned it incorrectly. Reverse the orientation of the transceiver and insert it again.

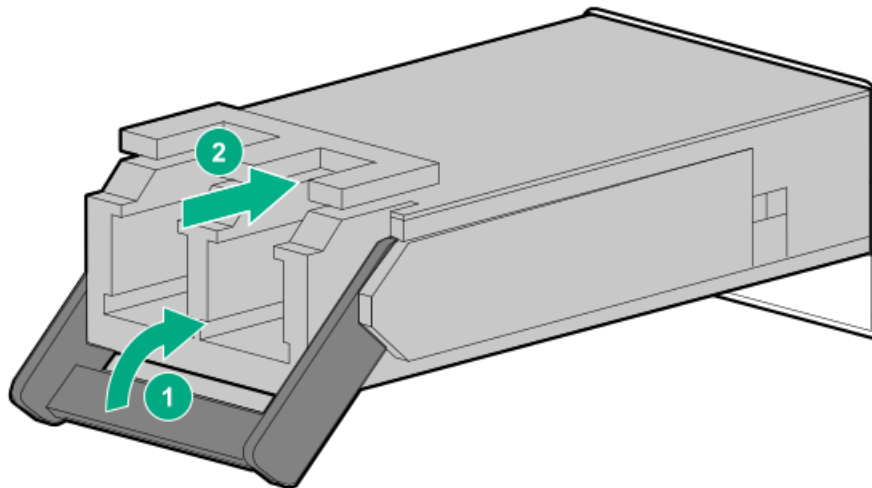

2. Remove the dust plug or protective cover from the transceiver.
3. Connect a compatible LAN segment cable to the transceiver.
4. Make sure that the NIC link LED on the port is solid green.

For more information on the port LED behavior, see the documentation that ships with the transceiver.

5. If needed, see the transceiver documentation for the model-specific fastening mechanism applicable to the transceiver.

Results

The installation is complete.

Energy pack options

If there is an unplanned server power outage, the flash-backed write cache (FBWC) feature of HPE storage controllers requires a centralized backup power source to back up the write cache data in a flash device. This server supports the following power options—collectively known as energy pack:

- [HPE Smart Storage Battery](#)
- [HPE Smart Storage Hybrid Capacitor](#)

One energy pack supports multiple devices. After it is installed, the status of the energy pack appears in HPE iLO. For more information, see the iLO user guide:

<https://www.hpe.com/support/ilo6>

Subtopics

[HPE Smart Storage Battery](#)

[HPE Smart Storage Hybrid Capacitor](#)

[Installing an energy pack](#)

[Installing an energy pack in an accelerator-optimized drive configuration](#)



HPE Smart Storage Battery

The HPE Smart Storage Battery supports both HPE SR and MR storage controllers.

A single 96 W battery can support up to 24 devices.

After the battery is installed, it might take up to two hours to charge. Controller features requiring backup power are not re-enabled until the battery is capable of supporting the backup power.

This server supports the 96 W HPE Smart Storage Battery with the 260 mm cable.

For more information, see HPE Smart Storage Batteries and Hybrid Capacitors QuickSpecs:

https://www.hpe.com/psnow/doc/a00028553enw.pdf?jumpid=in_pdp-psnow-qs

HPE Smart Storage Hybrid Capacitor

The HPE Smart Storage Hybrid Capacitor supports both HPE SR and MR storage controllers.

The capacitor pack can support up to three devices.

This server supports the HPE Smart Storage Hybrid Capacitor with the 260 mm cable.

Before installing the HPE Smart Storage Hybrid Capacitor, verify that the system BIOS meets the minimum firmware requirements to support the capacitor pack.



IMPORTANT:

If the system BIOS or controller firmware is older than the minimum recommended firmware versions, the capacitor pack will only support one device.

The capacitor pack is fully charged after the system boots.

For more information, see HPE Smart Storage Batteries and Hybrid Capacitors QuickSpecs:

https://www.hpe.com/psnow/doc/a00028553enw.pdf?jumpid=in_pdp-psnow-qs

Installing an energy pack

Prerequisites

- Make sure that a compatible type-p storage controller is installed.
- Make sure that you have the storage controller backup power cable that ships with the storage controller.

Procedure

1. Power down the server.
2. If installed, open the cable management arm.
3. Remove all power:
 - a. Disconnect each power cord from the power source.
 - b. Disconnect each power cord from the server.
4. Disconnect all peripheral cables from the server.
5. Remove the server from the rack.
6. Remove the access panel.
7. Do one of the following:

- Remove the air baffle.
- Remove the midplane drive cage.

8. Install the energy pack:

- Slide one end of energy pack into the tab on the chassis (callout 1).
- Push the energy pack down (callout 2).

Make sure that the energy pack is secure.

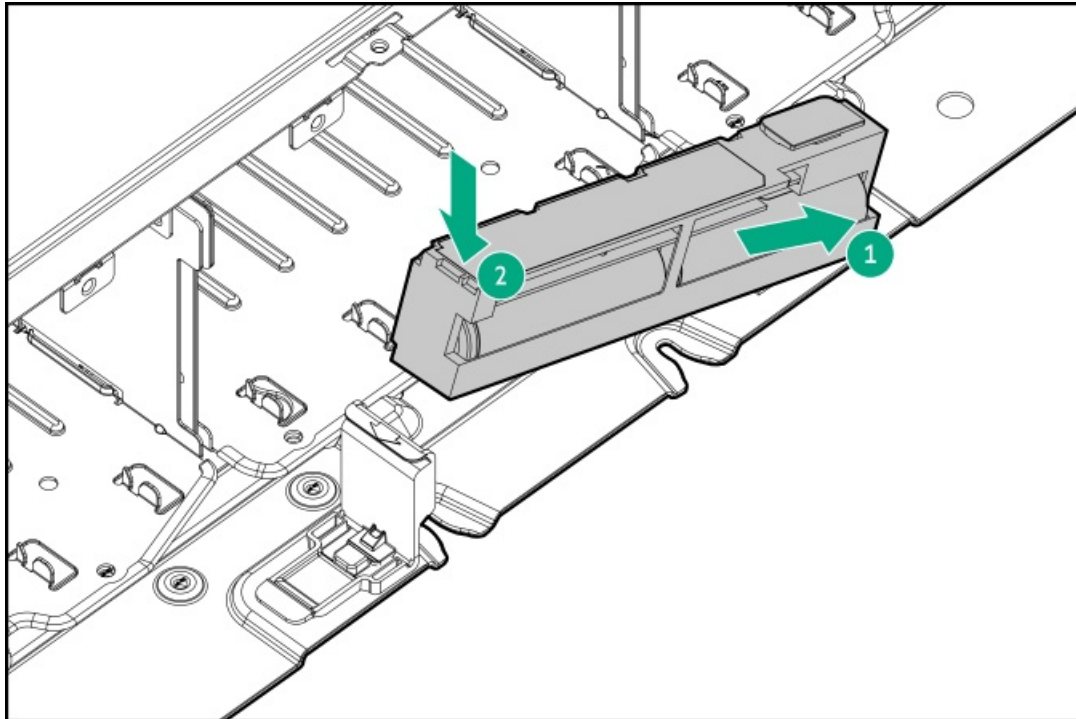

9. Connect the energy pack extension power cable to the system board and energy pack cable .
10. Connect the storage backup power cable.
11. Do one of the following:
 - Install the air baffle.
 - Install the midplane drive cage.
12. Install the access panel.
13. Install the server into the rack.
14. Connect all peripheral cables to the server.
15. Connect the power cords:
 - Connect each power cord to the server.
 - Connect each power cord to the power source.
16. If installed, close the cable management arm.

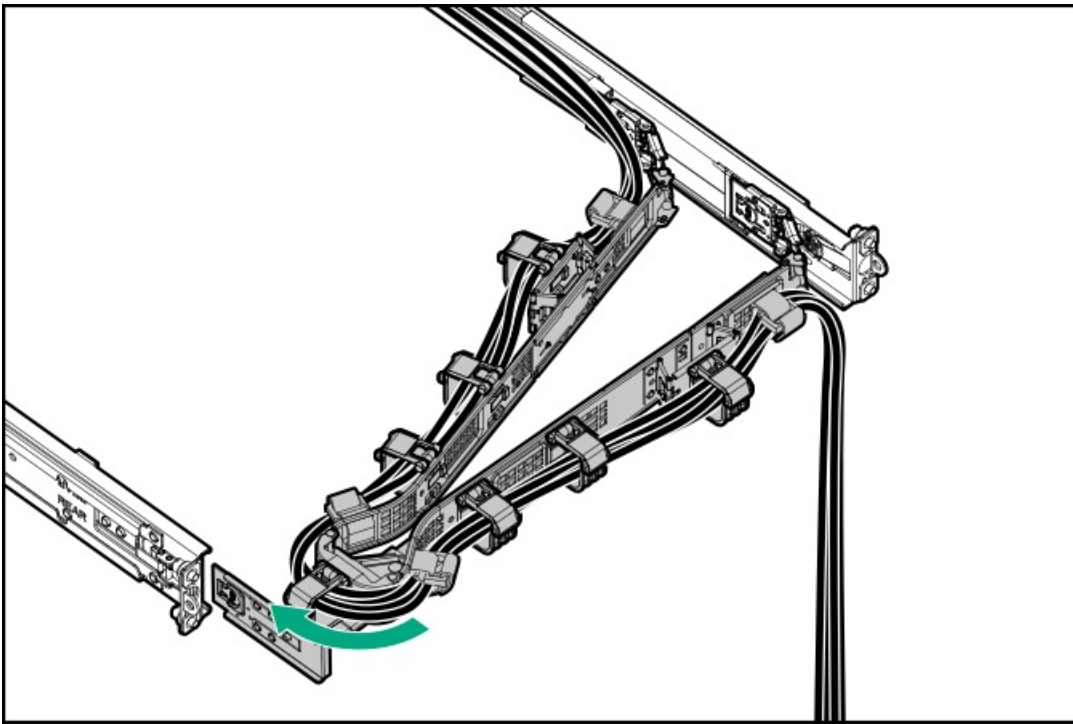

17. Power up the server.

Results

The installation procedure is complete.

Installing an energy pack in an accelerator-optimized drive configuration

Prerequisites

- Make sure that a compatible type-p storage controller is installed.
- Make sure that you have the storage controller backup power cable that ships with the storage controller.

About this task

This task applies to drive configurations with 4 dual-width accelerators.

Procedure

1. Power down the server.
2. If installed, open the cable management arm.
3. Remove all power:
 - a. Disconnect each power cord from the power source.
 - b. Disconnect each power cord from the server.
4. Disconnect all peripheral cables from the server.
5. Remove the server from the rack.
6. Remove the access panel.
7. Remove the middle cover:
 - a. Press and hold the release buttons.

b. Disengage the cover from the front cage.

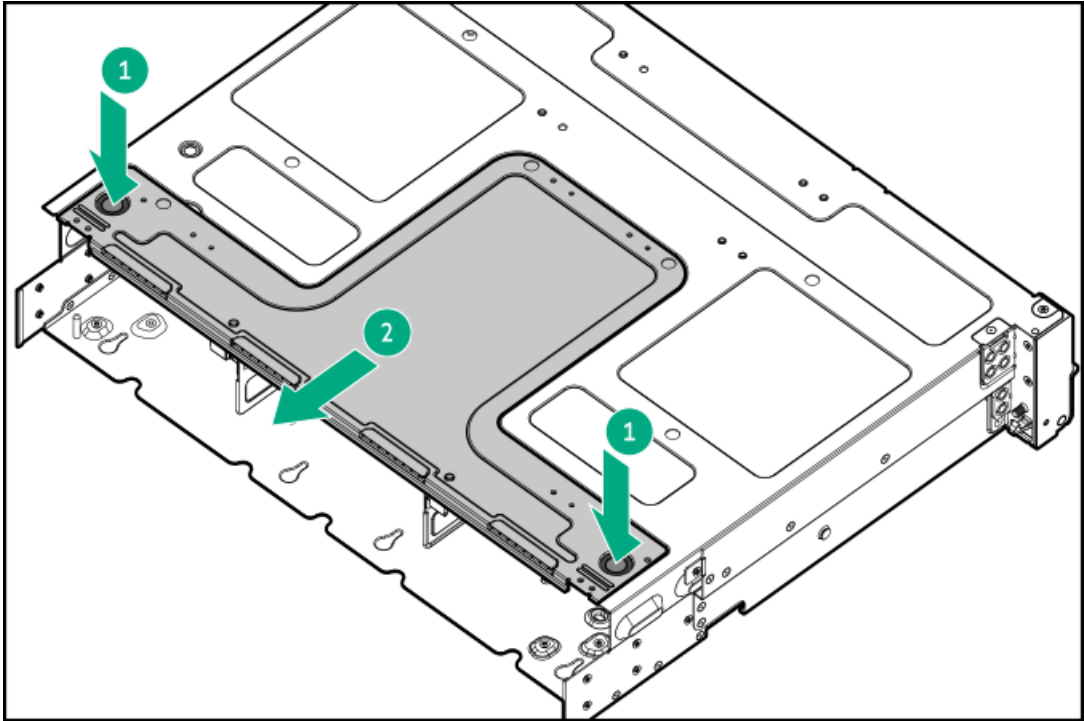

8. Connect the extension cable to the energy pack.

9. Install the energy pack onto the bracket.

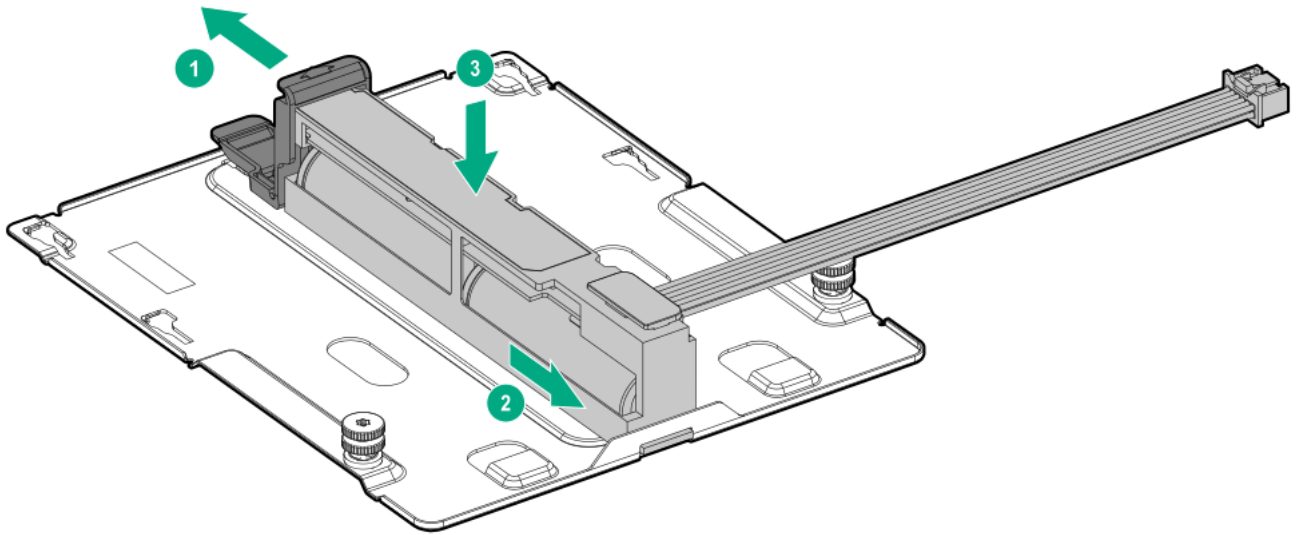

10. Install the bracket into the server.



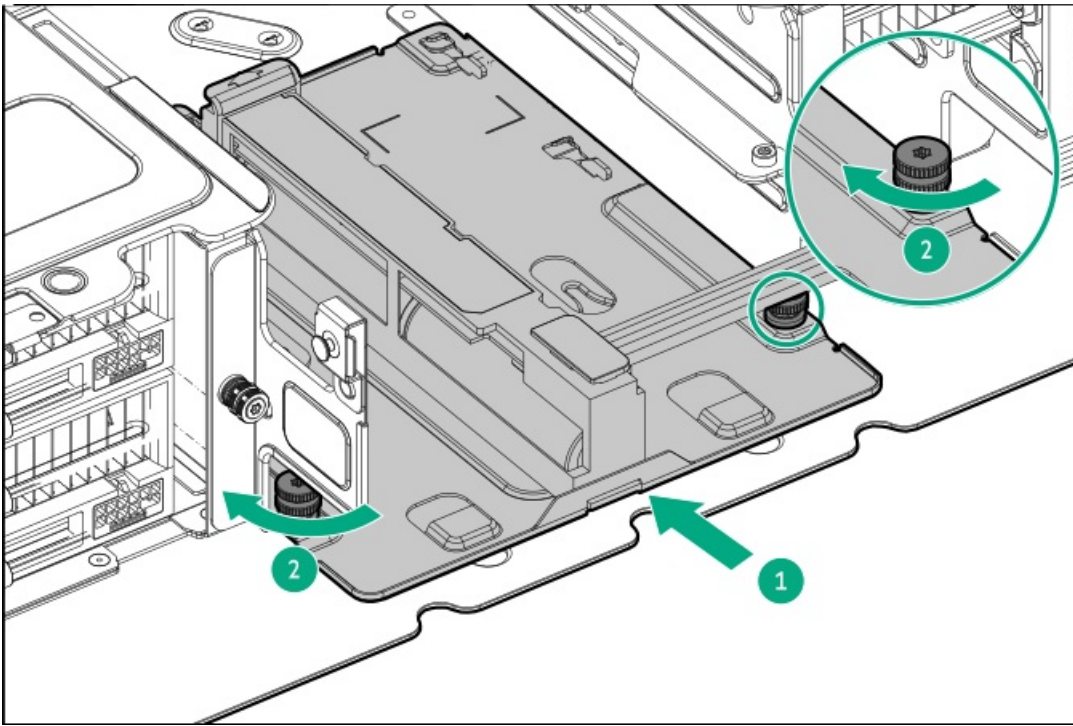

11. Cable the energy pack.
12. Connect the storage backup power cable.
13. Install the middle cover.

A click sound indicates that the cover is properly engaged with the front cage.

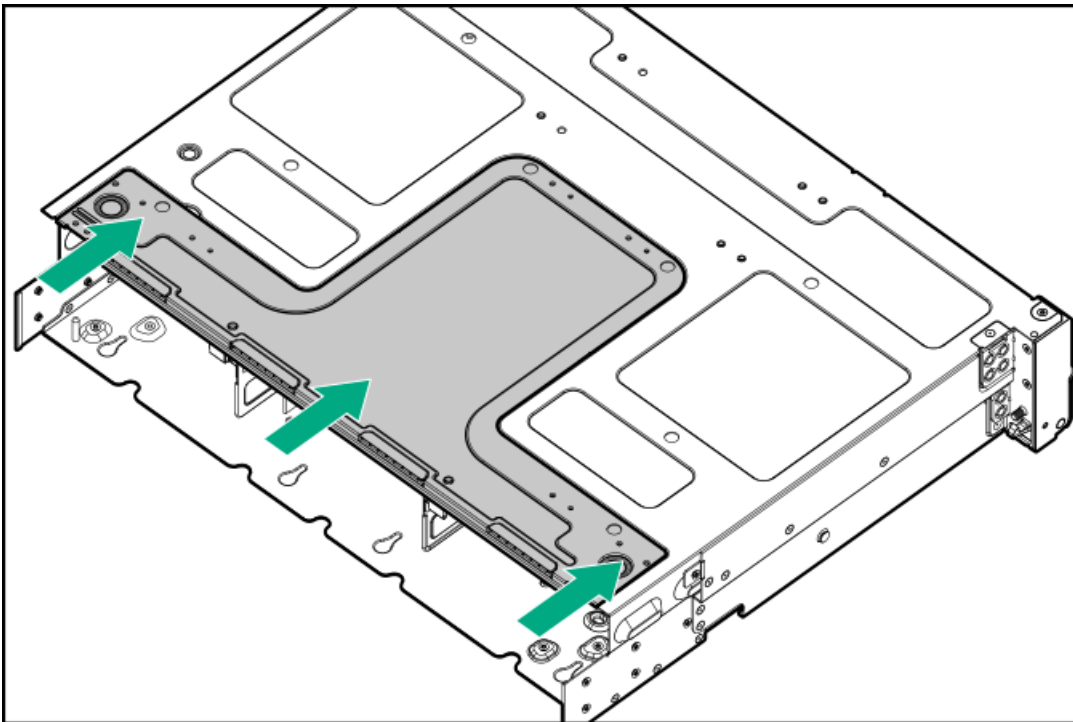

14. Install the access panel.
15. Install the server into the rack.
16. Connect all peripheral cables to the server.
17. Connect the power cords:
 - a. Connect each power cord to the server.



b. Connect each power cord to the power source.

18. If installed, close the cable management arm.

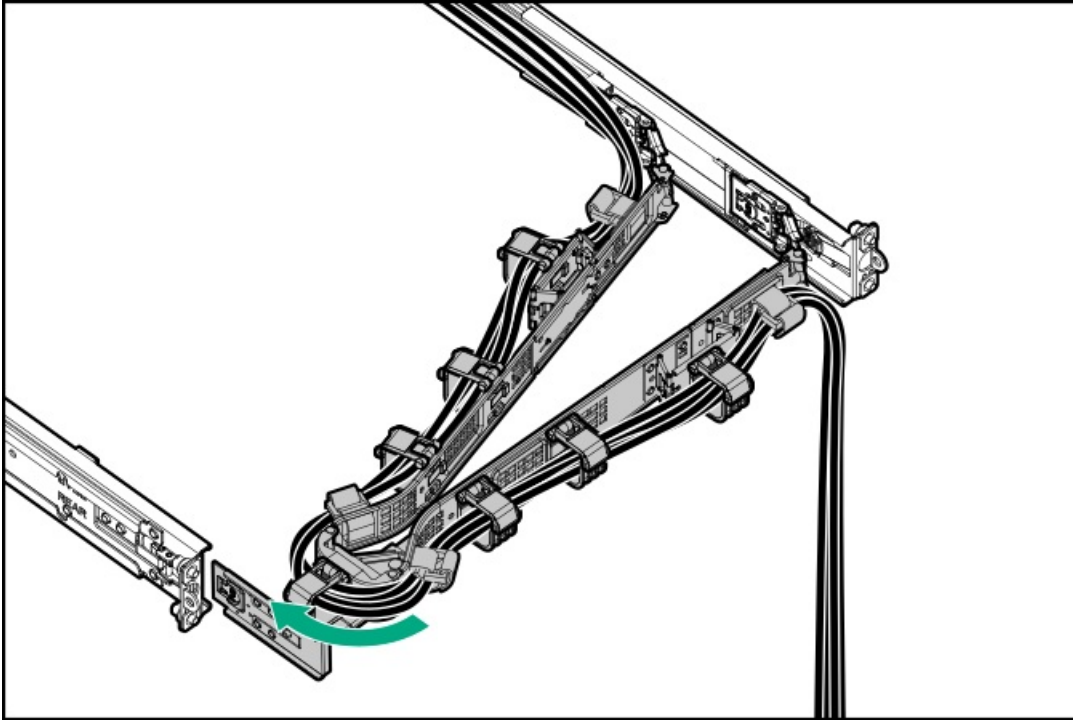

19. Power up the server.

Results

The installation procedure is complete.

Serial port option

Install the serial port option to enable communication to physical serial devices. You can also use the serial connection to remotely access the system BIOS and view POST error messages.

Subtopics

[Installing the serial port](#)

Installing the serial port

Prerequisites

Before you perform this procedure, make sure that you have a hex screwdriver available.

About this task

CAUTION: A discharge of static electricity from a finger or other conductor might damage system boards or other static-sensitive devices. To prevent damage, observe antistatic precautions.

CAUTION:
The port blank provides EMI shielding and helps maintain proper thermal status inside the server. Do not operate the server when a port blank is removed without the corresponding I/O port option installed.

Procedure

1. Power down the server.
2. If installed, open the cable management arm.
3. Remove all power:
 - a. Disconnect each power cord from the power source.
 - b. Disconnect each power cord from the server.
4. Disconnect all peripheral cables from the server.
5. Remove the server from the rack.
6. Remove the access panel.
7. If installed, remove the secondary riser cage.
8. Remove the serial port blank.

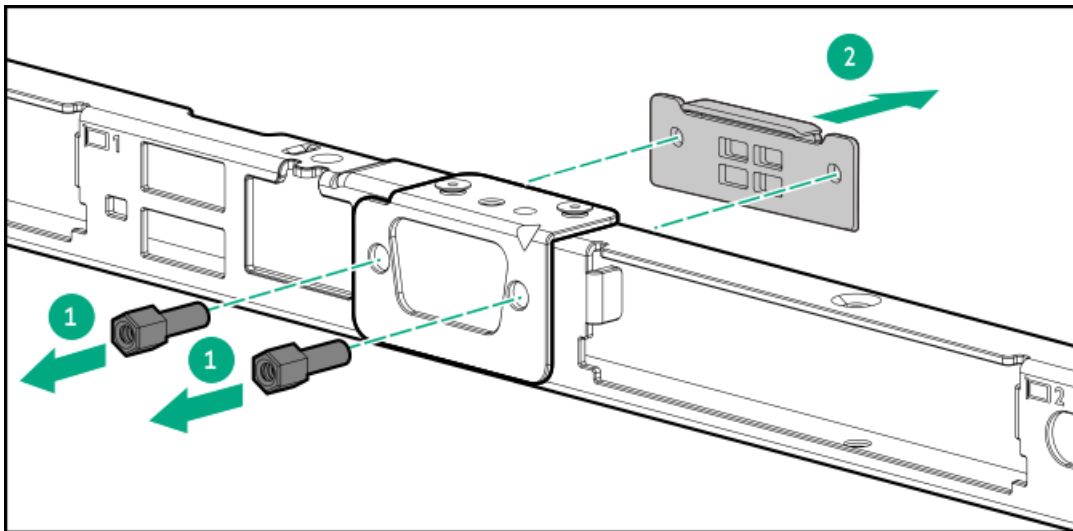

9. Install the serial port cable:
 - a. Insert the serial port into the rear panel opening.
 - b. Install the hex screws.

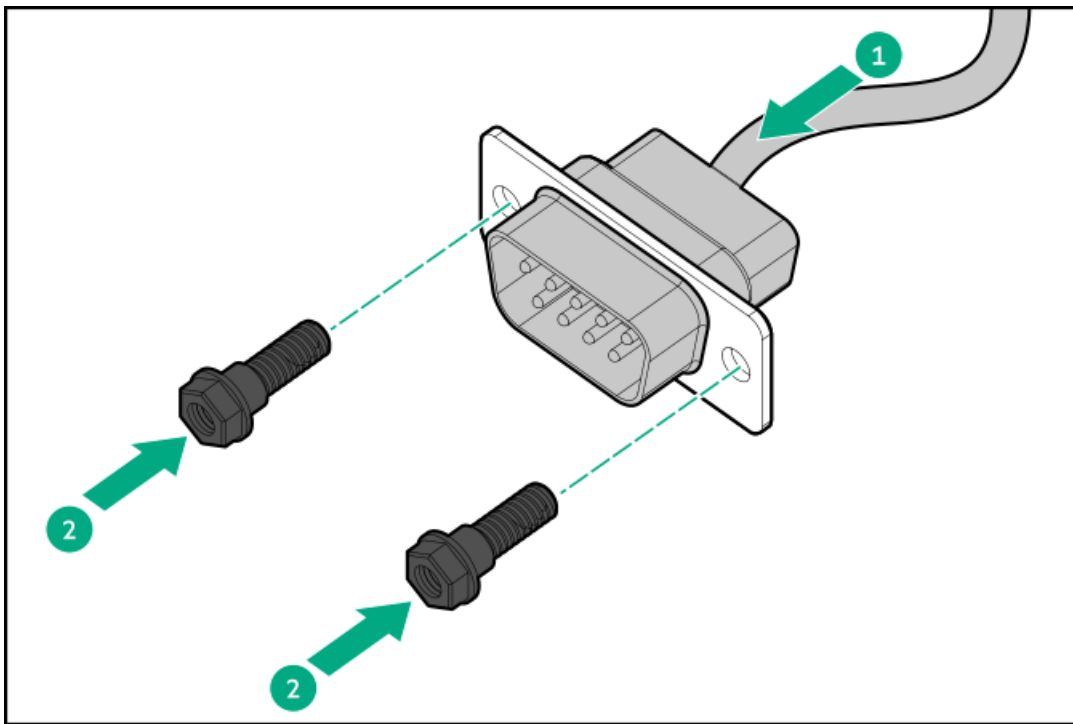

10. Connect the serial port cable.
11. Install the secondary riser cage.
12. Install the access panel.
13. Install the server into the rack.
14. Connect all peripheral cables to the server.
15. Connect the power cords:
 - a. Connect each power cord to the server.
 - b. Connect each power cord to the power source.
16. If installed, close the cable management arm.

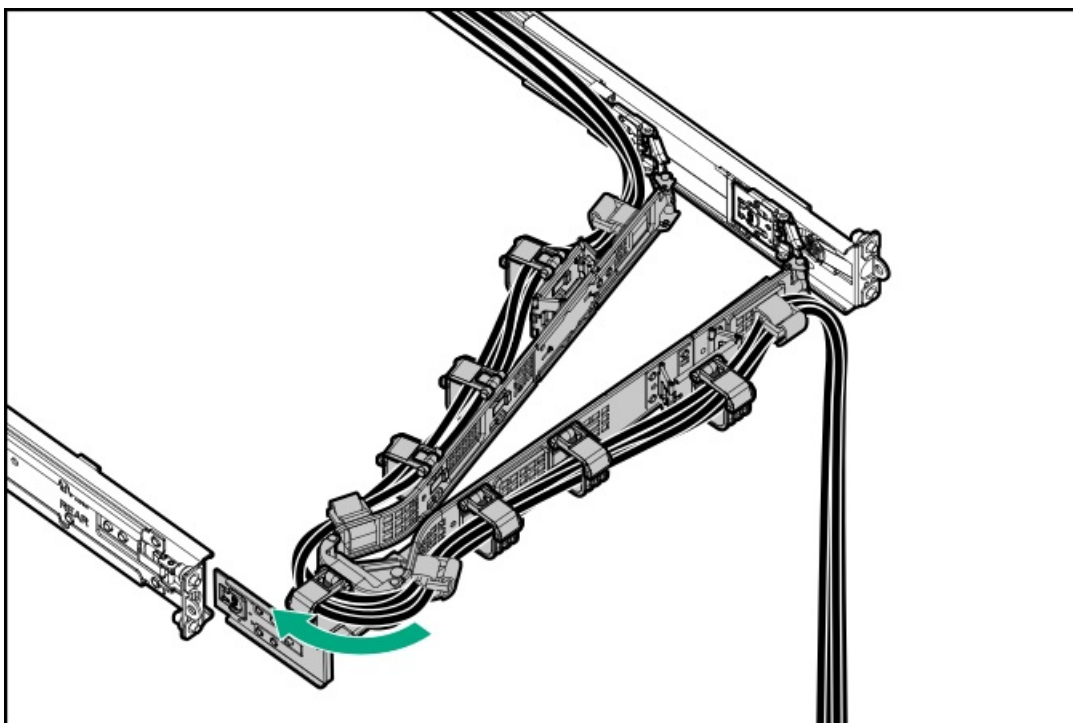

17. [Power up the server.](#)
18. To configure the serial port setting:
 - a. From the boot screen, press **F9** to access the UEFI System Utilities.
 - b. From the System Utilities screen, select System Configuration > BIOS/Platform Configuration (RBSU) > System Options > Serial Port Options > Embedded Serial Port.
 - c. Select a setting.
 - d. Press **F12** key to save your selection.
 - e. Click Yes-Save Changes.
 - f. Click Reboot.

Results

The installation procedure is complete.

Chassis intrusion detection switch option

The chassis intrusion detection switch enables iLO to record an event in the Integrated Management Log (IML) whenever the access panel is physically opened or removed. An alert is also sent to the BIOS whenever a chassis intrusion is detected. The chassis intrusion detection occurs as long as the server is plugged in, regardless of whether the server is powered on or off.

Subtopics

[Installing the chassis intrusion detection switch](#)

Installing the chassis intrusion detection switch

Prerequisites

Before you perform this procedure, make sure that you have the components included with the hardware option kit.

Procedure

1. [Power down the server.](#)
2. If installed, [open the cable management arm.](#)
3. Remove all power:
 - a. Disconnect each power cord from the power source.
 - b. Disconnect each power cord from the server.
4. Disconnect all peripheral cables from the server.
5. [Remove the server from the rack.](#)
6. [Remove the access panel.](#)
7. Install the chassis intrusion detection switch:
 - a. Insert the switch tab into the chassis slot until the switch clicks into place.
 - b. Connect the switch cable and secure it in the cable clamp.

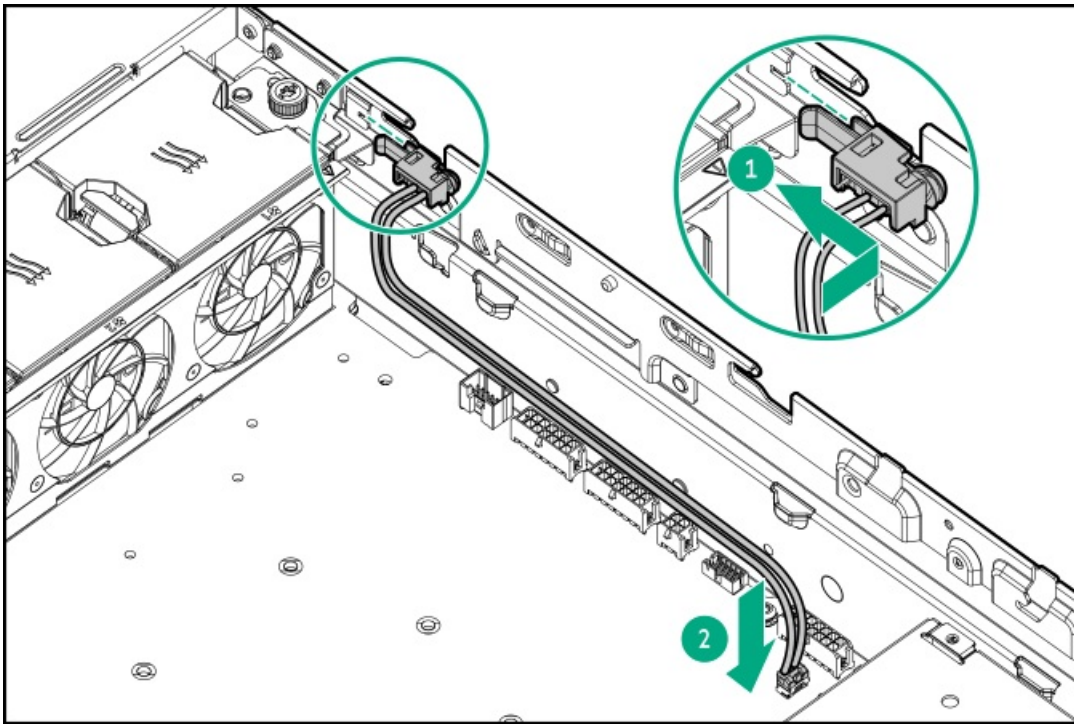

8. Install the access panel.
9. Install the server into the rack.
10. Connect all peripheral cables to the server.
11. Connect the power cords:
 - a. Connect each power cord to the server.
 - b. Connect each power cord to the power source.
12. If installed, close the cable management arm.

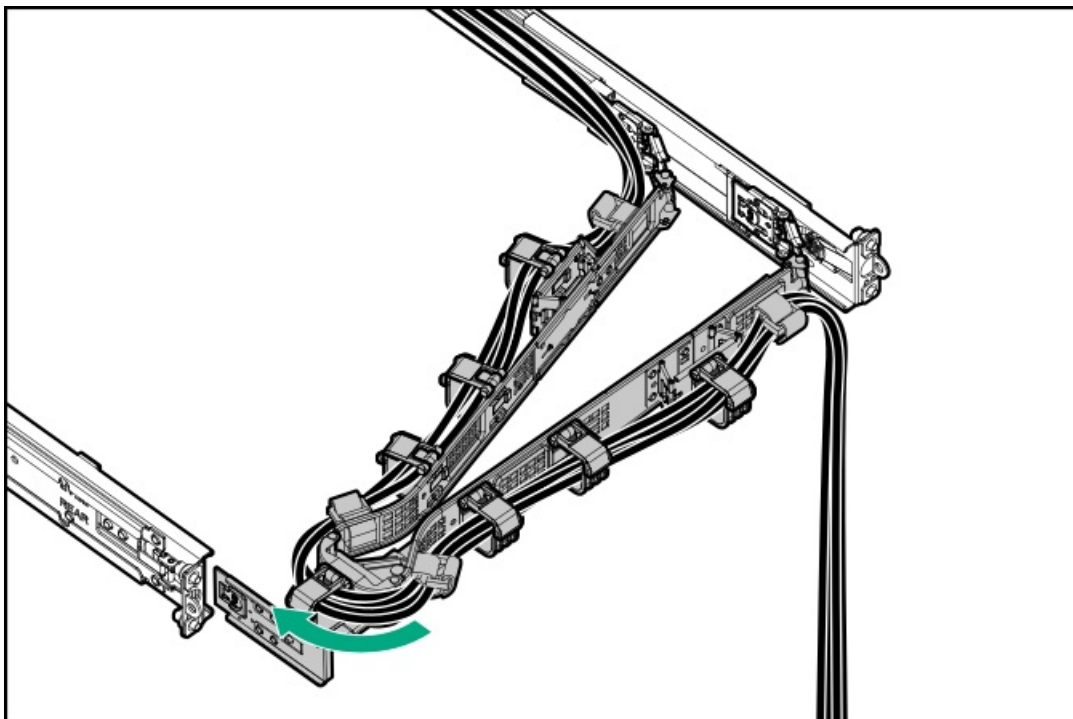

13. Power up the server.

Results



The installation procedure is complete.

Installing the System Insight Display module

Prerequisites

Before you perform this procedure, make sure that you have the following items available:

- The components included with the hardware option kit
- T-10 Torx screwdriver

About this task

The Systems Insight Display is supported on SFF models.

Procedure

1. If installed, remove the front bezel.
2. Power down the server.
3. If installed, open the cable management arm.
4. Remove all power:
 - a. Disconnect each power cord from the power source.
 - b. Disconnect each power cord from the server.
5. Disconnect all peripheral cables from the server.
6. Remove the server from the rack.
7. Remove the access panel.
8. Do one of the following:
 - Remove the air baffle.
 - Remove the midplane drive cage.
9. Remove the fan cage.

Installing the SID

10. Disconnect the blank from the power switch/SID module connector.

The SID module cable will be connected to this same connector.

11. Remove the power switch module. Retain the T-10 screw for later use.



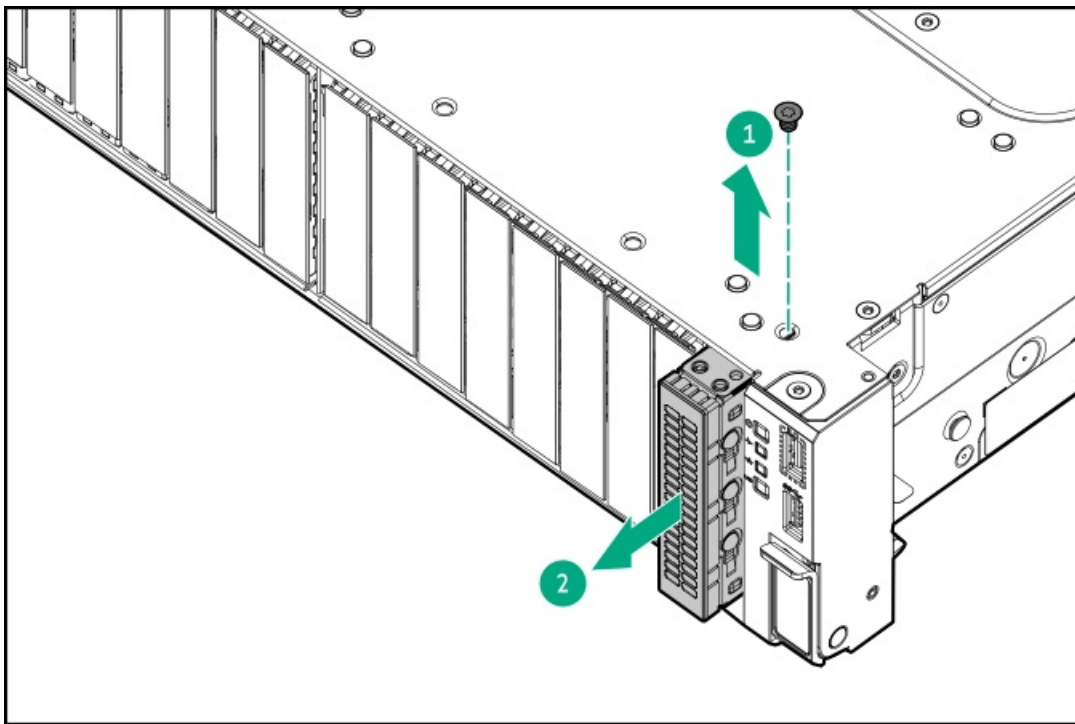

CAUTION: When routing cables, make sure that the cables are not in a position where they can be pinched or crimped.

12. Route the SID cable through the opening in the front of the server, and then install the SID module. Secure the module using the T-10 screw removed in step 8.

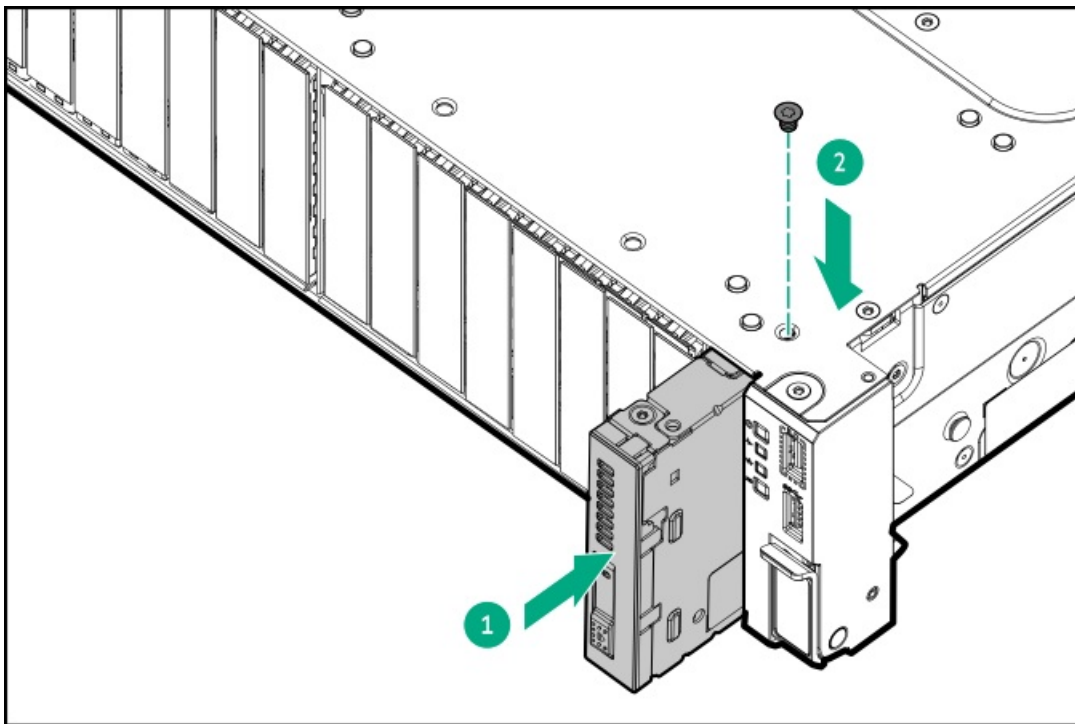

13. To access the SID, do the following:
 - a. Press and release the panel.
 - b. After the display fully ejects, rotate the display to view the LEDs.



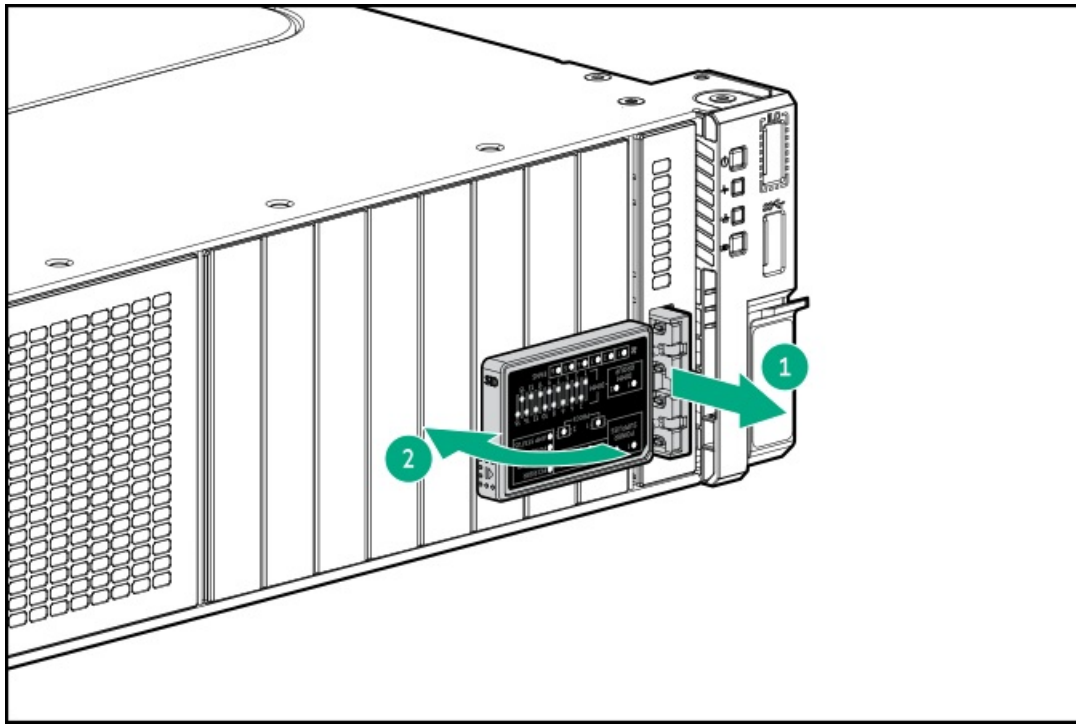

14. Connect the SID module cable to the power switch/SID module connector.
15. Cable the SID module.
16. Install the fan cage.
17. Do one of the following:
 - Install the air baffle.
 - Install the midplane drive cage.
18. Install the access panel.
19. Install the server into the rack.
20. Connect all peripheral cables to the server.
21. Connect the power cords:
 - a. Connect each power cord to the server.
 - b. Connect each power cord to the power source.
22. If installed, close the cable management arm.

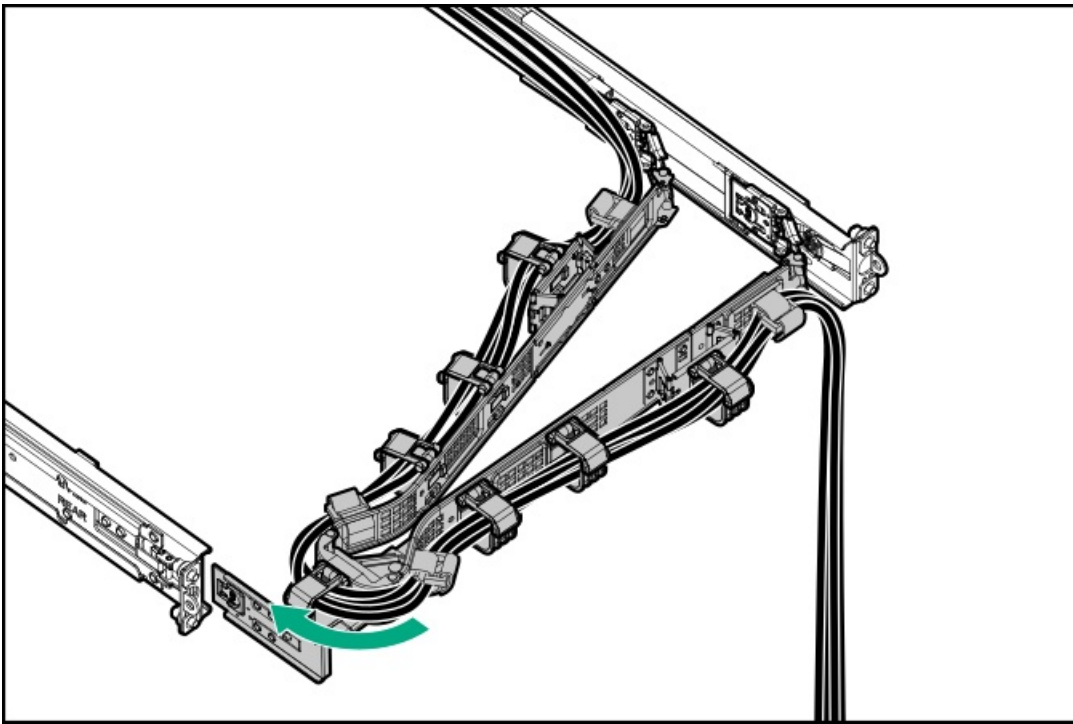

23. [Power up the server.](#)
24. If removed, [install the front bezel.](#)

Results

The installation procedure is complete.

Internal USB device option

The server has an internal 3.0 port to install a USB device that can be used as a flash boot media or for data backup/redundancy.

Subtopics

[Installing an internal USB device](#)

Installing an internal USB device

Procedure

1. [Power down the server.](#)
2. If installed, [open the cable management arm.](#)
3. Remove all power:
 - a. Disconnect each power cord from the power source.
 - b. Disconnect each power cord from the server.
4. Disconnect all peripheral cables from the server.
5. [Remove the server from the rack.](#)
6. [Remove the access panel.](#)

7. Do one of the following:
 - [Remove the air baffle.](#)
 - [Remove the midplane drive cage.](#)
8. Do one of the following:
 - [Remove the three-slot secondary riser cage.](#)
 - [Remove the rear 4 LFF drive cage.](#)
9. Plug in the USB device into the USB port.

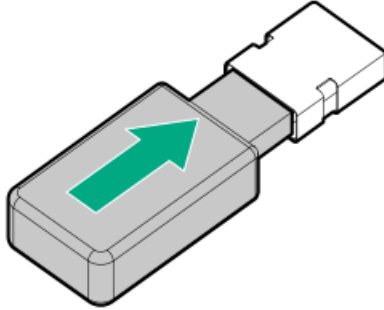

10. Do one of the following:
 - [Install the three-slot secondary riser cage.](#)
 - [Install the rear 4 LFF drive cage.](#)
11. Do one of the following:
 - [Install the air baffle.](#)
 - [Install the midplane drive cage.](#)
12. [Install the access panel.](#)
13. Connect all peripheral cables to the server.
14. Connect the power cords:
 - a. Connect each power cord to the server.
 - b. Connect each power cord to the power source.
15. If installed, close the cable management arm.

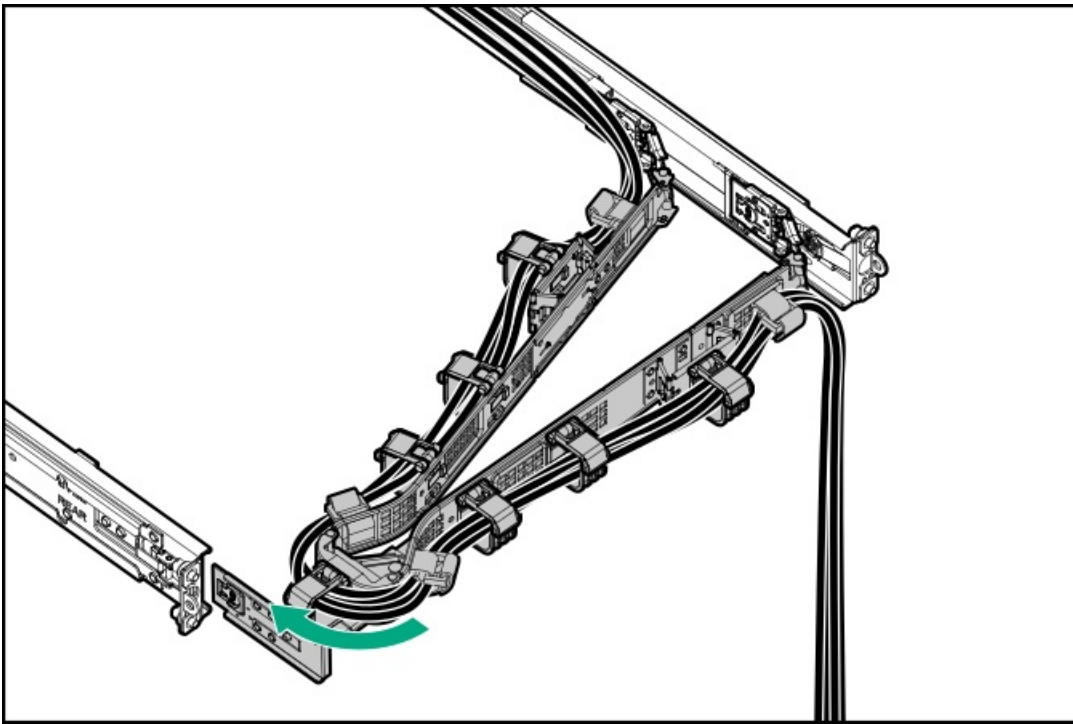

16. [Power up the server.](#)
17. If removed, [install the front bezel.](#)

Results

The installation procedure is complete.

Cabling

This chapter includes cabling guidelines and diagrams for internal component cabling.

Subtopics

[Cabling guidelines](#)

[Internal cabling management](#)

[Cabling diagrams](#)

[Storage cabling](#)

[GPU auxiliary power cabling](#)

[Riser cabling](#)

[Switch board cabling](#)

[HPE NS204i Boot Device cabling](#)

[System Insight Display cabling](#)

[Chassis intrusion switch cabling](#)

[Universal media bay cabling](#)

[DisplayPort cabling](#)



Front I/O cabling

Power distribution board cabling

Serial port cabling

Optical drive cabling

OCP bandwidth upgrade cabling

XGMI cabling

Cabling guidelines

Observe the following:

- For cable option kits, see the product QuickSpecs.
- For cable spare part numbers, see the Illustrated parts catalog in the maintenance and service guide.
- Some diagrams show alphabetical callouts such as A, B, C, etc. These callouts correspond to labels near the connectors on the cable.
- Some cables have more than one connector, such as a Y-cable, but not all connectors are used.
- The cable colors in the cabling diagrams used in this chapter are for illustration purposes only.
- Observe all guidelines when working with server cables.

Before connecting cables

- Note the port labels on the PCA components. Not all these components are used by all servers:
 - System board ports
 - Drive and power supply backplane ports
 - Expansion board ports (controllers, retimers, adapters, expanders, risers, and similar boards)
- Note the label near each cable connector. This label indicates the destination port for the cable connector.
- Some data cables are prebent. Do not unbend or manipulate the cables.
- To prevent mechanical damage or depositing oil that is present on your hands, and other contamination, do not touch the ends of the connectors.

When connecting cables

- Before connecting a cable to a port, lay the cable in place to verify the length of the cable.
- Use the internal cable management features to properly route and secure the cables.
- When routing cables, be sure that the cables are not in a position where they can be pinched or crimped.
- Avoid tight bend radii to prevent damaging the internal wires of a power cord or a server cable. Never bend power cords and server cables tight enough to cause a crease in the sheathing.
- Make sure that the excess length of cables is properly secured to avoid excess bends, interference issues, and airflow restriction.
- To prevent component damage and potential signal interference, make sure that all cables are in their appropriate routing position before installing a new component and before closing up the server after hardware installation/maintenance.

When disconnecting cables

- Grip the body of the cable connector. Do not pull on the cable itself because this action can damage the internal wires of the cable or the pins on the port.
- If a cable does not disconnect easily, check for any release latch that must be pressed to disconnect the cable.

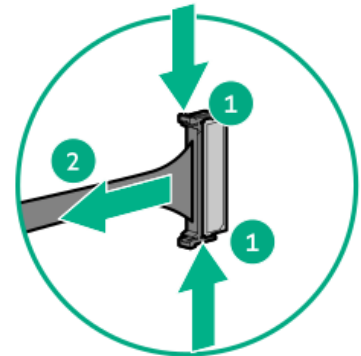
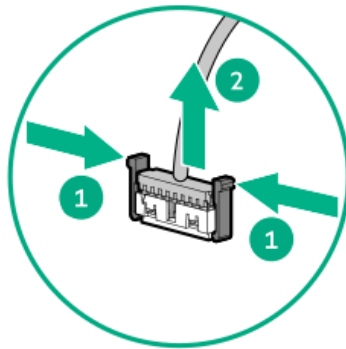
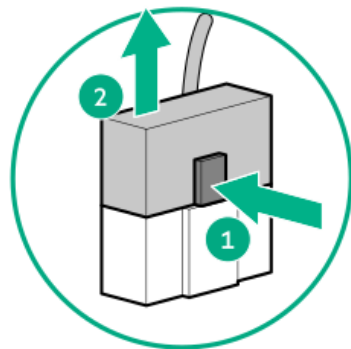
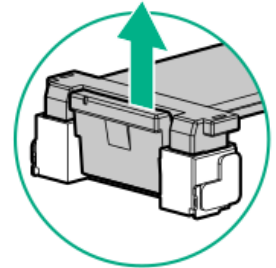
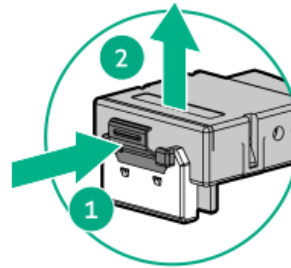
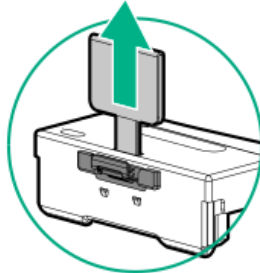
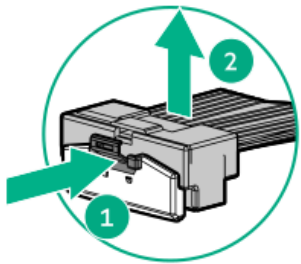
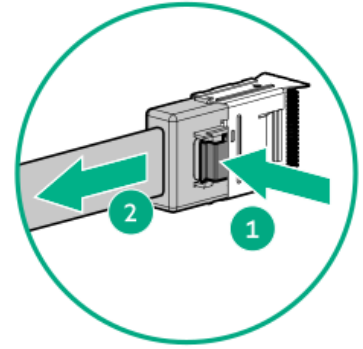
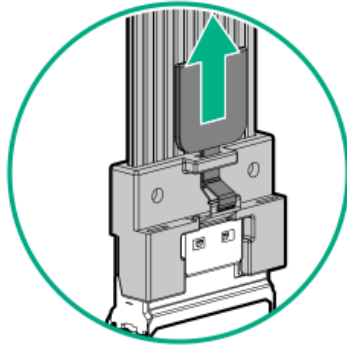
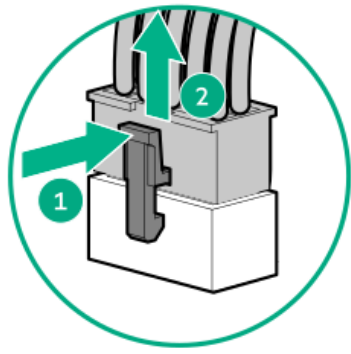

- Remove cables that are no longer being used. Retaining them inside the server can restrict airflow. If you intend to use the removed cables later, label and store them for future use.

Internal cabling management



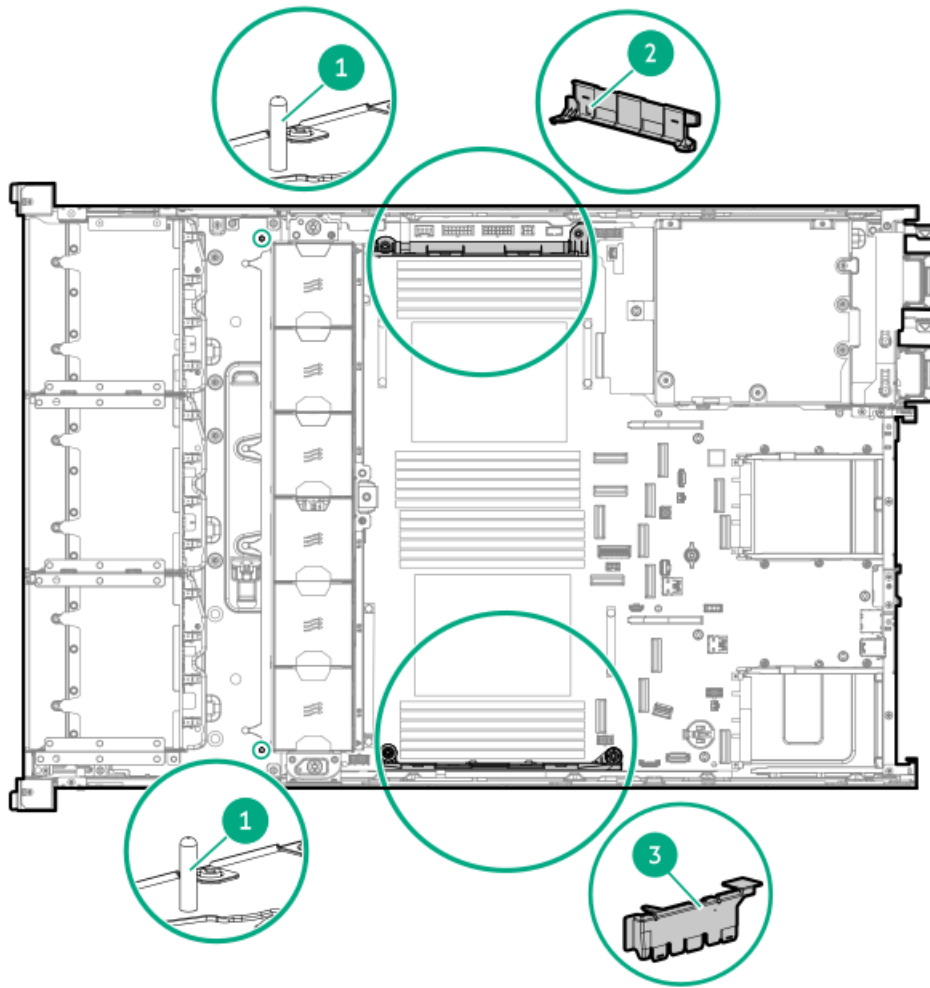

Item Description

1	Guide pins
2	DIMM guards
3	Cable guards ¹

¹ If a midtray is installed, there will be no cable guards.

Cabling diagrams

Observe the following:

- Before cabling components, see the [cabling guidelines](#).
- Use the cable part number or search feature to find your diagram.

Component cabling

Cable part number

Front SFF drive power cabling

- [P57198-001](#)
- [P58023-001](#)
- [P57209-001](#)

Component cabling	Cable part number
48 SFF drive power cabling	<ul style="list-style-type: none"> • P58024-001 • P58025-001 • P58026-001
Front LFF drive power cabling	<ul style="list-style-type: none"> • P58036-001 • P58867-001
E3.S drive power cabling	<ul style="list-style-type: none"> • P58115-001 • P58822-001
8 SFF drive power cabling in the GPU configuration	P58023-001
8 E3.S drive power cabling in the GPU configuration	P58034-001
Rear 2 SFF drive power cabling	P58086-001
Rear LFF drive power cabling	<ul style="list-style-type: none"> • P58085-001 • P58086-001
Stacked 2 SFF drive: Primary type-p controller cabling	P58146-001
Stacked 2 SFF drive: Type-o controller cabling	<ul style="list-style-type: none"> • P58145-001 • P58148-001
8/16/24/32 SFF drive: Onboard SAS/SATA cabling	<ul style="list-style-type: none"> • P58013-001 • P58012-001 • P58011-001
8/16/24 SFF drive: Onboard NVMe cabling	<ul style="list-style-type: none"> • P58171-001 • P58172-001 • P58169-001 • P58168-001
24/32 SFF drive: Onboard NVMe cabling	<ul style="list-style-type: none"> • P58107-001 • P58170-001 • P58106-001
8/16/24/32 SFF drive: SR932i-p controller cabling	<ul style="list-style-type: none"> • P58019-001 • P58020-001 • P58018-001
8/16/24/32 SFF drive: Primary type-p controller cabling	<ul style="list-style-type: none"> • P58020-001 • P58018-001 • P58120-001 • P58123-001 • P58127-001
8 SFF drive with two GPU riser cages: Primary type-p controller cabling	P58692-001
8 SFF drive with two GPU riser cages: Primary and secondary MR 216i-p controller cabling	P57057-002
8/16/24/32 SFF drive: Secondary type-p controller cabling	<ul style="list-style-type: none"> • P58017-001 • P58114-001 • P58124-001 • P58121-001
8/16/24/32 SFF drive: Type-o controller cabling	<ul style="list-style-type: none"> • P58015-001 • P58014-001 • P58016-001
48 SFF drive: Primary type-p controller cabling	P58119-001
48 SFF drive: Secondary type-p controller cabling	<ul style="list-style-type: none"> • P58112-001 • P58032-001

Component cabling	Cable part number
8 SFF drive with two GPU riser cages: Type-o controller cabling	P57334-002
8/12/16 LFF drive: Onboard SAS/SATA cabling	<ul style="list-style-type: none"> • P58102-001 • P58099-001
8/12/16/20 LFF drive: Type-o controller cabling	<ul style="list-style-type: none"> • P58104-001 • P58100-001
16/32 SFF drive: Onboard NVMe cabling	<ul style="list-style-type: none"> • P58087-001
16/32 SFF drive: Onboard NVMe cabling	<ul style="list-style-type: none"> • P58092-001 • P58093-001
16/32 SFF drive: Primary type-p controller cabling	P58089-001
32 SFF drive: Secondary type-p controller cabling	<ul style="list-style-type: none"> • P58095-001 • P58094-001
32 SFF drive: Secondary or tertiary type-p controller cabling	P58090-001
2 SFF drive: Primary type-p controller cabling	P58150-001
2 SFF drive: Secondary type-p controller cabling	P58151-001
2 SFF drive: Type-o controller cabling	<ul style="list-style-type: none"> • P58152-001 • P58149-001
4 LFF drive: Type-o controller cabling	P58098-001
8 E3.S drive: Primary riser cabling	P57057-002
12/24 E3.S drive: Onboard NVMe cabling for box 3	<ul style="list-style-type: none"> • P58108-001 • P58109-001
24 E3.S drive: Onboard NVMe cabling for box 1	<ul style="list-style-type: none"> • P58110-001 • P58111-001
32 E3.S drive: Onboard NVMe and Retimer cabling	<ul style="list-style-type: none"> • P58130-001 • P58111-001 • P68180-001 • P58108-001 • P58174-001
36 E3.S drive: Onboard NVMe cabling	<ul style="list-style-type: none"> • P58118-001 • P58117-001 • P58113-001 • P58116-001
12 E3.S drive: Primary riser cabling	P58125-001
24 E3.S drive: Secondary riser cabling	<ul style="list-style-type: none"> • P62389-001 • P62388-001 • P58126-001
8 SFF drive with two GPU riser cages: Onboard NVMe cabling	<ul style="list-style-type: none"> • P58153-001 • P58154-001
8 SFF drive with two GPU riser cages: Primary riser cabling	P57057-002
24 SFF drive: Energy pack cabling	P58176-001
12 LFF drive: Energy pack cabling	P58176-001

Component cabling	Cable part number
GPU auxiliary power cabling	<ul style="list-style-type: none"> • P58157-001 • P58159-001 • P58161-001 • P58064-001 • P58160-001 • P58162-001 • P58062-001
Primary stacking riser cabling	<ul style="list-style-type: none"> • P41276-001 • P41272-001
Secondary stacking riser cabling	<ul style="list-style-type: none"> • P55815-001 • P41276-001
Tertiary stacking riser cabling	<ul style="list-style-type: none"> • P50365-001 • P50364-001
GPU riser cabling	<ul style="list-style-type: none"> • P44218-001 • P55816-001
Switch board power cabling	<ul style="list-style-type: none"> • P58178-001 • P58177-001 • P58034-001
Switch board signal cabling	<ul style="list-style-type: none"> • P58163-001 • P58165-001 • P58166-001 • P58164-001 • P58046-001 • P54900-001
HPE NS204i Boot Device cabling on the secondary riser cage	<ul style="list-style-type: none"> • P54087-001 • P54088-001
HPE NS204i Boot Device cabling on top of the power supplies	<ul style="list-style-type: none"> • P54087-001 • P54088-001
System Insight Display cabling	P48971-001
Chassis intrusion switch cabling	P54901-001
Universal media bay cabling	<ul style="list-style-type: none"> • P14314-001 • P57248-001
DisplayPort cabling	869808-001
Front I/O cabling	<ul style="list-style-type: none"> • P43727-001 • P47750-001
Power distribution board cabling	P58028-001
Serial port cabling	873747-001
Optical drive cabling in the SFF chassis	P58077-001
Optical drive cabling in the LFF chassis	P58077-001
OCP bandwidth upgrade cabling	<ul style="list-style-type: none"> • P58174-001 • P58173-001
XGMI cabling	<ul style="list-style-type: none"> • P63462-001 • P58128-001

Storage cabling

Subtopics

[Drive power cabling](#)

[Storage controller cabling](#)

[Energy pack cabling](#)

[Storage controller backup power cabling](#)

Drive power cabling

Front SFF drive power cabling

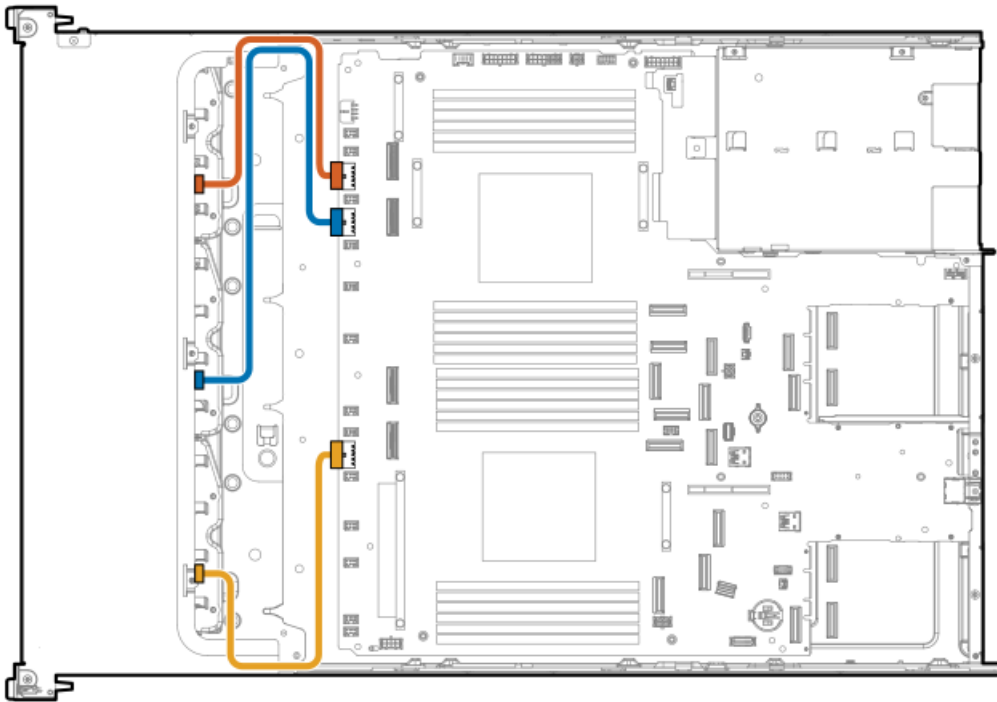

Cable part number	Color	From	To
P57198-001 ¹	Orange	Drive backplane power connector 1	Box 1
P58023-001 ¹	Blue	Drive backplane power connector 2	Box 2
P57209-001 ²	Yellow	Drive backplane power connector 3	Box 3

¹ Option kit: P57845-B21
¹ Option kit: P57952-B21

²

48 SFF drive power cabling



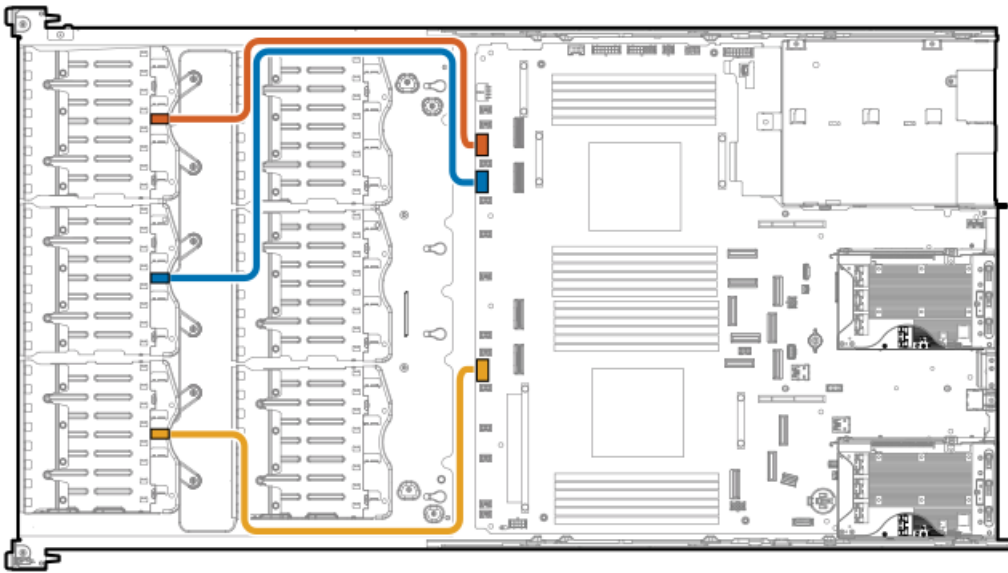

Cable part number	Color	From	To
P58026-001	Orange	Drive backplane power connector 1	Box 1
P58025-001	Blue	Drive backplane power connector 2	Box 2
P58024-001	Yellow	Drive backplane power connector 3	Box 3

Front LFF drive power cabling

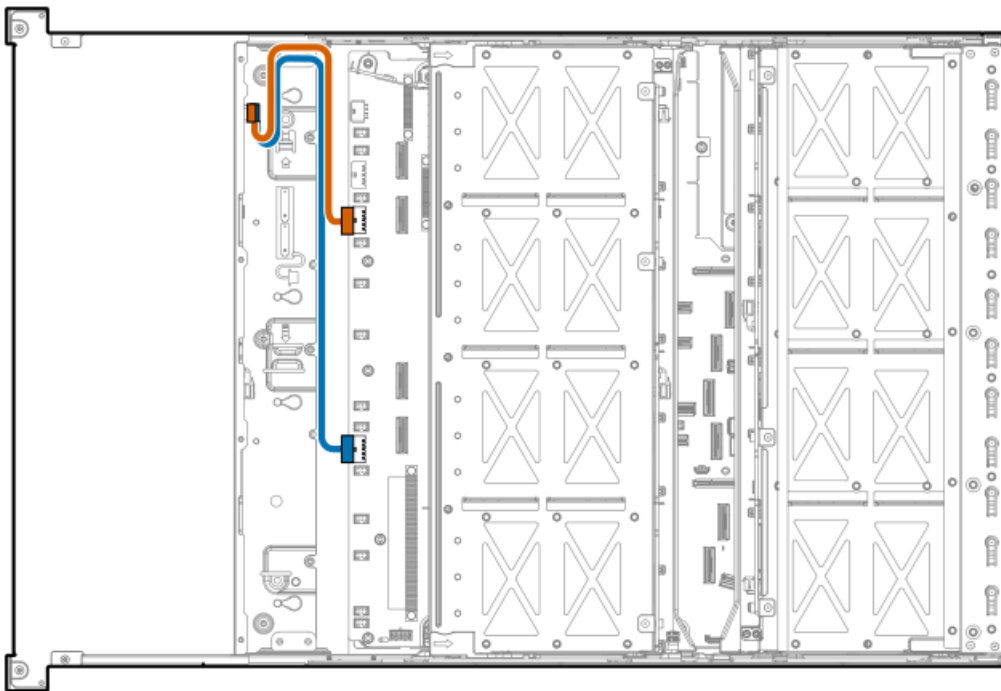

Cable part number	Color	From	To
P58036-001 ¹	Orange	Drive backplane power connector 2	Box 2
P58867-001 ²	Blue	Drive backplane power connector 3	Box 3

- ¹ Option kit: P55093-B21
- ² Option kit: P57957-B21

E3.S drive power cabling

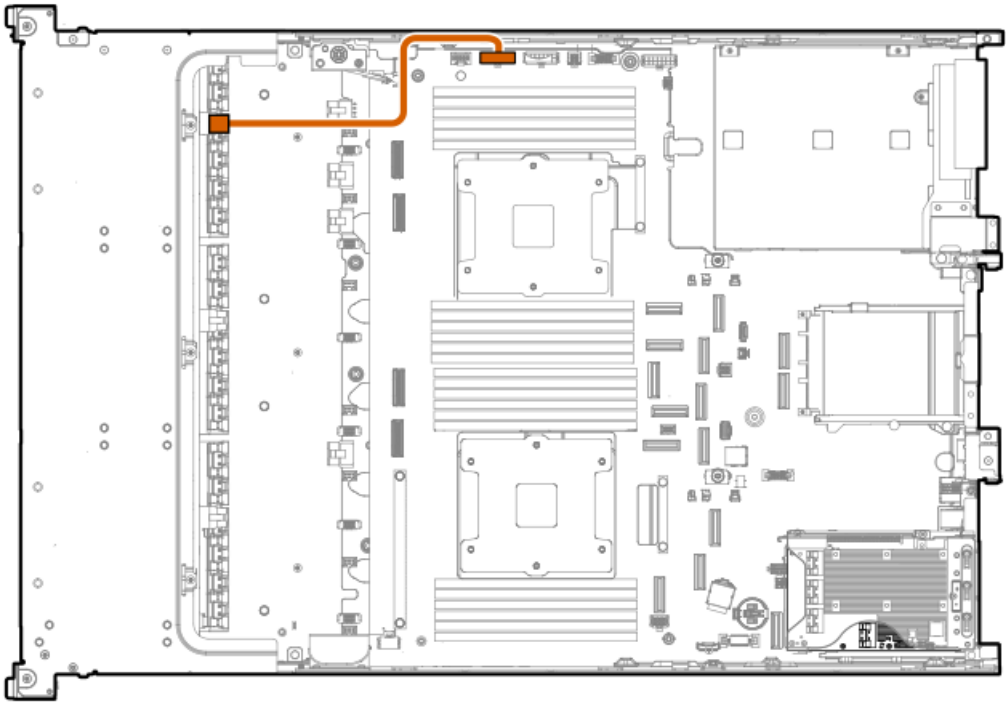

Cable part number	Color	From	To
P58115-001	Orange	GPU/Backplane/Switch Board power connector	Box 1



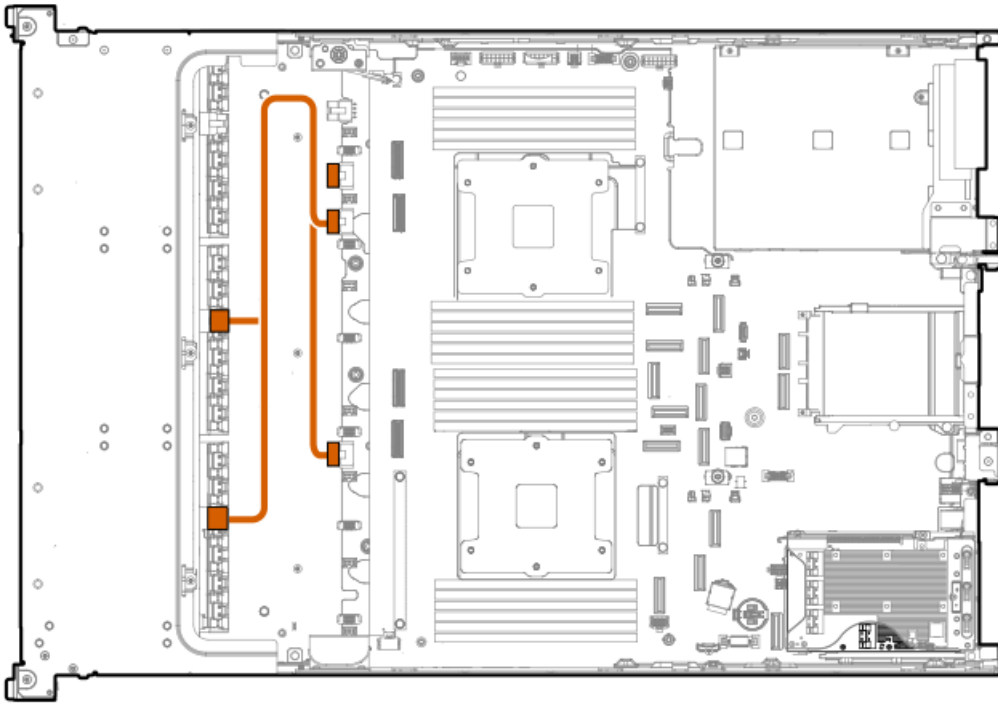

Cable part number	Color	From	To
P58822-001	Orange	Drive backplane power connector 1, 2, and 3	Box 2/3

8 SFF drive power cabling in the GPU configuration

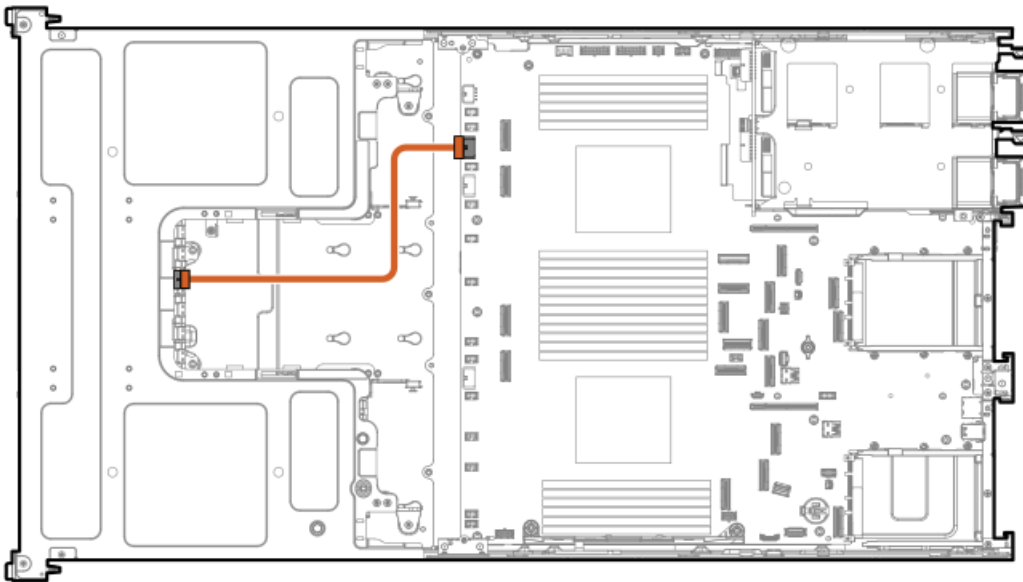

Cable part number	Color	From	To
P58023-001	Orange	Box 1	Drive backplane power connector 1



8 E3.S drive power cabling in the GPU configuration

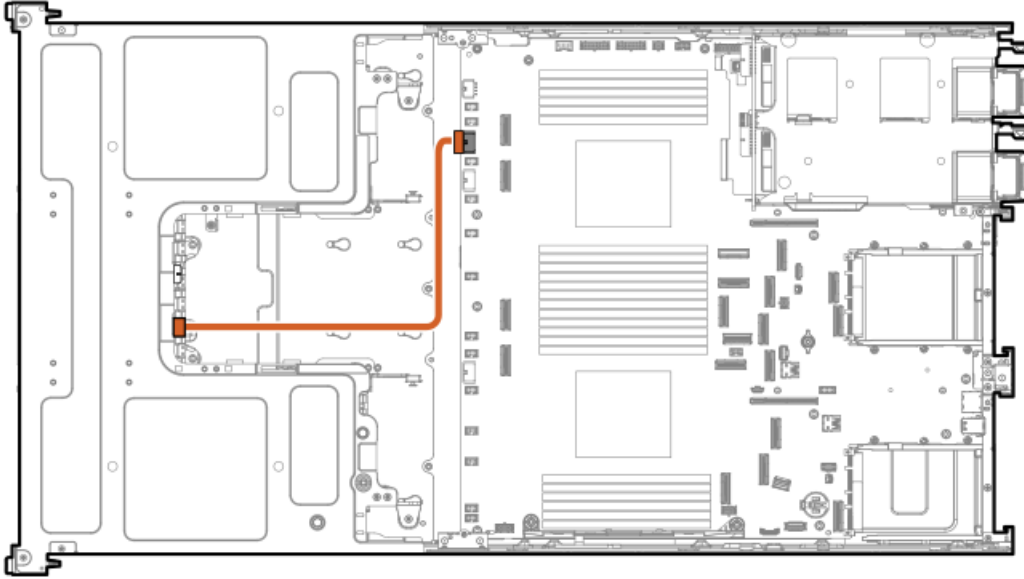

Cable part number	Color	From	To
P58034-001	Orange	Box 1	Drive backplane power connector 1

Rear 2 SFF drive power cabling

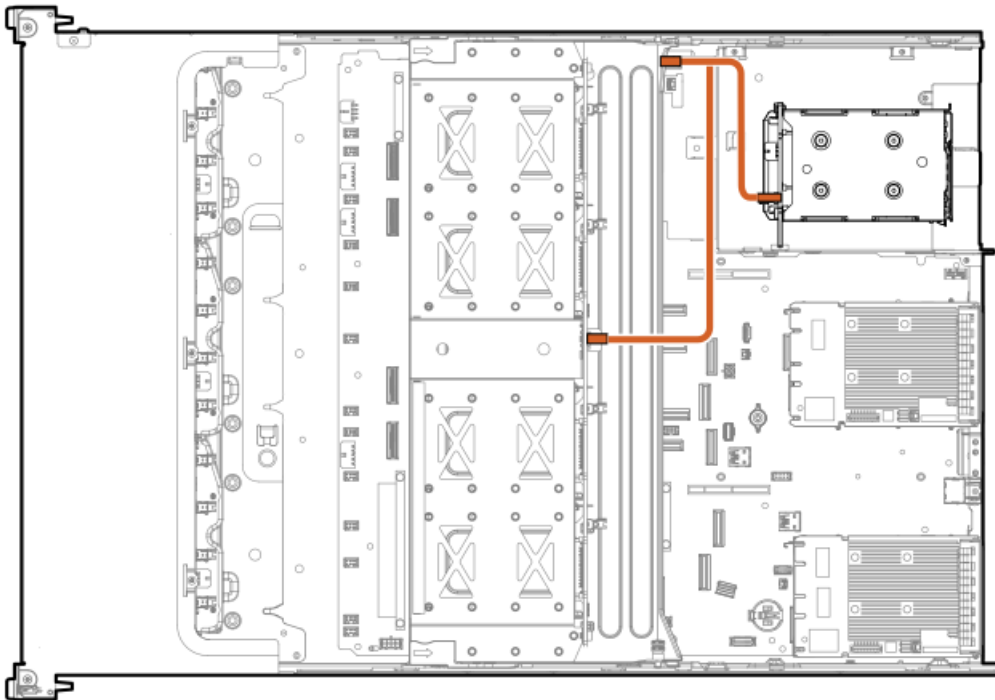

Cable part number	Color	From	To
P58086-001 ¹	Orange	Drive backplane power connector	Box 7/8



1

Rear LFF drive power cabling

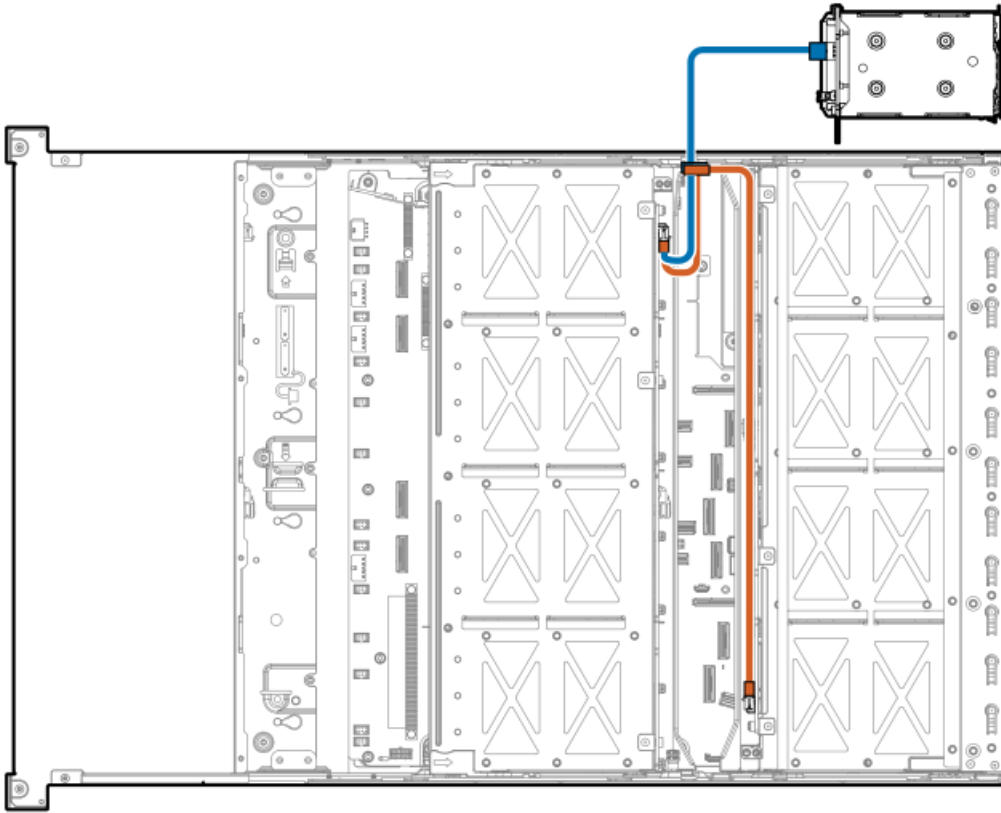

Cable part number	Color	From	To
P58085-001 ¹	Orange	Drive backplane power connector	Box 7/8
P58086-001 ²	Blue	Drive backplane power connector	Box 8

¹ Option kit: P55085-B21
² Option kit: P55086-B21; P55087-B21; P55091-B21

Storage controller cabling

Subtopics

[Front-end drive cabling](#)

[Midplane drive cabling](#)

[Rear-end drive controller cabling](#)

Front-end drive cabling

Subtopics

[SFF drive cabling](#)



LFF drive cabling

E3.S drive cabling

SFF drive cabling

Stacked 2 SFF drive: Primary type-p controller cabling

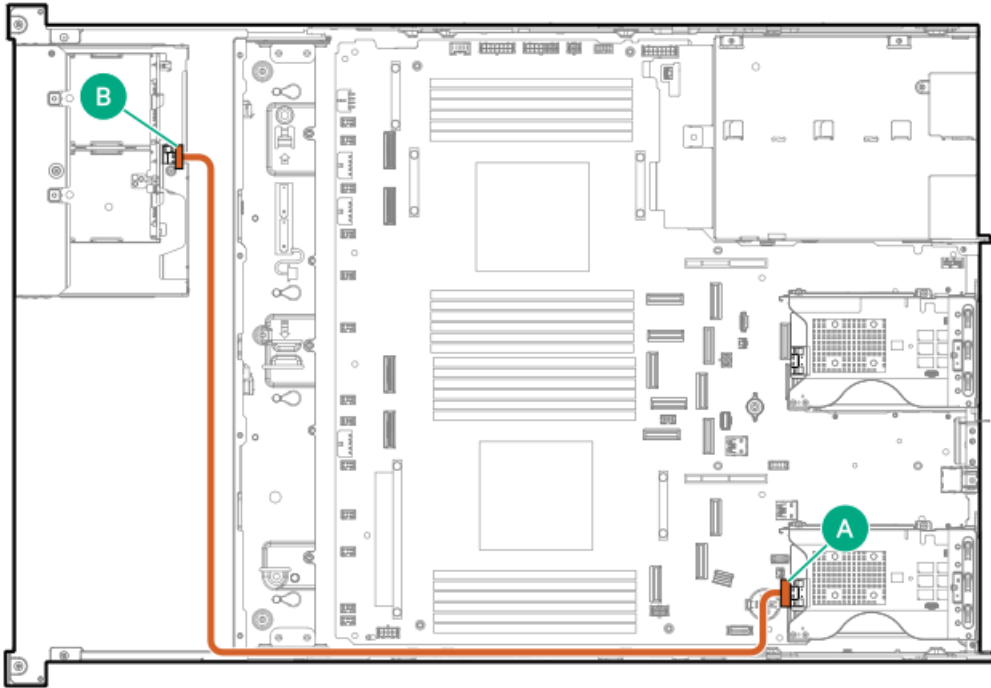

Cable part number	Color	From	To
P58146-001 ¹	Orange	Port 1	Box 1 port 1

¹ Option kit: P55091-B21; P55093-B21

Stacked 2 SFF drive: Type-o controller cabling

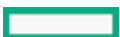

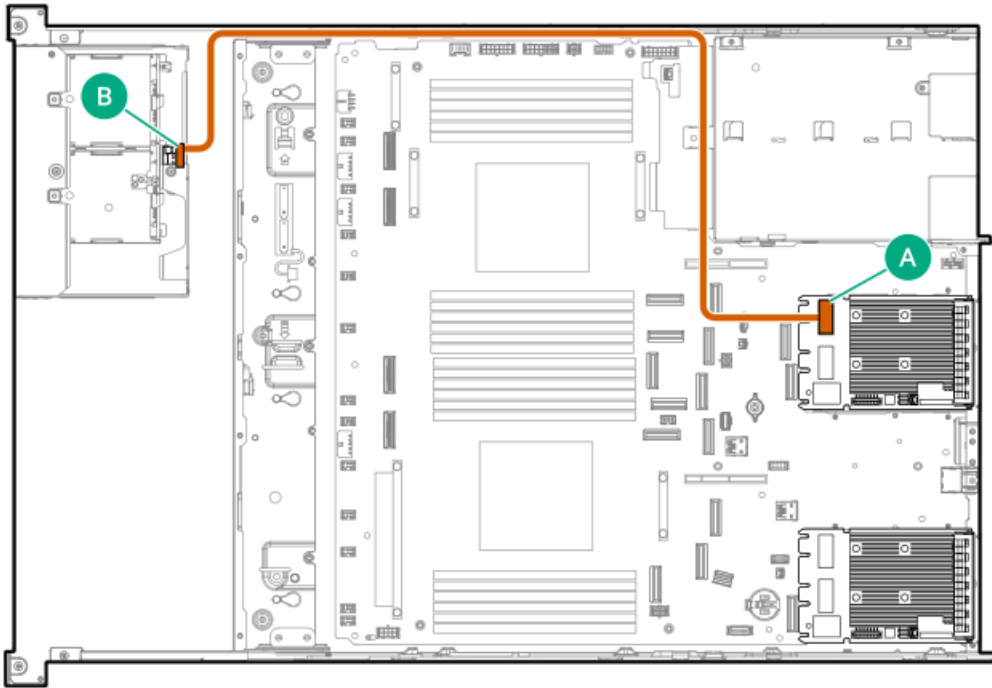

Cable part number	Color	From	To
P58145-001 ¹	Orange	Slot 22 port 1	Box 1 port 1

¹ Option kit: P55093-B21

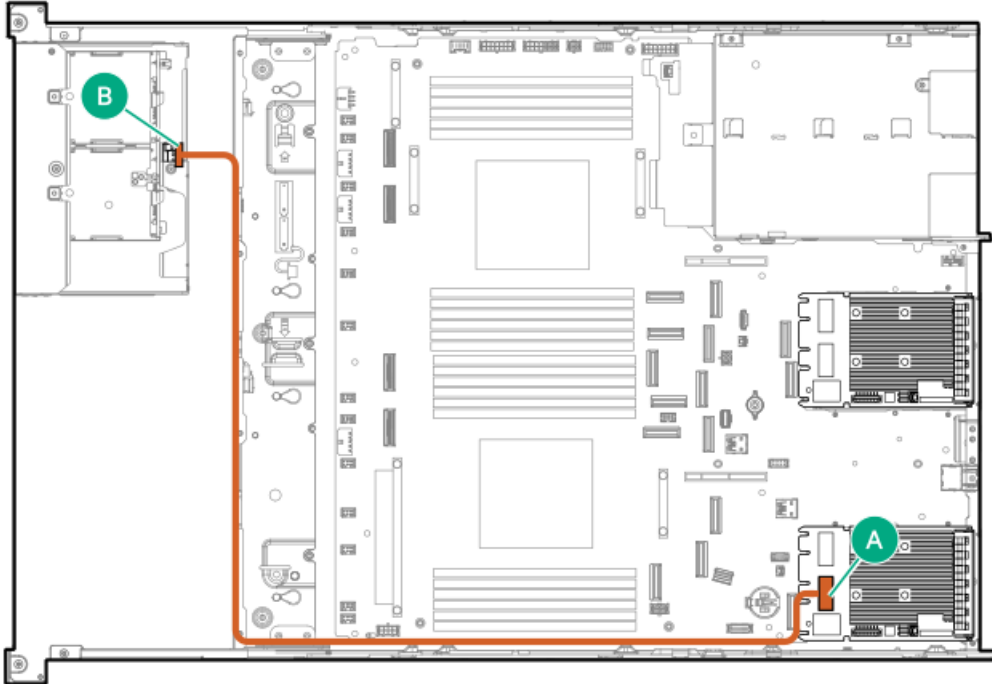

Cable part number	Color	From	To
P58148-001 ¹	Orange	Slot 21 port 1	Box 1 port 1

¹ Option kit: P55093-B21



8/16/24/32 SFF drive: Onboard SAS/SATA cabling

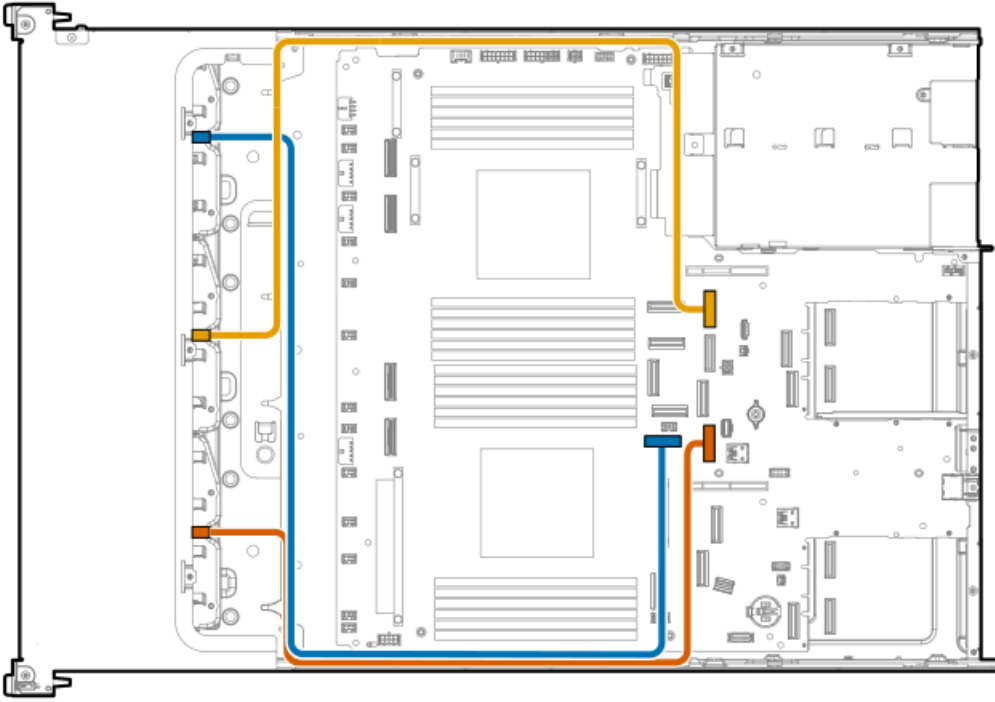

Cable part number	Color	From	To
P58013-001 ¹ / ₂	Blue	NVMe/SATA port 9A	Box 1 port 1
P58012-001 ¹	Yellow	NVMe/SATA port 9B	Box 2 port 1
P58011-001 ¹	Orange	NVMe/SATA port 1A	Box 3 port 1

- ¹ Option kit: P57846-B21
- ₂ This cabling connection is for 24 and 32 SFF with two processors.

8/16/24 SFF drive: Onboard NVMe cabling

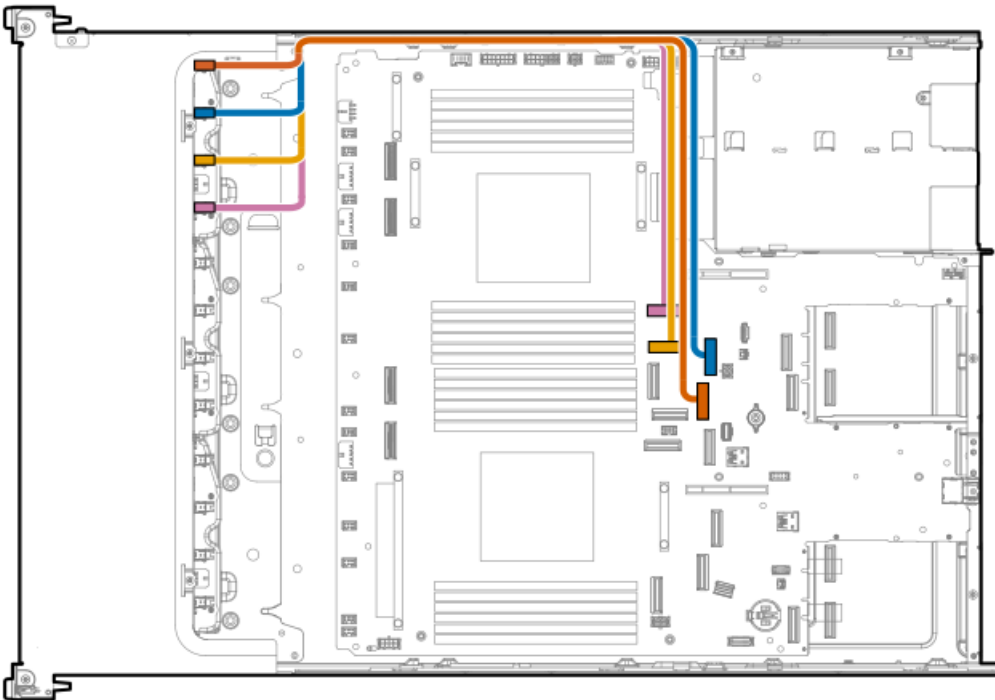

Cable part number	Color	From	To
P58171-001 ¹ ²	Orange	NVMe/SATA port 8B	Box 1 port 1
	Blue	NVMe/SATA port 9B	Box 1 port 2
	Yellow	NVMe port 6B	Box 1 port 3
	Pink	NVMe port 7B	Box 1 port 4

- ¹ Option kit: P57855-B21
- ² This cabling connection is for 24 SFF with two processors.

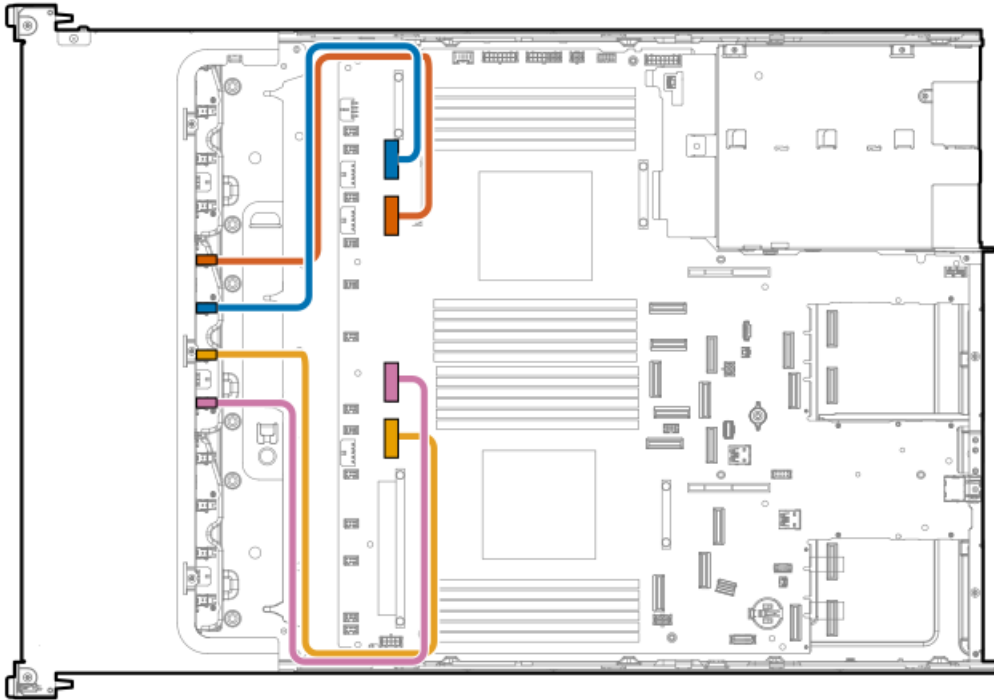

Cable part number	Color	From	To
P58172-001 ¹	Orange	NVMe port 2B	Box 2 port 1
	Blue	NVMe port 3B	Box 2 port 2
P58169-001 ¹	Yellow	NVMe port 2A	Box 2 port 3
	Pink	NVMe port 3A	Box 2 port 4

- ¹ Option kit: P57854-B21

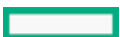

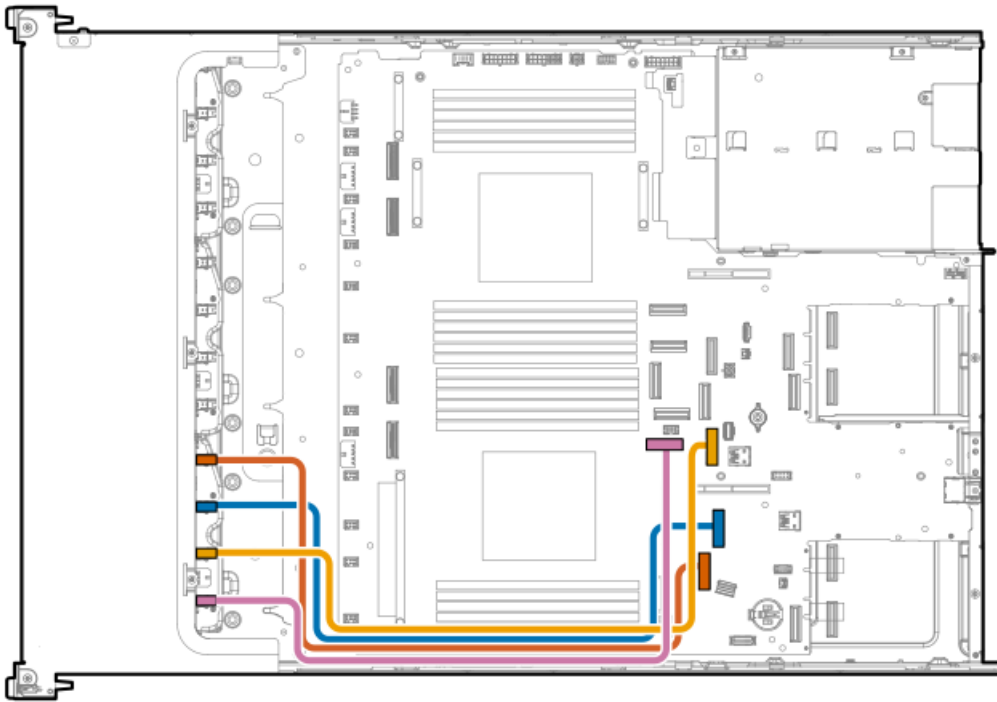

Cable part number	Color	From	To
P58168-001 ¹	Orange	NVMe port 6A	Box 3 port 1
	Blue	NVMe port 7A	Box 3 port 2
	Yellow	NVMe/SATA port 1A	Box 3 port 3
	Pink	NVMe/SATA port 9A	Box 3 port 4

¹ Option kit: P57853-B21

24/32 SFF drive: Onboard NVMe cabling

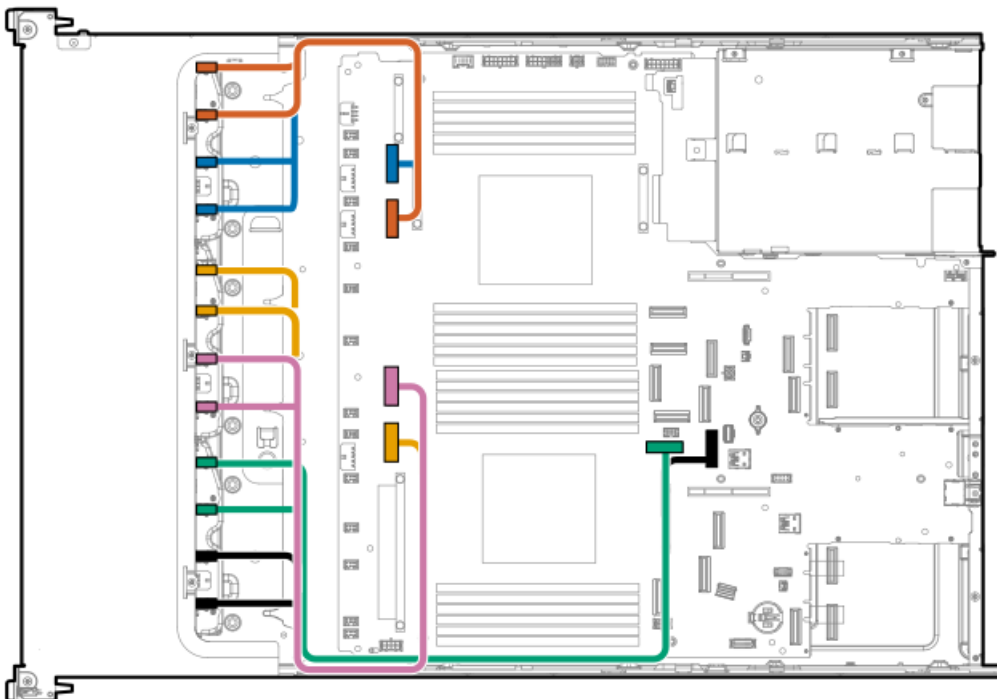

Cable part number	Color	From	To
P58107-001 ¹ ²	Orange	NVMe port 2B	Box 1 port 1 and port 2
	Blue	NVMe port 3B	Box 1 port 3 and port 4
P58170-001 ¹	Yellow	NVMe port 2A	Box 2 port 1 and port 2
	Pink	NVMe port 3A	Box 2 port 3 and port 4
P58106-001 ¹	Green	NVMe/SATA port 9A	Box 3 port 1 and port 2
	Black	NVMe/SATA port 1A	Box 3 port 3 and port 4

- ¹ Option kit: P57859-B21
- ² This cabling connection is for two processors.

8 SFF drive with two GPU riser cages: Onboard NVMe cabling

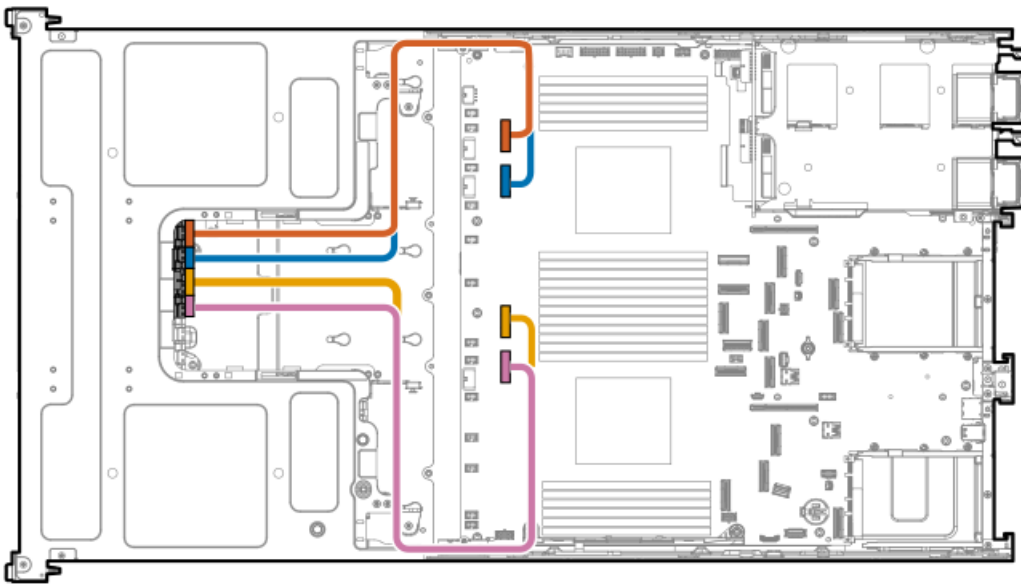

Cable part number	Color	From	To
P58153-001	Orange	NVMe port 3B	8 SFF drive box 1 port 1
	Blue	NVMe port 2B	8 SFF drive box 1 port 2
P58154-001	Yellow	NVMe port 3A	8 SFF drive box 1 port 3
	Pink	NVMe/SATA 2A	8 SFF drive box 1 port 4

8 SFF drive with two GPU riser cages: Primary riser cabling



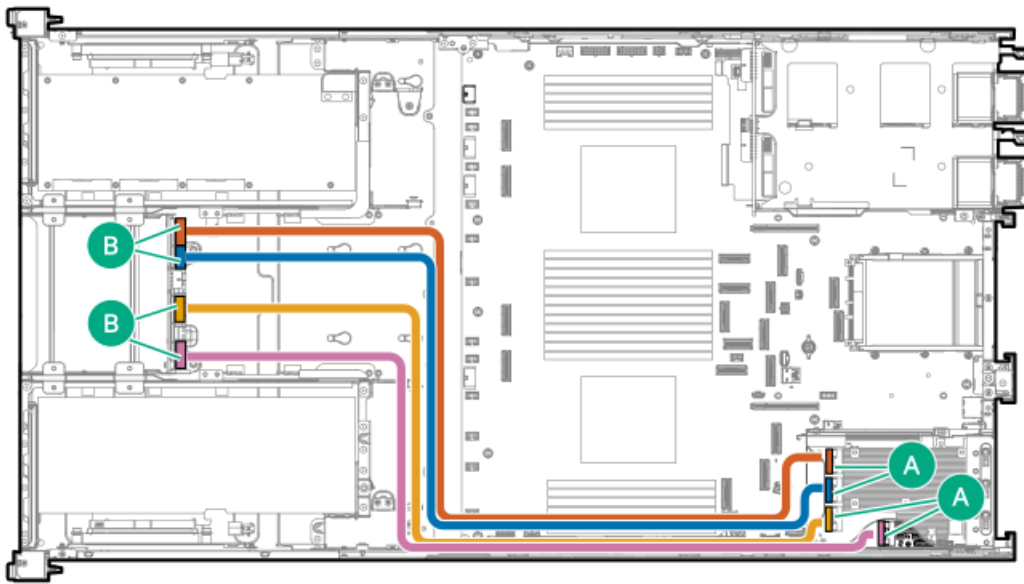

Cable part number	Color	From	To
P57057-002 ¹	Orange	Port 4	Port 1
	Blue	Port 3	Port 2
	Yellow	Port 2	Port 3
	Pink	Port 1	Port 4

¹ Option kit: P69866-B21

8/16/24/32 SFF drive: SR932i-p controller cabling

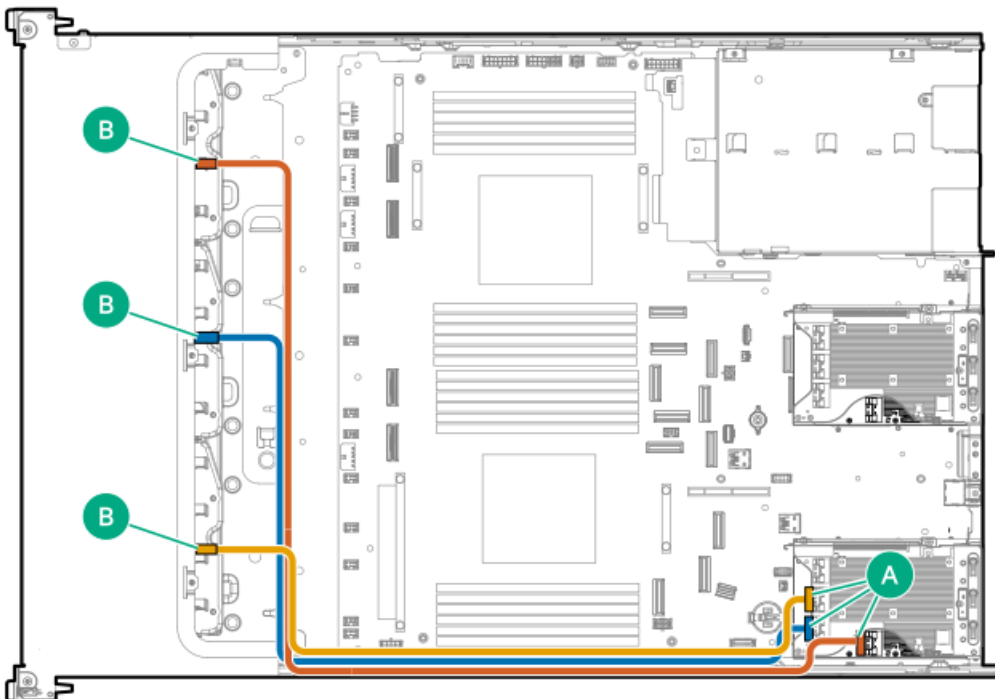

Cable part number	Color	From	To
P58019-001 ¹	Orange	Port 1	Box 1 port 1
P58020-001 ¹	Blue	Port 2	Box 2 port 1
P58018-001 ¹	Yellow	Port 3	Box 3 port 1

¹ Option kit: P57848-B21

8/16/24/32 SFF drive: Primary type-p controller cabling

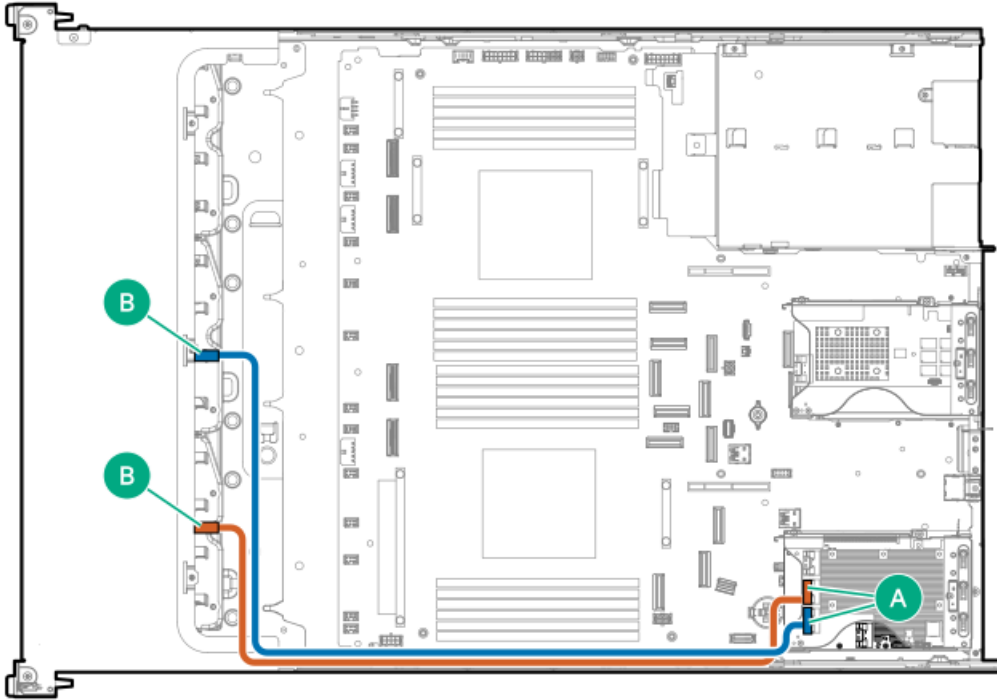

Cable part number	Color	From	To
P58018-001 ¹	Orange	Port 3	Box 3 port 1
P58020-001 ¹	Blue	Port 2	Box 2 port 1

¹ Option kit: P57848-B21



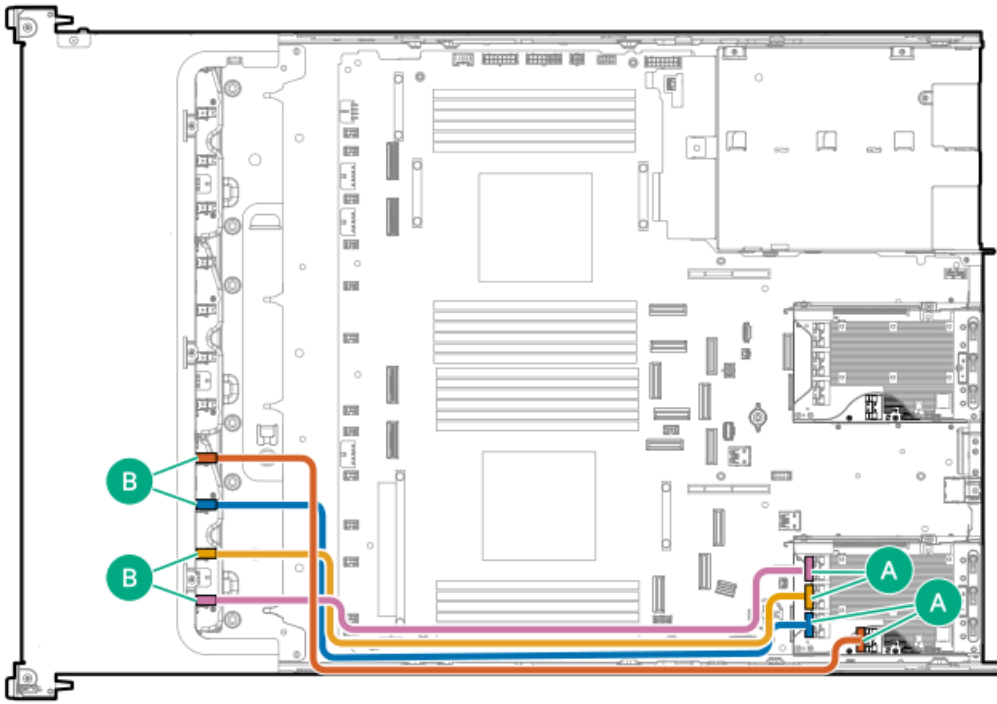

Cable part number	Color	From	To
P58120-001 ¹	Orange	Port 1	Box 3 port 1
	Blue	Port 2	Box 3 port 2
	Yellow	Port 3	Box 3 port 3
	Pink	Port 4	Box 3 port 4

¹ Option kit: P57856-B21

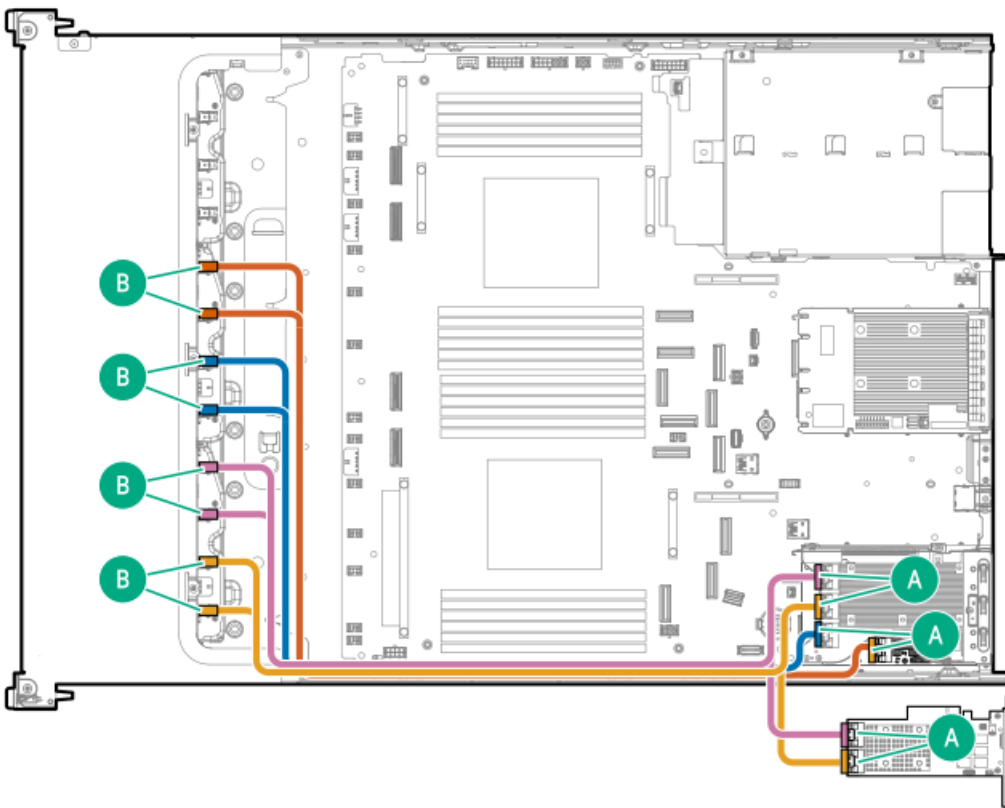

Cable part number	Color	From	To
P58123-001 ¹	Orange	Port 1	Box 2 port 1 and port 2
	Blue	Port 2	Box 2 port 3 and port 4
P58127-001 ¹	Yellow	Port 3 ²	Box 3 port 3 and port 4
		Port 1 ³	
	Pink	Port 4 ²	Box 3 port 1 and port 2
		Port 2 ³	

- ¹ Option kit: P57865-B21
This port is from an SR controller.
² This port is from an MR controller.

³ 8 SFF drive with two GPU riser cages: Primary type-p controller cabling

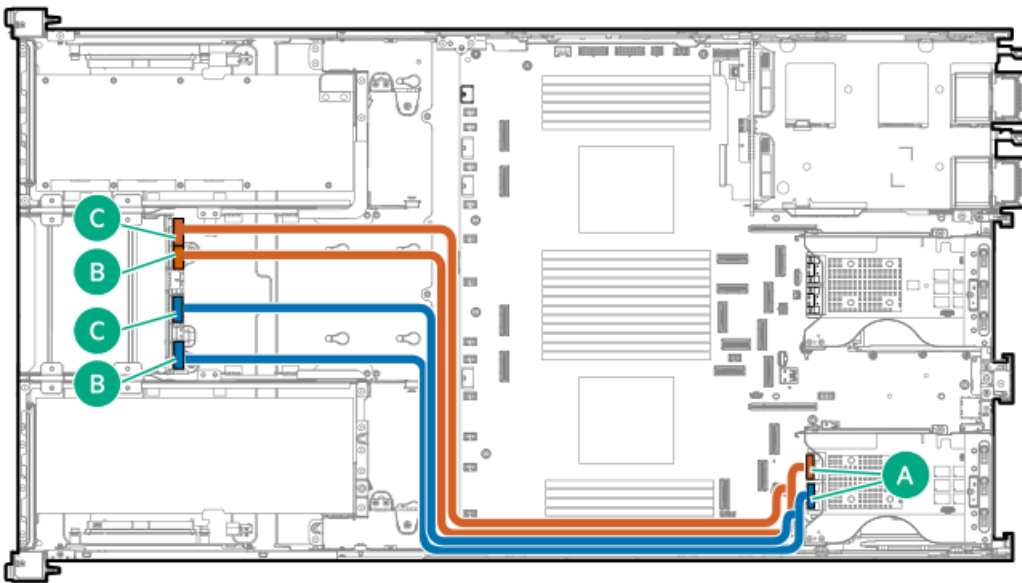

Cable part number	Color	From	To
P58692-001 ¹	Orange	Port 2	Ports 1 and 2
	Blue	Port 1	Ports 3 and 4

- ¹ Option kit: P70316-B21

8 SFF drive with two GPU riser cages: Primary and secondary MR216i-p controller cabling



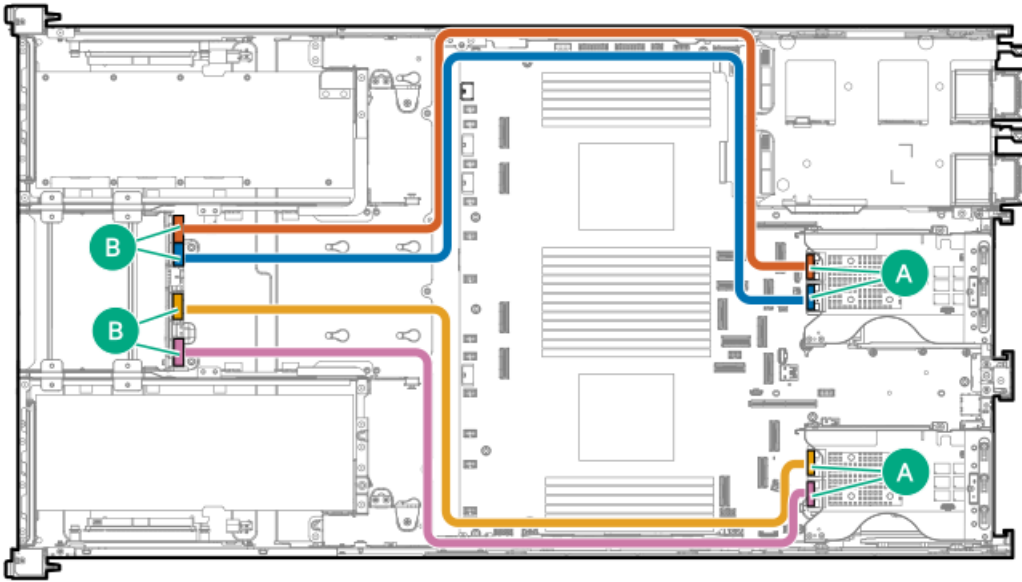

Cable part number	Color	From	To
P57057-002 ¹	Orange	Port 2	Port 1
	Blue	Port 1	Port 2
	Yellow	Port 2	Port 3
	Pink	Port 1	Port 4

¹ Option kit: P69866-B21

8/16/24/32 SFF drive: Secondary type-p controller cabling

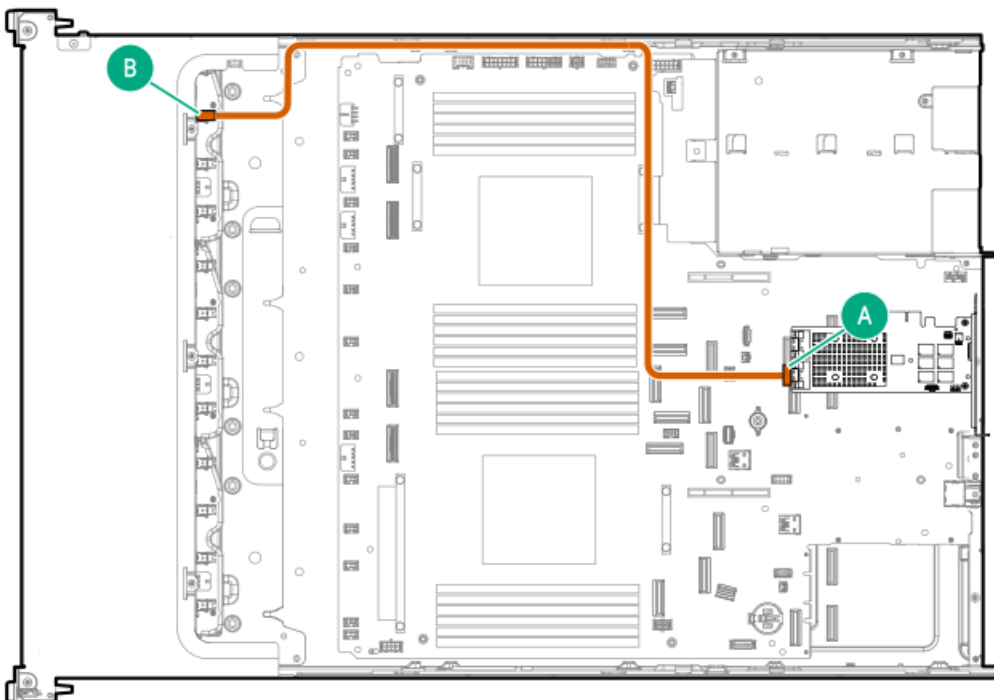

Cable part number	Color	From	To
P58017-001 ¹	Orange	Port 1	Box 1 port 1

¹ Option kit: P57848-B21

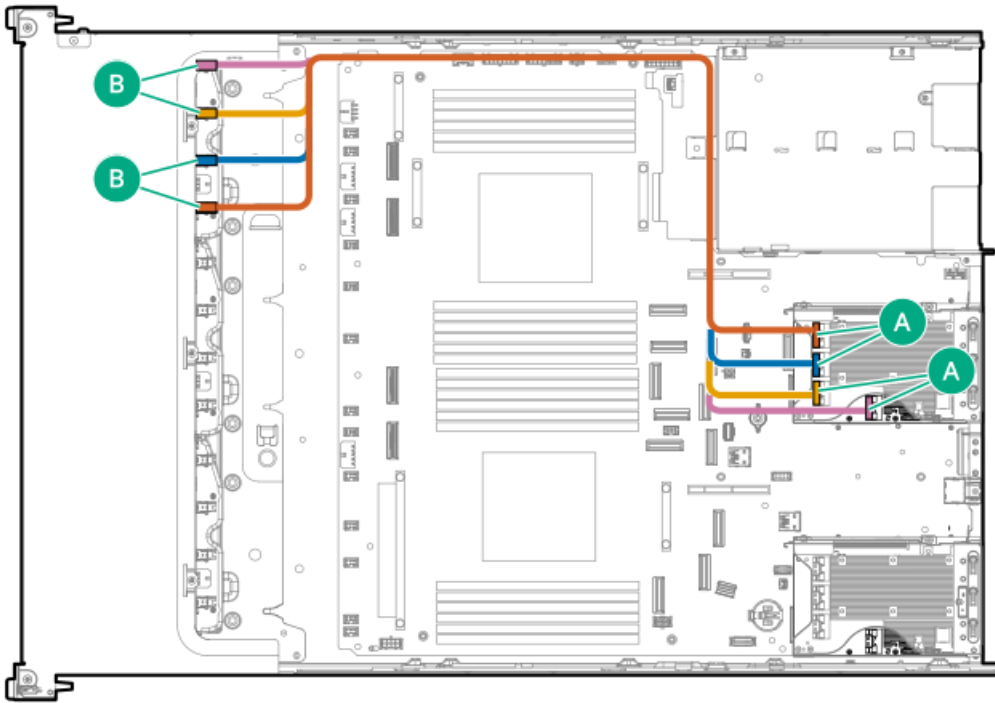

Cable part number	Color	From	To
P58114-001 ¹	Orange	Port 4	Box 1 port 4
	Blue	Port 3	Box 1 port 3
	Yellow	Port 2	Box 1 port 2
	Pink	Port 1	Box 1 port 1

¹ Option kit: P57856-B21

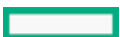

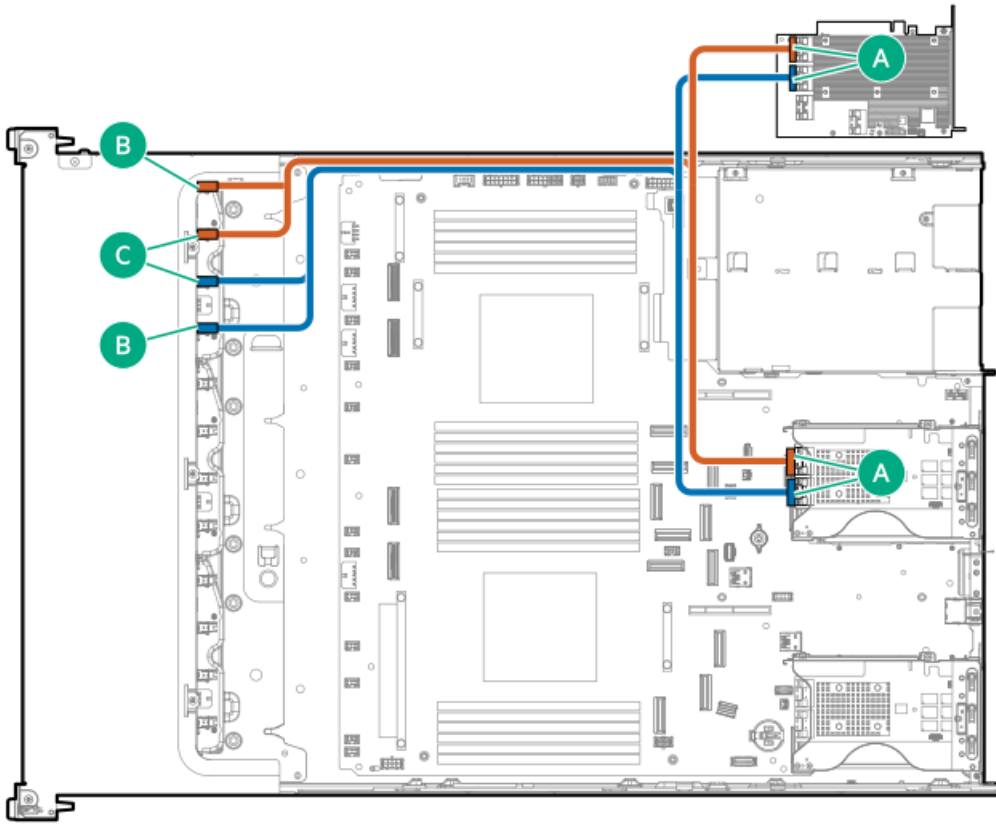

Cable part number	Color	From	To
P58124-001 ¹	Orange	Port 2 ² Port 4 ³	Box 1 port 1 and port 2
	Blue	Port 1 ² Port 3 ³	Box 1 port 3 and port 4

- ¹ Option kit: P57865-B21
- ² This port is from an MR controller
- ³ This port is from an SR controller



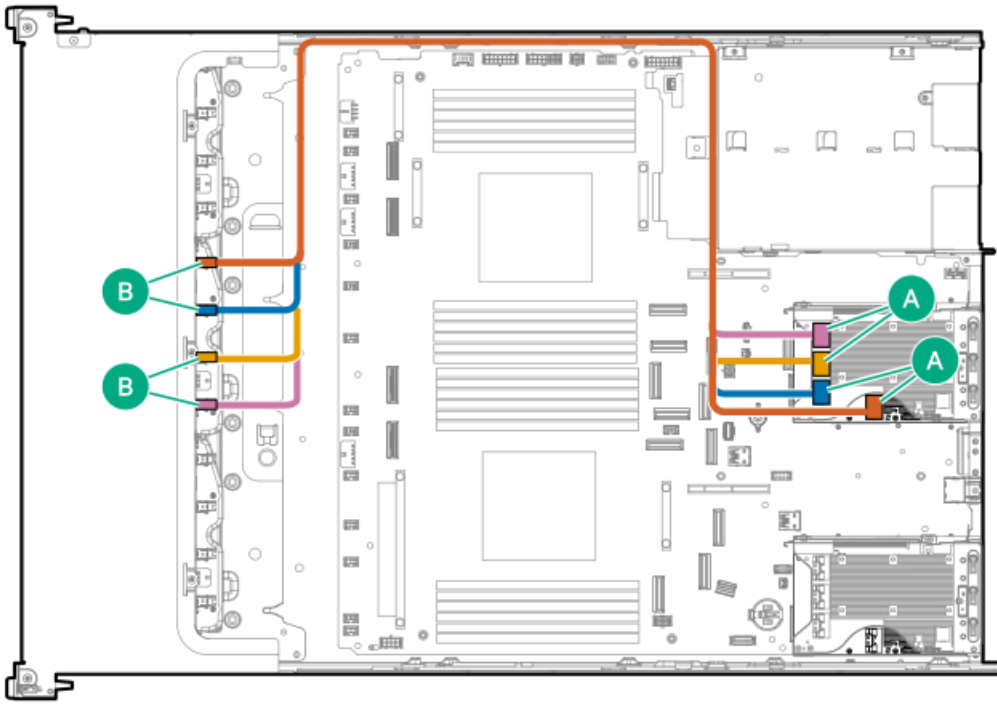

Cable part number	Color	From	To
P58121-001 ¹	Orange	Port 1	Box 2 port 1
	Blue	Port 2	Box 2 port 2
	Yellow	Port 3	Box 2 port 3
	Pink	Port 4	Box 2 port 4

¹ Option kit: P57856-B21

8/16/24/32 SFF drive: Type-o controller cabling

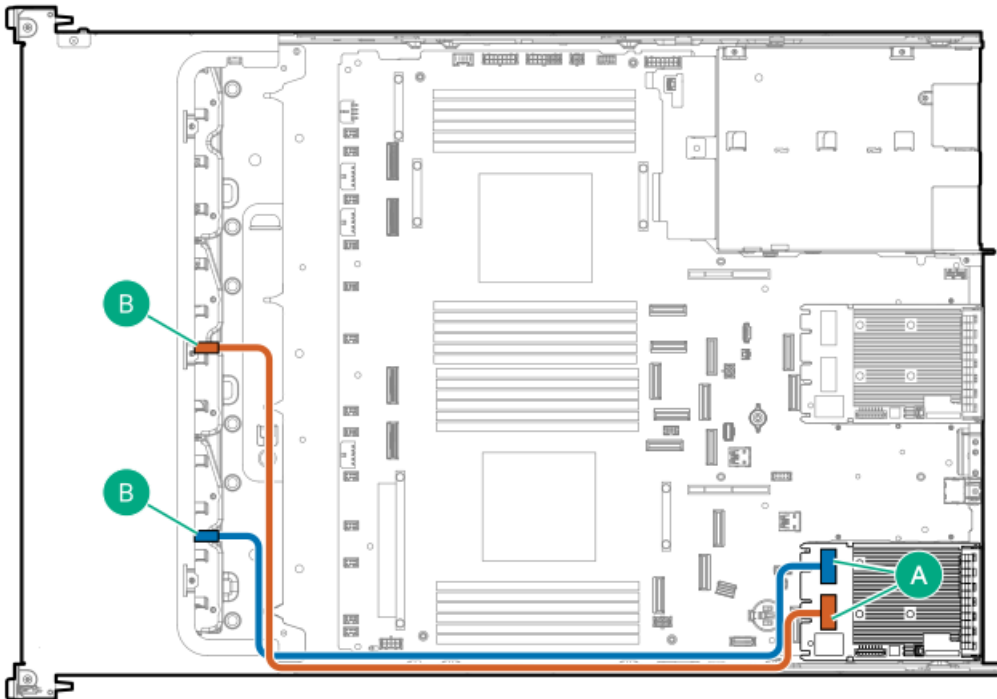

Cable part number	Color	From	To
P58015-001 ¹	Orange	Slot 21 port 1	Box 2 port 1
P58014-001 ¹	Blue	Slot 21 port 2	Box 3 port 1

¹ Option kit: P57847-B21

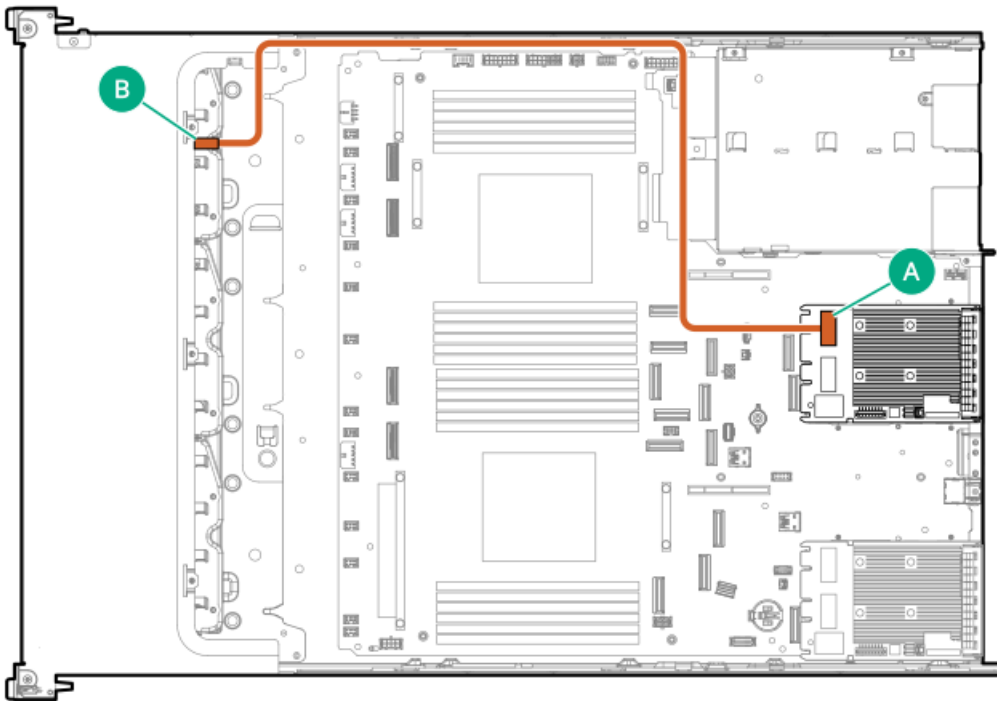

Cable part number	Color	From	To
P58016-001 ¹	Orange	Slot 22 port 2	Box 1 port 1

¹ Option kit: P57848-B21

48 SFF drive: Primary type-p controller cabling

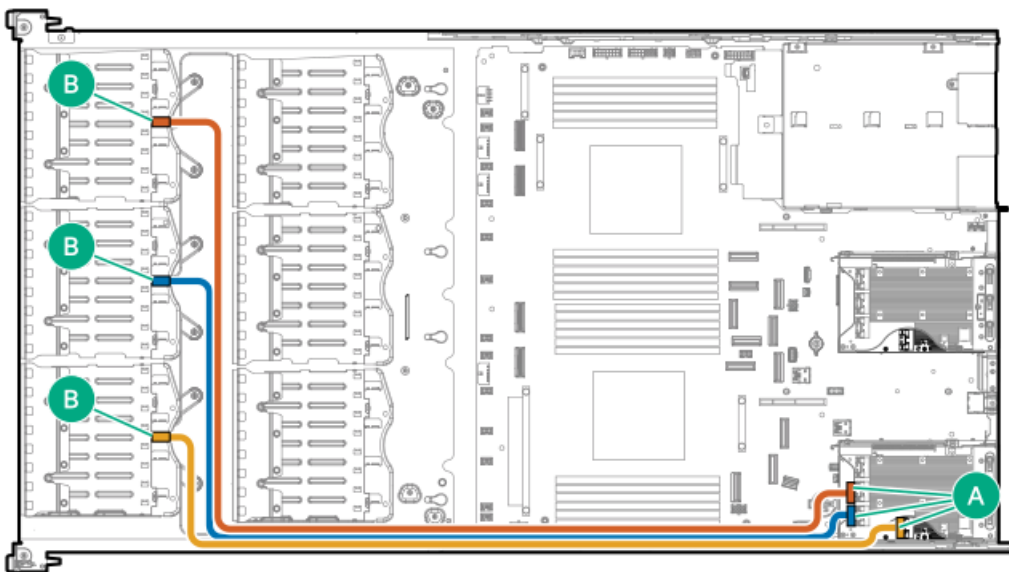

Cable part number	Color	From	To
P58119-001	Orange	Port 3	Box 1
	Blue	Port 2	Box 2
	Yellow	Port 1	Box 3

48 SFF drive: Secondary type-p controller cabling

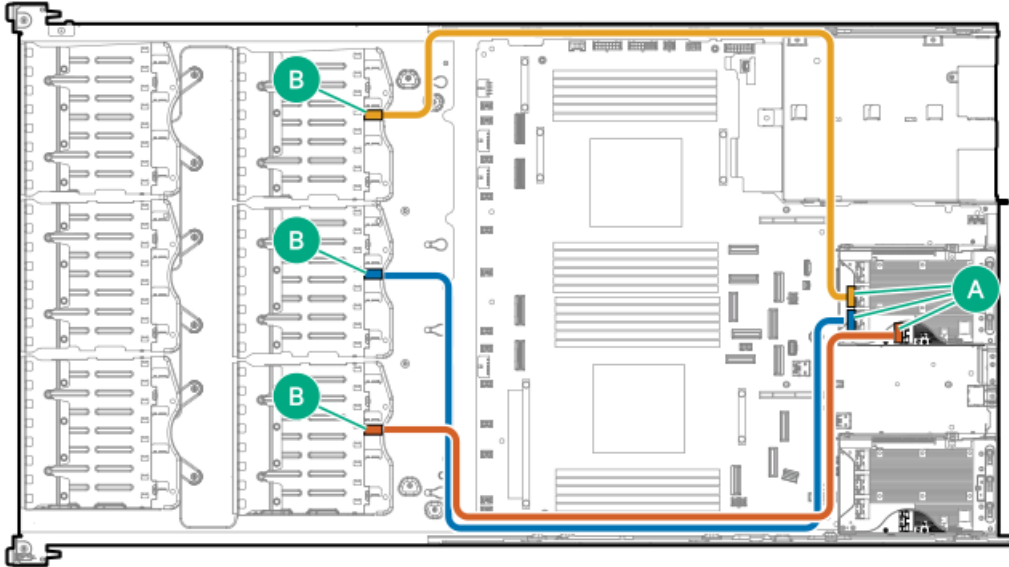

Cable part number	Color	From	To
P58112-001	Orange	Port 1	Box 6
	Blue	Port 2	Box 5
P58032-001	Yellow	Port 3	Box 4

8 SFF drive with two GPU riser cages: Type-o controller cabling

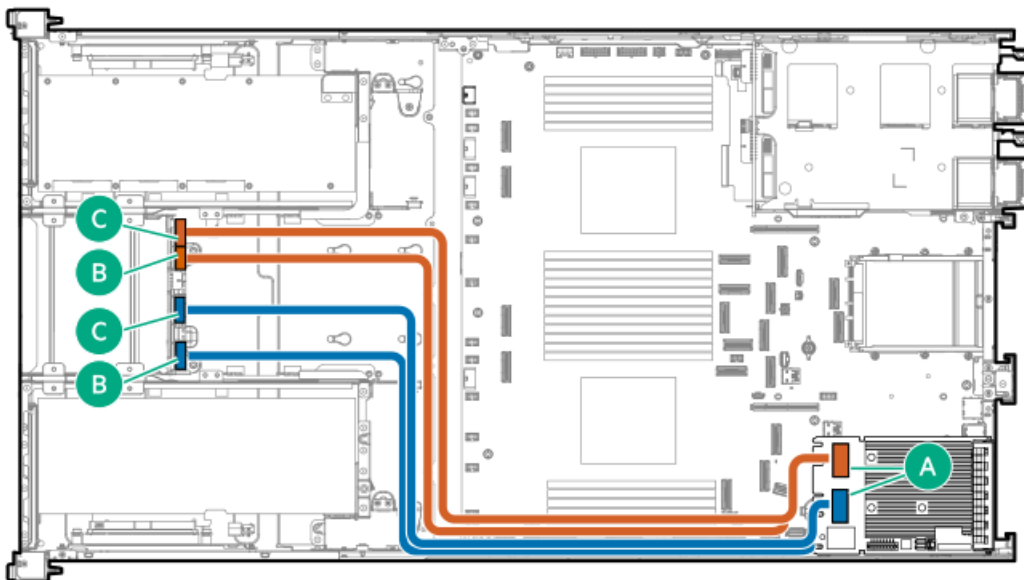

Cable part number	Color	From	To
P57334-002 ¹	Orange	Slot 21 port 2	Ports 1 and 2
	Blue	Slot 21 port 1	Ports 3 and 4

¹ Option kit: P69868-B21

LFF drive cabling

8/12/16 LFF drive: Onboard SAS/SATA cabling

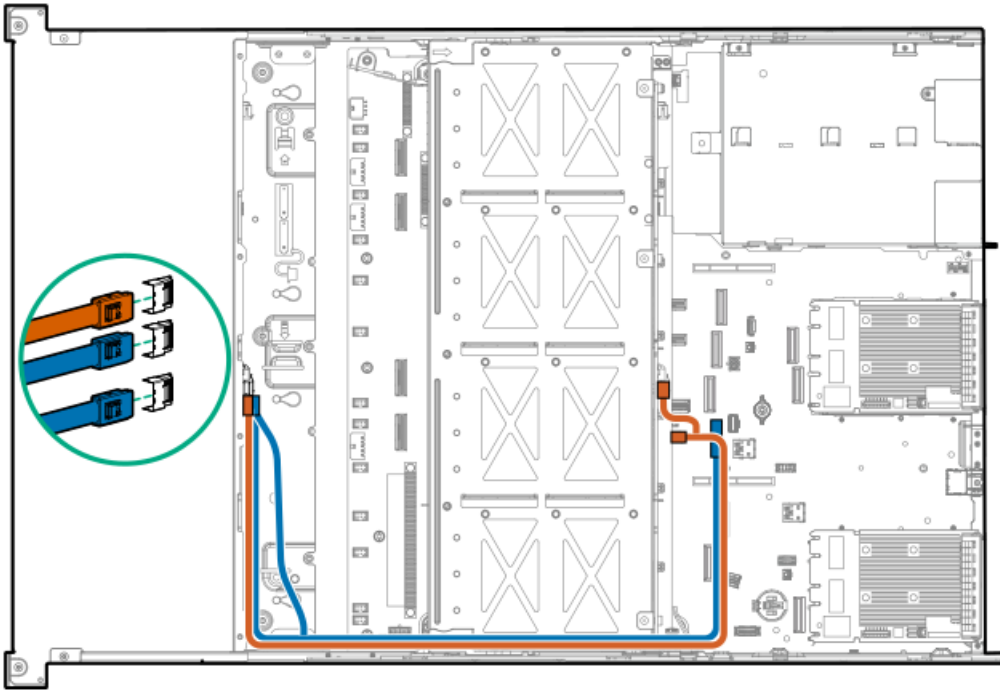

Cable part number	Color	From	To
P58102-001 ¹	Orange	NVMe/SATA port 9A	Box 1 port 1 and box 7 port 1
P58099-001 ^{2 3}	Blue	NVMe/SATA port 1A	Box 2 port 1 and box 3 port 1

¹ Option kit: P55089-B21; P55085-B21

² Option kit: P57958-B21

³ This cabling connection is only for 12 and 16 LFF.

8/12/16/20 LFF drive: Type-o controller cabling

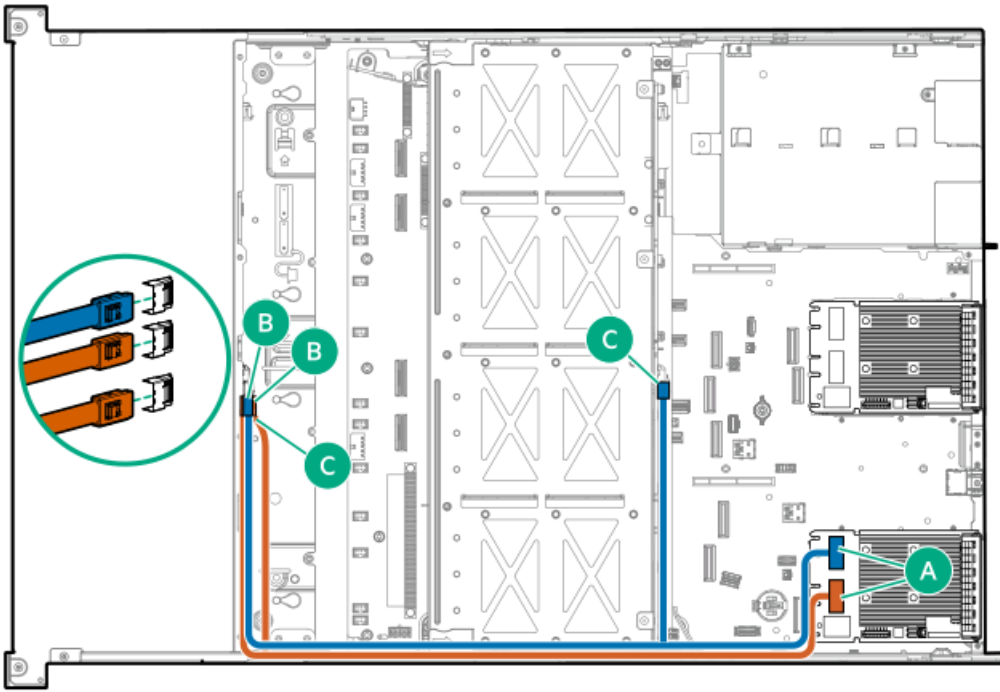

Cable part number	Color	From	To
P58104-001 ¹	Blue	Slot 21 port 2	Box 1 and box 7 port 1
P58100-001 ²	Orange	Slot 21 port 1	Box 2 and box 3 port 1

¹ This cabling connection is for 12, 16, and 20 LFF.
² Option kit: P57870-B21

E3.S drive cabling

8 E3.S drive: Primary riser cabling



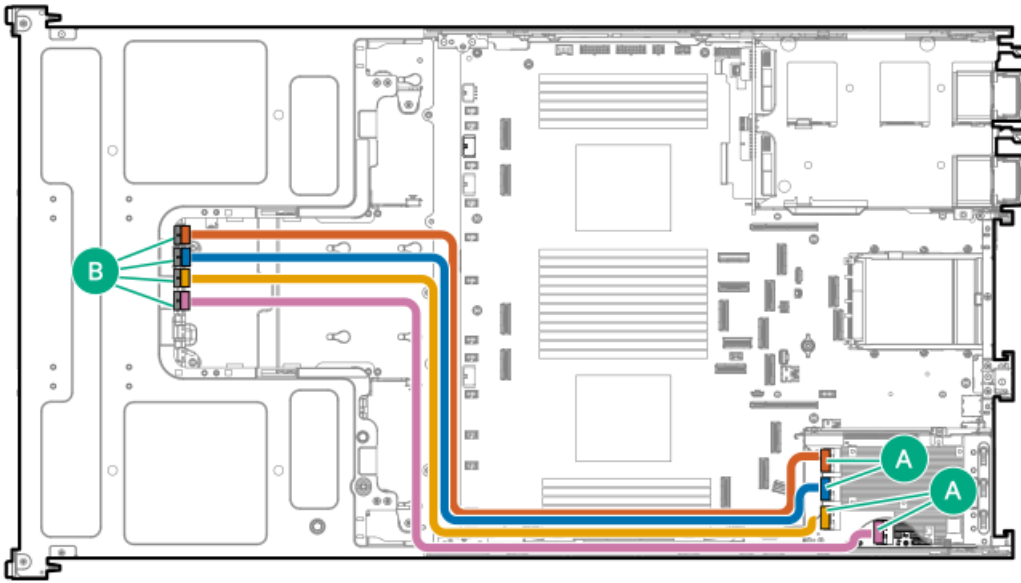

Cable part number	Color	From	To
P57057-002 ¹	Orange	Port 4	Port 1
	Blue	Port 3	Port 2
	Yellow	Port 2	Port 3
	Pink	Port 1	Port 4

¹ Option kit: P70406-B21; P69866-B21

12/24 E3.S drive: Onboard NVMe cabling for box 3

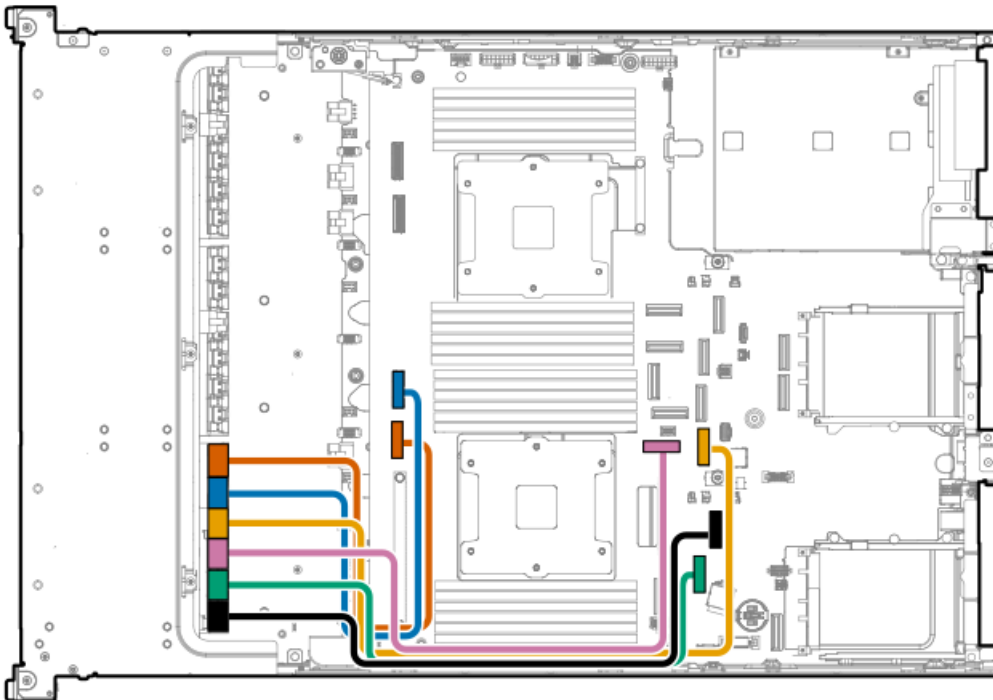

Cable part number	Color	From	To
P58108-001	Orange	NVMe port 2A	Box 3 port 1
	Blue	NVMe port 3A	Box 3 port 2
P58109-001	Yellow	NVMe/SATA port 1A	Box 3 port 3
	Pink	NVMe/SATA port 9A	Box 3 port 4
	Green	NVMe port 6A	Box 3 port 5
	Black	NVMe port 7A	Box 3 port 6

24 E3.S drive: Onboard NVMe cabling for box 1

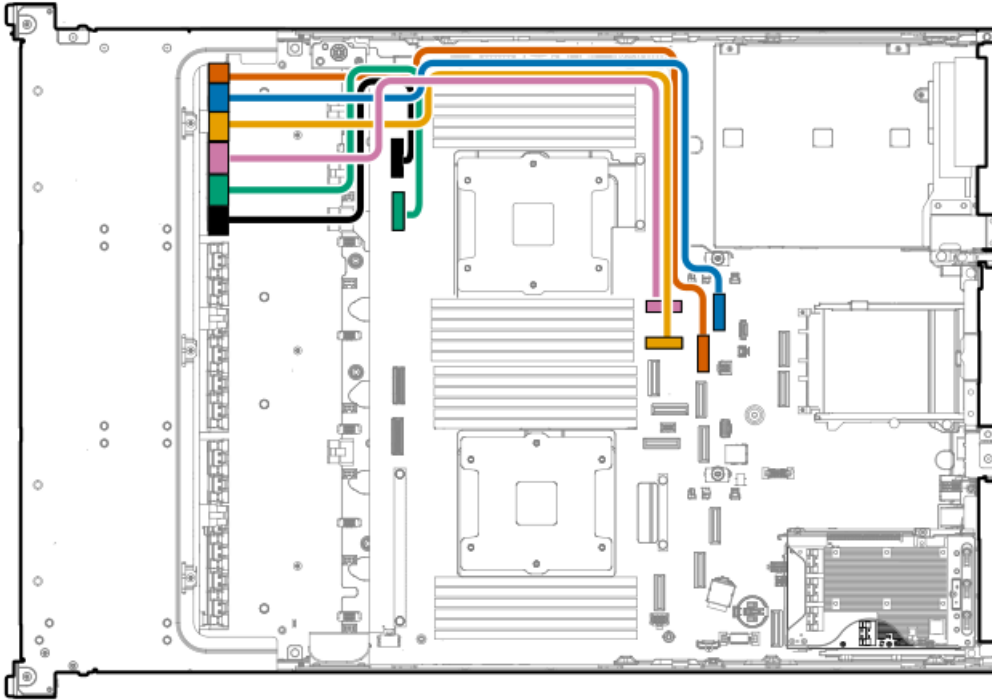

Cable part number	Color	From	To
P58110-001	Orange	NVMe/SATA port 8B	Box 1 port 1
	Blue	NVMe/SATA port 9B	Box 1 port 2
	Yellow	NVMe port 6B	Box 1 port 3
	Pink	NVMe port 7B	Box 1 port 4
P58111-001	Green	NVMe port 2B	Box 1 port 5
	Black	NVMe port 3B	Box 1 port 6

32 E3.S drive: Onboard NVMe and retimer cabling

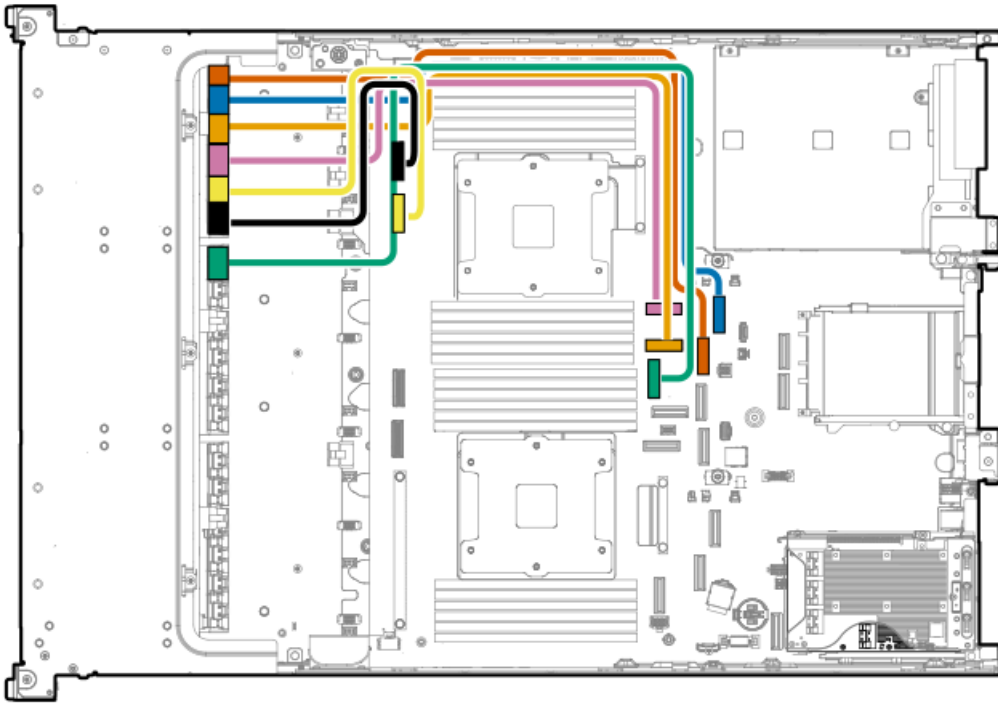

Cable part number	Color	From	To
P58130-001	Orange	NVMe/SATA port 8B	Box 1 port 1
	Blue	NVMe/SATA port 9B	Box 1 port 2
	Yellow	NVMe port 6B	Box 1 port 3
	Pink	NVMe port 7B	Box 1 port 4
	Green	NVMe port 4B	Box 2 port 1
P58111-001	Light yellow	NVMe port 2B	Box 1 port 5
	Black	NVMe port 3B	Box 1 port 6



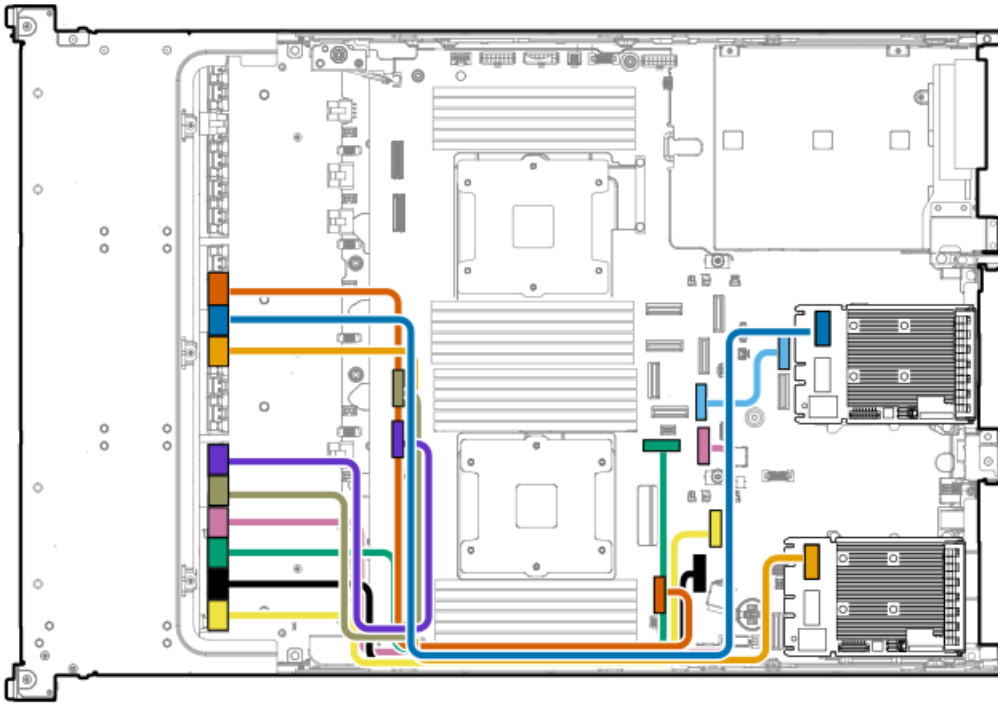

Cable part number	Color	From	To
P68180-001 ¹	Orange	NVMe port 4A	Box 2 port 2
	Blue	Port 1 ²	Box 2 port 3
	Yellow	Port 1 ²	Box 2 port 4
	Pink	NVMe/SATA port 1A	Box 3 port 3
	Green	NVMe/SATA port 9A	Box 3 port 4
	Black	NVMe port 6A	Box 3 port 5
	Light yellow	NVMe port 7A	Box 3 port 6
P58108-001	Purple	NVMe port 2A	Box 3 port 1
	Olive	NVMe port 3A	Box 3 port 2
P58174-001 ¹	Light blue	NVMe port 5B	OCP slot 22 port 1

¹ Option kit: P57965-B21
² This connection also works with an OCP retimer card with one port.

36 E3.S drive: Onboard NVMe cabling



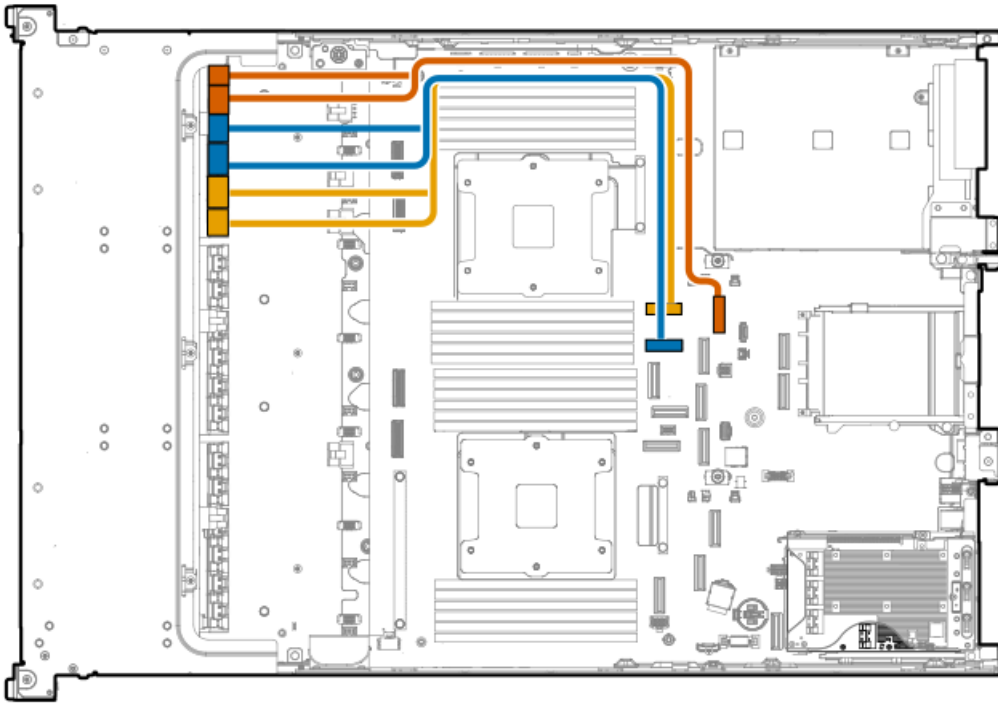

Cable part number	Color	From	To
P58118-001	Orange	NVMe/SATA port 9B	Box 1 port 1 and 2
	Blue	NVMe port 6B	Box 1 port 3 and 4
	Yellow	NVMe port 7B	Box 1 port 5 and 6

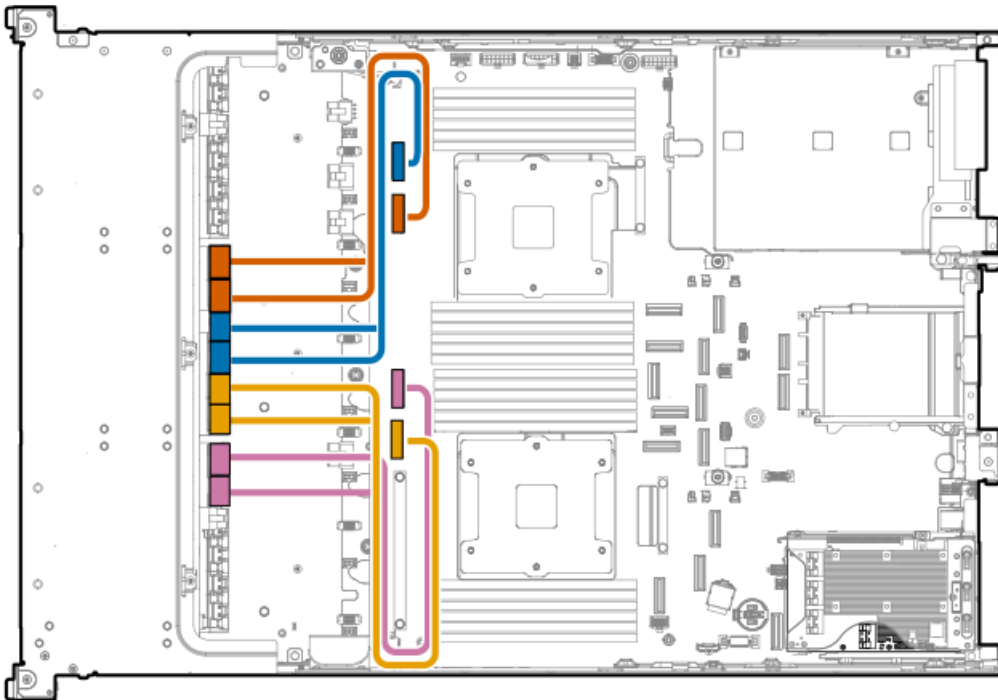

Cable part number	Color	From	To
P58117-001	Orange	NVMe port 2B	Box 2 port 1 and 2
	Blue	NVMe port 3B	Box 2 port 3 and 4
P58113-001	Yellow	NVMe port 2A	Box 2 port 5 and 6
	Pink	NVMe port 3A	Box 3 port 1 and 2

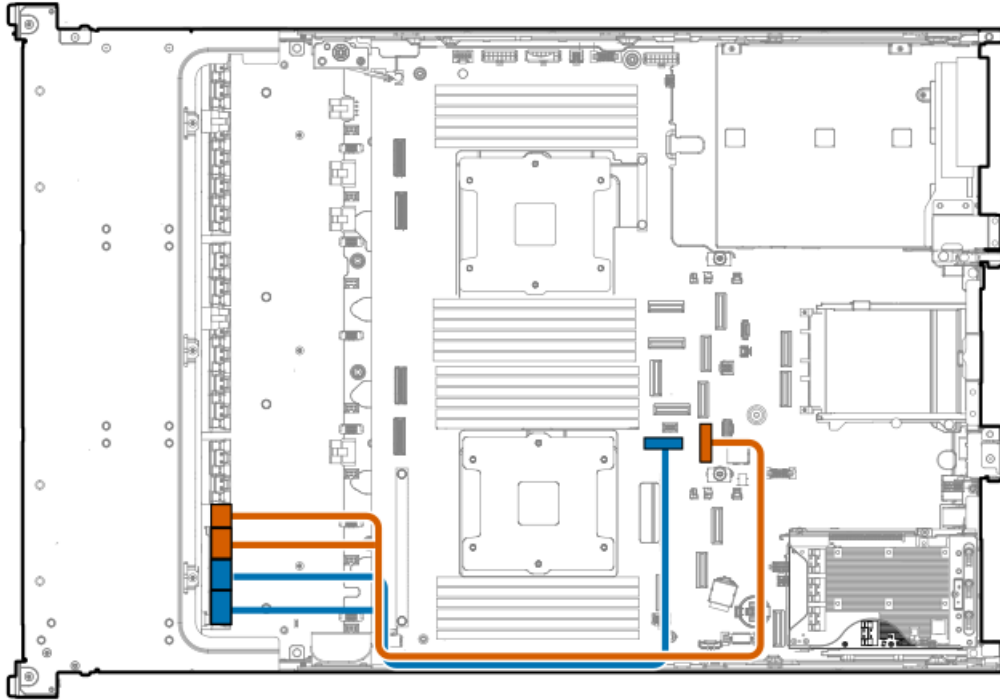

Cable part number	Color	From	To
P58116-001	Orange	NVMe/SATA port 1A	Box 3 port 3 and 4
	Blue	NVMe/SATA port 9A	Box 3 port 5 and 6

12 E3.S drive: Primary riser cabling



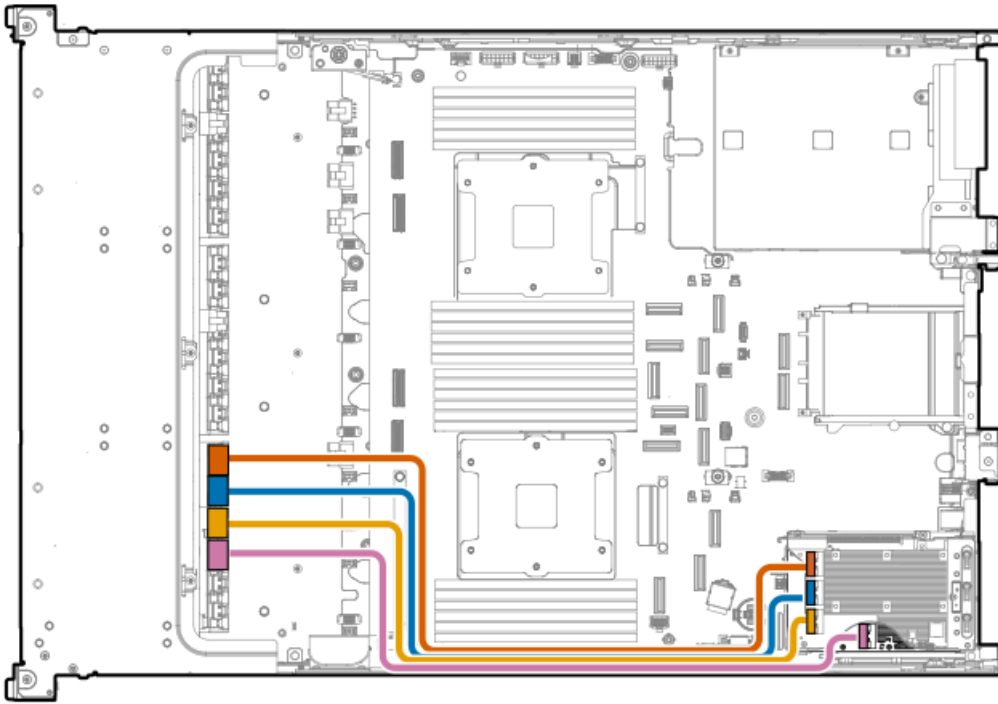

Cable part number	Color	From	To
P58125-001	Orange	Port 4	Box 3 port 1
	Blue	Port 3	Box 3 port 2
	Yellow	Port 2	Box 3 port 3
	Pink	Port 1	Box 3 port 4

24 E3.S drive: Secondary riser cabling

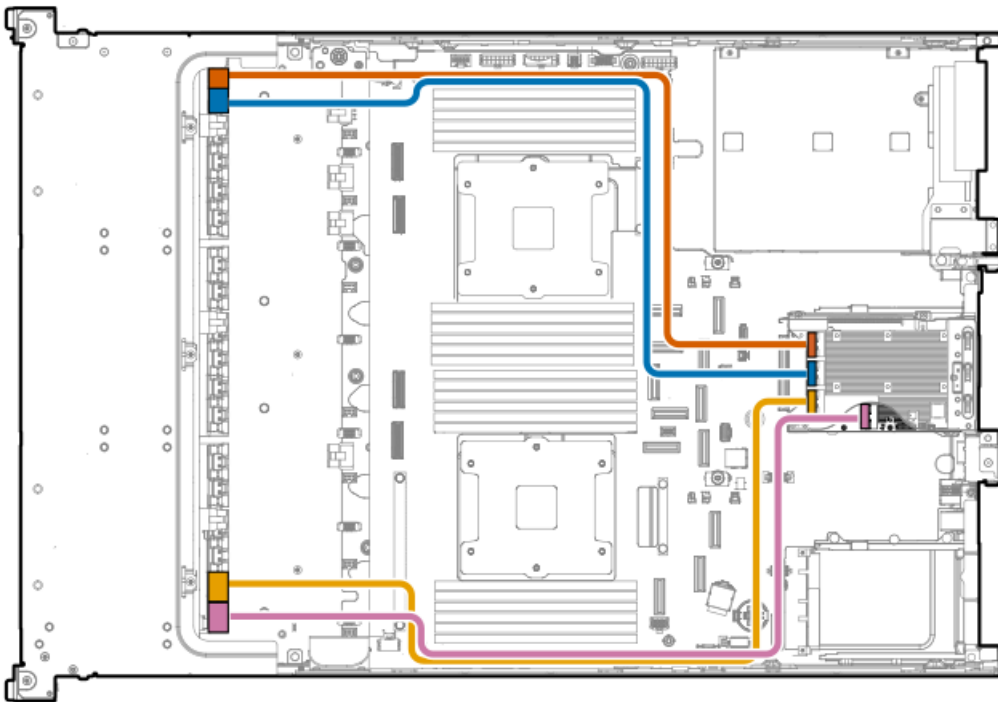

Cable part number	Color	From	To
P62389-001	Orange	Port 4	Box 1 port 1
	Blue	Port 3	Box 1 port 2
P62388-001	Yellow	Port 2	Box 3 port 5
	Pink	Port 1	Box 3 port 6

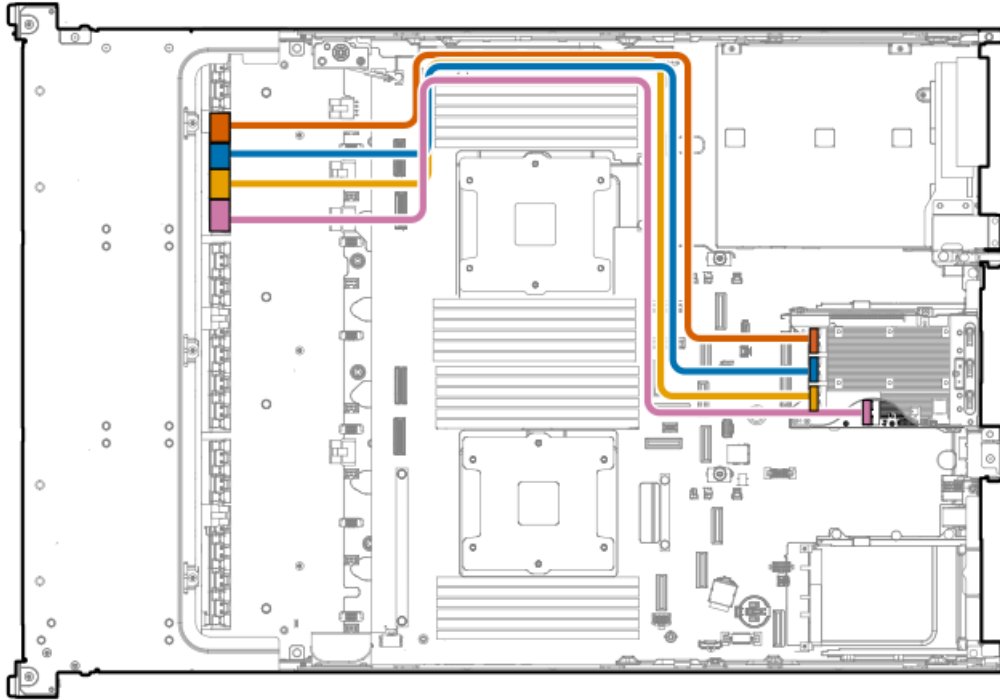

Cable part number	Color	From	To
P58126-001 ¹	Orange	Port 4	Box 1 port 3
	Blue	Port 3	Box 1 port 4
	Yellow	Port 2	Box 1 port 5
	Pink	Port 1	Box 1 port 6

¹ Option kit: P57878-B21

Midplane drive cabling

16/32 SFF drive: Onboard SAS/SATA cabling



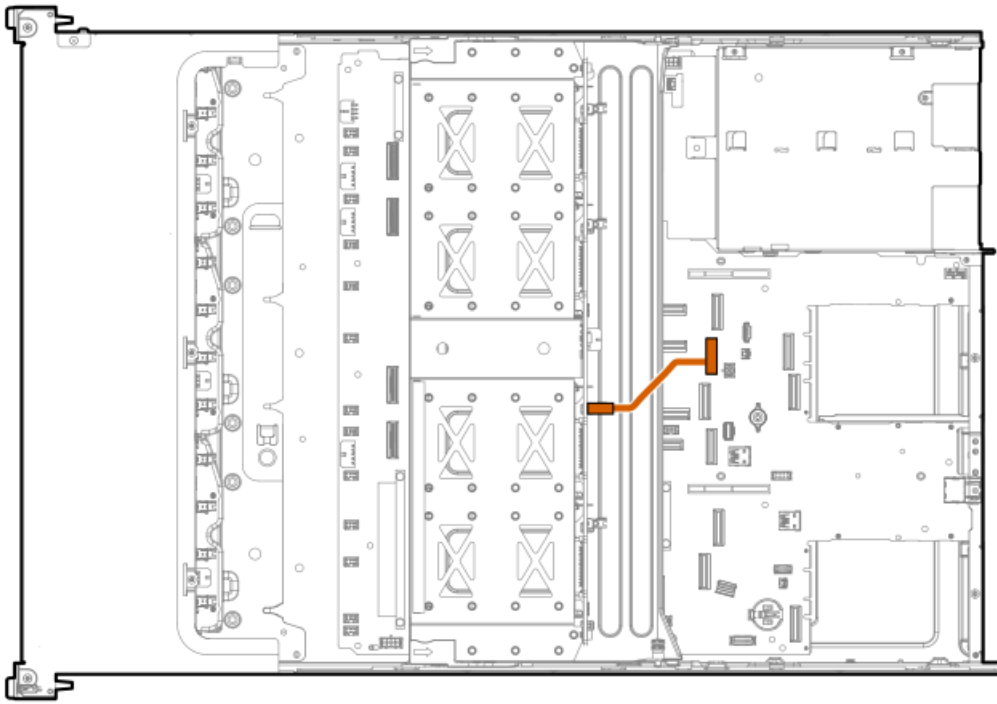

Cable part number	Color	From	To
P58087-001 ¹	Orange	NVMe port 8B	Box 7 port 3

¹ Option kit: P55086-B21

16/32 SFF drive: Onboard NVMe cabling

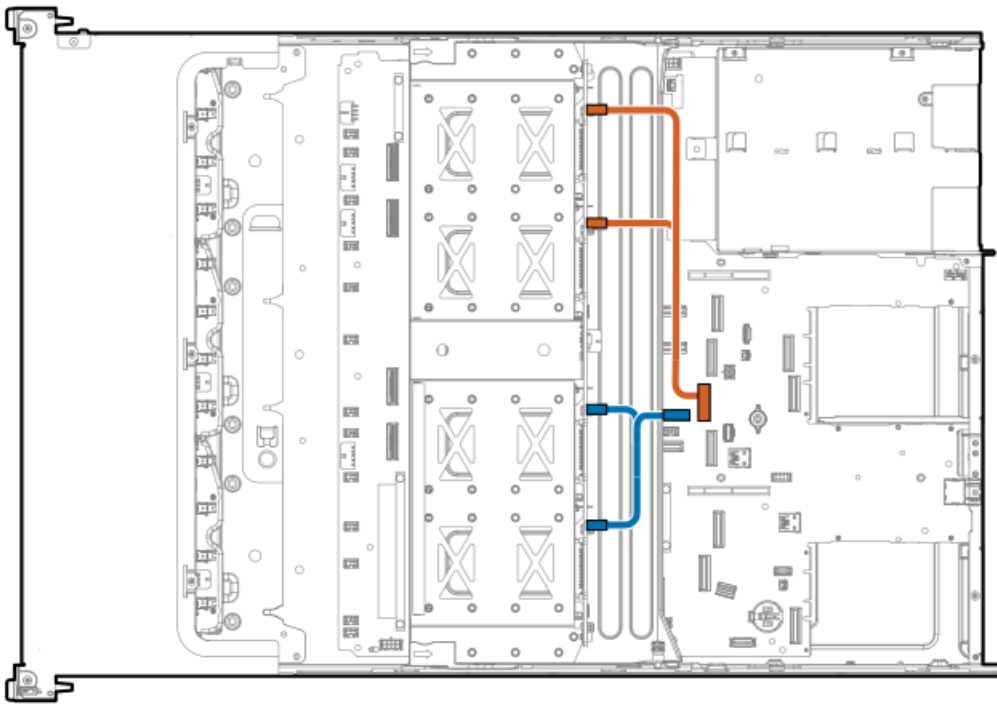

Cable part number	Color	From	To
P58093-001 ^{2 1}	Orange	NVMe port 5B	Box 7 port 1 and port 2
P58092-001 ¹	Blue	NVMe port 4B	Box 7 port 3 and port 4



- 1 Option kit: P55087-B21
- 2 This cabling connection is for 32 SFF.

16/32 SFF drive: Primary type-p controller cabling

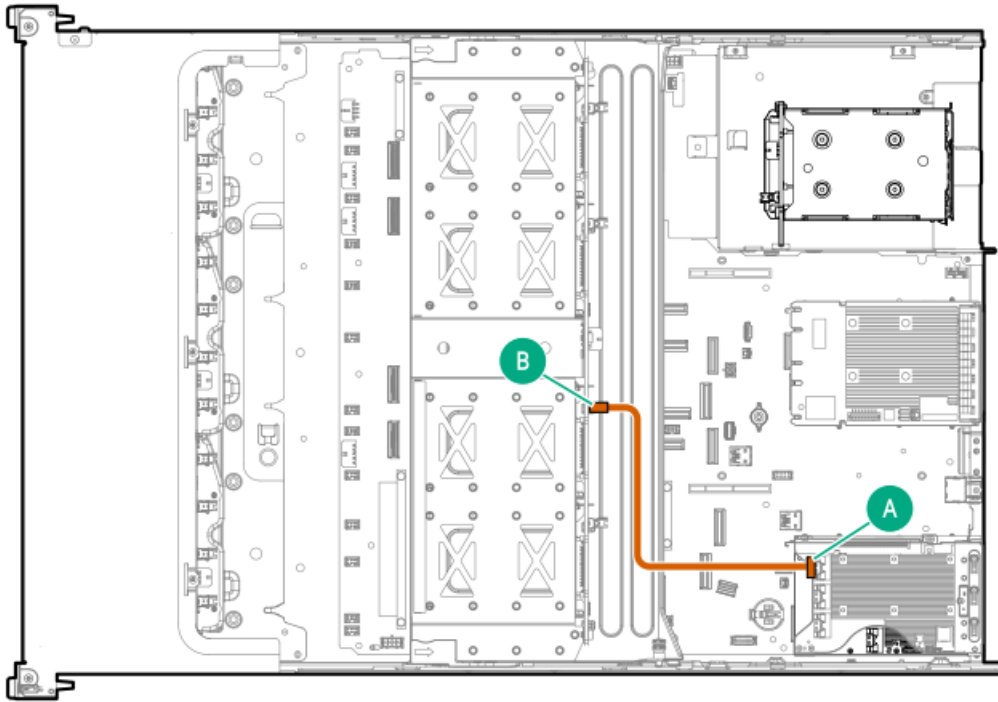

Cable part number	Color	From	To
P58089-001 ¹	Orange	Port 4	Box 7 port 1

- 1 Option kit: P57868-B21

32 SFF drive: Secondary type-p controller cabling

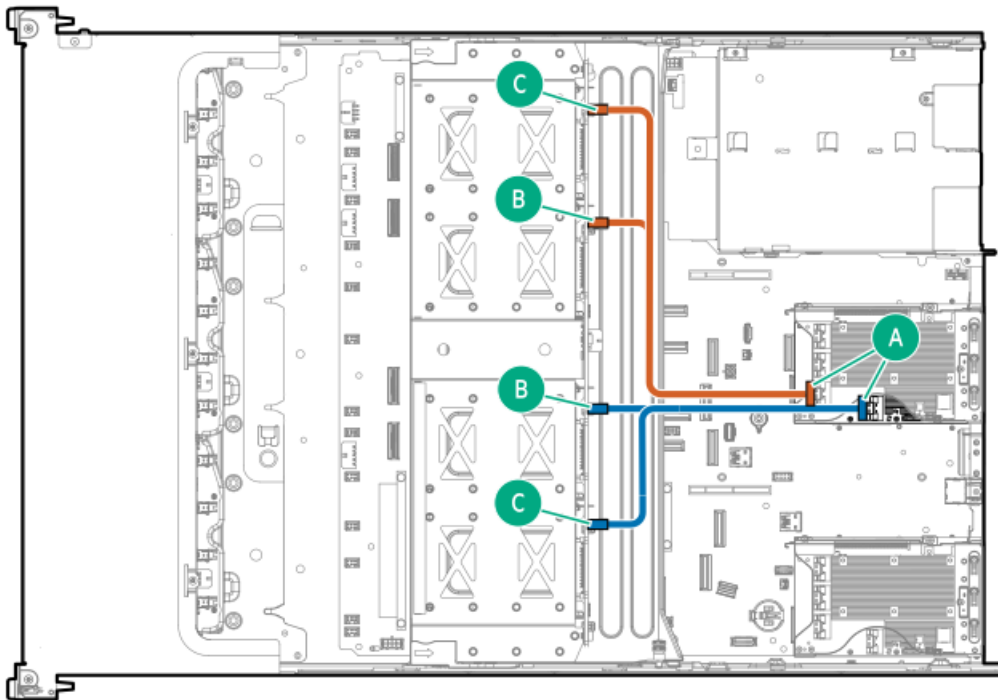

Cable part number	Color	From	To
P58095-001 ¹	Orange	Port 2	Box 7 port 1 and 2
P58094-001 ¹	Blue	Port 1	Box 7 port 3 and 4

¹ Option kit: P57869-B21

32 SFF drive: Secondary or tertiary type-p controller cabling

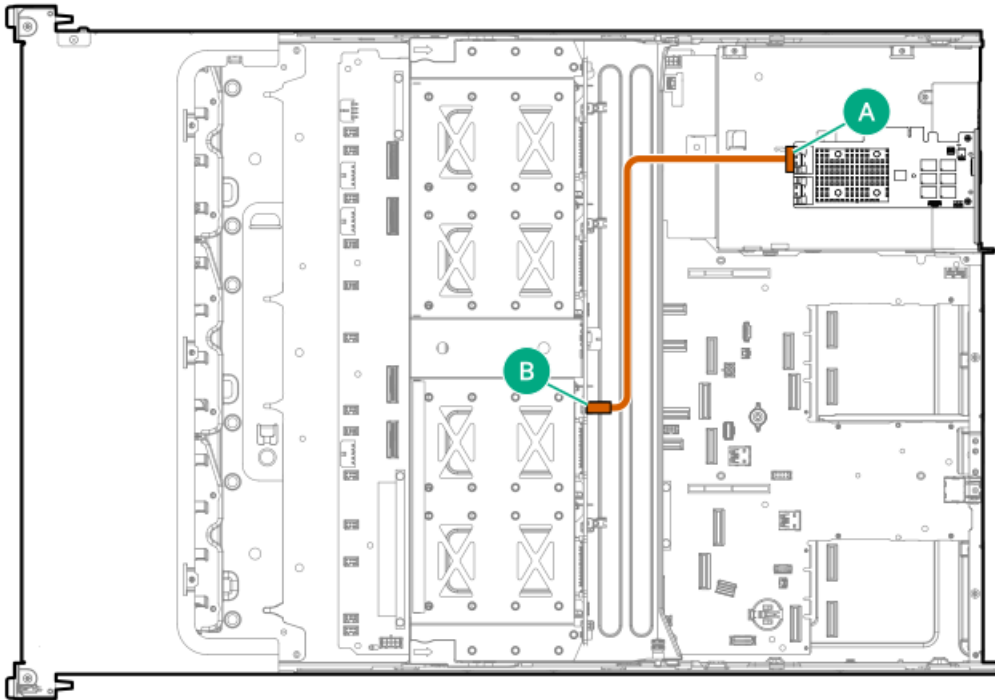

Cable part number	Color	From	To
P58090-001 ¹	Orange	Port 2	Box 7 port 1

¹ Option kit: P57868-B21

Rear-end drive controller cabling

Subtopics

[SFF drive cabling](#)

[LFF drive cabling](#)

SFF drive cabling

2 SFF drive: Primary type-p controller cabling

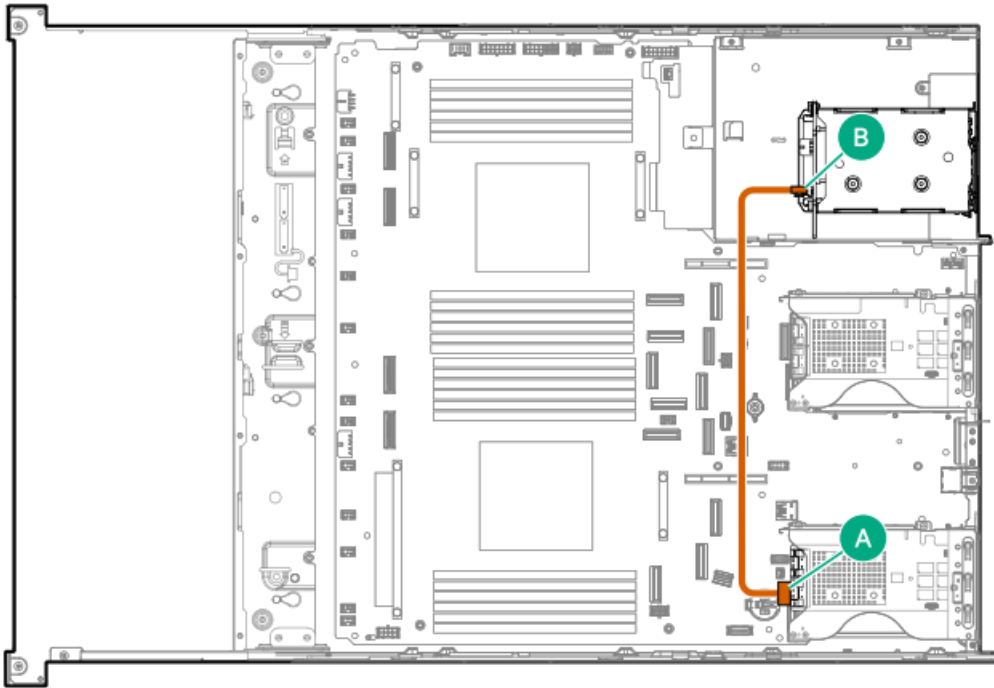

Cable part number	Color	From	To
P58150-001 ¹	Orange	Port 1	Box 8 port 1

¹ Option kit: P55091-B21

2 SFF drive: Secondary type-p controller cabling

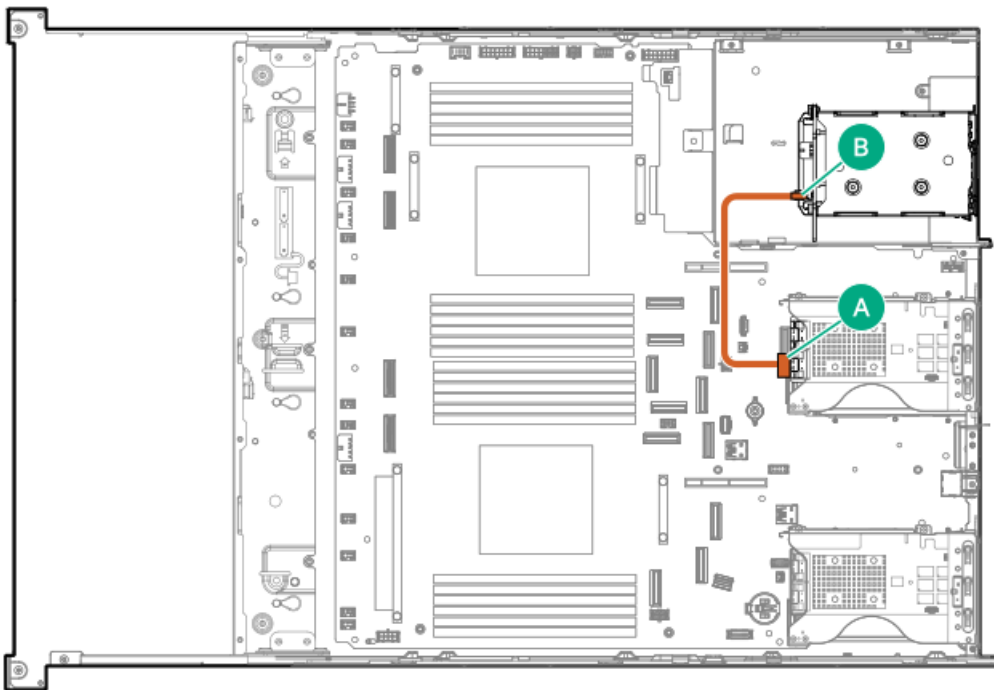

Cable part number	Color	From	To
P58151-001 ¹	Orange	Port 1	Box 8 port 1



1 Option kit: P55091-B21

2 SFF drive: Type-o controller cabling

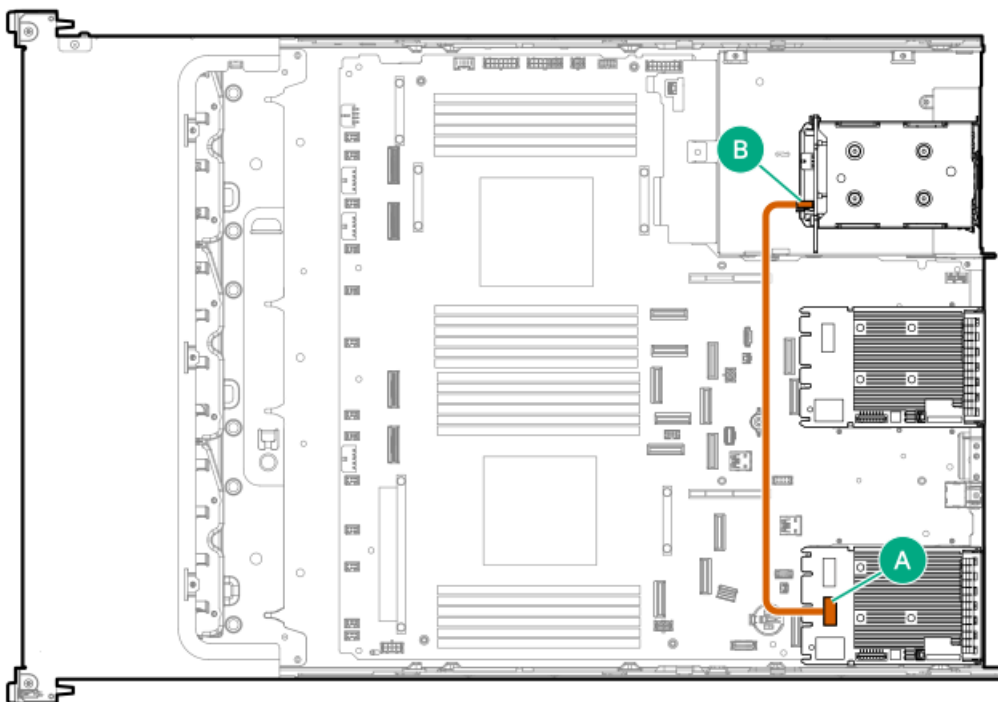

Cable part number	Color	From	To
P58152-001 ¹	Orange	Slot 21 port 1	Box 8 port 1

1 Option kit: P55091-B21

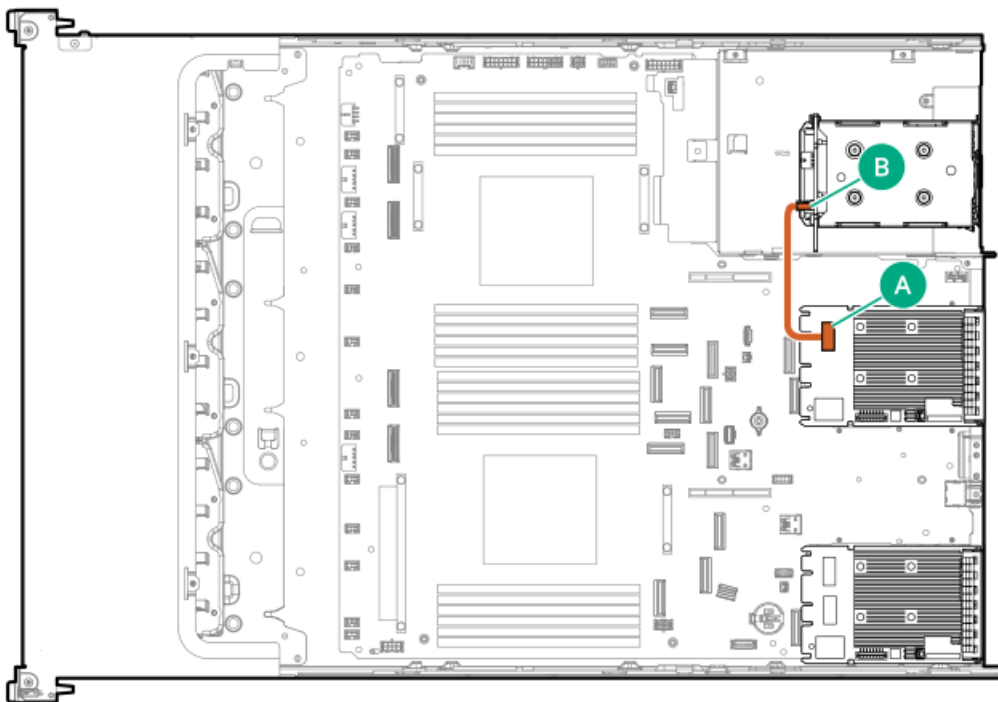

Cable part number	Color	From	To
P58149-001 ¹	Orange	Slot 22 port 1	Box 8 port 1

LFF drive cabling

4 LFF drive: Type-o controller cabling

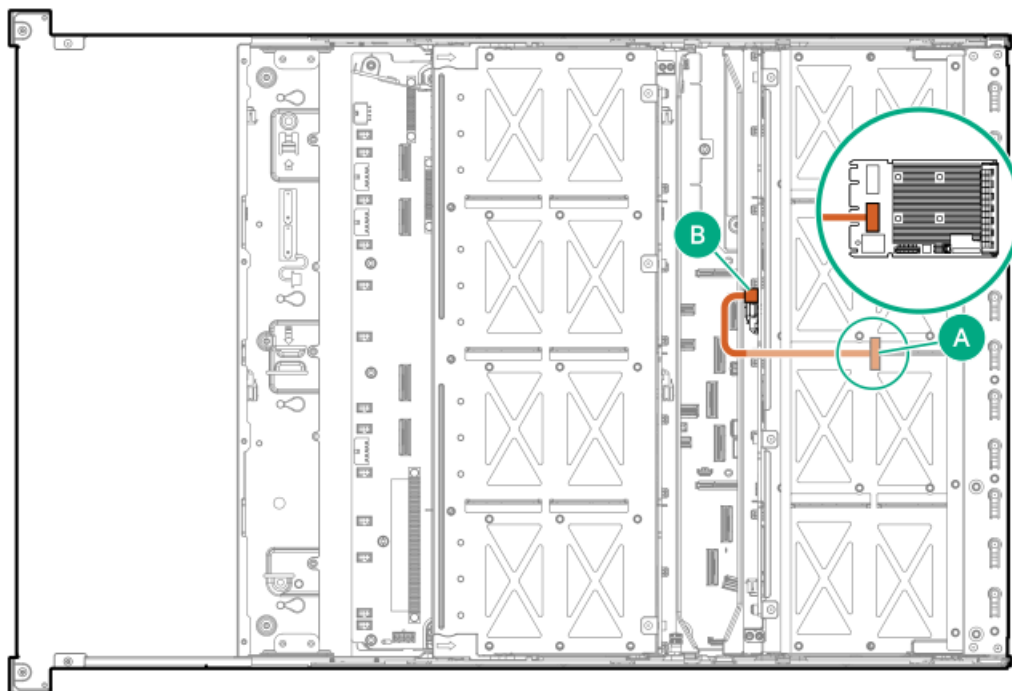

Cable part number	Color	From	To
P58098-001 ¹	Orange	Slot 22 port 2	Box 8 port 1

Energy pack cabling

24 SFF drive: Energy pack cabling



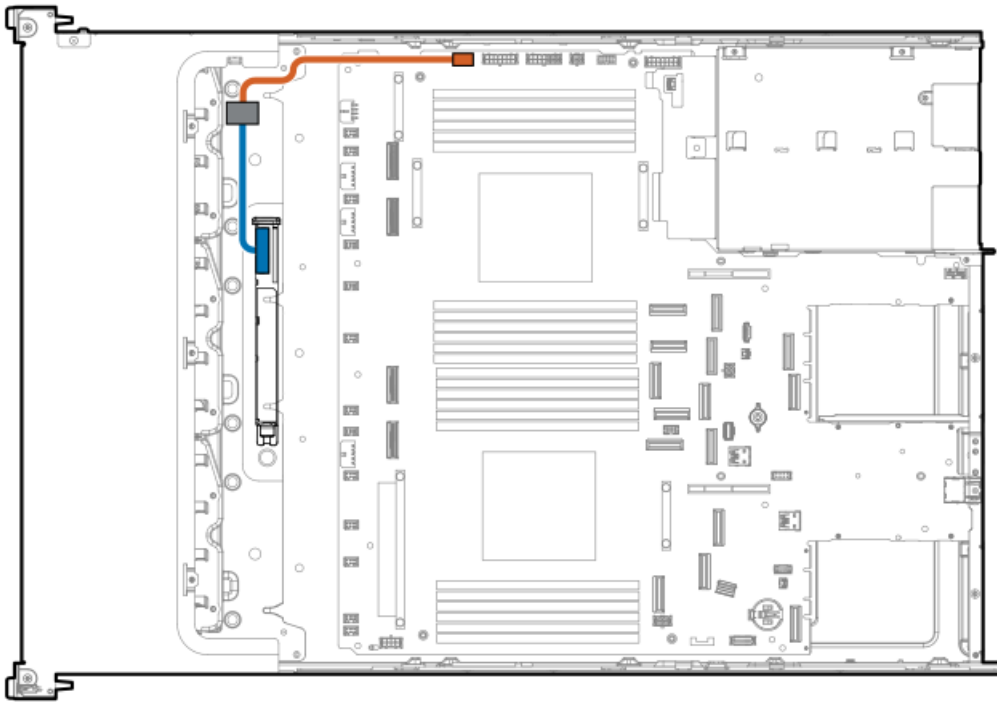

Cable part number	Color	From	To
P58176-001 ¹	Orange	Energy pack extension cable	Energy pack connector
—	Blue	Energy pack	Energy pack extension cable

¹ Option kit: P57884-B21

12 LFF drive: Energy pack cabling

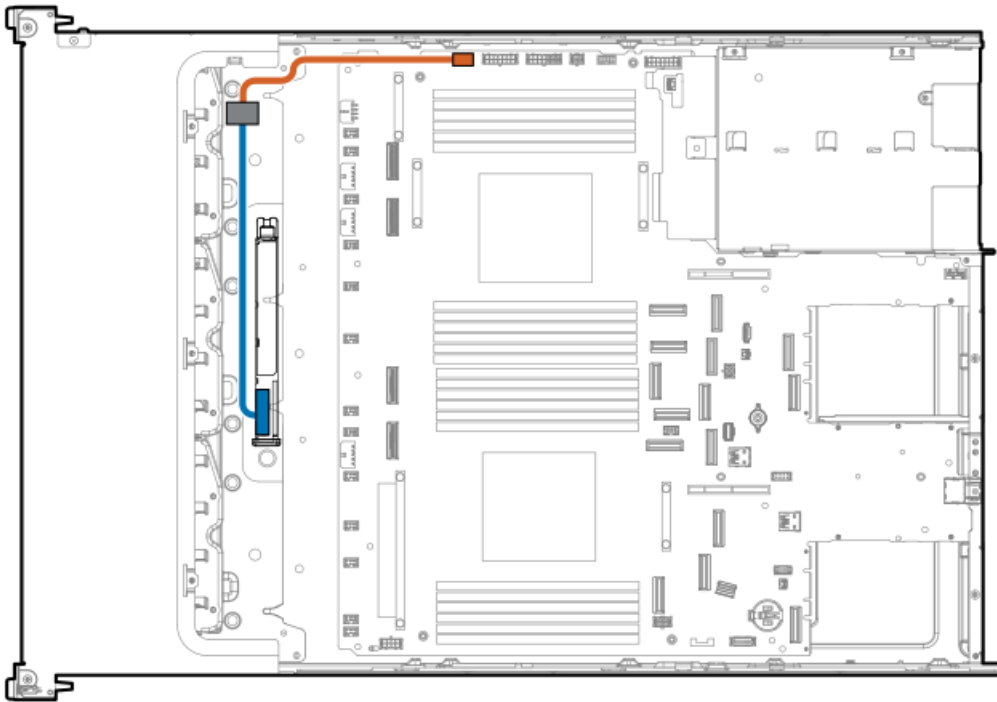

Cable part number	Color	From	To
P58176-001 ¹	Orange	Energy pack extension cable	Energy pack connector
—	Blue	Energy pack	Energy pack extension cable

¹ Option kit: P57884-B21

4 dual-width accelerator-optimized drive configuration: Energy pack cabling

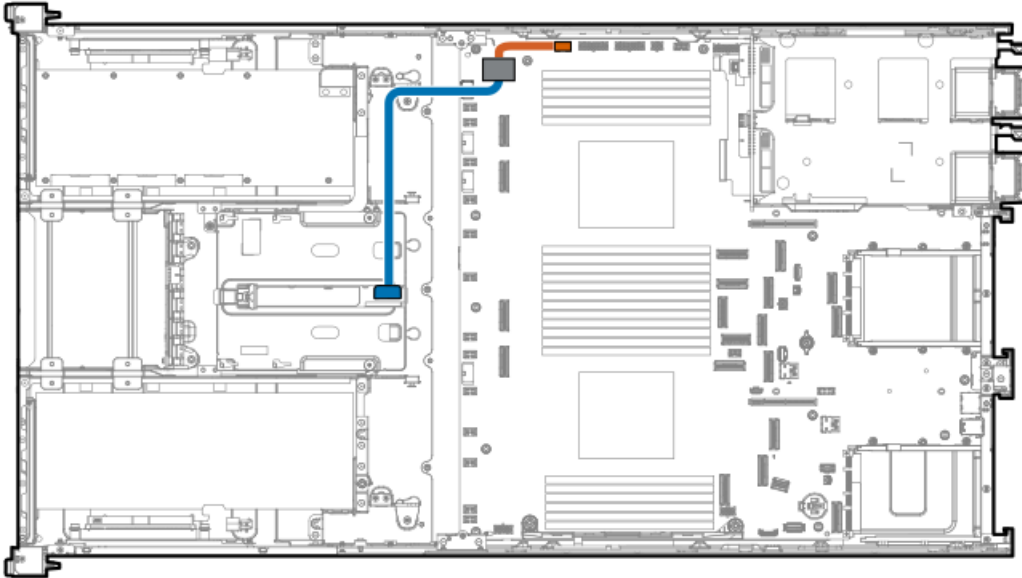

Cable part number	Color	From	To
P58176-001 ²	Orange	Energy pack extension cable	Energy pack connector
—	Blue	Energy pack	Energy pack extension cable

² Option kit: P57884-B21

Storage controller backup power cabling

The exact route of the storage controller backup power cabling will depend on:

- The riser slot where the controller is installed
- The location of the storage controller backup power connector on the controller

Use the following diagrams for reference only.

Type-o storage controller in slot 21



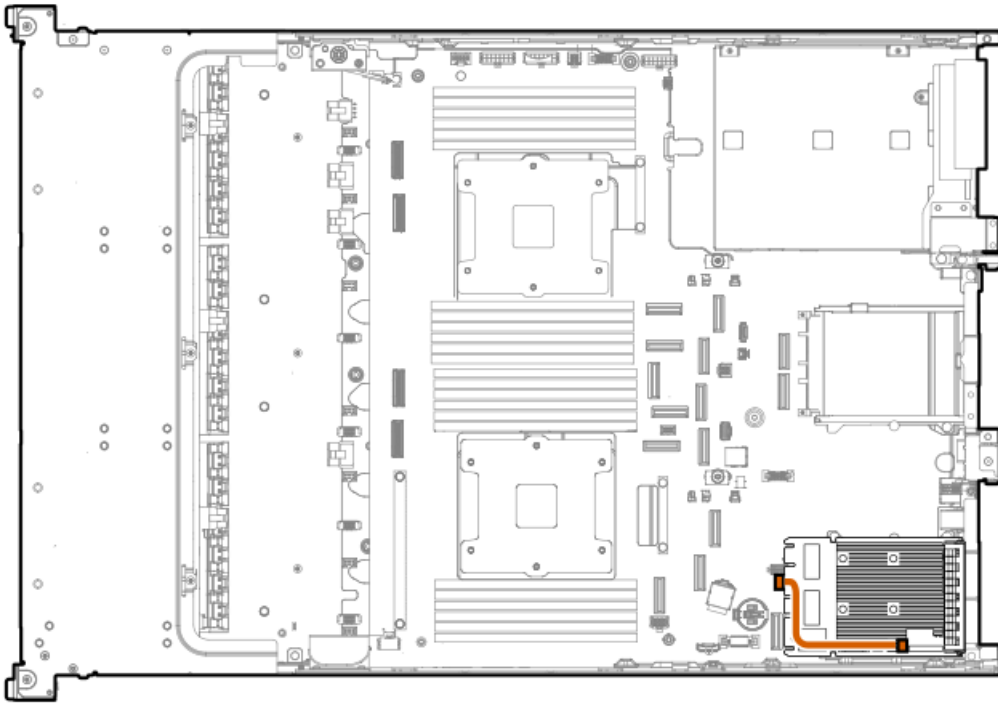

Color	From	To
Orange	Type-o controller in Slot 21	OCP slot 21 backup power connector

Type-o storage controller in slot 22

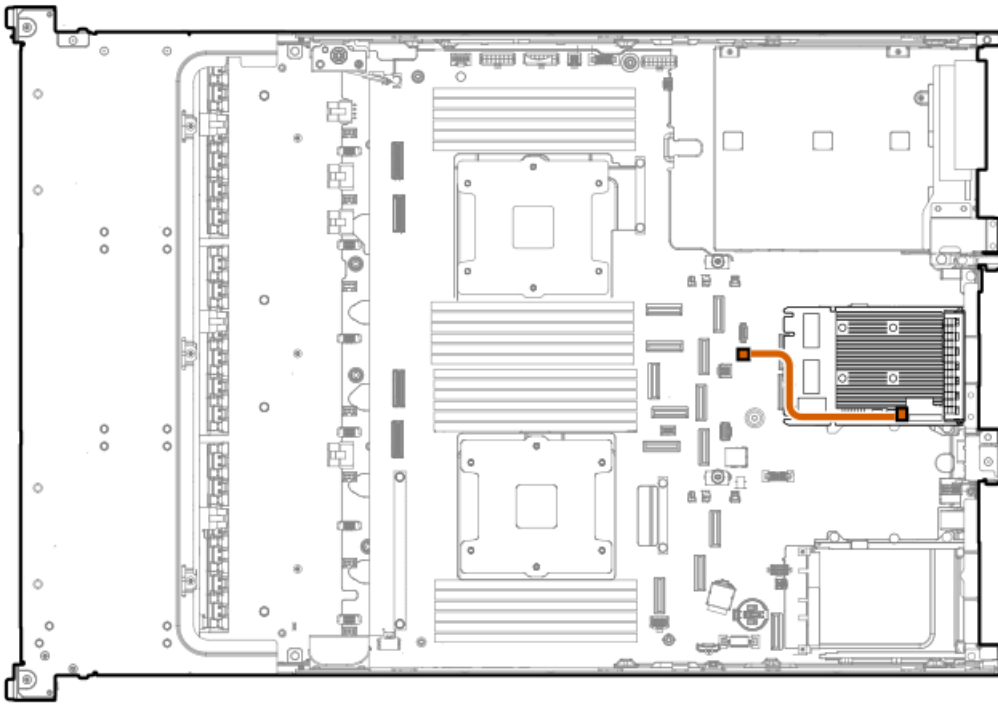

Color	From	To
Orange	Type-o controller in Slot 22	OCP slot 22 backup power connector

Type-p storage controller



The riser cage, riser board, and type-p storage controller might look different from the one shown in the following illustration.

Identify the Storage controller backup power connectors on the riser board.

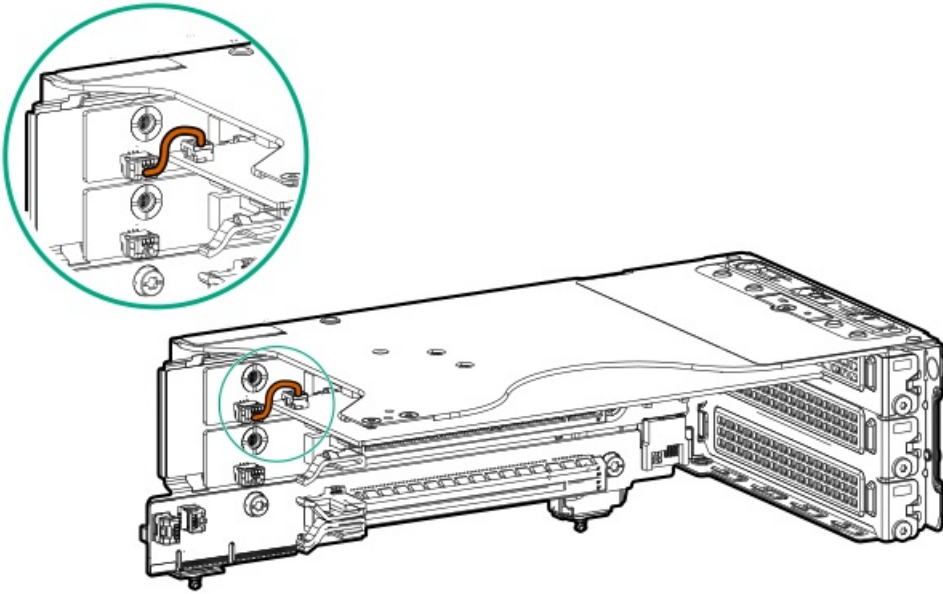

Color	From	To
Orange	Storage controller backup power connectors	Type-p controller card

GPU auxiliary power cabling

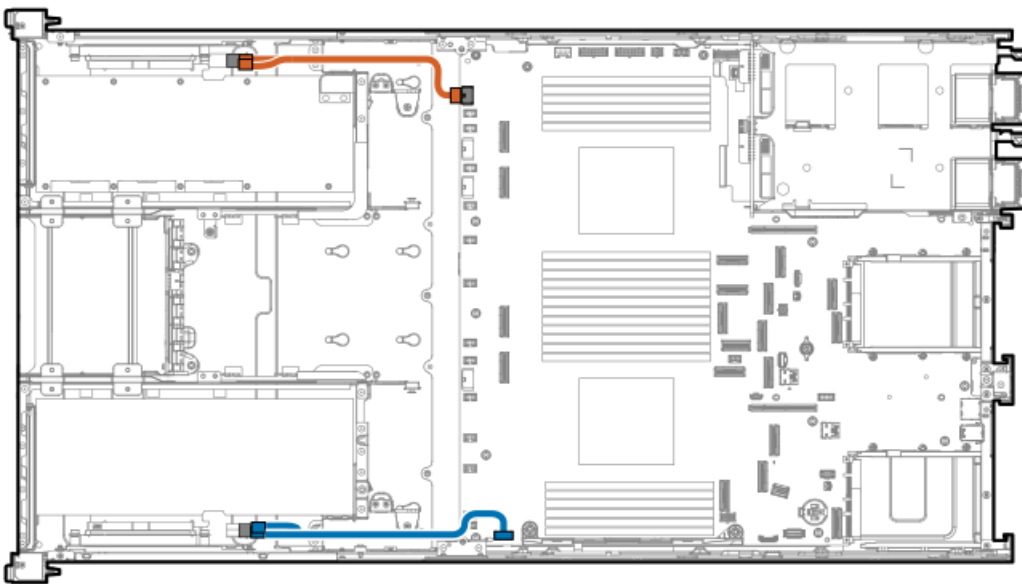

Cable part number	Color	From	To
P58157-001	Orange	GPU riser power connector	GPU riser card in slot 9 and 11
	Blue	GPU riser power connector	GPU riser card in slot 14 and 16

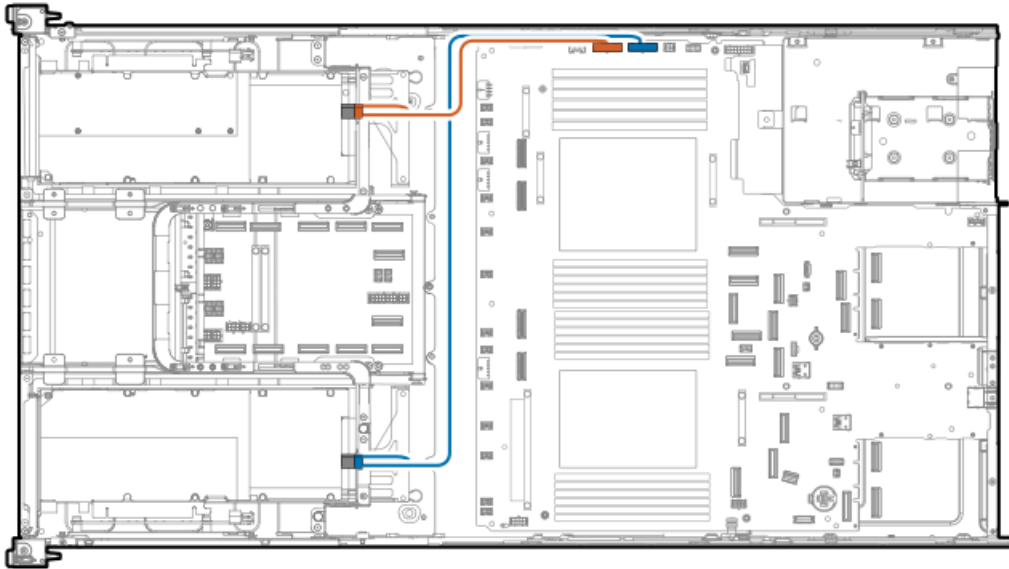

Cable part number	Color	From	To
P58159-001 ¹	Orange	GPU 1 and GPU 2 (8 pin)	GPU/Backplane/switch board power connector
P58161-001		GPU 1 and GPU 2 (PCIe 8 pin)	
P58064-001		GPU 1 and GPU 2 (PCIe 16 pin)	
P58160-001 ²	Blue	GPU 3 and GPU 4 (8 pin)	
P58162-001		GPU 3 and GPU 4 (PCIe 8 pin)	
P58062-001		GPU 3 and GPU 4 (PCIe 16 pin)	

- ¹ Option kit: P57851-B21
² Option kit: P57851-B21

Riser cabling

Subtopics

[Stacking riser cabling](#)

[GPU riser cabling](#)

Stacking riser cabling

Primary stacking riser cabling

When routing to slot 1, make sure to securely tuck the cable underneath the heatsink.

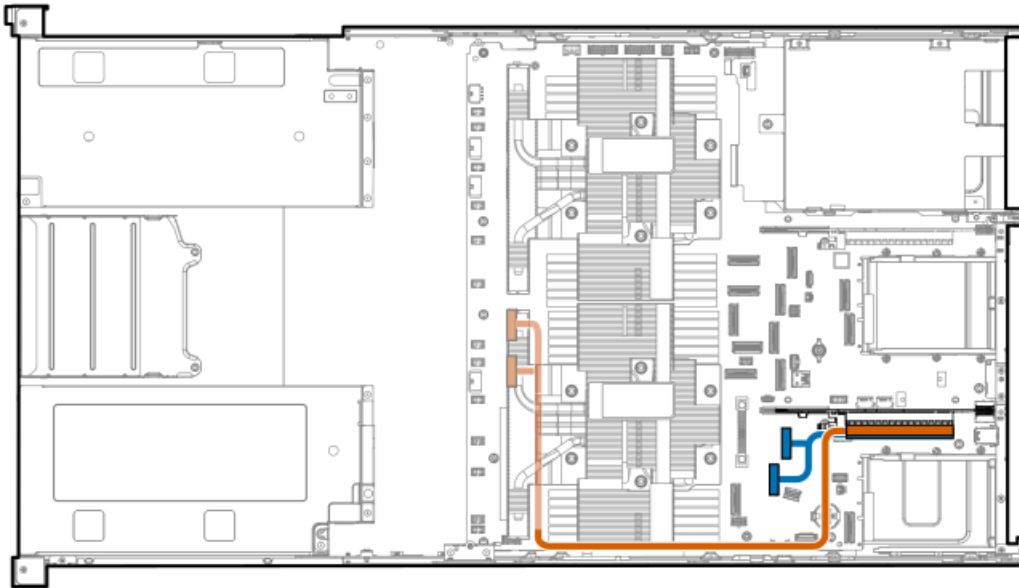

Cable part number	Color	From	To
P51472-001 ¹	Orange	NVMe port 2A (PRIM) or NVMe port 3A (SEC)	Slot 1
P41276-001 ¹	Blue	NVMe port 6A (SEC) or NVMe port 7A (PRIM)	Slot 2

¹ Option kit: P57890-B21

Secondary stacking riser cabling

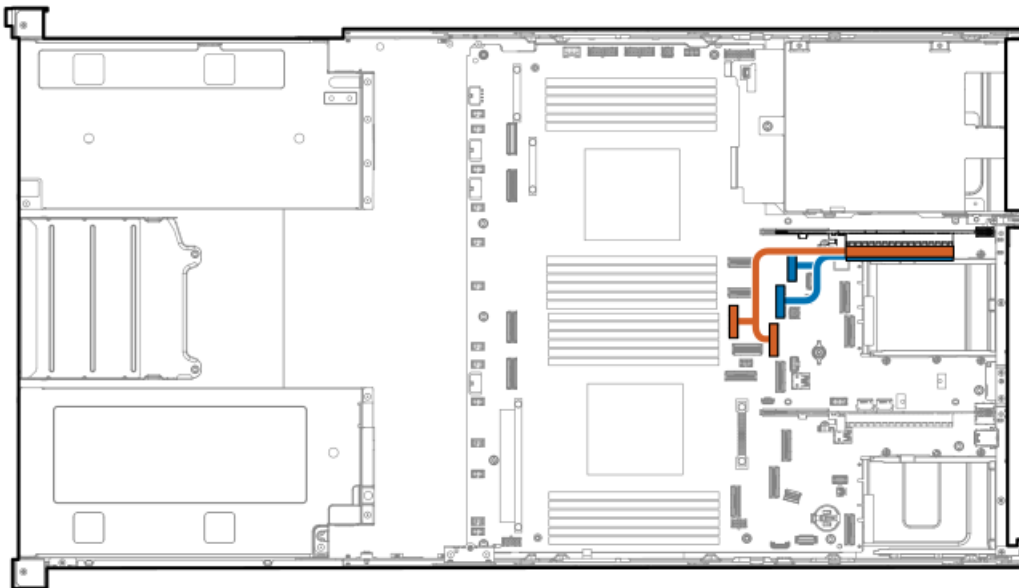

Cable part number	Color	From	To
P55815-001 ¹	Orange	NVMe port 5B (SEC) and 4B (PRIM)	Slot 5
P41276-001 ¹	Blue	NVMe/SATA port 9B (PRIM) and 8B (SEC)	Slot 4



¹ Option kit: P57891-B21

Tertiary stacking riser cabling

When routing to slot 7, make sure to securely tuck the cable underneath the heatsink.



Cable part number	Color	From	To
P50365-001 ¹	Orange	NVMe port 3B (SEC) and 2B (PRIM)	Slot 7
P50364-001 ¹	Blue	NVMe port 7B (PRIM) and 6B (SEC)	Slot 8

¹ Option kit: P57893-B21

GPU riser cabling



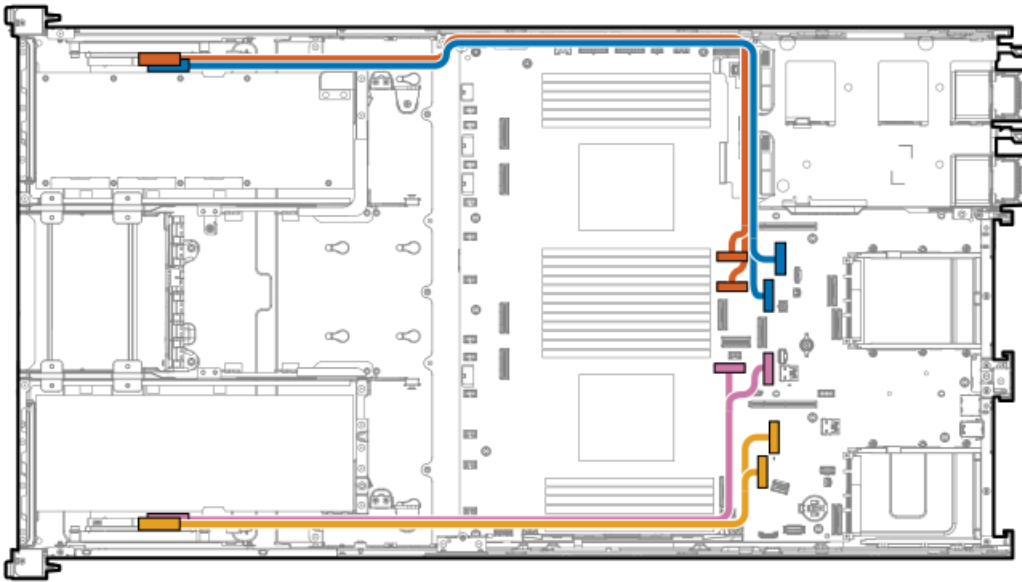

Cable part number	Color	From	To
P44218-001	Orange	NVMe port 7B (PRIM) and 6B (SEC)	Slot 9
	Blue	NVMe/SATA port 9B (PRIM) and 8B (SEC)	Slot 11
	Pink	NVMe/SATA port 1A (SEC) and 9A (PRIM)	Slot 14
P55816-001	Yellow	NVMe port 7A (PRIM) and 6A (SEC)	Slot 16

GPU riser cabling to the switch board

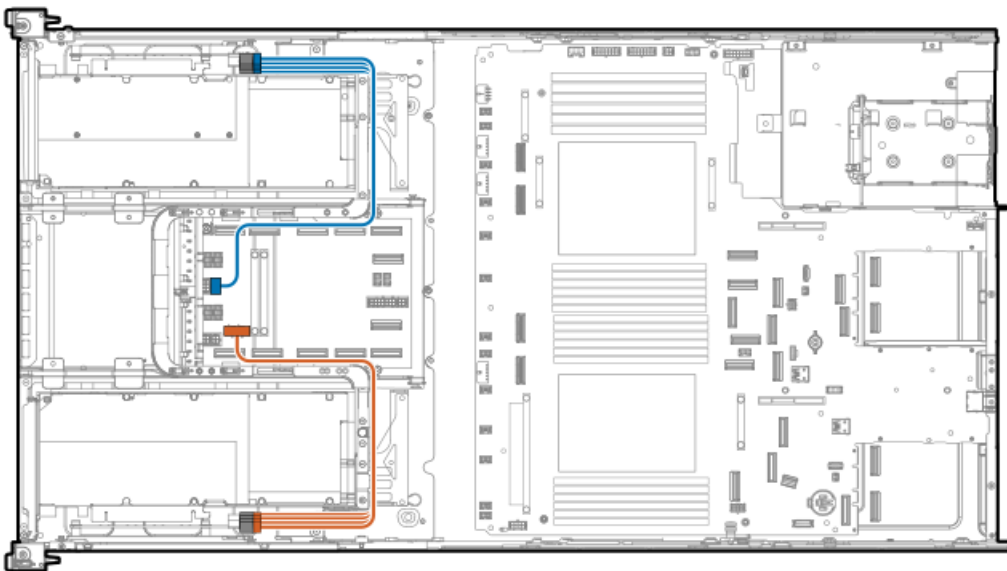

Cable part number	Color	From	To
P54887-001	Orange	<ul style="list-style-type: none"> Upper switch board: GPU riser slot 13 and 14 power connector Lower switch board: GPU riser 15 and 16 power connector 	GPU riser 13, 14, 15, and 16
	Blue	<ul style="list-style-type: none"> Upper switch board: GPU riser slot 9 and 10 power connector Lower switch board: GPU riser slot 11 and 12 power connector 	GPU riser 9, 10, 11, and 12

Upper switch board cabling to the GPU risers

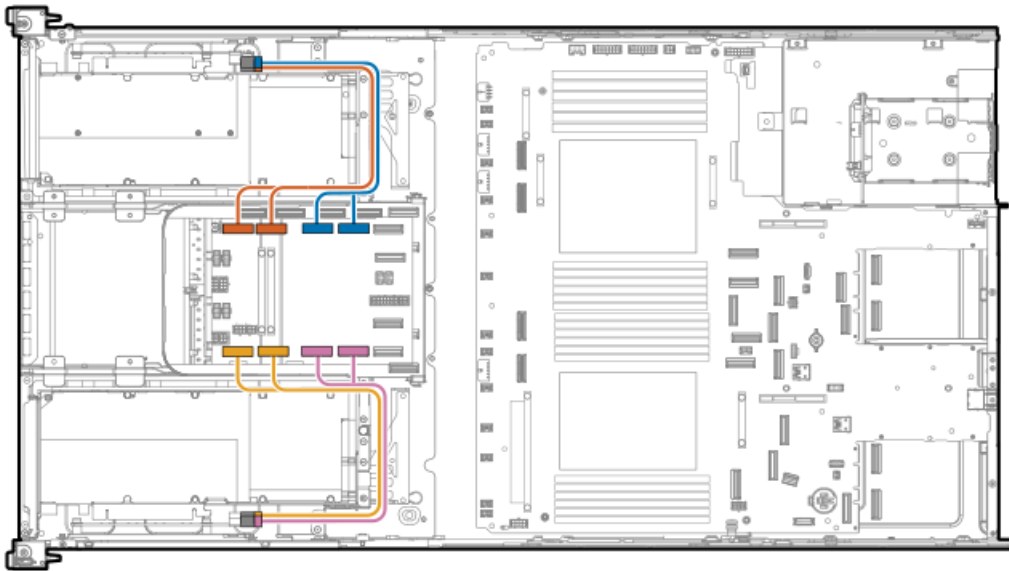

Cable part number	Color	From	To
P55910-001	Orange	GPU riser slot 9 MCIO connector (SEC) and GPU riser slot 9 MCIO connector (PRIM)	GPU riser slot 9
	Blue	GPU riser slot 10 MCIO connector (SEC) and GPU riser slot 10 MCIO connector (PRIM)	GPU riser slot 10
	Yellow	GPU riser slot 13 MCIO connector (SEC) and GPU riser slot 13 MCIO connector (PRIM)	GPU riser slot 13
	Pink	GPU riser slot 14 MCIO connector (SEC) and GPU riser slot 14 MCIO connector (PRIM)	GPU riser slot 14

Lower switch board cabling to the GPU risers



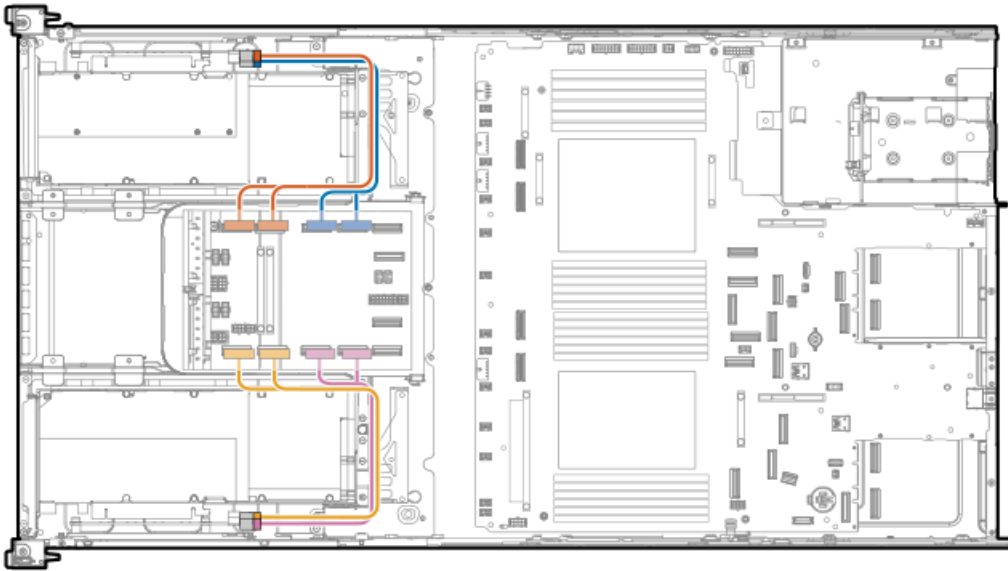

Cable part number	Color	From	To
P55910-001	Orange	GPU riser slot 11 MCIO connector (SEC) and GPU riser slot 11 MCIO connector (PRIM)	GPU riser slot 11
	Blue	GPU riser slot 12 MCIO connector (SEC) and GPU riser slot 12 MCIO connector (PRIM)	GPU riser slot 12
	Yellow	GPU riser slot 15 MCIO connector (SEC) and GPU riser slot 15 MCIO connector (PRIM)	GPU riser slot 15
	Pink	GPU riser slot 16 MCIO connector (SEC) and GPU riser slot 16 MCIO connector (PRIM)	GPU riser slot 16

Switch board cabling

Switch board power cabling



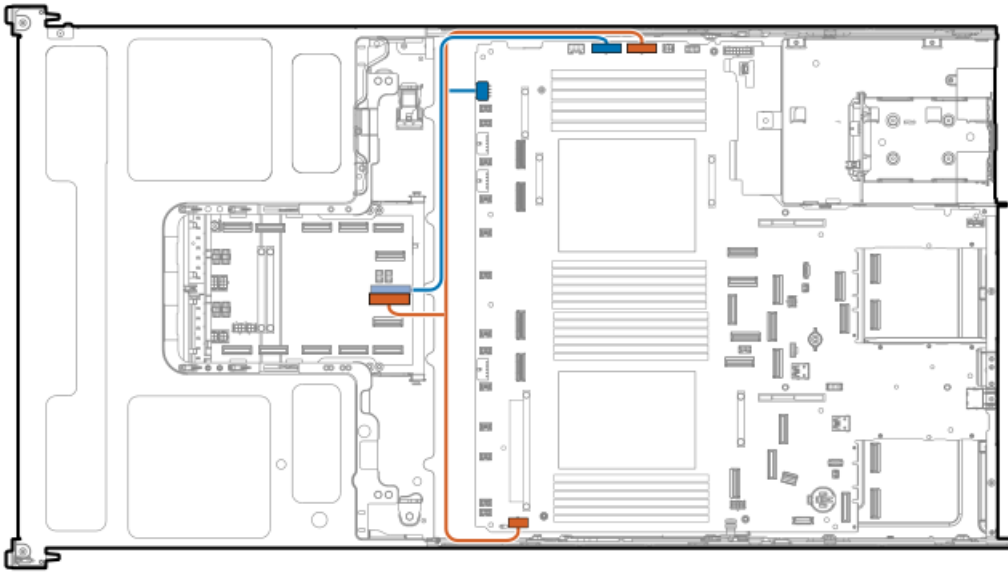

Cable part number	Color	From	To
P58178-001	Orange	Upper switch board power connector	GPU/Backplane/switch board power connector and GPU riser power connector
P58177-001	Blue	Lower switch board power connector	GPU/Backplane/switch board power connector and GPU riser power connector

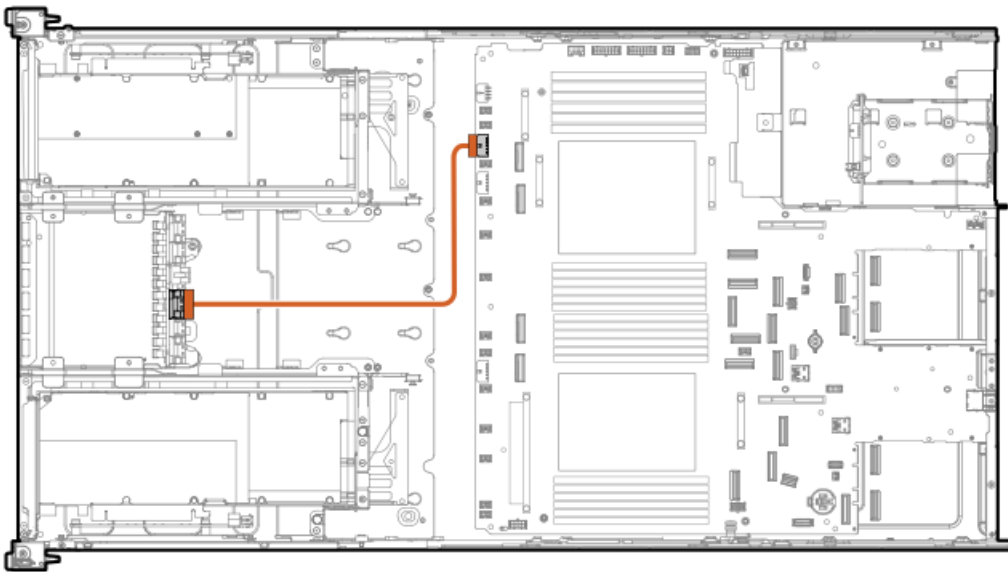

Cable part number	Color	From	To
P58034-001	Orange	Box 1	Drive backplane power connector 1

Switch board signal cabling



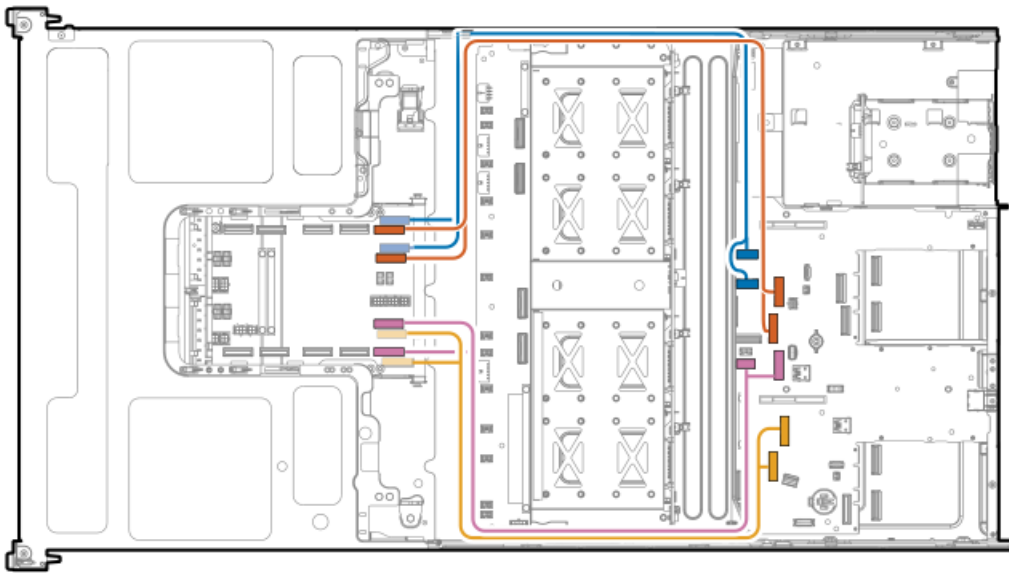

Cable part number	Color	From	To
P58163-001	Orange	NVMe/SATA port 9B (PRIM) and NVMe/SATA port 8B (SEC)	Upper switch board downstream port 1 (SEC) and Upper switch board downstream port 2 (PRIM)
P58165-001	Blue	NVMe port 7B (PRIM) and NVMe port 6B (SEC)	Lower switch board downstream port 1 (SEC) and Lower switch board downstream port 2 (PRIM)
P58166-001	Pink	NVMe/SATA port 1A (SEC) and NVMe/SATA port 9A (PRIM)	Upper switch board downstream port 3 (SEC) and Upper switch board downstream port 4 (PRIM)
P58164-001	Yellow	NVMe port 7A (PRIM) and NVMe port 6A (SEC)	Lower switch board downstream port 3 (SEC) and Lower switch board downstream port 4 (PRIM)

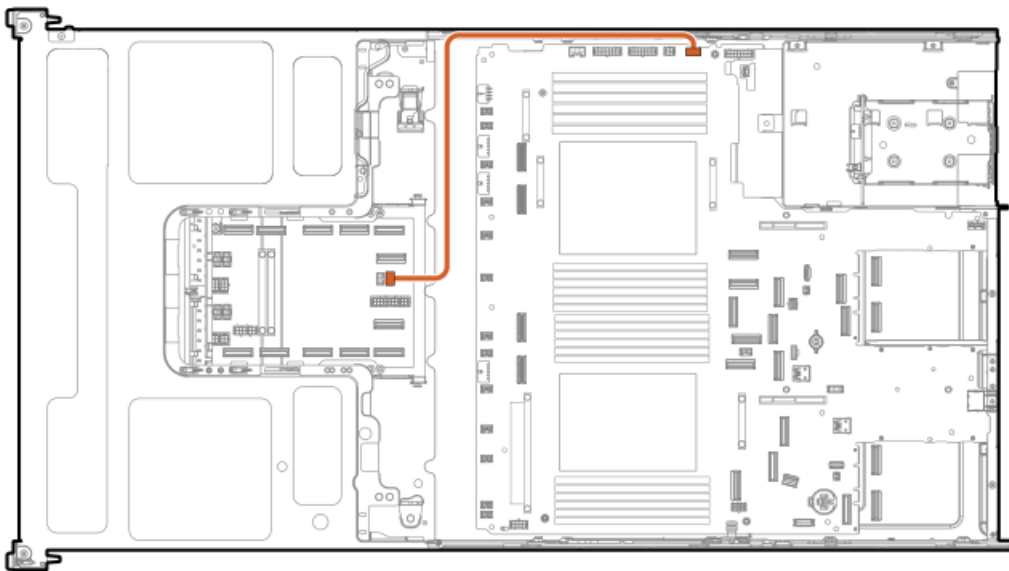

Cable part number	Color	From	To
P58046-001	Orange	Lower switch board signal connector	Free-height riser sideband connector



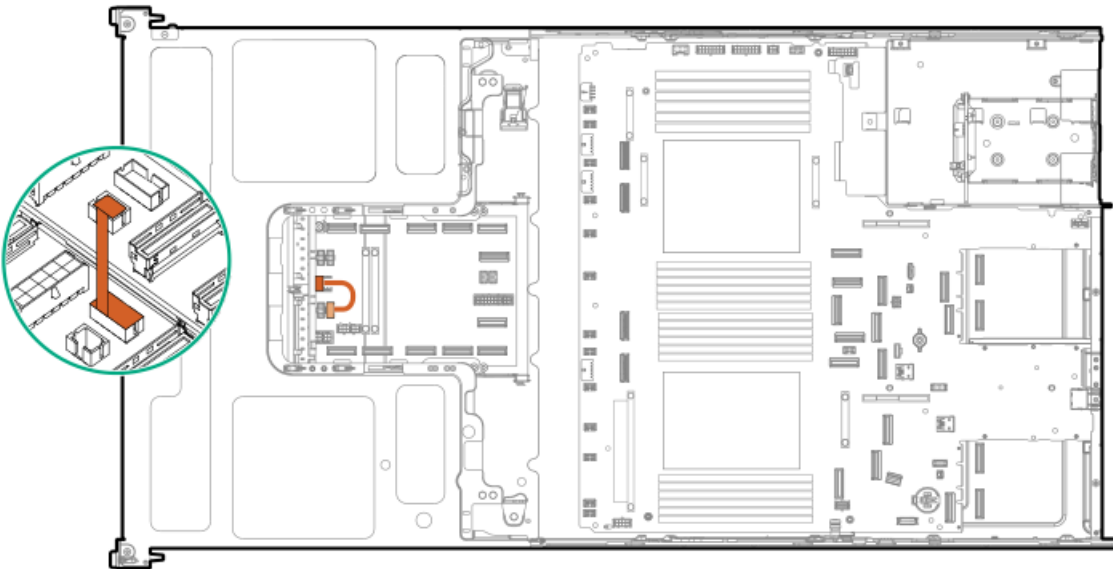

Cable part number	Color	From	To
P54900-001	Orange	Lower switch board signal extension connector	Upper switch board signal extension connector

HPE NS204i Boot Device cabling

HPE NS204i Boot Device cabling on the secondary riser cage

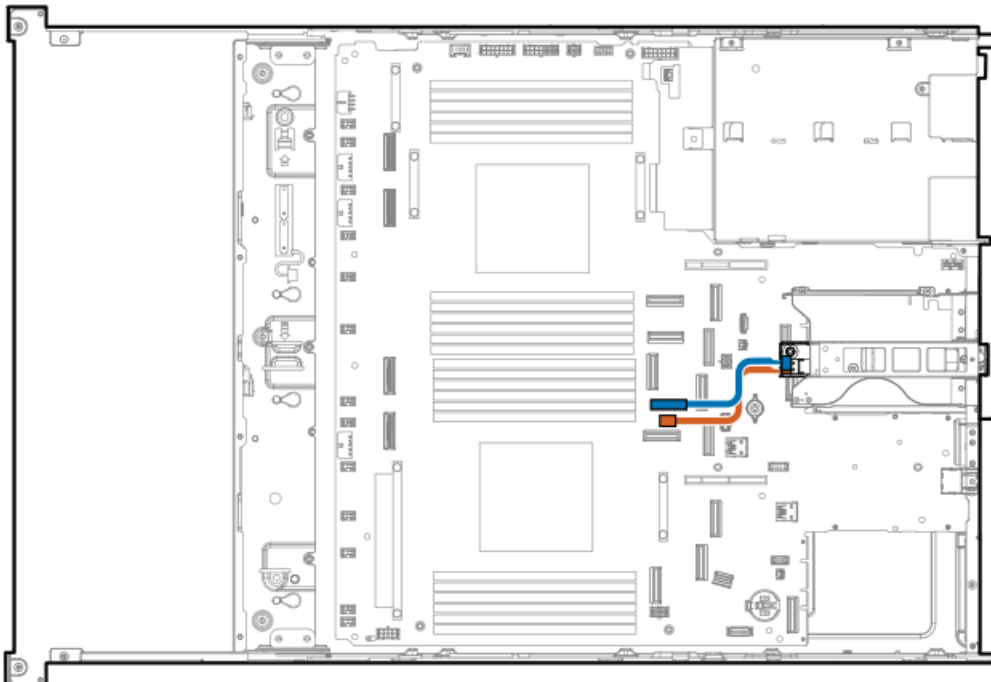

Cable part number	Color	From	To
P54088-001 ¹	Orange	NS204i-u power connector	HPE NS204i Boot Device
P54087-001 ²	Blue	NS204i-u signal connector	HPE NS204i Boot Device

- ¹ Option kit: P57885-B21
- ² Option kit: P57850-B21; P57885-B21

HPE NS204i Boot Device cabling on top of the power supplies

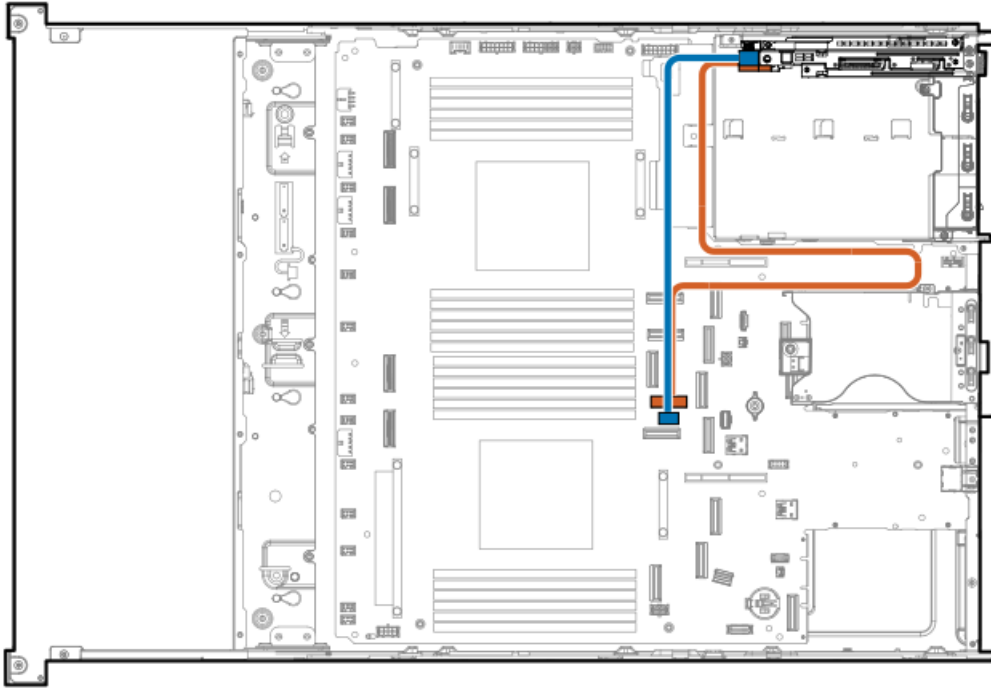

Cable part number	Color	From	To
P54087-001 ¹	Orange	NS204i-u signal connector	HPE NS204i Boot Device
P54089-001 ¹	Blue	NS204i-u power connector	HPE NS204i Boot Device

- ¹ Option kit: P57850-B21

System Insight Display cabling



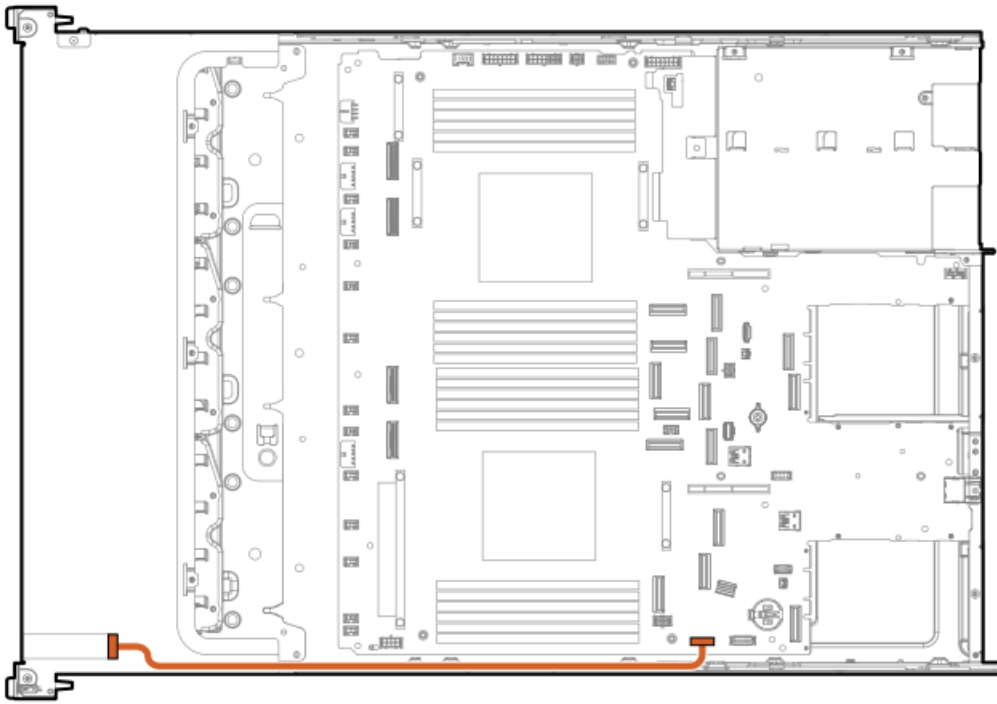

Cable part number	Color	From	To
P48971-001 ¹	Orange	SID connector	System Insight Display

¹ Option kit: P57895-B21

Chassis intrusion switch cabling

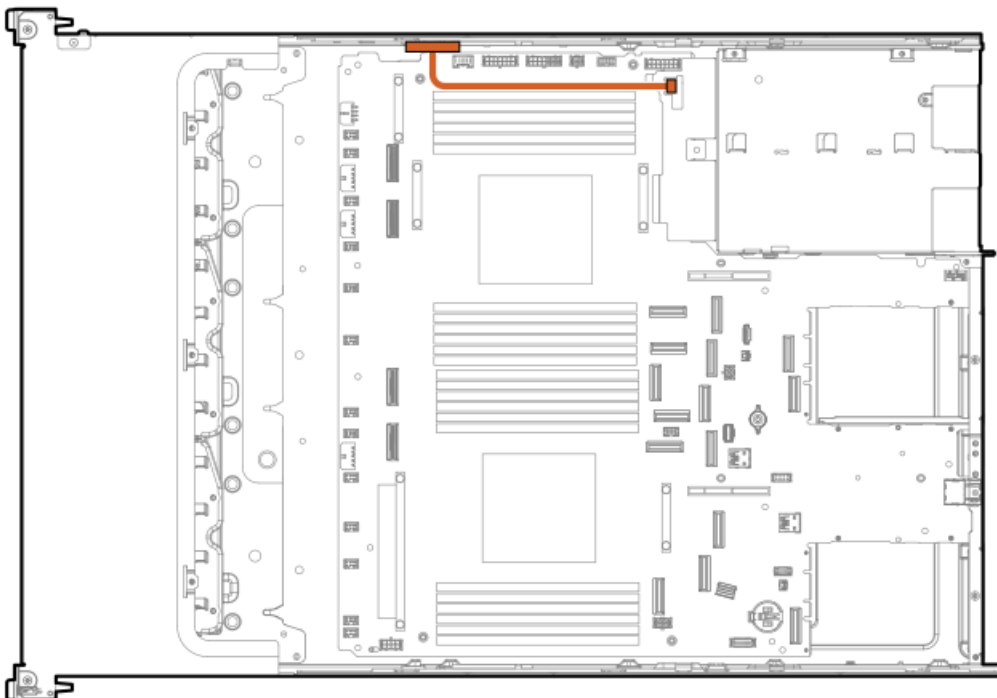

Cable part number	Color	From	To
P54901-001 ¹	Orange	Chassis intrusion detection switch	Chassis intrusion detection switch connector

¹ Option kit: P55713-B21

Universal media bay cabling

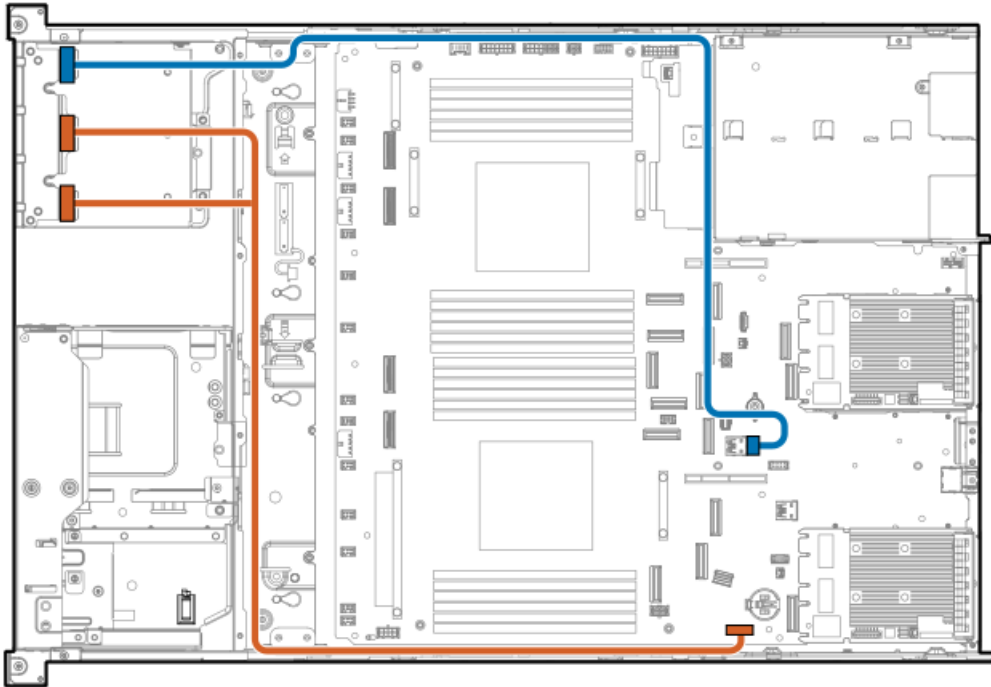

Cable part number	Color	From	To
P14314-001 ¹	Orange	USB 2.0 port and the DisplayPort	DisplayPort cable connector
P57248-001 ¹	Blue	USB 3.2 Gen 1 port	Internal USB 3.2 Gen 1 port

¹ Option kit: P57857-B21

DisplayPort cabling



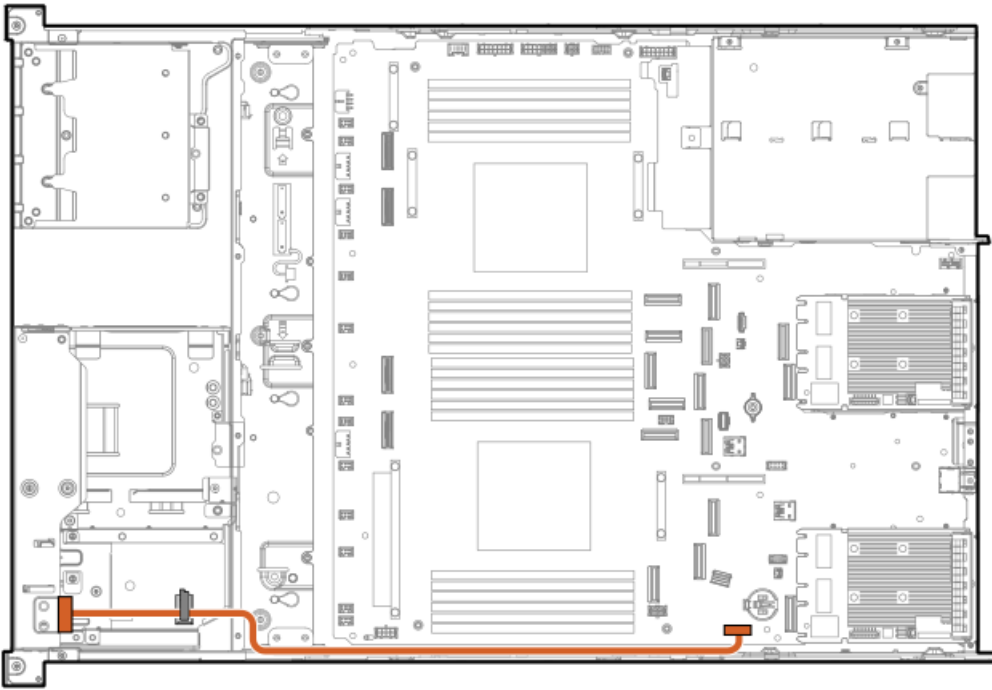

Cable part number	Color	From	To
869808-001	Orange	DisplayPort cable connector	Media bay display port

Front I/O cabling

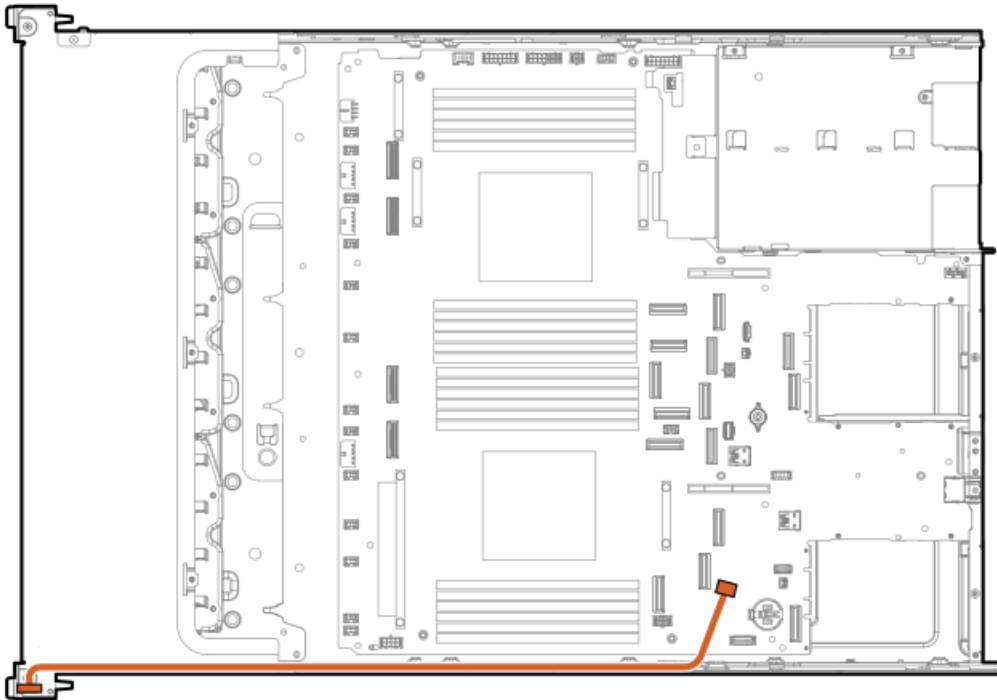

Cable part number	Color	From	To
P43727-001	Orange	Front I/O	Right chassis ear



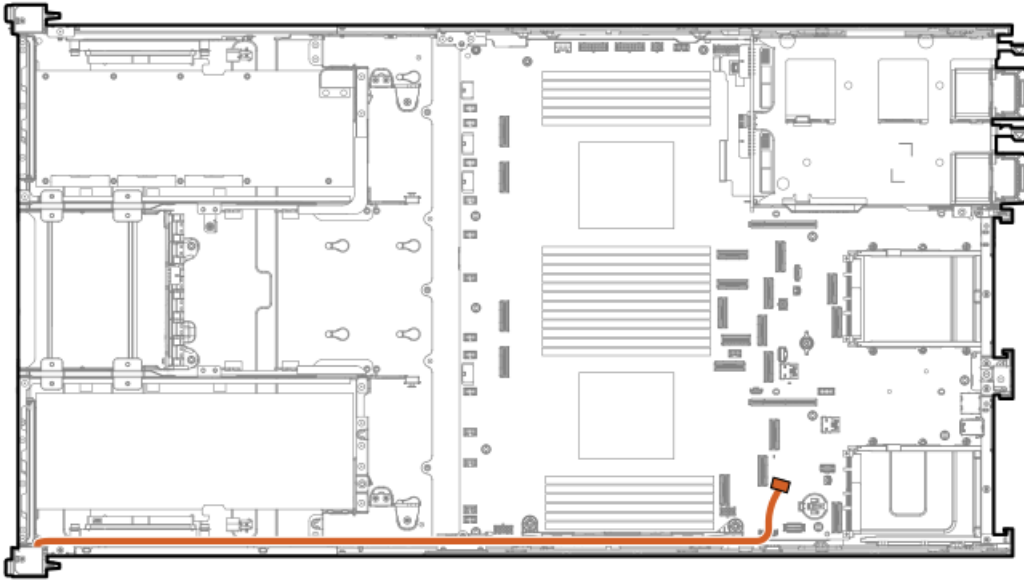

Cable part number	Color	From	To
P47750-001	Orange	Front I/O	Right chassis ear

Power distribution board cabling

48 SFF drive: Power distribution board cabling

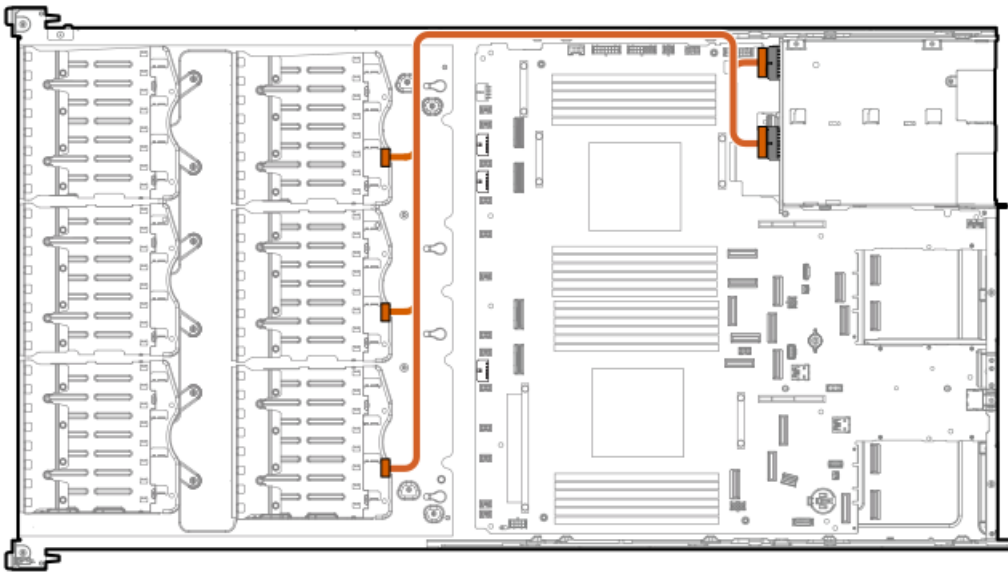

Cable part number	Color	From	To
P58028-001	Orange	Power distribution board	8 SFF drive box 4-6



Serial port cabling

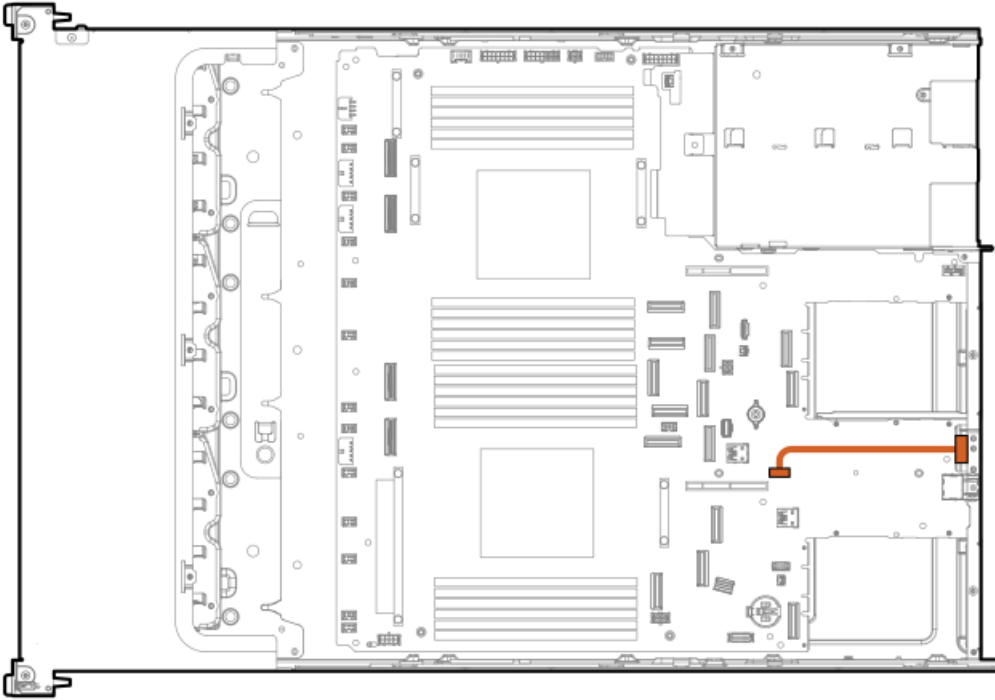

Cable part number	Color	From	To
873747-001 ¹	Orange	Serial port	Serial port connector

¹ Option kit: P59431-B21

Optical drive cabling

Optical drive cabling in the SFF chassis



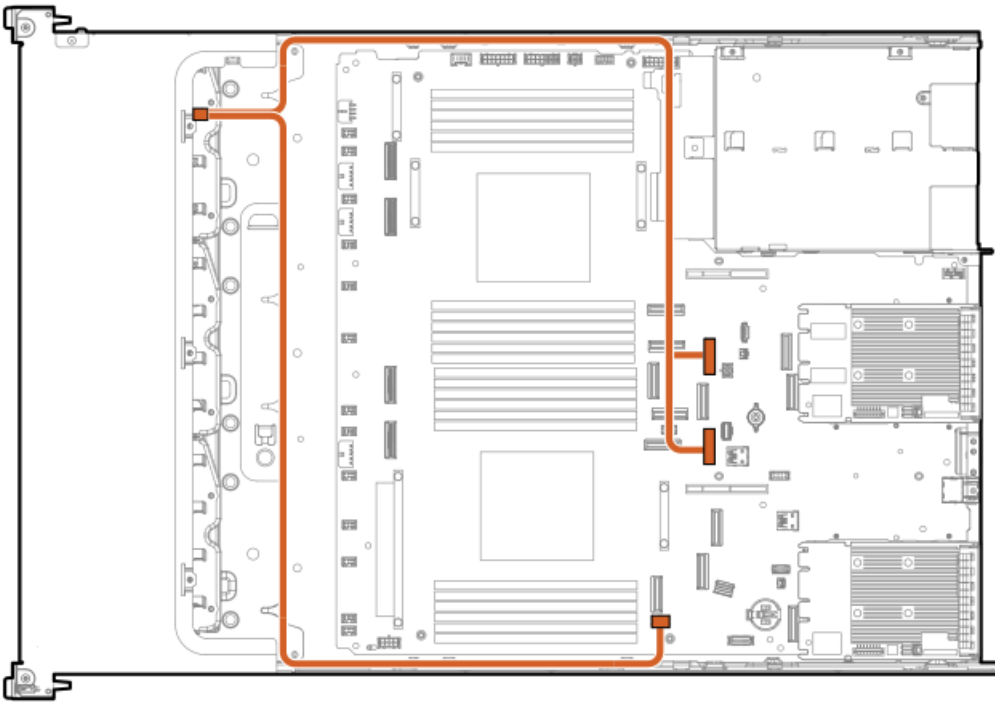

Cable part number	Color	From	To
P58077-001 ¹	Orange	ODD/2SFF power connector or NVMe/SATA port 1A or NVMe/SATA 8B	Optical drive

¹ Option kit: P57889-B21

Optical drive cabling in the LFF chassis

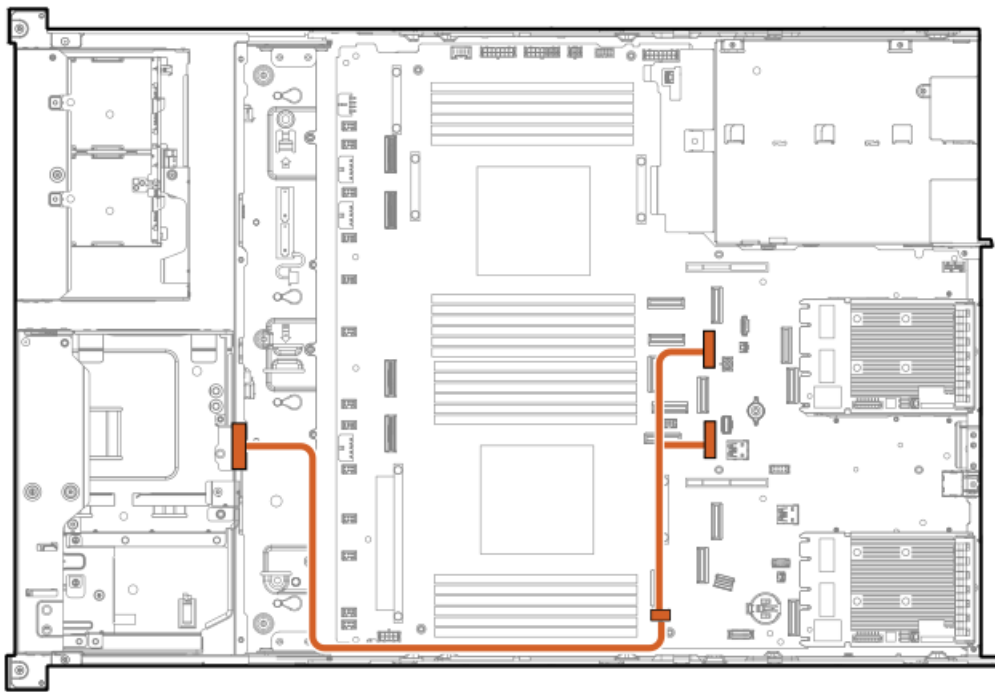

Cable part number	Color	From	To
P58077-001 ¹	Orange	ODD/2SFF power connector or NVMe/SATA port 8B or NVMe/SATA port 1A	Optical drive



OCP bandwidth upgrade cabling

OCP slot 22 cabling

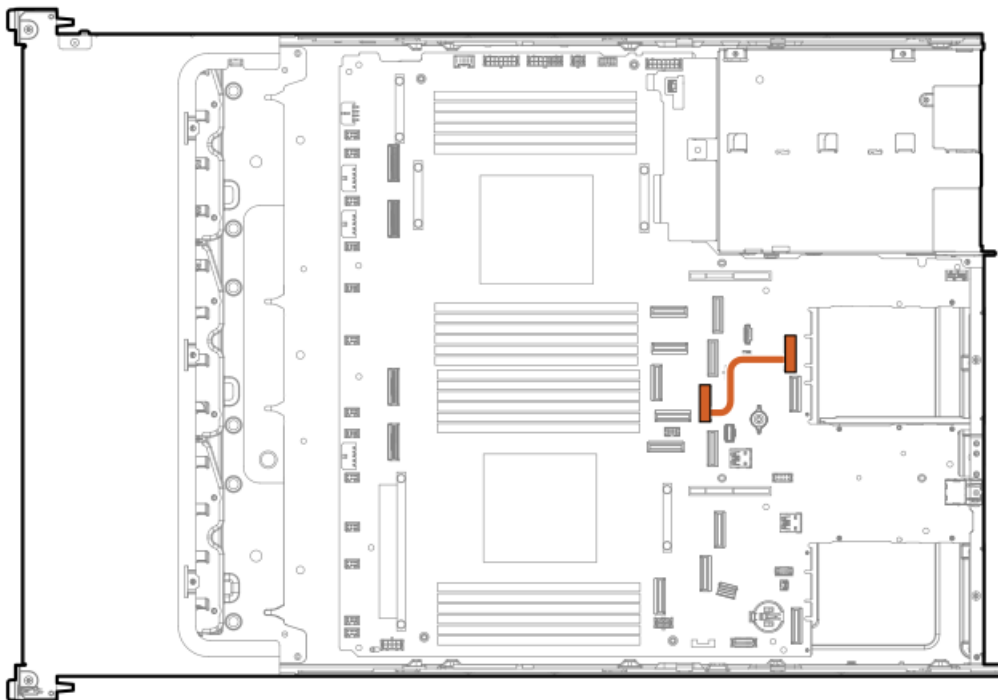

Cable part number	Color	From	To
P58174-001 ¹	Orange	NVMe port 5B	OCP slot 22 port 1

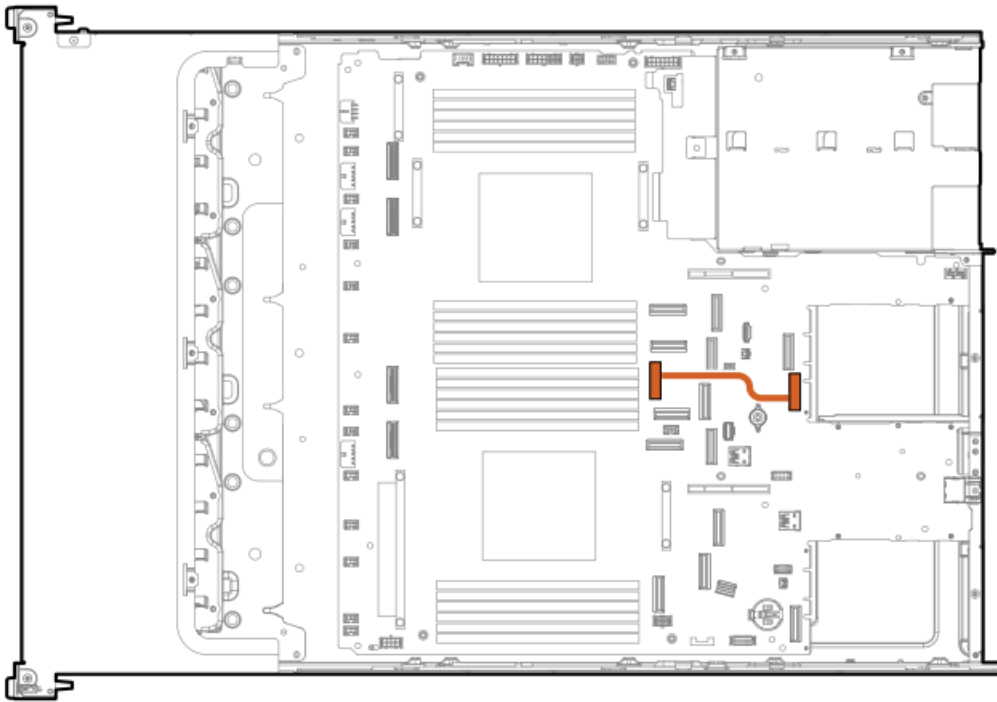

Cable part number	Color	From	To
P58174-001	Orange	NVMe port 4B	OCP slot 22 port 2

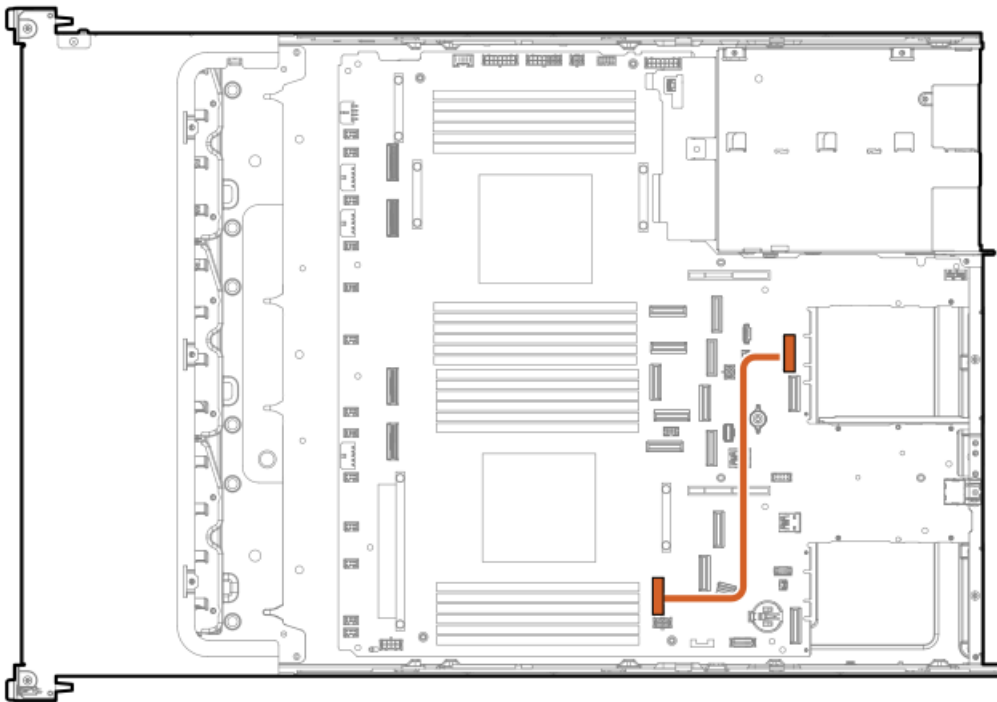

Cable part number	Color	From	To
P58173-001	Orange	NVMe port 4A	OCP slot 22 port 1

OCP slot 21 cabling

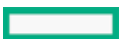

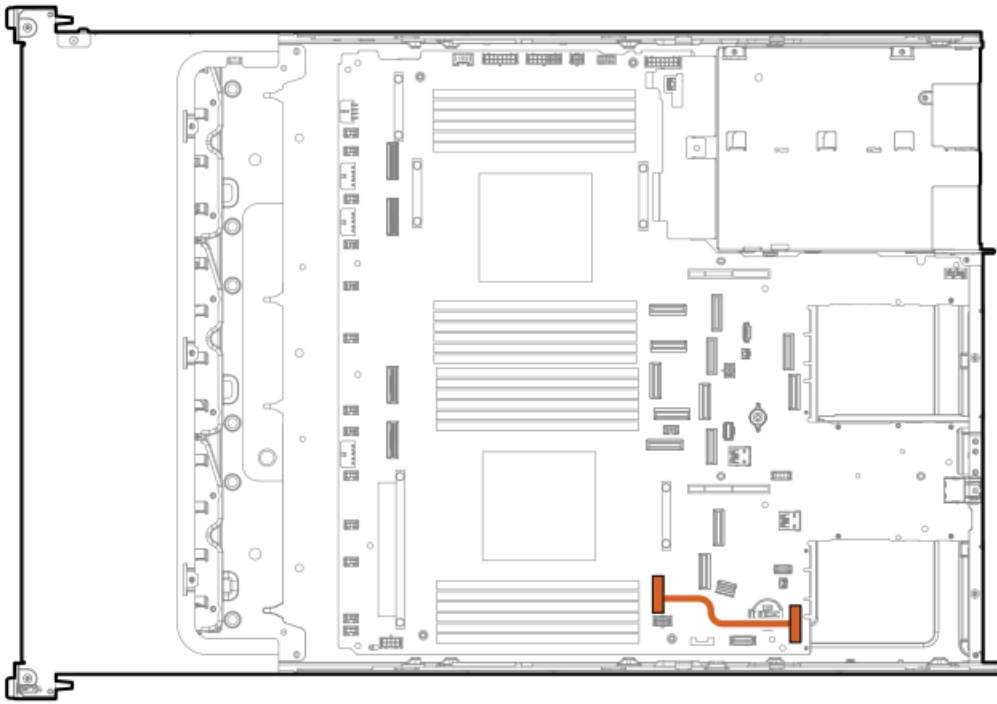

Cable part number	Color	From	To
P58174-001	Orange	NVMe port 4A	OCP slot 21 x16 upgrade connector

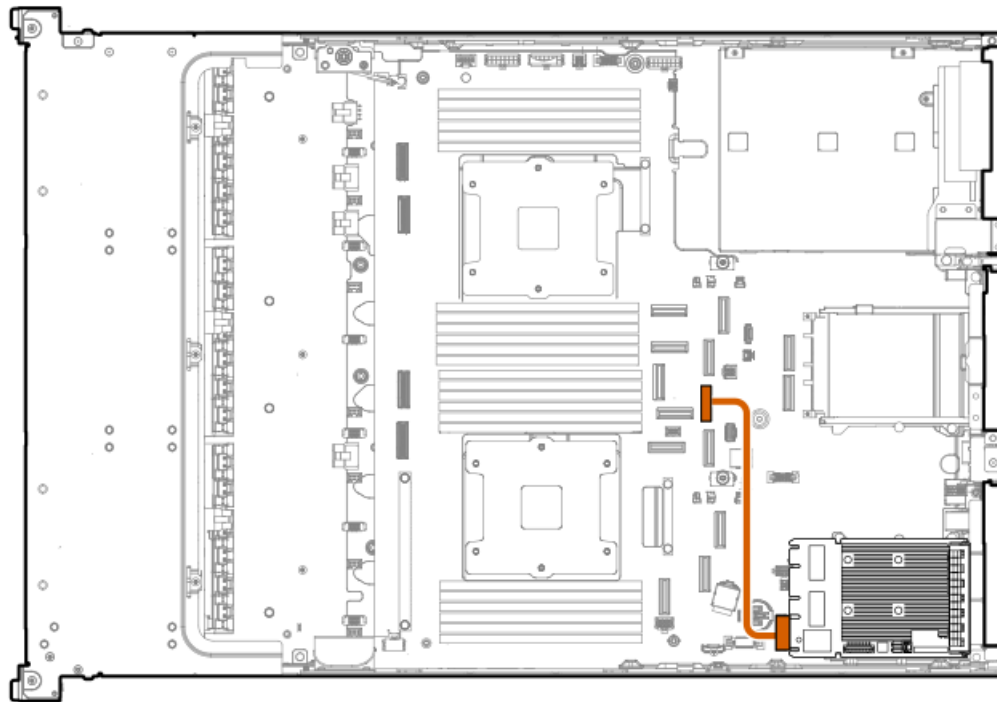

Cable part number	Color	From	To
P58173-001	Orange	NVMe port 5B	OCP slot 21 x16 upgrade connector



XGMI cabling

- Make sure you install the system board with the spare part number P65846-001. This system board supports XGMI cabling.
- Before using the cable with the part number P58128-001, bend the ends of the cable 90 degrees.
- Plug the XGMI cable according to the numbered sequence.

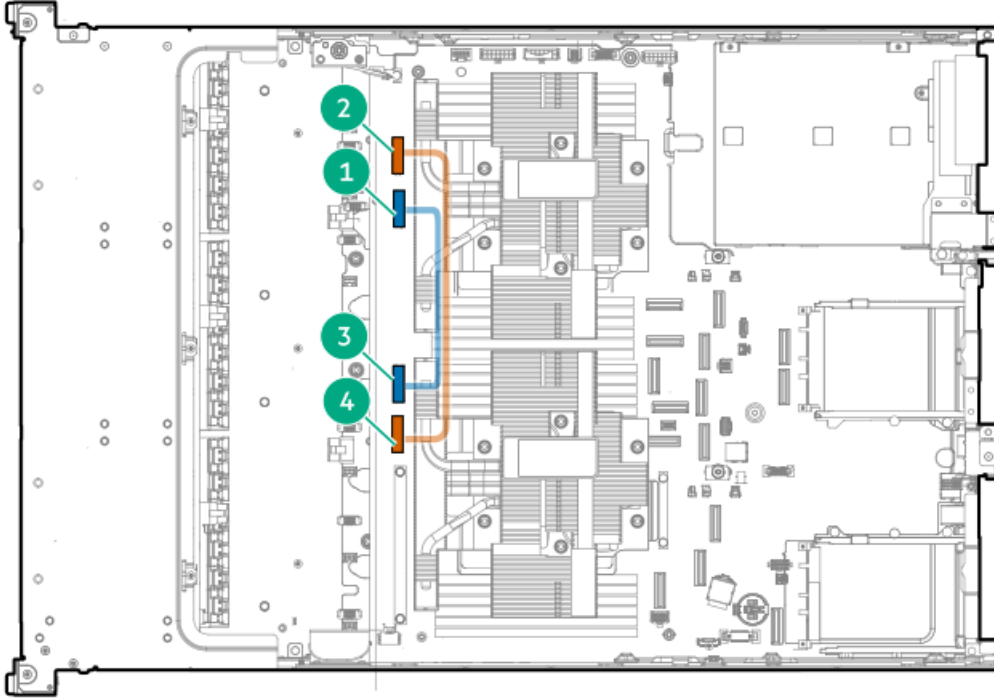

Cable part number	Color	From	To
P63462-001	Orange	NVMe port 3B	NVMe port 2A
	Blue	NVMe port 2B	NVMe port 3A
P58128-001 ¹	Orange	NVMe port 3B	NVMe port 2A
	Blue	NVMe port 2B	NVMe port 3A

¹ Option kit: P57880-B21

Configuration resources

Use the following resources to find documentation for configuring and managing your server.

- Some utilities might not apply to your server. For information about server compatibility with the products listed in this chapter, see the product QuickSpecs (<https://www.hpe.com/info/quickspecs>).
- Products ordered from HPE Factory Express might have already been configured with some or all the configurations in this chapter. To determine if any additional setup is required, see your HPE Factory Express order.
- For the most recent changes, feature enhancements, and bug fixes, see the latest product release notes.

Subtopics

[Updating firmware or system ROM](#)

[Configuring the server](#)

[Configuring storage controllers](#)

[Managing the HPE NS204i-u Boot Device](#)

[Deploying an OS](#)

[Configuring security](#)

[Optimizing the server](#)

[Server management](#)

[Managing Linux-based high performance compute clusters](#)

Updating firmware or system ROM

To	Use
Download service packs	Service Pack for ProLiant (SPP) https://www.hpe.com/servers/spp/download
Deploy service packs to a single server	Smart Update Manager (SUM) https://www.hpe.com/info/sum-docs
Deploy service packs to multiple servers	HPE OneView https://www.hpe.com/support/oneview-docs
Updating iLO or system firmware in a single server or multiple servers	iLO user guide https://www.hpe.com/support/ilo6
<ul style="list-style-type: none">• Enable policy-based management of server or server group firmware for distributed server infrastructure• Monitor server compliance with a configured firmware baseline• Receive automatic iLO firmware updates• Receive baseline update alerts	HPE GreenLake for Compute Ops Management https://www.hpe.com/info/com-docs

Configuring the server



To configure	Use
Single server (GUI)	<ul style="list-style-type: none"> Intelligent Provisioning https://www.hpe.com/info/intelligentprovisioning/docs iLO remote console or web interface https://www.hpe.com/support/ilo6 UEFI System Utilities https://www.hpe.com/info/UEFI-manuals HPE GreenLake for Compute Ops Management https://www.hpe.com/info/com-docs
Single server (scripting)	<ul style="list-style-type: none"> RESTful Interface Tool https://www.hpe.com/support/restfulinterface/docs Python iLO Redfish Library (python-iloest-library) https://github.com/HewlettPackard/python-iloest-library Scripting Tools for Windows Powershell https://www.hpe.com/info/powershell/docs iLO RESTful API https://servermanagementportal.ext.hpe.com/docs/redfishservices/ilos/ilo6/ HPE GreenLake for Compute Ops Management API https://developer.greenlake.hpe.com/
Multiple servers (either UI or scripting)	<ul style="list-style-type: none"> HPE OneView ¹ https://www.hpe.com/support/oneview-docs HPE GreenLake for Compute Ops Management https://www.hpe.com/info/com-docs <ul style="list-style-type: none"> Server settings: Define server-specific parameters such as firmware baselines, and then apply them to server groups. Server groups: Organize servers into custom-defined sets with associated server settings, and then apply group-specific policies to create a consistent configuration across the servers in the group.

¹ For servers running HPE OneView, do not use another tool, such as iLO, to delete or change certain settings. For more information about using HPE OneView and iLO to manage the same server, see the iLO user guide at <https://www.hpe.com/support/ilo6>.

Configuring storage controllers

Controller type	Documentation
HPE SR Gen11 controllers	<p>HPE SR Gen11 Controller User Guide</p> <p>https://hpe.com/support/SR-Gen11-UG</p> <p>Configuration guides:</p> <ul style="list-style-type: none"> • HPE Smart Storage Administrator GUI User Guide https://www.hpe.com/support/SSA-UG • HPE Smart Storage Administrator CLI User Guide https://www.hpe.com/support/SSACLI-UG
HPE MR Gen11 controllers	<p>HPE MR Gen11 Controller User Guide</p> <p>https://hpe.com/support/MR-Gen11-UG</p> <p>Configuration guides:</p> <ul style="list-style-type: none"> • HPE MR Storage Administrator User Guide https://www.hpe.com/support/MRSA • HPE StorCLI User Guide https://www.hpe.com/support/StorCLI

Managing the HPE NS204i-u Boot Device

For more information on supported features and maintenance information for the HPE NS204i-u Boot Device, see the HPE NS204i-u Boot Device User Guide:

<https://www.hpe.com/support/NS204-UG>

Deploying an OS

For a list of supported operating systems, see the HPE Servers Support & Certification Matrices:

<https://www.hpe.com/support/Servers-Certification-Matrices>



To	See
Deploy an OS using HPE GreenLake for Compute Ops Management	HPE GreenLake for Compute Ops Management User Guide https://www.hpe.com/info/com-docs
Deploy an OS using Intelligent Provisioning	Intelligent Provisioning user guide https://www.hpe.com/info/intelligentprovisioning/docs
Deploy an OS using iLO virtual media	iLO user guide https://www.hpe.com/support/ilo6
Configure the server to boot from a PXE server	UEFI System Utilities User Guide for HPE ProLiant Gen11 Servers and HPE Synergy https://www.hpe.com/support/UEFIGen11-UG-en
Configure the server to boot from a SAN	HPE Boot from SAN Configuration Guide https://www.hpe.com/info/boot-from-san-config-guide

Configuring security

To	See
Implement server security best practices.	<ul style="list-style-type: none"> HPE Compute Security Reference Guide https://www.hpe.com/info/server-security-reference-en HPE iLO 6 Security Technology Brief https://www.hpe.com/support/ilo6-security-en
Configure and use the Server Configuration Lock feature on HPE Trusted Supply Chain servers and other servers that have the Configuration Lock feature enabled.	Server Configuration Lock User Guide for HPE ProLiant servers and HPE Synergy https://www.hpe.com/info/server-config-lock-UG-en

Optimizing the server

To	See
Optimize server performance through management and tuning features.	HPE Server Performance Management and Tuning Guide https://www.hpe.com/info/server-performance-management-tuning-en
Obtain recommendations for resolving incorrect settings.	HPE InfoSight for Servers User Guide https://www.hpe.com/support/InfoSight-for-Servers-UG-en

Server management

To monitor	See
Single server	HPE iLO https://www.hpe.com/support/ilo6
Multiple servers	HPE OneView https://www.hpe.com/support/oneview-docs
Single or multiple servers	HPE GreenLake for Compute Ops Management https://www.hpe.com/info/com-docs

Managing Linux-based high performance compute clusters

To	Use
Provision, manage, and monitor clusters.	HPE Performance Cluster Manager https://www.hpe.com/support/hpcm_manuals
Optimize your applications.	HPE Performance Analysis Tools https://www.hpe.com/info/perftools
Optimize software library for low latency and high bandwidth, both on-node and off-node, for point-to-point and collective communications.	HPE Cray Programming Environment User Guide https://www.hpe.com/info/cray-pe-user-guides

Troubleshooting

Subtopics

[NMI functionality](#)

[Troubleshooting resources](#)

NMI functionality

An NMI crash dump enables administrators to create crash dump files when a system is not responding to traditional debugging methods.

An analysis of the crash dump log is an essential part of diagnosing reliability problems, such as hanging operating systems, device drivers, and applications. Many crashes freeze a system, and the only available action for administrators is to cycle the system power. Resetting the system erases any information that could support problem analysis, but the NMI feature preserves that information by performing a memory dump before a hard reset.

To force the OS to initiate the NMI handler and generate a crash dump log, the administrator can use the iLO Generate NMI feature.

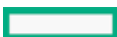

Troubleshooting resources

Troubleshooting resources are available for HPE Gen11 server products in the following documents:

- Troubleshooting Guide for HPE ProLiant Gen11 servers provides procedures for resolving common problems and comprehensive courses of action for fault isolation and identification, issue resolution, and software maintenance.

<https://www.hpe.com/info/gen11-troubleshooting>

- Integrated Management Log Messages for HPE ProLiant Gen10, Gen10 Plus, and Gen11 servers and HPE Synergy provides IML messages and associated troubleshooting information to resolve critical and cautionary IML events.

<https://www.hpe.com/info/Troubleshooting-IML-en>

System battery replacement

If the server no longer automatically displays the correct date and time, then replace the battery that provides power to the real-time clock. Under normal use, battery life is 5–10 years.

Subtopics

[System battery information](#)

[Replace the system battery](#)

System battery information

The server contains an internal lithium manganese dioxide, a vanadium pentoxide, or an alkaline battery that provides power to the real-time clock.



WARNING: If this battery is not properly handled, a risk of fire or burning exists. To reduce the risk of personal injury:

- Do not attempt to recharge the battery.
 - Do not expose the battery to temperatures higher than 60°C (140°F).
 - Do not expose the battery to low air pressure as it might lead to explosion or leakage of flammable liquid or gas.
 - Do not disassemble, crush, puncture, short external contacts, or dispose of the battery in fire or water.
-

Replace the system battery

Prerequisites

Before you perform this procedure make sure you have a small flat-bladed, nonconductive tool available.

Procedure

1. [Power down the server.](#)
2. If installed, [open the cable management arm.](#)

3. Remove all power:
 - a. Disconnect each power cord from the power source.
 - b. Disconnect each power cord from the server.
4. Disconnect all peripheral cables from the server.
5. Do one of the following:
 - a. Extend the server from the rack.
 - b. Remove the server from the rack.
6. Remove the access panel.
7. Locate the battery on the system board.
8. Use a small flat-bladed, nonconductive tool to carefully lift the front of the battery from the socket.
9. Remove the battery.

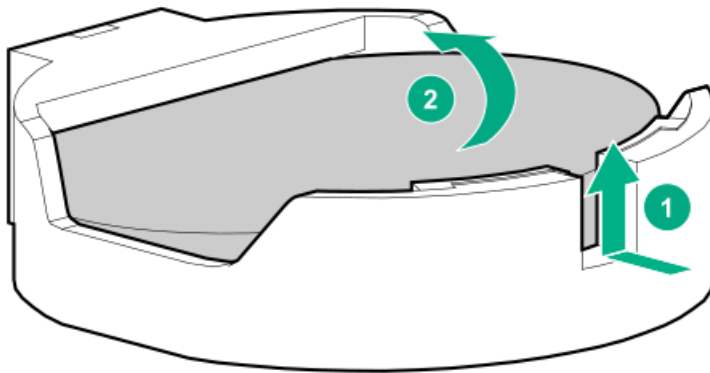

10. Install the system battery.

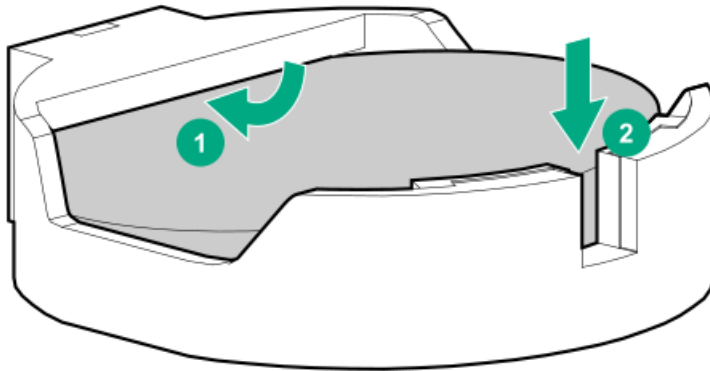

Results

For more information about battery replacement or proper disposal, contact an authorized reseller or an authorized service provider.

Subtopics

[Regulatory information](#)

[Warranty information](#)

Regulatory information

To view the regulatory information for your product, view the Safety and Compliance Information for Server, Storage, Power, Networking, and Rack Products, available at the Hewlett Packard Enterprise Support Center:

<https://www.hpe.com/support/Safety-Compliance-EnterpriseProducts>

Additional regulatory information

Hewlett Packard Enterprise is committed to providing our customers with information about the chemical substances in our products as needed to comply with legal requirements such as REACH (Regulation EC No 1907/2006 of the European Parliament and the Council). A chemical information report for this product can be found at:

<https://www.hpe.com/info/reach>

For Hewlett Packard Enterprise product environmental and safety information and compliance data, including RoHS and REACH, see:

<https://www.hpe.com/info/ecodata>

For Hewlett Packard Enterprise environmental information, including company programs, product recycling, and energy efficiency, see:

<https://www.hpe.com/info/environment>

Subtopics

[Notices for Eurasian Economic Union](#)

[Turkey RoHS material content declaration](#)

[Ukraine RoHS material content declaration](#)

Notices for Eurasian Economic Union



Manufacturer and Local Representative Information

Manufacturer information:

Hewlett Packard Enterprise Company, 1701 E Mossy Oaks Road, Spring, TX 77389 U.S.

Local representative information Russian:

- **Russia**
ООО "Хьюлетт Паккард Энтерпрайз", Российская Федерация, 125171, г. Москва, Ленинградское шоссе, 16А, стр.3, Телефон: +7 499 403 4248 Факс: +7 499 403 4677
- **Kazakhstan**
ТОО «Хьюлетт-Паккард (К)», Республика Казахстан, 050040, г. Алматы, Бостандыкский район, проспект Аль-Фараби, 77/7, Телефон/факс: + 7 727 355 35 50

Local representative information Kazakh:

- **Russia**
ЖШС "Хьюлетт Паккард Энтерпрайз", Ресей Федерациясы, 125171, Мәскеу, Ленинград тас жолы, 16А блок 3, Телефон: +7 499 403 4248 Факс: +7 499 403 4677
- **Kazakhstan**
ЖШС «Хьюлетт-Паккард (К)», Қазақстан Республикасы, 050040, Алматы қ., Бостандық ауданы, Әл-Фараби даңғылы, 77/7, Телефон/факс: +7 727 355 35 50

Manufacturing date:

The manufacturing date is defined by the serial number.

CCSYWWZZZZ (product serial number format)

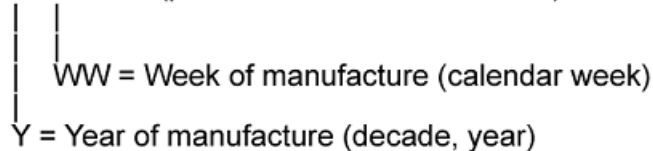

If you need help identifying the manufacturing date, contact tre@hpe.com.

Turkey RoHS material content declaration

Türkiye Cumhuriyeti: AEEE Yönetmeliğine Uygundur

Ukraine RoHS material content declaration

Обладнання відповідає вимогам Технічного регламенту щодо обмеження використання деяких небезпечних речовин в електричному та електронному обладнанні, затвердженого постановою Кабінету Міністрів України від 3 грудня 2008 № 1057

Warranty information

To view the warranty information for your product, see the [warranty check tool](#).

Specifications

Subtopics

[Environmental specifications](#)

[Mechanical specifications](#)

[Power supply specifications](#)



Environmental specifications

Specifications	Value
Temperature range*	—
Operating	10°C to 35°C (50°F to 95°F)
Nonoperating	-30°C to 60°C (-22°F to 140°F)
Relative humidity (noncondensing)	—
Operating	8% to 90% 28°C (82.4°F) maximum wet bulb temperature, noncondensing
Nonoperating	5% to 95% 38.7°C (101.7°F) maximum wet bulb temperature, noncondensing
Altitude	—
Operating	3050 m (10,000 ft) This value may be limited by the type and number of options installed. Maximum allowable altitude change rate is 457 m/min (1,500 ft/min).
Nonoperating	9144 m (30,000 ft) Maximum allowable altitude change rate is 457 m/min (1,500 ft/min).

Standard operating support

10° to 35°C (50° to 95°F) at sea level with an altitude derating of 1.0°C per every 305 m (1.8°F per every 1,000 ft) above sea level to a maximum of 3,050 m (10,000 ft), no direct sustained sunlight. Maximum rate of change is 20°C/hr (36°F/hr). The upper limit and rate of change may be limited by the type and number of options installed.

System performance during standard operating support might be reduced if operating above 30°C (86°F).

Extended ambient operating support

For approved hardware configurations, the supported system inlet range is extended to be:

- 5° to 10°C (41° to 50°F) and 35° to 40°C (95° to 104°F) at sea level with an altitude derating of 1.0°C per every 175 m (1.8°F per every 574 ft) above 900 m (2,953 ft) to a maximum of 3050 m (10,000 ft).
- 40°C to 45°C (104°F to 113°F) at sea level with an altitude derating of 1.0°C per every 125 m (1.8°F per every 410 ft) above 900 m (2,953 ft) to a maximum of 3,050 m (10,000 ft).

The approved hardware configurations for this system are listed in the Extended Ambient Temperature Guidelines for Gen11 HPE ProLiant servers:

<https://www.hpe.com/support/ASHRAEGen11>

Mechanical specifications

Specification	Value
Height	8.75 cm (3.44 in)
Depth, 24 SFF and EDSFF	64.64 cm (25.44 in)
Depth, 48 SFF	83.27 cm (32.78 in)
Depth, LFF	66.31 cm (26.11 in)
Depth, GPU	79.87 cm (31.4 in)
Width	43.47 cm (17.11 in)
Weight, 24 SFF minimum	16.78 kg (36.99 lb)
Weight, 24 SFF maximum	33.40 kg (73.63 lb)
Weight, 48 SFF minimum	20.47 kg (45.13 lb)
Weight, 48 SFF maximum	41.41 kg (91.29 lb)
Weight, LFF minimum	18.24 kg (40.21 lb)
Weight, LFF maximum	36.72 kg (80.95 lb)
Weight, EDSFF minimum	16.05 kg (35.38 lb)
Weight, EDSFF maximum	28.50 kg (62.83 lb)
Weight, GPU minimum	20.04 kg (44.18 lb)
Weight, GPU maximum	32.52 kg (71.69 lb)

Power supply specifications

Depending on the installed options and the regional location where the server was purchased, the server can be configured with one of the following power supplies. For detailed power supply specifications, see the QuickSpecs on the [Hewlett Packard Enterprise website](#).

Subtopics

[HPE 800W Flex Slot Platinum Hot-plug Low Halogen Power Supply](#)

[HPE 1600 W Flex Slot Platinum Hot-plug Low Halogen Power Supply](#)

[HPE 1600 W Flex Slot -48 VDC Hot-plug Power Supply](#)

HPE 800W Flex Slot Platinum Hot-plug Low Halogen Power Supply



Specification	Value
Input requirements	—
Rated input voltage	100 VAC to 240 VAC 240 VDC for China only
Rated input frequency	50 Hz to 60 Hz
Rated input current	9.4 A at 100 VAC 4.5 A at 200 VAC
Maximum rated input power	899 W at 100 VAC 867 W at 200 VAC
BTUs per hour	3067 at 100 VAC 2958 at 200 VAC
Power supply output	—
Rated steady-state power	800 W at 200 VAC to 240 VAC input 800 W at 240 VDC input
Maximum peak power	800 W at 100 VAC to 240 VAC input

For detailed power supply specifications, see the QuickSpecs on the [Hewlett Packard Enterprise website](#).

HPE 1600 W Flex Slot Platinum Hot-plug Low Halogen Power Supply



Specification	Value
Input requirements	—
Rated input voltage	200 VAC to 240 VAC 240 VDC for China only
Rated input frequency	50 Hz to 60 Hz
Rated input current	8.7 A at 200 VAC 7.2 A at 240 VAC
Maximum rated input power	1734 W at 200 VAC 1725 W at 240 VAC
BTUs per hour	5918 at 200 VAC 5884 at 240 VAC
Power supply output	—
Rated steady-state power	1600 W at 200 VAC to 240 VAC input 1600 W at 240 VDC input
Maximum peak power	1600 W for 1 ms (turbo mode) at 200 VAC to 240 VAC input

HPE 1600 W Flex Slot -48 VDC Hot-plug Power Supply

Specification	Value
Input requirements	—
Rated input voltage	-40 VDC to -72 VDC
Rated input frequency	DC
Nominal input current	45 A DC at -40 VDC input 36.6 A DC at -48 VDC input 24.4 A DC at -72 VDC input
Maximum Rated Input Wattage Rating	1798 W at -40 VDC input 1758 W at -48 VDC input 1755 W at -72 VDC input
BTUs per hour	6026 at -40 VDC input 6000 at -48 VDC input 5989 at -72 VDC input
Power supply output	—
Rated steady-state power	1600 W at -40 VDC to -72 VDC
Maximum peak power	1600 W at -40 VDC to -72 VDC

Websites

General websites

Single Point of Connectivity Knowledge (SPOCK) Storage compatibility matrix

<https://www.hpe.com/storage/spock>

Product white papers and analyst reports

<https://www.hpe.com/us/en/resource-library>

For additional websites, see [Support and other resources](#).

Product websites

HPE ProLiant DL385 Gen11 Server product page

<https://buy.hpe.com/us/en/gen11servers>

HPE ProLiant DL385 Gen11 Server user documents

<https://www.hpe.com/info/dl385gen11-docs>

Support and other resources

Subtopics

[Accessing Hewlett Packard Enterprise Support](#)

[HPE product registration](#)

[Accessing updates](#)

[Customer self repair](#)

[Remote support](#)

[Documentation feedback](#)

Accessing Hewlett Packard Enterprise Support

- For live assistance, go to the Contact Hewlett Packard Enterprise Worldwide website:

<https://www.hpe.com/info/assistance>

- To access documentation and support services, go to the Hewlett Packard Enterprise Support Center website:

<https://www.hpe.com/support/hpesc>

Information to collect

- Technical support registration number (if applicable)
- Product name, model or version, and serial number
- Operating system name and version
- Firmware version
- Error messages



- Product-specific reports and logs
- Add-on products or components
- Third-party products or components

HPE product registration

To gain the full benefits of the Hewlett Packard Enterprise Support Center and your purchased support services, add your contracts and products to your account on the HPESC.

- When you add your contracts and products, you receive enhanced personalization, workspace alerts, insights through the dashboards, and easier management of your environment.
- You will also receive recommendations and tailored product knowledge to self-solve any issues, as well as streamlined case creation for faster time to resolution when you must create a case.

To learn how to add your contracts and products, see <https://www.hpe.com/info/add-products-contracts>.

Accessing updates

- Some software products provide a mechanism for accessing software updates through the product interface. Review your product documentation to identify the recommended software update method.

- To download product updates:

Hewlett Packard Enterprise Support Center

<https://www.hpe.com/support/hpesc>

My HPE Software Center

<https://www.hpe.com/software/hpesoftwarecenter>

- To subscribe to eNewsletters and alerts:

<https://www.hpe.com/support/e-updates>

- To view and update your entitlements, and to link your contracts and warranties with your profile, go to the Hewlett Packard Enterprise Support Center More Information on Access to Support Materials page:

<https://www.hpe.com/support/AccessToSupportMaterials>

IMPORTANT:

Access to some updates might require product entitlement when accessed through the Hewlett Packard Enterprise Support Center. You must have an HPE Account set up with relevant entitlements.

Customer self repair

Hewlett Packard Enterprise customer self repair (CSR) programs allow you to repair your product. If a CSR part needs to be replaced, it will be shipped directly to you so that you can install it at your convenience. Some parts do not qualify for CSR.

For more information about CSR, contact your local service provider.

Remote support

Remote support is available with supported devices as part of your warranty or contractual support agreement. It provides intelligent event diagnosis, and automatic, secure submission of hardware event notifications to Hewlett Packard Enterprise, which initiates a fast and accurate resolution based on the service level of your product. Hewlett Packard Enterprise strongly recommends that you register your device for remote support.

If your product includes additional remote support details, use search to locate that information.

HPE Get Connected

<https://www.hpe.com/services/getconnected>

HPE Tech Care Service

<https://www.hpe.com/services/techcare>

HPE Complete Care Service

<https://www.hpe.com/services/complecare>

Documentation feedback

Hewlett Packard Enterprise is committed to providing documentation that meets your needs. To help us improve the documentation, use the Feedback button and icons (at the bottom of an opened document) on the Hewlett Packard Enterprise Support Center portal (<https://www.hpe.com/support/hpesc>) to send any errors, suggestions, or comments. This process captures all document information.

