

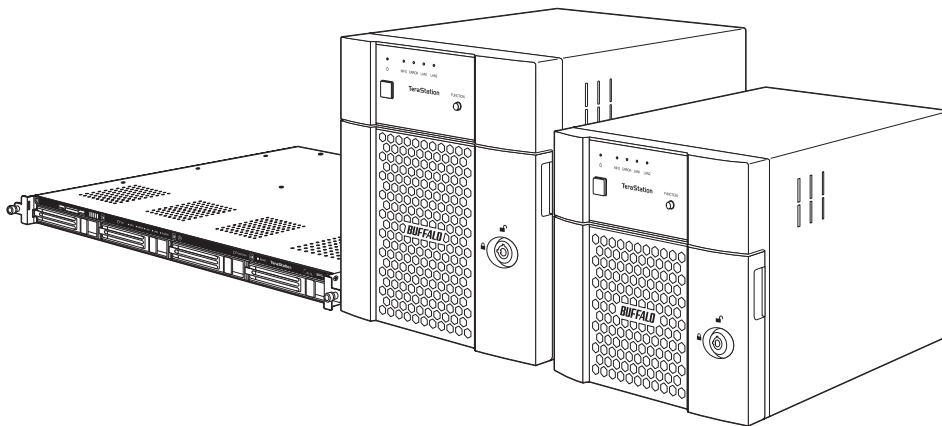

## Network Attached Storage

## TeraStation 3010/3020, TeraStation Essentials

# User Manual



TeraStation 3010	TS3210DN	TS3410DN
	TS3410RN	
TeraStation 3020	TS3220DN	TS3420DN
	TS3420RN	
TeraStation Essentials	TS3420DS	TS3420RS

Please make sure to read this manual before using and follow the procedures. If you have any inquiries about the product, contact the number on the warranty statement or the packing box. Do not discard the included documents, the warranty statement, or the packing box.

**Americas: [www.buffaloamericas.com](http://www.buffaloamericas.com)**

**Europe: [www.buffalo-technology.com](http://www.buffalo-technology.com)**

**Asia Pacific: [www.buffalo-asia.com](http://www.buffalo-asia.com)**

# Table of Contents

<b>Chapter 1 Notice .....</b>	<b>10</b>
Regulatory Compliance Information.....	10
Warning Symbols and Graphical Icons on the Product.....	11
Safety Precautions .....	11
<b>Chapter 2 Getting Started .....</b>	<b>12</b>
Diagrams.....	12
TS3010 Series TeraStations .....	12
TS3020 Series TeraStations, TeraStation Essentials .....	15
Turning the TeraStation On and Off.....	18
Creating a USB Initialization Drive .....	19
Accessing Settings .....	19
Opening Settings .....	19
Configuring Settings via Setup Wizard .....	22
Checking the Device Information from Dashboard .....	23
Shutting Down or Restarting the TeraStation from Settings .....	23
<b>Chapter 3 File Sharing .....</b>	<b>25</b>
Configuring Shared Folders .....	25
Adding a Shared Folder .....	25
Recycle Bin.....	27
Read-Only Shares.....	27
Hidden Shares .....	28
Configuring Users .....	28
Adding a User .....	28

<b>Importing User Information.....</b>	<b>31</b>
<b>Adding a Group .....</b>	<b>31</b>
<b>Configuring Access Restrictions .....</b>	<b>34</b>
<b>Restricting Local User Access to Shared Folders .....</b>	<b>34</b>
<b>Restricting AD Domain User Access to Shared Folders.....</b>	<b>36</b>
<b>Restricting Access to Subfolders .....</b>	<b>39</b>
<b>NFS .....</b>	<b>41</b>
<b>Enabling NFS .....</b>	<b>42</b>
<b>NFS Mount Commands .....</b>	<b>46</b>
<b>Offline Files for Windows.....</b>	<b>46</b>

## **Chapter 4 RAID Modes and Drive Management ..... 49**

<b>Available RAID Modes .....</b>	<b>49</b>
<b>Working with RAID Arrays .....</b>	<b>50</b>
<b>Using JBOD .....</b>	<b>50</b>
<b>Creating a RAID Array .....</b>	<b>51</b>
<b>Shutting Down the TeraStation Automatically If an Error Occurs.....</b>	<b>52</b>
<b>Configuring Actions for If a Drive Used for the RAID Array Has Not Been Detected .....</b>	<b>54</b>
<b>Configuring a Hot Spare.....</b>	<b>56</b>
<b>Managing a RAID Array Without Deleting Data .....</b>	<b>58</b>
<b>RAID Scanning.....</b>	<b>63</b>
<b>Configuring Low Drive Space Alerts .....</b>	<b>64</b>
<b>Adding an External Drive .....</b>	<b>65</b>
<b>Dismounting Drives .....</b>	<b>66</b>
<b>Using the Function Button .....</b>	<b>67</b>
<b>Using Settings .....</b>	<b>67</b>
<b>Checking Drives .....</b>	<b>68</b>

<b>S.M.A.R.T.</b> .....	<b>69</b>
<b>Displaying S.M.A.R.T. Information</b> .....	<b>69</b>
<b>Checking the Drive Condition</b> .....	<b>70</b>
<b>Formatting Drives</b> .....	<b>71</b>
<b>Encrypting Drives</b> .....	<b>72</b>
<b>Erasing Data on the TeraStation Completely</b> .....	<b>73</b>
<b>Performing a Full Format</b> .....	<b>73</b>
<b>Performing the Secure Erase Command</b> .....	<b>74</b>
<b>Quotas</b> .....	<b>75</b>
<b>Limits for Users</b> .....	<b>75</b>
<b>Limits for Groups</b> .....	<b>76</b>
<b>Limits for LVM Volumes</b> .....	<b>78</b>
<b>Using the TeraStation as an iSCSI Device</b> .....	<b>80</b>
<b>Introduction</b> .....	<b>81</b>
<b>Creating an iSCSI Volume</b> .....	<b>81</b>
<b>Connecting Volumes</b> .....	<b>83</b>
<b>Formatting Volumes</b> .....	<b>84</b>
<b>Disconnecting Volumes</b> .....	<b>85</b>
<b>Configuring Access Restrictions</b> .....	<b>85</b>
<b>Connecting Access-Restricted Volumes</b> .....	<b>88</b>
<b>Expanding Volume Capacity</b> .....	<b>89</b>
<b>Deleting Volumes</b> .....	<b>90</b>
<b>Enabling the iSNS Protocol</b> .....	<b>91</b>
<b>Advanced iSCSI Volume Settings</b> .....	<b>92</b>

## **Chapter 5 Backup .....** **94**

<b>Backing Up Data on the TeraStation</b> .....	<b>94</b>
<b>Backup Modes</b> .....	<b>94</b>

Preparing a Backup Destination.....	96
Configuring a Backup Job .....	99
If Backing Up from rsync-Compatible Devices to the TeraStation.....	101
Restoring Backup Data .....	102
Backup Logs for If Backup Fails .....	103
<b>Replication.....</b>	<b>105</b>
Preparing a Replication Destination .....	106
Configuring a Replication Job .....	108
Synchronizing Between Source and Destination TeraStations Periodically.....	111
<b>Failover .....</b>	<b>112</b>
Before Configuring Failover.....	113
Usage Restrictions .....	113
Configuring Failover .....	114
Changing Settings While Failover Is Configured.....	116
Maintenance Mode .....	117
Synchronizing Between Main and Backup TeraStations Periodically	120
Switching to the Backup TeraStation Manually.....	121
Reconfiguring After Failover Occurs .....	122
Stopping Failover.....	124
<b>Backing Up Your Mac with Time Machine .....</b>	<b>126</b>

## **Chapter 6 Cloud Services and Remote Access..... 133**

<b>Synchronizing with Amazon S3 .....</b>	<b>133</b>
Creating an Amazon S3 Job .....	133
Uploading Files to Amazon S3 .....	136
<b>Synchronizing with Box.....</b>	<b>140</b>
Creating a Box Storage Sync Job .....	140
Changing Job Settings .....	151

Corrective Actions for in Case of Error .....	154
<b>Synchronizing with Dropbox .....</b>	<b>156</b>
Creating a Dropbox Sync Job.....	156
Changing Job Settings .....	159
Creating a Shared Link (Windows Only).....	162
<b>Using Microsoft Azure for Data Preservation .....</b>	<b>162</b>
Creating an Azure Storage Sync Backup Job.....	162
Creating an Azure Storage Sync Restore Job.....	170
Changing Job Settings .....	175
<b>Synchronizing with Microsoft OneDrive .....</b>	<b>178</b>
Creating a OneDrive Sync Job.....	178
Changing Job Settings .....	189
Corrective Actions for in Case of Error .....	191
<b>WebAccess .....</b>	<b>193</b>
Configuring WebAccess.....	193
Accessing via WebAccess.....	196
Unable to Create a BuffaloNAS.com Name.....	196
<b>FTP.....</b>	<b>197</b>
Enabling FTP .....	197
Accessing the TeraStation with an FTP Client.....	199

## **Chapter 7 Security Enhancement..... 200**

<b>Two-Factor Authentication .....</b>	<b>200</b>
Enabling Two-Factor Authentication .....	200
Restricting Logins for Non-Admin Users.....	205
Disabling Two-Factor Authentication .....	207
<b>Antivirus Software .....</b>	<b>209</b>
Activating Virus Scanning .....	209

Changing the Quarantine Folder .....	210
Configuring Security Settings .....	211
Licenses .....	212
Connecting Through a Proxy Server .....	213
Updating Antivirus Pattern Files .....	214
Configuring Folders as Virus Scanning Targets .....	215
Configuring Virus Scanning .....	216
Checking the Log .....	217
Opening the Online Help .....	218
<b>Encrypting Data Transmission .....</b>	<b>219</b>
Encrypting Settings Data .....	219
Encrypting FTP Transfer Data .....	219
SSL.....	219
<b>Boot Authentication .....</b>	<b>221</b>
Notes Before Use.....	221
Important Notice .....	221
Setting Up the Authentication Server on a Windows PC .....	221
Configuring Boot Authentication on the TeraStation.....	222
If the TeraStation Cannot Be Accessed .....	224

## **Chapter 8 Settings Backup/Restoration .....** 226

<b>Saving and Applying Settings.....</b>	<b>226</b>
Saving Settings .....	227
Applying Settings .....	227
<b>Transferring Another Buffalo NAS Device's Settings .....</b>	<b>228</b>
Creating a Config File (.nas_config).....	229
Transferring Settings.....	229
<b>Restoring Factory Defaults.....</b>	<b>230</b>
Initializing from Settings .....	230

Initializing Using the USB Initialization Drive .....	231
Resetting the Administrator Password .....	232

## **Chapter 9 Network Settings ..... 234**

Wake-on-LAN .....	234
Port Trunking.....	234
SNMP .....	238
Proxy Server .....	240
Jumbo Frames .....	241
Changing the IP Address .....	242
Mapping IP Address and Hostname .....	243

## **Chapter 10 Advanced Features ..... 246**

Email Notification .....	246
Enabling Email Notification .....	246
Changing Events for Email Reports.....	247
Sleep Mode .....	248
UPS (Uninterruptible Power Supply).....	250
Logs .....	252
Displaying TeraStation's Logs .....	252
Transferring Logs to the Syslog Server .....	253
Creating a Shortcut to the Logs in the Shared Folder.....	253
Changing Archive Rules for File Access Logs.....	254
Updating the Firmware.....	255
Updating Manually Using Settings .....	255
Enabling Automatic Update.....	256



Configuring Update Notification.....	257
Name, Date, Time, and Language .....	258
Beep Alerts .....	260
LEDs.....	261

## **Chapter 11 Drive Replacement and Troubleshooting ...** **..... 263**

<b>Replacing a Defective Drive .....</b>	<b>263</b>
Drive Replacement for a Redundant RAID Array (TeraStation Is On)	264
Drive Replacement for a Redundant RAID Array (TeraStation Is Off)	266
Drive Replacement for a RAID 0 Array .....	267
Drive Replacement for a JBOD.....	268
Drive Replacement for a Hot Spare .....	268
<b>Replacing a Non-Malfunctioning Drive.....</b>	<b>269</b>
<b>Re-Inserting Drives .....</b>	<b>269</b>
<b>“Recovery needed” Appears under the “Status” Field on the RAID Array List.....</b>	<b>271</b>
<b>TeraStation Does Not Work Properly .....</b>	<b>272</b>
Power LED Keeps Blinking .....	272
Booting the TeraStation in Emergency Mode.....	274
<b>Unable to Access Shared Folders .....</b>	<b>274</b>
Opening the Network Credentials Window .....	274
Restoring Owner and Permission Settings .....	275
<b>Cleaning the Dustproof Filter .....</b>	<b>277</b>

## **Chapter 12 Utilities..... 279**

<b>NAS Navigator2.....</b>	<b>279</b>
----------------------------	------------

Windows .....	279
macOS .....	279
<b>NovaBACKUP .....</b>	<b>279</b>

**Chapter 13 Appendix ..... 280**

<b>Info and Error LEDs .....</b>	<b>280</b>
<b>Errors.....</b>	<b>280</b>
<b>Notices .....</b>	<b>281</b>
<b>Information Events .....</b>	<b>282</b>
<b>Default Settings .....</b>	<b>284</b>
<b>Specifications .....</b>	<b>285</b>
<b>TeraStation 3010 Models.....</b>	<b>285</b>
<b>TeraStation 3020 and TeraStation Essentials Models .....</b>	<b>286</b>

# Chapter 1 Notice

---

## Regulatory Compliance Information

---

### For Customers in the United States

This device complies with Part 15 of the FCC Rules. Operation is subject to the following two conditions: (1) this device may not cause harmful interference, and (2) this device must accept any interference received, including interference that may cause undesired operation.

**Note:** This equipment has been tested and found to comply with the limits for a Class A digital device, pursuant to part 15 of the FCC Rules. These limits are designed to provide reasonable protection against harmful interference when the equipment is operated in a commercial environment. This equipment generates, uses, and can radiate radio frequency energy and, if not installed and used in accordance with the instruction manual, may cause harmful interference to radio communications. Operation of this equipment in a residential area is likely to cause harmful interference in which case the user will be required to correct the interference at his own expense.

### For Customers in Europe

Warning: This is a class A product. In a domestic environment this product may be cause radio interference in which case the user may be required to take adequate measures.

This product may cause interference if used in residential areas. Such use must be avoided unless the user takes special measures to reduce electromagnetic emissions to prevent interference to the reception of radio and television broadcasts.

### Environmental Information



- The equipment that you have purchased has required the extraction and use of natural resources for its production.
- The equipment may contain hazardous substances that could impact health and the environment.
- In order to prevent the dissemination of those substances into the environment, and to relieve pressure on natural resources, we encourage you to seek out an appropriate take-back program. Take-back programs will reuse or recycle materials of any end-of-life equipment in a responsible way.
- Products with the crossed-out wheeled-bin symbol above should not be recycled. Instead, seek out a take-back program as mentioned.
- If you need more information on the collection, reuse, and recycling of our end-of-life products, please contact your local or regional waste administration.

### For Customers in Taiwan





#### BSMI

警告使用者：

此為甲類資訊技術設備，於居住環境中使用時，可能會造成射頻擾動，在此種情況下，使用者會被要求採取某些適當的對策。

## Warning Symbols and Graphical Icons on the Product

Warning symbols are used on the product for safety operation and prevention of injury to you and damage to the unit. The following explains the meanings of symbols used on the product.

	This symbol indicates important warnings or cautions for operation and maintenance. Additional information will follow this symbol.
	This symbol indicates the presence of an alternating current.
	This symbol indicates that the rack-mounted equipment should not be used for a shelf or a work space.
	This symbol indicates danger of hazardous high voltage.

## Safety Precautions

Before using your device, basic safety instructions should always be followed.

- (1) Read these instructions.
- (2) Keep these instructions.
- (3) Heed all warnings and follow all instructions.
- (4) The socket-outlet shall be installed near the equipment and shall be easily accessible.
- (5) Only use the cables and accessories that are included in the package. Don't use other accessories or cables unless specifically instructed to in the documentation. Also, do not use USB cables that are 3 meters or longer to connect USB devices.
- (6) The device can only be used in a fixed location, such as a telecommunication center or a dedicated computer room. When you install the device, ensure that the protective earthing connection of the socket-outlet is verified by a technician.

Translation to Norwegian:

Utstyr som er koplet til beskyttelsesjord via nettplugg og/eller via annet jordtilkoplet utstyr – og er tilkoplet et kabel-TV nett, kan forårsake brannfare. For å unngå dette skal det ved tilkopling av utstyret til kabel-TV nettet installeres en galvanisk isolator mellom utstyret og kabel-TV nettet.

Translation to Swedish:

Utrustning som är kopplad till skyddsjord via jordat vägguttag och/eller via annan utrustning och samtidigt är kopplad till kabel-TV nät kan i vissa fall medföra risk för brand. För att undvika detta skall vid anslutning av utrustningen till kabel-TV nät galvanisk isolator finnas mellan utrustningen och kabel-TV nätet.

# Chapter 2 Getting Started

The procedures in this manual correspond to firmware version 5.82 and later. To read the manual for older firmware versions installed on your TeraStation, click *View Manual* from Settings.

## Diagrams

Depending on the number or type of drives in the unit, the model name will be different. Check the sticker on the packing box for your unit's model name.

### TS3010 Series TeraStations

#### TS3210DN

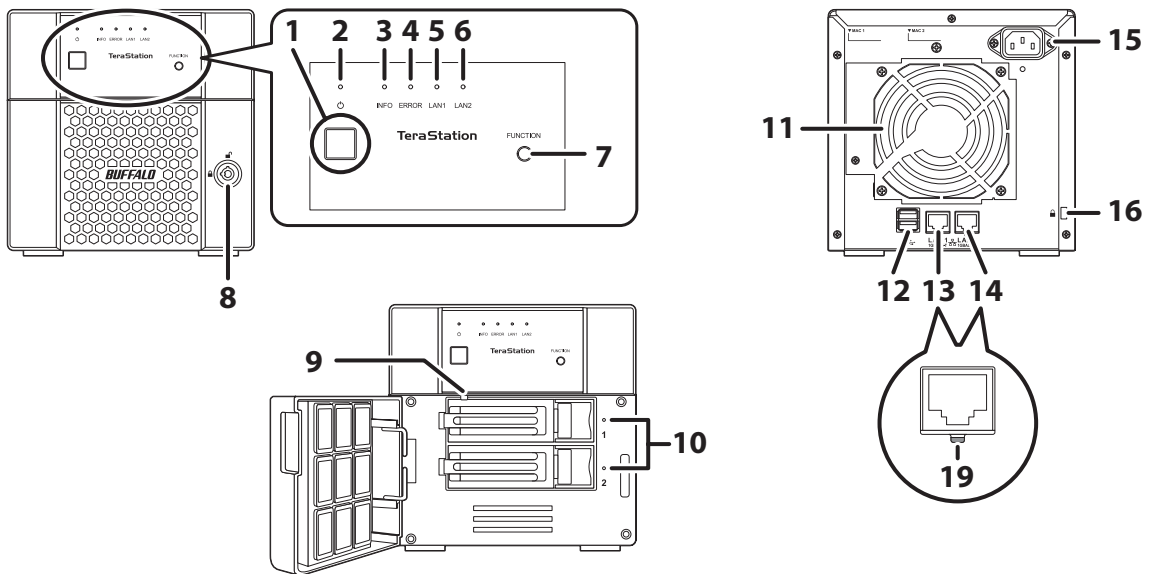

## TS3410DN

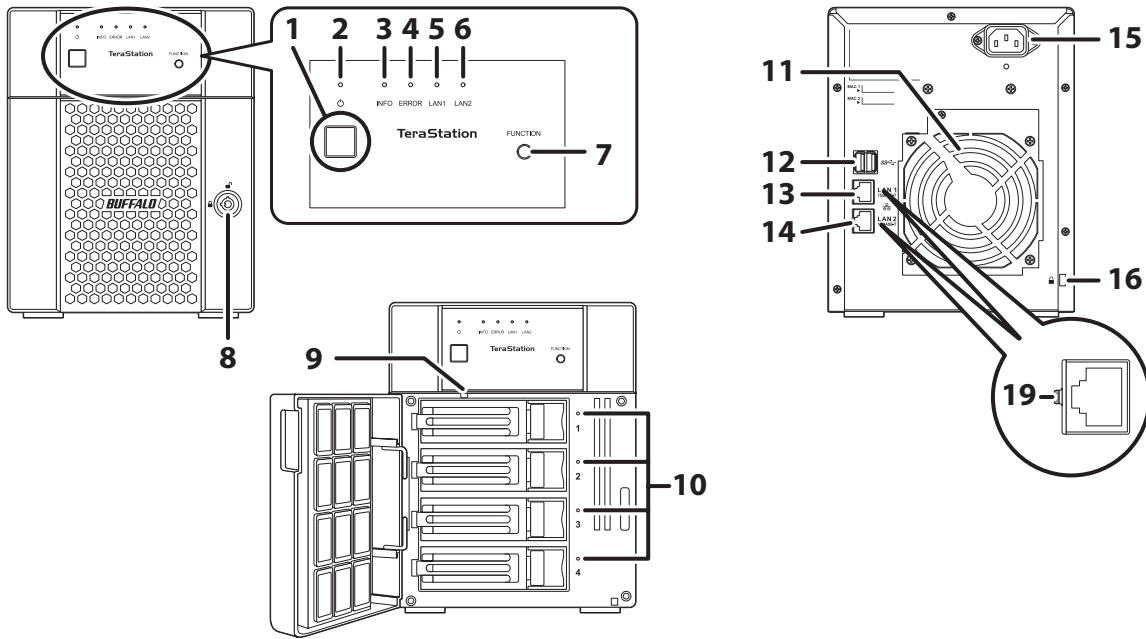

## TS3410RN

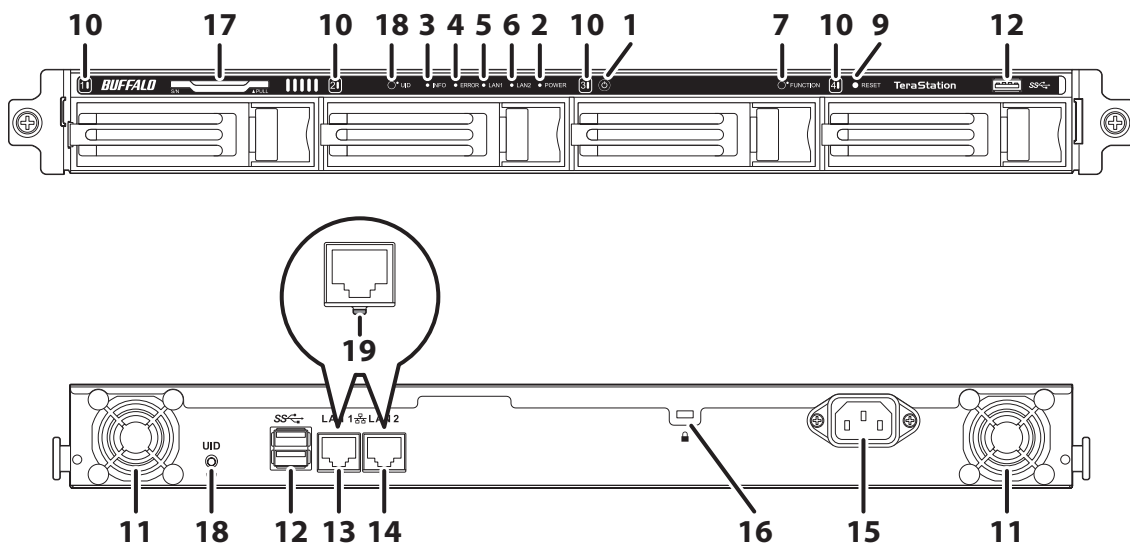

### 1 Power Button (⏻)

To power on the TeraStation, connect the power cable and wait for 10 seconds, then press the power button. To power off the TeraStation, press and hold down the power button for three seconds. If the TeraStation beeps, pressing and holding this button for a short period will stop the beeping.

### 2 Power LED

For the TS3210DN and TS3410DN TeraStation models, the LED glows green when the TeraStation is on. For the TS3410RN TeraStation model, the LED glows white when the TeraStation is on.

**Note:** If the LED continues to blink for longer than 15 minutes instead of turning into a solid glow, refer to the [“Power LED Keeps Blinking”](#) section in chapter 11 for more details.

### 3 Info LED

If there is a status message, the info LED will light up amber. Check the Settings interface or NAS Navigator2 to see the status message.

**4** Error LED

If there is an error, the error LED will light up red. Check the Settings interface or NAS Navigator2 to see the error message.

**5** LAN1 LED

When LAN port 1 is connected, this LED glows green and blinks when the connection is experiencing activity.

**6** LAN2 LED

When LAN port 2 is connected, this LED glows green and blinks when the connection is experiencing activity.

**7** Function Button

Use this button for dismounting USB devices, rebuilding RAID arrays, configuring failover, stopping the TeraStation's beeping, and initializing settings using a USB drive.

**8** Drive Lock (   )

Open the front panel with the key to replace drives or access the init button.

**9** Init Button

Press and hold down this button to initialize the TeraStation's admin username and password, two-factor authentication settings, IP settings, SSL, and service port restriction settings to their factory default values. The effects of this button can be changed in Settings.

During initialization, the TeraStation will beep and the I23 message will appear as a notification. When initialization finishes, the I23 message will disappear.

**10** Status LEDs

Normally, these LEDs blink green when drives are accessed. If a drive fails, its LED will turn red.

**11** Fan

Spins to prevent overheating inside. Do not block the fan.

**12** USB Port (  )

Compatible USB drives, USB memory devices, and USB UPS devices can be connected. USB hubs are not supported.

**13** LAN Port 1 (1GbE, )

Connect an Ethernet cable to use this port for your network. It is available for communicating at max. 1000 Mbps.

**14** LAN Port 2 (1GbE, )

Connect an Ethernet cable to use this port for your network. It is available for communicating at max. 1000 Mbps.

**15** Power Connector

Use the included power cable to connect to a UPS, surge protector, or outlet.

**16** Anti-Theft Security Slot (  )

Use this slot to secure your TeraStation with a cable lock (not included).

**17** Serial Number

This sticker shows the TeraStation's serial number.

**18** UID Button

Press this button to cycle the blue LED on and off.

## 19 Link LED

Glows green when the TeraStation is connected to a network.

# TS3020 Series TeraStations, TeraStation Essentials

### TS3220DN

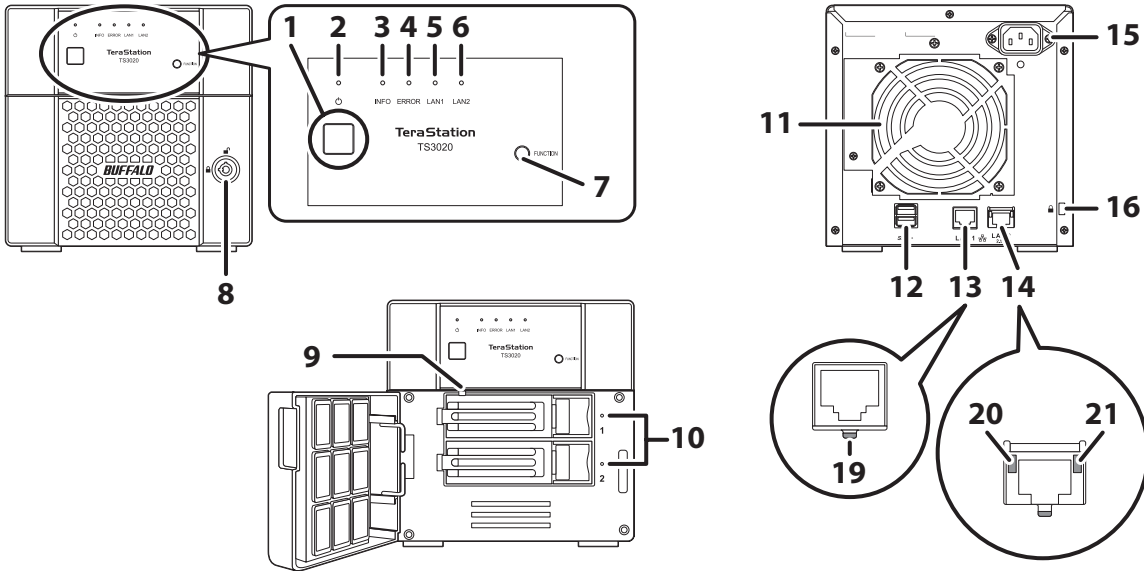

### TS3420DN

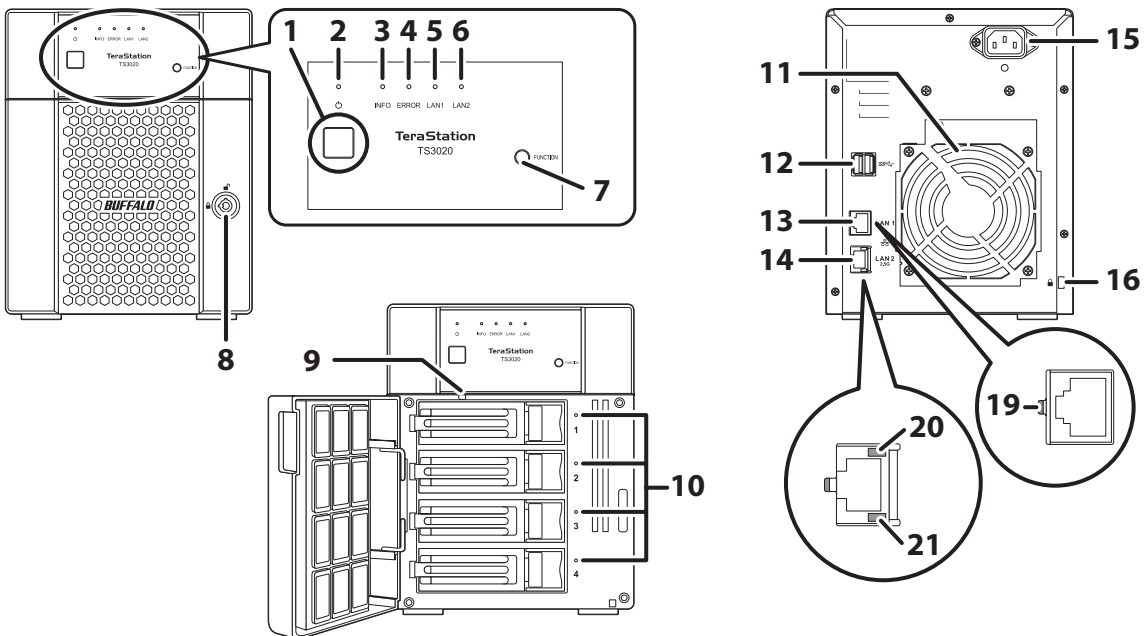



### TS3420DS

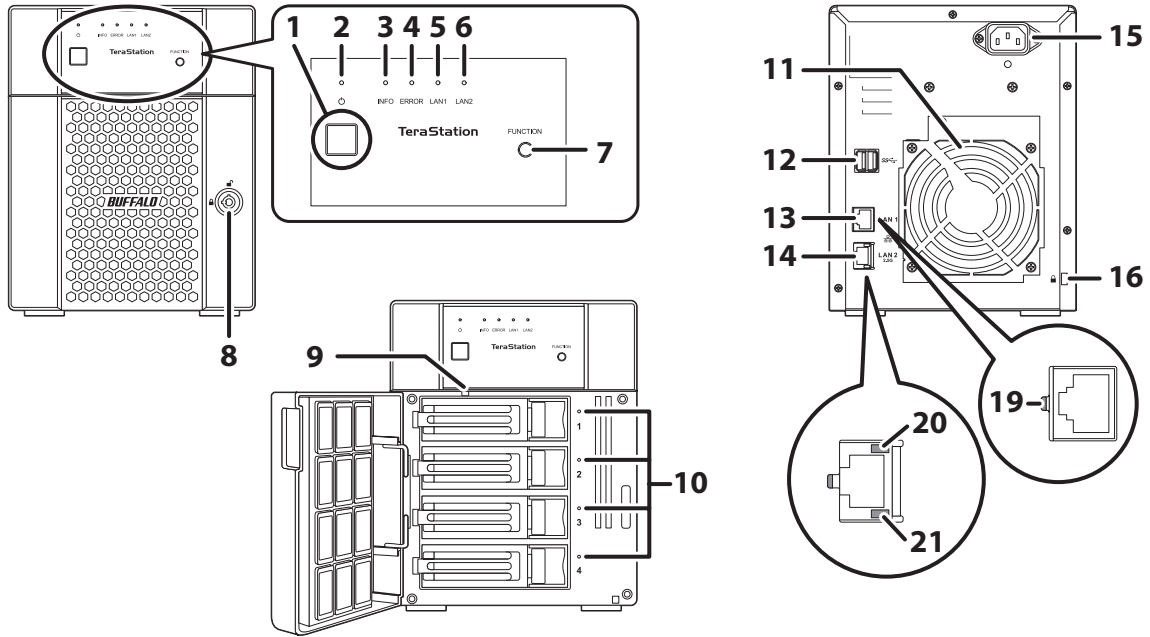

### TS3420RN

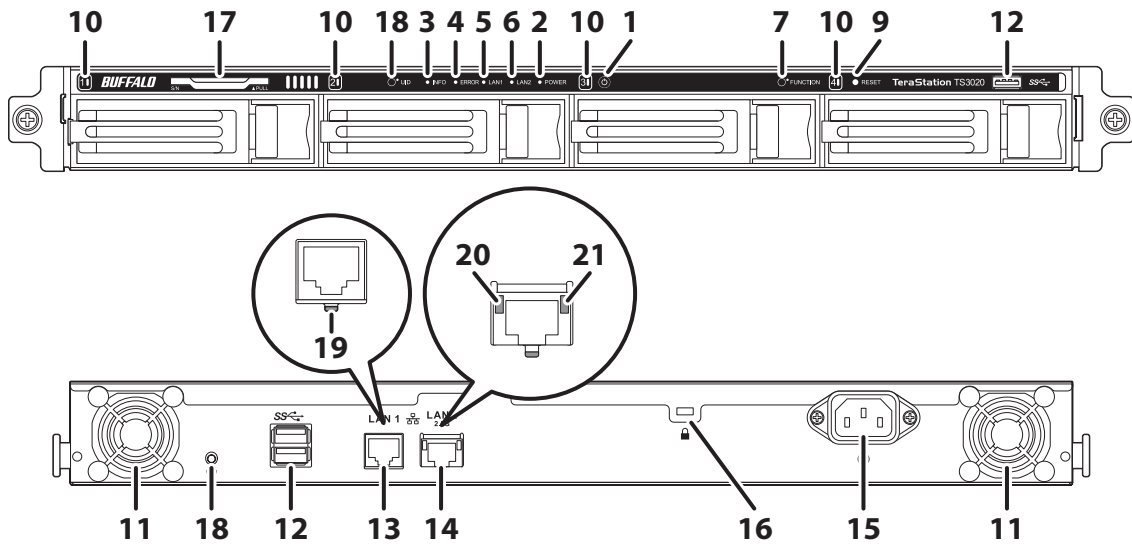

## TS3420RS

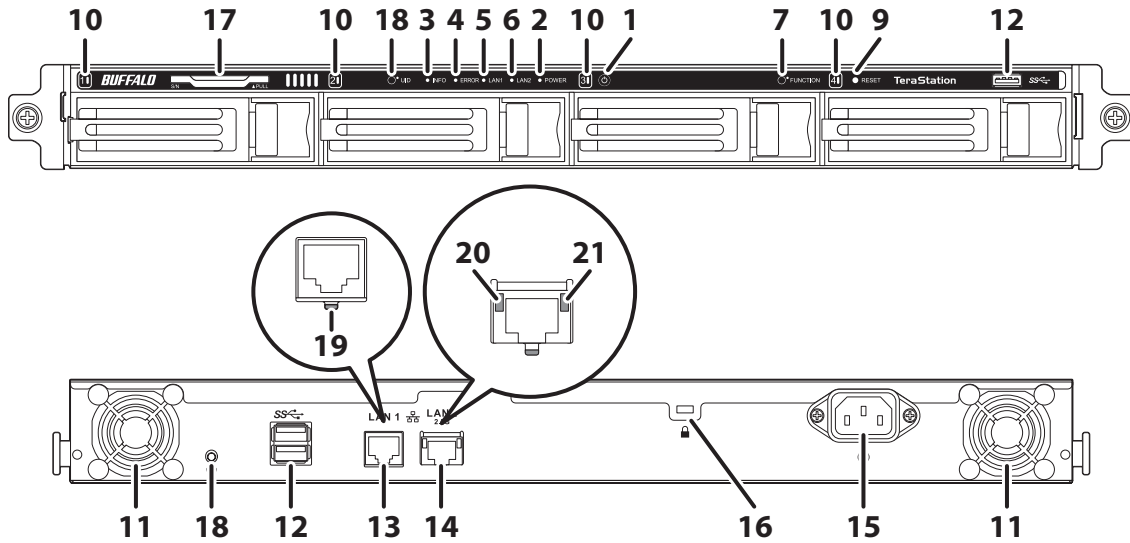

### 1 Power Button

To power on the TeraStation, connect the power cable and wait for 10 seconds, then press the power button. To power off the TeraStation, press and hold down the power button for three seconds. If the TeraStation beeps, pressing and holding this button for a short period will stop the beeping.

### 2 Power LED

For the TS3220DN, TS3420DN, and TS3420DS TeraStation models, the LED glows green when the TeraStation is on. For the TS3420RN and TS3420RS TeraStation models, the LED glows white when the TeraStation is on.

**Note:** If the LED continues to blink for longer than 15 minutes instead of turning into a solid glow, refer to the [“Power LED Keeps Blinking”](#) section in chapter 11 for more details.

### 3 Info LED

If there is a status message, the info LED will light up amber. Check the Settings interface or NAS Navigator2 to see the status message.

### 4 Error LED

If there is an error, the error LED will light up red. Check the Settings interface or NAS Navigator2 to see the error message.

### 5 LAN1 LED

When LAN port 1 is connected, this LED glows green and blinks when the connection is experiencing activity.

### 6 LAN2 LED

When LAN port 2 is connected, this LED glows green and blinks when the connection is experiencing activity.

### 7 Function Button

Use this button for dismounting USB devices, rebuilding RAID arrays, configuring failover, stopping the TeraStation’s beeping, and initializing settings using a USB drive.

### 8 Drive Lock

Open the front panel with the key to replace drives or access the init button.

## 9 Init Button

Press and hold down this button with something pointed to initialize the TeraStation's admin username and password, two-factor authentication settings, IP settings, SSL, and service port restriction settings to their factory default values. The effects of this button can be changed in Settings.

During initialization, the TeraStation will beep and the I23 message will appear as a notification. When initialization finishes, the I23 message will disappear.

## 10 Status LEDs

Normally, these LEDs blink green when drives are accessed. If a drive fails, its LED will turn red.

## 11 Fan

Spins to prevent overheating inside. Do not block the fan.

## 12 USB Port

Compatible USB drives, USB memory devices, and USB UPS devices can be connected. USB hubs are not supported.

## 13 LAN Port 1 (1GbE)

Connect an Ethernet cable to use this port for your network. It is available for communicating at max. 1000 Mbps.

## 14 LAN Port 2 (2.5GbE)

Connect an Ethernet cable to use this port for your network. It is available for communicating at max. 2.5 Gbps if using the included Ethernet or category 6A cable.

**Note:** To communicate at up to 2.5 Gbps, all network devices must be compatible with 2.5GbE.

## 15 Power Connector

Use the included power cable to connect to a UPS, surge protector, or outlet.

## 16 Anti-Theft Security Slot

Use this slot to secure your TeraStation with a cable lock (not included).

## 17 Serial Number

This sticker shows the TeraStation's serial number.

## 18 UID Button

Press this button to cycle the blue LED on and off.

## 19 Link/Act LED

Glow green when the TeraStation is connected to a network. It blinks when the connection is experiencing activity.

## 20 Link/Act LED

Glow amber when the TeraStation is connected to a network at 100 Mbps or 2.5 Gbps. It blinks when the connection is experiencing activity.

## 21 Link/Act LED

Glow green when the TeraStation is connected to a network at 1000 Mbps. It blinks when the connection is experiencing activity.

---

## Turning the TeraStation On and Off

---

Press the power button on the TeraStation to turn it on.

To turn off the TeraStation, press and hold down the power button for three seconds. When the power LED turns off, the shutdown process is finished.

Don't unplug the power cable without powering the TeraStation off first.

**Note:** Do not disconnect or reconnect the internal drives while turning the TeraStation on or off.

You can also shut down or restart the TeraStation remotely from Settings. For the detailed procedure, refer to the [“Shutting Down or Restarting the TeraStation from Settings”](#) section below.

---

## Creating a USB Initialization Drive

---

We recommend creating a USB initialization drive as soon as possible. This USB drive can be used to initialize the TeraStation's settings to its factory default values or recover the system if your TeraStation encounters an error that prevents the unit from booting. For the detailed procedure, refer to the [“Creating a USB Initialization Drive”](#) subsection in chapter 8.

---

## Accessing Settings

---

Configure and manage your TeraStation using the Settings interface, accessible from a browser window. Open the interface using the appropriate procedure below or type the TeraStation's IP address into the URL field of your browser.

**Note:** Microsoft Edge, Firefox, Google Chrome, Internet Explorer 9 or later, and Safari 9 or later are supported. If you have difficulty viewing Settings, check the following:

- If there are a large number of registered users, groups, or shared folders, use another browser instead of Internet Explorer.
- If you have a proxy server enabled in the browser settings, configure the exception settings for Settings or disable the proxy server.
- With Internet Explorer, set security to *Local intranet*. On Windows Server operating systems, higher-level security is configured by default. Set the security to a lower level temporarily.

---

## Opening Settings

---

- 1 Double-click the NAS Navigator2 icon (  ) to start NAS Navigator2.

- 2** Right-click your TeraStation's icon and select *Open Settings*. For macOS, select the TeraStation's icon while holding down the control key, then select *Open Settings*.

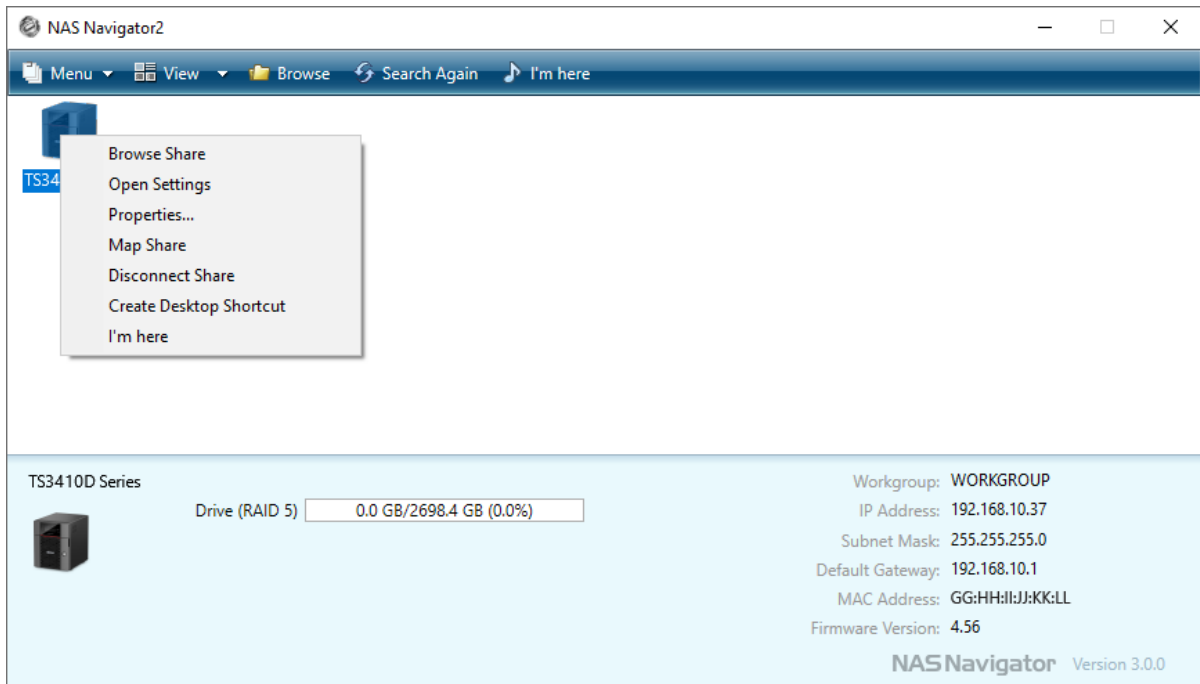

- 3** Enter the username and password, then click *OK*.

The screenshot shows the Buffalo login screen. At the top is the "BUFFALO" logo in red. Below it is a text input field containing "admin". Underneath is a checkbox labeled "Log in as a different user". Below that is a password input field containing "Password". Under the password field is the "Time-Out Period" section with two radio buttons: "10 minutes" (selected) and "Unlimited". At the bottom is a large blue "OK" button. Below the "OK" button is a link labeled "Secure Connection".

**Notes:**

- If the time-out period is set to "10 minutes", you will be logged out of Settings after 10 minutes of inactivity.
- Click *Secure Connection* to log in using an encrypted connection. For detailed information about encrypted connections, refer to the "[Encrypting Data Transmission](#)" section in chapter 7.

**4** If you did not enable two-factor authentication, skip to step 5. Otherwise, refer to the authenticator app on your mobile device for the verification code. Enter the verification code and click *OK*.

**Note:** For detailed information about two-factor authentication, refer to the [“Two-Factor Authentication”](#) section in chapter 7.

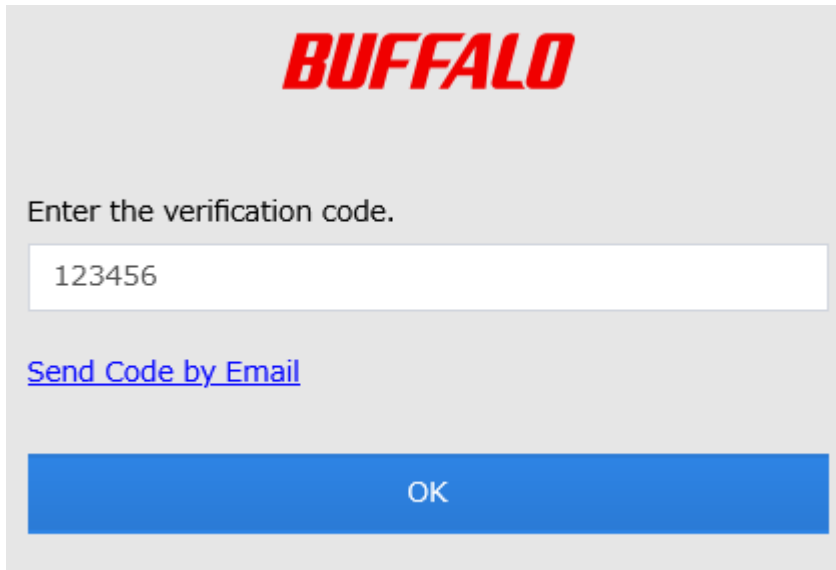

**5** The process is complete when Settings is opened.

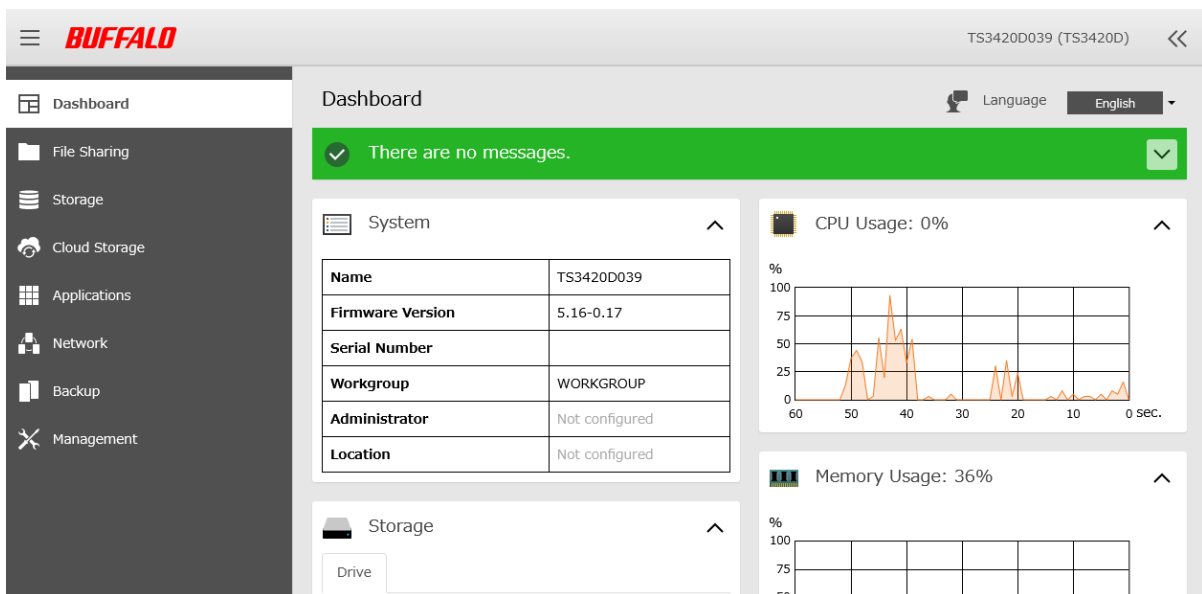

**Notes:**

- Username/Password Combinations:

Username	Password	Settings Available
admin (default)	password (default)	All
guest	blank	Guest user information
Your username	Your password	If a user is assigned as an administrator, all settings are available. If assigned to a power users group, creating or editing shared folders, users, and groups is available. If assigned to a general users group, only changing the password of logged-in users is available.

- Click  at the top-right of Settings and choose *I'm here* to have the TeraStation beep so it can be located easily.

## Configuring Settings via Setup Wizard

When you access Settings for the first time, or after initializing the TeraStation's settings, the setup wizard will automatically appear to help you configure several TeraStation settings, such as RAID mode and proxy server settings.

An example screen of the setup wizard is displayed below. Step through the wizard to configure any desired settings. If there is any setting you would like to configure later, click *Skip* to move to the next setup wizard screen, or click *Cancel* to exit the wizard. You may run the setup wizard at a later time after initial setup, or after system initialization.

### Example of Setup Wizard Screen

Change Administrator Password

---

**Change the administrator password.**  
For security reasons, please enter a new admin password below.

Show entered password

Password:  

Enter the password again to confirm.

Password (Confirm):

To launch the setup wizard at a later time, follow the procedure below.

- 1 From Settings, click *Management*.

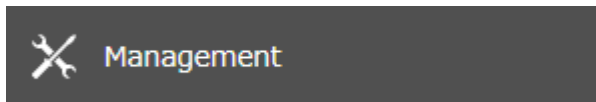

- 2 Click the settings icon (  ) to the right of "Restore/Erase".



- 3 Click *Execute Wizard*.

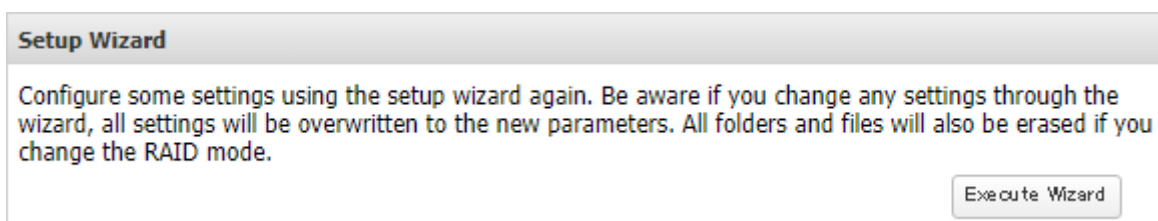

- 4 The "Confirm Operation" screen will open. Enter the confirmation number, then click *OK*.
- 5 Follow the procedure on the screen and finish the setup wizard.
- 6 The process is complete once you close the wizard.

## Checking the Device Information from Dashboard

When opening the Settings interface, the Dashboard page will appear first. Dashboard will show the following device information:

- Notices, such as information events and errors
- System information, such as hostname, firmware version, IP address, etc.
- Drive information, such as used space of internal drives, LVM volumes, iSCSI volumes, etc.
- CPU and system memory usage
- Network information, such as IP address, link speed, sent and received rates, etc.

The screenshot shows the Buffalo TeraStation Dashboard for device TS3420D039. The interface includes a sidebar with navigation options: Dashboard, File Sharing, Storage, Cloud Storage, Applications, Network, Backup, and Management. The main content area displays a 'System' section with the following information:

Name	TS3420D039
Firmware Version	5.16-0.17
Serial Number	
Workgroup	WORKGROUP
Administrator	Not configured
Location	Not configured

Below the system information, there are sections for 'Storage' (with a 'Drive' dropdown) and performance metrics. The 'CPU Usage' section shows 0% usage with a line graph over a 60-second period. The 'Memory Usage' section shows 36% usage with a bar chart.

### Notes:

- If the number of files on the TeraStation increases, it will also increase the memory usage of the TeraStation. This memory usage will decrease after a certain period of time passes. To reduce the memory usage immediately, try the following operations:
  - Restarting the TeraStation.
  - Dismounting the USB drive.
- If there is not enough free space on the TeraStation, it may cause abnormal system behavior. Make sure that there is always at least 1 GB or more of free space on the TeraStation.
- You can click the *Clear* button to delete any messages from the Dashboard.

## Shutting Down or Restarting the TeraStation from Settings

You can shut down or restart the TeraStation remotely. Follow the procedure below to remotely shut down or restart the TeraStation from Settings.

- 1 Log in to Settings using NAS Navigator2.



**2** Click  at the top-right of Settings and choose *Shut Down* or *Restart*.

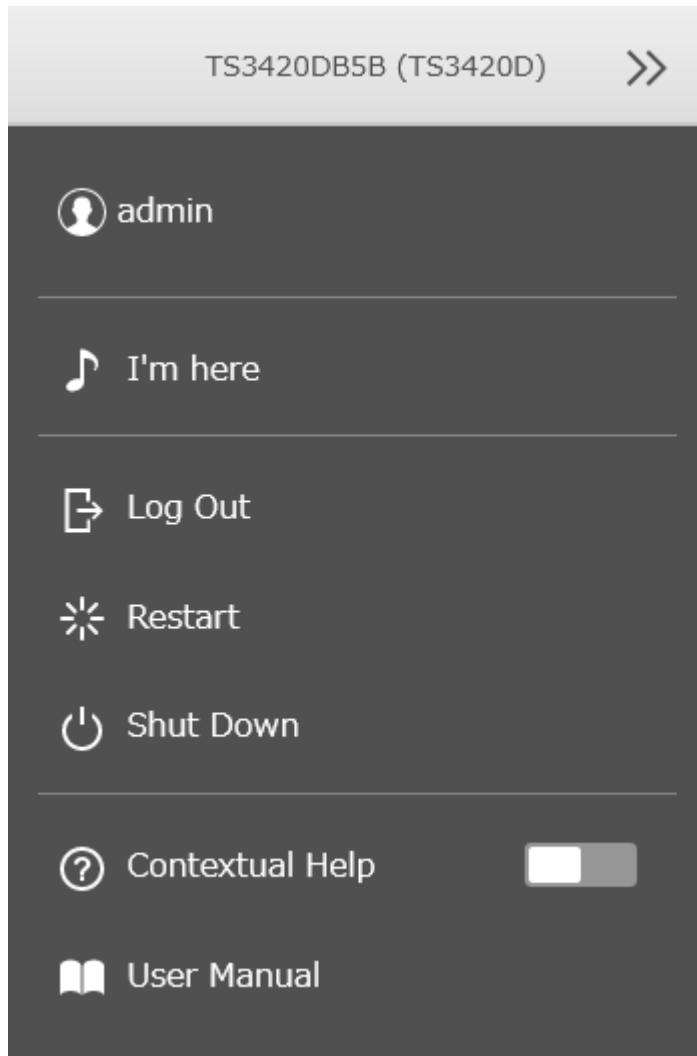

**3** Click *Yes*.

**4** The "Confirm Operation" screen will open. Enter the confirmation number, then click *OK*.

**5** The process is complete when the power LED is extinguished if you shut down, or turns from blinking to glowing if you restart.

# Chapter 3 File Sharing

You can create users and groups to access the shared folders on the TeraStation and configure access restrictions to limit access to key data.

## Configuring Shared Folders

### Adding a Shared Folder

1 From Settings, click *File Sharing*.

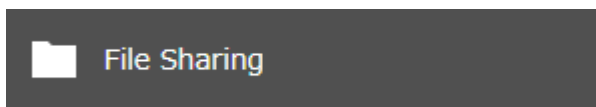

2 Click the settings icon (  ) to the right of "Folder Setup".



3 Click *Create Folder*.

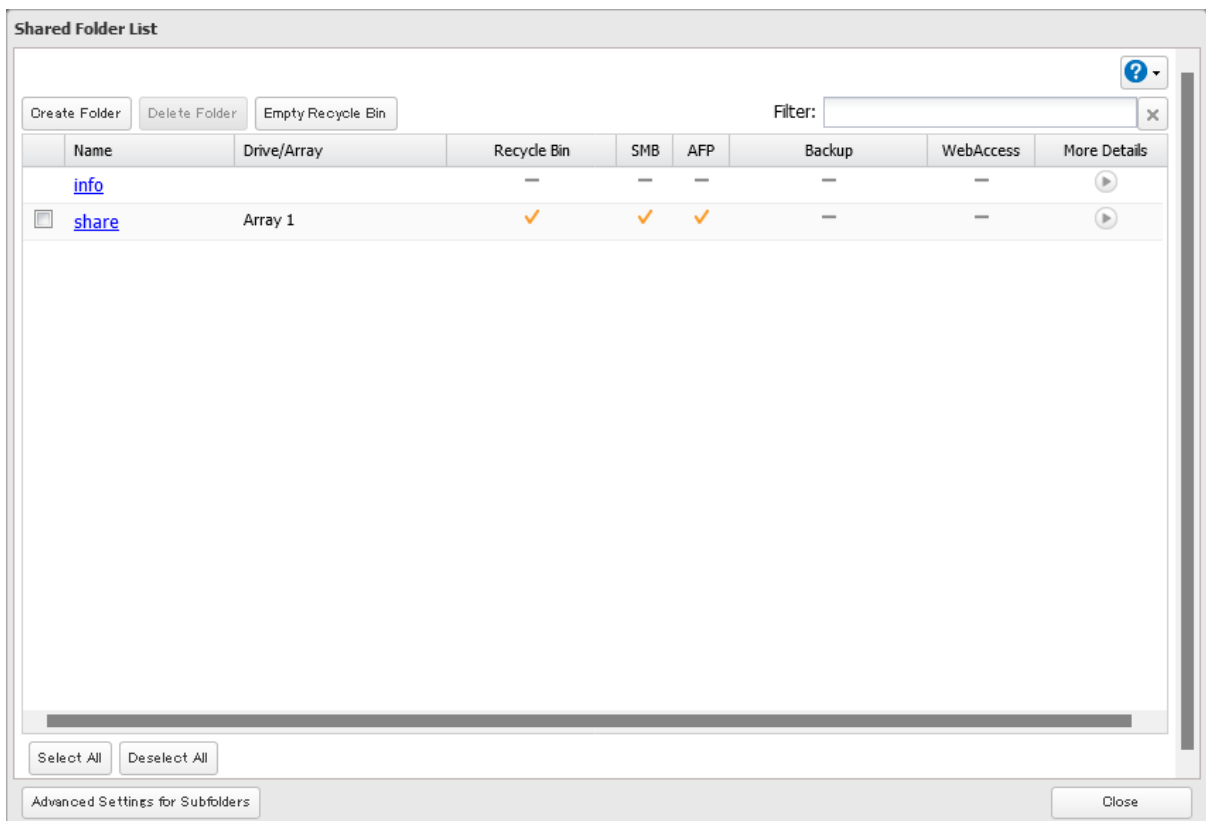

#### 4 Configure the desired settings, then click *OK*.

**Shared Folder Settings** \*Required ?

**Basic** | Option 1 | Option 2 | Access Restrictions

Copy Settings from:

Name \* :

Drive/Array:

Recycle Bin:  Enable  Disable

LAN Protocol Support:  SMB (Windows/Mac)  AFP (Mac)

FTP  Backup

SFTP  WebAccess

NFS

— NFS Path \_\_\_\_\_

OK Cancel

#### 5 The process is complete once you close the confirmation window that appears.

##### Notes:

- Names may contain up to 27 alphanumeric characters, hyphens (-), and underscores (\_). Multibyte characters are supported. The first character should not be a symbol.
- When you click the *Option 1* tab, you can enter the folder description. Descriptions may contain up to 75 alphanumeric characters, hyphens (-), underscores (\_), and spaces. Multibyte characters are supported. The first character should not be a space.
- You may create up to 400 shared folders.
- If the names of shared folders accessed via AFP and FTP connections contain multibyte characters, configure the client language in *Management > Name/Time/Language* to match the characters. If the setting and display language do not match, the shared folder name will not be displayed correctly.
- The following characters are handled differently by macOS and Windows devices. Avoid using these characters when sharing data between macOS and Windows devices:  
— ~ // - ¢ £ ¬
- Windows does not support some characters that macOS and the TeraStation allow. If you create a filename on a macOS device that includes any of the following symbols, it will not display correctly on a Windows computer. You may have to connect to the TeraStation via AFP in order to display or copy files that contain these symbols in their filenames.  
? ] [ / \ = + > < ; : " , | \*
- Do not use any of the following words for the name of a shared folder as these words are reserved for internal use by the TeraStation: authtest, global, homes, info, lost+found, lp, msdfs\_root, mt-daapd, printers, ram, spool, usbdisk x (where “x” is a number, for example: usbdisk1)



**Notes:**

- Configure the share attribute only through Settings. Configuring folder attributes through Windows is not supported and may cause unexpected behavior.
- To set a read-only share or USB drive to another attribute, follow the procedure above and change the attribute in step 2 from “Read only” to the desired attribute.

## Hidden Shares

---

If a shared folder becomes hidden, it will not be displayed under Network, and only certain users will be allowed to access it. To hide a shared SMB folder, follow the procedure below.

- 1** From Settings, navigate to *File Sharing > Folder Setup* and choose a shared folder to make hidden.
- 2** Click the *Option 2* tab and select the “Hidden share (SMB only)” checkbox, then click *OK*.
- 3** The process is complete once you close the confirmation window that appears.

**Notes:**

- If protocols other than “SMB (Windows/Mac)” or “Backup” under “LAN Protocol Support” on the *Basic* tab are enabled, the hidden shares option will be grayed out and cannot be selected.
- Configure hidden share attributes only through Settings. Configuring them through Windows is not supported and may cause unexpected behavior.

To access a hidden folder, open File Explorer in your computer and enter “\\TeraStation name\shared folder name\$” into the address bar. For example, if the TeraStation name is “TSXXX001” and the shared folder name is “share”, enter “\\TSXXX001\share\$” to open it.

---

## Configuring Users

---

### Adding a User

---

**Note:** You may add up to 300 users, which include the default users “admin” and “guest”.

- 1** From Settings, click *File Sharing*.

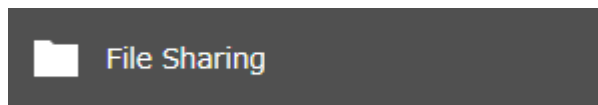

- 2** Click the settings icon (⚙️) to the right of “Users”.



### 3 Click *Create User*.

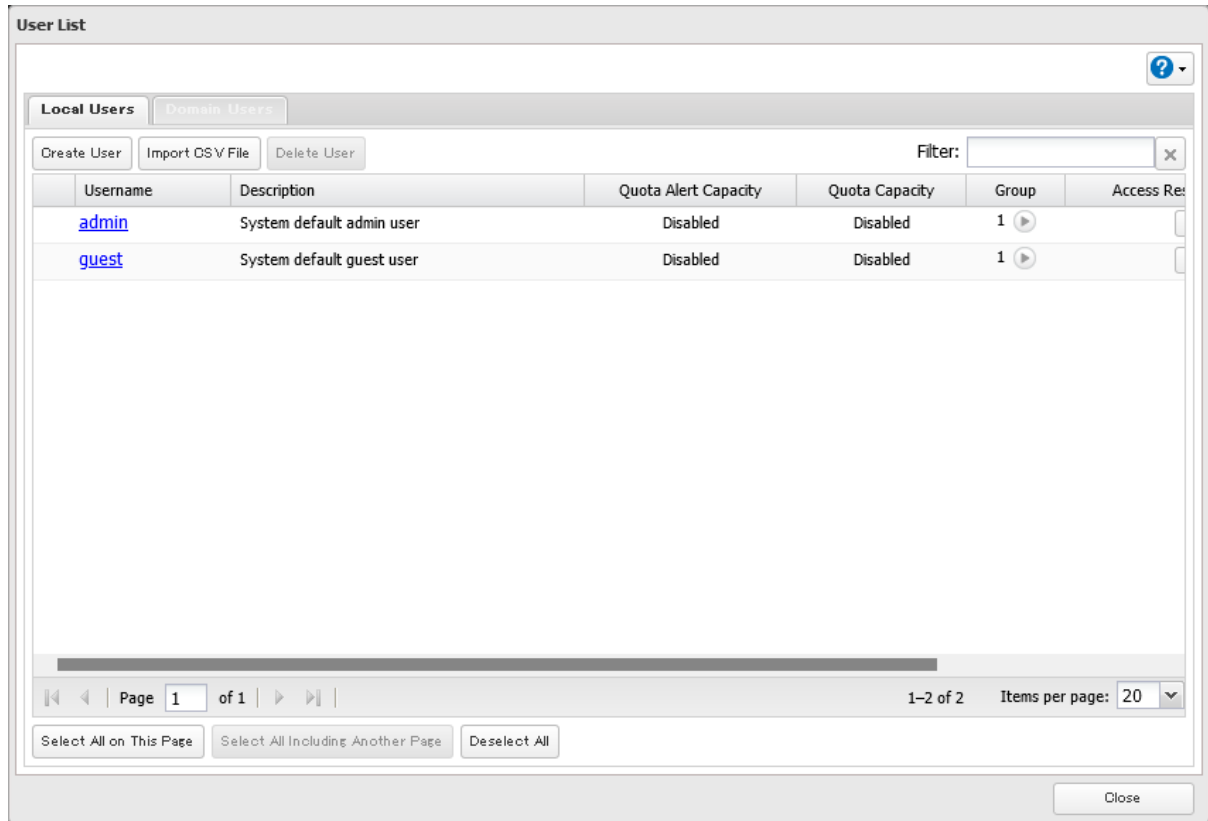

#### 4 Enter the desired settings, then click *OK*.

**User Settings**

**Username: \***

**User ID:**  
Enter a number between 1000 and 1999.

**Email Address:**

**Password: \***

**Password (Confirm): \***

**Description:**

**Quota:**

Enable (Units: GB)

Quota Alert Capacity: 1

Quota Capacity: 1

**Filter:**

Group
<input checked="" type="checkbox"/> hdusers
<input type="checkbox"/> admin

Select All Deselect All

**Primary Group:**  
hdusers

OK Cancel

#### 5 The process is complete once you close the confirmation window that appears.

##### Notes:

- Usernames may contain up to 128 alphanumeric characters, hyphens (-), underscores (\_), periods (.), and the symbols ! # & @ \$ \* ^ %. The first character should not be a symbol.
- The user ID should be a number from 1000 to 1999. Each user ID should be unique. If this field is left blank, a user ID is assigned automatically.
- Do not duplicate user IDs, group IDs, usernames, or group names. Each should be distinct and unique.
- User descriptions may contain up to 75 alphanumeric characters, hyphens (-), underscores (\_), and spaces. Multibyte characters are supported. The first character should not be a symbol or space.
- Passwords may contain up to 20 alphanumeric characters, hyphens (-), underscores (\_), spaces, commas (,), periods (.), semicolons (;), tildes (~), and the symbols ! # & @ \$ \* ^ % + : = ? [ ] { } \. The first character should not be a symbol unless it is an underscore.
- Use the same username and password for both Windows and the TeraStation or you may be unable to access shared folders.
- Do not use a name already in use as a group name; do not use any of the following words as a username as these words are reserved for internal use by the TeraStation: \_lldpd, adm, admin, administrator, admins, all, apache, avahi, avahi-autoipd, backup, bin, crontab, daemon, dialout, dip, disk, ftp, ftpuser, fuse, gnats, guest, guests, halt, hdusers, irc, kmem, libuuid, list, lp, mail, man, messagebus, mysql, netdev, news, nobody, nogroup, none, ntp, openldap, operator, plugdev, proftpd, proxy, puppet, root, rpc, rpcuser, sambashare, sasl, shadow, shutdown,

snmp, splx, src, ssh, sshd, staff, statd, sudo, sync, syslog, tmhttpd, tty, users, utmp, uucp, winbindd\_priv, www, www-data

## Importing User Information

---

You can import users in *File Sharing > Users* by clicking *Import CSV File*.

An example format for user data: Username (required), password (required), and user description (optional).

Example 1: Importing usernames, passwords, and comments

```
username1,password1,comment1
username2,password2,comment2
username3,password3,comment3
```

Example 2: Importing usernames and passwords

```
username1,password1,
username2,password2,
username3,password3,
```

### Guidelines:

- Use commas (,) as separators. Do not put spaces before or after commas. If you don't want user descriptions, use a comma after the password at the end.
- If a line is in an incorrect format, the username entered on that line will not be registered.
- If an unavailable name is used by a user or if the username already exists, an error will occur and cancel the import process. User whose usernames were entered during or after the error occurs will not be imported.
- Do not use commas (,) in the username, password, or user description.

**Note:** Imported users are added to the "hdusers" group automatically.

---

## Adding a Group

---

**Note:** You may add up to 300 groups.

- 1 From Settings, click *File Sharing*.

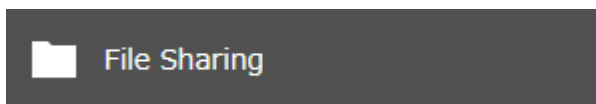

- 2 Click the settings icon (  ) to the right of "Groups".





**3** Click *Add Group*.

The screenshot shows a 'Group List' window with a tabbed interface. The 'Local Groups' tab is active. At the top, there are buttons for 'Add Group' and 'Delete Group', and a search filter box. Below this is a table with columns for Group Name, Description, Quota Alert Capacity, Quota Capacity, and Users. The table lists three groups: 'hdusers', 'admin', and 'guest'. At the bottom of the window, there is a pagination bar showing 'Page 1 of 1', '1-3 of 3', and 'Items per page: 20'. There are also buttons for 'Select All on This Page', 'Select All Including Another Page', and 'Deselect All', and a 'Close' button at the bottom right.

Group Name	Description	Quota Alert Capacity	Quota Capacity	Users
<a href="#">hdusers</a>	System default gene...	Disabled	Disabled	0
<a href="#">admin</a>	System default admi...	Disabled	Disabled	1 ▶
<a href="#">guest</a>	System default gues...	Disabled	Disabled	1 ▶

#### 4 Enter the desired settings, then click *OK*.

**Group Settings**

**Group Name: \*** \*Required ?

**Group ID:**  
Enter a number between 1000 and 1999.

**Group Privileges:**  
General users

Select a recipient for group notifications:

User (with email address configured)  
Disabled

Email address

**Description:**

**Quota:**  
 Enable (Units: GB)  
Quota Alert Capacity: 1

**Filter:**

Username	
<input checked="" type="checkbox"/>	admin

Select All Deselect All

OK Cancel

#### 5 The process is complete once you close the confirmation window that appears.

#### Notes:

- Group names may contain up to 20 alphanumeric characters, hyphens (-), underscores (\_), and periods (.). The first character should not be a symbol.
- Group descriptions may contain up to 75 alphanumeric characters, hyphens (-), underscores (\_), and spaces. Multibyte characters are supported. The first character should not be a symbol or space.
- If the group ID field is left blank, a group ID is automatically assigned. Use numbers between 1000 and 1999 to set a group ID manually. Don't use duplicate group IDs.
- If you are logged in as an administrator, you can change any setting, including other users' passwords. If you are logged in as a member of the power users group, you can create and edit shared folders, users, and groups. If you are logged in as a member of the general users group, you can only change your own password.
- Do not use a name in use as a username; do not use any of the following words as a group name as these words are reserved for internal use by the TeraStation: \_lldpd, adm, admin, administrator, admins, all, apache, avahi, avahi-autoipd, backup, bin, crontab, daemon, dialout, dip, disk, ftp, ftpuser, fuse, gnats, guest, guests, halt, hdusers, irc, kmem, libuuid, list, lp, mail, man, messagebus, mysql, netdev, news, nobody, nogroup, none, ntp, openldap, operator, plugdev, proftpd, proxy, puppet, root, rpc, rpcuser, sambashare, sasl, shadow, shutdown, snmp, splx, src, ssh, sshd, staff, statd, sudo, sync, syslog, tmhttpd, tty, users, utmp, uucp, winbindd\_priv, www, www-data

## Configuring Access Restrictions

You may restrict access for specific shared folders, including external USB drives.

### Notes:

- Configure access restrictions only through Settings. Configuring access restrictions through Windows is not supported and may cause unexpected behavior.
- Shared folders with limited access can still be used as backup destinations.
- If you grant both read-only and read and write access to the users or groups, the attributes will become as below:

	Group with read and write access	Group with read-only access	Group with no access
User with read and write access	R/W	R	R/W
User with read-only access	R	R	R
User with no access	R/W	R	-

R/W: Read and write, R: Read-only, -: No access

- If you change access restrictions for a user or group while they are accessing files, unexpected behavior may occur.

## Restricting Local User Access to Shared Folders

- 1 From Settings, click *File Sharing*.

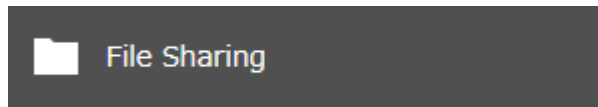

- 2 Click the settings icon (⚙️) to the right of "Folder Setup".



**3** Click the shared folder that you want to set access restrictions for.

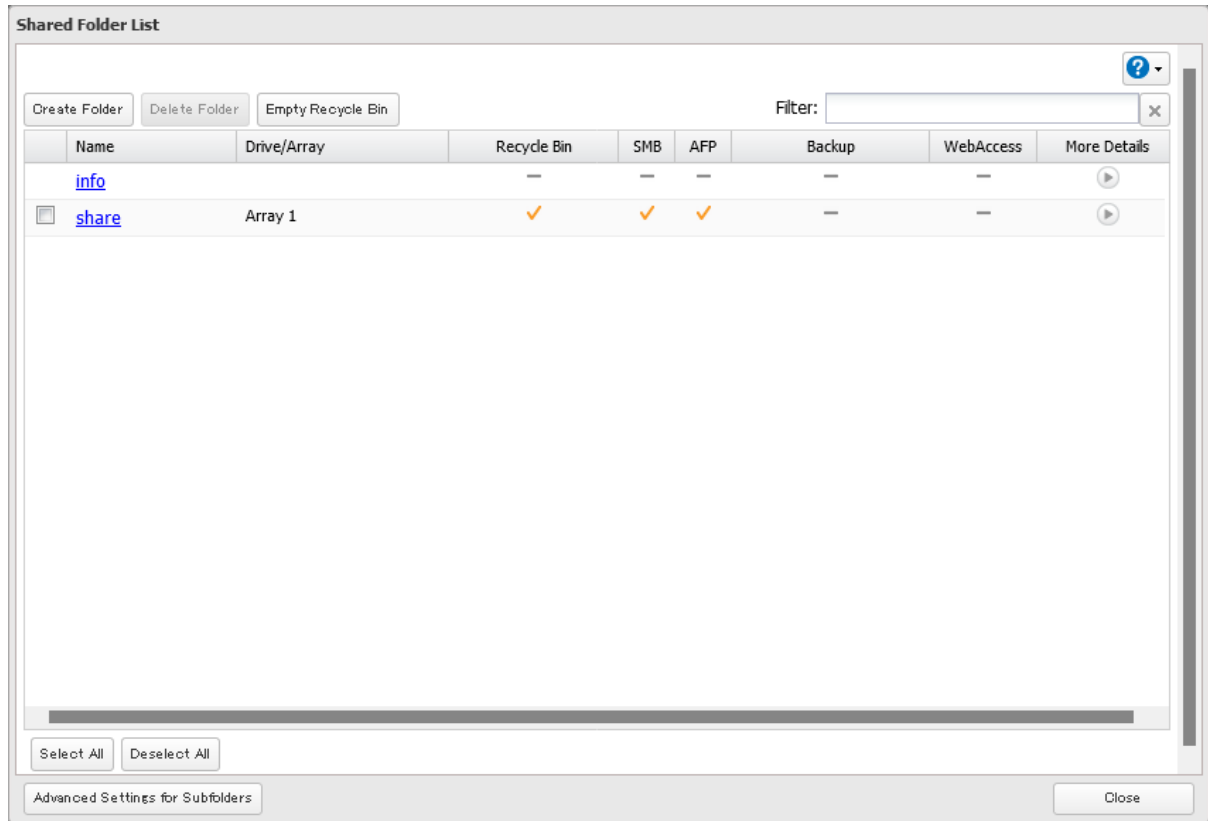

**4** Click the *Access Restrictions* tab, then enable "Access Restrictions for Shared Folders".

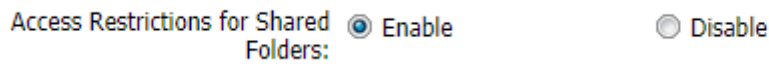

**5** Select the level of access for the user or group and click *OK*.

: Read and write    : Read-only    : No access



**Note:** The example above shows access restrictions by users. To restrict access by group, click the *Local Groups* tab and select group permissions.

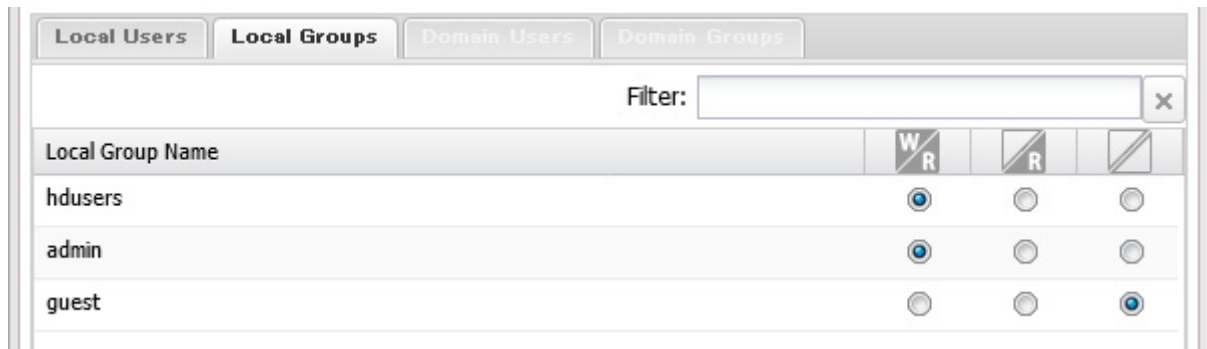

**6** The process is complete once you close the confirmation window that appears.

**Note:** For an access-restricted shared folder, if you change the access restrictions of all users and groups from read and write or read-only to access prohibited from the user or group list page in Settings, that shared folder can only be accessed by admin users and groups.

## Restricting AD Domain User Access to Shared Folders

If there is an Active Directory environment, the TeraStation will use account information from the Active Directory domain controller to set access restrictions for shared folders on the TeraStation. There is no need to perform individual account management for the TeraStation. If multiple TeraStations are installed on the network, the account information will be centrally managed in Active Directory, greatly reducing the operations required for installation and management.

### Notes:

- If usernames or group names from Active Directory include multibyte characters, you will not be able to configure access restrictions for them.
- The TeraStation supports an Active Directory domain environment with a maximum of 10,000 users and groups total.

**1** From Settings, click *Network*.



**2** Click the settings icon (  ) to the right of "Workgroup/Domain".



**3** Click *Edit* and select “Active Directory”, then click *Next*.

**Workgroup/Domain Settings**

Authentication Method

Workgroup

Active Directory

Next Cancel

**4** Enter the domain controller information and click *Search*. The domain controller on the same network will be detected and required settings will be populated into each field automatically. Alternatively, you can also manually enter the settings.

**Active Directory Domain Settings**

\*Required ?

Detect Domain Controller :  Search  
(IP Address, DNS Name, or Computer Name)

NetBIOS Name \* :

DNS Name \* :

Domain Controller Name \* :   
(Computer Name)

Administrator Name \* :

Administrator Password \* :

WINS Server IP Address:

Configure domain controller as an NTP server

OK Cancel

**5** If there is a difference of more than five minutes between the TeraStation’s clock and the domain controller’s clock, joining the domain or authenticating domain users and groups may fail. For best results, select “Configure domain controller as an NTP server” if the domain controller can function as the NTP server.

**6** Click *OK*.

**7** From Settings, click *File Sharing*.

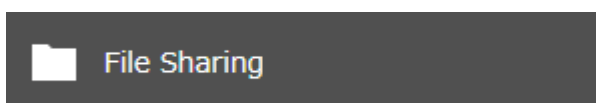

8 Click the settings icon (  ) to the right of “Folder Setup”.



9 Click the shared folder that you want to set access restrictions for.

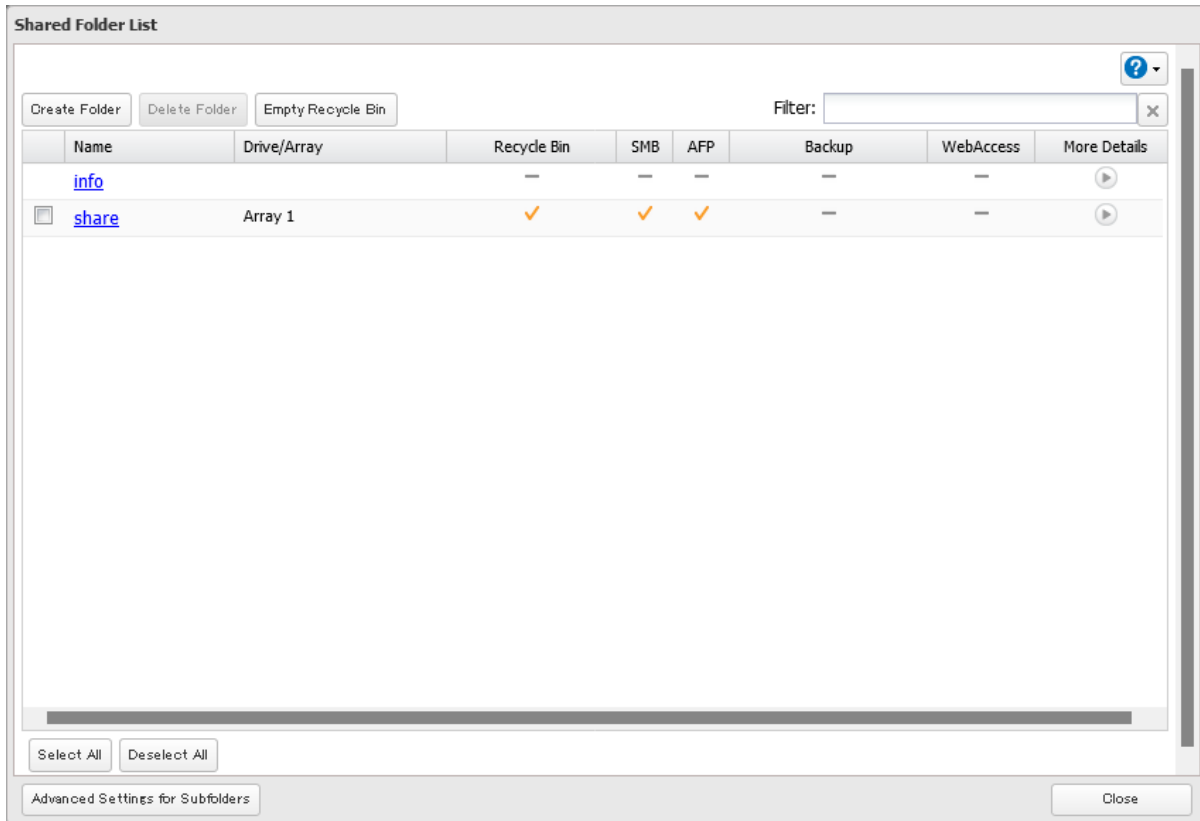

10 Click the *Access Restrictions* tab, then enable “Access Restrictions for Shared Folders”.

Access Restrictions for Shared Folders:  Enable  Disable

11 Select the level of access for the user or group and click *OK*.

 : Read and write    : Read-only    : No access

12 The process is complete once you close the confirmation window that appears.

#### Notes:

- To have the TeraStation join an Active Directory domain, configure it to use a DNS server that can resolve names for the Active Directory domain.
- After building an Active Directory domain, the administrator password for joining the domain must be changed at least once, or joining the Active Directory domain will fail.
- The DNS name and NetBIOS name of Active Directory domains should be identical.
- If the TeraStation is a member server of an Active Directory domain, you cannot connect as a guest user via AFP.
- If your TeraStation is a member server in an Active Directory domain and you change the authentication method to “Workgroup”, the account on the domain controller will not be deleted automatically.
- If FTP is enabled, local and domain group access restrictions from the AD network will not work. Use user access restrictions instead.

- For an access-restricted shared folder, if you change the access restrictions of all users and groups from read and write or read-only to access prohibited from the user or group list page in Settings, that shared folder can only be accessed by admin users and groups.
- If you allow read and write or read-only access for most users, group access restrictions are recommended.
- Depending on the domain controller's policy settings, the domain controller may force the TeraStation to leave the Active Directory domain. If this occurs, the TeraStation will lose the domain users and groups so if you have configured access restrictions using domain accounts, these users will no longer be able to access shared folders. In such a case, change the policy settings on the domain controller or let the TeraStation join the Active Directory domain again.
- If there is a local user with the same name as a domain user, access restrictions may not work properly.

## Restricting Access to Subfolders

---

You may restrict access to subfolders in shared folders by configuring access permissions from your computer using Windows File Explorer.

### Notes:

- Depending on the environment, the function may not work properly when enabled. We recommend verifying the functionality before using.
- Access permissions configuring from File Explorer is available for up to 18 files and 24 folders. This number of available access permissions may vary if access permissions are inherited from the parent object.

There is a limited number of available access permissions, so using group access permissions is recommended if the permission level is the same for multiple users; this will preserve the number of available access permissions.

- 1 From Settings, click *File Sharing*.

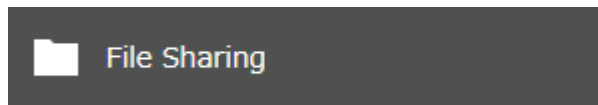

- 2 Click the settings icon (  ) to the right of "Folder Setup".





**3** Click the shared folder that you want to set access restrictions for.

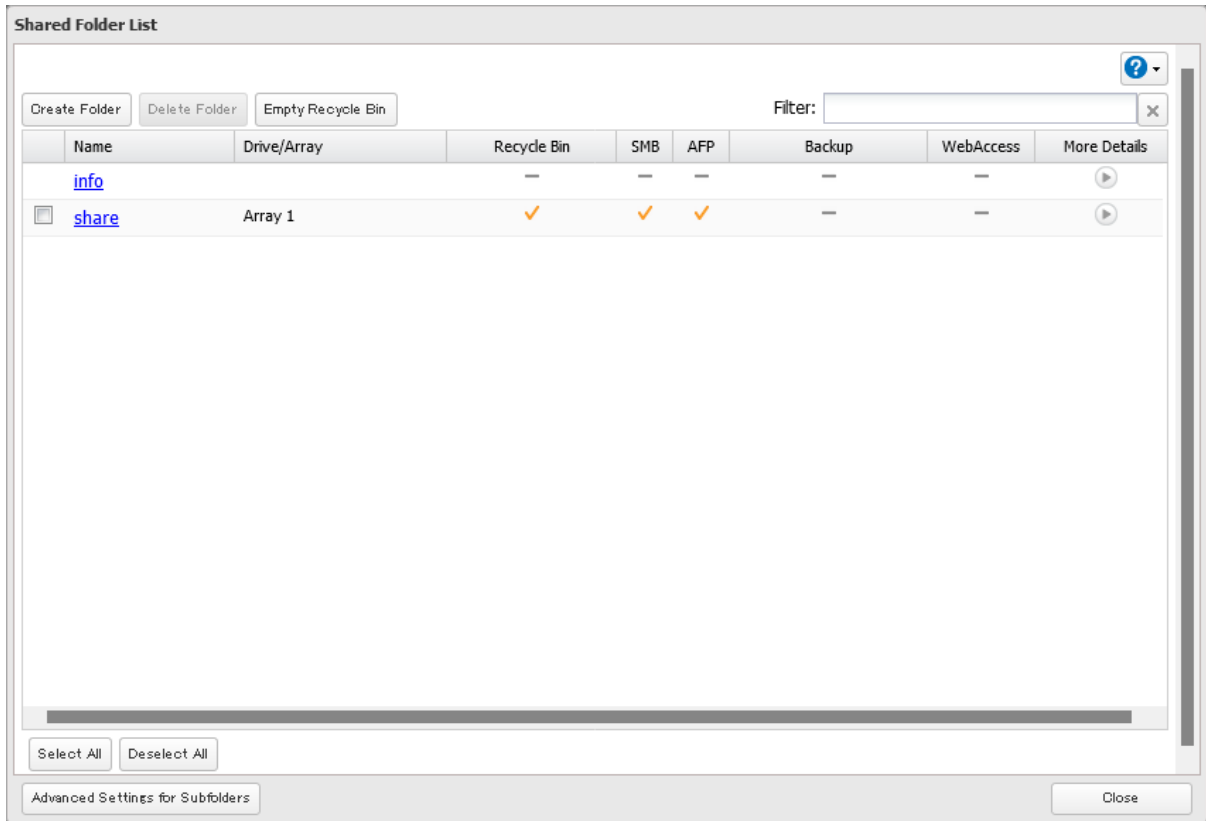

**4** If any or all of the “AFP”, “FTP”, and “SFTP” checkboxes for “LAN Protocol Support” are selected, clear them all.

**5** Click the *Option 2* tab. Enable “Access Restrictions for Subfolders” and click *OK*.

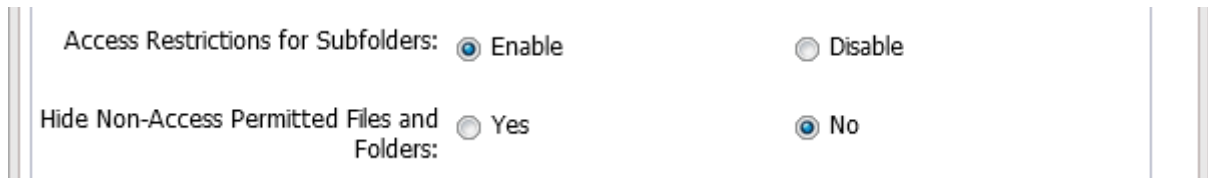

**Note:** If “Hide Non-Access Permitted Files and Folders” is enabled, non-access permitted sub-files and folders will not be displayed in shared folders.

**6** The process is complete once you close the confirmation window that appears.

Enabling subfolders’ access restrictions finished. Next, configure access permissions for each user or group to files and folders in subfolders from File Explorer.

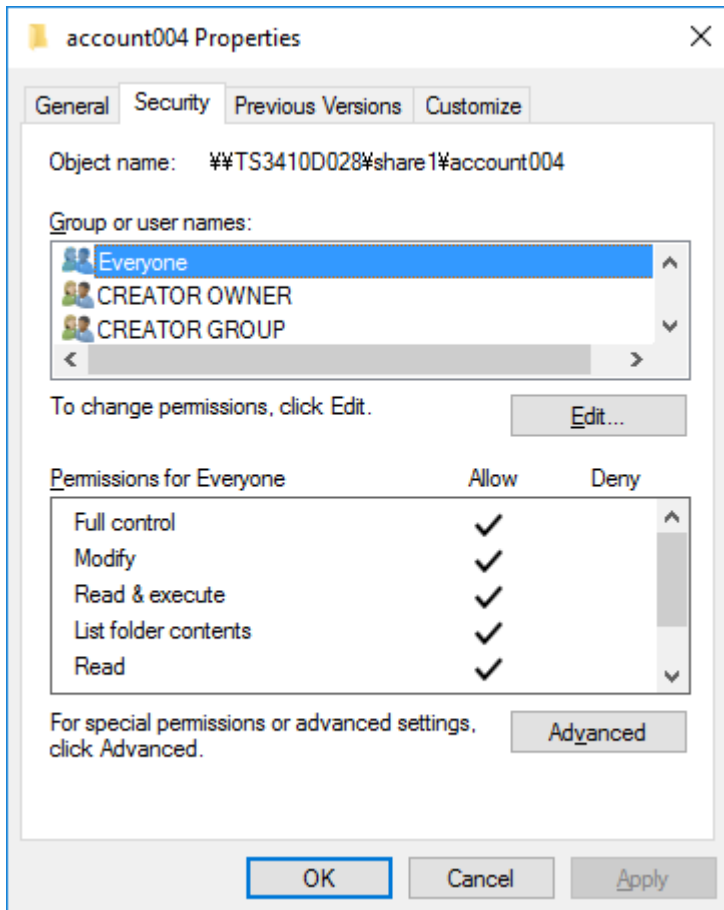

You may also configure access permissions for domain users and groups. You should have the TeraStation join your Active Directory domain before configuring access permissions from File Explorer.

#### Notes:

- If enabling subfolders' access restrictions for a USB drive, the drive should be formatted using XFS or ext3.
- The UID and GID of domain accounts should be updated before using the subfolders' access restrictions if the TeraStation had joined the AD network while running a firmware version earlier than 3.00 (and has since updated to version 3.00 or later). To update the UID and GID, navigate to *File Sharing > SMB > Edit* in Settings and click *Update* next to the "IDs for Domain Users" option.
- To back up or replicate files to backup or replication destinations while leaving access permissions of files and folders in subfolders unchanged, make sure the same workgroup name, user IDs, and group IDs are configured between backup or replication sources and destinations.
- If you enable subfolders' access restrictions and then clear the "Read & execute" checkbox under "Allow" on File Explorer for users or groups access permissions, these users or groups cannot be allowed to read and execute even if subfolders' access restrictions are disabled in Settings. If you deny reading and executing on the same window, this will remain after disabling subfolders' access restrictions.
- If the TeraStation's settings have been initialized but you configure the same UID and GID for new users and groups, access permissions to files and folders in subfolders may be inherited.

---

## NFS

---

**Note:** (US customers only) Buffalo's customer support will help configure the NFS settings on your TeraStation, and will support VMware and Windows clients but will not provide support for configuring your Linux or other UNIX clients. There are various types of UNIX and the procedures for configuring NFS with them will vary considerably. For help configuring your NetWare, Linux, or other UNIX clients for NFS support, please consult each client's own documentation and support.

## Enabling NFS

Follow the procedure below to enable NFS service to allow access from NFS clients.

- 1 From Settings, click *File Sharing*.

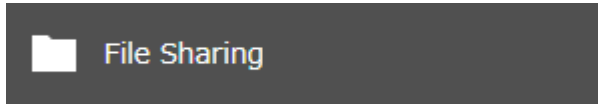

- 2 Click the settings icon (⚙️) to the right of "Folder Setup".



- 3 Choose the shared folder that will be accessible from the NFS client.

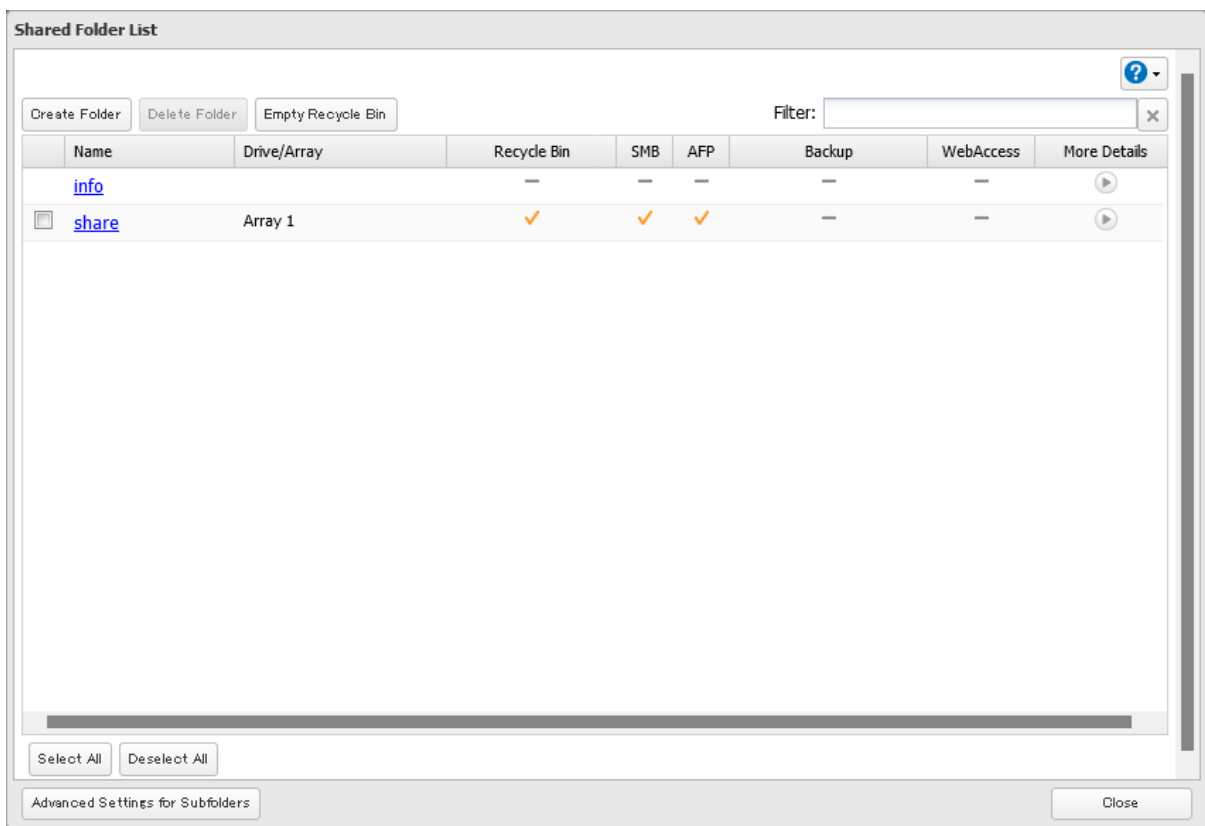

- 4** Under “LAN Protocol Support”, select the “NFS” checkbox on the *Basic* tab and click *OK*. Note the NFS path. It will be used later for accessing data from an NFS client.

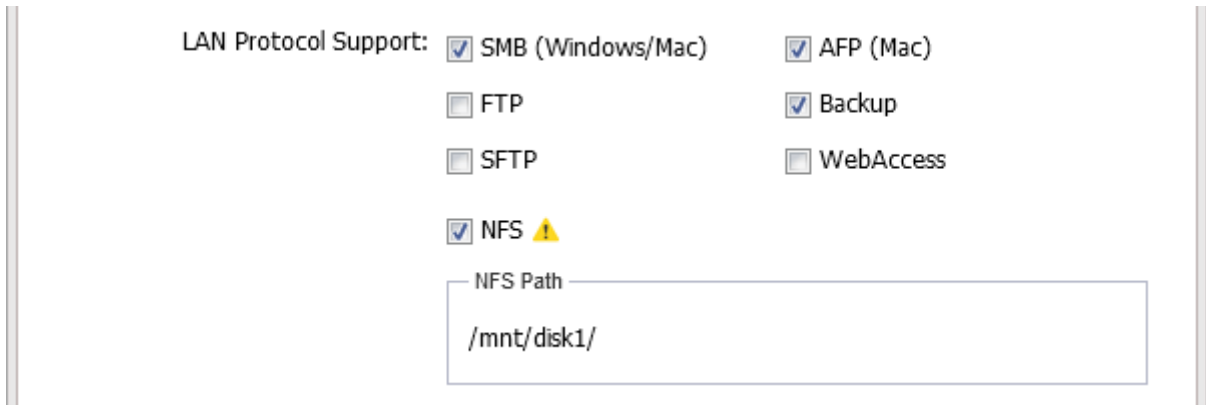

- 5** Click *Close*.

- 6** Move the NFS switch (  ) to the  position to enable NFS.



- 7** Click the settings icon (  ) to the right of “NFS”.



8 Click the *Client Settings* tab, then click *Add*.

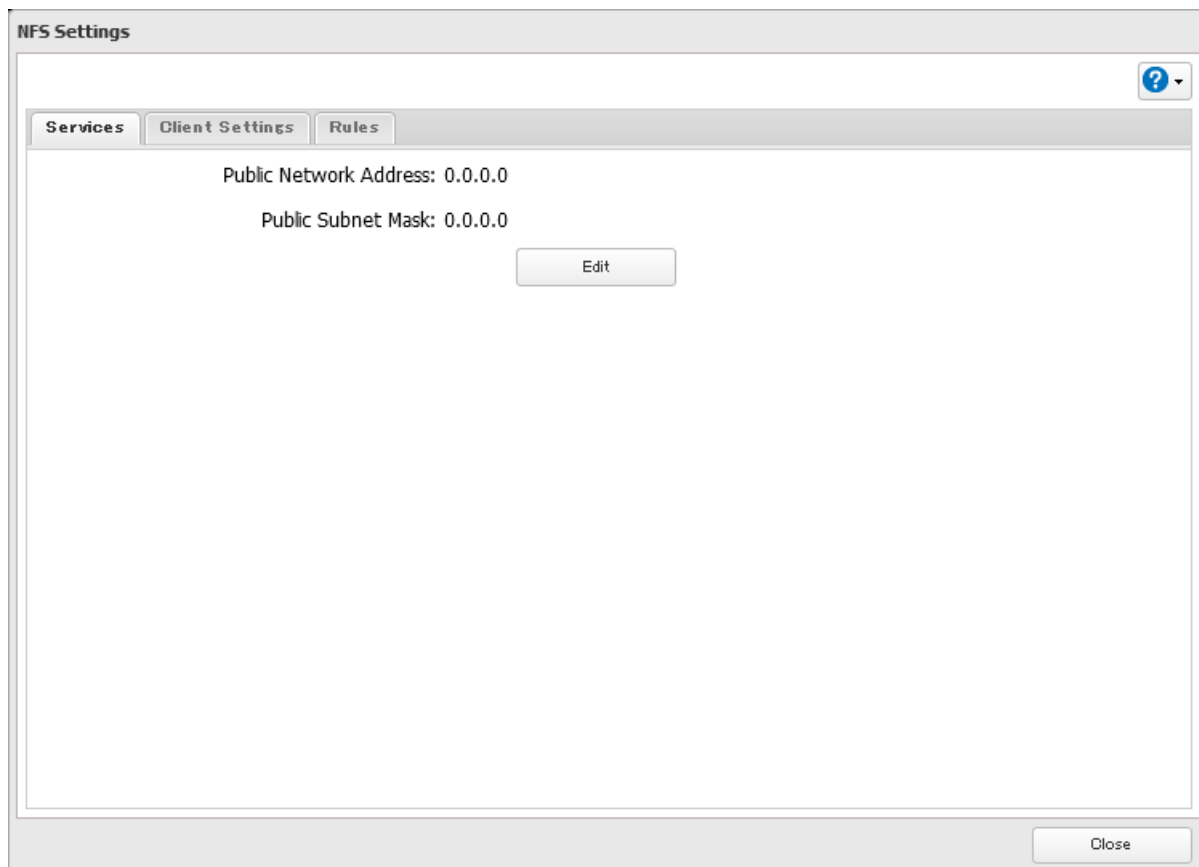

9 Enter the hostname and IP address of the NFS client, then click *OK*. You should add all NFS clients to access the shared folder.

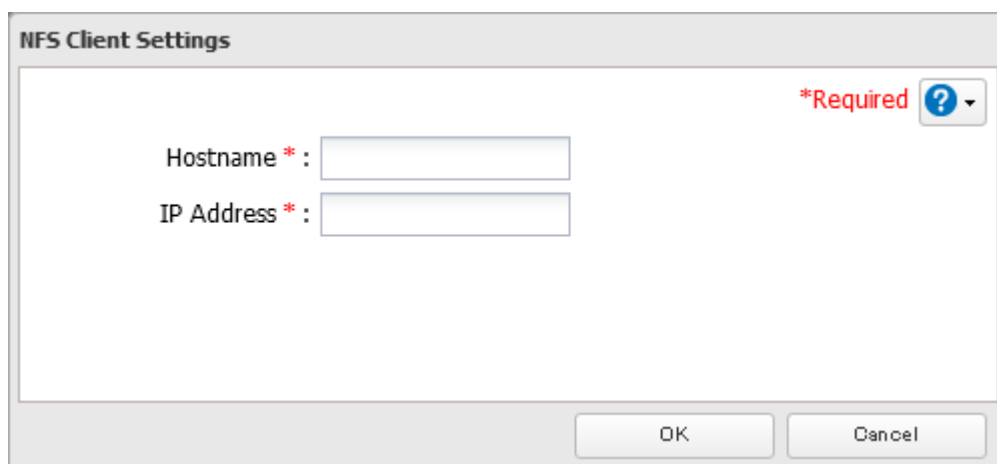

**10** Click the *Rules* tab, then click *Add*.

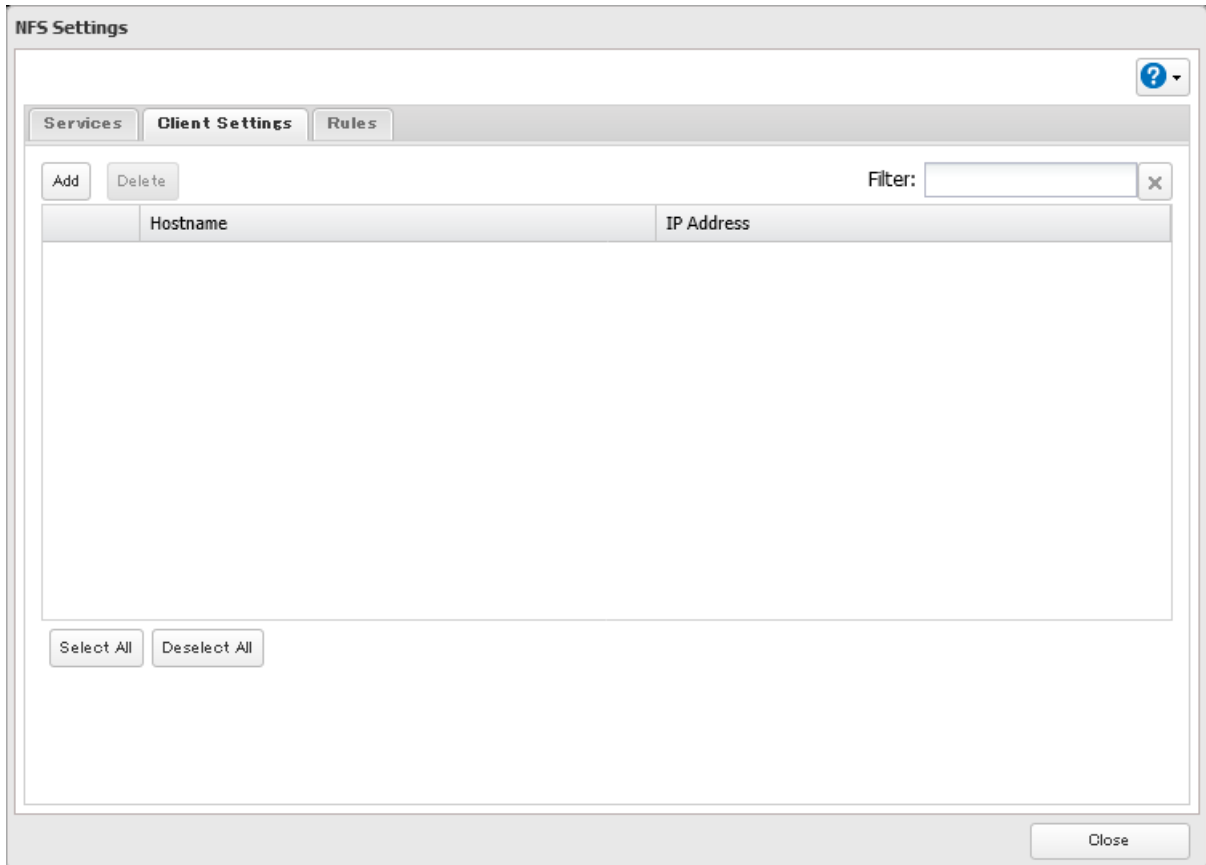

**11** Choose the folder to restrict access to, and enter the clients that will have restricted access into the “Hosts” field. Clients may be entered by hostname, IP address, or IP address range. Wildcards are supported. Separate multiple entries with commas. You may assign read-only or read and write access to the listed clients. Rules override any settings made from the *Services* tab.

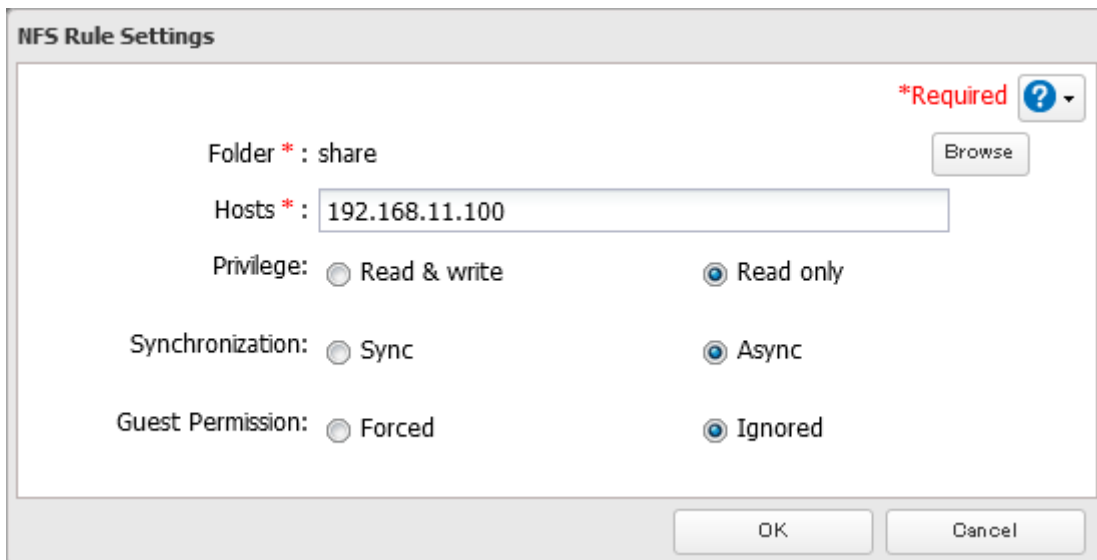

**12** Click *OK*. The process is complete once you close the confirmation window that appears.

**Notes:**

- To restrict NFS access to a specific network or client, navigate to *File Sharing > NFS > Services* and click *Edit*. Enter the address of the network. For example, if your local network subnet has a router at 192.168.1.1 and clients

with IP addresses in the range from 192.168.1.2 through 192.168.1.48 with subnet mask 255.255.255.0, then the “Public Network Address” would be 192.168.1.0 and the “Public Subnet Mask” would be 255.255.255.0. This would mean that only clients on this local network would be able to access the NFS share. If the default settings are used (0.0.0.0 for both the public network address and the public subnet mask), then access to the NFS share will not be restricted.

- If you configure “Guest Permission” to “Forced” on the screen after navigating to *Rules > Add*, the user ID and group ID should be 65534 when the data is written from NFS clients; this is recommended for SMB and other protocols as well. If the TeraStation only enables the NFS connection, select “Ignored” instead.
- Be aware that some NFS clients may be able to access via NFS although the clients do not exist in the allowed NFS client list.

## NFS Mount Commands

Enter the mount command to access the shared folder from the NFS client. The mount command depends on your operating system. The examples below assume that IP address of your TeraStation is 192.168.11.10, “/mnt/array1/share” is the desired NFS path, and “/mnt/nas” or drive letter “z” is the mount point.

### For Linux:

```
mount -t nfs 192.168.11.10:/mnt/array1/share /mnt/nas
```

### For Windows Service for Unix 3.5:

```
mount 192.168.11.10:/mnt/array1/share z:
```

**Note:** A shared folder whose folder name contains multibyte characters cannot be accessed.

### For Solaris 10:

```
mount -F nfs 192.168.11.10:/mnt/array1/share /mnt/nas
```

### For macOS:

```
sudo mount -t nfs -o resvport 192.168.11.10:/mnt/array1/share /mnt/nas
```

## Offline Files for Windows

The “offline files” feature that is included with many versions of Windows can be used with files on the TeraStation. You will be able to work on files stored on the TeraStation even when your PC is disconnected from the network. When you next connect to the network, the updated files are written and synchronized. Follow the procedure below to configure offline files.

- 1 From Settings, click *File Sharing*.

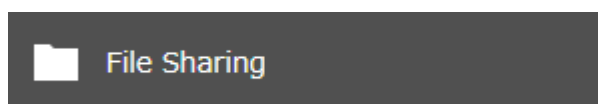

- 2 Click the settings icon (⚙️) to the right of “Folder Setup”.



### 3 Click the shared folder for offline files.

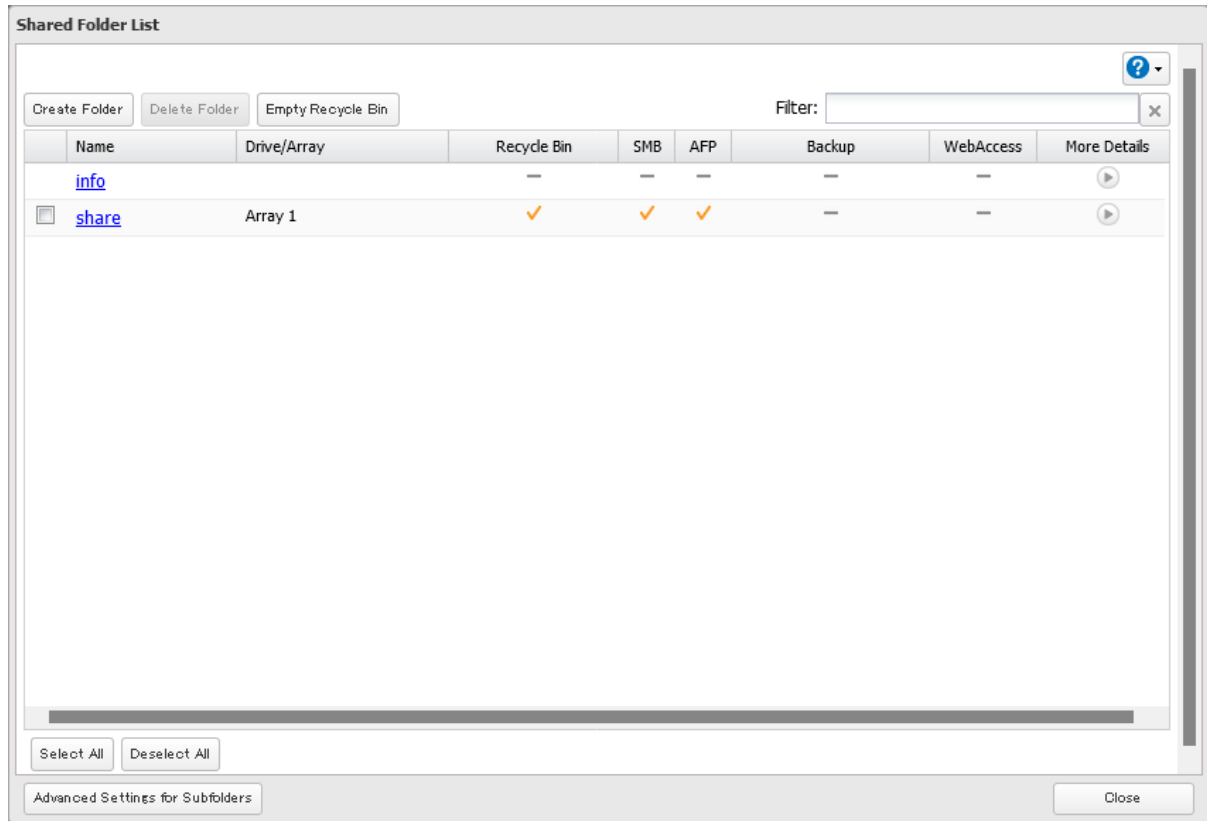

### 4 Choose either "Manual caching of documents", "Automatic caching of documents", or "Automatic caching of programs and documents" on the *Option 1* tab, then click *OK*.

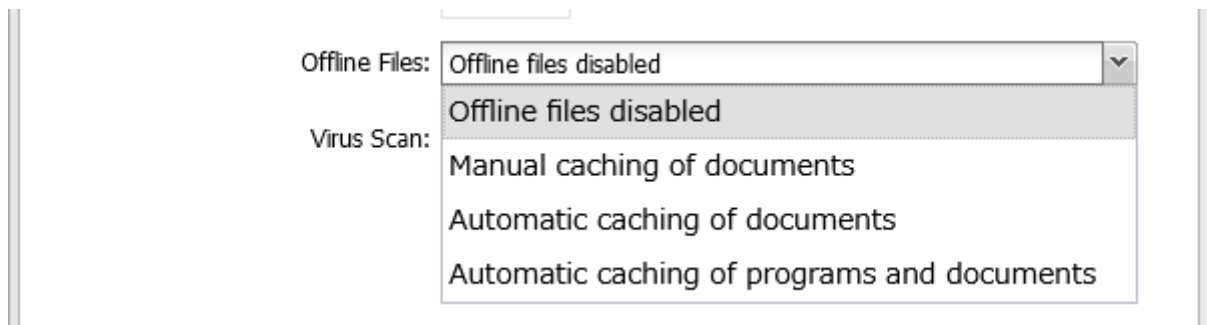

**Manual caching of documents:** User selects files that are cached.

**Automatic caching of documents:** Opened files can be cached locally for offline use. Previous versions of files that are not synchronized are automatically replaced by the latest versions.

**Automatic caching of programs and documents:** Opened files can be cached locally for use offline. Previous versions of files and applications executed on the network that are not synchronized are automatically replaced by the latest version of the files and applications.



- 5** From File Explorer, right-click the icon of the shared folder on the TeraStation for which you have set the offline feature, then click *Always available offline*.

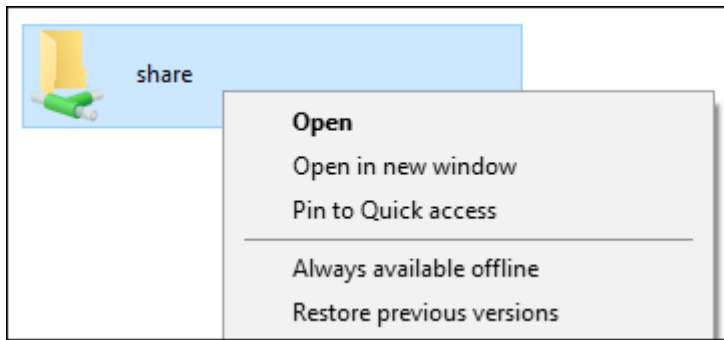

- 6** The process is complete when the shared folder icon is changed to  .

When the configuration of offline settings and synchronization settings is finished, synchronization will begin. If the computer is disconnected from the network after synchronization is finished, the offline file function can be used. Offline files can be accessed by the original Universal Naming Convention (UNC) where the data was saved.

**Notes:**

- If you cannot access offline files, try the following procedure:
  - (1) Reconnect the computer to the network.
  - (2) From Control Panel, change the view to the icon view and click *Sync Center*. Click *Sync All* to synchronize all offline files.
  - (3) Disconnect the computer from the network and verify that you can access offline files.
- If you have configured the recycle bin for the shared folder, temp files may be created in the recycle bin.

# Chapter 4 RAID Modes and Drive Management

---

## Available RAID Modes

---

The TeraStation supports multiple types of RAID. The type of RAID arrays available for use depends on how many drives are installed on your TeraStation.

### Notes:

- If you change the RAID mode, all data on the array is deleted. This is true for every procedure in this chapter. Always back up any important data before performing actions that affect your RAID array.
- Some arrays will allow you to change the RAID mode without losing data by adding drives. To change a RAID mode by adding drives to the existing array, refer to the [“Managing a RAID Array Without Deleting Data”](#) section below.
- Drive capacity is displayed in Settings in actual gigabytes. The Properties window in Windows may show GiB instead, which will be a smaller number.
- If the TeraStation is restarted or shut down while changing the RAID mode, the message will change from I46 or I47 to I18.
- RAID 5, 6, and 10 are only available for TeraStation models that allow three or more drives to be inserted. Please check Settings on your model before changing the RAID mode.

### JBOD

This mode treats the drives inside the TeraStation as individual drives. The usable space is equal to the total capacity of all drives on the TeraStation. If any of the drives fail, then all data on that drive will be lost.

### RAID 6

A RAID 6 array is available for TeraStations with four drives. RAID 6 combines four or more drives into a single array. The usable space is equal to the sum of the capacity of all drives minus the capacity of two drives. For example, if four drives are combined into a RAID 6 array, the usable space is the sum of the capacity of two drives. If up to two drives in the array fail, you can recover data by replacing any failed drives. If three or more drives fail, then all data in the array will be lost.

### RAID 5

A RAID 5 array is available for TeraStations with three or more drives. RAID 5 combines three or more drives into a single array. The usable space is equal to the sum of the capacity of the drives minus the capacity of one drive. For example, if four drives are combined into a RAID 5 array, the usable space is the sum of three drives. If one drive in the array fails, you can recover data by replacing the failed drive. If two or more drives fail at the same time, then all data in the array will be lost.

### RAID 1

A RAID 1 array combines two or more drives into a mirrored array. The usable space is equal to the capacity of a single drive. Identical data is written to each drive. If a drive fails, data can be recovered by replacing the failed drive. As long as one drive in the array remains undamaged, all data in the array can be recovered.

## RAID 0

A RAID 0 array combines two or more drives into a single array. The usable space is equal to the total capacity of all drives in the array. This simple RAID mode offers faster performance than RAID modes that include parity. If a single drive in the array fails, then all data in the array will be lost.

## RAID 10

A RAID 10 array is available for TeraStations with four drives. In this mode, mirrored pairs of drives in RAID 1 arrays are combined into a RAID 0 array. The usable space is equal to the capacity of the smallest drive multiplied by the number of drives divided by two.

The default RAID mode is RAID 1 for the TS3210DN and TS3220DN TeraStation models, and RAID 5 for all other TS3010 or TS3020 series TeraStation models.

# Working with RAID Arrays

## Using JBOD

With JBOD, each drive on the TeraStation is addressed separately. To put drives in an array into JBOD, follow the procedure below.

- 1 From Settings, click *Storage*.



- 2 Click the settings icon (  ) to the right of "RAID".



- 3 Click the array to delete.

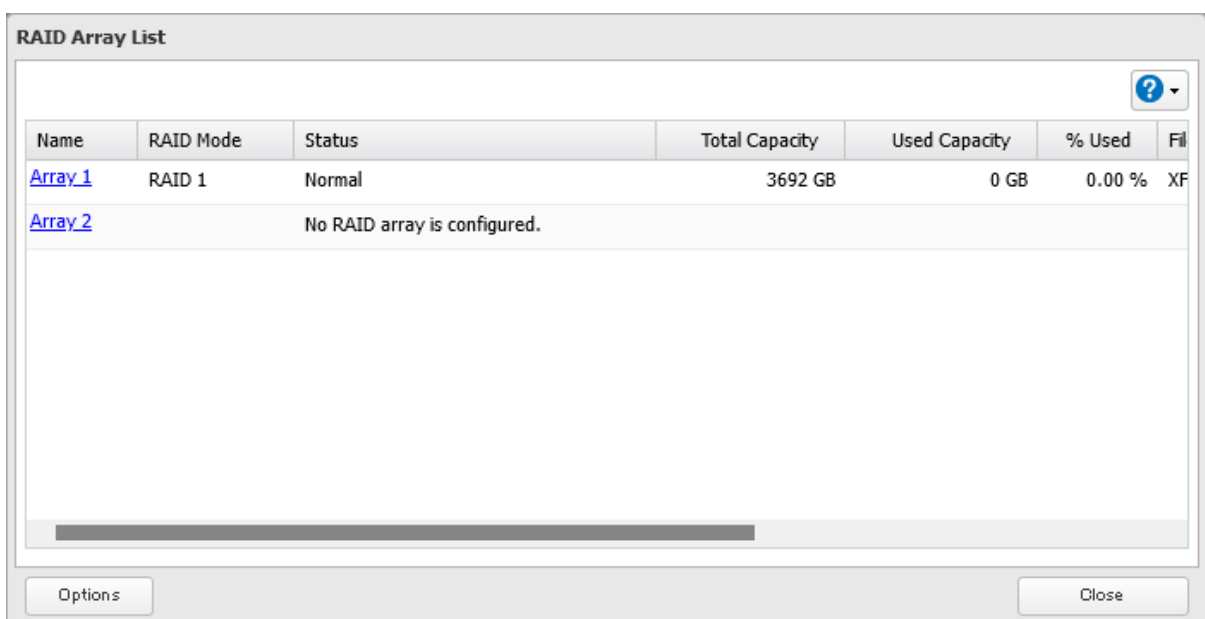

#### 4 Click *Delete RAID Array*.

**Array 1**

Current RAID Mode: RAID 1

New RAID Mode : RAID 1

Change at least one setting.

Select the drive to add to a RAID array.

	Drive	Status	Model Name	Shared Folder	Capacity	Spare Drive
<input checked="" type="checkbox"/>	Drive 1	Array 1 / Normal	ST4000VN008-2DR1	-	3694 GB	-
<input checked="" type="checkbox"/>	Drive 2	Array 1 / Normal	ST4000VN008-2DR1	-	3694 GB	-
<input type="checkbox"/>	Drive 3	Normal	ST4000VN008-2DR1	-	3692.1 GB	<a href="#">Set as a hot spare</a>
<input type="checkbox"/>	Drive 4	Normal	ST4000VN008-2DR1	-	3692.1 GB	<a href="#">Set as a hot spare</a>

Select All Deselect All

Delete RAID Array Change RAID Array Cancel

5 The “Confirm Operation” screen will open. Enter the confirmation number, then click *OK*.

6 The process is complete once you close the confirmation window that appears.

When the drives are put into JBOD, next create a shared folder by referring to the [“Adding a Shared Folder”](#) section in chapter 3.

## Creating a RAID Array

Before creating a new RAID array, first put the drives into JBOD by referring to the [“Using JBOD”](#) section above. Then, follow the procedure below.

1 From Settings, click *Storage*.



2 Click the settings icon (  ) to the right of “RAID”.

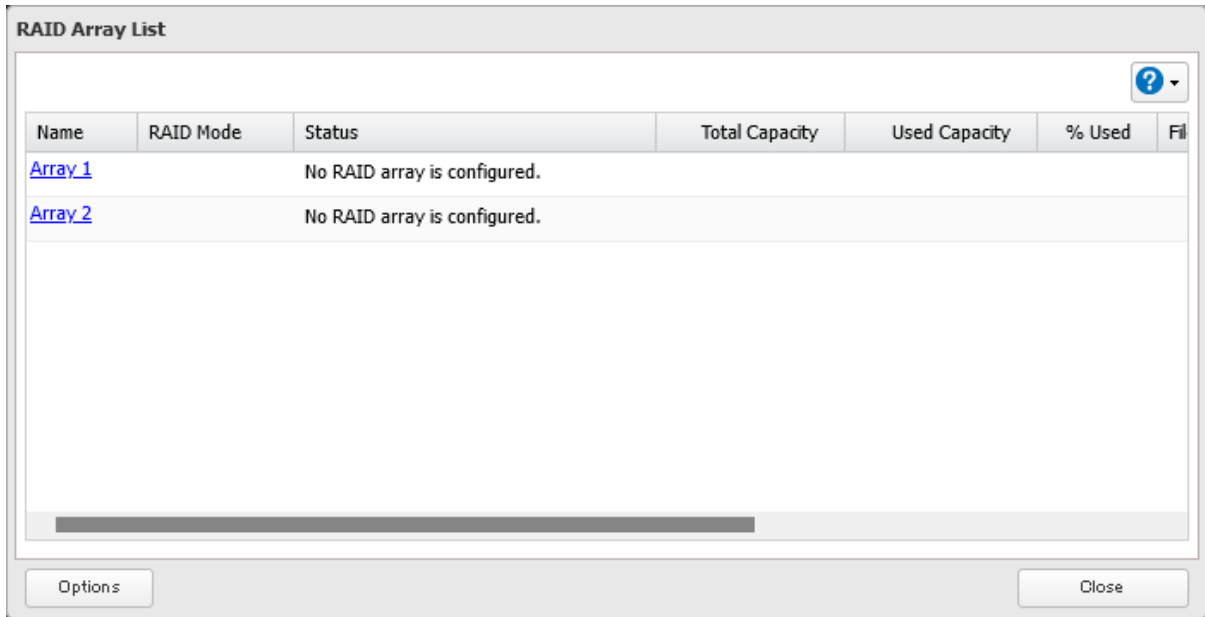
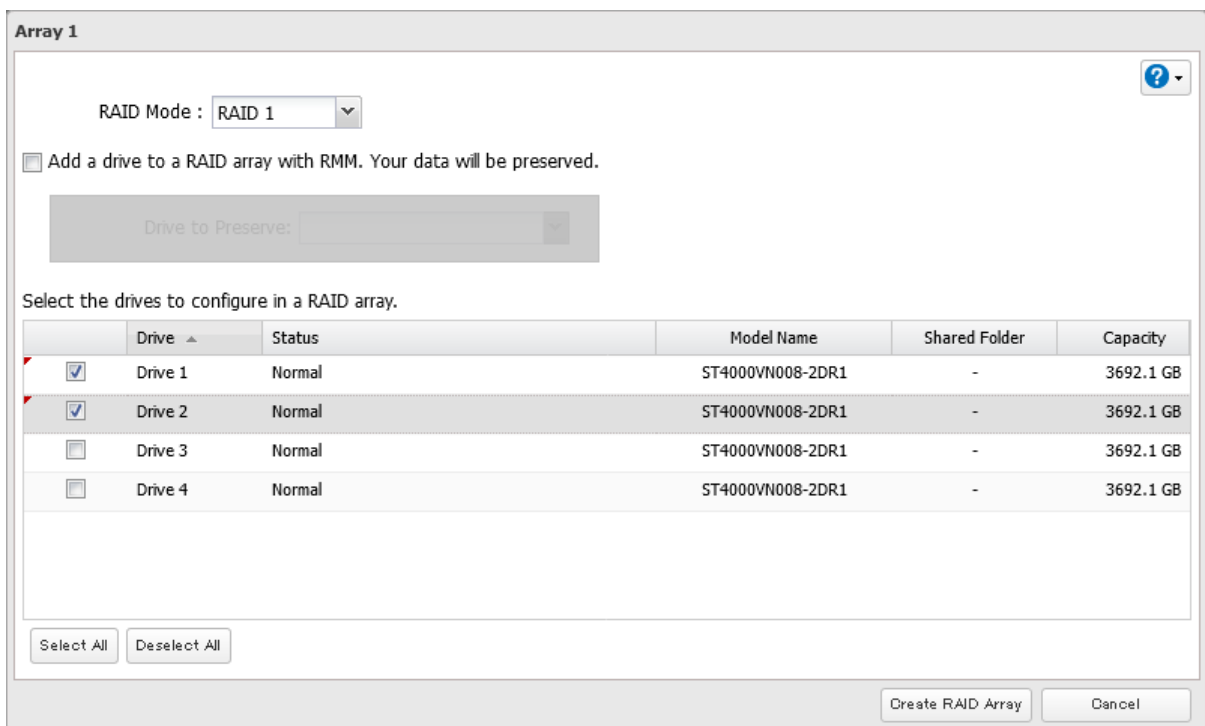

**3** Choose a RAID array.**4** Select a RAID mode and the drives to be used, then click *Create RAID Array*.**5** The "Confirm Operation" screen will open. Enter the confirmation number, then click *OK*.**6** The process is complete once you close the confirmation window that appears.

When the RAID array has been created, next create a shared folder by referring to the ["Adding a Shared Folder"](#) section in chapter 3.

## **Shutting Down the TeraStation Automatically If an Error Occurs**

This function will shut down the TeraStation automatically if an error occurs on a drive that is used in a redundant RAID array. To configure auto shutdown, follow the procedure below.

**1** From Settings, click *Storage*.



**2** Click the settings icon (  ) to the right of "RAID".

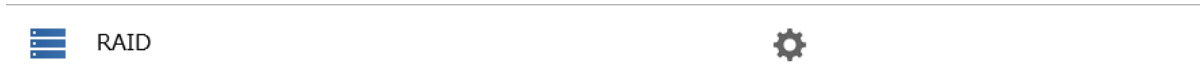

**3** Click *Options*.

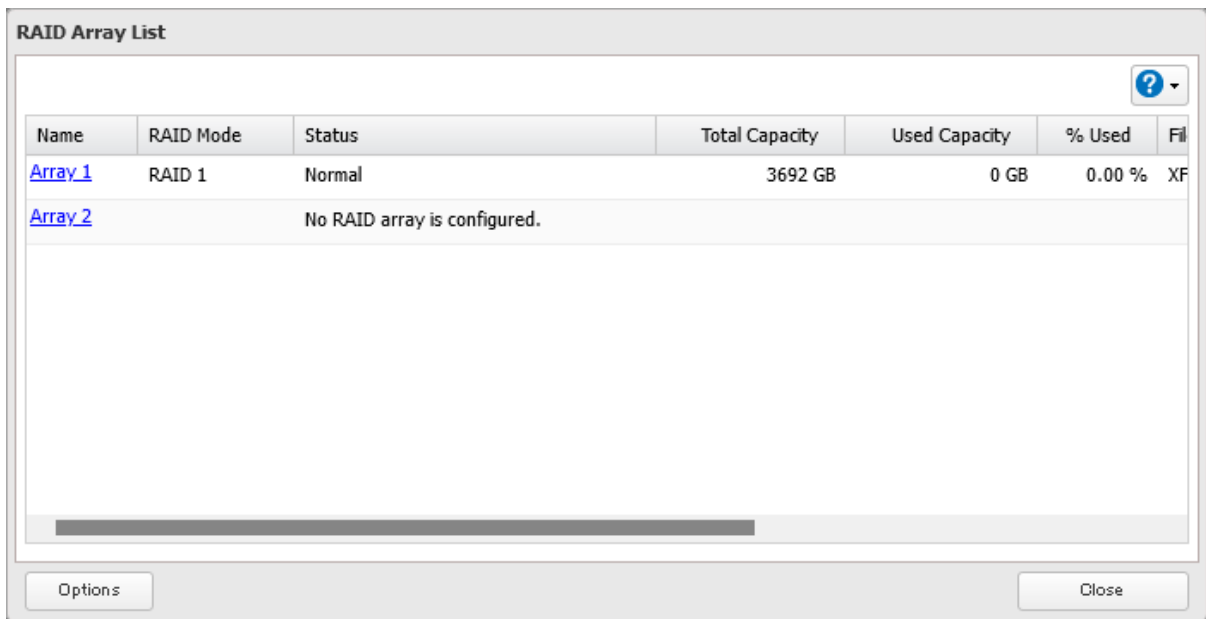

**4** Click *Edit* and change the "Error Behavior" option to "Shut down", then click *OK*.

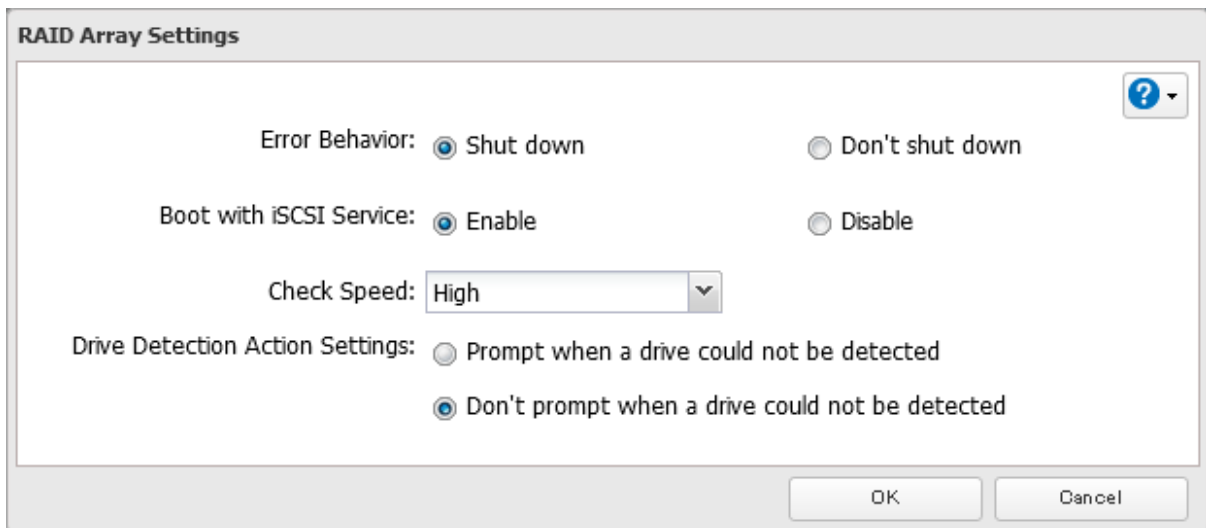

**5** The process is complete once you close the confirmation window that appears.

## Configuring Actions for If a Drive Used for the RAID Array Has Not Been Detected

You can configure actions to be taken by the TeraStation if a drive used for the RAID array cannot be mounted when booting.

### Hiding the Confirmation Screen

Configure to display or hide the confirmation screen that showcases the actions for if a drive used for the RAID array cannot be mounted when booting. The confirmation screen is configured to appear by default. To hide the screen, follow the procedure below.

- 1 From Settings, click *Storage*.



- 2 Click the settings icon (  ) to the right of "RAID".



- 3 Click *Options*.

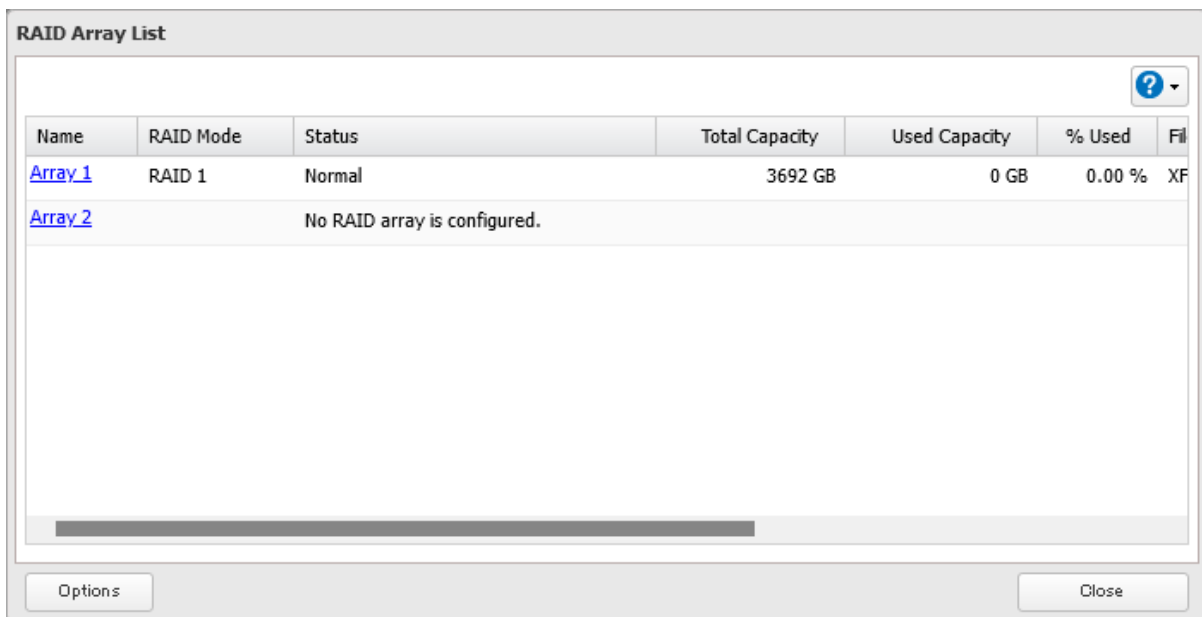

- 4 Click *Edit* and change the “Drive Detection Action Settings” option to “Don't prompt when a drive could not be detected”, then click *OK*.

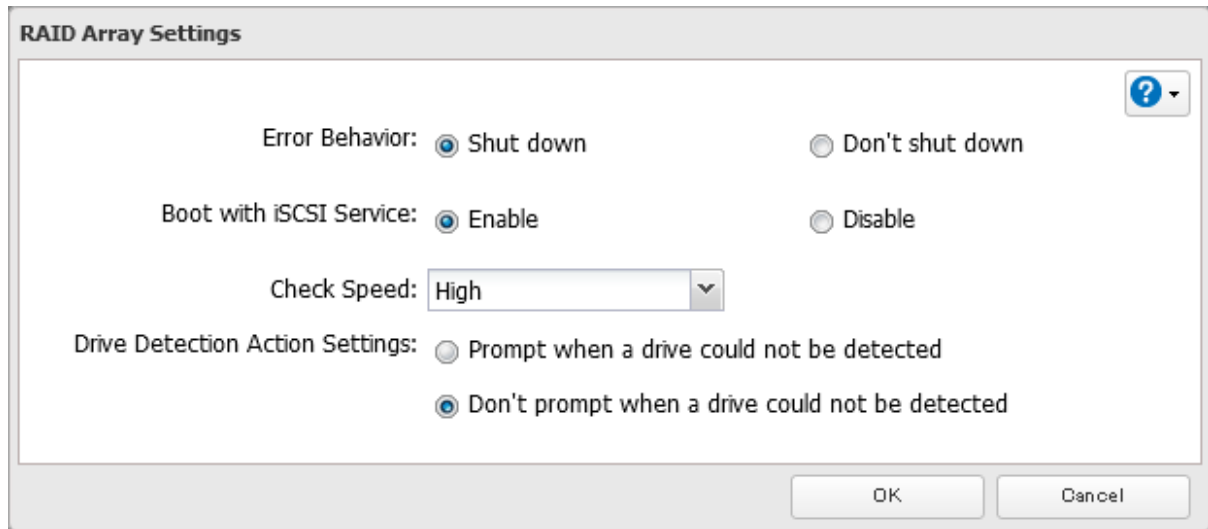

- 5 The process is complete once you close the confirmation window that appears.

If the confirmation screen is not set to appear, an undetected drive will automatically be dismounted from the TeraStation. Subsequently, the TeraStation will enter degraded mode if a redundant RAID mode has been configured and the RAID array will be corrupted if RAID 0 has been configured, resulting in data loss. It is recommended to proceed without changing settings that would prevent the confirmation screen from appearing.

### Selecting the Action on the Confirmation Screen

When the confirmation screen is displayed, the following screen will appear after logging in to Settings if the drive used for the RAID array could not be mounted. Select the action to run when the screen appears.

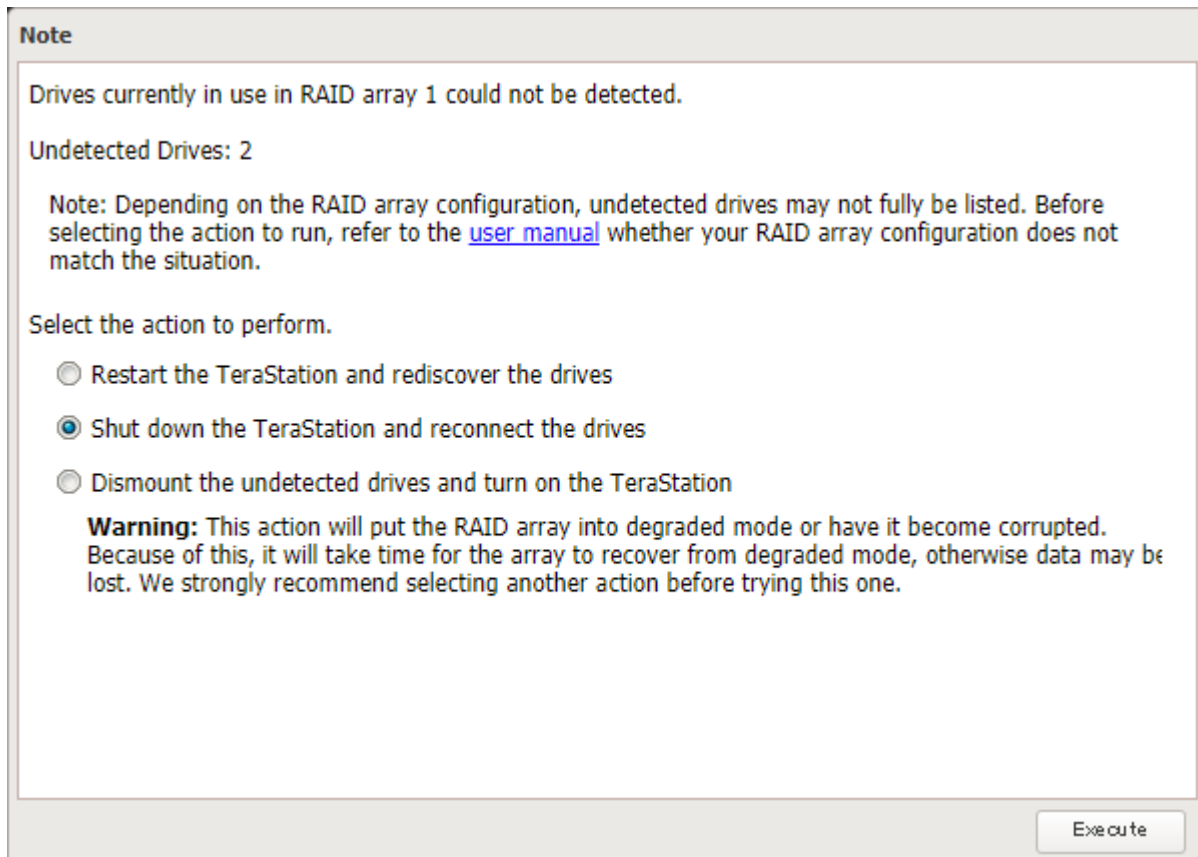



## Conditions and Corrective Actions If Undetected Drives Aren't Displayed Properly

Even when you configure the NAS to show the confirmation screen if a drive being used for the RAID array cannot be mounted, undetected drives will not be displayed under the following conditions. If you are using any of the RAID array configurations below, follow the corrective procedure.

Conditions	Corrective Actions
RAID 10 has been configured.	<ol style="list-style-type: none"> <li><b>1</b> Refer to the <a href="#">“Selecting the Action on the Confirmation Screen”</a> subsection above on how to access the confirmation screen.</li> <li><b>2</b> Select “Shut down the TeraStation and reconnect the drives” and click <i>Execute</i>.</li> <li><b>3</b> After the TeraStation shuts down, confirm that all drives have been inserted properly.</li> <li><b>4</b> Press the power button to power on the TeraStation.</li> <li><b>5</b> Log in to Settings and make sure the confirmation screen doesn't appear.</li> </ol>
Multiple arrays have been configured.	

## Configuring a Hot Spare

If you have a hot spare configured and an array fails, the TeraStation immediately switches over to the hot spare. To use a hot spare, you need a RAID 1 or RAID 5 array and an extra drive that's not part of an array.

### Notes:

- All data on the hot spare drive is deleted when it is configured as a hot spare and again when it changes from a spare to a drive in the array.
- A hot spare cannot be configured for TeraStation models with only two drives included.

**1** From Settings, click *Storage*.



**2** Click the settings icon (  ) to the right of “RAID”.



**3** Choose a RAID array.

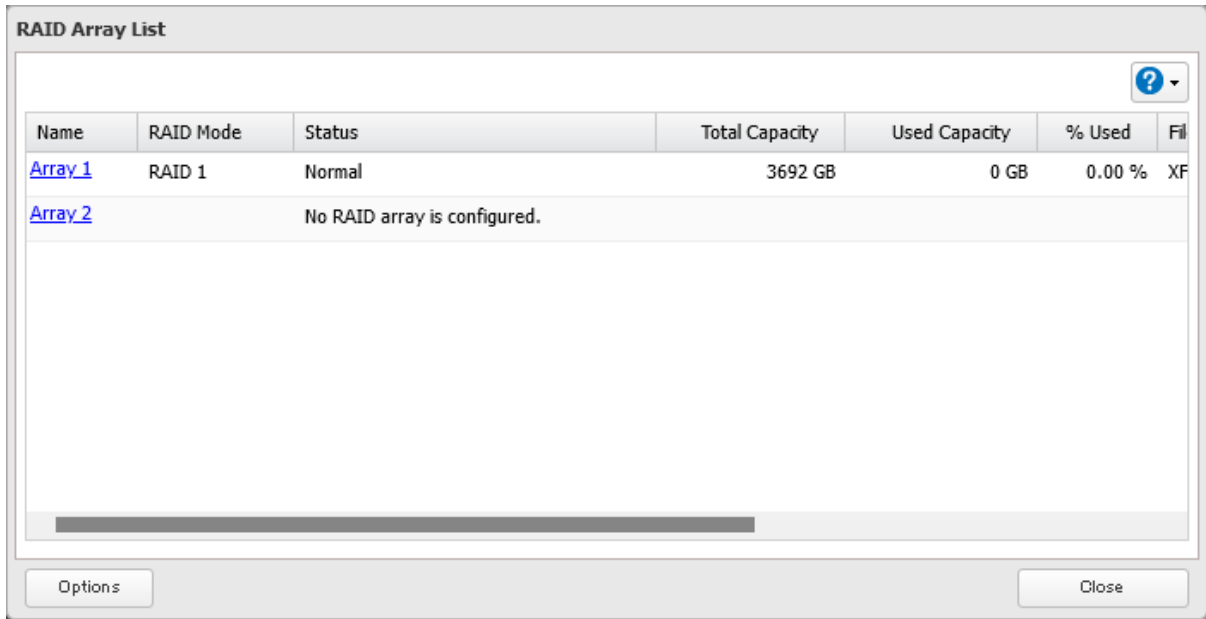

**4** Click *Set as a hot spare*.

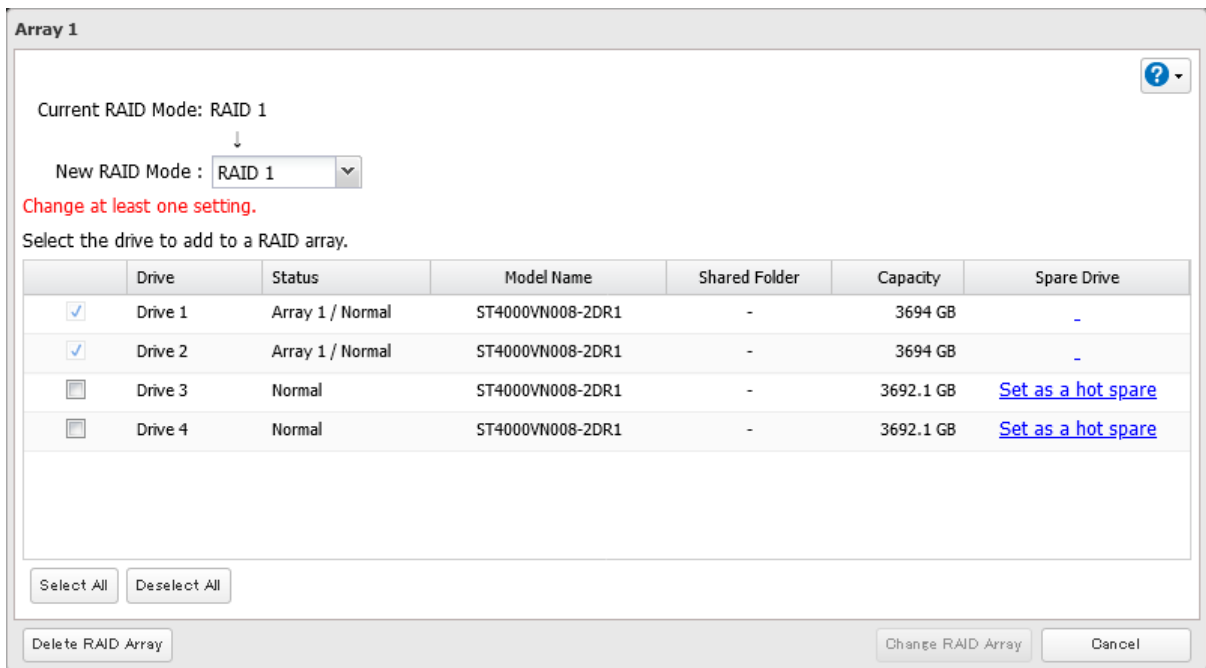

**5** Read the message carefully and select the checkbox, then click *OK*.

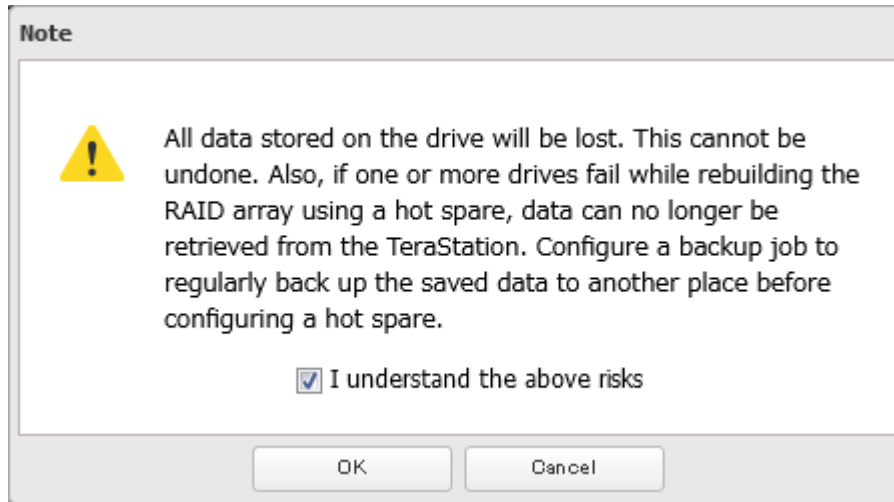

**6** The “Confirm Operation” screen will open. Enter the confirmation number, then click *OK*.

**7** The process is complete once you close the confirmation window that appears.

**Note:** To turn the hot spare back to a normal drive, choose *Set as a normal drive*.

## Managing a RAID Array Without Deleting Data

You can manage a RAID array without erasing data on the drives by using RMM (RAID Mode Manager).

### Notes:

- Creating a RAID array using RMM may take a few days to up to 20 days to complete. If you wish to avoid such a long process time, we recommend not using RMM. Instead, move data on the drives to another location, delete the existing RAID array, then create a new one using the drives.
- RMM can be used to expand an array by only one drive per operation. To expand by two or more drives, RMM must be activated multiple times. For example, if you want to create a RAID 6 array by adding two drives, change the RAID mode to RAID 5 first using one drive, then change it to RAID 6 using another drive.

The following chart explains the transition status of drives after using RMM. The “n” in the chart below refers to the number of drives that make up the RAID array.

Current Drive Status	New RAID Mode	Capacity	Redundancy (Drive Failure Resistance)
JBOD	RAID 1	No increase	Improve (1 drive)
RAID 1	RAID 1	No increase	Improve ( $n - 1$ drives)
	RAID 5	Increase	No change (1 drive)
RAID 5	RAID 5	Increase	No change (1 drive)
	RAID 6	No increase	Improve (2 drives)

If using a TeraStation model that currently has unoccupied drive slots, such as in the case of partially-populated models, follow the procedure below to add new drives first. Otherwise, refer to the procedures in this section to configure the RAID array. The following examples use the case of the TS3410DN TeraStation model.

### Adding a Drive

The procedure for adding a new drive will vary depending on your device.

**1** Open the front cover with the included key.

**2** Push the drive’s unlock button for the empty slot and swing the lock mechanism out.

- 3 Pull out the drive cartridge and remove it from the TeraStation.
- 4 Insert the new drive (sold separately) into the empty slot with the lock mechanism remaining open and swing the lock back down until it clicks into place.
- 5 Close the front cover.
- 6 When the drive is recognized, the status LED will flash red and the I32 message will appear as a notification.
- 7 From Settings, click *Storage*.



- 8 Click the settings icon (  ) to the right of "Drives".



- 9 Select the inserted new drive and click *Format Drive*.

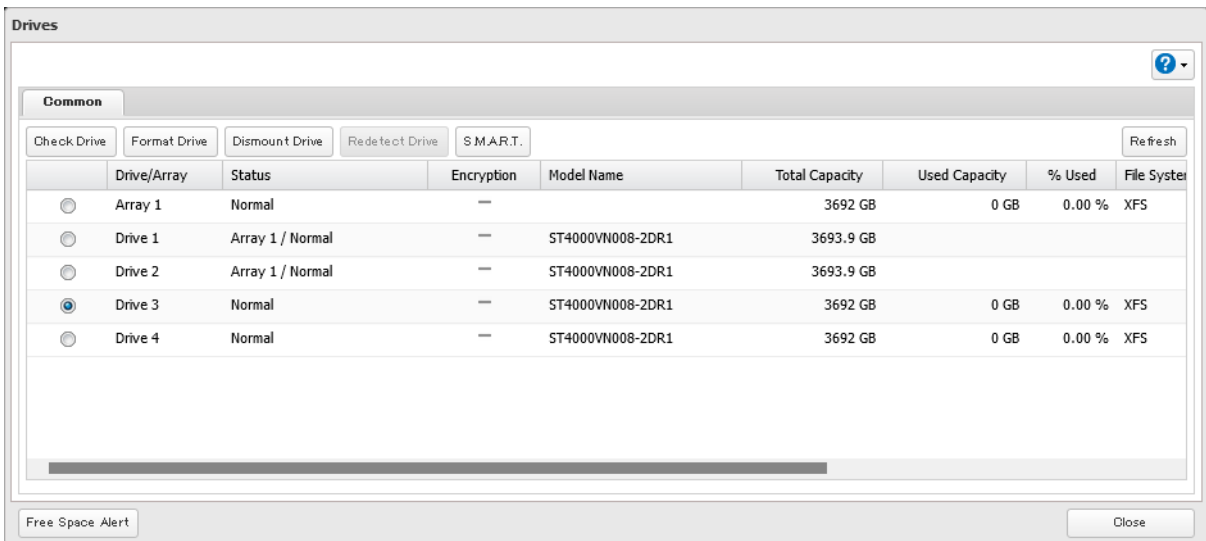

**10** Select a format type and click *Format*.

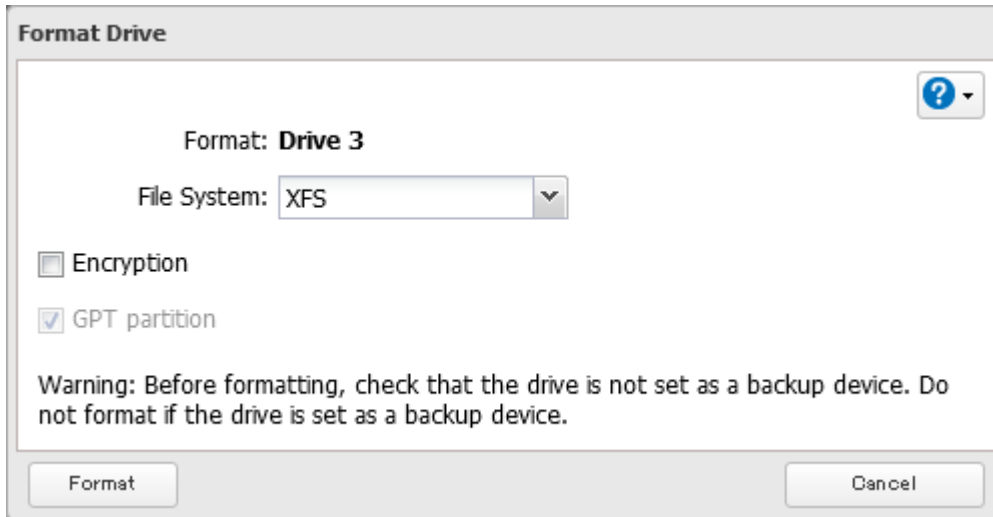

**11** The “Confirm Operation” screen will open. Enter the confirmation number, then click *OK*.

**12** The process is complete once you close the confirmation window that appears.

### Drives That Are Currently in JBOD

To use RMM for drives in JBOD, you must have at least two drives available in JBOD. Follow the procedure below.

**1** From Settings, click *Storage*.



**2** Click the settings icon (  ) to the right of “RAID”.

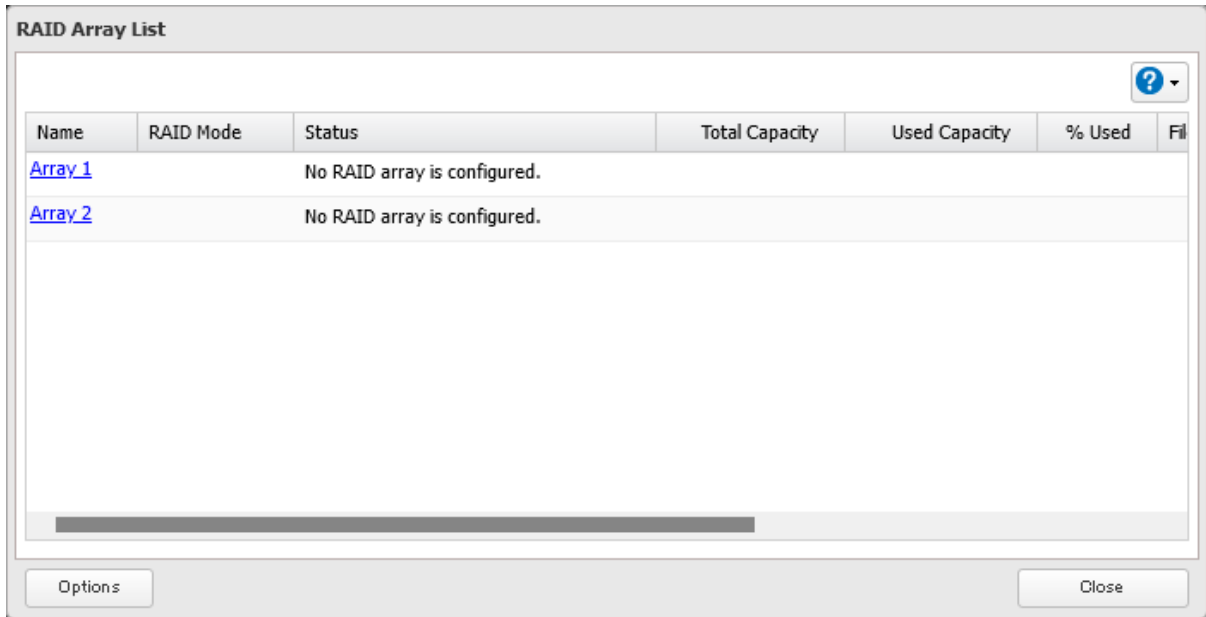
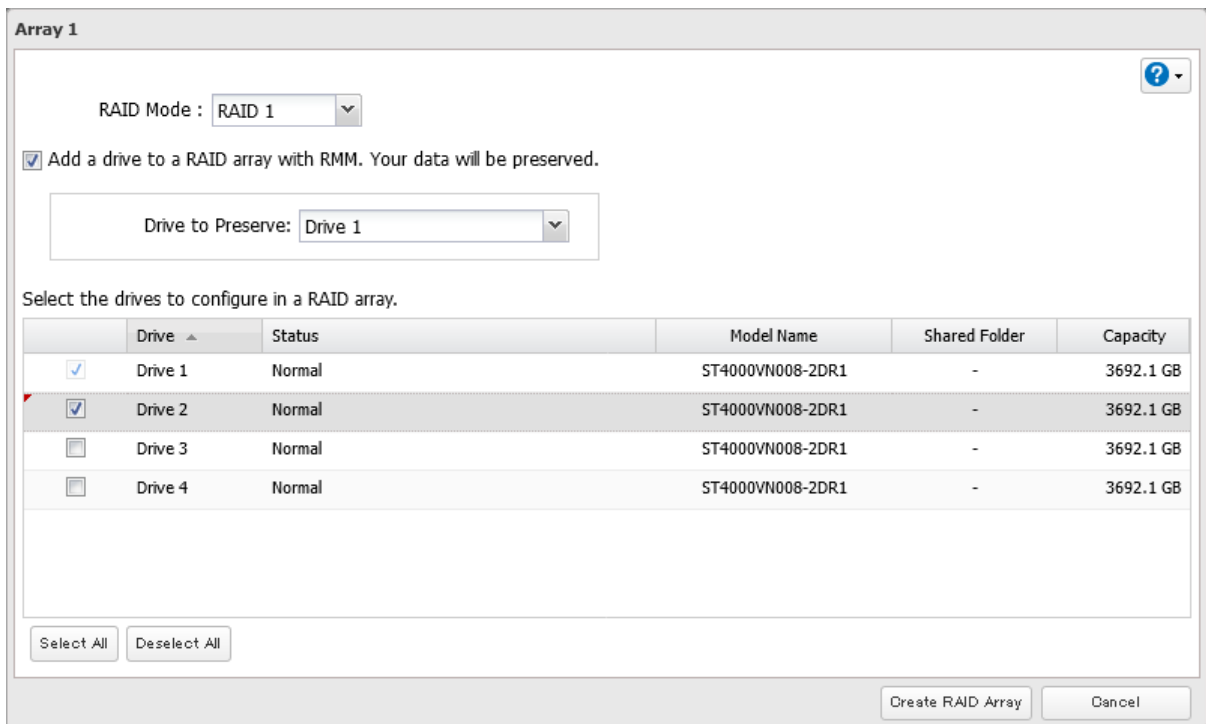

**3** Choose a RAID array.**4** Set the RAID mode to "RAID 1".**5** Select the "Add a drive to a RAID array with RMM. Your data will be preserved." checkbox.**6** Select the drive whose data will be saved from the drop-down list.**7** Select the drive to add to the RAID array.**8** Click *Create RAID Array*.**9** The "Confirm Operation" screen will open. Enter the confirmation number, then click *OK*.

**10** The process is complete once you close the confirmation window that appears.

### Drives That Are Currently in RAID 1 or RAID 5

To use RMM for redundant RAID arrays (RAID 1 or RAID 5), you must have at least one drive available in JBOD. Follow the procedure below.

**1** From Settings, click *Storage*.



**2** Click the settings icon (  ) to the right of "RAID".



**3** Choose a RAID array.

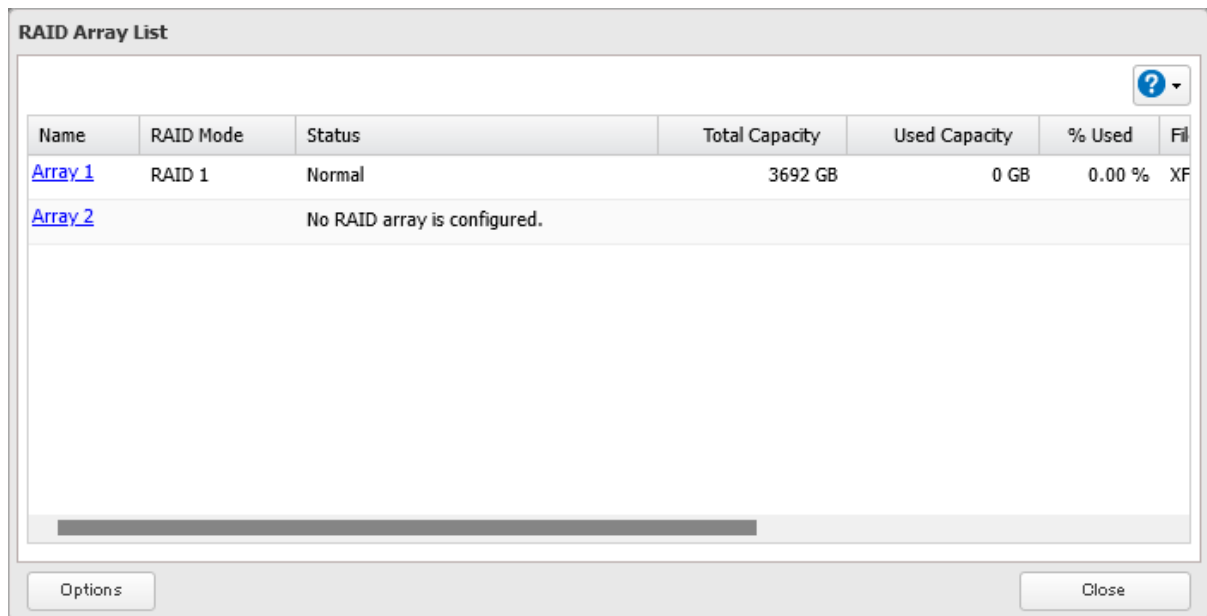

- 4** Select one drive to add to the RAID array. If changing the RAID mode, choose the desired mode for the array from the drop-down list. Otherwise, keep the current RAID mode as is.

**Array 1**

Current RAID Mode: RAID 1

New RAID Mode : RAID 5

Select the drive to add to a RAID array.

	Drive	Status	Model Name	Shared Folder	Capacity	Spare Drive
<input checked="" type="checkbox"/>	Drive 1	Array 1 / Normal	ST4000VN008-2DR1	-	3694 GB	-
<input checked="" type="checkbox"/>	Drive 2	Array 1 / Normal	ST4000VN008-2DR1	-	3694 GB	-
<input checked="" type="checkbox"/>	Drive 3	Normal	ST4000VN008-2DR1	-	3692.1 GB	<a href="#">Set as a hot spare</a>
<input type="checkbox"/>	Drive 4	Normal	ST4000VN008-2DR1	-	3692.1 GB	<a href="#">Set as a hot spare</a>

Select All Deselect All

Delete RAID Array Change RAID Array Cancel

- 5** Click *Change RAID Array*.
- 6** The “Confirm Operation” screen will open. Enter the confirmation number, then click *OK*.
- 7** The process is complete once you close the confirmation window that appears.

## RAID Scanning

A RAID scan checks your RAID array for bad sectors and if it finds any, it automatically repairs them. Arrays other than RAID 0 are supported. For best results, run RAID scans regularly.

- 1** From Settings, click *Storage*.



- 2** Move the RAID scanning switch (  ) to the  position to enable RAID scanning.



- 3** Click the settings icon (  ) to the right of “RAID Scanning”.





**4** Click *Edit* and select when to run the scan, then click *OK*.

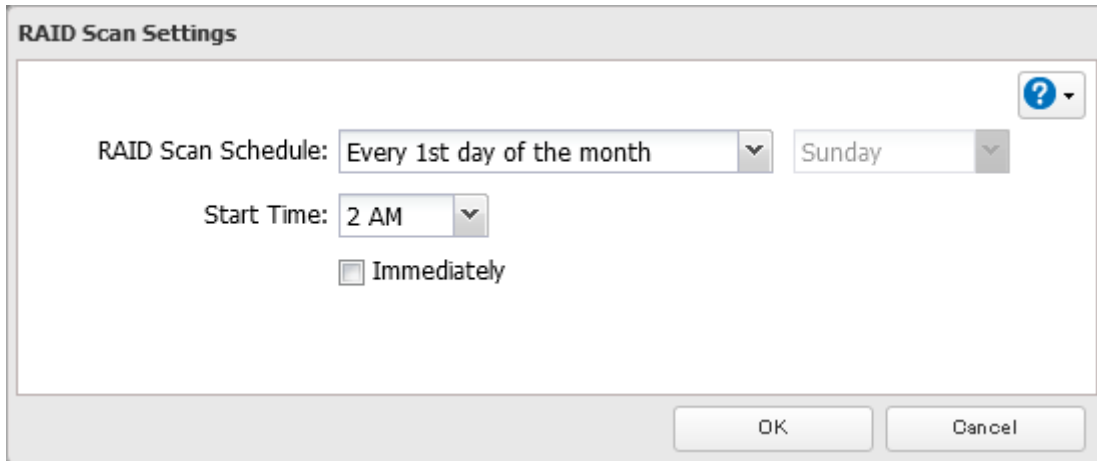

**5** The process is complete once you close the confirmation window that appears.

**Notes:**

- Select the “Immediately” checkbox to run a RAID scan immediately.
- To stop a RAID scan, click *Cancel RAID Scan*.

---

## Configuring Low Drive Space Alerts

---

You can configure the TeraStation to notify you when it is running low on free space, either by having a message displayed on the Dashboard in Settings or having the TeraStation send you an email notification. This function is applicable to internal drives, RAID arrays, and LVM volumes on the TeraStation.

**Note:** If you have configured low drive space alerts and created iSCSI volumes on the LVM-enabled area, the I65 message will appear as a notification.

**1** From Settings, click *Storage*.



**2** Click the settings icon (  ) to the right of “Drives”.

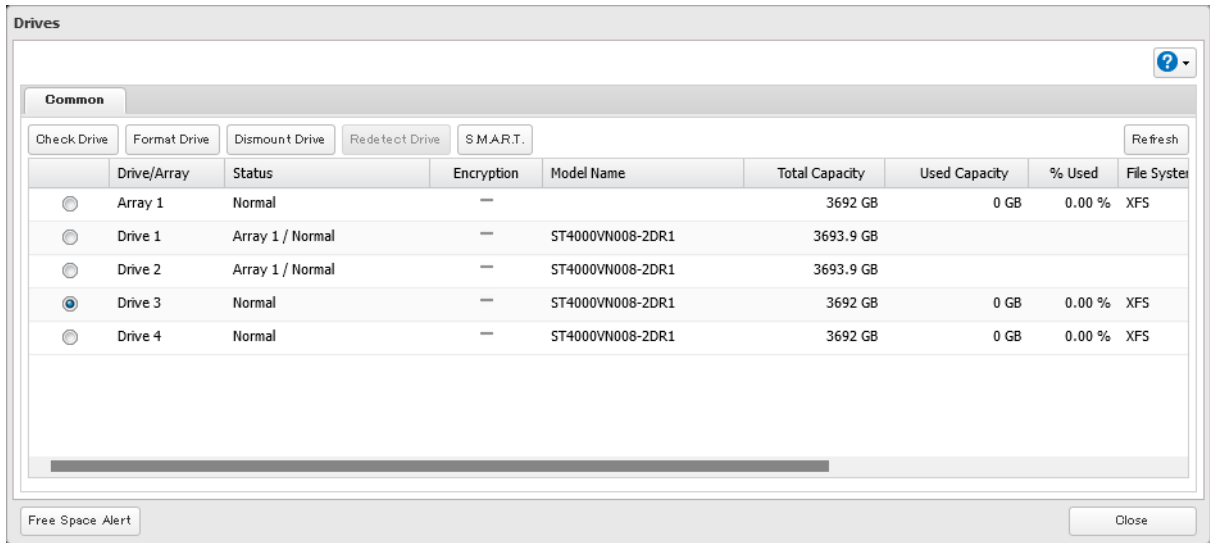
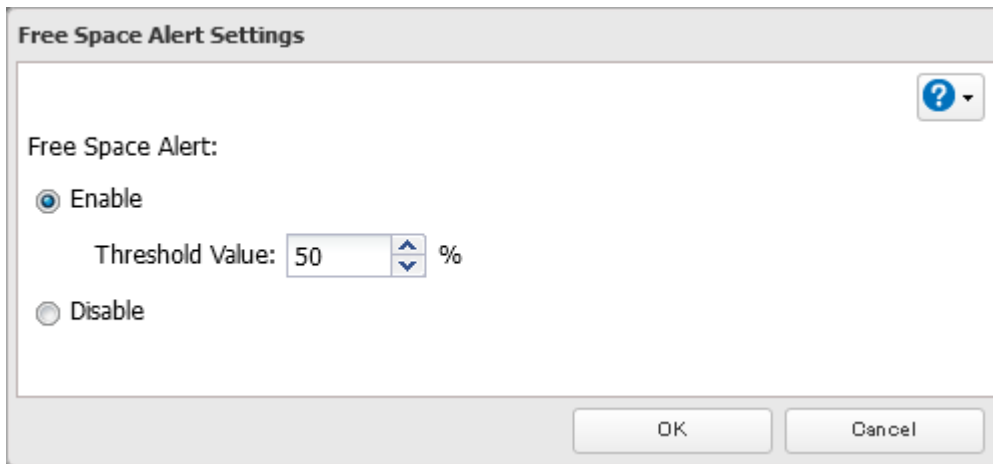

**3** Click *Free Space Alert*.**4** Enable “Free Space Alert” and enter the threshold value, then click *OK*.**5** The process is complete once you close the confirmation window that appears.

The free space alert is now enabled. If the percentage of remaining free space on the TeraStation decreases past the threshold percentage, a notification will appear on the Dashboard in Settings. To configure free space alert email notifications, refer to the [“Email Notification”](#) section in chapter 10.

---

## Adding an External Drive

---

Your TeraStation features multiple USB ports, and you can connect an external drive to any of these ports. Once connected, it appears as a shared folder on the TeraStation. A formatted drive is detected automatically. Unformatted drives should be formatted in Settings.

After a USB drive is recognized, the TeraStation adds “usbdisk x” to the shared folder list, where “x” is the USB port to which the drive is connected.

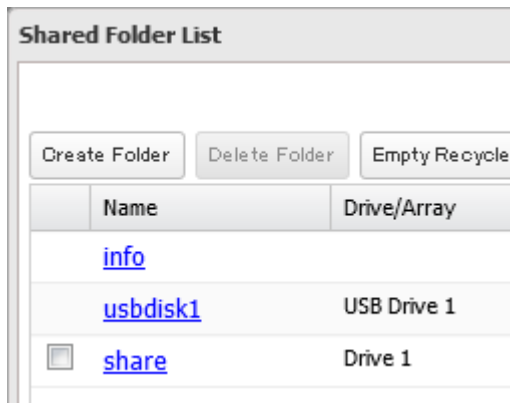

If a USB drive is unplugged without being dismounted first while the TeraStation is powered on, it may not be recognized properly when it is reconnected. If this occurs, restart the TeraStation and then reconnect the drive.

## Compatibility

Supported file systems for external USB drives are below:

File Systems	Recommended Situation
XFS	Connecting to another Buffalo NAS device.
Ext3	Connecting to another Buffalo NAS device. XFS is recommended because the more files stored in one folder, the slower the performance. The available capacity will be less than the area formatted to XFS.
NTFS*	Connecting to Windows computers. The NTFS-formatted drive can use many more functions of the operating system than an exFAT drive.
HFS Plus*, **	Connecting to macOS computers. The HFS Plus-formatted drive can use many more functions of the operating system than an exFAT drive.
exFAT*	Connecting to both Windows and macOS computers.
FAT32	Connecting to both Windows and macOS computers.

\*This cannot be formatted from Settings.

\*\*This is read-only from the TeraStation. Files on the USB drive can be copied to the TeraStation.

Make sure only one device is connected to a USB port on the TeraStation. Note that only the first partition of a connected USB drive is mounted. Additional partitions are not recognized.

### Notes:

- If your USB 3.0 drive is not reconfigured after rebooting the TeraStation, unplug and reconnect it.
- When copying a file that is over 100 MB to a FAT32-formatted USB drive using File Explorer, an error message may appear. In such a case, use an FTP or SFTP connection to copy the file.
- When copying files from a shared folder to a FAT32-formatted USB drive, the progress bar may not be displayed or the file copying may fail. Using a file system other than FAT32 is recommended for the USB drive.
- After connecting an RDX drive to the TeraStation, click *Redetect Drive* anytime.

## Dismounting Drives

If the TeraStation is off, then all drives are already dismounted and may be unplugged safely. If the TeraStation is powered on, dismount drives (internal and external) before unplugging them by following the procedure below.

### Notes:

- Do not dismount internal drives while a RAID array is rebuilding or RMM is being configured. If you do, data on the drives may be lost.

- To dismount an RDX cartridge from an RDX dock, first perform the dismount process either using the function button or from Settings, then press the eject button on the dock to disconnect the cartridge.

## Using the Function Button

When you press the function button, the TeraStation will beep once. Press and hold down the button until the TeraStation beeps again and the button starts blinking blue. It will take about six seconds. When the function button stops blinking and returns to glowing, the dismount is finished. You may now unplug any USB drives safely. After 60 seconds, the function button will go out and any drives that have not yet been unplugged will be remounted.

## Using Settings

- 1 From Settings, click *Storage*.



- 2 Click the settings icon (⚙️) to the right of "Drives" to dismount an internal drive or "USB Drives" to dismount an external drive.



- 3 Select the drive to dismount and click *Dismount Drive*.

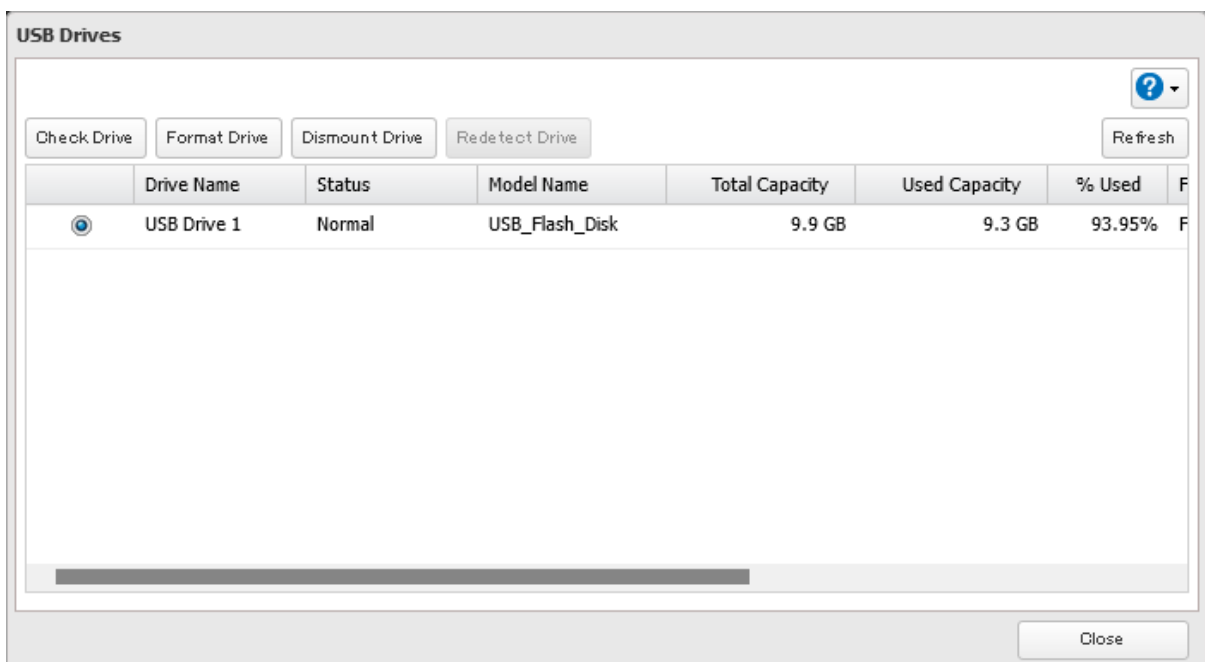

- 4 The "Confirm Operation" screen will open. Enter the confirmation number, then click *OK*.

- 5 The process is complete once you close the confirmation window that appears.

When the dismounting process is finished, it is safe to unplug the drive. Disconnect the drive from the TeraStation.

**Note:** To remount the drive, unplug it and then plug it back in.

## Checking Drives

A drive check tests the data on a drive on the TeraStation or one that is connected via USB for integrity. Detected errors are fixed automatically. With large drives, a drive check may run for many hours. Shared folders cannot be accessed during a drive check. Do not turn off the TeraStation until the drive check is finished. Follow the procedure below to run a drive check.

- 1 From Settings, click *Storage*.



- 2 Click the settings icon (⚙️) to the right of "Drives" to check an internal drive or "USB Drives" to check an external drive.

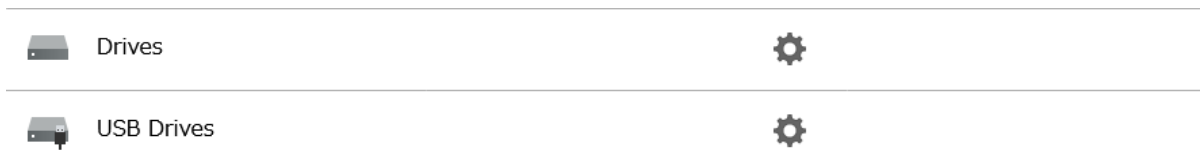

- 3 Select the drive or array to test, then click *Check Drive*.

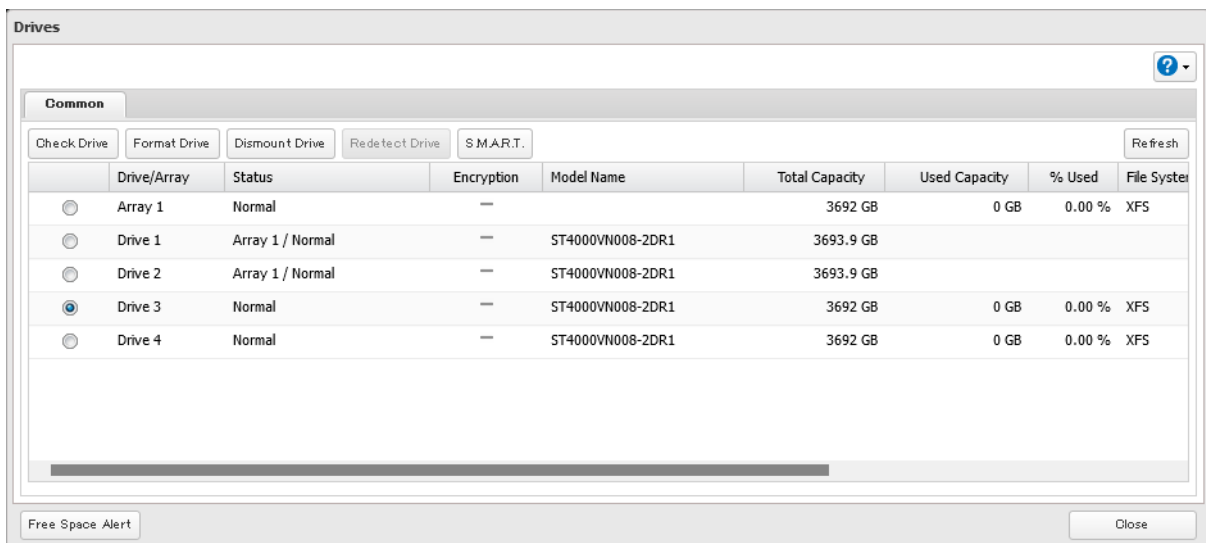

- 4** Click *Check*. You have the option of deleting information files from macOS during the check if desired.

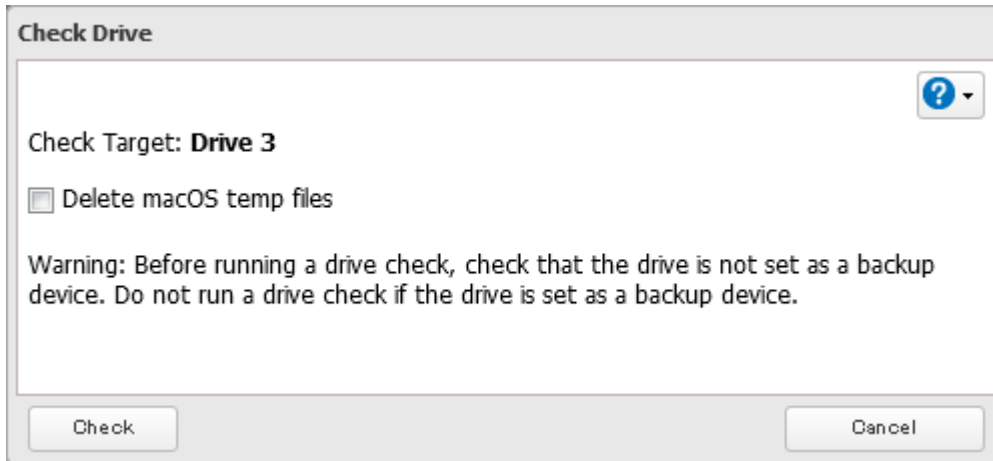

- 5** Either the **I14** message for RAID arrays, the **I21** message for drives, or the **I27** message for USB drives will appear as a notification.

- 6** The process is complete once you close the confirmation window that appears.

---

## S.M.A.R.T.

---

S.M.A.R.T. (Self-Monitoring, Analysis, and Reporting Technology) monitors internal drives to detect and report various indicators of reliability, in the hope of anticipating failures. If S.M.A.R.T. informs you of impending drive failure, you may choose to replace the drive to avoid outages and possible data loss. Follow the procedure below to check S.M.A.R.T. information for the TeraStation's internal drives.

**Note:** S.M.A.R.T. information is only available for internal drives.

## Displaying S.M.A.R.T. Information

---

- 1** From Settings, click *Storage*.



- 2** Click the settings icon (⚙️) to the right of "Drives".



**3** Select a drive to check and click *S.M.A.R.T.*

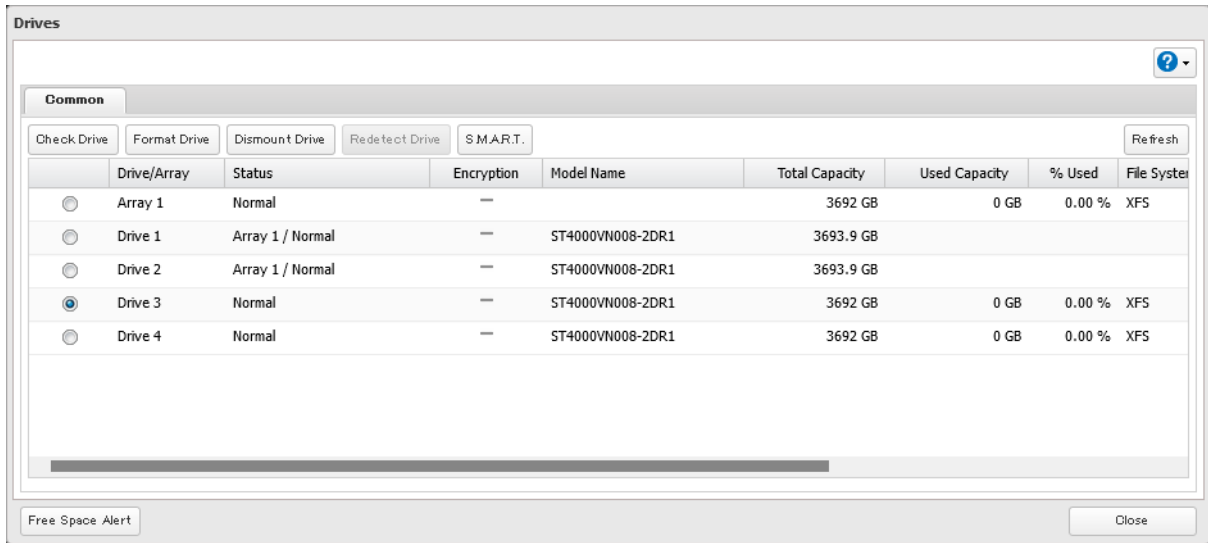

**4** The process is complete when the S.M.A.R.T. information for the drive is displayed. Different information may be displayed depending on the brand of drives on your TeraStation. Critical attributes are displayed in bold.

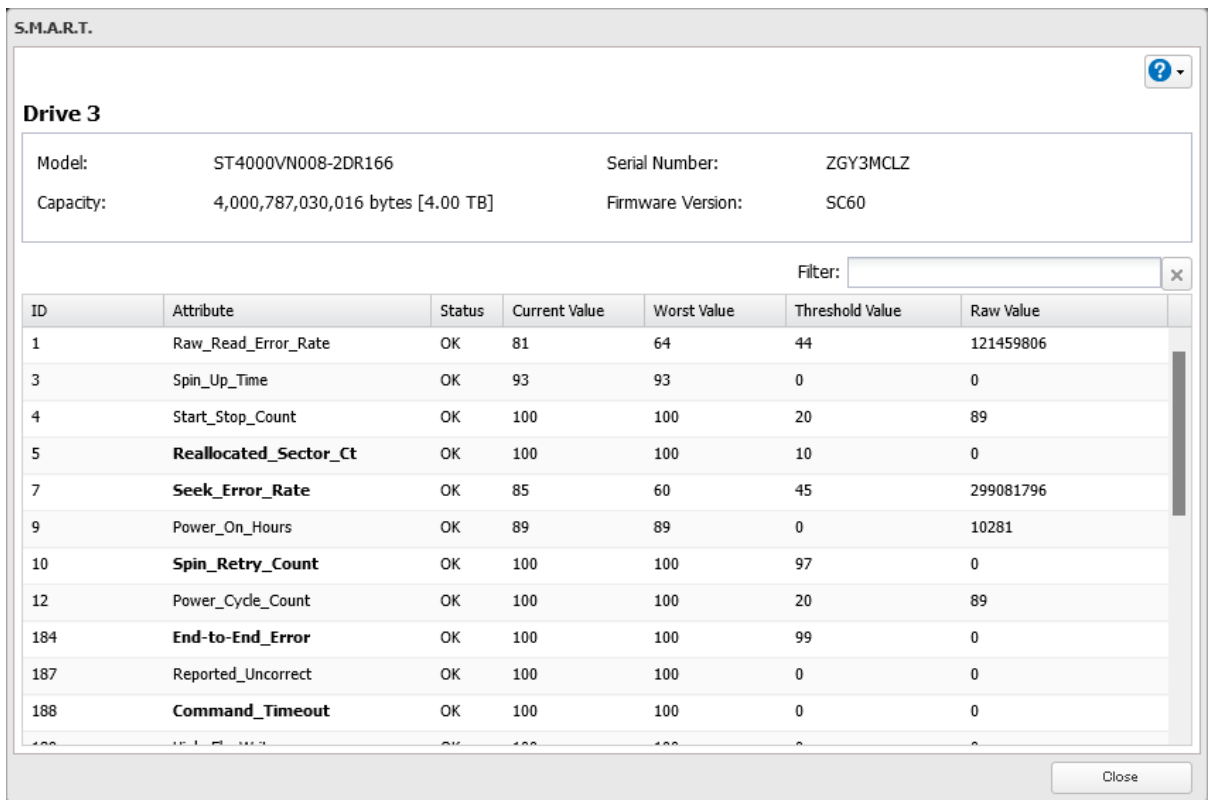

## Checking the Drive Condition

Attributes with the worst value that is equal to or less than the threshold value may be significant. If an attribute reports a failure, or has had one in the past, it will be displayed in the status column. In such a case, replacing that drive is recommended.

## Formatting Drives

**Note:** Under some circumstances, data deleted when a drive is formatted can be recovered. To ensure that data is “gone forever”, a format might not be sufficient. Refer to the [“Erasing Data on the TeraStation Completely”](#) section below for more information.

- 1 From Settings, click *Storage*.



- 2 Click the settings icon (⚙️) to the right of “Drives” to format an internal drive or “USB Drives” to format an external drive.



- 3 Select the drive or array to format, then click *Format Drive*.

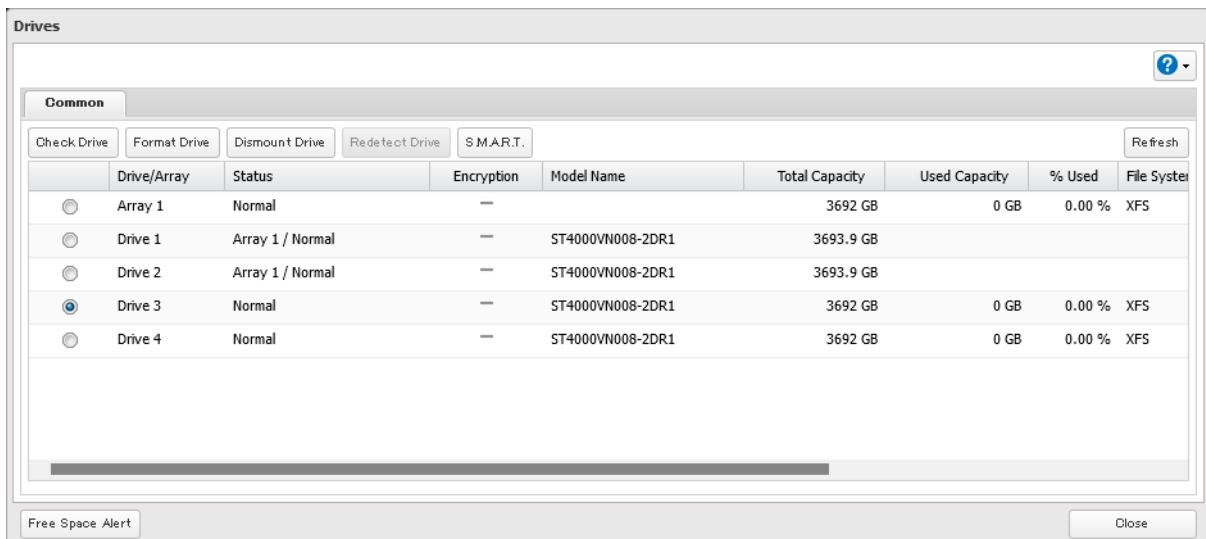



**4** Select a format type, then click *Format*.

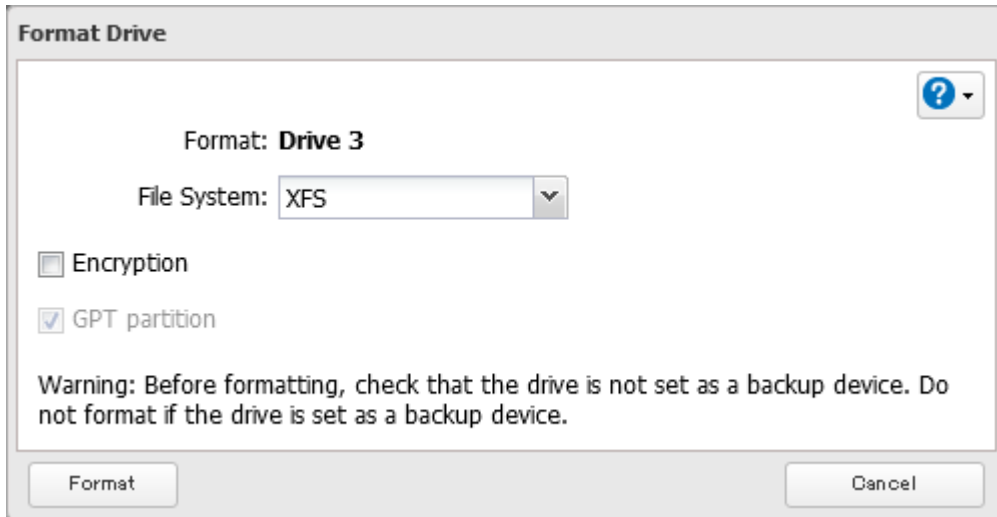

**5** The “Confirm Operation” screen will open. Enter the confirmation number, then click *OK*.

**6** Depending on the size and the formatted file system of your drive, the format may take several minutes or several hours to complete. Either the **I13** message for RAID arrays, the **I20** message for drives, or the **I28** message for USB drives will appear as a notification.

**7** The process is complete once you close the confirmation window that appears.

**Notes:**

- Do not turn off or disconnect power to the TeraStation while formatting a drive.
- For drives that are 2.2 TB or larger, make sure that the “GPT partition” checkbox is selected.

---

## Encrypting Drives

---

Internal drives (and arrays) can be encrypted with 256-bit AES during formatting. Encrypted drives and arrays are then readable only from that specific TeraStation. To decrypt a drive or array, clear the “Encryption” checkbox and format it again.

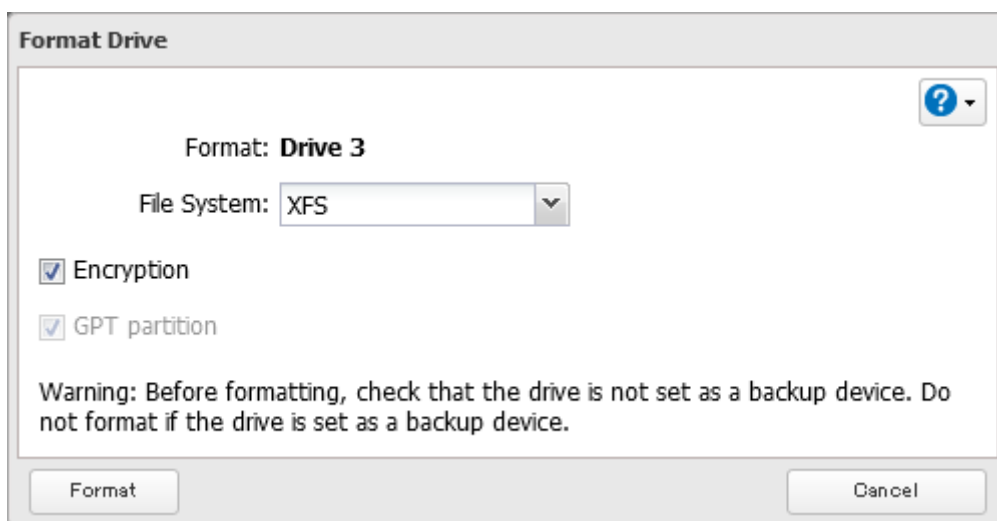

## Erasing Data on the TeraStation Completely

For data erasure, the TeraStation offers both drive formatting and Secure Erase features. Select the data erasure procedure that offers the appropriate level of security you prefer.

- **Full Format:** A full format will overwrite the drives with 0s. Typically, formatting drives on the TeraStation is sufficient to erase data, although data from formatted drives can still be recovered under some circumstances. This level of erasure is sufficient when you transfer, replace, or repair the TeraStation. Refer to the [“Performing a Full Format”](#) section below for the detailed procedure.
- **Secure Erase:** Secure Erase uses Secure Erase commands to fully erase data from the whole drive area. Secure Erase does a much more thorough job of erasing data, and is recommended for removing all data from a drive in a way that makes it nearly impossible to recover with current tools. This level of erasure is recommended if you are planning to dispose of the TeraStation. Refer to the [“Performing the Secure Erase Command”](#) section below for the detailed procedure.

### Performing a Full Format

Follow the procedure below to perform a full format to the TeraStation. After performing a full format, make sure the TeraStation is transferred, replaced, or repaired accordingly.

The TeraStation will be in the following state after a full format is performed:

- All drives in JBOD
- An empty shared folder on each drive
- All settings returned to their default values
- All logs deleted

**1** From Settings, click *Management*.

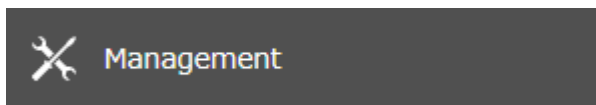

**2** Click the settings icon (  ) to the right of “Restore/Erase”.



**3** Click *Erase TeraStation*.

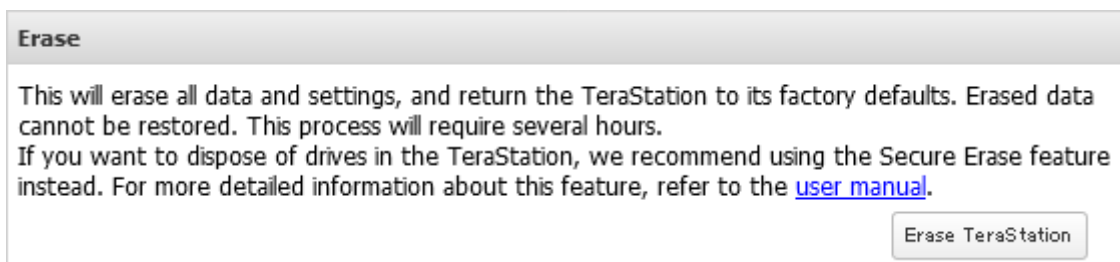

**4** The “Confirm Operation” screen will open. Enter the confirmation number, then click *OK*.

**5** The complete format process will begin. The process is complete when the TeraStation shuts down automatically. To power on the TeraStation, press the power button.

**Note:** If you remove a drive and then erase all data on the TeraStation, the E22 error along with the number of the removed drive will appear as a notification. You can still use the TeraStation.

## Performing the Secure Erase Command

The Secure Erase feature runs the Secure Erase command native on a drive to eliminate its data using methods that meet the Purge category according to NIST 800-88 standards.

Follow the procedure below to perform the Secure Erase command on the TeraStation. After performing the Secure Erase command, dispose of the TeraStation and its drives accordingly.

The Secure Erase feature is intended to be permanently data destructive. Buffalo's product warranty does not cover data loss in the use of this or any other system application.

- 1 Press and hold down the power button for three seconds to turn off the TeraStation.
- 2 Turn the TeraStation back on while holding down the function button. You should hold down the function button for at least 10 seconds after pressing the power button.
- 3 When the power LED changes from blinking to glowing, release the function button and open Settings from NAS Navigator2.
- 4 Click *OK*.
- 5 Under the "Secure Erase" section, click *Start Secure Erase*.

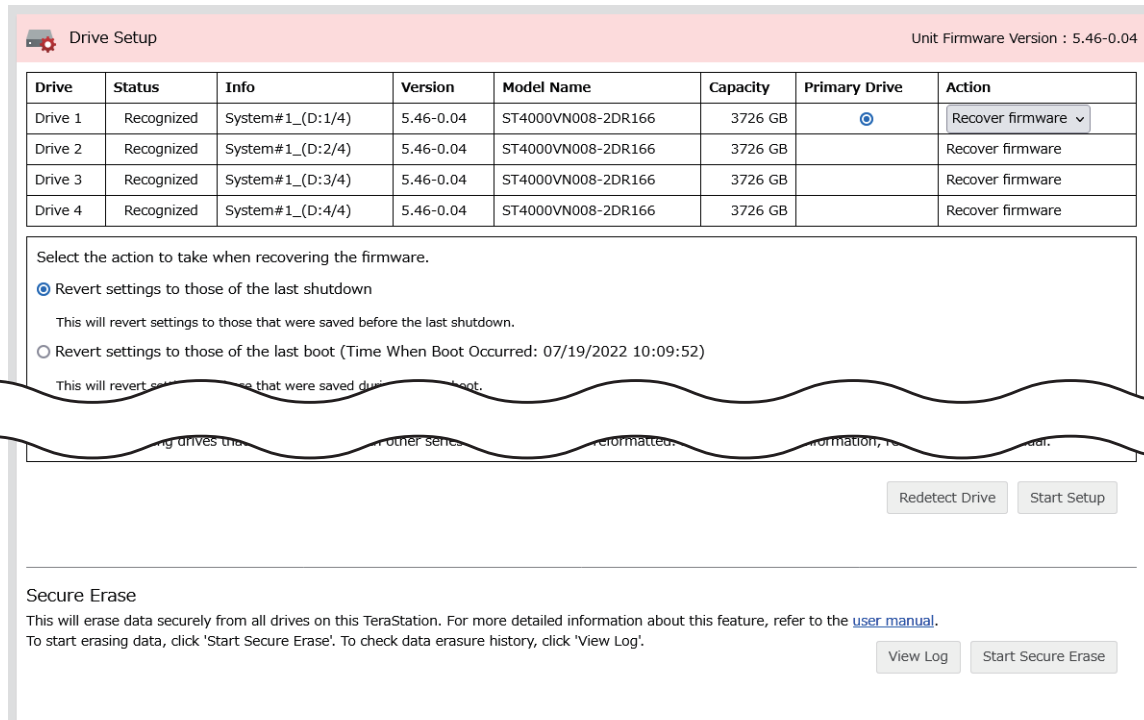

The screenshot shows the 'Drive Setup' window with the following table:

Drive	Status	Info	Version	Model Name	Capacity	Primary Drive	Action
Drive 1	Recognized	System#1_(D:1/4)	5.46-0.04	ST4000VN008-2DR166	3726 GB	<input checked="" type="radio"/>	Recover firmware ▾
Drive 2	Recognized	System#1_(D:2/4)	5.46-0.04	ST4000VN008-2DR166	3726 GB	<input type="radio"/>	Recover firmware
Drive 3	Recognized	System#1_(D:3/4)	5.46-0.04	ST4000VN008-2DR166	3726 GB	<input type="radio"/>	Recover firmware
Drive 4	Recognized	System#1_(D:4/4)	5.46-0.04	ST4000VN008-2DR166	3726 GB	<input type="radio"/>	Recover firmware

Below the table, there are radio buttons for selecting the action to take when recovering the firmware:

- Revert settings to those of the last shutdown. This will revert settings to those that were saved before the last shutdown.
- Revert settings to those of the last boot (Time When Boot Occurred: 07/19/2022 10:09:52). This will revert settings to those that were saved during the last boot.

At the bottom of the 'Drive Setup' window, there are buttons for 'Redetect Drive' and 'Start Setup'.

The 'Secure Erase' section is visible below, with the following text:

**Secure Erase**  
 This will erase data securely from all drives on this TeraStation. For more detailed information about this feature, refer to the [user manual](#).  
 To start erasing data, click 'Start Secure Erase'. To check data erasure history, click 'View Log'.

Buttons for 'View Log' and 'Start Secure Erase' are located at the bottom right of the 'Secure Erase' section.

- 6 Read the message carefully and click *OK*.

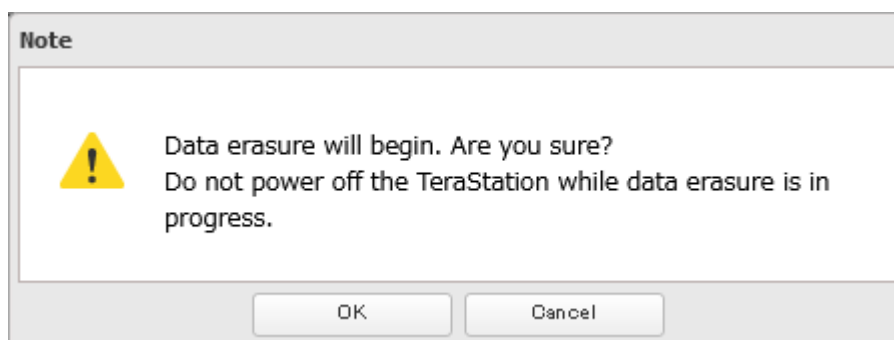

**7** The “Confirm Operation” screen will open. Enter the confirmation number, then click *OK*.

**8** The Secure Erase process will begin. Wait until it’s finished.

**Note:** The data erasure process will be run on multiple drives at the same time. The full process will take about 1.5 to 2.5 hours per terabyte, and the duration will vary depending on the model and status of the drives.

**9** The process is complete once you close the following window. If you want to save the erasure log, click *Save Log*, then save the log file to the desired location.

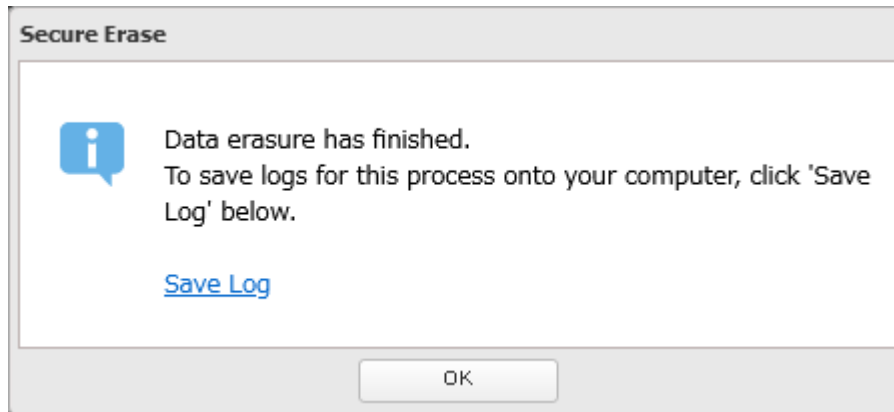

**Notes:**

- The Secure Erase feature will erase the system area where the firmware is installed. After running Secure Erase, the TeraStation will only be able to boot up in drive setup mode.
- If the TeraStation is powered off unexpectedly while the Secure Erase process is running such as due to a sudden power outage, follow the procedure below to recover it.
  - (1) If the TeraStation is currently on, turn the TeraStation off by pressing and holding down the power button for three seconds.
  - (2) Remove all drives from the TeraStation.
  - (3) Turn the TeraStation back on.
  - (4) When the power LED changes from blinking to glowing, reconnect the drives.
  - (5) Follow from step 3 in the [“Performing the Secure Erase Command”](#) section above to try the Secure Erase feature again.

## Quotas

You can set a quota for each user or group, as well as a threshold alert where you will receive an email notification if the space used exceeds the configured threshold. To configure email notifications for the quota, refer to the [“Email Notification”](#) section in chapter 10.

**Notes:**

- When using quotas, disable the recycle bin or empty the trash folder often. The limited space includes the space used for trash.
- Quotas apply per drive or per array. If a quota is set to 1 GB, each array or drive can use a maximum of 1 GB.
- Quotas cannot be set for external drives connected to the TeraStation.
- If both user and group quotas are configured for a user, the most restrictive quota will always apply.
- When joined to a domain, only local users and groups will be able to set quotas. Domain users and groups will be able to configure access restrictions for shares but cannot set quotas.

## Limits for Users

Follow this procedure to limit the shared folder space available for a user.

- 1 From Settings, click *File Sharing*.

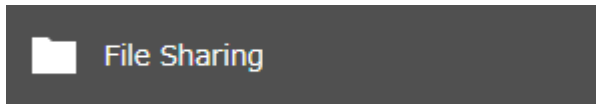

- 2 Click the settings icon (  ) to the right of "Users".



- 3 Select the user that will be given a quota and click *Edit*. If you want to set a quota for a new user, create a user by referring to the ["Adding a User"](#) section in chapter 3.

- 4 Enable "Quota" and choose the alert and the maximum amount of space the user will be allowed to use, then click *OK*.

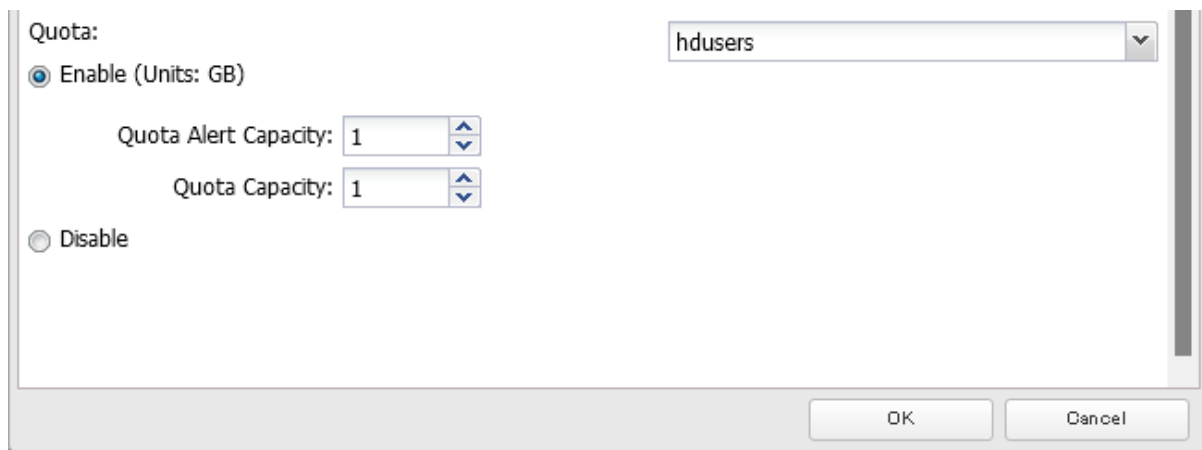

- 5 The process is complete once you close the confirmation window that appears.

**Note:** If you change the primary group, restart the TeraStation to apply the quota settings.

## Limits for Groups

Follow the procedure below to limit the space for shared folders that each group can use.

- 1 From Settings, click *File Sharing*.

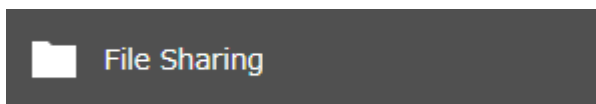

- 2 Click the settings icon (  ) to the right of "Groups".



- 3 Select the group that will be given a quota and click *Edit*. If you want to set a quota for a new group, create a group by referring to the ["Adding a Group"](#) section in chapter 3.

- 4 Enable “Quota” and choose the alert and the maximum amount of space the group will be allowed to use, then click *OK*.

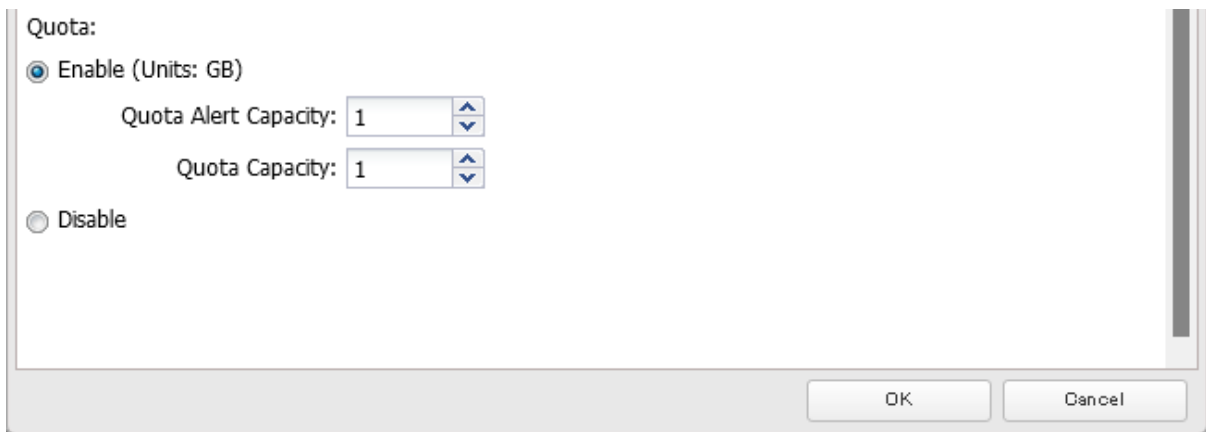

- 5 Click *Close*.

- 6 Click the settings icon (  ) to the right of “Users”.

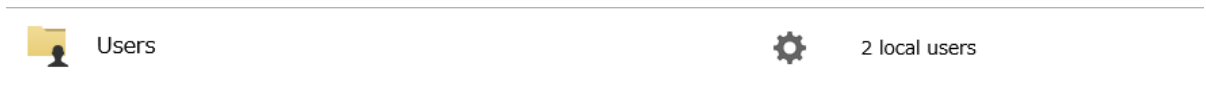

- 7 Select the user that will inherit the group quota settings and click *Edit*. If you want to add a new user to a group with a quota, create a user by referring to the [“Adding a User”](#) section in chapter 3.
- 8 Select the group’s checkbox to join and change the user’s primary group to the group with the quota, then click *OK*.
- 9 Click *Close*.

**10** Click  at the top-right of Settings and choose *Restart*.

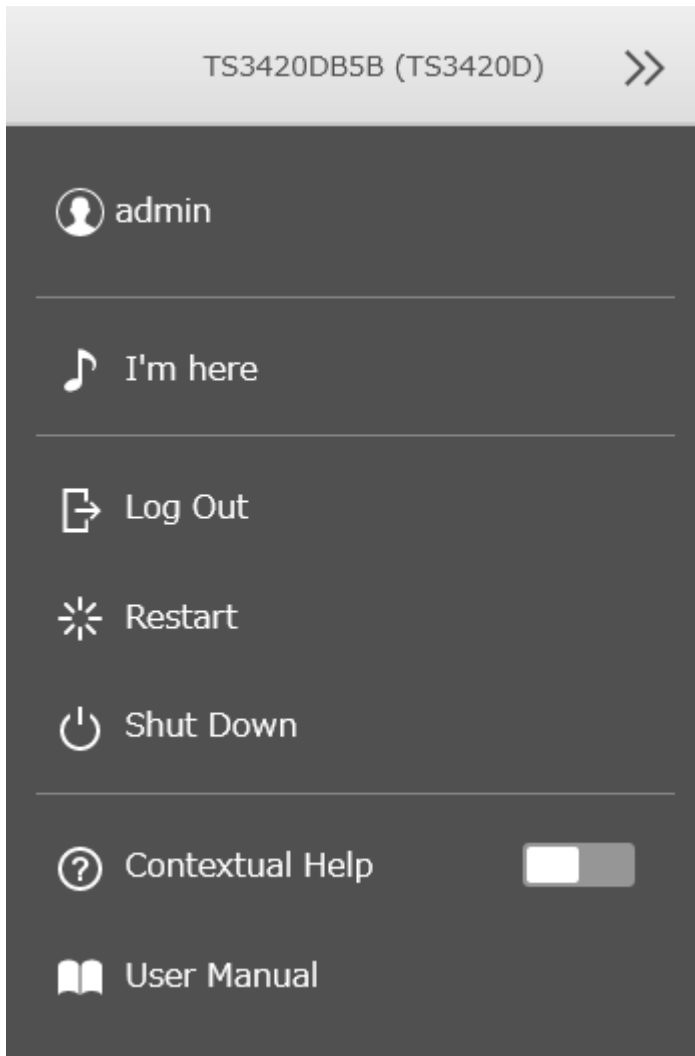

**11** The process is complete once after the TeraStation has been restarted.

## Limits for LVM Volumes

---

If LVM is enabled, volumes can be created with maximum size limits.

### Notes:

- When creating an LVM volume, all data in the area you specified for the LVM volume will be erased. Before changing any settings, back up any important data.
- Do not use any of the following words for the name of a volume as these words are reserved for internal use by the TeraStation: array *x*, authtest, disk *x*, global, homes, info, lost+found, lp, mediacartridge *x*, msdfs\_root, mt-daapd, printers, ram, spool, usbdisk *x*. Any instances of “*x*” denote a number (for example: array1 or disk3)

**1** From Settings, click *Storage*.



2 Click the settings icon (  ) to the right of “LVM”.

 LVM



3 Select the drive or array where the volume will be located and click *Enable LVM*.

**LVM List**

Enable LVM    Disable LVM    Filter:

	Drive/Array	Volume List	Status	LVM Status	NAS Volume
<input checked="" type="radio"/>	Array 1		Normal	Disabled	
<input type="radio"/>	Drive 1		Array 1 / Normal	Disabled	
<input type="radio"/>	Drive 2		Array 1 / Normal	Disabled	
<input type="radio"/>	Drive 3		Array 1 / Normal	Disabled	
<input type="radio"/>	Drive 4		Array 1 / Normal	Disabled	

iSCSI Volumes    Close

4 The “Confirm Operation” screen will open. Enter the confirmation number, then click *OK*.

5 Click *Edit* under “NAS Volume”.

**LVM List**

Enable LVM    Disable LVM    Filter:

	Drive/Array	Volume List	Status	LVM Status	NAS Volume
<input checked="" type="radio"/>	Array 1	<input type="button" value="Show"/>	LVM Enabled / Normal	Enabled	<input type="button" value="Edit"/>
<input type="radio"/>	Drive 1		Array 1 / Normal	Disabled	
<input type="radio"/>	Drive 2		Array 1 / Normal	Disabled	
<input type="radio"/>	Drive 3		Array 1 / Normal	Disabled	
<input type="radio"/>	Drive 4		Array 1 / Normal	Disabled	

iSCSI Volumes    Close

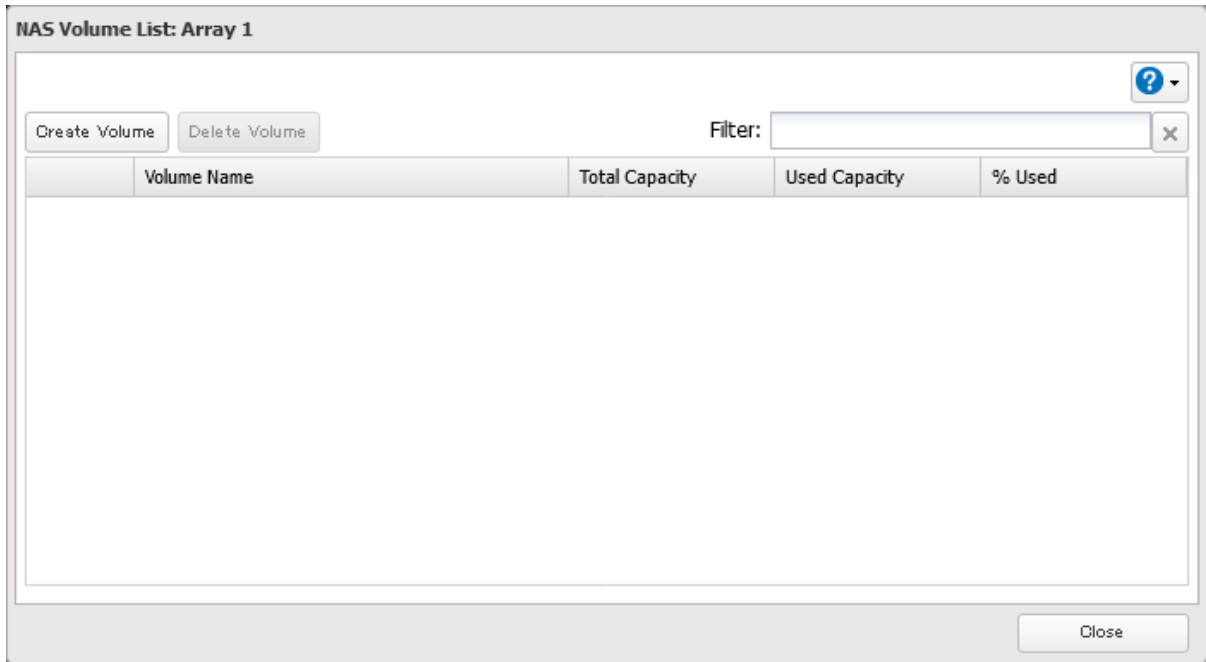
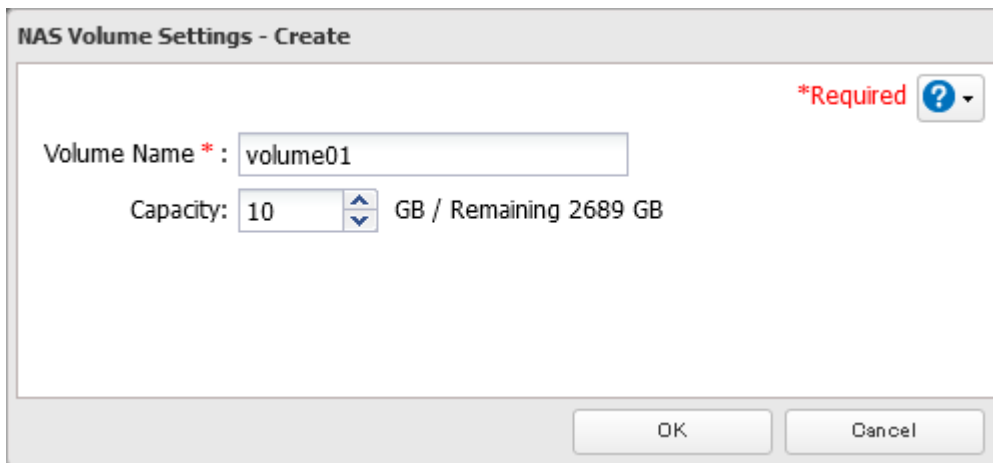

**6** Click *Create Volume*.**7** Configure the desired settings, then click *OK*.**8** The process is complete once you close the confirmation window that appears.

The usable capacity can now be limited by selecting the volume that you created for “Drive/Array” on the *Basic* tab when creating a shared folder.

**Notes:**

- If you click *Show* under “Volume List”, the volumes will be listed on the screen and you can see if these volumes are being used as iSCSI or NAS.
- If an LVM volume could not be mounted, try restarting the TeraStation. If an issue still exists, delete the LVM volume and recreate it. Deleting the LVM volume will erase all data on the volume.

---

## Using the TeraStation as an iSCSI Device

---

**Note:** This function is not available for the TS3420DS and TS3420RS TeraStation models, and will not appear in Settings for these models.

## Introduction

---

iSCSI is a protocol for carrying SCSI commands over IP networks. Unlike traditional SAN protocols such as Fibre Channel, which requires special-purpose cabling, iSCSI can be run over long distances using existing network infrastructure. Normal Windows formatting such as NTFS is supported.

### Differences Between NAS and iSCSI

With iSCSI, the TeraStation is connected to a single computer, such as a server. Other computers on the network access files on the TeraStation through the computer it's connected to. The TeraStation can be used as a local drive from Windows Server. Features of Windows Server such as Active Directory can be used normally.

As a NAS, the TeraStation is a server, and computers (including other servers) on the network can access shared folders on it directly. A separate server is not required, and features such as backup are built-in.

### Network Configuration

Use gigabit or faster network equipment with iSCSI. For best results, a dedicated network for iSCSI is recommended, separate from the regular network. By default, the IP address of the TeraStation is automatically assigned from a DHCP server. However, in this case, if you turn off and restart the TeraStation, the IP address may be changed and the volumes on the TeraStation may not be accessible. To avoid changing the IP address unexpectedly, using a static IP address for the TeraStation is recommended.

### Connection Tool

The Microsoft iSCSI Software Initiator is already installed on your computer. You don't need to download and install it.

## Creating an iSCSI Volume

---

To use the TeraStation as an iSCSI drive, create a volume first. Configure the TeraStation as described below.

#### Notes:

- If the volume settings are changed, all data on the volume will be erased. Before changing any settings, back up any important data.
- The TeraStation can have up to 255 volumes, but we recommend creating no more than 32. Exceeding this volume amount may cause irreparable damage to the unit.
- Do not use any of the following words for the name of a volume as these words are reserved for internal use by the TeraStation: array *x*, authtest, disk *x*, global, homes, info, lost+found, lp, mediacartridge *x*, msdfs\_root, mt-daapd, printers, ram, spool, usbdisk *x*. Any instances of "x" denote a number (for example: array1 or disk3)
- There are two options for the "Backstore" setting to select the type of iSCSI volume. Refer to the differences below.
  - **File I/O:** This type of volume can specify the volume capacity and multiple volumes can be created on one drive or RAID array. This also allows you to expand the volume capacity after the volume is created and data has been stored.
  - **Block I/O:** This type of volume will create an iSCSI volume for a whole drive or RAID array. However, if you enable LVM, you can create multiple volumes on the drive or the RAID array or expand the volume capacity later, just like a file I/O volume. It is recommended to enable LVM if you want to create multiple volumes on one drive or RAID array, or expand the volume later.

Block I/O volumes afford higher performance than file I/O volumes because there is less latency when bypassing the file system layer required for file I/O.

**1** From Settings, click *Storage*.



**2** Move the iSCSI switch (  ) to the  position to enable iSCSI.



**3** Click the settings icon (  ) to the right of “iSCSI”.



**4** Click *Create Volume*.

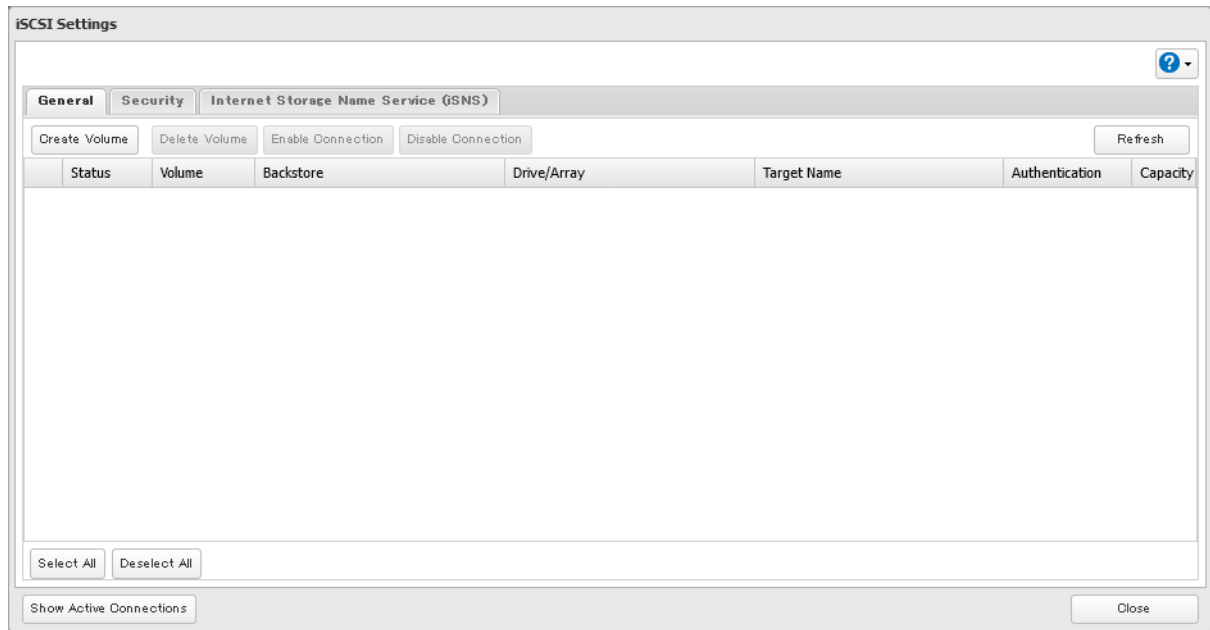

## 5 Configure the desired settings, then click *OK*.

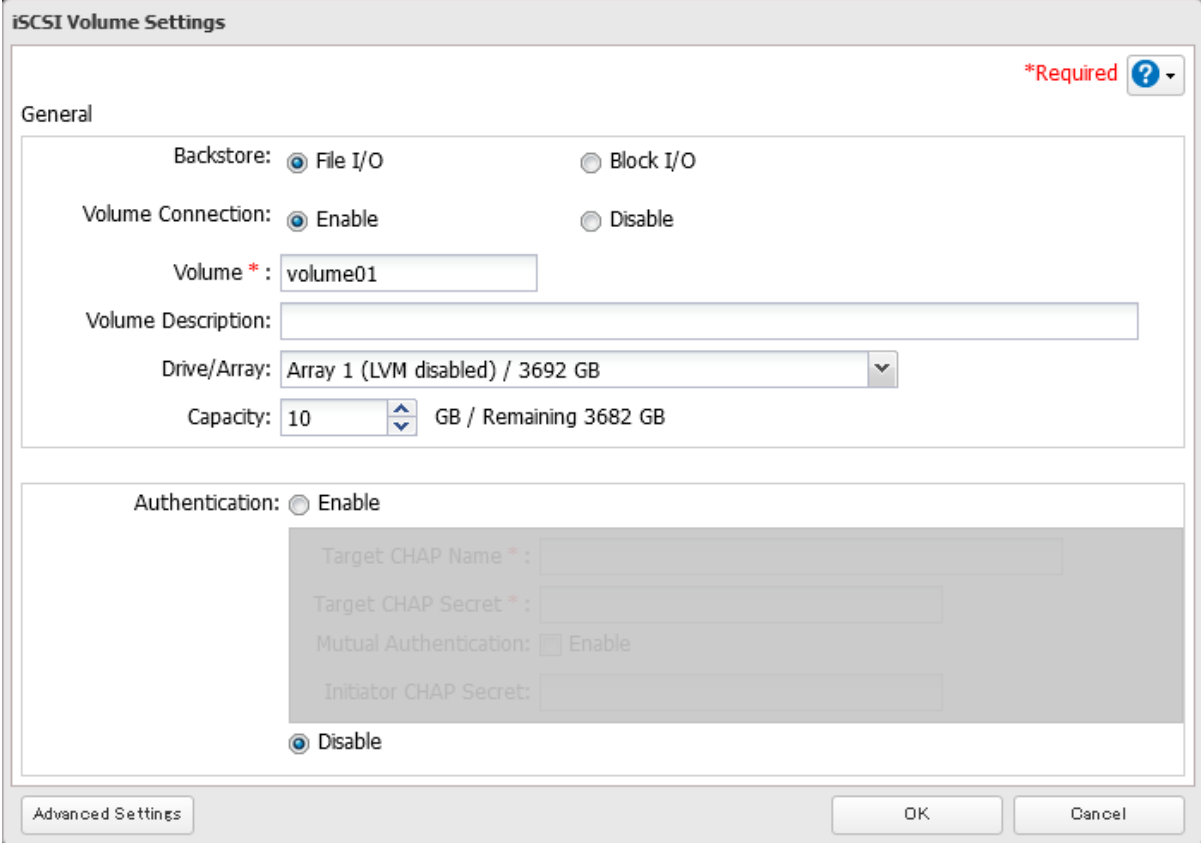

**iSCSI Volume Settings** \*Required ?

**General**

Backstore:  File I/O  Block I/O

Volume Connection:  Enable  Disable

Volume \*:

Volume Description:

Drive/Array:  ▼

Capacity:  ▲▼ GB / Remaining 3682 GB

---

Authentication:  Enable

Target CHAP Name \*:

Target CHAP Secret \*:

Mutual Authentication:  Enable

Initiator CHAP Secret:

Disable

### Notes:

- If you have selected “Block I/O”, write cache (WCE) cannot be configured from the “Advanced Settings” page.
- If using both iSCSI volumes and shared folders on the same area, it is recommended to create either file I/O volumes, or block I/O volumes with LVM enabled.

## 6 Read the message carefully and click *OK*.

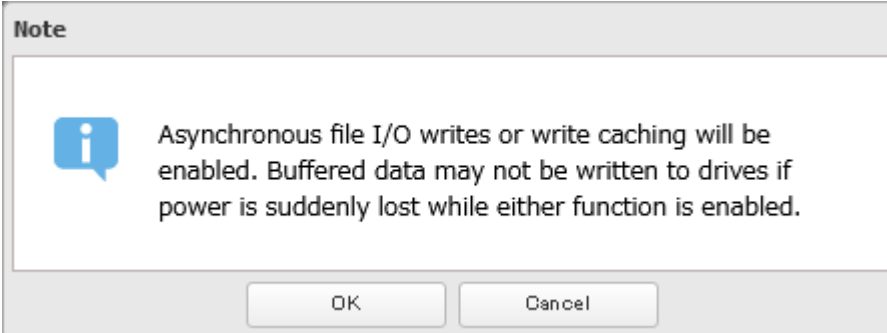

**Note**

 Asynchronous file I/O writes or write caching will be enabled. Buffered data may not be written to drives if power is suddenly lost while either function is enabled.

## 7 The process is complete once you close the confirmation window that appears.

**Note:** If you click *Disable Connection* for the selected volume in *Storage > iSCSI* in Settings, the selected iSCSI volume can no longer be accessed. If you click *Enable Connection*, the volume will become accessible from the iSCSI initiator software.

## Connecting Volumes

To connect a volume, follow the procedure below.

**Note:** Do not shut down the TeraStation while connecting to an iSCSI volume. It may cause unexpected data erasure. Make sure all connections are disconnected before shutdown.

- 1 From Windows, navigate to *Control Panel > System and Security > Administrative Tools > iSCSI Initiator*.
- 2 Enter the IP address of the TeraStation into the “Target” field and click *Quick Connect*.

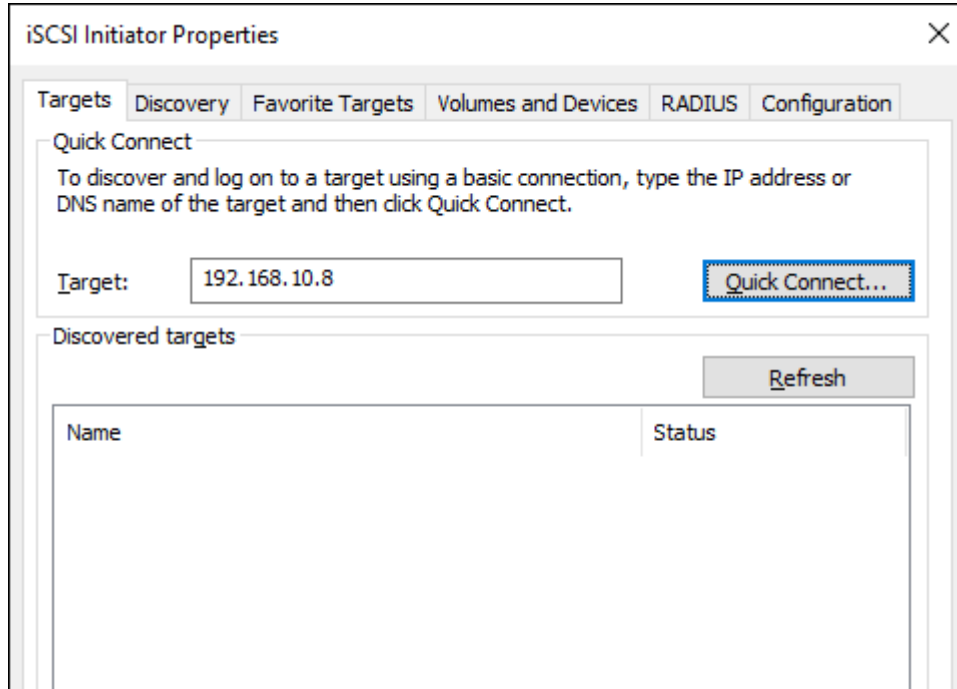

- 3 Confirm if the connection is established and click *Done*.
- 4 The process is complete when the status of the selected volume is displayed as “Connected” on the iSCSI initiator.  
You can also check that the volume status is “Connected” in Settings by navigating to *Storage > iSCSI*.

### Using with Multiple Computers

If the TeraStation is divided into multiple volumes (or drives), it can be used with multiple computers. However, it is not recommended to access a single volume or drive from multiple computers at the same time for security reasons. When using the TeraStation as an iSCSI device, it should only connect to a single initiator unless the computer running the initiator also has clustering enabled and configured on its operating system. To avoid using multiple initiators for access, enable mutual authentication.

### Formatting Volumes

If using the connected volume for the first time, the volume should be formatted to be used as a local drive. Follow the procedure below for formatting.

- 1 From Windows, navigate to *Control Panel > System and Security > Administrative Tools > Computer Management*.
- 2 Click *Disk Management*.  
When the “Initialize Disk” screen appears, click *OK* without changing any settings.
- 3 Right-click the drive volume that shows the status “Unallocated” and click *New Simple Volume* from the displayed menu. Follow the screen to finish formatting.

- 4 The process is complete when the drive is visible as an icon in Computer or This PC and can be used as a normal drive on the computer.

## Disconnecting Volumes

---

To disconnect a volume, follow the procedure below.

- 1 From Windows, navigate to *Control Panel > System and Security > Administrative Tools > iSCSI Initiator*. The status of the connecting volume will be displayed as “Connected” under “Discovered targets”.
- 2 Select a volume to disconnect and click *Disconnect*.
- 3 Click *Yes*.
- 4 The process is complete when the volume status is displayed as “Inactive” on the iSCSI initiator.

## Configuring Access Restrictions

---

A CHAP name and secret can be configured for the entire iSCSI volume or each existing volume. Access restrictions can be configured so that entering a target CHAP name and secret is required for each connection. The TeraStation can perform mutual authentication (two-way authentication). Dual passwords ensure that only authorized client computers can access the volume on the TeraStation.

### Configuring for the Entire TeraStation

Follow the procedure below to enable access restrictions for the entire TeraStation.

- 1 From Settings, click *Storage*.



- 2 Click the settings icon (  ) to the right of “iSCSI”.



**3** Click the *Security* tab, then click *Edit*.

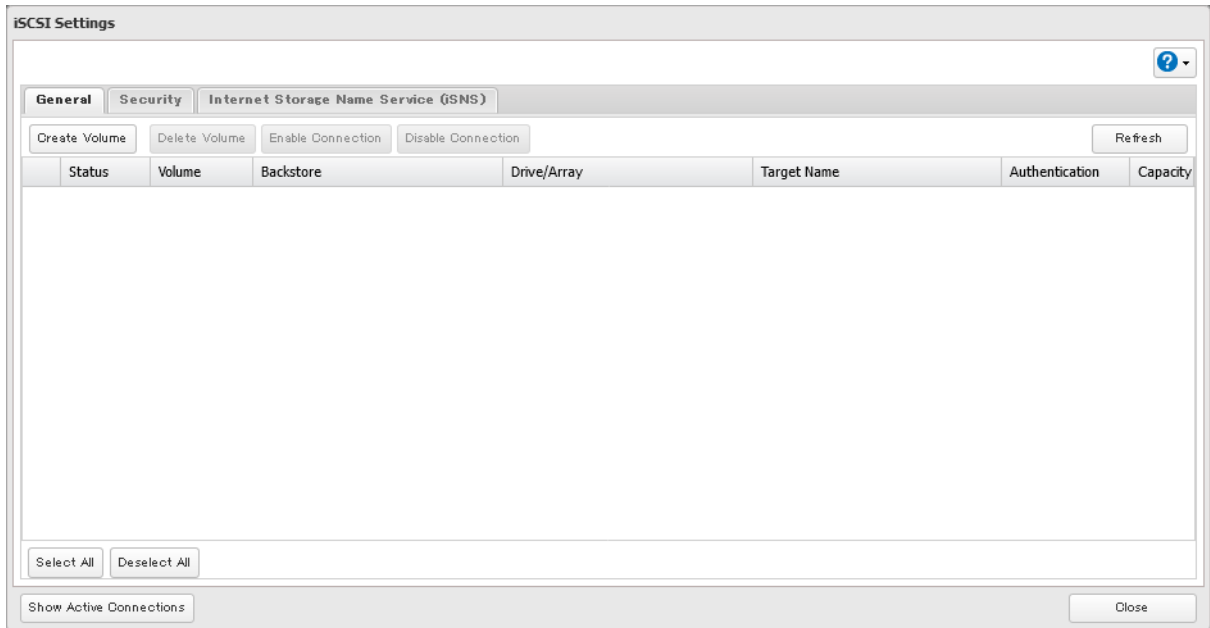

**4** Enable “Authentication” and enter the target CHAP name and secret, then click *OK*.

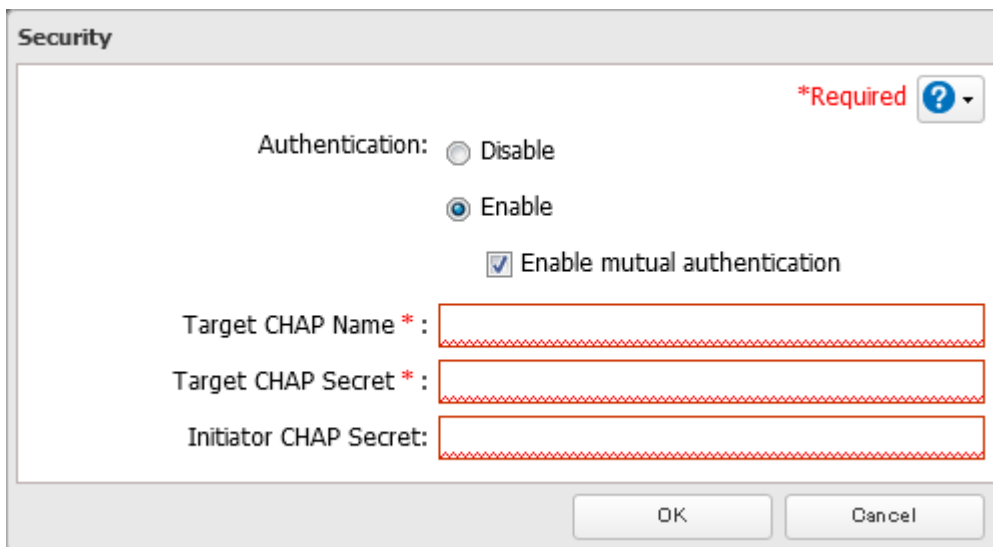

**Note:** To enable mutual authentication in addition to target CHAP name and secret authentication, select the “Enable mutual authentication” checkbox and enter the initiator CHAP secret.

To search or connect the volume which has mutual authentication enabled from Microsoft iSCSI Initiator, initiator CHAP secret settings should be configured.

**5** The process is complete once you close the confirmation window that appears.

## Configuring for Individual Volumes

Follow the procedure below to configure access restrictions for individual volumes.

**1** From Settings, click *Storage*.



2 Click the settings icon (  ) to the right of “iSCSI”.

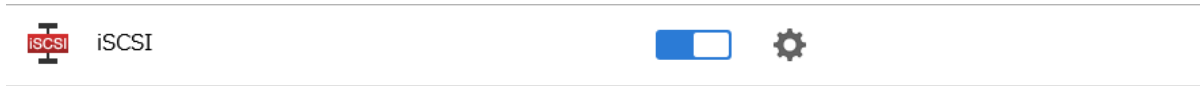

3 Click the volume to enable access restrictions.

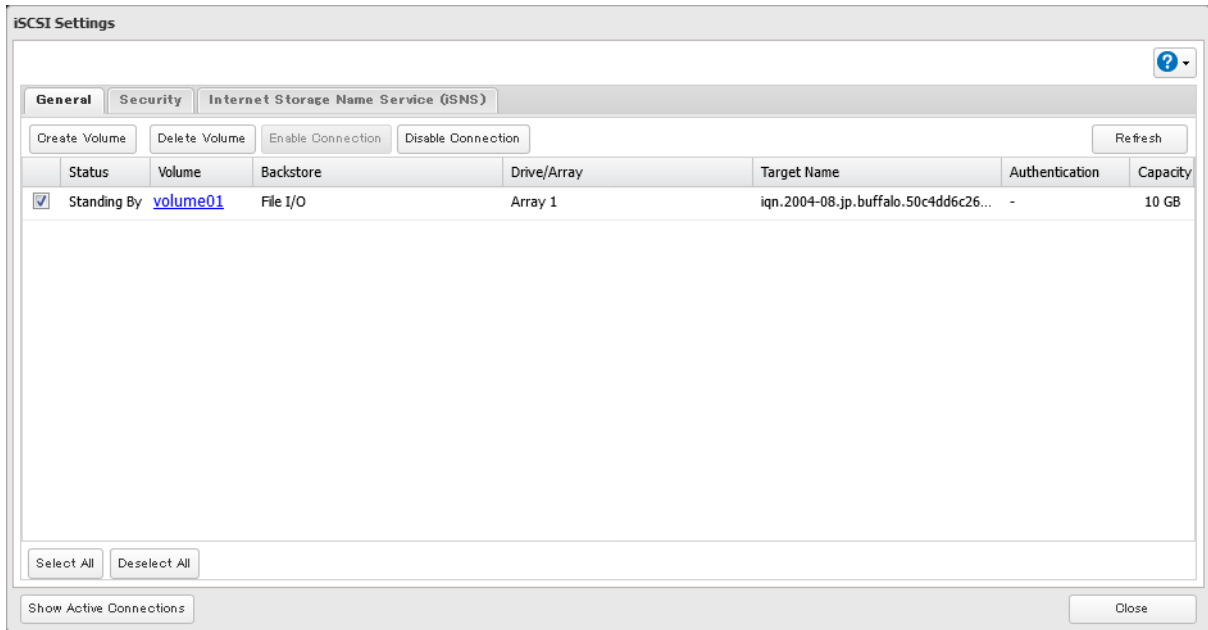

4 Enable “Authentication” and enter the target CHAP name and secret, then click OK.

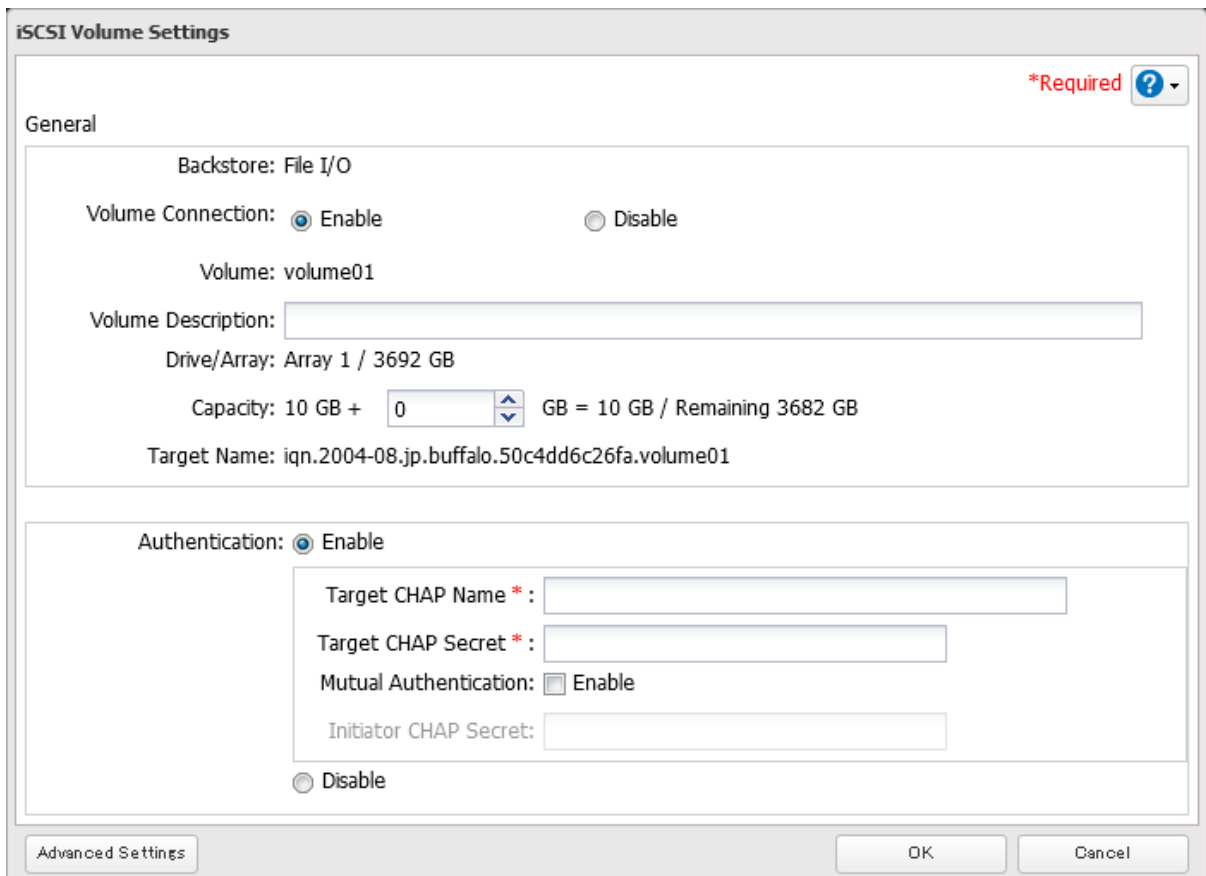



**Note:** To enable mutual authentication in addition to target CHAP secret authentication, select the “Enable” checkbox for “Mutual Authentication” and enter the initiator CHAP secret.

**5** The process is complete once you close the confirmation window that appears.

## Connecting Access-Restricted Volumes

---

### Connecting if Volume Access Is Restricted

If access restrictions are configured for the entire iSCSI volume, that volume will not be detected by Microsoft iSCSI Initiator. To connect that volume, the target CHAP name and secret should be authenticated.

- 1** Open the Microsoft iSCSI Initiator.
- 2** Register the initiator CHAP secret to your computer first. If you didn’t enable mutual authentication, skip this step.  
Click *CHAP* on the *Configuration* tab. Enter the configured initiator CHAP secret into the “Initiator CHAP secret” field and click *OK*.
- 3** From the *Discovery* tab, click *Discover Portal*.
- 4** Enter the TeraStation’s IP address into the “IP address or DNS name” field and click *Advanced*.
- 5** Select the “Enable CHAP log on” checkbox and enter the target CHAP name into the “Name” field and the target CHAP secret into the “Target secret” field.  
If mutual authentication is enabled, select the “Perform mutual authentication” checkbox.
- 6** Click *OK*, then click *OK* again.
- 7** The iSCSI volumes on the TeraStation will be listed under “Discovered targets” on the *Targets* tab. Select the desired volume to connect and click *Connect*.
- 8** The process is complete when the status of the selected volume is displayed as “Connected” on the iSCSI initiator.

### Connecting if Volume Access Is Partially Restricted

- 1** Open the Microsoft iSCSI Initiator.
- 2** Register the initiator CHAP secret to your computer first. If you didn’t enable mutual authentication, skip this step.  
Click *CHAP* on the *Configuration* tab. Enter the configured initiator CHAP secret into the “Initiator CHAP secret” field and click *OK*.
- 3** From the *Discovery* tab, click *Discover Portal*.
- 4** Enter the TeraStation’s IP address into the “IP address or DNS name” field and click *OK*.
- 5** The iSCSI volumes on the TeraStation will be listed under “Discovered targets” on the *Targets* tab. Select the desired volume to connect and click *Connect*.
- 6** Click *Advanced*.

**7** Select the “Enable CHAP log on” checkbox and enter the target CHAP name into the “Name” field and the target CHAP secret into the “Target secret” field.

If mutual authentication is enabled, select the “Perform mutual authentication” checkbox.

**8** Click *OK*, then click *OK* again.

**9** The process is complete when the status of the selected volume is displayed as “Connected” on the iSCSI initiator.

## Expanding Volume Capacity

The capacities of the existing volumes can be expanded after they are created.

### Notes:

- Expanding the volume capacity may erase all data on the volume depending on the formatting type. Backing up the data before expanding the volume capacity is recommended.
- To expand its capacity, the volume should be a file I/O volume; if expanding the capacity of a block I/O volume, it needs to have been created on a drive or array that has LVM enabled.

**1** From Settings, click *Storage*.



**2** Click the settings icon (  ) to the right of “iSCSI”.



**3** Select the volume to expand.

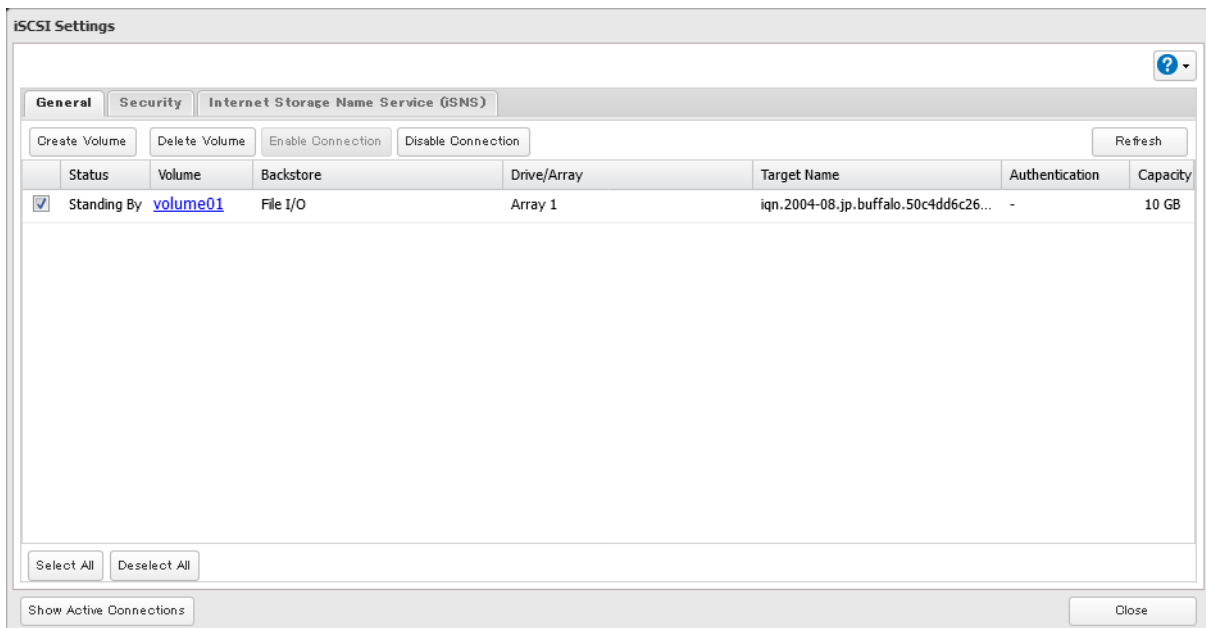

**4** Enter the desired volume capacity to add and click *OK*.

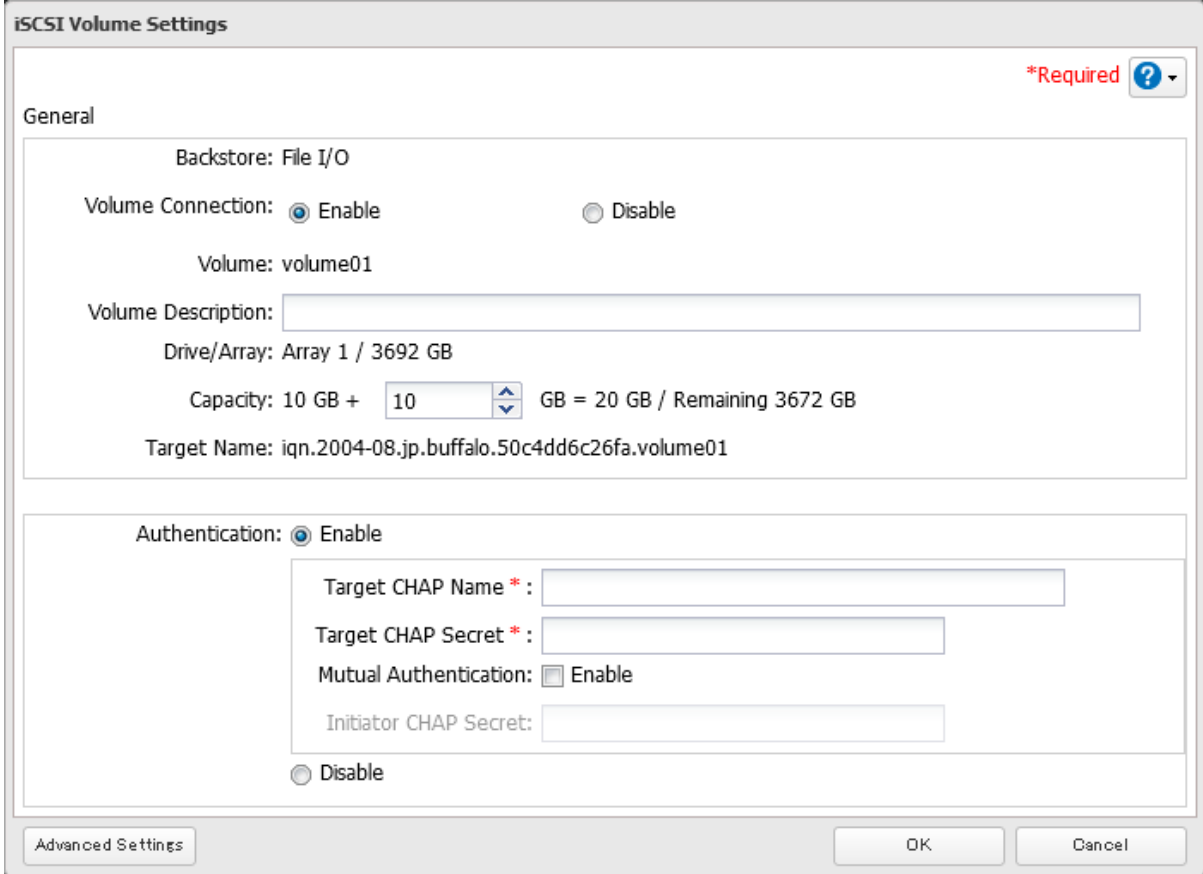

The image shows the 'iSCSI Volume Settings' dialog box. It has a title bar with the text 'iSCSI Volume Settings' and a '\*Required' indicator with a help icon. The dialog is divided into two main sections: 'General' and 'Authentication'. In the 'General' section, 'Backstore' is set to 'File I/O'. 'Volume Connection' has radio buttons for 'Enable' (selected) and 'Disable'. 'Volume' is set to 'volume01'. There is a text field for 'Volume Description'. 'Drive/Array' is 'Array 1 / 3692 GB'. 'Capacity' is set to '10 GB + 10' (with a spinner box) and 'GB = 20 GB / Remaining 3672 GB'. 'Target Name' is 'iqn.2004-08.jp.buffalo.50c4dd6c26fa.volume01'. In the 'Authentication' section, 'Authentication' has radio buttons for 'Enable' (selected) and 'Disable'. Below this are fields for 'Target CHAP Name \*', 'Target CHAP Secret \*', 'Mutual Authentication' (checkbox checked, labeled 'Enable'), and 'Initiator CHAP Secret'. At the bottom, there are buttons for 'Advanced Settings', 'OK', and 'Cancel'.

**5** The process is complete once you close the confirmation window that appears.

## Deleting Volumes

To delete an existing volume, follow the procedure below.

**Note:** Deleting a volume will erase all data on the volume. Back up the data before deleting the volume.

**1** From Settings, click *Storage*.



**2** Click the settings icon (  ) to the right of "iSCSI".



**3** Select the volume to delete and click *Delete Volume*.

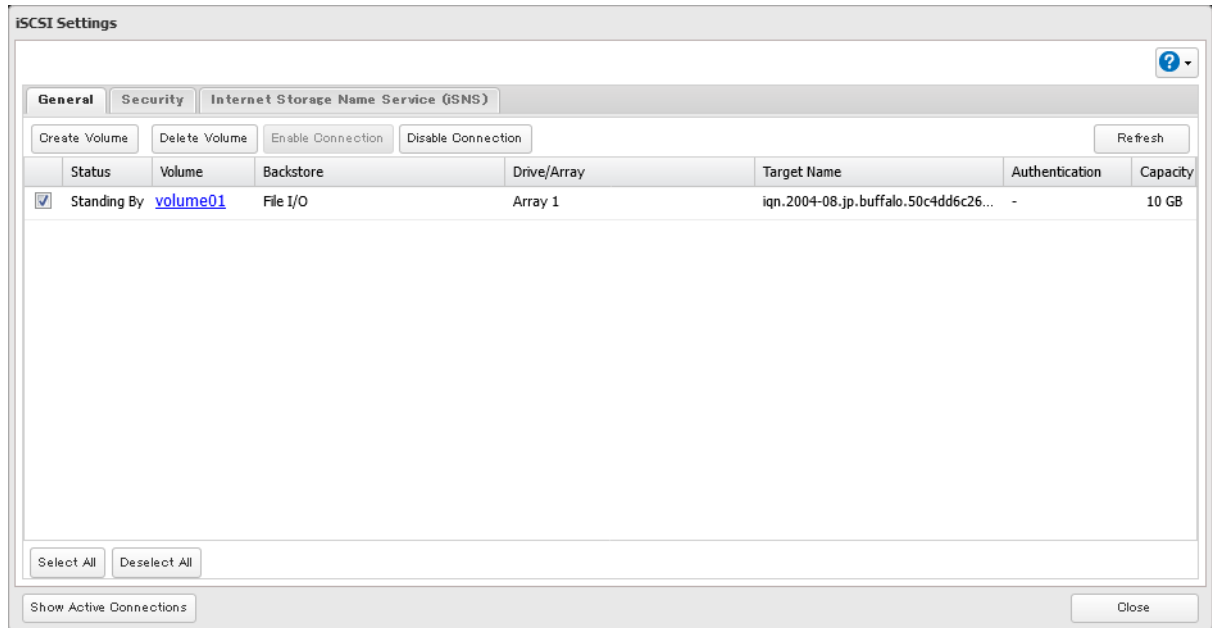

**4** Confirm that the volume is correctly selected on the screen and click *OK*.

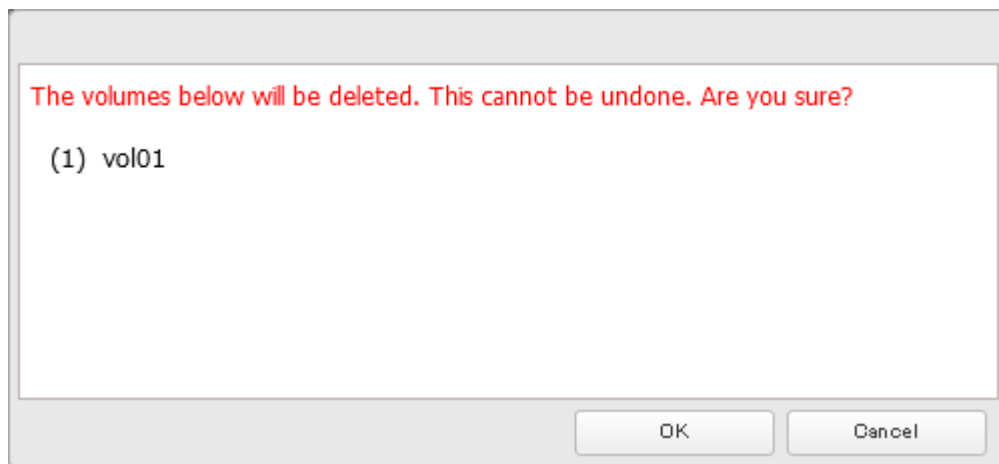

**5** The “Confirm Operation” screen will open. Enter the confirmation number, then click *OK*.

**6** The process is complete once you close the confirmation window that appears.

## Enabling the iSNS Protocol

By enabling the iSNS protocol on the TeraStation, you can register an iSCSI target (volume) to an iSNS server and use it to manage the registered targets. To enable the iSNS protocol, follow the procedure below.

**1** From Settings, click *Storage*.



2 Click the settings icon (  ) to the right of “iSCSI”.



3 Click the *Internet Storage Name Service (iSNS)* tab, then click *Edit*.

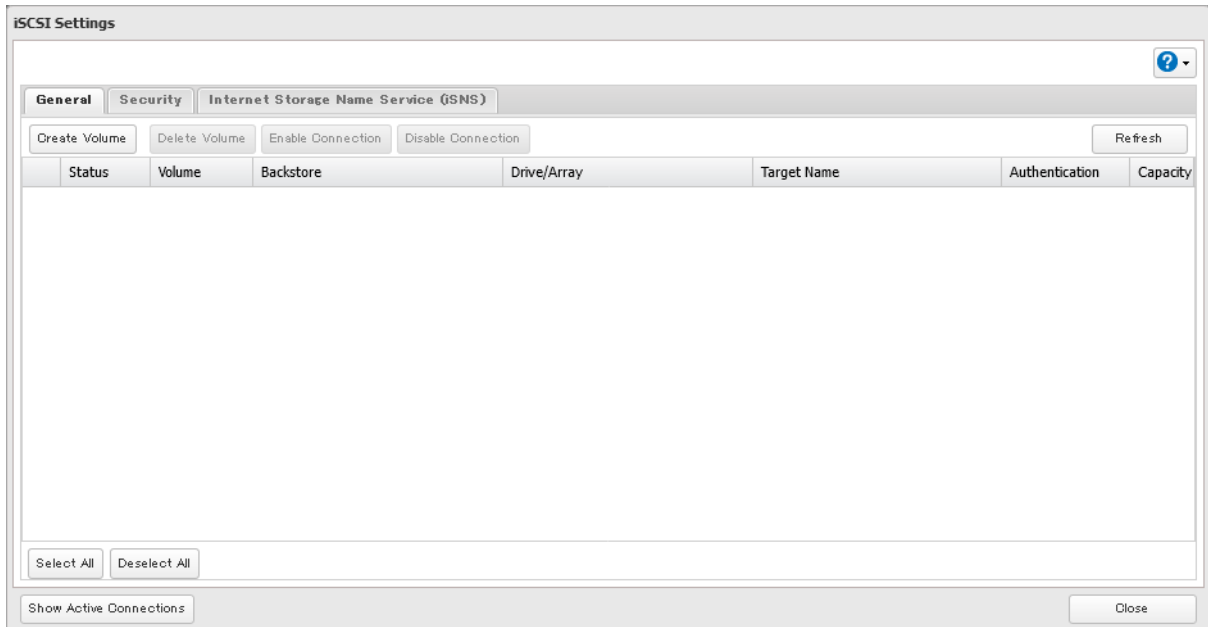

4 Enable “iSNS” and enter the IP address or hostname of the iSNS server, then click *OK*.

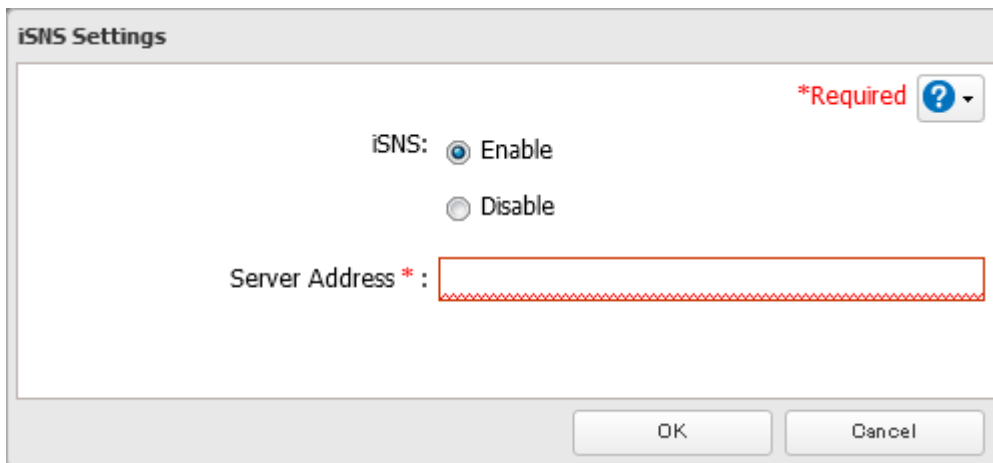

5 The process is complete once you close the confirmation window that appears.

## Advanced iSCSI Volume Settings

You can configure the following advanced parameters for each iSCSI volume.

Advanced Parameter	Description
HeaderDigest	Controls the HeaderDigest usage by the iSCSI target portal group endpoint.
DataDigest	Controls the DataDigest usage by the iSCSI target portal group (TPG) endpoint.
MaxConnections	Controls the usage of Multiple Connections per Session (MC/S). Initiator and target negotiate the maximum number of connections requested and/or acceptable.

Advanced Parameter	Description
InitialR2T	Turns the default use of R2T (Ready to Transfer) on or off for unidirectional and the output part of bidirectional commands.
ImmediateData	Indicates whether the initiator and target have agreed to support immediate data on this session.
MaxRecvDataSegmentLength	Maximum data segment length in bytes the initiator and target can receive in an iSCSI Protocol Data Unit (PDU).
MaxXmitDataSegmentLength	Maximum data segment length in bytes that can be sent.
MaxBurstLength	Maximum iSCSI data payload in a Data-In or a solicited Data-Out iSCSI sequence, in bytes.
FirstBurstLength	Maximum amount in bytes of unsolicited data an iSCSI initiator can send to the target during the execution of a single SCSI command.
MaxOutstandingR2T	The R2T PDUs that can be in transition before an acknowledge PDU is received.
QueuedCommands	Maximum number of commands queued to any session of this target.
File I/O Write Sync	Synchronous file I/O provides reliability but slower performance. Asynchronous writes are faster, but buffered data will be lost if a power outage occurs.
Write Cache (WCE)	Increases performance. This cannot be used when block I/O is selected.
LUN	Number used to identify a local unit.

# Chapter 5 Backup

## Backing Up Data on the TeraStation

You can back up the TeraStation folders to another shared folder on the same TeraStation, a connected USB drive, or a shared folder on another Buffalo NAS device, either on the same network or on another network.

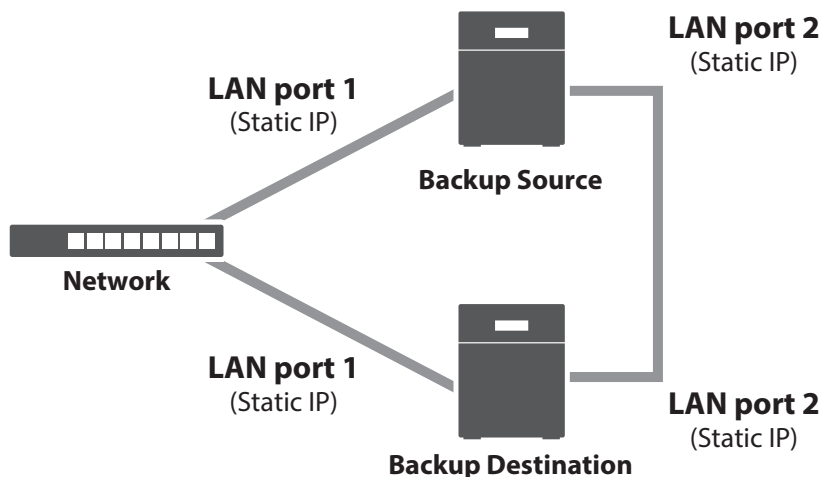

## Backup Modes

The following types of backup are available from this TeraStation. To restore data from backup, refer to the [“Restoring Backup Data”](#) section below.

### Full Backup

All files in the source will be backed up to the destination. You can specify how many backup versions to keep from 1–400, or select “Unlimited” to keep all backups until the drive is full. If you specify a number of backup versions, the backup destination folder should be on the same TeraStation or on an external USB drive attached to that TeraStation.

The backup data will be stored in the folder whose name will be the backup date and time.

- **Folders available as backup sources:**
  - Shared folder on the backup source TeraStation (excluding the “info” folder)<sup>\*1</sup>
  - USB drive connected to the backup source TeraStation<sup>\*1</sup>
  - Shared folder on another Buffalo NAS device<sup>\*2</sup>
  - Shared folder on another rsync-compatible device
- **Folders available as backup destinations:**
  - Shared folder on the backup source TeraStation (excluding the “info” folder)<sup>\*2</sup>
  - USB drive connected to the backup source TeraStation<sup>\*2,3</sup>
  - Shared folder on another Buffalo NAS device<sup>\*2,4</sup>
  - Shared folder on another rsync-compatible device

<sup>\*1</sup> You can select up to the second level of folders. However, if the folder name of a second level folder contains symbols, that folder may not appear as the target folder.

<sup>\*2</sup> The folder should have the “Backup” checkbox selected under “LAN Protocol Support” on the shared folder settings.

\*3 If the “Inherit subfolders' access restrictions” option is selected when creating a backup job, use XFS or ext3 file systems.

\*4 If the “Inherit subfolders' access restrictions” option is selected when creating a backup job, the device should be a Buffalo NAS device whose subfolders' access restrictions is available.

## Overwrite (Incremental)

The first backup job runs like a full backup. As each subsequent backup job runs, only files that have been changed since the last full backup will be backed up, but any files deleted from the backup source folder will also remain in the backup destination folder. The folder structure in the backup destination folder will be the same as the backup source folder.

- **Folders available as backup sources:**
  - Shared folder on the backup source TeraStation (excluding the “info” folder)\*<sup>1</sup>
  - USB drive connected to the backup source TeraStation\*<sup>1</sup>
  - Shared folder on another Buffalo NAS device\*<sup>2</sup>
  - Shared folder on another rsync-compatible device
- **Folders available as backup destinations:**
  - Shared folder on the backup source TeraStation (excluding the “info” folder)\*<sup>2</sup>
  - USB drive connected to the backup source TeraStation\*<sup>2,3</sup>
  - Shared folder on another Buffalo NAS device\*<sup>2,4</sup>
  - Shared folder on another rsync-compatible device

\*1 You can select up to the second level of folders. However, if the folder name of a second level folder contains symbols, that folder may not appear as the target folder.

\*2 The folder should have the “Backup” checkbox selected under “LAN Protocol Support” on the shared folder settings.

\*3 If the “Inherit subfolders' access restrictions” option is selected when creating a backup job, use XFS or ext3 file systems.

\*4 If the “Inherit subfolders' access restrictions” option is selected when creating a backup job, the device should be a Buffalo NAS device whose subfolders' access restrictions is available.

## Overwrite (Differential)

The first backup job runs like a full backup. As each subsequent backup job runs, only files that have been changed since the last full backup will be backed up, and any files deleted from the backup source folder will also be deleted from the backup destination folder. The backup destination folder will always remain the same size as the backup source folder, and the folder structure in the backup destination folder will be the same as the backup source folder.

- **Folders available as backup sources:**
  - Shared folder on the backup source TeraStation (excluding the “info” folder)\*<sup>1</sup>
  - USB drive connected to the backup source TeraStation\*<sup>1</sup>
  - Shared folder on another Buffalo NAS device\*<sup>2</sup>
  - Shared folder on another rsync-compatible device
- **Folders available as backup destinations:**
  - Shared folder on the backup source TeraStation (excluding the “info” folder)\*<sup>2</sup>
  - USB drive connected to the backup source TeraStation\*<sup>2,3</sup>
  - Shared folder on another Buffalo NAS device\*<sup>2,4</sup>
  - Shared folder on another rsync-compatible device

\*1 You can select up to the second level of folders. However, if the folder name of a second level folder contains symbols, that folder may not appear as the target folder.

\*2 The folder should have the “Backup” checkbox selected under “LAN Protocol Support” on the shared folder settings.

\*3 If the “Inherit subfolders' access restrictions” option is selected when creating a backup job, use XFS or ext3 file systems.

\*4 If the “Inherit subfolders' access restrictions” option is selected when creating a backup job, the device should be a Buffalo NAS device whose subfolders' access restrictions is available.



## Management Backup

Each time a backup is executed, management information is stored, and only files that have changed are backed up. Data is retrieved from the previous backup file for files that were not changed, which can help reduce the space used for backup and also for referencing status at a particular point in time (for data snapshot applications). You can specify how many backup versions to keep from 1–400, or select “Unlimited” to keep all backups until the drive is full. If using an external USB drive as the backup destination, do not use folders from drives formatted with FAT. The backup data will be stored in the folder whose name will be the backup date and time, and the destination folder will be set to read-only.

- **Folders available as backup sources:**
  - Shared folder on the backup source TeraStation (excluding the “info” folder)<sup>\*1</sup>
  - USB drive connected to the backup source TeraStation<sup>\*1</sup>
  - Shared folder on another Buffalo NAS device<sup>\*2</sup>
  - Shared folder on another rsync-compatible device
- **Folders available as backup destinations:**
  - Shared folder on the backup source TeraStation (excluding the “info” folder)<sup>\*2</sup>
  - USB drive connected to the backup source TeraStation<sup>\*2,3,4</sup>

\*1 You can select up to the second level of folders. However, if the folder name of a second level folder contains symbols, that folder may not appear as the target folder.

\*2 The folder should have the “Backup” checkbox selected under “LAN Protocol Support” on the shared folder settings.

\*3 If the “Inherit subfolders’ access restrictions” option is selected when creating a backup job, use XFS or ext3 file systems.

\*4 The compatible file systems are ext3, XFS, and NTFS. We recommend using the XFS file system, since the backup job may take a long time when the number of backup versions exceeds the configured value, especially if the NTFS file system is selected.

### Notes:

- For the destination folder, do not use a folder that has already been used as a target folder for another backup job. If you wish to use a folder that currently contains backup data as the destination folder for another backup job, format the folder first, or delete all data in the destination folder and change the folder attribute to read and write before configuring the folder as the destination folder.
- If a management backup job fails, all the backup data copied to the backup destination so far will be erased from it.

## Preparing a Backup Destination

Configure a shared folder on a Buffalo NAS device or connected USB drive as a backup destination. The following procedure explains using another shared folder on the TeraStation as a backup destination. The procedure may vary depending on which Buffalo NAS device is selected as a destination. If using a USB drive as a backup destination, make sure its attribute is set to read and write. To change a read-only USB drive’s attribute to read and write, refer to the “[Read-Only Shares](#)” section in chapter 3.

If you would like to back up data from multiple backup sources, we recommend not using the same backup destination, as data in the backup destination may be overwritten by subsequent backup jobs. If you must back up data from multiple backup sources to the same backup destination, using management backup is recommended for precise version control.

**Note:** If you want to set this TeraStation as the backup destination for an rsync-compatible device, refer to the “[If Backing Up from rsync-Compatible Devices to the TeraStation](#)” section instead of following the procedure below.

- 1 From Settings, click *File Sharing*.

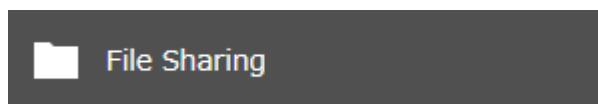

2 Click the settings icon (  ) to the right of “Folder Setup”.

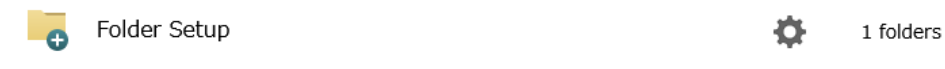

3 Choose the folder to be set as a backup destination.

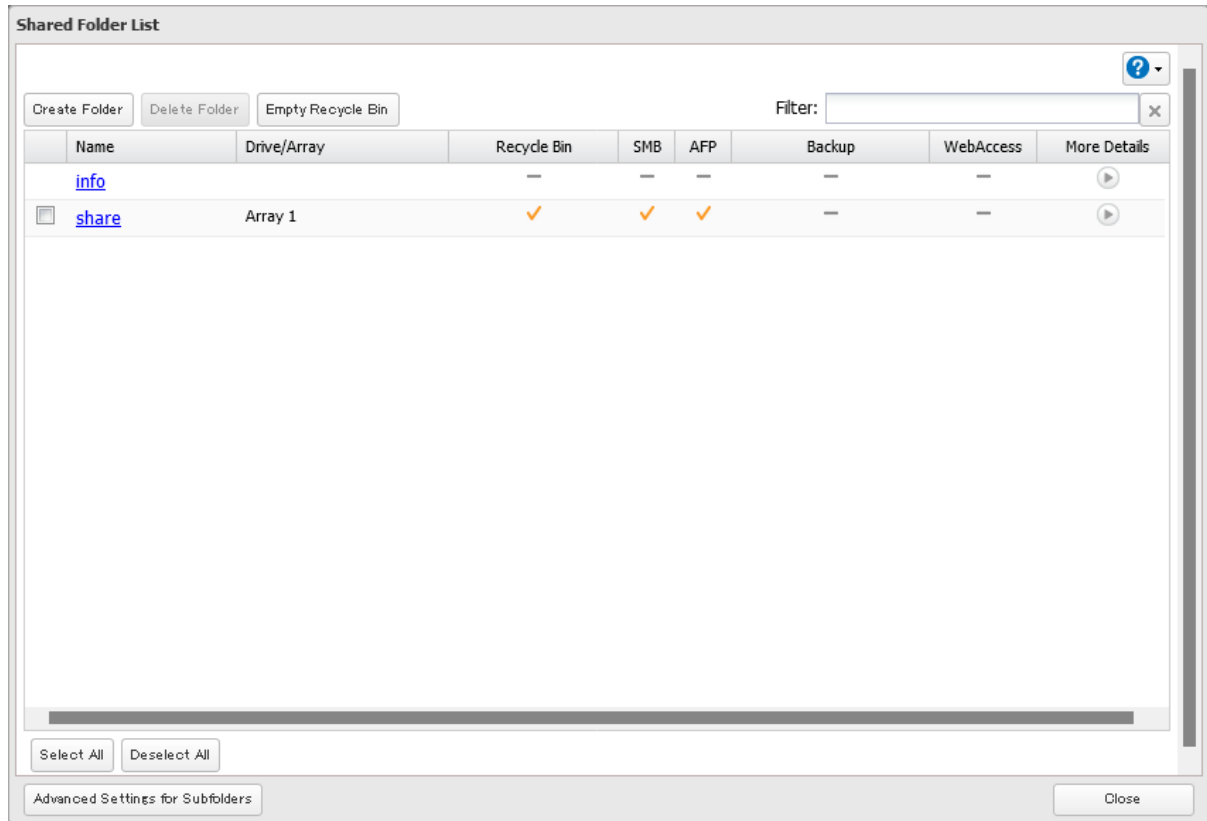

4 Under “LAN Protocol Support”, select the “Backup” checkbox on the *Basic* tab.

LAN Protocol Support:  SMB (Windows/Mac)  AFP (Mac)  
 FTP  Backup  
 SFTP  WebAccess  
 NFS

**5** Click *OK* and proceed to the next step to create a backup device access key.

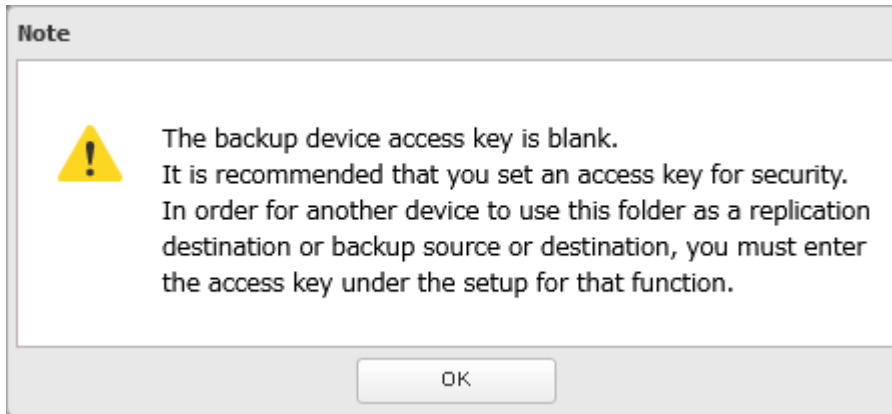

**6** Enter the desired characters into the backup device access key field and click *OK*.

Backup Device Access Key:

**Note:** You may leave this field blank if you do not want a backup device access key, but for security reasons we highly recommend entering one for the shared folder. If a backup device access key is configured for the shared folder, that folder will not show up as a target for the backup source or destination when configuring a backup job on another Buffalo NAS device unless it's entered. You may create multiple folders using different backup device access keys for backup and replication, but only one access key can be used on the TeraStation. Folders that are configured with a different access key cannot be used.

**7** The process is complete once you close the confirmation window that appears.

**Notes:**

- If you want to back up to a Buffalo NAS device on another network, follow the procedure below to add the Buffalo NAS device so it can be used as a backup destination.
  - (1) Create a new backup job by referring to the [“Configuring a Backup Job”](#) section below.
  - (2) On the screen that allows you to select a shared folder, click *List of Servers*.
  - (3) Click *Add*; select the “Add Buffalo NAS device” option, enter the IP address or hostname of the destination Buffalo NAS device, then click *OK*.
  - (4) Click *Close*.
  - (5) Click *Refresh* and make sure the desired Buffalo NAS device has been added to the list.
- If you want to back up to an rsync-compatible device, follow the procedure below to add the rsync-compatible device so it can be used as a backup destination.
  - (1) Create a new backup job by referring to the [“Configuring a Backup Job”](#) section below.
  - (2) On the screen that allows you to select a shared folder, click *List of Servers*.
  - (3) Click *Add*; select the “Add rsync-compatible device” option, enter the IP address or hostname of the destination device, then click *OK*. If you want to encrypt the rsync access, enable “rsync Over SSH” and enter the rsync account settings.  
If your rsync account username includes a symbol, first change the username to one that does not include any symbols.
  - (4) Click *Close*.
  - (5) Click *Refresh* and make sure the desired rsync-compatible device has been added to the list.

## Configuring a Backup Job

You can configure backup jobs by using another shared folder on the Buffalo NAS device or a USB drive connected to the TeraStation as a destination. You can also back up to a Buffalo NAS device on another network as long as the two networks are connected by a VPN or the route is configured properly.

- 1 From Settings, click *Backup*.



- 2 Click the settings icon (  ) to the right of "Backup".



- 3 If you had configured a backup device access key for the backup source folder on another Buffalo NAS device or the backup destination folder, click *Set*. If you hadn't, skip to step 5.

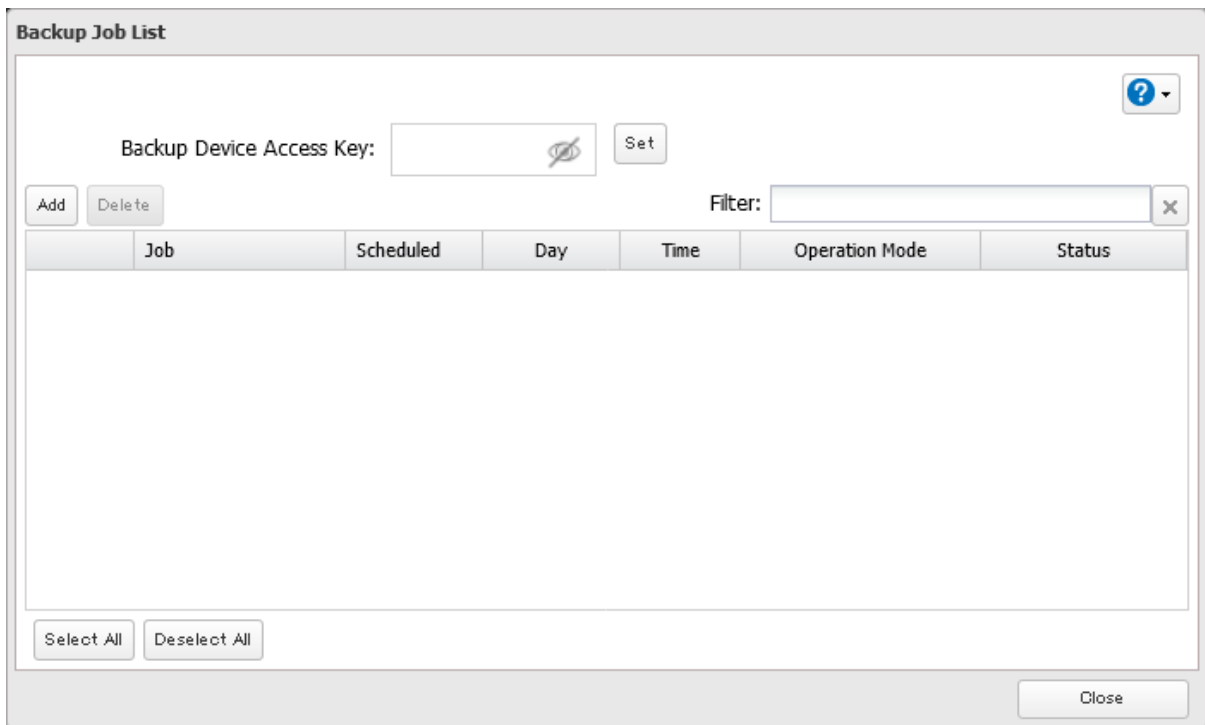

- 4 Enter the backup device access key and click *OK*.

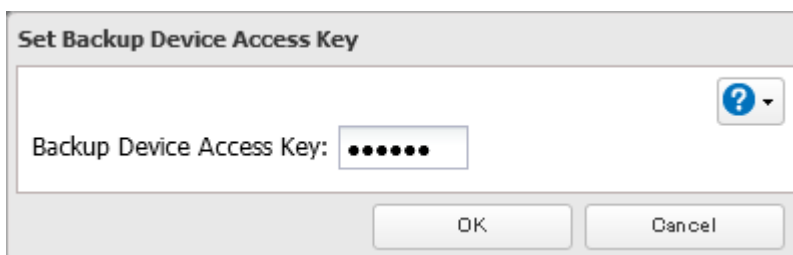

## 5 Click Add.

**Backup Job List**

Backup Device Access Key: \*\*\*\*\*

Filter:

Job	Scheduled	Day	Time	Operation Mode	Status

## 6 Select backup settings such as date and time to run, then select a backup mode for the "Operation Mode" drop-down list. Refer to the differences between the backup modes from the ["Backup Modes"](#) section above.

**Job Settings**

Job Name \* :

Schedule:

Date and Time:   hours  minutes

Operation Mode:

Versions:

Unlimited

Backup Process Speed:

Options:  Create a subfolder for backup

Create backup log file

Save backup logs in the backup source folder

Select the folder to save backup logs

Backup Log Target Folder:

Encrypted data transfer

Compress and transfer

Ignore backup errors and continue backup job on schedule

Do not back up recycle bin

Overwrite unchanged files

**7** Click *Add*.

**8** Select the shared folders that will be the backup source and destination.

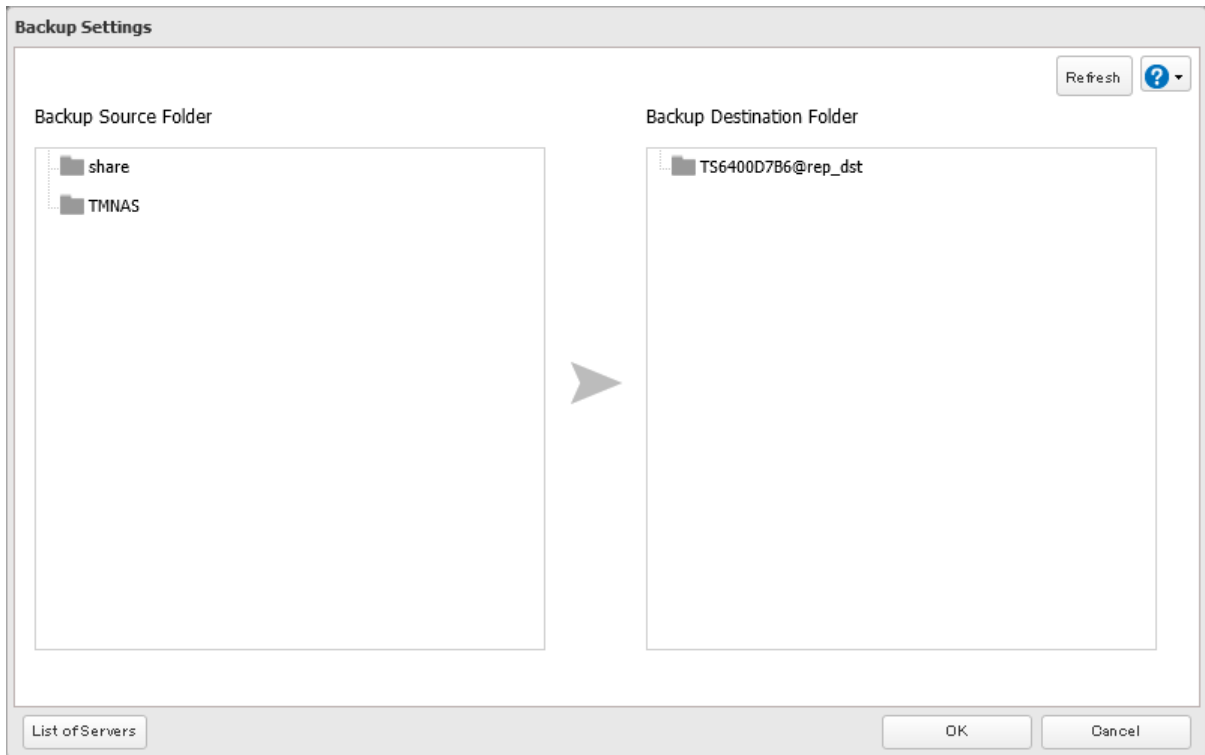

**9** Click *OK*, then click *OK* again.

**10** The process is complete once you close the confirmation window that appears. The backup job will be added to the backup jobs list.

**Notes:**

- Up to eight backup jobs can be configured at a time, and twenty-five backup source and destination folder pairs can be used in one backup job.
- To inherit the subfolders' access restriction settings to the backup destination, the backup destination should also support the subfolders' access restrictions. Check it before creating a backup job.
- To back up data between Buffalo NAS devices on a network using jumbo frames, make sure that both devices are configured to use identical (or similar) MTU sizes. If MTU sizes are significantly different, the backup job may not be properly performed. In such a case, select the default MTU size (1,500 bytes) for both devices.
- You can also specify a hostname by a fully qualified domain name (FQDN).
- Windows-based TeraStations with multibyte characters in the hostname may not be detected as a backup destination, and folders in these devices cannot be used as backup destination folders.
- Backup data, such as ".DS\_Store" files, from macOS may include characters that cannot be read on FAT32-formatted drives in its filename. For best results, reformat the drive before using it as a backup destination.

## **If Backing Up from rsync-Compatible Devices to the TeraStation**

If you want to set an rsync-compatible device as the backup source and back up data on the rsync-compatible device to the TeraStation, you will need to enable rsync access on the TeraStation.

- 1 From Settings, click *File Sharing*.

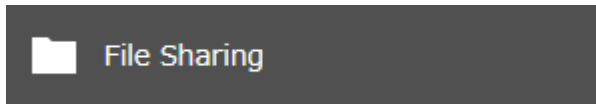

- 2 Click the settings icon (  ) to the right of "rsync".

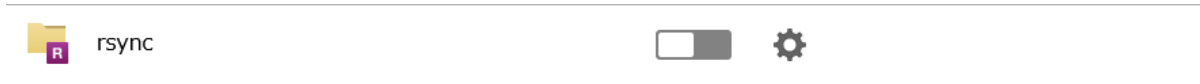



- 3 Enter this TeraStation's admin password into the "Password" field and click *OK*.

 A dialog box titled "rsync Server Settings" with a grey border. In the top right corner, there is a red "\*Required" label and a blue question mark icon. The dialog is divided into two sections:
 

- rsync Accounts:** Contains a text field for "Username: admin", a password field labeled "Password \*:" with a red asterisk, and a text field for "Port Number: 873".
- SSH Settings:** Contains a radio button group for "rsync Over SSH:" with "Enable" selected and "Disable" unselected. Below it is a text field for "Port Number: 22" and the text "Authentication Method: Password authentication".

 At the bottom right, there are "OK" and "Cancel" buttons.

**Note:** If you want to encrypt the rsync access, enable "rsync Over SSH".

- 4 The process is complete when you move the rsync switch (  ) to the  position to enable rsync.



## Restoring Backup Data

The procedure for restoring backup data varies depending on the backup mode. Refer to the following subsection corresponding to the backup mode you have used for backup. When restoring backup data, make sure you have enough available space on the TeraStation to accommodate the backup data, otherwise the restore process will fail.

### Full and Management Backups

Copy and paste the backed up files from the backup destination folder to a folder which you want to restore.

## Overwrite Backups (Incremental and Differential)

Files and folders have already been stored on the desired destination. You can access them by switching the operation to the backup destination TeraStation. Alternatively, you can restore any files or folders by creating a backup job and configuring the backup destination as a backup source and selecting the same backup mode for the “Operation Mode” drop-down list. Do not use the same folder as the backup destination to restore backup data from multiple backup sources, as this may cause the restored data to get overwritten.

## Backup Logs for If Backup Fails

If backup fails, the I54 message will appear as a notification and the following backup error codes may be displayed in the “Status” field. Read the description and try the respective corrective actions for each error to resolve it.

Code	Description	Corrective Action	Log Example
Code 3	The backup destination USB drive could not be found.	Check that the backup destination USB drive is connected to the TeraStation properly.	rsync error: errors selecting input/output files, dirs (code 3) at main.c(634) [Receiver=3.1.0]
			Can't write to backup destination(target disk is broken?).
Code 5	The backup destination shared folder could not be found.	Check that the Ethernet cable is securely connected and that the hub or other devices on the network are turned on.	rsync error: error starting client-server protocol (code 5) at main.c(1504)
	Authentication failed.	Try adding the rsync-compatible NAS device from the server list again.	@ERROR: auth failed on module
	A registered user does not have permission to run.	Check the settings of the rsync-compatible NAS device.	@ERROR: permission denied
Code 10	The Ethernet cable was disconnected from the backup source TeraStation when the backup job started.	Reconnect the Ethernet cable.	rsync error: error in socket IO (code 10) at clientserver.c(128) [sender=3.1.0pre1]
	A backup destination doesn't support the subfolders' access restrictions.	Select another backup destination or remove the subfolders' access restrictions.	
Code 11	The drive capacity of the backup destination TeraStation became full.	Delete unnecessary files and folders.	rsync error: error in file IO (code 11) at receiver.c(389) [receiver=3.1.0]
	Files larger than 4 GB were backed up to the FAT32-formatted USB drive.	Reduce the file size to 4 GB or less, or change the file system to one other than FAT32. Refer to the <a href="#">“Adding an External Drive”</a> section in chapter 4 for compatible file systems.	rsync: write failed on “filename”: File too large (27)
Code 12	Could not communicate between backup source and destination TeraStations.	Check that the Ethernet cable is securely connected and that the hub or other devices on the network are turned on.	rsync error: error in rsync protocol data stream (code 12) at io.c(515)
	The settings of the TeraStation were changed while the backup job was running.	Do not change the settings while the backup job is running. If changed, the connection will temporarily terminate and the backup job will fail.	



Code	Description	Corrective Action	Log Example
Code 14	There was insufficient memory on the TeraStation so the backup job did not run.	Reduce the number of backup destination files or disable any other functions running at the same time.	ERROR: out of memory in flist_expand
Code 22			rsync error: error in IPC code (code 14) at main.c(655) [receiver=2.6.8]
			rsync: fork failed in do_recv: Cannot allocate memory (12)
Code 20	The connection was disconnected while the backup job was running.	Do not change the settings while the backup job is running. If changed, the connection will temporarily terminate and the backup job will fail.	rsync error: received SIGINT, SIGTERM, or SIGHUP (code 20) at rsync.c(242)
Code 23	Invalid characters were used in the filename or folder name of the backup destinations.	Change the filename or folder name using compatible characters. Available characters are described in the <a href="#">“Adding a Shared Folder”</a> section in chapter 3.	rsync error: some files could not be transferred (code 23) at main.c(702)
	The backup destination files were updated while the backup job was running.	Do not overwrite the backup destination files while the backup job is running. If updated, the backup destination files will not be backed up and the backup job will fail.	
	The TeraStation backed up the data to the FAT32-formatted USB drive, then the capitalization of letters in the filenames or folder names on the backup source TeraStation was changed.	Do not change the capitalization of letters in the filenames and folder names on the backup source TeraStation if the backup destination USB drive is formatted to FAT32. Linux on the TeraStation is case-sensitive but FAT isn't, so files or folders with names that are identical save for the capitalization will not be identified and treated as the same file or folder. To back up properly, using XFS or ext3 is recommended.	
	A file system on the backup destination may be corrupted.	Run a drive check on the backup destination by referring to the <a href="#">“Checking Drives”</a> section in chapter 4.	
Code 24	The backup destination files were updated while the backup job was running.	Do not overwrite the backup destination files while the backup job is running. If updated, the backup destination files will not be backed up and the backup job will fail.	rsync warning: some files vanished before they could be transferred (code 24) at main.c

Code	Description	Corrective Action	Log Example
Code 30	The Ethernet cable was disconnected from the backup source or destination TeraStations while the backup job was running.	Reconnect the Ethernet cable.	rsync error: timeout in data send/receive (code 30) at io.c(195) [sender=3.1.0]
B14	Insufficient TeraStation memory.	Restart the TeraStation and try again.	-
B101	The backup destination TeraStation does not exist.	Check that the backup destination TeraStation is turned on, the Ethernet cables are securely connected, and the hostname of the backup destination TeraStation has not been changed.	-
B102		Check that the backup destination folders on the backup destination TeraStation are on the shared folder list and the backup destination folders are configured for backup in Settings.	-
B103	The backup source folders on the backup source TeraStation do not exist.	Check that the backup source folders on the backup source TeraStation are on the shared folder list.	-
B104	The backup destination folders on the backup destination TeraStation do not exist.	Check that the backup destination folders on the backup destination TeraStation are on the shared folder list.	-
B105	The drives were not recognized.	Check that the drives are recognized properly in Settings. If you configure the "usbdisk" folders for the backup source or destinations, check whether these folders are on the shared folder list.	-
B106	The file systems of the USB drive are not supported.	Check that the USB drive is formatted to the compatible file systems. If you configure the management backup in the backup job, FAT format cannot be used for the backup destination.	-
B107	The device files such as "/dev/null" etc. do not exist.	Restart the TeraStation and try again.	-
B108	Credentials to access a shared folder on the rsync-compatible NAS device were not found.	Try adding the rsync-compatible NAS device from the server list again.	-

## Replication

Replication copies all data from one shared folder to another shared folder on a different TeraStation. This is an easy way to set up a reliable data protection system in the event your main TeraStation fails. To configure replication, connect an Ethernet cable to the LAN port of each TeraStation and follow the procedure below. For best results, use static IP addresses and a 10GbE port for connecting both replication TeraStations (source and destination).

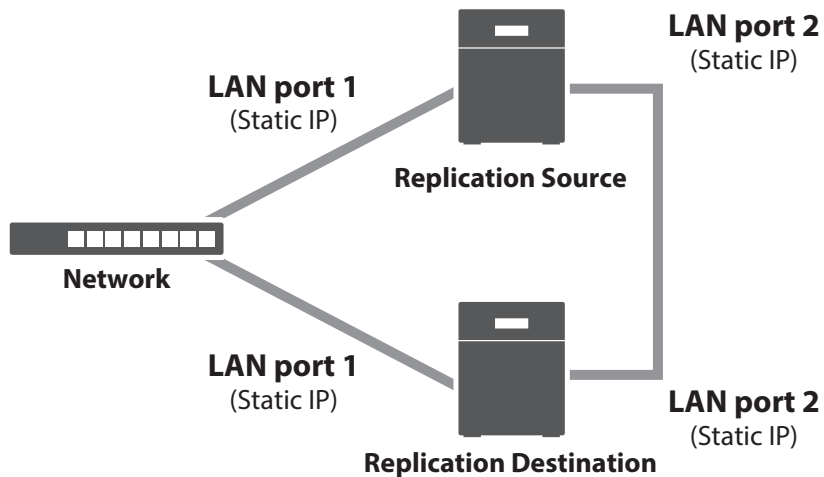

**Note:** Replication source data is copied to the replication destination folder with a differential overwrite. Any data not on the replication source will be overwritten.

The following describes what can be configured as replication sources and replication destinations.

### Folders Available as Replication Sources

- Shared folder on the replication source TeraStation (excluding the “info” folder)<sup>\*1,2</sup>
- USB drive connected to the replication source TeraStation<sup>\*2</sup>

### Folders Available as Replication Destinations<sup>\*3</sup>

- Shared folder on the replication source TeraStation (excluding the “info” folder)<sup>\*1</sup>
- USB drive connected to the replication source TeraStation<sup>\*4</sup>
- Shared folder on another Buffalo NAS device<sup>\*5</sup>

\*1 Do not use a shared folder that is currently being used for Box Storage Sync.

\*2 You can select up to the second level of folders. However, if the folder name of a second level folder contains symbols, that folder may not appear as the target folder.

\*3 The folder should have the “Backup” checkbox selected under “LAN Protocol Support” on the shared folder settings.

\*4 If the “Inherit subfolders’ access restrictions” option is selected when creating a replication job, use XFS or ext3 file systems.

\*5 If the “Inherit subfolders’ access restrictions” option is selected when creating a replication job, the device should be a Buffalo NAS device whose subfolders’ access restrictions is available.

## Preparing a Replication Destination

Configure a folder as a replication destination. Follow the procedure below to prepare a Buffalo NAS device as a replication destination.

**1** From Settings, click *File Sharing*.

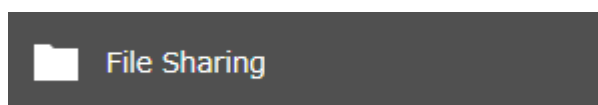

**2** Click the settings icon (⚙️) to the right of “Folder Setup”.



### 3 Choose the folder to be set as a replication destination.

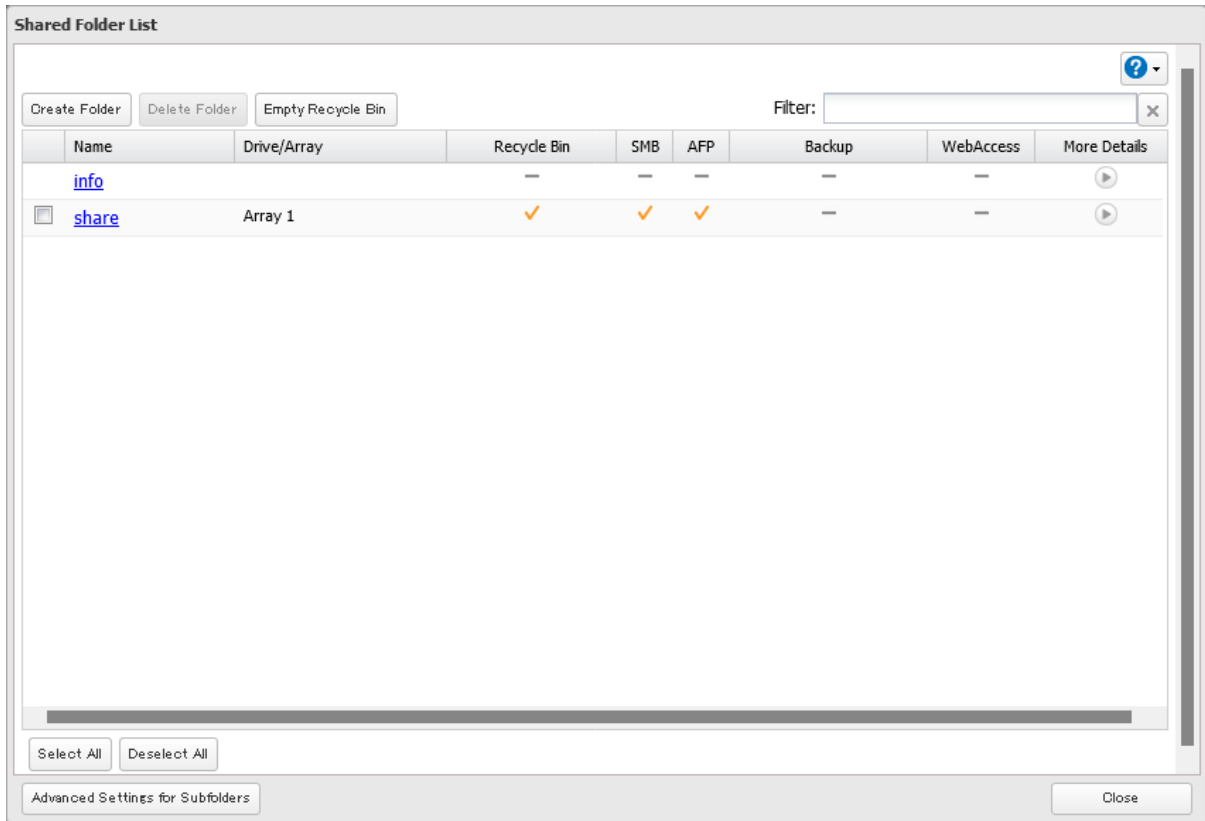

### 4 Under "LAN Protocol Support", select the "Backup" checkbox on the Basic tab.

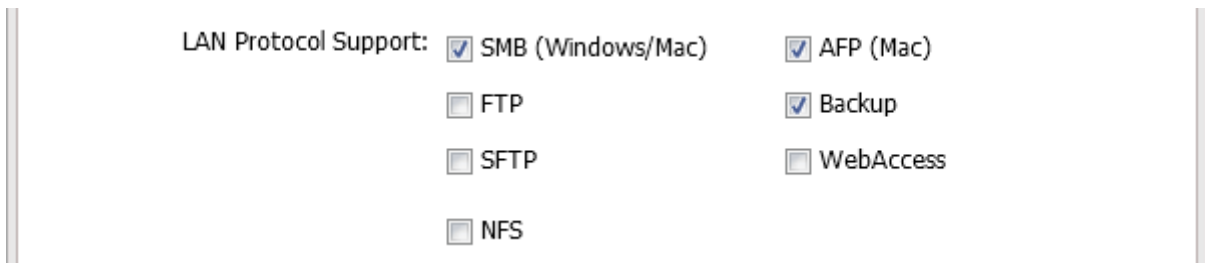

### 5 Click OK and proceed to the next step to create a backup device access key.

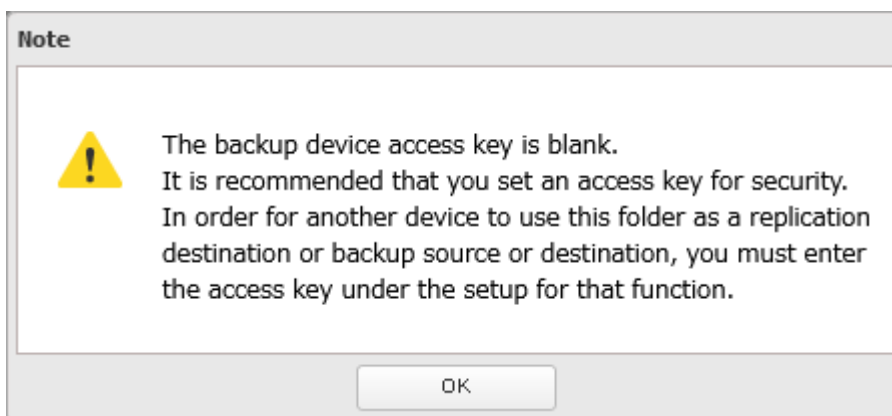

- 6** Enter the desired characters into the backup device access key field and click *OK*.

Backup Device Access Key:

**Note:** You may leave this field blank if you do not want a backup device access key, but for security reasons we highly recommend entering one for the shared folder. If a backup device access key is configured for the shared folder, that folder will not show up as the replication destination when configuring a replication job on another Buffalo NAS device unless it's entered. You may create multiple folders using different backup device access keys for backup and replication, but only one access key can be used on the TeraStation. Folders that are configured with a different access key cannot be used.

- 7** The process is complete once you close the confirmation window that appears.

**Note:** If you want to replicate to a Buffalo NAS device on another network, follow the procedure below to add the Buffalo NAS device so it can be used as a replication destination.

- (1) Create a new replication job by referring to the [“Configuring a Replication Job”](#) section below.
- (2) On the screen that allows you to select a shared folder, click *List of Servers*.
- (3) Click *Add*; select the “Add Buffalo NAS device” option, enter the IP address or hostname of the destination Buffalo NAS device, then click *OK*.
- (4) Click *Close*.
- (5) Click *Refresh* and make sure the desired Buffalo NAS device has been added to the list.

## Configuring a Replication Job

- 1** From Settings on a replication source NAS device, click *Backup*.



- 2** Move the replication switch (  ) to the  position to enable replication.



- 3** Click the settings icon (  ) to the right of “Replication”.



- 4** Click *Edit*.

- 5** If you had configured a backup device access key for the replication destination folder, click *Set*. If you hadn't, skip to step 7.

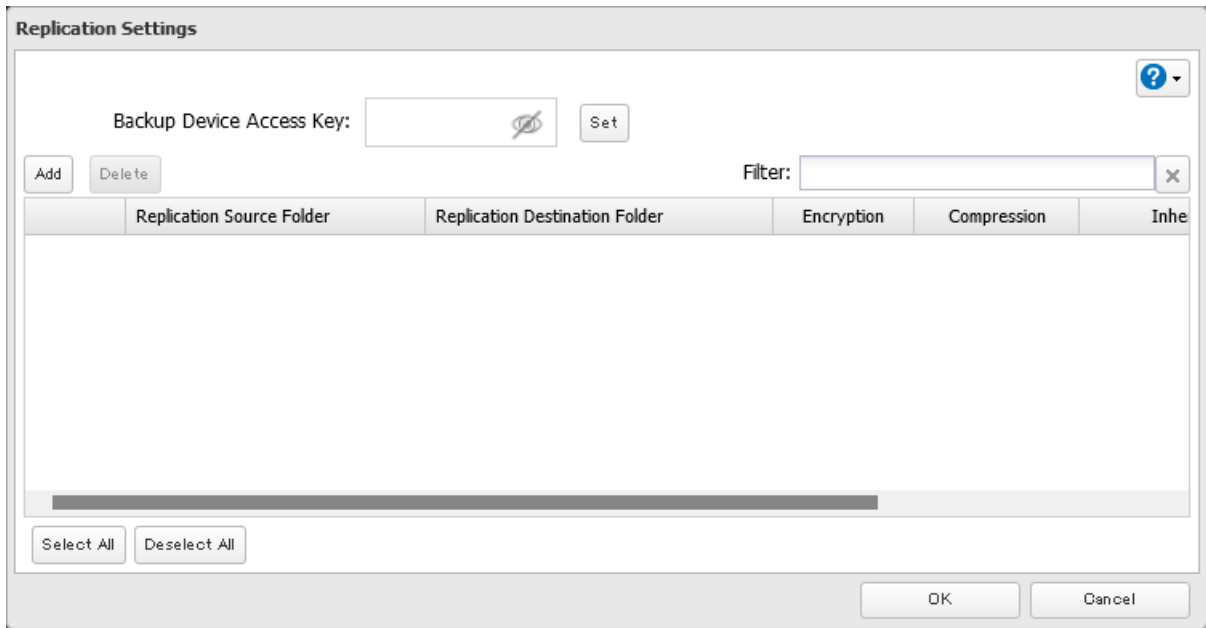

- 6** Enter the backup device access key and click *OK*.

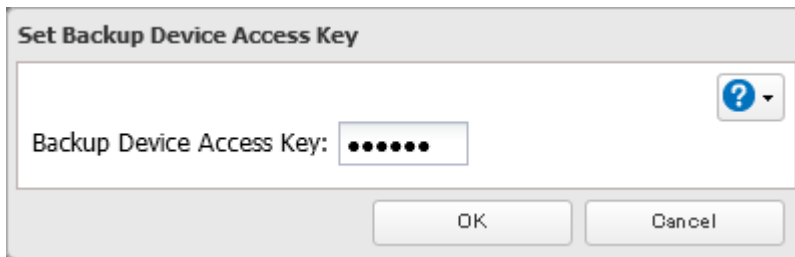

- 7** Click *Add*.

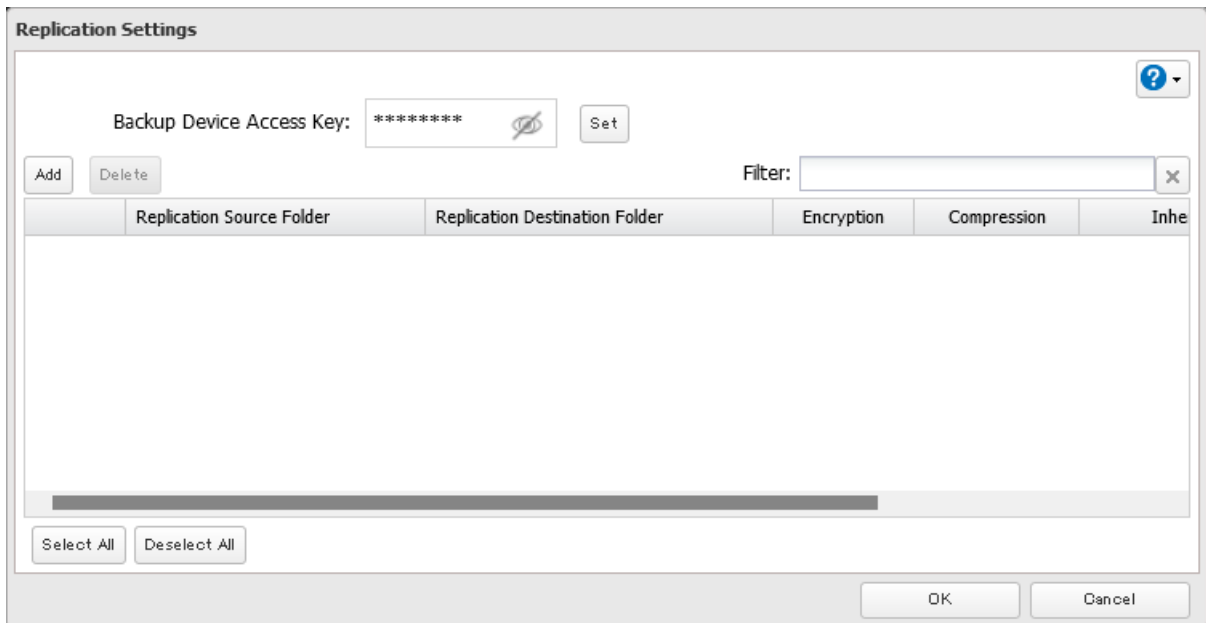

**8** Select the shared folders that will be the replication source and destination.

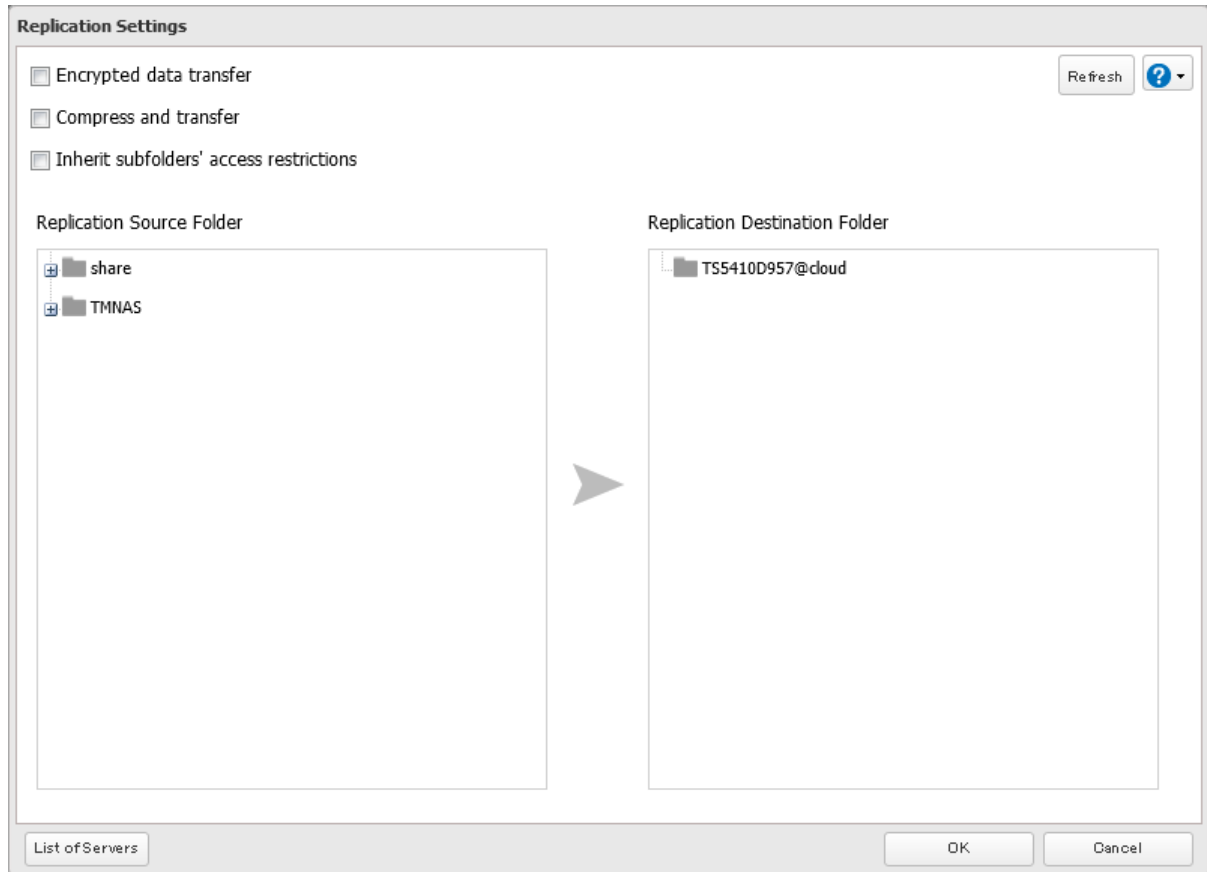

**9** Click *OK*, then *OK* again.

**10** Read the message carefully and click *Yes*.

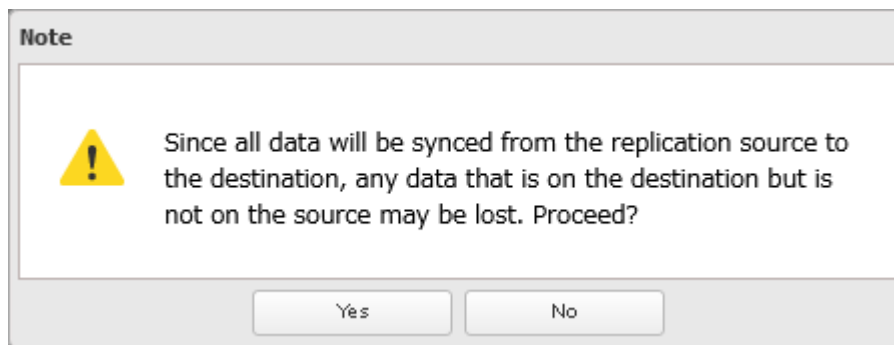

**11** The process is complete once you close the confirmation window that appears.

**Notes:**

- During setup, you may choose to encrypt and/or compress replication data. Encrypted data will be transferred securely on the network. Compressed data will ease network loading and is recommended for slow or heavily loaded network connections. Enabling either will increase the CPU load on the source TeraStation so that the transfer speed will become slower, and replication time will be slower than if they are disabled. Encrypted or compressed data will be decrypted or decompressed on the destination TeraStation.
- A maximum of 32 shared folders can be configured for replication.
- Don't use the same TeraStation for both failover and replication, or replication and Time Machine.
- Don't configure replication from one source folder to multiple destination folders.

- If a network problem causes a replication error, unsynced data may be shown as “0” even though replication is incomplete. Click *Resync* to recover from the replication error. All files from the source folder will be copied to the destination folder.

## Synchronizing Between Source and Destination TeraStations Periodically

To copy files that are saved via other file sharing protocols such as AFP or FTP to the replication destination regularly, configure “Periodic Sync” in Settings. Follow the procedure below.

- 1 From Settings, click *Backup*.



- 2 Click the settings icon (  ) to the right of “Replication”.



- 3 Click *Periodic Sync*.

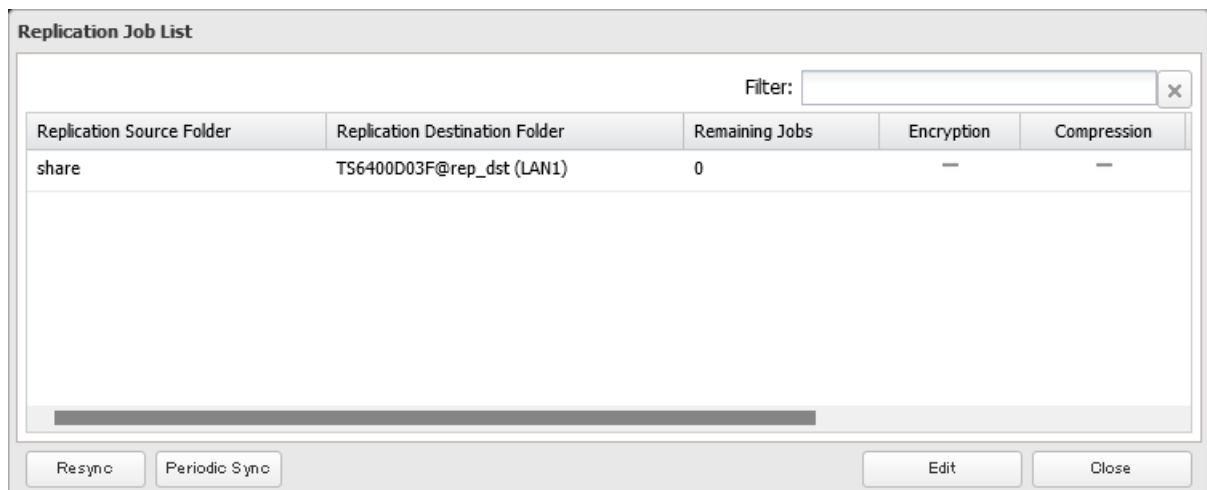



- 4 Select “Daily” or “Weekly” from the “Schedule” drop-down list. If “Daily” is selected, configure the sync period. If “Weekly” is selected, specify the weekdays and the sync period.

- 5 Click *OK*. The process is complete once you close the confirmation window that appears.

## Failover

With failover, two TeraStations are connected to the network for redundancy, with one being the main TeraStation and the other being the backup TeraStation. If an issue renders the main TeraStation inaccessible, operation automatically switches to the backup TeraStation.

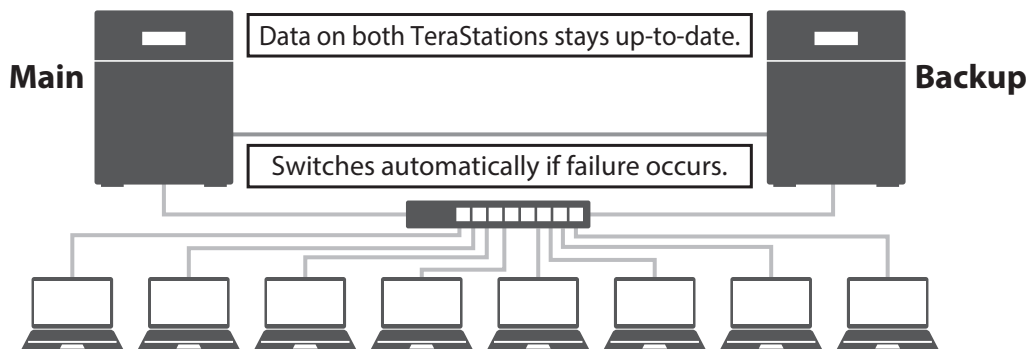

**Note:** This function is not available for the TS3420DS and TS3420RS TeraStation models, and will not appear in Settings for these models.

Failover will activate if any of the following occurs:

- **The backup TeraStation cannot detect the main TeraStation within a specified time**  
If the backup TeraStation has not received a packet from the main TeraStation within a specified time, the backup TeraStation considers the main TeraStation to have failed. By default, it will try five times and wait 60 seconds. If this is triggered by accident, reconfigure failover from the main TeraStation.
- **Errors**  
Failover will occur if any of the following errors occur:  
E12 (cooling failure), E14 (cannot mount RAID array), E16\* (drive not found), E22\* (cannot mount drive), E30\* (drive failure)

\*This triggers when the drive is configured in JBOD.

## Before Configuring Failover

Use the same LAN ports for transferring data and configure both TeraStations with static IP addresses for the purposes of failover.

### Using the Same LAN Port for Both File Sharing and Failover

Using this setup, if the main TeraStation fails, the backup TeraStation will replace it completely. The backup TeraStation will be updated over normal network traffic.

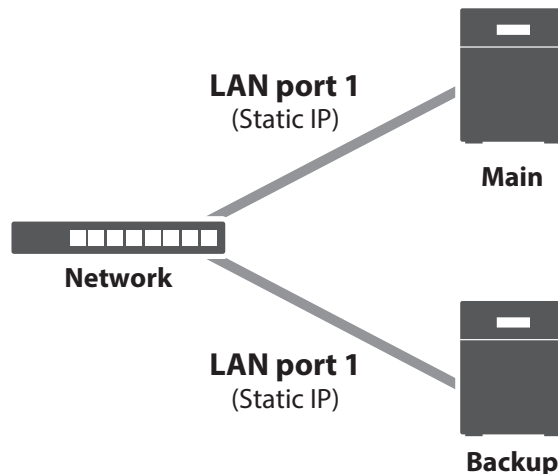

### Using Different LAN Ports Between File Sharing and Failover

With this setup, the backup TeraStation and main TeraStation are connected by a second Ethernet cable connecting their LAN port 2. Updating is done over this dedicated network path, so updates are quicker and don't interfere with normal network traffic.

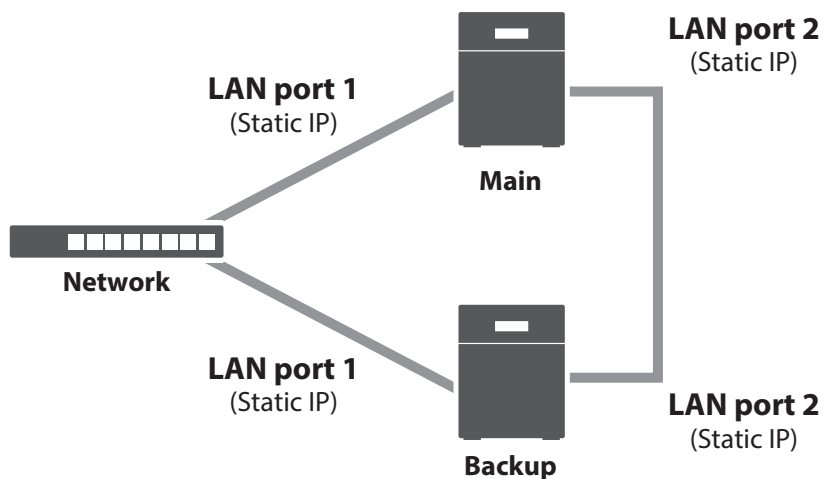

## Usage Restrictions

### Functional Restrictions

Failover is not available when any of the following functions are enabled:

Replication, sleep mode, LVM, iSCSI, port trunking, Amazon S3, Dropbox Sync, Microsoft Azure Storage Sync, Microsoft OneDrive Sync

Failover is not available when the I52 message appears, or if any of the following settings remain or have been configured:

Replication jobs, encrypted drive volume, Amazon S3 jobs, hot spare, access restrictions by Active Directory domain, multiple active LAN ports connecting to the same network

## Setting Restrictions

The following operations will not be available while failover is configured:

Initializing settings, changing the RAID settings, formatting drives, configuring iSCSI volume, changing the backup TeraStation's settings, turning the TeraStation on and off, updating the firmware

While failover is enabled, shutdown, power-on, and firmware update operations can be made available by temporarily putting the TeraStation into maintenance mode.

## Non-Transferable Settings

The settings below are not copied from the main TeraStation to the backup TeraStation. Make a note of the original settings so that they can be configured manually if a failover error occurs.

IP address, hostname\*, WebAccess, UPS sync, antivirus\*\*, the backup job settings for either when shared folders not on the main TeraStation are specified or when a USB drive is set as the backup destination, USB drives' shared folder settings, low drive space alerts

\*Since the hostname will not be transferred, use the virtual IP address configured for failover to access the shared folder after failover setup.

\*\*The settings configured on the Trend Micro NAS Security settings page will not be copied to the backup TeraStation. The settings configured on the main TeraStation's Settings page will be copied only if the antivirus is activated on the backup TeraStation.

## Using with UPS

Once failover is configured, you cannot set up a UPS for the backup TeraStation. Configure your UPS before configuring failover. UPS recovery can be configured for both the main and backup TeraStations.

## Configuring Failover

---

- 1 From Settings for the main TeraStation, click *Backup*.



- 2 Click the settings icon (  ) to the right of "Failover".



### 3 Click *Configure Failover*.

**Failover Settings**

Status: Standalone

Backup Device: Configure Failover

Remaining Jobs: —

**IP Settings for File Sharing** | Periodic Sync | Advanced Settings

LAN Port:

Virtual IP Address:

Subnet Mask:

Edit Close

### 4 Select a TeraStation to be the failover backup device and enter its administrator username and password (by default, the username is “admin” and the password is “password”).

**Failover Settings**

\*Required ?

Backup Device Settings: Backup Device: TS3420D039

Administrator Username \*: admin

Administrator Password \*: .....

IP Settings for File Sharing: LAN Port: (LAN1) 192.168.10.20

Virtual IP Address \*: 192.168.10.100

Subnet Mask \*: 255.255.255.0

Backup LAN Port: (LAN1) 192.168.10.20

Access Restrictions for Subfolders:  Inherit  Do not inherit

Use TeraStations of the same model and storage capacity for the main and backup units. Set the MTU size to 1,500 bytes for both units.

Continue Close

**5** Select the LAN port to be used for sharing files and enter a virtual IP address and subnet mask. The LAN port you have selected here will also be used for pinging. If you select the same LAN port as the backup LAN port, the backup TeraStation will replace the main TeraStation even if just a network error occurs.

**About virtual IP addresses:** A virtual IP address is an IP address that will be used for file sharing while failover is configured. By assigning a different IP address from the one to be assigned to the LAN port, you can access the TeraStation for sharing files, as well as open Settings using the virtual IP address. This IP address will be inherited to the backup TeraStation when failover occurs, so you can access the backup TeraStation even if you don't know the backup TeraStation's static IP address.

Configure an unused IP address for the virtual IP; make sure it uses the same segment as the main and backup TeraStations.

**6** Select the LAN port to be used for transferring data via failover.

**7** Configure whether or not to inherit the settings of subfolders' access restrictions to the backup TeraStation, then click *Continue*.

**8** If the admin username and password is correct, the **I51** message will appear as a notification for both main and backup TeraStations, and the backup TeraStation will beep. Press and hold down the function button on the backup TeraStation to accept the settings from the main TeraStation. When you press the function button, the backup TeraStation will stop beeping.

**9** Press the function button. When you press the function button, the TeraStation will beep once. Press and hold down the button until the backup TeraStation beeps again.

**10** Initialization on the main and backup TeraStations will begin.

**11** The process is complete when the **I51** message disappears.

#### Notes:

- Only use identical model and capacity TeraStations for failover. If the capacity of the main TeraStation is larger than that of the backup TeraStation, an **I33** replication error will occur.
- All drive bays of a TeraStation should be occupied if it will be used for failover. Failover will not work if a drive is missing from any bay.
- If replication is configured for more than one folder, initialize the TeraStation before configuring failover.
- The main TeraStation cannot be used as the backup location for Time Machine.
- Do not use the same TeraStation for both failover and replication, or failover and Time Machine.
- If email notification is enabled and failover occurs, navigate to *Management > Email Notification > Edit* in the main TeraStation's Settings and click *OK*.
- MTU size settings for main and backup TeraStations should be 1,500 bytes. To change the MTU size, refer to the ["Jumbo Frames"](#) section in chapter 9.
- Files whose filenames contain more than 80 alphanumeric characters will not be backed up.
- If the **I33** message appears as a notification, navigate to *Backup > Failover > Configure Failover* and click *Syncing*.
- The RAID array on the backup TeraStation may be reconfigured and resynchronized as part of the failover configuration process. This is expected behavior and not an error.

## Changing Settings While Failover Is Configured

---

Before changing any TeraStation settings while failover is configured, make sure the TeraStation has entered into maintenance mode. If you change any settings without entering into maintenance mode, the **I49** message may appear.

For the procedure to enter maintenance mode, refer to the ["Maintenance Mode"](#) section below.

## Maintenance Mode

The TeraStation has certain settings that cannot be configured or modified while other existing settings are in effect, such as failover. In such a case, putting the TeraStation into maintenance mode allows you to change certain TeraStation settings without affecting existing settings.

Follow the procedure below to make the TeraStation enter into maintenance mode.

- 1 From Settings for the main TeraStation, click *Backup*.



- 2 Click the settings icon (  ) to the right of "Failover".



- 3 Click *Configure Failover*.

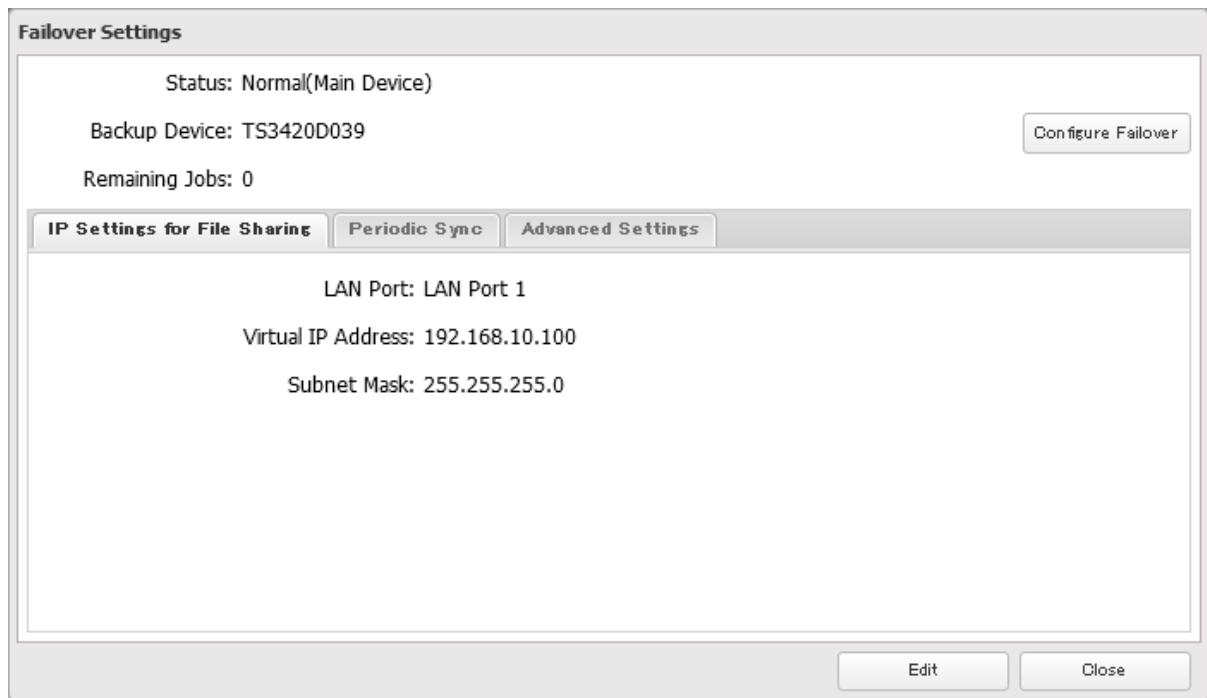

**4** Click *Maintenance Mode*.

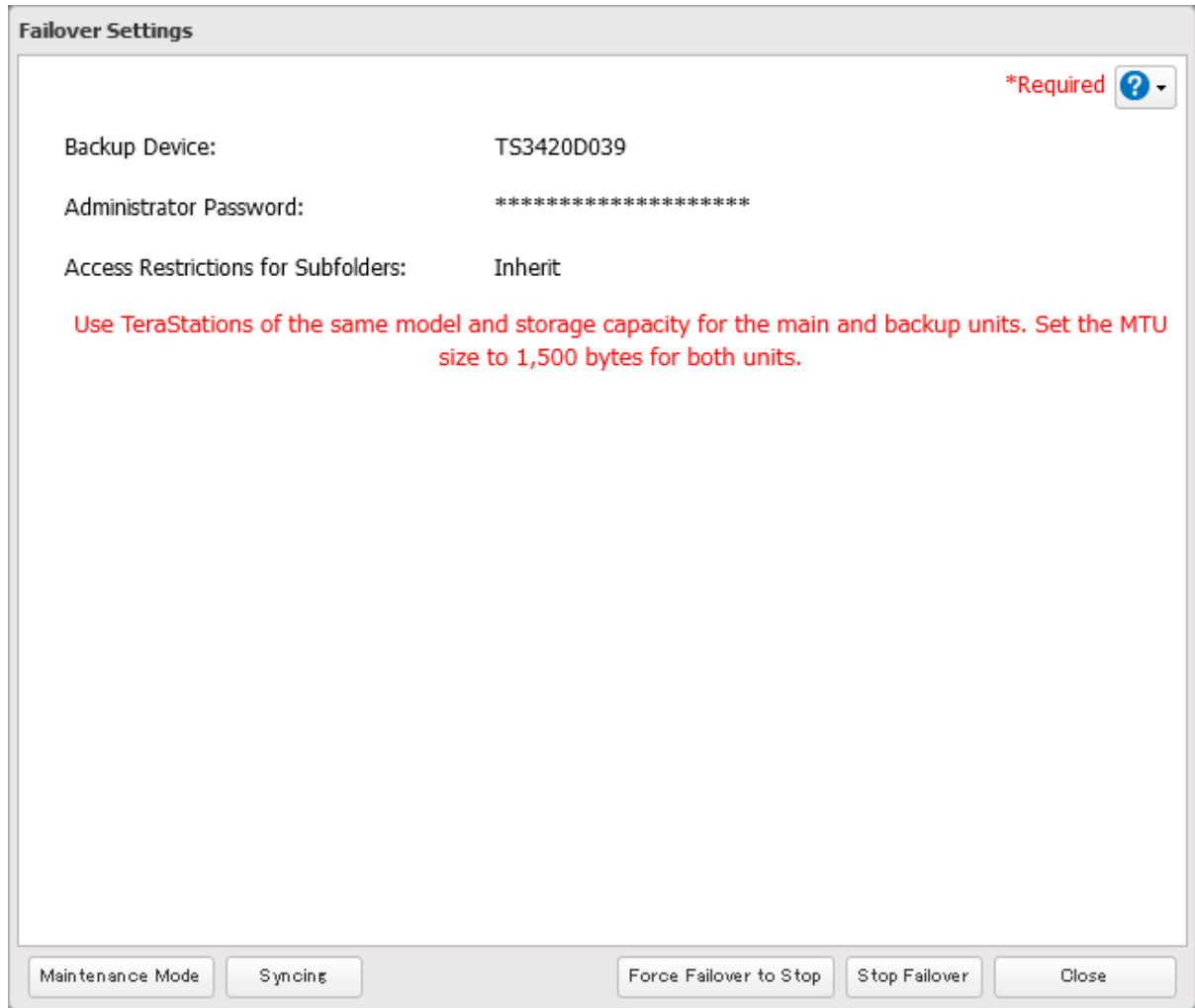

**5** Read the message carefully and click *Yes*.

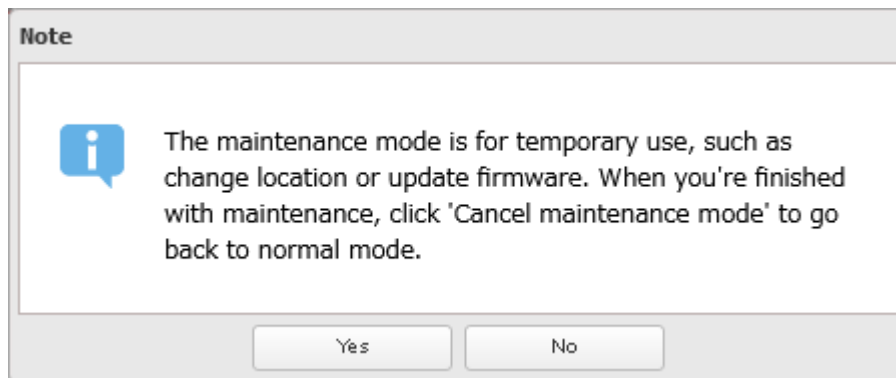

**6** The process is complete once the TeraStation enters maintenance mode.

Once you are finished with changing settings in maintenance mode, make sure the TeraStation leaves maintenance mode. You can make the TeraStation leave maintenance mode by either pressing and holding the function button, or follow the procedure below to exit maintenance mode from the main TeraStation's Settings.

- 1 From Settings for the main TeraStation, click *Backup*.



- 2 Click the settings icon (  ) to the right of "Failover".



- 3 Click *Configure Failover*.

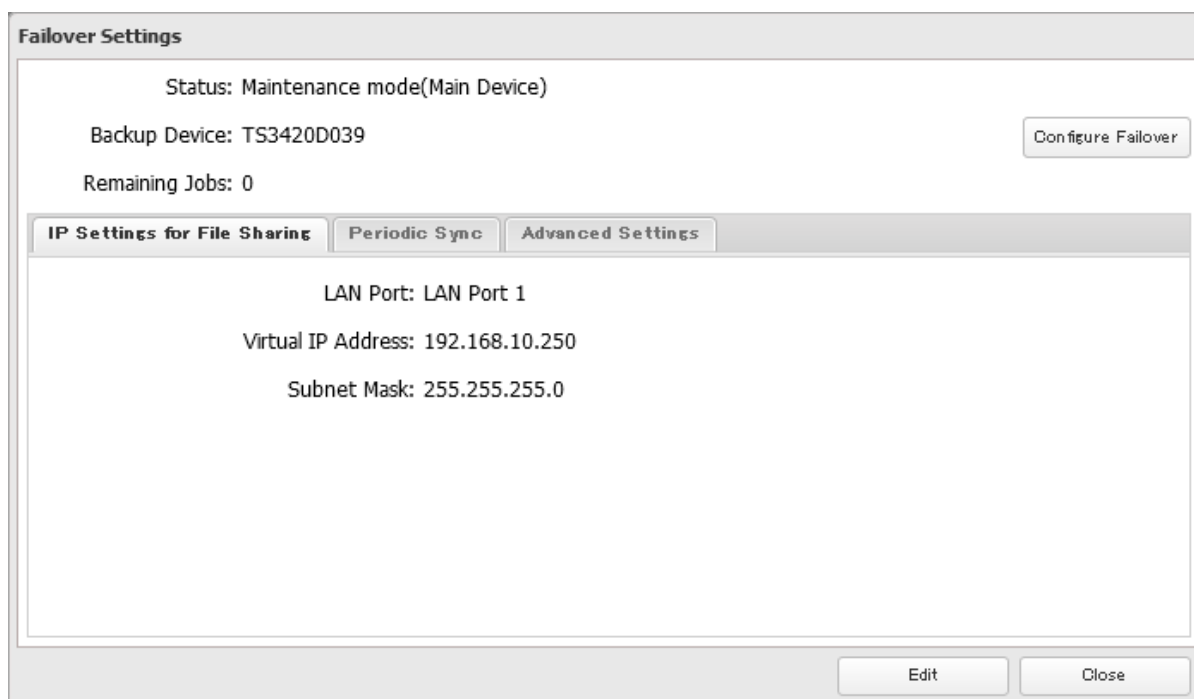



#### 4 Click *Cancel maintenance mode*.

**Failover Settings** \*Required ?

Backup Device: TS3420D039

Administrator Password: \*\*\*\*\*

Access Restrictions for Subfolders: Inherit

Use TeraStations of the same model and storage capacity for the main and backup units. Set the MTU size to 1,500 bytes for both units.

Cancel maintenance mode    Syncing    Force Failover to Stop    Close

#### 5 The process is complete once you close the confirmation window that appears.

**Note:** To update the firmware while in maintenance mode, the main TeraStation can be updated from Settings, but the backup TeraStation cannot. Download the firmware updater from the [Buffalo website](#) for the backup TeraStation and try updating the firmware on it.

## Synchronizing Between Main and Backup TeraStations Periodically

To copy files that are saved via other file sharing protocols such as AFP or FTP to the backup TeraStation regularly, configure “Periodic Sync” in Settings. Follow the procedure below.

#### 1 From Settings for the main TeraStation, click *Backup*.



#### 2 Click the settings icon ( ) to the right of “Failover”.



**3** Click the *Periodic Sync* tab, then click *Edit*.

**Failover Settings**

Status: Standalone

Backup Device: Configure Failover

Remaining Jobs: —

**IP Settings for File Sharing**   **Periodic Sync**   **Advanced Settings**

LAN Port:

Virtual IP Address:

Subnet Mask:

Edit   Close

**4** Select “Daily” or “Weekly” from the “Schedule” drop-down list and click *OK*. If “Daily” is selected, configure the sync period. If “Weekly” is selected, specify the weekdays and the sync period.

**Failover Settings**

Status: Standalone \*Required ?

Backup Device: Configure Failover

**IP Settings for File Sharing**   **Periodic Sync**   **Advanced Settings**

Schedule: Daily

Sunday    Monday    Tuesday    Wednesday    Thursday    Friday    Saturday

Sync Period:

00 hours 00 minutes

Once every hour

OK   Cancel

**5** The process is complete once you close the confirmation window that appears.

## Switching to the Backup TeraStation Manually

If “Switch to backup unit manually” is selected on the *Advanced Settings* tab in the main TeraStation’s Settings, the backup TeraStation will not replace the main TeraStation if the main TeraStation fails. To manually replace the main TeraStation with the backup TeraStation, you can either:

- Log in to Settings for the backup TeraStation and click *Set as Main Unit*.

- Press the function button on the backup TeraStation. The TeraStation will beep once. Press and hold down the function button until the backup TeraStation beeps again.

**Note:** If the main TeraStation fails but all LAN port connections on the backup TeraStation remain active, you cannot replace the main TeraStation with the backup TeraStation from Settings. In such a case, use the function button instead.

## Reconfiguring After Failover Occurs

---

When the backup TeraStation replaces the main TeraStation, the **I49** message may appear as a notification on the backup TeraStation. To configure failover again, follow the procedure below using a new TeraStation unit. The following procedure uses the example of a replaced backup TeraStation (“main TeraStation”) and the new TeraStation (“backup TeraStation”).

If you don’t want to configure failover with the new TeraStation, cancel the failover settings by following steps 1–5 below and restart both TeraStations. The **I49** message will disappear.

**Note:** The following procedure will also work if failover occurs unexpectedly.

**1** After failover occurs, log in to Settings for the new main TeraStation.

If you have configured to synchronize with the UPS device connected to the failed TeraStation, the **E10** error will appear as a notification on the main TeraStation. In such a case, follow the procedure below to change the UPS settings on the new main TeraStation. If you hadn’t, skip to the next step.

- Disconnect the UPS cable from the failed TeraStation and connect it to the main TeraStation.
- Click *Management*.
- Click the settings icon (  ) to the right of “Power Management”.
- Click *Edit* and select “Sync with UPS connected to this TeraStation”, then reconfigure the desired UPS settings.
- Click *OK*.

**2** Click *Backup*.



**3** Click the settings icon (  ) to the right of “Failover”.



**4** Click *Configure Failover*.

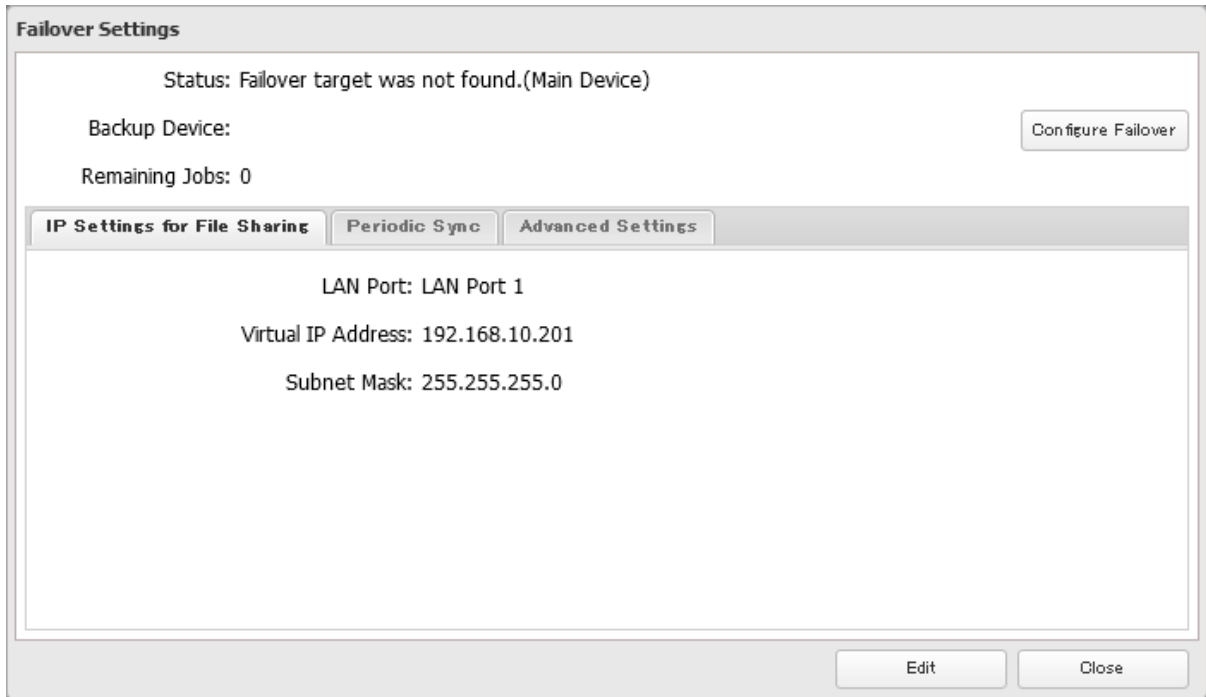

**5** Click *Force Failover to Stop* to cancel the failover settings.

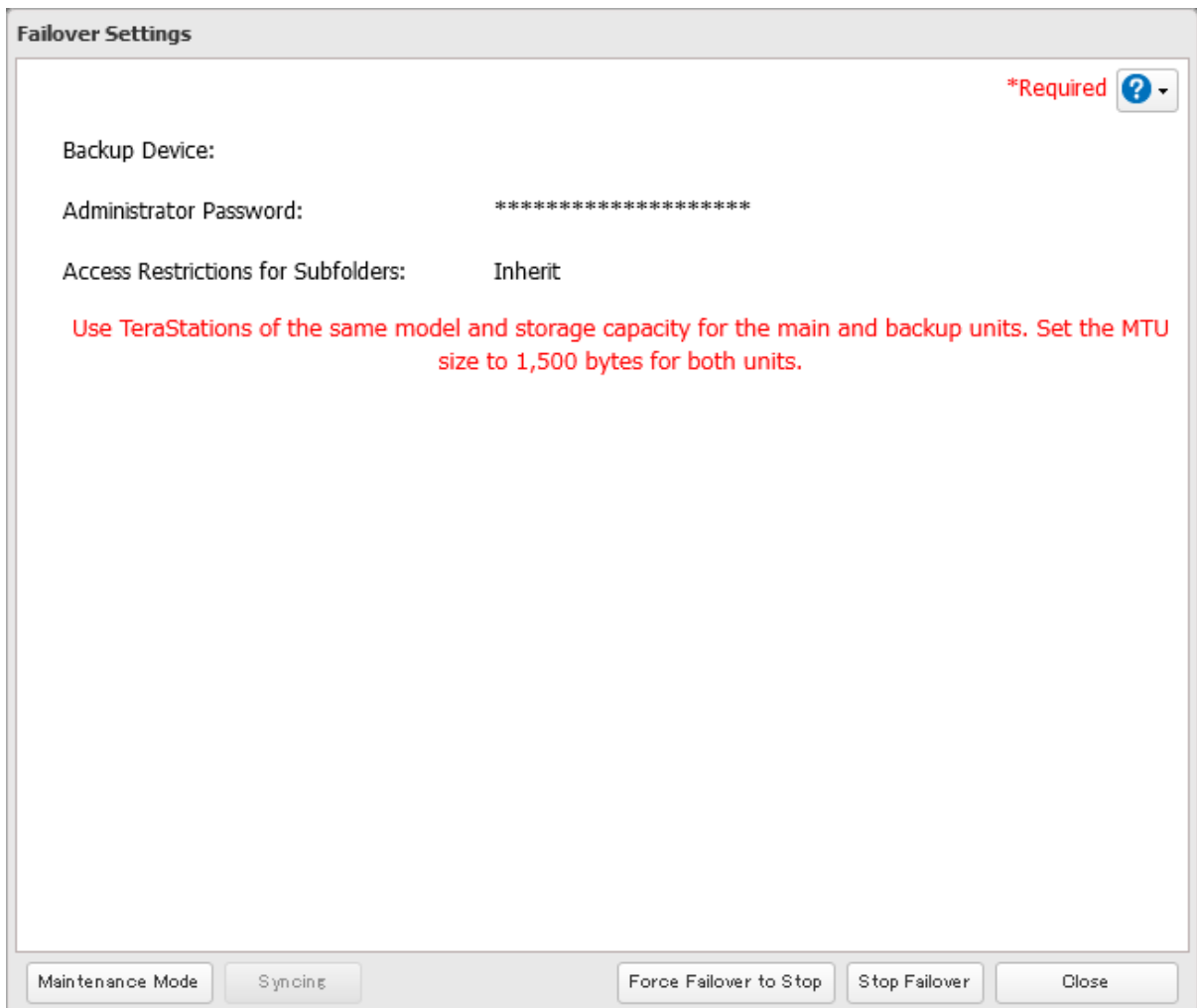

- 6** Shut down this main TeraStation.
- 7** Turn the backup TeraStation on.
- 8** Log in to Settings for the backup TeraStation, then rename the TeraStation's hostname and configure the IP address so that it has a new static IP address.
- 9** Power on the main TeraStation. To configure the UPS sync on the backup TeraStation, configure the settings here. Otherwise, skip to the next step.  
To synchronize with the UPS device connected to the main TeraStation, follow the procedure below on the backup TeraStation.
  - a. Click *Management*.
  - b. Click the settings icon (  ) to the right of "Power Management".
  - c. Click *Edit* and select "Sync with UPS connected to another Buffalo NAS device on the same network", then configure the main TeraStation as a sync source.
  - d. Click *OK*.
- 10** The process is complete once you reconfigure failover by referring to the "[Configuring Failover](#)" section above.

## Stopping Failover

---

If you want to stop failover while both the main and backup TeraStations are working properly, follow the procedure below.

### Stopping from the Main TeraStation

- 1** From Settings for the main TeraStation, click *Backup*.



- 2** Click the settings icon (  ) to the right of "Failover".



**3** Click *Configure Failover*.

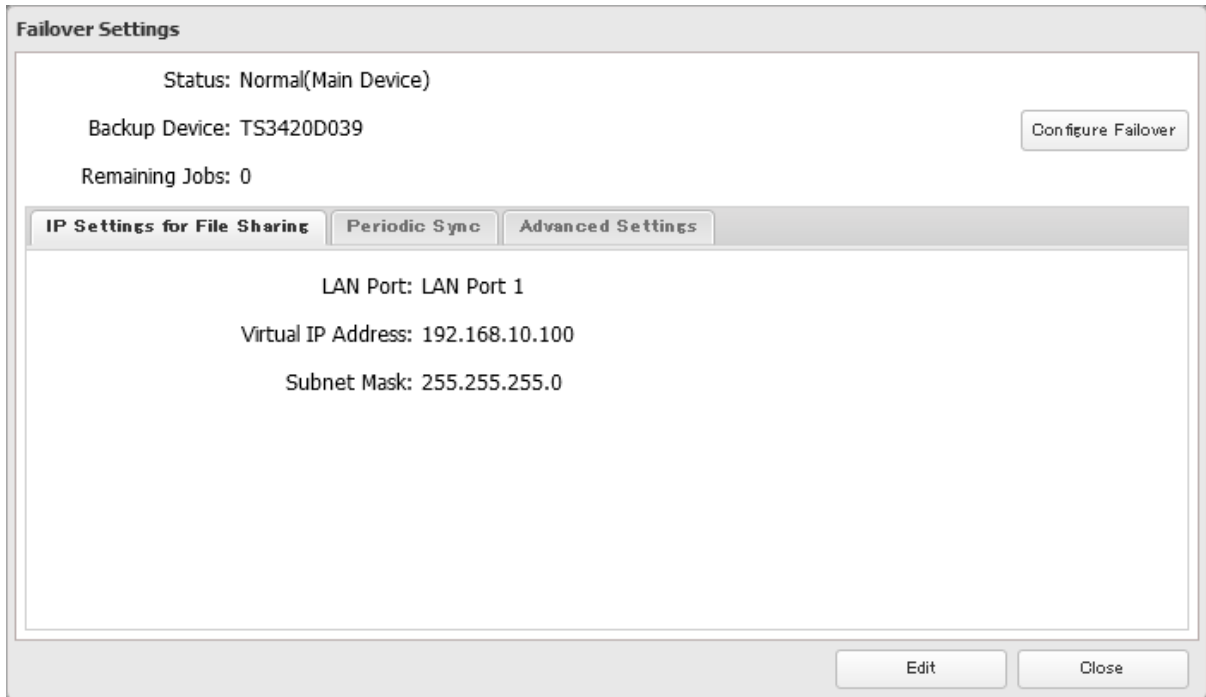

**4** Click *Stop Failover*.

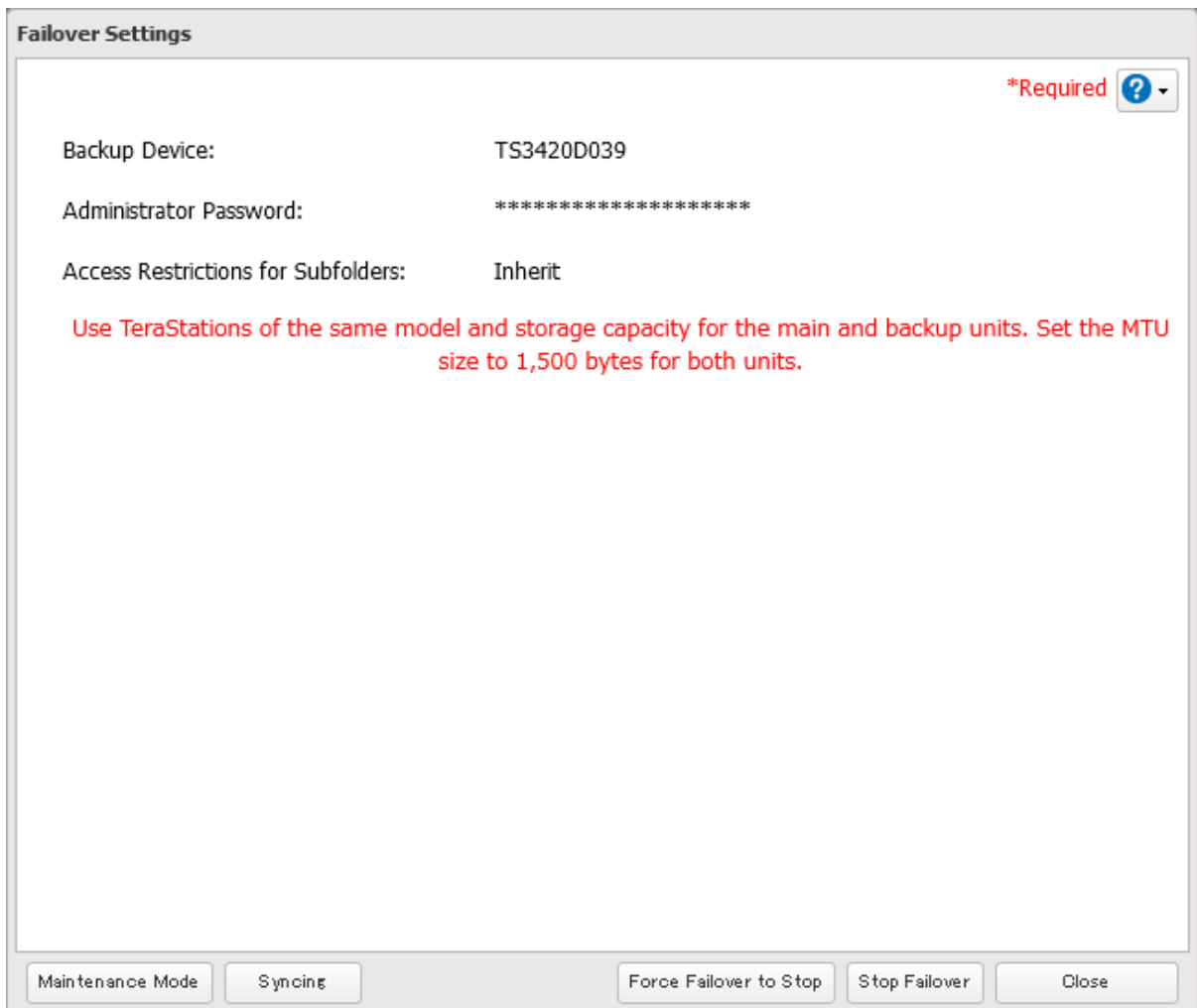

**5** The process is complete once you close the confirmation window that appears.

## Stopping from the Backup TeraStation

Log in to Settings for the backup TeraStation and click *Force Failover to Stop*.

## Stopping Failover Forcibly

If failover hasn't been stopped by taking actions from both the main and backup TeraStations, navigate to *Backup > Failover > Configure Failover* in Settings for the main TeraStation and click *Force Failover to Stop* to restart both TeraStations. After the TeraStations are restarted, make sure that all settings such as IP address and files in the shared folders are unchanged.

When you forcibly stop failover, attributes of the shared folders on the backup TeraStation will become read-only. Change the attribute settings to the desired options if necessary.

---

# Backing Up Your Mac with Time Machine

---

Time Machine is a backup program included with macOS. Configure your TeraStation as shown below to use Time Machine.

## 1. Preparing a Shared Folder for Time Machine

**1** From Settings, click *File Sharing*.

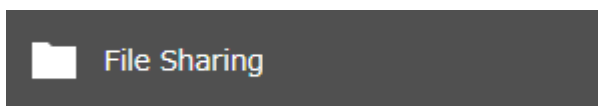

**2** Move the AFP switch (  ) to the  position to enable AFP.



**3** Click the settings icon (  ) to the right of "Folder Setup".



**4** Choose a shared folder as your backup destination for Time Machine.

**5** Under "LAN Protocol Support", select the "AFP (Mac)" checkbox on the *Basic* tab and click *OK*.

**6** The process is complete once you close the confirmation window that appears.

## 2. Configuring a Shared Folder as a Backup Destination

**1** From Settings, click *Backup*.



- 2** Click the settings icon (  ) to the right of “Time Machine”.



- 3** Click *Edit*, then *Browse*.



- 4** Select the shared folder and click *OK*.

- 5** Click *OK*, then click *OK* again.

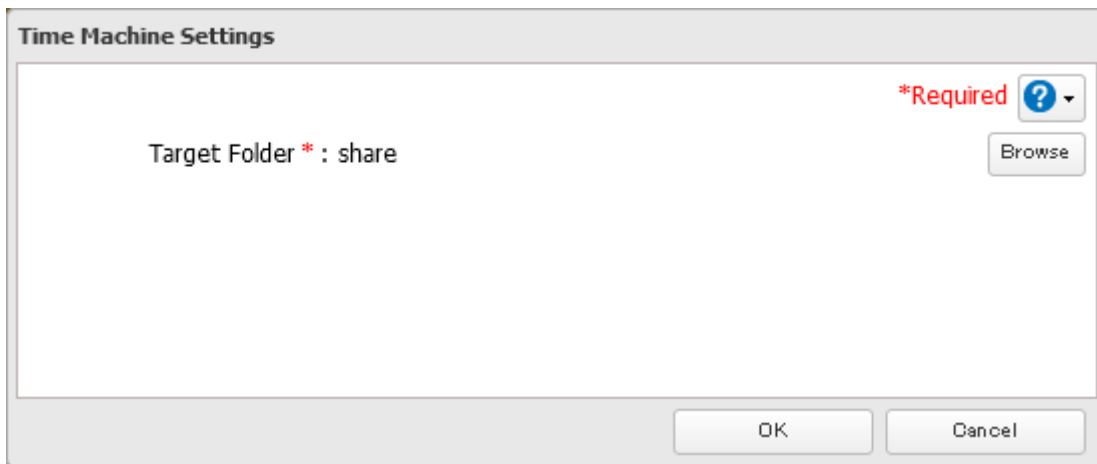

- 6** The process is complete when you move the Time Machine switch (  ) to the  position to enable Time Machine.



### 3. Configuring Time Machine on macOS

This procedure uses macOS 13.0 as an example.

- 1** From the Apple menu, open *System Settings*.



**2** Navigate to *General > Time Machine*.

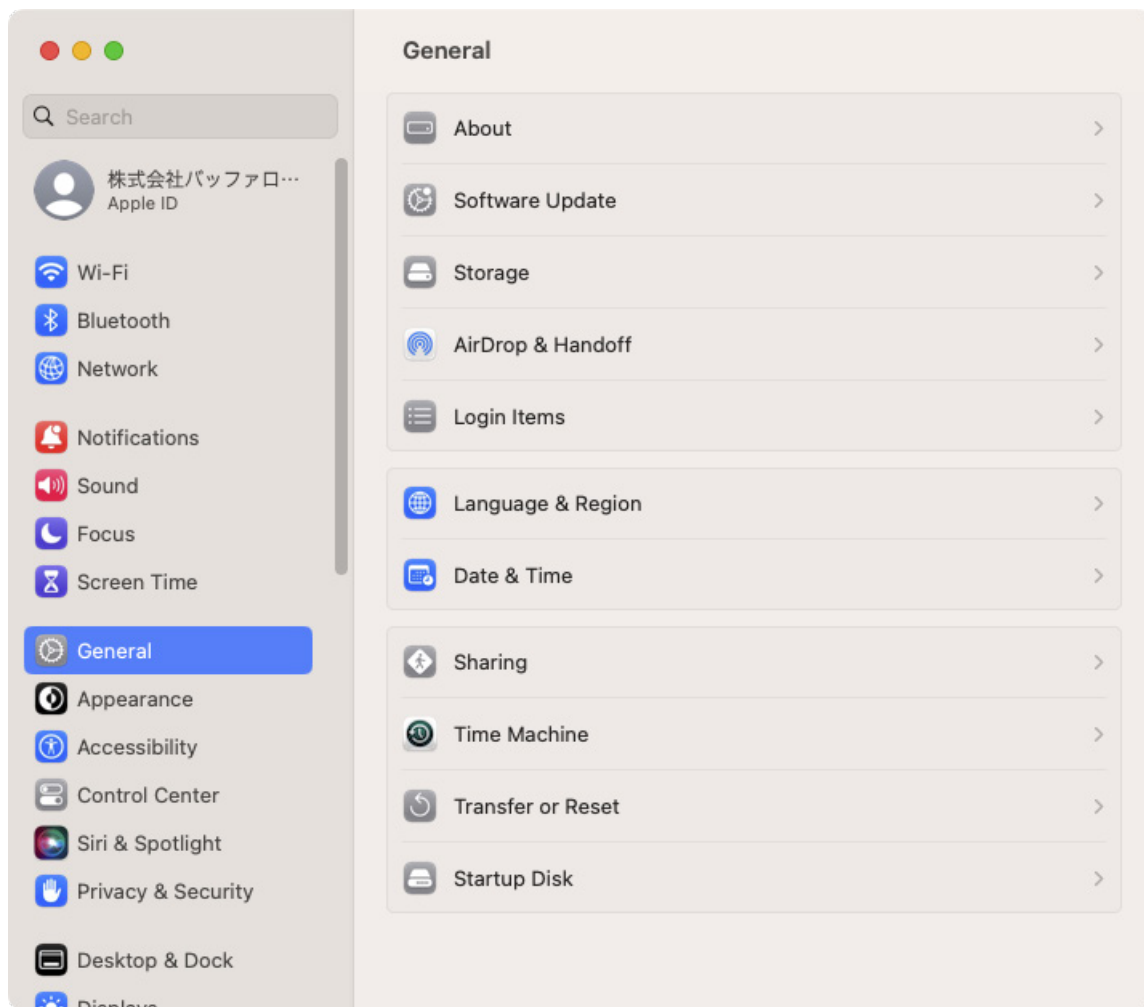

**3** Click *Add Backup Disk*.

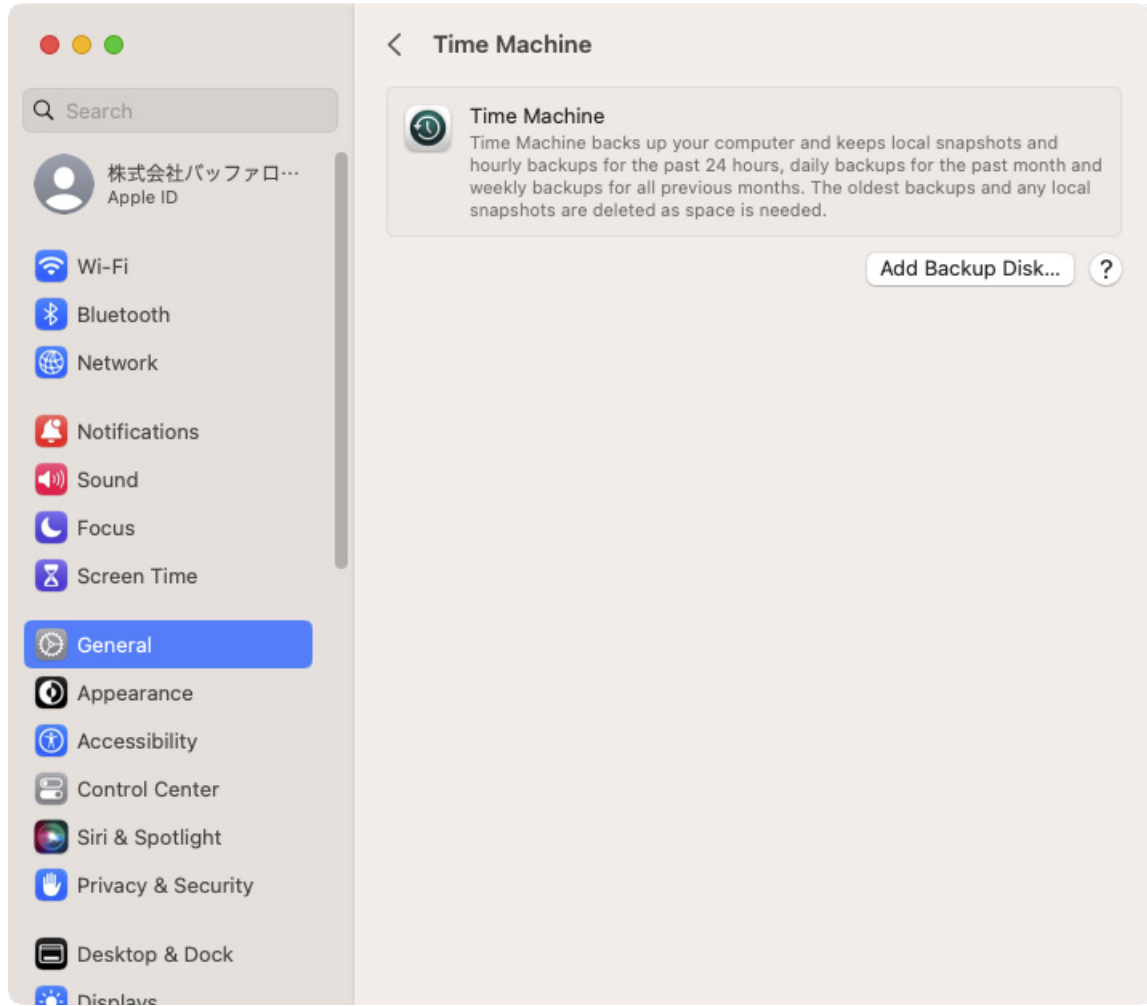

4 Select the shared folder, then click *Set Up Disk*.

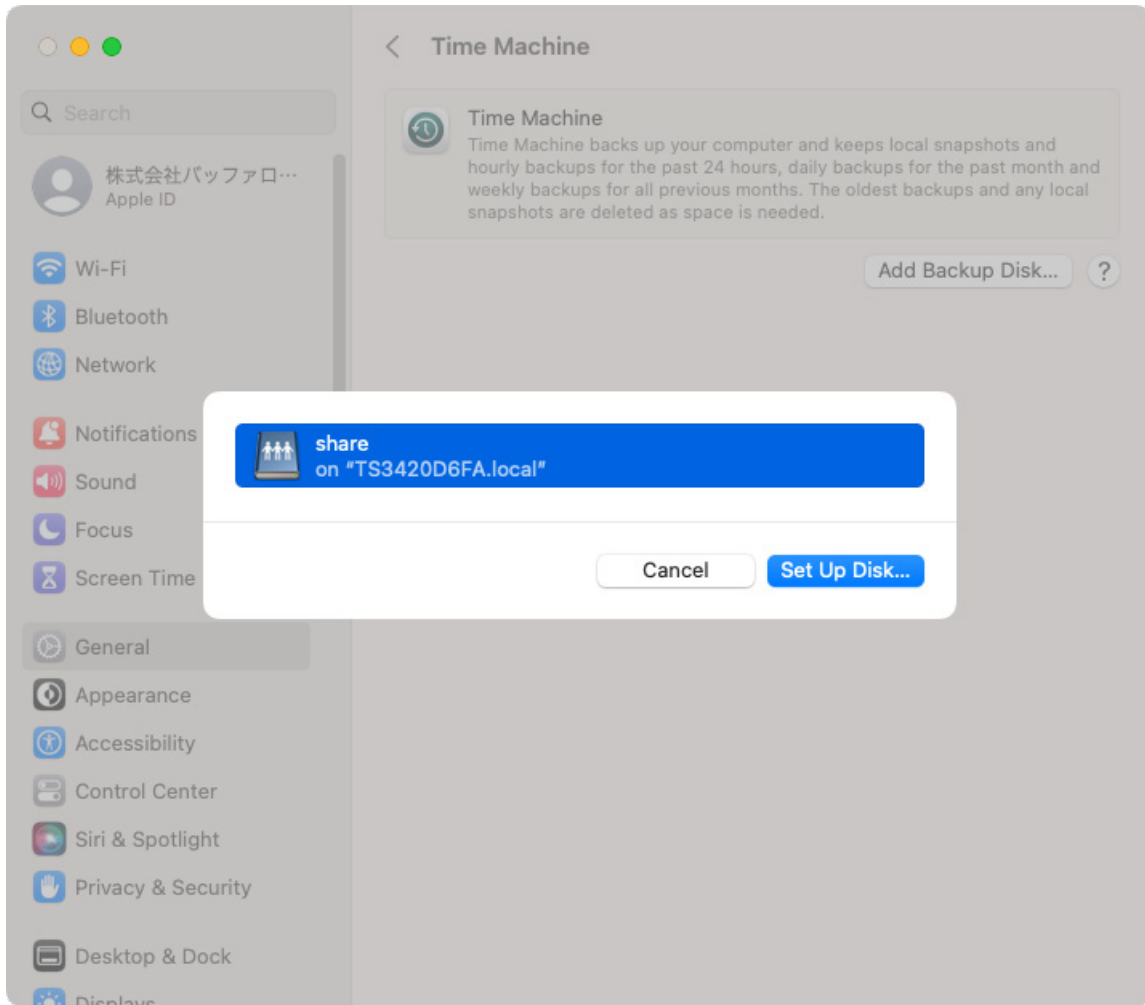

5 Click *Connect*.

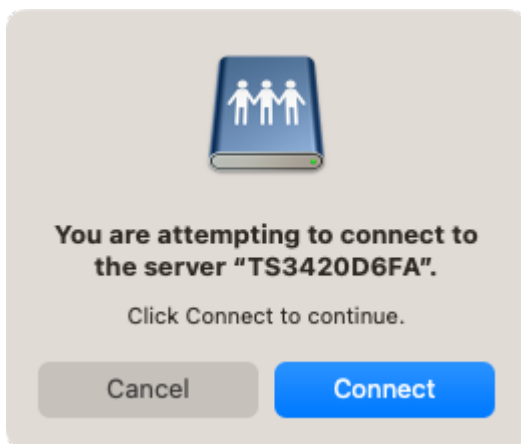

**6** Enter a username and password to be used for accessing the shared folder and click *Connect*.

If access restrictions are not configured on the destination share, log in using the administrator account. The default username and password for the administrator account are "admin" and "password". If access restrictions are configured, log in using an account with write privileges.

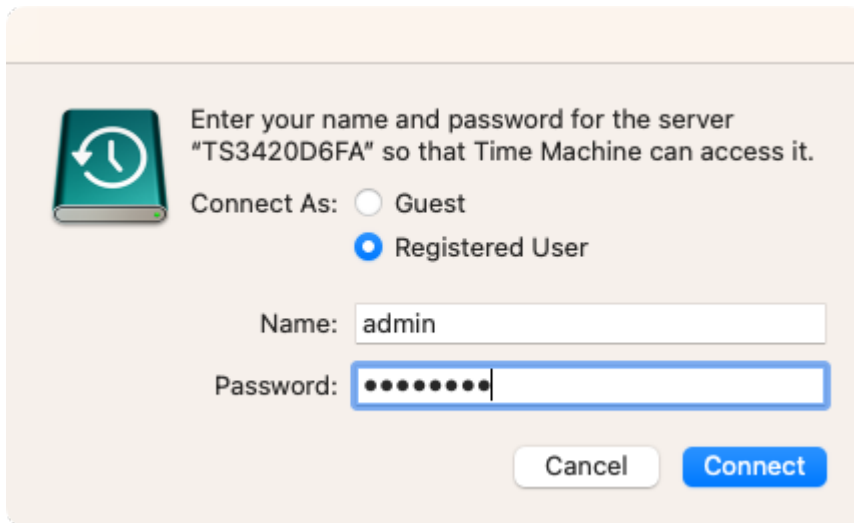
**7** Select whether to encrypt the backup data and click *Done*.

If enabling encryption, enter the password for backup twice.

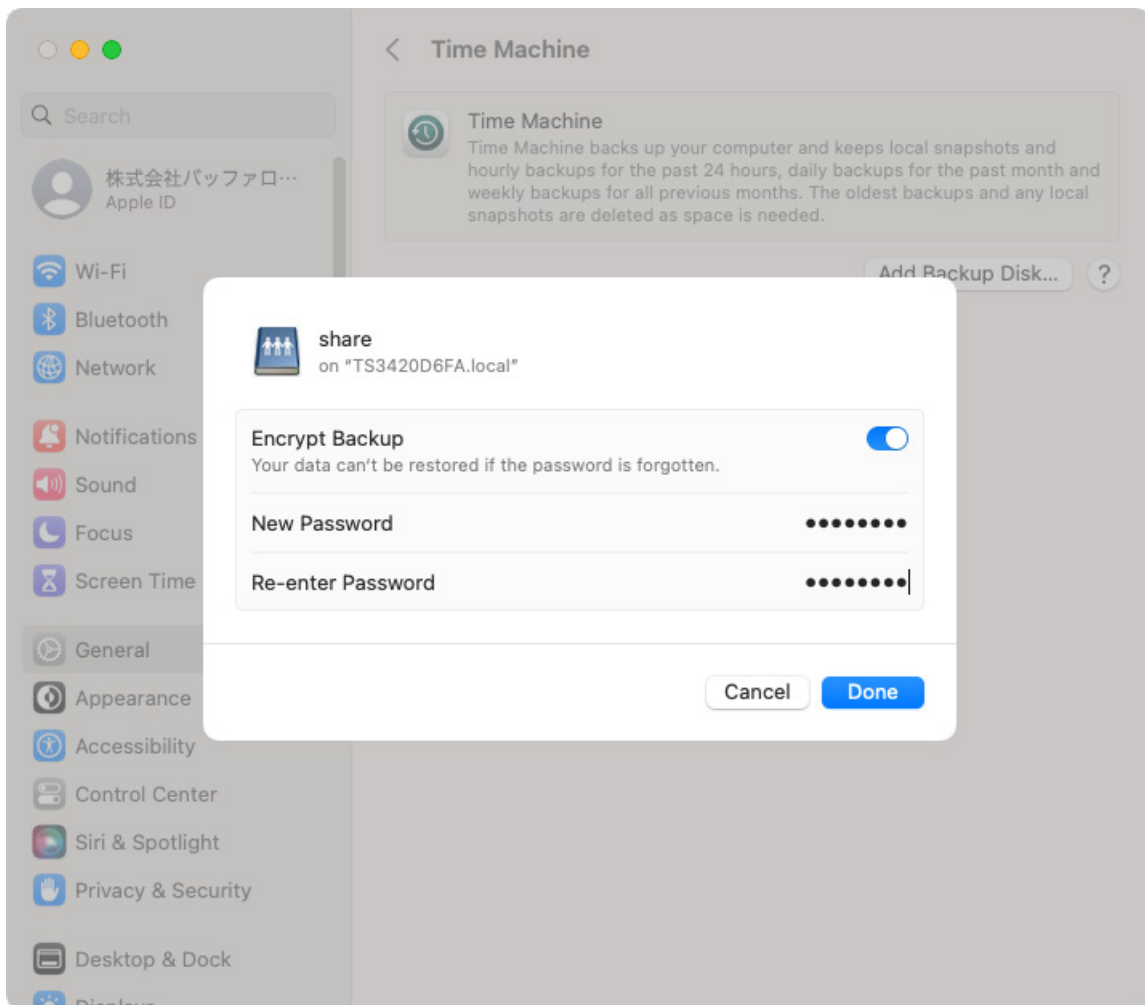

- 8 The process is complete once Time Machine finishes counting down from 60 seconds. The backup process will then start.

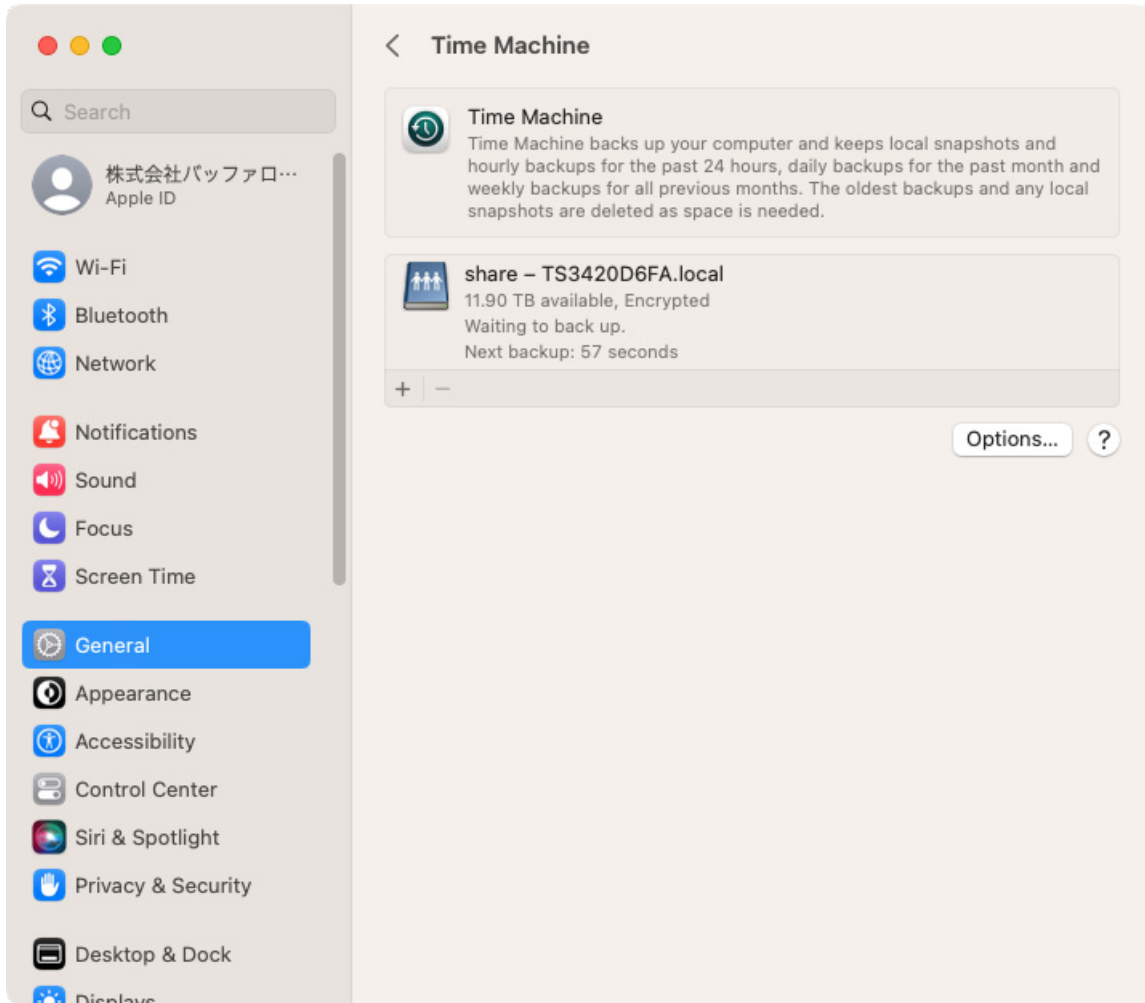

# Chapter 6 Cloud Services and Remote Access

---

## Synchronizing with Amazon S3

---

The TeraStation supports Amazon S3, a fee-based online storage service provided by Amazon, and other cloud storage services that share the Amazon S3 API. Data that is stored in a Amazon S3 remote folder on the TeraStation will be uploaded to an Amazon S3 bucket.

Depending on the services you have purchased from Amazon, prices for storage quantity and operations will vary. To avoid being unexpectedly overcharged, remain aware of the pricing structure and regularly check any accrued charges.

As a cost-saving measure, instead of uploading data directly to the Amazon S3 remote folder, we recommend using backups. Refer to the [“Uploading Files to Amazon S3”](#) section below for more information.

### Notes:

- Set the TeraStation’s time settings to the correct time. Using NTP is recommended. To configure NTP settings on the TeraStation, refer to the [“Name, Date, Time, and Language”](#) section in chapter 10.
- If using Amazon S3 through a proxy server, click *Proxy Settings* and select whether to use the configured settings or configure an identical proxy server. If using the identical proxy server, select “New settings” and enter the proxy server name, port number, username, and password. Consult your network administrator for detailed proxy server settings.
- This function doesn’t support Amazon S3 Glacier or S3 Object Lock.

---

## Creating an Amazon S3 Job

---

Follow the procedure below to create a new job.

**1** From the Amazon S3 portal, create your Amazon S3 account and a bucket before proceeding with the procedure.

**2** From Settings, click *Cloud Storage*.

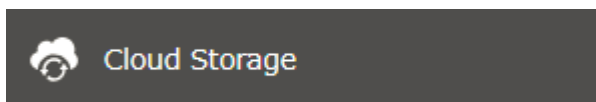

**3** Click the settings icon (  ) to the right of “Amazon S3”.

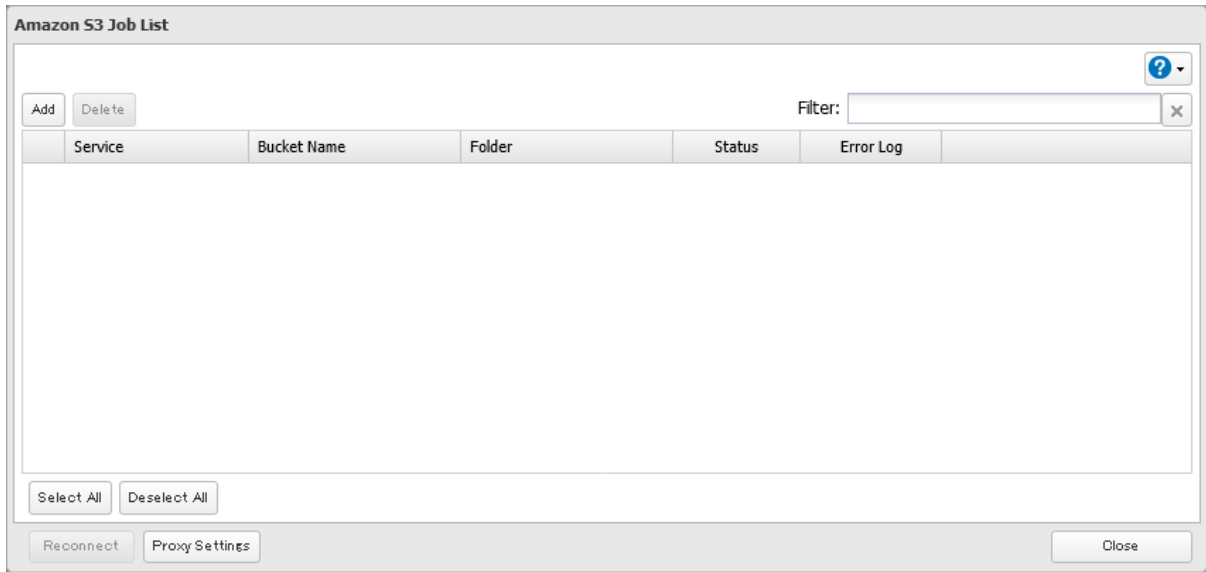
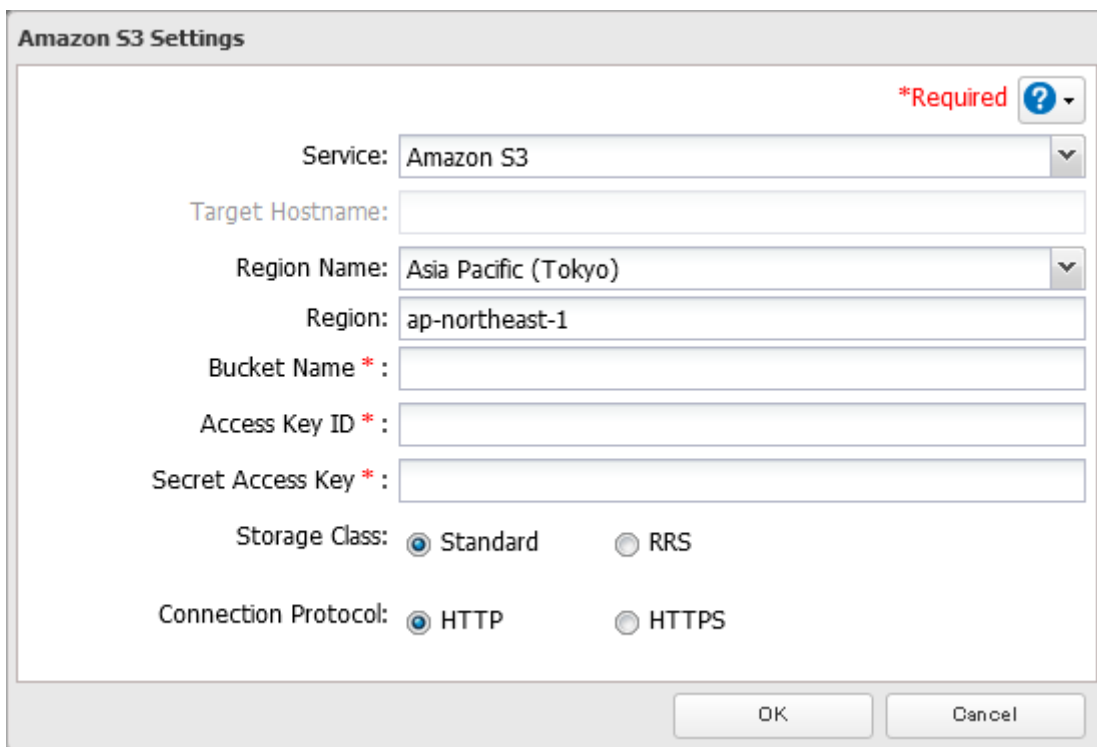

**4** Click *Add*.**5** Select the service name and region name that you have selected when creating the bucket from the drop-down list. Enter the bucket name, access key ID, and secret access key; select the storage class and the connection protocol, then click *OK*.

**6** Enter a remote folder name to use with Amazon S3 and click *OK*.

**7** Under “LAN Protocol Support”, select the “Backup” checkbox on the *Basic* tab.

**8** Click *OK*.

**9** Enter the desired characters into the backup device access key field and click *OK*.

**10** Configure the desired shared folder settings, then click *OK*.

**11** The process is complete once you close the confirmation window that appears.

**Notes:**

- If a remote folder created through this process is configured to use NFS, it cannot be mounted from an NFS client.
- Files cannot be uploaded to this remote folder using WebAccess.
- Do not configure a folder that is created through the procedure above as a replication destination folder.



- If you enter an incorrect bucket name and then cancel editing the Amazon S3 settings, the incorrect bucket name may still accidentally be registered. If this occurs, start from step 4 above and reconfigure the Amazon S3 settings correctly.
- If the TeraStation's performance seems unstable or slow, reduce the number of running jobs.

## Uploading Files to Amazon S3

Directly uploading files into the Amazon S3 remote folder will result in increased fees. Instead, we recommend using another shared folder to save data and back up regularly from the shared folder to the Amazon S3 remote folder in order to save costs.

The procedure below outlines using backups to save files into an Amazon S3 bucket instead of directly saving data into the Amazon S3 remote folder.

**Note:** To avoid unexpected data corruption while uploading to Amazon S3, the TeraStation will copy the upload target data to another location temporarily. Because of this, you will need free space equal to at most the total occupied size of an Amazon S3 remote folder.

- 1 From Settings, click *Backup*.



- 2 Click the settings icon (  ) to the right of "Backup".



- 3 If you had configured a backup device access key for the remote folder that was created through the ["Creating an Amazon S3 Job"](#) section above, click *Set*. If you hadn't, skip to step 5.

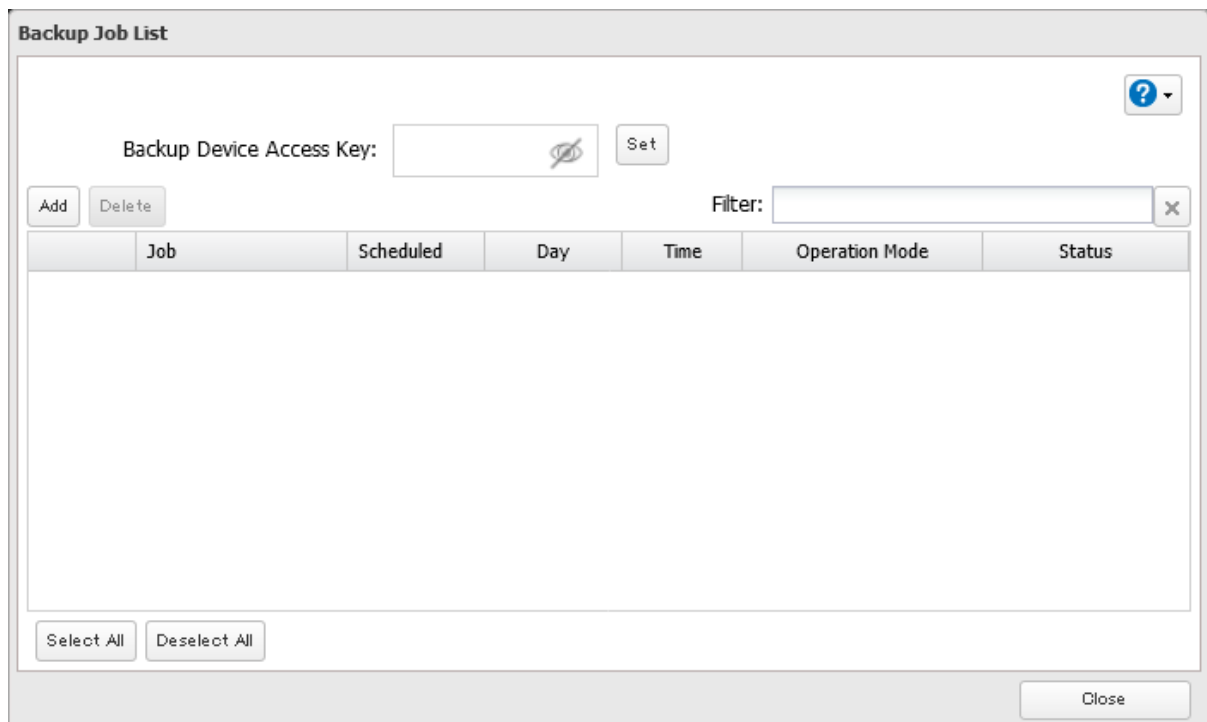

- 4** Enter the backup device access key and click *OK*.

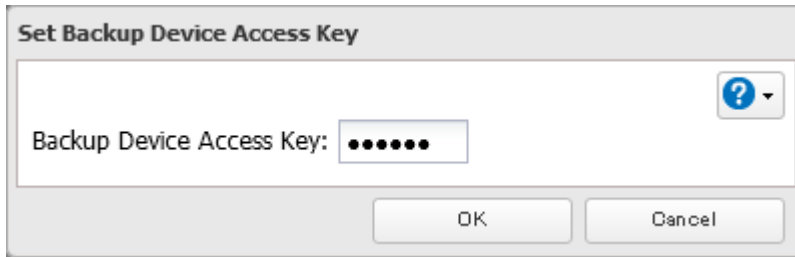

The dialog box titled "Set Backup Device Access Key" contains a text input field with the label "Backup Device Access Key:" followed by a masked key (seven dots). To the right of the input field is a help icon (a question mark in a blue circle) with a dropdown arrow. At the bottom of the dialog are two buttons: "OK" and "Cancel".

- 5** Click *Add*.

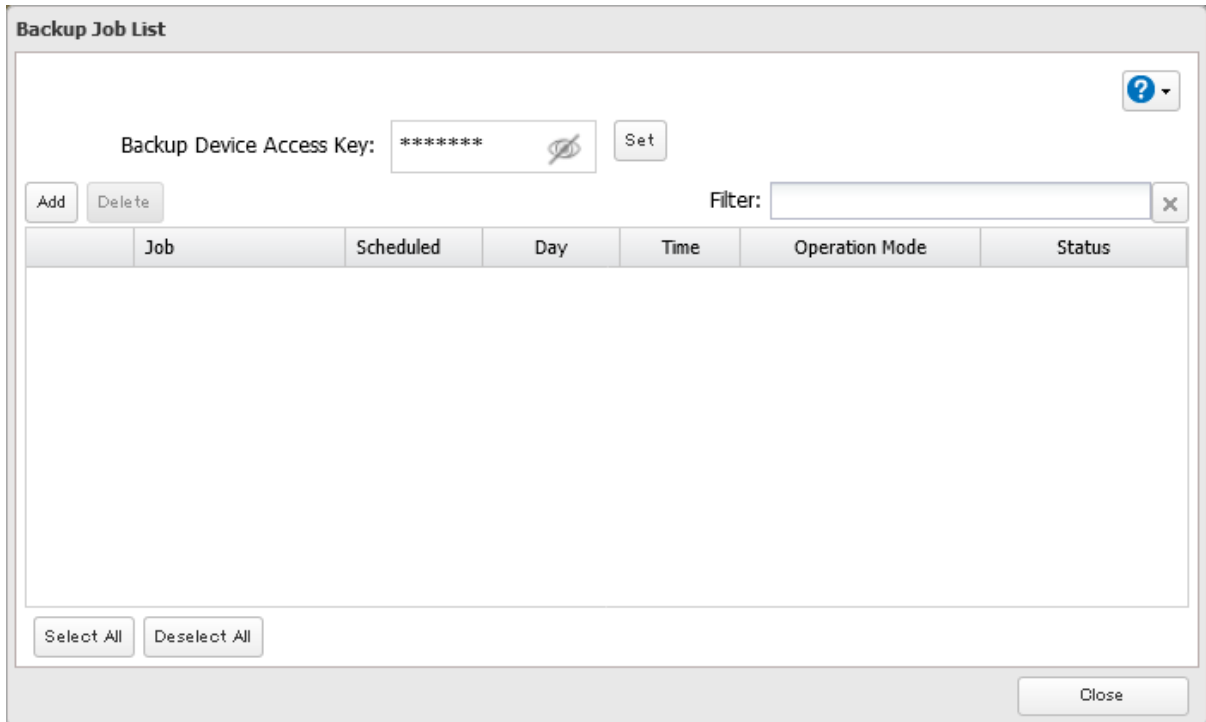

The "Backup Job List" window displays a table with the following columns: Job, Scheduled, Day, Time, Operation Mode, and Status. Above the table, there is a "Backup Device Access Key:" field containing "\*\*\*\*\*" with a "Set" button and a help icon. To the left of the table are "Add" and "Delete" buttons. To the right is a "Filter:" input field with a close button (X). At the bottom left are "Select All" and "Deselect All" buttons, and at the bottom right is a "Close" button.

Job	Scheduled	Day	Time	Operation Mode	Status

- 6** Select backup settings such as date and time to run, then select a backup mode for the "Operation Mode" drop-down list. It is recommended to configure a job to run periodically. Refer to the differences between the backup modes from the "[Backup Modes](#)" section in chapter 5.

**Note:** If you create a differential backup job and there are files that only exist in the destination folder, these files will be deleted when the job runs. Make sure that files are not saved when creating a backup job.

**Job Settings**

\*Required ?

Job Name \* :

Schedule:

Date and Time:   hours  minutes

Operation Mode:

Versions:

Unlimited

Backup Process Speed:

Options:  Create a subfolder for backup

Create backup log file

Save backup logs in the backup source folder

Select the folder to save backup logs

Backup Log Target Folder:

Encrypted data transfer

Compress and transfer

Ignore backup errors and continue backup job on schedule

Do not back up recycle bin

Overwrite unchanged files

**7** Click *Add*.

- 8** Select the shared folder that files will be saved to as a source, and the remote folder created through the [“Creating an Amazon S3 Job”](#) section above as a destination.

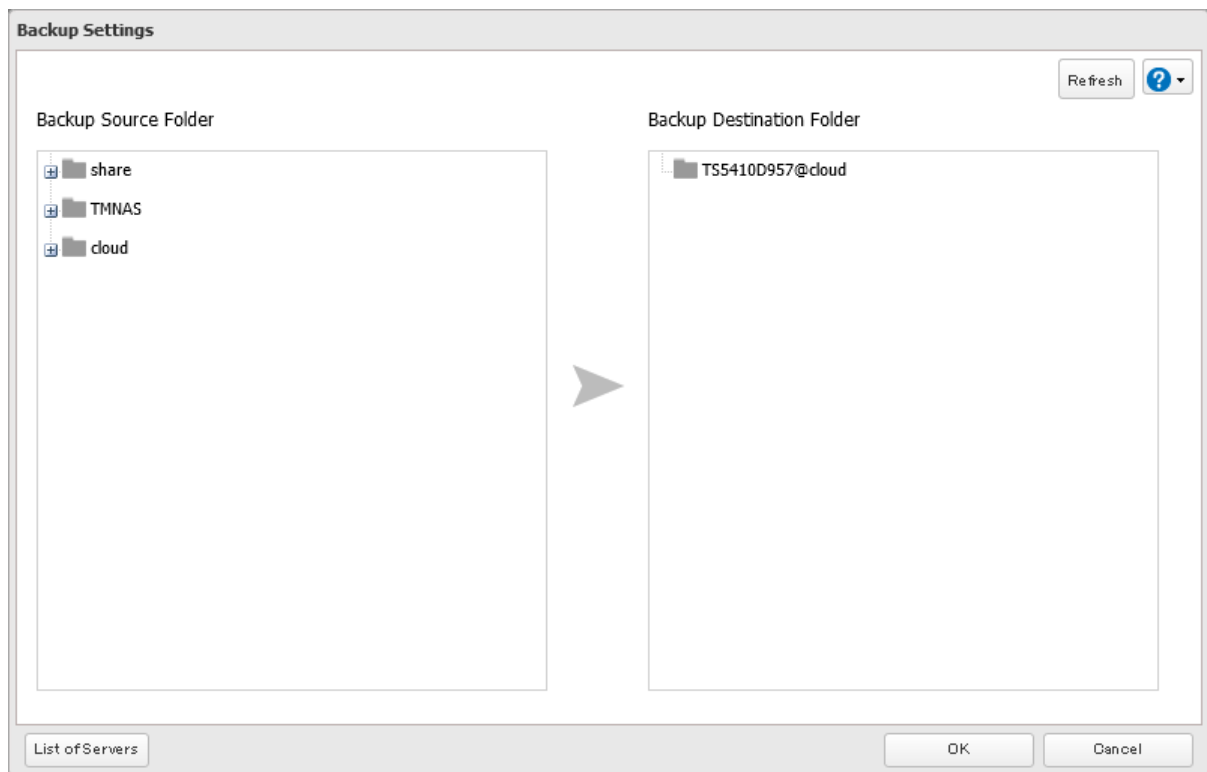

- 9** Click *OK*, then click *OK* again.

- 10** The process is complete once you close the confirmation window that appears. The backup job will be added to the backup jobs list.

**Notes:**

- To use the service after the network was temporarily disconnected, click *Reconnect*.
- If a file is directly added to the Amazon S3 bucket, the file will not be replicated to the remote folder.
- Do not copy 100,000 or more files to the backup source folder at once. If you do and uploading fails, check the network environment speed and try again with fewer files.
- Be careful with existing files in the remote folder, as files with the same name will be overwritten even if copied files are older.
- If you copy a file to the shared folder using File Explorer or a backup process, the file will also be uploaded sequentially to the Amazon S3 bucket. This second uploading process will start in the background during the first copying process and will not be visible. If the TeraStation is shut down or restarted immediately after copying a file to the shared folder, changing the settings, or disconnecting and reconnecting the Ethernet cable, the file may not be uploaded to the bucket. Try copying the file again if this occurs.
- If you encounter any upload or download errors, click *Error Log*. The log will display the filename and operation during which the error occurred.
- If uploading fails, try copying the file again. If it still fails, click *Reconnect* or set the Amazon S3 switch to off and on again, then restart the function service.

## Synchronizing with Box

The TeraStation supports synchronizing with Box, the online cloud storage service. Once linked, you can share files on the TeraStation via Box (or files on Box via the TeraStation). Follow the procedure below to configure your TeraStation for use with Box.

### Notes:

- This function is not available for the TS3210DN, TS3410DN, and TS3410RN TeraStation models, and will not appear in Settings for these models.
- To use Box Storage Sync, you need a Box account and an available empty Box folder. If you don't have a Box account, or if you need to create a Box folder, refer to the Box website.
- Read the Fair Usage Policy by Box carefully before use to comply with it. The policy can be referred to from <https://www.box.com/legal/fairusepolicy>.
- Set the TeraStation's time settings to the correct time. Using NTP is recommended. To configure NTP settings on the TeraStation, refer to the "[Name, Date, Time, and Language](#)" section in chapter 10.
- If using Box through a proxy server, click *Proxy Settings* and select whether to use the configured settings or configure an identical proxy server. This function is only available if using a proxy server with HTTP protocol. If the proxy server with HTTPS protocol has already been configured, or if using an identical proxy server, select "New settings" and enter the proxy server name (which is the HTTP protocol), port number, username, and password. Consult your network administrator for detailed proxy server settings.



## Creating a Box Storage Sync Job

Follow the procedure below to create a new job.

**1** From the Box portal, create your Box account before proceeding with the procedure.

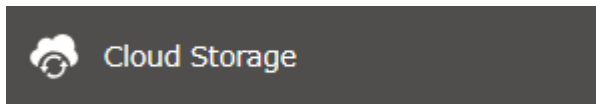
**2** From Settings, click *Cloud Storage*.



**3** Move the Box Storage Sync switch (  ) to the  position to enable Box Storage Sync.



**4** Click the settings icon (  ) to the right of "Box Storage Sync".

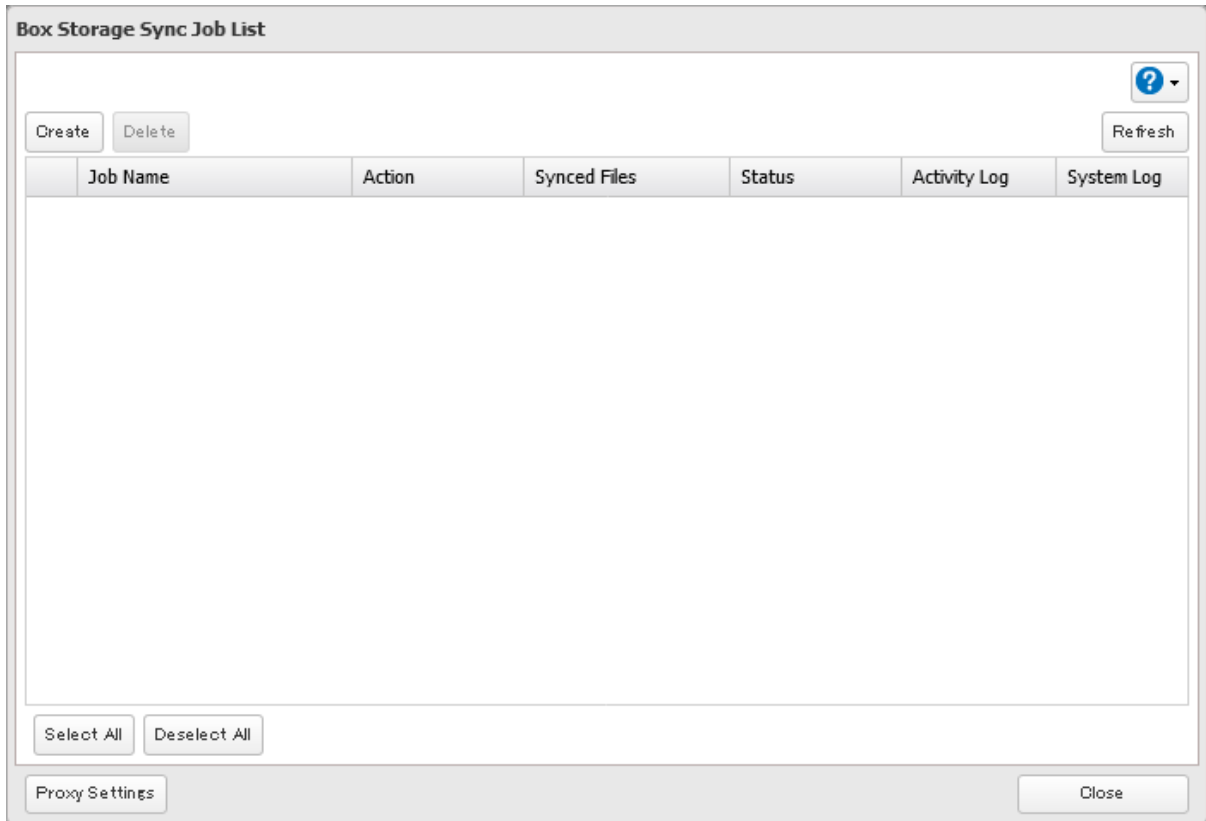

**5** Click *Create*.**6** The sign-in window will open in a different tab. Enter the username and password of your Box account, then sign in.

**Note:** If using the browser on Firefox, you may not be automatically redirected from the sign-in page to the Box Storage Sync job page. In such a case, return manually. The remaining tab should be closed after the job is created.

**7** Enter the desired job name and click *Next*.

**Job Setup Wizard for Box Storage Sync - Step 1 of 10**

### Enter a Job Name

---

Enter a name for the job to be created.

 ?

- 8** Select the sync action and behavior for when files with the same name are already in the target folder, then click *Next*.

There are three types of sync actions: bidirectional, uploading, and downloading. If bidirectional is selected as the sync action, files on both Box and the TeraStation will be updated. If uploading is selected as the sync action, only files on Box will be updated. If downloading is selected as the sync action, only files on the TeraStation will be updated. Both uploading and downloading will delete files from the sync destination folder that don't already exist on the source folder.

The behavior for when files with the same name already exist will occur when the files that have the same name on both the TeraStation and Box are changed.

**Job Setup Wizard for Box Storage Sync - Step 2 of 10**

### Select Sync Action

Select the sync action for your files.

Upload

Files with Same Names

- Keep files on Box  
If there is a file conflict when syncing, files on Box will be saved over other versions.
- Keep files on the TeraStation  
If there is a file conflict when syncing, files on the TeraStation will be saved over other versions.
- Keep files with newer modified date  
If there is a file conflict when syncing, files with the newer modified date will be saved over other versions.

Back Next Cancel



- 9 Select the desired TeraStation and Box folders. Do not use a TeraStation shared folder that is currently being used for certain TeraStation functions such as cloud storage sync jobs, including existing Box Storage Sync jobs. If you want to create an empty folder first, click *Browse* under “Folder on TeraStation”, then click *Create Folder* on the selecting folder window that appears. Click *Next* after selecting the folders.

**Job Setup Wizard for Box Storage Sync - Step 3 of 10**

### Configure Job Pairs

Select the Box and TeraStation folders you want to sync data between.

Folder on TeraStation	share	<input type="button" value="Browse"/>
Folder on Box	/Box_Storage_Sync	<input type="button" value="Browse"/>

**Note:** The sixth level and deeper of shared and Box folders cannot be selected.

- 10** Specify the sync method and click *Next*. If you have selected “Sync using configured time settings” for the sync method, skip to step 12.

**Job Setup Wizard for Box Storage Sync - Step 4 of 10**

### Configure Sync Method

Select the sync method to use between the Box and TeraStation folders.

Sync at specified recurring intervals  
This option will start the next synchronization occurrence at every specified minute mark of the hour.

minute mark

Sync using configured time settings  
This option will start the next synchronization occurrence at the specified start time and frequency.

Frequency:

Start Time:

Day of Week:

Sunday  Monday  Tuesday  Wednesday  Thursday  Friday  Saturday

Back Next Cancel

**Note:** If “Sync at specified recurring intervals” is selected, the sync process will start running at the beginning of every hour and at every time interval you set. For example, if “15 minutes” is selected, synchronization will begin as soon as the hour starts, followed by every 15-, 30-, and 45-minute mark of the hour.

- 11** Configure the sync frequency. Files will be uploaded during the start and end time of the interval configured in step 10 above. If you want to always upload files during the configured sync interval, select "Always sync within the specified interval" for "Frequency". Click *Next* after configuring.

**Job Setup Wizard for Box Storage Sync - Step 5 of 10**

### Configure Sync Frequency

Configure a sync frequency for a job. If you select "Daily" for frequency, specify the start and end time. If you select "Weekly" for frequency, specify the day of the week and times.

**Frequency**  
Always sync within the specified interval

**Start Time**  
00:00

**End Time**  
24:00

**Day of Week**  
 Sunday  Monday  Tuesday  Wednesday  Thursday  Friday  Saturday

Back Next Cancel

- 12** Select whether to check for file consistencies. If an inconsistency occurs with a file between the TeraStation and Box, that file will be updated with the latest file version. Click *Next* after selections are finished.

**Job Setup Wizard for Box Storage Sync - Step 6 of 10**

### Configure Consistency Check

Select whether to enable consistency checks. The hash values of files in the source and destination folders will be compared for uploading/downloading. If there are any inconsistencies between files, the system will try syncing again.

Enable                       Disable

Back      Next      Cancel

- 13** Select whether to limit the transfer speed. If you enable this feature, the file transfer speed between Box and the TeraStation will not exceed the configured speed.

**Job Setup Wizard for Box Storage Sync - Step 7 of 10**

### Limit Transfer Speed

Configure whether to limit the transfer speed for Box Storage Sync, which will reduce network load and impact other functions.

Enable  Disable

Maximum Speed:

- 14** Configure file filters for the sync process. The following screen enables file filtering configuration by file sizes and whether they're hidden. The file size filter will only apply to uploads. The available maximum size is up to 15,360 MB (15 GB). "Hidden files" refer to files whose filename starts with a period. Click *Next* after selections are finished.

**Job Setup Wizard for Box Storage Sync - Step 8 of 10**

### Configure File Filters 1

Configure the requirements for filtering files. If any files in the folder on either the TeraStation or Box meet any of the following requirements, those files will not be synced.

**Filter by File Size**

Enable  Disable

Maximum Size:  MB

**Filter Hidden Files**

Enable  Disable

Back Next Cancel

- 15** The following screen enables file filtering configuration by extensions. Configure the desired filter settings and click *Next*.

**Job Setup Wizard for Box Storage Sync - Step 9 of 10**

### Configure File Filters 2

Configure the requirements for filtering files. If any files in the folder on either the TeraStation or Box meet any of the following requirements, those files will not be synced.

**Filter by File Extension**

Enable  Disable

**Filtered Extensions**

Filtered Extensions
---------------------

Add

Delete

Back Next Cancel

- 16** Confirm that all settings are properly configured and click *OK*.

- 17** The process is complete once you close the confirmation window that appears.

**Notes:**

- Do not use UTF-8 4-byte characters (U+10000–U+10FFFF) such as emoji in file or folder names.
- Files whose name contains any of the symbols / \ > < : | ? \* " ' ` may be unable to be synchronized. If files could not be synchronized, make sure that these symbols are not used in the filenames.
- Depending on your network environment, you may be unable to download larger files. To prevent this issue, divide a larger file into smaller files or compress the files to a smaller size before uploading them to Box.
- When files are uploaded from the TeraStation folder using Box Storage Sync and then downloaded onto a computer from Box, time stamps for files may be changed to the download date.
- Do not copy 1 million or more files to the TeraStation folder at once. If you do and synchronization fails, try again with fewer files.
- If a user creates a folder and a different user shares a folder with the same name, both folders will appear within the Box console. In such a case, if either folder is selected as a destination folder for Box Storage Sync, the shared folder will always be used as the destination, even if you have selected the created folder. Be careful when creating a folder and make sure it has a different name than an existing shared folder.
- If you create multiple jobs on the same Box account, files may be unable to be synchronized due to rate limits set by Box.
- Do not rename or delete any folders used for Box Storage Sync.

- If the “Unknown error.” message appears when signing in to Box, check that the network environment and proxy server settings are correct. If the message still persists, wait for a while and try again.
- If a file is saved into the shared folder using a macOS computer while the sync process is running, that file may not be copied properly. The file will be copied in the next sync process.
- If any of the following operations is performed while the sync process is running, the process will be stopped and the I64 will appear as a notification: shutting down, disabling Box Storage Sync, restoring snapshots, checking a drive, or formatting a drive. Also, the job status will remain at the progress point of the stopped process until the sync process resumes.
- When creating 8 or more jobs at once, the TeraStation’s performance may become slow if multiple jobs are run concurrently. When creating multiple jobs, wait until the sync process of the previously-created job is finished before creating another job.
- If the TeraStation’s performance seems unstable or slow, change the sync start time so that they do not overlap. If the sync frequency has been set to “Always sync within the specified interval”, change it to “Daily” or “Weekly” and then set the start time.

## Changing Job Settings

---

Follow the procedure below to change any job settings you have already configured.

- 1 From Settings, click *Cloud Storage*.

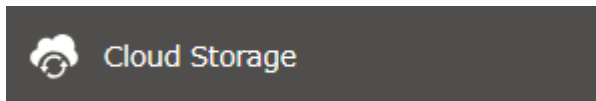

- 2 Click the settings icon (  ) to the right of “Box Storage Sync”.





**3** From the job list, click the job whose settings you want to change.

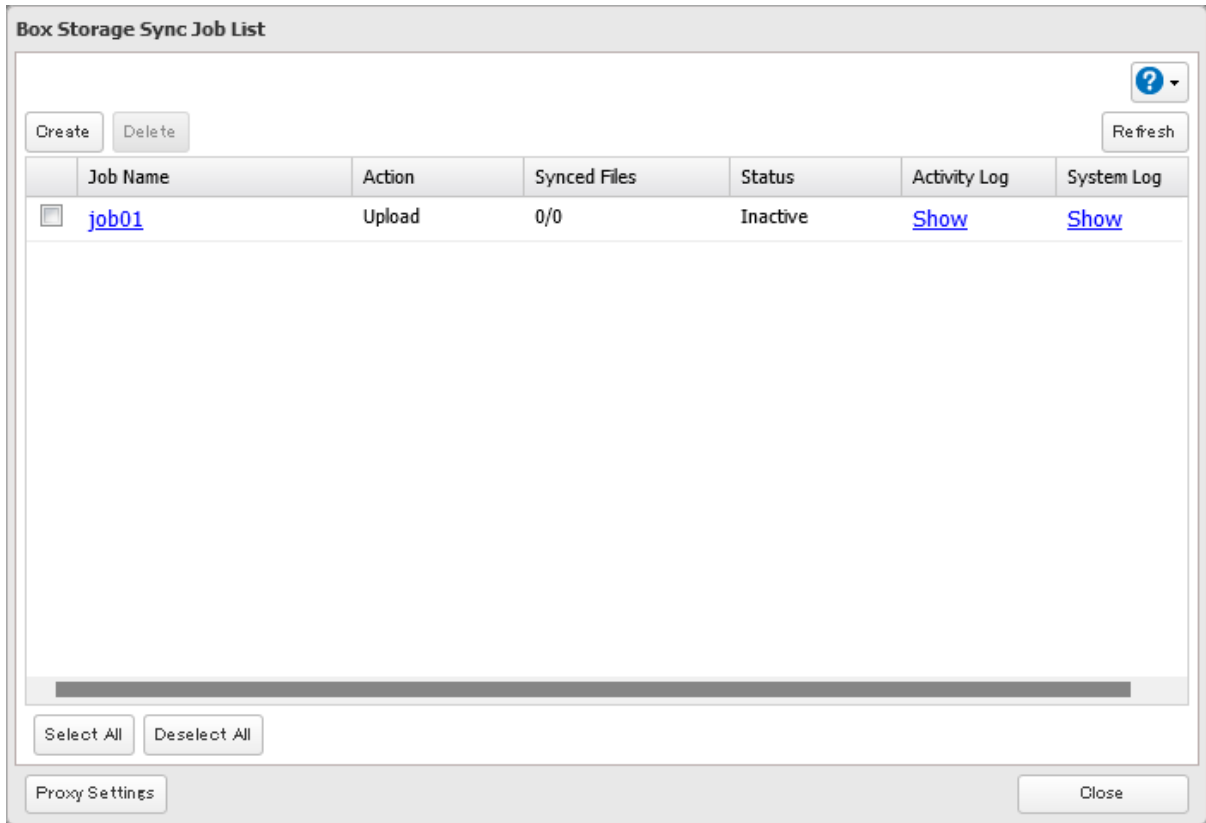

**4** Click the *Options* tab, then click *Edit*.

**Box Storage Sync Job Settings**

**Basic** **Options**

Job Name:	job01
Folder on TeraStation:	share
Folder on Box:	/Box_Storage_Sync
Used Capacity on Box:	0.0 GB
Total Capacity on Box:	10.0 GB
Account Name:	admin

Update Token Close

## 5 Configure the desired settings and click OK.

**Box Storage Sync Job Settings**

**Sync Settings** | Filter Settings

Sync Action: Upload

Files with Same Names: Keep files on the TeraStation

Sync Method:
 

- Sync at specified recurring intervals
- Sync using configured time settings

Sync Interval: 60 minute mark

Sync Frequency: Always sync within the specified interval

Start Time: 01:00

End Time: 24:00

Day of Week:
 

- Sunday
- Monday
- Tuesday
- Wednesday
- Thursday
- Friday
- Saturday

Consistency Check:
 

- Enable
- Disable

Transfer Speed Limit:
 

- Enable
- Disable

Maximum Speed: 100 Kbps

OK Cancel

## 6 The process is complete once you close the confirmation window that appears.

## Corrective Actions for in Case of Error

If an error occurs, the I64 message will appear as a notification. Click *Clear* to delete the message from the Dashboard in Settings.

### Error Appears in the “Status” Field of Job List

If any of the following messages appear in the “Status” field of the job list, the synchronization process did not complete properly. In such a case, try the corresponding corrective action.

Message	Description	Corrective Action
Failed in the past	There are some files that could not be synced.	Unsynced files will be synchronized in a subsequent job.
Low drive space	The capacity of the TeraStation has become full.	Delete unnecessary files and folders.
Low cloud storage space	The capacity of the cloud storage has become full.	Delete unnecessary files and folders.
Server busy	The cloud storage server is temporarily busy.	Please wait for about 10 minutes and try again.
Communication error	The TeraStation could not communicate with the cloud storage server.	Check that the network environment and proxy server settings are correct.

Message	Description	Corrective Action
Token error	An error occurred on a token.	<p>Update the token by following the procedure below.</p> <ol style="list-style-type: none"> <li>1 From Settings, click <i>Cloud Storage</i>.</li> <li>2 Click the settings icon (  ) to the right of “Box Storage Sync”.</li> <li>3 From the job list, click the job with the occurring token error.</li> <li>4 Click <i>Update Token</i> at the bottom-left of the window.</li> <li>5 The process is complete once you close the confirmation window that appears.</li> </ol>

### Error Appears While Creating a Job or Error Code Appears on the System Log

You may encounter error messages that contain the following error codes when creating Box Storage Sync jobs; the system log may contain the following error codes as well. If you encounter any of the following error codes, refer to the table below and try the respective corrective action. If the error code is not listed on the table, refer to the Box website instead: <https://developer.box.com/guides/api-calls/permissions-and-errors/common-errors/>.

HTTP Status Code	Error	Message	Corrective Action
400 Bad Request	cyclical_folder_structure	Moving a folder has created a cyclical folder structure.	Delete the cyclical folders (folders that are cross-referencing).
400 Bad Request	item_name_invalid	The file or folder name contains invalid characters.	Rename the files or folders to not contain the invalid characters described in the <a href="#">“Creating a Box Storage Sync Job”</a> section above.
400 Bad Request	item_name_too_long	The file or folder name is too long.	Shorten the length of the name to 255 bytes or less.
403 Forbidden	access_denied_insufficient_permissions	You don’t have appropriate permissions to move files.	Make sure a user has the appropriate permissions.
403 Forbidden	access_denied_item_locked	You are attempting to access a locked file or folder without the appropriate permissions.	Unlock the files or folders.
403 Forbidden	file_size_limit_exceeded	The file size exceeds the maximum size limit of the folder owner’s account.	Reduce the file size.
403 Forbidden	forbidden_by_policy	You don’t have appropriate permissions to copy files.	Make sure a user has the appropriate permissions.
403 Forbidden	storage_limit_exceeded	The account’s storage limit has been reached.	Files can no longer be uploaded. Delete unnecessary files from the storage, or reduce the size of the upload target files.

HTTP Status Code	Error	Message	Corrective Action
429 Too Many requests	rate_limit_exceeded	The request rate limit has been exceeded.	Check whether multiple jobs have been created or if too much data has been transferred using the same Box account. In such a case, wait for a while and try again or reduce the number of jobs that are concurrently running.
500 Internal Server Error	internal_server_error	An internal server error occurred on the Box server.	Please wait for about 10 minutes and try again.
502 Bad Gateway	bad_gateway	A communication error occurred with the Box server.	Please wait for about 10 minutes and try again.
503 Unavailable	unavailable	The request could not be processed by the Box server.	Please wait for about 10 minutes and try again.
503 Unavailable	-	The maximum process limit has been exceeded.	Please wait for about 10 minutes and try again.
504 Gateway Timeout	-	The session timed out before the process completed.	Please wait for about 10 minutes and try again.
-	disk quota exceeded	The quota capacity has been reached.	Files can no longer be downloaded. Delete unnecessary files from the remote folder on the TeraStation or expand the quota capacity settings.
-	file too big for remaining disk space	There is not enough free space on the TeraStation.	Files can no longer be downloaded. Delete unnecessary files from the TeraStation.

---

## Synchronizing with Dropbox

---

The TeraStation supports synchronizing with Dropbox, the online cloud service. Once linked, you can share TeraStation files via Dropbox (or Dropbox files via TeraStation). Follow the procedure below to configure your TeraStation for use with Dropbox.

### Notes:

- To use Dropbox Sync, you will need a Dropbox account and an available empty Dropbox folder. If you don't have a Dropbox account, or if you need to create a new empty Dropbox folder, refer to the Dropbox website.
- If using Dropbox through a proxy server, click *Proxy Settings* and select whether to use the configured settings or configure an identical proxy server. If using the identical proxy server, select "New settings" and enter the proxy server name, port number, username, and password. Consult your network administrator for detailed proxy server settings.
- This function doesn't support linking with team folders.

## Creating a Dropbox Sync Job

---

Follow the procedure below to create a new job. Up to eight Dropbox jobs can be configured at a time.

**1** From Settings, click *Cloud Storage*.

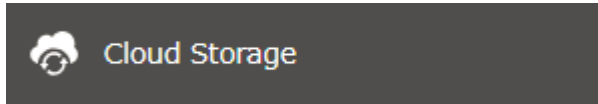

**2** Move the Dropbox Sync switch (  ) to the  position to enable Dropbox Sync.



**3** Click the settings icon (  ) to the right of "Dropbox Sync".



**4** Click *Add*.

The screenshot shows a window titled "Dropbox Sync Job List". At the top left are "Add" and "Delete" buttons. At the top right are a help icon (question mark in a blue circle) and a "Refresh" button. Below these is a table with the following columns: "Job Name", "Encryption", "Unsynced Files", "Status", and "Log". The table body is currently empty. At the bottom left are "Select All" and "Deselect All" buttons. At the bottom right is a "Close" button. A "Proxy Settings" button is located at the bottom left of the window frame.

**5** Click *View Dropbox Authentication Page*.

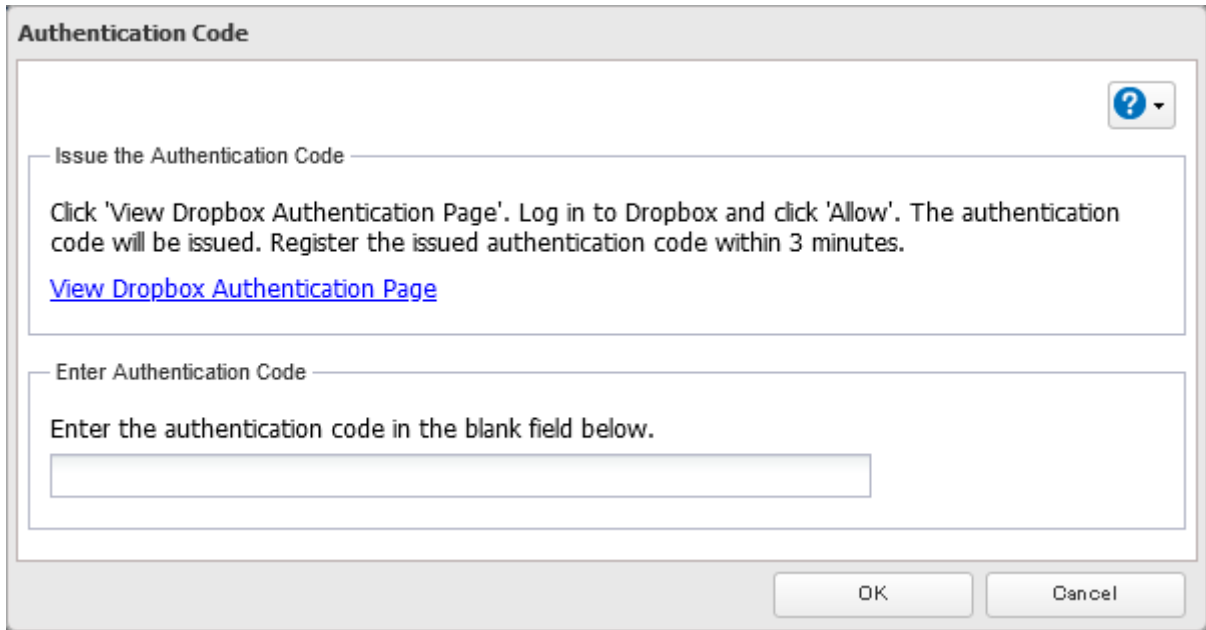

**6** The authentication site that is offered by Dropbox will be displayed. Log in to the website with your Dropbox account, then click *Allow*.

**7** The authentication code will be displayed. Copy the authentication code and return to Settings. Authentication code reregistration should be finished within three minutes.

**8** Paste the authentication code and click *OK*.

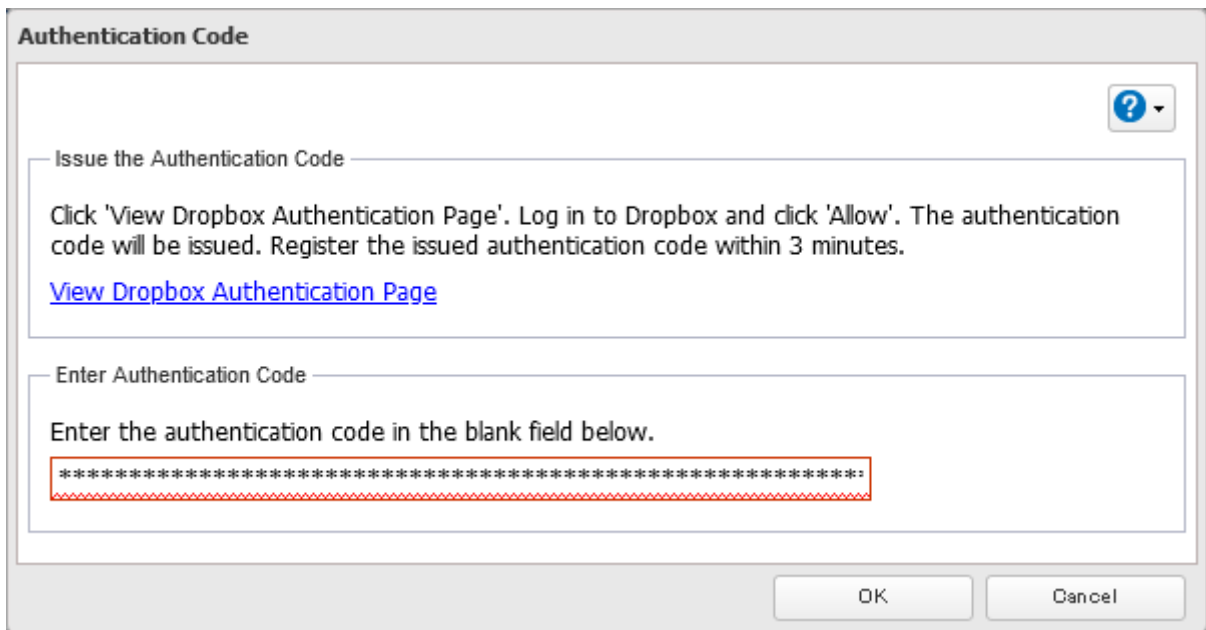

**9** Enter the desired job name; select the TeraStation and Dropbox folders, and configure encryption.

If you enable encryption, you will need to set an encryption password. The password cannot be changed once you configure it. Take note of the password and keep it secure. If you forget or lose the password, create a new job using the same Dropbox account, then delete the old job.

**10** Click *OK*. The process is complete once you close the confirmation window that appears.

#### Notes:

- When encryption is enabled, files uploaded to Dropbox not using Dropbox Sync will not be downloaded to the TeraStation even if the sync direction is configured to “Bidirectional” or “Download only”.
- Refer to the following website for synchronization restrictions between the TeraStation and Dropbox: <https://www.dropbox.com/help/145>
- Folders that are configured for Dropbox Sync cannot be renamed or used for replication.
- Files that are 900 MB or larger cannot be downloaded using Dropbox Sync. However, even if the file size is smaller than 900 MB, downloading may fail when multiple processes are running at the same time.
- If the TeraStation’s performance seems unstable or slow, reduce the number of running jobs.

## Changing Job Settings

Follow the procedure below to change any job settings you have already configured.

**1** From Settings, click *Cloud Storage*.

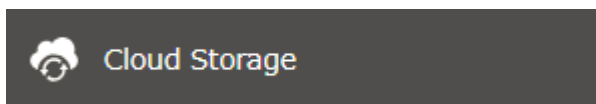

**2** Click the settings icon (  ) to the right of “Dropbox Sync”.





**3** From the job list, click the job whose settings you want to change.

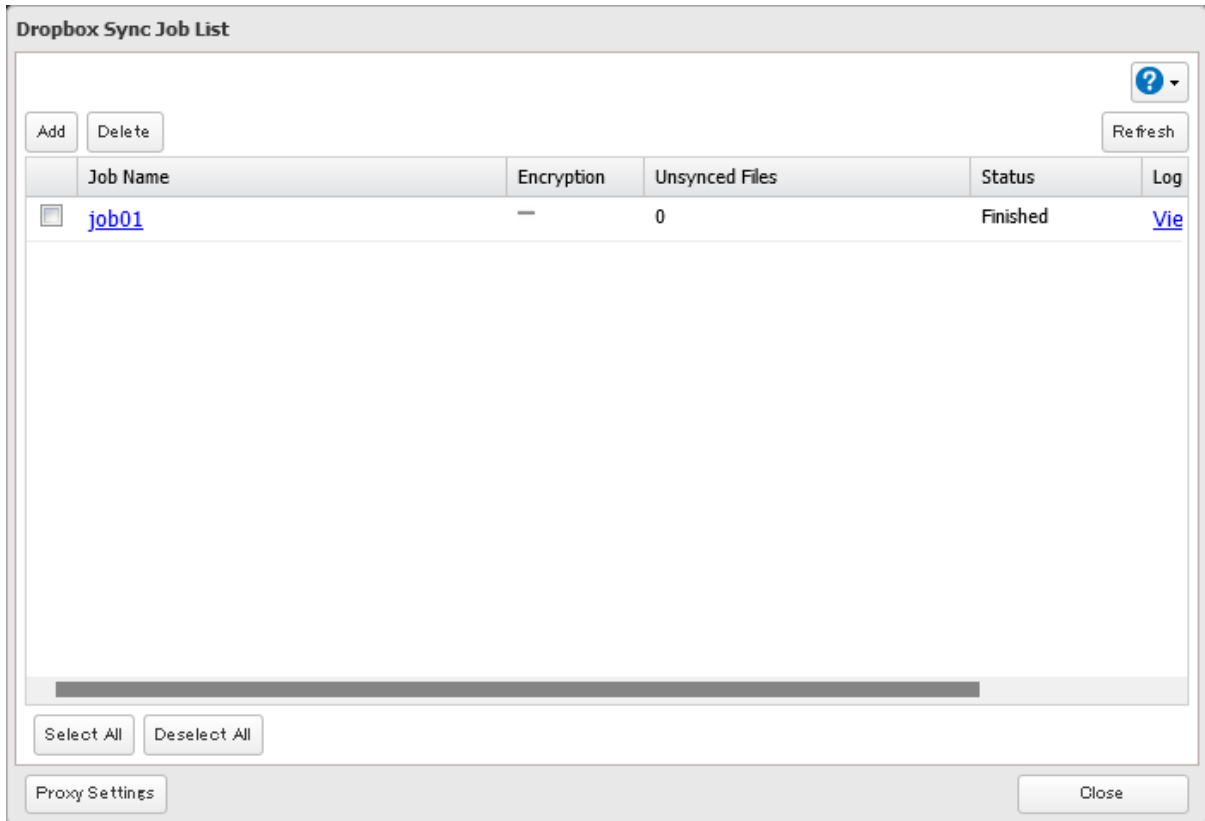

**4** Click the *Options* tab, then click *Edit*.

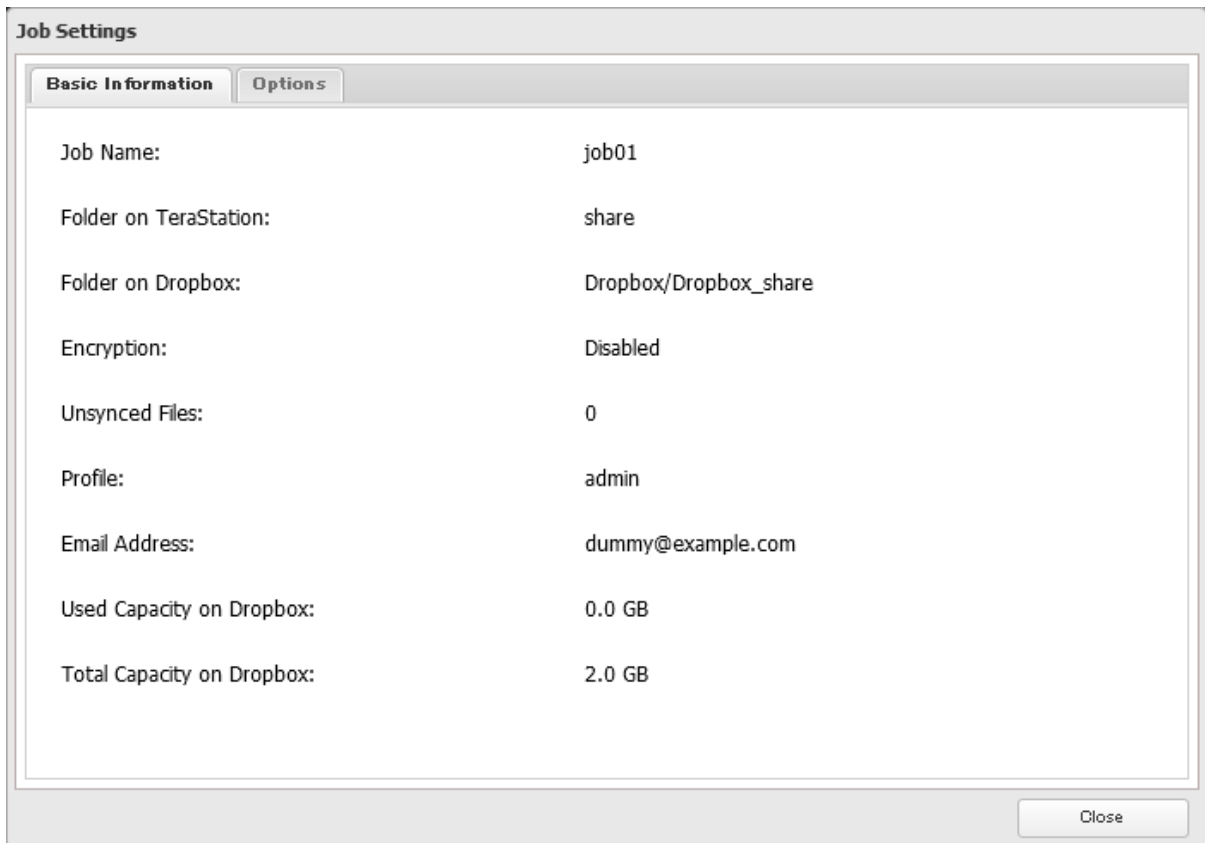

## 5 Configure the desired settings and click OK.

**Job Settings**

Sync Period: 5 minutes

Sync Direction: Bidirectional

Upload Size Limit:  Limit size  Allow full size

Size Limit: 1 MB

Filtered Extensions:

Extensions

Filter Hidden Files:  Enable  Disable

## 6 The process is complete once you close the confirmation window that appears.

### Notes:

- When specific settings are changed, the changes will not be applied and the files on Dropbox may not be synchronized to the TeraStation. In such a case, delete the target files to be synchronized and upload them to Dropbox again or delete the job and recreate it again. The following are the specific circumstances for when files may not be synchronized:
  - Uploading or downloading fails.
  - File extensions are removed from filtering.
  - The sync direction is changed.
- “Hidden files” from the “Filter Hidden Files” option refer to files whose filename starts with a period.
- Regardless of whether file filtering was configured, the following files will not be uploaded to Dropbox:
  - desktop.ini
  - thumbs.db
  - Files whose filename contains the symbols / \ > < : " | ? \*
  - Files whose filename ends with either a space or period
  - Files whose filename starts with either ~\$ or .~
  - Files whose filename starts with ~ and have the file extension .tmp

## Creating a Shared Link (Windows Only)

Buffalo offers a Windows application, “B-Sync”, that can create shared links for the files stored in the TeraStation folders. You can download the application from the [Buffalo website](#). Refer to the application help for the usage procedure.

## Using Microsoft Azure for Data Preservation

The TeraStation supports synchronizing with Microsoft Azure, the online cloud storage service. Once linked, you can back up data on the TeraStation to Azure Storage, or restore data from Azure Storage to the TeraStation.

Microsoft Azure offers multiple types of storage and the TeraStation is compatible with blob storage. There are three types of blobs: block blobs, page blobs, and append blobs. The TeraStation only works with block blobs to store your data.

This feature is meant for situations such as disaster recovery and not a catch-all backup function. After linking the TeraStation and Microsoft Azure, data on the TeraStation will not be bidirectionally synchronized between the TeraStation and an Azure container.

### Notes:

- Depending on the services you have purchased, prices for operations and amount of data will vary. To avoid being charged unexpectedly expensive fees, we recommend staying aware of the price structure for data storage and operations and regularly checking how much have been charged.
- To access data that have been backed up to the container, use “Microsoft Azure Storage Explorer”.
- If using Azure Storage through a proxy server, click *Proxy Settings* and select whether to use the configured settings or configure an identical proxy server. If using the identical proxy server, select “New settings” and enter the proxy server name, port number, username, and password. Consult your network administrator for detailed proxy server settings.

## Creating an Azure Storage Sync Backup Job

Follow the procedure below to create a new backup job.

**1** From the Azure portal, create your Azure Storage account and a container before proceeding with the procedure.

**2** From Settings, click *Cloud Storage*.

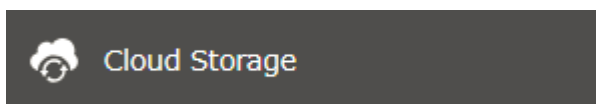

**3** Move the Microsoft Azure Storage Sync switch (  ) to the  position to enable Microsoft Azure Storage Sync.



**4** Click the settings icon (  ) to the right of “Microsoft Azure Storage Sync”.

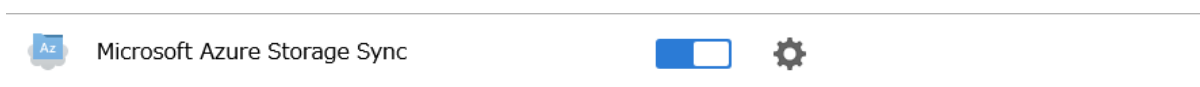

**5** Click *Add*.

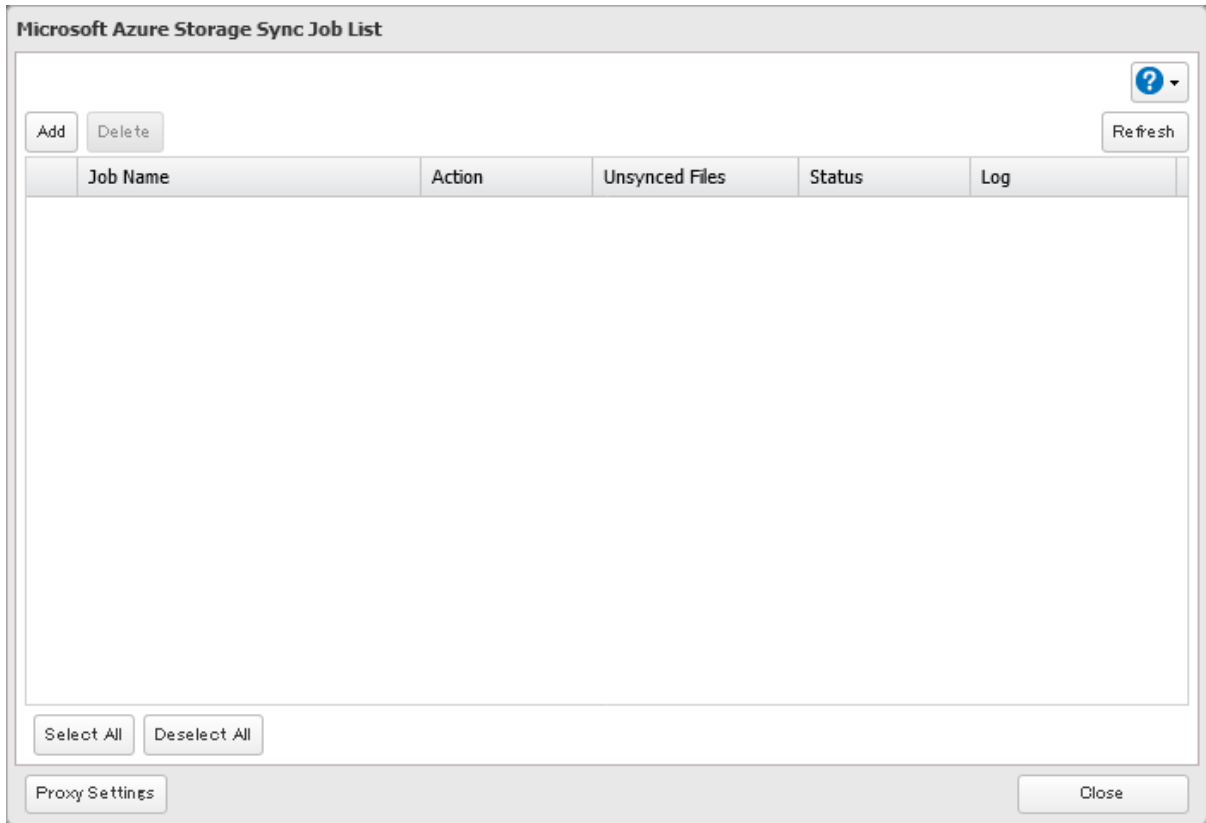

**6** The job setup wizard will open. Enter your Azure Storage account name and access key, then click *Next*.

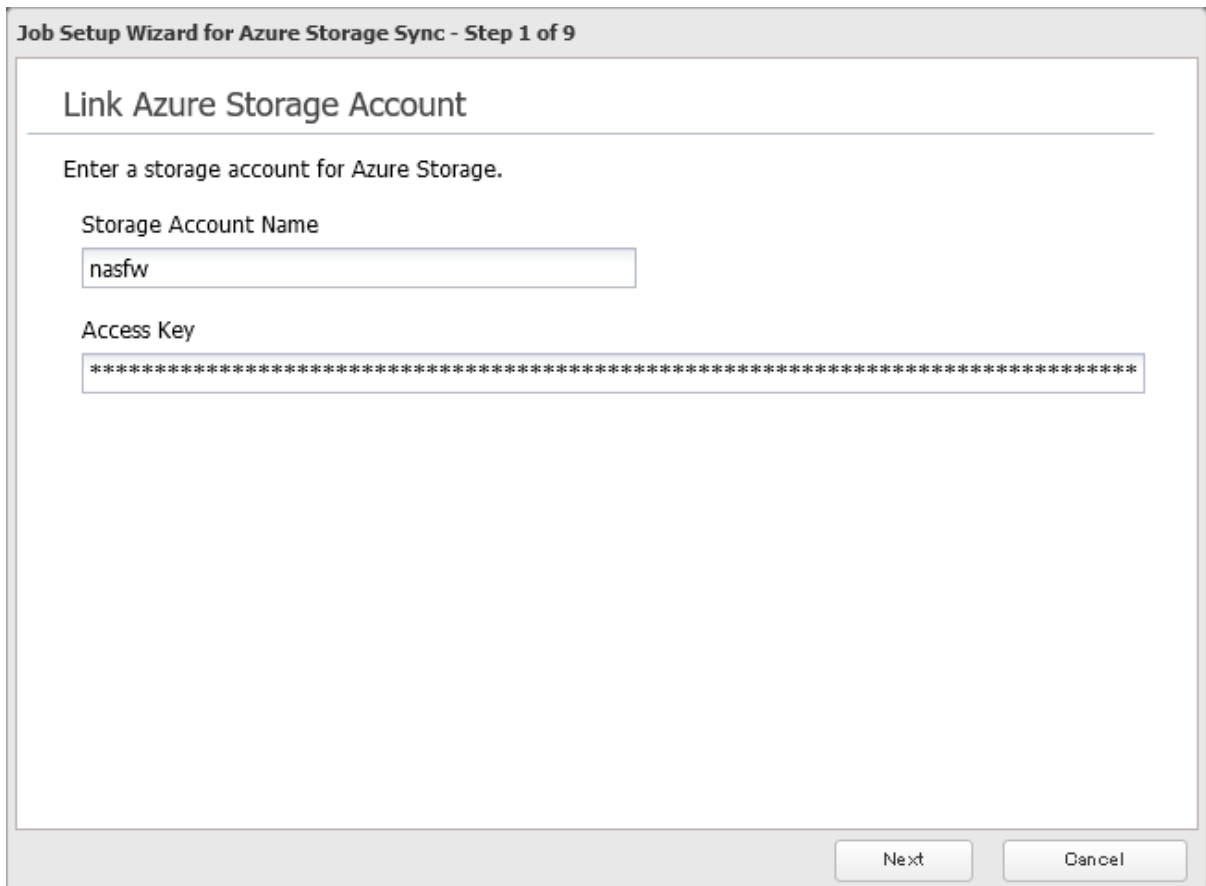

**7** Enter the desired job name and click *Next*.

**Job Setup Wizard for Azure Storage Sync - Step 2 of 9**

### Enter a Job Name

---

Enter a job name to create.

Job Name

**8** Select “Backup” and click *Next*.

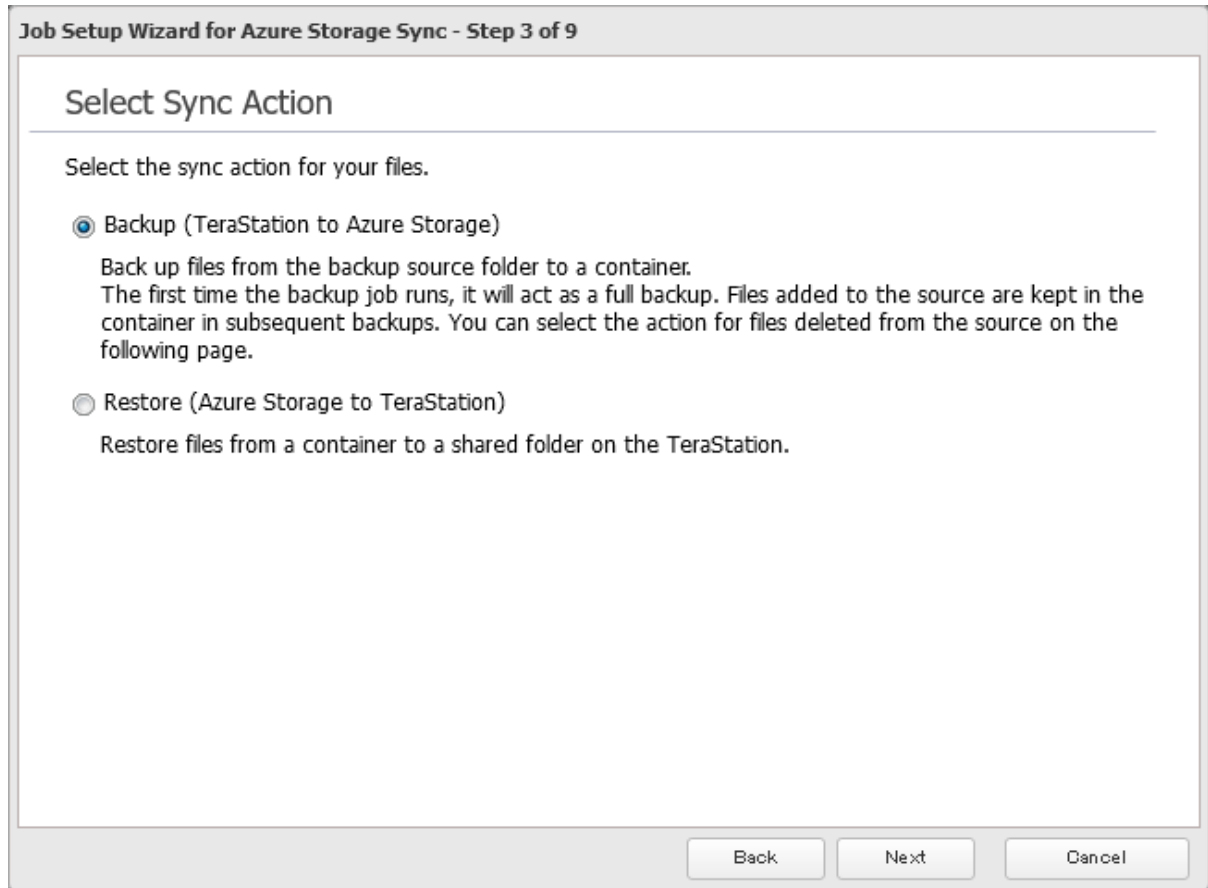

- 9 Select the desired shared folder on the TeraStation as the backup source folder and enter the container name for the backup destination, then click *Next*.

**Job Setup Wizard for Azure Storage Sync - Step 4 of 9**

### Configure Job Pairs

---

Select the shared folder that contains desired files for backup as the backup source and enter a container name.

Backup Source Folder  
share

Container Name  
test001

Back Next Cancel

**10** Specify the sync period and click *Next*.

**Job Setup Wizard for Azure Storage Sync - Step 5 of 9**

### Configure Sync Period

Select the interval of time between each backup.

Backup Interval

5 minutes

Back Next Cancel



- 11** Select the desired action to take for files in the container that share the same name as files in the backup source after they are deleted, then click *Next*.

**Job Setup Wizard for Azure Storage Sync - Step 6 of 9**

### Configure File Sync Action

Select the action to take for files in the backup destination container after deleting files with the same name from the backup source folder.

- Delete from container  
Delete the files from the backup destination container.
- Keep in container  
Keep the files as is in the backup destination container.

Back Next Cancel

**12** Configure whether to filter the backup target files. The following screen is available to configure file filtering by file size and whether they're hidden. "Hidden files" refer to files whose filename starts with a period. Configure the desired filtering settings and click *Next*.

**Job Setup Wizard for Azure Storage Sync - Step 7 of 9**

### Configure File Filters 1

Configure the requirements for filtering files. If any files in the backup source folder meet any of the following requirements, those files will not be backed up.

**Maximum Backup File Size**

Limit size  Allow full size

Size Limit:  MB

**Filter Hidden Files**

Enable  Disable

Back Next Cancel

- 13** The following screen is available to configure file filtering by extensions. Configure the desired filtering settings and click *Next*.

**Job Setup Wizard for Azure Storage Sync - Step 8 of 9**

### Configure File Filters 2

Configure the requirements for filtering files. If any files in the backup source folder meet any of the following requirements, those files will not be backed up.

**Filter by Extensions**

Enable  Disable

**Filtered Extensions**

Extensions

Add

Delete

Back Next Cancel

- 14** Confirm that all settings are properly configured and click *OK*.

- 15** The process is complete once you close the confirmation window that appears.

**Notes:**

- Regardless of whether file filtering was configured, the following files will not be backed up to an Azure Storage container:
  - desktop.ini
  - thumbs.db
  - Files whose filename contains the symbols / \ > < : " | ? \*
  - Files whose filename ends with either a space or period
  - Files whose filename starts with either ~\$ or .~
  - Files whose filename starts with ~ and have the file extension .tmp
- Do not copy files that are 10 GB or larger, and do not copy 100,000 or more files to the backup source folder at once. If you do and backup fails, check the network environment speed and try again with fewer or smaller files.
- If the TeraStation's performance seems unstable or slow, reduce the number of running jobs.

## **Creating an Azure Storage Sync Restore Job**

Follow the procedure below to create a new restore job.

- 1** From the Azure portal, create your Azure Storage account and a container before beginning the following procedure.

**2** From Settings, click *Cloud Storage*.

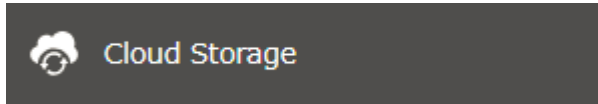

**3** Move the Microsoft Azure Storage Sync switch (  ) to the  position to enable Microsoft Azure Storage Sync.



**4** Click the settings icon (  ) to the right of "Microsoft Azure Storage Sync".



**5** Click *Add*.

The screenshot shows a window titled "Microsoft Azure Storage Sync Job List". At the top right is a help icon (question mark in a blue circle) with a dropdown arrow. Below it are "Add" and "Delete" buttons on the left, and a "Refresh" button on the right. The main area is a table with the following columns: "Job Name", "Action", "Unsynced Files", "Status", and "Log". The table is currently empty. At the bottom left are "Select All" and "Deselect All" buttons. At the bottom right is a "Close" button. A "Proxy Settings" button is located at the bottom left of the window frame.

**6** The job setup wizard will open. Enter your Azure Storage account name and access key, then click *Next*.

**Job Setup Wizard for Azure Storage Sync - Step 1 of 9**

### Link Azure Storage Account

Enter a storage account for Azure Storage.

Storage Account Name

Access Key

Next Cancel

**7** Enter the desired job name and click *Next*.

**Job Setup Wizard for Azure Storage Sync - Step 2 of 9**

### Enter a Job Name

---

Enter a job name to create.

Job Name

**8** Select “Restore” and click *Next*.

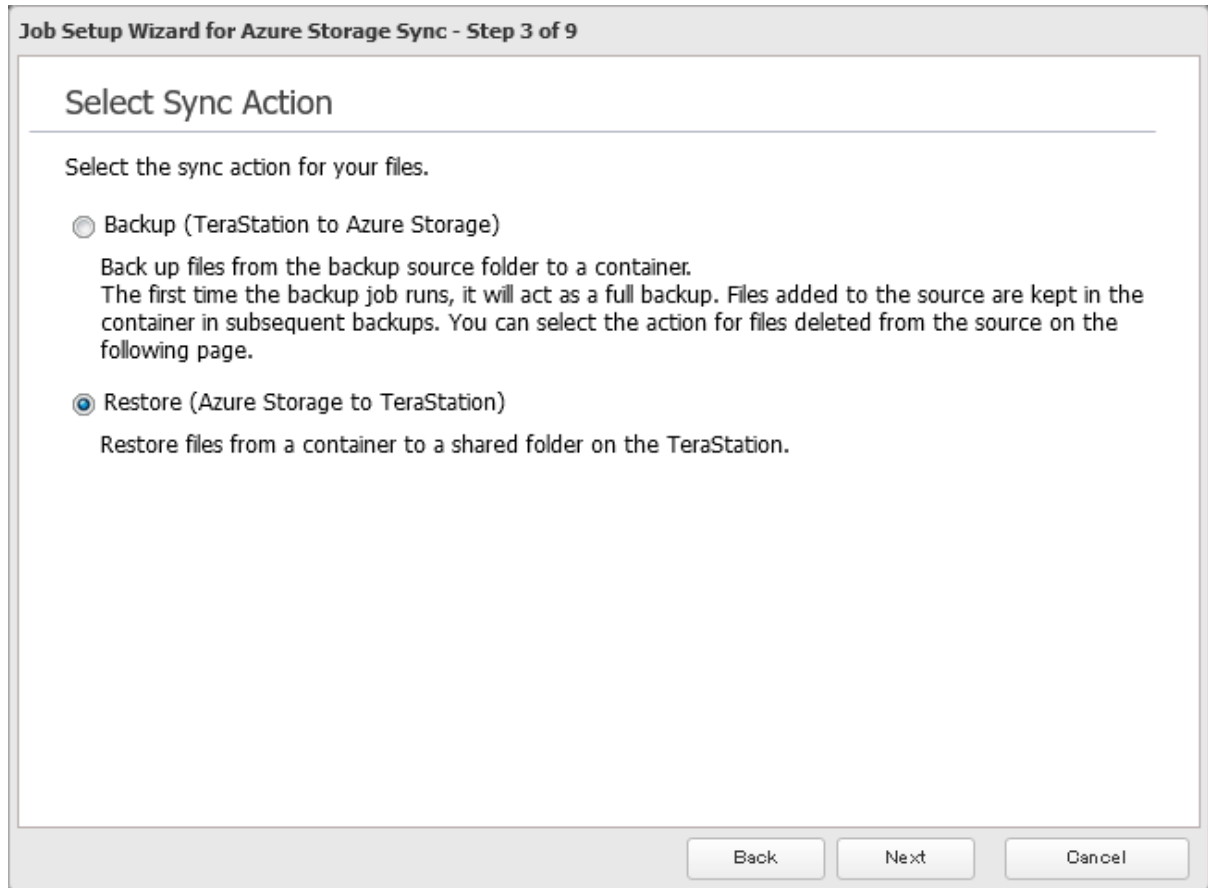

- 9** Enter the container name for the restore source and select the desired shared folder on the TeraStation as the restore destination, then click *Next*.

- 10** Select either to restore data into the first level folder (root folder) or the second level (subfolder) of the restore destination folder, then click *Next*.
- 11** Confirm that all settings are properly configured and click *OK*.
- 12** The process is complete once you close the confirmation window that appears.

**Notes:**

- When deleting a finished restore job, it can be converted to a backup job. If that restore job had been configured to restore to the second level of the shared folder, restored data will automatically be moved to the first level. If there are files with the same filename in the first level folder, those files will be overwritten.
- If the TeraStation's performance seems unstable or slow, reduce the number of running jobs.

## Changing Job Settings

Follow the procedure below to change any of the backup job settings you have already configured. Restore job settings cannot be changed.

- 1** From Settings, click *Cloud Storage*.

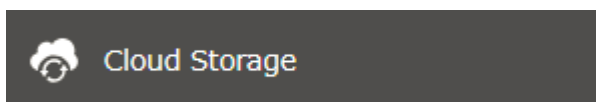



2 Click the settings icon (  ) to the right of “Microsoft Azure Storage Sync”.



3 From the job list, click the job whose settings you want to change.

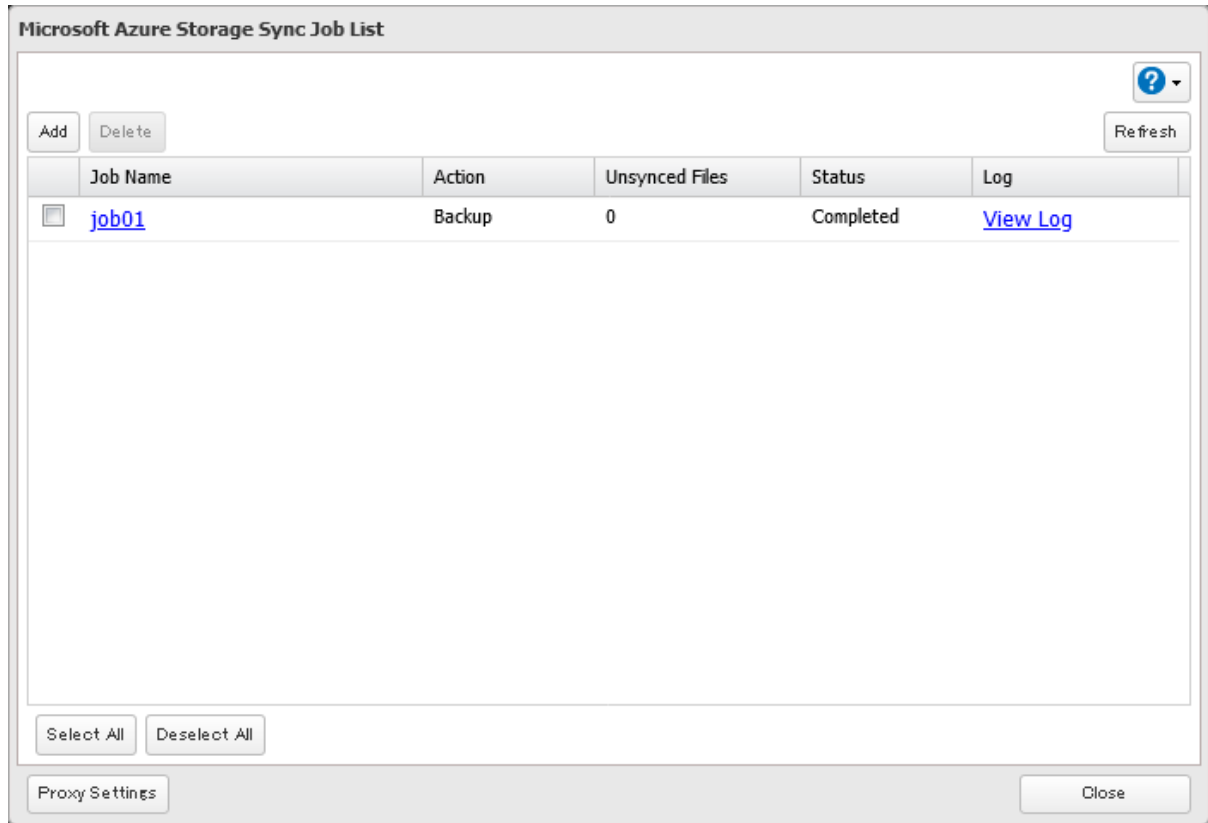

**4** Click the *Options* tab, then click *Edit*.

The screenshot shows a dialog box titled "Job Settings" with two tabs: "Basic" and "Options". The "Options" tab is selected. The dialog contains the following settings:

Storage Account Name:	nasfw
Job Name:	job01
Sync Action:	Backup
Files Deleted in Backup Source:	Delete from container
Backup Source Folder:	share
Container Name:	test001

A "Close" button is located in the bottom right corner of the dialog box.

## 5 Configure the desired settings and click OK.

**Job Settings**

Backup Interval: 5 minutes

Maximum Backup File Size:  Limit size  Allow full size

Size Limit: 1 MB

Filter Hidden Files:  Enable  Disable

Filter by Extensions:  Enable  Disable

Filtered Extensions:

Extensions

OK Cancel

## 6 The process is complete once you close the confirmation window that appears.

# Synchronizing with Microsoft OneDrive

The TeraStation supports synchronizing with Microsoft OneDrive, the online cloud storage service. Once linked, you can share files on the TeraStation via OneDrive (or files on OneDrive via the TeraStation). Follow the procedure below to configure your TeraStation for use with Microsoft OneDrive.

### Notes:

- To use Microsoft OneDrive Sync, you need a Microsoft account and an available empty OneDrive folder. If you don't have a Microsoft account, or if you need to create a OneDrive folder, refer to the Microsoft website.
- If using OneDrive through a proxy server, click *Proxy Settings* and select whether to use the configured settings or configure an identical proxy server. If using the identical proxy server, select "New settings" and enter the proxy server name, port number, username, and password. Consult your network administrator for detailed proxy server settings.

## Creating a OneDrive Sync Job

Follow the procedure below to create a new job.

### 1 From the Microsoft portal, create your Microsoft account before proceeding with the procedure.

**2** From Settings, click *Cloud Storage*.

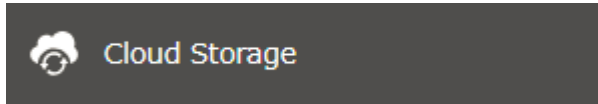

**3** Move the OneDrive Sync switch (  ) to the  position to enable OneDrive Sync.



**4** Click the settings icon (  ) to the right of "Microsoft OneDrive Sync".



**5** Click *Add*.

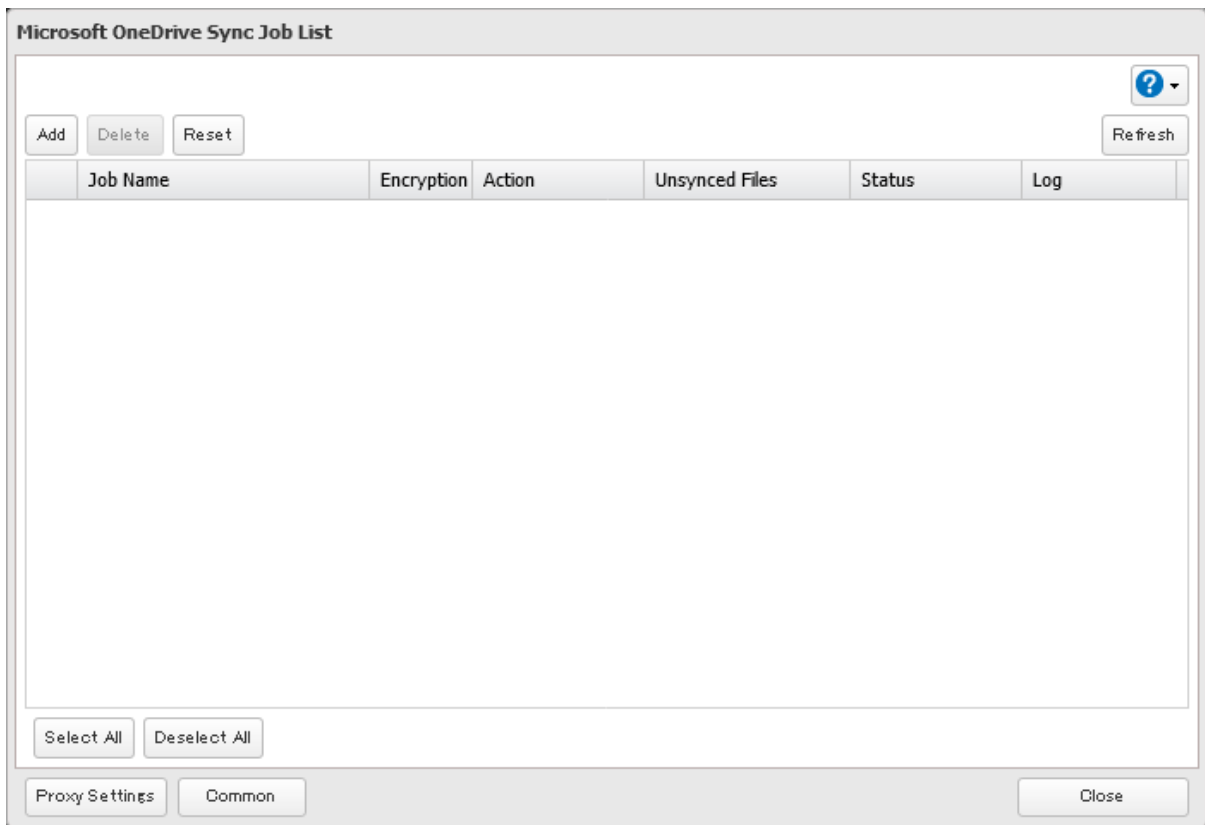

**6** The sign-in window will open. Enter the username and password of your Microsoft account, then sign in.

**7** Enter the desired job name and click *Next*.

**Job Setup Wizard for OneDrive Sync - Step 1 of 10**

### Enter a Job Name

---

Enter a job name to create.

 ?

- 8** Select the sync action and behavior for when files with the same name are already in the target folder, then click *Next*.

There are three types of sync actions: bidirectional, uploading, and downloading. If bidirectional is selected as the sync action, files on both OneDrive and the TeraStation will be updated. If uploading is selected as the sync action, only files on OneDrive will be updated. If downloading is selected as the sync action, only files on the TeraStation will be updated.

The behavior for when files with the same name already exist will occur when the files that have the same name on both the TeraStation and OneDrive are changed.

**Job Setup Wizard for OneDrive Sync - Step 2 of 10**

### Select Sync Action

Select the sync action for your files.

Upload

Files with Same Names

- Keep files on OneDrive  
If there is a file conflict when syncing, files on OneDrive will be saved over other versions.
- Keep files on the TeraStation  
If there is a file conflict when syncing, files on the TeraStation will be saved over other versions.
- Keep files with newer modified date  
If there is a file conflict when syncing, files with the newer modified date will be saved over other versions.

Back Next Cancel

- 9 Select the desired TeraStation and OneDrive folders. If you want to create an empty folder first, click *Browse* under “Folder on TeraStation”, then click *Create Folder* on the selecting folder window that appears. Click *Next* after selecting the folders.

**Job Setup Wizard for OneDrive Sync - Step 3 of 10**

### Configure Job Pairs

Select the folders on OneDrive and the TeraStation that files will be synced each other.

Folder on TeraStation	onedrive	<input type="button" value="Browse"/>
Folder on OneDrive	OneDrive/Drive1/doc-test	<input type="button" value="Browse"/>

**Notes:**

- Do not sync the quarantine folder (“TMNAS” by default) to OneDrive.
- The sixth level and deeper of shared and OneDrive folders cannot be selected.

- 10 Specify the sync period and click *Next*. The sync process will occur sequentially after the specified period of time has passed.

**Job Setup Wizard for OneDrive Sync - Step 4 of 10**

### Configure Sync Period

Select the interval of time between each synchronization.

60 minutes

Back Next Cancel



- 11** Configure the sync frequency. Files will be uploaded during the start and end time of the period configured in step 10 above. If you want to always upload files during the configured sync period, select "Always sync within the sync period" for "Frequency". Click *Next* after configuring.

**Job Setup Wizard for OneDrive Sync - Step 5 of 10**

### Configure Schedule

Configure a schedule for a job. If you select "Daily" for frequency, specify the start and end time. If you select "Weekly" for frequency, specify the day of the week and times.

Frequency

Start Time

End Time

Day of Week  
 Sunday  Monday  Tuesday  Wednesday  Thursday  Friday  Saturday

- 12** Select whether to encrypt the files using a password. When encryption is enabled, uploaded files will be archived in zip format and encrypted using the entered encryption password. Click *Next* after selections are finished.

**Job Setup Wizard for OneDrive Sync - Step 6 of 10**

### Configure Encryption

Enable encryption for the files when uploading to OneDrive.

Enable  Disable

Encryption Password

?

Setting an encryption password with 10 or more characters is recommended.  
The encryption password cannot be changed once it's configured. Make sure to manage the password carefully after it has been saved.

Back Next Cancel

**Note:** If the password contains spaces or backslashes (\), decrypting a file on a computer may fail.

- 13** Select whether to check for file consistencies and delete older files with the same name from OneDrive. Click *Next* after selections are finished.

**Job Setup Wizard for OneDrive Sync - Step 7 of 10**

### Configure File Options

**Consistency Check**  
Enable a consistency check. Files will be compared to a hash value between files on the source and destination folders for uploading/downloading. If there are any inconsistencies between files, the system will try syncing again.

Enable                       Disable

**Uploaded Files**  
Configure settings to delete old versions of files with the same name that have been uploaded onto OneDrive before an upload job starts to conserve space usage.

Delete old version                       Keep old version

Back      Next      Cancel

- 14** Configure file filters for the sync process. The following screen enables file filtering configuration by file sizes and whether they're hidden. The file size filter will only apply to uploads. The available maximum size is up to 15,360 MB (15 GB). "Hidden files" refer to files whose filename starts with a period. Click *Next* after selections are finished.

**Job Setup Wizard for OneDrive Sync - Step 8 of 10**

### Configure File Filters 1

Configure the requirements for filtering files. If any files in the folder on either the TeraStation or OneDrive meet any of the following requirements, those files will not be synced.

**Filter by File Size**

Enable  Disable

Maximum Size:  MB

**Filter Hidden Files**

Enable  Disable

Back Next Cancel

- 15** The following screen enables file filtering configuration by extensions. Configure the desired filter settings and click *Next*.

**Job Setup Wizard for OneDrive Sync - Step 9 of 10**

### Configure File Filters 2

Configure the requirements for filtering files. If any files in the folder on either the TeraStation or OneDrive meet any of the following requirements, those files will not be synced.

**Filter by Extensions**

Enable  Disable

**Filtered Extensions**

Filtered Extensions

Add

Delete

Back Next Cancel

- 16** Confirm that all settings are properly configured and click *OK*.

- 17** The process is complete once you close the confirmation window that appears.

**Notes:**

- Files whose name contains any of the symbols " # % & \* / : > < ? \ } { ~ may be unable to be synchronized. This symbol limitation is based on "Normalization Form Canonical Composition (NFC)". If synchronization fails, check whether these symbols are not included in the filename.  
If you copy files whose names contain any of these symbols to a TeraStation folder from macOS, the filenames may be converted to ones that don't contain these symbols.
- Depending on your network environment, you may be unable to download larger files. To prevent this issue, divide a larger file into smaller files or compress the files to a smaller size before uploading them to OneDrive.
- When files are uploaded from the TeraStation folder using OneDrive Sync and then downloaded onto a computer from OneDrive, time stamps for files may be changed to the download date.
- When synchronizing files, if there are nine or more jobs created, the TeraStation will re-arrange any running jobs to reduce the load.
- Do not copy 100,000 or more files to the TeraStation folder at once. If you do and synchronization fails, try again with fewer files.
- 4 or more concurrent running jobs will reduce stability on the TeraStation. If the TeraStation's performance seems unstable or slow, reduce the number of running jobs. If antivirus is enabled, it will use much more system resources than other TeraStation functions. In such a case, we recommend configuring only one job at a time.
- If a file's size is zero bytes, a sync error occurs and the file will not be synchronized. The I64 message will appear as a notification.

- If unexpected behaviors occur during file sync, such as some files not being synced, click *Reset* on the job list window. This will resync all files on the TeraStation and/or OneDrive the next time the sync process runs. The existing files will be overwritten, and files that will be resynced will vary depending on the sync action settings. To start resyncing immediately after clicking *Reset*, change the frequency settings to “Always sync within the sync period” by referring to the “[Changing Job Settings](#)” section below.

## Changing Job Settings

Follow the procedure below to change any job settings you have already configured.

- 1 From Settings, click *Cloud Storage*.

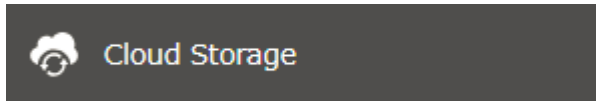

- 2 Click the settings icon (  ) to the right of “Microsoft OneDrive Sync”.



- 3 From the job list, click the job whose settings you want to change.

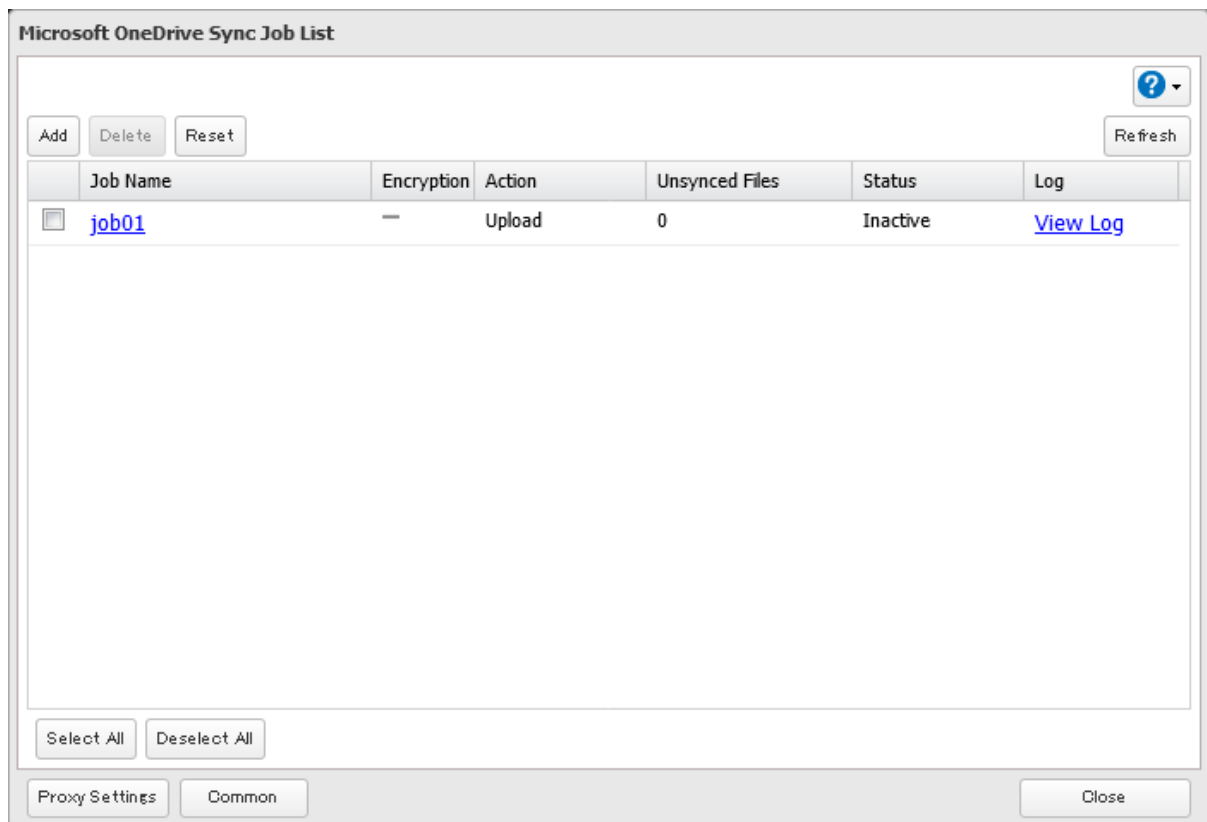

**4** Click the *Options* tab, then click *Edit*.

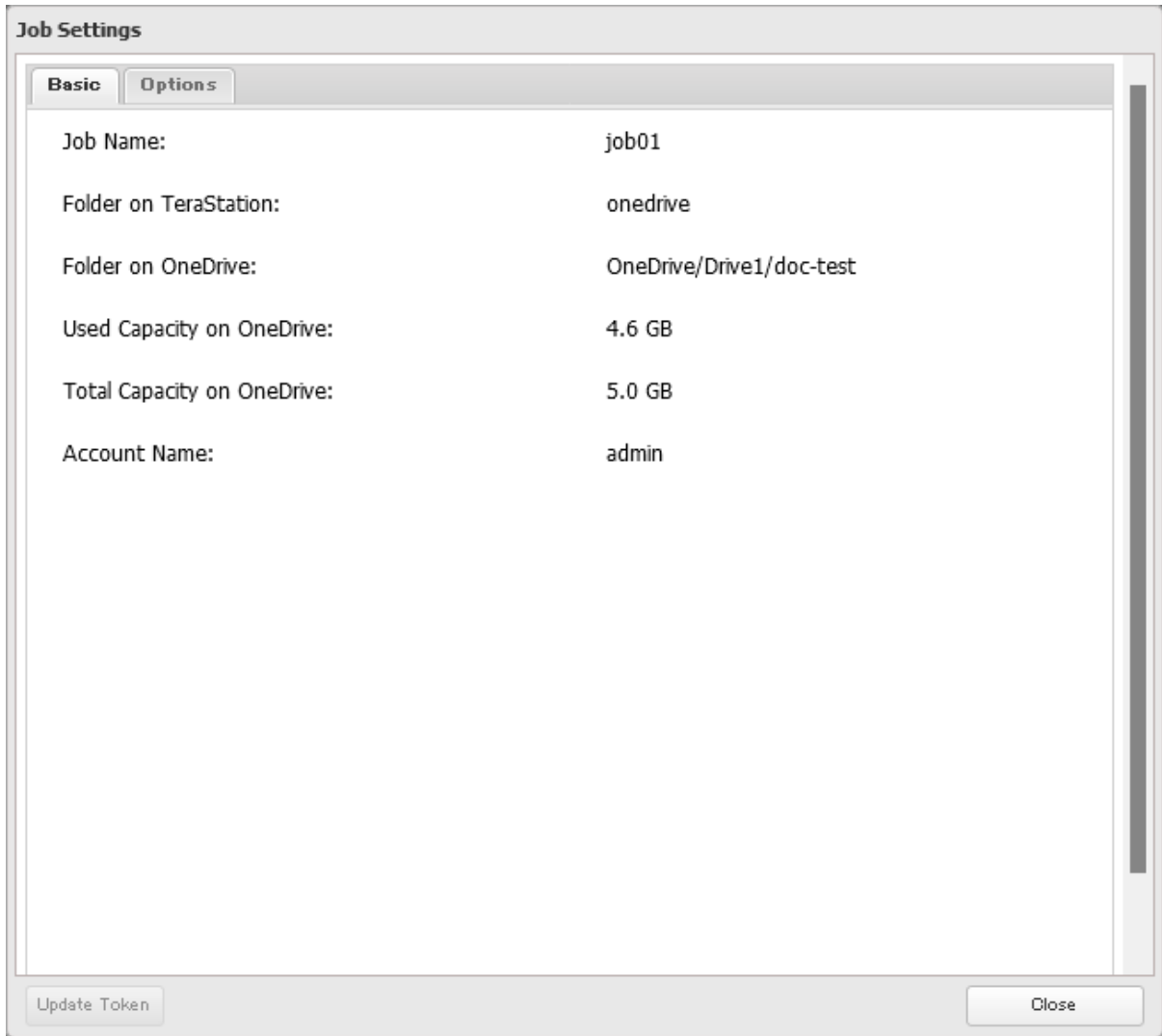

## 5 Configure the desired settings and click OK.

## 6 The process is complete once you close the confirmation window that appears.

## Corrective Actions for in Case of Error

### Error Appears in the “Status” Field of Job List

If any of the following messages appear in the “Status” field of the job list, the synchronization process did not complete properly. In such a case, try the corresponding corrective action.

Message	Description	Corrective Action
Some files were not synced due to OneDrive sync restrictions	There are some files that could not be synced because they meet certain OneDrive restriction conditions that exclude them from the sync target.	Delete the corresponding files from the sync folder.
Some files were not uploaded due to TeraStation sync restrictions	There are some files that could not be uploaded because they meet certain TeraStation restriction conditions that exclude them from the upload target.	Delete the corresponding files from the upload source folder.
Some files were not downloaded due to TeraStation sync restrictions	There are some files that could not be downloaded because they meet certain TeraStation restriction conditions that exclude them from the download target.	Delete the corresponding files from the download source folder.



Message	Description	Corrective Action
Failed in the past	There are some files that could not be synced.	Unsynced files will be synchronized in a subsequent job. To sync immediately, click <i>Reset</i> .
Token error	An error occurred on a token.	<p>Update the token by following the procedure below.</p> <ol style="list-style-type: none"> <li>1 From Settings, click <i>Cloud Storage</i>.</li> <li>2 Click the settings icon (  ) to the right of "Microsoft OneDrive Sync".</li> <li>3 From the job list, click the job with the occurring token error.</li> <li>4 Click <i>Update Token</i> at the bottom-left of the window.</li> <li>5 Click <i>Reset</i> after the token update process finishes.</li> <li>6 The process is complete once you close the confirmation window that appears.</li> </ol>

### Error Appears While Creating a Job or Error Code Appears on the Error Log

You may encounter error messages that contain the following error codes when creating OneDrive Sync jobs; the error log may contain the following error codes as well. If you encounter any of the following error codes, refer to the table below and try the respective corrective action. If the error code is not listed on the table, refer to the Microsoft website instead: <https://docs.microsoft.com/en-us/onedrive/developer/rest-api/concepts/errors?view=odsp-graph-online>.

Code	Description	Corrective Action
access_denied	Access denied for the requested information.	To link with OneDrive, please consent to the request from OneDrive.
server_error	The authentication server encountered a temporary error.	Please wait for about 10 minutes and try again.
temporarily_unavailable	The authentication server is too busy.	Please wait for about 10 minutes and try again.
authcode_notfound	The authentication server is too busy.	Please wait for about 10 minutes and try again.
auth_server_error	The authentication server encountered a temporary error.	The authentication server will recover within UTC 12:00 midnight–8:45 a.m. (Mon–Fri). Please wait until it recovers.
auth_server_maintenance	The authentication server is currently undergoing maintenance.	Maintenance will finish within UTC 12:00 midnight–8:45 a.m. (Mon–Fri). Please wait until maintenance finishes.
activityLimitReached	There are too many requests so data could not be synchronized.	Check that the same Microsoft account is used on another Buffalo NAS device or Microsoft software. This error may be resolved by reducing the maximum number of threads per job on the window that appears by navigating to the job list and then clicking <i>Common</i> .

Code	Description	Corrective Action
invalidRequest	A zero-byte file was going to be synchronized but failed.	Remove the zero-byte file and try again. If the I64 message persists on the Dashboard in Settings, click <i>Clear</i> to delete the message.
network_error	Could not register the authentication code.	Check that the network or proxy server settings are correct.
Unexpected error	An unknown error occurred.	Please wait for about 10 minutes and try again.

---

## WebAccess

---

WebAccess is a software utility for accessing the files in the shared folder of your TeraStation from your computer or mobile devices through the Internet. **Be careful when configuring WebAccess. Certain settings can make the files in the shared folder available to anyone on the Internet, without any access restrictions.**

**Note:** WebAccess supports downloading up to 60,000 files at a time. Attempting to download 60,000 or more files at a time may result in unexpected behavior.

## Configuring WebAccess

---

- 1 From Settings, click *File Sharing*.

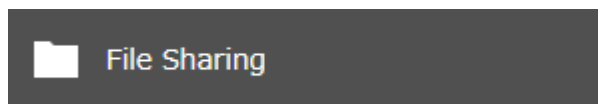

- 2 Click the settings icon (  ) to the right of "WebAccess".



**3** Click *Edit* and configure the desired settings, then click *OK*.

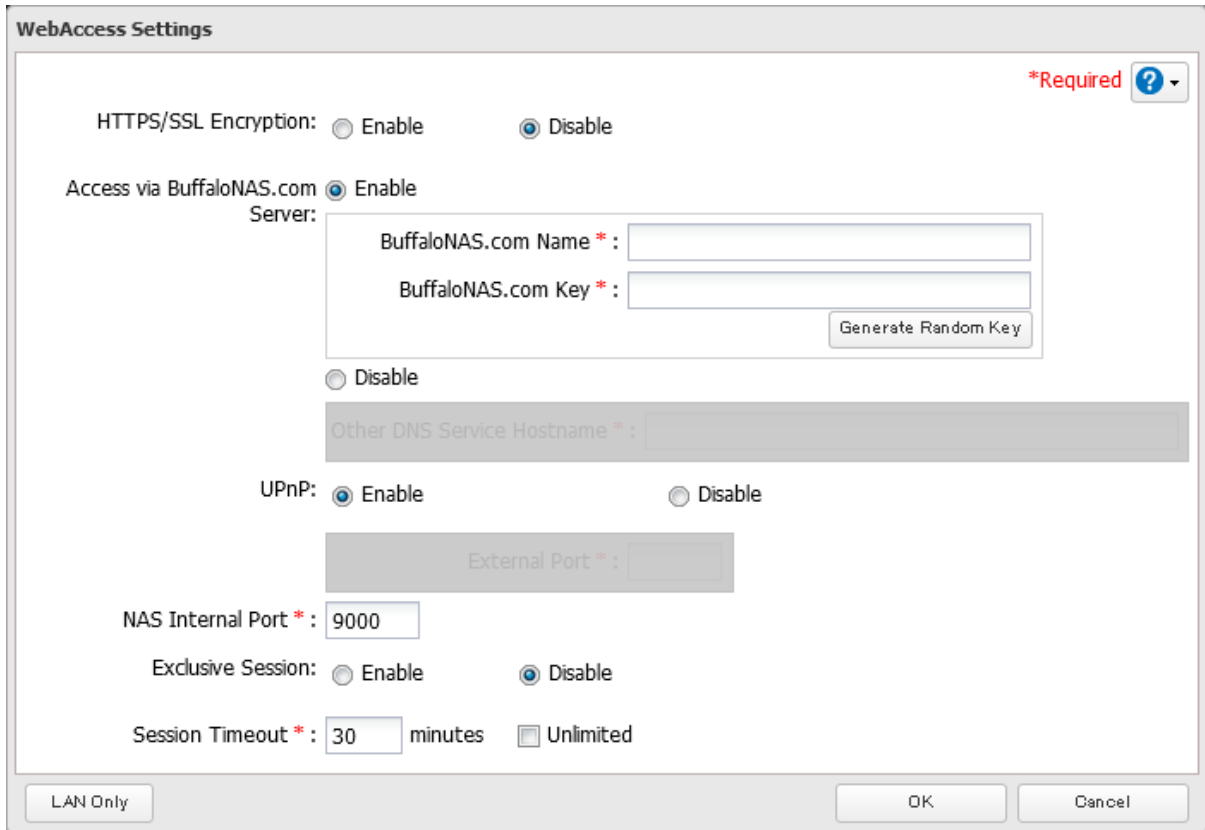

The image shows the 'WebAccess Settings' dialog box. It contains the following settings:

- HTTPS/SSL Encryption:** Radio buttons for 'Enable' and 'Disable'. 'Disable' is selected.
- Access via BuffaloNAS.com:** Radio buttons for 'Enable' and 'Disable'. 'Enable' is selected.
- Server:** A group box containing:
  - 'BuffaloNAS.com Name \*': A text input field.
  - 'BuffaloNAS.com Key \*': A text input field.
  - 'Generate Random Key': A button.
- Other DNS Service Hostname \*:** A text input field, currently disabled (greyed out).
- UPnP:** Radio buttons for 'Enable' and 'Disable'. 'Enable' is selected.
- External Port \*:** A text input field, currently disabled (greyed out).
- NAS Internal Port \*:** A text input field with the value '9000'.
- Exclusive Session:** Radio buttons for 'Enable' and 'Disable'. 'Disable' is selected.
- Session Timeout \*:** A text input field with the value '30' and the label 'minutes'. There is also an 'Unlimited' checkbox which is unchecked.

At the bottom of the dialog are buttons for 'LAN Only', 'OK', and 'Cancel'. A '\*Required' label with a help icon is in the top right corner.

- To use SSL encryption for more secure data transfers, enable “HTTPS/SSL Encryption”.
- You may use the BuffaloNAS.com server as a DNS server, or disable it to use a different DNS server.
- Choose a “BuffaloNAS.com Name” and “BuffaloNAS.com Key” for your WebAccess account. Names and keys may contain between 3 and 20 alphanumeric characters, underscores (\_), and hyphens (-).
- If “Exclusive Session” is enabled, multiple users cannot be logged in to WebAccess at the same time. Only the last login will be active.
- Enter a time in minutes (1 to 120, or “Unlimited”) before inactive users are logged out of WebAccess.

**4** Move the WebAccess switch (  ) to the  position to enable WebAccess.



**5** Click the settings icon (  ) to the right of “Folder Setup”.



**6** Click *Create Folder*.

For best results, create a new dedicated share for WebAccess to prevent opening files accidentally.

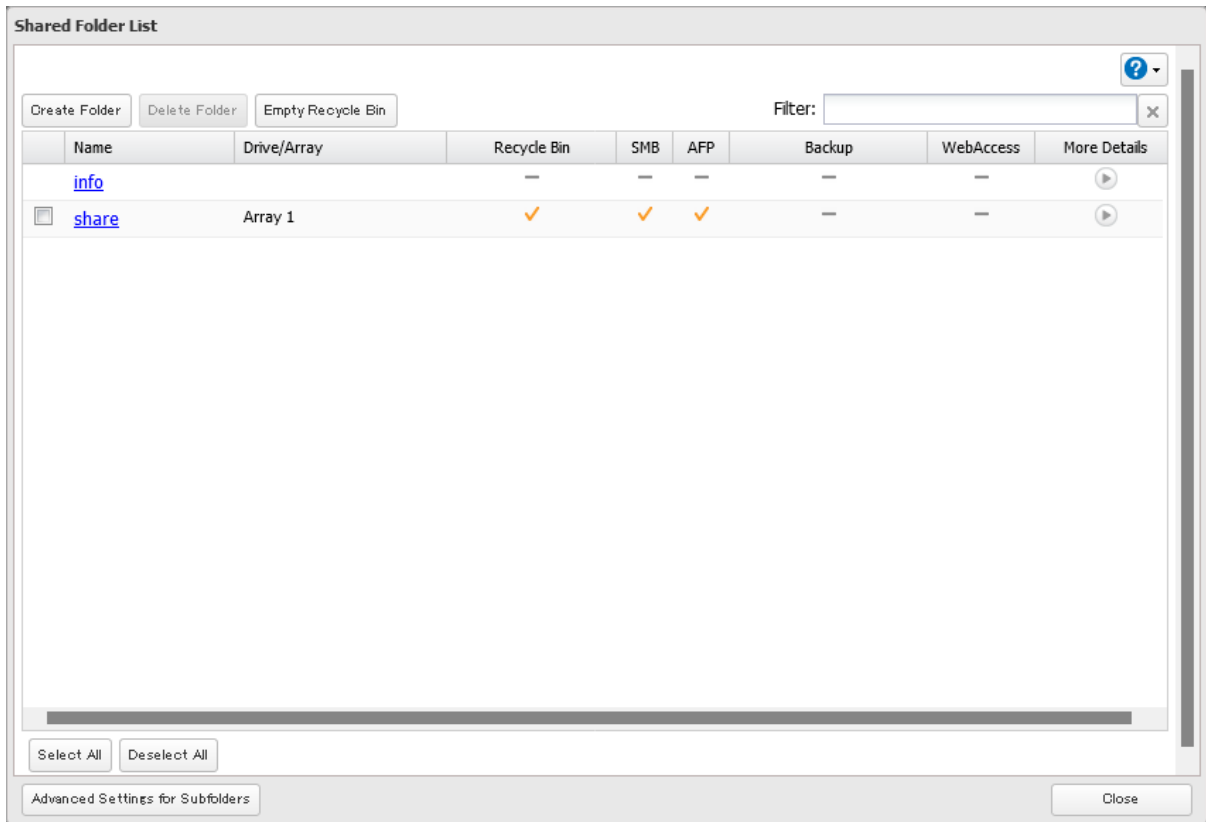

**7** Under “LAN Protocol Support”, select the “WebAccess” checkbox on the *Basic* tab.

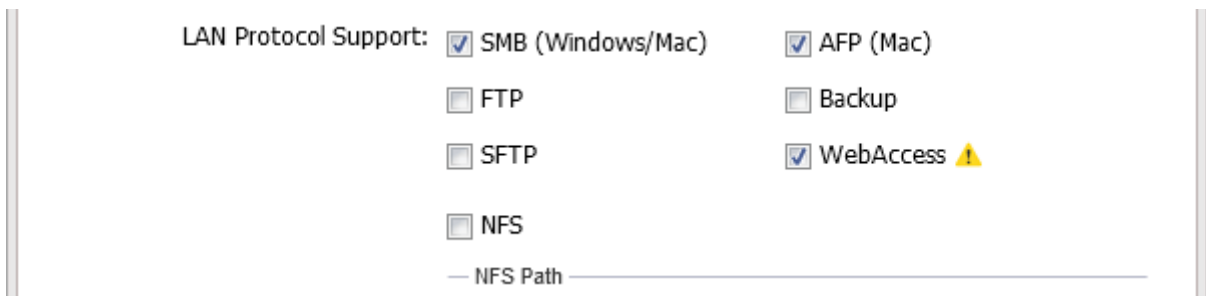

**8** Click the *Option 2* tab.

**9** Select the desired WebAccess security level for “WebAccess Permissions”. For more detailed information about each WebAccess security level, refer to the note below.

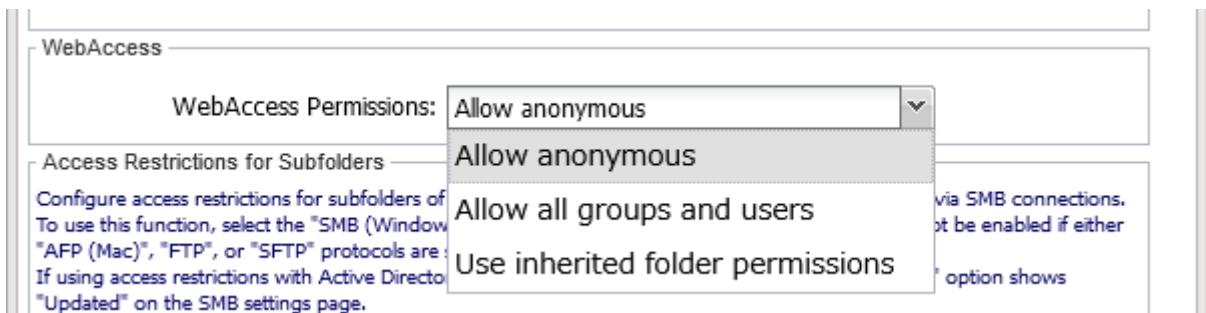

**10** Configure other settings such as a folder name and click *OK*.

**11** The process is complete once you close the confirmation window that appears.

**Note:** Whether a user or group can access a folder through WebAccess depends on a combination of WebAccess settings and the shared folder's settings.

**Allow anonymous:** Anyone can access (view) shared folders. (Access restrictions configured for shared folders will not work.)

**Allow all groups and users:** All groups and users registered on the Buffalo NAS device can use WebAccess. (Access restrictions configured for shared folders will not work.)

**Use inherited folder permissions:** Users and groups have the same access permissions with WebAccess that they do locally. If access restrictions are not set for the shared folder, then this option will not be shown.

		Not logged in	Access restrictions for the logged-in users		
			No access	Read-only	Read and write
WebAccess permissions	Allow anonymous	R	R/W	R/W	R/W
	Allow all groups and users	-	R/W	R/W	R/W
	Use inherited folder permissions	-	-	R	R/W

R/W: Read and write, R: Read-only, -: No access

## Accessing via WebAccess

There are many ways to access WebAccess folders depending on your device:

### For iOS or iPadOS Devices

To access from an iOS or iPadOS device, install the "WebAccess i" app for an iOS device or the "WebAccess i HD" app for an iPadOS device from the App Store. Refer to the app's help guide for more detailed information on using the app.

### For Android Devices

To access from an Android device, install the "WebAccess A" app from Google Play. Refer to the app's help guide for more detailed information on using the app.

### For Computers

Use a web browser on a computer; supported browsers include Microsoft Edge, Firefox, Google Chrome, Internet Explorer 9 or later, Safari 9 or later. Refer to the help guide at the BuffaloNAS.com website after connecting with your BuffaloNAS.com name for more detailed information.

## Unable to Create a BuffaloNAS.com Name

If UPnP is disabled on your router, creating the BuffaloNAS.com name may fail. If this occurs, try the following procedure.

**1** From Settings, click *File Sharing*.

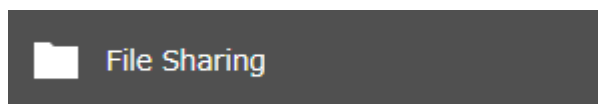

**2** Click the settings icon (  ) to the right of "WebAccess".



- 3** Click *Edit*, then enable “Access via BuffaloNAS.com Server” and the desired BuffaloNAS.com name and key.

**WebAccess Settings**

HTTPS/SSL Encryption:  Enable  Disable

Access via BuffaloNAS.com  Enable

Server:

BuffaloNAS.com Name \* :

BuffaloNAS.com Key \* :

Disable

Other DNS Service Hostname \* :

UPnP:  Enable  Disable



External Port \* :

NAS Internal Port \* :

Exclusive Session:  Enable  Disable

Session Timeout \* :  minutes  Unlimited

- 4** Disable “UPnP” and enter a router’s port number into the “External Port” field, then click *OK*.

- 5** Move the WebAccess switch (  ) to the  position to enable WebAccess.



- 6** After configuring the required settings on the Buffalo NAS device is finished, next configure the router using the port number set at step 5 above.

## FTP

By default, the TeraStation’s shares are only accessible by users connected to the same network or router as the TeraStation. The optional FTP server allows users outside the local network to access the TeraStation.

**Note:** FTP is intended for users who already have FTP client software and have experience with it.

### Enabling FTP

Follow the procedure below to enable FTP service to allow access via FTP connections.

- 1** From Settings, click *File Sharing*.

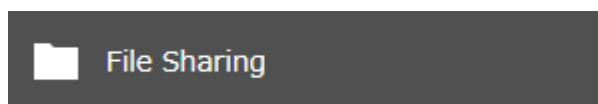

2 Move the FTP switch (  ) to the  position to enable FTP.



3 Click the settings icon (  ) to the right of "Folder Setup".



4 Choose a folder to enable remote FTP access on.

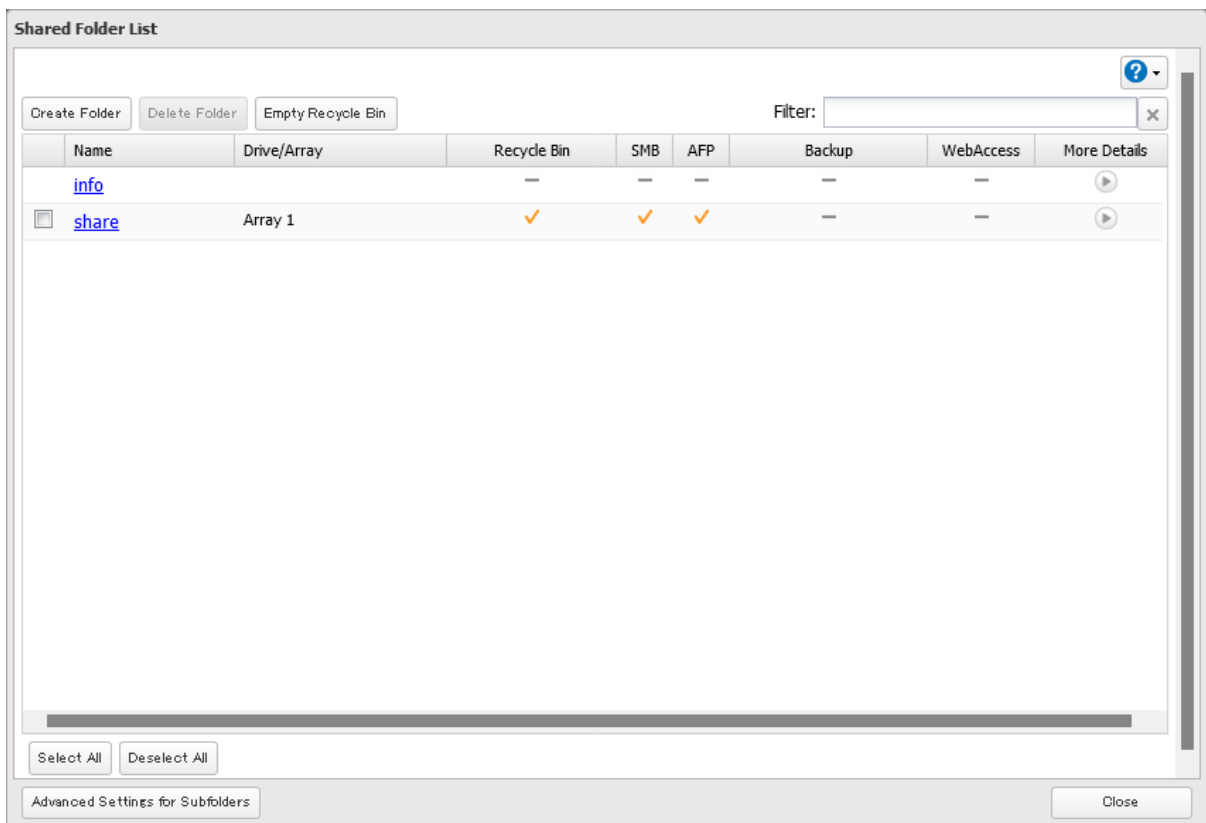

5 Under "LAN Protocol Support", select the "FTP" checkbox on the *Basic* tab; select read-only or read and write for the shared folder's attribute on the *Option 2* tab and click *OK*.

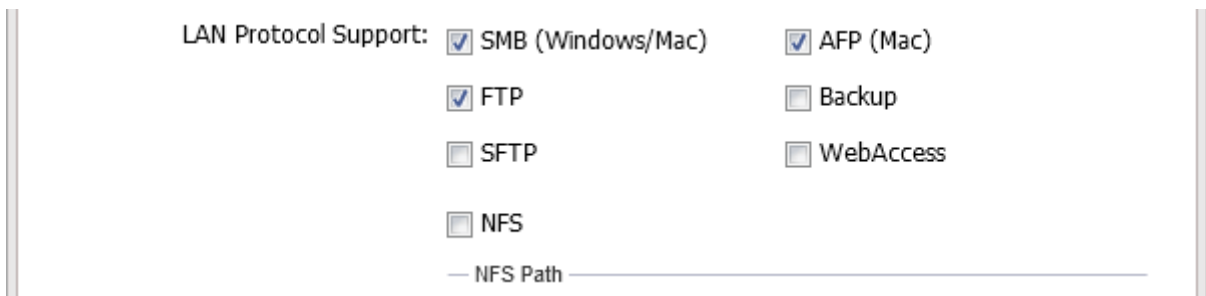

6 The process is complete once you close the confirmation window that appears.

## Accessing the TeraStation with an FTP Client

---

### Accessing as a Registered User

To access the TeraStation via FTP, configure your FTP client software with the following settings:

- Hostname: IP address of the TeraStation
- Username: the TeraStation's username
- Password: the TeraStation's password
- Port: 21

### Accessing as an Anonymous User

To allow anonymous access to your FTP share, disable access restrictions. Configure your FTP client software with the following settings for anonymous FTP access:

- Hostname: IP address of the TeraStation
- Username: "Anonymous"
- Password: any character string
- Port: 21

### Notes:

- If the TeraStation joins a domain, anonymous users cannot remote access via FTP.
- Shared folders connected by FTP are available from the "/mnt" folder. Examples of default locations are:
  - /mnt/array1/share
  - /mnt/disk1/share
  - /mnt/usbdisk1
- If a file was created or copied using AFP, you may be unable to delete it using an FTP connection. If this occurs, use an SMB or AFP connection instead to delete the file.
- For FTP connections, make sure that the total filename length including the folder path is 250 single-byte characters or fewer.



# Chapter 7 Security Enhancement

---

## Two-Factor Authentication

---

Two-factor authentication is a security feature that strengthens login security by requiring a verification code in addition to username and password to log in to Settings. Two-factor authentication can better protect both your login credentials and data on the TeraStation.

### Enabling Two-Factor Authentication

---

**Notes:**

- To enable two-factor authentication, enable email notification first. Refer to the [“Email Notification”](#) section in chapter 10 for the detailed procedure.
- Two-factor authentication requires an authenticator app to be installed onto your mobile device. The following authenticator apps are supported:
  - Google Authenticator
  - Microsoft Authenticator
  - Duo Mobile
  - Twilio Authy

**1** From Settings, click *File Sharing*.

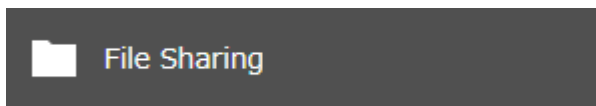

**2** Click the settings icon (  ) to the right of “Users”.



**3** Select the logged-in user for whom two-factor authentication will be enabled.

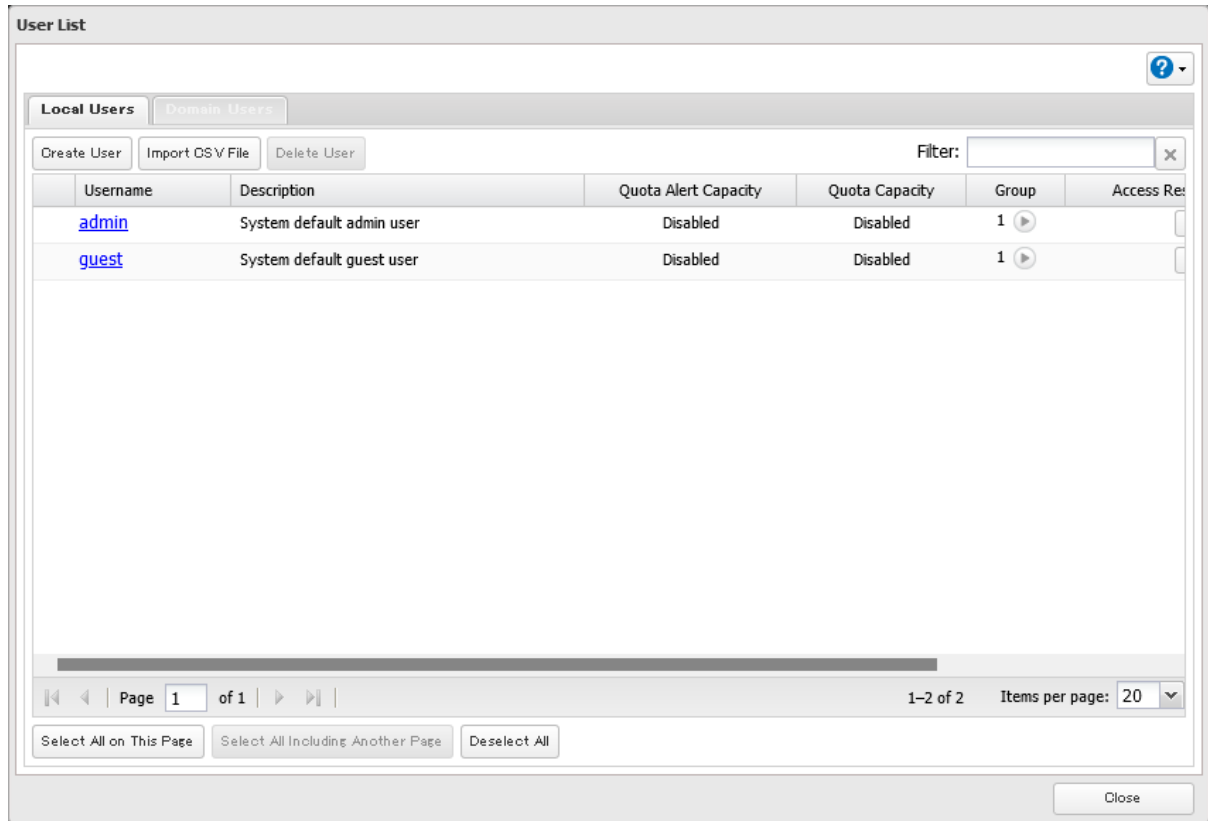

**4** Click *Two-Factor Authentication*.

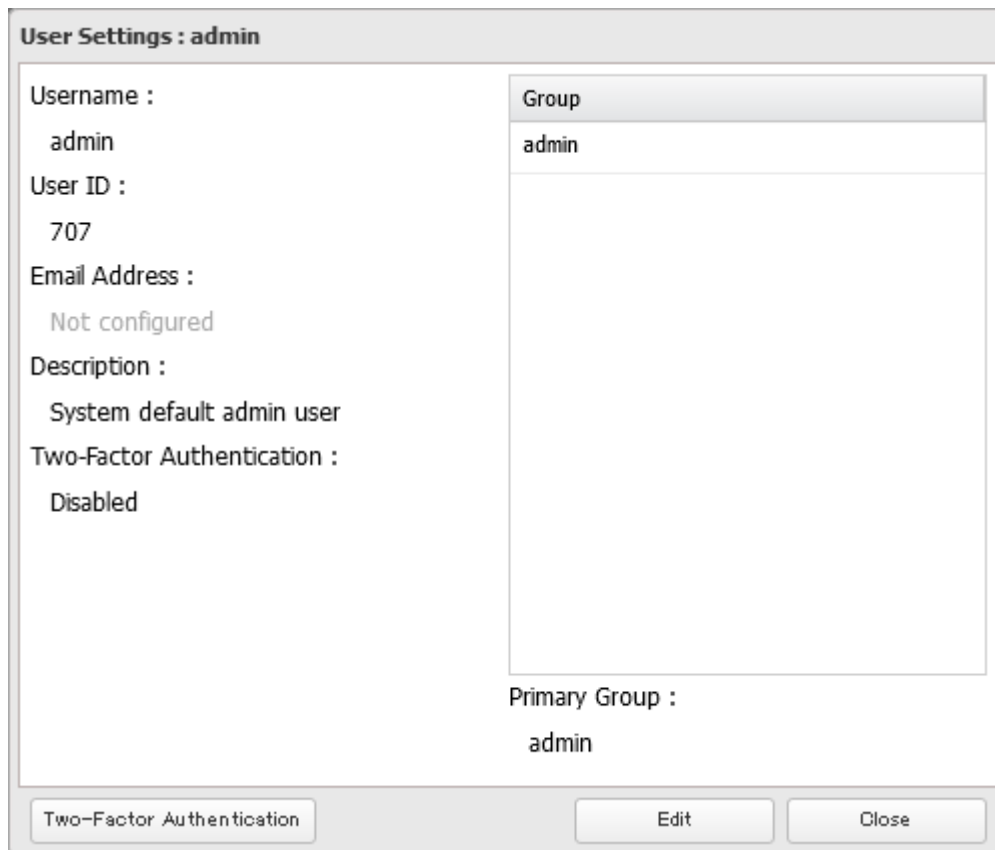

**5** Click *Next*.

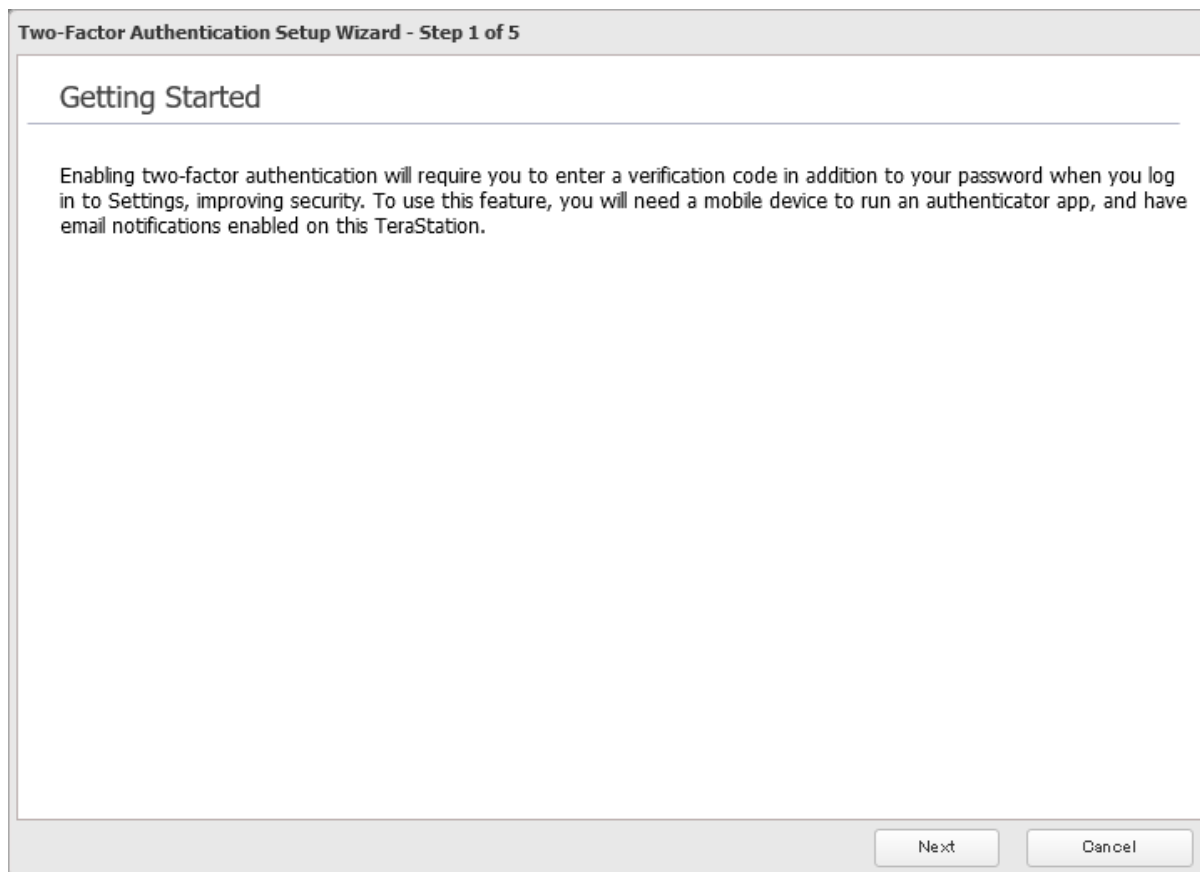

- 6 Enter an email address as an alternative method to receive the verification code and click *Next*.  
Click *Send Test Email* to have a test email sent to the entered address to confirm that the address is correct.

Two-Factor Authentication Setup Wizard - Step 2 of 5

### Configure Email Address for Verification Code

Set the email address to which the verification code will be sent if authentication fails through the app. After entering the email address, click 'Send Test Email' to confirm that the entered email address is correct.

Email Address

**Note:** The entered email address will be assigned to a user. If another email address had already been assigned to the user, it will be changed to the entered email address instead. The email address can be changed from the user settings page.

- 7 Open the installed authenticator app on your mobile device.

- 8 Use the authenticator app to scan the QR code displayed in Settings. Alternatively, enter the setup key into the app. Click *Next* after the app establishes the connection with the TeraStation.

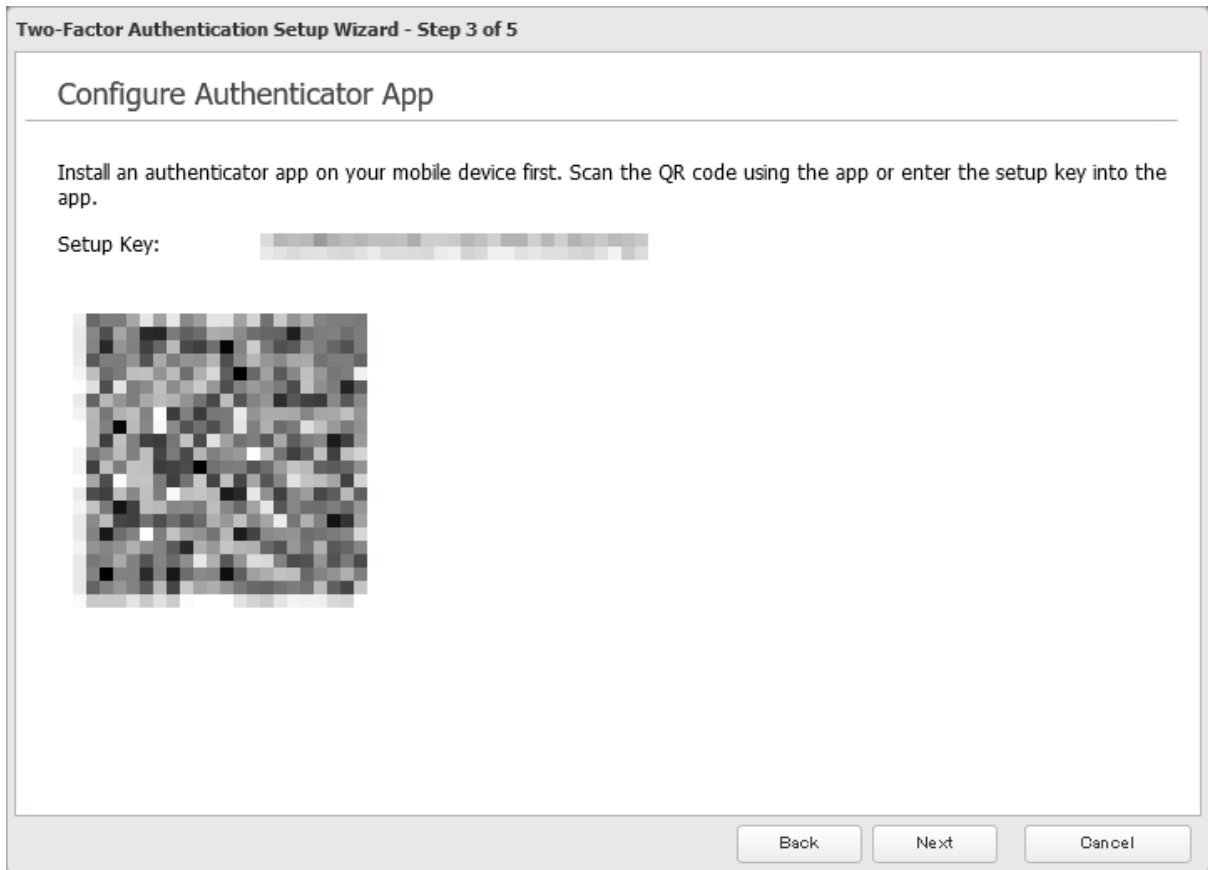

- 9** Enter the 6-digit verification code displayed on the authenticator app and click *Next*.

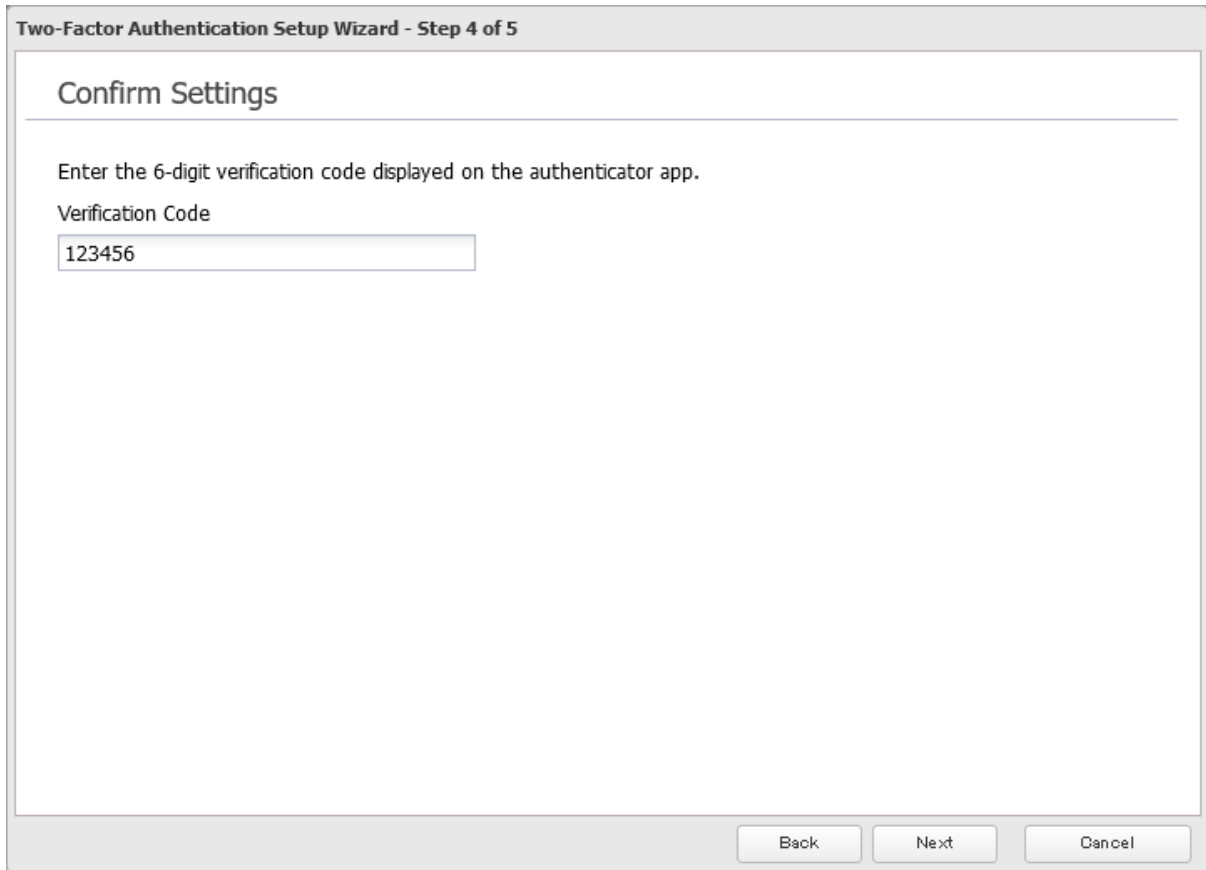

- 10** The process is complete once you close the wizard window that appears.

Two-factor authentication will become active after logging out from Settings. A verification code will be required the next time you log in to Settings using the same username.

**Note:** If authentication fails even if the verification code is valid, make sure the time settings on both the TeraStation and the mobile device are the same.

## Restricting Logins for Non-Admin Users

You can restrict users who do not have administrator privileges from being able to log in Settings.

- 1** From Settings, click *File Sharing*.

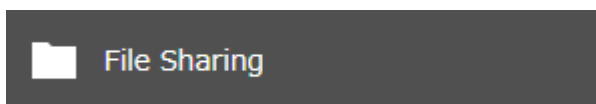

- 2** Click the settings icon (⚙️) to the right of "Users".



**3** Select a user from the user list.

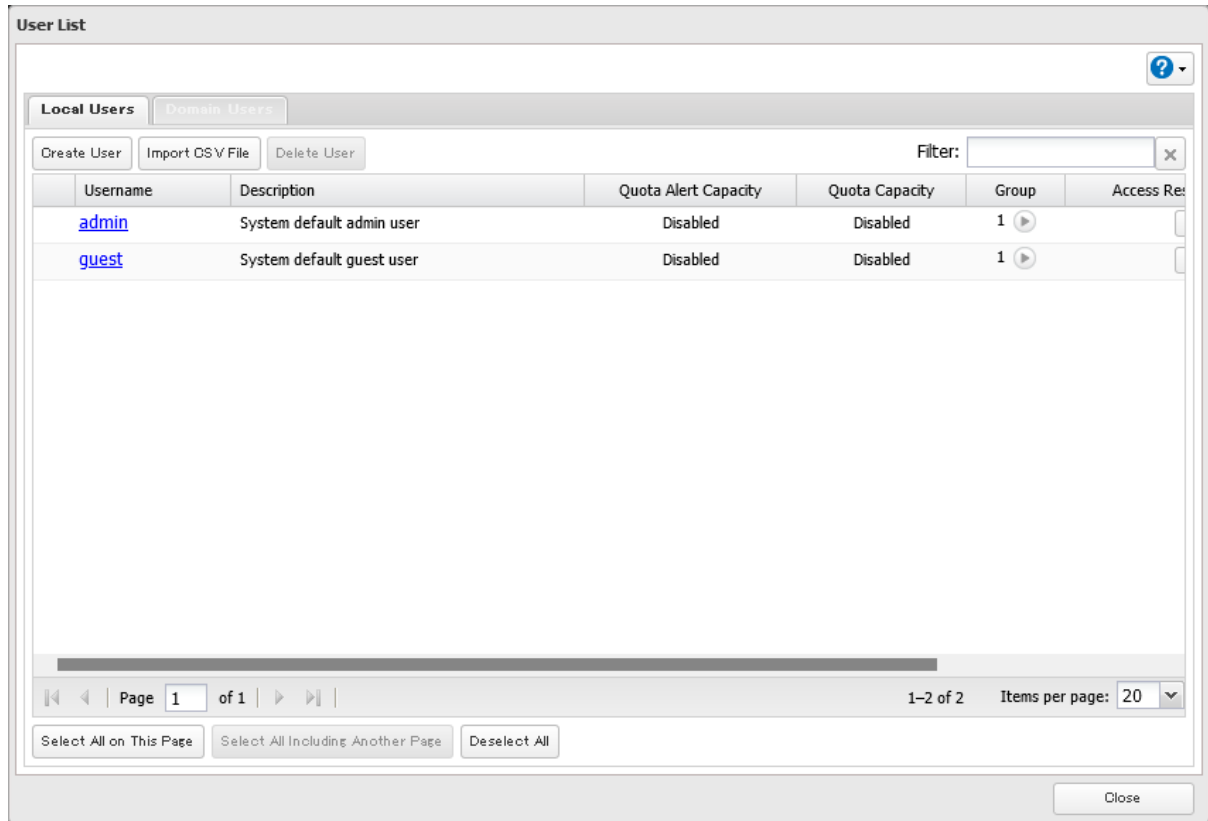

**4** Click *Two-Factor Authentication*.

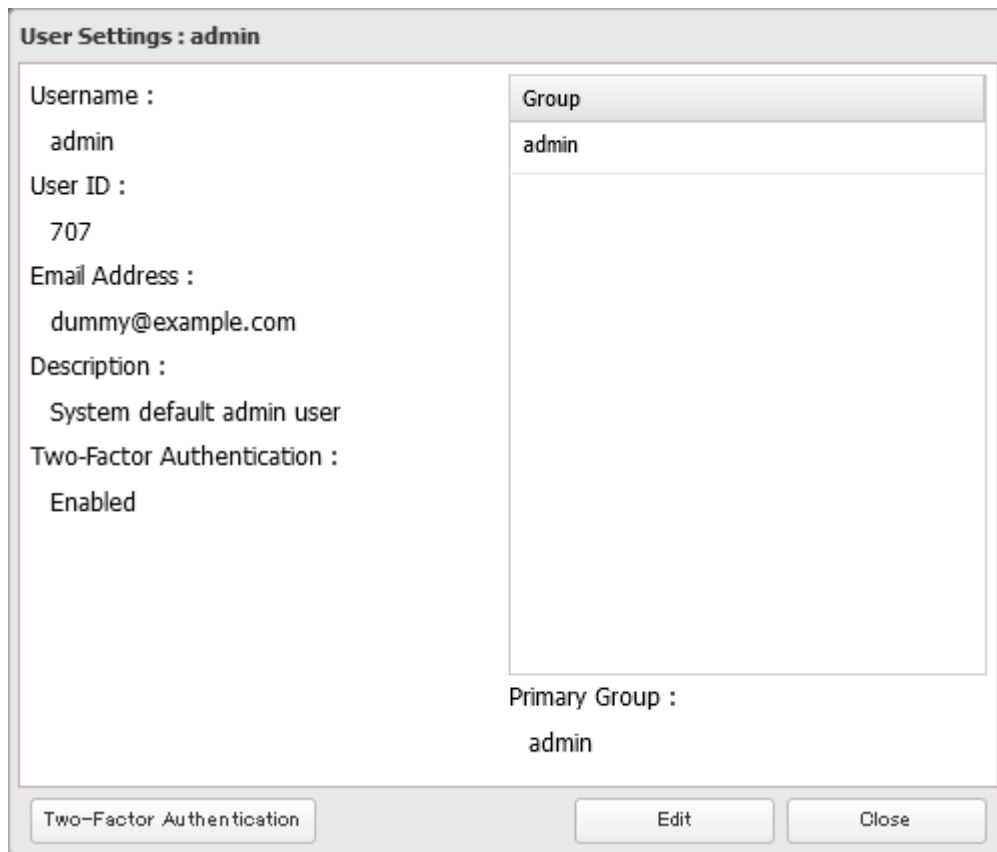

**5** Change the “Settings Interface Access” option to “Deny login by non-administrator users”, then click *OK*.

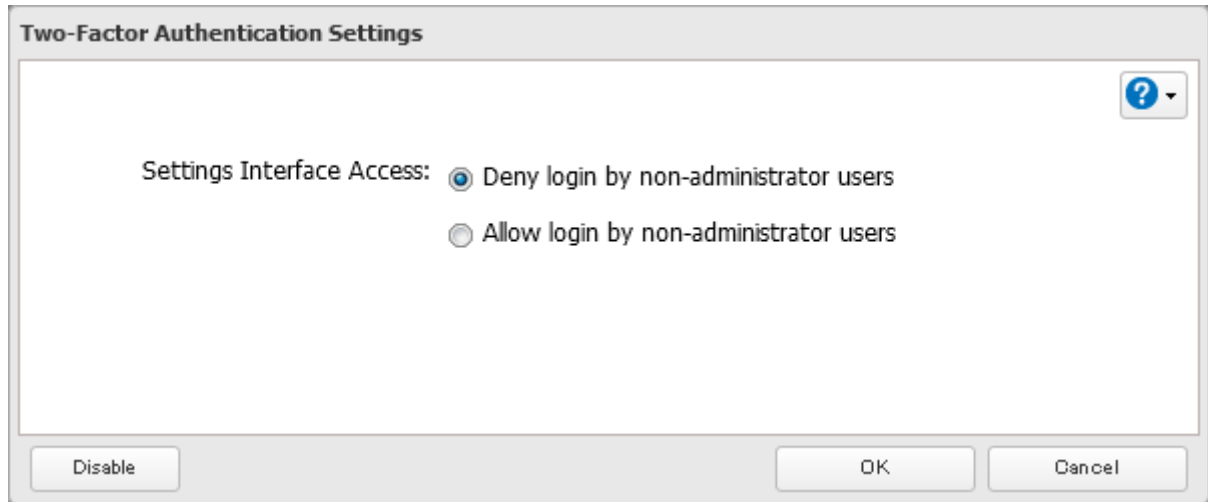

**6** The process is complete once you close the confirmation window that appears.

## Disabling Two-Factor Authentication

---

**1** From Settings, click *File Sharing*.

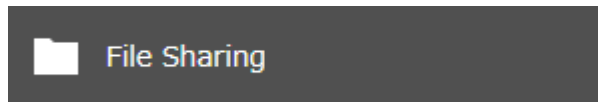

**2** Click the settings icon (  ) to the right of “Users”.





**3** Select the logged-in user for whom two-factor authentication will be disabled.

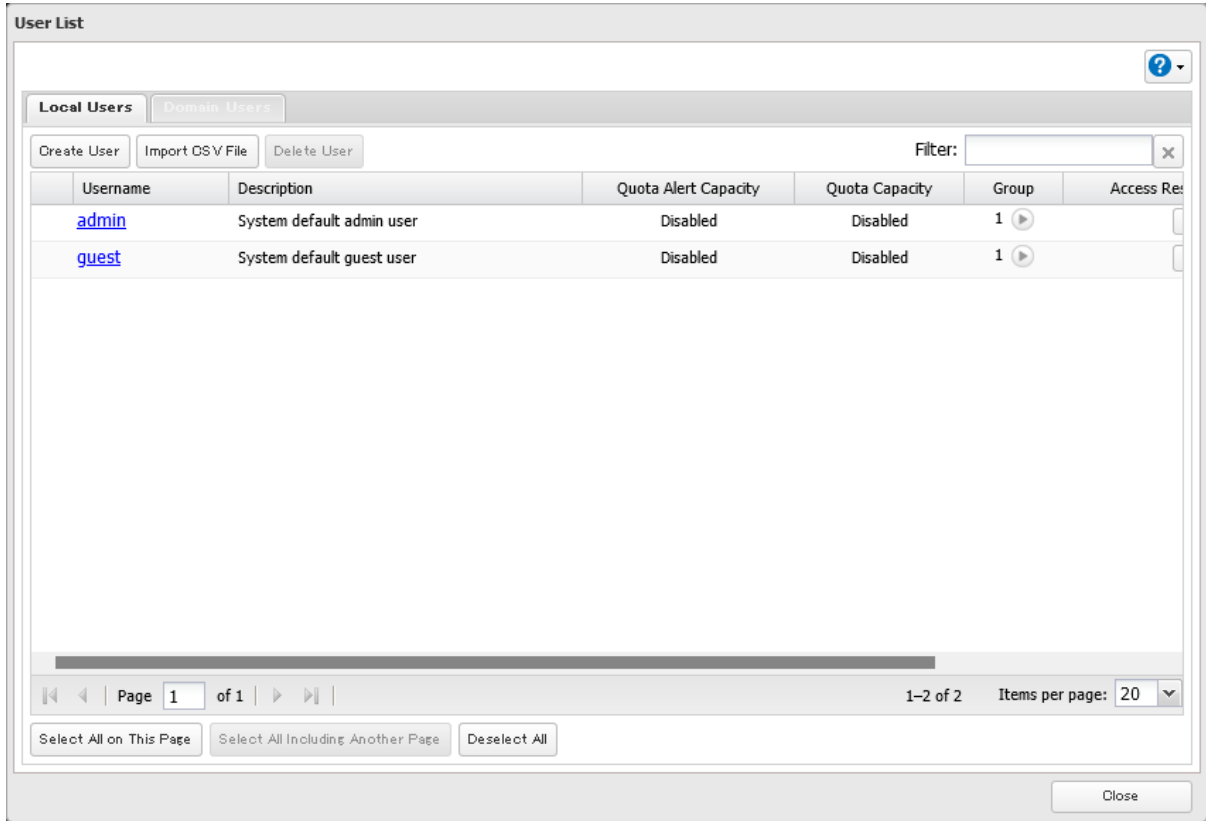

**4** Click *Two-Factor Authentication*.

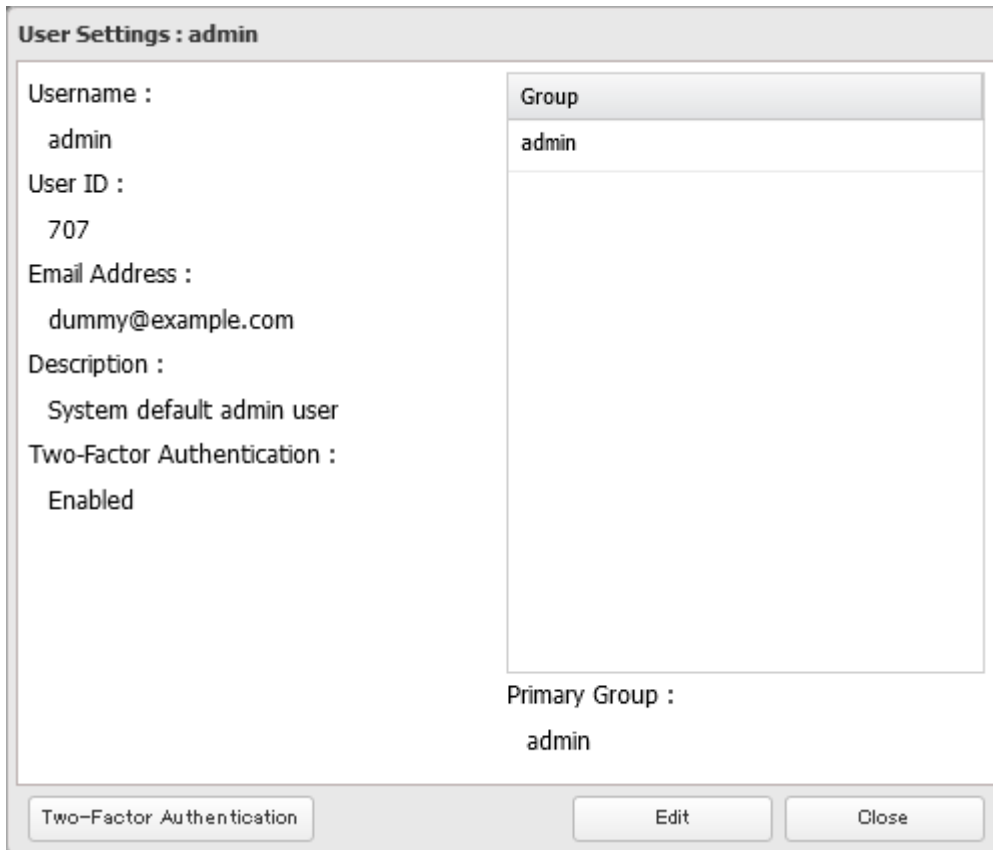

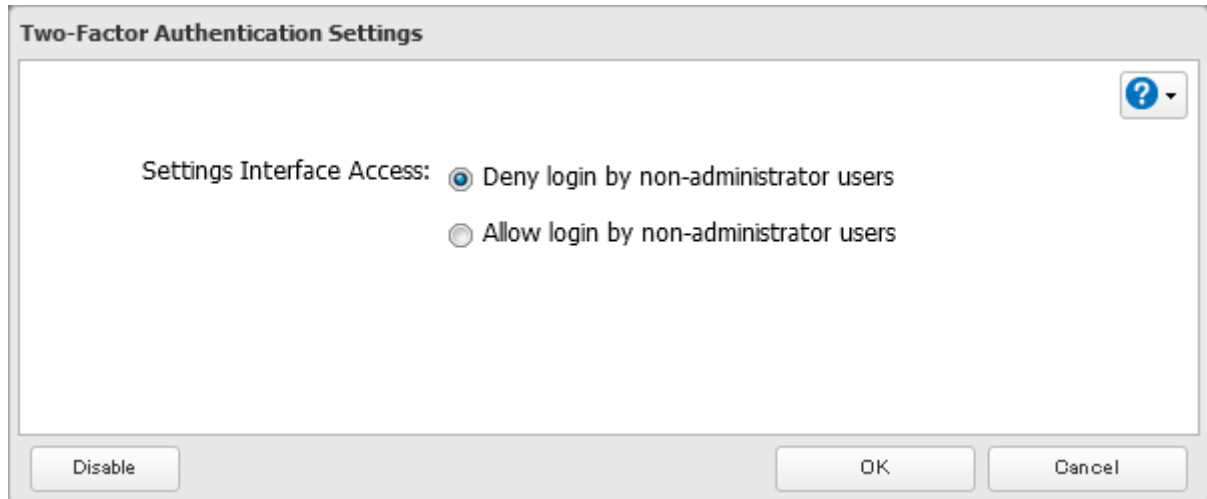
**5** Click *Disable*.**6** The process is complete once you close the confirmation window that appears.

---

## Antivirus Software

---

Trend Micro NAS Security can protect your network and data from software viruses and malware such as spyware and ransomware. Antivirus by Trend Micro NAS Security offers virus scanning for files in the TeraStation's shared folders except for the "usbdisk" folder. To use the antivirus software, you will need to purchase an OP-TSVC license pack (sold separately). If your TeraStation is already running an activated antivirus software, no license registration is necessary.

**Notes:**

- If LVM is enabled on the TeraStation, the antivirus software may not work properly. For best results, disable LVM before use.
- To use the antivirus software effectively, the TeraStation should be connected to the Internet. The connection can be routed through a proxy server if the appropriate settings are configured in *Administration > Proxy Settings* from the left-side menu of the Trend Micro NAS Security settings page.
- Trend Micro is a trademark of Trend Micro Incorporated.

## Activating Virus Scanning

---

Follow the procedure below to activate virus scanning.

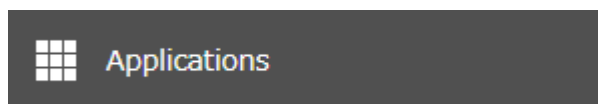
**1** From Settings, click *Applications*.**2** Move the antivirus switch (  ) to the  position to enable antivirus.

- 3** The license agreement screen will open. Read the agreement carefully and select the checkbox, then click *Enable*.

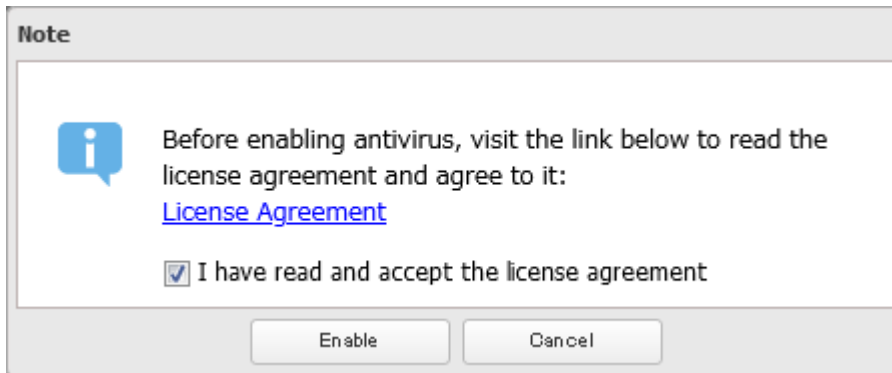

- 4** The process is complete when the applications menu list is displayed.

When antivirus is enabled, a quarantine folder named “TMNAS” will automatically be created on the TeraStation. If a virus is detected, it will be moved to this folder.

## Changing the Quarantine Folder

If you want to designate a specific shared folder as a quarantine folder, follow the procedure below.

- 1** Create a new shared folder by referring to the [“Adding a Shared Folder”](#) section in chapter 3.
- 2** From Settings, click *Applications*.

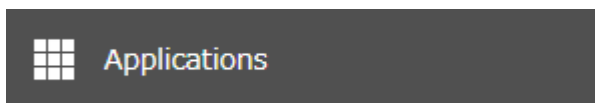

- 3** Click the settings icon (  ) to the right of “Antivirus”.



- 4** Click *Edit*, then *Browse* and select the quarantine folder.

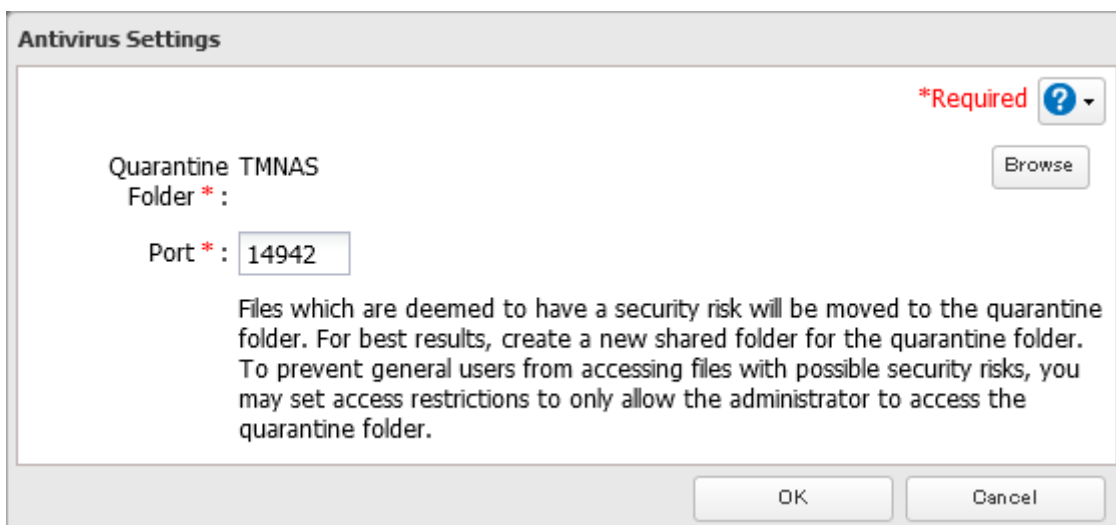

**5** Click *OK*. The process is complete when you close the confirmation window that appears.

## Configuring Security Settings

Use the Trend Micro NAS Security settings page to configure security settings such as updating pattern files, configuring scan schedules, and activating or extending the license. To open the settings page, follow the procedure below.

**1** From Settings, click *Applications*.

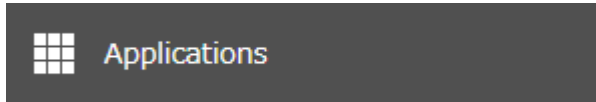

**2** Click the settings icon (  ) to the right of "Antivirus".



**3** Click *Options*.

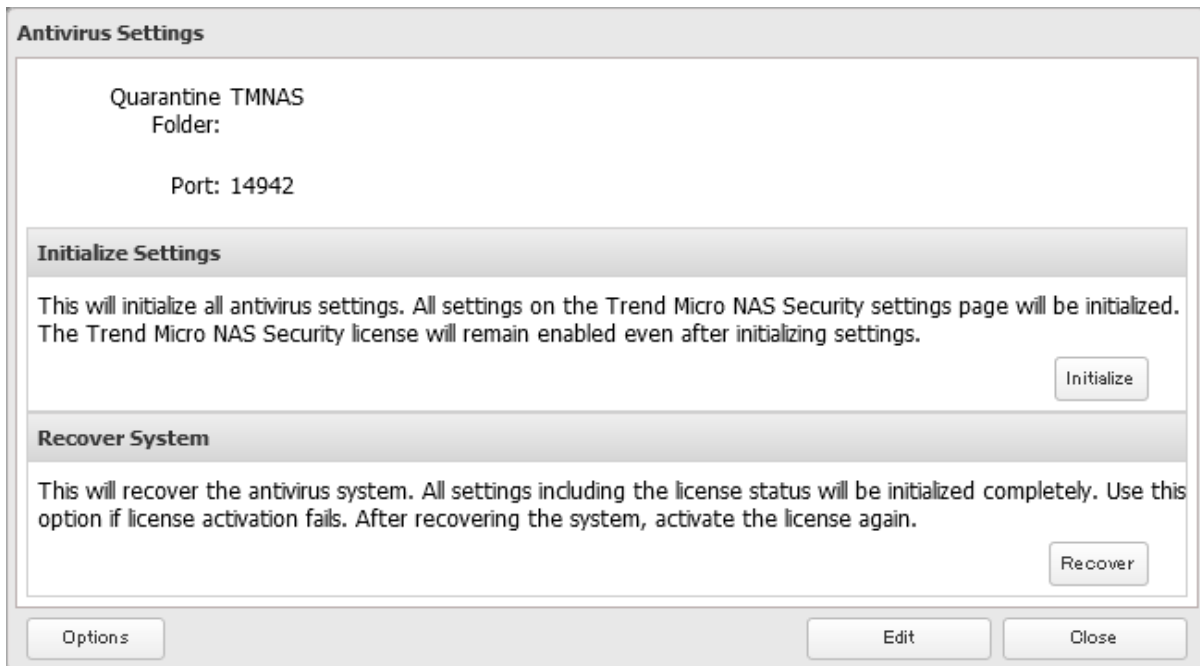

- 4 Enter your username and password, then click *Log On*.

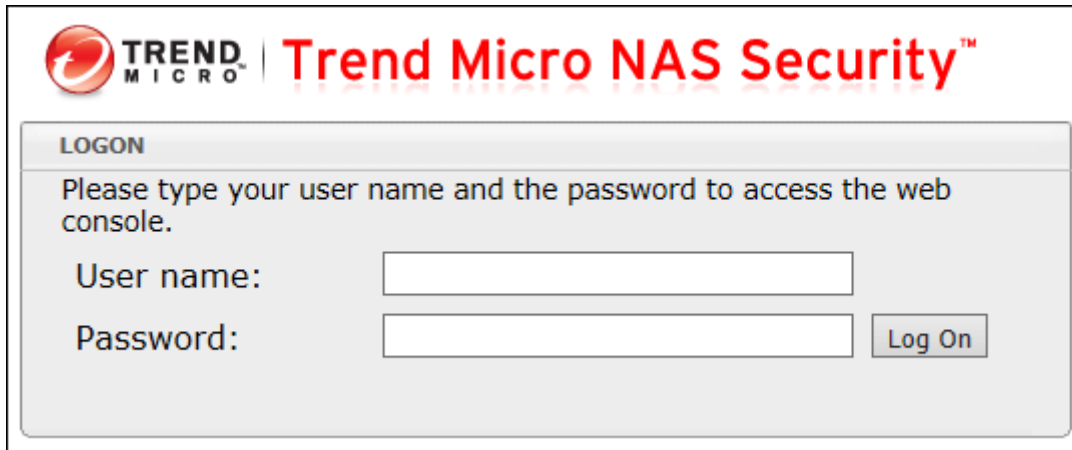

You can log on using the TeraStation's admin account. The default username and password are "admin" and "password".

- 5 The process is complete when the Trend Micro NAS Security settings page opens.

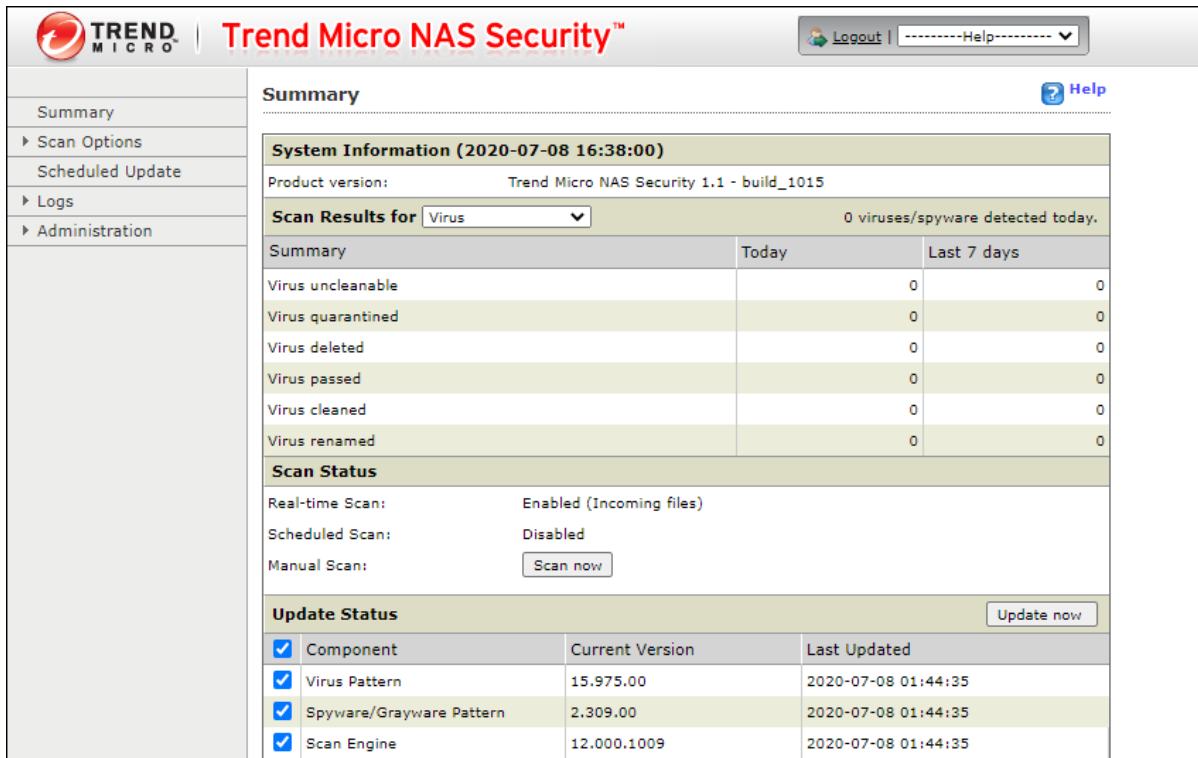

**System Information (2020-07-08 16:38:00)**

Product version: Trend Micro NAS Security 1.1 - build\_1015

**Scan Results for** Virus 0 viruses/spyware detected today.

Summary	Today	Last 7 days
Virus uncleanable	0	0
Virus quarantined	0	0
Virus deleted	0	0
Virus passed	0	0
Virus cleaned	0	0
Virus renamed	0	0

**Scan Status**

Real-time Scan: Enabled (Incoming files)  
 Scheduled Scan: Disabled  
 Manual Scan:

**Update Status**

Component	Current Version	Last Updated
<input checked="" type="checkbox"/> Virus Pattern	15.975.00	2020-07-08 01:44:35
<input checked="" type="checkbox"/> Spyware/Grayware Pattern	2.309.00	2020-07-08 01:44:35
<input checked="" type="checkbox"/> Scan Engine	12.000.1009	2020-07-08 01:44:35

**Notes:**

- The Trend Micro NAS Security settings page is compatible with IE 6.0 SP2 or later (Windows) and Firefox 1.5 or later (Windows or macOS).
- To change the display language of the Trend Micro NAS Security settings page, change the system language to the desired settings by referring to the ["Name, Date, Time, and Language"](#) section in chapter 10.

## Licenses

If the antivirus software on your TeraStation is not activated or has expired, please purchase an OP-TSVC license pack (sold separately). If your TeraStation includes activated antivirus software, no license registration is required. The total available period for active antivirus software updates is five years, including the remaining period.

### License Extension Example

The example below shows an initial one-year period for updates followed by an extension of an additional year.

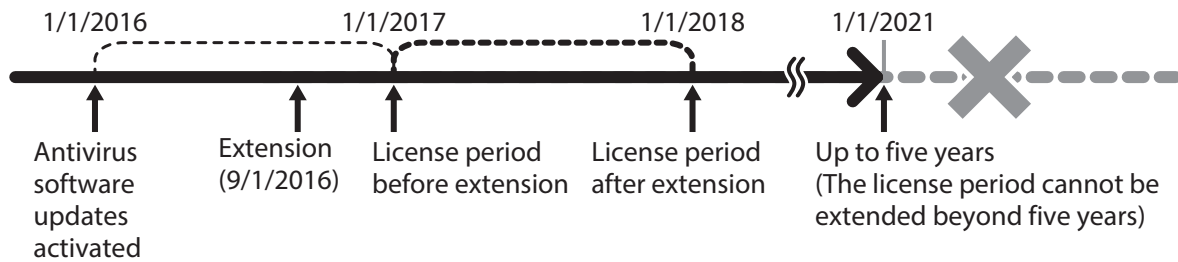

**Note:** It's not possible to register a serial number that would extend the total license period beyond five years, such as a second three-year license after three years.

- 1 From the left-side menu of the Trend Micro NAS Security settings page, click *Administration > Product License*.

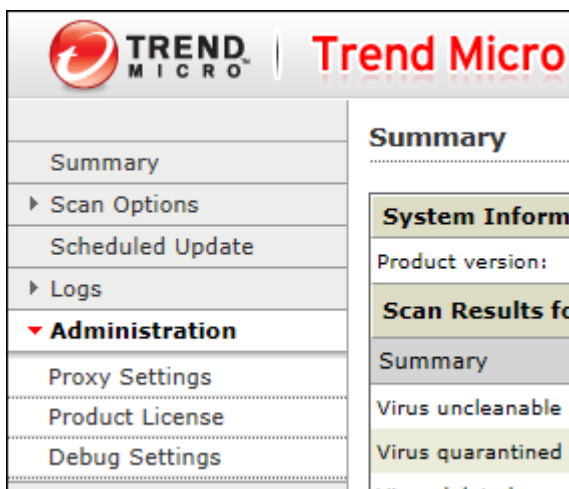

- 2 Enter the serial number from the "Trend Micro NAS Security License Pack Guide", included in your package. Click *Activate*.

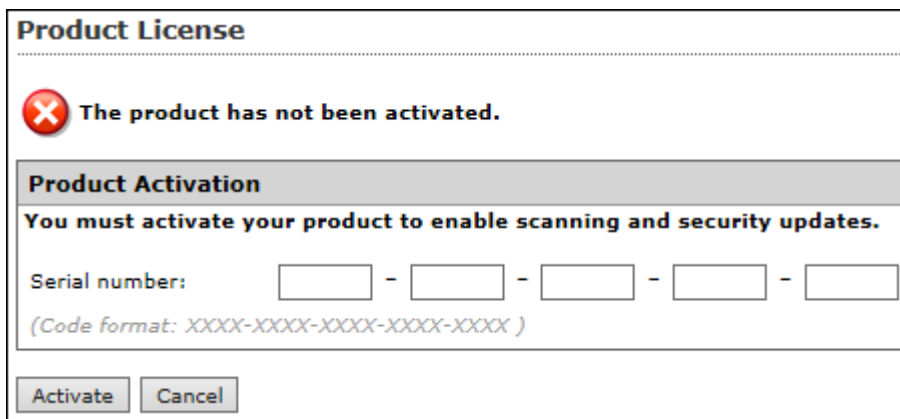

The new license is now registered.

To check the status of the current license, open the Trend Micro NAS Security settings page and navigate to *Administration > Product License* on the left-side menu.

### Connecting Through a Proxy Server

If you must pass through a proxy server to connect to the Internet in your network environment, follow this procedure to set the IP address of the proxy server and other settings.

- 1 From the left-side menu of the Trend Micro NAS Security settings page, click *Administration > Proxy Settings*.

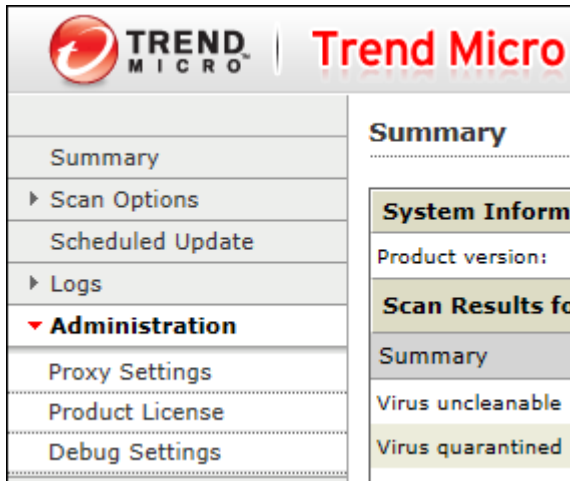

- 2 Select the “Use a proxy server to access the Internet (License update)” checkbox. Enter the IP address and port of the proxy server, then click *Save*.

The antivirus software is now configured to use a proxy server.

## Updating Antivirus Pattern Files

For best results, configure your antivirus software to update the antivirus pattern files automatically as described below.

- 1 From the left-side menu of the Trend Micro NAS Security settings page, choose *Scheduled Updates*.

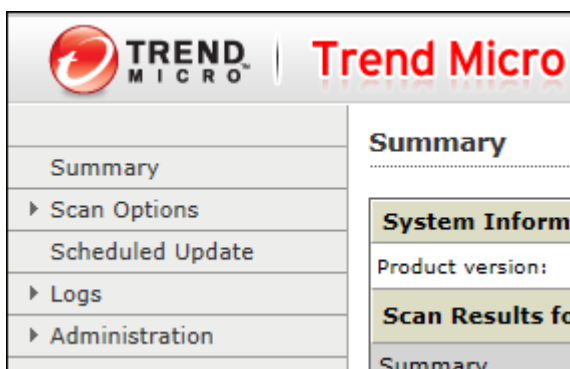

## 2 Check "Enable Scheduled Update".

**Scheduled Update**

---

Enable Scheduled Update

**Update Frequency**

Start time:  :  (hh:mm)

Repeat interval:  Hourly  
 Daily, update for

## 3 Select a time for updates to begin, an interval for updates, and an amount of time for updates to continue. Select the components to update. Click Save.

**Scheduled Update**

---

Enable Scheduled Update

**Update Frequency**

Start time:  :  (hh:mm)

Repeat interval:  Hourly  
 Daily, update for   
 Weekly, every   
update for:

**Components to Update**

<input checked="" type="checkbox"/>	Component	Current Version	Last Updated
<input checked="" type="checkbox"/>	Virus Pattern	12.827.00	2016-11-01 09:00:00
<input checked="" type="checkbox"/>	Spyware/Grayware Pattern	1.773.00	2016-11-01 09:00:00
<input checked="" type="checkbox"/>	Scan Engine	9.900.1010	2016-11-01 09:00:00

The antivirus software is now configured to update automatically at the scheduled time. Updates will not be downloaded if the TeraStation is turned off, in standby mode, or disconnected from the Internet.

## Configuring Folders as Virus Scanning Targets

By default, all folders on the TeraStation (including attached USB drives) will be scanned. Follow the procedure below to block specific shared folders from being scanned.

### 1 From Settings, click *File Sharing*.

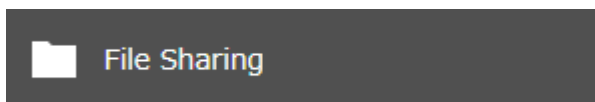

### 2 Click the settings icon (⚙) to the right of "Folder Setup".





**3** Click the shared folder that you want to exclude from the scan.

**4** If any scan options checkboxes are selected on the *Option 1* tab, the shared folder will undergo those scans. To exclude any scan options, clear their checkboxes.

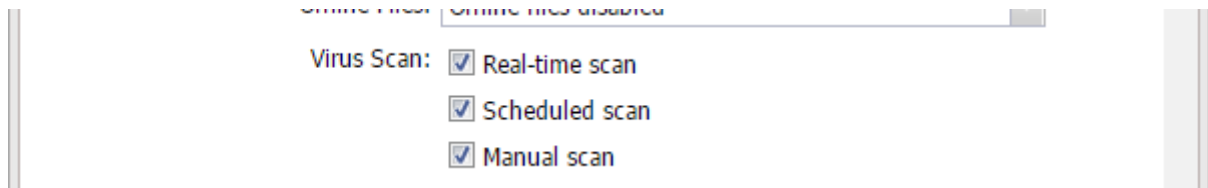

**5** Click *OK*.

**Note:** Even if the scan options are selected in the quarantine folder settings, the quarantine folder will be excluded from the virus scan.

## Configuring Virus Scanning

Three types of virus scans are available:

- **Real-time scan**  
The virus scan runs in the background, scanning every file that you read or write. This is the default type of scanning. Your TeraStation may run slower if real-time scanning is enabled.
- **Scheduled scan**  
A scheduled scan is executed at specific regular intervals, such as every Tuesday at 3 a.m.
- **Manual scan**  
A manual scan runs once when initiated. Initiate a manual scan as described below.

**1** From the left-side menu of the Trend Micro NAS Security settings page, choose *Scan Options > Manual Scan*.

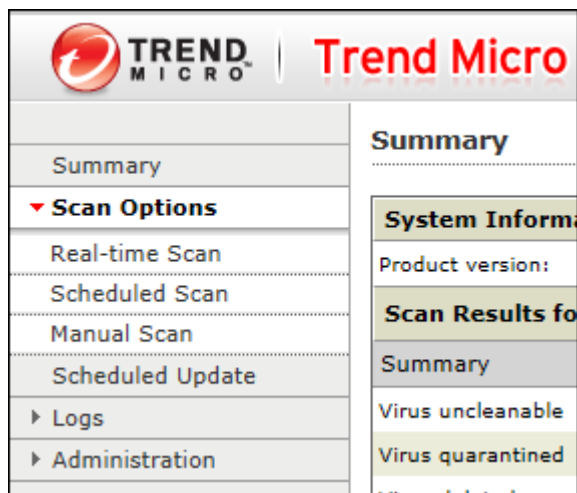

**2** Click *Scan now*. This starts the virus scan.

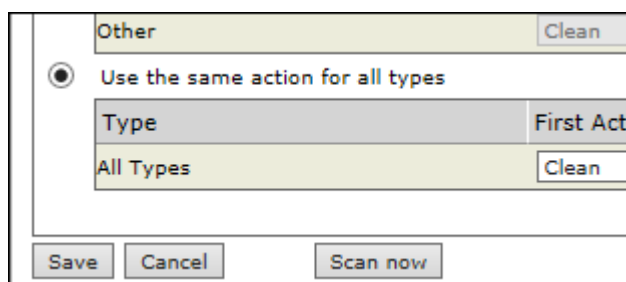

If the scan finds a virus, the user can be notified in two ways:

- The I34 virus alert message normally appears as a notification. Once the virus is removed from the quarantine folder, the message is no longer displayed. If the antivirus software is configured to delete viruses from the quarantine folder automatically, then the I34 virus alert message will disappear.
- If email notification is enabled in Settings, then the antivirus software notifies the user by email if a virus is found. Enabling email notifications is recommended.

Depending on how many files are on your TeraStation, a virus scan may take several hours. Estimated scanning times are shown below.

10,000 files: ~ 30 minutes

100,000 files: ~ 5 hours

1,000,000 files: ~ 50 hours

**Notes:**

- If the quarantine folder doesn't have enough space, the infected files may be unable to be moved to the quarantine folder. The Trend Micro NAS security scan log may identify any infected files as quarantined even if the quarantine did not actually occur. In such a case, remove non-essential files from the quarantine folder and try the virus scan again.
- If the infected file is too large, it may not be automatically moved to the quarantine folder. In such a case, check the scan log to see whether the quarantine was successful. If it was not, move the infected file to the quarantine folder manually.

## Checking the Log

---

Follow the procedure below to check the virus scan log.

- 1 From the left-side menu of the Trend Micro NAS Security settings page, choose *Logs*.

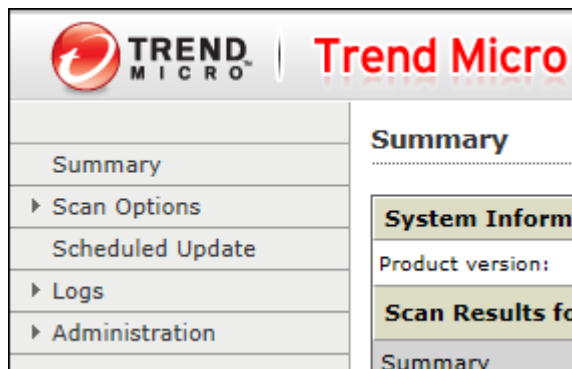

- 2 Click the log item that you want to check.

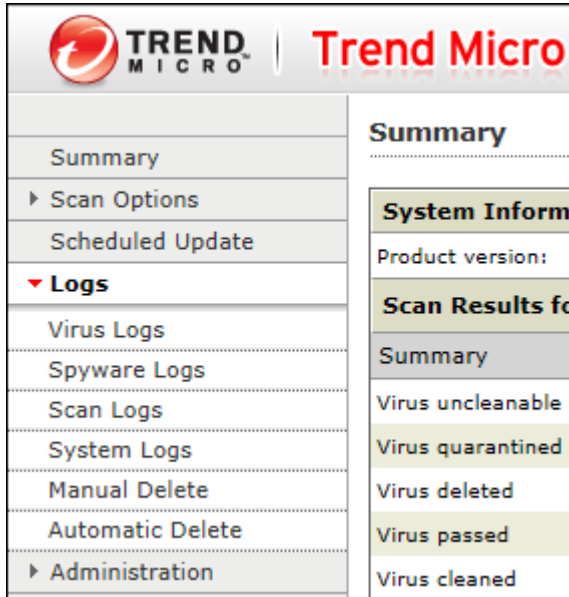

- 3 Click *Display Log*.

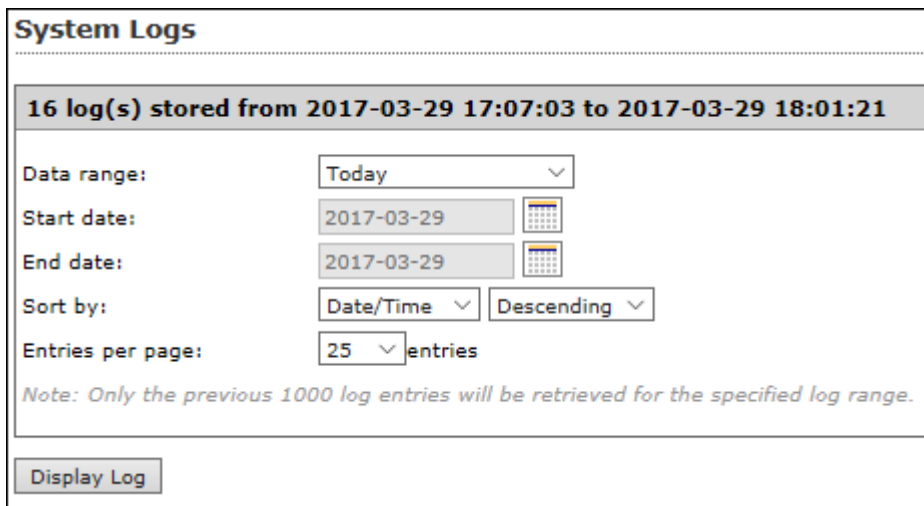

This completes the procedure for checking the log.

## Opening the Online Help

For more information on the antivirus software, refer to the online help. Follow the procedure below to access the online help.

- 1 From the right-top menu of the Trend Micro NAS Security settings page, choose *Help > Contents and Index*.

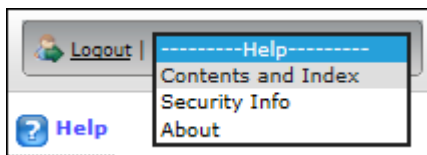

- 2 Online help will open.  
Online help is now viewable.

## Encrypting Data Transmission

### Encrypting Settings Data

All communication with Settings can use SSL encryption if you access the Settings page by changing “http://” to “https://” in the browser address bar or click *Secure Connection* from the login window. Once you are logged in using the HTTPS connection and wish to disable SSL encryption, click *Normal Connection* from the login window.

The screenshot shows the Buffalo login interface. At the top, the word "BUFFALO" is displayed in red. Below it is a text input field containing "admin". Underneath is a checkbox labeled "Log in as a different user" which is unchecked. Below that is a password input field labeled "Password". Under the password field, there is a "Time-Out Period" section with two radio button options: "10 minutes" (which is selected) and "Unlimited". At the bottom of the form is a large blue button labeled "OK". Below the button is a blue link labeled "Secure Connection".

### Encrypting FTP Transfer Data

You can encrypt passwords using SSH for secure FTP communication. First, open a shared folder's settings; under "LAN Protocol Support", select the "SFTP" checkbox on the *Basic* tab and click *OK*. Also, you have to enable the SFTP service by moving the SFTP switch to the **on** position on "File Sharing".

#### Notes:

- If SFTP is enabled, guest users and anonymous users will not be able to access shared folders.
- If the TeraStation joins a domain, local users cannot remote access via SFTP.

## SSL

SSL (Secure Socket Layer) is a protocol that uses a public key encryption system to establish secure communication channels between networked devices, allowing for encrypted Internet traffic and server identity verification. The SSL protocol uses a pair of keys – one private, one public – to authenticate and manage secure connections. SSL keys are used during setup screen operations and FTP communication.

### SSL Key Formats/Extensions

The SSL keys may include the following encoding formats and extensions:

#### SSL Certificate (server.crt)

The server.crt is the server public key, and is generated by the TeraStation. A computer that receives the server.crt uses it to encrypt data, and the TeraStation then uses the server.key file to decrypt the data.

In SSL, this key contains the server certificate, and depending on your computer environment, a check may be performed to determine the trustworthiness of the certificate. The server certificate included in the TeraStation's default settings was created by Buffalo, and in some cases, the security certificate warning message may appear in your browser or another security software. If this occurs, disregard the message and continue.

**Note:** Use TLS 1.2 SSL Certificate.

### SSL Private Key (server.key)

This file is the server private key, and it is usually not revealed. The server.key file is paired with the server.crt file to decrypt data encrypted by the SSL certificate.

**Note:** The passphrase for the private key must be removed before importing to the TeraStation.

## Updating SSL Key Files

To update a server certificate and a private key for SSL, follow this procedure.

- 1 From Settings, click *Management*.

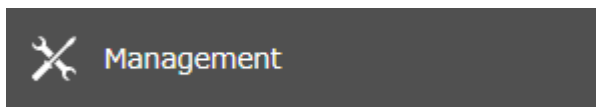

- 2 Click the settings icon (  ) to the right of "SSL".



- 3 Register "server.key" for "Secret Key" and "server.crt" for "Server Certificate (.crt)", then click *Import*.

 A dialog box titled "SSL Settings" with a light grey background. It contains two input fields: "Secret Key:" and "Server Certificate (.crt):". Each field has a "Browse" button to its right. Below these fields is an "Import" button. At the bottom right of the dialog is a "Close" button. There is also a help icon (question mark) in the top right corner of the dialog.

- 4 The process is complete once you close the confirmation window that appears.

#### Notes:

- Place the SSL key files (server.key, server.crt) directly below the C root drive. The SSL key files may be unable to be updated if they are placed in folders or paths that contain multibyte characters.
- If Settings cannot be displayed after updating, initialize the TeraStation settings.
- Updating the firmware initializes an SSL key.

## Boot Authentication

Boot authentication allows you to authenticate the TeraStation while it's booting, and also prevents the TeraStation from being used in an unauthorized or unexpected manner, such as in cases of theft.

If authentication fails, the TeraStation will stay on, but all functions and services are stopped. Users will not be able to log in to Settings to make changes or access any shares.

### Notes Before Use

- To use boot authentication, a Windows PC is necessary to serve as the authentication server.
- When activating boot authentication, the drives on the TeraStation will be formatted and all data on the drives will be erased. Back up any important data to another device. Even though the data is deleted, the RAID array will be kept as is.
- Assigning the TeraStation a static IP address is recommended for boot authentication.
- When boot authentication configuration finishes, export the configuration file for backup. Refer to the "Exporting Managed TeraStations to a File" section in the Boot Authentication Tool help for the procedure.
- Boot authentication cannot be enabled if any of the following functions are enabled: drive encryption, LVM, iSCSI, and failover. Conversely, these functions cannot be enabled while boot authentication is enabled.

### Important Notice

This feature was developed with the intention of preventing critical data leakage by rendering the TeraStation unusable in cases of misoperation or missing important setting files. Before configuring boot authentication, back up the data on the TeraStation by referring to the "[Backing Up Data on the TeraStation](#)" section in chapter 5, and then create a USB initialization drive by referring to the "[Creating a USB Initialization Drive](#)" subsection in chapter 8. With these preparations, a TeraStation that is unusable may be initialized and revert to a usable state.

If any of the situations below occur, the TeraStation will stop booting and become inaccessible.

- The TeraStation is unable to communicate with the authentication server due to the server crashing or it being on another network.
- The TeraStation unit has been deleted from Boot Authentication Tool or the Boot Authentication Tool database has been erased.
- Security level is configured to "High" and the incorrect passcode is entered three times.

### Setting Up the Authentication Server on a Windows PC

To set up the authentication server, follow the procedure below. The authentication server must be placed on the local network or VPN.

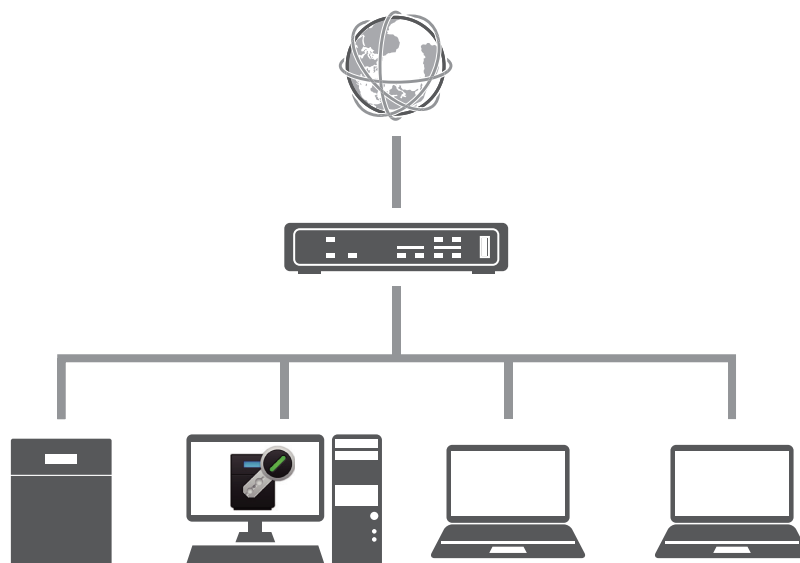

**Note:** For proper operation, make sure that the TeraStation and the authentication server are on a network with only one router. If there are two or more routers on the network, the authentication server may not acquire the correct

TeraStation status. For example, if the TeraStation's IP address has been changed, its status does not change to "Warning".

- 1** Download the application for the authentication server, "Boot Authentication Tool", from the [Buffalo website](#) and install it onto the Windows PC.
- 2** Register the specific port number that is used on the application as a firewall exception rule. Navigate to *Control Panel > System and Security > Windows Firewall* on the authentication server.
- 3** Click *Advanced settings*.
- 4** Click and right-click *Inbound Rules*, then click *New Rule*.
- 5** Select "Port" and click *Next*.
- 6** Select "TCP", enter the port number that is used on the application to the right of "Specific local ports", and click *Next*. The default port number on the application is "7010". The port number can be confirmed on the *Options* tab of the application.
- 7** Click *Next*, then click *Next* again.
- 8** Enter a desired name for the setting and click *Finish* to complete.

## Configuring Boot Authentication on the TeraStation

---

- 1** From Settings, click *Management*.

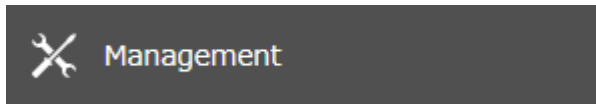

- 2** Click the settings icon (  ) to the right of "Boot Authentication".



- 3** Click *Edit*.

- 4 Enter the authentication server's IP address or hostname and port number, specify the security level and communication time settings, then click *Activate*.

**Boot Authentication Settings**

\*Required ?

Authentication Server Address \* : 192.168.10.15

Port Number \* : 7010

Security Level \* :  Medium  High

Medium: If the TeraStation cannot communicate with the authentication server and the passcode was entered incorrectly, the original passcode will remain valid.

High: If the TeraStation cannot communicate with the authentication server and the passcode was entered incorrectly 3 times, the TeraStation will become unusable.

Notes from Settings:

Server Communication Time \* : 09 Hours 32 Minutes

Buttons: Activate, Deactivate, OK, Cancel

- 5 The drive formatting process will start. Click *Yes*.
- 6 The "Confirm Operation" screen will open. Enter the confirmation number, then click *OK*.
- 7 The format will begin. Wait until it finishes.
- 8 The process is complete when formatting finishes and the TeraStation is added to Boot Authentication Tool.

**Boot Authentication Tool for TeraStation**

Managed Devices Options

Files Edit Help Refresh Period (Minutes) 5 Search

Icon	Hostname	Notes	Notes from Settings	Status	Last Accessed
	TS3410D028			Normal	2018/09/03 14:33:35



**Note:** To activate, deactivate, or change the boot authentication settings, the TeraStation must be communicating with the authentication server.

## If the TeraStation Cannot Be Accessed

If the TeraStation cannot communicate with the authentication server or vice versa, such as in a case of network failure, the TeraStation will not be accessible. If the TeraStation is not accessible, manually authenticate the TeraStation by following the procedure below.

**Note:** The procedure defines an “authentication server administrator” as someone who manages the authentication server using Boot Authentication Tool, and a “user” as one attempting to access the TeraStation from a remote location.

- 1 When the user tries to access the TeraStation’s Settings and the TeraStation is not available, the screen below will be displayed. Have the user forward the decryption key to the authentication server administrator.

A dialog box with a light gray background and a white content area. In the top right corner of the content area is a blue question mark icon with a dropdown arrow. The text "Decryption Key: 12345678" is displayed in the center. Below it, the label "Passcode:" is followed by an empty text input field. At the bottom right of the dialog box is an "OK" button.

- 2 Open Boot Authentication Tool on the authentication server.
- 3 From Boot Authentication Tool, right-click the target TeraStation from the list and click *Decrypt Passcode*.
- 4 Enter the decryption key received from the user and click *Decrypt*.

A dialog box titled "Entry" with a close button (X) in the top right corner. It contains the following fields and controls:
 

- Hostname: TS3410D028
- Decryption Key: A text input field containing "12345678". To its right is a "Decrypt" button with a blue dashed border.
- Decrypted Passcode: An empty text input field.

 Below the fields is a paragraph of instructions: "Enter the 8-digit decryption key that is displayed on the accessed NAS's Settings into the blank field, then click 'Decrypt'. The decrypted passcode (a 20-digit number) will be displayed." At the bottom right is a "Close" button.

**5** The decrypted 20-digit passcode will be displayed. Send the passcode to the user.

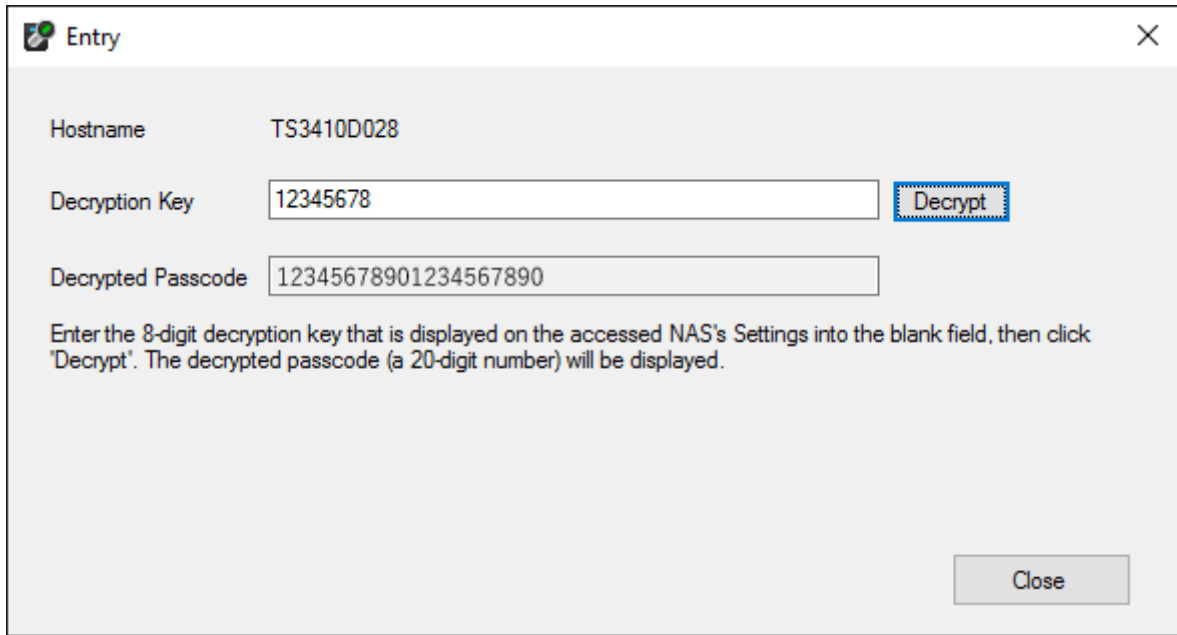

**6** The user can then enter the 20-digit passcode into Settings and click *OK*.

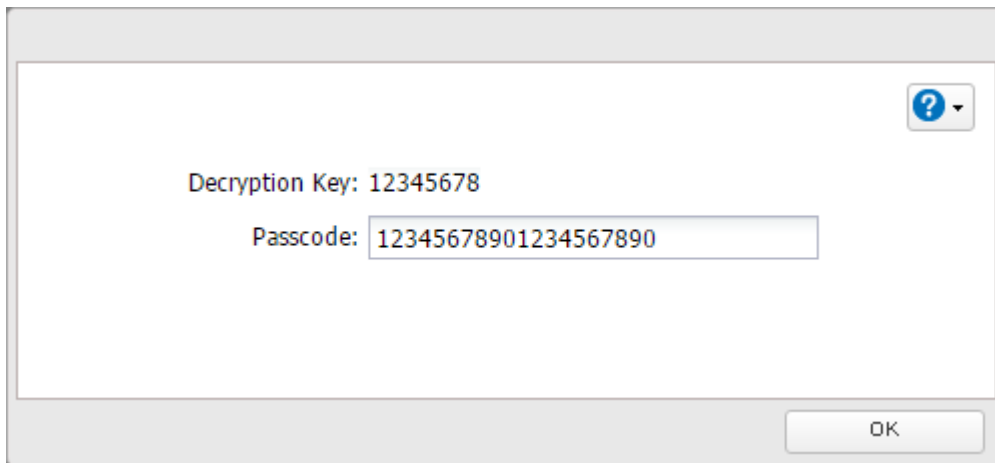

Once the passcode is authenticated, the TeraStation will become available. The user can click *OK* to log in to Settings.

# Chapter 8 Settings Backup/Restoration

## Saving and Applying Settings

The TeraStation's settings can be saved to a USB drive (the capacity is no more than 2 TB) and applied to another Buffalo NAS device of the same series. Use this feature to back up or copy settings to a new Buffalo NAS device.

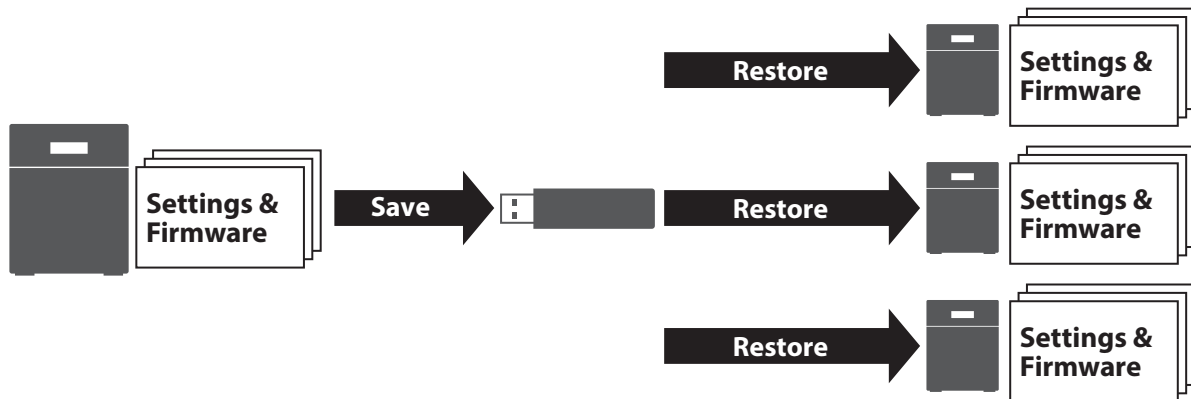

Write down the drive configuration (number of drives, RAID, LVM, etc.) of the Buffalo NAS device whose settings were saved. Make sure that any Buffalo NAS devices that you apply these settings to have the exact same drive configuration before you apply the settings. If the drive configuration is different, you may get unexpected results. The following settings are not saved or applied:

Category	Settings
File Sharing	Subfolders' access restriction settings in the shared folders
	All settings for USB drives
	Two-factor authentication settings in "Users"
Storage	All settings in "Drives"
	All settings in "LVM"
	All settings in "iSCSI"
	USB drive information
Cloud Storage	Job settings of Dropbox Sync
	Job settings of Microsoft OneDrive Sync
Network	All settings except for service port restrictions, Wake-on-LAN, MTU size settings, the "Services Restarted After" option, and FQDN mapping in "IP Address"
	All settings in "Port Trunking"
Backup	All settings except for the <i>Periodic Sync</i> and <i>Advanced Settings</i> tab settings in "Failover"
Management	The TeraStation's hostname
	All settings in "Power Management"
	All settings in "SSL"
	Display language in Settings
Remote Management Service	All settings

## Saving Settings

---

**1** Insert a 1 GB or larger USB drive (not included) into a USB port on the TeraStation.

**Note:** All data on the USB drive will be erased!

**2** From Settings, click *Management*.

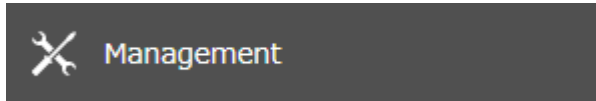

**3** Click the settings icon (  ) to the right of "Configuration Management".



**4** Select "Save current configuration to a USB drive".

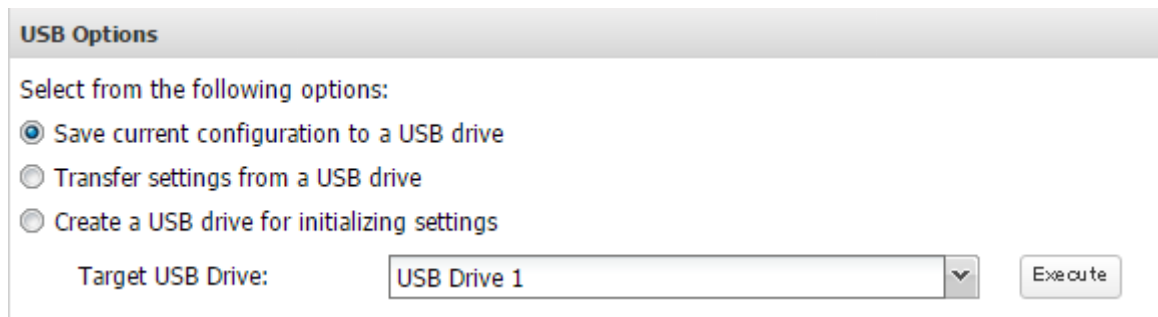

**5** From "Target USB Drive", select the USB drive that is connected to the USB port on the TeraStation, then click *Execute*.

**6** The "Confirm Operation" screen will open. Enter the confirmation number, then click *OK*.

**7** The process is complete once you close the confirmation window that appears.

### Troubleshooting:

If the settings are not saved to the USB drive successfully, you may receive an error message such as "The specified operation cannot be executed.". Verify:

- The USB drive has a capacity of 1 GB or more.
- The USB drive is not write-protected.
- Failover is configured on the TeraStation.

## Applying Settings

---

The saved settings can be applied to a different Buffalo NAS device of the same series. If applying settings to another Buffalo NAS device, the unit's current firmware version will be changed to the version used to save the settings.

### Notes:

- The saved settings on the TS3010 series TeraStations cannot be applied to the TS3020 series TeraStations and vice versa.
- For TS3010 series TeraStations, saved settings created on another TS3010 unit running firmware version 4.32 or earlier cannot be applied to a TS3010 unit running firmware version 4.34 and later. For TS3020 series TeraStations, saved settings created on another TS3020 unit running firmware version 5.18 or earlier cannot be applied to a

TS3020 unit running firmware version 5.20 and later. To apply saved settings to TS3010 or TS3020 units running later firmware versions, create the settings restoration USB drive again using respective TeraStation units with later firmware versions.

- Do not apply settings while boot authentication is configured.

**1** Insert the USB drive with the saved settings into a USB port on the TeraStation.

**2** From Settings, click *Management*.

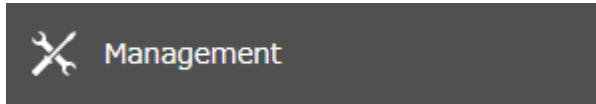

**3** Click the settings icon (  ) to the right of "Configuration Management".

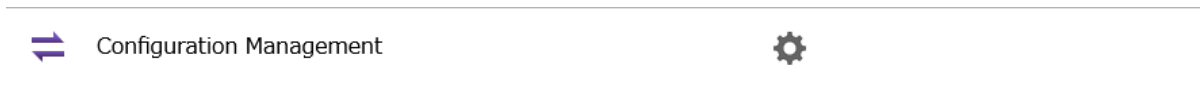

**4** Select "Transfer settings from a USB drive".

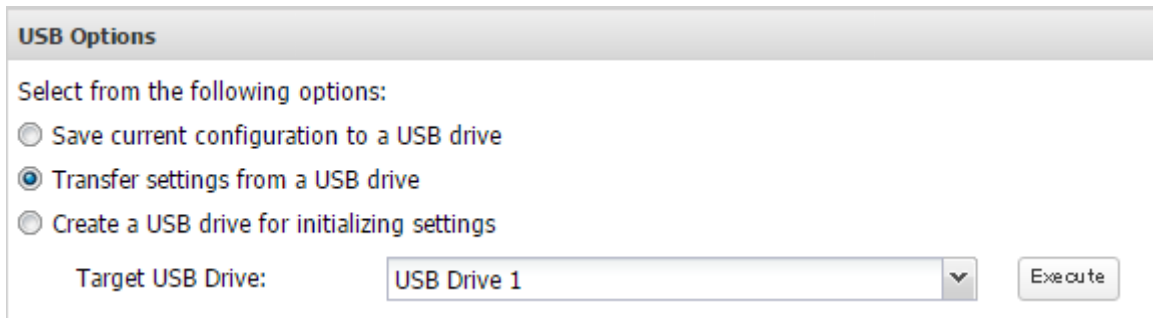

**5** From "Target USB Drive", select the USB drive that is connected to the USB port on the TeraStation, then click *Execute*.

**6** The "Confirm Operation" screen will open. Enter the confirmation number, then click *OK*.

**7** The process is complete once you close the confirmation window that appears.

---

## Transferring Another Buffalo NAS Device's Settings

---

You can transfer saved settings from another series Buffalo NAS device to your TeraStation. The following settings can be transferred:

- Shared folders which are created from "File Sharing" > "Folder Setup"
- Access restrictions
- Users\*
- Groups

\*Except two-factor authentication settings

**Note:** This feature currently supports the following Buffalo NAS devices as of November 2020. The latest compatibility information will be on the [Buffalo website](#).

- TS-X series (TS-XL/R5, TS-WXL/R1, TS-WXL/1D, TS-RXL/R5, TS-XEL/R5 TeraStation models) running firmware version 1.58 or later

- TS5000 series (TS5200D, TS5200DN, TS5400D, TS5400DN, TS5400R, TS5400RN, TS5600D, TS5600DN, TS5800D, TS5800DN TeraStation models)
- TS4000 series (TS4200D, TS4400D, TS4400R, TS4800D TeraStation models)
- TS3000 series (TS3200D, TS3400D, TS3400R TeraStation models)
- TS5010 series (TS5210DN, TS5410DN, TS5410RN, TS5810DN, TS51210RH TeraStation models)
- TS3010 series (TS3210DN, TS3410DN, TS3410RN TeraStation models)
- TS6000 series (TS6200DN, TS6400DN, TS6400RN TeraStation models)
- TS3020 series (TS3220DN, TS3420DN, TS3420RN TeraStation models)

## Creating a Config File (.nas config)

---

### Procedure for TS-X Series Models

To transfer settings from TS-X series TeraStations, it will use the “NS-SHFT” software to create a config file. NS-SHFT can be downloaded from the [Buffalo website](#).

For the procedure on creating the config file, refer to the NS-SHFT user guide.

### Procedure for Buffalo NAS Devices Other Than TS-X Series Models

Follow the procedure below to create a config file on a Buffalo NAS device that is not part of TS-X series TeraStations.

- 1 Refer to the user manual of the Buffalo NAS device whose settings will be saved to a USB drive.
- 2 Access the “usbdisk x” shared folder while connecting the USB drive to the Buffalo NAS device whose settings were saved in the previous step. The “x” in the folder name represents the USB port number you connected the drive to.
- 3 Copy and paste the .nas\_config file to the desired location on your computer.
- 4 The process is complete once the .nas\_config file is saved to the desired location.

## Transferring Settings

---

Follow the procedure below to transfer settings from another series Buffalo NAS device.

- 1 Before transferring access restrictions with Active Directory domain users, make sure the migration target Buffalo NAS devices are joined to the same domain controller. To have the unit join the domain network, refer to the procedure in the “[Restricting AD Domain User Access to Shared Folders](#)” section in chapter 3. If you didn’t configure access restrictions with Active Directory domain users, skip to the next step.
- 2 From Settings, click *Management*.

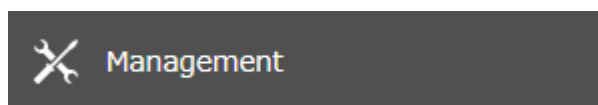

- 3 Click the settings icon (  ) to the right of “Configuration Management”.



- Click *Browse* and choose the config file (.nas\_config) that was created with the migration source Buffalo NAS device. If the config file was created with a password, enter it into the “Password” field.

**Configuration Migration**

Migrate another TeraStation's users, groups, shared folders, and access restriction settings. Select the config file (.nas\_config) that was saved on the other TeraStation.  
 Note: If the migration source TeraStation is configured with Active Directory, this TeraStation should also have the same configuration, or else migration will not work.

For detailed information about compatible products for migration or the procedure to save the config file, refer to the [user manual](#).

Config File (.nas\_config):

Password:   
(if needed)

- Click *Import*.
- The “Confirm Operation” screen will open. Enter the confirmation number, then click *OK*.
- The process is complete once you close the confirmation window that appears.

**Notes:**

- If the migration target Buffalo NAS device contains shared folders, users, and groups that share the same name as the transferred settings, the existing settings will be overwritten.
- If the migration target Buffalo NAS devices have already added some shared folders, users, and groups, the transferred settings may exceed the maximum number of allowed shared folders, users, or groups. Excess items will not be transferred. After migration finishes, open Settings and verify that all settings were properly transferred.

---

## Restoring Factory Defaults

---

The settings on the TeraStation can be restored to factory defaults using Settings or an USB drive.

### Initializing from Settings

---

To initialize the TeraStation to its factory defaults from Settings, follow the procedure below.

- From Settings, click *Management*.

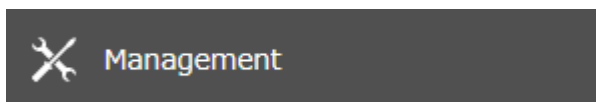

- Click the settings icon (  ) to the right of “Restore/Erase”.

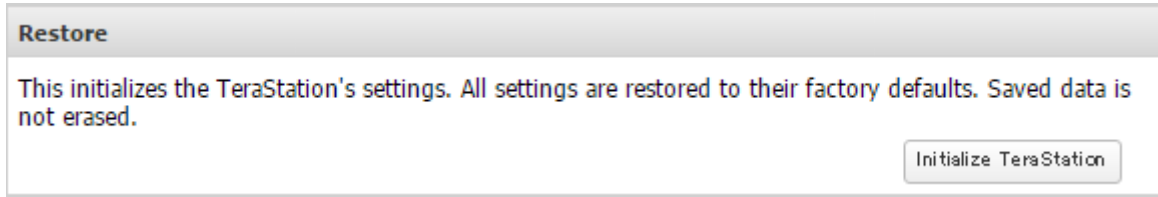

**3** Click *Initialize TeraStation*.**4** The “Confirm Operation” screen will open. Enter the confirmation number, then click *OK*.**5** The settings will be restored to its factory default settings. The I26 message will appear as a notification while settings are being restored.**6** The process is complete when the I26 message disappears.

## Initializing Using the USB Initialization Drive

---

A USB initialization drive will restore the settings on your TeraStation to their factory defaults. You can initialize them without logging in to Settings. Follow the procedure below to create a USB initialization drive.



**Notes:**

- You can use the USB initialization drive to initialize settings on the same TeraStation unit that created it.
- Normally, making and using a USB initialization drive will not affect data on the TeraStation. However, always back up your data regularly!
- This USB initialization drive can be used to recover the system if your TeraStation doesn't boot at all. In this case, if the data partition is damaged, then all your data will be deleted by the recovery process.

### Creating a USB Initialization Drive

**1** Insert a 1 GB or larger USB drive (not included) into a USB port on the TeraStation.

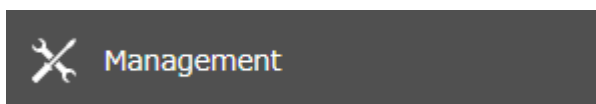
**Note:** All data on the USB drive will be erased!

**2** From Settings, click *Management*.**3** Click the settings icon (  ) to the right of “Configuration Management”.



- 4 Select “Create a USB drive for initializing settings”.

- 5 From “Target USB Drive”, select the USB drive that is connected to the USB port on the TeraStation, then click *Execute*.
- 6 The “Confirm Operation” screen will open. Enter the confirmation number, then click *OK*.
- 7 The process is complete once you close the confirmation window that appears. Refresh the browser and log in to Settings again.

## Starting Initialization

To initialize the settings on your TeraStation with the USB drive created above, follow the procedure below.

**Note:** If using the USB initialization drive to initialize, the unit’s current firmware version will be changed to the version used to create the USB initialization drive.

- 1 Turn off the TeraStation by pressing and holding down the power button for three seconds.
- 2 Insert the USB drive into a USB port on the TeraStation. Make sure that no other USB drives are currently connected to any USB ports on the TeraStation.
- 3 Power on the TeraStation while holding down the function button.
- 4 When the I41 message appears as a notification, press the function button.
- 5 The I37 message will appear as a notification while the initialization process is running. It will take several minutes to initialize the settings. The TeraStation will restart when it’s finished.
- 6 The process is complete when the I37 message disappears.

Dismount the USB drive before unplugging it. Refer to the [“Dismounting Drives”](#) section in chapter 4 for the procedure on dismounting drives.

---

## Resetting the Administrator Password

---

If you forget the admin username or password and cannot log in to Settings, or incorrect network settings are configured and Settings becomes inaccessible, initialize these settings by following the procedure below.

- 1 Press and hold down the init button (refer to the [“Diagrams”](#) section in chapter 2) for 10 seconds.
- 2 The TeraStation will beep and the I23 message will appear as a notification during initialization.
- 3 The process is complete when the I23 message disappears.

This will typically reset the admin username and password, two-factor authentication settings, IP settings, SSL, and service port restriction settings to their factory default values.

This button can be disabled in Settings; to do so, navigate to *Management > Restore/Erase > Edit* under "Init Button Settings", then select "Keep current admin username and password" and click *OK*.

# Chapter 9 Network Settings

## Wake-on-LAN

The TeraStation supports Wake-on-LAN, which allows it to be turned on remotely. The TeraStation will be turned on automatically in the following situations: receiving a Wake-on-LAN packet, recovering from a power outage, disconnecting and reconnecting the power cable.

- 1 From Settings, click *Network*.



- 2 Click the settings icon (  ) to the right of "IP Address".

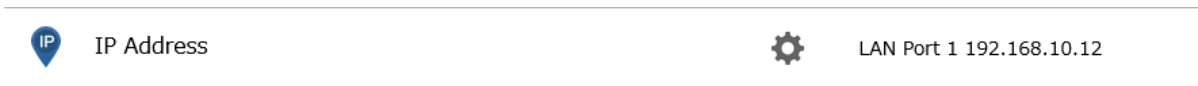

- 3 Click *Edit* and enable "Wake-on-LAN", then click *OK*.

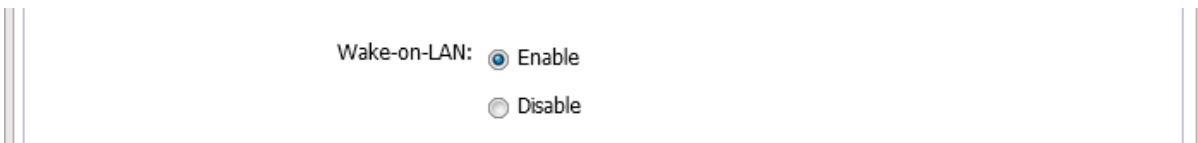

- 4 The process is complete once you close the confirmation window that appears.

Wake-on-LAN is now enabled. As long as the TeraStation is connected to a power source and the network, you can turn it on remotely.

### Notes:

- After receiving the Wake-on-LAN packet, the TeraStation may take up to five minutes to be ready to use.
- To use Wake-on-LAN, you'll need Wake-on-LAN software that sends Wake-on-LAN packets. The TeraStation does not include Wake-on-LAN software.
- The TeraStation does not support using Wake-on-LAN and port trunking at the same time. You may use either feature, but not both at the same time.

## Port Trunking

Two Ethernet cables can be used to establish two separate communication routes, providing LAN port redundancy and improving communication reliability. The use of two Ethernet cables enables access to the TeraStation even if one of the cables becomes disconnected.

The port trunking modes that can be set on the TeraStation are shown below:

Trunking Mode	Characteristics
Active-backup	Only one NIC slave in the bond is active. A different slave becomes active if and only if the active slave fails.

Trunking Mode	Characteristics
Dynamic link aggregation	Creates aggregation groups that share the network speed and duplex settings. Utilizes all slave network interfaces in the active aggregator group according to the 802.3ad specification. <b>Note:</b> To use this mode, a separate intelligent switch that supports IEEE 802.3ad is required. Configure LACP on the switch first.
TLB	The outgoing network packet traffic is distributed according to the current load (relative to the speed) on each network interface slave.
ALB	The incoming and outgoing network packet traffic is distributed according to the current load on each network interface slave. The receive load balancing is achieved by ARP negotiation.

**Notes:**

- If the TeraStation is being used as an iSCSI drive, disable iSCSI before changing network settings such as port trunking. Navigate to *Storage > iSCSI* in Settings and move the iSCSI switch to the **off** position temporarily.
- If you have selected dynamic link aggregation for the port trunking mode on the TS3020 series TeraStations, the link speed for LAN port 2 will be limited to up to 1000 Mbps. Disable the auto negotiation settings on the connected intelligent switch.
- If you have selected a port trunking mode other than dynamic link aggregation on the TS3020 series TeraStations, the port with the faster link speed will be used for access. You can check the link speed of each port from the Dashboard in Settings.

**1** Connect the hub's LAN port and TeraStation's LAN port using two Ethernet cables. If you are using an intelligent switch, connect the LAN port that was previously configured for port trunking.

**2** From Settings, click *Network*.



**3** Click the settings icon (  ) to the right of "Port Trunking".



**4** Select the LAN port that will be used from the drop-down list.

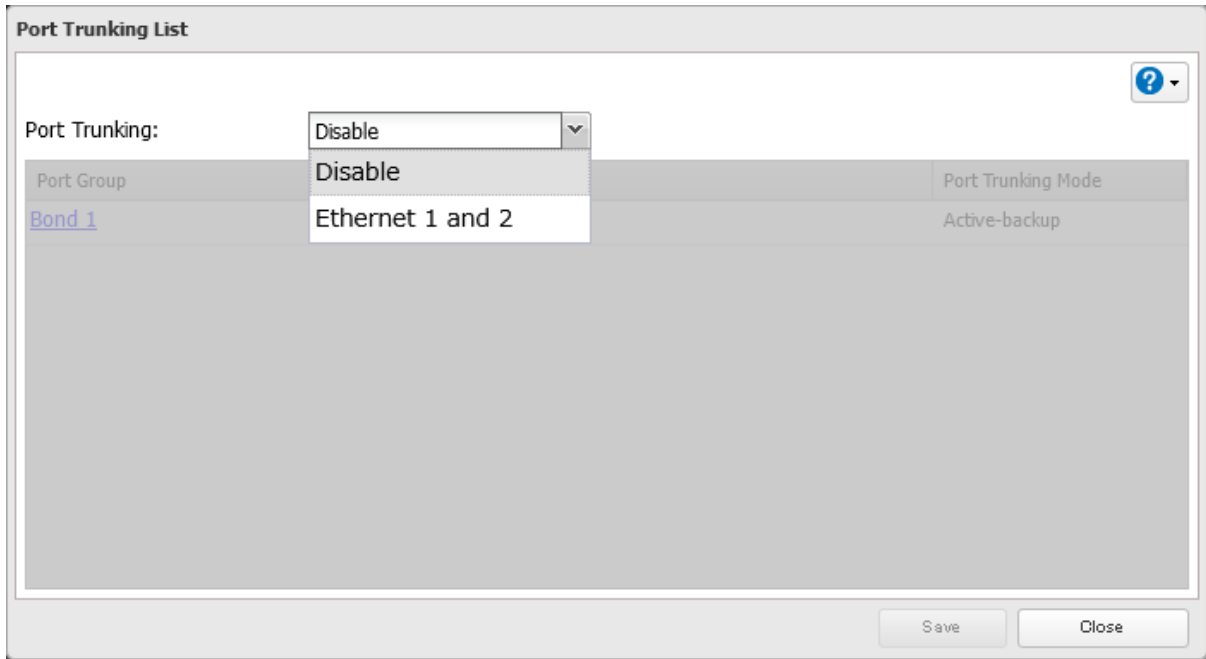

**5** Click a port trunking bond.

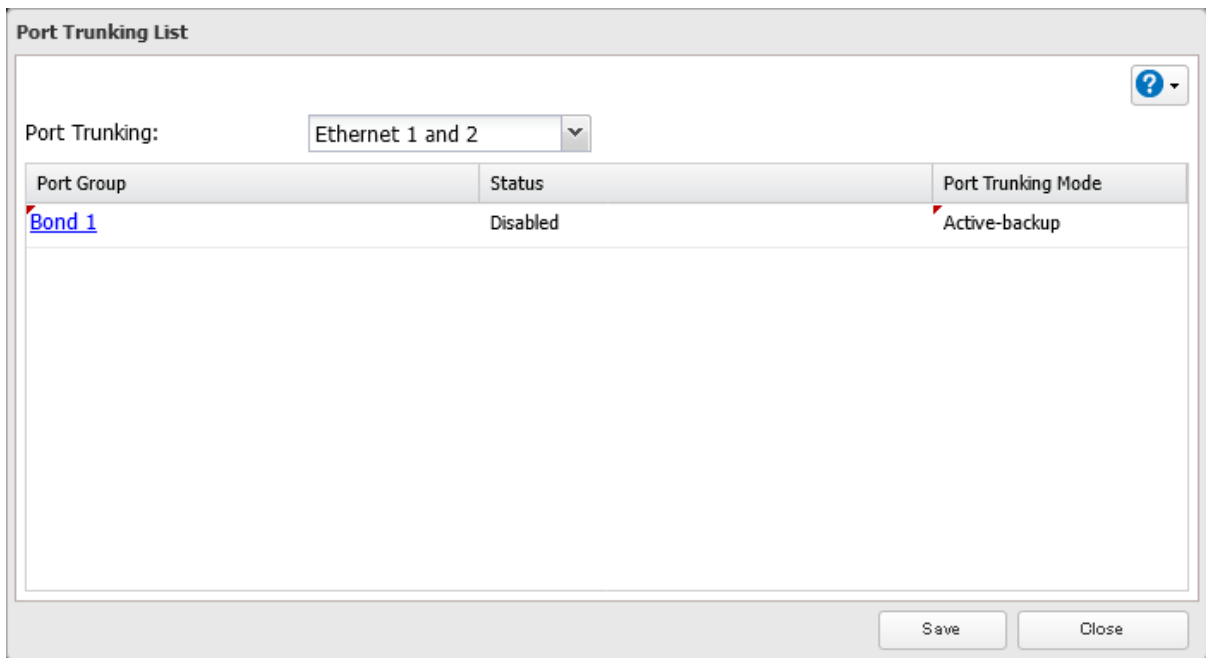

**6** Select the port trunking mode and click *OK*.

**Port Trunking Settings**

Port Trunking:

Device Name	IP Address	Subnet Mask	MTU Size
LAN Port 1	192.168.10.13	255.255.255.0	1500 bytes
LAN Port 2	--	--	1500 bytes

OK Cancel

**7** Click *Save*.

**Port Trunking List**

Port Trunking:

Port Group	Status	Port Trunking Mode
<a href="#">Bond 1</a>	Disabled	Active-backup

Save Close

**8** Read the message carefully and click *Yes*.

**Note**

 Are you sure you want to change your current port trunking configuration?

Yes No

- 9** Click Yes to restart the TeraStation. If you select “No”, make sure you restart the TeraStation at a later time to apply port trunking settings.

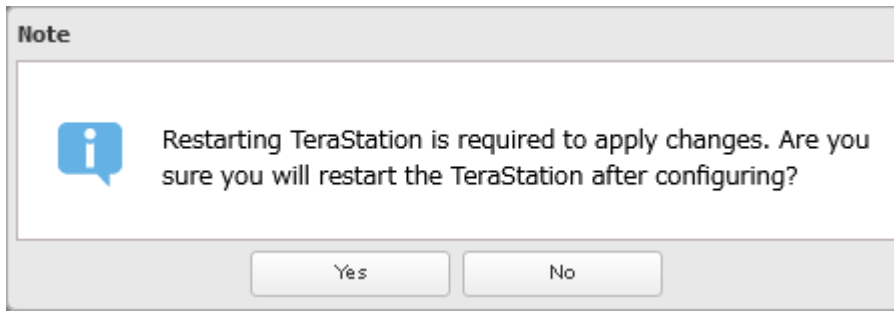

- 10** The process is complete after the TeraStation has been restarted.

---

## SNMP

---

If SNMP is enabled, you can browse your TeraStation from SNMP-compatible network management software. Examples of frequently-notified traps are described in the [“Relevant Trap List”](#) subsection below.

- 1** From Settings, click *Network*.



- 2** Move the SNMP switch (  ) to the  position to enable SNMP.



- 3** Click the settings icon (  ) to the right of “SNMP”.



**4** Click *Edit* and select whether to use SNMP version 2 or version 3.

The image shows a dialog box titled "SNMP Settings". At the top right, there is a red asterisk and the word "Required" next to a help icon. Below this, there are two radio button options: "Use SNMPv2" (which is selected) and "Use SNMPv3".

Under the "Use SNMPv2" section, there is a text input field for "SNMP Community Name \*" containing the text "TeraStation". Below this is a "Trap Notify:" section with two radio buttons: "Enable" (selected) and "Disable".

Below the "Trap Notify" section is a "Trap Settings" section, which is a smaller dialog box containing two text input fields: "Trap Notify Community Name \*" and "Trap Notify IP Address \*".

Under the "Use SNMPv3" section, there is a greyed-out area containing several fields: "Username \*" with the value "snmp", "Authentication and Privacy Protocol: SHA / AES", "Authentication and Privacy Password \*" (empty), and "Password (Confirm) \*" (empty).

At the bottom of the dialog box are two buttons: "OK" and "Cancel".

**5** Configure the desired settings, then click *OK*.

**6** The process is complete once you close the confirmation window that appears.

SNMP is now enabled. For further use, configure your SNMP-compatible network management software using the Buffalo-specific MIB (management information base) file. The MIB file is available from the [Buffalo website](#). Depending on which SNMP client software you use, the procedure for configuring the software will differ. For more detailed information on configuring the client software, refer to its help or included manual.

## Relevant Trap List

### Standard Public MIB Traps

Conditions	Trap Name	OID
SNMP service starts.	coldStart	1.3.6.1.6.3.1.1.5.1
SNMP service ends.	nsNotifyShutdown	1.3.6.1.4.1.8072.4.0.2

### Private MIB Traps

If any traps are not listed in the following chart, refer to the web page for downloading the private MIB file on the [Buffalo website](#) for more detailed information.



Conditions	Trap Name
Backup fails.	nasBackupStatus
The RAID array is in degraded mode.	nasDiskStatus
An error occurs and an error code is displayed.	nasErrorOccur
An event occurs and an event code is displayed.	nasInformationOccur

## Proxy Server

If you place the TeraStation on a network that passes through a proxy server, configuring the proxy server settings is recommended. Unless you configure the proxy settings, firmware updates in Settings will not work. To configure the settings, follow the procedure below.

- 1 From Settings, click *Network*.



- 2 Click the settings icon (  ) to the right of "Proxy Server".



- 3 Enable "Proxy Server".

 A screenshot of the 'Proxy Server Settings' dialog box. The title bar reads 'Proxy Server Settings'. In the top right corner, there is a red asterisk followed by the word '\*Required' and a blue question mark icon. The main area contains the following fields:
 

- 'Proxy Server:' with two radio buttons: 'Enable' (selected) and 'Disable'.
- 'Address \*:' with a dropdown menu showing 'http' and an empty text input field.
- 'Port \*:' with a numeric spinner set to '80'.
- 'Username:' with an empty text input field.
- 'Password:' with an empty text input field.

 At the bottom of the dialog, there are 'OK' and 'Cancel' buttons.

- 4 Enter the proxy server IP address or hostname, port number, username and password, then click *OK*.

- 5 The process is complete once you close the confirmation window that appears.

Once you configure the proxy server settings, you may use the settings for features that will link with cloud storage services by selecting the "Configured settings" option on each settings page.

## Jumbo Frames

If your other network devices support jumbo frames, you may be able to improve network performance.

**Note:** Make sure the TeraStation's MTU size is smaller than the hub or router's. Larger MTU sizes may cause data to not transfer properly to the TeraStation.

- 1 From Settings, click *Network*.









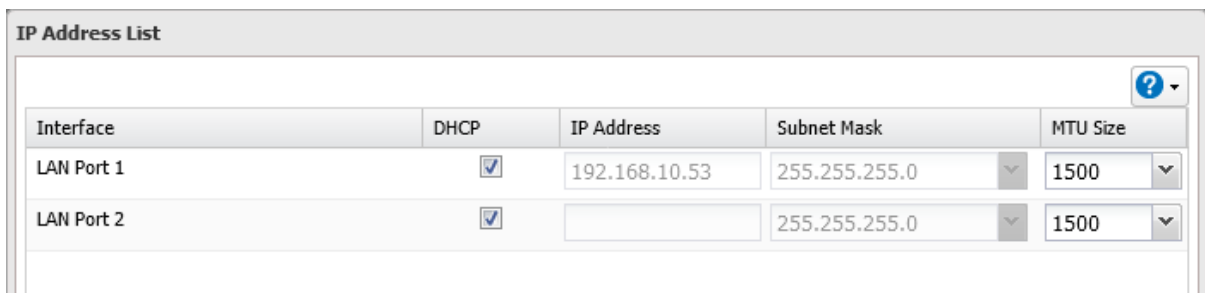









- 2 Click the settings icon (  ) to the right of "IP Address".



- 3 Click *Edit* and select or enter the desired MTU size, then click *OK*.



- 4 The process is complete once you close the confirmation window that appears.

Connection			Transmission	
				Transfer data using jumbo frames.
				Transfer data without using jumbo frames.
				Transfer data without using jumbo frames.
				No data can be transferred.

## Changing the IP Address

Normally, the TeraStation's IP address is set automatically by a DHCP server on your network. If you prefer, you can set it manually. An easy way to do this is to change it on NAS Navigator2. The procedure to change the IP address in Settings is below.

**Note:** If the TeraStation is being used as an iSCSI drive, to change the settings, navigate to *Storage > iSCSI* in Settings and move the iSCSI switch to the **off** position temporarily before changing settings.

- 1 From Settings, click *Network*.



- 2 Click the settings icon (  ) to the right of "IP Address".



- 3** Click *Edit* and clear the “DHCP” checkbox, then enter the desired IP address and its subnet mask.

Interface	DHCP	IP Address	Subnet Mask	MTU Size
LAN Port 1	<input type="checkbox"/>	192.168.10.53	255.255.255.0	1500
LAN Port 2	<input checked="" type="checkbox"/>		255.255.255.0	1500

- 4** Select “User (static)” from the drop-down list for both the “Gateway Owner” and “DNS Owner” options, then enter the desired default gateway address and DNS server addresses.

Gateway Owner: User (static)

Default Gateway Address: 192.168.10.1

DNS Owner: User (static)

Primary DNS Server: 192.168.10.1

Secondary DNS Server:

Services Restarted After: 1 seconds

NIC Offloads:  Enable  
 Disable

OK Cancel

- 5** Click *OK*. The process is complete once you close the confirmation window that appears.

**Notes:**

- Only one default gateway and DNS address can be configured for all LAN ports. Different network addresses cannot be assigned to the LAN ports.
- Do not set the IP address of the same segment for all LAN ports. This may cause unstable network communication.
- Network services such as SMB or FTP will restart when the Ethernet cable is disconnected/reconnected or if a network issue occurs. You can specify the time to delay the restart at the “Services Restarted After” option.
- When you disable DHCP, all addresses including default gateway and DHCP server addresses cannot be assigned automatically, even if you can select the “Assign automatically” options for them.

## Mapping IP Address and Hostname

The TeraStation allows you to map an IP address and a hostname (FQDN) of another host you would like the TeraStation to communicate with, such as the domain controller. If you configure the mapping pair, the TeraStation can be accessed using the configured pair when name resolution is needed. Follow the procedure below to configure FQDN mapping.

**1** From Settings, click *Network*.



**2** Click the settings icon (⚙️) to the right of "IP Address".



**3** Click *FQDN Mapping*.

**IP Address List**

Interface	Type	DHCP	IP Address	Subnet Mask	MTU Size	More D
LAN Port 1	1GbE	✓	192.168.10.38	255.255.255.0	1500 bytes	▶
LAN Port 2	2.5GbE	✓	—	—	1500 bytes	▶

Wake-on-LAN: Enabled

Gateway Owner: Automatically assigned (LAN port 1)

Default Gateway Address: 192.168.10.1

DNS Owner: Automatically assigned

Primary DNS Server: 192.168.10.1

Secondary DNS Server: Not assigned

Services Restarted After: 1 seconds

NIC Offloads: Enabled

Allowed Protocols for Each Port
Port Trunking
FQDN Mapping
Edit
Close

**4** Click *Add*.

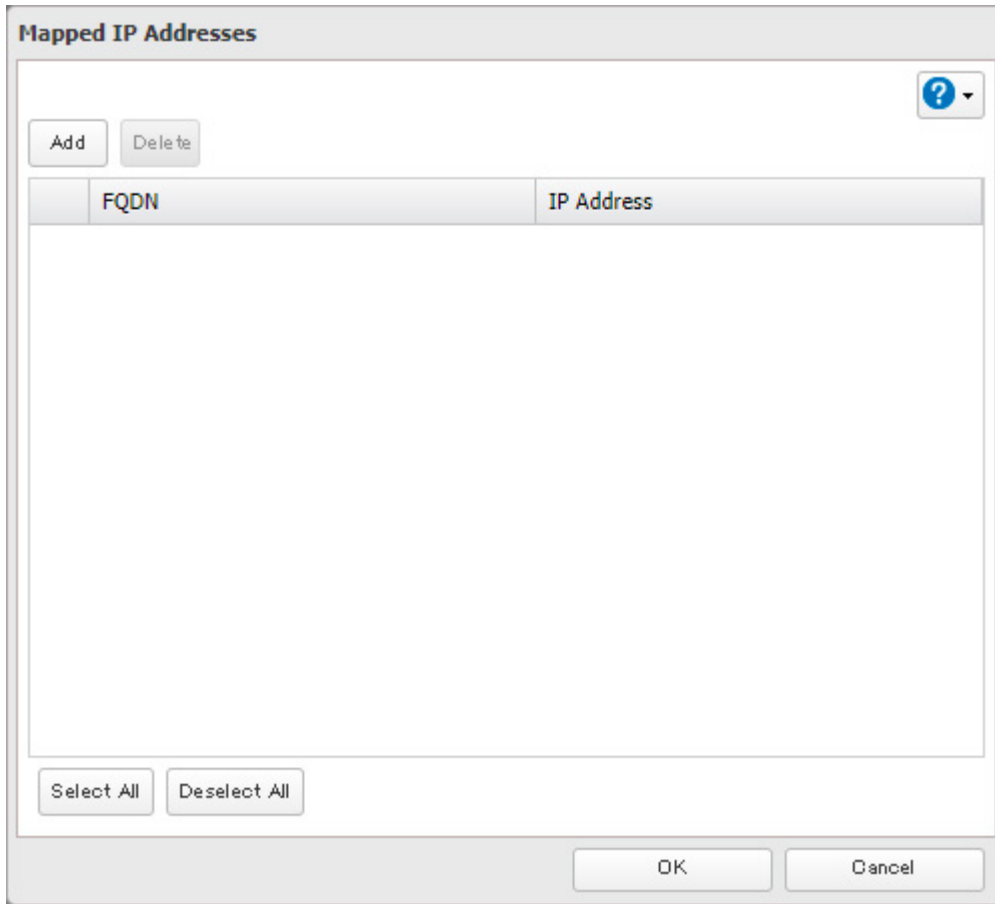

**5** Enter the hostname (FQDN) and the IP address that you want to map, then click *OK*.

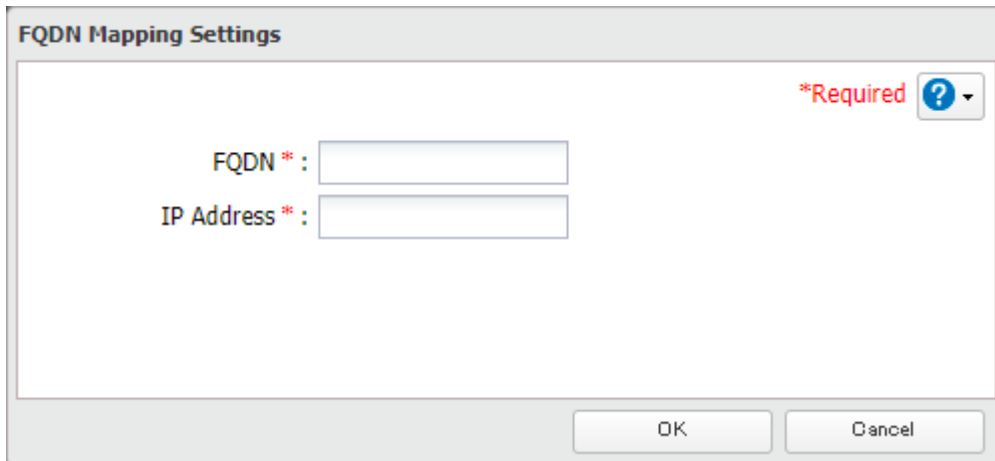

**6** Click *OK* again. The process is complete once you close the confirmation window that appears.

# Chapter 10 Advanced Features

## Email Notification

Your TeraStation can send you email reports daily, or whenever settings are changed or an error occurs. You can configure the events that will trigger notifications from any of the following functions: quotas, drives (internal, external, or RAID array), fan, backup, replication, failover, antivirus, system alert.



Refer to the contextual help in Settings for more detailed information such as when the notification email will be sent or the differences between the notification categories.

### Enabling Email Notification

Follow the procedure below to enable email notification functionality.

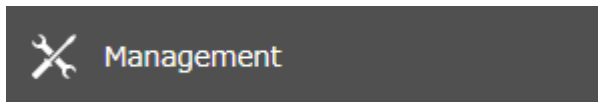
- 1 From Settings, click *Management*.



- 2 Move the email notification switch (  ) to the  position to enable email notification.



- 3 Click the settings icon (  ) to the right of "Email Notification".



- 4** Click *Edit* and enter your email server settings and the notification email's default subject, then configure recipients and the time when email reports will be sent.

If you select an authentication type other than "Disable" from the drop-down list, you can enter the sender email address and credentials of the email server.

**Email Notification Settings**

\*Required ?

SMTP Server Address \* :

SMTP Port \* :

Authentication Type:

Sender Address:

POP3 Server Address:

POP3 Port:

SSL/TLS:

Username:

Password:

Subject \* :

Recipients \* :

Name	Recipients	Class

Select All Deselect All

Send Daily Report at:  hours

OK Cancel

- 5** Click *OK*. The process is complete when you select either *Yes* or *No* to have a test email sent.

## Changing Events for Email Reports

- 1** From Settings, click *Management*.

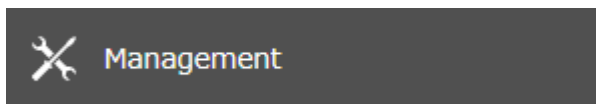

- 2** Click the settings icon (  ) to the right of "Email Notification".



- 3** Click *Advanced Report Settings*.



**4** On the displayed screen, select or clear the category's checkboxes, then click *OK*.

Categories	<input checked="" type="checkbox"/> Daily Report	<input checked="" type="checkbox"/> Info	<input checked="" type="checkbox"/> Notice	<input checked="" type="checkbox"/> Error
Drive Quota			<input checked="" type="checkbox"/>	
User			<input checked="" type="checkbox"/>	
Group			<input checked="" type="checkbox"/>	
Storage	<input checked="" type="checkbox"/>	<input checked="" type="checkbox"/>	<input checked="" type="checkbox"/>	<input checked="" type="checkbox"/>
Internal Drive	<input checked="" type="checkbox"/>	<input checked="" type="checkbox"/>	<input checked="" type="checkbox"/>	<input checked="" type="checkbox"/>
RAID Array	<input checked="" type="checkbox"/>	<input checked="" type="checkbox"/>	<input checked="" type="checkbox"/>	<input checked="" type="checkbox"/>
USB Drive	<input checked="" type="checkbox"/>			<input checked="" type="checkbox"/>
Fan				<input checked="" type="checkbox"/>
Backup		<input checked="" type="checkbox"/>	<input checked="" type="checkbox"/>	
Replication			<input checked="" type="checkbox"/>	
Failover		<input checked="" type="checkbox"/>	<input checked="" type="checkbox"/>	
Virus Scan		<input checked="" type="checkbox"/>	<input checked="" type="checkbox"/>	
System Alert		<input checked="" type="checkbox"/>		

Notification emails will be categorized into the following importance levels. Refer to the chart below for the detailed information of category importance levels.

Levels	Details
Daily Report	Describes the status of the TeraStation in a daily report email.
Info	Sends a notification email if an event occurs. Info reports will contain just information such as capacity information, job starts/completes, etc.
Notice	Sends a notification email if a non-critical error occurs. Refer to the <a href="#">“Notices”</a> section in chapter 13 for the list of events that will trigger this event notification. Notice reports will contain warnings such as something has failed, but the function or unit can continue operating as usual. It is recommended to perform the corrective action for the notice as soon as possible.
Error	Sends a notification email if a critical error occurs. Refer to the <a href="#">“Errors”</a> section in chapter 13 for the list of events that will trigger this event notification. Error reports will describe critical failures that prevented a function or unit from operating properly. It is recommended to perform the corrective action for the error immediately.

**5** Click *OK*. The process is complete once you close the confirmation window that appears.

## Sleep Mode

To save energy, you can specify times to put the TeraStation into sleep (standby) mode, during which the drives and LEDs are turned off.

**1** From Settings, click *Management*.

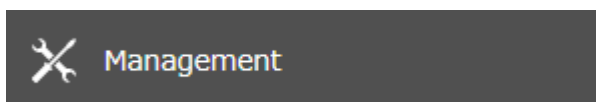

2 Click the settings icon (  ) to the right of “Sleep Timer”.



3 Click *Edit* and specify the timer interval, wake-up time, and time to enter sleep mode, then click *OK*.

**Sleep Timer Settings**

Timer 1

Schedule: Weekly

Sunday  Monday  Tuesday  Wednesday  Thursday  Friday  Saturday

Wake Up at: 07 hours 00 minutes

Begin Sleep at: 22 hours 00 minutes

Timer 2

Schedule: Disable

Sunday  Monday  Tuesday  Wednesday  Thursday  Friday  Saturday

Wake Up at: 00 hours 00 minutes

Begin Sleep at: 00 hours 00 minutes

Timer 3

Schedule: Disable

Sunday  Monday  Tuesday  Wednesday  Thursday  Friday  Saturday

Wake Up at: 00 hours 00 minutes

Begin Sleep at: 00 hours 00 minutes

OK Cancel

4 The process is complete once you close the confirmation window that appears.

#### Notes:

- Up to three timers can be set.
- The time to enter sleep mode can be set from 12:00 a.m. to 3:45 a.m. of the next day. The time to wake from sleep mode can be set from 12:00 a.m. to 11:45 p.m. If the time to enter sleep mode is after 12:00 a.m., the wake-up time setting may be from 4:00 a.m. to 11:45 p.m.
- The time to enter sleep mode should not be set to the same time as or earlier than the start time.
- If sleep mode timer is scheduled to go off while logging in to Settings, checking or formatting a drive, running a backup process, or setting a backup job within five minutes of the current time, the TeraStation will not enter sleep mode when the configured time is reached.
- Examples of timer settings are shown below:

- **Example 1:**

*Sleep Timer Settings*

Timer 1: Daily 12:00 (wake up)–24:00 (begin sleep)

Timer 2: Not used

Timer 3: Not used

*Actual Behavior*

Normal operation begins at 12:00 p.m. and the unit enters sleep mode at 12:00 a.m.

- **Example 2:**

*Sleep Timer Settings*

Timer 1: Daily 9:00 (wake up)–18:00 (begin sleep)

Timer 2: Wednesday 10:00 (wake up)–20:00 (begin sleep)

Timer 3: Not used

*Actual Behavior*

On days other than Wednesday, normal operation begins at 9:00 a.m. and the unit enters sleep mode at 6:00 p.m. On Wednesday, normal operation begins at 9:00 a.m. and the unit enters sleep mode at 8:00 p.m., as when scheduled times on the timer overlap on Wednesday, normal operation begins at the earliest time, and the unit enters sleep mode at the latest time.

- **Example 3:**

*Sleep Timer Settings*

Timer 1: Daily 9:00 (wake up)–18:00 (begin sleep)

Timer 2: Wednesday 10:00 (wake up)–1:00 a.m. of the next day (begin sleep)

Timer 3: Not used

*Actual Behavior*

On days other than Wednesday, normal operation begins at 9:00 a.m. and the unit enters sleep mode at 6:00 p.m. On Wednesday, normal operation begins at 9:00 a.m. and the unit enters sleep mode at 1:00 a.m. of the next day, as when scheduled times on the timer overlap on Wednesday, normal operation begins at the earliest time, and the unit enters sleep mode at the latest time.

- **Example 4:**

*Sleep Timer Settings*

Timer 1: Daily 9:00 (wake up)–18:00 (begin sleep)

Timer 2: Wednesday 7:30 (wake up)–22:00 (begin sleep)

Timer 3: Not used

*Actual Behavior*

On days other than Wednesday, normal operation begins at 9:00 a.m. and the unit enters sleep mode at 6:00 p.m. On Wednesday, normal operation begins at 7:30 a.m. and the unit enters sleep mode at 10:00 p.m., as when scheduled times on the timer overlap on Wednesday, normal operation begins at the earliest time, and the unit enters sleep mode at the latest time.

- To wake the TeraStation from sleep mode before the wake-up time, press and hold down the power button for three seconds.

---

## UPS (Uninterruptible Power Supply)

---

If a UPS device (sold separately) is attached, the TeraStation can be automatically shut down to protect data in the event of a power outage.

**Notes:**

- If the TeraStation is connected directly to a UPS device, select “Sync with UPS connected to this TeraStation”. If a different Buffalo NAS device is connected to the UPS device, select “Sync with UPS connected to another Buffalo NAS device on the same network”. After making this selection, enter the IP address of the Buffalo NAS device that will be the sync source into “Other Buffalo NAS’s IP Address”.
- If you don’t want to connect any UPS devices, select “Do not synchronize with UPS” and the operation for if a power supply failure occurred. If “Use last state” at “AC Power Recovery” is selected, the TeraStation will revert to the state before the power supply failure occurred. If “Stay off” is selected, the TeraStation will remain off even after the TeraStation shuts down due to the power supply failure.
- When the TeraStation restarts after an automatic shutdown such as from a power outage or power supply issue, verify that external power has been restored. If the TeraStation is turned on while it is still running on the UPS

device and external power has not been restored, the automatic shutdown will not be performed, even after the specified time elapses.

- If the power supply from the UPS device to the TeraStation stops and restarts when UPS recovery is enabled, the TeraStation will automatically restart.

- 1 Power off the TeraStation.
- 2 Plug the power cable of the UPS device into a wall socket.
- 3 Connect the power cable of the TeraStation to the UPS device.
- 4 Connect the UPS device and the TeraStation.
- 5 Turn on the UPS device, then the TeraStation.
- 6 From Settings, click *Management*.

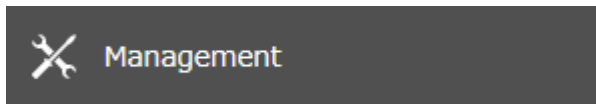

- 7 Click the settings icon (  ) to the right of "Power Management".



- 8 Click *Edit* and configure the desired settings, then click *OK*.

**Power Management Settings** \*Required 

**UPS Sync Settings**

UPS Sync:

Sync with UPS connected to this TeraStation

UPS Connection Type:

Shutdown Will Occur If:  Power outages longer than  minutes

UPS sends low battery signal

Override Shutdown Conditions:  Delay shut down until the number of iSCSI connections reaches zero

Shut Down UPS After TeraStation Shuts Down:  Yes

No

Wake Up TeraStation After Power Supply Recovers:  Yes

No

Sync with UPS connected to another Buffalo NAS device on the same network

Other Buffalo NAS's IP Address \* :

Wake Up TeraStation After Power Supply Recovers:  Yes

No

Do not synchronize with UPS

AC Power Recovery:  Use last state

Stay off

**9** The process is complete once you close the confirmation window that appears.

## Logs

### Displaying TeraStation's Logs

Follow the procedure to check the TeraStation's logs.

**1** From Settings, click *Management*.

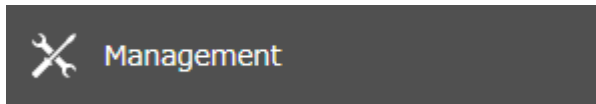

**2** Click the settings icon (  ) to the right of "Logs".



**3** Select a log to view.

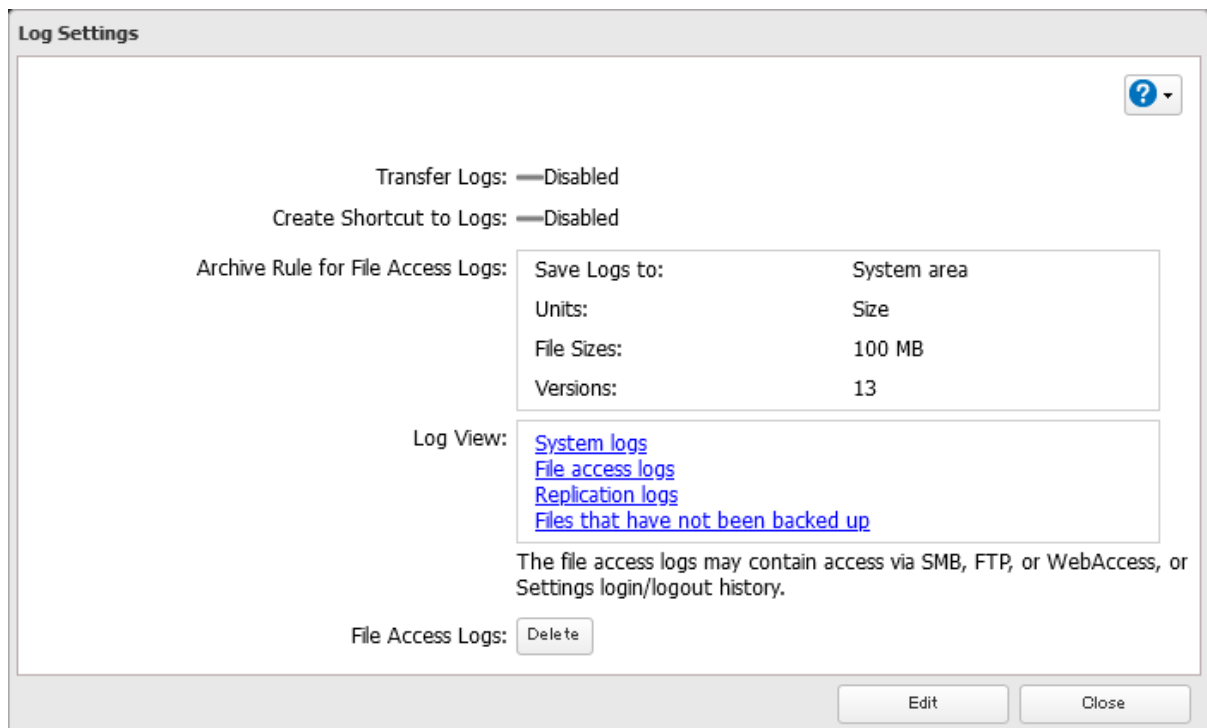

**Note:** The file access log stores file access events that occurred on the internal drives. File access on USB drives are not logged.

**4** The process is complete when the selected log is displayed.

**Note:** All logs are encoded in UTF-8 format. To make sure they display correctly, change the software encoding to "UTF-8".

## Transferring Logs to the Syslog Server

- 1 From Settings, click *Management*.

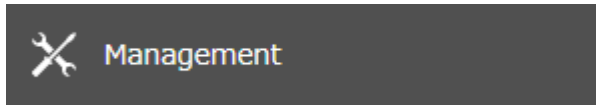

- 2 Click the settings icon (  ) to the right of "Logs".



- 3 Click *Edit* and enable "Syslog Transfer".

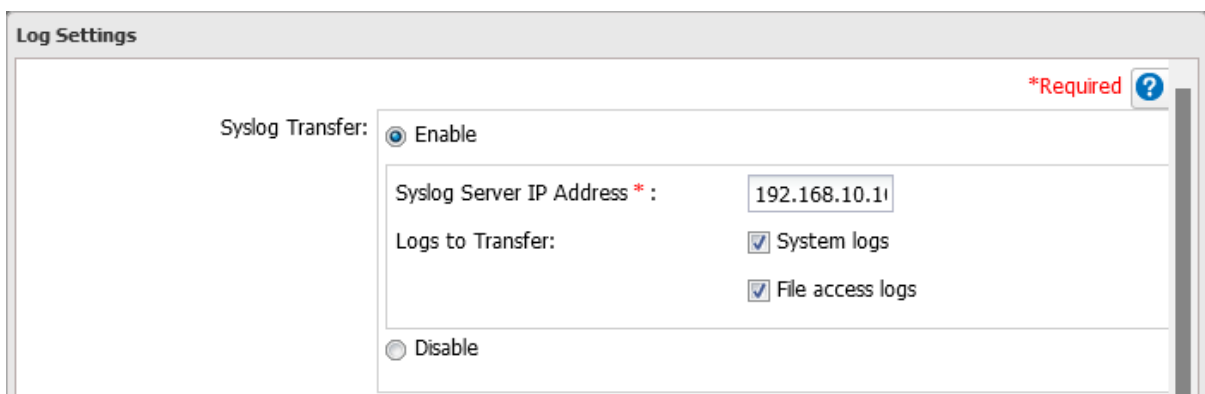

- 4 Enter the IP address of the syslog server where you want to transfer the logs to.

- 5 Select the type of log that you want to transfer from "Logs to Transfer" and click *OK*.

- 6 The process is complete once you close the confirmation window that appears.

## Creating a Shortcut to the Logs in the Shared Folder

- 1 From Settings, click *Management*.

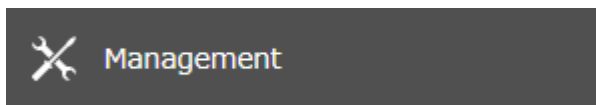

- 2 Click the settings icon (  ) to the right of "Logs".



- 3 Click *Edit* and enable "Create Shortcut to Logs".



- 4 Click *Browse* under “Target Folder” and select the shared folder where the created shortcut will lead, then click *OK*.
- 5 The process is complete once you close the confirmation window that appears.

In the selected shared folder, a folder named “system\_log” will now contain the shortcuts to logs.

## Changing Archive Rules for File Access Logs

You can configure how many logs are kept or how long each log will be kept on the TeraStation.

- 1 From Settings, click *Management*.

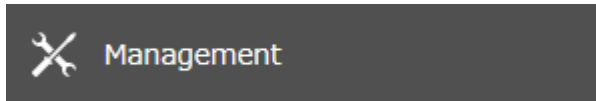

- 2 Click the settings icon (  ) to the right of “Logs”.

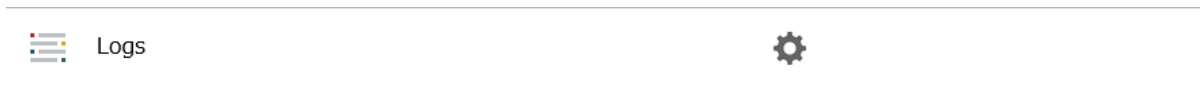

- 3 Click *Edit* and specify the location, then select the unit and version to save logs to the right of “Archive Rule for File Access Logs”. For example, if you select “Month” for the unit and enter “7” for the version, the file access logs for the next 7 months will be saved on the TeraStation.

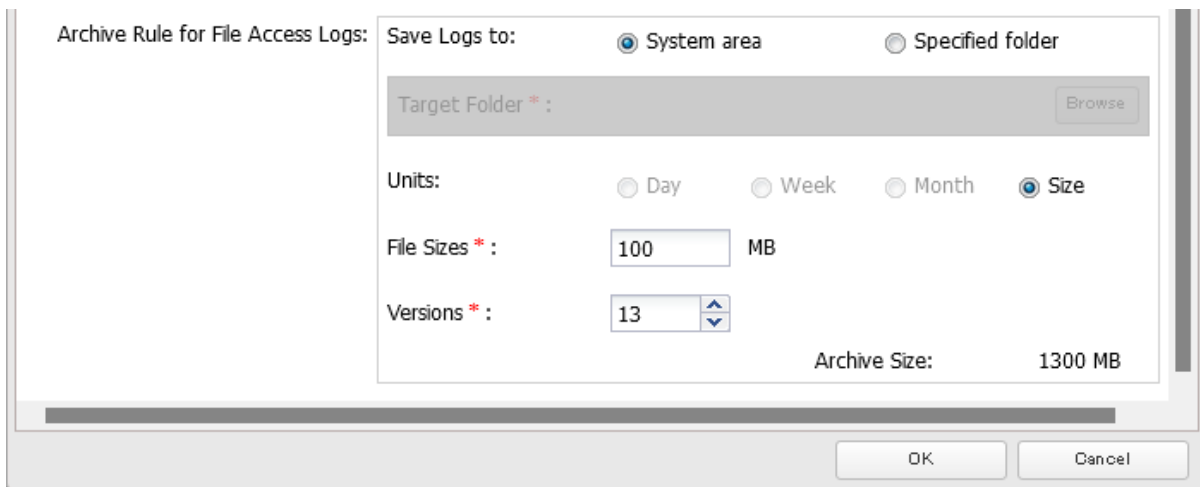

Available duration and capacity to save logs will vary depending on the unit. The following values are available:

- **Log destination is set to the system area**  
Unit (Size): 1–100 for file sizes and 1–13 for all versions
- **Log destination is set to a designated folder**
  - Unit (Day): 1–367 for all versions
  - Unit (Week): 1–53 for all versions
  - Unit (Month): 1–13 for all versions
  - Unit (Size): 1–100 for file sizes and 1–13 for all versions

- 4 Click *OK*. The process is complete once you close the confirmation window that appears.

### Notes:

- To delete the saved logs, click *Delete* at the window in step 3.

- If there is not enough space to save logs, the **I70** message will appear as a notification. If it does, free up space by deleting the current file access logs. If no free space is made available elsewhere, older logs will automatically be deleted.
- If the shared folder to which logs are saved was created on a drive or RAID array, and that drive or RAID array is later changed using RMM, the log folder will be automatically changed to the system area. The **I72** message will also appear as a notification.
- You cannot delete a RAID array, format a drive, or change a folder name while file access logs are being saved to the shared folder.

---

## Updating the Firmware

---

If a new firmware version is available, a message is displayed when you access Settings. To either manually or automatically update the firmware, follow the appropriate procedure below.

### Notes:

- If all drives and RAID arrays on the TeraStation have LVM enabled but no LVM volumes have been created, you will not be able to update the firmware from Settings.
- Settings will not be available while the firmware is updating. Don't try to access Settings from another computer until the update is finished.

## Updating Manually Using Settings

---

To update the firmware from Settings, follow the procedure below.

- 1** From Settings, click *Management*.

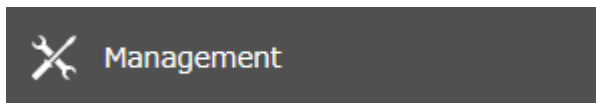

- 2** Click the settings icon (  ) to the right of "Update".



- 3** Click *OK*.

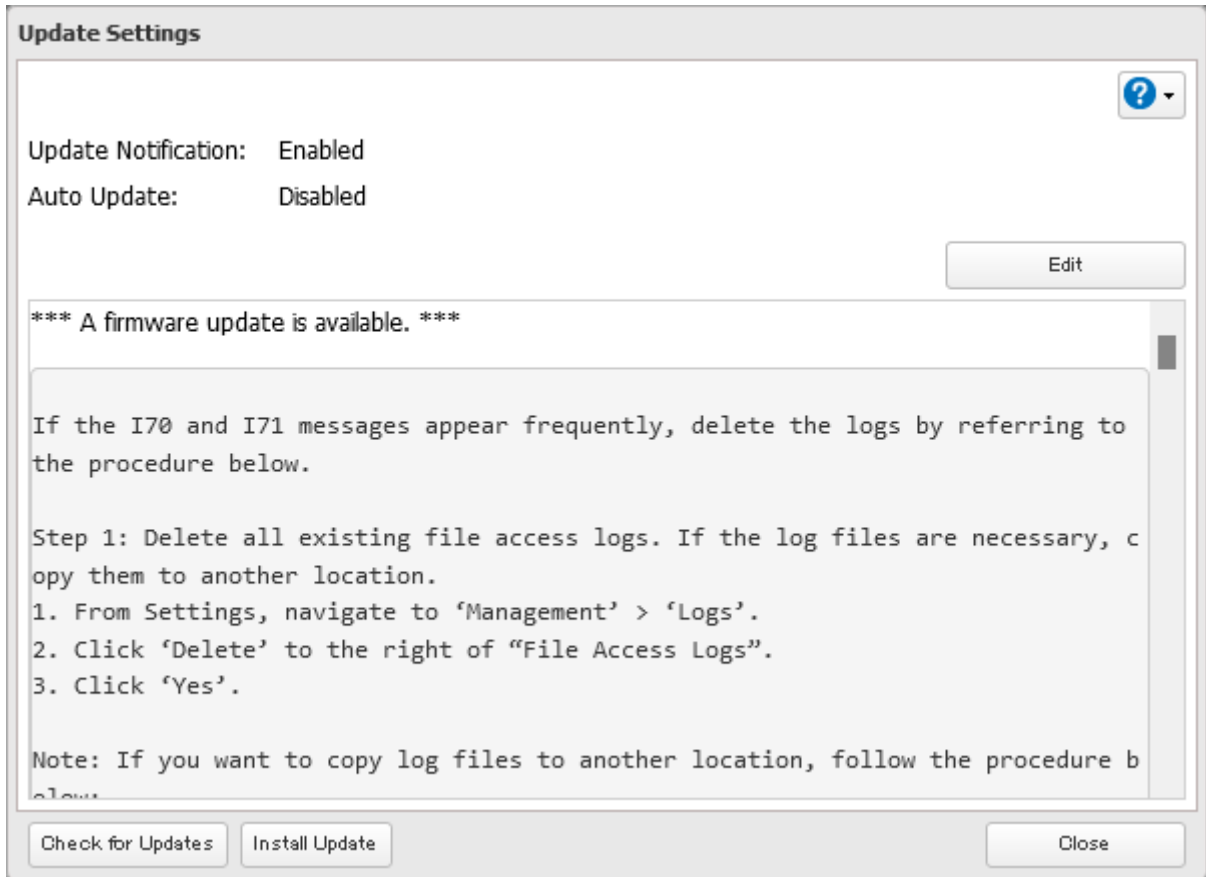

**4** Click *Install Update*.

**5** The “Confirm Operation” screen will open. Enter the confirmation number, then click *OK*.

**6** The process is complete once you close the confirmation window that appears. Refresh the browser and log in to Settings again.

You can also download the latest firmware from the [Buffalo website](#).

## Enabling Automatic Update

---

**1** From Settings, click *Management*.

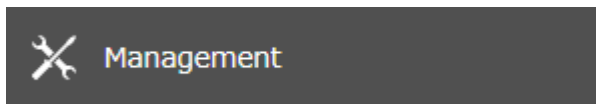

**2** Click the settings icon (  ) to the right of “Update”.



**3** Click *OK*.

- 4** Click *Edit* and select either “Update the firmware automatically” or “Update the firmware on schedule”, then click *OK*.

If you select to update on schedule, choose a specific time of day for the update to occur.

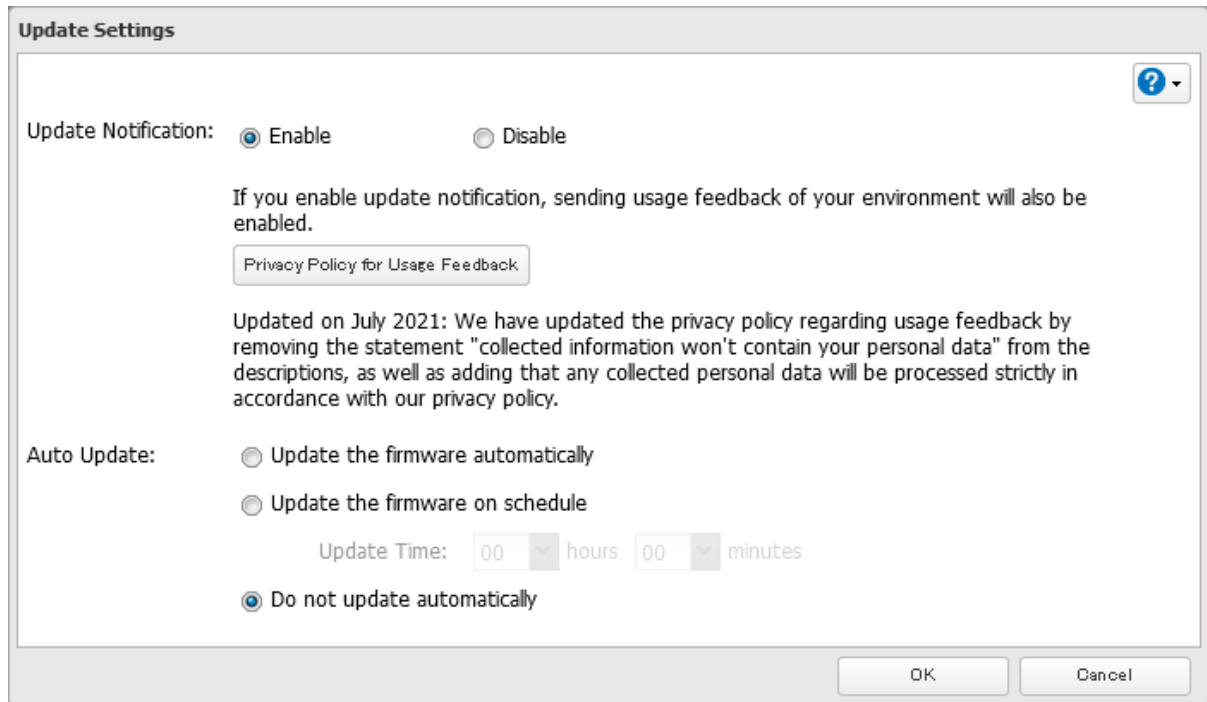

- 5** The process is complete once you close the confirmation window that appears.

## Configuring Update Notification

Configure whether or not to receive a notification when a new firmware version becomes available.

- 1** From Settings, click *Management*.

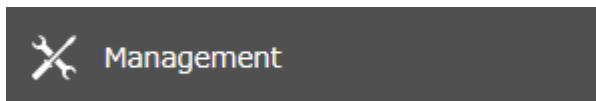

- 2** Click the settings icon (  ) to the right of “Update”.



- 3** Click *OK*.

- 4** Click *Edit* and select whether to enable or disable update notification, then click *OK*.

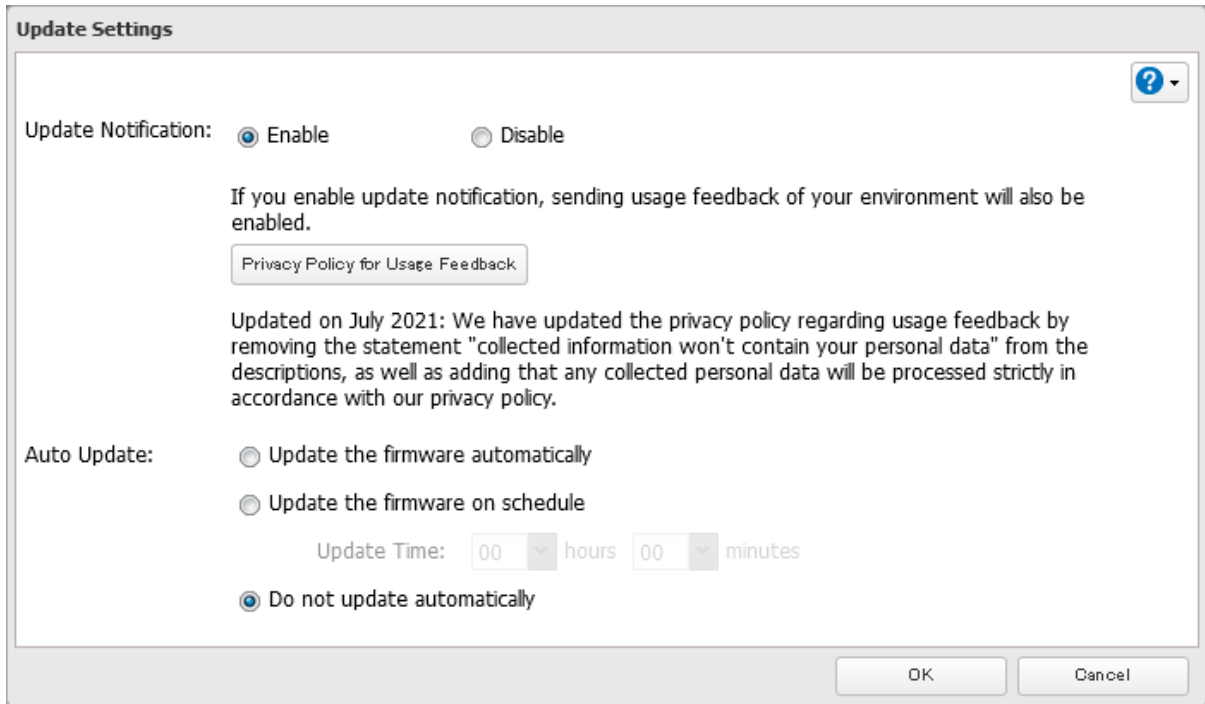

- 5** The process is complete once you close the confirmation window that appears.

For further optimized firmware updates and product usability improvements, Buffalo may ask you to send your usage and environment information. For more details such as the information sent and how it will be handled by us, click *Privacy Policy for Usage Feedback*.

If update notification is enabled, it will also automatically enable sending usage feedback to Buffalo. If you don't want to send this information to us, disable update notification.

---

## Name, Date, Time, and Language

---

Configure the TeraStation's hostname, date, time, and language as shown below.

**Note:** To change the settings of a TeraStation that is being used as an iSCSI drive, navigate to *Storage > iSCSI* in Settings and move the iSCSI switch to the **off** position temporarily before changing settings.

- 1** From Settings, click *Management*.

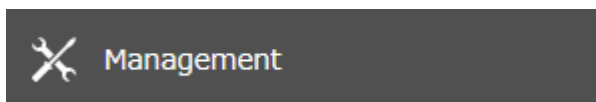

- 2** Click the settings icon (  ) to the right of "Name/Time/Language".



### 3 From the *Name* tab, click *Edit* and enter the TeraStation's name and description.

The name will be used for identifying your TeraStation on the network. When your TeraStation is detected, the name will be used as the hostname. The hostname may contain up to 15 alphanumeric characters and hyphens (-). The first and last characters should not be a hyphen; do not use the following word as a hostname: localhost.

The screenshot shows the 'Name/Time/Language' dialog box with the 'Name' tab selected. The 'Name' field contains 'TS3420D6FA' and the 'Description' field contains 'TeraStation'. There are 'OK' and 'Cancel' buttons at the bottom right. A red '\*Required' label and a help icon are visible in the top right corner.

### 4 Click the *Time* tab. Enable "Date/Time Source" and select the "Use default NTP server" checkbox. If you disable the NTP function, click *Use Local Date/Time* to use your computer's time settings for the TeraStation.

The screenshot shows the 'Name/Time/Language' dialog box with the 'Time' tab selected. The 'Date/Time Source' section has the 'Enable' radio button selected. The 'NTP IP Address' field contains 'ntp.jst.mfeed.ad.jp', the 'Use default NTP server' checkbox is checked, and the 'NTP Synchronization Frequency' is set to 'Daily'. The 'Disable' section is dimmed, showing a date of '06/28/2021' and a time of '16:31:05' with a 'Use Local Date/Time' button. The 'Time Zone' dropdown is set to '(UTC+09:00) Osaka, Sapporo, Tokyo'. There are 'OK' and 'Cancel' buttons at the bottom right. A red '\*Required' label and a help icon are visible in the top right corner.

By default, the TeraStation adjusts its clock automatically by using a default NTP server. This NTP server belongs to Internet Multi Feed Inc. For more information, visit <http://www.jst.mfeed.ad.jp>.

To use a different NTP server, clear the "Use default NTP server" checkbox and enter a new NTP IP address or its hostname, then click *OK*. If an NTP server is specified by name instead of IP address, make sure that a DNS server is configured for the TeraStation.

**Note:** The internal clocks of the TeraStation and other devices on your network may run at slightly different speeds. Over a long period of time, your network devices may show somewhat different times, which can cause network problems. If clocks on your network vary by more than five minutes, unexpected behavior may occur. For best results, keep all clocks on your network devices set to the same time by adjusting them regularly, or use an NTP server to correct them all automatically.

- 5** Click the *Language* tab and select the language to be used.

The screenshot shows a dialog box titled "Name/Time/Language". The "Language" tab is selected. In the top right corner, there is a red asterisk followed by the word "Required" and a blue question mark icon. Below the tabs, there are two dropdown menus: "Character Encoding" set to "CP437" and "Display Language" set to "English". At the bottom right, there are "OK" and "Cancel" buttons.

**Note:** This tab changes the language used by the TeraStation for email notifications and other functions. To change the language displayed in Settings, go to Settings and click *Language* from the menu bar. Choose your desired language from the drop-down list.

- 6** Click the *Management Information* tab. Enter the desired location and administrator information.

The screenshot shows the same dialog box, but the "Management Information" tab is selected. The "Character Encoding" and "Display Language" fields are no longer visible. Instead, there are two text input fields: "Location:" and "Administrator:". The "Required" indicator and "OK/Cancel" buttons remain the same.

- 7** Click *OK* when all settings are configured.

- 8** The process is complete once you close the confirmation window that appears.

## Beep Alerts

You can set the TeraStation to beep if certain errors occur.

- 1** From Settings, click *Management*.

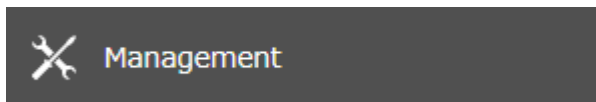

- 2** Click the settings icon (  ) to the right of "Notifications".



- 3** Click the *Alert Sound* tab, then click *Edit*.

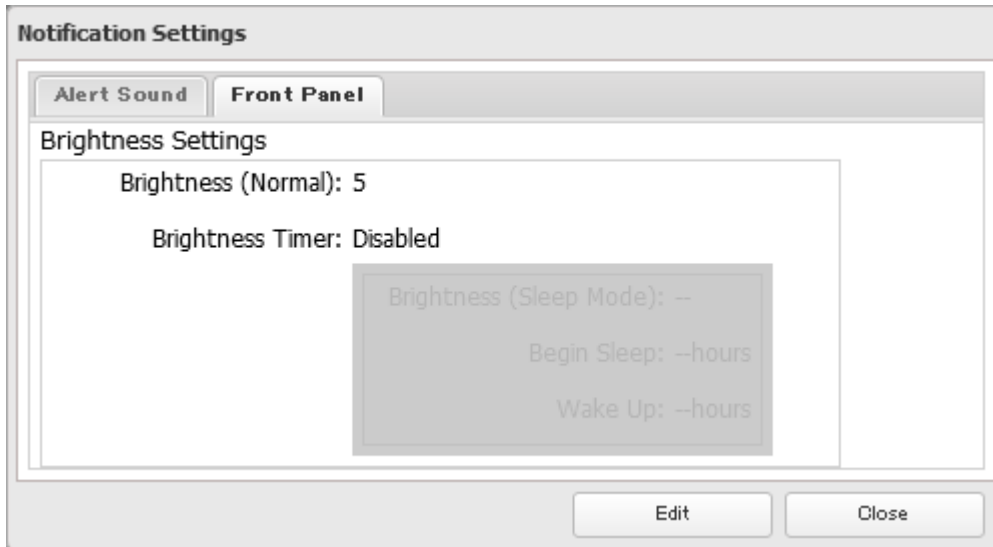

- 4** Select the triggers that make the alert beep, then click *OK*.

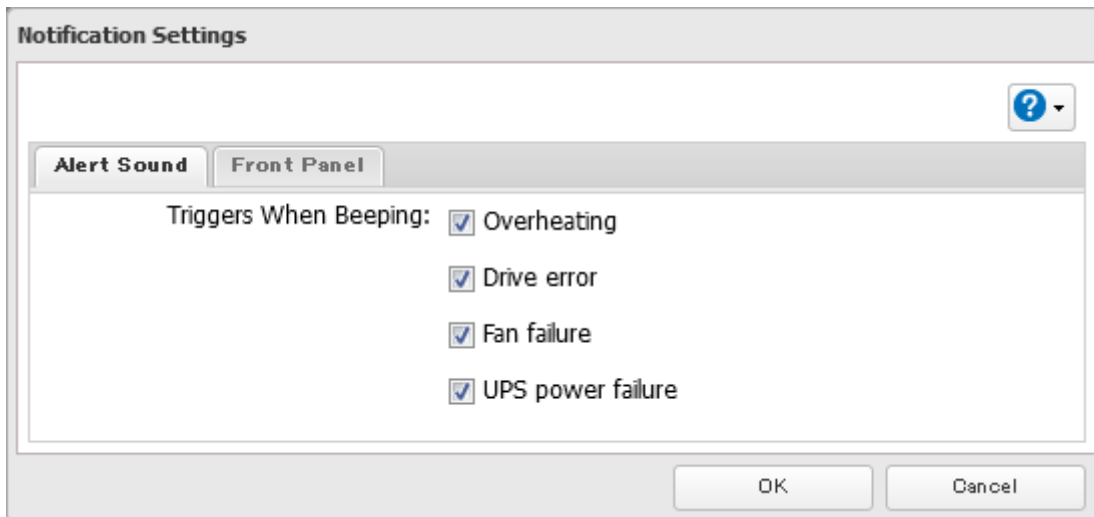

- 5** The process is complete once you close the confirmation window that appears.

---

## LEDs

---

You may adjust the brightness of the LEDs on the TeraStation.

- 1** From Settings, click *Management*.

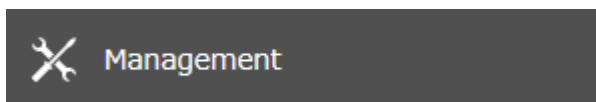

- 2** Click the settings icon (⚙️) to the right of "Notifications".



**3** From the *Front Panel* tab, click *Edit* and configure your desired settings, then click *OK*.

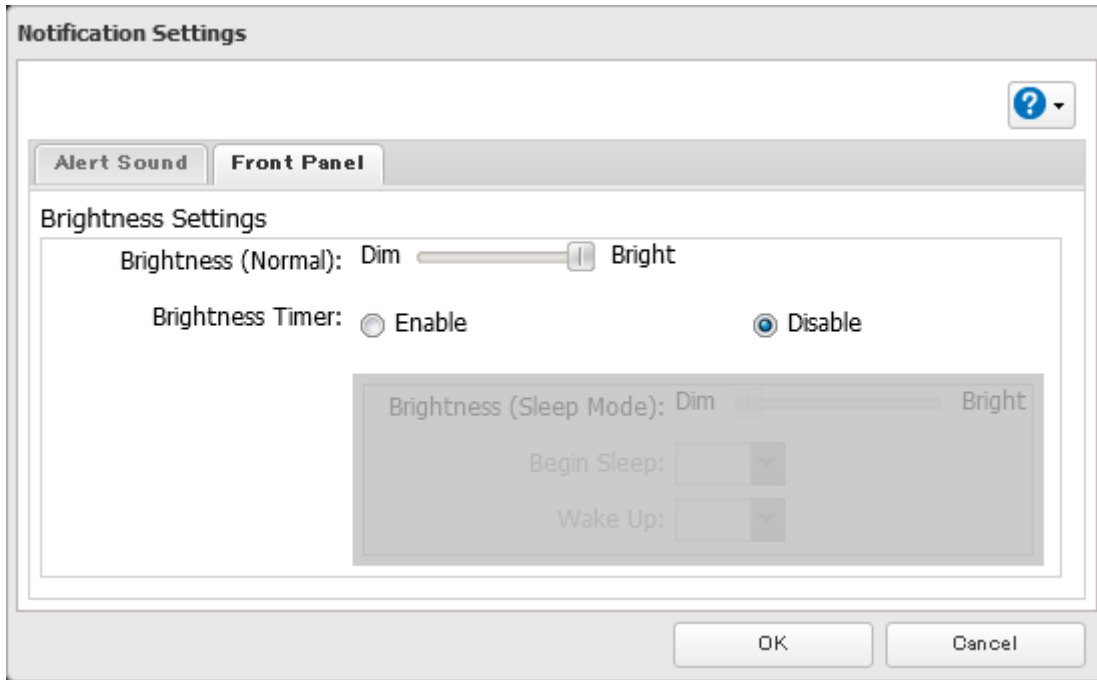

**4** The process is complete once you close the confirmation window that appears.

# Chapter 11 Drive Replacement and Troubleshooting

## Replacing a Defective Drive

Drive replacement procedures will vary depending on what RAID mode is configured for the TeraStation. Refer to the appropriate replacement procedure in the following sections that corresponds to the configured RAID mode. The following drive replacement examples use the case of the TS3410DN, TS3420DN, and TS3420DS TeraStation models.

### LEDs

Drives on the TeraStation will have its status LED glow green during normal operation. If a drive fails, its error LED will glow red.

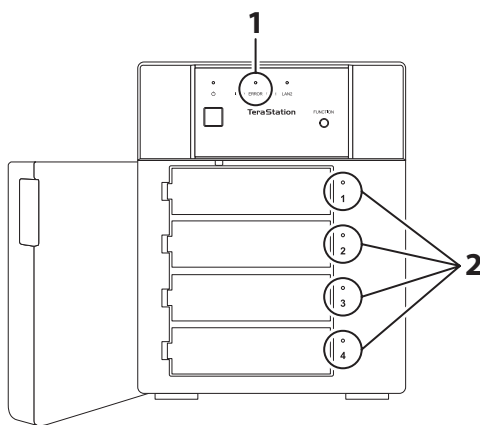

#### 1 Error LED

Glows red if a drive has failed.

#### 2 Status LEDs

The failed drive's status LED will be glowing a steady red. A drive with a red status LED is ready to hot-swap.

### Notes

- Do not unplug a drive whose status LED is green instead of red. Dismount it first or shut down the TeraStation before swapping a working drive. If you remove the drive without properly dismounting it, data may be lost and the TeraStation may malfunction.
- If using the TS3420DS or TS3420RS TeraStation models, use a Buffalo OP-HD-2Y series drive as the replacement drive. Use a Buffalo OP-HDN series drive as the replacement drive for other series TeraStations. The replacement drive should be the same capacity or larger as the original drive. If a larger drive is used, the extra space will not be usable in a RAID array.
- To avoid damaging the TeraStation with static electricity, ground yourself by touching something made of metal before handling any sensitive electronic parts.
- After a drive is replaced, it will take about 30 minutes before normal file reading and writing operations are restored. Settings may not be accessible during this period.



- Do not change the order of the drives on the TeraStation. For example, pulling out the drive in slot 1 and replacing it with the drive in slot 2 may cause data to be corrupted or lost.
- If the status LEDs do not change after a new drive is installed, click *Redetect Drive* in Settings.

## **Drive Replacement for a Redundant RAID Array (TeraStation Is On)**

If a drive used in a redundant RAID array fails, you will need to recover the RAID array after replacing the defective drive with a new drive. Follow the procedure below to replace a defective drive used in a redundant RAID array. If replacing multiple malfunctioning drives at once, refer to the [“Drive Replacement for a Redundant RAID Array \(TeraStation Is Off\)”](#) section.

- 1** Back up the saved data to another location before replacing the failed drive. If one or more drives fail during drive replacement, data can no longer be retrieved from the TeraStation.
- 2** Open the front cover with the included key.

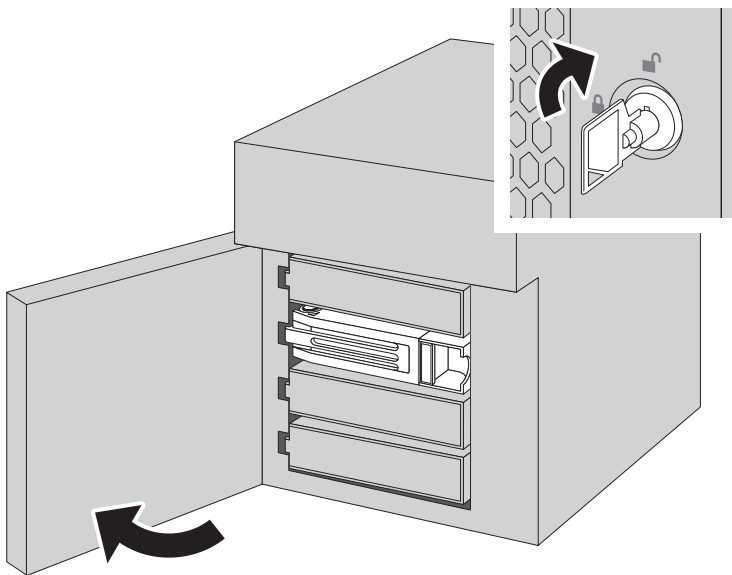

- 3** The failed drive's status LED will be glowing red. Push its unlock button and swing the lock mechanism out.

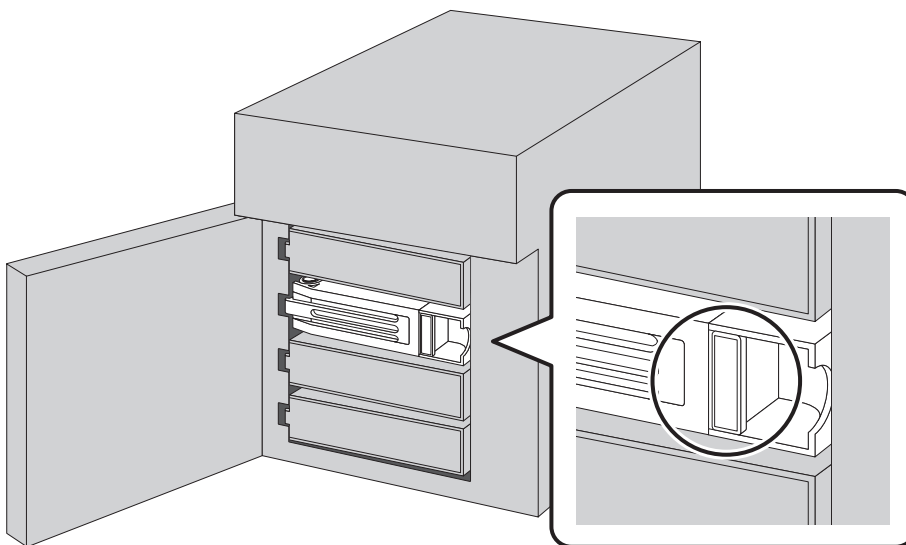

**Drives without red status LEDs lit are still on. Do not unplug or remove them.**

**4** Pull out the drive cartridge and remove it from the TeraStation.

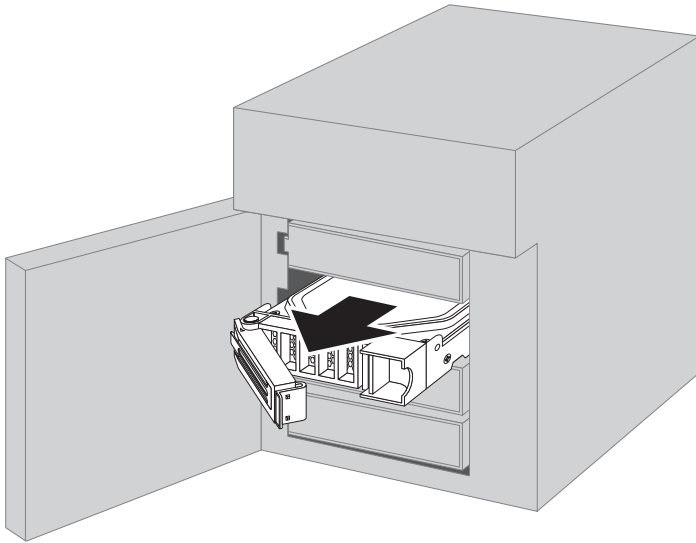

**5** Insert the new drive into the empty slot with the lock mechanism remaining open.

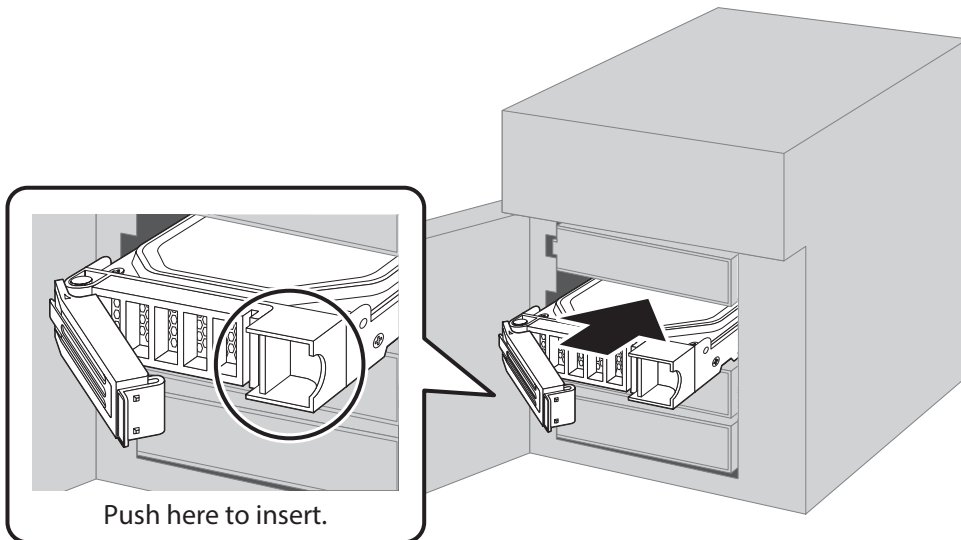

- 6 Swing the lock back down until it clicks into place.

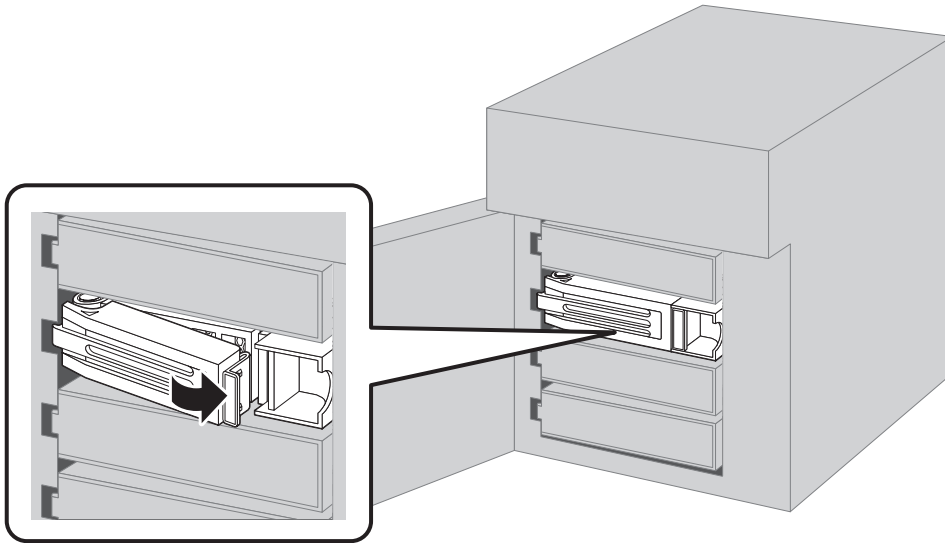

- 7 When the replaced drive is recognized, the status LED will flash red and the I31 message will appear as a notification.

- 8 Close the front cover.

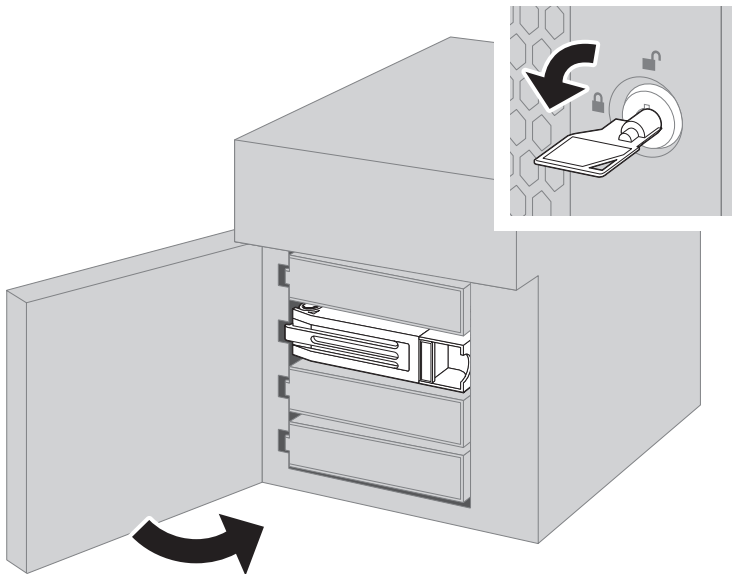

- 9 Press the function button. The TeraStation will beep once. Press and hold the button until the TeraStation beeps again.

- 10 The RAID array recovery will begin. The I18 message will appear as a notification after a few minutes. The process is complete when the I18 message disappears.

## **Drive Replacement for a Redundant RAID Array (TeraStation Is Off)**

If a drive used in a redundant RAID array fails, you will need to recover the RAID array after replacing the defective drive with a new drive. Follow the procedure below to replace a defective drive used in a redundant RAID array.

- 1 Back up the saved data to another location before replacing the failed drive. If one or more drives fail during drive replacement, data can no longer be retrieved from the TeraStation.

- 2** Open the front cover with the included key.
- 3** The failed drive's status LED will be glowing red. Push its unlock button and swing the lock mechanism out.
- 4** Pull out the drive cartridge and remove it from the TeraStation.
- 5** Insert the new drive into the empty slot with the lock mechanism remaining open.
- 6** Swing the lock back down until it clicks into place.
- 7** Press the power button on the TeraStation.
- 8** When the replaced drive is recognized, the status LED will flash red and the **I32** message will appear as a notification.
- 9** Close the front cover.
- 10** From Settings, navigate to *Storage > RAID*.
- 11** Click the RAID array that held the failed drive, then select the replaced drive and click *Recover RAID Array*.
- 12** The "Confirm Operation" screen will open. Enter the confirmation number, then click *OK*.
- 13** The RAID array recovery will begin. The **I18** message will appear as a notification after a few minutes. The process is complete when the **I18** message disappears.

## **Drive Replacement for a RAID 0 Array**

---

If a drive used in a RAID 0 array fails, you will need to create a RAID array again after replacing the defective drive with a new drive. Follow the procedure below to replace a defective drive used in a RAID 0 array.

**Note:** If a drive malfunctions in a RAID 0 array, all data on the RAID array will be lost. All of the settings for the shared folders (such as access restrictions) are erased after replacing a drive from a RAID 0 array.

- 1** Turn off the TeraStation.
- 2** Open the front cover with the included key.
- 3** The failed drive's status LED will be blinking red. Push its unlock button and swing the lock mechanism out.
- 4** Pull out the drive cartridge and remove it from the TeraStation.
- 5** Insert the new drive into the empty slot with the lock mechanism remaining open.
- 6** Swing the lock back down until it clicks into place.
- 7** Press the power button on the TeraStation.
- 8** When the replaced drive is recognized, the status LED will flash red and the **I32** message will appear as a notification.
- 9** Close the front cover.
- 10** Delete the RAID array that held the failed drive by referring to the "[Using JBOD](#)" section in chapter 4.

- 11** Format the replaced drive by referring to the [“Formatting Drives”](#) section in the same chapter.
- 12** Create a new RAID 0 array by referring to the [“Creating a RAID Array”](#) section in the same chapter.
- 13** The process is complete once the new RAID 0 array is created. Next, create a shared folder by referring to the [“Adding a Shared Folder”](#) section in chapter 3.

## Drive Replacement for a JBOD

---

If a drive used as a JBOD fails, you will need to format the replaced drive after replacing the defective drive with a new drive. Follow the procedure below to replace a defective drive used as a JBOD.

**Note:** If a drive malfunctions in JBOD, all data on the drive will be lost.

- 1** Turn off the TeraStation.
- 2** Open the front cover with the included key.
- 3** The failed drive’s status LED will be blinking red. Push its unlock button and swing the lock mechanism out.
- 4** Pull out the drive cartridge and remove it from the TeraStation.
- 5** Insert the new drive into the empty slot with the lock mechanism remaining open.
- 6** Swing the lock back down until it clicks into place.
- 7** Press the power button on the TeraStation.
- 8** When the replaced drive is recognized, the status LED will flash red.
- 9** Close the front cover.
- 10** Format the replaced drive by referring to the [“Formatting Drives”](#) section in chapter 4.
- 11** The process is complete once the drive is formatted. Next, create a shared folder by referring to the [“Adding a Shared Folder”](#) section in chapter 3.

## Drive Replacement for a Hot Spare

---

If your TeraStation’s drives are in a redundant RAID mode and you have a hot spare enabled, a malfunctioning drive in the array is replaced with a hot spare and the RAID array is rebuilt automatically. The status LED will continue to glow red for the failed drive even after the RAID array is rebuilt with the hot spare. After you replace the failed drive with a new drive, follow the procedure below to configure the new drive as a hot spare.

- 1** Open the front cover with the included key.
- 2** The failed drive’s status LED will be glowing red. Push its unlock button and swing the lock mechanism out.
- 3** Pull out the drive cartridge and remove it from the TeraStation.
- 4** Insert the new drive into the empty slot with the lock mechanism remaining open.
- 5** Swing the lock back down until it clicks into place.

- 6** When the replaced drive is recognized, the status LED will flash red and the **I31** message will appear as a notification.
- 7** Close the front cover.
- 8** Press the function button. The TeraStation will beep once. Press and hold the button until the TeraStation beeps again.
- 9** The process is completed once the replaced drive is registered as a hot spare.

If you want to use the replaced drive as a normal drive rather than a hot spare, navigate to *Storage > RAID* and click the RAID array, select the new drive, and click *Set as a normal drive*.

---

## Replacing a Non-Malfunctioning Drive

---

If you must change a drive that is not malfunctioning, **shut down the TeraStation, then disconnect the drive.** A new drive should be inserted after turning on the TeraStation. Make sure that the startup process is successful by checking that the power LED changes to a steady green. If you need to replace more than one drive all at once, replace the drives one at a time to preserve your data. When replacing the non-malfunctioning drive, the RAID array will function as below:

### Operating in a Redundant RAID Array

If you are using a redundant RAID mode such as RAID 1, 5, or 6, the RAID array will enter degraded mode after replacing the drive. You will be unable to use the TeraStation until you recover the RAID array with a new drive.

### Operating in RAID 0

All data on the RAID array will be deleted after replacing the drive. You will be unable to use the TeraStation until you delete and create a new RAID array with a new drive.

### Operating in JBOD

All data on that drive will be deleted after replacing the drive. You will be unable to use the TeraStation until you format a new drive.

---

## Re-Inserting Drives

---

If the **E14** or **E16** error appears as a notification after initial bootup, follow the procedure below to re-insert the internal drives.

- 1** Turn off the TeraStation.
- 2** Open the front cover with the included key.

- 3** Push a drive's unlock button and swing the lock mechanism out.

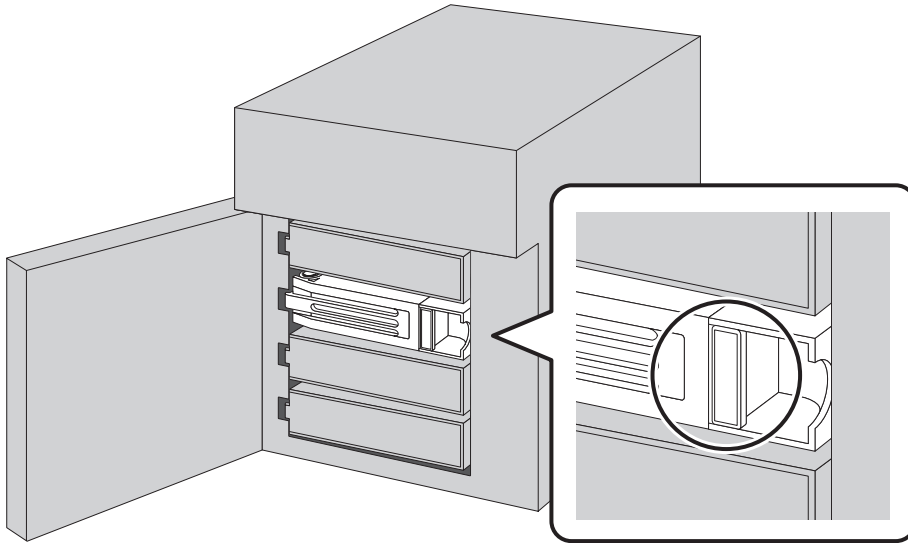

- 4** Pull out the drive cartridge and remove it from the TeraStation.

- 5** Insert the drive back into the same slot with the lock mechanism remaining open.

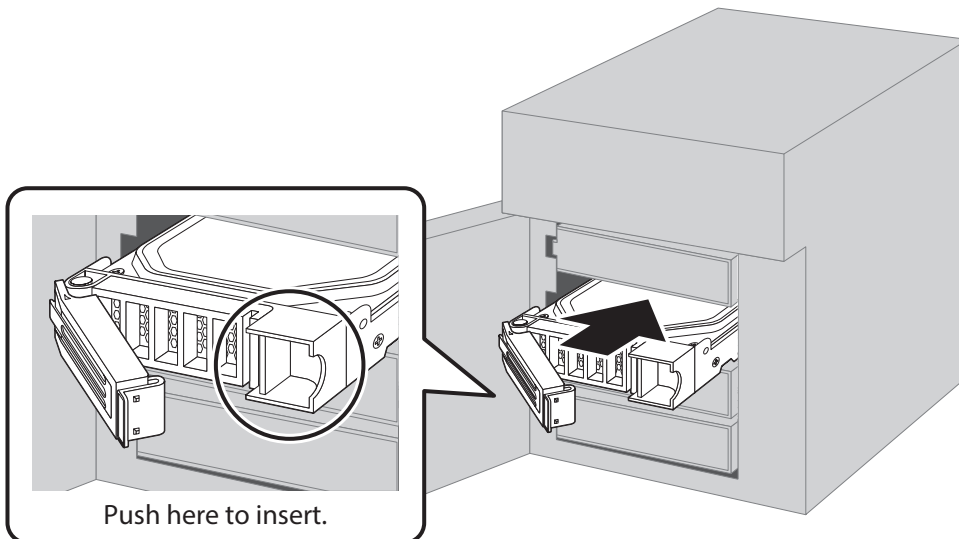

- 6** Swing the lock back down until it clicks into place.
- 7** Repeat steps 3–6 for all other installed drives.
- 8** Once every drive has been re-inserted, close the front cover.
- 9** Press the power button on the TeraStation.
- 10** The process is complete when any error messages disappear.

## “Recovery needed” Appears under the “Status” Field on the RAID Array List

If “Recovery needed” is displayed under the “Status” field for a RAID array on the RAID array list window as below, the RAID array needs to be recovered.

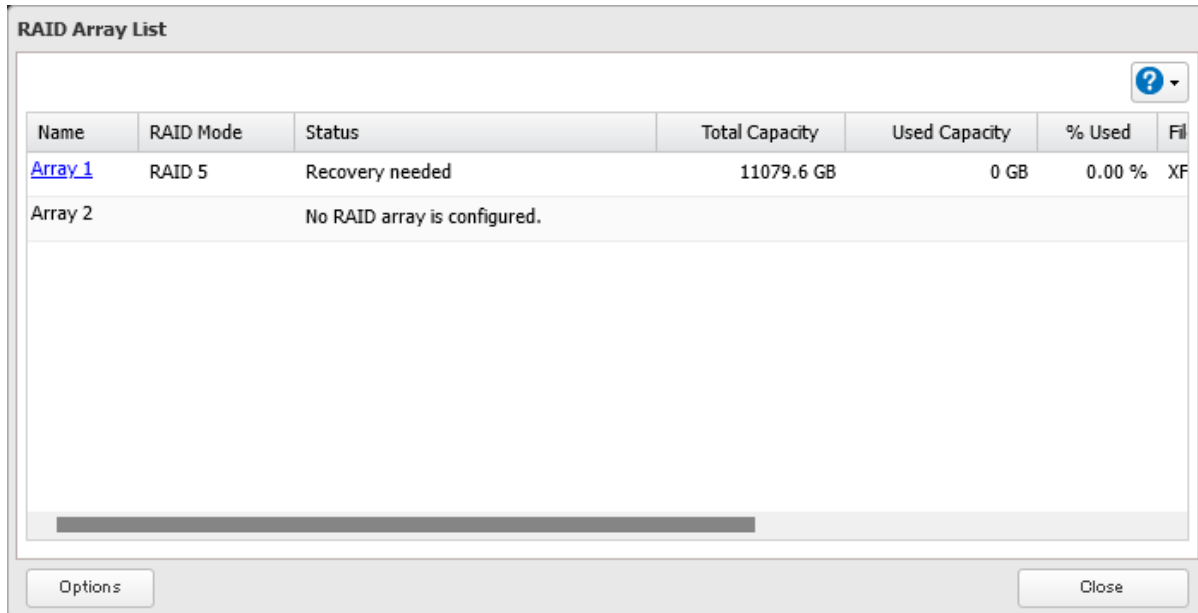

Follow the procedure below to recover the RAID array.

- 1 From Settings, click *Storage*.



- 2 Click the settings icon (⚙️) to the right of “RAID”.



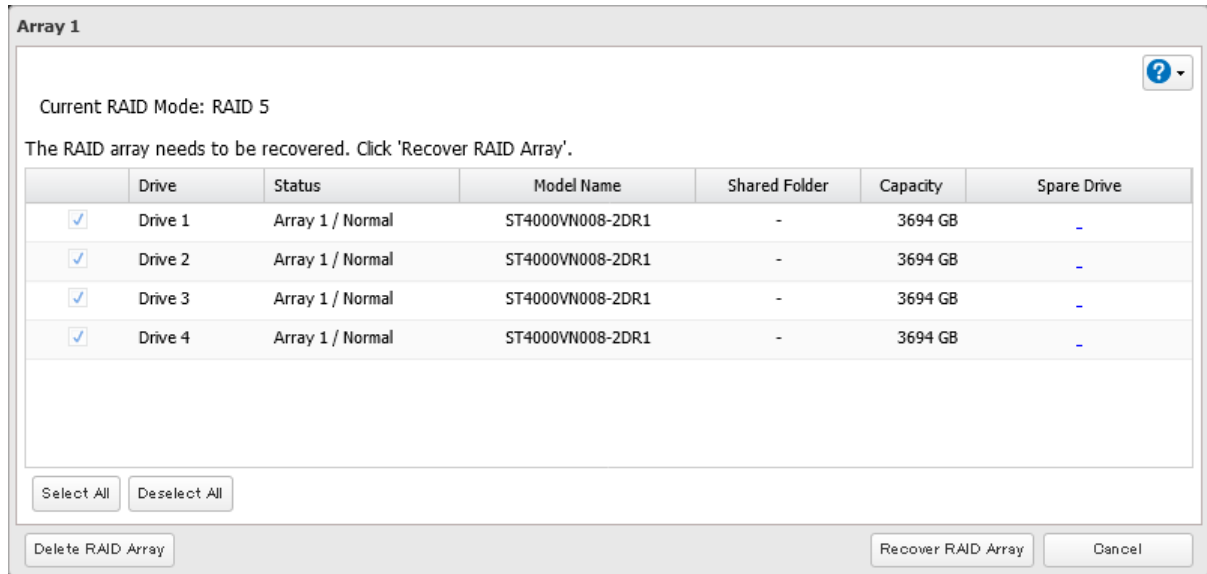

**3** Click *Recover RAID Array*.**4** The process is complete once you close the confirmation window that appears.

---

## TeraStation Does Not Work Properly

---

If an error occurs that prevents the TeraStation from booting up properly, one or more of the following symptoms may occur. In such a case, try the corresponding corrective action to recover from the error, described in each section below. If the error is still not resolved, contact Buffalo technical support for assistance.

- The power LED keeps blinking instead of turning into a solid glow; follow the procedure at the [“Power LED Keeps Blinking”](#) section below.
- An “i” symbol is displayed with the TeraStation icon and the I61 message appears as a notification; follow step 3 and after at the [“Power LED Keeps Blinking”](#) section below.
- An “i” symbol is displayed with the TeraStation icon and “EM” is added to your TeraStation’s hostname on NAS Navigator2; follow the procedure at the [“Booting the TeraStation in Emergency Mode”](#) section below.

### Power LED Keeps Blinking

---

While the TeraStation’s power LED keeps blinking, you may see the I61 message. In such a case, follow the procedure below to recover from drive setup mode.

- 1** Press and hold down the power button for three seconds to turn off the TeraStation.
- 2** Turn the TeraStation back on while holding down the function button. You should hold down the function button for at least 10 seconds after pressing the power button.
- 3** When the power LED changes from blinking to glowing, release the function button and open Settings from NAS Navigator2.

#### 4 Make sure that “Recover firmware” is selected from the drop-down list under “Action”, then click *Start Setup*.

Drive	Status	Info	Version	Model Name	Capacity	Primary Drive	Action
Drive 1	Recognized	System#1_(D:1/4)	5.46-0.04	ST4000VN008-2DR166	3726 GB	<input checked="" type="radio"/>	Recover firmware ▾
Drive 2	Recognized	System#1_(D:2/4)	5.46-0.04	ST4000VN008-2DR166	3726 GB	<input type="radio"/>	Recover firmware
Drive 3	Recognized	System#1_(D:3/4)	5.46-0.04	ST4000VN008-2DR166	3726 GB	<input type="radio"/>	Recover firmware
Drive 4	Recognized	System#1_(D:4/4)	5.46-0.04	ST4000VN008-2DR166	3726 GB	<input type="radio"/>	Recover firmware

Select the action to take when recovering the firmware.

Revert settings to those of the last shutdown  
This will revert settings to those that were saved before the last shutdown.

Revert settings to those of the last boot (Time When Boot Occurred: 07/19/2022 10:09:52)  
This will revert settings to those that were saved during the last boot.

---

**Secure Erase**  
This will erase data securely from all drives on this TeraStation. For more detailed information about this feature, refer to the [user manual](#).  
To start erasing data, click 'Start Secure Erase'. To check data erasure history, click 'View Log'.

**Note:** There are two more options for “Action” other than “Recover firmware”. The details for all options are below:

- **Use the drive's firmware:** The TeraStation will boot using the firmware on the drive.
- **Recover firmware:** The TeraStation will be recovered using the firmware on the NAND flash.
- **Format drive:** The drive will be formatted.

#### 5 The “Confirm Operation” screen will open. Enter the confirmation number, then click *OK*.

#### 6 The recovery process will start. When the process is finished, click *OK*.

#### 7 The TeraStation will shut down automatically. Press the power button to turn it on.

#### 8 The process is complete when the power LED turns from blinking to glowing.

The TeraStation will be recovered from the malfunction that is keeping the power LED blinking. Make sure the TeraStation finishes booting properly.

#### Notes:

- If the TeraStation does not recover from the error after trying the procedure above, try again from the first step.
- If the TeraStation did not power off properly in the previous shutdown, a message will appear in the window as below:

**This TeraStation was not shut down properly.**  
Select the action to take when recovering the firmware.

Revert settings to those of the last boot (Time When Boot Occurred: 06/07/2019 14:28:14)  
This will revert settings to those that were saved during the last boot.

Revert using latest settings  
This will revert settings to the latest ones before recovering the firmware. Some settings may not be restored if they do not apply to the recovered unit.

## Booting the TeraStation in Emergency Mode

---

If the TeraStation boots up in emergency mode, depending on your TeraStation model, an “i” symbol is displayed with the TeraStation icon and “EM” is added to your TeraStation’s hostname.

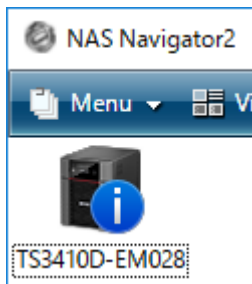

To recover from emergency mode, follow the procedure below.

- 1** Download the firmware updater from the [Buffalo website](#).
- 2** Extract the downloaded file by double-clicking it and launch the updater.
- 3** Update the firmware for the TeraStation unit that is currently in emergency mode.

When the “i” symbol and “EM” disappear from the icon and the hostname on NAS Navigator2, the TeraStation is no longer in emergency mode.

### Notes:

- Try updating the firmware several times, even if the process fails after the “Partition not found.” message appears. The update may succeed after several tries.
- If the TeraStation is not shut down properly such as due to a power outage or the power cable getting disconnected while the TeraStation is on, data on the TeraStation may be corrupted when the TeraStation boots in emergency mode. In such a case, the corrupted data may not be recoverable even if you try the procedure above.
- When the “Updating may have failed.” message appears, restart the TeraStation and check whether the unit has been recovered from emergency mode.

---

## Unable to Access Shared Folders

---

If you cannot access a shared folder, check the following aspects:

- The logged-in user information has been added to Windows network credentials.
- The folder owner and access permissions have been configured properly.

To configure the TeraStation to have the network credentials window appear when accessing a shared folder, refer to the [“Opening the Network Credentials Window”](#) section. If the folder owner and access permissions have accidentally been changed to incorrect parameters, restore them by referring to the [“Restoring Owner and Permission Settings”](#) section.

## Opening the Network Credentials Window

---

Due to security reasons, you may be unable to access shared folders from computers running certain Windows versions. In such a case, follow the procedure below to change the TeraStation settings so you can be prompted to enter a Windows credential.

- 1 From Settings, click *File Sharing*.

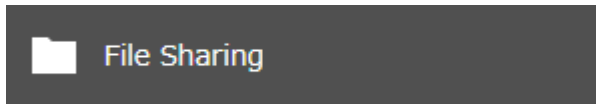

- 2 Click the settings icon (⚙️) to the right of "SMB".

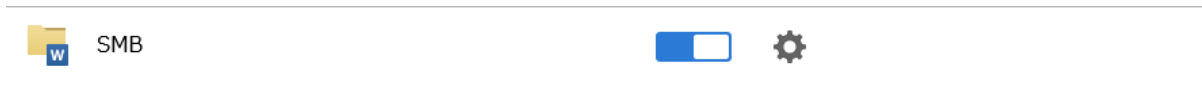

- 3 Click *Edit* and change the "Action When Authentication Fails" option to "Show network credentials window", then click *OK*.

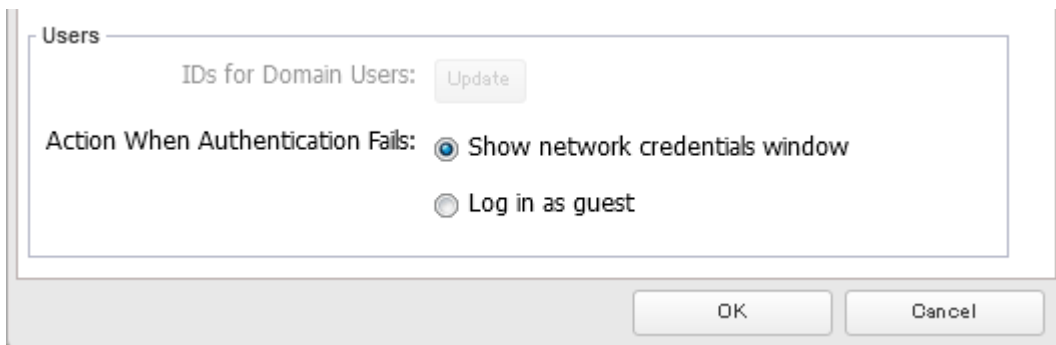

- 4 The process is complete when the file sharing menu list is displayed.

The settings are now changed. A window to enter a username and password will appear the next time you access a shared folder but fails.

## Restoring Owner and Permission Settings

If you changed the owner to an unexpected user or accidentally lost permissions to a specific folder, you can follow the procedure below to restore them.

- 1 From Settings, click *File Sharing*.

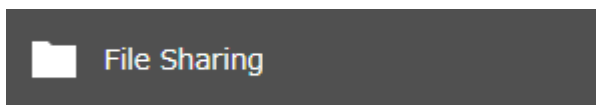

- 2 Click the settings icon (⚙️) to the right of "Folder Setup".

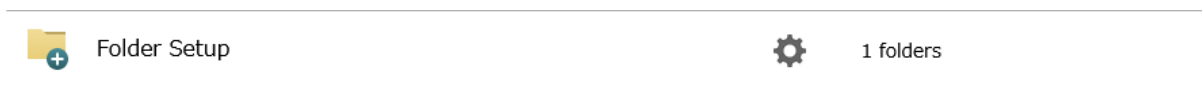

**3** Click *Advanced Settings for Subfolders*.

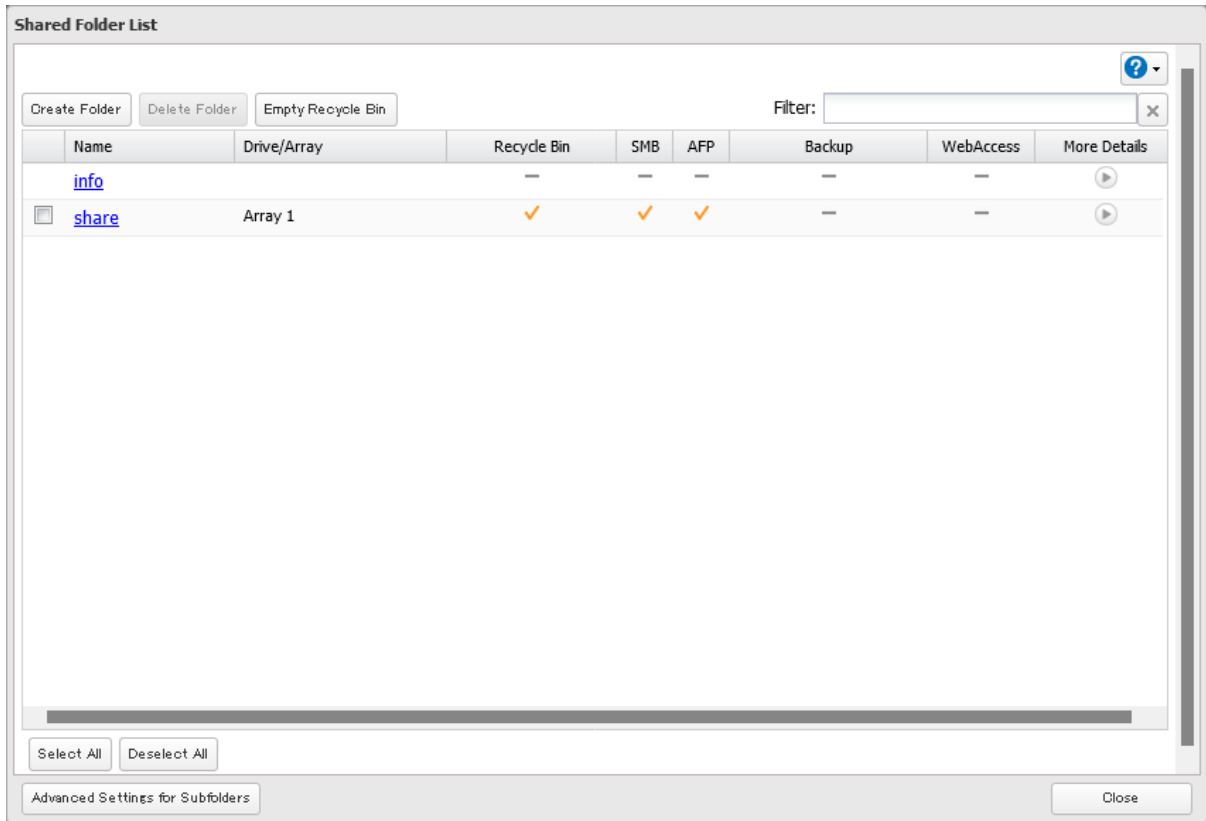

**4** Select a folder to restore permissions from the tree.

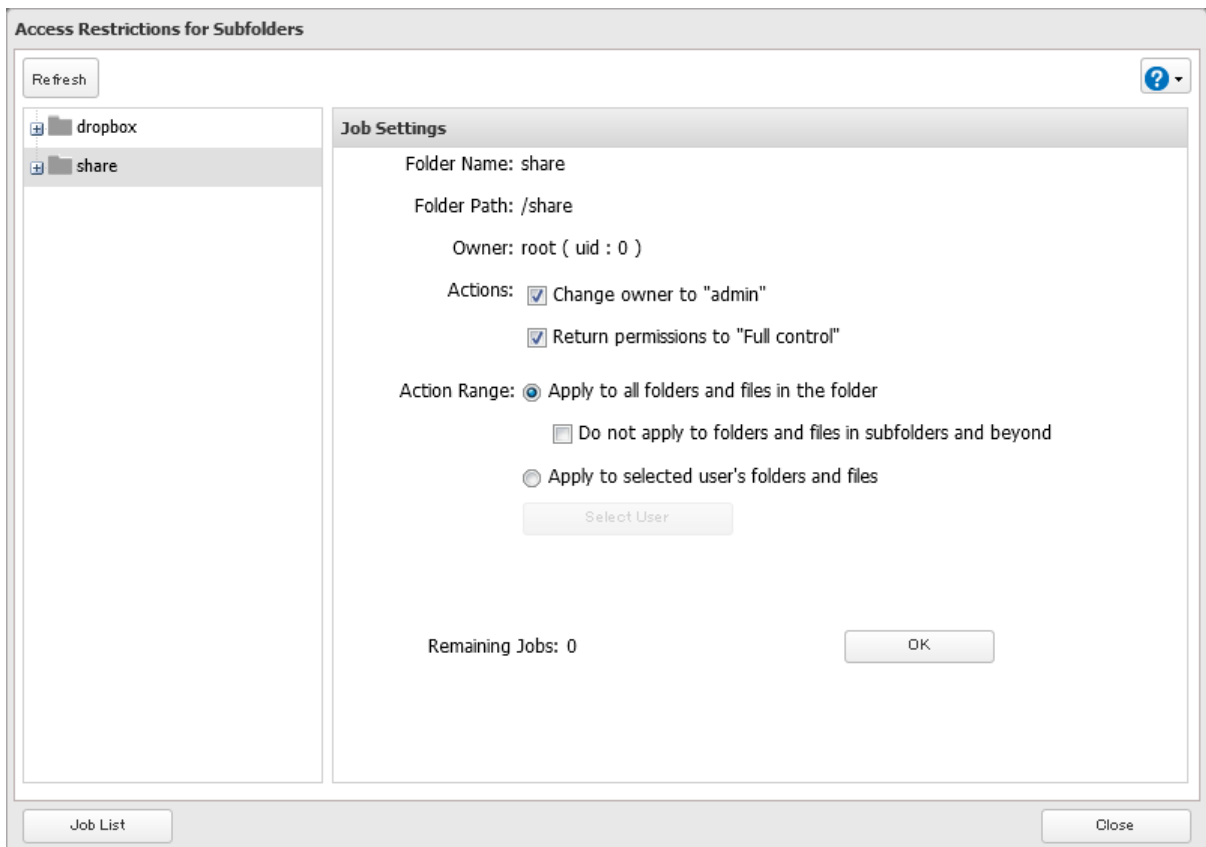

**Note:** If you select a root shared folder from the tree, the action will not apply to the recycle bin. To apply the action to the recycle bin, select it instead.

- 5** Select the actions and action range to run, then click *OK*.
- 6** The “Confirm Operation” screen will open. Enter the confirmation number, then click *OK*.
- 7** The process is complete once you close the confirmation window that appears.

---

## Cleaning the Dustproof Filter

---

If your TeraStation has a front cover and you are trying to clean the dustproof filter on the front cover, follow the procedure below.

- 1** Open the front cover with the included key.

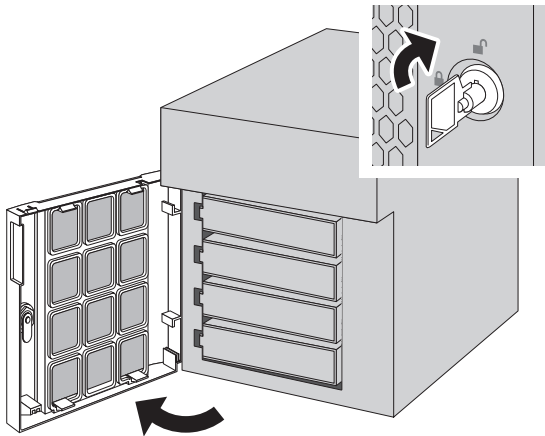

- 2** Remove the front cover while holding the hook downward.

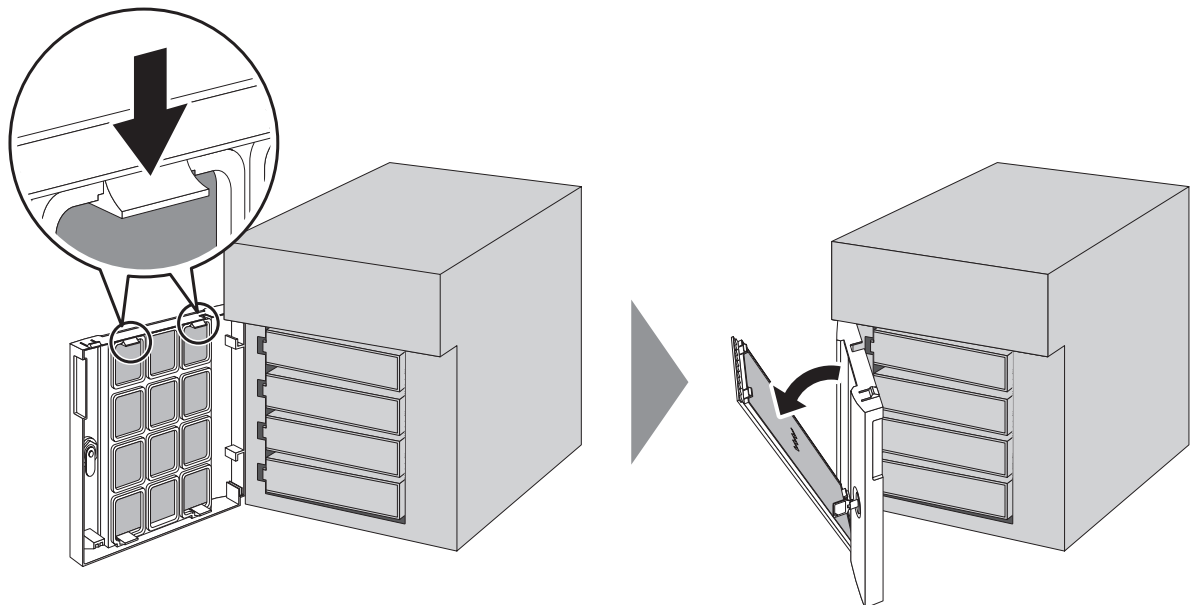

**3** Remove the dustproof filter from the front cover and clear any dust, such as by using a vacuum cleaner.

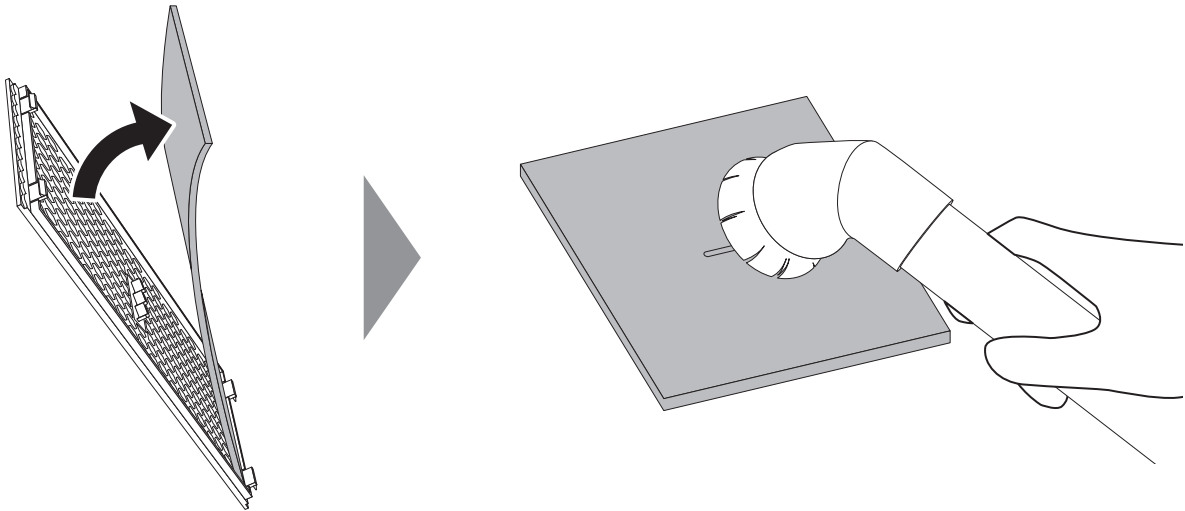

**4** When cleaning is finished, return the filter and the front cover.

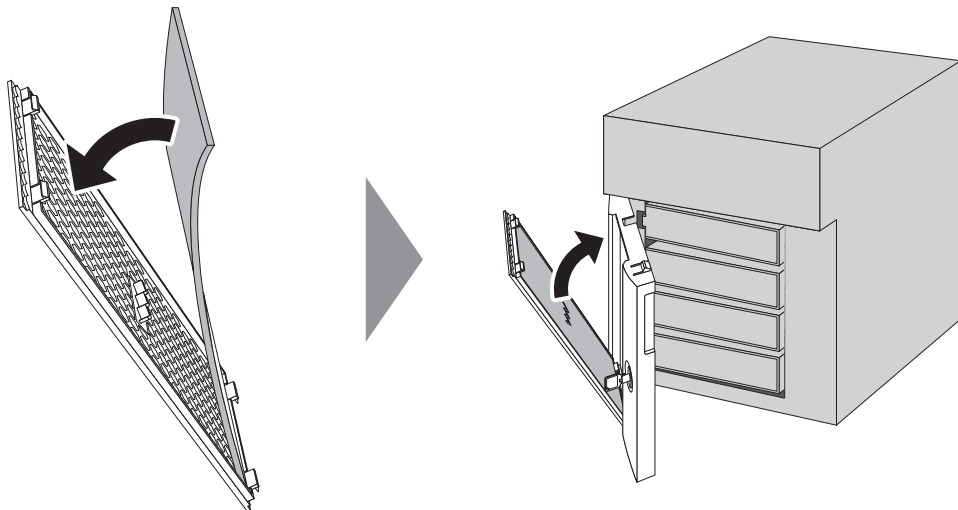

**5** Close the front cover.

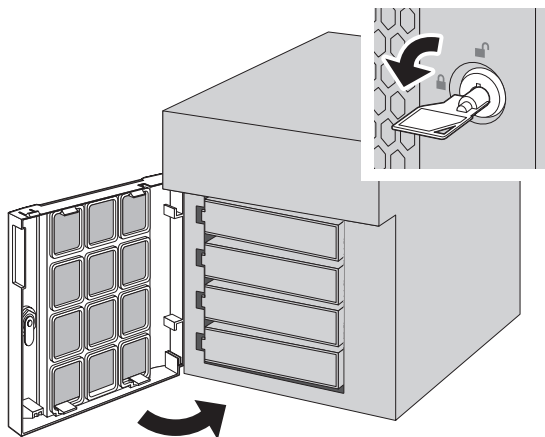

# Chapter 12 Utilities

---

## NAS Navigator2

---

NAS Navigator2 is a utility program that makes it easy to display Settings, change the Buffalo NAS device's IP address, or check its drives. To install NAS Navigator2, refer to the appropriate procedure below for your computer.

### Windows

---

The NAS Navigator2 installer for a Windows computer is available from the d.buffalo website, accessible from either <https://d.buffalo.jp/TS3010/> or <https://d.buffalo.jp/TS3020/>. For TeraStation Essentials users, the NAS Navigator2 installer is available from the same TS3020 URL.

Once you have accessed the URL, select the region and model to go to your specific model's d.buffalo website.

Download the NAS Navigator2 installer and install the utility onto your computer.

Refer to the software help for more detailed information on operating the software. To open the help, launch NAS Navigator2 and navigate to *Menu > Help*.

### macOS

---

The NAS Navigator2 app for a macOS computer is available from Mac App Store. Download the app and install it.

Refer to the software help for more detailed information on operating the software. To open the help, launch NAS Navigator2 and navigate to *Help > NAS Navigator2 Help* from the menu bar.

---

## NovaBACKUP

---

NovaBACKUP is a Windows utility that lets you back up data on your computer.

The NovaBACKUP installer is available from the d.buffalo website, accessible from either <https://d.buffalo.jp/TS3010/> or <https://d.buffalo.jp/TS3020/>. For TeraStation Essentials users, the NovaBACKUP installer is available from the same TS3020 URL.

Once you have accessed the URL, select the region and model to go to your specific model's d.buffalo website.

Download the NovaBACKUP installer and install the utility onto your computer.

To download the installer, you will need the serial number of your TeraStation. The serial number is printed on the label on the back or the top of the unit. For the TS3410RN, TS3420RN, and TS3420RS TeraStation models, the serial number can be found on the front as well. Refer to the "[Diagrams](#)" section in chapter 2 for information on where to find the serial number of your device.



# Chapter 13 Appendix

## Info and Error LEDs

If there is a corresponding corrective action described below for a code, try it first. If the code is still displayed after trying the corrective action, contact Buffalo technical support for assistance.

### Errors

If a critical error occurs, the error LED will glow red. Confirm the current status from the Dashboard in Settings or by using NAS Navigator2. If NAS Navigator2 displays the error as an unknown error, check the Dashboard in Settings for the error details.

Code	Description	Corrective Action
E10	The TeraStation is running on the UPS battery due to a power outage.	Shut down the TeraStation safely and wait until the power outage ends. If certain settings are configured, the TeraStation may shut down automatically when the error is detected.
	If the setting to use the UPS connected to this TeraStation has been configured, the UPS cable may be disconnected.	Verify that the UPS cable or Ethernet cable is connected properly.
	If the setting to use the UPS connected to another TeraStation on the same network has been configured, the Ethernet cable of this TeraStation may be disconnected.	
E11	An error occurred in the fan speed.	Check that no foreign objects or dust are clogging the fan. If any foreign objects or dust are found, use a pair of tweezers, an air duster, or other tools to remove them.
E12	A rise in the system temperature may have exceeded the allowable safety value.	Move the TeraStation to a cool location. Do not place objects in the area around the TeraStation.
E14	The RAID array cannot be mounted.	If the message appears after initial bootup, make sure drives are inserted properly by referring to the <a href="#">"Re-Inserting Drives"</a> section in chapter 11. For all other cases, run a drive check on the RAID array by referring to the <a href="#">"Checking Drives"</a> section in chapter 4.
E16	Unable to find the drive.	Re-insert the drive by referring to the <a href="#">"Re-Inserting Drives"</a> section in chapter 11.
E22	Unable to mount the drive.	Format the drive by referring to the <a href="#">"Formatting Drives"</a> section in chapter 4. After formatting, if the error still appears after rebooting, replace the drive by referring to the <a href="#">"Replacing a Defective Drive"</a> section in chapter 11.

Code	Description	Corrective Action
E27	Unable to find the failover backup TeraStation.	Reconfigure the failover backup TeraStation for failover by referring to the <a href="#">“Configuring Failover”</a> section in chapter 5.
E30	An error occurred, so the drive was removed from the RAID array.	Replace the drive by referring to the <a href="#">“Replacing a Defective Drive”</a> section in chapter 11.
E42	The migration process has been canceled because an error occurred.	Refer to the <a href="#">NAS migration guide</a> for the detailed corrective actions.

## Notices

If a non-critical error occurs, the info LED will glow amber. Confirm the current status from the Dashboard in Settings or by using NAS Navigator2. If NAS Navigator2 displays the error as an unknown error, check the Dashboard in Settings for the error details.

You can click the “Clear” button to delete messages from the Dashboard.

Code	Description	Corrective Action
I10	A rise in the system temperature may have exceeded the allowable safety value.	Move the TeraStation to a cool location. Do not place objects in the area around the TeraStation.
I11	The drive has too many bad sectors.	Replace the drive by referring to the <a href="#">“Replacing a Defective Drive”</a> section in chapter 11.
I12	Operating in degraded mode.	Check if the E30 error is also displayed. If it is, refer to the corrective action for the E30 error.
I33	An error occurred in replication, or synchronization between the main and backup TeraStations failed during failover configuration.	From Settings, navigate to <i>Backup &gt; Replication</i> and click <i>Resync</i> to execute resynchronization. If you configured the subfolders’ access restrictions to be inherited to the replication or failover destination, disable them or change the destination.
I34	A virus was detected during scanning.	Delete the infected files from the quarantine folder.
I44	Initialization from the USB initialization drive was initiated, but the drive in slot 1 was not detected.	Make sure that the drive in slot 1 is present and fully inserted into its slot.
I45	Initialization failed.	-
I49	The main TeraStation in the failover configuration cannot be found.	Make sure that the main TeraStation is on, working, and connected to the network.
I54	The backup job failed.	Refer to the <a href="#">“Backup Logs for If Backup Fails”</a> section in chapter 5 and try the respective corrective actions.
I55	Authentication during initialization of settings failed.	Settings can only be restored for the TeraStation whose settings were originally saved.
I59	Boot authentication failed.	Try using manual authentication instead by referring to the <a href="#">“If the TeraStation Cannot Be Accessed”</a> section in chapter 7.

Code	Description	Corrective Action
I64	Connecting to the cloud storage service failed.	Open Settings and check the status of the job that failed for the cloud service. Refer to the error log on the job list of the specific cloud storage service and check the cause of the error.
I66	The free space has decreased to 1% or less.	Increase the free space.
I70	There is not enough space to save file access logs.	Delete file access logs to free up space.
I72	The target folder for saving logs has been changed to the system area.	Reconfigure the settings by referring to the <a href="#">“Changing Archive Rules for File Access Logs”</a> section in chapter 10.
I75	Some items could not be migrated.	Refer to the <a href="#">NAS migration guide</a> for the detailed corrective actions.

## Information Events

After you change any settings, the info LED will glow amber. Confirm the current status from the Dashboard in Settings or by using NAS Navigator2. If NAS Navigator2 displays the status as an unknown error, check the Dashboard in Settings for the status details.

You can click the “Clear” button to delete messages from the Dashboard.

Code	Description	Corrective Action
I01	Checking the system area.	-
I13	Formatting the RAID array.	-
I14	Checking the RAID array.	-
I15	Examining the error status of the RAID array. <b>Note:</b> Transfer speeds are slower during the examination process.	-
I16	Creating the RAID array.	-
I17	Resynchronizing the RAID array. <b>Note:</b> Transfer speeds are slower during resynchronization.	-
I18	Recovering the RAID array. <b>Note:</b> Transfer speeds are slower during the rebuilding process.	-
I19	Rewriting drives in the TeraStation with 0s.	-
I20	Formatting the drive.	-
I21	Checking the drive.	-
I23	The initialization process has been started by using the init button and settings are being initialized.	-
I25	Updating the TeraStation firmware.	Do not turn off the TeraStation’s power.
I26	The initialization process has been started by using Settings and all settings are being initialized.	-
I27	Checking the USB drive.	-
I28	Formatting the USB drive.	-

Code	Description	Corrective Action
I31	Appears before the function button is pressed in order to use a newly-inserted drive.	Press the function button. If the RAID array enters degraded mode, the array will be rebuilt using the new drive. Otherwise, the new drive will be set as a hot spare. To use a drive as normal instead of a hot spare drive, refer to the <a href="#">“Drive Replacement for a Hot Spare”</a> section in chapter 11.
I32	Appears after replacing the drive when the RAID array needs to be rebuilt in Settings or formatting is necessary.	From Settings, either recover the RAID array or format the drive.
I37	The initialization process has been started by using the USB initialization drive and settings are being initialized.	-
I38	Settings initialization is finished.	-
I40	Beginning settings initialization. All data on the drive in slot 1 will be deleted.	-
I41	Press the function button to start the settings initialization process.	-
I42	Preparing to start the settings initialization process.	-
I43	The TeraStation was started from the USB initialization drive, but the settings cannot be initialized from this USB initialization drive.	-
I46	Data migration or conversion (RAID migration) is in progress.	Do not turn off the TeraStation’s power.
I47	Data migration or conversion (RAID migration) is in progress.	Do not turn off the TeraStation’s power.
I48	This TeraStation is ready to become the failover backup device for the main TeraStation.	Press and hold down the function button of the failover backup TeraStation until it stops beeping to accept failover backup status.
I50	Failover maintenance is in progress.	Do not turn off the TeraStation’s power.
I51	Initializing the failover configuration.	Do not turn off the TeraStation’s power.
I52	A new firmware version has been released.	Update the firmware by referring to the <a href="#">“Updating the Firmware”</a> section in chapter 10.
I61	The unit is in drive setup mode.	Recover from drive setup mode by referring to the <a href="#">“Power LED Keeps Blinking”</a> section in chapter 11.
I65	The free space has decreased past the configured threshold percentage.	Increase the free space or change the threshold to a lower value.
I71	The space is occupied so older logs were removed.	Delete file access logs to free up space.
I73	Data or settings migration is in progress.	-
I74	Data or settings migration has finished.	Refer to the <a href="#">NAS migration guide</a> for the detailed corrective actions.

## Default Settings

Administrator's Name	admin	
Password	password	
Shared Folders	<p>"share"* and "info"*** for both Windows and macOS computers.          *The recycle bin is enabled by default.          **It is a read-only share.</p>	
IP Address	<p>The TeraStation will get its IP address automatically from a DHCP server on the network. If no DHCP server is available, then an IP address will be assigned as follows:          IP Address: 169.254.xxx.xxx ("xxx" is a number randomly assigned when booting the TeraStation.)          Subnet Mask: 255.255.0.0</p>	
Registered Groups	<p>"hdusers", "admin", and "guest"          You cannot edit or delete these default groups.</p>	
Microsoft Network Group Settings	WORKGROUP	
MTU Size	1,500 bytes	
SMB	Enabled	
	SMB Protocol	Auto
	SMB Signing	Default
	Recycle Bin Permissions	All users
	macOS Temp Files	Keep when original file is deleted
	Action When Authentication Fails	Log in as guest
AFP	Enabled	
	AppleDouble Format	appledouble = ea
FTP	Disabled	
SFTP	Disabled	
WebAccess	Disabled	
NFS	Disabled	
rsync	Disabled	
RAID Scanning	Disabled	
iSCSI	Disabled	
Amazon S3	Disabled	
Box Storage Sync	Disabled	
Dropbox Sync	Disabled	
Microsoft Azure Storage Sync	Disabled	
Microsoft OneDrive Sync	Disabled	
Antivirus	Disabled	
SNMP	Disabled	
Replication	Disabled	
Time Machine	Disabled	
Name/Time/Language	NTP	Enabled
Email Notification	Disabled	
Initialize	Init Button Settings	Restore admin username and password to factory defaults
Boot Authentication	Disabled	

RAID Mode	TS3210DN, TS3220DN: RAID 1 TS3410DN, TS3420DN, TS3410RN, TS3420RN (partially-populated model): RAID 1 TS3410DN, TS3420DN, TS3420DS, TS3410RN, TS3420RN, TS3420RS: RAID 5
-----------	--

## Specifications

Check the [Buffalo website](#) for the latest product information and specifications.

For the information on the TS3020 series TeraStations and TeraStation Essentials, refer to the "[TeraStation 3020 and TeraStation Essentials Models](#)" section below.

### TeraStation 3010 Models

LAN Interface	Standards Compliance	IEEE 802.3ab (1000BASE-T), IEEE 802.3u (100BASE-TX), IEEE 802.3 (10BASE-T)
	Data Transfer Rates	10/100/1000 Mbps (auto sensing)
	Number of Ports	2
Common Specs for LAN Interface	Connector Type	RJ-45 8-pin (auto MDI-X)
	Supported Protocols	TCP/IP
	Network File Services	SMB/CIFS, AFP, FTP/SFTP, NFS, HTTP/HTTPS
	MTU Sizes	1,500–9,216 bytes
USB Interface	Standards Compliance	USB 3.2 Gen 1
	Data Transfer Rates	Max. 5 Gbps
	Number of Ports	TS3210DN, TS3410DN: 2 TS3410RN: 3
	Connector Type	Type A
Internal Drive	Number of Drive Bays	TS3210DN: 2 TS3410DN, TS3410RN: 4
	Drive Interface	SATA 6 Gbps
	Supported RAID	TS3210DN: 0, 1, JBOD (individual drives) TS3410DN, TS3410RN: 0, 1, 5, 6, 10, JBOD (individual drives)
	Replacement Drive	Buffalo OP-HDN series drive <b>Note:</b> The replacement drive should be the same capacity or larger as the original drive. The drives listed above are available from the <a href="#">Buffalo website</a> .

Others	Power Supply	TS3210DN, TS3410DN: AC 100–240 V, 1.5 A, 50/60 Hz TS3410RN: AC 100–240 V, 2.5–1.25 A, 50/60 Hz
	Dimensions (W × H × D, excluding protruding parts)	TS3210DN: 170 × 170 × 230 mm (6.7 × 6.7 × 9.1 in.) TS3410DN: 170 × 215 × 230 mm (6.7 × 8.5 × 9.1 in.) TS3410RN: 430 × 44.3 × 430 mm (16.9 × 1.7 × 16.9 in.)
	Weight	TS3210DN: approx. 4.8 kg (10.6 lbs) TS3410DN: approx. 7.0 kg (15.4 lbs) TS3410DN (partially-populated model): approx. 5.6 kg (12.3 lbs) TS3410RN: approx. 8.5 kg (18.7 lbs) TS3410RN (partially-populated model): approx. 6.8 kg (15.0 lbs)
	Maximum Power Consumption	TS3210DN, TS3410DN: 85 W TS3410RN: 100 W
	Operating Environment	Temperature: 0–40°C (32–104°F) Humidity: 10–85% non-condensing
	Compatible Devices	Windows PCs, Apple silicon- and Intel-based Mac computers with wired or wireless Ethernet connection.
	Supported OS	Windows 11, 10, 8.1, 7 SP1 or later Windows Server 2022, 2019, 2016, 2012 R2, 2012, 2008 R2, 2008 macOS 13.0, 12.0, 11.0, 10.15, 10.14, 10.13, 10.12, 10.11, 10.10, 10.9

## TeraStation 3020 and TeraStation Essentials Models

1GbE LAN Interface	Standards Compliance	IEEE 802.3ab (1000BASE-T), IEEE 802.3u (100BASE-TX), IEEE 802.3 (10BASE-T)
	Data Transfer Rates	10/100/1000 Mbps (auto sensing)
	Number of Ports	1
2.5GbE LAN Interface	Standard Compliance	IEEE 802.3bz (2.5GBASE-T), IEEE 802.3ab (1000BASE-T), IEEE 802.3u (100BASE-TX)
	Data Transfer Rates	2.5 Gbps, 100/1000 Mbps (auto sensing)
	Number of Ports	1
Common Specs for LAN Interface	Connector Type	RJ-45 8-pin (auto MDI-X)
	Supported Protocols	TCP/IP
	Network File Services	SMB/CIFS, AFP, FTP/SFTP, NFS, HTTP/HTTPS
	MTU Sizes	1,500–9,216 bytes
USB Interface	Standards Compliance	USB 3.2 Gen 1
	Data Transfer Rates	Max. 5 Gbps
	Number of Ports	TS3220DN, TS3420DN, TS3420DS: 2 TS3420RN, TS3420RS: 3
	Connector Type	Type A

Internal Drive	Number of Drive Bays	TS3220DN: 2 TS3420DN, TS3420DS, TS3420RN, TS3420RS: 4
	Drive Interface	SATA 6 Gbps
	Supported RAID	TS3220DN: 0, 1, JBOD (individual drives) TS3420DN, TS3420DS, TS3420RN, TS3420RS: 0, 1, 5, 6, 10, JBOD (individual drives)
	Replacement Drive	TS3220DN, TS3420DN, TS3420RN: Buffalo OP-HDN series drive TS3420DS, TS3420RS: Buffalo OP-HD-2Y series drive <b>Note:</b> The replacement drive should be the same capacity or larger as the original drive. The drives listed above are available from the <a href="#">Buffalo website</a> .
Others	Power Supply	TS3220DN, TS3420DN, TS3420DS: AC 100–240 V, 1.2 A, 50/60 Hz TS3420RN, TS3420RS: AC 100–240 V, 2.5–1.25 A, 50/60 Hz
	Dimensions (W × H × D, excluding protruding parts)	TS3220DN: 170 × 170 × 230 mm (6.7 × 6.7 × 9.1 in.) TS3420DN, TS3420DS: 170 × 215 × 230 mm (6.7 × 8.5 × 9.1 in.) TS3420RN, TS3420RS: 430 × 44.3 × 430 mm (16.9 × 1.7 × 16.9 in.)
	Weight	TS3220DN: approx. 4.7 kg (10.4 lbs) TS3420DN, TS3420DS: approx. 7.0 kg (15.4 lbs) TS3420DN (partially-populated model): approx. 5.2 kg (11.5 lbs) TS3420RN, TS3420RS: approx. 8.6 kg (19.0 lbs) TS3420RN (partially-populated model): approx. 6.7 kg (14.8 lbs)
	Maximum Power Consumption	TS3220DN, TS3420DN, TS3420DS: 85 W TS3420RN, TS3420RS: 100 W
	Operating Environment	Temperature: 0–40°C (32–104°F) Humidity: 10–85% non-condensing
	Compatible Devices	Windows PCs, Apple silicon- and Intel-based Mac computers with wired or wireless Ethernet connection.
	Supported OS	<ul style="list-style-type: none"> <li>• <b>TS3220DN, TS3420DN, and TS3420RN:</b> Windows 11, 10, 8.1, 7 SP1 or later Windows Server 2022, 2019, 2016, 2012 R2, 2012 macOS 13.0, 12.0, 11.0, 10.15, 10.14, 10.13, 10.12, 10.11</li> <li>• <b>TS3420DS and TS3420RS:</b> Windows 11, 10, 8.1 Windows Server 2022, 2019, 2016, 2012 R2 macOS 13.0, 12.0, 11.0, 10.15, 10.14, 10.13, 10.12, 10.11</li> </ul>