

User Manual

# 04LS Slate Touch Monitor



No part of this publication may be reproduced, transmitted, transcribed, stored in a retrieval system, or translated into any language or computer language, in any form or by any means, including, but not limited to, electronic, magnetic, optical, chemical, manual, or otherwise without prior written permission of Elo Touch Solutions, Inc.

## Disclaimer

The information in this document is subject to change without notice. Elo Touch Solutions, Inc. and its Affiliates (collectively “Elo”) make no representations or warranties with respect to the contents herein, and specifically disclaim any implied warranties of merchantability or fitness for a particular purpose. Elo reserves the right to revise this publication and to make changes from time to time in the content hereof without obligation to notify any person of such revisions or changes.

## Trademark Acknowledgments

Elo, Elo (logo), Elo Touch, Elo Touch Solutions, and TouchPro are trademarks of Elo and its Affiliates. Windows is a trademark of Microsoft Corporation.

# Table of Contents

Section 1: Introduction..... 4

Section 2: Installation ..... 5

Section 3: Hardware Installation..... 7

Section 4: Operation..... 10

Chapter 5: Technical Support..... 21

Section 6: Safety & Maintenance ..... 23

Section 7: Regulatory Information ..... 24

Section 8: Warranty Information..... 32

# Section 1: Introduction

## Product Description

Your new touch monitor combines the latest developments in touch technology and display design with reliability for use in high-traffic environments.

This touch monitor incorporates an active matrix thin-film-transistor LCD panel to provide high-quality display performance. ET1304LS/ET1504LS supporting full HD 1920 x 1080. ET0704LS/ET1004LS supporting 1280 x 800. Its LED backlight significantly reduces power consumption and eliminates the need for mercury (compared to CCFL-backlit panels). Other features that enhance this LCD monitor's display performance are USB-C (display, touch and video) only connectivity, Plug & Play compatibility, a touch-enabled menu with on-screen display (OSD) controls, and extremely thin design with optimized narrow PCAP borders.

## Precautions

Follow all warnings, precautions and maintenance as recommended in this user manual to maximize the life of your unit and prevent risks to user safety. See the Safety & Maintenance Section for more information.

This manual contains information that is important for the proper setup and maintenance of the unit. Before setting up and powering on your new Touch monitor, read through this manual, especially the Mounting, Hardware Installation and Operation chapters.

# Section 2: Installation

## Unpacking the Touch monitor

Open the carton and verify that the following items are present:

- Touch monitor
- Quick Installation Guide
- Fully-featured USB Type-C cable

## Connector Panel

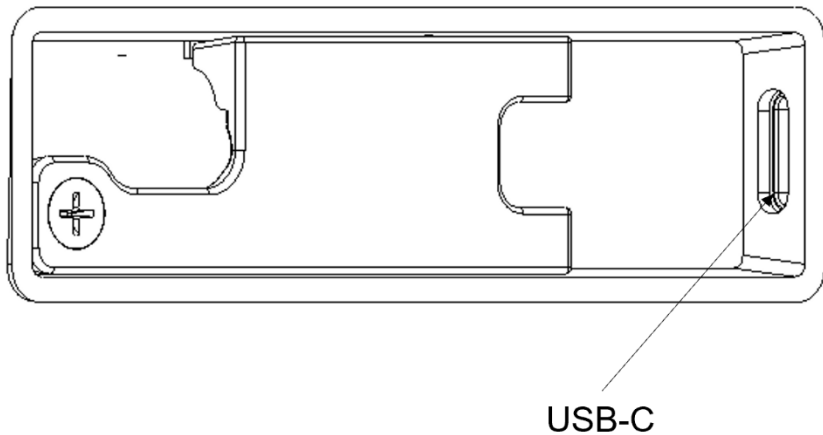

Note: The cable guard cover is secured by screws. You need to remove it before inserting the cable, and then install the cover and secure the screws after inserting the cable.

## Connecting the Touch Monitor

1. Connect one end of the Type-C cable to the monitor's Type-C input connector and the other end to your Type-C video source. (Once the connection is complete, tighten the screws for optimal performance.)
2. The touch monitor ships in an OFF state. Press the power button (on the rear of the machine) to turn it on.

## Installing Touch Technology Software Drivers

No additional drivers are required for your projected-capacitive Touch Monitors with Windows 7 or 10 operating systems. It uses Windows HID drivers. If the monitor is used with the Windows XP operating system, follow the steps below to install the Windows XP touch driver.

To download the latest touch drivers:

1. Please Visit <https://www.elotouch.com/support/downloads#/>
2. Select the "Operating System" from the "Operating System" dropdown menu.
3. Select the technology from the "Technologies" dropdown menu.
4. Download the driver version required for your touch monitor.

# Section 3: Hardware Installation

## Default Rear VESA Mount

A four-hole 75 x 75mm mounting interface for M4 screws is provided on the rear of the monitor. The interface is compatible with mounts that meet the VESA MISD, 75, C standard as defined by VESA FDMI.

Screw: M4 X4  
Maximum thread depth: 4mm  
Material: Steel

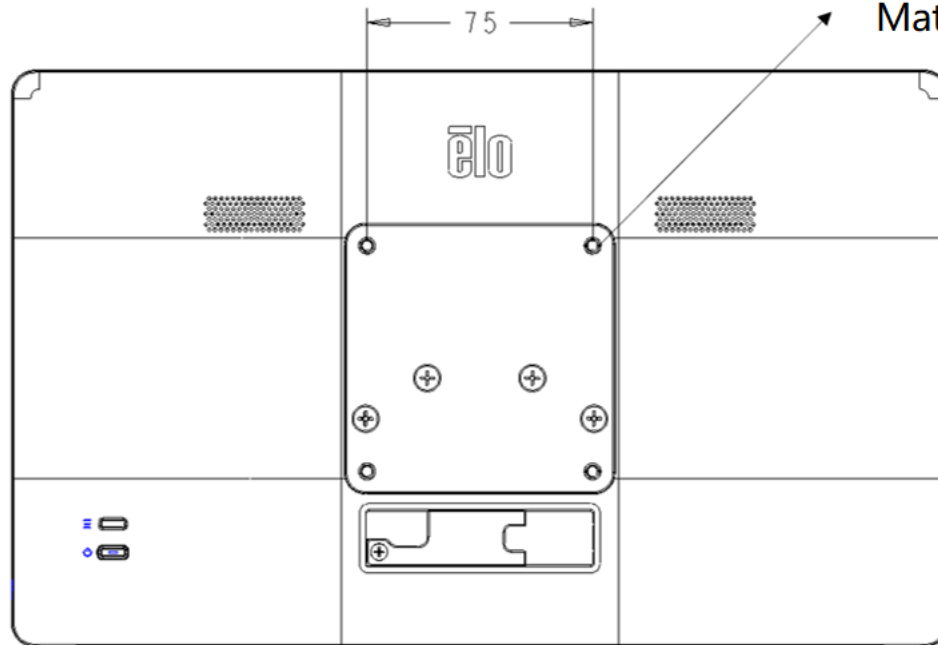

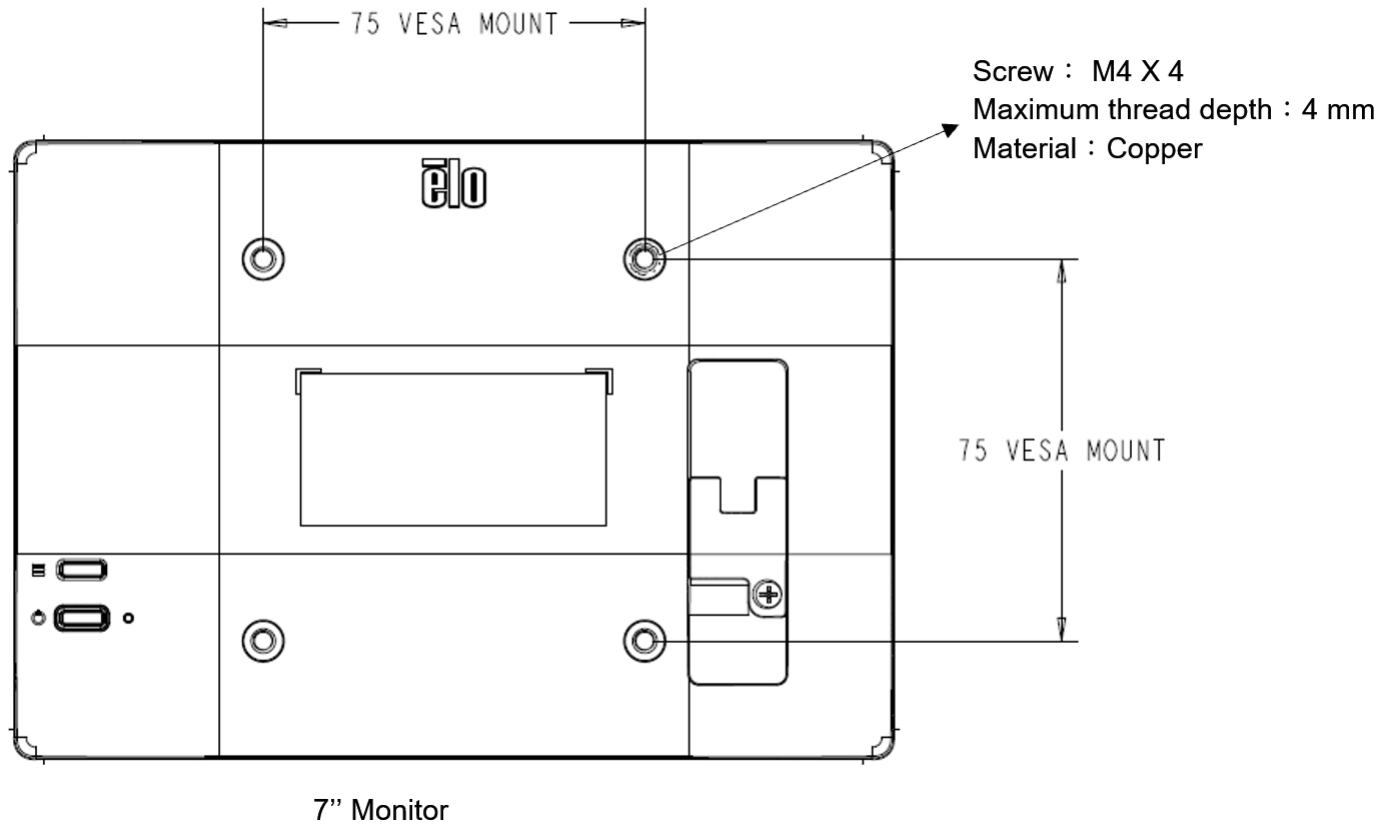

## Adaptation to ELO Z-HINGE Installation

The monitor is shipped from the factory with the VESA-compliant 75mm accessory installed by default. To mount the monitor for use on the Z10 POS STAND(E767159) remove the four M4 screws shown below with a screwdriver to remove the VESA-compliant accessory.

The 7-inch monitor comes with 75x75mm VESA mounting hole. To install the monitor on the Z10 POS STAND (E767159), you need to install the Z-HINGE adapter provided in the Z10 POS STAND accessory, or install it on the back of the Z10 POS STAND for CFD.



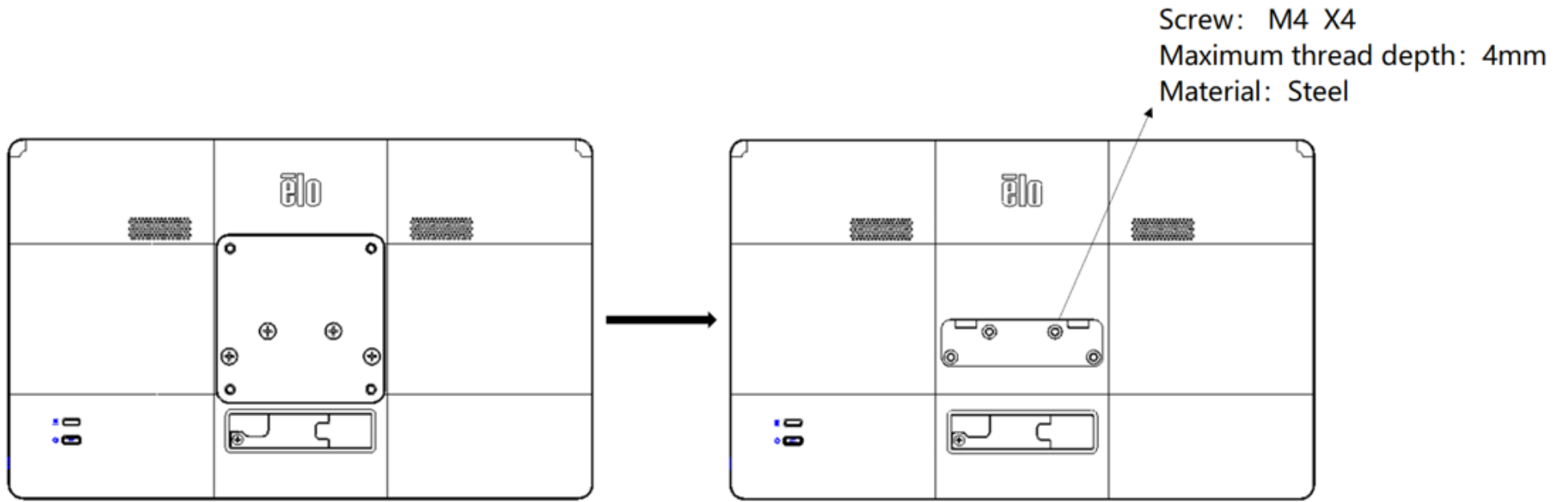

Note: Please refer to the Z10 POS Stand(E767159) installation instructions for detailed mounting of the base.

# Section 4: Operation

## POWER

To turn the touch monitor on or off, press the Monitor power button once.

The Power Status LED on the back of the touch monitor functions as follows:

| Touch monitor Status | LED Status  |
|----------------------|-------------|
| OFF                  | OFF         |
| Sleep mode           | Blinking    |
| ON                   | ON ( Green) |

The system consumes low power when in SLEEP or OFF modes. For detailed power-consumption specifications, refer to the technical specifications on the Elo website <http://www.elotouch.com>

Touching the screen will bring the attached host PC out of SLEEP mode (similar to moving the mouse or pressing a keyboard key).

To improve reliability and reduce wasteful power consumption, disconnect the TYPE-C cable from the monitor if long periods of disuse are planned.

## Touch

No calibration is required for projected capacitive touch technology. Your touch monitor can support up to 10 touches at once.

## Projected Capacitive Touch Technology

When connected to Windows 7 or 10 computers, the touch monitor can detect 10 simultaneous touches. When the touch monitor is connected to Windows XP computers, it detects only a single touch.

No additional drivers are required for this technology to work with Windows 7 or 10, as it uses Windows HID drivers.

Refer to Section 2, "Installing the Touch Technology Software Drivers," for instructions on downloading touch drivers for Windows XP.

No calibration is required for this technology.

## Gesture Support

TouchPro PCAP technology enables several gestures that support single and multiple touches. Refer to the Microsoft website at <http://msdn.microsoft.com/en-us/library/dd940543> on the various gestures that are supported in Windows 7, 10 and later OS versions.



## Video

A display's native resolution is its width and height measured in pixels. Generally, for best performance, an image displayed on this monitor will look best when your computer's output resolution matches this monitor's native resolution, which is 1920 x 1080 on the 1304LS.

For a computer output at non-native resolutions, the monitor will scale the video to its panel's native resolution. This involves stretching or compressing the input image as needed in the X and Y dimensions to fit the display's native resolution. An unavoidable byproduct of the scaling algorithms is a loss of fidelity when the computer's output video image is scaled by the monitor to fit the display. This loss of fidelity is most apparent when viewing feature-rich images at close distances (e.g., images containing small-font text).

## On-Screen Display (OSD)

Two buttons are located on the rear of the monitor, corresponding to the following functions:

| Button   | Key         | Features             |
|--|-------------|----------------------|
|   | Menu button | Open/Exit OSD menu   |
|  | Power key   | Power on/off display |





The OSD menu of the 04LS Slate Touch Monitor series allows you to adjust the parameters of the monitor by single touch interaction.

Press the Menu button to display the OSD main menu on the screen.

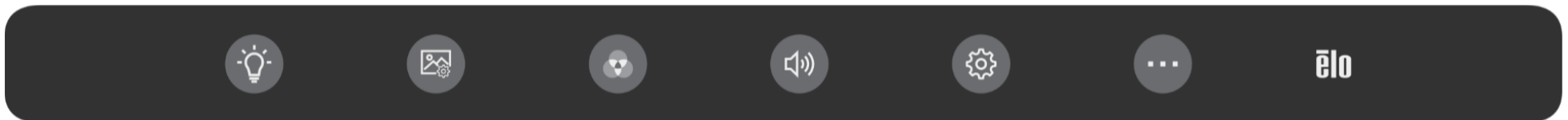
Touch the OSD menu icons to display the corresponding submenus and their parameters.

To hide the OSD menu, press the menu button again, or touch anywhere outside the menu.



| Menu   | Options        | Available Adjustment   |
|--|----------------|--|
| <br>Luminance Setting | Brightness     | Increase/decrease monitor brightness. Default: 100.  |
|  | Contrast       | Increase/decrease monitor contrast. Default: best gray-shade performance.  |
| <br>Image Adjustment  | Aspect Ratio   | <p>Switch the scaling method between fill screen and original ratio settings. Default: Full Screen<br/> Full Screen: Scales the X and Y dimensions of the input video (up or down as needed) to the display's native resolution.</p> <p>Original ratio setting: maintain the input video's aspect ratio (and fills the rest of the display with equal black bars on the left and right). Assuming a landscape orientation and an input video with an aspect ratio smaller than 16:9, scale the Y dimension of the input video (up or down as needed) to the display's Y resolution, scales the X-dimension.</p> <p><i>Other touchscreen technologies may need recalibration when switching between Aspect Ratio options.</i></p> |
|  | Sharpness      | <p>Adjusts sharpness of the displayed images. Default: no sharpness adjustment</p> <p><i>Only applicable at non-native input video resolutions</i></p>   |
| <br>Color Setting    | Color          | Select the display's color temperature. The available Color are 9300K, 7500K, 6500K, 5500K, Color Enhance, and User. If the User option is selected, the user can change the color temperature by individually changing the gains for red, green, and blue (ranging from 0 to 100). Default: User with R, G, and B all set to 100.   |
|  | Low Blue Light | Turn on/off low blue light function. Default: Off  |
| <br>Sound Setting   | Mute           | Mute/Unmute the monitor's internal speakers.<br>Default: Unmuted   |
|  | Volume         | <p>Adjust the sound volume</p> <p>Default: 50, can be adjusted between 0 and 100 (When only 5V power is supplied from the Source side, the default value of volume is 30, can be adjusted between 0 and 30)</p>  |
| <br>OSD Setting     | OSD Timeout    | <p>Adjust how long a period of OSD inactivity the touch monitor will wait before closing the OSD. The adjustable range is between 5 and 60 seconds.</p> <p>Default: 15 seconds</p>   |
|  | Language       | Select which language the OSD is displayed in. The available languages are English, French, Italian,   |

|  |                     |   |
|--|---------------------|---|
|  |                     | German, Spanish, Simplified Chinese, Traditional Chinese, and Japanese.<br>Default: English |
| <br>Other setting | Touch on Sleep mode | Whether the monitor supports touch control in sleep state<br>Default: On                    |
|  | Power LED           | Turn the power LED on/off<br>Default: On  |
|  | Touch Through       | Turn the Touch Through on/off<br>Default: Off   |
|  | Recall Default      | Restore all factory default settings for OSD-adjustable parameters (except OSD Language).   |

All touch monitor adjustments made through the OSD are automatically saved when the menu disappears. This feature prevents having to re-enter the settings every time the touch monitor is unplugged or powered off. If there is a power failure, the touch display settings will not default to the factory specifications.

## OSD and Power Lockouts

Press and hold the "Menu" buttons for 5 Sec to enable/disable the OSD Locking feature. If the OSD Lock feature is enabled, "OSD Lock" will be displayed when you press the Menu button. No user menu will be displayed.

Press and hold the "Menu" and "POWER" buttons simultaneously for 3 seconds to enable/disable the Power Locking feature. When Power Locking is enabled, pressing the power switch will prompt "Power Button Lock" and will not turn off the monitor.

## ENERGY STAR Certification

The 04LS Slate ET1304LS/ET1504LS Touch Monitor meets Energy Star 8.0 requirements.



ENERGY STAR is a program run by the U.S. Environmental Protection Agency (EPA) and the U.S. Department of Energy (DOE) that promotes energy efficiency.

This product qualifies for ENERGY STAR in the “factory default” settings and this is the setting in which power savings will be achieved. Changing the factory default picture settings or enabling other features will increase power consumption that could exceed the limits necessary to qualify for an ENERGY STAR rating.

For more information on the ENERGY STAR program, refer to [energystar.gov](http://energystar.gov).

## TUV Low Blue Light

The 04LS Slate Touch Monitor is certified by TUV Rheinland for low blue light, which reduces the damage of the monitor to human eyes. Refer to the following for details.

### **Low blue light (software solutions)**

The monitor industry has two different approaches to reducing blue light: one uses software solutions and the other uses hardware solutions.

Software solutions typically reduce blue light by reducing emissions from the blue light channel or applying blue light filters.

The 04LS Slate Touch Monitor achieves low blue light by reducing emissions from the blue light channel.

TUV Rheinland tested the product and determined it to be effective in reducing harmful blue light.

The keyword "Low Blue Light (Software Solution)" confirms that the product meets TUV Rheinland's testing standards.

**Refer to the OSD operating instructions for how to enable the low blue light.**

## TUV Flicker Free(Only ET0704LS Support)

TÜV Rheinland has tested this product to ascertain whether the display produces visibly and invisible flicker for the human eye and therefore strains the eye of the user.

The keyword "Flicker Free" confirms that the device has no visible and invisible flicker defined in this standard within the range of 0 - 3000 Hz under various brightness settings.

## Break time, eye excises, Look at distance objects, Neck Exercises

To reduce your risk for computer vision syndrome and neck, back and shoulder pain, take frequent screen breaks during your work day (at least one 10-minute break every hour). During these breaks, stand up, move about and stretch your arms, legs, back, neck and shoulders to reduce tension and muscle fatigue. Another cause of computer eye strain is focusing fatigue. To reduce your risk of tiring your eyes by constantly focusing on your screen, look away from your computer at least every 20 minutes and gaze at a distant object (at least 20 feet away) for at least 20 seconds. Some eye doctors call this the "20-20-20 rule." Looking far away relaxes the focusing muscle inside the eye to reduce fatigue. Another exercise is to look far away at an object for 10-15 seconds, then gaze at something up close for 10-15 seconds. Then look back at the distant object. Do this 10 times. This exercise reduces the risk of your eyes' focusing ability to "lock up" (a condition called accommodative spasm) after prolonged computer work

### Exercises for the eyes

1. Keep the body and the head upright. Turn the eyes up to look at the ceiling. then turn down to look at the floor.
2. Turn the eyes left and right slowly to look at objects on the two sides.
3. Turn the eyes to look at objects at the right upper direction and then the right lower direction. Repeat for the left upper and left lower directions.

### Exercises for the neck

Keep the arms relaxed at your side.

Bend your head forward slightly to stretch the neck

Hold for 5 seconds.

Keep the arms relaxed at your side.

Turn the head to one side and hold for 5 seconds.

Repeat for the other side.

Keep the arms relaxed at your side.

Swing the head to the left and hold for 5 seconds.

Repeat for the other side.

# Chapter 5: Technical Support

If you are experiencing trouble with your touch monitor, refer to the following suggestions.

If the problem persists, please contact your local dealer or contact Elo Touch Solutions Customer Service. Worldwide technical support phone numbers are available on the last page of this user manual.

## Solutions to Common Problems

| Problem  | Suggested Troubleshooting  |
|--|--|
| The Monitor does not respond when turning on the system. | Check that the TYPE -C cable is properly connected.  |
| Monitor display is dim.                                  | Use the OSD to increase the brightness. Use the OSD to increase the contrast.  |
| Monitor shutdowns and restarts automatically             | Host can NOT supply enough energy. Decrease the volume and brightness of the monitor.  |
| Monitor display is blank.                                | If the Power Status LED is blinking, the monitor or Computer Module may be in SLEEP mode. Press any key/move the mouse/touch the touchscreen to see if the image reappears. Check that the signal source device is turned on.<br>Check that there are no loose cable connections. Reconnect the TYPE -C cable. |
| Monitor displays the "Out of Range" message.             | Adjust your computer's resolution/timing mode to be within the allowable timing ranges specified for your touch display (see website for specifications)   |
| Monitor display image looks strange.                     | Adjust your computer's resolution/timing mode to be within the allowable timing ranges specified for your touch display (see website for specifications)<br>Use the Auto Adjust function in the OSD.   |
| Touch functionality doesn't work.                        | Verify your PC has the latest Elo drivers installed.<br>Press the POWER button to restart the monitor. Do not touch the screen while the monitor is activated  |
| Neither the OSD nor power buttons respond when pressed.  | Check to see if the OSD lock or power lock functions are on.   |
| There is no response when touching the OSD.              | Check that no other objects are touching the screen.<br>Press the POWER button to restart the monitor. Do not touch the screen while the monitor is activated  |



## Technical Assistance

### Technical Specifications

Visit [www.elotouch.com/products](http://www.elotouch.com/products) for technical specifications for this device

### Technical Support

Visit <https://www.elotouch.com/support> for technical support

See this user manual's last page for worldwide technical support phone numbers.

# Section 6: Safety & Maintenance

## Security

- To avoid the risk of electric shock, follow all safety notices and do not disassemble the touch computer. The touch monitors are not user-serviceable.
- Ensure that your installation is equipped to maintain the specified environmental conditions listed in the Technical Specifications Section.
- If you have any questions or need more information about your product, please contact your sales representative or the manufacturer.

## Care and Handling

The following tips will help keep your touch display functioning at an optimal level:

- Disconnect the AC power cable before cleaning.
- To clean the display unit cabinet, use a clean cloth lightly dampened with a mild detergent.
- It is important that your touch computer remains dry. Do not get liquids on or inside the unit. If liquid does get inside, turn the unit off and have a qualified service technician check it before you power it on again.
- Do not wipe the screen with a cloth or sponge that could scratch the surface. To clean the touchscreen, use a window or glass cleaner applied to a clean cloth or sponge. Never apply the cleaner directly to the touchscreen. Please use the following link to access the cleaning guide.
- <https://www.elotouch.com/support/technical-support/cleaning>
- Ensure the environmental temperature and humidity are maintained within specifications and do not block ventilation slots.
- Monitors are not designed for outdoors.

## Waste Electrical & Electronic Equipment Directive (WEEE)



This product should not be disposed of with household waste. It should be deposited at a facility that enables recovery and recycling.

# Section 7: Regulatory Information

## Electrical Safety Information

Compliance is required with respect to the voltage, frequency, and current requirements indicated on the manufacturer's label. Connection to a power source different than those specified herein will likely result in improper operation or damage to the equipment, or pose a fire hazard.

There are no user-serviceable parts inside this equipment. There are hazardous voltages generated by this equipment that constitute a safety hazard. Service should be provided by a qualified service technician only.

Contact a qualified electrician or the manufacturer if there are questions about the installation prior to connecting the equipment to mains power.

## Emissions and Immunity Information

### **Notice to Users in the United States:**

This equipment has been tested and found to comply with the limits for a Class B digital device, pursuant to part 15 of the FCC Rules. These limits are designed to provide reasonable protection against harmful interference in a residential installation. This equipment generates, uses and can radiate radio frequency energy and, if not installed and used in accordance with the instructions, may cause harmful interference to radio communications.

This device complies with Part 15C of FCC Rules. Operation is subject to the following two conditions:

- (1) This device may not cause harmful interference; and
- (2) This device must accept any interference received, including interference that may cause undesired operation.

**Notice to Users in Canada:**

This equipment complies with the Class B limits for radio noise emissions from a digital apparatus as established by the Radio Interference Regulations of Industrial Canada.

CAN ICES(B)/NMB(B)

This device complies with Industry Canada's license-exempt RSSs. Operation is subject to the following two conditions:

- (1) This device may not cause interference; and
- (2) This device must accept any interference, including interference that may cause undesired operation of the device.

Le présent appareil est conforme aux CNR d'Industrie Canada applicables aux appareils radio exempts de licence. L'exploitation est autorisée aux deux conditions suivantes :

- (1) l'appareil ne doit pas produire de brouillage; et
- (2) l'utilisateur de l'appareil doit accepter tout brouillage radioélectrique subi, même si le brouillage est susceptible d'en compromettre le fonctionnement.

**Notice to Users in the European Union:**

Use only the provided power cords and interconnecting cabling provided with the equipment. Substitution of provided cords and cabling may compromise electrical safety or CE Mark Certification for emissions or immunity as required by the following standards:

This Information Technology Equipment (ITE) is required to have a CE Mark on the Manufacturer's label, which means that the equipment has been tested to the following Directives and Standards: This equipment has been tested to the requirements for the CE Mark as required by EMC Directive 2014/30/ EU as indicated in European Standard EN 55032 Class B and the Low Voltage Directive 2014/35/EU as indicated in European Standard EN 62368-1.

**General Information to all Users:**

This equipment generates, uses and can radiate radio frequency energy. If not installed and used according to this manual, the equipment may cause interference with radio and television communications. There is, however, no guarantee that interference will not occur in any particular installation due to site-specific factors.

1. In order to meet emission and immunity requirements, the user must observe the following:
  - a. Use only the provided I/O cables to connect this digital device with any computer.
  - b. To ensure compliance, use only the provided manufacturer's approved line cord.
  - c. The user is cautioned that changes or modifications to the equipment not expressly approved by the party responsible for compliance could void the user's authority to operate the equipment.
  
2. If this equipment appears to cause interference with radio or television reception, or any other device:
  - a. Verify as an emission source by turning the equipment off and on. If you determine that this equipment is causing the interference, try to correct the interference by using one or more of the following measures:
    - i. Move the digital device away from the affected receiver.
    - ii. Reposition (turn) the digital device with respect to the affected receiver.
    - iii. Reorient the affected receiver's antenna.
    - iv. Plug the digital device into a different AC outlet so the digital device and the receiver are on different branch circuits.
    - v. Disconnect and remove any I/O cables the digital device is not using. (Unterminated I/O cables are a potential source of high RF emission levels.)
    - vi. Plug the digital device into a grounded outlet only. Do not use AC adapter plugs.  
(Removing or cutting the line cord ground may increase RF emission levels and may also present a lethal shock hazard to the user.)

If you need additional help, consult your dealer, manufacturer, or an experienced radio or television technician.



11 March 2024

## FCC Declaration of Conformity

Per FCC 47 CFR FCC Part15 subpart B Section 2.1077(a)  
In accordance with FCC Rules and Regulations

**Model Number:** ET1304LS, ET1504LS, ET0704LS,ET1004LS

**Equipment Category:** Information Technology and Telecommunications Equipment

**Equipment Class:** Commercial and Light Industrial

**Product Name:** Touch Monitor

**Manufacturer:** Elo Touch Solutions, Inc.  
670 N. McCarthy Blvd.  
Suite 100  
Milpitas, CA 95035  
[www.elotouch.com](http://www.elotouch.com)

**Trademark:** 

### Declaration:

This device complies with Part 15 of the FCC Rules. Operation is subject to the following two conditions:  
(1) This device may not cause harmful interference, and  
(2) this device must accept any interference received, including interference that may cause undesired operation



Kevin Huang  
Senior Director, Systems Engineering  
Elo Touch Solutions, Inc.

Elo Touch Solutions | 670 N. McCarthy Blvd., Suite 100 | Milpitas, CA 95035 | 800 ELO TOUCH | +1 408 597 8000 | [www.elotouch.com](http://www.elotouch.com)

## Agency Certifications

The following certifications and marks have been issued or declared for this monitor:

- Canada CUL, IC
- CE (Europe)
- UKCA(United Kingdom)
- KCC (Korea)
- BSMI (Taiwan)
- FCC, UL (US)
- VCCI (Japan)
- CB (International)
- RCM (Australia)
- Mexico NOM
- India BIS
- RoHS, China RoHS, WEEE, REACH
- TUV Rheinland Low Blue Light,
- TUV Rheinland Flick free (only for ET0704LS)
- ENERGY STAR 8.0(only for ET1304LS,ET1504LS)

## China RoHS

In accordance with Chinese law (Administration on the Control of Pollution Caused by Electronic Information Products), the section below lists the names and amounts of the toxic and/or hazardous materials that this product may contain.

| Component Name          | Toxic or Hazardous Substances and Elements |             |              |                            |                                |                                       |
|-------------------------|--|-------------|--------------|----------------------------|--------------------------------|---------------------------------------|
|                         | Lead(Pb)                                   | Mercury(Hg) | Cadmium (Cd) | Hexavalent Chromium (Cr6+) | Polybrominated Biphenyls (PBB) | Polybrominated Diphenyl Ethers (PBDE) |
| Plastic Parts           | O  | O           | O            | O                          | O                              | O                                     |
| Metal Parts             | X  | O           | O            | O                          | O                              | O                                     |
| Wire and Cable Assembly | X  | O           | O            | O                          | O                              | O                                     |
| LCD Panel               | X  | O           | O            | O                          | O                              | O                                     |
| Touch-Screen Panel      | X  | O           | O            | O                          | O                              | O                                     |
| PCBA                    | X  | O           | O            | O                          | O                              | O                                     |
| Software (CD, etc.)     | O  | O           | O            | O                          | O                              | O                                     |

O: Indicates that the amount of this toxic or hazardous substance contained in all the homogeneous materials for this component is below the limit requirement in SJ/T11363-2006.

X: Indicates that the amount of this toxic or hazardous substance contained in at least one of the homogeneous materials used for this component is above the limit requirement in SJ/T11363-2006.

For items marked with an X, exemptions were taken according to EU RoHS.



## Explanation of Markings

1. In accordance with the SJ/T11364-2006 requirement, the electronic information products are marked with the following pollution control logo. The Environment-Friendly Use Period for this product is 10 years. The product will not leak or mutate under normal operating conditions listed below, so that the use of this electronic information product will not result in any severe environmental pollution, any bodily injury, or damage to any assets.

Operating Temperature: 0 - 40°C / Humidity: 20%-80% (non-condensing).

Storage Temperature: -20 - 60°C / Humidity: 10% - 95% (non-condensing).



2. It is encouraged and recommended that this product be recycled and reused according to local laws. The product should not be thrown away casually.



# Monitor Specifications

---

| <b>Operating Conditions</b> |  |
|-----------------------------|--|
| Temperature                 | 0-40°C                                     |
| Humidity                    | 20%-80% (non-condensing).                  |
| Altitude                    | 0-3,048 m                                  |
| Input Rating                | 5V±5% 3A/9V±5% 3A/15V±5% 1.8A/20V±5% 1.35A |

---

| <b>Storage Conditions</b> |                          |
|---------------------------|--------------------------|
| Temperature               | -20-60°C                 |
| Humidity                  | 10-95% (non-condensing). |
| Altitude                  | 0-12,192 m               |

---

## Section 8: Warranty Information

Except as otherwise stated herein, or in an order acknowledgment delivered to Buyer, Seller warrants to Buyer that the Product shall be free of defects in materials and workmanship. The warranty for the touch monitors and their components is three years.

Seller makes no warranty regarding the model life of components. Seller's suppliers may at any time and from time to time make changes in the components delivered as Products or components.

Buyer shall notify Seller in writing promptly (and in no case later than 30 days after discovery) of the failure of any Product to conform to the warranty set forth above; shall describe in commercially reasonable detail in such notice the symptoms associated with such failure; and shall provide to Seller the opportunity to inspect such Products as installed, if possible. The notice must be received by Seller during the Warranty Period for such a product, unless otherwise directed in writing by the Seller. Within 30 days after submitting such notice, Buyer shall package the allegedly defective Product in its original shipping carton(s) or a functional equivalent and shall ship to Seller at Buyer's expense and risk.

Within a reasonable time after receipt of the allegedly defective Product and verification by Seller that the Product fails to meet the warranty set forth above, Seller shall correct such failure by, at Seller's discretion, either (i) modifying or repairing the Product, or (ii) replacing the Product. Such modification, repair, or replacement and the return shipment of the Product with minimum insurance to Buyer shall be at Seller's expense. Buyer shall bear the risk of loss or damage in transit, and may insure the Product. Buyer shall reimburse Seller for transportation cost incurred for Product returned but not found by Seller to be defective. Modification or repair of Products may, at Seller's discretion, take place either at Seller's facilities or at Buyer's premises. If Seller is unable to modify, repair, or replace a Product to conform to the warranty set forth above, then Seller shall, at Seller's discretion, either refund to Buyer or credit to Buyer's account the purchase price of the Product less depreciation calculated on a straight-line basis over Seller's stated Warranty Period.

These remedies shall be the buyer's exclusive remedies for breach of warranty. Except for the express warranty set forth above, the seller grants no other warranties, express or implied by statute or otherwise, regarding the products, their fitness for any purpose, their quality, their merchantability, their non-infringement, or otherwise. No employee of Seller or any other party is authorized to make any warranty for the goods other than the warranty set forth herein. Seller's liability under the warranty shall be limited to a refund of the purchase price of the product. In no event shall Seller be liable for the cost of procurement or installation of substitute goods by Buyer or for any special, consequential, indirect, or incidental damages.

Buyer assumes the risk and agrees to indemnify Seller against and hold Seller harmless from all liability relating to (i) assessing the suitability for Buyer's intended use of the Products and of any system design or drawing, and (ii) determining the compliance of Buyer's use of the Products with applicable laws, regulations, codes, and standards. Buyer retains and accepts full responsibility for all warranty and other claims relating to or arising from Buyer's products, which include or incorporate Products or components manufactured or supplied by Seller. Buyer is solely responsible for any and all representations and warranties regarding the Products made or authorized by Buyer. Buyer will indemnify Seller and hold Seller harmless from any liability, claims, loss, cost, or expenses (including reasonable attorney's fees) attributable to Buyer's products or representations or warranties concerning same.





# www.elotouch.com

Visit our website for the latest:

- Product Information
- Specifications
- Upcoming Events
- Press Releases
- Software Drivers
- Touch screen Display Newsletter

To find out more about our extensive range of Elo touch solutions, go to **www.elotouch.com**, or call the office nearest you.

---

#### The Americas

Tel +1 408 597 8000

[elosales.na@elotouch.com](mailto:elosales.na@elotouch.com)

#### Europe

Tel +32 16 930 136

[EMEA.Sales@elotouch.com](mailto:EMEA.Sales@elotouch.com)

#### Asia-Pacific

Tel +86 (21) 3329 1385

[EloAsia@elotouch.com](mailto:EloAsia@elotouch.com)

