



# MX953 MFP

---

## User's Guide

# Contents

## Safety information

Conventions .....	6
Product statements .....	6

## Learn about the printer

Finding information about the printer .....	11
Finding the printer serial number .....	12
Printer configurations .....	13
Using the control panel .....	16
Home screen icons .....	17
Colors of the indicator light.....	18
Using the automatic document feeder and scanner glass .....	18
Locating the security slot.....	18
Selecting paper .....	19
Additional printer features and support .....	90

## Set up, install, and configure

Selecting a location for the printer.....	91
Printer ports.....	92
Configuring apps and solutions.....	94
Setting up and using the accessibility features .....	97
Setting up the printer to fax .....	105
Loading paper and specialty media .....	113
Installing and updating software, drivers, and firmware .....	127
Installing hardware options .....	134
Networking .....	284

## Secure the printer

Erasing printer memory .....	289
Erasing printer storage drive .....	289
Restoring factory default settings.....	289
Statement of Volatility.....	289

## Print

Printing from a computer.....	291
Printing from a mobile device.....	292

## User's Guide

Printing from a flash drive .....	293
Configuring confidential jobs .....	295
Printing confidential and other held jobs .....	296
Printing a font sample list .....	297
Printing a directory list.....	297
Placing separator sheets in print jobs .....	297
Canceling a print job .....	297
Adjusting toner darkness.....	297

### Copy

Making copies .....	298
Copying photos .....	298
Copying on letterhead .....	298
Copying on both sides of the paper .....	298
Reducing or enlarging copies.....	299
Collating copies.....	299
Placing separator sheets between copies.....	299
Copying multiple pages onto a single sheet.....	299
Copying cards .....	299
Creating a copy shortcut .....	299

### Email

Configuring the email SMTP settings.....	300
Email service providers .....	302
Sending an email .....	312
Creating an email shortcut .....	312

### Fax

Sending a fax .....	314
Scheduling a fax.....	314
Creating a fax destination shortcut.....	315
Changing the fax resolution .....	315
Adjusting the fax darkness .....	315
Printing a fax log .....	315
Blocking junk faxes .....	315
Holding faxes .....	315
Forwarding a fax .....	316

### Scan

Scanning to a computer .....	317
------------------------------	-----

## User's Guide

Scanning to an FTP server .....	318
Creating an FTP shortcut .....	318
Scanning to a network folder.....	318
Configuring a network folder destination.....	319
Creating a network folder shortcut .....	319
Scanning to a flash drive.....	319

### Printer menus

Menu map .....	321
Device .....	322
Print.....	342
Paper.....	355
Copy .....	359
Fax .....	365
E-mail .....	382
FTP.....	390
USB Drive .....	395
Network/Ports.....	404
Security .....	428
Cloud Services.....	439
Reports.....	439
Troubleshooting.....	441
Forms Merge .....	442
Printing the Menu Settings Page.....	443

### Maintain the printer

Checking the status of parts and supplies .....	444
Configuring supply notifications .....	444
Setting up email alerts.....	444
Generating reports and logs.....	445
Ordering parts and supplies .....	446
Replacing parts and supplies .....	449
Cleaning printer parts.....	485
Saving energy and paper .....	494
Moving the printer to another location.....	495

### Troubleshoot a problem

Print quality problems.....	497
Printer error codes .....	499

## User's Guide

Printing problems .....	516
The printer is not responding .....	537
Unable to read flash drive .....	537
Enabling the USB port.....	538
Clearing jams .....	538
Network connection problems.....	588
Hardware options problems .....	589
Issues with supplies .....	591
Paper feed problems.....	592
Emailing problems.....	594
Faxing problems.....	595
Scanning problems .....	597
Contacting customer support .....	601
<b>Recycle and dispose</b>	
Recycling Lexmark products .....	603
Recycling Lexmark packaging .....	603
<b>Notices</b>	
Product information .....	604
Edition and legal notices .....	604
Specifications .....	608
Environmental and sustainability notices .....	610
Notices for wireless products .....	614
Class A device notices .....	617
Other regulatory notices.....	619
<b>Index .....</b>	<b>621</b>

# Safety information

## Conventions

**Note:** A *note* identifies information that could help you.

**Warning:** A *warning* identifies something that could damage the product hardware or software.

**CAUTION:** A *caution* indicates a potentially hazardous situation that could injure you. Different types of caution statements include:



**CAUTION—POTENTIAL INJURY**

Indicates a risk of injury.



**CAUTION—SHOCK HAZARD**

Indicates a risk of electrical shock.



**CAUTION—HOT SURFACE**

Indicates a risk of burn if touched.



**CAUTION—TIPPING HAZARD**

Indicates a crush hazard.



**CAUTION—PINCH HAZARD**

Indicates a risk of being caught between moving parts.

## Product statements



**CAUTION—POTENTIAL INJURY**

To avoid the risk of fire or electrical shock, connect the power cord to an appropriately rated and properly grounded electrical outlet that is near the product and easily accessible.



**CAUTION—POTENTIAL INJURY**

To avoid the risk of fire or electrical shock, use only the power cord provided with this product or the manufacturer's authorized replacement.



### **CAUTION—POTENTIAL INJURY**

Do not use this product with extension cords, multioutlet power strips, multioutlet extenders, or UPS devices. The power capacity of these types of accessories can be easily overloaded by a laser printer and may result in a risk of fire, property damage, or poor printer performance.



### **CAUTION—POTENTIAL INJURY**

Only a Lexmark Inline Surge Protector that is properly connected between the printer and the power cord provided with the printer may be used with this product. The use of non-Lexmark surge protection devices may result in a risk of fire, property damage, or poor printer performance.



### **CAUTION—POTENTIAL INJURY**

To reduce the risk of fire, use only a 26 AWG or larger telecommunications (RJ-11) cord when connecting this product to the public switched telephone network. For users in Australia, the cord must be approved by the Australian Communications and Media Authority.



### **CAUTION—SHOCK HAZARD**

To avoid the risk of electrical shock, do not place or use this product near water or wet locations.



### **CAUTION—SHOCK HAZARD**

To avoid the risk of electrical shock, do not set up this product or make any electrical or cabling connections, such as the power cord, fax feature, or telephone, during a lightning storm.



### **CAUTION—POTENTIAL INJURY**

Do not cut, twist, bind, crush, or place heavy objects on the power cord. Do not subject the power cord to abrasion or stress. Do not pinch the power cord between objects such as furniture and walls. If any of these things happen, a risk of fire or electrical shock results. Inspect the power cord regularly for signs of such problems. Remove the power cord from the electrical outlet before inspecting it.



### **CAUTION—SHOCK HAZARD**

To avoid the risk of electrical shock, make sure that all external connections (such as Ethernet and telephone system connections) are properly installed in their marked plug-in ports.



### **CAUTION—SHOCK HAZARD**

To avoid the risk of electrical shock, if you are accessing the controller board or installing optional hardware or memory devices sometime after setting up the printer, then turn the printer off, and unplug the power cord from the electrical outlet before continuing. If you have any other devices attached to the printer, then turn them off as well, and unplug any cables going into the printer.



### **CAUTION—SHOCK HAZARD**

To avoid the risk of electrical shock, do not use the fax feature during a lightning storm.



### **CAUTION—SHOCK HAZARD**

To avoid the risk of electrical shock when cleaning the exterior of the printer, unplug the power cord from the electrical outlet and disconnect all cables from the printer before proceeding.



### **CAUTION—POTENTIAL INJURY**

If the printer weight is greater than 20 kg (44 lb), then it may require two or more people to lift it safely.



### **CAUTION—POTENTIAL INJURY**

When moving the printer, follow these guidelines to avoid personal injury or printer damage:

- Make sure that all doors and trays are closed.
- Turn off the printer, and then unplug the power cord from the electrical outlet.
- Disconnect all cords and cables from the printer.
- If the printer has separate floor-standing optional trays or output options attached to it, then disconnect them before moving the printer.
- If the printer has a caster base, then carefully roll it to the new location. Use caution when passing over thresholds and breaks in flooring.
- If the printer does not have a caster base but is configured with optional trays or output options, then remove the output options and lift the printer off the trays. Do not try to lift the printer and any options at the same time.
- Always use the handholds on the printer to lift it.
- Any cart used to move the printer must have a surface able to support the full footprint of the printer.
- Any cart used to move the hardware options must have a surface able to support the dimensions of the options.
- Keep the printer in an upright position.
- Avoid severe jarring movements.
- Make sure that your fingers are not under the printer when you set it down.
- Make sure that there is adequate clearance around the printer.



### CAUTION—TIPPING HAZARD

Installing one or more options on your printer or MFP may require a caster base, furniture, or other feature to prevent instability causing possible injury. For more information on supported configurations, see [www.lexmark.com/multifunctionprinters](http://www.lexmark.com/multifunctionprinters).



### CAUTION—TIPPING HAZARD

To reduce the risk of equipment instability, load each tray separately. Keep all other trays closed until needed.



### CAUTION—HOT SURFACE

The inside of the printer might be hot. To reduce the risk of injury from a hot component, allow the surface to cool before touching it.



### CAUTION—PINCH HAZARD

To avoid the risk of a pinch injury, use caution in areas marked with this label. Pinch injuries may occur around moving parts, such as gears, doors, trays, and covers.



### CAUTION—POTENTIAL INJURY

This product uses a laser. Use of controls or adjustments or performance of procedures other than those specified in the *User's Guide* may result in hazardous radiation exposure.



### CAUTION—POTENTIAL INJURY

The lithium battery in this product is not intended to be replaced. There is a danger of explosion if a lithium battery is incorrectly replaced. Do not recharge, disassemble, or incinerate a lithium battery. Discard used lithium batteries according to the manufacturer's instructions and local regulations.



## WARNING

- **INGESTION HAZARD:** This product contains a button cell or coin battery.
- **DEATH** or serious injury can occur if ingested.
- A swallowed button cell or coin battery can cause **Internal Chemical Burns** in as little as **2 hours**.
- **KEEP** new and used batteries **OUT OF REACH** of **CHILDREN**.
- **Seek immediate medical attention** if a battery is suspected to be swallowed or inserted inside any part of the body.



## Safety information

---

Remove and immediately recycle or dispose of used batteries according to local regulations and keep away from children. Do not dispose of batteries in household trash or incinerate. Even used batteries may cause severe injury or death. Call a local poison control center for treatment information.

Battery type: CR6821

Nominal battery voltage: 3V

Do not force discharge, recharge, disassemble, heat above 60°C (140°F), or incinerate. Doing so may result in injury due to venting, leakage, or explosion resulting in chemical burns.



This product is designed, tested, and approved to meet strict global safety standards with the use of specific manufacturer's components. The safety features of some parts may not always be obvious. The manufacturer is not responsible for the use of other replacement parts.

Refer service or repairs, other than those described in the user documentation, to a service representative.

**SAVE THESE INSTRUCTIONS.**

# Learn about the printer

## Finding information about the printer

What are you looking for?	Find it here
Initial setup instructions	See the setup documentation that came with the printer.
<ul style="list-style-type: none"> <li>• Printer software</li> <li>• Print or fax driver</li> <li>• Printer firmware</li> <li>• Utility</li> </ul>	Go to <a href="http://www.lexmark.com/downloads">www.lexmark.com/downloads</a> .
Interactive <i>User's Guide</i>	Go to <a href="https://support.lexmark.com">https://support.lexmark.com</a> .
How-to videos	Go to <a href="https://infoserve.lexmark.com/ids/idv">https://infoserve.lexmark.com/ids/idv</a> .
Help information for using the printer software.	<p>Help for Microsoft Windows or Macintosh operating systems—Open a printer software program or application, and then click <b>Help</b>.</p> <p> Click  to view context-sensitive information.</p> <div style="background-color: #f0f0f0; padding: 10px; margin-top: 10px;"> <p><b>Notes</b></p> <ul style="list-style-type: none"> <li>• Help is automatically installed with the printer software.</li> <li>• Depending on the operating system, the printer software is either in the printer program folder or on the desktop.</li> </ul> </div>

What are you looking for?	Find it here
<ul style="list-style-type: none"> <li>• Documentation</li> <li>• Live chat support</li> <li>• E-mail support</li> <li>• Voice support</li> </ul>	<p>Go to <a href="https://support.lexmark.com">https://support.lexmark.com</a>.</p> <div style="border: 1px solid #ccc; padding: 5px; margin: 10px 0;"> <p><b>Note:</b> Select your country or region, and then select your product to view the appropriate support site.</p> </div> <p>Support contact information for your country or region can be found on the website or on the printed warranty that came with the printer.</p> <p>Have the following information ready when you contact customer support:</p> <ul style="list-style-type: none"> <li>• Place and date of purchase</li> <li>• Machine type and serial number</li> </ul> <p>For more information, see <a href="#">Finding the printer serial number on page 12</a>.</p>
<ul style="list-style-type: none"> <li>• Safety information</li> <li>• Regulatory information</li> <li>• Warranty information</li> <li>• Environmental information</li> </ul>	<p>Warranty information varies by country or region:</p> <ul style="list-style-type: none"> <li>• <b>In the U.S.</b>—See the Statement of Limited Warranty included with the printer, or go to <a href="https://support.lexmark.com">https://support.lexmark.com</a>.</li> <li>• <b>In other countries and regions</b>—See the printed warranty that came with the printer.</li> </ul> <p><i>Product Information Guide</i>—See the documentation that came with the printer or go to <a href="https://support.lexmark.com">https://support.lexmark.com</a>.</p>
<p>Information on Lexmark digital passport</p>	<p>Go to <a href="https://csr.lexmark.com/digital-passport.php">https://csr.lexmark.com/digital-passport.php</a>.</p>

## Finding the printer serial number

1. Open the tray.

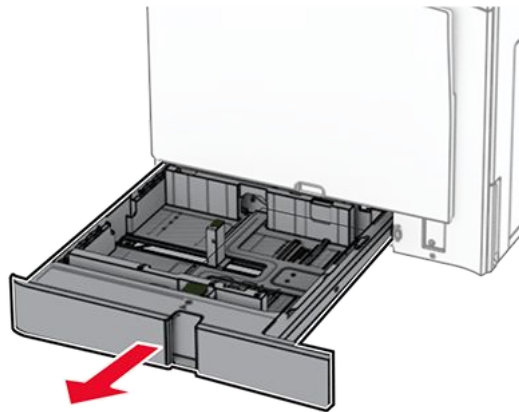

2. Locate the serial number at the right side of the printer.

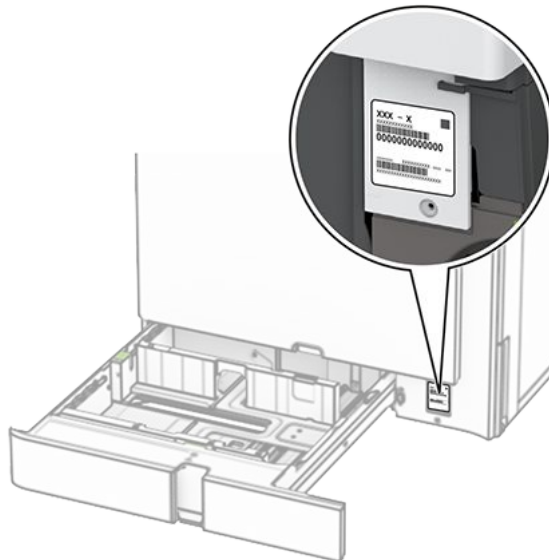

## Printer configurations

**Note:** Make sure to configure the printer on a flat, sturdy, and stable surface.

## Basic model

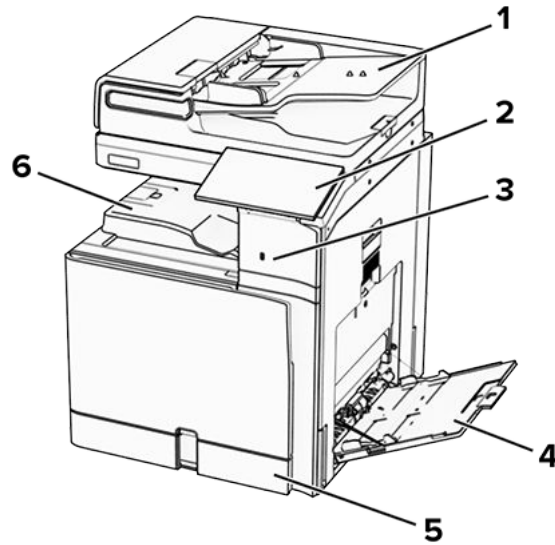

1	Automatic document feeder (ADF)
2	Control panel
3	USB port
4	Multipurpose feeder
5	Standard 550-sheet tray
6	Standard bin

## Configured model



### CAUTION—TIPPING HAZARD

Installing one or more options on your printer or MFP may require a caster base, furniture, or other feature to prevent instability causing possible injury. For more information on supported configurations, see [www.lexmark.com/multifunctionprinters](http://www.lexmark.com/multifunctionprinters).



### CAUTION—TIPPING HAZARD

To reduce the risk of equipment instability, load each tray separately. Keep all other trays closed until needed.

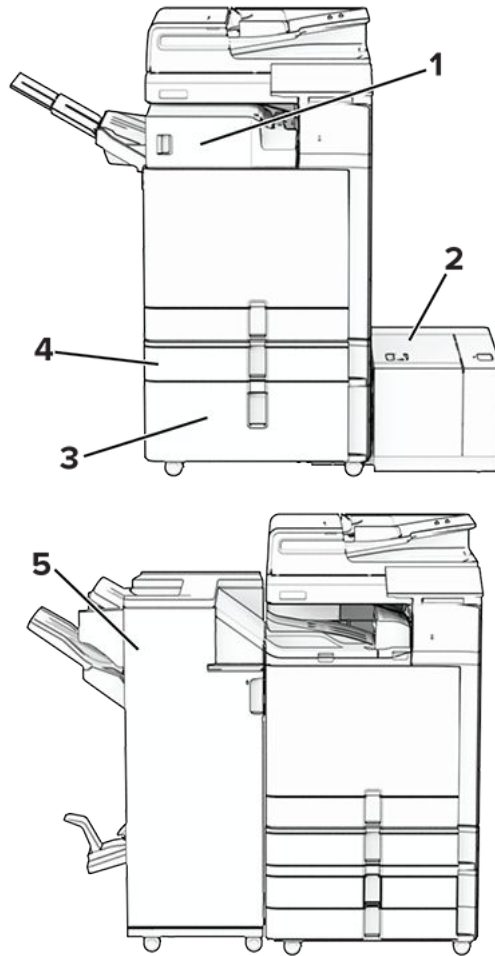

#	Hardware option	Alternative hardware option
1	Staple finisher <sup>1</sup>	<ul style="list-style-type: none"> <li>• Offset stacker<sup>1</sup></li> <li>• Paper transport</li> <li>• Folding paper transport</li> </ul>
2	1500-sheet tray <sup>2</sup>	None
3	Optional 550-sheet tray <sup>3</sup>	None
4	2000-sheet tandem tray <sup>4</sup>	<ul style="list-style-type: none"> <li>• 2 x 550-sheet tray<sup>4</sup></li> <li>• Cabinet<sup>4</sup></li> </ul>
5	Booklet finisher <sup>5</sup>	Staple, hole punch finisher <sup>5</sup>

<sup>1</sup> Cannot be installed together with a booklet finisher or staple, hole punch finisher.

<sup>2</sup> Must be always installed together with an optional 550-sheet tray and either the 2 x 550-sheet tray or 2000-sheet tandem tray.

<sup>3</sup> Must be always installed directly under the printer and must not be installed together with another optional 550-sheet tray.

<sup>4</sup> Must be always installed under the optional 550-sheet tray.

<sup>5</sup> Must be always installed together with an optional 550-sheet tray and one of the following: 2 x 550-sheet tray, 2000-sheet tandem tray, or cabinet.

## Using the control panel



	Control panel part	Function
1	Power button	<ul style="list-style-type: none"><li>• Turn on or turn off the printer.</li></ul> <div style="border: 1px solid gray; padding: 5px; margin: 10px 0;"><b>Note:</b> To turn off the printer, press and hold the power button for five seconds.</div> <ul style="list-style-type: none"><li>• Set the printer to Sleep mode.</li><li>• Wake the printer from Sleep or Hibernate mode.</li></ul>
2	Display	<ul style="list-style-type: none"><li>• View the printer messages and supply status.</li><li>• Set up and operate the printer.</li></ul>
3	Indicator light	Check the status of the printer.

# Home screen icons

**Note:** Your home screen may vary depending on your home screen customization settings, administrative setup, and active embedded solutions.

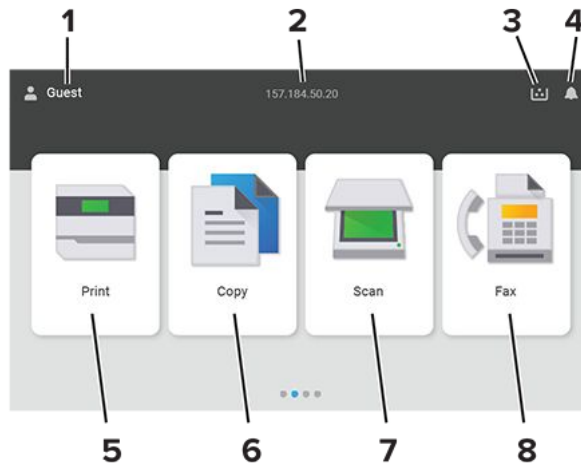

#	Icon name	Function
1	User	Show if a user is logged in to the printer.
2	Displayed information	Show customized printer information such as the printer IP address or the date and time.
3	Supply	Show the status of supplies.
4	Notification	<ul style="list-style-type: none"> <li>• Show a printer warning or error message whenever the printer requires intervention to continue processing.</li> <li>• View more information on the printer warning or message and how to clear it.</li> </ul>
5	Print	Print photos and documents.
6	Copy	Copy photos and documents.
7	Scan	Scan photos and documents.
8	Fax	Send fax messages.

## Colors of the indicator light

Color of the indicator light	Printer status
Off	The printer is off.
Solid blue	The printer is ready.
Blinking blue	The printer is printing or processing data.
Blinking red	The printer requires user intervention.
Solid amber	The printer is in Sleep mode.
Blinking amber	The printer is in Deep Sleep or Hibernate mode.

## Using the automatic document feeder and scanner glass

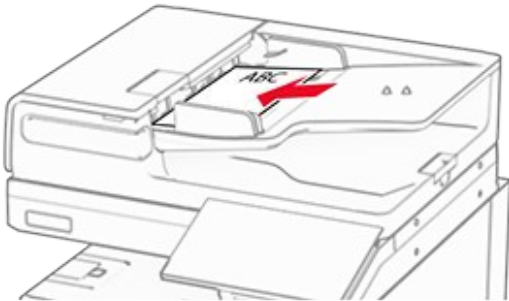
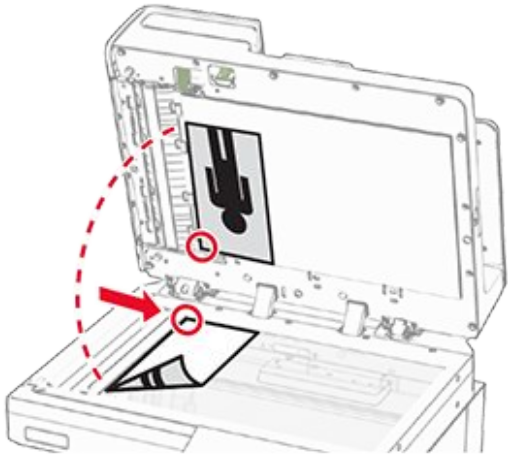
Automatic document feeder (ADF)	Scanner glass
 <ul style="list-style-type: none"><li>• Use the ADF for multiple-page or two-sided documents.</li><li>• Load an original document faceup. For multiple-page documents, make sure to align the leading edge before loading.</li><li>• Make sure to adjust the ADF guides to match the width of the paper that you are loading.</li></ul>	 <ul style="list-style-type: none"><li>• Use the scanner glass for single-page documents, book pages, small items (such as postcards or photos), transparencies, photo paper, or thin media (such as magazine clippings).</li><li>• Place the document facedown in the corner with the arrow.</li></ul>

## Locating the security slot

The printer is equipped with a security lock feature. Attach a security lock compatible with most laptop computers in the location shown to secure the printer in place.

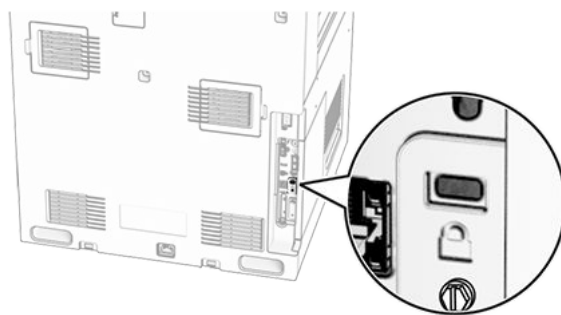

## Selecting paper

### Paper guidelines

Use the appropriate paper to prevent jams and help ensure trouble-free printing.

- Always use new, undamaged paper.
- Before loading paper, know the recommended printable side of the paper. This information is usually indicated on the paper package.
- Do not use paper that has been cut or trimmed by hand.
- Do not mix paper sizes, types, or weights in the same tray; mixing results in jams.
- Do not use coated papers unless they are specifically designed for electrophotographic printing.

For more information, see the *Paper and Specialty Media Guide*.

### Paper characteristics

The following paper characteristics affect print quality and reliability. Consider these factors before printing on them.

#### Weight

Trays can feed paper of varying weights. Paper lighter than 60 g/m<sup>2</sup> (16 lb-bond) may not be stiff enough to feed properly, and may cause jams. For more information, see the “Supported paper weights” topic.

#### Curl

Curl is the tendency for paper to curl at its edges. Excessive curl can cause paper feeding problems. Curl can occur after the paper passes through the printer, where it is exposed to high temperatures. Storing paper unwrapped in hot, humid, cold, or dry conditions can contribute to paper curling before printing and can cause feeding problems.

### Smoothness

Paper smoothness directly affects print quality. If paper is too rough, toner cannot fuse to it properly. If paper is too smooth, it can cause paper feeding or print quality issues. We recommend the use of paper with 50 Sheffield points.

### Moisture content

The amount of moisture in paper affects both print quality and the printer ability to feed the paper correctly. Leave paper in its original wrapper until you use it. Exposure of paper to moisture changes can degrade its performance.

Before printing, store paper in its original wrapper for 24 to 48 hours. The environment in which the paper is stored must be the same as the printer. Extend the time several days if the storage or transportation environment is very different from the printer environment. Thick paper may also require a longer conditioning period.

### Grain direction

Grain refers to the alignment of the paper fibers in a sheet of paper. Grain is either *grain long* which runs the length of the paper, or *grain short* which runs the width of the paper. For recommended grain direction, see the “Supported paper weights” topic.

### Fiber content

Most high-quality xerographic paper is made from 100 percent chemically treated pulped wood. This content provides the paper with a high degree of stability, resulting in fewer paper feeding problems and better print quality. Paper containing fibers such as cotton can negatively affect paper handling.

### Unacceptable paper

The following paper types are not recommended for use with the printer:

- Chemically treated papers that are used to make copies without carbon paper. They are also known as carbonless papers, carbonless copy paper (CCP), or no carbon required (NCR) paper.
- Preprinted papers with chemicals that may contaminate the printer.
- Preprinted papers that can be affected by the temperature in the printer fuser.
- Preprinted papers that require a registration (the precise print location on the page) greater than  $\pm 2.3$  mm ( $\pm 0.09$  in.). For example, optical character recognition (OCR) forms.

Sometimes, registration can be adjusted with a software app to print successfully on these forms.

- Coated papers (erasable bond), synthetic papers, or thermal papers.
- Rough-edged, rough or heavily textured surface papers, or curled papers.
- Papers that fail EN12281:2002 (European).
- Paper weighing less than  $60 \text{ g/m}^2$  (16 lb).
- Multiple-part forms or documents.

## Using recycled paper

Lexmark works to reduce the environmental impact of paper by providing customers choices when it comes to printing. One way we achieve this is by testing products to ensure recycled paper may be used—specifically, papers made with 30%, 50%, and 100% post-consumer recycled content. Our expectation is that recycled papers perform as well as virgin paper in our printers. While no official standard exists for office equipment use of paper, Lexmark uses European Standard EN 12281 as a minimum properties standard. To ensure breadth of testing, test paper includes 100% recycled papers from North America, Europe, and Asia, and tests are conducted at 8–80% relative humidity. Testing includes duplex printing. Office paper using renewable, recycled, or chlorine-free content may all be used.

## Storing paper

Use these paper storage guidelines to help avoid jams and uneven print quality:

- Store paper in its original wrapper in the same environment as the printer for 24 to 48 hours before printing.
- Extend the time several days if the storage or transportation environment is very different from the printer environment. Thick paper may also require a longer conditioning period.
- For best results, store paper where the temperature is 21°C (70°F) and the relative humidity is 40 percent.
- Most label manufacturers recommend printing in a temperature range of 18–24°C (65–75°F) with relative humidity between 40 and 60 percent.
- Store paper in cartons, on a pallet or shelf, rather than on the floor.
- Store individual packages on a flat surface.
- Do not store anything on top of individual paper packages.
- Take paper out of the carton or wrapper only when you are ready to load it in the printer. The carton and wrapper help keep the paper clean, dry, and flat.

## Selecting preprinted forms and letterhead

- Use grain long paper.
- Use only forms and letterhead printed using an offset lithographic or engraved printing process.
- Avoid paper with rough or heavily textured surfaces.
- Use inks that are not affected by the resin in toner. Inks that are oxidation-set or oil-based generally meet these requirements; latex inks might not.
- Print samples on preprinted forms and letterheads considered for use before buying large quantities. This action determines whether the ink in the preprinted form or letterhead affects print quality.
- When in doubt, contact your paper supplier.
- When printing on letterhead, load the paper in the proper orientation for your printer. For more information, see the *Paper and Specialty Media Guide*.

## Supported paper sizes

### Paper sizes supported by the basic configuration

Paper size	Orientation	Standard 550-sheet tray	Multipurpose feeder	Two-sided printing	Automatic document feeder
<b>4x6 Card</b>	Short-edge feed	X	✓	X	X
	Long-edge feed	X	X	X	X
<b>A6</b> 105 x 148 mm (4.13 x 5.83 in.)	Short-edge feed	✓	✓	✓	✓
	Long-edge feed	X	X	X	X
<b>A5</b> 148 x 210 mm (5.83 x 8.27 in.)	Short-edge feed	✓	X	✓	✓
	Long-edge feed	✓	✓	✓	✓
<b>A4</b> 210 x 297 mm (8.27 x 11.7 in.)	Short-edge feed	✓	X	✓	✓
	Long-edge feed	✓	✓	✓	✓
<b>A3</b> 297 x 420 mm (11.69 x 16.54 in.)	Short-edge feed	X	✓	✓	✓
<b>JIS B5</b> 182 x 257 mm (7.17 x 10.1 in.)	Short-edge feed	✓	X	✓	✓
	Long-edge feed	✓	✓	✓	✓
<b>JIS B4</b> 257 x 364 mm (10.12 x 14.33 in.)	Short-edge feed	X	✓	✓	✓

## Learn about the printer

Paper size	Orientation	Standard 550-sheet tray	Multipurpose feeder	Two-sided printing	Automatic document feeder
<b>Statement</b> 139.7 x 215.9 mm (5.5 x 8.5 in.)	Short-edge feed	✓	X	✓	✓
	Long-edge feed	✓	✓	✓	✓
<b>Executive</b> 184.2 x 266.7 mm (7.25 x 10.5 in.)	Short-edge feed	✓	X	✓	✓
	Long-edge feed	✓	✓	✓	✓
<b>Letter</b> 215.9 x 279.4 mm (8.5 x 11 in.)	Short-edge feed	✓	X	✓	✓
	Long-edge feed	✓	✓	✓	✓
<b>Folio</b> 215.9 x 330.2 mm (8.5 x 13 in.)	Short-edge feed	✓	✓	✓	✓
<b>Oficio (Mexico)</b> 215.9 x 340.4 mm (8.5 x 13.4 in.)	Short-edge feed	✓	✓	✓	✓
<b>Legal</b> 215.9 x 355.6 mm (8.5 x 14 in.)	Short-edge feed	✓	✓	✓	✓
<b>Ledger</b> 279.4 x 431.8 mm (11 x 17 in.)	Short-edge feed	X	✓	✓	✓

## Learn about the printer

Paper size	Orientation	Standard 550-sheet tray	Multipurpose feeder	Two-sided printing	Automatic document feeder
<b>12x18</b> 304.8 x 457.2 mm (12.0 x 18.0 in.)	Short-edge feed	X	✓	✓	X
<b>SRA3</b> 320.04 x 449.58 mm (12.6 x 17.7 in.)	Short-edge feed	X	✓	✓	X
<b>Envelope (Choukei #3)</b> 120 x 235 mm (4.75 x 9.25 in.)	Short-edge feed	✓	✓	X	X
<b>Hagaki</b> 100 x 148 mm (3.94 x 5.83 in.)	Short-edge feed	✓	✓	X	X
<b>B5 Envelope</b> 176 x 250 mm (6.93 x 9.84 in.)	Short-edge feed	✓	✓	X	X
<b>Envelope (Commercial #9)</b> 98.4 x 225.4 mm (3.875 x 8.9 in.)	Short-edge feed	✓	✓	X	X

## Learn about the printer

Paper size	Orientation	Standard 550-sheet tray	Multipurpose feeder	Two-sided printing	Automatic document feeder
<b>Envelope (Commercial #10)</b> 104.8 x 241.3 mm (4.12 x 9.5 in.)	Short-edge feed	✓	✓	X	X
<b>Envelope (Monarch 7-3/4)</b> 98.4 x 190.5 mm (3.875 x 7.5 in.)	Short-edge feed	✓	✓	X	X
<b>Envelope (DL)</b> 110 x 220 mm (4.33 x 8.66 in.)	Short-edge feed	✓	✓	X	X
<b>Envelope (ISO C4)</b> 229 x 324 mm (9 x 12.8 in.)	Short-edge feed	X	✓	X	X
<b>Envelope (ISO C5)</b> 162 x 229 mm (6.38 x 9 in.)	Short-edge feed	✓	✓	X	X
<b>Universal</b>	N/A	✓ <sup>1</sup>	✓ <sup>2, 3</sup>	✓ <sup>4</sup>	✓ <sup>5</sup>

<sup>1</sup> Supports paper sizes ranging from 95 x 139.7 mm (3.74 x 5.5 in.) to 297 x 355.6 mm (11.69 x 14 in.).

<sup>2</sup> The maximum length of the universal paper size in the case of banner paper is 1320.8 mm (52 in.). Load only one sheet of banner paper at a time.

<sup>3</sup> Supports paper sizes ranging from 95 x 139.7 mm (3.74 x 5.5 in.) to 320 x 457.2 mm (12.6 x 18 in.).

## Learn about the printer

<sup>4</sup> Supports paper sizes ranging from 105 x 139.7 mm (4.13 x 5.5 in.) to 320 x 457.2 mm (12.6 x 18 in.).

<sup>5</sup> Supports paper sizes ranging from 105 x 128 mm (4.13 x 5.04 in.) to 297 x 432 mm (11.69 x 17.01 in.).

## Paper sizes supported by the optional trays

Paper size	Orientation	Optional 550-sheet tray	2 x 550-sheet tray	2000-sheet tandem tray	1500-sheet tray
<b>4x6 Card</b>	Short-edge feed	X	X	X	X
	Long-edge feed	X	X	X	X
<b>A6</b> 105 x 148 mm (4.13 x 5.83 in.)	Short-edge feed	✓	✓	X	X
	Long-edge feed	X	X	X	X
<b>A5</b> 148 x 210 mm (5.83 x 8.27 in.)	Short-edge feed	✓	✓	X	X
	Long-edge feed	✓	✓	X	X
<b>A4</b> 210 x 297 mm (8.27 x 11.7 in.)	Short-edge feed	✓	✓	X	X
	Long-edge feed	✓	✓	✓	✓
<b>A3</b> 297 x 420 mm (11.69 x 16.54 in.)	Short-edge feed	✓	✓	X	X
<b>JIS B5</b> 182 x 257 mm (7.17 x 10.1 in.)	Short-edge feed	✓	✓	X	X
	Long-edge feed	✓	✓	X	✓

## Learn about the printer

Paper size	Orientation	Optional 550-sheet tray	2 x 550-sheet tray	2000-sheet tandem tray	1500-sheet tray
<b>JIS B4</b> 257 x 364 mm  (10.12 x 14.33 in.)	Short-edge feed	✓	✓	X	X
<b>Statement</b> 139.7 x 215.9 mm  (5.5 x 8.5 in.)	Short-edge feed	✓	✓	X	X
	Long-edge feed	X	X	X	X
<b>Executive</b> 184.2 x 266.7 mm  (7.25 x 10.5 in.)	Short-edge feed	✓	✓	X	X
	Long-edge feed	✓	✓	X	X
<b>Letter</b> 215.9 x 279.4 mm  (8.5 x 11 in.)	Short-edge feed	✓	✓	X	X
	Long-edge feed	✓	✓	✓	✓
<b>Folio</b> 215.9 x 330.2 mm  (8.5 x 13 in.)	Short-edge feed	✓	✓	X	X
<b>Oficio (Mexico)</b> 215.9 x 340.4 mm  (8.5 x 13.4 in.)	Short-edge feed	✓	✓	X	X
<b>Legal</b> 215.9 x 355.6 mm  (8.5 x 14 in.)	Short-edge feed	✓	✓	X	X

## Learn about the printer

Paper size	Orientation	Optional 550-sheet tray	2 x 550-sheet tray	2000-sheet tandem tray	1500-sheet tray
<b>Ledger</b> 279.4 x 431.8 mm (11 x 17 in.)	Short-edge feed	✓	✓	X	X
<b>12x18</b> 304.8 x 457.2 mm (12 x 18 in.)	Short-edge feed	✓	✓	X	X
<b>SRA3</b> 320.04 x 449.58 mm (12.6 x 17.7 in.)	Short-edge feed	✓	✓	X	X
<b>Envelope (Choukei #3)</b> 120 x 235 mm (4.75 x 9.25 in.)	Short-edge feed	X	X	X	X
<b>Hagaki</b> 100 x 148 mm (3.94 x 5.83 in.)	Short-edge feed	✓	✓	X	X
<b>B5 Envelope</b> 176 x 250 mm (6.93 x 9.84 in.)	Short-edge feed	X	X	X	X
<b>Envelope (Commercial #9)</b> 98.4 x 225.4 mm (3.875 x 8.9 in.)	Short-edge feed	X	X	X	X

## Learn about the printer

Paper size	Orientation	Optional 550-sheet tray	2 x 550-sheet tray	2000-sheet tandem tray	1500-sheet tray
<b>Envelope (Commercial #10)</b>  104.8 x 241.3 mm  (4.12 x 9.5 in.)	Short-edge feed	X	X	X	X
<b>Envelope (Monarch 7-3/4)</b>  98.4 x 190.5 mm  (3.875 x 7.5 in.)	Short-edge feed	✓	✓	X	X
<b>Envelope (DL)</b>  110 x 220 mm  (4.33 x 8.66 in.)	Short-edge feed	✓	✓	X	X
<b>Envelope (ISO C4)</b>  229 x 324 mm  (9 x 12.8 in.)	Short-edge feed	X	X	X	X
<b>Envelope (ISO C5)</b>  162 x 229 mm  (6.38 x 9 in.)	Short-edge feed	✓	✓	X	X
<b>Universal</b>	N/A	✓*	✓*	X	X

\* Supports paper sizes ranging from 139.7 x 215.9 mm (5.5 x 8.5 in.) to 304.8 x 457.2 mm (12 x 18 in.).

## Paper sizes supported by the output bins

**Note:** Make sure that the paper transport and either of the staple, hole punch finisher or booklet finisher are installed to the printer.

Paper size	Orientation	Paper transport + Staple, hole punch finisher		
		Standard bin (Finisher top bin)	Bin 1 (Finisher stapler/punch, offset bin)	Bin 2 (Paper transport bin)
<b>4x6 Card</b>	Short-edge feed	✓	✓	✓
	Long-edge feed	X	X	X
<b>A6</b> 105 x 148 mm (4.13 x 5.83 in.)	Short-edge feed	✓	✓	✓
	Long-edge feed	X	X	X
<b>A5</b> 148 x 210 mm (5.83 x 8.27 in.)	Short-edge feed	✓	✓	✓
	Long-edge feed	✓	✓	✓
<b>A4</b> 210 x 297 mm (8.27 x 11.7 in.)	Short-edge feed	✓	✓	✓
	Long-edge feed	✓	✓	✓
<b>A3</b> 297 x 420 mm (11.69 x 16.54 in.)	Short-edge feed	✓	✓	✓
<b>JIS B5</b> 182 x 257 mm (7.17 x 10.1 in.)	Short-edge feed	✓	✓	✓
	Long-edge feed	✓	✓	✓
<b>JIS B4</b> 257 x 364 mm (10.12 x 14.33 in.)	Short-edge feed	✓	✓	✓

## Learn about the printer

Paper size	Orientation	Paper transport + Staple, hole punch finisher		
		Standard bin (Finisher top bin)	Bin 1 (Finisher stapler/punch, offset bin)	Bin 2 (Paper transport bin)
<b>Statement</b> 139.7 x 215.9 mm (5.5 x 8.5 in.)	Short-edge feed	✓	✓	✓
	Long-edge feed	✓	✓	✓
<b>Executive</b> 184.2 x 266.7 mm (7.25 x 10.5 in.)	Short-edge feed	✓	✓	✓
	Long-edge feed	✓	✓	✓
<b>Letter</b> 215.9 x 279.4 mm (8.5 x 11 in.)	Short-edge feed	✓	✓	✓
	Long-edge feed	✓	✓	✓
<b>Folio</b> 215.9 x 330.2 mm (8.5 x 13 in.)	Short-edge feed	✓	✓	✓
<b>Oficio (Mexico)</b> 215.9 x 340.4 mm (8.5 x 13.4 in.)	Short-edge feed	✓	✓	✓
<b>Legal</b> 215.9 x 355.6 mm (8.5 x 14 in.)	Short-edge feed	✓	✓	✓
<b>Ledger</b> 279.4 x 431.8 mm (11 x 17 in.)	Short-edge feed	✓	✓	✓
<b>12x18</b> 304.8 x 457.2 mm (12 x 18 in.)	Short-edge feed	✓	✓	✓

## Learn about the printer

Paper size	Orientation	Paper transport + Staple, hole punch finisher		
		Standard bin (Finisher top bin)	Bin 1 (Finisher stapler/punch, offset bin)	Bin 2 (Paper transport bin)
<b>SRA3</b> 320.04 x 449.58 mm (12.6 x 17.7 in.)	Short-edge feed	✓	✓	X
<b>Envelope (Choukei #3)</b> 120 x 235 mm (4.75 x 9.25 in.)	Short-edge feed	X	X	✓
<b>Hagaki</b> 100 x 148 mm (3.94 x 5.83 in.)	Short-edge feed	X	X	✓
<b>B5 Envelope</b> 176 x 250 mm (6.93 x 9.84 in.)	Short-edge feed	X	X	✓
<b>Envelope (Commercial #9)</b> 98.4 x 225.4 mm (3.875 x 8.9 in.)	Short-edge feed	X	X	✓
<b>Envelope (Commercial #10)</b> 104.8 x 241.3 mm (4.12 x 9.5 in.)	Short-edge feed	X	X	✓
<b>Envelope (Monarch 7-3/4)</b> 98.4 x 190.5 mm (3.875 x 7.5 in.)	Short-edge feed	X	X	✓

## Learn about the printer

Paper size	Orientation	Paper transport + Staple, hole punch finisher		
		Standard bin (Finisher top bin)	Bin 1 (Finisher stapler/punch, offset bin)	Bin 2 (Paper transport bin)
<b>Envelope (DL)</b> 110 x 220 mm (4.33 x 8.66 in.)	Short-edge feed	X	X	✓
<b>Envelope (ISO C4)</b> 229 x 324 mm (9 x 12.8 in.)	Short-edge feed	X	X	✓
<b>Envelope (ISO C5)</b> 162 x 229 mm (6.38 x 9 in.)	Short-edge feed	X	X	✓
<b>Universal</b>	N/A	✓ <sup>1</sup>	✓ <sup>1</sup>	✓ <sup>2</sup>

Paper size	Orientation	Paper transport + Booklet finisher			
		Standard bin (Finisher top bin)	Bin 1 (Finisher stapler/punch, offset bin)	Bin 2 (Finisher booklet bin)	Bin 3 (Paper transport bin)
<b>4x6 Card</b>	Short-edge feed	✓	✓	X	✓
	Long-edge feed	X	X	X	✓
<b>A6</b> 105 x 148 mm (4.13 x 5.83 in.)	Short-edge feed	✓	✓	X	✓
	Long-edge feed	X	X	X	X
<b>A5</b> 148 x 210 mm (5.83 x 8.27 in.)	Short-edge feed	✓	✓	X	✓
	Long-edge feed	✓	✓	X	✓

## Learn about the printer

Paper size	Orientation	Paper transport + Booklet finisher			
		Standard bin (Finisher top bin)	Bin 1 (Finisher stapler/punch, offset bin)	Bin 2 (Finisher booklet bin)	Bin 3 (Paper transport bin)
<b>A4</b> 210 x 297 mm (8.27 x 11.7 in.)	Short-edge feed	✓	✓	✓	✓
	Long-edge feed	✓	✓	✓	✓
<b>A3</b> 297 x 420 mm (11.69 x 16.54 in.)	Short-edge feed	✓	✓	✓	✓
<b>JIS B5</b> 182 x 257 mm (7.17 x 10.1 in.)	Short-edge feed	✓	✓	✓	✓
	Long-edge feed	✓	✓	X	✓
<b>JIS B4</b> 257 x 364 mm (10.12 x 14.33 in.)	Short-edge feed	✓	✓	✓	✓
<b>Statement</b> 139.7 x 215.9 mm (5.5 x 8.5 in.)	Short-edge feed	✓	✓	X	✓
	Long-edge feed	✓	✓	X	✓
<b>Executive</b> 184.2 x 266.7 mm (7.25 x 10.5 in.)	Short-edge feed	✓	✓	X	✓
	Long-edge feed	✓	✓	X	✓
<b>Letter</b> 215.9 x 279.4 mm (8.5 x 11 in.)	Short-edge feed	✓	✓	✓	✓
	Long-edge feed	✓	✓	X	✓

## Learn about the printer

Paper size	Orientation	Paper transport + Booklet finisher			
		Standard bin (Finisher top bin)	Bin 1 (Finisher stapler/punch, offset bin)	Bin 2 (Finisher booklet bin)	Bin 3 (Paper transport bin)
<b>Folio</b> 215.9 x 330.2 mm (8.5 x 13 in.)	Short-edge feed	✓	✓	✓	✓
<b>Oficio (Mexico)</b> 215.9 x 340.4 mm (8.5 x 13.4 in.)	Short-edge feed	✓	✓	✓	✓
<b>Legal</b> 215.9 x 355.6 mm (8.5 x 14 in.)	Short-edge feed	✓	✓	✓	✓
<b>Ledger</b> 279.4 x 431.8 mm (11 x 17 in.)	Short-edge feed	✓	✓	✓	✓
<b>12x18</b> 304.8 x 457.2 mm (12 x 18 in.)	Short-edge feed	✓	✓	✓	✓
<b>SRA3</b> 320.04 x 449.58 mm (12.6 x 17.7 in.)	Short-edge feed	✓	✓	X	✓

## Learn about the printer

Paper size	Orientation	Paper transport + Booklet finisher			
		Standard bin (Finisher top bin)	Bin 1 (Finisher stapler/punch, offset bin)	Bin 2 (Finisher booklet bin)	Bin 3 (Paper transport bin)
<b>Envelope (Choukei #3)</b>  120 x 235 mm  (4.75 x 9.25 in.)	Short-edge feed	X	X	X	✓
<b>Hagaki</b>  100 x 148 mm  (3.94 x 5.83 in.)	Short-edge feed	X	X	X	✓
<b>B5 Envelope</b>  176 x 250 mm  (6.93 x 9.84 in.)	Short-edge feed	X	X	X	✓
<b>Envelope (Commercial #9)</b>  98.4 x 225.4 mm  (3.875 x 8.9 in.)	Short-edge feed	X	X	X	✓
<b>Envelope (Commercial #10)</b>  104.8 x 241.3 mm  (4.12 x 9.5 in.)	Short-edge feed	X	X	X	✓
<b>Envelope (Monarch 7-3/4)</b>  98.4 x 190.5 mm  (3.875 x 7.5 in.)	Short-edge feed	X	X	X	✓

## Learn about the printer

Paper size	Orientation	Paper transport + Booklet finisher			
		Standard bin (Finisher top bin)	Bin 1 (Finisher stapler/punch, offset bin)	Bin 2 (Finisher booklet bin)	Bin 3 (Paper transport bin)
<b>Envelope (DL)</b> 110 x 220 mm (4.33 x 8.66 in.)	Short-edge feed	X	X	X	✓
<b>Envelope (ISO C4)</b> 229 x 324 mm (9 x 12.8 in.)	Short-edge feed	X	X	X	✓
<b>Envelope (ISO C5)</b> 162 x 229 mm (6.38 x 9 in.)	Short-edge feed	X	X	X	✓
<b>Universal</b>	N/A	✓ <sup>1</sup>	✓ <sup>1</sup>	✓ <sup>3</sup>	✓ <sup>2</sup>

<sup>1</sup> Supports paper sizes ranging from 90 x 148 mm (3.55 x 5.83 in.) to 320 x 600 mm (12.59 x 23.62 in.).

<sup>2</sup> Supports paper sizes ranging from 90 x 148 mm (3.55 x 5.83 in.) to 320 x 1260 mm (12.59 x 49.6 in.).

<sup>3</sup> Supports paper sizes ranging from 182 x 257 mm (7.17 x 10.12 in.) to 304.8 x 457.2 mm (12 x 18 in.).

**Note:** Make sure that the folding paper transport and either of the staple, hole punch finisher or booklet finisher are installed to the printer.

Paper size	Orientation	Folding paper transport + Staple, hole punch finisher		
		Standard bin (Finisher top bin)	Bin 1 (Finisher stapler/punch, offset bin)	Bin 2 (Paper transport bin)
<b>4x6 Card</b>	Short-edge feed	✓	✓	✓

## Learn about the printer

Paper size	Orientation	Folding paper transport + Staple, hole punch finisher		
		Standard bin (Finisher top bin)	Bin 1 (Finisher stapler/punch, offset bin)	Bin 2 (Paper transport bin)
	Long-edge feed	X	X	X
<b>A6</b> 105 x 148 mm (4.13 x 5.83 in.)	Short-edge feed	✓	✓	✓
	Long-edge feed	X	X	X
<b>A5</b> 148 x 210 mm (5.83 x 8.27 in.)	Short-edge feed	✓	✓	✓
	Long-edge feed	✓	✓	✓
<b>A4</b> 210 x 297 mm (8.27 x 11.7 in.)	Short-edge feed	✓	✓	✓
	Long-edge feed	✓	✓	✓
<b>A3</b> 297 x 420 mm (11.69 x 16.54 in.)	Short-edge feed	✓	✓	✓
<b>JIS B5</b> 182 x 257 mm (7.17 x 10.1 in.)	Short-edge feed	✓	✓	✓
	Long-edge feed	✓	✓	✓
<b>JIS B4</b> 257 x 364 mm (10.12 x 14.33 in.)	Short-edge feed	✓	✓	✓
<b>Statement</b> 139.7 x 215.9 mm (5.5 x 8.5 in.)	Short-edge feed	✓	✓	✓
	Long-edge feed	✓	✓	✓

## Learn about the printer

Paper size	Orientation	Folding paper transport + Staple, hole punch finisher		
		Standard bin (Finisher top bin)	Bin 1 (Finisher stapler/punch, offset bin)	Bin 2 (Paper transport bin)
<b>Executive</b> 184.2 x 266.7 mm (7.25 x 10.5 in.)	Short-edge feed	✓	✓	✓
	Long-edge feed	✓	✓	✓
<b>Letter</b> 215.9 x 279.4 mm (8.5 x 11 in.)	Short-edge feed	✓	✓	✓
	Long-edge feed	✓	✓	✓
<b>Folio</b> 215.9 x 330.2 mm (8.5 x 13 in.)	Short-edge feed	✓	✓	✓
<b>Oficio (Mexico)</b> 215.9 x 340.4 mm (8.5 x 13.4 in.)	Short-edge feed	✓	✓	✓
<b>Legal</b> 215.9 x 355.6 mm (8.5 x 14 in.)	Short-edge feed	✓	✓	✓
<b>Ledger</b> 279.4 x 431.8 mm (11 x 17 in.)	Short-edge feed	✓	✓	✓
<b>12x18</b> 304.8 x 457.2 mm (12 x 18 in.)	Short-edge feed	✓	✓	X

## Learn about the printer

Paper size	Orientation	Folding paper transport + Staple, hole punch finisher		
		Standard bin (Finisher top bin)	Bin 1 (Finisher stapler/punch, offset bin)	Bin 2 (Paper transport bin)
<b>SRA3</b> 320.04 x 449.58 mm (12.6 x 17.7 in.)	Short-edge feed	✓	✓	X
<b>Envelope (Choukei #3)</b> 120 x 235 mm (4.75 x 9.25 in.)	Short-edge feed	X	X	✓
<b>Hagaki</b> 100 x 148 mm (3.94 x 5.83 in.)	Short-edge feed	X	X	✓
<b>B5 Envelope</b> 176 x 250 mm (6.93 x 9.84 in.)	Short-edge feed	X	X	✓
<b>Envelope (Commercial #9)</b> 98.4 x 225.4 mm (3.875 x 8.9 in.)	Short-edge feed	X	X	✓
<b>Envelope (Commercial #10)</b> 104.8 x 241.3 mm (4.12 x 9.5 in.)	Short-edge feed	X	X	✓

## Learn about the printer

Paper size	Orientation	Folding paper transport + Staple, hole punch finisher		
		Standard bin (Finisher top bin)	Bin 1 (Finisher stapler/punch, offset bin)	Bin 2 (Paper transport bin)
<b>Envelope (Monarch 7-3/4)</b>  98.4 x 190.5 mm  (3.875 x 7.5 in.)	Short-edge feed	X	X	✓
<b>Envelope (DL)</b>  110 x 220 mm  (4.33 x 8.66 in.)	Short-edge feed	X	X	✓
<b>Envelope (ISO C4)</b>  229 x 324 mm  (9 x 12.8 in.)	Short-edge feed	X	X	✓
<b>Envelope (ISO C5)</b>  162 x 229 mm  (6.38 x 9 in.)	Short-edge feed	X	X	✓
<b>Universal</b>	N/A	✓ <sup>1</sup>	✓ <sup>1</sup>	✓ <sup>2</sup>

Paper size	Orientation	Folding paper transport + Booklet finisher			
		Standard bin (Finisher top bin)	Bin 1 (Finisher stapler/punch, offset bin)	Bin 2 (Finisher booklet bin)	Bin 3 (Paper transport bin)
<b>4x6 Card</b>	Short-edge feed	✓	✓	X	✓
	Long-edge feed	X	X	X	X
<b>A6</b>  105 x 148 mm  (4.13 x 5.83 in.)	Short-edge feed	✓	✓	X	✓
	Long-edge feed	X	X	X	X

## Learn about the printer

Paper size	Orientation	Folding paper transport + Booklet finisher			
		Standard bin (Finisher top bin)	Bin 1 (Finisher stapler/punch, offset bin)	Bin 2 (Finisher booklet bin)	Bin 3 (Paper transport bin)
<b>A5</b> 148 x 210 mm (5.83 x 8.27 in.)	Short-edge feed	✓	✓	X	✓
	Long-edge feed	✓	✓	X	✓
<b>A4</b> 210 x 297 mm (8.27 x 11.7 in.)	Short-edge feed	✓	✓	✓	✓
	Long-edge feed	✓	✓	X	✓
<b>A3</b> 297 x 420 mm (11.69 x 16.54 in.)	Short-edge feed	✓	✓	✓	✓
<b>JIS B5</b> 182 x 257 mm (7.17 x 10.1 in.)	Short-edge feed	✓	✓	✓	✓
	Long-edge feed	✓	✓	X	✓
<b>JIS B4</b> 257 x 364 mm (10.12 x 14.33 in.)	Short-edge feed	✓	✓	✓	✓
<b>Statement</b> 139.7 x 215.9 mm (5.5 x 8.5 in.)	Short-edge feed	✓	✓	X	✓
	Long-edge feed	✓	✓	X	✓
<b>Executive</b> 184.2 x 266.7 mm (7.25 x 10.5 in.)	Short-edge feed	✓	✓	✓	✓
	Long-edge feed	✓	✓	X	✓

## Learn about the printer

Paper size	Orientation	Folding paper transport + Booklet finisher			
		Standard bin (Finisher top bin)	Bin 1 (Finisher stapler/punch, offset bin)	Bin 2 (Finisher booklet bin)	Bin 3 (Paper transport bin)
<b>Letter</b> 215.9 x 279.4 mm (8.5 x 11 in.)	Short-edge feed	✓	✓	✓	✓
	Long-edge feed	✓	✓	X	✓
<b>Folio</b> 215.9 x 330.2 mm (8.5 x 13 in.)	Short-edge feed	✓	✓	✓	✓
<b>Oficio (Mexico)</b> 215.9 x 340.4 mm (8.5 x 13.4 in.)	Short-edge feed	✓	✓	✓	✓
<b>Legal</b> 215.9 x 355.6 mm (8.5 x 14 in.)	Short-edge feed	✓	✓	✓	✓
<b>Ledger</b> 279.4 x 431.8 mm (11 x 17 in.)	Short-edge feed	✓	✓	✓	✓
<b>12x18</b> 304.8 x 457.2 mm (12 x 18 in.)	Short-edge feed	✓	✓	✓	X
<b>SRA3</b> 320.04 x 449.58 mm (12.6 x 17.7 in.)	Short-edge feed	✓	✓	X	X

## Learn about the printer

Paper size	Orientation	Folding paper transport + Booklet finisher			
		Standard bin (Finisher top bin)	Bin 1 (Finisher stapler/punch, offset bin)	Bin 2 (Finisher booklet bin)	Bin 3 (Paper transport bin)
<b>Envelope (Choukei #3)</b>  120 x 235 mm  (4.75 x 9.25 in.)	Short-edge feed	X	X	X	✓
<b>Hagaki</b>  100 x 148 mm  (3.94 x 5.83 in.)	Short-edge feed	X	X	X	✓
<b>B5 Envelope</b>  176 x 250 mm  (6.93 x 9.84 in.)	Short-edge feed	X	X	X	✓
<b>Envelope (Commercial #9)</b>  98.4 x 225.4 mm  (3.875 x 8.9 in.)	Short-edge feed	X	X	X	✓
<b>Envelope (Commercial #10)</b>  104.8 x 241.3 mm  (4.12 x 9.5 in.)	Short-edge feed	X	X	X	✓
<b>Envelope (Monarch 7-3/4)</b>  98.4 x 190.5 mm  (3.875 x 7.5 in.)	Short-edge feed	X	X	X	✓

## Learn about the printer

Paper size	Orientation	Folding paper transport + Booklet finisher			
		Standard bin (Finisher top bin)	Bin 1 (Finisher stapler/punch, offset bin)	Bin 2 (Finisher booklet bin)	Bin 3 (Paper transport bin)
<b>Envelope (DL)</b> 110 x 220 mm (4.33 x 8.66 in.)	Short-edge feed	X	X	X	✓
<b>Envelope (ISO C4)</b> 229 x 324 mm (9 x 12.8 in.)	Short-edge feed	X	X	X	✓
<b>Envelope (ISO C5)</b> 162 x 229 mm (6.38 x 9 in.)	Short-edge feed	X	X	X	✓
<b>Universal</b>	N/A	✓ <sup>1</sup>	✓ <sup>1</sup>	✓ <sup>3</sup>	✓ <sup>2</sup>

<sup>1</sup> Supports paper sizes ranging from 90 x 148 mm (3.55 x 5.83 in.) to 320 x 600 mm (12.59 x 23.62 in.).

<sup>2</sup> Supports paper sizes ranging from 90 x 148 mm (3.55 x 5.83 in.) to 297 x 1260 mm (11.69 x 49.6 in.).

<sup>3</sup> Supports paper sizes ranging from 182 x 257 mm (7.17 x 10.12 in.) to 304.8 x 457.2 mm (12 x 18 in.).

## Paper sizes supported for staple jobs

### Paper sizes supported by the staple finisher

Paper size	Orientation	Single	Dual	Dual Left
<b>4x6 Card</b>	Short-edge feed	X	X	X
	Long-edge feed	X	X	X

## Learn about the printer

Paper size	Orientation	Single	Dual	Dual Left
<b>A6</b> 105 x 148 mm (4.13 x 5.83 in.)	Short-edge feed	X	X	X
	Long-edge feed	X	X	X
<b>A5</b> 148 x 210 mm (5.83 x 8.27 in.)	Short-edge feed	X	X	X
	Long-edge feed	X	X	X
<b>A4</b> 210 x 297 mm (8.27 x 11.7 in.)	Short-edge feed	✓	✓	✓
	Long-edge feed	✓	✓	✓
<b>A3</b> 297 x 420 mm (11.69 x 16.54 in.)	Short-edge feed	✓	✓	✓
<b>JIS B5</b> 182 x 257 mm (7.17 x 10.1 in.)	Short-edge feed	✓	✓	✓
	Long-edge feed	✓	✓	✓
<b>JIS B4</b> 257 x 364 mm (10.12 x 14.33 in.)	Short-edge feed	✓	✓	✓
<b>Statement</b> 139.7 x 215.9 mm (5.5 x 8.5 in.)	Short-edge feed	X	X	X
	Long-edge feed	X	X	X
<b>Executive</b> 184.2 x 266.7 mm (7.25 x 10.5 in.)	Short-edge feed	✓	X	X
	Long-edge feed	✓	✓	✓

## Learn about the printer

Paper size	Orientation	Single	Dual	Dual Left
<b>Letter</b> 215.9 x 279.4 mm (8.5 x 11 in.)	Short-edge feed	✓	✓	X
	Long-edge feed	✓	✓	X
<b>Folio</b> 215.9 x 330.2 mm (8.5 x 13 in.)	Short-edge feed	✓	✓	X
<b>Oficio (Mexico)</b> 215.9 x 340.4 mm (8.5 x 13.4 in.)	Short-edge feed	✓	✓	X
<b>Legal</b> 215.9 x 355.6 mm (8.5 x 14 in.)	Short-edge feed	✓	✓	✓
<b>Ledger</b> 279.4 x 431.8 mm (11 x 17 in.)	Short-edge feed	✓	✓	✓
<b>12x18</b> 304.8 x 457.2 mm (12 x 18 in.)	Short-edge feed	X	X	X
<b>SRA3</b> 320.04 x 449.58 mm (12.6 x 17.7 in.)	Short-edge feed	X	X	X
<b>Envelope (Choukei #3)</b> 120 x 235 mm (4.75 x 9.25 in.)	Short-edge feed	X	X	X

## Learn about the printer

Paper size	Orientation	Single	Dual	Dual Left
<b>Hagaki</b> 100 x 148 mm (3.94 x 5.83 in.)	Short-edge feed	X	X	X
<b>B5 Envelope</b> 176 x 250 mm (6.93 x 9.84 in.)	Short-edge feed	X	X	X
<b>Envelope (Commercial #9)</b> 98.4 x 225.4 mm (3.875 x 8.9 in.)	Short-edge feed	X	X	X
<b>Envelope (Commercial #10)</b> 104.8 x 241.3 mm (4.12 x 9.5 in.)	Short-edge feed	X	X	X
<b>Envelope (Monarch 7-3/4)</b> 98.4 x 190.5 mm (3.875 x 7.5 in.)	Short-edge feed	X	X	X
<b>Envelope (DL)</b> 110 x 220 mm (4.33 x 8.66 in.)	Short-edge feed	X	X	X
<b>Envelope (ISO C4)</b> 229 x 324 mm (9 x 12.8 in.)	Short-edge feed	X	X	X

## Learn about the printer

Paper size	Orientation	Single	Dual	Dual Left
<b>Envelope (ISO C5)</b> 162 x 229 mm (6.38 x 9 in.)	Short-edge feed	X	X	X

## Paper sizes supported by the staple, hole punch finisher

Paper size	Orientation	Single	Dual	Dual Left
<b>4x6 Card</b>	Short-edge feed	X	X	X
	Long-edge feed	X	X	X
<b>A6</b> 105 x 148 mm (4.13 x 5.83 in.)	Short-edge feed	X	X	X
	Long-edge feed	X	X	X
<b>A5</b> 148 x 210 mm (5.83 x 8.27 in.)	Short-edge feed	X	X	X
	Long-edge feed	X	X	X
<b>A4</b> 210 x 297 mm (8.27 x 11.7 in.)	Short-edge feed	✓	✓	✓
	Long-edge feed	✓	✓	✓
<b>A3</b> 297 x 420 mm (11.69 x 16.54 in.)	Short-edge feed	✓	✓	✓
<b>JIS B5</b> 182 x 257 mm (7.17 x 10.1 in.)	Short-edge feed	✓	✓	✓
	Long-edge feed	✓	✓	✓
<b>JIS B4</b> 257 x 364 mm (10.12 x 14.33 in.)	Short-edge feed	✓	✓	X
<b>Statement</b> 139.7 x 215.9 mm (5.5 x 8.5 in.)	Short-edge feed	X	X	X
	Long-edge feed	X	X	X

## Learn about the printer

Paper size	Orientation	Single	Dual	Dual Left
<b>Executive</b> 184.2 x 266.7 mm (7.25 x 10.5 in.)	Short-edge feed	✓	✓	✓
	Long-edge feed	✓	✓	✓
<b>Letter</b> 215.9 x 279.4 mm (8.5 x 11 in.)	Short-edge feed	✓	✓	✓
	Long-edge feed	✓	✓	✓
<b>Folio</b> 215.9 x 330.2 mm (8.5 x 13 in.)	Short-edge feed	✓	✓	✓
<b>Oficio (Mexico)</b> 215.9 x 340.4 mm (8.5 x 13.4 in.)	Short-edge feed	✓	✓	✓
<b>Legal</b> 215.9 x 355.6 mm (8.5 x 14 in.)	Short-edge feed	✓	✓	✓
<b>Ledger</b> 279.4 x 431.8 mm (11 x 17 in.)	Short-edge feed	✓	✓	✓
<b>12x18</b> 304.8 x 457.2 mm (12 x 18 in.)	Short-edge feed	X	X	X
<b>SRA3</b> 320.04 x 449.58 mm (12.6 x 17.7 in.)	Short-edge feed	X	X	X
<b>Envelope (Choukei #3)</b> 120 x 235 mm (4.75 x 9.25 in.)	Short-edge feed	X	X	X
<b>Hagaki</b> 100 x 148 mm (3.94 x 5.83 in.)	Short-edge feed	X	X	X

## Learn about the printer

Paper size	Orientation	Single	Dual	Dual Left
<b>B5 Envelope</b> 176 x 250 mm (6.93 x 9.84 in.)	Short-edge feed	X	X	X
<b>Envelope (Commercial #9)</b> 98.4 x 225.4 mm (3.875 x 8.9 in.)	Short-edge feed	X	X	X
<b>Envelope (Commercial #10)</b> 104.8 x 241.3 mm (4.12 x 9.5 in.)	Short-edge feed	X	X	X
<b>Envelope (Monarch 7-3/4)</b> 98.4 x 190.5 mm (3.875 x 7.5 in.)	Short-edge feed	X	X	X
<b>Envelope (DL)</b> 110 x 220 mm (4.33 x 8.66 in.)	Short-edge feed	X	X	X
<b>Envelope (ISO C4)</b> 229 x 324 mm (9 x 12.8 in.)	Short-edge feed	X	X	X
<b>Envelope (ISO C5)</b> 162 x 229 mm (6.38 x 9 in.)	Short-edge feed	X	X	X

## Paper sizes supported by the booklet finisher

Paper size	Orientation	Single	Dual	Dual Left
<b>4x6 Card</b>	Short-edge feed	X	X	X
	Long-edge feed	X	X	X
<b>A6</b> 105 x 148 mm (4.13 x 5.83 in.)	Short-edge feed	X	X	X
	Long-edge feed	X	X	X

## Learn about the printer

Paper size	Orientation	Single	Dual	Dual Left
<b>A5</b> 148 x 210 mm (5.83 x 8.27 in.)	Short-edge feed	X	X	X
	Long-edge feed	X	X	X
<b>A4</b> 210 x 297 mm (8.27 x 11.7 in.)	Short-edge feed	✓	✓	✓
	Long-edge feed	✓	✓	✓
<b>A3</b> 297 x 420 mm (11.69 x 16.54 in.)	Short-edge feed	✓	✓	✓
<b>JIS B5</b> 182 x 257 mm (7.17 x 10.1 in.)	Short-edge feed	✓	✓	✓
	Long-edge feed	✓	✓	✓
<b>JIS B4</b> 257 x 364 mm (10.12 x 14.33 in.)	Short-edge feed	✓	✓	X
<b>Statement</b> 139.7 x 215.9 mm (5.5 x 8.5 in.)	Short-edge feed	X	X	X
	Long-edge feed	X	X	X
<b>Executive</b> 184.2 x 266.7 mm (7.25 x 10.5 in.)	Short-edge feed	✓	✓	✓
	Long-edge feed	✓	✓	✓
<b>Letter</b> 215.9 x 279.4 mm (8.5 x 11 in.)	Short-edge feed	✓	✓	✓
	Long-edge feed	✓	✓	✓
<b>Folio</b> 215.9 x 330.2 mm (8.5 x 13 in.)	Short-edge feed	✓	✓	✓
<b>Oficio (Mexico)</b> 215.9 x 340.4 mm (8.5 x 13.4 in.)	Short-edge feed	✓	✓	✓

## Learn about the printer

Paper size	Orientation	Single	Dual	Dual Left
<b>Legal</b> 215.9 x 355.6 mm (8.5 x 14 in.)	Short-edge feed	✓	✓	✓
<b>Ledger</b> 279.4 x 431.8 mm (11 x 17 in.)	Short-edge feed	✓	✓	✓
<b>12x18</b> 304.8 x 457.2 mm (12 x 18 in.)	Short-edge feed	X	X	X
<b>SRA3</b> 320.04 x 449.58 mm (12.6 x 17.7 in.)	Short-edge feed	X	X	X
<b>Envelope (Choukei #3)</b> 120 x 235 mm (4.75 x 9.25 in.)	Short-edge feed	X	X	X
<b>Hagaki</b> 100 x 148 mm (3.94 x 5.83 in.)	Short-edge feed	X	X	X
<b>B5 Envelope</b> 176 x 250 mm (6.93 x 9.84 in.)	Short-edge feed	X	X	X
<b>Envelope (Commercial #9)</b> 98.4 x 225.4 mm (3.875 x 8.9 in.)	Short-edge feed	X	X	X
<b>Envelope (Commercial #10)</b> 104.8 x 241.3 mm (4.12 x 9.5 in.)	Short-edge feed	X	X	X

## Learn about the printer

Paper size	Orientation	Single	Dual	Dual Left
<b>Envelope (Monarch 7-3/4)</b> 98.4 x 190.5 mm (3.875 x 7.5 in.)	Short-edge feed	X	X	X
<b>Envelope (DL)</b> 110 x 220 mm (4.33 x 8.66 in.)	Short-edge feed	X	X	X
<b>Envelope (ISO C4)</b> 229 x 324 mm (9 x 12.8 in.)	Short-edge feed	X	X	X
<b>Envelope (ISO C5)</b> 162 x 229 mm (6.38 x 9 in.)	Short-edge feed	X	X	X

## Paper sizes supported for punch jobs

### Paper sizes supported by the staple, hole punch finisher

Paper size	Orientation	Two-hole	Three-hole	Four-hole
<b>4x6 Card</b>	Short-edge feed	X	X	X
	Long-edge feed	X	X	X
<b>A6</b> 105 x 148 mm (4.13 x 5.83 in.)	Short-edge feed	X	X	X
	Long-edge feed	X	X	X
<b>A5</b> 148 x 210 mm (5.83 x 8.27 in.)	Short-edge feed	✓	X	X
	Long-edge feed	✓	X	X
<b>A4</b> 210 x 297 mm (8.27 x 11.7 in.)	Short-edge feed	✓	X	X
	Long-edge feed	✓	✓	✓

## Learn about the printer

Paper size	Orientation	Two-hole	Three-hole	Four-hole
<b>A3</b> 297 x 420 mm (11.69 x 16.54 in.)	Short-edge feed	✓	✓	✓
<b>JIS B5</b> 182 x 257 mm (7.17 x 10.1 in.)	Short-edge feed	✓	X	X
	Long-edge feed	✓	✓	✓
<b>JIS B4</b> 257 x 364 mm (10.12 x 14.33 in.)	Short-edge feed	✓	✓	✓
<b>Statement</b> 139.7 x 215.9 mm (5.5 x 8.5 in.)	Short-edge feed	✓	X	X
	Long-edge feed	✓	X	X
<b>Executive</b> 184.2 x 266.7 mm (7.25 x 10.5 in.)	Short-edge feed	✓	X	X
	Long-edge feed	✓	✓	✓
<b>Letter</b> 215.9 x 279.4 mm (8.5 x 11 in.)	Short-edge feed	✓	X	X
	Long-edge feed	✓	✓	✓
<b>Folio</b> 215.9 x 330.2 mm (8.5 x 13 in.)	Short-edge feed	✓	X	X
<b>Oficio (Mexico)</b> 215.9 x 340.4 mm (8.5 x 13.4 in.)	Short-edge feed	✓	X	X
<b>Legal</b> 215.9 x 355.6 mm (8.5 x 14 in.)	Short-edge feed	✓	X	X
<b>Ledger</b> 279.4 x 431.8 mm (11 x 17 in.)	Short-edge feed	✓	✓	✓

## Learn about the printer

Paper size	Orientation	Two-hole	Three-hole	Four-hole
<b>12x18</b> 304.8 x 457.2 mm (12 x 18 in.)	Short-edge feed	X	X	X
<b>SRA3</b> 320.04 x 449.58 mm (12.6 x 17.7 in.)	Short-edge feed	X	X	X
<b>Envelope (Choukei #3)</b> 120 x 235 mm (4.75 x 9.25 in.)	Short-edge feed	X	X	X
<b>Hagaki</b> 100 x 148 mm (3.94 x 5.83 in.)	Short-edge feed	X	X	X
<b>B5 Envelope</b> 176 x 250 mm (6.93 x 9.84 in.)	Short-edge feed	X	X	X
<b>Envelope (Commercial #9)</b> 98.4 x 225.4 mm (3.875 x 8.9 in.)	Short-edge feed	X	X	X
<b>Envelope (Commercial #10)</b> 104.8 x 241.3 mm (4.12 x 9.5 in.)	Short-edge feed	X	X	X
<b>Envelope (Monarch 7-3/4)</b> 98.4 x 190.5 mm (3.875 x 7.5 in.)	Short-edge feed	X	X	X
<b>Envelope (DL)</b> 110 x 220 mm (4.33 x 8.66 in.)	Short-edge feed	X	X	X

## Learn about the printer

Paper size	Orientation	Two-hole	Three-hole	Four-hole
<b>Envelope (ISO C4)</b> 229 x 324 mm (9 x 12.8 in.)	Short-edge feed	X	X	X
<b>Envelope (ISO C5)</b> 162 x 229 mm (6.38 x 9 in.)	Short-edge feed	X	X	X

## Paper sizes supported by the booklet finisher

Paper size	Orientation	Two-hole	Three-hole	Four-hole
<b>4x6 Card</b>	Short-edge feed	X	X	X
	Long-edge feed	X	X	X
<b>A6</b> 105 x 148 mm (4.13 x 5.83 in.)	Short-edge feed	X	X	X
	Long-edge feed	X	X	X
<b>A5</b> 148 x 210 mm (5.83 x 8.27 in.)	Short-edge feed	✓	X	X
	Long-edge feed	✓	X	X
<b>A4</b> 210 x 297 mm (8.27 x 11.7 in.)	Short-edge feed	✓	X	X
	Long-edge feed	✓	✓	✓
<b>A3</b> 297 x 420 mm (11.69 x 16.54 in.)	Short-edge feed	✓	✓	✓
<b>JIS B5</b> 182 x 257 mm (7.17 x 10.1 in.)	Short-edge feed	✓	X	X
	Long-edge feed	✓	X	X
<b>JIS B4</b> 257 x 364 mm (10.12 x 14.33 in.)	Short-edge feed	✓	✓	✓

## Learn about the printer

Paper size	Orientation	Two-hole	Three-hole	Four-hole
<b>Statement</b> 139.7 x 215.9 mm (5.5 x 8.5 in.)	Short-edge feed	✓	X	X
	Long-edge feed	✓	X	X
<b>Executive</b> 184.2 x 266.7 mm (7.25 x 10.5 in.)	Short-edge feed	✓	X	X
	Long-edge feed	✓	✓	✓
<b>Letter</b> 215.9 x 279.4 mm (8.5 x 11 in.)	Short-edge feed	✓	X	X
	Long-edge feed	✓	✓	✓
<b>Folio</b> 215.9 x 330.2 mm (8.5 x 13 in.)	Short-edge feed	✓	X	X
<b>Oficio (Mexico)</b> 215.9 x 340.4 mm (8.5 x 13.4 in.)	Short-edge feed	✓	X	X
<b>Legal</b> 215.9 x 355.6 mm (8.5 x 14 in.)	Short-edge feed	✓	X	X
<b>Ledger</b> 279.4 x 431.8 mm (11 x 17 in.)	Short-edge feed	✓	✓	✓
<b>12x18</b> 304.8 x 457.2 mm (12 x 18 in.)	Short-edge feed	X	X	X
<b>SRA3</b> 320.04 x 449.58 mm (12.6 x 17.7 in.)	Short-edge feed	X	X	X
<b>Envelope (Choukei #3)</b> 120 x 235 mm (4.75 x 9.25 in.)	Short-edge feed	X	X	X

## Learn about the printer

---

Paper size	Orientation	Two-hole	Three-hole	Four-hole
<b>Hagaki</b> 100 x 148 mm (3.94 x 5.83 in.)	Short-edge feed	X	X	X
<b>B5 Envelope</b> 176 x 250 mm (6.93 x 9.84 in.)	Short-edge feed	X	X	X
<b>Envelope (Commercial #9)</b> 98.4 x 225.4 mm (3.875 x 8.9 in.)	Short-edge feed	X	X	X
<b>Envelope (Commercial #10)</b> 104.8 x 241.3 mm (4.12 x 9.5 in.)	Short-edge feed	X	X	X
<b>Envelope (Monarch 7-3/4)</b> 98.4 x 190.5 mm (3.875 x 7.5 in.)	Short-edge feed	X	X	X
<b>Envelope (DL)</b> 110 x 220 mm (4.33 x 8.66 in.)	Short-edge feed	X	X	X
<b>Envelope (ISO C4)</b> 229 x 324 mm (9 x 12.8 in.)	Short-edge feed	X	X	X
<b>Envelope (ISO C5)</b> 162 x 229 mm (6.38 x 9 in.)	Short-edge feed	X	X	X

## Paper sizes supported for fold jobs

### Paper sizes supported by the folding paper transport

Paper size	Orientation	Folding paper transport only			
		C-fold	Z-fold	Z-fold half sheet	V-fold
		Standard bin			
<b>4x6 Card</b>	Short-edge feed	X	X	X	X
	Long-edge feed	X	X	X	X
<b>A6</b> 105 x 148 mm (4.13 x 5.83 in.)	Short-edge feed	X	X	X	X
	Long-edge feed	X	X	X	X
<b>A5</b> 148 x 210 mm (5.83 x 8.27 in.)	Short-edge feed	X	X	X	X
	Long-edge feed	X	X	X	X
<b>A4</b> 210 x 297 mm (8.27 x 11.7 in.)	Short-edge feed	✓	✓	✓	✓
	Long-edge feed	X	X	X	X
<b>A3</b> 297 x 420 mm (11.69 x 16.54 in.)	Short-edge feed	✓	✓	✓	✓
<b>JIS B5</b> 182 x 257 mm (7.17 x 10.1 in.)	Short-edge feed	X	X	X	X
	Long-edge feed	X	X	X	X

## Learn about the printer

Paper size	Orientation	Folding paper transport only			
		C-fold	Z-fold	Z-fold half sheet	V-fold
		Standard bin			
<b>JIS B4</b> 257 x 364 mm  (10.12 x 14.33 in.)	Short-edge feed	X	X	✓	✓
<b>Statement</b> 139.7 x 215.9 mm  (5.5 x 8.5 in.)	Short-edge feed	X	X	X	X
	Long-edge feed	X	X	X	X
<b>Executive</b> 184.2 x 266.7 mm  (7.25 x 10.5 in.)	Short-edge feed	X	X	X	X
	Long-edge feed	X	X	X	X
<b>Letter</b> 215.9 x 279.4 mm  (8.5 x 11 in.)	Short-edge feed	✓	✓	✓	✓
	Long-edge feed	X	X	X	X
<b>Folio</b> 215.9 x 330.2 mm  (8.5 x 13 in.)	Short-edge feed	X	X	X	X
<b>Oficio (Mexico)</b> 215.9 x 340.4 mm  (8.5 x 13.4 in.)	Short-edge feed	✓	✓	✓	✓
<b>Legal</b> 215.9 x 355.6 mm  (8.5 x 14 in.)	Short-edge feed	✓	✓	✓	✓

## Learn about the printer

Paper size	Orientation	Folding paper transport only			
		C-fold	Z-fold	Z-fold half sheet	V-fold
		Standard bin			
<b>Ledger</b> 279.4 x 431.8 mm (11 x 17 in.)	Short-edge feed	✓	✓	✓	✓
<b>12x18</b> 304.8 x 457.2 mm (12 x 18 in.)	Short-edge feed	X	X	X	X
<b>SRA3</b> 320.04 x 449.58 mm (12.6 x 17.7 in.)	Short-edge feed	X	X	X	X
<b>Envelope (Choukei #3)</b> 120 x 235 mm (4.75 x 9.25 in.)	Short-edge feed	X	X	X	X
<b>Hagaki</b> 100 x 148 mm (3.94 x 5.83 in.)	Short-edge feed	X	X	X	X
<b>B5 Envelope</b> 176 x 250 mm (6.93 x 9.84 in.)	Short-edge feed	X	X	X	X

## Learn about the printer

Paper size	Orientation	Folding paper transport only			
		C-fold	Z-fold	Z-fold half sheet	V-fold
		Standard bin			
<b>Envelope (Commercial #9)</b>  98.4 x 225.4 mm  (3.875 x 8.9 in.)	Short-edge feed	X	X	X	X
<b>Envelope (Commercial #10)</b>  104.8 x 241.3 mm  (4.12 x 9.5 in.)	Short-edge feed	X	X	X	X
<b>Envelope (Monarch 7-3/4)</b>  98.4 x 190.5 mm  (3.875 x 7.5 in.)	Short-edge feed	X	X	X	X
<b>Envelope (DL)</b>  110 x 220 mm  (4.33 x 8.66 in.)	Short-edge feed	X	X	X	X
<b>Envelope (ISO C4)</b>  229 x 324 mm  (9 x 12.8 in.)	Short-edge feed	X	X	X	X
<b>Envelope (ISO C5)</b>  162 x 229 mm  (6.38 x 9 in.)	Short-edge feed	X	X	X	X

## Paper sizes supported by the paper transport and booklet finisher

Paper size	Orientation	Paper transport + Booklet finisher	
		V-fold multiple	V-fold
		Bin 2	Standard bin, bin 1, bin 2
<b>4x6 Card</b>	Short-edge feed	X	X
	Long-edge feed	X	X
<b>A6</b> 105 x 148 mm (4.13 x 5.83 in.)	Short-edge feed	X	X
	Long-edge feed	X	X
<b>A5</b> 148 x 210 mm (5.83 x 8.27 in.)	Short-edge feed	X	X
	Long-edge feed	X	X
<b>A4</b> 210 x 297 mm (8.27 x 11.7 in.)	Short-edge feed	✓	✓
	Long-edge feed	X	X
<b>A3</b> 297 x 420 mm (11.69 x 16.54 in.)	Short-edge feed	✓	✓
<b>JIS B5</b> 182 x 257 mm (7.17 x 10.1 in.)	Short-edge feed	✓	✓
	Long-edge feed	X	X
<b>JIS B4</b> 257 x 364 mm (10.12 x 14.33 in.)	Short-edge feed	✓	✓
<b>Statement</b> 139.7 x 215.9 mm (5.5 x 8.5 in.)	Short-edge feed	X	X
	Long-edge feed	X	X
<b>Executive</b> 184.2 x 266.7 mm (7.25 x 10.5 in.)	Short-edge feed	X	X
	Long-edge feed	X	X

## Learn about the printer

Paper size	Orientation	Paper transport + Booklet finisher	
		V-fold multiple	V-fold
		Bin 2	Standard bin, bin 1, bin 2
<b>Letter</b> 215.9 x 279.4 mm (8.5 x 11 in.)	Short-edge feed	✓	✓
	Long-edge feed	X	X
<b>Folio</b> 215.9 x 330.2 mm (8.5 x 13 in.)	Short-edge feed	✓	✓
<b>Oficio (Mexico)</b> 215.9 x 340.4 mm (8.5 x 13.4 in.)	Short-edge feed	✓	✓
<b>Legal</b> 215.9 x 355.6 mm (8.5 x 14 in.)	Short-edge feed	✓	✓
<b>Ledger</b> 279.4 x 431.8 mm (11 x 17 in.)	Short-edge feed	✓	✓
<b>12x18</b> 304.8 x 457.2 mm (12 x 18 in.)	Short-edge feed	✓	✓
<b>SRA3</b> 320.04 x 449.58 mm (12.6 x 17.7 in.)	Short-edge feed	✓	✓
<b>Envelope (Choukei #3)</b> 120 x 235 mm (4.75 x 9.25 in.)	Short-edge feed	X	X
<b>Hagaki</b> 100 x 148 mm (3.94 x 5.83 in.)	Short-edge feed	X	X

## Learn about the printer

Paper size	Orientation	Paper transport + Booklet finisher	
		V-fold multiple	V-fold
		Bin 2	Standard bin, bin 1, bin 2
<b>B5 Envelope</b> 176 x 250 mm (6.93 x 9.84 in.)	Short-edge feed	X	X
<b>Envelope (Commercial #9)</b> 98.4 x 225.4 mm (3.875 x 8.9 in.)	Short-edge feed	X	X
<b>Envelope (Commercial #10)</b> 104.8 x 241.3 mm (4.12 x 9.5 in.)	Short-edge feed	X	X
<b>Envelope (Monarch 7-3/4)</b> 98.4 x 190.5 mm (3.875 x 7.5 in.)	Short-edge feed	X	X
<b>Envelope (DL)</b> 110 x 220 mm (4.33 x 8.66 in.)	Short-edge feed	X	X
<b>Envelope (ISO C4)</b> 229 x 324 mm (9 x 12.8 in.)	Short-edge feed	X	X
<b>Envelope (ISO C5)</b> 162 x 229 mm (6.38 x 9 in.)	Short-edge feed	X	X

## Paper sizes supported by the folding paper transport and staple, hole punch finisher

Paper size	Orientation	Folding paper transport + Staple, hole punch finisher			
		C-fold	Z-fold	Z-fold half sheet	V-fold
		Bin 2		Standard bin, bin 2	
<b>4x6 Card</b>	Short-edge feed	X	X	X	X
	Long-edge feed	X	X	X	X
<b>A6</b> 105 x 148 mm (4.13 x 5.83 in.)	Short-edge feed	X	X	X	X
	Long-edge feed	X	X	X	X
<b>A5</b> 148 x 210 mm (5.83 x 8.27 in.)	Short-edge feed	X	X	X	X
	Long-edge feed	X	X	X	X
<b>A4</b> 210 x 297 mm (8.27 x 11.7 in.)	Short-edge feed	✓	✓	✓	✓
	Long-edge feed	X	X	X	X
<b>A3</b> 297 x 420 mm (11.69 x 16.54 in.)	Short-edge feed	✓	✓	✓	✓
<b>JIS B5</b> 182 x 257 mm (7.17 x 10.1 in.)	Short-edge feed	X	X	X	X
	Long-edge feed	X	X	X	X

## Learn about the printer

Paper size	Orientation	Folding paper transport + Staple, hole punch finisher			
		C-fold	Z-fold	Z-fold half sheet	V-fold
		Bin 2		Standard bin, bin 2	
<b>JIS B4</b> 257 x 364 mm  (10.12 x 14.33 in.)	Short-edge feed	X	X	✓	✓
<b>Statement</b> 139.7 x 215.9 mm  (5.5 x 8.5 in.)	Short-edge feed	X	X	X	X
	Long-edge feed	X	X	X	X
<b>Executive</b> 184.2 x 266.7 mm  (7.25 x 10.5 in.)	Short-edge feed	X	X	X	X
	Long-edge feed	X	X	X	X
<b>Letter</b> 215.9 x 279.4 mm  (8.5 x 11 in.)	Short-edge feed	✓	✓	✓	✓
	Long-edge feed	X	X	X	X
<b>Folio</b> 215.9 x 330.2 mm  (8.5 x 13 in.)	Short-edge feed	X	X	X	X
<b>Oficio (Mexico)</b> 215.9 x 340.4 mm  (8.5 x 13.4 in.)	Short-edge feed	✓	✓	✓	✓
<b>Legal</b> 215.9 x 355.6 mm  (8.5 x 14 in.)	Short-edge feed	✓	✓	✓	✓

## Learn about the printer

Paper size	Orientation	Folding paper transport + Staple, hole punch finisher			
		C-fold	Z-fold	Z-fold half sheet	V-fold
		Bin 2		Standard bin, bin 2	
<b>Ledger</b> 279.4 x 431.8 mm (11 x 17 in.)	Short-edge feed	✓	✓	✓	✓
<b>12x18</b> 304.8 x 457.2 mm (12 x 18 in.)	Short-edge feed	X	X	X	✓
<b>SRA3</b> 320.04 x 449.58 mm (12.6 x 17.7 in.)	Short-edge feed	X	X	X	✓
<b>Envelope (Choukei #3)</b> 120 x 235 mm (4.75 x 9.25 in.)	Short-edge feed	X	X	X	X
<b>Hagaki</b> 100 x 148 mm (3.94 x 5.83 in.)	Short-edge feed	X	X	X	X
<b>B5 Envelope</b> 176 x 250 mm (6.93 x 9.84 in.)	Short-edge feed	X	X	X	X

## Learn about the printer

Paper size	Orientation	Folding paper transport + Staple, hole punch finisher			
		C-fold	Z-fold	Z-fold half sheet	V-fold
		Bin 2		Standard bin, bin 2	
<b>Envelope (Commercial #9)</b>  98.4 x 225.4 mm  (3.875 x 8.9 in.)	Short-edge feed	X	X	X	X
<b>Envelope (Commercial #10)</b>  104.8 x 241.3 mm  (4.12 x 9.5 in.)	Short-edge feed	X	X	X	X
<b>Envelope (Monarch 7-3/4)</b>  98.4 x 190.5 mm  (3.875 x 7.5 in.)	Short-edge feed	X	X	X	X
<b>Envelope (DL)</b>  110 x 220 mm  (4.33 x 8.66 in.)	Short-edge feed	X	X	X	X
<b>Envelope (ISO C4)</b>  229 x 324 mm  (9 x 12.8 in.)	Short-edge feed	X	X	X	X
<b>Envelope (ISO C5)</b>  162 x 229 mm  (6.38 x 9 in.)	Short-edge feed	X	X	X	X

## Paper sizes supported by the folding paper transport and booklet finisher

Paper size	Orientation	Folding paper transport + Booklet finisher				
		C-fold	Z-fold	Z-fold half sheet	V-fold multiple	V-fold
		Bin 3	Bin 3	Standard bin, bin 1, bin 3	Bin 2	Standard bin, bin 1, bin 2, bin 3
<b>4x6 Card</b>	Short-edge feed	X	X	X	X	X
	Long-edge feed	X	X	X	X	X
<b>A6</b> 105 x 148 mm (4.13 x 5.83 in.)	Short-edge feed	X	X	X	X	X
	Long-edge feed	X	X	X	X	X
<b>A5</b> 148 x 210 mm (5.83 x 8.27 in.)	Short-edge feed	X	X	X	X	X
	Long-edge feed	X	X	X	X	X
<b>A4</b> 210 x 297 mm (8.27 x 11.7 in.)	Short-edge feed	✓	✓	✓	✓	✓
	Long-edge feed	X	X	X	X	X
<b>A3</b> 297 x 420 mm (11.69 x 16.54 in.)	Short-edge feed	✓	✓	✓	✓	✓
<b>JIS B5</b> 182 x 257 mm (7.17 x 10.1 in.)	Short-edge feed	X	X	X	✓	✓
	Long-edge feed	X	X	X	X	X

## Learn about the printer

Paper size	Orientation	Folding paper transport + Booklet finisher				
		C-fold	Z-fold	Z-fold half sheet	V-fold multiple	V-fold
		Bin 3	Bin 3	Standard bin, bin 1, bin 3	Bin 2	Standard bin, bin 1, bin 2, bin 3
<b>JIS B4</b> 257 x 364 mm  (10.12 x 14.33 in.)	Short-edge feed	X	X	✓	✓	✓
<b>Statement</b> 139.7 x 215.9 mm  (5.5 x 8.5 in.)	Short-edge feed	X	X	X	X	X
	Long-edge feed	X	X	X	X	X
<b>Executive</b> 184.2 x 266.7 mm  (7.25 x 10.5 in.)	Short-edge feed	X	X	X	X	X
	Long-edge feed	X	X	X	X	X
<b>Letter</b> 215.9 x 279.4 mm  (8.5 x 11 in.)	Short-edge feed	✓	✓	✓	✓	✓
	Long-edge feed	X	X	X	X	X
<b>Folio</b> 215.9 x 330.2 mm  (8.5 x 13 in.)	Short-edge feed	X	X	X	✓	✓
<b>Oficio (Mexico)</b> 215.9 x 340.4 mm  (8.5 x 13.4 in.)	Short-edge feed	✓	✓	✓	✓	✓

## Learn about the printer

Paper size	Orientation	Folding paper transport + Booklet finisher				
		C-fold	Z-fold	Z-fold half sheet	V-fold multiple	V-fold
		Bin 3	Bin 3	Standard bin, bin 1, bin 3	Bin 2	Standard bin, bin 1, bin 2, bin 3
<b>Legal</b> 215.9 x 355.6 mm (8.5 x 14 in.)	Short-edge feed	✓	✓	✓	✓	✓
<b>Ledger</b> 279.4 x 431.8 mm (11 x 17 in.)	Short-edge feed	✓	✓	✓	✓	✓
<b>12x18</b> 304.8 x 457.2 mm (12 x 18 in.)	Short-edge feed	X	X	X	X	✓
<b>SRA3</b> 320.04 x 449.58 mm (12.6 x 17.7 in.)	Short-edge feed	X	X	X	X	✓
<b>Envelope (Choukei #3)</b> 120 x 235 mm (4.75 x 9.25 in.)	Short-edge feed	X	X	X	X	X
<b>Hagaki</b> 100 x 148 mm (3.94 x 5.83 in.)	Short-edge feed	X	X	X	X	X

## Learn about the printer

Paper size	Orientation	Folding paper transport + Booklet finisher				
		C-fold	Z-fold	Z-fold half sheet	V-fold multiple	V-fold
		Bin 3	Bin 3	Standard bin, bin 1, bin 3	Bin 2	Standard bin, bin 1, bin 2, bin 3
<b>B5 Envelope</b>  176 x 250 mm  (6.93 x 9.84 in.)	Short-edge feed	X	X	X	X	X
<b>Envelope (Commercial #9)</b>  98.4 x 225.4 mm  (3.875 x 8.9 in.)	Short-edge feed	X	X	X	X	X
<b>Envelope (Commercial #10)</b>  104.8 x 241.3 mm  (4.12 x 9.5 in.)	Short-edge feed	X	X	X	X	X
<b>Envelope (Monarch 7-3/4)</b>  98.4 x 190.5 mm  (3.875 x 7.5 in.)	Short-edge feed	X	X	X	X	X
<b>Envelope (DL)</b>  110 x 220 mm  (4.33 x 8.66 in.)	Short-edge feed	X	X	X	X	X

## Learn about the printer

Paper size	Orientation	Folding paper transport + Booklet finisher				
		C-fold	Z-fold	Z-fold half sheet	V-fold multiple	V-fold
		Bin 3	Bin 3	Standard bin, bin 1, bin 3	Bin 2	Standard bin, bin 1, bin 2, bin 3
<b>Envelope (ISO C4)</b> 229 x 324 mm (9 x 12.8 in.)	Short-edge feed	X	X	X	X	X
<b>Envelope (ISO C5)</b> 162 x 229 mm (6.38 x 9 in.)	Short-edge feed	X	X	X	X	X

## Paper sizes supported for offset stacking jobs

### Paper sizes supported by the offset stacker or staple finisher

Paper size	Orientation	Offset stacker	Staple finisher
<b>4x6 Card</b>	Short-edge feed	X	X
	Long-edge feed	X	X
<b>A6</b> 105 x 148 mm (4.13 x 5.83 in.)	Short-edge feed	X	X
	Long-edge feed	X	X
<b>A5</b> 148 x 210 mm (5.83 x 8.27 in.)	Short-edge feed	✓	✓
	Long-edge feed	✓	✓
<b>A4</b> 210 x 297 mm (8.27 x 11.7 in.)	Short-edge feed	✓	✓
	Long-edge feed	✓	✓

## Learn about the printer

Paper size	Orientation	Offset stacker	Staple finisher
<b>A3</b> 297 x 420 mm (11.69 x 16.54 in.)	Short-edge feed	✓	✓
<b>JIS B5</b> 182 x 257 mm (7.17 x 10.1 in.)	Short-edge feed	✓	✓
	Long-edge feed	✓	✓
<b>JIS B4</b> 257 x 364 mm (10.12 x 14.33 in.)	Short-edge feed	✓	✓
<b>Statement</b> 139.7 x 215.9 mm (5.5 x 8.5 in.)	Short-edge feed	✓	X
	Long-edge feed	✓	X
<b>Executive</b> 184.2 x 266.7 mm (7.25 x 10.5 in.)	Short-edge feed	✓	✓
	Long-edge feed	✓	✓
<b>Letter</b> 215.9 x 279.4 mm (8.5 x 11 in.)	Short-edge feed	✓	✓
	Long-edge feed	✓	✓
<b>Folio</b> 215.9 x 330.2 mm (8.5 x 13 in.)	Short-edge feed	✓	✓
<b>Oficio (Mexico)</b> 215.9 x 340.4 mm (8.5 x 13.4 in.)	Short-edge feed	✓	✓
<b>Legal</b> 215.9 x 355.6 mm (8.5 x 14 in.)	Short-edge feed	✓	✓
<b>Ledger</b> 279.4 x 431.8 mm (11 x 17 in.)	Short-edge feed	✓	✓

## Learn about the printer

Paper size	Orientation	Offset stacker	Staple finisher
<b>12x18</b> 304.8 x 457.2 mm (12 x 18 in.)	Short-edge feed	X	X
<b>SRA3</b> 320.04 x 449.58 mm (12.6 x 17.7 in.)	Short-edge feed	X	X
<b>Envelope (Choukei #3)</b> 120 x 235 mm (4.75 x 9.25 in.)	Short-edge feed	✓	X
<b>Hagaki</b> 100 x 148 mm (3.94 x 5.83 in.)	Short-edge feed	✓	X
<b>B5 Envelope</b> 176 x 250 mm (6.93 x 9.84 in.)	Short-edge feed	✓	X
<b>Envelope (Commercial #9)</b> 98.4 x 225.4 mm (3.875 x 8.9 in.)	Short-edge feed	✓	X
<b>Envelope (Commercial #10)</b> 104.8 x 241.3 mm (4.12 x 9.5 in.)	Short-edge feed	✓	X
<b>Envelope (Monarch 7-3/4)</b> 98.4 x 190.5 mm (3.875 x 7.5 in.)	Short-edge feed	✓	X
<b>Envelope (DL)</b> 110 x 220 mm (4.33 x 8.66 in.)	Short-edge feed	✓	X

## Learn about the printer

Paper size	Orientation	Offset stacker	Staple finisher
<b>Envelope (ISO C4)</b> 229 x 324 mm (9 x 12.8 in.)	Short-edge feed	✓	X
<b>Envelope (ISO C5)</b> 162 x 229 mm (6.38 x 9 in.)	Short-edge feed	✓	X
<b>Universal</b>	N/A	✓ <sup>1</sup>	✓ <sup>2</sup>

<sup>1</sup> Supports paper sizes ranging from 90 x 148 mm (3.55 x 5.83 in.) to 320 x 600 mm (12.59 x 23.62 in.).

<sup>2</sup> Supports paper sizes ranging from 148 x 148 mm (5.83 x 5.83 in.) to 297 x 431.8 mm (11.69 x 17 in.).

## Paper sizes supported by the output bins

Paper size	Orientation	Paper transport + Staple, hole punch finisher	Paper transport + Booklet finisher
		Bin 1	
<b>4x6 Card</b>	Short-edge feed	X	X
	Long-edge feed	X	X
<b>A6</b> 105 x 148 mm (4.13 x 5.83 in.)	Short-edge feed	X	X
	Long-edge feed	X	X
<b>A5</b> 148 x 210 mm (5.83 x 8.27 in.)	Short-edge feed	✓	✓
	Long-edge feed	✓	✓
<b>A4</b> 210 x 297 mm (8.27 x 11.7 in.)	Short-edge feed	✓	✓
	Long-edge feed	✓	✓
<b>A3</b> 297 x 420 mm (11.69 x 16.54 in.)	Short-edge feed	✓	✓

## Learn about the printer

Paper size	Orientation	Paper transport + Staple, hole punch finisher	Paper transport + Booklet finisher
		Bin 1	
<b>JIS B5</b> 182 x 257 mm (7.17 x 10.1 in.)	Short-edge feed	✓	✓
	Long-edge feed	✓	✓
<b>JIS B4</b> 257 x 364 mm (10.12 x 14.33 in.)	Short-edge feed	✓	✓
<b>Statement</b> 139.7 x 215.9 mm (5.5 x 8.5 in.)	Short-edge feed	✓	✓
	Long-edge feed	✓	✓
<b>Executive</b> 184.2 x 266.7 mm (7.25 x 10.5 in.)	Short-edge feed	✓	✓
	Long-edge feed	✓	✓
<b>Letter</b> 215.9 x 279.4 mm (8.5 x 11 in.)	Short-edge feed	✓	✓
	Long-edge feed	✓	✓
<b>Folio</b> 215.9 x 330.2 mm (8.5 x 13 in.)	Short-edge feed	✓	✓
<b>Oficio (Mexico)</b> 215.9 x 340.4 mm (8.5 x 13.4 in.)	Short-edge feed	✓	✓
<b>Legal</b> 215.9 x 355.6 mm (8.5 x 14 in.)	Short-edge feed	✓	✓
<b>Ledger</b> 279.4 x 431.8 mm (11 x 17 in.)	Short-edge feed	✓	✓

## Learn about the printer

Paper size	Orientation	Paper transport + Staple, hole punch finisher	Paper transport + Booklet finisher
		Bin 1	
<b>12x18</b> 304.8 x 457.2 mm (12 x 18 in.)	Short-edge feed	✓	✓
<b>SRA3</b> 320.04 x 449.58 mm (12.6 x 17.7 in.)	Short-edge feed	X	X
<b>Envelope (Choukei #3)</b> 120 x 235 mm (4.75 x 9.25 in.)	Short-edge feed	X	X
<b>Hagaki</b> 100 x 148 mm (3.94 x 5.83 in.)	Short-edge feed	X	X
<b>B5 Envelope</b> 176 x 250 mm (6.93 x 9.84 in.)	Short-edge feed	X	X
<b>Envelope (Commercial #9)</b> 98.4 x 225.4 mm (3.875 x 8.9 in.)	Short-edge feed	X	X
<b>Envelope (Commercial #10)</b> 104.8 x 241.3 mm (4.12 x 9.5 in.)	Short-edge feed	X	X
<b>Envelope (Monarch 7-3/4)</b> 98.4 x 190.5 mm (3.875 x 7.5 in.)	Short-edge feed	X	X
<b>Envelope (DL)</b> 110 x 220 mm (4.33 x 8.66 in.)	Short-edge feed	X	X

## Learn about the printer

Paper size	Orientation	Paper transport + Staple, hole punch finisher	Paper transport + Booklet finisher
		Bin 1	
<b>Envelope (ISO C4)</b> 229 x 324 mm (9 x 12.8 in.)	Short-edge feed	X	X
<b>Envelope (ISO C5)</b> 162 x 229 mm (6.38 x 9 in.)	Short-edge feed	X	X
<b>Universal</b>	N/A	√ <sup>1</sup>	√ <sup>2</sup>

<sup>1</sup> Supports paper sizes ranging from 139.7 x 148 mm (5.5 x 5.83 in.) to 304.8 x 600 mm (12 x 23.62 in.).

<sup>2</sup> Supports paper sizes ranging from 125 x 148 mm (4.93 x 5.83 in.) to 304.8 x 457.2 mm (12 x 18 in.).

## Paper sizes supported by the output bins (with folding paper transport)

Paper size	Orientation	Folding paper transport + Staple, hole punch finisher	Folding paper transport + Booklet finisher
		Bin 1	
<b>4x6 Card</b>	Short-edge feed	X	X
	Long-edge feed	X	X
<b>A6</b> 105 x 148 mm (4.13 x 5.83 in.)	Short-edge feed	X	X
	Long-edge feed	X	X
<b>A5</b> 148 x 210 mm (5.83 x 8.27 in.)	Short-edge feed	√	√
	Long-edge feed	√	√
<b>A4</b> 210 x 297 mm (8.27 x 11.7 in.)	Short-edge feed	√	√
	Long-edge feed	√	√

## Learn about the printer

Paper size	Orientation	Folding paper transport + Staple, hole punch finisher	Folding paper transport + Booklet finisher
		Bin 1	
<b>A3</b> 297 x 420 mm (11.69 x 16.54 in.)	Short-edge feed	✓	✓
<b>JIS B5</b> 182 x 257 mm (7.17 x 10.1 in.)	Short-edge feed	✓	✓
	Long-edge feed	✓	✓
<b>JIS B4</b> 257 x 364 mm (10.12 x 14.33 in.)	Short-edge feed	✓	✓
<b>Statement</b> 139.7 x 215.9 mm (5.5 x 8.5 in.)	Short-edge feed	✓	✓
	Long-edge feed	✓	✓
<b>Executive</b> 184.2 x 266.7 mm (7.25 x 10.5 in.)	Short-edge feed	✓	✓
	Long-edge feed	✓	✓
<b>Letter</b> 215.9 x 279.4 mm (8.5 x 11 in.)	Short-edge feed	✓	✓
	Long-edge feed	✓	✓
<b>Folio</b> 215.9 x 330.2 mm (8.5 x 13 in.)	Short-edge feed	✓	✓
<b>Oficio (Mexico)</b> 215.9 x 340.4 mm (8.5 x 13.4 in.)	Short-edge feed	✓	✓
<b>Legal</b> 215.9 x 355.6 mm (8.5 x 14 in.)	Short-edge feed	✓	✓

## Learn about the printer

Paper size	Orientation	Folding paper transport + Staple, hole punch finisher	Folding paper transport + Booklet finisher
		Bin 1	
<b>Ledger</b> 279.4 x 431.8 mm (11 x 17 in.)	Short-edge feed	✓	✓
<b>12x18</b> 304.8 x 457.2 mm (12 x 18 in.)	Short-edge feed	✓	✓
<b>SRA3</b> 320.04 x 449.58 mm (12.6 x 17.7 in.)	Short-edge feed	X	X
<b>Envelope (Choukei #3)</b> 120 x 235 mm (4.75 x 9.25 in.)	Short-edge feed	X	X
<b>Hagaki</b> 100 x 148 mm (3.94 x 5.83 in.)	Short-edge feed	X	X
<b>B5 Envelope</b> 176 x 250 mm (6.93 x 9.84 in.)	Short-edge feed	X	X
<b>Envelope (Commercial #9)</b> 98.4 x 225.4 mm (3.875 x 8.9 in.)	Short-edge feed	X	X
<b>Envelope (Commercial #10)</b> 104.8 x 241.3 mm (4.12 x 9.5 in.)	Short-edge feed	X	X
<b>Envelope (Monarch 7-3/4)</b> 98.4 x 190.5 mm (3.875 x 7.5 in.)	Short-edge feed	X	X

## Learn about the printer

Paper size	Orientation	Folding paper transport + Staple, hole punch finisher	Folding paper transport + Booklet finisher
		Bin 1	
<b>Envelope (DL)</b> 110 x 220 mm (4.33 x 8.66 in.)	Short-edge feed	X	X
<b>Envelope (ISO C4)</b> 229 x 324 mm (9 x 12.8 in.)	Short-edge feed	X	X
<b>Envelope (ISO C5)</b> 162 x 229 mm (6.38 x 9 in.)	Short-edge feed	X	X
<b>Universal</b>	N/A	√ <sup>1</sup>	√ <sup>2</sup>

<sup>1</sup> Supports paper sizes ranging from 139.7 x 148 mm (5.5 x 5.83 in.) to 304.8 x 600 mm (12 x 23.62 in.).

<sup>2</sup> Supports paper sizes ranging from 125 x 148 mm (4.93 x 5.83 in.) to 304.8 x 457.2 mm (12 x 18 in.).

## Supported paper weights

550-sheet tray, 2 x 550-sheet tray, 1500-sheet tray, and 2000-sheet tandem tray	Multipurpose feeder	Two-sided printing	Automatic document feeder
60–300 g/m <sup>2</sup> (16–80-lb bond)	60–300 g/m <sup>2</sup> (16–80-lb bond)	60–220 g/m <sup>2</sup> (16–59-lb bond)	50–150 g/m <sup>2</sup> (14–40-lb bond)

## Supported paper types

### Paper types supported by the basic configuration

Paper type	Standard 550-sheet tray	Multipurpose feeder	Two-sided printing	Automatic document feeder
<b>Plain paper</b>	✓	✓	✓	✓
<b>Card stock</b>	✓	✓	✓	X

## Learn about the printer

Paper type	Standard 550-sheet tray	Multipurpose feeder	Two-sided printing	Automatic document feeder
Recycled	✓	✓	✓	✓
Glossy	✓	✓	✓	X
Heavy glossy	✓	✓	✓	X
Labels	✓	✓	X	X
Vinyl labels	✓	✓	X	X
Bond	✓	✓	✓	✓
Envelope	✓	✓	X	X
Rough envelope	✓	✓	X	X
Letterhead	✓	✓	✓	✓
Preprinted	✓	✓	✓	✓
Colored paper	✓	✓	✓	✓
Light paper	✓	✓	✓	✓
Heavy paper	✓	✓	✓	✓
Rough cotton	✓	✓	✓	X
Custom type	✓	✓	✓	✓

## Paper types supported by the optional trays

Paper type	Optional 550-sheet tray	2 x 550-sheet tray	2000-sheet tandem tray	1500-sheet tray
Plain paper	✓	✓	✓	✓
Card stock	✓	✓	✓	✓
Transparenci es	X	X	X	X
Recycled	✓	✓	✓	✓
Glossy	✓	✓	✓	✓
Heavy glossy	✓	✓	✓	✓
Labels	✓	✓	X	X
Vinyl labels	✓	✓	X	X
Bond	✓	✓	✓	✓

## Learn about the printer

Paper type	Optional 550-sheet tray	2 x 550-sheet tray	2000-sheet tandem tray	1500-sheet tray
Envelope	✓	✓	X	X
Rough envelope	✓	✓	X	X
Letterhead	✓	✓	✓	✓
Preprinted	✓	✓	✓	✓
Colored paper	✓	✓	✓	✓
Light paper	✓	✓	✓	✓
Heavy paper	✓	✓	✓	✓
Rough cotton	✓	✓	✓	✓
Custom type	✓	✓	✓	✓

## Paper types supported by the output bin (with folding paper transport)

Paper type	Folding paper transport + Staple, hole punch finisher		
	Standard bin (Finisher top bin)	Bin 1 (Finisher stapler/punch, offset bin)	Bin 2 (Paper transport bin)
Plain paper	✓	✓	✓
Card stock	✓	✓	✓
Recycled	✓	✓	✓
Glossy	✓	✓	✓
Heavy glossy	✓	✓	✓
Labels	✓	✓	✓
Vinyl labels	✓	✓	✓
Bond	✓	✓	✓
Envelope	X	X	✓
Rough envelope	X	X	✓
Letterhead	✓	✓	✓
Preprinted	✓	✓	✓
Colored paper	✓	✓	✓
Light paper	✓	✓	✓

## Learn about the printer

Paper type	Folding paper transport + Staple, hole punch finisher		
	Standard bin (Finisher top bin)	Bin 1 (Finisher stapler/punch, offset bin)	Bin 2 (Paper transport bin)
Heavy paper	✓	✓	✓
Rough cotton	✓	✓	✓
Custom type	✓	✓	✓

Paper type	Folding paper transport + Booklet finisher			
	Standard bin (Finisher top bin)	Bin 1 (Finisher stapler/punch, offset bin)	Bin 2 (Finisher booklet bin)	Bin 3 (Paper transport bin)
Plain paper	✓	✓	✓	✓
Card stock	✓	✓	X	✓
Recycled	✓	✓	✓	✓
Glossy	✓	✓	✓	✓
Heavy glossy	✓	✓	X	✓
Labels	✓	✓	X	✓
Vinyl labels	✓	✓	X	✓
Bond	✓	✓	✓	✓
Envelope	X	X	X	✓
Rough envelope	X	X	X	✓
Letterhead	✓	✓	X	✓
Preprinted	✓	✓	X	✓
Colored paper	✓	✓	✓	✓
Light paper	✓	✓	✓	✓
Heavy paper	✓	✓	X	X
Rough cotton	✓	✓	X	X
Custom type	✓	✓	✓	✓

## Paper types supported by the folding paper transport, offset stacker, staple finisher

Paper type	Folding paper transport only	Offset stacker	Staple finisher
Plain paper	✓	✓	✓
Card stock	✓	✓	✓
Recycled	✓	✓	✓
Glossy	✓	✓	✓
Heavy glossy	✓	✓	✓
Labels	✓	✓	✓
Vinyl labels	✓	✓	✓
Bond	✓	✓	✓
Envelope	✓	✓	✓
Rough envelope	✓	✓	✓
Letterhead	✓	✓	✓
Preprinted	✓	✓	✓
Colored paper	✓	✓	✓
Light paper	✓	✓	✓
Heavy paper	✓	✓	✓
Rough cotton	✓	✓	✓
Custom type	✓	✓	✓

## Paper types supported by the staple, hole punch finisher and booklet finisher

Paper type	Finisher top bin (Standard bin)			
	Offset	Hole punch	Staple	Fold
Plain paper	✓	✓	X	✓
Card stock	X	✓	X	X
Recycled	X	✓	X	✓
Glossy	X	✓	X	✓
Heavy glossy	X	✓	X	X

## Learn about the printer

Paper type	Finisher top bin (Standard bin)			
	Offset	Hole punch	Staple	Fold
Labels	X	X	X	X
Vinyl labels	X	X	X	X
Bond	X	✓	X	✓
Letterhead	X	✓	X	✓
Preprinted	X	✓	X	✓
Colored paper	X	✓	X	✓
Light paper	X	✓	X	✓
Heavy paper	X	✓	X	X
Rough cotton	X	✓	X	X
Custom type	X	✓	X	✓

Paper type	Finisher staple bin (Bin 1)			
	Offset	Hole punch	Staple	Fold
Plain paper	✓	✓	✓	✓
Card stock	✓	X	X	X
Recycled	✓	✓	✓	✓
Glossy	✓	✓	✓	✓
Heavy glossy	✓	X	X	X
Labels	✓	X	X	X
Vinyl labels	✓	X	X	X
Bond	✓	✓	✓	✓
Letterhead	✓	✓	✓	✓
Preprinted	✓	✓	✓	✓
Colored paper	✓	✓	✓	✓
Light paper	✓	✓	✓	✓
Heavy paper	✓	X	X	X
Rough cotton	✓	✓	X	X
Custom type	✓	✓	✓	✓

# Additional printer features and support

## Supported applications

Application	Printer models
Scan Center	CX950, CX951, MX953, XC9525, XC9535
Display Customization	CX950, CX951, MX953, XC9525, XC9535
Customer Support	XC9525, XC9535
Device Quotas	XC9525, XC9535
Cloud Connector	XC9525, XC9535

## Supported flash drives and file types

### Flash drives

- Flash drives that support USB 2.0 or lower.
- Flash drives that support a New Technology File System (NTFS) or the File Allocation Table (FAT32) file system.

### File types

Documents	Images
<ul style="list-style-type: none"> <li>• PDF (version 1.7 or earlier)</li> <li>• Microsoft file formats (DOC, DOCX, XLS, XLSX, PPT, PPTX)</li> </ul>	<ul style="list-style-type: none"> <li>• JPEG or JPG</li> <li>• TIFF or TIF</li> <li>• GIF</li> <li>• BMP</li> <li>• PNG</li> <li>• PCX</li> <li>• DCX</li> </ul>

## Available internal options

- Hard disk
- Licensed features
  - IPDS
  - Bar Code
- Lexmark™ internal solutions port (ISP)
  - RS-232C Serial Card
  - MarkNet™ N8230 Fiber Ethernet 100BASE-FX(LC), 1000BASE-SX(LC)

# Set up, install, and configure

## Selecting a location for the printer

- Leave enough room to open trays, covers, and doors and to install hardware options.
- Set up the printer near an electrical outlet.



### CAUTION—POTENTIAL INJURY

To avoid the risk of fire or electrical shock, connect the power cord to an appropriately rated and properly grounded electrical outlet that is near the product and easily accessible.



### CAUTION—SHOCK HAZARD

To avoid the risk of electrical shock, do not place or use this product near water or wet locations.

- Make sure that airflow in the room meets the latest revision of the ASHRAE 62 standard or the CEN Technical Committee 156 standard.
- Provide a flat, sturdy, and stable surface.
- Keep the printer:
  - Clean, dry, and free of dust.
  - Away from stray staples and paper clips.
  - Away from the direct airflow of air conditioners, heaters, or ventilators.
  - Free from direct sunlight and humidity extremes.
- Observe the recommended temperatures and avoid fluctuations:

Ambient temperature	10 to 32.2°C (50 to 90°F)
Storage temperature	15.6 to 32.2°C (60 to 90°F)

- Allow the following recommended amount of space around the printer for proper ventilation:

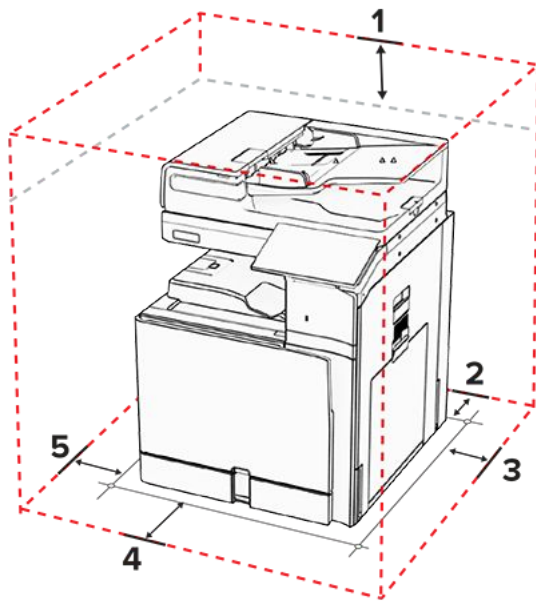

1	Top	356 mm (14 in.)
2	Rear	203 mm (8 in.)
3	Right side	574 mm (22.6 in.)
4	Front	338 mm (13.3 in.)
5	Left side	152 mm (6 in.)

## Printer ports



### CAUTION—SHOCK HAZARD

To avoid the risk of electrical shock, do not set up this product or make any electrical or cabling connections, such as the power cord, fax feature, or telephone, during a lightning storm.



### CAUTION—POTENTIAL INJURY

To avoid the risk of fire or electrical shock, connect the power cord to an appropriately rated and properly grounded electrical outlet that is near the product and easily accessible.



### CAUTION—POTENTIAL INJURY

To avoid the risk of fire or electrical shock, use only the power cord provided with this product or the manufacturer's authorized replacement.



**CAUTION—POTENTIAL INJURY**

To reduce the risk of fire, use only a 26 AWG or larger telecommunications (RJ-11) cord when connecting this product to the public switched telephone network. For users in Australia, the cord must be approved by the Australian Communications and Media Authority.

**Warning—Potential Damage**

To avoid loss of data or printer malfunction, do not touch the USB cable, any wireless network adapter, or the printer in the areas shown while actively printing.

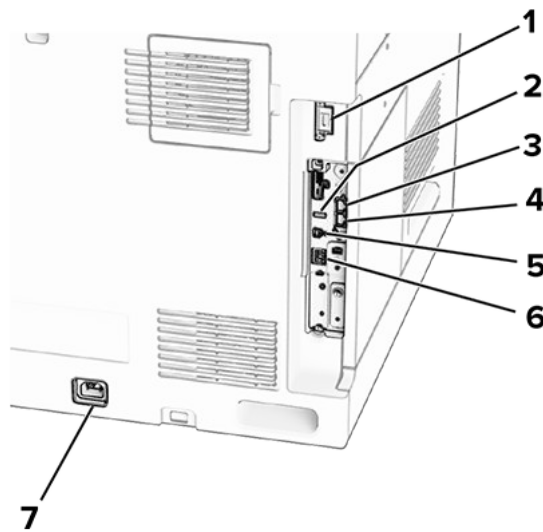

	Printer port	Function
1	Finisher or option port	Connect the printer to a finisher or an option.
2	USB port	Attach a keyboard or any compatible option.
3	LINE port  <b>Note:</b> Available only when a fax card is installed.	Connect the printer to an active telephone line through a standard wall jack (RJ-11), DSL filter, or VoIP adapter, or any other adapter that allows you to access the telephone line to send and receive faxes.
4	EXT port  <b>Note:</b> Available only when a fax card is installed.	Connect more devices (telephone or answering machine) to the printer and the telephone line. Use this port if you do not have a dedicated fax line for the printer and if this connection method is supported in your country or region.

	Printer port	Function
5	USB printer port	Connect the printer to a computer.
6	Ethernet port	Connect the printer to a network.
7	Power cord socket	Connect the printer to a properly grounded electrical outlet.

## Configuring apps and solutions

### Setting up Scan Center

1. From the control panel, select **Scan Center**.
2. Select and create a destination, and then configure the settings.

**Note:** Only destinations created from the Embedded Web Server are saved. For more information, see the documentation for the solution.

3. Scan the document.

### Using Display Customization

**Note:** Make sure that the **Screen Saver**, **Slideshow**, and **Wallpaper** settings are enabled from the Embedded Web Server. Navigate to **Apps > Display Customization > Configure**.

#### Managing screen saver and slide show images

1. In the **Screen Saver** and **Slideshow Images** section, add, edit, or delete an image.

##### Notes

- You can add up to 10 images.
- When enabled, the status icons appear on the screen saver only when there are errors, warnings, or cloud-based notifications.

2. Apply the changes.

#### Changing the wallpaper image

1. From the control panel, select **Change Wallpaper**.
2. Select an image to use.
3. Apply the changes.

### Running a slide show from a flash drive

1. Insert a flash drive into the USB port.
2. From the control panel, select **Slideshow**.

**Note:** You can remove the flash drive after the slide show starts, but the images are not stored in the printer. If the slide show stops, then insert the flash drive again to view the images.

## Configuring bookmarks

### Creating bookmarks

1. Open a web browser, and then type the printer IP address in the address field.

#### Notes

- View the printer IP address on the printer home screen. The IP address appears as four sets of numbers separated by periods, such as 123.123.123.123.
- If you are using a proxy server, then temporarily disable it to load the web page correctly.

2. Click **Bookmarks > Add Bookmark**, and then type a bookmark name.
3. Select an Address protocol type, and then do one of the following:
  - For HTTP and HTTPS, type the URL that you want to bookmark.
  - For HTTPS, make sure to use the host name instead of the IP address. For example, type myWebsite.com/sample.pdf instead of typing 123.123.123.123/sample.pdf. Make sure that the host name also matches the Common Name (CN) value in the server certificate. For more information on obtaining the CN value in the server certificate, see the help information for your web browser.
  - For FTP, type the FTP address. For example, myServer/myDirectory. Enter the FTP port number. Port 21 is the default port for sending commands.
  - For SMB, type the network folder address. For example, myServer/myShare/myFile.pdf. Type the network domain name.
  - If necessary, select the **Authentication** type for FTP and SMB.

To limit access to the bookmark, enter a PIN.

**Note:** The application supports the following file types: PDF, JPEG, and TIFF. Other file types such as DOCX and XLSX are supported in some printer models.

4. Click **Save**.

### Creating folders

1. Open a web browser, and then type the printer IP address in the address field.

### Notes

- View the printer IP address on the printer home screen. The IP address appears as four sets of numbers separated by periods, such as 123.123.123.123.
- If you are using a proxy server, then temporarily disable it to load the web page correctly.

2. Click **Bookmarks > Add Folder**, and then type a folder name.

**Note:** To limit access to the folder, enter a PIN.

3. Click **Save**.

## Configuring Address Book

### Adding contacts

1. Open a web browser, and then type the printer IP address in the address field.

### Notes

- View the printer IP address on the printer home screen. The IP address appears as four sets of numbers separated by periods, such as 123.123.123.123.
- If you are using a proxy server, then temporarily disable it to load the web page correctly.

2. Click **Address Book**, and then click **Add Contact**.
3. If necessary, specify a login method to allow application access.
4. Click **Save**.

### Adding groups

1. Open a web browser, and then type the printer IP address in the address field.

### Notes

- View the printer IP address on the printer home screen. The IP address appears as four sets of numbers separated by periods, such as 123.123.123.123.
- If you are using a proxy server, then temporarily disable it to load the web page correctly.

2. Click **Address Book**, and then click **Add Contact**.

**Note:** You can assign one or more contacts to the group.

3. Click **Save**.

# Setting up and using the accessibility features

## Activating Voice Guidance

### From the home screen

1. In one motion and using one finger, slowly swipe left then up on the display until you hear a voice message.
2. Using two fingers, select **OK**.

**Note:** If the gesture does not work, then apply more pressure.

### From the keyboard

1. Press and hold the **5** key until you hear a voice message.
2. Press **Tab** to navigate the focus cursor to the OK button, and then press **Enter**.

#### Notes

- When Voice Guidance is activated, always use two fingers to select any item on the display.
- Voice Guidance has limited language support.

## Deactivating Voice Guidance

1. In one motion and using one finger, slowly swipe left then up on the display until you hear a voice message.
2. Using two fingers, do either of the following:
  - Select **Voice Guidance**, and then select **OK**.
  - Select **Cancel**.



**Note:** If the gesture does not work, then apply more pressure.



Pressing the power button or putting the printer in Sleep or Hibernate mode also deactivates Voice Guidance.

## Navigating the screen using gestures

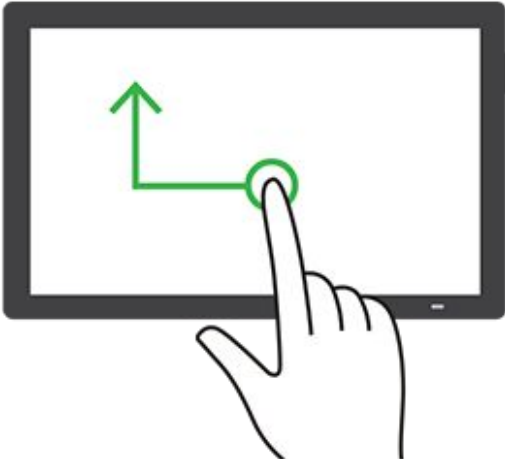
### Notes

- Most of the gestures are applicable only when Voice Guidance is activated.
- Use a physical keyboard to type characters and adjust certain settings.

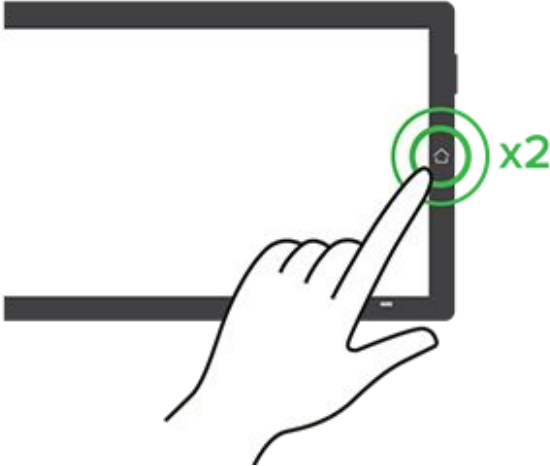
Gesture	Function
<p data-bbox="181 595 635 629">Swipe left then up using one finger</p> 	<p data-bbox="826 595 1294 629">Launch or exit <b>Accessibility mode</b>.</p> <div data-bbox="826 656 1410 786"><p data-bbox="879 689 1362 752"><b>Note:</b> This gesture is also applicable when the printer is in normal mode.</p></div>
<p data-bbox="181 1207 544 1240">Double-tap using one finger</p> 	<p data-bbox="826 1207 1331 1240">Select an option or item on the screen.</p>

Gesture	Function
<p data-bbox="181 226 751 259">Double-tap the home icon using two fingers</p> 	<p data-bbox="828 226 1299 259">Deactivate the <b>Accessibility mode</b>.</p>
<p data-bbox="181 801 523 835">Triple-tap using one finger</p> 	<p data-bbox="828 801 1321 835">Zoom in or zoom out text and images.</p> <div data-bbox="831 864 1410 992" style="background-color: #f0f0f0; padding: 10px;"><p data-bbox="882 898 1347 958"><b>Note:</b> Enable <b>Magnification mode</b> to use the zoom feature.</p></div>

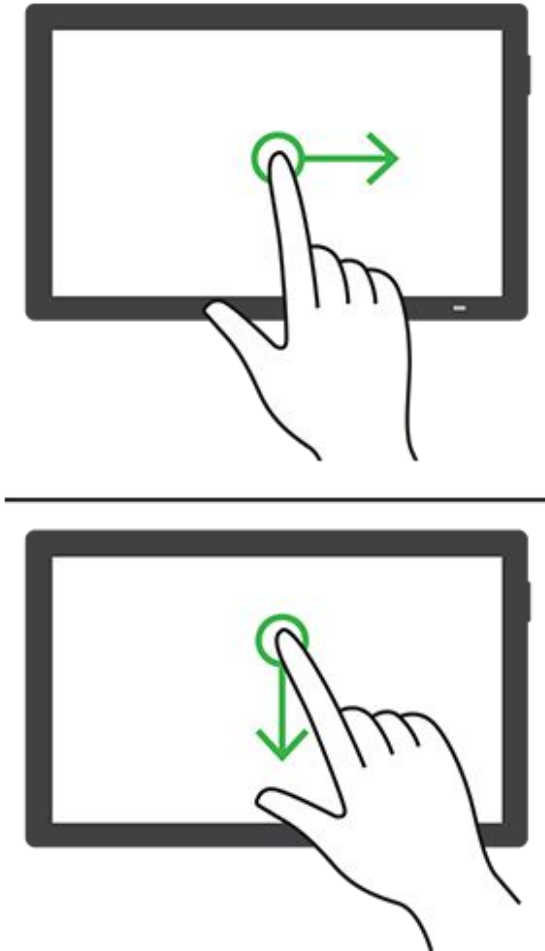
Gesture	Function
<p data-bbox="181 226 746 259">Swipe right or swipe down using one finger</p>  <p>The image contains two line drawings of a hand interacting with a tablet. The top drawing shows the index finger touching the screen, with a green circle at the contact point and a green arrow pointing to the right. The bottom drawing shows the index finger touching the screen, with a green circle at the contact point and a green arrow pointing downwards. A horizontal line separates the two drawings.</p>	<p data-bbox="826 226 1305 259">Move to the next item on the screen.</p>

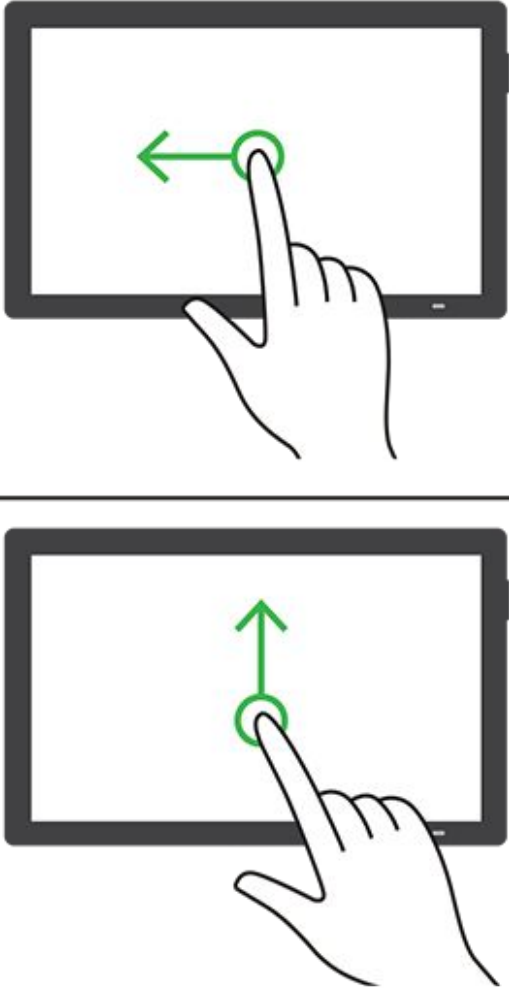
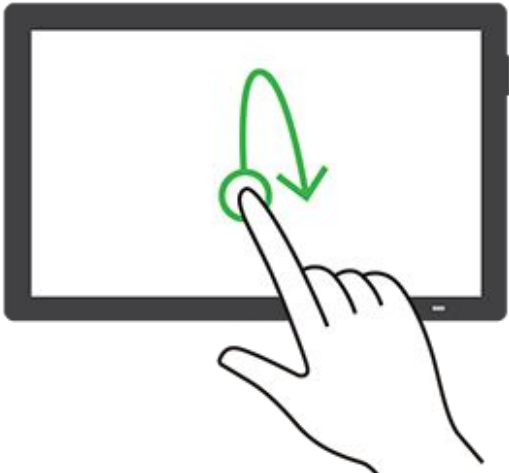
Gesture	Function
<p data-bbox="183 224 694 257">Swipe left or swipe up using one finger</p>  <p>The first diagram shows a hand with the index finger touching a green circle on a tablet screen. A green arrow points to the left from the circle. The second diagram shows a hand with the index finger touching a green circle on a tablet screen. A green arrow points upwards from the circle.</p>	<p data-bbox="821 224 1364 257">Move to the previous item on the screen.</p>
<p data-bbox="183 1344 670 1377">Swipe up then down using one finger</p>  <p>The diagram shows a hand with the index finger touching a green circle on a tablet screen. A green arrow starts at the circle, points upwards, loops around to the right, and then points downwards.</p>	<p data-bbox="821 1344 1300 1377">Move to the first item on the screen.</p>

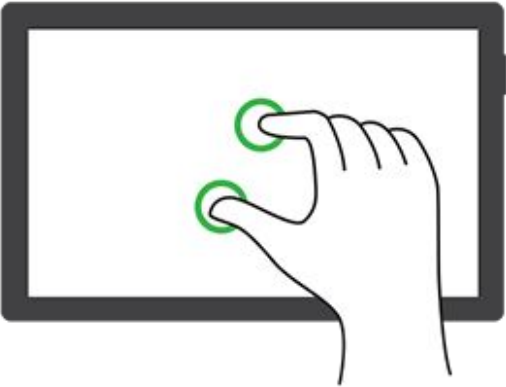
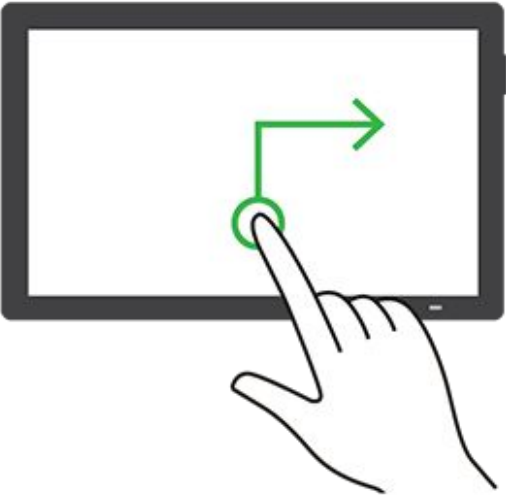
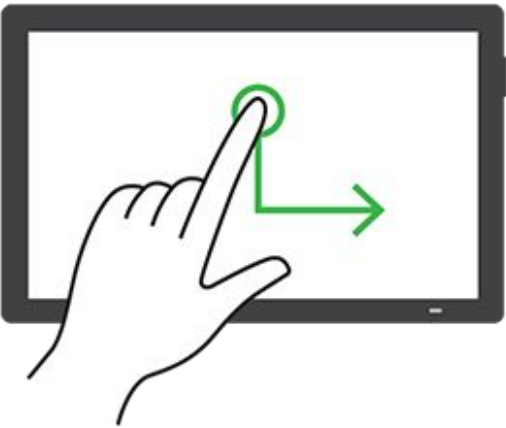
Gesture	Function
<p data-bbox="181 228 236 255">Pan</p> 	<p data-bbox="826 228 1391 286">Access parts of the zoomed image that are beyond the limit of the screen.</p> <div data-bbox="833 318 1414 622"><p data-bbox="880 349 973 376"><b>Notes</b></p><ul data-bbox="935 416 1343 560" style="list-style-type: none"><li data-bbox="935 416 1295 483">• Use two fingers to drag a zoomed image.</li><li data-bbox="935 488 1343 560">• Enable <b>Magnification mode</b> to use the pan gesture.</li></ul></div>
<p data-bbox="181 748 657 775">Swipe up then right using one finger</p> 	<p data-bbox="826 748 1101 775">Increase the volume.</p> <div data-bbox="833 806 1414 936"><p data-bbox="880 842 1366 900"><b>Note:</b> This gesture is also applicable when the printer is in normal mode.</p></div>
<p data-bbox="181 1366 692 1393">Swipe down then right using one finger</p> 	<p data-bbox="826 1366 1114 1393">Decrease the volume.</p> <div data-bbox="833 1429 1414 1559"><p data-bbox="880 1464 1366 1523"><b>Note:</b> This gesture is also applicable when the printer is in normal mode.</p></div>

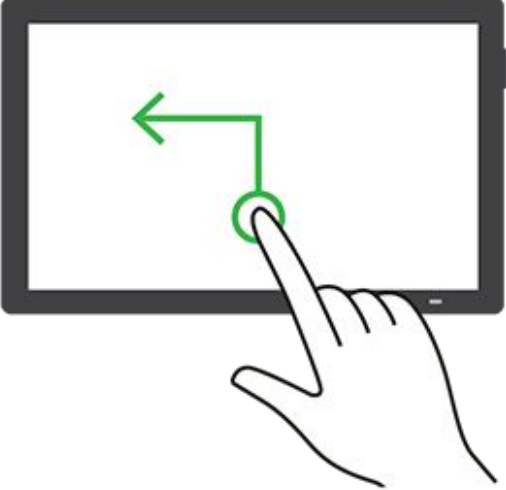
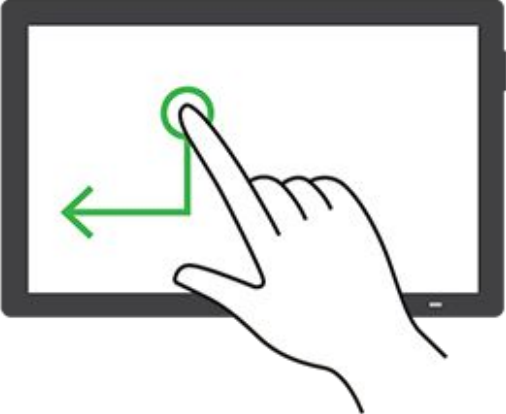
Gesture	Function
<p data-bbox="181 228 638 259">Swipe up then left using one finger</p> 	<p data-bbox="826 228 1375 286">Exit an application and return to the home screen.</p>
<p data-bbox="181 846 676 878">Swipe down then left using one finger</p> 	<p data-bbox="826 846 1241 878">Go back to the previous setting.</p>

## Using the on-screen keyboard

When the on-screen keyboard appears, do one or more of the following:

- Touch a key to announce and type the character in the field.
- Drag a finger across different characters to announce and type the character in the field.
- Touch a text box using two fingers to announce the characters in the field.
- Touch **Backspace** to delete characters.

## Enabling Magnification mode

1. In one motion and using one finger, slowly swipe left then up on the display until you hear a voice message.

**Note:** For printer models without built-in speakers, use headphones to hear the message.

2. Using two fingers, do the following:

**Note:** If the gesture does not work, then apply more pressure.

- a. Touch **Magnification mode**.
- b. Touch **OK**.

**Note:** If the gesture does not work, then apply more pressure.

For more information on navigating a magnified screen, see [Navigating the screen using gestures on page 98](#).

## Adjusting the Voice Guidance speech rate

1. From the control panel, navigate to **Settings > Device > Accessibility > Speech Rate**.
2. Select the speech rate.

## Adjusting the default headphone volume

1. From the control panel, navigate to **Settings > Device > Accessibility**.
2. Adjust the headphone volume.

**Note:** The volume resets to the default value after the user exits Accessibility mode or when the printer wakes from Sleep or Hibernate mode.

## Adjusting the default internal speaker volume

1. From the control panel, swipe right to the control center.
2. Adjust the volume.

### Notes

- If **Quiet Mode** is enabled, then the audible alerts are turned off. This setting also slows the printer performance.
- The volume resets to the default value after the user exits the Accessibility mode or when the printer wakes from Sleep or Hibernate mode.

## Enabling spoken passwords or personal identification numbers

1. From the control panel, navigate to **Settings > Device > Accessibility > Speak Passwords/PINs**.
2. Enable the setting.

## Setting up the printer to fax

### Setting up the fax function using analog fax

#### Notes

- A fax card must be installed for the printer to use analog fax.
- Some connection methods are applicable only in some countries or regions.
- If the fax function is enabled and not fully set up, then the indicator light may blink red.
- If you do not have a TCP/IP environment, then use the control panel to set up fax.

#### **Warning—Potential Damage**

To avoid loss of data or printer malfunction, do not touch cables or the printer in the area shown while actively sending or receiving a fax.



### Using the control panel

1. From the control panel, navigate to **Settings > Fax > Fax Setup > General Fax Settings**.
2. Configure the settings.

### Using the Embedded Web Server

1. Open a web browser, and then type the printer IP address in the address field.

#### Notes

- View the printer IP address on the control panel. The IP address appears as four sets of numbers separated by periods, such as 123.123.123.123.
- If you are using a proxy server, then temporarily disable it to load the web page correctly.

2. Click **Settings > Fax > Fax Setup > General Fax Settings**.
3. Configure the settings.
4. Apply the changes.

## Setting up the fax function using etherFAX

#### Notes

- The printer firmware must be updated to the latest version. For more information, see the “Printer firmware instructions” section.
- An appropriate license bundle must be installed in your printer. For more information, contact etherFAX.
- Make sure that you have registered your printer to the etherFAX portal. For more information, go to <https://www.etherfax.net/lexmark>.
- The printer serial number is required on registration. For more information, see [Finding the printer serial number on page 12](#).

1. Open a web browser, and then type the printer IP address in the address field.

### Notes

- View the printer IP address on the control panel. The IP address appears as four sets of numbers separated by periods, such as 123.123.123.123.
- If you are using a proxy server, then temporarily disable it to load the web page correctly.

2. Click **Settings > Fax > Fax Setup > General Fax Settings**.

**Note:** **Fax Setup** appears only if **Fax Mode** is set to **Fax**.

3. In the **Fax Name** field, type a unique name.
4. In the **Fax Number** field, enter the fax number that etherFAX provided.
5. From the **Fax Transport** menu, select etherFAX.

### Notes

- This menu shows up only when more than one fax transport is available.
- If the printer only has etherFAX installed, then it is automatically configured.

6. Apply the changes.

## Setting up the fax function using fax server

### Notes

- This feature lets you send fax messages to a fax service provider that supports email receiving.
- This feature supports outgoing fax messages only. To support fax receive, make sure that you have a device-based fax, such as analog fax, etherFAX, or Fax over IP (FoIP), configured in your printer.

1. Open a web browser, and then type the printer IP address in the address field.

### Notes

- View the printer IP address on the control panel. The IP address appears as four sets of numbers separated by periods, such as 123.123.123.123.
- If you are using a proxy server, then temporarily disable it to load the web page correctly.

2. Click **Settings > Fax**.

3. From the **Fax Mode** menu, select **Fax Server**, and then click **Save**.
4. Click **Fax Server Setup**.
5. In the To Format field, type [#]@myfax.com, where [#] is the fax number and **myfax.com** is the fax provider domain.

### Notes

- If necessary, configure the Reply Address, Subject, or Message fields.
- To let the printer receive fax messages, enable the device-based fax receive setting. Make sure that you have a device-based fax configured.

6. Click **Save**.
7. Click **Fax Server Email Settings**, and then enable **Use Email SMTP Server**.

**Note:** If the settings are not configured, then see [Configuring the email SMTP settings on page 300](#).

8. Apply the changes.

## Setting up fax using a standard telephone line

**Note:** These instructions apply only to printers that have a fax card installed.



### CAUTION—SHOCK HAZARD

To avoid the risk of electrical shock, do not set up this product or make any electrical or cabling connections, such as the power cord, fax feature, or telephone, during a lightning storm.



### CAUTION—SHOCK HAZARD

To avoid the risk of electrical shock, do not use the fax feature during a lightning storm.



### CAUTION—POTENTIAL INJURY

To reduce the risk of fire, use only a 26 AWG or larger telecommunications (RJ-11) cord when connecting this product to the public switched telephone network. For users in Australia, the cord must be approved by the Australian Communications and Media Authority.

## Setup 1: Printer is connected to a dedicated fax line

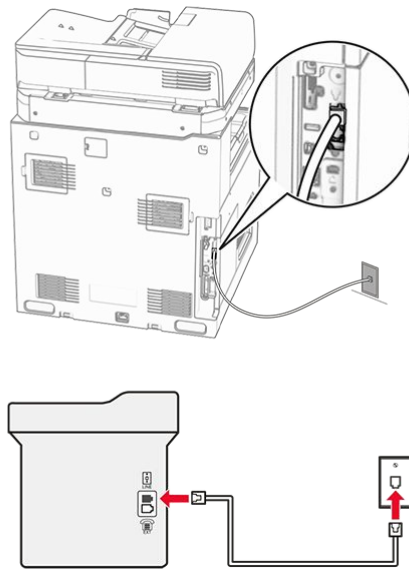

1. Connect one end of the telephone cable to the line port of the printer.
2. Connect the other end of the cable to an active analog telephone wall jack.

### Notes

- You can set the printer to receive faxes automatically (set **Auto Answer** to **On**) or manually (set **Auto Answer** to **Off**).
- If you want to receive faxes automatically, then set the printer to pick up on a specified number of rings.

## Setup 2: Printer is sharing the line with an answering machine

**Note:** If you subscribe to a distinctive ring service, then make sure that you set the correct ring pattern for the printer. Otherwise, the printer does not receive faxes even if you have set it to receive faxes automatically.

### Connected to the same telephone wall jack

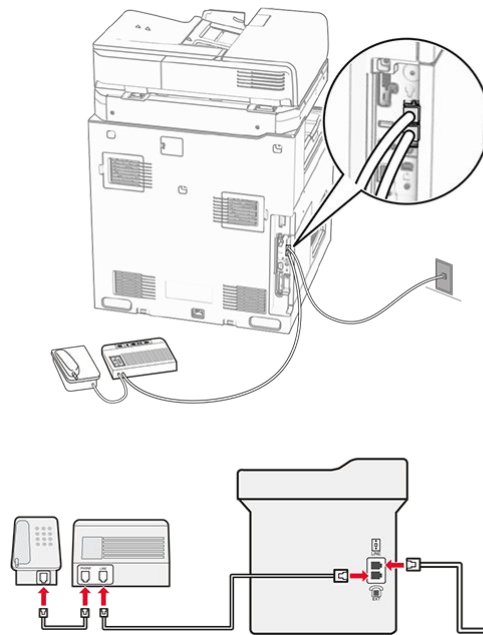

1. Connect one end of the telephone cable to the line port of the printer.
2. Connect the other end of the cable to an active analog wall jack.
3. Connect the answering machine to the telephone port of the printer.

### Connected to different wall jacks

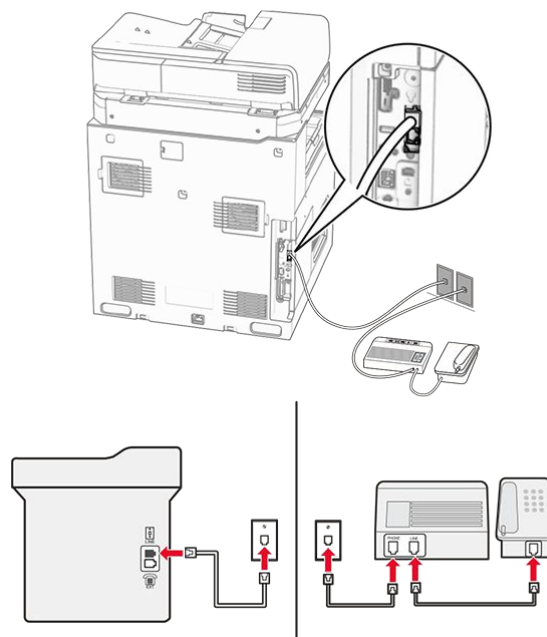

1. Connect one end of the telephone cable to the line port of the printer.
2. Connect the other end of the cable to an active analog wall jack.

### Notes

- If you have only one telephone number on your line, then set the printer to receive faxes automatically.
- Set the printer to pick up calls two rings after the answering machine. For example, if the answering machine picks up calls after four rings, then set the printer **Rings to Answer** setting to **6**.

## Setting up fax in countries or regions with different telephone wall jacks and plugs

**Note:** These instructions apply only to printers that have a fax card installed.



### CAUTION—SHOCK HAZARD

To avoid the risk of electrical shock, do not set up this product or make any electrical or cabling connections, such as the power cord, fax feature, or telephone, during a lightning storm.



### CAUTION—SHOCK HAZARD

To avoid the risk of electrical shock, do not use the fax feature during a lightning storm.



### CAUTION—POTENTIAL INJURY

To reduce the risk of fire, use only a 26 AWG or larger telecommunications (RJ-11) cord when connecting this product to the public switched telephone network. For users in Australia, the cord must be approved by the Australian Communications and Media Authority.

The standard wall jack adopted by most countries or regions is RJ-11. If the wall jack or equipment in your facility is not compatible with this type of connection, then use a telephone adapter. An adapter for your country or region may not come with your printer, and you may need to purchase it separately.

There may be an adapter plug installed in the telephone port of the printer. Do not remove the adapter plug from the telephone port of the printer if you are connecting to a serial or cascaded telephone system.

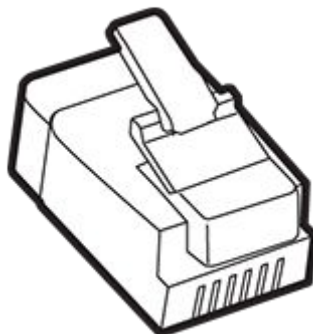

Part name	Part number
Lexmark adapter plug	40X8519

### Connecting the printer to a non-RJ-11 wall jack

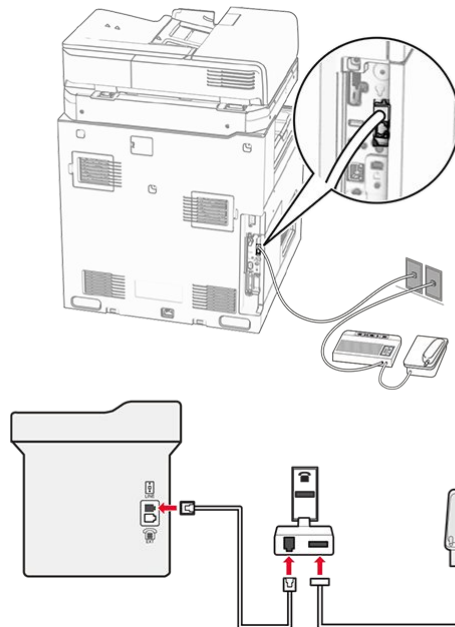

1. Connect one end of the telephone cable to the line port of the printer.
2. Connect the other end of the cable to the RJ-11 adapter, and then connect the adapter to the wall jack.

**Note:** If you want to connect another device with a non-RJ-11 connector to the same wall jack, then connect it directly to the telephone adapter.

### Connecting to a distinctive ring service

A distinctive ring service lets you have multiple telephone numbers on one telephone line. Each telephone number is assigned a different ring pattern.

1. From the control panel, navigate to **Settings > Fax > Fax Setup > Fax Receive Settings > Admin Controls > Answer On**.
2. Select a ring pattern.

### Setting the fax date and time

1. From the control panel, navigate to **Settings > Device > Preferences > Date and Time > Configure**.
2. Configure the settings.

## Configuring daylight saving time

1. From the control panel, navigate to **Settings > Device > Preferences > Date and Time > Configure**.
2. In the **Time Zone** menu, select **(UTC+user) Custom**.
3. In the **Configure** menu, select **UTC Offset**.
4. Configure the settings.

## Configuring the fax speaker settings

1. From the control panel, navigate to **Settings > Fax > Fax Setup > Speaker Settings**.
2. Do the following:
  - Set **Speaker Mode** to **Always On**.
  - Set **Speaker Volume** to **High**.
  - Activate **Ringer Volume**.

## Loading paper and specialty media

### Setting the size and type of the specialty media

For specialty media like labels, card stock, or envelopes, do the following:

1. From the control panel, navigate to **Settings > Paper > Tray Configuration > Paper Size/Type**.
2. Select a paper source, and then set the size and type of the specialty media.

## Configuring Universal paper settings

The **Universal Setup** menu lets you set the width and height of a paper size that is not preset in the printer.

1. From the control panel, navigate to **Settings > Paper > Media Configuration > Universal Setup**.
2. Select **All Input Trays**, and then configure the settings for the paper size that you want to customize.

## Loading the 550-sheet tray



### CAUTION—TIPPING HAZARD

To reduce the risk of equipment instability, load each tray separately. Keep all other trays closed until needed.

1. Open the tray.

**Note:** To avoid jams, do not open trays while the printer is busy.

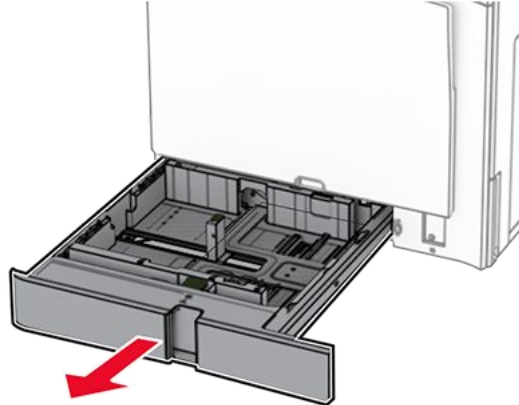

2. Adjust the guides to match the size of the paper that you are loading.

### Notes

- Use the indicators on the bottom of the tray to position the guides.
- Prepunched paper is supported only in the standard 550-sheet tray.
- A3-size paper is supported only in the optional 550-sheet tray.

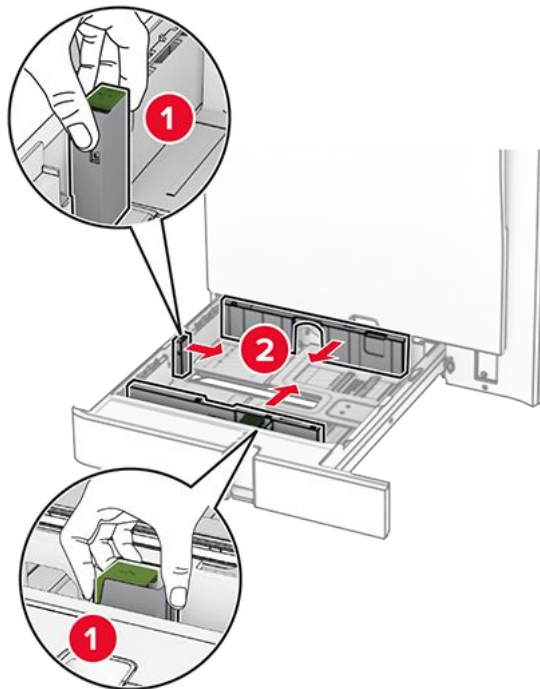

3. Flex, fan, and align the paper edges before loading.

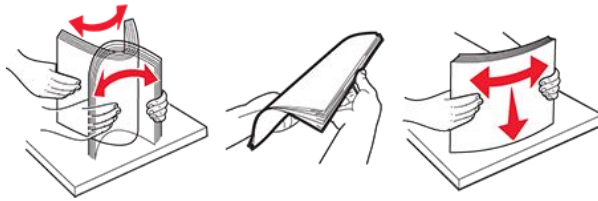

4. Load the paper stack with the printable side faceup.

### Notes

- Do not slide paper into the tray.
- Make sure that the side guides fit snugly against the paper.
- Make sure that the stack height is below the maximum paper fill indicator. Overfilling may cause paper jams.

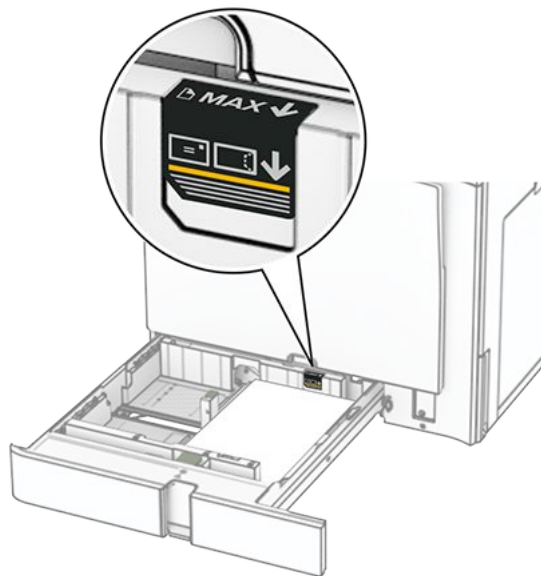



5. Insert the tray.

If necessary, set the paper size and paper type to match the paper loaded in the tray.

**Note:** When a finisher is installed, the pages are rotated to 180° when printed.

**When loading letterhead, do any of the following:**

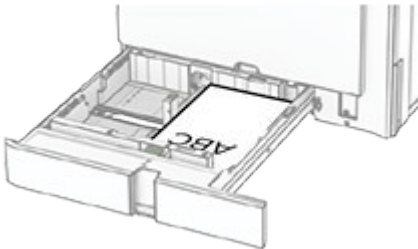
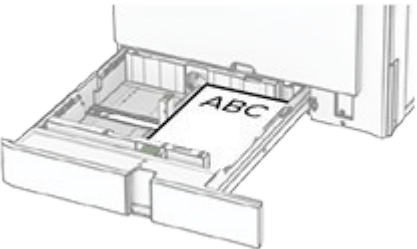
## Set up, install, and configure

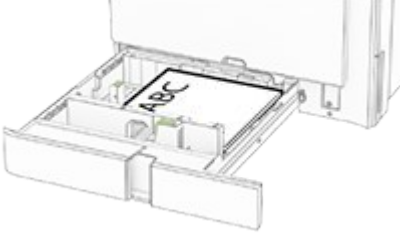
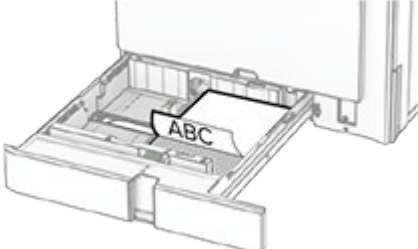
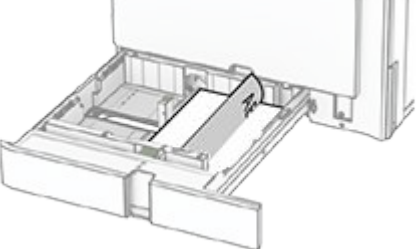
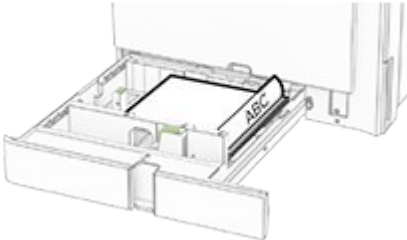
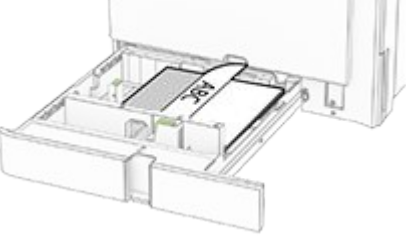
Without an optional finisher	With an optional finisher
 <p data-bbox="277 501 670 533">One-sided, long-edge printing</p>	 <p data-bbox="925 501 1318 533">One-sided, long-edge printing</p>
 <p data-bbox="277 837 670 869">One-sided, short-edge printing</p>	 <p data-bbox="922 837 1315 869">One-sided, short-edge printing</p>
 <p data-bbox="277 1173 670 1205">Two-sided, long-edge printing</p>	 <p data-bbox="925 1173 1318 1205">Two-sided, long-edge printing</p>
 <p data-bbox="277 1509 670 1541">Two-sided, short-edge printing</p>	 <p data-bbox="925 1509 1318 1541">Two-sided, short-edge printing</p>

**When loading prepunched paper, do any of the following:**

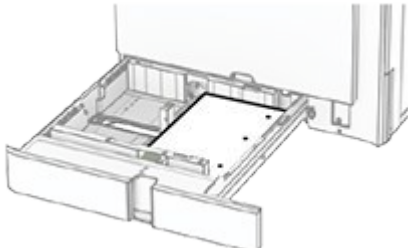
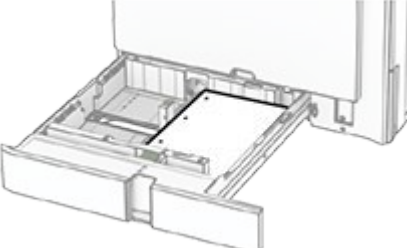
Without an optional finisher	With an optional finisher
 <p data-bbox="277 1991 670 2022">One-sided, long-edge printing</p>	 <p data-bbox="925 1991 1318 2022">One-sided, long-edge printing</p>

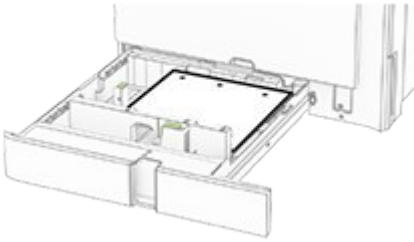
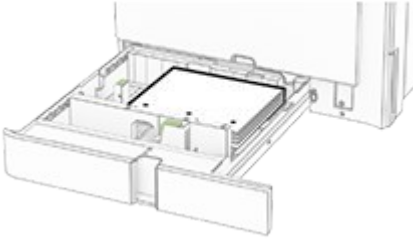
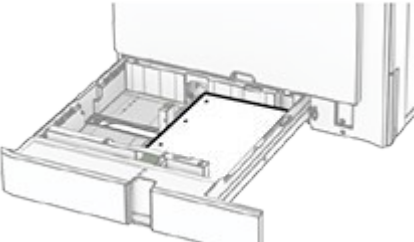
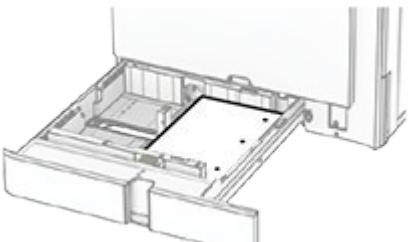
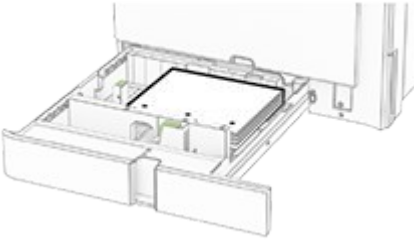
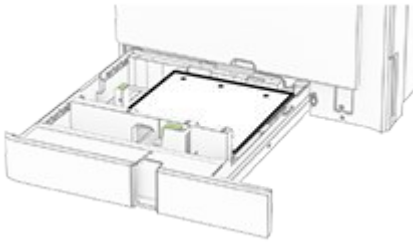
Without an optional finisher	With an optional finisher
 <p>One-sided, short-edge printing</p>	 <p>One-sided, short-edge printing</p>
 <p>Two-sided, long-edge printing</p>	 <p>Two-sided, long-edge printing</p>
 <p>Two-sided, short-edge printing</p>	 <p>Two-sided, short-edge printing</p>

## Loading the 2000-sheet tandem tray



### CAUTION—TIPPING HAZARD

To reduce the risk of equipment instability, load each tray separately. Keep all other trays closed until needed.

1. Open the tray.

**Note:** To avoid jams, do not pull out trays while the printer is busy.

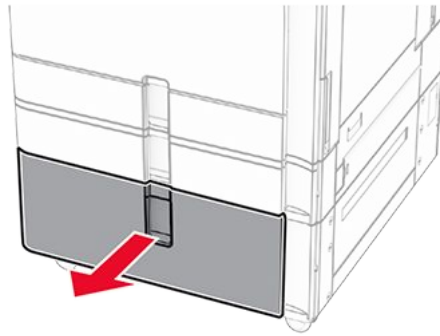

2. Flex, fan, and align the paper edges before loading.

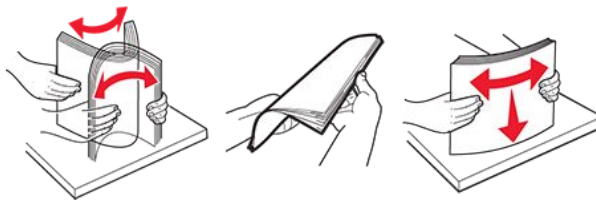

3. Load the paper stack to the right tray insert with the printable side faceup.

### Notes

- Do not slide paper into the tray.
- Make sure that the stack height is below the maximum paper fill indicator. Overfilling may cause paper jams.

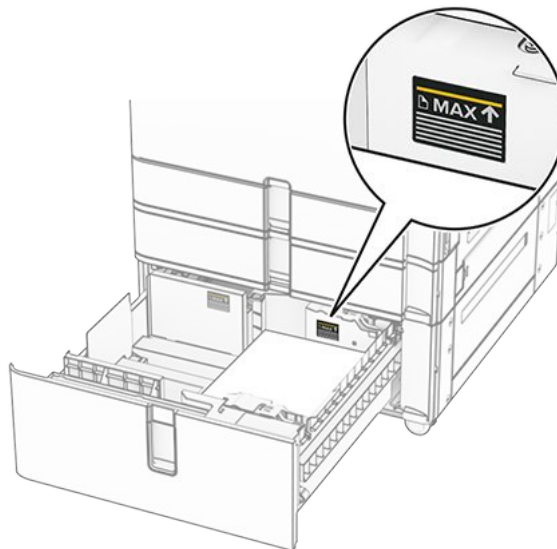

4. Insert the right tray insert into the printer.
5. Load the paper stack to the left tray insert with the printable side faceup.

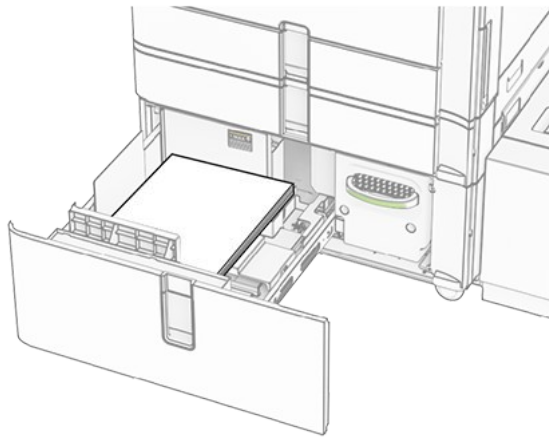

6. Insert the tray.

If necessary, set the paper size and type to match the paper loaded in the tray.

**Note:** When a finisher is installed, the pages are rotated to 180° when printed.

When loading letterhead for one-sided printing, load it faceup with the header toward the front of the tray.

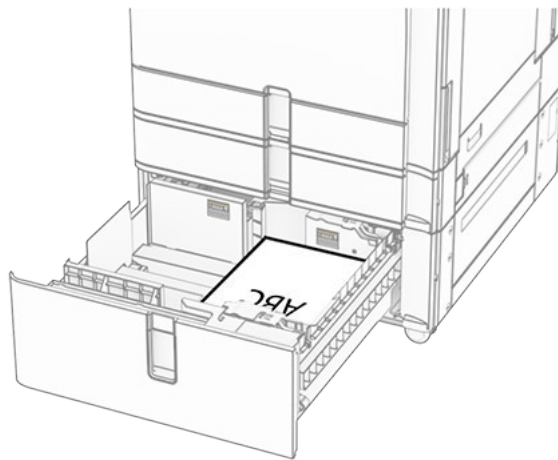

When loading letterhead for two-sided printing, load it facedown with the header toward the front of the tray.

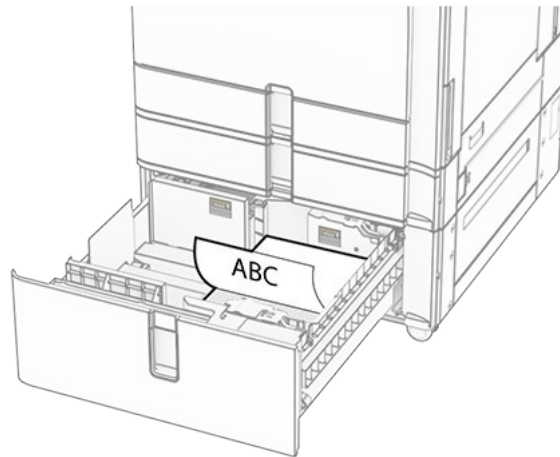

## Loading the 1500-sheet tray



### CAUTION—TIPPING HAZARD

To reduce the risk of equipment instability, load each tray separately. Keep all other trays closed until needed.

1. Open door K.

**Note:** To avoid jams, do not open trays while the printer is busy.

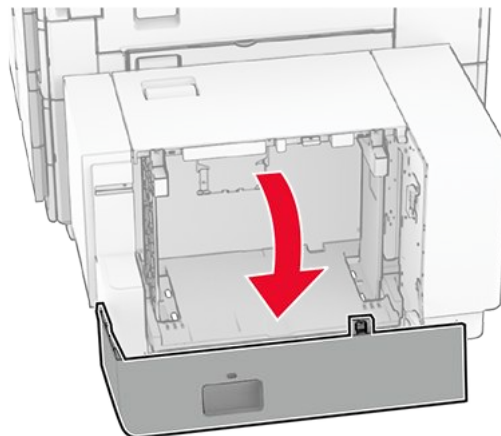

2. Flex, fan, and align the paper edges before loading.

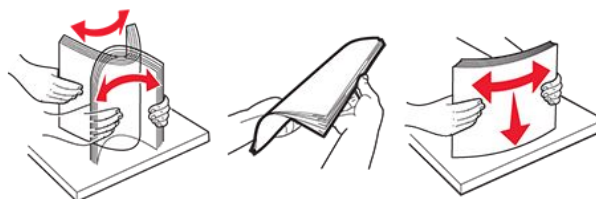

3. Load the paper stack with the printable side facedown.

### Notes

- Do not slide paper into the tray.
- Make sure that the stack height is below the maximum paper fill indicator. Overfilling may cause paper jams.

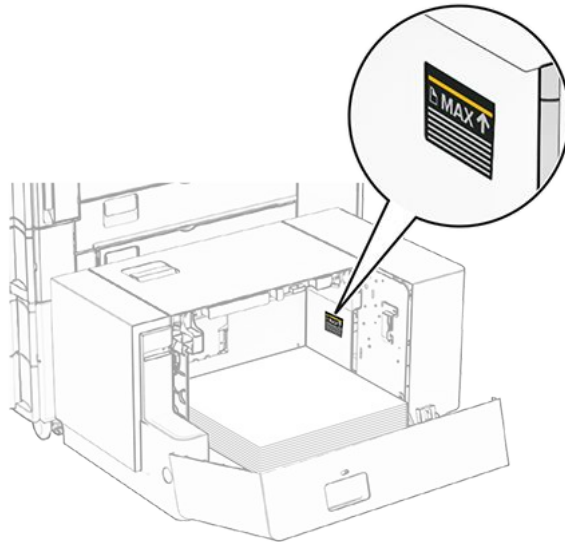

4. Close door K.

If necessary, set the paper size and type to match the paper loaded in the tray.

When loading letterhead for one-sided printing, load it facedown with the header toward the rear of the printer.

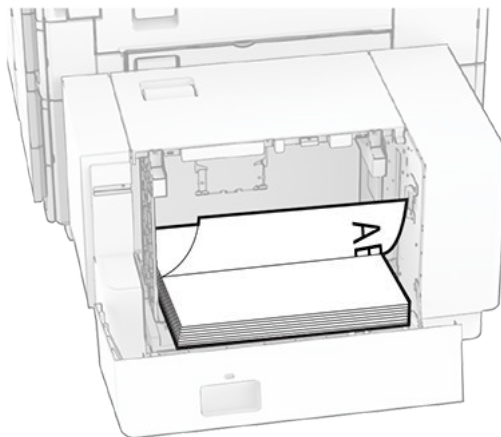

When loading letterhead for two-sided printing, load it faceup with the header toward the rear of the printer.

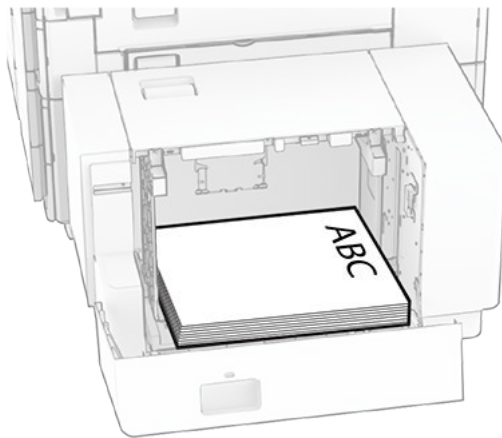

When loading a different paper size, make sure to adjust the guides. Do the following:

1. Using a flat-head screwdriver, remove the screws from the paper guides.

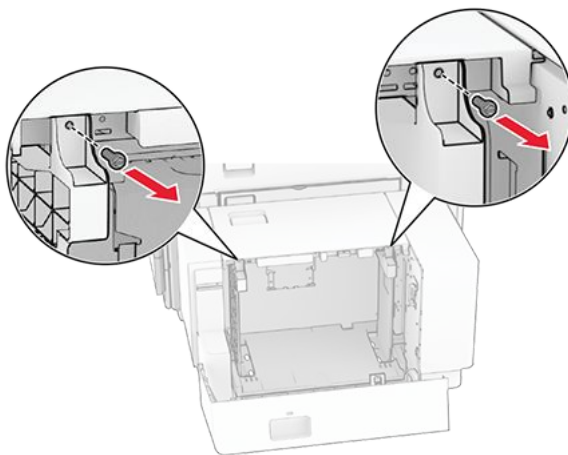

2. Remove the paper guides.

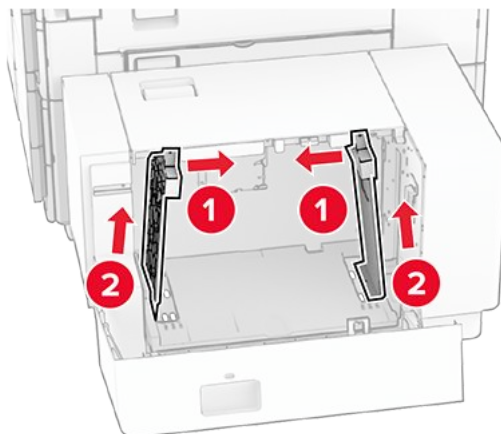

3. Align the paper guides to match the size of the paper that you are loading.

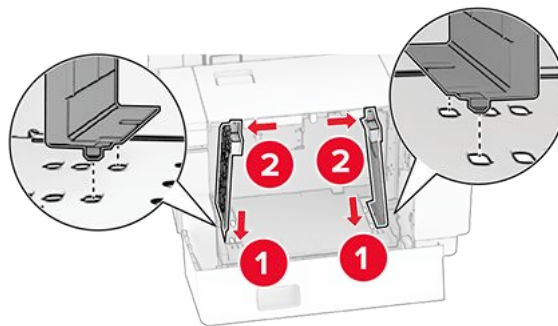
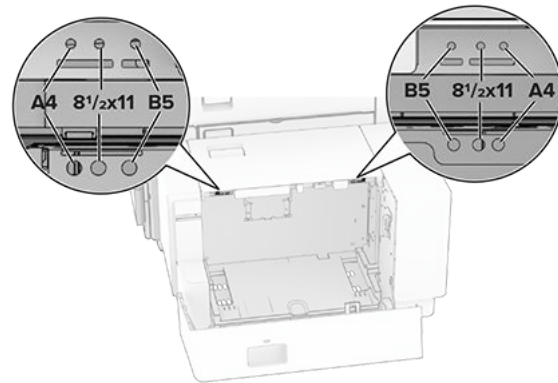
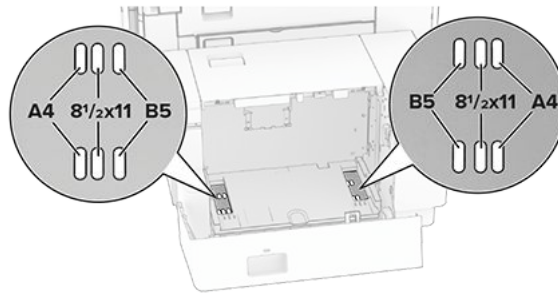

4. Install the screws on the paper guides.

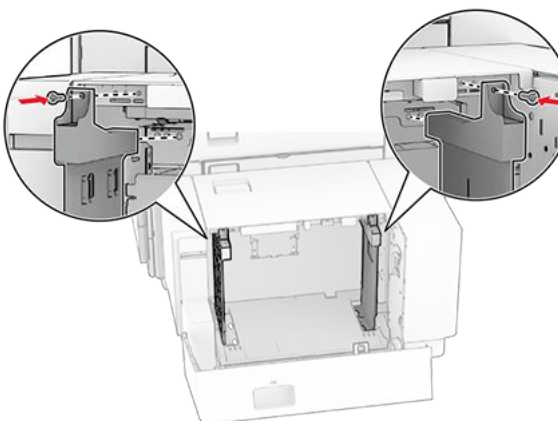

## Loading the multipurpose feeder

1. Open the multipurpose feeder.

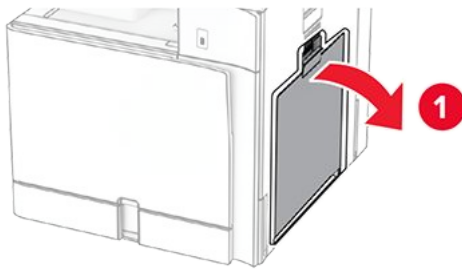

2. Adjust the side guides to match the size of the paper that you are loading.

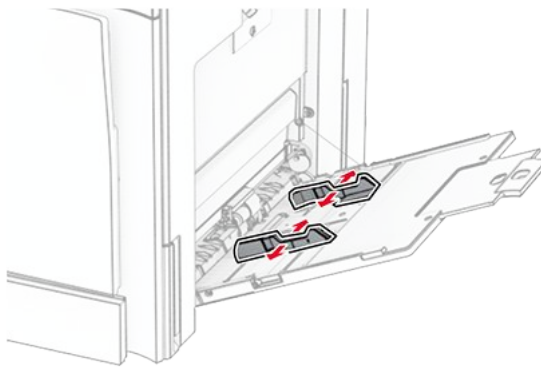

3. Flex, fan, and align the paper edges before loading.

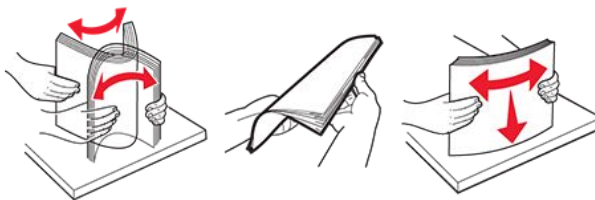

4. Load the paper.

**Note:** Make sure that the side guides fit snugly against the paper.

- When loading letterhead, do either of the following:

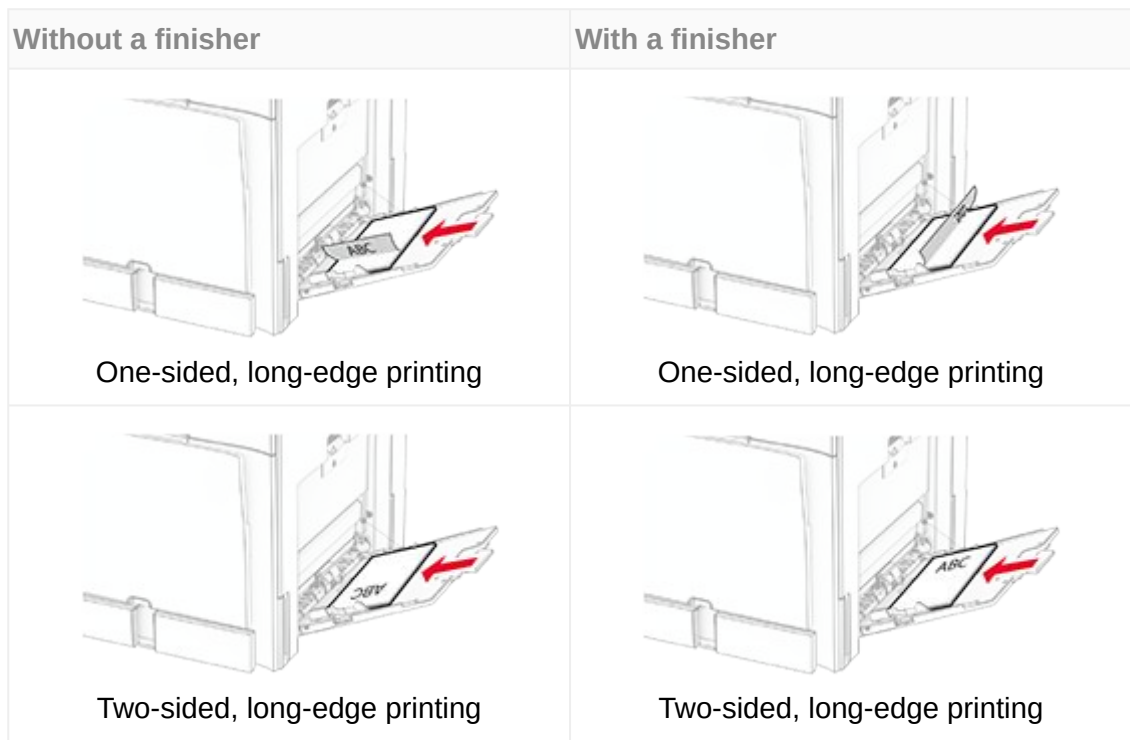

- When loading prepunched paper, do either of the following:

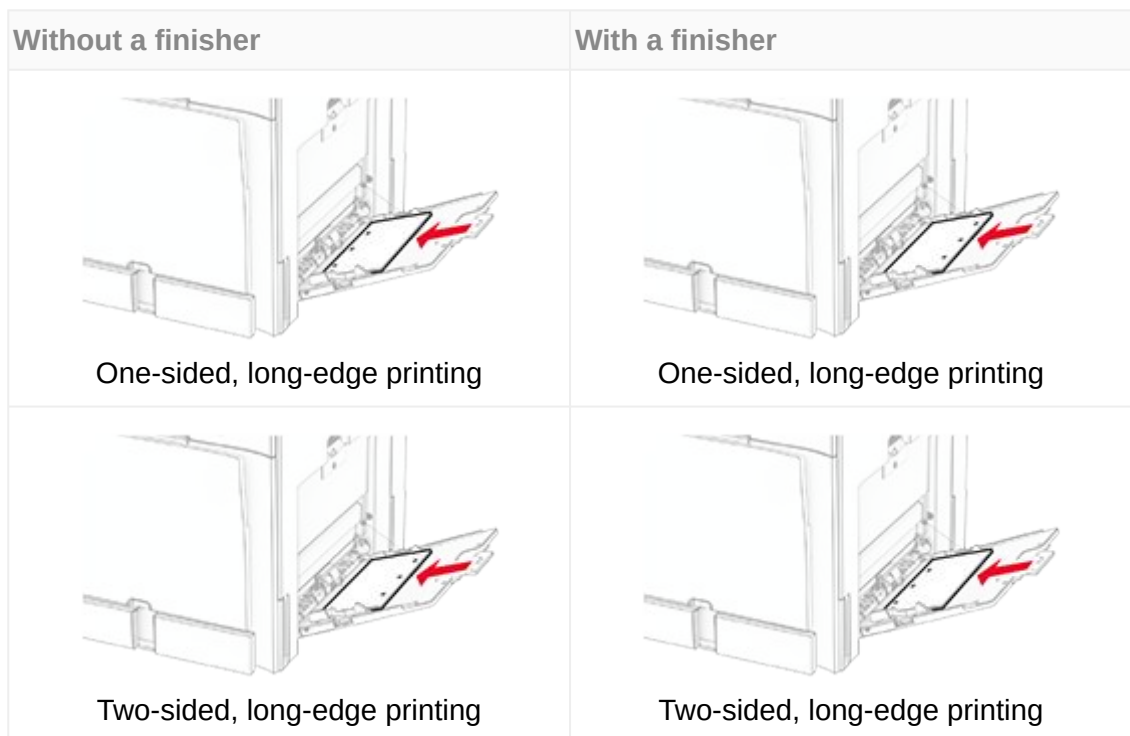

### For envelopes

Load envelope with the flap faceup toward the rear of the printer. Load European envelope with the flap faceup entering the multipurpose feeder first.

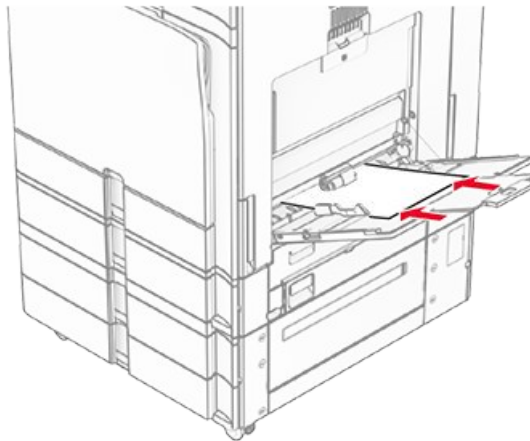
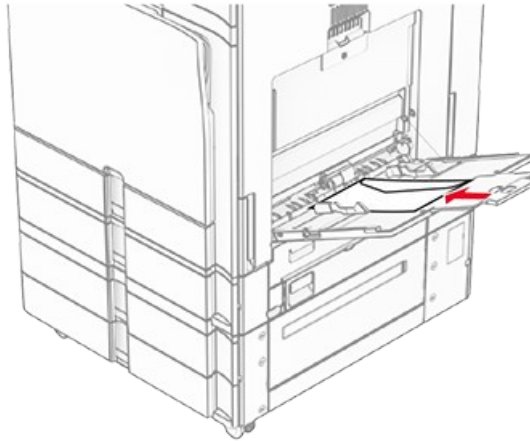

**Note:** When a finisher is installed, the pages are rotated to 180° when printed.

## Linking trays

1. Open a web browser, and then type the printer IP address in the address field.

### Notes

- View the printer IP address on the printer home screen. The IP address appears as four sets of numbers separated by periods, such as 123.123.123.123.
- If you are using a proxy server, then temporarily disable it to load the web page correctly.

2. Click **Settings > Paper > Tray Configuration**.
3. Set the same paper size and paper type for the trays that you are linking.

**Note:** Make sure to load the linked trays with the same paper orientation.

4. Save the settings.
5. Click **Settings > Device > Maintenance > Configuration Menu > Tray Configuration**.
6. Set **Tray Linking** to **Automatic**.
7. Save the settings.

To unlink the trays, make sure that no trays have the same paper size and paper type settings.

### **Warning—Potential Damage**

The temperature of the fuser varies according to the specified paper type. To avoid printing issues, match the paper type setting in the printer with the paper loaded in the tray.

## Installing and updating software, drivers, and firmware

### Installing the printer software

#### Notes

- The print driver is included in the software installer package.
- For Macintosh computers with macOS version 10.7 or later, you do not need to install the driver to print on an AirPrint-certified printer. If you want custom printing features, then download the print driver.

1. Obtain a copy of the software installer package.
  - From the software CD that came with your printer.
  - Go to [www.lexmark.com/downloads](http://www.lexmark.com/downloads).
2. Run the installer, and then follow the instructions on the computer screen.

### Installing the fax driver

1. Go to [www.lexmark.com/downloads](http://www.lexmark.com/downloads), search for your printer model, and then download the appropriate installer package.
2. From your computer, click **Printer Properties**, and then navigate to the **Configuration** tab.
3. Select **Fax**, and then click **Apply**.

### Adding printers to a computer

Before you begin, do one of the following:

## Set up, install, and configure

---

- Connect the printer and the computer to the same network. For more information on connecting the printer to a network, see [Connecting the printer to a Wi-Fi network on page 284](#).
- Connect the computer to the printer. For more information, see [Connecting a computer to the printer on page 287](#).
- Connect the printer to the computer using a USB cable. For more information, see [Printer ports on page 92](#).

**Note:** The USB cable is sold separately.

### For Windows users

1. Install the print driver on the computer.

**Note:** For more information, see [Installing the printer software on page 127](#).

2. Open **Printers & scanners**, and then click **Add a printer or scanner**.
  3. Depending on your printer connection, do one of the following:
    - Select a printer from the list, and then click **Add device**.
    - Click **Show Wi-Fi Direct printers**, select a printer, and then click **Add device**.
    - Click **The printer that I want isn't listed**, and then from the **Add Printer** window, do the following:
      1. Select **Add a printer using an IP address or hostname**, and then click **Next**.
      2. In the Device type field, select **TCP/IP Device**.
      3. In the Hostname or IP address field, type the printer IP address, and then click **Next**.
- Notes**

  - View the printer IP address on the printer home screen. The IP address appears as four sets of numbers separated by periods, such as 123.123.123.123.
  - If you are using a proxy server, then temporarily disable it to load the web page correctly.
4. Select a print driver, and then click **Next**.
  5. Select **Use the driver that is currently installed (recommended)**, and then click **Next**.
  6. Type a printer name, and then click **Next**.
  7. Click **Finish**.

### For Macintosh users

1. Open **Printers & Scanners**.
2. Click **Add Printer, Scanner, or Fax**, and then select a printer.
3. From the **Add Printer** menu, select a print driver.

### Notes

- To use the Macintosh print driver, select either **AirPrint** or **Secure AirPrint**.
- If you want custom printing features, then select the Lexmark print driver. To install the driver, see [Installing the printer software on page 127](#).

4. Add the printer.

## Exporting a configuration file

1. Open a web browser, and then type the printer IP address in the address field.

### Notes

- View the printer IP address on the printer home screen. The IP address appears as four sets of numbers separated by periods, such as 123.123.123.123.
- If you are using a proxy server, then temporarily disable it to load the web page correctly.

2. From the Embedded Web Server, click **Export Configuration**.
3. Select a configuration to export.

**Note:** Depending on the configuration that you selected, the files are either exported in a ZIP or CSV format.

## Importing a configuration file

1. Open a web browser, and then type the printer IP address in the address field.

### Notes

- View the printer IP address on the printer home screen. The IP address appears as four sets of numbers separated by periods, such as 123.123.123.123.
- If you are using a proxy server, then temporarily disable it to load the web page correctly.

2. From the Embedded Web Server, click **Import Configuration**.
3. Browse to the location that the file is saved.

**Note:** The files are either saved in a ZIP or CSV format.

4. Click **Import**.

## Adding available options in the print driver

### For Windows users

1. Open the printers folder.
2. Select the printer that you want to update, and then do either of the following:
  - For Windows 7 or later, select **Printer properties**.
  - For earlier versions, select **Properties**.
3. Navigate to the **Configuration** tab, and then select **Update Now - Ask Printer**.
4. Apply the changes.

### For Macintosh users

1. Open **Printers & Scanners**.
2. Click **Add Printer, Scanner, or Fax**, and then select a printer.
3. Choose a print driver.
4. Apply the changes.

## Printer firmware instructions

### Checking the printer firmware version

#### Using the Embedded Web Server

**Note:** Make sure that the printer is connected to the network.

1. Open a web browser, and then type the printer IP address in the address field.

#### Notes

- The IP address appears as four sets of numbers separated by periods. For example, 123.123.123.123.
- If you are using a proxy server, then temporarily disable it to load the web page correctly.

2. Click **Reports > Device > Device Information**.

3. Look for **Base**.

**Note:** The firmware version appears as sets of letters and numbers separated by periods. For example, ABCDE.123.123.

### Using the control panel

1. Navigate to **Settings > Device > About this printer**.
2. Look for **Firmware Version**.

**Note:** The firmware version appears as sets of letters and numbers separated by periods. For example, ABCDE.123.123.

### Downloading the printer firmware

1. Go to the [drivers and downloads](#) page.
2. Type the printer model, and then click **Find Drivers & Downloads**.
3. In the **Recommended Firmware** section, click the zip file.
4. Accept the End-User License Agreement, and then start the download.

**Note:** You can save the file either to your computer or flash drive.

5. After downloading the firmware, extract the zip file, and then locate the firmware flash file (.fls).

### Updating firmware

#### Updating the firmware using the control panel

#### Using the notification center

**Note:** This method is applicable only in some printer models.

1. From the home screen, navigate to the notification center, and then select **Firmware update**

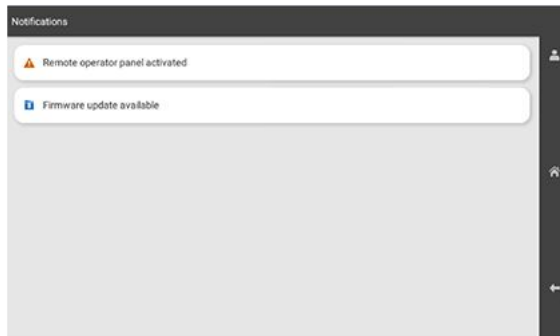

available.



2. Select **Install now**.

The printer restarts automatically after the update.

### Using the Settings menu

1. From the control panel, navigate to **Settings > Device**.
2. Depending on your printer model, select **Update firmware** or **Firmware Update**.
3. Depending on your printer model, select **Check for updates** or **Check for updates now**.

If an update is available, then select **Install now**.

The printer restarts automatically after the update.

### Updating the firmware using the Embedded Web Server

#### Notes

- Before you begin, make sure that you have downloaded the firmware and saved it on your computer or flash drive. For more information, see [Downloading the printer firmware on page 131](#).
- Make sure that the printer is connected to the network.

### Using the update button

1. Open a web browser, and then type the printer IP address in the address field.

#### Notes

- The IP address appears as four sets of numbers separated by periods. For example, 123.123.123.123.
- If you are using a proxy server, then temporarily disable it to load the web page correctly.

2. Click **Device**.
3. Scroll down, and then click **Firmware Update**.
4. Depending on your printer model, click **Check for updates** or **Check for updates now**.

If an update is available, then click **Install now**.

The printer restarts automatically after the update.

### Using the firmware flash file (.fls)

1. Open a web browser, and then type the printer IP address in the address field.

#### Notes

- The IP address appears as four sets of numbers separated by periods. For example, 123.123.123.123.
- If you are using a proxy server, then temporarily disable it to load the web page correctly.

2. Click **Device**.
3. Scroll down, and then click **Firmware Update**.
4. In the **Update Firmware from File** section, click **Browse**.
5. Search, and then select the **.fls** file.
6. Click **Upload**.

The printer restarts automatically after the update.

### Updating the firmware using a flash drive

#### Notes

- Before you begin, make sure that you have downloaded the firmware and saved it on your computer or flash drive. For more information, see [Downloading the printer firmware on page 131](#).
- The flash drive is formatted to FAT32.

1. Insert the flash drive into the front USB port of the printer.

The flash drive contents appear automatically on the printer display. If the files do not appear, then select **USB Drive** on the home screen.

2. Search, and then select the **.fls** file.
3. Select **Update Code**.

The printer restarts automatically after the update.

## Installing hardware options

### Installing the optional 550-sheet tray



#### CAUTION—SHOCK HAZARD

To avoid the risk of electrical shock, if you are accessing the controller board or installing optional hardware or memory devices sometime after setting up the printer, then turn the printer off, and unplug the power cord from the electrical outlet before continuing. If you have any other devices attached to the printer, then turn them off as well, and unplug any cables going into the printer.

#### Notes

- This option must be always installed directly under the printer and must not be installed together with another optional 550-sheet tray.
- This task requires a flat-head screwdriver.

1. Turn off the printer.

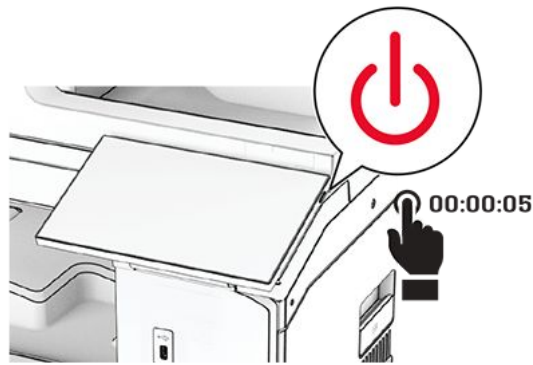

2. Unplug the power cord from the electrical outlet, and then from the printer.

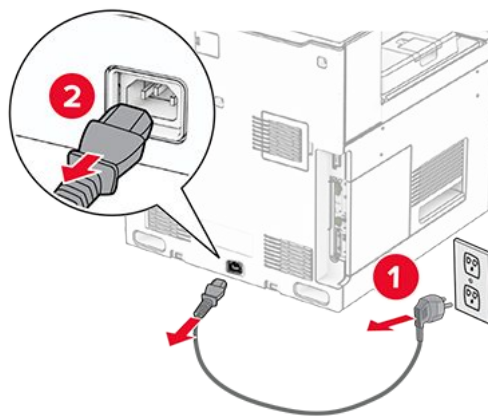

3. Unpack the optional 550-sheet tray.

**Note:** To avoid damaging the tray, make sure to hold the front and rear sides when lifting it.

4. Attach the right tray cover.

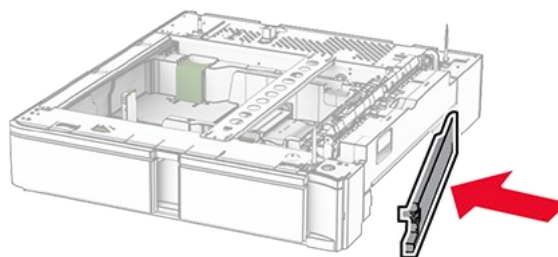

5. Pull out the 550-sheet tray insert.

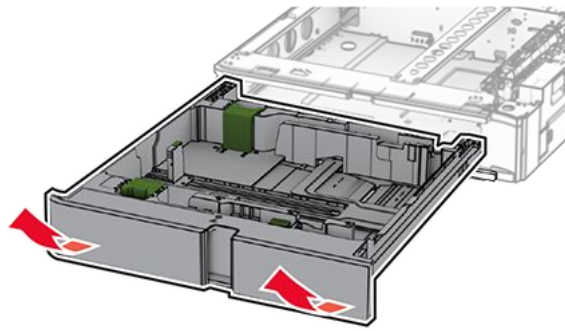

6. Remove the upper tray cover.

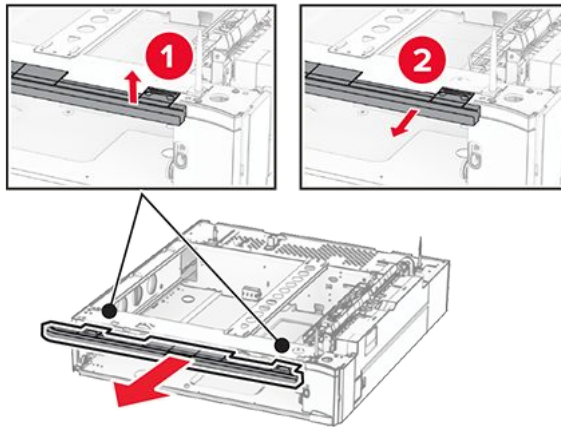

7. Remove the screws.

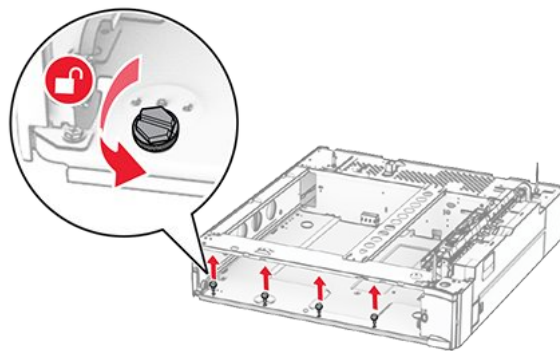

8. Attach the lower tray cover.

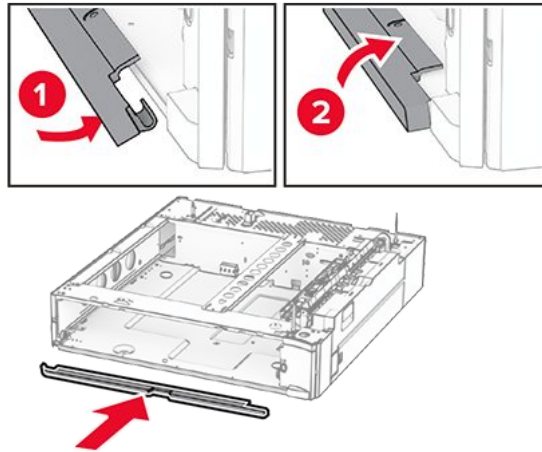

9. Install the screws.

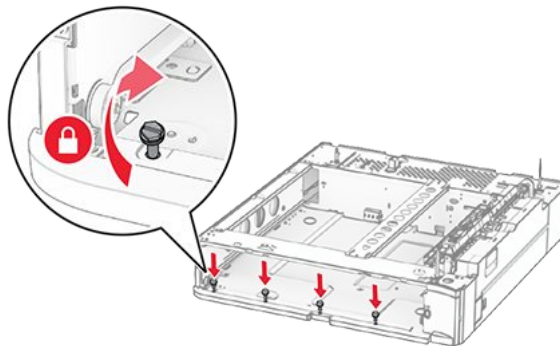

10. Attach the upper tray cover.

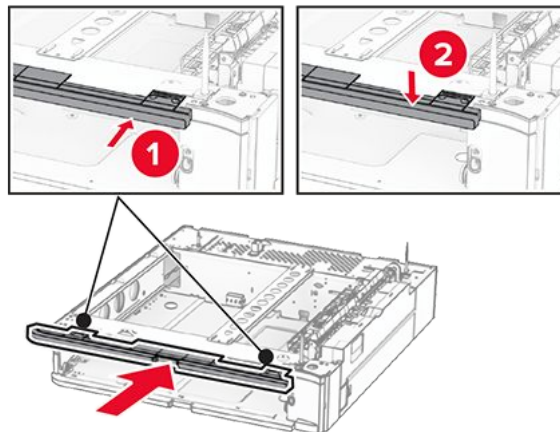

11. Insert the 550-sheet tray insert.

12. Remove the cover under the right side of the printer.

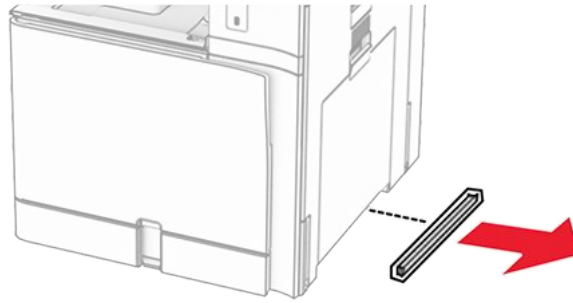

13. Align the printer with the 550-sheet tray, and then lower it into place.



**CAUTION—POTENTIAL INJURY**

If the printer weight is greater than 20 kg (44 lb), then it may require two or more people to lift it safely.

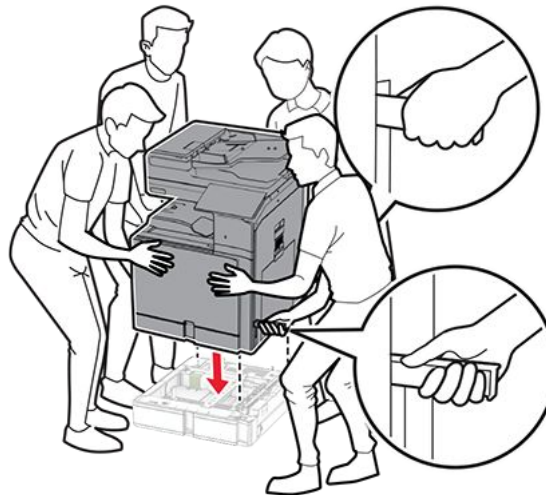

14. Pull out the standard tray insert.

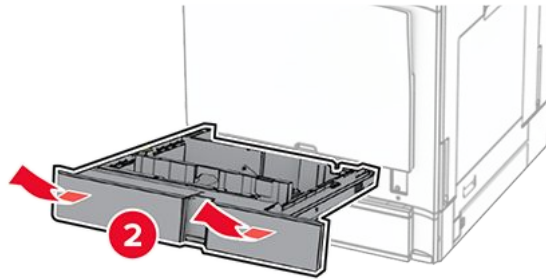
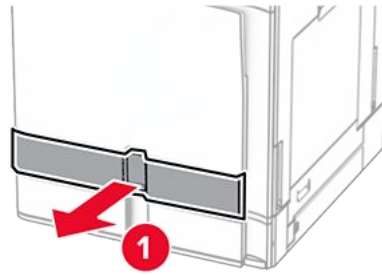

15. Secure the 550-sheet tray to the printer.

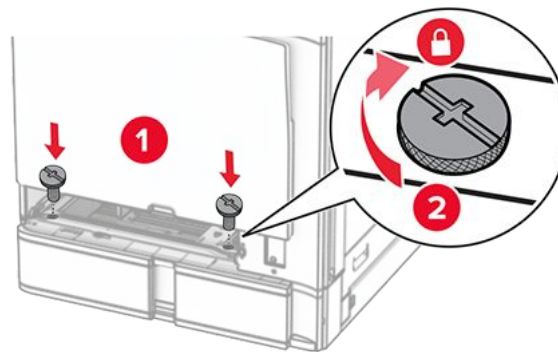

16. Insert the standard tray insert.

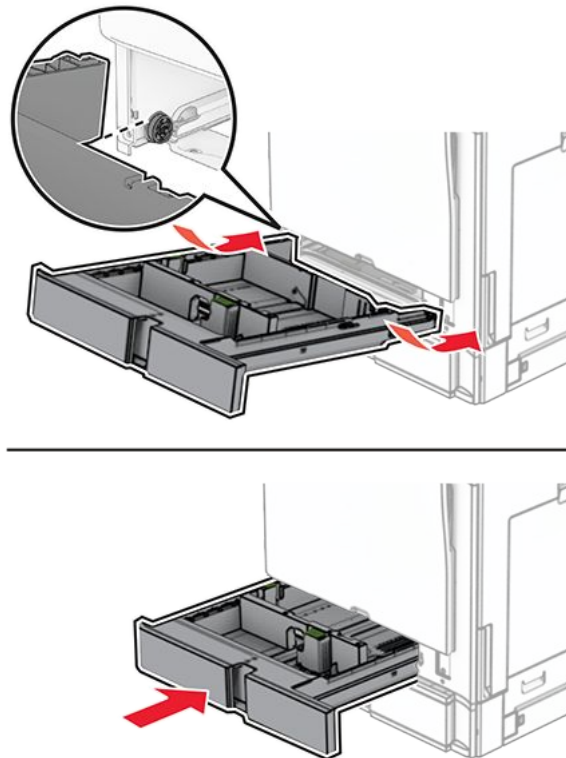

17. Secure the rear part of the 550-sheet tray to the printer.

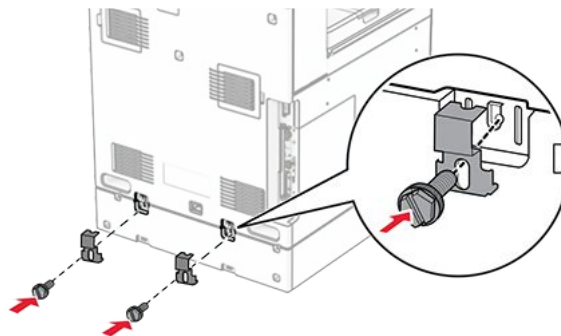

18. Connect one end of the power cord to the printer, and then the other end to the electrical outlet.

 **CAUTION—POTENTIAL INJURY**  
To avoid the risk of fire or electrical shock, connect the power cord to an appropriately rated and properly grounded electrical outlet that is near the product and easily accessible.

19. Turn on the printer.

Add the tray in the print driver to make it available for print jobs. For more information, see [Adding available options in the print driver on page 130](#).

## Installing the 2 x 550-sheet tray



### CAUTION—SHOCK HAZARD

To avoid the risk of electrical shock, if you are accessing the controller board or installing optional hardware or memory devices sometime after setting up the printer, then turn the printer off, and unplug the power cord from the electrical outlet before continuing. If you have any other devices attached to the printer, then turn them off as well, and unplug any cables going into the printer.

### Notes

- This option must be installed together with an optional 550-sheet tray. Place the option at the bottom of the configuration.
- If a 550-sheet tray is already installed, uninstall the tray, remove the tray side cover, remove the lower tray cover, and then place the tray on top of this option.
- This task requires a flat-head screwdriver.

1. Turn off the printer.

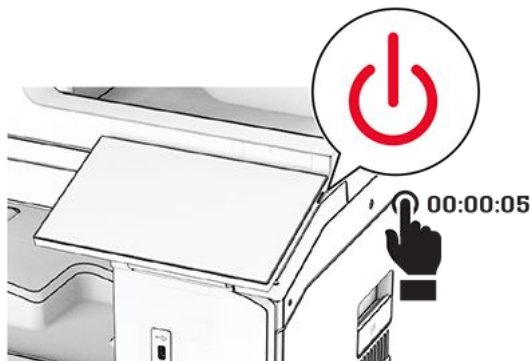

2. Unplug the power cord from the electrical outlet, and then from the printer.

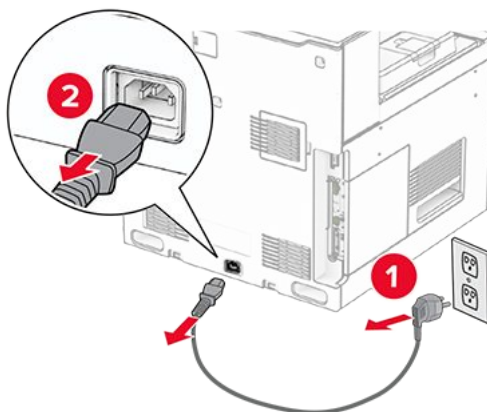

## Set up, install, and configure

---

3. Unpack the 2 x 550-sheet tray.
4. Lock the caster to keep the 2 x 550-sheet tray from moving.

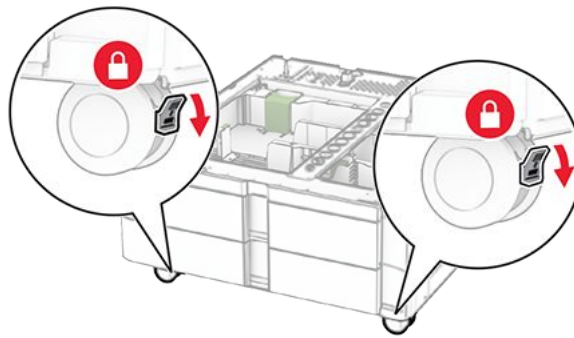

5. Align the 550-sheet tray with the 2 x 550-sheet tray, and then lower it into place.

**Note:** To avoid damaging the tray, make sure to hold the front and rear sides when lifting it.

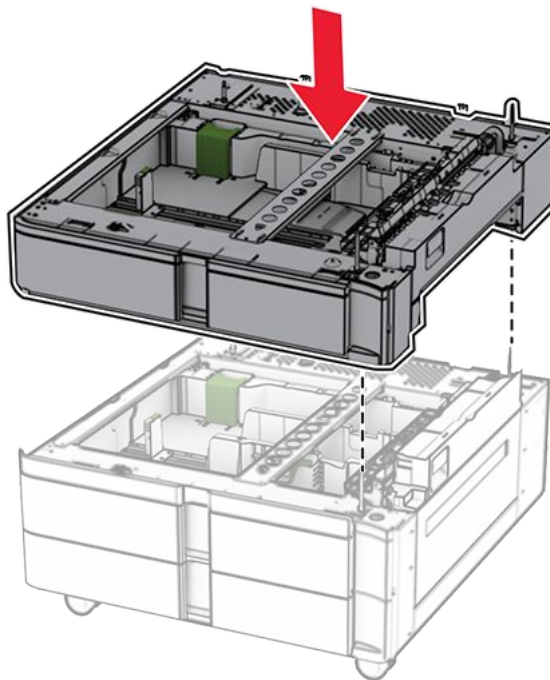

6. Pull out the 550-sheet tray insert.

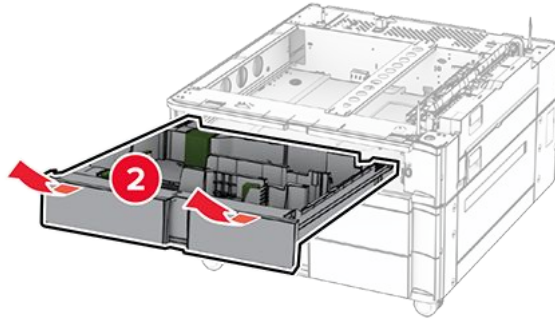
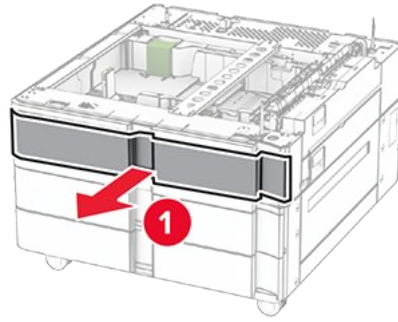

7. Secure the 550-sheet tray to the 2 x 550-sheet tray.

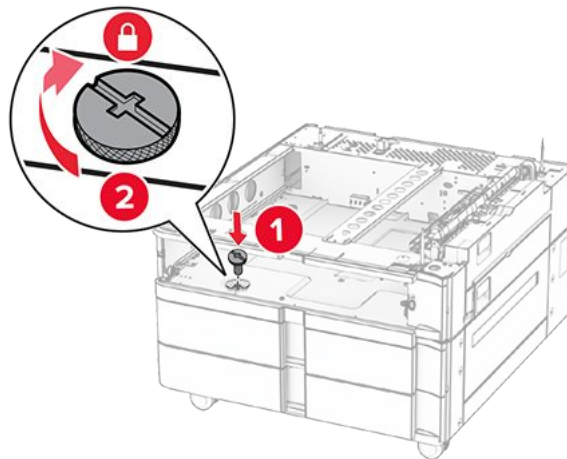

8. Insert the 550-sheet tray insert.

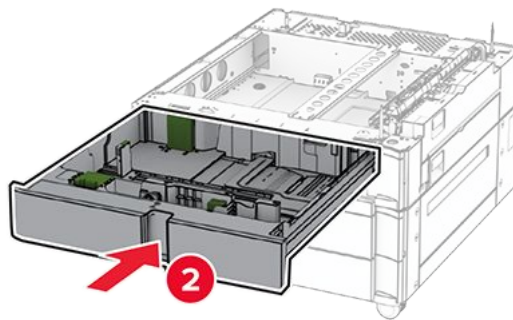
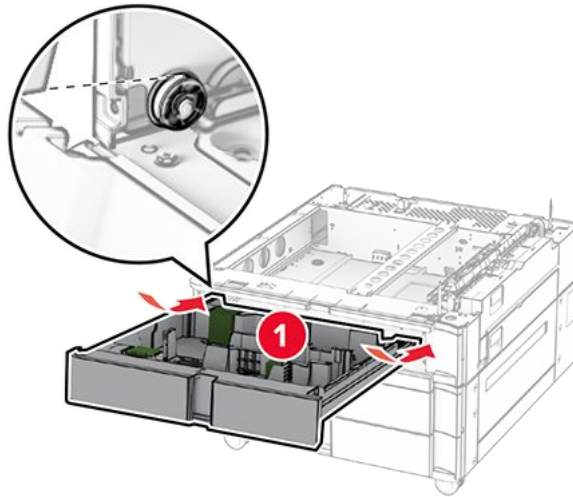

9. Secure the rear part of the 550-sheet tray to the 2 x 550-sheet tray.

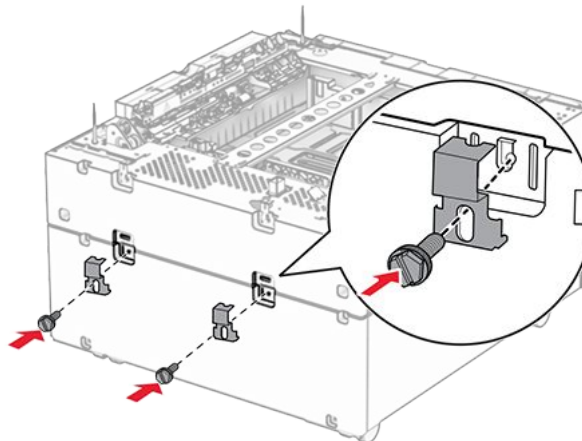

10. Remove the cover under the right side of the printer.

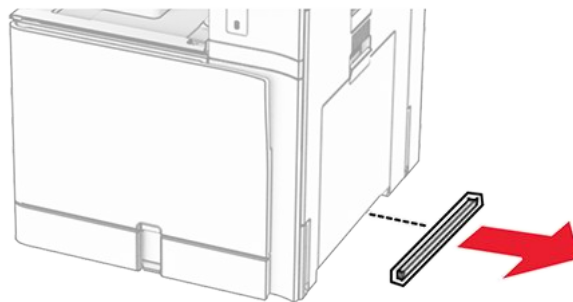

11. Align the printer with the optional trays, and then lower it into place.



**CAUTION—POTENTIAL INJURY**

If the printer weight is greater than 20 kg (44 lb), then it may require two or more people to lift it safely.

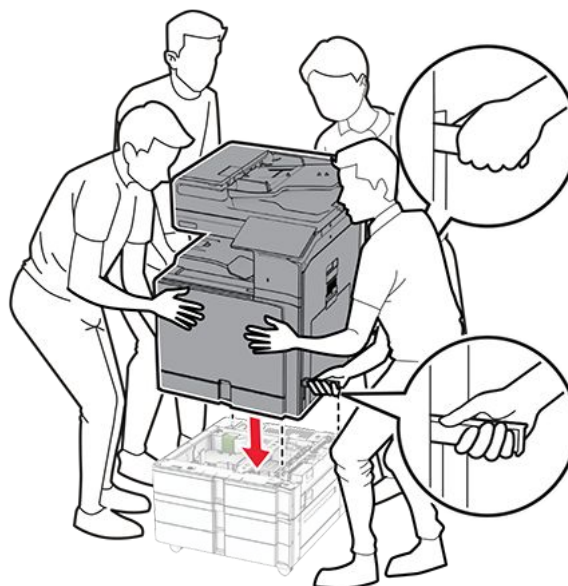

12. Pull out the standard tray insert.

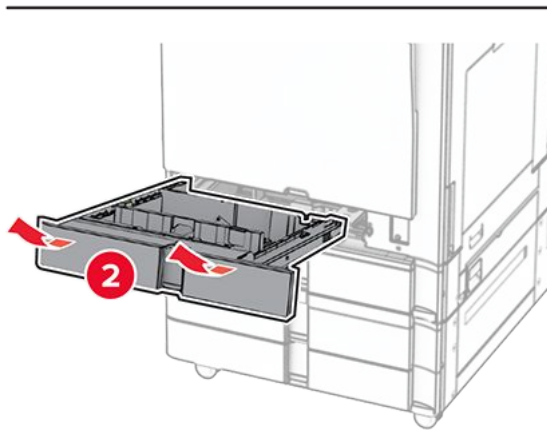
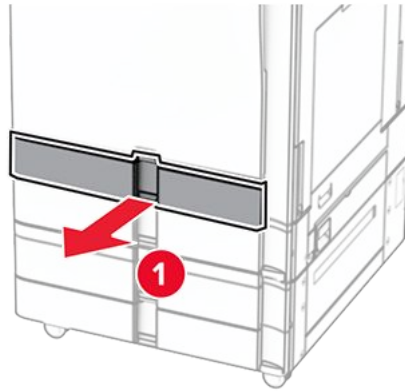

13. Secure the 550-sheet tray to the printer.

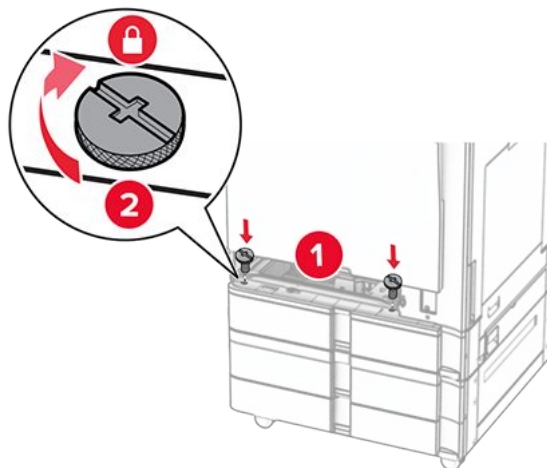

14. Insert the standard tray insert.

15. Secure the rear part of the 550-sheet tray to the printer.

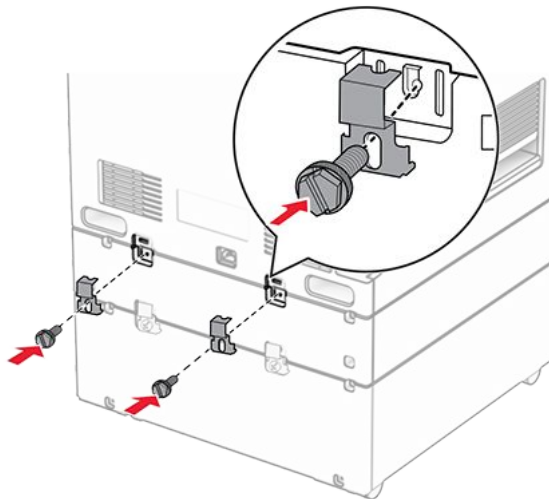

16. Connect one end of the power cord to the printer, and then the other end to the electrical outlet.



**CAUTION—POTENTIAL INJURY**

To avoid the risk of fire or electrical shock, connect the power cord to an appropriately rated and properly grounded electrical outlet that is near the product and easily accessible.

17. Turn on the printer.

Add the tray in the print driver to make it available for print jobs. For more information, see [Adding available options in the print driver on page 130](#).

## Installing the 2000-sheet tandem tray



**CAUTION—SHOCK HAZARD**

To avoid the risk of electrical shock, if you are accessing the controller board or installing optional hardware or memory devices sometime after setting up the printer, then turn the printer off, and unplug the power cord from the electrical outlet before continuing. If you have any other devices attached to the printer, then turn them off as well, and unplug any cables going into the printer.

### Notes

- This option must be installed together with an optional 550-sheet tray. Place this option at the bottom of the configuration.
- If a 550-sheet tray is already installed, uninstall the tray, remove the tray side cover, remove the lower tray cover, and then place the tray on top of this option.
- This task requires a flat-head screwdriver.

1. Turn off the printer.

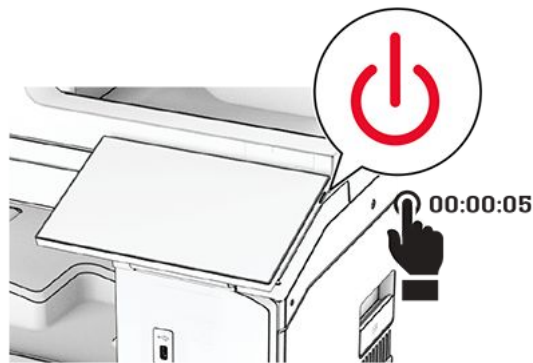

2. Unplug the power cord from the electrical outlet, and then from the printer.

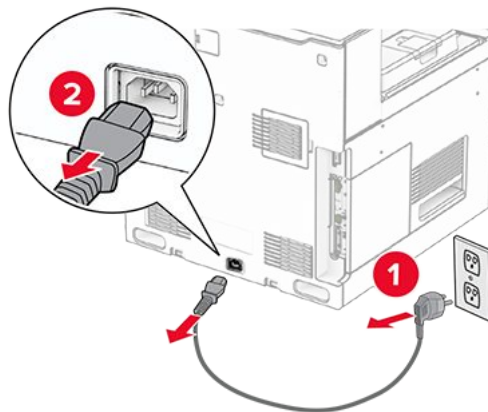

3. Unpack the tandem tray, and then remove all the packing material.
4. Lock the caster to keep the tandem tray from moving.

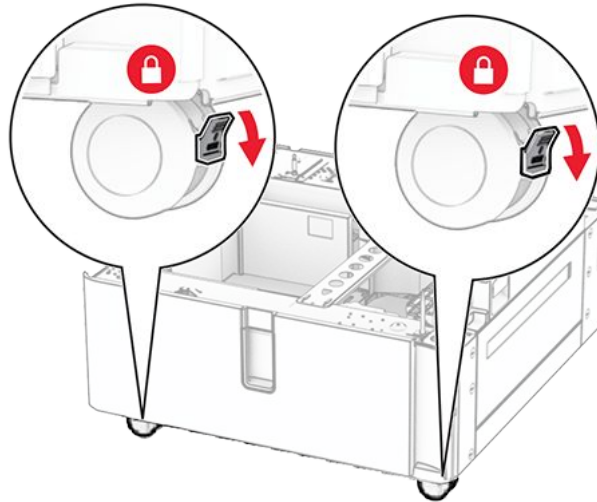

5. Align the 550-sheet tray with the tandem tray, and then lower it into place.

**Note:** To avoid damaging the tray, make sure to hold the front and rear sides when lifting it.

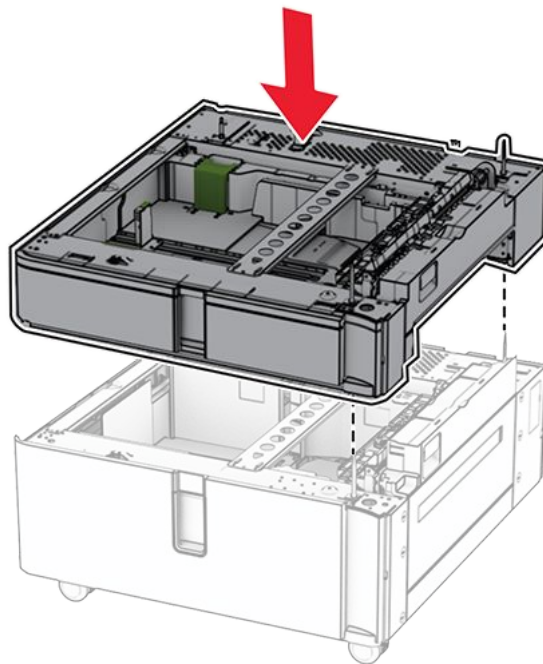

6. Pull out the 550-sheet tray insert.

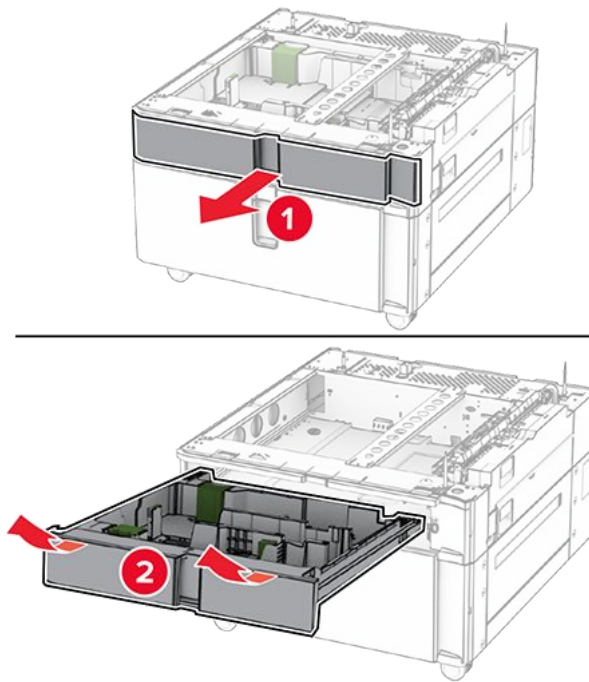

7. Secure the 550-sheet tray to the tandem tray.

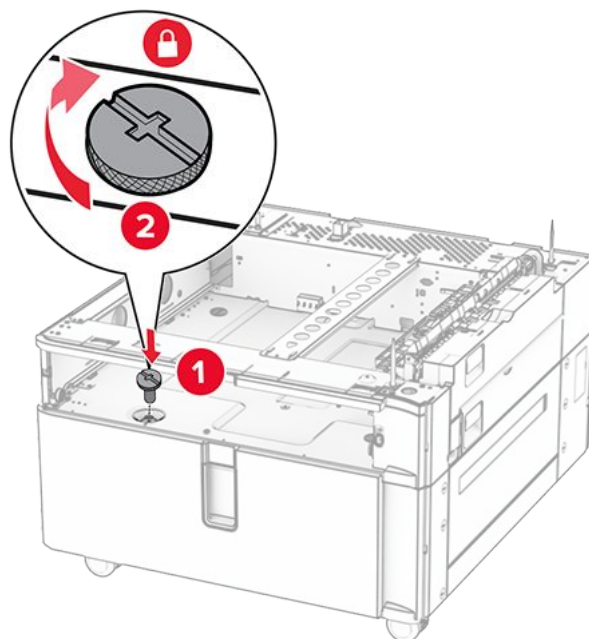

8. Insert the tray insert.

9. Secure the rear part of the 550-sheet tray to the tandem tray.

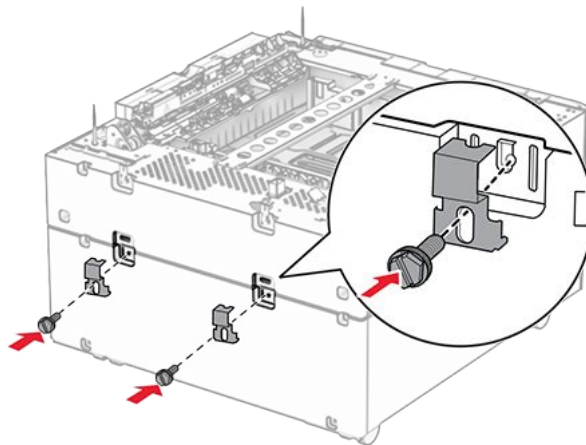

10. Remove the cover under the right side of the printer.

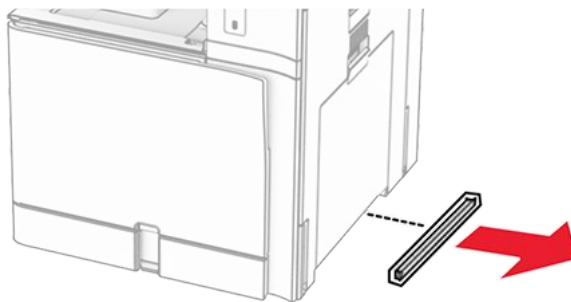

11. Align the printer with the optional trays, and then lower it into place.



**CAUTION—POTENTIAL INJURY**

If the printer weight is greater than 20 kg (44 lb), then it may require two or more people to lift it safely.

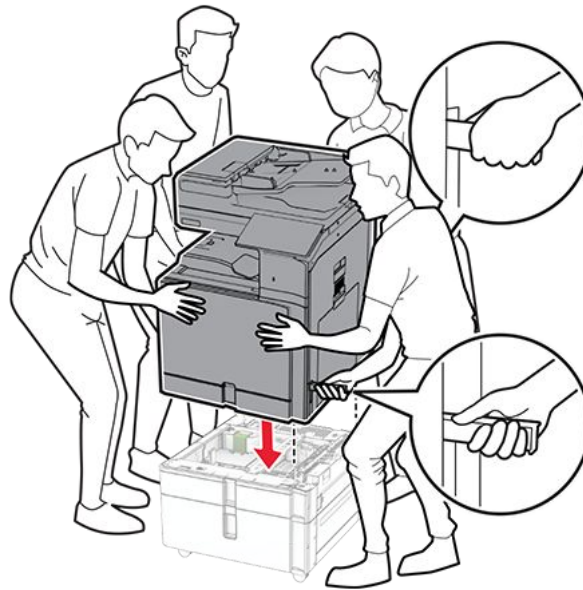

12. Pull out the standard tray.

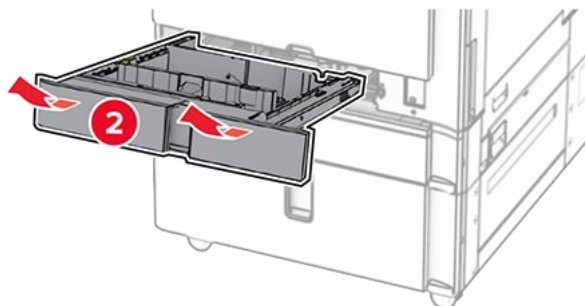
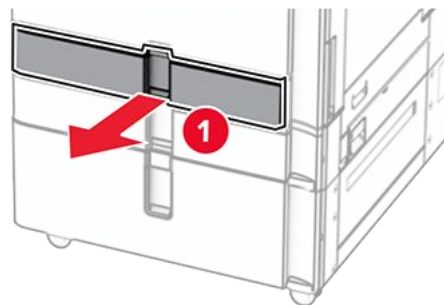

13. Secure the 550-sheet tray to the printer.

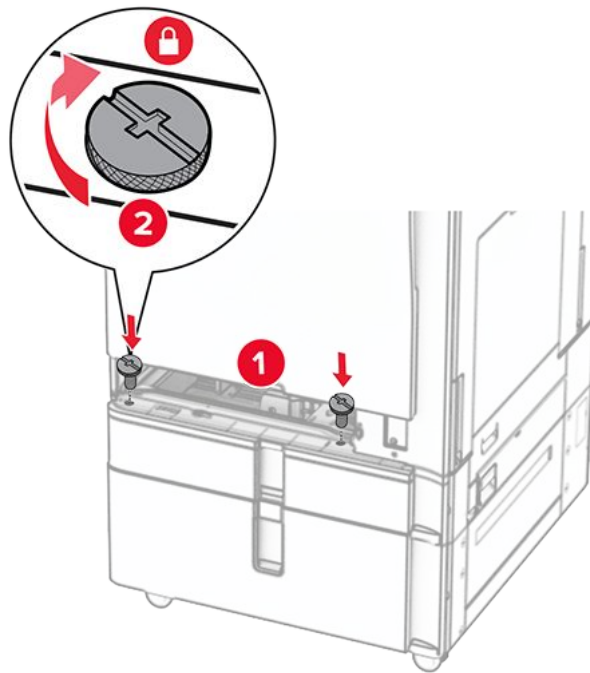

14. Insert the tray.
15. Secure the rear part of the 550-sheet tray to the printer.

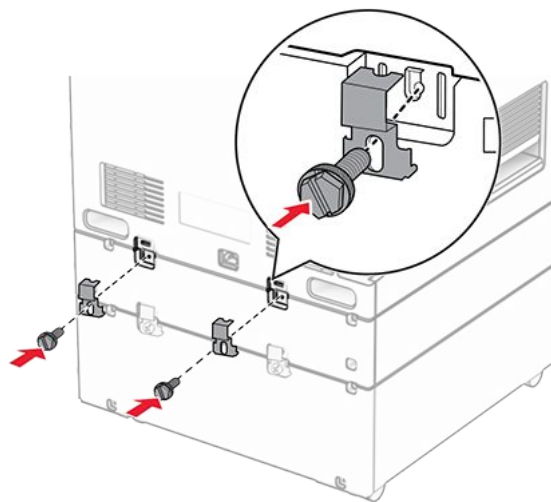

16. Connect one end of the power cord to the printer, and then the other end to the electrical outlet.



**CAUTION—POTENTIAL INJURY**

To avoid the risk of fire or electrical shock, connect the power cord to an appropriately rated and properly grounded electrical outlet that is near the product and easily accessible.

17. Turn on the printer.

Add the tray in the print driver to make it available for print jobs. For more information, see [Adding available options in the print driver on page 130](#).

## Installing the cabinet



### CAUTION—SHOCK HAZARD

To avoid the risk of electrical shock, if you are accessing the controller board or installing optional hardware or memory devices sometime after setting up the printer, then turn the printer off, and unplug the power cord from the electrical outlet before continuing. If you have any other devices attached to the printer, then turn them off as well, and unplug any cables going into the printer.

### Notes

- This option must be installed together with a 550-sheet tray. Place this option at the bottom of the configuration.
- If a 550-sheet tray is already installed, then uninstall the tray, remove the lower tray cover and place it on top of this option.
- This task requires a flat-head screwdriver.

1. Unpack, and then assemble the cabinet.
2. Turn off the printer.

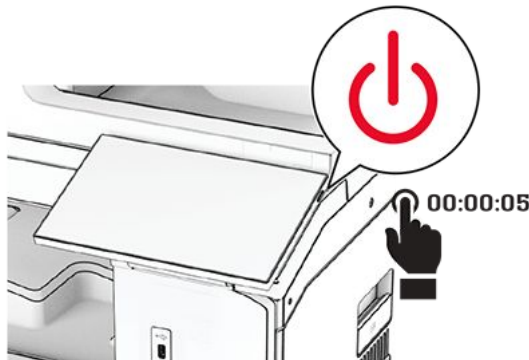

3. Unplug the power cord from the electrical outlet, and then from the printer.

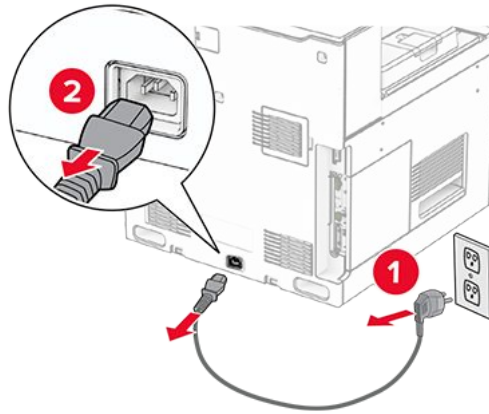

4. Lock the caster to keep the cabinet from moving.

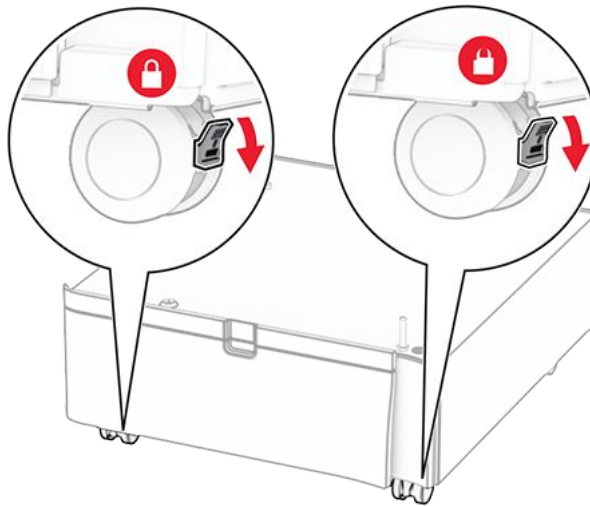

5. Attach the side cover of the 550-sheet tray.

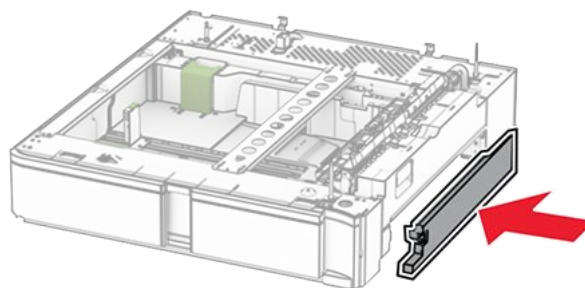

6. Align the tray with the cabinet, and then lower it into place.

**Note:** To avoid damaging the tray, make sure to hold the front and rear sides when lifting it.

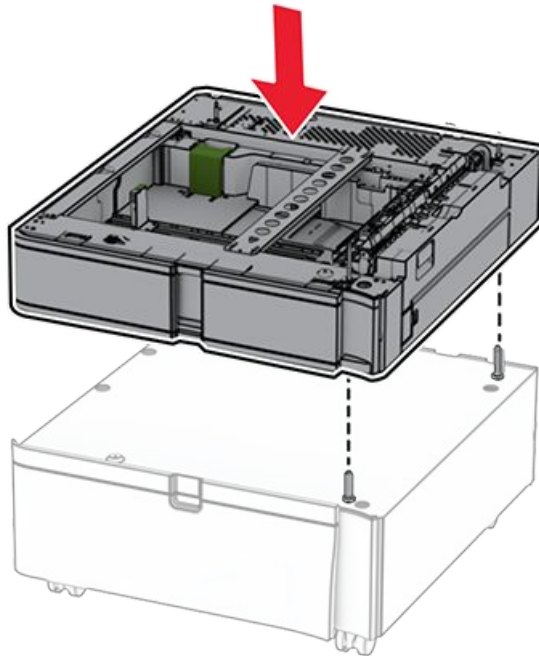

7. Pull out the tray insert.

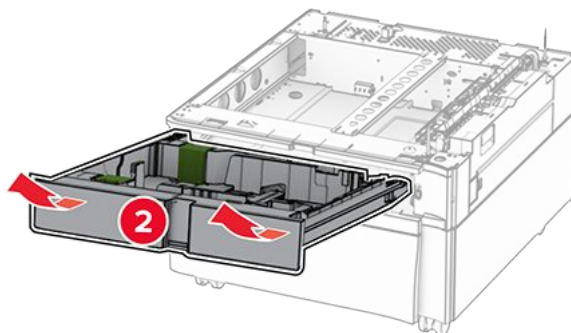
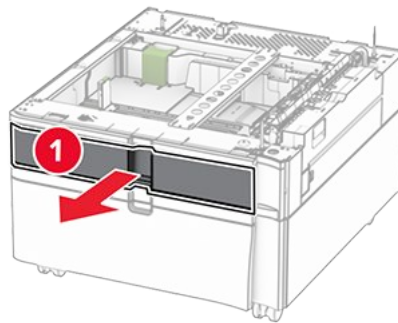

8. Secure the tray to the cabinet.

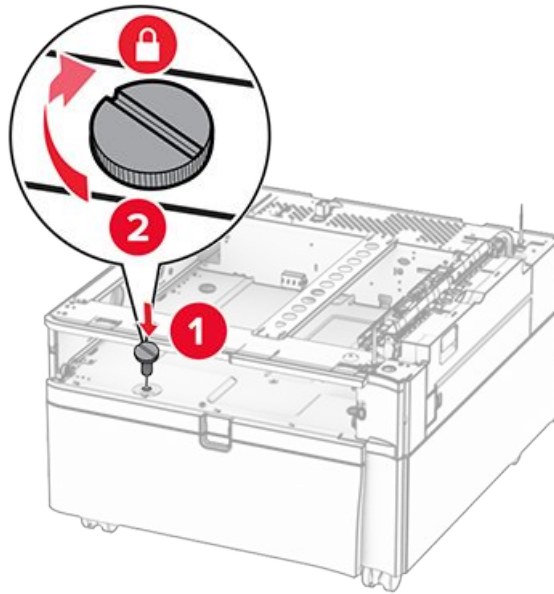

9. Insert the tray insert.
10. Secure the rear part of the tray to the cabinet.

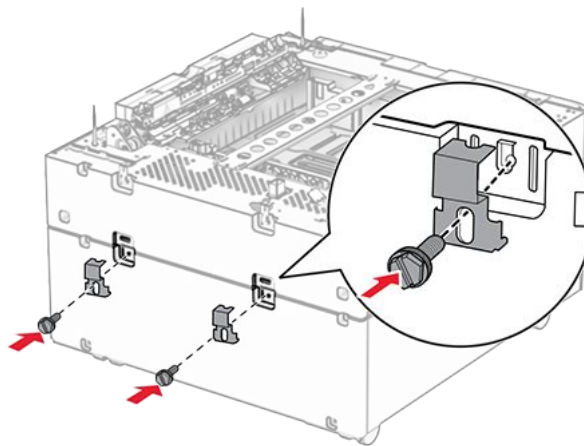

11. Remove the cover under the right side of the printer.

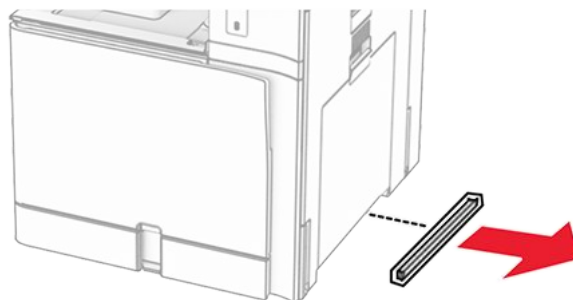

12. Align the printer with the cabinet and the tray, and then lower it into place.



**CAUTION—POTENTIAL INJURY**

If the printer weight is greater than 20 kg (44 lb), then it may require two or more people to lift it safely.

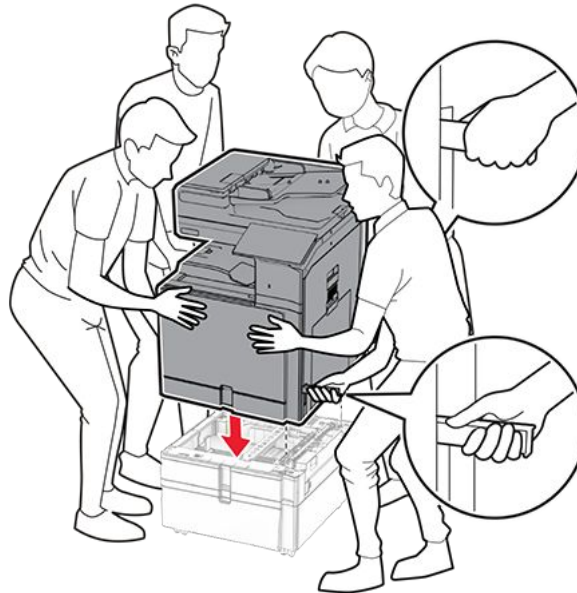

13. Pull out the standard tray insert.
14. Secure the 550-sheet tray to the printer.

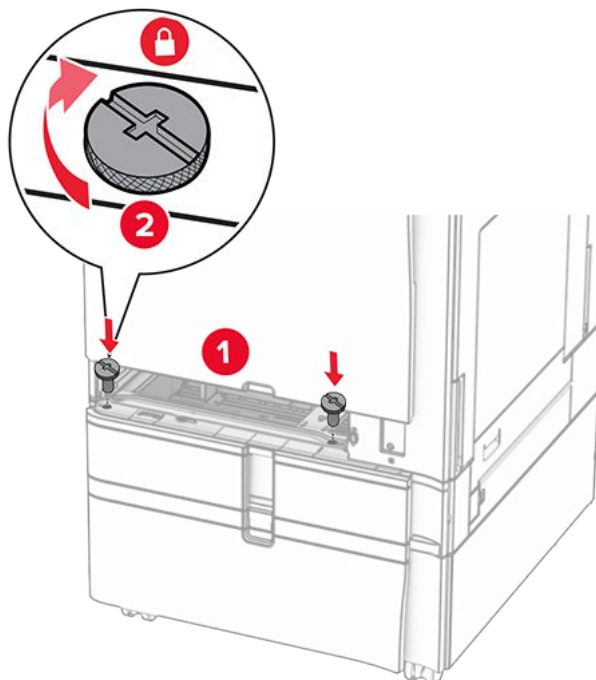

15. Insert the standard tray insert.
16. Secure the rear part of the 550-sheet tray to the printer.

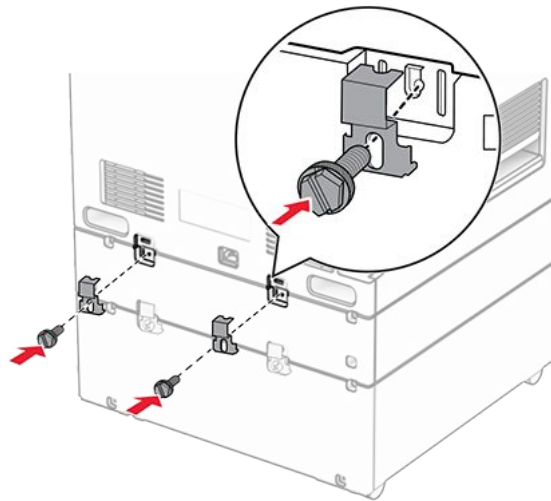

17. Connect one end of the power cord to the printer, and then the other end to the electrical outlet.



### **CAUTION—POTENTIAL INJURY**

To avoid the risk of fire or electrical shock, connect the power cord to an appropriately rated and properly grounded electrical outlet that is near the product and easily accessible.

18. Turn on the printer.

## Installing the 1500-sheet tray



### **CAUTION—SHOCK HAZARD**

To avoid the risk of electrical shock, if you are accessing the controller board or installing optional hardware or memory devices sometime after setting up the printer, then turn the printer off, and unplug the power cord from the electrical outlet before continuing. If you have any other devices attached to the printer, then turn them off as well, and unplug any cables going into the printer.

### **Notes**

- Before installing this option, make sure that an optional 550-sheet tray and either of the 2 x 500-sheet tray or 2000-sheet tray are already installed.
- This task requires a flat-head screwdriver.

1. Turn off the printer.

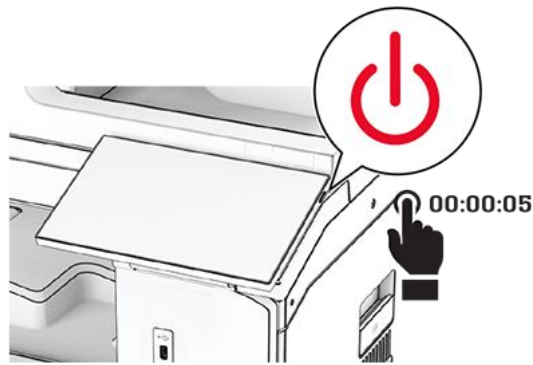

2. Unplug the power cord from the electrical outlet, and then from the printer.

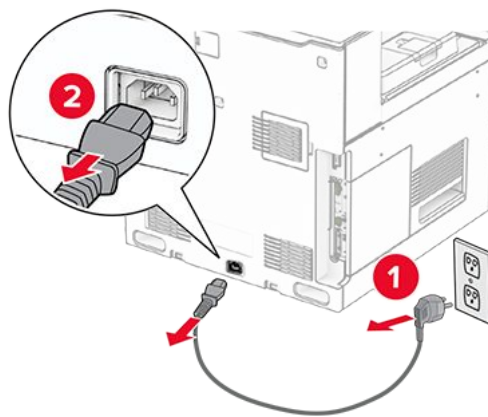

3. Remove the connection cover.

**Note:** Do not throw away the cover.

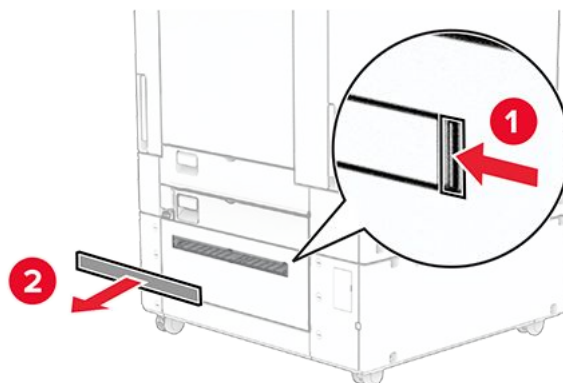

4. Remove the port cover.

**Note:** Do not throw away the cover.

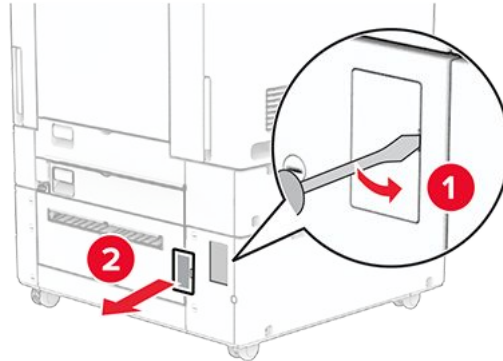

5. Remove the screw caps from the printer.

**Note:** Do not throw away the screw caps.

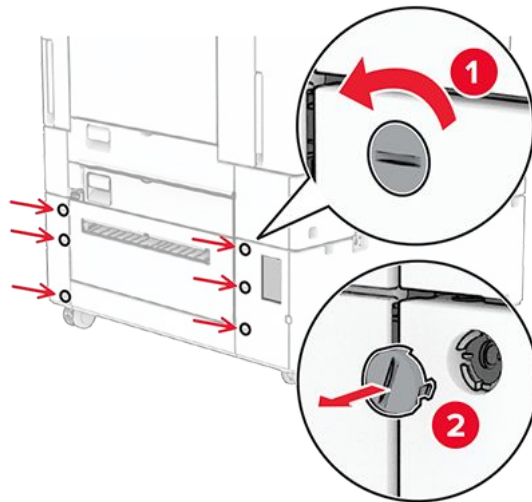

6. Unpack the 1500-sheet tray.
7. Install the screws for the mounting bracket.

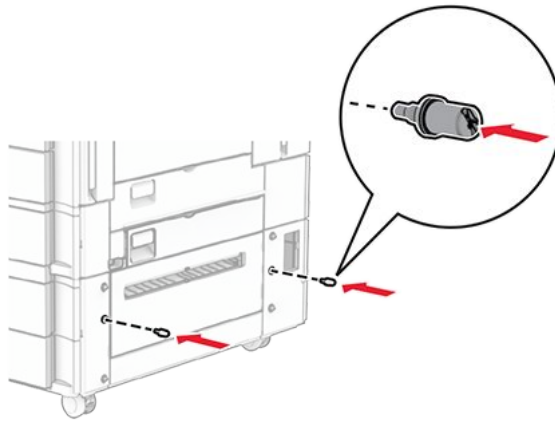

8. Attach the mounting bracket to the printer.

**Note:** Use the mounting bracket and screws that came with the 1500-sheet tray.

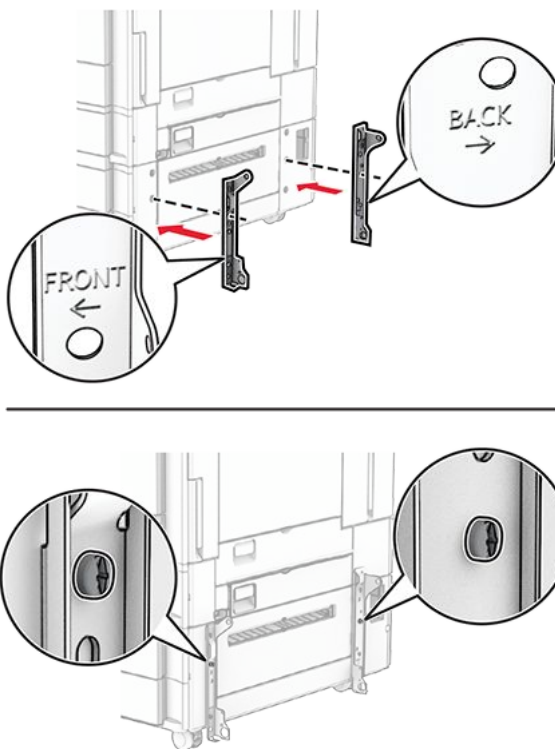

9. Install the remaining screws.

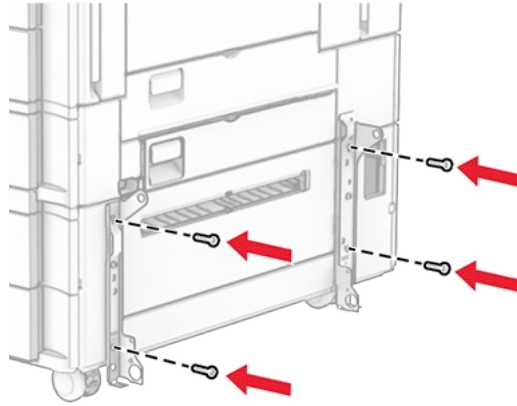

10. Install the 1500-sheet tray.

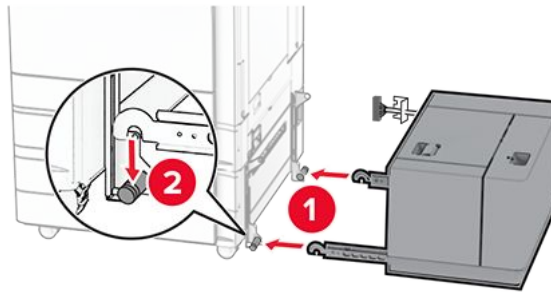

11. Connect the tray cable to the printer.

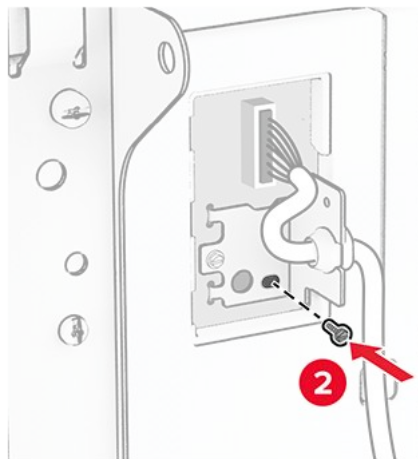
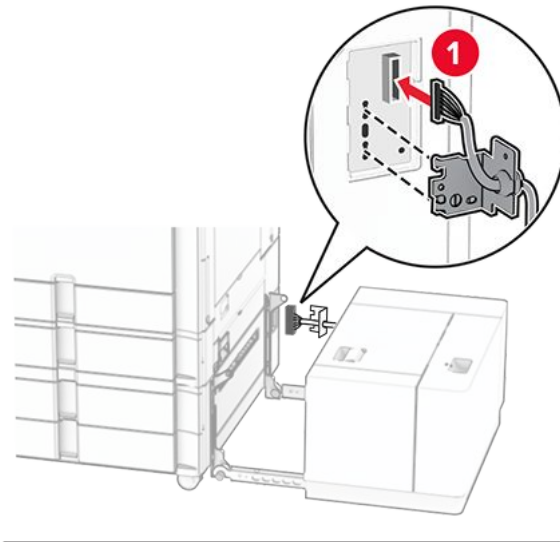

12. Attach the tray cable cover.

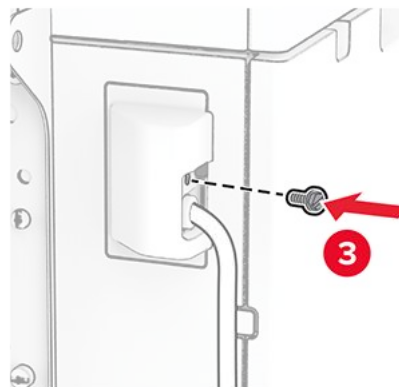
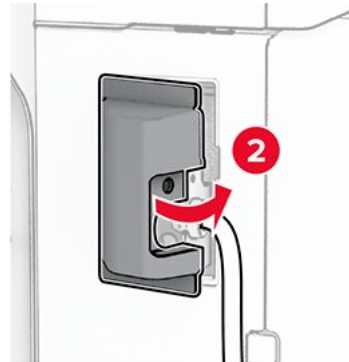
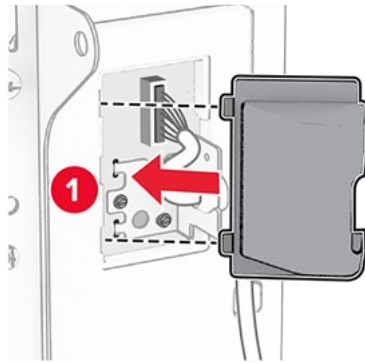

13. Slide the 1500-sheet tray toward the printer.

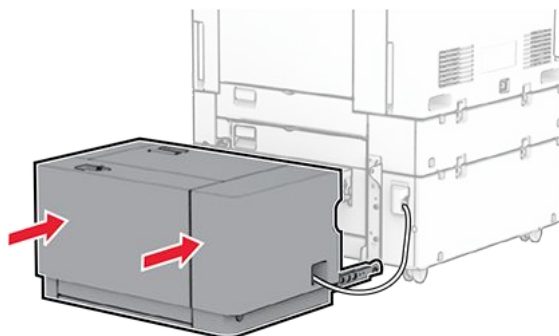

14. Connect one end of the printer power cord to the printer, and then the other end to the electrical outlet.



### CAUTION—POTENTIAL INJURY

To avoid the risk of fire or electrical shock, connect the power cord to an appropriately rated and properly grounded electrical outlet that is near the product and easily accessible.

15. Turn on the printer.

Add the tray in the print driver to make it available for print jobs. For more information, see [Adding available options in the print driver on page 130](#).

## Installing the staple finisher



### CAUTION—SHOCK HAZARD

To avoid the risk of electrical shock, if you are accessing the controller board or installing optional hardware or memory devices sometime after setting up the printer, then turn the printer off, and unplug the power cord from the electrical outlet before continuing. If you have any other devices attached to the printer, then turn them off as well, and unplug any cables going into the printer.

**Note:** This task requires a flat-head screwdriver.

1. Turn off the printer.



2. Unplug the power cord from the electrical outlet, and then from the printer.

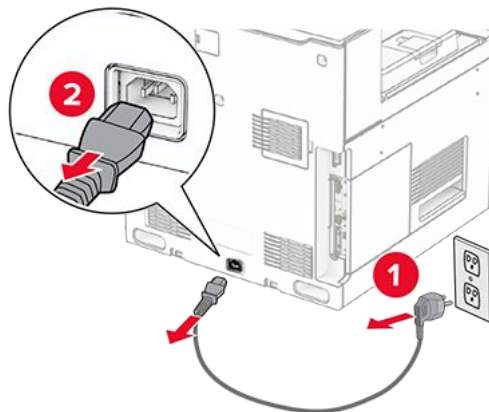

3. Unpack the staple finisher, and then remove all the packing material.
4. Install the feed guide.

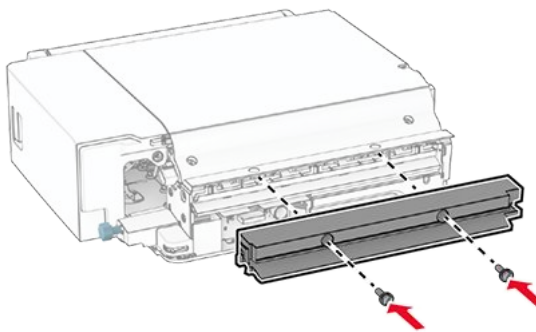

5. Remove the standard bin.

**Note:** Do not throw away the bin.

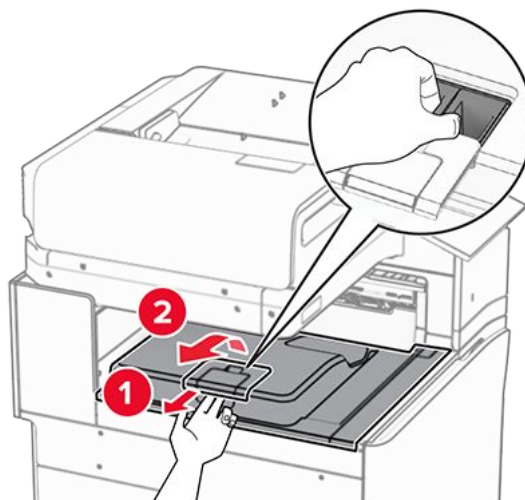

6. Before installing the option, place the exit bin flag into the closed position.

**Note:** When the option is removed, place the exit bin flag into the open position.

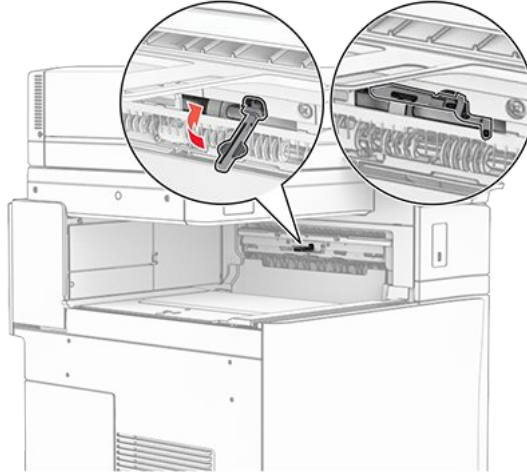

7. Remove the backup roller.

**Note:** Do not throw away the roller.

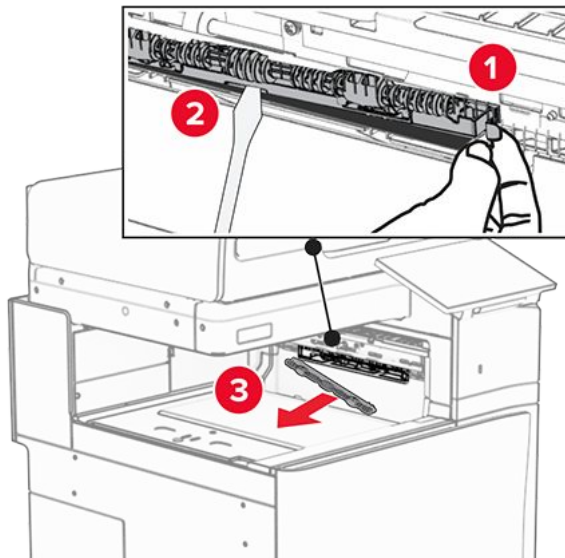

8. Insert the feed roller that came with the staple finisher until it clicks into place.

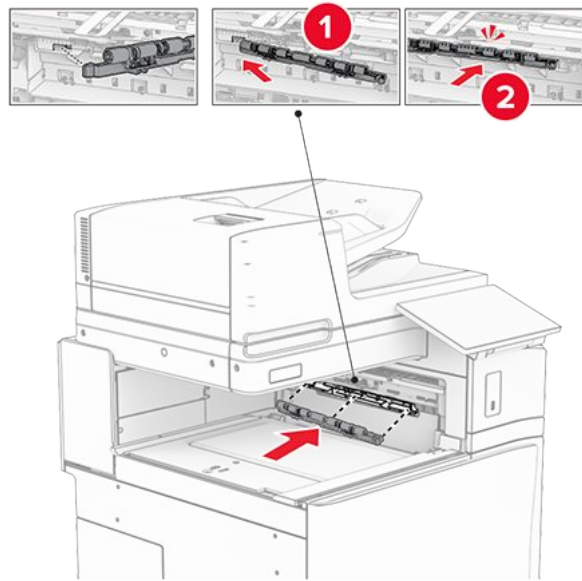

**Note:** Make sure that the metal spring is in front of the feed roller.

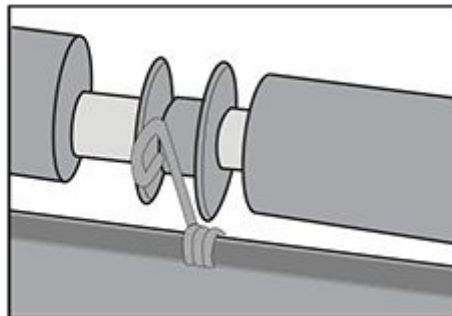

9. Attach the roller cover until it clicks into place.

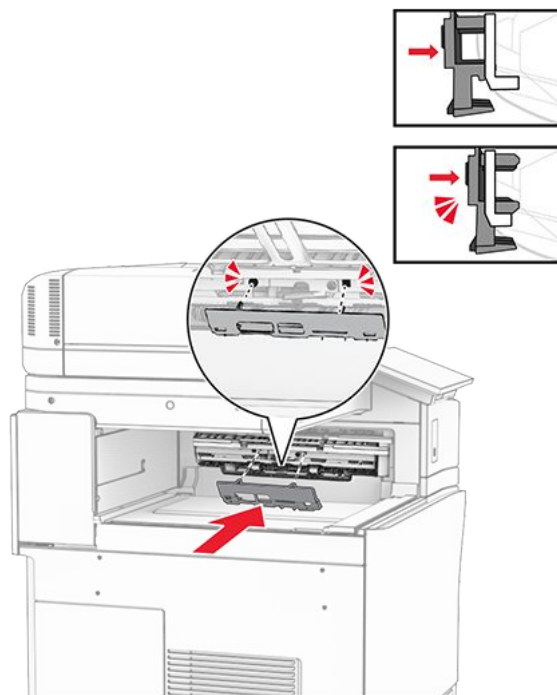

10. Open the front door, and then remove the cover on the left side of the printer.

**Note:** Do not throw away the screw and cover.

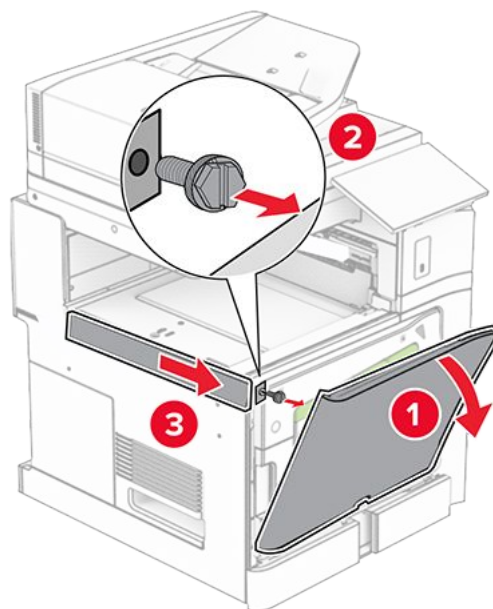

11. Remove the left rear cover.

**Note:** Do not throw away the screw and cover.

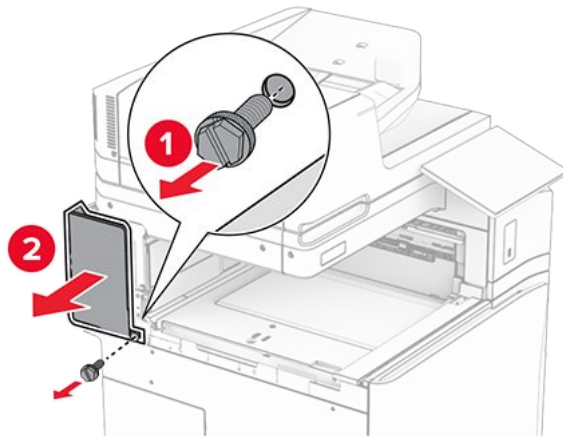

12. Remove the inner bin cover.

**Note:** Do not throw away the cover.

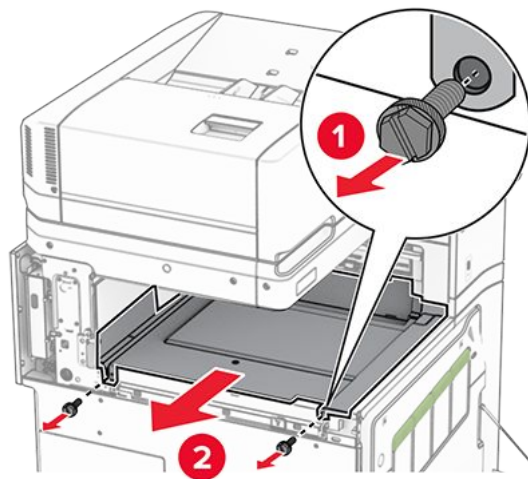

13. Align, and then insert the inner bin cover that came with the staple finisher.

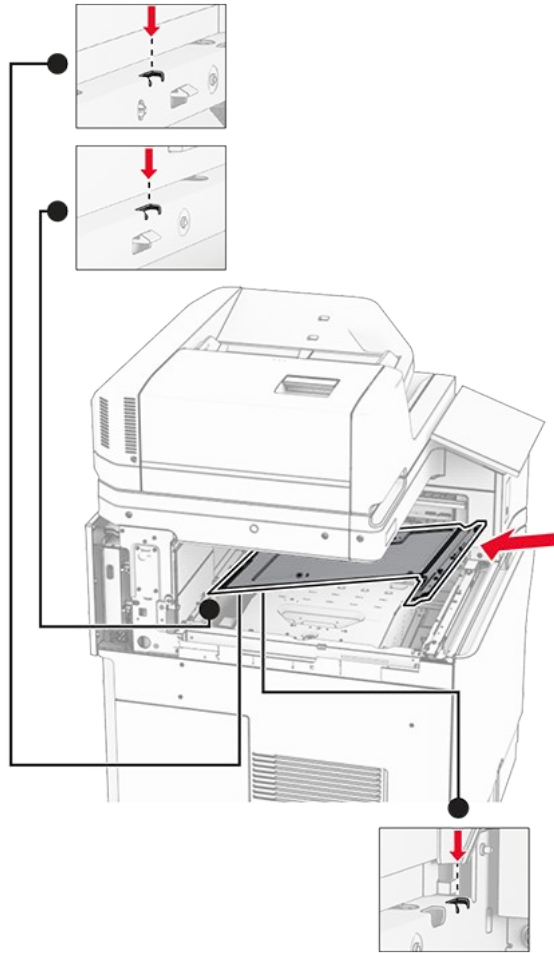

14. Install the screws to the inner bin cover.

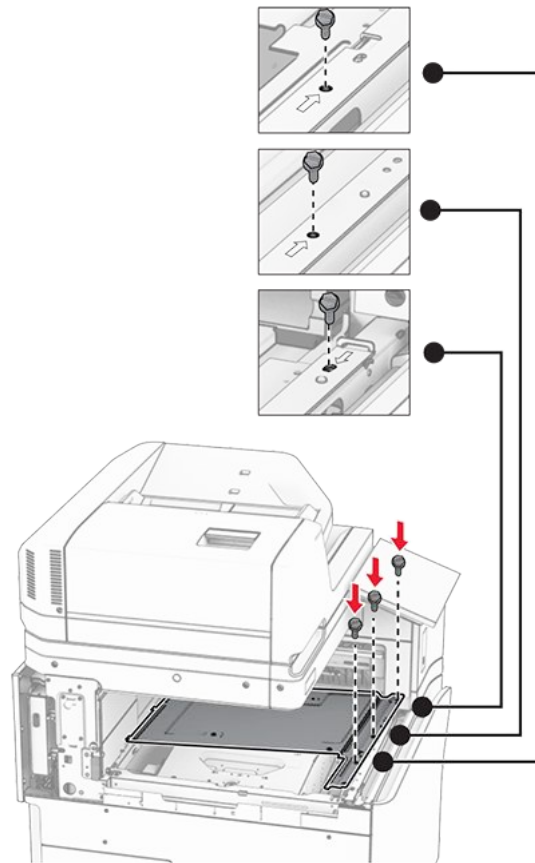

15. Attach the staple finisher slider.

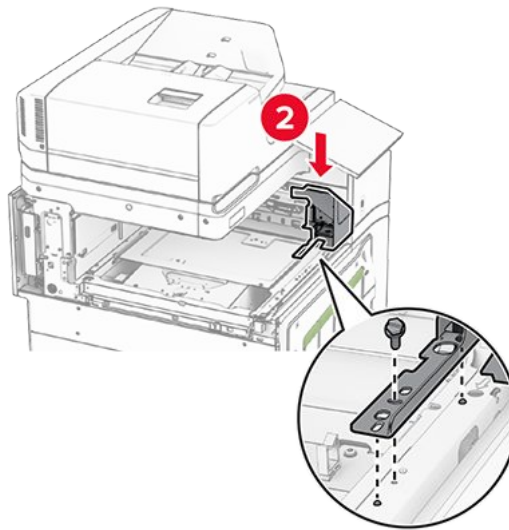
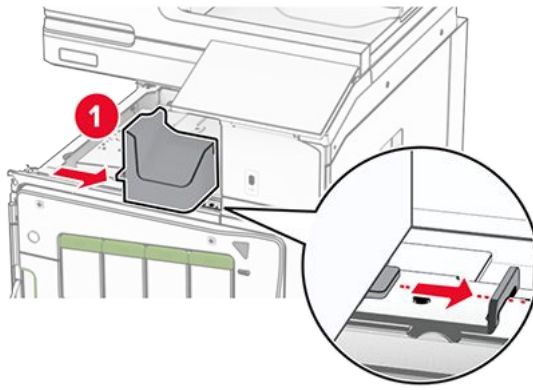

16. Insert the staple finisher.

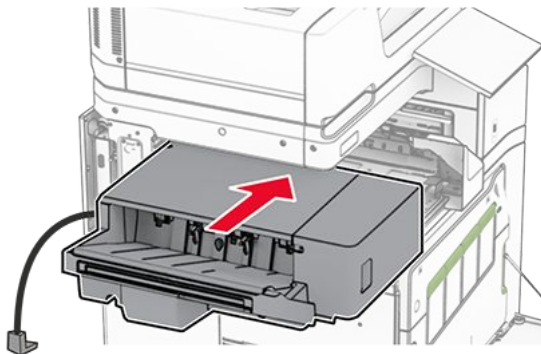

17. Install the mounting bracket to secure the finisher to the printer.

**Note:** Use the screw that came with the finisher.

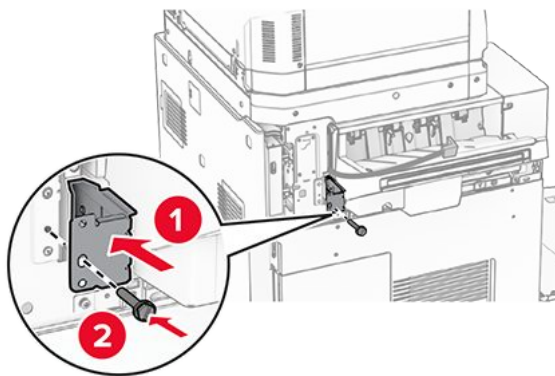

18. Attach the left rear cover, and then slide the staple finisher to the left.

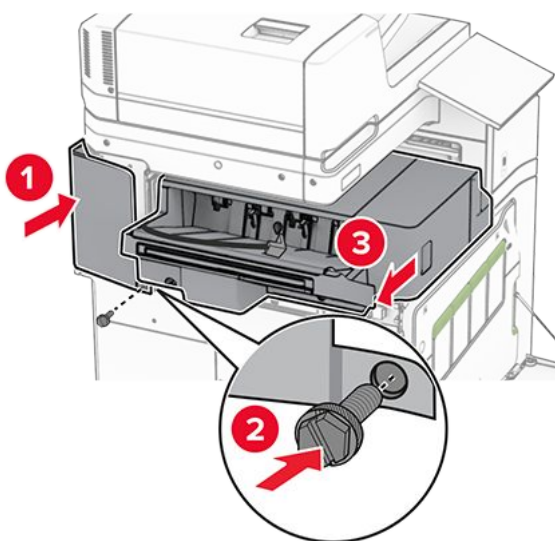

19. Attach the left upper trim cover that came with the finisher.

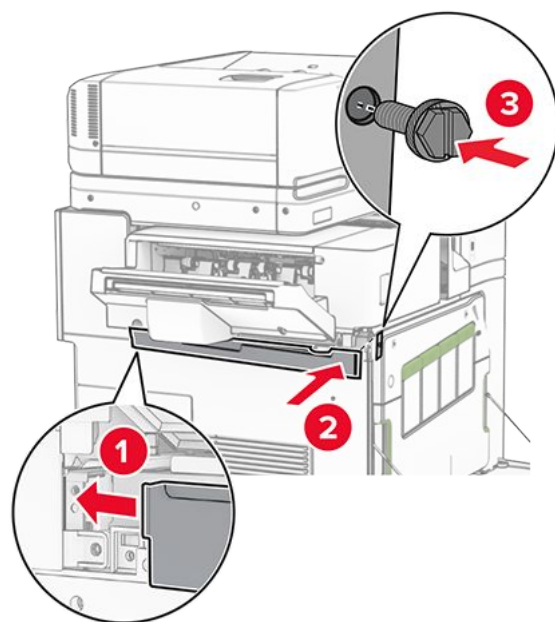

20. Insert the staple cartridge into the finisher until it clicks into place.

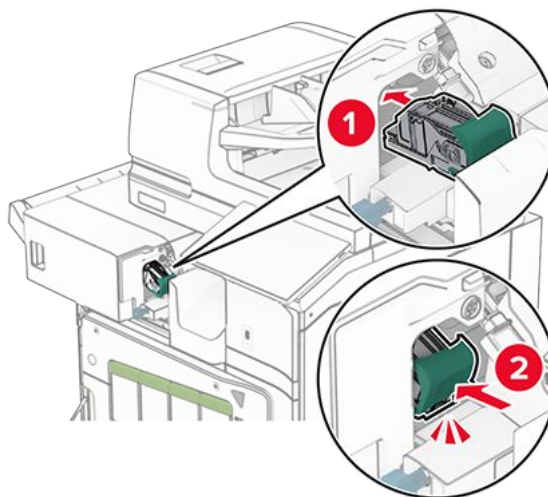

21. Close the front door, and then slide the finisher toward the printer.

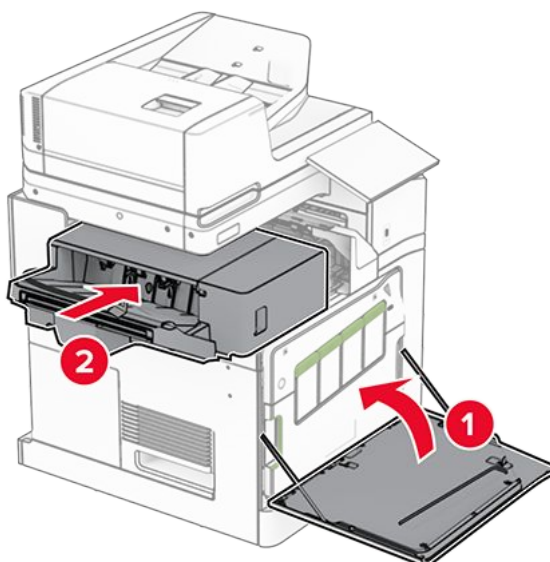

22. Connect the option cable to the printer.

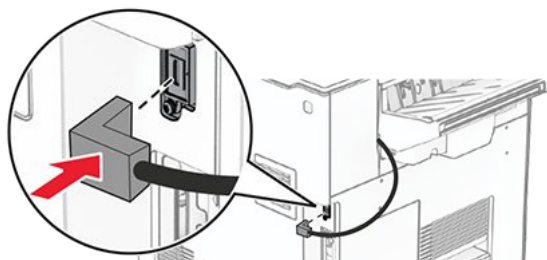

23. Connect one end of the printer power cord to the printer, and then the other end to the electrical outlet.



### CAUTION—POTENTIAL INJURY

To avoid the risk of fire or electrical shock, connect the power cord to an appropriately rated and properly grounded electrical outlet that is near the product and easily accessible.

24. Turn on the printer.

Add the finisher in the print driver to make it available for print jobs. For more information, see [Adding available options in the print driver on page 130](#).

## Installing the offset stacker



### CAUTION—SHOCK HAZARD

To avoid the risk of electrical shock, if you are accessing the controller board or installing optional hardware or memory devices sometime after setting up the printer, then turn the printer off, and unplug the power cord from the electrical outlet before continuing. If you have any other devices attached to the printer, then turn them off as well, and unplug any cables going into the printer.

1. Turn off the printer.

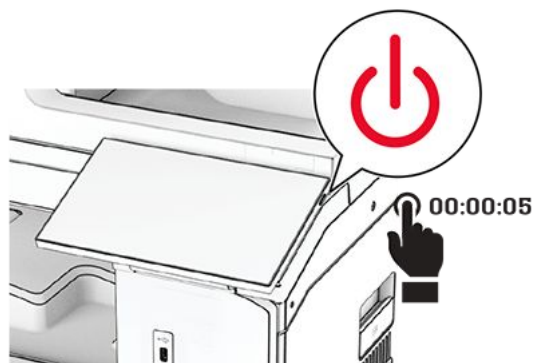

2. Unplug the power cord from the electrical outlet, and then from the printer.

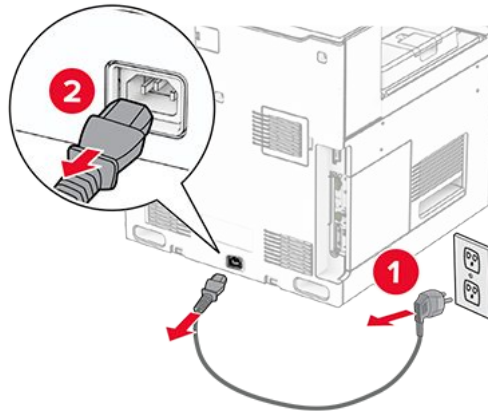

3. Unpack the offset stacker, and then remove all the packing material.
4. Attach the inner rear cover to the offset stacker.

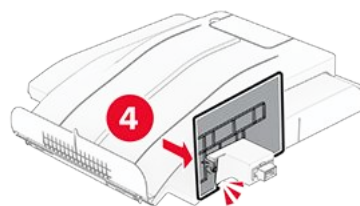
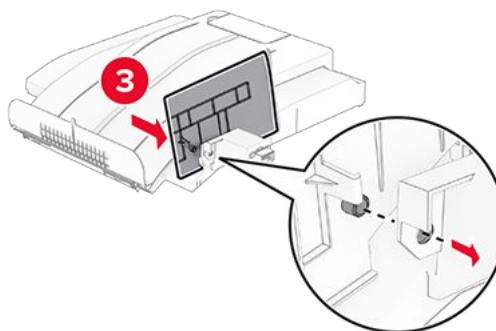
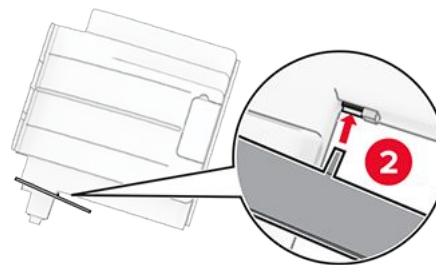
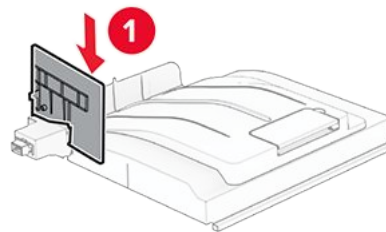

5. Remove the standard bin.

**Note:** Do not throw away the bin.

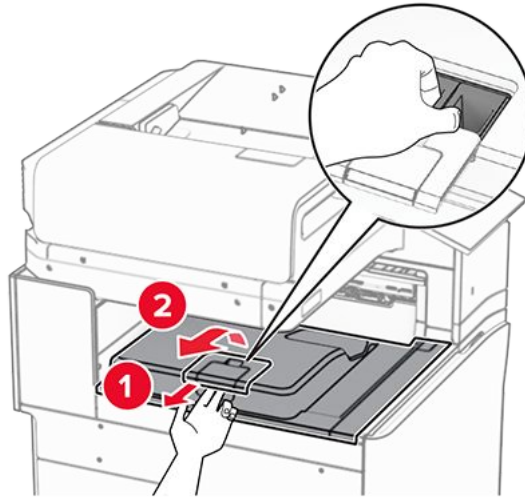

6. Remove the paper transport connector cover.

**Note:** Do not throw away the cover.

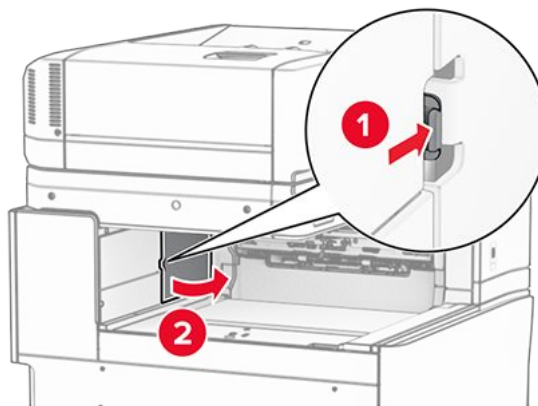

7. Before installing the option, place the exit bin flag into the closed position.

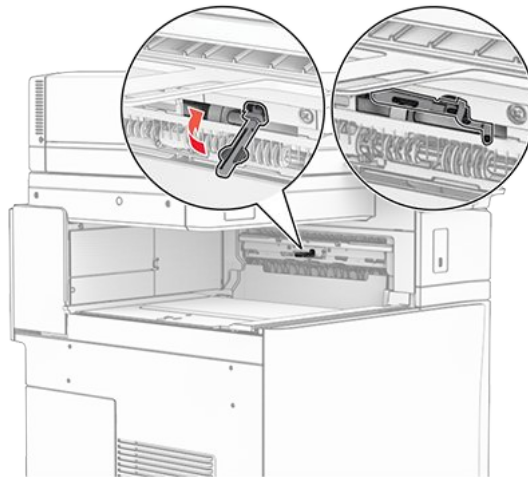

8. Align, and then install the offset stacker to the printer.

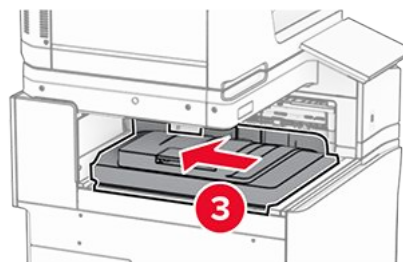
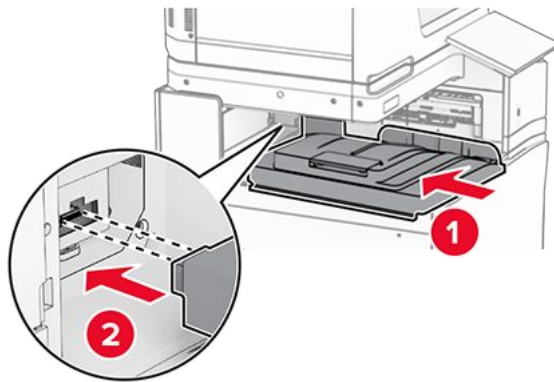

**Note:** Make sure that the parts are securely attached and aligned to the printer.

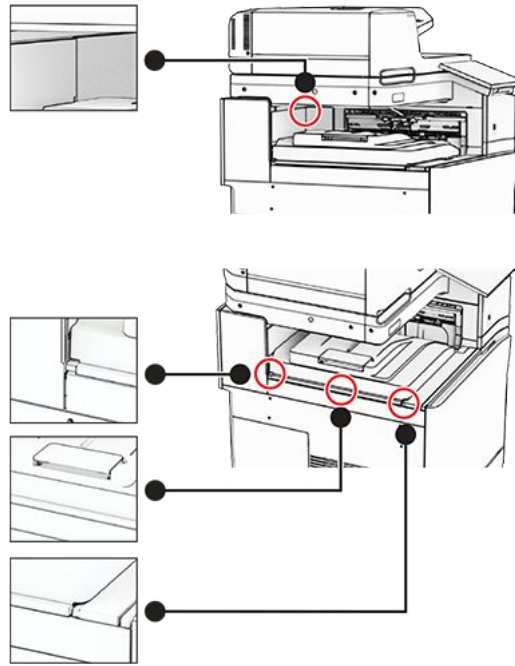

9. Attach the protective strips of the offset stacker to the printer.

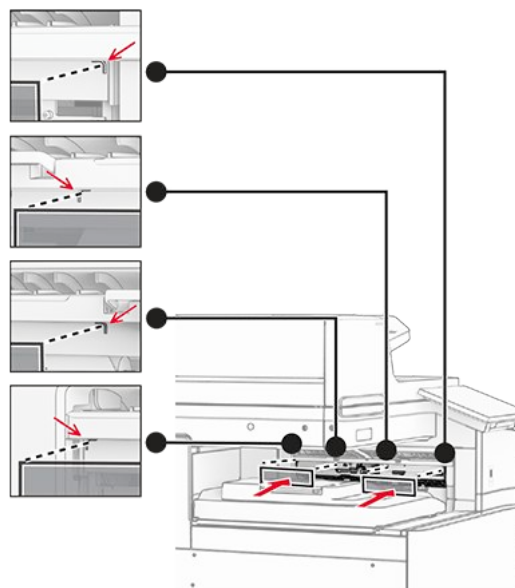

10. Place the exit bin flag into the open position.

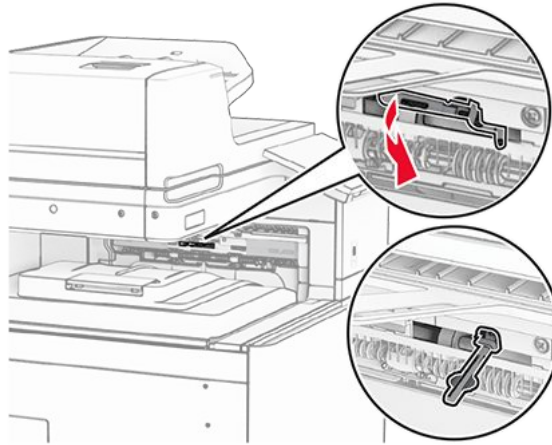

11. Attach the bin flag cover until it clicks into place.

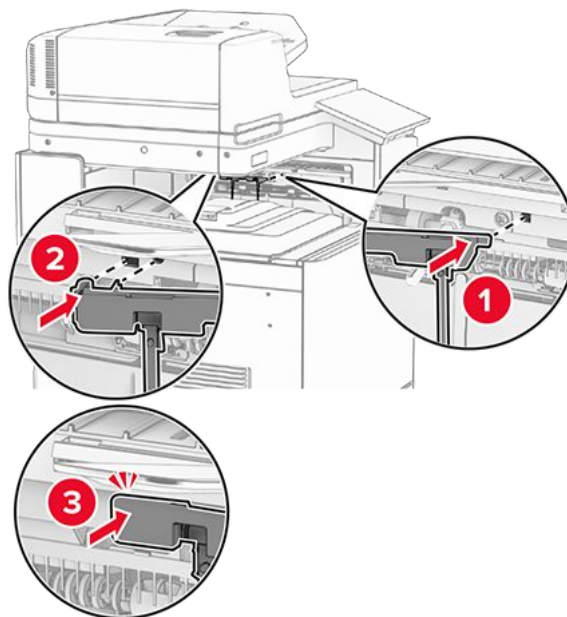

12. Connect one end of the printer power cord to the printer, and then the other end to the electrical outlet.



### **CAUTION—POTENTIAL INJURY**

To avoid the risk of fire or electrical shock, connect the power cord to an appropriately rated and properly grounded electrical outlet that is near the product and easily accessible.

13. Turn on the printer.

Add the offset stacker in the print driver to make it available for print jobs. For more information, see [Adding available options in the print driver on page 130](#).

## Installing the folding paper transport



### CAUTION—SHOCK HAZARD

To avoid the risk of electrical shock, if you are accessing the controller board or installing optional hardware or memory devices sometime after setting up the printer, then turn the printer off, and unplug the power cord from the electrical outlet before continuing. If you have any other devices attached to the printer, then turn them off as well, and unplug any cables going into the printer.

### Notes

- This option can also be installed together with a staple, hole punch finisher or booklet finisher.
- This task requires a flat-head screwdriver.

1. Turn off the printer.

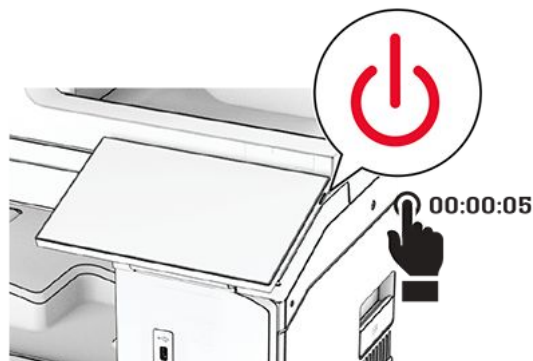

2. Unplug the power cord from the electrical outlet, and then from the printer.

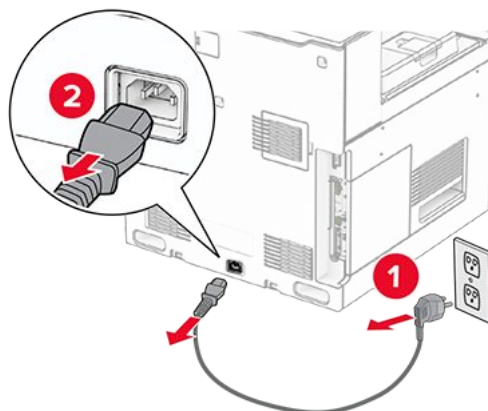

3. Unpack the folding paper transport, and then remove all the packing material.
4. Remove the standard bin.

**Note:** Do not throw away the bin.

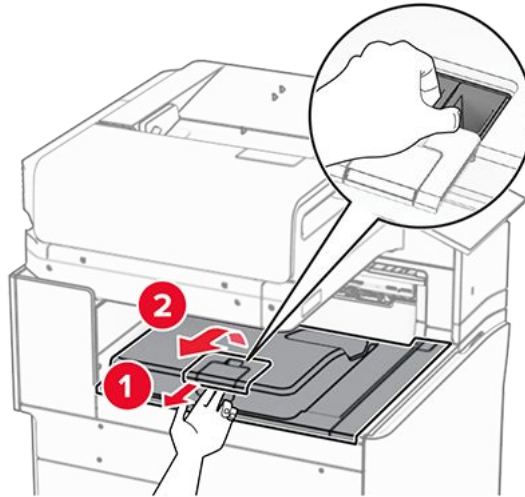

5. Before installing the option, place the exit bin flag into the closed position.

**Note:** When the option is removed, place the exit bin flag into the open position.

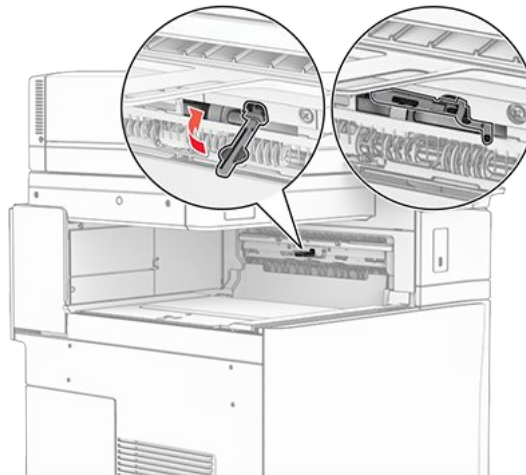

6. Remove the backup roller.

**Note:** Do not throw away the roller.

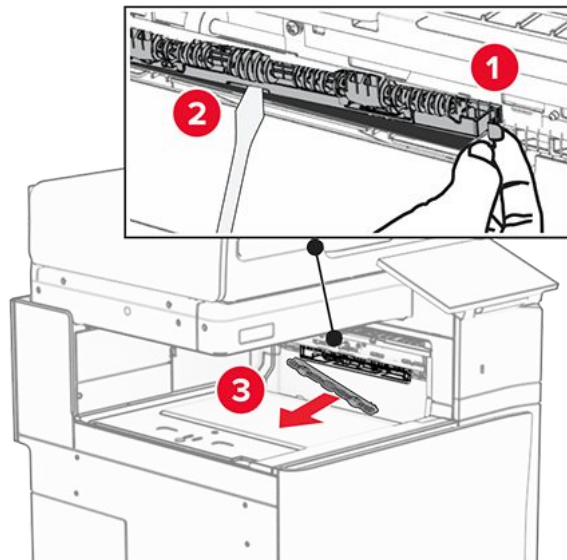

7. Insert the feed roller that came with the option until it clicks into place.

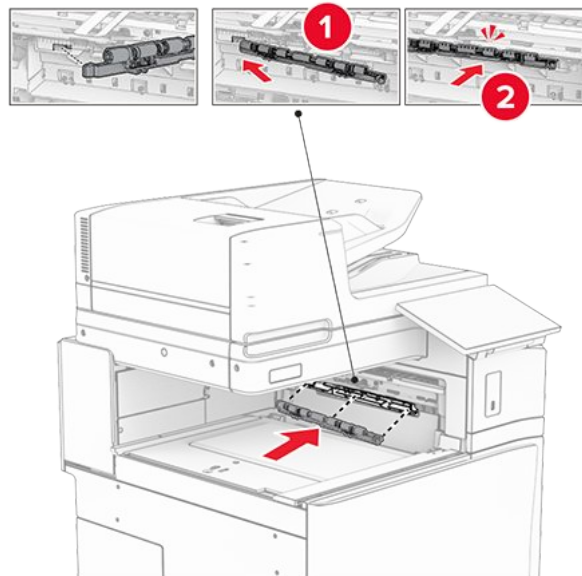

**Note:** Make sure that the metal spring is in front of the feed roller.

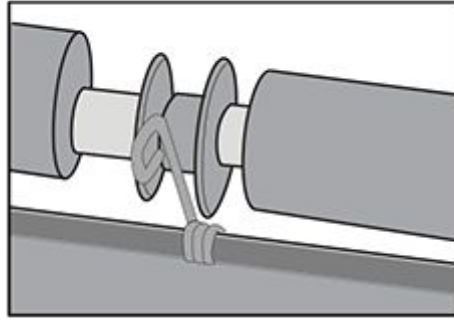

8. Attach the roller cover until it clicks into place.

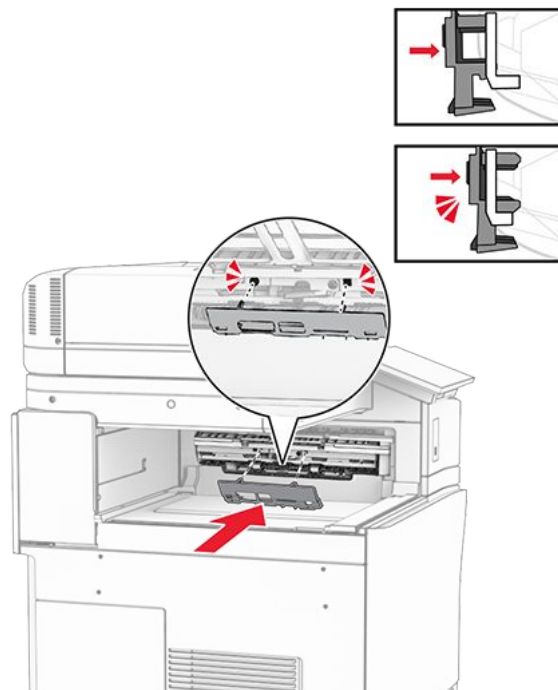

9. Open the front door, and then remove the cover on the left side of the printer.

**Note:** Do not throw away the screw and cover.

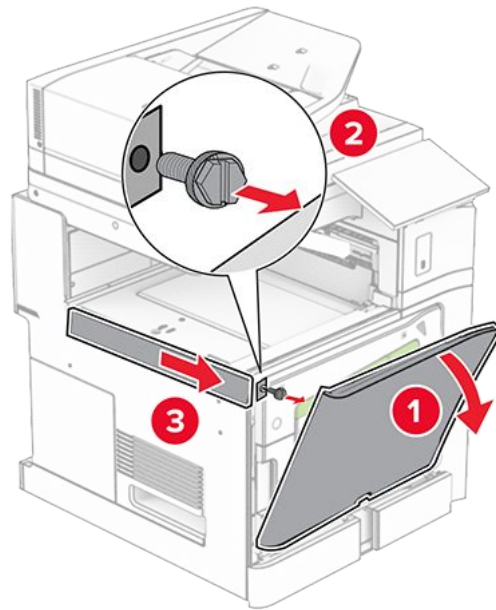

10. Close the front door.
11. Remove the paper transport connector cover.

**Note:** Do not throw away the cover.

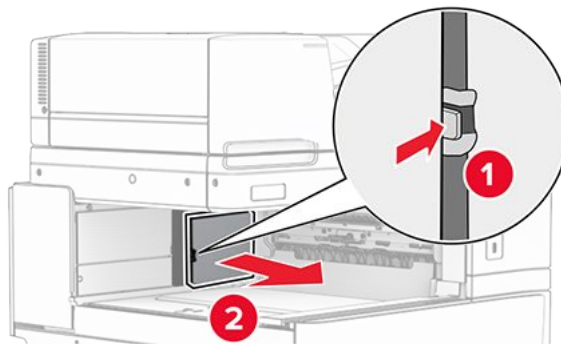

12. Remove the left rear cover.

**Note:** Do not throw away the screw and cover.

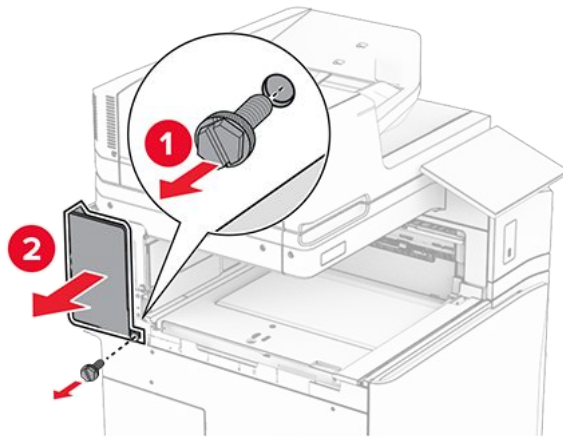

13. Remove the inner bin cover.

**Note:** Do not throw away the screw and cover.

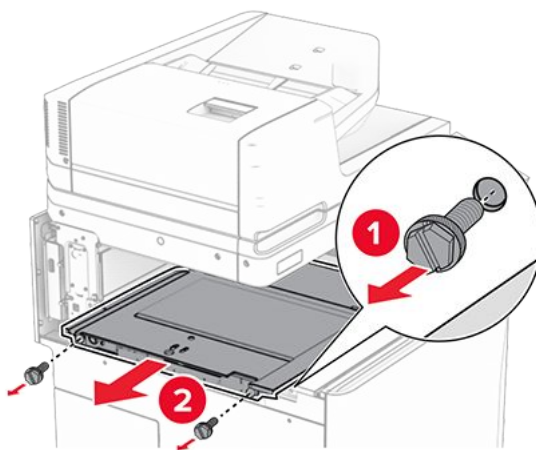

14. Align, and then insert the inner bin cover that came with the option.

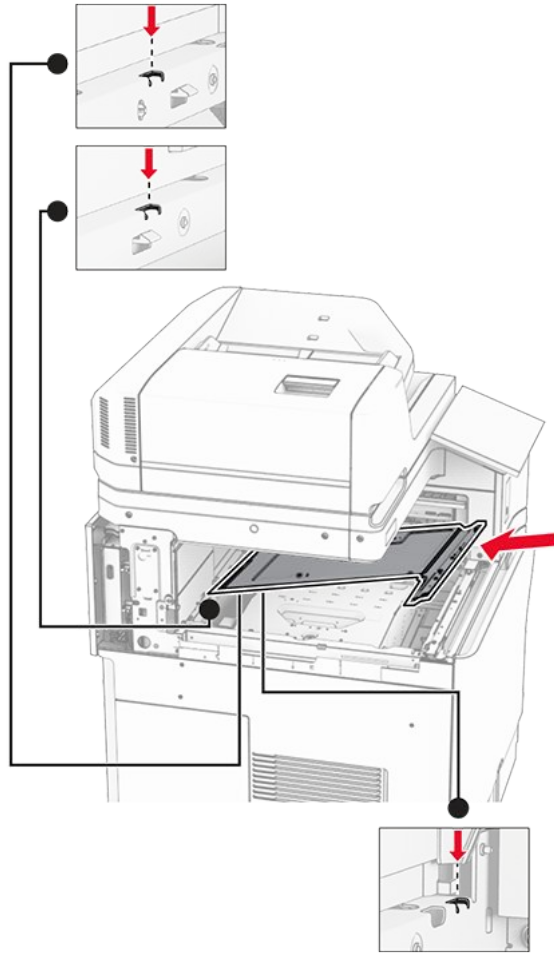

15. Install the screws to the inner bin cover.

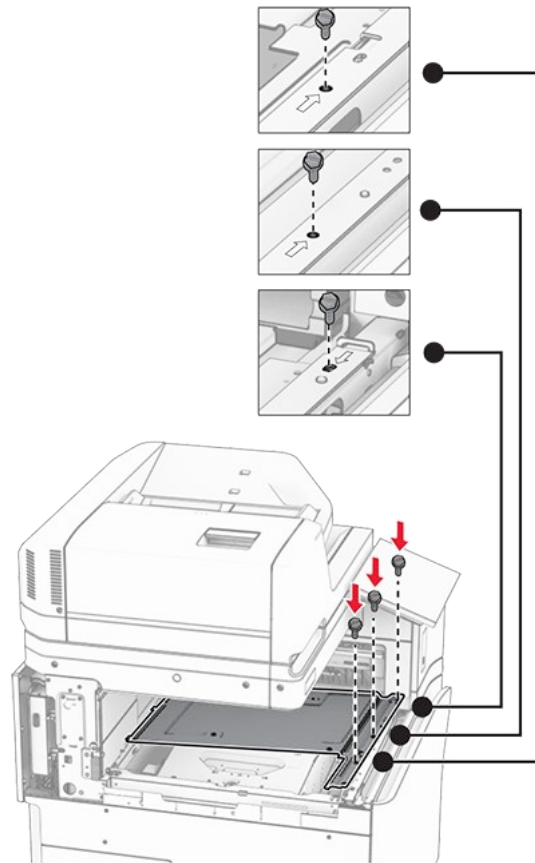

16. Attach the pieces of foam tape to the option.

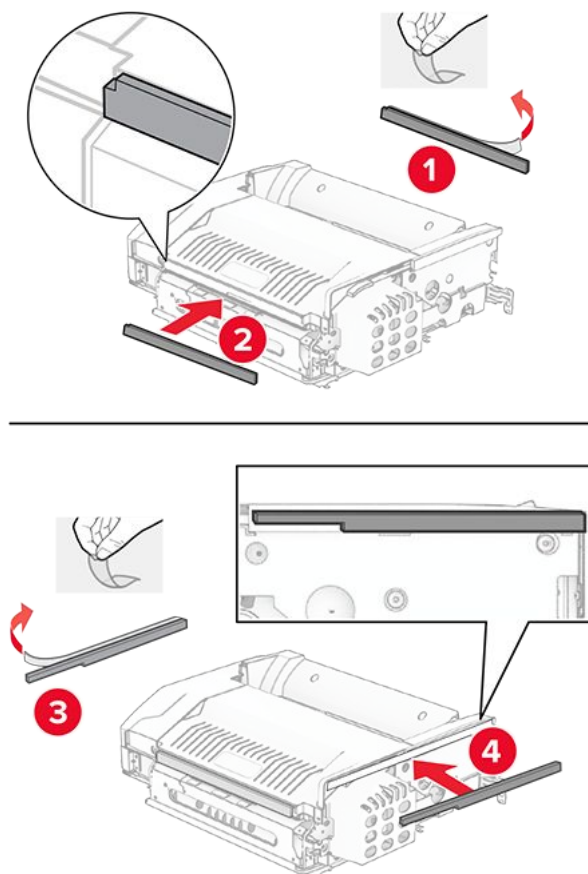

17. Open door F, and then tighten the screws.

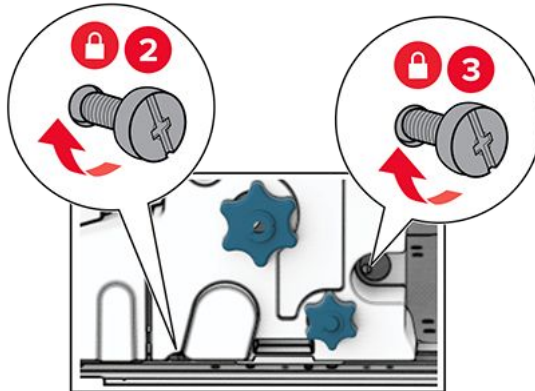
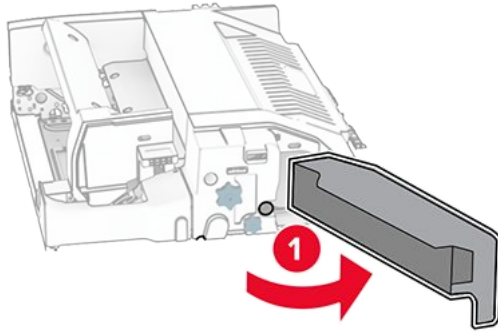

18. Close door F.  
19. Attach the metal bracket to the option.

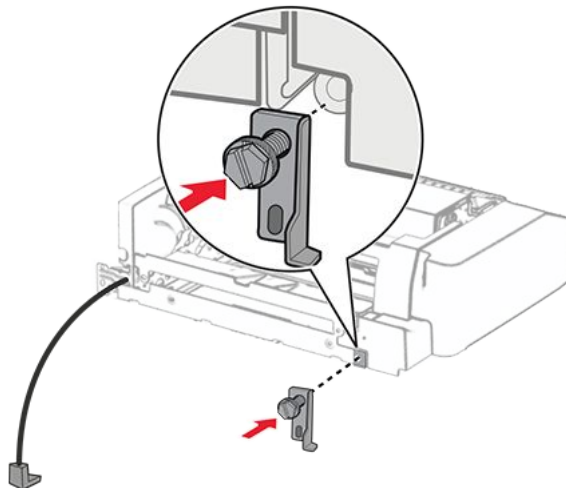

20. Insert the option.

**Note:** Make sure that the metal bracket is in front of the printer.

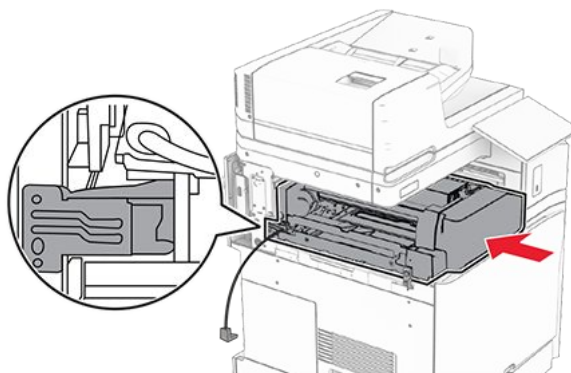

21. Open door F, and then using the screwdriver that came with the option, install the screw.

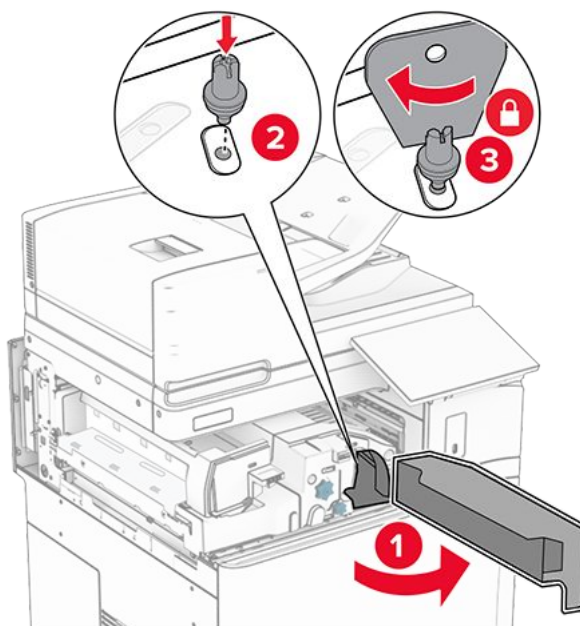

22. Close door F.

23. Install the screws into the option.

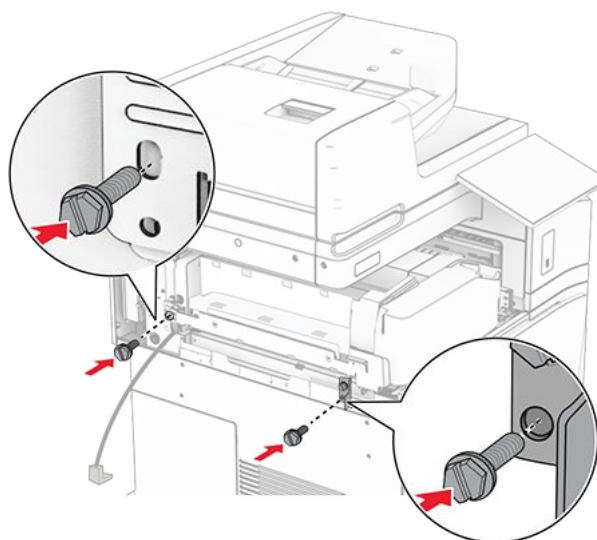

24. Attach the left rear cover.

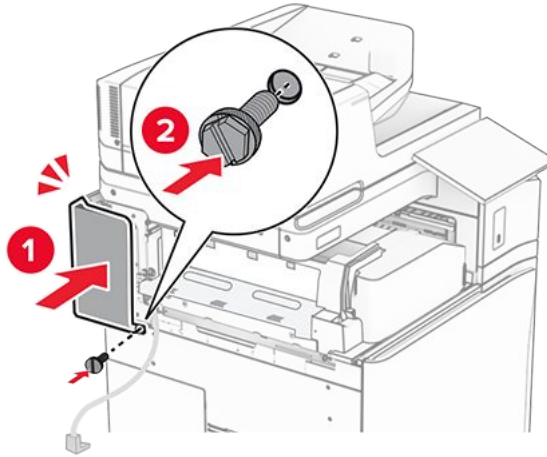

25. Open the front door, and then attach the cover to the left side of the printer.

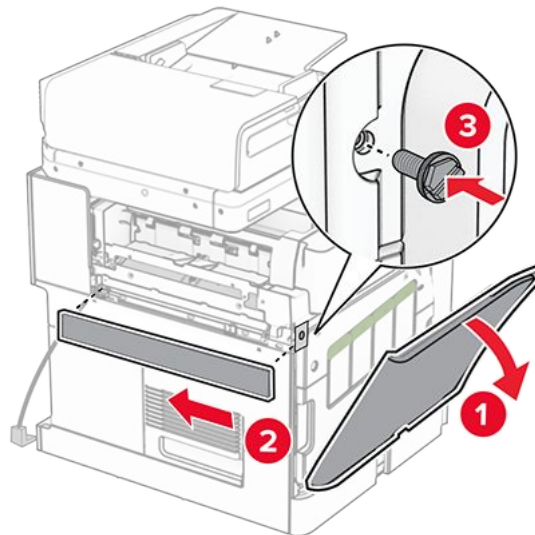

26. Close the front door.

27. Raise the bin flap, and then align and attach the option bin.

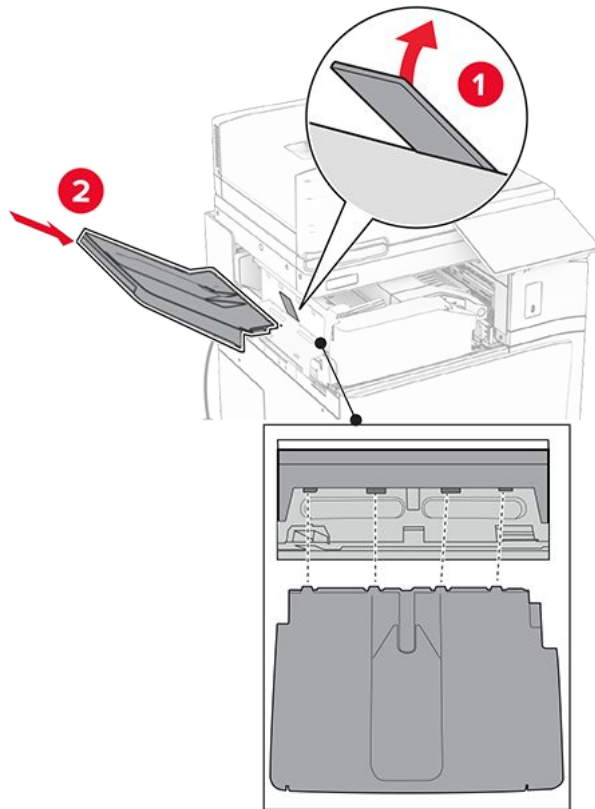

28. Install the screws to the option bin.

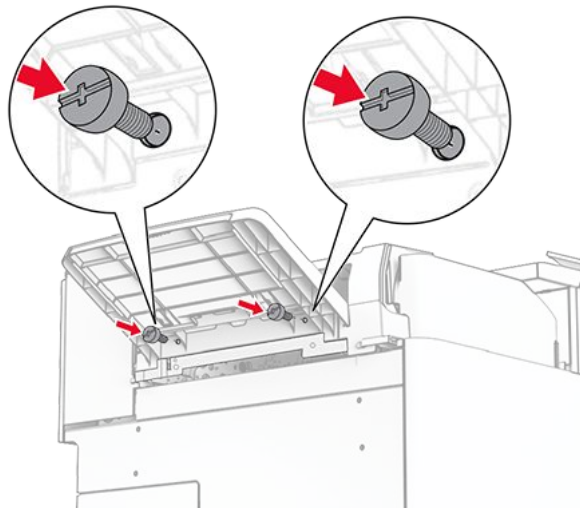

29. Attach the trim cover.

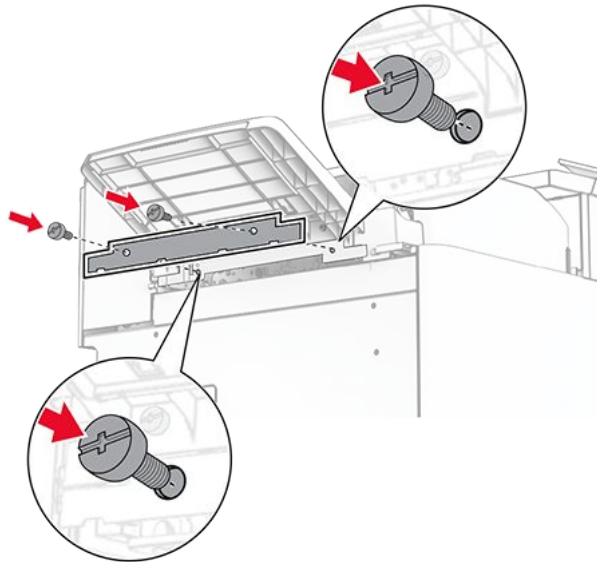

30. Connect the option cable to the printer.

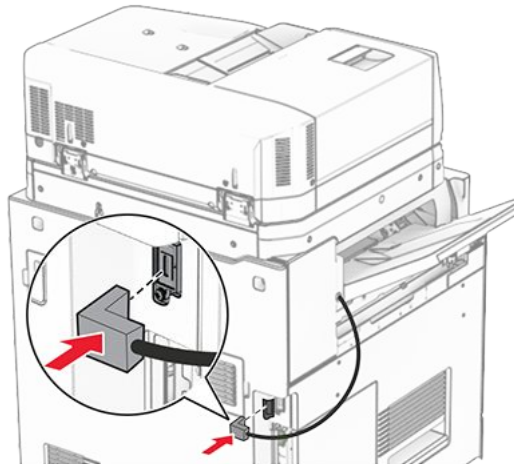

31. Connect one end of the power cord to the printer, and then the other end to the electrical outlet.



**CAUTION—POTENTIAL INJURY**

To avoid the risk of fire or electrical shock, connect the power cord to an appropriately rated and properly grounded electrical outlet that is near the product and easily accessible.

32. Turn on the printer.

## Installing the staple, hole punch finisher and paper transport option



### CAUTION—SHOCK HAZARD

To avoid the risk of electrical shock, if you are accessing the controller board or installing optional hardware or memory devices sometime after setting up the printer, then turn the printer off, and unplug the power cord from the electrical outlet before continuing. If you have any other devices attached to the printer, then turn them off as well, and unplug any cables going into the printer.

**Note:** This task requires a flat-head screwdriver.

1. Turn off the printer.

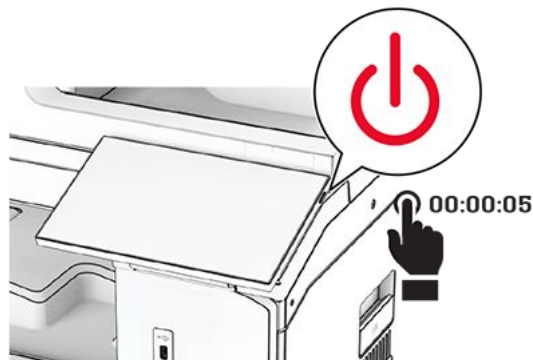

2. Unplug the power cord from the electrical outlet, and then from the printer.

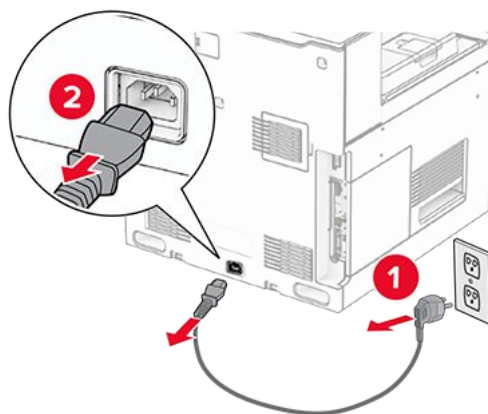

3. Unpack the paper transport.
4. Remove the standard bin.

**Note:** Do not throw away the bin.

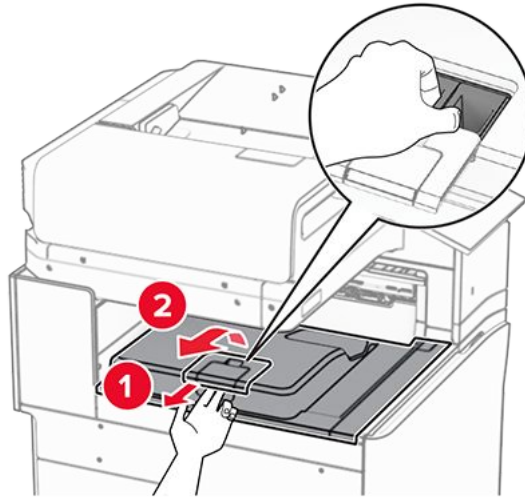

5. Before installing the option, place the exit bin flag into the closed position.

**Note:** When the option is removed, place the exit bin flag into the open position.

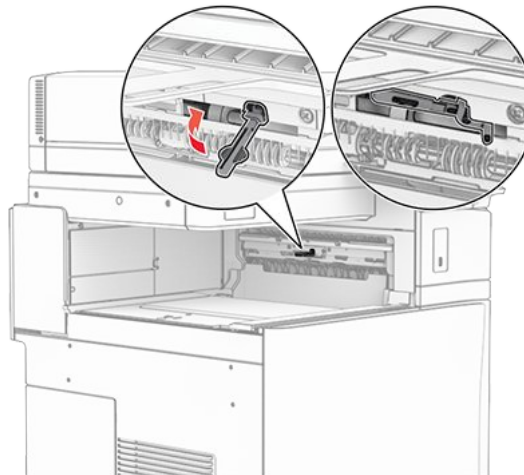

6. Remove the backup roller.

**Note:** Do not throw away the roller.

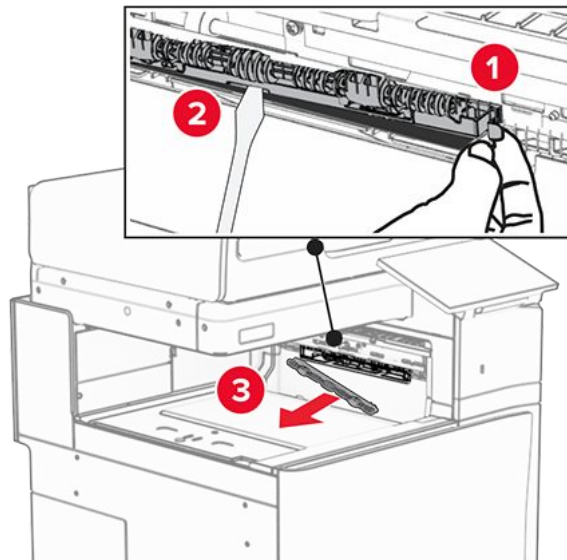

7. Insert the feed roller that came with the paper transport until it clicks into place.

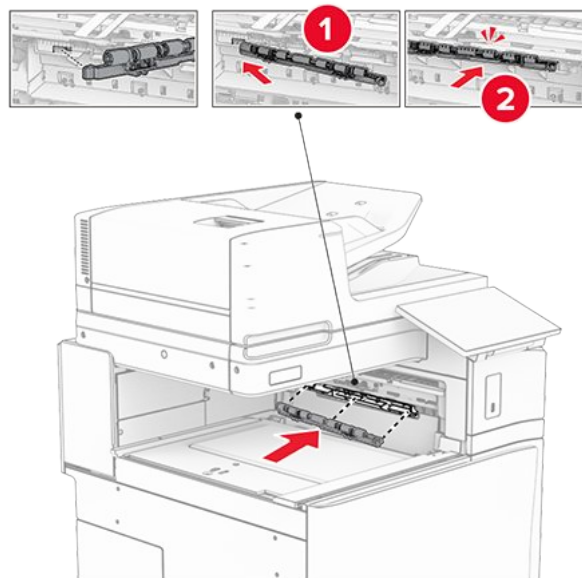

**Note:** Make sure that the metal spring is in front of the feed roller.

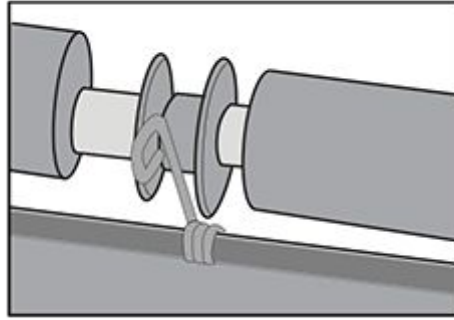

8. Attach the cover until it clicks into place.

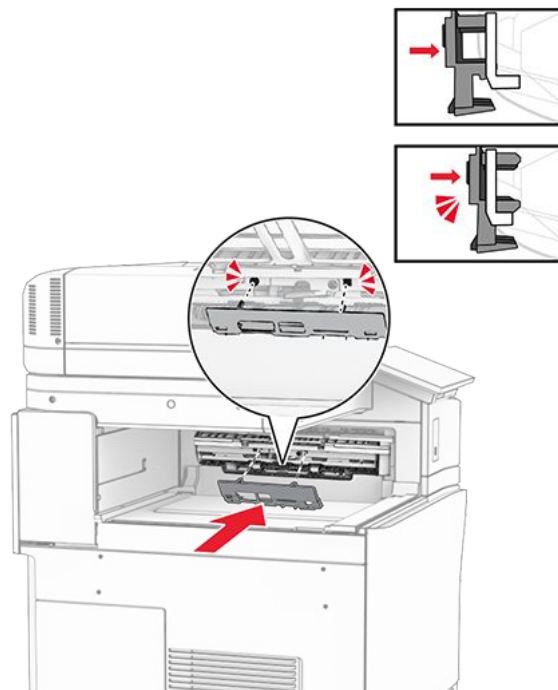

9. Open the front door, and then remove the cover on the left side of the printer.

**Note:** Do not throw away the screw and cover.

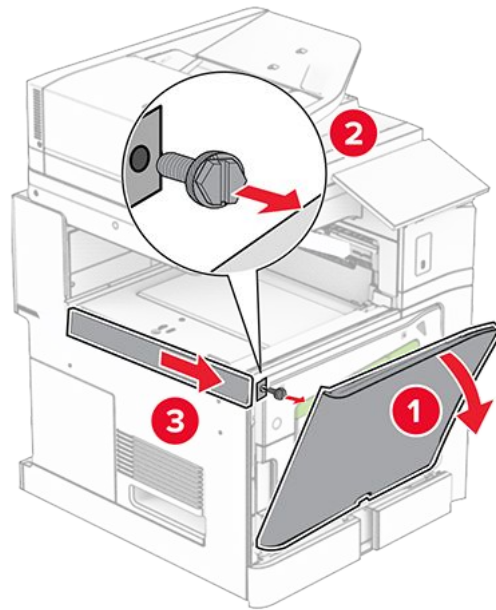

10. Close the front door.
11. Remove the paper transport connector cover.

**Note:** Do not throw away the cover.

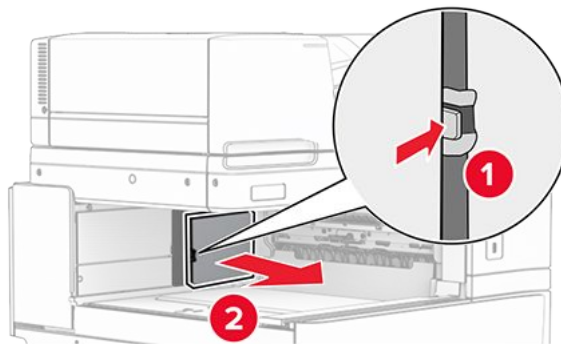

12. Remove the cover.

**Note:** Do not throw away the cover.

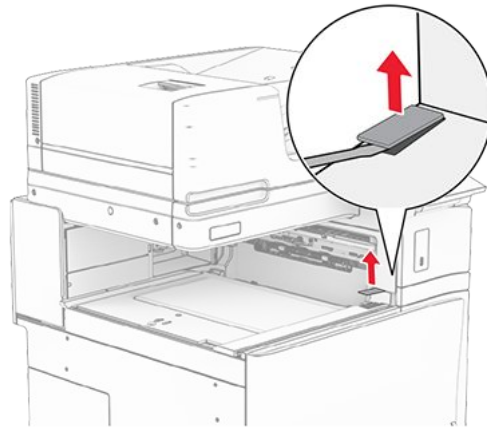

13. Attach the metal bracket.

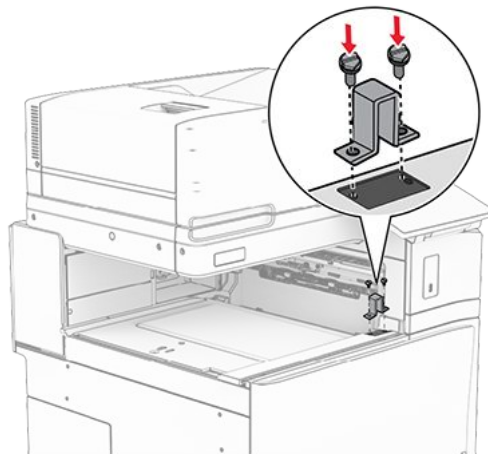

14. Insert the paper transport.

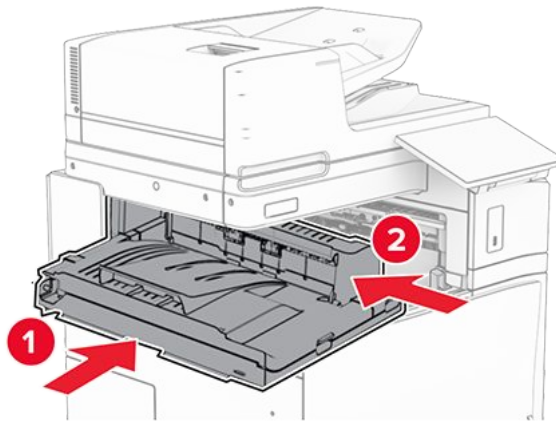

15. Open handle G, and then install the screw into the front of the paper transport.

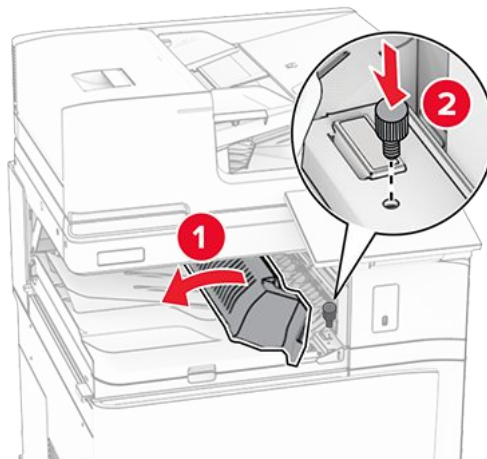

16. Close handle G.

17. Install the screw into the rear of the paper transport.

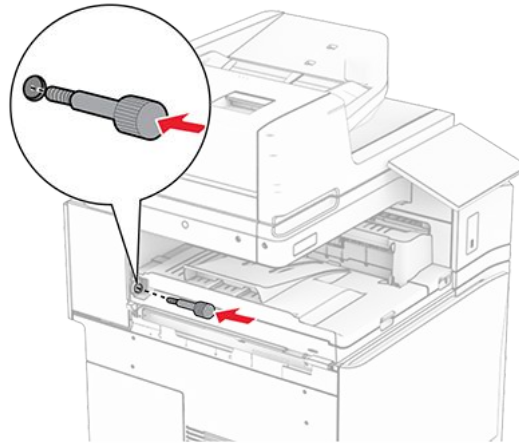

18. Open the front door, and then attach the cover that came with the paper transport to the left side of the printer.

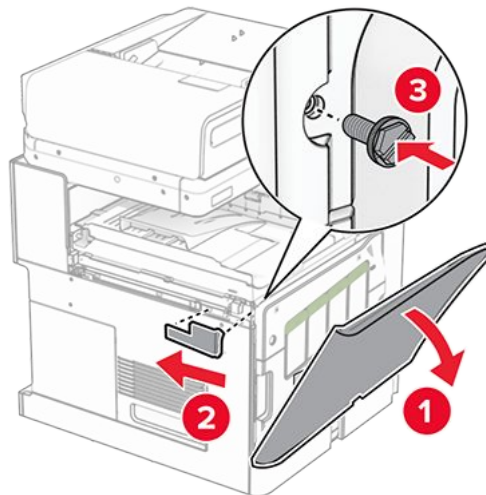

19. Close the front door.
20. Unpack the staple, hole punch finisher.
21. Install the stabilizer.

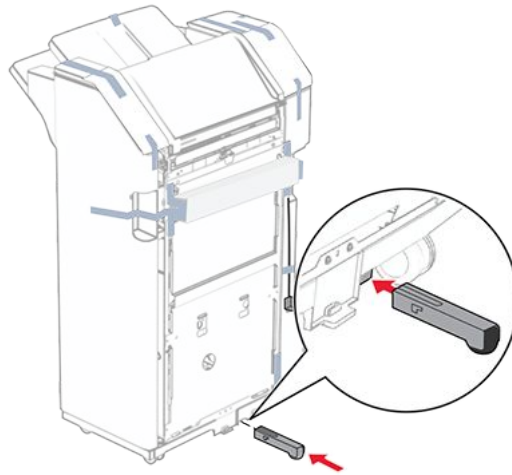

- 22. Remove the pieces of tape around the finisher.
- 23. Attach the bracket to the finisher.

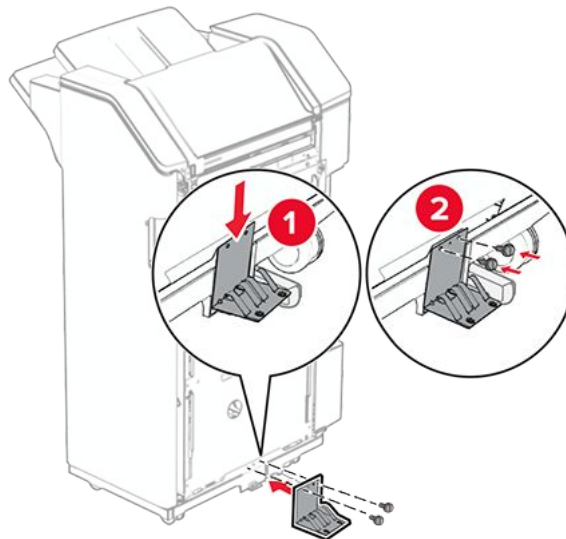

- 24. Attach the foam tape to the finisher.

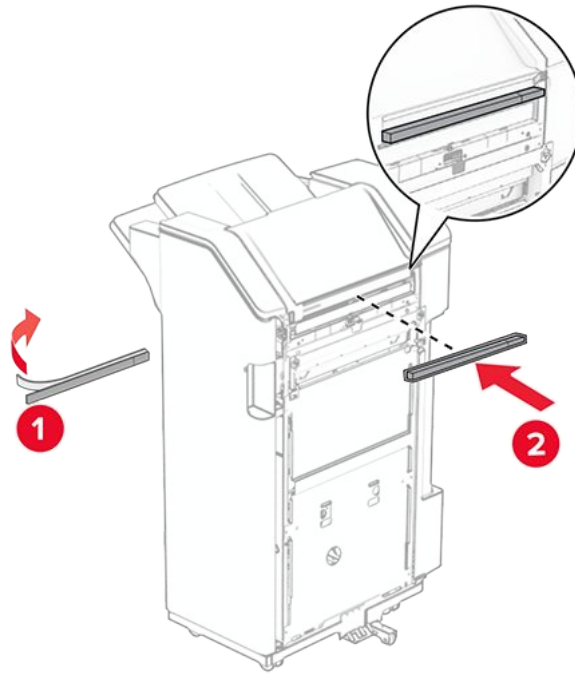

25. Attach the feed guide to the finisher.

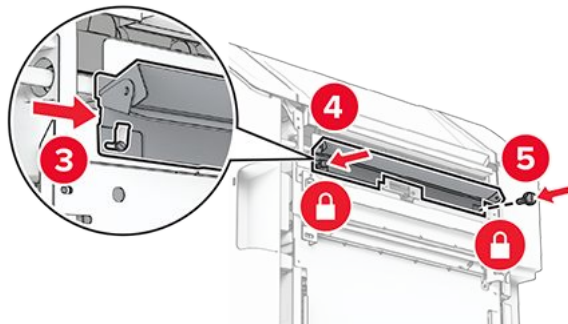
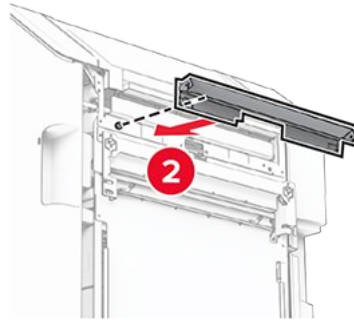
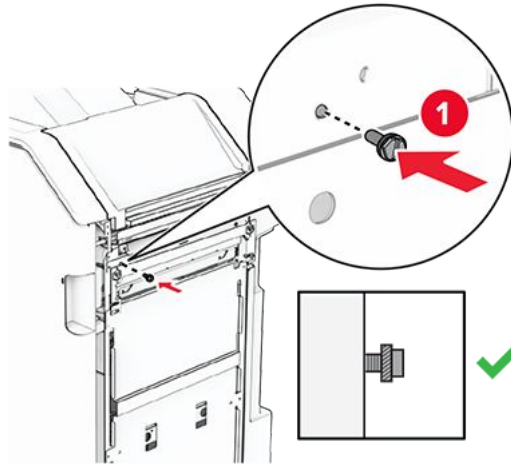

26. Attach the bin to the finisher.

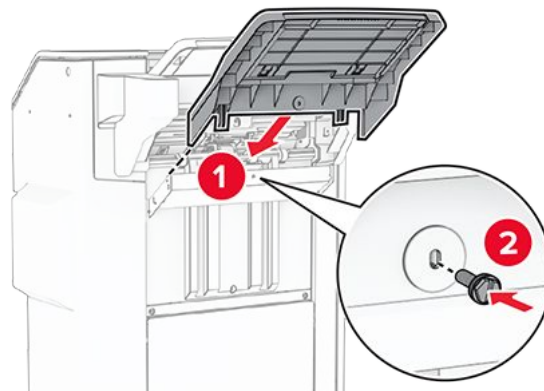

27. Open the finisher door, and then insert the hole punch box.

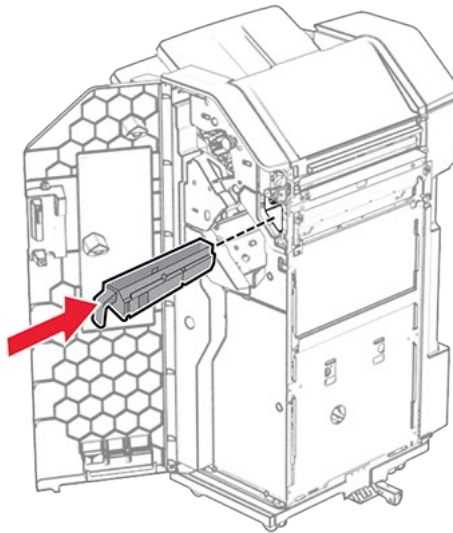

28. Place the bin extender into the finisher bin.

### Notes

- The bin extender is used for A3-size paper or longer and in high humidity conditions to help in stacking the paper.
- The bin capacity is reduced when the bin extender is used.

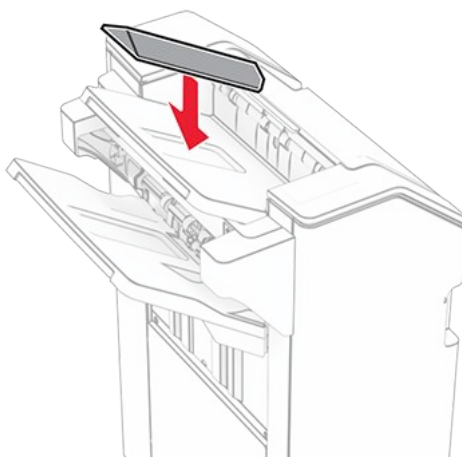

29. Close the finisher door.

30. Attach the mounting bracket to the printer.

**Note:** Make sure that the screws are aligned to the markers on the mounting bracket.

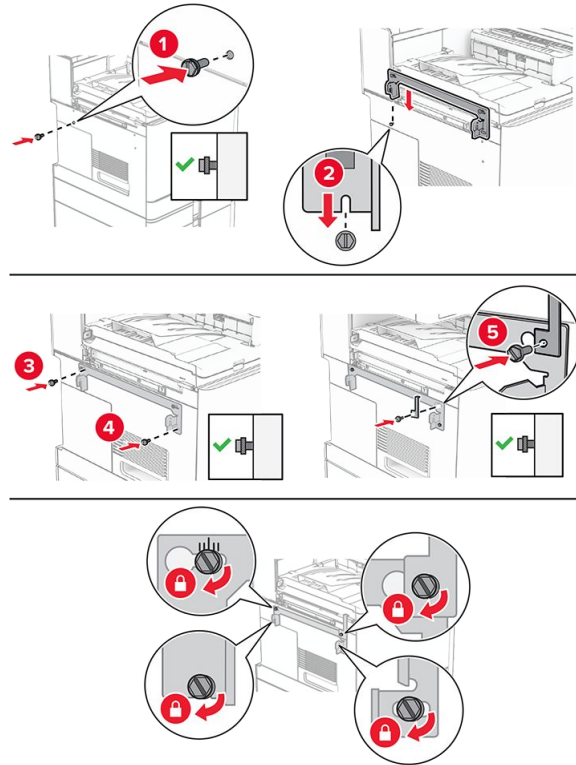

31. Attach the metal bracket that came with the paper transport to the printer.

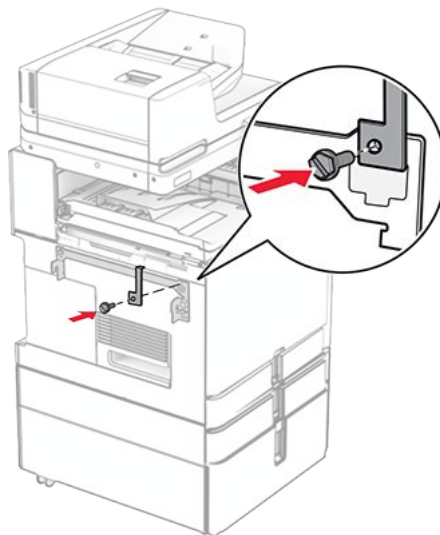

32. Open the finisher door, remove the screw, and then pull the finisher lock.

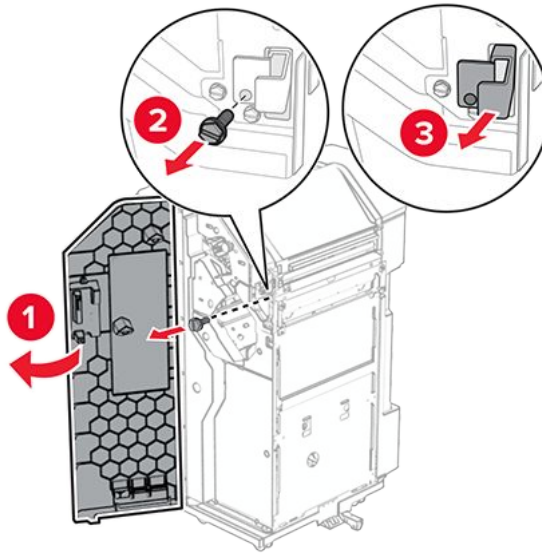

33. Attach the finisher to the printer.

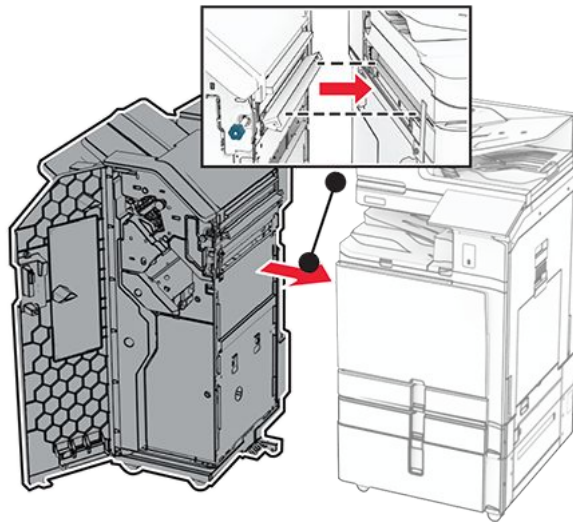

34. Lock the finisher to the printer, and then install the screw.

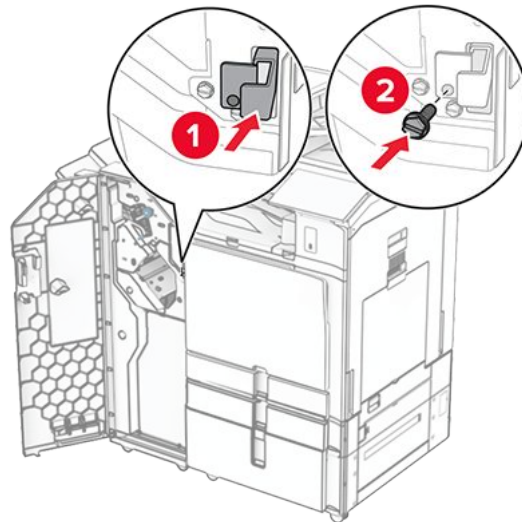

35. Connect the finisher cable to the printer.

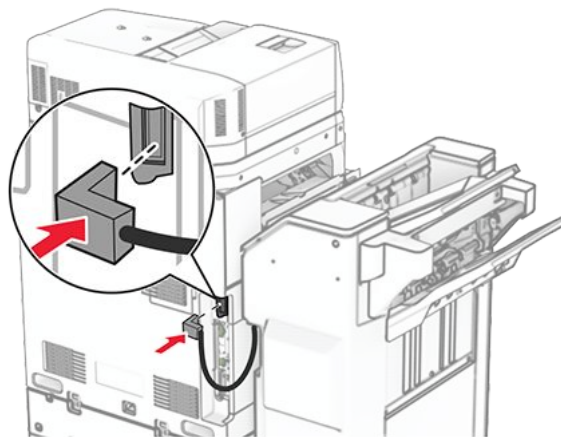

36. Connect one end of the power cord to the printer, and then the other end to the electrical outlet.



**CAUTION—POTENTIAL INJURY**

To avoid the risk of fire or electrical shock, connect the power cord to an appropriately rated and properly grounded electrical outlet that is near the product and easily accessible.

37. Turn on the printer.

## Installing the staple, hole punch finisher and folding paper transport



### CAUTION—SHOCK HAZARD

To avoid the risk of electrical shock, if you are accessing the controller board or installing optional hardware or memory devices sometime after setting up the printer, then turn the printer off, and unplug the power cord from the electrical outlet before continuing. If you have any other devices attached to the printer, then turn them off as well, and unplug any cables going into the printer.

**Note:** This task requires a flat-head screwdriver.

1. Turn off the printer.

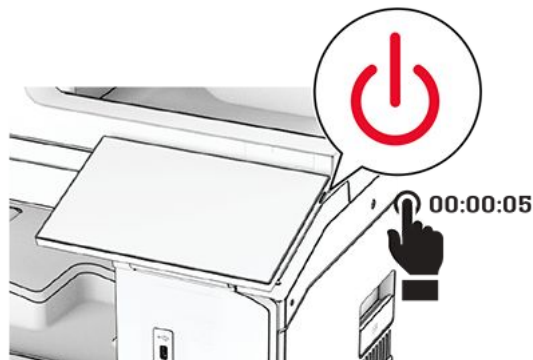

2. Unplug the power cord from the electrical outlet, and then from the printer.

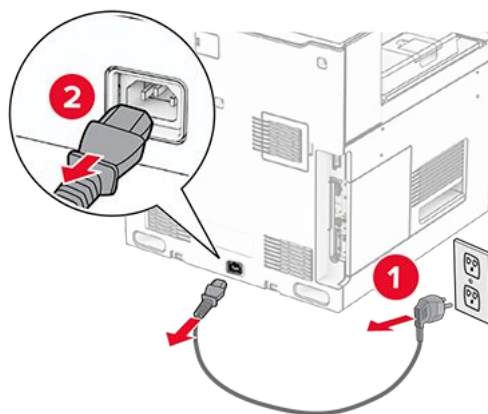

3. Unpack the folding paper transport, and then remove all the packing material.
4. Remove the standard bin.

**Note:** Do not throw away the bin.

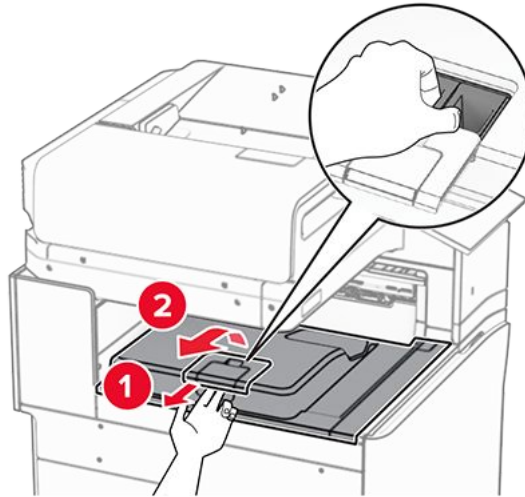

5. Before installing the option, place the exit bin flag into the closed position.

**Note:** When the option is removed, place the exit bin flag into the open position.

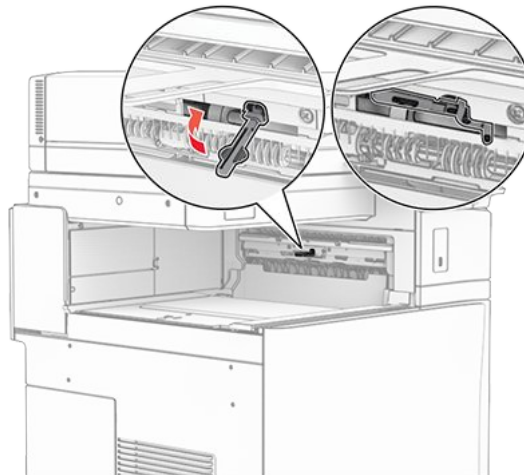

6. Remove the backup roller.

**Note:** Do not throw away the roller.

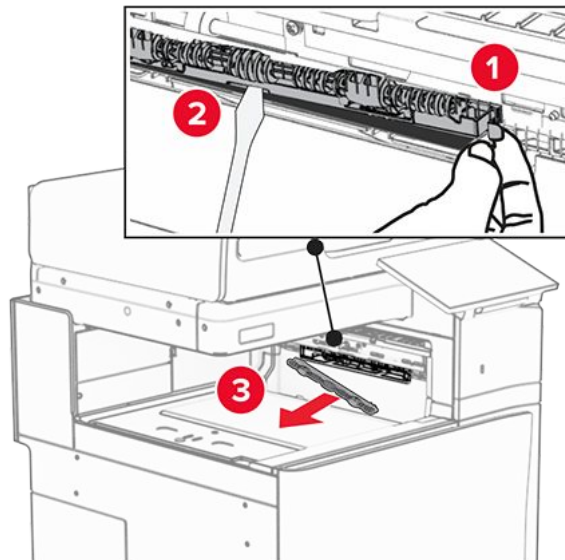

7. Insert the feed roller that came with the option until it clicks into place.

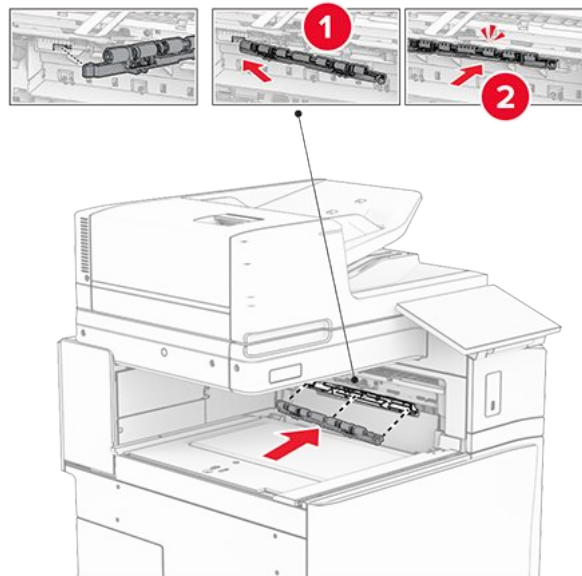

**Note:** Make sure that the metal spring is in front of the feed roller.

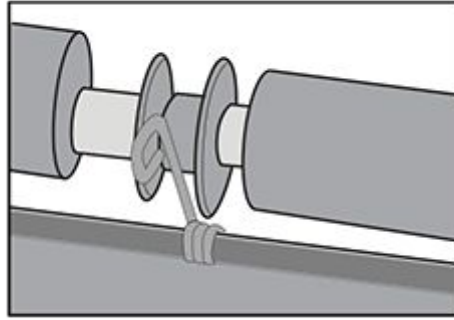

8. Attach the cover until it clicks into place.

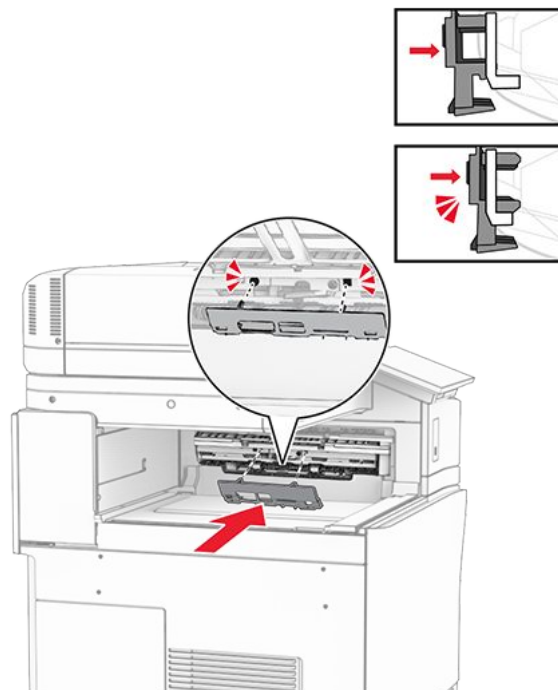

9. Open the front door, and then remove the cover on the left side of the printer.

**Note:** Do not throw away the screw and cover.

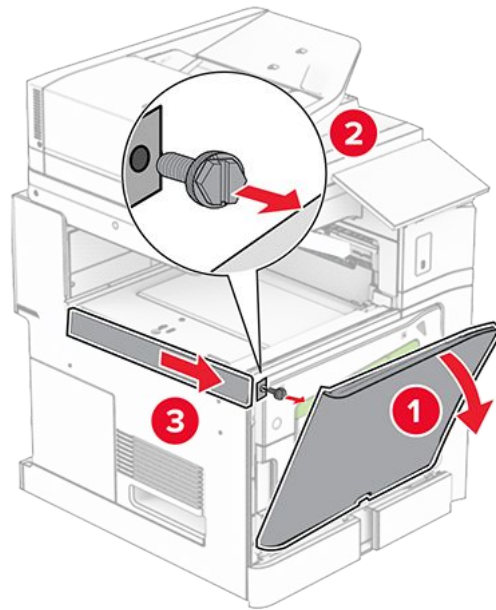

10. Close the front door.
11. Remove the paper transport connector cover.

**Note:** Do not throw away the cover.

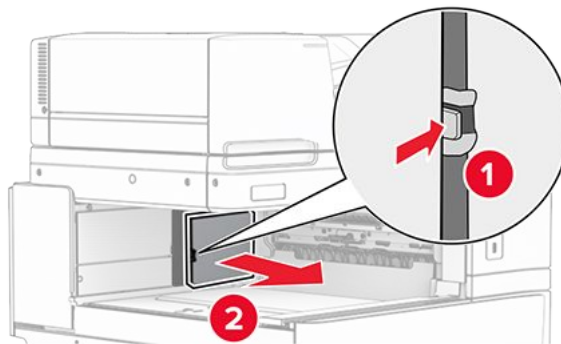

12. Remove the left rear cover.

**Note:** Do not throw away the screw and cover.

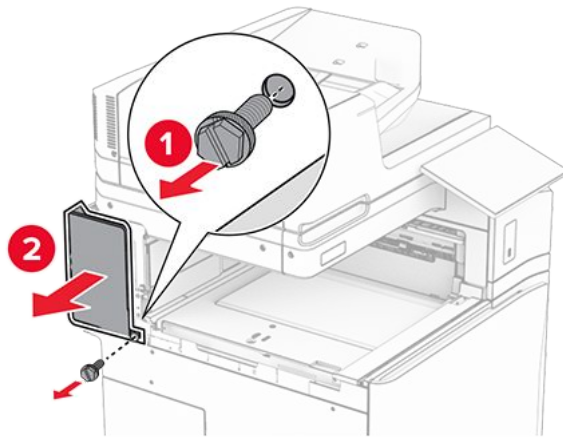

13. Remove the inner bin cover.

**Note:** Do not throw away the screw and cover.

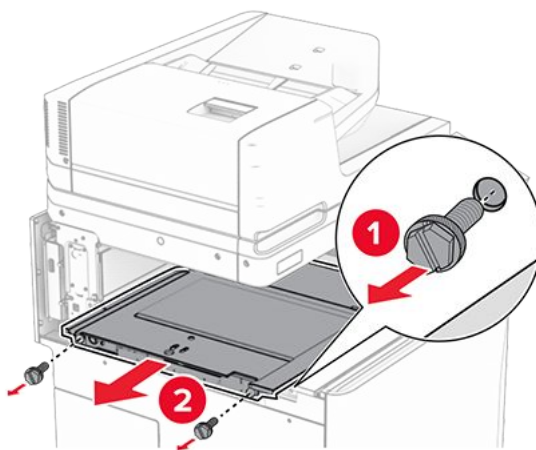

14. Align, and then insert the inner bin cover that came with the folding paper transport.

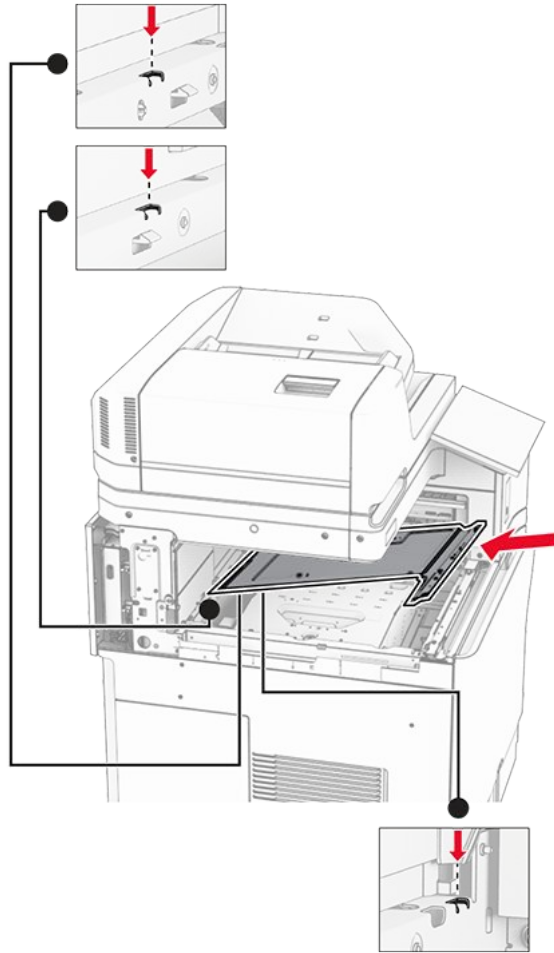

15. Install the screws to the inner bin cover.

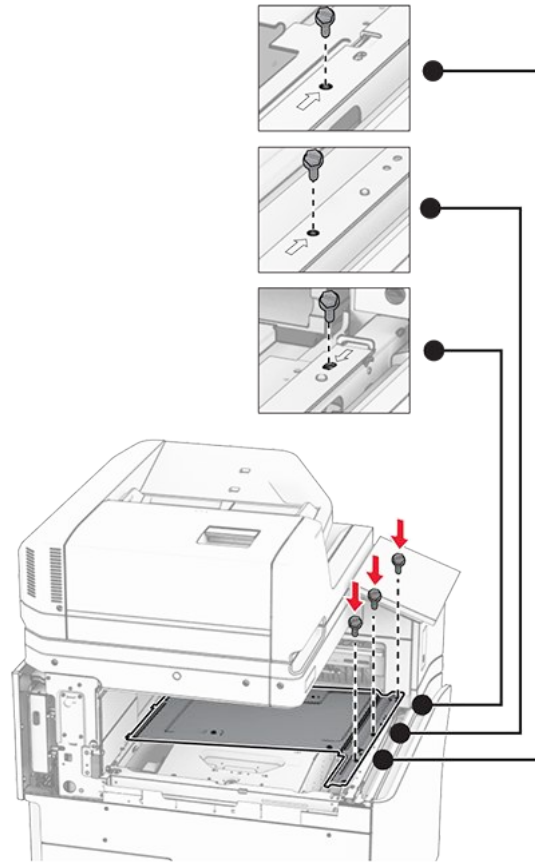

16. Attach the pieces of foam tape to the option.

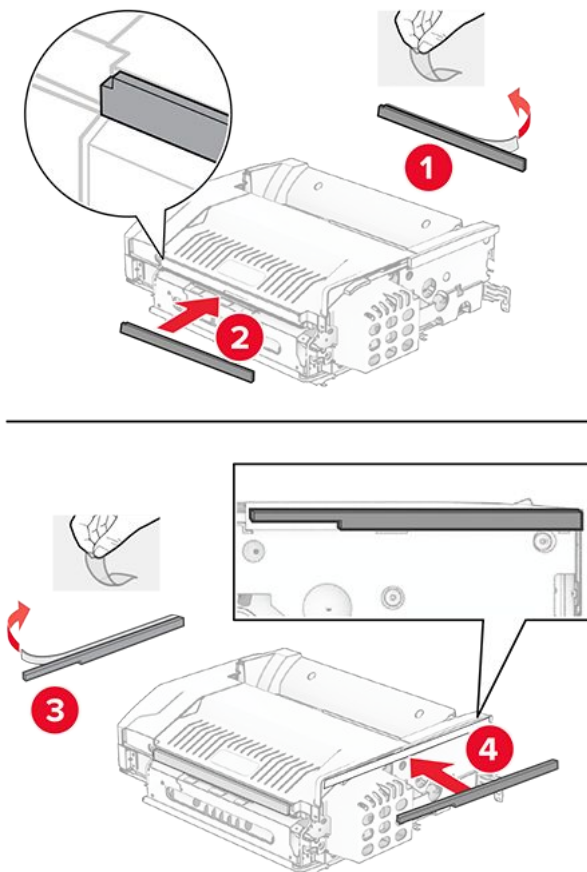

17. Open door F, and then tighten the screws.

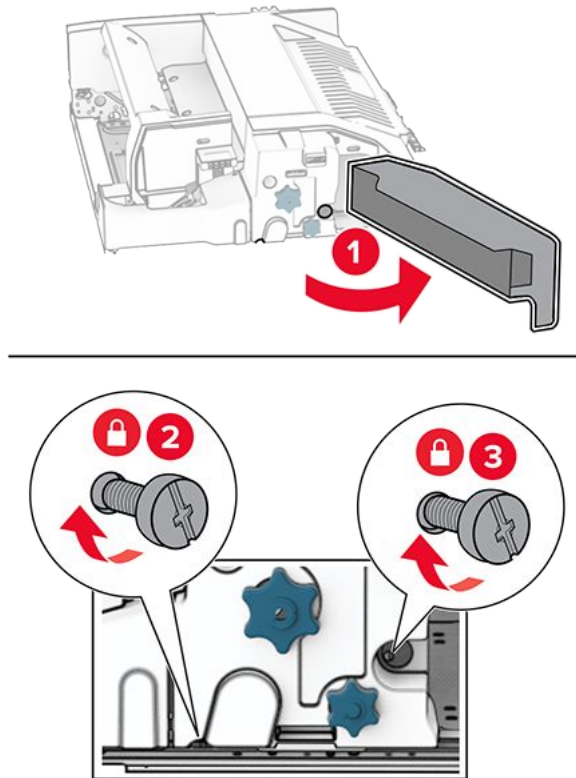

18. Close door F.  
19. Attach the bracket to the option.

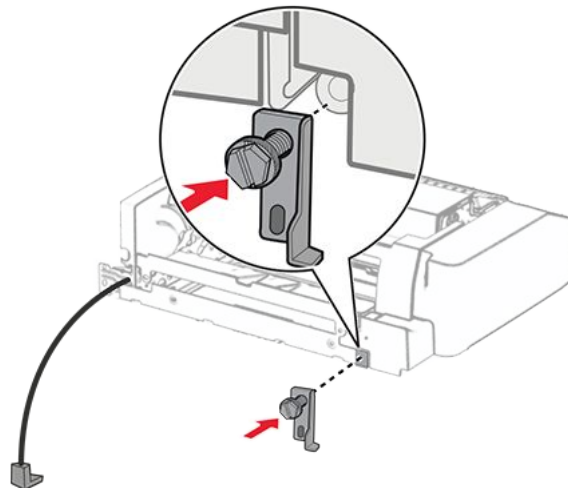

20. Insert the option.

**Note:** Make sure that the metal bracket is in front of the printer.

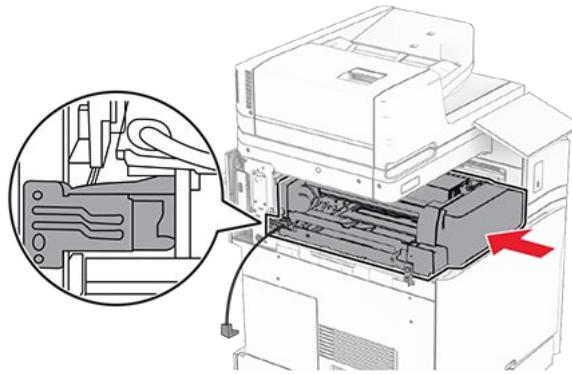

21. Open door F, and then using the screwdriver that came with the option, install the screw.

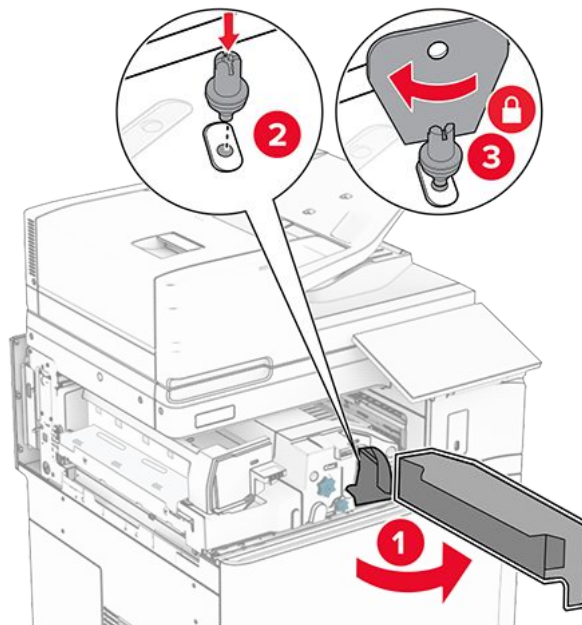

22. Close door F.

23. Install the screws into the option.

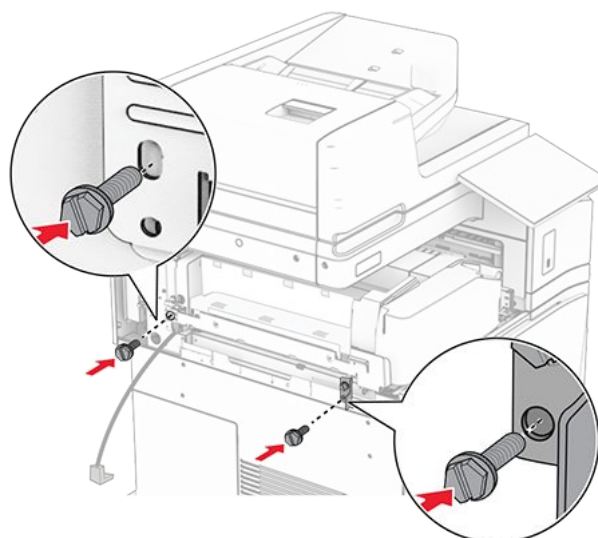

24. Attach the left rear cover.

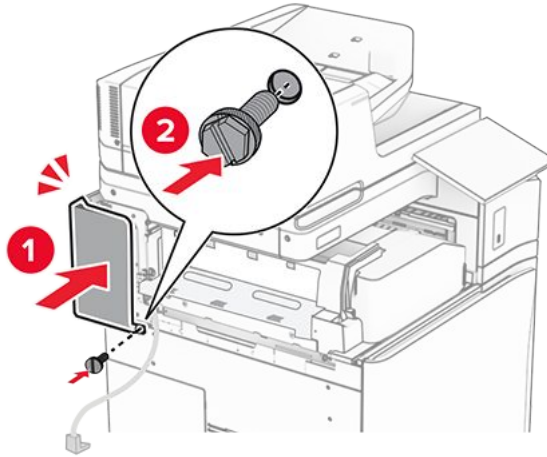

25. Unpack the staple, hole punch finisher.

26. Install the stabilizer.

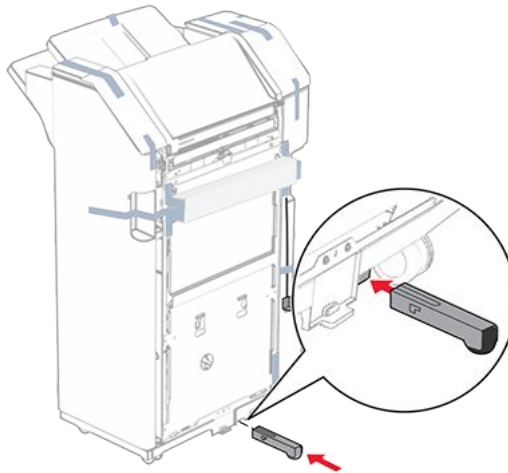

27. Remove the pieces of tape around the finisher.

28. Attach the bracket to the finisher.

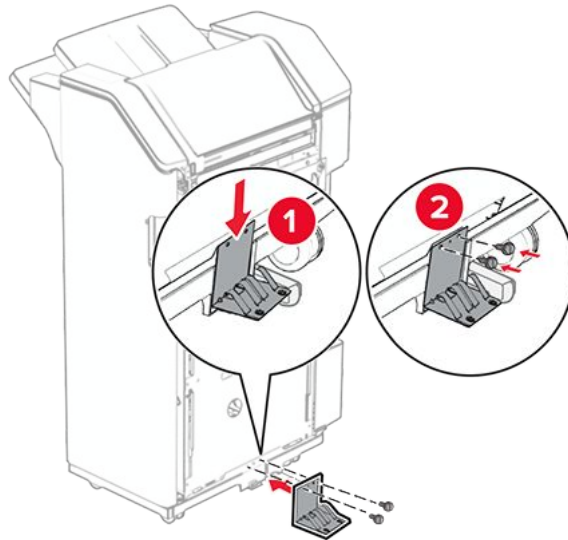

29. Attach the foam tape to the finisher.

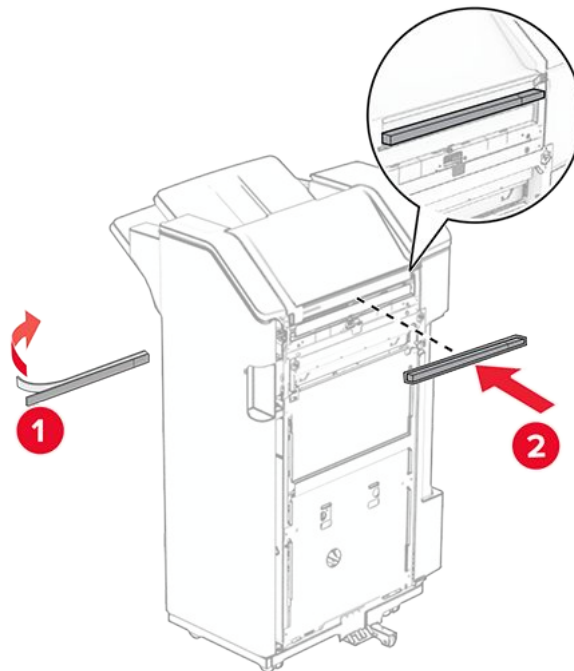

**Note:** Remove the small portion of foam on the right side of the finisher.

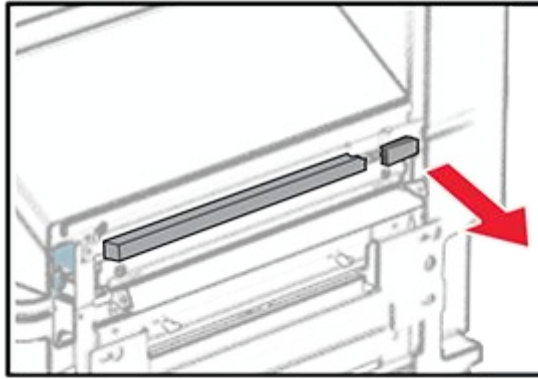

30. Attach the feed guide to the finisher.

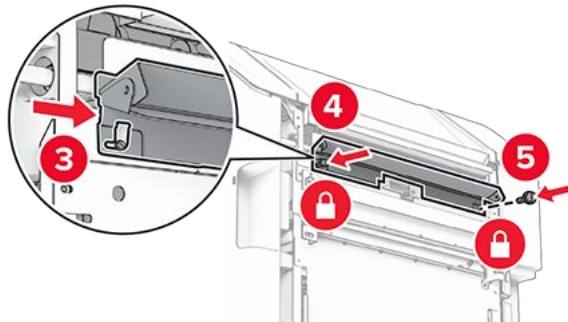
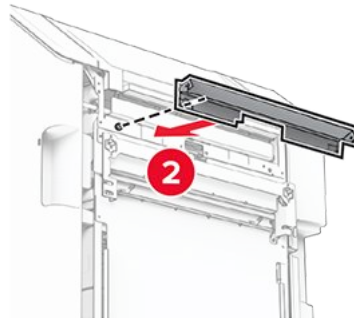
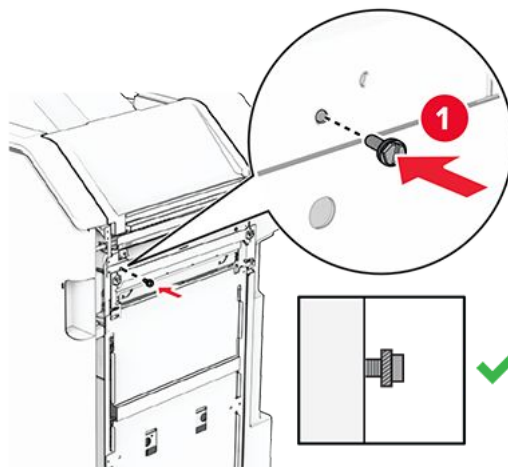

31. Attach the bin to the finisher.

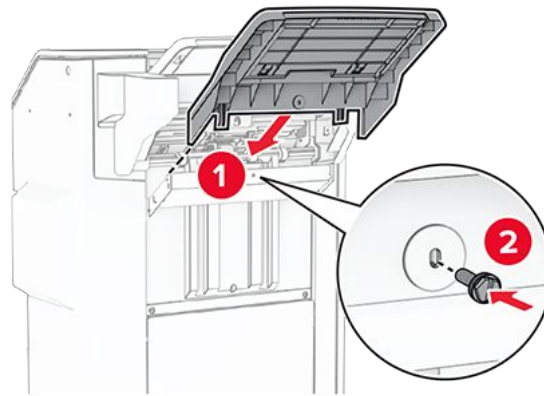

32. Open the finisher door, and then insert the hole punch box.

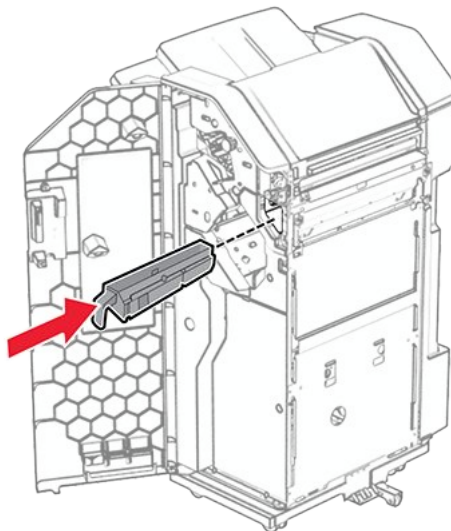

33. Place the bin extender into the finisher bin.

### Notes

- The bin extender is used for A3-size paper or longer and in high humidity conditions to help in stacking the paper.
- The bin capacity is reduced when the bin extender is used.

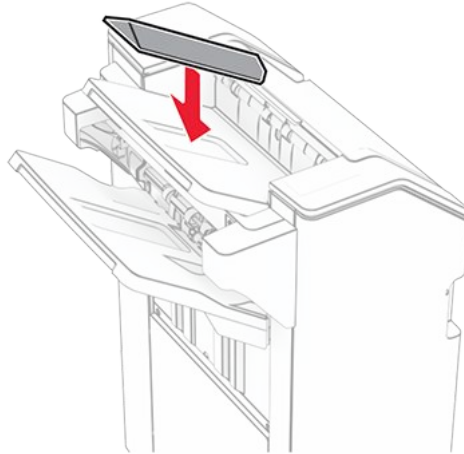

34. Close the finisher door.

35. Raise the bin flap, and then align and attach the cover to the option.

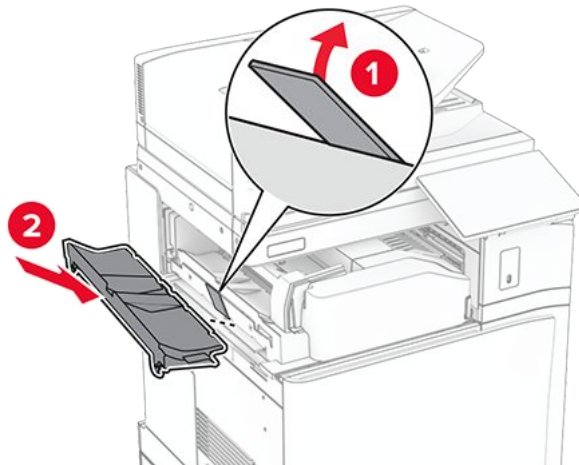

36. Install the screws.

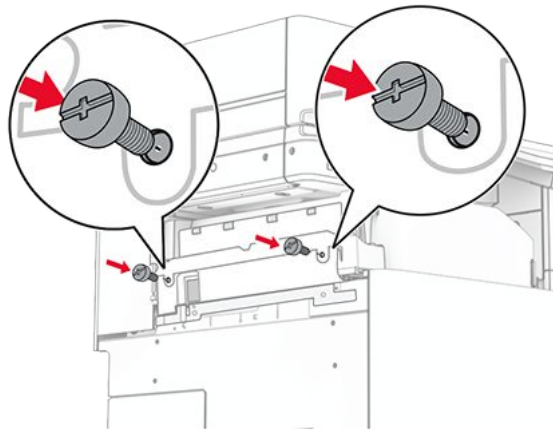

37. Open the front door, and then attach the trim cover that came with the option.

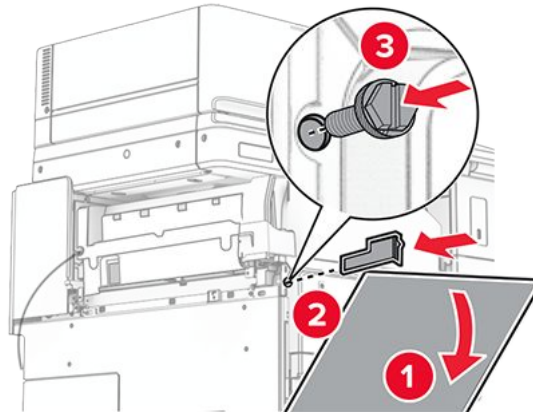

38. Loosely attach a screw to the printer.

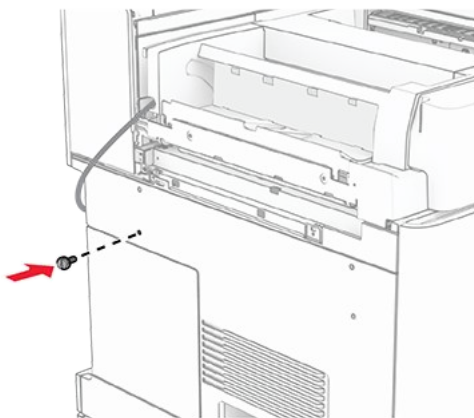

39. Align the mounting bracket to the screw.

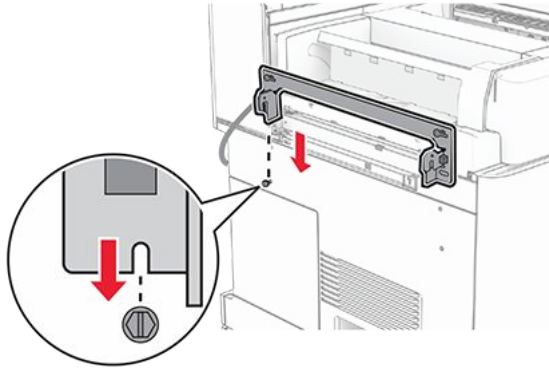

40. Loosely attach screws into the mounting bracket.

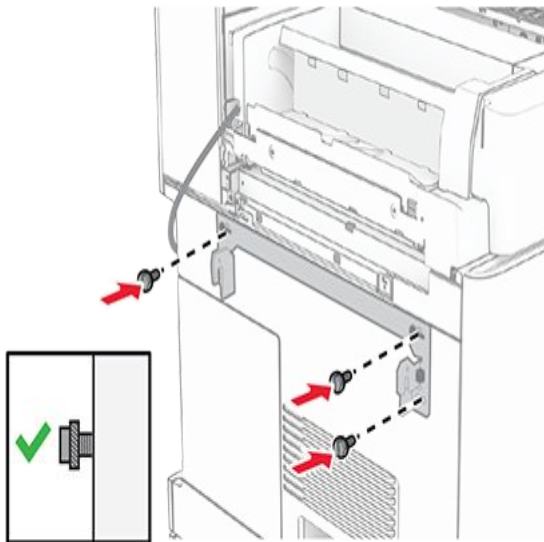

41. Tighten the screws to secure the mounting bracket onto the printer.

**Note:** Make sure that the screws are aligned to the markers on the mounting bracket.

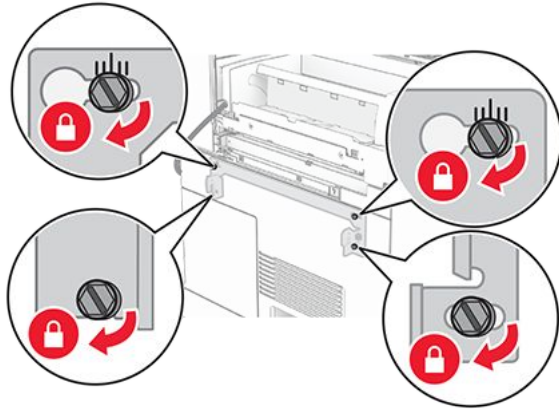

42. Open the finisher door, remove the screw, and then pull the finisher lock.

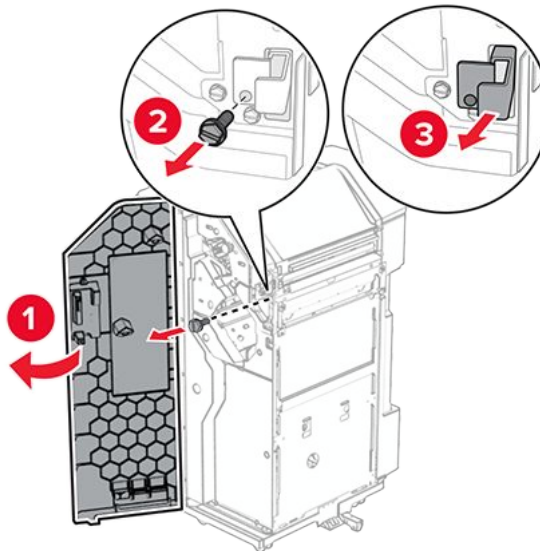

43. Connect the option cable to the printer.

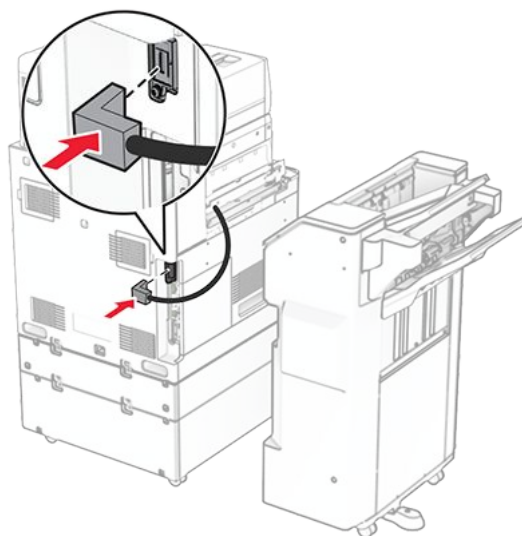

44. Connect the finisher cable to the option.

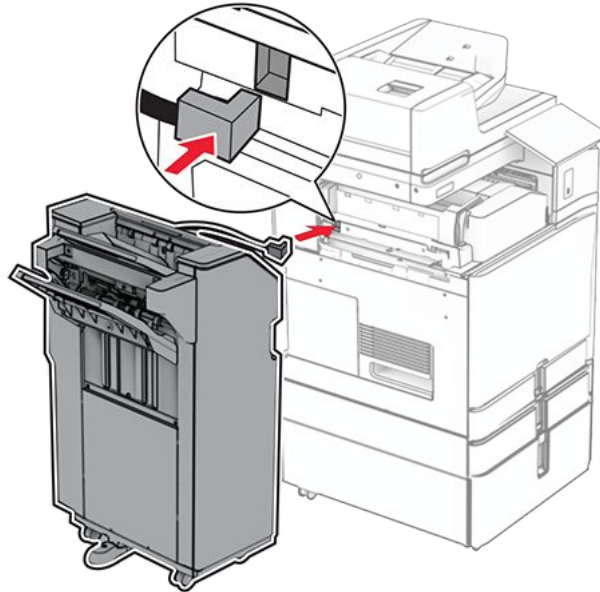

45. Attach the finisher to the printer.

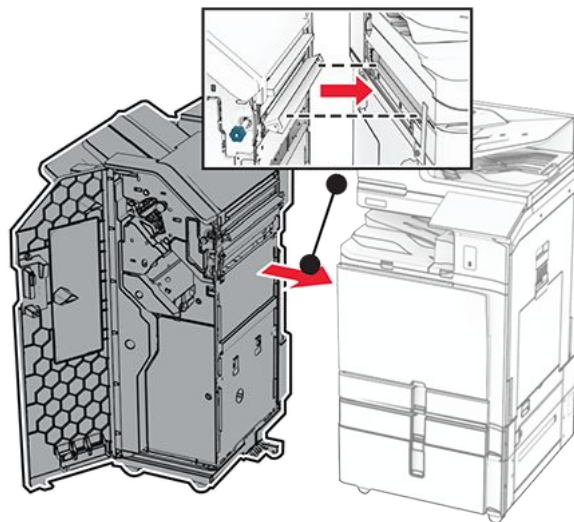

46. Lock the finisher to the printer, and then install the screw.

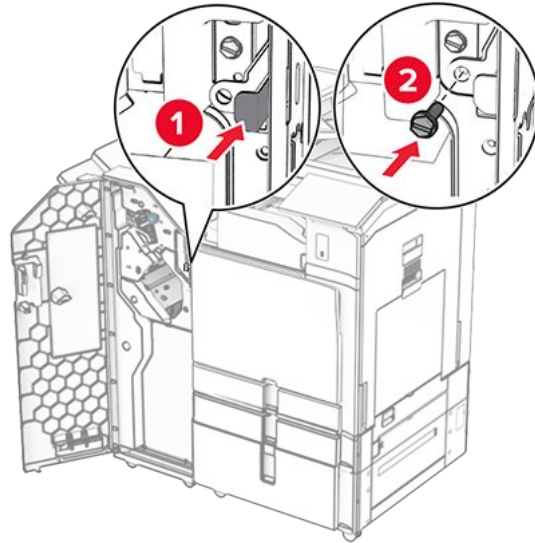

47. Close the finisher door.
48. Connect one end of the power cord to the printer, and then the other end to the electrical outlet.



**CAUTION—POTENTIAL INJURY**

To avoid the risk of fire or electrical shock, connect the power cord to an appropriately rated and properly grounded electrical outlet that is near the product and easily accessible.

49. Turn on the printer.

## Installing the booklet finisher and paper transport option



**CAUTION—SHOCK HAZARD**

To avoid the risk of electrical shock, if you are accessing the controller board or installing optional hardware or memory devices sometime after setting up the printer, then turn the printer off, and unplug the power cord from the electrical outlet before continuing. If you have any other devices attached to the printer, then turn them off as well, and unplug any cables going into the printer.

**Note:** This task requires a flat-head screwdriver.

1. Turn off the printer.

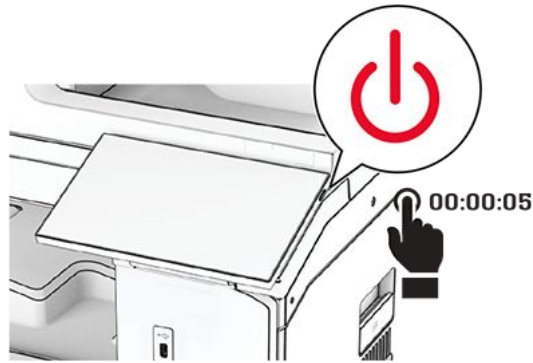

2. Unplug the power cord from the electrical outlet, and then from the printer.

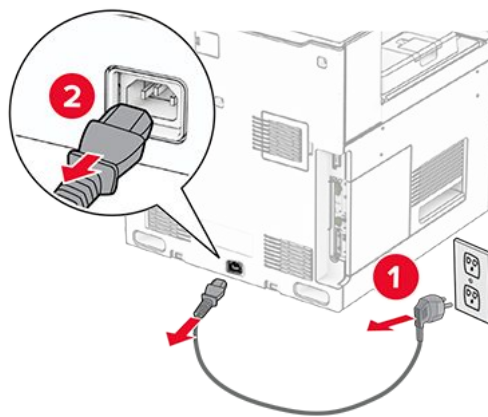

3. Unpack the paper transport.
4. Remove the standard bin.

**Note:** Do not throw away the bin.

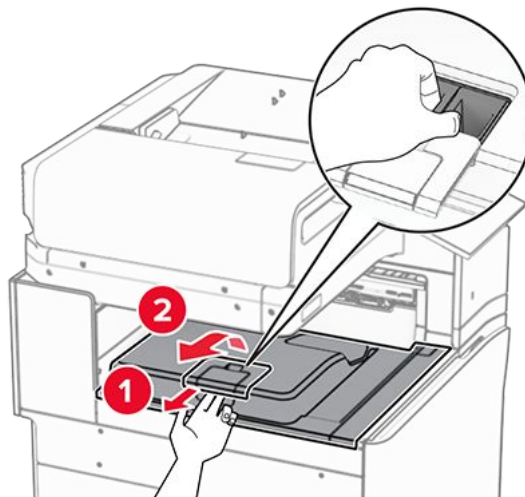

## Set up, install, and configure

5. Before installing the option, place the exit bin flag into the closed position.

**Note:** When the option is removed, place the exit bin flag into the open position.

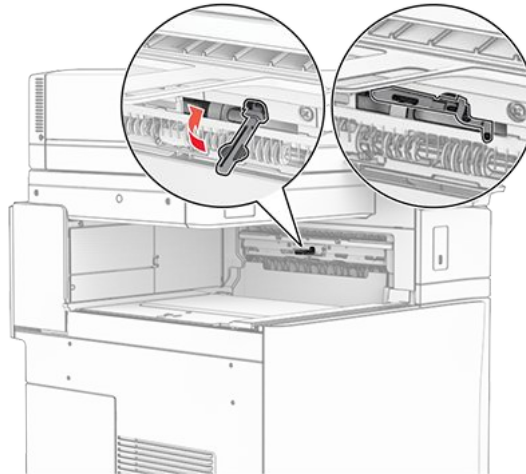

6. Remove the backup roller.

**Note:** Do not throw away the roller.

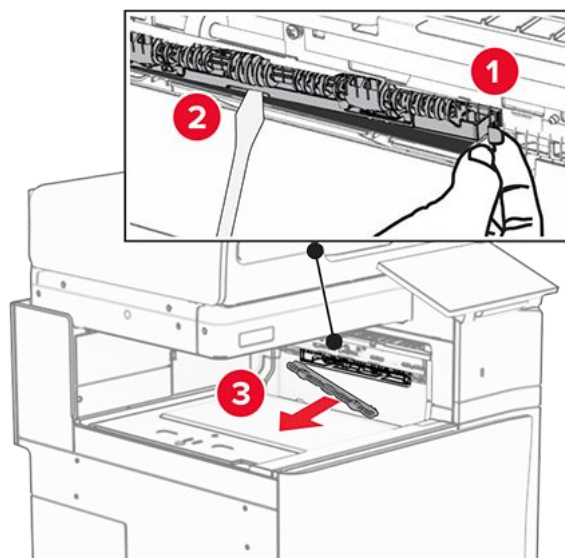

7. Insert the feed roller that came with the paper transport until it clicks into place.

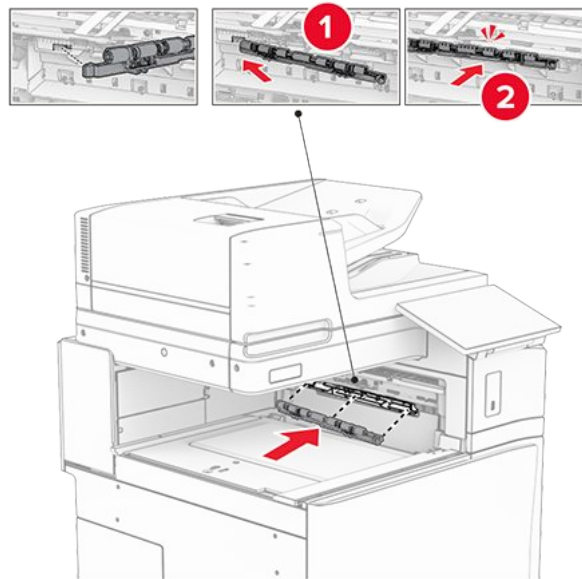

**Note:** Make sure that the metal spring is in front of the feed roller.

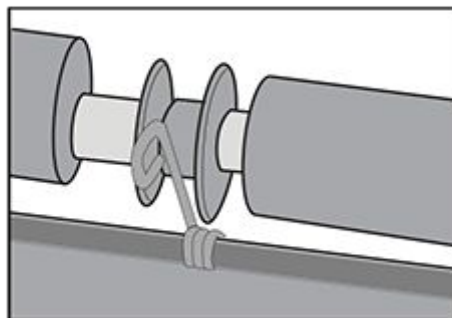

8. Attach the roller cover until it clicks into place.

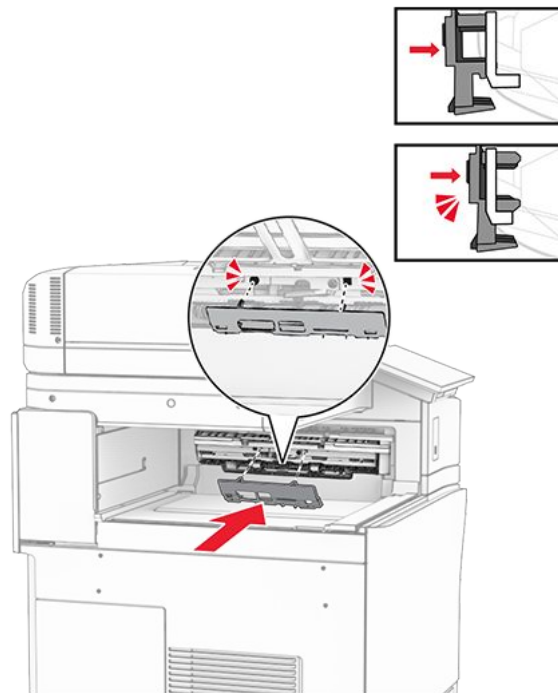

9. Open the front door, and then remove the cover on the left side of the printer.

**Note:** Do not throw away the screw and cover.

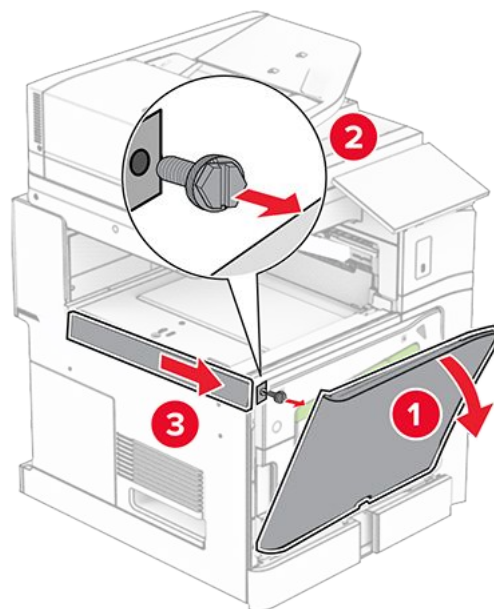

10. Close the front door.
11. Remove the paper transport connector cover.

**Note:** Do not throw away the cover.

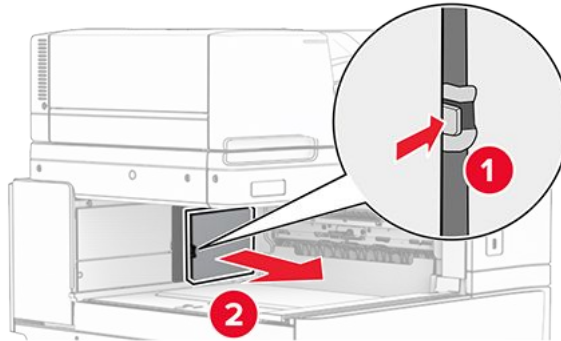

12. Remove the cover.

**Note:** Do not throw away the cover.

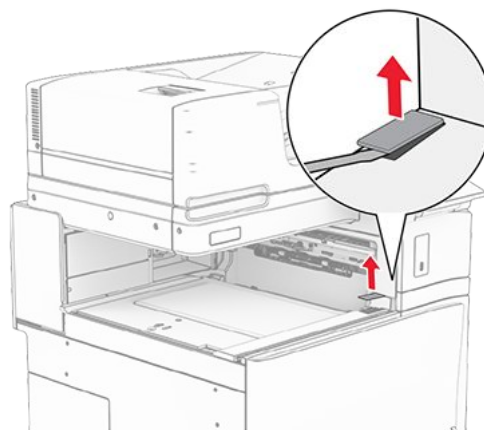

13. Attach the metal bracket.

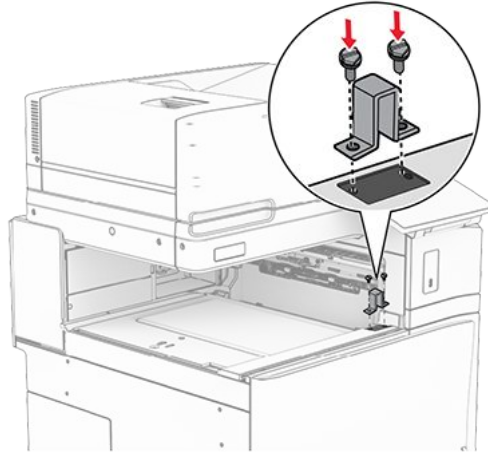

14. Insert the paper transport.

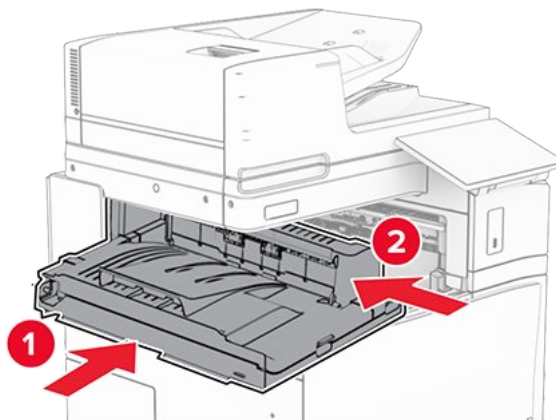

15. Open handle G, and then install the screw into the front of the paper transport.

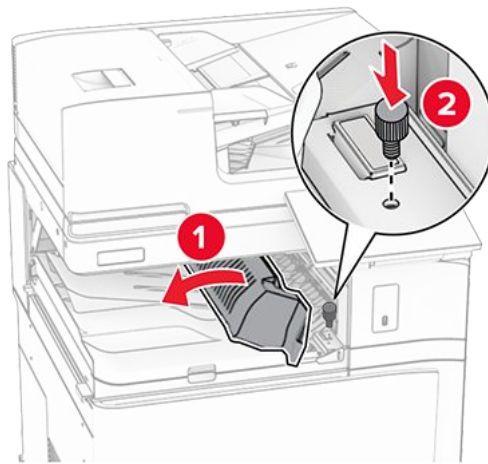

- 16. Close handle G.
- 17. Install the screw into the rear of the paper transport.

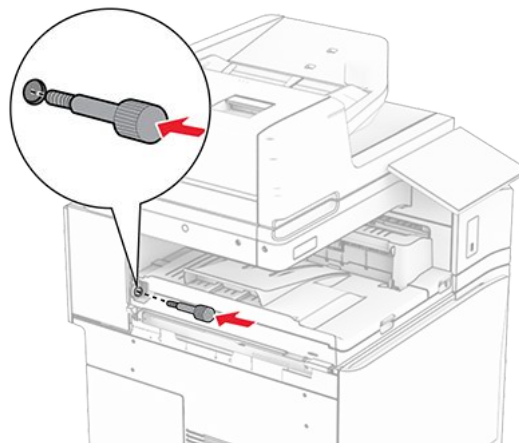

- 18. Open the front door, and then attach the cover that came with the paper transport to the left side of the printer.

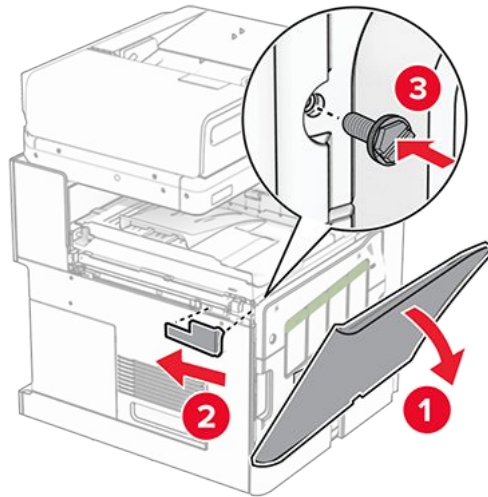

19. Close the front door.
20. Unpack the booklet finisher, and then remove all the packing material.
21. Attach the bracket to the finisher.

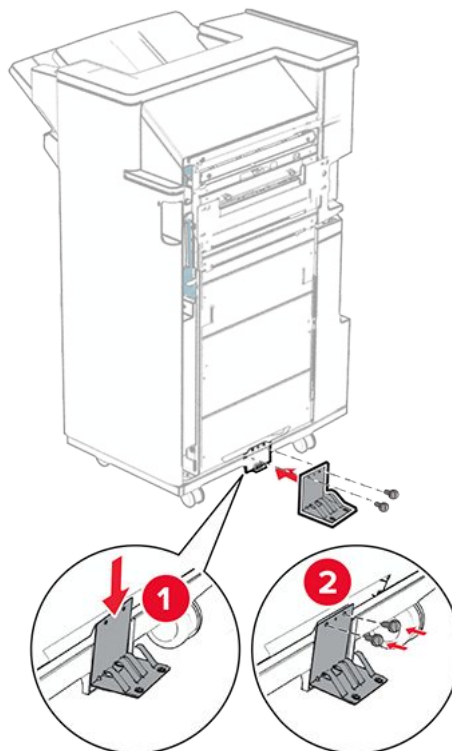

22. Attach the foam tape to the finisher.

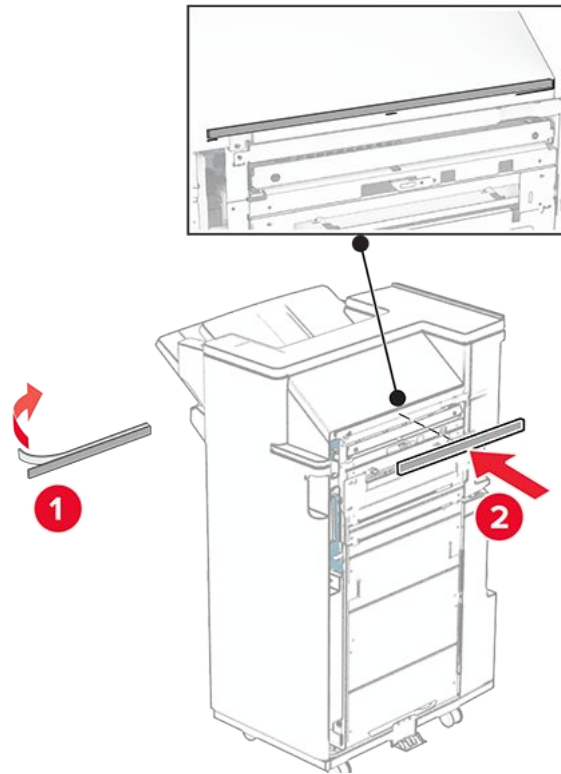

23. Attach the feed guide to the finisher.

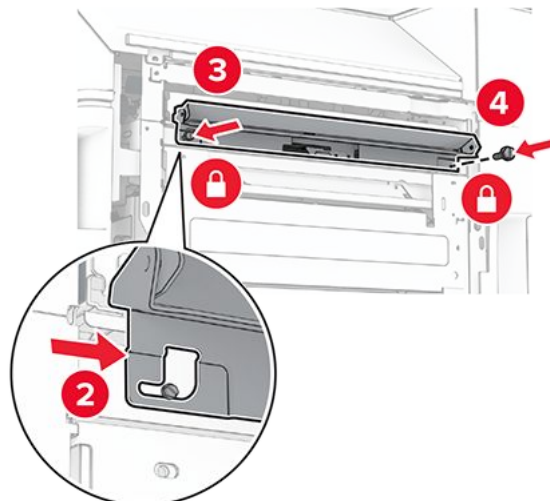
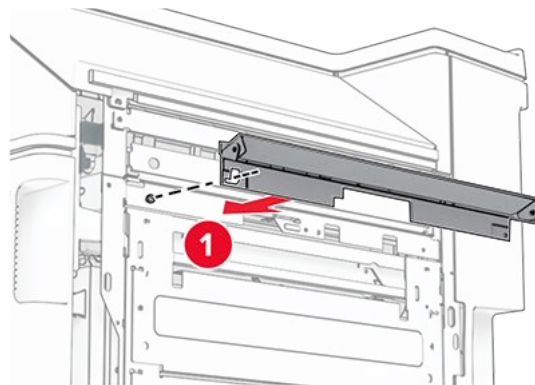

24. Attach the upper bin to the finisher.

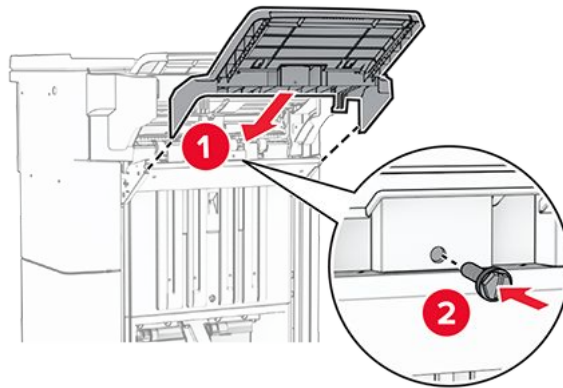

25. Raise the bin flap, and then attach the lower bin to the finisher.

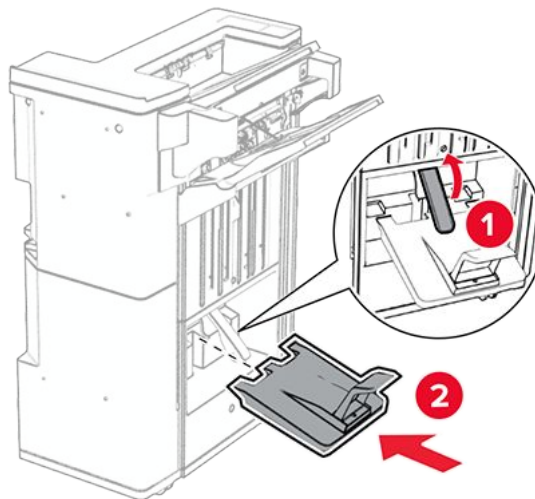

26. Open the finisher door.

27. Remove the packing material from the hole punch box, and then insert it into the finisher.

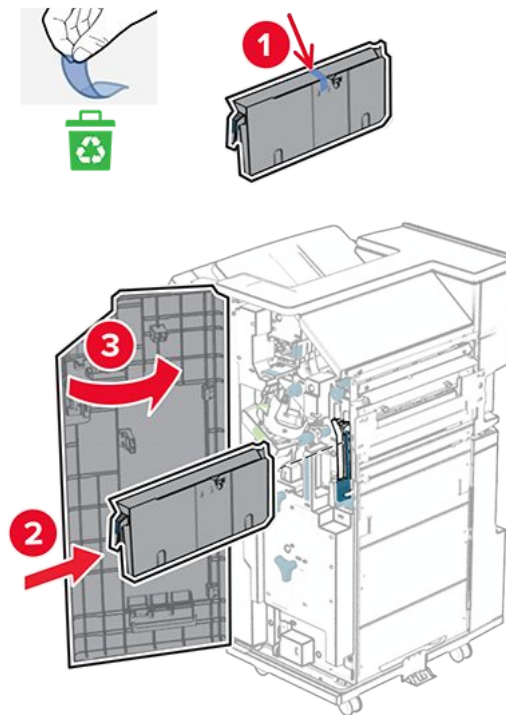

28. Place the bin extender on the finisher bin.

### Notes

- The bin extender is used for A3-size paper or longer and in high humidity conditions to help in stacking the paper.
- The bin capacity is reduced when the bin extender is used.

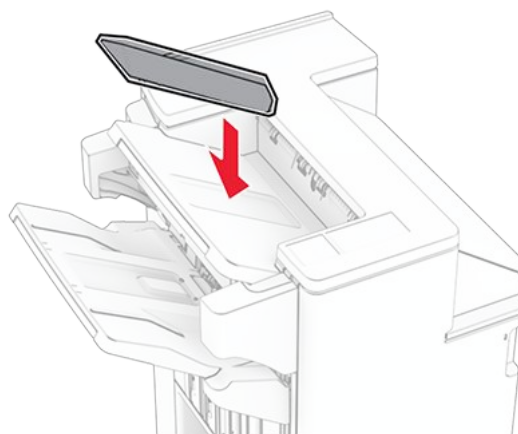

29. Attach the basket to the rear of the finisher.

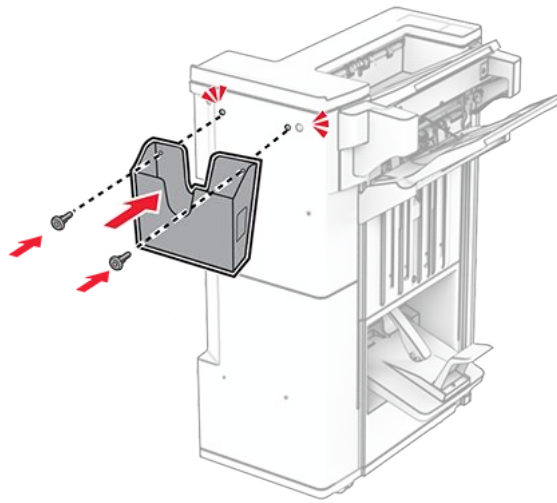

- 30. Close the finisher door.
- 31. Loosely attach a screw to the printer.

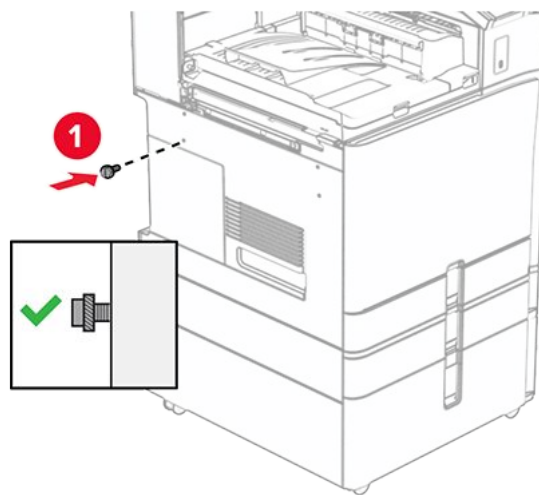

- 32. Align the mounting bracket to the screw.

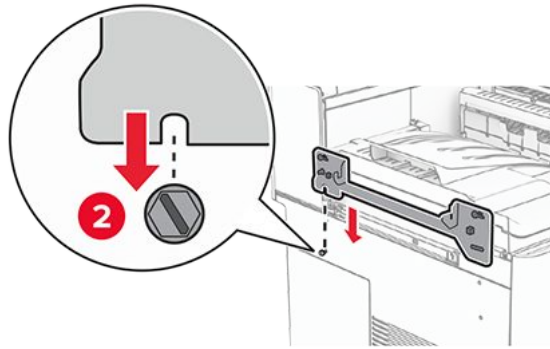

33. Loosely attach screws to the mounting bracket.

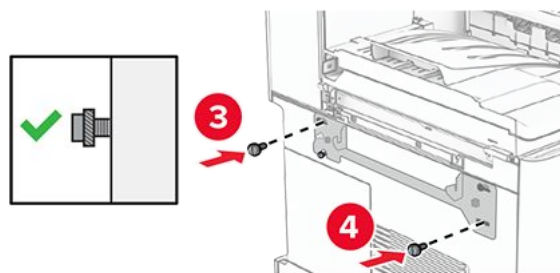

34. Attach the bracket that came with the paper transport to the printer.

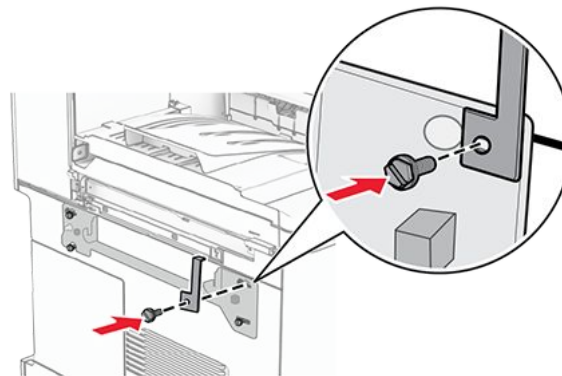

35. Tighten the screws to secure the mounting bracket onto the printer.

**Note:** Make sure that the screws are aligned to the markers on the mounting bracket.

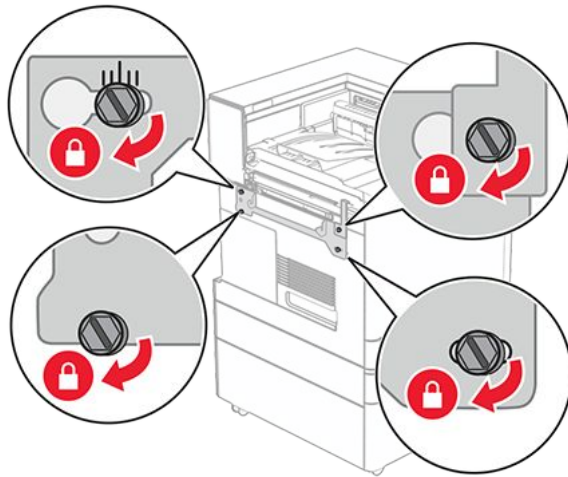

36. Open the finisher door, remove the screw, and then pull the finisher lock.

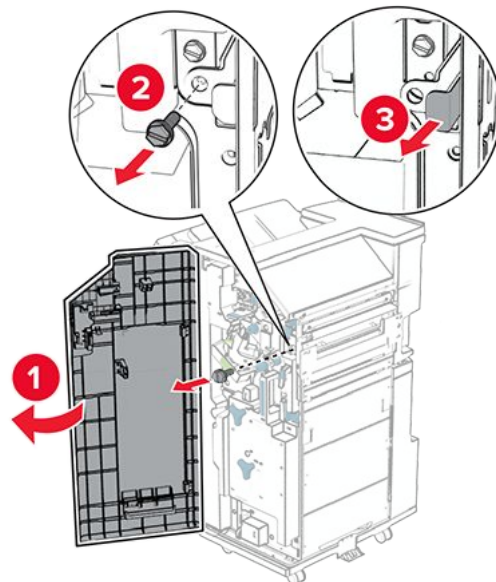

37. Attach the finisher to the printer.

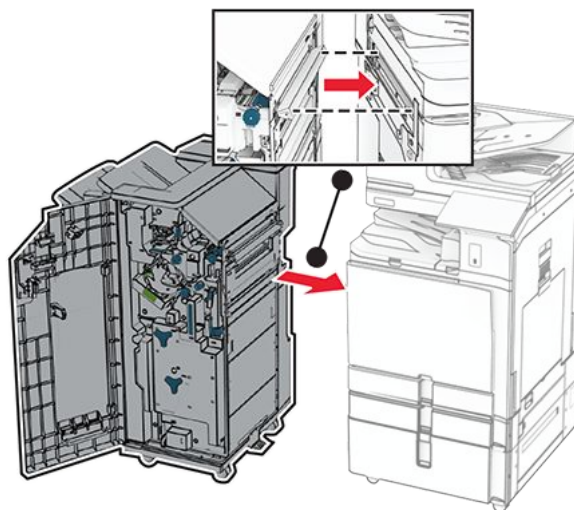

38. Lock the finisher to the printer, and then install the screw.

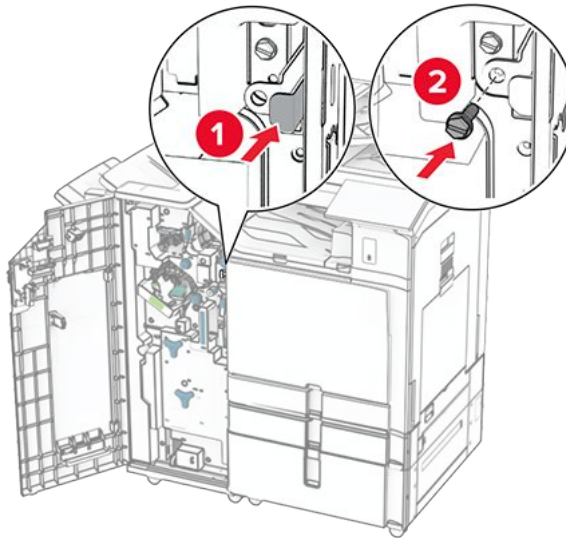

39. Close the finisher door.  
40. Connect the finisher cable to the printer.

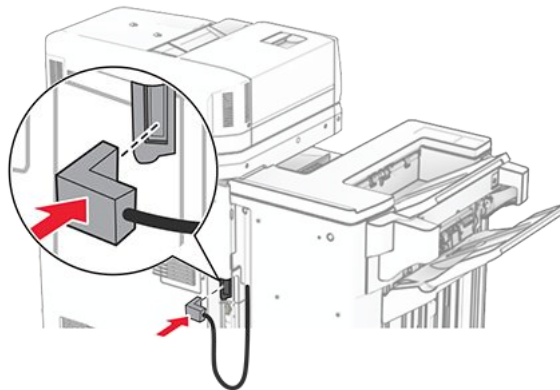

41. Connect one end of the power cord to the printer, and then the other end to the electrical outlet.



### **CAUTION—POTENTIAL INJURY**

To avoid the risk of fire or electrical shock, connect the power cord to an appropriately rated and properly grounded electrical outlet that is near the product and easily accessible.

42. Turn on the printer.

## Installing the booklet finisher and folding paper transport



### CAUTION—SHOCK HAZARD

To avoid the risk of electrical shock, if you are accessing the controller board or installing optional hardware or memory devices sometime after setting up the printer, then turn the printer off, and unplug the power cord from the electrical outlet before continuing. If you have any other devices attached to the printer, then turn them off as well, and unplug any cables going into the printer.

**Note:** This task requires a flat-head screwdriver.

1. Turn off the printer.

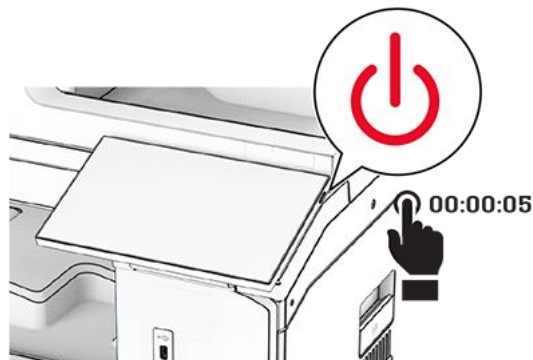

2. Unplug the power cord from the electrical outlet, and then from the printer.

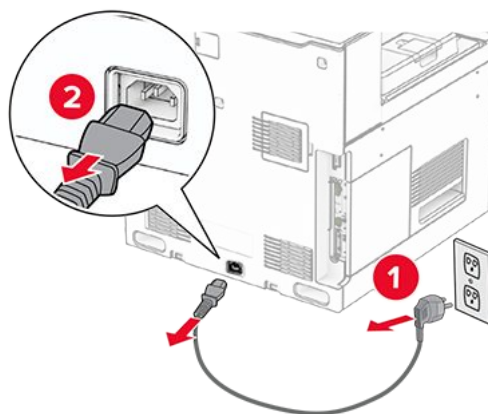

3. Unpack the folding paper transport.
4. Remove the standard bin.

**Note:** Do not throw away the bin.

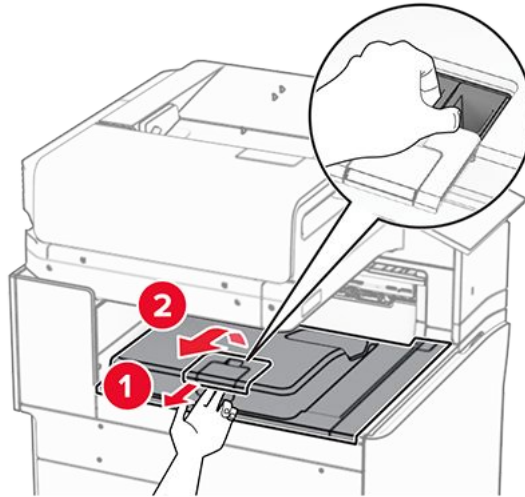

5. Before installing the option, place the exit bin flag into the closed position.

**Note:** When the option is removed, place the exit bin flag into the open position.

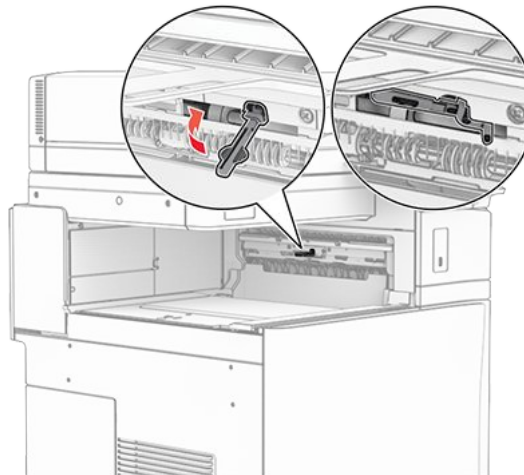

6. Remove the backup roller.

**Note:** Do not throw away the roller.

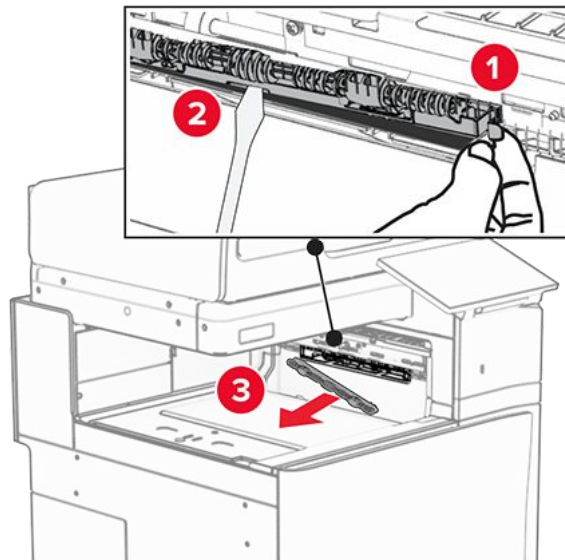

7. Insert the feed roller that came with the option until it clicks into place.

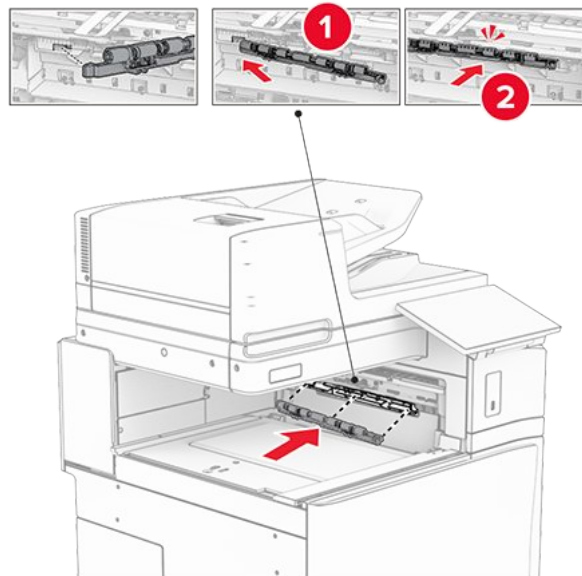

**Note:** Make sure that the metal spring is in front of the feed roller.

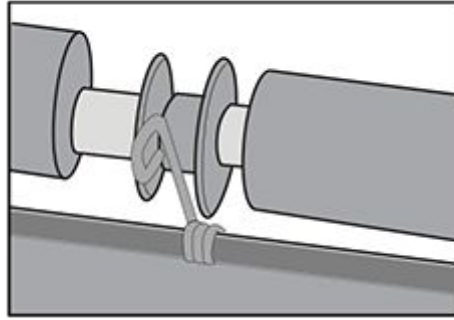

8. Attach the roller cover until it clicks into place.

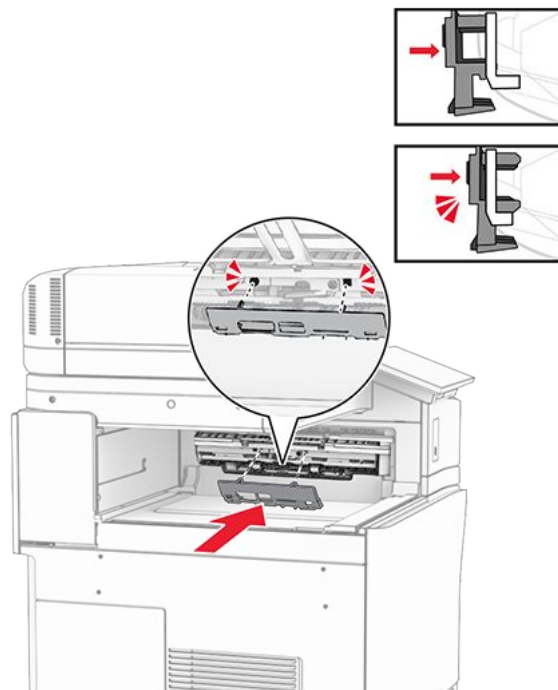

9. Open the front door, and then remove the cover on the left side of the printer.

**Note:** Do not throw away the screw and cover.

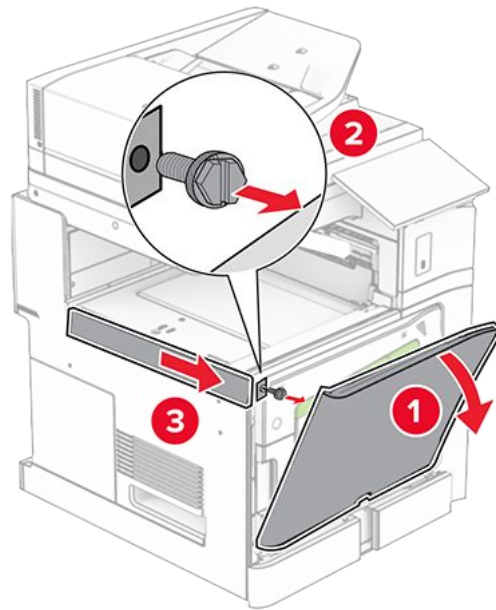

- 10. Close the front door.
- 11. Remove the paper transport connector cover.

**Note:** Do not throw away the cover.

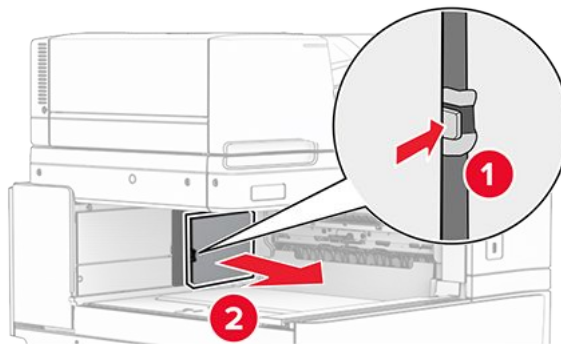

- 12. Remove the left rear cover.

**Note:** Do not throw away the screw and cover.

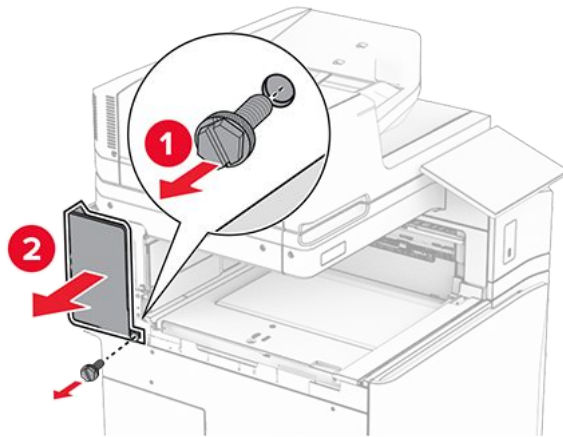

13. Remove the inner bin cover.

**Note:** Do not throw away the screw and cover.

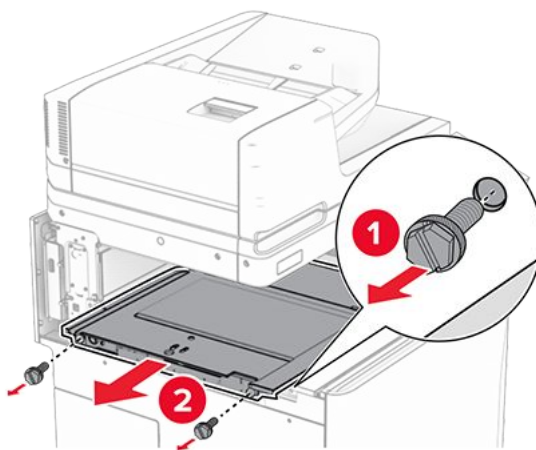

14. Align, and then insert the inner bin cover that came with the option.

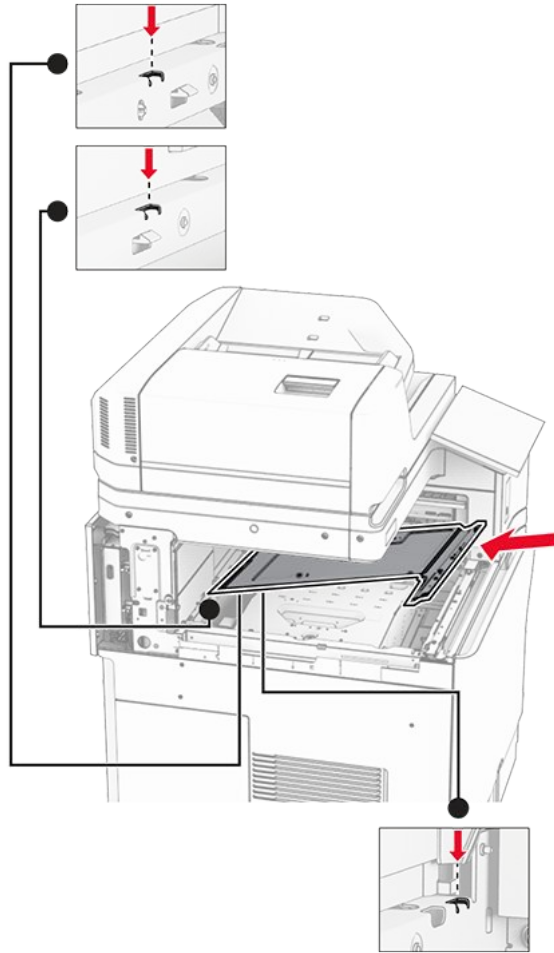

15. Install the screws to the inner bin cover.

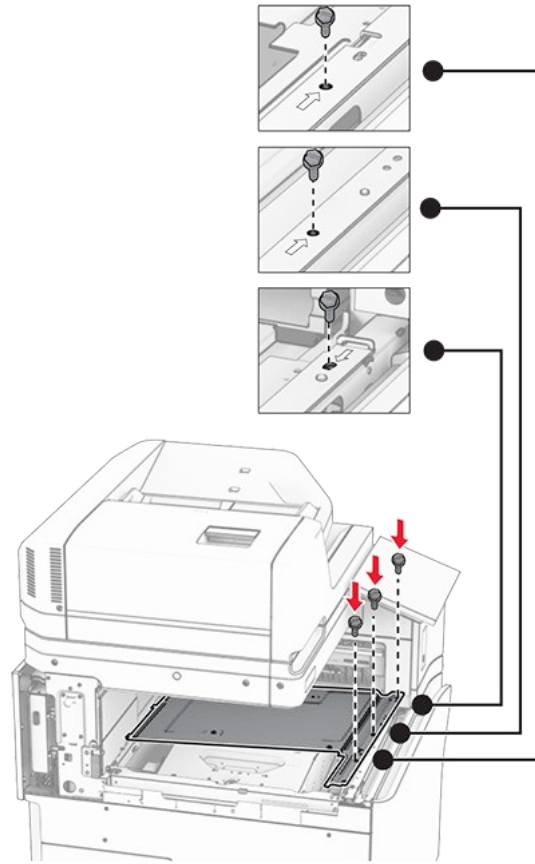

16. Attach the pieces of foam tape to the option.

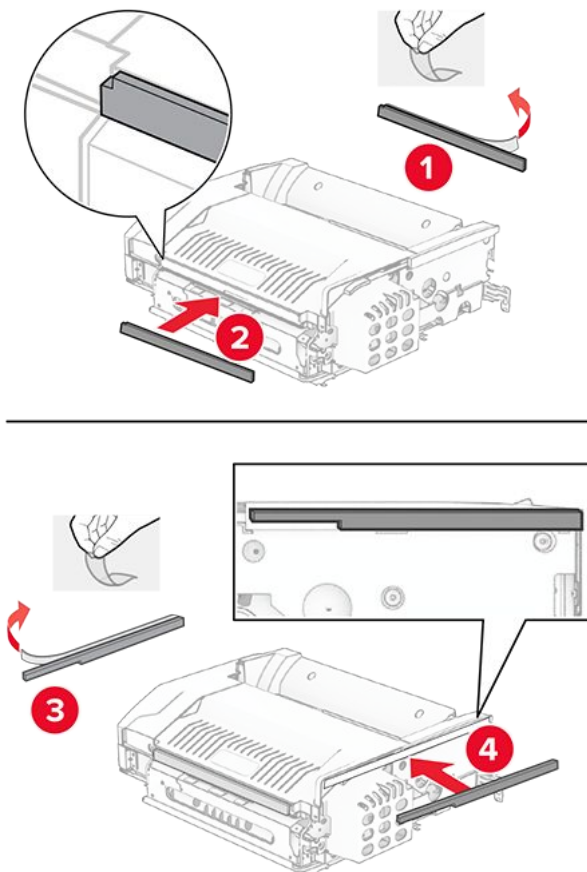

17. Open door F, and then tighten the screws.

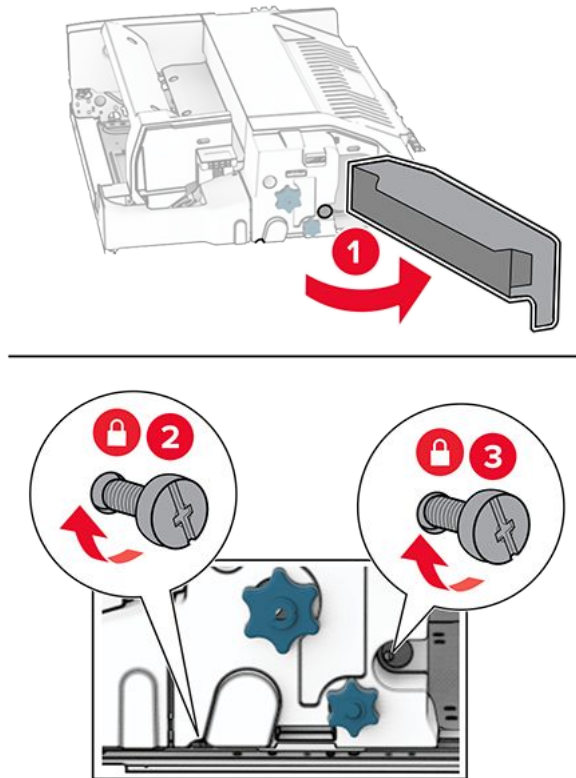

18. Close door F.  
19. Attach the bracket to the option.

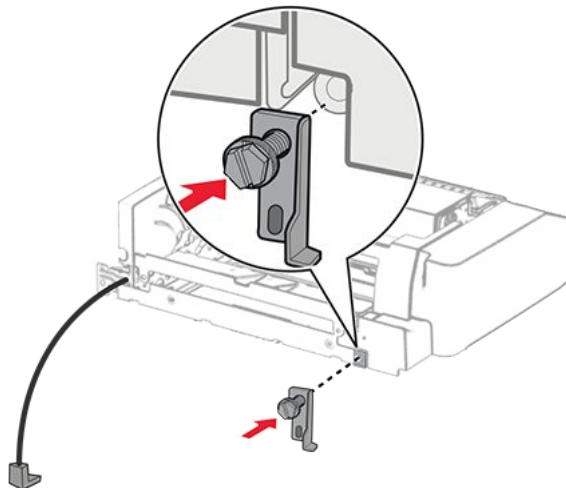

20. Insert the option.

**Note:** Make sure that the metal bracket is in front of the printer.

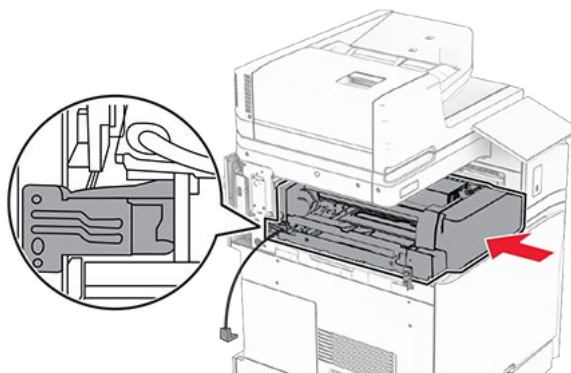

21. Open door F, and then using the screwdriver that came with the option, install the screw.

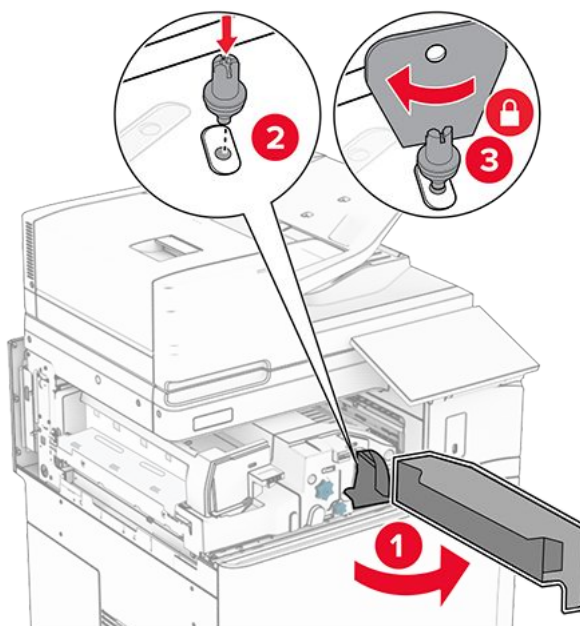

22. Close door F.

23. Install the screws into the option.

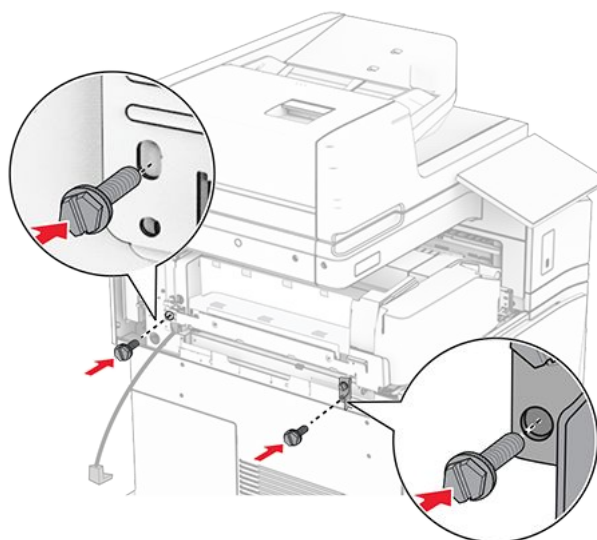

24. Attach the left rear cover.

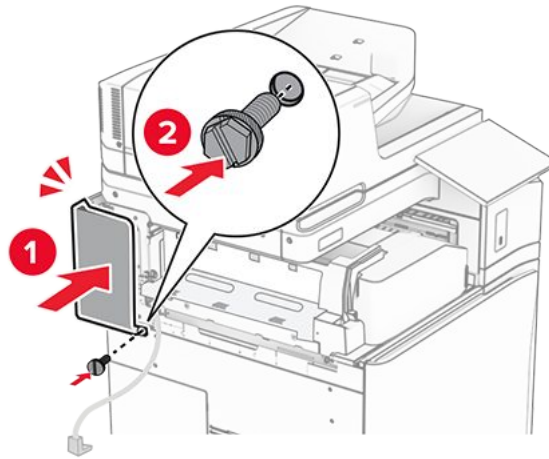

25. Unpack the booklet finisher, and then remove all the packing material.

26. Attach the bracket to the finisher.

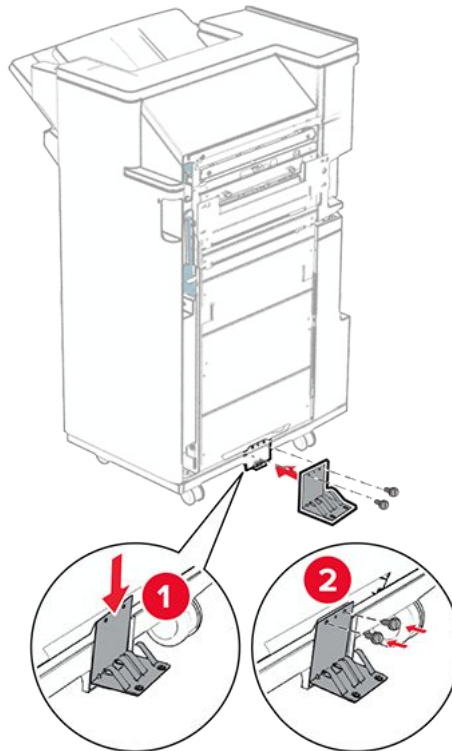

27. Attach the foam tape to the finisher.

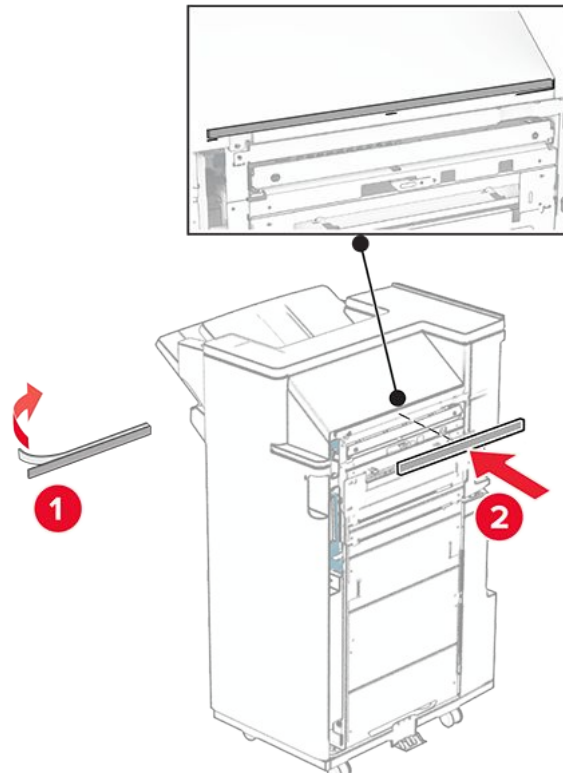

28. Attach the feed guide to the finisher.

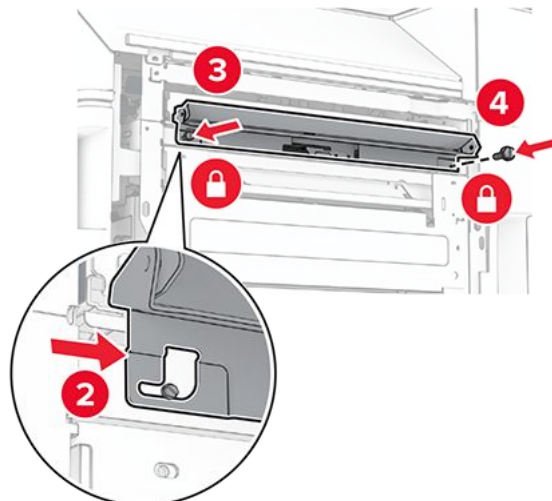
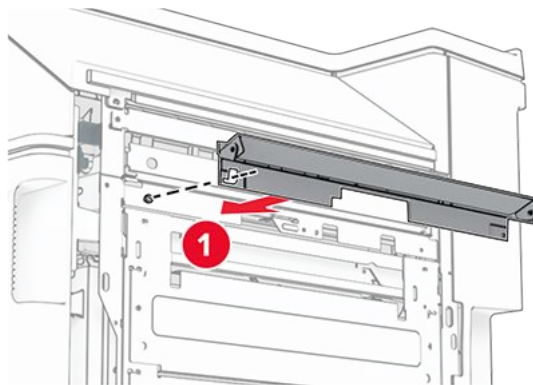

29. Attach the upper bin to the finisher.

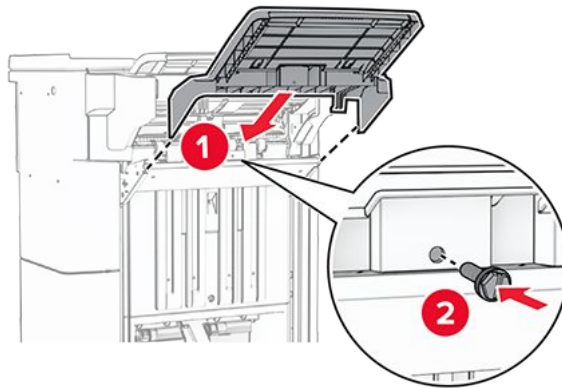

30. Raise the bin flap, and then attach the lower bin to the finisher.

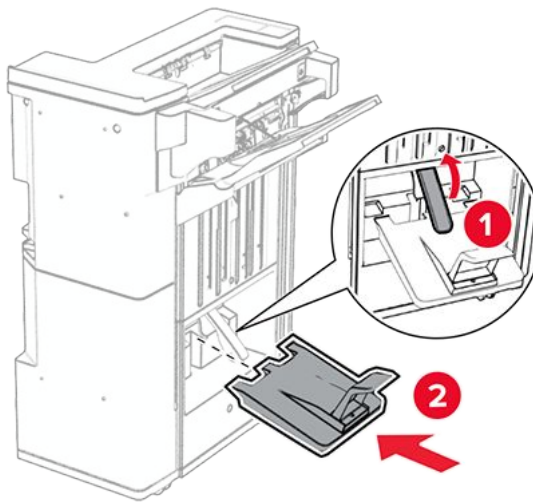

31. Open the finisher door.

32. Remove the packing material from the hole punch box, and then insert it into the finisher.

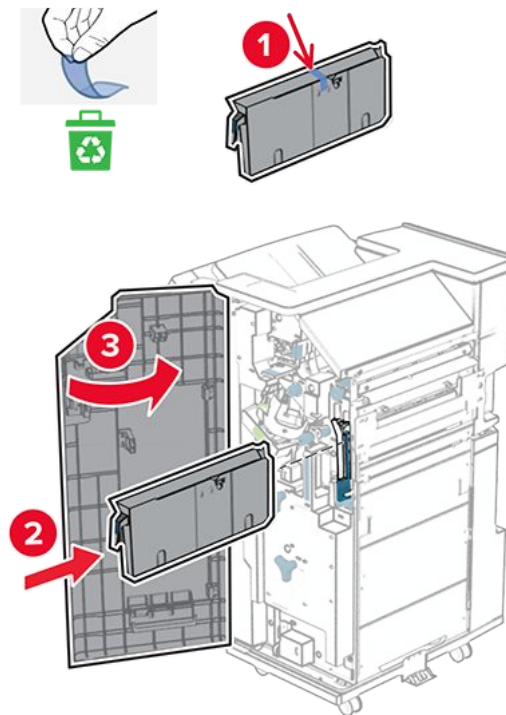

33. Place the bin extender on the finisher bin.

### Notes

- The bin extender is used for A3-size paper or longer and in high humidity conditions to help in stacking the paper.
- The bin capacity is reduced when the bin extender is used.

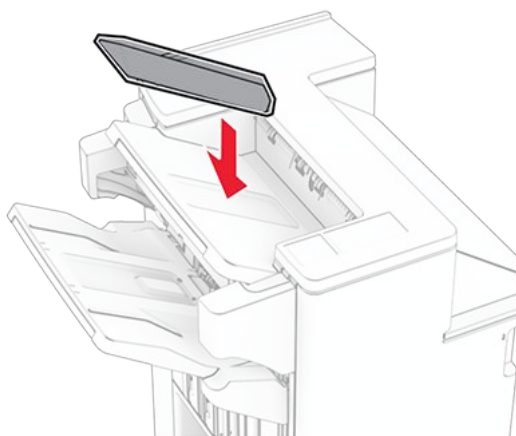

34. Attach the basket to the rear of the finisher.

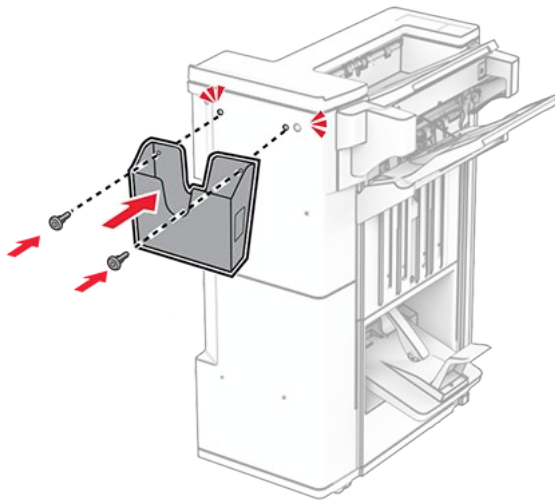

35. Close the finisher door.

36. Raise the bin flap, and then align and attach the cover to the option.

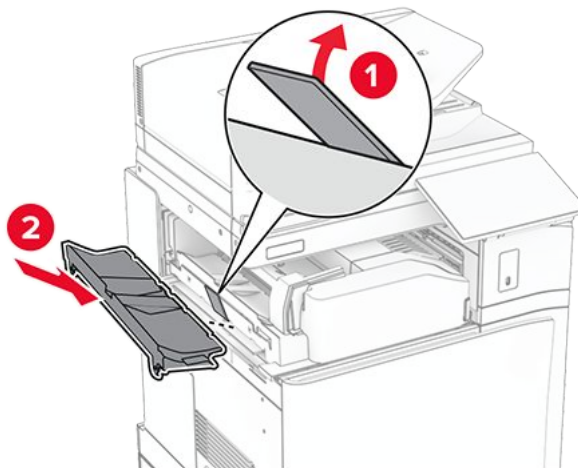

37. Install the screws.

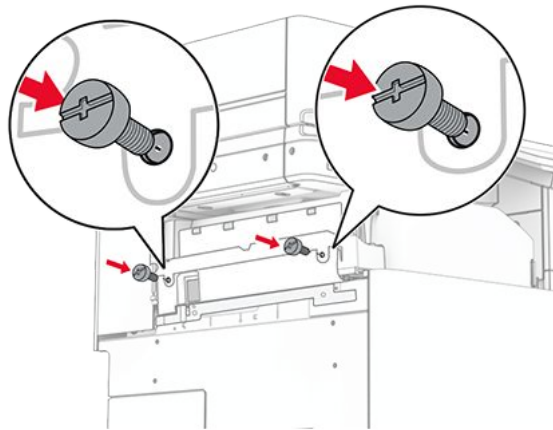

38. Open the front door, and then attach the trim cover that came with the option.

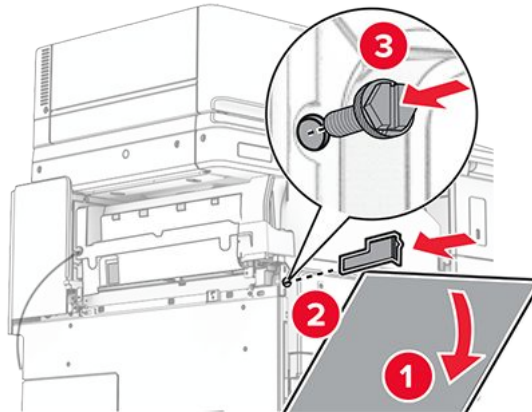

39. Loosely attach a screw to the printer.

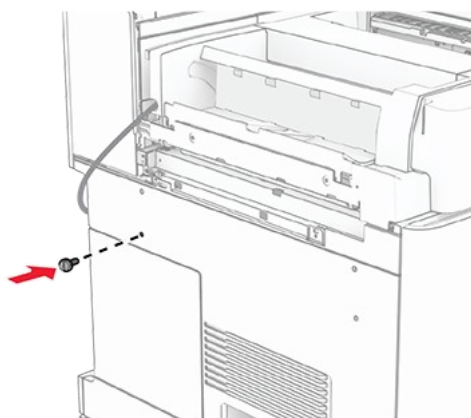

40. Align the mounting bracket to the screw.

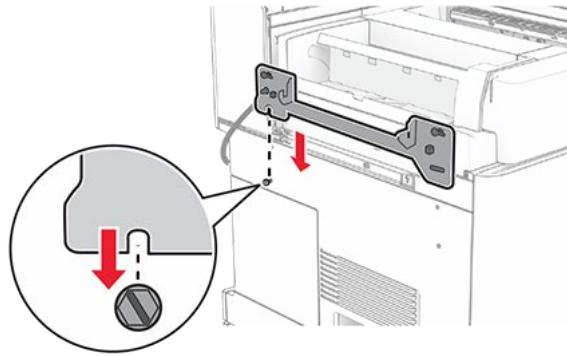

41. Loosely attach screws into the mounting bracket.

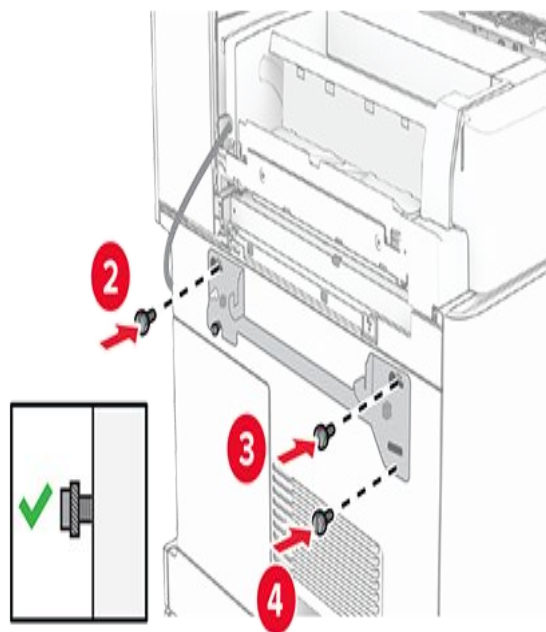

42. Tighten the screws to secure the mounting bracket onto the printer.

**Note:** Make sure that the screws are aligned to the markers on the mounting bracket.

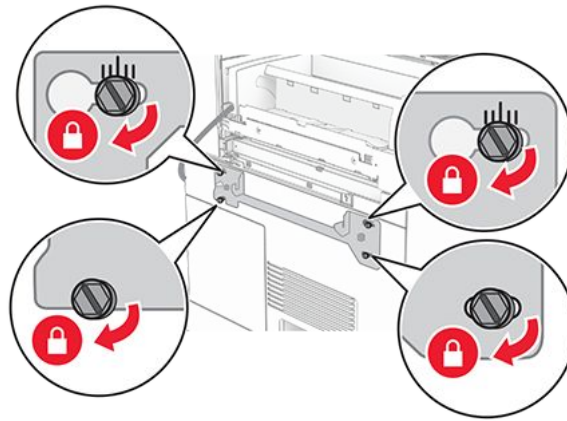

43. Open the finisher door, remove the screw, and then pull the finisher lock.

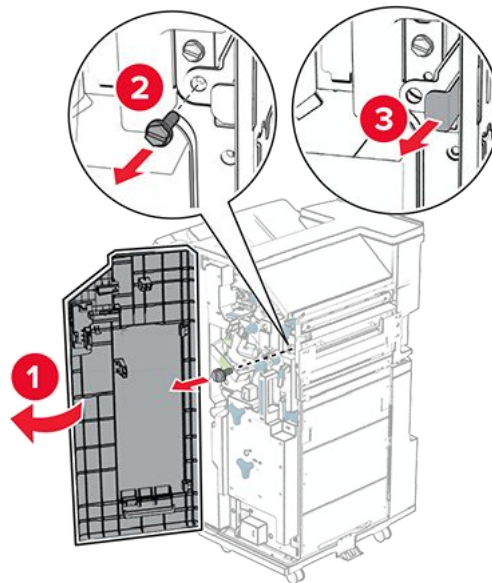

44. Connect the option cable to the printer.

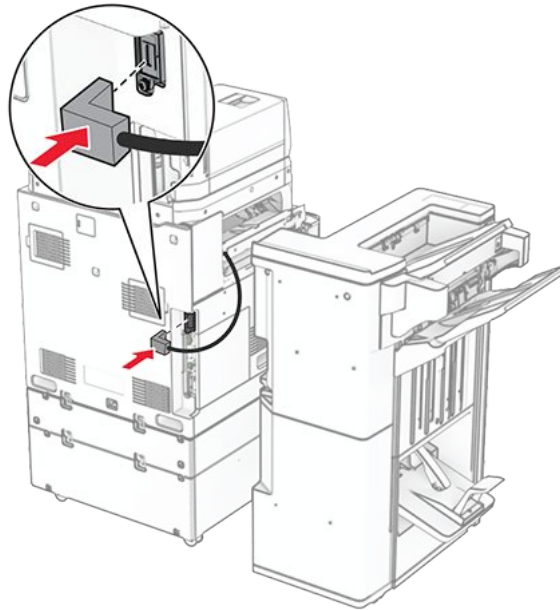

45. Connect the finisher cable to the option.

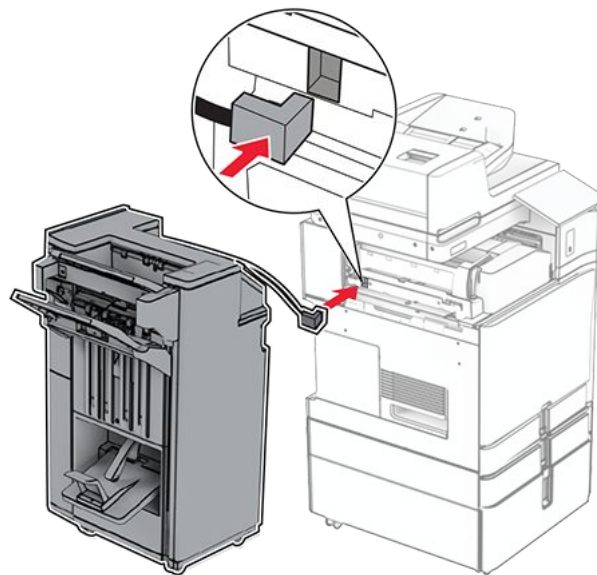

46. Attach the finisher to the printer.

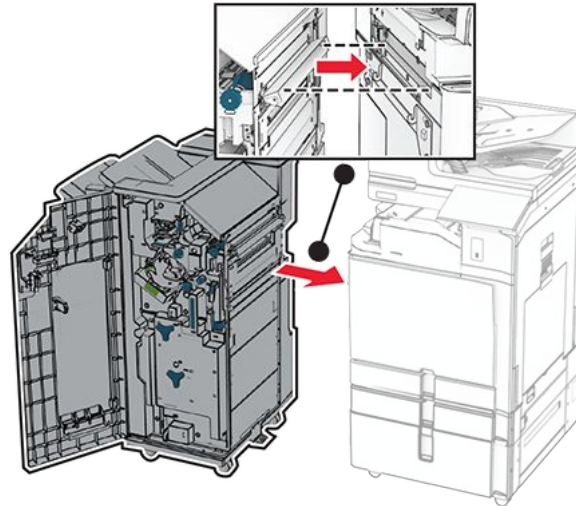

47. Lock the finisher to the printer, and then install the screw.

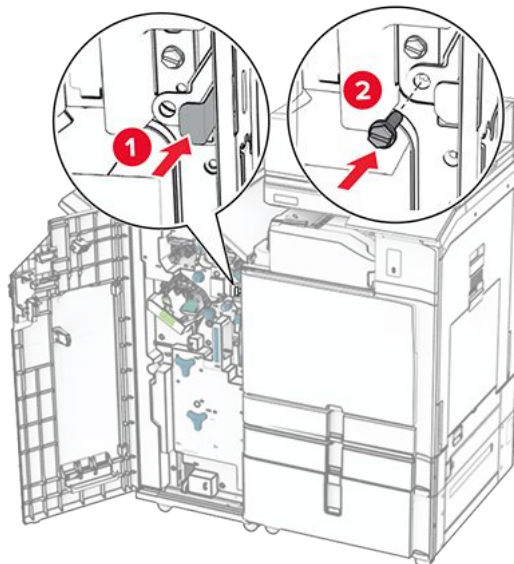

48. Close the finisher door.

49. Connect one end of the power cord to the printer, and then the other end to the electrical outlet.



**CAUTION—POTENTIAL INJURY**

To avoid the risk of fire or electrical shock, connect the power cord to an appropriately rated and properly grounded electrical outlet that is near the product and easily accessible.

50. Turn on the printer.

## Installing the keyboard shelf

1. Turn off the printer.

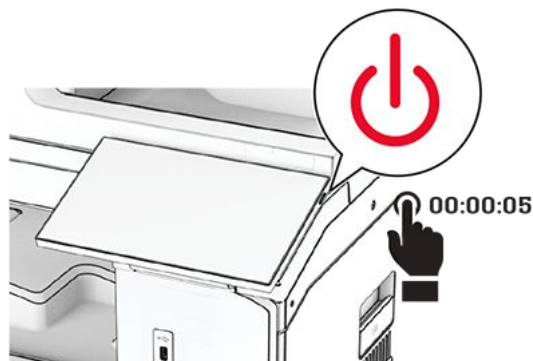

2. Open door B.

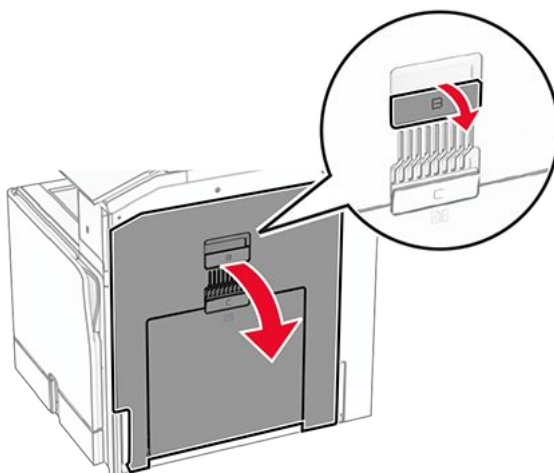

3. Remove the front cover, and then close door B.

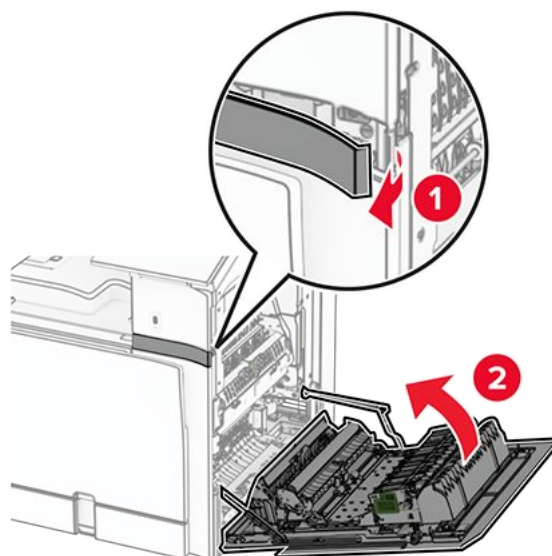

4. Unpack the keyboard shelf.

## Set up, install, and configure

---

5. Insert the keyboard cable into the shelf.

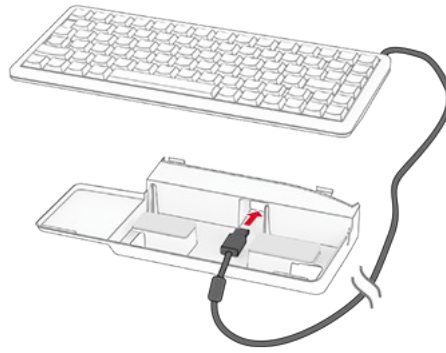

6. Loop the cable inside the shelf.

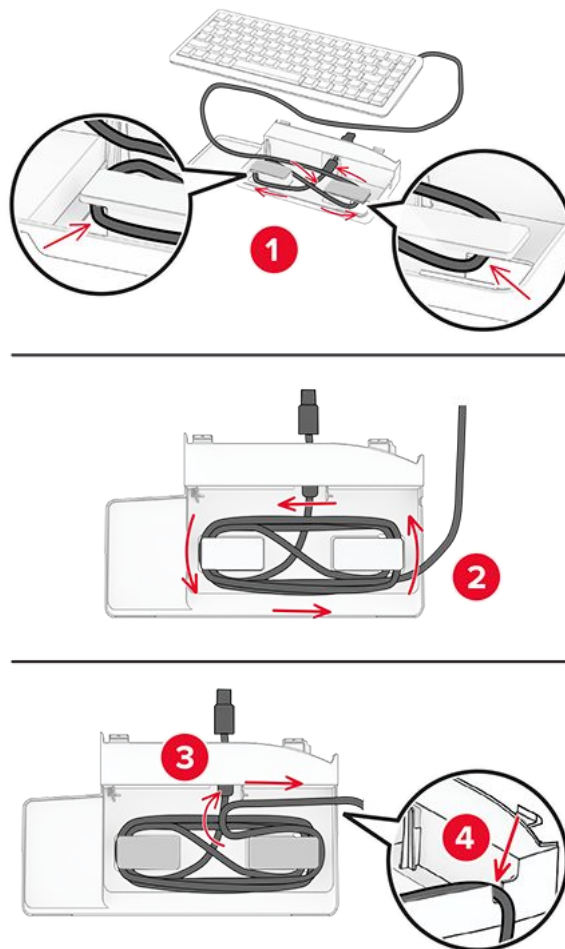

7. Remove the adhesive cover.

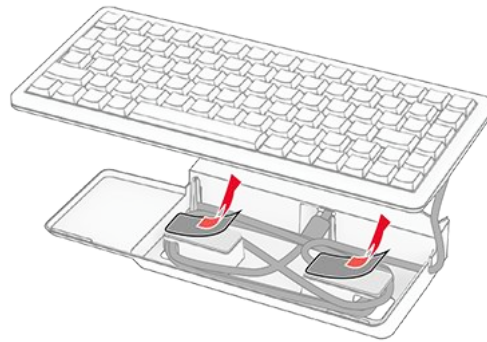

8. Align, and then attach the keyboard to the base.

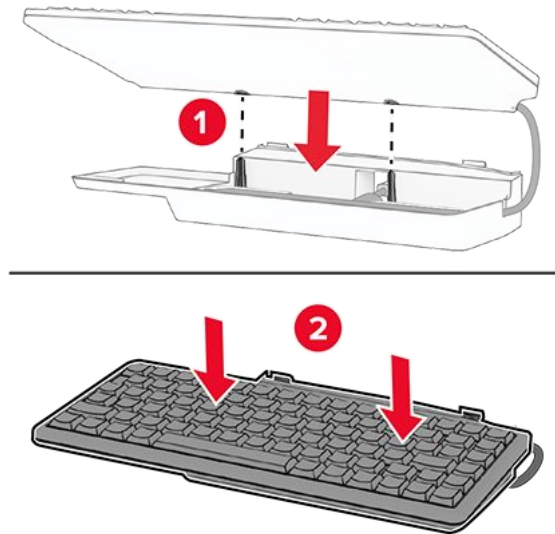

9. Align the shelf, connect the keyboard cable to the printer, insert the shelf, and then attach it to the printer.

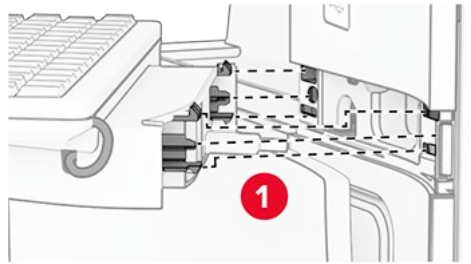

10. Turn on the printer.

## Installing a fax card



### CAUTION—SHOCK HAZARD

To avoid the risk of electrical shock, if you are accessing the controller board or installing optional hardware or memory devices sometime after setting up the printer, then turn the printer off, and unplug the power cord from the electrical outlet before continuing. If you have any other devices attached to the printer, then turn them off as well, and unplug any cables going into the printer.

**Note:** This task requires a flat-head screwdriver.

1. Turn off the printer.

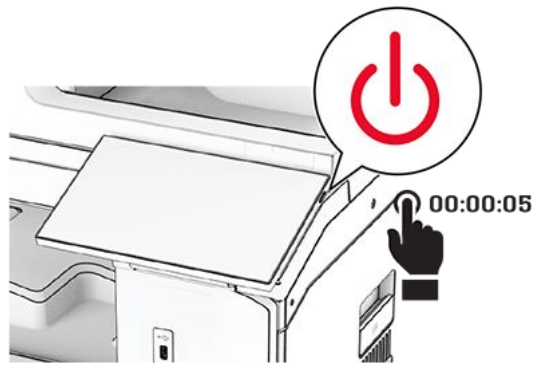

2. Unplug the power cord from the electrical outlet, and then from the printer.

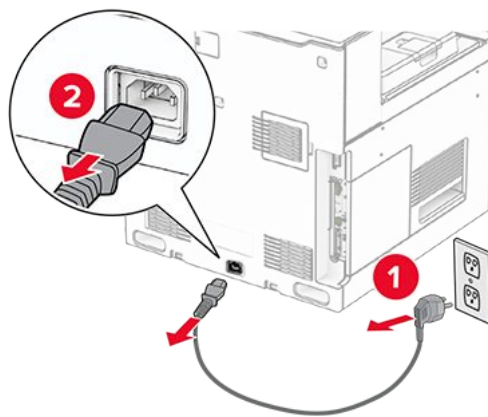

3. Open the controller board access cover.

**Warning—Potential Damage**

Controller board electronic components are easily damaged by static electricity. Touch a metal surface on the printer before touching any controller board electronic components or connectors.

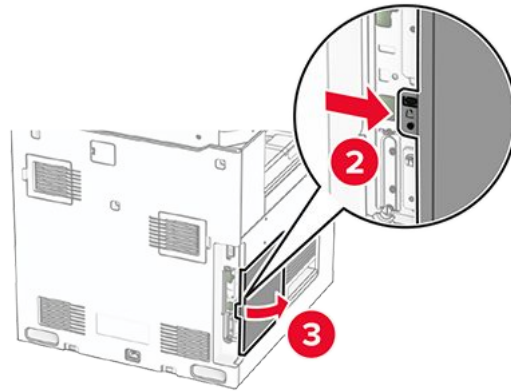
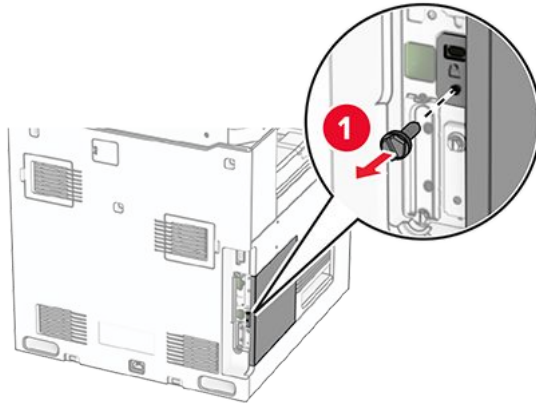

4. Remove the fax port cover.

**Note:** Do not throw away the screw and cover.

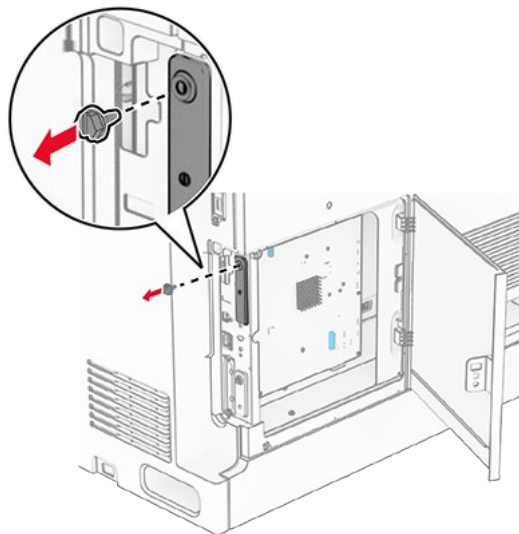

5. Unpack the fax card.
6. Connect the fax cable to the controller board.

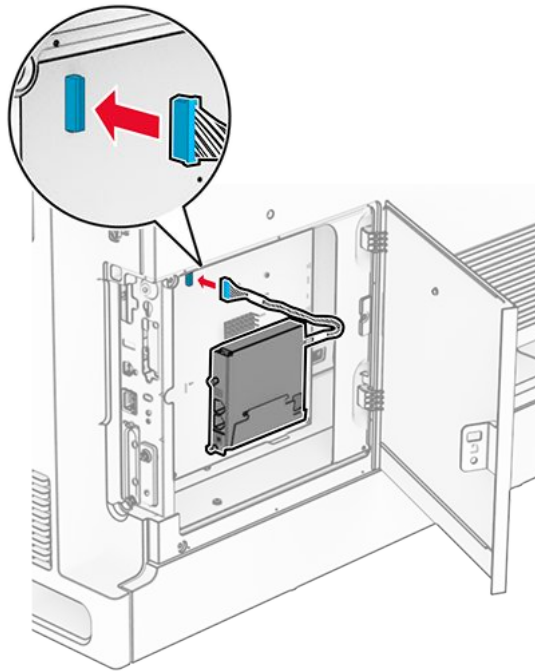

7. Align, and then install the fax card to the printer.

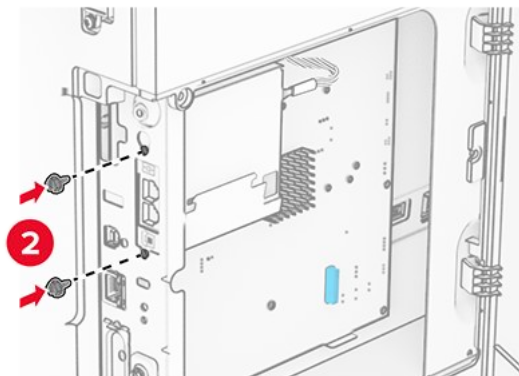
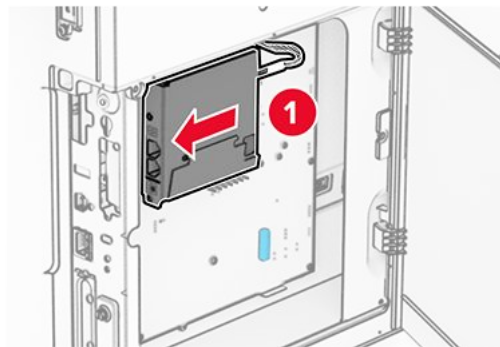

8. Close the controller board access cover until it clicks into place, and then install the screw.

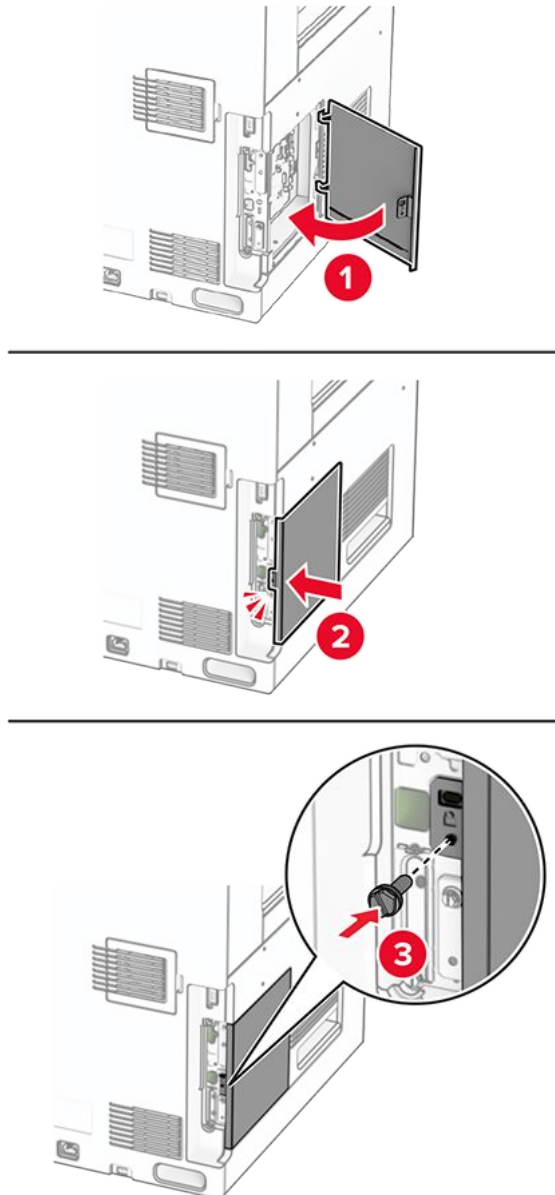

9. Connect one end of the power cord to the printer, and then the other end to the electrical outlet.



**CAUTION—POTENTIAL INJURY**

To avoid the risk of fire or electrical shock, connect the power cord to an appropriately rated and properly grounded electrical outlet that is near the product and easily accessible.

10. Turn on the printer.

## Installing the card reader



### CAUTION—SHOCK HAZARD

To avoid the risk of electrical shock, if you are accessing the controller board or installing optional hardware or memory devices sometime after setting up the printer, then turn the printer off, and unplug the power cord from the electrical outlet before continuing. If you have any other devices attached to the printer, then turn them off as well, and unplug any cables going into the printer.

1. Turn off the printer.

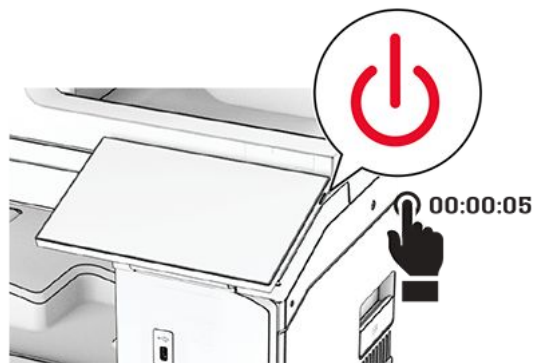

2. Open door B.

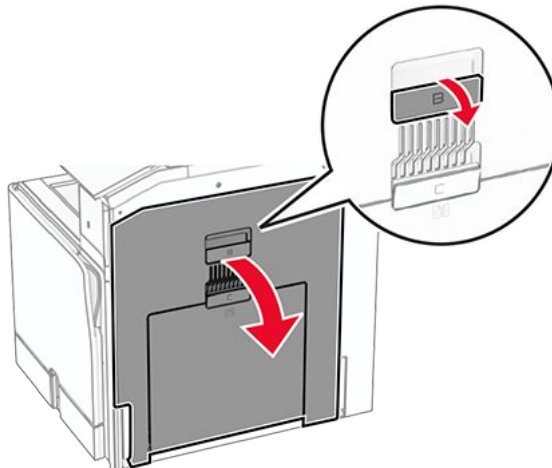

3. Open the front USB port cover.

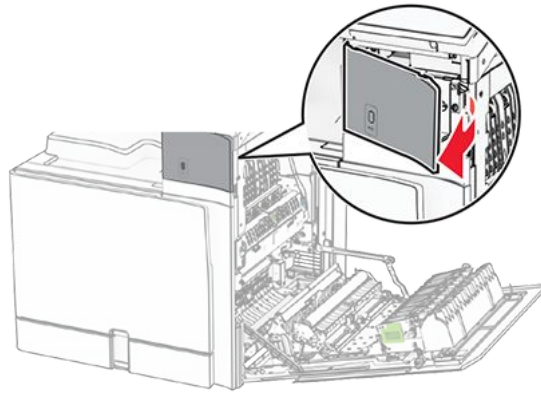

4. Remove the lower cover of the front USB port.

**Note:** If your printer does not have this part, then proceed to the next step.

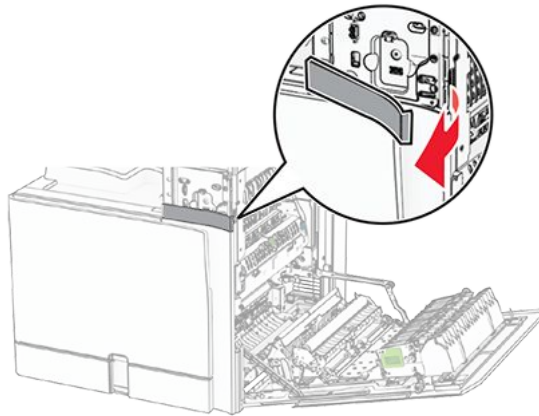

5. Remove the protective cover from the card reader.

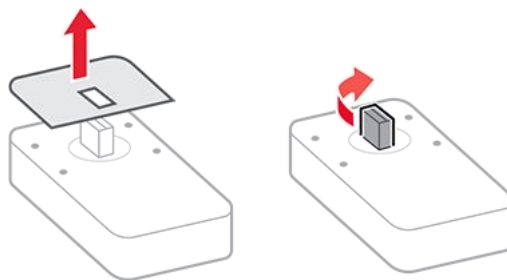

6. Insert the card reader.

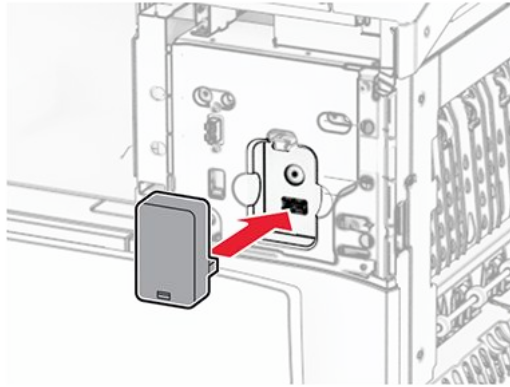

7. Attach the lower cover until it clicks into place.

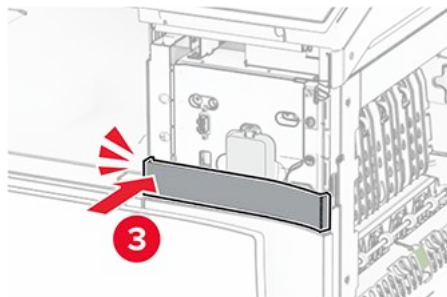
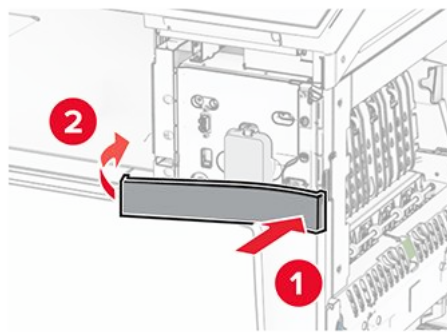

8. Attach the sticker guide to front USB port cover.

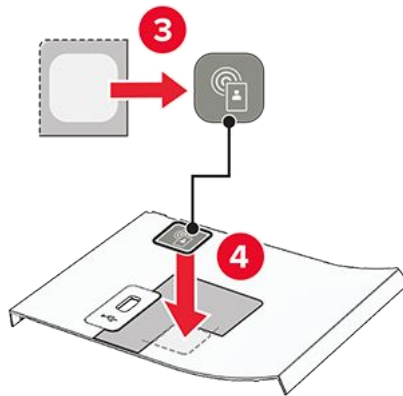
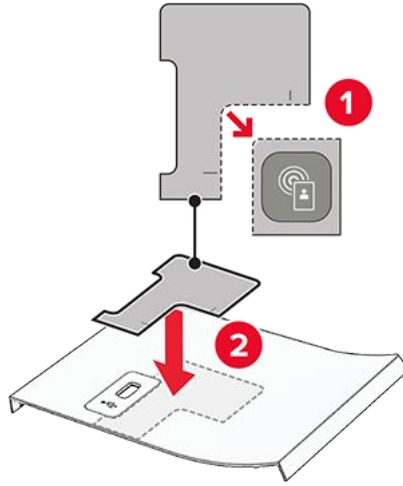

9. Attach the front USB port cover until it clicks into place.

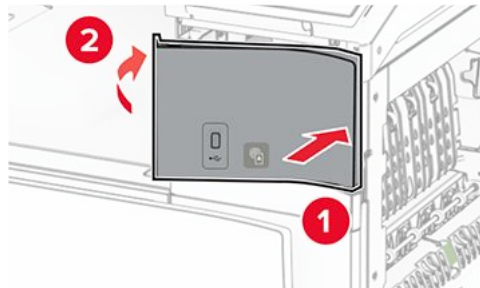

10. Close door B until it clicks into place.

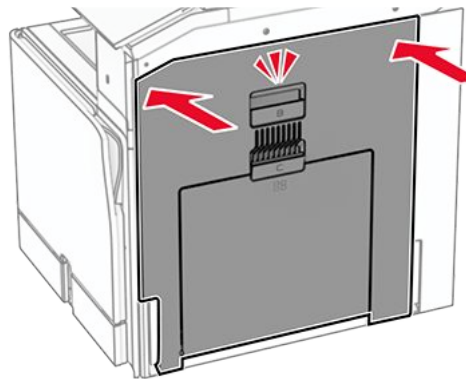
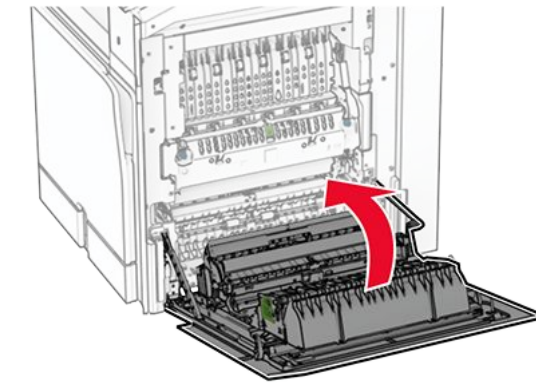

11. Turn on the printer.

## Installing an internal solutions port



### CAUTION—SHOCK HAZARD

To avoid the risk of electrical shock, if you are accessing the controller board or installing optional hardware or memory devices sometime after setting up the printer, then turn the printer off, and unplug the power cord from the electrical outlet before continuing. If you have any other devices attached to the printer, then turn them off as well, and unplug any cables going into the printer.

**Note:** This task requires a flat-head screwdriver.

1. Turn off the printer.

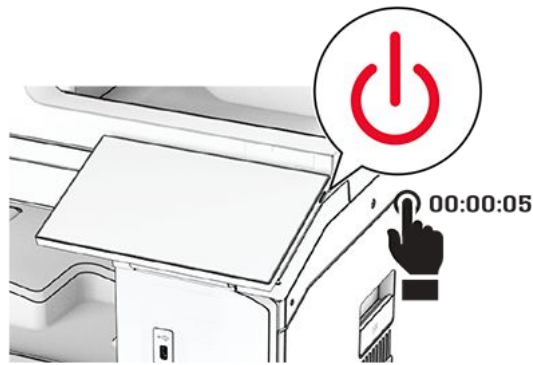

2. Unplug the power cord from the electrical outlet, and then from the printer.

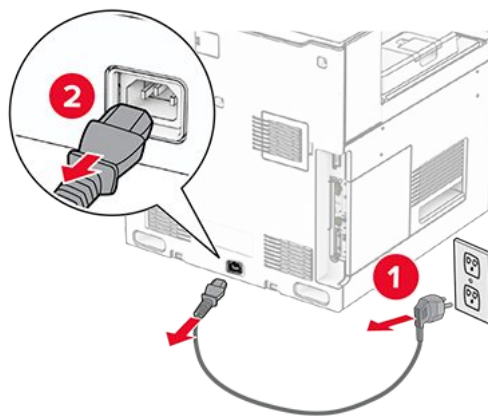

3. Open the controller board access cover.

**Warning—Potential Damage**

Controller board electronic components are easily damaged by static electricity. Touch a metal surface on the printer before touching any controller board electronic components or connectors.

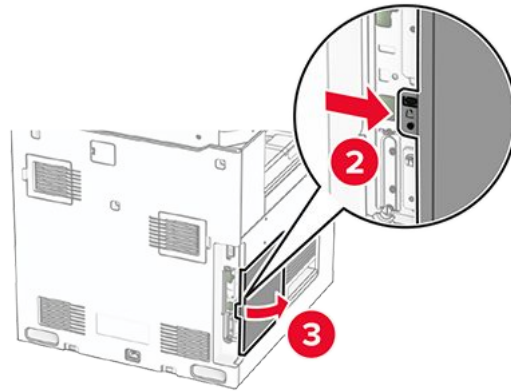
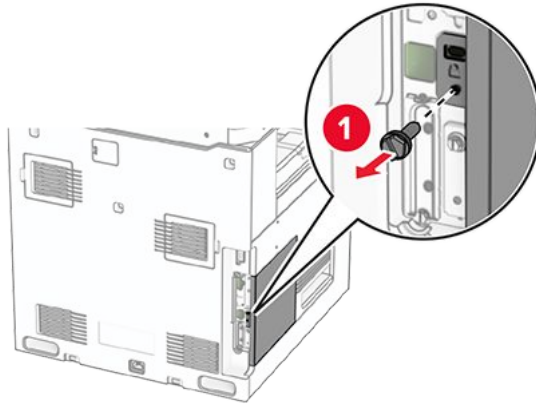

4. Remove the internal solutions port (ISP) cover.

**Note:** Do not throw away the screw and cover.

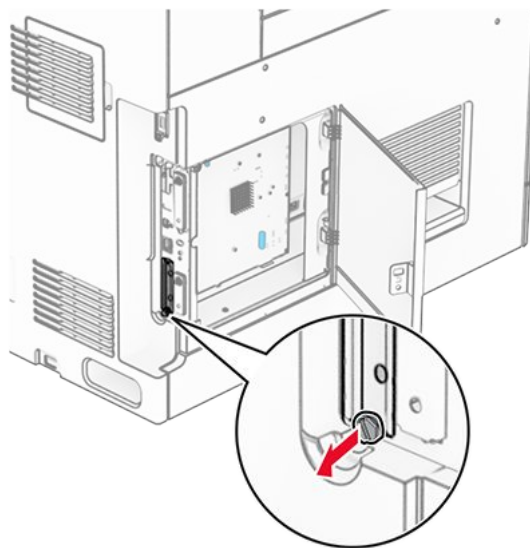

5. Unpack the ISP kit.

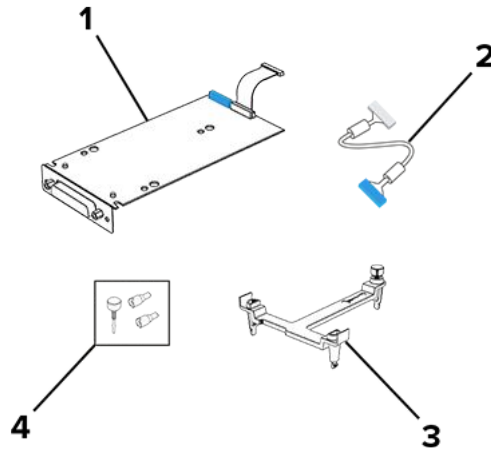

1	ISP
2	ISP extended cable
3	Mounting bracket
4	Thumbscrews

6. Attach the mounting bracket to the controller board until it clicks into place.

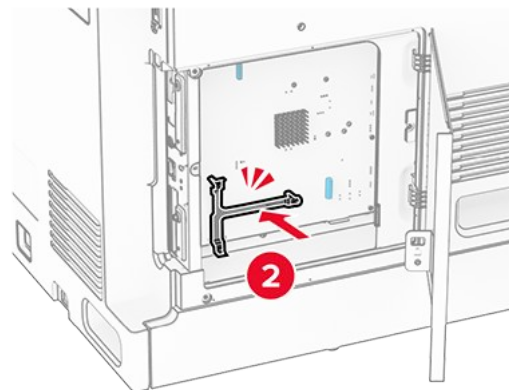
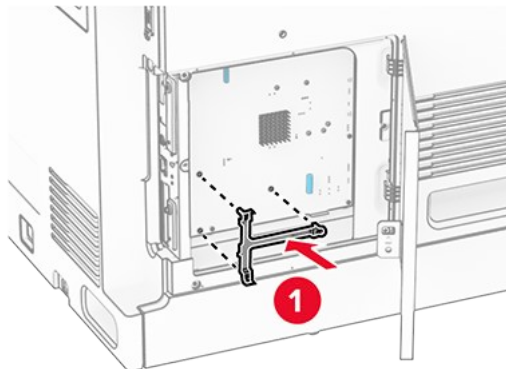

## Set up, install, and configure

---

7. Attach the ISP to the mounting bracket, and then connect the ISP extended cable to its connector on the controller board.

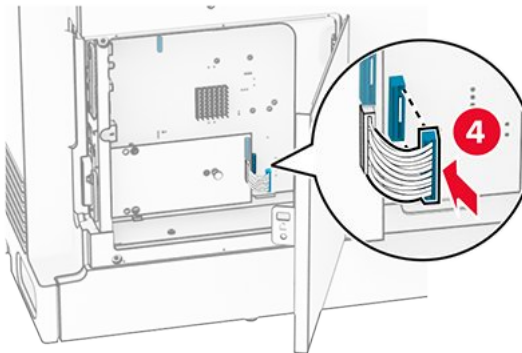
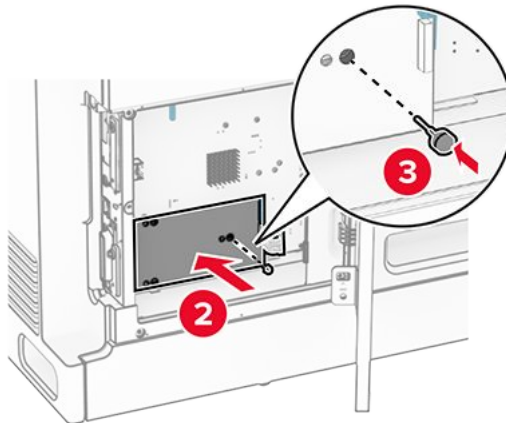
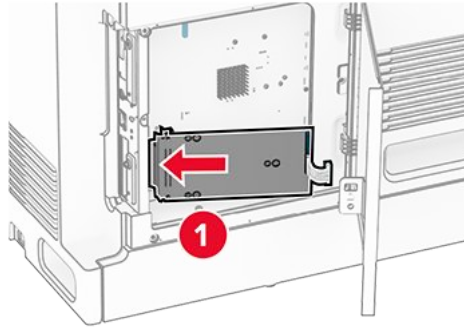

8. Secure the ISP to the printer.

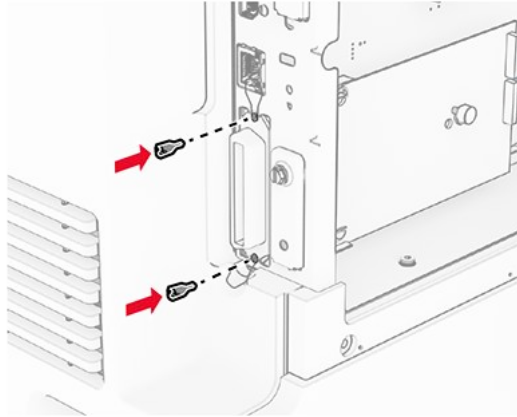

9. Close the controller board access cover.

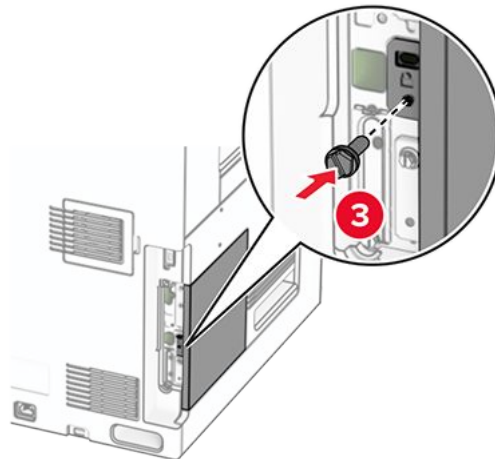
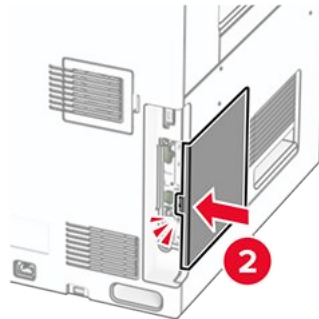
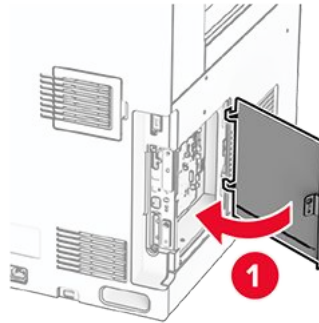

10. Connect one end of the power cord to the printer, and then the other end to the electrical outlet.



### CAUTION—POTENTIAL INJURY

To avoid the risk of fire or electrical shock, connect the power cord to an appropriately rated and properly grounded electrical outlet that is near the product and easily accessible.

11. Turn on the printer.

## Changing the printer port settings after installing an internal solutions port

### Notes

- If the printer has a static IP address, then do not change the configuration.
- If the computers are configured to use the network name instead of an IP address, then do not change the configuration.
- If you are adding a wireless internal solutions port (ISP) to a printer previously configured for an Ethernet connection, then disconnect the printer from the Ethernet network.

### For Windows users

1. Open the printers folder.
2. From the shortcut menu of the printer with the new ISP, open the printer properties.
3. Configure the port from the list.
4. Update the IP address.
5. Apply the changes.

### For Macintosh users

1. From **System Preferences** in the **Apple** menu, navigate to the list of printers, and then select **+ > IP**.
2. Type the IP address in the address field.
3. Apply the changes.

## Networking

### Connecting the printer to a Wi-Fi network

Before you begin, make sure that:

- Active Adapter is set to **Auto**. From the control panel, navigate to **Settings > Network/Ports > Network Overview > Active Adapter**.

- The Ethernet cable is not connected to the printer.

### Using the control panel

1. From the control panel, navigate to **Settings > Network/Ports > Wireless > Setup On Printer Panel > Choose Network**.
2. Select a Wi-Fi network, and then type the network password.

**Note:** For printers with built-in Wi-Fi capability, a prompt for setting up the Wi-Fi network appears during initial setup.

## Connecting the printer to a wireless network using Wi-Fi Protected Setup (WPS)

Before you begin, make sure that:

- The access point (wireless router) is WPS-certified or WPS-compatible. For more information, see the documentation that came with your access point.
- A wireless network adapter is installed in your printer. For more information, see the instructions that came with the adapter.
- **Active Adapter** is set to **Auto**. From the control panel, navigate to **Settings > Network/Ports > Network Overview > Active Adapter**.

### Using the Push Button method

1. From the control panel, navigate to **Settings > Network/Ports > Wireless > Wi-Fi Protected Setup > Start Push Button Method**.
2. Follow the instructions on the display.

### Using the personal identification number (PIN) method

1. From the control panel, navigate to **Settings > Network/Ports > Wireless > Wi-Fi Protected Setup > Start PIN Method**.
2. Copy the eight-digit WPS PIN.
3. Open a web browser, and then type the IP address of your access point in the address field.

#### Notes

- To know the IP address, see the documentation that came with your access point.
- If you are using a proxy server, then temporarily disable it to load the web page correctly.

4. Access the WPS settings. For more information, see the documentation that came with your access point.
5. Enter the eight-digit PIN, and then save the changes.

## Configuring Wi-Fi Direct

Wi-Fi Direct® enables Wi-Fi devices to connect directly to each other without using an access point (wireless router).

1. From the control panel, navigate to **Settings > Network/Ports > Wi-Fi Direct**.
2. Configure the settings.
  - **Enable Wi-Fi Direct**—Enables the printer to broadcast its own Wi-Fi Direct network.
  - **Wi-Fi Direct Name**—Assigns a name for the Wi-Fi Direct network.
  - **Wi-Fi Direct Password**—Assigns the password for negotiating the wireless security when using the peer-to-peer connection.
  - **Show Password on Setup Page**—Shows the password on the Network Setup Page.
  - **Preferred Channel Number**—Assigns the preferred channel of the Wi-Fi Direct network.
  - **Group Owner IP Address**—Assigns the IP address of the group owner.
  - **Auto-Accept Push Button Requests**—Lets the printer accept connection requests automatically.

**Note:** Accepting push-button requests automatically is not secured.

### Notes

- By default, the Wi-Fi Direct network password is not visible on the printer display. To show the password, enable the password peek icon. From the control panel, navigate to **Settings > Security > Miscellaneous > Enable Password/PIN Reveal**.
- To know the password of the Wi-Fi Direct network without showing it on the printer display, print the **Network Setup Page**. From the control panel, navigate to **Settings > Reports > Network > Network Setup Page**.

## Connecting a mobile device to the printer

Before connecting your mobile device, make sure that Wi-Fi Direct has been configured. For more information, see [Configuring Wi-Fi Direct on page 286](#).

## Using Wi-Fi Direct

**Note:** These instructions apply only to mobile devices running on the Android™ platform.

1. From the mobile device, go to the **Settings** menu.

2. Enable **Wi-Fi**, and then tap  > **Wi-Fi Direct**.
3. Select the printer Wi-Fi Direct name.
4. Confirm the connection on the printer control panel.

## Using Wi-Fi

1. From the mobile device, go to the **Settings** menu.
2. Tap **Wi-Fi**, and then select the printer Wi-Fi Direct name.

**Note:** The string DIRECT-xy (where x and y are two random characters) is added before the Wi-Fi Direct name.

3. Enter the Wi-Fi Direct password.

## Connecting a computer to the printer

Before connecting your computer, make sure that Wi-Fi Direct has been configured. For more information, see [Configuring Wi-Fi Direct on page 286](#).

### For Windows users

1. Open **Printers & scanners**, and then click **Add a printer or scanner**.
2. Click **Show Wi-Fi Direct printers**, and then select the printer Wi-Fi Direct name.
3. From the printer display, take note of the eight-digit PIN of the printer.
4. Enter the PIN on the computer.

**Note:** If the print driver is not already installed, then Windows downloads the appropriate driver.

### For Macintosh users

1. Click the wireless icon, and then select the printer Wi-Fi Direct name.

**Note:** The string DIRECT-xy (where x and y are two random characters) is added before the Wi-Fi Direct name.

2. Type the Wi-Fi Direct password.

## Deactivating the Wi-Fi network

1. From the control panel, navigate to **Settings > Network/Ports > Network Overview > Active Adapter > Standard Network**.
2. Select **Yes** to restart the printer.

## Checking the printer connectivity

1. From the control panel, navigate to **Settings > Reports > Network > Network Setup Page**.
2. Check the first section of the page, and confirm that the status is connected.

If the status is not connected, then the LAN drop may be inactive or the network cable may be malfunctioning. Contact your administrator for assistance.

## Setting up serial printing (Windows only)

1. Set the parameters in the printer.
  - a. From the control panel, navigate to the menu for the port settings.
  - b. Locate the menu for the serial port settings, and then adjust the settings, if necessary.
  - c. Apply the changes.
2. From your computer, open the printers folder, and then select your printer.
3. Open the printer properties, and then select the COM port from the list.
4. Set the COM port parameters in Device Manager.

### Notes

- Serial printing reduces printing speed.
- Make sure that the serial cable is connected to the serial port on your printer.

# Secure the printer

## Erasing printer memory

To erase volatile memory or buffered data in your printer, turn off the printer. To erase nonvolatile memory, device and network settings, security settings, and embedded solutions, do the following:

1. From the control panel, navigate to **Settings > Device > Maintenance > Out of Service Erase**.
2. Select **Sanitize all information on nonvolatile memory**, and then select **ERASE**.
3. Select **Start initial setup wizard** or **Leave printer offline**, and then select **Next**.
4. Start the process.

**Note:** This process also destroys the encryption key that is used to protect user data. Destroying the encryption key makes the data irrecoverable.

## Erasing printer storage drive

1. From the control panel, navigate to **Settings > Device > Maintenance > Out of Service Erase**.
2. Depending on the storage drive that is installed on your printer, do either of the following:
  - For hard disk, select **Sanitize all information on hard disk**, select **ERASE**, and then select a method to erase data.

**Note:** The process to sanitize the hard disk can take from several minutes to more than an hour, making the printer unavailable for other tasks.

- For intelligent storage drive, select **Cryptographically erase all user data on ISD**, and then select **ERASE**.

## Restoring factory default settings

1. From the control panel, navigate to **Settings > Device > Restore Factory Defaults**. Select **Restore Settings**.
2. Select the settings that you want to restore, and then select **RESTORE**.

## Statement of Volatility

Type of memory	Description
Volatile memory	The printer uses standard random access memory (RAM) to buffer temporarily user data during simple print and copy jobs.

Type of memory	Description
Nonvolatile memory	The printer may use two forms of nonvolatile memory: EEPROM and NAND (flash memory). Both types store the operating system, printer settings, and network information. They also store scanner and bookmark settings and embedded solutions.
Hard disk storage drive	Some printers may have a hard disk drive installed. The printer hard disk is designed for printer-specific functionality. The hard disk lets the printer retain buffered user data from complex print jobs, form data, and font data.
Intelligent storage drive (ISD)	Some printers may have an ISD installed. ISD uses nonvolatile flash memory to store user data from complex print jobs, form data, and font data.

Erase the content of any installed printer memory in the following circumstances:

- The printer is decommissioned.
- The printer hard disk or ISD is replaced.
- The printer is moved to a different department or location.
- The printer is serviced by someone from outside your organization.
- The printer is removed from your premises for service.
- The printer is sold to another organization.

**Note:** To dispose a storage drive, follow the policies and procedures of your organization.

# Print

## Printing from a computer

### For Windows users

If you are printing from a Microsoft app, such as Word or PowerPoint, then do the following:

1. Click **File > Print**.

**Note:** You can also press the **CTRL** and **P** keys to open the Print dialog.

2. In the **Printer** menu, select a printer, and then click **Printer Properties**.

**Note:** The Printing Preferences dialog appears which contains the settings to perform print jobs.

If you are printing from Adobe Acrobat™, then do the following:

1. Click **File** or **Menu>Print**.

**Note:** You can also press the **CTRL** and **P** keys to open the Print dialog.

2. In the **Printer** menu, select a printer, and then click **Properties**.

**Note:** The Printing Preferences dialog appears which contains the settings to perform print jobs.

If you are printing from a web browser, then do the following:

1. Click the **Settings** menu (three dots), and then click **Print**.

**Note:** You can also press the **CTRL** and **P** keys to open the Print dialog.

2. Select **More settings**, scroll down, and then click **Print using system dialogue**.
3. In the **Select Printer** menu, select a printer, and then click **Preferences**.

**Note:** The Printing Preferences dialog appears which contains the settings to perform print jobs.

### For Macintosh users

1. With a document open, click **File > Print**.

**Note:** You can also press the **Command** and **P** keys to open the Print dialog which contains the settings to perform print jobs.

## Printing from a mobile device

### Printing from a mobile device using Lexmark Print

Lexmark™ Print is a mobile printing solution for mobile devices running on Android™ platform version 6.0 or later. It lets you send documents and images to network-connected printers and print management servers.

#### Notes

- Make sure that you download the Lexmark Print app from the Google Play™ store and enable it in the mobile device.
- Make sure that the printer and mobile device are connected to the same network.

1. From your mobile device, select a document from the file manager.
2. Send or share the document to Lexmark Print.

**Note:** Some third-party apps may not support the send or share feature. For more information, see the documentation that came with the app.

3. Select a printer.  
If necessary, adjust the settings.
4. Print the document.

### Printing from a mobile device using Mopria™ Print Service

Mopria Print Service is a mobile printing solution for mobile devices running on Android™ version 5.0 or later. It lets you print directly to any Mopria™ certified printer.

**Note:** Make sure that you download Mopria Print Service from the Google Play™ store and enable it on your mobile device.

1. From your mobile device, launch a compatible application or select a document from the file manager.
2. Tap  > **Print**.
3. Select a printer, and then adjust the settings, if necessary.

4. Tap .

## Printing from a mobile device using AirPrint

The AirPrint software feature is a mobile printing solution that lets you print directly from Apple devices to an AirPrint-certified printer.

### Notes



- Make sure that the Apple device and the printer are connected to the same network. If the network has multiple wireless hubs, then make sure that both devices are connected to the same subnet.
- This application is supported only in some Apple devices.

1. From your mobile device, select a document from your file manager or launch a compatible application.
2. Tap  > **Print**.
3. Select a printer, and then adjust the settings, if necessary.
4. Print the document.

## Printing from a mobile device using Wi-Fi Direct®

Wi-Fi Direct® is a printing service that lets you print to any Wi-Fi Direct-ready printer.

**Note:** Make sure that the mobile device is connected to the printer wireless network. For more information, see [Connecting a mobile device to the printer on page 286](#).

1. From your mobile device, launch a compatible application or select a document from your file manager.
2. Depending on your mobile device, do one of the following:
  - Tap  > **Print**.
  - Tap  > **Print**.
  - Tap  > **Print**.
3. Select a printer, and then adjust the settings, if necessary.
4. Print the document.

## Printing from a flash drive

1. Insert the flash drive.

For more information on supported flash drives, see [Supported flash drives and file types on page 90](#).

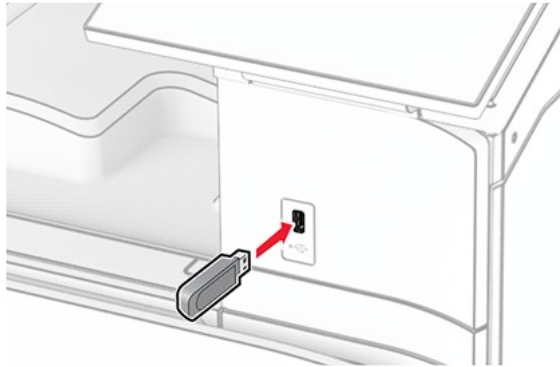

### Notes

- If you insert the flash drive when an error message appears, then the printer ignores the flash drive.
- If you insert the flash drive while the printer is processing other print jobs, then Busy appears on the display.

2. From the control panel, select **Print**.
3. Select **USB Drive**, and then select the document that you want to print.

If necessary, configure the settings.

4. Print the document.

### Warning—Potential Damage

To avoid loss of data or printer malfunction, do not touch the flash drive or the printer in the area shown while actively printing, reading, or writing from the memory device.



## Configuring confidential jobs

1. From the control panel, navigate to **Settings > Security > Confidential Print Setup**.
2. Configure the settings.

Setting	Description
<b>Max Invalid PIN</b>	<p>Set the limit for entering an invalid PIN.</p> <p><b>Note:</b> When the limit is reached, the print jobs for that username are deleted.</p>
<b>Confidential Job Expiration</b>	<p>Set an individual expiration time for each held job before it is automatically deleted from the printer memory, hard disk, or intelligent storage drive.</p> <p><b>Note:</b> A held job is either <b>Confidential, Repeat, Reserve, or Verify</b>.</p>
<b>Repeat Job Expiration</b>	<p>Set the expiration time for print jobs that you want to repeat.</p>
<b>Verify Job Expiration</b>	<p>Set the expiration time for printing a copy of a job for you to check its quality before printing the remaining copies.</p>
<b>Reserve Job Expiration</b>	<p>Set the expiration time for jobs that you want to store in the printer for printing later.</p>

Setting	Description
<b>Require All Jobs to be Held</b>	Set the printer to hold all print jobs.
<b>Keep duplicate documents</b>	Set the printer to keep all documents with the same file name.

## Printing confidential and other held jobs

**Note:** Held jobs may get deleted before they expire or without any intervention if memory resources become low. If your printer supports a storage drive, then install a hard disk or an intelligent storage drive to increase its storage for held jobs.

### For Windows users

1. With a document open, click **File > Print**.
2. Select a printer, and then click **Properties, Preferences, Options, or Setup**.
3. Click **Print and Hold**.
4. Click **Use Print and Hold**, and then assign a username.
5. Select from any of the following print job types:

- **Confidential print**—The printer asks for a personal identification number before letting you print the job.

**Note:** If you select this job type, then enter a four-digit personal identification number (PIN).

- **Verify print**—The printer prints one copy and holds the remaining copies that you requested from the driver in printer memory.
  - **Reserve print**—The printer stores the job in memory so that you can print the job later.
  - **Repeat print**—The printer prints all requested copies of the job and stores the job in memory so you can print additional copies later.
6. Click **OK**.
  7. Click **Print**.
  8. From the printer control panel, release the print job.
    - a. Select **Print**.
    - b. Select **Held jobs**, and then select your username.

**Note:** For confidential print jobs, select **Confidential**, enter the PIN, and then select **OK**.

- c. Select the print job, and then select **Print**.

### For Macintosh users

1. With a document open, choose **File > Print**.
2. Select a printer.
3. From the **Print Job Security** drop-down menu, enable **Print with PIN**, and then enter a four-digit PIN.
4. Click **Print**.
5. From the printer control panel, release the print job.
  - a. Select **Held jobs**, and then select the computer name.
  - b. Select **Confidential**, and then enter the PIN.
  - c. Select the print job, and then select **Print**.

## Printing a font sample list

1. From the control panel, navigate to **Settings > Reports > Print > Print Fonts**.
2. Select the type of font.

## Printing a directory list

1. From the control panel, navigate to **Settings > Reports > Print**.
2. Select **Print Directory**.

## Placing separator sheets in print jobs

1. With a document open, click **File > Print**.
2. Select a printer, and then click **Properties, Preferences, Options, or Setup**.
3. Click **Paper/Finishing**.
4. In the **Separator sheets** menu, select a setting.
5. Click **OK**, and then click **Print**.

## Canceling a print job

1. From the control panel, select **Job Queue**.
2. Select **Print**, and then select a job to cancel.

**Note:** If a document is already printing, then select **Cancel job** in the lower-right corner of the display to stop printing.

## Adjusting toner darkness

1. From the control panel, navigate to **Settings > Print > Quality**.
2. Adjust the setting for **Toner Darkness**.

# Copy

## Making copies

1. Load an original document into the ADF tray or on the scanner glass.

**Note:** To avoid a resized image, make sure that the original document and output have the same paper size.

2. From the control panel, select **Copy**, and then specify the number of copies.  
If necessary, adjust the copy settings.
3. Copy the document.

## Copying photos

1. Place a photo on the scanner glass.
2. From the control panel, navigate to **Copy > More Settings > Content > Content Type > Photo**.
3. Select **Content Source**, and then select the setting that best matches the original photo.
4. Copy the photo.

## Copying on letterhead

1. Load an original document into the ADF tray or on the scanner glass.
2. From the control panel, navigate to **Copy > Copy From**.
3. Select the size of the original document.
4. Select **Copy To**, and then select the paper source that contains the letterhead.  
If you loaded the letterhead into the multipurpose feeder, select **Multipurpose Feeder**, select a paper size, and then select **Letterhead**.
5. Copy the document.

## Copying on both sides of the paper

1. Load an original document into the ADF tray or on the scanner glass.
2. From the control panel, navigate to **Copy > More Settings > Sides**.
3. Select a setting.
4. Copy the document.

## Reducing or enlarging copies

1. Load an original document into the ADF tray or on the scanner glass.
2. From the control panel, navigate to **Copy > More Settings > Scale**.
3. Select a setting.

**Note:** Changing the size of the original document or output after setting **Scale** restores the scale value to **Auto**.

4. Copy the document.

## Collating copies

1. Load an original document into the ADF tray or on the scanner glass.
2. From the control panel, navigate to **Copy > More Settings > Collate > On [1,2,1,2,1,2]**.
3. Copy the document.

## Placing separator sheets between copies

1. Load an original document into the ADF tray or on the scanner glass.
2. From the control panel, navigate to **Copy > More Settings > Separator Sheets**.
3. Enable the menu, and then select a setting.
4. Copy the document.

## Copying multiple pages onto a single sheet

1. Load an original document into the ADF tray or on the scanner glass.
2. From the control panel, navigate to **Copy > More Settings > Pages per Side**.
3. Enable the menu, and then select a setting.
4. Copy the document.

## Copying cards

1. Load a card on the scanner glass.
2. From the control panel, navigate to **Copy > Copy From > ID Card**.
3. Copy the card.

## Creating a copy shortcut

1. From the control panel, select **Copy**.
2. Configure the settings, and then select .
3. Create a shortcut.

# Email

## Configuring the email SMTP settings

Configure the Simple Mail Transfer Protocol (SMTP) settings to send a scanned document through email. The settings vary with each service provider. For more information, see [email service providers](#).

Before you begin, make sure that the printer is connected to a network and that the network is connected to the Internet.

## Using the Embedded Web Server

1. Open a web browser, and then type the printer IP address in the address field.

### Notes

- View the printer IP address on the printer home screen. The IP address appears as four sets of numbers separated by periods, such as 123.123.123.123.
- If you are using a proxy server, then temporarily disable it to load the web page correctly.

2. Click **Settings > Email**.
3. Configure the email settings. For more information, see [Email service providers](#).

### Notes

- For email service providers that are not on the list, contact your provider and ask for the settings.
- For video instructions on configuring the SMTP settings for Gmail™ email service, go to <https://infoserve.lexmark.com/ref/common/configuring-email-video.html>.
- For Microsoft 365 OAuth 2.0 Authentication, you must register your printer to OAuth 2.0 Authentication. For more information, see [Setting up OAuth 2.0 Authentication for Email Server using the Embedded Web Server](#).

4. Click **Save**.

## Setting up OAuth 2.0 Authentication for Email Server using the Embedded Web Server

1. Open a web browser, and then type the printer IP address in the address field.

### Notes

- View the printer IP address on the printer home screen. The IP address appears as four sets of numbers separated by periods, such as 123.123.123.123.
- If you are using a proxy server, then temporarily disable it to load the web page correctly.

2. Click **Settings > Email**.
3. Scroll down to the **Set Up OAuth 2 for Email Server** section, and then click **Register**.
4. Go to <https://microsoft.com/devicelogin>.
5. Enter the code that was generated in the Embedded Web Server.
6. Log in to your Outlook account.
7. Follow the instructions on the screen.

## Using the email setup wizard in the printer

The wizard appears when you attempt to send an email and the SMTP settings are not yet configured. These instructions apply only to some printer models.

### Notes

- Before using the wizard, make sure that the printer firmware is updated. For more information, see the “Printer firmware instructions” section.
- Setting up the SMTP settings using the email setup wizard is not applicable for OAuth 2.0 Authentication.

1. From the home screen, touch **Email**.
2. Touch **Set up now**, and then type your email address.
3. Type the password.

### Notes

- Depending on your email service provider, type your account password, app password, or authentication password. For more information on the password, see [email service providers](#), and then look for Device Password.
- If your provider is not listed, then contact your provider and ask for the Primary SMTP Gateway, Primary SMTP Gateway Port, Use SSL/TLS, and SMTP Server Authentication settings. Proceed with the setup after getting the settings.

4. Touch **OK**.

## Using the email setup wizard in the printer

1. From the control panel, navigate to **Settings > Email > Email Setup**.
2. Configure the settings.

### Notes

- For more information on the password, see [email service providers](#).
- If your service provider is not listed, then contact your provider.

## Email service providers

Use the following table to determine the SMTP settings of your service provider.

### Notes

- If you encounter errors using the settings provided, then contact your service provider.
- If your service provider is not listed, then contact your provider.

- [AOL Mail](#)
- [Comcast Mail](#)
- [Gmail](#)
- [iCloud Mail](#)
- [Mail.com](#)
- [NetEase Mail \(mail.126.com\)](#)
- [NetEase Mail \(mail.163.com\)](#)
- [NetEase Mail \(mail.yeah.net\)](#)
- [Outlook Live or Microsoft 365](#)
- [QQ Mail](#)
- [Sina Mail](#)
- [Sohu Mail](#)
- [Yahoo! Mail](#)
- [Zoho Mail](#)

### Notes

- If you encounter errors using the settings provided, then contact your email service provider.
- For email service providers that are not on the list, contact your provider.

### AOL Mail

Setting	Value
<b>Primary SMTP Gateway</b>	smtp.aol.com
<b>Primary SMTP Gateway Port</b>	587
<b>Use SSL/TLS</b>	Required
<b>Require Trusted Certificate</b>	Disabled

## Email

---

Setting	Value
Reply Address	Your email address
SMTP Server Authentication	Login / Plain
Device-Initiated E-mail	Use Device SMTP Credentials
Device UserID	Your email address
Device Password	App password

**Note:** To create an app password, go to the [AOL Account Security](#) page, log in to your account, and then click **Generate app password**.

## Comcast Mail

Setting	Value
Primary SMTP Gateway	smtp.comcast.net
Primary SMTP Gateway Port	587
Use SSL/TLS	Required
Require Trusted Certificate	Disabled
Reply Address	Your email address
SMTP Server Authentication	Login / Plain
Device-Initiated E-mail	Use Device SMTP Credentials
Device UserID	Your email address
Device Password	Account password

## Gmail™

**Note:** Make sure that two-step verification is enabled on your Google account. To enable two-step verification, go to the [Google Account Security](#) page, log in to your account, and then from the “Signing in to Google” section, click **2-Step Verification**.

Setting	Value
Primary SMTP Gateway	smtp.gmail.com
Primary SMTP Gateway Port	587
Use SSL/TLS	Required
Require Trusted Certificate	Disabled

## Email

---

Setting	Value
Reply Address	Your email address
SMTP Server Authentication	Login / Plain
Device-Initiated E-mail	Use Device SMTP Credentials
Device UserID	Your email address
Device Password	App password

**Notes**

- To create an app password, go to the [Google Account Security](#) page, log in to your account, and then from the “Signing in to Google” section, click **App passwords**.
- “App passwords” shows only if two-step verification is enabled.

## iCloud Mail

**Note:** Make sure that two-step verification is enabled on your account.

Setting	Value
Primary SMTP Gateway	smtp.mail.me.com
Primary SMTP Gateway Port	587
Use SSL/TLS	Required
Require Trusted Certificate	Disabled
Reply Address	Your email address
SMTP Server Authentication	Login / Plain
Device-Initiated E-mail	Use Device SMTP Credentials
Device UserID	Your email address

## Email

---

Setting	Value
Device Password	App password

**Note:** To create an app password, go to the [iCloud Account Management](#) page, log in to your account, and then from the Security section, click **Generate Password**.

## Mail.com

Setting	Value
Primary SMTP Gateway	smtp.mail.com
Primary SMTP Gateway Port	587
Use SSL/TLS	Required
Require Trusted Certificate	Disabled
Reply Address	Your email address
SMTP Server Authentication	Login / Plain
Device-Initiated E-mail	Use Device SMTP Credentials
Device UserID	Your email address
Device Password	Account password

## NetEase Mail (mail.126.com)

**Note:** Make sure that the SMTP service is enabled on your account. To enable the service, from the NetEase Mail home page, click **Settings > POP3/SMTP/IMAP**, and then enable either **IMAP/SMTP service** or **POP3/SMTP service**.

Setting	Value
Primary SMTP Gateway	smtp.126.com
Primary SMTP Gateway Port	465
Use SSL/TLS	Required
Require Trusted Certificate	Disabled
Reply Address	Your email address
SMTP Server Authentication	Login / Plain
Device-Initiated E-mail	Use Device SMTP Credentials
Device UserID	Your email address

## Email

---

Setting	Value
<b>Device Password</b>	Authorization password  <b>Note:</b> The authorization password is provided when IMAP/SMTP service or POP3/SMTP service is enabled.

### NetEase Mail (mail.163.com)

**Note:** Make sure that the SMTP service is enabled on your account. To enable the service, from the NetEase Mail home page, click **Settings > POP3/SMTP/IMAP**, and then enable either **IMAP/SMTP service** or **POP3/SMTP service**.

Setting	Value
<b>Primary SMTP Gateway</b>	smtp.163.com
<b>Primary SMTP Gateway Port</b>	465
<b>Use SSL/TLS</b>	Required
<b>Require Trusted Certificate</b>	Disabled
<b>Reply Address</b>	Your email address
<b>SMTP Server Authentication</b>	Login / Plain
<b>Device-Initiated E-mail</b>	Use Device SMTP Credentials
<b>Device UserID</b>	Your email address
<b>Device Password</b>	Authorization password  <b>Note:</b> The authorization password is provided when IMAP/SMTP service or POP3/SMTP service is enabled.

### NetEase Mail (mail.yeah.net)

**Note:** Make sure that the SMTP service is enabled on your account. To enable the service, from the NetEase Mail home page, click **Settings > POP3/SMTP/IMAP**, and then enable either **IMAP/SMTP service** or **POP3/SMTP service**.

Setting	Value
<b>Primary SMTP Gateway</b>	smtp.yeah.net
<b>Primary SMTP Gateway Port</b>	465

## Email

Setting	Value
Use SSL/TLS	Required
Require Trusted Certificate	Disabled
Reply Address	Your email address
SMTP Server Authentication	Login / Plain
Device-Initiated E-mail	Use Device SMTP Credentials
Device UserID	Your email address
Device Password	Authorization password
	<p><b>Note:</b> The authorization password is provided when IMAP/SMTP service or POP3/SMTP service is enabled.</p>

### Outlook Live or Microsoft 365

These settings apply to outlook.com and hotmail.com email domains, and Microsoft 365 accounts.

Setting	Value (Simple Authentication)	Value (OAuth2.0 Authentication)
Primary SMTP Gateway	smtp.office365.com	smtp.office365.com
Primary SMTP Gateway Port	587	587
Use SSL/TLS	Required	Required
Require Trusted Certificate	Disabled	Disabled
Reply Address	Your email address	The email address used to register OAuth 2.0 Authentication
SMTP Server Authentication	Login / Plain	OAuth2.0
User-Initiated Email	N/A	Use Device SMTP Credentials
Device-Initiated E-mail	Use Device SMTP Credentials	Use Device SMTP Credentials
Device UserID	Your email address	N/A

Setting	Value (Simple Authentication)	Value (OAuth2.0 Authentication)
<b>Device Password</b>	<p>Account password or app password</p> <div style="background-color: #f0f0f0; padding: 10px; margin-top: 10px;"> <p><b>Notes</b></p> <ul style="list-style-type: none"> <li>• For accounts with two-step verification disabled, use your account password.</li> <li>• For outlook.com or hotmail.com accounts with two-step verification enabled, use an app password. To create an app password, go to the <a href="#">Outlook Live Account Management</a> page, and then log in to your account.</li> </ul> </div>	N/A

**Note:** For more setup options for business using Microsoft 365, go to the [Microsoft 365 help page](#).

### QQ Mail

**Note:** Make sure that the SMTP service is enabled on your account. To enable the service, from the QQ Mail home page, click **Settings > Account**, and then from the POP3/IMAP/SMTP/Exchange/CardDAV/CalDAV Service section, enable either **POP3/SMTP service** or **IMAP/SMTP service**.

Setting	Value
<b>Primary SMTP Gateway</b>	smtp.qq.com

## Email

---

Setting	Value
Primary SMTP Gateway Port	587
Use SSL/TLS	Required
Require Trusted Certificate	Disabled
Reply Address	Your email address
SMTP Server Authentication	Login / Plain
Device-Initiated E-mail	Use Device SMTP Credentials
Device UserID	Your email address
Device Password	Authorization code

**Note:** To generate an authorization code, from the QQ Mail home page, click **Settings > Account**. From the POP3/IMAP/SMTP/Exchange/CardDAV/CalDAV Service section, click **Generate authorization code**.

## Sina Mail

**Note:** Make sure that the POP3/SMTP service is enabled on your account. To enable the service, from the Sina Mail home page, click **Settings > More settings > User-end POP/IMAP/SMTP**, and then enable **POP3/SMTP service**.

Setting	Value
Primary SMTP Gateway	smtp.sina.com
Primary SMTP Gateway Port	587
Use SSL/TLS	Required
Require Trusted Certificate	Disabled
Reply Address	Your email address
SMTP Server Authentication	Login / Plain
Device-Initiated E-mail	Use Device SMTP Credentials
Device UserID	Your email address

Setting	Value
Device Password	Authorization code  <div style="border: 1px solid #ccc; padding: 5px; background-color: #f9f9f9;"> <p><b>Note:</b> To create an authorization code, from the email home page, click <b>Settings &gt; More settings &gt; User-end POP/IMAP/SMTP</b>, and then enable <b>Authorization code status</b>.</p> </div>

### Sohu Mail

**Note:** Make sure that the SMTP service is enabled on your account. To enable the service, from the Sohu Mail home page, click **Options > Settings > POP3/SMTP/IMAP**, and then enable either **IMAP/SMTP service** or **POP3/SMTP service**.

Setting	Value
Primary SMTP Gateway	smtp.sohu.com
Primary SMTP Gateway Port	465
Use SSL/TLS	Required
Require Trusted Certificate	Disabled
Reply Address	Your email address
SMTP Server Authentication	Login / Plain
Device-Initiated E-mail	Use Device SMTP Credentials
Device UserID	Your email address
Device Password	Independent password  <div style="border: 1px solid #ccc; padding: 5px; background-color: #f9f9f9;"> <p><b>Note:</b> The independent password is provided when IMAP/SMTP service or POP3/SMTP service is enabled.</p> </div>

### Yahoo! Mail

Setting	Value
Primary SMTP Gateway	smtp.mail.yahoo.com
Primary SMTP Gateway Port	587
Use SSL/TLS	Required
Require Trusted Certificate	Disabled

## Email

---

Setting	Value
Reply Address	Your email address
SMTP Server Authentication	Login / Plain
Device-Initiated E-mail	Use Device SMTP Credentials
Device UserID	Your email address
Device Password	App password

**Note:** To create an app password, go to the [Yahoo Account Security](#) page, log in to your account, and then click **Generate app password**.

## Zoho Mail

Setting	Value
Primary SMTP Gateway	smtp.zoho.com
Primary SMTP Gateway Port	587
Use SSL/TLS	Required
Require Trusted Certificate	Disabled
Reply Address	Your email address
SMTP Server Authentication	Login / Plain
Device-Initiated E-mail	Use Device SMTP Credentials
Device UserID	Your email address

Setting	Value
<b>Device Password</b>	Account password or app password <div style="border: 1px solid #ccc; padding: 10px; background-color: #f9f9f9;"><p><b>Notes</b></p><ul style="list-style-type: none"><li>• For accounts with two-step verification disabled, use your account password.</li><li>• For accounts with two-step verification enabled, use an app password. To create an app password, go to the <a href="#">Zoho Mail Account Security</a> page, log in to your account, and then from the Application-Specific Passwords section, click <b>Generate New Password</b>.</li></ul></div>

## Sending an email

Before you begin, make sure that the SMTP settings are configured. For more information, see [Configuring the email SMTP settings on page 300](#).

1. Load an original document into the ADF tray or on the scanner glass.
2. From the control panel, navigate to **Scan > Email**.
3. Enter the needed information, and then select **Next**.

If necessary, configure the settings.

4. Select **Scan**, and then send the email.

## Creating an email shortcut

### Using the control panel

1. From the control panel, navigate to **Scan > E-mail**.
2. Enter the needed information, and then select .
3. Create a shortcut.

### Using the Embedded Web Server

1. Open a web browser, and then type the printer IP address in the address field.

### Notes

- View the printer IP address on the printer home screen. The IP address appears as four sets of numbers separated by periods, such as 123.123.123.123.
- If you are using a proxy server, then temporarily disable it to load the web page correctly.

2. Click **Shortcuts > Add Shortcut**.
3. Configure the settings.
4. Click **Save**.

# Fax

## Sending a fax

### Using the control panel

1. Load an original document into the ADF tray or on the scanner glass.
2. From the control panel, select **Fax**.
3. Select **Add Recipient** or **Address Book**.

If necessary, adjust the settings.

4. Send the fax.

### Using the computer

Before you begin, make sure that the fax driver is installed. For more information, see [Installing the fax driver on page 127](#).

#### For Windows users

1. With a document open, click **File > Print**.
2. Select a printer, and then click **Properties, Preferences, Options, or Setup**.
3. Click **Fax > Enable fax > Always display settings prior to faxing**, and then enter the recipient number.

If necessary, configure the settings.

4. Send the fax.

#### For Macintosh users

1. With a document open, choose **File > Print**.
2. Select the printer that has **- Fax** added after its name.
3. In the To field, enter the recipient number.

If necessary, configure the settings.

4. Send the fax.

## Scheduling a fax

1. Load an original document into the ADF tray or on the scanner glass.
2. From the control panel, select **Fax**.
3. Select **Add Recipient** or **Address Book**, and then enter the needed information.
4. Select **Send Time**, configure the date and time, and then select **Done**.

If necessary, configure other fax settings.

5. Send the fax.

## Creating a fax destination shortcut

1. From the control panel, select **Fax**.
2. Select **Add Recipient** or **Address Book**, and then enter the needed information.

If necessary, adjust the settings.

3. Select .
4. Create a shortcut.

## Changing the fax resolution

1. Load an original document into the ADF tray or on the scanner glass.
2. From the control panel, select **Fax**.
3. Select **Add Recipient** or **Address Book**, and then enter the needed information.
4. Select **Resolution**, and then select a setting.
5. Send the fax.

## Adjusting the fax darkness

1. Load an original document into the ADF tray or on the scanner glass.
2. From the control panel, select **Fax**.
3. Select **Add Recipient** or **Address Book**, and then enter the needed information.
4. Select **More Settings > Darkness**, and then adjust the setting.
5. Send the fax.

## Printing a fax log

1. From the control panel, navigate to **Settings > Reports > Fax**.
2. Select a fax log.

## Blocking junk faxes

1. From the control panel, navigate to **Settings > Fax > Fax Setup > Fax Receive Settings > Admin Controls**.
2. Enable the **Block No Name Fax** menu.

## Holding faxes

1. From the control panel, navigate to **Settings > Fax > Fax Setup > Fax Receive Settings > Holding Faxes**.
2. Select a setting.

## | Forwarding a fax

1. From the control panel, navigate to **Settings > Fax > Fax Setup > Fax Receive Settings > Admin Controls**.
2. Select **Fax Forwarding**, and then select **Print and Forward** or **Forward**.
3. In the **Forward to** menu, select a destination and then configure the settings.

# Scan

## Scanning to a computer

Before you begin, make sure that the computer and the printer are connected to the same network.

### For Windows users

#### Using Lexmark ScanBack Utility

1. From the computer, run **Lexmark ScanBack Utility**, and then click **Create profile**.

#### Notes

- To download the utility, go to [www.lexmark.com/downloads](http://www.lexmark.com/downloads).
- If you prefer to use an existing scanning profile, click **Existing profile**.

2. Click **Setup**, add then add the printer IP address.

**Note:** View the printer IP address on the printer home screen. The IP address appears as four sets of numbers separated by periods, such as 123.123.123.123.

3. Click **OK**, and then click **Close**.
4. Select the format and the size of the document to be scanned.
5. Select a file format and scan resolution, and then click **Next**.
6. Type a unique scan profile name.
7. Browse to the location that you want to save the scanned document to, and then create a file name.

**Note:** To reuse the scan profile, enable **Create Shortcut**, and then create a unique shortcut name.

8. Click **Finish**.
9. Load an original document into the automatic document feeder or on the scanner glass.
10. From the control panel, navigate to **Scan Profiles > Scan to Computer**, and then select a scan profile.
11. On your computer, click **Scan Complete**.

#### Using Windows Fax and Scan

**Note:** Make sure that the printer is added to the computer. For more information, see [Adding printers to a computer on page 127](#).

1. Load an original document into the automatic document feeder or on the scanner glass.
2. From the computer, open **Windows Fax and Scan**.

3. Click **New Scan**, and then select a scanner source.
4. If necessary, change the scan settings.
5. Scan the document.
6. Click **Save as**, type a file name, and then click **Save**.

### For Macintosh users

**Note:** Make sure that the printer is added to the computer. For more information, see [Adding printers to a computer on page 127](#).

1. Load an original document into the automatic document feeder or on the scanner glass.
2. From the computer, do either of the following:
  - Open **Image Capture**.
  - Open **Printers & Scanners**, and then select a printer. Click **Scan > Open Scanner**.
3. From the **Scanner** dialog, do one or more of the following:
  - Select the location that you want to save the scanned document to.
  - Select the size of the original document.
  - To scan from the ADF, select **Document Feeder** from the **Scan Menu** or enable **Use Document Feeder**.
  - If necessary, configure the scan settings.
4. Click **Scan**.

## Scanning to an FTP server

Before you begin, make sure that the printer is connected to an FTP server.

1. Load an original document into the ADF tray or on the scanner glass.
2. From the control panel, navigate to **Scan > FTP**.
3. Enter the needed information, and then select **Next**.  
If necessary, configure the FTP settings.
4. Scan the document.

## Creating an FTP shortcut

1. From the control panel, navigate to **Scan > FTP**.
2. Enter the FTP server address, and then select  .
3. Create a shortcut.

## Scanning to a network folder

Before you begin, make sure that the network folder that you want to scan the document to is already configured.

1. Load an original document into the ADF tray or on the scanner glass.
2. From the control panel, navigate to **Scan Center > Network Folder**.
3. Select the applicable network folder.

**Note:** To add a network folder, see [Configuring a network folder destination on page 319](#).

4. Scan the document.

## Configuring a network folder destination

1. From the control panel, navigate to **Scan Center > Network Folder > Create Network Folder**.
2. Configure the necessary settings.
3. Log in to the network, and then select **Next**.
4. Configure the network folder settings, and then select **Done**.

**Note:** To scan a document to a network folder, see [Scanning to a network folder on page 318](#).

## Creating a network folder shortcut

1. Open a web browser, and then type the printer IP address in the address field.

### Notes

- View the printer IP address on the printer home screen. The IP address appears as four sets of numbers separated by periods, such as 123.123.123.123.
- If you are using a proxy server, then temporarily disable it to load the web page correctly.

2. Click **Shortcuts > Add Shortcut**.
3. From the **Shortcut Type** menu, select **Network Folder**, and then configure the settings.
4. Apply the changes.

## Scanning to a flash drive

1. Load an original document into the ADF tray or on the scanner glass.
2. Insert the flash drive.

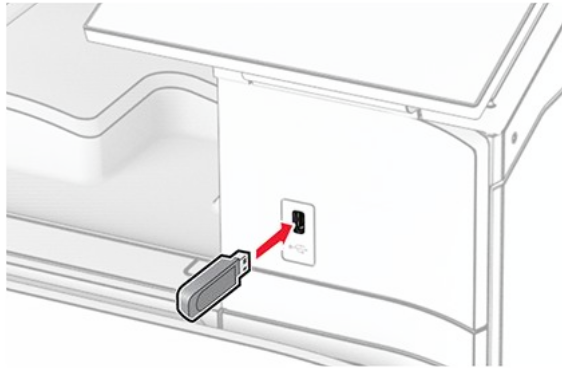

3. From the control panel, select **Scan**, and then select **USB Drive**.
4. Select a location to save the file, create a file name, and then select **Next**.
5. Configure the scan settings.
6. Scan the document.

### **Warning—Potential Damage**

To avoid loss of data or printer malfunction, do not touch the flash drive or the printer in the area shown while actively printing, reading, or writing from the memory device.

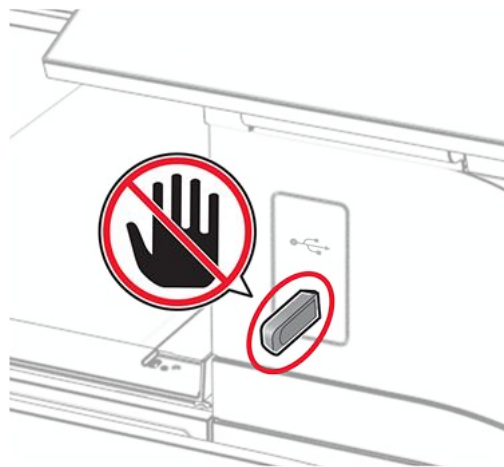

# Printer menus

## Menu map

<b>Device</b>	<ul style="list-style-type: none"> <li>• Preferences</li> <li>• Eco-Mode</li> <li>• Remote Operator Panel</li> <li>• Notifications</li> <li>• Power Management</li> <li>• Share Data with Lexmark</li> </ul>	<ul style="list-style-type: none"> <li>• Accessibility</li> <li>• Restore Factory Defaults</li> <li>• <b>Maintenance</b></li> <li>• Firmware Update</li> <li>• About this Printer</li> </ul>
<b>Print</b>	<ul style="list-style-type: none"> <li>• Layout</li> <li>• Finishing<sup>1</sup></li> <li>• Setup</li> <li>• Quality</li> <li>• Job Accounting</li> </ul>	<ul style="list-style-type: none"> <li>• PDF</li> <li>• PostScript</li> <li>• PCL</li> <li>• Image</li> </ul>
<b>Paper</b>	<ul style="list-style-type: none"> <li>• Tray Configuration</li> <li>• Media Configuration</li> </ul>	<ul style="list-style-type: none"> <li>• Bin Configuration<sup>1</sup></li> </ul>
<b>Copy</b>	Copy Defaults	
<b>Fax</b>	Fax Defaults	
<b>Email</b>	<ul style="list-style-type: none"> <li>• Email Setup</li> <li>• Email Defaults</li> </ul>	<ul style="list-style-type: none"> <li>• Web Link Setup</li> </ul>
<b>FTP</b>	FTP Defaults	
<b>USB Drive</b>	<ul style="list-style-type: none"> <li>• Flash Drive Scan</li> </ul>	<ul style="list-style-type: none"> <li>• Flash Drive Print</li> </ul>
<b>Network/Ports</b>	<ul style="list-style-type: none"> <li>• Network Overview</li> <li>• Wireless</li> <li>• Wi-Fi Direct</li> <li>• Mobile Services Management</li> </ul>	<ul style="list-style-type: none"> <li>• IPSec</li> <li>• 802.1x</li> <li>• LPD Configuration</li> <li>• HTTP/FTP Settings</li> </ul>

<b>Network/Ports</b>	<ul style="list-style-type: none"> <li>• Ethernet</li> <li>• TCP/IP</li> <li>• SNMP</li> </ul>	<ul style="list-style-type: none"> <li>• ThinPrint</li> <li>• USB</li> <li>• Restrict external network access</li> </ul>
<b>Security</b>	<ul style="list-style-type: none"> <li>• <b>Login Methods</b></li> <li>• Schedule USB Devices</li> <li>• Security Audit Log</li> <li>• Login Restrictions</li> <li>• Confidential Print Setup</li> </ul>	<ul style="list-style-type: none"> <li>• Encryption</li> <li>• Erase Temporary Data Files</li> <li>• Solutions LDAP Settings</li> <li>• Miscellaneous</li> </ul>
<b>Cloud Services</b>	<a href="#">Cloud Services Enrollment</a>	
<b>Reports</b>	<ul style="list-style-type: none"> <li>• <a href="#">Menu Settings Page</a></li> <li>• <a href="#">Device</a></li> <li>• <a href="#">Print</a></li> </ul>	<ul style="list-style-type: none"> <li>• <a href="#">Shortcuts</a></li> <li>• <a href="#">Fax</a></li> <li>• <a href="#">Network</a></li> </ul>
<a href="#">Troubleshooting</a>	<b>Print Quality Test Pages</b>	<b>Cleaning the Scanner</b>
<b>Forms Merge</b> <sup>2</sup>	<a href="#">Forms Merge</a>	

<sup>1</sup> Appears only when a finisher is installed.

<sup>2</sup> Appears only when a storage drive is installed.

## Device

### Preferences

**Note:** An asterisk (\*) next to a value indicates the factory default setting.

Menu item	Submenu item	Settings	Description
<b>Display Language</b>	N/A	[List of languages]	Set the language of the text that appears on the display.
<b>Country/Region</b>	N/A	[List of countries or regions]	Identify the country or region where the printer is configured to operate.
<b>Run initial setup</b>	N/A	<b>Off*</b> <b>On</b>	Run the setup wizard.

Menu item	Submenu item	Settings	Description
<b>Keyboard</b>	<b>Keyboard Type</b>	[List of languages]	<p>Select a language as a keyboard type.</p> <div style="border: 1px solid gray; padding: 5px; background-color: #f0f0f0;"> <p><b>Note:</b> All the <b>Keyboard Type</b> values may not appear or may require special hardware to appear.</p> </div>
<b>Date and Time</b>	<b>Configure</b>	<p><b>Current Date and Time</b></p> <p><b>Manually Set Date and Time</b></p> <p><b>Date Format (MM-DD-YYYY*)</b></p> <p><b>Time Format (12 hour A.M./P.M.*)</b></p> <p><b>Time Zone</b></p> <p><b>DST (GMT) Offset</b></p> <p><b>DST Start</b></p> <p><b>DST End</b></p> <p><b>DST Offset</b></p>	<p>Configure the printer date and time and network time protocol.</p> <div style="border: 1px solid gray; padding: 5px; background-color: #f0f0f0;"> <p><b>Notes</b></p> <ul style="list-style-type: none"> <li>• <b>MM-DD-YYYY</b> is the U.S. factory default setting.</li> <li>• <b>DD-MM-YYYY</b> is the international factory default setting.</li> <li>• <b>UTC (GMT) Offset, DST Start, DST End, and DST Offset</b> appear only when <b>Time Zone</b> is set to <b>(UTC+user) Custom</b>.</li> <li>• <b>Key ID</b> and <b>Password</b> appear only when <b>Enable Authentication</b> is set to <b>MD5 key</b>.</li> </ul> </div>
	<b>Network Time Protocol</b>	<p><b>Enable NTP (On*)</b></p> <p><b>NTP Server</b></p> <p><b>Enable Authentication (None*)</b></p> <p><b>Key ID</b></p> <p><b>Password</b></p>	

## Printer menus

Menu item	Submenu item	Settings	Description
<b>Paper Sizes</b>	N/A	<b>U.S.*</b> <b>Metric</b>	Specify the unit of measurement for paper sizes.  <b>Note:</b> The country or region selected in the initial setup wizard determines the initial paper size setting.
<b>Screen Brightness</b>	N/A	<b>20% to 100%</b> <b>(100*)</b>	Adjust the brightness of the display.
<b>Flash Drive Access</b>	N/A	<b>Disabled</b> <b>Enabled*</b>	Enable access to the flash drive function of the printer.
<b>Allow Background Removal</b>	N/A	<b>Off</b> <b>On*</b>	Specify whether background removal is allowed.
<b>Allow Custom Job scans</b>	N/A	<b>Off</b> <b>On*</b>	Specify whether the <b>Custom Job Scanning</b> setting appears for copy, scan, and fax.  <b>Note:</b> This menu item appears only when a storage drive is installed.
<b>One Page Flatbed Scanning</b>	N/A	<b>Off*</b> <b>On</b>	Set the printer to scan any type of job involving the scanner glass as a single page.  <b>Note:</b> The printer returns to the home screen after performing a single flatbed scan instead of displaying prompts.
<b>Device Sounds</b>	<b>Mute All Sounds</b>	<b>Off*</b> <b>On</b>	Configure the sound settings of the printer.
	<b>Button Feedback</b>	<b>Off</b> <b>On*</b>	
	<b>Volume</b>	<b>0 to 10 (5*)</b>	

## Printer menus

---

Menu item	Submenu item	Settings	Description
	<b>ADF Loaded Beep</b>	<b>Off</b> <b>On*</b>	
	<b>Alarm Control</b>	<b>Off</b> <b>Single*</b> <b>Continuous</b>	
	<b>Cartridge Alarm</b>	<b>Off</b> <b>Single*</b> <b>Continuous</b>	
	<b>Speaker Mode</b>	<b>Always Off*</b> <b>Always On</b> <b>On until Connected</b>	
	<b>Ringer Volume</b>	<b>Off*</b> <b>On</b>	
<b>Screen Timeout</b>	N/A	<b>5 to 300 seconds (60*)</b>	Set the idle time in seconds before the display shows the home screen, or before the printer logs out a user account automatically.

## Eco-Mode

**Note:** An asterisk (\*) next to a value indicates the factory default setting.

Menu item	Submenu item	Settings	Description
<b>Print</b>	<b>Sides</b>	<b>1-Sided</b> <b>2-Sided*</b>	Specify whether to print on one side or both sides of the paper.

## Printer menus

Menu item	Submenu item	Settings	Description
	<b>Pages per Side</b>	<b>Off*</b> <b>2 pages per side</b> <b>3 pages per side</b> <b>4 pages per side</b> <b>6 pages per side</b> <b>9 pages per side</b> <b>12 pages per side</b> <b>16 pages per side</b>	Specify the number of pages to print on one side of a sheet of paper.
	<b>Toner Darkness</b>	<b>1 to 10 (8*)</b>	Determine the lightness or darkness of text images.
<b>Copy</b>	<b>Sides</b>	<b>1 sided to 1 sided*</b> <b>1 sided to 2 sided</b> <b>2 sided to 1 sided</b> <b>2 sided to 2 sided</b>	Specify the scanning behavior based on the original document.
	<b>Pages per Side</b>	<b>Off*</b> <b>2 Portrait pages</b> <b>4 Portrait pages</b> <b>2 Landscape pages</b> <b>4 Landscape pages</b>	Specify the number of pages to copy on one side of a sheet of paper.
	<b>Darkness</b>	<b>1 to 9 (5*)</b>	Determine the darkness of the scanned text images.

## Remote Operator Panel

**Note:** An asterisk (\*) next to a value indicates the factory default setting.

Menu item	Settings	Description
<b>External VNC Connection</b>	<b>Don't Allow*</b> <b>Allow</b>	Connect an external Virtual Network Computing (VNC) client to the remote control panel.
<b>Authentication Type</b>	<b>None*</b> <b>Standard Authentication</b>	Set the authentication type when accessing the VNC client server.
<b>VNC Password</b>	The setting is user-defined.	Specify the password to connect to the VNC client server.  <b>Note:</b> This menu item appears only if <b>Authentication Type</b> is set to <b>Standard Authentication</b> .

## Notifications

**Note:** An asterisk (\*) next to a value indicates the factory default setting.

Menu item	Submenu item	Settings	Description
<b>ADF Loaded Beep</b>	N/A	<b>Off</b> <b>On*</b>	Specify whether the printer emits a custom beep when an original document is loaded into the ADF.
<b>Alarm Control</b>	N/A	<b>Off</b> <b>Single*</b> <b>Continuous</b>	Set the number of times that the alarm sounds when the printer requires user intervention.
<b>Supplies</b>	<b>Show Supply Estimates</b>	<b>Show estimates*</b> <b>Do not show estimates</b>	Show the estimated status of the supplies.
	<b>Cartridge Alarm</b>	<b>Off</b> <b>Single*</b> <b>Continuous</b>	Set the number of times that the alarm sounds when the toner cartridge is low.

Menu item	Submenu item	Settings	Description
	<b>Staple Alarm</b>	<b>Off*</b> <b>Single</b> <b>Continuous</b>	Set the number of times that the alarm sounds when the staple cartridge is empty.  <b>Note:</b> This menu item appears only when a staple finisher is installed.
	<b>Hole Punch Alarm</b>	<b>Off*</b> <b>Single</b> <b>Continuous</b>	Set the number of times that the alarm sounds when the hole punch container is full or missing.  <b>Note:</b> This menu item appears only when a staple, hole punch finisher is installed.
<b>E-mail Alerts Setup</b>	<b>Primary SMTP Gateway</b>	The setting is user-defined.	Type the IP address or host name of the primary SMTP server.
	<b>Primary SMTP Gateway Port</b>	<b>1 to 65535 (25*)</b>	Enter the port number of the primary SMTP server.
	<b>Secondary SMTP Gateway</b>	The setting is user-defined.	Type the IP address or host name of the secondary SMTP server.
	<b>Secondary SMTP Gateway Port</b>	<b>1 to 65535 (25*)</b>	Enter the server port number of your secondary SMTP server.
	<b>SMTP Timeout</b>	<b>5 to 30 seconds (30*)</b>	Specify the time that the SMTP server waits before it stops trying to send an email.
	<b>Reply Address</b>	The setting is user-defined.	Specify a reply address in the email.
	<b>Always use SMTP default Reply Address</b>	<b>On</b> <b>Off*</b>	Always use the default reply address in the SMTP server.
	<b>Use SSL/TLS</b>	<b>Disabled*</b> <b>Negotiate</b> <b>Required</b>	Send an email using an encrypted link.
	<b>Require Trusted Certificate</b>	<b>On*</b> <b>Off</b>	Require a trusted certificate when accessing the SMTP server.

Menu item	Submenu item	Settings	Description
	<b>SMTP Server Authentication</b>	<b>No authentication required*</b>  <b>Login/Plain</b>  <b>NTLM</b>  <b>CRAM-MD5</b>  <b>Digest-MD5</b>  <b>Kerberos 5</b>  <b>OAuth 2</b>	Set the authentication type for the SMTP server.
	<b>Device-Initiated Email</b>	<b>None*</b>  <b>Use Device SMTP Credentials</b>	Set whether credentials are required for device-initiated emails.
	<b>User-Initiated Email</b>	<b>None*</b>  <b>Use Device SMTP Credentials</b>  <b>Use Session User ID &amp; Password</b>  <b>Use Session Email address and Password</b>  <b>Prompt user</b>	Set whether credentials are required for user-initiated emails.
	<b>Use Active Directory Device Credentials</b>	<b>On</b>  <b>Off*</b>	Enable user credentials and group designations to connect to the SMTP server.
	<b>Device Userid</b>	The setting is user-defined.	Specify the user ID to log in to the SMTP server.
	<b>Device Password</b>	The setting is user-defined.	Specify the password to log in to the SMTP server.
	<b>Kerberos 5 REALM</b>	The setting is user-defined.	Specify the realm for the Kerberos 5 authentication protocol.
	<b>NTLM Domain</b>	The setting is user-defined.	Specify the domain name for the NTLM security protocol.
	<b>Disable "SMTP server not set up" error</b>	<b>On</b>  <b>Off*</b>	Disable an error message about the SMTP server setup.

Menu item	Submenu item	Settings	Description
	<b>Setup Email Lists and Alerts</b>	The setting is user-defined.	Specify the email addresses and enable the email alert.  <b>Note:</b> This menu item appears only in the Embedded Web Server.
<b>Error Prevention</b>	<b>ADF Multifeed Sensor</b>	<b>Off</b> <b>On*</b>	Set the printer to detect when the ADF picks more than one sheet of paper at once.
	<b>Auto Continue</b>	<b>Off</b> <b>On*</b>	Let the printer continue processing or printing a job automatically after clearing certain attendance conditions.  <b>Note:</b> When set to <b>On</b> , the default setting is 5 seconds.
	<b>Auto Reboot</b>	<b>Reboot when idle</b>  <b>Reboot always*</b>  <b>Reboot never</b>	Set the printer to restart when an error occurs.
	<b>Max Auto Reboots</b>	<b>1 to 20 (2*)</b>	Set the number of automatic reboots that the printer can perform.
	<b>Auto Reboot Window</b>	<b>1 to 525600 (720*)</b>	Set the number of seconds before the printer performs an automatic reboot.
	<b>Auto Reboot Counter</b>	The setting is a read-only information.	Show the number of automatic reboots that the printer has performed.
	<b>Reset Auto Reboot Counter</b>	<b>Reset</b>	Resets the Auto Reboot Counter back to 0.
	<b>Display Short Paper Error</b>	<b>On</b> <b>Auto-clear*</b>	Set the printer to show a message when a short paper error occurs.  <b>Note:</b> Short paper refers to the size of the paper loaded.

Menu item	Submenu item	Settings	Description
	<b>Page Protect</b>	<b>Off*</b> <b>On</b>	Set the printer to process the entire page into the memory before printing it.
<b>Jam Content Recovery</b>	<b>Jam Recovery</b>	<b>Off</b> <b>On</b> <b>Auto*</b>	Set the printer to reprint jammed pages.
	<b>Scanner Jam Recovery</b>	<b>Job level</b> <b>Page level*</b>	Specify how to restart a scan job after resolving a paper jam.

## Power Management

**Note:** An asterisk (\*) next to a value indicates the factory default setting.

Menu item	Submenu item	Settings	Description
<b>Sleep Mode Profile</b>	<b>Print from Sleep Mode</b>	<b>Stay awake after printing</b> <b>Enter Sleep Mode after printing*</b>	Set the printer to stay awake or enter <b>Sleep Mode</b> after printing.
	<b>Touch to Wake from Deep Sleep</b>	<b>Off</b> <b>On*</b>	Wake the printer from <b>Deep Sleep Mode</b> .
<b>Timeouts</b>	<b>Sleep Mode</b>	<b>1 to 114 minutes</b> <b>(15*)</b>	Set the idle time before the printer begins operating in <b>Sleep Mode</b> .

Menu item	Submenu item	Settings	Description
	<b>Hibernate Timeout</b>	<b>Disabled</b> <b>1 hour</b> <b>2 hours</b> <b>3 hours</b> <b>6 hours</b> <b>1 day</b> <b>2 days</b> <b>3 days*</b> <b>1 week</b> <b>2 weeks</b> <b>1 month</b>	Set the time before the printer turns off.
	<b>Hibernate Timeout on Connection</b>	<b>Hibernate</b> <b>Do Not Hibernate*</b>	Set <b>Hibernate Timeout</b> to turn off the printer while an active Ethernet connection exists.
<b>Schedule Power Modes</b>	<b>Schedules</b>	<b>Add New Schedule</b>	Schedule the printer when to enter <b>Sleep Mode</b> or <b>Hibernate</b> mode.

## Share Data with Lexmark

**Note:** An asterisk (\*) next to a value indicates the factory default setting.

Menu item	Settings	Description
<b>Share Data with Lexmark</b>	<b>Yes</b> <b>No*</b>	Send printer usage and performance information to Lexmark.
<b>Share Data Send Time</b>	<b>Start Time</b> <b>Stop Time</b>	Select the time window for data collection and transmission.  <div style="border: 1px solid gray; padding: 5px; background-color: #f0f0f0;"> <p><b>Note: Share Data Send Time</b> appears only when you select <b>Yes</b> in <b>Share Data with Lexmark</b>.</p> </div>

## Accessibility

**Note:** An asterisk (\*) next to a value indicates the factory default setting.

Menu item	Settings	Description
<b>Duplicate Key Strike Interval</b>	<b>0.00</b> to <b>5.00</b> (0.00*)	Set the interval in seconds during which the printer ignores duplicate key presses on an attached keyboard.
<b>Key Repeat Initial Delay</b>	<b>0.25</b> to <b>5.00</b> (1.00*)	Set the initial length of delay in seconds before a repeating key starts repeating.
<b>Key Repeat Rate</b>	<b>0.5</b> to <b>30.0</b> (30.0*)	Set the number of presses per second for a repeating key.
<b>Prolong Screen Timeout</b>	<b>Off*</b> <b>On</b>	Let the user remain in the same location and reset the <b>Screen Timeout</b> timer when it expires instead of returning to the home screen.
<b>Headphone Volume</b>	<b>1</b> to <b>10</b> (5*)	Adjust the headphone volume.
<b>Enable Voice Guidance When Headphone is Attached</b>	<b>Off*</b> <b>On</b>	Enable Voice Guidance when headphones are inserted into the headphone jack.
<b>Speak Passwords/PINs</b>	<b>Off*</b> <b>On</b>	Set the printer to read out loud passwords or personal identification numbers.
<b>Speech Rate</b>	<b>Very Slow</b> <b>Slow</b> <b>Normal*</b> <b>Fast</b> <b>Faster</b> <b>Very Fast</b> <b>Rapid</b> <b>Very Rapid</b> <b>Fastest</b>	Set the Voice Guidance speech rate.

## Restore Factory Defaults

Menu item	Settings	Description
<b>Restore Settings</b>	<b>Restore all settings</b>	Restore the printer factory default settings.
	<b>Restore printer settings</b>	
	<b>Restore network settings</b>	
	<b>Restore fax settings</b>	
	<b>Restore app settings</b>	

## Maintenance

### Configuration Menu

**Note:** An asterisk (\*) next to a value indicates the factory default setting.

Menu item	Submenu item	Settings	Description
<b>USB Configuration</b>	<b>USB PnP</b>	<b>1*</b> <b>2</b>	Change the USB driver mode of the printer to improve its compatibility with a personal computer.
	<b>USB Scan to Local</b>	<b>On*</b> <b>Off</b>	Set whether the USB device driver enumerates as a USB Simple device (single interface) or as a USB Composite device (multiple interfaces).
	<b>USB Speed</b>	<b>Full</b> <b>Auto*</b>	Set the USB port to run at full speed and disable its high-speed capabilities.
<b>Tray Configuration</b>	<b>Size Sensing</b>	<b>Tray [x] Sensing (On*)</b>	Set the tray to sense automatically the paper size loaded into it.
	<b>Tray Linking</b>	<b>Automatic*</b> <b>Off</b>	Set the printer to link the trays that have the same paper type and paper size settings.

Menu item	Submenu item	Settings	Description
	<b>Show Tray Insert Message</b>	<b>Off</b> <b>Only for unknown sizes*</b> <b>Always</b>	Display a message that lets the user change the paper size and paper type settings after inserting the tray.
	<b>Paper Prompts</b>	<b>Auto*</b> <b>Multipurpose Feeder</b> <b>Manual Paper</b>	Set the paper source that the user fills when a prompt to load paper appears.  <div style="border: 1px solid gray; padding: 5px;"> <p><b>Note:</b> For <b>Multipurpose Feeder</b> to appear, in the <b>Paper</b> menu set <b>Configure MP</b> to <b>Cassette</b>.</p> </div>
	<b>Envelope Prompts</b>	<b>Auto*</b> <b>Multipurpose Feeder</b> <b>Manual Envelope</b>	Set the paper source that the user fills when a prompt to load envelope appears.  <div style="border: 1px solid gray; padding: 5px;"> <p><b>Note:</b> For <b>Multipurpose Feeder</b> to appear, in the <b>Paper</b> menu set <b>Configure MP</b> to <b>Cassette</b>.</p> </div>
	<b>Action for Prompts</b>	<b>Prompt user*</b> <b>Continue</b> <b>Use current</b>	Set the printer to resolve paper- or envelope-related change prompts.
	<b>Multiple Universal Sizes</b>	<b>Off*</b> <b>On</b>	Set the tray to support multiple universal paper sizes.
<b>Reports</b>	N/A	<b>Menu Settings Page</b> <b>Event Log</b> <b>Event Log Summary</b>	Print reports about printer menu settings, status, and event logs.
<b>Supply Usage And Counters</b>	<b>Clear Supply Usage History</b>	<b>Start</b>	Reset the supply usage history to the factory shipped level.
	<b>Reset Black Cartridge Counter</b>	<b>Start</b>	Reset the counter after installing a new supply item or maintenance kit.

## Printer menus

Menu item	Submenu item	Settings	Description	
	Reset Imaging Unit Counter	Start		
	Reset MPF Roller Kit Counter	Start		
	Reset 1500 Sheet Roller Kit Counter	Start		
	Reset Roller Kit Counter	Start		
	Large Media Adjustments	Off* On	Allow adjustments when printing for large or thick paper.	
Printer Emulations	PPDS Emulation	Off* On	Set the printer to recognize and use the PPDS data stream.	
	PS Emulation	Off On*	Set the printer to recognize and use the PostScript® emulation data stream.	
	Enable Formsmerge	Off* On	Activate Forms Merge.	
	Enable Prescribe	Off* On	Activate the PRESCRIBE printer language.	
	Emulator Security	Page Timeout (60*)		Set the page timeout during emulation.
		Reset Emulator After Job (Off*)		Reset the emulator after a print job.
Disable Printer Message Access (On*)			Determine whether the emulator can access the initial printer setup or not.	
Fax Configuration	Fax Low Power Support	Disable Sleep Permit Sleep Auto*	Determine if the printer supports the fax portion of the low power architecture.	
	Fax Storage Location	Disk* NAND	Set the storage location for all faxes.  <b>Note:</b> This menu item appears only when a storage drive is installed.	

Menu item	Submenu item	Settings	Description
<b>Print Configuration</b>	<b>Font Sharpening</b>	<b>0 to 150 (24*)</b>	<p>Set a text point-size value below which the high-frequency screens are used when printing font data.</p> <p>For example, if the value is 24, then all fonts sized 24 points or less use the high-frequency screens.</p>
	<b>Use Native ISD Fonts</b>	<b>On*</b> <b>Off</b>	<p>Let the user choose whether to use the free fonts that are in the intelligent storage drive (ISD).</p> <p><b>Note:</b> This menu item appears only when an ISD is installed.</p>
<b>Device Operations</b>	<b>Quiet Mode</b>	<b>Off*</b> <b>On</b>	<p>Adjust the amount of noise that the printer produces.</p> <p><b>Note:</b> Enabling this setting slows down the overall performance of the printer.</p>
	<b>Safe Mode</b>	<b>Off*</b> <b>On</b>	<p>Set the printer to operate in a special mode where it offers as much functionality as possible despite known issues.</p> <p>For example, when set to <b>On</b> and the duplex motor is nonfunctional, one-sided printing is performed even if a job is set to two-sided printing.</p> <p><b>Note:</b> Enabling this setting allows printing only from the multipurpose feeder.</p>

## Printer menus

Menu item	Submenu item	Settings	Description
	<b>Minimum Copy Memory</b>	<b>20 MB *</b> <b>30 MB</b> <b>50 MB</b> <b>80 MB</b> <b>100 MB</b>	Set the minimum memory allocation for storing copy jobs.
	<b>Clear Custom Status</b>	<b>Start</b>	Erase user-defined strings for the <b>Default</b> or <b>Alternate</b> custom messages.
	<b>Clear all remotely installed messages</b>	<b>Start</b>	Erase messages that were remotely installed.
	<b>Automatically Display Error Screens</b>	<b>Off</b> <b>On*</b>	Show existing error messages on the display after the printer remains inactive on the home screen for a length of time.
	<b>Honor orientation on fast path copy</b>	<b>Off*</b> <b>On</b>	Enable the printer to use the orientation setting under the <b>Copy</b> menu when sending quick copy jobs.
	<b>Service Nonvolatile Memory</b>	<b>Encryption Status</b>	Show the encryption status of the storage drive.
		<b>Encrypt Service Nonvolatile Memory</b>	Enable mirror encryption manually.
<b>Toner patch sensor setup</b>	<b>Calibration frequency preference</b>	<b>Disabled</b> <b>Fewest adjustments</b> <b>Fewer adjustments</b> <b>Normal*</b> <b>Better accuracy</b> <b>Best accuracy</b>	Set the printer to put down the correct amount of toner to maintain color consistency.
	<b>Full calibration</b>	<b>Start</b>	Run the full color calibration.
	<b>TPS information Page</b>	<b>Print TPS Information Page</b>	Print a diagnostic page that contains information on toner patch sensor calibration.
<b>App Configuration</b>	<b>LES Applications</b>	<b>Off</b> <b>On*</b>	Enable Lexmark Embedded Solutions (LES) applications.

Menu item	Submenu item	Settings	Description
Scanner Configuration	Scanner Manual Registration	Print Quick Test	<p>Print a Quick Test target page, or manually register the flatbed and automatic document feeder (ADF) after replacing the ADF, scanner glass, or controller board.</p> <div style="border: 1px solid gray; padding: 10px; background-color: #f0f0f0;"> <p><b>Note:</b> When printing a Quick Test target page, make sure that the margin spacing on the target page is uniform all the way around the target. If it is not, then the printer margins must be reset.</p> </div>
		Front ADF Registration	
		Rear ADF Registration	
		Flatbed Registration	
	Reset Maintenance Counter	Resetting ADF Maintenance Counter (Start)	Reset the counter after replacing the ADF maintenance kit.
	Edge Erase	Flatbed Edge Erase (3*) ADF Edge Erase (3*)	Set the size, in millimeters, of the no-print area around an ADF or flatbed scan job.
	ADF Deskew	ADF Electronic Deskew (On*)	Reduce skewing of documents that are scanned from the ADF.
	Disable Scanner	No* Yes ADF Only	Disable the scanner when it is not working properly.
Tiff Byte Order	CPU Endianness* Little Endian Big Endian	Set the byte order of a TIFF-formatted scan output.	
Exact Tiff Rows Per Strip	On* Off	Set the RowsPerStrip tag value of a TIFF-formatted scan output.	
Scanner Glass Cleaning Threshold	1000 to 30000 (10000*)	Set the number of scans before the user receives a prompt to clean the scanner glass.	

## Out of Service Erase

Menu item	Submenu item	Settings	Description
<b>Out of Service Erase</b>	<b>Memory Last Sanitized</b>	The setting is a read-only information.	Show when the printer memory was last erased.
	<b>Hard Disk Last Sanitized</b>	The setting is a read-only information.	Show when hard disk was last erased.  <b>Note:</b> This menu item appears only when a hard disk is installed.
	<b>ISD last erased</b>	The setting is a read-only information.	Show when the intelligent storage drive (ISD) was last erased.  <b>Note:</b> This menu item appears only when an ISD is installed.
	<b>Sanitize all information on nonvolatile memory</b>	<b>Erase all printer and network settings</b>  <b>Erase all apps and app settings</b>  <b>Erase all shortcuts and shortcut settings</b>	Clear all information on nonvolatile memory.
	<b>Sanitize all information on hard disk</b>	<b>Erase downloads (Erases all macros, fonts, PFOs, etc.)</b>  <b>Erase buffered jobs</b>  <b>Erase Held Jobs</b>	Clear all information on the hard disk.  <b>Note:</b> This menu item appears only when a hard disk is installed.

Menu item	Submenu item	Settings	Description
	<b>Erase Intelligent Storage Drive</b>	<b>Erase</b>	Clear all information on the ISD.  <b>Note:</b> This menu item appears only when an ISD is installed.

## Firmware Update

**Note:** An asterisk (\*) next to a value indicates the factory default setting.

Menu item	Submenu Item	Settings	Description
<b>Installed Version</b>	N/A	The setting is a read-only information.	Show the current firmware version installed on the printer.
<b>Date Installed</b>	N/A	The setting is a read-only information.	Shows the date when the firmware was installed on the printer.
<b>Check for updates</b>	N/A	The setting is a read-only information.	Check for firmware updates.
<b>Update Firmware from Server</b>	<b>Auto Update</b>	<b>Disabled*</b> <b>Check Only</b> <b>Check and Install</b>	Configure when firmware is updated and limits the download speed of the update.
	<b>Scheduled Day</b>	The setting is a user-defined setting.	
	<b>Scheduled Time</b>	The setting is a user-defined setting.	
	<b>Download Settings</b>	<b>Background Download (Off*)</b> <b>Limit Download Speed (Off*)</b>	

## About this Printer

Menu item	Description
<b>Asset Tag</b>	Specify the identity of the printer.
<b>Printer's Location</b>	Specify the printer location.
<b>Contact</b>	Specify the contact information for the printer.
<b>Firmware Version</b>	Show the firmware version installed on the printer.
<b>Engine</b>	Show the engine number of the printer.
<b>Serial Number</b>	Show the serial number of the printer.
<b>Export Configuration File to USB</b>	Export the configuration file to a flash drive.
<b>Export Compressed Logs to USB</b>	Export the compressed log files to a flash drive.
<b>Send Logs</b>	Send printer log information to Lexmark.

## Print

### Layout

**Note:** An asterisk (\*) next to a value indicates the factory default setting.

Menu item	Settings	Description
<b>Sides</b>	<b>1-Sided</b> <b>2-Sided*</b>	Specify whether to print on one side or both sides of the paper.
<b>Flip Style</b>	<b>Long Edge*</b> <b>Short Edge</b>	Determine which side of the paper is bound when performing two-sided printing.
<b>Blank Pages</b>	<b>Print</b> <b>Do Not Print*</b>	Print blank pages that are included in a print job.
<b>Collate</b>	<b>Off (1,1,1,2,2,2)</b> <b>On (1,2,1,2,1,2)*</b>	Keep the pages of a print job stacked in sequence, particularly when printing multiple copies of the job.

## Printer menus

Menu item	Settings	Description
<b>Separator Sheets</b>	<b>None*</b> <b>Between Copies</b> <b>Between Jobs</b> <b>Between Pages</b>	Insert blank separator sheets when printing.
<b>Separator Sheet Source</b>	<b>Tray [x] (1*)</b> <b>Multipurpose Feeder</b>	Specify the paper source for the separator sheet.
<b>Pages per Side</b>	<b>Off*</b> <b>2 pages per side</b> <b>3 pages per side</b> <b>4 pages per side</b> <b>6 pages per side</b> <b>9 pages per side</b> <b>12 pages per side</b> <b>16 pages per side</b>	Print multiple page images on one side of a sheet of paper.
<b>Pages per Side Ordering</b>	<b>Horizontal*</b> <b>Reverse Horizontal</b> <b>Vertical</b> <b>Reverse Vertical</b>	Specify the positioning of multiple page images when using the <b>Pages per Side</b> menu.
<b>Pages per Side Orientation</b>	<b>Auto*</b> <b>Landscape</b> <b>Portrait</b>	Specify the orientation of multiple page images when using the <b>Pages per Side</b> menu.
<b>Pages per Side Border</b>	<b>None*</b> <b>Solid</b>	Print a border around each page image when using the <b>Pages per Side</b> menu.
<b>Copies</b>	<b>1 to 9999 (1*)</b>	Specify the number of copies for each print job.
<b>Print Area</b>	<b>Normal*</b> <b>Fit to page</b> <b>Whole Page</b>	Set the printable area on a sheet of paper.

## Finishing

**Note:** An asterisk (\*) next to a value indicates the factory default setting.

Menu item	Settings	Description
<b>Staple Job</b>	<b>Off*</b> <b>1 staple, top left corner</b> <b>2 staples, left</b> <b>1 staple, top right corner</b> <b>2 staples, top</b> <b>1 staple, bottom left corner</b> <b>2 staples, bottom</b> <b>1 staple, bottom right corner</b> <b>2 staples, right</b>	Specify the staple position for all print jobs.  <b>Note:</b> This menu item appears only when a staple finisher is installed.
<b>Staple Test</b>	<b>Start</b>	Determine whether the staple finisher is functioning properly.  <b>Note:</b> This menu item appears only when a staple finisher is installed.
<b>Hole Punch</b>	<b>Off*</b> <b>On</b>	Punch holes along the edge of the printed output.  <b>Note:</b> This menu item appears only when a staple, hole punch finisher is installed.

Menu item	Settings	Description
<b>Hole Punch Mode</b>	<p><b>2 holes</b></p> <p><b>3 holes</b></p> <p><b>4 holes</b></p>	<p>Set the hole punch mode for the printed output.</p> <div style="background-color: #f0f0f0; padding: 10px; margin-top: 10px;"> <p><b>Notes</b></p> <ul style="list-style-type: none"> <li>• <b>3 holes</b> is the U.S. factory default setting. <b>4 holes</b> is the international factory default setting.</li> <li>• This menu item appears only when a staple, hole punch finisher or booklet finisher is installed.</li> </ul> </div>
<b>Offset Pages</b>	<p><b>None*</b></p> <p><b>Between Copies</b></p> <p><b>Between Jobs</b></p>	<p>Offset the output of each print job or each copy of a print job.</p> <div style="background-color: #f0f0f0; padding: 10px; margin-top: 10px;"> <p><b>Notes</b></p> <ul style="list-style-type: none"> <li>• <b>Between Copies</b> offsets each copy of a print job if <b>Collate</b> is set to <b>On [1,2,1,2,1,2]</b>. If <b>Collate</b> is set to <b>Off [1,1,1,2,2,2]</b>, then each set of printed pages is offset, such as all pages designated as 1 and all pages designated as 2.</li> <li>• <b>Between Jobs</b> sets the same offset position for the entire print job regardless of the number of copies printed.</li> </ul> </div>

## Setup

**Note:** An asterisk (\*) next to a value indicates the factory default setting.

## Printer menus

---

Menu item	Settings	Description
<b>Printer Language</b>	<b>PCL Emulation</b> <b>PS Emulation*</b>	Set the printer language.  <b>Note:</b> Setting a printer language default does not prevent a software program from sending print jobs that use another printer language.
<b>Job Waiting</b>	<b>Off*</b> <b>On</b>	Preserve print jobs requiring supplies so that jobs not requiring the missing supplies can print.  <b>Note:</b> This menu item appears only when a storage drive is installed.
<b>Job Hold Timeout</b>	<b>0 to 255 (30*)</b>	Set the time in seconds that the printer waits for user intervention before it holds jobs that require unavailable resources.  <b>Note:</b> This menu item appears only when a storage drive is installed.
<b>Download Target</b>	<b>RAM*</b> <b>Flash</b> <b>Disk</b>	Specify where to save all permanent resources that have been downloaded to the printer.  <b>Note:</b> This menu item appears only when a storage drive is installed.

Menu item	Settings	Description
<b>Resource Save</b>	<b>Off*</b> <b>On</b>	<p>Determine what the printer does with downloaded resources when it receives a job that requires more than the available memory.</p> <div style="border: 1px solid #ccc; background-color: #f0f0f0; padding: 10px; margin-top: 10px;"> <p><b>Notes</b></p> <ul style="list-style-type: none"> <li>• When set to <b>Off</b>, the printer retains downloaded resources only until memory is needed. Resources associated with the inactive printer language are deleted.</li> <li>• When set to <b>On</b>, the printer preserves all the permanent downloaded resources across all language switches. When necessary, the printer shows memory full messages instead of deleting permanent resources.</li> </ul> </div>
<b>Print All Order</b>	<b>Alphabetical*</b> <b>Newest First</b> <b>Oldest First</b>	Specify the order when you choose to print all held and confidential jobs.
<b>Automatic Deletion of Suspended Print Jobs</b>	<b>Off*</b> <b>On</b>	Set the printer to cancel automatically the queued print jobs that are interrupted by errors such as paper jams and missing supplies.

## Quality

**Note:** An asterisk (\*) next to a value indicates the factory default setting.

Menu item	Submenu item	Settings	Description
<b>Print Resolution</b>	N/A	<b>600 dpi</b> <b>1200 IQ</b> <b>2400 IQ*</b> <b>1200 dpi</b> <b>300 dpi</b>	Set the resolution for the printed output.

## Printer menus

Menu item	Submenu item	Settings	Description
<b>Toner Darkness</b>	N/A	<b>1 to 10 (8*)</b>	Determine the lightness or darkness of text images.
<b>Halftone</b>	N/A	<b>Normal*</b> <b>Detail</b>	Enhance the printed output to have smoother lines with sharper edges.
<b>Brightness</b>	N/A	<b>-6 to 6 (0*)</b>	Adjust the brightness of every gray object on the page.  <b>Note:</b> This setting does not affect files where CMYK specifications are used.
<b>Contrast</b>	N/A	<b>0 to 5 (0*)</b>	Adjust the contrast of every gray object on a page.  <b>Note:</b> This setting does not affect files where CMYK specifications are used.
<b>Gray Correction</b>	N/A	<b>Off</b> <b>Auto*</b>	Apply gray correction functionality on printed images.
<b>Advanced Imaging</b>	<b>Darkness Adjust</b>	<b>Submit</b>	Initiate full calibration for toner patch sensing (TPS) from the control panel to the Embedded Web Server.  <b>Note:</b> TPS is used to ensure accurate toner density.

## Job Accounting

**Note:** An asterisk (\*) next to a value indicates the factory default setting.

Menu item	Settings	Description
<b>Job Accounting</b>	<b>Off*</b> <b>On</b>	Set the printer to create a log of the print jobs that it receives.

## Printer menus

Menu item	Settings	Description
<b>Accounting Log Frequency</b>	<b>Daily</b> <b>Weekly</b> <b>Monthly*</b>	Specify how often the printer creates a log file.
<b>Log Action at End of Frequency</b>	<b>None*</b> <b>Email Current Log</b> <b>Email &amp; Delete Current Log</b> <b>Post Current Log</b> <b>Post &amp; Delete Current Log</b>	Specify how the printer responds when the frequency threshold expires.  <div style="background-color: #f0f0f0; padding: 5px;"> <p><b>Note:</b> The value defined in <b>Accounting Log Frequency</b> determines when this action is triggered.</p> </div>
<b>Log Near Full Level</b>	<b>On* (5MB)</b> <b>Off</b>	Specify the maximum size of the log file before the printer executes the <b>Log Action at Near Full</b> .  <div style="background-color: #f0f0f0; padding: 5px;"> <p><b>Note:</b> This menu item appears only when a storage drive is installed.</p> </div>
<b>Log Action at Near Full</b>	<b>None*</b> <b>Email Current Log</b> <b>Email &amp; Delete Current Log</b> <b>Email &amp; Delete Oldest Log</b> <b>Post Current Log</b> <b>Post &amp; Delete Current Log</b> <b>Post &amp; Delete Oldest Log</b> <b>Delete Current Log</b> <b>Delete Oldest Log</b> <b>Delete All But Current</b> <b>Delete All Logs</b>	Specify how the printer responds when a storage drive is nearly full.  <div style="background-color: #f0f0f0; padding: 5px;"> <p><b>Note:</b> The value defined in <b>Log Near Full Level</b> determines when this action is triggered.</p> </div>

Menu item	Settings	Description
<b>Log Action at Full</b>	<p><b>None*</b></p> <p><b>Email &amp; Delete Current Log</b></p> <p><b>Email &amp; Delete Oldest Log</b></p> <p><b>Post &amp; Delete Current Log</b></p> <p><b>Post &amp; Delete Oldest Log</b></p> <p><b>Delete Current Log</b></p> <p><b>Delete Oldest Log</b></p> <p><b>Delete All But Current</b></p> <p><b>Delete All Logs</b></p>	Specify how the printer responds when a storage drive usage reaches the maximum limit (100MB).
<b>URL to Post Log</b>	The setting is user-defined.	Specify where the printer posts job accounting logs.
<b>Email Address to Send Logs</b>	The setting is user-defined.	Specify the email address to which the printer sends job accounting logs.
<b>Log File Prefix</b>	The setting is user-defined.	Specify the prefix for the log files.

**Note:** The current host name defined in the TCP/IP menu is used as the default log file prefix.

## PDF

**Note:** An asterisk (\*) next to a value indicates the factory default setting.

Menu item	Settings	Description
<b>Scale To Fit</b>	<p><b>Off*</b></p> <p><b>On</b></p>	Scale the page content to fit the selected paper size.
<b>Annotations</b>	<p><b>Print</b></p> <p><b>Do Not Print*</b></p>	Specify whether to print annotations in the PDF.
<b>Print PDF Error</b>	<p><b>Off</b></p> <p><b>On*</b></p>	Enable the printing of PDF error.

## PostScript

**Note:** An asterisk (\*) next to a value indicates the factory default setting.

Menu item	Settings	Description
<b>Print PS Error</b>	<b>Off*</b> <b>On</b>	<p>Print a page that describes the PostScript® emulation error.</p> <p><b>Note:</b> When an error occurs, processing of the job stops, the printer prints an error message, and the rest of the print job is flushed.</p>
<b>Minimum Line Width</b>	<b>1 to 30 (2*)</b>	<p>Set the minimum stroke width.</p> <p><b>Note:</b> Jobs printed in 1200 dpi use the value directly.</p>
<b>Lock PS Startup Mode</b>	<b>Off</b> <b>On*</b>	<p>Disable the SysStart file.</p> <p><b>Note:</b> Enabling the SysStart file exposes your printer or network to a security risk.</p>
<b>Font Priority</b>	<b>Resident*</b> <b>Flash/Disk</b>	<p>Establish the font search order.</p> <p><b>Notes</b></p> <ul style="list-style-type: none"> <li>• <b>Resident</b>—Sets the printer to search its memory for the requested font before searching the storage drive.</li> <li>• <b>Flash/Disk</b>—Sets the printer to search the storage drive for the requested font before searching the printer memory.</li> <li>• This menu item appears only when a storage drive is installed.</li> </ul>

Menu item	Settings	Description
<b>Wait Timeout</b>	<b>Off</b> <b>On*</b>	Enable the printer to wait for more data before canceling a print job.  <div style="border: 1px solid gray; padding: 5px; background-color: #f0f0f0;"> <p><b>Note:</b> When set to <b>On</b>, 40 seconds is the factory default setting.</p> </div>

## PCL

**Note:** An asterisk (\*) next to a value indicates the factory default setting.

Menu item	Settings	Description
<b>Scale To Fit</b>	<b>Off*</b> <b>On</b>	Scale the page content to fit the selected paper size.
<b>Font Source</b>	<b>Resident*</b> <b>Disk</b> <b>Download</b> <b>Flash</b> <b>Font Card</b> <b>All</b>	Select the source which contains the default font selection.  <div style="border: 1px solid gray; padding: 5px; background-color: #f0f0f0;"> <p><b>Notes</b></p> <ul style="list-style-type: none"> <li>• <b>Disk</b>—Appears only and if a non-defective, non-read/write protected hard disk that contains fonts is installed.</li> <li>• <b>Download</b>—Appears only if downloaded fonts exist in the printer memory.</li> <li>• <b>Flash</b>—Appears only if a non-defective, non-read/write protected flash memory that contains fonts is installed.</li> <li>• <b>Font Card</b>—Appears only if a valid font card is installed or an intelligent storage drive is configured.</li> </ul> </div>
<b>Font Name</b>	[List of available fonts] ( <b>Courier*</b> )	Select a font from the specified font source.

Menu item	Settings	Description
<b>Symbol Set</b>	[List of available symbol sets] (10U PC-8*)	Specify the symbol set for each font name.  <b>Note:</b> A symbol set is a set of alphabetic and numeric characters, punctuation, and special symbols. Symbol sets support the different languages or specific programs such as math symbols for scientific text.
<b>Pitch</b>	<b>0.08 to 100.00</b> (10.00*)	Specify the pitch for fixed or monospaced fonts.  <b>Note:</b> This menu item refers to the number of fixed-space characters in a horizontal inch of type.
<b>Orientation</b>	<b>Portrait*</b> <b>Landscape</b> <b>Reverse Portrait</b> <b>Reverse Landscape</b>	Specify the orientation of text and graphics on the page.
<b>Lines per Page</b>	<b>1 to 255</b>	Specify the number of lines of text for each page printed through the PCL® emulation data stream.  <b>Notes</b> <ul style="list-style-type: none"> <li>• This menu item activates vertical escapement that causes the selected number of requested lines to print between the default margins of the page.</li> <li>• 60 is the U.S. factory default setting. 64 is the international factory default setting.</li> </ul>
<b>PCL5 Minimum Line Width</b>	<b>1 to 30 (2*)</b>	Set the initial minimum stroke width value of any job printed in 1200 dpi through the applicable emulator.
<b>PCLXL Minimum Line Width</b>	<b>1 to 30 (2*)</b>	

Menu item	Settings	Description
<b>A4 Width</b>	<b>198 mm*</b> <b>203 mm</b>	Set the width of the logical page on A4-size paper.  <b>Note:</b> Logical page is the space on the physical page where data is printed.
<b>Auto CR after LF</b>	<b>On</b> <b>Off*</b>	Set the printer to perform a carriage return after a line feed control command.  <b>Note:</b> Carriage return is a mechanism that commands the printer to move the position of the cursor to the first position on the same line.
<b>Auto LF after CR</b>	<b>On</b> <b>Off*</b>	Set the printer to perform a line feed after a carriage return control command.
<b>Tray Renumber</b>	<b>Assign MP Feeder</b> <b>Assign Tray [x]</b> <b>Assign Manual Paper</b> <b>Assign Manual Envelope</b>	Configure the printer to work with a different print driver or custom application that uses a different set of source assignments to request a given paper source.  Choose from the following options: <b>Off*</b> —The printer uses the factory default paper source assignments. <b>None</b> —The paper source ignores the Select Paper Feed command. <b>0 to 199</b> —Select a numeric value to assign a custom value to a paper source.
	<b>View Factory Defaults</b>	Show the factory default value assigned for each paper source.
	<b>Restore Defaults</b>	Restore the tray renumber values to their factory defaults.
<b>Print Timeout</b>	<b>Off</b> <b>On* (90)</b>	Set the printer to end a print job after it has been idle for the specified amount of time.

## Image

**Note:** An asterisk (\*) next to a value indicates the factory default setting.

Menu item	Settings	Description
<b>Auto Fit</b>	<b>On</b> <b>Off*</b>	Select the best available paper size and orientation setting for an image.  <b>Note:</b> When set to <b>On</b> , this menu item overrides the scaling and orientation settings for the image.
<b>Invert</b>	<b>Off*</b> <b>On</b>	Invert bitonal monochrome images.  <b>Note:</b> This menu item does not apply to GIF or JPEG image formats.
<b>Scaling</b>	<b>Best Fit*</b> <b>Anchor Top Left</b> <b>Anchor Center</b> <b>Fit Height/Width</b> <b>Fit Height</b> <b>Fit Width</b>	Adjust the image to fit the printable area.  <b>Note:</b> When <b>Auto Fit</b> is set to <b>On</b> , <b>Scaling</b> is automatically set to <b>Best Fit</b> .
<b>Orientation</b>	<b>Portrait*</b> <b>Landscape</b> <b>Reverse Portrait</b> <b>Reverse Landscape</b>	Specify the orientation of text and graphics on the page.

## Paper

### Tray Configuration

**Note:** An asterisk (\*) next to a value indicates the factory default setting.

## Printer menus

Menu item	Submenu item	Settings	Description
<b>Default Source</b>	N/A	<b>Tray [x] (1*)</b> <b>Multipurpose Feeder</b> <b>Manual Paper</b> <b>Manual Envelope</b>	Set the default paper source for all print jobs.
<b>Paper Size/Type</b>	<b>Tray [x]</b> <b>Multipurpose Feeder</b> <b>Manual Paper</b> <b>Manual Envelope</b>	<b>Size</b> <b>Type</b>	Specify the paper size or paper type loaded in each paper source.
<b>Substitute Size</b>	N/A	<b>Off</b> <b>Statement/A5</b> <b>Letter/A4</b> <b>11 x 17/A3</b> <b>All Listed*</b>	Set the printer to substitute a specified paper size if the requested size is not loaded in any paper source. <div data-bbox="938 992 1412 1373" style="background-color: #f0f0f0; padding: 10px; margin-top: 10px;"> <p><b>Notes</b></p> <ul style="list-style-type: none"> <li>• <b>Off</b>—Prompts the user to load the required paper size.</li> <li>• <b>All Listed</b>—Allows all available substitutions.</li> </ul> </div>

Menu item	Submenu item	Settings	Description
<b>Configure MP</b>	N/A	<b>Cassette*</b> <b>Manual</b> <b>First</b>	Determine the behavior of the multipurpose feeder.  <div style="border: 1px solid #ccc; background-color: #f0f0f0; padding: 10px;"> <p><b>Notes</b></p> <ul style="list-style-type: none"> <li>• <b>Cassette</b>—Configures the multipurpose feeder as the automatic paper source.</li> <li>• <b>Manual</b>—Sets the multipurpose feeder only for manual-feed print jobs.</li> <li>• <b>First</b>—Configures the multipurpose feeder as the primary paper source.</li> </ul> </div>

## Media Configuration

**Note:** An asterisk (\*) next to a value indicates the factory default setting.

Menu item	Submenu item	Settings	Description
<b>Units of Measure</b>	N/A	<b>Inches</b> <b>Millimeters</b>	Specify the unit of measurement for the universal paper.  <div style="border: 1px solid #ccc; background-color: #f0f0f0; padding: 10px;"> <p><b>Note:</b> <b>Inches</b> is the U.S. factory default setting. <b>Millimeters</b> is the international factory default setting.</p> </div>
<b>Universal Setup</b>	<b>All Input Trays</b>	<b>Portrait Width</b>	Set the portrait width of the universal paper.
		<b>Portrait Height</b>	Set the portrait height of the universal paper.

Menu item	Submenu item	Settings	Description
		<b>Feed Direction (Short Edge*)</b>	Set the printer to pick paper from the short edge or long edge direction.  <b>Note: Long Edge</b> appears only when the longest edge is shorter than the maximum width supported.
<b>Custom Scan Sizes</b>	<b>Scan Size Name</b>	The setting is user-defined.	Assign a name for the custom scan.
	<b>Width</b>	<b>1 to 8.5 inches</b> (8.5*) <b>25 to 215.9 mm</b> (215.9*)	Specify the width of the original document.
	<b>Height</b>	<b>1 to 25 inches</b> (11*) <b>25 to 635 mm</b> (279.4*)	Specify the height of the original document.
	<b>Orientation</b>	<b>Portrait*</b> <b>Landscape</b>	Specify the orientation of the content on the original document.
	<b>2 scans per side</b>	<b>Off*</b> <b>On</b>	Set the default number of scans on each side of the printer.
<b>Media Type Setup</b>	[List of paper types]	<b>Texture</b> <b>Weight</b> <b>Loading Orientation</b> <b>Send to Bin</b>	Specify the texture, weight, and orientation of the paper.

## Bin Configuration

**Note:** An asterisk (\*) next to a value indicates the factory default setting.

Menu item	Settings	Description
<b>Output Bin</b>	<b>Standard Bin*</b> <b>Bin [x]</b>	Specify the output bin for the print jobs.
<b>Configure Bins</b>	<b>Mailbox*</b> <b>Link</b> <b>Link Optional</b> <b>Type Assignment</b>	Configure the mode of operation for the output bins.  <div style="border: 1px solid #ccc; background-color: #f0f0f0; padding: 10px;"> <p><b>Notes</b></p> <ul style="list-style-type: none"> <li>• <b>Mailbox</b>—Allows the standard bin and any optional bin to be selected individually.</li> <li>• <b>Link</b>—Allows all output bins to be linked together as though they were one large bin.</li> <li>• <b>Link Optional</b>—Treats all optional bins as one large output bin.</li> <li>• <b>Type Assignment</b>—Assigns each paper type a bin or a linked bin set.</li> </ul> </div>
<b>Custom Bin Names</b>	<b>Standard Bin</b> <b>Bin [x]</b>	Assign a name for each bin.

## Copy

### Copy Defaults

**Note:** An asterisk (\*) next to a value indicates the factory default setting.

Menu item	Submenu items	Settings	Description
<b>Content Type</b>	N/A	<b>Text</b> <b>Text/Photo*</b> <b>Photo</b> <b>Graphics</b>	Improve the output result based on the content of the original document.

## Printer menus

Menu item	Submenu items	Settings	Description
<b>Content Source</b>	N/A	<b>Black and White Laser*</b> <b>Color Laser</b> <b>Inkjet</b> <b>Photo/Film</b> <b>Magazine</b> <b>Newspaper</b> <b>Press</b> <b>Other</b>	Improve the output result based on the source of the original document.
<b>Sides</b>	N/A	<b>1 sided to 1 sided*</b> <b>1 sided to 2 sided</b> <b>2 sided to 1 sided</b> <b>2 sided to 2 sided</b>	Specify the scanning behavior based on the original document.
<b>Separator Sheets</b>	N/A	<b>None*</b> <b>Between Copies</b> <b>Between Jobs</b> <b>Between Pages</b>	Specify whether to insert blank separator sheets when printing.
<b>Separator Sheet Source</b>	N/A	<b>Tray [x] (1*)</b> <b>Multipurpose Feeder</b>	Specify the paper source for the separator sheet.
<b>Pages per Side</b>	N/A	<b>Off*</b> <b>2 Portrait pages</b> <b>4 Portrait pages</b> <b>2 Landscape pages</b> <b>4 Landscape pages</b>	Specify the number of page images to print on one side of a sheet of paper.
<b>Print Page Borders</b>	N/A	<b>Off*</b> <b>On</b>	Place a border around each image when printing multiple pages on a single page.

Menu item	Submenu items	Settings	Description
<b>Collate</b>	N/A	<b>Off [1,1,1,2,2,2]</b> <b>On [1,2,1,2,1,2]*</b>	Print multiple copies in sequence.
<b>Offset Pages</b>	N/A	<b>None*</b> <b>Between Copies</b> <b>Between Jobs</b>	Offset the output of each print job or each copy of a print job. <div data-bbox="1011 465 1410 1720" style="background-color: #f0f0f0; padding: 10px; margin-top: 10px;"> <p><b>Notes</b></p> <ul style="list-style-type: none"> <li>• <b>Between Copies</b>—Offsets each copy of a print job if <b>Collate</b> is set to <b>On [1,2,1,2,1,2]</b>. If <b>Collate</b> is set to <b>Off [1,1,1,2,2,2]</b>, then each set of printed pages is offset, such as all page 1s and all page 2s.</li> <li>• <b>Between Jobs</b>—Sets the same offset position for the entire print job regardless of the number of copies printed.</li> <li>• This menu item appears only when an offset stacker or a staple, hole punch finisher is installed.</li> </ul> </div>

Menu item	Submenu items	Settings	Description
<b>Staple</b>	N/A	<b>Off*</b> <b>1 staple, top left corner</b> <b>2 staples, left</b> <b>1 staple, top right corner</b> <b>2 staples, top</b> <b>1 staple, bottom left corner</b> <b>2 staples, bottom</b> <b>1 staple, bottom right corner</b> <b>2 staples, right</b> <b>4 staples</b>	<p>Specify the staple position for all print jobs.</p> <p><b>Note:</b> This menu item appears only when a staple finisher is installed.</p>
<b>Punch</b>	N/A	<b>Off*</b> <b>2 holes</b> <b>3 holes</b> <b>4 holes</b>	<p>Punch holes on the printed output.</p> <p><b>Note:</b> This menu item appears only when a staple, hole punch finisher or booklet finisher is installed.</p>
<b>“Copy from” Size</b>		[List of paper sizes]	<p>Set the paper size of the original document.</p> <p><b>Note:</b> <b>Letter</b> is the U.S. factory default setting. <b>A4</b> is the international factory default setting.</p>
<b>“Copy to” Source</b>	N/A	<b>Tray [x] (1*)</b> <b>Multipurpose Feeder</b> <b>Auto Size Match</b>	<p>Specify the paper source for the copy job.</p>
<b>Darkness</b>	N/A	<b>1 to 9 (5*)</b>	<p>Adjust the darkness of the scanned image.</p>

## Printer menus

Menu item	Submenu items	Settings	Description
<b>Number of Copies</b>	N/A	<b>1 to 9999 (1*)</b>	Specify the number of copies.
<b>Header/Footer</b>	N/A	<b>Left Header</b> <b>Middle Header</b> <b>Right Header</b> <b>Left Footer</b> <b>Middle Footer</b> <b>Right Footer</b>	Specify the header or footer information on the scanned image.
<b>Overlay</b>	N/A	<b>Confidential</b> <b>Copy</b> <b>Draft</b> <b>Urgent</b> <b>Custom</b> <b>Off*</b>	Specify the overlay text to print on each copy.
<b>Custom overlay</b>	N/A	The setting is user-defined.	Type the text for the <b>Custom</b> choice in the <b>Overlay</b> menu.
<b>Advanced Imaging</b>	<b>Color Dropout</b>	<b>Color Dropout (None*)</b> <b>Default Red Threshold (128*)</b> <b>Default Green Threshold (128*)</b> <b>Default Blue Threshold (128*)</b>	Specify which color to drop during scanning, and adjust the dropout setting for that color.
	<b>Contrast</b>	<b>Best for content*</b> <b>0 to 5</b>	Specify the contrast for the scanned image.

Menu item	Submenu items	Settings	Description
	<b>Background Removal</b>	<b>Background Detection (Content-based*)</b>  Level (0*)	Remove the background color or image noise from the original document.  <div style="background-color: #f0f0f0; padding: 10px; border: 1px solid #ccc;"> <p><b>Notes</b></p> <ul style="list-style-type: none"> <li>• <b>Content-based</b>—removes the background color from the original document.</li> <li>• <b>Fixed</b>—removes image noise from a photo.</li> </ul> </div>
	<b>Auto Center</b>	<b>Off*</b> <b>On</b>	Align the content at the center of the page.
	<b>Mirror Image</b>	<b>Off*</b> <b>On</b>	Create a mirror image of the original document.
	<b>Negative Image</b>	<b>Off*</b> <b>On</b>	Create a negative image of the original document.
	<b>Shadow Detail</b>	-4 to 4 (0*)	Adjust the shadow detail in the original document.
	<b>Scan Edge to Edge</b>	<b>Off*</b> <b>On</b>	Scan the original document from edge to edge.
	<b>Sharpness</b>	1 to 5 (3*)	Adjust the sharpness of the scanned image.
<b>Admin Controls</b>	<b>Allow Priority Copies</b>	<b>Off</b> <b>On*</b>	Interrupt a print job to make copies
	<b>Custom Job Scanning</b>	<b>Off*</b> <b>On</b>	Set the printer to scan the first set of original documents using the specified settings, and then the next set with the same or different settings.
	<b>Allow Save as Shortcut</b>	<b>Off</b> <b>On*</b>	Save copy settings as a shortcut.

Menu item	Submenu items	Settings	Description
	<b>Sample Copy</b>	<b>Off*</b> <b>On</b>	Print a sample copy to check the quality before printing the remaining copies.

## Fax

### Fax Defaults

### Fax Mode

**Note:** An asterisk (\*) next to a value indicates the factory default setting.

Menu item	Settings	Description
<b>Fax Mode</b>	<b>Fax*</b> <b>Fax Server</b> <b>Disabled</b>	Select a fax mode.

### Fax Setup

**Note:** An asterisk (\*) next to a value indicates the factory default setting.

Menu item	Submenu item	Settings	Description
<b>General Fax Settings</b>	<b>Fax Name</b>	The setting is user-defined.	Specify your fax ID.
	<b>Fax Number</b>	The setting is user-defined.	Specify your fax number.
	<b>Fax ID</b>	<b>Fax Name *</b> <b>Fax Number</b>	Set the fax ID to use during fax negotiation.

Menu item	Submenu item	Settings	Description
	<b>Enable Manual Fax</b>	<b>Off*</b> <b>On</b>	Turn on the manual fax function in the printer.  <div style="background-color: #f0f0f0; padding: 10px;"> <p><b>Notes</b></p> <ul style="list-style-type: none"> <li>• This menu item requires a line splitter and a telephone handset.</li> <li>• Use a regular telephone line to answer an incoming fax job and to dial a fax number.</li> <li>• To go directly to the manual fax function, touch # and 0 on the keypad.</li> </ul> </div>
	<b>Memory Use</b>	<b>All receive</b> <b>Mostly receive</b> <b>Equal*</b> <b>Mostly send</b> <b>All send</b>	Set the amount of internal printer memory allocated for faxing.  <div style="background-color: #f0f0f0; padding: 10px;"> <p><b>Note:</b> This menu item prevents memory buffer conditions and failed faxes.</p> </div>
	<b>Cancel Faxes</b>	<b>Allow*</b> <b>Don't Allow</b>	Cancel outgoing or incoming faxes.
	<b>Fax Number Masking</b>	<b>Off*</b> <b>From Left</b> <b>From Right</b>	Specify the format for masking an outgoing fax number.
	<b>Digits to Mask</b>	<b>0 to 58 (0*)</b>	Specify the number of digits to mask in an outgoing fax number.

Menu item	Submenu item	Settings	Description
	<b>Enable Line Connected Detection</b>	<b>Off</b> <b>On*</b>	Determine whether a telephone line is connected to the printer.  <b>Note:</b> Events are detected immediately.
	<b>Enable Line In Wrong Jack Detection</b>	<b>Off</b> <b>On*</b>	Determine whether a telephone line is connected to the correct port on the printer.  <b>Note:</b> Events are detected immediately.
	<b>Enable Extension in Use Support</b>	<b>Off</b> <b>On*</b>	Determine whether a telephone line is used by another device, such as another phone on the same line.  <b>Note:</b> Events are detected immediately.
	<b>Optimize Fax Compatibility</b>	The setting is user-defined.	Configure the printer fax functionality for optimal compatibility with other fax machines.
	<b>Fax Transport</b>	<b>T.38</b> <b>Analog*</b> <b>G.711</b> <b>etherFAX</b> <b>None</b>	Set the fax transport method.  <b>Note:</b> This menu item appears only if an etherFAX or Fax over IP (FoIP) license bundle is installed in the printer.

Menu item	Submenu item	Settings	Description
<b>HTTPS Fax Settings</b>	<b>HTTPS service URL</b>	The setting is user-defined.	Specify the etherFAX service URL.
	<b>HTTPS Proxy</b>	The setting is user-defined.	Specify a proxy server URL.
	<b>HTTPS Proxy User</b>	The setting is user-defined.	Specify the username and password for the proxy server.
	<b>HTTPS Proxy Password</b>		
	<b>Fax Send Encryption</b>	<b>Disabled</b> <b>Enabled*</b> <b>Required</b>	Enable encryption for outgoing fax messages.
	<b>Fax Receive Encryption</b>	<b>Disabled</b> <b>Enabled*</b> <b>Required</b>	Enable encryption for incoming fax messages.
	<b>HTTPS Fax Status</b>	The setting is a read-only information.	Show the etherFAX communication status.
<b>Fax Send Settings</b>	<b>Resolution</b>	<b>Standard*</b> <b>Fine</b> <b>Super Fine</b> <b>Ultra Fine</b>	Set the resolution of the scanned image.  <div style="border: 1px solid gray; padding: 5px; background-color: #f0f0f0;"> <p><b>Note:</b> A higher resolution increases fax transmission time and requires more memory.</p> </div>
	<b>Original Size</b>	[List of paper sizes] ( <b>Mixed Sizes*</b> )	Specify the size of the original document.
	<b>Orientation</b>	<b>Portrait*</b> <b>Landscape</b>	Specify the orientation of the original document.
	<b>Sides</b>	<b>Off*</b> <b>Short Edge</b> <b>Long Edge</b>	Specify the orientation of the original document when scanning on both sides of the document.
	<b>Content Type</b>	<b>Text*</b> <b>Text/Photo</b> <b>Photo</b> <b>Graphics</b>	Improve the output result based on the content of the original document.

Menu item	Submenu item	Settings	Description
	<b>Content Source</b>	<b>Black and White Laser*</b> <b>Color Laser</b> <b>Inkjet</b> <b>Photo/Film</b> <b>Magazine</b> <b>Newspaper</b> <b>Press</b> <b>Other</b>	Improve the output result based on the source of the original document.
	<b>Darkness</b>	<b>1 to 9 (5*)</b>	Adjust the darkness of the scanned image.
	<b>Behind a PABX</b>	<b>On</b> <b>Off*</b>	Set the printer to dial a fax number without waiting to recognize the dial tone.  <div style="border: 1px solid gray; padding: 5px; background-color: #f0f0f0;"> <p><b>Note:</b> Private Automated Branch Exchange (PABX) is a telephone network that allows a single access number to offer multiple lines to outside callers.</p> </div>
	<b>Dial Mode</b>	<b>Tone*</b> <b>Pulse</b>	Specify the dial mode for incoming or outgoing faxes.
<b>Advanced Imaging</b>	<b>Color Balance</b>	<b>Cyan - Red (0*)</b> <b>Magenta - Green (0*)</b> <b>Yellow - Blue (0*)</b>	Adjust the color intensity during scanning.
	<b>Color Dropout</b>	<b>Best for Content*</b> <b>0</b> <b>1</b> <b>2</b> <b>3</b> <b>4</b> <b>5</b>	Set the contrast of the output.

## Printer menus

Menu item	Submenu item	Settings	Description
	<b>Mirror Image</b>	<b>Off*</b> <b>On</b>	Create a mirror image of the original document.
	<b>Shadow Detail</b>	<b>-4 to 4 (0*)</b>	Adjust the amount of shadow detail visible on a scanned image.
	<b>Scan Edge to Edge</b>	<b>Off</b> <b>On*</b>	Allow edge-to-edge scanning of the original document.
	<b>Sharpness</b>	<b>1 to 5 (3*)</b>	Adjust the sharpness of the scanned image.
	<b>Temperature</b>	<b>-4 to 4 (0*)</b>	Specify whether to generate a cooler or warmer output.
<b>Admin Controls</b>	<b>Automatic Redial</b>	<b>0 to 9 (5*)</b>	Specify the number of attempts that the printer redials before it cancels sending the fax to a specified destination.
	<b>Redial Frequency</b>	<b>1 to 200 minutes (3*)</b>	Increase the time between redial attempts to increase the chance of sending fax successfully.
	<b>Enable ECM</b>	<b>On*</b> <b>Off</b>	Activate Error Correction Mode (ECM) for fax jobs.  <b>Note:</b> ECM detects and corrects errors in the fax transmission process caused by telephone line noise and poor signal strength.
	<b>Enable Fax Scans</b>	<b>On*</b> <b>Off</b>	Create faxes using the printer scanner.
	<b>Driver to Fax</b>	<b>On*</b> <b>Off</b>	Allow the print driver to send fax.
	<b>Allow Save as Shortcut</b>	<b>On*</b> <b>Off</b>	Save fax numbers as shortcuts on the printer.

## Printer menus

Menu item	Submenu item	Settings	Description
	<b>Max Speed</b>	<b>33600*</b> 14400 9600 4800 2400	Set the maximum speed for sending fax.
	<b>Custom Job Scanning</b>	<b>Off*</b> On	Turn on scanning of custom jobs by default.
	<b>Scan Preview</b>	<b>Off*</b> On	Show a preview of the scan on the display.
	<b>Adjust ADF Skew</b>	<b>Off</b> On*	Correct slight skew in the scanned image.
	<b>Enable Color Fax Scans</b>	<b>Off by Default*</b> On by Default Never Use Always Use	Enable color scans for fax.
	<b>Auto Convert Color Faxes to Mono Faxes</b>	<b>On*</b> Off	Convert all outgoing color faxes to black and white.
	<b>Confirm Fax Number</b>	<b>Off*</b> On	Ask the user to confirm the fax number.
	<b>Dial Prefix</b>	The setting is user-defined.	Set a dialing prefix.
	<b>Dialing Prefix Rules</b>	The setting is user-defined.	Establish a dialing prefix rule.
<b>Fax Receive Settings</b>	<b>Fax Job Waiting</b>	<b>None*</b> Toner Toner and Supplies	Remove fax jobs that request specific unavailable resources from the print queue.
	<b>Rings to Answer</b>	<b>1 to 25 (3*)</b>	Set the number of rings required before the printer answers the incoming calls.
	<b>Auto Reduction</b>	<b>On*</b> Off	Scale incoming fax to fit on the page.
	<b>Paper Source</b>	<b>Tray [x]</b> Auto*	Set the paper source for printing incoming fax.

Menu item	Submenu item	Settings	Description
	<b>Sides</b>	<b>On</b> <b>Off*</b>	Print on both sides of the paper.
	<b>Separator Sheets</b>	<b>None*</b> <b>Before Job</b> <b>After Job</b>	Specify whether to insert blank separator sheets when printing.
	<b>Separator Sheet Source</b>	<b>Tray [x] (1*)</b>	Specify the paper source for the separator sheet.
	<b>Output Bin</b>	<b>Standard Bin</b>	Specify the output bin for received faxes.
	<b>Fax Footer</b>	<b>On</b> <b>Off*</b>	Print the transmission information at the bottom of each page from a received fax.
	<b>Fax Footer Time Stamp</b>	<b>Receive*</b> <b>Print</b>	Print the time stamp at the bottom of each page from a received fax.
	<b>Holding Faxes</b>	<b>Held Fax Mode (Off*)</b>	Hold received faxes from printing until they are released.
		<b>Fax Holding Schedule</b>	Assign a schedule for holding faxes.  <b>Note:</b> This menu item appears only if <b>Held Fax Mode</b> is set to <b>Scheduled</b> .
<b>Admin Controls</b>	<b>Enable Fax Receive</b>	<b>On*</b> <b>Off</b>	Set the printer to receive fax.
	<b>Enable Color Fax Receive</b>	<b>On*</b> <b>Off</b>	Set the printer to receive fax in color.
	<b>Enable Caller ID</b>	<b>On*</b> <b>Off</b>	Show the caller ID information of the incoming call on the printer display.
	<b>Block No Name Fax</b>	<b>On</b> <b>Off*</b>	Block incoming faxes without fax IDs.
	<b>Banned Fax List</b>	<b>Add Banned Fax</b>	Specify the phone numbers that you want to block.

Menu item	Submenu item	Settings	Description
	<b>Answer On</b>	<b>All Rings*</b> <b>Single Ring Only</b> <b>Double Ring Only</b> <b>Triple Ring Only</b> <b>Single or Double Rings Only</b> <b>Single or Triple Rings Only</b> <b>Double or Triple Rings Only</b>	Set a distinctive ring pattern for incoming fax.
	<b>Auto Answer</b>	<b>On*</b> <b>Off</b>	Set the printer to receive fax automatically.
	<b>Manual Answer Code</b>	<b>0 to 9 (9*)</b>	Manually enter a code on the telephone number pad to begin receiving fax.  <div style="background-color: #f0f0f0; padding: 10px; border: 1px solid #ccc;"> <p><b>Notes</b></p> <ul style="list-style-type: none"> <li>• This menu item appears only when the printer shares a line with a telephone.</li> <li>• This menu item appears only when you set the printer to receive fax manually.</li> </ul> </div>
	<b>Fax Forwarding</b>	<b>Print*</b> <b>Print and Forward</b> <b>Forward</b>	Specify whether to forward received fax.

Menu item	Submenu item	Settings	Description
	<b>Forward To</b>	<b>Destination 1</b> <b>Destination 2</b>	Specify where to forward received fax.  <b>Note:</b> This menu item appears only when <b>Fax Forwarding</b> is set to <b>Print and Forward</b> or <b>Forward</b> .
	<b>Max Speed</b>	<b>33600*</b> <b>14400</b> <b>9600</b> <b>4800</b> <b>2400</b>	Set the maximum speed for transmitting fax.
<b>Fax Cover Page</b>	<b>Fax Cover Page</b>	<b>Off by Default*</b> <b>On by Default</b> <b>Never Use</b> <b>Always Use</b>	Configure the settings for the fax cover page.
	<b>Include To field</b>	<b>Off*</b> <b>On</b>	
	<b>Include From field</b>	<b>Off*</b> <b>On</b>	
	<b>From</b>	The setting is user-defined.	
	<b>Include Message Field</b>	<b>Off*</b> <b>On</b>	
	<b>Message:</b>	The setting is user-defined.	
	<b>Include Logo</b>	<b>Off*</b> <b>On</b>	
	<b>Include Footer [x]</b>	<b>Off*</b> <b>On</b>	
	<b>Footer [x]</b>	The setting is user-defined.	

Menu item	Submenu item	Settings	Description
<b>Fax Log Settings</b>	<b>Transmission Log Frequency</b>	<b>Always*</b> <b>Never</b> <b>Only for Error</b>	Specify how often the printer creates a transmission log.
	<b>Transmission Log Action</b>	<b>Print (On*)</b> <b>Email (Off*)</b>	Print or email a log for successful fax transmission or transmission error.
	<b>Receive Error Log</b>	<b>Print Never*</b> <b>Print on Error</b>	Print a log for fax-receive failures.
	<b>Auto Print Logs</b>	<b>On*</b> <b>Off</b>	Print all fax activity.
	<b>Log Paper Source</b>	<b>Tray [x] (1*)</b>	Specify the paper source for printing logs.
	<b>Logs Display</b>	<b>Remote Fax Name*</b> <b>Dialed Number</b>	Identify the sender by remote fax name or fax number.
	<b>Enable Job Log</b>	<b>On*</b> <b>Off</b>	View a summary of all fax jobs.
	<b>Enable Call Log</b>	<b>On*</b> <b>Off</b>	View a summary of the fax call history.
	<b>Log Output Bin</b>	<b>Standard Bin*</b> <b>Bin [x]</b>	Specify the output bin for printed logs.
<b>Speaker Settings</b>	<b>Speaker Mode</b>	<b>Always Off*</b> <b>Always On</b> <b>On until Connected</b>	Set the fax speaker mode.
	<b>Speaker Volume</b>	<b>Low*</b> <b>High</b>	Adjust the fax speaker volume.
	<b>Ringer Volume</b>	<b>Off*</b> <b>On</b>	Enable the ringer volume.
<b>VoIP Settings</b>	<b>VoIP Protocol</b>	<b>SIP*</b> <b>H.323</b>	Set the Voice over Internet Protocol (VoIP) protocol.
	<b>STUN Server</b>	The setting is user-defined.	Specify the STUN server to traverse a firewall.

Menu item	Submenu item	Settings	Description
	<b>Force Fax Mode</b>	<b>Off</b> <b>On*</b>	Switch VoIP gateway from analog to T.38 at the beginning of a fax call.
	<b>Force Fax Mode Delay</b>	<b>0 to 15 (7*)</b>	Set the time delay in seconds when sending another invite of <b>Force Fax Mode</b> .
<b>SIP Settings</b>	<b>Proxy</b>	The setting is user-defined.	Specify the IP address of the system that converts the phone number to an IP address where the fax is sent.
	<b>Registrar</b>	The setting is user-defined.	Specify a name or IP address of the system that handles the registration of Session Initiation Protocol (SIP) clients.
	<b>User</b>	The setting is user-defined.	Specify the name of the user for SIP.
	<b>Password</b>	The setting is user-defined.	Specify the password that is used in registering with the SIP Registrar.
	<b>Auth ID</b>	The setting is user-defined.	The username that is used when registering.  <b>Note:</b> If the <b>Auth ID</b> setting is not set, the setting uses the username of the User field instead.
	<b>Transport For Registration</b>	<b>UDP*</b> <b>TCP</b>	Set the SIP transport type for registration.
	<b>Transport For Incoming Calls</b>	<b>UDP</b> <b>TCP</b> <b>UDP And TCP*</b>	Set the SIP transport type for incoming calls.
	<b>Transport For Outgoing Calls</b>	<b>UDP*</b> <b>TCP</b>	Set the SIP transport type for outgoing calls.
	<b>Outbound Proxy</b>	The setting is user-defined.	Specify an outbound proxy to forward all SIP communication.
	<b>Contact</b>	The setting is user-defined.	Specify a contact name for SIP.

Menu item	Submenu item	Settings	Description
	<b>Realm</b>	The setting is user-defined.	Specify a realm name for SIP.  <b>Note:</b> If the Realm setting is not set, the setting uses the name of the <b>Contact</b> instead.
	<b>SIP Registration Status</b>	The setting is a read-only information.	Show the status of the SIP Registration.
<b>H.323 Settings</b>	<b>Gateway</b>	The setting is user-defined.	Specify the H.323 gateway IP address.
	<b>Gatekeeper</b>	The setting is user-defined.	Specify the H.323 gatekeeper.
	<b>User</b>	The setting is user-defined.	Specify the username used with the H.323 gateway.
	<b>Password</b>	The setting is user-defined.	Specify the password for the H.323 gateway.
	<b>Enable Fast Start</b>	<b>Off*</b> <b>On</b>	Enable Fast Start.
	<b>Disable H.245 Tunneling</b>	<b>Off*</b> <b>On</b>	Disable H.323 Tunneling.
	<b>Disable Gatekeeper Discovery</b>	<b>Off</b> <b>On*</b>	Disable H.323 Gatekeeper Discovery.
<b>T.38 Settings</b>	<b>Indicator Redundancy</b>	<b>0 to 5 (3*)</b>	Set the number of times that a fax indicator is repeated in the T.38 communication.
	<b>Low Speed Redundancy</b>	<b>0 to 5 (3*)</b>	Set the number of times that low-speed data is repeated in the T.38 communication.
	<b>High Speed Redundancy</b>	<b>0 to 5 (1*)</b>	Set the number of times that high-speed data is repeated in the T.38 communication.

## Fax Server Setup

### General Fax Settings

**Note:** An asterisk (\*) next to a value indicates the factory default setting.

Menu item	Settings	Description
<b>To Format</b>	N/A	Specify a fax recipient.  <b>Note:</b> If you want to use the fax number, then type the number sign (#) before a number.
<b>Reply Address</b>	N/A	Specify a reply address for sending fax.
<b>Subject</b>	N/A	Specify the fax subject and message.
<b>Message</b>	N/A	
<b>Enable analog receive</b>	<b>Off*</b> <b>On</b>	Set the printer to receive analog faxes.

### Fax Server Email Settings

**Note:** An asterisk (\*) next to a value indicates the factory default setting.

Menu item	Settings	Description
<b>Use Email SMTP Server</b>	<b>On*</b> <b>Off</b>	Use the Simple Mail Transfer Protocol (SMTP) settings for email in receiving and sending faxes.  <b>Note:</b> When set to <b>On</b> , all other settings of the <b>Fax Server Email Settings</b> menu are not shown.

## Printer menus

---

Menu item	Settings	Description
<b>Primary SMTP Gateway</b>	N/A	Type the IP address or host name of the primary SMTP server.
<b>Primary SMTP Gateway Port</b>	1 to 65535 (25*)	Enter the port number of the primary SMTP server.
<b>Secondary SMTP Gateway</b>	N/A	Type the server IP address or host name of your secondary or backup SMTP server.
<b>Secondary SMTP Gateway Port</b>	1 to 65535 (25*)	Enter the server port number of your secondary or backup SMTP server.
<b>SMTP Timeout</b>	5 to 30 (30*)	Set the time before the printer times out if the SMTP server does not respond.
<b>Reply Address</b>	N/A	Specify a reply address for sending fax.
<b>Use SSL/TLS</b>	<b>Disabled*</b> <b>Negotiate</b> <b>Required</b>	Specify whether to send a fax using an encrypted link.
<b>Require Trusted Certificate</b>	<b>Off</b> <b>On*</b>	Specify a trusted certificate when accessing the SMTP server.
<b>SMTP Server Authentication</b>	<b>No authentication required*</b> <b>Login / Plain</b> <b>NTLM</b> <b>CRAM-MD5</b> <b>Digest-MD5</b> <b>Kerberos 5</b> <b>OAuth 2</b>	Set the authentication type for the SMTP server.
<b>Device-Initiated Email</b>	<b>None*</b> <b>Use Device SMTP Credentials</b>	Specify whether credentials are required for device-initiated email.

## Printer menus

Menu item	Settings	Description
<b>User-Initiated Email</b>	<b>None*</b> <b>Use Device SMTP Credentials</b> <b>Use Session User ID and Password</b> <b>Use Session Email address and Password</b> <b>Prompt user</b>	Specify whether credentials are required for user-initiated email.
<b>Use Active Directory Device Credentials</b>	<b>Off*</b> <b>On</b>	Enable user credentials and group destinations to connect to the SMTP server.
<b>Device Userid</b>	N/A	Specify the user ID and password to connect to the SMTP server.
<b>Device Password</b>	N/A	
<b>Kerberos 5 REALM</b>	N/A	Specify the realm for the Kerberos 5 authentication protocol.
<b>NTLM Domain</b>	N/A	Specify the domain name for the NTLM security protocol.
<b>Disable "SMTP server not set up" error</b>	<b>Off*</b> <b>On</b>	Hide the "SMTP server not set up" error message.

## Fax Server Scan Settings

**Note:** An asterisk (\*) next to a value indicates the factory default setting.

Menu item	Settings	Description
<b>Image Format</b>	<b>TIFF (.tif)</b> <b>PDF (.pdf)*</b> <b>XPS (.xps)</b> <b>TXT (.txt)</b> <b>RTF (.rtf)</b> <b>DOCX (.docx)</b> <b>XLSX (.xlsx)</b> <b>CSV (.csv)</b>	Specify the file format for the scanned image.

## Printer menus

---

Menu item	Settings	Description
<b>Content Type</b>	<b>Text*</b> <b>Text/Photo</b> <b>Photo</b> <b>Graphics</b>	Improve the output result based on the content of the original document.
<b>Content Source</b>	<b>Black and White Laser*</b> <b>Color Laser</b> <b>Inkjet</b> <b>Photo/Film</b> <b>Magazine</b> <b>Newspaper</b> <b>Press</b> <b>Other</b>	Improve the output result based on the source of the original document.
<b>Fax Resolution</b>	<b>Standard*</b> <b>Fine</b> <b>Super Fine</b> <b>Ultra Fine</b>	Set the fax resolution.
<b>Sides</b>	<b>Off*</b> <b>Short Edge</b> <b>Long Edge</b>	Specify the orientation of the original document when scanning on both sides of the document.
<b>Darkness</b>	<b>1 to 9 (5*)</b>	Set the darkness of the output.
<b>Orientation</b>	<b>Portrait*</b> <b>Landscape</b>	Specify the orientation of text and graphics on the page.

Menu item	Settings	Description
<b>Original Size</b>	[List of paper sizes]	Set the paper size of the original document.  <div style="border: 1px solid gray; padding: 10px; background-color: #f0f0f0;"> <p><b>Notes</b></p> <ul style="list-style-type: none"> <li>• <b>Mixed Sizes</b> is the U.S. factory default setting. <b>A4</b> is the international factory default setting.</li> <li>• This setting may vary depending on your printer model.</li> </ul> </div>
<b>Use Multi-Page TIFF</b>	<b>Off</b> <b>On*</b>	Choose between single- and multiple-page TIFF files.

## E-mail

### Email Setup

**Note:** An asterisk (\*) next to a value indicates the factory default setting.

Menu item	Settings	Description
<b>Primary SMTP Gateway</b>	The setting is user-defined.	Type the IP address or host name of the primary SMTP server for sending email.
<b>Primary SMTP Gateway Port</b>	<b>1 to 65535 (25*)</b>	Enter the port number of the primary SMTP server.
<b>Secondary SMTP Gateway</b>	The setting is user-defined.	Type the server IP address or host name of your secondary or backup SMTP server.
<b>Secondary SMTP Gateway Port</b>	<b>1 to 65535 (25*)</b>	Enter the server port number of your secondary or backup SMTP server.
<b>SMTP Timeout</b>	<b>5 to 30 seconds (30*)</b>	Set the time before the printer times out if the SMTP server does not respond.

## Printer menus

Menu item	Settings	Description
<b>Reply Address</b>	The setting is user-defined.	Specify a reply address in the email.
<b>Always use SMTP default Reply Address</b>	<b>On</b> <b>Off*</b>	Always use the default reply address in the SMTP server.
<b>Use SSL/TLS</b>	<b>Disabled*</b> <b>Negotiate</b> <b>Required</b>	Specify whether to send an email using an encrypted link.
<b>Require Trusted Certificate</b>	<b>Off</b> <b>On*</b>	Require a trusted certificate when accessing the SMTP server.
<b>SMTP Server Authentication</b>	<b>No authentication required*</b> <b>Login / Plain</b> <b>NTLM</b> <b>CRAM-MD5</b> <b>Digest-MD5</b> <b>Kerberos 5</b> <b>OAuth 2</b>	Set the authentication type for the SMTP server.
<b>Device-Initiated Email</b>	<b>None*</b> <b>Use Device SMTP Credentials</b>	Specify whether credentials are required for device-initiated email.
<b>User-Initiated Email</b>	<b>None*</b> <b>Use Device SMTP Credentials</b> <b>Use Session User ID and Password</b> <b>Use Session Email address and Password</b> <b>Prompt user</b>	Specify whether credentials are required for user-initiated email.
<b>Use Active Directory Device Credentials</b>	<b>Off*</b> <b>On</b>	Specify whether credentials are required for user-initiated email.
<b>Device Userid</b>	The setting is user-defined.	Specify the user ID and password to connect to the SMTP server.
<b>Device Password</b>	The setting is user-defined.	

Menu item	Settings	Description
<b>Kerberos 5 REALM</b>	The setting is user-defined.	Specify the realm for the Kerberos 5 authentication protocol.
<b>NTLM Domain</b>	The setting is user-defined.	Specify the domain name for the NTLM security protocol.
<b>Disable “SMTP server not set up” error</b>	<b>Off*</b> <b>On</b>	Hide the “SMTP server not set up” error message.

## Email Defaults

**Note:** An asterisk (\*) next to a value indicates the factory default setting.

Menu item	Submenu items	Settings	Description
<b>Subject:</b>	N/A	The setting is user-defined.	Specify the email subject and message.
<b>Message:</b>	N/A	The setting is user-defined.	
<b>File Name</b>	N/A	The setting is user-defined.	Specify the filename for the scanned document.
<b>Format</b>	N/A	<b>JPEG (.jpg)</b> <b>PDF (.pdf)*</b> <b>TIFF (.tif)</b> <b>XPS (.xps)</b> <b>TXT (.txt)</b> <b>RTF (.rtf)</b> <b>DOCX (.docx)</b> <b>XLSX (.xlsx)</b> <b>CSV (.csv)</b>	Specify the file format of the scanned document.  <b>Note:</b> The menu items may vary depending on your printer model.
<b>Global OCR Settings</b>	<b>Recognized Languages</b>	[List of languages]	Configure the settings for optical character recognition (OCR).  <b>Note:</b> This menu item appears only if you have purchased and installed an OCR solution.
	<b>Auto Rotate</b>	<b>Off*</b> <b>On</b>	
	<b>Despeckle</b>	<b>Off*</b> <b>On</b>	

Menu item	Submenu items	Settings	Description
	<b>Auto Contrast Enhance</b>	<b>Off*</b> <b>On</b>	
<b>PDF Settings</b>	<b>PDF Version</b>	<b>1.3</b>	Configure the PDF settings of the scanned image.  <b>Notes</b>  <ul style="list-style-type: none"> <li>• <b>Archival Version</b> and <b>Archival (PDF/A)</b> are supported only when <b>PDF Version</b> is set to 1.4 or 1.7.</li> <li>• <b>Archival Version A-2u</b> is the default value if PDF version is set to 1.7. It is not selectable if PDF version is set to 1.4.</li> <li>• <b>Highly Compressed</b> appears only when a storage drive is installed.</li> <li>• <b>Secure</b> is supported only when <b>PDF Version</b> is set to 1.4 or higher.</li> </ul>
		<b>1.4</b>	
		<b>1.5*</b>	
		<b>1.6</b>	
		<b>1.7</b>	
		<b>2.0</b>	
	<b>Archival (PDF/A)</b>	<b>Off*</b> <b>On</b>	
<b>Archival Version</b>	<b>A-1a*</b> <b>A-1b</b> <b>A-2u</b>		
	<b>Highly Compressed</b>	<b>Off*</b> <b>On</b>	
	<b>Secure</b>	<b>Off*</b> <b>On</b>	
	<b>Searchable</b>	<b>Off*</b> <b>On</b>	
	<b>Split Job by Pages</b>	<b>0*</b>	
<b>Content Type</b>	N/A	<b>Text</b> <b>Text/Photo*</b> <b>Photo</b> <b>Graphics</b>	Specify the content of the original document.

## Printer menus

Menu item	Submenu items	Settings	Description
<b>Content Source</b>	N/A	<b>Black and White Laser*</b> <b>Color Laser</b> <b>Inkjet</b> <b>Photo/Film</b> <b>Magazine</b> <b>Newspaper</b> <b>Press</b> <b>Other</b>	Specify the source of the original document.
<b>Color</b>	N/A	<b>Black and White</b> <b>Gray</b> <b>Color*</b> <b>Auto</b>	Specify how the original document is captured.
<b>Resolution</b>	N/A	<b>75 dpi</b> <b>150 dpi*</b> <b>200 dpi</b> <b>300 dpi</b> <b>400 dpi</b> <b>600 dpi</b>	Set the resolution of the scanned image.
<b>Darkness</b>	N/A	<b>1 to 9 (5*)</b>	Adjust the darkness of the scanned image.
<b>Orientation</b>	N/A	<b>Portrait*</b> <b>Landscape</b>	Specify the orientation of the original document.
<b>Original Size</b>	N/A	<b>Mixed Sizes</b>	Set the paper size of the original document.
<b>Sides</b>	N/A	<b>Off*</b> <b>Short Edge</b> <b>Long Edge</b>	Specify the orientation of the original document when scanning on both sides of the document.
<b>Advanced Imaging</b>	<b>Color Balance</b>	<b>Cyan (0*)</b> <b>Magenta (0*)</b> <b>Yellow (0*)</b>	Adjust the color intensity for cyan, magenta, and yellow.

Menu item	Submenu items	Settings	Description
	<b>Color Dropout</b>	<b>Color Dropout (None *)</b> <b>Default Red Threshold (128*)</b> <b>Default Green Threshold (128*)</b> <b>Default Blue Threshold (128*)</b>	Specify which color to drop during scanning, and adjust the dropout setting for that color.
	<b>Auto Color Detect</b>	<b>Color Sensitivity (5*)</b> <b>Area Sensitivity (5*)</b> <b>E-mail Bit Depth (1 bit*)</b> <b>Minimum Scan Resolution (300 dpi*)</b>	Configure the auto color detection setting.
	<b>JPEG Quality</b>	<b>Best for content*</b> <b>5 to 95</b>	Set the JPEG quality of the scanned image.
	<b>Contrast</b>	<b>Best for content*</b> <b>0 to 5</b>	Specify the contrast for the scanned image.
	<b>Background Removal</b>	<b>Background Detection (Content-based*)</b> <b>Level (0*)</b>	Remove the background color or image noise from the original document.
	<b>Mirror Image</b>	<b>Off*</b> <b>On</b>	Create a mirror image of the original document.
	<b>Negative Image</b>	<b>Off*</b> <b>On</b>	Create a negative image of the original document.
	<b>Shadow Detail</b>	<b>-4 to 4 (0*)</b>	Adjust the shadow detail in the scanned image.
	<b>Scan Edge to Edge</b>	<b>Off*</b> <b>On</b>	Scan the original document from edge to edge.
	<b>Sharpness</b>	<b>1 to 5 (3*)</b>	Adjust the sharpness in the scanned image.

Menu item	Submenu items	Settings	Description
	<b>Temperature</b>	<b>-4 to 4 (0*)</b>	Generate a bluer or redder output of the original document.
	<b>Blank Pages</b>	<b>Blank Page Removal (Do Not Remove*)</b>	Remove the blank pages from the original document.
		<b>Blank Page Sensitivity (5*)</b>	Set the sensitivity of scans in relation to blank pages in the original document.
<b>Admin Controls</b>	<b>Max Email Size</b>	<b>0 to 65535 (0*)</b>	Set the allowable file size for each email.
	<b>Size Error Message</b>	The setting is user-defined.	Specify an error message that the printer sends when an email exceeds its allowable file size.  <b>Note:</b> You can type up to 1024 characters.
	<b>Limit Destinations</b>	The setting is user-defined.	Limit sending of email only to the specified list of domain name.  <b>Note:</b> Use a comma to separate each domain.
	<b>Send Me a Copy</b>	<b>Never appears*</b> <b>On by Default</b> <b>Off by Default</b> <b>Always On</b>	Send a copy of the email to yourself.
	<b>Allow self emails only</b>	<b>Off*</b> <b>On</b>	Set the printer to send emails to yourself only.
	<b>Use cc:/bcc:</b>	<b>Off*</b> <b>On</b>	Enable carbon copy and blind carbon copy in email.
	<b>Use Multi-Page TIFF</b>	<b>Off</b> <b>On*</b>	Enable scanning of multiple TIFF images in one TIFF file.
	<b>TIFF Compression</b>	<b>JPEG</b> <b>LZW*</b>	Specify the compression type for TIFF files.

Menu item	Submenu items	Settings	Description
	<b>Text Default</b>	<b>5 to 95 (75*)</b>	Set the text quality of the content being scanned.
	<b>Text/Photo Default</b>	<b>5 to 95 (75*)</b>	Set the text and photo quality of the content being scanned.
	<b>Photo Default</b>	<b>5 to 95 (50*)</b>	Set the photo quality of the content being scanned.
	<b>Adjust ADF Skew</b>	<b>Off*</b> <b>On</b>	Set the printer to adjust the skewed images from documents that are scanned from the ADF.
	<b>Transmission Log</b>	<b>Print log*</b> <b>Do Not Print Log</b> <b>Print Only For Error</b>	Print a transmission log for email scans.
	<b>Log Paper Source</b>	<b>Tray [x] (1*)</b> <b>Multipurpose Feeder</b>	Specify the paper source for printing logs.
	<b>Custom Job Scanning</b>	<b>Off*</b> <b>On</b>	Set the printer to scan the first set of original documents using the specified settings, and then the next set with the same or different settings.  <b>Note:</b> This menu item appears only when a storage drive is installed.
	<b>Scan Preview</b>	<b>Off*</b> <b>On</b>	Show a scan preview of the original document.  <b>Note:</b> This menu item appears only when a storage drive is installed.
	<b>Allow Save as Shortcut</b>	<b>Off</b> <b>On*</b>	Save an email address as a shortcut.
	<b>E-mail Images Sent As</b>	<b>Attachment*</b> <b>Web Link</b>	Specify how to send the images that are included in the email.

Menu item	Submenu items	Settings	Description
	<b>Reset Email Information After Sending</b>	<b>Off</b> <b>On*</b>	Reset the <b>To</b> , <b>Subject</b> , <b>Message</b> , and <b>Filename</b> fields to their default values after sending an email.

## Web Link Setup

Menu item	Settings	Description
<b>Server</b>	The setting is user-defined.	Specify the credentials of the server that is hosting the images that are included in the email.
<b>Login</b>	The setting is user-defined.	
<b>Password</b>	The setting is user-defined.	
<b>Path</b>	The setting is user-defined.	
<b>File Name</b>	The setting is user-defined.	
<b>Web Link</b>	The setting is user-defined.	

## FTP

### FTP Defaults

**Note:** An asterisk (\*) next to a value indicates the factory default setting.

Menu item	Submenu items	Settings	Description
<b>Format</b>	N/A	<b>JPEG (.jpg)</b> <b>PDF (.pdf)*</b> <b>TIFF (.tif)</b> <b>XPS (.xps)</b> <b>TXT (.txt)</b> <b>RTF (.rtf)</b> <b>DOCX (.docx)</b> <b>XLSX (.xlsx)</b> <b>CSV (.csv)</b>	Specify the file format for the scanned image.

Menu item	Submenu items	Settings	Description
<b>Global OCR Settings</b>	<b>Recognized Languages</b>	[List of languages]	Configure the settings for optical character recognition (OCR).  <div style="border: 1px solid gray; padding: 5px;"> <p><b>Note:</b> This menu appears only if you have purchased and installed an OCR solution.</p> </div>
	<b>Auto Rotate</b>	Off* On	
	<b>Despeckle</b>	Off* On	
	<b>Auto Contrast Enhance</b>	Off* On	
<b>PDF Settings</b>	<b>PDF Version</b>	1.3	Configure the PDF settings for the scanned image.  <div style="border: 1px solid gray; padding: 5px;"> <p><b>Notes</b></p> <ul style="list-style-type: none"> <li>• <b>Archival Version</b> and <b>Archival (PDF/A)</b> are supported only when <b>PDF Version</b> is set to 1.4 or 1.7.</li> <li>• <b>Archival Version A-2u</b> is the default value if PDF version is set to 1.7. It is not selectable if PDF version is set to 1.4.</li> <li>• <b>Highly Compressed</b> appears only when a storage drive is installed.</li> <li>• <b>Secure</b> is supported only when <b>PDF Version</b> is set to 1.4 or higher.</li> </ul> </div>
		1.4	
		1.5*	
		1.6	
		1.7	
		2.0	
	<b>Archival (PDF/A)</b>	Off* On	
	<b>Archival Version</b>	A-1a* A-1b A-2u	
<b>Highly Compressed</b>	Off* On		
<b>Secure</b>	Off* On		
<b>Searchable</b>	Off* On		

## Printer menus

Menu item	Submenu items	Settings	Description
<b>Content Type</b>	N/A	<b>Text</b> <b>Text/Photo*</b> <b>Graphics</b> <b>Photo</b>	Improve the output result based on the content type of the original document.
<b>Content Source</b>	N/A	<b>Black and White Laser</b> <b>Color Laser*</b> <b>Inkjet</b> <b>Photo/Film</b> <b>Magazine</b> <b>Newspaper</b> <b>Press</b> <b>Other</b>	Improve the output result based on the content source of the original document.
<b>Color</b>	N/A	<b>Black and White</b> <b>Gray</b> <b>Color*</b> <b>Auto</b>	Set the printer to capture file content in color or in mono.
<b>Resolution</b>	N/A	<b>75 dpi</b> <b>150 dpi*</b> <b>200 dpi</b> <b>300 dpi</b> <b>400 dpi</b> <b>600 dpi</b>	Set the resolution of the scanned image.
<b>Darkness</b>	N/A	<b>1 to 9 (5*)</b>	Adjust the darkness of the scanned image.
<b>Orientation</b>	N/A	<b>Portrait*</b> <b>Landscape</b>	Specify the orientation of the original document.
<b>Original Size</b>	N/A	<b>Mixed Sizes*</b>	Set the paper size of the original document.
<b>Sides</b>	N/A	<b>Off*</b> <b>Long Edge</b> <b>Short Edge</b>	Specify the orientation when scanning on both sides of the document.

Menu item	Submenu items	Settings	Description
<b>File Name</b>	N/A	The setting is user-defined.	Specify the file name of the scanned image.
<b>Advanced Imaging</b>	<b>Color Balance</b>	<b>Cyan (0*)</b>	Adjust the color intensity for cyan, magenta, and yellow.
		<b>Magenta (0*)</b>	
		<b>Yellow (0*)</b>	
	<b>Color Dropout</b>	<b>Color Dropout (None*)</b>	Specify which color to drop during scanning, and adjust the dropout setting for that color.
		<b>Default Red Threshold (128*)</b>	
		<b>Default Green Threshold (128*)</b>	
		<b>Default Blue Threshold (128*)</b>	
	<b>Auto Color Detect</b>	<b>Color Sensitivity (5*)</b>	Configure the auto color detection setting.
<b>Area Sensitivity (5*)</b>			
<b>FTP Bit Depth (1 bit*)</b>			
<b>Minimum Scan Resolution (300 dpi*)</b>			
<b>JPEG Quality</b>	<b>Best for content*</b> <b>5 to 95</b>	Set the JPEG quality of the scanned image.	
<b>Contrast</b>	<b>Best for content*</b> <b>0 to 5</b>	Specify the contrast for the scanned image.	
<b>Background Removal</b>	<b>Background Detection</b> ( <b>Content-based*</b> ) <b>Level (0*)</b>	Remove the background color or image noise from the original document.	
<b>Mirror Image</b>	<b>Off*</b> <b>On</b>	Create a mirror image of the original document.	

Menu item	Submenu items	Settings	Description
	<b>Negative Image</b>	<b>Off*</b> <b>On</b>	Create a negative image of the original document.
	<b>Shadow Detail</b>	<b>-4 to 4 (0*)</b>	Adjust the shadow detail in the scanned image.
	<b>Scan Edge to Edge</b>	<b>Off*</b> <b>On</b>	Scan the original document from edge to edge.
	<b>Sharpness</b>	<b>1 to 5 (3*)</b>	Adjust the sharpness in the scanned image.
	<b>Temperature</b>	<b>-4 to 4 (0*)</b>	Generate a bluer or redder output of the original document.
	<b>Blank Pages</b>	<b>Blank Page Removal (Do Not Remove *)</b>	Remove the blank pages from the original document.
		<b>Blank Page Sensitivity (5*)</b>	Set the sensitivity of scans in relation to blank pages in the original document.
<b>Admin Controls</b>	<b>Text Default</b>	<b>5 to 95 (75*)</b>	Set the quality of text on the scanned image.
	<b>Text/Photo Default</b>	<b>5 to 95 (75*)</b>	Set the quality of text and photo on the scanned image.
	<b>Photo Default</b>	<b>5 to 95 (50*)</b>	Set the quality of photo on the scanned image.
	<b>Use Multi-Page TIFF</b>	<b>On*</b> <b>Off</b>	Enable scanning of multiple TIFF images in one TIFF file.
	<b>TIFF Compression</b>	<b>LZW*</b> <b>JPEG</b>	Specify the compression type for TIFF files.
	<b>Transmission Log</b>	<b>Print Log*</b> <b>Do Not Print Log</b> <b>Print Only For Error</b>	Print a transmission log for FTP scans.
	<b>Log Paper Source</b>	<b>Tray [x] (1*)</b> <b>Multipurpose Feeder</b>	Specify the paper source for printing FTP logs.

Menu item	Submenu items	Settings	Description
	<b>Custom Job Scanning</b>	<b>Off*</b> <b>On</b>	Set the printer to scan the first set of original documents using the specified settings, and then the next set with the same or different settings.  <b>Note:</b> This menu item appears only when a storage drive is installed.
	<b>Scan Preview</b>	<b>Off*</b> <b>On</b>	Show a preview of the original document.  <b>Note:</b> This menu item appears only when a storage drive is installed.
	<b>Allow Save as Shortcut</b>	<b>Off</b> <b>On*</b>	Save an FTP address as a shortcut.
	<b>Adjust ADF Skew</b>	<b>On*</b> <b>Off</b>	Set the printer to adjust the skewed images from documents that are scanned from the ADF.
	<b>Use Passive FTP</b>	<b>Off*</b> <b>On</b>	Let the FTP server specify the data port that the printer connects to.

## USB Drive

### Flash Drive Scan

**Note:** An asterisk (\*) next to a value indicates the factory default setting.

## Printer menus

Menu item	Submenu item	Settings	Description
<b>Format</b>	N/A	<b>JPEG (.jpg)</b>	Specify the file format for the scanned image.  <b>Note: TXT (.txt), RTF (.rtf), DOCX (.docx), XLSX (.xlsx), and CSV (.csv)</b> appear only if you have purchased and installed an optical character recognition (OCR) solution.
		<b>PDF (.pdf)*</b>	
		<b>TIFF (.tif)</b>	
		<b>XPS (.xps)</b>	
		<b>TXT (.txt)</b>	
		<b>RTF (.rtf)</b>	
		<b>DOCX (.doc)</b>	
		<b>XLSX (.xlsx)</b>	
	<b>CSV (.csv)</b>		
<b>Global OCR Settings</b>	<b>Recognized Languages</b>	[List of languages]	Configure the settings for OCR.  <b>Note: Global OCR Settings</b> appears only if you have purchased and installed an OCR solution.
	<b>Auto Rotate</b>	<b>Off*</b>	
		<b>On</b>	
	<b>Despeckle</b>	<b>Off*</b>	
<b>On</b>			
<b>Auto Contrast Enhance</b>	<b>Off*</b>		
	<b>On</b>		

Menu item	Submenu item	Settings	Description
<b>PDF Settings</b>	<b>PDF Version</b>	<b>1.3</b>	Configure the PDF settings of the scanned image. <div style="border: 1px solid #ccc; padding: 10px; margin-top: 10px;"> <p><b>Notes</b></p> <ul style="list-style-type: none"> <li>• <b>Archival (PDF/A)</b> and <b>Archival Version</b> are supported only when <b>PDF Version</b> is set to 1.4 or 1.7.</li> <li>• <b>Archival Version A-2u</b> is the default value if PDF version is set to 1.7. It is not selectable if PDF version is set to 1.4.</li> <li>• <b>Highly Compressed</b> appears only when a hard disk is installed.</li> <li>• <b>Secure</b> is supported only when <b>PDF Version</b> is set to 1.4 or higher.</li> </ul> </div>
		<b>1.4</b>	
		<b>1.5*</b>	
		<b>1.6</b>	
		<b>1.7</b>	
	<b>2.0</b>		
<b>Archival (PDF/A)</b>	<b>Off*</b> <b>On</b>		
<b>Archival Version</b>	<b>A-1a*</b> <b>A-1b</b> <b>A-2u</b>		
<b>Highly Compressed</b>	<b>Off*</b> <b>On</b>		
<b>Secure</b>	<b>Off*</b> <b>On</b>		
<b>Searchable</b>	<b>Off*</b> <b>On</b>		
<b>Content Type</b>	N/A	<b>Text</b> <b>Text/Photo*</b> <b>Photo</b> <b>Graphics</b>	Improve the output result based on the content type of the original document.
<b>Content Source</b>	N/A	<b>Black and White Laser*</b> <b>Color Laser</b> <b>Inkjet</b> <b>Photo/Film</b> <b>Magazine</b> <b>Newspaper</b> <b>Press</b> <b>Other</b>	Improve the output result based on the content source of the original document.

## Printer menus

Menu item	Submenu item	Settings	Description
<b>Color</b>	N/A	<b>Black and White</b> <b>Gray</b> <b>Color*</b> <b>Auto</b>	Set the printer to capture file content in color or in mono.
<b>Resolution</b>	N/A	<b>75 dpi</b> <b>150 dpi*</b> <b>200 dpi</b> <b>300 dpi</b> <b>400 dpi</b> <b>600 dpi</b>	Set the resolution of the scanned image.
<b>Darkness</b>	N/A	<b>1 to 9 (5*)</b>	Adjust the darkness of the scanned image.
<b>Orientation</b>	N/A	<b>Portrait*</b> <b>Landscape</b>	Specify the orientation of the original document.
<b>Original Size</b>	N/A	<b>Mixed Sizes*</b>	Set the paper size of the original document.
<b>Sides</b>	N/A	<b>Off*</b> <b>Short edge</b> <b>Long edge</b>	Specify the orientation of the original document when scanning on both sides of the document.
<b>File Name</b>	N/A	The setting is user-defined.	Specify the file name of the scanned image.
<b>Advanced Imaging</b>	<b>Color Balance</b>	<b>Cyan (0*)</b> <b>Magenta (0*)</b> <b>Yellow (0*)</b>	Adjust the color intensity for cyan, magenta, and yellow.

Menu item	Submenu item	Settings	Description
	<b>Color Dropout</b>	<b>Color Dropout (None*)</b>  <b>Default Red Threshold (128*)</b>  <b>Default Green Threshold (128*)</b>  <b>Default Blue Threshold (128*)</b>	Specify which color to drop during scanning, and adjust the dropout setting for that color.
	<b>Auto Color Detect</b>	<b>Color Sensitivity (5*)</b>  <b>Area Sensitivity (5*)</b>  <b>Scan Bit Depth (1 bit*)</b>  <b>Minimum Scan Resolution (300 dpi*)</b>	Configure the auto color detection setting.
	<b>JPEG Quality</b>	<b>Best for content*</b>  <b>5 to 95</b>	Set the JPEG quality of the scanned image.
	<b>Contrast</b>	<b>Best for content*</b>  <b>0 to 5</b>	Specify the contrast for the scanned image.
	<b>Background Removal</b>	<b>Background Detection (Content-based*)</b>  <b>Level (0*)</b>	Remove the background color or image noise from the original document.
	<b>Mirror Image</b>	<b>Off*</b>  <b>On</b>	Create a mirror image of the original document.
	<b>Negative Image</b>	<b>Off*</b>  <b>On</b>	Create a negative image of the original document.

## Printer menus

Menu item	Submenu item	Settings	Description
	<b>Shadow Detail</b>	<b>-4 to 4 (0*)</b>	Adjust the shadow detail in the scanned image.
	<b>Scan Edge to Edge</b>	<b>Off*</b> <b>On</b>	Scan the original document from edge to edge.
	<b>Sharpness</b>	<b>1 to 5 (3*)</b>	Adjust the sharpness in the scanned image.
	<b>Temperature</b>	<b>-4 to 4 (0*)</b>	Generate a bluer or redder output of the original document.
	<b>Blank Pages</b>	<b>Blank Page Removal (Do Not Remove*)</b> <b>Blank Page Sensitivity (5*)</b>	Set the sensitivity of scans in relation to blank pages in the original document.
<b>Admin Controls</b>	<b>Text Default</b>	<b>5 to 95 (75*)</b>	Set the quality of text on the scanned image.
	<b>Text/Photo Default</b>	<b>5 to 95 (75*)</b>	Set the quality of text and photo on the scanned image.
	<b>Photo Default</b>	<b>5 to 95 (50*)</b>	Set the quality of a photo on the scanned image.
	<b>Use Multi-Page TIFF</b>	<b>Off</b> <b>On*</b>	Enable scanning of multiple TIFF images in one TIFF file.
	<b>TIFF Compression</b>	<b>JPEG</b> <b>LZW*</b>	Specify the compression type for TIFF files.
	<b>Custom Job Scanning</b>	<b>Off*</b> <b>On</b>	Set the printer to scan the first set of original documents using the specified settings, and then the next set with the same or different settings.
			<div style="border: 1px solid gray; background-color: #f0f0f0; padding: 5px;"> <p><b>Note:</b> This menu item appears only when a storage drive is installed.</p> </div>

Menu item	Submenu item	Settings	Description
	<b>Scan Preview</b>	<b>Off*</b> <b>On</b>	Show a scan preview of the original document.  <b>Note:</b> This menu item appears only when a storage drive is installed.
	<b>Adjust ADF Skew</b>	<b>Off</b> <b>On*</b>	Set the printer to adjust the skewed images from documents that are scanned from the automatic document feeder.

## Flash Drive Print

**Note:** An asterisk (\*) next to a value indicates the factory default setting.

Menu item	Settings	Description
<b>Number of Copies</b>	<b>1 to 9999 (1*)</b>	Set the number of copies in a print job.
<b>Paper Source</b>	<b>Tray [x] (1*)</b> <b>Multipurpose Feeder</b> <b>Manual Paper</b> <b>Manual Envelope</b>	Set the paper source for the print job.
<b>Collate</b>	<b>Off [1,1,1,2,2,2]</b> <b>On [1,2,1,2,1,2]*</b>	Keep the pages of a print job stacked in sequence, particularly when printing multiple copies of the job.
<b>Sides</b>	<b>1-Sided*</b> <b>2-Sided</b>	Specify whether to print on one side or both sides of the paper.

Menu item	Settings	Description
<b>Staple</b>	<b>Off*</b> <b>1 staple, top left corner</b> <b>2 staples, left</b> <b>1 staple, top right corner</b> <b>2 staples, top</b> <b>1 staple, bottom left corner</b> <b>2 staples, bottom</b> <b>1 staple, bottom right corner</b> <b>2 staples, right</b>	<p>Specify the staple position for all print jobs.</p> <p><b>Note:</b> <b>Staple</b> appears only when a staple finisher is installed.</p>
<b>Hole Punch</b>	<b>Off*</b> <b>2 holes</b> <b>3 holes</b> <b>4 holes</b>	<p>Set the punch mode for all print jobs.</p> <p><b>Note:</b> This menu item appears only when a staple, hole punch finisher or booklet finisher is installed.</p>
<b>Offset Pages</b>	<b>None*</b> <b>Between Copies</b> <b>Between Jobs</b>	<p>Offset the output of each print job or each copy of a print job.</p> <p><b>Notes</b></p> <ul style="list-style-type: none"> <li>• <b>Between Copies</b>—Offsets each copy of a print job if <b>Collate</b> is set to <b>On [1,2,1,2,1,2]</b>. If <b>Collate</b> is set to <b>Off [1,1,1,2,2,2]</b>, then each set of printed pages is offset, such as all pages designated as 1 and all pages designated as 2.</li> <li>• <b>Between Jobs</b>—Sets the same offset position for the entire print job regardless of the number of copies printed.</li> </ul>
<b>Flip Style</b>	<b>Long Edge*</b> <b>Short Edge</b>	<p>Determine which side of the paper is bound when performing two-sided printing.</p>

## Printer menus

---

Menu item	Settings	Description
<b>Pages per Side</b>	<b>Off*</b> <b>2 pages per side</b> <b>3 pages per side</b> <b>4 pages per side</b> <b>6 pages per side</b> <b>9 pages per side</b> <b>12 pages per side</b> <b>16 pages per side</b>	Print multiple page images on one side of a sheet of paper.
<b>Pages per Side Ordering</b>	<b>Horizontal*</b> <b>Reverse Horizontal</b> <b>Reverse Vertical</b> <b>Vertical</b>	Specify the positioning of multiple page images when using the <b>Pages per Side</b> menu.
<b>Pages per Side Orientation</b>	<b>Auto*</b> <b>Landscape</b> <b>Portrait</b>	Specify the orientation of multiple page images when using the <b>Pages per Side</b> menu.
<b>Pages per Side Border</b>	<b>None*</b> <b>Solid</b>	Print a border around each page image when using the <b>Pages per Side</b> menu.
<b>Separator Sheets</b>	<b>Off*</b> <b>Between Copies</b> <b>Between Jobs</b> <b>Between Pages</b>	Insert blank separator sheets when printing.
<b>Separator Sheet Source</b>	<b>Tray [x] (1*)</b> <b>Multipurpose Feeder</b>	Specify the paper source for the separator sheet.
<b>Blank Pages</b>	<b>Do Not Print*</b> <b>Print</b>	Print blank pages in a print job.

# Network/Ports

## Network Overview

**Note:** An asterisk (\*) next to a value indicates the factory default setting.

Menu item	Settings	Description
<b>Active Adapter</b>	<b>Auto*</b> <b>Standard Network</b> <b>Wireless</b>	Specify the type of the network connection.  <div style="border: 1px solid #ccc; padding: 5px; background-color: #f0f0f0;"> <p><b>Note:</b> <b>Wireless</b> is available only in printers connected to a wireless network.</p> </div>
<b>Network Status</b>	The setting is a read-only information.	Show the connectivity status of the printer network.
<b>Display Network Status on Printer</b>	<b>Off</b> <b>On*</b>	Show the network status on the display.
<b>Speed, Duplex</b>	The setting is a read-only information.	Show the speed of the currently active network card.
<b>IPv4</b>	The setting is a read-only information.	Show the IPv4 address.
<b>All IPv6 Addresses</b>	The setting is a read-only information.	Show all the IPv6 addresses.
<b>Reset Print Server</b>	<b>Start</b>	Reset all active network connections to the printer.  <div style="border: 1px solid #ccc; padding: 5px; background-color: #f0f0f0;"> <p><b>Note:</b> Pressing <b>Start</b> removes all network configuration settings.</p> </div>
<b>Network Job Timeout</b>	<b>Off</b> <b>On*</b> (90 seconds)	Set the time before the printer cancels a network print job.
<b>Banner Page</b>	<b>Off*</b> <b>On</b>	Print a banner page.
<b>Scan to PC Port Range</b>	The setting is user-defined.	Specify a valid port range for printers that are behind a port blocking firewall.

Menu item	Settings	Description
<b>Enable Network Connections</b>	<b>Off</b> <b>On*</b>	Enable the printer to connect to a network.
<b>Enable LLDP</b>	<b>Off*</b> <b>On</b>	Show the network status on the home screen.

## Wireless

### Notes

- This menu is available only in printers connected to a Wi-Fi network or printers that have a wireless network adapter.
- An asterisk (\*) next to a value indicates the factory default setting.

Menu item	Submenu item	Settings	Description
<b>Setup On Printer Panel</b>	<b>Choose Network</b>	[List of available wireless networks]	Determine the wireless network that the printer connects to.
	<b>Add Wi-Fi Network</b>	<b>Network Name</b> <b>Network Mode (Infrastructure*)</b> <b>Wireless Security Mode (Disabled*)</b>	Manually enter a network name and network type.

Menu item	Submenu item	Settings	Description
<b>Wi-Fi Protected Setup</b>	N/A	<b>Start Push Button Method</b>  <b>Start PIN Method</b>	Establish a Wi-Fi network and enable network security.  <div style="background-color: #f0f0f0; padding: 10px;"> <p><b>Notes</b></p> <ul style="list-style-type: none"> <li>• <b>Start Push-Button Method</b> connects the printer to a Wi-Fi network when buttons on both the printer and the access point (wireless router) are pressed within a given time.</li> <li>• <b>Start PIN Method</b> connects the printer to a Wi-Fi network when a PIN on the printer is entered into the wireless settings of the access point.</li> </ul> </div>
<b>Network Mode</b>	N/A	<b>BSS Type</b>  <b>Infrastructure</b> *	Specify the network mode.

Menu item	Submenu item	Settings	Description
<b>Compatibility</b>	N/A	<b>802.11b/g/n (2.4GHz)*</b>  <b>802.11a/b/g/n/ac (2.4GHz/5GHz)</b>  <b>802.11a/n/ac (5GHz)</b>	Specify the standard for the Wi-Fi network.  <div style="border: 1px solid gray; padding: 5px;"> <p><b>Note:</b> <b>802.11a/b/g/n/ac (2.4GHz/5GHz)</b> and <b>802.11a/n/ac (5GHz)</b> appear only when a Wi-Fi option is installed.</p> </div>
<b>Wireless Security Mode</b>	N/A	<b>Disabled*</b>  <b>WPA2/WPA-Personal</b>  <b>WPA2-Personal</b>  <b>WPA2/WPA3-Personal</b>  <b>WPA3-Personal</b>  <b>802.1x - RADIUS</b>	Set the security mode for connecting the printer to Wi-Fi devices.
<b>WPA2/WPA Personal</b>	N/A	<b>AES</b>	Enable Wi-Fi security through Wi-Fi Protected Access (WPA).  <div style="border: 1px solid gray; padding: 5px;"> <p><b>Note:</b> This menu item appears only when <b>Wireless Security Mode</b> is set to <b>WPA2/WPA-Personal</b>.</p> </div>

## Printer menus

---

Menu item	Submenu item	Settings	Description
<b>Set PSK</b>	N/A	The setting is user-defined.	<p>Set the password for a secure Wi-Fi connection.</p> <p><b>Note:</b> This menu item appears only when <b>Wireless Security Mode</b> is set to any of the following:</p> <ul style="list-style-type: none"><li>• <b>WPA2/WPA-Personal</b></li><li>• <b>WPA2-Personal</b></li><li>• <b>WPA3/WPA-Personal</b></li><li>• <b>WPA3-Personal</b></li></ul>
<b>WPA2-Personal</b>	N/A	<b>AES</b>	<p>Enable Wi-Fi security through WPA2.</p> <p><b>Note:</b> This menu item appears only when <b>Wireless Security Mode</b> is set to <b>WPA2-Personal</b>.</p>

Menu item	Submenu item	Settings	Description
<b>802.1x Encryption Mode</b>	N/A	<b>WPA+</b> <b>WPA2*</b> <b>WPA2 + PMF</b>	Enable Wi-Fi security through the 802.1x standard.  <div style="border: 1px solid gray; background-color: #f0f0f0; padding: 10px;"> <p><b>Notes</b></p> <ul style="list-style-type: none"> <li>This menu item appears only when <b>Wireless Security Mode</b> is set to <b>802.1x - RADIUS</b>.</li> <li><b>802.1x - RADIUS</b> can be configured only from the Embedded Web Server.</li> </ul> </div>
<b>IPv4</b>	<b>Enable DHCP</b>	<b>On*</b> <b>Off</b>	Enable and configure the IPv4 settings in the printer.
	<b>Set Static IP Address</b>	<b>IP Address</b> <b>Netmask</b> <b>Gateway</b>	
<b>IPv6</b>	<b>Enable IPv6</b>	<b>On*</b> <b>Off</b>	Enable and configure the IPv6 settings in the printer.
	<b>Enable DHCPv6</b>	<b>On</b> <b>Off*</b>	
	<b>Stateless Address Autoconfiguration</b>	<b>On*</b> <b>Off</b>	
	<b>IPv6 Address Generation Mode</b>	<b>EUI64*</b> <b>Stable Privacy</b> <b>Random</b>	
	<b>DNS Server Address</b>	The setting is user-defined.	

## Printer menus

Menu item	Submenu item	Settings	Description
	<b>Manually Assigned IPv6 Address</b>	The setting is user-defined.	
	<b>Manually Assigned IPv6 Router</b>	The setting is user-defined.	
	<b>Address Prefix</b>	The setting is user-defined.	
	<b>All IPv6 Addresses</b>	The setting is user-defined.	
	<b>All IPv6 Router Addresses</b>	The setting is user-defined.	
<b>Network Address</b>	N/A	<b>UAA</b> <b>LAA</b>	View the network addresses.
<b>PCL SmartSwitch</b>	N/A	<b>Off</b> <b>On*</b>	Set the printer to switch automatically to PCL emulation when a print job requires it, regardless of the default printer language.  <div style="border: 1px solid gray; padding: 5px; background-color: #f0f0f0;"> <p><b>Note:</b> If <b>PCL SmartSwitch</b> is set to <b>Off</b>, then the printer does not examine incoming data and uses the default printer language specified in the <b>Setup</b> menu.</p> </div>
<b>PS SmartSwitch</b>	N/A	<b>Off</b> <b>On*</b>	Set the printer to switch automatically to PS emulation when a print job requires it, regardless of the default printer language.  <div style="border: 1px solid gray; padding: 5px; background-color: #f0f0f0;"> <p><b>Note:</b> If <b>PS SmartSwitch</b> is set to <b>Off</b>, then the printer does not examine incoming data and uses the default printer language specified in the <b>Setup</b> menu.</p> </div>

Menu item	Submenu item	Settings	Description
<b>Job Buffering</b>	N/A	<b>On</b> <b>Off*</b>	Temporarily store print jobs in the storage drive before printing.  <b>Note:</b> This menu item appears only when a storage device is installed.
<b>Mac Binary PS</b>	N/A	<b>Auto*</b> <b>On</b> <b>Off</b>	Set the printer to process Macintosh binary PostScript emulation print jobs.  <b>Notes</b> <ul style="list-style-type: none"> <li>• <b>On</b>—Processes raw binary PostScript emulation print jobs.</li> <li>• <b>Off</b>—Filters print jobs using the standard protocol.</li> </ul>

## Wi-Fi Direct

**Note:** An asterisk (\*) next to a value indicates the factory default setting.

Menu item	Settings	Description
<b>Enable Wi-Fi Direct</b>	<b>On</b> <b>Off*</b>	Set the printer to connect directly to Wi-Fi devices.
<b>Wi-Fi Direct Name</b>	The setting is user-defined.	Specify the name of the Wi-Fi Direct network.
<b>Wi-Fi Direct Password</b>	The setting is user-defined.	Set the password to authenticate and validate users on a Wi-Fi connection.
<b>Show Password on Setup Page</b>	<b>Off</b> <b>On*</b>	Show the <b>Wi-Fi Direct Password</b> on the <b>Network Setup Page</b> .

## Printer menus

---

Menu item	Settings	Description
<b>Preferred Channel Number</b>	<b>1 to 11</b> <b>Auto*</b>	Set the preferred channel of the Wi-Fi network.
<b>Group Owner IP Address</b>	The setting is user-defined.	Specify the IP address of the group owner.
<b>Auto-Accept Push Button Requests</b>	<b>Off*</b> <b>On</b>	Accept requests to connect to the network automatically.  <b>Note:</b> Accepting clients automatically is not secured.

## Mobile Services Management

**Note:** An asterisk (\*) next to a value indicates the factory default setting.

Menu item	Settings	Description
<b>Enable IPP Print</b>	<b>On*</b> <b>Off</b>	Enable a network printer to print jobs using Internet Printing Protocol (IPP).
<b>Enable IPP Fax</b>	<b>On*</b> <b>Off</b>	Enable a USB printer to send fax jobs using IPP.
<b>Enable IPP Over USB</b>	<b>On*</b> <b>Off</b>	Enable a USB printer to print jobs using IPP.  <b>Note:</b> IPP is normally designed for network printers.
<b>Enable Scan</b>	<b>On*</b> <b>Off</b>	Enable a network printer to print jobs using eSCL protocol.
<b>Enable Mopria Discovery</b>	<b>On*</b> <b>Off</b>	Enable mobile devices to discover a Mopria™ certified printer.

## Ethernet

**Note:** An asterisk (\*) next to a value indicates the factory default setting.

## Printer menus

Menu item	Submenu item	Settings	Description
<b>Network Speed</b>	N/A	The setting is a read-only information.	Show the speed of the active network adapter.
<b>IPv4</b>	<b>Enable DHCP</b>	<b>On*</b> <b>Off</b>	Configure the IPv4 settings.  <b>Note:</b> The settings are user-defined.
	<b>Set Static IP Address</b>	<b>IP Address</b> <b>Netmask</b> <b>Gateway</b>	
<b>IPv6</b>	<b>Enable IPv6</b>	<b>On*</b> <b>Off</b>	Configure the IPv6 settings.
	<b>Enable DHCPv6</b>	<b>Off*</b> <b>On</b>	
	<b>Stateless Address Autoconfiguration</b>	<b>On*</b> <b>Off</b>	
	<b>IPv6 Address Generation Mode</b>	<b>EUI64*</b> <b>Stable Privacy</b> <b>Random</b>	
	<b>DNS Server Address</b>	The setting is user-defined.	
	<b>Manually Assigned IPv6 Address</b>	The setting is user-defined.	
	<b>Manually Assigned IPv6 Router</b>	The setting is user-defined.	
	<b>Address Prefix</b>	<b>0 to 128</b> (64*)	
	<b>All IPv6 Addresses</b>	The setting is a read-only information.	
	<b>All IPv6 Router Addresses</b>	The setting is a read-only information.	
<b>Network Address</b>	N/A	<b>UAA</b> <b>LAA</b>	Specify the network address.

## Printer menus

---

Menu item	Submenu item	Settings	Description
<b>PCL SmartSwitch</b>	N/A	<b>Off</b> <b>On*</b>	<p>Set the printer to switch automatically to PCL emulation when a print job requires it, regardless of the default printer language.</p> <p><b>Note:</b> When this setting is disabled, the printer does not examine incoming data and uses the default printer language specified in the <b>Setup</b> menu.</p>
<b>PS SmartSwitch</b>	N/A	<b>Off</b> <b>On*</b>	<p>Set the printer to switch automatically to PostScript emulation when a print job requires it, regardless of the default printer language.</p> <p><b>Note:</b> When this setting is disabled, the printer does not examine incoming data and uses the default printer language specified in the <b>Setup</b> menu.</p>
<b>Job Buffering</b>	N/A	<b>Off*</b> <b>On</b>	<p>Temporarily store jobs on the storage drive before printing.</p> <p><b>Note:</b> This menu item appears only when a storage drive is installed.</p>

Menu item	Submenu item	Settings	Description
<b>Mac Binary PS</b>	N/A	<b>Auto*</b> <b>Off</b> <b>On</b>	Set the printer to process Macintosh binary PostScript emulation print jobs.  <div style="border: 1px solid #ccc; background-color: #f0f0f0; padding: 10px;"> <p><b>Notes</b></p> <ul style="list-style-type: none"> <li>• <b>Auto</b>—Processes print jobs from computers using either Windows or Macintosh operating systems.</li> <li>• <b>Off</b>—Filters PostScript emulation print jobs using the standard protocol.</li> </ul> </div>
<b>Energy Efficient Ethernet</b>	N/A	<b>On</b> <b>Off</b> <b>Auto*</b>	Reduce power consumption when the printer does not receive data from the Ethernet network.

## TCP/IP

### Notes

- This menu appears only in network printers or printers attached to print servers.
- An asterisk (\*) next to a value indicates the factory default setting.

Menu item	Settings	Description
<b>Set Hostname</b>	The setting is user-defined.	Set the current TCP/IP host name.
<b>Domain Name</b>	The setting is user-defined.	Set the domain name.
<b>Allow DHCP/ BOOTP to update NTP server</b>	<b>On*</b> <b>Off</b>	Allow the Dynamic Host Configuration Protocol (DHCP) and BOOTstrap Protocol (BOOTP) clients to update the NTP settings of the printer.
<b>Zero Configuration Name</b>	The setting is user-defined.	Specify a service name for the zero configuration network.

Menu item	Settings	Description
<b>Enable Auto IP</b>	<b>Off</b> <b>On*</b>	Assign an IP address automatically.
<b>DNS Server Address</b>	The setting is user-defined.	Specify the current Domain Name System (DNS) server address.
<b>Backup DNS Server Address</b>	The setting is user-defined.	Specify the backup DNS server addresses.
<b>Backup DNS Server Address 2</b>		
<b>Backup DNS Server Address 3</b>		
<b>Domain Search Order</b>	The setting is user-defined.	Specify a list of domain names to locate the printer and its resources that reside in different domains on the network.
<b>Enable DDNS</b>	<b>Off*</b> <b>On</b>	Update the Dynamic DNS settings.
<b>DDNS TTL</b>	The setting is user-defined.	Specify the current DDNS settings.
<b>Default TTL</b>		
<b>DDNS Refresh Time</b>		
<b>Enable mDNS</b>	<b>Off</b> <b>On*</b>	Update the multicast DNS settings.
<b>WINS Server Address</b>	The setting is user-defined.	Specify a server address for Windows Internet Name Service (WINS).
<b>Enable BOOTP</b>	<b>Off*</b> <b>On</b>	Allow the BOOTP to assign a printer IP address.
<b>Restricted Server List</b>	The setting is user-defined.	Specify the IP addresses that are allowed to communicate with the printer over TCP/IP.  <div style="border: 1px solid #ccc; background-color: #f0f0f0; padding: 10px; margin-top: 10px;"> <p><b>Notes</b></p> <ul style="list-style-type: none"> <li>Use a comma to separate each IP address.</li> <li>You can add up to 50 IP addresses.</li> </ul> </div>

Menu item	Settings	Description
<b>Restricted Server List Options</b>	<b>Block All Ports*</b> <b>Block Printing Only</b> <b>Block Printing and HTTP Only</b>	Specify the access option for IP addresses that are not in the list.
<b>MTU</b>	<b>256 to 1500 Ethernet (1500*)</b>	Specify a maximum transmission unit (MTU) parameter for the TCP connections.
<b>Raw Print Port</b>	<b>1 to 65535 (9100*)</b>	Specify a raw port number for printers connected on a network.
<b>Outbound Traffic Maximum Speed</b>	<b>Off*</b> <b>On</b>	Set the maximum transfer rate of the printer.  <div style="border: 1px solid gray; padding: 5px; background-color: #f0f0f0;"> <p><b>Note:</b> When enabled, the option for this setting is 100–1000000 Kilobits/second.</p> </div>
<b>TLS Support</b>	<b>Enable TLSv1.0 (Off*)</b> <b>Enable TLSv1.1 (Off*)</b> <b>Enable TLSv1.2 (On*)</b>	Enable the Transport Layer Security protocol.
<b>SSL Cipher List</b>	The setting is user-defined.	Specify the cipher algorithms to use for the SSL or the TLS connections.
<b>TLSv1.3 SSL Cipher List</b>		

## SNMP

### Notes

- This menu appears only in network printers or printers attached to print servers.
- An asterisk (\*) next to a value indicates the factory default setting.

Menu item	Submenu Item	Settings	Description
<b>SNMP Versions 1 and 2c</b>	<b>Enabled</b>	<b>Off</b>	Configure Simple Network Management Protocol (SNMP) versions 1 and 2c to install print drivers and applications.
		<b>On*</b>	
<b>Allow SNMP Set</b>		<b>Off</b>	
		<b>On*</b>	

Menu item	Submenu Item	Settings	Description
	<b>Enable PPM MIB</b>	<b>Off</b> <b>On*</b>	
	<b>SNMP Community</b>	The setting is user-defined.	
<b>SNMP Version 3</b>	<b>Enabled</b>	<b>Off</b> <b>On*</b>	Enable the SNMP version 3 to install and update the printer security.
	<b>Context Name</b>	The setting is user-defined.	Enter the context name.
	<b>Set Read/Write Credentials</b>	<b>Username</b> <b>Authentication Password</b> <b>Privacy Password</b>	Enter the read and write credentials for SNMP version 3.
	<b>Set Read-only Credentials</b>	<b>Username</b> <b>Authentication Password</b> <b>Privacy Password</b>	Enter the read-only credentials for SNMP version 3.
	<b>Authentication Hash</b>	<b>MD5</b> <b>SHA1*</b>	Set the applicable authentication hash.
	<b>Minimum Authentication Level</b>	<b>No Authentication, No Privacy</b> <b>Authentication, No Privacy</b> <b>Authentication, Privacy*</b>	Set the applicable minimum authentication level.
	<b>Privacy Algorithm</b>	<b>DES</b> <b>AES-128*</b>	Set the applicable privacy algorithm.

## IPSec

### Notes

- This menu appears only in network printers or printers attached to print servers.
- An asterisk (\*) next to a value indicates the factory default setting.

Menu item	Settings	Description
<b>Enable IPsec</b>	<b>Off*</b> <b>On</b>	Enable Internet Protocol Security (IPsec).
<b>Base Configuration</b>	<b>Default*</b> <b>Compatibility</b> <b>Secure</b>	Set the IPsec base configuration.  <b>Note:</b> This menu item appears only when <b>Enable IPsec</b> is set to <b>On</b> .
<b>DH (Diffie-Hellman) Group Proposal</b>	<b>modp2048 (14)*</b> <b>modp3072 (15)</b> <b>modp4096 (16)</b> <b>modp6144 (17)</b>	Set the IPsec base configuration.  <b>Note:</b> This menu item appears only when <b>Base Configuration</b> is set to <b>Compatibility</b> .
<b>Proposed Encryption Method</b>	<b>3DES</b> <b>AES*</b>	Set the encryption method.  <b>Note:</b> This menu item appears only when <b>Base Configuration</b> is set to <b>Compatibility</b> .
<b>Proposed Authentication Method</b>	<b>SHA1</b> <b>SHA256*</b> <b>SHA512</b>	Set the authentication method.  <b>Note:</b> This menu item appears only when <b>Base Configuration</b> is set to <b>Compatibility</b> .
<b>IKE SA Lifetime (Hours)</b>	<b>1</b> <b>2</b> <b>4</b> <b>8</b> <b>24*</b>	Specify the IKE SA expiry period.  <b>Note:</b> This menu item appears only when <b>Base Configuration</b> is set to <b>Secure</b> .
<b>IPsec SA Lifetime (Hours)</b>	<b>1</b> <b>2</b> <b>4</b> <b>8*</b> <b>24</b>	Specify the IPsec SA expiry period.  <b>Note:</b> This menu item appears only when <b>Base Configuration</b> is set to <b>Secure</b> .

Menu item	Settings	Description
<b>IPSec Device Certificate</b>	<b>default*</b>	Specify an IPSec certificate.  <b>Note:</b> This menu item appears only when <b>Enable IPSec</b> is set to <b>On</b> .
<b>Pre-Shared Key Authenticated Connections</b>	<b>Host [x]</b>	Configure the authenticated connections of the printer.  <b>Note:</b> These menu items appear only when <b>Enable IPSec</b> is set to <b>On</b> .
<b>Certificate Authenticated Connections</b>	<b>Host [x] Address/[subnet]</b>	

## 802.1x

### Notes

- This menu appears only in network printers or printers attached to print servers.
- An asterisk (\*) next to a value indicates the factory default setting.

Menu item	Submenu Items	Settings	Description
<b>Active</b>	N/A	<b>Off*</b> <b>On</b>	Let the printer join networks that require authentication before allowing access.
<b>802.1x Authentication</b>	<b>Device Login Name</b>	The setting is user-defined.	Specify the unique login name.
	<b>Device Login Password</b>	The setting is user-defined.	Specify the unique password.
	<b>Validate Server Certificate</b>	<b>On*</b> <b>Off</b>	Enable this option to require verification of the security certificate on the authenticating server.
	<b>Enable Event Logging</b>	<b>On</b> <b>Off*</b>	Enable the printer to record connection logs.

Menu item	Submenu Items	Settings	Description
	<b>802.1x Device Certificate</b>	<b>default*</b>	<p>Select the digital certificate that you want to use.</p> <div style="border: 1px solid gray; padding: 5px; background-color: #f0f0f0;"> <p><b>Note:</b> If only one certificate is installed, then <b>default</b> is the only option that appears.</p> </div>
<b>Authentication Mechanism</b>	<b>EAP - MD5</b>	<b>On*</b> <b>Off</b>	Enable the Extensible Authentication Protocol (EAP) MD5 framework.
	<b>EAP - MSCHAPv2</b>	<b>On*</b> <b>Off</b>	Enable the EAP Microsoft Challenge Handshake Authentication Protocol (MSCHAP) version 2 authentication method.
	<b>LEAP</b>	<b>On*</b> <b>Off</b>	Enable Lightweight Extensible Authentication Protocol (LEAP), a modified version of MSCHAP.
	<b>PEAP</b>	<b>On*</b> <b>Off</b>	Enable Protected Extensible Authentication Protocol (PEAP), a method that provides more secure authentication for 802.11 WLANs. PEAP supports 802.1x port access control.
	<b>EAP - TLS</b>	<b>On*</b> <b>Off</b>	Enable EAP Transport Layer Security (TLS), a protocol in which the client and server authenticate each other using digital certificates.
	<b>EAP - TTLS</b>	<b>On*</b> <b>Off</b>	Enable EAP tunneled Transport Layer Security (TLS), a protocol similar to EAP_TLS except that only the server has a certificate to authenticate itself to the client first.
	<b>TTLS Authentication Method</b>	<b>CHAP</b> <b>MSCHAP</b> <b>MSCHAPv2*</b> <b>PAP</b>	Select which EAP TTLS method to use for your device.

## LPD Configuration

### Notes

- This menu appears only in network printers or printers attached to print servers.
- An asterisk (\*) next to a value indicates the factory default setting.

Menu item	Settings	Description
<b>LPD Timeout</b>	<b>0 to 665535 seconds (90*)</b>	Set the timeout value to stop the Line Printer Daemon (LPD) server from waiting indefinitely for hung or invalid print jobs.
<b>LPD Banner Page</b>	<b>Off*</b> <b>On</b>	Print a banner page for all LPD print jobs.  <b>Note:</b> A banner page is the first page of a print job used as a separator of print jobs and to identify the originator of the print job request.
<b>LPD Trailer Page</b>	<b>Off*</b> <b>On</b>	Print a trailer page for all LPD print jobs.  <b>Note:</b> A trailer page is the last page of a print job.
<b>LPD Carriage Return Conversion</b>	<b>Off*</b> <b>On</b>	Enable carriage return conversion.  <b>Note:</b> Carriage return is a mechanism that commands the printer to move the position of the cursor to the first position on the same line.

## HTTP/FTP Settings

**Note:** An asterisk (\*) next to a value indicates the factory default setting.

Menu item	Submenu Item	Settings	Description
<b>Proxy</b>	<b>HTTP Proxy IP Address</b>	The setting is user-defined.	Configure the HTTP server settings.

Menu item	Submenu Item	Settings	Description
	<b>HTTP Default IP Port</b>	The setting is user-defined.	Configure the HTTP default IP port address.  <b>Note:</b> The factory default port for HTTP is 80.
	<b>FTP Proxy IP Address</b>	The setting is user-defined.	Configure the FTP settings.
	<b>FTP Default IP Port</b>	The setting is user-defined.	Configure the FTP default IP port address.  <b>Note:</b> The factory default port for HTTP is 21.
	<b>Authentication</b>	<b>None</b> <b>Auto*</b> <b>Basic</b> <b>Digest</b> <b>NTLM</b>	Specify the authentication credentials.
	<b>Username</b>	The setting is user-defined.	Specify the unique username.
	<b>Password</b>	The setting is user-defined.	Specify the unique password.
	<b>Local Domains</b>	The setting is user-defined.	Specify domain names for HTTP and FTP servers.
<b>Other Settings</b>	<b>Enable HTTP Server</b>	<b>On*</b> <b>Off</b>	Access the Embedded Web Server to monitor and manage the printer.
	<b>Enable HTTPS</b>	<b>On*</b> <b>Off</b>	Enable Hypertext Transfer Protocol Secure (HTTPS) to encrypt data transferring to and from the print server.
	<b>Force HTTPS Connections</b>	<b>On</b> <b>Off*</b>	Force the printer to use HTTPS connections.
	<b>Enable FTP/TFTP</b>	<b>On*</b> <b>Off</b>	Send files using FTP/TFTP.

## Printer menus

Menu item	Submenu Item	Settings	Description
	<b>HTTPS Device Certificate</b>	<b>default*</b>	View the HTTP device certificate used on the printer.
	<b>Timeout for HTTP/FTP Requests</b>	<b>1 to 299 seconds (30*)</b>	Specify the amount of time before the server connection stops.
	<b>Retries for HTTP/FTP Requests</b>	<b>1 to 299 seconds (3*)</b>	Set the number of retries to connect to the HTTP/FTP server.

## ThinPrint

**Note:** An asterisk (\*) next to a value indicates the factory default setting.

Menu item	Settings	Description
<b>Enable ThinPrint</b>	<b>Off*</b> <b>On</b>	Print using ThinPrint.
<b>Port Number</b>	<b>4000 to 4999 (4000*)</b>	Set the port number for the ThinPrint server.  <b>Note:</b> This menu item can only be configured when <b>Enable ThinPrint</b> is set to <b>On</b> .
<b>Bandwidth (bits/sec)</b>	<b>100 to 1000000 (0*)</b>	Set the speed to transmit data in a ThinPrint environment.  <b>Note:</b> This menu item can only be configured when <b>Enable ThinPrint</b> is set to <b>On</b> .
<b>Packet Size (kbytes)</b>	<b>0 to 64000 (0*)</b>	Set the packet size for data transmission.  <b>Note:</b> This menu item can only be configured when <b>Enable ThinPrint</b> is set to <b>On</b> .

## USB

**Note:** An asterisk (\*) next to a value indicates the factory default setting.

Menu item	Settings	Description
<b>PCL SmartSwitch</b>	<b>Off</b> <b>On*</b>	<p>Set the printer to switch to PCL emulation when a print job received through a USB port requires it, regardless of the default printer language.</p> <p><b>Note:</b> When this setting is disabled, the printer does not examine incoming data and uses the default printer language specified in the <b>Setup</b> menu.</p>
<b>PS SmartSwitch</b>	<b>Off</b> <b>On*</b>	<p>Set the printer to switch to PostScript emulation when a print job received through a USB port requires it, regardless of the default printer language.</p> <p><b>Note:</b> When this setting is disabled, the printer does not examine incoming data and uses the default printer language specified in the <b>Setup</b> menu.</p>
<b>Job Buffering</b>	<b>Off*</b> <b>On</b>	<p>Temporarily store jobs on the storage drive before printing.</p> <p><b>Note:</b> This menu item appears only when a storage drive is installed.</p>

Menu item	Settings	Description
<b>Mac Binary PS</b>	<b>Auto*</b> <b>On</b> <b>Off</b>	Set the printer to process Macintosh binary PostScript emulation print jobs.  <div style="border: 1px solid #ccc; padding: 10px; background-color: #f9f9f9;"> <p><b>Notes</b></p> <ul style="list-style-type: none"> <li>• <b>Auto</b>—Processes print jobs from computers using either Windows or Macintosh operating systems.</li> <li>• <b>Off</b>—Filters PostScript emulation print jobs using the standard protocol.</li> </ul> </div>
<b>Enable USB Port</b>	<b>Off</b> <b>On*</b>	Enable the front and rear USB ports.

## Restrict External Network Access

**Note:** An asterisk (\*) next to a value indicates the factory default setting.

Menu item	Settings	Description
<b>Restrict external network access</b>	<b>Off*</b> <b>On</b>	Restrict access to network sites.
<b>External network address</b>	The setting is user-defined.	Specify the network addresses with restricted access.  <div style="border: 1px solid #ccc; padding: 10px; background-color: #f9f9f9;"> <p><b>Note:</b> This menu item can only be configured when <b>Restrict external network access</b> is set to <b>On</b>.</p> </div>
<b>Email address for notification</b>	The setting is user-defined.	Specify an email address to send a notification of logged events.  <div style="border: 1px solid #ccc; padding: 10px; background-color: #f9f9f9;"> <p><b>Note:</b> This menu item can only be configured when <b>Restrict external network access</b> is set to <b>On</b>.</p> </div>

## Printer menus

---

Menu item	Settings	Description
<b>Ping frequency</b>	<b>1 to 300</b> (10*)	Specify the network query interval in seconds.  <b>Note:</b> This menu item can only be configured when <b>Restrict external network access</b> is set to <b>On</b> .
<b>Subject</b>	The setting is user-defined.	Specify the subject and message of the notification email.  <b>Note:</b> This menu item can only be configured when <b>Restrict external network access</b> is set to <b>On</b> .
<b>Message</b>		

# Security

## Login Methods

### Manage Permissions

Menu item	Settings	Description
<b>Function Access</b>	<b>Access Address Book in Apps</b> <b>Modify Address Book</b> <b>Manage Shortcuts</b> <b>Create Profiles</b> <b>Manage Bookmarks</b> <b>Flash Drive Print</b> <b>Flash Drive Scan</b> <b>Copy Function</b> <b>Color Dropout</b> <b>E-mail Function</b> <b>Fax Function</b> <b>FTP Function</b> <b>Release Held Faxes</b> <b>Held Jobs Access</b> <b>Use Profiles</b> <b>Cancel Jobs at the Device</b> <b>Change Language</b> <b>Internet Printing Protocol (IPP)</b> <b>Initiate Scans Remotely</b> <b>B/W Print</b> <b>Network Folder - Scan</b> <b>Hard Disk - Print</b>	<p>Specify the printer functions that the user can access.</p> <p><b>Note:</b> Some menu items appear only when a storage drive is installed.</p>

## Printer menus

Menu item	Settings	Description
	<b>Hard Disk - Scan</b>	
<b>Administrative Menus</b>	<b>Security Menu</b> <b>Network/Ports Menu</b> <b>Paper Menu</b> <b>Reports Menu</b> <b>Function Configuration Menus</b> <b>Supplies Menu</b> <b>Option Card Menu</b> <b>SE Menu</b> <b>Device Menu</b>	Specify the printer menus that the user can access.
<b>Device Management</b>	<b>Remote Management</b> <b>Firmware Updates</b> <b>Apps Configuration</b> <b>Operator Panel Lock</b> <b>Embedded Web Server Access</b> <b>Import / Export All Settings</b> <b>Out of Service Erase</b> <b>Cloud Services Enrollment</b>	Specify the <b>Device Management</b> functions that the user can access.
<b>Apps</b>	<b>New Apps</b> <b>Slideshow</b> <b>Change Wallpaper</b> <b>Screen Saver</b> <b>Scan Center</b> <b>Scan Center Custom [x]</b>	Control access to the printer apps.

## Local Accounts

Menu item	Submenu Item	Settings	Description
<b>Manage Groups/Permissions</b>	<b>Add Group</b>	The setting is user-defined.	Specify the groups that have access to printer functions, administrative menus, printer management options, and apps.
	<b>All Users</b>	<b>Import Access Controls</b>	Import access controls from accounts enrolled in the printer.
<b>Add User</b>	<b>Username/Password</b> <b>Username</b> <b>Password</b> <b>PIN</b>	The setting is user-defined.	Add a user and specify the login method to the printer.

## Default Login Methods

**Note:** This menu appears only when the **Local Accounts** menu is configured.

Menu item	Settings	Description
<b>Control Panel</b>	<b>Username/Password</b> <b>Username</b> <b>Password</b> <b>PIN</b>	Specify the default login method to access the control panel.
<b>Browser</b>	<b>Username/Password</b> <b>Username</b> <b>Password</b> <b>PIN</b>	Specify the default login method to access the browser.

## Schedule USB Devices

Menu item	Submenu items	Settings	Description
<b>Schedules</b>	<b>Add New Schedule</b>	<b>Save Schedule</b>  <b>Action</b>  <b>Day(s)</b>  <b>Time</b>	Schedule access to the front USB port.

## Security Audit Log

**Note:** An asterisk (\*) next to a value indicates the factory default setting.

Menu item	Settings	Description
<b>Enable Audit</b>	<b>Off*</b>  <b>On</b>	Set the printer to record the events in the secure audit log and remote syslog.
<b>Enable Remote Syslog</b>	<b>Off*</b>  <b>On</b>	Set the printer to send audit logs to a remote server.
<b>Remote Syslog Server</b>	The setting is user-defined.	Specify the remote syslog server.
<b>Remote Syslog Port</b>	<b>1 to 65535 (514*)</b>	Specify the port over which the printer sends logged events to a remote server.
<b>Remote Syslog Method</b>	<b>Normal UDP*</b>  <b>Stunnel</b>	Identify the protocol that the printer uses to transmit logged events to a remote server.

Menu item	Settings	Description
<p><b>Remote Syslog Facility</b></p>	<p><b>0 - Kernel Messages</b></p> <p><b>1 - User-Level Messages</b></p> <p><b>2 - Mail System</b></p> <p><b>3 - System Daemons</b></p> <p><b>4 - Security/ Authorization Messages*</b></p> <p><b>5 - Messages Generated Internally by Syslogd</b></p> <p><b>6 - Line Printer Subsystem</b></p> <p><b>7 - Network News Subsystem</b></p> <p><b>8 - UUCP Subsystem</b></p> <p><b>9 - Clock Daemon</b></p> <p><b>10 - Security/ Authorization Messages</b></p> <p><b>11 - FTP Daemon</b></p> <p><b>12 - NTP Subsystem</b></p> <p><b>13 - Log Audit</b></p> <p><b>14 - Log Alert</b></p> <p><b>15 - Clock Daemon</b></p> <p><b>16 - Local Use 0 (local0)</b></p> <p><b>17- Local Use 1 (local1)</b></p> <p><b>18 - Local Use 2 (local2)</b></p> <p><b>19 - Local Use 3 (local3)</b></p> <p><b>20 - Local Use 4 (local4)</b></p>	<p>Specify a <b>Facility</b> value that the printer uses when sending log events to the remote syslog server.</p>

Menu item	Settings	Description
	<b>21 - Local Use 5 (local5)</b> <b>22 - Local Use 6 (local6)</b> <b>23 - Local Use 7 (local7)</b>	
<b>Severity of Events to Log</b>	<b>0 - Emergency</b> <b>1 - Alert</b> <b>2 - Critical</b> <b>3 - Error</b> <b>4 - Warning*</b> <b>5 - Notice</b> <b>6 - Informational</b> <b>7 - Debug</b>	Specify the severity value of each event.
<b>Remote Syslog Non-Logged Events</b>	<b>Off*</b> <b>On</b>	Set the printer to send any applicable events.
<b>Admin's Email Address</b>	The setting is user-defined.	Specify the email address of the printer administrator who is notified of certain log events.
<b>Email Log Cleared Alert</b>	<b>Off*</b> <b>On</b>	Set the printer to send an email to the administrator every time a log is deleted.
<b>Email Log Wrapped Alert</b>	<b>Off*</b> <b>On</b>	Set the printer to send the administrator an email when log entries are wrapping.
<b>Log Full Behavior</b>	<b>Wrap Over Oldest Entries*</b> <b>Email Log Then Delete All Entries</b>	Determine how the printer resolves log storage issues when the log fills its allotted memory.
<b>Email % Full Alert</b>	<b>Off*</b> <b>On</b>	Set the printer to send the administrator an email when the log fills its allotted memory.
<b>% Full Alert Level</b>	<b>1 to 99 (90*)</b>	Determine if the space occupied by the log equals or exceeds the value of the full alert level.
<b>Email Log Exported Alert</b>	<b>Off*</b> <b>On</b>	Send an email notification to the administrator when a log is exported.
<b>Email Log Settings Changed Alert</b>	<b>Off*</b> <b>On</b>	Set the printer to send an email to the administrator when the value of the <b>Enable Audit</b> menu is changed.

Menu item	Settings	Description
<b>Log Line Endings</b>	<b>LF (\n)*</b> <b>CR (\r)</b> <b>CRLF (\r\n)</b>	Determine how the printer handles line endings in the log file, depending on the operating system that the file is parsed or viewed.
<b>Digitally Sign Exports</b>	<b>Off*</b> <b>On</b>	Set the printer to sign exported security logs automatically.
<b>Clear Log</b>	<b>Clear</b>	Delete all audit logs.
<b>Export Log</b>	<b>Syslog (RFC 5424)</b> <b>Syslog (RFC 3164)</b> <b>CSV</b>	Export logs from the printer or flash drive.

## Login Restrictions

**Note:** An asterisk (\*) next to a value indicates the factory default setting.

Menu item	Settings	Description
<b>Login failures</b>	<b>1 to 10 (3*)</b>	Specify the number of failed login attempts before the user is locked out.
<b>Failure time frame</b>	<b>1 to 60 minutes (5*)</b>	Specify the time frame that failed login attempts are allowed before the user is locked out.
<b>Lockout time</b>	<b>1 to 60 minutes (5*)</b>	Specify the amount of time where no logins are allowed.
<b>Web Login Timeout</b>	<b>1 to 120 minutes (10*)</b>	Specify the amount of time that a remote interface such as a web page can remain idle before the user is logged off automatically.

## Confidential Print Setup

**Note:** An asterisk (\*) next to a value indicates the factory default setting.

Menu item	Settings	Description
<b>Max Invalid PIN</b>	<p><b>2 to 10</b></p>	<p>Set the limit for entering an invalid PIN.</p> <div style="background-color: #f0f0f0; padding: 10px; margin-top: 10px;"> <p><b>Note:</b> When the limit is reached, the print jobs for that username are deleted.</p> </div>
<b>Confidential Job Expiration</b>	<p><b>Off*</b></p> <p><b>1 Hour</b></p> <p><b>4 Hours</b></p> <p><b>24 Hours</b></p> <p><b>72 Hours</b></p> <p><b>1 Week</b></p>	<p>Set an individual expiration time for each type of held job before the printer deletes it automatically from memory.</p> <div style="background-color: #f0f0f0; padding: 10px; margin-top: 10px;"> <p><b>Notes</b></p> <ul style="list-style-type: none"> <li>The types of held jobs are <b>Confidential, Repeat, Reserve, and Verify</b>.</li> <li>If the expiration time setting is changed while confidential print jobs reside on the printer memory or hard disk, then the expiration time for those print jobs does not change to the new default value.</li> <li>If the printer is turned off, then all confidential jobs held in the printer memory are deleted.</li> </ul> </div>
<b>Repeat Job Expiration</b>	<p><b>Off*</b></p> <p><b>1 Hour</b></p> <p><b>4 Hours</b></p> <p><b>24 Hours</b></p> <p><b>72 Hours</b></p> <p><b>1 Week</b></p>	<p>Set the expiration time for print jobs that you want to repeat.</p>
<b>Verify Job Expiration</b>	<p><b>Off*</b></p> <p><b>1 Hour</b></p> <p><b>4 Hours</b></p> <p><b>24 Hours</b></p> <p><b>72 Hours</b></p> <p><b>1 Week</b></p>	<p>Set the expiration time for printing a copy of a job for you to check its quality before printing the remaining copies.</p>

Menu item	Settings	Description
<b>Reserve Job Expiration</b>	<b>Off*</b> <b>1 Hour</b> <b>4 Hours</b> <b>24 Hours</b> <b>72 Hours</b> <b>1 Week</b>	Set the expiration time for jobs that you want to store in the printer for printing later.
<b>Require All Jobs to be Held</b>	<b>Off*</b> <b>On</b>	Set the printer to hold all print jobs.
<b>Keep duplicate documents</b>	<b>Off*</b> <b>On</b>	Set the printer to keep all documents with the same file name.

## Encryption

Menu item	Settings	Description
<b>Internal Storage</b>	The setting is a read-only information.	Show the encryption status of the internal storage.
<b>Hard Disk</b>	The setting is a read-only information.	Show the encryption status of the hard disk.  <div style="background-color: #f0f0f0; padding: 5px;"><b>Note:</b> This menu item appears only when a hard disk is installed.</div>
<b>Intelligent Storage Drive</b>	The setting is a read-only information.	Show the encryption status of the intelligent storage drive (ISD).  <div style="background-color: #f0f0f0; padding: 5px;"><b>Note:</b> This menu item appears only when an ISD is installed.</div>

## Erase Temporary Data Files

**Note:** An asterisk (\*) next to a value indicates the factory default setting.

## Printer menus

---

Menu item	Settings	Description
Stored in onboard memory	Off* On	Set the printer to erase all the data of a job from its memory after the job is finished.
Stored on hard disk	1 Pass Erase* 3 Pass Erase 7 Pass Erase	Specify the method that the printer uses to erase all the data of a job from the hard disk after the job is finished.  <b>Note:</b> This menu item appears only when a hard disk is installed.

## Solutions LDAP Settings

**Note:** An asterisk (\*) next to a value indicates the factory default setting.

Menu item	Settings	Description
Follow LDAP Referrals	Off* On	Search the different servers in the domain for the logged-in user account.
LDAP Certificate Verification	Yes No*	Enable verification of LDAP certificates.

## Miscellaneous

**Note:** An asterisk (\*) next to a value indicates the factory default setting.

Menu item	Settings	Description
Protected Features	Show* Hide	Show all the features that Function Access Control (FAC) protects regardless of the security permission that the user has.  <b>Note: Hide</b> —Displays only FAC-protected features that the user has access.
Print Permission	Off* On	Require the user to log in before printing.

Menu item	Settings	Description
<b>Default Print Permission Login</b>	<b>PIN*</b> <b>Username/Password</b> <b>Username</b>	Set the default login for <b>Print Permission</b> .  <div style="background-color: #f0f0f0; padding: 5px;"> <p><b>Note:</b> The settings appear only when security logins accounts are created and depend on the type of login account added.</p> </div>
<b>Security Reset Jumper</b>	<b>Enable “Guest” access*</b> <b>No Effect</b>	Specify user access to the printer.  <div style="background-color: #f0f0f0; padding: 5px;"> <p><b>Notes</b></p> <ul style="list-style-type: none"> <li>• <b>Enable “Guest” access</b> gives anyone access to all aspects of the printer.</li> <li>• <b>No Effect</b> may make access to the printer impossible when the required security information is unavailable.</li> </ul> </div>
<b>Reset Device Modes</b>	<b>Allow with FAC</b> <b>Allow*</b> <b>Don't Allow</b>	Allow the printer mode to be reset.
<b>Use Intelligent Storage Drive for User Data</b>	<b>Off</b> <b>On*</b>	Enable the intelligent storage drive to store user data.  <div style="background-color: #f0f0f0; padding: 5px;"> <p><b>Note:</b> This menu item is disabled when a hard disk is installed.</p> </div>
<b>Minimum Password Length</b>	<b>0 to 32 (0*)</b>	Specify the minimum password length that is used for internal accounts such as <b>Password</b> and <b>Username/Password</b> accounts.
<b>Enable Password/PIN Reveal</b>	<b>Off*</b> <b>On</b>	Show the password or personal identification number.
<b>Allow Encryption of Service Nonvolatile Memory</b>	<b>Off*</b> <b>On</b>	Enable the encryption of service nonvolatile memory in your device.  <div style="background-color: #f0f0f0; padding: 5px;"> <p><b>Note:</b> This menu item appears only if <b>Encrypt Service Nonvolatile Memory</b> is disabled.</p> </div>

## Cloud Services

### Cloud Services Enrollment

**Note:** An asterisk (\*) next to a value indicates the factory default setting.

Menu item	Settings	Description
<b>View More Information</b>	The setting is a read-only information.	View more information on the usage of Lexmark Cloud Services.
<b>Enable communication with Lexmark Cloud Services</b>	<b>Off*</b> <b>On</b>	Enable the printer to communicate with Lexmark Cloud Services.
<b>View Current Status</b>	The setting is a read-only information.	View the connection status between the printer and Lexmark Cloud Services.
<b>Get Enrollment Code</b>	The setting is a read-only information.	Gives the enrollment code for cloud services.
<b>Enroll Printer</b>	The setting is a user-defined setting.	Allows enrollment of the printer when the enrollment code is available.

## Reports

### Menu Settings Page

Menu item	Description
<b>Menu Settings Page</b>	Print a report that contains the printer menus.

### Device

Menu item	Description
<b>Device Information</b>	Print a report that contains information about the printer.
<b>Device Statistics</b>	Print a report about supply status, paper count, job information, and more.
<b>Profiles List</b>	Print a list of profiles that are stored in the printer.

Menu item	Description
<b>Asset Report</b>	<p>Print a diagnostic tool for print problems.</p> <p><b>Note:</b> To avoid clipping the content, print the report on letter- or A4-size paper.</p>

## Print

Menu item	Settings	Description
<b>Print Fonts</b>	<p><b>PCL Fonts</b></p> <p><b>PS Fonts</b></p>	Print samples and information about the fonts that are available in each printer language.
<b>Print Demo</b>	<b>Demo Page</b>	<p>Print a diagnostic tool for print problems.</p> <p><b>Notes</b></p> <ul style="list-style-type: none"> <li>• To avoid clipping the content, print the report on letter- or A4-size paper.</li> <li>• This menu item appears only when the printer has a demo page installed.</li> </ul>
<b>Print Directory</b>	The setting is user-defined.	Print a report that shows the resources that are stored in the flash drive or hard disk.

## Shortcuts

Menu item	Description
<b>All Shortcuts</b>	<p>Print a report that lists the shortcuts that are stored in the printer.</p> <p><b>Note:</b> <b>Fax Shortcuts</b> appears only when <b>Fax</b> is installed.</p>
<b>Fax Shortcuts</b>	
<b>Copy Shortcuts</b>	
<b>Email Shortcuts</b>	
<b>FTP Shortcuts</b>	
<b>Network Folder Shortcuts</b>	

## Fax

**Note:** This menu appears only if **Fax** is configured, and **Enable Job Log** is set to **On**.

Menu item	Description
<b>Fax Job Log</b>	Print a report about the last 200 completed fax jobs.
<b>Fax Call Log</b>	Print a report about the last 100 attempted, received, and blocked calls.

## Network

Menu item	Description
<b>Network Setup Page</b>	Print a page that shows the configured network and wireless settings on the printer.  <b>Note:</b> This menu item appears only in network printers or printers connected to print servers.
<b>Wi-Fi Direct Connected Clients</b>	Print a page that shows the list of devices that are connected to the printer using Wi-Fi Direct.  <b>Note:</b> This menu item appears only when <b>Enable Wi-Fi Direct</b> is set to <b>On</b> .

## Troubleshooting

Menu item	Description
<b>Print Quality Test Pages</b>	Print sample pages to identify and correct print quality defects.
<b>Cleaning the Scanner</b>	Print instructions on how to clean the scanner.

# Forms Merge

## Notes

- This menu item appears only when a storage drive is installed.
- An asterisk (\*) next to a value indicates the factory default setting.

Menu item	Submenu item	Settings	Description
<b>Merge Mode</b>	N/A	<b>Print*</b> <b>Data Capture</b> <b>Disabled</b>	Specify the mode of operation for Forms Merge.
<b>Data Capture Target</b>	N/A	<b>Flash*</b>	Set the target destination where the captured data is forwarded.  <b>Note:</b> This menu item appears only when <b>Merge Mode</b> is set to <b>Data Capture</b> .
<b>Print Port and Filter Settings</b>	<b>Network Port</b>	<b>On*</b> <b>Off</b>	Enable Forms Merge to process all data that are sent to the network port.
	<b>Network Filter</b>	<b>Disabled*</b> <b>NULL</b> <b>OFIS</b> <b>OFIS+NULL</b> <b>OFIS+AS400</b> <b>AS400</b> <b>PCL</b> <b>ZPL</b> <b>ZPLF</b>	Specify the network filter for all data that are sent to the printer.
	<b>USB Port</b>	<b>On*</b> <b>Off</b>	Enable Forms Merge to process all data that are sent to the USB port.

Menu item	Submenu item	Settings	Description
	<b>USB Filter</b>	<b>Disabled*</b> <b>NULL</b> <b>OFIS</b> <b>OFIS+NULL</b> <b>OFIS+AS400</b> <b>AS400</b> <b>PCL</b> <b>ZPL</b> <b>ZPLF</b>	Specify the USB filter for all data that are sent to the printer.
	<b>Local Port Timeout</b>	<b>1 to 100 (10*)</b>	Specify the timeout value for Forms Merge jobs that are sent to the local port.
<b>Miscellaneous</b>	<b>Print All Forms</b>	<b>Start</b>	Print all form sets that are stored in the intelligent storage drive or hard disk.
	<b>Error Page Print</b>	<b>On*</b> <b>Off</b>	Enable printing of an error page when an error is encountered in a Forms Merge job.

## Printing the Menu Settings Page

1. From the control panel, navigate to **Settings > Reports**.
2. Select **Menu Settings Page**.

# Maintain the printer

## Checking the status of parts and supplies

1. From the upper-right corner of the control panel, select .
2. View the status of the printer parts and supplies.

**Note:** You can also select  to check notifications that require user intervention.

## Configuring supply notifications

1. Open a web browser, and then type the printer IP address in the address field.

### Notes

- View the printer IP address on the printer home screen. The IP address appears as four sets of numbers separated by periods, such as 123.123.123.123.
- If you are using a proxy server, then temporarily disable it to load the web page correctly.

2. Click **Settings > Device > Notifications**.
3. Click **Custom Supply Notifications**.
4. Select a notification for each supply item.
5. Apply the changes.

## Setting up email alerts

1. Open a web browser, and then type the printer IP address in the address field.

### Notes

- View the printer IP address on the printer home screen. The IP address appears as four sets of numbers separated by periods, such as 123.123.123.123.
- If you are using a proxy server, then temporarily disable it to load the web page correctly.

2. Click **Settings > Device > Notifications**.
3. Click **Email Alert Setup**, and then configure the settings.

**Note:** For more information on SMTP settings, contact your email provider.

4. Apply the changes.
5. Click **Setup Email Lists and Alerts**, and then configure the settings.
6. Apply the changes.

## Generating reports and logs

1. From the control panel, navigate to **Settings > Reports**.
2. Select the report or log that you want to print.

- **Menu Settings Page**—Show the current printer preferences, settings, and configurations.
- **Device**

**Device Information**—Show the printer serial number, installed solutions, and fax.

**Device Statistics**—Show supply status, total printed sheets, and printer job information.

**Profiles List**—Show a list of profiles or shortcuts that are stored in the printer.

**Asset Report**—Show the report containing printer asset information, such as serial number and model name.

- **Print**

**Print Fonts**—Show the fonts that are available in each printer language.

**Print Demo**—Show the demo files that are available in the firmware, the flash option, and the disk option.

**Print Directory**—Show the resources that are stored on the flash drive, hard disk, or intelligent storage drive (ISD).

**Note:** The report appears only when a flash drive, a printer hard disk, or an ISD is installed.

- **Shortcuts**

**All Shortcuts**—Show a list of all the shortcuts that are stored on the printer.

**Fax Shortcuts**—Show a list of fax shortcuts that are stored on the printer.

**Copy Shortcuts**—Show a list of copy shortcuts that are stored on the printer.

**E-mail Shortcuts**—Show a list of email shortcuts that are stored on the printer.

**FTP Shortcuts**—Show a list of File Transfer Protocol (FTP) shortcuts that are stored on the printer.

**Network Folder Shortcuts**—Show a list of network folder shortcuts that are stored on the printer.

- **Fax**

**Fax Job Log**—List the last 200 completed fax jobs.

**Note:** This report appears only when **Enable Job Log** is enabled.

**Fax Call Log**—Show the resources that are stored on the flash drive or storage drive.

**Note:** This report appears only when a flash drive or storage drive is installed.

- **Network**

**Network Setup Page**—Show the configured network and wireless settings on the printer.

**Note:** This report appears only in network printers and printers connected to print servers.

**Wi-Fi Direct Connected Clients**—Show the list of devices that are connected to the printer using Wi-Fi Direct.

**Note:** This report appears only when **Enable Wi-Fi Direct** is set to **On**.

## Ordering parts and supplies

### Contact information and precaution

To order supplies in the U.S., contact Lexmark at 1-800-539-6275 for information about Lexmark authorized supplies dealers in your area. In other countries or regions, go to [www.lexmark.com](http://www.lexmark.com) or contact the place where you purchased the printer.

**Note:** All life estimates for printer supplies assume printing on letter- or A4-size plain paper.

**Warning—Potential Damage**

Failure to maintain optimum printer performance, or to replace parts and supplies, may cause damage to your printer.

### Using genuine Lexmark parts and supplies

Your Lexmark printer is designed to function best with genuine Lexmark parts and supplies. Use of third-party supplies or parts may affect the performance, reliability, or life of the printer and its imaging components. It can also affect warranty coverage. Damage caused by the use of third-party parts and supplies is not covered by the warranty. All life indicators are designed to function with Lexmark parts and supplies, and may deliver unpredictable results if third-party parts and supplies are used. Imaging component usage beyond the intended life may damage your Lexmark printer or its associated components.

### **Warning—Potential Damage**

Supplies and parts without Return Program agreement terms may be reset and remanufactured. However, the manufacturer's warranty does not cover any damage caused by non-genuine supplies or parts. Resetting counters on the supply or part without proper remanufacturing can cause damage to your printer. After resetting the supply or part counter, your printer may display an error indicating the presence of the reset item.

## Ordering a toner cartridge

### **Notes:**

- The estimated cartridge yield is based on the ISO/IEC 19752 standard.
- Extremely low print coverage for extended periods of time may negatively affect actual yield.

## Return Program toner cartridges

### Lexmark MX953

Item	United States, Canada, Australia, and New Zealand	European Union, European Economic Area, Iceland, Liechtenstein, Norway, Switzerland	Rest of Asia Pacific	Latin America, Puerto Rico, and Mexico	Rest of Europe, Middle East, Africa, Central Eastern Europe, Commonwealth of Independent States
Black	77L10K0	77L20K0	77L30K0	77L40K0	77L50K0

For more information on countries in each region, go to [www.lexmark.com/regions](http://www.lexmark.com/regions).

## High Yield Return Program toner cartridges

### Lexmark MX953

Item	United States, Canada, Australia, and New Zealand	European Union, European Economic Area, Iceland, Liechtenstein, Norway, Switzerland	Rest of Asia Pacific	Latin America, Puerto Rico, and Mexico	Rest of Europe, Middle East, Africa, Central Eastern Europe, Commonwealth of Independent States
Black	77L1HK0	77L2HK0	77L3HK0	77L4HK0	77L5HK0

For more information on countries in each region, go to [www.lexmark.com/regions](http://www.lexmark.com/regions).

## High Yield Regular toner cartridges

### Lexmark MX953

Item	Worldwide
Black	79L0H10

For more information on countries in each region, go to [www.lexmark.com/regions](http://www.lexmark.com/regions).

## Ordering a black imaging unit

Item	Part number
Return Program black imaging unit	77L0ZK0
Black imaging unit	77L0Z10

## Ordering the waste toner bottle

Item	Part number
Waste toner bottle	79L0W00

## Ordering a staple cartridge

Item	Part number
Staple cartridge (4-pack) <sup>1</sup>	20L7500
Staple cartridge (3-pack) <sup>2</sup>	25A0013

<sup>1</sup> Available only for the booklet maker.

<sup>2</sup> Available only for the booklet finisher, staple finisher, and staple, hole punch finisher.

## Ordering a maintenance kit

Match the maintenance kit to the printer voltage.

### Notes

- Using certain types of paper may require more frequent replacement of the maintenance kit.
- The maintenance kit includes a fuser and pick tires. These parts may be individually ordered and replaced if necessary.

Item	Part number
100 V Return Program fuser maintenance kit, Type 02	41X5654
110-120 V Return Program fuser maintenance kit, Type 00	41X5655
220-240 V Return Program fuser maintenance kit, Type 01	41X5656
100 V Regular fuser maintenance kit, Type 12	41X6053
110-120 V Regular fuser maintenance kit, Type 10	41X6051
220-240 V Regular fuser maintenance kit, Type 11	41X6052

**Note:** Only an authorized service technician can replace the maintenance kit. Contact your service provider.

## Replacing parts and supplies

### Replacing a toner cartridge

1. Open the front door.

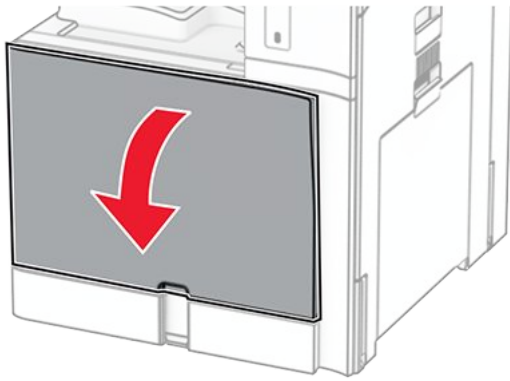

2. Remove the used toner cartridge.

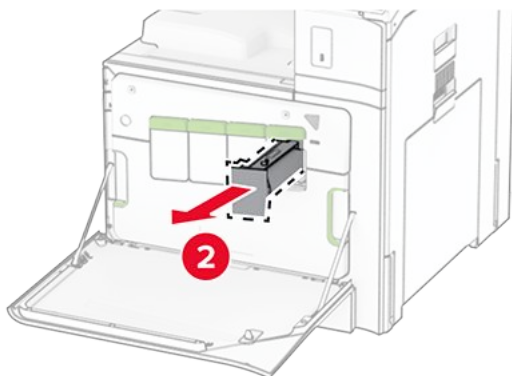
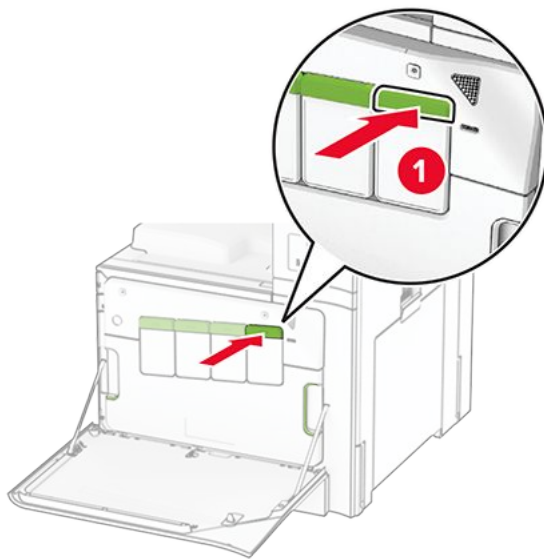

3. Unpack the new toner cartridge.

4. Insert the new toner cartridge until it clicks into place.

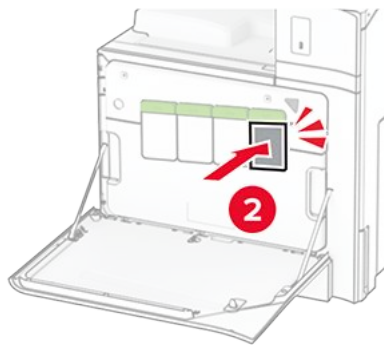
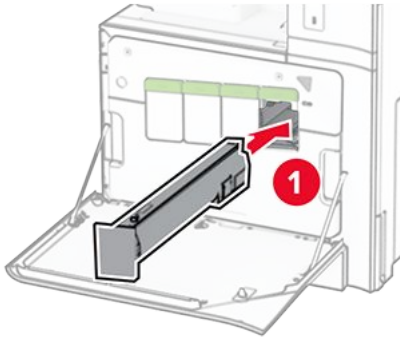

5. Close the door.

## Replacing the imaging unit

1. Open the front door.

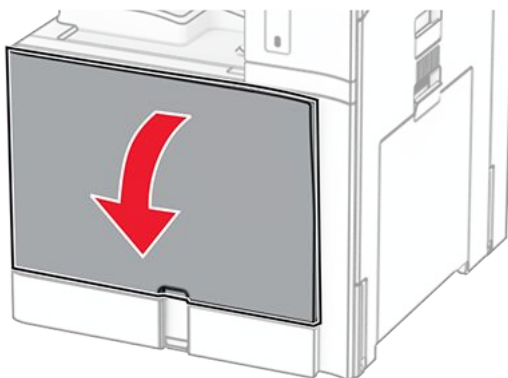

2. Remove the toner cartridge.

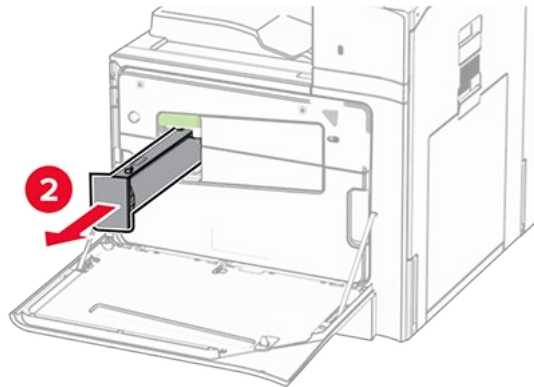
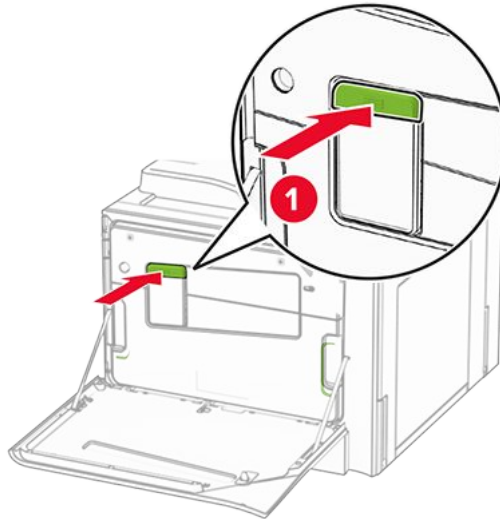

3. Remove the waste toner bottle.

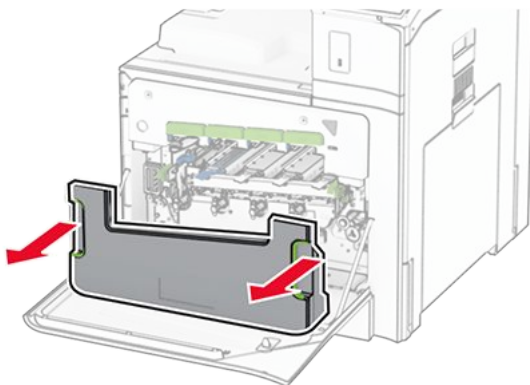

**Note:** To avoid spilling the toner, place the bottle in an upright position.

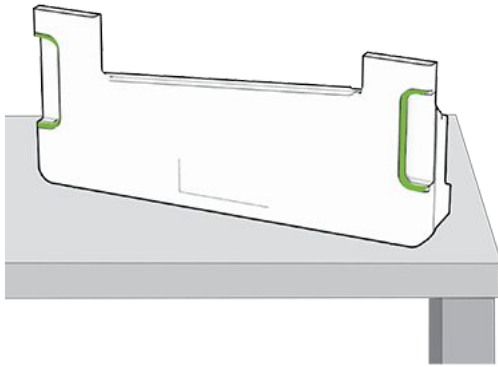

4. Remove the imaging support basket.

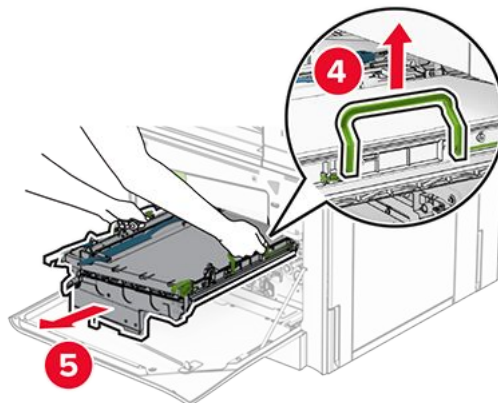
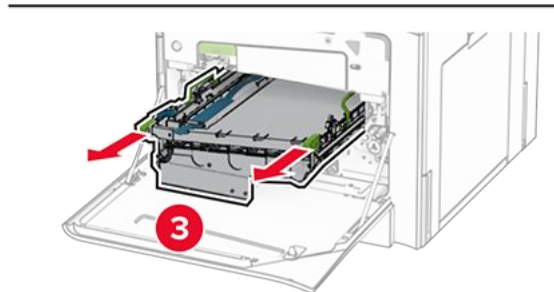
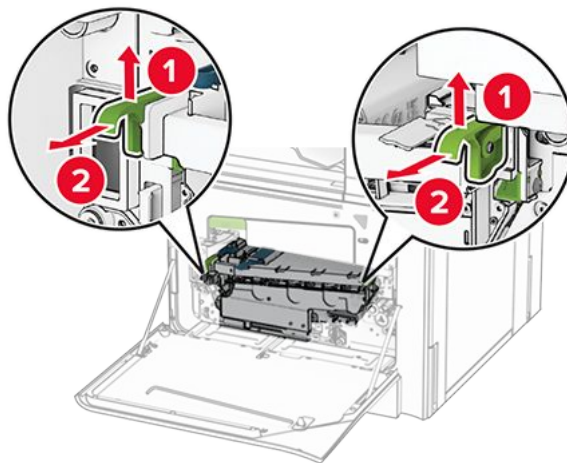

**Warning—Potential Damage**

Do not touch the photoconductor drum. Doing so may affect the quality of future print jobs.

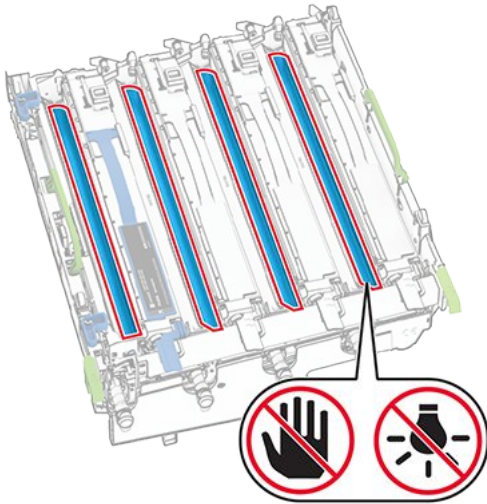

5. Unlock the used imaging unit.

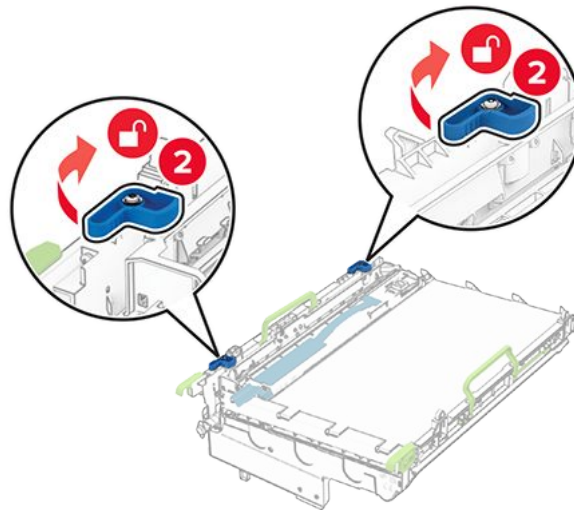
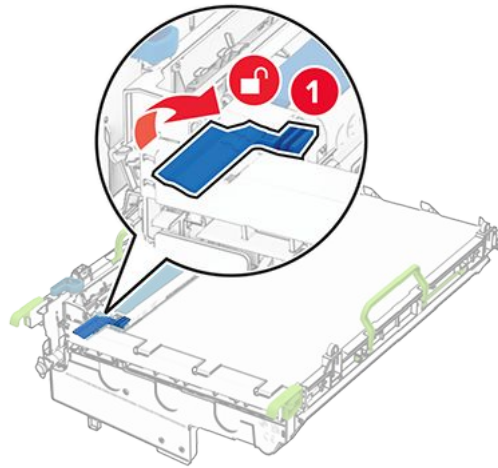

6. Remove the used imaging unit.

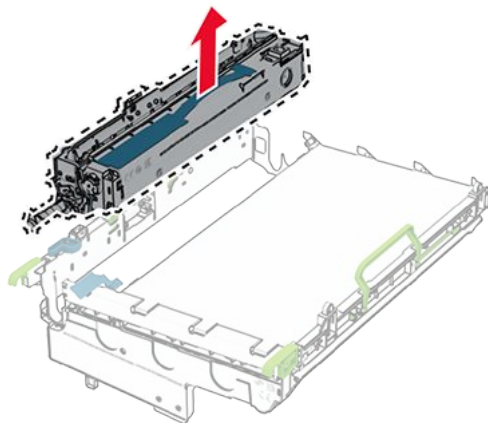

- 7. Unpack the new imaging unit.
- 8. Insert the new imaging unit.

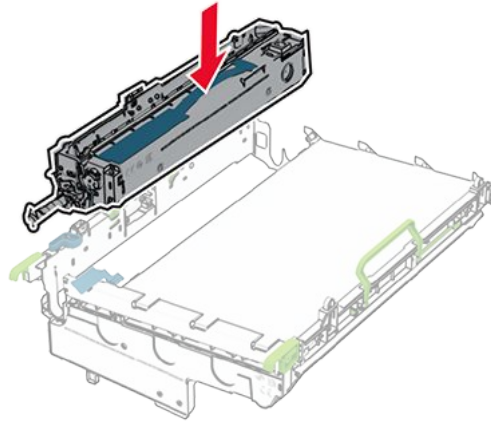

9. Lock the new imaging unit in place.

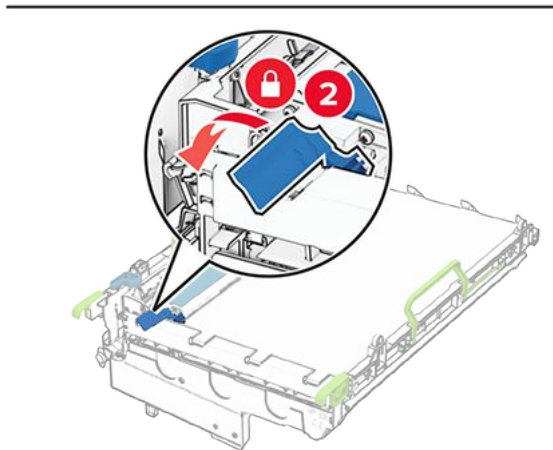
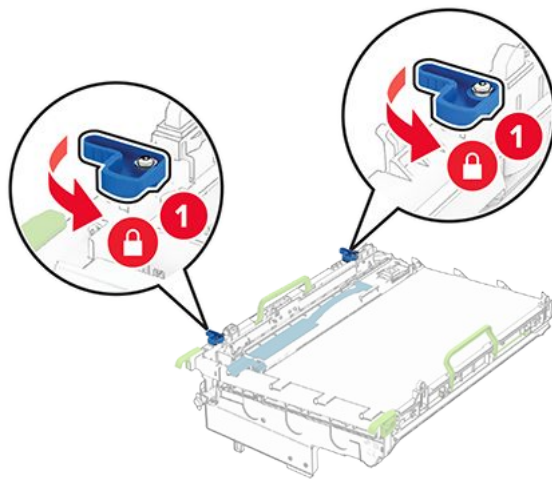

10. Insert the imaging support basket until it is fully seated.

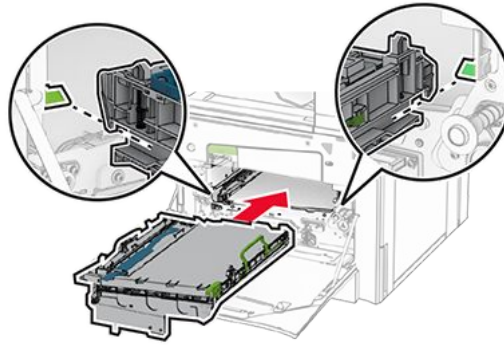

11. Insert the waste toner bottle until it clicks into place.

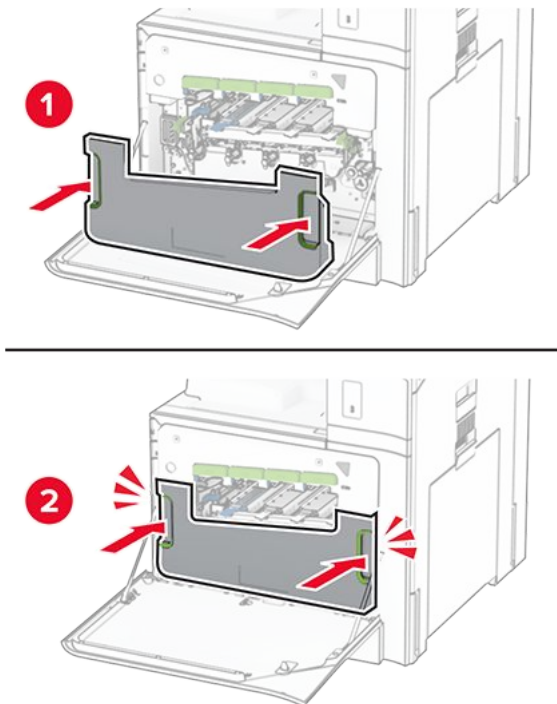

12. Gently pull out the printhead wiper, and then clean the printhead lens.

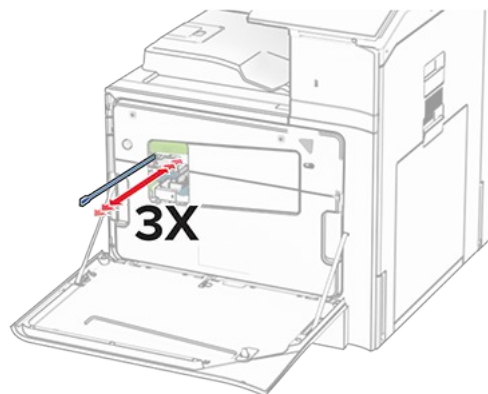

For more information on cleaning the printhead lens, see [Cleaning the printhead lens on page 490](#).

13. Insert the toner cartridge.

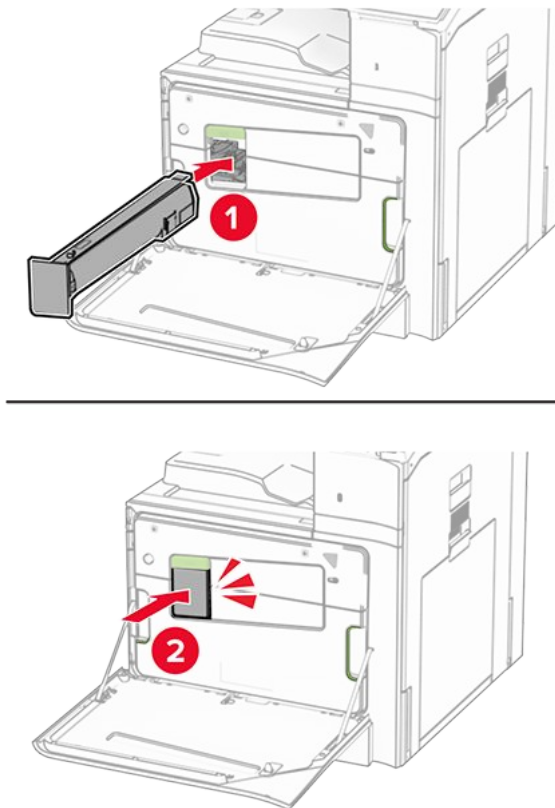

14. Close the door.

## Replacing the waste toner bottle

1. Open the front door.

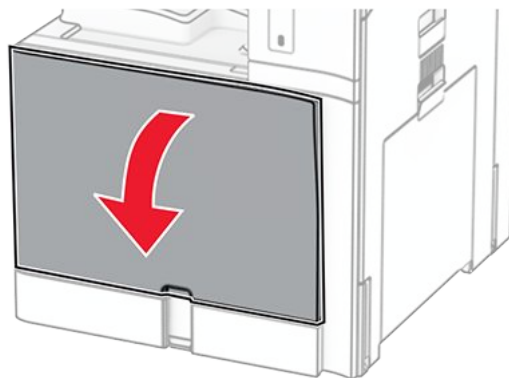

2. Remove the used waste toner bottle.

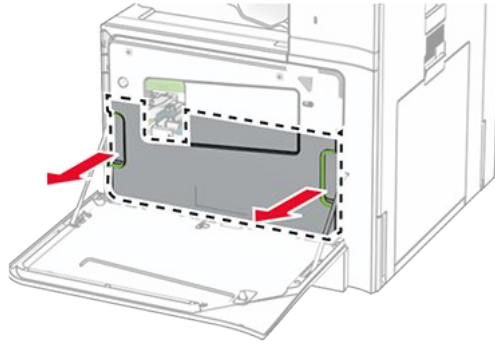

**Note:** To avoid spilling the toner, place the bottle in an upright position.

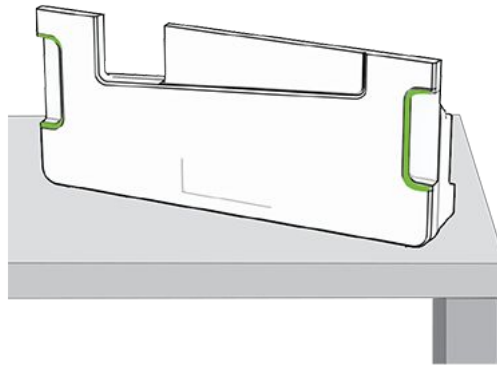

3. Unpack the new waste toner bottle.
4. Insert the new waste toner bottle until it clicks into place, and then close the door.

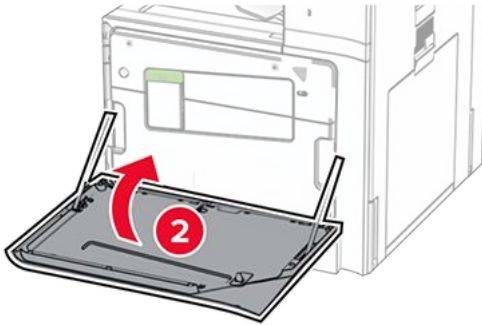
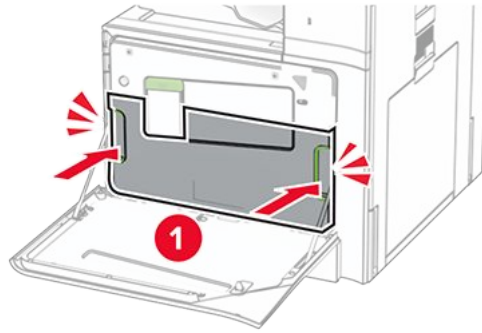

## Replacing the fuser

1. Turn off the printer.

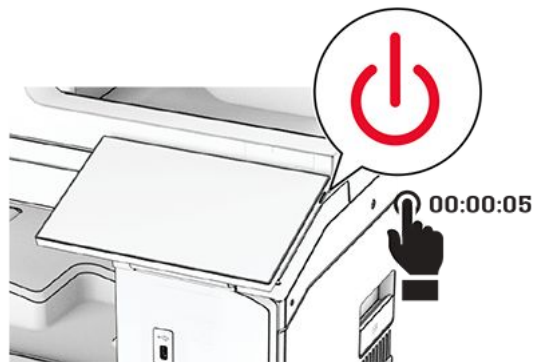

2. Unplug the power cord from the electrical outlet, and then from the printer.
3. Open door B.



### **CAUTION—HOT SURFACE**

The inside of the printer might be hot. To reduce the risk of injury from a hot component, allow the surface to cool before touching it.

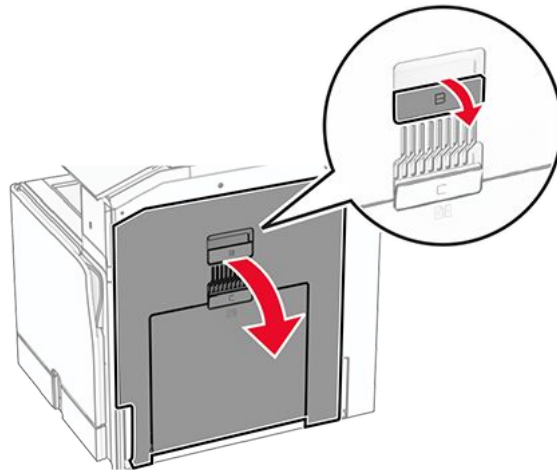

4. Loosen the screws, and then remove the used fuser.

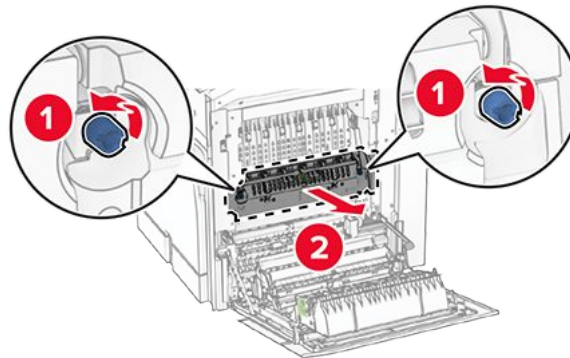

5. Unpack the new fuser.
6. Insert the new fuser until it clicks into place, and then tighten the screws.

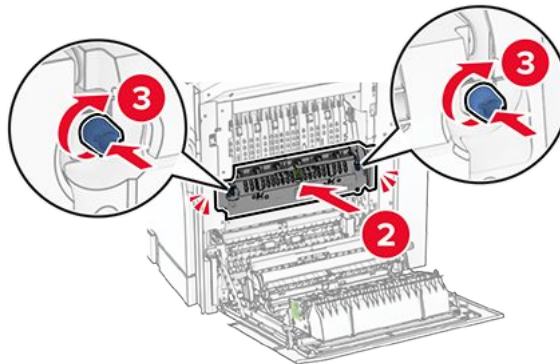
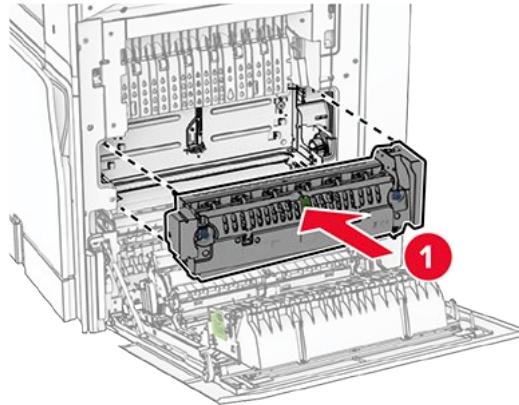

7. Close the door.
8. Connect one end of the power cord to the printer, and then the other end to the electrical outlet.



### **CAUTION—POTENTIAL INJURY**

To avoid the risk of fire or electrical shock, connect the power cord to an appropriately rated and properly grounded electrical outlet that is near the product and easily accessible.

9. Turn on the printer.

## Replacing the tray insert

1. Pull out the used tray insert.

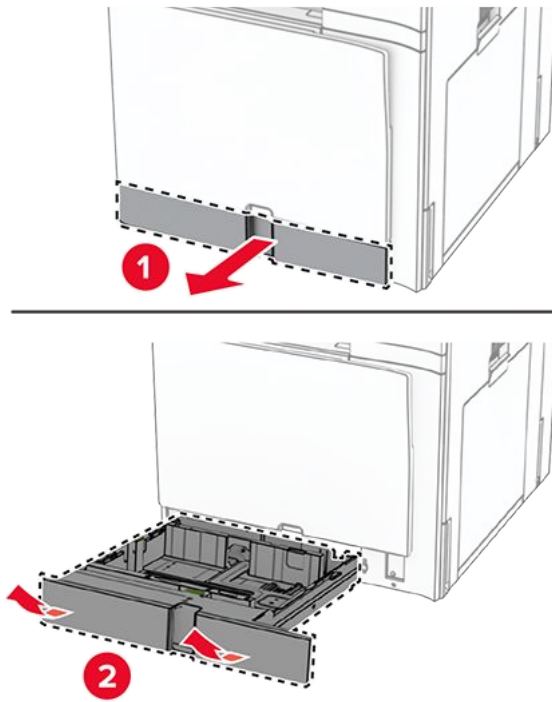

2. Unpack the new tray insert.
3. Insert the new tray insert.

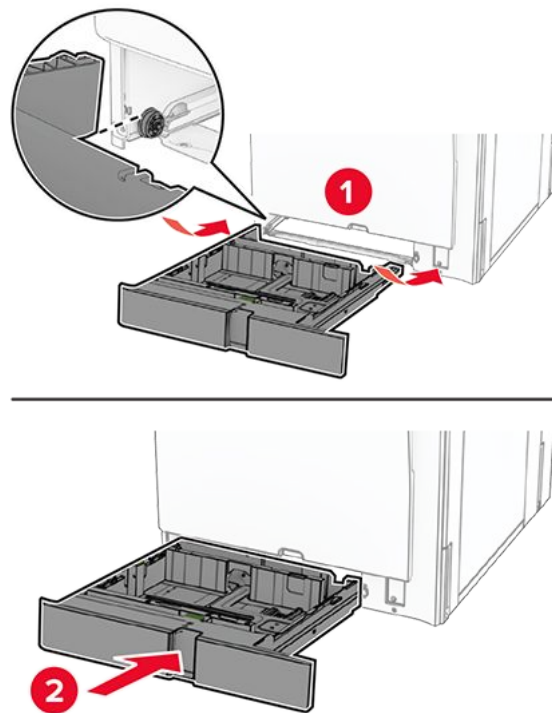

## Replacing the size guides in the optional 550-sheet tray

1. Pull out the tray.

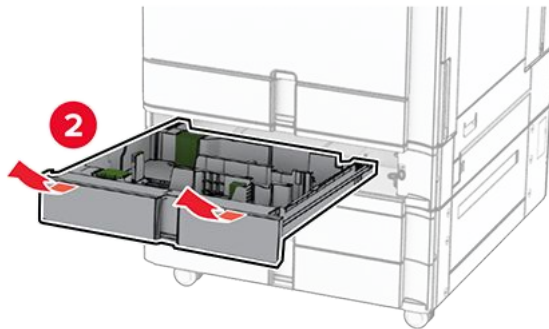
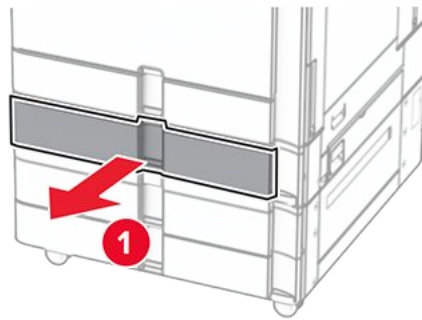

2. Remove the used size guides.

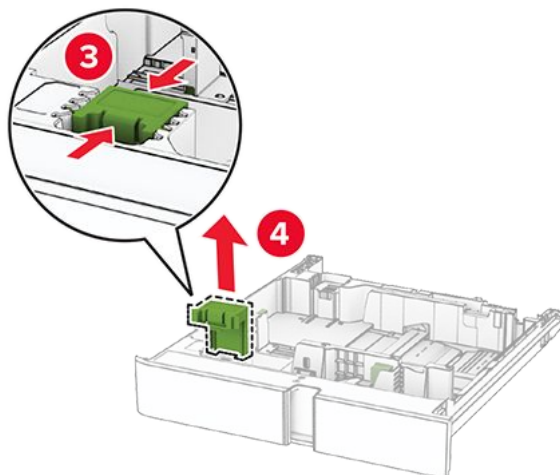
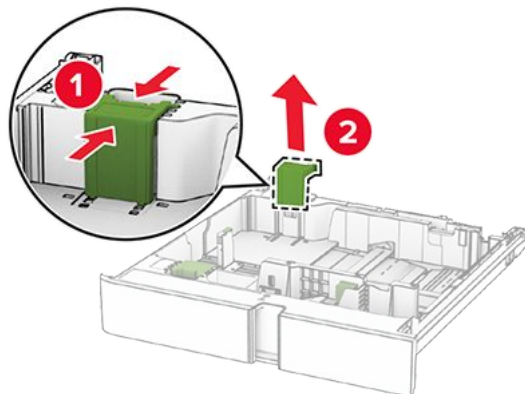

- 3. Unpack the new size guides.
- 4. Insert the new size guides until they click into place.

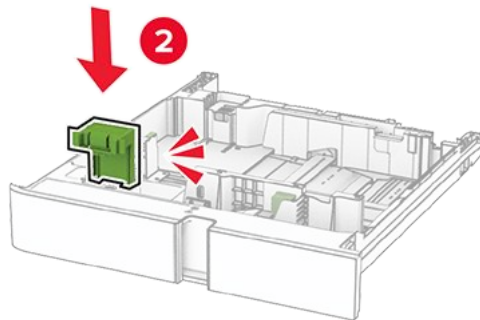
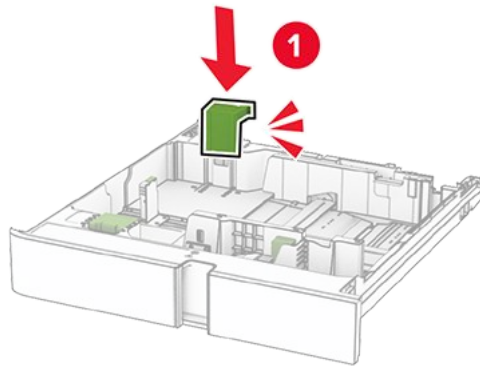

5. Insert the tray.

## Replacing the cover in the optional 550-sheet tray

1. Remove the used tray cover.

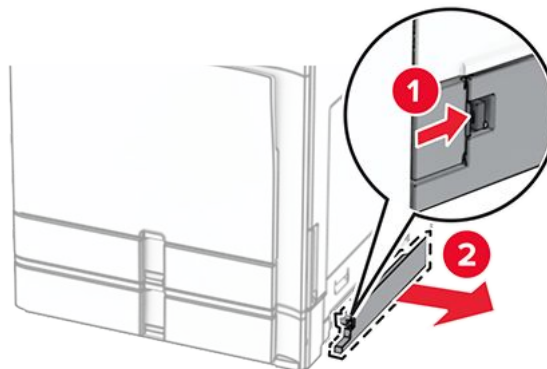

2. Unpack the new tray cover.
3. Insert the new tray cover until it clicks into place.

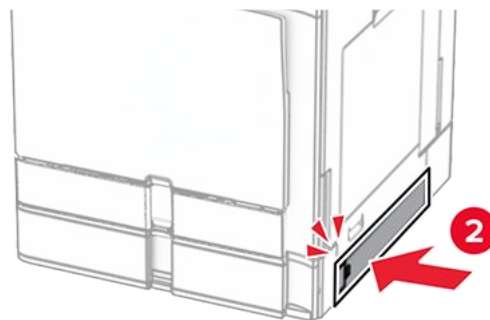
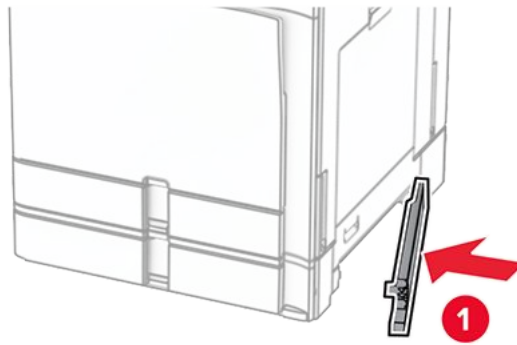

## Replacing the booklet finisher top bin extension

1. Remove the used top bin extension.

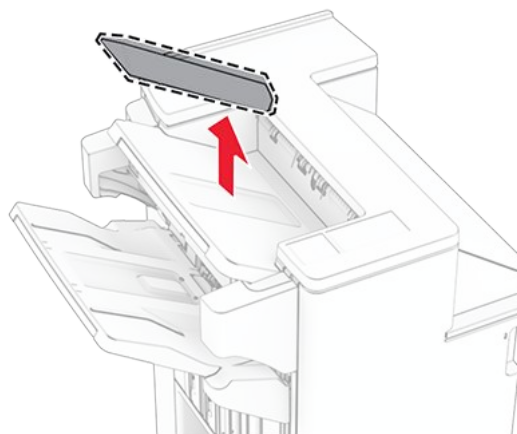

2. Unpack the new top bin extension.
3. Insert the new top bin extension.

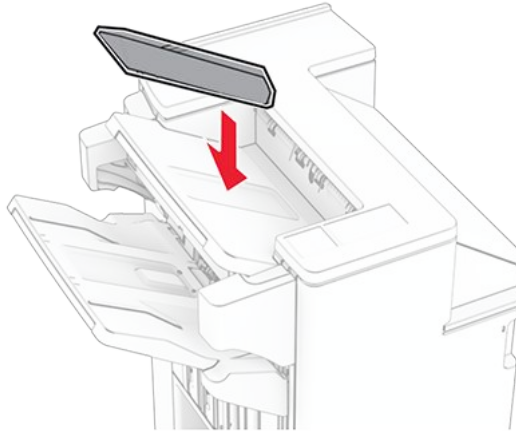

## Replacing the hole punch box

**Note:** Depending on the finisher installed, the appearance of the hole punch box may vary.

1. Open the finisher door.

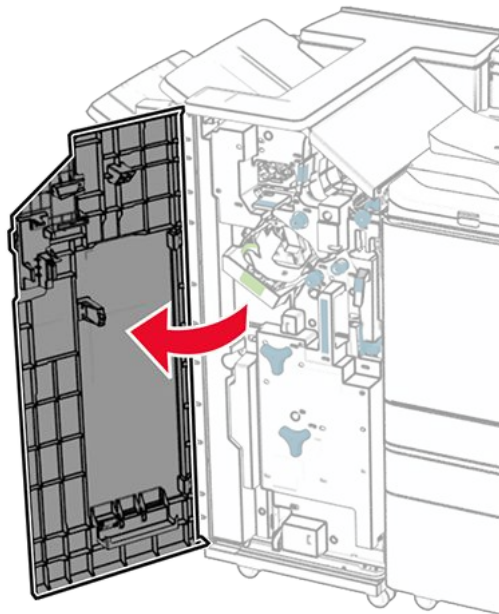

2. Remove the used hole punch box.

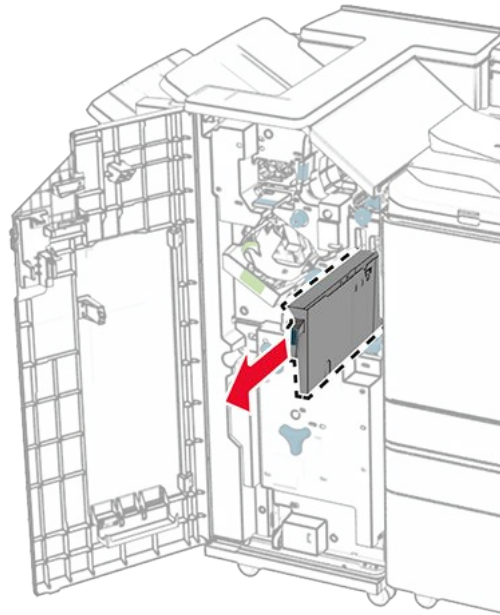

3. Unpack the new hole punch box.
4. Insert the new hole punch box.

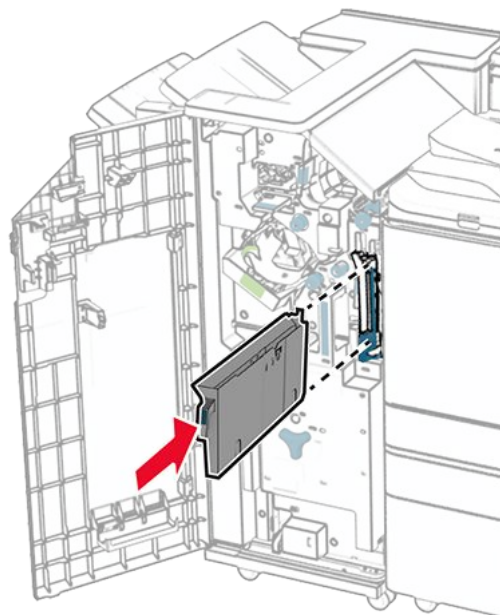

5. Close the finisher door.

## Replacing the standard bin

1. Remove the used standard bin.

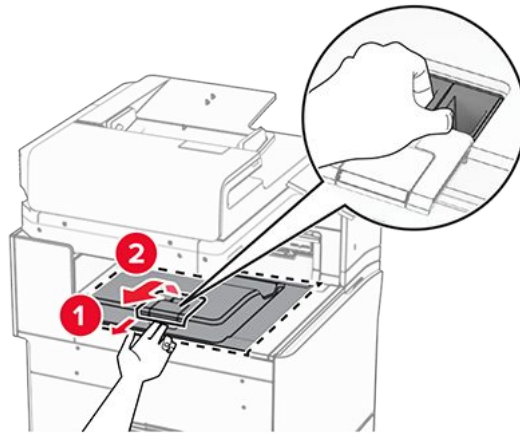

2. Unpack the new standard bin.
3. Attach the new standard bin.

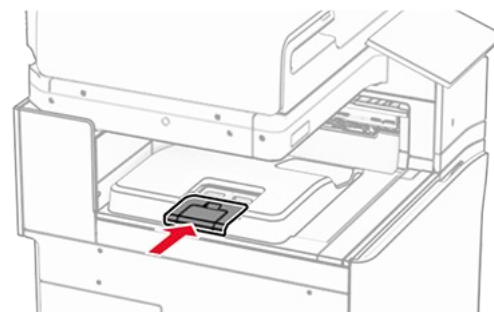
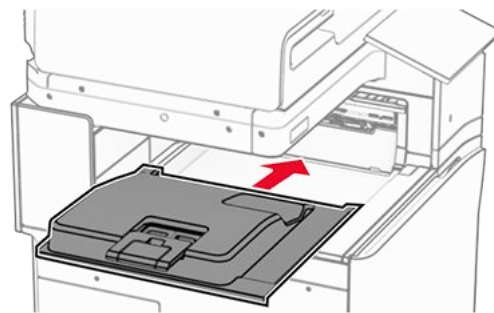

## Replacing the fan cover

1. Remove the used fan cover.

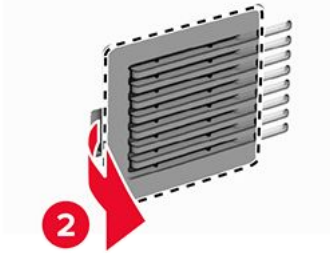
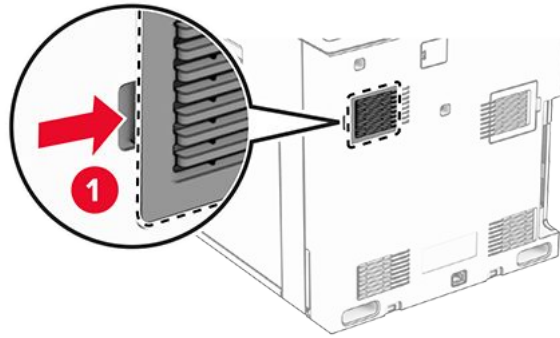

2. Unpack the new cover.
3. Insert the new cover until it clicks into place.

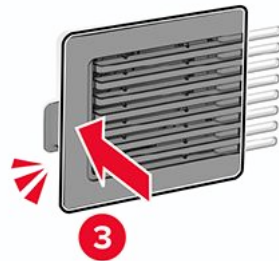
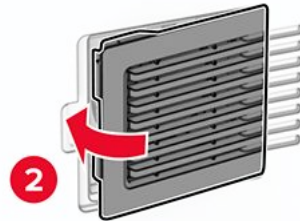
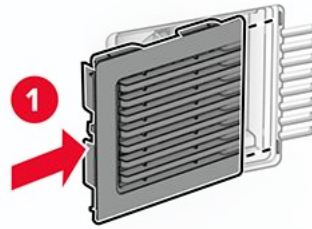

## Replacing the right cover

1. Remove the used right cover.

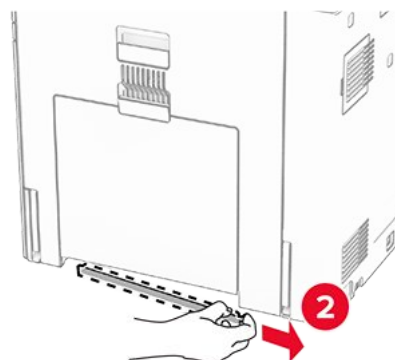
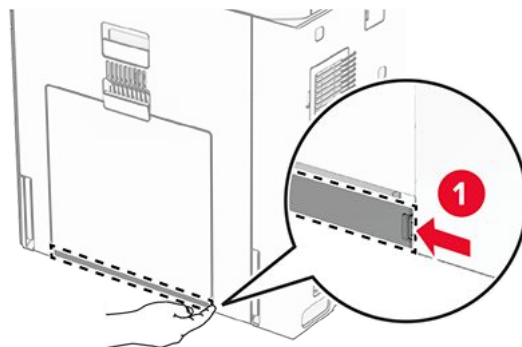

2. Unpack the new cover.
3. Insert the new cover until it clicks into place.

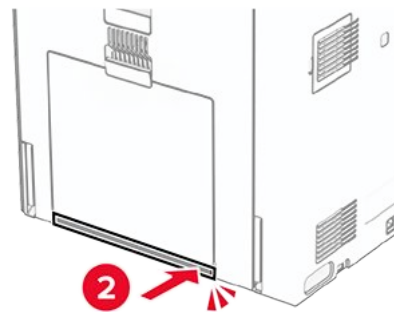
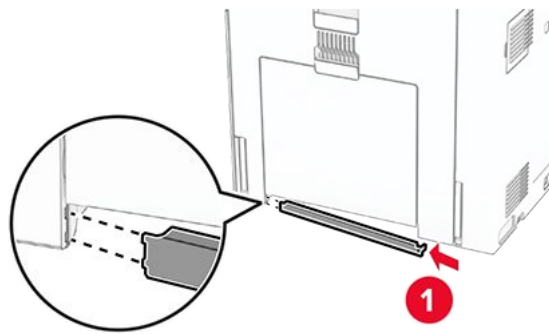

## Replacing the glass cleaner tool

1. Open the scanner cover.

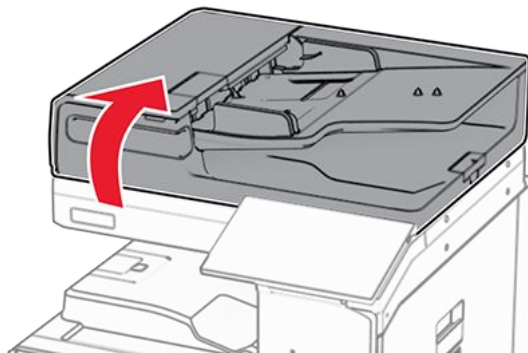

2. Remove the used glass cleaner tool.

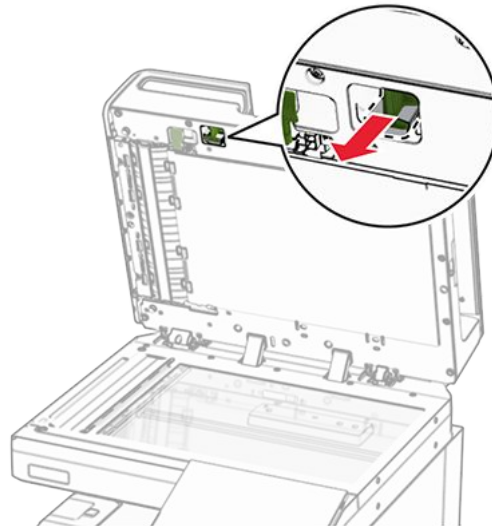

3. Unpack the new glass cleaner tool.
4. Insert the new glass cleaner tool.

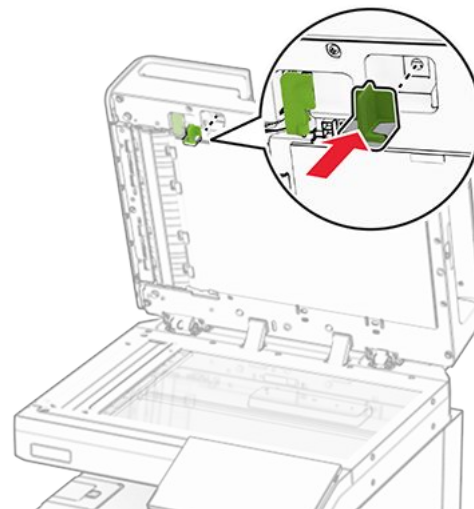

5. Close the scanner cover.

## Replacing the paper transport connector cover

1. Remove the standard bin.

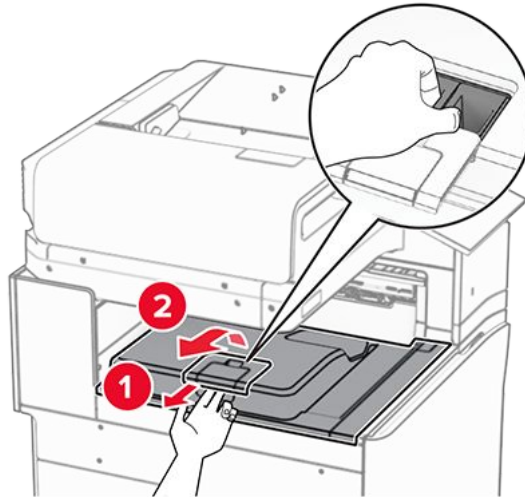

2. Remove the used paper transport connector cover.

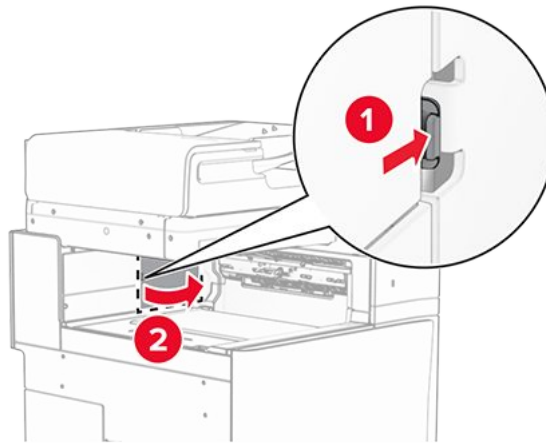

3. Unpack the new connector cover.

4. Attach the new connector cover until it clicks into place.

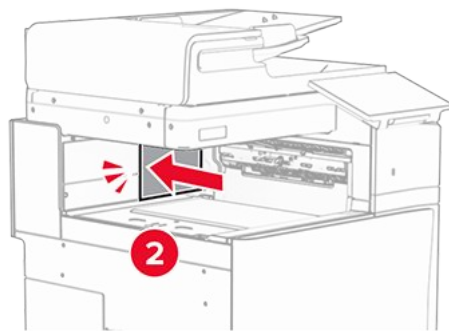
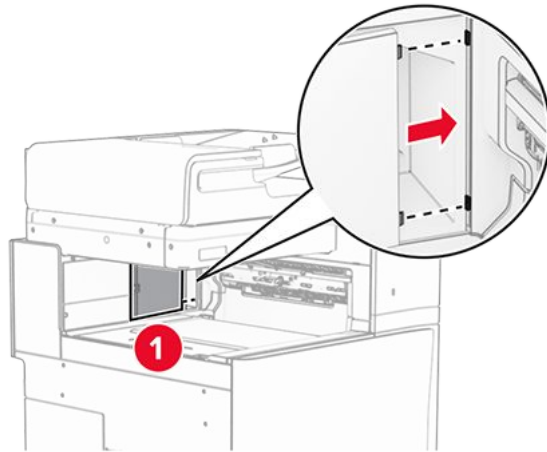

5. Attach the standard bin.

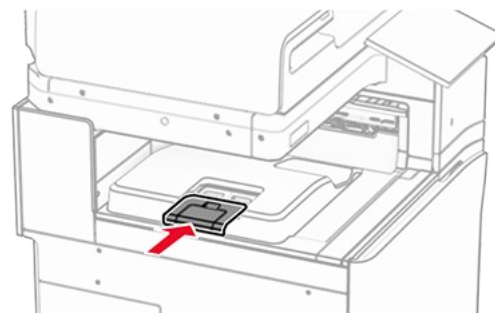
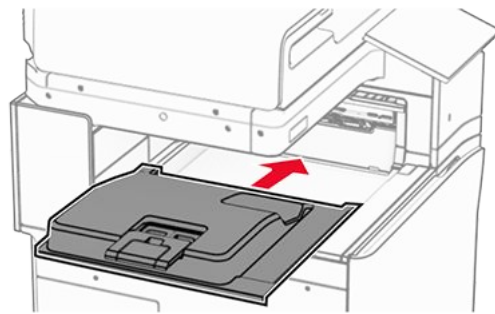

## Replacing the staple cartridge unit

### Replacing the staple cartridge in the staple finisher

1. Grab handle F, and then slide the staple finisher to the left.

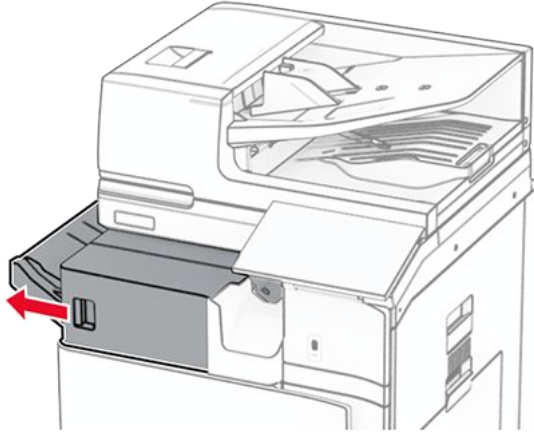

2. Remove the staple cartridge holder.

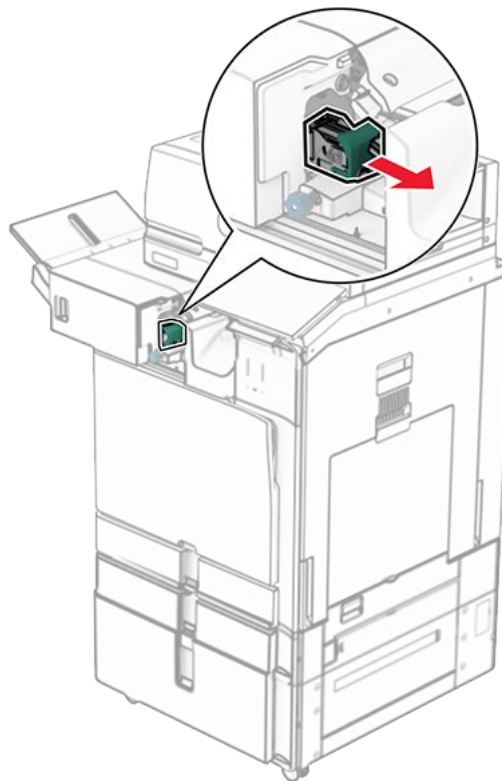

3. Remove the empty staple cartridge.

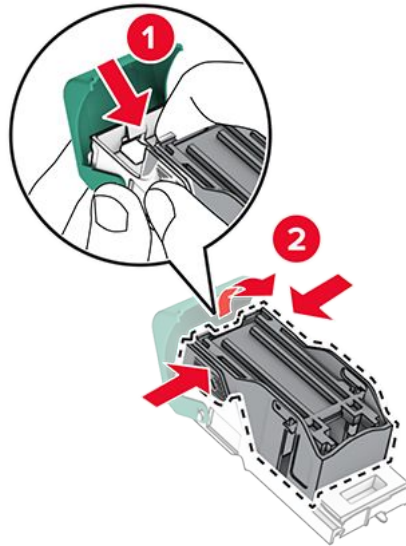

4. Insert the new staple cartridge until it clicks into place.

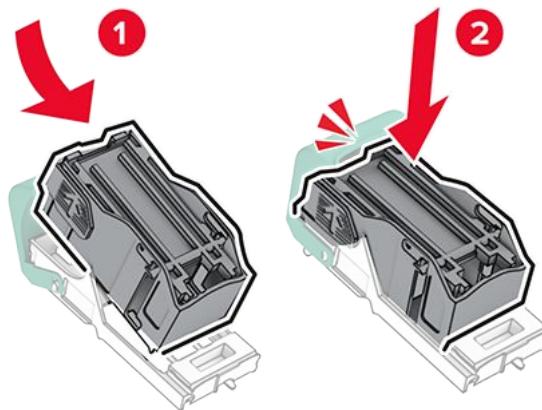

5. Insert the staple cartridge holder until it clicks into place.

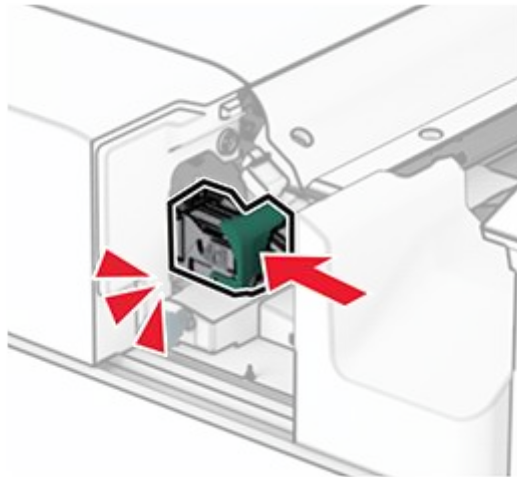

6. Slide the staple finisher to the right.

## Replacing the staple cartridge in the staple, hole punch finisher

1. Open door H.

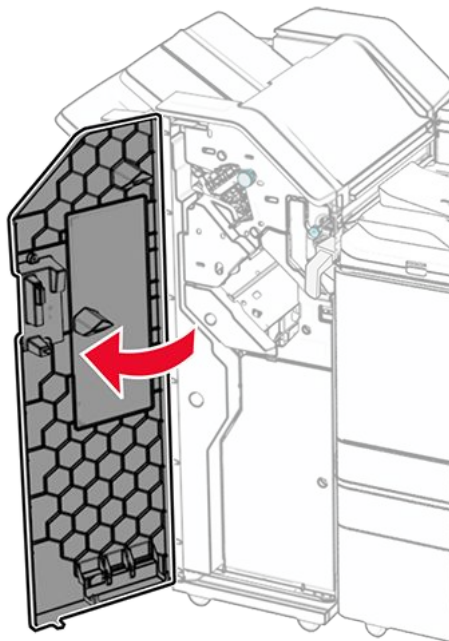

2. Pull out the green handle, and then remove the staple cartridge holder.

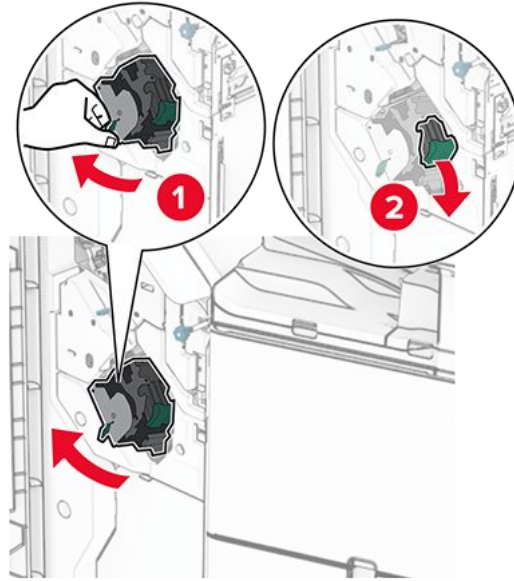

3. Remove the empty staple cartridge.

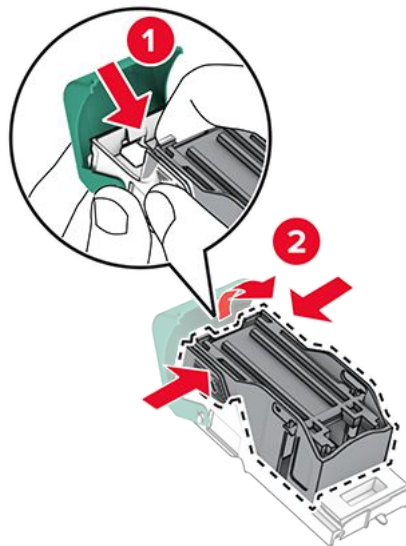

4. Unpack the new staple cartridge.

5. Insert the new staple cartridge until it clicks into place.

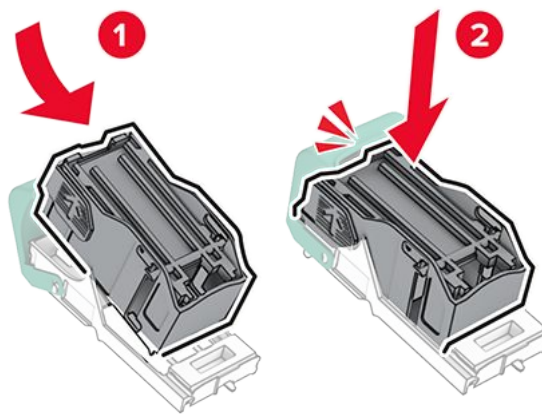

6. Insert the staple cartridge holder until it clicks into place.

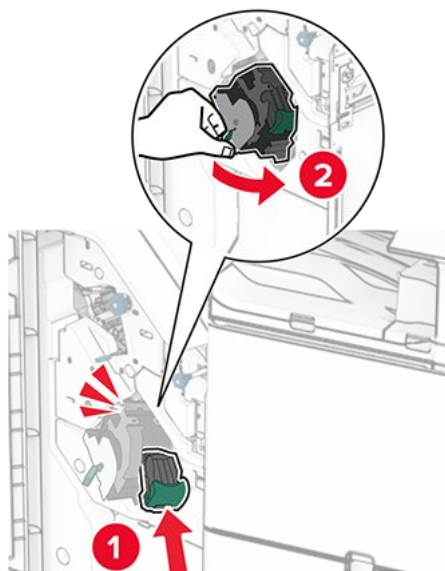

7. Close door H.

## Replacing the staple cartridge in the booklet finisher

1. Open door H.

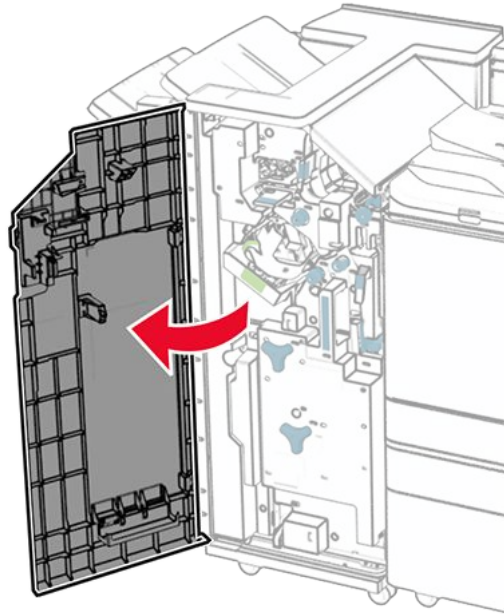

2. Pull out the green handle, and then remove the staple cartridge holder.

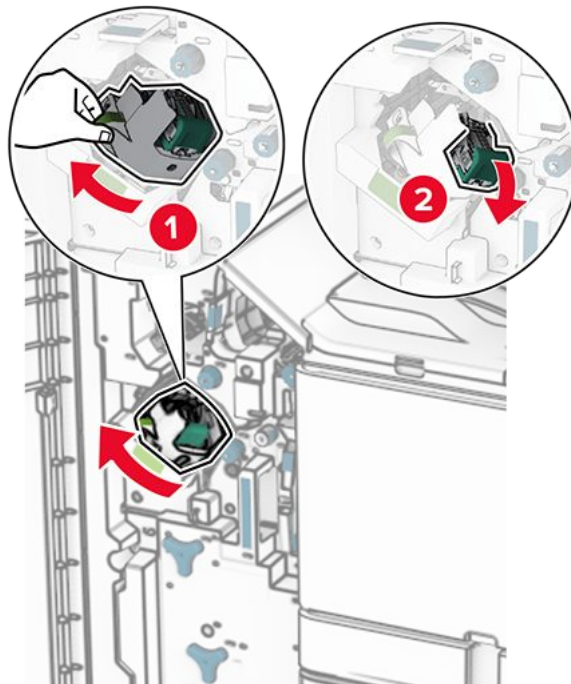

3. Remove the empty staple cartridge.

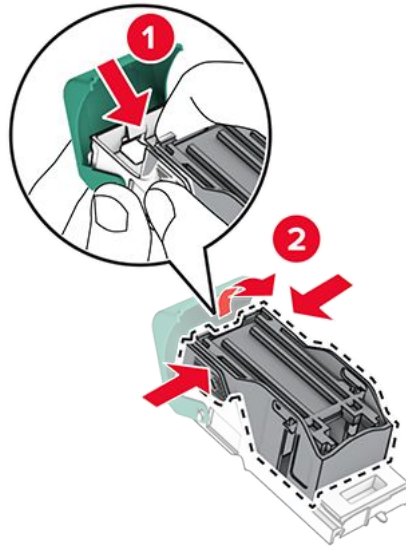

4. Unpack the new staple cartridge.
5. Insert the new staple cartridge until it clicks into place.

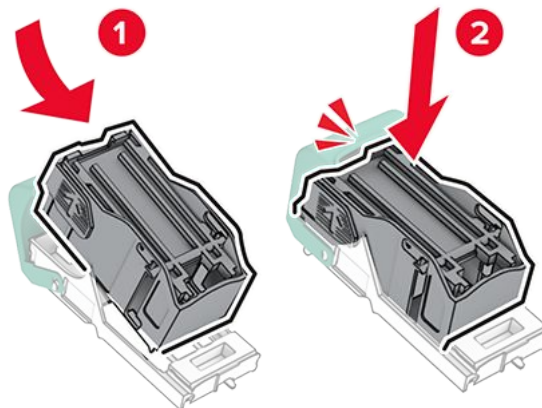

6. Insert the staple cartridge holder until it clicks into place.

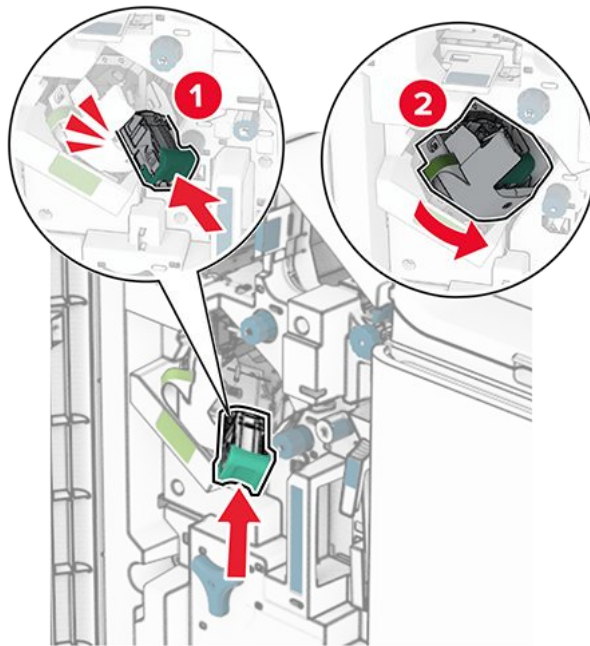

7. Close door H.

## Replacing the staple cartridge holders in the booklet finisher

1. Open the finisher door.

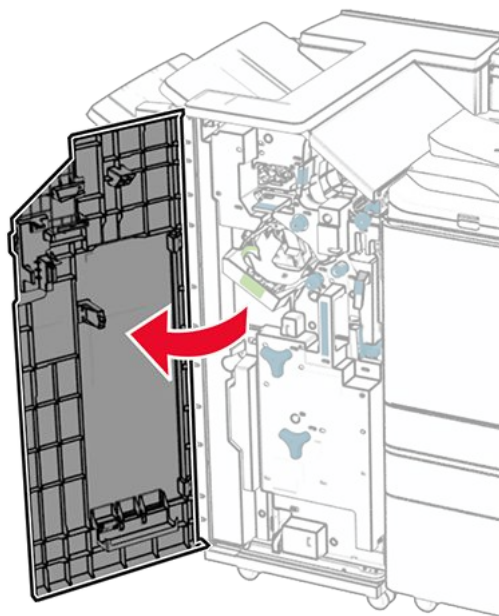

2. Pull out the booklet maker, and then remove the used staple cartridge holders.

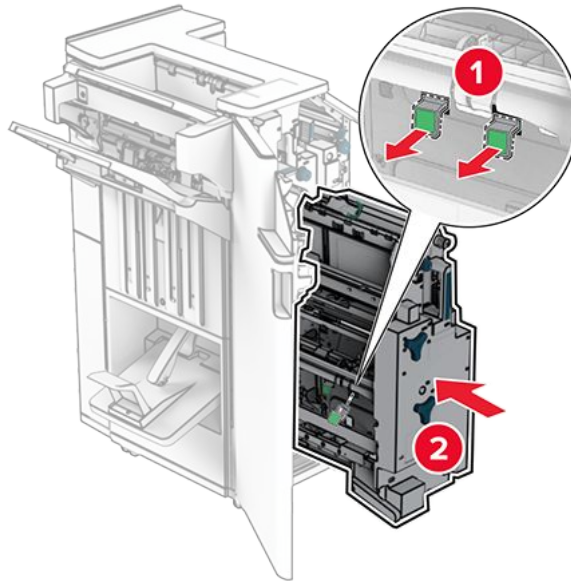

3. Unpack the new staple cartridge holders.
4. Insert the new staple cartridge holders.

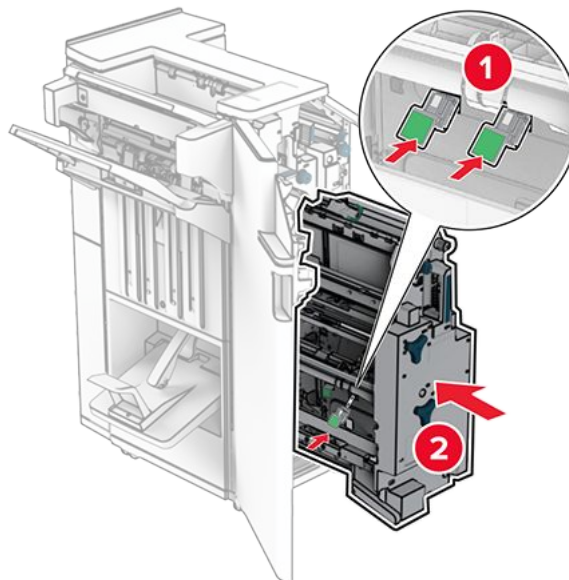

5. Insert the booklet maker, and then close the finisher door.

## Resetting the supply usage counters

1. From the control panel, navigate to **Settings > Device > Maintenance > Configuration Menu > Supply Usage And Counters**.
2. Select the counter that you want to reset.

### **Warning—Potential Damage**

Supplies and parts without Return Program agreement terms may be reset and remanufactured. However, the manufacturer's warranty does not cover any damage caused by non-genuine supplies or parts. Resetting counters on the supply or part without proper remanufacturing can cause damage to your printer. After resetting the supply or part counter, your printer may display an error indicating the presence of the reset item.

## Cleaning printer parts

### Cleaning the printer



#### **CAUTION—SHOCK HAZARD**

To avoid the risk of electrical shock when cleaning the exterior of the printer, unplug the power cord from the electrical outlet and disconnect all cables from the printer before proceeding.

#### **Notes**

- Perform this task after every few months.
- Damage to the printer caused by improper handling is not covered by the printer warranty.

1. Turn off the printer, and then unplug the power cord from the electrical outlet.
2. Remove paper from the standard bin and multipurpose feeder.
3. Using a soft brush or vacuum, remove any dust, lint, and pieces of paper around the printer.
4. Using a damp, soft, lint-free cloth, wipe the outside of the printer.

#### **Notes**

- Do not use household cleaners or detergents, as they may damage the finish of the printer.
- Make sure that all areas of the printer are dry after cleaning.

5. Connect the power cord to the electrical outlet, and then turn on the printer.



### CAUTION—POTENTIAL INJURY

To avoid the risk of fire or electrical shock, connect the power cord to an appropriately rated and properly grounded electrical outlet that is near the product and easily accessible.

## Cleaning the touch screen



### CAUTION—SHOCK HAZARD

To avoid the risk of electric shock when cleaning the exterior of the printer, unplug the power cord from the electrical outlet and disconnect all cables from the printer before proceeding.

1. Turn off the printer, and then unplug the power cord from the electrical outlet.
2. Using a damp, soft, lint-free cloth, wipe the touch screen.

### Notes

- Do not use household cleaners or detergents as they may damage the touch screen.
- Make sure that the touch screen is dry after cleaning.

3. Connect the power cord to the electrical outlet, and then turn on the printer.



### CAUTION—POTENTIAL INJURY

To avoid the risk of fire or electrical shock, connect the power cord to an appropriately rated and properly grounded electrical outlet that is near the product and easily accessible.

## Cleaning the scanner

1. Open the scanner cover.

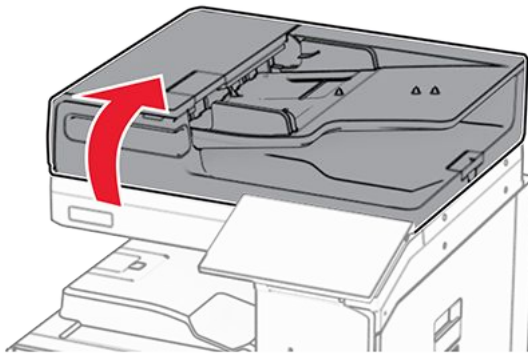

2. Remove the glass cleaner tool.

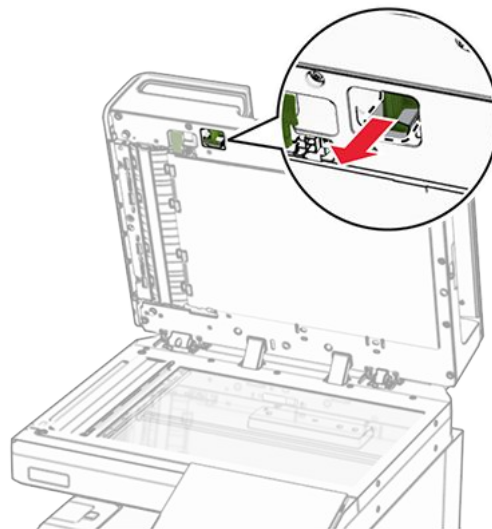

- 3. Close the scanner cover.
- 4. Open door A.
- 5. Using the glass cleaner tool, wipe the following areas:

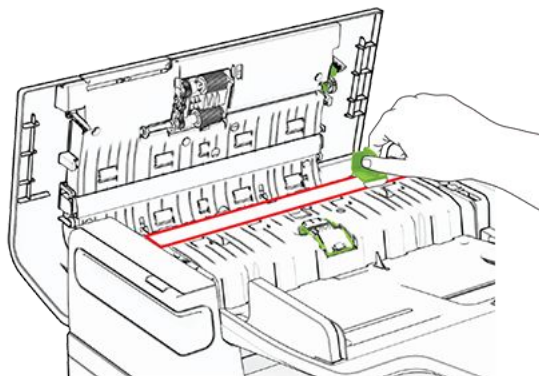

a. ADF glass in door A

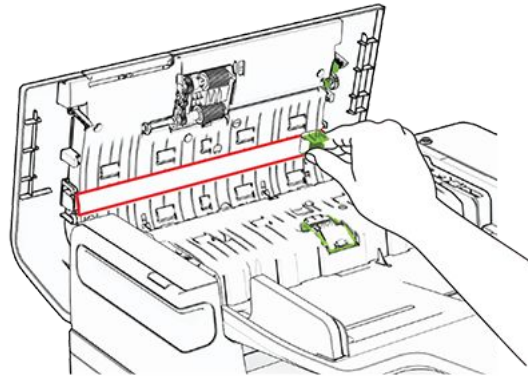

- b. ADF glass pad in door A
- 6. Close door A.
- 7. Open the scanner cover.

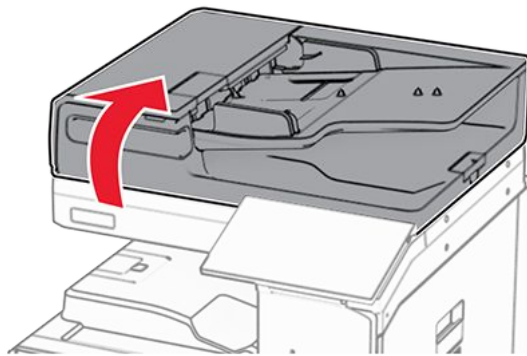

- 8. Using a damp, soft, lint-free cloth, wipe the following areas:
  - a. Scanner glass pad

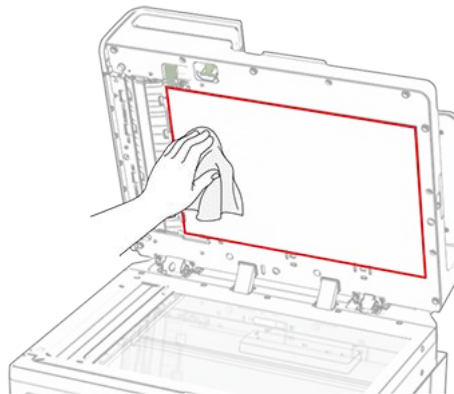

- b. Scanner glass

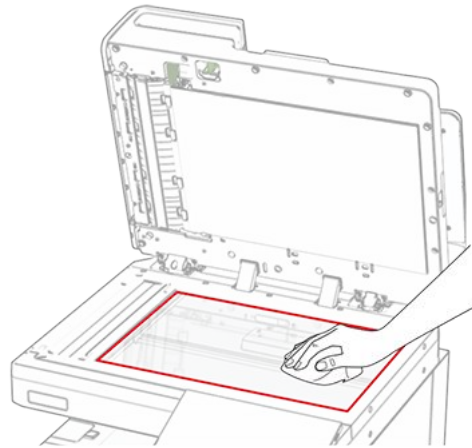

9. Using the glass cleaner tool, wipe the following areas:
- a. ADF glass pad in the scanner area

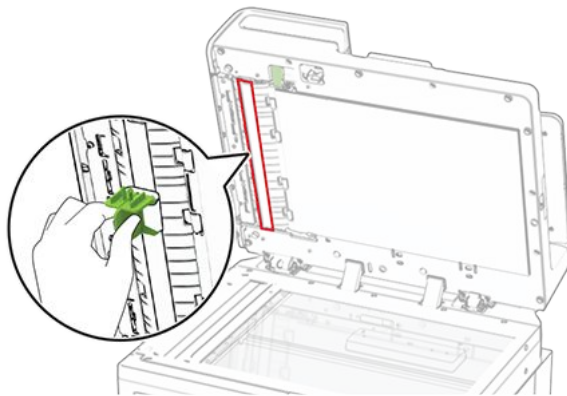

- b. ADF glass in the scanner area

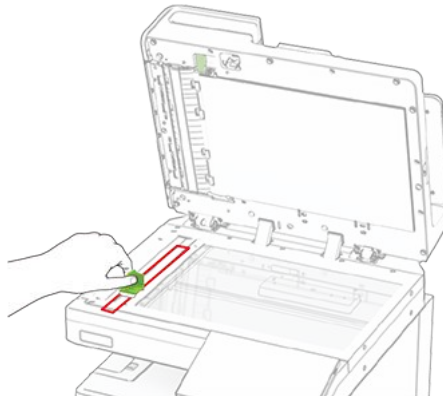

10. Return the glass cleaner tool to its place.

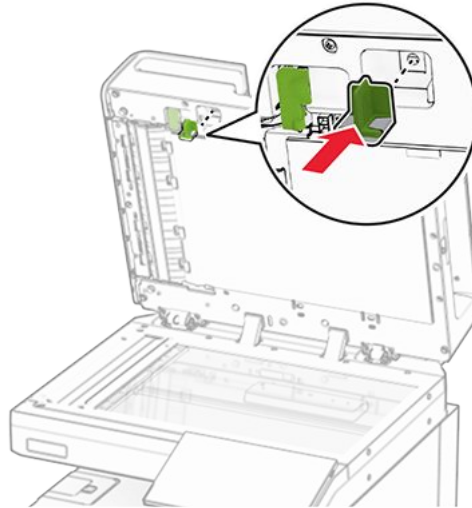

11. Close the scanner cover.

## Cleaning the printhead lens

1. Open the front door.

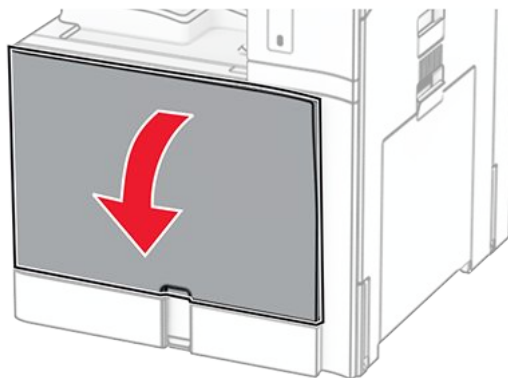

2. Remove the toner cartridge.

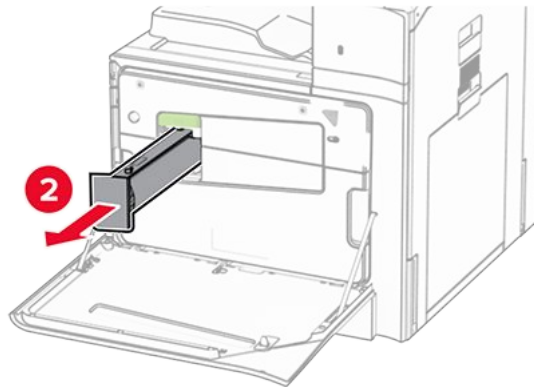
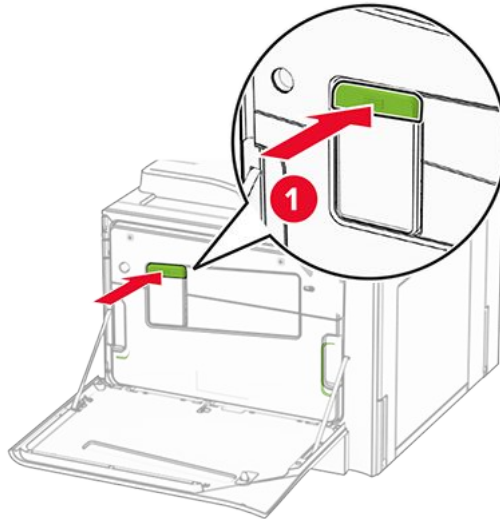

3. Gently pull out the wiper until it stops.

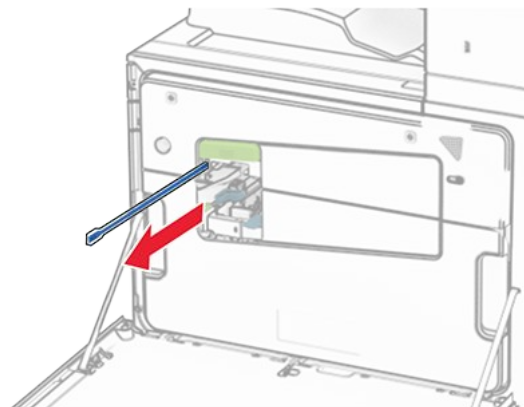

**Note:** The wiper does not detach from the printer.

4. Push the wiper back into the printhead until it stops.

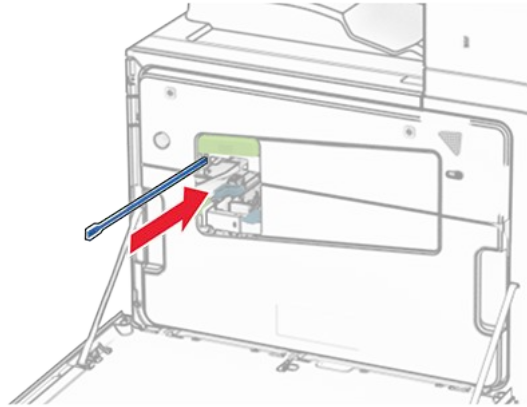

5. Repeat [step 3](#) and [step 4](#) three times.
6. Insert the toner cartridge.

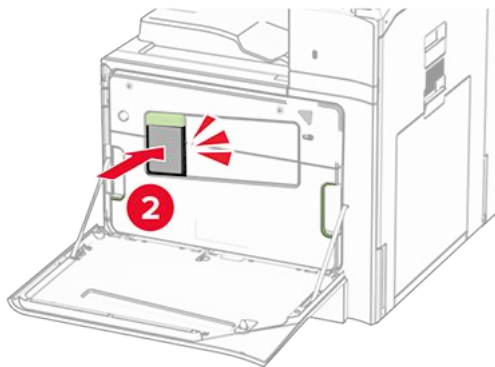
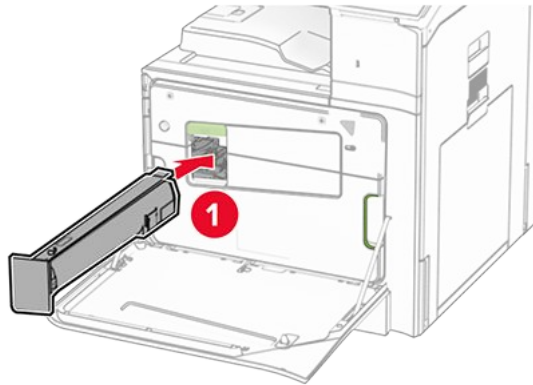

7. Close the front door.

## Emptying the hole punch box

**Note:** Depending on the finisher installed, the appearance of the hole punch box may vary.

1. Open the finisher door.

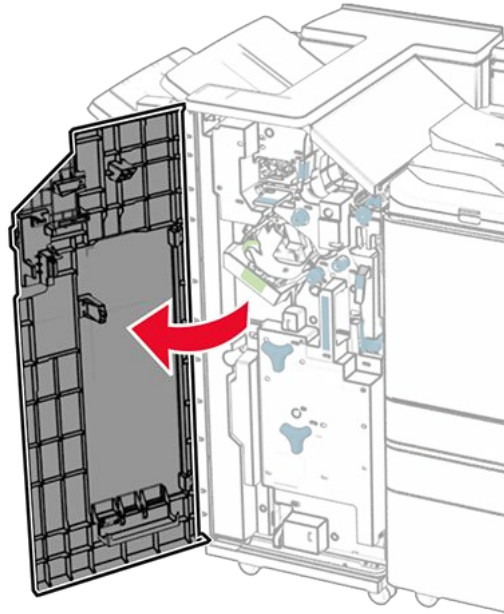

2. Remove, and then empty the hole punch box.

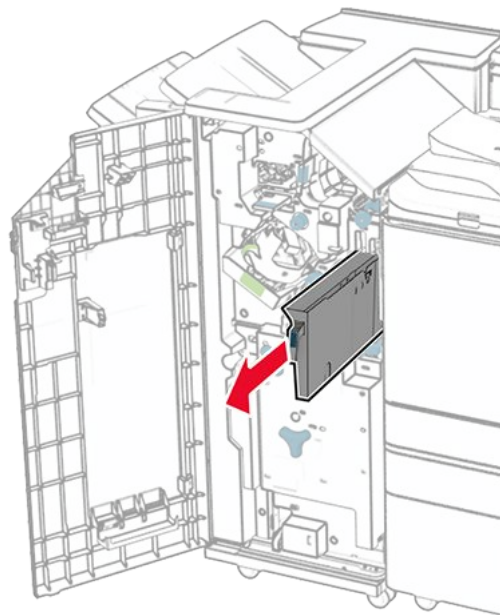

3. Insert the hole punch box.

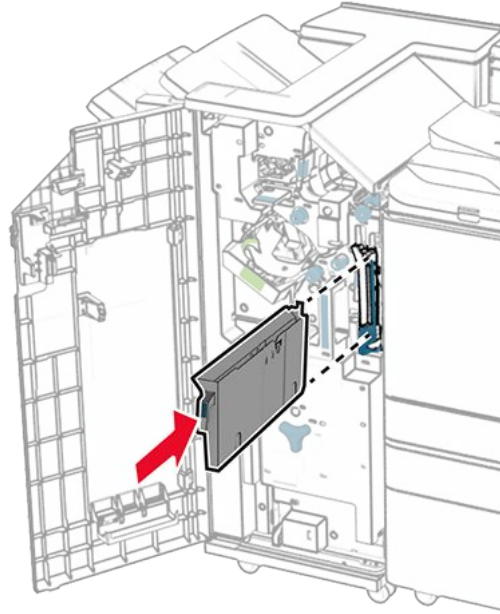

4. Close the finisher door.

## Saving energy and paper

### Configuring the power save mode settings

#### Sleep mode

1. From the control panel, navigate to **Settings > Device > Power Management > Timeouts > Sleep Mode**.
2. Set the amount of time that the printer stays idle before it enters **Sleep Mode**.

#### Hibernate mode

1. From the control panel, navigate to **Settings > Device > Power Management > Timeouts > Hibernate Timeout**.
2. Set the amount of time that the printer stays idle before it enters hibernate mode.

#### Notes

- For **Hibernate Timeout** to work, set **Hibernate Timeout on Connection to Hibernate**.
- The Embedded Web Server is disabled when the printer is in hibernate mode.

## Adjusting the brightness of the display

1. From the control panel, navigate to **Settings > Device > Preferences**.
2. In the **Screen Brightness** menu, adjust the setting.

## Conserving supplies

- Print on both sides of the paper.

**Note:** Two-sided printing is the default setting in the printer.

- Print multiple pages on a single sheet of paper.
- Use the preview feature to see how the document looks like before printing it.
- Print one copy of the document to check its content and format for accuracy.

## Moving the printer to another location



### CAUTION—POTENTIAL INJURY

If the printer weight is greater than 20 kg (44 lb), then it may require two or more people to lift it safely.



### CAUTION—POTENTIAL INJURY

To avoid the risk of fire or electrical shock, use only the power cord provided with this product or the manufacturer's authorized replacement.



### CAUTION—POTENTIAL INJURY

When moving the printer, follow these guidelines to avoid personal injury or printer damage:

- Make sure that all doors and trays are closed.
- Turn off the printer, and then unplug the power cord from the electrical outlet.
- Disconnect all cords and cables from the printer.
- If the printer has separate floor-standing optional trays or output options attached to it, then disconnect them before moving the printer.
- If the printer has a caster base, then carefully roll it to the new location. Use caution when passing over thresholds and breaks in flooring.
- If the printer does not have a caster base but is configured with optional trays or output options, then remove the output options and lift the printer off the trays. Do not try to lift the printer and any options at the same time.
- Always use the handholds on the printer to lift it.
- Any cart used to move the printer must have a surface able to support the full footprint of the printer.
- Any cart used to move the hardware options must have a surface able to support the dimensions of the options.

## Maintain the printer

---

- Keep the printer in an upright position.
- Avoid severe jarring movements.
- Make sure that your fingers are not under the printer when you set it down.
- Make sure that there is adequate clearance around the printer.

**Note:** Damage to the printer caused by improper moving is not covered by the printer warranty.

# Troubleshoot a problem

## Print quality problems

Find the image that resembles the print quality problem you are having, and then click the link below it to read problem-solving steps.

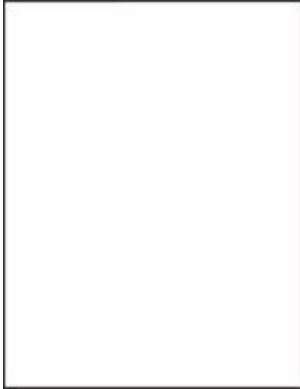

[Blank or white pages on page 516](#)



[Dark print on page 517](#)



[Fine lines are not printed correctly on page 518](#)



[Folded or wrinkled paper on page 519](#)



[Gray background on page 520](#)



[Incorrect margins on page 521](#)



[Light print on page 522](#)



[Mottled print and dots on page 523](#)



[Print crooked or skewed on page 524](#)



Solid black pages on page 525



Text or images cut off on page 526



Toner easily rubs off on page 527



Horizontal light bands on page 528



Vertical light bands on page 529



Vertical white lines on page 531



Vertical dark bands on page 532



Horizontal dark lines on page 530



Vertical dark lines or streaks on page 533



Repeating defects on page 534

## Printer error codes

Error codes	Error message	Solution
2.01	Wait for supplies.	Select <b>Cancel Job</b> and order the needed supply. For more information, see the "Ordering parts and supplies" section.
3.01	The standard bin is full.	Remove the paper from the bin, and then select <b>Continue</b> .
3.02, 3.03, 3.04	Remove paper from bin [x].	Remove the paper from the bin, and then select <b>Continue</b> .
7.13, 7.23, 7.33, 7.43	Insert tray [x].	Insert the indicated tray.
8.01	Close the front door.	Keep the front door closed unless performing maintenance.
8.02, 8.03, 8.04, 8.05, 8.08, 8.10, 8.11	Close door [x].	Keep the indicated door closed unless performing maintenance.
8.06	Reattach the 1500-sheet tray.	Make sure that the tray is properly attached to the printer.
8.07	Reattach staple finisher.	Make sure that the finisher is properly attached to the printer.
8.08	Close paper transport cover F.	Keep the cover closed unless performing maintenance.
8.09	Close paper transport cover G.	
9	Printer had to restart. Last job may be incomplete.	Select <b>Continue</b> to clear the message and continue printing.
11.11, 11.21, 11.31, 11.41, 11.51, 11.81, 11.91	Load <source/> with <type/> <size/> >.	Load the indicated tray with paper. For more information, see the "Loading paper and specialty media" section.

## Troubleshoot a problem

Error codes	Error message	Solution
11.12, 11.22, 11.32, 11.42, 11.82, 11.92	Load <source/> with <type/> <size/> <orientation/>.	
12.11, 12.21, 12.31, 12.32, 12.41, 12.51, 12.91	Change <source/> to <type/> <size/>.	Pull out the indicated tray, remove paper, and then load the correct paper type and size. For more information, see the "Loading paper and specialty media" section.
12.12, 12.22, 12.32, 12.42, 12.92	Change <source/> to <type/> <size/> <orientation/>.	
14.1, 14.2	[pick up text from 'data1' and 'data2' but not 'userMessage1' and 'userMessage2']	Write down the message, and then contact your system administrator.
31.00	Hole punch box missing or full.	<ol style="list-style-type: none"> <li>1. Open door H.</li> <li>2. Remove the hole punch box.</li> </ol> <div style="background-color: #f0f0f0; padding: 10px; margin: 10px 0;"> <p><b>Note:</b> If the hole punch box is full, then empty it.</p> </div> <ol style="list-style-type: none"> <li>3. Insert the hole punch box.</li> <li>4. Close door H.</li> </ol>
31.35, 31.35A, 31.35B	Reinstall the missing or unresponsive waste toner bottle.	<ol style="list-style-type: none"> <li>1. Open the front door.</li> <li>2. Remove the waste toner bottle.</li> </ol> <div style="background-color: #f0f0f0; padding: 10px; margin: 10px 0;"> <p><b>Note:</b> To avoid spilling the toner, place the bottle in an upright position.</p> </div> <ol style="list-style-type: none"> <li>3. Insert the waste toner bottle.</li> <li>4. Close the front door.</li> </ol>
31.40z, 43.40z	Reinstall missing or unresponsive cartridge.	<ol style="list-style-type: none"> <li>1. Open the front door.</li> <li>2. Remove the cartridge.</li> <li>3. Insert the cartridge.</li> <li>4. Close the front door.</li> </ol>

Error codes	Error message	Solution
31.60z	Reinstall missing or unresponsive imaging unit.	<ol style="list-style-type: none"><li>1. Open the front door.</li><li>2. Remove the toner cartridge.</li><li>3. Remove the waste toner bottle.</li></ol> <p><b>Note:</b> To avoid spilling the toner, place the bottle in an upright position.</p> <ol style="list-style-type: none"><li>4. Pull out the imaging support basket.</li></ol> <p><b>Warning—Potential Damage</b> Do not touch the photoconductor drum. Doing so may affect the quality of future print jobs.</p> <ol style="list-style-type: none"><li>5. Unlock, and then remove the black imaging unit.</li><li>6. Insert the black imaging unit, and then lock it in place.</li><li>7. Insert the imaging support basket until it is fully seated.</li><li>8. Insert the waste toner bottle.</li><li>9. Insert the toner cartridge.</li><li>10. Close the front door.</li></ol>

Error codes	Error message	Solution
31.80z	Reinstall missing or unresponsive fuser.	<ol style="list-style-type: none"> <li>1. Open door B.</li> </ol> <div style="border: 1px solid gray; padding: 10px; margin: 10px 0;">  <p><b>CAUTION—HOT SURFACE</b> The inside of the printer might be hot. To reduce the risk of injury from a hot component, allow the surface to cool before touching it.</p> </div> <ol style="list-style-type: none"> <li>2. Unlock, and then remove the fuser.</li> <li>3. Insert the fuser, and then lock it in place.</li> <li>4. Close door B.</li> </ol>
32.40p	Reinstall the used toner cartridge.	<ol style="list-style-type: none"> <li>1. Open the front door.</li> <li>2. Remove the toner cartridge.</li> <li>3. Insert the toner cartridge.</li> <li>4. Close the front door.</li> </ol>
32.40z	Replace unsupported cartridge.	For more information, see <a href="#">Replacing a toner cartridge on page 449</a> .
32.60z	Replace unsupported imaging unit.	For more information, see <a href="#">Replacing the imaging unit on page 451</a> .
33.40z	Refilled regular cartridge.	For more information, see <a href="#">Refilled regular cartridge on page 591</a> .
33.60z	Non-genuine imaging unit, see User's Guide.	For more information, see <a href="#">Non-Lexmark supply on page 591</a> .
34	Paper too short.	Set the paper size setting to match the paper loaded in the tray. From the control panel, navigate to <b>Settings &gt; Paper &gt; Tray &gt; Configuration &gt; Paper Size/Type</b> .
37.1	Insufficient memory to collate job.	<p>Try either of the following:</p> <ul style="list-style-type: none"> <li>• Select <b>Continue</b> to print the part of the job that is stored and to begin collating the rest of the print job.</li> <li>• Cancel the current print job.</li> </ul>

## Troubleshoot a problem

---

Error codes	Error message	Solution
37.3	Insufficient memory, some held jobs were deleted.	Select <b>Continue</b> to clear the message and continue printing.
38.1	Memory full.	Try one or more of the following: <ul style="list-style-type: none"><li>• Select <b>Continue</b> to clear the message and continue printing.</li><li>• Cancel the current print job.</li><li>• Install more printer memory.</li><li>• Reduce the number of pages in the print job.</li></ul>
39.1	Complex page, some data may not have printed.	Try one or more of the following: <ul style="list-style-type: none"><li>• Select <b>Continue</b> to clear the message and continue printing.</li><li>• Cancel the current print job.</li><li>• Install more printer memory.</li><li>• Reduce the complexity and size of the print job before sending it to print again.</li><li>• Reduce the number of pages in the print job.</li><li>• Reduce the number and size of any downloaded fonts.</li><li>• Delete any unnecessary fonts or macros from the print job.</li><li>• Reduce the number of graphics in the print job.</li></ul>
42.yyK	Replace cartridge, printer region mismatch.	For more information, see <a href="#">Replace cartridge, printer region mismatch on page 591</a> .
43.40Y	Reinstall cartridge.	<ol style="list-style-type: none"><li>1. Open the front door.</li><li>2. Remove the cartridge.</li><li>3. Insert the cartridge.</li><li>4. Close the front door.</li></ol>
43.40Z	Replace cartridge.	For more information, see <a href="#">Replacing a toner cartridge on page 449</a> .
50	PPDS font error.	Install the PPDS font indicated in the print job, and then select <b>Continue</b> to let the printer search for the substitute font.

## Troubleshoot a problem

Error codes	Error message	Solution
51	Defective flash detected.	<p>Try one or more of the following:</p> <ul style="list-style-type: none"> <li>• Replace the flash memory.</li> <li>• Select <b>Continue</b> to clear the message and continue printing.</li> <li>• Cancel the current print job.</li> </ul>
52	Not enough free space in flash memory for resources.	<p>Try one or more of the following:</p> <ul style="list-style-type: none"> <li>• Select <b>Continue</b> to clear the message and continue printing.</li> <li>• Delete fonts, macros, and other data stored in the flash memory.</li> <li>• Install a storage drive.</li> </ul> <div style="border: 1px solid gray; padding: 5px; margin-top: 10px;"> <p><b>Note:</b> Downloaded fonts and macros that are not previously stored in the flash memory are deleted.</p> </div>
58.4	Incorrect output option configuration.	Turn off the printer, and then install the correct bin or finisher.
61	Remove defective disk.	Replace the defective storage drive.
62	Disk full.	<p>Try one or more of the following:</p> <ul style="list-style-type: none"> <li>• Select <b>Continue</b> to clear the message and continue printing.</li> <li>• Delete fonts, macros, and other data stored in the storage drive.</li> <li>• Install a storage drive.</li> </ul>
63	Format the disk.	<p>Formatting now wipes all information from the storage drive.</p> <p>To format the disk, do the following:</p> <ol style="list-style-type: none"> <li>1. From the control panel, navigate to <b>Settings &gt; Device &gt; Maintenance &gt; Out of Service Erase</b>.</li> <li>2. Select <b>Sanitize all information on hard disk</b>, and then select <b>ERASE</b>.</li> </ol>
71.01	Fax Station Name not set up. Contact system administrator.	For more information, see <a href="#">Setting up the fax function using analog fax on page 105</a> .

## Troubleshoot a problem

---

Error codes	Error message	Solution
71.02	Fax Station Number not set up. Contact system administrator.	
71.03	No analog phone line connected to modem, fax is disabled.	Check the connection and the line for a signal. For more information, see <a href="#">Setting up the fax function using analog fax on page 105</a> .
71.04	Analog phone line is connected to the wrong port.	Unplug the phone line, and then connect it to the LINE port.
71.06	Unable to connect to HTTPS Fax Server.	Connection to HTTPS Fax Server is disconnected. Check the Internet connection of the printer.
71.07	Printer is not registered to HTTPS Fax Server.	Make sure that the printer is added to the device list in the HTTPS Fax Server portal. Contact the system administrator.
71.11	Fax partition.	The fax partition is not working. Contact the system administrator.
71.12	Memory full, cannot print faxes.	Select <b>Print All</b> to print as many of the faxes as have been saved.
71.13	Memory full. Cannot send faxes.	Try either of the following: <ul style="list-style-type: none"><li>• Continue and try sending the fax again.</li><li>• Scan the original document one page at a time, dial the fax number, and then fax the document.</li></ul>
71.4	Printer's time is incorrect.	Configure the printer time. From the control panel, navigate to <b>Settings &gt; Device &gt; Preferences &gt; Date and Time &gt; Configure</b> .
72.01	Email SMTP server not set up. Contact system administrator.	Try either of the following: <ul style="list-style-type: none"><li>• Set up the email function. For more information, see <a href="#">Configuring the email SMTP settings on page 300</a>.</li><li>• Disable the error message. For more information, see <a href="#">Disabling the "SMTP server not set up" error message on page 594</a>.</li></ul>
72.02	Web Link server not set up. Contact system administrator.	Contact your system administrator.

Error codes	Error message	Solution
72.04	Fax server To Format not set up. Contact system administrator.	<p>Try either of the following:</p> <ul style="list-style-type: none"> <li>• Configure the <b>To Format</b>. From the control panel, navigate to <b>Settings &gt; Fax &gt; Fax Server Setup &gt; General Fax Settings</b>.</li> <li>• Contact your system administrator.</li> </ul>
75.01	Secure Element detected.	<p>Try either of the following:</p> <ul style="list-style-type: none"> <li>• Use the installed Secure Element.</li> </ul> <div style="background-color: #f0f0f0; padding: 10px; margin: 10px 0;"> <p><b>Note:</b> The printer erases all existing certificates and may also erase and reformat the storage drive.</p> </div> <ul style="list-style-type: none"> <li>• Turn off the printer, and then remove the Secure Element.</li> </ul>
75.02	Secure Element not recognized.	
75.03	Error communicating with Secure Element.	<p>Try either of the following:</p> <ul style="list-style-type: none"> <li>• Stop using the Secure Element.</li> </ul> <div style="background-color: #f0f0f0; padding: 10px; margin: 10px 0;"> <p><b>Note:</b> The printer erases all existing certificates and may also erase and reformat the storage drive.</p> </div> <ul style="list-style-type: none"> <li>• Turn off the printer, remove, and then install the Secure Element.</li> </ul>
75.11	Secure Element update failed.	<p>Try either of the following:</p> <ul style="list-style-type: none"> <li>• Try the update again.</li> <li>• Cancel the update.</li> </ul> <div style="background-color: #f0f0f0; padding: 10px; margin: 10px 0;"> <p><b>Note:</b> The printer may erase all existing certificates and storage drive contents.</p> </div>

## Troubleshoot a problem

Error codes	Error message	Solution
75.12	Secure Element update incomplete.	<p>Try either of the following:</p> <ul style="list-style-type: none"> <li>Restart the printer.</li> </ul> <div style="background-color: #f0f0f0; padding: 5px; margin: 10px 0;"> <p><b>Note:</b> Wait for 10 seconds to complete the update.</p> </div> <ul style="list-style-type: none"> <li>Cancel the update.</li> </ul> <div style="background-color: #f0f0f0; padding: 5px; margin: 10px 0;"> <p><b>Note:</b> The printer may erase all existing certificates and storage drive contents.</p> </div>
80.01, 80.09	Maintenance kit nearly low.	Select <b>Continue</b> to clear the message.
80.11, 80.19	Maintenance kit low.	
80.21, 80.29	Maintenance kit very low.	
80.31	Replace maintenance kit to continue printing.	For more information, see <a href="#">Replacing the fuser on page 460</a> .
80.31	Replace maintenance kit, recommended life exceeded.	
81.11	1500-sheet tray roller kit low.	Select <b>Continue</b> to clear the message.
81.31	Replace 1500-sheet tray roller kit, recommended life exceeded.	For more information, contact <a href="#">customer support</a> .
82.00, 82.02, 82.09	Waste toner bottle is nearly full.	For more information, see <a href="#">Replacing the waste toner bottle on page 458</a> .
82.3, 82.32, 82.33, 82.39	Replace the waste toner bottle.	
83.3y	Replace transfer module, recommended life exceeded.	For more information, contact <a href="#">customer support</a> .
83.4y	Replace transfer module.	

## Troubleshoot a problem

Error codes	Error message	Solution
83.20	Staple cartridge low.	Select <b>Continue</b> to clear the message.
83.20	Staple S2 inner low.	
83.20	Staple S2 outer low.	
83.30	Staple cartridge empty or missing.	<p>Try either of the following:</p> <ul style="list-style-type: none"> <li>Remove, and then insert the staple cartridge.</li> <li>Replace the staple cartridge. For more information, see <a href="#">Replacing the staple cartridge in the staple, hole punch finisher on page 478</a> or <a href="#">Replacing the staple cartridge in the staple finisher on page 476</a>.</li> </ul>
83.30	Staple cartridge S1 empty or missing.	<p>Try either of the following:</p> <ul style="list-style-type: none"> <li>Remove, and then insert the staple cartridge.</li> <li>Replace the staple cartridge. For more information, see <a href="#">Replacing the staple cartridge in the booklet finisher on page 480</a>.</li> </ul>
83.30	Inner staple cartridge S2 empty or missing.	<p>Try either of the following:</p> <ul style="list-style-type: none"> <li>Remove, and then insert the staple cartridge.</li> <li>Replace the staple cartridge. For more information, see <a href="#">Replacing the staple cartridge holders in the booklet finisher on page 483</a>.</li> </ul>
83.30	Outer staple cartridge S2 empty or missing.	
84.01K, 84.03K, 84.09K	Imaging unit nearly low.	Select <b>Continue</b> to clear the message.
84.11K, 84.13K, 84.19K	Imaging unit low.	
84.21K, 84.23K, 84.29K	Imaging unit very low.	
84.31, 84.33	Replace imaging unit, recommended life exceeded.	For more information, see <a href="#">Replacing the imaging unit on page 451</a> .
84.41, 84.43, 84.48	Replace imaging unit to continue printing.	For more information, see <a href="#">Replacing the imaging unit on page 451</a> .

## Troubleshoot a problem

---

Error codes	Error message	Solution
86.23	Scanner maintenance required soon.	Select <b>Continue</b> to clear the message.
86.33	Replace ADF kit, recommended life exceeded.	For more information, contact <a href="#">customer support</a> .
88.00k, 88.07k, 88.08k, 88.09k	Cartridge is nearly low.	Select <b>Continue</b> to clear the message.
88.10k, 88.17k, 88.18k, 88.19k	Cartridge is low.	
88.20k, 88.27k, 88.28k, 88.29k	Cartridge is very low.	
88.30k, 88.37k, 88.38k	Replace cartridge, <NUM/> estimated pages remaining.	
88.30k, 88.37k, 88.38k	Replace cartridge.	For more information, see <a href="#">Replacing a toner cartridge on page 449</a> .
88.40k, 88.47k, 88.48k	Replace cartridge, 0 pages remain.	
88.40k, 88.47k, 88.48k	Replace cartridge.	

## Troubleshoot a problem

Error codes	Error message	Solution
200.03, 200.05, 200.12, 200.13, 200.14, 200.15, 200.22, 200.23, 200.24, 200.25, 200.26, 200.32, 200.33, 200.34, 200.35, 200.36, 200.42, 200.43, 200.44, 200.45, 200.46, 200.52, 200.53, 200.54, 200.55, 200.56, 200.91, 201.91, 202.02, 202.03, 202.04, 202.05, 202.12, 202.13, 202.14, 202.15, 202.22, 202.23, 202.24, 202.25, 202.32, 202.33, 202.34, 202.35, 202.42, 202.43, 202.44, 202.45, 202.52, 202.53, 202.54, 202.55, 202.91, 202.93, 202.95, 231.03, 231.05, 231.13, 231.15, 231.23, 231.25, 231.33, 231.35, 231.43, 231.45, 231.53, 231.55, 231.91, 232.03, 232.05, 232.13, 232.15, 232.23, 232.25, 232.33, 232.35, 232.43, 232.45, 232.53, 232.55, 232.93, 232.94, 232.95, 240.05, 240.25, 240.35, 240.45, 240.55, 240.91, 240.95, 241.12, 241.14, 241.15, 241.91	Paper jam in <LOCATION/>.	For more information, see <a href="#">Paper jam in door B on page 550</a> .
240.06	Paper jam in <LOCATION/>.	For more information, see <a href="#">Paper jam in the multipurpose feeder on page 546</a> .
241.16, 241.82, 241.83, 241.84, 661.13, 661.84	Paper loading error in <LOCATION/>.	<ol style="list-style-type: none"> <li>1. Open tray 1.</li> <li>2. Remove, and then readjust the paper stack.</li> <li>3. If necessary, adjust the paper guides.</li> <li>4. Reload tray 1.</li> <li>5. Close tray 1.</li> </ol>

## Troubleshoot a problem

Error codes	Error message	Solution
242.23, 242.25, 242.35, 242.45, 242.55, 242.91	Paper jam in <LOCATION/>.	For more information, see <a href="#">Paper jam in the optional 550-sheet tray on page 542</a> .
242.33, 242.43, 243.33, 243.35, 243.36, 243.43, 243.35, 243.45, 243.45, 243.55, 243.91, 244.43, 244.45, 244.91	Paper jam in <LOCATION/>.	For more information, see either of the following: <ul style="list-style-type: none"> <li>• <a href="#">Paper jam in the 2 x 550-sheet tray on page 546</a></li> <li>• <a href="#">Paper jam in the 2000-sheet tandem tray on page 548</a></li> </ul>
243.43, 243.53, 244.43, 244.45, 244.46, 244.91, 245.53, 245.56, 245.55, 245.91, 602.59, 664.43, 665.53	Paper jam in <LOCATION/>.	For more information, see <a href="#">Paper jam in the 1500-sheet tray on page 549</a> .
28X.13K, 28X.93K, 28X.15K, 28X.95K, 281.16K, 281.96K, 680.20K, 680.40K	Replace all originals if restarting job.	Try either of the following: <ul style="list-style-type: none"> <li>• Restart the job.</li> <li>• Cancel the job.</li> </ul>
28X.13Q, 28X.93Q, 28X.15Q, 28X.95Q, 281.16Q, 281.96Q, 680.20Q	Replace jammed originals if continuing job.	Try one or more of the following: <ul style="list-style-type: none"> <li>• Scan from the scanner glass.</li> <li>• Scan from the automatic document feeder.</li> <li>• Finish the job without further scanning.</li> <li>• Cancel the job.</li> </ul>
280.06	Reload originals in ADF and restart job.	
280.11/280.91, 280.13/280.93, 280.15/280.95, 281.11/281.91, 281.15/281.95, 281.16/281.96, 284.11/284.91, 284.13/284.93, 284.15/284.95, 288.10/288.90, 295.01, 680.1, 680.2	Scanner jam.	For more information, see <a href="#">Paper jam in the automatic document feeder on page 543</a> .
289.01	Cannot communicate with the scanner card.	Select <b>Continue</b> to clear the message.

## Troubleshoot a problem

---

Error codes	Error message	Solution
291.06	Close flatbed cover and load originals if restarting job.	Try one or more of the following: <ul style="list-style-type: none"><li>• Scan from the scanner glass.</li><li>• Scan from the automatic document feeder.</li><li>• Finish the job without further scanning.</li><li>• Cancel the job.</li></ul>
400.11, 400.13, 400.15, 401.11, 401.13, 401.15, 404.19, 438.11, 438.21, 444.66, 450.21, 450.23, 450.25, 450.98, 450.99, 451.21, 451.23, 451.25, 452.66, 453.21, 453.23, 454.21, 454.23, 454.25, 457.21, 457.23, 457.25, 460.66, 461.66, 464.66, 465.66, 466.66, 467.66, 468.66, 469.66, 472.66, 477.66, 480.66, 483.66, 486.29, 504.11, 504.15, 505.11, 505.15, 514.19, 698.29	Paper jam in <LOCATION/>.	For more information, see <a href="#">Paper jam in the staple, hole punch finisher on page 559</a> .

## Troubleshoot a problem

Error codes	Error message	Solution
400.11, 400.13, 400.15, 401.11, 401.13, 401.15, 404.19, 438.11, 438.21, 442.66, 444.66, 445.66, 450.21, 450.23, 450.25, 451.21, 451.23, 451.25, 451.98, 451.99, 452.66, 453.21, 453.23, 453.25, 454.21, 454.23, 454.25, 457.21, 457.23, 457.25, 459.66, 460.66, 461.66, 462.66, 463.66, 464.66, 465.66, 466.66, 467.66, 468.66, 469.66, 470.66, 472.66, 473.66, 476.66, 477.66, 480.66, 483.66, 486.29, 490.66, 491.21, 491.25, 491.66, 493.21, 494.21, 492.66, 494.66, 495.66, 496.66, 497.66, 504.11, 504.15, 505.11, 505.15, 514.19, 698.29	Paper jam in <LOCATION/>.	For more information, see <a href="#">Paper jam in the booklet finisher on page 570</a> .
420.11, 420.13, 420.15, 420.99, 421.56, 422.56, 423.56, 424.56, 425.13, 425.15, 425.11, 426.11, 426.15, 428.56A, 428.56B, 431.56, 435.56, 438.11, 439.19, 461.56, 698.19	Paper jam in <LOCATION/>.	For more information, see <a href="#">Paper jam in the staple finisher on page 554</a> .
438.11, 500.11, 500.13, 500.15, 500.99, 502.11, 502.13, 502.15, 504.11, 504.13, 504.15, 505.13, 506.11, 506.13, 506.15, 507.11, 507.13, 507.15, 508.56, 509.56, 510.56, 511.56, 512.56, 513.56, 514.19, 698.19, 698.29	Paper jam in <LOCATION/>.	For more information, see <a href="#">Paper jam in the folding paper transport on page 556</a> .

## Troubleshoot a problem

---

Error codes	Error message	Solution
602.29, 662.23	Paper loading error in tray 2.	For more information, see <a href="#">Loading the 550-sheet tray on page 113</a> .
602.39, 663.33	Paper loading error in tray 3.	For more information, see either of the following: <ul style="list-style-type: none"><li>• <a href="#">Loading the 550-sheet tray on page 113</a></li><li>• <a href="#">Loading the 2000-sheet tandem tray on page 117</a></li></ul>
602.49, 664.43	Paper loading error in tray 4.	For more information, see <a href="#">Loading the 550-sheet tray on page 113</a> .
680.1, 680.2	Scanner jam.	For more information, see <a href="#">Paper jam in the automatic document feeder</a> .
680.20K	Replace all originals if restarting job.	Try one or more of the following: <ul style="list-style-type: none"><li>• Select <b>Cancel job</b> to clear the message and cancel the scan job.</li><li>• Select <b>Scan from automatic feeder</b> to continue scanning from the ADF immediately after the last successful scan job.</li><li>• Select <b>Scan from flatbed</b> to continue scanning from the scanner immediately after the last successful scan job.</li><li>• Select <b>Finish job without further scanning</b> to end the last successful scan job.</li><li>• Select <b>Restart job</b> to restart the scan job with the same settings from the previous scan job.</li></ul>

## Troubleshoot a problem

---

Error codes	Error message	Solution
680.20Q	Replace jammed originals if continuing job.	Try one or more of the following: <ul style="list-style-type: none"><li>• Select <b>Cancel job</b> to clear the message and cancel the scan job.</li><li>• Select <b>Scan from automatic feeder</b> to continue scanning from the ADF immediately after the last successful scan job.</li><li>• Select <b>Scan from flatbed</b> to continue scanning from the scanner immediately after the last successful scan job.</li><li>• Select <b>Finish job without further scanning</b> to end the last successful scan job.</li><li>• Select <b>Restart job</b> to restart the scan job with the same settings from the previous scan job.</li></ul>
680.50	Scan failed.	Unable to scan this original. For more information, see <a href="https://rulesforuse.org/">https://rulesforuse.org/</a> . Select <b>Continue</b> to clear the message.
843.00	The flatbed scanner carriage failed to reach home position.	Remove the shipping screw.

## Printing problems

### Print quality is poor

#### Blank or white pages

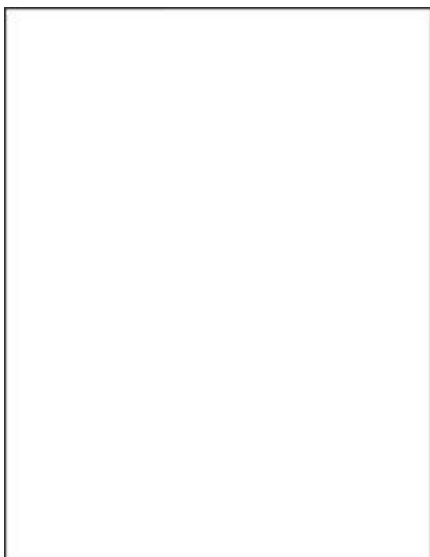

Before solving the problem, print the Print Quality Test Pages. From the control panel, navigate to **Settings** › **Troubleshooting** › **Print Quality Test Pages**.

**Note:** Use tray 1 to print the sample pages and make sure that the paper is loaded in the portrait orientation.

#### Try one or more of the following:

- Make sure that all packing material is removed from the imaging unit and toner cartridge.
- Check if the printer is using a genuine and supported Lexmark toner cartridge.

**Note:** If the cartridge is not supported, then install a supported one.

- Make sure that the imaging unit is properly installed.
  1. Pull out the imaging support basket, and then remove the imaging unit.

#### **Warning—Potential Damage**

Do not expose the imaging unit to direct light for more than 10 minutes. Extended exposure to light may cause print quality problems.

#### **Warning—Potential Damage**

Do not touch the photoconductor drum under the imaging unit. Doing so may affect the quality of future print jobs.

2. Insert the imaging unit, and then insert the imaging support basket.

If the problem persists, then contact [customer support](#).

### Dark print



Before solving the problem, print the Print Quality Test Pages. From the control panel, navigate to **Settings > Troubleshooting > Print Quality Test Pages**.

**Note:** Use tray 1 to print the sample pages and make sure that the paper is loaded in the portrait orientation.

### Try one or more of the following:

- Depending on your operating system, reduce the toner darkness from the Printing Preferences or Print dialog.

**Note:** You can also change the setting on the printer control panel. Navigate to **Settings > Print > Quality > Toner Darkness**.

- Depending on your operating system, specify the paper type from the Printing Preferences or Print dialog. Make sure that the setting matches the paper loaded in the tray.

**Note:** You can also change the setting on the printer control panel. Navigate to **Settings > Paper > Tray Configuration > Paper Size/Type**.

- Make sure that the paper does not have a texture or rough finish.
- Load paper from a fresh package.

**Note:** Paper absorbs moisture due to high humidity. Store the paper in its original wrapper until you are ready to use it.

## Troubleshoot a problem

---

If the problem persists, then contact [customer support](#).

### Fine lines are not printed correctly



Before solving the problem, print the Print Quality Test Pages. From the control panel, navigate to **Settings** › **Troubleshooting** › **Print Quality Test Pages**.

**Note:** Use tray 1 to print the sample pages and make sure that the paper is loaded in the portrait orientation.

#### Try one or more of the following:

- Check if the printer is using a genuine and supported Lexmark toner cartridge.

**Note:** If the cartridge is not supported, then install a supported one.

- Adjust Toner Darkness to 7. From the control panel, navigate to **Settings** › **Print** › **Quality** › **Toner Darkness**

If the problem persists, then contact [customer support](#).

## Folded or wrinkled paper



Before solving the problem, print the Print Quality Test Pages. From the control panel, navigate to **Settings > Troubleshooting > Print Quality Test Pages**.

**Note:** Use tray 1 to print the sample pages and make sure that the paper is loaded in the portrait orientation.

### Try one or more of the following:

- Check if the printer is using a genuine and supported Lexmark toner cartridge.

**Note:** If the cartridge is not supported, then install a supported one.

- Load paper from a fresh package.

**Note:** Paper absorbs moisture due to high humidity. Store the paper in its original wrapper until you are ready to use it.

- Depending on your operating system, specify the paper type from the Printing Preferences or Print dialog. Make sure that the setting matches the paper loaded in the tray.

**Note:** You can also change the setting on the printer control panel. Navigate to **Settings > Paper > Tray Configuration > Paper Size/Type**.

If the problem persists, then contact [customer support](#).

## Gray background



Before solving the problem, print the Print Quality Test Pages. From the control panel, navigate to **Settings > Troubleshooting > Print Quality Test Pages**.

**Note:** Use tray 1 to print the sample pages and make sure that the paper is loaded in the portrait orientation.

### Try one or more of the following:

- Depending on your operating system, increase the toner darkness from the Printing Preferences or Print dialog.

**Note:** You can also change the setting on the printer control panel. Navigate to **Settings > Print > Quality > Toner Darkness**.

- Check if the printer is using a genuine and supported Lexmark toner cartridge.

**Note:** If the cartridge is not supported, then install a supported one.

- Depending on your operating system, specify the paper type from the Printing Preferences or Print dialog. Make sure that the setting matches the paper loaded in the tray.

**Note:** You can also change the setting on the printer control panel. Navigate to **Settings > Paper > Tray Configuration > Paper Size/Type**.

- Make sure that the imaging unit is properly installed.
  1. Pull out the imaging support basket, and then remove the imaging unit.

### Warning—Potential Damage

Do not expose the imaging unit to direct light for more than 10 minutes. Extended exposure to light may cause print quality problems.

### Warning—Potential Damage

Do not touch the photoconductor drum under the imaging unit. Doing so may affect the quality of future print jobs.

2. Insert the imaging unit, and then insert the imaging support basket.
  - Update the printer firmware. For more information, see the “Printer firmware instructions” section.
  - Replace the imaging unit.

If the problem persists, then contact [customer support](#).

## Incorrect margins



Before solving the problem, print the Print Quality Test Pages. From the control panel, navigate to **Settings > Troubleshooting > Print Quality Test Pages**.

**Note:** Use tray 1 to print the sample pages and make sure that the paper is loaded in the portrait orientation.

### Try one or more of the following:

- Adjust the paper guides in the tray to the correct position for the paper loaded.
- Depending on your operating system, specify the paper size from the Printing Preferences or Print dialog. Make sure that the setting matches the paper loaded.

**Note:** You can also change the setting on the printer control panel. Navigate to **Settings > Paper > Tray Configuration > Paper Size/Type**.

If the problem persists, then contact [customer support](#).

### Light print



Before solving the problem, print the Print Quality Test Pages. From the control panel, navigate to **Settings > Troubleshooting > Print Quality Test Pages**.

**Note:** Use tray 1 to print the sample pages and make sure that the paper is loaded in the portrait orientation.

#### Try one or more of the following:

- Make sure that all packing material is removed from the imaging unit and toner cartridge.
- Depending on your operating system, increase the toner darkness from the Printing Preferences or Print dialog.

**Note:** You can also change the setting on the printer control panel. Navigate to **Settings > Print > Quality > Toner Darkness**.

- Depending on your operating system, specify the paper type from the Printing Preferences or Print dialog. Make sure that the setting matches the paper loaded.

**Note:** You can also change the setting on the printer control panel. Navigate to **Settings > Paper > Tray Configuration > Paper Size/Type**.

- Make sure that the paper does not have a texture or rough finish.
- Load paper from a fresh package.

**Note:** Paper absorbs moisture due to high humidity. Store the paper in its original wrapper until you are ready to use it.

## Troubleshoot a problem

---

- Make sure that the imaging unit is properly installed.
  1. Pull out the imaging support basket, and then remove the imaging unit.

### **Warning—Potential Damage**

Do not expose the imaging unit to direct light for more than 10 minutes. Extended exposure to light may cause print quality problems.

### **Warning—Potential Damage**

Do not touch the photoconductor drum under the imaging unit. Doing so may affect the quality of future print jobs.

2. Insert the imaging unit, and then insert the imaging support basket.

If the problem persists, then contact [customer support](#).

## Mottled print and dots



Before solving the problem, print the Print Quality Test Pages. From the control panel, navigate to **Settings > Troubleshooting > Print Quality Test Pages**.

**Note:** Use tray 1 to print the sample pages and make sure that the paper is loaded in the portrait orientation.

### Try one or more of the following:

- Check the printer for leaked toner contamination.
- Make sure that the paper size and paper type settings match the paper loaded. From the control panel, navigate to **Settings > Paper > Tray Configuration > Paper Size/Type**.

**Note:** Make sure that the paper does not have a texture or rough finish.

## Troubleshoot a problem

---

- Depending on your operating system, specify the paper size and paper type from the Printing Preferences or Print dialog. Make sure that the settings match the paper loaded in the tray.
- Load paper from a fresh package.

**Note:** Paper absorbs moisture due to high humidity. Store the paper in its original wrapper until you are ready to use it.

- Make sure that the imaging unit is properly installed.
  1. Pull out the imaging support basket, and then remove the imaging unit.

### **Warning—Potential Damage**

Do not expose the imaging unit to direct light for more than 10 minutes. Extended exposure to light may cause print quality problems.

### **Warning—Potential Damage**

Do not touch the photoconductor drum under the imaging unit. Doing so may affect the quality of future print jobs.

2. Insert the imaging unit, and then insert the imaging support basket.

If the problem persists, then contact [customer support](#).

## Print crooked or skewed



Before solving the problem, print the Print Quality Test Pages. From the control panel, navigate to **Settings** > **Troubleshooting** > **Print Quality Test Pages**.

**Note:** Use tray 1 to print the sample pages and make sure that the paper is loaded in the portrait orientation.

### Try one or more of the following:

- Load paper from a fresh package.
  1. Open the tray, and then remove the paper.
  2. Load paper from a fresh package.

**Note:** Paper absorbs moisture due to high humidity. Store the paper in its original wrapper until you are ready to use it.

3. Adjust the paper guides in the tray to the correct position for the paper loaded.
- Make sure that you are printing on a supported paper.

If the problem persists, then contact [customer support](#).

## Solid black pages



Before solving the problem, print the Print Quality Test Pages. From the control panel, navigate to **Settings** › **Troubleshooting** › **Print Quality Test Pages**.

**Note:** Use tray 1 to print the sample pages and make sure that the paper is loaded in the portrait orientation.

### Try one or more of the following:

- Check if the printer is using a genuine and supported Lexmark toner cartridge.

**Note:** If the cartridge is not supported, then install a supported one.

- Make sure that the imaging unit is properly installed.
  1. Pull out the imaging support basket, and then remove the imaging unit.

### **Warning—Potential Damage**

Do not expose the imaging unit to direct light for more than 10 minutes. Extended exposure to light may cause print quality problems.

### **Warning—Potential Damage**

Do not touch the photoconductor drum under the imaging unit. Doing so may affect the quality of future print jobs.

2. Insert the imaging unit, and then insert the imaging support basket.
  - Check the imaging unit for signs of damage.
  - Replace the imaging unit.

If the problem persists, then contact [customer support](#).

## Text or images cut off



Before solving the problem, print the Print Quality Test Pages. From the control panel, navigate to **Settings > Troubleshooting > Print Quality Test Pages**.

**Note:** Use tray 1 to print the sample pages and make sure that the paper is loaded in the portrait orientation.

### **Try one or more of the following:**

- Make sure that all packing material is removed from the imaging unit and toner cartridge.
- Adjust the paper guides in the tray to the correct position for the paper loaded.
- Depending on your operating system, specify the paper size from the Printing Preferences or Print dialog. Make sure that the setting matches the paper loaded in the tray.

**Note:** You can also change the setting on the printer control panel. Navigate to **Settings > Paper > Tray Configuration > Paper Size/Type**.

## Troubleshoot a problem

---

- Make sure that the imaging unit is properly installed.
  1. Pull out the imaging support basket, and then remove the imaging unit.

### **Warning—Potential Damage**

Do not expose the imaging unit to direct light for more than 10 minutes. Extended exposure to light may cause print quality problems.

### **Warning—Potential Damage**

Do not touch the photoconductor drum under the imaging unit. Doing so may affect the quality of future print jobs.

2. Insert the imaging unit, and then insert the imaging support basket.

If the problem persists, then contact [customer support](#).

## Toner easily rubs off



Before solving the problem, print the Print Quality Test Pages. From the control panel, navigate to **Settings** > **Troubleshooting** > **Print Quality Test Pages**.

**Note:** Use tray 1 to print the sample pages and make sure that the paper is loaded in the portrait orientation.

### Try any of the following:

- Make sure that the printer power cord is plugged into an appropriately rated and properly grounded electrical outlet.
- Depending on your operating system, specify the paper type from the Printing Preferences or Print dialog. Make sure that the setting matches the paper loaded.
- Configure the paper type from the control panel. Navigate to **Settings** > **Paper** > **Tray Configuration** > **Paper Size/Type**.

If the problem persists, then contact [customer support](#).

### Horizontal light bands



Before solving the problem, print the Print Quality Test Pages. From the control panel, navigate to **Settings** > **Troubleshooting** > **Print Quality Test Pages**.

**Note:** Use tray 1 to print the sample pages and make sure that the paper is loaded in the portrait orientation.

#### Try one or more of the following:

- Check if the printer is using a genuine and supported Lexmark toner cartridge.

**Note:** If the cartridge is not supported, then install a supported one.

- Make sure that the imaging unit is properly installed.

1. Pull out the imaging support basket, and then remove the imaging unit.

#### **Warning—Potential Damage**

Do not expose the imaging unit to direct light for more than 10 minutes. Extended exposure to light may cause print quality problems.

#### **Warning—Potential Damage**

Do not touch the photoconductor drum under the imaging unit. Doing so may affect the quality of future print jobs.

2. Insert the imaging unit, and then insert the imaging support basket.
- Replace the imaging unit.

## Troubleshoot a problem

---

- Clean the printhead lens. For more information, see [Cleaning the printhead lens on page 490](#).
- Turn off the printer, wait for 10 seconds, and then turn on the printer.

If the problem persists, then contact [customer support](#).

## Vertical light bands



Before solving the problem, print the Print Quality Test Pages. From the control panel, navigate to **Settings** > **Troubleshooting** > **Print Quality Test Pages**.

**Note:** Use tray 1 to print the sample pages and make sure that the paper is loaded in the portrait orientation.

Check if the printer is using a genuine and supported Lexmark toner cartridge.

**Note:** If the cartridge is not supported, then install a supported one.

If the problem persists, then contact [customer support](#).

### Horizontal dark lines



#### Notes

Before solving the problem, do the following:

1. Perform Color Adjust. From the control panel, navigate to **Settings > Print > Quality > Advanced Imaging > Color Adjust**.
2. Print the Print Quality Test Pages. From the control panel, navigate to **Settings > Troubleshooting > Print Quality Test Pages**.

**Note:** Use tray 1 to print the sample pages and make sure that the paper is loaded in the portrait orientation.

#### Try one or more of the following:

- If the issue is seen on a copied document, then clean the scanner.
  1. From the home screen, touch **Settings > Troubleshooting > Cleaning the Scanner**.
  2. Using a damp, soft, lint-free cloth, clean the scanner. For more information, see [Cleaning the scanner on page 486](#).
- Depending on your operating system, specify the paper type from the Printing Preferences or Print dialog. Make sure that the setting matches the paper loaded.

**Note:** You can also change the setting on the printer control panel. Navigate to **Settings > Paper > Tray Configuration > Paper Size/Type**.

- Make sure that the paper does not have a texture or rough finish.
- Load paper from a fresh package.

**Note:** Paper absorbs moisture due to high humidity. Store the paper in its original wrapper until you are ready to use it.

- Make sure that the imaging support basket and imaging unit are properly installed.
  1. Remove the imaging support basket, and then remove the imaging unit.

**Warning—Potential Damage**

Do not touch the photoconductor drum under the imaging support basket and imaging unit. Doing so may affect the quality of future print jobs.

2. Insert the imaging unit, and then insert the imaging support basket.

If the problem persists, then contact [customer support](#).

## Vertical white lines



Before solving the problem, print the Print Quality Test Pages. From the control panel, navigate to **Settings > Troubleshooting > Print Quality Test Pages**.

**Note:** Use tray 1 to print the sample pages and make sure that the paper is loaded in the portrait orientation.

### Try one or more of the following:

- Check if the printer is using a genuine and supported Lexmark toner cartridge.

**Note:** If the cartridge is not supported, then install a supported one.

- Depending on your operating system, specify the paper type from the Printing Preferences or Print dialog. Make sure that the setting matches the paper loaded.

**Note:** You can also change the setting on the printer control panel. Navigate to **Settings > Paper > Tray Configuration > Paper Size/Type**.

- Clean the printhead lens. For more information, see [Cleaning the printhead lens on page 490](#).

If the problem persists, then contact [customer support](#).

### Vertical dark bands



Before solving the problem, print the Print Quality Test Pages. From the control panel, navigate to **Settings > Troubleshooting > Print Quality Test Pages**.

**Note:** Use tray 1 to print the sample pages and make sure that the paper is loaded in the portrait orientation.

#### Try one or more of the following:

- Make sure that all packing material is removed from the imaging unit and toner cartridge.
- Check if the printer is using a genuine and supported Lexmark toner cartridge.

**Note:** If the cartridge is not supported, then install a supported one.

- Make sure that the imaging unit is properly installed.
  1. Pull out the imaging support basket, and then remove the imaging unit.

#### **Warning—Potential Damage**

Do not expose the imaging unit to direct light for more than 10 minutes. Extended exposure to light may cause print quality problems.

### **Warning—Potential Damage**

Do not touch the photoconductor drum under the imaging unit. Doing so may affect the quality of future print jobs.

2. Insert the imaging unit, and then insert the imaging support basket.
- Check if a bright light enters the right side of the printer, and then move the printer if necessary.

If the problem persists, then contact [customer support](#).

## Vertical dark lines or streaks



Before solving the problem, print the Print Quality Test Pages. From the control panel, navigate to **Settings** › **Troubleshooting** › **Print Quality Test Pages**.

**Note:** Use tray 1 to print the sample pages and make sure that the paper is loaded in the portrait orientation.

### Try one or more of the following:

- If the issue is seen on a copied document, then clean the scanner.
  1. From the home screen, touch **Settings** › **Troubleshooting** › **Cleaning the Scanner**.
  2. Using a damp, soft, lint-free cloth, clean the scanner. For more information, see [Cleaning the scanner on page 486](#).
- Check if the printer is using a genuine and supported Lexmark toner cartridge.

**Note:** If the cartridge is not supported, then install a supported one.

- Make sure that the imaging unit is properly installed.
  1. Pull out the imaging support basket, and then remove the imaging unit.

### Warning—Potential Damage

Do not expose the imaging unit to direct light for more than 10 minutes. Extended exposure to light may cause print quality problems.

### Warning—Potential Damage

Do not touch the photoconductor drum under the imaging unit. Doing so may affect the quality of future print jobs.

2. Insert the imaging unit, and then insert the imaging support basket.
  - Replace the imaging unit.

If the problem persists, then contact [customer support](#).

## Repeating defects



### Notes

- Before solving the problem, print the Print Quality Test Pages. From the control panel, navigate to **Settings > Troubleshooting > Print Quality Test Pages**.
- Use tray 1 to print the sample pages and make sure that the paper is loaded in the portrait orientation.

1. Measure the distance between the repeating defects on the affected color page. Using the Maintenance Defect Ruler, measure the distance between the repeating defects on the affected color page.
2. Replace the supply item or part that matches the measurement on the affected color page.

### Imaging unit

- 94.5 mm (3.72 in.)

## Troubleshoot a problem

---

- 19.9 mm (1.18 in.)
- 23.2 mm (0.19 in.)

### Developer unit

- 43.6 mm (1.72 in.)
- 45.0 mm (1.77 in.)

### Fuser

- 95 mm (3.74 in.)
- 110 mm (4.33 in.)

If the problem persists, then contact [customer support](#).

## Print jobs do not print

### Try one or more of the following:

- From the document that you are trying to print, open the Printing Preferences or Print dialog, and then check if the correct printer is selected.
- Check if the printer is on, and then resolve any error messages that appear on the display.
- Check if the ports are working and if the cables are securely connected to the computer and the printer. For more information, see the setup documentation that came with the printer.
- Turn off the printer, wait for about 10 seconds, and then turn on the printer.
- Remove, and then reinstall the print driver.

If the problem persists, then contact [customer support](#).

## Confidential and other held documents do not print

### Try one or more of the following:

- From the control panel, check if the documents appear in the **Held Jobs** list.

**Note:** If the documents are not listed, then print the documents using the Print and Hold options.

- Resolve possible formatting errors or invalid data in the print job.
  - Delete the print job, and then send it again.
  - For PDF files, generate a new file, and then print the document.
- If you are printing from the Internet, then the printer may be reading the multiple job titles as duplicates.
  - For Windows users, make sure to select **Keep duplicate documents** in the Printing Preferences or Print dialog.
  - For Macintosh users, name each job differently.
- Delete some held jobs to free up printer memory.
- Install more printer memory.

If the problem persists, then contact [customer support](#).

## Job prints from the wrong tray or on the wrong paper

Try one or more of the following:

- Make sure that you are printing on the correct paper.
- Depending on your operating system, specify the paper size and paper type from the Printing Preferences or Print dialog. Make sure that the settings match the paper loaded.

**Note:** You can also change the settings on the printer control panel. Navigate to **Settings > Paper > Tray Configuration > Paper Size/Type**.

- Check if the trays are linked. For more information, see [Linking trays on page 126](#).

If the problem persists, then contact [customer support](#).

## Slow printing

Try one or more of the following:

- Make sure that the printer cable is securely connected to the printer, computer, print server, option, and other network device.
- Make sure that the printer is not in **Quiet Mode**.

From the control panel, navigate to **Settings > Device > Maintenance > Config Menu > Device Operations > Quiet Mode**.

- Specify the resolution of the document that you want to print.
  1. Depending on your operating system, access the Printing Preferences or Print dialog.
  2. Set the resolution to **2400 IQ**.

**Note:** You can also change the setting on the control panel. Navigate to **Settings > Print > Quality > Print Resolution**.

- Depending on your operating system, specify the paper type from the Printing Preferences or Print dialog.

### Notes

- You can also change the setting on the control panel. Navigate to **Settings > Paper > Tray Configuration > Paper Size/Type**.
- Heavier paper print more slowly.
- Paper that is narrower than letter, A4, and legal may print more slowly.

- Make sure that the printer settings for texture and weight match the paper being loaded.

From the control panel, navigate to **Settings > Paper > Media Configuration > Media Types**.

**Note:** Rough paper texture and heavy paper weight may print more slowly.

- Remove held jobs.
- Make sure that the printer is not overheating.

### Notes

- Allow the printer to cool down after a long print job.
- Observe the recommended ambient temperature for the printer. For more information, see [Selecting a location for the printer on page 91](#).

If the problem persists, then contact [customer support](#).

## The printer is not responding

Try one or more of the following:

- Check if the power cord is connected to the electrical outlet.



### CAUTION—POTENTIAL INJURY

To avoid the risk of fire or electrical shock, connect the power cord to an appropriately rated and properly grounded electrical outlet that is near the product and easily accessible.

- Make sure that the electrical outlet is not turned off by a switch or breaker.
- Check if the printer is on.
- Make sure that the printer is not in Sleep or Hibernate Mode.
- Make sure that the cables connecting the printer and computer are connected to the correct ports.
- Turn off the printer, install the hardware options, and then turn on the printer. For more information, see the documentation that came with the option.
- Install the correct print driver.
- Turn off the printer, wait for about 10 seconds, and then turn on the printer.

If the problem persists, then contact [customer support](#).

## Unable to read flash drive

Try one or more of the following:

- Make sure that the printer is not busy processing multiple jobs.
- Make sure that the flash drive is inserted into the front USB port.

**Note:** The flash drive does not work when it is inserted into the rear USB port.

## Troubleshoot a problem

---

- Make sure that the flash drive is supported. For more information, see [Supported flash drives and file types on page 90](#).
- Remove, and then insert the flash drive.

If the problem persists, then contact [customer support](#).

## Enabling the USB port

1. From the control panel, navigate to **Settings > Network/Ports > USB**.
2. Select **Enable USB Port**.

## Clearing jams

### Avoiding jams

#### Load paper properly

- Make sure that the paper lies flat in the tray.

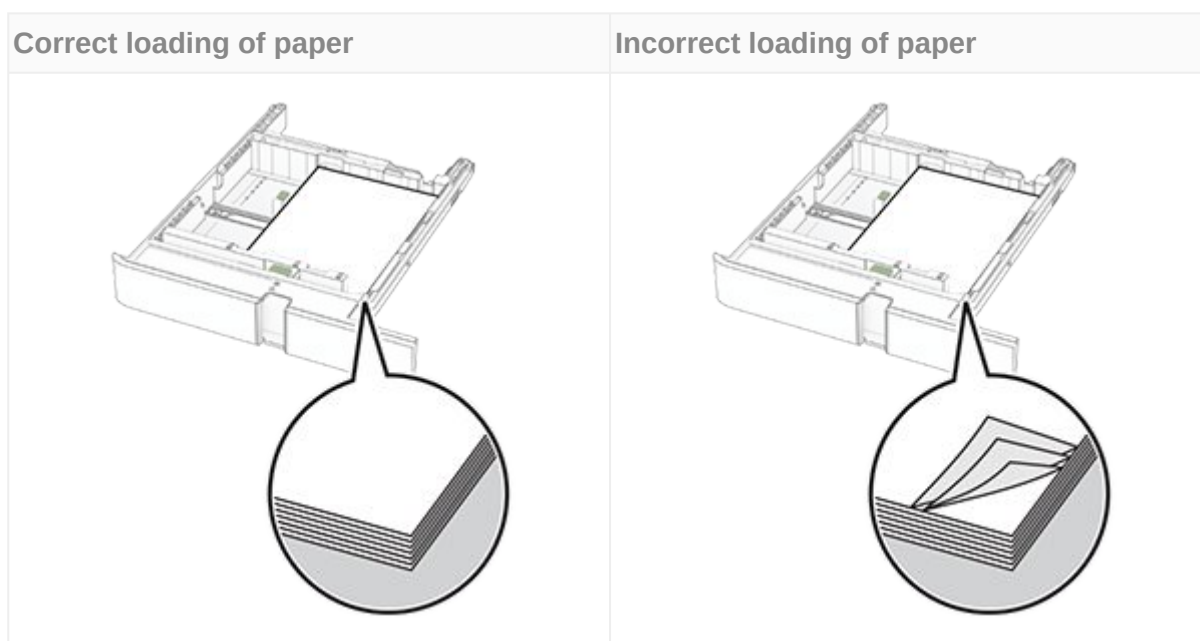

- Do not load or remove a tray while the printer is printing.
- Do not load too much paper. Make sure that the stack height is below the maximum paper fill indicator.
- Do not slide paper into the tray. Load paper as shown in the illustration.

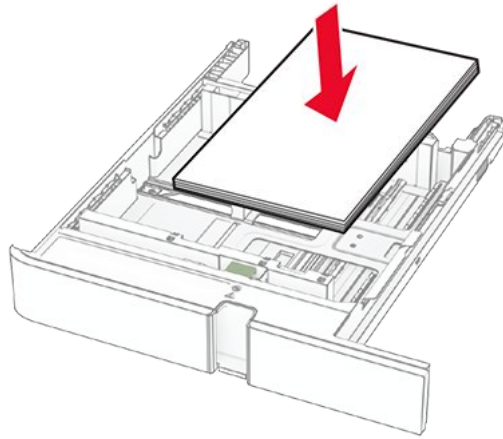

- Make sure that the paper guides are positioned correctly and are not pressing tightly against the paper or envelopes.
- Push the tray firmly into the printer after loading paper.

### Use recommended paper

- Use only recommended paper or specialty paper.
- Do not load paper that is wrinkled, creased, damp, bent, or curled.
- Flex, fan, and align the paper edges before loading.

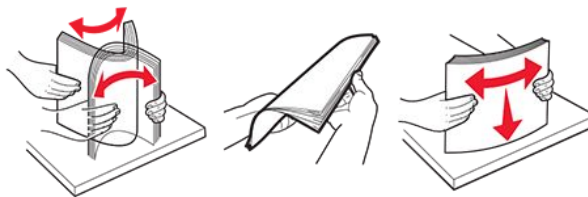

- Do not use paper that has been cut or trimmed by hand.
- Do not mix paper sizes, weights, or types in the same tray.
- Make sure that the paper size and type are set correctly on the computer or printer control panel.
- Store paper according to manufacturer recommendations.

## Identifying jam locations

### Notes

- When **Jam Assist** is set to **On**, the printer flushes blank pages or pages with partial prints after a jammed page has been cleared. Check your printed output for blank pages.
- When **Jam Recovery** is set to **On** or **Auto**, the printer reprints jammed pages.

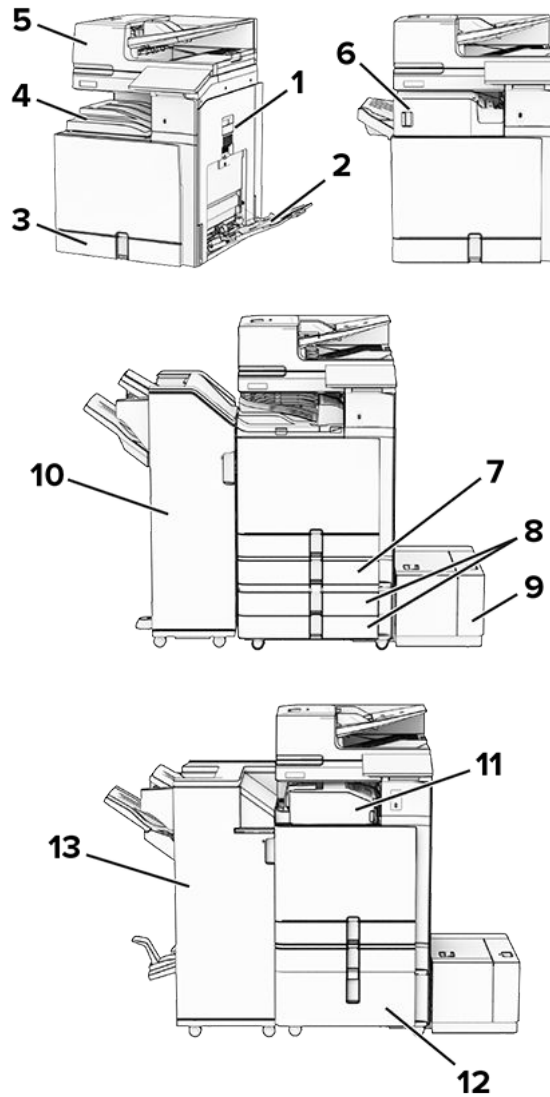

	Jam locations
<b>1</b>	Door B
<b>2</b>	Multipurpose feeder
<b>3</b>	Standard tray
<b>4</b>	Standard bin
<b>5</b>	Automatic document feeder
<b>6</b>	Staple finisher
<b>7</b>	Optional 550-sheet tray
<b>8</b>	2 x 550-sheet tray
<b>9</b>	1500-sheet tray
<b>10</b>	Staple, hole punch finisher
<b>11</b>	Folding paper transport
<b>12</b>	2000-sheet tandem tray

	Jam locations
13	Booklet finisher

### Paper jam in the standard tray

1. Pull out the standard tray.

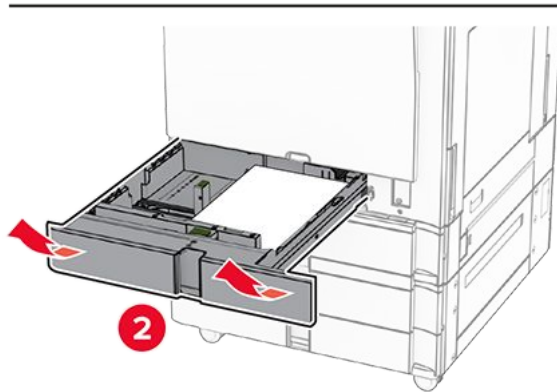
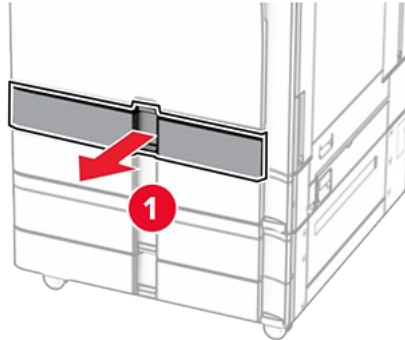

2. Remove the jammed paper.

**Note:** Make sure that all paper fragments are removed.

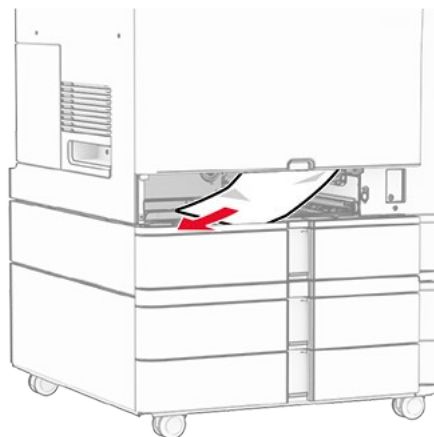

3. Insert the tray.

## Paper jam in the optional 550-sheet tray

1. Open door D.

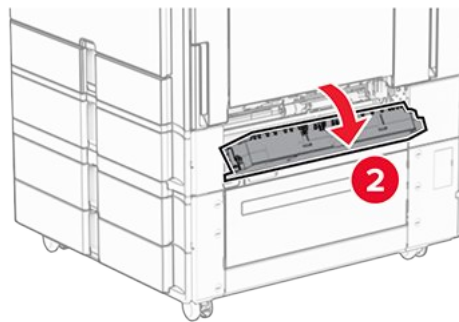
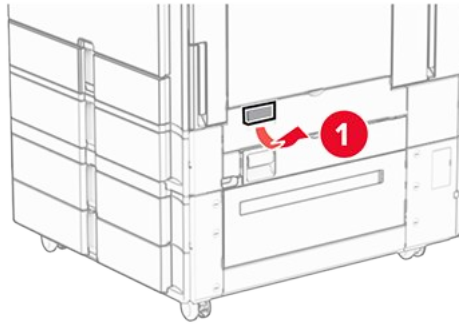

2. Remove the jammed paper.

**Note:** Make sure that all paper fragments are removed.

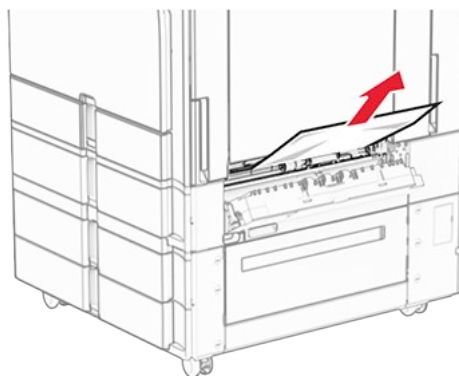

3. Close the door.
4. Pull out the optional 550-sheet tray.

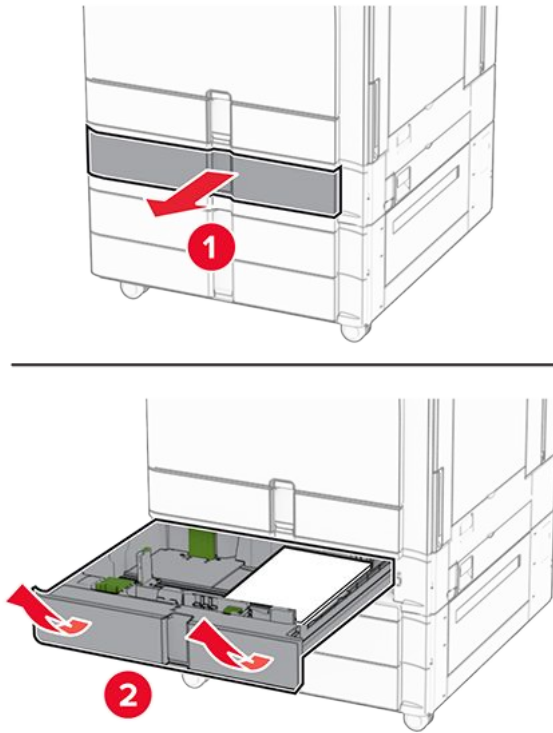

5. Remove the jammed paper.

**Note:** Make sure that all paper fragments are removed.

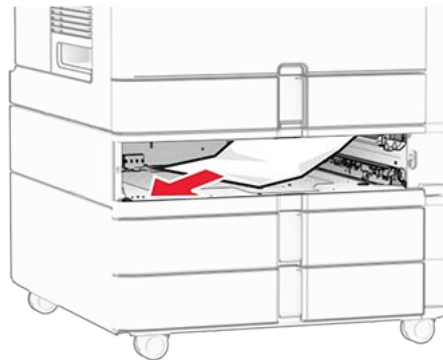

6. Insert the tray.

## Paper jam in the automatic document feeder

### Paper jam in door A

1. Open door A.

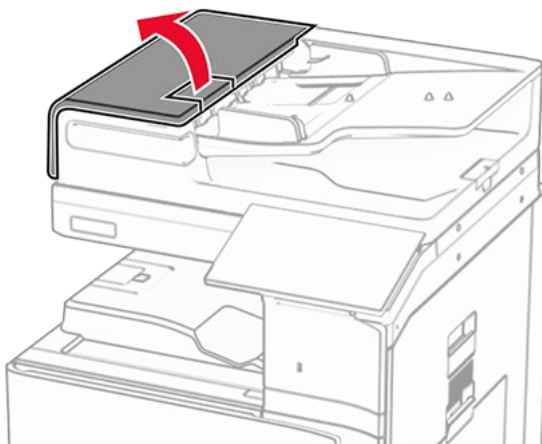

2. Remove the jammed paper.

**Note:** Make sure that all paper fragments are removed.

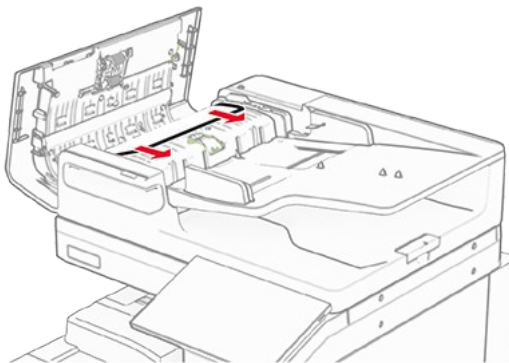

3. Close door A.

### Paper jam in door A1

1. Open the scanner cover.

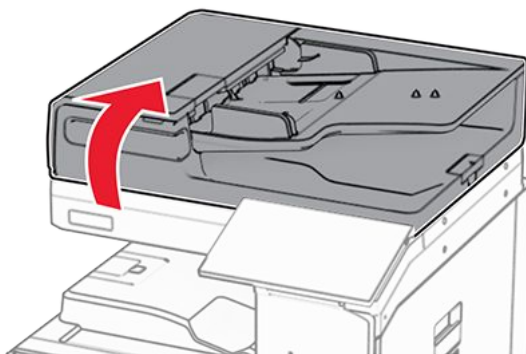

2. Pull the green latch to open door A1.

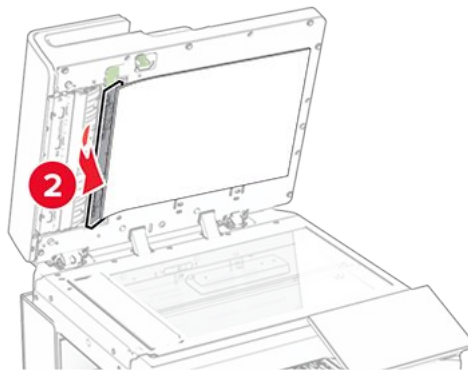
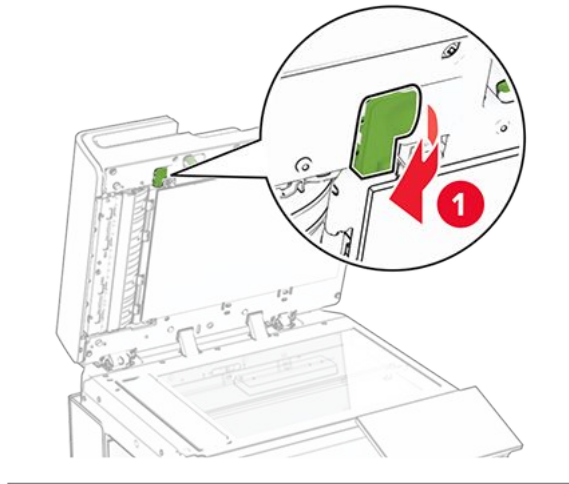

3. Remove the jammed paper.

**Note:** Make sure that all paper fragments are removed.

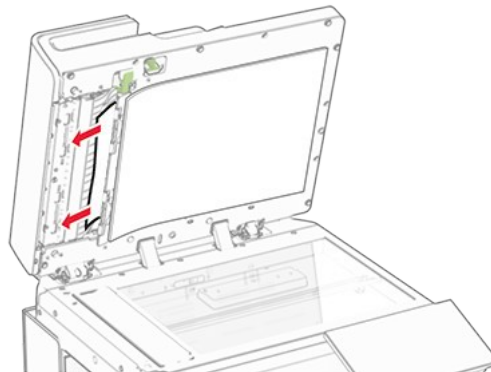

4. Close door A1, and then close the scanner cover.

### Paper jam in the automatic document feeder bin

1. Remove any paper from the automatic document feeder bin.
2. Remove the jammed paper.

**Note:** Make sure that all paper fragments are removed.

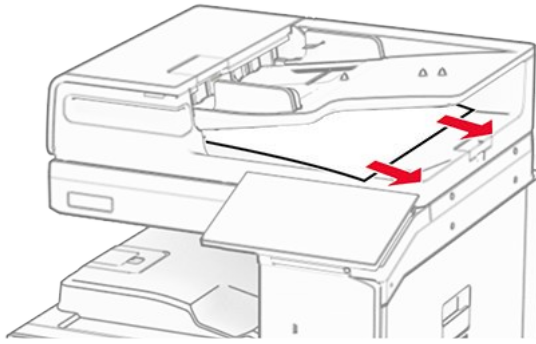

## Paper jam in the multipurpose feeder

1. Remove any paper from the multipurpose feeder.
2. Remove the jammed paper.

**Note:** Make sure that all paper fragments are removed.

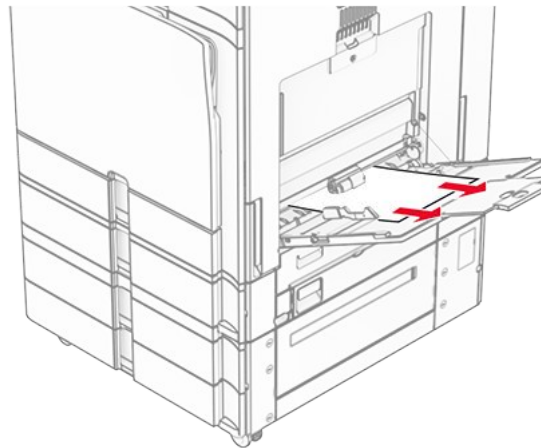

## Paper jam in the 2 x 550-sheet tray

1. Open door E.

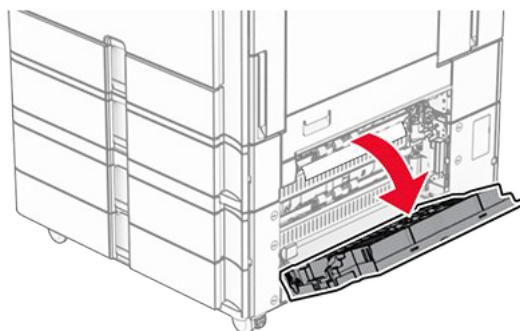

2. Remove the jammed paper inside door E.

**Note:** Make sure that all paper fragments are removed.

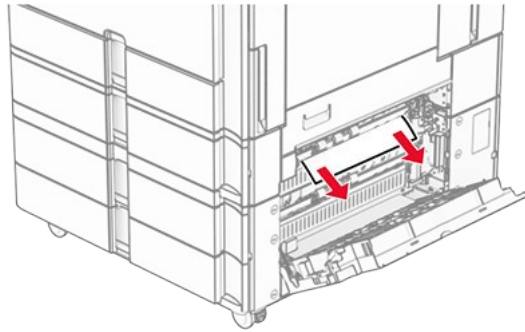

3. Close door E.
4. Pull out tray 3.

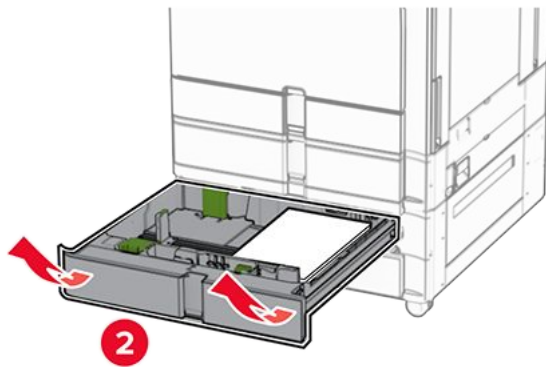
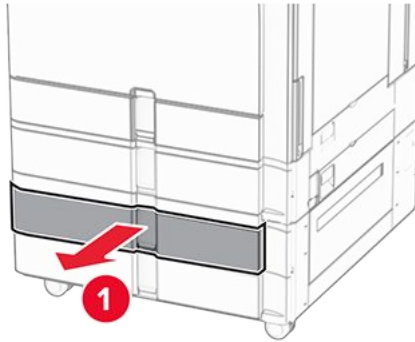

5. Remove the jammed paper.

**Note:** Make sure that all paper fragments are removed.

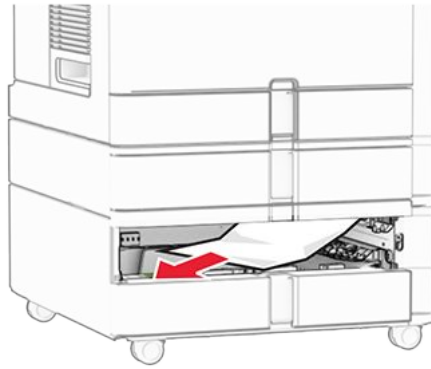

6. Insert tray 3.
7. Repeat [step 4](#) through [step 6](#) for tray 4.

## Paper jam in the 2000-sheet tandem tray

1. Open door E.

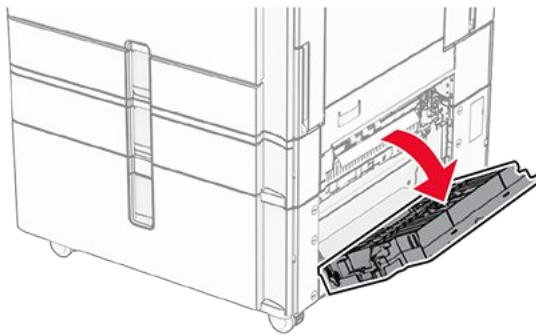

2. Remove the jammed paper inside door E.

**Note:** Make sure that all paper fragments are removed.

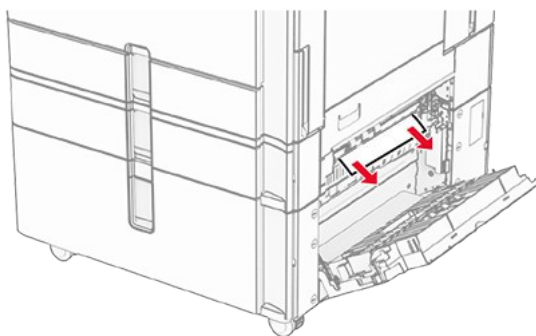

3. Close door E.

## Paper jam in the 1500-sheet tray

1. Open door K.

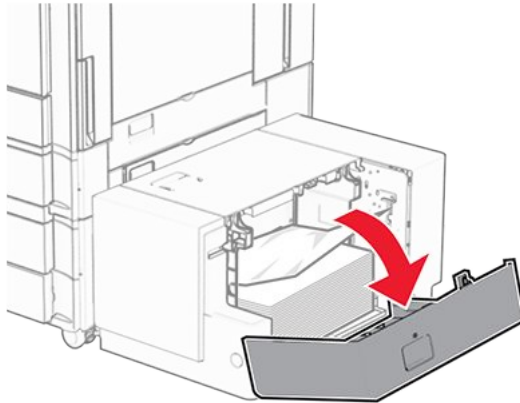

2. Remove the jammed paper.

**Note:** Make sure that all paper fragments are removed.

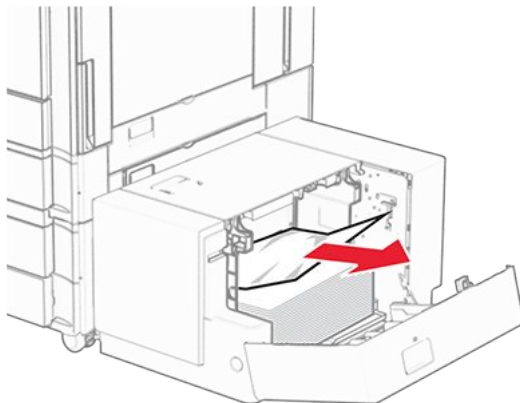

3. Close door K.
4. Grab handle J, and then slide the tray to the right.

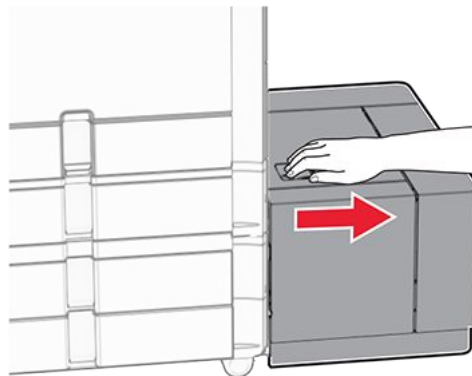

## Troubleshoot a problem

---

5. Remove the jammed paper.

**Note:** Make sure that all paper fragments are removed.

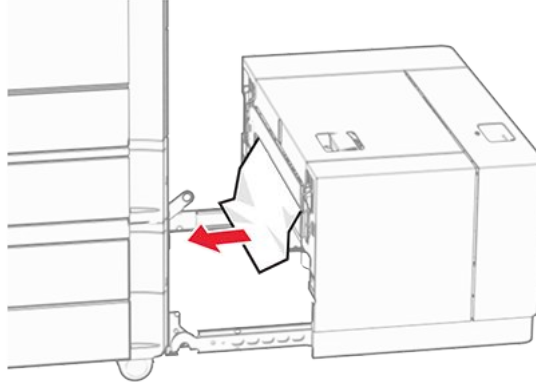

6. Slide the tray back into place.

## Paper jam in door B

1. Open door B.



### **CAUTION—HOT SURFACE**

The inside of the printer might be hot. To reduce the risk of injury from a hot component, allow the surface to cool before touching it.

### **Warning—Potential Damage**

To prevent damage from electrostatic discharge, touch any exposed metal frame of the printer before accessing or touching interior areas of the printer.

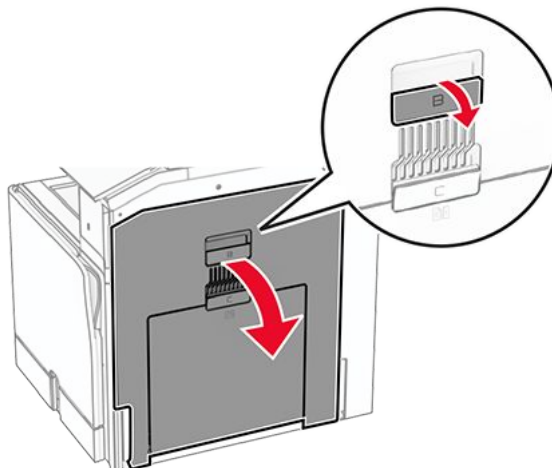

## Troubleshoot a problem

2. Remove the jammed paper in any of the following locations:

**Note:** Make sure that all paper fragments are removed.

- Above the fuser

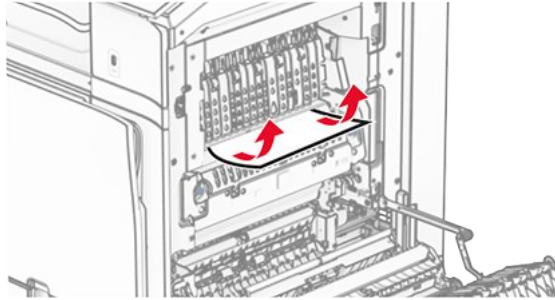

- In the fuser

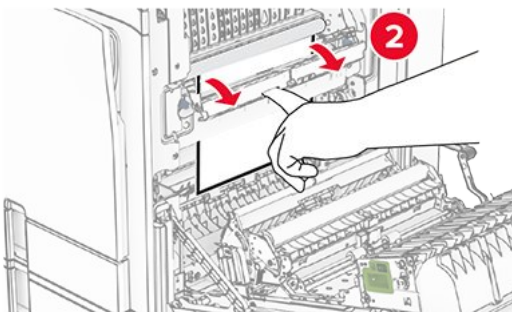
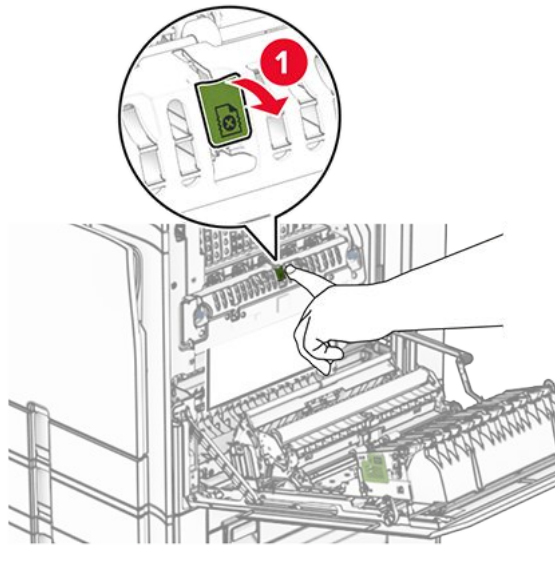

- Below the fuser

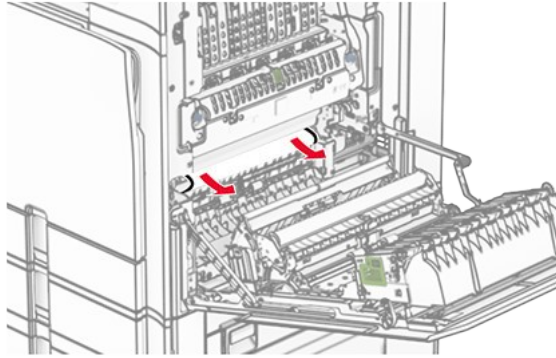

- Under the standard bin exit roller

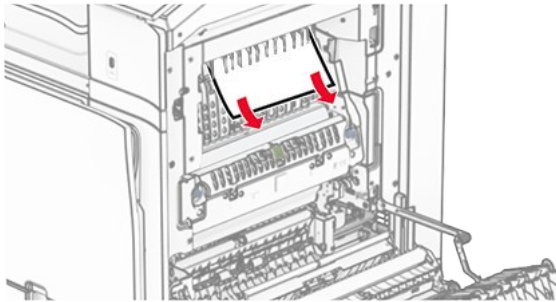

- In the duplex unit

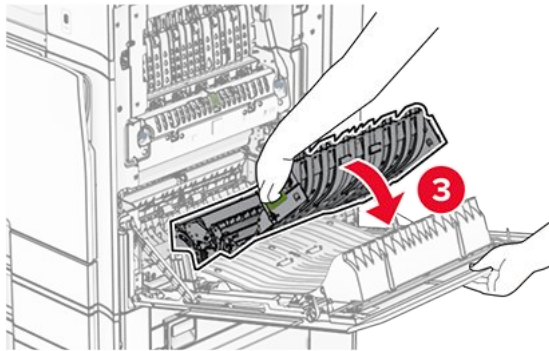
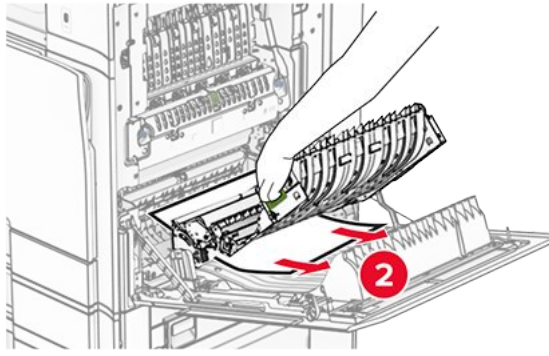
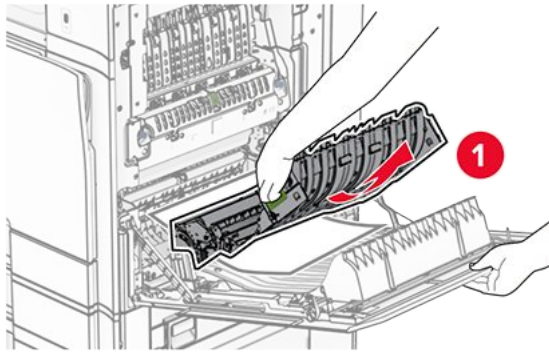

3. Close door B.

## Paper jam in the standard bin

1. Remove any paper from the standard bin.
2. Remove the jammed paper.

**Note:** Make sure that all paper fragments are removed.

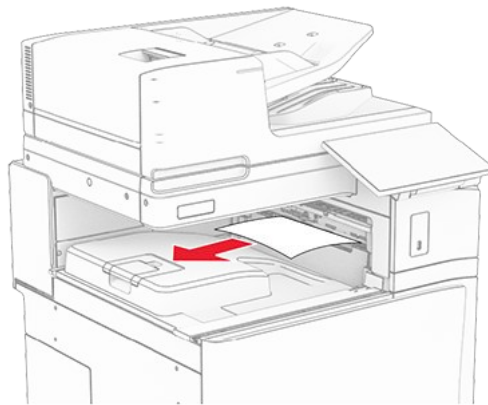

## Paper jam in the staple finisher

1. Remove the jammed paper in the staple finisher bin.

**Note:** Make sure that all paper fragments are removed.

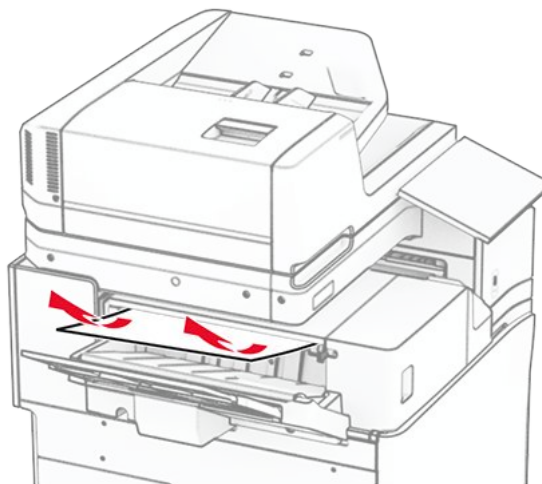

2. Grab handle F, and then slide the staple finisher to the left.

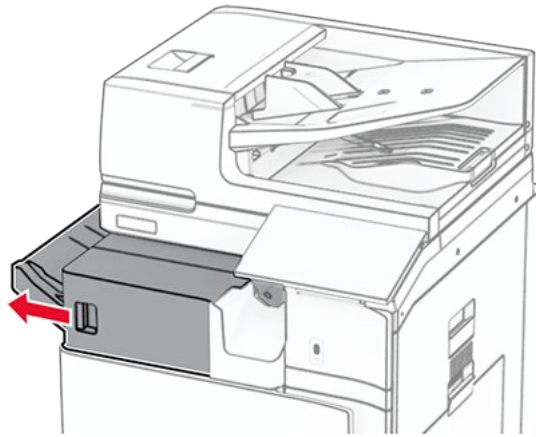

3. Open door R1, and then rotate the knob R2 clockwise.

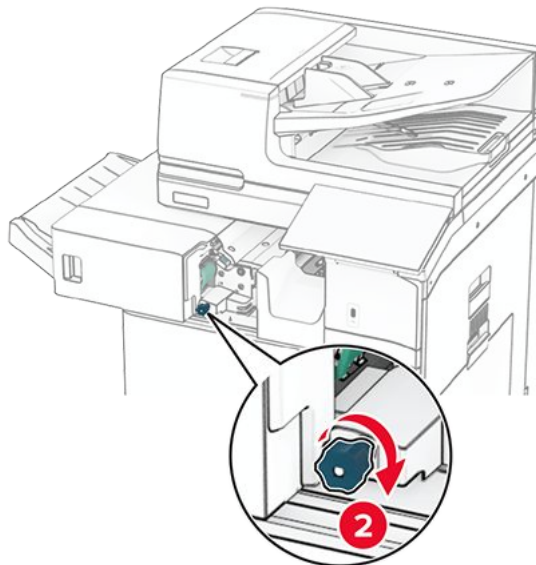
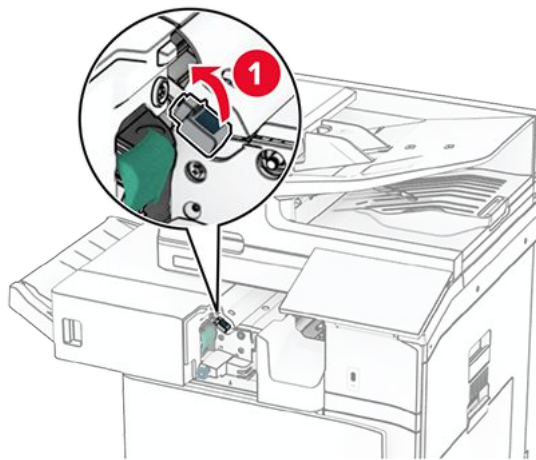

4. Remove the jammed paper.

**Note:** Make sure that all paper fragments are removed.

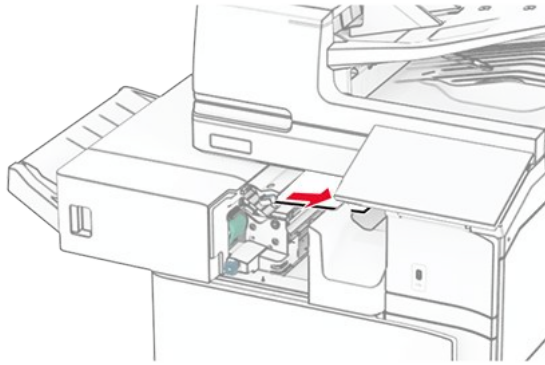

5. Close door R1.
6. Remove the jammed paper in the standard bin exit roller.

**Note:** Make sure that all paper fragments are removed.

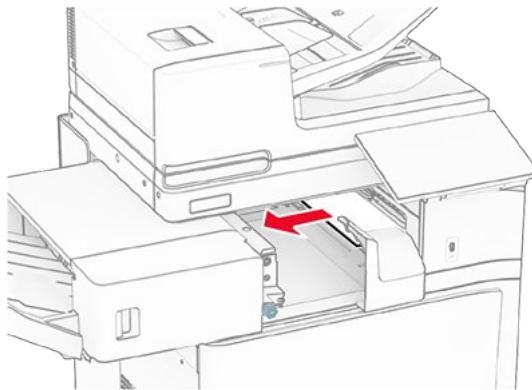

7. Slide the staple finisher back into place.

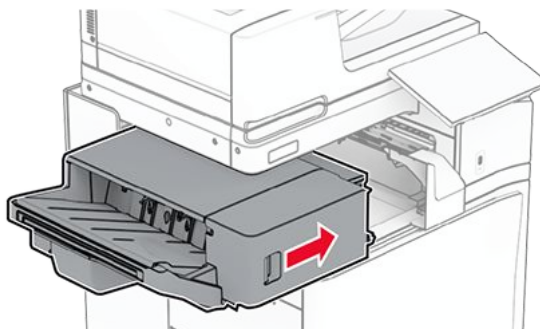

## Paper jam in the folding paper transport

1. Remove the jammed paper.

**Note:** Make sure that all paper fragments are removed.

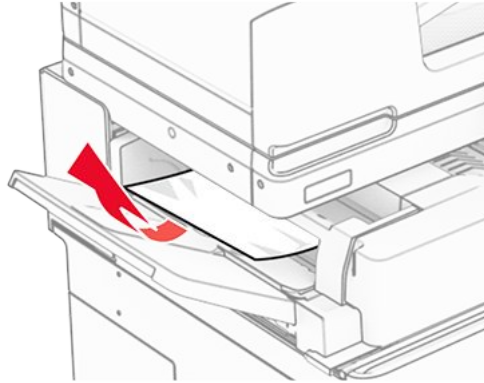

2. Open door F.

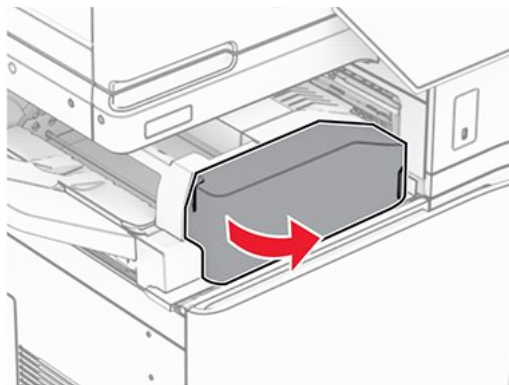

3. Lift handle N4.

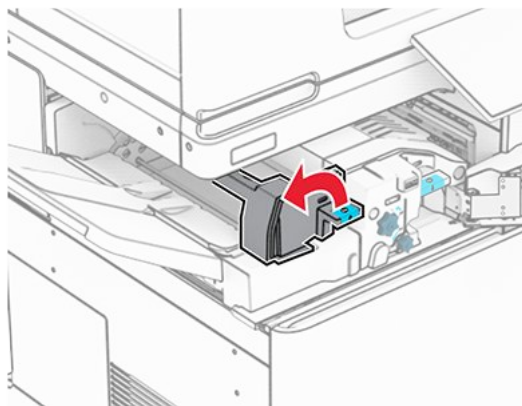

4. Lift handle N5.

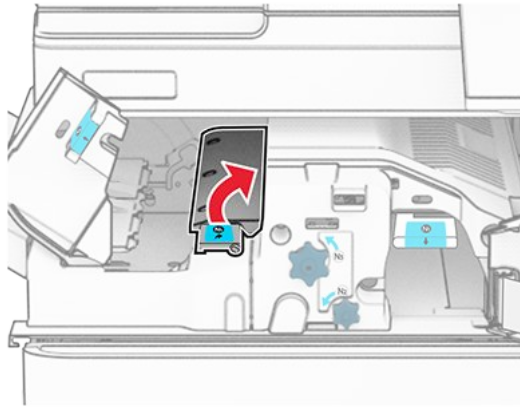

5. Remove the jammed paper.

**Note:** Make sure that all paper fragments are removed.

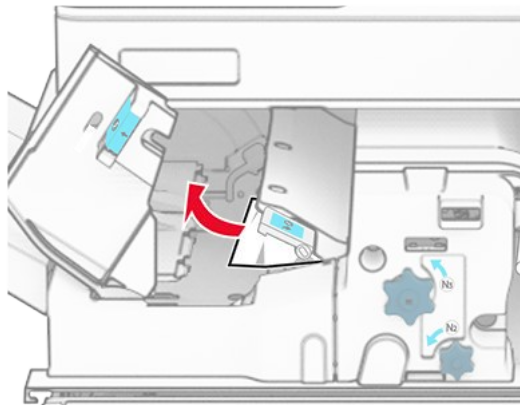

6. Close handle N5, and then close handle N4.
7. Push down handle N1.

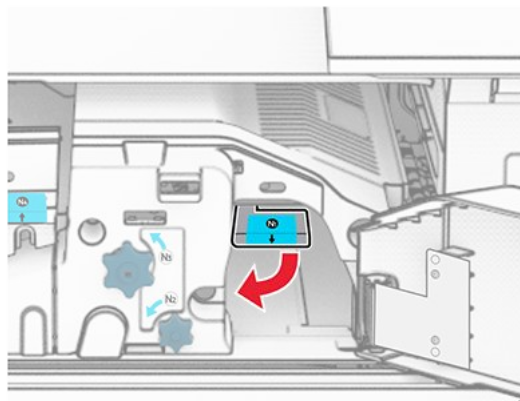

8. Turn knob N2 counterclockwise.

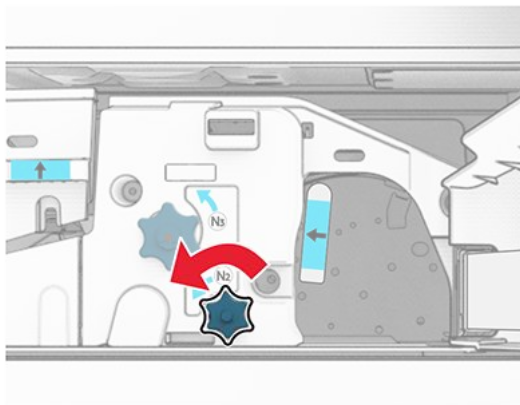

9. Remove the jammed paper.

**Warning—Potential Damage**

To prevent damage to the printer, remove any hand accessories before removing the jammed paper.

**Note:** Make sure that all paper fragments are removed.

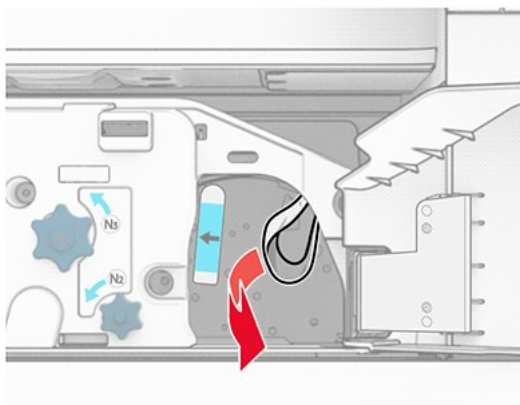

10. Put handle N1 back into place.
11. Close door F.

## Paper jam in the staple, hole punch finisher

If your printer is configured with a paper transport, then do the following:

1. Remove the jammed paper in bin 1.

### Notes

- Make sure that all paper fragments are removed.
- Do not remove the printed pages that are in the staple compiler to avoid missing pages.

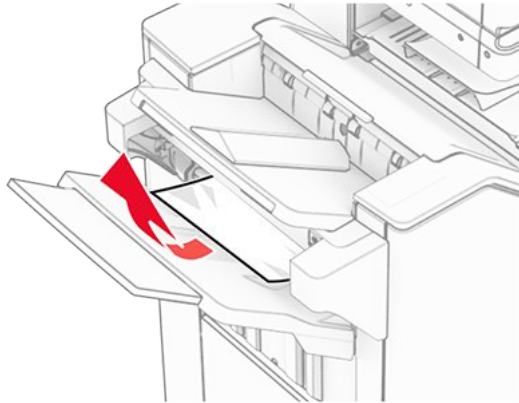

2. Remove the jammed paper in the finisher standard bin.

**Note:** Make sure that all paper fragments are removed.

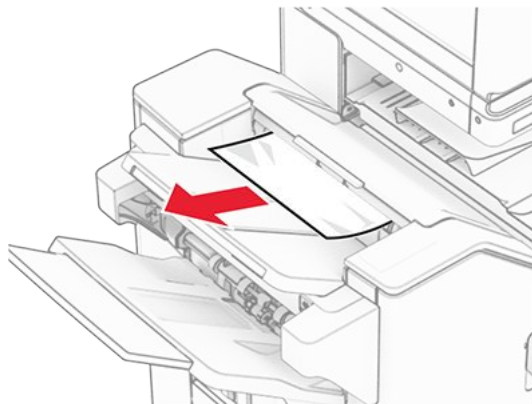

3. Remove the jammed paper in bin 2.

**Note:** Make sure that all paper fragments are removed.

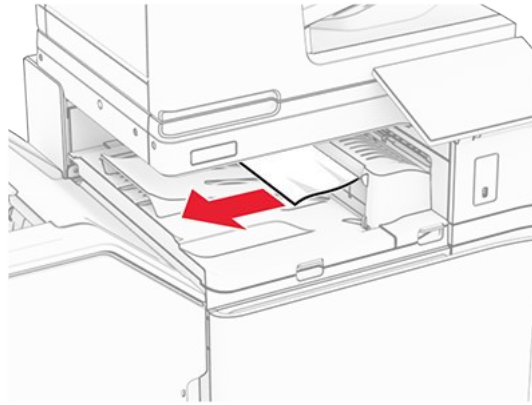

4. Open paper transport cover G, and then remove the jammed paper.

**Note:** Make sure that all paper fragments are removed.

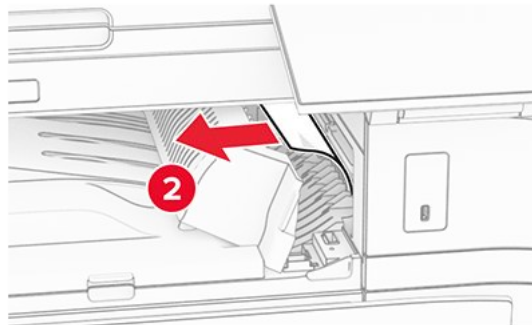
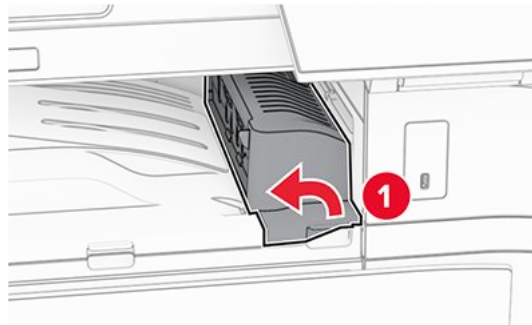

5. Close paper transport cover G.
6. Open door I, open door R1, and then remove the jammed paper.

**Note:** Make sure that all paper fragments are removed.

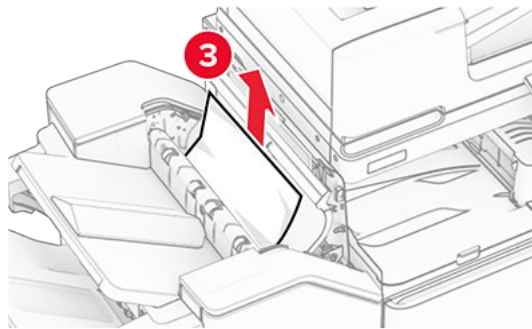
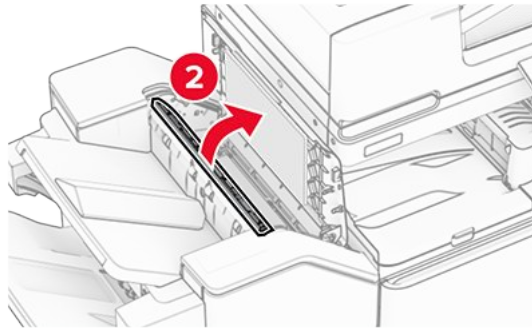
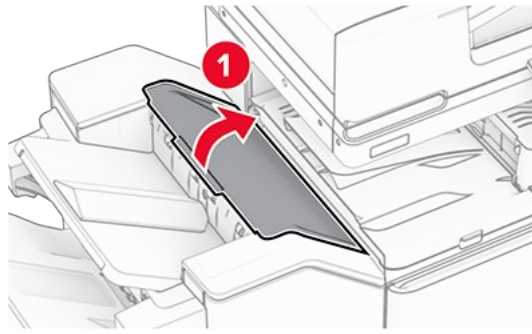

7. Close door R1, and then close door I.
8. Open paper transport cover F.

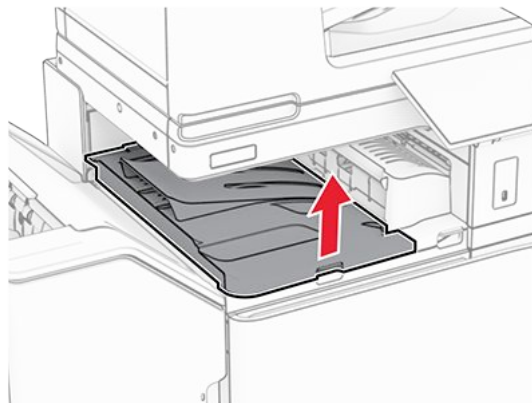

9. Open door H.

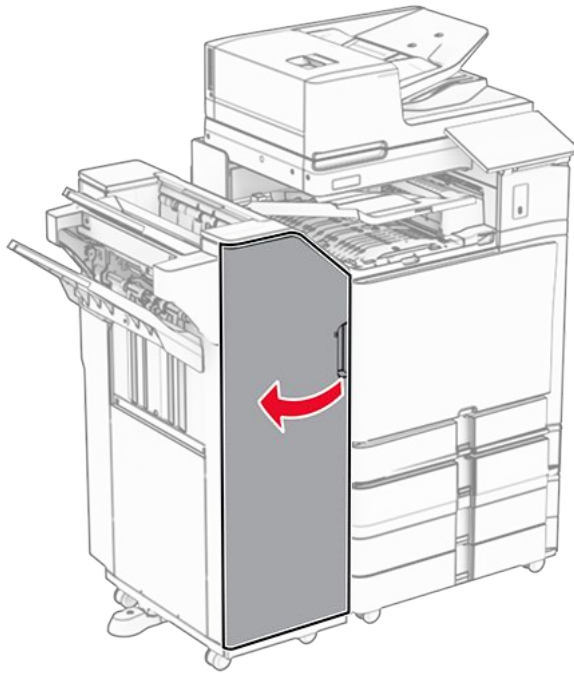

10. Lift handle R4.

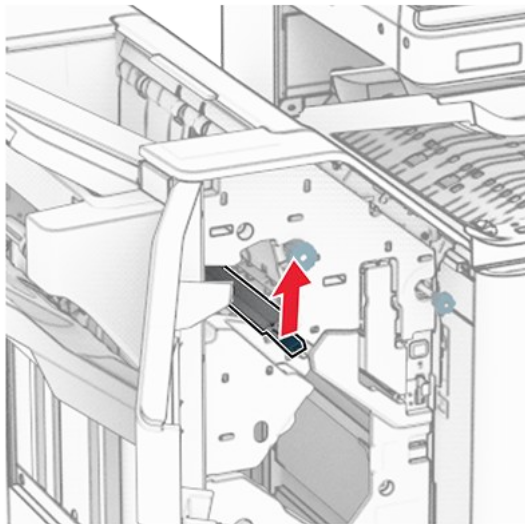

11. Turn knob R3 counterclockwise, and then remove the jammed paper in bin 1.

**Note:** Make sure that all paper fragments are removed.

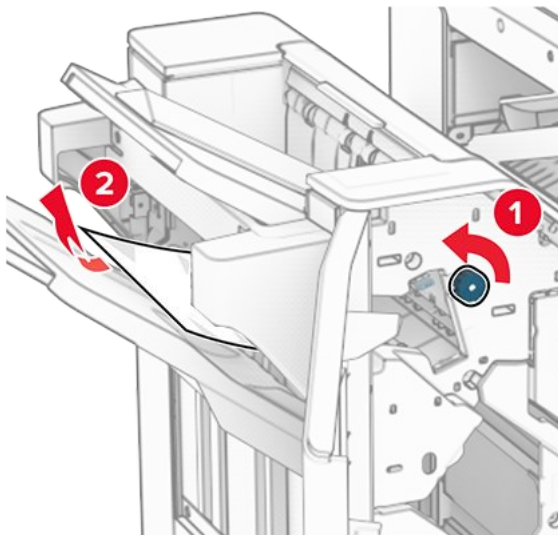

12. Turn knob R2 counterclockwise, and then remove the jammed paper in paper transport cover F.

**Note:** Make sure that all paper fragments are removed.

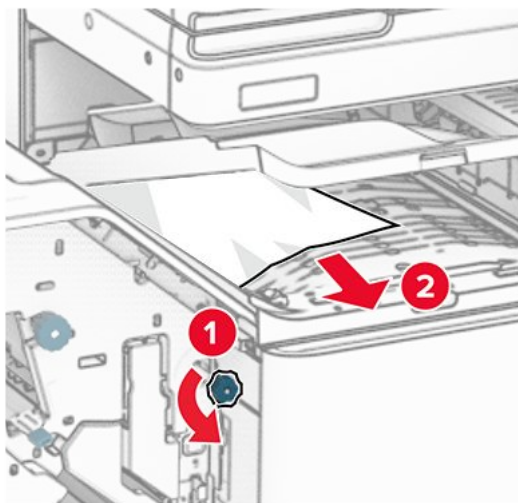

13. Close paper transport cover F.
14. Return handle R4 to its original position.
15. Close door H.

**If your printer is configured with a folding paper transport, then do the following:**

1. Remove the jammed paper in bin 1.

### Notes

- Make sure that all paper fragments are removed.
- Do not remove the printed pages that are in the staple compiler to avoid missing pages.

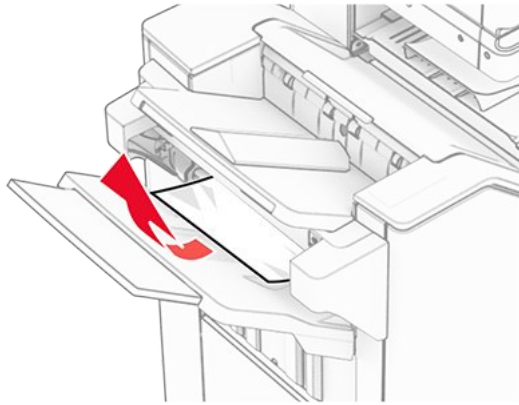

2. Remove the jammed paper in the finisher standard bin.

**Note:** Make sure that all paper fragments are removed.

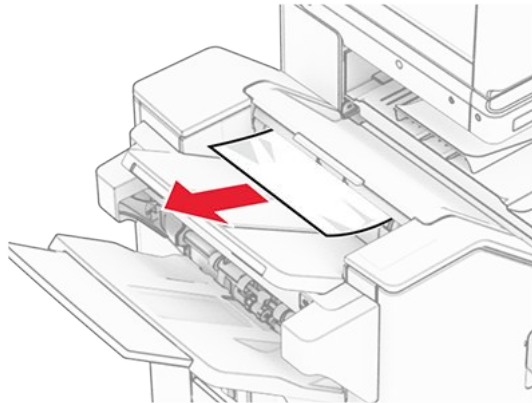

3. Remove the jammed paper in bin 2.

**Note:** Make sure that all paper fragments are removed.

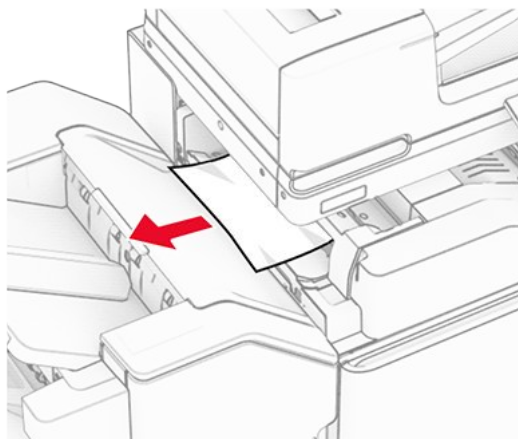

4. Open door F.

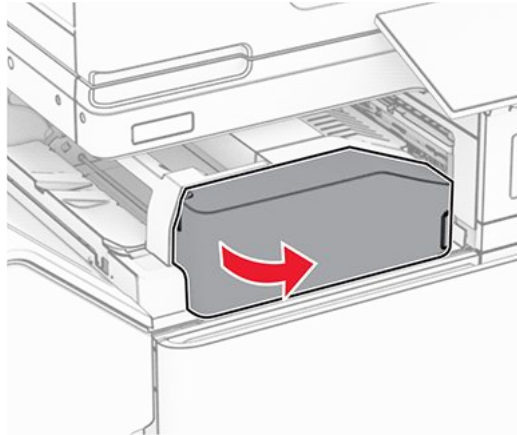

5. Open door N4.

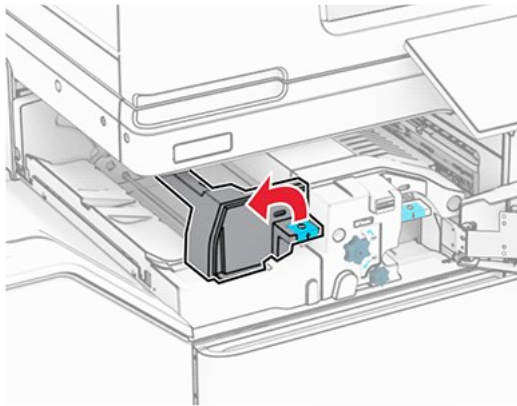

6. Open door N5.

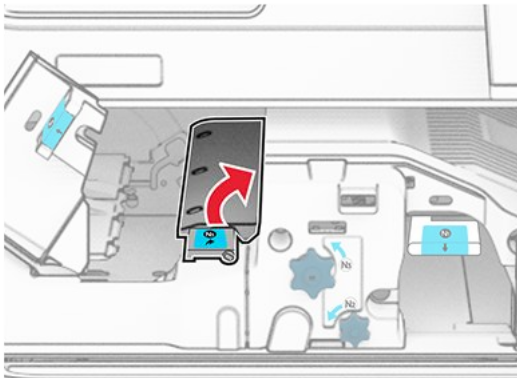

7. Open door H.

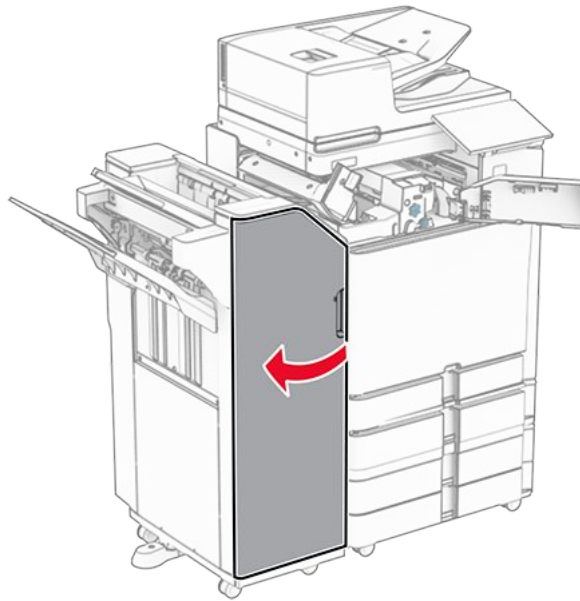

8. Lift handle R4.

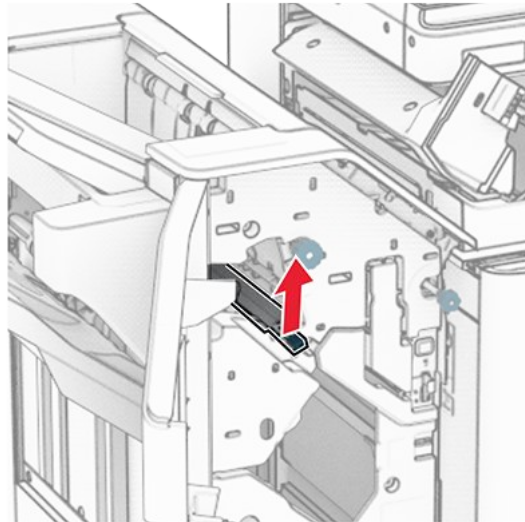

9. Turn knob R3 counterclockwise, and then remove the jammed paper in bin 1.

**Note:** Make sure that all paper fragments are removed.

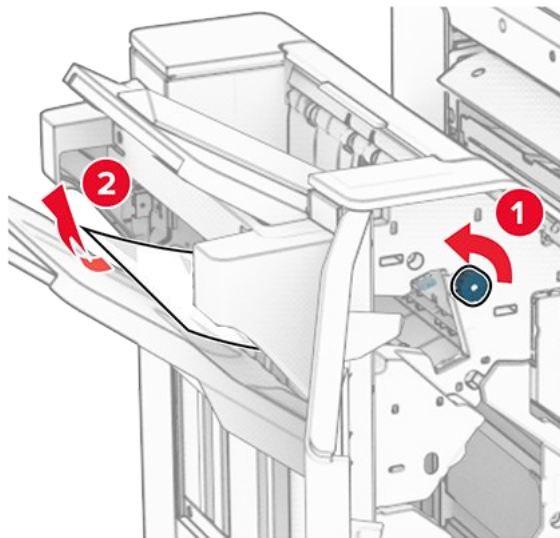

10. Turn knob R2 counterclockwise, and then remove the jammed paper between doors N4 and N5.

**Note:** Make sure that all paper fragments are removed.

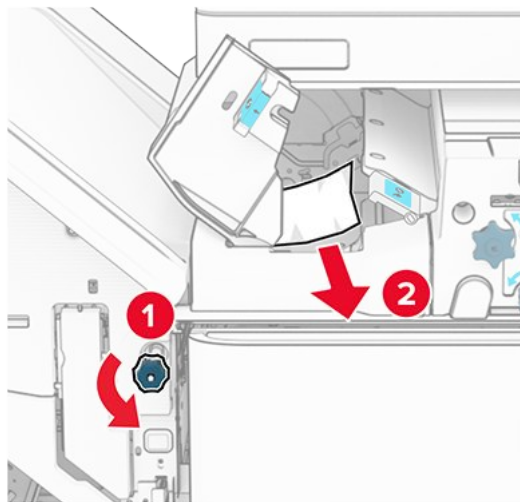

11. Open door B.



### **CAUTION—HOT SURFACE**

The inside of the printer might be hot. To reduce the risk of injury from a hot component, allow the surface to cool before touching it.

### **Warning—Potential Damage**

To prevent damage from electrostatic discharge, touch any exposed metal frame of the printer before accessing or touching interior areas of the printer.

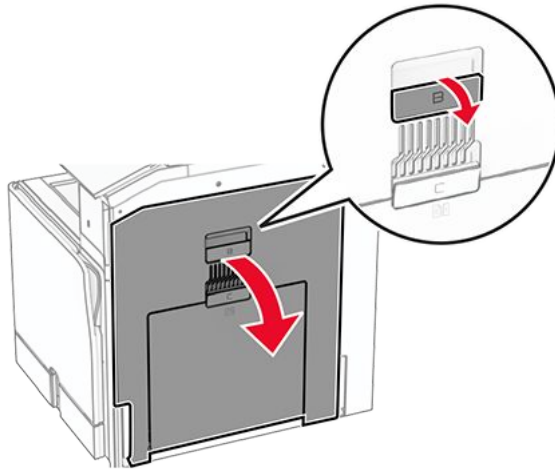

12. Remove the jammed paper under the standard bin exit roller.

**Note:** Make sure that all paper fragments are removed.

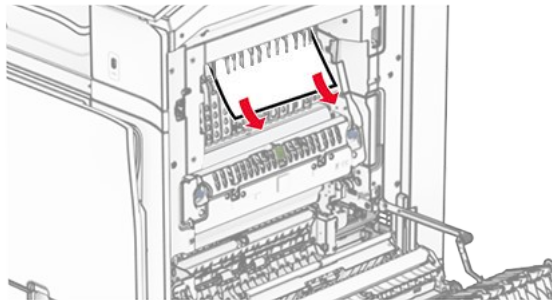

13. Close door B.
14. Push down handle N1.

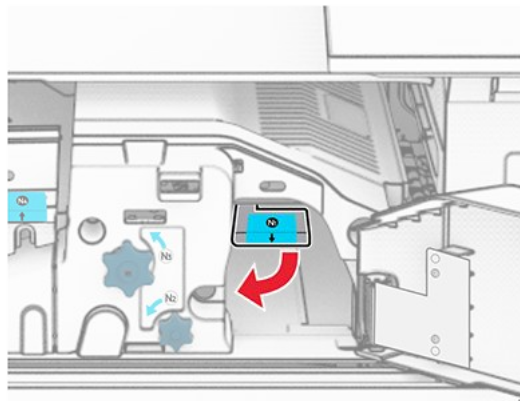

15. Turn knob N2 counterclockwise.



16. Remove the jammed paper.

### **Warning—Potential Damage**

To prevent damage to the printer, remove any hand accessories before removing the jammed paper.

**Note:** Make sure that all paper fragments are removed.

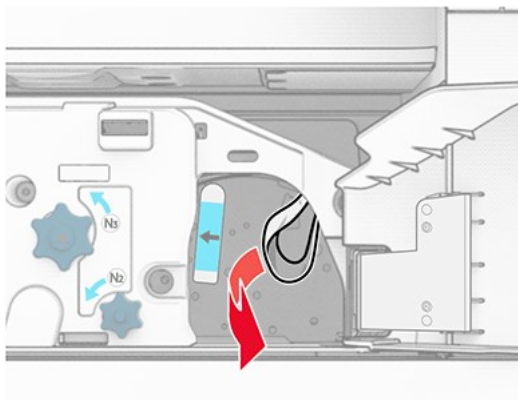

17. Put handle N1 back into place.
18. Close handle N5, and then close handle N4.
19. Close door F.
20. Return handle R4 to its original position.
21. Close door H.

## Paper jam in the booklet finisher

If your printer is configured with a paper transport, then do the following:

1. Remove the jammed paper in the finisher standard bin.

**Note:** Make sure that all paper fragments are removed.

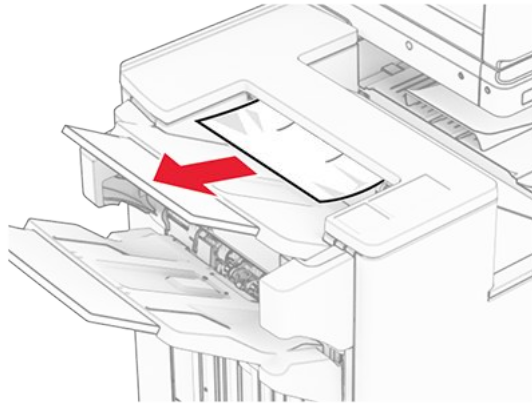

2. Remove the jammed paper in bin 1.

**Note:** Make sure that all paper fragments are removed.

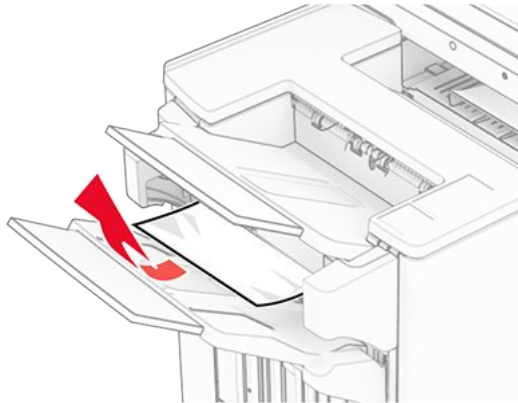

3. Remove the jammed paper in bin 1.

**Notes**

- Make sure that all paper fragments are removed.
- Do not remove the printed pages that are in the staple compiler to avoid missing pages.

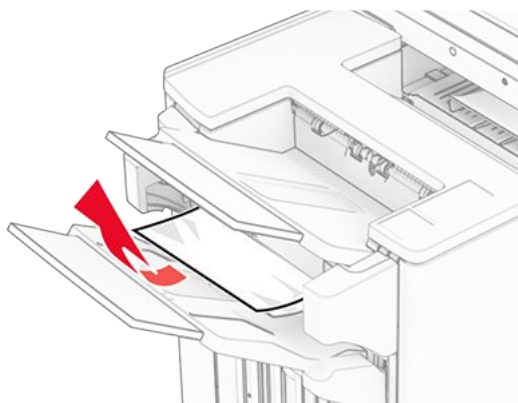

## Troubleshoot a problem

---

4. Remove the jammed paper in bin 3.

**Note:** Make sure that all paper fragments are removed.

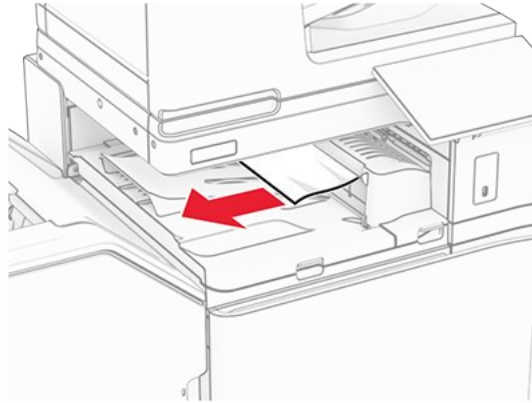

5. Open paper transport cover G, and then remove the jammed paper.

**Note:** Make sure that all paper fragments are removed.

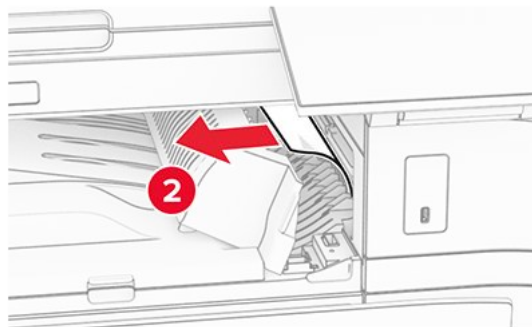
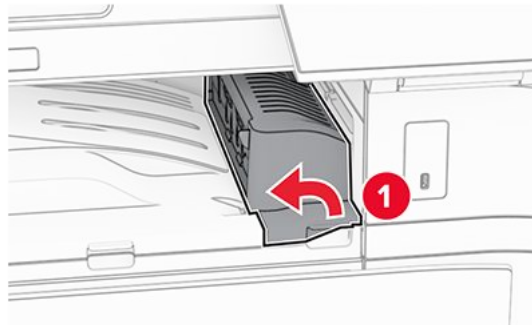

6. Close paper transport cover G.
7. Open paper transport cover F.

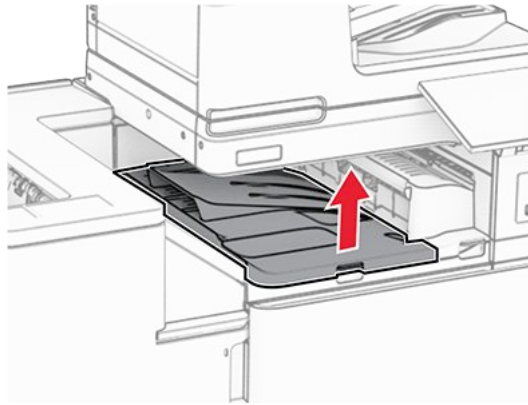

8. Open door H.

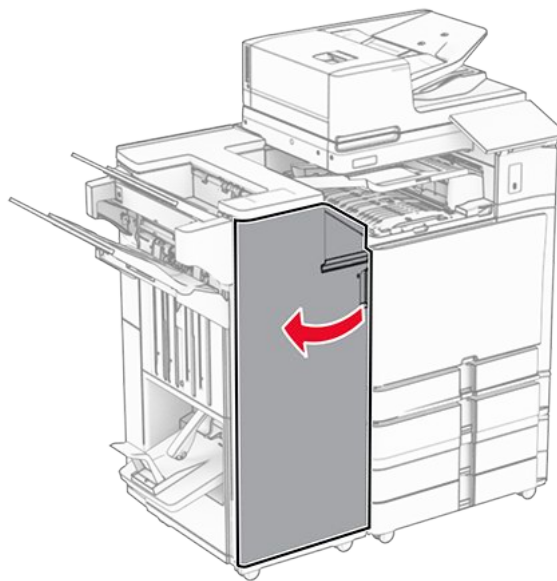

9. Move handle R3 to the right, and then remove the jammed paper.

**Note:** Make sure that all paper fragments are removed.

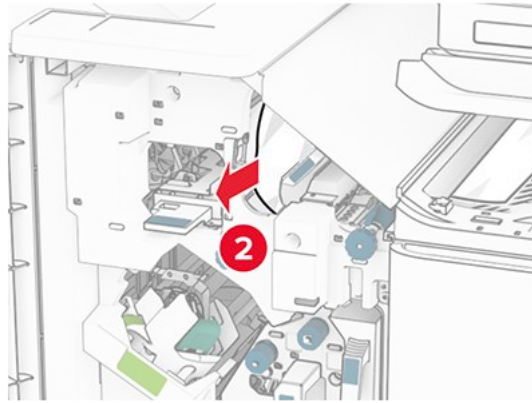

10. Move handle R1 to the left, turn knob R2 counterclockwise, and then remove the jammed paper.

**Note:** Make sure that all paper fragments are removed.

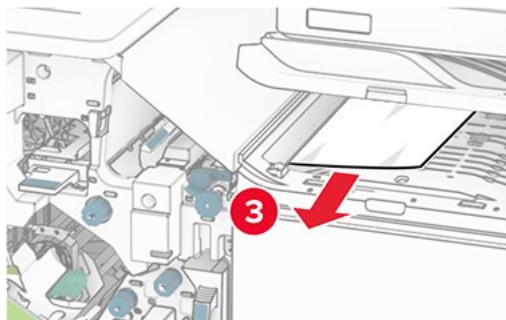
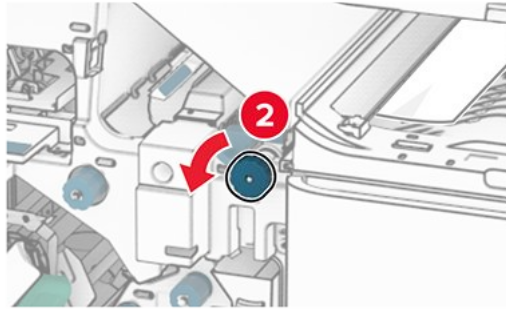

11. Turn knob R5 counterclockwise, and then remove the jammed paper from the finisher standard bin.

**Note:** Make sure that all paper fragments are removed.

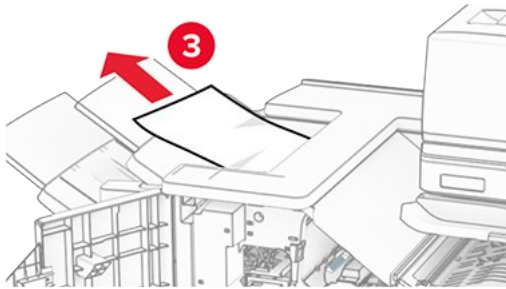
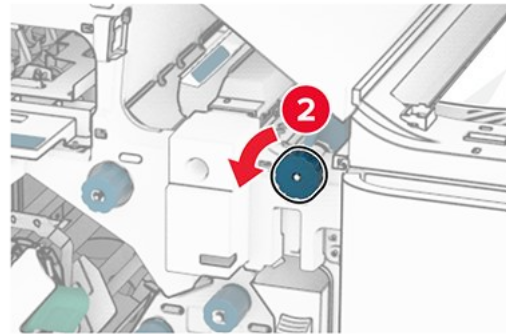
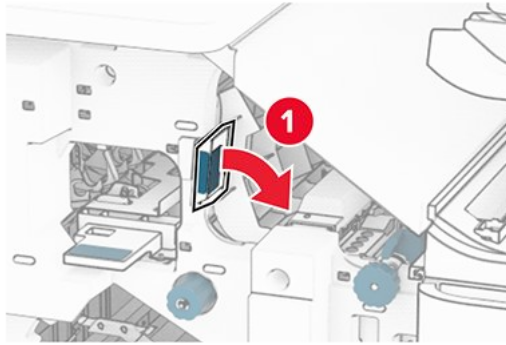

12. Lift handle R4, turn knob R2 clockwise, and then remove the jammed paper.

**Note:** Make sure that all paper fragments are removed.

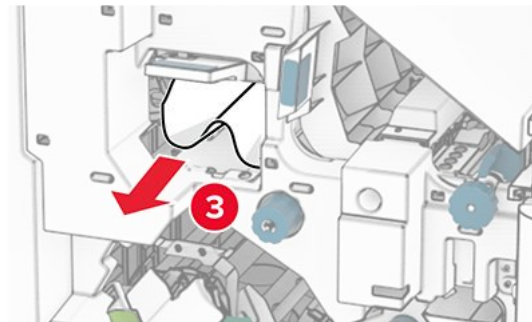
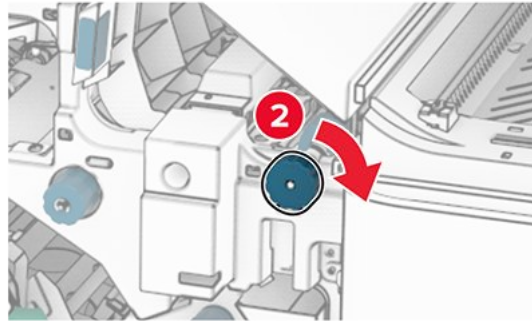
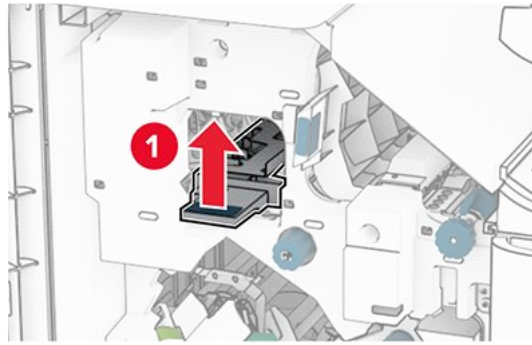

13. Close paper transport cover F.
14. Return handles R1, R3, and R4 to their original position.
15. Close door H.

**If your printer is configured with a folding paper transport, then do the following:**

1. Remove the jammed paper in the finisher standard bin.

**Note:** Make sure that all paper fragments are removed.

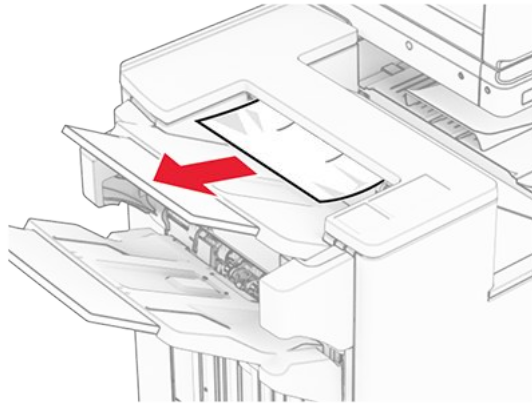

2. Remove the jammed paper in bin 1.

**Note:** Make sure that all paper fragments are removed.

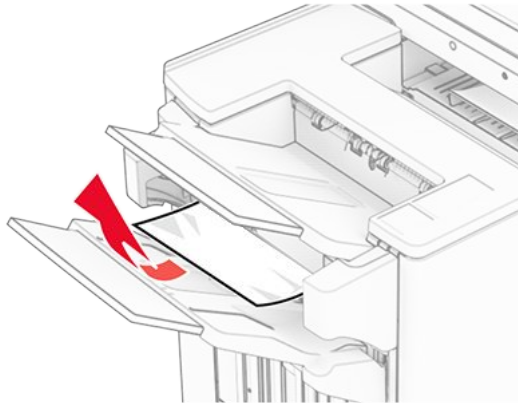

3. Remove the jammed paper in bin 1.

**Notes**

- Make sure that all paper fragments are removed.
- Do not remove the printed pages that are in the staple compiler to avoid missing pages.

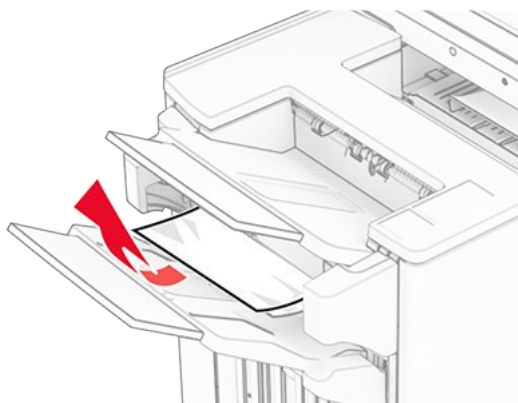

## Troubleshoot a problem

---

4. Remove the jammed paper in bin 3.

**Note:** Make sure that all paper fragments are removed.

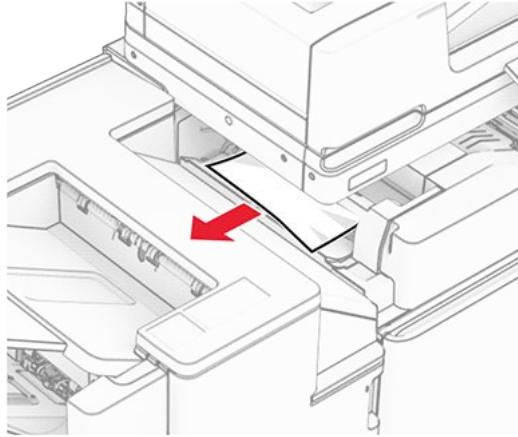

5. Open door F.

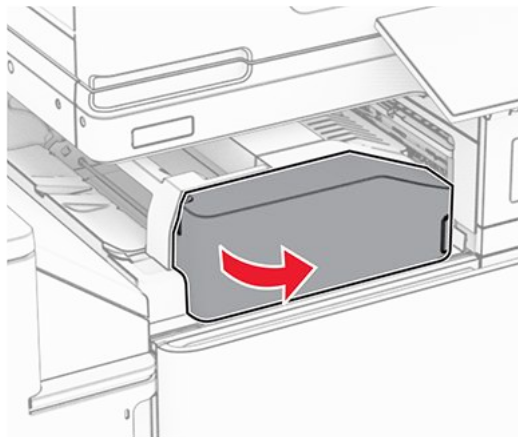

6. Open door H.

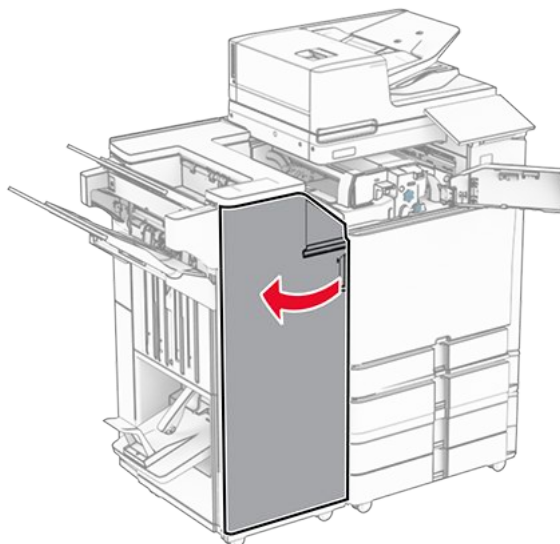

7. Open door N4.

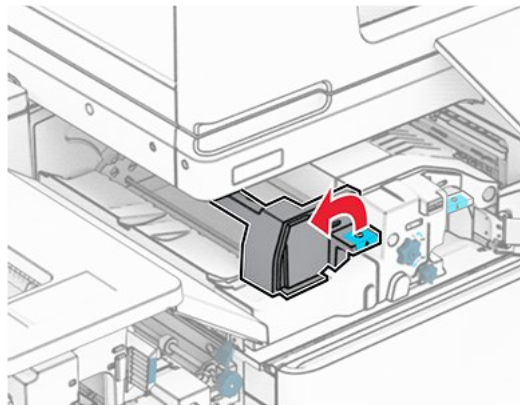

8. Open door N5.

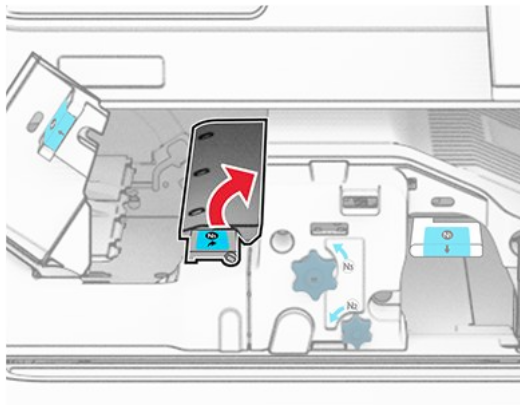

9. Lift handle R4.

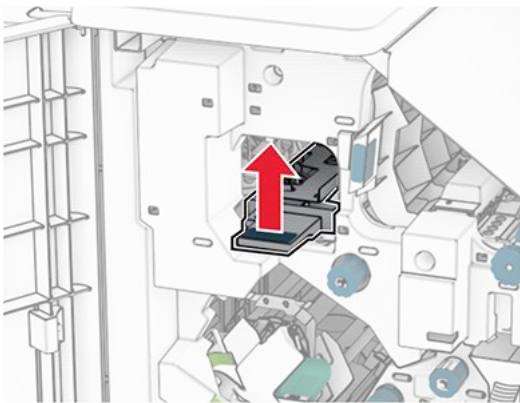

10. Turn knob R2 clockwise, and then remove the jammed paper in handle R4.

**Note:** Make sure that all paper fragments are removed.

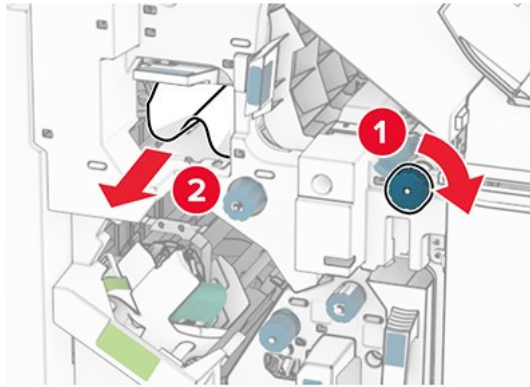

11. Move handle R1 to the left, turn knob R2 counterclockwise, and then remove the jammed paper between doors N4 and N5.

**Note:** Make sure that all paper fragments are removed.

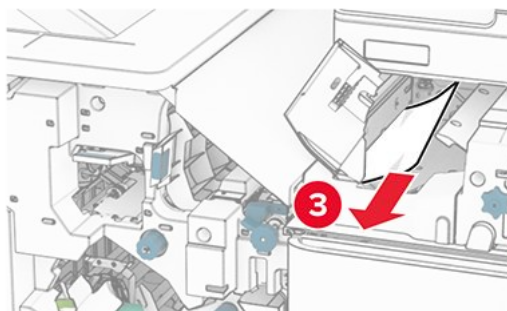
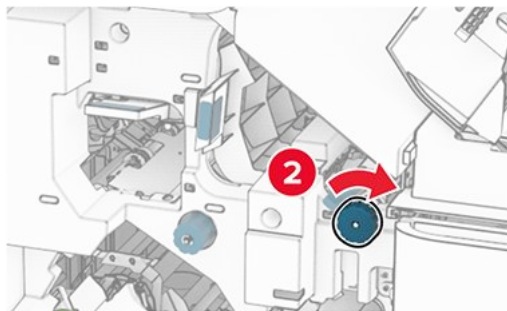
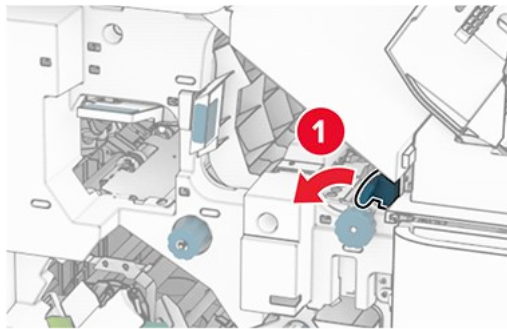

12. Open door B.



### CAUTION—HOT SURFACE

The inside of the printer might be hot. To reduce the risk of injury from a hot component, allow the surface to cool before touching it.

### Warning—Potential Damage

To prevent damage from electrostatic discharge, touch any exposed metal frame of the printer before accessing or touching interior areas of the printer.

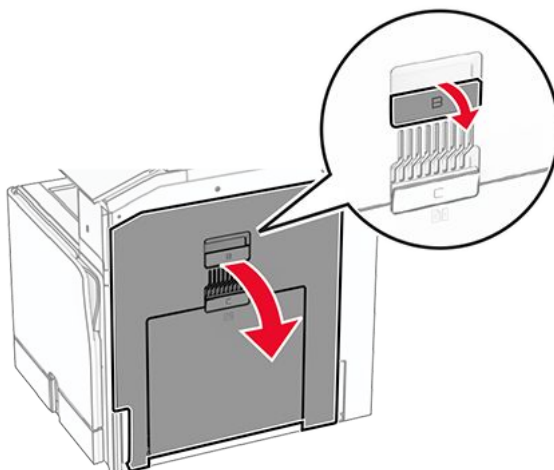

13. Remove the jammed paper under the standard bin exit roller.

**Note:** Make sure that all paper fragments are removed.

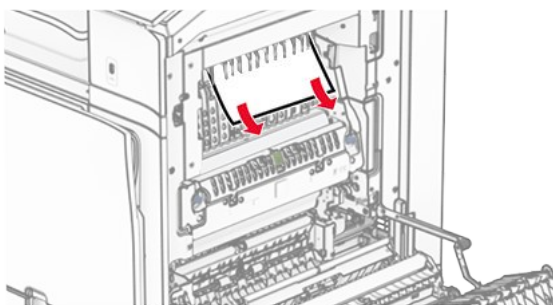

14. Close door B.
15. Push down handle N1.

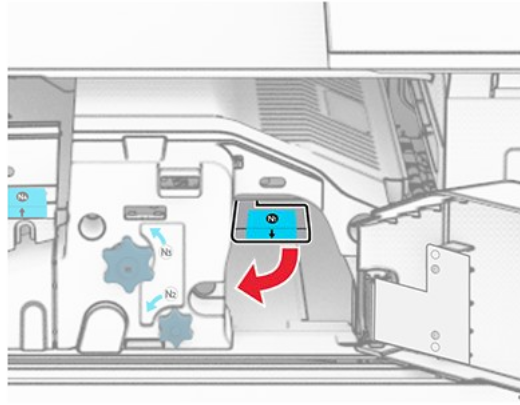

16. Turn knob N2 counterclockwise.



17. Remove the jammed paper.

**Warning—Potential Damage**

To prevent damage to the printer, remove any hand accessories before removing the jammed paper.

**Note:** Make sure that all paper fragments are removed.

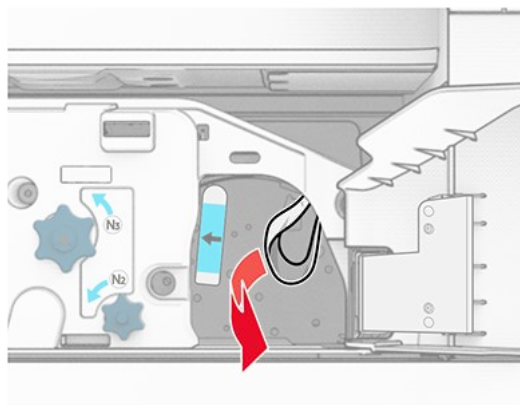

18. Put handle N1 back into place.

## Troubleshoot a problem

---

19. Close door N5, and then close door N4.
20. Close door F.
21. Return handles R1 and R4 back into their original positions.
22. Close door H.

### Paper jam in the booklet maker

1. Remove jammed paper in bin 2.

**Note:** Make sure that all paper fragments are removed.

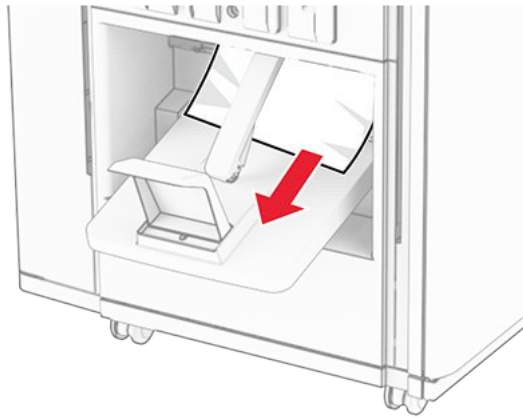

2. Open door H.

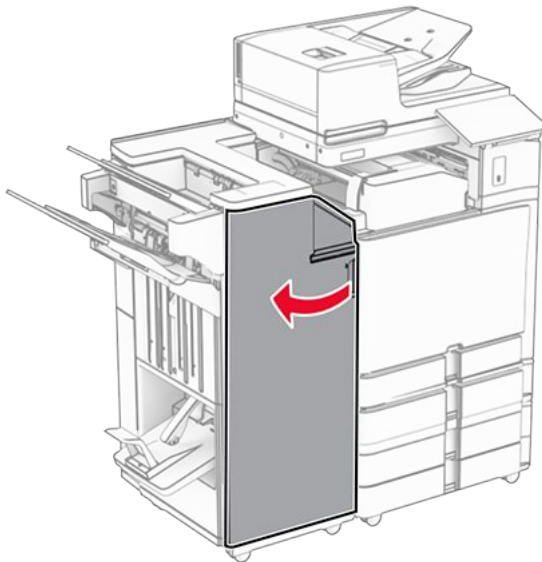

3. Turn knobs R6, R11, and R10 clockwise.

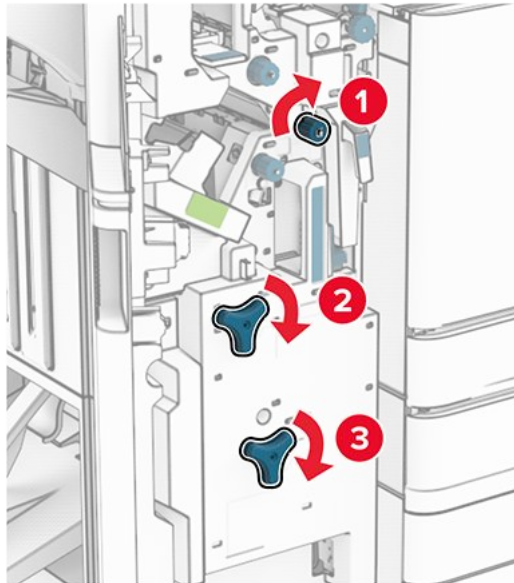

4. Pull out the booklet maker.

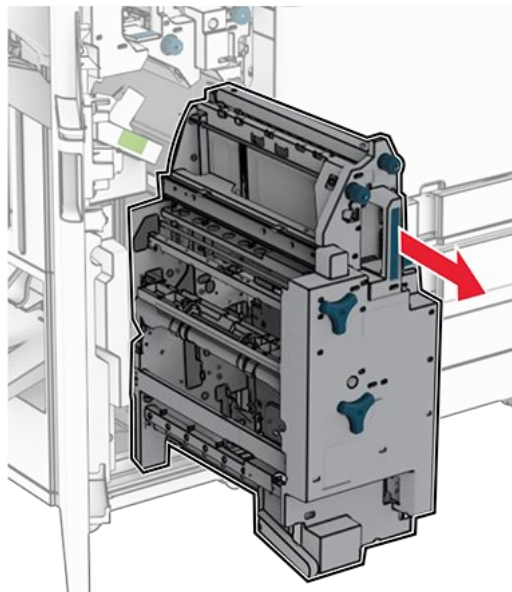

5. Remove the jammed paper.

**Note:** Make sure that all paper fragments are removed.

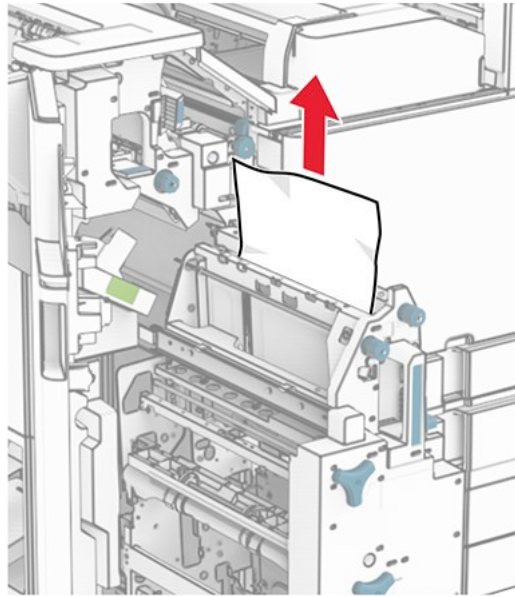

6. Turn knob R9 counterclockwise until it stops.

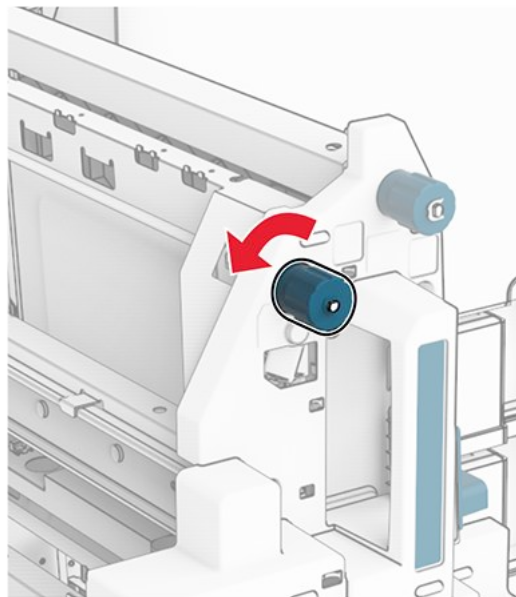

7. Open door R8.

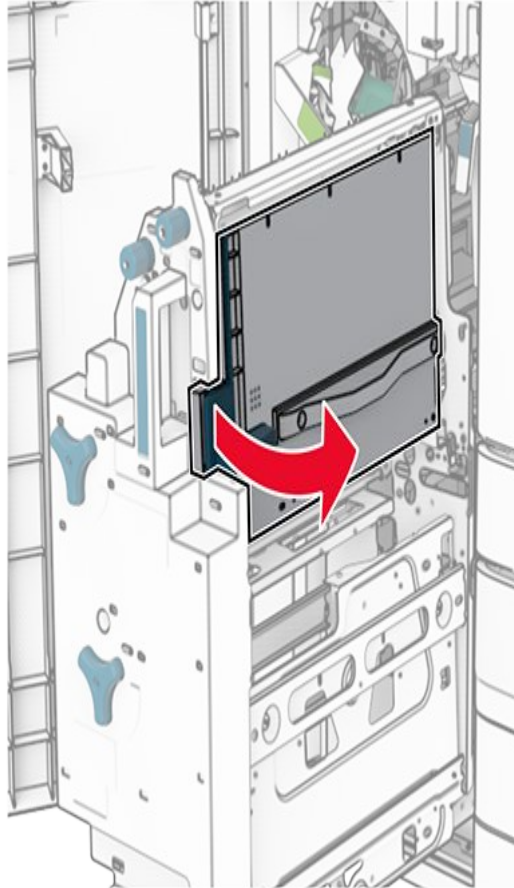

8. Remove the jammed paper.

**Note:** Make sure that all paper fragments are removed.

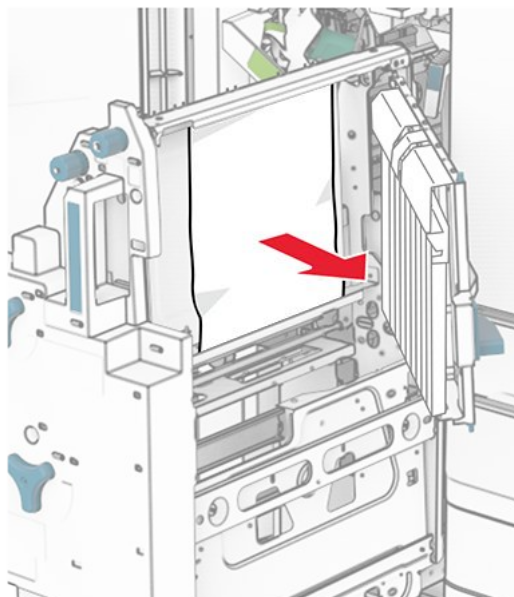

9. Close door R8.
10. Return the booklet maker into the booklet finisher.

11. Close door H.

# Network connection problems

## Cannot open Embedded Web Server

Try one or more of the following:

- Make sure that the printer is on.
- Make sure that the printer IP address is correct.

### Notes

- View the IP address on the control panel.
- The IP address appears as four sets of numbers separated by periods, such as 123.123.123.123.

- Make sure that you installed a supported browser.
  - Internet Explorer version 11 or later
  - Microsoft Edge
  - Safari version 6 or later
  - Google Chrome™ version 32 or later
  - Mozilla Firefox version 24 or later
- Check if the network connection is working.

**Note:** If the connection is not working, then contact your administrator.

- Make sure that the cable connections to the printer and print server are secure. For more information, see the documentation that came with the print server.
- Check if the web proxy servers are disabled.

**Note:** If the servers are disabled, then contact your administrator.

If the problem persists, then contact [customer support](#).

## Cannot connect the printer to the Wi-Fi network

Try one or more of the following:

- From the control panel, navigate to **Settings > Network/Ports > Network Overview > Active Adapter**, and then select **Auto**.
- Make sure that the computer is connected to the correct Wi-Fi network. For more information, see [Connecting the printer to a Wi-Fi network on page 284](#).

**Note:** Some routers may share the default Wi-Fi name.

- Make sure that you entered the correct network password.

**Note:** Take note of the spaces, numbers, and capitalization in the password.

- Make sure that the correct wireless security mode is selected. From the control panel, navigate to **Settings > Network/Ports > Wireless > Wireless Security Mode**.

If the problem persists, then contact [customer support](#).

## Hardware options problems

### Cannot detect internal option

Try one or more of the following:

- Turn off the printer, wait for about 10 seconds, and then turn on the printer.
- Print the **Menu Settings Page**, and then check if the internal option appears in the Installed Features list. From the control panel, navigate to **Settings > Reports > Menu Settings Page**.
- Check if the internal option is installed properly into the controller board.
  1. Turn off the printer, and then unplug the power cord from the electrical outlet.
  2. Make sure that the internal option is installed into the appropriate connector on the controller board.
  3. Connect the power cord to the electrical outlet, and then turn on the printer.



#### **CAUTION—POTENTIAL INJURY**

To avoid the risk of fire or electrical shock, connect the power cord to an appropriately rated and properly grounded electrical outlet that is near the product and easily accessible.

- Check if the internal option is available in the print driver.

**Note:** If necessary, manually add the internal option in the print driver to make it available for print jobs. For more information, see [Adding available options in the print driver on page 130](#).

If the problem persists, then contact [customer support](#).

### Internal solutions port does not operate correctly

Try one or more of the following:

- Print the **Menu Settings Page**, and then check if the internal solutions port (ISP) appears in the Installed Features list. From the control panel, navigate to **Settings > Reports > Menu Settings Page**.
- Remove, and then reinstall the ISP. For more information, see [Installing an internal solutions port on page 278](#).
- Check the cable and the ISP connection.
  1. Use the correct cable, and then make sure that it is securely connected to the ISP.
  2. Check if the ISP solution interface cable is securely connected to its slot on the controller board.

If the problem persists, then contact [customer support](#).

## Parallel or serial interface card does not operate correctly

Try one or more of the following:

- Print the **Menu Settings Page**, and then check if the parallel or serial interface card appears in the Installed Features list. From the control panel, navigate to **Settings > Reports > Menu Settings Page**.
- Remove, and then reinstall the parallel or serial interface card. For more information, see [Installing an internal solutions port on page 278](#).
- Check the connection between the cable and the parallel or serial interface card.

If the problem persists, then contact [customer support](#).

## Defective flash detected

Try one or more of the following:

- Replace the defective flash memory.
- Select **Continue** to ignore the message and continue printing.
- Cancel the current print job.

## Not enough free space in flash memory for resources

Try one or more of the following:

- Select **Continue** to clear the message and continue printing.
- Delete fonts, macros, and other data that are stored in the flash memory.
- Install a storage drive.

**Note:** Downloaded fonts and macros that are not previously stored in the flash memory are deleted.

## Issues with supplies

### Replace cartridge, printer region mismatch

To correct this problem, purchase a cartridge with the correct region that matches the printer region, or purchase a worldwide cartridge.

- The first number in the message after 42 indicates the region of the printer.
- The second number in the message after 42 indicates the region of the cartridge.

Region	Numeric code
Worldwide or Undefined region	0
North America (United States, Canada)	1
European Economic Area, Western Europe, Nordic countries, Switzerland	2
Asia Pacific	3
Latin America	4
Rest of Europe, Middle East, Africa	5
Australia, New Zealand	6
Invalid region	9

**Note:** To find the region settings of the printer and toner cartridge, print the **Print Quality Test Pages**. From the control panel, navigate to **Settings > Troubleshooting > Print Quality Test Pages**.

### Refilled regular cartridge

The printer has detected a Lexmark Regular cartridge that has been refilled with non-genuine toner by a party other than Lexmark.

Select **OK** to continue.

All printer component life indicators are designed to function with Lexmark supplies and parts and may deliver unpredictable results when using supplies or parts in your Lexmark printer that are remanufactured by parties other than Lexmark.

For more information, see the printer statement of limited warranty.

### Non-Lexmark supply

The printer has detected a non-Lexmark supply or part installed in the printer.

Your Lexmark printer is designed to function best with genuine Lexmark supplies and parts. Use of third-party supplies or parts may affect the performance, reliability, or life of the printer and its imaging components.

## Troubleshoot a problem

---

All life indicators are designed to function with Lexmark supplies and parts and may deliver unpredictable results if third-party supplies or parts are used. Imaging component usage beyond the intended life may damage your Lexmark printer or associated components.

### **Warning—Potential Damage**

Use of third-party supplies or parts can affect warranty coverage. Damage caused by the use of third-party supplies or parts may not be covered by the warranty.

To accept any and all of these risks and to proceed with the use of non-genuine supplies or parts in your printer, touch and hold the error message on the display using two fingers for 15 seconds. When a confirmation dialog box appears, touch **Continue**.

If you do not want to accept these risks, then remove the third-party supply or part from your printer and install a genuine Lexmark supply or part. For more information, see [Using genuine Lexmark parts and supplies on page 446](#).

If the printer does not print after clearing the error message, then reset the supply usage counter.

1. From the control panel, navigate to **Settings > Device > Maintenance > Configuration Menu > Supply Usage And Counters**.
2. Select the part or supply that you want to reset, and then select **Start**.
3. Read the warning message, and then select **Continue**.
4. Using two fingers, touch the display for 15 seconds to clear the message.

**Note:** If you are unable to reset the supply usage counters, then return the supply item to the place of purchase.

## Paper feed problems

### Paper curl

Try one or more of the following:

- Adjust the guides in the tray to the correct position for the paper loaded.
- Depending on your operating system, specify the paper type from the Printing Preferences or Print dialog. Make sure that the setting matches the paper loaded.

**Note:** You can also change the setting on the printer control panel. Navigate to **Settings > Paper > Tray Configuration > Paper Size/Type**.

- Remove the paper, flip it over, and then reload the paper.
- Load paper from a fresh package.

**Note:** Paper absorbs moisture due to high humidity. Store the paper in its original wrapper until you are ready to use it.

If the problem persists, then contact [customer support](#).

### Envelope seals when printing

Try one or more of the following:

- Use an envelope that has been stored in a dry environment.

**Note:** Printing on envelopes with high moisture content can seal the flaps.

- Make sure that the paper type is set to **Envelope**. From the control panel, navigate to **Settings > Paper > Tray Configuration > Paper Size/Type**.

If the problem persists, then contact [customer support](#).

### Collated printing does not work

Try one or more of the following:

- From the control panel, navigate to **Settings > Print > Layout > Collate**, and then select **On [1,2,1,2,1,2]**.
- From the document that you are trying to print, open the Printing Preferences or Print dialog, and then select **Collate**.
- Reduce the number of pages to print.

If the problem persists, then contact [customer support](#).

### Tray linking does not work

Try one or more of the following:

- Make sure that the linked trays contain the same paper size, orientation, and paper type.
- Make sure that the paper guides are positioned correctly.
- Set the paper size and paper type to match the paper loaded in the linked trays. From the control panel, navigate to **Settings > Paper > Tray Configuration > Paper Size/Type**.
- Make sure that **Tray Linking** is set to **Automatic**. For more information, see [Linking trays on page 126](#).

If the problem persists, then contact [customer support](#).

### Paper frequently jams

Try one or more of the following:

- Check if the paper is loaded correctly.

### Notes

- Make sure that the paper guides are positioned correctly.
- Make sure that the stack height is below the maximum paper fill indicator.
- Make sure to print on the recommended paper size and paper type.

- Set the correct paper size and paper type. From the control panel, navigate to **Settings > Paper > Tray Configuration > Paper Size/Type**.
- Load paper from a fresh package.

**Note:** Paper absorbs moisture due to high humidity. Store the paper in its original wrapper until you are ready to use it.

If the problem persists, then contact [customer support](#).

## Jammed pages are not reprinted

1. From the control panel, navigate to **Settings > Device > Notifications > Jam Content Recovery**.
2. In the **Jam Recovery** menu, select **On** or **Auto**.

If the problem persists, then contact [customer support](#).

## Emailing problems

### Disabling the “SMTP server not set up” error message

1. From the control panel, navigate to **Settings > Email > Email Setup**.
2. Set **Disable “SMTP server not set up” error** to **On**.

To prevent the error from happening again, do one or more of the following:

- Update the printer firmware. For more information, see the “Printer firmware instructions” section.
- Configure the email SMTP settings. For more information, see [Configuring the email SMTP settings on page 300](#).

### Cannot send emails

Try one more of the following:

- Make sure that the email SMTP settings are configured correctly. For more information, see [Configuring the email SMTP settings on page 300](#).
- Make sure that the printer is connected to a network and the network is connected to the Internet.

If the problem persists, then contact [customer support](#).

## | Faxing problems

### Caller ID is not shown

1. From the control panel, navigate to **Settings > Fax > Fax Setup > Fax Receive Settings > Admin Controls**.
2. Set **Enable Caller ID** to **On**.

If the problem persists, then contact [customer support](#).

### Cannot send or receive faxes using analog fax

Try one or more of the following:

- Resolve any error messages that appear on the display.
- Make sure that the cable connections for the telephone, handset, or answering machine are secure.
- Check for a dial tone.
  - Call the fax number to check if it is working properly.
  - If you are using the On Hook Dial feature, then turn up the volume to check if you hear a dial tone.
- Check the telephone wall jack.
  1. Connect the analog telephone directly to the wall jack.
  2. Listen for a dial tone.
  3. If you do not hear a dial tone, then use a different telephone cable.
  4. If you still do not hear a dial tone, then connect the analog telephone to a different wall jack.
  5. If you hear a dial tone, then connect the printer to that wall jack.
- Check if the printer is connected to an analog phone service or to the correct digital connector.
  - If you are using an Integrated Services for Digital Network (ISDN) telephone service, then connect to an analog telephone port of an ISDN terminal adapter. For more information, contact your ISDN provider.
  - If you are using DSL, then connect to a DSL filter or router that supports analog use. For more information, contact your DSL provider.
  - If you are using a private branch exchange (PBX) telephone service, then make sure that you are connecting to an analog connection on the PBX. If none exists, then consider installing an analog telephone line for the fax machine.
- Temporarily disconnect other equipment and disable other telephone services.
  1. Disconnect other equipment (such as answering machines, computers, modems, or telephone line splitters) between the printer and the telephone line.
  2. Disable call waiting and voice mail. For more information, contact your telephone company.
- Scan the original document one page at a time.

If the problem persists, then contact [customer support](#).

### Can receive but not send faxes using analog fax

Try one or more of the following:

- Load an original document into the ADF tray or on the scanner glass.
- Set up the shortcut number properly.
  - Check if the shortcut number is set for the telephone number that you want to dial.
  - Dial the telephone number manually.

If the problem persists, then contact [customer support](#).

## Can send but not receive faxes using analog fax

Try one or more of the following:

- Make sure that the paper source is not empty.
- Check the ring count delay settings. From the control panel, navigate to **Settings > Fax > Fax Setup > Fax Receive Settings > Rings to Answer**.
- If the printer is printing blank pages, then see [Blank or white pages on page 516](#).

If the problem persists, then contact [customer support](#).

## Cannot set up etherFAX

Try one or more of the following:

- Check the printer connectivity.
  1. From the control panel, navigate to **Settings > Reports > Network > Network Setup Page**.
  2. Check the network status on the printed page.
- Make sure that the printer is connected to a network and the network is connected to the Internet.
- Make sure that etherFAX is set up correctly. For more information, see [Setting up the fax function using etherFAX on page 106](#).

If the problem persists, then go to <https://www.etherfax.net/lexmark>.

## Cannot send or receive faxes using etherFAX

Try one or more of the following:

- Make sure that the printer is connected to a network and the network is connected to the Internet.
- Make sure that etherFAX is set up correctly. For more information, see [Setting up the fax function using etherFAX on page 106](#).
- Split large documents into smaller file sizes.

If the problem persists, then go to <https://www.etherfax.net/lexmark>.

## Poor fax print quality

Try one or more of the following:

- Resolve any print quality defects.
  1. Print the **Test Quality Pages**. From the control panel, navigate to **Settings > Troubleshooting > Print Quality Test Pages**.
  2. Correct any print quality defects. For more information, see the "Print quality is poor" section.
- If you are using an analog fax, then decrease the incoming fax transmission speed.
  1. From the control panel, navigate to **Settings > Fax > Fax Setup > Fax Receive Settings > Admin Controls**.
  2. In the **Max Speed** menu, select a lower transmission speed.

If the problem persists, then contact [customer support](#).

## Missing information on the fax cover page

1. Turn off the printer, wait for about 10 seconds, and then turn on the printer.
2. Send or retrieve the fax.

If the problem persists, then contact [customer support](#).

## Cannot send the fax cover page from the computer

Try one or more of the following:

- Make sure that the print driver is updated. For more information, go to [www.lexmark.com/downloads](http://www.lexmark.com/downloads).
- Clear the **Always display settings prior to faxing** setting.
  1. From the document that you are trying to fax, open the **Print** dialog.
  2. Select the printer, and then click **Properties**, **Preferences**, **Options**, or **Setup**.
  3. Click **Fax**, and then clear the **Always display settings prior to faxing** setting.

If the problem persists, then contact [customer support](#).

## Scanning problems

### Cannot scan to a computer

Try one or more of the following:

- Perform a copy job. If the job failed, then turn off the printer, wait for about 10 seconds, and then turn on the printer.
- Check the printer connectivity.
  1. Print the **Network Setup Page**. From the control panel, navigate to **Settings > Reports > Network**, and then select **Network Setup Page**.
  2. Check the first section of the page and confirm if the status is connected.
- Make sure that the printer and the computer are connected to the same network.

If the problem persists, then contact [customer support](#).

## Cannot scan to a network folder

### Try one or more of the following:

- Create a network folder shortcut, and then scan a document using the shortcut. For more information, see [Scanning to a network folder on page 318](#).
  - Make sure that the network folder path and format are correct. For example, // *server\_hostname*/foldername/path, where *server\_hostname* is a fully qualified domain (FQDN) or IP address.
  - Make sure that you have a write access permission to the network folder.
  - Update the network folder shortcut.
1. Open a web browser, and then type the printer IP address in the address field.

#### Notes

- View the printer IP address on the printer home screen. The IP address appears as four sets of numbers separated by periods, such as 123.123.123.123.
- If you are using a proxy server, then temporarily disable it to load the web page correctly.

2. Click **Shortcuts**, and then select a shortcut.

**Note:** If you have multiple shortcut types, then select **Network Folder**.

3. In the Share Path field, type the network folder path. For example, \ *server\_hostname*\foldername\path.

**Note:** Always use forward slashes when typing the share path.

4. From the **Authentication** menu, select your authentication method.

**Note:** If **Authentication** is set to “Use assigned username and password,” then in the Username and Password fields, type your credentials.

5. Click **Save**.
- Make sure that the printer and the network folder are connected to the same network.

If the problem persists, then contact [customer support](#).

## Partial copies of document or photo

### Try one or more of the following:

- Make sure that the document or photo is loaded facedown on the upper left corner of the scanner glass.

- Match the paper size setting and the paper loaded in the tray.

If the problem persists, then contact [customer support](#).

## Poor copy quality

Try one or more of the following:

- Clean the scanner glass and the ADF glass with a damp, soft, lint-free cloth.

**Note:** If your printer has a second ADF glass inside the ADF, then also clean that glass. For more information, see [Cleaning the scanner on page 486](#).

- Make sure that the document or photo is loaded facedown on the upper left corner of the scanner glass.
- Check the quality of the original document or photo and adjust the scan quality settings accordingly.

If the problem persists, then contact [customer support](#).

## Vertical dark streaks when scanning from the ADF

1. Raise the scanner cover, and then remove the glass cleaner tool.
2. Wipe the ADF glass beside the scanner glass.
3. Open door A1, and then clean the ADF glass.
4. Return the tool to its place.
5. Close the scanner cover.

**Note:** For more information on cleaning the scanner, see [Cleaning the scanner on page 486](#).

If the problem persists, then contact [customer support](#).

## Jagged image or text when scanning from the ADF

1. Load 50 sheets of clean, plain paper into the ADF.

**Note:** The plain paper helps clean or remove dust and other coatings from the ADF feed rollers.

2. From the control panel, swipe right to the control center, and then select .
3. Load an original document into the ADF.
4. Scan the document.

If the problem persists, then contact [customer support](#).

## Scan job was not successful

Try one or more of the following:

- Make sure that the Ethernet or USB cable is securely connected to the computer and the printer.
- Check the file that you want to scan, and make sure that:
  - The file name is not already used in the destination folder.
  - The document or photo that you want to scan is not open in another application.
- Make sure that the **Append time stamp** or the **Overwrite existing file** check box is selected in the destination configuration settings.

If the problem persists, then contact [customer support](#).

## Scanner does not close

1. Remove obstructions that keep the scanner cover open.
2. Close the scanner.

If the problem persists, then contact [customer support](#).

## Scanning takes too long or freezes the computer

1. Close all applications that are interfering with the scan.
2. Scan the document again.

If the problem persists, then contact [customer support](#).

## Scanner does not respond

Try one or more of the following:

- Check if the power cord is connected properly to the printer and the electrical outlet.



### CAUTION—POTENTIAL INJURY

To avoid the risk of fire or electrical shock, connect the power cord to an appropriately rated and properly grounded electrical outlet that is near the product and easily accessible.

- Check if the printer is turned on, and then resolve any error messages that appear on the display.
- Turn off the printer, wait for about 10 seconds, and then turn on the printer.

If the problem persists, then contact [customer support](#).

## Adjusting scanner registration

1. From the control panel, navigate to **Settings > Device > Maintenance > Configuration Menu > Scanner Configuration > Scanner Manual Registration**.
2. In the **Print Quick Test** menu, select **Start**.
3. Place the test page on the scanner glass, and then select **Flatbed Registration**.
4. In the **Copy Quick Test** menu, select **Start**.
5. Compare the test page with the original document.

**Note:** If the margins of the test page are different from the original document, then adjust the **Left Margin** and **Top Margin** settings.

6. Repeat [step 4](#) and [step 5](#) until the margins of the **Copy Quick Test** page closely match the original document.

## Adjusting ADF registration

1. From the control panel, navigate to **Settings > Device > Maintenance > Configuration Menu > Scanner Configuration > Scanner Manual Registration**.
2. In the **Print Quick Test** menu, select **Start**.
3. Place the test page on the ADF tray.
4. Select **Front ADF Registration** or **Rear ADF Registration**.

### Notes

- To align **Front ADF Registration**, place the test page faceup, short edge first into the ADF.
- To align **Rear ADF Registration**, place the test page facedown, short edge first into the ADF.

5. In the **Copy Quick Test** menu, select **Start**.
6. Compare the test page with the original document.

**Note:** If the margins of the test page are different from the original document, then adjust the **Horizontal Adjust** and **Top Margin** settings.

7. Repeat [step 5](#) and [step 6](#) until the margins of the **Copy Quick Test** page closely match the original document.

## Contacting customer support

Before contacting customer support, make sure to have the following information:

## Troubleshoot a problem

---

- Printer problem
- Error message
- Printer model type and serial number

Go to <https://support.lexmark.com> to receive email or chat support, or browse through the library of manuals, support documentation, drivers, and other downloads.

Technical support via telephone is also available. In the U.S. or Canada, call 1-800-539-6275. For other countries or regions, go to [the international support contact directory](#).

# Recycle and dispose

## Recycling Lexmark products

1. Go to [www.lexmark.com/recycle](http://www.lexmark.com/recycle).
2. Select your country or region.
3. Select a recycling program.

## Recycling Lexmark packaging

Lexmark continually strives to minimize packaging. Less packaging helps to ensure that Lexmark printers are transported in the most efficient and environmentally sensitive manner and that there is less packaging to dispose of. These efficiencies result in fewer greenhouse emissions, energy savings, and natural resource savings.

Lexmark cartons are 100% recyclable where corrugated recycling facilities exist. Facilities may not exist in your area.

The foam used in Lexmark packaging is recyclable where foam recycling facilities exist. Facilities may not exist in your area.

When you return a cartridge to Lexmark, you can reuse the box that the cartridge came in. Lexmark will recycle the box.

## Notices

### Product information

Product name:

Lexmark MX953se MFPs

Machine type:

7466

Models:

688

### Edition and legal notices

#### Edition notices

March 2025

**The following paragraph does not apply to any country where such provisions are inconsistent with local law:** LEXMARK INTERNATIONAL, INC., PROVIDES THIS PUBLICATION "AS IS" WITHOUT WARRANTY OF ANY KIND, EITHER EXPRESS OR IMPLIED, INCLUDING, BUT NOT LIMITED TO, THE IMPLIED WARRANTIES OF MERCHANTABILITY OR FITNESS FOR A PARTICULAR PURPOSE. Some states do not allow disclaimer of express or implied warranties in certain transactions; therefore, this statement may not apply to you.

This publication could include technical inaccuracies or typographical errors. Changes are periodically made to the information herein; these changes will be incorporated in later editions. Improvements or changes in the products or the programs described may be made at any time.

References in this publication to products, programs, or services do not imply that the manufacturer intends to make these available in all countries in which it operates. Any reference to a product, program, or service is not intended to state or imply that only that product, program, or service may be used. Any functionally equivalent product, program, or service that does not infringe any existing intellectual property right may be used instead. Evaluation and verification of operation in conjunction with other products, programs, or services, except those expressly designated by the manufacturer, are the user's responsibility.

For Lexmark technical support, go to <https://support.lexmark.com>.

For information on Lexmark's privacy policy governing the use of this product, go to [www.lexmark.com/privacy](http://www.lexmark.com/privacy).

For information on supplies and downloads, go to [www.lexmark.com](http://www.lexmark.com).

© 2025 Lexmark International, Inc.

**All rights reserved.**

### GOVERNMENT END USERS

The Software Program and any related documentation are "Commercial Items," as that term is defined in 48 C.F.R. 2.101, "Computer Software" and "Commercial Computer Software Documentation," as such terms are used in 48 C.F.R. 12.212 or 48 C.F.R. 227.7202, as applicable. Consistent with 48 C.F.R. 12.212 or 48 C.F.R. 227.7202-1

through 227.7207-4, as applicable, the Commercial Computer Software and Commercial Software Documentation are licensed to the U.S. Government end users (a) only as Commercial Items and (b) with only those rights as are granted to all other end users pursuant to the terms and conditions herein.

## Trademarks

Lexmark, the Lexmark logo, and MarkNet are trademarks or registered trademarks of Lexmark International, Inc. in the United States and/or other countries.

Gmail, Android, Google Play, and Google Chrome are trademarks of Google LLC.

Macintosh, macOS, Safari, and AirPrint are trademarks of Apple Inc., registered in the U.S. and other countries. iCloud is a service mark of Apple Inc., registered in the U.S. and other countries. Use of the Works with Apple badge means that an accessory has been designed to work specifically with the technology identified in the badge and has been certified by the developer to meet Apple performance standards.

Microsoft, Internet Explorer, Microsoft 365, Microsoft Edge, Outlook, and Windows are trademarks of the Microsoft group of companies.

The Mopria™ word mark is a registered and/or unregistered trademark of Mopria Alliance, Inc. in the United States and other countries. Unauthorized use is strictly prohibited.

PCL® is a registered trademark of the Hewlett-Packard Company. PCL is Hewlett-Packard Company's designation of a set of printer commands (language) and functions included in its printer products. This printer is intended to be compatible with the PCL language. This means the printer recognizes PCL commands used in various application programs, and that the printer emulates the functions corresponding to the commands.

PostScript is a registered trademark of Adobe Systems Incorporated in the United States and/or other countries.

Wi-Fi® and Wi-Fi Direct® are registered trademarks of Wi-Fi Alliance®.

All other trademarks are the property of their respective owners.

## Licensing notices

All licensing notices associated with this product can be viewed from the CD:\NOTICES directory of the installation software CD.

## STATEMENT OF LIMITED WARRANTY FOR LEXMARK LASER PRINTERS, LEXMARK LED PRINTERS, AND LEXMARK MULTIFUNCTION LASER PRINTERS

### Lexmark International, Inc., Lexington, KY

This limited warranty applies to the United States and Canada. For customers outside the U.S., refer to the country-specific warranty information that came with your product.

This limited warranty applies to this product only if it was originally purchased for your use, and not for resale, from Lexmark or a Lexmark Remarketer, referred to in this statement as "Remarketer."

### Limited warranty

Lexmark warrants that this product:

—Is manufactured from new parts, or new and serviceable used parts, which perform like new parts

—Is, during normal use, free from defects in material and workmanship

If this product does not function as warranted during the warranty period, contact a Remarketer or Lexmark for repair or replacement (at Lexmark's option).

If this product is a feature or option, this statement applies only when that feature or option is used with the product for which it was intended. To obtain warranty service, you may be required to present the feature or option with the product.

If you transfer this product to another user, warranty service under the terms of this statement is available to that user for the remainder of the warranty period. You should transfer proof of original purchase and this statement to that user.

### Limited warranty service

The warranty period starts on the date of original purchase as shown on the purchase receipt and ends 12 months later provided that the warranty period for any supplies and for any maintenance items included with the printer shall end earlier if it, or its original contents, are substantially used up, depleted, or consumed. Fuser Units, Transfer/Transport Units, Paper Feed items, if any, and any other items for which a Maintenance Kit is available are substantially consumed when the printer displays a "Life Warning" or "Scheduled Maintenance" message for such item.

To obtain warranty service you may be required to present proof of original purchase. You may be required to deliver your product to the Remarketer or Lexmark, or ship it prepaid and suitably packaged to a Lexmark designated location. You are responsible for loss of, or damage to, a product in transit to the Remarketer or the Lexmark designated location.

When warranty service involves the exchange of a product or part, the item replaced becomes the property of the Remarketer or Lexmark. The replacement may be a new or repaired item.

The replacement item assumes the remaining warranty period of the original product.

Replacement is not available to you if the product you present for exchange is defaced, altered, in need of a repair not included in warranty service, damaged beyond repair, or if the product is not free of all legal obligations, restrictions, liens, and encumbrances.

As part of your warranty service and/or replacement, Lexmark may update the firmware in your printer to the latest version. Firmware updates may modify printer settings and cause counterfeit and/or unauthorized products, supplies, parts, materials (such as toners and inks), software, or interfaces to stop working. Authorized use of genuine Lexmark products will not be impacted.

Before you present this product for warranty service, remove all print cartridges, programs, data, and removable storage media (unless directed otherwise by Lexmark).

For further explanation of your warranty alternatives and the nearest Lexmark authorized servicer in your area contact Lexmark on the World Wide Web.

Remote technical support is provided for this product throughout its warranty period. For products no longer covered by a Lexmark warranty, technical support may not be available or only be available for a fee.

## Extent of limited warranty

Lexmark does not warrant uninterrupted or error-free operation of any product or the durability or longevity of prints produced by any product.

Warranty service does not include repair of failures caused by:

- Modification or unauthorized attachments
- Accidents, misuse, abuse or use inconsistent with Lexmark user's guides, manuals, instructions or guidance
- Unsuitable physical or operating environment
- Maintenance by anyone other than Lexmark or a Lexmark authorized servicer
- Operation of a product beyond the limit of its duty cycle
- Use of printing media outside of Lexmark specifications
- Refurbishment, repair, refilling or remanufacture by a third party of products, supplies or parts
- Products, supplies, parts, materials (such as toners and inks), software, or interfaces not furnished by Lexmark

**TO THE EXTENT PERMITTED BY APPLICABLE LAW, NEITHER LEXMARK NOR ITS THIRD PARTY SUPPLIERS OR REMARKETERS MAKE ANY OTHER WARRANTY OR CONDITION OF ANY KIND, WHETHER EXPRESS OR IMPLIED, WITH RESPECT TO THIS PRODUCT, AND SPECIFICALLY DISCLAIM THE IMPLIED WARRANTIES OR CONDITIONS OF MERCHANTABILITY, FITNESS FOR A PARTICULAR PURPOSE, AND SATISFACTORY QUALITY. ANY WARRANTIES THAT MAY NOT BE DISCLAIMED UNDER APPLICABLE LAW ARE LIMITED IN DURATION TO THE WARRANTY PERIOD. NO WARRANTIES, EXPRESS OR IMPLIED, WILL APPLY AFTER THIS PERIOD. ALL INFORMATION, SPECIFICATIONS, PRICES, AND SERVICES ARE SUBJECT TO CHANGE AT ANY TIME WITHOUT NOTICE.**

## Limitation of liability

Your sole remedy under this limited warranty is set forth in this document. For any claim concerning performance or nonperformance of Lexmark or a Remarketer for this product under this limited warranty, you may recover actual damages up to the limit set forth in the following paragraph.

Lexmark's liability for actual damages from any cause whatsoever will be limited to the amount you paid for the product that caused the damages. This limitation of liability will not apply to claims by you for bodily injury or damage to real property or tangible personal property for which Lexmark is legally liable. **IN NO EVENT WILL LEXMARK BE LIABLE FOR ANY LOST PROFITS, LOST SAVINGS, INCIDENTAL DAMAGE, OR OTHER ECONOMIC OR CONSEQUENTIAL DAMAGES.** This is true even if you advise Lexmark or a Remarketer of the possibility of such damages. Lexmark is not liable for any claim by you based on a third party claim.

This limitation of remedies also applies to claims against any Suppliers and Remarketers of Lexmark. Lexmark's and its Suppliers' and Remarketers' limitations of remedies are not cumulative. Such Suppliers and Remarketers are intended beneficiaries of this limitation.

## Additional rights

Some states do not allow limitations on how long an implied warranty lasts, or do not allow the exclusion or limitation of incidental or consequential damages, so the limitations or exclusions contained above may not apply to you.

This limited warranty gives you specific legal rights. You may also have other rights that vary from state to state.

## Specifications

### Laser notice

The printer is certified in the U.S. to conform to the requirements of DHHS 21 CFR, Chapter I, Subchapter J for Class I (1) laser products, and elsewhere is certified as a Class 1 consumer laser product conforming to the requirements of IEC 60825-1:2014, EN 60825-1:2014+A11:2021, and EN 50689:2021.

Class I laser products are not considered to be hazardous. The laser system and printer are designed so there is never any human access to laser radiation above a Class I level during normal operation, user maintenance, or prescribed service conditions. The printer has a non-serviceable printhead assembly that contains a laser with the following specifications:

Class: IIIb (3b) AlGaAs

Nominal output power (milliwatts): 25

Wavelength (nanometers): 770–800

### Temperature information

Operating temperature and relative humidity (RH) <sup>1</sup>	10 to 32.2°C (50 to 90°F) and 15 to 80% RH  15.6 to 32.2°C (60 to 90°F) and 8 to 80% RH  Maximum wet-bulb temperature <sup>2</sup> : 22.8°C (73°F)  Non-condensing environment
Printer / cartridge / imaging unit long-term storage <sup>2</sup>	15.6 to 32.2°C (60 to 90°F) and 8 to 80% RH  Maximum wet-bulb temperature <sup>2</sup> : 22.8°C (73°F)
Printer / cartridge / imaging unit short-term shipping <sup>3</sup>	-40 to 40°C (-40 to 104°F)

<sup>1</sup> In some cases, performance specifications (such as cartridge usage and first-page-out speed) must be measured at a standard office environment of approximately 22.2°C (72°F) and 45% RH.

<sup>2</sup> Supplies shelf life is approximately 2 years. This is based on storage in a standard office environment at 22°C (72°F) and 45% humidity.

<sup>3</sup> Wet-bulb temperature is determined by the air temperature and the relative humidity.

## Product power consumption

The following table documents the power consumption characteristics of the product.

**Note:** Some modes may not apply to your product.

Mode	Description	Power consumption (Watts)
Printing	The product is generating hard-copy output from electronic inputs.	One-sided: 756; Two-sided: 707
Copy	The product is generating hard-copy output from hard-copy original documents.	762
Scan	The product is scanning hard-copy documents.	61.0
Ready	The product is waiting for a print job.	41.5
Sleep Mode	The product is in a high-level energy-saving mode.	1.0
Hibernate	The product is in a low-level energy-saving mode.	0.2
Off	The product is plugged into an electrical outlet, but the power switch is turned off.	0.2

The power consumption levels listed in the previous table represent time-averaged measurements. Instantaneous power draws may be substantially higher than the average. Values are subject to change. See [www.lexmark.com](http://www.lexmark.com) for current values.

## Sleep Mode

This product is designed with an energy-saving mode called **Sleep Mode**. The Sleep Mode saves energy by lowering power consumption during extended periods of inactivity. The Sleep Mode is automatically engaged after this product is not used for a specified period of time, called the **Sleep Mode Timeout**.

Factory default Sleep Mode Timeout for this product (in minutes):	15
---	----

By using the configuration menus, the Sleep Mode Timeout can be modified between 1 minute and 120 minutes, or between 1 minute and 114 minutes, depending on the printer model. If the printer speed is less than or equal to 30 pages per minute, then you can set the timeout only up to 60 minutes or 54 minutes, depending on the printer model. Setting

the Sleep Mode Timeout to a low value reduces energy consumption, but may increase the response time of the product. Setting the Sleep Mode Timeout to a high value maintains a fast response, but uses more energy.

Some models support a **Deep Sleep Mode**, which further reduces power consumption after longer periods of inactivity.

## Hibernate Mode

This product is designed with an ultra-low power operating mode called **Hibernate mode**. When operating in Hibernate Mode, all other systems and devices are powered down safely.

The Hibernate mode can be entered in any of the following methods:

- Using the Hibernate Timeout
- Using the Schedule Power modes

Factory default Hibernate Timeout for this product in all countries or regions	3 days
--	--------

The amount of time the printer waits after a job is printed before it enters Hibernate mode can be modified between one hour and one month.

### Notes on EPEAT-registered imaging equipment products:

- Standby power level occurs in Hibernate or Off mode.
- The product shall automatically power down to a standby power level of  $\leq 1$  W. The auto standby function (Hibernate or Off) shall be enabled at product shipment.

## Off mode

If this product has an off mode which still consumes a small amount of power, then to completely stop product power consumption, disconnect the power supply cord from the electrical outlet.

## Total energy usage

It is sometimes helpful to estimate the total product energy usage. Since power consumption claims are provided in power units of Watts, the power consumption should be multiplied by the time the product spends in each mode in order to calculate energy usage. The total product energy usage is the sum of each mode's energy usage.

## Environmental and sustainability notices

### Noise emission levels

The following measurements were made in accordance with ISO 7779 and reported in conformance with ISO 9296.

**Note:** Some modes may not apply to your product.

1-meter average sound pressure, dBA	
Printing	One-sided: 51 Two-sided: 52
Scanning	Mono: 55 Color: 42
Copying	Mono: 53
Ready	14

Values are subject to change. See [www.lexmark.com](http://www.lexmark.com) for current values.

## Waste from Electrical and Electronic Equipment (WEEE) directive



The WEEE logo signifies specific recycling programs and procedures for electronic products in countries of the European Union. We encourage the recycling of our products. If you have further questions about recycling options, visit the Lexmark Web site at [www.lexmark.com](http://www.lexmark.com) for your local sales office phone number.

## India E-Waste notice



This product including components, consumables, parts and spares complies with the "India E-Waste Rules" and prohibits use of lead, mercury, hexavalent chromium, polybrominated biphenyls or polybrominated diphenyl ethers in concentrations exceeding 0.1% by weight and 0.01% by weight for cadmium, except for the exemption set in the Rule.

## Lithium-ion rechargeable battery



This product may contain a coin-cell, lithium-ion rechargeable battery, which should only be removed by a trained technician. Crossed-out wheeled bin means the product should not be discarded as unsorted waste but must be sent to separate collection facilities for recovery and recycling. In the event the battery is removed, do not dispose of the battery in your household waste. There may be separate collection systems for batteries in your local community, such as a battery-recycling drop-off location. The separate collection of waste batteries assures appropriate treatment of waste including reuse and recycling and prevents any potential negative effects on human health and environment. Please responsibly dispose of the batteries.

## Regulation (EU) 2023/1542

This product may contain a coin-cell lithium rechargeable battery. This battery complies with Regulation (EU) 2023/1542. Compliance is indicated by the CE marking:



This product may contain one of the following coin-cell batteries:

- Battery identification: Seiko Model Number MS621FE  
Manufacturer: Seiko Instruments Inc.

Manufacturer address: 8, Nakase 1-chome, Mihama-ku, Chiba-shi, Chiba 261-8507, Japan

- Battery identification: Panasonic Model Number ML621  
Manufacturer: Panasonic Energy Co., Ltd.



Manufacturer address: 1-1 Matsushita-cho, Moriguchi City, Osaka 570-8511, Japan

- Battery identification: FDK Model Number ML621  
Manufacturer: FDK Corporation

Manufacturer address: Shibaura Crystal Shinagawa, 1-6-41 Konan, Minato-ku, Tokyo 108-8212 Japan

## Environmental labeling for packaging

Per Commission Regulation Decision 97/129/EC Legislative Decree 152/2006, the product packaging may contain one or more of the following symbols.

	<p>This symbol indicates that the packaging may contain corrugated fiberboard.</p>
	<p>This symbol indicates that the packaging may contain non-corrugated fiberboard.</p>
	<p>This symbol indicates that the packaging may contain paper.</p>

For more information, go to [www.lexmark.com/recycle](http://www.lexmark.com/recycle), and then choose your country or region. Information on available packaging recycling programs is included with the information on product recycling.

## Product disposal

Do not dispose of the printer or supplies in the same manner as normal household waste. Consult your local authorities for disposal and recycling options.

## Returning Lexmark cartridges for reuse or recycling

The Lexmark Cartridge Collection Program allows you to return used cartridges for free to Lexmark for reuse or recycling. One hundred percent of the empty cartridges returned to Lexmark are either reused or demanufactured for recycling. The boxes used to return the cartridges are also recycled.

To return Lexmark cartridges for reuse or recycling, do the following:

1. Go to [www.lexmark.com/recycle](http://www.lexmark.com/recycle).
2. Select your country or region.

3. Select **Lexmark Cartridge Collection Program**.
4. Follow the instructions on the screen.

## ENERGY STAR

Any Lexmark product bearing the ENERGY STAR® emblem on the product or on a start-up screen is certified to comply with Environmental Protection Agency (EPA) ENERGY STAR requirements as of the date of manufacture.



## Notices for wireless products

### Regulatory notices for wireless products

This section contains regulatory information that applies only to wireless models. If in doubt as to whether your model is a wireless model, go to <http://support.lexmark.com>.

### Modular component notice

Wireless models contain one of the following modular components:  
Lexmark MarkNet N8450 / AzureWave AW-CM467-SUR; FCC ID:TLZ-CM467; IC:6100A-CM467

To determine which modular components are installed in your particular product, refer to the labeling on your actual product.

### Exposure to radio frequency radiation

The radiated output power of this device is far below the radio frequency exposure limits of the FCC and other regulatory agencies. A minimum separation of 20 cm (8 inches) must be maintained between the antenna and any persons for this device to satisfy the RF exposure requirements of the FCC and other regulatory agencies.

### Innovation, Science and Economic Development Canada

This device complies with Innovation, Science and Economic Development Canada license-exempt RSS standards. Operation is subject to the following two conditions: (1) this device may not cause interference, and (2) this device must accept any interference, including interference that may cause undesired operation of the device.

## Innovation, Sciences et Développement économique Canada

Cet appareil est conforme aux normes RSS exemptes de licence d'Innovation, Sciences et Développement économique Canada. Son fonctionnement est soumis aux deux conditions suivantes : (1) cet appareil ne doit pas causer d'interférences et (2) il doit accepter toutes les interférences, y compris les celles qui peuvent entraîner un fonctionnement indésirable.

## European Community (EC) directives conformity

This product is in conformity with the protection requirements of EC Council directive 2014/53/EU on the approximation and harmonization of the laws of the Member States relating to radio equipment.

The manufacturer of this product is: Lexmark International, Inc., 740 West New Circle Road, Lexington, KY, 40550 USA. The EEA/EU authorized representative is: Lexmark International Technology Hungária Kft., 8 Lechner Ödön fasor, Millennium Tower III, 1095 Budapest HUNGARY. The EEA/EU Importer is: Lexmark International Technology S.à.r.l. 20, Route de Pré-Bois, ICC Building, Bloc A, CH-1215 Genève, Switzerland. A declaration of conformity to the requirements of the Directives is available upon request from the Authorized Representative or may be obtained at [www.lexmark.com/en\\_us/about/regulatory-compliance/european-union-declaration-of-conformity.html](http://www.lexmark.com/en_us/about/regulatory-compliance/european-union-declaration-of-conformity.html).

Compliance is indicated by the CE marking:



## Restrictions

This radio equipment is restricted to indoor use only. Outdoor use is prohibited. This restriction applies to all the countries listed in the table below:

AT	BE	BG	CH	CY	CZ	DE	DK	EE
EL	ES	FI	FR	HR	HU	IE	IS	IT
LI	LT	LU	LV	MT	NL	NO	PL	PT
RO	SE	SI	SK	TR	UK (NI)			

## EU and other countries statement of radio transmitter operational frequency bands and maximum RF power

This radio product transmits in either the 2.4GHz (2.412–2.472GHz in the EU) or 5GHz (5.15–5.35, 5.47–5.725GHz in the EU) bands. The maximum transmitter EIRP power output, including antenna gain, is  $\leq 20\text{dBm}$  for both bands.

## United Kingdom (UK) conformity

This product is in conformity with the protection requirements of the Radio Equipment Regulations 2017.

The manufacturer of this product is: Lexmark International, Inc., 740 West New Circle Road, Lexington, KY, 40550 USA. The UK Importer is: Lexmark International Ltd, Building Q1 Quantum Business Park, 60 Norden Road, Maidenhead, Berkshire, United Kingdom SL6 4AY. A declaration of conformity is available upon request from the UK Importer or may be obtained at [www.lexmark.com/en\\_us/about/regulatory-compliance/uk-declaration-of-conformity.html](http://www.lexmark.com/en_us/about/regulatory-compliance/uk-declaration-of-conformity.html).

Compliance is indicated by the UKCA marking:



## Restrictions or requirements in the UK

This radio equipment is restricted to indoor use only. Outdoor use is prohibited.

## UK statement of radio transmitter operational frequency bands and maximum RF power

This radio product transmits in either the 2.4GHz (2.412–2.472 GHz in the UK) or 5GHz (5.15–5.35, 5.47–5.725 in the UK) bands. The maximum transmitter EIRP power output, including antenna gain, is  $\leq 20\text{dBm}$  for both bands.

## Notice to users in Thailand

ประกาศถึงผู้ใช้ในประเทศไทย

This radiocommunication equipment has the electromagnetic field strength in compliance with the Safety Standard for the Use of Radiocommunication Equipment on Human Health announced by the National Telecommunications Commission.

เครื่องวิทยุคมนาคมนี้มีระดับการแผ่คลื่นแม่เหล็กไฟฟ้าสอดคล้องตามมาตรฐานความปลอดภัยต่อสุขภาพของมนุษย์จากการใช้เครื่องวิทยุคมนาคมที่คณะกรรมการกิจการโทรคมนาคมแห่งชาติประกาศกำหนด



## Class A device notices

### Federal Communications Commission (FCC) compliance information statement

This product has been tested and found to comply with the limits for a Class A digital device, pursuant to Part 15 of the FCC Rules. Operation is subject to the following two conditions: (1) this device may not cause harmful interference, and (2) this device must accept any interference received, including interference that may cause undesired operation.

The FCC Class A limits are designed to provide reasonable protection against harmful interference when the equipment is operated in a commercial environment. This equipment generates, uses, and can radiate radio frequency energy and, if not installed and used in accordance with the instruction manual, may cause harmful interference to radio communications. Operation of this equipment in a residential area is likely to cause harmful interference, in which case the user will be required to correct the interference at his own expense.

The manufacturer is not responsible for any radio or television interference caused by using other than recommended cables or by unauthorized changes or modifications to this equipment. Unauthorized changes or modifications could void the user's authority to operate this equipment.

**Note:** To assure compliance with FCC regulations on electromagnetic interference for a Class A computing device, use a properly shielded and grounded cable such as Lexmark part number 1021231 for parallel attach or 1021294 for USB attach. Use of a substitute cable not properly shielded and grounded may result in a violation of FCC regulations.

Any questions regarding this compliance information statement should be directed to:  
 Director of Lexmark Technology & Services

Lexmark International, Inc.

740 West New Circle Road

Lexington, KY 40550

Telephone: (859) 232–2000

E-mail: [regulatory@lexmark.com](mailto:regulatory@lexmark.com)

## **Innovation, Science and Economic Development Canada compliance statement**

This Class A digital apparatus meets all requirements of the Canadian Interference-Causing Equipment Standard ICES-003.

## **Avis de conformité aux normes de l'Innovation, Sciences et Développement économique Canada**

Cet appareil numérique de classe A est conforme aux exigences de la norme canadienne relative aux équipements pouvant causer des interférences NMB-003.

## **European Community (EC) directives conformity**

This product is in conformity with the protection requirements of EC Council directives 2014/30/EU, 2014/35/EU, and 2011/65/EU as amended by (EU) 2015/863 on the approximation and harmonization of the laws of the Member States relating to electromagnetic compatibility, safety of electrical equipment designed for use within certain voltage limits, and on the restrictions of use of certain hazardous substances in electrical and electronic equipment.

The manufacturer of this product is: Lexmark International, Inc., 740 West New Circle Road, Lexington, KY, 40550 USA. The EEA/EU authorized representative is: Lexmark International Technology Hungária Kft., 8 Lechner Ödön fasor, Millennium Tower III, 1095 Budapest HUNGARY. The EEA/EU Importer is: Lexmark International Technology S.à.r.l. 20, Route de Pré-Bois, ICC Building, Bloc A, CH-1215 Genève, Switzerland. A declaration of conformity to the requirements of the Directives is available upon request from the Authorized Representative or may be obtained at [www.lexmark.com/en\\_us/about/regulatory-compliance/european-union-declaration-of-conformity.html](http://www.lexmark.com/en_us/about/regulatory-compliance/european-union-declaration-of-conformity.html).

This product satisfies the Class A limits of EN 55032 and safety requirements of EN 62368-1.

## **United Kingdom (UK) conformity**

This product is in conformity with the protection requirements of the Electromagnetic Compatibility Regulations 2016, the Electrical Equipment (Safety) Regulations 2016, and the Restriction of the Use of Certain Hazardous Substances in Electrical and Electronic Equipment Regulations 2012.

The manufacturer of this product is: Lexmark International, Inc., 740 West New Circle Road, Lexington, KY, 40550 USA. The UK Importer is: Lexmark International Ltd, Building Q1 Quantum Business Park, 60 Norden Road, Maidenhead, Berkshire, United Kingdom SL6 4AY. A declaration of conformity is available upon request from the UK Importer or may be obtained at [www.lexmark.com/en\\_us/about/regulatory-compliance/uk-declaration-of-conformity.html](http://www.lexmark.com/en_us/about/regulatory-compliance/uk-declaration-of-conformity.html).

This product satisfies the Class A limits of BS EN 55032 and safety requirements of BS EN 62368-1.

## Radio interference notice

### Warning

This is a product that complies with the emission requirements of EN 55032 Class A limits and immunity requirements of EN 55035. This product is not intended to be used in residential/domestic environments.

This is a Class A product. In a domestic environment, this product may cause radio interference, in which case the user may be required to take adequate measures.

## Other regulatory notices

### Static sensitivity notice



This symbol identifies static-sensitive parts. Do not touch the areas near these symbols without first touching a metal surface in an area away from the symbol.

To prevent damage from electrostatic discharge when performing maintenance tasks such as clearing paper jams or replacing supplies, touch any exposed metal frame of the printer before accessing or touching interior areas of the printer even if the symbol is not present.

### Applicability of Regulation (EU) 2019/2015 and (EU) 2019/2020

Per Commission Regulation (EU) 2019/2015 and (EU) 2019/2020, the light source contained within this product or its component is intended to be used for Image Capture or Image Projection only, and is not intended for use in other applications.

### The UK Product Security and Telecommunications Infrastructure Act 2022 (PSTI Act)—Summary Statement of Compliance

Lexmark International Inc., 740 West New Circle Road, Lexington, KY 40550 USA, declares that this product complies with the applicable security requirements in Schedule 1 of The Product Security and Telecommunications Infrastructure (Security Requirements for Relevant Connectable Products) Regulations 2023. The defined support period for this product can be found at the following web page: <https://www.lexmark.com/firmware-eos>. A copy of the Statement of Compliance is available for download at the following web page: [https://www.lexmark.com/en\\_us/about/regulatory-compliance/all-regulatory-docs.html](https://www.lexmark.com/en_us/about/regulatory-compliance/all-regulatory-docs.html).

## Thailand NBTC technical standards conformity statement

คำประกาศเรื่องการเป็นไปตามมาตรฐานทางเทคนิคของ กสทช. ประเทศไทย

This telecommunication equipment conforms to the technical standards or requirements of NBTC.

เครื่องโทรคมนาคมและอุปกรณ์นี้มีความสอดคล้องตามมาตรฐานหรือข้อกำหนดทางเทคนิคของ กสทช.

# Index

## 1

1500-sheet tray

loading [120](#)

installing [159](#)

## 2

2000-sheet tandem tray

loading [117](#)

2 x 550-sheet tray

installing [141](#)

2000-sheet tandem tray

installing [147](#)

## 5

550-sheet tray

loading [113](#)

installing [134](#)

550-sheet tray cover [465](#)

## A

adding contacts [96](#)

adding groups [96](#)

Address Book [96](#)

adjusting speech rate

Voice Guidance [104](#)

Voice Guidance [104](#)

adjusting headphone volume [104](#)

adjusting speaker volume [104](#)

assigning ring pattern to printer [112](#)

activating Voice Guidance [97](#)

adding hardware options

in print driver [130](#)

analog fax

setting up [105](#)

adding printers to a computer [127](#)

answering machine

setting up [108](#)

adjusting toner darkness [297](#)

adjusting fax darkness [315](#)

adding shortcut

network folder [319](#)

email [312](#)

copy [299](#)

fax destination [315](#)

FTP address [318](#)

adjusting brightness [495](#)

avoiding paper jams [538](#)

adjusting

scanner registration [601](#)

ADF registration

adjusting [601](#)

adjusting ADF registration [601](#)

## B

bookmarks

creating [95](#)

booklet finisher

- installing [246](#)
  - blocking junk faxes [315](#)
  - black imaging unit
    - ordering [448](#)
  - booklet finisher top bin extension
    - replacing [466](#)
  - blank pages [516](#)
  - black pages [525](#)
- ## C
- customizing the display [94](#)
  - changing the wallpaper [94](#)
  - creating bookmarks [95](#)
  - connecting printer to distinctive ring service [112](#)
  - configuring daylight saving time [113](#)
  - configuring settings
    - fax speaker [113](#)
  - customizing paper size [113](#)
  - configuration file
    - exporting [129](#)
    - importing [129](#)
  - changing the printer port settings after installing ISP [284](#)
  - connecting printer to Wi-Fi [284](#)
  - connecting printer to wireless network [284](#)
  - connecting to wireless network
    - using PIN method [285](#)
    - using Push Button method [285](#)
  - configuring Wi-Fi Direct [286](#)
  - checking network connection [288](#)
  - connecting computer to printer [287](#)
  - cabinet
    - installing [154](#)
  - card reader
    - installing [274](#)
  - control panel
    - using [16](#)
  - copying
    - using the automatic document feeder (ADF) [18](#)
    - using the scanner glass [18](#)
    - photos [298](#)
    - documents [298](#)
    - using ADF [298](#)
    - using scanner glass [298](#)
    - on both sides of paper [298](#)
    - on letterhead [298](#)
    - cards [299](#)
  - connecting mobile device
    - to printer [286](#)
  - connecting to printer
    - using Wi-Fi Direct [286](#)
  - confidential print jobs
    - configuring [295](#)
    - printing [296](#)
  - canceling print job [297](#)
  - collating copies [299](#)
  - copy size
    - adjusting [299](#)
  - copying multiple pages
    - onto a single sheet [299](#)

- cards, copying [299](#)
- changing fax resolution [315](#)
- creating shortcut
  - network folder [319](#)
  - email [312](#)
  - copy [299](#)
  - fax destination [315](#)
  - FTP address [318](#)
- configuring the email server settings [300](#)
- computer, scanning to [317](#)
- creating a network folder [319](#)
- Cleaning the Scanner [441](#)
- configuring supply notifications [444](#)
- cleaning printer [485](#)
- cleaning touch screen [486](#)
- conserving supplies [495](#)
- checking, supplies status [444](#)
- cleaning scanner [486](#)
- cleaning the printhead lenses [490](#)
- clearing jam
  - in standard tray [541](#)
  - in multipurpose feeder [546](#)
  - in 550-sheet tray [542](#)
  - in automatic document feeder [543](#)
  - in 2000-sheet tandem tray [548](#)
  - 2 x 550-sheet tray [546](#)
  - in 1500-sheet tray [549](#)
  - in fuser [550](#)
  - in duplex unit [550](#)
  - in staple finisher [554](#)
  - s standard bin [553](#)
  - in folding paper transport [556](#)
  - in booklet finisher [570](#)
  - in staple, hole punch finisher [559](#)
- confidential documents do not print [535](#)
- cannot open Embedded Web Server [588](#)
- cannot connect printer to Wi-Fi [588](#)
- cannot detect internal option [589](#)
- cut off text in print [526](#)
- cut off images in print [526](#)
- crooked print [524](#)
- cartridge, printer region mismatch [591](#)
- contacting customer support [601](#)
- customer support
  - contacting [601](#)
- collated printing does not work [593](#)
- cannot send emails [594](#)
- caller ID is not shown [595](#)
- cannot send or receive faxes using analog fax [595](#)
- cannot send faxes using analog fax [595](#)
- cannot send fax cover page from computer [597](#)
- cannot scan to a computer [597](#)
- copy problem
  - partial copies of documents [598](#)
  - partial copies of photos [598](#)
  - poor copy quality [599](#)
  - scanner does not respond [600](#)
- cannot set up etherFAX [596](#)
- cannot receive faxes using analog fax [596](#)

cannot send or receive faxes using etherFAX  
596

cannot scan to network folder 598

## D

Display Customization

using 94

distinctive ring service 112

date and time

fax settings 112

daylight saving time

configuring 113

deactivating the Wi-Fi network 288

deactivating Voice Guidance 97

documents, printing

from computer 291

directory list

printing 297

double-sided copying 298

display brightness

adjusting 495

dark print 517

dots on printed page 523

defective flash memory 590

disabling SMTP server not set up error 594

## E

exporting configuration file 129

erasing

storage drive 289

hard disk 289

intelligent storage drive 289

printer memory 289

volatile memory 289

nonvolatile memory 289

erasing printer memory 289

enabling Magnification mode 103

etherFAX

setting up fax function 106

Ethernet port 92

enlarging copy size 299

email

sending 312

email service providers 300

email function

setting up 300

email server

configuring 300

email shortcut

creating 312

email alerts

setting up 444

error codes 499

error messages 499

emptying hole punch box 492

enabling USB port 538

emission notices 614, 610

envelope seals when printing 593

email problem

cannot send emails 594

## F

faxing

- setting date and time [112](#)
- fax speaker
  - configuring settings [113](#)
- factory default settings
  - restoring [289](#)
- firmware card [90](#)
- fax driver
  - installing [127](#)
- fax server, using
  - setting up fax function [107](#)
- folding paper transport
  - installing [183](#)
  - installing [211](#)
  - installing [246](#)
- fax card
  - installing [269](#)
- fax setup [111](#)
- fax setup
  - using standard telephone line connection [108](#)
- finding printer information [11](#)
- font sample list
  - printing [297](#)
- fax, scheduling [314](#)
- fax log
  - printing [315](#)
- fax darkness
  - adjusting [315](#)
- fax resolution
  - changing [315](#)
- fax
  - holding [315](#)
  - forwarding [316](#)
  - forwarding fax [316](#)
  - FTP server
    - scanning to [318](#)
  - fax destination
    - creating shortcut [315](#)
  - fax, sending [314](#)
  - flash drive
    - scanning to [319](#)
  - flash drive, printing from [293](#)
  - fuser maintenance kit
    - ordering [449](#)
  - fuser
    - replacing [460](#)
  - fan cover
    - replacing [469](#)
  - fine lines not printed correctly [518](#)
  - folder paper [519](#)
  - FCC notices [614](#)
  - fax problem
    - caller ID is not shown [595](#)
    - cannot send or receive faxes using analog fax [595](#)
    - cannot send faxes using analog fax [595](#)
    - poor print quality [596](#)
    - cannot send fax cover page from computer [597](#)
    - missing information on fax cover page [597](#)
    - cannot set up etherFAX [596](#)

can send but not receive faxes using analog fax [596](#)

cannot send or receive faxes using etherFAX [596](#)

## G

genuine parts and supplies [446](#)

genuine Lexmark parts and supplies [446](#)

glass cleaner tool

replacing [472](#)

gray background on prints [520](#)

## H

headphone volume, adjusting [104](#)

hard disk [90](#)

hard disk

erasing [289](#)

hard disk storage drive [289](#)

hardware options

cabinet [154](#)

folding paper transport [183](#)

paper transport [196](#)

staple, hole punch finisher [196](#)

folding paper transport [211](#)

staple, hole punch finisher [211](#)

folding paper transport [246](#)

booklet finisher [246](#)

keyboard shelf [266](#)

550-sheet tray [134](#)

2 x 550-sheet tray [141](#)

2000-sheet tandem tray [147](#)

staple finisher [166](#)

1500-sheet tray [159](#)

installing [177](#)

home screen icons [17](#)

held jobs

configuring [295](#)

printing [296](#)

holding print jobs [295](#)

holding faxes [315](#)

Hibernate mode

configuring [494](#)

hole punch box

replacing [467](#)

emptying [492](#)

held documents do not print [535](#)

hardware options problem

cannot detect internal option [589](#)

horizontal light bands [528](#)

horizontal dark lines [530](#)

humidity around the printer [608](#)

## I

importing configuration file [129](#)

intelligent storage drive [289](#)

intelligent storage drive

erasing [289](#)

indicator light [18](#)

internal options [90](#)

internal options

card reader [274](#)

installing the printer software [127](#)

installing the print driver [127](#)

- installing the fax driver [127](#)
- installing cabinet [154](#)
- installing paper transport [230](#)
- installing
  - paper transport [230](#)
  - booklet finisher [230](#)
- installing booklet finisher [230](#)
- installing keyboard shelf [266](#)
- installing internal options
  - fax card [269](#)
- internal solutions port
  - installing [278](#)
- installing options
  - internal solutions port [278](#)
- installing 550-sheet tray [134](#)
- installing 2 x 550-sheet tray [141](#)
- installing 2000-sheet tandem tray [147](#)
- installing staple finisher [166](#)
- installing 1500-sheet tray [159](#)
- installing offset stacker [177](#)
- imaging unit
  - replacing [451](#)
- internal option is not detected [589](#)
- internal solutions port does not operate correctly [589](#)
- incorrect margins [521](#)
- J**
- junk faxes
  - blocking [315](#)
- jam locations
  - identifying [539](#)
- jams, paper
  - avoiding [538](#)
- job prints from the wrong tray [536](#)
- job prints on the wrong paper [536](#)
- jammed pages are not reprinted [594](#)
- jagged image from ADF scan [599](#)
- jagged text from ADF scan [599](#)
- K**
- keyboard shelf
  - installing [266](#)
- L**
- letterhead
  - selecting [21](#)
  - copying on [298](#)
- linking trays [126](#)
- loading 2000-sheet tandem tray [117](#)
- loading trays [117](#), [113](#)
- loading tray [120](#)
- loading 550-sheet tray [113](#)
- loading paper
  - in multipurpose feeder [123](#)
- loading letterhead [123](#)
- loading prepunched paper [123](#)
- locating the security slot [18](#)
- Lexmark Print
  - using [292](#)
- Lexmark ScanBack Utility [317](#)
- light print [522](#)

### M

- managing screen saver [94](#)
- Magnification mode
  - enabling [103](#)
- moving the printer [91](#), [495](#)
- mobile device
  - printing from [292](#)
  - printing from [293](#)
  - printing from [292](#)
  - printing from [293](#)
- making copies [298](#)
- menu
  - Eco-Mode [325](#)
  - Preferences [322](#)
  - Remote Operator Panel [327](#)
  - Share Data with Lexmark [332](#)
  - Accessibility [333](#)
  - Restore Factory Defaults [334](#)
  - Out of Service Erase [340](#)
  - About this Printer [342](#)
  - Layout [342](#)
  - Finishing [344](#)
  - Quality [347](#)
  - Job Accounting [348](#)
  - PDF [350](#)
  - PostScript [351](#)
  - Image [354](#)
  - Tray Configuration [355](#)
  - Media Configuration [357](#)
  - Copy Defaults [359](#)
  - Fax Mode [365](#)
  - Bin Configuration [358](#)
  - Web Link Setup [390](#)
  - Flash Drive Print [401](#)
  - Wi-Fi Direct [411](#)
  - Mobile Services Management [412](#)
  - TCP/IP [415](#)
  - SNMP [417](#)
  - 802.1x [420](#)
  - LPD Configuration [422](#)
  - HTTP/FTP Settings [422](#)
  - USB [425](#)
  - Local Accounts [430](#)
  - Default Login Methods [430](#)
  - Schedule USB Devices [431](#)
  - Confidential Print Setup [434](#)
  - Login Restrictions [434](#)
  - Encryption [436](#)
  - Power Management [331](#)
  - Notifications [327](#)
  - Configuration Menu [334](#)
  - Update firmware [341](#)
  - Setup [345](#)
  - PCL [352](#)
  - Fax Setup [365](#)
  - Fax Server Setup [378](#)
  - Email Defaults [384](#)
  - Email Setup [382](#)
  - FTP Defaults [390](#)

Flash Drive Scan [395](#)

Network Overview [404](#)

Wireless [405](#)

Ethernet [412](#)

IPSec [418](#)

ThinPrint [424](#)

Restrict external network access [426](#)

Manage Permissions [428](#)

Security Audit Log [431](#)

Solutions LDAP Settings [437](#)

Miscellaneous [437](#)

Menu Settings Page [439](#)

Device [439](#)

Cloud Services Enrollment [439](#)

Shortcuts [440](#)

Erase Temporary Data Files [436](#)

Print [440](#)

Troubleshooting [441](#)

Fax [441](#)

Network [441](#)

Forms Merge [442](#)

menu map [321](#)

Mopria Print Service [292](#)

Menu Settings Page

- printing [443](#)

meter reading, viewing [445](#)

mottled print and dots [523](#)

missing information on fax cover page [597](#)

## N

Nonvolatile memory [289](#)

nonvolatile memory

- erasing [289](#)

navigating the screen

- using gestures [98](#)

network folder

- scanning to [318](#)

network folder destination

- configuring [319](#)

Not enough free space in flash memory for resources [590](#)

non-genuine toner [591](#)

notices [610](#), [613](#), [614](#), [609](#), [610](#)

noise emission levels [610](#)

Non-Lexmark supply [591](#)

## O

on-screen keyboard

- using [103](#)

offset stacker

- installing [177](#)

ordering supplies

- toner cartridge [447](#)
- waste toner bottle [448](#)
- black imaging unit [448](#)
- staple cartridge [448](#)
- fuser maintenance kit [449](#)

## P

paper

- recycled [21](#)
- selecting [19](#)

- preprinted forms [21](#)
  - letterhead [21](#)
- personal identification numbers
  - enabling [105](#)
- printer port settings
  - changing [284](#)
- printer connection to network
  - checking [288](#)
- printer settings
  - restoring factory default [289](#)
- printer status [18](#)
- printer condition [18](#)
- paper guidelines [19](#)
- paper characteristics [19](#)
- preprinted forms
  - selecting [21](#)
- paper sizes
  - supported [22](#)
  - supported [26](#)
  - supported [30](#)
  - supported [54](#)
  - supported [75](#)
  - supported [60](#)
  - supported [45](#)
- paper weights
  - supported [84](#)
- paper types
  - supported [84](#)
- printer apps [90](#)
- preinstalled apps [90](#)
- print driver
  - adding hardware options [130](#)
  - installing [127](#)
- printer software
  - installing [127](#)
- printer memory
  - erasing [289](#)
- printer serial number [12](#)
- paper transport
  - installing [196](#)
- printer
  - selecting a location for [91](#)
  - minimum clearances [91](#)
- printer configurations [13](#)
- printer ports [92](#)
- power cord socket [92](#)
- printing
  - from computer [291](#)
  - held jobs [296](#)
  - confidential print jobs [296](#)
  - font sample list [297](#)
  - directory list [297](#)
  - from a mobile device [293](#)
  - from a mobile device [292](#)
  - using Mopria Print Service [292](#)
  - from flash drive [293](#)
  - from a mobile device [293](#)
  - using Wi-Fi Direct [293](#)
  - Menu Settings Page [443](#)
- printing documents

- from a mobile device [292](#)
- placing separator sheets [297](#), [299](#)
- print job
  - canceling [297](#)
- photos, copying [298](#)
- printing fax log [315](#)
- printer menus [321](#), [443](#)
- Print Quality Test Pages [441](#)
- printing reports [445](#)
- printing logs [445](#)
- printed sheets, viewing [445](#)
- printer, cleaning [485](#)
- power save modes
  - configuring [494](#)
- printer error codes [499](#)
- printer messages [499](#)
- printer messages
  - defective flash detected [590](#)
  - Replace cartridge, printer region mismatch [591](#)
  - Not enough free space in flash memory for resources [590](#)
  - refilled regular cartridge [591](#)
  - Non-Lexmark supply [591](#)
- printer parts status
  - checking [444](#)
- paper transport connector cover
  - replacing [473](#)
- print quality
  - cleaning scanner [486](#)
- printhead lenses
  - cleaning [490](#)
- paper jams
  - locating [539](#)
  - avoiding [538](#)
- paper jam in standard tray [541](#)
- paper jam in multipurpose feeder [546](#)
- paper jam in 550-sheet tray [542](#)
- paper jam
  - in automatic document feeder [543](#)
  - in 2000-sheet tray [548](#)
  - 2 x 550-sheet tray [546](#)
  - in 1500-sheet tray [549](#)
  - in staple finisher [554](#)
  - in folding paper transport [556](#)
- paper jam in door B [550](#)
- paper jam in fuser [550](#)
- paper jam in duplex unit [550](#)
- paper jam in standard bin [553](#)
- paper jam in booklet finisher [570](#)
- paper jam in staple, hole punch finisher [559](#)
- printing problem
  - print jobs do not print [535](#)
  - printer is not responding [537](#)
  - job prints from the wrong tray [536](#)
  - job prints on the wrong paper [536](#)
  - unable to read flash drive [537](#)
  - slow printing [536](#)
- print jobs not printed [535](#)
- print jobs do not print [535](#)
- print quality problem

- confidential and other held documents do not print [535](#)
  - vertical dark lines or streaks [533](#)
  - white pages [516](#)
  - blank pages [516](#)
  - fine lines not printed correctly [518](#)
  - incorrect margins [521](#)
  - dark print [517](#)
  - light print [522](#)
  - gray background on prints [520](#)
  - mottled print and dots [523](#)
  - folded paper [519](#)
  - wrinkled paper [519](#)
  - text or images cut off [526](#)
  - solid black pages [525](#)
  - toner easily rubs off [527](#)
  - skewed print [524](#)
  - crooked print [524](#)
  - horizontal light bands [528](#)
  - vertical light bands [529](#)
  - horizontal dark lines [530](#)
  - vertical dark bands [532](#)
  - vertical white lines [531](#)
  - repeating print defects [534](#)
  - paper curl [592](#)
  - printer is not responding [537](#)
  - printer options problem
    - internal solutions port [589](#)
    - parallel interface card [590](#)
    - serial interface card [590](#)
  - paper curl [592](#)
  - paper feed problem
    - envelope seals when printing [593](#)
    - collated printing does not work [593](#)
    - paper frequently jams [593](#)
    - tray linking does not work [593](#)
  - paper frequently jams [593](#)
  - print problem
    - jammed pages are not reprinted [594](#)
  - poor fax print quality [596](#)
  - partial copies of documents or photos [598](#)
  - poor copy quality [599](#)
  - poor scan quality [599](#)
- ## R
- recycled paper
    - using [21](#)
  - running a slideshow [94](#)
  - reducing copy size [299](#)
  - received faxes
    - holding [315](#)
  - resetting supply usage counters [484](#)
  - replacing supplies
    - toner cartridge [449](#)
    - waste toner bottle [458](#)
    - staple cartridge [476](#)
    - staple cartridge [478](#)
    - staple cartridge [480](#)
    - imaging unit [451](#)
  - replacing parts
    - tray insert [462](#)

- fuser [460](#)
- size guides [463](#)
- tray cover [465](#)
- right cover [471](#)
- hole punch box [467](#)
- paper transport connector cover [473](#)
- glass cleaner tool [472](#)
- standard bin [468](#)
- booklet finisher top bin extension [466](#)
- staple cartridge holder [483](#)
- fan cover [469](#)
- right cover
  - replacing [471](#)
- removing paper jam
  - in standard tray [541](#)
  - in multipurpose feeder [546](#)
  - in 550-sheet tray [542](#)
  - in automatic document feeder [543](#)
  - in 2000-sheet tandem tray [548](#)
  - 2 x 550-sheet tray [546](#)
  - in 1500-sheet tray [549](#)
  - in fuser [550](#)
  - in duplex unit [550](#)
  - in staple finisher [554](#)
  - in standard bin [553](#)
  - in folding paper transport [556](#)
  - in booklet finisher [570](#)
  - in staple, hole punch finisher [559](#)
- repeating print defects [534](#)
- Replace cartridge, printer region mismatch [591](#)
- recycling products [603](#)
- recycling
  - Lexmark packaging [603](#)
- resetting
  - supply usage counters [591](#)
- resetting the supply usage counters [591](#)
- S**
- Scan Center
  - setting up [94](#)
- speaker volume
  - adjusting [104](#)
- spoken passwords
  - enabling [105](#)
- setting paper size [113](#), [113](#)
- setting up serial printing [288](#)
- serial printing
  - setting up [288](#)
- storage drive
  - erasing [289](#)
- statement of volatility [289](#)
- securing printer data [289](#)
- storing paper [21](#)
- supported paper sizes [22](#), [26](#), [30](#), [54](#), [75](#), [60](#), [45](#)
- supported paper weights [84](#)
- supported paper types [84](#)
- supported flash drives [90](#)
- supported file types [90](#)
- setting paper type [113](#)
- setting up fax function using fax server [107](#)
- setting up fax function

- using etherFAX [106](#)
- setting up analog fax [105](#)
- serial number [12](#)
- staple, hole punch finisher
  - installing [196](#)
  - installing [211](#)
- selecting location
  - for the printer [91](#)
- security slot
  - locating [18](#)
- screen gestures [98](#)
- setting up fax [111](#)
- setting up fax
  - using standard telephone line connection [108](#)
- staple finisher
  - installing [166](#)
- storing print jobs [295](#)
- separator sheets
  - placing [297](#)
  - in copy jobs [299](#)
- sorting multiple copies [299](#)
- saving paper [299](#)
- scheduling fax [314](#)
- scanning
  - to FTP server [318](#)
  - to computer [317](#)
  - to network folder [318](#)
  - to flash drive [319](#)
- sending email [312](#)
- SMTP settings
  - configuring [300](#)
- shortcut, creating
  - fax destination [315](#)
- sending fax [314](#)
- supply notifications
  - configuring [444](#)
- setting up email alerts [444](#)
- staple cartridge
  - ordering [448](#)
  - replacing [476](#)
  - replacing [478](#)
  - replacing [480](#)
- supply usage counters
  - resetting [484](#)
  - resetting [591](#)
- Sleep mode
  - configuring [494](#)
- supplies, conserving [495](#)
- supplies status
  - checking [444](#)
- size guides
  - replacing [463](#)
- standard bin
  - replacing [468](#)
- staple cartridge holder
  - replacing [483](#)
- scanner
  - cleaning [486](#)
- setting up USB port [538](#)
- slow printing [536](#)

- solid black pages [525](#)
  - skewed print [524](#)
  - SMTP server not set up error
    - disabling [594](#)
  - scan problem
    - cannot scan to a computer [597](#)
    - partial copies of documents [598](#)
    - partial copies of photos [598](#)
    - poor copy quality [599](#)
    - vertical dark streaks on output when scanning from the ADF [599](#)
    - scan job was not successful [600](#)
    - scanner does not close [600](#)
    - scanner does not respond [600](#)
    - scanning takes too long [600](#)
    - scanning freezes computer [600](#)
    - cannot scan to network folder [598](#)
    - jagged image [599](#)
    - jagged text [599](#)
  - scanning quality problem [599](#)
  - scan job was not successful [600](#)
  - scanner does not close [600](#)
  - scanner does not respond [600](#)
  - scanning takes too long or freezes computer [600](#)
- ## T
- tray linking [126](#)
  - tray unlinking [126](#)
  - touch-screen gestures [98](#)
  - toner darkness
    - adjusting [297](#)
  - two-sided copying [298](#)
  - toner cartridge
    - ordering [447](#)
    - replacing [449](#)
  - touch screen, cleaning [486](#)
  - tray insert
    - replacing [462](#)
  - tray cover
    - replacing [465](#)
  - troubleshooting
    - cannot open Embedded Web Server [588](#)
    - cannot connect printer to Wi-Fi [588](#)
    - internal solutions port [589](#)
    - defective flash memory [590](#)
    - SMTP server not set up error [594](#)
    - scan job was not successful [600](#)
    - parallel interface card [590](#)
    - serial interface card [590](#)
    - jagged image from ADF scan [599](#)
    - jagged text from ADF scan [599](#)
  - toner easily rubs off [527](#)
  - third-party supplies [591](#)
  - temperature around the printer [608](#)
  - tray linking does not work [593](#)
- ## U
- unacceptable paper [20](#)
  - unlinking trays [126](#)
  - USB port [92](#)

### USB port

enabling [538](#)

using AirPrint [293](#)

using genuine Lexmark parts and supplies [446](#)

unable to read flash drive [537](#)

## V

### Voice Guidance

adjusting speech rate [104](#)

activating [97](#)

deactivating [97](#)

volatile memory [289](#)

### volatile memory

erasing [289](#)

viewing reports and logs [445](#)

vertical dark lines on prints [533](#)

vertical streaks on prints [533](#)

vertical light bands [529](#)

vertical dark bands on prints [532](#)

vertical white lines [531](#)

vertical dark streaks on output when scanning from the ADF [599](#)

## W

wireless networking [284](#)

### Wi-Fi Protected Setup

wireless network [285](#)

### wireless network

Wi-Fi Protected Setup [285](#)

### Wi-Fi Direct

configuring [286](#)

printing from a mobile device [293](#)

Wi-Fi network, deactivating [288](#)

### waste toner bottle

ordering [448](#)

replacing [458](#)

white pages [516](#)

wrinkled paper [519](#)

# **User's Guide**