

## User's and Installation Guide



**Eaton 93PM UPS**  
**30-200 kW**  
**User's and Installation Guide**

## **IMPORTANT SAFETY INSTRUCTIONS**

### **SAVE THESE INSTRUCTIONS**

This manual contains important instructions that you should follow during installation and maintenance of the UPS and batteries. Please read all instructions before operating the equipment and save this manual for future reference.

**This is a product for commercial and industrial application in the second environment. Installation restrictions or additional measures may be needed to prevent disturbances.**

**© 2013 Eaton Corporation  
All Rights Reserved**

The contents of this manual are the copyright of the publisher and may not be reproduced (even extracts) without the written approval of Eaton Corporation. Every care has been taken to ensure the accuracy of the information contained in this manual, but no liability can be accepted for any errors or omission. The right to make design modifications is reserved.

# Contents

<b>1 Safety instructions</b>	<b>1</b>
1.1 Audience	3
1.2 CE marking	3
1.3 User precautions	4
1.4 Environment	4
1.5 Symbols on the UPS and accessories	5
1.6 Conventions used in this manual	6
1.7 For more information	6
<b>2 Introduction to Eaton UPS</b>	<b>8</b>
2.1 Looking inside the UPS system	9
2.2 UPS operating modes	13
2.2.1 Normal operating modes	13
2.2.1.1 Double conversion mode	13
2.2.1.2 Energy Saver System mode	15
2.2.2 Stored energy and battery mode	15
2.2.3 Bypass mode	16
2.3 UPS features	17
2.3.1 Advanced Battery Management	18
2.3.2 Powerware Hot Sync	18
2.4 Software and connectivity features	18
2.4.1 Customer interface	18
2.4.2 Power Management Software	18
2.5 Options and accessories	19
2.5.1 Maintenance Bypass Switch	19
2.5.2 Top air exhaust kit	22
2.5.3 Top cable access kit	22
2.5.4 Field Installed UPM	22
2.6 Battery system	22
2.7 Basic system configurations	23
<b>3 UPS installation plan and unpacking</b>	<b>25</b>
3.1 Creating an installation plan	25
3.2 Site preparations	25
3.2.1 Environmental and installation considerations	25
3.2.2 UPS system power wiring preparation	30
3.2.3 UPS system interface wiring preparation	34
3.3 Unpacking and unloading the UPS	34
<b>4 UPS system installation</b>	<b>36</b>
4.1 Steps to install the UPS	36
4.2 Battery system installation	40
4.3 Installing UPS external battery cabinet and battery power wiring	41
4.4 Installing a remote EPO switch	45
4.5 Installing interface connections	46
4.5.1 Installing customer input signals interface	46
4.5.2 Battery breaker wiring interface	47
4.5.3 Relay output interface connections	47
4.5.4 Mini-slot interface connections	47
4.5.5 Installing signal interface connections in parallel system	47
4.6 Wiring parallel 93PM UPS systems	48
4.6.1 Power wiring overview	48
4.6.2 Control signals overview	50
4.6.3 Installing bypass control wiring	50
<b>5 Communication interfaces</b>	<b>53</b>
5.1 Mini-slot cards	53
5.2 Intelligent Power Software	56
5.3 Signal input monitoring	56
5.4 General purpose relay contact	56
<b>6 UPS operating instructions</b>	<b>58</b>
6.1 UPS controls and indicators	58

6.1.1 Control panel.....	58
6.1.2 Status indicators.....	60
6.1.3 System events.....	61
6.2 Steps to operate the UPS.....	61
6.3 Signing in.....	62
6.4 System control instructions.....	63
6.4.1 Starting the UPS system in Double conversion mode.....	63
6.4.2 Starting the UPS system in Bypass mode.....	64
6.4.3 Transfer from Double conversion mode to Bypass mode.....	64
6.4.4 Transfer from Bypass to Double conversion mode.....	65
6.4.5 Transfer from Double conversion mode to Energy Saver System Mode.....	65
6.4.6 Transfer from Energy Saver System Mode to Double conversion mode.....	65
6.4.7 UPS system and critical load shutdown.....	66
6.4.8 De-energizing the Critical Load.....	66
6.5 UPS control instructions.....	67
6.5.1 Starting a single UPS.....	67
6.5.2 UPS shutdown.....	67
6.5.3 Enabling and disabling the battery charger.....	68
6.6 UPM control instructions.....	68
6.6.1 Starting the UPMs.....	68
6.6.2 UPM shutdown.....	68
6.7 Using the Remote Emergency Power-off switch.....	69
6.8 Turning UPS from double conversion mode to mechanical bypass.....	69
6.9 Turning UPS from mechanical bypass to double conversion mode.....	71
<b>7 UPS maintenance.....</b>	<b>72</b>
7.1 Important safety instructions.....	72
7.2 Performing preventive maintenance.....	73
7.2.1 DAILY maintenance.....	73
7.2.2 MONTHLY maintenance.....	73
7.2.3 PERIODIC maintenance.....	73
7.2.4 ANNUAL maintenance.....	74
7.2.5 BATTERY maintenance.....	74
7.3 Recycling the used UPS or batteries.....	74
7.4 Maintenance training.....	75
<b>8 Technical data.....</b>	<b>76</b>
8.1 Standards.....	76
8.2 UPS system input.....	77
8.3 UPS system output.....	77
8.4 Battery specification.....	78
8.5 UPS environmental specifications.....	79
<b>9 Warranty.....</b>	<b>81</b>
<b>10 Installation checklist.....</b>	<b>82</b>
<b>11 APPENDIX A: User settings.....</b>	<b>84</b>

## List of Figures

Figure 1-1: Recycling batteries symbol.....	5
Figure 1-2: WEEE symbol.....	6
Figure 2-1: Eaton 93PM UPS.....	9
Figure 2-2: 93PM 50 kW UPS wiring diagram.....	11
Figure 2-3: 93PM 150 kW UPS wiring diagram.....	12
Figure 2-4: Path of current through the UPS in double conversion mode.....	14
Figure 2-5: Path of current through the UPS in Energy Saver System.....	15
Figure 2-6: Path of current through the UPS in battery mode.....	16
Figure 2-7: Path of current through the UPS in bypass mode.....	17
Figure 2-8: Two-switch MBS electrical connection drawing.....	20
Figure 2-9: Three-switch MBS electrical connection drawing.....	21
Figure 3-1: UPS cabinet clearances. See Table 3-3.....	27
Figure 3-2: 93PM 30-150 kW UPS dimensions.....	28
Figure 3-3: 93PM 160-200 kW UPS dimensions.....	29
Figure 3-4: Eaton 93PM 80-150 kW UPS Top air exhaust kit dimensions.....	29
Figure 3-5: Eaton 93PM 200 kW UPS Top air exhaust kit dimensions.....	30
Figure 4-1: 93PM 30-50 kW gland plate and connector locations.....	37
Figure 4-2: 93PM 80-150 kW UPS gland plate and connector locations.....	38
Figure 4-3: 93PM 160-200 kW UPS gland plate and connector locations.....	39
Figure 4-4: 93PM 30-150 kW Top cable access kit.....	40
Figure 4-5: 93PM battery cabinet (EBC-S).....	42
Figure 4-6: 93PM battery cabinet (EBC-L).....	43
Figure 4-7: UPS cabinet through holes.....	44
Figure 4-8: Connections of the EPO switch.....	46
Figure 4-9: Principle of paralleled UPS systems.....	49
Figure 4-10: Communication interfaces.....	50
Figure 4-11: Simplified CAN and Pull-Chain wiring for parallel UPS system.....	51
Figure 4-12: CAN and Pull-Chain wiring for parallel UPS with MOBs.....	51
Figure 4-13: CAN and Pull-Chain wiring for parallel UPS without MOBs.....	52
Figure 5-1: Communication interfaces.....	53
Figure 5-2: Network Card-MS.....	54
Figure 5-3: PX Gateway Card.....	54
Figure 5-4: Relay Card-MS.....	55
Figure 5-5: Network and MODBUS Card - MS.....	55
Figure 5-6: Industrial Relay Card-MS.....	56
Figure 6-1: Parts of the display.....	59
Figure 6-2: Green symbol.....	60
Figure 6-3: Yellow symbol — battery mode.....	60
Figure 6-4: Yellow symbol — bypass mode.....	60
Figure 6-5: Red symbol.....	60
Figure 6-6: The normal positions of the MBS switches and rectifier disconnect switch (must be located in the site wiring).....	70
Figure 6-7: Mechanical bypass mode.....	70
Figure 6-8: Mechanical bypass mode.....	71
Figure 6-9: Double conversion mode.....	71
Figure 7-1: WEEE symbol.....	74
Figure 7-2: Recycling batteries symbol.....	75

## List of Tables

Table 2-1: UPS configurations.....	23
Table 2-2: Standard and optional UPS options.....	23
Table 3-1: Dimensions.....	26
Table 3-2: UPS cabinet weights.....	26
Table 3-3: UPS cabinet minimum clearances.....	26
Table 3-4: UPS cabinet minimum clearances with top air exhaust kit.....	27
Table 3-5: Air conditioning or ventilation requirements during full load operation.....	28
Table 3-6: Minimum recommended multi-core cable and fuse sizes.....	31
Table 3-7: Rated and maximum currents for rated power and voltage.....	31
Table 3-8: UPS power cable terminations.....	33
Table 4-1: Remote EPO wire terminations.....	46
Table 6-1: UPS menu structure.....	61
Table 8-1: Standards.....	76
Table 8-2: UPS system input.....	77
Table 8-3: UPS system output.....	77
Table 8-4: Battery specification.....	78
Table 8-5: UPS environmental specifications.....	79
Table 11-1: User settings.....	84
Table 11-2: Config settings.....	84



# 1 Safety instructions

## IMPORTANT SAFETY INSTRUCTIONS

### SAVE THESE INSTRUCTIONS

This manual contains important instructions that should be followed during installation and maintenance of the UPS and batteries. Please read all instructions before operating the equipment and save this manual for future reference.

The UPS operates with mains, battery or bypass power. It contains components that carry high currents and voltages. The properly installed enclosure is earthed and IP21 rated against electrical shock and foreign objects. However, the UPS is a sophisticated power system and only qualified personnel is allowed to install and service the UPS.



**WARNING**

**Operations inside the UPS must be performed by a service engineer from the manufacturer or from an agent authorized by the manufacturer.**

---



**DANGER**

**This UPS contains LETHAL VOLTAGES. All repairs and service should be performed by AUTHORIZED SERVICE PERSONNEL ONLY. There are NO USER SERVICEABLE PARTS inside the UPS.**

---



## WARNING

- The UPS is powered by its own energy source (batteries). The output terminals may be energised even when the UPS is disconnected from an AC source. To reduce the risk of fire or electric shock, install this UPS in a temperature and humidity controlled, indoor environment, free of conductive contaminants. Ambient temperature must not exceed 40 °C (104 °F). Do not operate near water or excessive humidity (95 % maximum). The system is not intended for outdoor use.
  - Ensure all AC and DC power sources are disconnected before performing installation or service. Power may come from multiple sources.
  - In parallel system, output terminals may be energised even when the UPS is turned off.
  - Ensure system grounding/PE continuity when undertaking installation or service.
  - Batteries can present a risk of electrical shock or burn from high short-circuit current.
  - **ELECTRIC ENERGY HAZARD.** Do not attempt to alter any battery wiring or connectors. Attempting to alter wiring can cause injury.
  - Do not open or mutilate batteries. Released electrolyte is harmful to the skin and eyes. It may be toxic.
  - **IMPORTANT:** the battery may consist of multiple parallel strings, disconnect all strings before installation.
-



## CAUTION

- **Installation or servicing should be performed by qualified service personnel knowledgeable of batteries and required precautions. Keep unauthorized personnel away from batteries. Consider all warnings, cautions, and notes before installing or replacing batteries. DO NOT DISCONNECT the batteries while the UPS is in Battery mode.**
  - **Replace batteries with the same number and type of batteries as originally installed in the UPS.**
  - **Disconnect the charging source prior to connecting or disconnecting terminals.**
  - **Determine if the battery is inadvertently grounded. If it is, remove the source of the ground. Contacting any part of a grounded battery can cause a risk of electric shock. An electric shock is less likely if you disconnect the grounding connection before you work on the batteries.**
  - **Proper disposal of batteries is required. Refer to local codes for disposal requirements.**
  - **Do not dispose of batteries in a fire. Batteries may explode when exposed to flame.**
  - **Keep the UPS door closed and front panels installed to ensure proper cooling airflow and to protect personnel from dangerous voltages inside the unit.**
  - **Do not install or operate the UPS system close to gas or electric heat sources.**
  - **The operating environment should be maintained within the parameters stated in this manual.**
  - **Keep surroundings uncluttered, clean, and free from excess moisture.**
  - **Observe all DANGER, CAUTION, and WARNING notices affixed to the inside and outside of the equipment.**
- 

## 1.1 Audience

The intended audience of this manual are people who plan the installation, install, and use the UPS. This manual provides guidelines for checking the delivery, installing, and operating of the UPS.

The reader is expected to know the fundamentals of electricity, wiring, electrical components and electrical schematic symbols. This manual is written for a global reader.

---



## NOTE

**Read the manual before operating or working on the UPS.**

---

## 1.2 CE marking

The product has the CE marking in compliance with the following European directives:

- LV Directive (Safety) 2006/95/EC

- EMC Directive 2004/108/EC

Declaration of conformity with UPS harmonised standards and directives EN 62040-1 (Safety) and EN 62040-2 (EMC) are available at [www.eaton.eu/93PM](http://www.eaton.eu/93PM) or by contacting your nearest Eaton office or authorized partner.

## 1.3 User precautions

The only user operations permitted are:

- Start up and shut down of the UPS, excluding the commissioning start up.
- Use of the LCD control panel and Maintenance Bypass Switch (MBS).
- Use of optional connectivity modules and their software.

The user must follow the precautions and only perform the described operations. Any deviation from the instructions could be dangerous to the user or cause accidental load loss.



**WARNING**

**The user is not permitted to open any screws excluding connectivity plates and the MBS locking plate. Failure to recognise the electrical hazards could prove fatal.**

---



**WARNING**

**The 30-50 kW models are available as C2 UPS product which can be placed both in a residential and commercial/industrial environment. When included in a residential environment, this product may cause radio interference, in which case the user may be required to take additional measures.**

**By standard, the 30-200 kW models are category C3 UPS products, meant for all commercial and industrial establishments.**

---

## 1.4 Environment

The UPS must be installed according to the recommendations in this manual. Under no circumstances should the UPS be installed in an airtight room, in the presence of flammable gases, or in an environment exceeding the specifications.

Excessive amount of dust in the operating environment of the UPS may cause damage or lead to malfunction. The UPS should always be protected from the outside weather and sunshine. In order to maximize internal battery service life time, the recommended operating temperature range is from +20 to +25 °C.



**WARNING**

Hydrogen and oxygen gases are emitted from batteries into the surrounding atmosphere during charge, float charge, heavy discharge, and overcharge. Explosive gas mixture may be created if the hydrogen concentration exceeds 4 % by volume in air. Necessary air flow rate for ventilation of UPS location must be ensured.

As an example, for 93PM 30-50 kW UPS, a minimum air flow is 5 m<sup>3</sup>/ hour for the room where one 93PM UPS with internal VRLA batteries is placed. If more than one UPS with internal VRLA batteries are located in the same room, ventilation air flow must be dimensioned accordingly. If external flooded cell batteries are used in same location, ventilation air flow must be recalculated and dimensioned accordingly.

---

## 1.5 Symbols on the UPS and accessories

The following are examples of symbols used on the UPS or accessories to alert you to important information:



**DANGER**

RISK OF ELECTRIC SHOCK - Indicates that a risk of electric shock is present and the associated warning should be observed.

---



**CAUTION**

CAUTION: REFER TO OPERATOR'S MANUAL - Refer to your operator's manual for additional information, such as important operating and maintenance instructions.

---

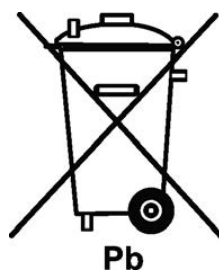

This symbol indicates that you should not discard the UPS or the UPS batteries in the trash. This product involves sealed, lead-acid batteries and must be disposed of properly. For more information, contact your local recycling/reuse or hazardous waste center.

**Figure 1-1: Recycling batteries symbol**

---

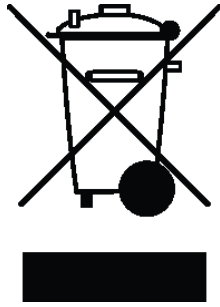

This symbol indicates that you should not discard waste electrical or electronic equipment (WEEE) in the trash. For proper disposal, contact your local recycling/reuse or hazardous waste center.

**Figure 1-2: WEEE symbol**

---

## 1.6 Conventions used in this manual

This manual uses these type conventions:

- **Bold type** highlights important concepts in discussions, key terms in procedures, and menu options, or represents a command or option that you type or enter at a prompt.
- *Italic type* highlights notes and new terms where they are defined.
- `Screen type`

represents information that appears on the screen or LCD.

Icon	Description
 <b>NOTE</b>	Information notes call attention to important features or instructions.
[Keys]	Brackets are used when referring to a specific key, such as [Enter] or [Ctrl].

In this manual, the term UPS refers only to the UPS cabinet and its internal elements. The term UPS system refers to the entire power protection system – the UPS cabinet, the battery cabinet, and options or accessories installed.

## 1.7 For more information

Address any inquiries about the UPS and battery cabinet to the local office or agent authorized by the manufacturer. Please quote the type code and the serial number of the equipment.

Call your local service representative if help is needed with any of the following:

- Scheduling initial startup

- Regional locations and telephone numbers
- A question about any of the information in this manual
- A question this manual does not answer

## 2 Introduction to Eaton UPS

The Eaton® 93PM uninterruptible power supply (UPS) is a true online, continuous-duty, transformerless, double-conversion, solid-state, three-phase system, supplying conditioned and uninterruptible AC power to critical load and protecting it from power failures.

The UPS is used to prevent loss of valuable electronic information, minimize equipment downtime, and minimize the adverse effect on production equipment due to unexpected power problems.

The Eaton UPS continually monitors incoming electrical power and removes the surges, spikes, sags, and other irregularities that are inherent in commercial utility power. Working with a building's electrical system, the UPS system supplies clean, consistent power that sensitive electronic equipment requires for reliable operation. During brownouts, blackouts, and other power interruptions, batteries provide emergency power to safeguard operation.

The UPS system is housed in a single, free-standing cabinet with safety shields behind the door for hazardous voltage protection. Each UPS cabinet has a centralised system static bypass. The available static bypass ratings are 50 kW, 100 kW, 150 kW and 200 kW. The static bypass size is chosen according to UPS system power. For example, if future requirement is to upgrade the UPS capacity, the UPS bypass rating will have to be selected accordingly. In addition, the bypass ratings of all UPS cabinets in a parallel system need to be matched.

Eaton 93PM output power ratings are based on 50 kW rated uninterruptible power modules (UPMs). A single UPS cabinet can house one to four UPM modules to get ratings of:

- 1 x 50 kW = 50 kW
- 2 x 50 kW = 100 kW
- 3 x 50 kW = 150 kW
- 4 x 50 kW = 200 kW

A UPM includes a rectifier, inverter, battery converter, and independent controls. Each UPM is able to operate independently from the other power modules.



### NOTE

**Startup and operational checks must be performed by an authorized Eaton Customer Service Engineer, or the warranty terms specified in Chapter 9 Warranty on page 81 become void. This service is offered as part of the sales contract for the UPS. Contact service in advance (usually a two-week notice is required) to reserve a preferred startup date.**

---



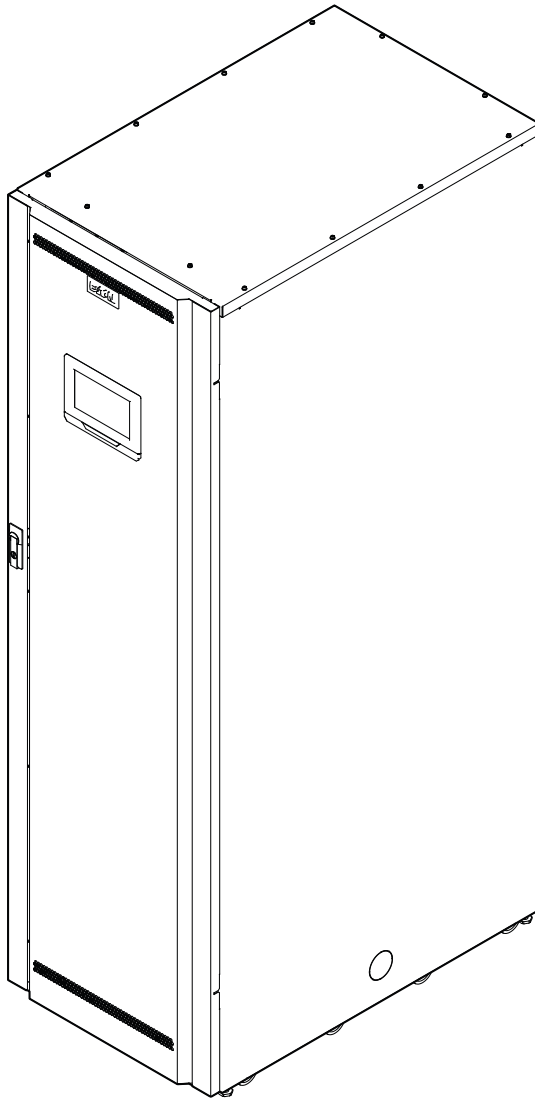

**Figure 2-1: Eaton 93PM UPS**

## **2.1 Looking inside the UPS system**

The system level static bypass in the Eaton 93PM UPS cabinet determines the attainable output power of the UPS. The static bypass line consists of static switch and a backfeed protection isolation device connected in series. In addition, there is a system level control unit that constantly monitors the power delivered through the bypass line or to the input of the UPS. Transfers to static bypass are seamless and performed automatically by the system as needed, for example, in case of an extended system overload.

Each UPM power module includes a rectifier, battery converter, inverter and independent controls. Each UPM is able to operate and share the load independently, despite the status of the other UPMs.

In addition, the system can have a UPS internal maintenance bypass switch as a factory installed option.

The 30-50 kW 93PM UPS includes a 50 kW rated static bypass section, one UPM power module, and internal batteries. In addition to the internal batteries, also external batteries can be connected. The main components of this UPS are depicted in *Figure 2-2: 93PM 50 kW UPS wiring diagram* on page 11.

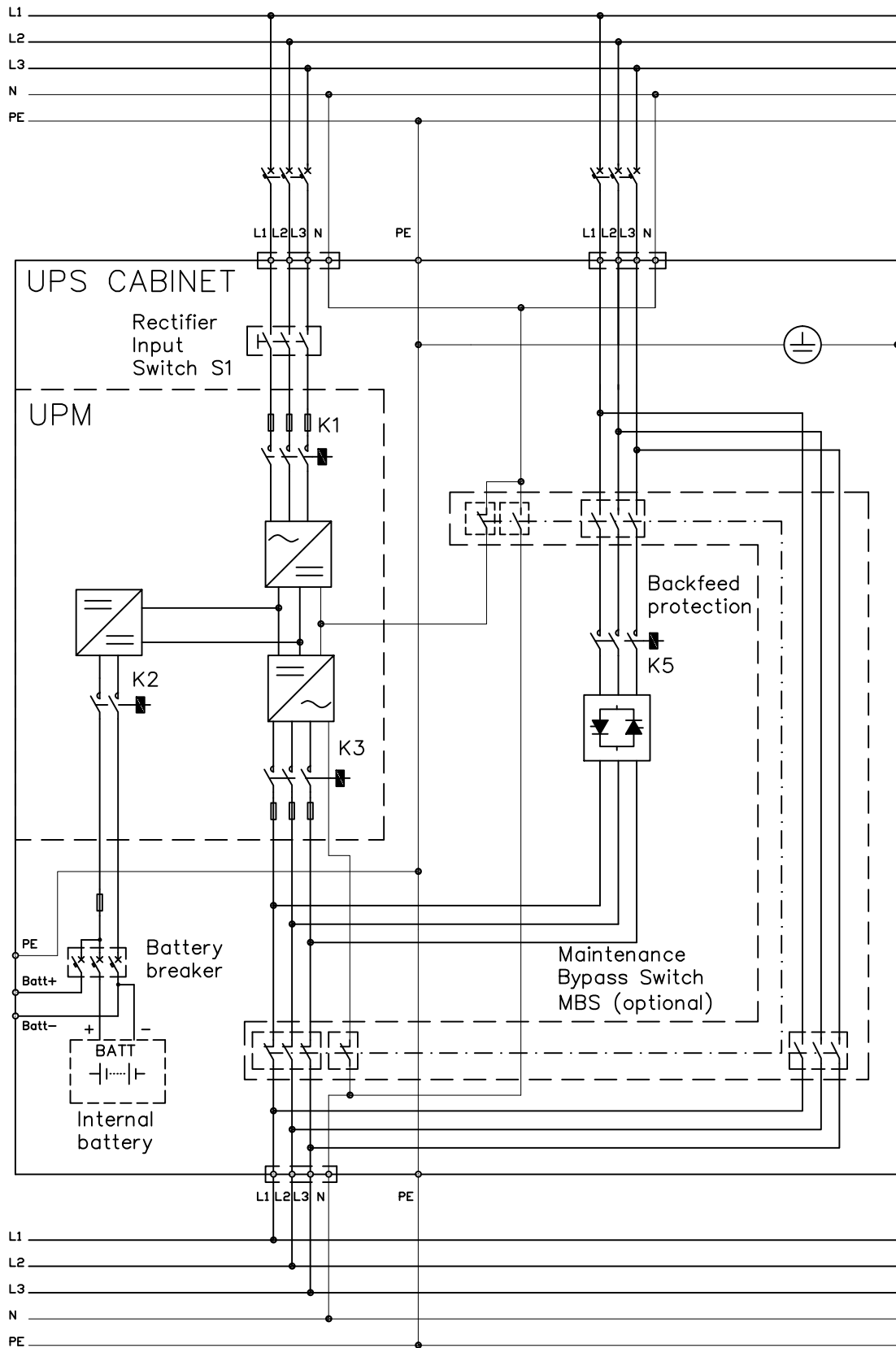

**Figure 2-2: 93PM 50 kW UPS wiring diagram**

In the 80-200 kW units, the UPM power modules are paralleled internally. These units do not include internal batteries. *Figure 2-3: 93PM 150 kW UPS wiring diagram* on page 12 shows the construction of the 150 kW 93PM UPS with three power modules.

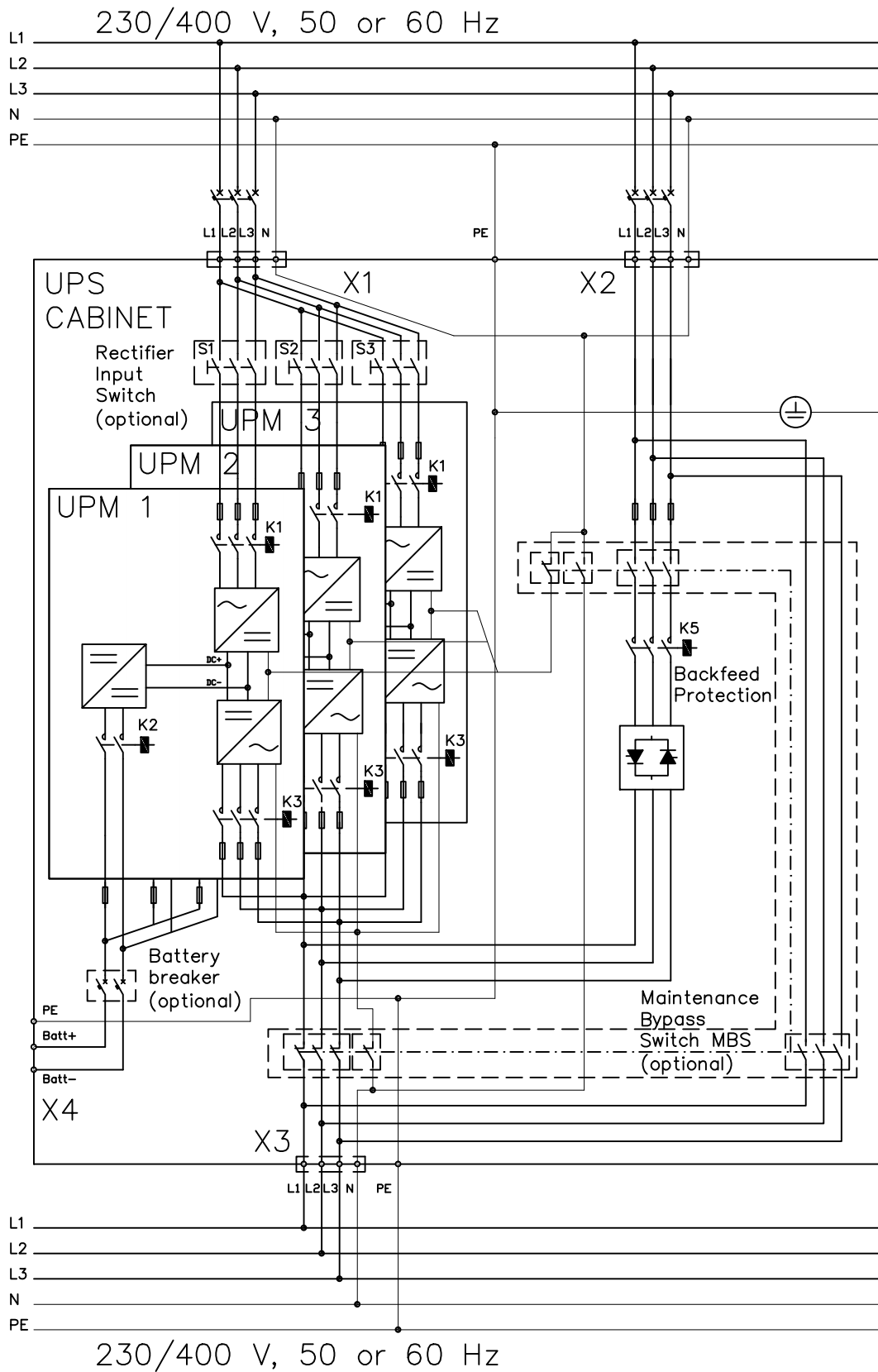

**Figure 2-3: 93PM 150 kW UPS wiring diagram**

The rectifier input switch and battery breaker are available as standard for the 30-50 kW units, and as optional for the 80-150 kW units. The internal MBS is available as optional for the 30-150 kW units. These options are not available for the 160-200 kW units, and will have to be included externally in the installation.

If utility power is interrupted or falls outside the parameters specified in *Chapter 8 Technical data* on page 76, the UPS uses a backup battery supply to maintain power to the critical load for a specified period of time or until the utility power returns. For extended power outages, the UPS allows you to either transfer to an alternative power system (such as a generator) or shut down your critical load in an orderly manner. The UPS bypass consists of a continuous-duty static switch and backfeed protection isolation device K5. The backfeed protection is located in series with the static switch. Transfers to static bypass are seamless and performed automatically by the system as needed, for example, in case of an extended system overload.

## 2.2 UPS operating modes

UPS operating modes:

- Normal operating modes:
  - In double conversion mode, the critical load is supplied by the inverter, which derives its power from rectified utility AC power. In this mode, the battery charger also provides charging current for the battery, if needed.
  - In Energy Saver System (ESS) mode, the critical load is supported securely by utility power through static bypass switch with double conversion available on-demand with typically less than a 2 ms transition time, should any abnormal condition be detected in the utility. When operating in ESS mode, the load is protected with inherent surge suppression. Operating the UPS in ESS mode increases system efficiency to 99 % allowing significant savings in energy losses without compromising system reliability.
- In stored energy mode, the energy is drawn from a DC backup power source and converted to AC power by the UPS inverter. Most commonly VRLA batteries are introduced to the system for this purpose, and the mode of operation is called battery mode.
- In bypass mode, the critical load is supported directly by utility power through the UPS static switch.

### 2.2.1 Normal operating modes

During normal UPS operation, power for the system is derived from a utility input source. "Unit Online" is displayed on the front panel, indicating that the incoming power is within voltage and frequency acceptance windows.

#### 2.2.1.1 Double conversion mode

*Figure 2-4: Path of current through the UPS in double conversion mode* on page 14 shows the path of electrical power through the UPS system when the UPS is operating in double conversion mode.

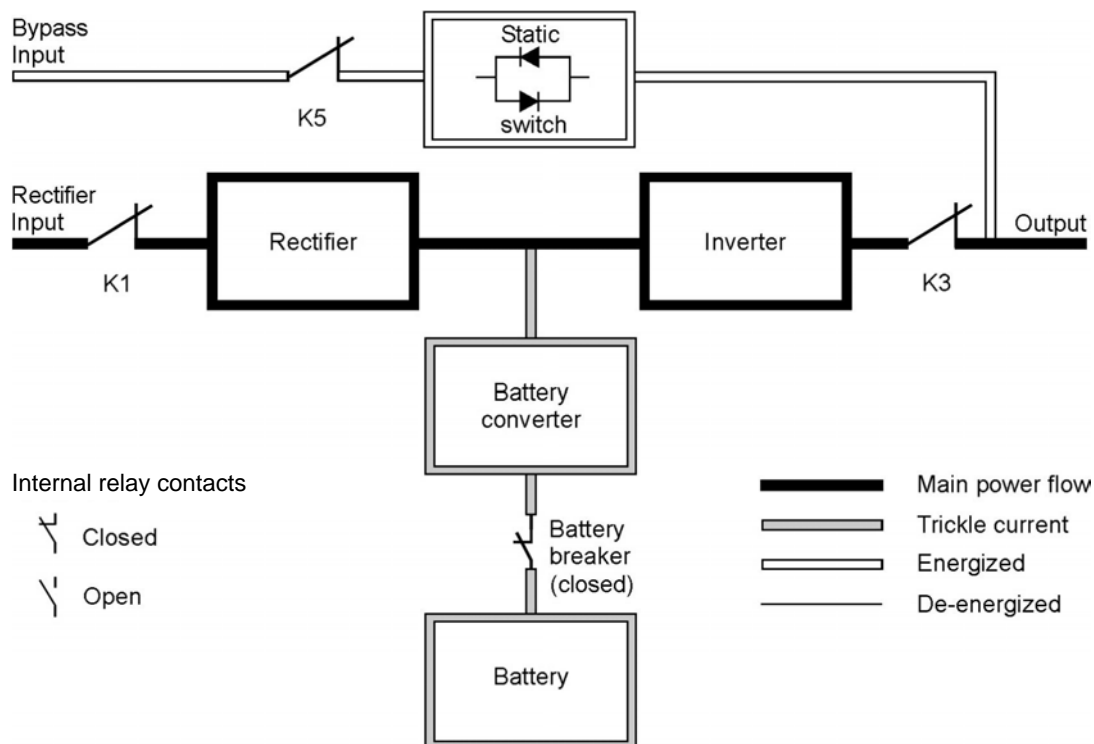

**Figure 2-4: Path of current through the UPS in double conversion mode**

Three-phase AC input power is converted to DC using a multilevel converter with IGBT devices to produce a regulated DC voltage to the inverter. The UPS status indicated on the display is “Unit Online” and the UPM status is “Active”.

The battery converter derives its input from the regulated DC output of the rectifier and provides regulated charge current to the battery. The battery is always connected to the UPS and ready to support the inverter should the utility input become unavailable.

The inverter produces a three-phase AC output to the critical load. The inverter derives regulated DC from the rectifier and uses multilevel converter technology with IGBT devices and pulse-width modulation (PWM) to produce a regulated and filtered AC output.

If the utility AC power is interrupted or is out of specification, the UPS automatically switches to Battery mode to support the critical load without interruption. When utility power returns, the UPS returns to double conversion mode automatically.

If the UPS becomes overloaded or unavailable, the UPS seamlessly switches to Bypass mode and continues supplying the load through the static bypass. The UPS automatically returns to double conversion mode when the abnormal condition, such as an extended time overload, is cleared and system operation is restored within specified limits.

If a UPM power module within the UPS suffers an internal failure, the remaining UPMs will continue supporting the load in double conversion. The UPS is automatically internally redundant when the UPS is not operating in full load. However, if there is no redundancy between the UPMs due to high load level, the UPS switches automatically to Bypass mode and remains in that mode until the failure is corrected and the UPS is back in service.

In an external parallel redundant system, each one UPS can be isolated from the system for service while the remaining UPSs support the load in double conversion.

### 2.2.1.2 Energy Saver System mode

In ESS mode the UPS safely provides mains current directly to the load when the input is within the acceptable limits by its voltage and frequency. The UPS status indicated on the display is "Unit Online ESS", and the UPM status is "Active". Surge protection and some filtering is also provided, ensuring that clean power is delivered to the load equipment. Should there be any disturbances detected in the incoming power, the UPS switches to double conversion and continues to supply the critical load through its inverter. In case of a complete utility outage or if input power is outside the tolerances of the system, the UPS transfers to battery mode and continues to supply conditioned, clean power to the critical load.

When operating in ESS, the UPS superior detection and control algorithms continuously monitor incoming power quality and allow the fast engagement of power converters. Typical transition time to double conversion is less than two milliseconds, which is practically seamless.

When power conditions are within acceptable limits, the UPS operates as a high-efficiency, energy-saving system — providing surge protection for IT equipment and ensuring clean power is delivered to the facility. Energy saver system increases system efficiency to 99 % when supplying 20-100 % nominal load, reducing energy losses by up to 80 %.

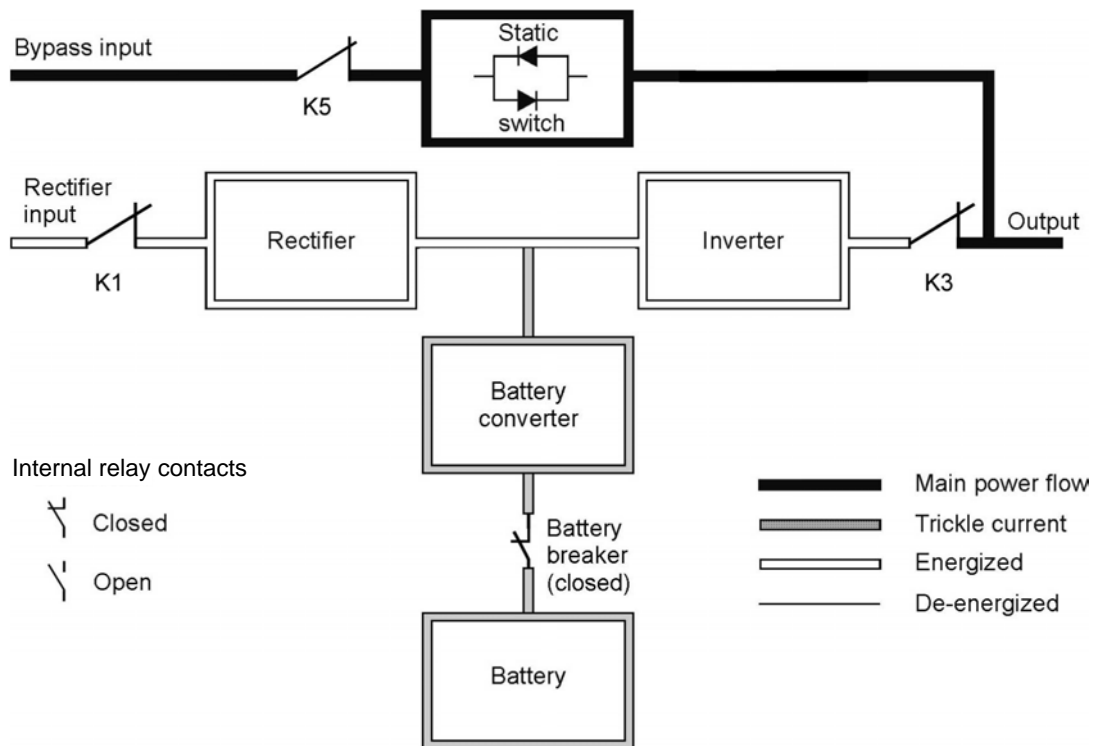
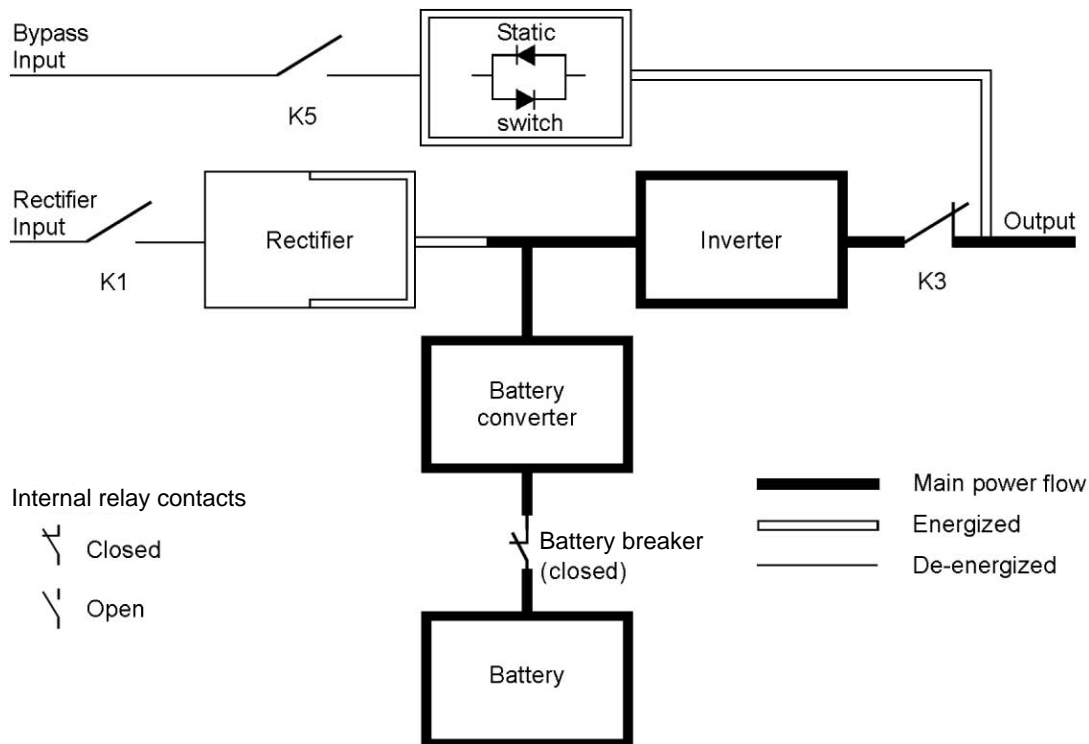

Figure 2-5: Path of current through the UPS in Energy Saver System

### 2.2.2 Stored energy and battery mode

When running normally in double conversion or ESS mode, the UPS automatically transfers to supply the load from batteries or other stored energy source if a utility power outage occurs, or if the utility power does not conform to specified parameters. The UPS status indicated on the display is "On Battery", and the UPM status is "Active". In battery mode, the battery provides emergency DC power which is converted to regulated output power by the inverter. *Figure 2-6: Path of current through the UPS in battery mode* on page 16 shows the path of electrical power through the UPS system when operating in battery mode.



**Figure 2-6: Path of current through the UPS in battery mode**

During a utility power failure, the rectifier no longer has an AC utility source from which to supply the DC output current required to support the inverter. The input relay K1 opens and the UPS output is powered from batteries through the inverter. As the inverter operates uninterrupted through the transition, the load remains supported continuously without disturbance. If the UPS static bypass is supplied from the same source as the UPS rectifier, the backfeed protection contactor K5 also opens. The opening of K1 and K5 prevent system voltages from bleeding backwards and re-entering the input source through the static switch or rectifier.

If the input power fails to return or is not within the acceptance windows required for normal operation, the battery continues discharging until a DC voltage level is reached where the inverter output can no longer support the connected loads. When this event occurs, the UPS issues a set of audible and visual alarms indicating that the batteries are having a minimal capacity left and a system shutdown is imminent. Unless utility power is restored, the output can be supported for maximum two minutes before the output of the system shuts down. If the bypass source is available, the UPS transfers to bypass instead of shutting down.

If at any time during the battery discharge the input power becomes available again, K1 and K5 close and the UPS returns to normal operation. The UPS will also start to recharge batteries to restore the capacity.

### 2.2.3 Bypass mode

The UPS automatically switches to bypass mode if it detects an overload, load fault, or internal failure. The bypass source supplies the commercial AC power to the load directly. The UPS can also be commanded to transfer to bypass manually through the display. The UPS status indicated on the display is "On Bypass". *Figure 2-7: Path of current through the UPS in bypass mode* on page 17 shows the path of electrical power through the UPS system when operating in Bypass mode.





## NOTE

**The critical load is not protected while the UPS is in Bypass mode.**

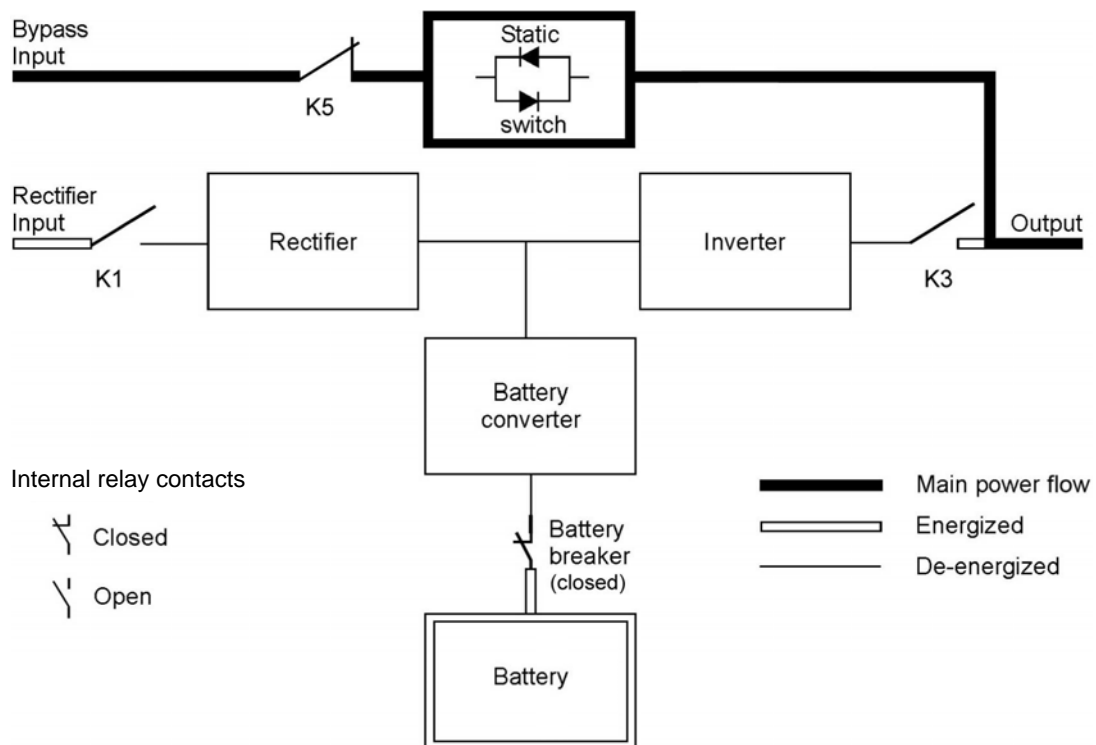

**Figure 2-7: Path of current through the UPS in bypass mode**

In bypass mode, the output of the system is provided with three-phase AC power directly from the system input. While in this mode, the output of the system is not protected from voltage or frequency fluctuations or power outages from the source. Some power line filtering and transient protection is provided to the load but no active power conditioning or battery support is available to the output of the system in the bypass mode of operation.

The static bypass is comprised of a solid-state, silicon-controlled rectifier (SCR) static switch (SSW) and a backfeed protection isolation device K5. The static switch is rated as a continuous-duty device that is used anytime the inverter is unable to support the applied load. The static switch, being an electronically-controlled device, can be turned on immediately to pick up the load from the inverter without interruption. The backfeed protection is normally always closed, ready to support the static switch unless the bypass input source becomes unavailable.

## 2.3 UPS features

The Eaton UPS has many features that provide cost-effective and consistently reliable power protection. The feature descriptions provide a brief overview of the UPS standard features.

## 2.3.1 Advanced Battery Management

Advanced Battery Management technology uses sophisticated sensing circuitry and a three-stage charging technique that extends the useful service life of UPS batteries while optimizing the battery recharge time. ABM also protects batteries from damage caused by high current charging and inverter ripple currents. Charging at high currents can overheat and damage batteries.

In *charge mode*, the batteries are recharged. Charging lasts only as long as it takes to bring the battery system up to a predetermined float level. Once this level is reached, the UPS battery charger enters *float stage* and the charger is operating in constant voltage mode.

*Rest mode* begins at the end of charge mode; that is, after 48 hours of float charging (customer adjustable). In Rest mode, the battery charger is completely turned off. The battery system receives no charge current during this rest period of about 28 days (customer adjustable). During Rest mode, the open circuit battery voltage is monitored constantly, and battery charging is resumed when necessary.

## 2.3.2 Powerware Hot Sync

Eaton Powerware Hot Sync technology is an algorithm that eliminates the single point of failure in a parallel system and therefore enhances the system reliability. The Hot Sync technology is incorporated in all Eaton 93PM UPSs, and it is utilised in both multi-module internal parallel and external parallel systems.

Hot Sync technology enables all uninterruptible power modules (UPMs) to operate independently in a parallel system, even without inter-module communications. The power modules utilising the Hot Sync technology are completely autonomous; each module monitors their own output independently, to remain in complete synchronization with the other modules. The UPM power modules share the load perfectly even in changing capacity or changing load conditions.

Powerware Hot Sync technology combines digital signal processing and an advanced control algorithm to provide automatic load sharing and selective tripping in a parallel UPS system. The load share control algorithms maintain synchronization and load balance by constantly making minute adjustments to variations in the output power requirements. The modules conform to demand and are not in conflict with each other for the load. Powerware Hot Sync systems are capable of paralleling for both redundancy and capacity.

## 2.4 Software and connectivity features

### 2.4.1 Customer interface

**Mini-Slot Communication Bays** — there are three communication bays for mini-slot connectivity cards. Mini-slot cards are quickly installed and are hot-pluggable. See *Chapter 5 Communication interfaces* on page 53 for additional information.

### 2.4.2 Power Management Software

Intelligent Power software products offer tools for monitoring and managing power devices across the network. See *Chapter 5 Communication interfaces* on page 53 for more information.

## 2.5 Options and accessories

Contact an Eaton sales representative for information about the available options.

### 2.5.1 Maintenance Bypass Switch

The Maintenance Bypass Switch (MBS) enables power to completely bypass and isolate the UPS so that the UPS can be safely serviced or replaced without interrupting power to critical systems.

An internal maintenance bypass switch is provided as a factory installed option for 30-150 kW units. Alternatively, MBS solutions are also available in external enclosure as accessory items.

#### External Maintenance Bypass Switch Panel

The external MBS is enclosed in its own separate cabinet, and it can be either a wall-mounted or stand-alone cabinet depending on the MBS power rating. The MBS wiring has two different options: two- and three-switch configuration. The two-switch model contains a Maintenance Isolation Switch (MIS) and a Maintenance Bypass Switch (MBP). The three-switch model contains a Bypass Input Breaker (BIB) in addition to a MIS and an MBP.

The two-switch model assumes that the UPS rectifier and bypass are coupled through dedicated breakers and separate cables from the switchgear. However, the three-breaker model can be connected to the switchgear with only a single cable, and the cable connections between the panel and UPS are run separately.

For more information, see *Figure 2-8: Two-switch MBS electrical connection drawing* on page 20 and *Figure 2-9: Three-switch MBS electrical connection drawing* on page 21.

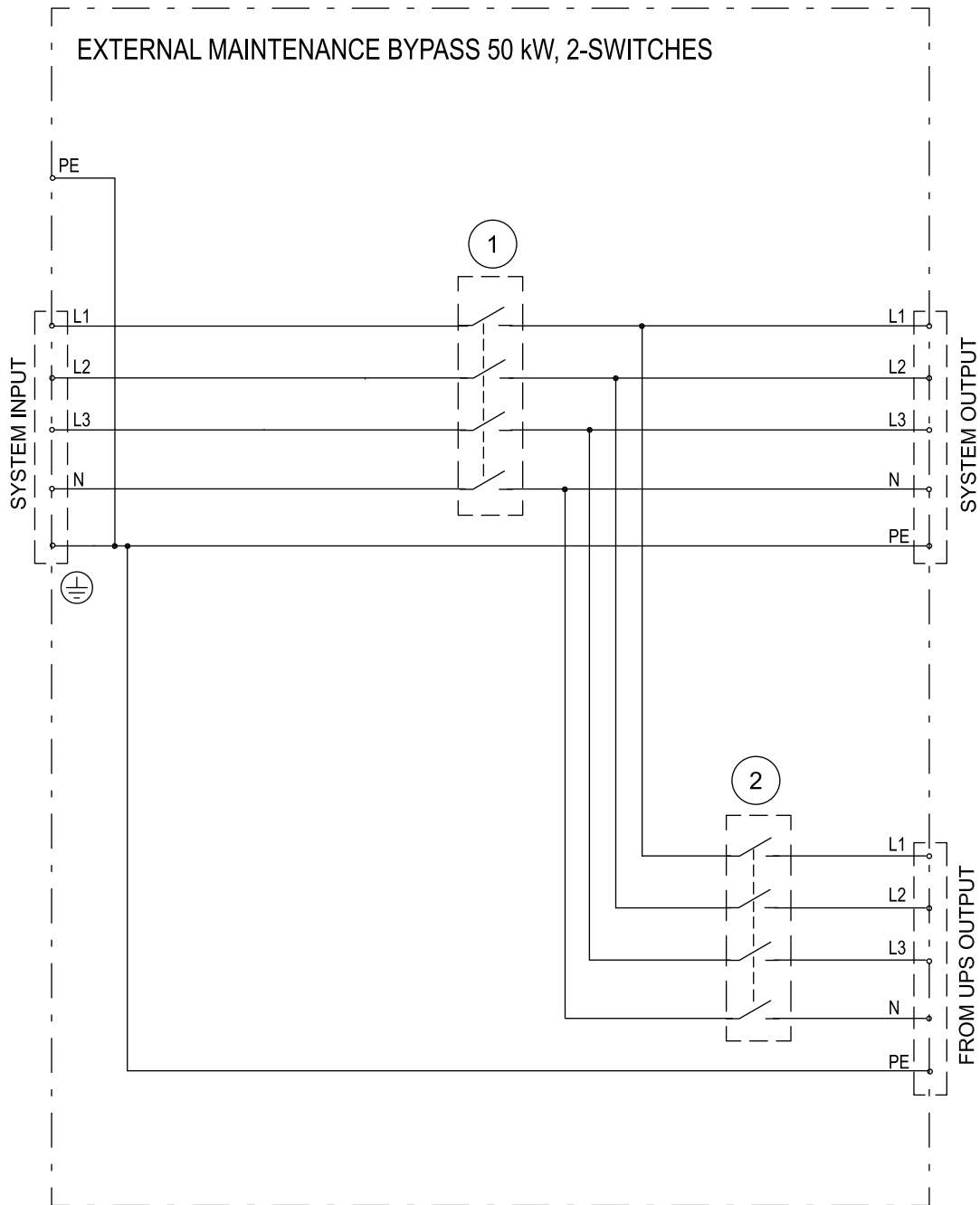

1. Maintenance Bypass Switch (MBP)
2. Maintenance Isolation Switch (MIS)

**Figure 2-8: Two-switch MBS electrical connection drawing**

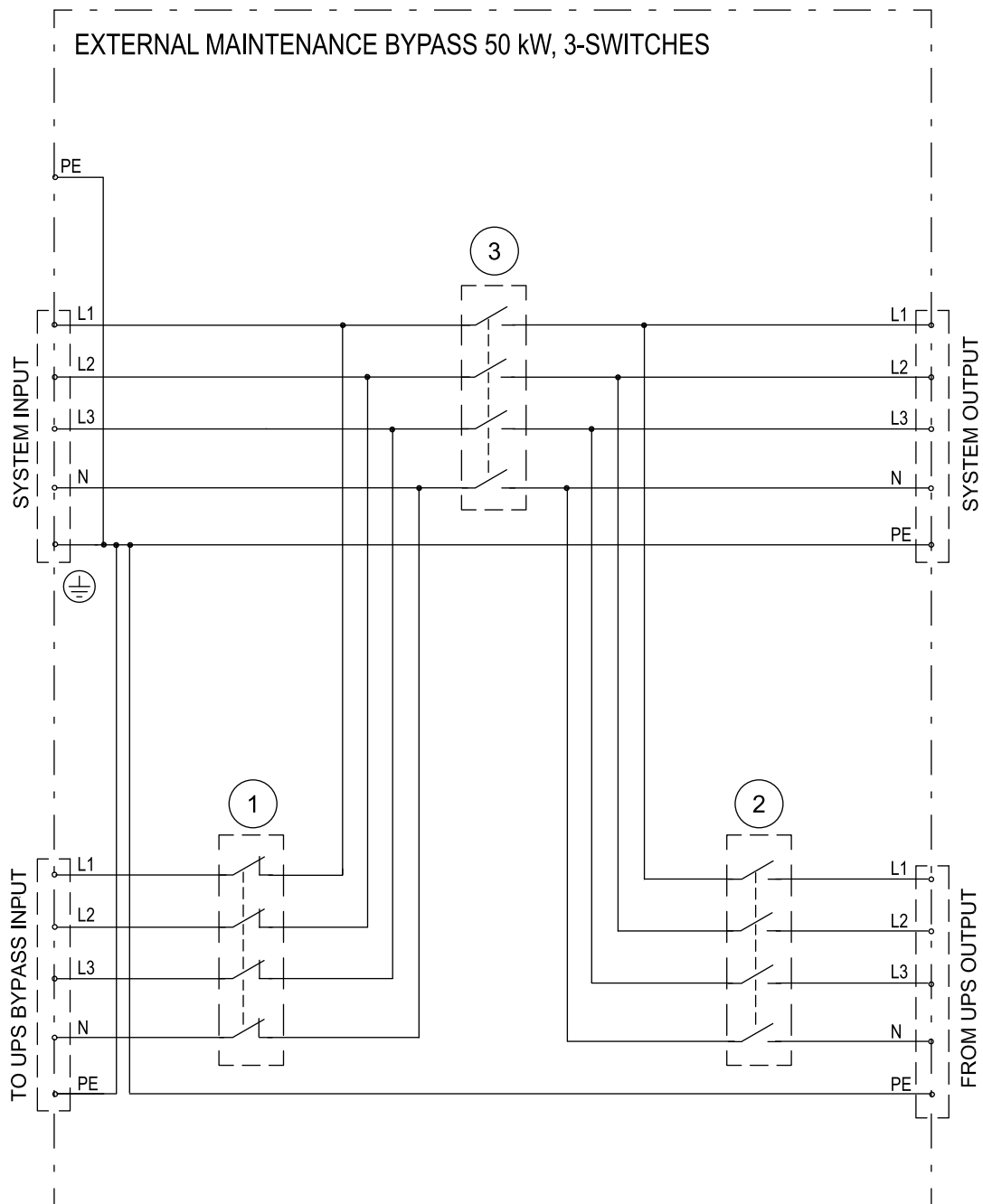

1. Bypass Input Breaker (BIB)
2. Maintenance Isolation Switch (MIS)
3. Maintenance Bypass Switch (MBP)

**Figure 2-9: Three-switch MBS electrical connection drawing**

For external MBS installation instructions, see a separate manual.

## 2.5.2 Top air exhaust kit

The top air exhaust kit is used to direct the UPS cooling air front-to-top. The kit will eliminate the cooling clearance requirement from the back of the unit, and enable installing the 93PM UPS even against a wall, in a corner or back-to-back. The kit increases the depth of the unit by 200 mm.

Refer to *Chapter 3.2 Site preparations* on page 25 for further information.

## 2.5.3 Top cable access kit

The top cable access kit is designed to support top cabling to the 30-150 kW 93PM UPS in sites where the cabling is distributed through overhead cable trays. The kit is installed at the right hand side of the UPS unit.

The 200 kW 93PM UPS does not require this kit, since the unit supports bottom, rear, and top cable entry by standard.

Refer to *Chapter 3.2 Site preparations* on page 25 and *Chapter 4.1 Steps to install the UPS* on page 36 for further information.

See also *Figure 4-4: 93PM 30-150 kW Top cable access kit* on page 40.

## 2.5.4 Field Installed UPM

A Field Installed UPM (FI-UPM) can be installed in the cabinet any time in the future when power needs change. This enables the UPS system to grow with the business, thus lowering the initial investment required for the system Day1.

In order to install an FI-UPM, the UPS cabinet needs to have upgradeability, which is determined by the power rating of the static bypass. For example, if the static bypass is rated for 150 kW, the fourth UPM cannot be installed into the frame. For listing of upgradeable configurations, see *Table 2-1: UPS configurations* on page 23.

## 2.6 Battery system

The battery system provides emergency short-term backup power to safeguard operation during brownouts, blackouts, and other power interruptions. By default, UPS is configured to use VRLA batteries. Should there be a need to connect other type of batteries or other energy storage means, a certified service technician should be consulted prior to proceeding with installation.

### 93PM 30-50 kW units

The Eaton 93PM 30-50 kW UPS can be equipped with internal batteries to provide a 10-20 min full load runtime depending on UPS rating. In addition, external battery cabinets can be introduced to the system to allow extended autonomy. Internal and external batteries can be used in parallel.

### 93PM 80-200 kW units

The Eaton 93PM 80-200 kW UPS can be equipped with an external battery, and no internal batteries are available.

For detailed battery specifications, see *Chapter 8 Technical data* on page 76.

## 2.7 Basic system configurations

### UPS power rating

The maximum attainable UPS system power rating is determined by the size of static bypass. The number of UPM power modules determines the nominal power rating of the UPS. If upgradeability is required, the system static bypass should be chosen according to the future maximum load rating, and number of UPMs is chosen according to Day1 capacity requirements.

The following UPS configurations with different static bypass sizes and number of UPMs are possible:

Description	UPS power rating	Upgradeability	Size of bypass and size of the frame
93PM-50(50)	50 kW	-	50 kW
93PM-50(100)	50 kW	to 100 kW	100 kW
93PM-50(150)	50 kW	to 100 kW and 150 kW	150 kW
93PM-50(200)	50 kW	to 100 kW, 150 kW, and 200 kW	200 kW
93PM-100(100)	100 kW	-	100 kW
93PM-100(150)	100 kW	to 150 kW	150 kW
93PM-100(200)	100 kW	to 150 and 200 kW	200 kW
93PM-150(150)	150 kW	-	150 kW
93PM-150(200)	150 kW	to 200 kW	200 kW
93PM-200(200)	200 kW	-	200 kW

**Table 2-1: UPS configurations**

A single UPS frame can house maximum four UPM power modules, resulting in maximum power rating of 200 kW. In addition, the UPS frames can be connected in parallel to create even larger systems. A maximum of four UPSs can be connected in parallel.

### UPS Options

The following table shows different standard and optional UPS options and the models where they apply.

	30-50 kW	80-100 kW	120-150 kW	160-200 kW
Smart touch screen display for system control and monitoring	Standard	Standard	Standard	Standard
SNMP web interface	Standard	Standard	Standard	Standard
Internal MBS	Option	Option	Option	-

	<b>30-50 kW</b>	<b>80-100 kW</b>	<b>120-150 kW</b>	<b>160-200 kW</b>
Rectifier input switch IS	Standard	Option	Option	-
Internal battery breaker BB	Standard	Option	Option	-
Chimney / front-to-top air flow	-	Option	Option	Option
Battery start	Standard	Standard	Standard	Standard
Integrated backfeed protection	Standard	Standard	Standard	Standard

**Table 2-2: Standard and optional UPS options**

Additional options and accessories are also available. These include different software and connectivity options and external switchgear and power distribution options.



## 3 UPS installation plan and unpacking

Use the following basic sequence of steps to install the UPS:

1. Create an installation plan for the UPS system
2. Prepare your site for the UPS system
3. Inspect and unpack the UPS cabinet
4. Unload and install the UPS cabinet, and wire the system
5. Complete the installation checklist (*Chapter 10 Installation checklist* on page 82)
6. Have authorized service personnel perform preliminary operational checks and startup.



### NOTE

**Startup and operational checks must be performed by an authorized Eaton Customer Service Engineer, or the warranty terms specified in Warranty become void. This service is offered as part of the sales contract for the UPS. Contact service in advance (usually a two-week notice is required) to reserve a preferred startup date.**

---

### 3.1 Creating an installation plan

Before installing the UPS system, read and understand how these instructions apply to the system being installed. Use the procedures and illustrations in Chapter 3.2 Site preparations and Chapter 4 UPS system installation to create a logical plan for installing the system.

### 3.2 Site preparations

For the UPS system to operate at peak efficiency, the installation site should meet the environmental parameters outlined in these instructions. If the UPS needs to be operated at an altitude higher than 1000 m, contact your service representative for important information about high altitude operation. The operating environment must meet the weight, clearance, and environmental requirements specified.

#### 3.2.1 Environmental and installation considerations

The UPS system can be installed where there is TN or TT power distribution system.

The UPS system installation must meet the following guidelines:

- The system must be installed on a level floor suitable for computer or electronic equipment. The floor must be suitable for heavy weight and wheeling.
- The system must be installed in a temperature and humidity controlled indoor area free of conductive contaminants.
- The cabinet can be installed in line-up-and-match or standalone configurations.

Failure to follow guidelines may void your warranty.

The UPS equipment operating environment must meet the weight requirements shown in *Table 3-2: UPS cabinet weights* on page 26, and the size requirements shown in *Table 3-1: Dimensions* on page 26, *Figure 3-2: 93PM 30-150 kW UPS dimensions* on page 28, *Figure 3-3: 93PM 160-200 kW UPS dimensions* on page 29, *Figure 3-4: Eaton 93PM 80-150 kW UPS Top air exhaust kit dimensions* on page 29, and *Figure 3-5: Eaton 93PM 200 kW UPS Top air exhaust kit dimensions* on page 30.

	30-150 kW	160-200 kW
Shipping dimensions (WxDxH)	760 x 1100 x 2060 mm	900 x 1135 x 2035 mm
Cabinet dimensions (WxDxH)	560 x 914x 1876 mm	760 x 914 x 1876 mm

**Table 3-1: Dimensions**

	30-50 kW	80-100 kW	120-150 kW	160-200 kW
Shipping weight	895 kg	360 kg	440 kg	635 kg
Installed weight	825 kg	290 kg	370 kg	555 kg
Floor loading	1600 kg/m <sup>2</sup>	570 kg/m <sup>2</sup>	720 kg/m <sup>2</sup>	800 kg/m <sup>2</sup>

**Table 3-2: UPS cabinet weights**

The UPS cabinets use forced air cooling to regulate internal component temperature. By standard, air inlets are in the front of the cabinet and outlets are in the back. You must allow clearance in front of and behind each cabinet for proper air circulation.

With the optional top air exhaust kit, it is possible to configure the air outlets in the top rear of the cabinet. With this option, the UPS can be installed against a wall or back-to-back.

The clearances required around the UPS cabinet in both of these situations are shown in *Table 3-3: UPS cabinet minimum clearances* on page 26 and *Table 3-4: UPS cabinet minimum clearances with top air exhaust kit* on page 27. In addition, a minimum of 20 mm clearance is recommended on the right and left side of the cabinet.

	30-50 kW	80-100 kW	120-150 kW	160-200 kW
From top of cabinet	500 mm	800 mm	800 mm	800 mm
From front of cabinet	900 mm	900 mm	900 mm	900 mm
From back of cabinet	200 mm*	400 mm*	500 mm*	500 mm*

**Table 3-3: UPS cabinet minimum clearances**

**\*Cabling may require more space.**

	30-50 kW	80-200 kW
From top of cabinet	500 mm	800 mm
From front of cabinet	900 mm	900 mm
From back of cabinet	0 mm	0 mm

**Table 3-4: UPS cabinet minimum clearances with top air exhaust kit**

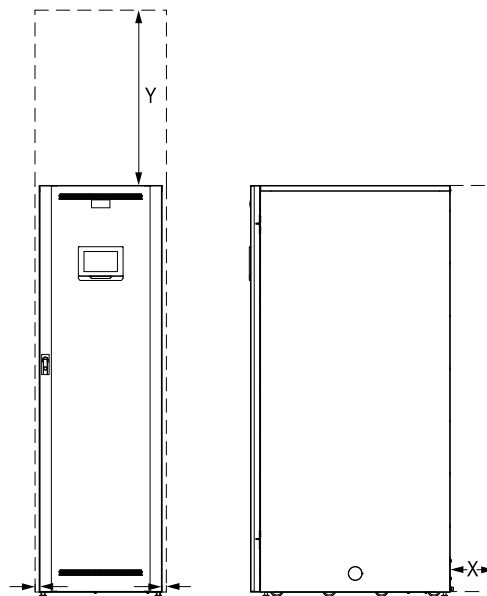

- X = clearance at back of cabinet
- Y = clearance at top of cabinet

**Figure 3-1: UPS cabinet clearances. See Table 3-3.**

The basic environmental requirements for operation of the UPS system are:

- Ambient Temperature Range: from +5 to +40 °C
- Recommended Operating Range: from +20 to +25 °C
- Maximum Relative Humidity: 95 %, noncondensing

It is required to arrange ventilation of the UPS room. Sufficient amount of air cooling is needed to keep the maximum room temperature rise at desired level:

- Temperature rise of max. +5 °C requires the airflow of 600 m<sup>3</sup> per 1 kW of losses
- Temperature rise of max. +10 °C requires the airflow of 300 m<sup>3</sup> per 1 kW of losses

An ambient temperature from +20 to +25 °C is recommended to achieve a long life of the UPS and batteries. The cooling air entering the UPS must not exceed +40 °C. Avoid high ambient temperature, moisture, and humidity.

The UPS ventilation requirements are shown in the following table:

Rating	Heat rejection (BTU/h x 1000)	Heat rejection (kW)
30 kW	4.30	1.3
40 kW	5.73	1.7
50 kW	7.16	2.1
80 kW	11.45	3.4
100 kW	14.32	4.2
120 kW	17.18	5.0
150 kW	21.48	6.3
160 kW	22.91	6.7
200 kW	28.64	8.4

**Table 3-5: Air conditioning or ventilation requirements during full load operation**

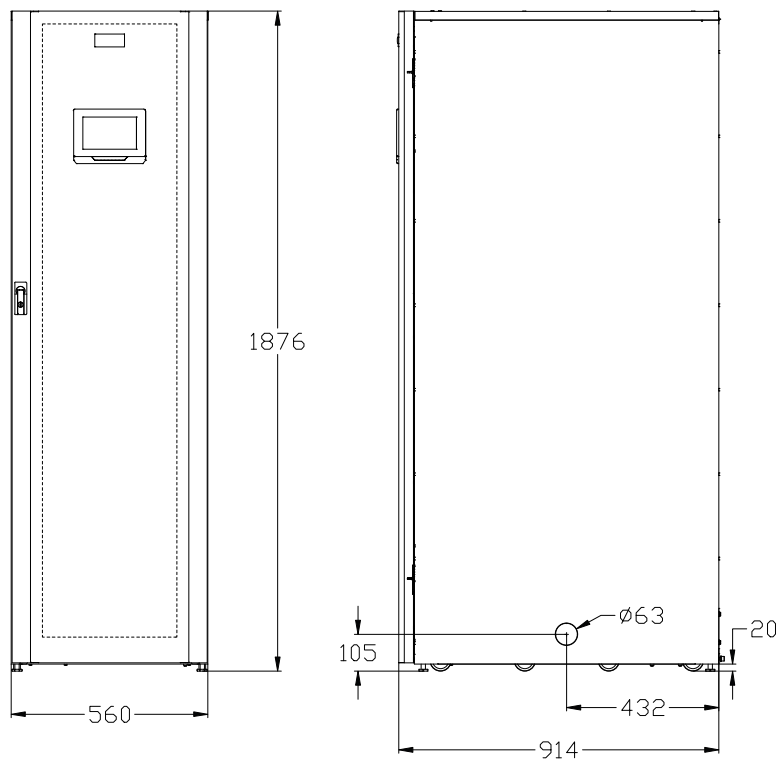

**Figure 3-2: 93PM 30-150 kW UPS dimensions**

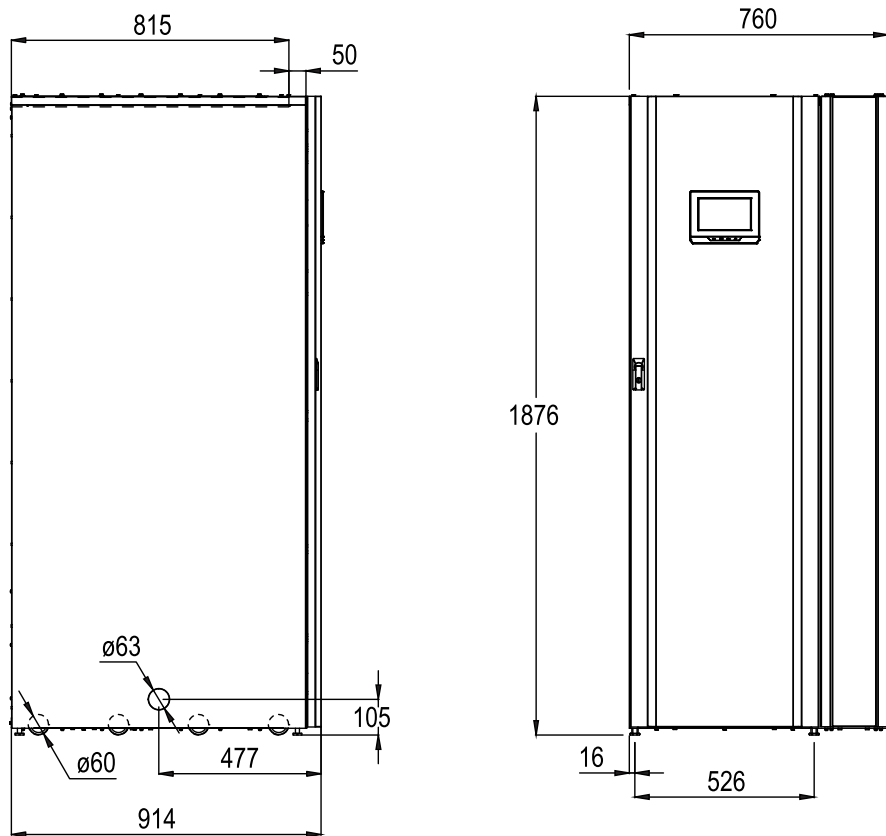

**Figure 3-3: 93PM 160-200 kW UPS dimensions**

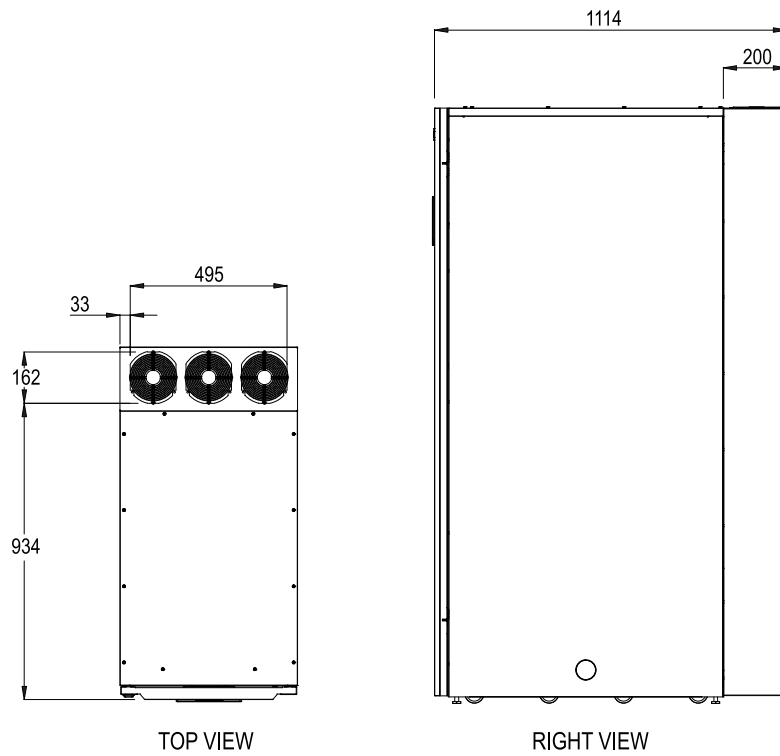

**Figure 3-4: Eaton 93PM 80-150 kW UPS Top air exhaust kit dimensions**

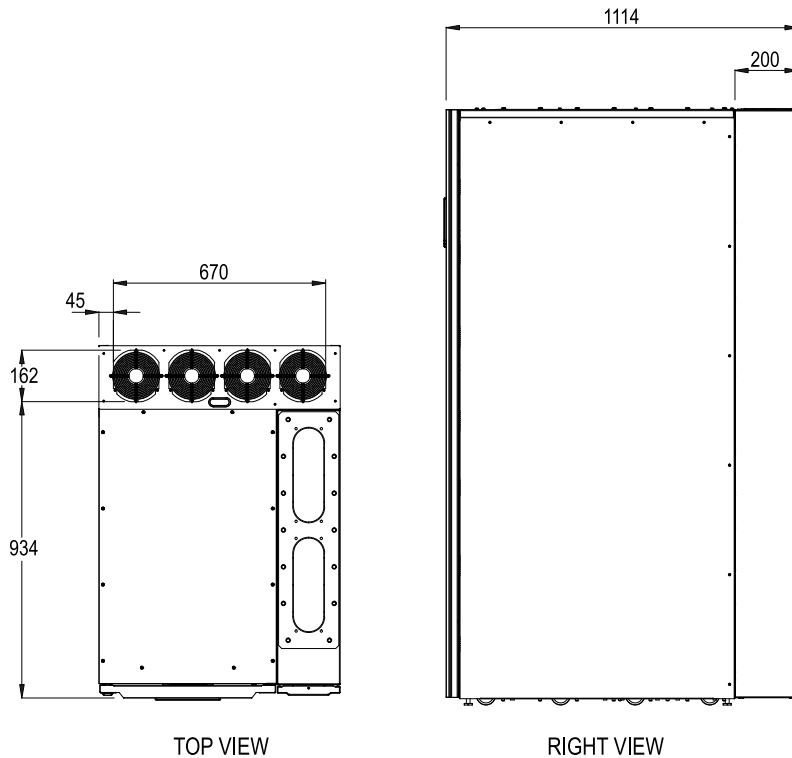

**Figure 3-5: Eaton 93PM 200 kW UPS Top air exhaust kit dimensions**

### 3.2.2 UPS system power wiring preparation



**NOTE**

**If installing a maintenance bypass, a minimum of two separate feeds with upstream feeder breakers, or a single feed with two upstream feeder breakers, must be provided: one for the UPS or rectifier input breaker (if installed) and one for the maintenance bypass input. DO NOT use a single feed or a single feeder breaker to supply both the UPS or rectifier input breaker and the maintenance bypass. If a bypass input breaker is installed in the maintenance bypass and a single-feed UPS is being installed, a single feed to the maintenance bypass is acceptable for supplying both the UPS and the bypass.**

Read and understand the following notes while planning and performing the installation:

- Refer to national and local electrical codes for acceptable external wiring practices.
- To allow for future kVA upgrades (software and/or hardware), consider using conductors sized for full bypass rating of the UPS.
- Material and labor for external wiring requirements are to be provided by designated personnel.
- For external wiring, use 90 °C copper wire. See the appropriate information in *Table 3-6: Minimum recommended multi-core cable and fuse sizes* on page 31. Wire sizes are based on using the specified breakers.
- If wire is run in an ambient temperature greater than 30 °C, higher temperature wire and/or larger size wire may be necessary.
- Specification is for copper wire with a 90 °C rating.

- The bypass feed into this equipment uses four wires. The rectifier feed into this equipment uses three or four wires. The phases must be symmetrical about ground (from a Wye source) for proper equipment operation.
- If the load requires a neutral, a bypass source neutral must be provided. If the load does not require a neutral and there is no neutral conductor connected at the bypass input, a neutral must be installed to source star point.
- A readily accessible disconnect device must be incorporated in all fixed input wiring.

UPS rating	Rectifier input		Bypass input		UPS output (380/400/415V)	PE	Battery	
	Fuse	Cable	Fuse	Cable			Cable	Fuse
<b>50 kW</b>	3x 100 A	4x 35 mm <sup>2</sup>	3x 100 A	4x 35 mm <sup>2</sup>	4x 35 mm <sup>2</sup>	35 mm <sup>2</sup>	200 A	2x 70 mm <sup>2</sup>
<b>50 kW Maximum</b>	-	4x 50 mm <sup>2</sup>	-	4x 50 mm <sup>2</sup>	4x 50 mm <sup>2</sup>	35 mm <sup>2</sup>	-	2x 95 mm <sup>2</sup>
<b>100 kW</b>	3x 200 A	4x 70 mm <sup>2</sup>	3x 200 A	4x 70 mm <sup>2</sup>	4x 70 mm <sup>2</sup>	35 mm <sup>2</sup>	400 A	2x 150 mm <sup>2</sup>
<b>150 kW</b>	3x 315 A	4x 150 mm <sup>2</sup>	3x 315 A	4x 150 mm <sup>2</sup>	4x 150 mm <sup>2</sup>	95 mm <sup>2</sup>	500 A	4x 150 mm <sup>2</sup>
<b>200 kW</b>	3x 400 A	4x 240 mm <sup>2</sup>	3x 400 A	4x 240 mm <sup>2</sup>	4x 240 mm <sup>2</sup>	120 mm <sup>2</sup>	630 A	4x 240 mm <sup>2</sup>

**Table 3-6: Minimum recommended multi-core cable and fuse sizes**

Rated power	Rated voltage	Rectifier input	Rectifier input	UPS Output/Bypass	UPS Output/Bypass	Battery	Battery
		<i>Rated current</i>	<i>Max. current</i>	<i>Rated current</i>	<i>Max. current</i>	<i>Rated current</i>	<i>Max. current</i>
<b>30 kW</b>	380 V	48	57	46	55	73	95
	400 V	46	54	44	52	73	95
	415 V	44	52	42	50	73	95
<b>40 kW</b>	380 V	64	76	62	73	97	126
	400 V	61	72	59	70	97	126
	415 V	58	69	56	66	97	126
<b>50 kW</b>	380 V	80	95	77	91	121	158

<b>Rated power</b>	<b>Rated voltage</b>	<b>Rectifier input</b> <i>Rated current</i>	<b>Rectifier input</b> <i>Max. current</i>	<b>UPS Output/Bypass</b> <i>Rated current</i>	<b>UPS Output/Bypass</b> <i>Max. current</i>	<b>Battery</b> <i>Rated current</i>	<b>Battery</b> <i>Max. current</i>
	400 V	76	90	74	87	121	158
	415 V	73	86	71	83	121	158
<b>80 kW</b>	380 V	127	164	122	145	193	231
	400 V	121	156	116	138	193	231
	415 V	116	150	112	133	193	231
<b>100 kW</b>	380 V	159	196	152	181	241	289
	400 V	151	186	145	172	241	289
	415 V	145	179	140	166	241	289
<b>120 kW</b>	380 V	190	235	182	218	290	346
	400 V	181	223	174	206	290	346
	415 V	174	214	168	199	290	346
<b>150 kW</b>	380 V	238	294	228	272	362	433
	400 V	226	279	218	258	362	433
	415 V	217	268	210	249	362	433
<b>160 kW</b>	380 V	254	328	244	289	386	463
	400 V	241	311	231	275	386	463
	415 V	232	300	223	265	386	463
<b>200 kW</b>	380 V	317	391	304	362	483	578
	400 V	301	371	289	344	483	578
	415 V	290	358	279	331	483	578

**Table 3-7: Rated and maximum currents for rated power and voltage**

See the following table for power cable terminations.



Terminal function	Terminal	Function	Tightening torque Nm
AC input to UPS rectifier	X1	L1, L2, L3, N	Check the tightening torque from the connector label.
AC input to bypass	X2	L1, L2, L3, N	Check the tightening torque from the connector label.
UPS output	X3	L1, L2, L3, N	Check the tightening torque from the connector label.
DC input from external battery to UPS	X4	battery +, battery –	Check the tightening torque from the connector label.
Protective Earth	PE	PE	Check the tightening torque from the connector label.

**Table 3-8: UPS power cable terminations**



**NOTE**

**External overcurrent protection is not provided by this product, but is required by codes. Refer to Table 3-6: Minimum recommended multi-core cable and fuse sizes on page 31 for wiring requirements. If an output lockable disconnect is required, it is to be supplied by the user.**



**CAUTION**

**To reduce the risk of fire, connect only to a circuit provided with maximum input circuit breaker current ratings from Table 3-7: Rated and maximum currents for rated power and voltage on page 31 in accordance with the national and local installation rules.**

The line-to-line unbalanced output capability of the UPS is limited only by the full load per phase current values for AC output to critical load shown in *Table 3-7: Rated and maximum currents for rated power and voltage* on page 31. The recommended line-to-line load unbalance is 50 % or less.

Source Protection for the AC Input to Bypass should suit the characteristics of the load and take account of effects such as Inrush or Starting Current.

Bypass and output overcurrent protection and bypass and output disconnect switches are to be provided by the user.

**For UPS wiring diagrams, see Chapter 2.1 Looking inside the UPS system on page 9.**

### 3.2.3 UPS system interface wiring preparation

Control wiring for features and options should be connected at the customer interface terminal blocks located on top front of the UPS, behind the door.



**DANGER**

**Do not directly connect relay contacts to the mains related circuits. Reinforced insulation to the mains is required.**

---

Read and understand the following notes while planning and performing the installation:

- All interface wiring is to be provided by the customer.
- When installing internal interface wiring to Mini-slot terminals, route the wiring through the internal opening in the Mini-slot communication bay.
- All signal inputs or remote features require an isolated normally-open contact or switch (rated at 24 VDC, 20 mA minimum) connected between the alarm input and common terminal. All control wiring and relay and switch contacts are customer-supplied. Use twisted-pair wires for each alarm input and common.
- The signal inputs can be programmed to display the alarm functional name.
- LAN and telephone drops for use with Mini-slot cards must be provided by facility planners or the customer.
- The UPS Battery Aux and 24 VDC Shunt Trip signal wiring from the UPS must be connected to the DC source disconnect device.
- Battery Aux and 24 VDC Shunt Trip wiring should be a minimum of 1.5 mm<sup>2</sup>.
- The Remote EPO feature opens all switchgear in the UPS cabinet and isolates power from your critical load. Local electrical codes may also require tripping upstream protective devices to the UPS.
- The Remote EPO switch must be a dedicated switch not tied to any other circuits.
- A jumper wire must be connected between pins 1 and 2 on connector EPO, if the normally-closed (NC) Remote EPO contact is used.
- Remote EPO wiring should be a minimum of 0.75 mm<sup>2</sup> and a maximum of 2.5 mm<sup>2</sup>.
- The maximum distance between the Remote EPO and the UPS cannot exceed 150 meters.
- Alarm relay contacts have a maximum current rating of 5 A and a switched voltage rating of 30 VAC (RMS) and 30 VDC.
- Alarm relay wiring should be a minimum of 0.75 mm<sup>2</sup>.

## 3.3 Unpacking and unloading the UPS

If the equipment has been transported in the upright position the outside 'Tip&Tell' indicator on the package surface should be intact. If the arrow has turned all blue, contact the appropriate parties for reporting inappropriate transportation.

**NOTE**

**The UPS cabinet is heavy. If unpacking instructions are not closely followed, the cabinet may tip and cause serious injury.**

---

The UPS cabinet is bolted to a wooden pallet supported by wood skids. To remove the pallet, perform the following procedure:

1. If not already accomplished, use a forklift or other material handling equipment to move the cabinet to the installation area, or as close as possible, before unloading from the pallet. Insert the forklift jacks between the skids on the bottom of the unit.
2. Open the UPS package by forcing the locking pieces open in the corners of the package. Locking pieces are also holding the ramp.

**Make a visual inspection and check that there are no signs of shipping damages. The 'Drop&Tell' indicator on the rear side of the unit shall be intact if the equipment has been handled properly.**

3. Unmount the ramp from the pallet and place it on the floor firmly against the pallet so that it can be safely used for wheeling the UPS off the pallet.
4. If the leveling feet are not fully retracted, turn the leveling feet until they are retracted.
5. Unfasten front door latch and swing the door open.
6. Remove bolts and shipping brackets which are used to fasten the UPS to the pallet.

**NOTE**

**After removing the shipping brackets, the unit must be immediately moved from the pallet.**

**After removing the shipping brackets and retracting the leveling feet, the unit must not be moved with a jack lift while still on pallet. Note that the UPS cabinet is heavy and there are casters under the cabinet.**

---

7. Slowly roll the cabinet toward the ramp edge. Be careful not to push the cabinet too much or fast since it may cause the cabinet to tip.
8. Roll the cabinet to the final installation location.
9. Secure the UPS cabinet in position by lowering the levelling feet, until the cabinet is not resting on the casters and the cabinet is level.

**NOTE**

**If the cabinet is removed from its original installation location and transferred to a new location on the pallet, the leveling feet must be lowered until the cabinet is not resting on the casters. In addition, the shipping brackets must be attached to the cabinet and pallet.**

---

# 4 UPS system installation

The customer has to supply the wiring to connect the UPS to the local power source. The electrical installation procedure is described in the following section. The installation inspection and the initial start-up of the UPS and installing an extra battery cabinet must be carried out by qualified service personnel such as a licensed service engineer from the manufacturer or from an agent authorized by the manufacturer.



**WARNING**

**Physical injury or death may follow, or damage may occur to the UPS or the load equipment if these instructions are ignored.**

---

## 4.1 Steps to install the UPS

Power and control wiring can be routed through the rear, bottom, or top of the cabinet, depending on the model of the cabinet, with connections made to easily accessible terminals, see *Figure 4-1: 93PM 30-50 kW gland plate and connector locations* on page 37, *Figure 4-2: 93PM 80-150 kW UPS gland plate and connector locations* on page 38, *Figure 4-3: 93PM 160-200 kW UPS gland plate and connector locations* on page 39, and *Figure 4-4: 93PM 30-150 kW Top cable access kit* on page 40.

1. If not already open, unfasten front door latch and swing door open.
2. If the internal Maintenance Bypass Switch (MBS) is included, remove the screws securing the MBS protection cover on bottom left of front panel. Then remove the Maintenance Bypass Switch knob by loosening the screw in the middle of knob and pulling the knob off of the shaft.
3. Remove the screws securing the safety shield panel in front of the connectors to gain access to terminal blocks.
4. Remove screws securing the rear wire entry plate to gain access through back wire entry way. If the cables are to be installed with top-access kit, is not necessary to remove the rear plate.
5. If installing power wiring from the bottom of the cabinet, proceed to step 6; rear access, proceed to step 8. If installing the power wiring from top, proceed to step 7.
6. Remove screws securing bottom wire entry plate.
7. Remove the right side plate for cable installation access. Remove the needed cable gland plates from the top of the top access cabinet.
8. Drill or punch holes for the cable glands on the plate used for cable entry. Work must be performed while the plate is outside the UPS cabinet to prevent metal shavings or chips from entering on or into electronics.
9. Install suitable cable glands on the plate.
10. Route all the cables through wire way to the UPS terminal blocks.
11. Reinstall wire entry plate and install conduit if needed.
12. Route and connect power wiring.

13. When all wiring is complete, reinstall safety shield panels removed in previous steps.
14. Close the door and secure with latch.
15. If installing a parallel system, repeat the above steps to all units in the system.

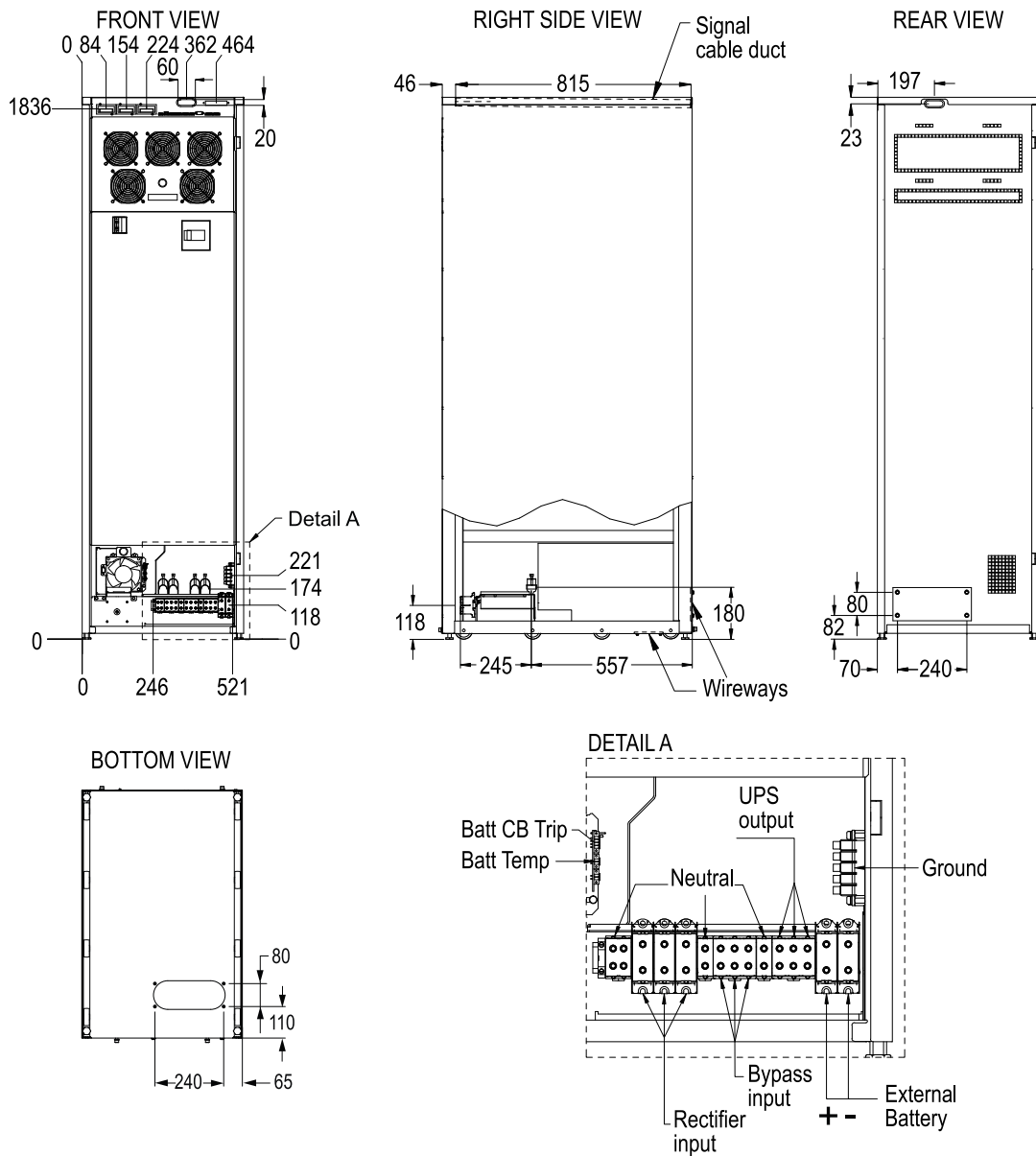

**Figure 4-1: 93PM 30-50 kW gland plate and connector locations**

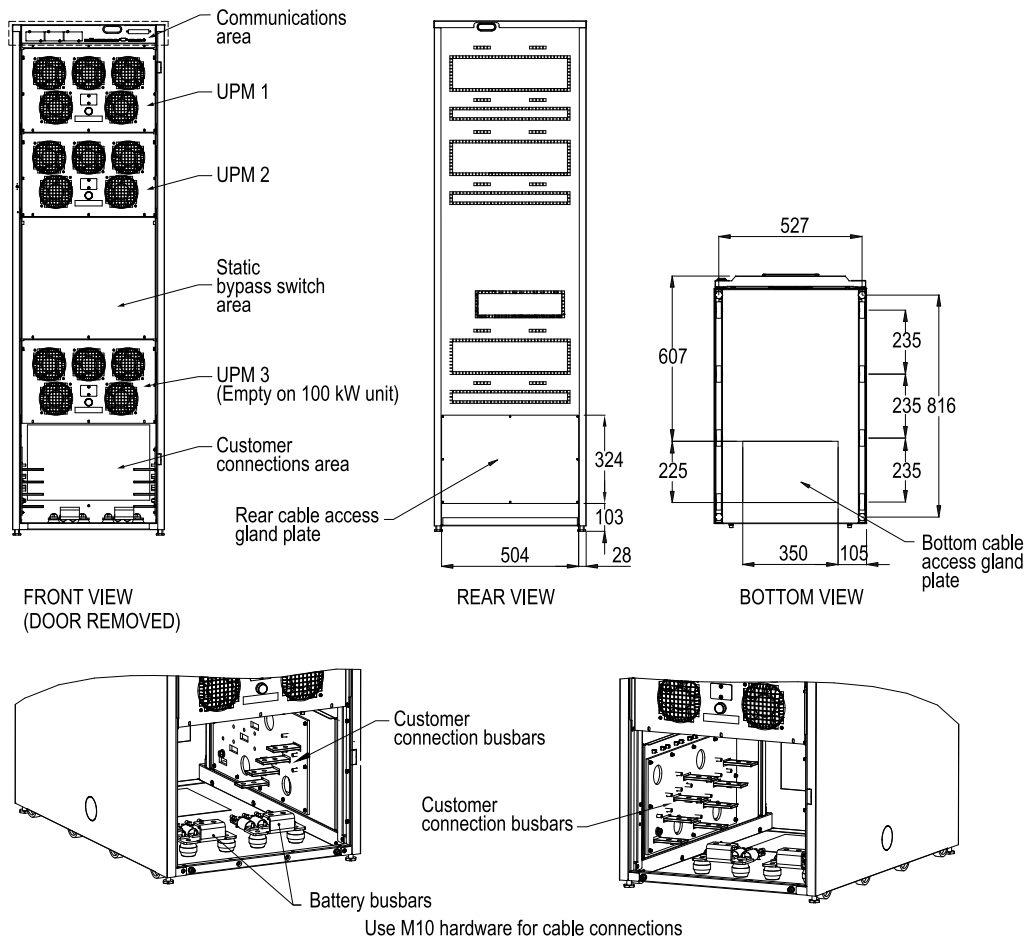

**Figure 4-2: 93PM 80-150 kW UPS gland plate and connector locations**

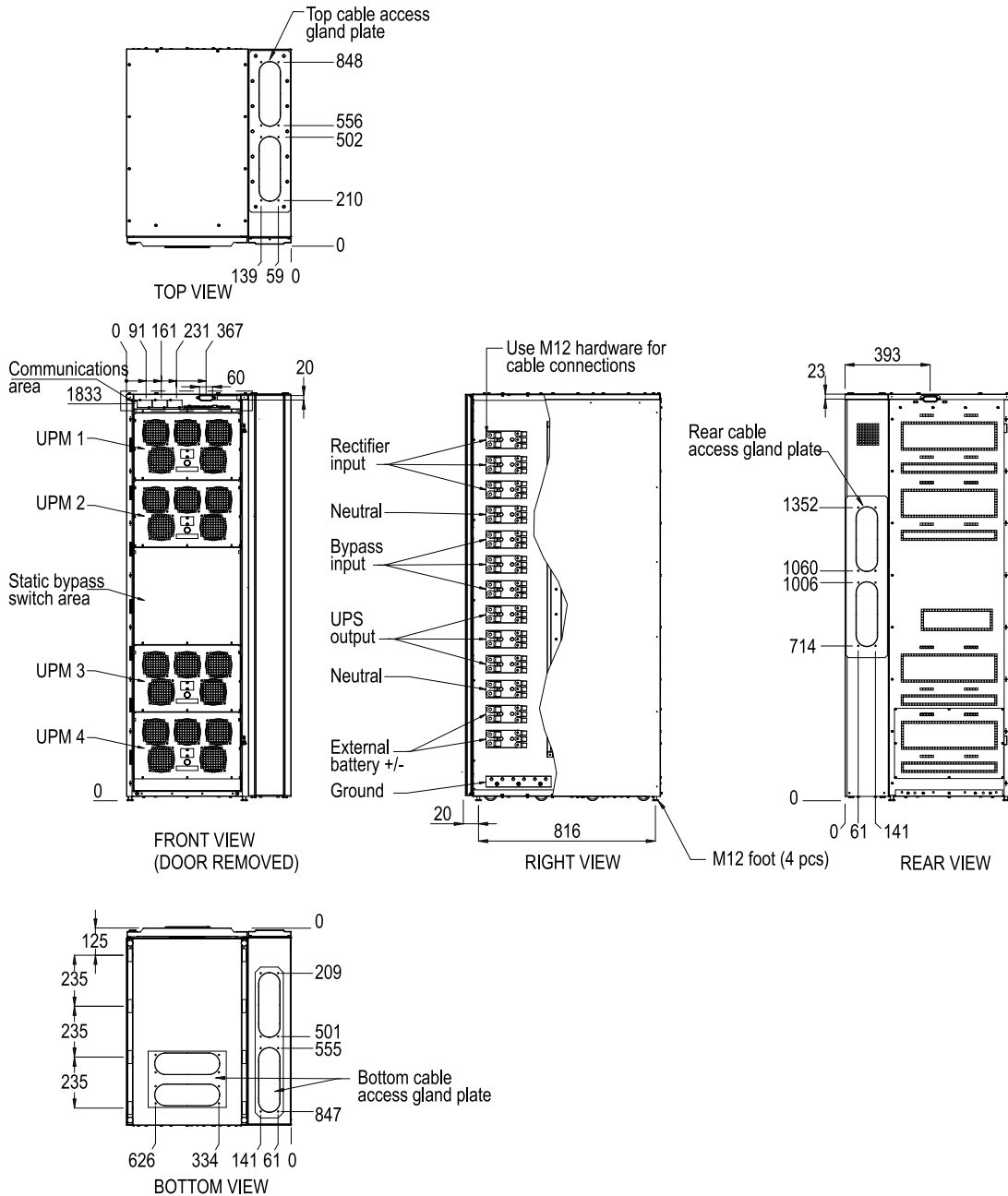

**Figure 4-3: 93PM 160-200 kW UPS gland plate and connector locations**

**Top cable access kit**

The following figure shows the top cable access kit for 30-150 kW UPS units. The top cable access kit is optional. For more information, see *Chapter 2.5.3 Top cable access kit* on page 22.

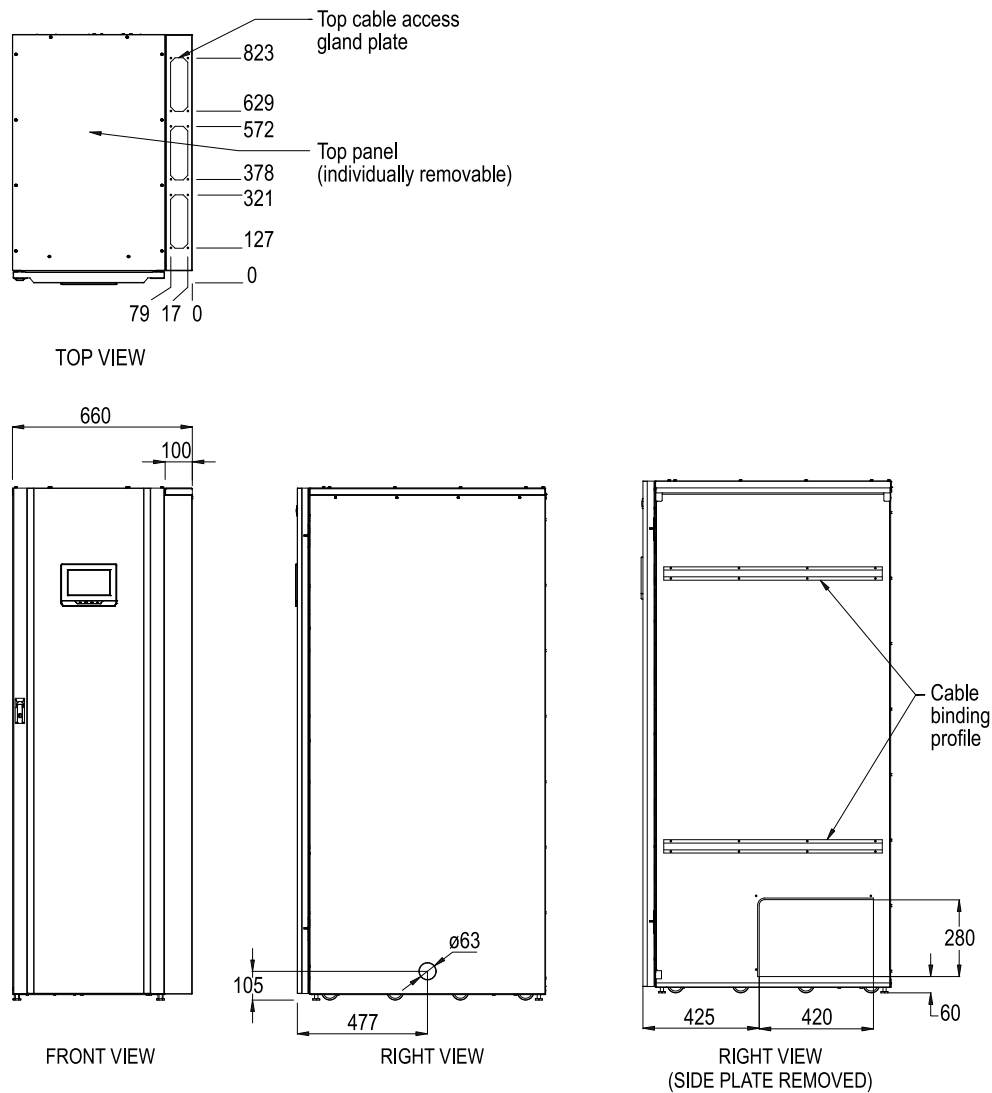

**Figure 4-4: 93PM 30-150 kW Top cable access kit**

## 4.2 Battery system installation

This UPS may have internal batteries. Connection of these batteries is to be left to the responsibility of the commissioning personnel in order to avoid damages to the equipment or personal injuries in case of an incorrect connection. The batteries are designed to deliver a large amount of energy and an incorrect connection may lead to short circuit and cause serious injuries to the personnel or damages to the equipment.

If installing a customer-supplied battery system, install the battery system according to the battery and battery system manufacturer's instructions and all applicable national codes and regulations. Only qualified personnel may install the battery system. Battery cables must be protected against current and thermal overload, that is, the battery system must include proper fuses or breaker with protection function.

The default battery settings of the UPS are for 12 VDC VRLA batteries. If requested to use other battery types, contact your Eaton representative. For the battery specification, see *Chapter 8.4 Battery specification* on page 78.



## 4.3 Installing UPS external battery cabinet and battery power wiring

For the 93PM product line, there are two different battery cabinets: EBC-S and EBC-L. The 93PM 30-50 kW UPS uses 36 battery blocks per string, and the 80-200 kW UPS uses 36 or 40 battery blocks per string.



### NOTE

**Battery strings with different battery quantity and voltage may not be connected in parallel.**

---

Power and control wiring for integral line-up and match battery cabinets are supplied with the cabinets. The battery cabinet must be located to the right of the 93PM 30-150 kW UPS cabinet if wiring through cabinet inside panels. The 93PM 160-200 kW UPS does not enable wiring through its side panel.

There are several cable entries in the battery cabinets. They can be wired in the following ways:

- through the left side panel
- through the right side panel
- through the back wall
- through the roof
- through the bottom (only EBC-L)

Cable entry to the UPS is always on the back wall or the bottom of the cabinet, and to 30-150 kW UPS also on the lower right.



### NOTE

**If batteries are wired outside the cabinets, follow the installation instructions given in Chapter 3.2.2 UPS system power wiring preparation on page 30.**

---

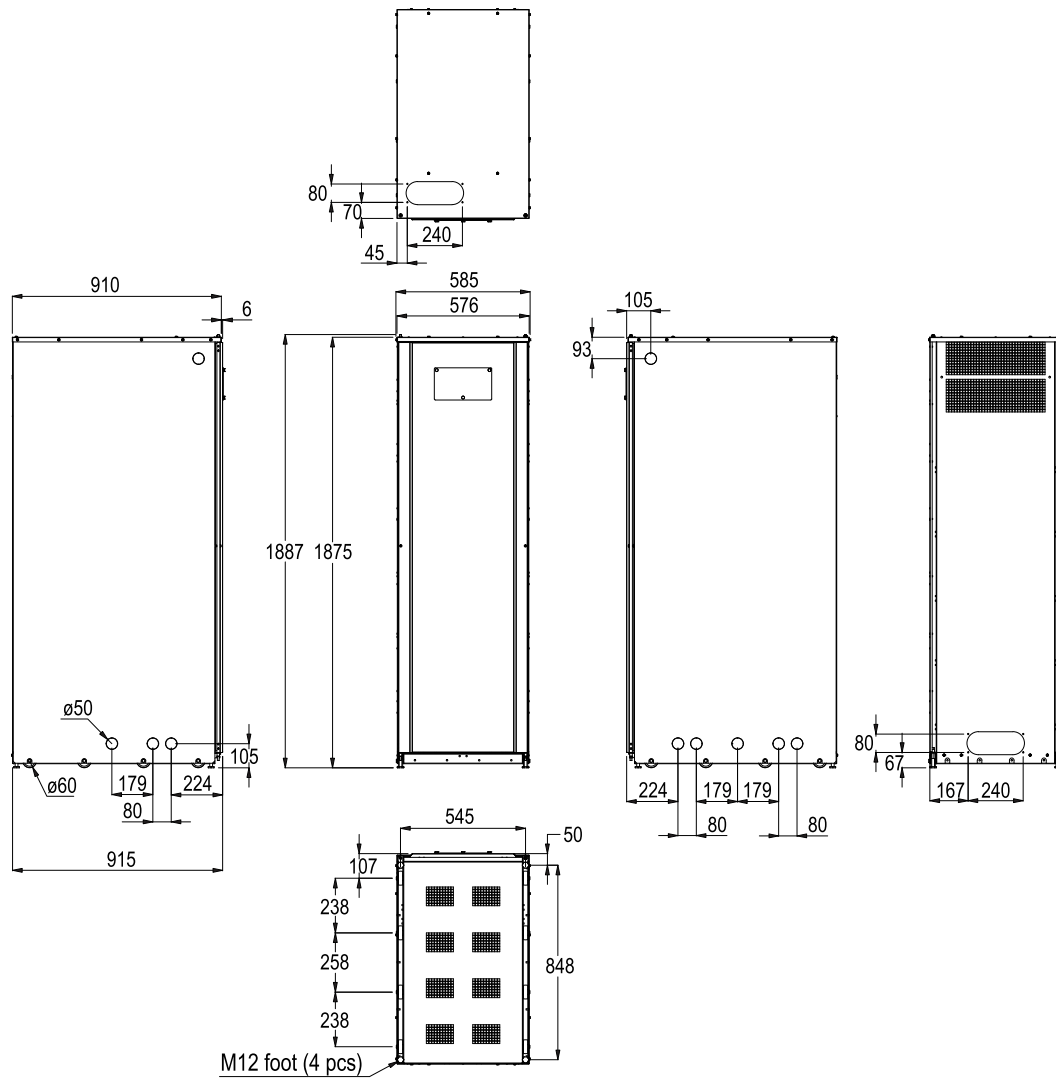

**Figure 4-5: 93PM battery cabinet (EBC-S)**

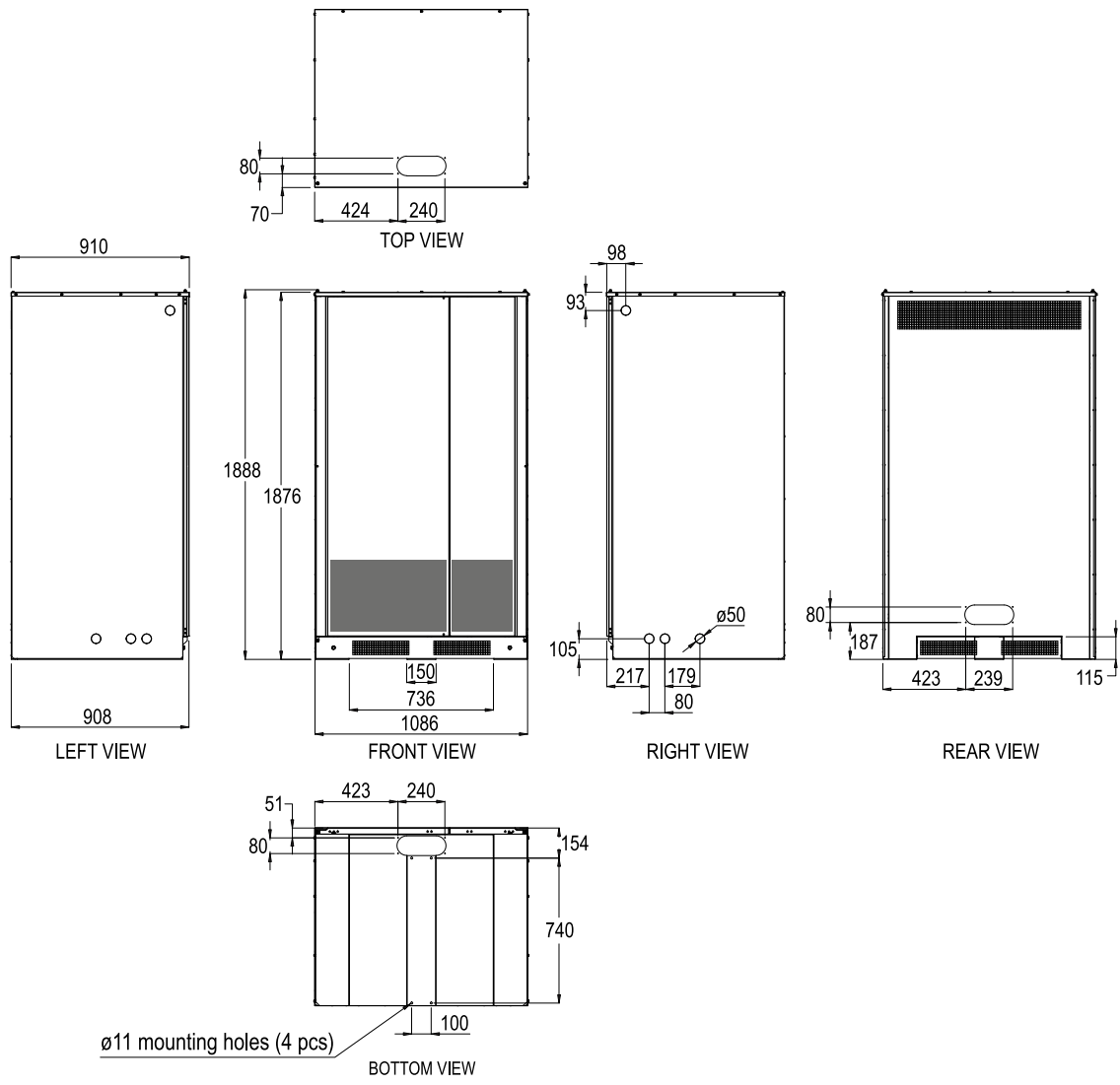

**Figure 4-6: 93PM battery cabinet (EBC-L)**

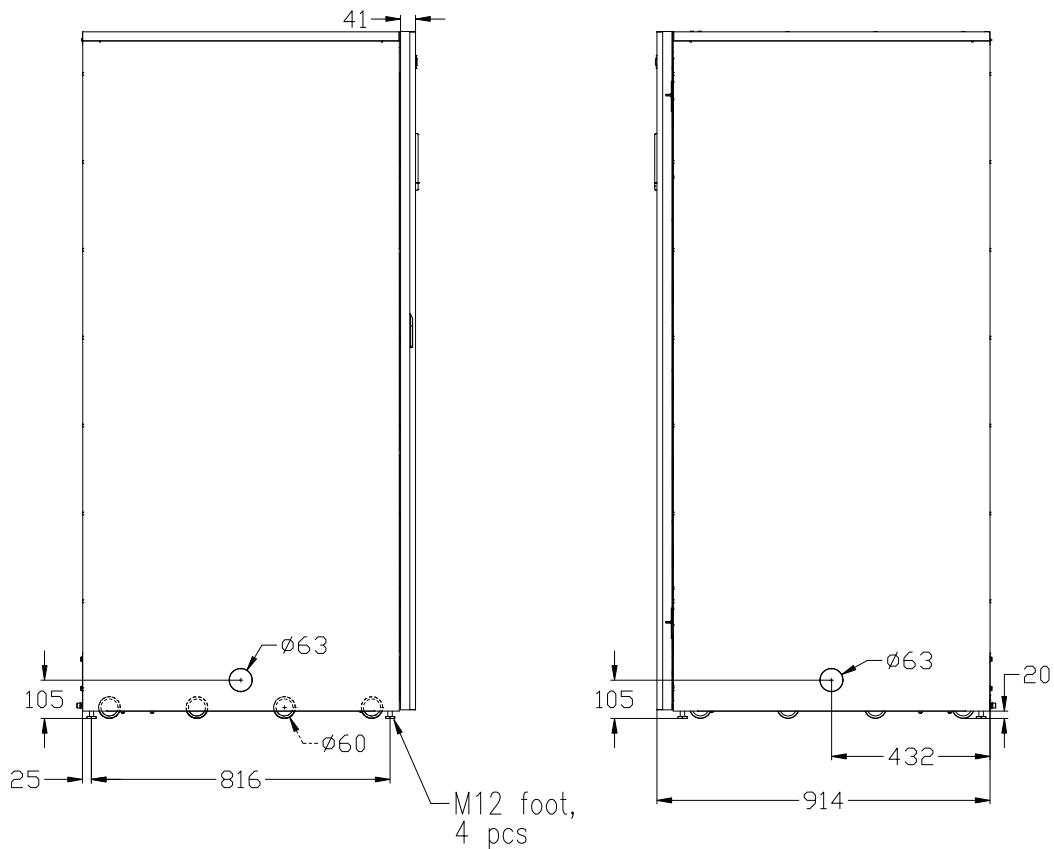

**Figure 4-7: UPS cabinet through holes**

A DC-rated circuit breaker within each cabinet provides protection and servicing isolation.

The battery cabinets use convection cooling to regulate internal component temperature. Air inlets are on the bottom, and in EBC-L also in the front of the cabinet and outlets are in the top back of the cabinet. Clearance must be allowed in front and back of each cabinet for proper air circulation.

- The system must be installed on a level floor suitable for computer or electronic equipment.
- The system must be installed in a temperature and humidity controlled indoor area free of conductive contaminants.

### Preparing the EBC-S cabinet installation

1. If not already accomplished, use a forklift or other material handling equipment to move the cabinet to the installation area, or as close as possible, before unloading from the pallet. Insert the forklift jacks between the skids on the bottom of the unit.
2. Open the package, remove the front and back mounting brackets, and place the ramp in front of the pallet.
3. Carefully slide the battery cabinet off the pallet. Now the battery cabinet is ready to be placed aside the UPS. Both sides can be used for battery cabinet placement but for easier service access, on the 30-150 kW UPS right side is preferred, and on the 160-200 kW left side is preferred.
4. Open the battery cabinet and locate the cable looms shipped along the cabinet for pre-designed installation.
5. Select the cable routing out of four different options and route the cables to the dedicated connectors inside UPS cabinet.
6. Apply cable glands and/or plastic pass-through collars accordingly.
7. Connect the cables and signal wires to the UPS.

8. If multiple cabinets are to be used, repeat the steps to the rest of the cabinets and be sure to daisy chain the signal wire harnesses in the next cabinet.



#### NOTE

**The battery cabinet is heavy. If unpacking instructions are not closely followed, the cabinet may tip and cause serious injury.**

---

#### Preparing the EBC-L cabinet installation

1. If not already accomplished, use a forklift or other material handling equipment to move the cabinet to the installation area, or as close as possible, before unloading from the pallet. Insert the forklift jacks between the skids on the bottom of the unit.
2. Open the package and remove the two front mounting brackets on the side feet and two back mounting bolts inside the middle foot.
3. Carefully use a forklift and lift the cabinet to the final place aside the UPS. Both sides can be used for battery cabinet placement but for easier service access, on the 30-150 kW UPS right side is preferred, and on the 160-200 kW left side is preferred.
4. Open the battery cabinet and locate the cable looms shipped along the cabinet for pre-designed installation.
5. Select the cable routing out of five different options and route the cables to the dedicated connectors inside UPS cabinet.
6. Apply cable glands and/or plastic pass-through collars accordingly.
7. Connect the cables and signal wires to the UPS.
8. Battery installation is to be done on-site by authorized and trained service personnel. Follow carefully the wiring instructions and detailed battery mounting instructions which are placed inside the door.
9. If multiple cabinets are to be used, repeat the steps for the rest of the cabinets and be sure to daisy chain the signal wire harnesses in the next cabinet.

## 4.4 Installing a remote EPO switch

A remote EPO switch can be used in an emergency to shut down the UPS and remove power to the critical load from a location away from where the UPS is installed.

EPO is to be connected to the UPS's top front panel, on connector EPO. Below are the NO and NC connections of the EPO switch.

EPO connector (front view):

- **A** Normally open
- **B** Normally closed

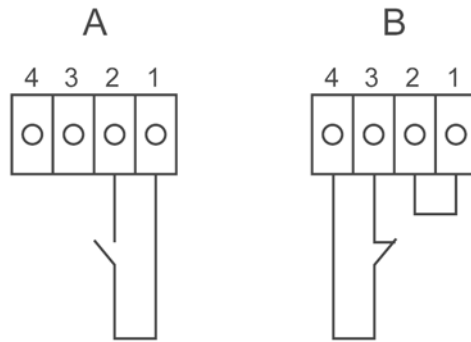

**Figure 4-8: Connections of the EPO switch**

From remote EPO switch	To customer interface Terminal block EPO in UPS cabinet	Remarks
NO	1-2	
NC	3-4	Wire jumper between 1-2 must be installed for proper functions.

**Table 4-1: Remote EPO wire terminations**

## 4.5 Installing interface connections

93PM UPS contains a total of five (5) signal input connectors for customers which can be used for giving remote control commands to the UPS. Customer interface connector CN5 can be used for these purposes. Each input is a dry relay contact input and requires two wire signaling. None of the inputs are pre-programmed but need to be separately programmed by qualified service personnel.

When using an external battery system (either the original 93PM battery cabinet or a customer sourced battery cabinet/rack), external signaling wiring is recommended to be connected.

One (1) general alarm relay output is also on the front panel. This output is either normally open (NO) or normally closed (NC). Polarity selection is made with wiring connection. By default, the general alarm relay activates when a system alarm is active, that is, any *ALARM* condition in the system is active. Alternatively, it can be activated with any particular event but this must be programmed separately by qualified service personnel. The alarm relay is designed for signal level (ELV or SELV) voltages only, not for utility use. For higher signaling circuit voltage requirements, please use Industrial Relay Adapter in Mini-slot.

### 4.5.1 Installing customer input signals interface

These inputs are located behind the UPS door, on top section of the UPS. See *Figure 5-1: Communication interfaces* on page 53 for connector locations.

Tie points with strain relief for communication cables are located on the right and left side of the cable conduit.

Signal inputs can be configured to different functions. Normally these functions are either informative (for example "On Generator") or functional (for example remote "Go to bypass" command).

## 4.5.2 Battery breaker wiring interface

When using the original accessory battery cabinet from the manufacturer, the battery breaker interface wiring is provided with the cabinet. Connecting it requires only routing the wires from the cabinet to the bottom section of the UPS. The connector for the battery circuit breaker monitoring signal and battery circuit breaker trip signal are to the left from the power cabling.

When using third party battery system, the breaker must be equipped with auxiliary signal and should have a 24 V shunt trip for remote opening of the breaker, when needed.

Wire entry for battery breaker signal wiring is always located on the lower section of the UPS cabinet. Punch holes are located on the left or right side panel, back wall or bottom plate.

## 4.5.3 Relay output interface connections

The general alarm relay is a dry relay signal output. The relay can be used for informing the operators about UPS alarm conditions, for example through a building management system. By default, the relay is configured to activate when the UPS general alarm is active, that is, any event having *ALARM* status is active. The relay can also be configured to activate by some other event but this needs to be done by authorized service.

Relay signal wiring can be installed only through the signal cabling canal, from back to front, on the top section of the UPS.

## 4.5.4 Mini-slot interface connections

For Mini-slot accessories and communication devices selection see *Chapter 5 Communication interfaces* on page 53. For installation and setup of a Mini-slot card, please contact your Eaton representative.

To install wiring to connections:

1. If not already installed, install the LAN and telephone drops.
2. Open the front door of the UPS.
3. Remove the particular Mini-slot cover plate by removing the two screws securing the plate and install the device by pushing it all the way in.
4. Secure the Mini-slot communication device with two screws.
5. Route and install the LAN, telephone, and other cables to the appropriate Mini-slot cards. Cable route is through the signal cable canal, on top section of the UPS.
6. Refer to the manual supplied with the Mini-slot card for operator instructions.
7. When all wiring is completed, close the front door and secure the latch.

## 4.5.5 Installing signal interface connections in parallel system

Installation of signal interface connections in parallel system is done by following the aforementioned instructions. Signal inputs can be paralleled between the units, that is, the same contact can be used for several units' signal input signaling. This concerns also the EPO-signal.

## 4.6 Wiring parallel 93PM UPS systems

The outputs of multiple 93PM UPS systems can be connected in parallel. Up to four (4) units can be paralleled. The UPS static bypass power rating needs to be identical among all paralleled units. However, paralleled UPS cabinets can be housed with different number of UPM power modules.

The outputs are paralleled to increase the load capacity of the power system and for redundancy. The system is paralleled for (N+1) redundancy, as long as there is always one or more UPS online than required to support the load. The system is paralleled for capacity if all UPSs in a system are required to support the load.

Communication is required between the UPSs for system metering and mode control. System level communication and control are accomplished using a Controller Area Network (CAN). A pull-chain signal in each UPS, connected to the other UPSs in parallel and tied to the bypass Status Relay in each UPS, is used for a secondary communication path. This arrangement ensures bypass control even if the CAN bus is lost.



**WARNING**

---

**Units with an internal MBS switch may not be connected in parallel.**

---

### 4.6.1 Power wiring overview

Refer to *Chapter 3.2.2 UPS system power wiring preparation* on page 30 for recommended cable and external fuse sizes and installation practices.

#### **Input Feed**

The Input feed is defined as the power source connected to the UPS rectifier. The feed to all UPS's inputs must be derived from the same source.

#### **Bypass Feed**

The Bypass feed is defined as the power source connected to the UPS Bypass. The feed to all UPS's bypass must be derived from the same source. The shortest length of power wire from the source to the UPS must be a minimum of 95 % of the length of the longest wire.

#### **Output**

The neutrals of all UPSs must be connected. The shortest length of wire from the source to the UPS must be a minimum of 95 % of the length of the longest wire. The measurement is with respect to where the UPS's outputs are tied.

#### **Dual Source**

The Input Feed and Bypass feed may be separate sources. The sources must share a common neutral.

#### **Battery connection**

A separate battery shall be connected to each UPS, and the battery capacity for each UPS must be identical. A common battery for all UPSs is **not** supported.



## MOB's

Module Output Breakers (MOBs) allow the output of the UPS to be disconnected from the other UPSs and system load for maintenance and service. Design considerations assume that each UPS has a Module Output Breaker (MOB). The breaker shall not disconnect neutral.

The MOB must have a Form "C" auxiliary contact. The N.C contact is connected to the corresponding UPS's input used for signal input. The N.O. contact is used to disconnect the Bypass Pull-Chain when the MOB is open. *Figure 4-9: Principle of paralleled UPS systems* on page 49 shows the principles of paralleled UPS systems including MOBs and outputs from UPSs.

## MOB Override

Users without MOBs installed can simply leave the MOB signal input disabled. The user should be aware that systems without MOB have limited maintenance capability.

## Parallel system wiring

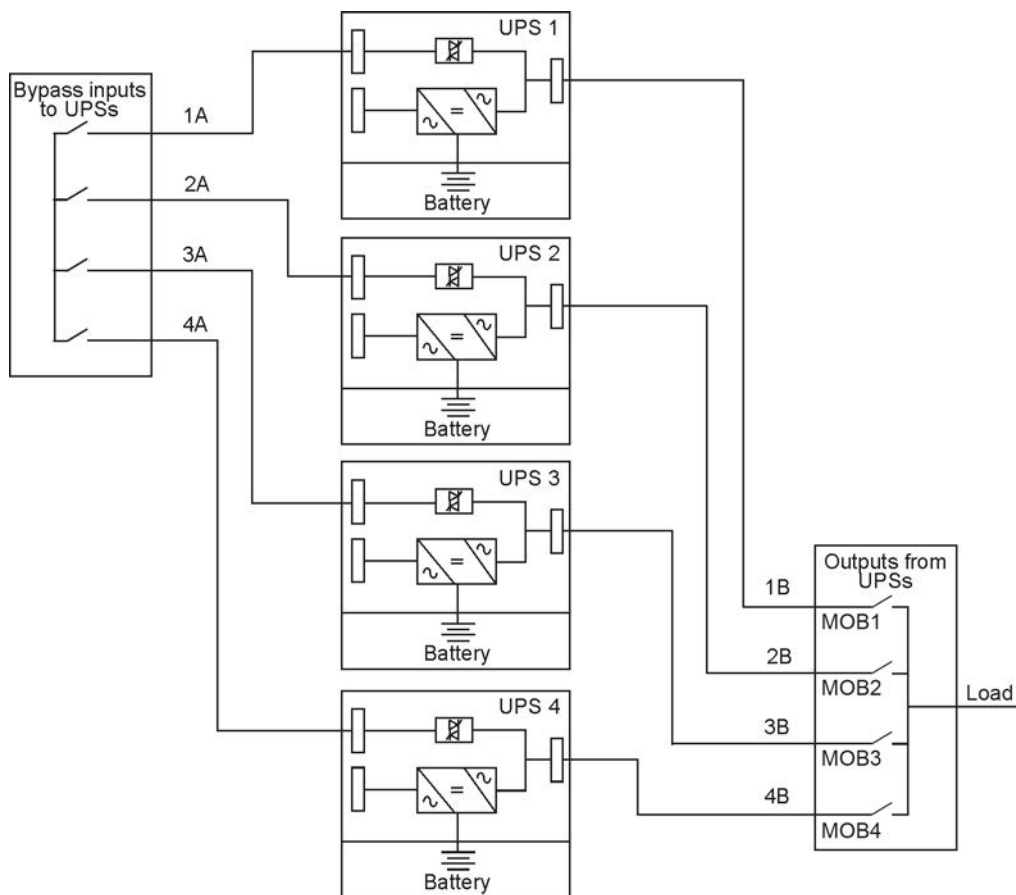

**Figure 4-9: Principle of paralleled UPS systems**

Required parallel system wiring length must be equal to ensure approximately equal current sharing when in Bypass mode.

For proper operation the following must be true:  $1A+1B=2A+2B=3A+3B=4A+4B$ .

Any difference in wire length will result in decreased capacity and improper operation of the UPS system while on bypass.

## 4.6.2 Control signals overview

Two controls signals (External CAN Network, Bypass Pull-Chain) are required for external paralleling. Both of these control signals are fault tolerant and alarmed when disconnected.

### External CAN (ECAN)

ECAN provides means for communications between the UPS's in a parallel system. The system will continue to share load and protect the load when this network fails.

### Bypass Pull-Chain

Bypass Pull-Chain is an open collector signal that goes low when the Bypass static switch of any UPS is online. When External CAN (ECAN) is down, the pull-chain is low, and the UPS is online, the UPS will lock to and transfer to bypass. Service can manually short this signal in some rare failure modes to force a system transfer to bypass.

### Signal Inputs Actions

Each UPS has maximum eight signal inputs, 5 native and one in each Mini-slot when using a suitable connectivity device. These inputs can be configured with action items. The following action items affect all UPSs in the system. When an action item is active on a UPS and the MOB is closed, the action item is transmitted on the ECAN to all UPSs. All UPSs react in the same manner as if the action item was active on that UPS.

### Wiring EPO switch in parallel

It is recommended to use separate EPO circuit for each parallel unit.

## 4.6.3 Installing bypass control wiring

1. During the installation, follow all the safety instructions given in the 93PM User's and Installation Guide.
2. A 12-pin terminal block for external parallel control signals is accessible on the right side of the communication interface, on the top section of the UPS. (See *Figure 4-10: Communication interfaces* on page 50.)
3. The Phoenix Contact FRONT-MSTB 2,5/12-STF-5,08 plug component shall be used for cable wiring termination.

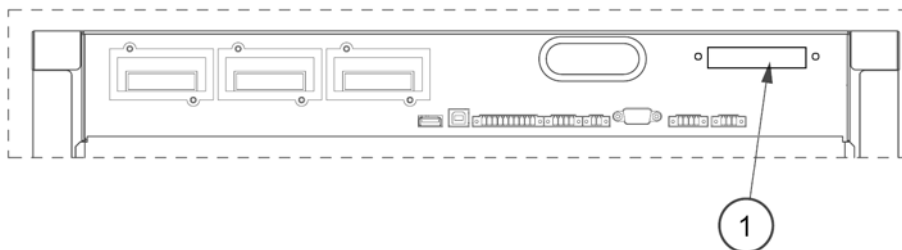

1. External parallel connector

**Figure 4-10: Communication interfaces**

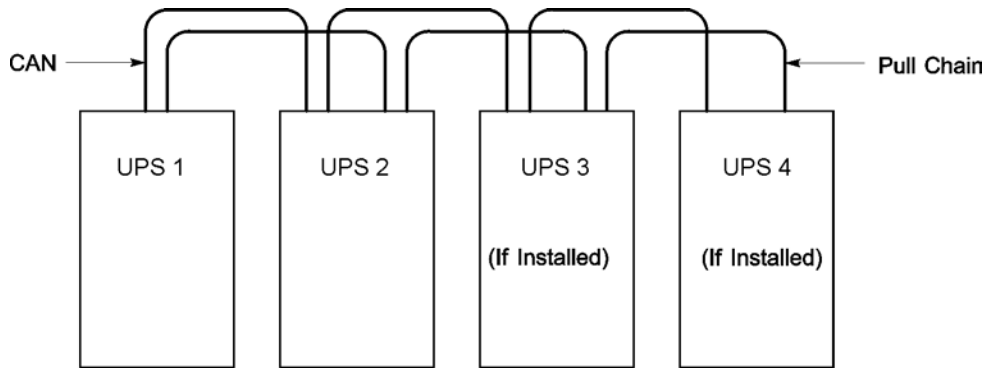

**Figure 4-11: Simplified CAN and Pull-Chain wiring for parallel UPS system**



**NOTE**

**This drawing is for distributed bypass wiring purposes and is not a floor layout plan. UPSs can be placed in any physical order.**



**NOTE**

**External CAN connections between UPSs require shielded twisted pair wire.**



**NOTE**

**Use twisted pair wiring between the UPS and MOB AUX contacts.**

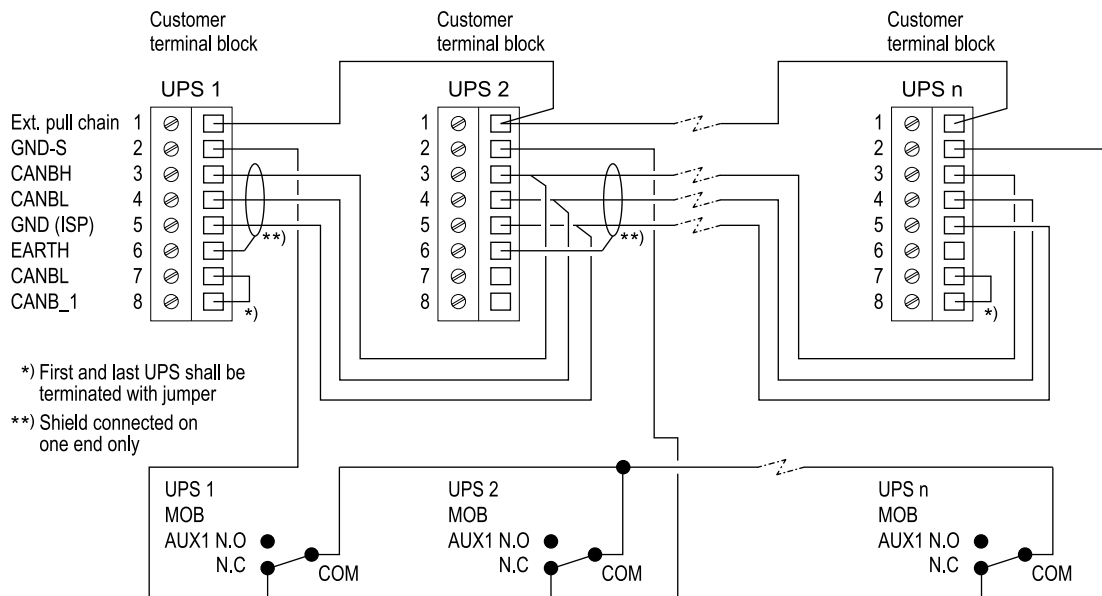

**Figure 4-12: CAN and Pull-Chain wiring for parallel UPS with MOB**

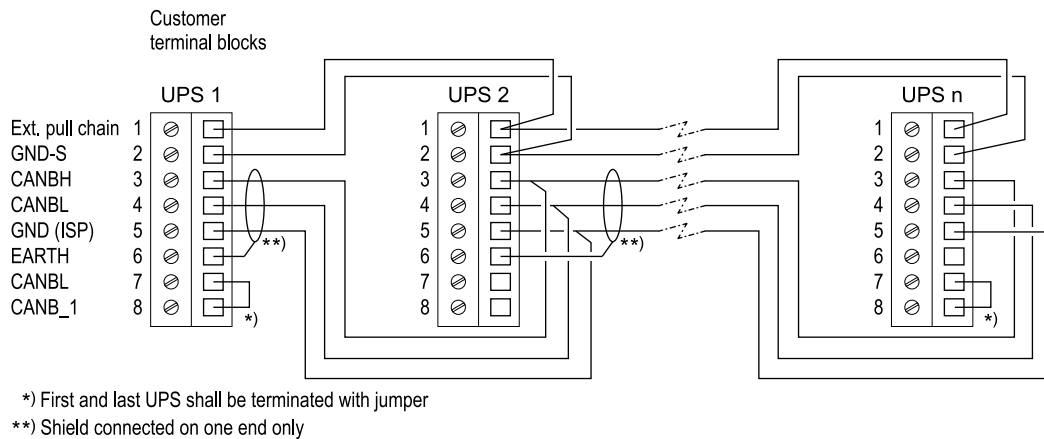

**Figure 4-13: CAN and Pull-Chain wiring for parallel UPS without MOBs**



**NOTE**

**NC and NO designations on MOB AUX contacts are defined with breaker in OFF (open) position. If MOB contacts have pigtail leads, use the same wire gauge to connect to the UPS and use the correct crimp connections for the wire gauge. External CAN connections between UPS cabinets require shielded twisted pair wire. Use twisted pair wiring between the UPS and MOB AUX contacts. Always confirm contact operation prior to wiring.**

# 5 Communication interfaces

This section describes the communication features of the Eaton 93PM UPS.

The UPS has the following communication interfaces:

1. Mini-slot 1
2. Mini-slot 2
3. Mini-slot 3
4. USB device (connection to computer)
5. Communication cable conduit
6. Emergency Power Off (EPO)
7. Relay output
8. USB host (connection to accessories)
9. Signal inputs
10. RS-232 port for service
11. External parallel connector

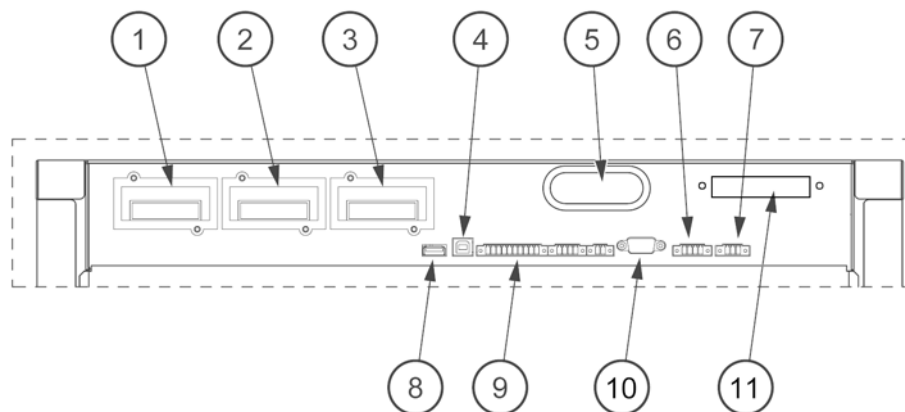

**Figure 5-1: Communication interfaces**

## 5.1 Mini-slot cards

The Eaton 93PM UPS has three Mini-slot communication bays. The UPS is compatible with the following Mini-slot cards:

- Network Card-MS

Provides remote monitoring through a Web browser interface, e-mail, and a network management system (NMS) using SNMP and connects to a twisted-pair Ethernet (10/100BaseT) network.



**Figure 5-2: Network Card-MS**

- PX Gateway Card

Provides remote monitoring through a Web browser interface, e-mail, and a network management system (NMS) using SNMP and connects to a twisted-pair Ethernet (10/100BaseT) network. The card also provides direct integration of UPS information (meters and status) to a Building Management System (BMS) using the Modbus RTU and TCP protocols.



**Figure 5-3: PX Gateway Card**

- Relay Card-MS

Two types of interfaces via a DB9 connector are available with this card. Dry contact mode provides a simple way to transmit UPS information to an alarm system, PLC, or computer system via dry relay contacts. By default the transmitted information is load powered, load on bypass, load on battery, load on utility, battery fault, and low battery. RS232 mode provides an RS232 interface for connection to a PC or to a UPS Control display unit. Jumpers are used to select the interface (contacts or RS232).



**Figure 5-4: Relay Card-MS**

- Network and MODBUS Card - MS

Provides remote monitoring through a Web browser interface, e-mail, and a network management system (NMS) using SNMP and connects to a twisted-pair Ethernet (10/100BaseT) network. The card also provides direct integration of UPS information (meters and status) to a Building Management System (BMS) using the Modbus RTU protocol.

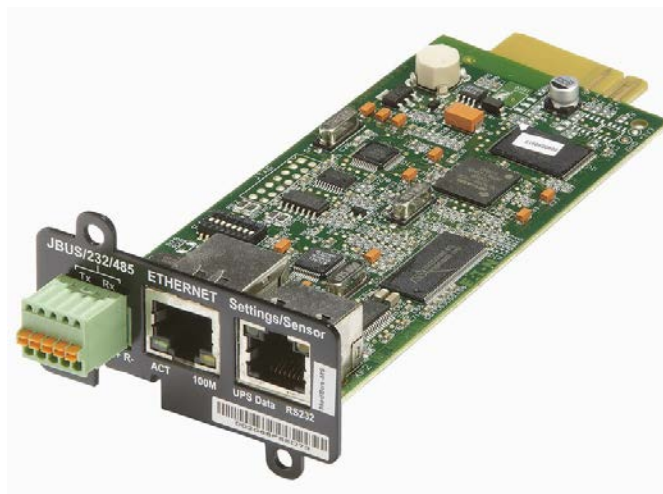

**Figure 5-5: Network and MODBUS Card - MS**

- Industrial Relay Card-MS

The Mini-Slot Industrial Relay Card provides a way of connecting the 93PM to industrial and electrical monitoring systems. It also enables a wide range of control applications by allowing up to 250 volts and 5 Amperes through its 5 relay connections. By connecting wires to the corresponding places in its terminal blocks you can choose Normally Open or Normally Closed setup for each output.



**Figure 5-6: Industrial Relay Card-MS**

## 5.2 Intelligent Power Software

Intelligent Power Software are productivity tools for UPS power management. The Intelligent Power Protector (IPP) application provides automatic, graceful shutdown of computers and virtual machines or servers powered by an Eaton UPS during a power outage that lasts longer than your available battery runtime. Intelligent Power Protector can be remotely supervised and managed by the Intelligent Power Manager (IPM) application. The IPM delivers a global view of power devices across the network from any PC with an Internet browser. The software enables single, Web-based interface for remote monitoring and management of Eaton and other manufacturers' UPSs, environmental sensors and Power Distribution Units (ePDU) products, even in virtualized environments.

The Intelligent Power Software is delivered on a CD with the UPS. Alternatively, you can download it from the Eaton web page.

## 5.3 Signal input monitoring

This standard feature lets you connect the UPS to your signal inputs, such as smoke detectors or overtemperature alarms. The customer interface terminals for external connections are located inside the UPS. You should use twisted-pair wires for each alarm input and common.

The signal inputs can be programmed to display the alarm functional name.

## 5.4 General purpose relay contact

One general purpose relay contact is provided as a standard feature on the UPS. An alarm contact is also provided.

You can use a normally-closed or normally-open contact. If the state of the contact changes from the state you specify as normal, a signal is issued. You can connect this contact to equipment at your facility (such as a light or an alarm bell) to let you know when an alarm is active on the UPS. This feature is useful if the UPS is located in a remote area where the UPS horn may not be heard immediately.





**NOTE**

**Contacts should not be operated in excess of 30 VAC (RMS) and 30 VDC at 5 A maximum.**

# 6 UPS operating instructions

This section describes how to operate the UPS.

---



## NOTE

**Before starting the UPS, ensure all installation tasks are complete and a preliminary startup has been performed by authorized service personnel.**

**The preliminary startup verifies all electrical interconnections to ensure the installation was successful and the system operates properly.**

**Read these instructions and have a thorough understanding of UPS operation before attempting to operate any of the controls.**

**The UPS is configured to operate with one of following nominal voltages: 380, 400, or 415 VAC.**

**Before operating the UPS, confirm the UPS nominal voltage and frequency from display by selecting Settings > Info.**

**If the UPS need to be operated with another voltage or frequency, contact your closest Eaton office or Eaton authorized partner.**

---



## NOTE

**The UPS in not a measuring device. All displayed measurements are only approximate values.**

---

## 6.1 UPS controls and indicators

### 6.1.1 Control panel

The control panel, located on the UPS front door, contains a color touch screen display. It is used to display the status of the UPS system and control the operation of the UPS.



**Figure 6-1: Parts of the display**

The display consists of the following parts:

- **A:** Status bar

The status bar displays the UPS name, state, current date and time, meters information, and a sign in/out button. Active alarms and warnings are also shown.

- **B:** Main navigation

Select a screen by tapping on its name.

- **C:** Secondary navigation/additional information bar

The bar displays buttons and selectors related to the current screen.

- **D:** Content area

Main area for showing information on UPS status and operations.

## 6.1.2 Status indicators

The four symbols below the display are status indicators. They are colored light emitting diode (LED) lamps, and they work in conjunction with the alarm horn to let you know the operating status of the UPS.

Indicator	Status	Description
Green	On	The UPS is operating normally and supplying power to the critical load.
	Off	The UPS is turned off.

**Figure 6-2: Green symbol**

Yellow	On	The UPS is in Battery mode. Because Battery mode is a normal condition of the UPS, the Normal indicator also remains illuminated.
		

**Figure 6-3: Yellow symbol — battery mode**

Yellow	On	The UPS is in Bypass mode. The critical load is supported by the bypass source. The Normal indicator is not illuminated when the system is in Bypass mode.
		

**Figure 6-4: Yellow symbol — bypass mode**

Red	On	The UPS has an active alarm and requires immediate attention. The screen shows the highest priority active alarms. All alarms are accompanied by an audible horn. To silence the horn, press any control panel button once. The Alarm indicator may be illuminated along with other indicators.
		

**Figure 6-5: Red symbol**

### 6.1.3 System events

When the UPS system is running in Double conversion mode, it continually monitors itself and the incoming utility power. In Battery or Bypass modes, the UPS may issue alarms to let you know exactly what event caused the change from Double conversion mode. System events on the UPS can be indicated by horns, lights, messages, or all three.

Select **Logs** from the main menu screen to look at any currently active events.

- **System Event Horn** - The system event horn beeps to alert an operator that an event needing attention is taking place.
- **System Event Indicators** - The status indicators on the UPS control panel and the event horn let you know when the UPS system is operating in any mode other than Double conversion mode. Only the Normal indicator is visible during normal UPS system operation. The other indicators illuminate to indicate alarms or events. When an alarm occurs, first check these indicators to see what type of event has taken place.
- **System Event Messages** - When a system event occurs, a message appears in the status bar of the display. This message is also written to the Active Events log. Some notices and alarms may be accompanied by an audible horn. To silence the horn, press any button once.

## 6.2 Steps to operate the UPS

The following table shows the menu structure of the 93PM UPS.

Main menu	Submenu	Functions
<b>Home</b>	-	An overview of UPS operation, including information on load, efficiency and consumption.
<b>Meters</b>	Meters summary	A summary of the UPS or system meters.
	Input meters	Detailed information on UPS or system input meters.
	Bypass meters	Detailed information on UPS or system bypass meters.
	Output meters	Detailed information on UPS or system output meters.
	Battery meters	Detailed information on UPS or system battery meters.
<b>Mimics</b>	UPS mimic	An overview of UPS operation, including information on load, efficiency and consumption. If there is an error, an error indicator is displayed next to the affected part. Active events log can be opened by tapping the error indicator.

Main menu	Submenu	Functions
	UPS module map	Module map shows the status of each UPM.
	System overview	System overview shows the status and meters summary for each UPS.
	ESS	ESS mimic screen shows the approximated consumption and energy savings of ESS mode.
<b>Logs</b>	Active events	All active events are displayed.
	System log	A log of all system events.
	Service log	A detailed log of UPS operations.
	Change log	A log of all changed settings and their values.
<b>Statistics</b>	Statistics summary	A summary of UPS statistics.
	Statistics details	Details are available by pressing on different statistics.
<b>Controls</b>	System controls	Go to bypass, Load Off / Start system
	UPS controls	Start charger, Run battery test, Shut down UPS / Start UPS
	Module controls	Start charger, Run battery test / Shut down module / Start module
	Service controls	Enable / Disable / Configure ESS, Enable / Disable / Configure VMMS, Enable / Disable / Configure ABM, Clear status, Clear alarms, Clear logs
<b>Settings</b>	Setting group	Configurable user settings. See <i>Chapter 11 APPENDIX A: User settings</i> on page 84 for details.

**Table 6-1: UPS menu structure**

## 6.3 Signing in

If the level 1 password is enabled, you need to sign in.

1. Press the lock  button in the upper right corner of the screen.
2. Type your passcode and press **OK**.
3. You are signed in. Press **Continue** to return to the previous screen.

There are three attempts to input the password. If an incorrect password is given more than three times, you need to wait for 30 minutes before trying again.

To modify the user settings, you need to enter level 2 password.

For the default passwords, see *Chapter 11 APPENDIX A: User settings* on page 84.

## 6.4 System control instructions

### 6.4.1 Starting the UPS system in Double conversion mode

The UPS system can consist of a single UPS or several parallel UPSs. UPSs with their MOB open are not considered as part of the system.

To start the UPS system:

1. Unfasten the front door latch and swing the door open.
2. Verify that rectifier input switches are closed if included inside the UPS system, and verify that battery breaker is closed, and close the front door.
3. Close the UPS input feeder circuit breaker.
4. Close the UPS bypass input feeder circuit breaker.
5. Observe the UPS control panel display becoming active, indicating logic power.  
Repeat steps 1-5 for each individual UPS in the system.
6. Press the **Controls** button in the main menu. The System Controls screen appears.
7. On the System Controls screen, the system status should indicate SHUTDOWN.
8. Press the **Go online** button on the System Controls screen. If Auto Bypass is enabled (factory default), the critical load is immediately supplied by the bypass source, in Bypass mode, until the inverter turns on and the UPS transfers to double conversion mode. The status indicator on the UPS control panel indicates the UPS is in Bypass mode. If auto bypass is not enabled, the UPS output remains off until the UPS system transfers to double conversion mode.
9. Observe the following messages appear sequentially on the System Controls screen:

#### STARTING ONLINE

The rectifier and inverter turn on. The DC voltage continues to ramp up to full voltage. Once the DC link reaches full voltage, and the battery breaker is closed, the UPS output relay K3 closes and the static switch turns off. Power is now supplied to the Critical load in double conversion mode. It takes approximately 20 seconds for the UPS system to achieve double conversion mode.

10. The UPS system is now operating in double conversion mode and the NORMAL status indicator is illuminated in all UPSs in the system.

## 6.4.2 Starting the UPS system in Bypass mode

If the inverter output of the UPS is not available and the critical load needs to be energized, perform the following procedure:



### CAUTION

**In Bypass mode, the critical load is not protected from commercial power interruptions and abnormalities.**

---

1. Unfasten the front door latch and swing the door open.
2. Verify that rectifier input switches are closed if included inside the UPS system, and verify that battery breaker is closed, and close the front door.
3. Close the UPS input feeder circuit breaker.
4. Close the UPS bypass input feeder circuit breaker.
5. Observe the UPS control panel becoming active, indicating logic power.  
Repeat steps 1-5 for each single UPS in the system.
6. Press the **Controls** button in the main menu. The System Controls screen appears.
7. On the System Controls screen, the system status should indicate SHUTDOWN.
8. Press the **Go to bypass** button in the System Controls screen.  
The critical load is immediately supplied by the bypass source, in Bypass mode.
9. The UPS system is now operating in Bypass mode and the BYPASS status indicator is illuminated.

## 6.4.3 Transfer from Double conversion mode to Bypass mode

To transfer the critical load to Bypass mode, perform the following procedure:



### NOTE

**In Bypass mode, the critical load is not protected from commercial power interruptions and abnormalities.**

---

1. Press the **Controls** button in the main menu. The System controls screen appears.
2. Press the **Go to bypass** button in the System Controls screen. The UPS system transfers to Bypass mode and the critical load is immediately supplied by the bypass source. If the bypass source is not available, the power processor remains on and an alarm sounds.
3. The UPS system is now operating in Bypass mode and the BYPASS status indicator is illuminated. The UPM status indicates READY. The system status indicates ON BYPASS.



### DANGER

**Power is present inside the UPS cabinets.**

---



## 6.4.4 Transfer from Bypass to Double conversion mode

To transfer the critical load to double conversion mode, perform the following procedure:

1. Press the **Controls** button in the main menu. The System controls screen appears.
2. Press the **Go online** button on the System controls screen. The UPS system transfers to double conversion mode. If enough UPM capacity is not available, the system remains on bypass and an alarm sounds.
3. The UPS is now operating in double conversion mode, and the NORMAL status indicator is illuminated. The system status indicates UNIT ONLINE.

## 6.4.5 Transfer from Double conversion mode to Energy Saver System Mode

Note that the Energy Saver System mode commands are displayed only if enabled at the factory or by an Eaton Customer Service Engineer.

To transfer the critical load to Energy Saver System mode:

1. Press the **Controls** button in the main menu.
2. Select **Service controls**.
3. Select **Enable ESS**.

The entire UPS system transfers to Energy Saver System mode and the critical load is supplied by the bypass source. If the bypass source is not available or conditions are not correct for ESS mode, the power module remains on and an alarm sounds. The NORMAL status indicator is illuminated. The UPS status indicates UNIT ONLINE, ESS. The UPM status indicates READY.

## 6.4.6 Transfer from Energy Saver System Mode to Double conversion mode

Note that the Energy Saver System mode commands are displayed only if enabled at the factory or by an Eaton Customer Service Engineer.

To transfer the critical load to Double conversion mode:

1. Press the **Controls** button in the main menu.
2. Select **Service controls**.
3. Select **Disable ESS**.

The UPS system transfers to Battery mode and then to Double conversion mode. If the power module is not available, the system remains on bypass and an alarm sounds. The NORMAL status indicator is illuminated. The UPS status indicates UNIT ONLINE. The UPM status indicates ACTIVE.

## 6.4.7 UPS system and critical load shutdown

To perform maintenance or service on the critical load, shut down power to the load by performing the following procedure:

1. Turn off all equipment that is being powered by the UPS system.
2. Perform the LOAD OFF procedure (see *Chapter 6.4.8 De-energizing the Critical Load* on page 66). The input, output, and bypass backfeed contactors open, the battery breaker or disconnect is tripped, and the power module is turned off.



### DANGER

**Power is present inside the UPS cabinet until the upstream input feeder circuit breaker is opened.**

---

3. Unfasten the front door latch and swing the door open.
4. Open the rectifier input switches if included in the UPS system, and verify that battery breaker is open, and close the front door.
5. Open the UPS input and bypass feeder circuit breakers.
6. Repeat steps 3-5 for all UPSs in the system.

## 6.4.8 De-energizing the Critical Load

A UPS system Load Off is initiated by the **Load Off** button from **Controls > System Controls** screen. This button can be pressed to control the UPS output. The **Load Off** button de-energizes the critical load and powers down the UPS system.

The UPS system (including Bypass) remains off until restarted.

1. Press **Load Off**.  
The shut down screen appears, providing a choice to proceed or abort the shutdown.



### NOTE

**All power to the critical load is lost when Load Off is selected in the following step. You should use this feature only when you want to de-energize the critical load.**

---

2. To shut down the UPS, press **Load Off**. To abort the shutdown, press ABORT. When **Load Off** is selected, the input, output, and bypass backfeed contactors open, the battery breaker or disconnect is tripped, and all the UPSs in the system are turned off.



### DANGER

**Do not attempt to restart the system after Load Off until the cause of the shutdown has been identified and cleared.**

---

3. To restart the UPS system, follow the procedure in *Chapter 6.4.1 Starting the UPS system in Double conversion mode* on page 63 or *Chapter 6.4.2 Starting the UPS system in Bypass mode* on page 64.

## 6.5 UPS control instructions

### 6.5.1 Starting a single UPS

Ensure that load level does not exceed single UPS capacity.

To start the UPS

1. Unfasten the front door latch and swing the door open.
2. Verify that rectifier input switches are closed if included inside the UPS system, and verify that battery breaker is closed, and close the front door.
3. Close the UPS input feeder circuit breaker.
4. Close the UPS bypass input feeder circuit breaker.
5. Observe the UPS control panel display becoming active, indicating logic power.
6. Press the **Controls** button in the main menu. Press the **UPS controls** button.
7. On the UPS Controls screen, the system status should indicate SHUTDOWN.
8. Press the **Go online** button on the System Controls screen. If Auto Bypass is enabled (factory default), the critical load is immediately supplied by the bypass source, in Bypass mode, until the inverter turns on and the UPS transfers to double conversion mode. The status indicator on the UPS control panel indicates the UPS is in Bypass mode. If auto bypass is not enabled, the UPS output remains off until the UPS system transfers to double conversion mode.
9. Press the **Go online** button on the UPS control screen.
10. Observe the following messages appear sequentially on the UPS status line:

STARTING  
ONLINE

The rectifier and inverter turn on. The DC voltage continues to ramp up to full voltage. Once the DC link reaches full voltage, and the battery breaker is closed, the UPS output relay K3 closes. Power is now supplied to the Critical load in double conversion mode. It takes approximately 20 seconds for the UPS system to achieve double conversion mode.

11. The UPS system is now operating in double conversion mode and the NORMAL status indicator is illuminated.

### 6.5.2 UPS shutdown

A single UPS in the system can be shut down only if it is redundant. In practice that means a UPS is not allowed to be shut down if doing so would lead to an overload condition in the remaining UPSs in the system.

To shut down a single UPS:

1. Press the **Controls** button in the main menu. The System controls screen is displayed.
2. On the **System controls** screen, press UPS controls.
3. On the **UPS control** screen, select Shut down UPS.

## 6.5.3 Enabling and disabling the battery charger

To turn the battery charger on or off, perform the following procedure:

1. Press the **Controls** button in the main menu. The System controls screen appears.
2. On the **System controls** screen, press UPS controls.
3. Press the **Start charger / Stop charger** button.

## 6.6 UPM control instructions

### 6.6.1 Starting the UPMs

Make sure that load level does not exceed single UPM capacity.

To start an individual power module in double conversion mode:

1. Unfasten the front door latch and swing the door open.
2. Verify that rectifier input switches are closed if included inside the UPS system, and verify that battery breaker is closed, and close the front door.
3. Close the UPS input feeder circuit breaker.
4. Close the UPS Bypass input feeder circuit breaker.
5. Observe the UPS control panel becoming active, indicating logic power.
6. Press the **Controls** button in the main menu. The System controls screen is displayed.
7. On the System controls screen, the UPS status should indicate SHUTDOWN.
8. Verify no alarms are active.
9. On the System controls screen, press **Module controls**. Select module screen is displayed.
10. Select the UPM you want to start (**UPM 1 - UPM 4**).
11. The UPM control screen is displayed and the UPM status should indicate SHUTDOWN.
12. On the UPM control screen, select **Start module**.
13. Verify the following messages display sequentially on the UPM status line:

```
READY  
ACTIVE
```

The UPM rectifier and inverter turn on and the UPM will transfer to double conversion mode and supply the critical load.

### 6.6.2 UPM shutdown

A single UPM in the system can be shut down only if it is redundant. In practice that means a UPM is not allowed to be shut down if doing so would lead to an overload condition in the remaining UPMs or UPSs in the system.

To shutdown a single UPM:

1. Press the **Controls** button in the main menu. The System controls screen is displayed.
2. On the System controls screen, press **Module controls**. Select module screen is displayed.
3. Select the UPM you want to shut down (**UPM 1 - UPM 4**).

4. On the UPM control screen, select **Shut down module**.

## 6.7 Using the Remote Emergency Power-off switch

A UPS emergency power-off is initiated by the EPO pushbutton switch. In an emergency, you can use this switch to control the UPS output. The EPO switch de-energizes the critical load and powers down the UPS immediately, without asking for verification. The UPS, including Bypass, remains off until restarted.



### CAUTION

**All power to the critical load is lost when the EPO switch is activated in the following step. You should use this feature only when you want to de-energize the critical load.**

---



### NOTE

**The following instructions are for the Eaton Corporation-supplied EPO switch. If a customer-supplied EPO switch is used, it may not activate in the same manner; refer to the operating instructions provided with the switch.**

---

To use the EPO switch:

1. Press the EPO pushbutton switch.

The input, output, and bypass backfeed relays open, the battery breaker or disconnect is tripped, and the power module is turned off immediately, without asking for verification.



### DANGER

**Do not attempt to restart the system after Load Off until the cause of the shutdown has been identified and cleared.**

---

2. To restart the UPS after using the EPO pushbutton, reset the EPO switch and then follow the procedure in *Chapter 6.4.1 Starting the UPS system in Double conversion mode* on page 63 or *Chapter 6.4.2 Starting the UPS system in Bypass mode* on page 64.

## 6.8 Turning UPS from double conversion mode to mechanical bypass

The operation of the internal MBS is allowed for a trained person only who is familiar with the UPS behavior and functions. The full UPS wiring diagram with a MBS switch is presented in the installation instructions.



**NOTE**

**The integral MBS and Static Bypass need to be supplied by the same source.**

To turn the UPS to mechanical bypass switch:

1. The normal start position should be following:

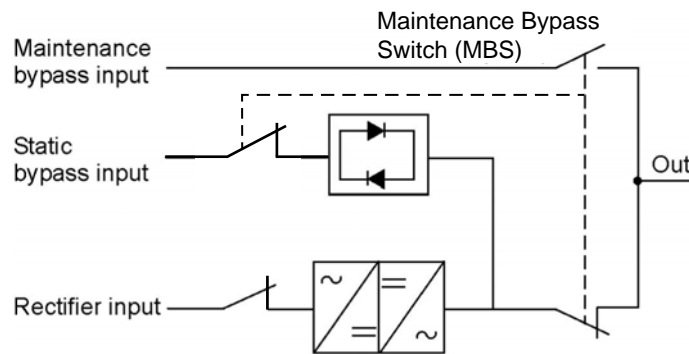

**Figure 6-6: The normal positions of the MBS switches and rectifier disconnect switch (must be located in the site wiring)**

2. Perform transfer from double conversion mode to bypass mode as described in *Chapter 6.4.3 Transfer from Double conversion mode to Bypass mode* on page 64. Remember to verify the transfer before proceeding to the next step.
3. Turn the MBS from UPS position to Bypass position.
4. Perform the LOAD OFF procedure in *Chapter 6.4.7 UPS system and critical load shutdown* on page 66.
5. Turn OFF the rectifier switch to disconnect UPS rectifier input.
6. Turn OFF the Static bypass switch to disconnect UPS bypass input.

UPS is now in the mechanical bypass mode:

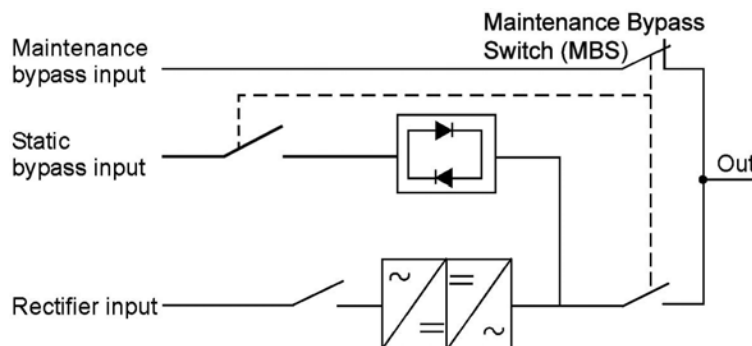
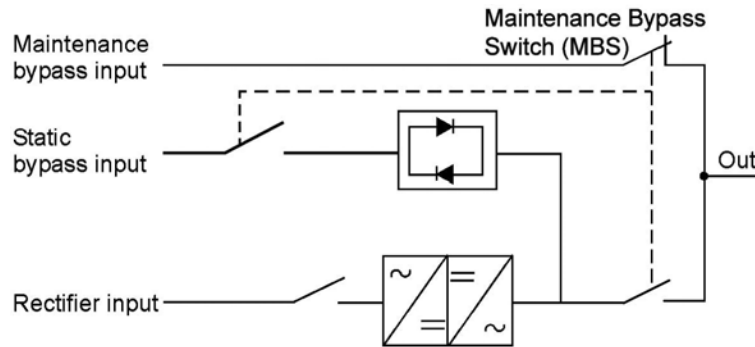

**Figure 6-7: Mechanical bypass mode**

## 6.9 Turning UPS from mechanical bypass to double conversion mode

To turn the UPS back to double conversion mode:

1. The normal start position should be the following:



**Figure 6-8: Mechanical bypass mode**

2. Turn ON rectifier switch to connect rectifier input to UPS.
3. Turn ON Static bypass switch to connect bypass input to UPS:
4. Perform the UPS start-up procedure (bypass mode) in *Chapter 6.4.2 Starting the UPS system in Bypass mode* on page 64.
5. Turn MBS from bypass position to UPS position to connect UPS output to load.
6. Perform transfer from bypass to double conversion mode as described in *Chapter 6.4.4 Transfer from Bypass to Double conversion mode* on page 65.

The UPS is now in double conversion mode:

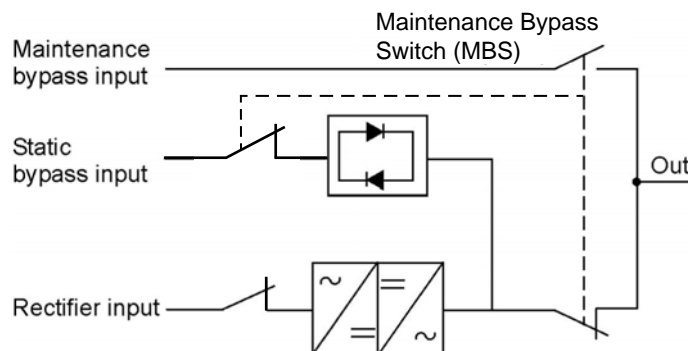

**Figure 6-9: Double conversion mode**

# 7 UPS maintenance

The components inside the UPS cabinet are secured to a sturdy metal frame. All repairable parts and assemblies are located for easy removal, with very little disassembly. This design allows authorized service personnel to perform routine maintenance and servicing quickly. You must schedule periodic performance checks of your UPS system to keep it running properly. Regular routine checks of operation and system parameters enable your system to function efficiently for many trouble-free years.

## 7.1 Important safety instructions

Remember that your UPS system is designed to supply power **EVEN WHEN DISCONNECTED FROM THE UTILITY POWER**. The UPS module interiors are unsafe until the DC power source is disconnected and the electrolytic capacitors are discharged. After disconnecting the utility power and the DC power, authorized service personnel should wait at least five minutes for capacitor bleed-off before attempting internal access to the UPS module.



### CAUTION

- **Servicing and maintenance should be performed by qualified service personnel only.**
  - **LETHAL VOLTAGE PRESENT. This unit should not be operated with the cabinet doors open or protective panels removed. Do not make any assumptions about the electrical state of any cabinet in the UPS system.**
- 

Since each battery string is an energy source in itself, opening the battery circuit breaker does not de-energize the voltage within the battery string. **DO NOT ATTEMPT TO ACCESS ANY INTERNAL AREA OF THE BATTERY STRING YOURSELF. VOLTAGES ARE ALWAYS PRESENT IN THE BATTERY STRING.** If you suspect that a battery string needs service, you should contact your service representative.

If the string requires service, refer to the battery manufacturer's operating manual for instructions on battery maintenance or contact your service representative.

Observe these precautions when working on or around batteries:

- Remove watches, rings, or other metal objects.
- Use tools with insulated handles.
- Wear rubber gloves and boots.
- Do not lay tools or metal parts on top of batteries or battery cabinets.
- Disconnect the charging source prior to connecting or disconnecting terminals.
- Determine if the battery is inadvertently grounded. If it is, remove the source of the ground. Contact with any part of a grounded battery can result in electrical shock. The likelihood of such shock is reduced if such grounds are removed during installation and maintenance.
- When replacing batteries, use the same number of sealed, lead-acid batteries.
- Proper disposal of batteries is required. Refer to your local codes for disposal requirements.



## 7.2 Performing preventive maintenance

The UPS system requires very little preventive maintenance. However, the system should be inspected periodically to verify that the units are operating normally and that the batteries are in good condition.

Majority of the work must be performed by Eaton authorized service personnel. Only the actions described in *Chapter 7.2.1 DAILY maintenance* on page 73 and *Chapter 7.2.2 MONTHLY maintenance* on page 73 are allowed for the user.

### 7.2.1 DAILY maintenance

Perform the following steps daily:

1. Check the area surrounding the UPS system. Ensure the area is not cluttered, allowing free access to the unit.
2. Ensure the air intakes (vents on the front doors) and exhaust opening (the back of the UPS cabinet sections) are not blocked.
3. Ensure the operating environment is within the parameters specified in *Chapter 3.2.1 Environmental and installation considerations* on page 25 and *Chapter 8 Technical data* on page 76.
4. Ensure the UPS is in Normal mode (Normal status indicator is illuminated). If an alarm lamp is illuminated or the Normal status indicator is not illuminated, contact your service representative.

### 7.2.2 MONTHLY maintenance

Perform the following steps monthly:

1. Monitor system parameters on the control panel (*Chapter 6.2 Steps to operate the UPS* on page 61).
2. If the optional air filters are installed, check them (located behind the front doors) and wash or replace as necessary. Contact your service representative for replacement filters. To replace the filters:
  - a. Open the front door latch and swing the doors open.
  - b. Replace the filters.
  - c. Close the doors and secure the latch.
3. Record the check results and any corrective actions in a suitable log.

### 7.2.3 PERIODIC maintenance

Periodic inspections of the UPS should be made to determine if components, wiring, and connections exhibit evidence of overheating. Particular attention should be given to bolted connections.

Maintenance procedures should specify that the bolted connections be re-torqued.



**NOTE**

**Work on energized circuit must be performed only by authorized personnel.**

---

### **7.2.4 ANNUAL maintenance**

Annual preventive maintenance should be performed only by authorized service personnel familiar with maintenance and servicing of the UPS system. Contact your service representative for more information about service offerings.

### **7.2.5 BATTERY maintenance**

Contact your service representative for battery maintenance. Battery replacement and maintenance should be performed only by authorized service personnel.

## **7.3 Recycling the used UPS or batteries**

Before scrapping UPS or its battery cabinet, the battery bank must be removed. Local requirements must be followed in battery recycling or discard. The removal of batteries is allowed only by authorized service personnel due to high energy and voltage.

Do not discard waste electrical or electronic equipment in the trash. For proper disposal, contact your local collecting/recycling/reuse or hazardous waste center and follow the local legislation.

These symbols indicate on a product:



**Figure 7-1: WEEE symbol**

Use proper local collecting centers meeting local legislation when handling waste of electrical and electronic equipment.



**DANGER**

**HAZARDOUS MATERIALS.** Batteries may contain **HIGH VOLTAGES**, and **CAUSTIC, TOXIC** and **FLAMMABLE** substances. Batteries can injure or kill people and damage equipment if used improperly. **DO NOT DISCARD** unwanted batteries or battery material in the public waste disposal system. Follow **ALL** applicable, local regulations for storage, handling and disposal of batteries and battery materials.

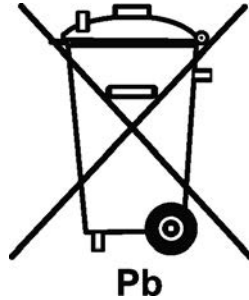

**Figure 7-2: Recycling batteries symbol**

---

## **7.4 Maintenance training**

For more information about training and other services, contact your Eaton representative.

## 8 Technical data

For complete technical specification, contact your Eaton representative. Due to continuous product improvement programs, specifications are subject to change without notice.

### 8.1 Standards

<b>Safety:</b>	IEC 62040-1, IEC 60950-1
<b>EMC, Emissions:</b>	IEC 62040-2/Ed.2
<b>EMC, Immunity:</b>	IEC 61000-2-2 (Low-frequency conducted) IEC 61000-4-2 (ESD) IEC 61000-4-3 (RF electromagnetic field) IEC 61000-4-4 (Fast transient-burst) IEC 61000-4-5 (Surge) IEC 61000-4-6 (Conducted RF common mode) IEC 61000-4-8 (Power frequency magnetic field)
<b>Performance &amp; tests:</b>	IEC 62040-3
<b>Environmental:</b>	IEC 62430
<b>RoHS:</b>	2002/95/EC
<b>WEEE:</b>	2002/96/EC
<b>ECO Design Directive:</b>	2009/125/EC
<b>Batteries:</b>	2006/66/EC
<b>Packaging:</b>	94/62/EC

**Table 8-1: Standards**

## 8.2 UPS system input

Rated input voltage	220/380 V; 230/400 V; 240/415 V
Voltage tolerance, (Rectifier input)	230 V -15 % / +20 %
Voltage tolerance, (Bypass input)	230 V -15 % / +10 %
Rated input frequency	50 or 60 Hz, user configurable
Frequency tolerance	40 to 72 Hz
Number of input phases, (Rectifier input)	3 phases + N
Number of input phases, (Bypass input)	3 phases + N
Input power factor	0,99
Rated mains input current	See <i>Table 3-7: Rated and maximum currents for rated power and voltage</i> on page 31
Maximum mains input current	
Input current distortion at rated input current, iTHD	30 kW: < 4,5 % 40-200 kW: < 3 %
Rectifier ramp-up, rectifier start and load step	10 A/s (default), configurable. Min 1A/s
Backfeed protection	Yes, for rectifier and bypass lines

**Table 8-2: UPS system input**

## 8.3 UPS system output

Number of output phases	3 phases + N
Rated output voltage	220/380 V; 230/400 V; 240/415 V, configurable

Total voltage harmonic distortion	< 1 %
100 % linear load	< 5 %
100 % non-linear load	
Rated output frequency	50 or 60 Hz, configurable
Output frequency variation	± 0,1 Hz
Slew rate	1 Hz/s
Overload capability at ambient 40 °C (On inverter)	10 min 102-110 % load 60 sec 111-125 % load 10 sec 126-150 % load 300 ms > 150 % load
Overload capability at ambient 40 °C (On inverter, stored energy mode)	10 min 102-110 % load 60 sec 111-125 % load 300 ms > 126 % load
Overload capability at ambient 40 °C (On bypass)	Continuous < 125 % load 10 ms 1000 % load Note! Bypass fuses may limit the overload capability.
Output current	See <i>Table 3-7: Rated and maximum currents for rated power and voltage</i> on page 31
Load power factor, (Rated)	1.0
Load power factor, (Permitted range)	From 0.8 lagging to 0.8 leading

**Table 8-3: UPS system output**

## 8.4 Battery specification

Battery type	VRLA, 12 VCD
--------------	--------------

Battery quantity	30-50 kW units: 36 blocks, 216 cells per battery string  80-200 kW units: 36 blocks, 216 cells per battery string, or 40 blocks, 240 cells per battery string  <b>Note! Battery strings with different battery quantity and voltage may not be connected in parallel!</b>
Battery voltage	432 V (36 blocks) or 480 V (40 blocks)
Recharge profile	ABM or float charge
End of discharge voltage	1.67 VPC to 1.75 VPC, configurable or automatic (load adaptive)
Charge current	Configurable:
30-50 kW units	Default 12 A, max 22 A (common for internal and external batteries)
80-100 kW units	Default 24 A, max 44 A
120-150 kW units	Default 36 A, max 66 A
160-200 kW units	Default 48 A, max 88 A
Battery start option	Yes

**Table 8-4: Battery specification**

Note! For external battery connection, 24 VDC Shunt Trip signal wiring from the UPS must be connected to the auxiliary signal connection of the battery breaker.

## 8.5 UPS environmental specifications

Acoustic noise at 1 m	30-50 kW: <60 dBA  80-200 kW: <65 dBA  ESS operation: <45 dBA
Ambient UPS storage temperature range	From -25 °C to +55 °C in the protective package*

Ambient service temperature range, (UPS)	From +5 °C to +40 °C* No output power derating required.
Relative humidity range	5 to 95 %, no condensation allowed
Maximum service altitude	1000 m (3300 ft) above sea level Maximum 2000 m (6600 ft) with 1 % derating per each additional 100 m.

**Table 8-5: UPS environmental specifications**

\*Maximum recommended operating and storage temperature with VRLA batteries is +25 °C.



# 9 Warranty

The product is warranted against defects in materials and workmanship for a period of twelve (12) months from its original date of purchase. The local office or distributor may grant a warranty period different to the above. Please refer to local terms of liability as defined in the supply contract.

The UPS manufacturer is not responsible for

- Any costs resulting from a failure if the installation, commissioning, repair, alternation, or ambient conditions of the equipment do not fulfil the requirements specified in the documentation delivered with the unit and other relevant documentation.
- Equipment subjected to misuse, negligence or accident.
- Equipment comprised of materials provided or designs stipulated by the purchaser.

The warranty is only valid if the installation inspection and initial start up of the UPS unit is carried out by a service engineer approved by Eaton. Service and maintenance of the UPS shall also be performed only by a service engineer approved by Eaton. Otherwise the warranty will be voided.

If the product fails to meet its published specifications due to a defect in material and workmanship, covered by this warranty, the seller will repair or replace the warranted product. Such repair or replacement will be made by Eaton or by a service provider approved by Eaton. Repair or replacement during the warranty period does not extend the original warranty. Warranty does not cover taxes, which will be due in connection with replacement or repair of the product.

Batteries are warranted against failures in material and workmanship, not against the normal aging and reduction of ampere-hour capacity. The product storage environment has to meet manufacturer's specifications, failure to do this will cause the warranty to be voided.

Under no circumstances shall the manufacturer, its suppliers or subcontractors be liable for special, indirect, incidental or consequential damages, losses or penalties.

The technical data, information and specifications are valid at the time of printing. The UPS manufacturer reserves the right to modifications without prior notice.

# 10 Installation checklist

---

All packing materials and restraints have been removed from each cabinet.

---

Each cabinet in the UPS system is placed in its installed location.

---

A cabinet grounding/mounting kit is installed between any cabinets that are bolted together.

---

All conduits and cables are properly routed to the UPS and any ancillary cabinets.

---

All power cables are properly sized and terminated.

---

Neutral conductors are installed or bonded to ground as per requirements.

---

A ground conductor is properly installed.

---

Battery cables are terminated and connected to battery connectors.

---

Battery Shunt trip and Aux contact signal wiring is connected from the UPS to the battery breaker.

---

LAN and telephone drops are installed.

---

All telephone and LAN connections have been completed.

---

Air conditioning equipment is installed and operating correctly.

---

The area around the installed UPS system is clean and dust-free. (It is recommended that the UPS be installed on a level floor suitable for computer or electronic equipment.)

---

Adequate workspace exists around the UPS and other cabinets.

---

Adequate lighting is provided around all UPS equipment.

---

A 230 VAC service outlet is located within 7.5 meters of the UPS equipment.

---

The Remote Emergency Power-off (REPO) device is mounted in its installed location and its wiring is terminated inside the UPS cabinet.

---

Jumper is installed on EPO between pins 1 and 2 if EPO is used in the NC configuration.

---

Alarm relays and signal inputs are wired appropriately. (OPTIONAL)

---

A remote battery disconnect control is mounted in its installed location and its wiring is terminated inside the UPS and battery cabinet. (OPTIONAL)

---

Accessories are mounted in installed locations and wiring is terminated inside the UPS cabinet. (OPTIONAL)

---

Startup and operational checks are performed by an authorized Eaton Customer Service Engineer.

---

# 11 APPENDIX A: User settings

The UPS has the following settings that are user modifiable. In the Home screen, select **Settings**.

**User** settings:

Setting	Description
Info	Information on the UPS model, including part number and serial number.
About	Version information.
GSM	GSM Modem.
Call Service	Send automatic e-mail to service center in case of a failure.

**Table 11-1: User settings**

To modify the **Config** settings, you need to sign in.

Setting	Description
Language	Change the user interface language.
Unit Name	Change the unit name.
Clock	Change the date and time, change the clock format or enable/disable NTP clock setup.
Signal Inputs	Select signal input name and function.
Relay Outputs	Configure the relay outputs.
Battery Test	Change the power level and duration for battery test.
Bypass Limits	Change bypass voltage, bypass frequency or bypass slew rate limits.
Screen Saver Timeout	Change the screen saver timeout.
Meters	Change the meters format.
Lamp Test	Enable the lamp test.
HMI backlight	Adjust the backlight brightness.
Control P/W level 1	Change the level 1 password, or remove the password on level 1. The default value is 1111.

<b>Setting</b>	<b>Description</b>
Config P/W level 2	Change the level 2 password. The default value is 101.

**Table 11-2: Config settings**