



# ThinkSystem SR630 V3 User Guide



**Machine Type:** 7D72, 7D73, 7D74

**Note**

Before using this information and the product it supports, be sure to read and understand the safety information and the safety instructions, which are available at:

[https://pubs.lenovo.com/safety\\_documentation/](https://pubs.lenovo.com/safety_documentation/)

In addition, be sure that you are familiar with the terms and conditions of the Lenovo warranty for your server, which can be found at:

<http://datacentersupport.lenovo.com/warrantylookup>

**Second Edition (May 2023)**

**© Copyright Lenovo 2023.**

LIMITED AND RESTRICTED RIGHTS NOTICE: If data or software is delivered pursuant to a General Services Administration "GSA" contract, use, reproduction, or disclosure is subject to restrictions set forth in Contract No. GS-35F-05925.

# Contents

<b>Contents</b> . . . . .	<b>i</b>	Power on and power off the server . . . . .	68
<b>Safety</b> . . . . .	<b>v</b>	Power on the server . . . . .	68
Safety inspection checklist . . . . .	vi	Power off the server . . . . .	68
<b>Chapter 1. Introduction</b> . . . . .	<b>1</b>	Server replacement . . . . .	69
Features. . . . .	1	Remove the server from the rack . . . . .	69
Tech Tips . . . . .	2	Install the server to the rack . . . . .	72
Security advisories . . . . .	3	Air baffle replacement . . . . .	77
Specifications . . . . .	3	Remove the air baffle . . . . .	77
Technical specifications. . . . .	4	Install the air baffle . . . . .	78
Mechanical specifications . . . . .	10	Backplane replacement. . . . .	80
Environmental specifications . . . . .	10	Remove the front 2.5-inch drive backplane . . . . .	80
Management options. . . . .	15	Install the front 2.5-inch drive backplane . . . . .	81
<b>Chapter 2. Server components</b> . . . . .	<b>19</b>	Remove the front 3.5-inch drive backplane . . . . .	82
Front view . . . . .	19	Install the front 3.5-inch drive backplane . . . . .	84
Rear view . . . . .	26	Remove the front 16-EDSFF drive backplane . . . . .	85
Top view . . . . .	31	Install the front 16-EDSFF drive backplane . . . . .	86
Front I/O module . . . . .	33	Remove the 2.5-inch rear drive backplane. . . . .	88
System-board-assembly layout . . . . .	35	Install the 2.5-inch rear drive backplane . . . . .	90
System-board-assembly connectors. . . . .	36	Remove the 7mm drive backplanes . . . . .	91
System-board-assembly switches. . . . .	38	Install the 7mm drive backplanes . . . . .	93
System LEDs and diagnostics display . . . . .	40	CMOS battery replacement . . . . .	94
<b>Chapter 3. Parts list</b> . . . . .	<b>41</b>	Remove the CMOS battery . . . . .	94
Power cords . . . . .	44	Install the CMOS battery . . . . .	97
<b>Chapter 4. Unboxing and setup</b> . . . . .	<b>47</b>	EDSFF cage replacement . . . . .	99
Server package contents . . . . .	47	Remove an EDSFF cage . . . . .	99
Identify the server and access the Lenovo XClarity Controller . . . . .	47	Install an EDSFF cage . . . . .	100
Server setup checklist . . . . .	49	Front I/O module replacement . . . . .	102
<b>Chapter 5. Hardware replacement procedures.</b> . . . . .	<b>51</b>	Remove the front I/O module. . . . .	102
Installation Guidelines . . . . .	51	Install the front I/O module. . . . .	103
Safety inspection checklist. . . . .	52	Remove the integrated diagnostics panel assembly . . . . .	104
System reliability guidelines . . . . .	53	Install the integrated diagnostics panel assembly . . . . .	106
Working inside the server with the power on . . . . .	54	Remove the external LCD cable (4 x 3.5" chassis) . . . . .	108
Handling static-sensitive devices . . . . .	54	Install the external LCD cable (4 x 3.5" chassis) . . . . .	111
Memory module installation rules and order . . . . .	56	Heat sink Torx T30 nut replacement . . . . .	112
DDR5 DIMMs installation order . . . . .	58	Remove a heat sink Torx T30 nut . . . . .	112
Technical rules . . . . .	61	Install a heat sink Torx T30 nut . . . . .	113
PCIe slots and adapters. . . . .	61	Hot-swap drive replacement . . . . .	115
Technical rules for drives . . . . .	64	Remove a 2.5/3.5-inch hot-swap drive . . . . .	115
Thermal rules . . . . .	65	Install a 2.5/3.5-inch hot-swap drive . . . . .	117
		Remove a hot-swap EDSFF drive . . . . .	119
		Install a hot-swap EDSFF drive . . . . .	121
		Hot-swap power supply unit replacement . . . . .	123

Remove a hot-swap power supply unit . . . . .	123	Install the RAID flash power module on the air baffle . . . . .	195
Install a hot-swap power supply unit . . . . .	128	Remove the RAID flash power module on the riser . . . . .	196
Internal CFF RAID adapter replacement . . . . .	133	Install the RAID flash power module on the riser . . . . .	197
Remove the internal CFF RAID adapter . . . . .	133	Rear drive assembly replacement . . . . .	198
Install the internal CFF RAID adapter . . . . .	134	Remove the 2.5-inch rear drive assembly . . . . .	198
Intrusion switch replacement . . . . .	135	Install the 2.5-inch rear drive assembly . . . . .	199
Remove an intrusion switch . . . . .	135	Remove the 7mm rear drive assembly . . . . .	202
Install an intrusion switch . . . . .	138	Install the 7mm rear drive assembly . . . . .	203
Lenovo Neptune(TM) liquid assisted cooling module replacement (trained technicians only) . . . . .	140	Riser card replacement . . . . .	204
Remove the Lenovo Neptune(TM) liquid assisted cooling module . . . . .	140	Remove a riser card . . . . .	208
Install the Lenovo Neptune(TM) liquid assisted cooling module . . . . .	143	Install a riser card . . . . .	211
Memory module replacement . . . . .	150	Security bezel replacement . . . . .	213
Remove a memory module . . . . .	150	Remove the security bezel . . . . .	213
Install a memory module . . . . .	151	Install the security bezel . . . . .	215
MicroSD card replacement . . . . .	153	Serial port module replacement . . . . .	217
Remove the MicroSD card . . . . .	154	Remove a serial port module . . . . .	217
Install the MicroSD card . . . . .	155	Install a serial port module . . . . .	219
M.2 backplane and M.2 drive replacement . . . . .	157	System board assembly replacement (trained technicians only) . . . . .	221
Remove the M.2 backplane and M.2 drive. . . . .	157	Firmware and RoT Security Module replacement (Lenovo trained technicians only) . . . . .	223
Adjust the retainer on the M.2 backplane . . . . .	159	System I/O board replacement (trained technicians only). . . . .	229
Install the M.2 backplane and M.2 drive. . . . .	160	Processor board replacement (trained technicians only). . . . .	233
Remove the M.2 cage and M.2 backplane (16-EDSFF chassis) . . . . .	162	System fan replacement . . . . .	239
Install the M.2 cage and M.2 backplane (16-EDSFF chassis) . . . . .	164	Remove a system fan. . . . .	239
OCP module replacement . . . . .	166	Install a system fan. . . . .	241
Remove the OCP module . . . . .	166	Top cover replacement . . . . .	243
Install the OCP module . . . . .	167	Remove the top cover . . . . .	243
PCIe adapter replacement. . . . .	169	Install the top cover . . . . .	244
Remove a PCIe adapter . . . . .	170	Complete the parts replacement . . . . .	246
Install a PCIe adapter . . . . .	171		
Power-supply-unit air baffle replacement . . . . .	172	<b>Chapter 6. Internal cable routing . . .249</b>	
Remove a power-supply-unit air baffle . . . . .	173	Identifying connectors . . . . .	250
Install a power-supply-unit air baffle . . . . .	174	Drive backplane connectors . . . . .	250
Processor and heat sink replacement . . . . .	176	RAID and HBA adapter connectors . . . . .	254
Remove a processor and heat sink . . . . .	176	Re-timer adapter connectors . . . . .	257
Separate the processor from carrier and heat sink. . . . .	180	Processor-board connectors for cable routing . . . . .	257
Install a processor and heat sink . . . . .	181	CFF RAID adapter . . . . .	260
Rack latches replacement . . . . .	187	Front I/O module . . . . .	262
Remove the rack latches . . . . .	187	Intrusion switch . . . . .	263
Install the rack latches . . . . .	188	RAID flash power modules . . . . .	264
RAID flash power module replacement . . . . .	189	M.2 drive backplane . . . . .	267
Remove the RAID flash power module on the chassis . . . . .	190	M.2 backplane to SFF RAID adapters . . . . .	269
Install the RAID flash power module on the chassis . . . . .	191	7mm drive backplane . . . . .	270
Remove the RAID flash power module on the air baffle . . . . .	194	7mm backplane to SFF RAID adapters . . . . .	272

Rear NVMe drive backplane . . . . .	272
Cable routing for backplane power . . . . .	274
Liquid assisted cooling module . . . . .	275
6 x 2.5" SAS/SATA + 4 x 2.5" AnyBay (liquid cooling) . . . . .	277
6 x 2.5" SAS/SATA + 2 x 2.5" AnyBay + 2 x 2.5" NVMe (liquid cooling) . . . . .	283
8 x 2.5" SAS/SATA (liquid cooling) . . . . .	287
8 x 2.5" U.3 drives with 10 x 2.5" AnyBay backplane (liquid cooling) . . . . .	291
10 x 2.5" SAS/SATA (liquid cooling) . . . . .	292
10 x 2.5" NVMe (liquid cooling) . . . . .	296
Cable routing for backplane signals (one processor) . . . . .	298
4 x 3.5" front drives (one processor) . . . . .	298
4 x 2.5" front drives (one processor) . . . . .	311
8 x 2.5" front drives (one processor) . . . . .	318
10 x 2.5" front drives (one processor) . . . . .	331
Cable routing for backplane signals (two processors) . . . . .	350
4 x 3.5" front drives . . . . .	350
4 x 2.5" front drives . . . . .	366
8 x 2.5" front drives . . . . .	372
10 x 2.5" front drives . . . . .	382
16-EDSFF drive backplane . . . . .	428

**Chapter 7. System configuration . . .431**

Set the network connection for the Lenovo XClarity Controller . . . . .	431
Set front USB port for Lenovo XClarity Controller connection. . . . .	432
Update the firmware . . . . .	433
Configure the firmware . . . . .	436
Enable Software Guard Extensions (SGX). . . . .	437
RAID configuration . . . . .	438
Deploy the operating system. . . . .	438
Back up the server configuration . . . . .	439

**Chapter 8. Problem determination . . .441**

Event logs . . . . .	441
Troubleshooting by system LEDs and diagnostics display . . . . .	443
External diagnostics handset . . . . .	443
Integrated diagnostics panel . . . . .	448
LEDs and buttons on the front operator panel . . . . .	453
LEDs on drives . . . . .	455
LEDs on the Firmware and RoT Security Module . . . . .	456

LEDs on the system board assembly. . . . .	458
Rear LEDs . . . . .	461
The LED on the liquid detection sensor module . . . . .	463
General problem determination procedures . . . . .	463
Resolving suspected power problems . . . . .	464
Resolving suspected Ethernet controller problems . . . . .	464
Troubleshooting by symptom . . . . .	465
Coolant leak problems . . . . .	465
Hard disk drive problems . . . . .	467
Intermittent problems. . . . .	469
Keyboard, mouse, KVM switch or USB-device problems . . . . .	470
Memory problems . . . . .	471
Monitor and video problems . . . . .	473
Observable problems. . . . .	474
Optional-device problems . . . . .	477
Performance problems . . . . .	478
Power on and power off problems. . . . .	479
Power problems. . . . .	480
Serial-device problems . . . . .	481
Software problems. . . . .	481

**Appendix A. Hardware disassembling for recycle . . . . .483**

Disassemble the system board assembly for recycle . . . . .	483
---	-----

**Appendix B. Getting help and technical assistance . . . . .487**

Before you call . . . . .	487
Collecting service data . . . . .	488
Contacting Support . . . . .	489

**Appendix C. Documents and supports . . . . .491**

Documents download . . . . .	491
Support websites . . . . .	491

**Appendix D. Notices. . . . .493**

Trademarks . . . . .	494
Important notes. . . . .	494
Electronic emission notices . . . . .	494
Taiwan Region BSMI RoHS declaration . . . . .	495
Taiwan Region import and export contact information . . . . .	495



---

## Safety

Before installing this product, read the Safety Information.

قبل تركيب هذا المنتج، يجب قراءة الملاحظات الأمنية

Antes de instalar este produto, leia as Informações de Segurança.

在安装本产品之前，请仔细阅读 Safety Information（安全信息）。

安裝本產品之前，請先閱讀「安全資訊」。

Prije instalacije ovog produkta obavezno pročitajte Sigurnosne Upute.

Před instalací tohoto produktu si přečtěte příručku bezpečnostních instrukcí.

Læs sikkerhedsforskrifterne, før du installerer dette produkt.

Lees voordat u dit product installeert eerst de veiligheidsvoorschriften.

Ennen kuin asennat tämän tuotteen, lue turvaohjeet kohdasta Safety Information.

Avant d'installer ce produit, lisez les consignes de sécurité.

Vor der Installation dieses Produkts die Sicherheitshinweise lesen.

Πριν εγκαταστήσετε το προϊόν αυτό, διαβάστε τις πληροφορίες ασφαλείας (safety information).

לפני שתתקינו מוצר זה, קראו את הודאות הבטיחות.

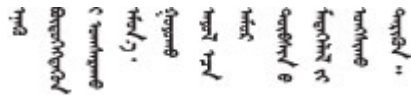
A termék telepítése előtt olvassa el a Biztonsági előírásokat!

Prima di installare questo prodotto, leggere le Informazioni sulla Sicurezza.

製品の設置の前に、安全情報をお読みください。

본 제품을 설치하기 전에 안전 정보를 읽으십시오.

Пред да се инсталира овој продукт, прочитајте информацијата за безбедност.



Les sikkerhetsinformasjonen (Safety Information) før du installerer dette produktet.

Przed zainstalowaniem tego produktu, należy zapoznać się z książką "Informacje dotyczące bezpieczeństwa" (Safety Information).

Antes de instalar este produto, leia as Informações sobre Segurança.

Перед установкой продукта прочтите инструкции по технике безопасности.

Před inštaláciou tohto zariadenia si pečítajte Bezpečnostné predpisy.

Pred namestitvijo tega proizvoda preberite Varnostne informacije.

Antes de instalar este producto, lea la información de seguridad.

Läs säkerhetsinformationen innan du installerar den här produkten.

ཐོན་ཁུངས་འདི་བདེ་སྤྱོད་མ་བྱས་གོང་། སྐྱོར་གྱི་ཡིད་གཟབ་  
བྱ་འདྲ་མིན་ཡིད་པའི་འོད་ཟེར་བལྟ་དགོས།

Bu ürünü kurmadan önce güvenlik bilgilerini okuyun.

مەزكۇر مەھسۇلاتنى ئورنىتىشتىن بۇرۇن بىخەتەرلىك ئۇچۇرلىرىنى ئوقۇپ چىقىڭ.

Youq mwngz yungh canjbinj neix gaxgonq, itdingh aeu doeg aen  
canjbinj soengq cungj vahgangj ancien siusik.

---

## Safety inspection checklist

Use the information in this section to identify potentially unsafe conditions with your server. As each machine was designed and built, required safety items were installed to protect users and service technicians from injury.

**Note:** The product is not suitable for use at visual display workplaces according to §2 of the Workplace Regulations.

**Note:** The set-up of the server is made in the server room only.

### CAUTION:

**This equipment must be installed or serviced by trained personnel, as defined by the NEC, IEC 62368-1 & IEC 60950-1, the standard for Safety of Electronic Equipment within the Field of Audio/Video, Information Technology and Communication Technology. Lenovo assumes that you are qualified in the servicing of equipment and trained in recognizing hazards energy levels in products. Access to the equipment is by the use of a tool, lock and key, or other means of security, and is controlled by the authority responsible for the location.**

**Important:** Electrical grounding of the server is required for operator safety and correct system function. Proper grounding of the electrical outlet can be verified by a certified electrician.

Use the following checklist to verify that there are no potentially unsafe conditions:

1. If your working condition necessitates the server being powered off or you intend to power off, make sure that the power cord is disconnected.

### S002



### CAUTION:



**The power-control button on the device and the power switch on the power supply do not turn off the electrical current supplied to the device. The device also might have more than one power cord. To remove all electrical current from the device, ensure that all power cords are disconnected from the power source.**

**Note:** Under certain circumstances, powering off the server is not a prerequisite. Refer to the precautions before conducting any tasks.

2. Check the power cord.

- Make sure that the third-wire ground connector is in good condition. Use a meter to measure third-wire ground continuity for 0.1 ohm or less between the external ground pin and the frame ground.
- Make sure that the power cord is the correct type.

To view the power cords that are available for the server:

a. Go to:

<http://dcsc.lenovo.com/#/>

b. Click **Preconfigured Model** or **Configure to order**.

c. Enter the machine type and model for your server to display the configurator page.

d. Click **Power → Power Cables** to see all line cords.

- Make sure that the insulation is not frayed or worn.

3. Check for any obvious non-Lenovo alterations. Use good judgment as to the safety of any non-Lenovo alterations.

4. Check inside the server for any obvious unsafe conditions, such as metal filings, contamination, water or other liquid, or signs of fire or smoke damage.

5. Check for worn, frayed, or pinched cables.

6. Make sure that the power-supply cover fasteners (screws or rivets) have not been removed or tampered with.



---

## Chapter 1. Introduction

The ThinkSystem SR630 V3 server (7D72, 7D73, 7D74) is a high-performance, multi-core 1U rack server designed to support many kinds of Information Technology (IT) workloads with high agility. It carries the most advanced processing and memory units and can scale up to the state-of-the-art liquid cooling solutions. This server is ideally suited for IT environments that require superior processor performance, flexible manageability, and thermal efficiency.

Figure 1. ThinkSystem SR630 V3



---

## Features

Performance, ease of use, reliability, and expansion capabilities are key considerations in the design of your server. These design features make it possible for you to customize the system hardware to meet your needs today, and provide flexible expansion capabilities for the future.

Your server implements the following features and technologies:

- **Features on Demand**

If a Features on Demand feature is integrated in the server or in an optional device that is installed in the server, you can purchase an activation key to activate the feature. For information about Features on Demand, see:

<https://fod.lenovo.com/lkms>

- **Lenovo XClarity Controller (XCC)**

The Lenovo XClarity Controller is the common management controller for Lenovo ThinkSystem server hardware. The Lenovo XClarity Controller consolidates multiple management functions in a single chip on the server system board (system board assembly). Some of the features that are unique to the Lenovo XClarity Controller are enhanced performance, higher-resolution remote video, and expanded security options.

The server supports Lenovo XClarity Controller 2 (XCC2). For additional information about Lenovo XClarity Controller 2 (XCC2), refer to [https://sysmgt.lenovofiles.com/help/topic/lxcc\\_frontend/lxcc\\_overview.html](https://sysmgt.lenovofiles.com/help/topic/lxcc_frontend/lxcc_overview.html).

- **UEFI-compliant server firmware**

Lenovo ThinkSystem firmware is Unified Extensible Firmware Interface (UEFI) compliant. UEFI replaces BIOS and defines a standard interface between the operating system, platform firmware, and external devices.

Lenovo ThinkSystem servers are capable of booting UEFI-compliant operating systems, BIOS-based operating systems, and BIOS-based adapters as well as UEFI-compliant adapters.

**Note:** The server does not support Disk Operating System (DOS).

- **Active Memory**

The Active Memory feature improves the reliability of memory through memory mirroring. Memory mirroring mode replicates and stores data on two pairs of DIMMs within two channels simultaneously. If a failure occurs, the memory controller switches from the primary pair of memory DIMMs to the backup pair of DIMMs.

- **Large system-memory capacity**

The server supports synchronous dynamic random-access memory (SDRAM) registered dual inline memory modules (DIMMs) with error correcting code (ECC). For more information about the specific types and maximum amount of memory, see [“Technical specifications” on page 4](#).

- **Integrated network support**

The server comes with an integrated 1-port Gigabit Ethernet controller with an RJ-45 connector, which supports connection to a 1000 Mbps network.

- **Large data-storage capacity and hot-swap capability**

With the hot-swap feature, you can add, remove, or replace hard disk drives without turning off the server.

Storage capacity is different depending on server models. See [“Technical specifications” on page 4](#) for more information.

- **Lightpath Diagnostics**

Lightpath Diagnostics provides LEDs to help you diagnose problems. For more information about the Lightpath Diagnostics, see [“System LEDs and diagnostics display” on page 40](#).

- **Mobile access to Lenovo Service Information website**

The server provides a QR code on the system service label, which is on the cover of the server, that you can scan using a QR code reader and scanner with a mobile device to get quick access to the Lenovo Service Information website. The Lenovo Service Information website provides additional information for parts installation, replacement videos, and error codes for server support.

- **Active Energy Manager**

Lenovo XClarity Energy Manager is a power and temperature management solution for data centers. You can monitor and manage the power consumption and temperature of Converged, NeXtScale, System x, and ThinkServer servers, and improve energy efficiency using Lenovo XClarity Energy Manager.

- **Redundant networking connection**

The Lenovo XClarity Controller provides failover capability to a redundant Ethernet connection with the applicable application installed. If a problem occurs with the primary Ethernet connection, all Ethernet traffic that is associated with the primary connection is automatically switched to the optional redundant Ethernet connection. If the applicable device drivers are installed, this switching occurs without data loss and without user intervention.

- **Redundant cooling**

The redundant cooling by the fans in the server enables continued operation if one of the fan rotors fails. See [“Thermal rules” on page 65](#) for more information.

- **ThinkSystem RAID support**

The ThinkSystem RAID adapter provides hardware redundant array of independent disks (RAID) support to create configurations. The standard RAID adapter provides RAID levels 0, 1, and 10. Optional RAID adapter with RAID 5, 50, 6, and 60 is available for purchase.

---

## Tech Tips

Lenovo continually updates the support website with the latest tips and techniques that you can use to solve issues that your server might encounter. These Tech Tips (also called retain tips or service bulletins) provide procedures to work around issues or solve problems related to the operation of your server.

To find the Tech Tips available for your server:

1. Go to <http://datacentersupport.lenovo.com>, and input the model name or machine type of your server in the search bar to navigate to the support page.
2. Click on **How To's** from the navigation pane.
3. Click **Article Type** → **Solution** from the drop-down menu.

Follow the on-screen instructions to choose the category for the problem that you are having.

---

## Security advisories

In order to protect our customers and their data, Lenovo is committed to developing products and services that adhere to the highest security standards. When potential vulnerabilities are reported, it is the responsibility of the Lenovo Product Security Incident Response Team (PSIRT) to investigate and provide information to our customers so that they may put mitigation plans in place as we work toward providing solutions.

The list of current advisories is available at the following site:

[https://datacentersupport.lenovo.com/product\\_security/home](https://datacentersupport.lenovo.com/product_security/home)

---

## Specifications

Summary of the features and specifications of the server. Depending on the model, some features might not be available, or some specifications might not apply.

Refer to the below table for specifications categories and the content of each category.

Specification category	Technical specifications	Mechanical specifications	Environmental specifications
Content	<ul style="list-style-type: none"><li>• Processor</li><li>• Memory</li><li>• Internal drives</li><li>• Expansion slots</li><li>• Graphics processing units (GPU)</li><li>• Integrated functions and I/O connectors</li><li>• Network</li><li>• Rear button</li><li>• RAID adapter</li><li>• Host bus adapter</li><li>• System fan</li><li>• Electrical input</li><li>• Minimal configuration for debugging</li><li>• Operating systems</li></ul>	<ul style="list-style-type: none"><li>• Dimension</li><li>• Weight</li></ul>	<ul style="list-style-type: none"><li>• Acoustical noise emissions</li><li>• Ambient temperature management</li><li>• Environmental</li></ul>

## Technical specifications

Summary of the technical specifications of the server. Depending on the model, some features might not be available, or some specifications might not apply.

- “Processor” on page 4
- “Memory” on page 5
- “Internal drives” on page 6
- “Expansion slots” on page 6
- “Graphics processing unit (GPU)” on page 6
- “Integrated functions and I/O connectors” on page 7
- “Network” on page 7
- “Rear button” on page 7
- “RAID adapter” on page 8
- “Host bus adapter” on page 8
- “System fan” on page 9
- “Electrical input” on page 9
- “Minimal configuration for debugging” on page 10
- “Operating systems” on page 10

### Processor

Processor
<p>Supports multi-core Intel Xeon processors, with integrated memory controller and Intel Mesh UPI (Ultra Path Interconnect) topology.</p> <ul style="list-style-type: none"><li>• Up to two 4th Gen Intel Xeon scalable processors with the new LGA 4677-X socket</li><li>• Up to 60 cores per socket</li><li>• Up to 4 UPI links at up to 16 GT/s</li><li>• Thermal Design Power (TDP): up to 350 watts</li></ul> <p>For a list of supported processors, see: <a href="https://serverproven.lenovo.com">https://serverproven.lenovo.com</a>.</p>

## Memory

### Memory

See “[Memory module installation rules and order](#)” on page 56 for detailed information about memory configuration and setup.

- Slots: 32 dual inline memory module (DIMM) connectors that support up to:
  - 32 DDR5 DIMMs
- Memory module type:
  - TruDDR5 4800MHz RDIMM: 16 GB (1Rx8), 32 GB (2Rx8)
  - TruDDR5 4800MHz 10x4 RDIMM: 32 GB (1Rx4), 64 GB (2Rx4)
  - TruDDR5 4800MHz 9x4 RDIMM: 32 GB (1Rx4), 64 GB (2Rx4)
  - TruDDR5 4800MHz 3DS RDIMM: 128 GB (4Rx4), 256 GB (8Rx4)
- Speed: Operating speed depends on processor model and UEFI settings.
  - 4800 MT/s for 1 DIMM per channel
  - 4400 MT/s for 2 DIMMs per channel
- Minimum memory: 16 GB
- Maximum memory: 8 TB: 32 x 256 GB 3DS RDIMMs

For a list of supported memory options, see <https://serverproven.lenovo.com>.

For technical rules for memory modules, see “[Memory module installation rules and order](#)” on page 56.

## Internal drives

Internal drives
<p>Front:</p> <ul style="list-style-type: none"><li>• Up to four 3.5-inch hot-swap SAS/SATA drives</li><li>• Up to four 3.5-inch hot-swap AnyBay (SAS/SATA/NVMe) drives</li><li>• Up to four 2.5-inch hot-swap SAS/SATA drives</li><li>• Up to four 2.5-inch hot-swap NVMe drives</li><li>• Up to eight 2.5-inch hot-swap SAS/SATA drives</li><li>• Up to six 2.5-inch hot-swap SAS/SATA and four 2.5-inch hot-swap AnyBay (SAS/SATA/NVMe) drives</li><li>• Up to six 2.5-inch hot-swap SAS/SATA and two 2.5-inch hot-swap AnyBay (SAS/SATA/NVMe) and two 2.5-inch hot-swap NVMe drives</li><li>• Up to ten 2.5-inch hot-swap SAS/SATA drives</li><li>• Up to eight 2.5-inch hot-swap NVMe drives</li><li>• Up to ten 2.5-inch hot-swap NVMe drives</li><li>• Up to ten 2.5-inch hot-swap AnyBay (SAS/SATA/NVMe) drives</li><li>• Up to 16 hot-swap EDSFF drives</li></ul> <p>Inside:</p> <ul style="list-style-type: none"><li>• Up to two internal SATA or NVMe M.2 drives</li></ul> <p>Rear:</p> <ul style="list-style-type: none"><li>• Up to two 2.5-inch hot-swap SAS/SATA or NVMe drives</li><li>• Up to two 7mm hot-swap SATA or NVMe drives</li></ul> <p><b>Notes:</b></p> <ul style="list-style-type: none"><li>• M.2 and 7mm drives are not supported at the same time.</li><li>• If 256 GB DIMM is used, rear 2.5-inch drives are not supported.</li></ul>

## Expansion slots

Expansion slots
<p>Depending on the model, your server supports up to three PCIe slots in the rear and up to two PCIe slots in the front.</p> <ul style="list-style-type: none"><li>• PCIe x16, low-profile</li><li>• PCIe x16/x16, low-profile + low-profile</li><li>• PCIe x16/x16, low profile + full-height</li><li>• PCIe x16, full-height</li></ul>

## Graphics processing unit (GPU)

Graphics processing unit (GPU)
<p>Your server supports the following GPUs:</p> <ul style="list-style-type: none"><li>• Half-length, single-wide:<ul style="list-style-type: none"><li>– NVIDIA® A2</li><li>– NVIDIA® L4</li></ul></li></ul> <p><b>Note:</b> For GPU supporting rules, see <a href="#">“Thermal rules” on page 65</a>.</p>



## Integrated functions and I/O connectors

Integrated functions and I/O connectors
<ul style="list-style-type: none"><li>• Lenovo XClarity Controller (XCC), which provides service processor control and monitoring functions, video controller, and remote keyboard, video, mouse, and remote drive capabilities.<ul style="list-style-type: none"><li>– The server supports Lenovo XClarity Controller 2 (XCC2). For additional information about Lenovo XClarity Controller 2 (XCC2), refer to <a href="https://sysmgt.lenovofiles.com/help/topic/lxcc_frontend/lxcc_overview.html">https://sysmgt.lenovofiles.com/help/topic/lxcc_frontend/lxcc_overview.html</a>.</li></ul></li><li>• One XCC system management port on the rear to connect to a systems-management network. This RJ-45 connector is dedicated to the Lenovo XClarity Controller functions and runs at 1 GB speed.</li><li>• A group of two or four Ethernet connectors on OCP module</li><li>• Up to four USB 3.2 Gen1 (5 Gbps) ports:<ul style="list-style-type: none"><li>– Three on the rear of the server</li><li>– (Optional) One on the front of the server<sup>1</sup></li></ul></li><li>• One internal USB 3.2 Gen1 (5 Gbps) port</li><li>• (Optional) One USB 2.0 port on the front of the server<sup>1</sup></li><li>• (Optional) External LCD diagnostics handset connector on the front of the server<sup>1</sup></li><li>• Up to two VGA connectors<ul style="list-style-type: none"><li>– One on the rear of the server</li><li>– (Optional) One on the front of the server<sup>1</sup></li></ul></li><li>• (Optional) One serial port connector on the rear of the server<sup>2</sup></li></ul> <p><b>Notes:</b></p> <ol style="list-style-type: none"><li>1. Available when the front I/O module is installed in the server.</li><li>2. Available when the serial port cable is installed in the server.</li></ol>

## Network

Network
<ul style="list-style-type: none"><li>• OCP module</li></ul> <p><b>Note:</b> The OCP module is an optional part. It is default to be installed in the rear and optional in the front of the server.</p>

## Rear button

Rear button
<ul style="list-style-type: none"><li>• NMI button</li></ul>

## RAID adapter

### RAID adapter

#### Support the following RAID adapters:

- ThinkSystem RAID 5350-8i PCIe 12Gb Adapter
- ThinkSystem RAID 540-8i PCIe 12Gb Adapter
- ThinkSystem RAID 540-16i PCIe 12Gb Adapter
- ThinkSystem RAID 9350-8i 2GB Flash PCIe 12Gb Adapter
- ThinkSystem RAID 9350-16i 4GB Flash PCIe 12Gb Adapter
- ThinkSystem RAID 940-8i 4GB Flash PCIe Gen4 12Gb Adapter
- ThinkSystem RAID 940-8i 4GB Flash PCIe Gen4 12Gb Adapter (Tri-mode)
- ThinkSystem RAID 940-16i 4GB Flash PCIe Gen4 12Gb Adapter
- ThinkSystem RAID 940-16i 4GB Flash PCIe Gen4 12Gb Adapter (Tri-mode)
- ThinkSystem RAID 940-8e 4GB Flash PCIe Gen4 12Gb Adapter
- ThinkSystem RAID 940-16i 8GB Flash PCIe Gen4 12Gb Adapter
- ThinkSystem RAID 940-16i 8GB Flash PCIe Gen4 12Gb Adapter (Tri-mode)
- ThinkSystem RAID 5350-8i PCIe 12Gb Internal Adapter
- ThinkSystem RAID 940-16i 8GB Flash PCIe Gen4 12Gb Internal Adapter
- ThinkSystem RAID 9350-8i 2GB Flash PCIe Gen 4 12Gb Internal Adapter
- ThinkSystem RAID 9350-16i 4GB Flash PCIe Gen 4 12Gb Internal Adapter

## Host bus adapter

### Host bus adapter

#### Support the following HBAs:

- ThinkSystem 4350-8i SAS/SATA 12Gb HBA
- ThinkSystem 4350-16i SAS/SATA 12Gb HBA
- ThinkSystem 440-8i SAS/SATA 12Gb HBA
- ThinkSystem 440-8e SAS/SATA 12Gb HBA
- ThinkSystem 440-16i SAS/SATA 12Gb HBA
- ThinkSystem 440-16e SAS/SATA 12Gb HBA
- ThinkSystem 440-16i SAS/SATA PCIe Gen4 12Gb Internal HBA
- ThinkSystem QLogic 16Gb Enhanced Gen5 FC Single-port HBA
- ThinkSystem QLogic 16Gb Enhanced Gen5 FC Dual-port HBA
- ThinkSystem Emulex 16Gb Gen6 FC Single-port HBA
- ThinkSystem Emulex 16Gb Gen6 FC Dual-port HBA

## System fan

System fan
<ul style="list-style-type: none"><li>Supported fan types:<ul style="list-style-type: none"><li>Standard fan 4056 (21000 RPM)</li><li>Performance fan 4056 (28000 RPM)</li></ul></li><li>Fan redundancy: N+1 redundancy, one redundant fan rotor<ul style="list-style-type: none"><li>One processor: six hot-swap dual-rotor system fans (one redundant fan rotor)</li><li>Two processors: eight hot-swap dual-rotor system fans (one redundant fan rotor)</li></ul></li></ul> <p><b>Note:</b> The redundant cooling by the fans in the server enables continued operation if one rotor of a fan fails.</p> <p>If there is an OCP module installed, when the system is powered off but still plugged in to AC power, system fan 1 and fan 2 will continue to spin at a much lower speed. This is the system design to provide proper cooling for the OCP module.</p>

## Electrical input

Electrical input																																								
One or two hot-swap power supply units for redundancy support:																																								
<i>Table 1. Electrical input for power supply units</i>																																								
<table border="1"><thead><tr><th>Power supply</th><th>100–127 V ac</th><th>200–240 V ac</th><th>240 V dc</th><th>-48 V dc</th></tr></thead><tbody><tr><td>750-watt 80 PLUS Platinum</td><td>√</td><td>√</td><td>√</td><td></td></tr><tr><td>1100-watt 80 PLUS Platinum</td><td>√</td><td>√</td><td>√</td><td></td></tr><tr><td>1800-watt 80 PLUS Platinum</td><td></td><td>√</td><td>√</td><td></td></tr><tr><td>750-watt 80 PLUS Titanium</td><td></td><td>√</td><td>√</td><td></td></tr><tr><td>1100-watt 80 PLUS Titanium</td><td></td><td>√</td><td>√</td><td></td></tr><tr><td>1800-watt 80 PLUS Titanium</td><td></td><td>√</td><td>√</td><td></td></tr><tr><td>1100-watt -48 V DC</td><td></td><td></td><td></td><td>√</td></tr></tbody></table>	Power supply	100–127 V ac	200–240 V ac	240 V dc	-48 V dc	750-watt 80 PLUS Platinum	√	√	√		1100-watt 80 PLUS Platinum	√	√	√		1800-watt 80 PLUS Platinum		√	√		750-watt 80 PLUS Titanium		√	√		1100-watt 80 PLUS Titanium		√	√		1800-watt 80 PLUS Titanium		√	√		1100-watt -48 V DC				√
Power supply	100–127 V ac	200–240 V ac	240 V dc	-48 V dc																																				
750-watt 80 PLUS Platinum	√	√	√																																					
1100-watt 80 PLUS Platinum	√	√	√																																					
1800-watt 80 PLUS Platinum		√	√																																					
750-watt 80 PLUS Titanium		√	√																																					
1100-watt 80 PLUS Titanium		√	√																																					
1800-watt 80 PLUS Titanium		√	√																																					
1100-watt -48 V DC				√																																				
<b>CAUTION:</b> <ul style="list-style-type: none"><li><b>240 V dc input is supported in Chinese Mainland ONLY.</b></li><li><b>Power supply with 240 V dc input cannot support hot plugging power cord function. Before removing the power supply with dc input, please turn off server or disconnect dc power sources at the breaker panel or by turning off the power source. Then, remove the power cord.</b></li></ul>																																								

## Minimal configuration for debugging

Minimal configuration for debugging
<ul style="list-style-type: none"><li>• One processor in processor socket 1</li><li>• One memory module in slot 7</li><li>• One power supply unit</li><li>• One HDD/SSD drive, one M.2 drive, or one 7mm drive (if OS is needed for debugging)</li><li>• Six system fans (with one processor)</li></ul>

## Operating systems

Operating systems
Supported and certified operating systems: <ul style="list-style-type: none"><li>• Microsoft Windows Server</li><li>• VMware ESXi</li><li>• Red Hat Enterprise Linux</li><li>• SUSE Linux Enterprise Server</li><li>• Canonical Ubuntu</li></ul>
References: <ul style="list-style-type: none"><li>• Complete list of available operating systems: <a href="https://lenovopress.lenovo.com/osig">https://lenovopress.lenovo.com/osig</a>.</li><li>• OS deployment instructions: Follow the adopted combination to install DDR5 DIMMs (see “Deploy the operating system” on page 438).</li></ul>

## Mechanical specifications

Summary of the mechanical specifications of the server. Depending on the model, some features might not be available, or some specifications might not apply.

Dimension
1U server <ul style="list-style-type: none"><li>• Height: 43.0 mm (1.69 inches)</li><li>• Width:<ul style="list-style-type: none"><li>– With rack latches: 482 mm (18.98 inches)</li><li>– Without rack latches: 434.4 mm (17.10 inches)</li></ul></li><li>• Depth: 787.6 mm (31.01 inches)</li></ul> <p><b>Note:</b> The depth is measured with rack latches and the handle of the power supply unit included.</p>

Weight
<ul style="list-style-type: none"><li>• With package: up to 26.3 kg (57.98 lb)</li><li>• Without package: up to 20 kg (44.09 lb)</li></ul>

## Environmental specifications

Summary of the environmental specifications of the server. Depending on the model, some features might not be available, or some specifications might not apply.

- “Acoustical noise emissions” on page 12
- “Ambient temperature management” on page 13
- “Environment” on page 14

## Acoustical noise emissions

Acoustical noise emissions					
The server has the following acoustic noise emissions declaration:					
<i>Table 2. Acoustic noise emissions declaration</i>					
Scenario	Used configuration	Sound power level (L <sub>WAd</sub> )		Sound pressure level (L <sub>pAm</sub> ):	
		Idling	Operating	Idling	Operating
Minimal	Two 150 W processors Thirty two 64 GB RDIMMs Eight SAS hard disk drives RAID 440-16i CFF adapter Intel X710-T2L 10GBASE-T 2-port OCP adapter Two 750-watt power supply units	5.8 Bel	6.4 Bel	45 dBA	50 dBA
Typical	Two 205 W processors Thirty two 64 GB RDIMMs Ten SAS hard disk drives RAID 940-16i SFF adapter Intel X710-T2L 10GBASE-T 2-port OCP adapter Two 1100-watt power supply units	6.7 Bel	7.7 Bel	54 dBA	61 dBA
Storage rich	Two 165 W processors Thirty two 64 GB RDIMMs 12 SAS hard disk drives RAID 940-16i SFF adapter Intel X710-T2L 10GBASE-T 2-port OCP adapter Two 750-watt power supply units	7.5 Bel	7.6 Bel	60 dBA	61 dBA
GPU rich	Two 205 W processors Thirty two 64 GB RDIMMs Ten SAS hard disk drives RAID 940-16i SFF adapter Intel X710-T2L 10GBASE-T 2-port OCP adapter Two 1100-watt power supply units	6.7 Bel	8.3 Bel	53 dBA	68 dBA

**Notes:**

### Acoustical noise emissions

- These sound power levels are measured in controlled acoustical environments according to procedures specified by ISO 7779 and are reported in accordance with ISO 9296.
- The declared sound levels may change depending on configuration/conditions, for example, with high-power NICs, high-power processors and GPUs, such as ThinkSystem Mellanox ConnectX-6 HDR/200GbE QSFP56 1-port/2-port PCIe Adapter, ThinkSystem Broadcom 57454 10GBASE-T 4-port OCP Ethernet Adapter.
- Government regulations (such as those prescribed by OSHA or European Community Directives) may govern noise level exposure in the workplace and may apply to you and your server installation. The actual sound pressure levels in your installation depend upon a variety of factors, including the number of racks in the installation; the size, materials, and configuration of the room; the noise levels from other equipment; the room ambient temperature, and employee's location in relation to the equipment. Further, compliance with such government regulations depends on a variety of additional factors, including the duration of employees' exposure and whether employees wear hearing protection. Lenovo recommends that you consult with qualified experts in this field to determine whether you are in compliance with the applicable regulations.

## Ambient temperature management

### Ambient temperature management

The server is supported in the following environment:

- Air temperature:
  - Operating:
    - ASHRAE class H1: 5–25°C (41–77°F); when the altitude exceeds 900 m (2953 ft), the maximum ambient temperature value decreases by 1°C (1.8°F) with every 500 m (1640 ft) of altitude increase.
    - ASHRAE class A2: 10–35°C (50–95°F); when the altitude exceeds 900 m (2953 ft), the maximum ambient temperature value decreases by 1°C (1.8°F) with every 300 m (984 ft) of altitude increase.
    - ASHRAE class A3: 5–40°C (41–104°F); when the altitude exceeds 900 m (2953 ft), the maximum ambient temperature value decreases by 1°C (1.8°F) with every 175 m (574 ft) of altitude increase.
    - ASHRAE class A4: 5–45°C (41–113°F); when the altitude exceeds 900 m (2953 ft), the maximum ambient temperature value decreases by 1°C (1.8°F) with every 125 m (410 ft) of altitude increase.
  - Server off: 5–45°C (41–113°F)
  - Shipping or storage: -40–60°C (-40–140°F)
- Maximum altitude: 3050 m (10 000 ft)
- Relative humidity (non-condensing):
  - Operating:
    - ASHRAE Class H1: 8%–80%, maximum dew point: 17°C (62.6°F)
    - ASHRAE Class A2: 8%–80%, maximum dew point: 21°C (70°F)
    - ASHRAE Class A3: 8%–85%, maximum dew point: 24°C (75°F)
    - ASHRAE Class A4: 8%–90%, maximum dew point: 24°C (75°F)
  - Shipment or storage: 8%–90%
- Particulate contamination

**Attention:** Airborne particulates and reactive gases acting alone or in combination with other environmental factors such as humidity or temperature might pose a risk to the server. For information about the limits for particulates and gases, see [“Particulate contamination” on page 14](#).

## Environment

Environment
<p>ThinkSystem SR630 V3 complies with ASHRAE Class A2 specifications. System performance may be affected when operating temperature is outside of AHSARE A2 specification.</p> <ul style="list-style-type: none"><li>• Air temperature:<ul style="list-style-type: none"><li>– Operating<ul style="list-style-type: none"><li>– ASHARE Class A2: 10°C to 35°C (50°F to 95°F); the maximum ambient temperature decreases by 1°C for every 300 m (984 ft) increase in altitude above 900 m (2,953 ft).</li></ul></li><li>– Server off: 5°C to 45°C (41°F to 113°F)</li><li>– Shipment/storage: -40°C to 60°C (-40°F to 140°F)</li></ul></li><li>• Maximum altitude: 3,050 m (10,000 ft)</li><li>• Relative Humidity (non-condensing):<ul style="list-style-type: none"><li>– Operating<ul style="list-style-type: none"><li>– ASHRAE Class A2: 8% to 80%; maximum dew point: 21°C (70°F)</li></ul></li><li>– Shipment/storage: 8% to 90%</li></ul></li><li>• Particulate contamination</li></ul> <p><b>Attention:</b> Airborne particulates and reactive gases acting alone or in combination with other environmental factors such as humidity or temperature might pose a risk to the server. For information about the limits for particulates and gases, see <a href="#">“Particulate contamination” on page 14</a>.</p> <p><b>Note:</b> The server is designed for standard data center environment and recommended to be placed in industrial data centers.</p> <p>When the ambient temperature is greater than the supported max temperature (ASHARE A4 45°C), the server will shut down. The server will not power on again until the ambient temperature falls within the supported temperature range. Depending on hardware configurations, the server complies with ASHRAE Class H1, A2, A3, or A4 specifications with certain thermal restrictions. System performance may be impacted when operating temperature is out of permitted conditions.</p>

## Particulate contamination

**Attention:** Airborne particulates (including metal flakes or particles) and reactive gases acting alone or in combination with other environmental factors such as humidity or temperature might pose a risk to the device that is described in this document.

Risks that are posed by the presence of excessive particulate levels or concentrations of harmful gases include damage that might cause the device to malfunction or cease functioning altogether. This specification sets forth limits for particulates and gases that are intended to avoid such damage. The limits must not be viewed or used as definitive limits, because numerous factors, such as temperature or moisture in the air, can influence the effect of particulates or environmental corrosives and gaseous contaminant transfer. In the absence of specific limits that are set forth in this document, you must implement practices that maintain particulate and gas levels that are consistent with the protection of human health and safety. If Lenovo determines that the levels of particulates or gases in your environment have caused damage to the device, Lenovo may condition provision of repair or replacement of devices or parts on implementation of appropriate remedial measures to mitigate such environmental contamination. Implementation of such remedial measures is a customer responsibility.



Table 3. Limits for particulates and gases

Contaminant	Limits
Reactive gases	<p>Severity level G1 as per ANSI/ISA 71.04-1985<sup>1</sup>:</p> <ul style="list-style-type: none"> <li>• The copper reactivity level shall be less than 200 Angstroms per month (<math>\text{\AA}/\text{month} \approx 0.0035 \mu\text{g}/\text{cm}^2\text{-hour}</math> weight gain).<sup>2</sup></li> <li>• The silver reactivity level shall be less than 200 Angstroms per month (<math>\text{\AA}/\text{month} \approx 0.0035 \mu\text{g}/\text{cm}^2\text{-hour}</math> weight gain).<sup>3</sup></li> <li>• The reactive monitoring of gaseous corrosivity must be conducted approximately 5 cm (2 in.) in front of the rack on the air inlet side at one-quarter and three-quarter frame height off the floor or where the air velocity is much higher.</li> </ul>
Airborne particulates	<p>Data centers must meet the cleanliness level of ISO 14644-1 class 8.</p> <p>For data centers without airside economizer, the ISO 14644-1 class 8 cleanliness might be met by choosing one of the following filtration methods:</p> <ul style="list-style-type: none"> <li>• The room air might be continuously filtered with MERV 8 filters.</li> <li>• Air entering a data center might be filtered with MERV 11 or preferably MERV 13 filters.</li> </ul> <p>For data centers with airside economizers, the choice of filters to achieve ISO class 8 cleanliness depends on the specific conditions present at that data center.</p> <ul style="list-style-type: none"> <li>• The deliquescent relative humidity of the particulate contamination should be more than 60% RH.<sup>4</sup></li> <li>• Data centers must be free of zinc whiskers.<sup>5</sup></li> </ul>
<p><sup>1</sup> ANSI/ISA-71.04-1985. <i>Environmental conditions for process measurement and control systems: Airborne contaminants</i>. Instrument Society of America, Research Triangle Park, North Carolina, U.S.A.</p> <p><sup>2</sup> The derivation of the equivalence between the rate of copper corrosion growth in the thickness of the corrosion product in <math>\text{\AA}/\text{month}</math> and the rate of weight gain assumes that <math>\text{Cu}_2\text{S}</math> and <math>\text{Cu}_2\text{O}</math> grow in equal proportions.</p> <p><sup>3</sup> The derivation of the equivalence between the rate of silver corrosion growth in the thickness of the corrosion product in <math>\text{\AA}/\text{month}</math> and the rate of weight gain assumes that <math>\text{Ag}_2\text{S}</math> is the only corrosion product.</p> <p><sup>4</sup> The deliquescent relative humidity of particulate contamination is the relative humidity at which the dust absorbs enough water to become wet and promote ionic conduction.</p> <p><sup>5</sup> Surface debris is randomly collected from 10 areas of the data center on a 1.5 cm diameter disk of sticky electrically conductive tape on a metal stub. If examination of the sticky tape in a scanning electron microscope reveals no zinc whiskers, the data center is considered free of zinc whiskers.</p>	

## Management options

The XClarity portfolio and other system management options described in this section are available to help you manage the servers more conveniently and efficiently.

## Overview

Options	Description
Lenovo XClarity Controller	<p>Baseboard management controller. (BMC)</p> <p>Consolidates the service processor functionality, Super I/O, video controller, and remote presence capabilities into a single chip on the server system board (system board assembly).</p> <p><b>Interface</b></p> <ul style="list-style-type: none"> <li>• CLI application</li> <li>• Web GUI interface</li> <li>• Mobile application</li> <li>• Redfish API</li> </ul> <p><b>Usage and downloads</b></p> <p><a href="https://sysmgt.lenovofiles.com/help/topic/lxcc_frontend/lxcc_overview.html">https://sysmgt.lenovofiles.com/help/topic/lxcc_frontend/lxcc_overview.html</a></p>
Lenovo XCC Logger Utility	<p>Application that reports the XCC events to local OS system log.</p> <p><b>Interface</b></p> <ul style="list-style-type: none"> <li>• CLI application</li> </ul> <p><b>Usage and downloads</b></p> <p><a href="https://sysmgt.lenovofiles.com/help/topic/lxcc-logger-frontend/lxcc-logger-overview.html">https://sysmgt.lenovofiles.com/help/topic/lxcc-logger-frontend/lxcc-logger-overview.html</a></p>
Lenovo XClarity Administrator	<p>Centralized interface for multi-server management.</p> <p><b>Interface</b></p> <ul style="list-style-type: none"> <li>• Web GUI interface</li> <li>• Mobile application</li> <li>• REST API</li> </ul> <p><b>Usage and downloads</b></p> <p><a href="http://sysmgt.lenovofiles.com/help/topic/com.lenovo.lxca.doc/aug_product_page.html">http://sysmgt.lenovofiles.com/help/topic/com.lenovo.lxca.doc/aug_product_page.html</a></p>
Lenovo XClarity Essentials toolset	<p>Portable and light toolset for server configuration, data collection, and firmware updates. Suitable both for single-server or multi-server management contexts.</p> <p><b>Interface</b></p> <ul style="list-style-type: none"> <li>• <b>OneCLI:</b> CLI application</li> <li>• <b>Bootable Media Creator:</b> CLI application, GUI application</li> <li>• <b>UpdateXpress:</b> GUI application</li> </ul> <p><b>Usage and downloads</b></p> <p><a href="http://sysmgt.lenovofiles.com/help/topic/xclarity_essentials/overview.html">http://sysmgt.lenovofiles.com/help/topic/xclarity_essentials/overview.html</a></p>

Options	Description
Lenovo XClarity Provisioning Manager	<p>UEFI-based embedded GUI tool on a single server that can simplify management tasks.</p> <p><b>Interface</b></p> <ul style="list-style-type: none"> <li>• Web interface (BMC remote access)</li> <li>• GUI application</li> </ul> <p><b>Usage and downloads</b></p> <p><a href="https://sysmgt.lenovofiles.com/help/topic/lxpm_frontend/lxpm_product_page.html">https://sysmgt.lenovofiles.com/help/topic/lxpm_frontend/lxpm_product_page.html</a></p> <p><b>Important:</b> Lenovo XClarity Provisioning Manager (LXPM) supported version varies by product. All versions of Lenovo XClarity Provisioning Manager are referred to as Lenovo XClarity Provisioning Manager and LXPM in this document, unless specified otherwise. To see the LXPM version supported by your server, go to <a href="https://sysmgt.lenovofiles.com/help/topic/lxpm_frontend/lxpm_product_page.html">https://sysmgt.lenovofiles.com/help/topic/lxpm_frontend/lxpm_product_page.html</a>.</p>
Lenovo XClarity Integrator	<p>Series of applications that integrate the management and monitoring functionalities of the Lenovo physical servers with the software used in a certain deployment infrastructure, such as VMware vCenter, Microsoft Admin Center, or Microsoft System Center while delivering additional workload resiliency.</p> <p><b>Interface</b></p> <ul style="list-style-type: none"> <li>• GUI application</li> </ul> <p><b>Usage and downloads</b></p> <p><a href="https://sysmgt.lenovofiles.com/help/topic/lxci/lxci_product_page.html">https://sysmgt.lenovofiles.com/help/topic/lxci/lxci_product_page.html</a></p>
Lenovo XClarity Energy Manager	<p>Application that can manage and monitor server power and temperature.</p> <p><b>Interface</b></p> <ul style="list-style-type: none"> <li>• Web GUI Interface</li> </ul> <p><b>Usage and downloads</b></p> <p><a href="https://datacentersupport.lenovo.com/solutions/Invo-lxem">https://datacentersupport.lenovo.com/solutions/Invo-lxem</a></p>
Lenovo Capacity Planner	<p>Application that supports power consumption planning for a server or rack.</p> <p><b>Interface</b></p> <ul style="list-style-type: none"> <li>• Web GUI Interface</li> </ul> <p><b>Usage and downloads</b></p> <p><a href="https://datacentersupport.lenovo.com/solutions/Invo-lcp">https://datacentersupport.lenovo.com/solutions/Invo-lcp</a></p>

## Functions

Options		Functions							
		Multi-system mgmt	OS deployment	System configuration	Firmware updates <sup>1</sup>	Event/alert monitoring	Inventory/logs	Power mgmt	Power planning
Lenovo XClarity Controller				√	√ <sup>2</sup>	√	√ <sup>4</sup>		
Lenovo XCC Logger Utility						√			
Lenovo XClarity Administrator		√	√	√	√ <sup>2</sup>	√	√ <sup>4</sup>		
Lenovo XClarity Essentials toolset	OneCLI	√		√	√ <sup>2</sup>	√	√		
	Bootable Media Creator			√	√ <sup>2</sup>		√ <sup>4</sup>		
	UpdateXpress			√	√ <sup>2</sup>				
Lenovo XClarity Provisioning Manager			√	√	√ <sup>3</sup>		√ <sup>5</sup>		
Lenovo XClarity Integrator		√	√ <sup>6</sup>	√	√	√	√	√ <sup>7</sup>	
Lenovo XClarity Energy Manager		√				√		√	
Lenovo Capacity Planner									√ <sup>8</sup>

### Notes:

1. Most options can be updated through the Lenovo tools. Some options, such as GPU firmware or Omni-Path firmware require the use of supplier tools.
2. The server UEFI settings for option ROM must be set to **Auto** or **UEFI** to update firmware using Lenovo XClarity Administrator, Lenovo XClarity Essentials, or Lenovo XClarity Controller.
3. Firmware updates are limited to Lenovo XClarity Provisioning Manager, Lenovo XClarity Controller, and UEFI updates only. Firmware updates for optional devices, such as adapters, are not supported.
4. The server UEFI settings for option ROM must be set to **Auto** or **UEFI** for detailed adapter card information, such as model name and firmware levels, to be displayed in Lenovo XClarity Administrator, Lenovo XClarity Controller, or Lenovo XClarity Essentials.
5. Limited inventory.
6. The Lenovo XClarity Integrator deployment check for System Center Configuration Manager (SCCM) supports Windows operating system deployment.
7. Power management function is supported only by Lenovo XClarity Integrator for VMware vCenter.
8. It is highly recommended that you check the power summary data for your server using Lenovo Capacity Planner before purchasing any new parts.

## Chapter 2. Server components

This section includes information about the front view, rear view, and top view of the server. Front I/O modules, the system board assembly and LEDs are also illustrated in details.

### Front view

The front view of the server varies by model. Depending on the model, your server might look slightly different from the illustrations in this topic.

Refer to the following front view for different server models:

- “Server models with four 2.5-inch front drive bays” on page 19
- “Server models with eight 2.5-inch front drive bays” on page 20
- “Server models with ten 2.5-inch front drive bays” on page 21
- “Server models with 16 EDSFF front drives” on page 21
- “Server model with 16 EDSFF drives and an M.2 cage” on page 22
- “Server models with four 3.5-inch front drive bays” on page 23
- “Server models with 2.5-inch front drive bays (backplane-less)” on page 23
- “Server models with 3.5-inch front drive bays (backplane-less)” on page 24
- “Server models with eight 2.5-inch front drive bays (with LCD diagnostics panel)” on page 24
- “Server models with 16 EDSFF front drives (with LCD diagnostics panel)” on page 25

#### Server model with four 2.5-inch drive bays

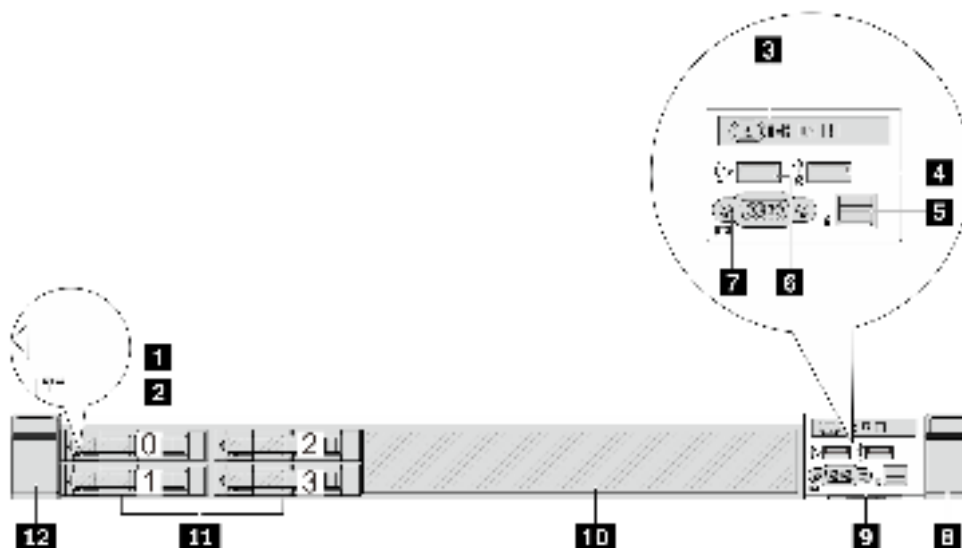


Table 4. Components on the front of the server

Callout	Callout
<b>1</b> Drive status LED	<b>2</b> Drive activity LED
<b>3</b> Diagnostics panel	<b>4</b> USB 3.2 Gen 1 (5Gbps) connector
<b>5</b> External LCD connector	<b>6</b> XClarity Controller USB connector

Table 4. Components on the front of the server (continued)

Callout	Callout
<b>7</b> VGA connector (optional)	<b>8</b> Rack latch (right)
<b>9</b> Pull-out information tab	<b>10</b> Drive filler (1)
<b>11</b> Drive bays (4)	<b>12</b> Rack latch (left)

**Note:** For more information about each component, see [“Front components overview”](#) on page 25.

### Server model with eight 2.5-inch drive bays

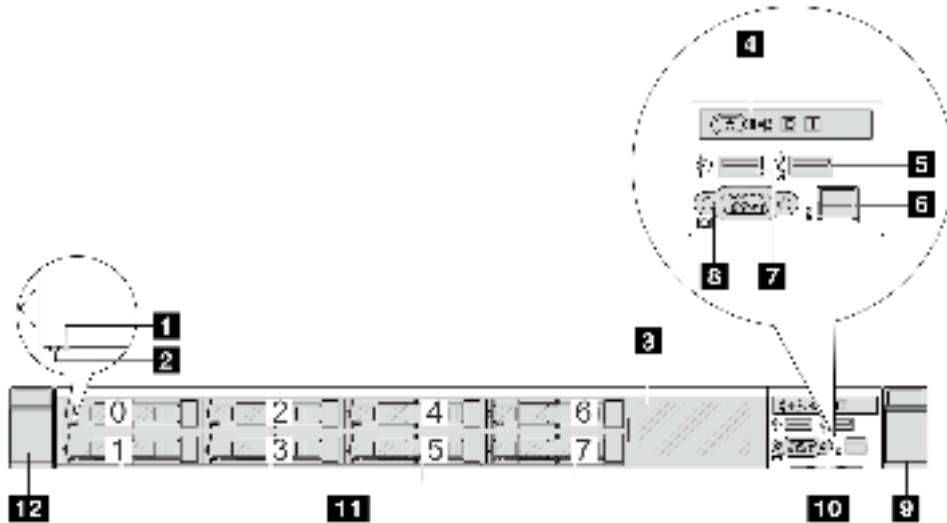


Table 5. Components on the front of the server

Callout	Callout
<b>1</b> Drive status LED	<b>2</b> Drive activity LED
<b>3</b> Drive filler (1)	<b>4</b> Diagnostics panel
<b>5</b> USB 3.2 Gen 1 (5Gbps) connector	<b>6</b> External LCD connector
<b>7</b> XClarity Controller USB connector	<b>8</b> VGA connector (optional)
<b>9</b> Rack latch (right)	<b>10</b> Pull-out information tab
<b>11</b> Drive bays (8)	<b>12</b> Rack latch (left)

**Note:** For more information about each component, see [“Front components overview”](#) on page 25.

**Server model with ten 2.5-inch drive bays**

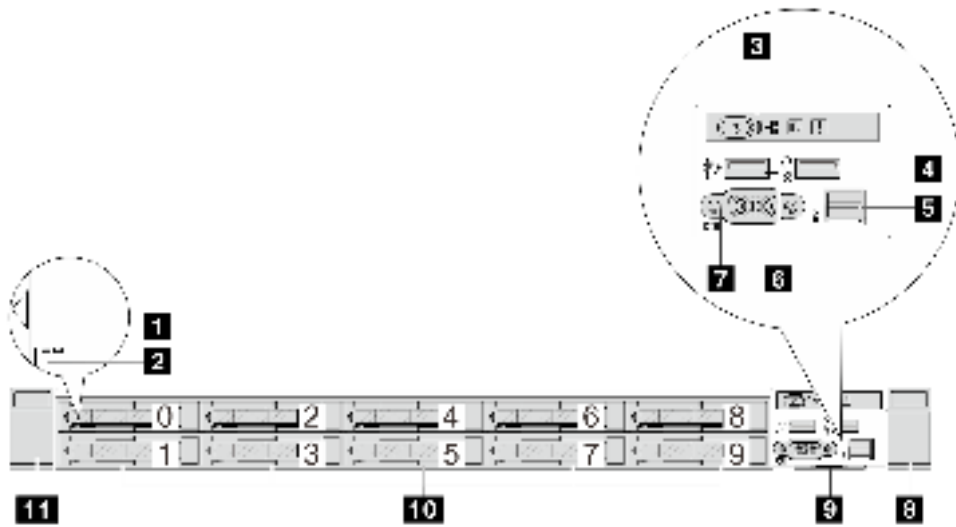


Table 6. Components on the front of the server

Callout	Callout
<b>1</b> Drive status LED	<b>2</b> Drive activity LED
<b>3</b> Diagnostics panel	<b>4</b> USB 3.2 Gen 1 (5Gbps) connector
<b>5</b> External LCD connector	<b>6</b> XClarity Controller USB connector
<b>7</b> VGA connector (optional)	<b>8</b> Rack latch (right)
<b>9</b> Pull-out information tab	<b>10</b> Drive bays (10)
<b>11</b> Rack latch (left)	

**Note:** For more information about each component, see [“Front components overview”](#) on page 25.

**Server model with 16 EDSFF drives**

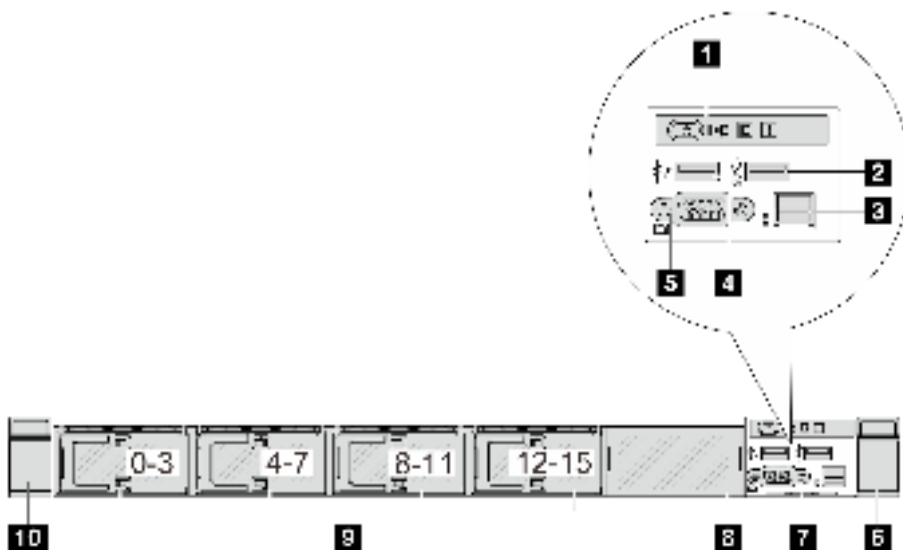


Table 7. Components on the front of the server

Callout	Callout
<b>1</b> Diagnostics panel	<b>2</b> USB 3.2 Gen 1 (5Gbps) connector
<b>3</b> External LCD connector	<b>4</b> XClarity Controller USB connector
<b>5</b> VGA connector (optional)	<b>6</b> Rack latch (right)
<b>7</b> Pull-out information tab	<b>8</b> Drive filler (1)
<b>9</b> Drive bays (16)	<b>10</b> Rack latch (left)

**Note:** For more information about each component, see [“Front components overview” on page 25](#).

**Server model with 16 EDSFF drives and an M.2 cage**

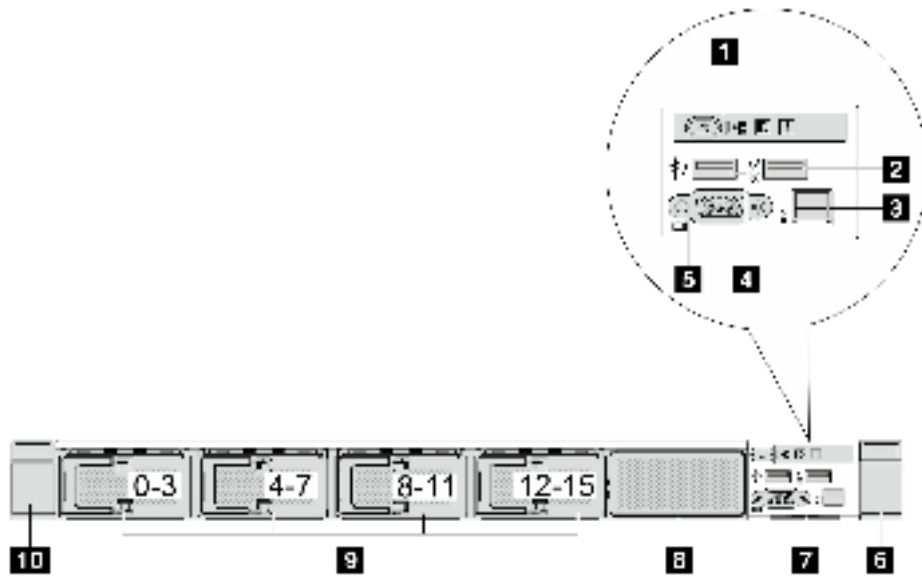


Table 8. Components on the front of the server

Callout	Callout
<b>1</b> Diagnostics panel	<b>2</b> USB 3.2 Gen 1 (5Gbps) connector
<b>3</b> External LCD connector	<b>4</b> XClarity Controller USB connector
<b>5</b> VGA connector (optional)	<b>6</b> Rack latch (right)
<b>7</b> Pull-out information tab	<b>8</b> M.2 cage
<b>9</b> Drive bays (16)	<b>10</b> Rack latch (left)

**Note:** For more information about each component, see [“Front components overview” on page 25](#).



**Server model with four 3.5-inch drive bays**

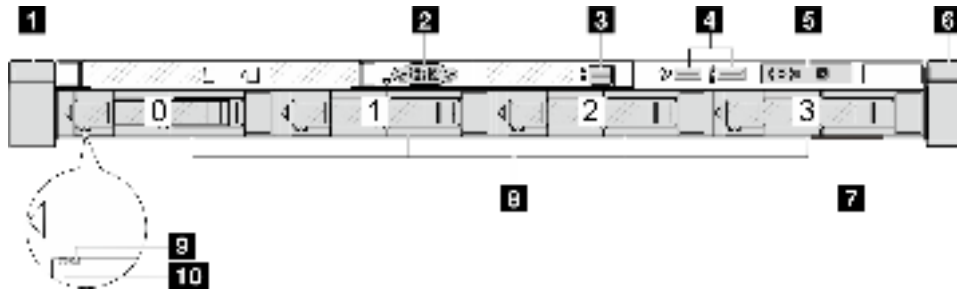


Table 9. Components on the front of the server

Callout	Callout
<b>1</b> Rack latch (left)	<b>2</b> VGA connector (optional)
<b>3</b> External LCD connector	<b>4</b> XClarity Controller USB connector and USB 3.2 Gen 1 (5Gbps) connector
<b>5</b> Diagnostics panel	<b>6</b> Rack latch (right)
<b>7</b> Pull-out information tab	<b>8</b> Drive bays (4)
<b>9</b> Drive status LED	<b>10</b> Drive activity LED

**Note:** For more information about each component, see [“Front components overview”](#) on page 25.

**Server model with 2.5-inch drive bays (backplane-less)**

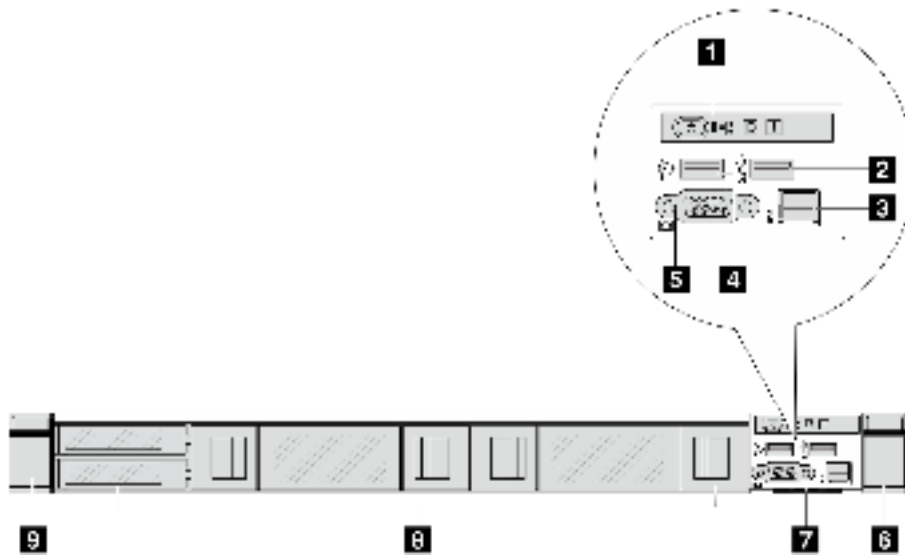


Table 10. Components on the front of the server

Callout	Callout
<b>1</b> Diagnostics panel	<b>2</b> USB 3.2 Gen 1 (5Gbps) connector
<b>3</b> External LCD connector (reserved)	<b>4</b> XClarity Controller USB connector
<b>5</b> VGA connector (optional)	<b>6</b> Rack latch (right)

Table 10. Components on the front of the server (continued)

Callout	Callout
<b>7</b> Pull-out information tab	<b>8</b> Drive fillers (4)
<b>9</b> Rack latch (left)	

**Note:** For more information about each component, see [“Front components overview”](#) on page 25.

**Server model with 3.5-inch drive bays (backplane-less)**

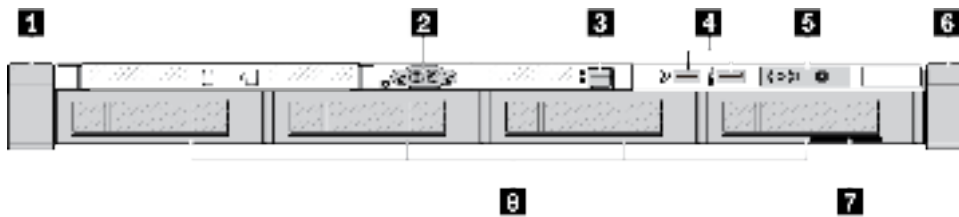


Table 11. Components on the front of the server

Callout	Callout
<b>1</b> Rack latch (left)	<b>2</b> VGA connector (optional)
<b>3</b> External LCD connector	<b>4</b> XClarity Controller USB connector and USB 3.2 Gen 1 (5Gbps) connector
<b>5</b> Diagnostics panel	<b>6</b> Rack latch (right)
<b>7</b> Pull-out information tab	<b>8</b> Drive fillers (4)

**Note:** For more information about each component, see [“Front components overview”](#) on page 25.

**Server model with eight 2.5-inch drive bays (with LCD diagnostics panel assembly)**

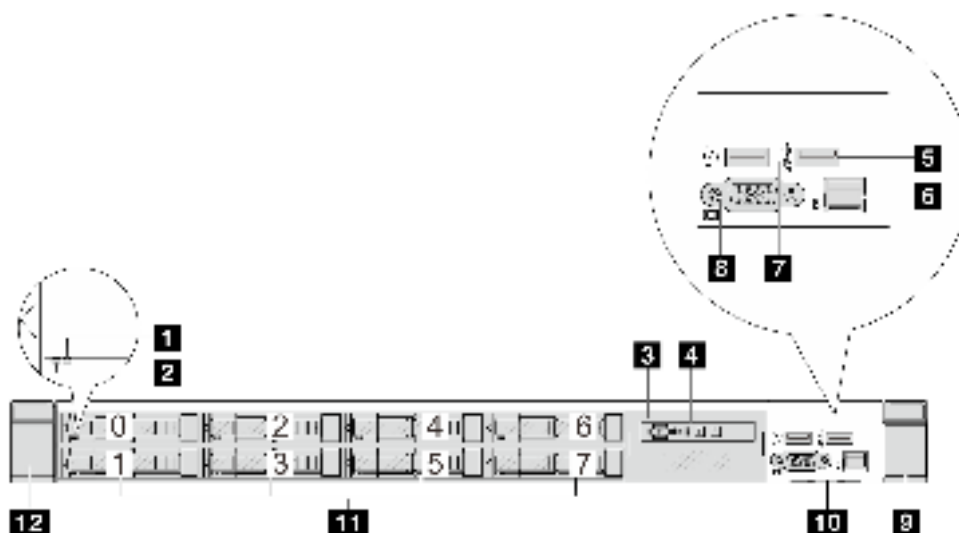


Table 12. Components on the front of the server

Callout	Callout
<b>1</b> Drive status LED	<b>2</b> Drive activity LED
<b>3</b> LCD diagnostics panel assembly	<b>4</b> LCD diagnostics panel
<b>5</b> USB 3.2 Gen 1 (5Gbps) connector	<b>6</b> External LCD connector
<b>7</b> XClarity Controller USB connector	<b>8</b> VGA connector (optional)
<b>9</b> Rack latch (right)	<b>10</b> Pull-out information tab
<b>11</b> Drive bays (8)	<b>12</b> Rack latch (left)

**Note:** For more information about each component, see [“Front components overview” on page 25](#).

**Server model with 16 EDSFF drives (with LCD diagnostics panel assembly)**

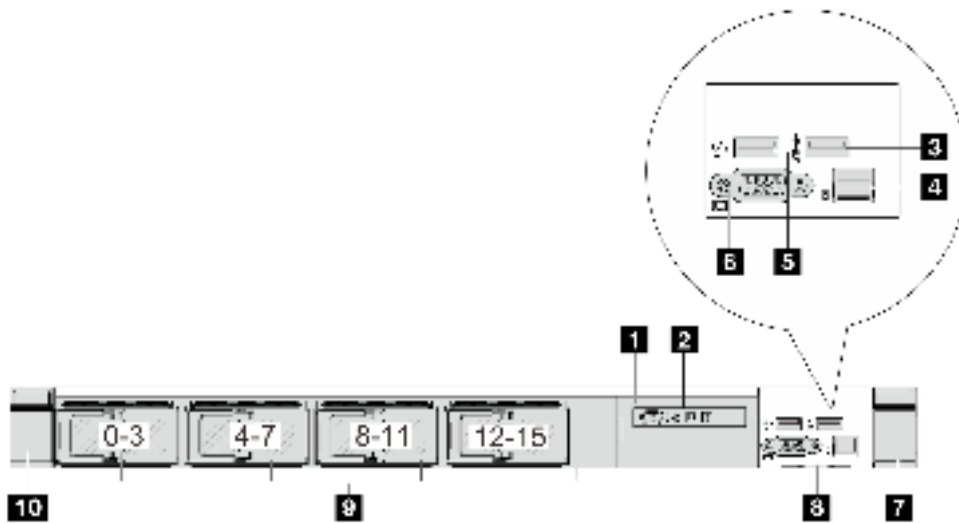


Table 13. Components on the front of the server

Callout	Callout
<b>1</b> LCD diagnostics panel assembly	<b>2</b> LCD diagnostics panel
<b>3</b> USB 3.2 Gen 1 (5Gbps) connector	<b>4</b> External LCD connector
<b>5</b> XClarity Controller USB connector	<b>6</b> VGA connector (optional)
<b>7</b> Rack latch (right)	<b>8</b> Pull-out information tab
<b>9</b> Drive bays (16)	<b>10</b> Rack latch (left)

**Note:** For more information about each component, see [“Front components overview” on page 25](#).

**Front components overview**

**Integrated diagnostics panel**

The diagnostics panel is integrated in front I/O assembly on some models. For information about the controls and status LEDs on the diagnostics panel, see [“Integrated diagnostics panel” on page 449](#).

## External diagnostics port

The connector is for connecting an external diagnostics handset. For more about its functions, see [“External LCD diagnostics handset” on page 443](#).

## Front operator panel

The assembly comes with an integrated LCD diagnostics panel that can be used to quickly obtain system status, firmware levels, network information, and health information about the system. For more about the panel functions, see [“Front operator panel” on page 453](#).

## Hot-swap drives and drive bays

The drive bays on the front and rear of your server are designed for hot-swap drives. The number of the installed drives in your server varies by model. When you install drives, follow the order of the drive bay numbers.

The EMI integrity and cooling of the server are protected by having all drive bays occupied. Vacant drive bays must be occupied by drive fillers.

## Pull-out information tab

The Lenovo XClarity Controller network access label is attached on the pull-out information tab. The default Lenovo XClarity Controller hostname and the IPv6 Link Local Address (LLA) are provided on the tab.

## Rack latches

If your server is installed in a rack, you can use the rack latches to help you slide the server out of the rack. You also can use the rack latches and screws to secure the server in the rack so that the server cannot slide out, especially in vibration-prone areas. For more information, refer to the *Rack Installation Guide* that comes with your rail kit.

## USB 3.2 Gen 1 (5Gbps) connectors

The USB 3.2 Gen 1 (5Gbps) connectors can be used to attach a USB-compatible device, such as a USB keyboard, USB mouse, or USB storage device.

## VGA connector

The VGA connectors on the front and rear of the server can be used to attach a high-performance monitor, a direct-drive monitor, or other devices that use a VGA connector.

## XClarity Controller USB connector

The XClarity Controller USB connector can function as a regular USB 2.0 connector to the host OS. In addition, it can also be used to connect the server to an android or iOS device, where you can then install and launch the Lenovo XClarity Mobile app to manage the system using XClarity Controller.

For details about using the Lenovo XClarity Mobile app, refer to [http://sysmgt.lenovofiles.com/help/topic/com.lenovo.lxca.doc/lxca\\_usemobileapp.html](http://sysmgt.lenovofiles.com/help/topic/com.lenovo.lxca.doc/lxca_usemobileapp.html).

---

## Rear view

The rear view of the server varies by model. Depending on the model, your server might look slightly different from the illustrations in this topic.

Refer to the following rear view for different server models:

- [“Server model with three PCIe slots” on page 27](#)
- [“Server model with two PCIe slots” on page 27](#)

- “Server model with two 2.5-inch hot-swap rear drive bays and one PCIe slot” on page 28
- “Server model with two 7mm hot-swap rear drive bays and two PCIe slots” on page 29
- “Server model with two 7mm hot-swap rear drive bays and one PCIe slot” on page 29

### Server model with three PCIe slots

The following illustration shows the rear view of server model with three PCIe slots. Depending on the model, your server might look slightly different from the illustration below.

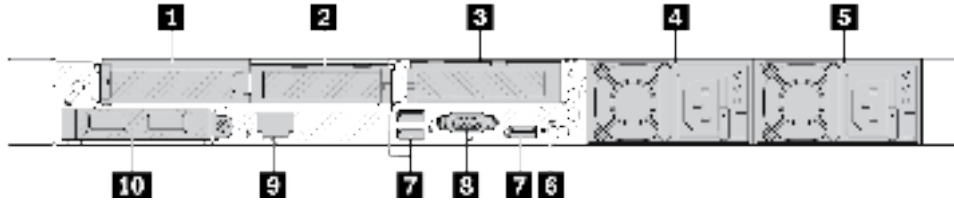


Figure 2. Rear view with three low profile PCIe adapters

Table 14. Components on the rear of the server

Callout	Callout
<b>1</b> PCIe slot 1 on riser 1 assembly	<b>2</b> PCIe slot 2 on riser 1 assembly
<b>3</b> PCIe slot 3 on riser 2 assembly	<b>4</b> Power supply 2 (optional)
<b>5</b> Power supply 1	<b>6</b> NMI button
<b>7</b> USB 3.2 Gen 1 (5Gbps) connectors (3 DCIs)	<b>8</b> VGA connector
<b>9</b> XClarity Controller network connector	<b>10</b> Ethernet connectors on OCP module (optional)

**Note:** For more information about each component, see “Rear components overview” on page 30.

### Server model with two PCIe slots

The following illustration shows the rear views of the server model with two PCIe slots. Depending on the model, your server might look slightly different from the illustration below.

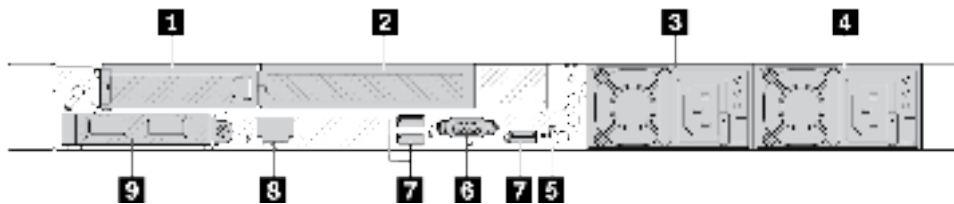


Figure 3. Rear view with one low profile PCIe adapter, one full height PCIe adapter, and one filler

Table 15. Components on the rear of the server

Callout	Callout
<b>1</b> PCIe slot 1 on riser 1 assembly	<b>2</b> PCIe slot 2 on riser 1 assembly
<b>3</b> Power supply 2 (optional)	<b>4</b> Power supply 1
<b>5</b> NMI button	<b>6</b> VGA connector

Table 15. Components on the rear of the server (continued)

Callout	Callout
<b>7</b> USB 3.2 Gen 1 (5Gbps) connectors (3 DCIs)	<b>8</b> XClarity Controller network connector
<b>9</b> Ethernet connectors on OCP module (optional, two or four connectors may be available)	

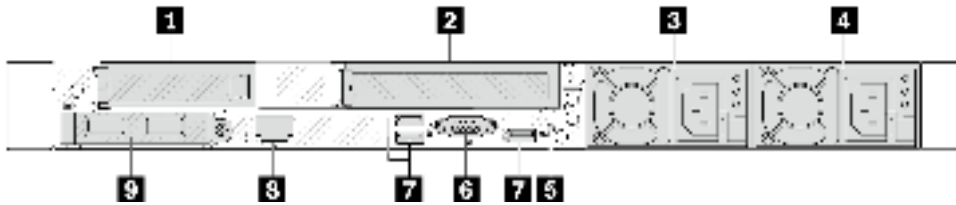


Figure 4. Rear view with one low profile PCIe adapter, one filler, and one full height PCIe adapter

Table 16. Components on the rear of the server

Callout	Callout
<b>1</b> PCIe slot 1 on riser 1 assembly	<b>2</b> PCIe slot 3 on riser 2 assembly
<b>3</b> Power supply 2 (optional)	<b>4</b> Power supply 1
<b>5</b> NMI button	<b>6</b> VGA connector
<b>7</b> USB 3.2 Gen 1 (5Gbps) connectors (3 DCIs)	<b>8</b> XClarity Controller network connector
<b>9</b> Ethernet connectors on OCP module (optional, two or four connectors may be available)	

**Note:** For more information about each component, see [“Rear components overview” on page 30](#).

### Server model with two 2.5-inch hot-swap rear drive bays and one PCIe slot

The following illustration shows the rear view of the server model with two hot-swap drive bays and one PCIe slot. Depending on the model, your server might look slightly different from the illustration below.

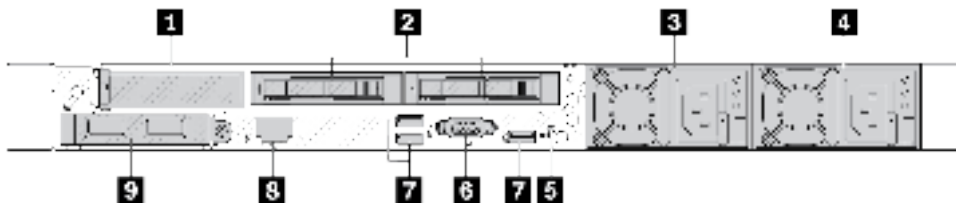


Table 17. Components on the rear of the server

<b>1</b> PCIe slot 1 on riser 1 assembly	<b>2</b> Rear 2.5-inch drive bays (2)
<b>3</b> Power supply 2 (optional)	<b>4</b> Power supply 1
<b>5</b> NMI button	<b>6</b> VGA connector
<b>7</b> USB 3.2 Gen 1 (5Gbps) connectors (3 DCIs)	<b>8</b> XClarity Controller network connector
<b>9</b> Ethernet connectors on OCP module (optional, two or four connectors may be available)	

**Note:** For more information about each component, see [“Rear components overview” on page 30](#).

### Server model with two 7mm hot-swap rear drive bays and two PCIe slots

The following illustration shows the rear view of the server model with two 7mm hot-swap rear drive bays and two PCIe slots. Depending on the model, your server might look slightly different from the illustration below.

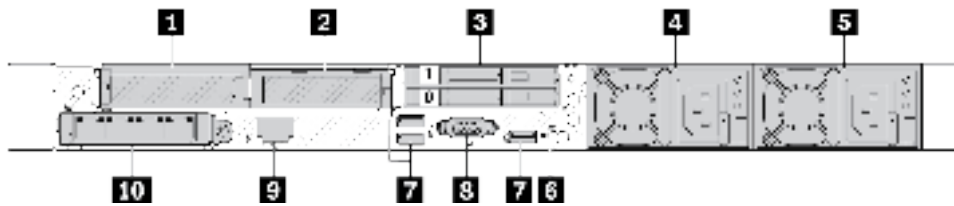


Table 18. Components on the rear of the server

<b>1</b> PCIe slot 1 on riser 1 assembly	<b>2</b> PCIe slot 2 on riser 1 assembly
<b>3</b> Rear 7mm drive bays (2)	<b>4</b> Power supply 2 (optional)
<b>5</b> Power supply 1	<b>6</b> NMI button
<b>7</b> USB 3.2 Gen 1 (5Gbps) connectors (3 DCIs)	<b>8</b> VGA connector
<b>9</b> XClarity Controller network connector	<b>10</b> Ethernet connectors on OCP module (optional, two or four connectors may be available)

**Note:** For more information about each component, see [“Rear components overview” on page 30](#).

### Server model with two 7mm hot-swap rear drive bays and one PCIe slot

The following illustration shows the rear view of the server model with two 7mm hot-swap rear drive bays and one PCIe slots. Depending on the model, your server might look slightly different from the illustration below.

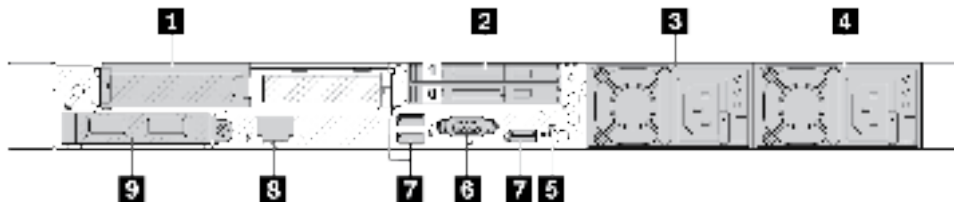


Table 19. Components on the rear of the server

<b>1</b> PCIe slot 1 on riser 1 assembly	<b>2</b> Rear 7mm drive bays (2)
<b>3</b> Power supply 2 (optional)	<b>4</b> Power supply 1
<b>5</b> NMI button	<b>6</b> VGA connector
<b>7</b> USB 3.2 Gen 1 (5Gbps) connectors (3 DCIs)	<b>8</b> XClarity Controller network connector
<b>9</b> Ethernet connectors on OCP module (optional, two or four connectors may be available)	

**Note:** For more information about each component, see [“Rear components overview” on page 30](#).

## Rear components overview

### Ethernet connectors

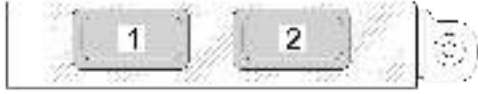


Figure 5. OCP module (two connectors)



Figure 6. OCP module (four connectors)

The OCP module provides two or four extra Ethernet connectors for network connections.

By default, any Ethernet connector on the OCP module can also function as a management connector using the shared management capacity.

**Note:** The OCP module is an optional part. It is default to be installed in the rear and optional in the front of the server.

### Hot-swap drives and drive bays

The drive bays on the front and rear of your server are designed for hot-swap drives. The number of the installed drives in your server varies by model. When you install drives, follow the order of the drive bay numbers.

The EMI integrity and cooling of the server are protected by having all drive bays occupied. Vacant drive bays must be occupied by drive fillers.

### NMI button

Press this button to force a nonmaskable interrupt (NMI) to the processor. By this way, you can make the operating system halt (such as Windows Blue Screen of Death) and take a memory dump. You might have to use a pen or the end of a straightened paper clip to press the button.

### PCIe slots

The PCIe slots are on the rear of the server and your server supports up to three PCIe slots on riser 1 and 2 assemblies.

### Power supply units

The hot-swap redundant power supply helps you avoid significant interruption to the operation of the system when a power supply fails. You can purchase a power supply option from Lenovo and install the power supply to provide power redundancy without turning off the server.

On each power supply, there are three status LEDs near the power cord connector. For information about the LEDs, see [“System LEDs and diagnostics display” on page 40](#).

### USB 3.2 Gen 1 (5Gbps) connectors

The USB 3.2 Gen 1 (5Gbps) connectors are direct connect interfaces (DCIs) for debugging, which can be used to attach a USB-compatible device, such as a USB keyboard, USB mouse, or USB storage device.



## VGA connector

The VGA connectors on the front and rear of the server can be used to attach a high-performance monitor, a direct-drive monitor, or other devices that use a VGA connector.

## XClarity Controller network connector

The XClarity Controller network connector can be used to attach an Ethernet cable to manage the baseboard management controller (BMC).

## Rear LEDs

- For more information about the LEDs on the XCC system management port, see [“LEDs on the XCC system management port” on page 462](#).
- For more information about the system error LED and system ID LED, see [“LEDs on the system board assembly” on page 458](#).
- For more information about the LEDs on the power supply unit, see [“LEDs on the power supply unit” on page 461](#).

---

## Top view

This section contains information on the top view of the server.

The following illustrations show the top views of the server without any air baffle or rear cage installed.

- [“Top view of 2.5-inch drive configuration” on page 32](#)
- [“Top view of a server with the liquid assisted cooling module installed” on page 33](#)

## Top view of 2.5-inch drive configuration

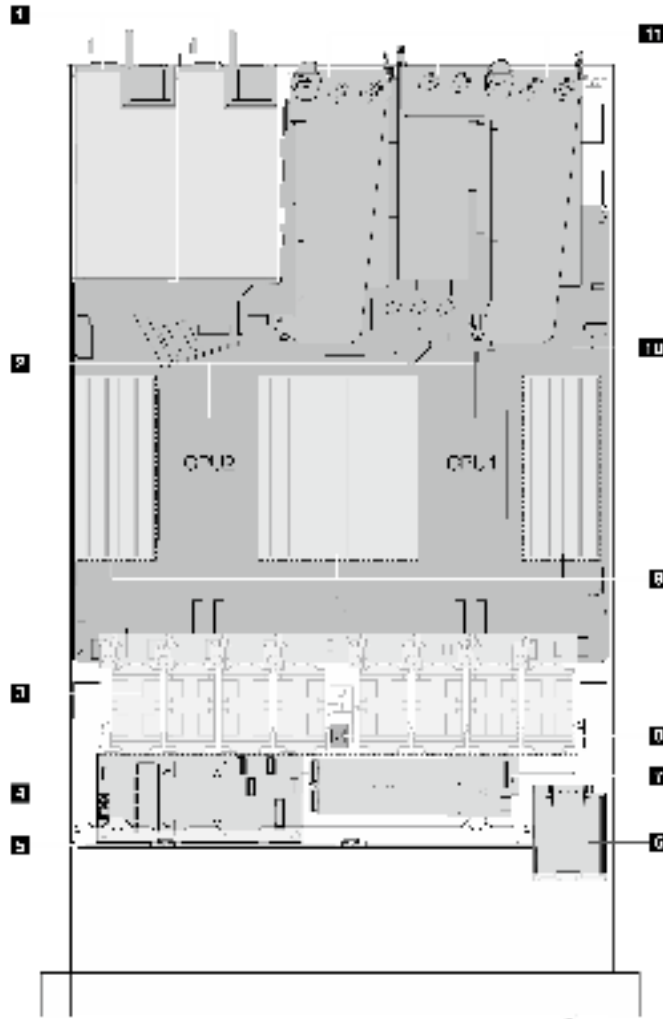


Figure 7. Top view of 2.5-inch drive configuration

Table 20. Components on the top view of 2.5-inch drive configuration

<b>1</b> Power supply units	<b>7</b> M.2 drive module
<b>2</b> Processors	<b>8</b> Intrusion switch
<b>3</b> Fan modules	<b>9</b> Memory modules
<b>4</b> Internal RAID adapter	<b>10</b> System board assembly
<b>5</b> Front backplane	<b>11</b> Riser assemblies
<b>6</b> RAID flash power module	

### Notes:

1. The illustration shows the server rear configuration with three riser assemblies. The server rear configurations vary by server model. For details, see [“Rear view” on page 26](#).
2. The illustration shows the location of certain parts. Some parts may not be supported at the same time within certain configuration(s).

## Top view of a server with the liquid assisted cooling module installed

The illustration below singles out the Liquid Assisted Cooling Module (LACM) from other components in the chassis. The parts contained depend on the configuration of the server.

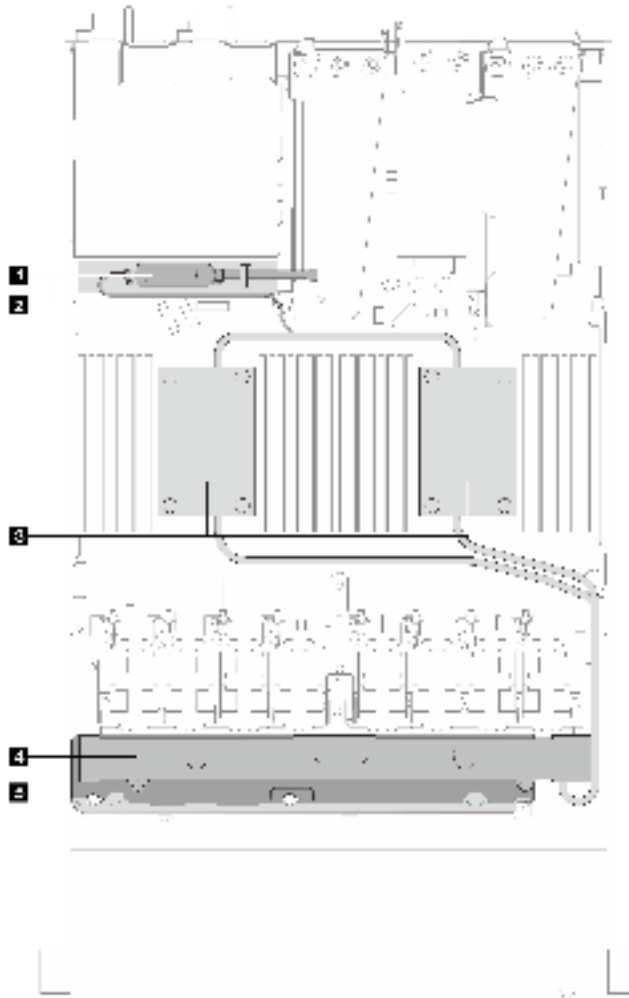


Figure 8. Top view of the LACM

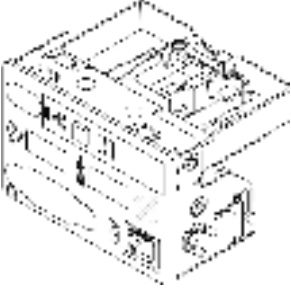
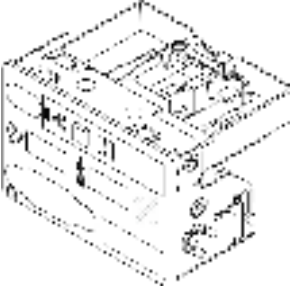
Table 21. Components on the top view of the LACM

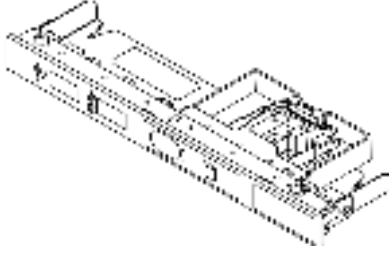
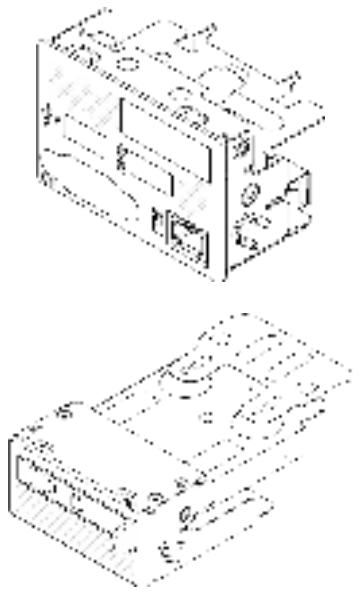
<b>1</b> Liquid detection sensor module	<b>4</b> Radiator
<b>2</b> The holder for the liquid detection sensor module	<b>5</b> The holder for the radiator
<b>3</b> Cold plate assembly	

## Front I/O module

The front I/O module of the server provides controls, connectors, and LEDs. The front I/O module varies by model.

Depending on server models, your server supports the following front I/O modules.

FIO modules	For server models with
 <p data-bbox="168 579 461 609"><i>Figure 9. FIO module type 1</i></p>	<ul data-bbox="594 243 899 390" style="list-style-type: none"> <li>• 4 x 2.5" front drive bays</li> <li>• 8 x 2.5" front drive bays</li> <li>• 10 x 2.5" front drive bays</li> <li>• 16 EDSFF front drive bays</li> </ul>
 <p data-bbox="168 978 477 1008"><i>Figure 10. FIO module type 2</i></p>	<ul data-bbox="594 642 889 672" style="list-style-type: none"> <li>• 10 x 2.5" front drive bays</li> </ul>

FIO modules	For server models with
 <p data-bbox="203 535 527 598"><i>Figure 11. FIO module type 3 + external LCD cable</i></p>	<ul data-bbox="625 241 909 273" style="list-style-type: none"> <li>• 4 x 3.5" front drive bays</li> </ul>
 <p data-bbox="203 1249 527 1312"><i>Figure 12. FIO module type 4 + integrated diagnostics panel</i></p>	<ul data-bbox="625 630 933 693" style="list-style-type: none"> <li>• 8 x 2.5" front drive bays</li> <li>• 16 EDSFF front drive bays</li> </ul>

## System-board-assembly layout

The illustrations in this section provide information about the layout, connectors and switches that are available on the system board assembly.

The following illustration shows the layout of the system board assembly which contains the Firmware and RoT security module, system I/O board, and processor board.

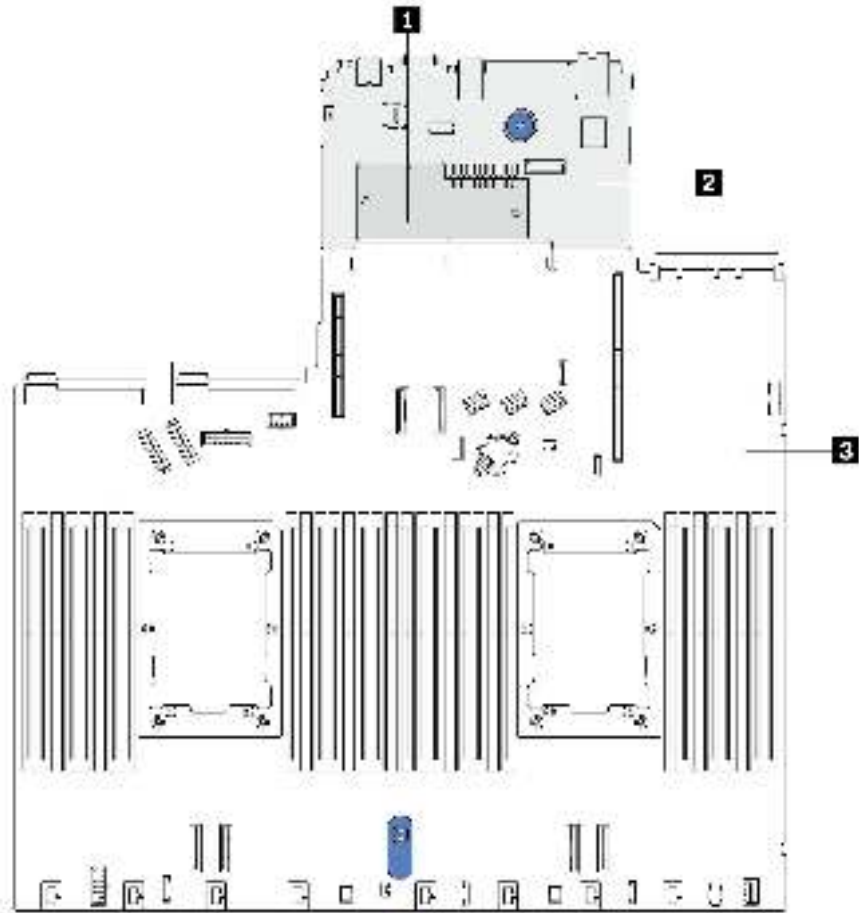


Figure 13. System-board-assembly layout

<b>1</b> Firmware and RoT Security Module	<b>2</b> System I/O board	<b>3</b> Processor board
---	---------------------------	--------------------------

For more information about the LEDs that are available on the system board assembly, see [“LEDs on the system board assembly”](#) on page 458.

## System-board-assembly connectors

The following illustrations show the internal connectors on the system board assembly.

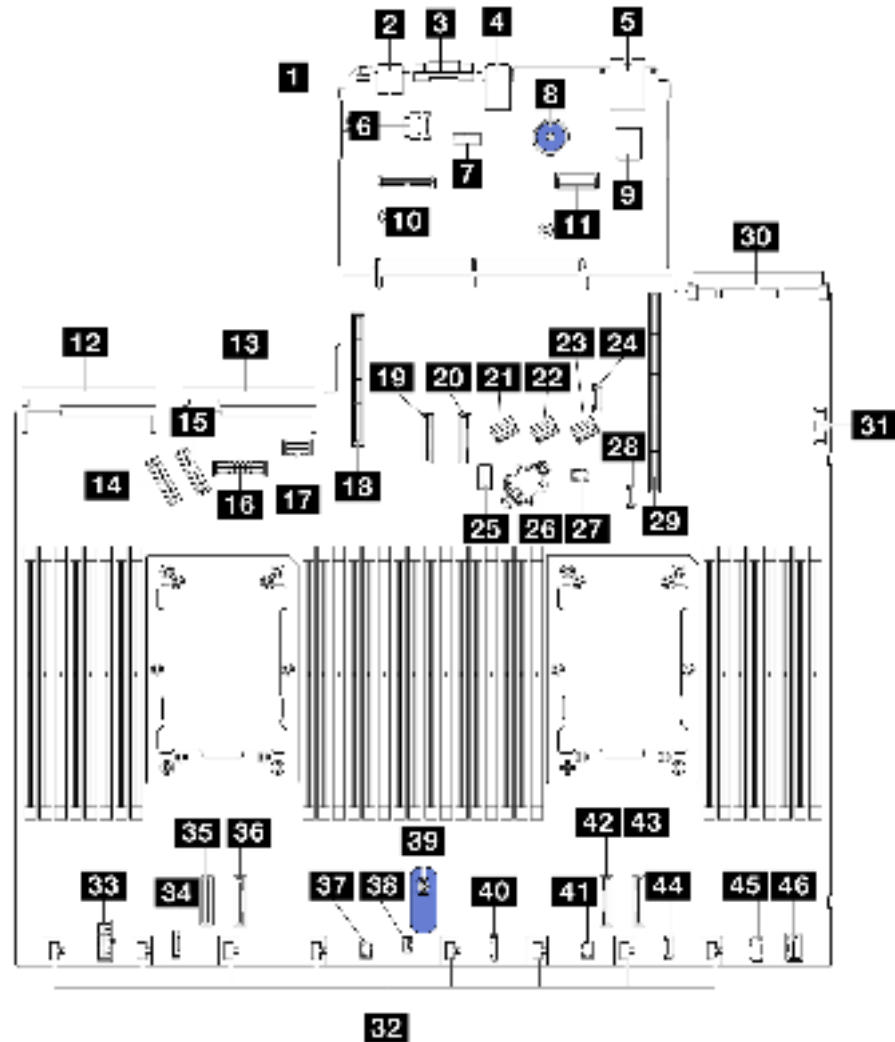


Figure 14. System-board-assembly connectors

Table 22. System-board-assembly connectors

<b>1</b> NMI button	<b>24</b> Rear backplane sideband connector
<b>2</b> Rear USB connector 1	<b>25</b> M.2/7mm backplane signal connector
<b>3</b> VGA connector	<b>26</b> CMOS battery socket
<b>4</b> Rear USB connector 2	<b>27</b> Pump 1 connector
<b>5</b> Management NIC connector	<b>28</b> Leak detection connector
<b>6</b> MicroSD card socket	<b>29</b> Riser 1 slot
<b>7</b> Serial port connector	<b>30</b> OCP 3.0 slot
<b>8</b> Plunger	<b>31</b> Front USB connector
<b>9</b> Internal USB connector	<b>32</b> Fan 1-8 connectors
<b>10</b> Firmware and RoT Security Module connector	<b>33</b> Internal RAID power connector
<b>11</b> Second management Ethernet connector	<b>34</b> CFF re-timer clock connector

Table 22. System-board-assembly connectors (continued)

<b>12</b> Power supply unit 1 connector	<b>35</b> PCIe connector 4
<b>13</b> Power supply unit 2 connector	<b>36</b> PCIe connector 3
<b>14</b> PCIe connector 5	<b>37</b> Pump 2 connector
<b>15</b> PCIe connector 6	<b>38</b> Intrusion switch connector
<b>16</b> Front backplane power connector	<b>39</b> System-board-assembly handle
<b>17</b> GPU and rear backplane power connector	<b>40</b> Front panel connector
<b>18</b> Riser 2 slot	<b>41</b> Front panel LCD connector
<b>19</b> PCIe connector 7	<b>42</b> PCIe connector 2
<b>20</b> PCIe connector 8	<b>43</b> PCIe connector 1
<b>21</b> SAS/SATA connector 0	<b>44</b> External LCD connector
<b>22</b> SAS/SATA connector 1	<b>45</b> M.2 power connector
<b>23</b> SAS/SATA connector 2	<b>46</b> Front VGA connector

## System-board-assembly switches

The following illustrations show the location of the switches on the server.

**Note:** If there is a clear protective sticker on the top of the switch blocks, you must remove and discard it to access the switches.

### Important:

- Before you change any switch settings or move any jumpers, turn off the server; then, disconnect all power cords and external cables. Review the following information:
  - [https://pubs.lenovo.com/safety\\_documentation/](https://pubs.lenovo.com/safety_documentation/)
  - “Installation Guidelines” on page 51
  - “Handling static-sensitive devices” on page 54
  - “Power off the server” on page 68
- Any system-board switch or jumper block that is not shown in the illustrations in this document are reserved.



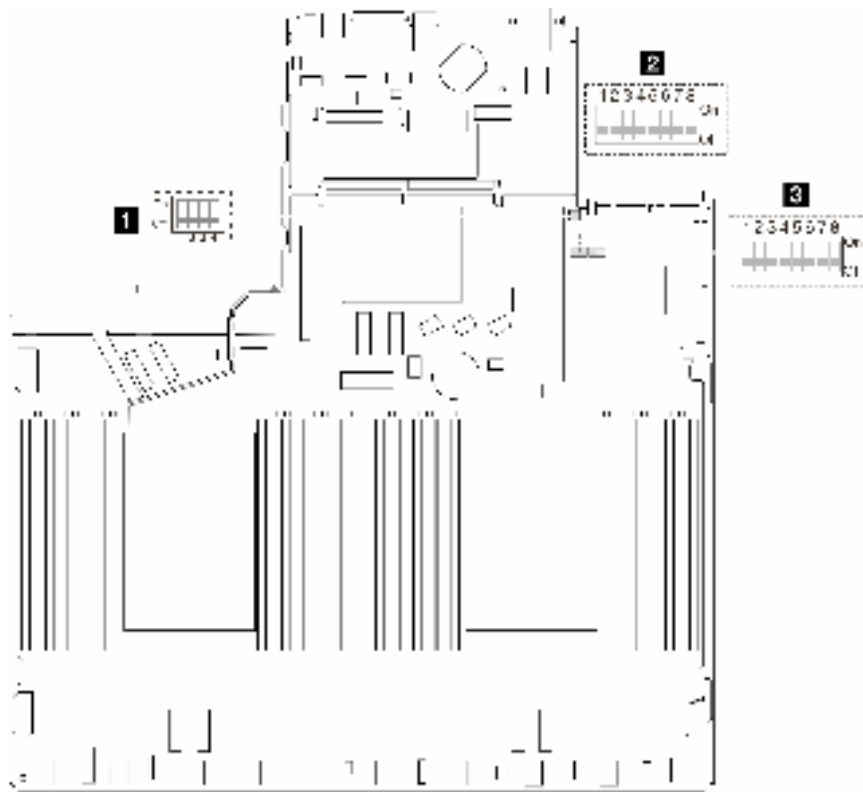


Figure 15. System-board-assembly switches

<b>1</b> “Switch 2 (SW2)” on page 39	<b>2</b> “Switch 7 (SW7)” on page 39	<b>3</b> “Switch 6 (SW6)” on page 40
--------------------------------------	--------------------------------------	--------------------------------------

### SW2 switch block

The following table describes the functions of the SW2 switch block on the system board assembly.

Table 23. SW2 switch block description

Switch-bit number	Switch name	Default position	Description
<b>1</b> SW2-1	FPGA reset	OFF	Forces FPGA into reset when switched to ON.
<b>2</b> SW2-2	Force BMC CPU reset	OFF	Forces BMC and CPU into reset when switched to ON.
<b>3</b> SW2-3	Reserved	OFF	Reserved
<b>4</b> SW2-4	BIOS image swap	OFF	Enables BIOS image swap when switched to ON.

### SW7 switch block

The following table describes the functions of the SW7 switch block on the system board assembly.

Table 24. SW7 switch block description

Switch-bit number	Switch name	Default position	Description
<b>1</b> SW7-1	XCC boot primary	OFF	XCC boots from upper half of flash region when switched to ON.
<b>2</b> SW7-2	XCC force update	OFF	XCC boots from kernel code only when switched to ON.
<b>3</b> SW7-3	Power permission override	OFF	Ignores Power Permission and allows system to power-on when switched to ON.
<b>4</b> SW7-4	Force XCC reset	OFF	Forces XCC into reset when switched to ON.
<b>5</b> SW7-5	Reserved	OFF	Reserved
<b>6</b> SW7-6	Reserved	OFF	Reserved
<b>7</b> SW7-7	Reserved	OFF	Reserved
<b>8</b> SW7-8	Reserved	OFF	Reserved

### SW6 switch block

The following table describes the functions of the SW6 switch block on the system board assembly.

Table 25. SW6 switch block description

Switch-bit number	Switch name	Default position	Description
<b>1</b> SW6-1	ME security override	OFF	Disables ME Security checks when switched to ON.
<b>2</b> SW6-2	Clear CMOS	OFF	Clears the real-time clock (RTC) registry when switched to ON.
<b>3</b> SW6-3	Password override	OFF	Overrides the power-on password when switched to ON.
<b>4</b> SW6-4	ME recovery	OFF	Boots ME into recovery mode when switched to ON.
<b>5</b> SW6-5	BIOS recovery	OFF	Boots BIOS into recovery mode when switched to ON.
<b>6</b> SW6-6	Reserved	OFF	Reserved
<b>7</b> SW6-7	Reserved	OFF	Reserved
<b>8</b> SW6-8	Reserved	OFF	Reserved

---

## System LEDs and diagnostics display

See the following section for information on available system LEDs and diagnostics display.

For more information, refer to [“Troubleshooting by system LEDs and diagnostics display”](#) on page 443.

## Chapter 3. Parts list

Identify each of the components that is available for your server with the parts list.

For more information about ordering parts:

1. Go to <http://datacentersupport.lenovo.com>, and enter the model name or machine type of your server in the search bar to navigate to the support page.
2. Click **Parts**.
3. Enter the serial number to view a listing of parts for your server.

It is highly recommended that you check the power summary data for your server using Lenovo Capacity Planner before purchasing any new parts.

**Note:** Depending on the model, your server might look slightly different from the illustration.

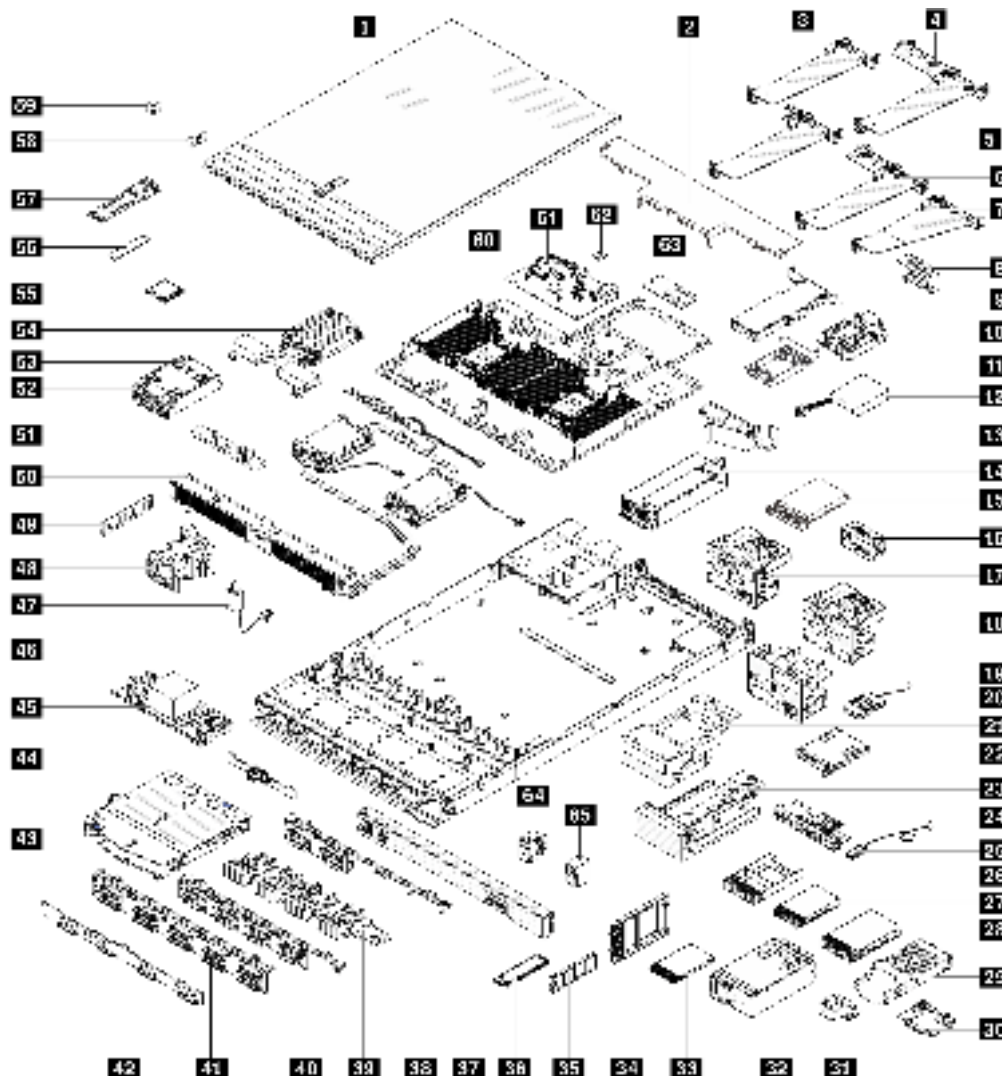


Figure 16. Server components

The parts listed in the following table are identified as one of the following:

- **Tier 1 customer replaceable unit (CRU):** Replacement of Tier 1 CRUs is your responsibility. If Lenovo installs a Tier 1 CRU at your request with no service agreement, you will be charged for the installation.
- **Tier 2 customer replaceable unit (CRU):** You may install a Tier 2 CRU yourself or request Lenovo to install it, at no additional charge, under the type of warranty service that is designated for your server.
- **Field replaceable unit (FRU):** FRUs must be installed only by trained service technicians.
- **Consumable and Structural parts:** Purchase and replacement of consumable and structural parts is your responsibility. If Lenovo acquires or installs a structural component at your request, you will be charged for the service.

Table 26. Parts list

Index	Description	Tier 1 CRU	Tier 2 CRU	FRU	Consumable and Structural part
For more information about ordering parts:					
1. Go to <a href="http://datacentersupport.lenovo.com">http://datacentersupport.lenovo.com</a> , and enter the model name or machine type of your server in the search bar to navigate to the support page.					
2. Click <b>Parts</b> .					
3. Enter the serial number to view a listing of parts for your server.					
<b>1</b>	Top cover	√			
<b>2</b>	Standard air baffle	√			
<b>3</b>	Riser bracket (low profile, LP)	√			
<b>4</b>	Riser bracket (low profile-full height, LP-FH)	√			
<b>5</b>	Riser bracket (low profile-filler, LP-filler)	√			
<b>6</b>	Riser bracket (low profile-low profile, LP-LP)	√			
<b>7</b>	Riser bracket (full height, FH)	√			
<b>8</b>	Rear wall bracket				√
<b>9</b>	PCIe adapter	√			
<b>10</b>	RAID flash power module holder (on chassis)	√			
<b>11</b>	RAID flash power module holder (in riser bracket)	√			
<b>12</b>	RAID flash power module	√			
<b>13</b>	Power supply unit air duct	√			
<b>14</b>	Power supply unit	√			
<b>15</b>	OCP module	√			
<b>16</b>	Power supply unit filler				√
<b>17</b>	Front I/O module with diagnostics panel (1)	√			
<b>18</b>	Front I/O module with diagnostics panel (2)	√			
<b>19</b>	Front I/O module (3)	√			
<b>20</b>	External diagnostics handset	√			

Table 26. Parts list (continued)

Index	Description	Tier 1 CRU	Tier 2 CRU	FRU	Consumable and Structural part
21	Integrated diagnostics panel assembly	√			
22	Integrated diagnostics panel	√			
23	M.2 cage		√		
24	Front I/O module with diagnostics panel (4)	√			
25	External LCD cable	√			
26	2.5-inch drive bay filler				√
27	2.5-inch drive	√			
28	3.5-inch drive	√			
29	7mm drive cage	√			
30	7mm drive backplane (bottom)		√		
31	7mm drive backplane (top)		√		
32	4-EDSFF cage	√			
33	7mm drive	√			
34	7mm drive bay filler				√
35	EDSFF drive bay filler				√
36	EDSFF drive	√			
37	Security bezel				√
38	4 x 2.5-inch front drive backplane	√			
39	16-EDSFF front drive backplane	√			
40	8 x 2.5-inch front drive backplane	√			
41	10 x 2.5-inch front drive backplane (AnyBay)		√		
	10 x 2.5-inch front drive backplane (6 x SAS/SATA + 4 x AnyBay)	√			
42	4 x 3.5-inch front drive backplane	√			
43	2 x 2.5-inch rear drive cage	√			
44	2 x 2.5-inch rear drive backplane	√			
45	Internal RAID adapter		√		
46	Chassis			√	
47	Intrusion switch	√			
48	System fan	√			
49	Memory module	√			
50	Liquid assisted cooling module			√	

Table 26. Parts list (continued)

Index	Description	Tier 1 CRU	Tier 2 CRU	FRU	Consumable and Structural part
51	Liquid detection sensor module holder	√			
52	Heat sink PEEK nut		√		
53	Standard heat sink			√	
54	Performance heat sink (T-shape)			√	
55	Processor			√	
56	M.2 drive	√			
57	M.2 PCIe x4 backplane	√			
58	M.2 retainer clip	√			
59	CMOS battery				√
60	Processor board			√	
61	System I/O board			√	
62	MicroSD card	√			
63	Firmware and RoT Security Module			√	
64	Rack latch (left)	√			
65	Rack latch (right)	√			

## Power cords

Several power cords are available, depending on the country and region where the server is installed.

To view the power cords that are available for the server:

1. Go to:  
<http://dcsc.lenovo.com/#/>
2. Click **Preconfigured Model** or **Configure to order**.
3. Enter the machine type and model for your server to display the configurator page.
4. Click **Power** → **Power Cables** to see all line cords.

### Notes:

- For your safety, a power cord with a grounded attachment plug is provided to use with this product. To avoid electrical shock, always use the power cord and plug with a properly grounded outlet.
- Power cords for this product that are used in the United States and Canada are listed by Underwriter's Laboratories (UL) and certified by the Canadian Standards Association (CSA).
- For units intended to be operated at 115 volts: Use a UL-listed and CSA-certified cord set consisting of a minimum 18 AWG, Type SVT or SJT, three-conductor cord, a maximum of 15 feet in length and a parallel blade, grounding-type attachment plug rated 15 amperes, 125 volts.

- For units intended to be operated at 230 volts (U.S. use): Use a UL-listed and CSA-certified cord set consisting of a minimum 18 AWG, Type SVT or SJT, three-conductor cord, a maximum of 15 feet in length and a tandem blade, grounding-type attachment plug rated 15 amperes, 250 volts.
- For units intended to be operated at 230 volts (outside the U.S.): Use a cord set with a grounding-type attachment plug. The cord set should have the appropriate safety approvals for the country in which the equipment will be installed.
- Power cords for a specific country or region are usually available only in that country or region.





---

## Chapter 4. Unboxing and setup

Information in this section assists you on unboxing and setting up the server. When unboxing the server, check if the items in the package are correct, and learn where to find information of server serial number and Lenovo XClarity Controller access. Make sure to follow the instructions in [“Server setup checklist” on page 49](#) when setting up the server.

---

### Server package contents

When you receive your server, verify that the shipment contains everything that you expected to receive.

The server package includes the following items:

- Server
- Rail installation kit\*. Installation guide is provided in the package.
- Cable management arm\*. Installation guide is provided in the package.
- Material box, including items such as power cords\*, accessory kit, and printed documents.

#### Notes:

- Some of the items listed are available on select models only.
- Items marked with asterisk(\*) are optional.

If any item is missing or damaged, contact your place of purchase. Ensure that you retain your proof of purchase and packing material. They might be required to receive warranty service.

---

### Identify the server and access the Lenovo XClarity Controller

This section contains instruction on how to identify your server and where to find the Lenovo XClarity Controller access information.

#### Identifying your server

When you contact Lenovo for help, the machine type, model, and serial number information help support technicians to identify your server and provide faster service.

The illustration below shows the location of the ID label which contains the model number, machine type, and serial number of the server.

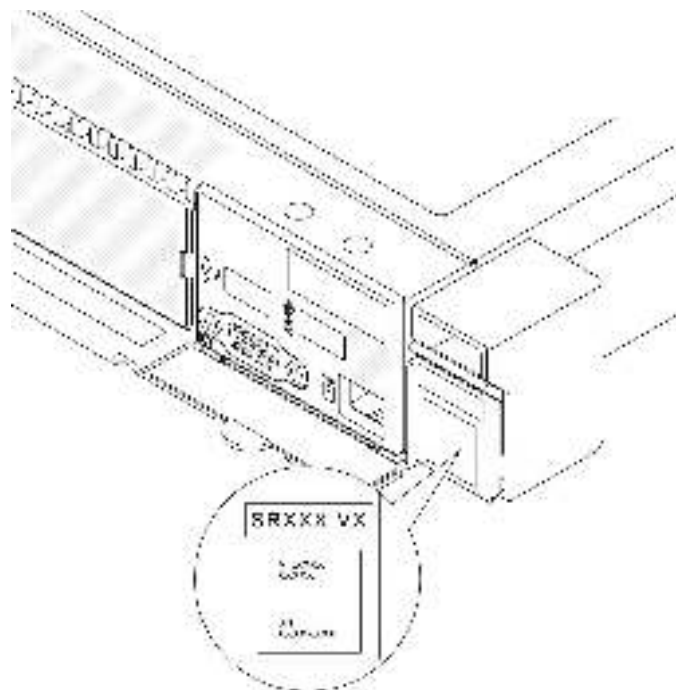


Figure 17. Location of the ID label

### Lenovo XClarity Controller network access label

In addition, the Lenovo XClarity Controller network access label is attached to the pull-out information tab in the front of the chassis, with MAC address accessible with a pull.

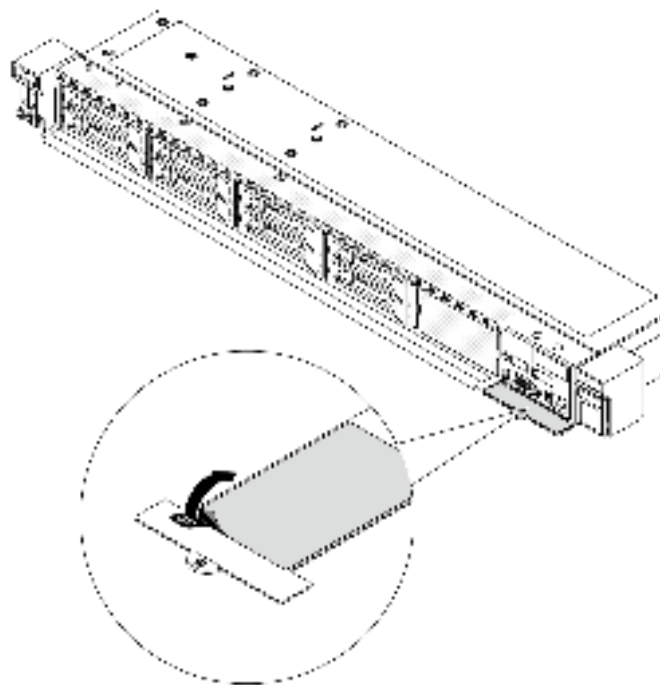


Figure 18. Lenovo XClarity Controller network access label on the pull-out information tab

## Service Label and QR code

In addition, the system Service Label is located on the surface of the top cover, providing a quick response (QR) code for mobile access to service information. You can scan the QR code with a mobile device using a QR code reader application and get quick access to the Service Information web page. The Service Information web page provides additional information for parts installation and replacement videos, and error codes for solution support.

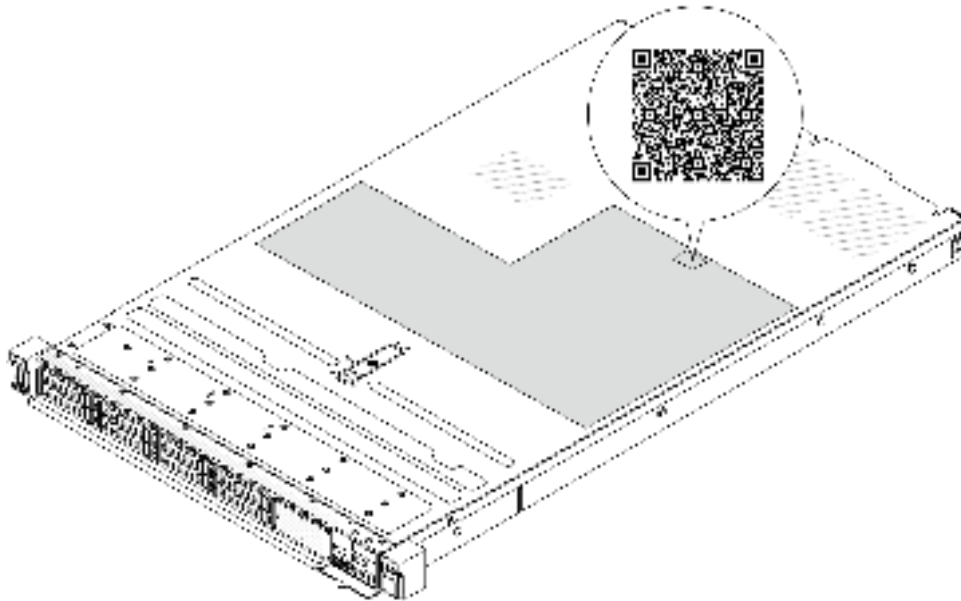


Figure 19. Service Label and QR code

---

## Server setup checklist

Use the server setup checklist to ensure that you have performed all tasks that are required to set up your server.

The server setup procedure varies depending on the configuration of the server when it was delivered. In some cases, the server is fully configured and you just need to connect the server to the network and an AC power source, and then you can power on the server. In other cases, the server needs to have hardware options installed, requires hardware and firmware configuration, and requires an operating system to be installed.

The following steps describe the general procedure for setting up a server.

### Setup the server hardware

Complete the following procedures to setup the server hardware.

1. Unpack the server package. See [“Server package contents” on page 47](#).
2. Install any required hardware or server options. See the related topics in [Chapter 5 “Hardware replacement procedures” on page 51](#).
3. If necessary, install the rail and CMA to a standard rack cabinet. Follow the instruction in *Rail Installation Guide* and *CMA Installation Guide* that comes with the rail installation kit.
4. If necessary, install the server into a standard rack cabinet. See [“Install the server to the rack” on page 72](#).

5. Connect all external cables to the server. See [Chapter 2 “Server components” on page 19](#) for connectors locations.

Typically, you will need to connect the following cables:

- Connect server to the power source
- Connect server to the data network
- Connect the server to the storage device
- Connect the server to the management network

6. Power on the server.

Power button location and power LED are specified in:

- [Chapter 2 “Server components” on page 19](#)
- [“Troubleshooting by system LEDs and diagnostics display” on page 443](#)

The server can be turned on (power LED on) in any of the following ways:

- You can press the power button.
- The server can restart automatically after a power interruption.
- The server can respond to remote power-on requests sent to the Lenovo XClarity Controller.

**Note:** You can access the management processor interface to configure the system without powering on the server. Whenever the server is connected to power, the management processor interface is available. For details about accessing the management server processor, see “Opening and Using the XClarity Controller Web Interface” section in the XCC documentation compatible with your server at [https://sysmgt.lenovofiles.com/help/topic/lxcc\\_frontend/lxcc\\_overview.html](https://sysmgt.lenovofiles.com/help/topic/lxcc_frontend/lxcc_overview.html).

7. Validate the server. Make sure that the power LED, Ethernet connector LED, and network LED are lit with green light, which means the server hardware was set up successfully.

See [“System LEDs and diagnostics display” on page 40](#) for more information on the LED indications.

## Configure the system

Complete the following procedures to configure the system. For detailed instructions, refer to [Chapter 7 “System configuration” on page 431](#).

1. Set the network connection for the Lenovo XClarity Controller to the management network.
2. Update the firmware for the server, if necessary.
3. Configure the firmware for the server.

The following information is available for RAID configuration:

- <https://lenovopress.lenovo.com/lp0578-lenovo-raid-introduction>
- <https://lenovopress.lenovo.com/lp0579-lenovo-raid-management-tools-and-resources>

4. Install the operating system.
5. Back up the server configuration.
6. Install the applications and programs that the server intends to use.

---

## Chapter 5. Hardware replacement procedures

This section provides installation and removal procedures for all serviceable system components.

---

### Installation Guidelines

Before installing components in your server, read the installation guidelines.

Before installing optional devices, read the following notices carefully:

**Attention:** By keeping static-sensitive components in their static-protective packages until installation, and handling these devices with an electrostatic-discharge wrist strap or other grounding system to prevent exposure to static electricity which might lead to system halt and loss of data.

- Read the safety information and guidelines to ensure your safety at work:
  - A complete list of safety information for all products is available at:  
[https://pubs.lenovo.com/safety\\_documentation/](https://pubs.lenovo.com/safety_documentation/)
  - The following guidelines are available as well: “Working inside the server with the power on” on page 54 and “Handling static-sensitive devices” on page 54.
- Make sure the components you are installing are supported by your server.
  - For a list of supported optional components for the server, see <https://serverproven.lenovo.com>.
  - For the option package contents, see <https://serveroption.lenovo.com/>.
- For more information about ordering parts:
  1. Go to <http://datacentersupport.lenovo.com>, and enter the model name or machine type of your server in the search bar to navigate to the support page.
  2. Click **Parts**.
  3. Enter the serial number to view a listing of parts for your server.
- When you install a new server, download and apply the latest firmware. This will help ensure that any known issues are addressed, and that your server is ready to work with optimal performance. Go to <https://datacentersupport.lenovo.com/products/servers/thinksystem/sr630v3/7d72/downloads/driver-list/> and download firmware updates for your server.

**Important:** Some cluster solutions require specific code levels or coordinated code updates. If the component is part of a cluster solution, verify that the latest Best Recipe code level menu for cluster supported firmware and driver before you update the code.

- If you replace a part, such as an adapter that contains firmware, you might also need to update the firmware for that part. For more information about updating firmware, See “Update the firmware” on page 433.
- It is good practice to make sure that the server is working normally before you install an optional component.
- Keep the working area clean, and place removed components on a flat and sturdy surface that does not shake or tilt.
- Do not attempt to lift an object that might be too heavy for you. If you have to lift a heavy object, read the following precautions carefully:
  - Make sure that you can stand steadily without slipping.
  - Distribute the weight of the object equally between your feet.

- Use a slow lifting force. Never move suddenly or twist when you lift a heavy object.
- To avoid straining the muscles in your back, lift by standing or by pushing up with your leg muscles.
- Back up all important data before you make changes related to the disk drives.
- Have a small flat-blade screwdriver, a small Phillips screwdriver, and a Torx T8 and a T30 screwdriver available.
- To view the error LEDs on the system board (system board assembly) and internal components, leave the power on.
- You do not have to turn off the server to remove or install hot-swap power supply units, hot swap fans, or hot-plug USB devices. However, you must turn off the server before you perform any steps that involve removing or installing adapter cables, and you must disconnect the power source from the server before you perform any steps that involve removing or installing a riser card.
- When replacing power supply units or fans, make sure to refer to redundancy rules for these components.
- Blue on a component indicates touch points, where you can grip to remove a component from or install it in the server, open or close a latch, and so on.
- Terra-cotta on a component or a terra-cotta label on or near a component indicates that the component can be hot-swapped if the server and operating system support hot-swap capability, which means that you can remove or install the component while the server is still running. (Terra-cotta can also indicate touch points on hot-swap components.) See the instructions for removing or installing a specific hot-swap component for any additional procedures that you might have to perform before you remove or install the component.
- The Red strip on the drives, adjacent to the release latch, indicates that the drive can be hot-swapped if the server and operating system support hot-swap capability. This means that you can remove or install the drive while the server is still running.

**Note:** See the system specific instructions for removing or installing a hot-swap drive for any additional procedures that you might need to perform before you remove or install the drive.

- After finishing working on the server, make sure that you reinstall all safety shields, guards, labels, and ground wires.

## Safety inspection checklist

Use the information in this section to identify potentially unsafe conditions with your server. As each machine was designed and built, required safety items were installed to protect users and service technicians from injury.

**Note:** The product is not suitable for use at visual display workplaces according to §2 of the Workplace Regulations.

**Note:** The set-up of the server is made in the server room only.

### CAUTION:

**This equipment must be installed or serviced by trained personnel, as defined by the NEC, IEC 62368-1 & IEC 60950-1, the standard for Safety of Electronic Equipment within the Field of Audio/Video, Information Technology and Communication Technology. Lenovo assumes that you are qualified in the servicing of equipment and trained in recognizing hazards energy levels in products. Access to the equipment is by the use of a tool, lock and key, or other means of security, and is controlled by the authority responsible for the location.**

**Important:** Electrical grounding of the server is required for operator safety and correct system function. Proper grounding of the electrical outlet can be verified by a certified electrician.

Use the following checklist to verify that there are no potentially unsafe conditions:

1. If your working condition necessitates the server being powered off or you intend to power off, make sure that the power cord is disconnected.

#### **S002**



#### **CAUTION:**

**The power-control button on the device and the power switch on the power supply do not turn off the electrical current supplied to the device. The device also might have more than one power cord. To remove all electrical current from the device, ensure that all power cords are disconnected from the power source.**

**Note:** Under certain circumstances, powering off the server is not a prerequisite. Refer to the precautions before conducting any tasks.

2. Check the power cord.
  - Make sure that the third-wire ground connector is in good condition. Use a meter to measure third-wire ground continuity for 0.1 ohm or less between the external ground pin and the frame ground.
  - Make sure that the power cord is the correct type.

To view the power cords that are available for the server:

    - a. Go to:  
<http://dcsc.lenovo.com/#/>
    - b. Click **Preconfigured Model** or **Configure to order**.
    - c. Enter the machine type and model for your server to display the configurator page.
    - d. Click **Power** → **Power Cables** to see all line cords.
  - Make sure that the insulation is not frayed or worn.
3. Check for any obvious non-Lenovo alterations. Use good judgment as to the safety of any non-Lenovo alterations.
4. Check inside the server for any obvious unsafe conditions, such as metal filings, contamination, water or other liquid, or signs of fire or smoke damage.
5. Check for worn, frayed, or pinched cables.
6. Make sure that the power-supply cover fasteners (screws or rivets) have not been removed or tampered with.

## **System reliability guidelines**

Review the system reliability guidelines to ensure proper system cooling and reliability.

Make sure the following requirements are met:

- When the server comes with redundant power, a power supply unit must be installed in each power-supply bay.
- Adequate space around the server must be spared to allow server cooling system to work properly. Leave approximately 50 mm (2.0 in.) of open space around the front and rear of the server. Do not place any object in front of the fans.
- For proper cooling and airflow, refit the server cover before you turn the power on. Do not operate the server for more than 30 minutes with the server cover removed, for it might damage server components.

- Cabling instructions that come with optional components must be followed.
- A failed fan must be replaced within 48 hours after malfunction.
- A removed hot-swap fan must be replaced within 30 seconds after removal.
- A removed hot-swap drive must be replaced within two minutes after removal.
- A removed hot-swap power supply unit must be replaced within two minutes after removal.
- Every air baffle that comes with the server must be installed when the server starts (some servers might come with more than one air baffle). Operating the server with a missing air baffle might damage the processor.
- All processor sockets must contain either a socket cover or a processor with heat sink.
- When more than one processor is installed, fan population rules for each server must be strictly followed.

## Working inside the server with the power on

You might need to keep the power on with the server cover removed to look at system information on the display panel or to replace hot-swap components. Review these guidelines before doing so.

**Attention:** The server might stop and data loss might occur when internal server components are exposed to static electricity. To avoid this potential problem, always use an electrostatic-discharge wrist strap or other grounding systems when working inside the server with the power on.

- Avoid loose-fitting clothing, particularly around your forearms. Button or roll up long sleeves before working inside the server.
- Prevent your necktie, scarf, badge rope, or hair from dangling into the server.
- Remove jewelry, such as bracelets, necklaces, rings, cuff links, and wrist watches.
- Remove items from your shirt pocket, such as pens and pencils, in case they fall into the server as you lean over it.
- Avoid dropping any metallic objects, such as paper clips, hairpins, and screws, into the server.

## Handling static-sensitive devices

Review these guidelines before you handle static-sensitive devices to reduce the possibility of damage from electrostatic discharge.

**Attention:** By keeping static-sensitive components in their static-protective packages until installation, and handling these devices with an electrostatic-discharge wrist strap or other grounding system to prevent exposure to static electricity which might lead to system halt and loss of data.

- Limit your movement to prevent building up static electricity around you.
- Take additional care when handling devices during cold weather, for heating would reduce indoor humidity and increase static electricity.
- Always use an electrostatic-discharge wrist strap or other grounding system, particularly when working inside the server with the power on.
- While the device is still in its static-protective package, touch it to an unpainted metal surface on the outside of the server for at least two seconds. This drains static electricity from the package and from your body.
- Remove the device from the package and install it directly into the server without putting it down. If it is necessary to put the device down, put it back into the static-protective package. Never place the device on the server or on any metal surface.
- When handling a device, carefully hold it by the edges or the frame.
- Do not touch solder joints, pins, or exposed circuitry.



- Keep the device from others' reach to prevent possible damages.

## Memory module installation rules and order

Memory modules must be installed in a specific order based on the memory configuration that you implement and the number of processors and memory modules installed in the server.

### Supported memory types

For information on the types of memory module supported by this server, see “Memory” section in [“Technical specifications” on page 4](#).

For a list of supported memory options, see <https://serverproven.lenovo.com>.

Information about optimizing memory performance and configuring memory is available at the Lenovo Press website:

<https://lenovopress.lenovo.com/servers/options/memory>

In addition, you can take advantage of a memory configurator, which is available at the following site:

[https://dcsc.lenovo.com/#/memory\\_configuration](https://dcsc.lenovo.com/#/memory_configuration)

Specific information about the required installation order of memory modules in your server based on the system configuration and memory mode that you are implementing is shown below.

### Memory modules and processors layout

The following illustration helps you to locate the memory module slots on the processor board. The memory-channel identification table below shows the relationship between the processors, memory controllers, memory channels, and memory module slot numbers.

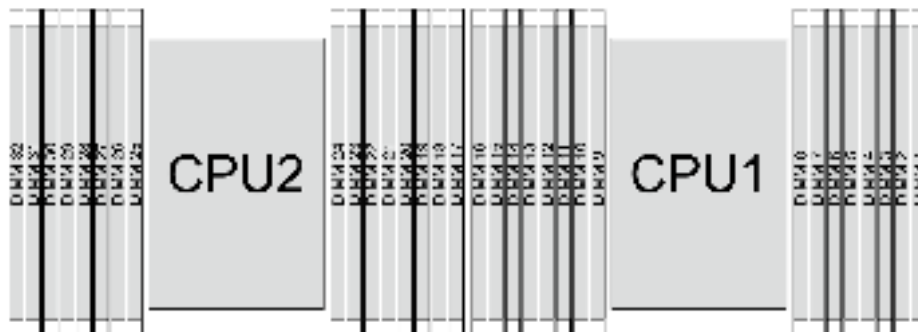


Figure 20. Memory module slots on the processor board

Table 27. Memory slot and channel identification

Processor	CPU 1															
Controller	iMC3				iMC2				iMC0				iMC1			
Channel	CH1		CH0		CH1		CH0		CH0		CH1		CH0		CH1	
Slot No.	0	1	0	1	0	1	0	1	1	0	1	0	1	0	1	0
DIMM No.	16	15	14	13	12	11	10	9	8	7	6	5	4	3	2	1
Processor	CPU 2															

Table 27. Memory slot and channel identification (continued)

Controller	iMC3				iMC2				iMC0				iMC1			
Channel	CH1		CH0		CH1		CH0		CH0		CH1		CH0		CH1	
Slot No.	0	1	0	1	0	1	0	1	1	0	1	0	1	0	1	0
DIMM No.	32	31	30	29	28	27	26	25	24	23	22	21	20	19	18	17

- Slot No.: DIMM slot number in each memory channel. Each memory channel has two DIMM slots: slot 0 (further from the processor) and slot 1 (closer to the processor).
- DIMM No.: DIMM slot number on the processor board. Each processor has 16 DIMM slots.

**Memory module installation guideline**

- For the installation rules and population sequence, see [“DDR5 DIMMs installation order” on page 58](#).
- At least one DIMM is required for each processor. Install at least eight DIMMs per processor for good performance.
- When you replace a DIMM, the server provides automatic DIMM enablement capability without requiring you to use the Setup Utility to enable the new DIMM manually.

## DDR5 DIMMs installation order

This section contains information of how to install DDR5 DIMMs properly.

### RDIMMs and 3DS RDIMMs installation order

For RDIMMs, 10x4 RDIMMs and 3DS RDIMMs, the following two memory modes are available. For 9x4 RDIMMs, only independent mode is available.

#### Independent mode installation order

In independent mode, memory channels can be populated with DIMMs in any order and you can populate all channels for each processor in any order with no matching requirements. Independent mode provides the highest level of memory performance, but lacks failover protection. The DIMM installation order for independent mode varies based on the number of processors and memory modules installed in the server.

#### Independent mode installation rules

Follow the rules below when installing memory modules in independent mode:

- There should be at least one DDR5 DIMM per processor.
- All DDR5 memory modules must operate at the same speed in the same system.
- Memory population must be identical between processors.
- Memory modules from different vendors are supported.
- In each memory channel, populate the slot farthest from the processor (slot 0) first.
- All DIMMs must be all DDR5 DIMMs.
- x8 DIMMs and x4 DIMMs cannot be mixed in a system.
- All memory modules to be installed must be of the same type.
  - 9x4 RDIMM cannot be mixed with non-9x4 RDIMMs in a system.
  - 3DS RDIMM cannot be mixed with non-3DS RDIMMs in a system.
- All memory modules in a system must have the same number of ranks, except for below conditions:
  - Single-rank RDIMMs can be mixed with dual-rank RDIMMs when there are 16 DIMMs populated for each processor.
  - Quad-rank 3DS RDIMMs can be mixed with octal-rank 3DS RDIMMs when there are 16 DIMMs populated for each processor.

**Note:** System hang on POST may occur on a server operating in this configuration. In this case, contact Lenovo service to replace the failed DIMM for proper operation.

- See [“Independent mode with mixing rank” on page 60](#) for more information on the installation sequence when installing memory modules with different ranks.

The following table shows the sequence of populating memory modules for independent mode when only one processor (processor 1) is installed.

Table 28. Independent mode with one processor

Total DIMMs	Processor 1															
	16	15	14	13	12	11	10	9	8	7	6	5	4	3	2	1
1 DIMM										7						
2 DIMMs <sup>1</sup>			14							7						
4 DIMMs <sup>1</sup>			14				10			7				3		
6 DIMMs <sup>1</sup>			14		12		10			7				3		1

Table 28. Independent mode with one processor (continued)

8 DIMMs <sup>1,2</sup>	16		14		12		10			7		5		3		1	
12 DIMMs <sup>1</sup>	16		14	13	12		10	9		8	7		5	4	3		1
16 DIMMs <sup>1,2,3</sup>	16	15	14	13	12	11	10	9		8	7	6	5	4	3	2	1

**Notes:**

1. DIMM configurations that support Sub NUMA Clustering (SNC), which can be enabled via UEFI. SNC is not supported if DIMM population does not follow the sequence indicated by the table above.
2. DIMM configurations that support Software Guard Extensions (SGX). See [“Enable Software Guard Extensions \(SGX\)” on page 437](#) to enable this feature.
3. Rank mixing is supported between single-rank and dual-rank RDIMMs, or between quad-rank and octal-rank 3DS RDIMMs when there are 16 DIMMs populated for each processor. See [“Independent mode with mixing rank” on page 60](#) for more information on the installation sequence when installing memory modules with different ranks.

The following table shows the sequence of populating memory modules for independent mode when two processors (processor 1 and processor 2) are installed.

Table 29. Independent mode with two processors

Total DIMMs	Processor 1																
	16	15	14	13	12	11	10	9	8	7	6	5	4	3	2	1	
2 DIMMs										7							
4 DIMMs <sup>1</sup>			14							7							
8 DIMMs <sup>1</sup>			14				10			7				3			
12 DIMMs <sup>1</sup>			14		12		10			7				3		1	
16 DIMMs <sup>1,2</sup>	16		14		12		10			7		5		3		1	
24 DIMMs <sup>1</sup>	16		14	13	12		10	9		8	7		5	4	3		1
32 DIMMs <sup>1,2,3</sup>	16	15	14	13	12	11	10	9		8	7	6	5	4	3	2	1
Total DIMMs	Processor 2																
	32	31	30	29	28	27	26	25	24	23	22	21	20	19	18	17	
2 DIMMs										23							
4 DIMMs <sup>1</sup>			30							23							
8 DIMMs <sup>1</sup>			30				26			23				19			
12 DIMMs <sup>1</sup>			30		28		26			23				19		17	
16 DIMMs <sup>1,2</sup>	32		30		28		26			23		21		19		17	
24 DIMMs <sup>1</sup>	32		30	29	28		26	25		24	23		21	20	19		17
32 DIMMs <sup>1,2,3</sup>	32	31	30	29	28	27	26	25		24	23	22	21	20	19	18	17

**Notes:**

1. DIMM configurations that support Sub NUMA Clustering (SNC), which can be enabled via UEFI. SNC is not supported if DIMM population does not follow the sequence indicated by the table above.
2. DIMM configurations that support Software Guard Extensions (SGX). See [“Enable Software Guard Extensions \(SGX\)” on page 437](#) to enable this feature.
3. Rank mixing is supported between single-rank and dual-rank RDIMMs, or between quad-rank and octal-rank 3DS RDIMMs when there are 16 DIMMs populated for each processor. See [“Independent mode with mixing rank” on page 60](#) for more information on the installation sequence when installing memory modules with different ranks.

### ***Independent mode with mixing rank***

Follow the memory module installation sequence in this section when installing memory modules with different ranks in independent mode.

### **DIMM slot installation sequence for one processor**

When installing DIMMs with different ranks with only one processor (processor 1) installed, follow the sequence below and install higher rank DIMMs first; then, install the lower rank DIMMs into the remaining slots.

Table 30. DIMM slot installation sequence for one processor

Processor 1																
DIMM slot	16	15	14	13	12	11	10	9	8	7	6	5	4	3	2	1
Sequence	8	16	7	15	4	12	3	11	9	1	10	2	13	5	14	6

### **DIMM slot installation sequence for two processors**

When installing DIMMs with different ranks with two processors (processor 1 and processor 2) installed, follow the sequence below and install higher rank DIMMs first; then, install the lower rank DIMMs into the remaining slots.

Table 31. DIMM slot installation sequence for two processors

Processor 1																
DIMM slot	16	15	14	13	12	11	10	9	8	7	6	5	4	3	2	1
Sequence	15	31	13	29	7	23	5	21	17	1	19	3	25	9	27	11
Processor 2																
DIMM slot	32	31	30	29	28	27	26	25	24	23	22	21	20	19	18	17
Sequence	16	32	14	30	8	24	6	22	18	2	20	4	26	10	28	12

### **Mirroring mode installation order**

Mirroring mode provides full memory redundancy while reducing the total system memory capacity in half. Memory channels are grouped in pairs with each channel receiving the same data. If a failure occurs, the memory controller switches from the DIMMs on the primary channel to the DIMMs on the backup channel. The DIMM installation order for memory mirroring varies based on the number of processors and DIMMs installed in the server.

In mirroring mode, each memory module in a pair must be identical in size and architecture. The channels are grouped in pairs with each channel receiving the same data. One channel is used as a backup of the other, which provides redundancy.

Follow the rules below when installing memory modules in mirroring mode:

- All memory modules to be installed must be of the same type with the same capacity, frequency, voltage, and ranks.
- Mirroring can be configured across channels in the same iMC, and the total TruDDR5 memory size of the primary and secondary channels must be the same.
- 9x4 RDIMMs do not support mirroring mode.
- Partial Memory Mirroring is a sub-function of memory mirroring. It requires to follow the memory population for memory mirroring.

The following table shows the memory module population sequence for mirroring mode when only one processor (processor 1) is installed.

Table 32. Mirroring mode with one processor (processor 1)

Configura- tion	DIMM slots															
	16	15	14	13	12	11	10	9	8	7	6	5	4	3	2	1
8 DIMMs	16		14		12		10			7		5		3		1
16 DIMMs	16	15	14	13	12	11	10	9	8	7	6	5	4	3	2	1

**Note:** DIMM configurations listed in the table support the Sub NUMA Clustering (SNC) feature, which can be enabled via UEFI. SNC is not supported if DIMM population does not follow the sequence indicated by the table above.

The following table shows the memory module population sequence for mirroring mode when two processors (processor 1 and processor 2) are installed.

Table 33. Mirroring mode with two processors (processor 1 and processor 2)

Configura- tion	DIMM slots															
	16	15	14	13	12	11	10	9	8	7	6	5	4	3	2	1
16 DIMMs	16		14		12		10			7		5		3		1
32 DIMMs	16	15	14	13	12	11	10	9	8	7	6	5	4	3	2	1
Configura- tion	DIMM slots															
	32	31	30	29	28	27	26	25	24	23	22	21	20	19	18	17
16 DIMMs	32		30		28		26			23		21		19		17
32 DIMMs	32	31	30	29	28	27	26	25	24	23	22	21	20	19	18	17

**Note:** DIMM configurations listed in the table support the Sub NUMA Clustering (SNC) feature, which can be enabled via UEFI. SNC is not supported if DIMM population does not follow the sequence indicated by the table above.

## Technical rules







Refer to the below technical rules and limitations when you install the related server components.

## PCIe slots and adapters

Understanding the technical rules for PCIe adapters helps you correctly install and configure PCIe adapters in the system.

## PCIe adapters supported for different models

Table 34. PCIe adapters supported and locations

Server rear view	Supported types and slot location
	<p><b>Riser 1 assembly</b></p> <ul style="list-style-type: none"> <li>Slot 1: PCIe x16 (x8, x4, x1), low-profile</li> <li>Slot 2: PCIe x16 (x8, x4, x1), low-profile</li> </ul> <p><b>Riser 2 assembly</b></p> <ul style="list-style-type: none"> <li>Slot 3: PCIe x16 (x8, x4, x1), low-profile</li> </ul>
	<p><b>Riser 1 assembly</b></p> <ul style="list-style-type: none"> <li>Slot 1: PCIe x16 (x8, x4, x1), low-profile</li> <li>Slot 2: PCIe x16 (x8, x4, x1), full-height</li> </ul> <p><b>Note:</b> One rear wall bracket must be installed next to the two PCIe slots.</p>
	<p><b>Riser 1 assembly</b></p> <ul style="list-style-type: none"> <li>Slot 1: PCIe x16 (x8, x4, x1), low-profile</li> <li>Slot 2: PCIe x16 (x8, x4, x1), low-profile</li> </ul>
	<p><b>Riser 1 assembly</b></p> <ul style="list-style-type: none"> <li>Slot 1: PCIe x16 (x8, x4, x1), low-profile</li> </ul>
	<p><b>Riser 1 assembly</b></p> <ul style="list-style-type: none"> <li>Slot 1: PCIe x16 (x8, x4, x1), low-profile</li> </ul>
	<p><b>Riser 1 assembly</b></p> <ul style="list-style-type: none"> <li>Slot 1: PCIe x16 (x8, x4, x1), low-profile</li> </ul> <p><b>Riser 2 assembly</b></p> <ul style="list-style-type: none"> <li>Slot 3: PCIe x16 (x8, x4, x1), full-height</li> </ul>

To locate the PCIe slots, see [“Rear view” on page 26](#).

## PCIe adapter installation rules and order

When installing different types of PCIe adapters, refer to the following suggested installation priority:

Table 35. Recommended installation priority for different types of PCIe adapters

Installation priority	
1. OCP module	7. InfiniBand adapter
2. Custom form factor (CFF) internal HBA/RAID adapter	8. Fiber channel adapter
3. Standard form factor (SFF) RAID adapter	9. Network adapter
4. SFF internal HBA adapter	10. NVMe PCIe flash adapter



Table 35. Recommended installation priority for different types of PCIe adapters (continued)

Installation priority	
5. Re-timer adapter	11. External storage controller
6. GPU adapter	12. COM port bracket

When installing a specific PCIe adapter, refer to the following suggested slot installation priority:

Table 36. Recommended slot installation priority for PCIe adapters

Recommended slot installation priority	PCIe adapters
<b>Slot 1</b>	<ul style="list-style-type: none"> <li>SFF HBA/RAID adapter</li> <li>ThinkSystem x16 Gen 4.0 Re-timer adapter (for 4 x NVMe)</li> <li>ThinkSystem x16 Gen 5.0 Re-timer adapter</li> </ul> <p><b>Note:</b> The RAID/HBA 4350/5350/9350-8i adapters are supported only in the server configuration with 4 x 3.5-inch SAS/SATA front bays or 8 x 2.5-inch SAS/SATA front drive bays.</p>
<b>Slot 2 (configured as a full-height slot)</b>	<ul style="list-style-type: none"> <li>ThinkSystem Broadcom 57504 10/25GbE SFP28 4-Port PCIe Ethernet Adapter</li> <li>ThinkSystem Intel E810-DA4 10/25GbE SFP28 4-Port PCIe Ethernet Adapter</li> </ul> <p><b>Note:</b> Both Broadcom 57504 PCIe Ethernet adapter and Intel E810-DA4 PCIe Ethernet adapter can be installed to slot 2 or slot 3.</p>
<b>Slot 1 &gt; Slot 3 &gt; Slot 2</b>	<ul style="list-style-type: none"> <li>ThinkSystem Mellanox ConnectX-6 HDR100 IB/100GbE VPI 1-port x16 PCIe 3.0 HCA</li> <li>ThinkSystem Mellanox ConnectX-6 HDR100 IB/100GbE VPI 2-port x16 PCIe 3.0 HCA</li> <li>ThinkSystem Mellanox ConnectX-6 Dx 100GbE QSFP56 2-port PCIe Ethernet Adapter</li> <li>ThinkSystem NVIDIA ConnectX-7 NDR400 OSFP 1-port PCIe Gen5 Adapter</li> <li>ThinkSystem NVIDIA ConnectX-7 NDR200/HDR QSFP112 2-port PCIe Gen5 x16 InfiniBand Adapter</li> <li>ThinkSystem NVIDIA A2 16GB PCIe Gen4 Passive GPU</li> <li>ThinkSystem NVIDIA A2 16GB PCIe Gen4 Passive GPU w/o CEC</li> </ul>
<b>Slot 2 &gt; Slot 3</b>	A COM port upgrade kit needs to be installed in slot 2 or 3 as a normal PCIe adapter. In this case, a riser and a bracket are needed.
<b>Slot 1 &gt; Slot 2 &gt; Slot 3</b>	<p>Other PCIe adapters not mentioned above.</p> <p><b>Notes:</b></p> <ul style="list-style-type: none"> <li>For Mellanox ConnectX-6 HDR IB/200GbE Single Port x16 PCIe Adapter, refer to the following slot priority depending on the quantity of adapters to be installed: <ul style="list-style-type: none"> <li>Two adapters: slot 1, slot 3 or slot 2, slot 3</li> <li>Three adapters: slot 1, slot 2, slot 3</li> </ul> </li> <li>The RAID/HBA 4350/5350/9350-8i/16i adapters and the Intel E810-DA2 OCP adapter or the Intel E810-DA2 PCIe adapter cannot be installed in the same system.</li> </ul>

**Note:** The RAID 940-8i or RAID 940-16i adapter supports Tri-mode. When Tri-mode is enabled, the server supports SAS, SATA and U.3 NVMe drives at the same time. NVMe drives are connected via a PCIe x1 link to the controller.

To support Tri-mode with U.3 NVMe drives, **U.3 x1 mode** must be enabled for the selected drive slots on the backplane through the XCC Web GUI. Otherwise, the U.3 NVMe drives cannot be detected. For more information, see [“U.3 NVMe drive can be detected in NVMe connection, but cannot be detected in Tri-mode” on page 469](#).

The virtual RAID on CPU (VROC) key and Tri-mode are not supported at the same time.

#### Notes:

1. PCIe adapters that can be installed to **LP-LP** riser bracket only:
  - ThinkSystem Broadcom 5719 1GbE RJ45 4-Port PCIe Ethernet Adapter
  - ThinkSystem Intel I350-T4 PCIe 1Gb 4-Port RJ45 Ethernet Adapter
  - ThinkSystem QLogic QL41134 PCIe 10Gb 4-Port Base-T Ethernet Adapter
  - ThinkSystem Intel I350-T4 ML2 1Gb 4-Port RJ45 Ethernet Adapter
  - ThinkSystem Broadcom 57454 10GBASE-T 4-port PCIe Ethernet Adapter
2. PCIe adapters that can be installed to **FH** riser bracket only:
  - ThinkSystem Broadcom 57454 10/25GbE SFP28 4-port PCIe Ethernet Adapter\_Refresh
  - ThinkSystem Broadcom 57504 10/25GbE SFP28 4-port PCIe Ethernet Adapter

## Technical rules for drives

Understanding the technical rules for drives helps you correctly install and configure drives in the system.

### Drive installation rules

The following rules for drives provide information that you must consider when you install a drive.

#### General rules

1. The drive bays are numbered to indicate the installation order (starting from number “0”). Follow the installation order when you install a drive. See [“Front view” on page 19](#).
2. The drives in a single RAID array must be of the same type (as in hard disk drives, solid-state drives, and so on), same size, and same capacity.
3. If your server comes with rear drives, always install the rear backplane first. The drive installation should be rear drive bay 16 → 17, and then front drive bay 0 → 1 → 2 → 3 → 4 → 5 → 6 → 7 → 8 → 9.
4. The installation order of different drive interface types: NVMe → SAS → SATA.
5. For EDSFF drives, follow the numerical order of the drive bay sequence. Do not skip bays when installing EDSFF drives.

#### Mixing rules

1. You can use drives from different vendors.
2. You can mix drives of different types and different capacities in one system, but not in one RAID array. And when you deploy a drive mix, install drives of lower capacity first.
3. You can install a 2.5-inch solid-state/SAS/SATA drive in a 3.5-inch hard disk drive bay.
4. When mixing NVMe/SAS/SATA drives in one system, install NVMe drives in a descending bay sequence order, 9 → 8 → 7...; and SAS/SATA drives in an ascending bay sequence order, 0 → 1 → 2....
5. Mixing EDSFF, U.2 or U.3 drives in one RAID array is not supported.

#### Special notes

1. For the server models with a single type or mixed types of drives, take 10 x 2.5" AnyBay drives for instance:

- The installation order of a single type of drives (SAS/SATA/NVMe) should be: front drive bay 0 → 1 → 2 → 3 → 4 → 5 → 6 → 7 → 8 → 9.
  - The installation order of mixed types of drives should be: SAS/SATA installed from front drive bay 0 → 1 → 2..., and NVMe installed from front drive bay 9 → 8 → 7 → 6 → 5 → 4 → 3 → 2 → 1 → 0.
2. For the server models with rear drives installed, take 8 x 2.5" SAS/SATA front drives and 2 x 2.5" SAS/SATA rear drives for instance:
- Drives can be installed to rear drive bay 16 → 17 first, and then front drive bay 0 → 1 → 2 → 3 → 4 → 5 → 6 → 7.

## Thermal rules

This topic provides thermal rules for the server.

- [“Server models with front drive bays only” on page 65](#)
- [“Server models with front and rear drive bays” on page 66](#)
- [“Server models with GPU\(s\)” on page 66](#)
- [“Server models with liquid assisted cooling module” on page 67](#)

### Server models with front drive bays only

This section provides thermal information for server models with front drive bays only.

Configuration	<ul style="list-style-type: none"> <li>• 4 x 2.5" SAS/SATA</li> <li>• 4 x 2.5" NVMe</li> <li>• 4 x 3.5" SAS/SATA</li> <li>• 4 x 3.5" AnyBay</li> <li>• 6 x SAS/SATA + 2 x AnyBay + 2 x NVMe</li> <li>• 6 x SAS/SATA + 4 x AnyBay</li> <li>• 8 x 2.5" SAS/SATA</li> <li>• 10 x 2.5" SAS/SATA</li> </ul>			<ul style="list-style-type: none"> <li>• 4 x 2.5" SAS/SATA</li> <li>• 4 x 2.5" NVMe</li> </ul>	
Max. Ambient Temp. (at sea level)	45°C	35°C		30°C	
CPU TDP <sup>1</sup> (watts)	TDP ≤ 165	165 < TDP < 205	TDP = 205	205 < TDP ≤ 300	300 < TDP ≤ 350
Heat sink	Standard	Standard	T-shape	T-shape	T-shape
Air baffle	√	√	x	x	x
Fan type	Standard	Performance	Performance	Performance	Performance
Max. DIMM Qty. <sup>2</sup>	32	32	32	32	32

Configuration	<ul style="list-style-type: none"> <li>• 8 x 2.5" AnyBay drives with one processor</li> <li>• 8 x 2.5" U.2 drives with one processor</li> <li>• 10 x 2.5" AnyBay</li> <li>• 10 x 2.5" NVMe</li> <li>• 16-EDSFF</li> </ul>				
Max. Ambient Temp. (at sea level)	35°C			30°C	
CPU TDP <sup>1</sup> (watts)	TDP ≤ 165	165 < TDP < 205	TDP = 205	205 < TDP ≤ 300	
Heat sink	Standard	Standard	T-shape	T-shape	
Air baffle	√	√	x	x	

Fan type	Performance	Performance	Performance	Performance
Max. DIMM Qty. <sup>2</sup>	32	32	32	32

**Notes:**

1. TDP, short for Thermal Design Power. When processor 6434/6434H-195W installed, use the T-shape heat sink and performance fans.
2. When a 256 GB 3DS RDIMM is installed, the ambient temperature must be limited to 30°C or lower and performance fans are required.

**Server models with front and rear drive bays**

This section provides thermal information for server models with front and rear drive bays.

Configuration	<ul style="list-style-type: none"> <li>• 4 x 2.5" SAS/SATA</li> <li>• 4 x 2.5" NVMe</li> <li>• 4 x 3.5" SAS/SATA</li> <li>• 4 x 3.5" AnyBay</li> <li>• 6 x SAS/SATA + 2 x AnyBay + 2 x NVMe</li> <li>• 6 x SAS/SATA + 4 x AnyBay</li> <li>• 8 x 2.5" SAS/SATA</li> <li>• 8 x 2.5" AnyBay drives with one processor</li> <li>• 8 x 2.5" U.2 drives with one processor</li> <li>• 10 x 2.5" SAS/SATA</li> <li>• 10 x 2.5" AnyBay</li> <li>• 10 x 2.5" NVMe</li> <li>• Rear 2 x 2.5" SAS/SATA<sup>1</sup></li> <li>• Rear 2 x 2.5" U.2<sup>1</sup></li> <li>• Rear 2 x 2.5" U.3<sup>1</sup></li> </ul>		
Max. Ambient Temp. (at sea level)	35°C with rear SAS/SATA drives 30°C with rear U.2/U.3 drives		
CPU TDP <sup>2</sup> (watts)	TDP ≤ 165	165 < TDP < 205	TDP = 205
Heat sink	Standard	Standard	T-shape
Air baffle	√	√	x
Fan type	Performance	Performance	Performance
Max. DIMM Qty. <sup>3</sup>	32	32	32

**Notes:**

1. In the configuration of 10 x 2.5" AnyBay or 10 x 2.5" NVMe, rear U.2 or U.3 is supported, but rear SAS/SATA is not supported.
2. TDP, short for Thermal Design Power. When processor 6434/6434H-195W installed, use the T-shape heat sink and performance fans.
3. The 256 GB 3DS RDIMMs are not supported.

**Server models with GPU(s)**

This section provides thermal information for server models with GPUs.

GPUs supported:

- NVIDIA® A2
- NVIDIA® L4

Configuration	<ul style="list-style-type: none"> <li>• 4 x 2.5" SAS/SATA</li> <li>• 4 x 2.5" NVMe</li> <li>• 4 x 3.5" SAS/SATA</li> <li>• 4 x 3.5" AnyBay</li> <li>• 6 x SAS/SATA + 2 x AnyBay + 2 x NVMe</li> <li>• 6 x SAS/SATA + 4 x AnyBay</li> <li>• 8 x 2.5" SAS/SATA</li> <li>• 8 x 2.5" AnyBay drives with one processor</li> <li>• 8 x 2.5" U.2 drives with one processor</li> <li>• 10 x 2.5" SAS/SATA</li> <li>• 10 x 2.5" AnyBay</li> <li>• 10 x 2.5" NVMe</li> </ul>					<ul style="list-style-type: none"> <li>• 4 x 2.5" SAS/SATA</li> <li>• 4 x 2.5" NVMe</li> </ul>
Max. Ambient Temp. (at sea level)	30°C					
CPU TDP <sup>1</sup> (watts)	TDP ≤ 165	165 < TDP < 205	TDP = 205	205 < TDP ≤ 250	250 < TDP ≤ 300	
Heat sink	Standard	Standard	T-shape	T-shape	T-shape	
Air baffle	√	√	x	x	x	
Fan type	Performance	Performance	Performance	Performance	Performance	
Max GPU Qty	3	3	3	3	3	
Max. DIMM Qty.	32	32	32	32	32	

**Notes:**

1. TDP, short for Thermal Design Power. When processor 6434/6434H-195W installed, use the T-shape heat sink and performance fans.

**Server models with liquid assisted cooling module**

This section provides thermal information for server models installed with the Liquid Assisted Cooling Module (LACM).

Configuration	<ul style="list-style-type: none"> <li>• 6 x SAS/SATA + 2 x AnyBay + 2 x NVMe</li> <li>• 6 x SAS/SATA + 4 x AnyBay</li> <li>• 8 x 2.5" SAS/SATA</li> <li>• 8 x 2.5" U.2 drives with one processor</li> <li>• 10 x 2.5" SAS/SATA</li> <li>• 10 x 2.5" NVMe</li> </ul>					
Max. Ambient Temp. (at sea level)	25°C					
CPU TDP (watts)	300 ≤ TDP ≤ 350					
Heat sink	Liquid assisted cooling module					
Air baffle	x					
Fan type	Performance					
Max. DIMM Qty. <sup>1</sup>	32					

**Notes:**

1. The 256 GB 3DS RDIMMs are not supported.

Use performance fans when your server is installed with any of the following adapters:

- ThinkSystem Broadcom 57454 10GBASE-T 4-port OCP Ethernet Adapter

- ThinkSystem Broadcom 57508 100GbE QSFP56 2-Port OCP Ethernet Adapter
- ThinkSystem Broadcom 57508 100GbE QSFP56 2-port PCIe 4 Ethernet Adapter

Use performance fans and the ambient temperature must be limited to 30°C or lower when your server is installed with any of the following adapters:

**Note:** The ambient temperature must be limited to 30°C or lower when 100/200 GB NIC adapters with active transceivers and fiber cables installed; and 35°C or lower when the adapters use passive copper cables.

- ThinkSystem Broadcom 57508 100GbE QSFP56 2-port PCIe 4 Ethernet Adapter V2 with Active Fiber cables
- ThinkSystem Mellanox ConnectX-6 HDR100 IB/100GbE VPI 1-port x16 PCIe 3.0 HCA
- ThinkSystem Mellanox ConnectX-6 HDR100 IB/100GbE VPI 2-port x16 PCIe 3.0 HCA
- ThinkSystem Mellanox ConnectX-6 HDR IB/200GbE Single Port x16 PCIe Adapter
- ThinkSystem Mellanox ConnectX-6 Dx 100GbE QSFP56 2-port PCIe Ethernet Adapter
- ThinkSystem Mellanox ConnectX-6 Dx 100GbE QSFP56 1-port PCIe Ethernet Adapter
- ThinkSystem NVIDIA ConnectX-7 NDR400 OSFP 1-port PCIe Gen5 Adapter
- ThinkSystem Nvidia ConnectX-7 NDR200/HDR QSFP112 2-port PCIe Gen5 x16 InfiniBand Adapter

---

## Power on and power off the server

Follow the instructions in this section to power on and power off the server.

### Power on the server

After the server performs a short self-test (power status LED flashes quickly) when connected to input power, it enters a standby state (power status LED flashes once per second).

Power button location and power LED are specified in:

- [Chapter 2 “Server components” on page 19](#)
- [“Troubleshooting by system LEDs and diagnostics display” on page 443](#)

The server can be turned on (power LED on) in any of the following ways:

- You can press the power button.
- The server can restart automatically after a power interruption.
- The server can respond to remote power-on requests sent to the Lenovo XClarity Controller.

For information about powering off the server, see [“Power off the server” on page 68](#).

### Power off the server

The server remains in a standby state when it is connected to a power source, allowing the Lenovo XClarity Controller to respond to remote power-on requests. To remove all power from the server (power status LED off), you must disconnect all power cables.

Power button location and power LED are specified in:

- [Chapter 2 “Server components” on page 19](#)
- [“Troubleshooting by system LEDs and diagnostics display” on page 443](#)

To place the server in a standby state (power status LED flashes once per second):

**Note:** The Lenovo XClarity Controller can place the server in a standby state as an automatic response to a critical system failure.

- Start an orderly shutdown using the operating system (if supported by your operating system).
- Press the power button to start an orderly shutdown (if supported by your operating system).
- Press and hold the power button for more than 4 seconds to force a shutdown.

When in a standby state, the server can respond to remote power-on requests sent to the Lenovo XClarity Controller. For information about powering on the server, see [“Power on the server” on page 68](#).

---

## Server replacement

Follow instructions in this section to remove and install the server.

### Remove the server from the rack

Follow instructions in this section to remove the server from the rack.

#### S036



18 - 32 kg (39 - 70 lb)



32 - 55 kg (70 - 121 lb)

**CAUTION:**  
Use safe practices when lifting.

#### R006



**CAUTION:**  
Do not place any object on top of a rack-mounted device unless that rack-mounted device is intended for use as a shelf.

**CAUTION:**

- Potential stability hazards exist. The rack might tip over and cause serious personal injury.
- Before extending the rack to the installation position, read the [“Installation Guidelines” on page 51](#). Do not put any load on the slide-rail mounted equipment in the installation position. Do not leave the slide-rail mounted equipment in the installation position.

### About this task

**Attention:**

- Read [“Installation Guidelines” on page 51](#) and [“Safety inspection checklist” on page 52](#) to ensure that you work safely.

- Power off the server and peripheral devices and disconnect the power cords and all external cables. See [“Power off the server” on page 68](#).
- Prevent exposure to static electricity, which might lead to system halt and loss of data, by keeping static-sensitive components in their static-protective packages until installation, and handling these devices with an electrostatic-discharge wrist strap or other grounding systems.

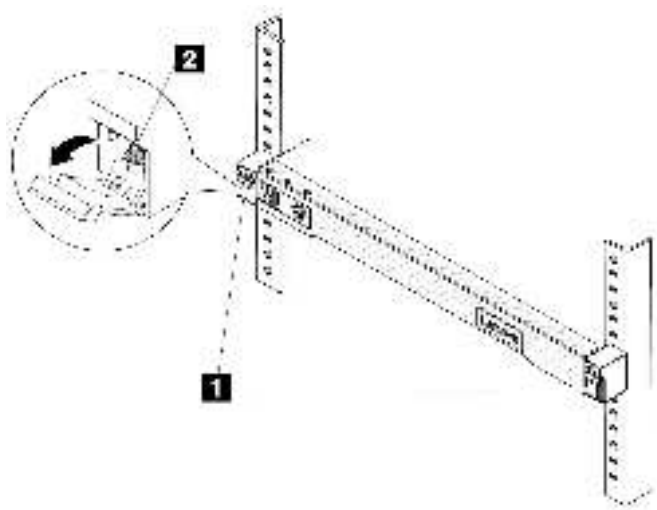
**CAUTION:**

**Make sure to have three people operate the server removal procedures to prevent injury.**

**Procedure**

Step 1. Loosen the two **2** thumbscrews located on the **1** rack latches to disengage it from the rack.

## Rack front



*Figure 21. Disengaging server from the rack*

Step 2. Hold the **1** mounting ears on the front of the server; then, slide the server all the way out until it stops.



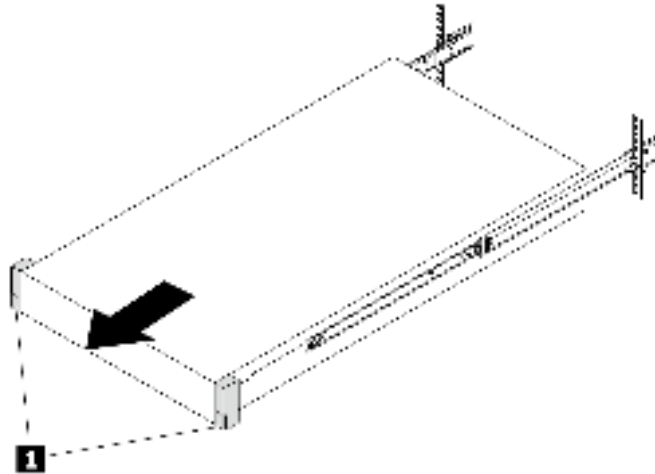


Figure 22. Pulling out the server

Step 3. Remove the server from the rack.

**CAUTION:**

Make sure three people are lifting the sever by holding the **1** lift points.

## Rack front

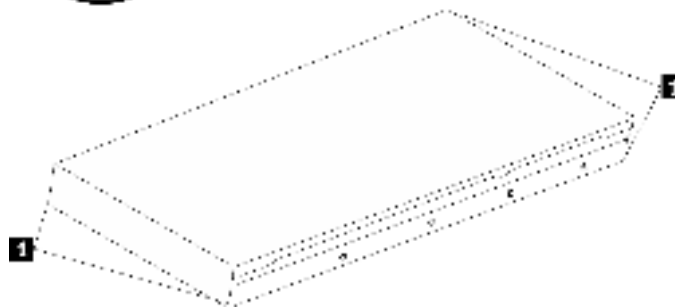


Figure 23. Lifting up the server

# Rack Front

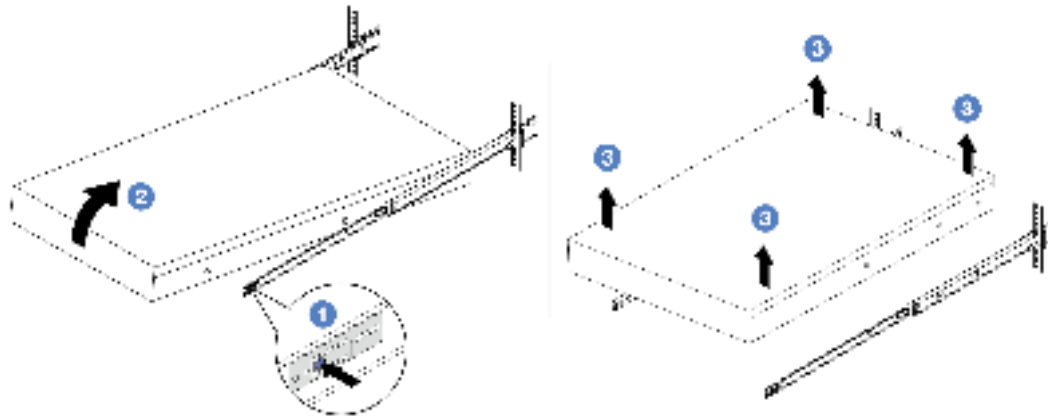


Figure 24. Removing the server from the rack.

- 1 Press the release tabs to disengage the rails from the server.
- 2 Carefully lift up the front end of the server slightly to detach the nailheads from the slots on the rails.
- 3 With three people, lift up the server to remove it from the rails completely. Place the server on a flat and sturdy surface.

## After you finish

Carefully lay the server on a flat, static-protective surface.

## Install the server to the rack

Follow instructions in this section to install the server to the rack.

### S036



18 - 32 kg (39 - 70 lb)



32 - 55 kg (70 - 121 lb)

**CAUTION:**  
Use safe practices when lifting.

### R006



**CAUTION:**

**Do not place any object on top of a rack-mounted device unless that rack-mounted device is intended for use as a shelf.**

**CAUTION:**

- **Potential stability hazards exist. The rack might tip over and cause serious personal injury.**
- **Before extending the rack to the installation position, read the [“Installation Guidelines” on page 51](#). Do not put any load on the slide-rail mounted equipment in the installation position. Do not leave the slide-rail mounted equipment in the installation position.**

## About this task

**Attention:**

- Read [“Installation Guidelines” on page 51](#) and [“Safety inspection checklist” on page 52](#) to ensure that you work safely.
- Power off the server and peripheral devices and disconnect the power cords and all external cables. See [“Power off the server” on page 68](#).
- Prevent exposure to static electricity, which might lead to system halt and loss of data, by keeping static-sensitive components in their static-protective packages until installation, and handling these devices with an electrostatic-discharge wrist strap or other grounding systems.

**CAUTION:**

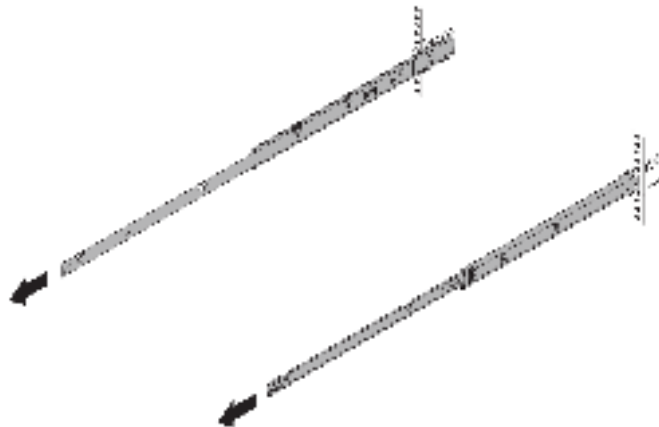
**Make sure to have three people operate the server installation procedures to prevent injury.**

## Procedure

Step 1. From the front of the rack, pull the rails all the way out until they stop.

**Attention:** You can only install the server successfully when the rails are fully extended.

## Rack front



*Figure 25. Pulling out the rails*

Step 2. Carefully lift up the server with three people.

**CAUTION:**

Make sure three people are lifting the sever by holding the **1** lift points.

## Rack front

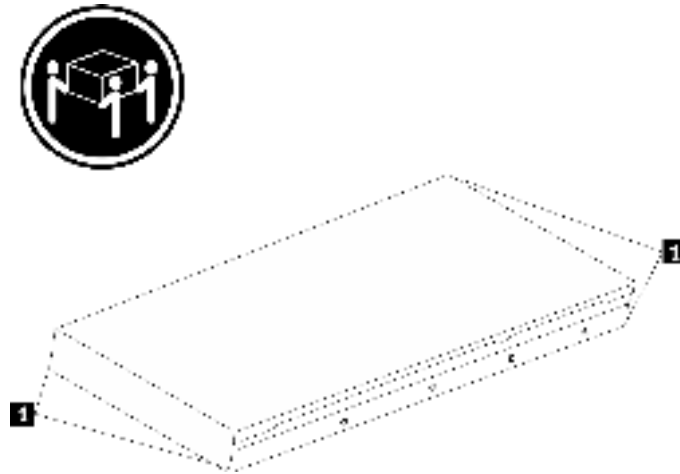
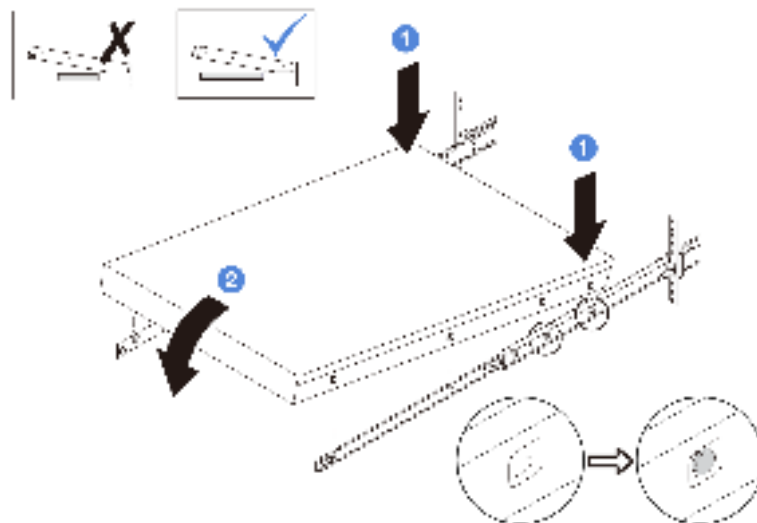


Figure 26. Lifting up the server

Step 3. From the front of the rack, install server into the rails.

**Attention:** You can only install the server successfully when the rails are fully extended.



- 1** Tilt the server and slowly lower the its rear end; then, push the rails toward the server and make sure the farthest nailheads on server's left and right side go into the slots on the rail.
- 2** Slowly lower the server down and make sure the other 3 nailheads on server's left and right side slip into corresponding slots.

Step 4. Slide the server into rack.

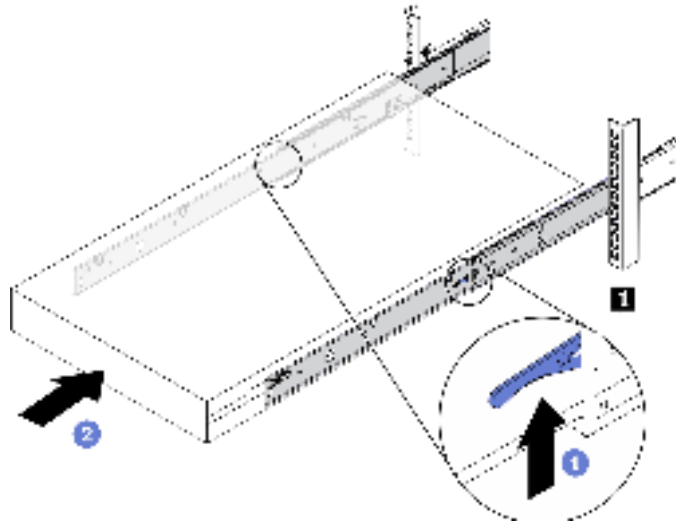


Figure 27. Installing the server into the rack

- a. **1** Push up the **1** latches on the rails.
- b. **2** Push the server all the way into the rack until both latches lock into position with a click.

Step 5. (Optional) Secure the server to the rack.

- a. Install one M6 screw to each of the rails to secure the server to the rear of the rack.

## Rack rear

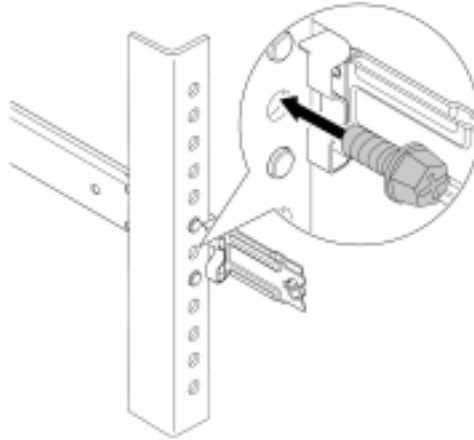


Figure 28. Securing the server to the rear of the rack

- b. Secure the server to the front of the rack. Fasten the two **2** thumbscrews located on the **1** rack latches.

## Rack front

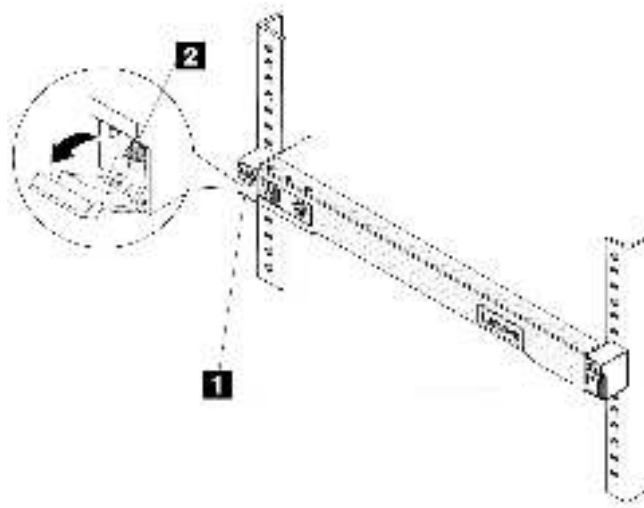


Figure 29. Securing the server to the front of the rack

### After you finish

1. Reconnect the power cords and any cables that you removed.
2. Power on the server and any peripheral devices. See [“Power on the server” on page 68.](#)
3. Update the server configuration. See [“Complete the parts replacement” on page 246.](#)

---

## Air baffle replacement

Follow instructions in this section to remove and install the air baffle.

**Note:** Air baffles are unavailable when the performance heat sink or the liquid assisted cooling module is installed.

### Remove the air baffle

Follow instructions in this section to remove the air baffle.

#### About this task

Depending on the model, your server might not have an air baffle installed. The air baffle you want to remove might be different from following illustrations, but the removal method is the same.

#### S033



**CAUTION:**

**Hazardous energy present. Voltages with hazardous energy might cause heating when shorted with metal, which might result in spattered metal, burns, or both.**

#### S017



**CAUTION:**

**Hazardous moving fan blades nearby. Keep fingers and other body parts away.**

**Attention:**

- Read “[Installation Guidelines](#)” on page 51 and “[Safety inspection checklist](#)” on page 52 to ensure that you work safely.
- Power off the server and peripheral devices and disconnect the power cords and all external cables. See “[Power off the server](#)” on page 68.
- Prevent exposure to static electricity, which might lead to system halt and loss of data, by keeping static-sensitive components in their static-protective packages until installation, and handling these devices with an electrostatic-discharge wrist strap or other grounding systems.
- If you intend to install memory modules in the server, you must first remove the air baffle from the server.

#### Watch the procedure

A video of this procedure is available on YouTube: <https://www.youtube.com/playlist?list=PLYV5R7hVcs-CfNsWy-689CRZHExrZEI9I>.

#### Procedure

- Step 1. Remove the top cover. See [“Remove the top cover”](#) on page 243.
- Step 2. If there is a RAID flash power module installed on the back side of the air baffle, disconnect the RAID flash power module cable first.
- Step 3. Grasp the air baffle and carefully lift it out of the server.

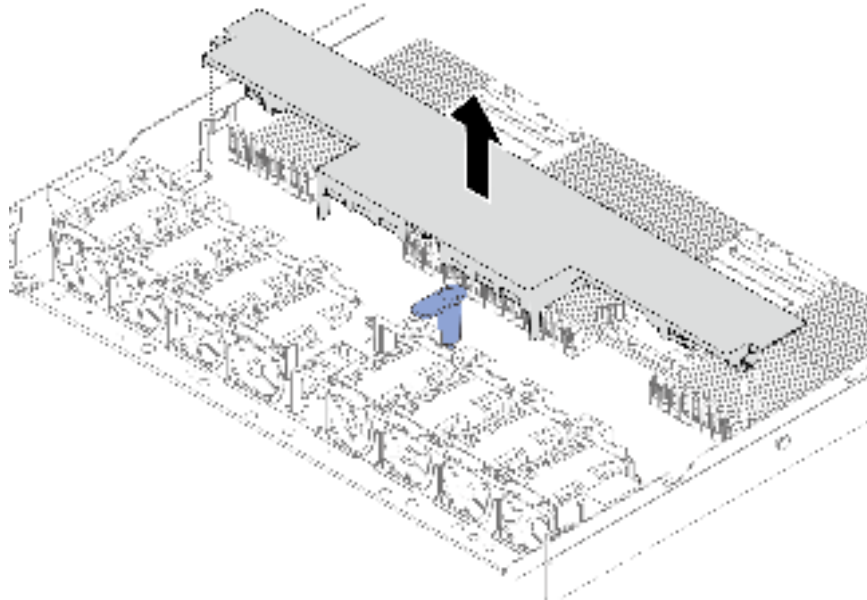


Figure 30. Air baffle removal

**Attention:** Operating the server with the air baffle removed might damage server components. For proper cooling and airflow, install the air baffle before you power on the server.

## After you finish

If you are instructed to return the component or optional device, follow all packaging instructions, and use any packaging materials for shipping that are supplied to you.

## Install the air baffle

Follow instructions in this section to install the air baffle.

## About this task

Depending on the model, your server might not have an air baffle installed. The air baffle you want to install might be different from following illustrations, but the installation method is the same.

### S033



#### **CAUTION:**

**Hazardous energy present. Voltages with hazardous energy might cause heating when shorted with metal, which might result in spattered metal, burns, or both.**



## S017



### CAUTION:

Hazardous moving fan blades nearby. Keep fingers and other body parts away.

### Attention:

- Read “Installation Guidelines” on page 51 and “Safety inspection checklist” on page 52 to ensure that you work safely.
- Power off the server and peripheral devices and disconnect the power cords and all external cables. See “Power off the server” on page 68.
- Prevent exposure to static electricity, which might lead to system halt and loss of data, by keeping static-sensitive components in their static-protective packages until installation, and handling these devices with an electrostatic-discharge wrist strap or other grounding systems.

### Watch the procedure

A video of this procedure is available on YouTube: <https://www.youtube.com/playlist?list=PLYV5R7hVcs-CfNsWy-689CRZHExrZEi9l>.

### Procedure

- Step 1. If you need to install a RAID flash power module on the back side of the air baffle, install it first. See “Install the RAID flash power module on the air baffle” on page 195.
- Step 2. Align the clips on the air baffle to the sockets on the cable walls.

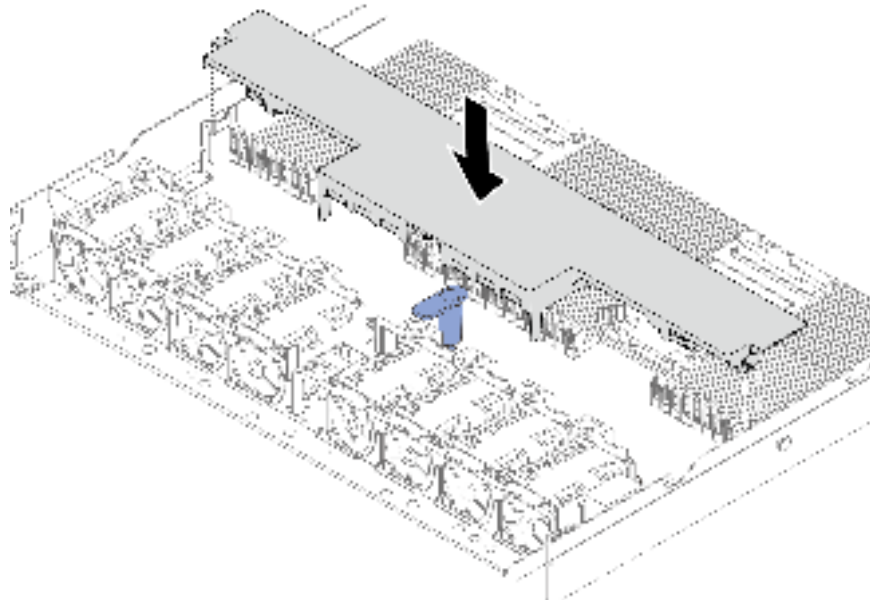


Figure 31. Air baffle installation

- Step 3. Lower the air baffle into the chassis and press the air baffle down until it is securely seated.

## After you finish

Complete the parts replacement. See [“Complete the parts replacement” on page 246](#).

---

## Backplane replacement

Use this information to remove and install a backplane.

### Remove the front 2.5-inch drive backplane

Use this information to remove the backplane for four, eight, or ten 2.5-inch hot-swap drives.

#### About this task

The following describes how to remove the backplane for ten 2.5-inch hot-swap drives. You can remove the backplane for four or eight 2.5-inch hot-swap drives in the same way.

#### Attention:

- Read [“Installation Guidelines” on page 51](#) and [“Safety inspection checklist” on page 52](#) to ensure that you work safely.
- Power off the server and peripheral devices and disconnect the power cords and all external cables. See [“Power off the server” on page 68](#).
- Prevent exposure to static electricity, which might lead to system halt and loss of data, by keeping static-sensitive components in their static-protective packages until installation, and handling these devices with an electrostatic-discharge wrist strap or other grounding systems.

#### Procedure

- Step 1. Remove the top cover. See [“Remove the top cover” on page 243](#).
- Step 2. Remove all the installed drives and drive fillers from the drive bays. See [“Remove a 2.5/3.5-inch hot-swap drive” on page 115](#).
- Step 3. Disconnect the cables from the backplane. See [Chapter 6 “Internal cable routing” on page 249](#). If the cable connectors come with protective dust caps, make sure to put them back on.

Step 4. Grasp the backplane and carefully lift it out of the chassis.

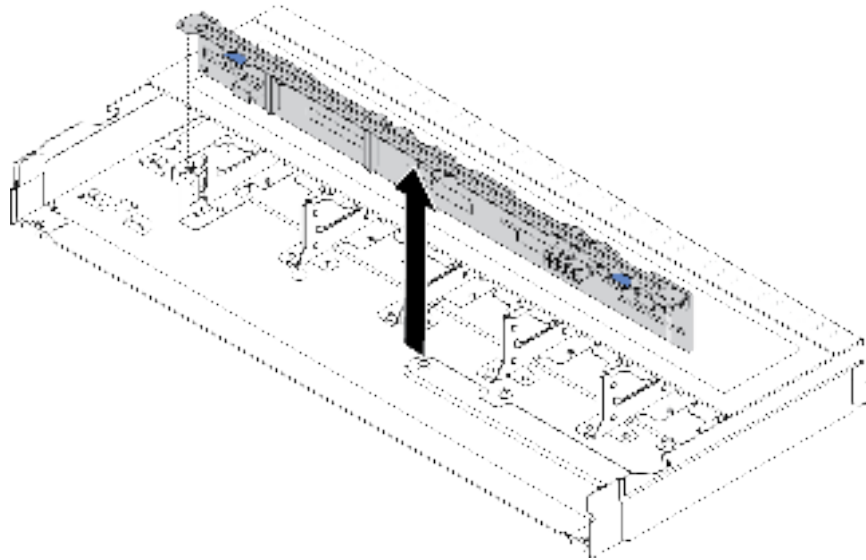


Figure 32. Removal of backplane for ten 2.5-inch hot-swap drives

## After you finish

If you are instructed to return the component or optional device, follow all packaging instructions, and use any packaging materials for shipping that are supplied to you.

### Demo video

[Watch the procedure on YouTube](#)

## Install the front 2.5-inch drive backplane

Use this information to install the backplane for four, eight, or ten 2.5-inch hot-swap drives.

### About this task

The following describes how to install the backplane for ten 2.5-inch hot-swap drives. You can install the backplane for four or eight 2.5-inch hot-swap drives in the same way.

#### Attention:

- Read [“Installation Guidelines” on page 51](#) and [“Safety inspection checklist” on page 52](#) to ensure that you work safely.
- Power off the server and peripheral devices and disconnect the power cords and all external cables. See [“Power off the server” on page 68](#).
- Prevent exposure to static electricity, which might lead to system halt and loss of data, by keeping static-sensitive components in their static-protective packages until installation, and handling these devices with an electrostatic-discharge wrist strap or other grounding systems.

## Procedure

- Step 1. Touch the static-protective package that contains the backplane to any unpainted surface on the outside of the server. And then, take the backplane out of the package and place it on a static-protective surface.
- Step 2. Align the two pins on the backplane with the corresponding holes in the chassis.

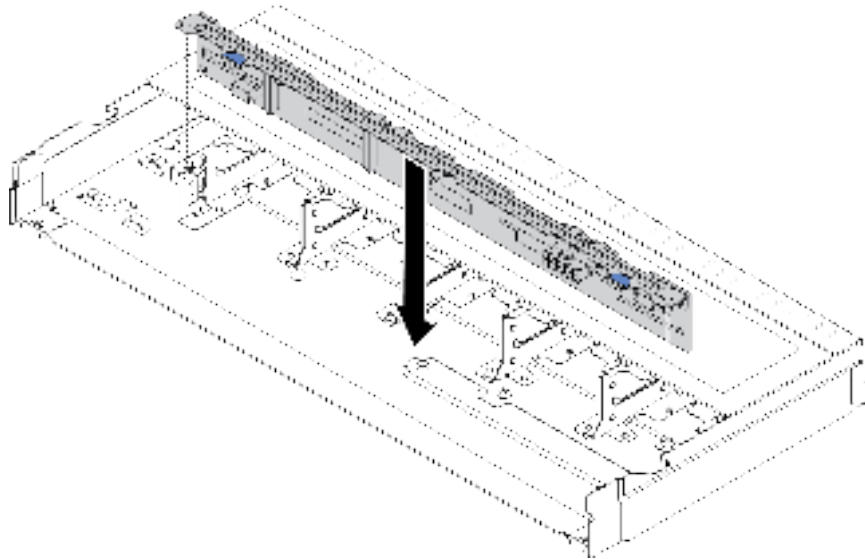


Figure 33. Installation of backplane for ten 2.5-inch hot-swap drives

- Step 3. Lower the backplane into the chassis. Ensure that the pins pass through the holes and the backplane is fully seated in place.
- Step 4. Connect the cables to the system board assembly and the backplane. See [Chapter 6 “Internal cable routing” on page 249](#). If the cable connectors come with protective dust caps, make sure to remove them before plugging in.

## After you finish

1. Reinstall all the drives and drive fillers into the drive bays. See [“Install a 2.5/3.5-inch hot-swap drive” on page 117](#).
2. Complete the parts replacement. See [“Complete the parts replacement” on page 246](#).

## Demo video

[Watch the procedure on YouTube](#)

## Remove the front 3.5-inch drive backplane

Use this information to remove the front 3.5-inch drive backplane.

## About this task

### Attention:

- Read [“Installation Guidelines” on page 51](#) and [“Safety inspection checklist” on page 52](#) to ensure that you work safely.
- Power off the server and peripheral devices and disconnect the power cords and all external cables. See [“Power off the server” on page 68](#).

- Prevent exposure to static electricity, which might lead to system halt and loss of data, by keeping static-sensitive components in their static-protective packages until installation, and handling these devices with an electrostatic-discharge wrist strap or other grounding systems.

### Watch the procedure

A video of this procedure is available on YouTube: <https://www.youtube.com/playlist?list=PLYV5R7hVcs-CfNsWy-689CRZHExrZEi9I>.

### Procedure

**Note:** Depending on the specific type, your backplane might look different from the illustration in this topic.

Step 1. Prepare your server.

- Remove the top cover. See “Remove the top cover” on page 243.
- Remove the system fan cage for easier operation. See “Remove a system fan” on page 239.
- Remove all installed drives and fillers (if any) from the drive bays. See “Remove a 2.5/3.5-inch hot-swap drive” on page 115.

Step 2. Record the cable connections on the backplane and then disconnect all cables from the backplane. See Chapter 6 “Internal cable routing” on page 249. If the cable connectors come with protective dust caps, make sure to put them back on.

Step 3. Remove the backplane from the chassis.

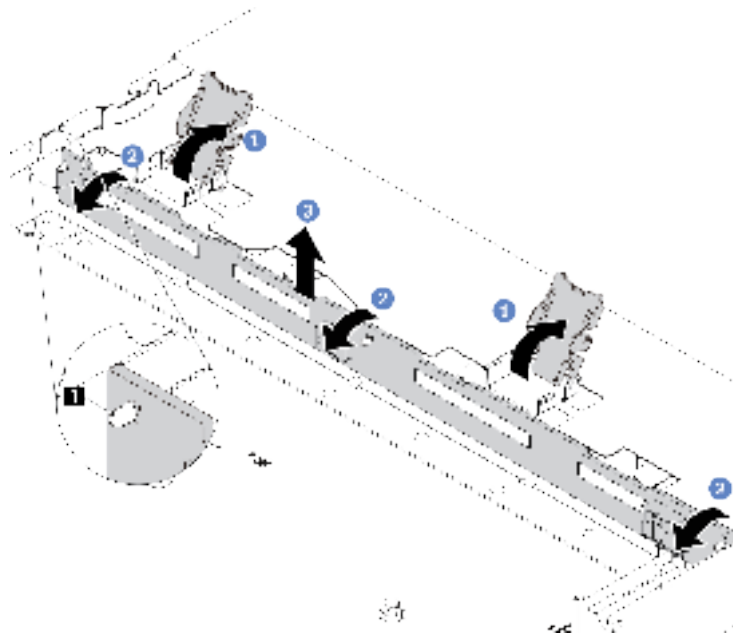


Figure 34. 3.5-inch drive backplane removal

- 1 Open the release latches that secure the backplane.
- 2 Pivot the backplane backward slightly to release it from the three pins 1 on the chassis.
- 3 Carefully remove the backplane out of the chassis.

### After you finish

If you are instructed to return the component or optional device, follow all packaging instructions, and use any packaging materials for shipping that are supplied to you.

## Install the front 3.5-inch drive backplane

Use this information to install the front 3.5-inch drive backplane.

### About this task

#### Attention:

- Read “[Installation Guidelines](#)” on page 51 and “[Safety inspection checklist](#)” on page 52 to ensure that you work safely.
- Power off the server and peripheral devices and disconnect the power cords and all external cables. See “[Power off the server](#)” on page 68.
- Prevent exposure to static electricity, which might lead to system halt and loss of data, by keeping static-sensitive components in their static-protective packages until installation, and handling these devices with an electrostatic-discharge wrist strap or other grounding systems.

#### Watch the procedure

A video of this procedure is available on YouTube: <https://www.youtube.com/playlist?list=PLYV5R7hVcs-CfNsWy-689CRZHExrZEi9I>.

### Procedure

- Step 1. Touch the static-protective package that contains the backplane to any unpainted surface on the outside of the server. Then, take the backplane out of the package and place it on a static-protective surface.

Step 2. Put the backplane down into place.

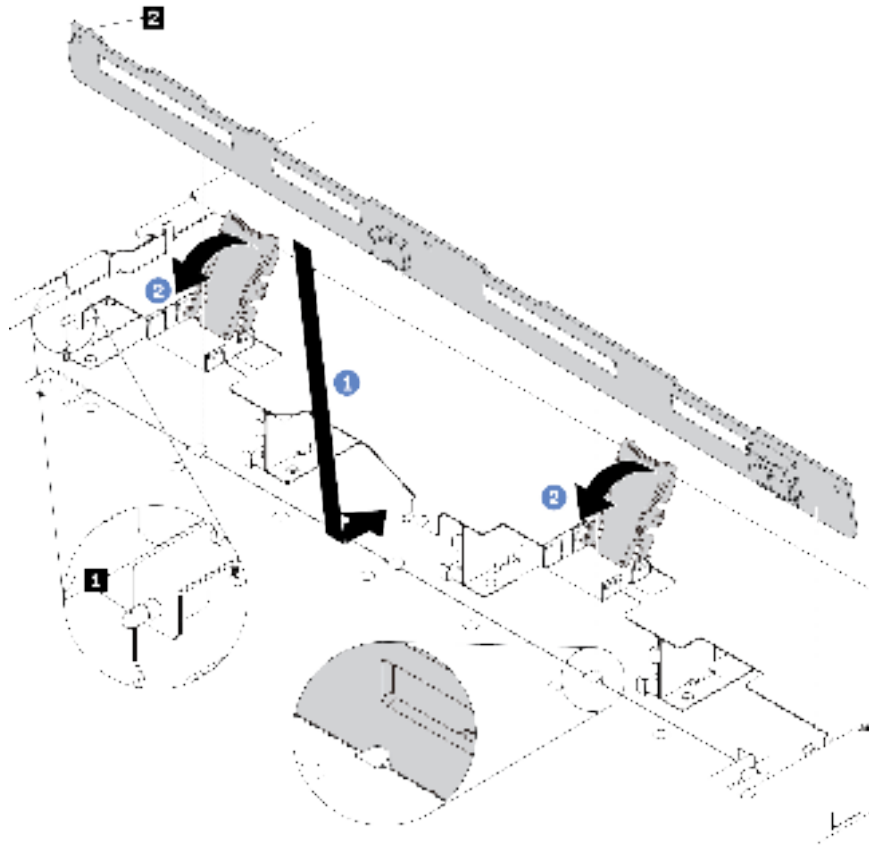


Figure 35. Installation of backplane for four 3.5-inch hot-swap drives

- a. **1** Put the backplane under the front I/O assembly cables, align it with the chassis, and lower it into the chassis. Put the backplane into place with it leaning backward slightly so that the three pins **1** on the chassis pass through the three holes **2** in the backplane.
- b. **2** Close the release latches to secure the backplane in place.

Step 3. Connect the cables to the system board assembly and the backplane. See [Chapter 6 “Internal cable routing” on page 249](#). If the cable connectors come with protective dust caps, make sure to remove them before plugging in.

### After you finish

1. Reinstall all the drives and drive fillers into the drive bays. See [“Install a 2.5/3.5-inch hot-swap drive” on page 117](#).
2. Complete the parts replacement. See [“Complete the parts replacement” on page 246](#).

## Remove the front 16-EDSFF drive backplane

Use this information to remove the backplane for front 16 EDSFF drives.

### About this task

#### Attention:

- Read “[Installation Guidelines](#)” on page 51 and “[Safety inspection checklist](#)” on page 52 to ensure that you work safely.
- Power off the server and peripheral devices and disconnect the power cords and all external cables. See “[Power off the server](#)” on page 68.
- Prevent exposure to static electricity, which might lead to system halt and loss of data, by keeping static-sensitive components in their static-protective packages until installation, and handling these devices with an electrostatic-discharge wrist strap or other grounding systems.

## Procedure

- Step 1. Remove the top cover. See “[Remove the top cover](#)” on page 243.
- Step 2. Remove all the installed drives and drive cages from the drive bays. See “[Remove a hot-swap EDSFF drive](#)” on page 119.
- Step 3. Disconnect the cables from the backplane. See “[16-EDSFF drive backplane](#)” on page 428. If the cable connectors come with protective dust caps, make sure to put them back on.
- Step 4. Remove the backplane from the chassis.

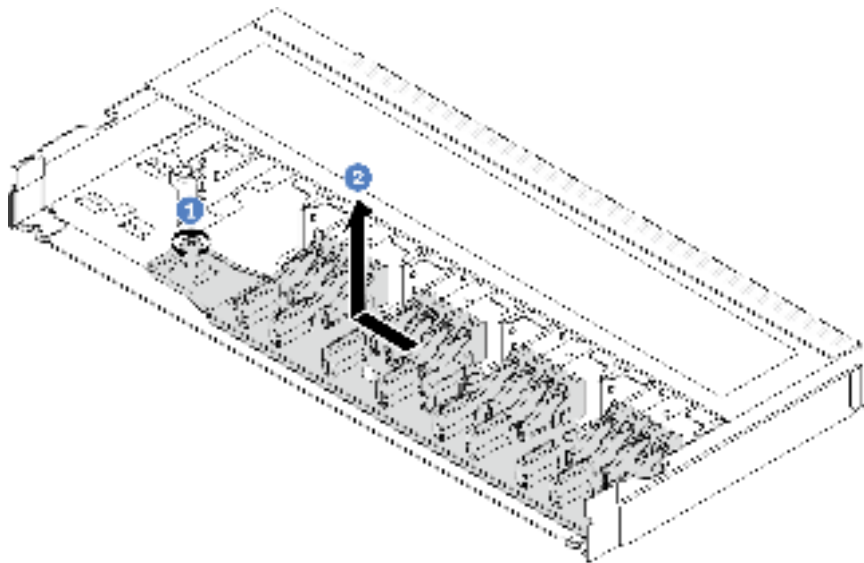


Figure 36. Removal of backplane for 16 EDSFF drives

- 1 Loosen the screw.
- 2 Slightly slide the backplane as shown and then lift it up.

## After you finish

If you are instructed to return the component or optional device, follow all packaging instructions, and use any packaging materials for shipping that are supplied to you.

## Demo video

[Watch the procedure on YouTube](#)

## Install the front 16-EDSFF drive backplane

Use this information to install the backplane for front 16 EDSFF drives.



## About this task

### Attention:

- Read [“Installation Guidelines” on page 51](#) and [“Safety inspection checklist” on page 52](#) to ensure that you work safely.
- Power off the server and peripheral devices and disconnect the power cords and all external cables. See [“Power off the server” on page 68](#).
- Prevent exposure to static electricity, which might lead to system halt and loss of data, by keeping static-sensitive components in their static-protective packages until installation, and handling these devices with an electrostatic-discharge wrist strap or other grounding systems.

### Procedure

- Step 1. Touch the static-protective package that contains the backplane to any unpainted surface on the outside of the server. And then, take the backplane out of the package and place it on a static-protective surface.
- Step 2. Connect the cables to the backplane. See [Chapter 6 “Internal cable routing” on page 249](#).
- Step 3. Put the backplane down into place.

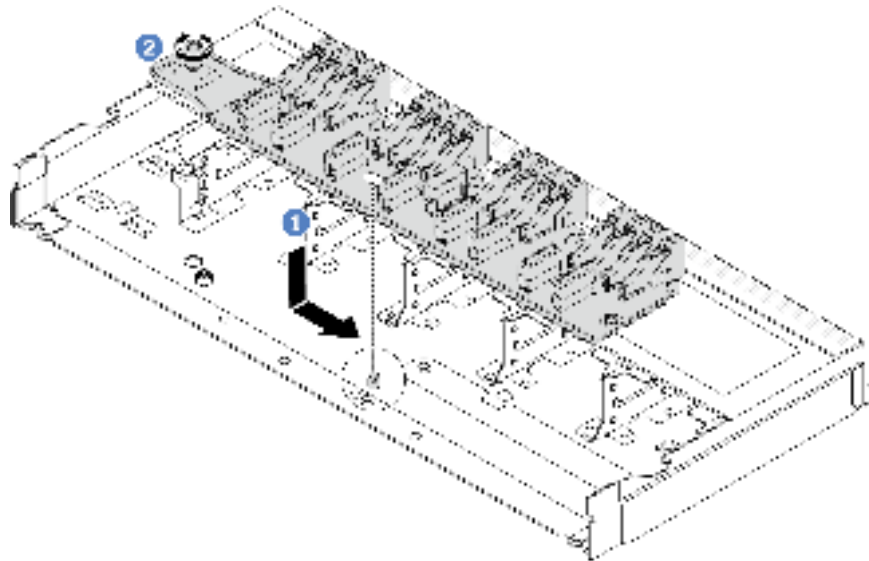


Figure 37. Installation of backplane for 16 EDSFF drives

- a. **1** Align the hole on the backplane with the pin on the chassis, place it down, and slightly slide it as shown.
  - b. **2** Tighten the screw to secure the backplane.
- Step 4. Connect the cables to the system board assembly and the backplane. See [Chapter 6 “Internal cable routing” on page 249](#). If the cable connectors come with protective dust caps, make sure to remove them before plugging in.

### After you finish

1. Reinstall all the drives and drive cages into the drive bays. See [“Install a hot-swap EDSFF drive” on page 121](#).
2. Complete the parts replacement. See [“Complete the parts replacement” on page 246](#).

## Demo video

[Watch the procedure on YouTube](#)

## Remove the 2.5-inch rear drive backplane

Use this information to remove the 2.5-inch rear drive backplane.

### About this task

#### Attention:

- Read [“Installation Guidelines” on page 51](#) and [“Safety inspection checklist” on page 52](#) to ensure that you work safely.
- Power off the server and peripheral devices and disconnect the power cords and all external cables. See [“Power off the server” on page 68](#).
- Prevent exposure to static electricity, which might lead to system halt and loss of data, by keeping static-sensitive components in their static-protective packages until installation, and handling these devices with an electrostatic-discharge wrist strap or other grounding systems.

### Procedure

Step 1. Prepare your server.

- a. Remove the top cover. See [“Remove the top cover” on page 243](#).
- b. Remove all installed drives and fillers (if any) from the drive bays. See [“Remove a 2.5/3.5-inch hot-swap drive” on page 115](#).

Step 2. Gently press and hold the tab on the rear hot-swap drive cage as shown and remove the air baffle from the rear hot-swap drive cage.

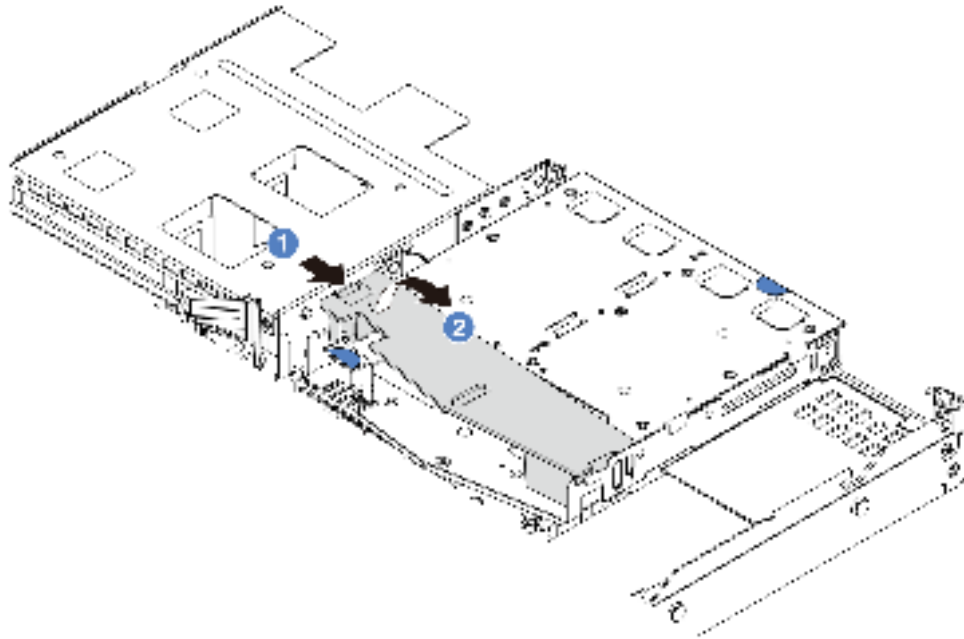


Figure 38. Air baffle removal

- a. ① Press the tab on one side to disengage the air baffle.
  - b. ② Lift the air baffle to remove it from drive cage.
- Step 3. Record the cable connections for 2.5-inch rear drive and then disconnect all cables from the backplanes. For information about the backplane cable routing, see [Chapter 6 “Internal cable routing” on page 249](#).
- Step 4. Carefully lift the 2.5-inch rear drive backplane out of the rear hot-swap drive cage.

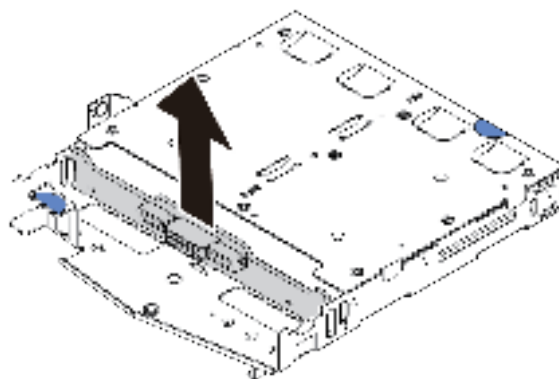


Figure 39. 2.5-inch rear drive backplane removal

## After you finish

If you are instructed to return the component or optional device, follow all packaging instructions, and use any packaging materials for shipping that are supplied to you.

## Demo video

[Watch the procedure on YouTube](#)

## Install the 2.5-inch rear drive backplane

Use this information to install the 2.5-inch rear drive backplane.

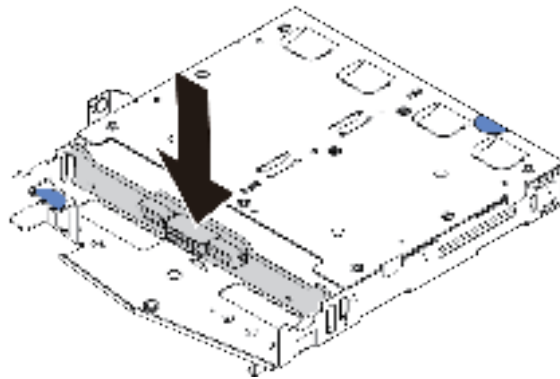
### About this task

#### Attention:

- Read [“Installation Guidelines” on page 51](#) and [“Safety inspection checklist” on page 52](#) to ensure that you work safely.
- Power off the server and peripheral devices and disconnect the power cords and all external cables. See [“Power off the server” on page 68](#).
- Prevent exposure to static electricity, which might lead to system halt and loss of data, by keeping static-sensitive components in their static-protective packages until installation, and handling these devices with an electrostatic-discharge wrist strap or other grounding systems.

### Procedure

- Step 1. Touch the static-protective package that contains the rear backplane to any unpainted surface on the outside of the server. Then, take the rear backplane out of the package and place it on a static-protective surface.
- Step 2. Align the rear backplane with the rear hot-swap drive cage and lower it into the rear hot-swap drive cage.



*Figure 40. Rear backplane installation*

- Step 3. Connect the cables to the system board assembly and the backplane. See [Chapter 6 “Internal cable routing” on page 249](#). If the cable connectors come with protective dust caps, make sure to remove them before plugging in.
- Step 4. Install the air baffle into the rear hot-swap drive cage as shown.

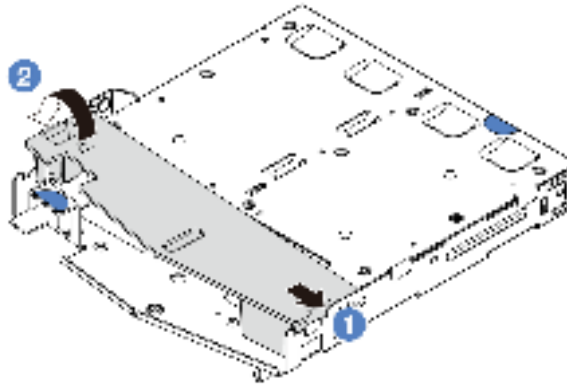


Figure 41. Air baffle installation

- a. **1** Align the air baffle edge with the notch on the drive cage.
- b. **2** Press the air baffle down and make sure that it is seated in place.

### After you finish

1. Reinstall drives or drive fillers into the rear hot-swap drive cage. See [“Install a 2.5/3.5-inch hot-swap drive” on page 117](#).
2. Reinstall the drive assembly to the server. See [“Install the 2.5-inch rear drive assembly” on page 199](#).
3. Complete the parts replacement. See [“Complete the parts replacement” on page 246](#).

### Demo video

[Watch the procedure on YouTube](#)

## Remove the 7mm drive backplanes

Use this information to remove the 7mm drive backplanes.

### About this task

#### Attention:

- Read [“Installation Guidelines” on page 51](#) and [“Safety inspection checklist” on page 52](#) to ensure that you work safely.
- Power off the server and peripheral devices and disconnect the power cords and all external cables. See [“Power off the server” on page 68](#).
- Prevent exposure to static electricity, which might lead to system halt and loss of data, by keeping static-sensitive components in their static-protective packages until installation, and handling these devices with an electrostatic-discharge wrist strap or other grounding systems.

### Procedure

**Note:** Depending on the specific type, your backplanes might look different from the illustration in this topic.

Step 1. Prepare your server.

- a. Remove the top cover. See [“Remove the top cover” on page 243](#).
- b. Record the cable connections for 7mm drives and then disconnect all cables from the backplanes. For information about the backplane cable routing, See [“7mm drive backplane”](#)

on page 270. If the cable connectors come with protective dust caps, make sure to put them back on.

Step 2. Remove the 7mm drive backplane on the top.

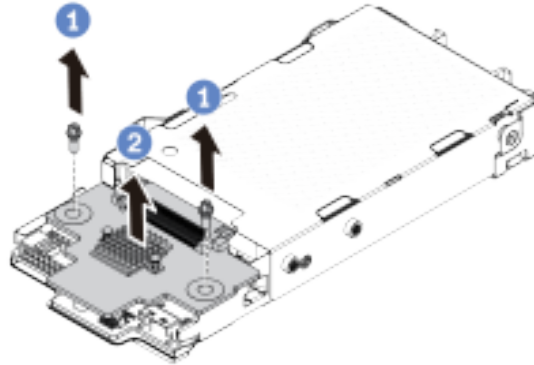


Figure 42. 7mm drive backplane removal (top)

- a. 1 Remove the two screws as shown.
- b. 2 Lift the top backplane up and put it aside.

Step 3. Remove the 7mm drive backplane at the bottom.

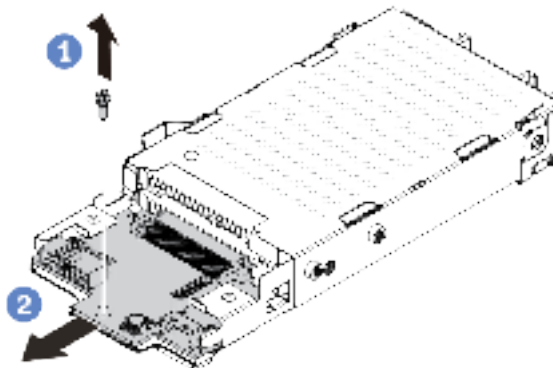


Figure 43. 7mm drive backplane removal (bottom)

- a. 1 Remove the screw as shown.
- b. 2 Slide the bottom backplane out from the cage as shown.

## After you finish

If you are instructed to return the component or optional device, follow all packaging instructions, and use any packaging materials for shipping that are supplied to you.

## Demo video

[Watch the procedure on YouTube](#)

## Install the 7mm drive backplanes

Use this information to install the 7mm drive backplanes.

### About this task

#### Attention:

- Read [“Installation Guidelines” on page 51](#) and [“Safety inspection checklist” on page 52](#) to ensure that you work safely.
- Power off the server and peripheral devices and disconnect the power cords and all external cables. See [“Power off the server” on page 68](#).
- Prevent exposure to static electricity, which might lead to system halt and loss of data, by keeping static-sensitive components in their static-protective packages until installation, and handling these devices with an electrostatic-discharge wrist strap or other grounding systems.

### Procedure

- Step 1. Touch the static-protective package that contains new backplanes to any unpainted surface on the outside of the server. And then, take new backplanes out of the package and place them on a static-protective surface.
- Step 2. Install the 7mm drive bottom backplane.

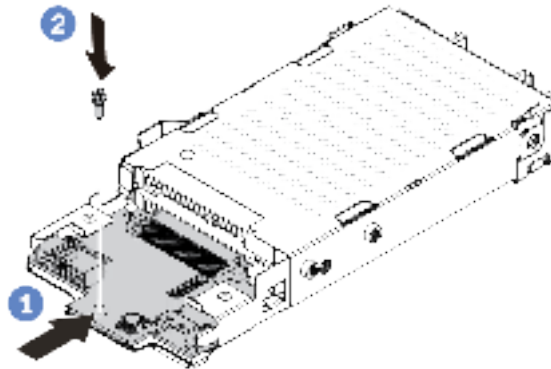


Figure 44. 7mm drive backplane installation (bottom)

- a. **1** Align the pin on the cage and slightly slide the bottom backplane into the cage until it is fully seated.
- b. **2** Install the screw as shown.

- Step 3. Install the 7mm drive top backplane.

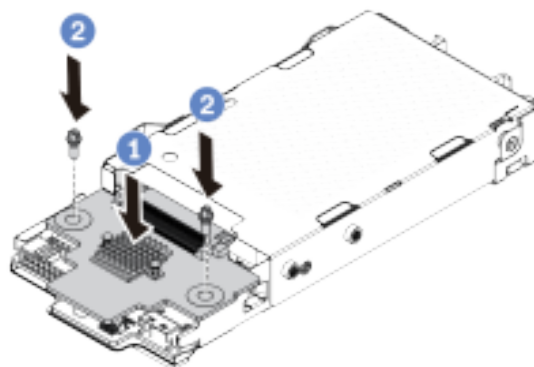


Figure 45. 7mm drive backplane installation (top)

- a. **1** Put the backplane down on the cage as shown.
- b. **2** Install the two screws to secure the top backplane in place.

Step 4. Connect the cables to the system board assembly and the backplane. See [Chapter 6 “Internal cable routing” on page 249](#). If the cable connectors come with protective dust caps, make sure to remove them before plugging in.

## After you finish

Complete the parts replacement. See [“Complete the parts replacement” on page 246](#).

## Demo video

[Watch the procedure on YouTube](#)

---

## CMOS battery replacement

Use this information to remove and install the CMOS battery.

### Remove the CMOS battery

Use this information to remove the CMOS battery.

### About this task

The following tips describe information that you must consider when removing the CMOS battery.

- Lenovo has designed this product with your safety in mind. The lithium CMOS battery must be handled correctly to avoid possible danger. If you replace the CMOS battery, you must adhere to local ordinances or regulations for battery disposal.
- If you replace the original lithium battery with a heavy-metal battery or a battery with heavy-metal components, be aware of the following environmental consideration. Batteries and accumulators that contain heavy metals must not be disposed of with normal domestic waste. They will be taken back free of charge by the manufacturer, distributor, or representative, to be recycled or disposed of in a proper manner.



- To order replacement batteries, call your support center or business partner. For Lenovo support telephone numbers, see <https://datacentersupport.lenovo.com/supportphonenumberlist> for your region support details.

**Note:** After you replace the CMOS battery, you must reconfigure the server and reset the system date and time.

#### **S004**



#### **CAUTION:**

When replacing the lithium battery, use only Lenovo specified part number or an equivalent type battery recommended by the manufacturer. If your system has a module containing a lithium battery, replace it only with the same module type made by the same manufacturer. The battery contains lithium and can explode if not properly used, handled, or disposed of.

*Do not:*

- Throw or immerse into water
- Heat to more than 100°C (212°F)
- Repair or disassemble

Dispose of the battery as required by local ordinances or regulations.

#### **S002**



#### **CAUTION:**

The power-control button on the device and the power switch on the power supply do not turn off the electrical current supplied to the device. The device also might have more than one power cord. To remove all electrical current from the device, ensure that all power cords are disconnected from the power source.

#### **Attention:**

- Read “[Installation Guidelines](#)” on page 51 and “[Safety inspection checklist](#)” on page 52 to ensure that you work safely.
- Power off the server and peripheral devices and disconnect the power cords and all external cables. See “[Power off the server](#)” on page 68.
- Prevent exposure to static electricity, which might lead to system halt and loss of data, by keeping static-sensitive components in their static-protective packages until installation, and handling these devices with an electrostatic-discharge wrist strap or other grounding systems.

### **Procedure**

Step 1. Remove the top cover. See “[Remove the top cover](#)” on page 243.

Step 2. Remove any parts and disconnect any cables that might impede your access to the CMOS battery.

- Step 3. Locate the CMOS battery. See [“System-board-assembly connectors”](#) on page 36.
- Step 4. Open the battery clip as shown and carefully take the CMOS battery out of the socket.

**Attention:**

- Failing to remove the CMOS battery properly might damage the socket on the processor board. Any damage to the socket might require replacing the processor board.
- Do not tilt or push the CMOS battery by using excessive force.

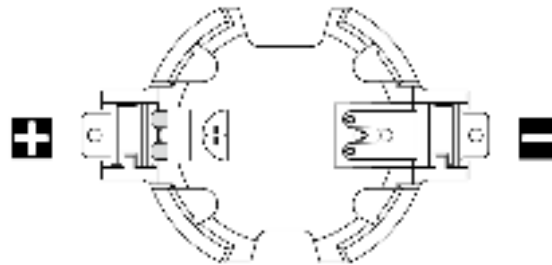


Figure 46. The positive and negative end on the CMOS battery socket

**Note:** Before you remove or install the CMOS battery from or into the socket, differentiate between the positive and negative ends. Use the illustration above for guidance.

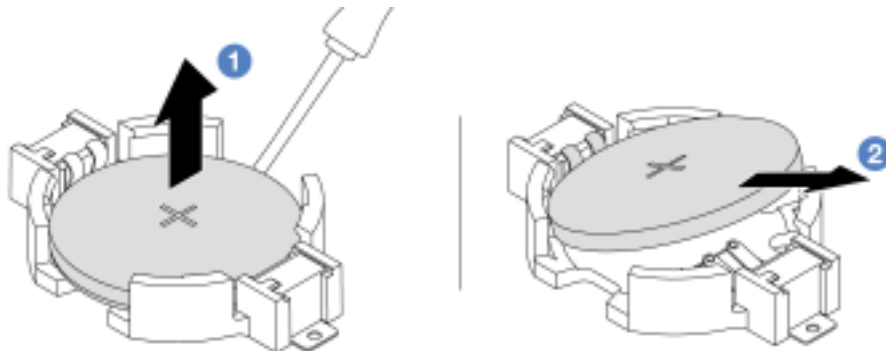


Figure 47. CMOS battery removal

1. Pry the CMOS battery from the socket with a flat-blade screwdriver.
2. Remove the CMOS battery.

**After you finish**

1. Install a new CMOS battery. See [“Install the CMOS battery”](#) on page 97.
2. If you are instructed to return the component or optional device, follow all packaging instructions, and use any packaging materials for shipping that are supplied to you.
3. Dispose of the CMOS battery as required by local ordinances or regulations.

**Demo video**

[Watch the procedure on YouTube](#)

## Install the CMOS battery

Use this information to install the CMOS battery.

### About this task

The following tips describe information that you must consider when installing the CMOS battery.

- Lenovo has designed this product with your safety in mind. The lithium CMOS battery must be handled correctly to avoid possible danger. If you replace the CMOS battery, you must adhere to local ordinances or regulations for battery disposal.
- If you replace the original lithium battery with a heavy-metal battery or a battery with heavy-metal components, be aware of the following environmental consideration. Batteries and accumulators that contain heavy metals must not be disposed of with normal domestic waste. They will be taken back free of charge by the manufacturer, distributor, or representative, to be recycled or disposed of in a proper manner.
- To order replacement batteries, call your support center or business partner. For Lenovo support telephone numbers, see <https://datacentersupport.lenovo.com/supportphonenumberlist> for your region support details.

**Note:** After you replace the CMOS battery, you must reconfigure the server and reset the system date and time.

### S004



#### **CAUTION:**

**When replacing the lithium battery, use only Lenovo specified part number or an equivalent type battery recommended by the manufacturer. If your system has a module containing a lithium battery, replace it only with the same module type made by the same manufacturer. The battery contains lithium and can explode if not properly used, handled, or disposed of.**

*Do not:*

- **Throw or immerse into water**
- **Heat to more than 100°C (212°F)**
- **Repair or disassemble**

**Dispose of the battery as required by local ordinances or regulations.**

## S002



### CAUTION:

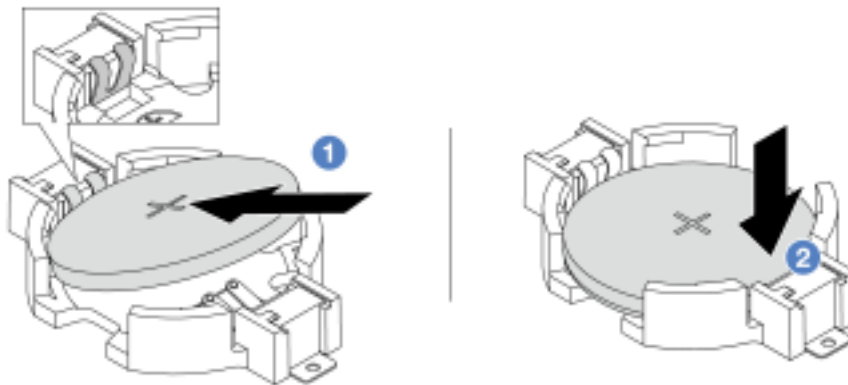
The power-control button on the device and the power switch on the power supply do not turn off the electrical current supplied to the device. The device also might have more than one power cord. To remove all electrical current from the device, ensure that all power cords are disconnected from the power source.

### Attention:

- Read [“Installation Guidelines”](#) on page 51 and [“Safety inspection checklist”](#) on page 52 to ensure that you work safely.
- Power off the server and peripheral devices and disconnect the power cords and all external cables. See [“Power off the server”](#) on page 68.
- Prevent exposure to static electricity, which might lead to system halt and loss of data, by keeping static-sensitive components in their static-protective packages until installation, and handling these devices with an electrostatic-discharge wrist strap or other grounding systems.

## Procedure

- Step 1. Touch the static-protective package that contains the CMOS battery to any unpainted surface on the outside of the server. Then, take the CMOS battery out of the package.
- Step 2. Install the CMOS battery. Ensure that the CMOS battery is seated in place.



**Note:** Before you install the battery into the socket, make sure that the positive side faces upward.

1. **1** Tilt the battery and insert it to the positive end on the socket, and make sure that the battery goes tight to the metal clip.
2. **2** Press the battery down until it clicks into the socket.

Figure 48. CMOS battery installation

## After you finish

1. Complete the parts replacement. See [“Complete the parts replacement”](#) on page 246.
2. Use the Setup utility to set the date, time, and any passwords.

## Demo video

[Watch the procedure on YouTube](#)

---

## EDSFF cage replacement

Use this information to remove and install an EDSFF cage

### Remove an EDSFF cage

Use this information to remove an EDSFF cage.

### About this task

#### Attention:

- Read [“Installation Guidelines” on page 51](#) and [“Safety inspection checklist” on page 52](#) to ensure that you work safely.
- Power off the server and peripheral devices and disconnect the power cords and all external cables. See [“Power off the server” on page 68](#).
- Prevent exposure to static electricity, which might lead to system halt and loss of data, by keeping static-sensitive components in their static-protective packages until installation, and handling these devices with an electrostatic-discharge wrist strap or other grounding systems.

### Procedure

- Step 1. If the security bezel is installed, remove it first. See [“Remove the security bezel” on page 213](#).
- Step 2. Locate the EDSFF cage you need to remove, and then remove all the EDSFF drives installed in it. See [“Remove a hot-swap EDSFF drive” on page 119](#).

Step 3. Remove the EDSFF cage from the chassis.

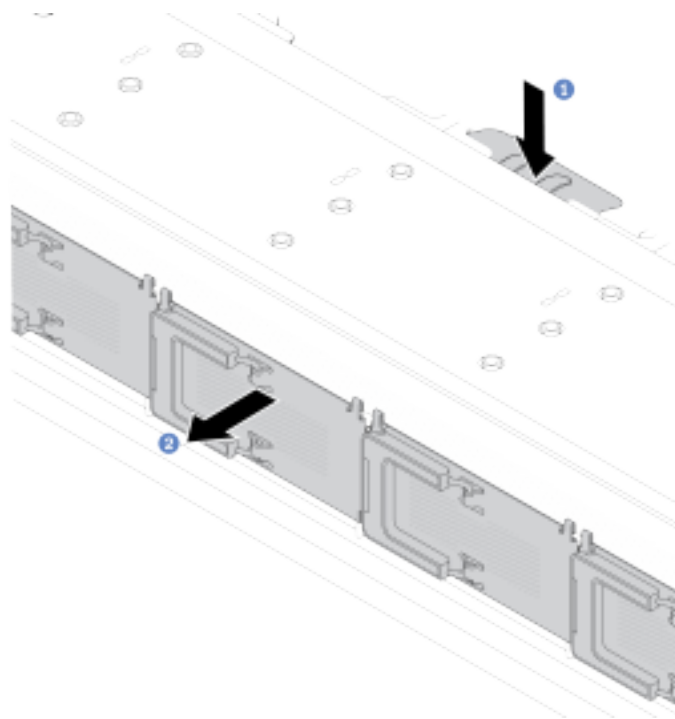


Figure 49. EDSFF cage removal

- a. **1** Press down the extended tab on the other side of the front chassis.
- b. **2** Slide the EDSFF cage out of the front chassis.

### After you finish

1. Install a new EDSFF cage. See [“Install an EDSFF cage” on page 100](#).
2. If you are instructed to return the component or optional device, follow all packaging instructions, and use any packaging materials for shipping that are supplied to you.

### Demo video

[Watch the procedure on YouTube](#)

## Install an EDSFF cage

Use this information to install an EDSFF cage.

### About this task

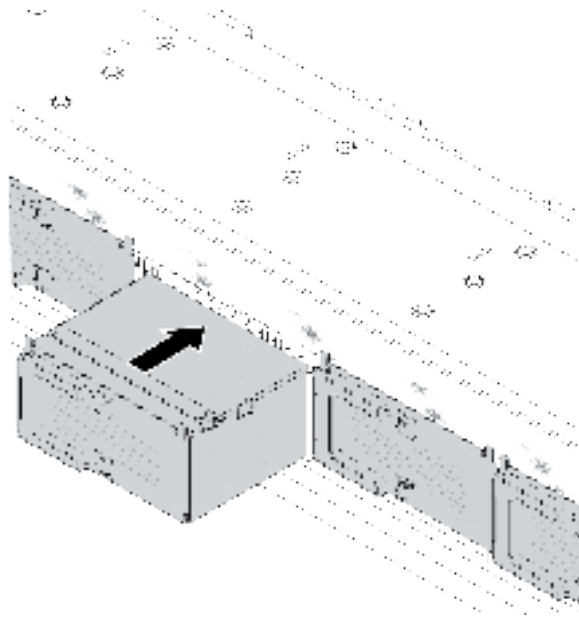
#### Attention:

- Read [“Installation Guidelines” on page 51](#) and [“Safety inspection checklist” on page 52](#) to ensure that you work safely.
- Power off the server and peripheral devices and disconnect the power cords and all external cables. See [“Power off the server” on page 68](#).

- Prevent exposure to static electricity, which might lead to system halt and loss of data, by keeping static-sensitive components in their static-protective packages until installation, and handling these devices with an electrostatic-discharge wrist strap or other grounding systems.

## Procedure

- Step 1. Touch the static-protective package that contains the EDSFF cage to any unpainted surface on the outside of the server. And then, take the EDSFF cage out of the package and place it on a static-protective surface.
- Step 2. Slide the diagnostics panel assembly into the front chassis as shown. And ensure that it is seated in place.



*Figure 50. EDSFF cage installation*

Step 3. Remove the EDSFF drive cage cover.

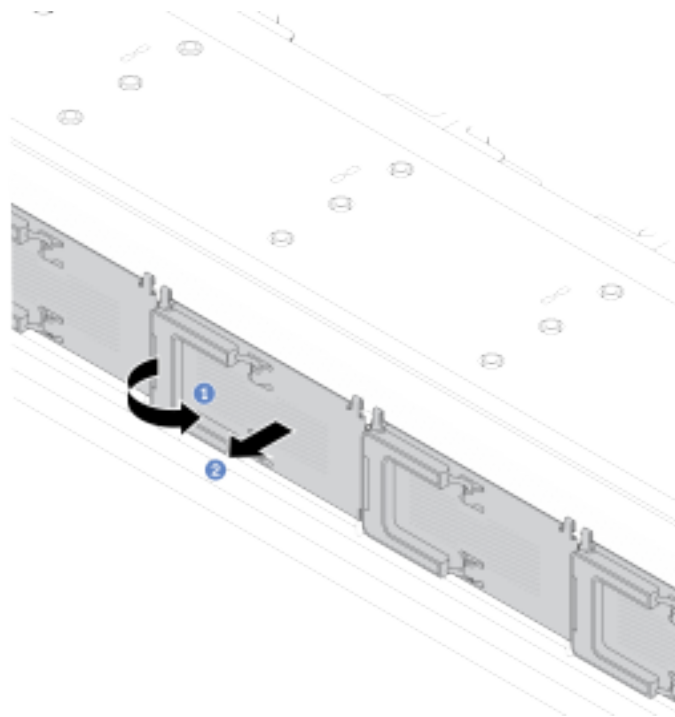


Figure 51. EDSFF drive cage cover removal

- a. 1 Open the handle as shown.
- b. 2 Grasp the handle and remove the drive cage cover.

Step 4. Install EDSFF drives into the EDSFF cage. See [“Install a hot-swap EDSFF drive” on page 121](#).

## After you finish

Complete the parts replacement. See [“Complete the parts replacement” on page 246](#).

## Demo video

[Watch the procedure on YouTube](#)

---

## Front I/O module replacement

Use this information to remove and install the front I/O module.

### Remove the front I/O module

Use this information to remove the front I/O module.

### About this task

The following illustrates how to remove the front I/O module with a diagnostics panel. You can remove other front I/O modules in the same way.

### Attention:



- Read “[Installation Guidelines](#)” on page 51 and “[Safety inspection checklist](#)” on page 52 to ensure that you work safely.
- Power off the server and peripheral devices and disconnect the power cords and all external cables. See “[Power off the server](#)” on page 68.
- Prevent exposure to static electricity, which might lead to system halt and loss of data, by keeping static-sensitive components in their static-protective packages until installation, and handling these devices with an electrostatic-discharge wrist strap or other grounding systems.

## Procedure

- Step 1. Remove the top cover. See “[Remove the top cover](#)” on page 243.
- Step 2. If the security bezel is installed, remove it. See “[Remove the security bezel](#)” on page 213.
- Step 3. Disconnect the front I/O cables from the processor board.
- Step 4. Remove the front I/O module.

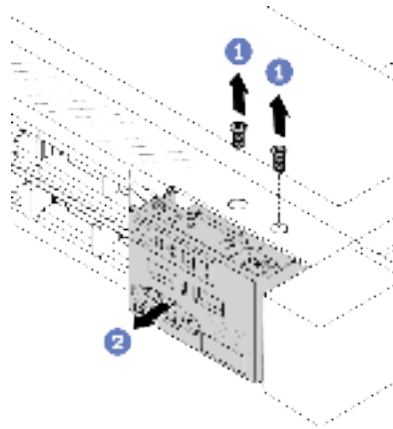


Figure 52. Remove a front I/O module on 2.5" chassis

- 1 Remove the screws that secure the front I/O module.
- 2 Slide the front I/O module out of the front chassis.

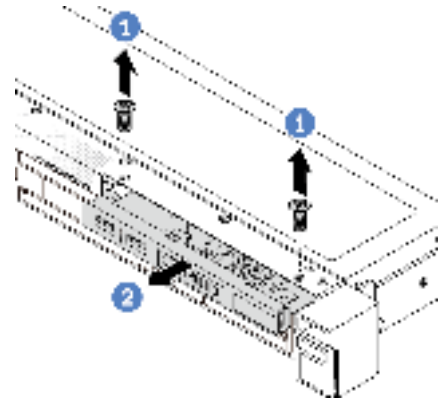


Figure 53. Remove a front I/O module on 3.5" chassis

## After you finish

If you are instructed to return the component or optional device, follow all packaging instructions, and use any packaging materials for shipping that are supplied to you.

### Demo video

[Watch the procedure on YouTube](#)

## Install the front I/O module

Use this information to install the front I/O module.

### About this task

The following illustrates how to install the front I/O module with the diagnostics panel. You can install other front I/O modules in the same way.

**Attention:**

- Read “[Installation Guidelines](#)” on page 51 and “[Safety inspection checklist](#)” on page 52 to ensure that you work safely.
- Power off the server and peripheral devices and disconnect the power cords and all external cables. See “[Power off the server](#)” on page 68.
- Prevent exposure to static electricity, which might lead to system halt and loss of data, by keeping static-sensitive components in their static-protective packages until installation, and handling these devices with an electrostatic-discharge wrist strap or other grounding systems.

**Procedure**

Step 1. Touch the static-protective package that contains the front I/O module to any unpainted surface on the outside of the server. Then, take the front I/O module out of the package and place it on a static-protective surface.

Step 2. Install the front I/O module.

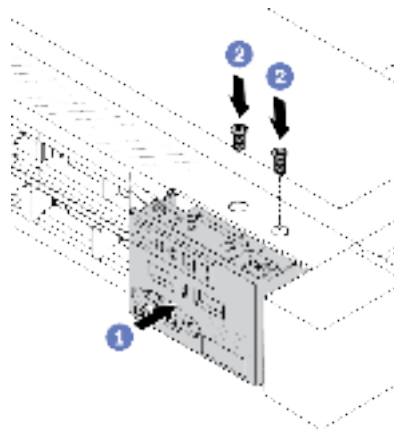


Figure 54. Install a front I/O module on 2.5" chassis

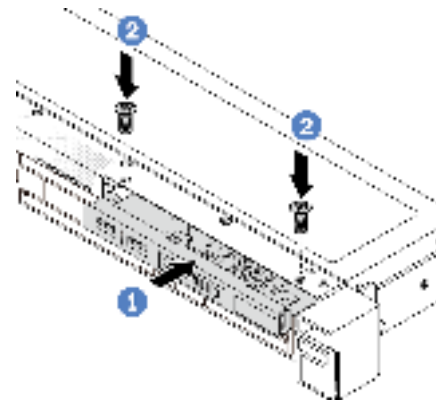


Figure 55. Install a front I/O module on 3.5" chassis

- a. 1 Insert the front I/O module into the front chassis.
- b. 2 Install the screws to secure the front I/O module in place.

**After you finish**

1. Connect the front I/O cables to the processor board. See “[Front I/O module](#)” on page 262.
2. Complete the parts replacement. See “[Complete the parts replacement](#)” on page 246.

**Demo video**

[Watch the procedure on YouTube](#)

**Remove the integrated diagnostics panel assembly**

Use this information to remove the integrated diagnostics panel assembly.

**About this task****Attention:**

- Read “[Installation Guidelines](#)” on page 51 and “[Safety inspection checklist](#)” on page 52 to ensure that you work safely.
- Power off the server and peripheral devices and disconnect the power cords and all external cables. See “[Power off the server](#)” on page 68.
- Prevent exposure to static electricity, which might lead to system halt and loss of data, by keeping static-sensitive components in their static-protective packages until installation, and handling these devices with an electrostatic-discharge wrist strap or other grounding systems.

### Watch the procedure

A video of this procedure is available on YouTube: <https://www.youtube.com/playlist?list=PLYV5R7hVcs-CfNsWy-689CRZHExrZEi9I>.

### Procedure

- Step 1. Remove the top cover. See “[Remove the top cover](#)” on page 243.
- Step 2. If the security bezel is installed, remove it. See “[Remove the security bezel](#)” on page 213.
- Step 3. Remove the integrated diagnostics panel assembly from the chassis.

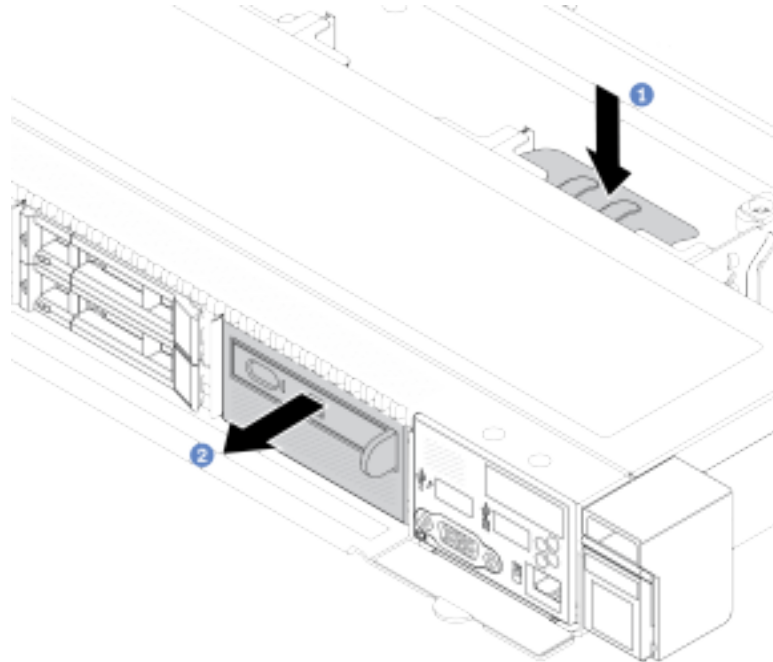


Figure 56. Integrated diagnostics panel assembly removal

- a. **1** Press down the extended tab on the other side of the front chassis.
- b. **2** Slide the assembly out of the front chassis.

Step 4. Remove the integrated diagnostics panel from its assembly.

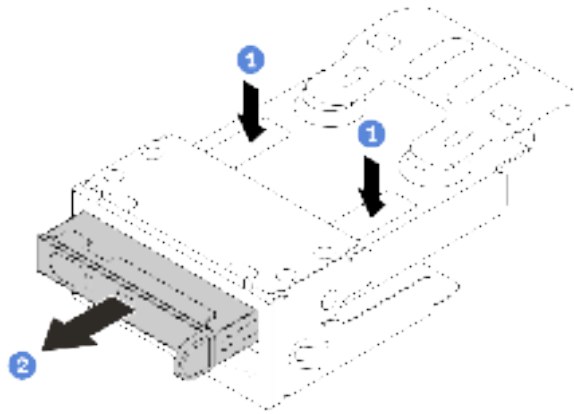


Figure 57. LCD diagnostics panel removal

- a. 1 Press down the clips as shown.
- b. 2 Pull the integrated diagnostics panel by its handle to get it out of its assembly.

### After you finish

1. Install a new integrated diagnostics panel assembly or filler. See “[Install the integrated diagnostics panel assembly](#)” on page 106.
2. If you are instructed to return the component or optional device, follow all packaging instructions, and use any packaging materials for shipping that are supplied to you.

## Install the integrated diagnostics panel assembly

Use this information to install the diagnostics panel assembly.

### About this task

#### Attention:

- Read “[Installation Guidelines](#)” on page 51 and “[Safety inspection checklist](#)” on page 52 to ensure that you work safely.
- Power off the server and peripheral devices and disconnect the power cords and all external cables. See “[Power off the server](#)” on page 68.
- Prevent exposure to static electricity, which might lead to system halt and loss of data, by keeping static-sensitive components in their static-protective packages until installation, and handling these devices with an electrostatic-discharge wrist strap or other grounding systems.

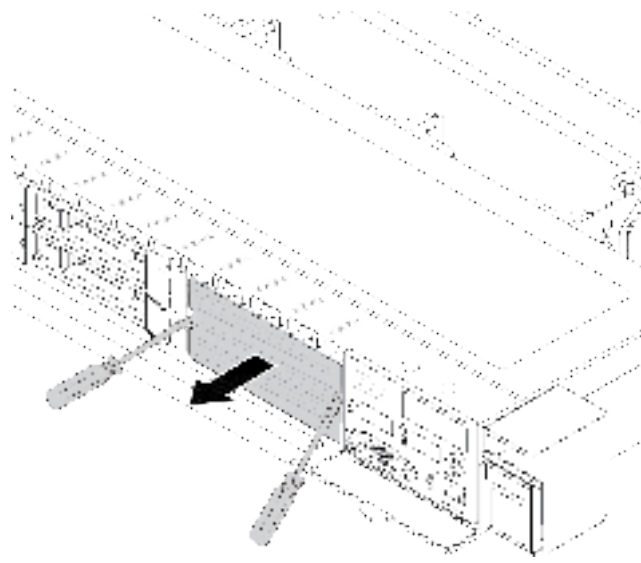
#### Watch the procedure

A video of this procedure is available on YouTube: <https://www.youtube.com/playlist?list=PLYV5R7hVcs-CfNsWy-689CRZHExrZEi9I>.

### Procedure

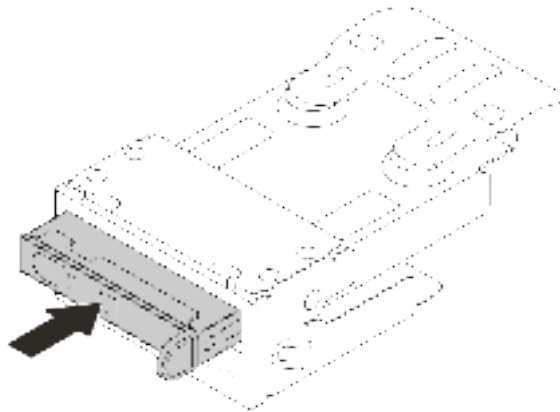
- Step 1. Touch the static-protective package that contains the diagnostics panel assembly to any unpainted surface on the outside of the server. And then, take the assembly out of the package and place it on a static-protective surface.

Step 2. If there is a filler installed on the front chassis, remove it as shown.



*Figure 58. Filler removal*

Step 3. Insert the integrated diagnostics panel into its assembly. Ensure that the panel is fully seated into its assembly.



*Figure 59. Integrated diagnostics panel installation into its assembly*

Step 4. Slide the diagnostics panel assembly into the front chassis as shown. And ensure that it is seated in place.

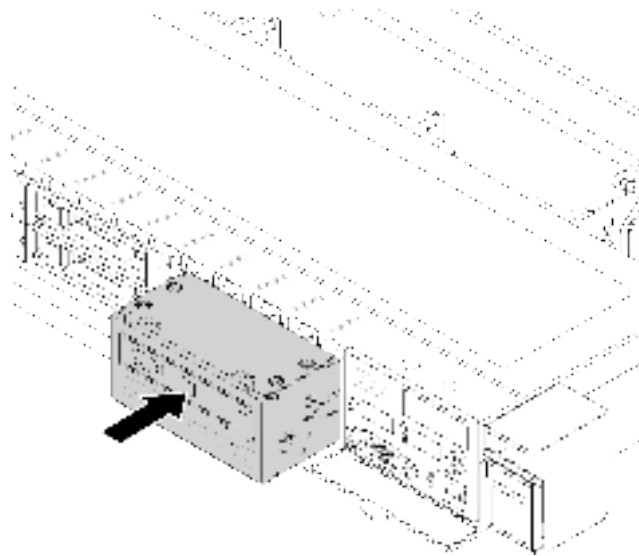


Figure 60. Diagnostics panel assembly installation

## After you finish

Complete the parts replacement. See [“Complete the parts replacement” on page 246](#).

## Remove the external LCD cable (4 x 3.5" chassis)

Use this information to remove the external LCD cable.

In the 4 x 3.5" chassis configuration, the external LCD cable is an optional part. You can choose either install or remove the cable according to your actual needs. Refer to the location of external LCD cable from the front view as below:



1 The external LCD cable connector

Figure 61. A front view with the cable installed



1 A filler for external LCD cable connector

Figure 62. A front view with a filler installed

**Note:** Before installing the cable, remove the filler first; after removing the cable, install the filler afterwards.

## About this task

The following illustrates how to remove the external LCD cable from the chassis.

**Attention:**

- Read “[Installation Guidelines](#)” on page 51 and “[Safety inspection checklist](#)” on page 52 to ensure that you work safely.
- Power off the server and peripheral devices and disconnect the power cords and all external cables. See “[Power off the server](#)” on page 68.
- Prevent exposure to static electricity, which might lead to system halt and loss of data, by keeping static-sensitive components in their static-protective packages until installation, and handling these devices with an electrostatic-discharge wrist strap or other grounding systems.

### Watch the procedure

A video of this procedure is available on YouTube: <https://www.youtube.com/playlist?list=PLYV5R7hVcs-CfNsWy-689CRZHExrZEI9I>.

### Procedure

- Step 1. Remove the top cover. See “[Remove the top cover](#)” on page 243.
- Step 2. If the security bezel is installed, remove it. See “[Remove the security bezel](#)” on page 213.
- Step 3. Disconnect the external LCD cable from the processor board.
- Step 4. To get a better view of the cable connector latch inside the chassis, remove the front I/O module first.

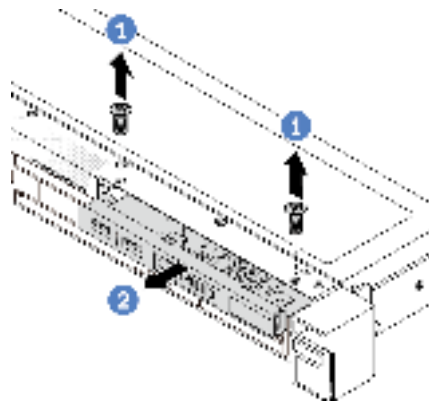


Figure 63. Front I/O module removal

- a. 1 Remove the screws that secure the front I/O module.
- b. 2 Slide the front I/O module out of the front chassis.

Step 5. Remove the external LCD cable.

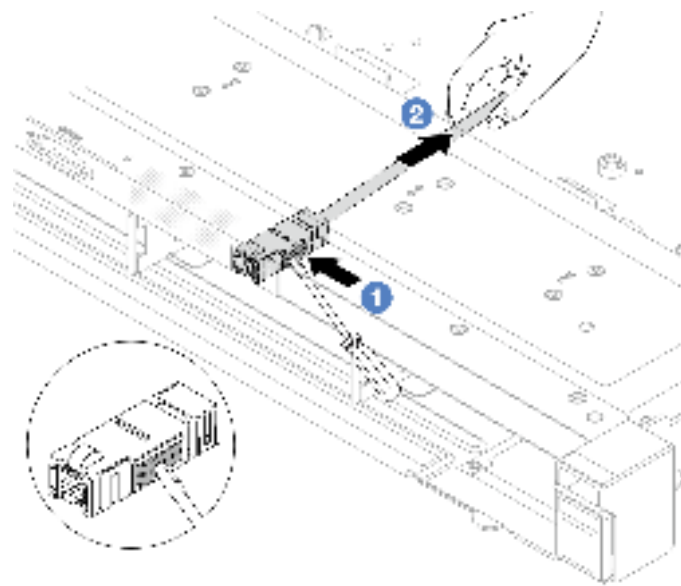


Figure 64. Removal of the external LCD cable

- a. 1 Poke the connector latch with the tip of a flat-blade screwdriver (3 or 4 mm) to disengage the connector from the chassis.
- b. 2 Pull out the cable from the back side.

Step 6. Install the front I/O module back to the chassis.

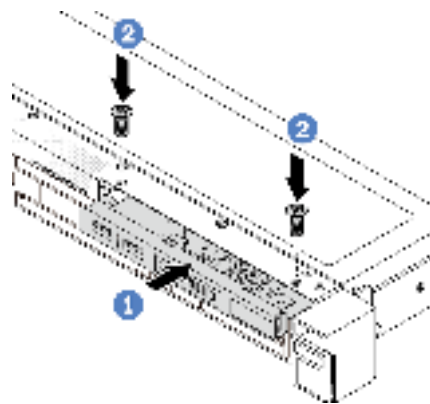


Figure 65. Front I/O module installation

- a. 1 Insert the front I/O module into the front chassis.
- b. 2 Install the screws to secure the front I/O module in place.

## After you finish

If you are instructed to return the component or optional device, follow all packaging instructions, and use any packaging materials for shipping that are supplied to you.



## Install the external LCD cable (4 x 3.5" chassis)

Use this information to install the external LCD cable.

In the 4 x 3.5" chassis configuration, the external LCD cable is an optional part. You can choose either install or remove the cable according to your actual needs. Refer to the location of external LCD cable from the front view as below:



**1** The external LCD cable connector

*Figure 66. A front view with the cable installed*



**1** A filler for external LCD cable connector

*Figure 67. A front view with a filler installed*

**Note:** Before installing the cable, remove the filler first; after removing the cable, install the filler afterwards.

### About this task

The following illustrates how to remove the external LCD cable from the chassis.

#### Attention:

- Read “Installation Guidelines” on page 51 and “Safety inspection checklist” on page 52 to ensure that you work safely.
- Power off the server and peripheral devices and disconnect the power cords and all external cables. See “Power off the server” on page 68.
- Prevent exposure to static electricity, which might lead to system halt and loss of data, by keeping static-sensitive components in their static-protective packages until installation, and handling these devices with an electrostatic-discharge wrist strap or other grounding systems.

#### Watch the procedure

A video of this procedure is available on YouTube: <https://www.youtube.com/playlist?list=PLYV5R7hVcs-CfNsWy-689CRZHExrZEi9I>.

### Procedure

- Step 1. Touch the static-protective package that contains the external LCD cable to any unpainted surface on the outside of the server. Then, take the external LCD cable out of the package and place it on a static-protective surface.

Step 2. Install the external LCD cable.

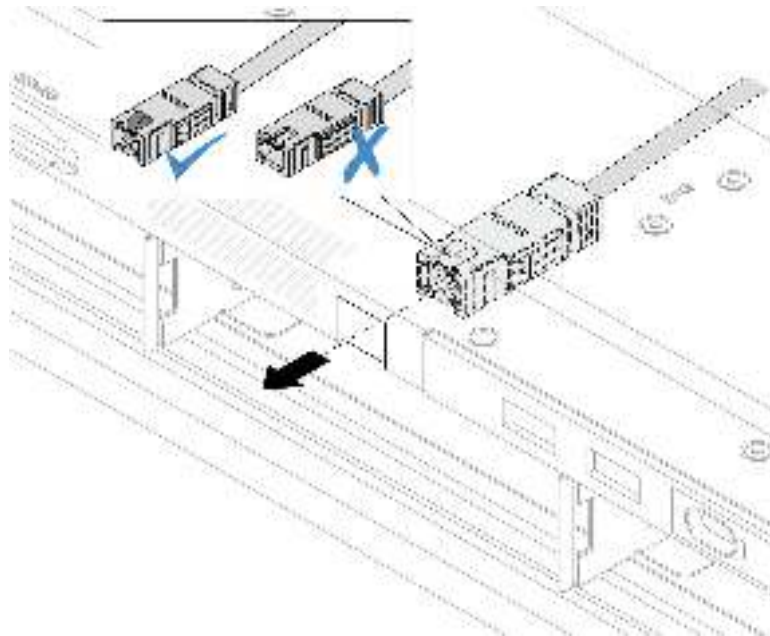


Figure 68. Installation of the external LCD cable

**Note:** The front and back sides of the connector to external diagnostics slot are different, and it is required to plug in with the front side.

When plugging in, face the front side upward and slide the connector into the chassis. Refer to the illustration above.

### After you finish

1. Connect the external LCD cable to the processor board. See [Chapter 6 “Internal cable routing” on page 249](#).
2. Complete the parts replacement. See [“Complete the parts replacement” on page 246](#).

---

## Heat sink Torx T30 nut replacement

Use this information to remove and install a heat sink Torx T30 nut.

### Remove a heat sink Torx T30 nut

This task has instructions for removing a PEEK (Polyether ether ketone) Torx T30 nut on the heat sink.

### About this task

#### Attention:

- Read [“Installation Guidelines” on page 51](#) and [“Safety inspection checklist” on page 52](#) to ensure that you work safely.
- Power off the server and peripheral devices and disconnect the power cords and all external cables. See [“Power off the server” on page 68](#).

- Prevent exposure to static electricity, which might lead to system halt and loss of data, by keeping static-sensitive components in their static-protective packages until installation, and handling these devices with an electrostatic-discharge wrist strap or other grounding systems.
- Do not touch the processor contacts. Contaminants on the processor contacts, such as oil from your skin, can cause connection failures.

**Note:** The heat sink, processor, and processor carrier for your system might be different from those shown in the illustrations.

## Procedure

Step 1. Make preparations for this task.

- Remove the top cover. See [“Remove the top cover” on page 243](#).
- Remove the air baffle. See [“Remove the air baffle” on page 77](#).
- Remove the PHM. See [“Remove a processor and heat sink” on page 176](#).

Step 2. Remove the Torx T30 nut.

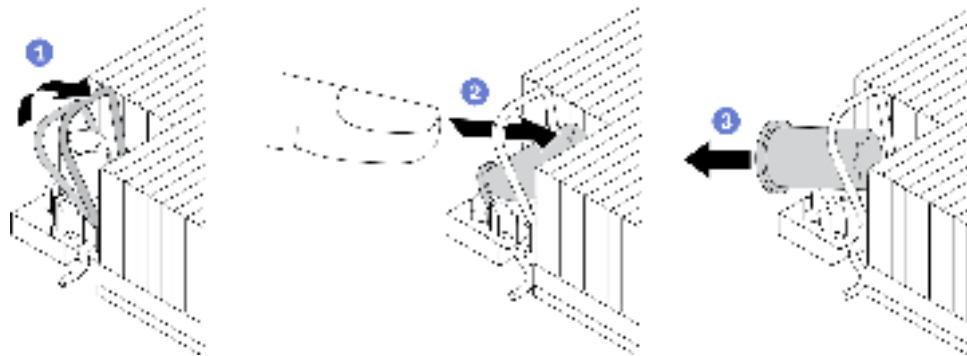


Figure 69. Removing a Torx T30 nut from the heat sink

**Note:** Do not touch the gold contacts on the bottom of the processor.

- 1 Rotate the anti-tilt wire bail inwards.
- 2 Push the upper edge of the Torx T30 nut towards the center of the heat sink until it disengages.
- 3 Remove the Torx T30 nut.

**Attention:** Visually inspect the removed Torx T30 nut, if the nut is cracked or damaged, make sure no debris or broken pieces are left inside your server.

## After you finish

1. Install a new Torx T30 nut. See [“Install a heat sink Torx T30 nut” on page 113](#).
2. If you are instructed to return the component or optional device, follow all packaging instructions, and use any packaging materials for shipping that are supplied to you.

## Demo video

[Watch the procedure on YouTube](#)

## Install a heat sink Torx T30 nut

This task has instructions for installing a PEEK (Polyether ether ketone) Torx T30 nut on the heat sink.

## About this task

### Attention:

- Read “Installation Guidelines” on page 51 and “Safety inspection checklist” on page 52 to ensure that you work safely.
- Power off the server and peripheral devices and disconnect the power cords and all external cables. See “Power off the server” on page 68.
- Prevent exposure to static electricity, which might lead to system halt and loss of data, by keeping static-sensitive components in their static-protective packages until installation, and handling these devices with an electrostatic-discharge wrist strap or other grounding systems.
- Do not touch the processor contacts. Contaminants on the processor contacts, such as oil from your skin, can cause connection failures.

**Note:** The heat sink, processor, and processor carrier for your system might be different from those shown in the illustrations.

**Firmware and driver download:** You might need to update the firmware or driver after replacing a component.

- Go to <https://datacentersupport.lenovo.com/products/servers/thinksystem/sr630v3/7d72/downloads/driver-list/> to see the latest firmware and driver updates for your server.
- Go to “Update the firmware” on page 433 for more information on firmware updating tools.

### Procedure

Step 1. Install the Torx T30 nut.

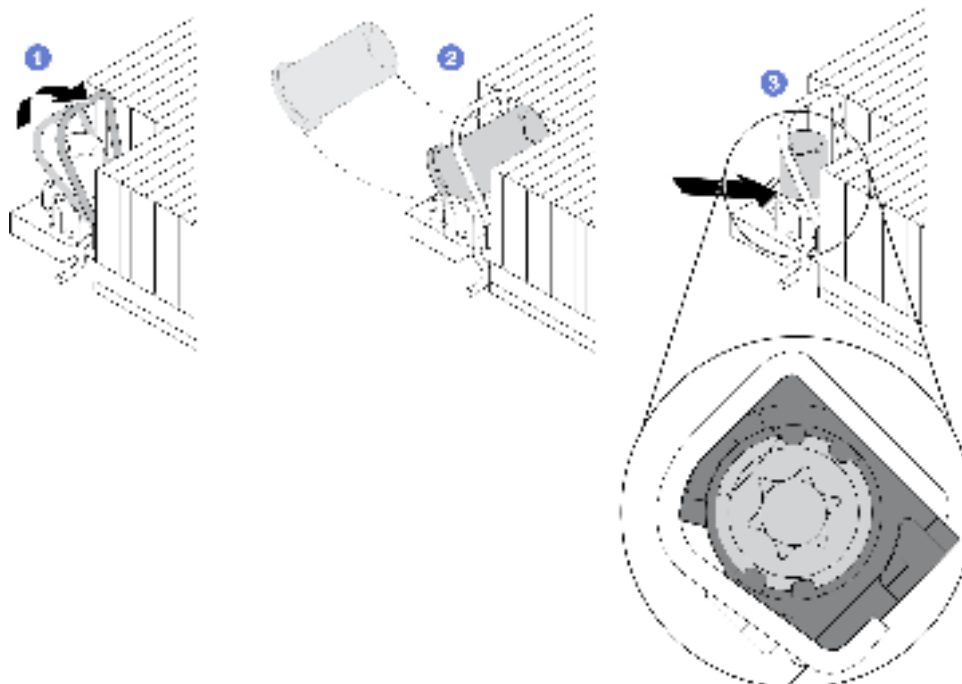




Figure 70. Installing a Torx T30 nut into the heat sink

**Note:** Do not touch the gold contacts on the bottom of the processor.

- a. 1 Rotate the anti-tilt wire bail inwards.

- b.  Orient the Torx T30 nut under the anti-tilt wire bail; then, align the Torx T30 nut with the socket at an angle as shown.
- c.  Push the lower edge of the Torx T30 nut into the socket until it clicks into place. Make sure the Torx T30 nut is secured under the four clips in the socket.

## After you finish

1. Reinstall the PHM. See [“Install a processor and heat sink” on page 181](#).
2. Complete the parts replacement. See [“Complete the parts replacement” on page 246](#).

## Demo video

[Watch the procedure on YouTube](#)

---

## Hot-swap drive replacement

Use this information to remove and install a hot-swap drive. You can remove or install a hot-swap drive without turning off the server, which helps you avoid significant interruption to the operation of the system.

### Notes:

- The term “hot-swap drive” refers to all the supported types of hot-swap hard disk drives, hot-swap solid-state drives, and hot-swap NVMe drives.
- Use any documentation that comes with the drive, and follow the instructions and those in this topic.
- The electromagnetic interference (EMI) integrity and cooling of the server are protected by having all drive bays covered or occupied. The vacant bays are either covered by an EMI-protective panel or occupied by drive fillers. When installing a drive, save any removed drive fillers for future use to cover vacant bays.
- To avoid damage to the drive connectors, ensure that the top cover is in place and fully closed whenever you install or remove a drive.

## Remove a 2.5/3.5-inch hot-swap drive

Use this information to remove a 2.5/3.5-inch hot-swap drive.

### About this task

The following describes the information that you must consider for this task:

- Ensure that you have backed up data on your drive, especially if it is part of a RAID array.
  - Before you make changes to drives, RAID adapters, or drive backplanes, back up all important data that is stored on the drives.
  - Before you remove any component of a RAID array, back up all RAID configuration information.
- If one or more NVMe drives are to be removed, it is recommended to disable them first in Safely Remove Hardware and Eject Media (Windows) or filesystem (Linux). Log in to XClarity Controller and go to the **Storage** menu to identify and locate the drive type and corresponding drive bay number. If the drive bay numbers come with the term “NVMe”, it indicates that the installed drives are NVMe drives.

### Attention:

- Read [“Installation Guidelines” on page 51](#) and [“Safety inspection checklist” on page 52](#) to ensure that you work safely.

- Prevent exposure to static electricity, which might lead to system halt and loss of data, by keeping static-sensitive components in their static-protective packages until installation, and handling these devices with an electrostatic-discharge wrist strap or other grounding systems.
- To ensure that there is adequate system cooling, do not operate the server for more than two minutes without either a drive or a drive filler installed in each bay.

## Procedure

Step 1. If the security bezel is installed, remove it first. See [“Remove the security bezel”](#) on page 213.

Step 2. Remove a hot-swap drive.

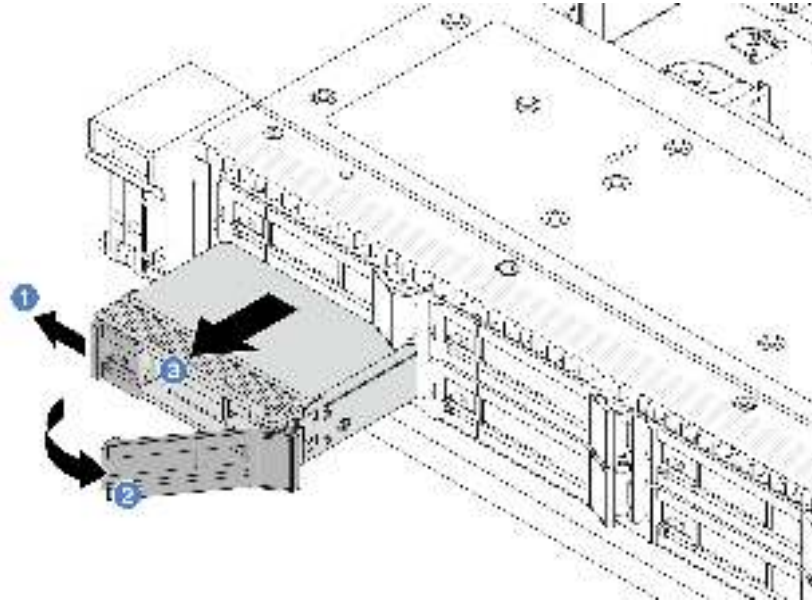


Figure 71. Remove a hot-swap drive

- a. 1 Slide the release latch to the left to open the drive tray handle.
- b. 2 Open the drive handle.
- c. 3 Slide the drive out of the drive bay.

## After you finish

1. Install a drive filler or a new drive to cover the drive bay.

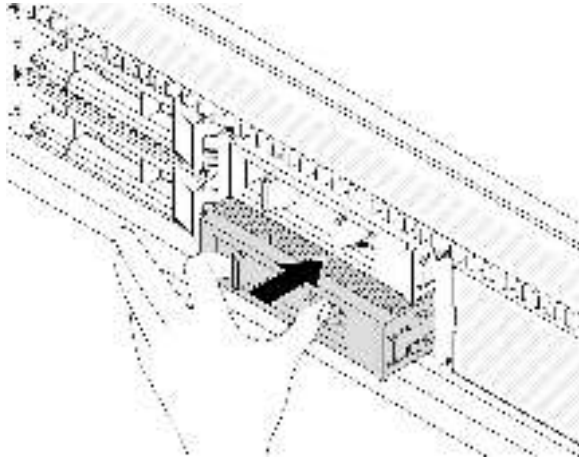


Figure 72. Install a drive filler

2. If you are instructed to return the component or optional device, follow all packaging instructions, and use any packaging materials for shipping that are supplied to you.

### Demo video

[Watch the procedure on YouTube](#)

## Install a 2.5/3.5-inch hot-swap drive

Use this information to install a 2.5/3.5-inch hot-swap drive.

### About this task

#### Attention:

- Read “[Installation Guidelines](#)” on page 51 and “[Safety inspection checklist](#)” on page 52 to ensure that you work safely.
- Prevent exposure to static electricity, which might lead to system halt and loss of data, by keeping static-sensitive components in their static-protective packages until installation, and handling these devices with an electrostatic-discharge wrist strap or other grounding systems.

### Procedure

Step 1. Touch the static-protective package that contains the drive to any unpainted surface on the outside of the server. And then, take the drive out of the package and place it on a static-protective surface.

**Note:** Ensure that drive installation meets “[Technical rules for drives](#)” on page 64.

Step 2. Remove the drive filler from the drive bay and keep the drive filler in a safe place.

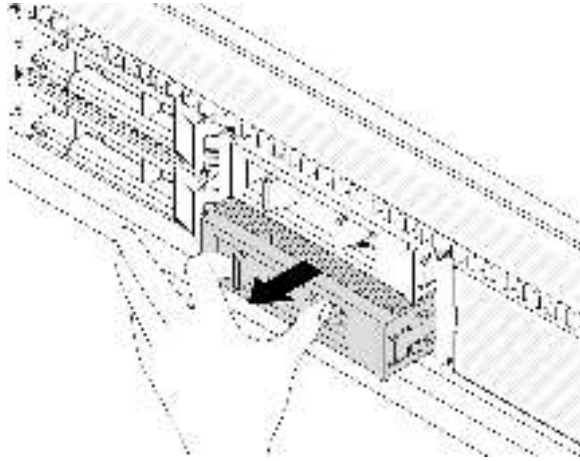


Figure 73. Remove a drive filler

Step 3. Install the drive in the drive bay.

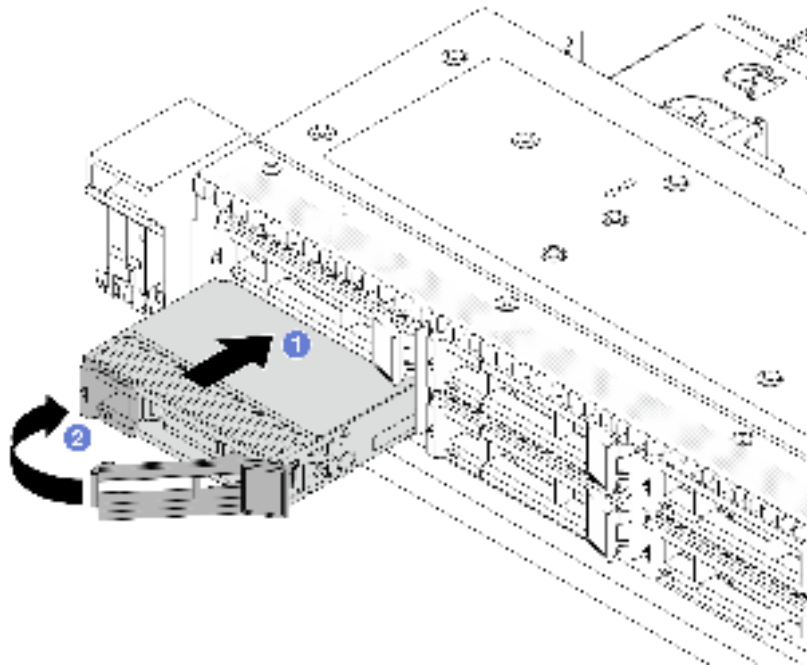


Figure 74. Hot-swap drive installation

- a. 1 Ensure that the drive tray handle is in the open position. Slide the drive into the drive bay until it snaps into position.
- b. 2 Close the drive tray handle to lock the drive in place.

Step 4. Check the drive LEDs to verify that the drive is operating normally. For details, see [“Drive LEDs” on page 455](#).

Step 5. Continue to install additional hot-swap drives if necessary.

## After you finish

1. Reinstall the security bezel if you removed it. See [“Install the security bezel” on page 215](#).



2. Use the Lenovo XClarity Provisioning Manager to configure the RAID if necessary. For more information, see:  
[https://sysmgt.lenovofiles.com/help/topic/lxpm\\_frontend/lxpm\\_product\\_page.html](https://sysmgt.lenovofiles.com/help/topic/lxpm_frontend/lxpm_product_page.html)

### Demo video

[Watch the procedure on YouTube](#)

## Remove a hot-swap EDSFF drive

Use this information to remove an EDSFF drive.

### About this task

The following describes the information that you must consider for this task:

- Ensure that you have backed up data on your drive, especially if it is part of a RAID array.
  - Before you make changes to drives, RAID adapters, or drive backplanes, back up all important data that is stored on the drives.
  - Before you remove any component of a RAID array, back up all RAID configuration information.
- If one or more NVMe drives are to be removed, it is recommended to disable them first in Safely Remove Hardware and Eject Media (Windows) or filesystem (Linux). Log in to XClarity Controller and go to the **Storage** menu to identify and locate the drive type and corresponding drive bay number. If the drive bay numbers come with the term “NVMe”, it indicates that the installed drives are NVMe drives.

### Attention:

- Read “[Installation Guidelines](#)” on page 51 and “[Safety inspection checklist](#)” on page 52 to ensure that you work safely.
- Prevent exposure to static electricity, which might lead to system halt and loss of data, by keeping static-sensitive components in their static-protective packages until installation, and handling these devices with an electrostatic-discharge wrist strap or other grounding systems.
- To ensure that there is adequate system cooling, do not operate the server for more than two minutes without either a drive or a drive filler installed in each bay.

### Procedure

Step 1. If the security bezel is installed, remove it first. See “[Remove the security bezel](#)” on page 213.

Step 2. Remove the EDSFF drive cage cover.

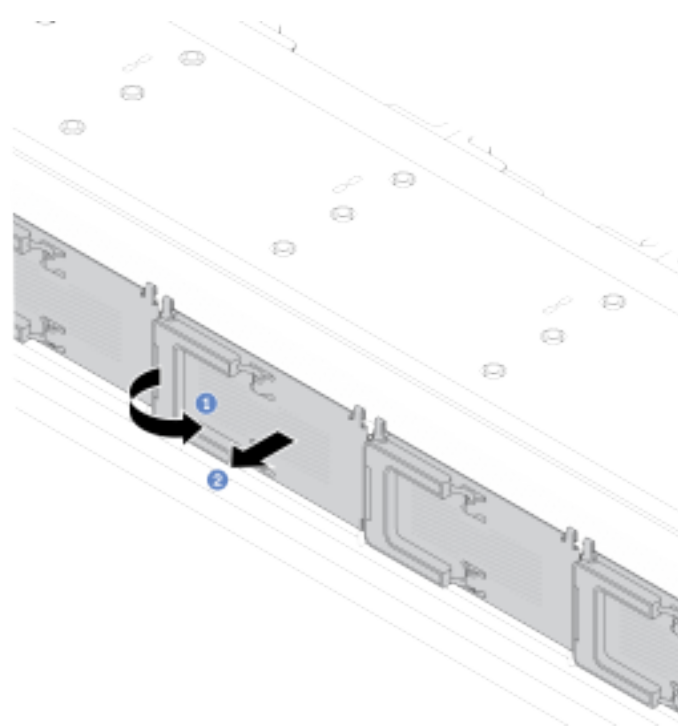


Figure 75. EDSFF drive cage cover removal

- a. 1 Open the handle as shown.
- b. 2 Grasp the handle and remove the drive cage cover.

Step 3. Remove the EDSFF drive.

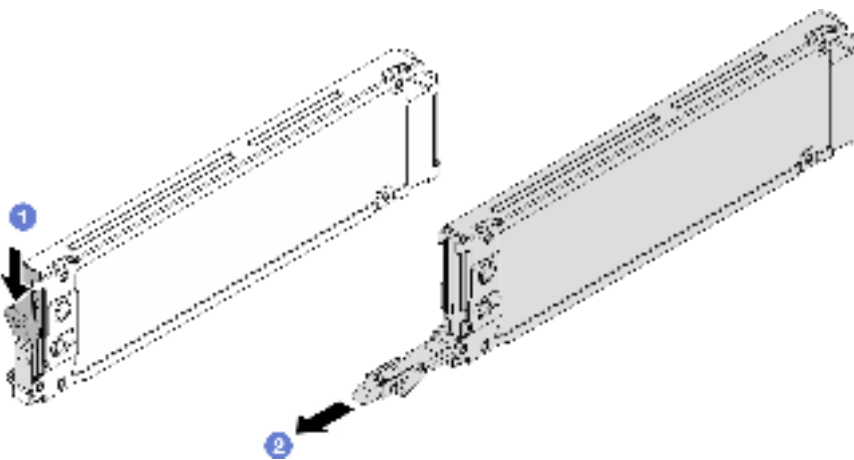


Figure 76. EDSFF drive removal

- a. 1 Slide the release latch as shown to open the drive tray handle.
- b. 2 Grasp the handle and slide the drive out of the drive bay.

## After you finish

1. Install a new drive or a drive cage cover to cover the drive bay.

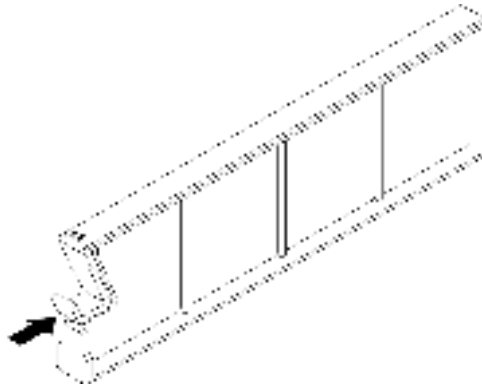


Figure 77. EDSFF drive filler installation

2. If you are instructed to return the component or optional device, follow all packaging instructions, and use any packaging materials for shipping that are supplied to you.

### Demo video

[Watch the procedure on YouTube](#)

## Install a hot-swap EDSFF drive

Use this information to install an EDSFF drive.

### About this task

#### Attention:

- Read “[Installation Guidelines](#)” on page 51 and “[Safety inspection checklist](#)” on page 52 to ensure that you work safely.
- Prevent exposure to static electricity, which might lead to system halt and loss of data, by keeping static-sensitive components in their static-protective packages until installation, and handling these devices with an electrostatic-discharge wrist strap or other grounding systems.

### Procedure

- Step 1. Touch the static-protective package that contains the drive to any unpainted surface on the outside of the server. Then, take the drive out of the package and place it on a static-protective surface.
- Step 2. Remove the drive filler from the drive bay and keep the drive filler in a safe place.

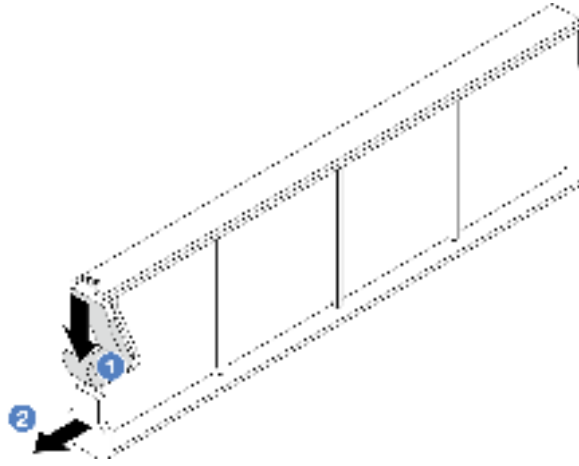


Figure 78. Remove an EDSFF drive filler

- a. 1 Press the latch down to disengage the drive clip from the cage.
- b. 2 Pull and slide the filler out.

Step 3. Install the EDSFF drive.

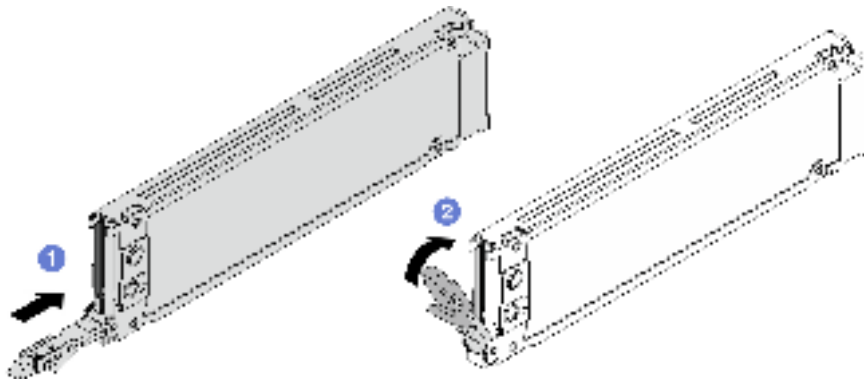


Figure 79. EDSFF drive installation

- a. 1 Ensure that the drive tray handle is in the open position. Slide the drive into the drive bay until it snaps into position.
- b. 2 Close the drive tray handle to lock the drive in place.

Step 4. Continue to install additional EDSFF drives if necessary.

Step 5. Install the EDSFF drive cage cover.

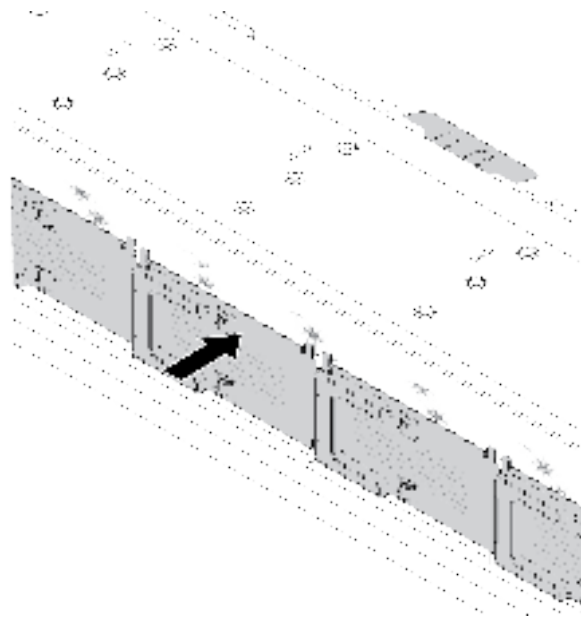


Figure 80. EDSFF drive cage cover installation

### After you finish

1. Reinstall the security bezel if you have removed it. See “[Install the security bezel](#)” on page 215.
2. Use the Lenovo XClarity Provisioning Manager to configure the RAID if necessary. For more information, see:  
[https://sysmgmt.lenovofiles.com/help/topic/ixpm\\_frontend/ixpm\\_product\\_page.html](https://sysmgmt.lenovofiles.com/help/topic/ixpm_frontend/ixpm_product_page.html)

### Demo video

[Watch the procedure on YouTube](#)

---

## Hot-swap power supply unit replacement

Use this information to remove and install a hot-swap power supply unit.

### Remove a hot-swap power supply unit

Use this information to remove a power supply unit.

### About this task

If the power supply unit to be removed is the only one installed, the power supply unit is not hot-swappable. Before removing it, you must turn off the server first. To support redundancy mode or hot-swap, install an additional hot-swap power supply unit.

### Safety information for AC power supplies

### S035



#### **CAUTION:**

Never remove the cover on a power supply or any part that has this label attached. Hazardous voltage, current, and energy levels are present inside any component that has this label attached. There are no serviceable parts inside these components. If you suspect a problem with one of these parts, contact a service technician.

### S002



#### **CAUTION:**

The power-control button on the device and the power switch on the power supply do not turn off the electrical current supplied to the device. The device also might have more than one power cord. To remove all electrical current from the device, ensure that all power cords are disconnected from the power source.

### S001



Electrical current from power, telephone, and communication cables is hazardous.  
To avoid a shock hazard:

- Connect all power cords to a properly wired and grounded electrical outlet/source.
- Connect any equipment that will be attached to this product to properly wired outlets/sources.
- When possible, use one hand only to connect or disconnect signal cables.
- Never turn on any equipment when there is evidence of fire, water, or structural damage.
- The device might have more than one power cord, to remove all electrical current from the device, ensure that all power cords are disconnected from the power source.

#### Safety information for DC power supplies

#### **CAUTION:**

240 V dc input (input range: 180-300 V dc) is supported in Chinese Mainland ONLY. Power supply with 240 V dc input cannot support hot plugging power cord function. Before removing the power supply with dc input, please turn off server or disconnect dc power sources at the breaker panel or by turning off the power source. Then, remove the power cord.



在直流输入状态下，若电源供应器插座不支持热插拔功能，请务必不要对设备电源线进行热插拔，此操作可能导致设备损坏及数据丢失。因错误执行热插拔导致的设备故障或损坏，不属于保修范围。

NEVER CONNECT AND DISCONNECT THE POWER SUPPLY CABLE AND EQUIPMENT WHILE YOUR EQUIPMENT IS POWERED ON WITH DC SUPPLY (hot-plugging). Otherwise you may damage the equipment and result in data loss, the damages and losses result from incorrect operation of the equipment will not be covered by the manufacturers' warranty.

#### **S035**



#### **CAUTION:**

**Never remove the cover on a power supply or any part that has this label attached. Hazardous voltage, current, and energy levels are present inside any component that has this label attached. There are no serviceable parts inside these components. If you suspect a problem with one of these parts, contact a service technician.**

#### **S019**



#### **CAUTION:**

**The power-control button on the device does not turn off the electrical current supplied to the device. The device also might have more than one connection to dc power. To remove all electrical current from the device, ensure that all connections to dc power are disconnected at the dc power input terminals.**

## S029



**For -48V dc power supply, electrical current from power cords is hazardous.  
To avoid a shock hazard:**

- **To connect or disconnect -48V dc power cords when you need to remove/install redundancy power supply unit(s).**

### To Connect:

1. Turn OFF subject dc power source(s) and equipment (s) that are attached to this product.
2. Install the power supply unit(s) into the system housing.
3. Attach dc power cord(s) to the product.
  - Ensure correct polarity of -48 V dc connections: RTN is + and -Vin (typical -48 V) dc is -. Earth ground should be connected very well.
4. Connect dc power cord(s) to subject power source (s).
5. Turn ON all the power source(s).

### To Disconnect:

1. Disconnect or turn off the subject dc power source(s) (at the breaker panel) before removing the power supply unit(s).
2. Remove the subject dc cord(s) and make sure the wire terminal of power cord(s) is insulated.
3. Unplug the subject power supply unit(s) from the system housing.

### Attention:

- Read [“Installation Guidelines” on page 51](#) and [“Safety inspection checklist” on page 52](#) to ensure that you work safely.
- Prevent exposure to static electricity, which might lead to system halt and loss of data, by keeping static-sensitive components in their static-protective packages until installation, and handling these devices with an electrostatic-discharge wrist strap or other grounding systems.

## Procedure



Step 1. If the server is in a rack, adjust the cable management arm (CMA) to gain access to the power supply unit bay.

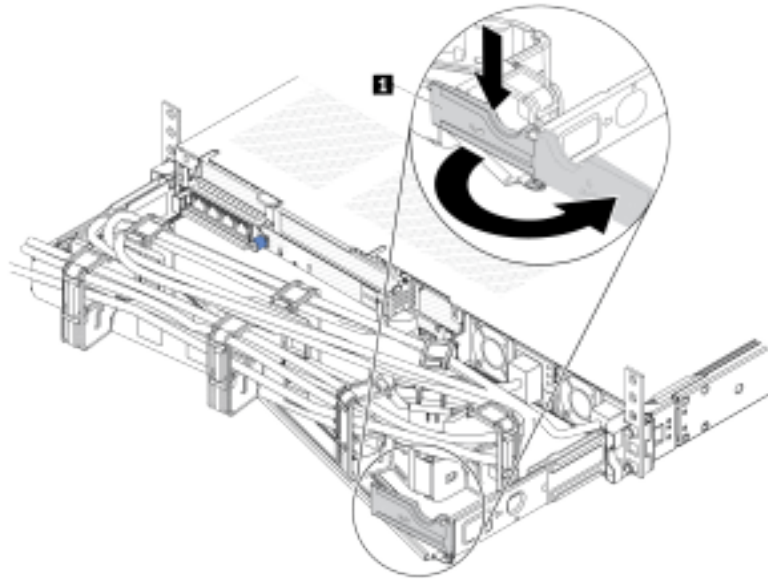


Figure 81. CMA adjustment

1. Press down the stop bracket **1** and rotate it to the open position.
  2. Rotate the CMA out of the way to gain access to the power supply units.
- Step 2. Disconnect the power cord from the hot-swap power supply unit.
- For 240 V DC power supply units, turn off the server, and then, disconnect both ends of the power cord and keep it in an ESD-safe place.
  - For AC power supply units, disconnect both ends of the power cord and keep it in an ESD-safe place.
  - For -48V DC power supply units:
    1. Disconnect the power cords from the electrical outlet.
    2. Use a slotted screwdriver to loosen the captive screws on the power supply terminal block.
    3. Disconnect the power cords from the power supply unit, make the wire terminal insulated, and keep them in an ESD-safe place.

**Note:** If you are replacing two power supply units, replace them one by one to ensure that the power supply to the server is not interrupted. Do not disconnect the power cord from the secondly replaced power supply unit until the power output LED for the firstly replaced power supply unit is lit. For the location of the power output LED, refer to [“LEDs on the power supply unit” on page 461](#).

- Step 3. Press the release tab toward the handle and carefully pull the handle at the same time to slide the hot-swap power supply unit out of the chassis.

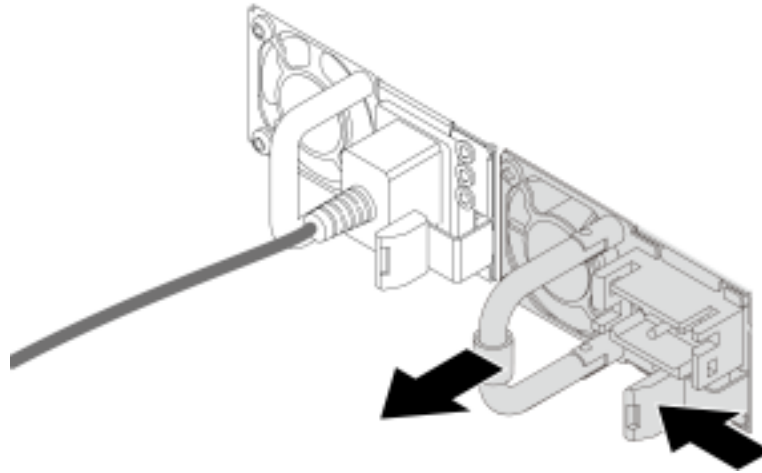


Figure 82. Hot-swap power supply removal

## After you finish

1. Install a new power supply unit or install the power-supply-unit filler to cover the power supply bay. See “Install a hot-swap power supply unit” on page 128.

**Important:** To ensure proper cooling during normal server operation, both power supply bays must be occupied. This means that each bay must have a power supply unit installed; or one has a power supply unit installed and the other has a power-supply-unit filler installed.

2. If you are instructed to return the component or optional device, follow all packaging instructions, and use any packaging materials for shipping that are supplied to you.

## Demo video

[Watch the procedure on YouTube](#)

## Install a hot-swap power supply unit

Use this information to install a hot-swap power supply unit.

## About this task

The following describes the information that you must consider when installing a power supply unit:

- If the power supply unit to be removed is the only one installed, the power supply unit is not hot-swappable. Before removing it, you must turn off the server first. To support redundancy mode or hot-swap, install an additional hot-swap power supply unit.
- If you are replacing the existing power supply with a new power supply:
  - Use Lenovo Capacity Planner to calculate the required power capacity for what is configured for your server. More information about Lenovo Capacity Planner is available at: <https://datacentersupport.lenovo.com/solutions/Invo-lcp>
  - Ensure that the devices that you are installing are supported. For a list of supported optional devices for the server, go to: <https://serverproven.lenovo.com>

- Attach the power information label that comes with this option on the existing label near the power supply.



Figure 83. Example power supply unit label on the top cover

## Safety information for AC power supplies

### S035



#### **CAUTION:**

Never remove the cover on a power supply or any part that has this label attached. Hazardous voltage, current, and energy levels are present inside any component that has this label attached. There are no serviceable parts inside these components. If you suspect a problem with one of these parts, contact a service technician.

### S002



#### **CAUTION:**

The power-control button on the device and the power switch on the power supply do not turn off the electrical current supplied to the device. The device also might have more than one power cord. To remove all electrical current from the device, ensure that all power cords are disconnected from the power source.

### S001



 **DANGER**

Electrical current from power, telephone, and communication cables is hazardous.  
To avoid a shock hazard:

- Connect all power cords to a properly wired and grounded electrical outlet/source.
- Connect any equipment that will be attached to this product to properly wired outlets/sources.
- When possible, use one hand only to connect or disconnect signal cables.
- Never turn on any equipment when there is evidence of fire, water, or structural damage.
- The device might have more than one power cord, to remove all electrical current from the device, ensure that all power cords are disconnected from the power source.

**Safety information for DC power supplies**

**CAUTION:**

240 V dc input (input range: 180-300 V dc) is supported in Chinese Mainland ONLY. Power supply with 240 V dc input cannot support hot plugging power cord function. Before removing the power supply with dc input, please turn off server or disconnect dc power sources at the breaker panel or by turning off the power source. Then, remove the power cord.



在直流输入状态下，若电源供应器插座不支持热插拔功能，请务必不要对设备电源线进行热插拔，此操作可能导致设备损坏及数据丢失。因错误执行热插拔导致的设备故障或损坏，不属于保修范围。

NEVER CONNECT AND DISCONNECT THE POWER SUPPLY CABLE AND EQUIPMENT WHILE YOUR EQUIPMENT IS POWERED ON WITH DC SUPPLY (hot-plugging). Otherwise you may damage the equipment and result in data loss, the damages and losses result from incorrect operation of the equipment will not be covered by the manufacturers' warranty.

**S035**



**CAUTION:**

Never remove the cover on a power supply or any part that has this label attached. Hazardous voltage, current, and energy levels are present inside any component that has this label attached. There are no serviceable parts inside these components. If you suspect a problem with one of these parts, contact a service technician.

## S019



### CAUTION:

The power-control button on the device does not turn off the electrical current supplied to the device. The device also might have more than one connection to dc power. To remove all electrical current from the device, ensure that all connections to dc power are disconnected at the dc power input terminals.

## S029



**For -48V dc power supply, electrical current from power cords is hazardous.  
To avoid a shock hazard:**

- **To connect or disconnect -48V dc power cords when you need to remove/install redundancy power supply unit(s).**

### To Connect:

1. Turn OFF subject dc power source(s) and equipment (s) that are attached to this product.
2. Install the power supply unit(s) into the system housing.
3. Attach dc power cord(s) to the product.
  - Ensure correct polarity of -48 V dc connections: RTN is + and -Vin (typical -48 V) dc is -. Earth ground should be connected very well.
4. Connect dc power cord(s) to subject power source (s).
5. Turn ON all the power source(s).

### To Disconnect:

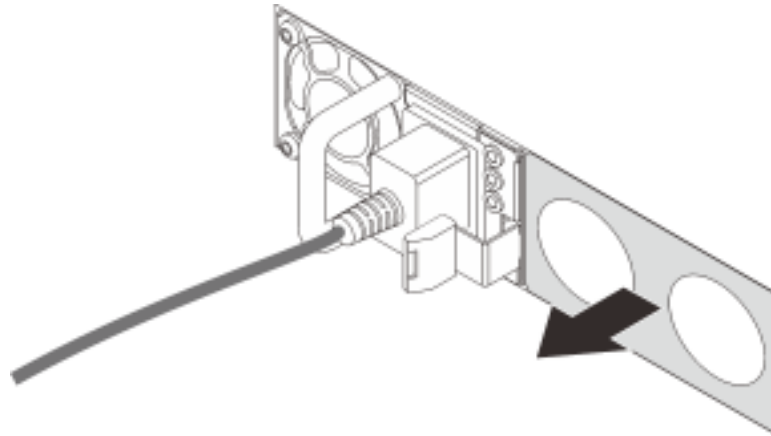
1. Disconnect or turn off the subject dc power source(s) (at the breaker panel) before removing the power supply unit(s).
2. Remove the subject dc cord(s) and make sure the wire terminal of power cord(s) is insulated.
3. Unplug the subject power supply unit(s) from the system housing.

### Attention:

- Read [“Installation Guidelines” on page 51](#) and [“Safety inspection checklist” on page 52](#) to ensure that you work safely.
- Prevent exposure to static electricity, which might lead to system halt and loss of data, by keeping static-sensitive components in their static-protective packages until installation, and handling these devices with an electrostatic-discharge wrist strap or other grounding systems.

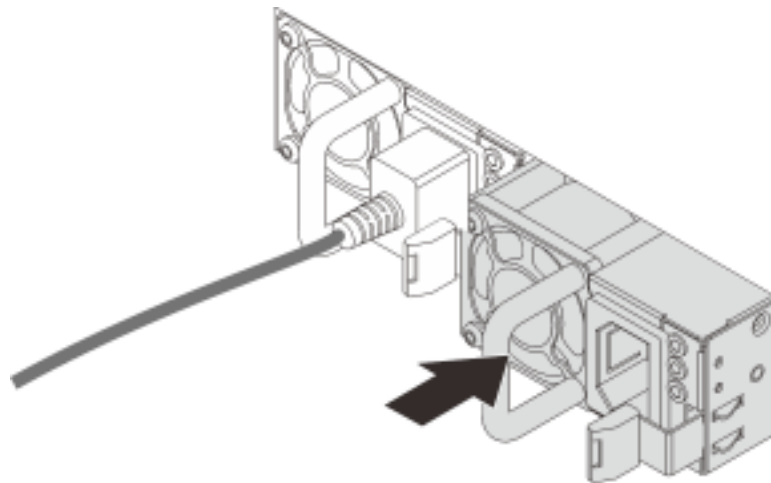
## Procedure

- Step 1. Touch the static-protective package that contains the hot-swap power supply unit to any unpainted surface on the outside of the server. And then, take the hot-swap power supply unit out of the package and place it on a static-protective surface.
- Step 2. If there is a power-supply-unit filler installed, remove it.



*Figure 84. Hot-swap power supply filler removal*


- Step 3. Slide the new hot-swap power supply unit into the bay until it snaps into position.



*Figure 85. Hot-swap power supply installation*

- Step 4. Connect the power supply unit to a properly grounded electrical outlet.
- For 240 V DC power supply units:
    1. Turn off the server.
    2. Connect one end of the power cord to the power connector on the power supply unit.
    3. Connect the other end of the power cord to a properly grounded electrical outlet.
  - For AC power supply units:
    1. Connect one end of the power cord to the power connector on the power supply unit.
    2. Connect the other end of the power cord to a properly grounded electrical outlet.

- For –48V DC power supply units:
  1. Use a slotted screwdriver to loosen the 3 captive screws on the power supply terminal block.
  2. Check the type label on the power supply block and each power cord.

Type	PSU terminal block	Power cord
Input	-Vin	-Vin
Ground		GND
Input	RTN	RTN

3. Face the groove side of each power cord pin upwards, and then plug the pins into corresponding holes on the power block. Use the table above for guidance to ensure that the pins find correct slots.
4. Tighten the captive screws on the power block. Ensure that the screws and cord pins are secured in place and no bare metal parts are shown.
5. Connect the other end of the cables to a properly grounded electrical outlet. Ensure that the cable ends find correct outlets.

### After you finish

1. If you have adjusted the CMA to gain access to the power supply bay, readjust the CMA back in place.
2. If the server is turned off, turn on the server. Ensure that both the power input LED and the power output LED on the power supply unit are lit, indicating that the power supply unit is operating properly.

### Demo video

[Watch the procedure on YouTube](#)

## Internal CFF RAID adapter replacement

Use this information to remove and install the internal CFF RAID adapter.

### Remove the internal CFF RAID adapter

Use this information to remove the internal CFF RAID adapter.

### About this task

#### Attention:

- Read [“Installation Guidelines” on page 51](#) and [“Safety inspection checklist” on page 52](#) to ensure that you work safely.
- Power off the server and peripheral devices and disconnect the power cords and all external cables. See [“Power off the server” on page 68](#).
- Prevent exposure to static electricity, which might lead to system halt and loss of data, by keeping static-sensitive components in their static-protective packages until installation, and handling these devices with an electrostatic-discharge wrist strap or other grounding systems.

## Procedure

- Step 1. Remove the top cover. See [“Remove the top cover” on page 243](#).
- Step 2. Remove any components that may impede access to the internal CFF RAID adapter.
- Step 3. Disconnect all cables from the internal CFF RAID adapter.
- Step 4. Lift the release pin, slightly slide the internal CFF RAID adapter as shown, and carefully lift it out of the chassis.

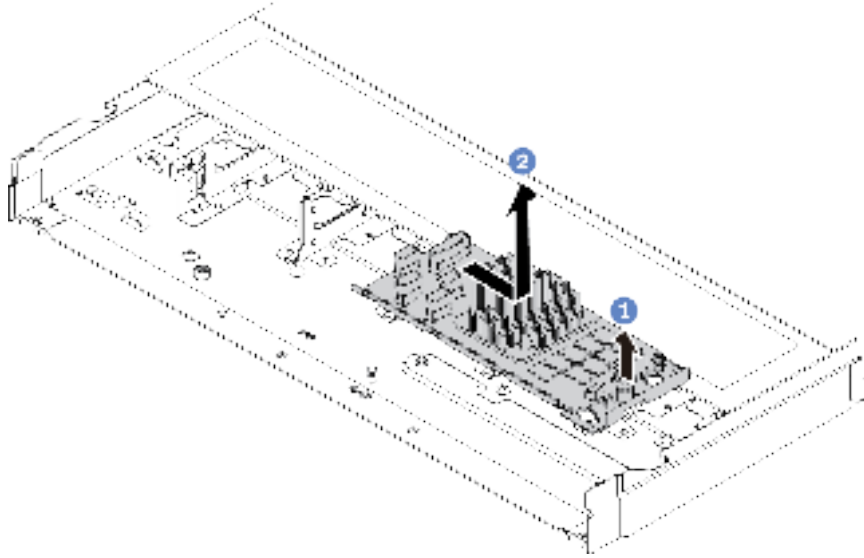


Figure 86. internal CFF RAID adapter removal

- a. **1** Release the push pin on the internal CFF RAID adapter.
- b. **2** Move the adapter to the right and then lift it out of the chassis.

## After you finish

If you are instructed to return the component or optional device, follow all packaging instructions, and use any packaging materials for shipping that are supplied to you.

### Demo video

[Watch the procedure on YouTube](#)

## Install the internal CFF RAID adapter

Use this information to install the internal CFF RAID adapter.

### About this task

#### Attention:

- Read [“Installation Guidelines” on page 51](#) and [“Safety inspection checklist” on page 52](#) to ensure that you work safely.
- Power off the server and peripheral devices and disconnect the power cords and all external cables. See [“Power off the server” on page 68](#).



- Prevent exposure to static electricity, which might lead to system halt and loss of data, by keeping static-sensitive components in their static-protective packages until installation, and handling these devices with an electrostatic-discharge wrist strap or other grounding systems.

## Procedure

- Step 1. Touch the static-protective package that contains the internal CFF RAID adapter to any unpainted surface on the outside of the server. Then, take the internal CFF RAID adapter out of the package and place it on a static-protective surface.
- Step 2. Align the notches on the tray with the pins on the chassis, place down the internal CFF RAID adapter, and slightly slide it as shown to secure it on the chassis.

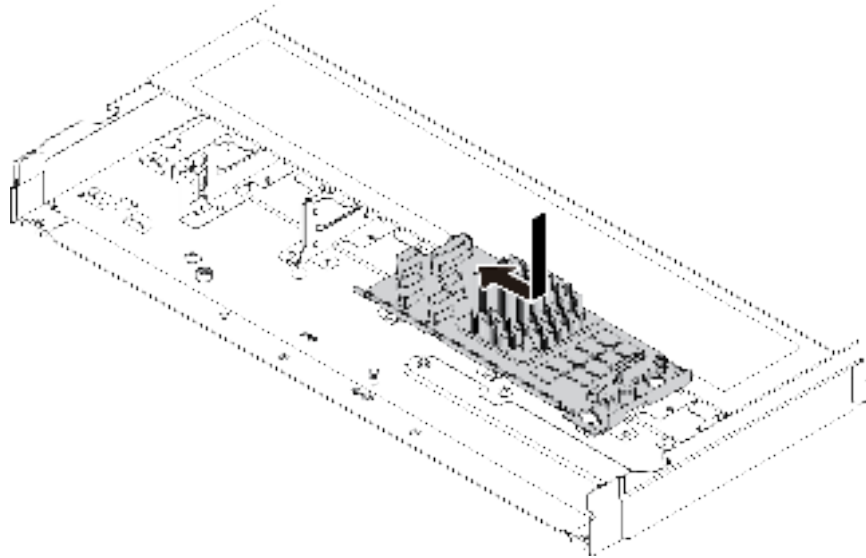


Figure 87. internal CFF RAID adapter installation

- Step 3. Connect cables to the internal RAID adapter. See [“CFF RAID adapter” on page 260](#).

## After you finish

Complete the parts replacement. See [“Complete the parts replacement” on page 246](#).

## Demo video

[Watch the procedure on YouTube](#)

---

## Intrusion switch replacement

Use this information to remove and install an intrusion switch.

The intrusion switch informs you that the server cover is not properly installed or closed by creating an event in the system event log (SEL).

## Remove an intrusion switch

Use this information to remove an intrusion switch.

## About this task

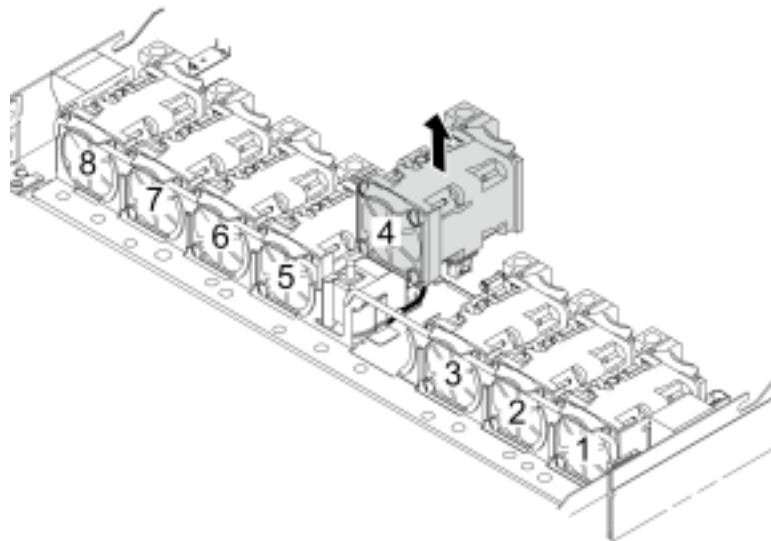
**Attention:**

- Read [“Installation Guidelines” on page 51](#) and [“Safety inspection checklist” on page 52](#) to ensure that you work safely.
- Power off the server and peripheral devices and disconnect the power cords and all external cables. See [“Power off the server” on page 68](#).
- Prevent exposure to static electricity, which might lead to system halt and loss of data, by keeping static-sensitive components in their static-protective packages until installation, and handling these devices with an electrostatic-discharge wrist strap or other grounding systems.

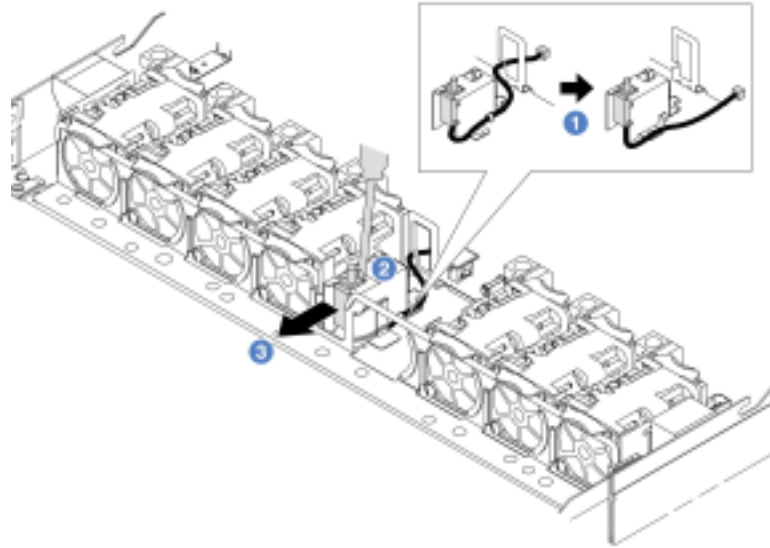
**Procedure**

Step 1. Remove the top cover. See [“Remove the top cover” on page 243](#).

Step 2. Remove the system fan 4.

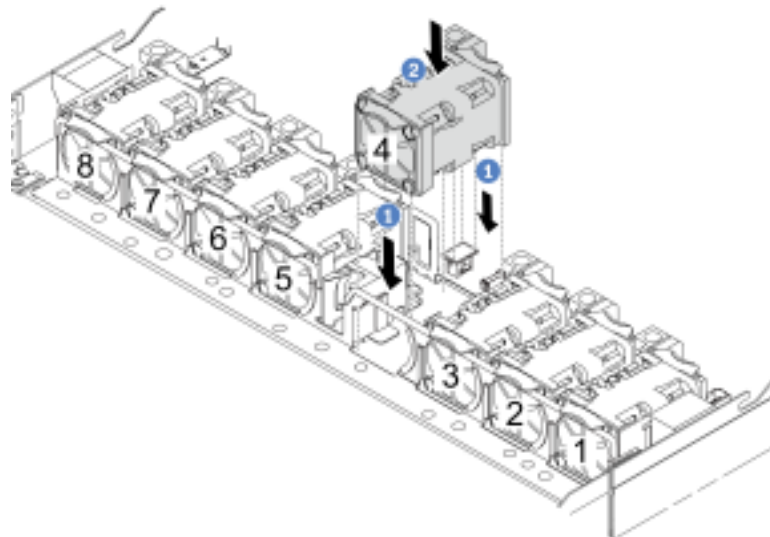


Step 3. Remove the intrusion switch.



- a. ❶ Disconnect the cable of the intrusion switch from the processor board. For the location of the intrusion switch connector and cable routing information, refer to [“System-board-assembly connectors” on page 36](#) and [“Intrusion switch” on page 263](#). Route the cable out of the cable clip.
- b. ❷ Insert the tip of a slotted screwdriver into the gap between the cage and switch and push outwards.
- c. ❸ Slide the intrusion switch as shown to remove it.

Step 4. Re-install the system fan 4.



- a. ❶ Align the four corners of the fan to fan module socket and put it down.
- b. ❷ Press the fan latch down to ensure that it is plugged in the connector.

## After you finish

If you are instructed to return the component or optional device, follow all packaging instructions, and use any packaging materials for shipping that are supplied to you.

### Demo video

[Watch the procedure on YouTube](#)

## Install an intrusion switch

Use this information to install an intrusion switch.

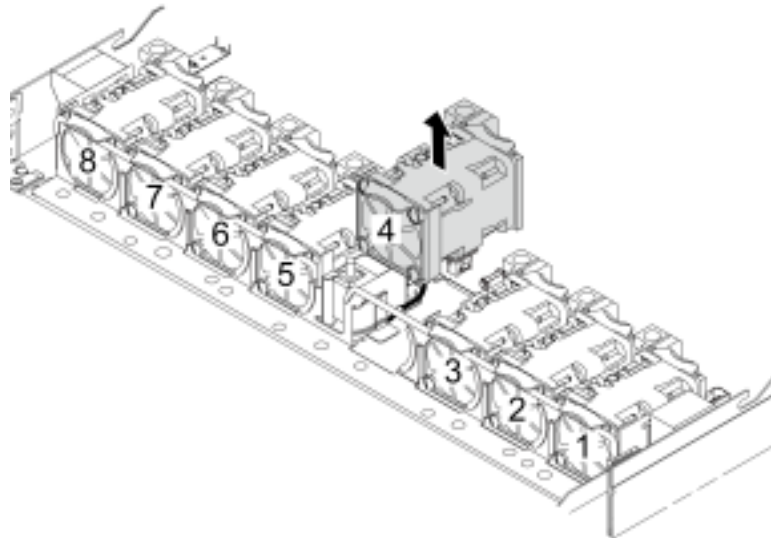
### About this task

#### Attention:

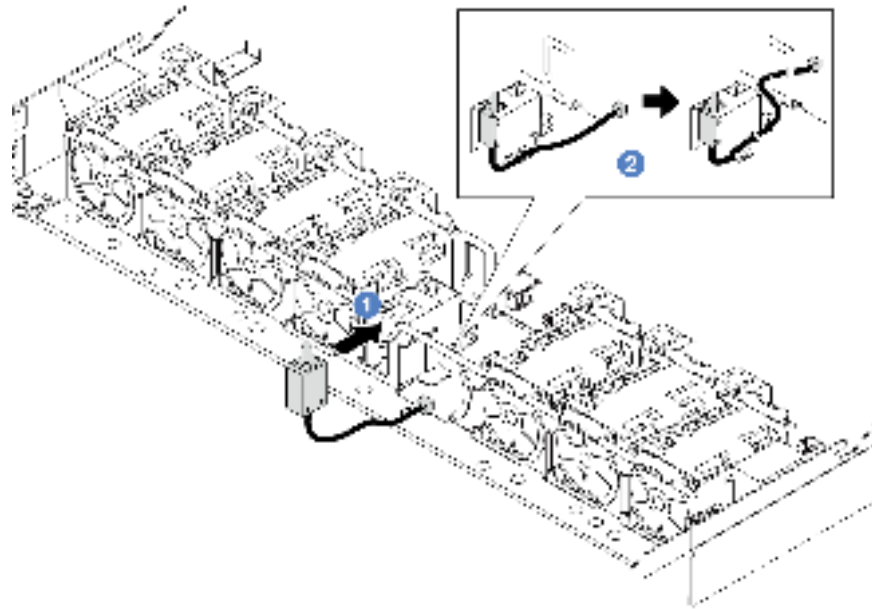
- Read [“Installation Guidelines” on page 51](#) and [“Safety inspection checklist” on page 52](#) to ensure that you work safely.
- Power off the server and peripheral devices and disconnect the power cords and all external cables. See [“Power off the server” on page 68](#).
- Prevent exposure to static electricity, which might lead to system halt and loss of data, by keeping static-sensitive components in their static-protective packages until installation, and handling these devices with an electrostatic-discharge wrist strap or other grounding systems.

### Procedure

- Step 1. Touch the static-protective package that contains the intrusion switch to any unpainted surface on the outside of the server. Then, take the intrusion switch out of the package and place them on a static-protective surface.
- Step 2. Remove the system fan 4.



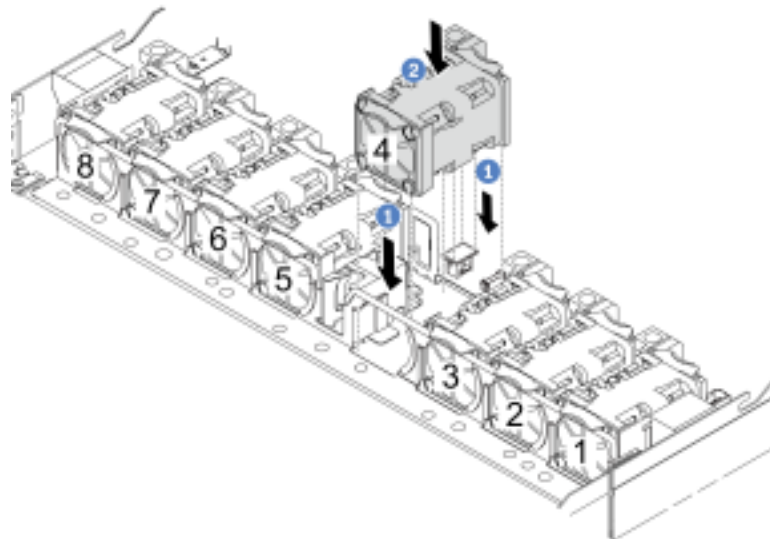
- Step 3. Install the intrusion switch.



- a. 1 Insert the intrusion switch into the cage.
- b. 2 Route the cable into the cable clip.

Step 4. Connect the cable of the intrusion switch to the intrusion switch connector on the processor board. See [“Intrusion switch” on page 263](#).

Step 5. Re-install the system fan 4.



- a. 1 Align the four corners of the fan to fan module socket and put it down.
- b. 2 Press the fan latch down to ensure that it is plugged in the connector.

## After you finish

Complete the parts replacement. See [“Complete the parts replacement” on page 246](#).

## Demo video

[Watch the procedure on YouTube](#)

---

## Lenovo Neptune(TM) liquid assisted cooling module replacement (trained technicians only)

Follow instructions in this section to remove and install the Liquid Assisted Cooling Module (LACM).

**Important:** This task must be operated by trained technicians that are certified by Lenovo Service. Do not attempt to remove or install it without proper training and qualification.

### Remove the Lenovo Neptune(TM) liquid assisted cooling module

Follow instructions in this section to remove the Liquid Assisted Cooling Module (LACM).

**Important:** This task must be operated by trained technicians that are certified by Lenovo Service. Do not attempt to remove or install it without proper training and qualification.

### About this task

#### Safety information for liquid detection sensor module cable

##### S011



**CAUTION:**

Sharp edges, corners, or joints nearby.

**Attention:**

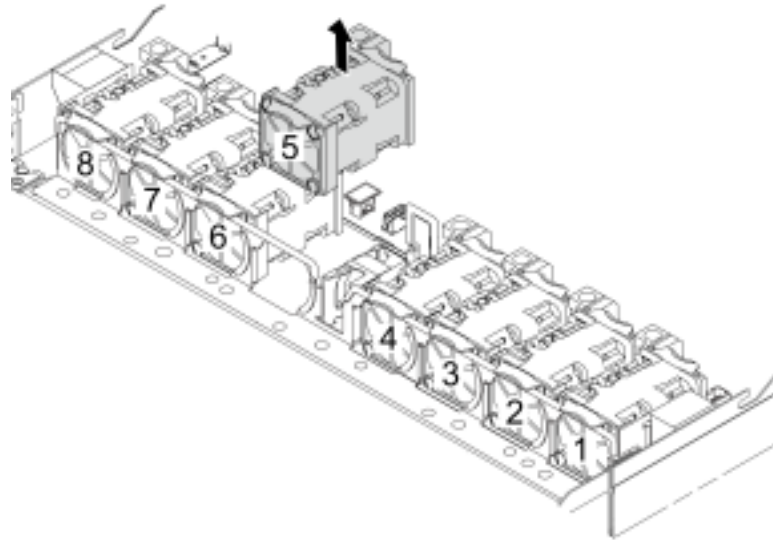
- Read [“Installation Guidelines” on page 51](#) and [“Safety inspection checklist” on page 52](#) to ensure that you work safely.
- Power off the server and peripheral devices and disconnect the power cords and all external cables. See [“Power off the server” on page 68](#).
- Prevent exposure to static electricity, which might lead to system halt and loss of data, by keeping static-sensitive components in their static-protective packages until installation, and handling these devices with an electrostatic-discharge wrist strap or other grounding systems.

Prepare the following screwdrivers to ensure you can install and remove the corresponding screws properly.

Torque screwdriver type list	Screw Type
Torx T30 head screwdriver	Torx T30 screw

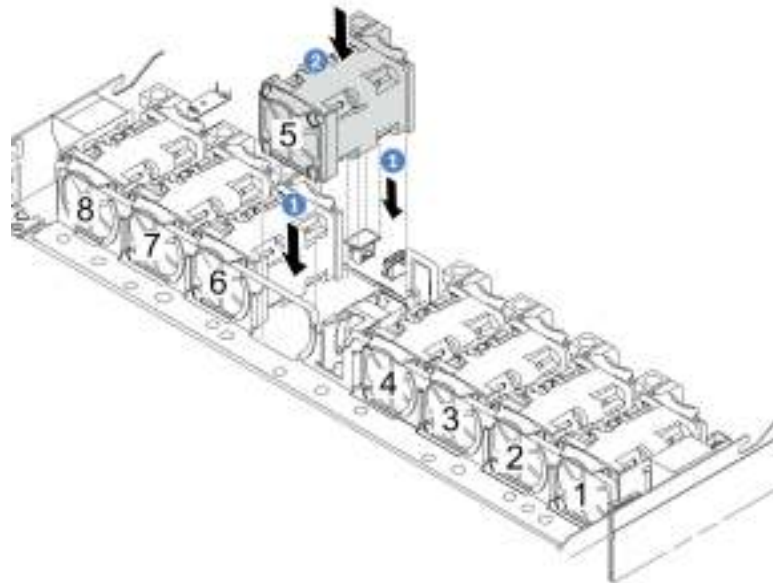
### Procedure

- Step 1. Remove the top cover. See [“Remove the top cover” on page 243](#).
- Step 2. Remove the system fan 5 from the fan module.



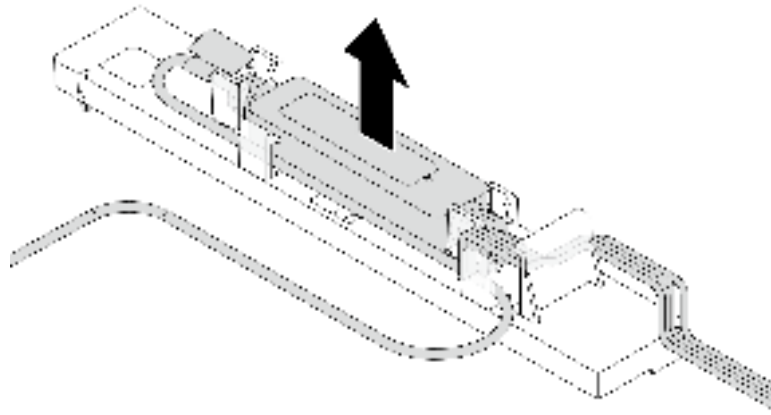
Step 3. Disconnect the pump 1 cable of the LACM from the connector on the system board assembly. See [“Liquid assisted cooling module” on page 275](#).

Step 4. Re-install the system fan 5 into the fan module.

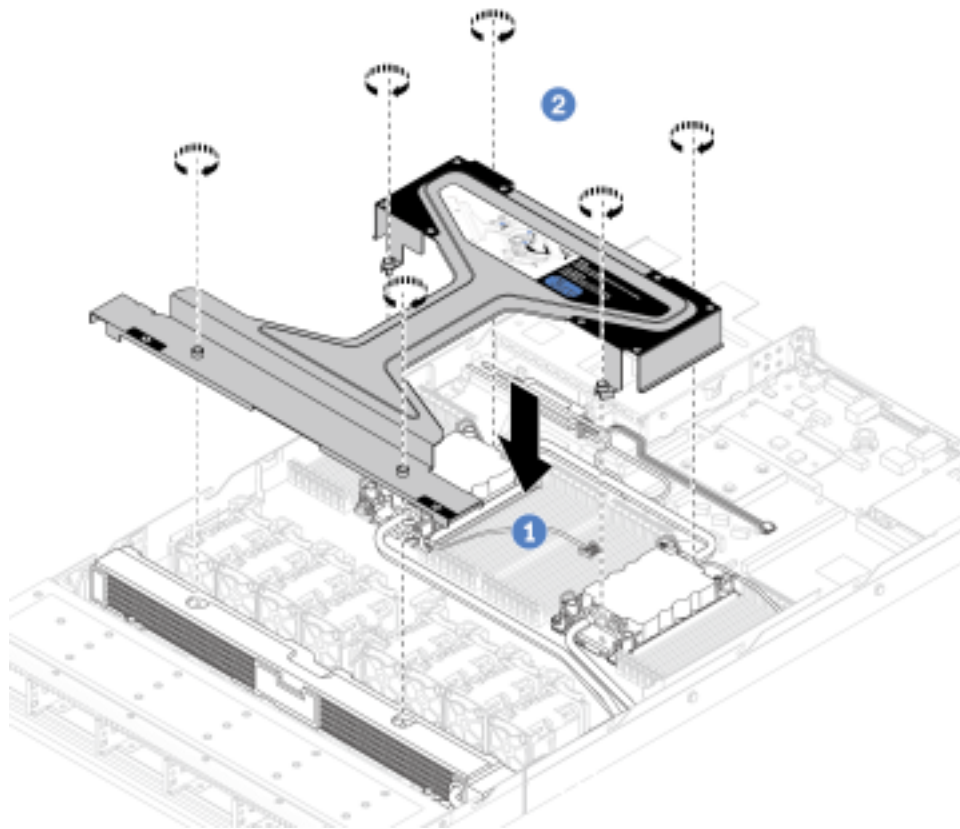


- a. ① Align the four corners of the fan to fan module socket and put it down.
- b. ② Press the fan latch down to ensure that it is plugged in the connector.

Step 5. Disconnect the leak detection cable from the processor board, and route it out of the cable clips on the liquid detection sensor module holder.



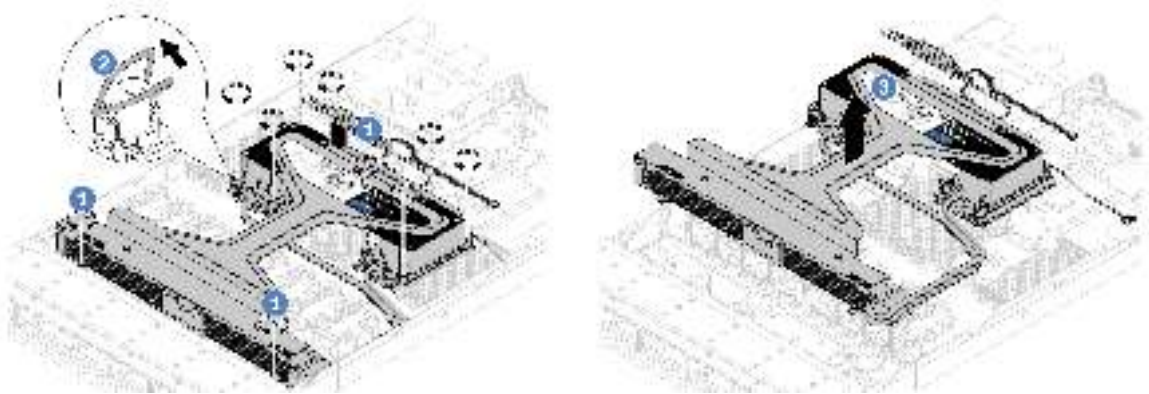
Step 6. Re-install the handle to the LACM.



- a. 1 Place the module handle (LACM heat sink bracket) evenly on the LACM and align screw holes.
- b. 2 Tighten the screws. Ensure that the screws are secured in place.

Step 7. Disengage the LACM from processors.





- a. 1 Fully loosen the Torx T30 nuts on the cold plate assembly and radiator.
- b. 2 Rotate the anti-tilt wire bails inward.
- c. 3 Carefully lift the LACM from the processor sockets by the module handle (LACM heat sink bracket). If the LACM cannot be fully lifted out of the socket, further loosen the Torx T30 nuts and try lifting the LACM again.

Step 8. Place the LACM on the shipping tray.

Step 9. If there is any old thermal grease on the processors and the cold plates, gently clean the top of the processors and the cold plates with an alcohol cleaning pad.

## After you finish

If you are instructed to return the component or optional device, follow all packaging instructions, and use any packaging materials for shipping that are supplied to you.

## Demo video

[Watch the procedure on YouTube](#)

## Install the Lenovo Neptune(TM) liquid assisted cooling module

Follow instructions in this section to install the Liquid Assisted Cooling Module (LACM).

**Important:** This task must be operated by trained technicians that are certified by Lenovo Service. Do not attempt to remove or install it without proper training and qualification.

## About this task

### Safety information for liquid detection sensor module cable

#### S011



**CAUTION:**  
Sharp edges, corners, or joints nearby.

**Attention:**

- Read “[Installation Guidelines](#)” on page 51 and “[Safety inspection checklist](#)” on page 52 to ensure that you work safely.
- Power off the server and peripheral devices and disconnect the power cords and all external cables. See “[Power off the server](#)” on page 68.
- Prevent exposure to static electricity, which might lead to system halt and loss of data, by keeping static-sensitive components in their static-protective packages until installation, and handling these devices with an electrostatic-discharge wrist strap or other grounding systems.

**CAUTION:**

**When removing a new LACM from the shipping box, lift out the cold plate assembly with the shipping tray attached to prevent thermal grease on the cold plate assembly from damage.**

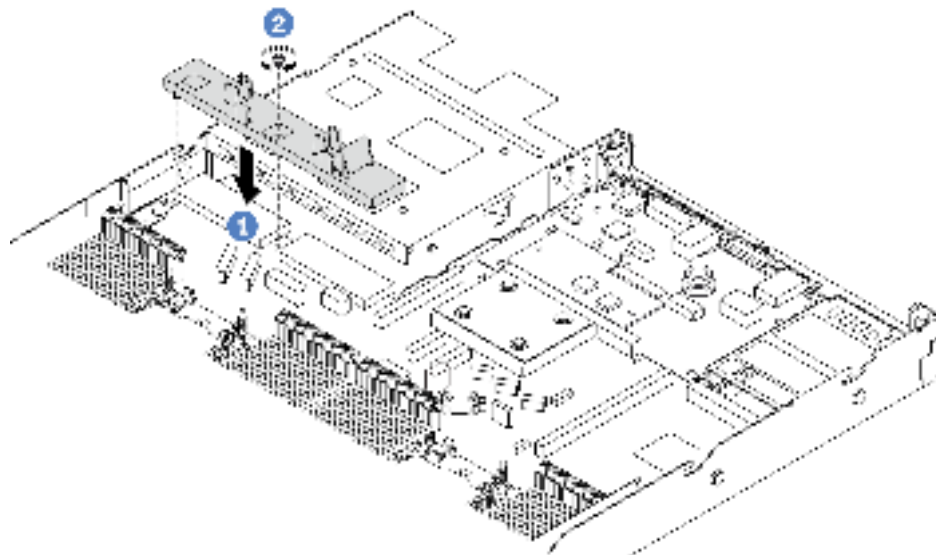
Prepare the following screwdrivers to ensure you can install and remove the corresponding screws properly.

Torque screwdriver type list	Screw Type
Torx T30 head screwdriver	Torx T30 screw

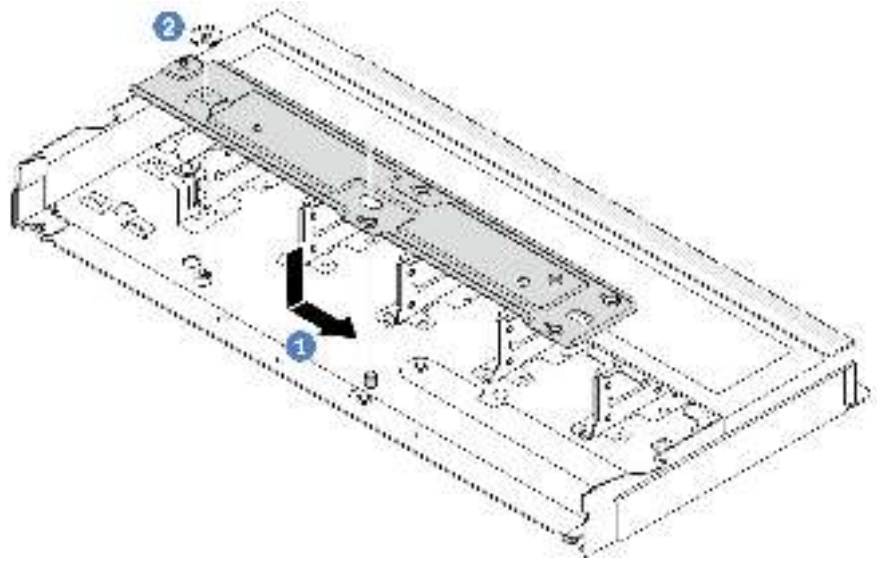
**Procedure**

Step 1. Prepare your server.

- a. Install the liquid detection sensor module holder to the chassis.

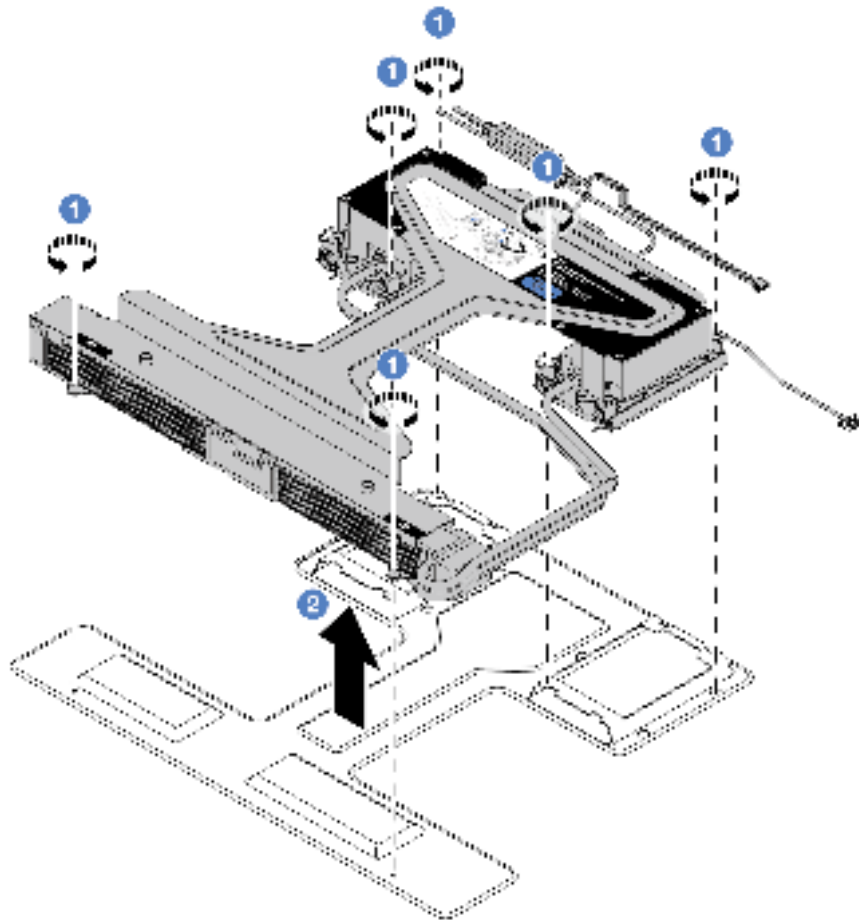


1. **1** Align the liquid detection sensor module holder to the corresponding screw hole on the chassis.
  2. **2** Tighten the screw and ensure that the holder is secured in place.
- b. Install the radiator tray to the chassis.



1. 1 Place the tray evenly into the chassis and then move it to the right so that the screw hole on the tray aligns with the hole on the chassis.
2. 2 Tighten the screw.

Step 2. Separate the LACM module from the shipping tray.

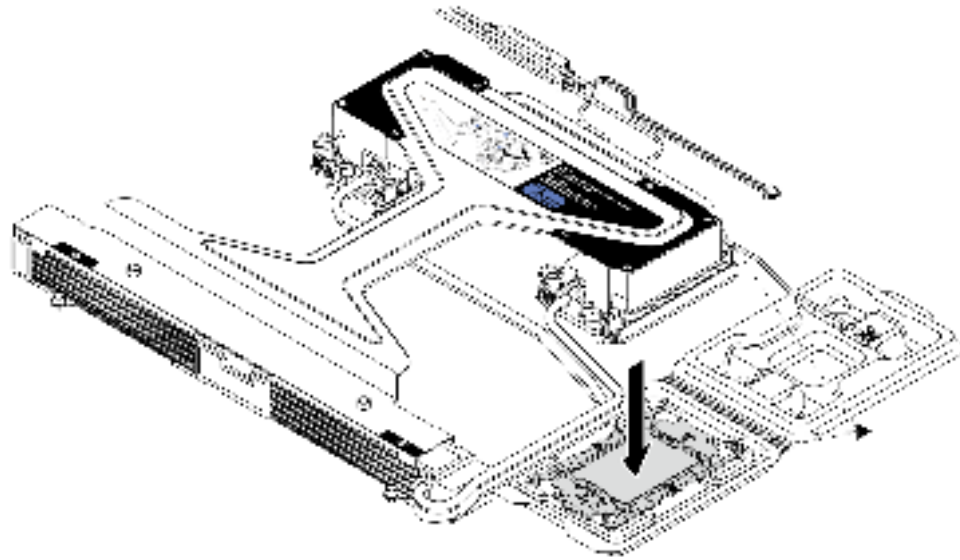


- a. 1 Loosen the six screws on the LACM module shipping tray.
- b. 2 Lift the LACM by the module handle (LACM heat sink bracket) to separate the module from the shipping tray.

Step 3. Make sure you have an alcohol cleaning pad available.

**Attention:** If there is any old thermal grease on the processors, gently clean the top of the processors with an alcohol cleaning pad.

Step 4. Install the processor to the LACM.



1. Align the triangular mark on the cold plate assembly label with the triangular mark on the processor carrier and processor.
2. Install the LACM onto the processor-carrier.
3. Press the carrier into place until the clips at all four corners engage.

**Note:** If your server only has one processor installed, generally processor one, it is required to install a cover to the empty socket of processor two before you proceed with further installation.

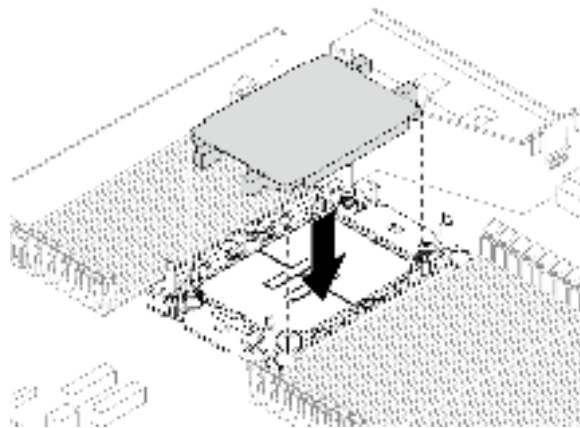
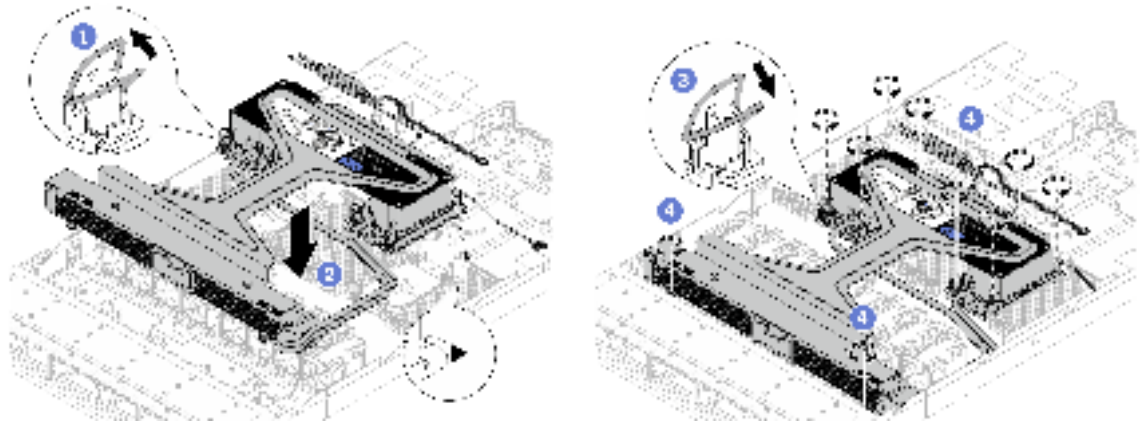


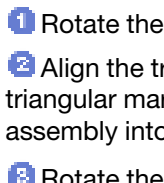
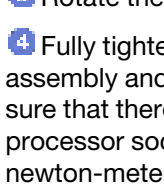


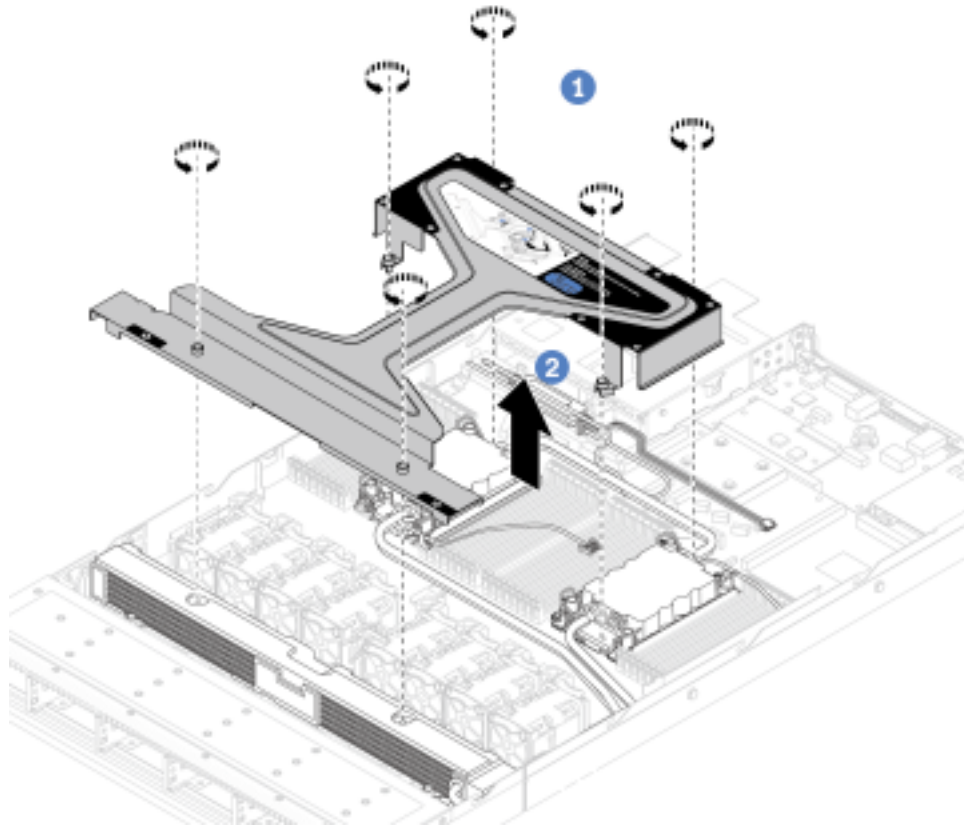
Figure 88. Install the processor socket cover

Step 5. Install the processor-LACM to the system board assembly.



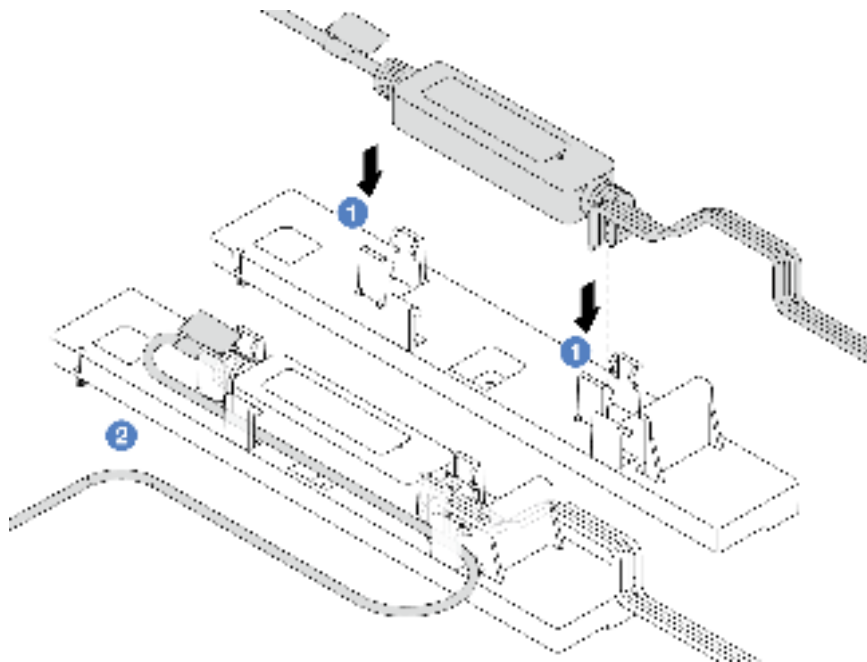
1.  Rotate the anti-tilt wire bails inward.
2.  Align the triangular mark and four Torx T30 nuts on the cold plate assembly with the triangular mark and threaded posts of the processor socket; then, insert the cold plate assembly into the processor socket.
3.  Rotate the anti-tilt wire bails outward until they engage with the hooks in the socket.
4.  Fully tighten the Torx T30 nuts *in the installation sequence shown* on the cold plate assembly and the radiator. Tighten the screws until they stop; then, visually inspect to make sure that there is no gap between the screw shoulder beneath the cold plate assembly and the processor socket. (For reference, the torque required for the fasteners to fully tighten is 0.9-1.3 newton-meters, 8-12 inch-pounds.)

Step 6. Separate the module handle (LACM heat sink bracket) from the module.



1. ❶ Loosen the six screws on the module handle (LACM heat sink bracket).
2. ❷ Lift the module handle (LACM heat sink bracket) to separate it from the module.

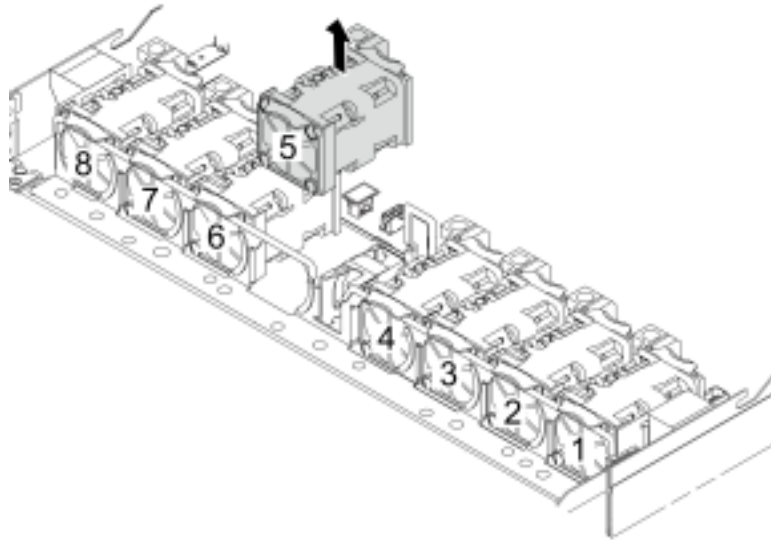
Step 7. Install the leak detection module to the holder.



**Note:** For liquid detection sensor module working status, see [“The LED on the liquid detection sensor module” on page 463](#).

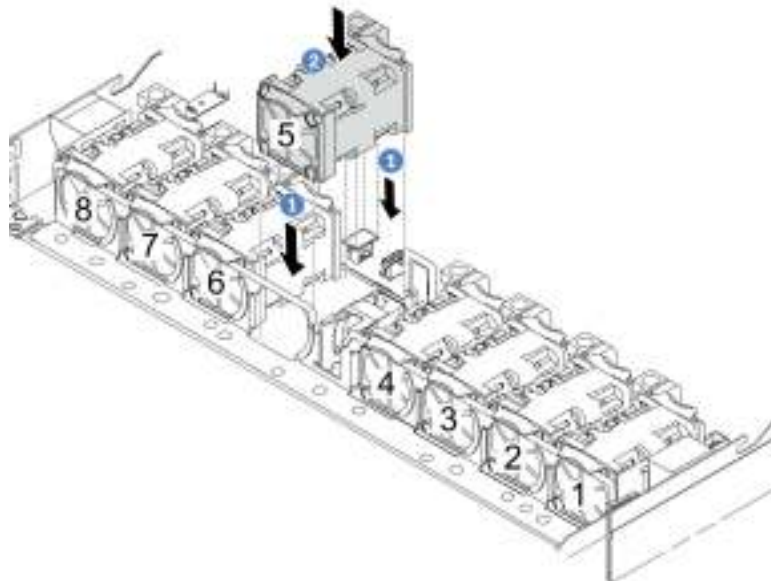
- a. ❶ Install the liquid detection sensor module into the two clips on the holder. Ensure that the module is secured in place.
- b. ❷ After the module is secured, route the cable through the cable clips to keep tidy for later cable routing arrangements.

Step 8. Remove the system fan 5 from the fan module.



Step 9. Connect the pump 1 cable of the LACM to the connector on the system board assembly. See [“Liquid assisted cooling module” on page 275](#).

Step 10. Re-install the system fan 5 into the fan module.



- a. ❶ Align the four corners of the fan to fan module socket and put it down.
- b. ❷ Press the fan latch down to ensure that it is plugged in the connector.

## After you finish

Complete the parts replacement. See [“Complete the parts replacement” on page 246](#).

### Demo video

[Watch the procedure on YouTube](#)

---

## Memory module replacement

Use the following procedures to remove and install a memory module.

### Remove a memory module

Use this information to remove a memory module.

#### About this task

##### Attention:

- Read [“Installation Guidelines” on page 51](#) and [“Safety inspection checklist” on page 52](#) to ensure that you work safely.
- Power off the server and peripheral devices and disconnect the power cords and all external cables. See [“Power off the server” on page 68](#).
- Prevent exposure to static electricity, which might lead to system halt and loss of data, by keeping static-sensitive components in their static-protective packages until installation, and handling these devices with an electrostatic-discharge wrist strap or other grounding systems.
- If you are not installing a replacement memory module to the same slot, make sure you have memory module filler available.
- Memory modules are sensitive to static discharge and require special handling. Refer to the standard guidelines for [“Handling static-sensitive devices” on page 54](#).
  - Always wear an electrostatic-discharge strap when removing or installing memory modules. Electrostatic-discharge gloves can also be used.
  - Never hold two or more memory modules together so that they do not touch each other. Do not stack memory modules directly on top of each other during storage.
  - Never touch the gold memory module connector contacts or allow these contacts to touch the outside of the memory module connector housing.
  - Handle memory modules with care: never bend, twist, or drop a memory module.
  - Do not use any metal tools (such as jigs or clamps) to handle the memory modules, because the rigid metals may damage the memory modules.
  - Do not insert memory modules while holding packages or passive components, which can cause package cracks or detachment of passive components by the high insertion force.

**Important:** Remove or install memory modules for one processor at a time.

#### Procedure

- Step 1. Power off the server and disconnect all power cords.
- Step 2. Remove the top cover. See [“Remove the top cover” on page 243](#).
- Step 3. If your server comes with an air baffle, remove it. See [“Remove the air baffle” on page 77](#).



Step 4. Remove the memory module from the slot.

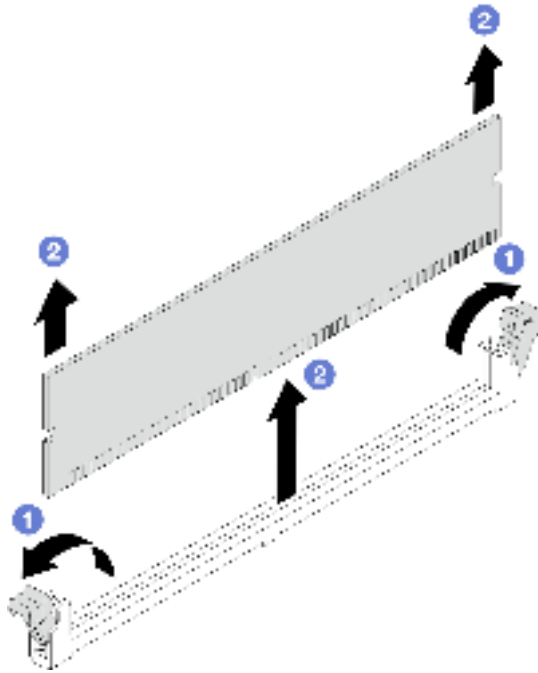


Figure 89. Memory module removal

- a. 1 Open the retaining clip on each end of the memory module slot.

**Attention:** To avoid breaking the retaining clips or damaging memory module slots, handle the clips gently.

- b. 2 Grasp the memory module at both ends and carefully lift it out of the slot.

## After you finish

1. A memory module slot must be installed with a memory module or a memory module filler. See [“Install a memory module” on page 151](#).
2. If you are instructed to return the component or optional device, follow all packaging instructions, and use any packaging materials for shipping that are supplied to you.

## Demo video

[Watch the procedure on YouTube](#)

## Install a memory module

Follow instructions in this section to install a memory module.

## About this task

### Attention:

- Read [“Installation Guidelines” on page 51](#) and [“Safety inspection checklist” on page 52](#) to ensure that you work safely.
- Power off the server and peripheral devices and disconnect the power cords and all external cables. See [“Power off the server” on page 68](#).

- Prevent exposure to static electricity, which might lead to system halt and loss of data, by keeping static-sensitive components in their static-protective packages until installation, and handling these devices with an electrostatic-discharge wrist strap or other grounding systems.
- Make sure to adopt one of the supported configurations listed in [“Memory module installation rules and order” on page 56](#).
- Memory modules are sensitive to static discharge and require special handling. Refer to the standard guidelines at [“Handling static-sensitive devices” on page 54](#):
  - Always wear an electrostatic-discharge strap when removing or installing memory modules. Electrostatic-discharge gloves can also be used.
  - Never hold two or more memory modules together so that they do not touch each other. Do not stack memory modules directly on top of each other during storage.
  - Never touch the gold memory module connector contacts or allow these contacts to touch the outside of the memory module connector housing.
  - Handle memory modules with care: never bend, twist, or drop a memory module.
  - Do not use any metal tools (such as jigs or clamps) to handle the memory modules, because the rigid metals may damage the memory modules.
  - Do not insert memory modules while holding packages or passive components, which can cause package cracks or detachment of passive components by the high insertion force.

**Important:** Remove or install memory modules for one processor at a time.

**Firmware and driver download:** You might need to update the firmware or driver after replacing a component.

- Go to <https://datacentersupport.lenovo.com/products/servers/thinksystem/sr630v3/7d72/downloads/driver-list/> to see the latest firmware and driver updates for your server.
- Go to [“Update the firmware” on page 433](#) for more information on firmware updating tools.

## Procedure

- Step 1. Power off the server and disconnect all power cords.
- Step 2. Touch the static-protective package that contains the memory module to any unpainted surface on the outside of the server. Then, take the memory module out of the package and place it on a static-protective surface.
- Step 3. Locate the required memory module slot on the processor board.

**Note:** Ensure that you observe the installation rules and sequence in [“Memory module installation rules and order” on page 56](#).

Step 4. Install the memory module into the slot.

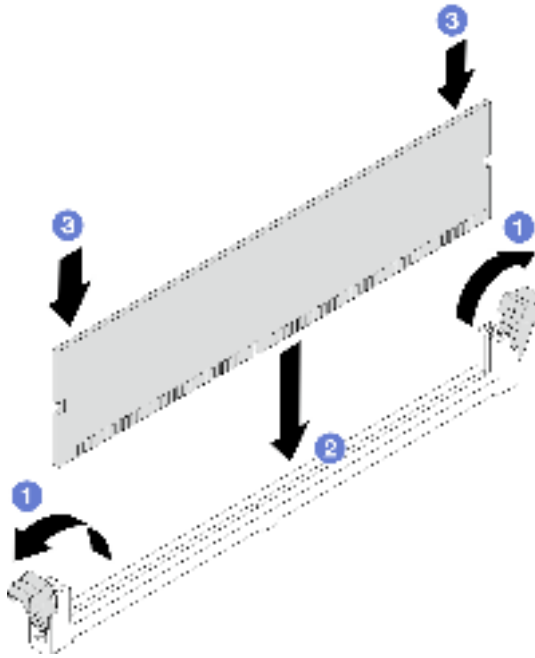


Figure 90. Memory module installation

**Attention:**

- Before you install a memory module into the slot, make sure that the clips are on open position, and the slot is clear of any debris.
  - To avoid breaking the retaining clips or damaging the memory module slots, open and close the clips gently.
- a. 1 Open the retaining clip on each end of the memory module slot.
  - b. 2 Identify the key on the memory module and then align the key to the slot, and gently place the memory module into the slot with both hands.
  - c. 3 Press both ends of the memory module straight down into the slot until the retaining clips snap into the locked position.

**Note:** If there is a gap between the memory module and the retaining clips, the memory module has not been correctly inserted. In this case, open the retaining clips, remove the memory module, and then reinsert it.

## After you finish

Complete the parts replacement. See [“Complete the parts replacement” on page 246](#).

### Demo video

[Watch the procedure on YouTube](#)

---

## MicroSD card replacement

Follow the instructions in this section to remove and install the MicroSD card.

## Remove the MicroSD card

Follow the instructions in this section to remove the MicroSD card.

### About this task

#### Attention:

- Read [“Installation Guidelines” on page 51](#) and [“Safety inspection checklist” on page 52](#) to ensure that you work safely.
- Power off the server and peripheral devices and disconnect the power cords and all external cables. See [“Power off the server” on page 68](#).
- Prevent exposure to static electricity, which might lead to system halt and loss of data, by keeping static-sensitive components in their static-protective packages until installation, and handling these devices with an electrostatic-discharge wrist strap or other grounding systems.

### Procedure

Step 1. Prepare your server.

- a. Remove the top cover. See [“Remove the top cover” on page 243](#).
- b. If your server comes with riser assemblies, remove them first, see [“Remove a PCIe adapter” on page 170](#).
- c. If your server comes with a rear drive assembly, remove it first. See [“Remove the 2.5-inch rear drive assembly” on page 198](#).
- d. If your server comes with a 7mm rear drive assembly, remove it first. See [“Remove the 7mm rear drive assembly” on page 202](#).
- e. Record where the cables are connected to the system board assembly; then, disconnect all the cables.

**Attention:** Disengage all latches, cable clips, release tabs, or locks on cable connectors beforehand. Failing to release them before removing the cables will damage the cable connectors on the system board assembly. Any damage to the cable connectors may require replacing the system board assembly.

Step 2. Remove the MicroSD card.

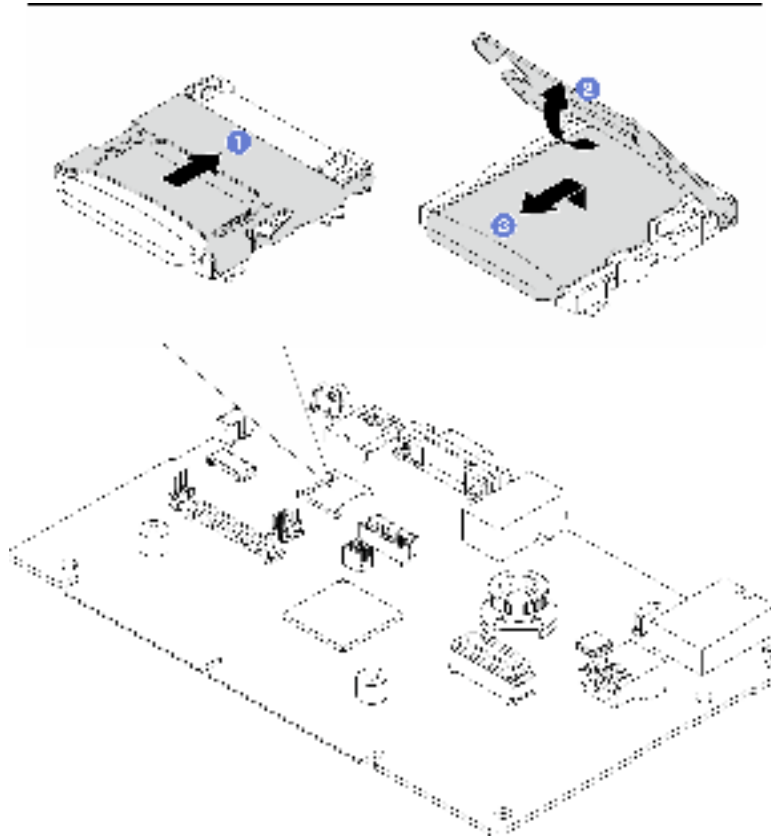


Figure 91. Removing MicroSD card

- a. 1 Slide the socket lid to OPEN position.
- b. 2 Lift open the socket lid.
- c. 3 Remove the MicroSD card from the socket.

**Note:** After the MicroSD card is removed, the historical data of the firmware and user data uploaded through Remote Disc On Card (RDOC) will be lost, and the firmware rollback function and extended RDOC space will not be supported. To enable the two features, it will need to install a new MicroSD card.

## After you finish

If you are instructed to return the component or optional device, follow all packaging instructions, and use any packaging materials for shipping that are supplied to you.

## Install the MicroSD card

Follow the instructions in this section to install the MicroSD card.

## About this task

### Attention:

- Read [“Installation Guidelines” on page 51](#) and [“Safety inspection checklist” on page 52](#) to ensure that you work safely.

- Power off the server and peripheral devices and disconnect the power cords and all external cables. See [“Power off the server” on page 68](#).
- Prevent exposure to static electricity, which might lead to system halt and loss of data, by keeping static-sensitive components in their static-protective packages until installation, and handling these devices with an electrostatic-discharge wrist strap or other grounding systems.

## Procedure

Step 1. Install the MicroSD card.

### Notes:

- If replacing with a new MicroSD card, the firmware historical data and user data stored in the defective MicroSD card would be lost. After a new MicroSD card is installed, subsequent firmware update history will be saved to the new card.
- To update firmware, refer to “Updating Server Firmware” section in [Lenovo XClarity Controller 2](#).

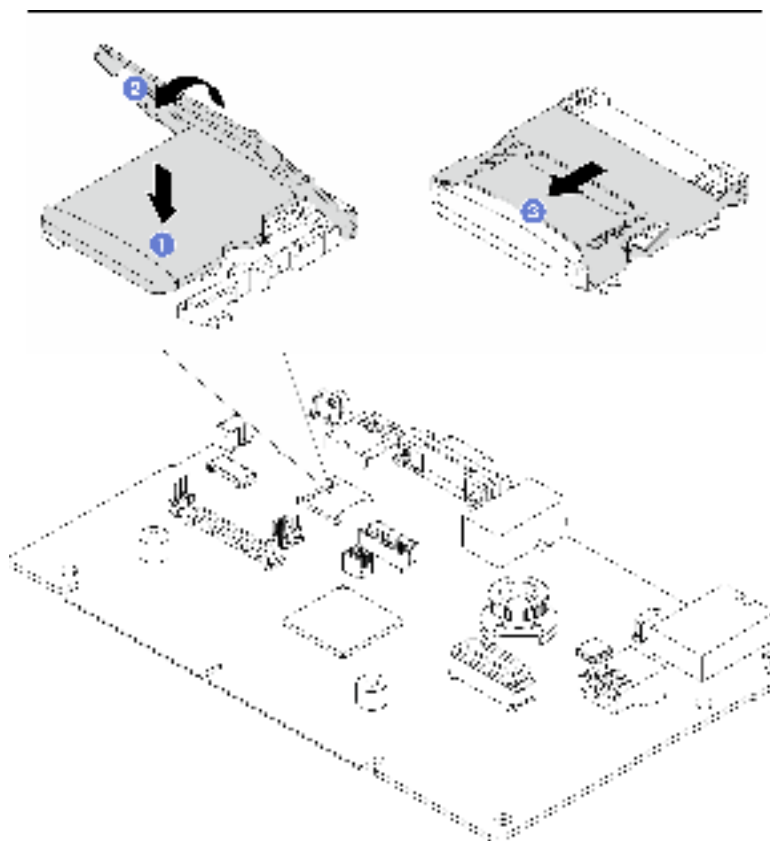


Figure 92. Installing MicroSD card

- 1 Place the MicroSD card into the socket.
- 2 Close the socket lid.
- 3 Slide the socket lid to LOCK position.

## After you finish

1. Install any components that you have removed:
  - a. [“Install a PCIe adapter” on page 171](#)

- b. [“Install the 7mm rear drive assembly” on page 203](#)
  - c. [“Install the 2.5-inch rear drive assembly” on page 199](#)
  - d. [“Install the top cover” on page 244](#)
2. Complete the parts replacement. See [“Complete the parts replacement” on page 246](#).

---

## M.2 backplane and M.2 drive replacement

Use this information to remove and install the M.2 backplane and M.2 drive (an assembled M.2 backplane and M.2 drive is also known as M.2 module).

### Remove the M.2 backplane and M.2 drive

Use this information to remove the M.2 backplane and M.2 drive.

#### About this task

##### Attention:

- Read [“Installation Guidelines” on page 51](#) and [“Safety inspection checklist” on page 52](#) to ensure that you work safely.
- Power off the server and peripheral devices and disconnect the power cords and all external cables. See [“Power off the server” on page 68](#).
- Prevent exposure to static electricity, which might lead to system halt and loss of data, by keeping static-sensitive components in their static-protective packages until installation, and handling these devices with an electrostatic-discharge wrist strap or other grounding systems.

#### Procedure

Step 1. Remove the top cover. See [“Remove the top cover” on page 243](#).

Step 2. Remove the M.2 drive from the M.2 backplane.

**Note:** The M.2 backplane you want to remove might be different from the following illustrations, but the removal method is the same.

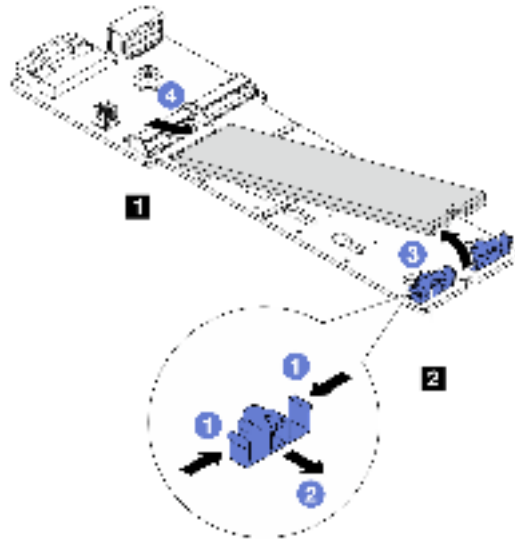


Figure 93. M.2 drive removal

- a. 1 Press both sides of the 2 retainer.
- b. 2 Slide the retainer backward to loosen the M.2 drive from the M.2 backplane.
- c. 3 Rotate the M.2 drive away from the M.2 backplane.
- d. 4 Pull the M.2 drive away from the 1 connector at an angle of approximately 30 degrees.



Step 3. Remove the M.2 module from the chassis.

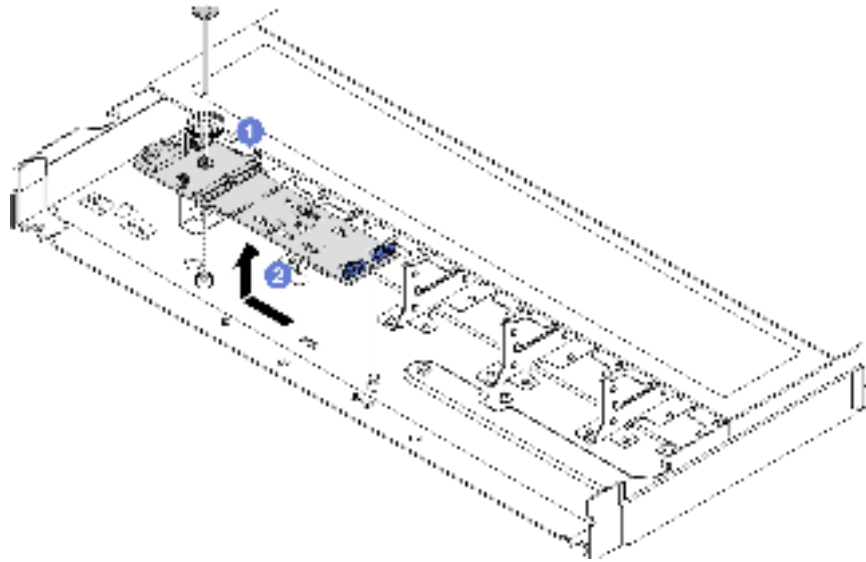


Figure 94. M.2 module removal

- a. 1 Loosen the screw.
- b. 2 Release the M.2 backplane from the pin and carefully lift the M.2 backplane out from the chassis.

Step 4. Disconnect all M.2 cables from the processor board.

## After you finish

If you are instructed to return the component or optional device, follow all packaging instructions, and use any packaging materials for shipping that are supplied to you.

## Demo video

[Watch the procedure on YouTube](#)

## Adjust the retainer on the M.2 backplane

Use this information to adjust the retainer on the M.2 backplane.

## About this task

### Attention:

- Read “[Installation Guidelines](#)” on page 51 and “[Safety inspection checklist](#)” on page 52 to ensure that you work safely.
- Power off the server and peripheral devices and disconnect the power cords and all external cables. See “[Power off the server](#)” on page 68.
- Prevent exposure to static electricity, which might lead to system halt and loss of data, by keeping static-sensitive components in their static-protective packages until installation, and handling these devices with an electrostatic-discharge wrist strap or other grounding systems.

## Watch the procedure

A video of this procedure is available on YouTube: <https://www.youtube.com/playlist?list=PLYV5R7hVcs-CfNsWy-689CRZHExrZEi9I>.

## Procedure

**Note:** The M.2 backplane you want to adjust might be different from the following illustrations, but the adjustment method is the same.

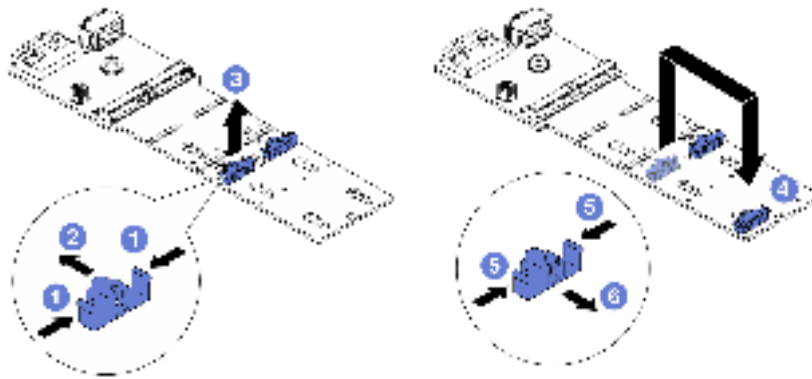


Figure 95. M.2 retainer adjustment

- Step 1. 1 Press both sides of the retainers.
- Step 2. 2 Move the retainer forward until it is in the large opening of the keyhole.
- Step 3. 3 Take the retainer out of the keyhole.
- Step 4. 4 Insert the retainer into the correct keyhole into which the retainer should be installed to accommodate the particular size of the M.2 drive you wish to install.
- Step 5. 5 Press both sides of the retainer.
- Step 6. 6 Slide the retainer backwards until it is seated in place.

## Install the M.2 backplane and M.2 drive

Use this information to install the M.2 backplane and M.2 drive.

### About this task

#### Attention:

- Read “[Installation Guidelines](#)” on page 51 and “[Safety inspection checklist](#)” on page 52 to ensure that you work safely.
- Power off the server and peripheral devices and disconnect the power cords and all external cables. See “[Power off the server](#)” on page 68.
- Prevent exposure to static electricity, which might lead to system halt and loss of data, by keeping static-sensitive components in their static-protective packages until installation, and handling these devices with an electrostatic-discharge wrist strap or other grounding systems.

## Procedure

- Step 1. Touch the static-protective package that contains the M.2 backplane and M.2 drive to any unpainted surface on the outside of the server. Then, take the M.2 backplane and M.2 drive out of the package and place them on a static-protective surface.

**Note:** The M.2 backplane you want to install might be different from the following illustrations, but the installation method is the same.

Step 2. Adjust the retainer on the M.2 backplane to accommodate the particular size of the M.2 drive you wish to install. See [“Adjust the retainer on the M.2 backplane”](#) on page 159.

Step 3. Locate the M.2 drive slot on the M.2 backplane.

**Note:** For some M.2 backplanes that support two identical M.2 drives, install the M.2 drive in slot 0 first.



Figure 96. M.2 drive slot

Step 4. Install the M.2 backplane onto the chassis.

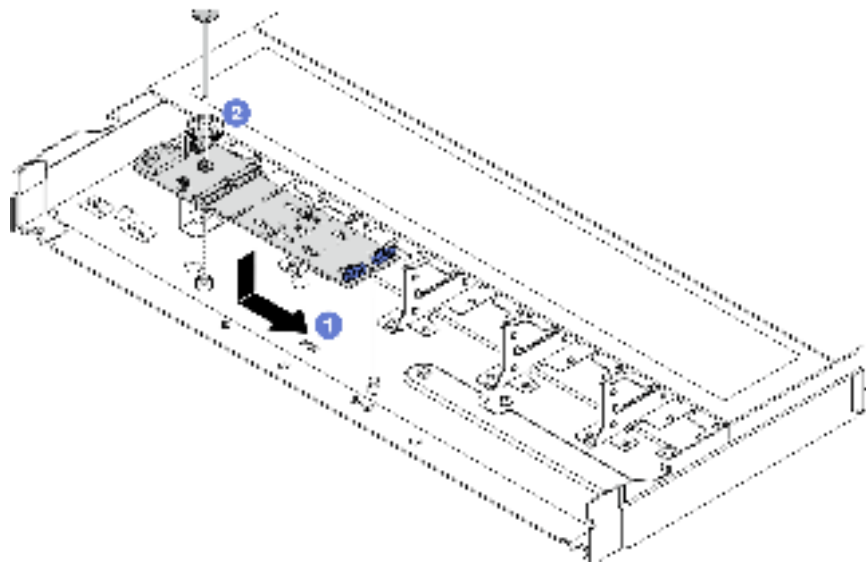


Figure 97. M.2 backplane installation

- a. 1 Align the notch of the M.2 backplane with the pin on the chassis, and then place down the M.2 backplane.
- b. 2 Tighten the screw to secure the M.2 backplane.

Step 5. Install the M.2 drive on the M.2 backplane.

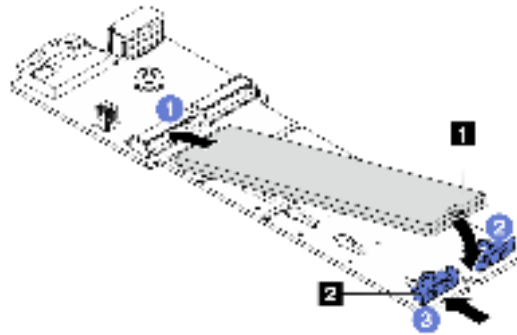


Figure 98. M.2 drive installation

- a. 1 Insert the M.2 drive at an angle of approximately 30 degrees into the connector.
- b. 2 Rotate the M.2 drive down until the notch 1 catches on the lip of the retainer 2.
- c. 3 Slide the retainer forward (toward the connector) to secure the M.2 drive into place.

Step 6. Connect the cables to the M.2 backplane and processor board. See “M.2 drive backplane” on page 267.

## After you finish

1. Complete the parts replacement. See “Complete the parts replacement” on page 246.
2. Use the Lenovo XClarity Provisioning Manager to configure the RAID. For more information, see: [https://sysmgt.lenovofiles.com/help/topic/ixpm\\_frontend/ixpm\\_product\\_page.html](https://sysmgt.lenovofiles.com/help/topic/ixpm_frontend/ixpm_product_page.html)

## Demo video

[Watch the procedure on YouTube](#)

## Remove the M.2 cage and M.2 backplane (16-EDSFF chassis)

Use the information in this topic to remove the M.2 cage and M.2 backplane from the 16-EDSFF chassis.

## About this task

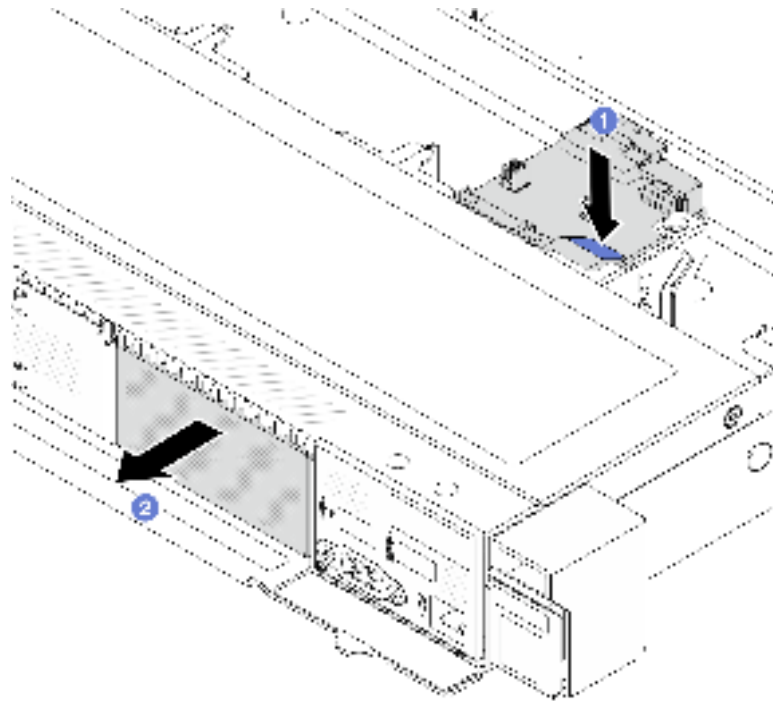
### Attention:

- Read “Installation Guidelines” on page 51 and “Safety inspection checklist” on page 52 to ensure that you work safely.
- Power off the server and peripheral devices and disconnect the power cords and all external cables. See “Power off the server” on page 68.
- Prevent exposure to static electricity, which might lead to system halt and loss of data, by keeping static-sensitive components in their static-protective packages until installation, and handling these devices with an electrostatic-discharge wrist strap or other grounding systems.

## Procedure

Step 1. Remove the top cover. See “Remove the top cover” on page 243.

- Step 2. Disconnect the cables routed to the M.2 backplane. See [“M.2 drive backplane”](#) on page 267 for more details.
- Step 3. Remove the M.2 cage from the chassis.



*Figure 99. M.2 cage removal*

- a. **1** Press down the blue touch point on release latch of the M.2 cage.
  - b. **2** Push the cage to the direction as shown to disengage the cage from the chassis.
- Step 4. Remove the M.2 backplane from the M.2 cage.

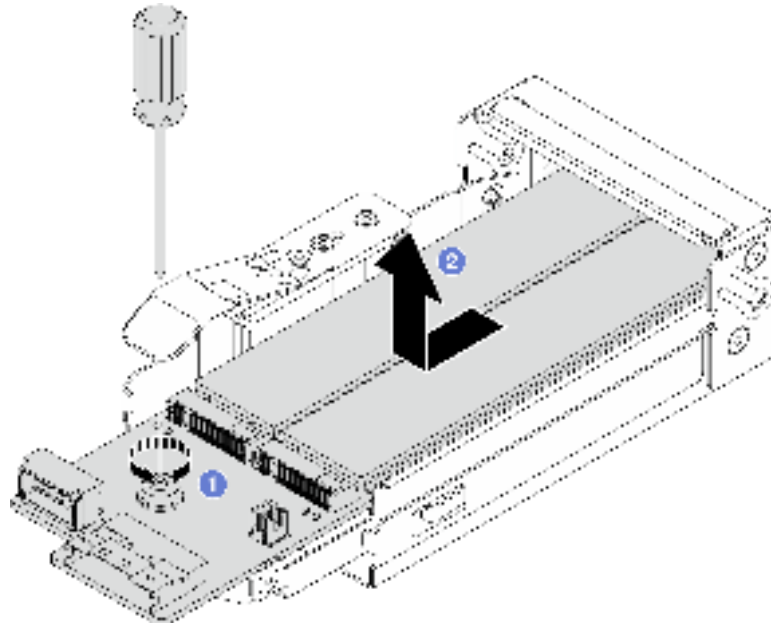


Figure 100. M.2 backplane removal

- a. 1 Loosen the captive screw on the M.2 backplane.
- b. 2 Slide the backplane out and take it out of the cage.

Step 5. Remove the M.2 drives if necessary, see [“Remove the M.2 backplane and M.2 drive” on page 157](#).

## After you finish

If you are instructed to return the component or optional device, follow all packaging instructions, and use any packaging materials for shipping that are supplied to you.

## Demo video

[Watch the procedure on YouTube](#)

## Install the M.2 cage and M.2 backplane (16-EDSFF chassis)

Use the information in this topic to install the M.2 cage and M.2 backplane to the 16-EDSFF chassis.

## About this task

### Attention:

- Read [“Installation Guidelines” on page 51](#) and [“Safety inspection checklist” on page 52](#) to ensure that you work safely.
- Power off the server and peripheral devices and disconnect the power cords and all external cables. See [“Power off the server” on page 68](#).
- Prevent exposure to static electricity, which might lead to system halt and loss of data, by keeping static-sensitive components in their static-protective packages until installation, and handling these devices with an electrostatic-discharge wrist strap or other grounding systems.

## Procedure

Step 1. Touch the static-protective package that contains the M.2 backplane, M.2 drive and M.2 cage to any unpainted surface on the outside of the server. Then, take the M.2 backplane, M.2 drive and M.2 cage out of the package and place them on a static-protective surface.

**Note:** The M.2 backplane you want to install might be different from the following illustrations, but the installation method is the same.

Step 2. To install the M.2 drives to M.2 backplane, see [“Install the M.2 backplane and M.2 drive”](#) on page 160.

Step 3. Install the M.2 backplane to M.2 cage.

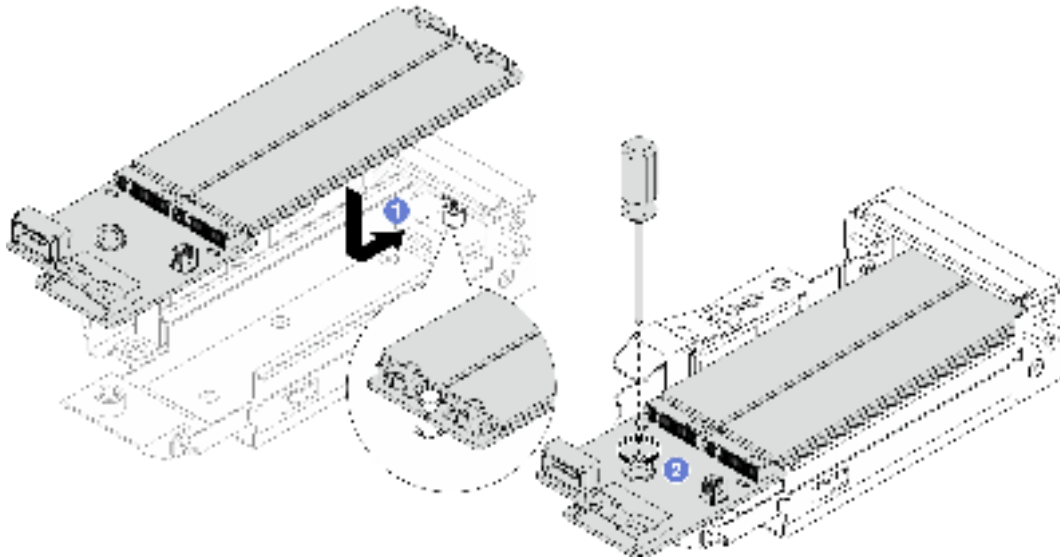


Figure 101. M.2 backplane installation

- a. ① Place the M.2 backplane evenly to the rails on the M.2 cage, and slide the backplane into the cage until the notch on the backplane mounts the groove on the standoff.
- b. ② Tighten the captive screw on the backplane, and make sure that the backplane is secured in place.

Step 4. Install the M.2 cage to the chassis.

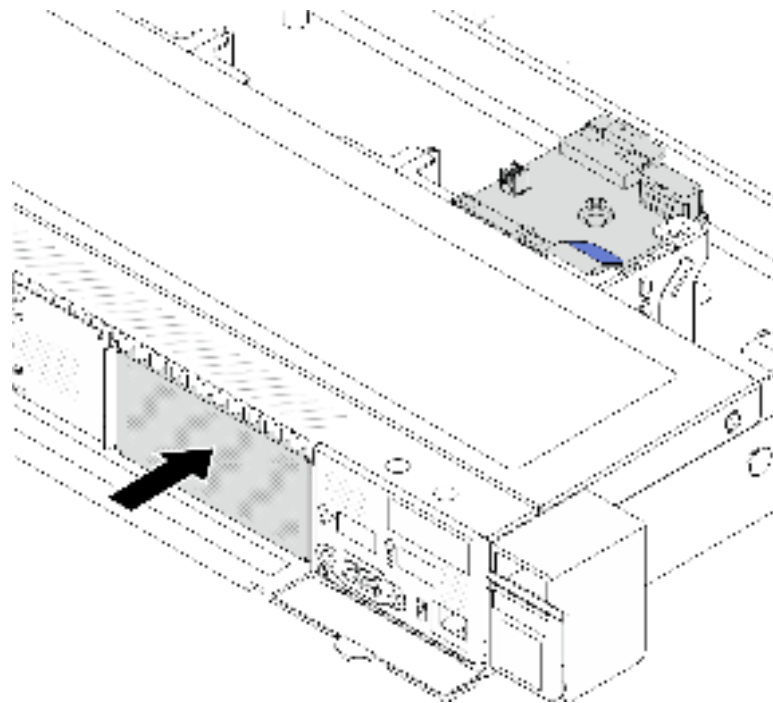


Figure 102. M.2 cage installation

Push the M.2 cage into the chassis until the release latch clicks into place.

Step 5. Reconnect the cables to the M.2 backplane. See [“M.2 drive backplane” on page 267](#).

Step 6. Install the top cover. See [“Install the top cover” on page 244](#).

### After you finish

1. Complete the parts replacement. See [“Complete the parts replacement” on page 246](#).
2. Use the Lenovo XClarity Provisioning Manager to configure the RAID. For more information, see: [https://sysmgt.lenovofiles.com/help/topic/ixpm\\_frontend/ixpm\\_product\\_page.html](https://sysmgt.lenovofiles.com/help/topic/ixpm_frontend/ixpm_product_page.html).

### Demo video

[Watch the procedure on YouTube](#)

---

## OCP module replacement

Use this information to remove and install the OCP module.

### Notes:

- The OCP module is available only on some models.
- If ThinkSystem Redundant System Management Port Adapter is installed on the server, it will not be displayed on the PCIe card list of system management software, such as XCC, LXPM, and so on.

## Remove the OCP module

Use this information to remove the OCP module.

### About this task



**Attention:**

- Read “[Installation Guidelines](#)” on page 51 and “[Safety inspection checklist](#)” on page 52 to ensure that you work safely.
- Power off the server and peripheral devices and disconnect the power cords and all external cables. See “[Power off the server](#)” on page 68.
- Prevent exposure to static electricity, which might lead to system halt and loss of data, by keeping static-sensitive components in their static-protective packages until installation, and handling these devices with an electrostatic-discharge wrist strap or other grounding systems.

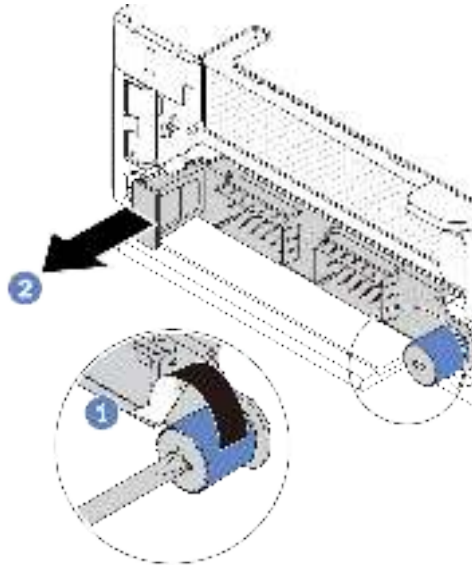
**Procedure**

Figure 103. OCP module removal

- Step 1. ① Loosen the thumbscrew that secures the module.
- Step 2. ② Pull out the OCP module by its handle on the left as shown.

**After you finish**

1. Install a new OCP module or a card filler. See “[Install the OCP module](#)” on page 167.
2. If you are instructed to return the component or optional device, follow all packaging instructions, and use any packaging materials for shipping that are supplied to you.

**Demo video**

[Watch the procedure on YouTube](#)

**Install the OCP module**

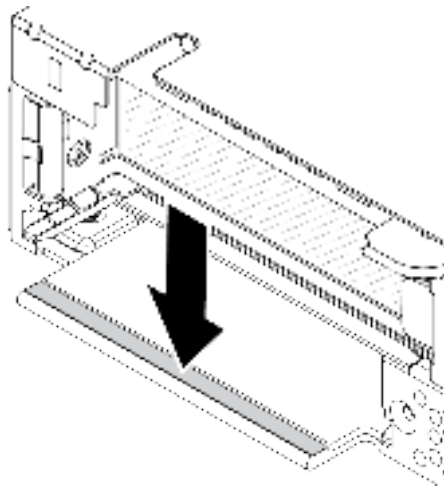
Use this information to install the OCP module.

**About this task****Attention:**

- Read [“Installation Guidelines” on page 51](#) and [“Safety inspection checklist” on page 52](#) to ensure that you work safely.
- Power off the server and peripheral devices and disconnect the power cords and all external cables. See [“Power off the server” on page 68](#).
- Prevent exposure to static electricity, which might lead to system halt and loss of data, by keeping static-sensitive components in their static-protective packages until installation, and handling these devices with an electrostatic-discharge wrist strap or other grounding systems.

## Procedure

- Step 1. Touch the static-protective package that contains the OCP module to any unpainted surface on the outside of the server. Then, take the OCP module out of the package and place it on a static-protective surface.
- Step 2. Attach the OCP module label that comes with this option on the rear of the server.



*Figure 104. OCP module label installation*

Step 3. Install the OCP module.

**Notes:**

- Ensure that the Ethernet adapter is fully seated and the thumbscrew is securely tightened. Otherwise, the OCP module will not get full connection and may not function.
- If there is an OCP module installed, when the system is powered off but still plugged in to AC power, system fan 1 and fan 2 will continue to spin at a much lower speed. This is the system design to provide proper cooling for the OCP module.

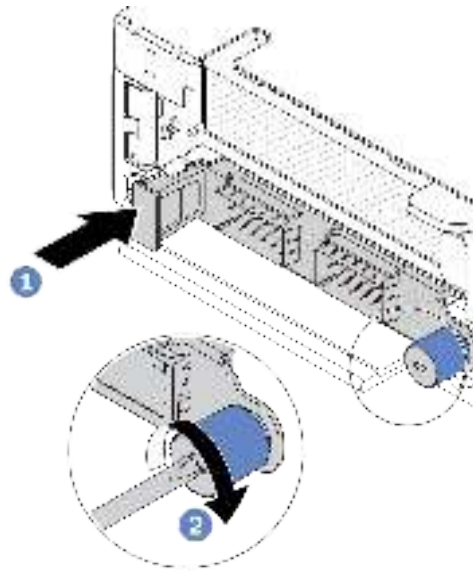


Figure 105. OCP module installation

- a. 1 Push the OCP module by its handle on the left until it is fully inserted into the connector on the processor board.
- b. 2 Fully tighten the thumbscrew to secure the adapter.

## After you finish

Complete the parts replacement. See [“Complete the parts replacement” on page 246](#).

## Demo video

[Watch the procedure on YouTube](#)

---

## PCIe adapter replacement

Use this information to remove and install a PCIe adapter.

The PCIe adapter can be an Ethernet adapter, a host bus adapter (HBA), a PCIe RAID adapter, a PCIe interposer adapter, a PCIe solid-state drive, a PCIe GPU, and any other supported PCIe adapter.

**Notes:**

- Depending on different types, the PCIe adapter might look different from the illustrations in this topic.
- Use any documentation that comes with the PCIe adapter, and follow the instructions in this topic.

## Remove a PCIe adapter

Use this information to remove a PCIe adapter.

### About this task

#### Attention:

- Read [“Installation Guidelines” on page 51](#) and [“Safety inspection checklist” on page 52](#) to ensure that you work safely.
- Power off the server and peripheral devices and disconnect the power cords and all external cables. See [“Power off the server” on page 68](#).
- Prevent exposure to static electricity, which might lead to system halt and loss of data, by keeping static-sensitive components in their static-protective packages until installation, and handling these devices with an electrostatic-discharge wrist strap or other grounding systems.

### Procedure

- Step 1. Remove the top cover. See [“Remove the top cover” on page 243](#).
- Step 2. Remove the riser assembly. See [“Remove a riser card” on page 208](#).
- Step 3. Remove the PCIe adapter from the riser assembly.

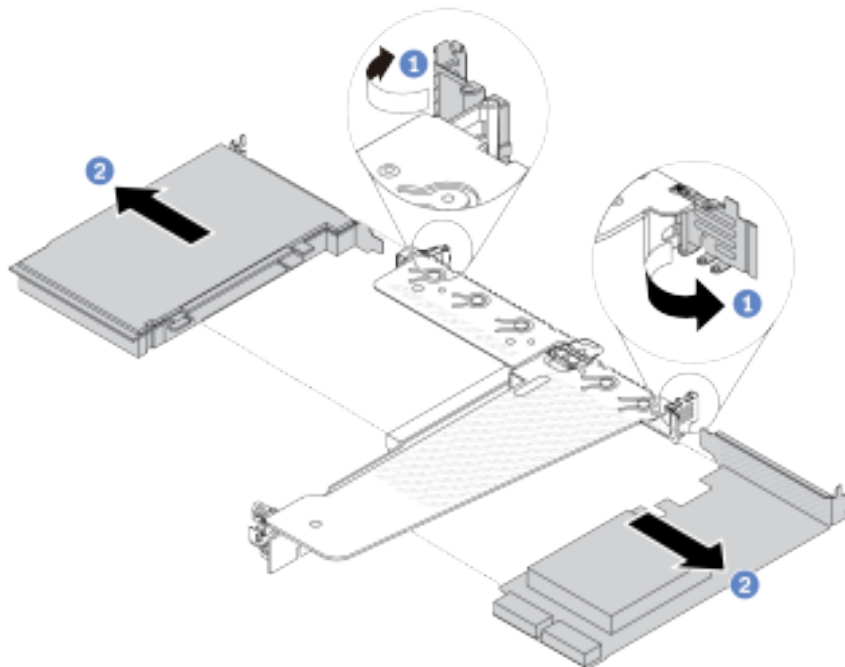


Figure 106. PCIe adapter removal from the LP-FH riser assembly

- 1 Rotate the latch on the riser bracket to open position.
- 2 Grasp the PCIe adapter by its edges and carefully pull it out of the PCIe adapter slot on the riser card.

**Note:** The procedure for removing a PCIe adapter is similar for different types of riser assembly. In this topic, the LP-FH riser assembly is used as an example.

### After you finish

1. Install a PCIe adapter or PCIe adapter filler. See [“Install a PCIe adapter” on page 171](#).
2. If you are instructed to return the component or optional device, follow all packaging instructions, and use any packaging materials for shipping that are supplied to you.

### Demo video

[Watch the procedure on YouTube](#)

## Install a PCIe adapter

Use this information to install a PCIe adapter.

### About this task

#### Attention:

- Read [“Installation Guidelines” on page 51](#) and [“Safety inspection checklist” on page 52](#) to ensure that you work safely.
- Power off the server and peripheral devices and disconnect the power cords and all external cables. See [“Power off the server” on page 68](#).
- Prevent exposure to static electricity, which might lead to system halt and loss of data, by keeping static-sensitive components in their static-protective packages until installation, and handling these devices with an electrostatic-discharge wrist strap or other grounding systems.

### Procedure

- Step 1. Touch the static-protective package that contains the PCIe adapter to any unpainted surface on the outside of the server. Then, take the PCIe adapter out of the package and place it on a static-protective surface.
- Step 2. Locate the correct PCIe slot for the PCIe adapter. For information about the PCIe slots and supported PCIe adapters, see [“Rear view” on page 26](#).

Step 3. Install the PCIe adapter and secure it to the riser assembly.

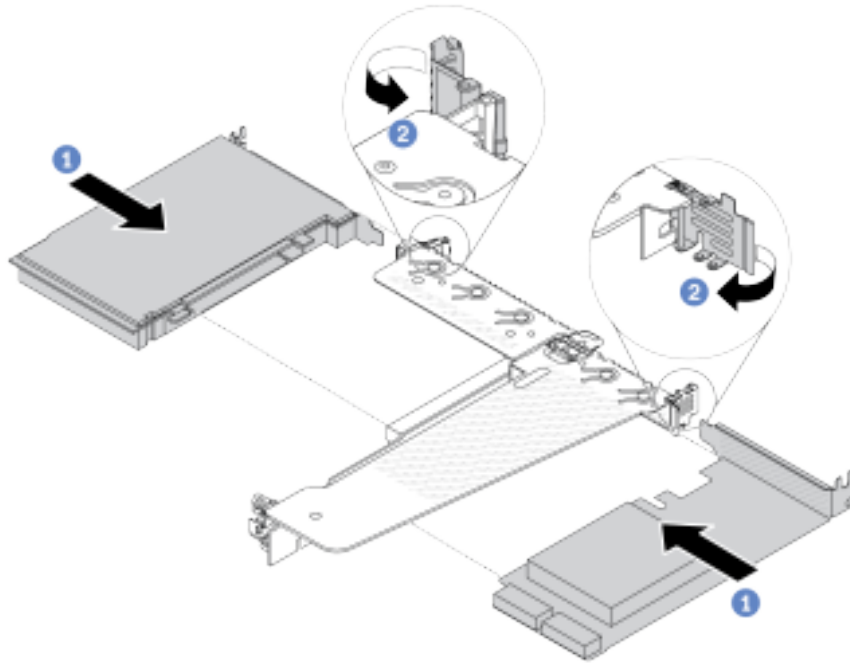


Figure 107. PCIe adapter installation into the LP-FH riser assembly

- a. 1 Align the PCIe adapter with the PCIe slot on the riser card. Then, carefully press the PCIe adapter straight into the slot until it is securely seated and its bracket is secured.
- b. 2 Rotate the latch on the riser bracket to closed position.

**Notes:**

1. Ensure that PCIe adapter installation meets the rules in [“PCIe slots and adapters” on page 61](#).
2. The procedure for installing a PCIe adapter is similar for different types of riser assembly. In this topic, the LP-FH riser assembly is used as an example.

Step 4. Connect cables to the PCIe adapter in the riser assembly. See [Chapter 6 “Internal cable routing” on page 249](#).

## After you finish

1. Reinstall the riser assembly. See [“Install a riser card” on page 211](#).
2. Complete the parts replacement. See [“Complete the parts replacement” on page 246](#).

## Demo video

[Watch the procedure on YouTube](#)

---

## Power-supply-unit air baffle replacement

Use this information to remove and install a power-supply-unit air baffle.

## Remove a power-supply-unit air baffle

Use this information to understand how to remove a power-supply-unit air baffle.

### About this task

#### S033



#### **CAUTION:**

**Hazardous energy present. Voltages with hazardous energy might cause heating when shorted with metal, which might result in spattered metal, burns, or both.**

**Attention:** Read [“Installation Guidelines” on page 51](#) and [“Safety inspection checklist” on page 52](#) to ensure that you work safely.

Power off the server and peripheral devices and disconnect the power cords and all external cables. See [“Power off the server” on page 68](#).

Prevent exposure to static electricity, which might lead to system halt and loss of data, by keeping static-sensitive components in their static-protective packages until installation, and handling these devices with an electrostatic-discharge wrist strap or other grounding systems.

#### **Watch the procedure**

A video of this procedure is available on YouTube: <https://www.youtube.com/playlist?list=PLYV5R7hVcs-CfNsWy-689CRZHExrZEi9l>.

#### **Procedure**

- Step 1. Remove the top cover. See [“Remove the top cover” on page 243](#).
- Step 2. Disconnect the cables adjacent to the power-supply-unit air baffle. For proper operation guidelines, see [Chapter 6 “Internal cable routing” on page 249](#).
- Step 3. Remove the power-supply-unit air baffle.

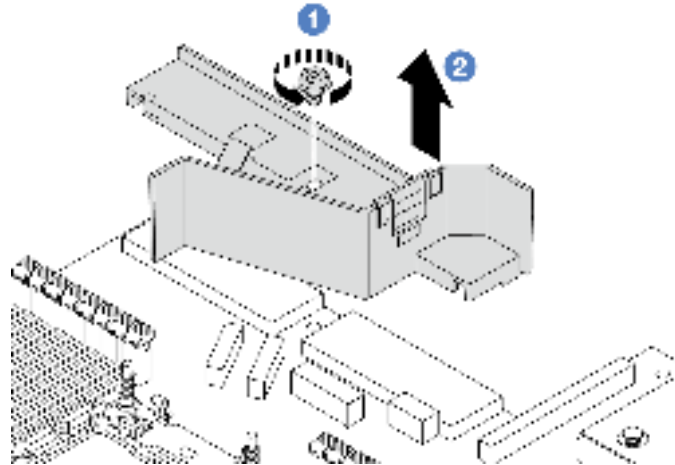


Figure 108. Power-supply-unit air baffle removal

- a. 1 Loosen the screw on the air baffle.
- b. 2 Lift the air baffle out of the chassis.

## After you finish

If you are instructed to return the component or optional device, follow all packaging instructions, and use any packaging materials for shipping that are supplied to you.

## Install a power-supply-unit air baffle

Use this information to understand how to install a power-supply-unit air baffle.

## About this task

### S033



#### **CAUTION:**

**Hazardous energy present. Voltages with hazardous energy might cause heating when shorted with metal, which might result in spattered metal, burns, or both.**

**Attention:** Read [“Installation Guidelines” on page 51](#) and [“Safety inspection checklist” on page 52](#) to ensure that you work safely.

Power off the server and peripheral devices and disconnect the power cords and all external cables. See [“Power off the server” on page 68](#).

Prevent exposure to static electricity, which might lead to system halt and loss of data, by keeping static-sensitive components in their static-protective packages until installation, and handling these devices with an electrostatic-discharge wrist strap or other grounding systems.

## Watch the procedure



A video of this procedure is available on YouTube: <https://www.youtube.com/playlist?list=PLYV5R7hVcs-CfNsWy-689CRZHExrZEi9I>.

## Procedure

- Step 1. Remove the top cover. See “Remove the top cover” on page 243.
- Step 2. Install the power-supply-unit air baffle.

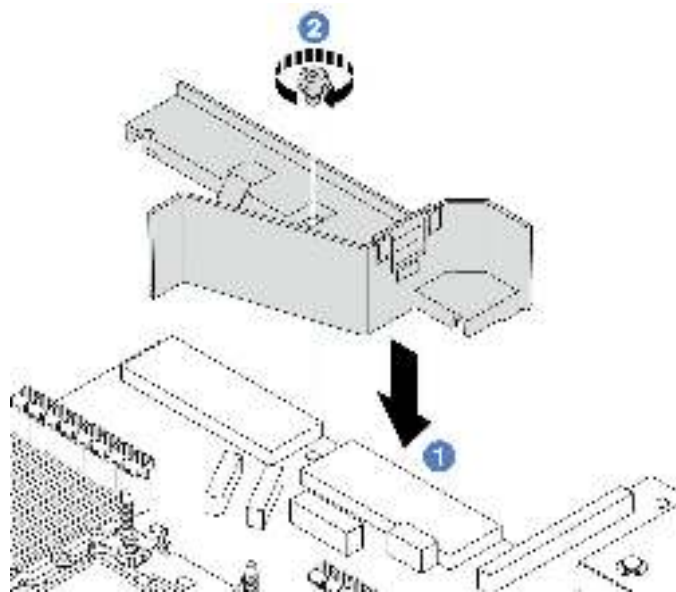


Figure 109. Power-supply-unit air baffle installation

- a. 1 Align the screw holes on the air baffle and the chassis, and put the air baffle down.
- b. 2 Tighten the screw and ensure that the air baffle is secured in place.

## After you finish

- Properly route and secure the cables in the server. Refer to detailed cable routing information for each component in [Chapter 6 “Internal cable routing” on page 249](#).
- Complete the parts replacement. See “Complete the parts replacement” on page 246.

---

## Processor and heat sink replacement

Follow the instruction in this section to replace an assembled processor and heat sink, known as a processor-heat-sink module (PHM), a processor, or a heat sink.

**Attention:** Before you begin replacing a processor, make sure that you have an alcohol cleaning pad (part number 00MP352) and thermal grease.

**Important:** The processor in your server can throttle in response to thermal conditions, temporarily lowering its speed to reduce heat output. In instances where a few processor cores are throttled for an extremely short time period (100 ms or less), the only indication might be an entry in the operating system event log with no corresponding entry in the system XCC event log. If this situation occurs, the event can be ignored and processor replacement is not required.

When the server has a Liquid Assisted Cooling Module (LACM) installed, you must apply for a LACM module handle (LACM heat sink bracket) first if you need to install or remove the system board assembly or processor. However, while replacing the old LACM with a new one, you do not need to apply for a module handle (LACM heat sink bracket) as the new LACM package contains it.

**Note:** This section is for processor and heat sink replacement. For the replacement of the Liquid Assisted Cooling Module (LACM), refer to [“Lenovo Neptune\(TM\) liquid assisted cooling module replacement \(trained technicians only\)”](#) on page 140.

## Remove a processor and heat sink

This task has instructions for removing an assembled processor and heat sink, known as a processor-heat-sink module (PHM). This task requires a Torx T30 driver. This procedure must be executed by a trained technician.

### About this task

#### S002



#### **CAUTION:**

**The power-control button on the device and the power switch on the power supply do not turn off the electrical current supplied to the device. The device also might have more than one power cord. To remove all electrical current from the device, ensure that all power cords are disconnected from the power source.**

#### **Attention:**

- Read [“Installation Guidelines”](#) on page 51 and [“Safety inspection checklist”](#) on page 52 to ensure that you work safely.
- Power off the server and peripheral devices and disconnect the power cords and all external cables. See [“Power off the server”](#) on page 68.
- Prevent exposure to static electricity, which might lead to system halt and loss of data, by keeping static-sensitive components in their static-protective packages until installation, and handling these devices with an electrostatic-discharge wrist strap or other grounding systems.
- If the server is installed in a rack, slide the server out on its rack slide rails to gain access to the top cover, or remove the server from the rack. See [“Remove the server from the rack”](#) on page 69.

- Each processor socket must always contain a cover or a PHM. When removing or installing a PHM, protect empty processor sockets with a cover.
- Do not touch the processor socket or processor contacts. Processor-socket contacts are very fragile and easily damaged. Contaminants on the processor contacts, such as oil from your skin, can cause connection failures.
- Do not allow the thermal grease on the processor or heat sink to come in contact with anything. Contact with any surface can compromise the thermal grease, rendering it ineffective. Thermal grease can damage components, such as the electrical connectors in the processor socket.
- Remove and install only one PHM at a time. If the processor board supports multiple processors, install the PHMs starting with the first processor socket.

**Note:** The heat sink, processor, and processor carrier for your system might be different from those shown in the illustrations.

The following illustration shows the components of the PHM.

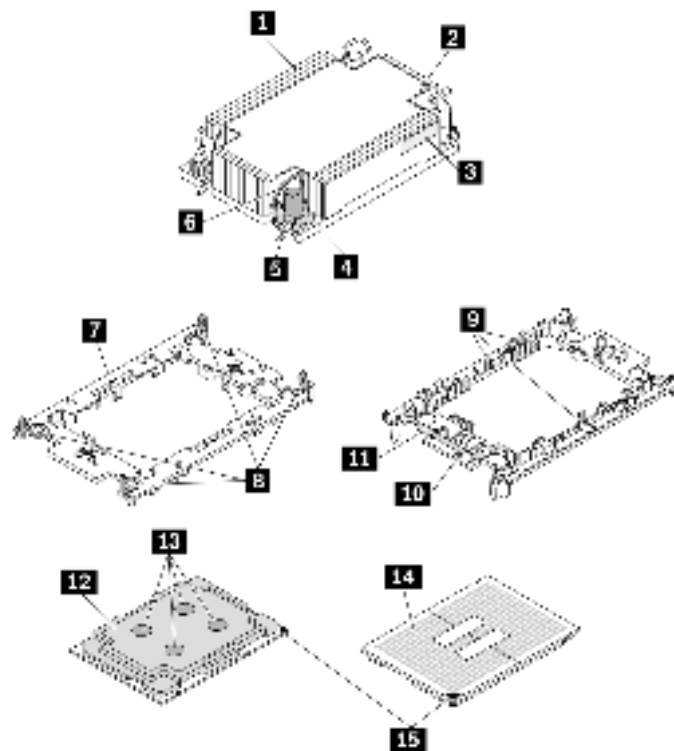


Figure 110. PHM components

<b>1</b> Heat sink	<b>9</b> Clips to secure processor in carrier
<b>2</b> Heat sink triangular mark	<b>10</b> Carrier triangular mark
<b>3</b> Processor identification label	<b>11</b> Processor ejector handle
<b>4</b> Nut and wire bail retainer	<b>12</b> Processor heat spreader
<b>5</b> Torx T30 nut	<b>13</b> Thermal grease
<b>6</b> Anti-tilt wire bail	<b>14</b> Processor contacts

<b>7</b> Processor carrier	<b>15</b> Processor triangular mark
<b>8</b> Clips to secure carrier to heat sink	

Torque screwdriver type list	Screw Type
Torx T30 head screwdriver	Torx T30 screw

## Procedure

Step 1. Make preparations for this task.

- a. Remove the top cover. See [“Remove the top cover” on page 243](#).

Step 2. If the processor comes with a T-shaped heat sink, fully loosen the two heat sink screws as shown.

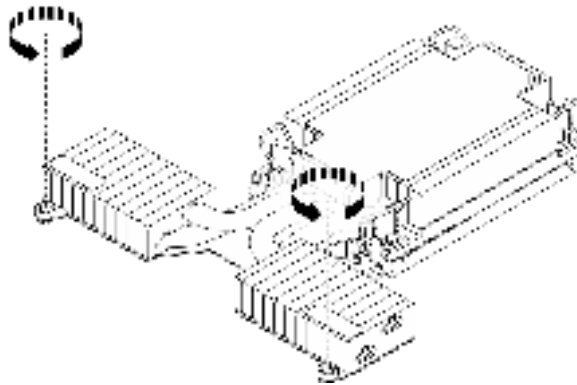


Figure 111. Loosening T-shaped heat sink screws

Step 3. Remove the PHM from the processor board.

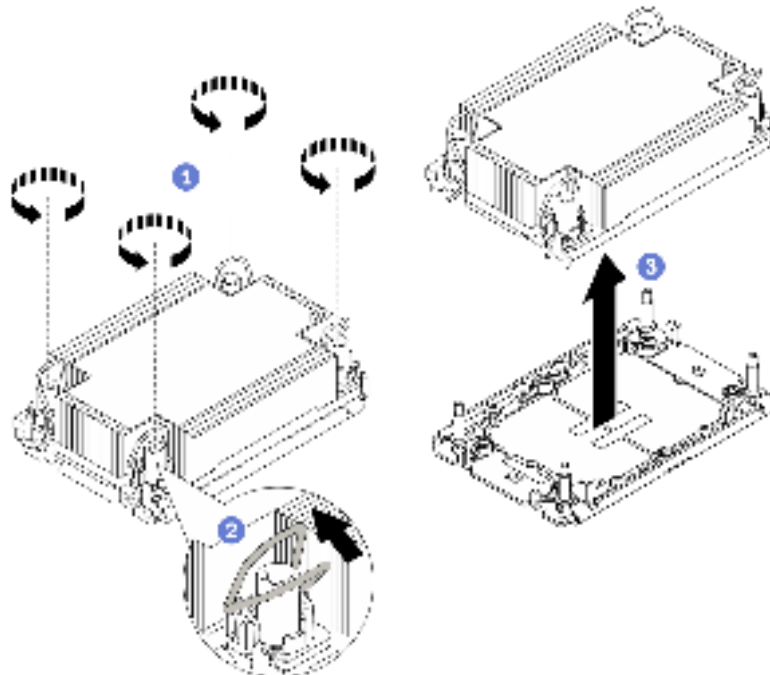


Figure 112. Removing a PHM

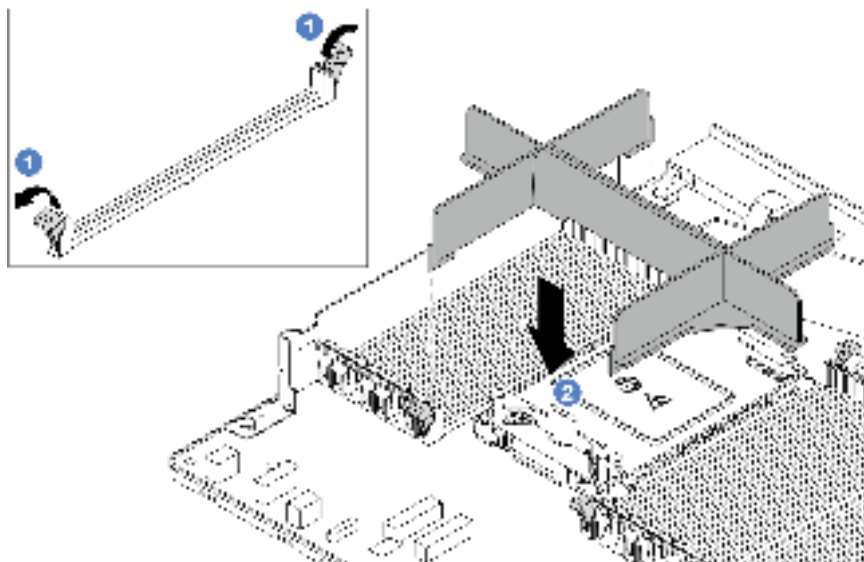
- a. ① Fully loosen the Torx T30 nuts on the PHM *in the removal sequence shown* on the heat-sink label.
- b. ② Rotate the anti-tilt wire bails inward.
- c. ③ Carefully lift the PHM from the processor socket. If the PHM cannot be fully lifted out of the socket, further loosen the Torx T30 nuts and try lifting the PHM again.

**Notes:**

- Do not touch the contacts on the bottom of the processor.
- Keep the processor socket clean from any object to prevent possible damages.

**After you finish**

- Each processor socket must always contain a cover or a PHM. Protect empty processor sockets with a cover or install a new PHM.
- If you are not going to install a PHM back, cover the processor socket with the socket cover and install a PHM filler.



- ① Open the retaining clip on each end of the memory module slots next to the left and right sides of the processor two slot.
- ② Align the PHM filler with the slots, and place the filler on the slots with both hands. Firmly press the filler straight down into the slots until the retaining clips snap into the locked position.
- If you are removing the PHM as part of a processor board replacement, set the PHM aside.
- If you are reusing the processor or heat sink, separate the processor from its retainer. See [“Separate the processor from carrier and heat sink” on page 180](#).
- If you are instructed to return the component or optional device, follow all packaging instructions, and use any packaging materials for shipping that are supplied to you.

**Demo video**

[Watch the procedure on YouTube](#)

## Separate the processor from carrier and heat sink

This task has instructions for separating a processor and its carrier from an assembled processor and heat sink, known as a processor-heat-sink module (PHM). This procedure must be executed by a trained technician.

### About this task

#### Attention:

- Read “[Installation Guidelines](#)” on page 51 and “[Safety inspection checklist](#)” on page 52 to ensure that you work safely.
- Power off the server and peripheral devices and disconnect the power cords and all external cables. See “[Power off the server](#)” on page 68.
- Prevent exposure to static electricity, which might lead to system halt and loss of data, by keeping static-sensitive components in their static-protective packages until installation, and handling these devices with an electrostatic-discharge wrist strap or other grounding systems.
- Do not touch the processor contacts. Contaminants on the processor contacts, such as oil from your skin, can cause connection failures.
- Do not allow the thermal grease on the processor or heat sink to come in contact with anything. Contact with any surface can compromise the thermal grease, rendering it ineffective. Thermal grease can damage components, such as the electrical connectors in the processor socket.

**Note:** The heat sink, processor, and processor carrier for your system might be different than those shown in the illustrations.

### Procedure

Step 1. Separate the processor from the heat sink and carrier.

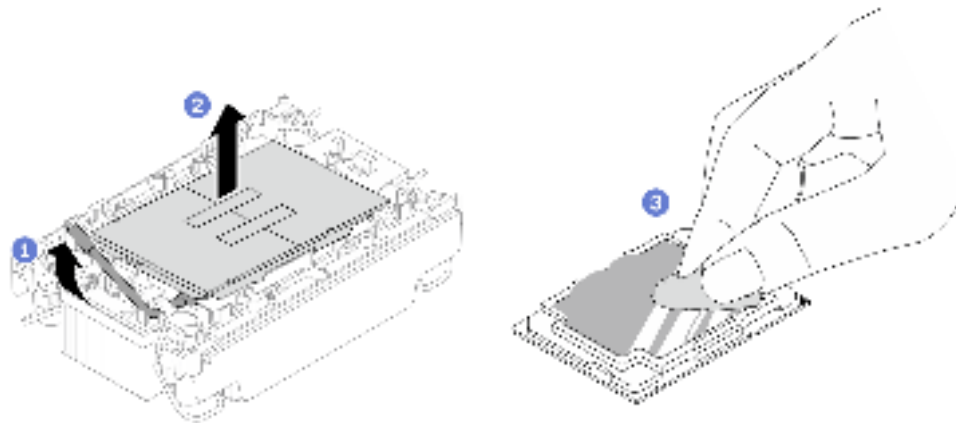


Figure 113. Separating a processor from the heat sink and carrier

**Note:** Do not touch the contacts on the processor.

- a. 1 Lift the handle to release the processor from the carrier.
- b. 2 Hold the processor by its edges; then, lift the processor from the heat sink and carrier.
- c. 3 Without putting the processor down, wipe the thermal grease from the top of the processor with an alcohol cleaning pad; then, place the processor on a static protective surface with the processor-contact side up.

Step 2. Separate the processor carrier from the heat sink.

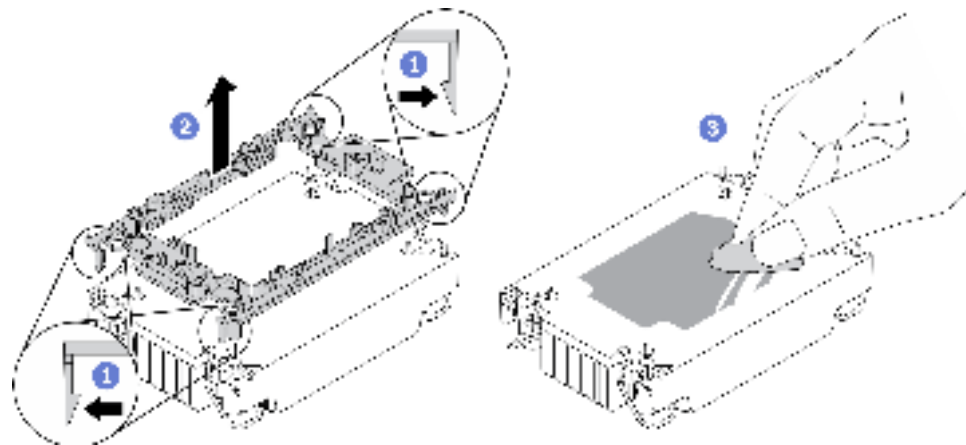


Figure 114. Separating a processor carrier from the heat sink

**Note:** The processor carrier will be discarded and replaced with a new one.

- a. ① Release the retaining clips from the heat sink.
- b. ② Lift the carrier from the heat sink.
- c. ③ Wipe the thermal grease from the bottom of the heat sink with an alcohol cleaning pad.

## After you finish

If you are instructed to return the defective component, please package the part to prevent any shipping damage. Reuse the packaging the new part arrived in and follow all packaging instructions.

## Install a processor and heat sink

This task has instructions for installing an assembled processor and heat sink, known as a processor-heat-sink module (PHM). This task requires a Torx T30 driver. This procedure must be executed by a trained technician.

### About this task

#### Attention:

- Read [“Installation Guidelines” on page 51](#) and [“Safety inspection checklist” on page 52](#) to ensure that you work safely.
- Power off the server and peripheral devices and disconnect the power cords and all external cables. See [“Power off the server” on page 68](#).
- Prevent exposure to static electricity, which might lead to system halt and loss of data, by keeping static-sensitive components in their static-protective packages until installation, and handling these devices with an electrostatic-discharge wrist strap or other grounding systems.
- Each processor socket must always contain a cover or a PHM. When removing or installing a PHM, protect empty processor sockets with a cover.
- Do not touch the processor socket or processor contacts. Processor-socket contacts are very fragile and easily damaged. Contaminants on the processor contacts, such as oil from your skin, can cause connection failures.
- Do not allow the thermal grease on the processor or heat sink to come in contact with anything. Contact with any surface can compromise the thermal grease, rendering it ineffective. Thermal grease can damage components, such as the electrical connectors in the processor socket.

- Remove and install only one PHM at a time. If the processor board supports multiple processors, install the PHMs starting with the first processor socket.
- To ensure the best performance, check the manufacturing date on the new heat sink and make sure it does not exceed 2 years. Otherwise, wipe off the existing thermal grease and apply the new grease onto it for optimal thermal performance.

**Notes:**

- The heat sink, processor, and processor carrier for the system might be different from those shown in the illustrations.
- PHMs are keyed for the socket where they can be installed and for their orientation in the socket.
- See <https://serverproven.lenovo.com> for a list of processors supported for your server. All processors on the processor board must have the same speed, number of cores, and frequency.
- Before you install a new PHM or replacement processor, update your system firmware to the latest level. See “Update the firmware” on page 433.

The following illustration shows the components of the PHM.

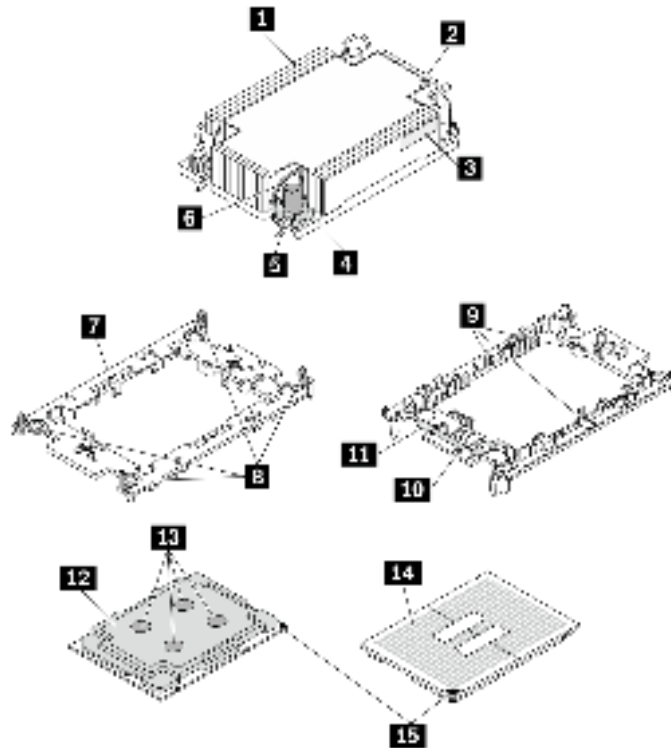


Figure 115. PHM components

<b>1</b> Heat sink	<b>9</b> Clips to secure processor in carrier
<b>2</b> Heat sink triangular mark	<b>10</b> Carrier triangular mark
<b>3</b> Processor identification label	<b>11</b> Processor ejector handle
<b>4</b> Nut and wire bail retainer	<b>12</b> Processor heat spreader
<b>5</b> Torx T30 nut	<b>13</b> Thermal grease



<b>6</b> Anti-tilt wire bail	<b>14</b> Processor contacts
<b>7</b> Processor carrier	<b>15</b> Processor triangular mark
<b>8</b> Clips to secure carrier to heat sink	

Torque screwdriver type list	Screw Type
Torx T30 head screwdriver	Torx T30 screw

## Procedure

- Step 1. If you are replacing a processor and reusing the heat sink.
- Remove the processor identification label from the heat sink and replace it with the new label that comes with the replacement processor.
  - If there is any old thermal grease on the heat sink, wipe the thermal grease from the bottom of the heat sink with an alcohol cleaning pad.
- Step 2. If you are replacing a heat sink and reusing the processor.
- Remove the processor identification label from the old heat sink and place it on the new heat sink in the same location. The label is on the side of the heat sink closest to the triangular alignment mark.
- Note:** If you are unable to remove the label and place it on the new heat sink, or if the label is damaged during transfer, write the processor serial number from the processor identification label on the new heat sink in the same location as the label would be placed using a permanent marker.
- Install processor in new carrier.

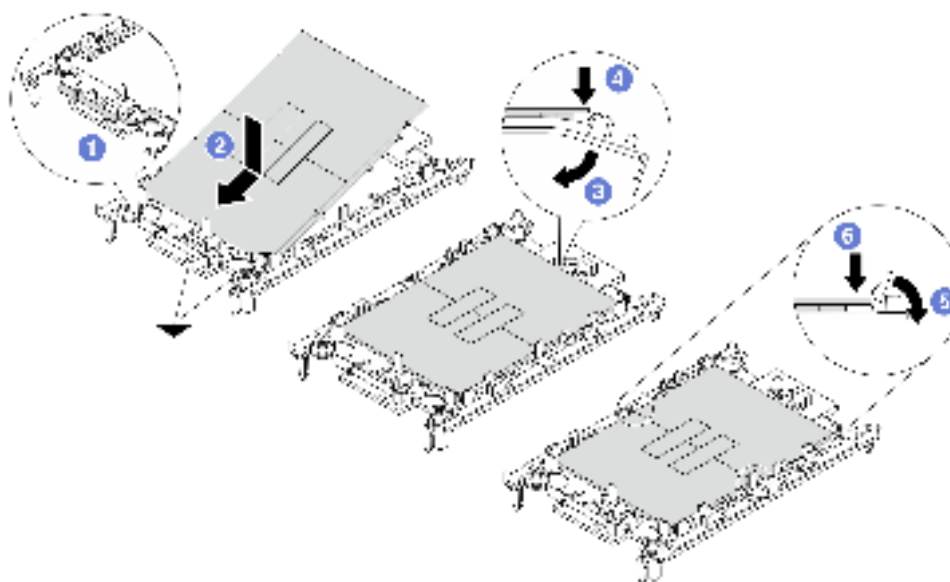







Figure 116. Installing a processor carrier

**Note:** Replacement heat sinks come with both gray and black processor carriers. Make sure to use the carrier with the same color as the one you discarded earlier.

- 1** Make sure the handle on the carrier is in the closed position.

2.  Align the processor on the new carrier so that the triangular marks align; then, insert the marked end of the processor into the carrier.
3.  Hold the inserted end of the processor in place; then, pivot the unmarked end of the carrier down and away from the processor.
4.  Press the processor and secure the unmarked end under the clip on the carrier.
5.  Carefully pivot the sides of the carrier down and away from the processor.
6.  Press the processor and secure the sides under the clips on the carrier.

**Note:** To prevent the processor from falling out of the carrier, keep the processor-contact side up and hold the processor-carrier assembly by the sides of the carrier.

Step 3. Apply thermal grease.

- a. Carefully place the processor and carrier in the shipping tray with the processor-contact side down. Make sure the triangular mark on the carrier is aligned with the triangular mark in the shipping tray.
- b. If there is any old thermal grease on the processor, gently wipe the top of the processor with an alcohol cleaning pad.

**Note:** Make sure the alcohol has fully evaporated before applying new thermal grease.

- c. Apply the thermal grease on the top of the processor with a syringe by forming four uniformly spaced dots, while each dot consists of about 0.1 ml of thermal grease.

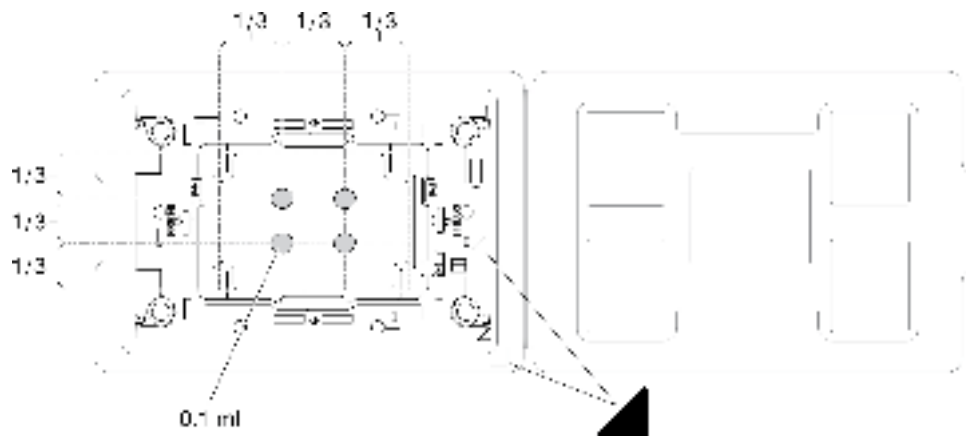


Figure 117. Thermal grease application with processor in shipping tray

Step 4. Assemble the processor and heat sink.

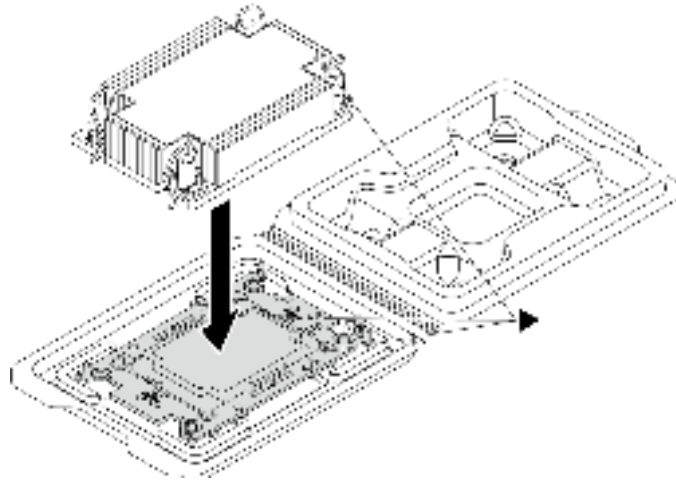


Figure 118. Assembling the PHM with processor in shipping tray

- a. Align the triangular mark on the heat sink label with the triangular mark on the processor carrier and processor.
- b. Install the heat sink onto the processor-carrier.
- c. Press the carrier into place until the clips at all four corners engage.

Step 5. (Optional) If the server has been pre-installed with a PHM filler and a socket filler, generally on processor two, it is required to remove the fillers first before you proceed with further installation.

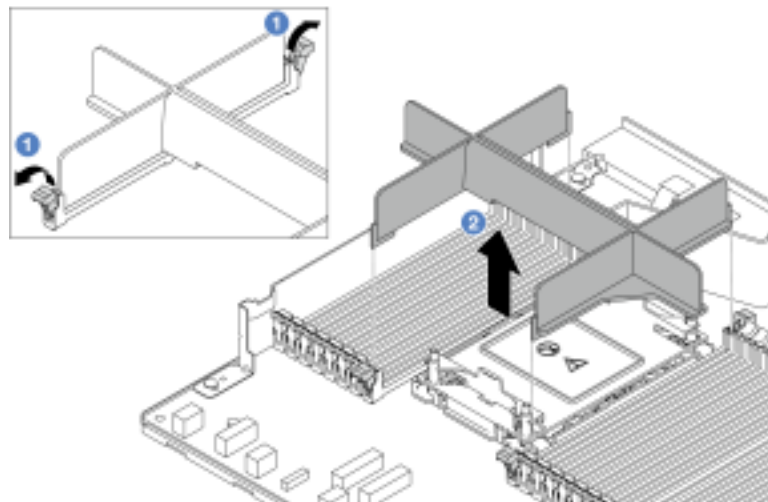


Figure 119. PHM filler removal

- a. ① Open the retaining clip on each end of the memory module slots next to the left and right sides of the processor two slot.
- b. ② Lift the PHM filler from the slots.

Step 6. Install the processor-heat-sink module to the processor board.

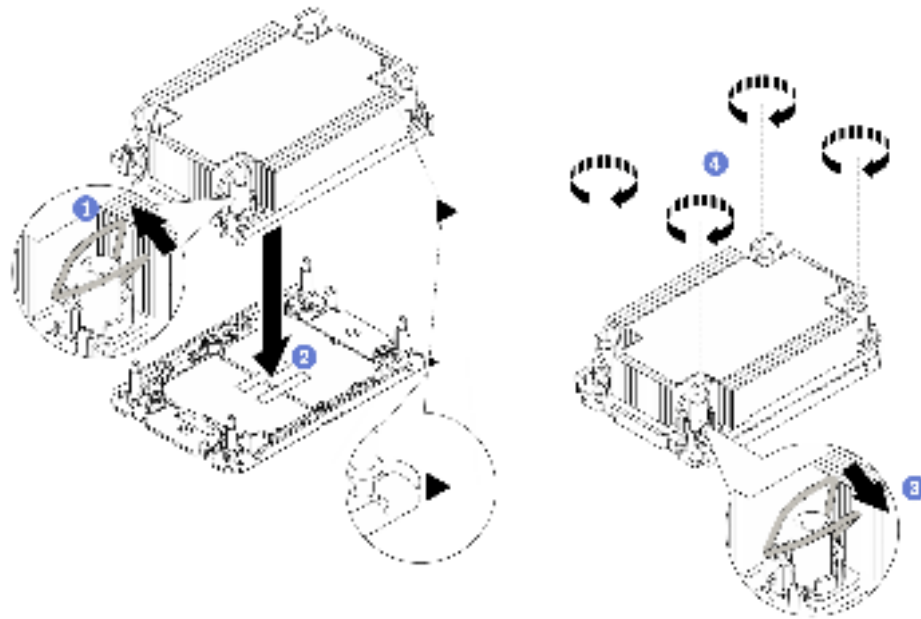


Figure 120. Installing a PHM

- a. 1 Rotate the anti-tilt wire bails inward.
- b. 2 Align the triangular mark and four Torx T30 nuts on the PHM with the triangular mark and threaded posts of the processor socket; then, insert the PHM into the processor socket.
- c. 3 Rotate the anti-tilt wire bails outward until they engage with the hooks in the socket.
- d. 4 Fully tighten the Torx T30 nuts *in the installation sequence shown* on the heat-sink label. Tighten the screws until they stop; then, visually inspect to make sure that there is no gap between the screw shoulder beneath the heat sink and the processor socket. (For reference, the torque required for the fasteners to fully tighten is 0.9-1.3 newton-meters, 8-12 inch-pounds.)

Step 7. If the processor comes with a T-shaped heat sink, fully tighten the two heat sink screws as shown. (For reference, the torque required for the fasteners to fully tighten is 0.9-1.3 newton-meters, 8-12 inch-pounds.)

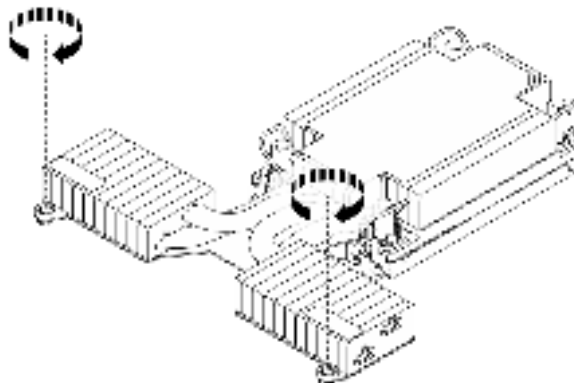


Figure 121. Tightening T-shaped heat sink screws

## After you finish

Complete the parts replacement. See [“Complete the parts replacement” on page 246](#).

### Demo video

[Watch the procedure on YouTube](#)

---

## Rack latches replacement

Use this information to remove and install the rack latches.

### Remove the rack latches

Use this information to remove the rack latches.

### About this task

#### Attention:

- Read [“Installation Guidelines” on page 51](#) and [“Safety inspection checklist” on page 52](#) to ensure that you work safely.
- Prevent exposure to static electricity, which might lead to system halt and loss of data, by keeping static-sensitive components in their static-protective packages until installation, and handling these devices with an electrostatic-discharge wrist strap or other grounding systems.

### Procedure

- Step 1. If the server is installed with the security bezel, remove it first. See [“Remove the security bezel” on page 213](#).
- Step 2. Remove the rack latch.

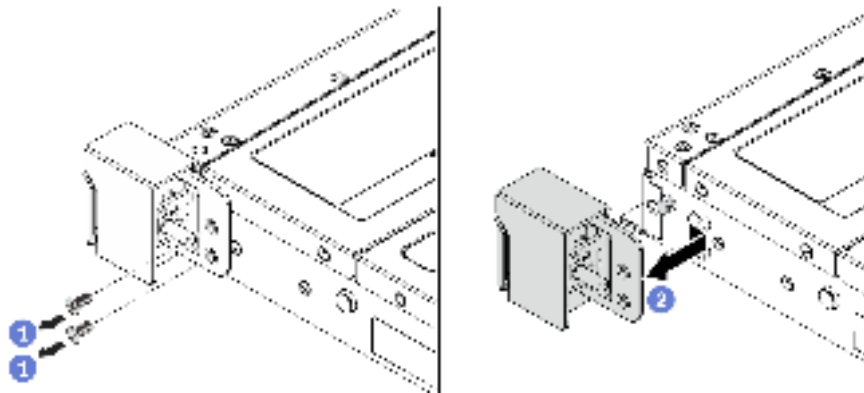


Figure 122. Rack latch removal

- a. **1** On each side of the server, remove the two screws that secure the rack latch.
- b. **2** On each side of the server, remove the rack latch from the chassis as shown.

## After you finish

If you are instructed to return the component or optional device, follow all packaging instructions, and use any packaging materials for shipping that are supplied to you.

## Demo video

[Watch the procedure on YouTube](#)

## Install the rack latches

Use this information to install the rack latches.

### About this task

#### Attention:

- Read [“Installation Guidelines” on page 51](#) and [“Safety inspection checklist” on page 52](#) to ensure that you work safely.
- Prevent exposure to static electricity, which might lead to system halt and loss of data, by keeping static-sensitive components in their static-protective packages until installation, and handling these devices with an electrostatic-discharge wrist strap or other grounding systems.

### Procedure

- Step 1. Touch the static-protective package that contains the rack latches to any unpainted surface on the outside of the server. Then, take the rack latches out of the package and place them on a static-protective surface.
- Step 2. Install the rack latch.

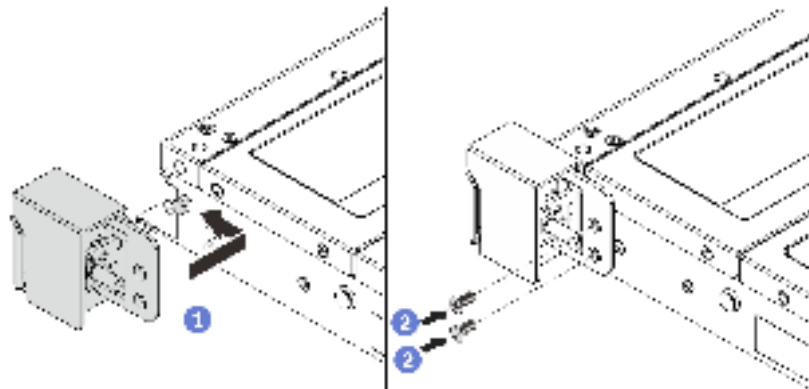


Figure 123. Rack latch installation

- a. **1** On each side of the server, align the rack latch with the pin on the chassis. Then, press the rack latch onto the chassis and slightly slide it forward as shown.
- b. **2** Install the two screws to secure the rack latch on each side of the server.

### After you finish

Complete the parts replacement. See [“Complete the parts replacement” on page 246](#).

## Demo video

[Watch the procedure on YouTube](#)

---

## RAID flash power module replacement

The RAID flash power module protects the cache memory on the installed RAID adapter. You can purchase a RAID flash power module from Lenovo. Use this information to remove and install a RAID flash power module.

For a list of supported options, see:  
<https://serverproven.lenovo.com>

RAID flash power modules can be installed on the chassis, in the air baffle, or to one riser slot.

### Locations of RAID flash power modules

Use the illustration and table below to locate the RAID flash power modules.

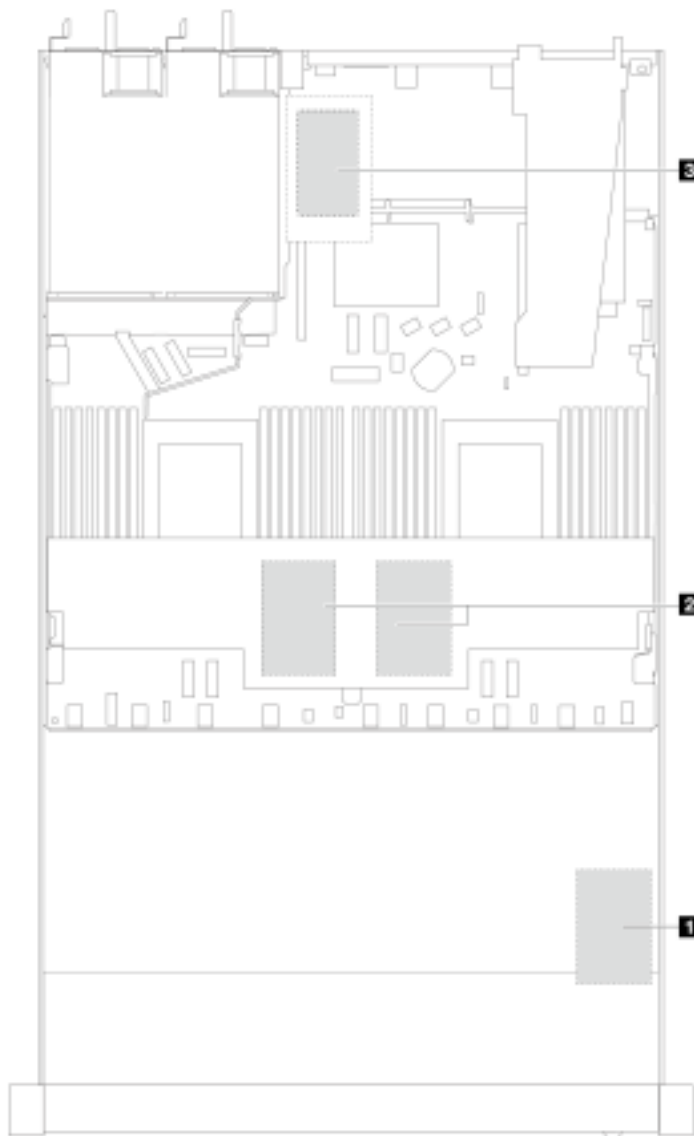


Figure 124. RAID flash power modules in the chassis

Location	Scenario
1 RAID flash power module on the chassis	2.5" chassis installed with a standard or performance heat sink
2 RAID flash power module on the air baffle	2.5" or 3.5" chassis installed with a standard heat sink
3 RAID flash power module on slot 3	<ul style="list-style-type: none"> <li>3.5" chassis installed with a performance heat sink</li> <li>2.5" chassis installed with liquid assisted cooling module</li> </ul>

An extension cable is provided for each RAID flash power module for connection. Connect the flash power module cable to the flash power module connector on the corresponding RAID adapter as shown.

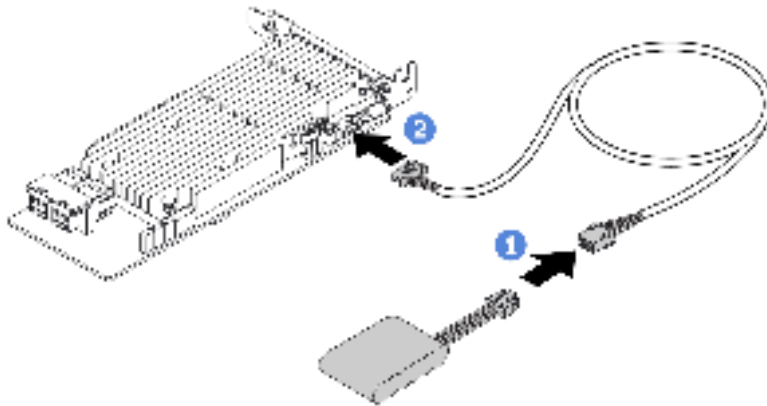


Figure 125. Power cable routing for flash power module

- 1 Connect the RAID flash power module to the extension cable.
- 2 Connect the extension cable to the SFF/CFF RAID/HBA adapter.

## Remove the RAID flash power module on the chassis

Use this information to remove the RAID flash power module on the chassis.

### About this task

#### Attention:

- Read [“Installation Guidelines” on page 51](#) and [“Safety inspection checklist” on page 52](#) to ensure that you work safely.
- Power off the server and peripheral devices and disconnect the power cords and all external cables. See [“Power off the server” on page 68](#).
- Prevent exposure to static electricity, which might lead to system halt and loss of data, by keeping static-sensitive components in their static-protective packages until installation, and handling these devices with an electrostatic-discharge wrist strap or other grounding systems.

### Procedure

- Step 1. Remove the top cover. See [“Remove the top cover” on page 243](#).
- Step 2. Disconnect the cable of the RAID flash power module.



Step 3. Remove the RAID flash power module on the chassis.

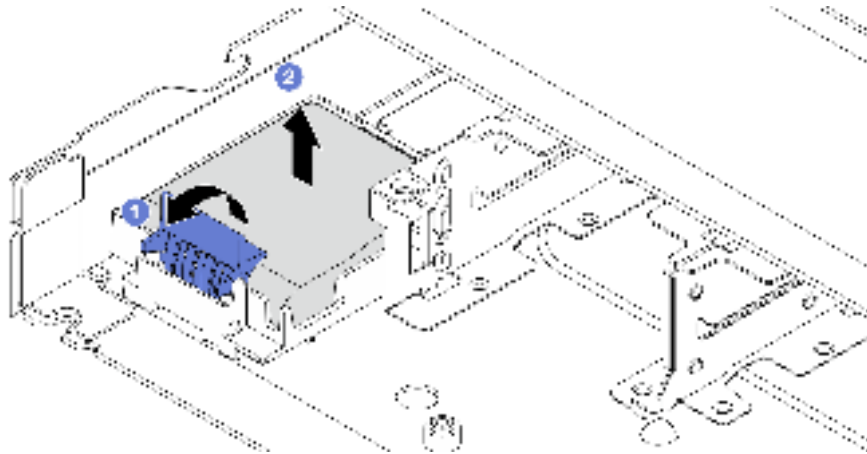


Figure 126. Removal of the RAID flash power module on the chassis

- a. ① Open the retention clip on the holder of the RAID flash power module.
- b. ② Take the RAID flash power module out of the holder.

Step 4. Remove the RAID flash power module holder as shown if necessary.

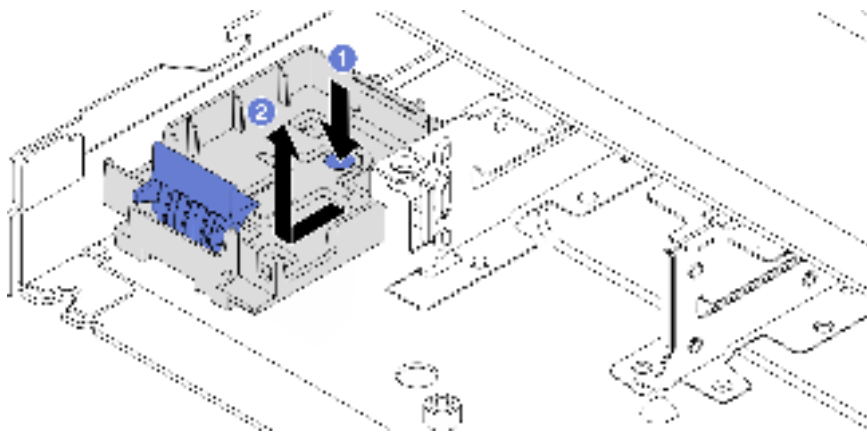


Figure 127. RAID flash power module holder removal

## After you finish

If you are instructed to return the component or optional device, follow all packaging instructions, and use any packaging materials for shipping that are supplied to you.

## Demo video

[Watch the procedure on YouTube](#)

## Install the RAID flash power module on the chassis

Use this information to install the RAID flash power module on the chassis.

## About this task

**Attention:**

- Read “Installation Guidelines” on page 51 and “Safety inspection checklist” on page 52 to ensure that you work safely.
- Power off the server and peripheral devices and disconnect the power cords and all external cables. See “Power off the server” on page 68.
- Prevent exposure to static electricity, which might lead to system halt and loss of data, by keeping static-sensitive components in their static-protective packages until installation, and handling these devices with an electrostatic-discharge wrist strap or other grounding systems.

**Procedure**

- Step 1. Touch the static-protective package that contains the RAID flash power module to any unpainted surface on the outside of the server. Then, take the RAID flash power module out of the package and place it on a static-protective surface.
- Step 2. If the server comes with a tray that covers the place of the RAID flash power module on the chassis, remove it first.

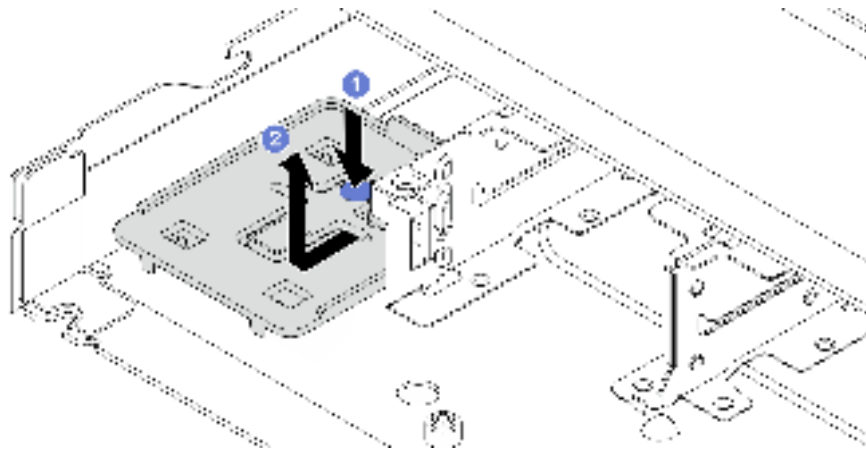


Figure 128. Tray removal

- a. 1 Press the blue touch point to disengage the tray from the chassis.
- b. 2 Move the tray to the direction as shown and lift it out of the chassis.

Step 3. If the server does not have a RAID flash power module holder on the chassis, install one first.

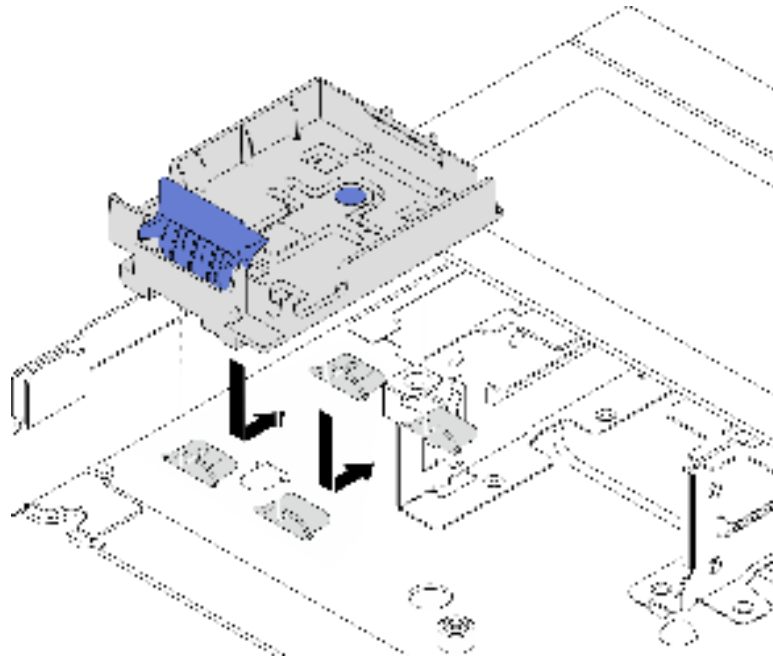


Figure 129. RAID flash power module holder installation

Put the holder down, and move it to the direction as shown to lock the holder onto the chassis.

Step 4. Install the RAID flash power module on the chassis.

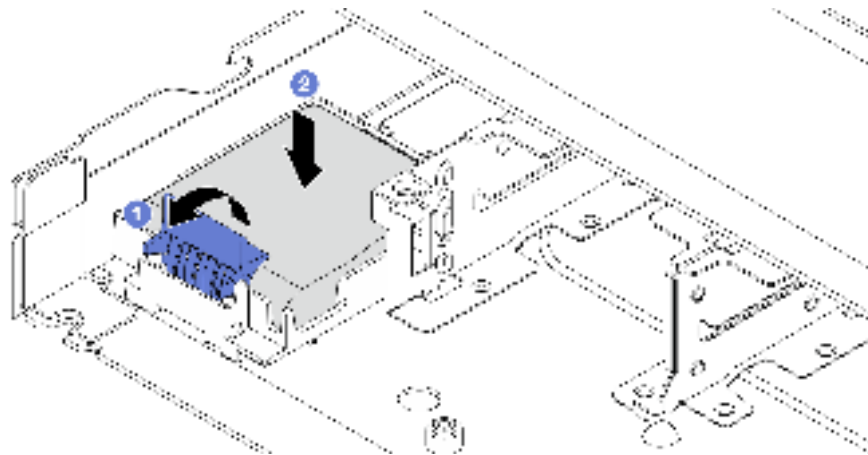


Figure 130. Installation of the RAID flash power module on the chassis

- a. 1 Open the retention clip on the holder.
- b. 2 Put the RAID flash power module into the holder and press it down to secure it into the holder.

## After you finish

1. Connect the super capacitor module to an adapter with the extension cable that comes with the flash power module. See [“RAID flash power modules” on page 264](#).

2. Complete the parts replacement. See [“Complete the parts replacement”](#) on page 246.

### Demo video

[Watch the procedure on YouTube](#)

## Remove the RAID flash power module on the air baffle

Use this information to remove the RAID flash power module on the air baffle.

### About this task

#### Attention:

- Read [“Installation Guidelines”](#) on page 51 and [“Safety inspection checklist”](#) on page 52 to ensure that you work safely.
- Power off the server and peripheral devices and disconnect the power cords and all external cables. See [“Power off the server”](#) on page 68.
- Prevent exposure to static electricity, which might lead to system halt and loss of data, by keeping static-sensitive components in their static-protective packages until installation, and handling these devices with an electrostatic-discharge wrist strap or other grounding systems.

#### Watch the procedure

A video of this procedure is available on YouTube: <https://www.youtube.com/playlist?list=PLYV5R7hVcs-CfNsWy-689CRZHExrZEi9I>.

### Procedure

- Step 1. Remove the top cover. See [“Remove the top cover”](#) on page 243.
- Step 2. Disconnect the cable of the RAID flash power module.
- Step 3. Remove the air baffle from the chassis. See [“Remove the air baffle”](#) on page 77.
- Step 4. Remove the RAID flash power module on the air baffle.

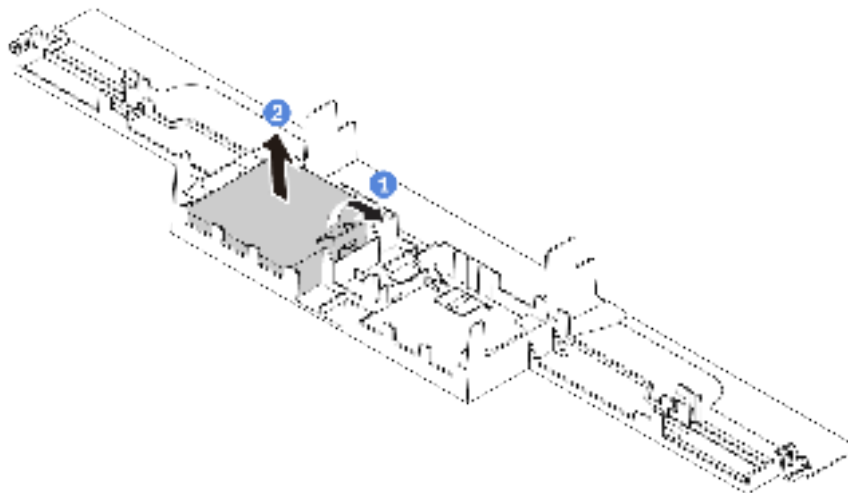


Figure 131. Removal of the RAID flash power module on the air baffle

- a. ① Open the retention clip on the holder of the RAID flash power module.
- b. ② Take the RAID flash power module out of the holder.

## After you finish

If you are instructed to return the component or optional device, follow all packaging instructions, and use any packaging materials for shipping that are supplied to you.

## Install the RAID flash power module on the air baffle

Use this information to install the RAID flash power module on the air baffle.

### About this task

#### Attention:

- Read “Installation Guidelines” on page 51 and “Safety inspection checklist” on page 52 to ensure that you work safely.
- Power off the server and peripheral devices and disconnect the power cords and all external cables. See “Power off the server” on page 68.
- Prevent exposure to static electricity, which might lead to system halt and loss of data, by keeping static-sensitive components in their static-protective packages until installation, and handling these devices with an electrostatic-discharge wrist strap or other grounding systems.

#### Watch the procedure

A video of this procedure is available on YouTube: <https://www.youtube.com/playlist?list=PLYV5R7hVcs-CfNsWy-689CRZHExrZEi9I>.

### Procedure

- Step 1. Touch the static-protective package that contains the RAID flash power module to any unpainted surface on the outside of the server. Then, take the RAID flash power module out of the package and place it on a static-protective surface.
- Step 2. Install the RAID flash power module on the air baffle.

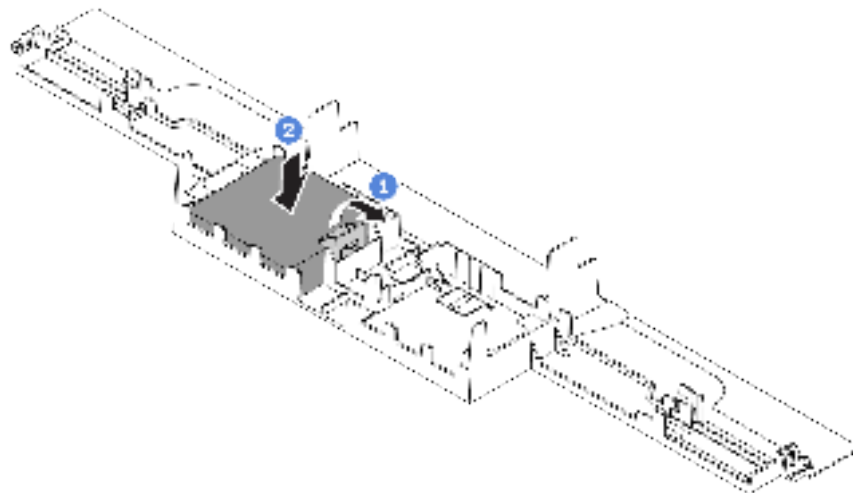


Figure 132. Installation of the RAID flash power module on the air baffle

- a. 1 Open the retention clip on the holder.
- b. 2 Put the RAID flash power module into the air baffle and press it down to secure it into the air baffle.

## After you finish

1. Install the air baffle on the chassis. See [“Install the air baffle” on page 78](#).
2. Connect the flash power module to an adapter with the extension cable that comes with the flash power module. See [“RAID flash power modules” on page 264](#).
3. Complete the parts replacement. See [“Complete the parts replacement” on page 246](#).

## Remove the RAID flash power module on the riser

Use this information to remove the RAID flash power module on the riser.

### About this task

#### Attention:

- Read [“Installation Guidelines” on page 51](#) and [“Safety inspection checklist” on page 52](#) to ensure that you work safely.
- Power off the server and peripheral devices and disconnect the power cords and all external cables. See [“Power off the server” on page 68](#).
- Prevent exposure to static electricity, which might lead to system halt and loss of data, by keeping static-sensitive components in their static-protective packages until installation, and handling these devices with an electrostatic-discharge wrist strap or other grounding systems.

#### Watch the procedure

A video of this procedure is available on YouTube: <https://www.youtube.com/playlist?list=PLYV5R7hVcs-CfNsWy-689CRZHExrZEi9I>.

### Procedure

- Step 1. Remove the top cover. See [“Remove the top cover” on page 243](#).
- Step 2. Disconnect the cable of the RAID flash power module.
- Step 3. Remove the riser assembly. See [“Remove a riser card” on page 208](#).

Step 4. Remove the RAID flash power module from the riser.

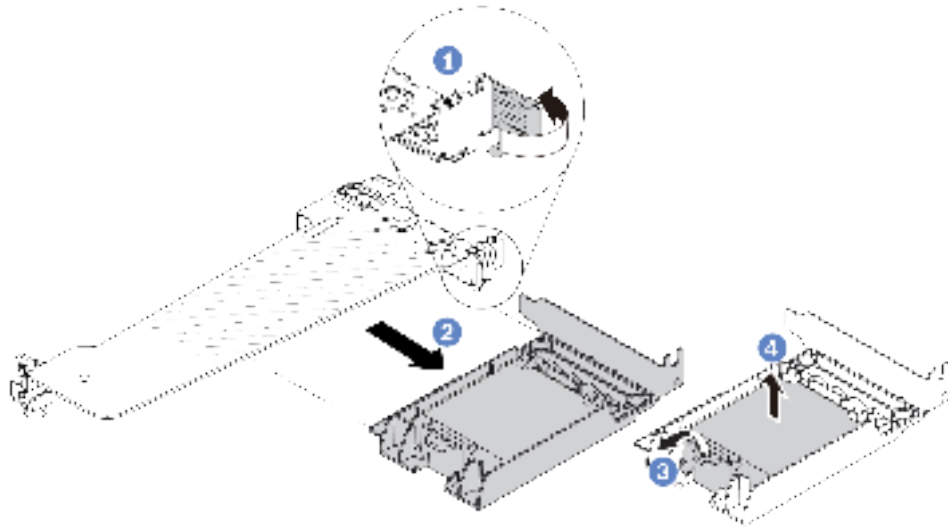


Figure 133. Removal of the RAID super capacitor assembly from the riser

- a. 1 Rotate the latch on the riser bracket to the open position.
- b. 2 Remove the RAID flash power assembly from the riser.
- c. 3 Open the retention clip on the holder of the RAID flash power module.
- d. 4 Take the RAID flash power module out of the holder.

## After you finish

If you are instructed to return the component or optional device, follow all packaging instructions, and use any packaging materials for shipping that are supplied to you.

## Install the RAID flash power module on the riser

Use this information to install the RAID flash power module on the riser.

## About this task

### Attention:

- Read “Installation Guidelines” on page 51 and “Safety inspection checklist” on page 52 to ensure that you work safely.
- Power off the server and peripheral devices and disconnect the power cords and all external cables. See “Power off the server” on page 68.
- Prevent exposure to static electricity, which might lead to system halt and loss of data, by keeping static-sensitive components in their static-protective packages until installation, and handling these devices with an electrostatic-discharge wrist strap or other grounding systems.

### Watch the procedure

A video of this procedure is available on YouTube: <https://www.youtube.com/playlist?list=PLYV5R7hVcs-CfNsWy-689CRZHExrZEI9I>.

## Procedure

- Step 1. Touch the static-protective package that contains the RAID flash power module to any unpainted surface on the outside of the server. Then, take the RAID flash power module out of the package and place it on a static-protective surface.
- Step 2. Install the RAID flash power module on the riser.

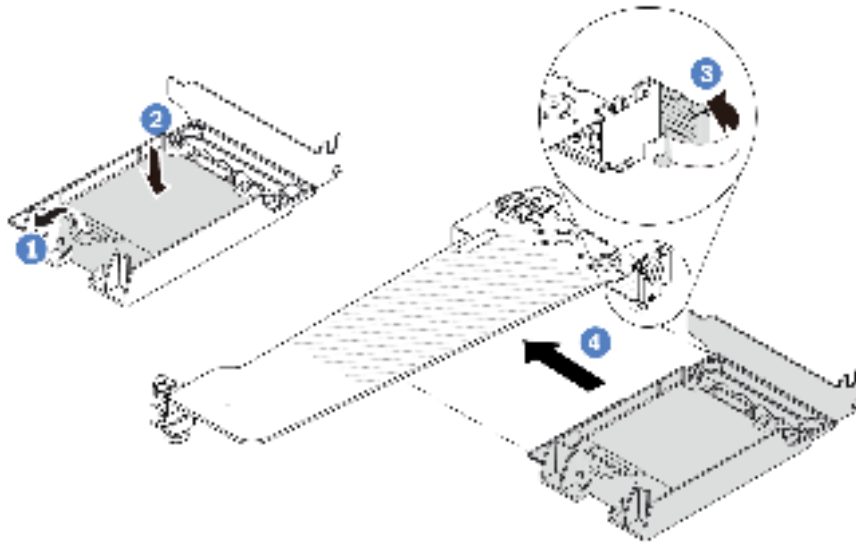


Figure 134. Installation of the RAID flash power module on the riser

- a. 1 Open the retention clip on the holder.
- b. 2 Put the RAID flash power module into the holder and press it down to secure it into the holder.
- c. 3 Rotate the latch on the riser bracket to the open position.
- d. 4 Align the RAID flash power assembly with the slot on the riser card. Then, carefully press the RAID flash power assembly straight into the slot until it is securely seated and its bracket is secured.

## After you finish

1. Install the riser assembly on the chassis. See [“Install a riser card” on page 211](#).
2. Connect the flash power module to an adapter with the extension cable that comes with the flash power module. See [“RAID flash power modules” on page 264](#).
3. Complete the parts replacement. See [“Complete the parts replacement” on page 246](#).

---

## Rear drive assembly replacement

Use this information to remove and install the rear drive assembly.

### Remove the 2.5-inch rear drive assembly

Use this information to remove the 2.5-inch rear drive assembly.

### About this task

#### Attention:



- Read [“Installation Guidelines” on page 51](#) and [“Safety inspection checklist” on page 52](#) to ensure that you work safely.
- Power off the server and peripheral devices and disconnect the power cords and all external cables. See [“Power off the server” on page 68](#).
- Prevent exposure to static electricity, which might lead to system halt and loss of data, by keeping static-sensitive components in their static-protective packages until installation, and handling these devices with an electrostatic-discharge wrist strap or other grounding systems.

## Procedure

- Step 1. Remove the top cover. See [“Remove the top cover” on page 243](#).
- Step 2. Remove the drives or drive fillers installed in the 2.5-inch rear drive cage. See [“Remove a 2.5/3.5-inch hot-swap drive” on page 115](#).
- Step 3. Disconnect the 2.5-inch rear drive cage cables from the processor board or the PCIe adapter. See [Chapter 6 “Internal cable routing” on page 249](#).
- Step 4. Hold the two blue touch points and directly lift the 2.5-inch rear drive cage out of the chassis.

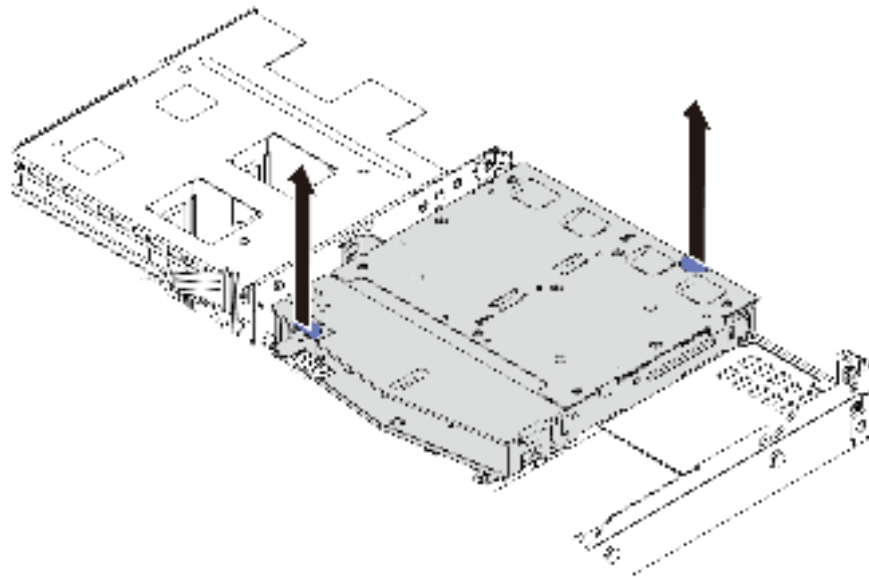


Figure 135. 2.5-inch rear drive cage removal

- Step 5. If the rear backplane is reused, remove the rear backplane. See [“Remove the 2.5-inch rear drive backplane” on page 88](#).

## After you finish

If you are instructed to return the component or optional device, follow all packaging instructions, and use any packaging materials for shipping that are supplied to you.

### Demo video

[Watch the procedure on YouTube](#)

## Install the 2.5-inch rear drive assembly

Use this information to install the 2.5-inch rear drive assembly.

## About this task

The following illustrates how to install the 2.5-inch rear drive assembly.

### Attention:

- Read [“Installation Guidelines” on page 51](#) and [“Safety inspection checklist” on page 52](#) to ensure that you work safely.
- Power off the server and peripheral devices and disconnect the power cords and all external cables. See [“Power off the server” on page 68](#).
- Prevent exposure to static electricity, which might lead to system halt and loss of data, by keeping static-sensitive components in their static-protective packages until installation, and handling these devices with an electrostatic-discharge wrist strap or other grounding systems.

### Procedure

- Step 1. Touch the static-protective package that contains the 2.5-inch rear drive cage to any unpainted surface on the outside of the server. And then, take the 2.5-inch rear drive cage out of the package and place it on a static-protective surface.
- Step 2. Gently press and hold the tab on the 2.5-inch rear drive cage as shown and remove the air baffle from the 2.5-inch rear drive cage.

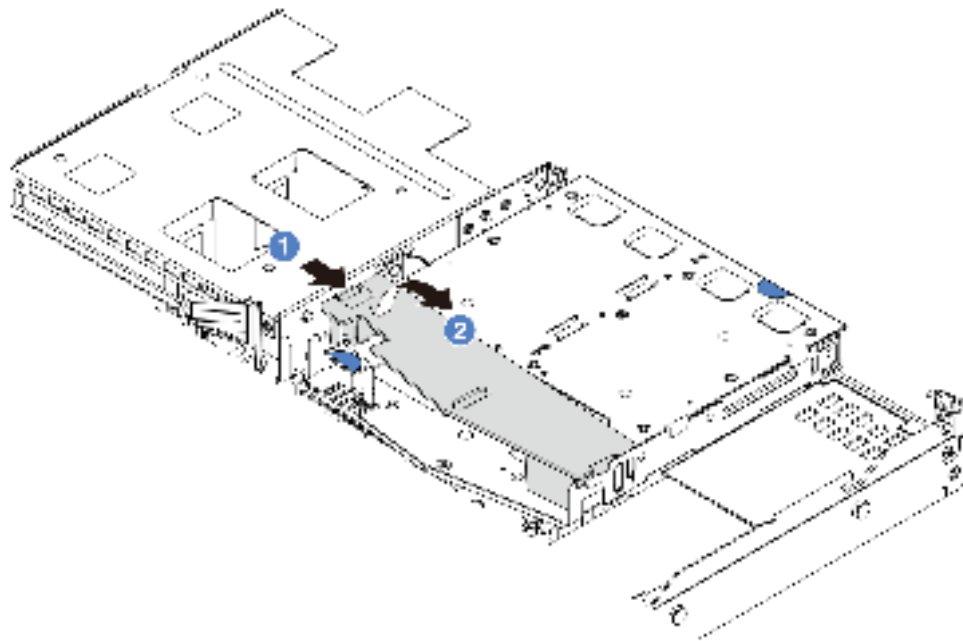


Figure 136. Air baffle removal

- a. **1** Press the tab on one side to disengage the air baffle.
  - b. **2** Lift the air baffle to remove it from drive cage.
- Step 3. Align the rear backplane with the 2.5-inch rear drive cage and lower it into the 2.5-inch rear drive cage.

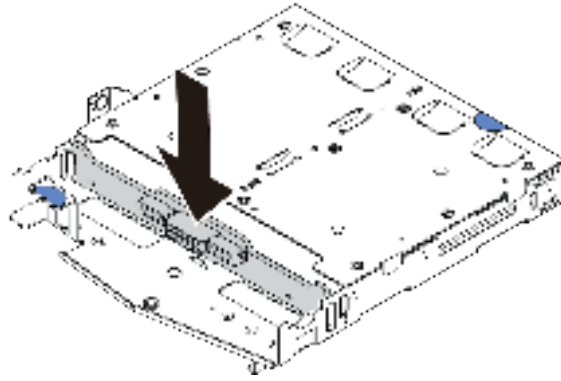


Figure 137. Rear backplane installation

Step 4. Connect the cables to the backplane.

Step 5. Install the air baffle into the 2.5-inch rear drive cage as shown.

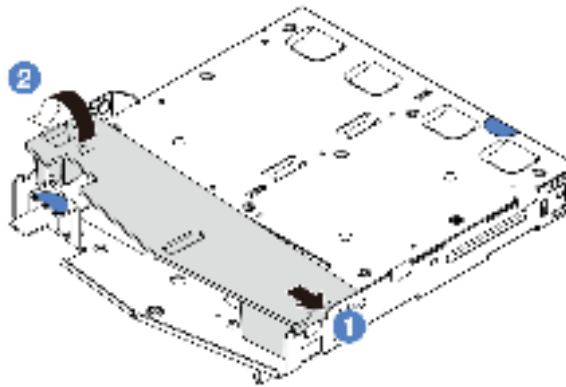


Figure 138. Air baffle installation

- a. 1 Align the air baffle edge with the notch on the drive cage.
- b. 2 Press the air baffle down and make sure that it is seated in place.

- Step 6. Align the pins on the 2.5-inch rear drive cage with the corresponding hole and slot in the chassis. Then, lower the 2.5-inch rear drive cage into the chassis until it is fully seated.

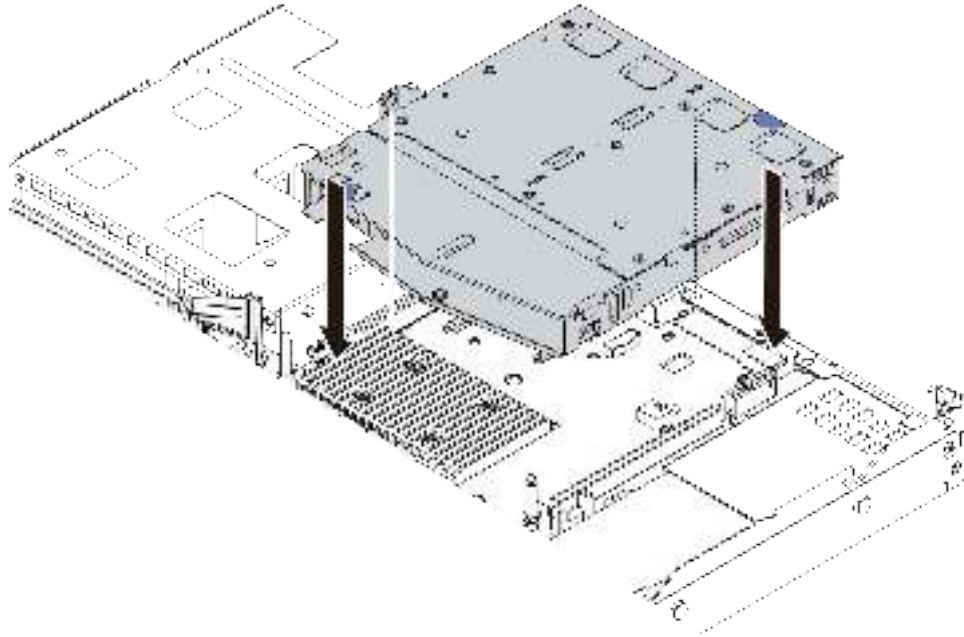


Figure 139. 2.5-inch rear drive cage installation

- Step 7. Connect the cables to the processor board or expansion slots. See [Chapter 6 “Internal cable routing” on page 249](#).

### After you finish

1. Reinstall the drives or drive fillers into the 2.5-inch rear drive cage. See [“Install a 2.5/3.5-inch hot-swap drive” on page 117](#).
2. Complete the parts replacement. See [“Complete the parts replacement” on page 246](#).

### Demo video

[Watch the procedure on YouTube](#)

## Remove the 7mm rear drive assembly

Use this information to remove the 7mm rear drive assembly.

### About this task

The following illustrates how to remove the 7mm rear drive assembly.

#### Attention:

- Read [“Installation Guidelines” on page 51](#) and [“Safety inspection checklist” on page 52](#) to ensure that you work safely.
- Power off the server and peripheral devices and disconnect the power cords and all external cables. See [“Power off the server” on page 68](#).

- Prevent exposure to static electricity, which might lead to system halt and loss of data, by keeping static-sensitive components in their static-protective packages until installation, and handling these devices with an electrostatic-discharge wrist strap or other grounding systems.

## Procedure

- Step 1. Remove the top cover. See [“Remove the top cover” on page 243](#).
- Step 2. Remove the drives or drive fillers installed in the 7mm rear drive cage. See [“Remove a 2.5/3.5-inch hot-swap drive” on page 115](#).
- Step 3. Disconnect the 7mm rear drive cage cables from the processor board or the PCIe adapter.
- Step 4. Lift the 7mm rear drive cage out of the chassis.

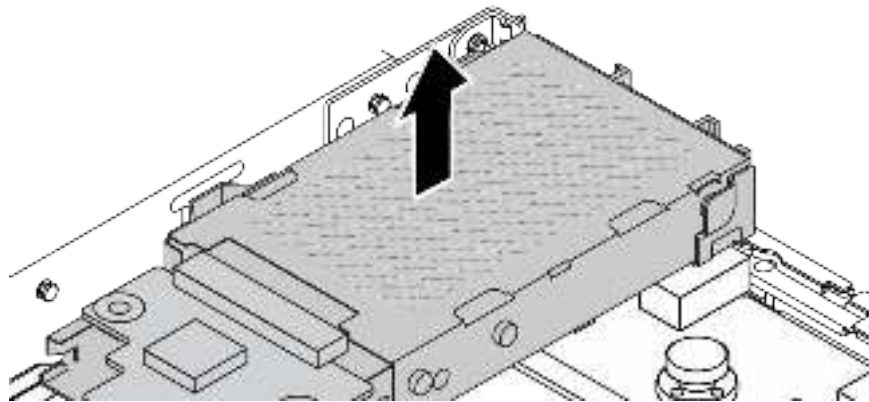


Figure 140. 7mm rear drive cage removal

- Step 5. If the rear backplane is reused, remove the rear backplane. See [“Remove the 7mm drive backplanes” on page 91](#).

## After you finish

If you are instructed to return the component or optional device, follow all packaging instructions, and use any packaging materials for shipping that are supplied to you.

### Demo video

[Watch the procedure on YouTube](#)

## Install the 7mm rear drive assembly

Use this information to install the 7mm rear drive assembly.

## About this task

The following illustrates how to install the 7mm rear drive assembly.

### Attention:

- Read [“Installation Guidelines” on page 51](#) and [“Safety inspection checklist” on page 52](#) to ensure that you work safely.
- Power off the server and peripheral devices and disconnect the power cords and all external cables. See [“Power off the server” on page 68](#).

- Prevent exposure to static electricity, which might lead to system halt and loss of data, by keeping static-sensitive components in their static-protective packages until installation, and handling these devices with an electrostatic-discharge wrist strap or other grounding systems.

## Procedure

- Step 1. Touch the static-protective package that contains the 7mm rear drive cage to any unpainted surface on the outside of the server. And then, take the 7mm rear drive cage out of the package and place it on a static-protective surface.
- Step 2. Install the 7mm backplane, see [“Install the 7mm drive backplanes” on page 93](#).
- Step 3. Align the pins on the 7mm rear drive cage with the corresponding pin and slot in the chassis. Then, lower the 7mm rear drive cage into the chassis until it is fully seated.

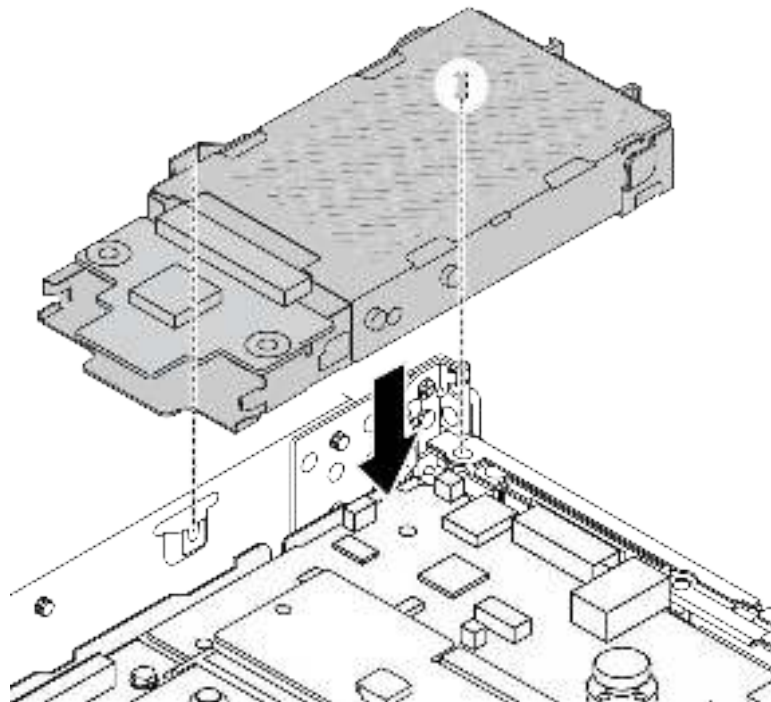


Figure 141. 7mm rear drive cage installation

- Step 4. Connect the cables from the backplanes to the processor board and riser slot. See [Chapter 6 “Internal cable routing” on page 249](#).

## After you finish

1. Reinstall the drives or drive fillers into the 7mm rear drive cage. See [“Install a 2.5/3.5-inch hot-swap drive” on page 117](#).
2. Complete the parts replacement. See [“Complete the parts replacement” on page 246](#).

## Demo video

[Watch the procedure on YouTube](#)

---

## Riser card replacement

Use this information to remove and install a riser card.

- “Server rear configuration and riser assemblies” on page 205
- “The overview of riser brackets” on page 207
- “The overview of riser cards” on page 208

### Server rear configuration and riser assemblies

See this section to identify the correlations between the rear configuration and riser assemblies.

Table 37. Server rear configuration and riser assemblies<sup>1</sup>

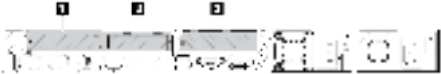

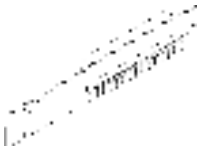

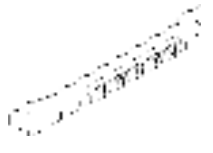


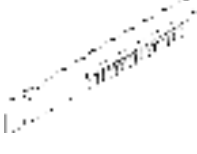
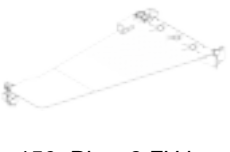
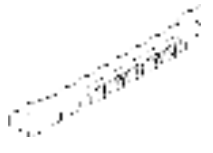
Server rear configuration	Riser 1 assembly	Riser 2 assembly
 <p>Figure 142. Three PCIe slots</p>	 <p>Figure 143. Riser 1 LP-LP bracket</p>  <p>Figure 144. Riser 1 BF<sup>2</sup> card</p>	 <p>Figure 145. Riser 2 bracket</p>  <p>Figure 146. Riser 2 card</p>
 <p>Figure 147. Two PCIe slots</p>	 <p>Figure 148. Riser 1 LP-filler bracket</p>  <p>Figure 149. Riser 1 card</p>	 <p>Figure 150. Riser 2 FH bracket</p>  <p>Figure 151. Riser 2 card</p>

Table 37. Server rear configuration and riser assemblies<sup>1</sup> (continued)

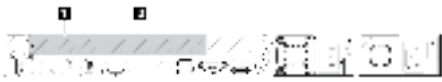

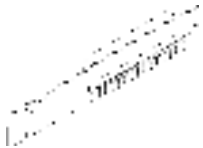




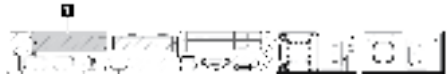


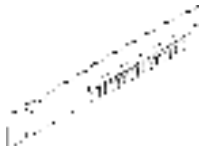


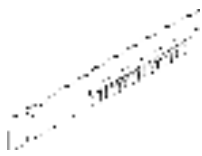
Server rear configuration	Riser 1 assembly	Riser 2 assembly
 <p>Figure 152. Two PCIe slots</p>	 <p>Figure 153. Riser 1 LP-FH bracket</p>  <p>Figure 154. Riser 1 BF card</p>	<p>Riser 2 assembly is not supported.</p> <p>A rear wall bracket is required for this configuration.</p>  <p>Figure 155. A rear wall bracket</p>
 <p>Figure 156. Two PCIe slots</p>	 <p>Figure 157. Riser 1 LP-LP bracket</p>  <p>Figure 158. Riser 1 BF card</p>	<p>Riser 2 assembly is not supported.</p>



Table 37. Server rear configuration and riser assemblies<sup>1</sup> (continued)

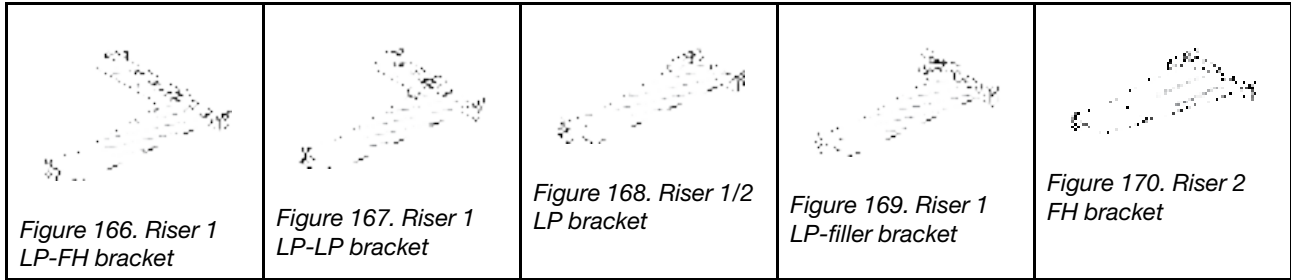
Server rear configuration	Riser 1 assembly	Riser 2 assembly
 <p>Figure 159. One PCIe slot</p>	 <p>Figure 160. Riser 1 LP-LP bracket</p> <p>Choose either one below to assemble:</p> <ul style="list-style-type: none"> <li>  <p>Figure 161. Riser 1 BF card</p> </li> <li>  <p>Figure 162. Riser 1 card</p> </li> </ul>	<p>Riser 2 assembly is not supported.</p>
 <p>Figure 163. One PCIe slot</p>	 <p>Figure 164. Riser 1 LP bracket</p>  <p>Figure 165. Riser 1 card</p>	<p>Riser 2 assembly is not supported.</p>

**Notes:**

1. The illustrations of riser brackets and cards may look slightly different from the physical ones.
2. BF: “butterfly”, a riser card with slots on both sides.




**The overview of riser brackets**

See this section to identify different riser brackets.



### The overview of riser cards

See this section to identify different riser cards.

Riser card	Notes
 <p>Figure 171. A Gen 4/5 BF riser card</p>	<ul style="list-style-type: none"> <li>Depending on the server configuration or specific orders, the riser card can be a Gen 4 or Gen 5 card.</li> <li>This section only breaks down how to match the cards with the brackets as the appearance and the installation methods are the same for the Gen 4 and Gen 5 BF cards.</li> </ul>
 <p>Figure 172. A Gen 4/5 riser card</p>	<p>This card can be:</p> <ul style="list-style-type: none"> <li>A Gen 4 riser 1 card</li> <li>A Gen 5 BF riser 1 card with one slot removed</li> </ul>
 <p>Figure 173. A Gen 4/5 riser card</p>	<p>Gen 4/5 riser 2 card</p>

### Remove a riser card

Use this information to remove a riser card.

#### About this task

For more riser brackets supported, see [“Riser card replacement” on page 204](#).

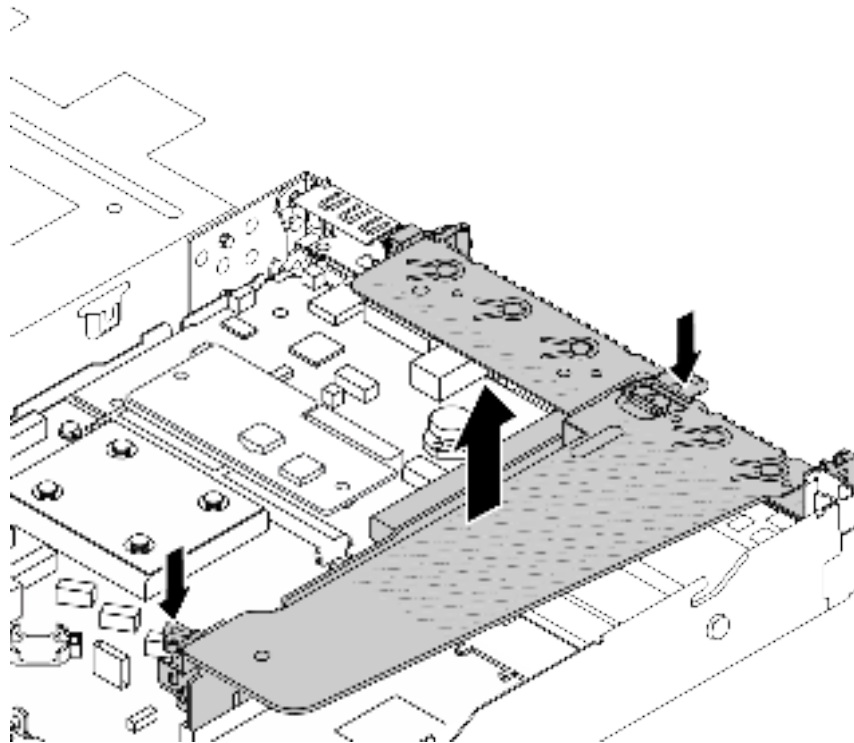
The riser assembly you want to remove might be different from the following illustrations, but the removal method is the same. The following takes the LP-FH riser assembly as an example.

**Attention:**

- Read [“Installation Guidelines” on page 51](#) and [“Safety inspection checklist” on page 52](#) to ensure that you work safely.
- Power off the server and peripheral devices and disconnect the power cords and all external cables. See [“Power off the server” on page 68](#).
- Prevent exposure to static electricity, which might lead to system halt and loss of data, by keeping static-sensitive components in their static-protective packages until installation, and handling these devices with an electrostatic-discharge wrist strap or other grounding systems.

**Procedure**

- Step 1. Remove the top cover. See [“Remove the top cover” on page 243](#).
- Step 2. If there is any PCIe adapter installed on the riser card, record the cable connections first. Then, disconnect all cables from the PCIe adapter.
- Step 3. Press the two latches on both ends at the same time, and carefully lift it out of the chassis by the two latches.



*Figure 174. Riser assembly removal*

- Step 4. If necessary, remove the PCIe adapters that are installed on the riser card. See [“Remove a PCIe adapter” on page 170](#).

Step 5. Remove the riser card from the bracket.

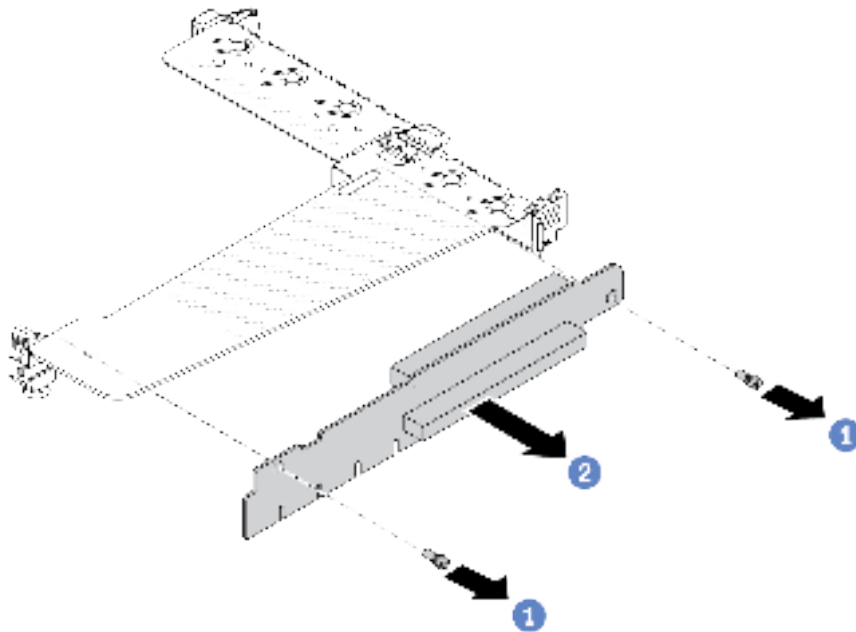


Figure 175. Riser card removal

- a. 1 Remove the two screws that secure the riser card to the bracket.
- b. 2 Remove the riser card.

### After you finish

1. If you are instructed to return the component or optional device, follow all packaging instructions, and use any packaging materials for shipping that are supplied to you.
2. Remove the rear wall bracket if you would like to install a non-LP-FH riser assembly.

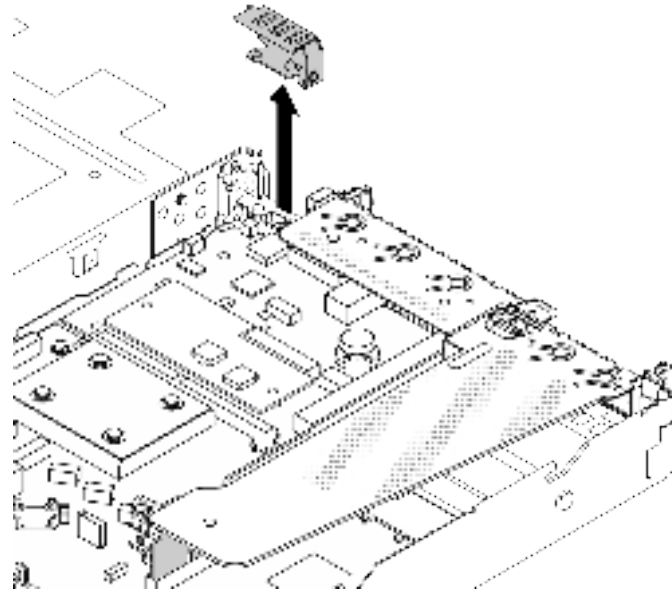


Figure 176. Rear wall bracket removal

### Demo video

[Watch the procedure on YouTube](#)

## Install a riser card

Use this information to install a riser card.

### About this task

For more riser brackets supported, see [“Riser card replacement” on page 204](#).

The riser assembly you want to install might be different from the following illustrations, but the installation method is the same. The following takes the LP-FH riser assembly as an example.

### Attention:

- Read [“Installation Guidelines” on page 51](#) and [“Safety inspection checklist” on page 52](#) to ensure that you work safely.
- Power off the server and peripheral devices and disconnect the power cords and all external cables. See [“Power off the server” on page 68](#).
- Prevent exposure to static electricity, which might lead to system halt and loss of data, by keeping static-sensitive components in their static-protective packages until installation, and handling these devices with an electrostatic-discharge wrist strap or other grounding systems.

### Procedure

- Step 1. Touch the static-protective package that contains the riser card to any unpainted surface on the outside of the server. Then, take the riser card out of the package and place it on a static-protective surface.

Step 2. Install the riser card and secure it to the bracket.

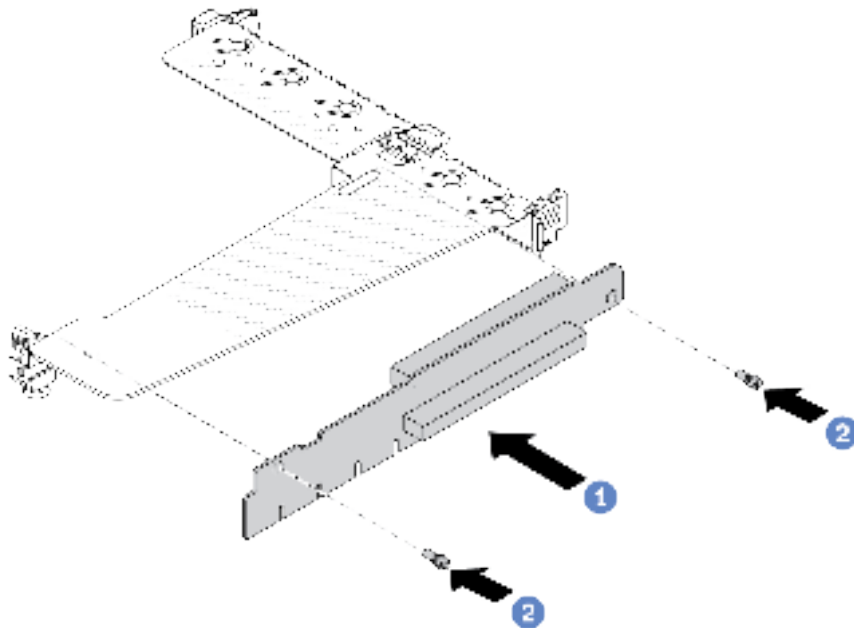


Figure 177. Riser card installation

1. **1** Align the screw holes in the riser card with the corresponding ones in the bracket.
2. **2** Install the two screws to secure the riser card to the bracket.

Step 3. If necessary, reinstall the PCIe adapters on the riser card. See [“Install a PCIe adapter” on page 171](#). Then, refer to your note to reconnect any cables of the PCIe adapters on the riser card. Or you can refer to the [Chapter 6 “Internal cable routing” on page 249](#) and locate the cable routing information for your configuration options.

Step 4. Position the riser assembly on the chassis. Align the plastic clip and two pins on the bracket with the guide pin and two holes on the chassis, and align the riser card with the riser slot on the system board assembly. Then, carefully press the riser assembly straight down into the slot until it is fully seated.

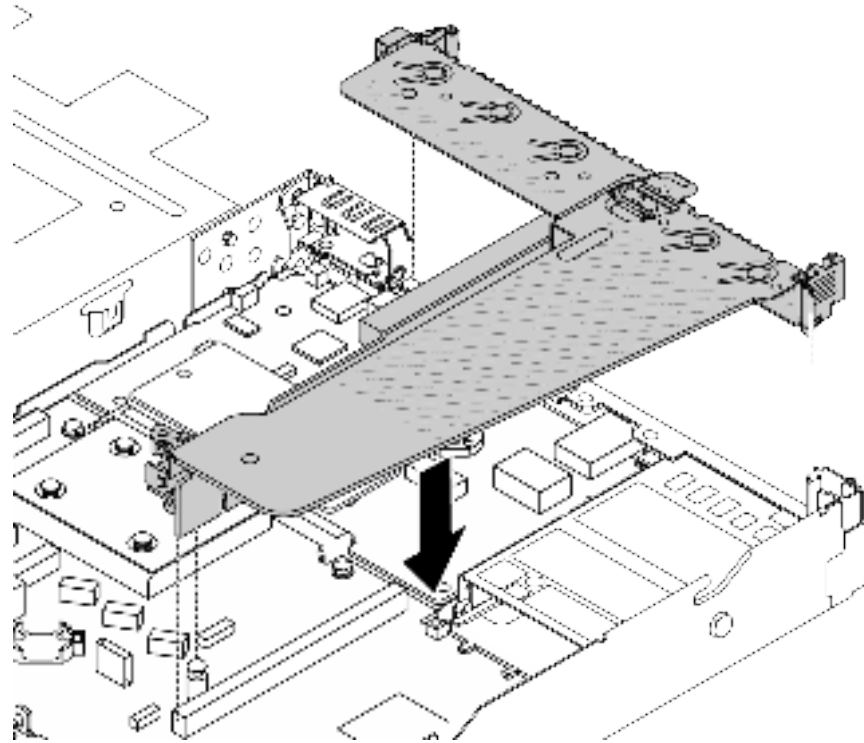


Figure 178. Riser assembly installation

## After you finish

Complete the parts replacement. See [“Complete the parts replacement”](#) on page 246.

## Demo video

[Watch the procedure on YouTube](#)

---

## Security bezel replacement

Use this information to remove and install the security bezel.

**Note:** The security bezel is available on some models.

## Remove the security bezel

Use this information to remove the security bezel.

## About this task

**Attention:**

- Read “[Installation Guidelines](#)” on page 51 and “[Safety inspection checklist](#)” on page 52 to ensure that you work safely.
- Prevent exposure to static electricity, which might lead to system halt and loss of data, by keeping static-sensitive components in their static-protective packages until installation, and handling these devices with an electrostatic-discharge wrist strap or other grounding systems.

### Watch the procedure

A video of this procedure is available on YouTube: <https://www.youtube.com/playlist?list=PLYV5R7hVcs-CfNsWy-689CRZHExrZEi9I>.

### Procedure

Step 1. Use the key to unlock the security bezel.

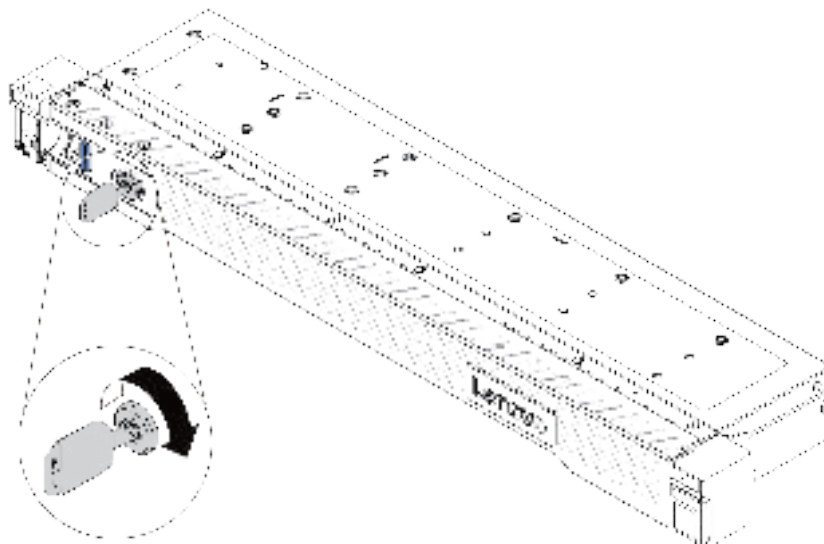


Figure 179. Unlocking the security bezel



Step 2. Remove the security bezel.

**Attention:** Before you ship the rack with the server installed, reinstall and lock the security bezel into place.

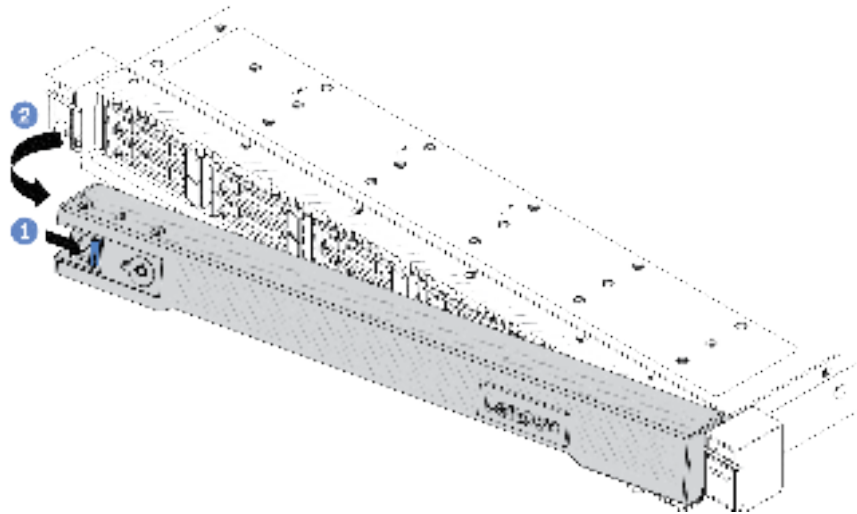


Figure 180. Security bezel removal

- a. 1 Press the release latch.
- b. 2 Rotate the security bezel outward to remove it from the chassis.

## After you finish

If you are instructed to return the component or optional device, follow all packaging instructions, and use any packaging materials for shipping that are supplied to you.

## Install the security bezel

Use this information to install the security bezel.

## About this task

### Attention:

- Read “Installation Guidelines” on page 51 and “Safety inspection checklist” on page 52 to ensure that you work safely.
- Prevent exposure to static electricity, which might lead to system halt and loss of data, by keeping static-sensitive components in their static-protective packages until installation, and handling these devices with an electrostatic-discharge wrist strap or other grounding systems.

### Watch the procedure

A video of this procedure is available on YouTube: <https://www.youtube.com/playlist?list=PLYV5R7hVcs-CfNsWy-689CRZHExrZEi9I>.

## Procedure

Step 1. If you have removed the rack latches, reinstall them. See “Install the rack latches” on page 188.

Step 2. If the key is held inside the security bezel, remove it out of the security bezel.

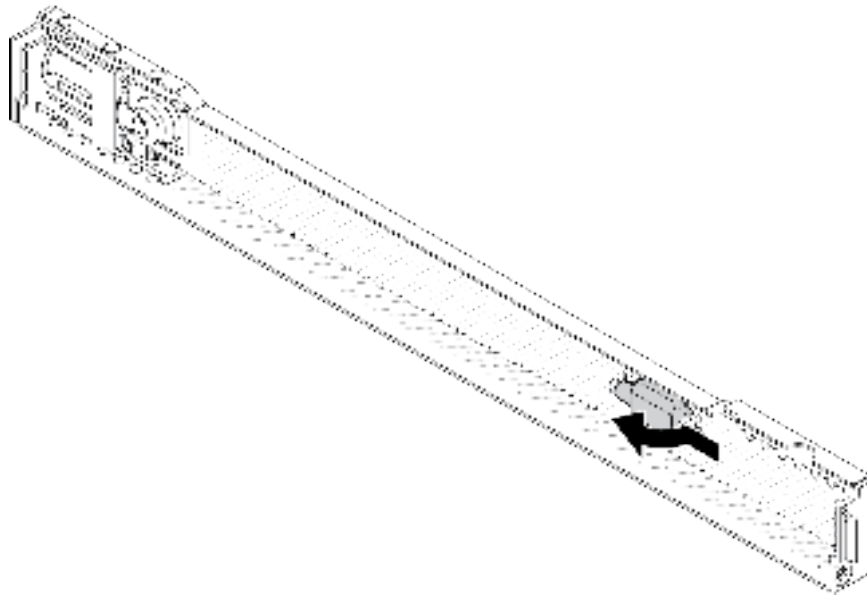


Figure 181. Key removal

Step 3. Install the security bezel to the chassis.

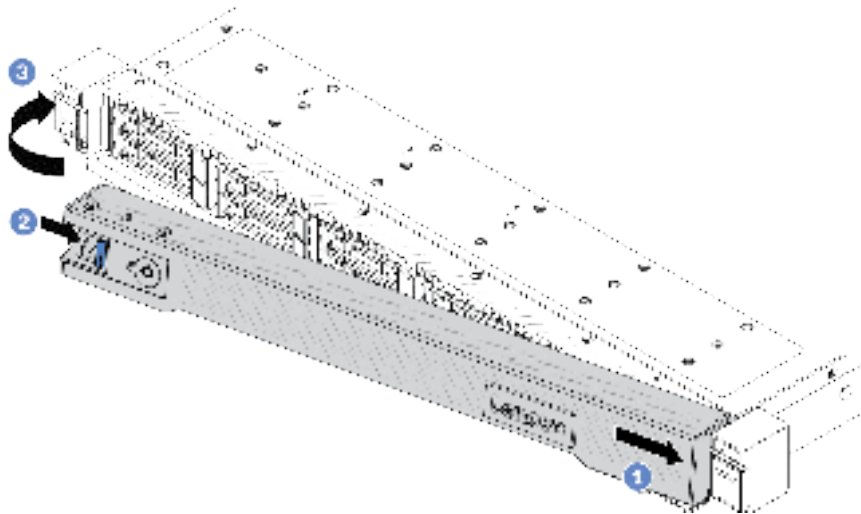


Figure 182. Security bezel installation

- a. 1 Insert the tab on the security bezel into the slot on the right rack latch.
- b. 2 Press and hold the blue release latch.
- c. 3 Rotate the security bezel inward until the left side clicks into place.

Step 4. Use the key to lock the security bezel to the closed position.

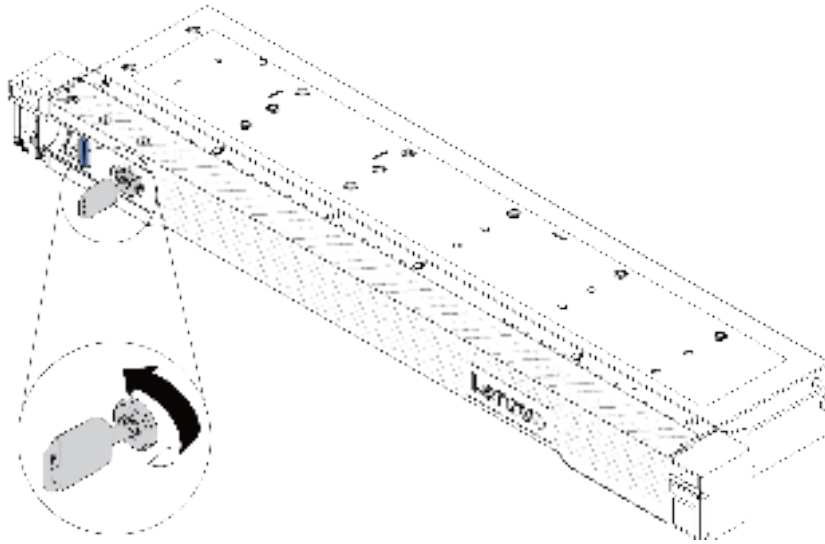


Figure 183. Locking the security bezel

## After you finish

Complete the parts replacement. See [“Complete the parts replacement” on page 246](#).

---

## Serial port module replacement

Use this information to remove and install a serial port module.

### Remove a serial port module

Use this information to remove a serial port module.

### About this task

#### Attention:

- Read [“Installation Guidelines” on page 51](#) and [“Safety inspection checklist” on page 52](#) to ensure that you work safely.
- Power off the server and peripheral devices and disconnect the power cords and all external cables. See [“Power off the server” on page 68](#).
- Prevent exposure to static electricity, which might lead to system halt and loss of data, by keeping static-sensitive components in their static-protective packages until installation, and handling these devices with an electrostatic-discharge wrist strap or other grounding systems.

#### Watch the procedure

A video of this procedure is available on YouTube: <https://www.youtube.com/playlist?list=PLYV5R7hVcs-CfNsWy-689CRZHExrZEI9l>.

### Procedure

Step 1. Remove the top cover. See [“Remove the top cover” on page 243](#).

Step 2. Disconnect the cable of the serial port module from the system board assembly.

Step 3. Press the two latches on both ends at the same time, and carefully lift the riser cage out of the chassis by two latches.

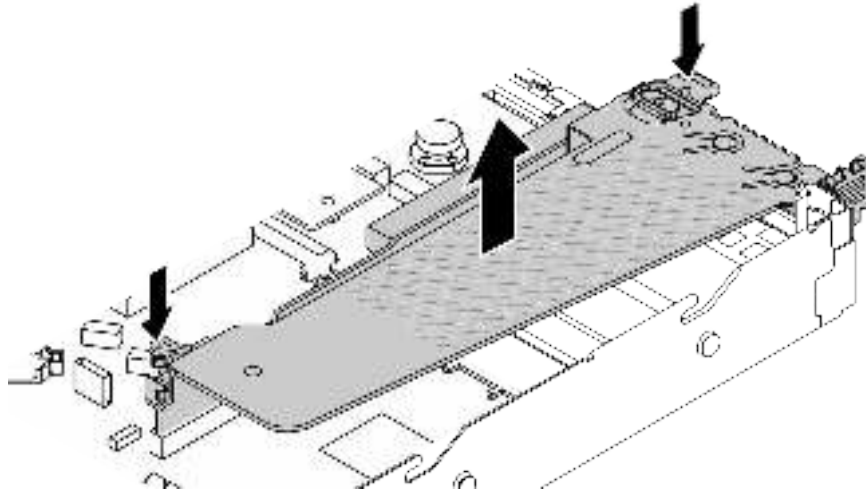


Figure 184. Removing the riser bracket

Step 4. Open the retention latch and remove the serial port module from the riser bracket.

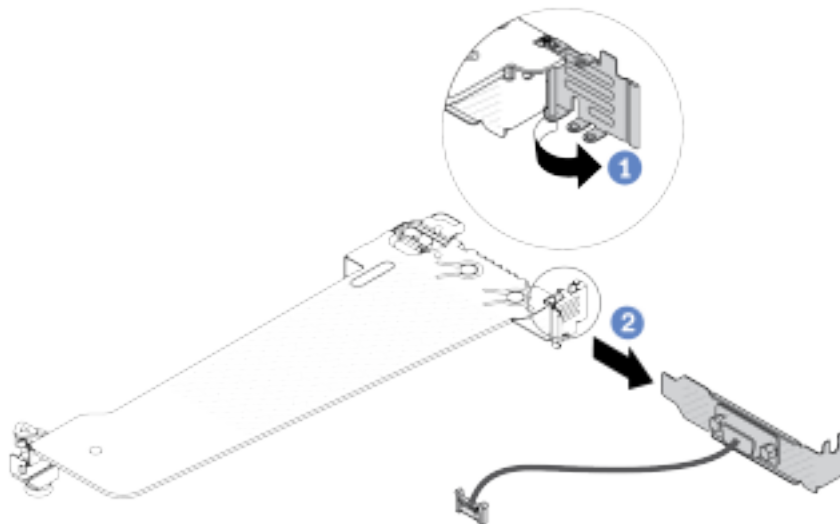


Figure 185. Removing the riser bracket

- a. 1 Open the retention latch.
- b. 2 Remove the serial port module from the riser bracket.

Step 5. (Optional) If you need to replace the serial port bracket, use a 5 mm wrench to disassemble the serial port cable from the bracket.



Figure 186. Disassembling the serial port module

- a. ① Loosen the two screws.
- b. ② Pull out the serial port cable from the bracket.

## After you finish

1. Install a new serial port module, a PCIe adapter, or a PCIe slot bracket to cover the place. See “[Install a serial port module](#)” on page 219 and “[Install a PCIe adapter](#)” on page 171.
2. If you are instructed to return the component or optional device, follow all packaging instructions, and use any packaging materials for shipping that are supplied to you.

## Install a serial port module

Use this information to install a serial port module.

### About this task

#### Attention:

- Read “[Installation Guidelines](#)” on page 51 and “[Safety inspection checklist](#)” on page 52 to ensure that you work safely.
- Power off the server and peripheral devices and disconnect the power cords and all external cables. See “[Power off the server](#)” on page 68.
- Prevent exposure to static electricity, which might lead to system halt and loss of data, by keeping static-sensitive components in their static-protective packages until installation, and handling these devices with an electrostatic-discharge wrist strap or other grounding systems.
- Read the “[PCIe slots and adapters](#)” on page 61 to ensure that you install the serial port module to a correct PCIe slot.

#### Watch the procedure

A video of this procedure is available on YouTube: <https://www.youtube.com/playlist?list=PLYV5R7hVcs-CfNsWy-689CRZHExrZEi9l>.

### Procedure

- Step 1. Touch the static-protective package that contains the component to any unpainted surface on the outside of the server. Then, take the component out of the package and place it on a static-protective surface.
- Step 2. Use a 5 mm wrench to install the serial port cable into the bracket.



Figure 187. Assembling the serial port module

- a. 1 Align the two screw holes on the cable connector to the bracket.
- b. 2 Install the two screws to the bracket.

Step 3. Install the serial port module to the riser bracket.

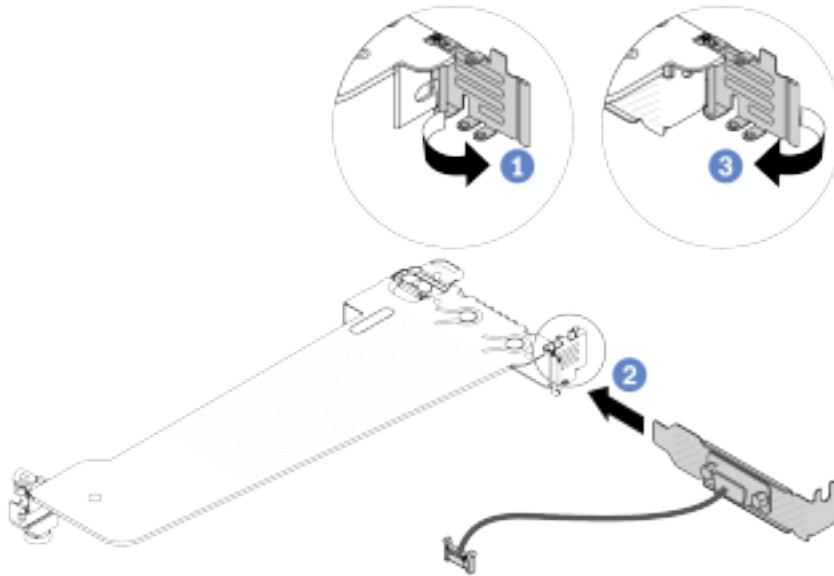


Figure 188. Installing the serial port module

- a. 1 Open the retention latch on the riser cage.
- b. 2 Install the serial port module to the riser bracket.
- c. 3 Close the retention latch and ensure that the serial port module is securely installed.

Step 4. Install the riser assembly to the server.

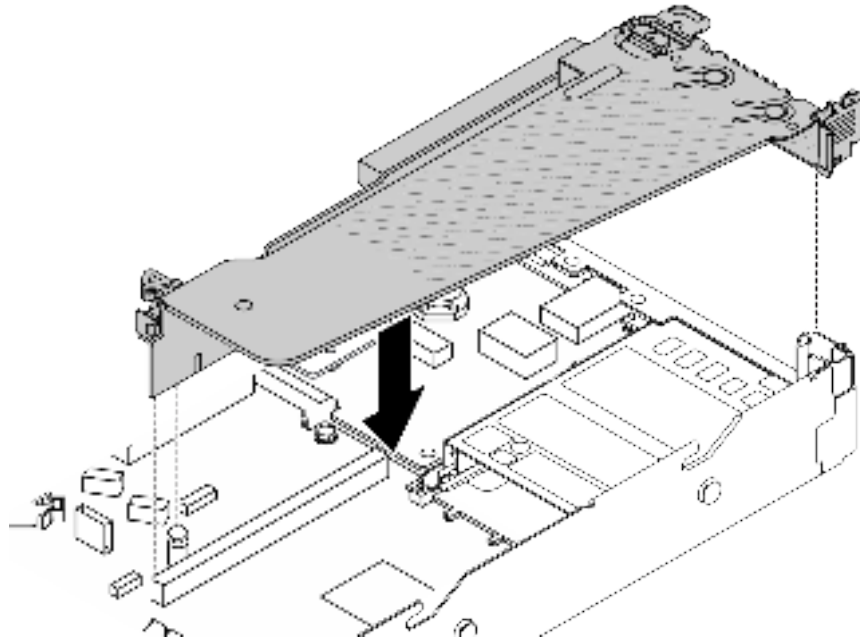


Figure 189. Installing the riser assembly

- Step 5. Connect the cable of the serial port module to the serial-port-module connector on the system board assembly. For the location of the serial-port-module connector, refer to [“System-board-assembly connectors”](#) on page 36.

## After you finish

1. Complete the parts replacement. See [“Complete the parts replacement”](#) on page 246.
2. To enable the serial port module, do one of the followings according to the installed operating system:
  - For Linux operating system:

Open the ipmitool and enter the following command to disable the Serial over LAN (SOL) feature:

```
-I lanplus -H IP -U USERID -P PASSWORD sol deactivate
```
  - For Microsoft Windows operating system:
    - a. Open the ipmitool and enter the following command to disable the SOL feature:

```
-I lanplus -H IP -U USERID -P PASSWORD sol deactivate
```
    - b. Open Windows PowerShell and enter the following command to disable the Emergency Management Services (EMS) feature:

```
Bcdedit /ems no
```
    - c. Restart the server to ensure that the EMS setting takes effect.

---

## System board assembly replacement (trained technicians only)

Follow instructions in this section to remove and install the system board assembly.

**Important:** This task must be operated by trained technicians that are certified by Lenovo Service. Do not attempt to remove or install it without proper training and qualification.

When the server has a Liquid Assisted Cooling Module (LACM) installed, you must apply for a LACM module handle (LACM heat sink bracket) first if you need to install or remove the system board assembly or processor. However, while replacing the old LACM with a new one, you do not need to apply for a module handle (LACM heat sink bracket) as the new LACM package contains it.

**CAUTION:**

**Hazardous moving parts. Keep fingers and other body parts away.**



**CAUTION:**



**The heat sinks and processors might be very hot. Turn off the server and wait several minutes to let the server cool before removing the server cover.**

The following illustration shows the layout of the system board assembly which contains the Firmware and RoT security module, system I/O board, and processor board.



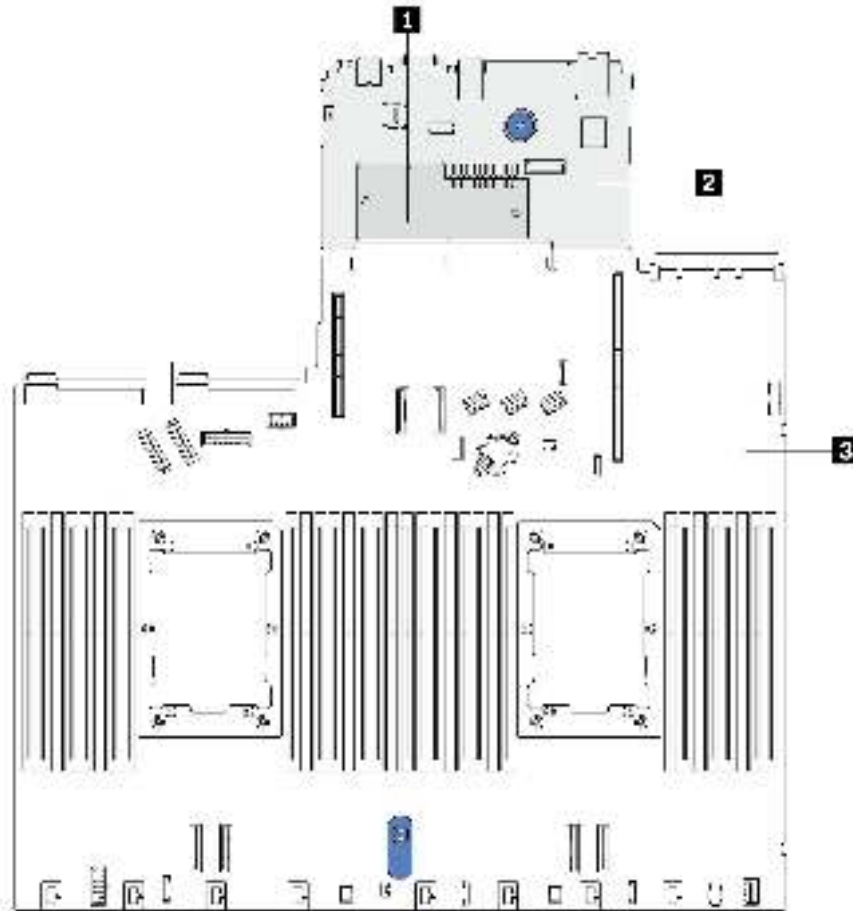


Figure 190. System-board-assembly layout

<b>1</b> Firmware and RoT Security Module	<b>2</b> System I/O board	<b>3</b> Processor board
---	---------------------------	--------------------------

## Firmware and RoT Security Module replacement (Lenovo trained technicians only)

Use this information to remove and install the Firmware and RoT Security Module.

**Attention:** Removing and installing this component requires trained technicians that are certified by Lenovo Service. Do no attempt to remove or install it without proper training and qualification.

### Remove the Firmware and RoT Security Module

Use this information to remove the Firmware and RoT Security Module.

### About this task

**Important:** This task must be operated by trained technicians that are certified by Lenovo Service. Do no attempt to remove or install it without proper training and qualification.

**Attention:**

- Read “[Installation Guidelines](#)” on page 51 and “[Safety inspection checklist](#)” on page 52 to ensure that you work safely.
- Power off the server and peripheral devices and disconnect the power cords and all external cables. See “[Power off the server](#)” on page 68.
- Prevent exposure to static electricity, which might lead to system halt and loss of data, by keeping static-sensitive components in their static-protective packages until installation, and handling these devices with an electrostatic-discharge wrist strap or other grounding system.
- After replacing the Firmware and RoT Security Module, update the firmware to the specific version supported by the server. Make sure that you have the required firmware or a copy of the pre-existing firmware before you proceed.

**Firmware and driver download:** You might need to update the firmware or driver after replacing a component.

- Go to <https://datacentersupport.lenovo.com/products/servers/thinksystem/sr630v3/7d72/downloads/driver-list/> to see the latest firmware and driver updates for your server.
- Go to “[Update the firmware](#)” on page 433 for more information on firmware updating tools.

Step 1. Prepare your server.

- Perform OneCLI commands to back up the UEFI settings. See [https://sysmgt.lenovofiles.com/help/topic/toolstr\\_cli\\_lenovo/onecli\\_r\\_save\\_command.html](https://sysmgt.lenovofiles.com/help/topic/toolstr_cli_lenovo/onecli_r_save_command.html).
- Perform both OneCLI commands and XCC actions to back up the XCC settings. See [https://sysmgt.lenovofiles.com/help/topic/toolstr\\_cli\\_lenovo/onecli\\_r\\_save\\_command.html](https://sysmgt.lenovofiles.com/help/topic/toolstr_cli_lenovo/onecli_r_save_command.html) and [https://sysmgt.lenovofiles.com/help/topic/com.lenovo.systems.management.xcc2.doc/NN1ia\\_c\\_backupthexc.html](https://sysmgt.lenovofiles.com/help/topic/com.lenovo.systems.management.xcc2.doc/NN1ia_c_backupthexc.html).
- Remove the top cover. See “[Remove the top cover](#)” on page 243.
- If your server comes with a rear drive assembly, remove it first. See “[Remove the 2.5-inch rear drive assembly](#)” on page 198.
- If your server comes with a 7mm rear drive assembly, remove it first. See “[Remove the 7mm rear drive assembly](#)” on page 202.
- If your server comes with riser assemblies, remove them first, see “[Riser assemblies](#)” on page 204.

Step 2. Remove the Firmware and RoT Security Module.

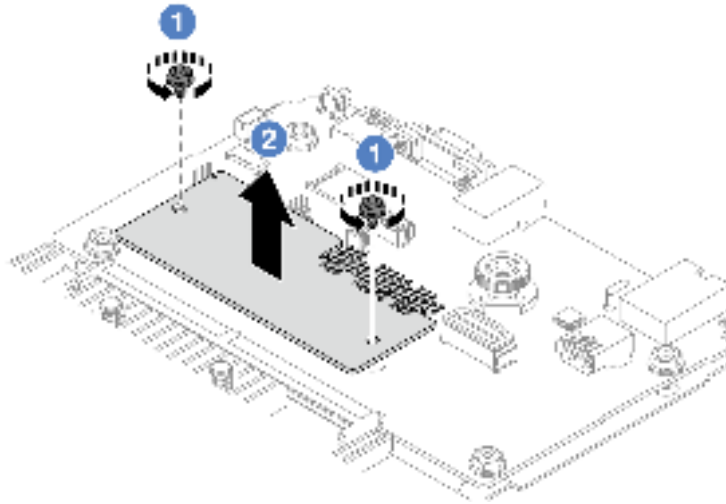


Figure 191. RoT module removal

- a. 1 Loosen the two screws on the RoT module.
- b. 2 Lift the RoT module out of the chassis.

## After you finish

If you are instructed to return the component or optional device, follow all packaging instructions, and use any packaging materials for shipping that are supplied to you.

### Demo video

[Watch the procedure on YouTube](#)

## Install the Firmware and RoT Security Module

Use this information to install the Firmware and RoT Security Module.

**Important:** This task must be operated by trained technicians that are certified by Lenovo Service. Do not attempt to remove or install it without proper training and qualification.

(Lenovo trained technicians only) After replacing the Firmware and RoT Security Module, update the UEFI firmware to the specific version supported by the server. For detailed information on how to update the firmware, see [Tip for replacing a Firmware and RoT Security Module](#).

### Attention:

- Read [“Installation Guidelines” on page 51](#) and [“Safety inspection checklist” on page 52](#) to ensure that you work safely.
- Power off the server and peripheral devices and disconnect the power cords and all external cables. See [“Power off the server” on page 68](#).
- Prevent exposure to static electricity, which might lead to system halt and loss of data, by keeping static-sensitive components in their static-protective packages until installation, and handling these devices with an electrostatic-discharge wrist strap or other grounding systems.

## Procedure

- Step 1. Touch the static-protective package that contains the new part to any unpainted surface on the outside of the server. Then, take the new part out of the package and place it on a static-protective surface.
- Step 2. Install the Firmware and RoT Security Module to the server.

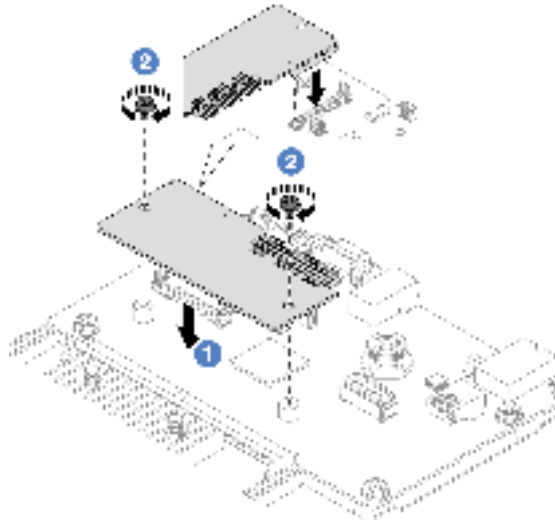


Figure 192. Firmware and RoT Security Module installation

- a. **1** Lower the Firmware and RoT Security Module onto the system I/O board and ensure that the connector on the module is correctly inserted into the slot on the system I/O board.
- b. **2** Tighten the two screws to secure the Firmware and RoT Security Module in place.

## After you finish

1. Install any components that you have removed:
    - “Install a riser card” on page 211
    - “Install the rear 7mm drive assembly” on page 203
    - “Install the rear hot-swap drive assembly” on page 199
  2. Complete the parts replacement. See “Complete the parts replacement” on page 246.
  3. Perform OneCLI commands to restore the UEFI settings. See [https://sysmgt.lenovofiles.com/help/topic/toolstr\\_cli\\_lenovo/onecli\\_r\\_save\\_command.html](https://sysmgt.lenovofiles.com/help/topic/toolstr_cli_lenovo/onecli_r_save_command.html).
  4. Perform both OneCLI commands and XCC actions to restore the XCC settings. See [https://sysmgt.lenovofiles.com/help/topic/toolstr\\_cli\\_lenovo/onecli\\_r\\_save\\_command.html](https://sysmgt.lenovofiles.com/help/topic/toolstr_cli_lenovo/onecli_r_save_command.html) and [https://sysmgt.lenovofiles.com/help/topic/com.lenovo.systems.management.xcc2.doc/NN1ia\\_c\\_backupthexcc.html](https://sysmgt.lenovofiles.com/help/topic/com.lenovo.systems.management.xcc2.doc/NN1ia_c_backupthexcc.html).
  5. Update the UEFI firmware to the specific version supported by the server. See [Tip for replacing a Firmware and RoT Security Module](#).
  6. If there is a software (SW) key, for example, XCC FoD key, installed in the system, inject the key again to ensure that the key functions properly. See [Using Lenovo Features on Demand](#).
- Note:** If you need to replace the processor board together with the Firmware and RoT Security Module, update the VPD before injecting the key. See “Update the Vital Product Data (VPD)” on page 238.
7. Optionally, do the following if needed:

- Hide TPM, see “Hide TPM” on page 227.
- Update the TPM firmware, see “Update the TPM firmware” on page 228.
- Enable UEFI Secure Boot, “Enable UEFI Secure Boot” on page 228.

## Demo video

[Watch the procedure on YouTube](#)

## Hide/observe TPM

TPM is enabled by default to encrypt data transfer for system operation. Optionally, you can disable TPM using Lenovo XClarity Essentials OneCLI.

To disable TPM, do the following:

1. Download and install Lenovo XClarity Essentials OneCLI.

To download Lenovo XClarity Essentials OneCLI, go to the following site:

<https://datacentersupport.lenovo.com/solutions/HT116433>

2. Run the following command:

```
OneCli.exe config set TrustedComputingGroup.HideTPMfromOS "Yes" --imm <userid>:<password>@<ip_address> --override
```

where:

- `<userid>:<password>` are the credentials used to access the BMC (Lenovo XClarity Controller interface) of your server. The default user ID is USERID, and the default password is PASSWORD (zero, not an uppercase o)
- `<ip_address>` is the IP address of the BMC.

Example:

```

C:\Users\j\OneCLI>onecli.exe config set TrustedComputingGroup.HideTPMfromOS "Yes" --imm USERID:PASSWORD@10.245.39.70 --override
Lenovo XClarity Essentials OneCLI Exec onecli1016-2.3.0
Licensed Materials - Property of Lenovo
© Copyright Lenovo Corp. 2018-2019 All Rights Reserved.
If the parameter you input includes password, please Note that:
* The password must consist of a sequence of characters from "0-9-a-z_+!@#$%^&* " set.
* Use "" to quote when password parameters include special characters.
* Do not use reserved characters in path name when parameter contains path.
Working SET command...
Connected to BMC at IP address 10.245.39.70 by TPM
TrustedComputingGroup.HideTPMfromOS-Yes
Success
  
```

3. Reboot the system.

If you want to enable TPM again, run the following command and reboot the system:

```
OneCli.exe config set TrustedComputingGroup.HideTPMfromOS "No" --imm <userid>:<password>@<ip_address> --override
```

Example:

```
:\onecli\Onecli.exe config set TrustedComputingGroup.DeviceOperation "Update to TPM 2.0 firmware version <x.x.x.x>" --bmc
<userid>:<password>@<ip_address>

Lenovo XClarity Essentials OneCLI Issue: onecli@In-3.0.1
(C) Lenovo 2019-2020 All Rights Reserved

OneCLI License Agreement and OneCLI Legal Information can be found at the following location:
"/onecli2cli"

Installation check finished [100%]-----
Pressing F11 command ...
Connected to BMC at IP address 10.145.30.70 by F11
TrustedComputingGroup.HideTPMWarning:No
Configure successfully, please reboot system
Success.
```

## Update the TPM firmware

Optionally, you can update the TPM firmware using Lenovo XClarity Essentials OneCLI.

**Note:** TPM firmware update is irreversible. After update, the TPM firmware cannot be downgraded to earlier versions.

## TPM firmware version

Follow the procedure below to see the TPM firmware version:

From Lenovo XClarity Provisioning Manager

1. Start the server and press the key specified in the on-screen instructions to display the Lenovo XClarity Provisioning Manager interface. For more information, see the “Startup” section in the LXPM documentation compatible with your server at [https://sysmgt.lenovofiles.com/help/topic/lxpm\\_frontend/lxpm\\_product\\_page.html](https://sysmgt.lenovofiles.com/help/topic/lxpm_frontend/lxpm_product_page.html).
2. If the power-on Administrator password is required, enter the password.
3. From the UEFI Setup page, click **System Settings** → **Security** → **Trusted Platform Module** → **TPM 2.0** → **TPM Firmware Version**.

## Update the TPM firmware

To update the TPM firmware, do the following:

1. Download and install Lenovo XClarity Essentials OneCLI.

To download Lenovo XClarity Essentials OneCLI, go to the following site:

<https://datacentersupport.lenovo.com/solutions/HT116433>

2. Run the following command:

```
OneCli.exe config set TrustedComputingGroup.DeviceOperation "Update to TPM 2.0 firmware version <x.x.x.x>" --bmc
<userid>:<password>@<ip_address>
```

where:

- <x.x.x.x> is the target TPM version.

e.g. TPM 2.0 (7.2.1.0) -> TPM 2.0 (7.2.2.0):

```
OneCli.exe config set TrustedComputingGroup.DeviceOperation "Update to TPM 2.0 firmware version 7.2.2.0" --bmc
<userid>:<password>@<ip_address>
```

- <userid>:<password> are the credentials used to access the BMC (Lenovo XClarity Controller interface) of your server. The default user ID is USERID, and the default password is PASSWORD (zero, not an uppercase o).
- <ip\_address> is the IP address of the BMC.

## Enable UEFI Secure Boot

Optionally, you can enable UEFI Secure Boot.

There are two methods available to enable UEFI Secure Boot:

- From Lenovo XClarity Provisioning Manager

To enable UEFI Secure Boot from Lenovo XClarity Provisioning Manager:

1. Start the server and press the key specified in the on-screen instructions to display the Lenovo XClarity Provisioning Manager interface. For more information, see the “Startup” section in the LXPM documentation compatible with your server at [https://sysmgmt.lenovofiles.com/help/topic/lxpm\\_frontend/lxpm\\_product\\_page.html](https://sysmgmt.lenovofiles.com/help/topic/lxpm_frontend/lxpm_product_page.html).
2. If the power-on Administrator password is required, enter the password.
3. From the UEFI Setup page, click **System Settings → Security → Secure Boot**.
4. Enable Secure Boot and save the settings.

**Note:** If disabling UEFI secure boot is needed, select Disable in step 4.

- From Lenovo XClarity Essentials OneCLI

To enable UEFI Secure Boot from Lenovo XClarity Essentials OneCLI:

1. Download and install Lenovo XClarity Essentials OneCLI.

To download Lenovo XClarity Essentials OneCLI, go to the following site:

<https://datacentersupport.lenovo.com/solutions/HT116433>

2. Run the following command to enable Secure Boot:

```
OneCli.exe config set SecureBootConfiguration.SecureBootSetting Enabled --bmc <userid>:<password>@<ip_address>
```

where:

- *<userid>:<password>* are the credentials used to access the BMC (Lenovo XClarity Controller interface) of your server. The default user ID is USERID, and the default password is PASSWORD (zero, not an uppercase o)
- *<ip\_address>* is the IP address of the BMC.

For more information about the Lenovo XClarity Essentials OneCLI `set` command, see:

[http://sysmgmt.lenovofiles.com/help/topic/toolstr\\_cli\\_lenovo/onecli\\_r\\_set\\_command.html](http://sysmgmt.lenovofiles.com/help/topic/toolstr_cli_lenovo/onecli_r_set_command.html)

**Note:** If disabling UEFI secure boot is needed, run the following command:

```
OneCli.exe config set SecureBootConfiguration.SecureBootSetting Disabled --bmc <userid>:<password>@<ip_address>
```

## System I/O board replacement (trained technicians only)

Use this section to remove and install the system I/O board from the system board assembly.

**Note:** When the server has a Liquid Assisted Cooling Module (LACM) installed, you must apply for a LACM module handle (LACM heat sink bracket) first if you need to install or remove the system board assembly or processor. However, while replacing the old LACM with a new one, you do not need to apply for a module handle (LACM heat sink bracket) as the new LACM package contains it.

### Remove the system I/O board

Follow the instructions to remove the system I/O board.

### About this task

#### Attention:

- Read “[Installation Guidelines](#)” on page 51 and “[Safety inspection checklist](#)” on page 52 to ensure that you work safely.
- Power off the server and peripheral devices and disconnect the power cords and all external cables. See “[Power off the server](#)” on page 68.
- Prevent exposure to static electricity, which might lead to system halt and loss of data, by keeping static-sensitive components in their static-protective packages until installation, and handling these devices with an electrostatic-discharge wrist strap or other grounding systems.

### Watch the procedure

A video of this procedure is available on YouTube: <https://www.youtube.com/playlist?list=PLYV5R7hVcs-CfNsWy-689CRZHExrZEi9I>.

## Procedure

Step 1. Prepare your server.

- Remove the top cover. See “[Remove the top cover](#)” on page 243.
- If your server comes with an air baffle, remove it first. See “[Remove the air baffle](#)” on page 77.
- If your server comes with a rear drive assembly, remove it first. See “[Remove the 2.5-inch rear drive assembly](#)” on page 198.
- Record where the cables are connected to the system board assembly; then, disconnect all the cables.

**Attention:** Disengage all latches, cable clips, release tabs, or locks on cable connectors beforehand. Failing to release them before removing the cables will damage the cable connectors on the system board assembly. Any damage to the cable connectors may require replacing the system board assembly.

- Remove any of the following components that are installed on the system board assembly and put them in a safe, static-protective place.
  - “[Processor and heat sink](#)” on page 176
  - “[Memory modules](#)” on page 150
  - “[System fans](#)” on page 239
  - “[RAID flash power modules](#)” on page 189
  - “[Riser assemblies](#)” on page 204
  - “[CMOS battery](#)” on page 94
  - “[OCP module](#)” on page 166
- Pull out the power supplies gently. Ensure that they are disconnected from the system board assembly.

Step 2. Remove the Firmware and RoT Security module, see “[Remove the Firmware and RoT Security Module](#)” on page 223.

Step 3. Remove the MicroSD card, see “[Remove the MicroSD card](#)” on page 154.

Step 4. Separate the system I/O board from the processor board.

**Note:** To prevent the contact of the IO board from damage, pinch and lift the plunger on the IO board upward a little and pull out the IO board outward. During the entire pulling action, ensure that the IO board remains as horizontal as possible.



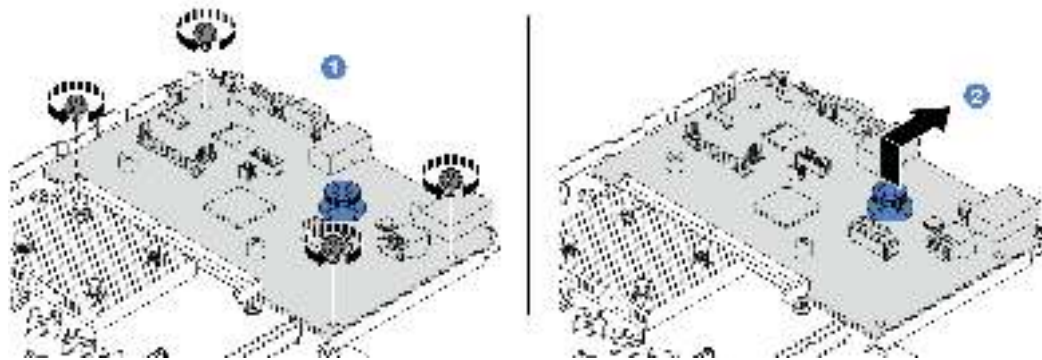


Figure 193. System I/O board removal

- a. 1 Remove the screws that secure the system I/O board.
- b. 2 Lift and hold the plunger and slide the system I/O board towards the rear to disengage it from the processor board.

## After you finish

### Important:

- Before you return the processor board, make sure that you install the processor socket covers to the new processor board.
- If replacing a new system I/O board, transfer the MicroSD card from the old system I/O board to the new one. See [“Remove the MicroSD card” on page 154](#) and [“Install the MicroSD card” on page 155](#).
- If you are planning to recycle the system board assembly, follow the instructions in [Appendix A “Hardware disassembling for recycle” on page 483](#) for compliance with local regulations.

## Install the system I/O board

Follow the instructions in this section to install the system I/O board.

## About this task

### Attention:

- Read [“Installation Guidelines” on page 51](#) and [“Safety inspection checklist” on page 52](#) to ensure that you work safely.
- Power off the server and peripheral devices and disconnect the power cords and all external cables. See [“Power off the server” on page 68](#).
- Prevent exposure to static electricity, which might lead to system halt and loss of data, by keeping static-sensitive components in their static-protective packages until installation, and handling these devices with an electrostatic-discharge wrist strap or other grounding systems.

### Watch the procedure

A video of this procedure is available on YouTube: <https://www.youtube.com/playlist?list=PLYV5R7hVcs-CfNsWy-689CRZHExrZEi9I>.

## Procedure

- Step 1. Touch the static-protective package that contains the system I/O board to any unpainted surface on the outside of the server. Then, take the system I/O board out of the package and place it on a static-protective surface.
- Step 2. Install the system I/O board.

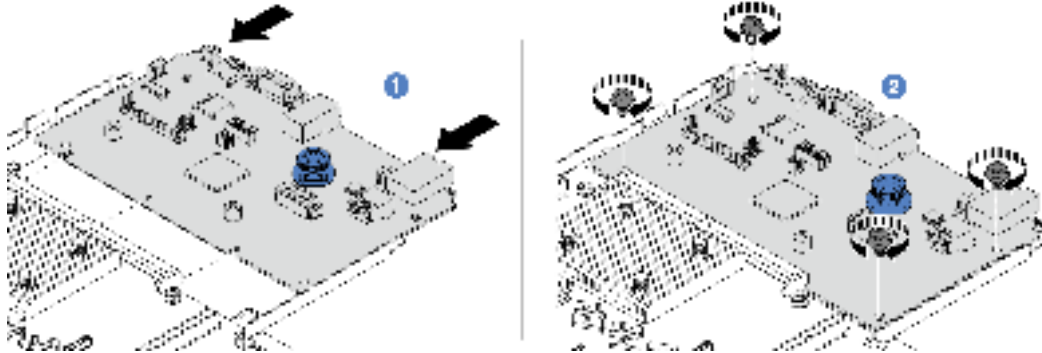


Figure 194. System I/O board installation

- a. **1** Align the contacts on the system I/O board with the slots on the processor board, and use both hands to push the system I/O board and slightly insert it into the connector.

**Note:** To prevent the contacts of the system I/O board from damage, ensure that the system I/O board is aligned correctly with the connector on the processor board, and remains as horizontal as possible during the insertion.

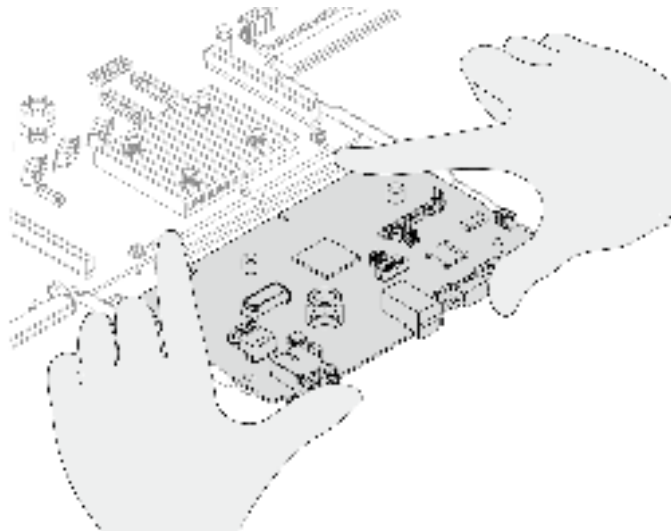


Figure 195. Install with both hands

- b. **2** Install the screws to install the system I/O board to the supporting metal sheet.

Step 3. Install the Firmware and RoT Security Module, see [“Install the Firmware and RoT Security Module” on page 225](#).

Step 4. Install the MicroSD card, see [“Install the MicroSD card” on page 155](#).

## After you finish

1. Install any components that you have removed before the removal of system I/O board.
  - [“Processor and heat sink” on page 176](#)
  - [“Memory modules” on page 150](#)
  - [“System fans” on page 239](#)
  - [“RAID flash power modules” on page 189](#)
  - [“Riser assemblies” on page 204](#)
  - [“CMOS battery” on page 94](#)
  - [“OCP module” on page 166](#)
  - [“Install the Firmware and RoT Security Module” on page 225](#)
2. Properly route and secure the cables in the server. Refer to detailed cable routing information for each component in [Chapter 6 “Internal cable routing” on page 249](#).
3. Install the rear drive cage if you have removed it. See [“Install the 2.5-inch rear drive assembly” on page 199](#).
4. Install the air baffle if you have removed it. See [“Install the air baffle” on page 78](#).
5. Install the top cover. See [“Install the top cover” on page 244](#).
6. Push the power supplies into the bays until they click into place.
7. Connect power cords to the server and turn on the server.
8. Update the Vital Product Data (VPD) of the system board assembly. See [“Update the Vital Product Data \(VPD\)” on page 238](#).
9. If hiding TPM or updating TPM firmware is needed, see [“Hide/observe TPM” on page 227](#) or [“Update the TPM firmware” on page 228](#).
10. Optionally, enable Secure Boot. See [“Enable UEFI Secure Boot” on page 228](#).

## Processor board replacement (trained technicians only)

Use this section to remove and install the processor board from the system board assembly.

**Note:** When the server has a Liquid Assisted Cooling Module (LACM) installed, you must apply for a LACM module handle (LACM heat sink bracket) first if you need to install or remove the system board assembly or processor. However, while replacing the old LACM with a new one, you do not need to apply for a module handle (LACM heat sink bracket) as the new LACM package contains it.

### Remove the processor board

Follow instructions in this section to remove the processor board.

### About this task

A processor board provides different connectors or slots to connect different components or peripherals of the system for communication. The board and the supporting metal sheet constitute a base for the system board assembly. If the processor board fails, it must be replaced.

#### Attention:

- Read [“Installation Guidelines” on page 51](#) and [“Safety inspection checklist” on page 52](#) to ensure that you work safely.
- Power off the server and peripheral devices and disconnect the power cords and all external cables. See [“Power off the server” on page 68](#).

- Prevent exposure to static electricity, which might lead to system halt and loss of data, by keeping static-sensitive components in their static-protective packages until installation, and handling these devices with an electrostatic-discharge wrist strap or other grounding systems.

## Procedure

Step 1. Prepare your server.

- a. Remove the top cover. See [“Remove the top cover” on page 243](#).
- b. If your server comes with an air baffle, remove it first. See [“Remove the air baffle” on page 77](#).
- c. If your server comes with a rear drive assembly, remove it first. See [“Remove the 2.5-inch rear drive assembly” on page 198](#).
- d. Record where the cables are connected to the system board assembly; then, disconnect all the cables.

**Attention:** Disengage all latches, cable clips, release tabs, or locks on cable connectors beforehand. Failing to release them before removing the cables will damage the cable connectors on the system board assembly. Any damage to the cable connectors may require replacing the system board assembly.

- e. Remove any of the following components that are installed on the system board assembly and put them in a safe, static-protective place.
  - [“Processor and heat sink” on page 176](#)
  - [“Memory modules” on page 150](#)
  - [“System fans” on page 239](#)
  - [“RAID flash power modules” on page 189](#)
  - [“Riser assemblies” on page 204](#)
  - [“CMOS battery” on page 94](#)
  - [“OCP module” on page 166](#)
- f. Pull out the power supplies gently. Ensure that they are disconnected from the system board assembly.

Step 2. Remove the system board assembly from the chassis.

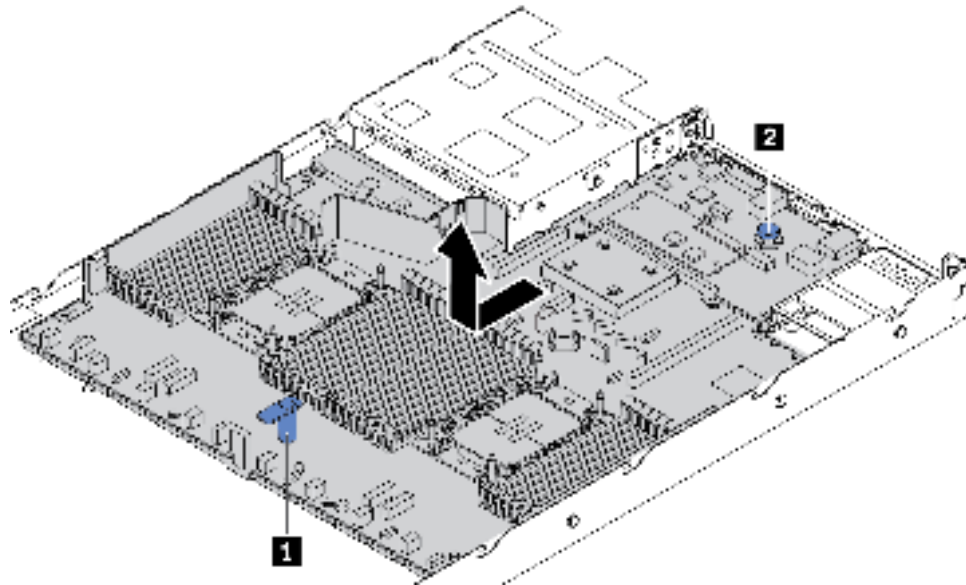


Figure 196. System board assembly removal

- a. Hold the lift handle **1** and lift the release pin **2** at the same time and slide the system board assembly toward the front of the server.
- b. Lift the system board assembly out of the chassis.

Step 3. Remove the Firmware and RoT Security module, see [“Remove the Firmware and RoT Security Module” on page 223](#).

Step 4. Remove the system I/O board, see [“Remove the system I/O board” on page 229](#).

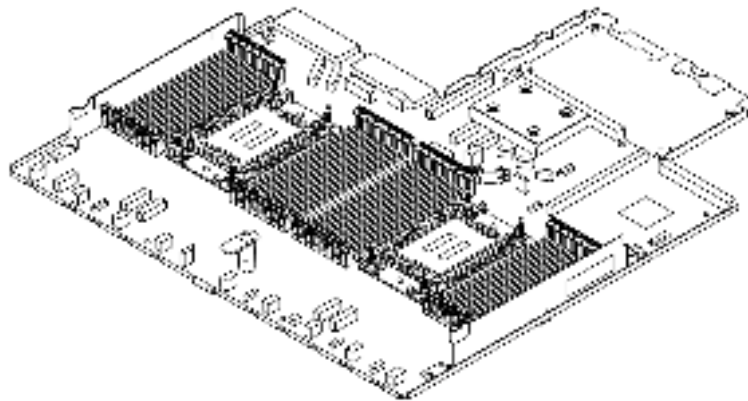


Figure 197. The processor board

**Note:** The processor board comes with a supporting metal sheet. No further removal is needed.

### After you finish

**Important:** Before you return the system board assembly, make sure that the processor socket is covered. There is a processor external cap covering the processor socket on the new system board assembly. Slide

the processor external cap out from the processor socket on the new system board assembly, and install the external cap on the processor socket on the removed system board assembly.

If you are planning to recycle the system board assembly, follow the instructions in [Appendix A “Hardware disassembling for recycle” on page 483](#) for compliance with local regulations.

### Demo video

[Watch the procedure on YouTube](#)

## Install the processor board

Follow instructions in this section to install the processor board.

### About this task

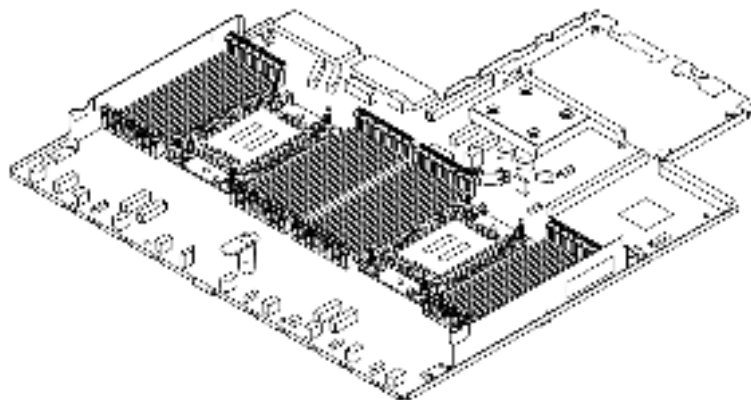
A processor board provides different connectors or slots to connect different components or peripherals of the system for communication. The board and the supporting metal sheet constitute a base for the system board assembly. If the processor board fails, it must be replaced.

#### Attention:

- Read [“Installation Guidelines” on page 51](#) and [“Safety inspection checklist” on page 52](#) to ensure that you work safely.
- Power off the server and peripheral devices and disconnect the power cords and all external cables. See [“Power off the server” on page 68](#).
- Prevent exposure to static electricity, which might lead to system halt and loss of data, by keeping static-sensitive components in their static-protective packages until installation, and handling these devices with an electrostatic-discharge wrist strap or other grounding systems.

## Procedure

Step 1. Touch the static-protective package that contains the system board assembly to any unpainted surface on the outside of the server. Then, take the processor board out of the package and place it on a static-protective surface.



*Figure 198. The processor board*

Step 2. Install the system I/O board, see [“Install the system I/O board” on page 231](#).

Step 3. Install the Firmware and RoT Security Module, see [“Install the Firmware and RoT Security Module” on page 225](#).

Step 4. Install the system board assembly to the server.

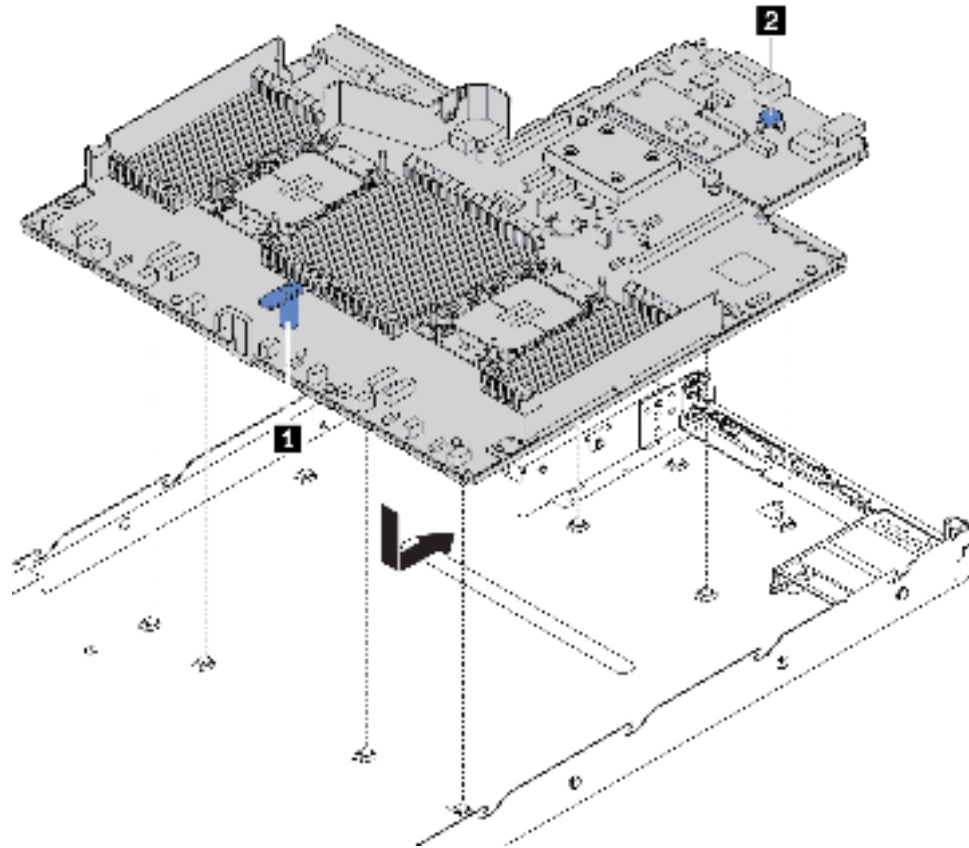


Figure 199. System board assembly installation

- a. Hold the lift handle **1** and the release pin **2** at the same time to lower the system board assembly into the chassis.
- b. Slide the system board assembly to the rear of the server until the system board assembly snaps into position. Ensure that:
  - The rear connectors on the new system board assembly are inserted into the corresponding holes in the rear panel.
  - The release pin **2** secures the system board assembly in place.

## After you finish

1. Install any components that you have removed from the failing system board assembly.
  - [“Processor and heat sink” on page 176](#)
  - [“Memory modules” on page 150](#)
  - [“System fans” on page 239](#)
  - [“RAID flash power modules” on page 189](#)
  - [“Riser assemblies” on page 204](#)
  - [“CMOS battery” on page 94](#)
  - [“OCP module” on page 166](#)

2. Properly route and secure the cables in the server. Refer to detailed cable routing information for each component in [Chapter 6 “Internal cable routing” on page 249](#).
3. Install the rear drive cage if you have removed it. See [“Install the 2.5-inch rear drive assembly” on page 199](#).
4. Install the air baffle if you have removed it. See [“Install the air baffle” on page 78](#).
5. Install the top cover. See [“Install the top cover” on page 244](#).
6. Push the power supplies into the bays until they click into place.
7. Connect power cords to the server and turn on the server.
8. Update the Vital Product Data (VPD) of the system board assembly. See [“Update the Vital Product Data \(VPD\)” on page 238](#).
9. Optionally, enable Secure Boot. See [“Enable UEFI Secure Boot” on page 228](#).

## Demo video

[Watch the procedure on YouTube](#)

## Update the Vital Product Data (VPD)

Use this topic to update the Vital Product Data (VPD).

- **(Required)** Machine type
- **(Required)** Serial number
- (Optional) Asset tag
- (Optional) UUID

### Recommended tools:

- Lenovo XClarity Provisioning Manager
- Lenovo XClarity Essentials OneCLI commands

## Using Lenovo XClarity Provisioning Manager

### Steps:

1. Start the server and press the key according to the on-screen instructions. The Lenovo XClarity Provisioning Manager interface is displayed by default.
2. Choose **System Summary**. The “System Summary” tab page is displayed.
3. Click **Update VPD**, then, follow on-screen instructions to update the VPD.

## Using Lenovo XClarity Essentials OneCLI commands

- Updating **machine type**  
`onecli config set SYSTEM_PROD_DATA.SysInfoProdName <m/t_model> [access_method]`
- Updating **serial number**  
`onecli config set SYSTEM_PROD_DATA.SysInfoSerialNum <s/n> [access_method]`
- Updating **system model**  
`onecli config set SYSTEM_PROD_DATA.SysInfoProdIdentifier <system model> [access_method]`  
`onecli config set SYSTEM_PROD_DATA.SysInfoProdIdentifierEx <system model> --override [access_method]`
- Updating **asset tag**  
`onecli config set SYSTEM_PROD_DATA.SysEncloseAssetTag <asset_tag> [access_method]`
- Updating **UUID**  
`onecli config createuuid SYSTEM_PROD_DATA.SysInfoUUID [access_method]`



Variable	Description
<m/t_model>	The server machine type and model number. Type xxxxyyy, where xxxx is the machine type and yyy is the server model number.
<s/n>	The serial number on the server. Type zzzzzzz, where zzzzzzz is the serial number.
<system model>	The system model on the server. Type system yyyyyyyy, where yyyyyyyy is the product identifier.
<asset_tag>	The server asset tag number. Type aaaaaaaaaaaaaaaaaaaaaaaaaaaaaa, where aaaaaaaaaaaaaaaaaaaaaaaaaaaaaa is the asset tag number.
[access_method]	<p>The access method that you select to access the target server.</p> <ul style="list-style-type: none"> <li>• Online KCS (unauthenticated and user restricted): You can directly delete [access_method] from the command.</li> <li>• Online authenticated LAN: In this case, specify below LAN account information at the end of the OneCLI command: --bmc-username &lt;user_id&gt; --bmc-password &lt;password&gt;</li> <li>• Remote WAN/LAN: In this case, specify below XCC account information and IP address at the end of the OneCLI command: --bmc &lt;bmc_user_id&gt;:&lt;bmc_password&gt;@&lt;bmc_external_IP&gt;</li> </ul> <p><b>Notes:</b></p> <ul style="list-style-type: none"> <li>– &lt;bmc_user_id&gt; The BMC account name (1 of 12 accounts). The default value is USERID.</li> <li>– &lt;bmc_password&gt; The BMC account password (1 of 12 accounts).</li> </ul>

## System fan replacement

Use this information to remove and install a system fan.

### Remove a system fan

Use this information to remove a system fan. You can remove a hot-swap fan without powering off the server, which helps you avoid significant interruption to the operation of the system.

### About this task

### **S033**



#### **CAUTION:**

**Hazardous energy present. Voltages with hazardous energy might cause heating when shorted with metal, which might result in spattered metal, burns, or both.**

### **S017**



#### **CAUTION:**

**Hazardous moving fan blades nearby. Keep fingers and other body parts away.**

#### **Attention:**

- Read [“Installation Guidelines” on page 51](#) and [“Safety inspection checklist” on page 52](#) to ensure that you work safely.
- Power off the server and peripheral devices and disconnect the power cords and all external cables. See [“Power off the server” on page 68](#).
- Prevent exposure to static electricity, which might lead to system halt and loss of data, by keeping static-sensitive components in their static-protective packages until installation, and handling these devices with an electrostatic-discharge wrist strap or other grounding systems.

### **Procedure**

Step 1. Remove the top cover. See [“Remove the top cover” on page 243](#).

Step 2. Grasp the fan tabs on both ends of the system fan and carefully lift the system fan out of the server.

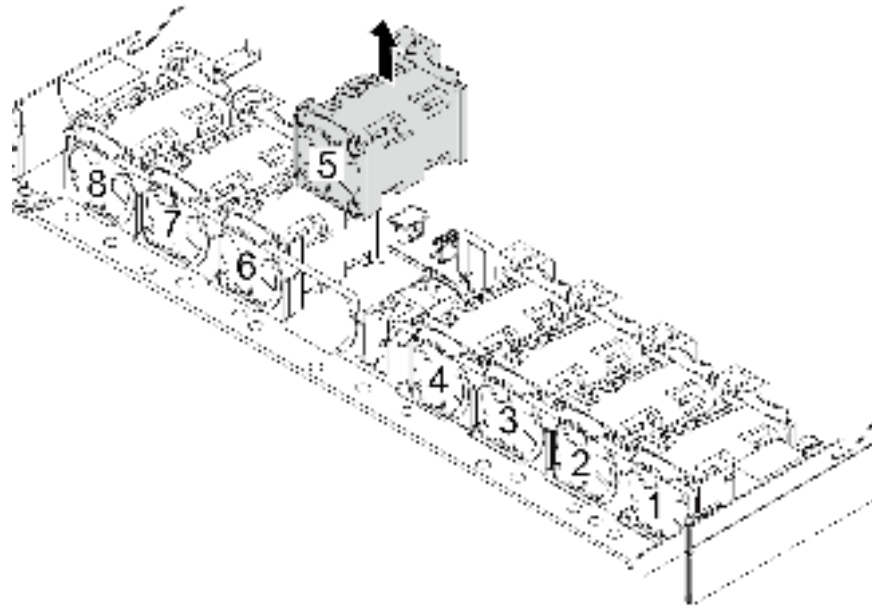


Figure 200. System fan removal

### After you finish

1. Install a new system fan or install a fan filler to cover the place. See “[Install a system fan](#)” on page 241.
2. If you are instructed to return the component or optional device, follow all packaging instructions, and use any packaging materials for shipping that are supplied to you.

### Demo video

[Watch the procedure on YouTube](#)

## Install a system fan

Use this information to install a system fan. You can install a hot-swap fan without powering off the server, which helps you avoid significant interruption to the operation of the system.

### About this task

S033



#### CAUTION:

**Hazardous energy present. Voltages with hazardous energy might cause heating when shorted with metal, which might result in spattered metal, burns, or both.**

## S017



### CAUTION:

Hazardous moving fan blades nearby. Keep fingers and other body parts away.

### Attention:

- Read “[Installation Guidelines](#)” on page 51 and “[Safety inspection checklist](#)” on page 52 to ensure that you work safely.
- Power off the server and peripheral devices and disconnect the power cords and all external cables. See “[Power off the server](#)” on page 68.
- Prevent exposure to static electricity, which might lead to system halt and loss of data, by keeping static-sensitive components in their static-protective packages until installation, and handling these devices with an electrostatic-discharge wrist strap or other grounding systems.

### Procedure

Step 1. Touch the static-protective package that contains the system fan to any unpainted surface on the outside of the server. Then, take the system fan out of the package and place it on a static-protective surface.

Step 2. Install the system fan.

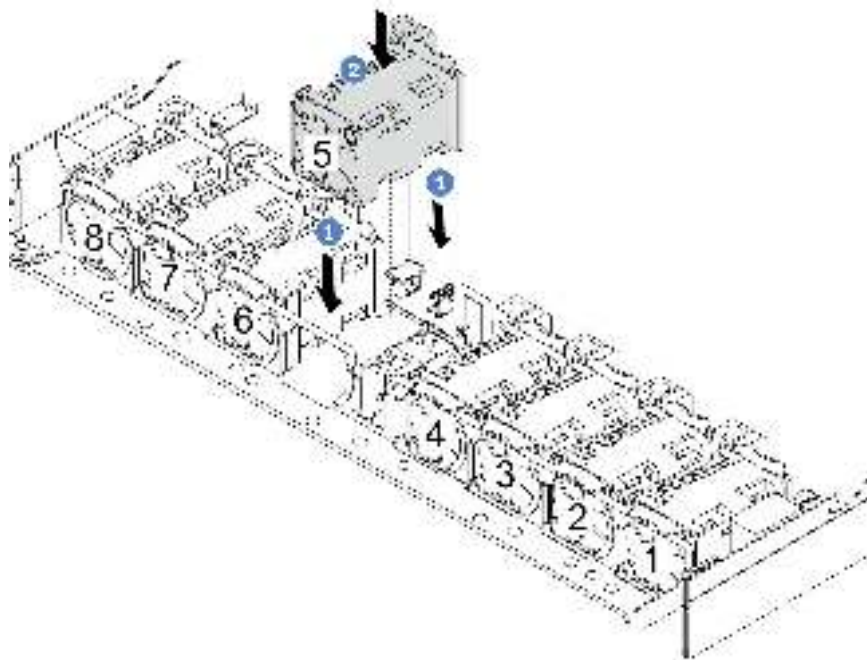


Figure 201. System fan installation

- 1 Align the four corners of the fan to fan module socket and put it down.
- 2 Press the fan latch down to ensure that it is plugged in the connector.

## After you finish

Complete the parts replacement. See [“Complete the parts replacement” on page 246](#).

### Demo video

[Watch the procedure on YouTube](#)

---

## Top cover replacement

Follow instructions in this section to remove and install the top cover.

### Remove the top cover

Follow instructions in this section to remove the top cover.

### About this task

#### S033



#### CAUTION:

**Hazardous energy present. Voltages with hazardous energy might cause heating when shorted with metal, which might result in spattered metal, burns, or both.**

#### S014



#### CAUTION:

**Hazardous voltage, current, and energy levels might be present. Only a qualified service technician is authorized to remove the covers where the label is attached.**

#### Attention:

- Read [“Installation Guidelines” on page 51](#) and [“Safety inspection checklist” on page 52](#) to ensure that you work safely.
- Power off the server and peripheral devices and disconnect the power cords and all external cables. See [“Power off the server” on page 68](#).
- Prevent exposure to static electricity, which might lead to system halt and loss of data, by keeping static-sensitive components in their static-protective packages until installation, and handling these devices with an electrostatic-discharge wrist strap or other grounding systems.

### Procedure

- Step 1. If the server is installed in a rack, remove the server from the rack. See the Rack Installation Guide that comes with the rail kit for your server.

Step 2. Remove the top cover.

**Attention:** Handle the top cover carefully. Dropping the top cover with the cover latch open might damage the cover latch.

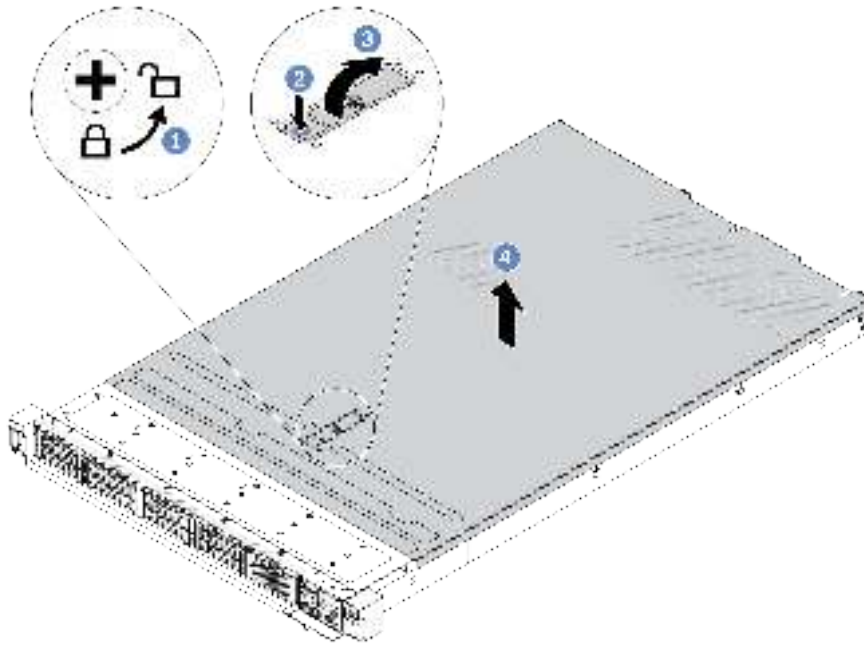


Figure 202. Top cover removal

- a. 1 Use a screwdriver to turn the cover lock to the unlocked position as shown.
- b. 2 Press the release button on the cover latch. The cover latch then gets released to some extent.
- c. 3 Fully open the cover latch as shown.
- d. 4 Slide the top cover to the rear until it is disengaged from the chassis. Then, lift the top cover off the chassis and place the top cover on a flat clean surface.

### After you finish

1. Replace any options as required or install a new top cover. See [“Install the top cover” on page 244](#).
2. If you are instructed to return the component or optional device, follow all packaging instructions, and use any packaging materials for shipping that are supplied to you.

### Demo video

[Watch the procedure on YouTube](#)

## Install the top cover

Follow instructions in this section to install the top cover.

### About this task

**S033**



**CAUTION:**

**Hazardous energy present. Voltages with hazardous energy might cause heating when shorted with metal, which might result in spattered metal, burns, or both.**

**S014**



**CAUTION:**

**Hazardous voltage, current, and energy levels might be present. Only a qualified service technician is authorized to remove the covers where the label is attached.**

**Attention:**

- Read [“Installation Guidelines” on page 51](#) and [“Safety inspection checklist” on page 52](#) to ensure that you work safely.
- Power off the server and peripheral devices and disconnect the power cords and all external cables. See [“Power off the server” on page 68](#).
- Prevent exposure to static electricity, which might lead to system halt and loss of data, by keeping static-sensitive components in their static-protective packages until installation, and handling these devices with an electrostatic-discharge wrist strap or other grounding systems.

Operating the server with the top cover removed might damage server components. For proper cooling and airflow, install the top cover before you turn on the server.

**Note:** A new top cover comes without a service label attached. If you need a service label, order it together with the new top cover and attach the service label to the new top cover first.

**Procedure**

Step 1. Check your server and ensure that:

- All cables, adapters, and other components are installed and seated correctly and that you have not left loose tools or parts inside the server.
- All internal cables are connected and routed correctly. See [Chapter 6 “Internal cable routing” on page 249](#).

Step 2. Install the top cover to your server.

**Attention:** Handle the top cover carefully. Dropping the top cover with the cover latch open might damage the cover latch.

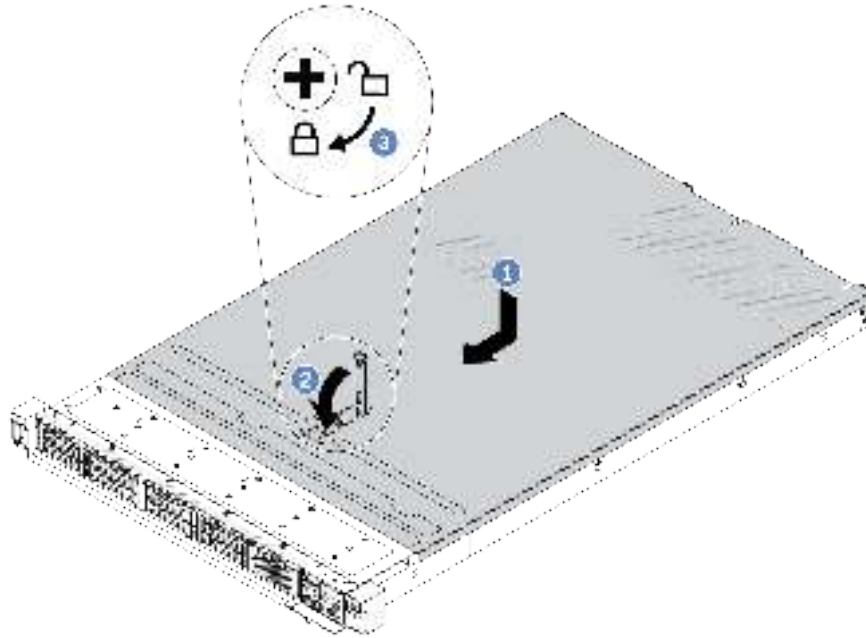


Figure 203. Top cover installation

- a. **1** Ensure that the cover latch is in the open position. Lower the top cover onto the chassis until both sides of the top cover engage the guides on both sides of the chassis. Then, slide the top cover to the front of the chassis.

**Note:** Before you slide the top cover forward, ensure that all the tabs on the top cover engage the chassis correctly.

- b. **2** Press down the cover latch and ensure that the cover latch is completely closed.
- c. **3** Use a screwdriver to turn the cover lock to the locked position.

## After you finish

After installing the top cover, complete the parts replacement. See [“Complete the parts replacement” on page 246](#).

## Demo video

[Watch the procedure on YouTube](#)

---

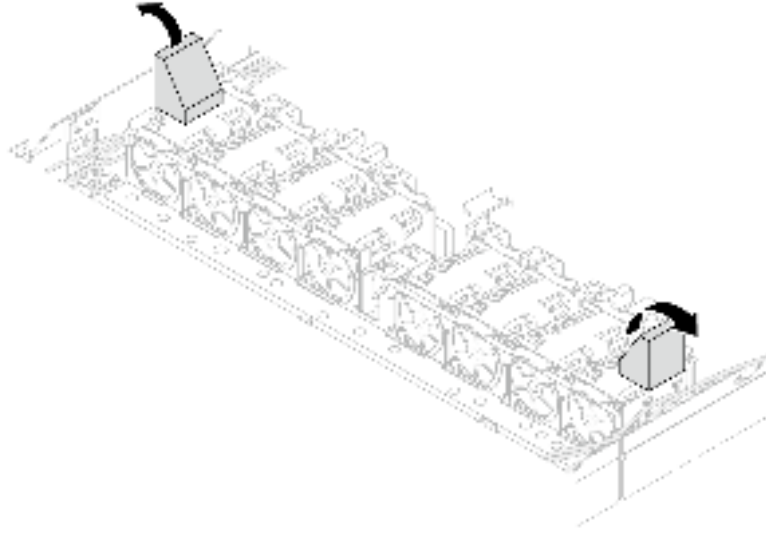
## Complete the parts replacement

Go through the checklist to complete parts replacement

To complete the parts replacement, do the following:



1. Ensure that all components have been reassembled correctly and that no tools or loose screws are left inside your server.
2. Properly route and secure the cables in the server. Refer to detailed cable routing information for each component in [Chapter 6 “Internal cable routing” on page 249](#).
3. After the cables are properly routed, make sure to close the sponge cable clips.



*Figure 204. Close the sponge cable clips*

4. If you have removed the top cover, reinstall it. See [“Install the top cover” on page 244](#).
5. Reconnect external cables and power cords to the server.

**Attention:** To avoid component damage, connect the power cords last.



---

## Chapter 6. Internal cable routing

See this section to do cable routing for specific components.

**Notes:** Follow below guidelines when connecting cables:

- Turn off the server before you connect or disconnect any internal cables.
- See the documentation that comes with any external devices for additional cabling instructions. It might be easier for you to route cables before you connect the devices to the server.
- Cable identifiers of some cables are printed on the cables that come with the server and optional devices. Use these identifiers to connect the cables to the correct connectors.
- Ensure that the cable is not pinched and does not cover any connectors or obstruct any components on the system board assembly.
- Ensure that the relevant cables pass through the cable clips.
- If the cable to be routed goes through the cable walls, make sure that the sponge cable clips are on open position.

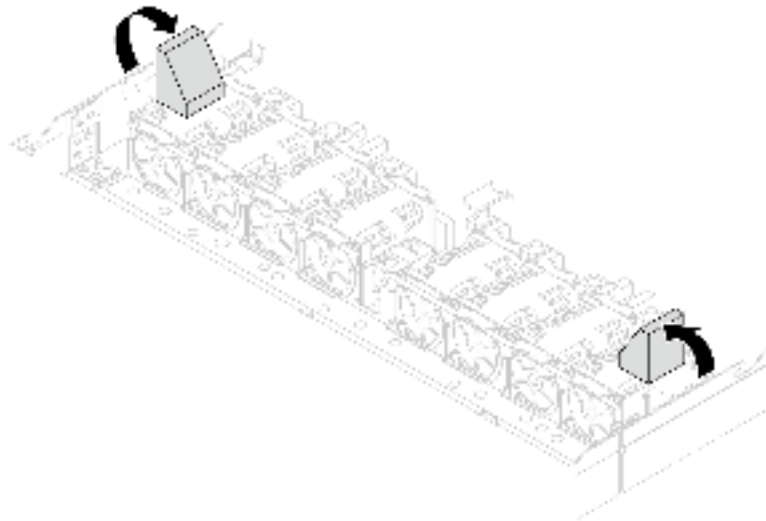
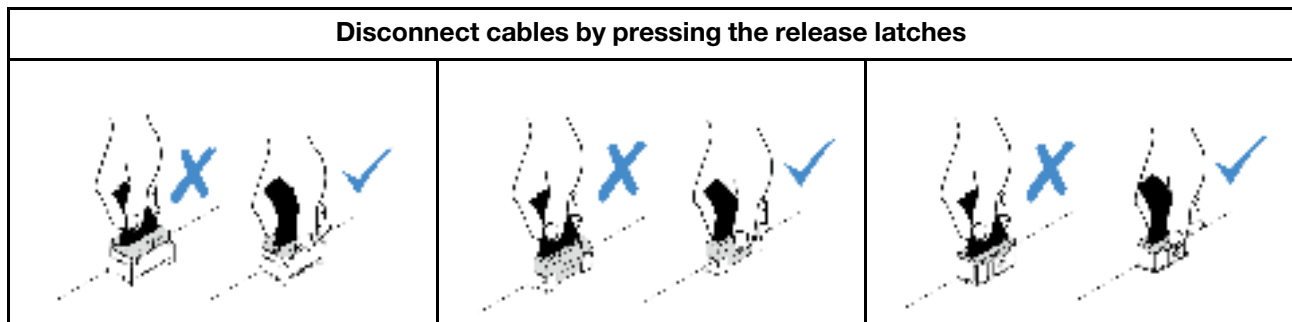
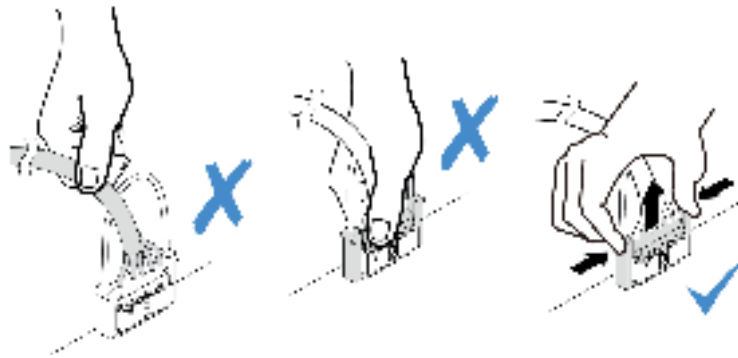


Figure 205. Open the sponge cable clips

**Note:** Disengage all latches, release tabs, or locks on cable connectors when you disconnect cables from the system board assembly. Failing to release them before removing the cables will damage the cable ports on the system board assembly. Any damage to the cable ports might require replacing the system board assembly.



### Disconnect cables by pinching the release latches



## Identifying connectors

See this section to locate and identify the connectors on the electric boards.

### Drive backplane connectors

See this section to locate the connectors on the drive backplanes.

- “10 x 2.5-inch SAS/SATA/AnyBay backplane” on page 250
- “8 x 2.5-inch SAS/SATA backplane” on page 251
- “4 x 3.5-inch SAS/SATA/AnyBay backplane” on page 252
- “4 x 2.5-inch SAS/SATA/NVMe backplane” on page 252
- “16 x EDSFF backplane” on page 252
- “Rear 7mm SAS/SATA/NVMe backplane” on page 253
- “Rear 2 x 2.5-inch SAS/SATA/NVMe backplane” on page 253
- “M.2 drive backplane” on page 254

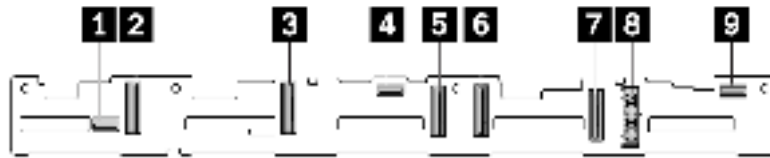
#### 10 x 2.5-inch SAS/SATA/AnyBay backplane

See this section to locate the connectors on the 10 x 2.5-inch drive backplane.



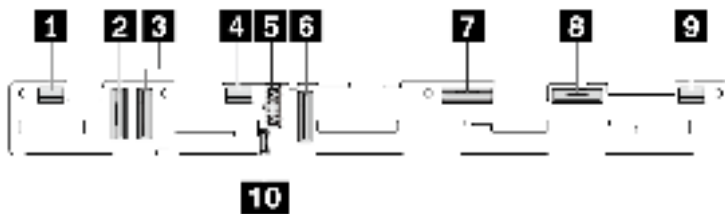
- ❶ SAS 2
- ❷ NVMe 2-3
- ❸ NVMe 0-1
- ❹ SAS 1
- ❺ Power
- ❻ SAS 0

Figure 206. 6 x SAS/SATA + 4 x AnyBay backplane



- 1 SAS 2
- 2 NVMe 8-9
- 3 NVMe 6-7
- 4 SAS 1
- 5 NVMe 4-5
- 6 NVMe 2-3
- 7 NVMe 0-1
- 8 Power
- 9 SAS 0

Figure 207. 10 x 2.5-inch AnyBay backplane



- 1 SAS 8-9
- 2 NVMe 8-9
- 3 NVMe 6-7
- 4 SAS 4-7
- 5 Power
- 6 NVMe 4-5
- 7 NVMe 2-3
- 8 NVMe 0-1
- 9 SAS 0-3
- 10 Sideband connector

Figure 208. 10 x 2.5-inch AnyBay backplane (Gen 5)

### 8 x 2.5-inch SAS/SATA backplane

See this section to locate the connectors on the 8 x 2.5-inch drive backplane.

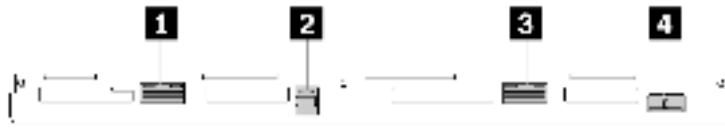


- 1 SAS 1
- 2 Power
- 3 SAS 0

Figure 209. 8 x 2.5-inch SAS/SATA backplane

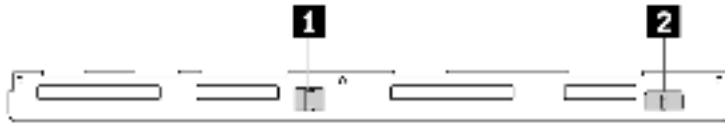
### 4 x 3.5-inch SAS/SATA/AnyBay backplane

See this section to locate the connectors on the 4 x 3.5-inch drive backplane.



- 1 NVMe 2-3
- 2 SAS
- 3 NVMe 0-1
- 4 Power

Figure 210. 4 x 3.5-inch AnyBay backplane



- 1 SAS
- 2 Power

Figure 211. 4 x 3.5-inch SAS/SATA backplane

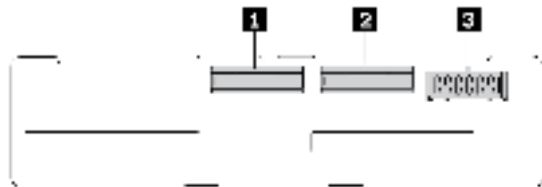
### 4 x 2.5-inch SAS/SATA/NVMe backplane

See this section to locate the connectors on the 4 x 2.5-inch drive backplane.



- 1 Power
- 2 SAS

Figure 212. 4 x 2.5-inch SAS/SATA backplane

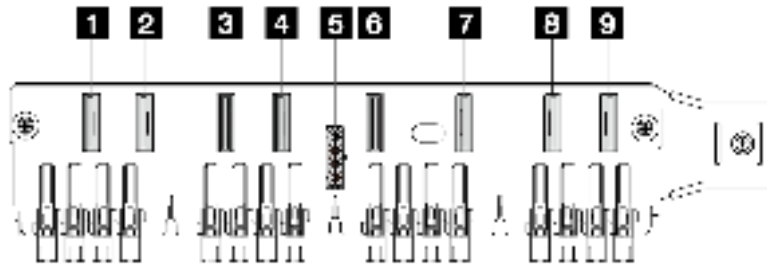


- 1 NVMe 2-3
- 2 NVMe 0-1
- 3 Power

Figure 213. 4 x 2.5-inch NVMe backplane

### 16 x EDSFF backplane

See this section to locate the connectors on the 16 x EDSFF drive backplane.

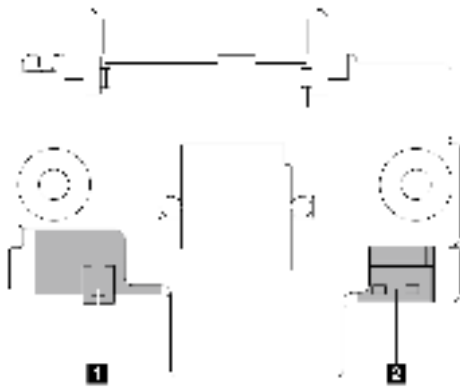


- 1 EDSFF 0-1
- 2 EDSFF 2-3
- 3 EDSFF 4-5
- 4 EDSFF 6-7
- 5 Power
- 6 EDSFF 8-9
- 7 EDSFF 10-11
- 8 EDSFF 12-13
- 9 EDSFF 14-15

Figure 214. 16 x EDSFF backplane

### Rear 7mm SAS/SATA/NVMe backplane

See this section to locate the connectors on the rear 7mm drive backplane.

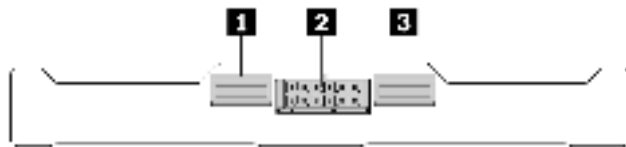


- 1 Power
- 2 Signal

Figure 215. 7mm SAS/SATA/NVMe backplane (top + bottom)

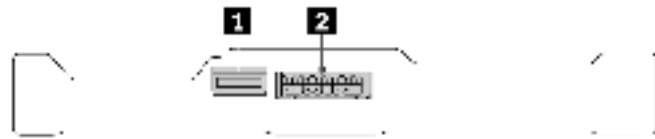
### Rear 2 x 2.5-inch SAS/SATA/NVMe backplane

See this section to locate the connectors on the rear 2 x 2.5-inch drive backplane.



- 1 NVMe 1
- 2 Power
- 3 NVMe 0

Figure 216. Rear 2 x 2.5-inch NVMe backplane



- 1 SAS
- 2 Power

Figure 217. Rear 2 x 2.5-inch SAS/SATA backplane

### M.2 drive backplane

To locate the connectors on the M.2 drive backplane, see [“M.2 backplane and M.2 drive replacement” on page 157](#) for details.

## RAID and HBA adapter connectors

See this section to locate the connectors on RAID and HBA adapters.

The following adapter illustrations are examples taken from the storage controller matrix of your server, see [“Technical specifications” on page 4](#) for more adapters supported. The illustrations might look slightly different from physical adapters.

- [“SFF RAID and HBA adapters” on page 254](#)
  - [Figure 218 “A Gen 3 8i SFF HBA adapter \(two port connectors\)” on page 255](#)
  - [Figure 219 “A Gen 3 16i SFF RAID adapter \(four port connectors\)” on page 255](#)
  - [Figure 220 “A Gen 4 8i SFF RAID adapter \(one port connector\)” on page 256](#)
- [“CFF RAID adapters” on page 256](#)
  - [Figure 221 “A Gen 3 16i CFF RAID adapter \(four port connectors\)” on page 256](#)
  - [Figure 222 “A Gen 4 16i CFF RAID adapter \(four port connectors\)” on page 257](#)

### SFF RAID and HBA adapters

See this section to locate the connectors on SFF RAID and HBA adapters.



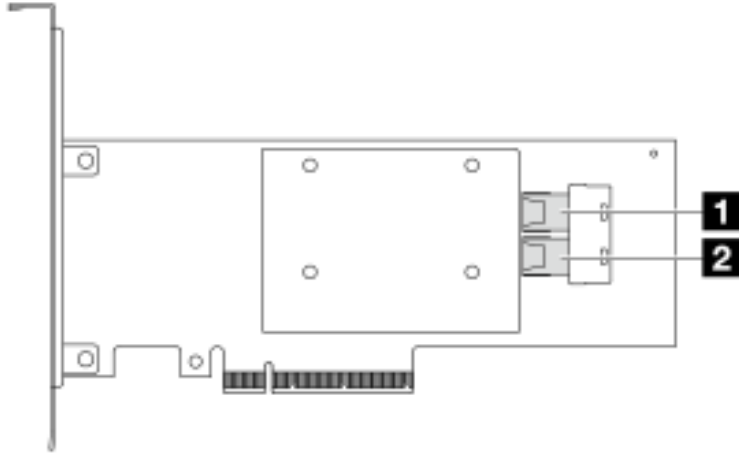


Figure 218. A Gen 3 8i SFF RAID/HBA adapter (two port connectors)

- 1** C0
- 2** C1

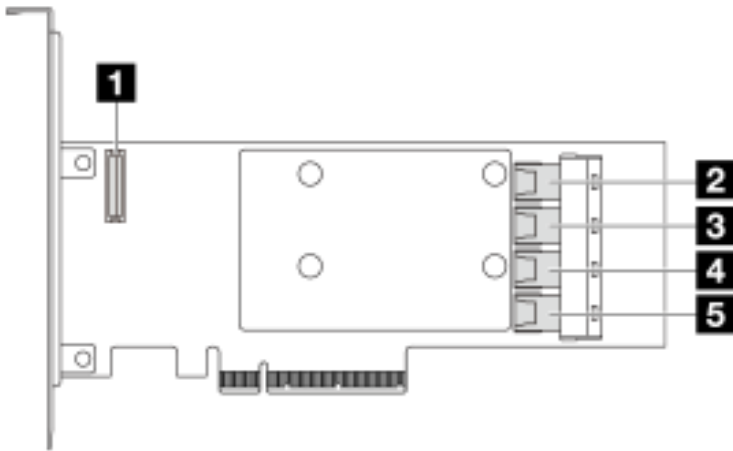


Figure 219. A Gen 3 16i SFF RAID/HBA adapter (four port connectors)

- 1** RAID flash power module connector
- 2** C0
- 3** C1
- 4** C2
- 5** C3

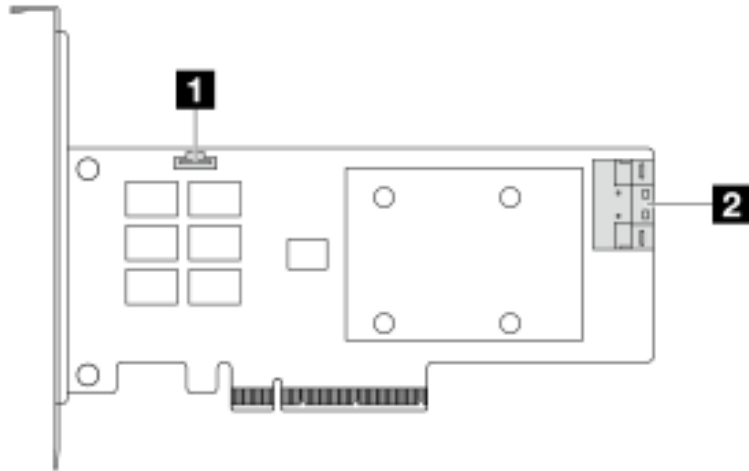


Figure 220. A Gen 4 8i SFF RAID/HBA adapter (one port connector)

- 1 RAID flash power module connector
- 2 C0

### CFF RAID adapters

See this section to locate the connectors on CFF RAID adapters.

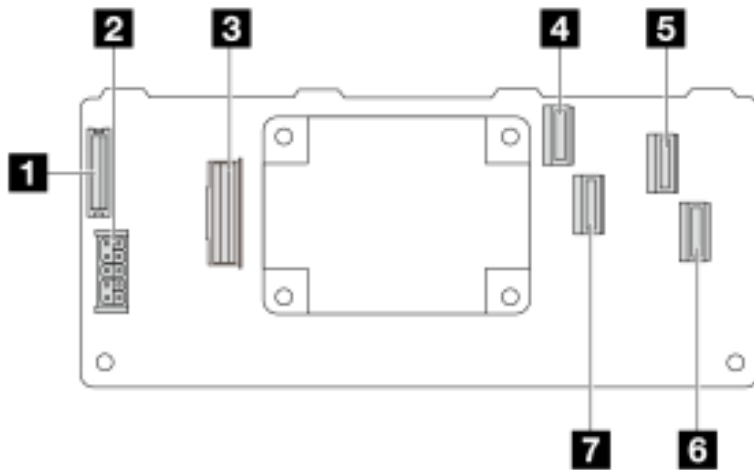


Figure 221. A Gen 3 16i CFF RAID adapter (four port connectors)

- 1 RAID flash power module connector
- 2 Power
- 3 MB input connector
- 4 C0
- 5 C2
- 6 C3
- 7 C1

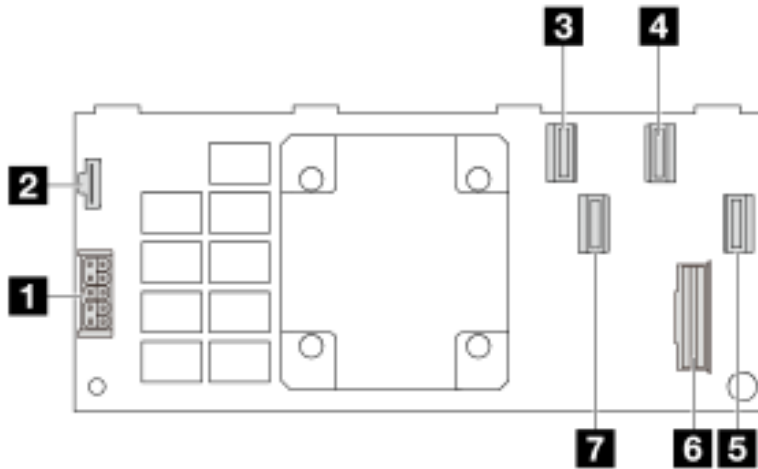


Figure 222. A Gen 4 16i CFF RAID adapter (four port connectors)

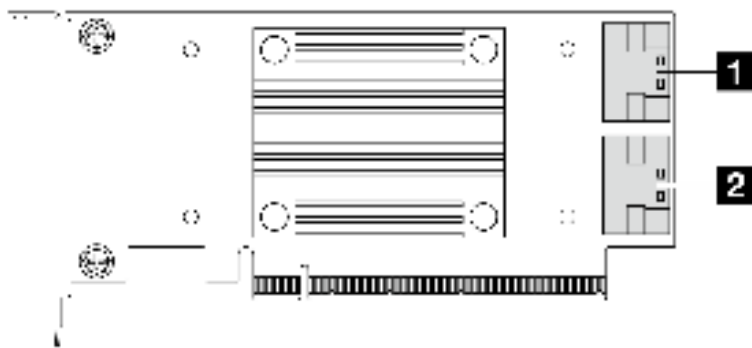
- 1 Power
- 2 RAID flash power module connector
- 3 C0
- 4 C2
- 5 C3
- 6 MB input connector
- 7 C1

## Re-timer adapter connectors

See this section to locate the connectors on the re-timer adapters.

### An SFF re-timer adapter

See this section to locate the connectors on an SFF re-timer adapter.



- 1 C0
- 2 C1

Figure 223. A Gen 4/5 SFF re-timer adapter

## Processor-board connectors for cable routing

The following illustrations show the internal connectors on the processor board that are used for internal cable routing.

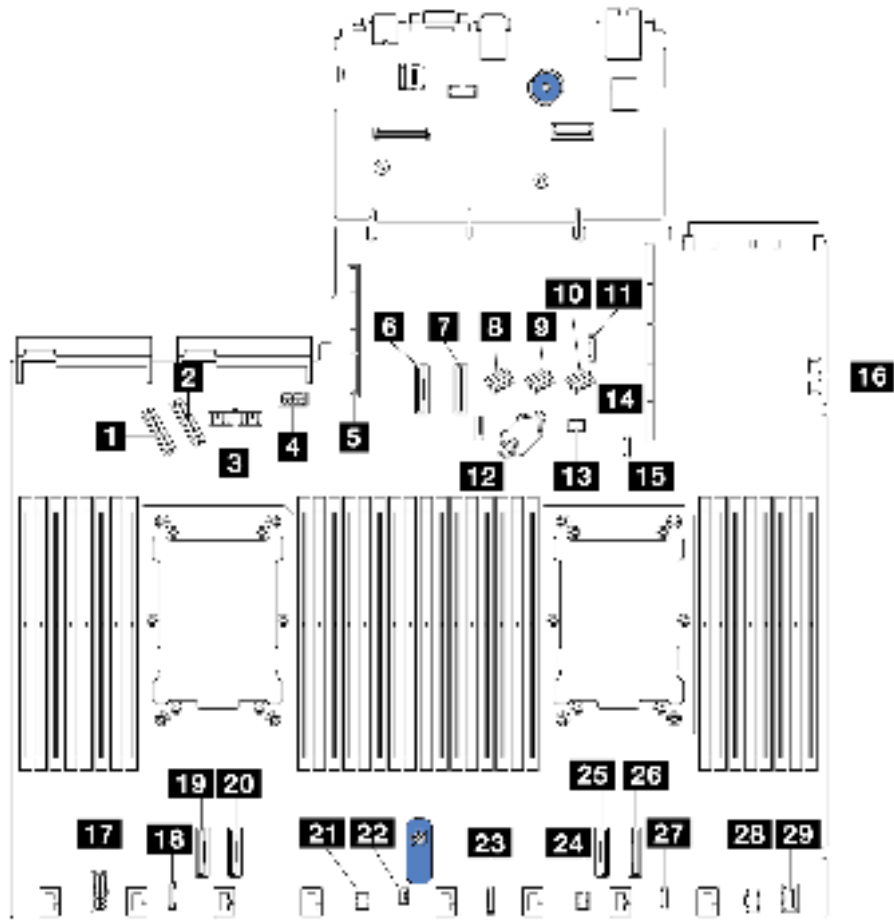


Figure 224. Processor-board connectors for cable routing

Table 38. Processor-board connectors for cable routing

Connectors	
<b>1</b> PCIe connector 5	<b>16</b> Front USB connector
<b>2</b> PCIe connector 6	<b>17</b> Internal RAID power connector
<b>3</b> Front backplane power connector	<b>18</b> CFF Re-timer clock connector
<b>4</b> GPU and rear backplane power connector	<b>19</b> PCIe connector 4
<b>5</b> Riser 2 Slot	<b>20</b> PCIe connector 3
<b>6</b> PCIe connector 7	<b>21</b> Pump 2 connector
<b>7</b> PCIe connector 8	<b>22</b> Intrusion switch connector
<b>8</b> SAS/SATA connector 0	<b>23</b> Front panel connector
<b>9</b> SAS/SATA connector 1	<b>24</b> Front panel LCD connector
<b>10</b> SAS/SATA connector 2	<b>25</b> PCIe connector 2

Table 38. Processor-board connectors for cable routing (continued)

<b>Connectors</b>	
<b>11</b> Rear backplane sideband connector	<b>26</b> PCIe connector 1
<b>12</b> M.2/7mm backplane signal connector	<b>27</b> External LCD connector
<b>13</b> Pump 1 connector	<b>28</b> M.2 power connector
<b>14</b> Leak detection connector	<b>29</b> Front VGA connector
<b>15</b> Riser 1 slot	

---

## CFF RAID adapter

Use the section to understand the power cable and signal input cable routing for CFF RAID adapters.

### Cable routing for CFF RAID adapters

- For the locations of connectors on CFF RAID adapters and the processor board, see [“RAID and HBA adapter connectors” on page 254](#) and [“Processor-board connectors for cable routing” on page 257](#) for details.
- For more information about the CFF RAID adapters supported, see [“RAID adapter” on page 8](#).
- The table below presents that how the power cables and MB input cables are connected with one and two processors installed. Find more connections in different configuration at [“Cable routing for backplane signals \(one processor\)” on page 298](#) and [“Cable routing for backplane signals \(two processors\)” on page 350](#).
- [“Cable routing for Gen 4 CFF RAID adapters” on page 261](#)
- [“Cable routing for Gen 3 CFF RAID adapters” on page 262](#)

## Cable routing for Gen 4 CFF RAID adapters

Table 39. Cable routing for Gen 4 CFF RAID adapters

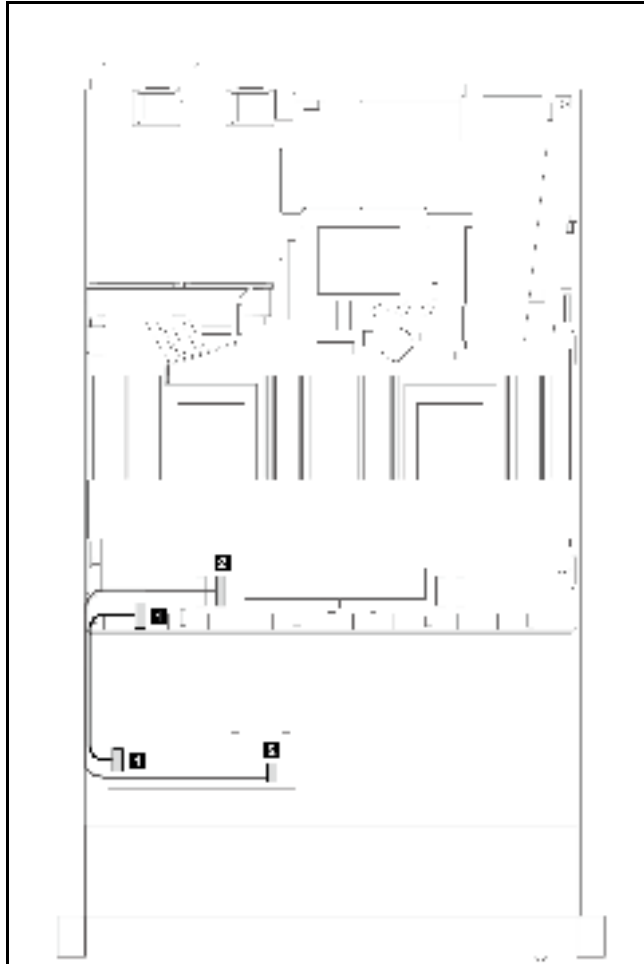


Figure 225. Gen 4 CFF RAID adapter cabling with two processors installed

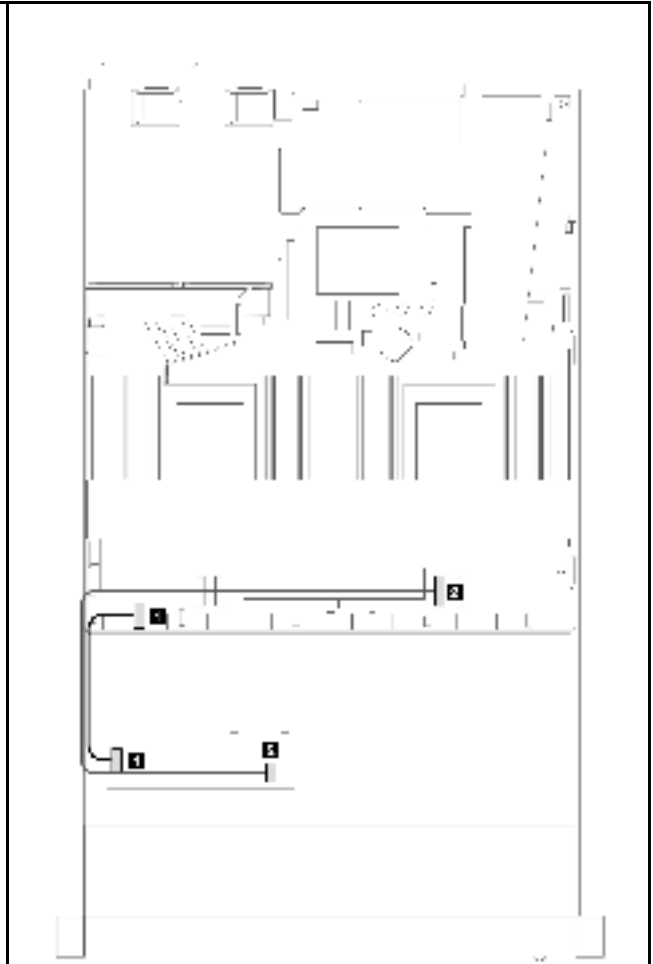
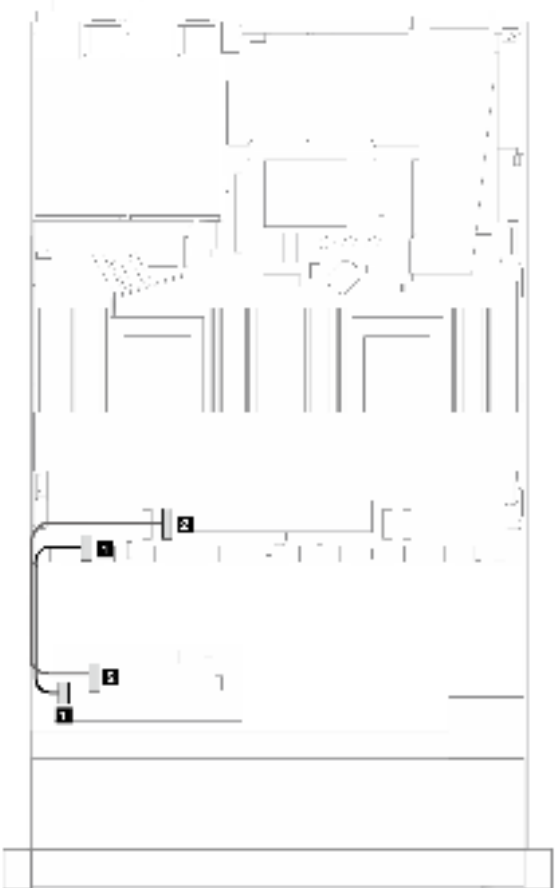
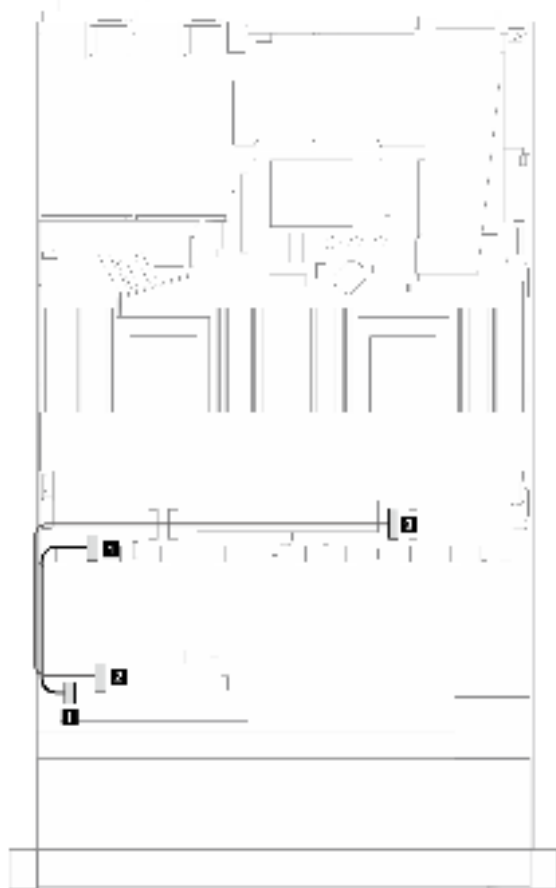


Figure 226. Gen 4 CFF RAID adapter cabling with one processor installed

From	To	From	To
<b>1</b> Power	<b>1</b> Internal RAID power connector	<b>1</b> Power	<b>1</b> Internal RAID power connector
<b>2</b> MB input	<b>2</b> PCIe 3	<b>2</b> MB input	<b>2</b> PCIe 2

## Cable routing for Gen 3 CFF RAID adapters

Table 40. Cable routing for Gen 3 CFF RAID adapters

			
<p>Figure 227. Gen 3 CFF RAID adapter cabling with two processors installed</p>		<p>Figure 228. Gen 3 CFF RAID adapter cabling with one processor installed</p>	
From	To	From	To
<b>1</b> Power	<b>1</b> Internal RAID power connector	<b>1</b> Power	<b>1</b> Internal RAID power connector
<b>2</b> MB input	<b>2</b> PCIe 3	<b>2</b> MB input	<b>2</b> PCIe 2

**Note:** When the server is installed with 4 x 2.5" NVMe drives with two processors, the “MB input” connector on the CFF RAID adapters connects to PCIe 2 on the processor board.

## Front I/O module

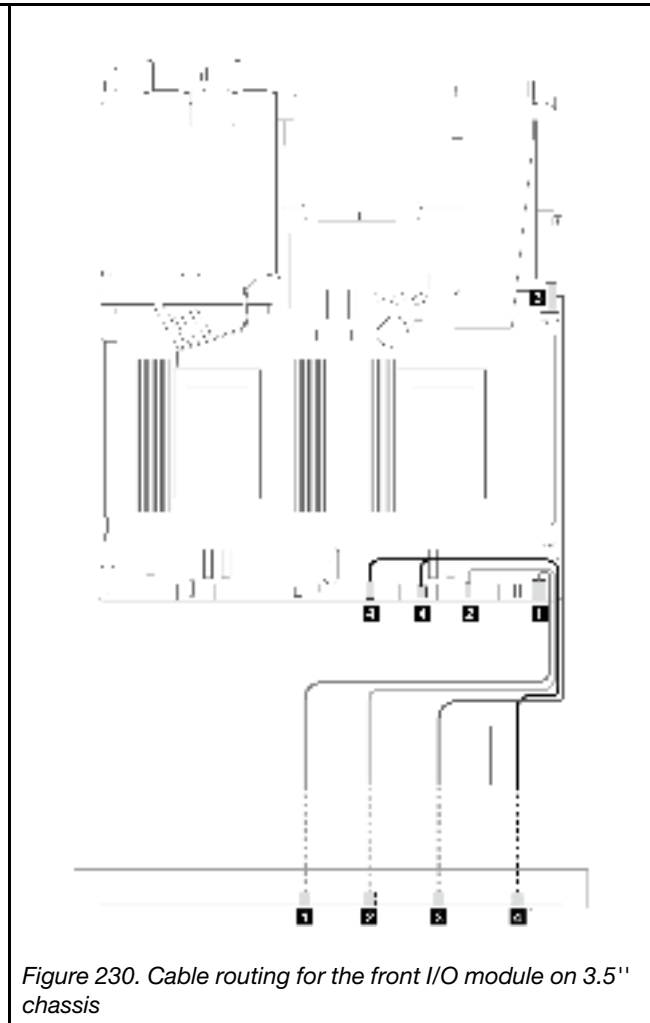
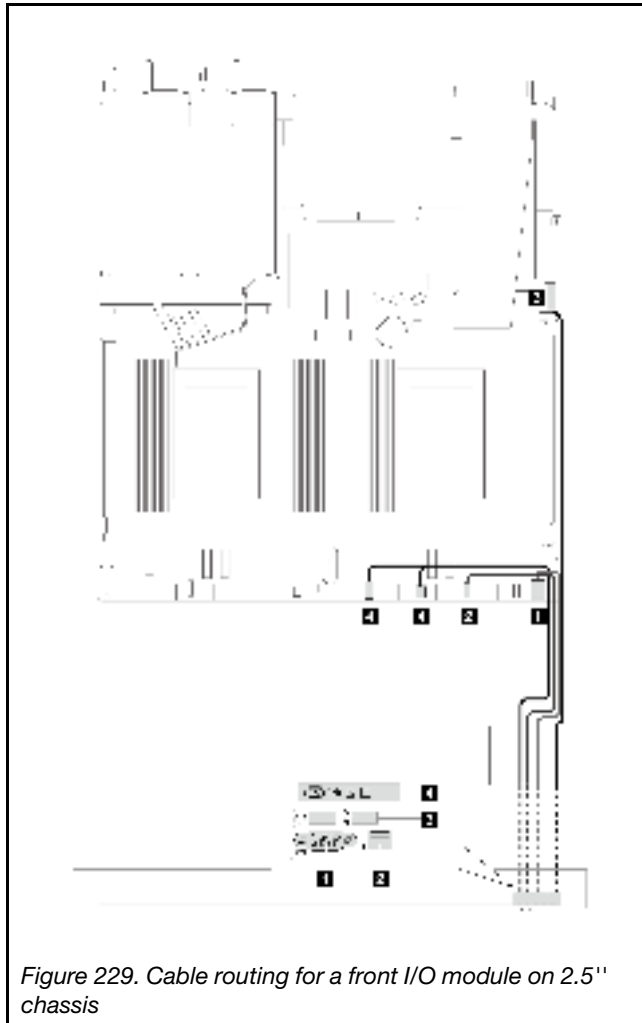
Use the section to understand the cable routing for front I/O modules.

### Cable routing for front I/O modules

- For the locations of front I/O module connectors on the processor board, see [“Processor-board connectors for cable routing” on page 257](#) for details.



- The illustrations show the cabling scenario for server models with 2.5-inch and 3.5-inch front drive bays. Location of each connector on the front of the server varies by models. For detailed locations of front I/O components for different models, see “Front view” on page 19 and “Front I/O module” on page 33.



From	To
<b>1</b> VGA connector	<b>1</b> VGA connector
<b>2</b> External LCD diagnostics handset connector <sup>Note</sup>	<b>2</b> External LCD diagnostics handset connector
<b>3</b> Front USB connector	<b>3</b> Front USB connector
<b>4</b> Front operator panel	<b>4</b> Left: front panel connector <b>4</b> Right: front panel LCD connector

**Note:** The external LCD connector is not available on certain front I/O modules of 10 x 2.5-inch server models.

## Intrusion switch

Use the section to understand the cable routing for the intrusion switch.

For the locations of the intrusion switch connector on the processor board, see “[Processor-board connectors for cable routing](#)” on page 257 for details.

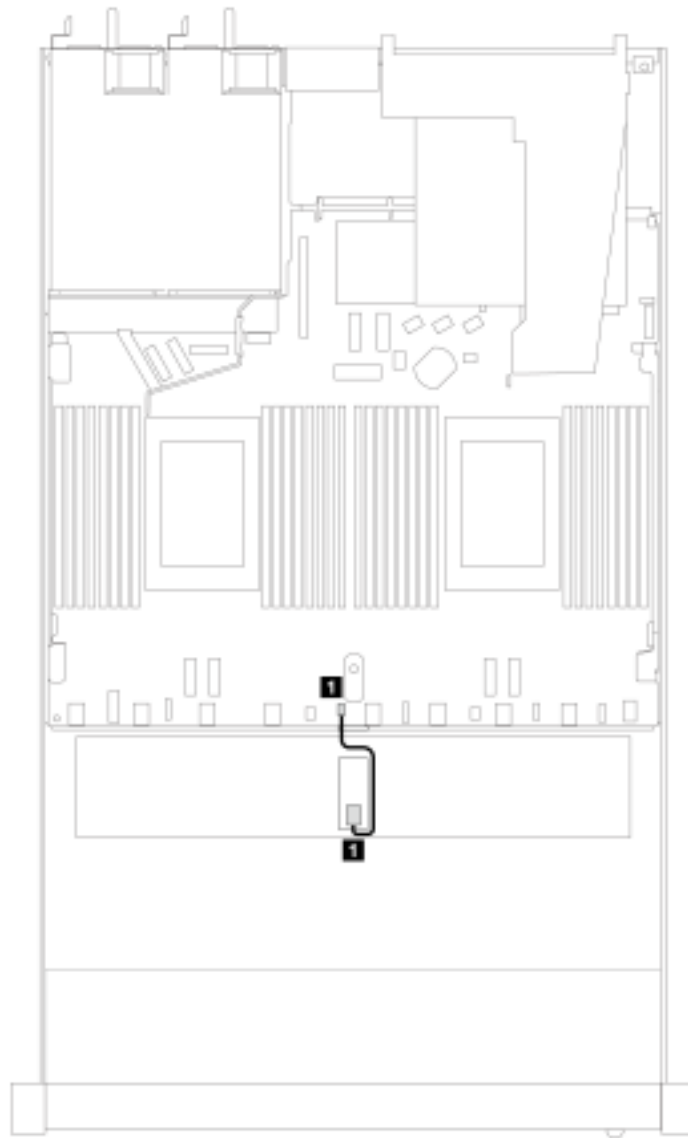


Figure 231. Intrusion switch cable routing

From	To
1 Intrusion switch cable	1 Intrusion switch connector

## RAID flash power modules

Use the section to understand the cable routing for RAID flash power modules.

### Locations of RAID flash power modules

Use the illustration and table below to locate the RAID flash power modules.

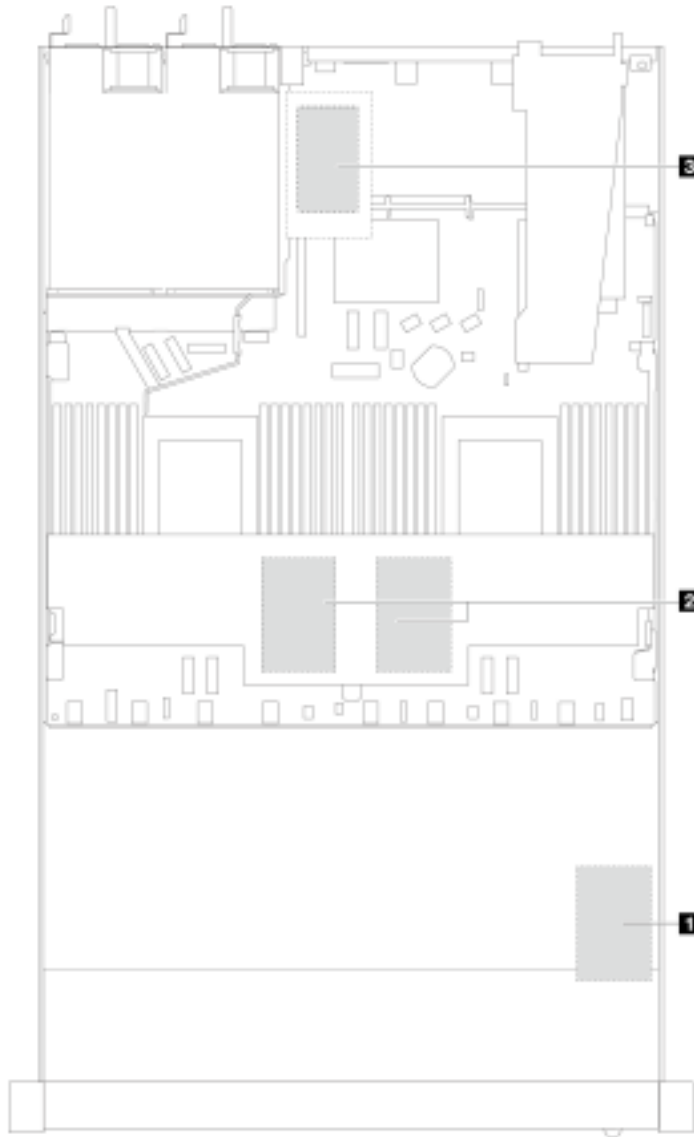


Figure 232. RAID flash power modules in the chassis

Location	Scenario
<b>1</b> RAID flash power module on the chassis	2.5" chassis installed with a standard or performance heat sink
<b>2</b> RAID flash power module on the air baffle	2.5" or 3.5" chassis installed with a standard heat sink
<b>3</b> RAID flash power module on slot 3	<ul style="list-style-type: none"> <li>• 3.5" chassis installed with a performance heat sink</li> <li>• 2.5" chassis installed with liquid assisted cooling module</li> </ul>

### Cable routing of the RAID flash power modules

The following illustrations show the cable routing of the RAID flash power modules on different locations:

**1** On the chassis

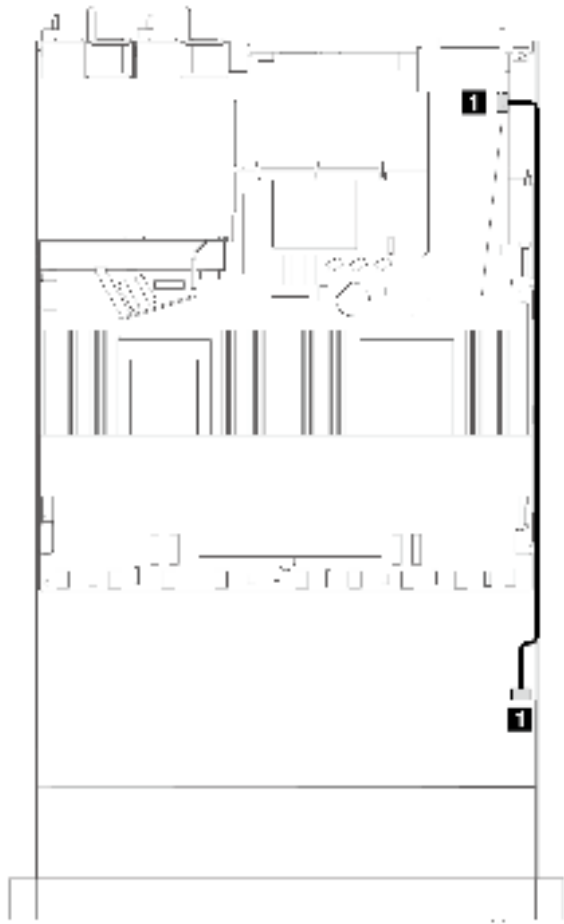


Figure 233. Flash power for SFF RAID/HBA adapters

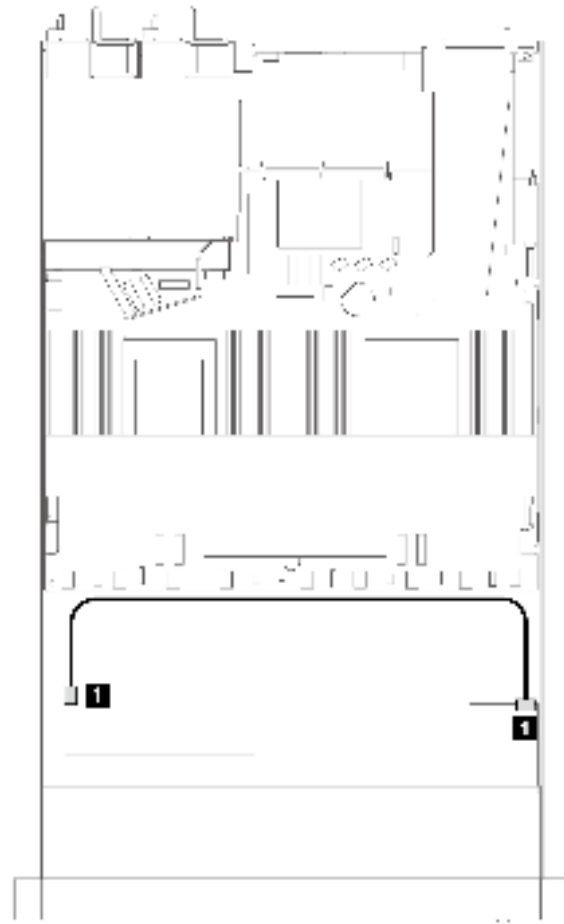
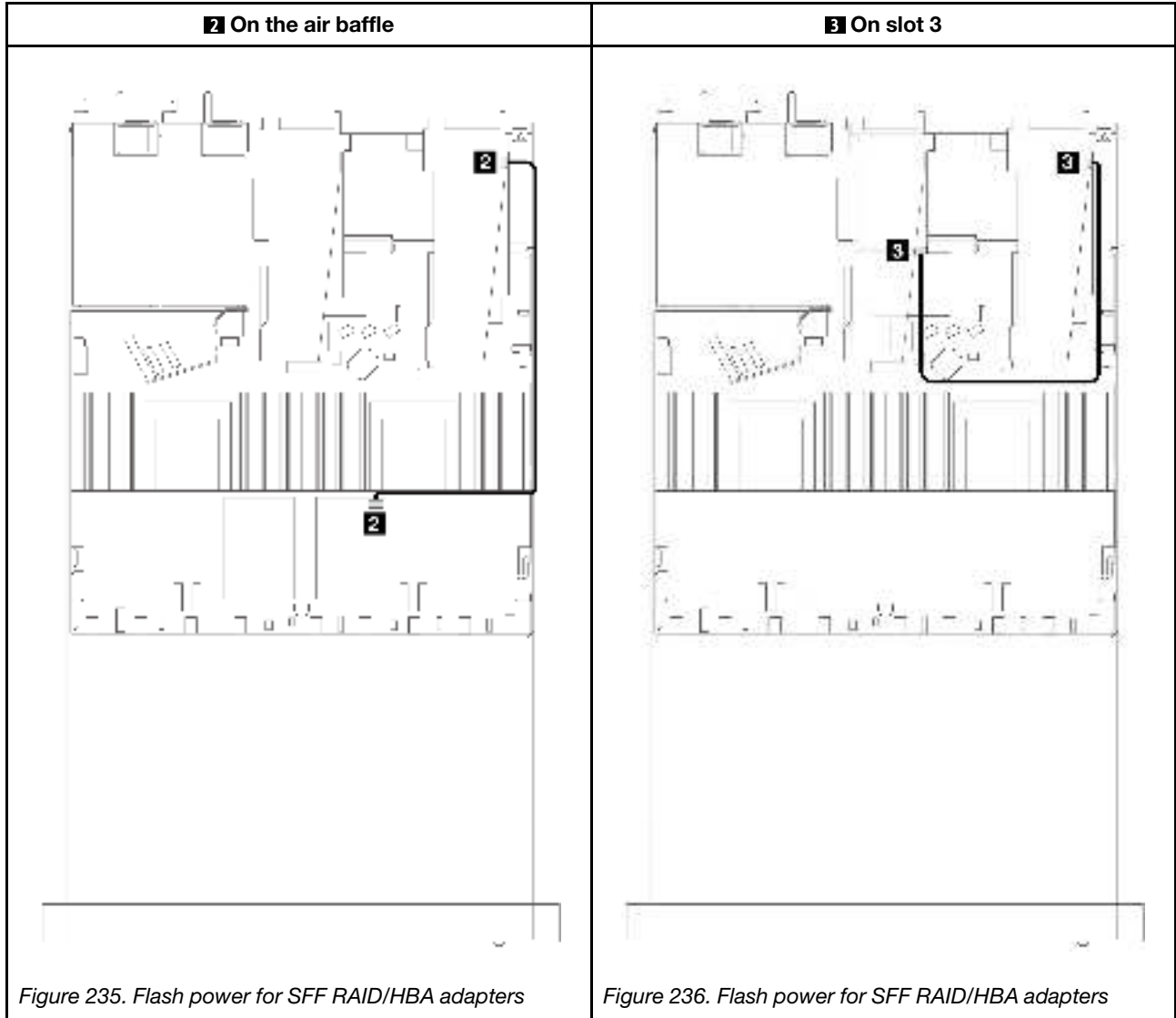


Figure 234. Flash power for CFF RAID adapters



From	To
<b>1 2 3</b> RAID flash power module	<b>1 2 3</b> RAID flash power port on the RAID/HBA adapter

## M.2 drive backplane

This section provides cable routing information for the M.2 drives. Your server supports M.2 SATA/NVMe drive backplanes.

### Locations of M.2 drive assemblies

The locations of M.2 drive assemblies vary in different configuration. The server has two locations for M.2 drive assemblies.

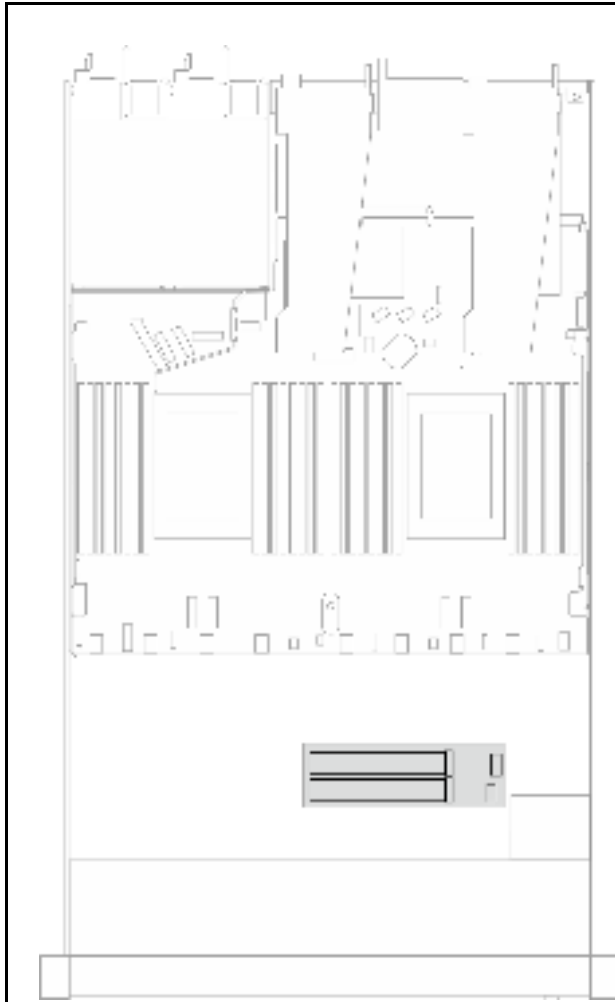


Figure 237. An M.2 drive assembly in the 2.5/3.5-inch drive chassis

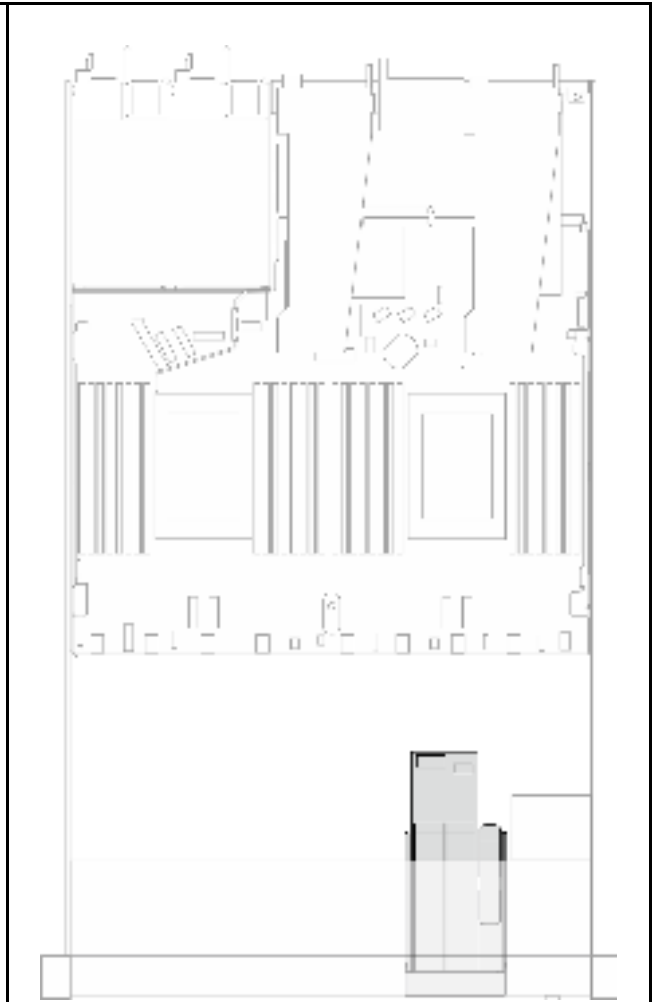
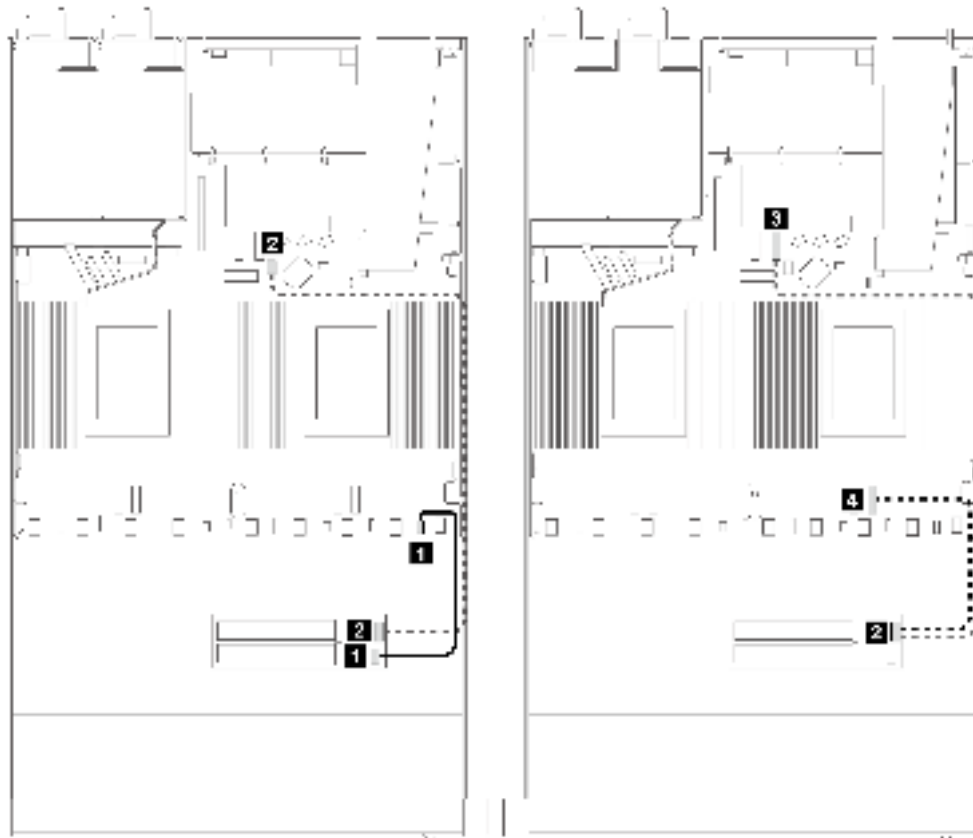


Figure 238. An M.2 drive assembly in the 16-EDSFF drive chassis

### Cable routing of the M.2 drive backplane

- For the locations of M.2 connectors on the backplanes and the processor board, see [“M.2 backplane and M.2 drive replacement”](#) on page 157 and [“Processor-board connectors for cable routing”](#) on page 257 for details.
- The following illustration and table list the M.2 drive backplane supported:

## Cable routing for M.2 SATA/NVMe x4 backplane



From	To
<b>1</b> M.2 power	<b>1</b> M.2 power connector
<b>2</b> M.2 signal	<b>2</b> 7mm/M.2 signal port on the processor board (for SATA signal)
	<b>3</b> PCIe 8 (for NVMe signal, connected when two processors are installed)
	<b>4</b> PCIe 1 (for NVMe signal, connected when one processor is installed)

**Note:** The illustrations above take the M.2 drive assembly in the 2.5/3.5-inch drive chassis for an example. In the 16-EDSFF drive chassis, the cable routing method remains the same.

## M.2 backplane to SFF RAID adapters

See this section to understand the cable routing between an M.2 drive backplane and an SFF RAID adapter.

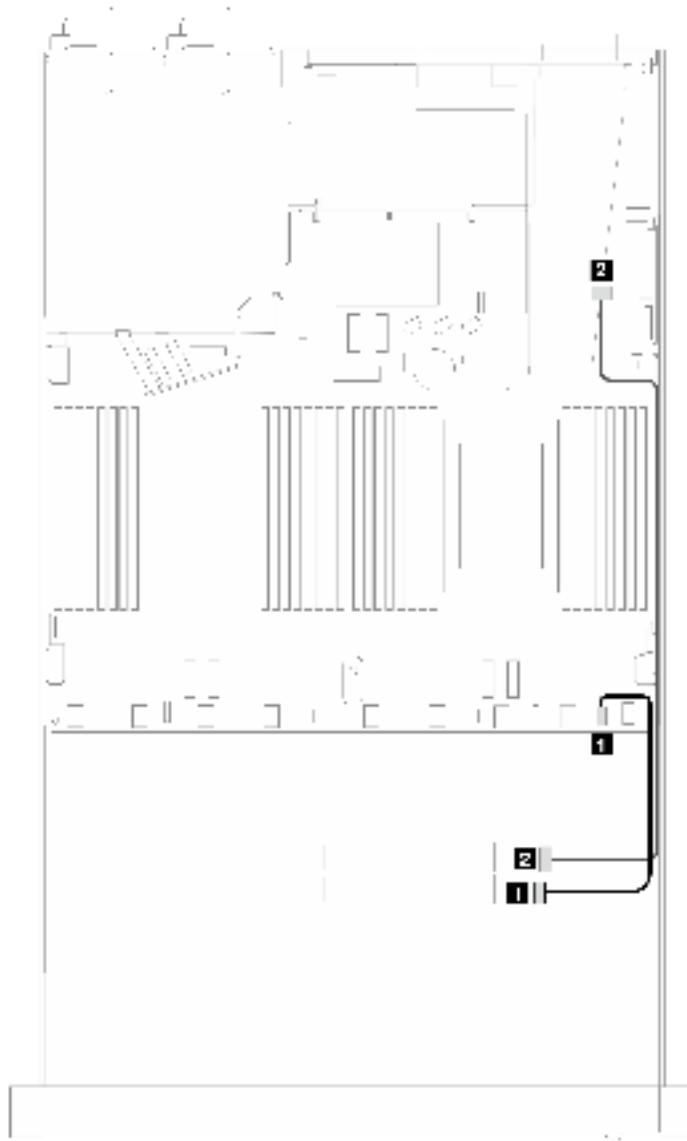


Figure 239. M.2 backplane to a Gen 3 SFF RAID adapter

From	To
<b>1</b> Power	<b>1</b> Power
<b>2</b> M.2 PCIe	<b>2</b> SFF C0

## 7mm drive backplane

This section provides cable routing information for the 7mm drives.

For the locations of 7mm drive connectors on the processor board, see [“Processor-board connectors for cable routing” on page 257](#) for details.



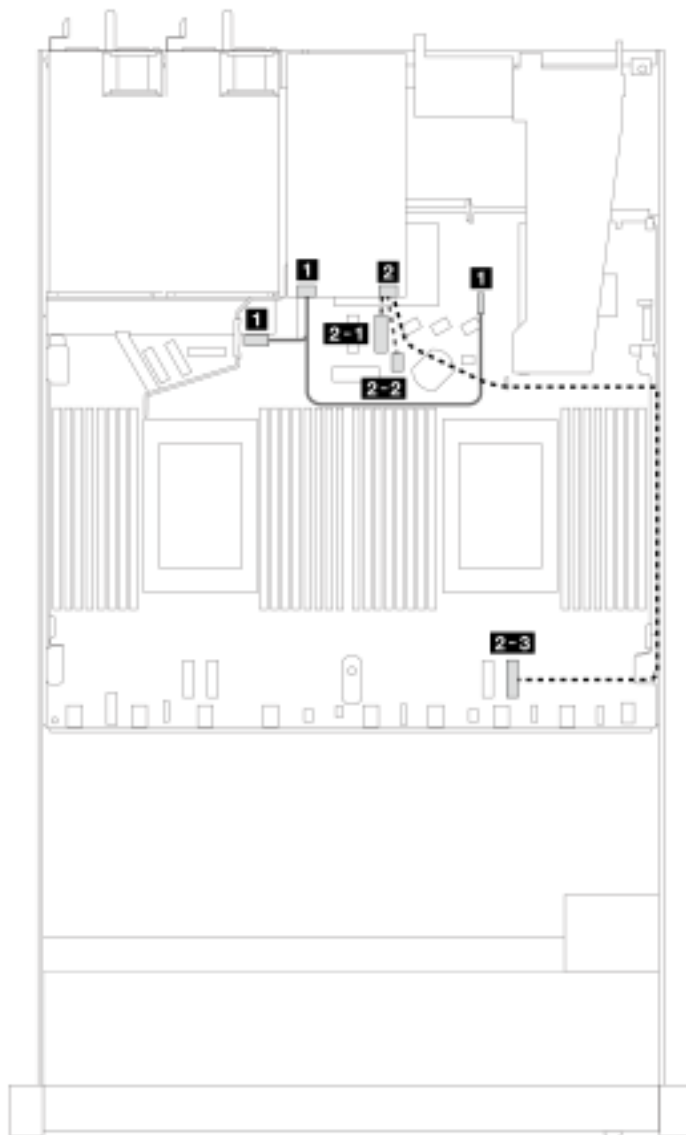


Figure 240. Cable routing for 7mm drives

From	To
<b>1</b> Power port on the 7mm solid-state drive	<b>1</b> Left: rear hard drive power connector <b>1</b> Right: rear hard drive sideband connector
	<b>2</b> Signal port on the 7mm solid-state drive

## 7mm backplane to SFF RAID adapters

See this section to understand the cable routing between a 7mm drive backplane and an SFF RAID adapter.

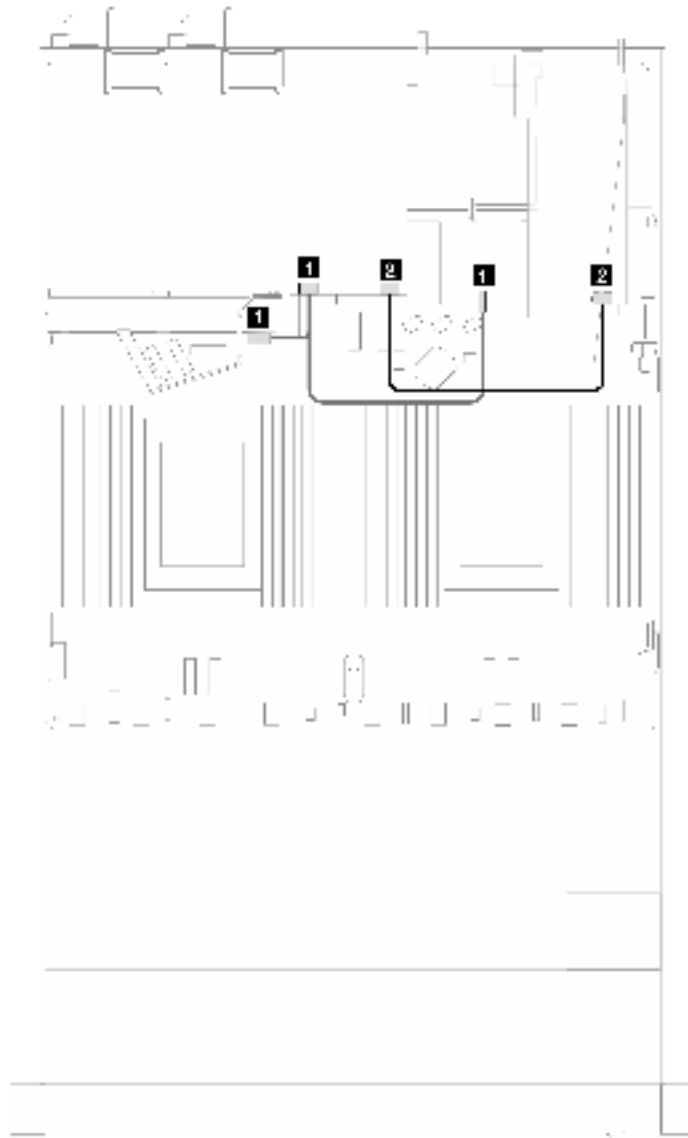


Figure 241. 7mm backplane to a Gen 3 SFF RAID adapter

From	To
<b>1</b> Power	<b>1</b> Power and sideband
<b>2</b> 7mm signal	<b>2</b> SFF C0

---

## Rear NVMe drive backplane

Use this section to understand the cable routing of rear NVMe backplanes with both one and two processors installed.

- The onboard connection of rear NVMe drive backplane are different based on whether one or two processors installed.
- For the locations of rear NVMe drive backplane connectors on the processor board, see “[Processor-board connectors for cable routing](#)” on page 257 for details.

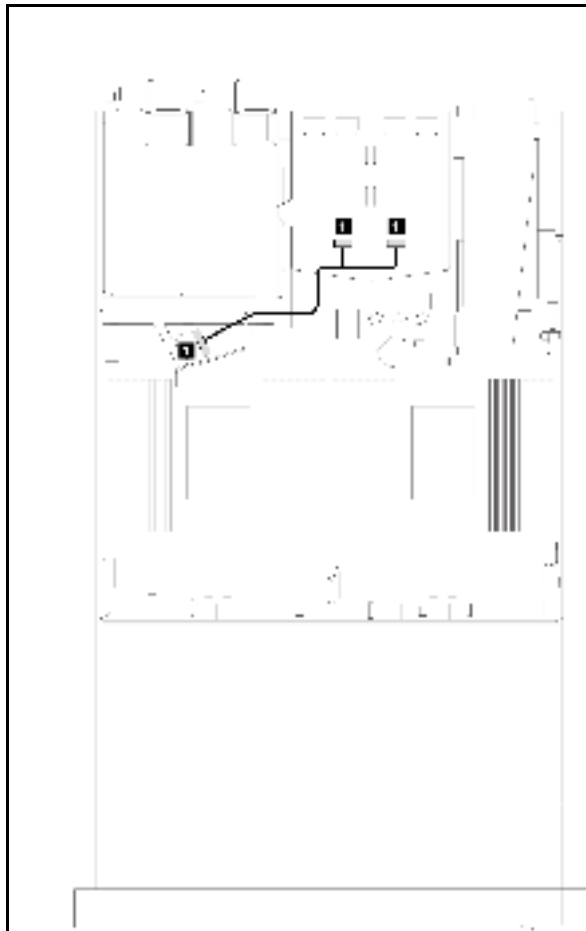


Figure 242. Rear NVMe backplane cable routing with two processors installed

**1** From NVMe 0, 1 to PCIe 6

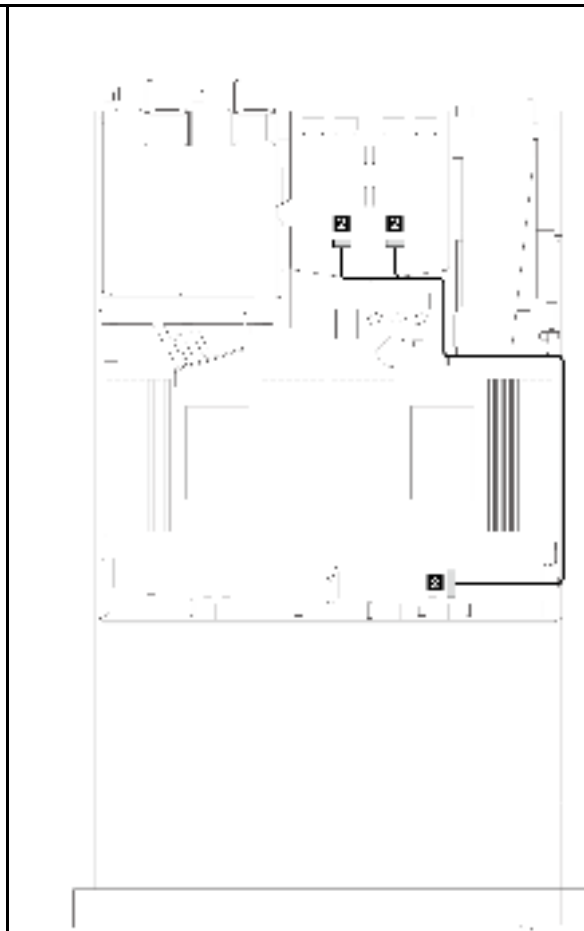


Figure 243. Rear NVMe backplane cable routing with one processor installed

**2** From NVMe 0, 1 to PCIe 1

### Rear NVMe backplane cable routing with 10 x 2.5" AnyBay backplane (Gen 5) installed

**Note:** With the 10 x 2.5" AnyBay backplane (Gen 5) installed, the rear NVMe connection to the processor board is different from other customary configuration.

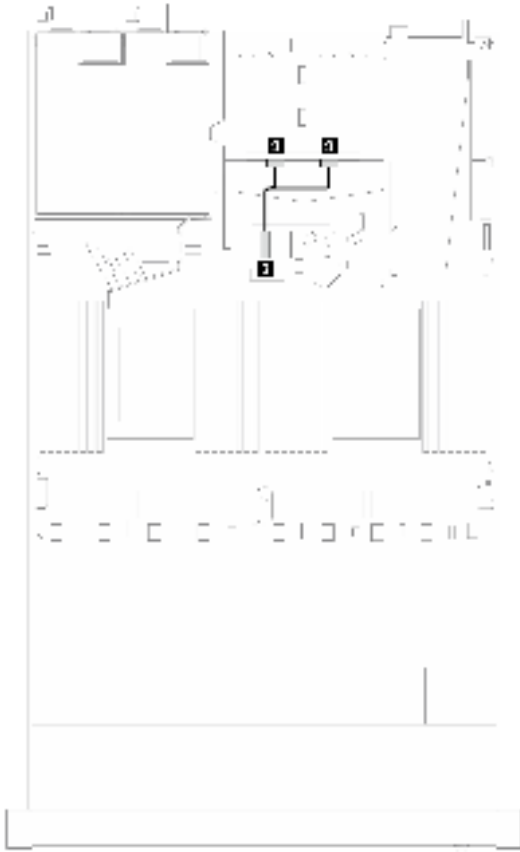


Figure 244. Mapping between the rear NVMe backplane signal cable and the processor board

**1** From NVMe 0, 1 to PCIe 7

---

## Cable routing for backplane power

Use the section to understand the power cable routing for both front and rear drive backplanes.

- The backplanes your server supports require power connection. This section singles out the power connection from signal connection for better understanding.
- For the locations of backplane power connectors on the processor board, see [“Processor-board connectors for cable routing” on page 257](#) for details.
- For more information about backplanes supported and their connectors, see [“Drive backplane connectors” on page 250](#).

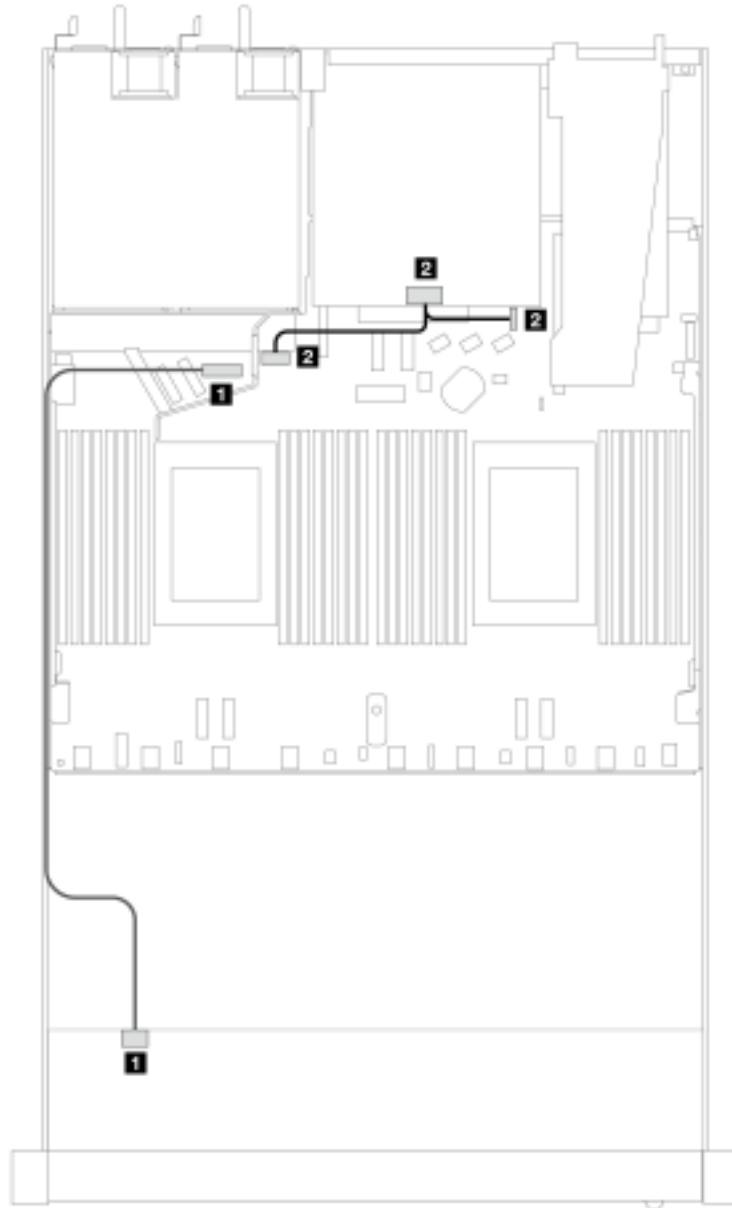


Figure 245. Backplane power cable connection

From	To
<b>1</b> Power connector on the front drive backplane	<b>1</b> Front backplane power connector
<b>2</b> Power connector on the rear drive backplane	<b>2</b> Left: rear hard drive power connector <b>2</b> Right: rear hard drive sideband connector

## Liquid assisted cooling module

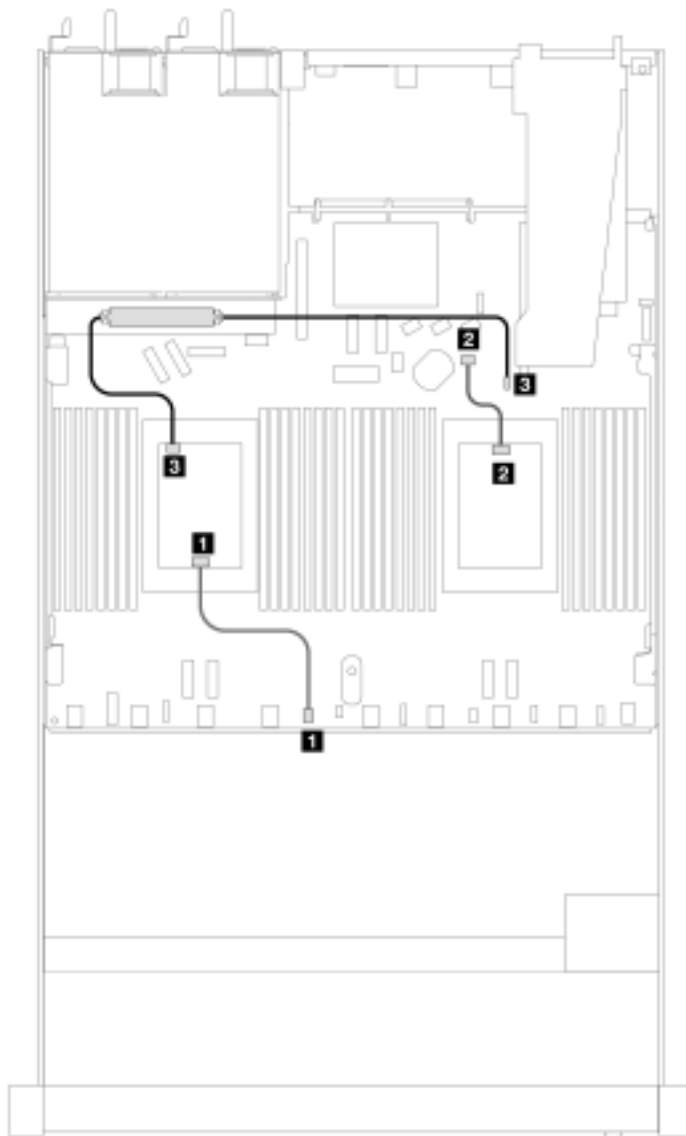
Use this section to understand the cable routing of the Liquid Assisted Cooling Module (LACM).

- For the locations of the LACM connectors on the processor board, see [“Processor-board connectors for cable routing” on page 257](#) for details.

- The two pump cables and one cable for the leakage detection sensor module are integrated to the LACM, make sure that all three cables are connected.

**Note:** For better cable arrangement, it is required to install the liquid detection sensor module to a designated holder, and make sure that the module is secured in holder clips. Use the illustration below or [“Install the Lenovo Neptune\(TM\) liquid assisted cooling module” on page 143](#) for details.

### Liquid assisted cooling module cable routing



Cable	From	To
<b>1</b> Pump 1	Pump 1 cable	Pump 1 connector
<b>2</b> Pump 2	Pump 2 cable	Pump 2 connector
<b>3</b> Leak detection	Leak detection cable	Leak detection connector

With the LACM installed, your server supports below drive combinations:

## 6 x 2.5" SAS/SATA + 4 x 2.5" AnyBay (liquid cooling)

Use this section to understand the cable routing of six SAS/SATA front drives and four AnyBay front drives for liquid cooling configuration with the 6 x 2.5" SAS/SATA and 4 x 2.5" AnyBay front backplane installed.

To connect power cables for a backplane for standard 2.5-inch or 3.5-inch drives, refer to [“Cable routing for backplane power” on page 274](#).

To connect cables for a 7mm drive backplane, refer to [“7mm drive backplane” on page 270](#).

To connect signal cables for a backplane for standard six SAS/SATA and four AnyBay front drives, refer to the following cable routing scenarios depending on your server configuration:

- [“Cable routing for onboard configuration” on page 277](#)
- [“Cable routing with an SFF HBA/RAID adapter” on page 279](#)

### Cable routing for onboard configuration

The following illustrations and tables show the mapping relationship between backplane connectors and processor board connectors for onboard configuration.

The following figure illustrates the cable routing for the configuration of six SAS/SATA and four AnyBay front drives bays. Connections between connectors: **1** ↔ **1**, **2** ↔ **2**, **3** ↔ **3**, ... **n** ↔ **n**.

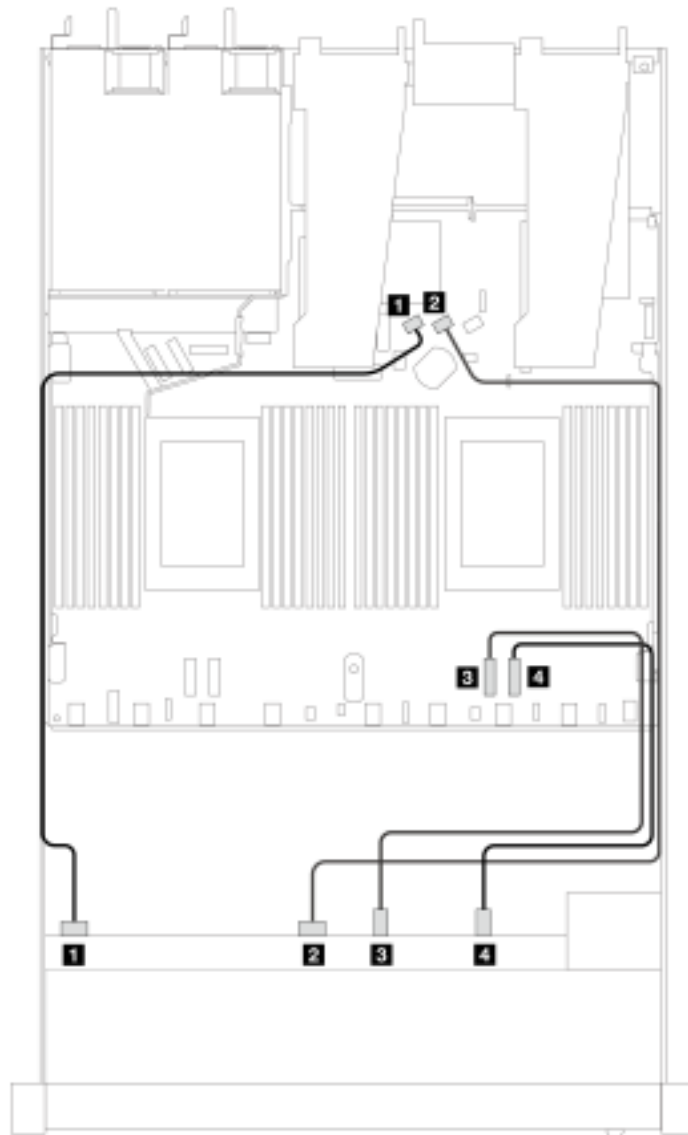


Figure 246. Cable routing for onboard configuration of six SAS/SATA and four NVMe front drives

Table 41. Mapping between one front AnyBay backplane and processor board for onboard configuration

Backplane	From	To
Front BP (SAS)	1 SAS 0	1 SATA 0
	2 SAS 1	2 SATA 1
Front BP (NVMe)	3 NVMe 0-1	3 PCIe 2
	4 NVMe 2-3	4 PCIe 1



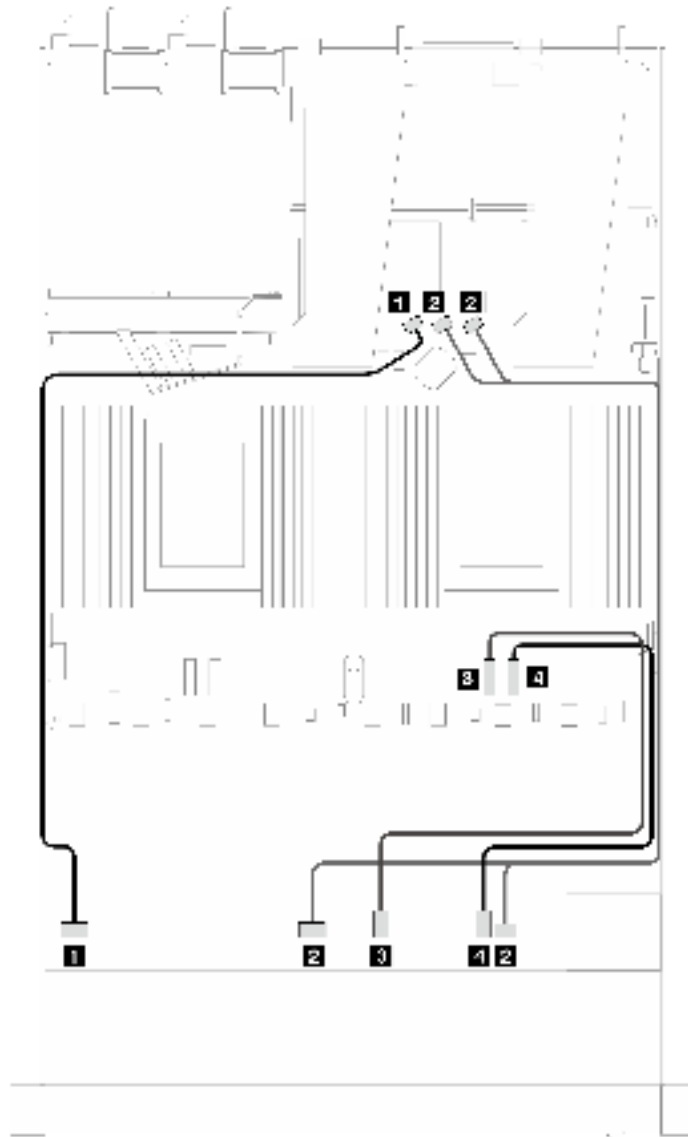


Figure 247. Cable routing for onboard configuration of six SAS/SATA and four NVMe front drives

Table 42. Mapping between one front AnyBay backplane and processor board for onboard configuration

Backplane	From	To
Front BP (SAS)	1 SAS 0	1 SATA 0
	2 SAS 1, 2	2 SATA 1, 2
Front BP (NVMe)	3 NVMe 0-1	3 PCIe 2
	4 NVMe 2-3	4 PCIe 1

#### Cable routing with an SFF HBA/RAID adapter

The following tables show the mapping relationship between backplane connectors and an 8i or 16i SFF HBA/RAID adapter (Gen 4).

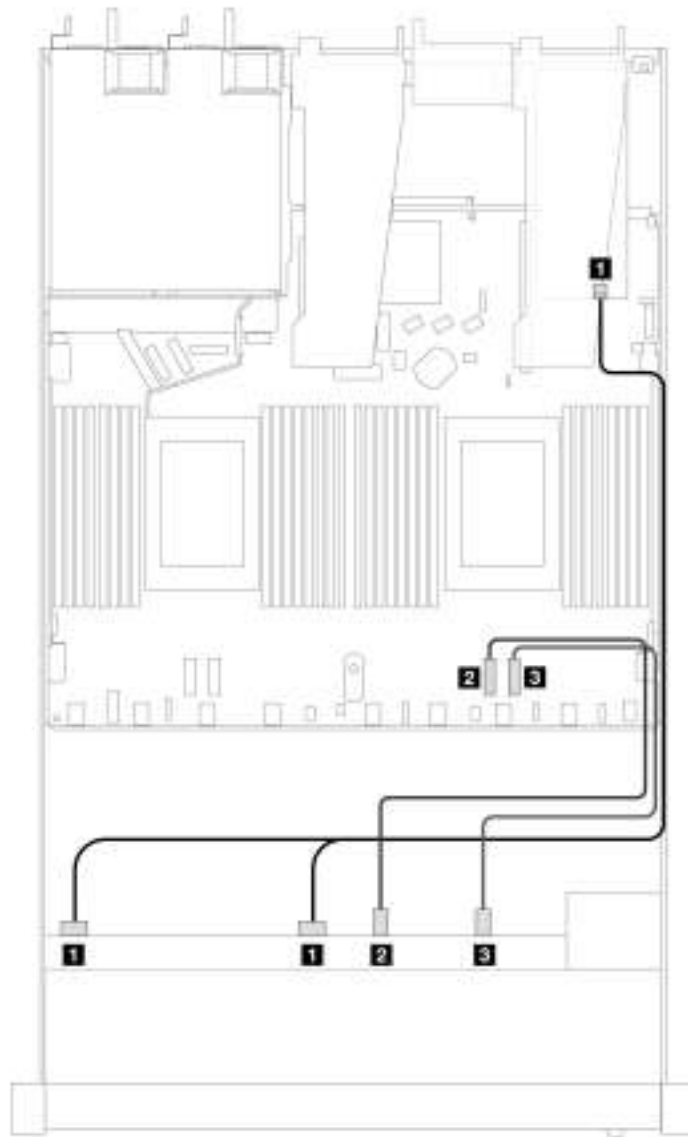


Figure 248. Cable routing for six front SAS/SATA drives and four front AnyBay drives bays with an 8i or 16i SFF RAID adapter (Gen 4)

Table 43. Mapping between one front AnyBay backplane and an SFF HBA/RAID adapter

Backplane	From	To
Front BP (SAS)	<b>1</b> SAS 0, SAS 1	<b>1</b> C0
Front BP (NVMe)	<b>2</b> NVMe 0–1	<b>2</b> PCIe 2
	<b>3</b> NVMe 2–3	<b>3</b> PCIe 1

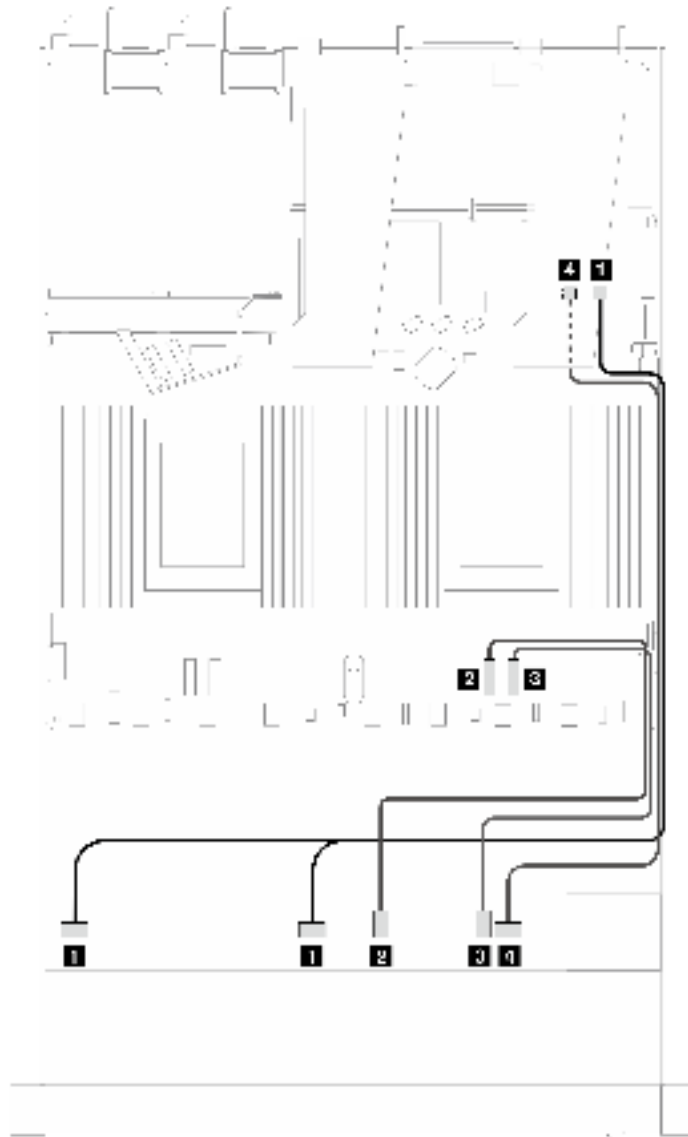


Figure 249. Cable routing for six front SAS/SATA drives and four front AnyBay drives bays with an 8i or 16i SFF RAID adapter (Gen 4)

Table 44. Mapping between one front AnyBay backplane and an SFF HBA/RAID adapter

Backplane	From	To
Front BP (SAS)	1 SAS 0, SAS 1	1 C0
Front BP (NVMe)	2 NVMe 0-1	2 PCIe 2
	3 NVMe 2-3	3 PCIe 1
Front BP (SAS)	4 SAS 2	4 C1

The following illustrations and tables show the mapping relationship between backplane connectors and an 8i or 16i SFF HBA/RAID adapter (Gen 3).

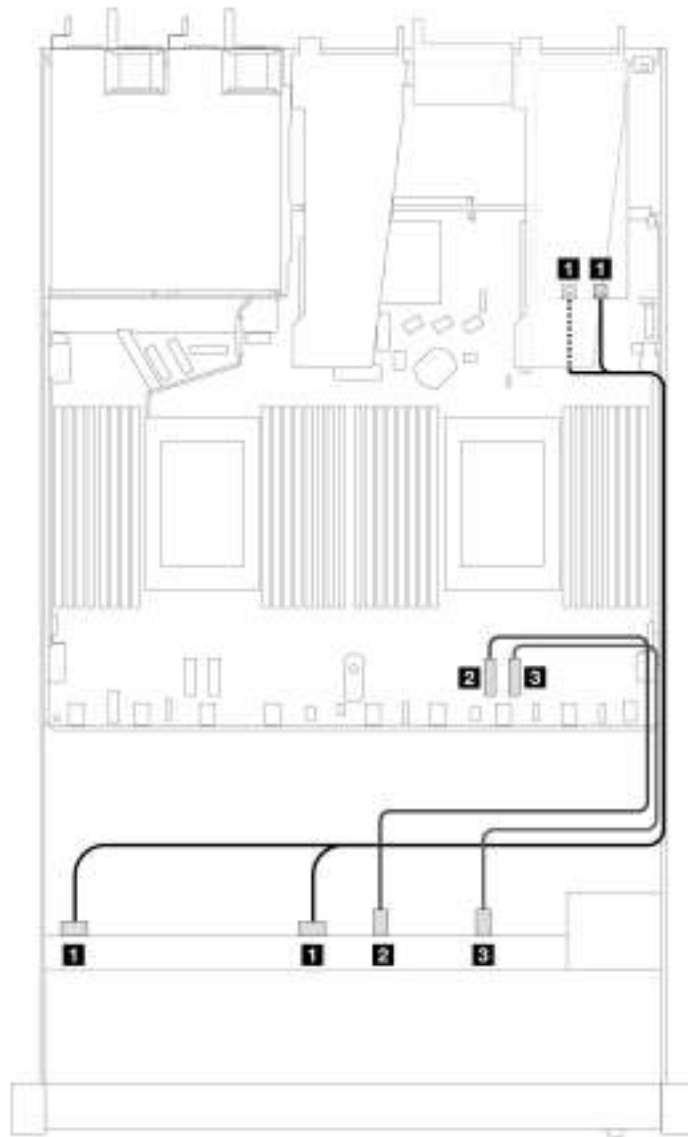


Figure 250. Cable routing for six front SAS/SATA drives and four front AnyBay drives bays with an 8i or 16i SFF RAID adapter (Gen 3)

Table 45. Mapping between one front AnyBay backplane and an SFF HBA/RAID adapter

Backplane	From	To
Front BP (SAS)	<b>1</b> SAS 0, SAS 1	<b>1</b> C0, C1
Front BP (NVMe)	<b>2</b> NVMe 0–1	<b>2</b> PCIe 2
	<b>3</b> NVMe 2–3	<b>3</b> PCIe 1

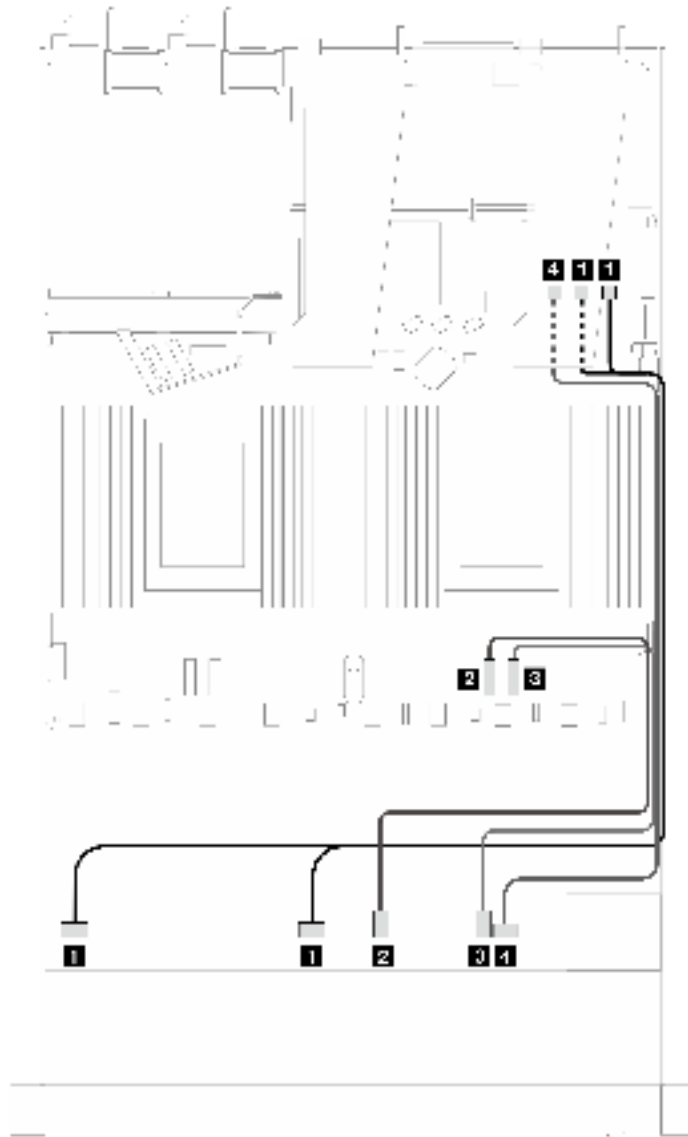


Figure 251. Cable routing for six front SAS/SATA drives and four front AnyBay drives bays with an 8i or 16i SFF RAID adapter (Gen 3)

Table 46. Mapping between one front AnyBay backplane and an SFF HBA/RAID adapter

Backplane	From	To
Front BP (SAS)	1 SAS 0, SAS 1	1 C0, C1
Front BP (NVMe)	2 NVMe 0-1	2 PCIe 2
	3 NVMe 2-3	3 PCIe 1
Front BP (SAS)	4 SAS 2	4 C2

## 6 x 2.5" SAS/SATA + 2 x 2.5" AnyBay + 2 x 2.5" NVMe (liquid cooling)

See this section to understand the cable routing of six front SAS/SATA drives, two AnyBay drives and two front NVMe drives for the liquid cooling configuration.

To connect cables for a 7mm drive backplane, refer to [“7mm drive backplane” on page 270](#).

To connect power cables for a backplane for standard 2.5-inch or 3.5-inch drives, refer to [“Cable routing for backplane power” on page 274](#).

To connect signal cables for a backplane for standard six front SAS/SATA drives, two AnyBay drives and two front NVMe drives, refer to the following cable routing scenarios depending on your server configuration:

- [“Cable routing for onboard configuration” on page 284](#)
- [“Cable routing with an SFF HBA/RAID adapter” on page 285](#)

### **Cable routing for onboard configuration**

The following tables show the mapping relationship between backplane connectors and processor board connectors for onboard configuration.

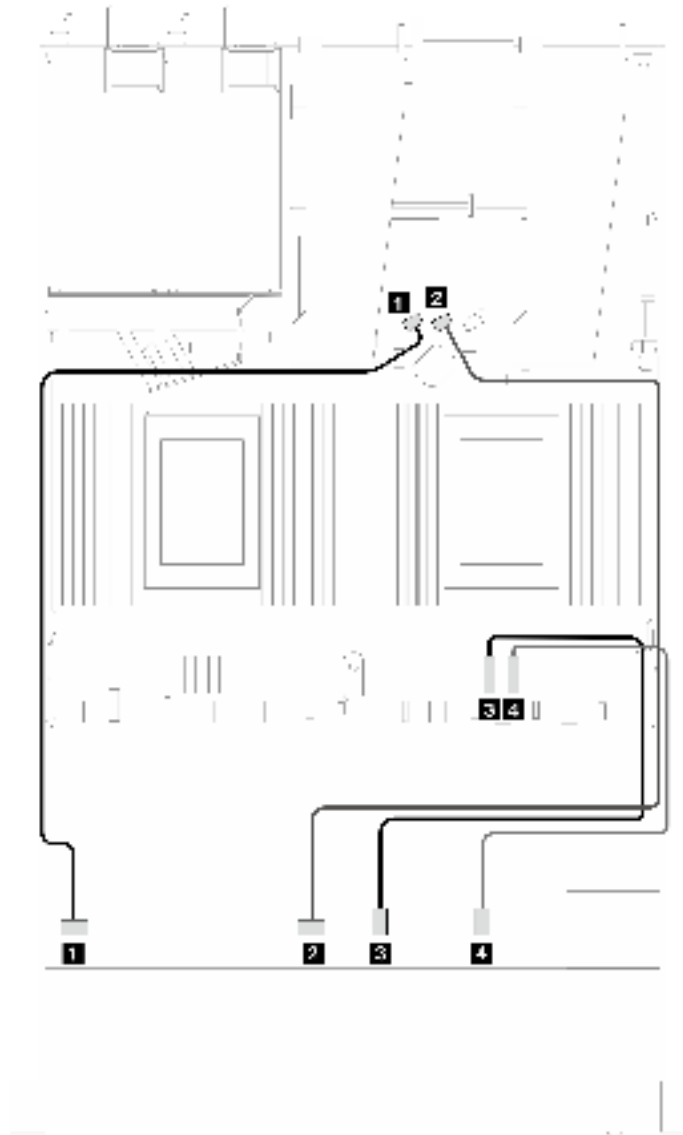


Figure 252. Cable routing for onboard configuration of six SAS/SATA drives and two AnyBay and two NVMe front drives bays

Table 47. Mapping between one front AnyBay backplane and processor board for onboard configuration

Backplane	From	To
Front BP (SAS)	1 SAS 0	1 SATA 0
	2 SAS 1	2 SATA 1
Front BP (NVMe)	3 NVMe 0-1	3 PCIe 2
	4 NVMe 2-3	4 PCIe 1

### Cable routing with an SFF HBA/RAID adapter

The following tables show the mapping relationship between backplane connectors and an SFF HBA/RAID adapter.

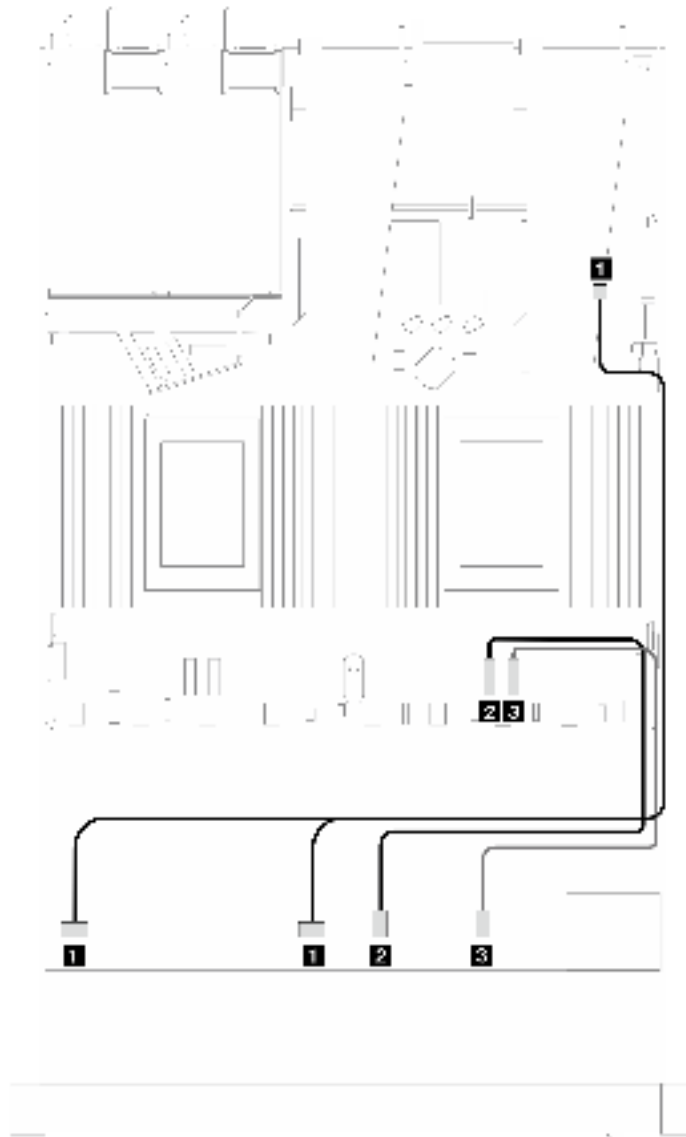


Figure 253. Cable routing for 6 SAS/SATA drives and 2 AnyBay drives and 2 NVMe front drive bays with an 8i or 16i SFF RAID adapter (Gen 4)

Table 48. Mapping between one front AnyBay backplane and an SFF HBA/RAID adapter

Backplane	From	To
Front BP (SAS)	1 SAS 0, SAS 1	1 C0
Front BP (NVMe)	2 NVMe 0-1	2 PCIe 2
	3 NVMe 2-3	3 PCIe 1



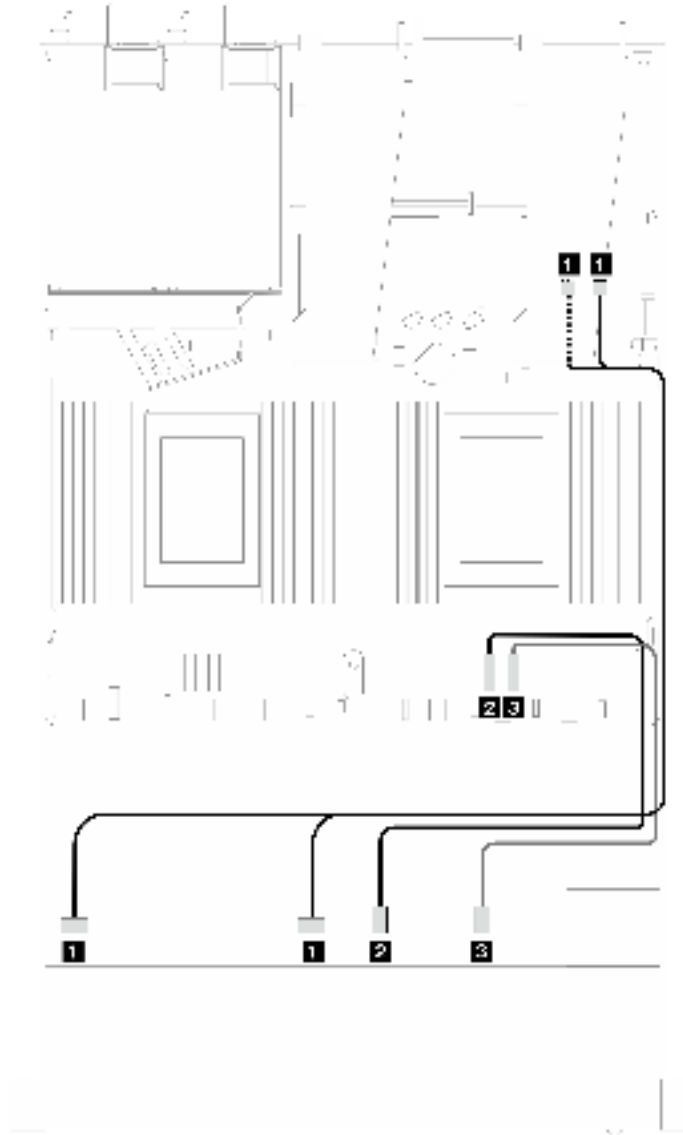


Figure 254. Cable routing for 6 SAS/SATA drives and 2 AnyBay drives and 2 NVMe front drive bays with an 8i or 16i SFF RAID adapter (Gen 3)

Table 49. Mapping between one front AnyBay backplane and an SFF HBA/RAID adapter

Backplane	From	To
Front BP (SAS)	1 SAS 0, SAS 1	1 C0, C1
Front BP (NVMe)	2 NVMe 0-1	2 PCIe 2
	3 NVMe 2-3	3 PCIe 1

## 8 x 2.5" SAS/SATA (liquid cooling)

Use this section to understand the cable routing of eight SAS/SATA front drives for liquid cooling configuration with 10 x 2.5" AnyBay front backplane installed.

To connect cables for a 7mm drive backplane, refer to [“7mm drive backplane” on page 270](#).

To connect power cables for a backplane for standard 2.5-inch or 3.5-inch drives, refer to [“Cable routing for backplane power” on page 274](#).

To connect signal cables for a backplane for standard 4 x 3.5-inch front drives, refer to the following cable routing scenarios depending on your server configuration:

- [“Cable routing for onboard configuration” on page 288](#)
- [“Cable routing with an SFF HBA/RAID adapter” on page 289](#)

### **Cable routing for onboard configuration**

The following illustrations and tables show the mapping relationship between backplane connectors and processor board connectors for onboard configuration.

The following figure illustrates the cable routing for the onboard configuration of 8 x 2.5-inch front SAS/SATA drive bays. Connections between connectors: **1** ↔ **1**, **2** ↔ **2**, **3** ↔ **3**, ... **n** ↔ **n**.

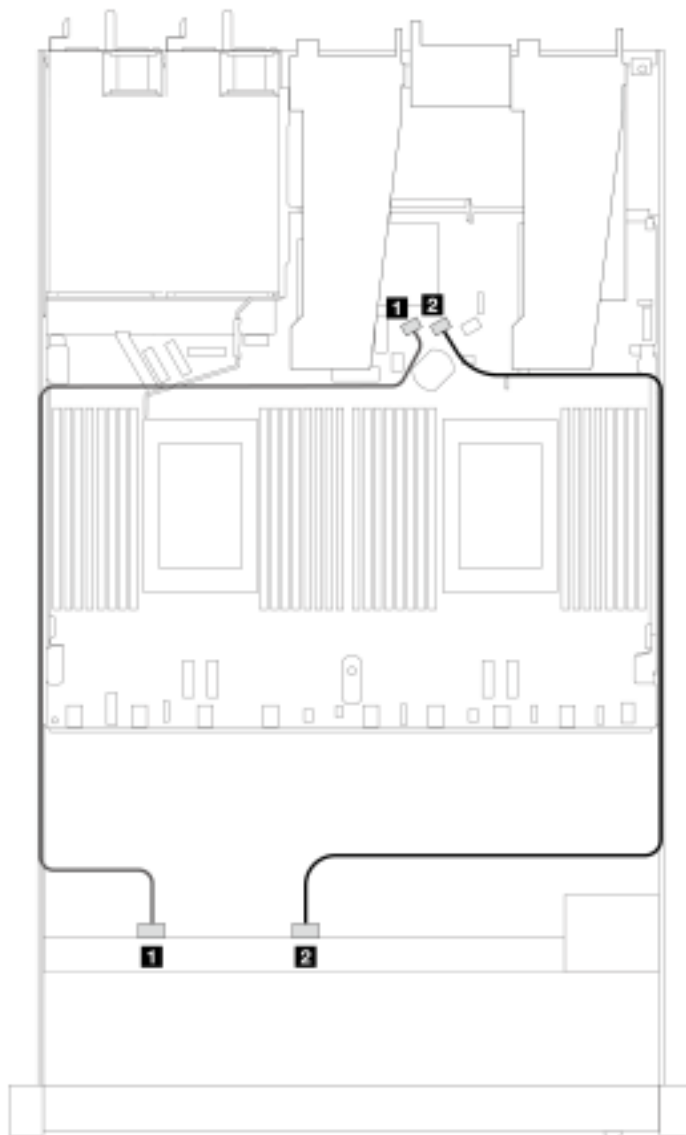


Figure 255. Cable routing for onboard configuration of 8 x 2.5 SAS/SATA front drives

Table 50. Mapping between one front SAS/SATA backplane and processor board for onboard configuration

Backplane	From	To
Front BP (SAS)	1 SAS 0	1 SATA 0
	2 SAS 1	2 SATA 1

### Cable routing with an SFF HBA/RAID adapter

The following illustrations and tables show the mapping relationship between backplane connectors and an 8i or 16i SFF HBA/RAID adapter (Gen 3 or Gen 4).

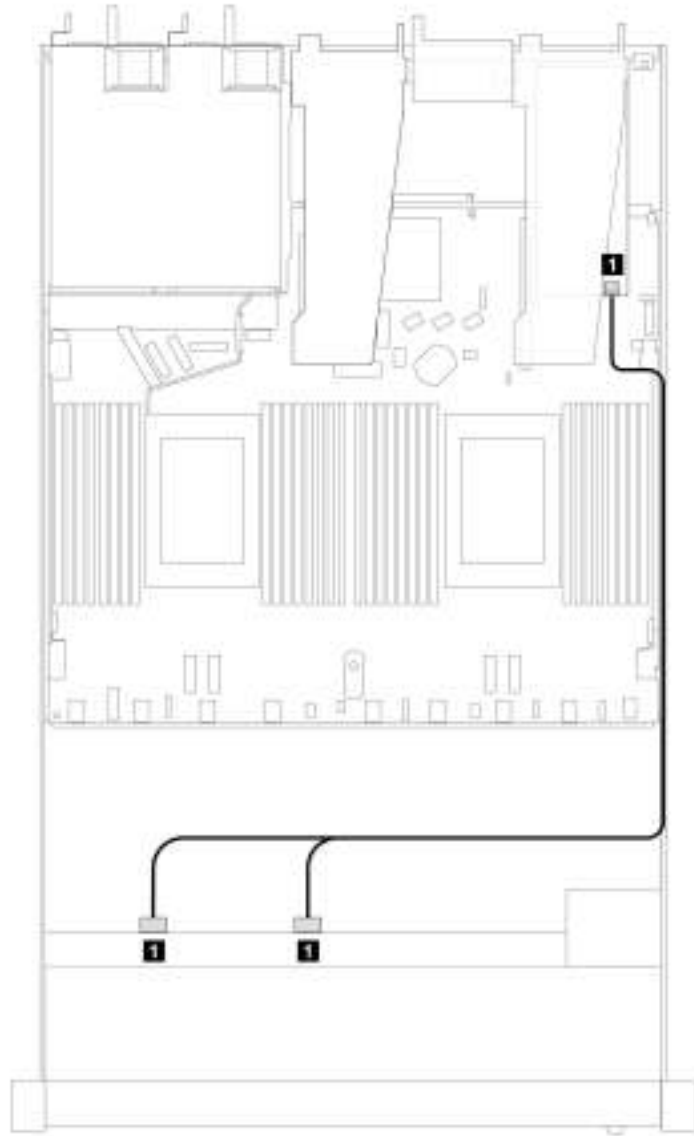


Figure 256. Cable routing for 8 x 2.5-inch front SAS/SATA drive bays with an 8i SFF RAID adapter (Gen 4)

Table 51. Mapping between one front SAS/SATA backplane and an SFF HBA/RAID adapter

Backplane	From	To
Front BP (SAS)	1 SAS 0, SAS 1	1 C0

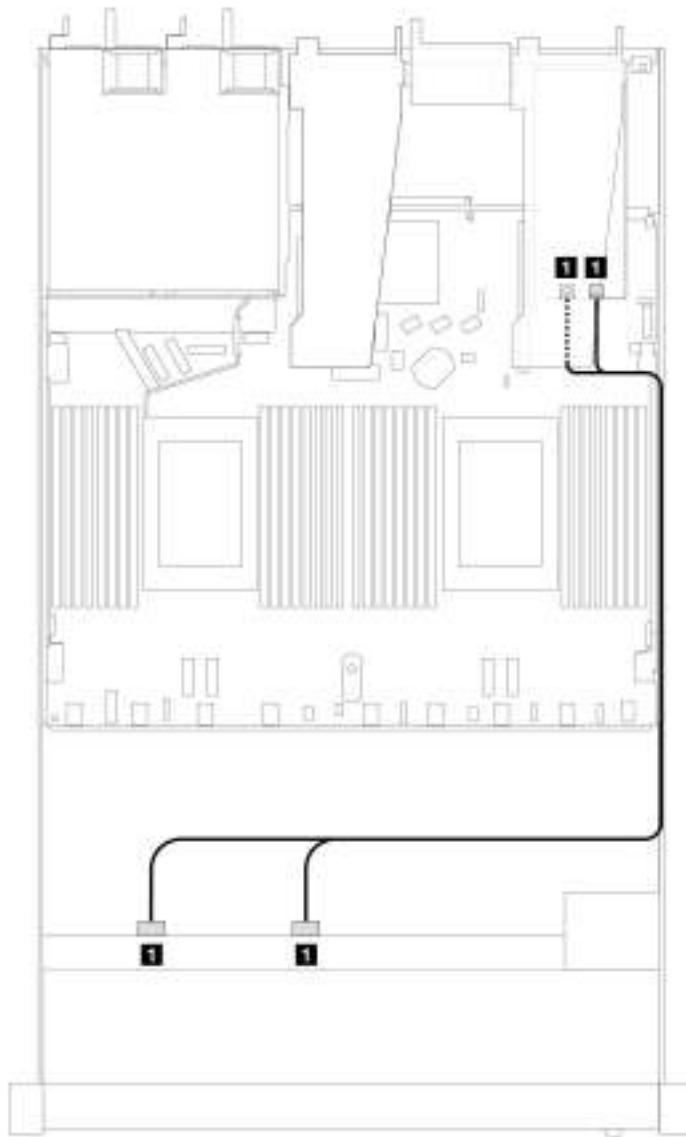


Figure 257. Cable routing for 8 x 2.5-inch front SAS/SATA drive bays with an 8i or 16i SFF RAID adapter (Gen 3)

Table 52. Mapping between one front SAS/SATA backplane and an SFF HBA/RAID adapter

Backplane	From	To
Front BP (SAS)	1 SAS 0, SAS 1	1 C0, C1

## 8 x 2.5" U.3 drives with 10 x 2.5" AnyBay backplane (liquid cooling)

Use this section to understand the cable routing for eight U.3 drives for liquid cooling configuration with 10 x 2.5" Anybay backplane and one processor installed.

To connect cables for a 7mm drive backplane, refer to ["7mm drive backplane" on page 270](#).

To connect power cables for a backplane for standard 2.5-inch or 3.5-inch drives, refer to ["Cable routing for backplane power" on page 274](#).

### Cable routing with an SFF HBA/RAID adapter

The following illustrations and tables show the mapping relationship between backplane connectors and an 8i SFF RAID adapter (Gen 4).

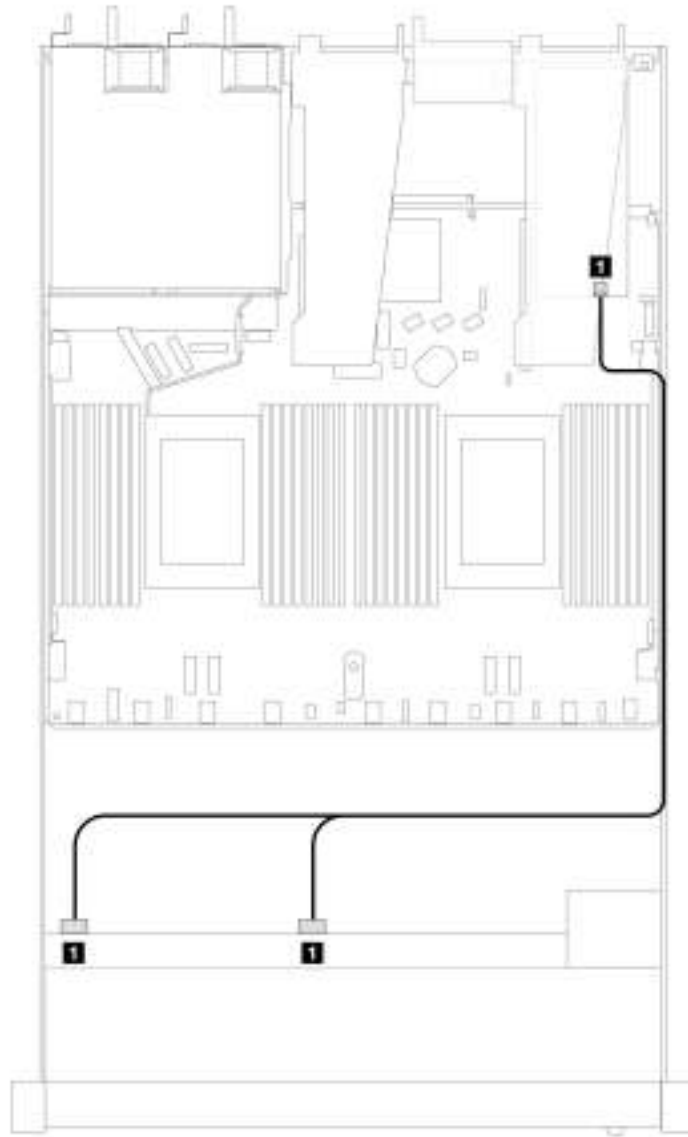


Figure 258. Cable routing for 8 x 2.5-inch front U.3 drives with an 8i SFF RAID adapter (Gen 4)

Table 53. Mapping between one front AnyBay backplane and an SFF HBA/RAID adapter

Backplane	From	To
Front BP (SAS)	SAS 0, SAS 1	C0

### 10 x 2.5" SAS/SATA (liquid cooling)

Use this section to understand the cable routing of 10 SAS/SATA front drives for liquid cooling configuration with 10 x 2.5" AnyBay front backplane installed.

To connect cables for a 7mm drive backplane, refer to [“7mm drive backplane” on page 270](#).

To connect power cables for a backplane for standard 2.5-inch or 3.5-inch drives, refer to [“Cable routing for backplane power” on page 274](#).

To connect signal cables for a backplane for standard 4 x 3.5-inch front drives, refer to the following cable routing scenarios depending on your server configuration:

- [“Cable routing for onboard configuration” on page 293](#)
- [“Cable routing with an SFF HBA/RAID adapter” on page 294](#)

### **Cable routing for onboard configuration**

The following illustrations and tables show the mapping relationship between backplane connectors and processor board connectors for onboard configuration.

The following figure illustrates the cable routing for the configuration of 10 front SAS/SATA drives bays. Connections between connectors: **1 ↔ 1, 2 ↔ 2, 3 ↔ 3, ... n ↔ n.**

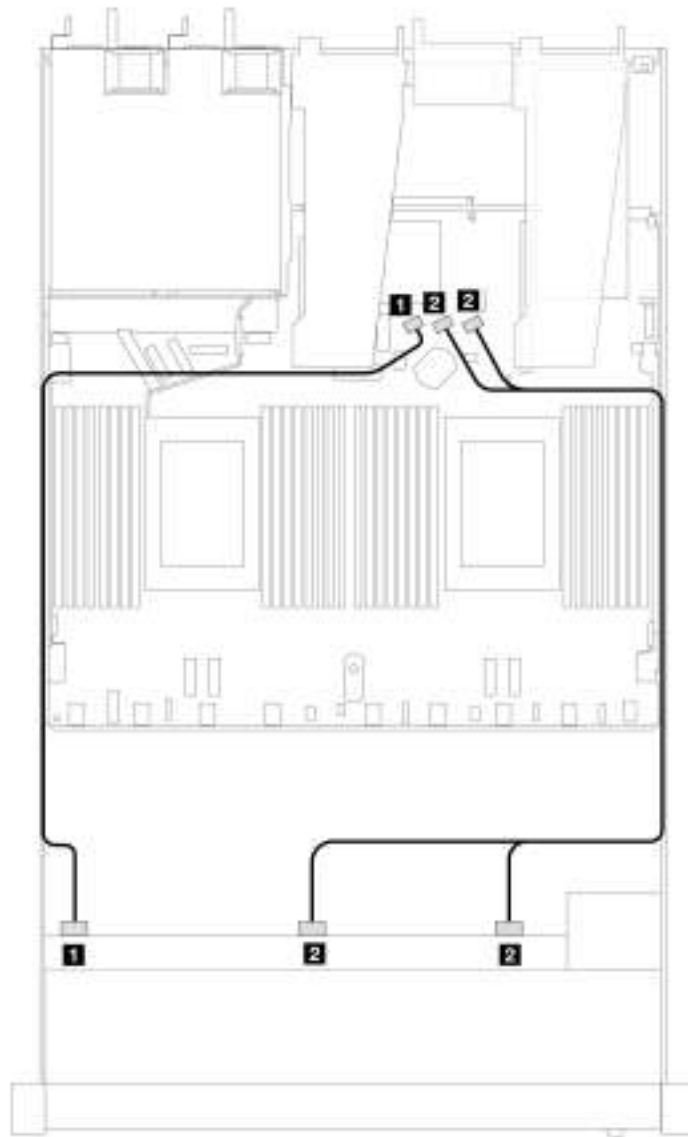


Figure 259. Cable routing for onboard configuration of 10 x 2.5 SAS/SATA front drives

Table 54. Mapping between one front AnyBay backplane and processor board for onboard configuration

Backplane	From	To
Front BP (SAS)	1 SAS 0	1 SATA 0
	2 SAS 1, SAS 2	2 SATA 1, SATA 2

#### Cable routing with an SFF HBA/RAID adapter

The following tables show the mapping relationship between backplane connectors and a 16i SFF HBA/RAID adapter (Gen 3 or Gen 4).



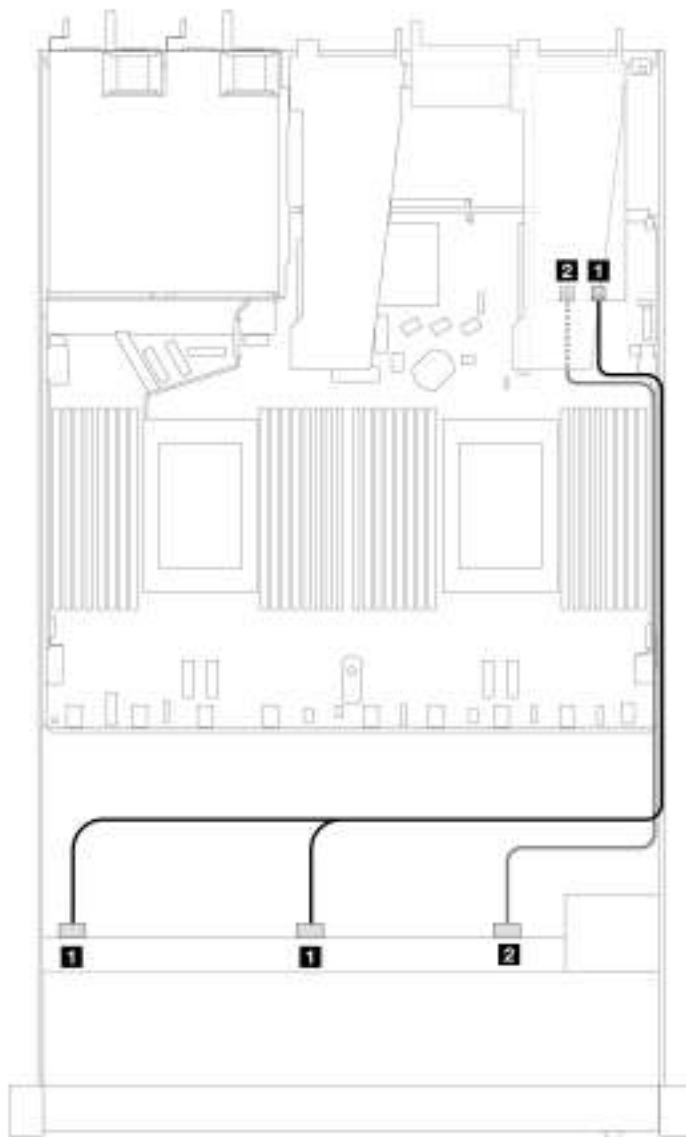


Figure 260. Cable routing for 10 front SAS/SATA drives bays with a 16i SFF RAID adapter (Gen 4)

Table 55. Mapping between one front AnyBay backplane and an SFF HBA/RAID adapter

Backplane	From	To
Front BP (SAS)	1 SAS 0, SAS 1	1 C0
	2 SAS 2	2 C1

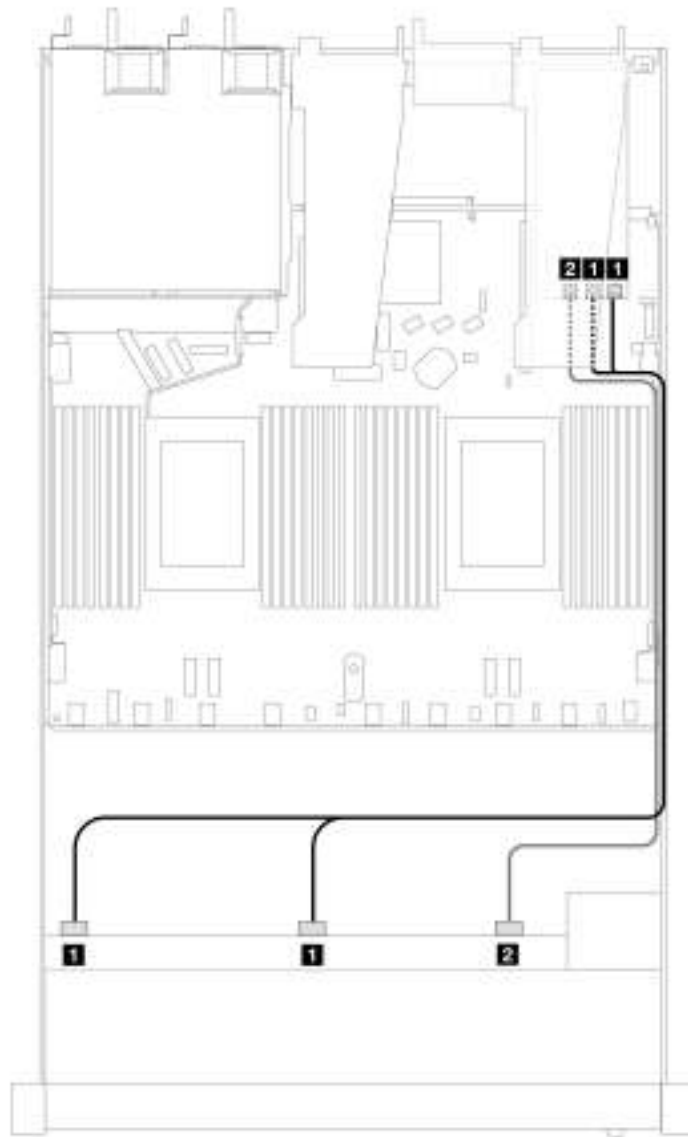


Figure 261. Cable routing for 10 front SAS/SATA drives bays with a 16i SFF RAID adapter (Gen 3)

Table 56. Mapping between one front AnyBay backplane and an SFF HBA/RAID adapter

Backplane	From	To
Front BP (SAS)	1 SAS 0, SAS 1	1 C0, C1
	2 SAS 2	2 C2

## 10 x 2.5" NVMe (liquid cooling)

Use this section to understand the cable routing of ten NVMe front drives for liquid cooling configuration with 10 x 2.5" AnyBay front backplane installed.

To connect cables for a 7mm drive backplane, refer to [“7mm drive backplane” on page 270](#).

To connect power cables for a backplane for standard 2.5-inch or 3.5-inch drives, refer to [“Cable routing for backplane power”](#) on page 274.

The following illustration and table show the cabling between the backplane and processor board for onboard configuration.

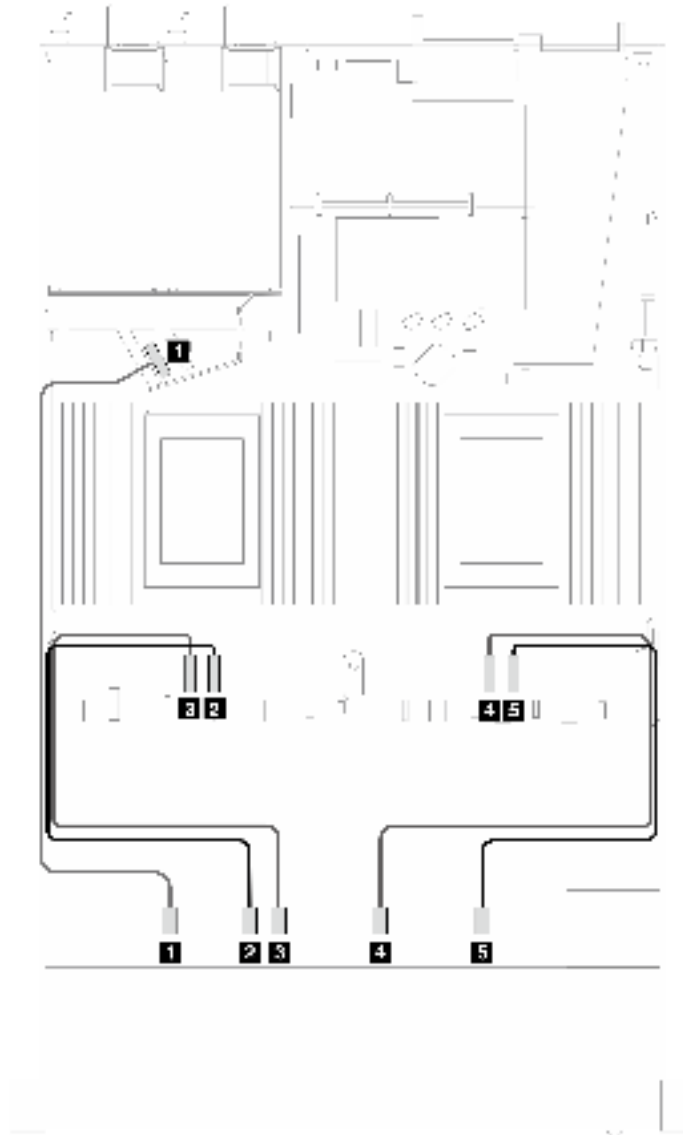


Figure 262. Onboard cabling of 10 NVMe drives for liquid cooling

Table 57. Mapping between one front AnyBay backplane and processor board for onboard configuration

Backplane	From	To
Front BP (NVMe)	1 NVMe 0–1	1 PCIe 5
	2 NVMe 2–3	2 PCIe 3
	3 NVMe 4–5	3 PCIe 4

Table 57. Mapping between one front AnyBay backplane and processor board for onboard configuration (continued)

Backplane	From	To
	4 NVMe 6–7	4 PCIe 2
	5 NVMe 8–9	5 PCIe 1

## Cable routing for backplane signals (one processor)

In this section, you can find cable routing of backplane signals when only one processor installed.

- Each backplane your server supports offers multiple signal connections. This section singles out the signal connection from power connection for better understanding. For backplane power connection, see [“Cable routing for backplane power” on page 274](#).
- For the locations of backplane signal connectors on the processor board and adapters, see [“Processor-board connectors for cable routing” on page 257](#) and [“RAID and HBA adapter connectors” on page 254](#) for details.
- For more information about backplanes supported and their connectors, see [“Drive backplane connectors” on page 250](#).

## 4 x 3.5" front drives (one processor)

Use the section to understand the cable routing for signal cable connections for 4 x 3.5" front drive backplanes when one processor installed.

### 4 x 3.5" SAS/SATA backplane (one processor)

Use this section to understand the SAS/SATA backplane cable routing for server model with four 3.5-inch front drives.

To connect cables for a 7mm drive backplane, refer to [“7mm drive backplane” on page 270](#).

To connect power cables for a backplane for standard 2.5-inch or 3.5-inch drives, refer to [“Cable routing for backplane power” on page 274](#).

To connect cables for M.2 drives, refer to [“M.2 drive backplane” on page 267](#).

To connect signal cables for a SAS/SATA backplane for standard 4 x 3.5-inch front drives, refer to the following cable routing scenarios depending on your server configuration:

- [“Cable routing for onboard configuration” on page 299](#)
- [“Cable routing with an SFF HBA/RAID adapter” on page 301](#)

### Cable routing for onboard configuration

The following table shows the mapping relationship between backplane connectors and processor board connectors for onboard configuration.

The following figure illustrates the cable routing for the onboard configuration of 4 x 3.5-inch front SAS/SATA drive bays. Connections between connectors: **1** ↔ **1**, **2** ↔ **2**, **3** ↔ **3**, ... **n** ↔ **n**.

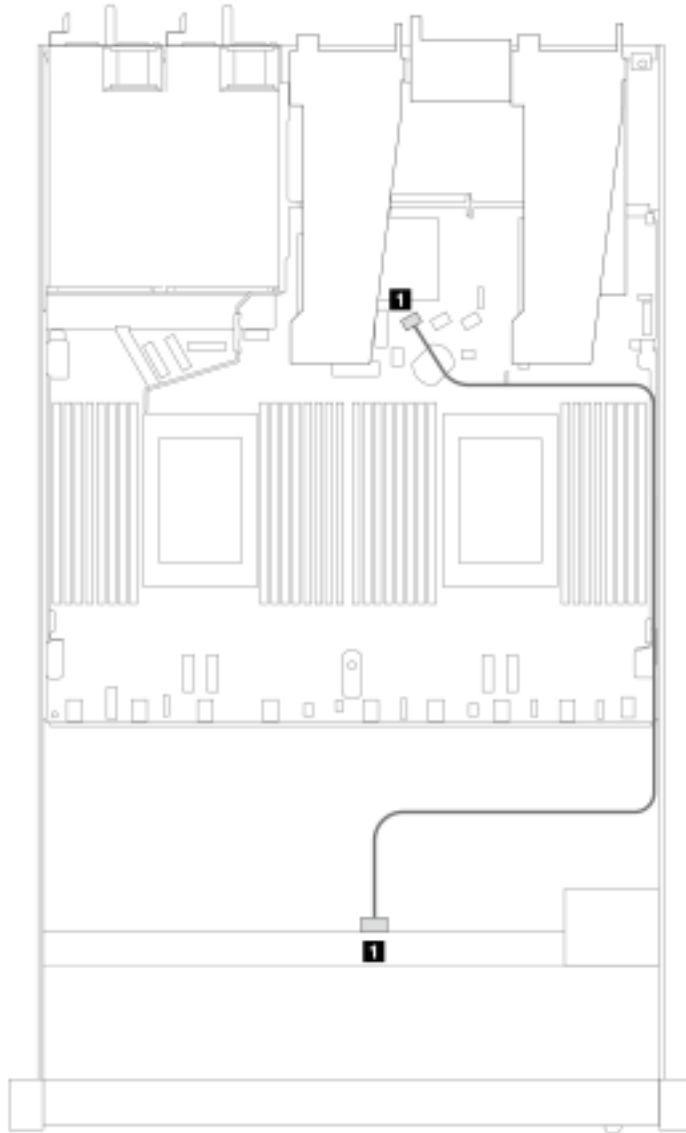


Figure 263. Cable routing for onboard configuration of 4 x 3.5-inch front SAS/SATA drive bays

Table 58. Mapping between one front SAS/SATA backplane and processor board for onboard configuration

Backplane	From	To
<b>1</b> Front BP (SAS)	SAS	SATA 0

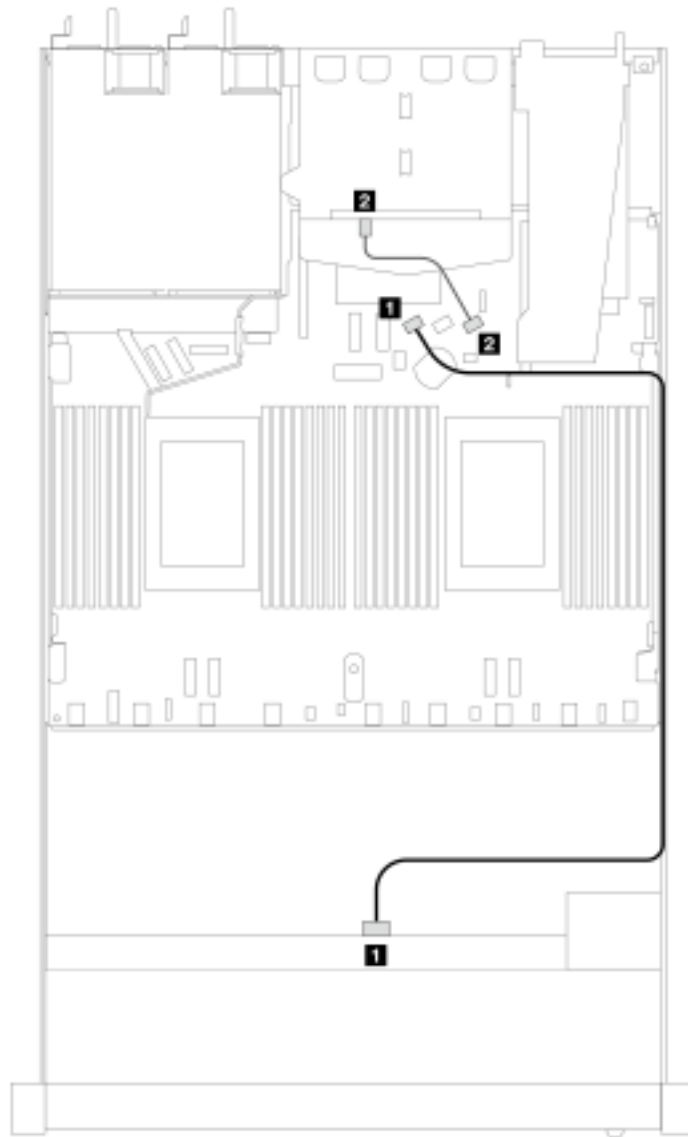


Figure 264. Cable routing for onboard configuration of 4 x 3.5-inch front SAS/SATA drive bays with 2 x 2.5 rear SAS/SATA drives

Table 59. Mapping between one front SAS/SATA backplane with one rear SAS/SATA backplane and processor board for onboard configuration

Backplane	From	To
<b>1</b> Front BP (SAS)	SAS (front)	SATA 0
<b>2</b> Rear BP (SAS)	SAS (rear)	SATA 2

### Cable routing with an SFF HBA/RAID adapter

The following table shows the mapping relationship between backplane connectors and processor board/adapter connectors when an 8i SFF HBA/RAID adapter (Gen 3 or Gen 4) is installed.

The following figure illustrates the cable routing for the configuration of 4 x 3.5-inch front SAS/SATA drive bays with an 8i SFF RAID adapter. Connections between connectors: **1** ↔ **1**, **2** ↔ **2**, **3** ↔ **3**, ... **n** ↔ **n**.

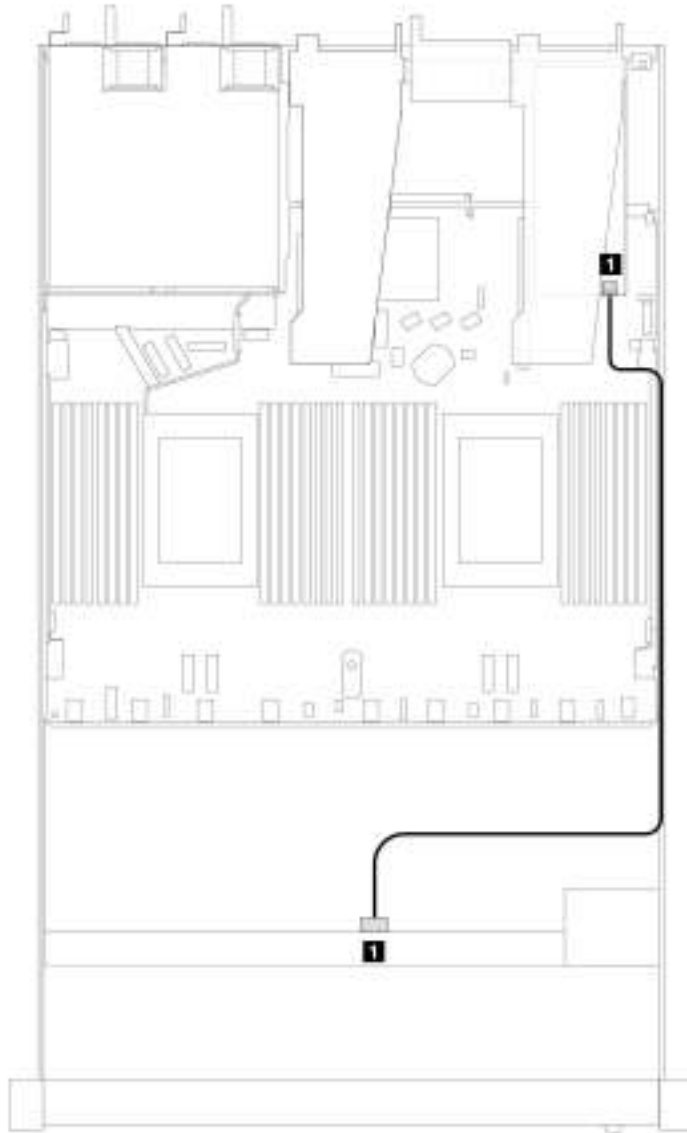


Figure 265. Cable routing for 4 x 3.5-inch front SAS/SATA drive bays with an 8i SFF RAID adapter

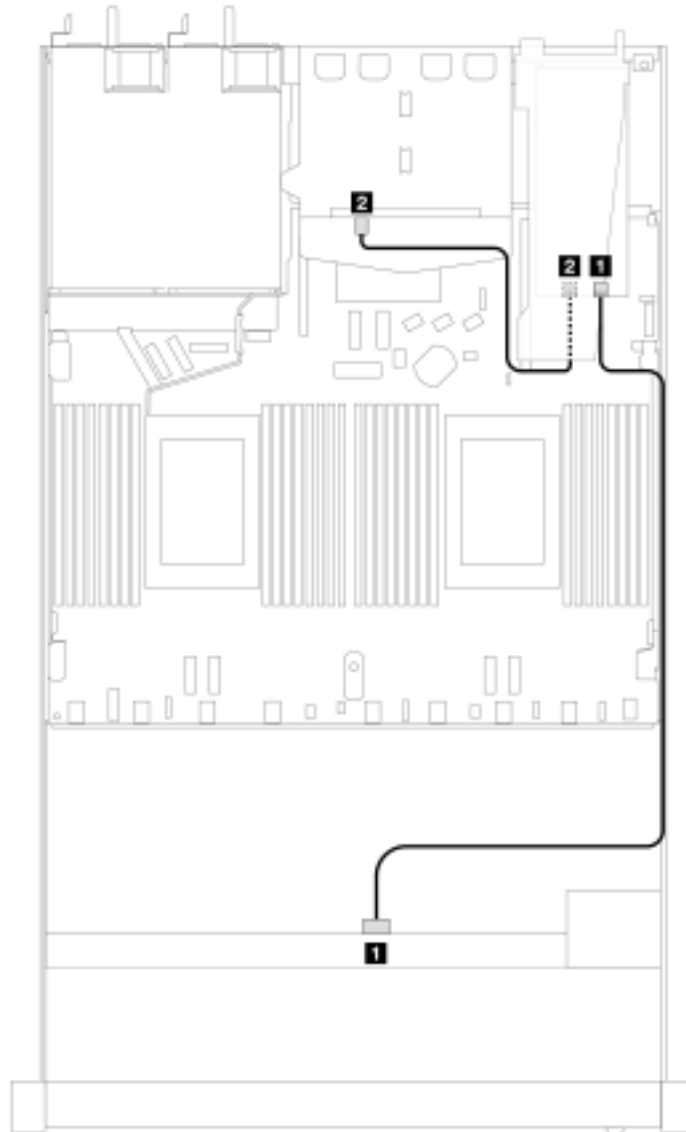
Table 60. Mapping between backplane connectors and processor board/adapter connectors when an SFF HBA/RAID adapter is installed

Backplane	From	To
<b>1</b> Front BP (SAS)	SAS	C0

#### Notes:

- Gen 3 and Gen 4 SFF HBA/RAID adapters are slightly different in their connectors, but the cable routing method is similar.
- To connect cables for RAID flash power module, refer to [“RAID flash power modules” on page 264](#).

The following table shows the mapping relationship between backplane connectors and processor board/ adapter connectors when an 8i SFF HBA/RAID adapter (Gen 3) is installed.



*Figure 266. Cable routing for 4 x 3.5-inch front SAS/SATA drive bays with an 8i SFF RAID adapter (Gen 3) and rear 2 x 2.5-inch SAS/SATA drives*



Table 61. Mapping between backplane connectors and processor board/adaptor connectors when an SFF HBA/RAID adapter is installed

Backplane	From	To
1 Front BP (SAS)	SAS	C0
2 Rear BP (SAS)	SAS (rear)	C1

The following table shows the mapping relationship between backplane connectors and processor board/adaptor connectors when an 8i SFF HBA/RAID adapter (Gen 4) is installed.

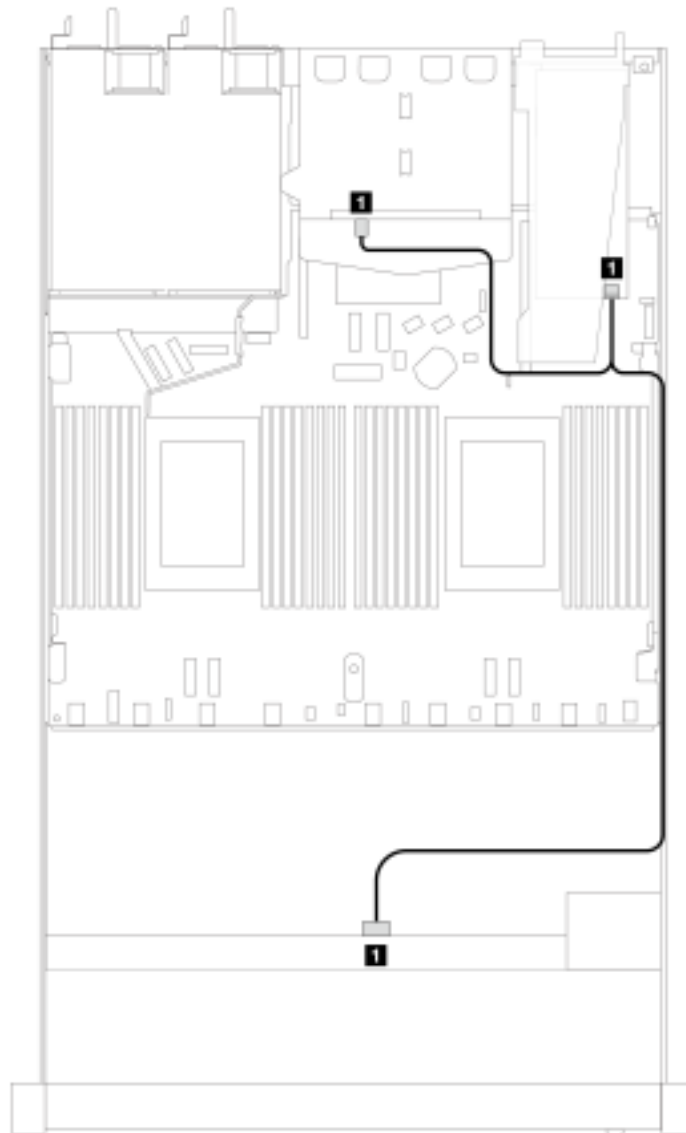


Figure 267. Cable routing for 4 x 3.5-inch front SAS/SATA drive bays with an 8i SFF RAID adapter (Gen 4) and rear 2 x 2.5-inch SAS/SATA drives

Table 62. Mapping between backplane connectors and processor board/adaptor connectors when an SFF HBA/RAID adapter is installed

Backplane	From	To
Front and Rear BP (SAS)	SAS	C0

## 4 x 3.5" AnyBay backplane (one processor)

Use this section to understand the AnyBay backplane cable routing for server model with four 3.5-inch front drives.

To connect cables for a 7mm drive backplane, refer to [“7mm drive backplane” on page 270](#).

To connect power cables for a backplane for standard 2.5-inch or 3.5-inch drives, refer to [“Cable routing for backplane power” on page 274](#).

To connect cables for M.2 drives, refer to [“M.2 drive backplane” on page 267](#).

To connect signal cables for a backplane for standard 4 x 3.5-inch front drives, refer to the following cable routing scenarios depending on your server configuration:

- [“Cable routing for onboard configuration” on page 306](#)
- [“Cable routing with an SFF HBA/RAID adapter” on page 307](#)

### Cable routing for onboard configuration

The following table shows the mapping relationship between backplane connectors and processor board connectors for onboard configuration.

Table 63. Mapping between one front AnyBay backplane and processor board for onboard configuration

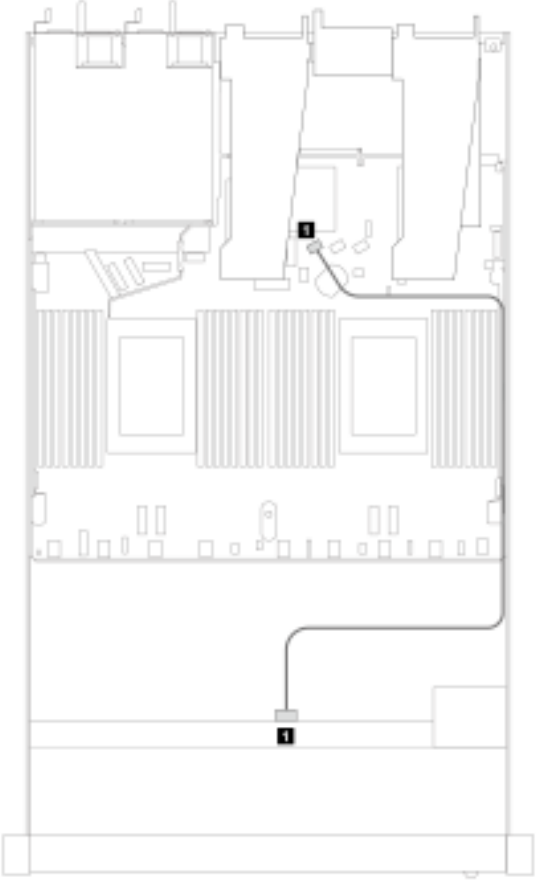
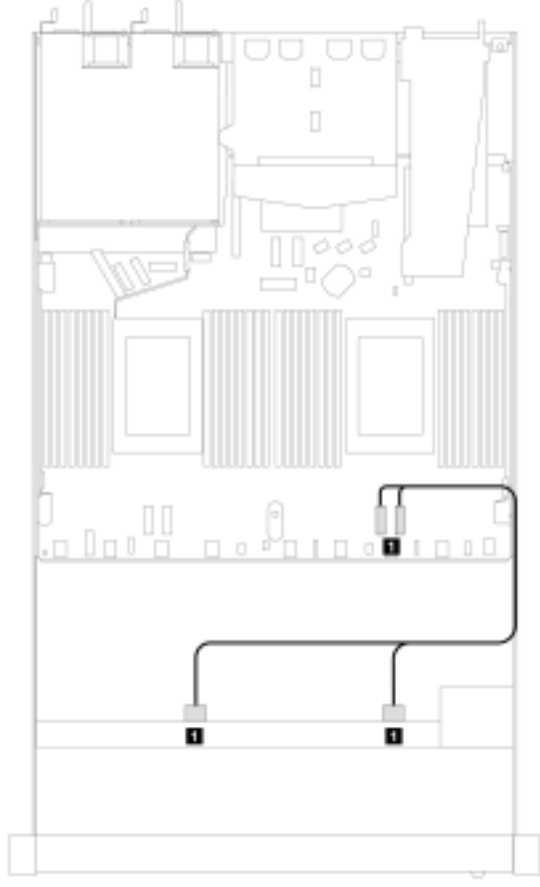
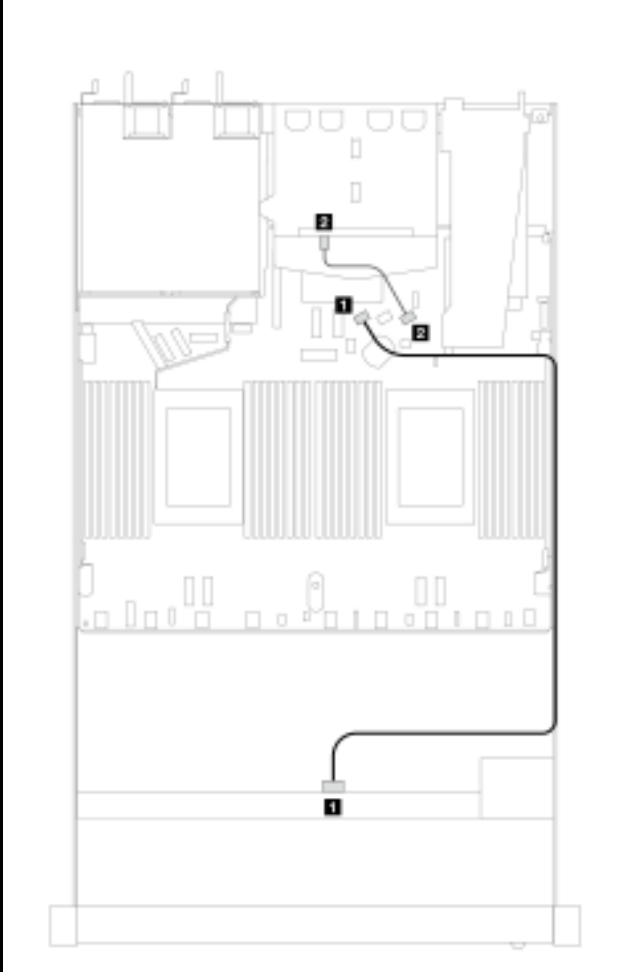
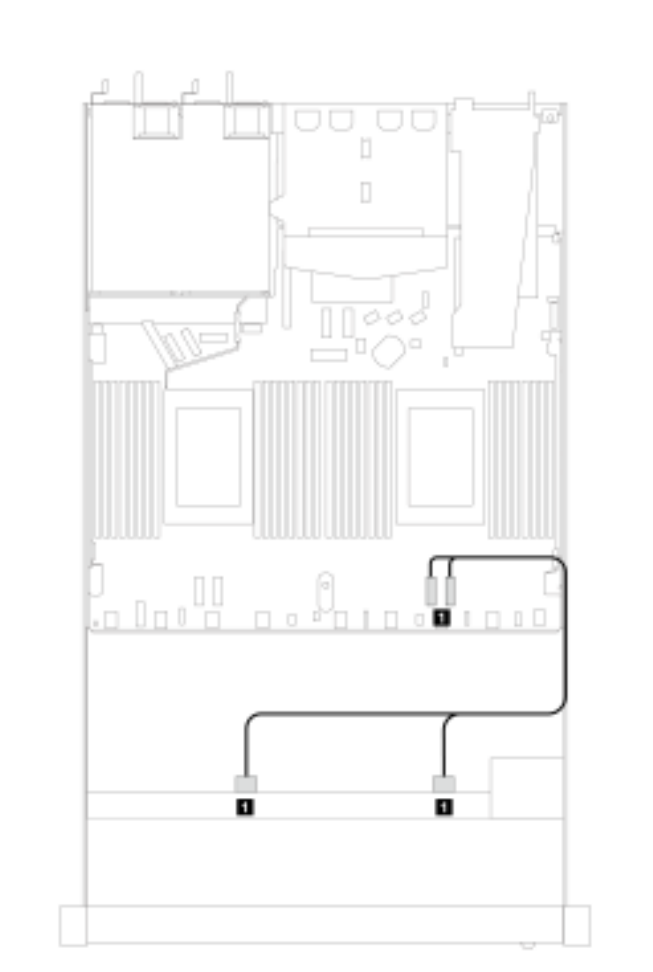
					
SAS/SATA cable routing			NVMe cable routing		
SAS/SATA connector	From	To	NVMe connector	From	To
<b>1</b> SAS	Front BP	SATA 0	<b>1</b> 2-3, 0-1	Front BP	PCIe 1, PCIe 2

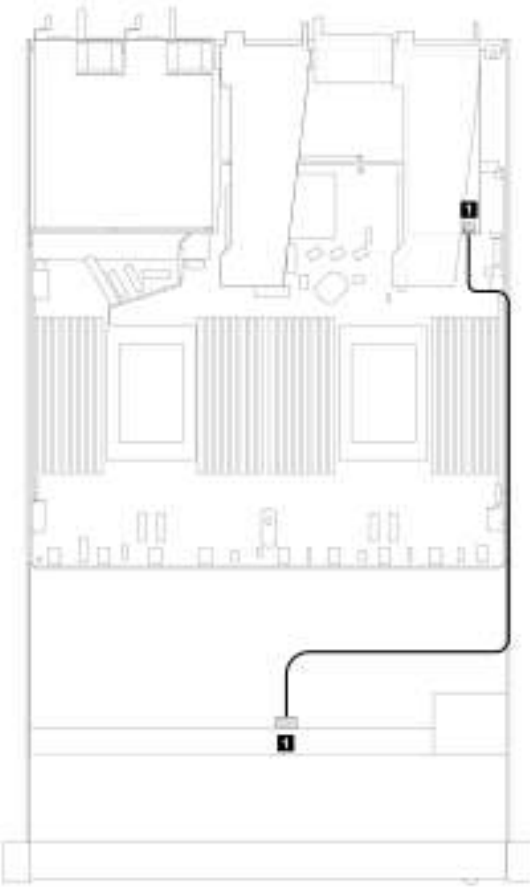
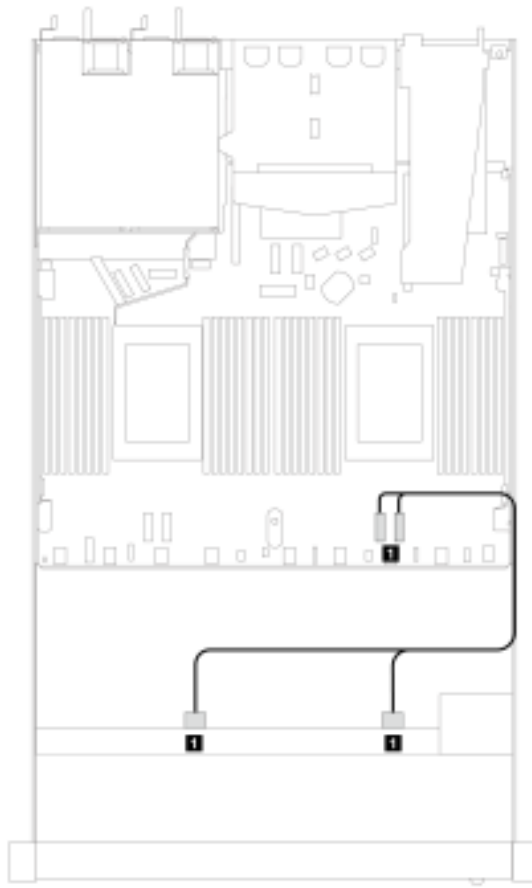
Table 64. Cable routing for onboard configuration of 4 x 3.5-inch front AnyBay drive bays with 2 x 2.5 rear SAS/SATA drives

					
SAS/SATA cable routing			NVMe cable routing		
<b>1</b> SAS	Front BP	SATA 0	NVMe connector	From	To
<b>2</b> SAS	Rear BP	SATA 2	<b>1</b> 2-3, 0-1	Front BP	PCIe 1, PCIe 2

**Cable routing with an SFF HBA/RAID adapter**

The following table shows the mapping relationship between backplane connectors and processor board/ adapter connectors when an 8i SFF HBA/RAID adapter (Gen 3 or Gen 4) is installed.

Table 65. Mapping between backplane connectors and processor board/adaptor connectors when an SFF HBA/RAID adapter is installed

					
SAS/SATA cable routing			NVMe cable routing		
SAS/SATA connector	From	To	NVMe connector	From	To
<b>1</b> SAS	Front BP	C0	<b>1</b> 2-3, 0-1	Front BP	PCIe 1, PCIe 2

**Note:** Gen 3 and Gen 4 SFF HBA/RAID adapters are slightly different in their connectors, but the cable routing method is similar.

Table 66. Mapping between backplane connectors and processor board/adaptor connectors when an 8i SFF RAID adapter (Gen 3) and rear 2 x 2.5-inch SAS/SATA drives are installed

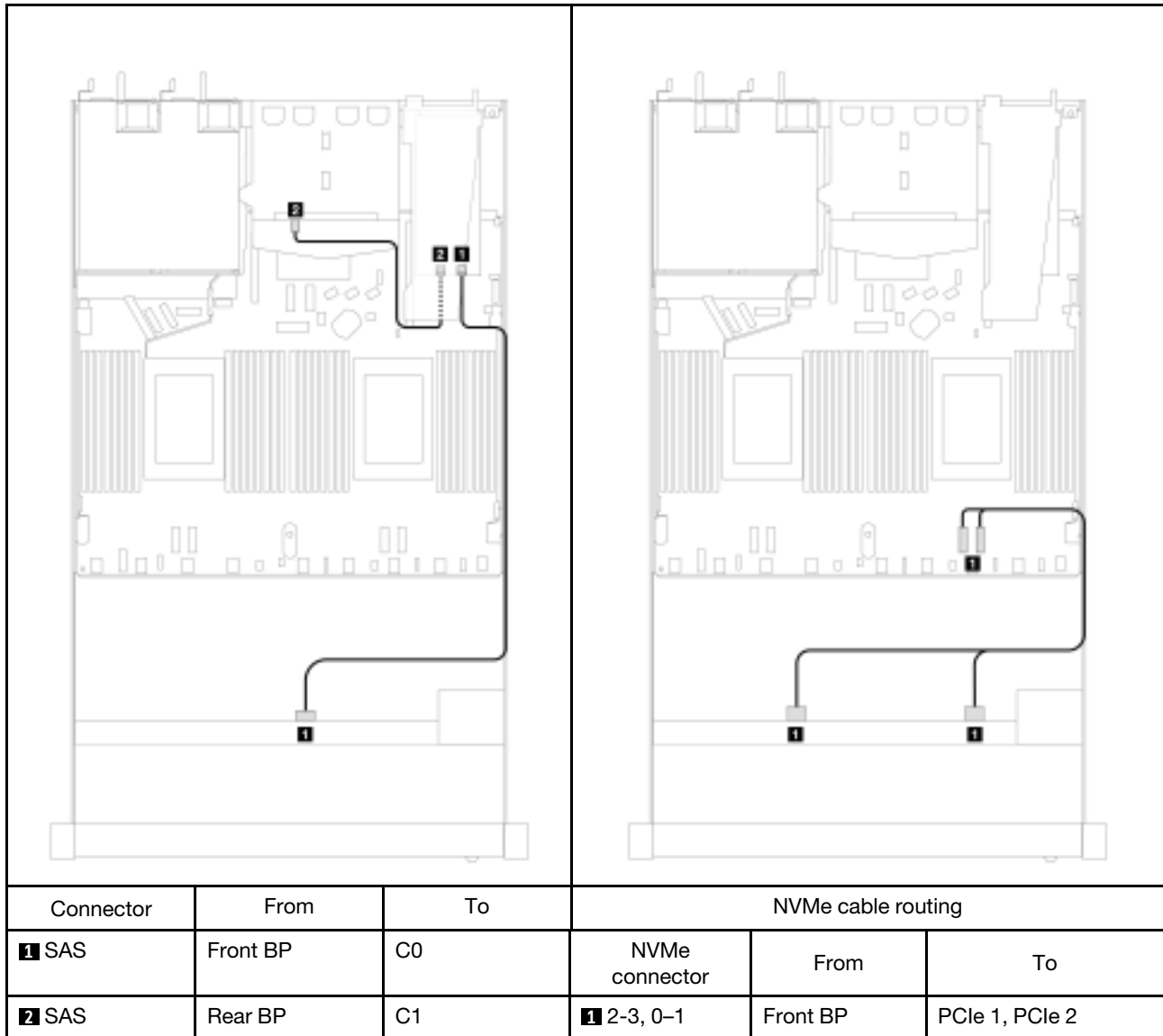
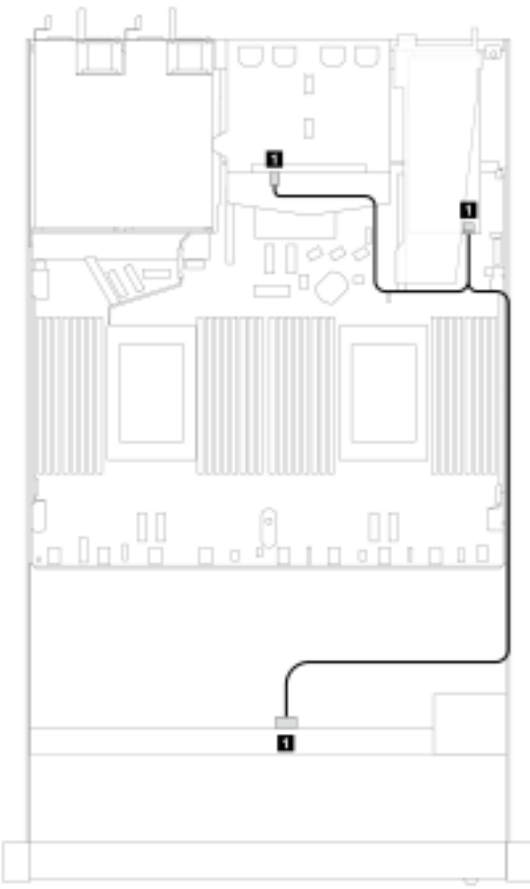
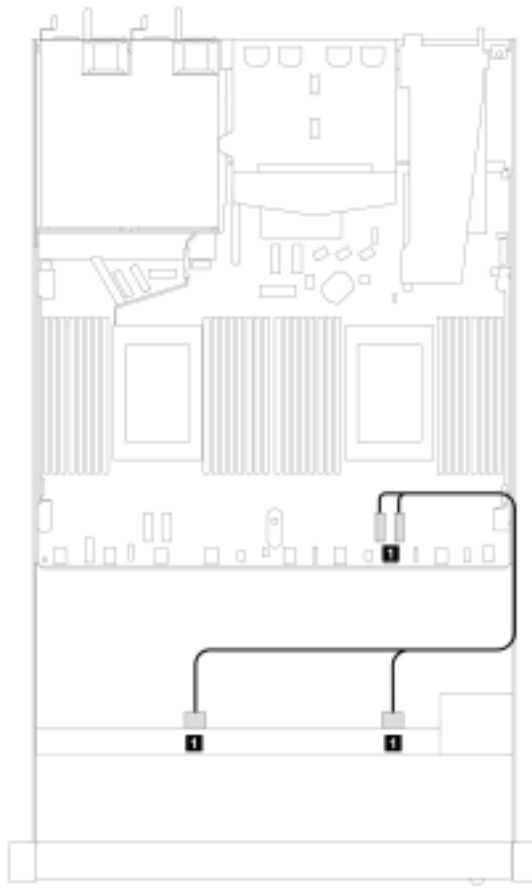


Table 67. Mapping between backplane connectors and processor board/adaptor connectors when an 8i SFF RAID adapter (Gen 4) and rear 2 x 2.5-inch SAS/SATA drives are installed

					
SAS/SATA cable routing			NVMe cable routing		
SAS/SATA connector	From	To	NVMe connector	From	To
<b>1</b> SAS	Front and rear BP	C0	<b>1</b> 2-3, 0-1	Front BP	PCIe 1, PCIe 2



## 4 x 2.5" front drives (one processor)

Use the section to understand the cable routing for signal cable connections for 4 x 2.5" front drive backplanes when one processor installed.

### 4 x 2.5" SAS/SATA backplane (one processor)

Use this section to understand the SAS/SATA backplane cable routing for server model with four 2.5-inch front drives.

To connect cables for a 7mm drive backplane, refer to [“7mm drive backplane” on page 270](#).

To connect power cables for a backplane for standard 2.5-inch or 3.5-inch drives, refer to [“Cable routing for backplane power” on page 274](#).

To connect signal cables for a backplane for standard 4 x 2.5-inch front drives, refer to the following cable routing scenarios depending on your server configuration:

- [“Cable routing for onboard configuration” on page 312](#)
- [“Cable routing with an SFF HBA/RAID adapter” on page 313](#)
- [“Cable routing for 4 x 2.5-inch front SAS/SATA drive bays with an 8i CFF RAID adapter \(Gen 3\) installed” on page 314](#)

### Cable routing for onboard configuration

The following table shows the mapping relationship between backplane connectors and processor board connectors for onboard configuration.

The following figure illustrates the cable routing for the onboard configuration of 4 x 2.5-inch front AnyBay drive bays. Connections between connectors: **1** ↔ **1**, **2** ↔ **2**, **3** ↔ **3**, ... **n** ↔ **n**

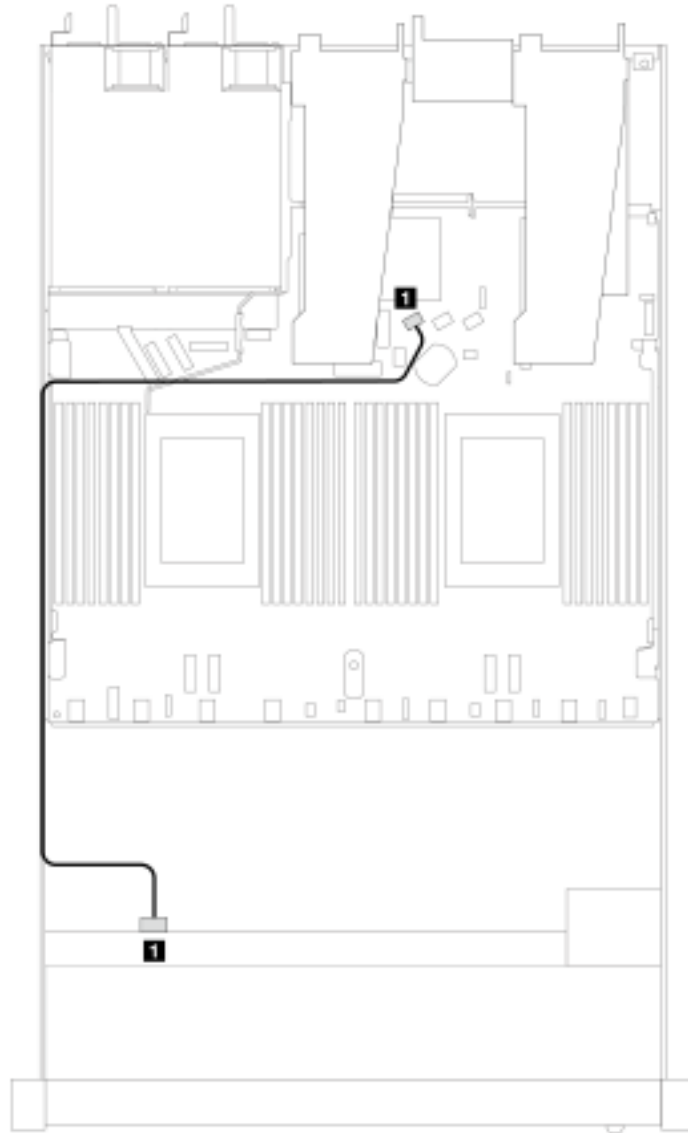


Figure 268. Cable routing for onboard configuration of 4 x 2.5-inch front AnyBay drive bays

Table 68. Mapping between backplane connectors and processor board connectors for onboard configuration

Backplanes	From	To
Front BP (SAS)	SAS	SATA 0

### Cable routing with an SFF HBA/RAID adapter

The following table shows the mapping relationship between backplane connectors and processor board/adapter connectors when an 8i SFF HBA/RAID adapter (Gen 3 or Gen 4) is installed.

The following figure illustrates the cable routing for the configuration of 4 x 2.5-inch front AnyBay drive bays with an 8i SFF RAID adapter. Connections between connectors: **1** ↔ **1**, **2** ↔ **2**, **3** ↔ **3**, ... **n** ↔ **n**

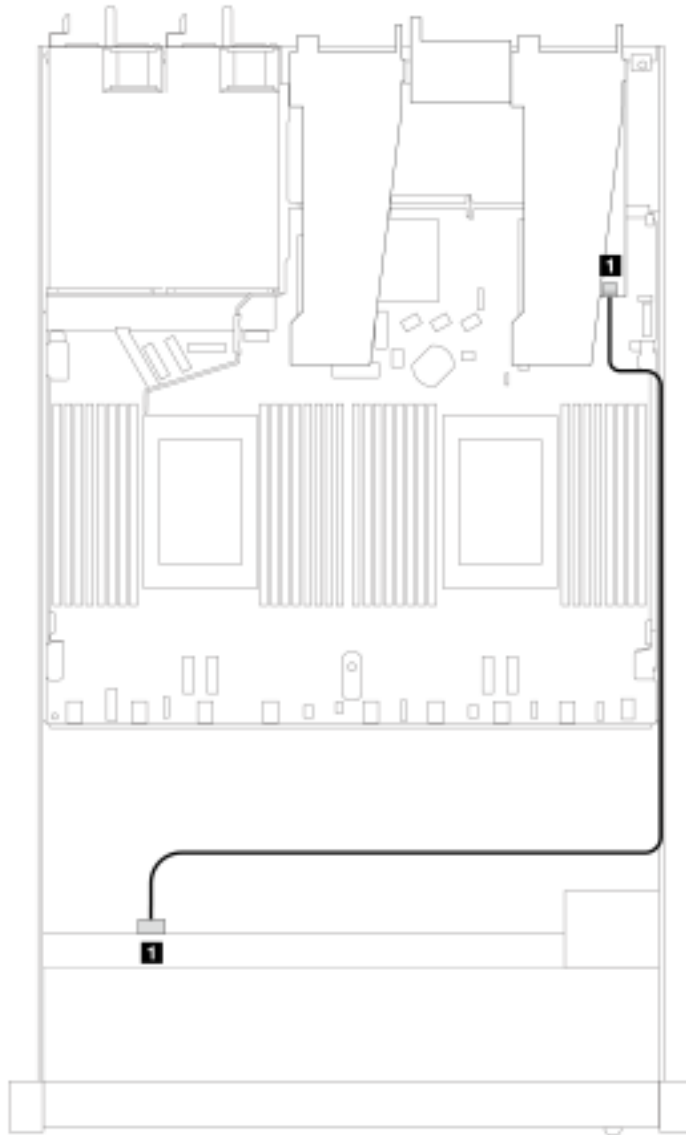


Figure 269. Cable routing for 4 x 2.5-inch front AnyBay drive bays with an 8i SFF RAID adapter

Table 69. Mapping between backplane connectors and processor board/adapter connectors when an SFF HBA/RAID adapter is installed

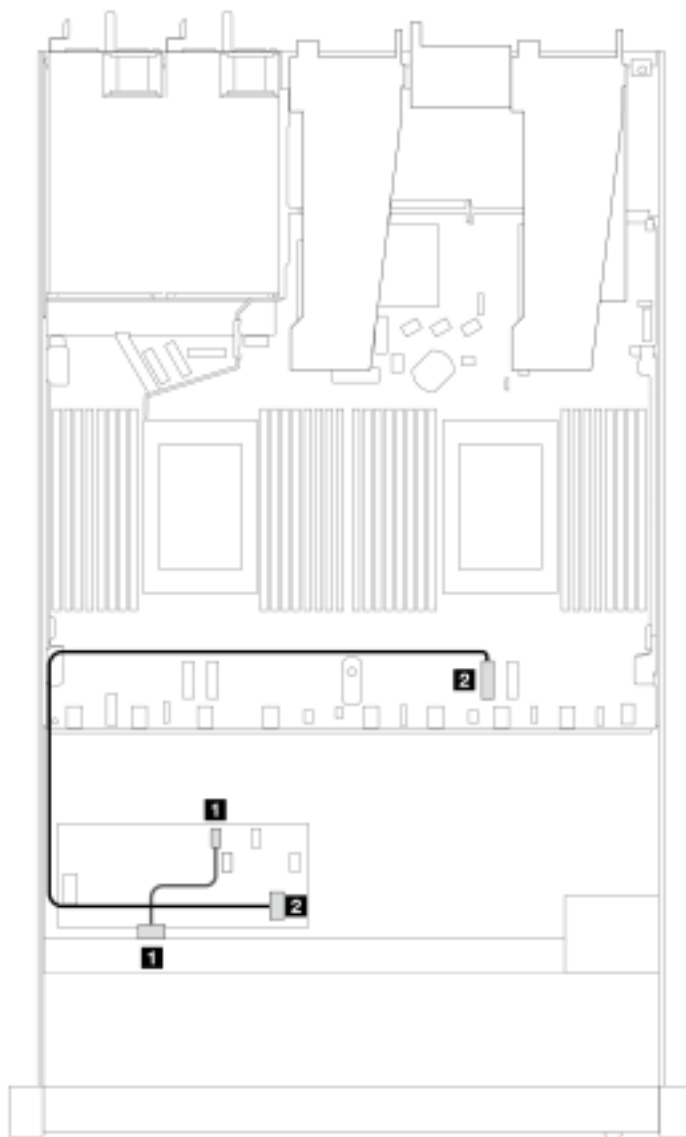
Backplanes	From	To
Front BP (SAS)	SAS	C0

**Notes:**

- Gen 3 and Gen 4 SFF HBA/RAID adapters are slightly different in their connectors, but the cable routing method is similar.
- To connect cables for RAID flash power module, refer to [“RAID flash power modules” on page 264](#).

**Cable routing for 4 x 2.5-inch front SAS/SATA drive bays with an 8i CFF RAID adapter (Gen 3) installed**

The following table shows the mapping relationship between backplane connectors and processor board/ adapter connectors when an 8i CFF RAID adapter (Gen 3) is installed.



*Figure 270. Cable routing for 4 x 2.5-inch front SAS/SATA drive bays with an 8i CFF RAID adapter installed*

Table 70. Mapping between backplane connectors and processor board/adaptor connectors when a CFF RAID adapter is installed

Backplanes	From	To
Front BP (SAS)	SAS	C0
CFF RAID adapter	MB input	PCIe 2

#### 4 x 2.5" NVMe backplane (one processor)

Use this section to understand the NVMe backplane cable routing for server model with four 2.5-inch front drives.

To connect cables for a 7mm drive backplane, refer to [“7mm drive backplane” on page 270](#).

To connect power cables for a backplane for standard 2.5-inch or 3.5-inch drives, refer to [“Cable routing for backplane power” on page 274](#).

### Cable routing for onboard configuration with one processor

The following table shows the mapping relationship between backplane connectors and processor board connectors for onboard configuration.

The following figure illustrates the cable routing for the onboard configuration of 4 x 2.5-inch front NVMe drive bays. Connections between connectors: **1** ↔ **1**, **2** ↔ **2**, **3** ↔ **3**, ... **n** ↔ **n**

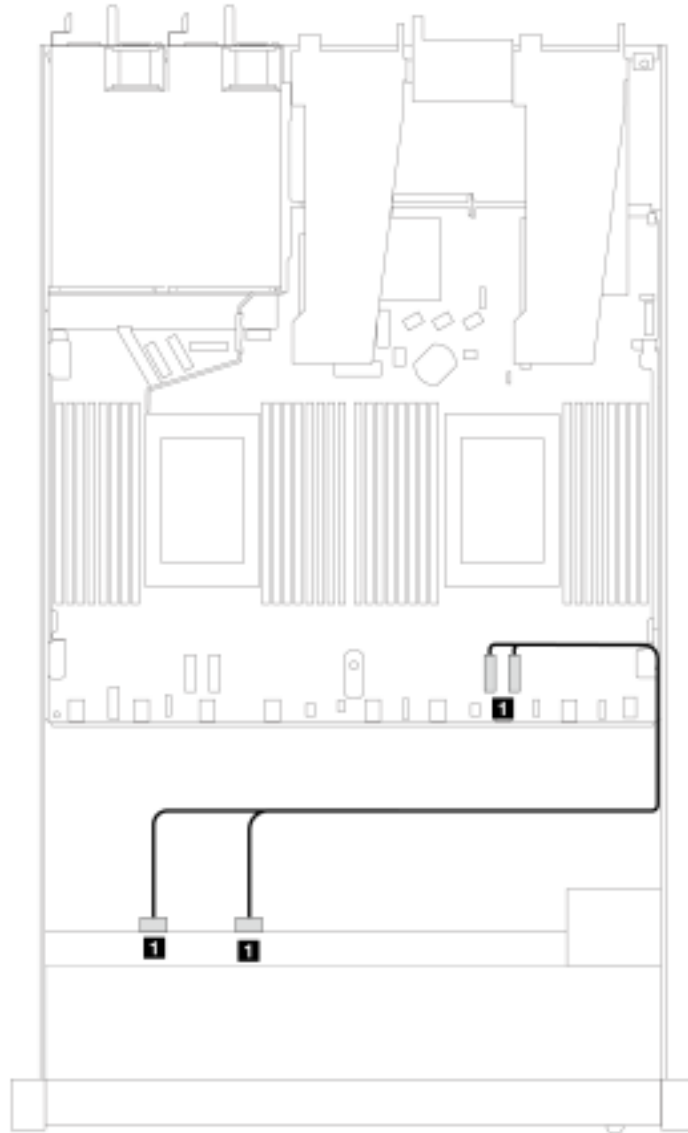


Figure 271. Cable routing for onboard configuration of 4 x 2.5-inch front NVMe drive bays with one processor

Table 71. Mapping between backplane connectors and processor board connectors for onboard configuration

Backplanes	From	To
Front BP (NVMe)	NVMe 2-3, NVMe 0-1	PCIe 1, PCIe 2

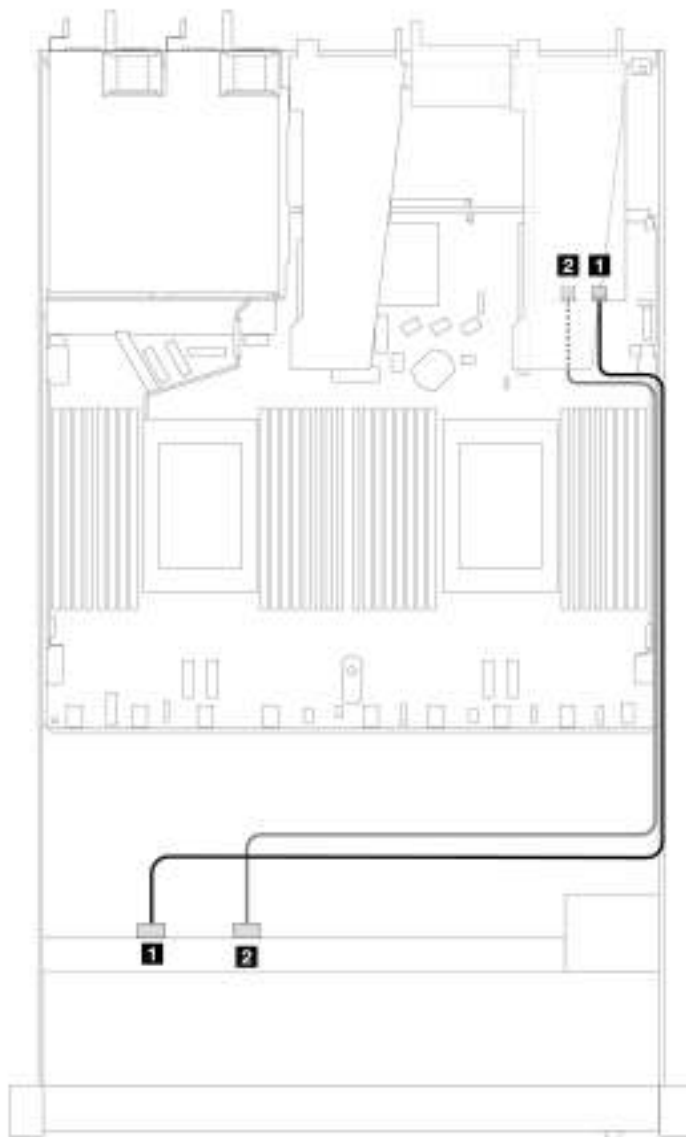


Figure 272. Cable routing of 4 x 2.5-inch front NVMe drive bays and a re-timer adapter (Gen 4) with one processor

Table 72. Mapping between a front backplane and a re-timer adapter connectors

Backplanes	From	To
Front BP (NVMe)	NVMe 0–1, NVMe 2–3	C0, C1

#### 4 x 2.5" U.3 front drives with 4 x 3.5" AnyBay backplane (one processor)

##### Cable routing with an SFF HBA/RAID adapter

The following illustrations and tables show the mapping relationship between backplane connectors and an 8i SFF RAID adapter (Gen 4).

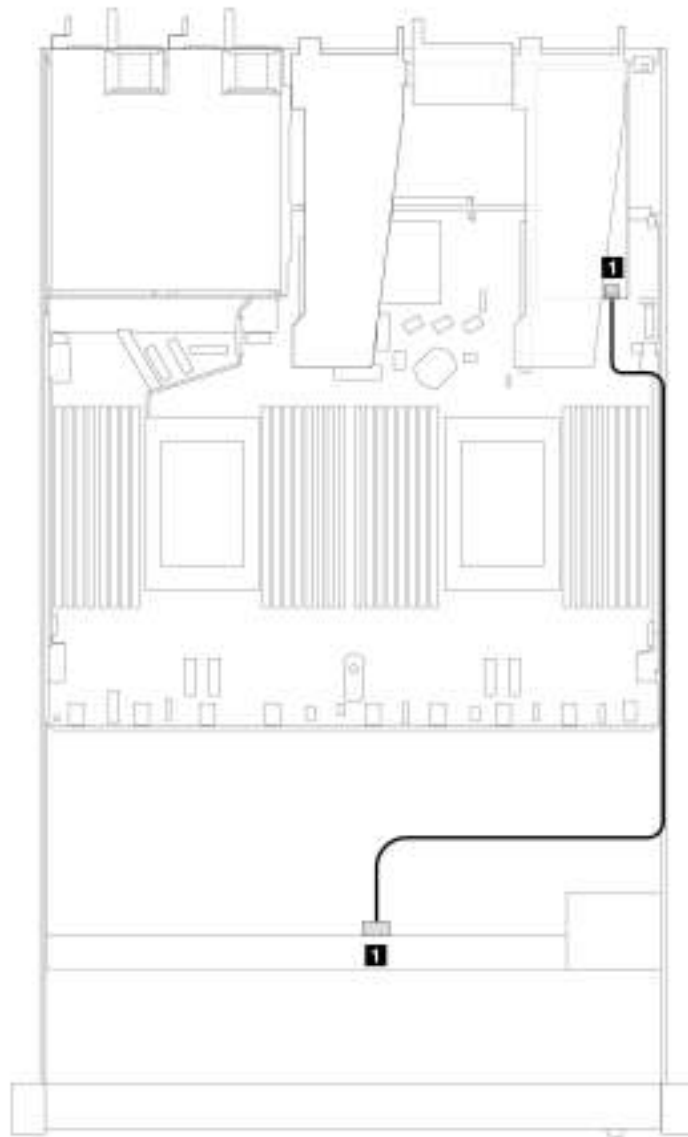


Figure 273. Cable routing for 4 x 2.5-inch front U.3 drives with an 8i SFF RAID adapter (Gen 4)

Table 73. Mapping between one front AnyBay backplane and an SFF HBA/RAID adapter

Backplane	From	To
Front BP (SAS)	SAS	C0

### 8 x 2.5" front drives (one processor)

Use the section to understand the cable routing for signal cable connections for 8 x 2.5" front drive backplanes when one processor installed.

### 8 x 2.5" SAS/SATA backplane (one processor)

Use this section to understand the SAS/SATA backplane cable routing for server model with eight 2.5-inch front drives.



To connect cables for a 7mm drive backplane, refer to [“7mm drive backplane” on page 270](#).

To connect power cables for a backplane for standard 2.5-inch or 3.5-inch drives, refer to [“Cable routing for backplane power” on page 274](#).

To connect cables for M.2 drives, refer to [“M.2 drive backplane” on page 267](#).

To connect signal cables for a backplane for standard 4 x 3.5-inch front drives, refer to the following cable routing scenarios depending on your server configuration:

- [“Cable routing for onboard configuration” on page 319](#)
- [“Cable routing with an SFF HBA/RAID adapter” on page 321](#)
- [“Cable routing with a CFF RAID adapter” on page 325](#)

### **Cable routing for onboard configuration**

The following illustrations and tables show the mapping relationship between backplane connectors and processor board connectors for onboard configuration.

The following figure illustrates the cable routing for the onboard configuration of 8 x 2.5-inch front SAS/SATA drive bays. Connections between connectors: **1** ↔ **1**, **2** ↔ **2**, **3** ↔ **3**, ... **n** ↔ **n**.

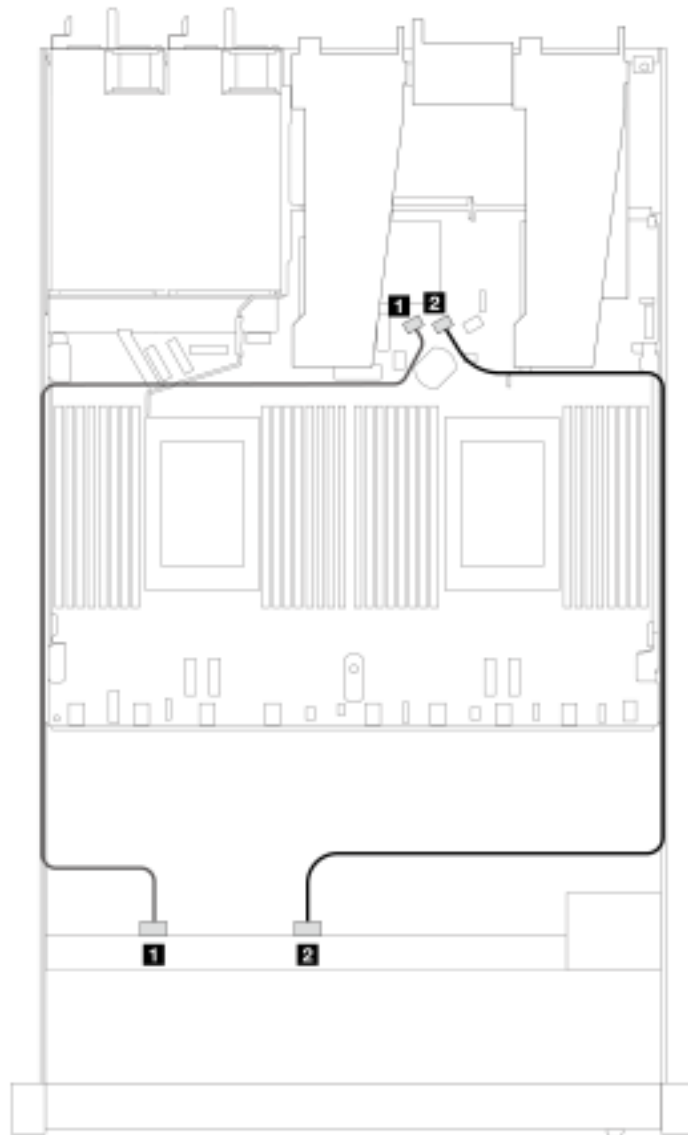


Figure 274. Cable routing for onboard configuration of 8 x 2.5 SAS/SATA front drives

Table 74. Mapping between one front SAS/SATA backplane and processor board for onboard configuration

Backplane	From	To
Front BP (SAS)	1 SAS 0	1 SATA 0
	2 SAS 1	2 SATA 1

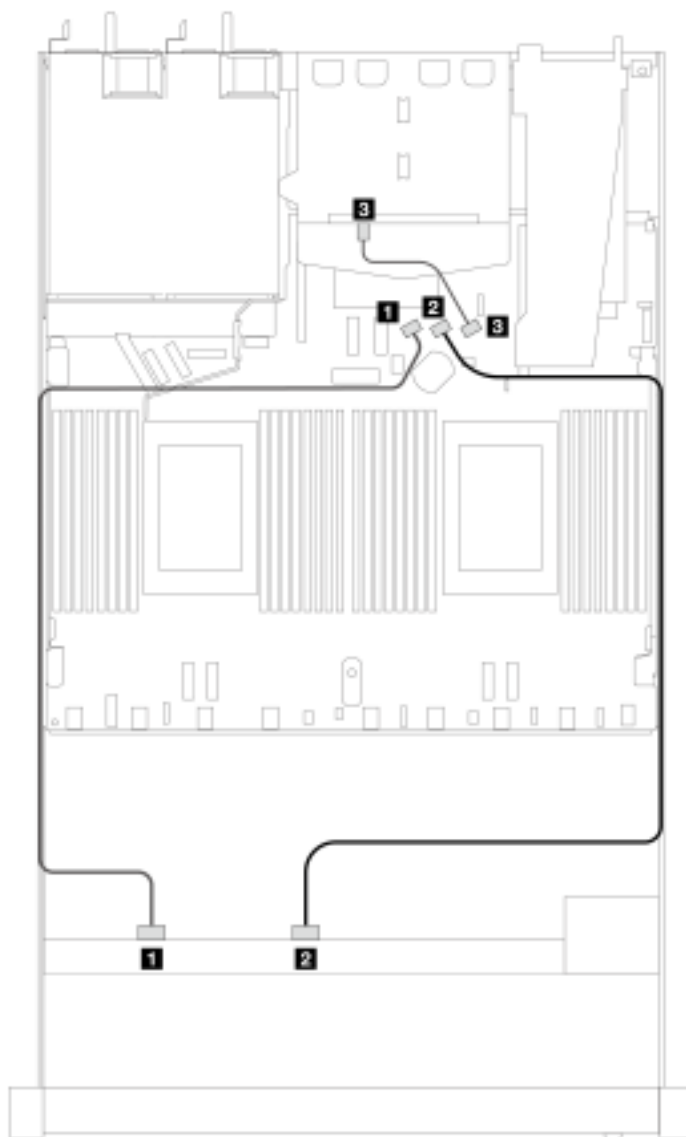


Figure 275. Cable routing for onboard configuration of 8 x 2.5 SAS/SATA front drives with 2 x 2.5 rear SAS/SATA drives installed

Table 75. Mapping between one front and one rear SAS/SATA backplanes and processor board for onboard configuration

Backplane	From	To
Front BP (SAS)	1 SAS 0	1 SATA 0
	2 SAS 1	2 SATA 1
Rear BP (SAS)	3 SAS	3 SATA 2

### Cable routing with an SFF HBA/RAID adapter

The following illustrations and tables show the mapping relationship between backplane connectors and an 8i or 16i SFF HBA/RAID adapter (Gen 3 or Gen 4).

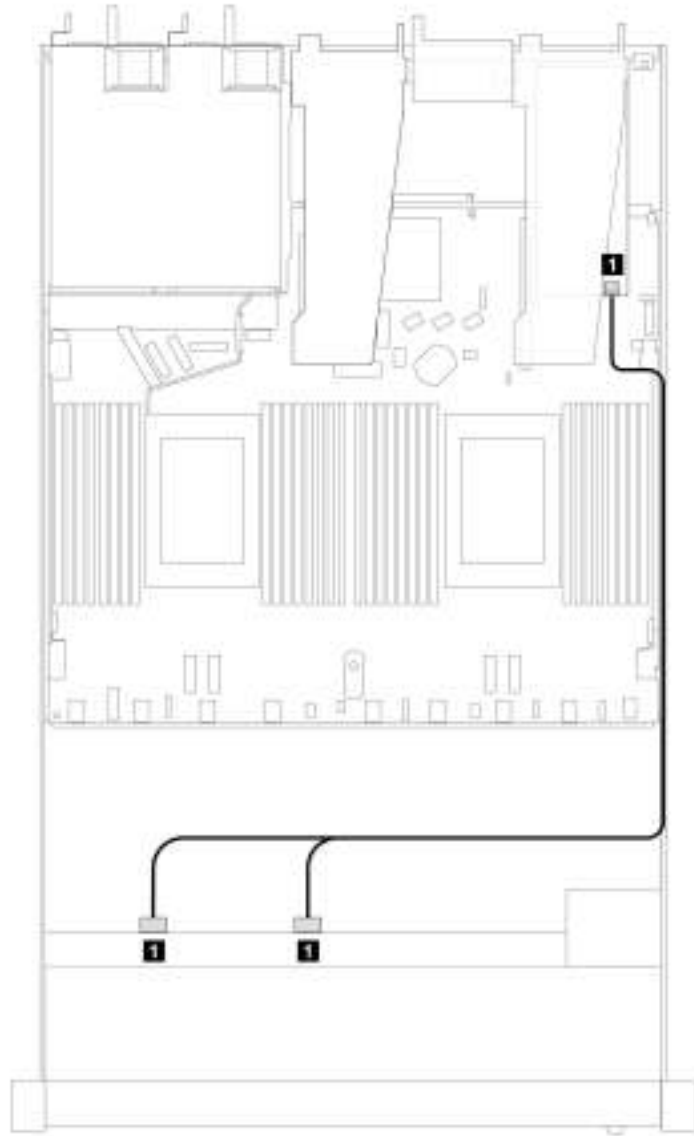


Figure 276. Cable routing for 8 x 2.5-inch front SAS/SATA drive bays with an 8i or 16i SFF RAID adapter (Gen 4)

Table 76. Mapping between one front SAS/SATA backplane and an SFF HBA/RAID adapter

Backplane	From	To
Front BP (SAS)	1 SAS 0, SAS 1	1 C0

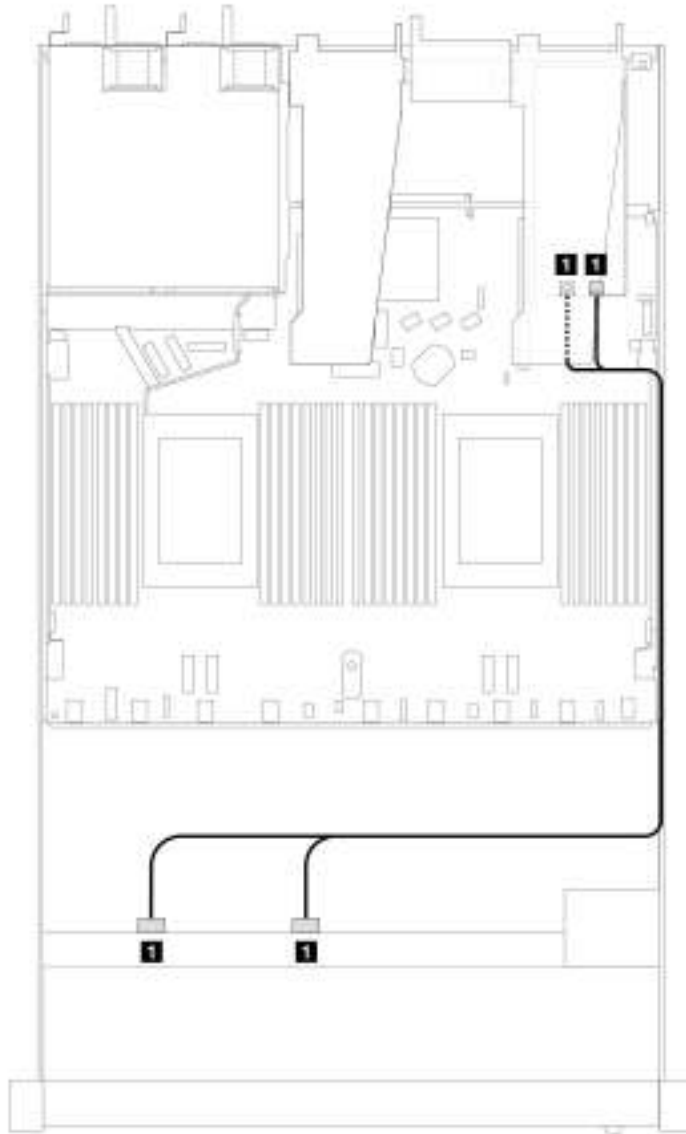


Figure 277. Cable routing for 8 x 2.5-inch front SAS/SATA drive bays with an 8i or 16i SFF RAID adapter (Gen 3)

Table 77. Mapping between one front SAS/SATA backplane and an SFF HBA/RAID adapter

Backplane	From	To
Front BP (SAS)	1 SAS 0, SAS 1	1 C0, C1

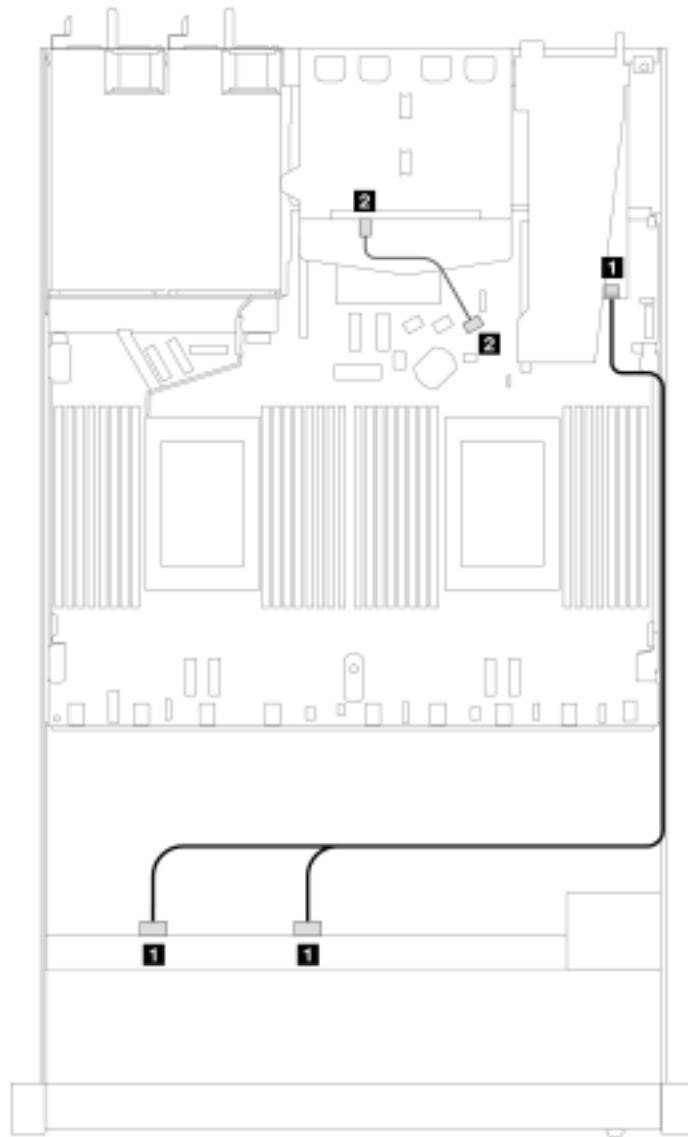


Figure 278. Cable routing for 8 x 2.5-inch front SAS/SATA drive bays with an 8i SFF RAID adapter (Gen 4) with 2 x 2.5 SAS/SATA rear drives installed

Table 78. Mapping between one front and one rear SAS/SATA backplanes and an SFF HBA/RAID adapter

Backplane	From	To
Front BP (SAS)	<b>1</b> SAS 0, SAS 1	<b>1</b> C0
Rear BP (SAS)	<b>2</b> SAS	<b>2</b> SATA 2

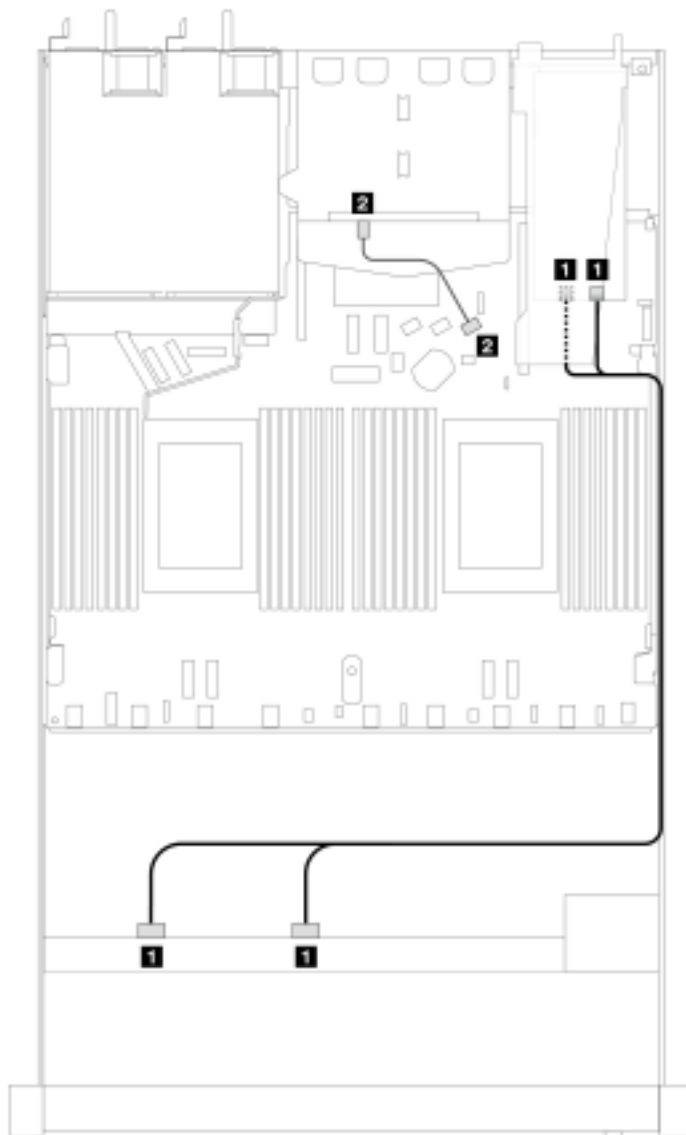


Figure 279. Cable routing for 8 x 2.5-inch front SAS/SATA drive bays with an 8i SFF RAID adapter (Gen 3) with 2 x 2.5 SAS/SATA rear drives installed

Table 79. Mapping between one front SAS/SATA backplane and an SFF HBA/RAID adapter

Backplane	From	To
Front BP (SAS)	1 SAS 0, SAS 1	1 C0, C1
Rear BP (SAS)	2 SAS	2 SATA 2

### Cable routing with a CFF RAID adapter

The following illustration and table show the mapping relationship between backplane connectors and an 8i or 16i CFF RAID adapter (Gen 3).

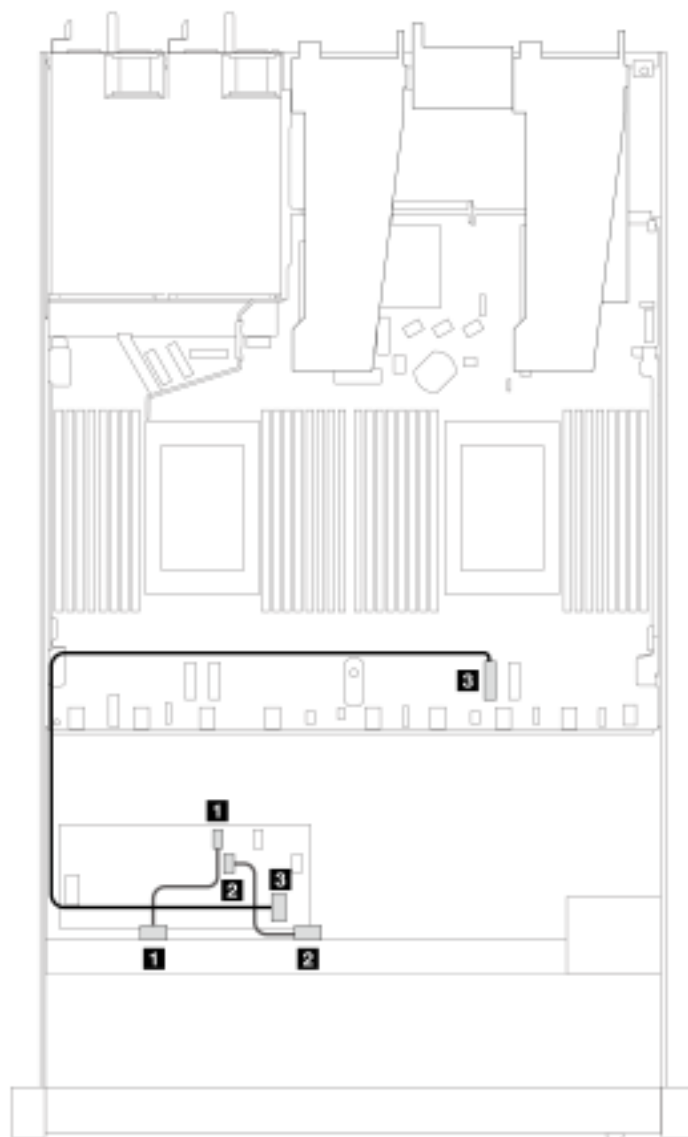


Figure 280. Cable routing for 8 x 2.5-inch front SAS/SATA drive bays with an 8i or 16i CFF RAID adapter (Gen 3)

Table 80. Mapping between one front SAS/SATA backplane and a CFF RAID adapter

Backplane/adaptor	From	To
Front BP (SAS)	<b>1</b> SAS 0	<b>1</b> C0
	<b>2</b> SAS 1	<b>2</b> C1
CFF RAID adaptor	<b>3</b> MB input	<b>3</b> PCIe 2

The following illustration and table show the mapping relationship between backplane connectors and an 8i CFF RAID adapter (Gen 3).



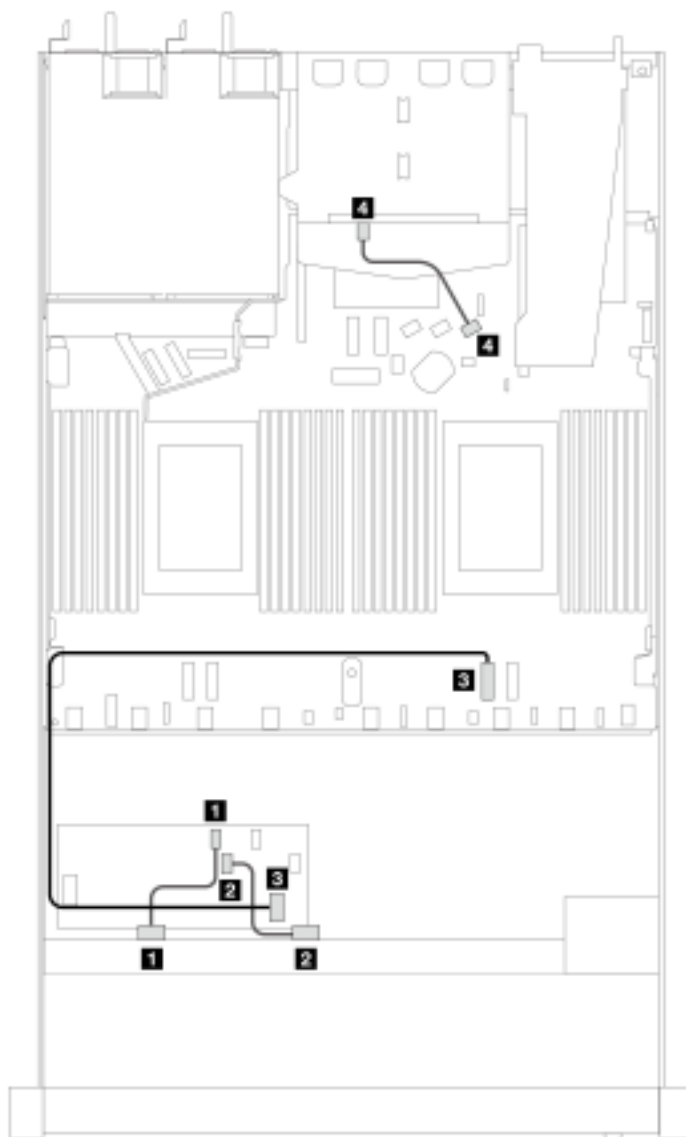


Figure 281. Cable routing for 8 x 2.5-inch front SAS/SATA drive bays with an 8i CFF RAID adapter (Gen 3) with 2 x 2.5 SAS/SATA drives installed

Table 81. Mapping between one front and one rear SAS/SATA backplane and a CFF RAID adapter

Backplane/adaptor	From	To
Front BP (SAS)	1 SAS 0	1 C0
	2 SAS 1	2 C1
CFF RAID adapter	3 MB input	3 PCIe 2
Rear BP (SAS)	4 SAS (rear)	4 SATA 2

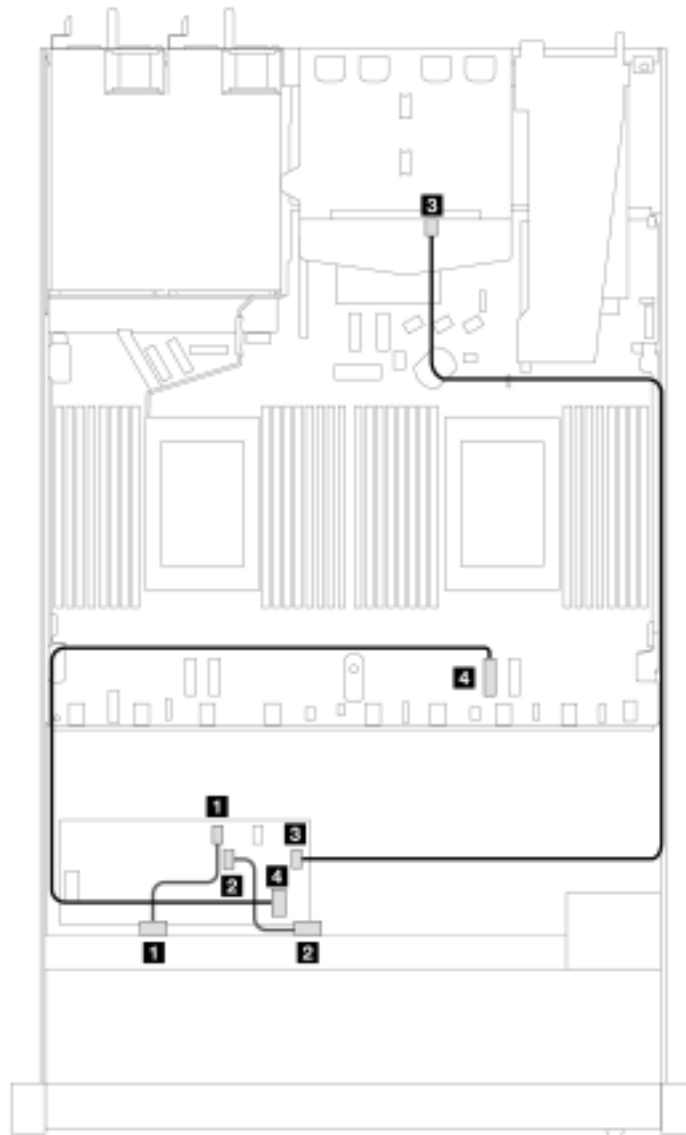


Figure 282. Cable routing for 8 x 2.5-inch front SAS/SATA drive bays with a 16i CFF RAID adapter (Gen 3 or Gen 4) with 2 x 2.5 SAS/SATA drives installed

Table 82. Mapping between one front and one rear SAS/SATA backplane and a CFF RAID adapter

Backplane/adapter	From	To
Front BP (SAS)	1 SAS 0	1 C0
	2 SAS 1	2 C1
CFF RAID adapter	3 C3	3 SAS (rear)
	4 MB input	4 PCIe 2

### 8 x 2.5" U.3 drives with 10 x 2.5" AnyBay backplane (one processor)

Use this section to understand the cable routing for eight U.3 drives with 10 x 2.5 Anybay backplane and one processor installed.

### Cable routing with an SFF HBA/RAID adapter

The following illustrations and tables show the mapping relationship between backplane connectors and an 8i SFF RAID adapter (Gen 4).

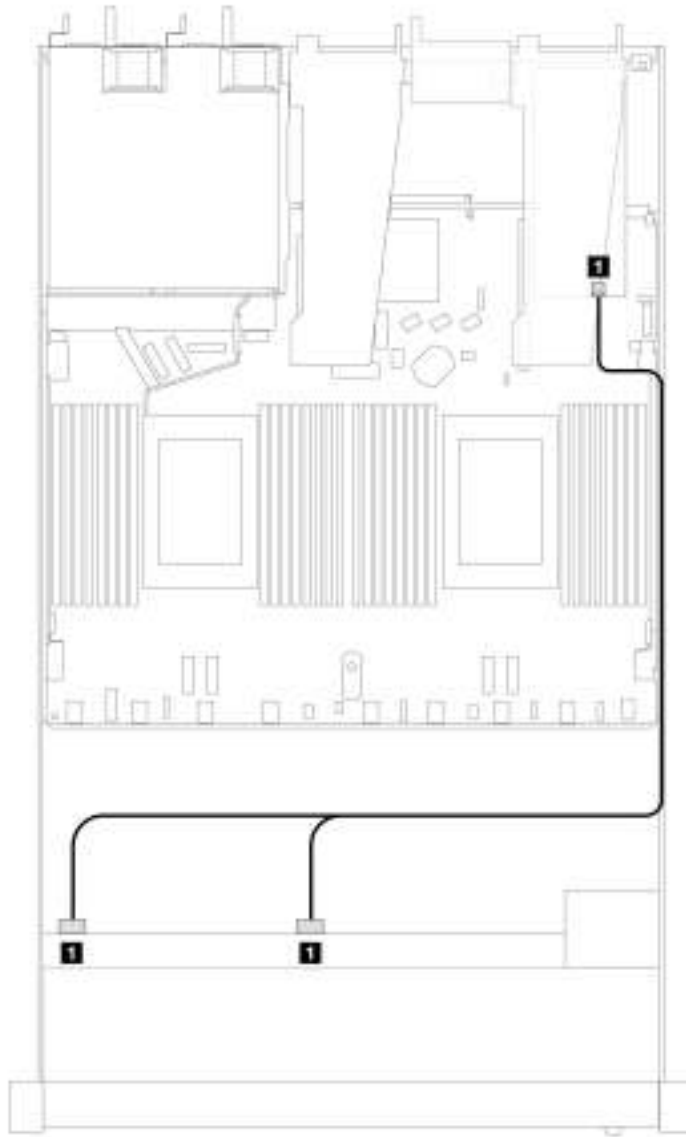


Figure 283. Cable routing for 8 x 2.5-inch front U.3 drives with an 8i SFF RAID adapter (Gen 4)

Table 83. Mapping between one front AnyBay backplane and an SFF HBA/RAID adapter

Backplane	From	To
Front BP (SAS)	SAS 0, SAS 1	C0

### 8 x 2.5" AnyBay drives with 10 x 2.5" AnyBay backplane (one processor)

Use this section to understand the cable routing for eight AnyBay drives with 10 x 2.5 Anybay backplane and one processor installed.

To connect cables for a 7mm drive backplane, refer to [“7mm drive backplane” on page 270](#).

To connect power cables for a backplane for standard 2.5-inch or 3.5-inch drives, refer to [“Cable routing for backplane power” on page 274](#).

The following illustration and table show the cabling among the front backplane, the processor board and a Gen 4 SFF re-timer adapter.

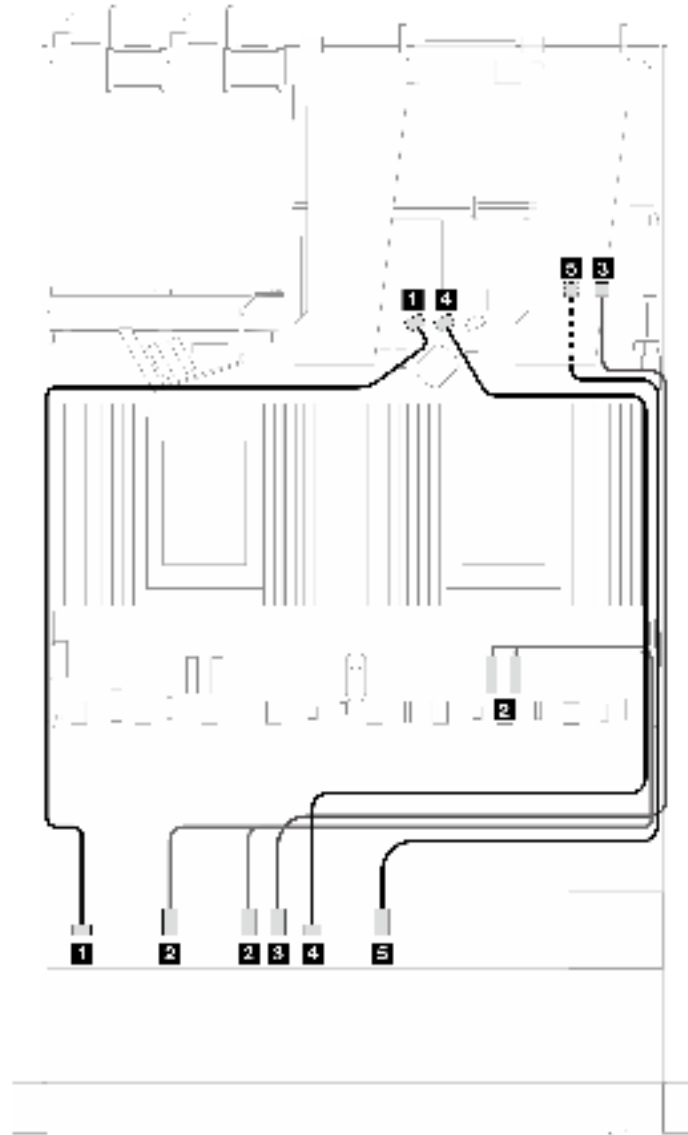


Figure 284. Cable routing of eight AnyBay front drives for both connections onboard and to a Gen 4 SFF re-timer adapter

Table 84. Mapping between one front AnyBay backplane, the processor board and a re-timer adapter

Backplane	From	To
Front BP (SAS)	1 SAS 0	1 SATA 0
Front BP (NVMe)	2 NVMe 0–1, 2–3	2 PCIe 2, PCIe 1

Table 84. Mapping between one front AnyBay backplane, the processor board and a re-timer adapter (continued)

Backplane	From	To
	<b>3</b> NVMe 4–5	<b>3</b> C0
Front BP (SAS)	<b>4</b> SAS 1	<b>4</b> SATA 1
Front BP (NVMe)	<b>5</b> NVMe 6–7	<b>5</b> C1

## 10 x 2.5" front drives (one processor)

Use the section to understand the cable routing for signal cable connections for 10 x 2.5" front drive backplanes when one processor installed.

## 6 x 2.5" SAS/SATA + 4 x 2.5" AnyBay (one processor)

See this section to understand the cable routing of 6 front SAS/SATA drives and 4 front AnyBay drives with 6 x 2.5" SAS/SATA + 4 x 2.5" AnyBay backplane installed.

To connect cables for a 7mm drive backplane, refer to [“7mm drive backplane” on page 270](#).

To connect power cables for a backplane for standard 2.5-inch or 3.5-inch drives, refer to [“Cable routing for backplane power” on page 274](#).

To connect cables for M.2 drives, refer to [“M.2 drive backplane” on page 267](#).

To connect signal cables for a backplane for standard 6 front SAS/SATA drives and 4 front AnyBay drives, refer to the following cable routing scenarios depending on your server configuration:

- [“Cable routing for onboard configuration” on page 331](#)
- [“Cable routing with an SFF HBA/RAID adapter” on page 333](#)

### Cable routing for onboard configuration

The following tables show the mapping relationship between backplane connectors and processor board connectors for onboard configuration.

The following figure illustrates the cable routing for the configuration of 6 front SAS/SATA drives and 4 front AnyBay drives bays. Connections between connectors: **1** ↔ **1**, **2** ↔ **2**, **3** ↔ **3**, ... **n** ↔ **n**.

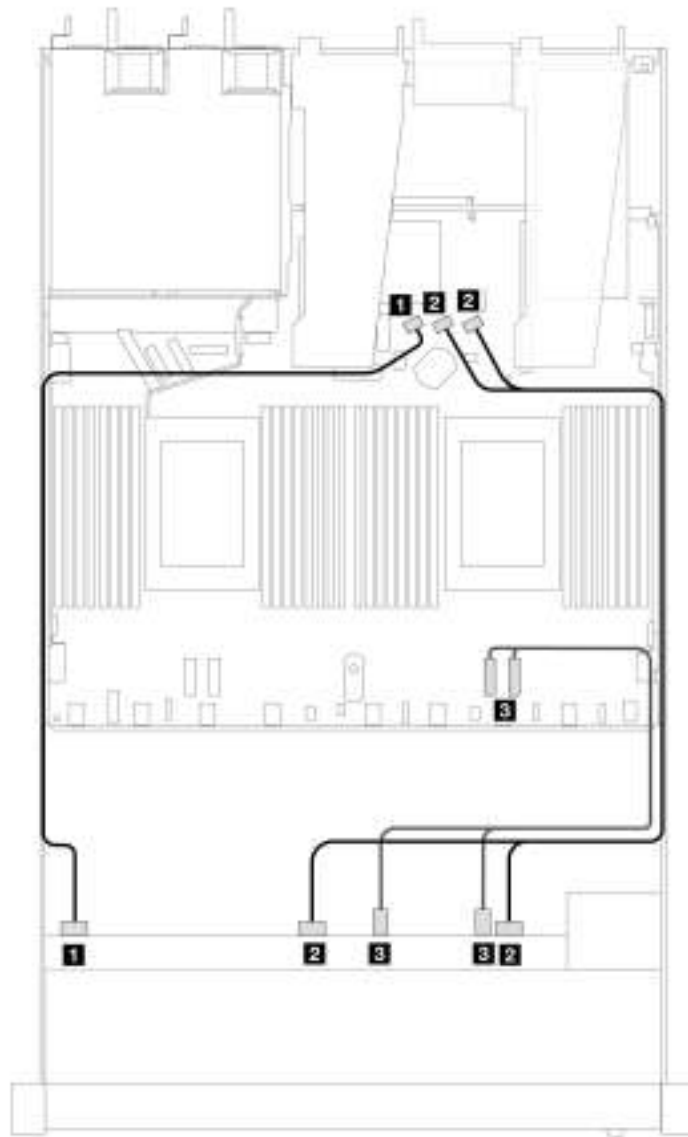


Figure 285. Cable routing for onboard configuration of 6 front SAS/SATA drives and 4 front AnyBay drives bays

Table 85. Mapping between one front AnyBay backplane and processor board for onboard configuration

Backplane	From	To
Front BP (SAS)	1 SAS 0	1 SATA 0
	2 SAS 1, SAS 2	2 SATA 1, SATA 2
Front BP (NVMe)	3 NVMe 2-3, 0-1	3 PCIe 1, 2

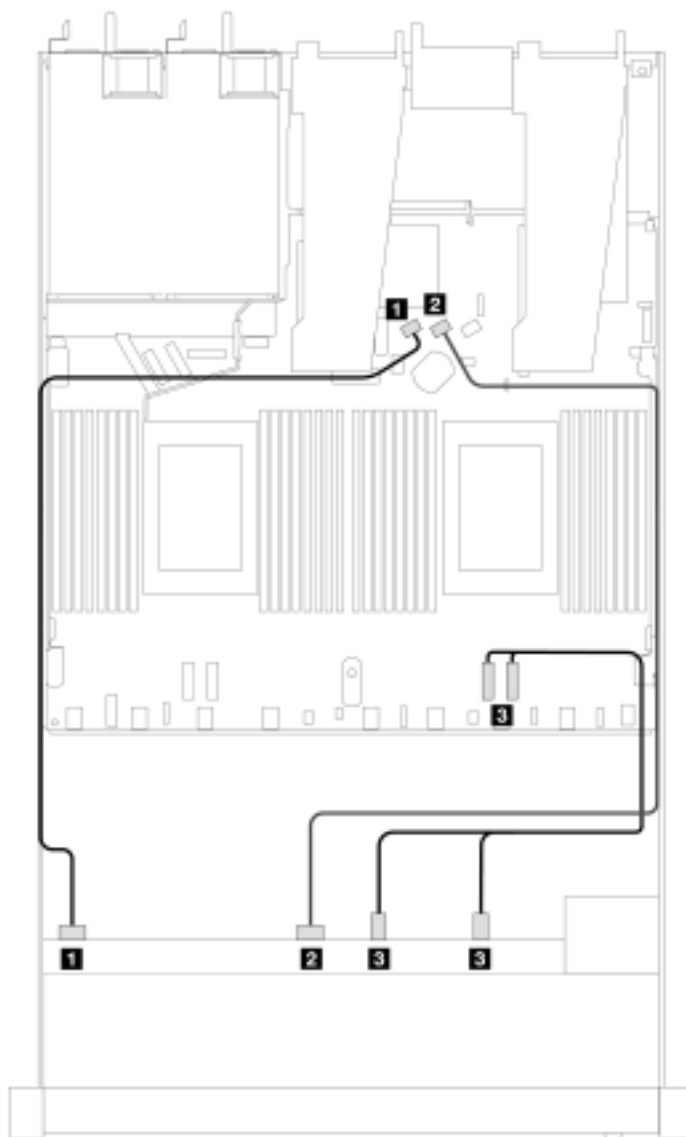


Figure 286. Cable routing for onboard configuration of 6 front SAS/SATA drives and 4 front NVMe drives bays

Table 86. Mapping between one front AnyBay backplane and processor board for onboard configuration

Backplane	From	To
Front BP (SAS)	1 SAS 0	1 SATA 0
	2 SAS 1	2 SATA 1
Front BP (NVMe)	3 NVMe 2-3, 0-1	3 PCIe 1, PCIe 2

### Cable routing with an SFF HBA/RAID adapter

The following tables show the mapping relationship between backplane connectors and a 16i SFF HBA/RAID adapter (Gen 3 or Gen 4).

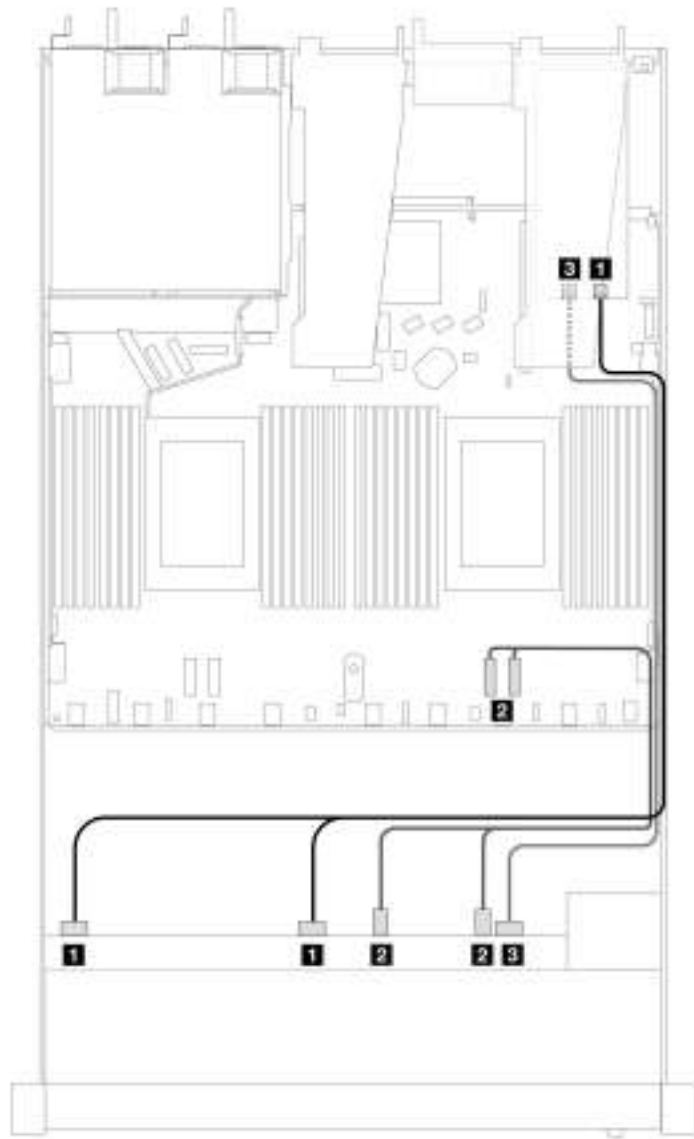


Figure 287. Cable routing for 6 front SAS/SATA drives and 4 front AnyBay drives bays with a 16i SFF RAID adapter (Gen 4)

Table 87. Mapping between one front AnyBay backplane and an SFF HBA/RAID adapter

Backplane	From	To
Front BP (SAS)	<b>1</b> SAS 0, SAS 1	<b>1</b> C0
Front BP (NVMe)	<b>2</b> NVMe 2-3, 0-1	<b>2</b> PCIe 1, 2
Front BP (SAS)	<b>3</b> SAS 2	<b>3</b> C1



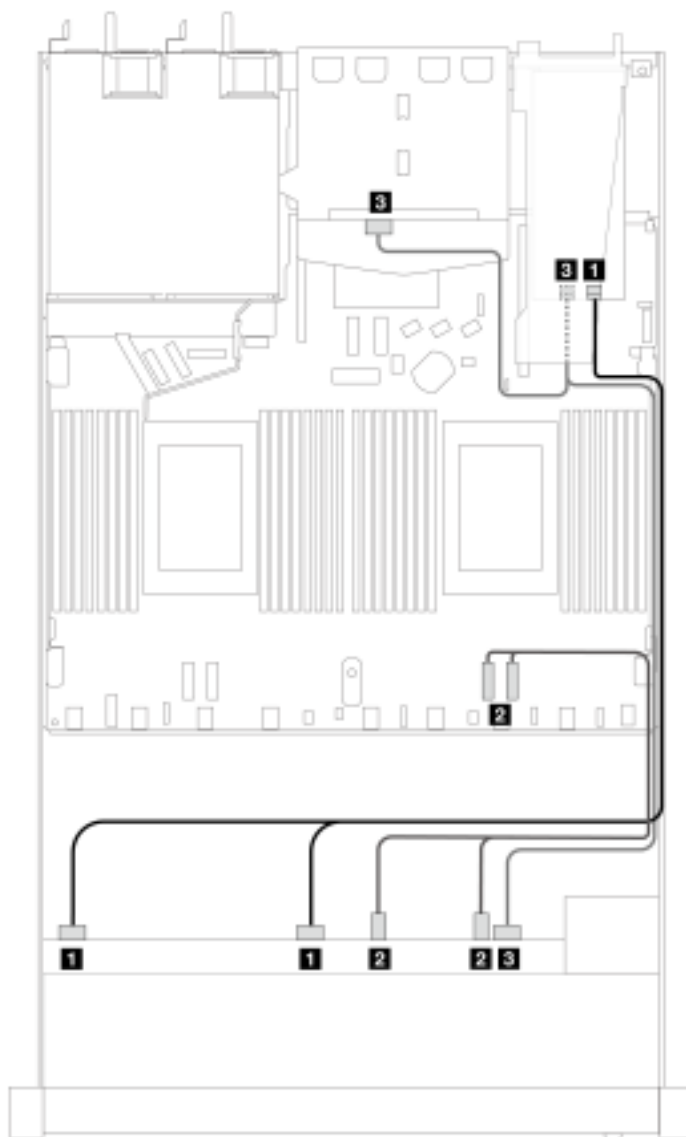


Figure 288. Cable routing for 6 front SAS/SATA drives and 4 front AnyBay drives bays and a 16i SFF RAID adapter (Gen 4) with 2 x 2.5 rear SAS/SATA drives installed

Table 88. Mapping between one front AnyBay and one rear SAS/SATA backplanes and an SFF HBA/RAID adapter

Backplane	From	To
Front BP (SAS)	1 SAS 0, SAS 1	1 C0
Front BP (NVMe)	2 NVMe 2-3, 0-1	2 PCIe 1, 2
Front and Rear BP (SAS)	3 SAS 2 (front), SAS (rear)	3 C1

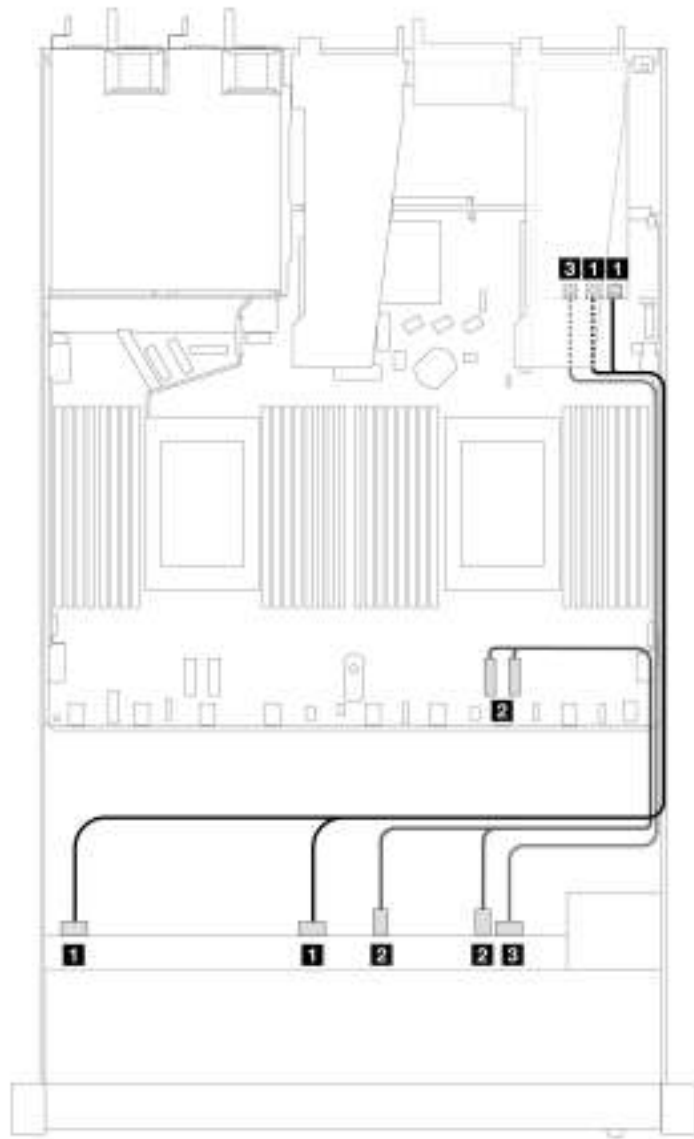


Figure 289. Cable routing for 6 front SAS/SATA drives and 4 front AnyBay drives bays with a 16i SFF RAID adapter (Gen 3)

Table 89. Mapping between one front AnyBay backplane and an SFF HBA/RAID adapter

Backplane	From	To
Front BP (SAS)	<b>1</b> SAS 0, SAS 1	<b>1</b> C0, C1
Front BP (NVMe)	<b>2</b> NVMe 2-3, 0-1	<b>2</b> PCIe 1, 2
Front BP (SAS)	<b>3</b> SAS 2	<b>3</b> C2

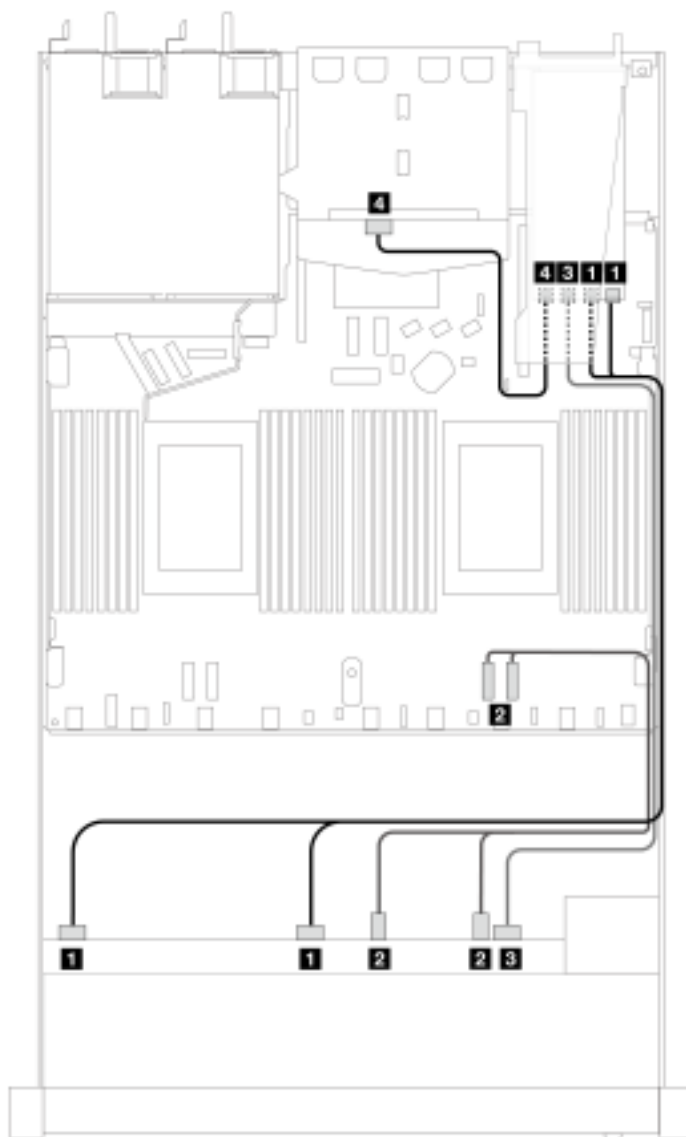


Figure 290. Cable routing for 6 front SAS/SATA drives and 4 front AnyBay drives bays and a 16i SFF RAID adapter (Gen 3) with 2 x 2.5 rear SAS/SATA drives installed

Table 90. Mapping between one front AnyBay and one rear SAS/SATA backplanes and an SFF HBA/RAID adapter

Backplane	From	To
Front BP (SAS)	1 SAS 0, SAS 1	1 C0, C1
Front BP (NVMe)	2 NVMe 2-3, 0-1	2 PCIe 1, 2
Front and Rear BP (SAS)	3 SAS 2	3 C2
	4 SAS (rear)	4 C3

### 6 x 2.5" SAS/SATA + 2 x 2.5" AnyBay + 2 x 2.5" NVMe (one processor)

See this section to understand the cable routing of 6 front SAS/SATA drives, 2 AnyBay drives and 2 front NVMe drives.

To connect cables for a 7mm drive backplane, refer to [“7mm drive backplane” on page 270](#).

To connect power cables for a backplane for standard 2.5-inch or 3.5-inch drives, refer to [“Cable routing for backplane power” on page 274](#).

To connect cables for M.2 drives, refer to [“M.2 drive backplane” on page 267](#).

To connect signal cables for a backplane for standard 6 front SAS/SATA drives, 2 AnyBay drives and 2 front NVMe drives, refer to the following cable routing scenarios depending on your server configuration:

- [“Cable routing for onboard configuration” on page 338](#)
- [“Cable routing with an SFF HBA/RAID adapter” on page 339](#)

### **Cable routing for onboard configuration**

The following tables show the mapping relationship between backplane connectors and processor board connectors for onboard configuration.

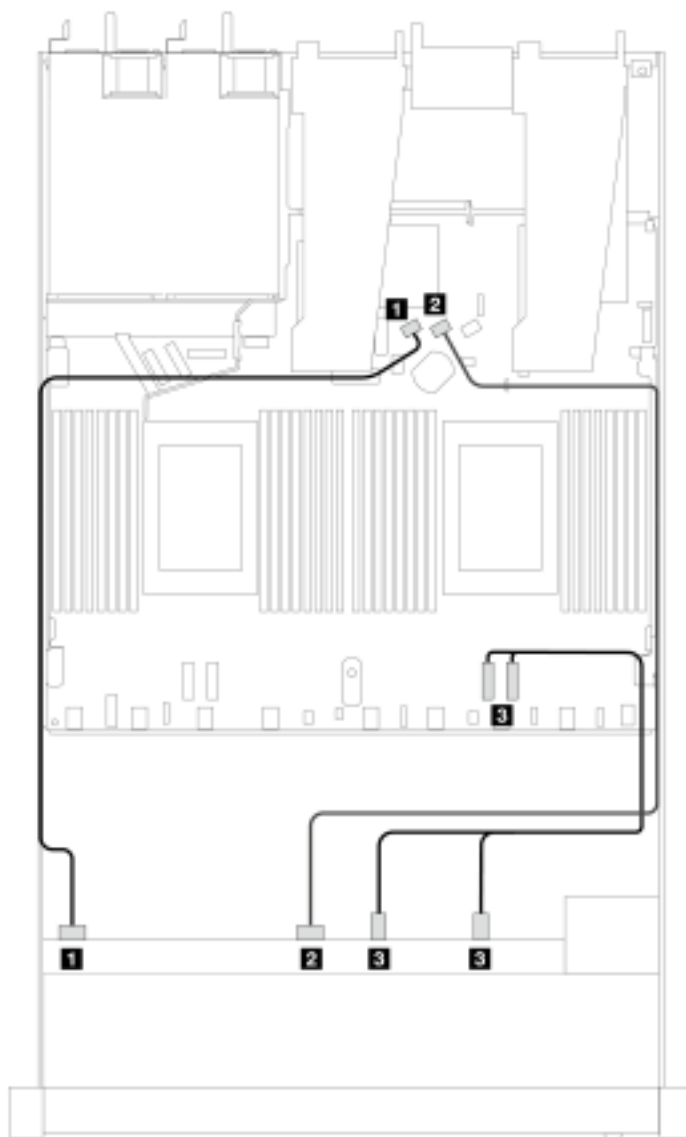


Figure 291. Cable routing for onboard configuration of 6 SAS/SATA drives and 2 AnyBay and 2 NVMe front drives bays

Table 91. Mapping between one front AnyBay backplane and processor board for onboard configuration

Backplane	From	To
Front BP (SAS)	1 SAS 0	1 SATA 0
	2 SAS 1	2 SATA 1
Front BP (NVMe)	3 NVMe 2-3, 0-1	3 PCIe 1, 2

### Cable routing with an SFF HBA/RAID adapter

The following tables show the mapping relationship between backplane connectors and an SFF HBA/RAID adapter.

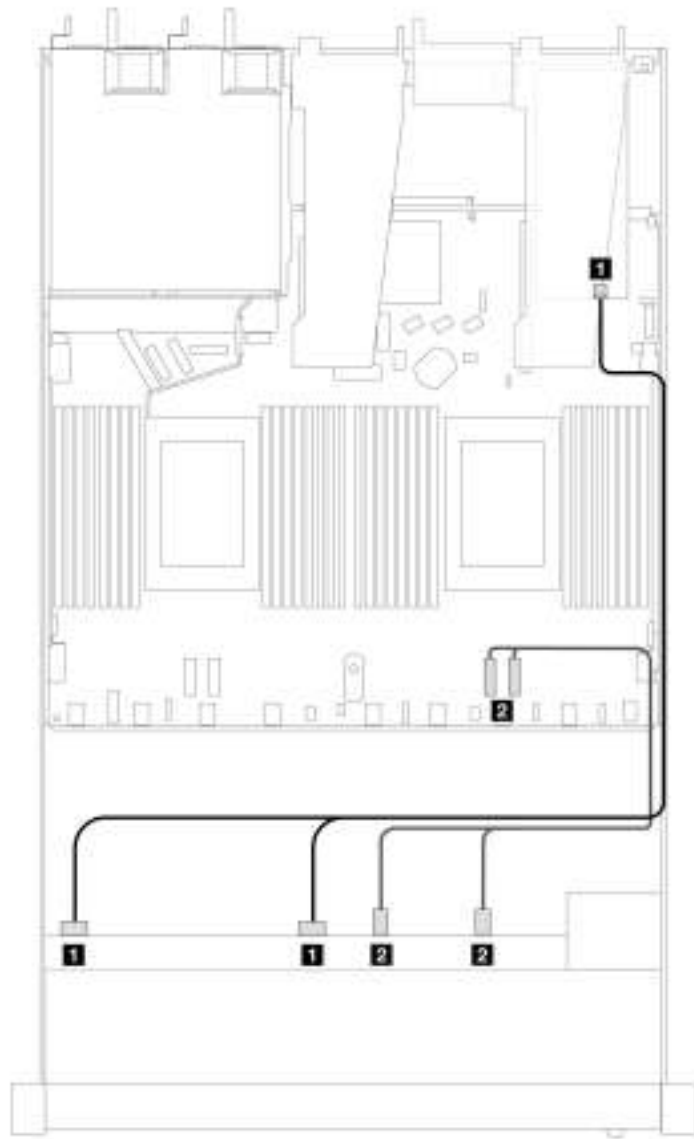


Figure 292. Cable routing for 6 SAS/SATA drives and 2 AnyBay drives and 2 NVMe front drive bays with an 8i or 16i SFF RAID adapter (Gen 4)

Table 92. Mapping between one front AnyBay backplane and an SFF HBA/RAID adapter

Backplane	From	To
Front BP (SAS)	<b>1</b> SAS 0, SAS 1	<b>1</b> C0
Front BP (NVMe)	<b>2</b> NVMe 2–3, 0–1	<b>2</b> PCIe 1, 2

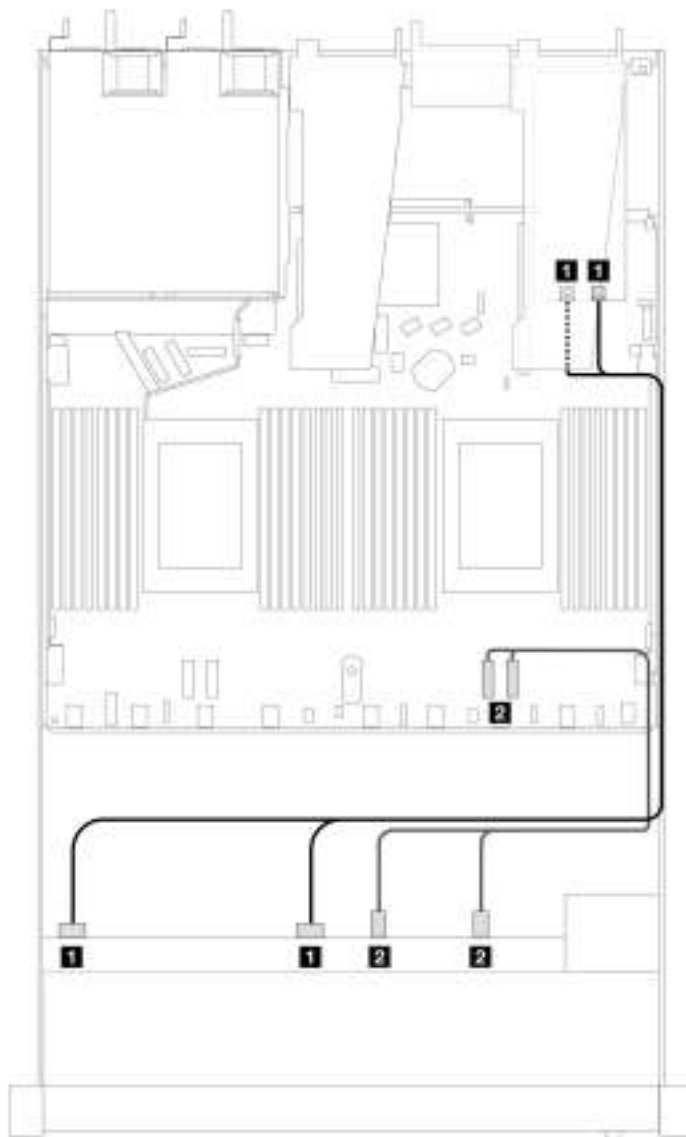


Figure 293. Cable routing for 6 SAS/SATA drives and 2 AnyBay drives and 2 NVMe front drive bays with an 8i or 16i SFF RAID adapter (Gen 3)

Table 93. Mapping between one front AnyBay backplane and an SFF HBA/RAID adapter

Backplane	From	To
Front BP (SAS)	1 SAS 0, SAS 1	1 C0, C1
Front BP (NVMe)	2 NVMe 2-3, 0-1	2 PCIe 1, 2

### 10 x 2.5" SAS/SATA (one processor)

See this section to understand the cable routing of 10 front SAS/SATA drives with the 10 x 2.5 AnyBay backplane (Gen 4) installed.

To connect cables for a 7mm drive backplane, refer to [“7mm drive backplane” on page 270](#).

To connect power cables for a backplane for standard 2.5-inch or 3.5-inch drives, refer to [“Cable routing for backplane power” on page 274](#).

To connect cables for M.2 drives, refer to [“M.2 drive backplane” on page 267](#).

To connect signal cables for a backplane for standard 6 front SAS/SATA drives and 4 front AnyBay drives, refer to the following cable routing scenarios depending on your server configuration:

- [“Cable routing for onboard configuration” on page 342](#)
- [“Cable routing with an SFF HBA/RAID adapter” on page 343](#)
- [“Cable routing with a CFF RAID adapter” on page 347](#)

### **Cable routing for onboard configuration**

The following illustrations and tables show the mapping relationship between backplane connectors and processor board connectors for onboard configuration.

The following figure illustrates the cable routing for the configuration of 10 front SAS/SATA drives bays. Connections between connectors: **1** ↔ **1**, **2** ↔ **2**, **3** ↔ **3**, ... **n** ↔ **n**.



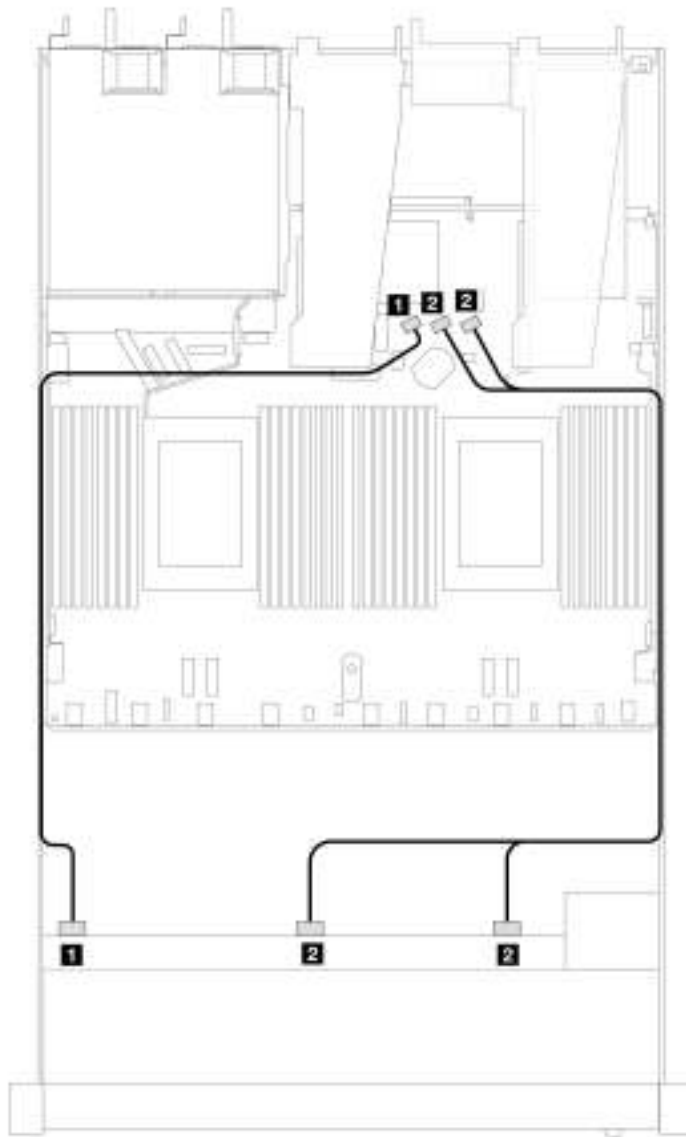


Figure 294. Cable routing for onboard configuration of 10 x 2.5 SAS/SATA front drives

Table 94. Mapping between one front AnyBay backplane and processor board for onboard configuration

Backplane	From	To
Front BP (SAS)	1 SAS 0	1 SATA 0
	2 SAS 1, SAS 2	2 SATA 1, SATA 2

#### Cable routing with an SFF HBA/RAID adapter

The following tables show the mapping relationship between backplane connectors and a 16i SFF HBA/RAID adapter (Gen 3 or Gen 4).

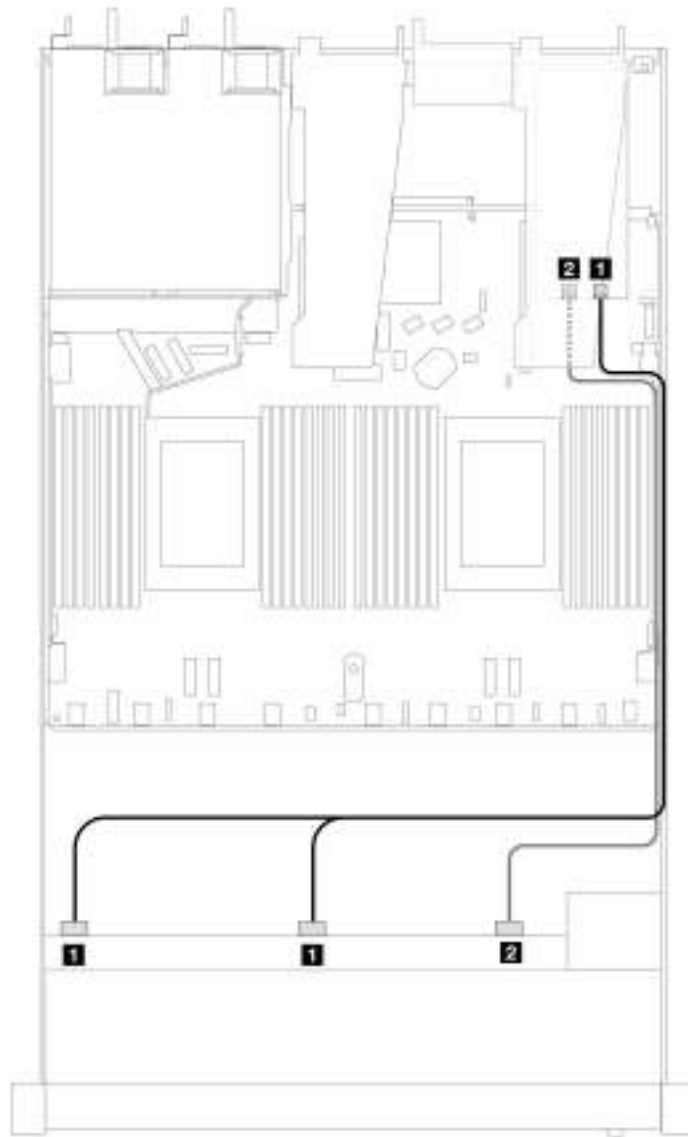


Figure 295. Cable routing for 10 front SAS/SATA drives bays with a 16i SFF RAID adapter (Gen 4)

Table 95. Mapping between one front AnyBay backplane and an SFF HBA/RAID adapter

Backplane	From	To
Front BP (SAS)	1 SAS 0, SAS 1	1 C0
	2 SAS 2	2 C1

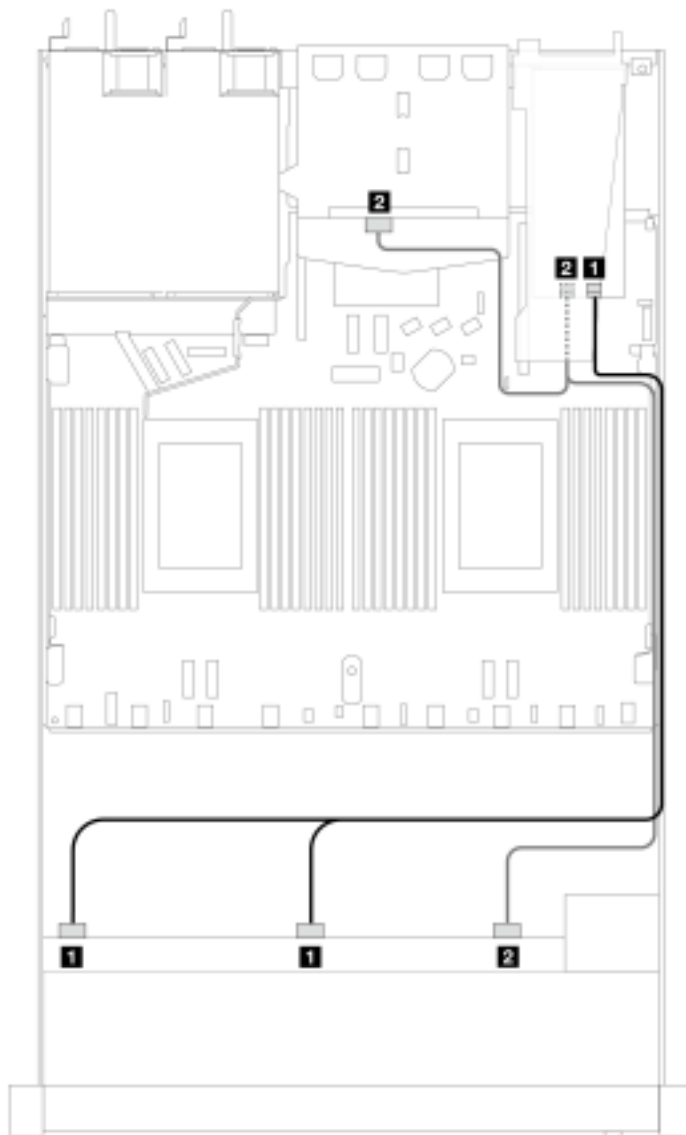


Figure 296. Cable routing for 10 front SAS/SATA drives bays and a 16i SFF RAID adapter (Gen 4) with 2 x 2.5 rear SAS/SATA drives installed

Table 96. Mapping between one front AnyBay and one rear SAS/SATA backplanes and an SFF HBA/RAID adapter

Backplane	From	To
Front BP (SAS)	1 SAS 0, SAS 1	1 C0
Rear BP (SAS)	2 SAS 2 (front), SAS (rear)	2 C1

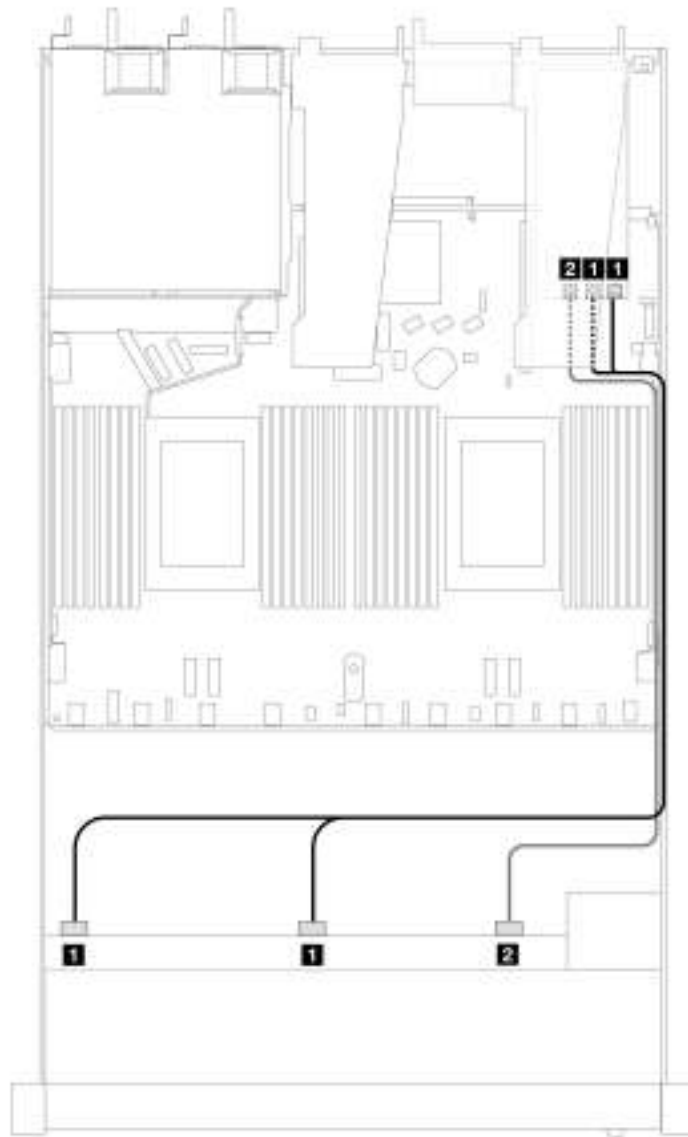


Figure 297. Cable routing for 10 front SAS/SATA drives bays with a 16i SFF RAID adapter (Gen 3)

Table 97. Mapping between one front AnyBay backplane and an SFF HBA/RAID adapter

Backplane	From	To
Front BP (SAS)	1 SAS 0, SAS 1	1 C0, C1
	2 SAS 2	2 C2

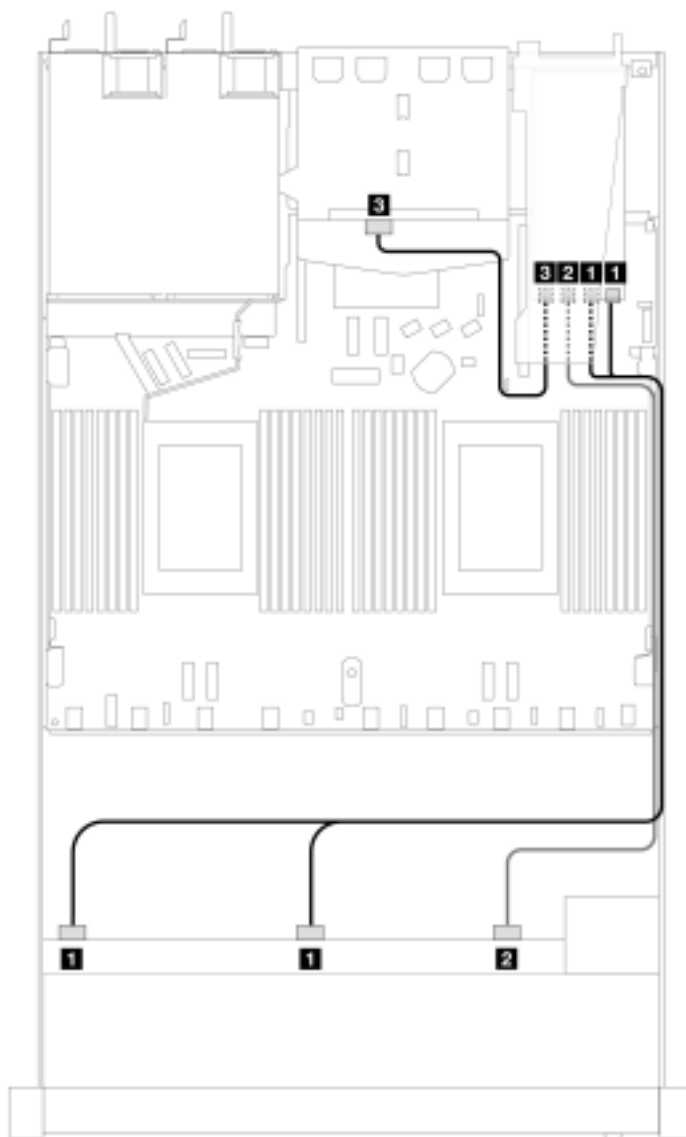


Figure 298. Cable routing for 10 front SAS/SATA drives bays and a 16i SFF RAID adapter (Gen 3) with 2 x 2.5 rear SAS/SATA drives installed

Table 98. Mapping between one front AnyBay and one rear SAS/SATA backplanes and an SFF HBA/RAID adapter

Backplane	From	To
Front BP (SAS)	1 SAS 0, SAS 1	1 C0, C1
	2 SAS 2	2 C2
Rear BP (SAS)	3 SAS	3 C3

### Cable routing with a CFF RAID adapter

The following tables show the mapping relationship between backplane connectors and a 16i CFF RAID adapter (Gen 3 or Gen 4).

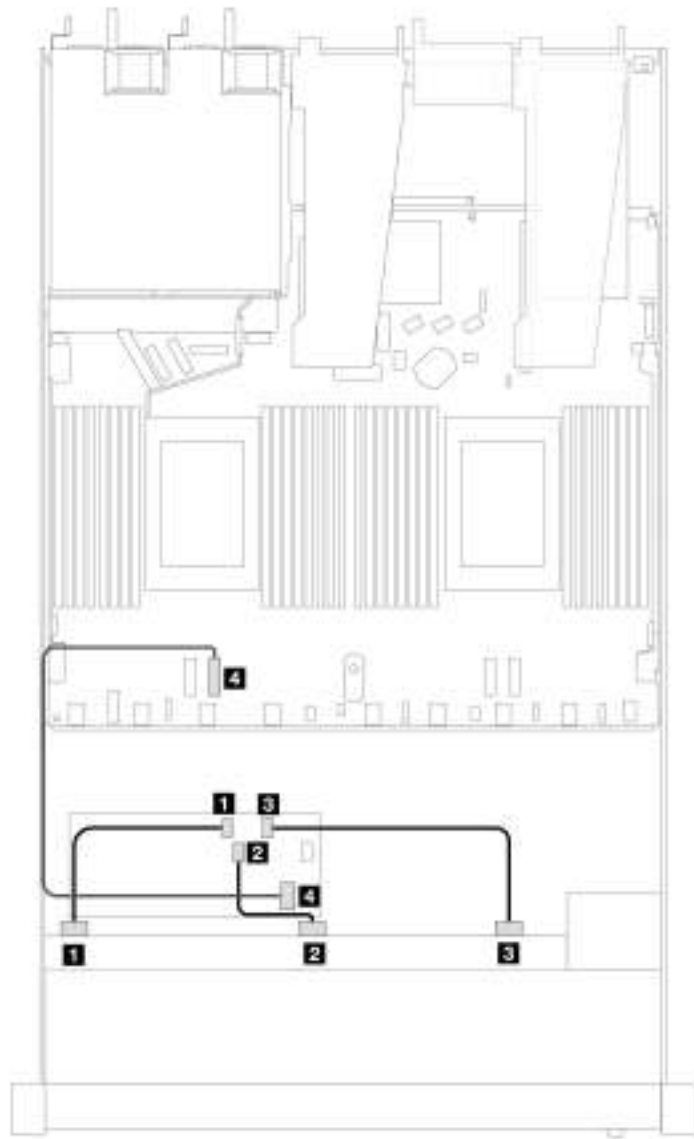


Figure 299. Cable routing for 10 front SAS/SATA drives bays with a 16i CFF RAID adapter (Gen 3 or Gen 4)

Table 99. Mapping between one front SAS/SATA backplane and a CFF RAID adapter

Backplane/adapter	From	To
Front backplane	<b>1</b> SAS 0	<b>1</b> C0
	<b>2</b> SAS 1	<b>2</b> C1
	<b>3</b> SAS 2	<b>3</b> C2
CFF RAID adapter	<b>4</b> MB input	<b>4</b> PCIe 2

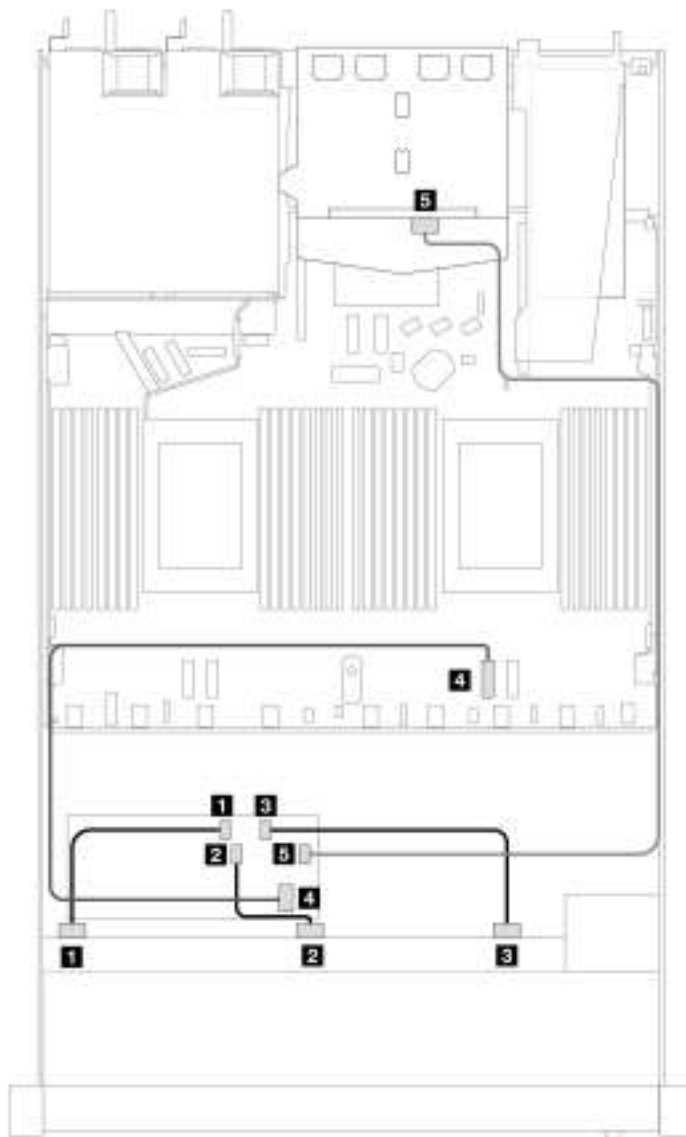


Figure 300. Cable routing for 10 front SAS/SATA drives bays and a 16i CFF RAID adapter (Gen 3 or Gen 4) with 2 x 2.5 rear SAS/SATA drives installed

Table 100. Mapping between one front AnyBay and one rear SAS/SATA backplane and a CFF RAID adapter

Backplane/adapter	From	To
Front backplane	1 SAS 0	1 C0
	2 SAS 1	2 C1
	3 SAS 2	3 C2
CFF RAID adapter	4 MB input	4 PCIe 2
	5 C3	5 SAS (rear)

---

## Cable routing for backplane signals (two processors)

In this section, you can find cable routings of backplane signals when two processors installed.

- Each backplane your server supports offers multiple signal connections. This section singles out the signal connection from power connection for better understanding. For backplane power connection, see [“Cable routing for backplane power” on page 274](#).
- For the locations of backplane signal connectors on the processor board and adapters, see [“Processor-board connectors for cable routing” on page 257](#) and [“RAID and HBA adapter connectors” on page 254](#) for details.
- For more information about backplanes supported and their connectors, see [“Drive backplane connectors” on page 250](#).

### 4 x 3.5" front drives

Use the section to understand the cable routing for signal cable connections for 4 x 3.5-inch drive backplanes.

In the configuration of 4 x 3.5-inch front drives, your server supports the following front backplanes:

#### 4 x 3.5" SAS/SATA backplane

Use this section to understand the SAS/SATA backplane cable routing for server model with four 3.5-inch front drives.

To connect cables for a 7mm drive backplane, refer to [“7mm drive backplane” on page 270](#).

To connect power cables for a backplane for standard 2.5-inch or 3.5-inch drives, refer to [“Cable routing for backplane power” on page 274](#).

To connect cables for M.2 drives, refer to [“M.2 drive backplane” on page 267](#).

To connect signal cables for a SAS/SATA backplane for standard 4 x 3.5-inch front drives, refer to the following cable routing scenarios depending on your server configuration:

- [“Cable routing for onboard configuration” on page 351](#)
- [“Cable routing with an SFF HBA/RAID adapter” on page 354](#)



### Cable routing for onboard configuration

The following table shows the mapping relationship between backplane connectors and processor board connectors for onboard configuration.

The following figure illustrates the cable routing for the onboard configuration of 4 x 3.5-inch front SAS/SATA drive bays. Connections between connectors: **1** ↔ **1**, **2** ↔ **2**, **3** ↔ **3**, ... **n** ↔ **n**.

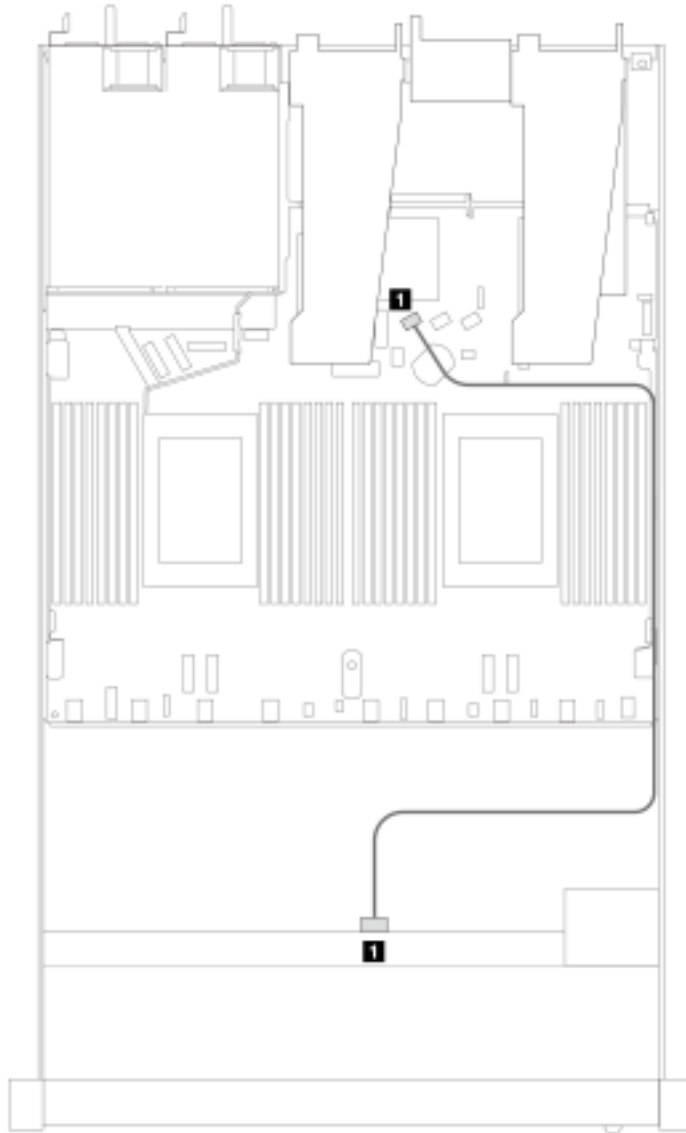


Figure 301. Cable routing for onboard configuration of 4 x 3.5-inch front SAS/SATA drive bays

Table 101. Mapping between one front SAS/SATA backplane and processor board for onboard configuration

Backplane	From	To
<b>1</b> Front BP (SAS)	SAS	SATA 0

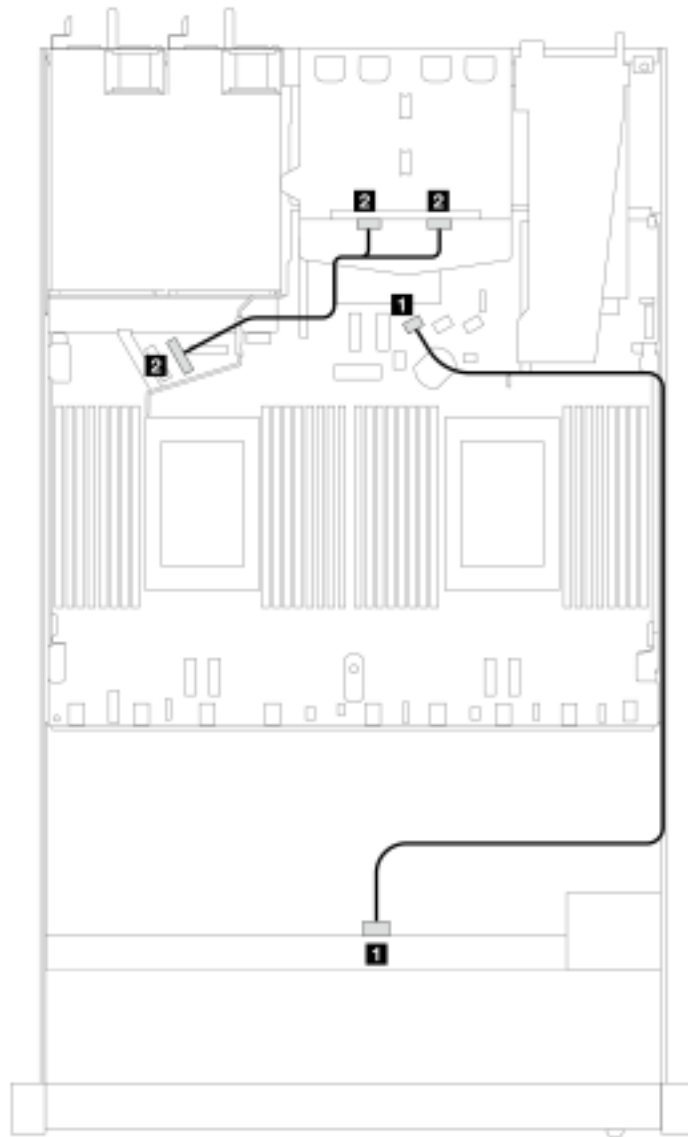


Figure 302. Cable routing for onboard configuration of 4 x 3.5-inch front SAS/SATA drive with 2 x 2.5 rear NVMe drives

Table 102. Mapping between one front SAS/SATA backplane with one rear NVMe backplane and processor board for onboard configuration

Backplane	From	To
<b>1</b> Front BP (SAS)	SAS	SATA 0
<b>2</b> Rear BP (NVMe)	NVMe 0, NVMe 1	PCIe 6

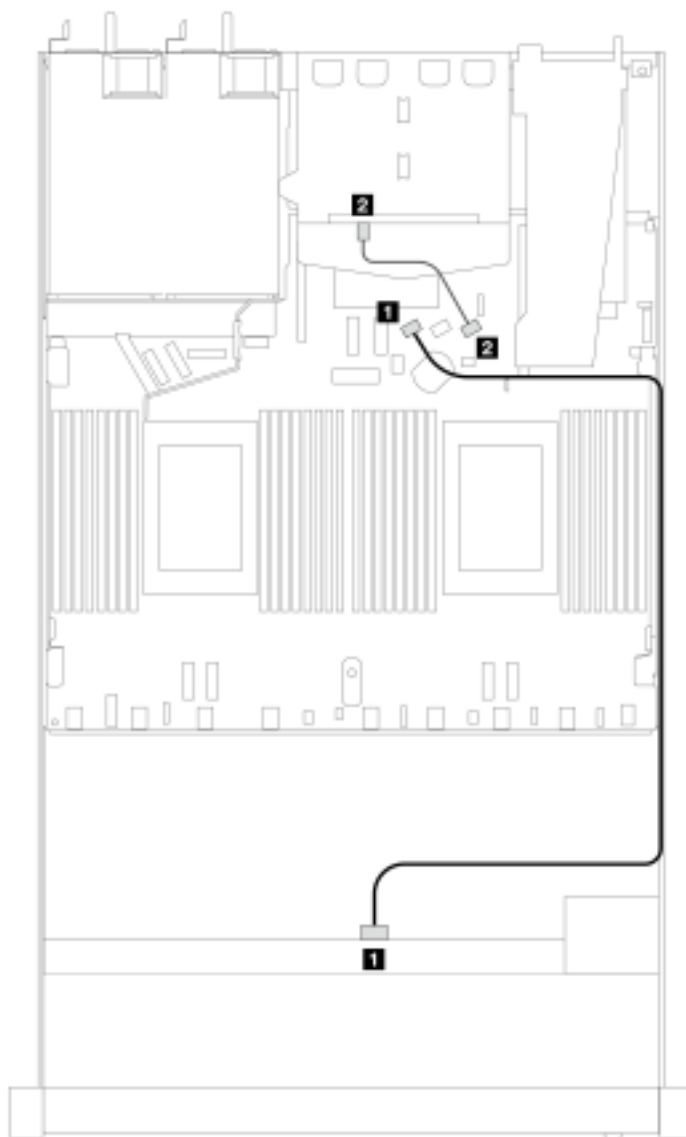


Figure 303. Cable routing for onboard configuration of 4 x 3.5-inch front SAS/SATA drive bays with 2 x 2.5 rear SAS/SATA drives

Table 103. Mapping between one front SAS/SATA backplane with one rear SAS/SATA backplane and processor board for onboard configuration

Backplane	From	To
1 Front BP (SAS)	SAS (front)	SATA 0
2 Rear BP (SAS)	SAS (rear)	SATA 2

### Cable routing with an SFF HBA/RAID adapter

The following table shows the mapping relationship between backplane connectors and processor board/adapter connectors when an 8i SFF HBA/RAID adapter (Gen 3 or Gen 4) is installed.

The following figure illustrates the cable routing for the configuration of 4 x 3.5-inch front SAS/SATA drive bays with an 8i SFF RAID adapter. Connections between connectors: **1** ↔ **1**, **2** ↔ **2**, **3** ↔ **3**, ... **n** ↔ **n**.

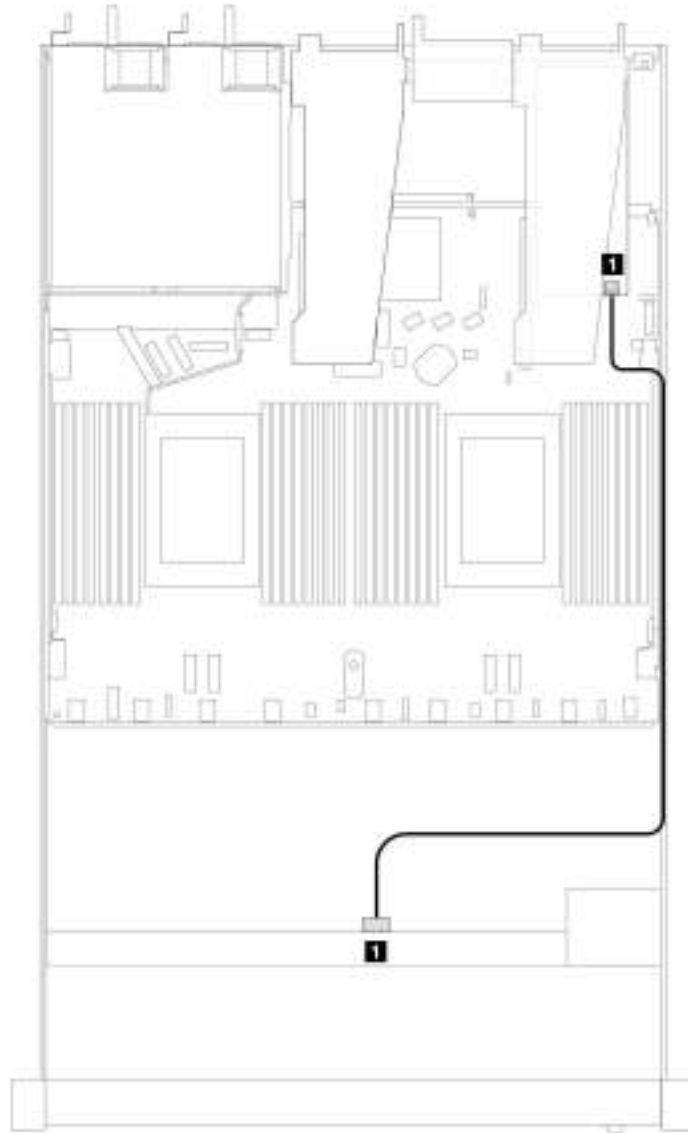


Figure 304. Cable routing for 4 x 3.5-inch front SAS/SATA drive bays with an 8i SFF RAID adapter

Table 104. Mapping between backplane connectors and processor board/adapter connectors when an SFF HBA/RAID adapter is installed

Backplane	From	To
<b>1</b> Front BP (SAS)	SAS	C0

#### Notes:

- Gen 3 and Gen 4 SFF HBA/RAID adapters are slightly different in their connectors, but the cable routing method is similar.
- To connect cables for RAID flash power module, refer to [“RAID flash power modules” on page 264.](#)

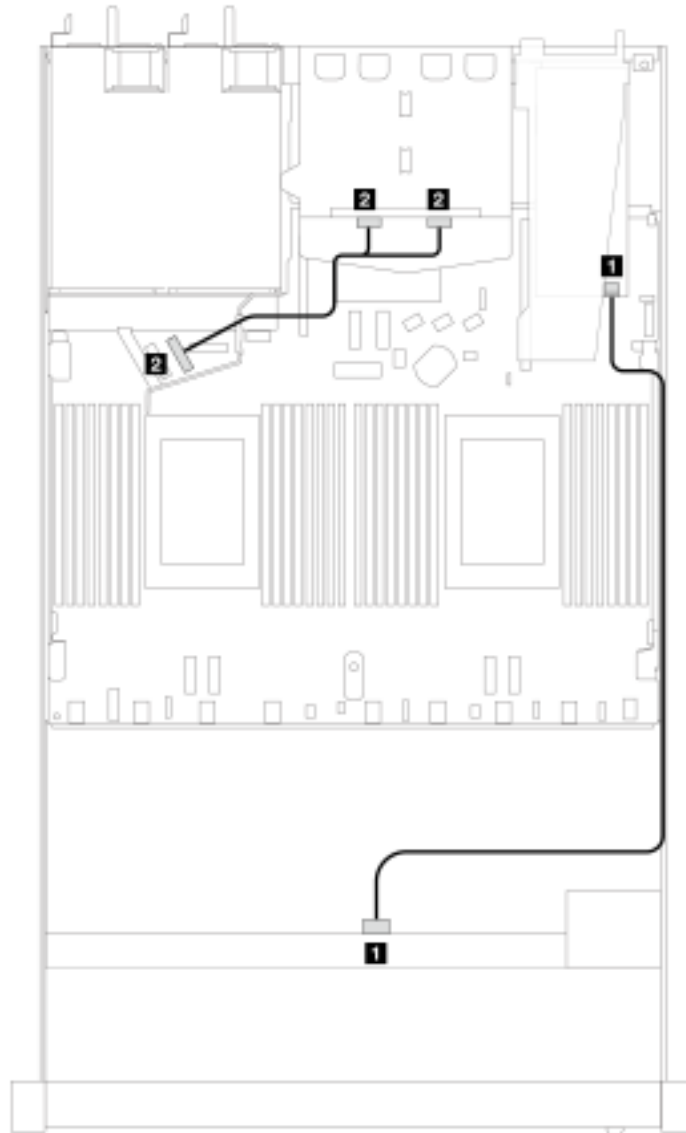


Figure 305. Cable routing for 4 x 3.5-inch front SAS/SATA drive bays with an 8i SFF RAID adapter and rear 2 x 2.5-inch NVMe drives

Table 105. Mapping between backplane connectors and processor board/adapter connectors when an SFF HBA/RAID adapter is installed

Backplane	From	To
<b>1</b> Front BP (SAS)	SAS	C0
<b>2</b> Rear BP (NVMe)	NVMe 0, NVMe 1	PCIe 6

The following table shows the mapping relationship between backplane connectors and processor board/ adapter connectors when an 8i SFF HBA/RAID adapter (Gen 3) is installed.

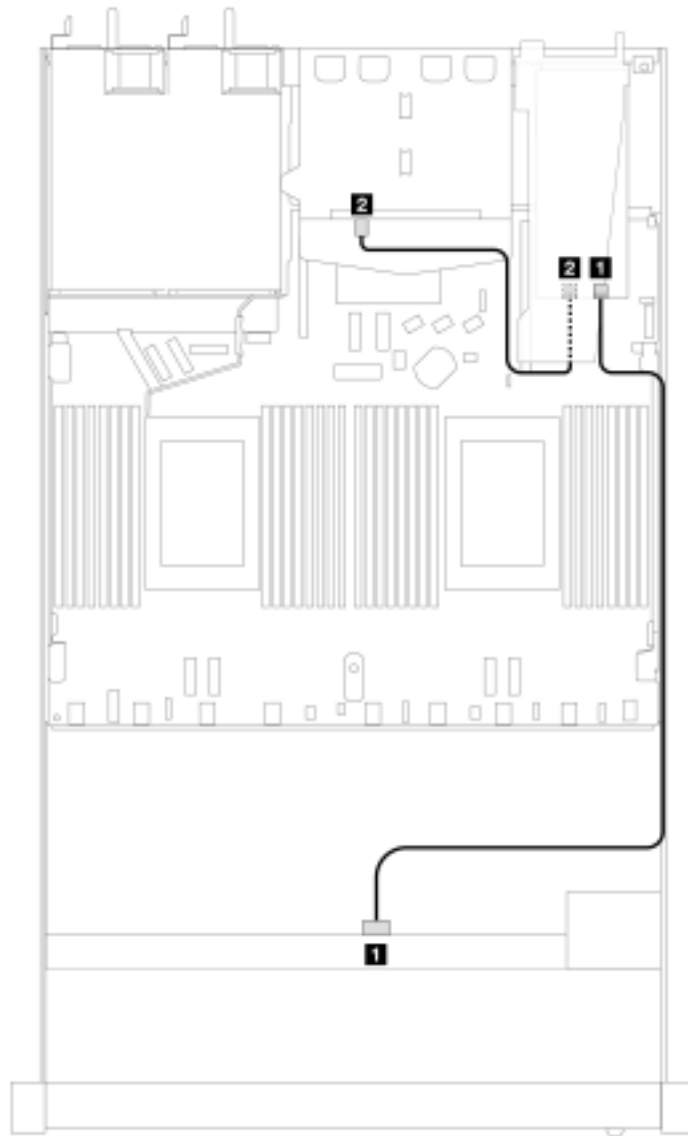


Figure 306. Cable routing for 4 x 3.5-inch front SAS/SATA drive bays with an 8i SFF RAID adapter (Gen 3) and rear 2 x 2.5-inch SAS/SATA drives

Table 106. Mapping between backplane connectors and processor board/ adapter connectors when an SFF HBA/RAID adapter is installed

Backplane	From	To
1 Front BP (SAS)	SAS	C0
2 Rear BP (SAS)	SAS (rear)	C1

The following table shows the mapping relationship between backplane connectors and processor board/ adapter connectors when an 8i SFF HBA/RAID adapter (Gen 4) is installed.

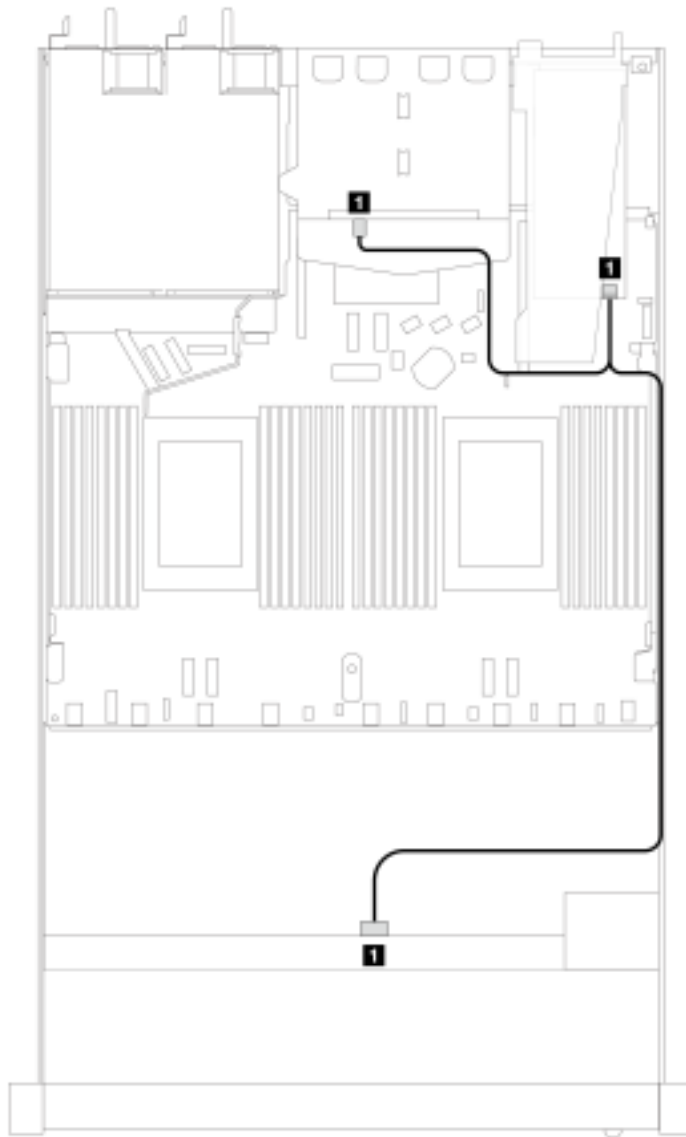


Figure 307. Cable routing for 4 x 3.5-inch front SAS/SATA drive bays with an 8i SFF RAID adapter (Gen 4) and rear 2 x 2.5-inch SAS/SATA drives

Table 107. Mapping between backplane connectors and processor board/adapter connectors when an SFF HBA/RAID adapter is installed

Backplane	From	To
1 Front and Rear BP (SAS)	SAS	C0

## 4 x 3.5" AnyBay backplane

Use this section to understand the AnyBay backplane cable routing for server model with four 3.5-inch front drives.

To connect cables for a 7mm drive backplane, refer to [“7mm drive backplane” on page 270](#).

To connect power cables for a backplane for standard 2.5-inch or 3.5-inch drives, refer to [“Cable routing for backplane power” on page 274](#).

To connect cables for M.2 drives, refer to [“M.2 drive backplane” on page 267](#).

To connect signal cables for a backplane for standard 4 x 3.5-inch front drives, refer to the following cable routing scenarios depending on your server configuration:

- [“Cable routing for onboard configuration” on page 359](#)
- [“Cable routing with an SFF HBA/RAID adapter” on page 361](#)



### Cable routing for onboard configuration

The following table shows the mapping relationship between backplane connectors and processor board connectors for onboard configuration.

Table 108. Mapping between one front AnyBay backplane and processor board for onboard configuration

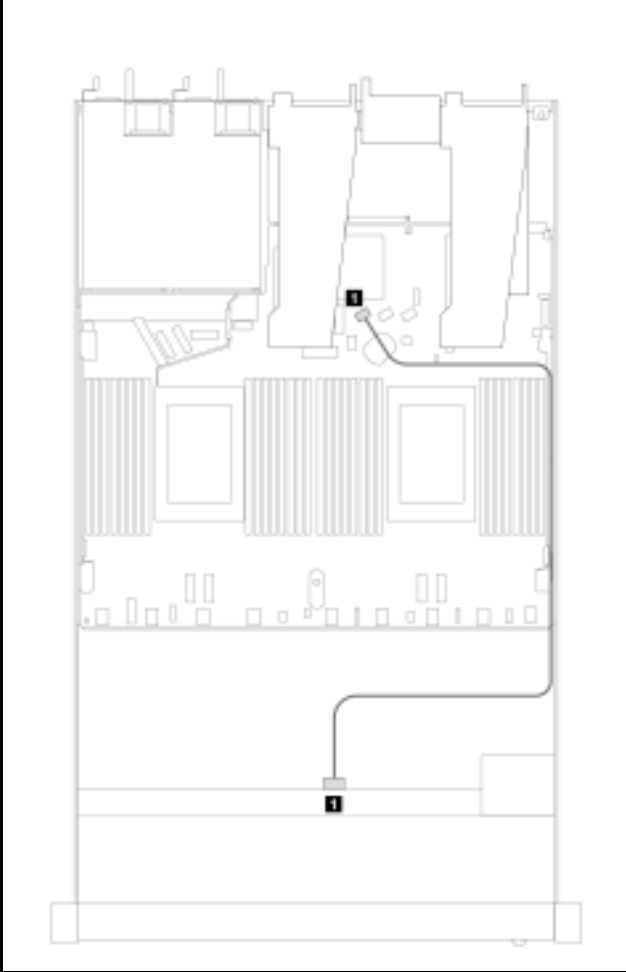
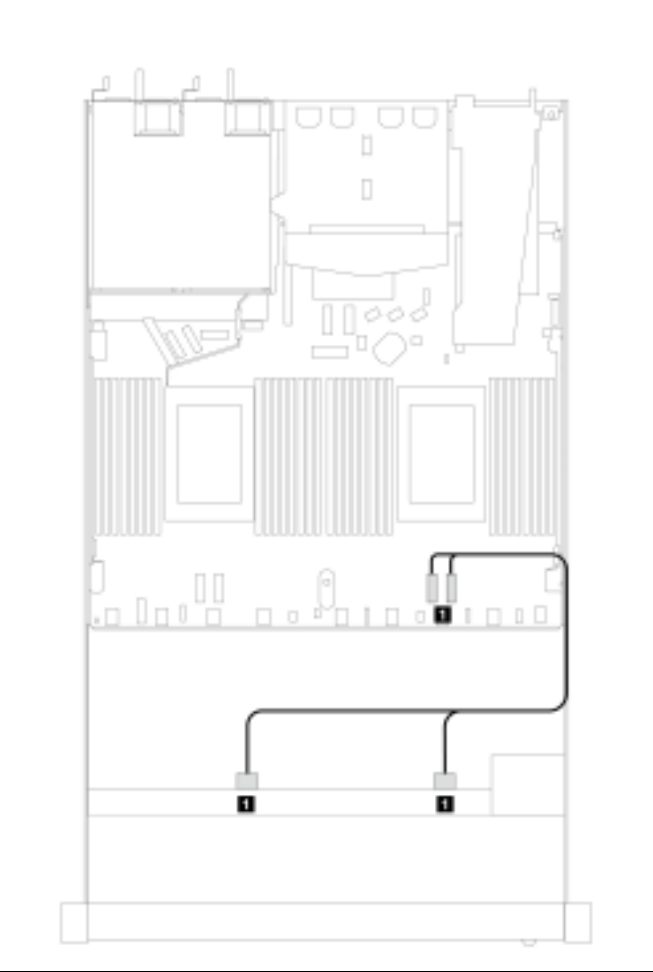
					
SAS/SATA cable routing			NVMe cable routing		
SAS/SATA connector	From	To	NVMe connector	From	To
<b>1</b> SAS	Front BP	SATA 0	<b>1</b> 2-3, 0-1	Front BP	PCIe 1, PCIe 2

Table 109. Mapping between one front AnyBay backplane with one rear NVMe backplane and processor board for onboard configuration

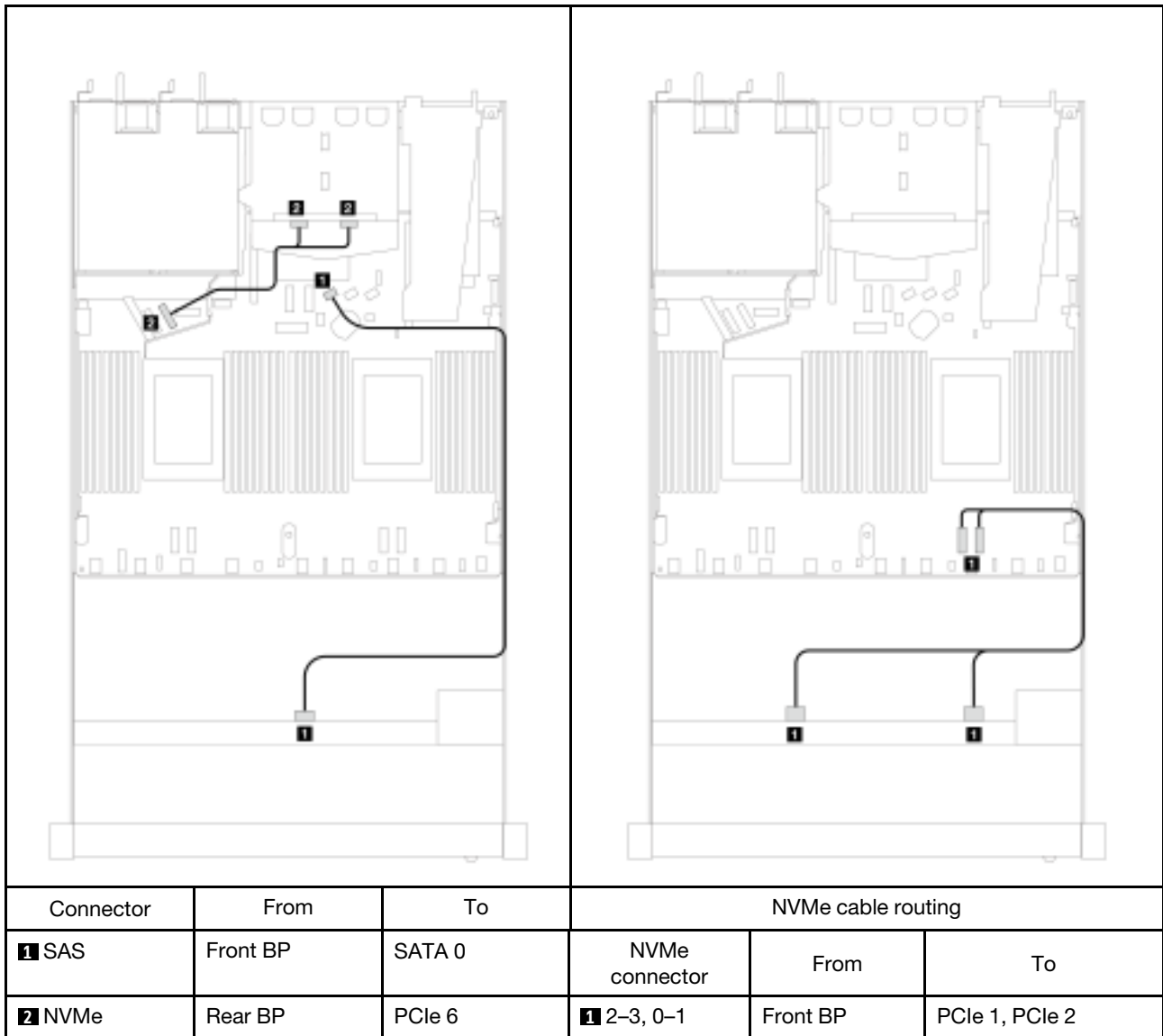
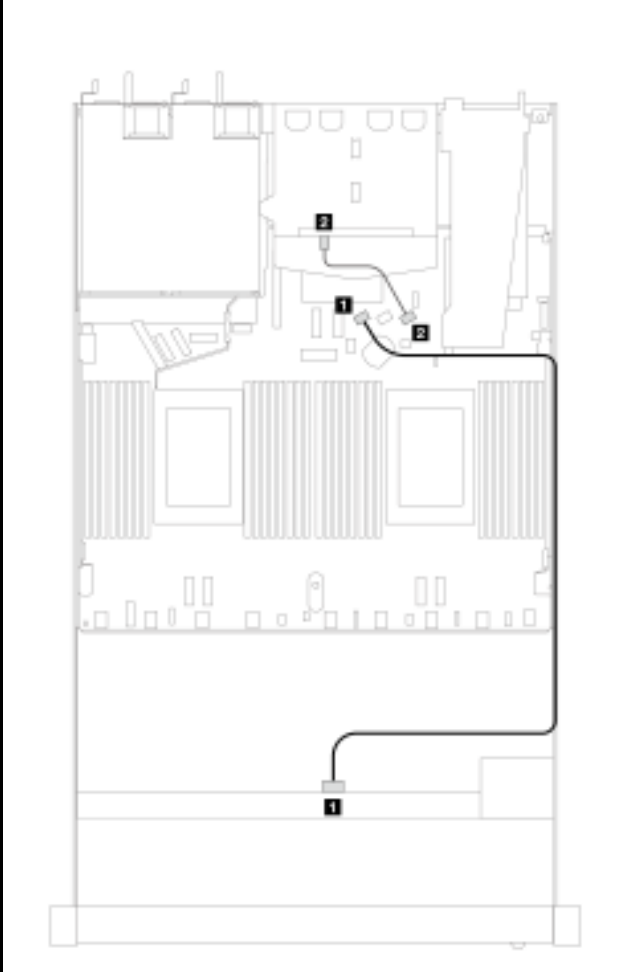
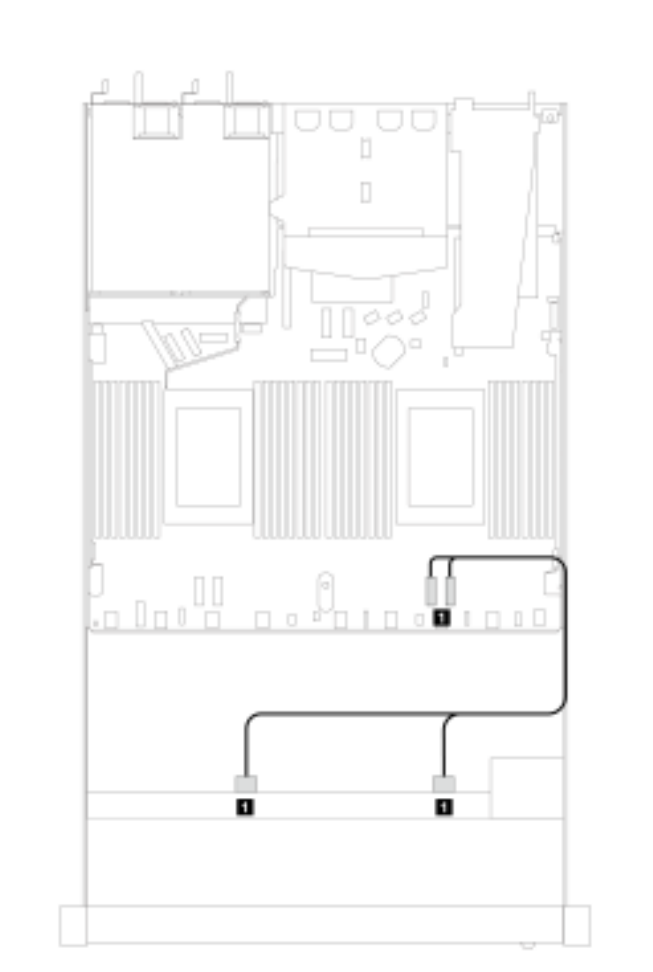


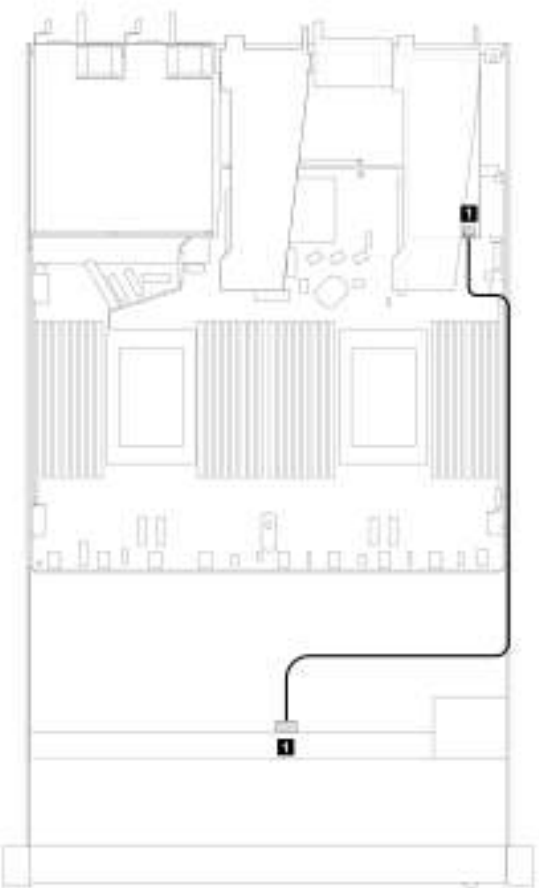
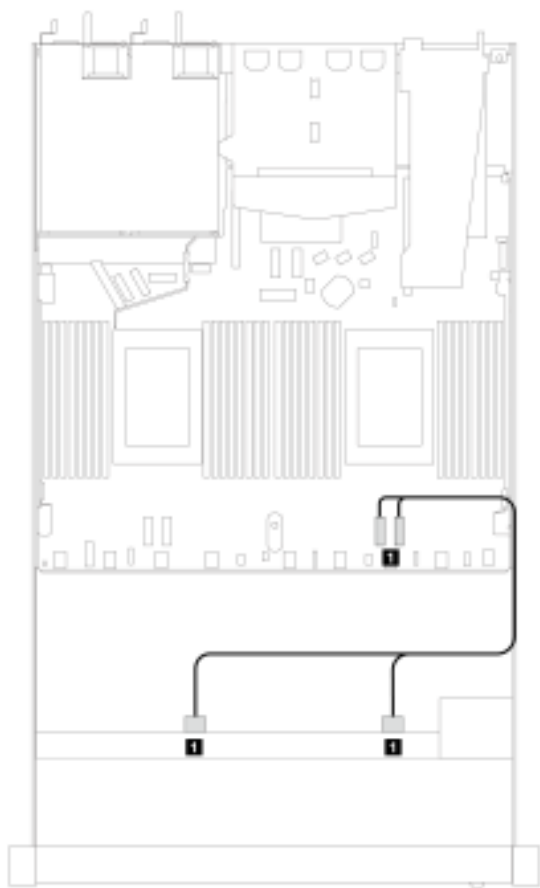
Table 110. Cable routing for onboard configuration of 4 x 3.5-inch front AnyBay drive bays with 2 x 2.5 rear SAS/SATA drives

					
SAS/SATA cable routing			NVMe cable routing		
<b>1</b> SAS	Front BP	SATA 0	NVMe connector	From	To
<b>2</b> SAS	Rear BP	SATA 2	<b>1</b> 2-3, 0-1	Front BP	PCIe 1, PCIe 2

#### Cable routing with an SFF HBA/RAID adapter

The following table shows the mapping relationship between backplane connectors and processor board/adapter connectors when an 8i SFF HBA/RAID adapter (Gen 3 or Gen 4) is installed.

Table 111. Mapping between backplane and processor board/adaptor when an SFF HBA/RAID adapter is installed

					
SAS/SATA cable routing			NVMe cable routing		
SAS/SATA connector	From	To	NVMe connector	From	To
1 SAS	Front BP	C0	1 2-3, 0-1	Front BP	PCIe 1, PCIe 2

**Note:** Gen 3 and Gen 4 SFF HBA/RAID adapters are slightly different in their connectors, but the cable routing method is similar.

Table 112. Mapping between backplane and processor board/adaptor when an SFF HBA/RAID adapter and rear 2 x 2.5-inch NVMe drives are installed

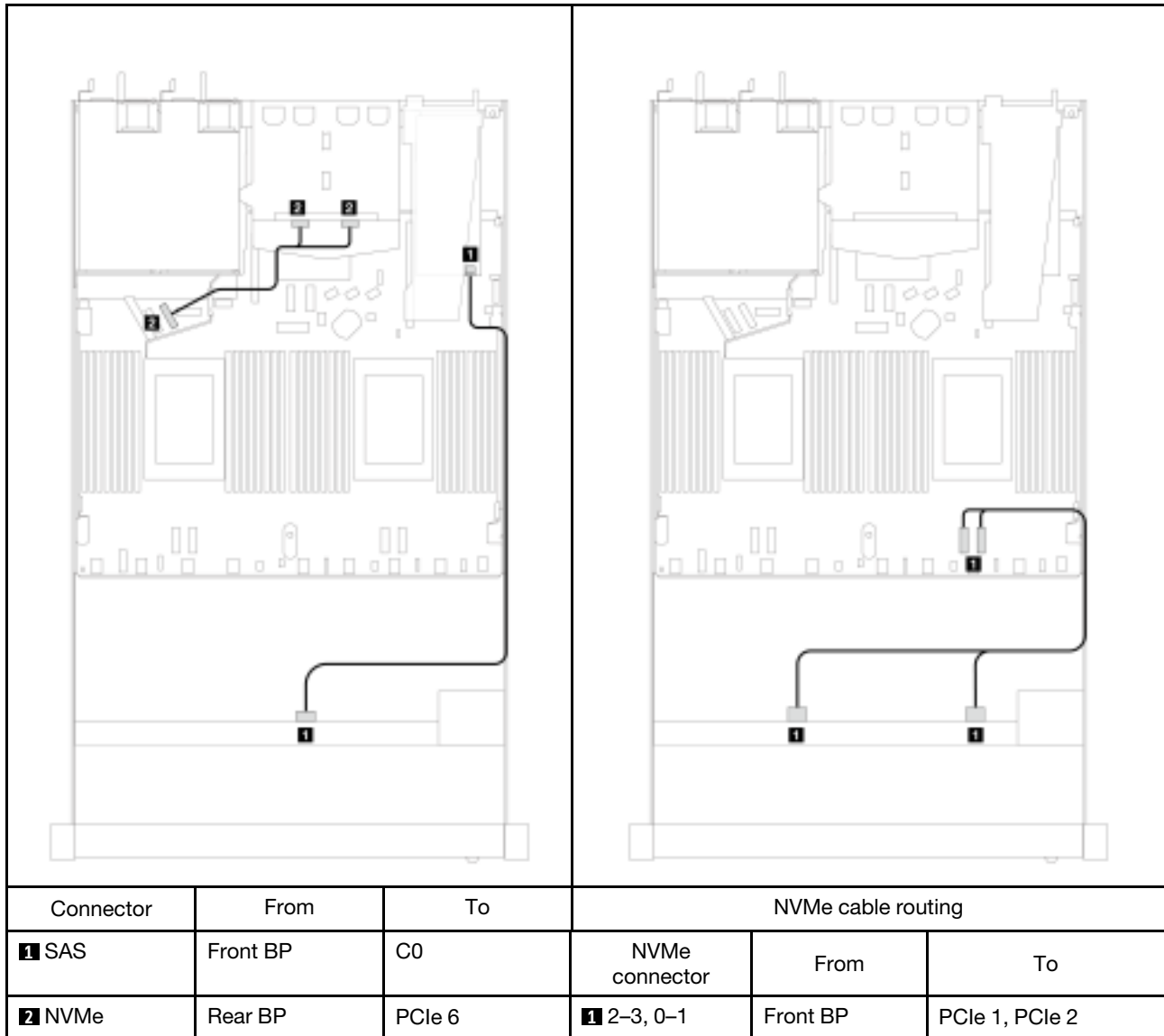


Table 113. Mapping between backplane and processor board/adaptor when an 8i SFF RAID adapter (Gen 3) and rear 2 x 2.5-inch SAS/SATA drives are installed

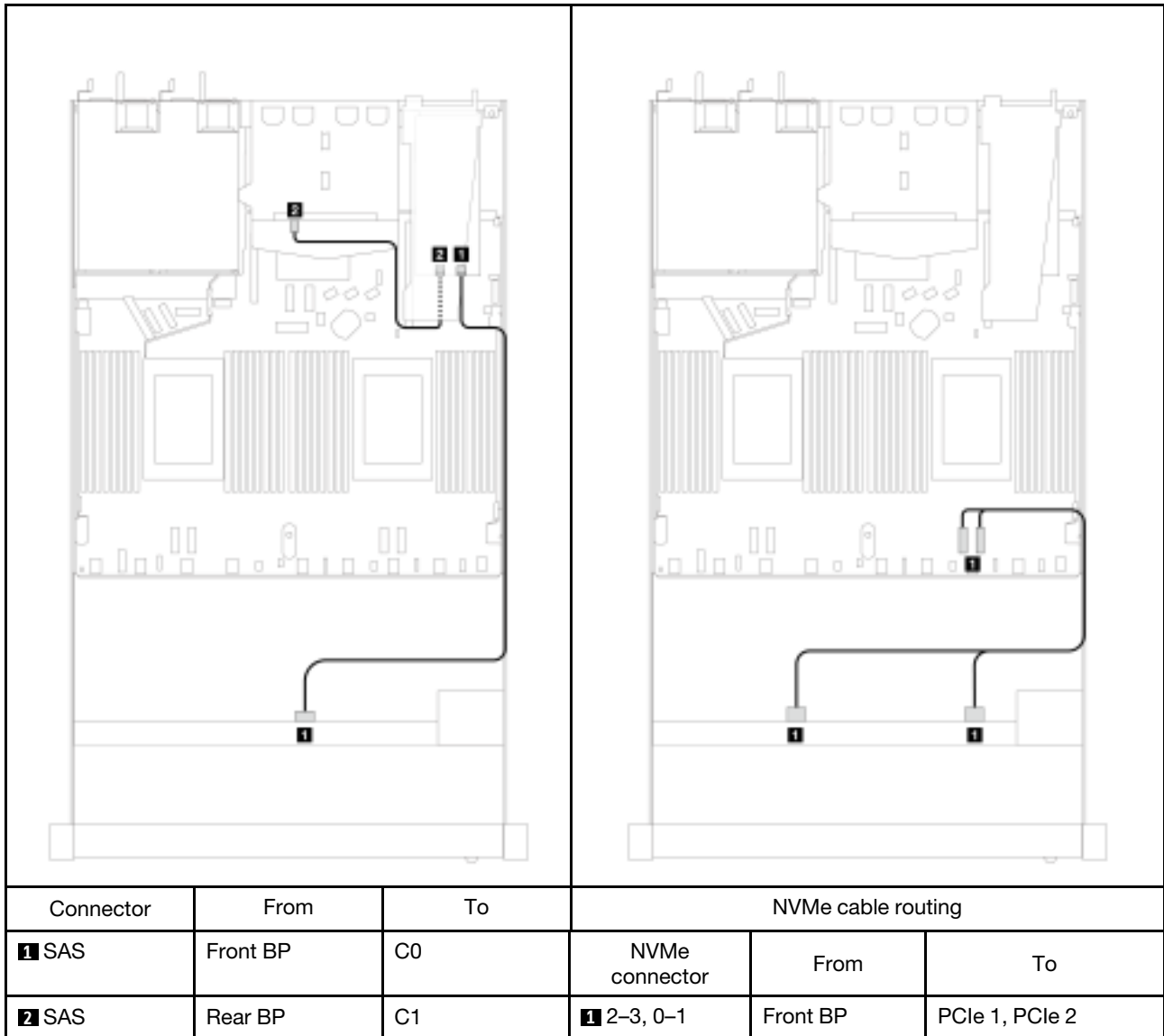
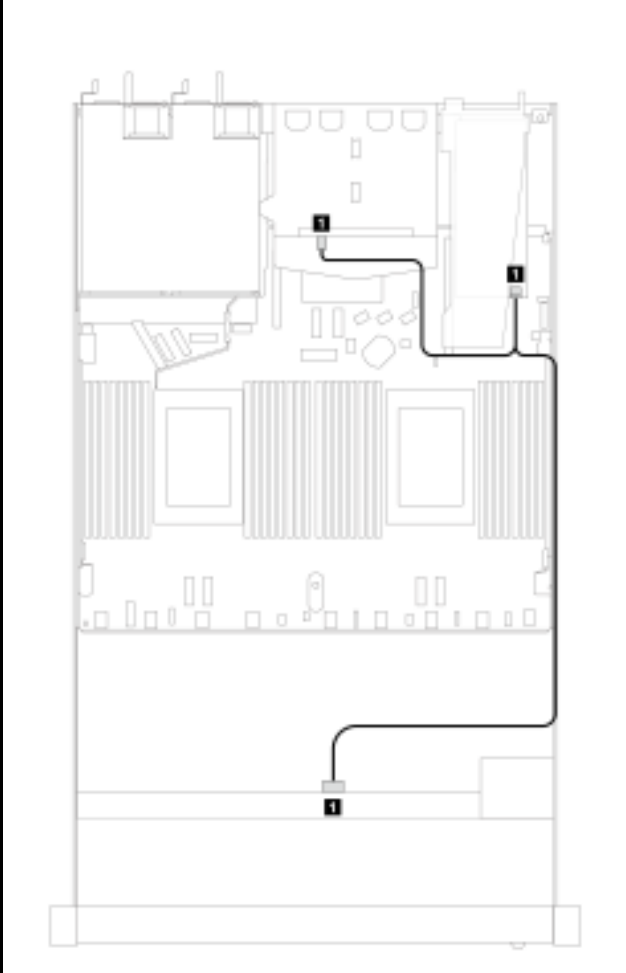
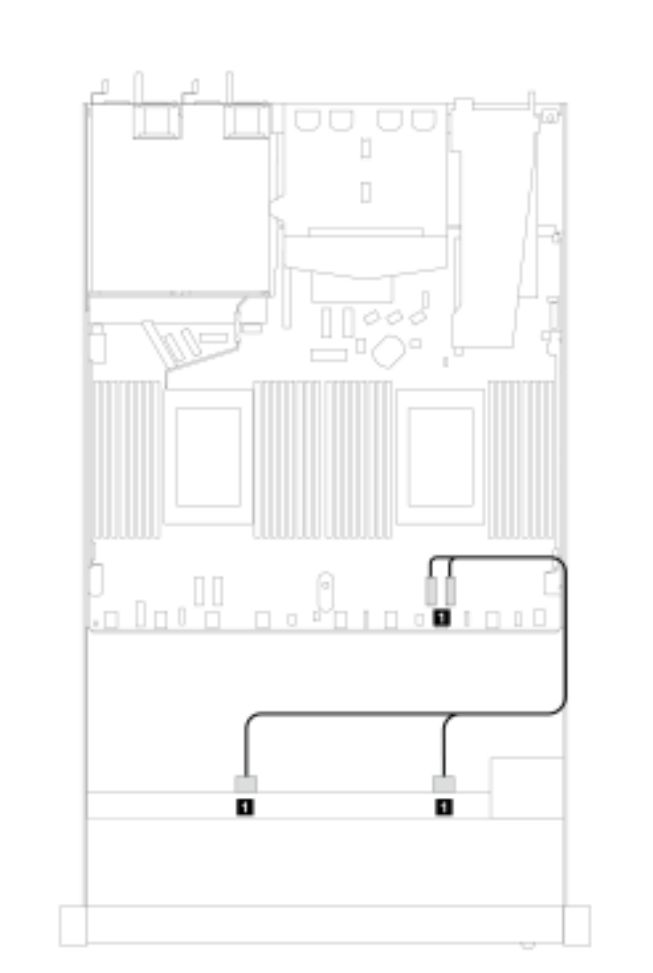


Table 114. Mapping between backplane and processor board/adaptor when an 8i SFF RAID adapter (Gen 4) and rear 2 x 2.5-inch SAS/SATA drives are installed

					
SAS/SATA cable routing			NVMe cable routing		
SAS/SATA connector	From	To	NVMe connector	From	To
<b>1</b> SAS	Front and rear BP	C0	<b>1</b> 2-3, 0-1	Front BP	PCIe 1, PCIe 2

## 4 x 2.5" front drives

Use the section to understand the cable routing for signal cable connections for 4 x 2.5-inch drive backplanes.

Under the configuration of 4 x 2.5-inch front drives, your server supports the following front backplanes:

### 4 x 2.5" SAS/SATA backplane

Use this section to understand the SAS/SATA backplane cable routing for server model with four 2.5-inch front drives.

To connect cables for a 7mm drive backplane, refer to [“7mm drive backplane” on page 270](#).

To connect power cables for a backplane for standard 2.5-inch or 3.5-inch drives, refer to [“Cable routing for backplane power” on page 274](#).

To connect signal cables for a backplane for standard 4 x 2.5-inch front drives, refer to the following cable routing scenarios depending on your server configuration:

- [“Cable routing for onboard configuration” on page 367](#)
- [“Cable routing with an SFF HBA/RAID adapter” on page 368](#)
- [“Cable routing for 4 x 2.5-inch front SAS/SATA drive bays with an 8i CFF RAID adapter \(Gen 3\) installed” on page 369](#)



### Cable routing for onboard configuration

The following table shows the mapping relationship between backplane connectors and processor board connectors for onboard configuration.

The following figure illustrates the cable routing for the onboard configuration of 4 x 2.5-inch front AnyBay drive bays. Connections between connectors: **1** ↔ **1**, **2** ↔ **2**, **3** ↔ **3**, ... **n** ↔ **n**

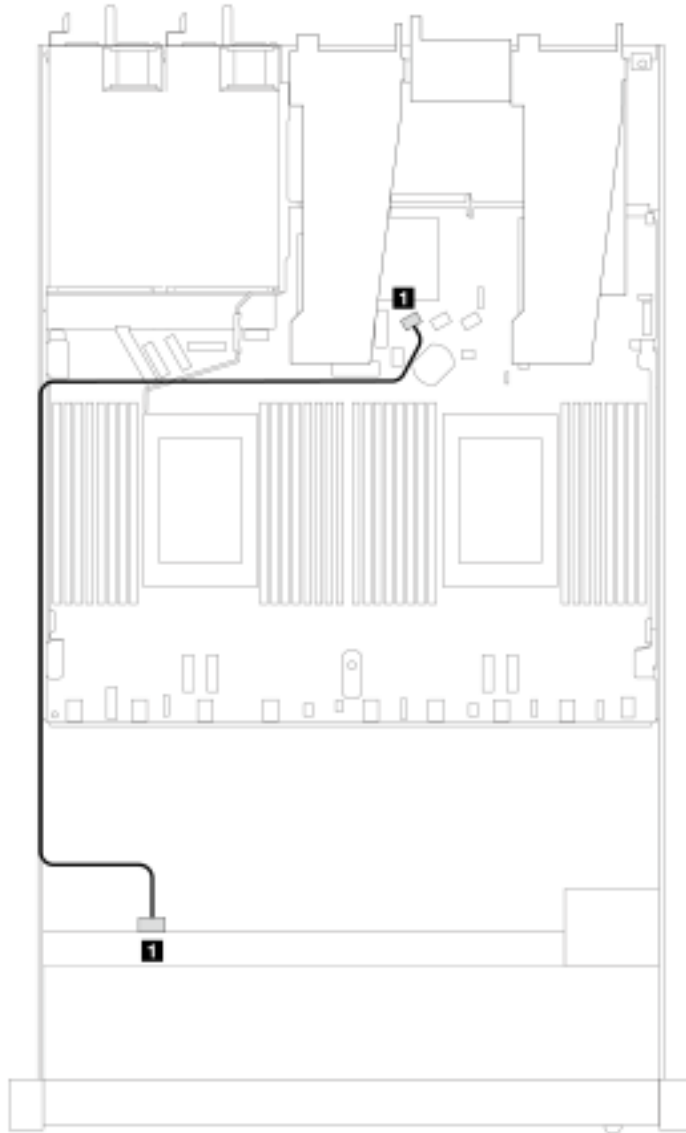


Figure 308. Cable routing for onboard configuration of 4 x 2.5-inch front AnyBay drive bays

Table 115. Mapping between backplane and processor board for onboard configuration

Backplanes	From	To
Front BP (SAS)	SAS	SATA 0

### Cable routing with an SFF HBA/RAID adapter

The following table shows the mapping relationship between backplane connectors and processor board/adapter connectors when an 8i SFF HBA/RAID adapter (Gen 3 or Gen 4) is installed.

The following figure illustrates the cable routing for the configuration of 4 x 2.5-inch front AnyBay drive bays with an 8i SFF RAID adapter. Connections between connectors: **1** ↔ **1**, **2** ↔ **2**, **3** ↔ **3**, ... **n** ↔ **n**

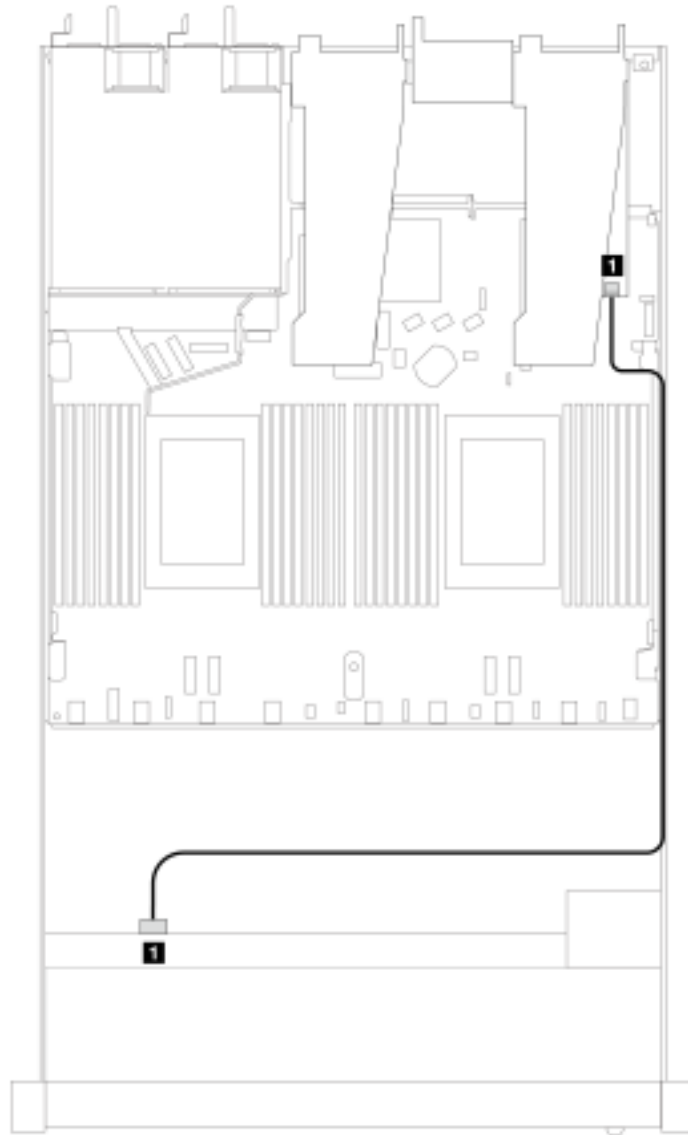


Figure 309. Cable routing for 4 x 2.5-inch front AnyBay drive bays with an 8i SFF RAID adapter

Table 116. Mapping between backplane and processor board/adapter when an SFF HBA/RAID adapter is installed

Backplanes	From	To
Front BP (SAS)	SAS	C0

**Notes:**

- Gen 3 and Gen 4 SFF HBA/RAID adapters are slightly different in their connectors, but the cable routing method is similar.
- To connect cables for RAID flash power module, refer to [“RAID flash power modules” on page 264](#).

**Cable routing for 4 x 2.5-inch front SAS/SATA drive bays with an 8i CFF RAID adapter (Gen 3) installed**

The following table shows the mapping relationship between backplane connectors and processor board/adapter connectors when an 8i CFF RAID adapter (Gen 3) is installed.

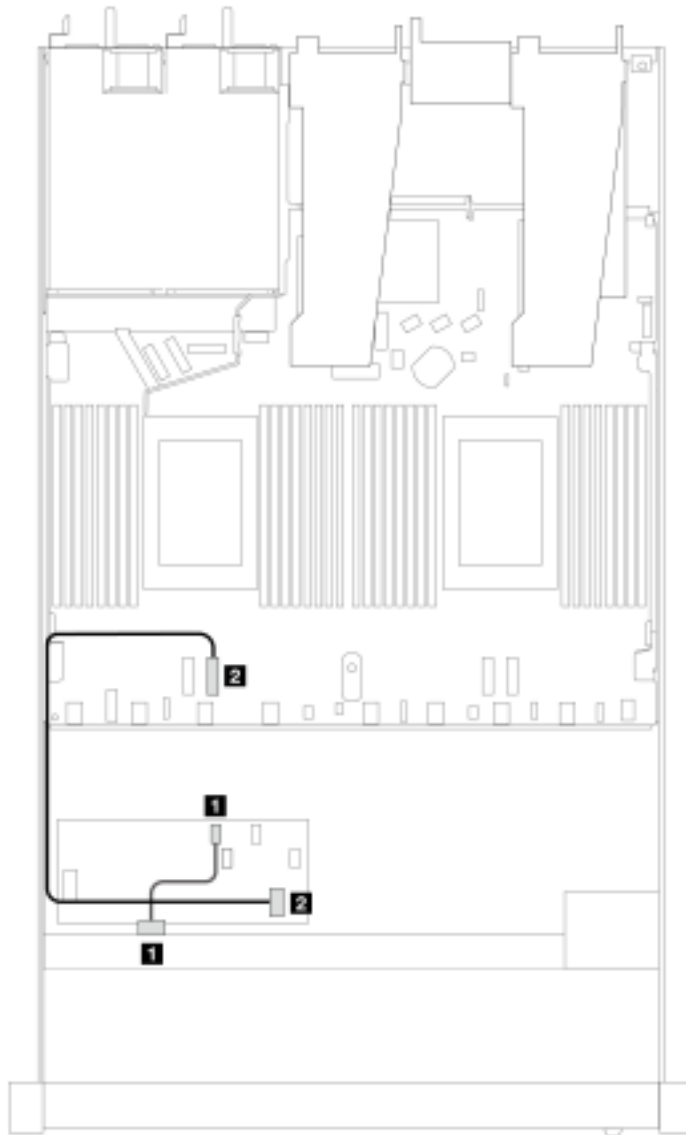


Figure 310. Cable routing for 4 x 2.5-inch front SAS/SATA drive bays with an 8i CFF RAID adapter installed

Table 117. Mapping between backplane and processor board/adapter when a CFF RAID adapter is installed

Backplanes	From	To
Front BP (SAS)	SAS	C0
CFF RAID adapter	MB input	PCIe 3

## 4 x 2.5" NVMe backplane

Use this section to understand the NVMe backplane cable routing for server model with four 2.5-inch front drives.

To connect cables for a 7mm drive backplane, refer to [“7mm drive backplane” on page 270](#).

To connect power cables for a backplane for standard 2.5-inch or 3.5-inch drives, refer to [“Cable routing for backplane power” on page 274](#).

To connect signal cables for a backplane for standard 4 x 2.5-inch front drives, refer to the following cable routing scenarios depending on your server configuration:

- [“Cable routing for onboard configuration with two processors” on page 370](#)

### Cable routing for onboard configuration with two processors

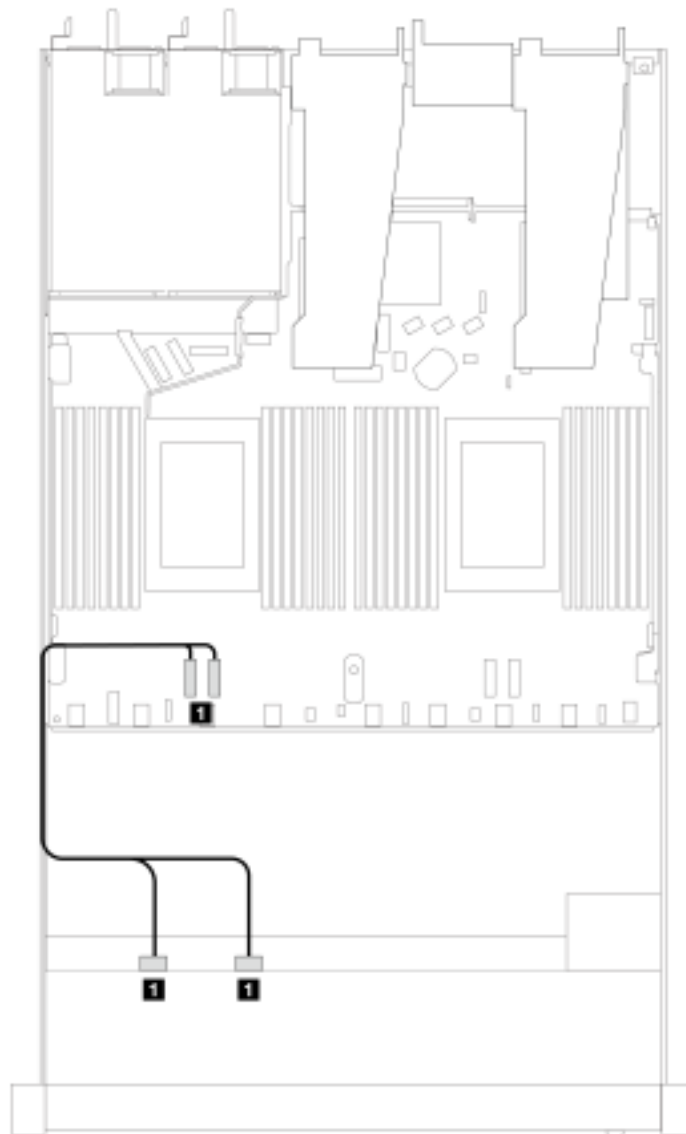


Figure 311. Cable routing for onboard configuration of 4 x 2.5-inch front NVMe drive bays with two processors

Table 118. Mapping between backplane and processor board for onboard configuration

Backplanes	From	To
Front BP (NVMe)	NVMe 0-1, NVMe 2-3	PCIe 3, PCIe 4

#### 4 x 2.5" U.3 front drives with 4 x 3.5" AnyBay backplane

Use this section to understand the cable routing for four U.3 drives with 4 x 3.5" Anybay backplane and two processors installed.

#### Cable routing with an SFF HBA/RAID adapter

The following illustrations and tables show the mapping relationship between backplane connectors and an 8i SFF RAID adapter (Gen 4).

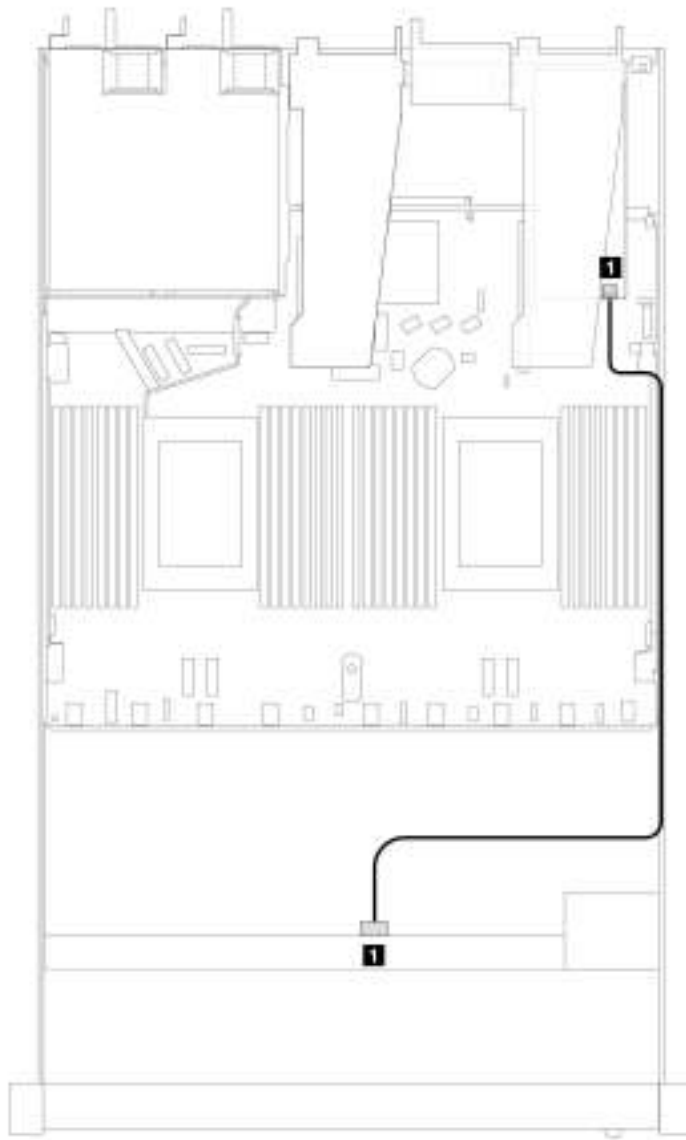


Figure 312. Cable routing for 4 x 2.5-inch front U.3 drives with an 8i SFF RAID adapter (Gen 4)

Table 119. Mapping between one front AnyBay backplane and an SFF HBA/RAID adapter

Backplane	From	To
Front BP (SAS)	SAS	C0

## 8 x 2.5" front drives

Use the section to understand the cable routing for signal cable connections for 8 x 2.5-inch drive backplanes.

Under the configuration of 8 x 2.5-inch front drives, your server supports the following front backplane:

### 8 x 2.5" SAS/SATA backplane

Use this section to understand the SAS/SATA backplane cable routing for server model with eight 2.5-inch front drives.

To connect cables for a 7mm drive backplane, refer to [“7mm drive backplane” on page 270](#).

To connect power cables for a backplane for standard 2.5-inch or 3.5-inch drives, refer to [“Cable routing for backplane power” on page 274](#).

To connect cables for M.2 drives, refer to [“M.2 drive backplane” on page 267](#).

To connect signal cables for a backplane for standard 4 x 3.5-inch front drives, refer to the following cable routing scenarios depending on your server configuration:

- [“Cable routing for onboard configuration” on page 372](#)
- [“Cable routing with an SFF HBA/RAID adapter” on page 374](#)
- [“Cable routing with a CFF RAID adapter” on page 378](#)

### Cable routing for onboard configuration

The following illustrations and tables show the mapping relationship between backplane connectors and processor board connectors for onboard configuration.

The following figure illustrates the cable routing for the onboard configuration of 8 x 2.5-inch front SAS/SATA drive bays. Connections between connectors: **1** ↔ **1**, **2** ↔ **2**, **3** ↔ **3**, ... **n** ↔ **n**.

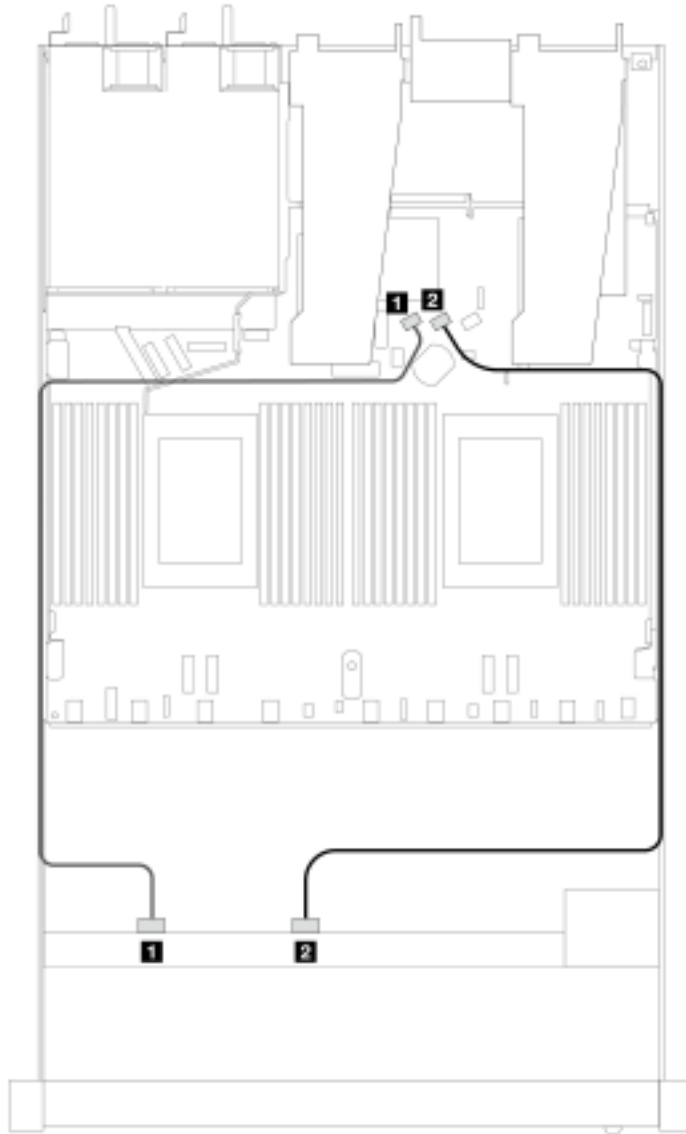


Figure 313. Cable routing for onboard configuration of 8 x 2.5 SAS/SATA front drives

Table 120. Mapping between one front SAS/SATA backplane and processor board for onboard configuration

Backplane	From	To
Front BP (SAS)	1 SAS 0	1 SATA 0
	2 SAS 1	2 SATA 1

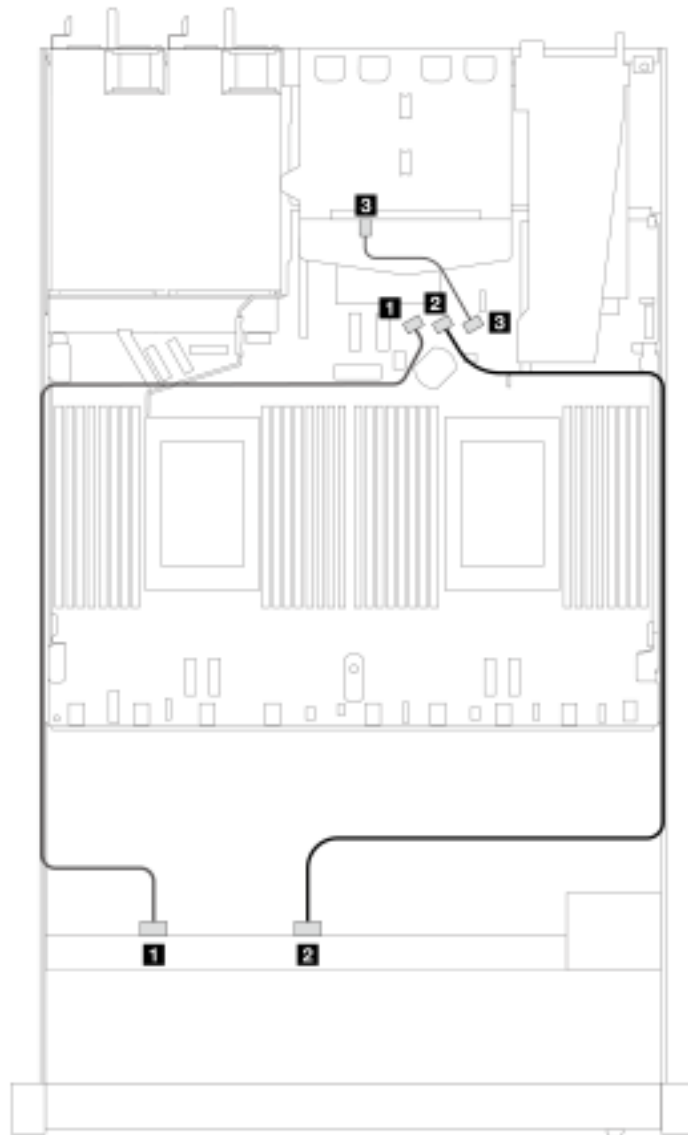


Figure 314. Cable routing for onboard configuration of 8 x 2.5 SAS/SATA front drives with 2 x 2.5 rear SAS/SATA drives installed

Table 121. Mapping between one front and one rear SAS/SATA backplanes and processor board for onboard configuration

Backplane	From	To
Front BP (SAS)	1 SAS 0	1 SATA 0
	2 SAS 1	2 SATA 1
Rear BP (SAS)	3 SAS	3 SATA 2

### Cable routing with an SFF HBA/RAID adapter

The following illustrations and tables show the mapping relationship between backplane connectors and an 8i or 16i SFF HBA/RAID adapter (Gen 3 or Gen 4).



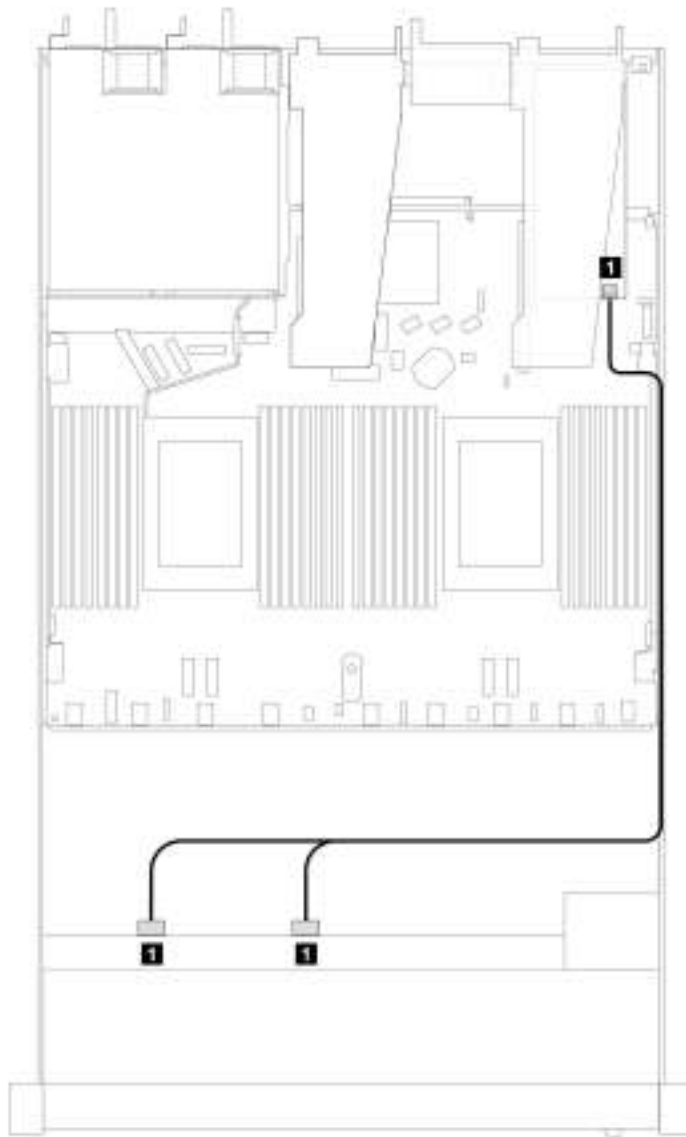


Figure 315. Cable routing for 8 x 2.5-inch front SAS/SATA drive bays with an 8i SFF RAID adapter (Gen 4)

Table 122. Mapping between one front SAS/SATA backplane and an SFF HBA/RAID adapter

Backplane	From	To
Front BP (SAS)	1 SAS 0, SAS 1	1 C0

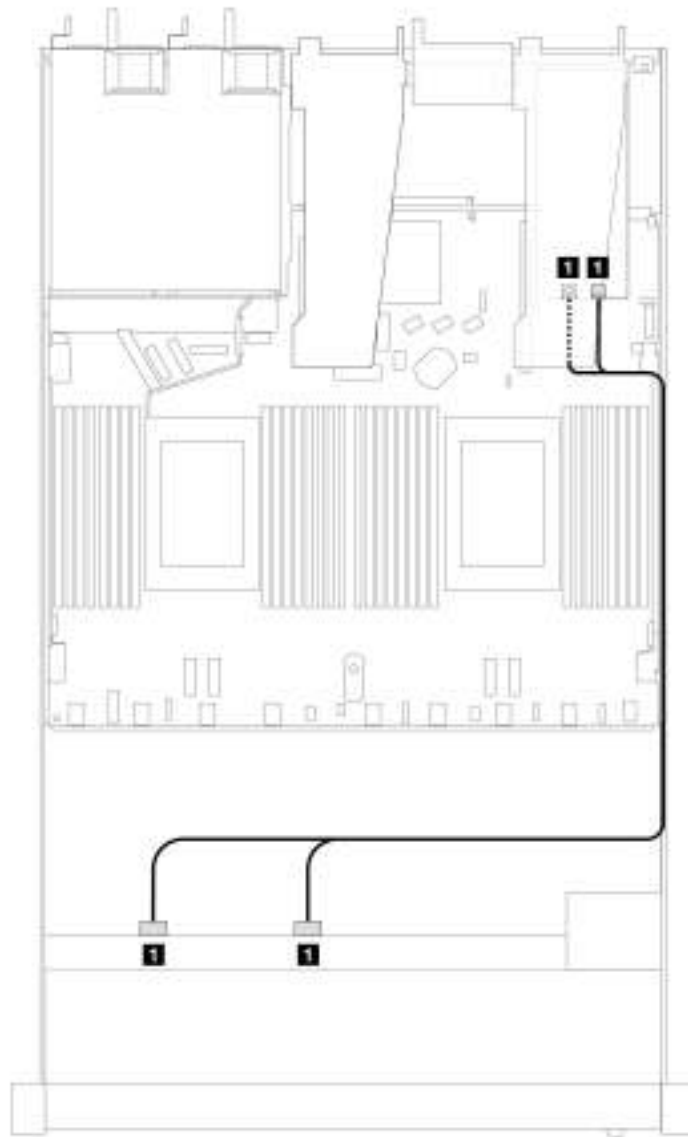


Figure 316. Cable routing for 8 x 2.5-inch front SAS/SATA drive bays with an 8i or 16i SFF RAID adapter (Gen 3)

Table 123. Mapping between one front SAS/SATA backplane and an SFF HBA/RAID adapter

Backplane	From	To
Front BP (SAS)	1 SAS 0, SAS 1	1 C0, C1

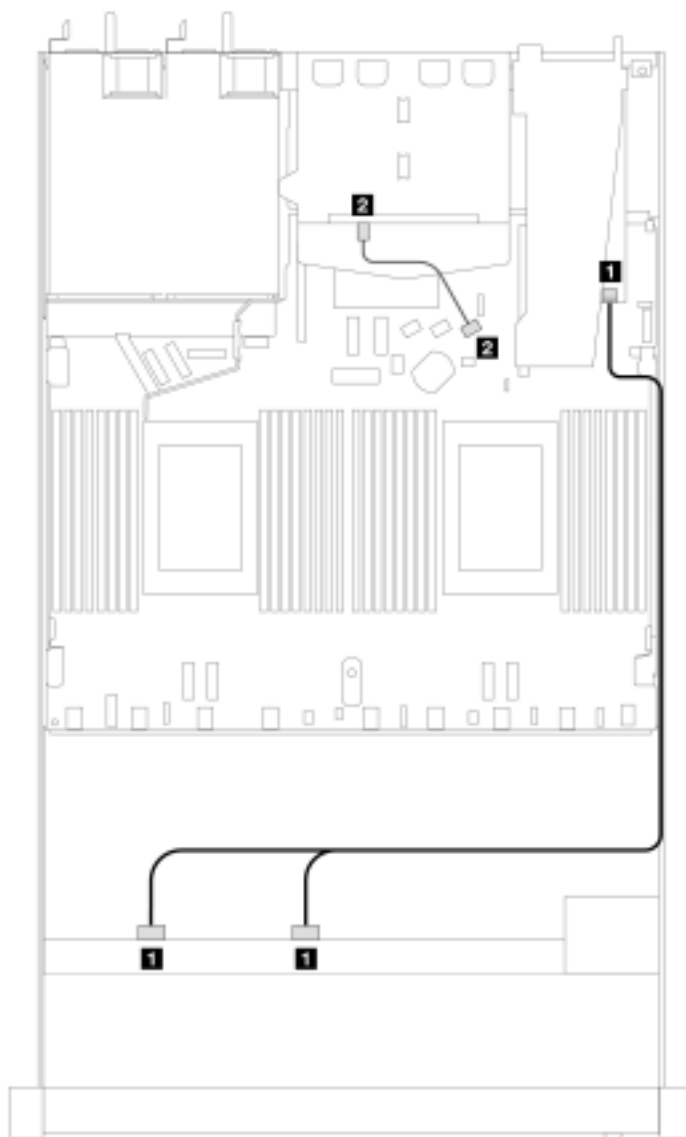


Figure 317. Cable routing for 8 x 2.5-inch front SAS/SATA drive bays with an 8i or 16i SFF RAID adapter (Gen 4) with 2 x 2.5 SAS/SATA rear drives installed

Table 124. Mapping between one front and one rear SAS/SATA backplanes and an SFF HBA/RAID adapter

Backplane	From	To
Front BP (SAS)	1 SAS 0, SAS 1	1 C0
Rear BP (SAS)	2 SAS	2 SATA 2

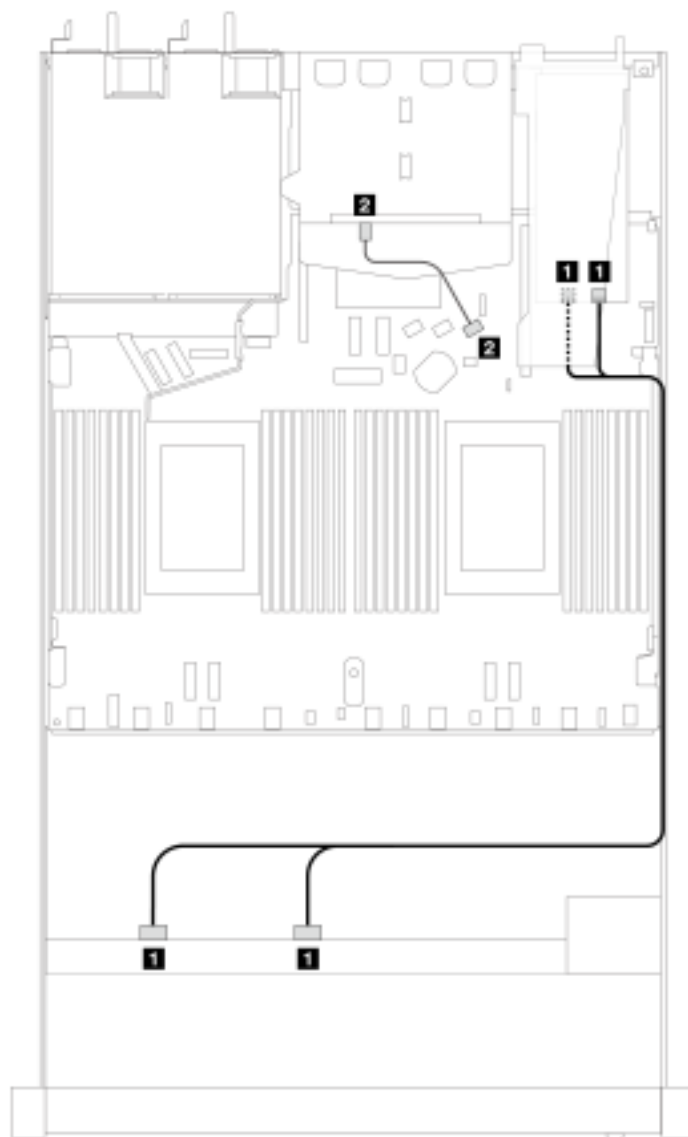


Figure 318. Cable routing for 8 x 2.5-inch front SAS/SATA drive bays with an 8i or 16i SFF RAID adapter (Gen 3) with 2 x 2.5 SAS/SATA rear drives installed

Table 125. Mapping between one front and one rear SAS/SATA backplanes and an SFF HBA/RAID adapter

Backplane	From	To
Front BP (SAS)	1 SAS 0, SAS 1	1 C0, C1
Rear BP (SAS)	2 SAS	2 SATA 2

### Cable routing with a CFF RAID adapter

The following illustrations and tables show the mapping relationship between backplane connectors and an 8i or 16i CFF RAID adapter (Gen 3 or Gen 4).

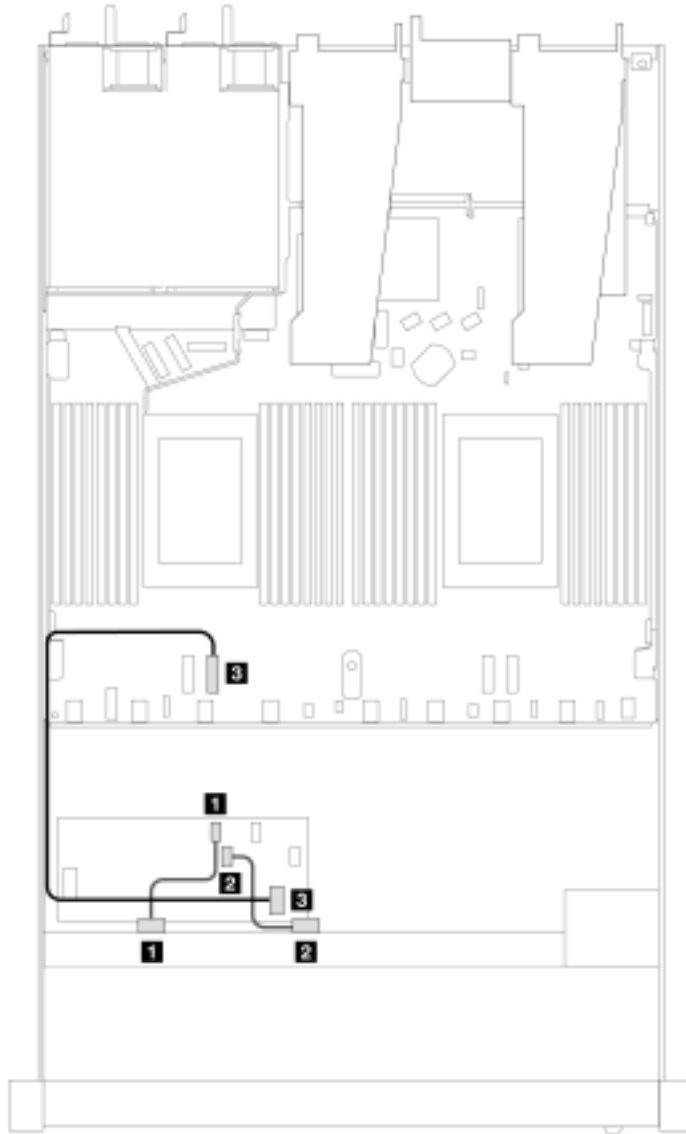


Figure 319. Cable routing for 8 x 2.5-inch front SAS/SATA drive bays with an 8i or 16i CFF RAID adapter (Gen 3 or Gen 4)

Table 126. Mapping between one front SAS/SATA backplane and a CFF RAID adapter

Backplane/adapter	From	To
Front BP (SAS)	1 SAS 0	1 C0
	2 SAS 1	2 C1
CFF RAID adapter	3 MB input	3 PCIe 3

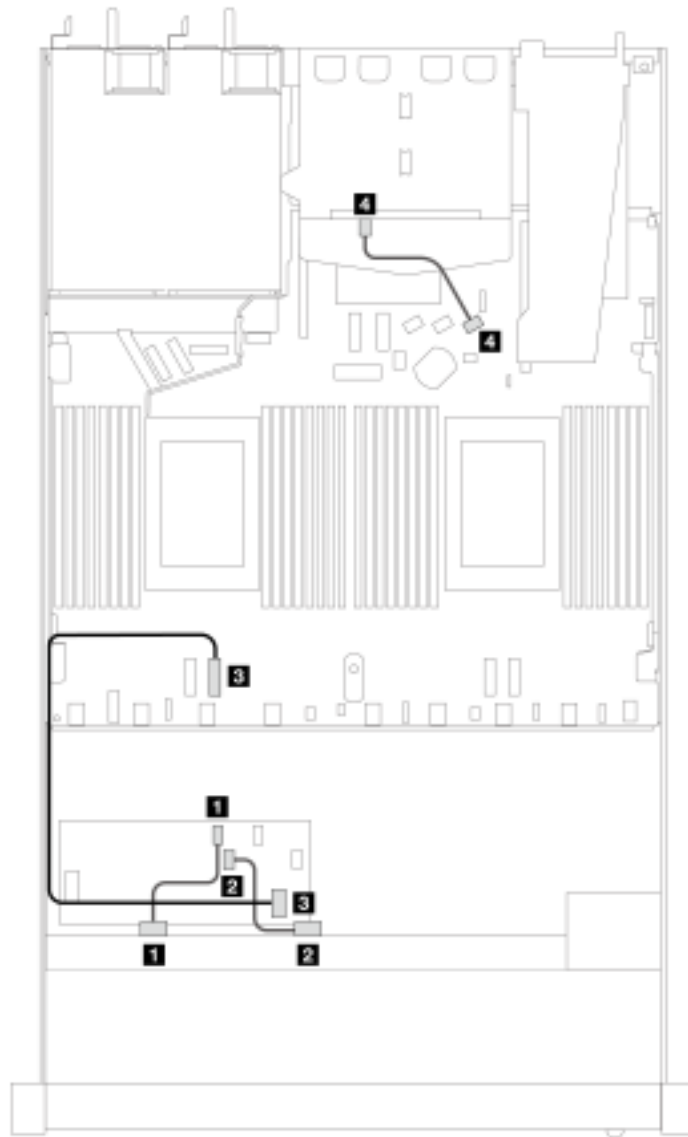


Figure 320. Cable routing for 8 x 2.5-inch front SAS/SATA drive bays with an 8i CFF RAID adapter (Gen 3) with 2 x 2.5 SAS/SATA drives installed

Table 127. Mapping between one front and one rear SAS/SATA backplane and a CFF RAID adapter

Backplane/adapter	From	To
Front BP (SAS)	1 SAS 0	1 C0
	2 SAS 1	2 C1
CFF RAID adapter	3 MB input	3 PCIe 3
Rear BP (SAS)	4 SAS (rear)	4 SATA 2

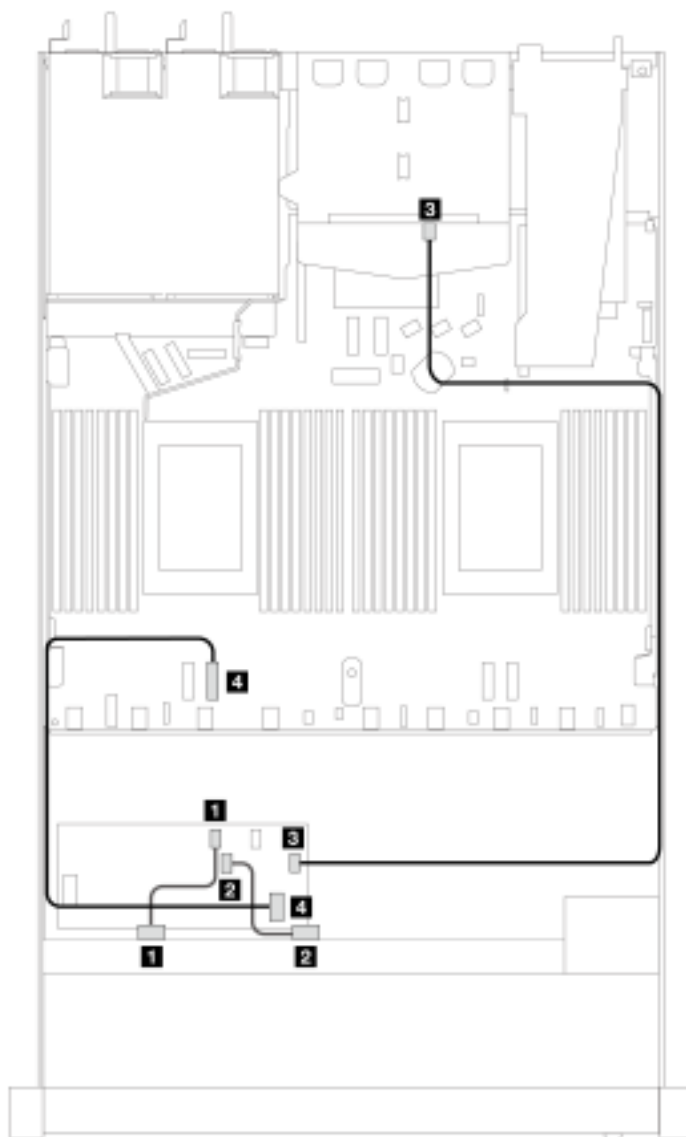


Figure 321. Cable routing for 8 x 2.5-inch front SAS/SATA drive bays with a 16i CFF RAID adapter (Gen 3 or Gen 4) with 2 x 2.5 SAS/SATA drives installed

Table 128. Mapping between one front and one rear SAS/SATA backplane and a CFF RAID adapter

Backplane/adapter	From	To
Front BP (SAS)	1 SAS 0	1 C0
	2 SAS 1	2 C1
CFF RAID adapter	3 C3	3 SAS (rear)
	4 MB input	4 PCIe 3

### 8 x 2.5" U.3 drives with 10 x 2.5 AnyBay backplane

Use this section to understand the cable routing for eight U.3 drives with 10 x 2.5 Anybay backplane and two processors installed.

### Cable routing with an SFF HBA/RAID adapter

The following illustrations and tables show the mapping relationship between backplane connectors and an 8i SFF RAID adapter (Gen 4).

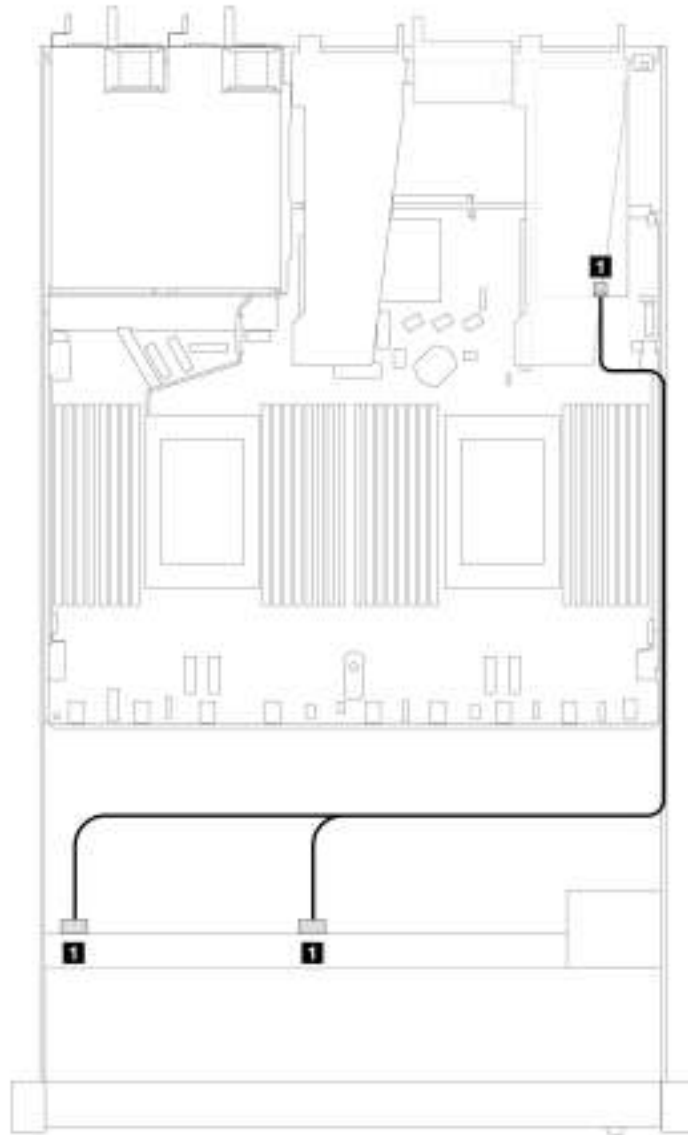


Figure 322. Cable routing for 8 x 2.5-inch front U.3 drives with an 8i SFF RAID adapter (Gen 4)

Table 129. Mapping between one front AnyBay backplane and an SFF HBA/RAID adapter

Backplane	From	To
Front BP (SAS)	SAS 0, SAS 1	C0

### 10 x 2.5" front drives

Use the section to understand the cable routing for signal cable connections for 10 x 2.5-inch drive backplanes.



Under the configuration of 10 x 2.5-inch front drives, your server supports the following front backplanes:

### **6 x 2.5" SAS/SATA + 4 x 2.5" AnyBay backplane**

Use this section to understand the alternatives that a 6 x SAS/SATA + 4 x AnyBay backplane offers.

With a 6 x SAS/SATA + 4 x AnyBay backplane, following front drive combinations are supported:

#### **6 x 2.5" SAS/SATA + 4 x 2.5" AnyBay**

See this section to understand the cable routing of 6 front SAS/SATA drives and 4 front AnyBay drives with the 6 x 2.5" SAS/SATA + 4 x 2.5" AnyBay backplane installed.

To connect cables for a 7mm drive backplane, refer to [“7mm drive backplane” on page 270](#).

To connect power cables for a backplane for standard 2.5-inch or 3.5-inch drives, refer to [“Cable routing for backplane power” on page 274](#).

To connect cables for M.2 drives, refer to [“M.2 drive backplane” on page 267](#).

To connect signal cables for a backplane for standard 6 front SAS/SATA drives and 4 front AnyBay drives, refer to the following cable routing scenarios depending on your server configuration:

- [“Cable routing for onboard configuration” on page 383](#)
- [“Cable routing with an SFF HBA/RAID adapter” on page 385](#)
- [“Cable routing with a CFF RAID adapter” on page 389](#)

#### **Cable routing for onboard configuration**

The following tables show the mapping relationship between backplane connectors and processor board connectors for onboard configuration.

The following figure illustrates the cable routing for the configuration of 6 front SAS/SATA drives and 4 front AnyBay drives bays. Connections between connectors: **1** ↔ **1**, **2** ↔ **2**, **3** ↔ **3**, ... **n** ↔ **n**.

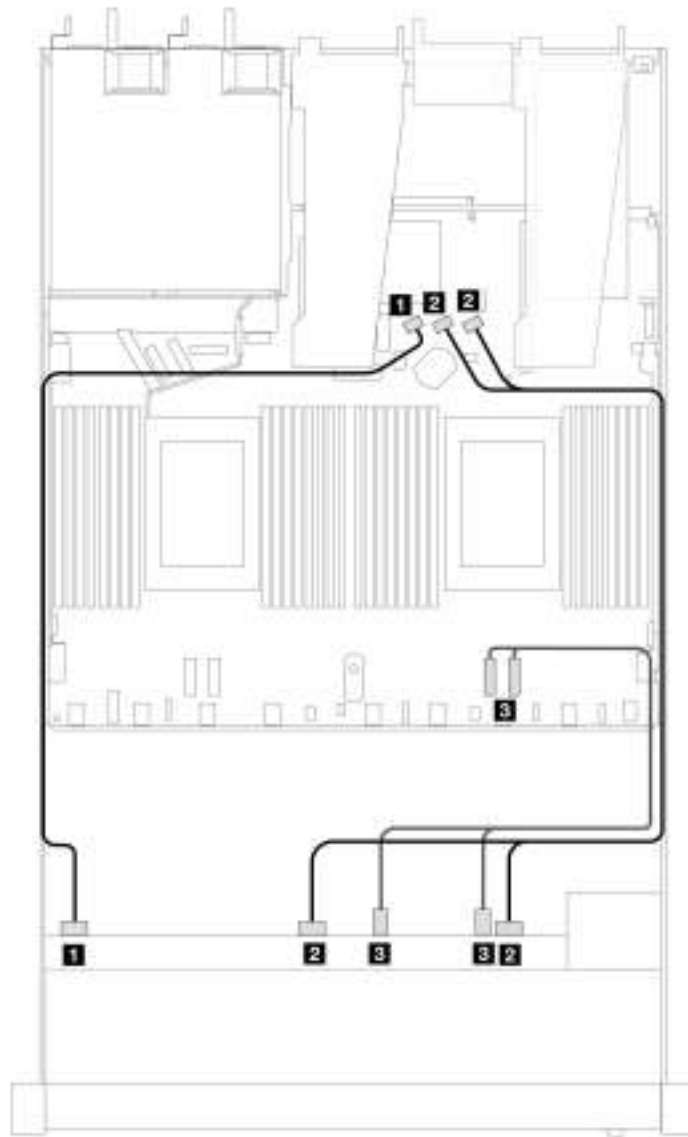


Figure 323. Cable routing for onboard configuration of 6 front SAS/SATA drives and 4 front AnyBay drives bays

Table 130. Mapping between one front AnyBay backplane and processor board for onboard configuration

Backplane	From	To
Front BP (SAS)	1 SAS 0	1 SATA 0
	2 SAS 1, SAS 2	2 SATA 1, SATA 2
Front BP (NVMe)	3 NVMe 2-3, 0-1	3 PCIe 1, 2

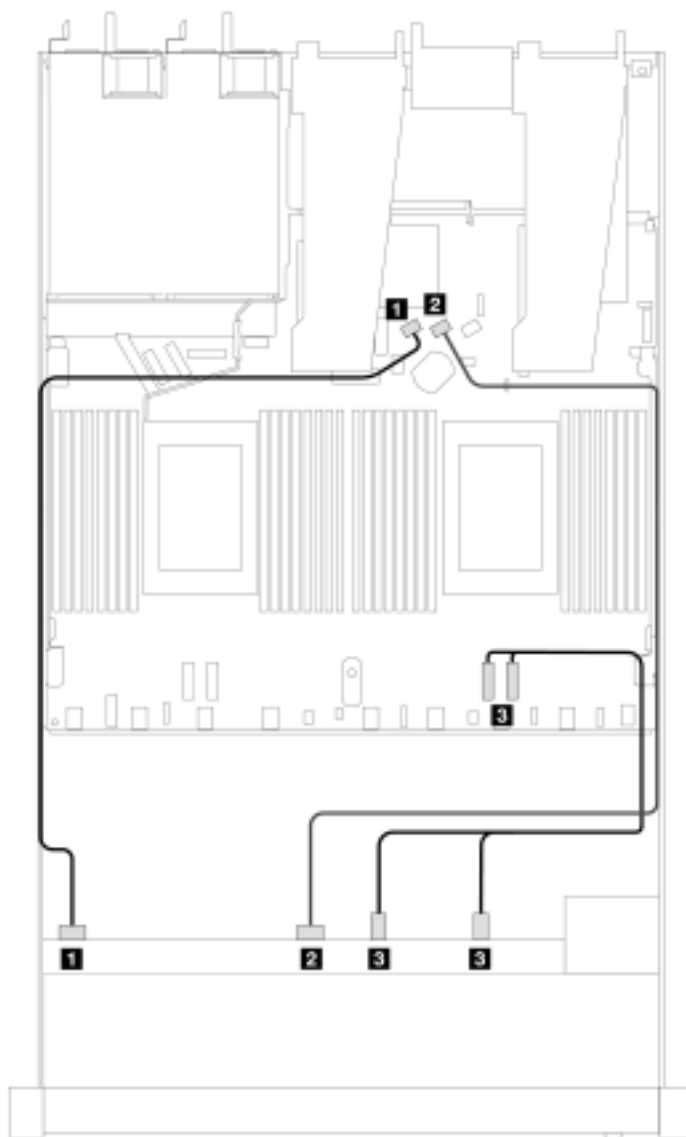


Figure 324. Cable routing for onboard configuration of 6 front SAS/SATA drives and 4 front NVMe drives bays

Table 131. Mapping between one front AnyBay backplane and processor board for onboard configuration

Backplane	From	To
Front BP (SAS)	1 SAS 0	1 SATA 0
	2 SAS 1	2 SATA 1
Front BP (NVMe)	3 NVMe 2-3, 0-1	3 PCIe 1, PCIe 2

### Cable routing with an SFF HBA/RAID adapter

The following tables show the mapping relationship between backplane connectors and a 16i SFF HBA/RAID adapter (Gen 3 or Gen 4).

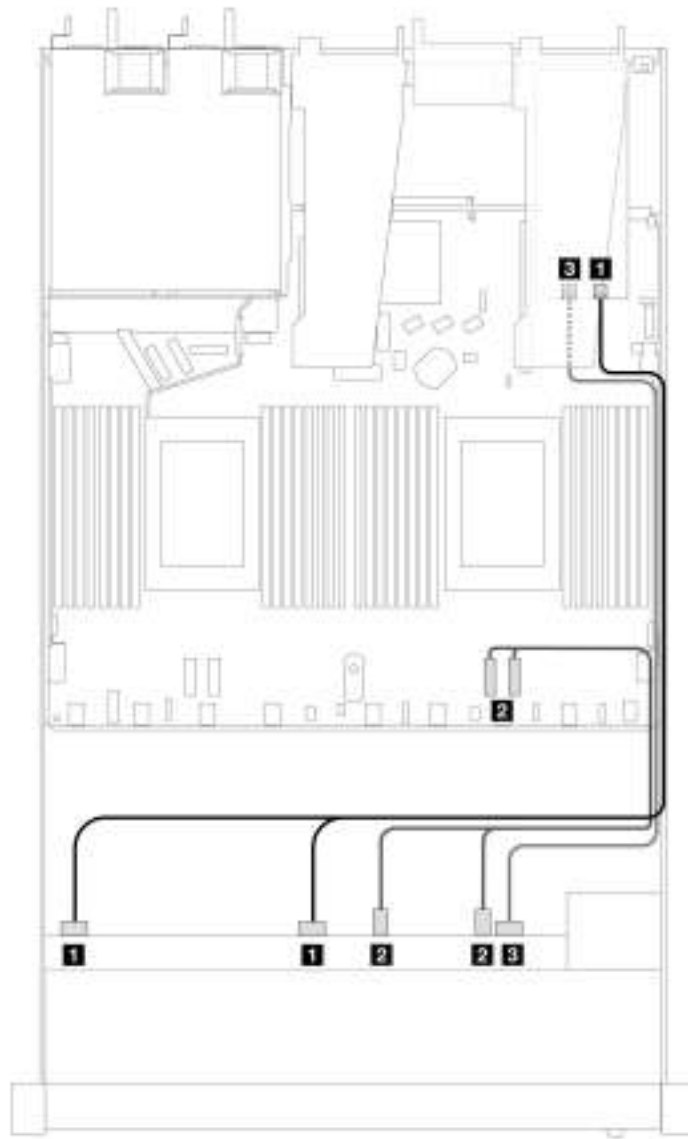


Figure 325. Cable routing for 6 front SAS/SATA drives and 4 front AnyBay drives bays with a 16i SFF RAID adapter (Gen 4)

Table 132. Mapping between one front AnyBay backplane and an SFF HBA/RAID adapter

Backplane	From	To
Front BP (SAS)	<b>1</b> SAS 0, SAS 1	<b>1</b> C0
Front BP (NVMe)	<b>2</b> NVMe 2-3, 0-1	<b>2</b> PCIe 1, 2
Front BP (SAS)	<b>3</b> SAS 2	<b>3</b> C1

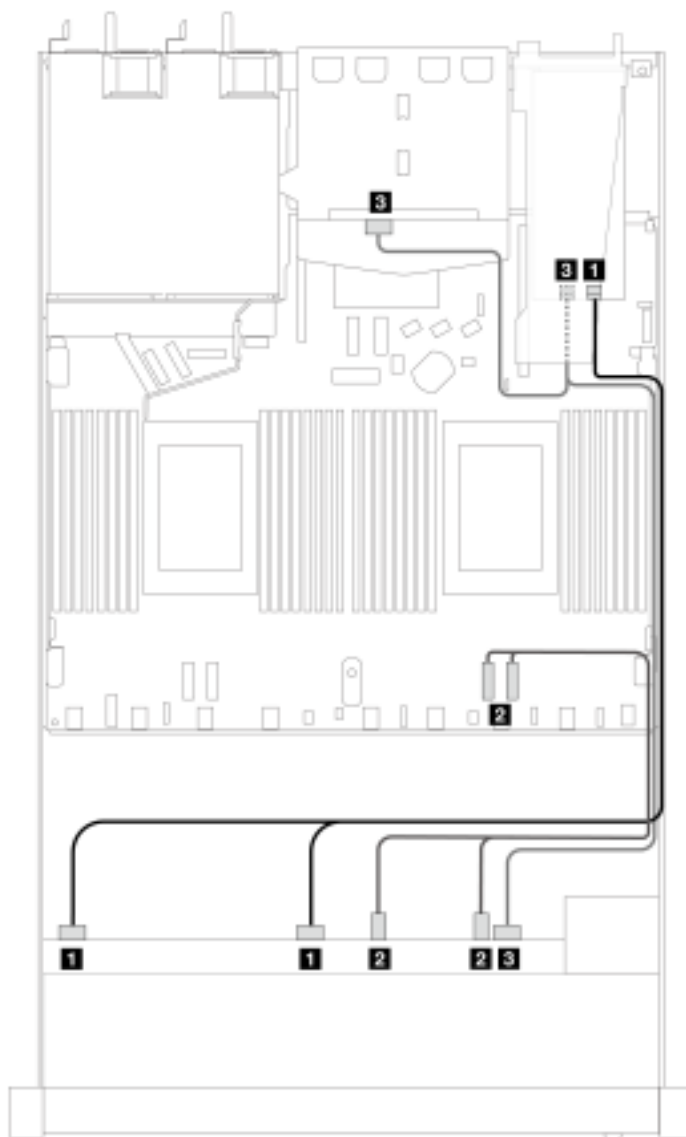


Figure 326. Cable routing for 6 front SAS/SATA drives and 4 front AnyBay drives bays and a 16i SFF RAID adapter (Gen 4) with 2 x 2.5 rear SAS/SATA drives installed

Table 133. Mapping between one front AnyBay and one rear SAS/SATA backplanes and an SFF HBA/RAID adapter

Backplane	From	To
Front BP (SAS)	1 SAS 0, SAS 1	1 C0
Front BP (NVMe)	2 NVMe 2-3, 0-1	2 PCIe 1, 2
Front and Rear BP (SAS)	3 SAS 2 (front), SAS (rear)	3 C1

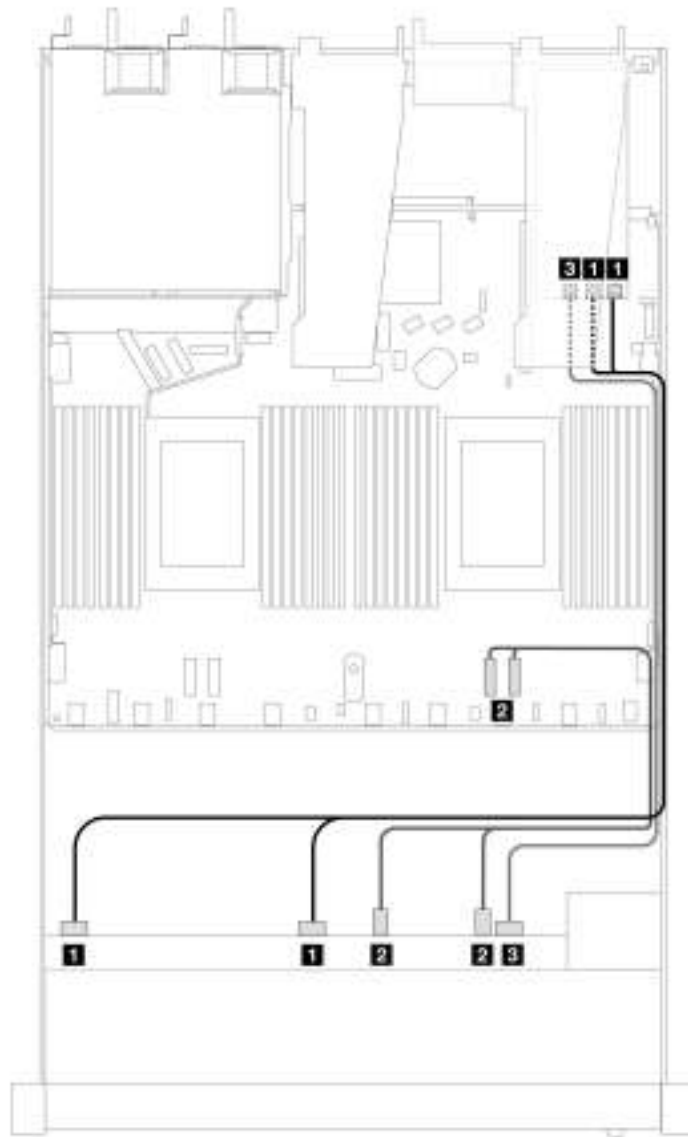


Figure 327. Cable routing for 6 front SAS/SATA drives and 4 front AnyBay drives bays with a 16i SFF RAID adapter (Gen 3)

Table 134. Mapping between one front AnyBay backplane and an SFF HBA/RAID adapter

Backplane	From	To
Front BP (SAS)	<b>1</b> SAS 0, SAS 1	<b>1</b> C0, C1
Front BP (NVMe)	<b>2</b> NVMe 2-3, 0-1	<b>2</b> PCIe 1, 2
Front BP (SAS)	<b>3</b> SAS 2	<b>3</b> C2

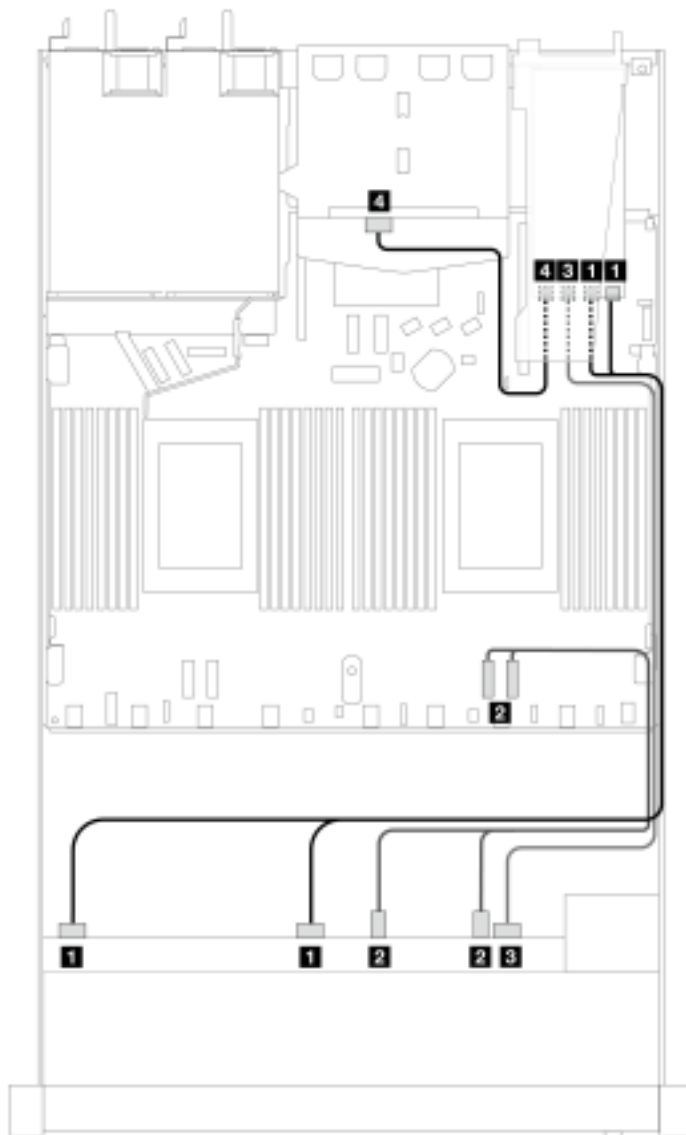


Figure 328. Cable routing for 6 front SAS/SATA drives and 4 front AnyBay drives bays and a 16i SFF RAID adapter (Gen 3) with 2 x 2.5 rear SAS/SATA drives installed

Table 135. Mapping between one front AnyBay and one rear SAS/SATA backplanes and an SFF HBA/RAID adapter

Backplane	From	To
Front BP (SAS)	1 SAS 0, SAS 1	1 C0, C1
Front BP (NVMe)	2 NVMe 2-3, 0-1	2 PCIe 1, 2
Front BP (SAS)	3 SAS 2	3 C2
Front and Rear BP (SAS)	4 SAS (rear)	4 C3

### Cable routing with a CFF RAID adapter

The following tables show the mapping relationship between backplane connectors and a 16i CFF RAID adapter (Gen 3 or Gen 4).

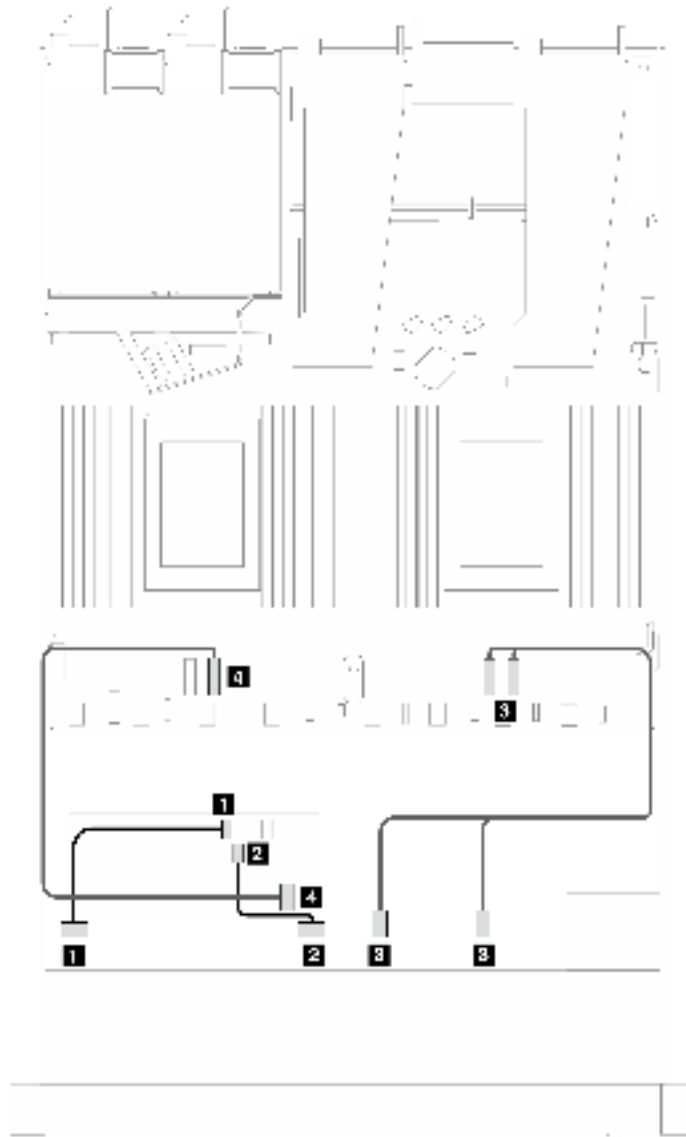


Figure 329. Cable routing for 6 front SAS/SATA drives and 4 front AnyBay drives bays with a 16i CFF RAID adapter (Gen 3 or Gen 4)

Table 136. Mapping between one front SAS/SATA backplane and a CFF RAID adapter

Backplane/adapter	From	To
Front BP (SAS)	1 SAS 0	1 C0
	2 SAS 1	2 C1
Front BP (NVMe)	3 NVMe 2-3, 0-1	3 PCIe 1, 2
Front BP (SAS)	4 SAS 2	4 C2
CFF RAID adapter	5 MB input	5 PCIe 3



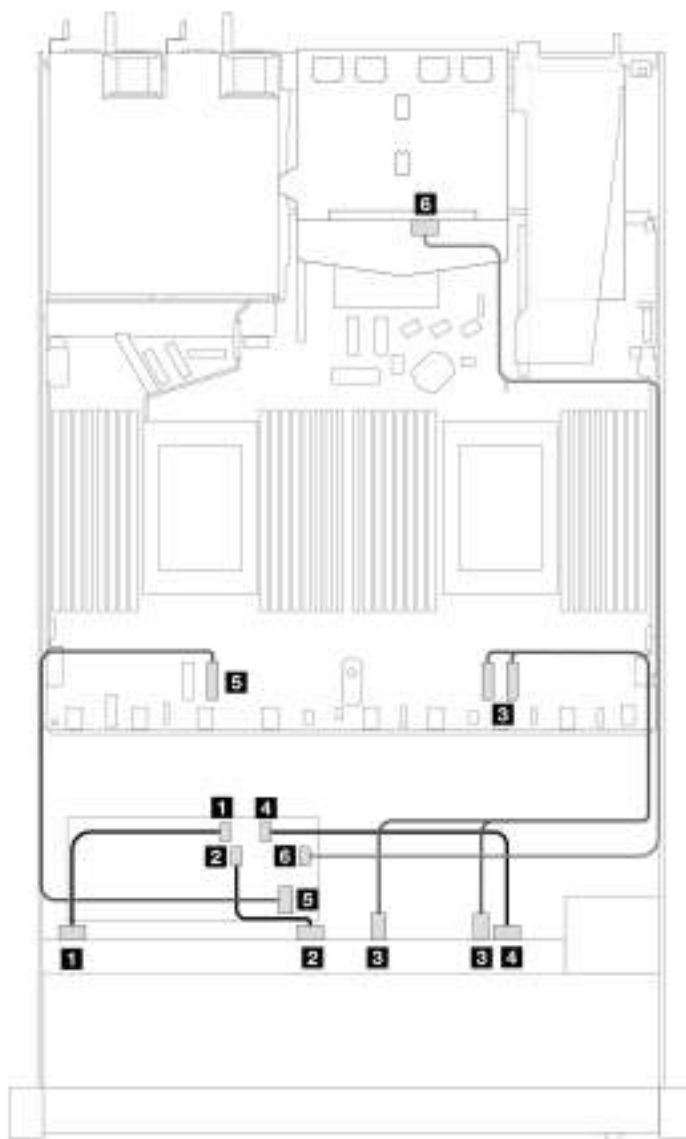


Figure 330. Cable routing for 6 front SAS/SATA drives and 4 front AnyBay drives bays with a 16i CFF RAID adapter (Gen 3 or Gen 4) with 2 x 2.5 rear SAS/SATA drives installed

Table 137. Mapping between one front AnyBay and one rear SAS/SATA backplane and a CFF RAID adapter

Backplane/adapter	From	To
Front BP (SAS)	1 SAS 0	1 C0
	2 SAS 1	2 C1
Front BP (NVMe)	3 NVMe 2-3, 0-1	3 PCIe 1, 2
Front BP (SAS)	4 SAS 2	4 C2
CFF RAID adapter	5 MB input	5 PCIe 3
	6 C3	6 SAS (rear)

### **6 x 2.5" SAS/SATA + 2 x 2.5" AnyBay + 2 x 2.5" NVMe**

See this section to understand the cable routing of 6 front SAS/SATA drives, 2 front AnyBay drives and 2 front NVMe drives.

To connect cables for a 7mm drive backplane, refer to [“7mm drive backplane” on page 270](#).

To connect power cables for a backplane for standard 2.5-inch or 3.5-inch drives, refer to [“Cable routing for backplane power” on page 274](#).

To connect cables for M.2 drives, refer to [“M.2 drive backplane” on page 267](#).

To connect signal cables for a backplane for standard 6 front SAS/SATA drives, 2 AnyBay drives and 2 front NVMe drives, refer to the following cable routing scenarios depending on your server configuration:

- [“Cable routing for onboard configuration” on page 392](#)
- [“Cable routing with an SFF HBA/RAID adapter” on page 393](#)
- [“Cable routing with a CFF RAID adapter” on page 395](#)

#### **Cable routing for onboard configuration**

The following tables show the mapping relationship between backplane connectors and processor board connectors for onboard configuration.

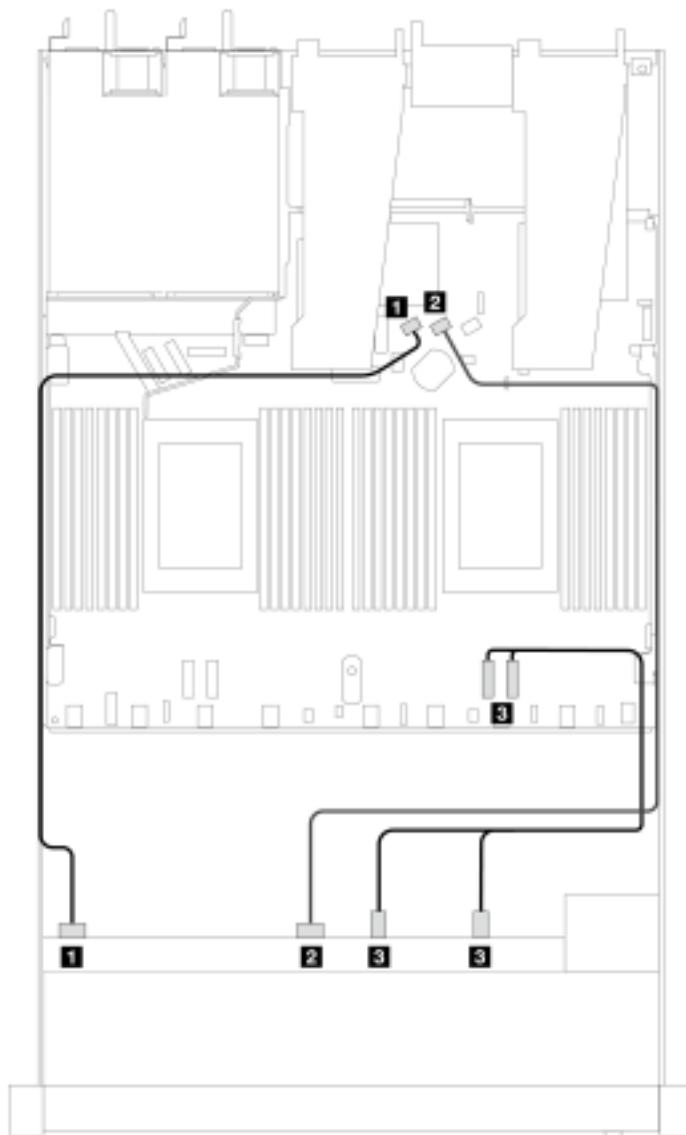


Figure 331. Cable routing for onboard configuration of 6 SAS/SATA drives and 2 AnyBay and 2 NVMe front drives bays

Table 138. Mapping between one front AnyBay backplane and processor board for onboard configuration

Backplane	From	To
Front BP (SAS)	1 SAS 0	1 SATA 0
	2 SAS 1	2 SATA 1
	3 NVMe 2-3, 0-1	3 PCIe 1, 2

### Cable routing with an SFF HBA/RAID adapter

The following tables show the mapping relationship between backplane connectors and an SFF HBA/RAID adapter.

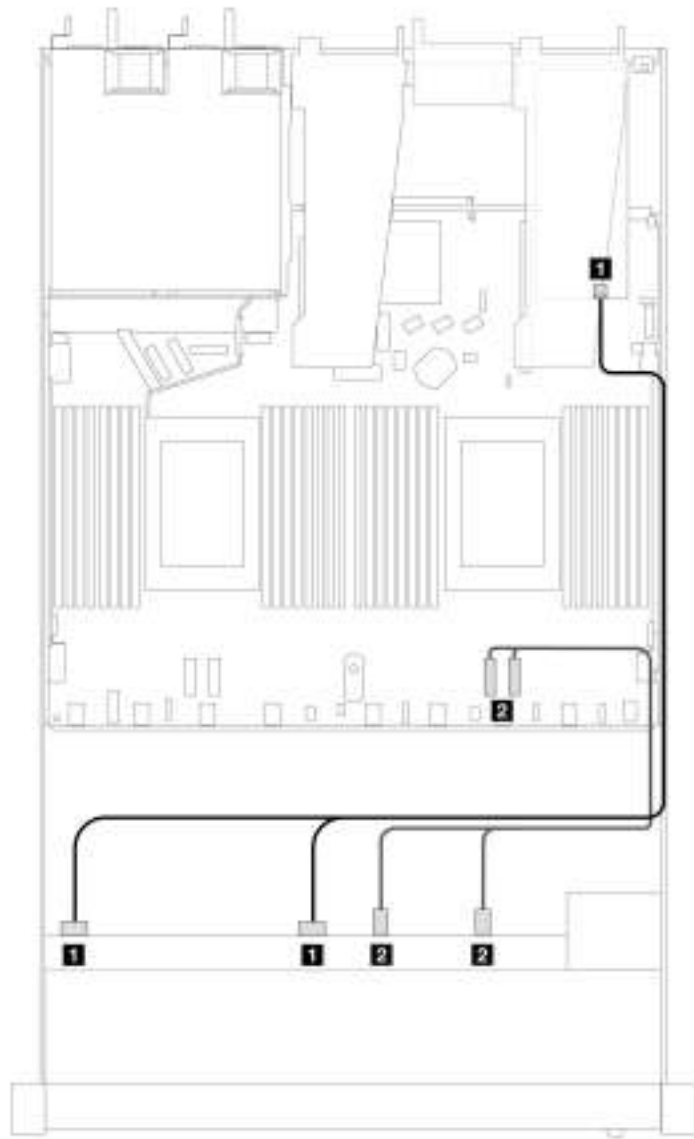


Figure 332. Cable routing for 6 SAS/SATA drives and 2 AnyBay drives and 2 NVMe front drive bays with an 8i or 16i SFF RAID adapter (Gen 4)

Table 139. Mapping between one front AnyBay backplane and an SFF HBA/RAID adapter

Backplane	From	To
Front BP (SAS)	1 SAS 0, SAS 1	1 C0
	2 NVMe 2-3, 0-1	2 PCIe 1, 2

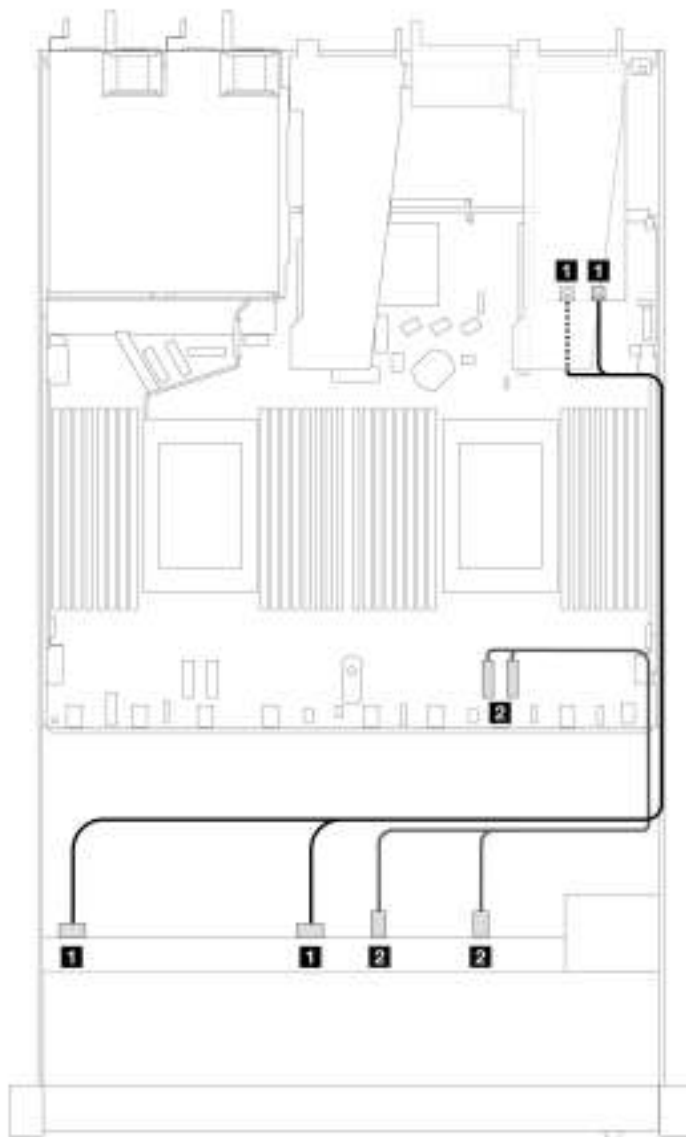


Figure 333. Cable routing for 6 SAS/SATA drives and 2 AnyBay drives and 2 NVMe front drive bays with an 8i or 16i SFF RAID adapter (Gen 3)

Table 140. Mapping between one front AnyBay backplane and an SFF HBA/RAID adapter

Backplane	From	To
Front BP (SAS)	1 SAS 0, SAS 1	1 C0, C1
	2 NVMe 2-3, 0-1	2 PCIe 1, 2

### Cable routing with a CFF RAID adapter

The following tables show the mapping relationship between backplane connectors and an 8i or 16i CFF RAID adapter (Gen 3 or Gen 4).

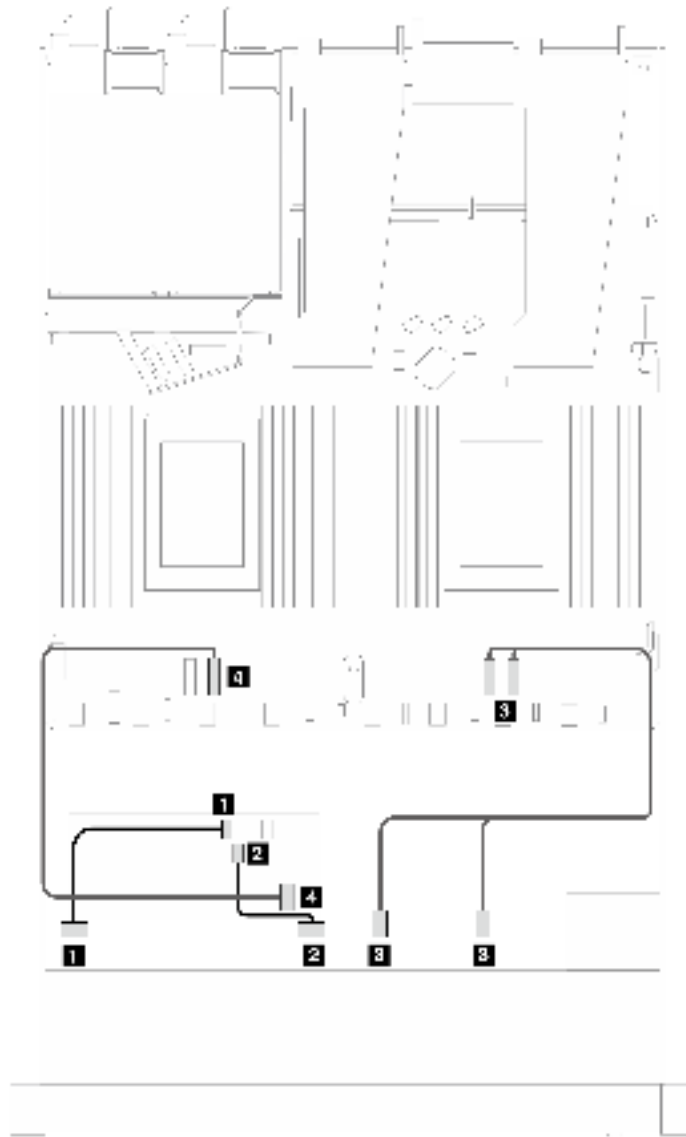


Figure 334. Cable routing for 6 SAS/SATA drives and 2 AnyBay drives and 2 NVMe front drive bays with an 8i or 16i CFF RAID adapter (Gen 3 or Gen 4)

Table 141. Mapping between one front SAS/SATA backplane and a CFF RAID adapter

Backplane/adaptor	From	To
Front BP (SAS)	1 SAS 0	1 C0
	2 SAS 1	2 C1
Front BP (NVMe)	3 NVMe 2-3, 0-1	3 PCIe 1, 2
CFF RAID adapter	4 MB input	4 PCIe 3

### 10 x 2.5" SAS/SATA

See this section to understand the cable routing of 10 front SAS/SATA drives with the 6 x 2.5" SAS/SATA + 4 x 2.5" AnyBay backplane installed.

To connect cables for a 7mm drive backplane, refer to [“7mm drive backplane” on page 270](#).

To connect power cables for a backplane for standard 2.5-inch or 3.5-inch drives, refer to [“Cable routing for backplane power” on page 274](#).

To connect cables for M.2 drives, refer to [“M.2 drive backplane” on page 267](#).

To connect signal cables for a backplane for standard 10 front SAS/SATA drives, refer to the following cable routing scenarios depending on your server configuration:

- [“Cable routing for onboard configuration” on page 397](#)
- [“Cable routing with an SFF HBA/RAID adapter” on page 398](#)
- [“Cable routing with a CFF RAID adapter” on page 402](#)

### **Cable routing for onboard configuration**

The following illustrations and tables show the mapping relationship between backplane connectors and processor board connectors for onboard configuration.

The following figure illustrates the cable routing for the configuration of 10 front SAS/SATA drives bays. Connections between connectors: **1 ↔ 1, 2 ↔ 2, 3 ↔ 3, ... n ↔ n.**

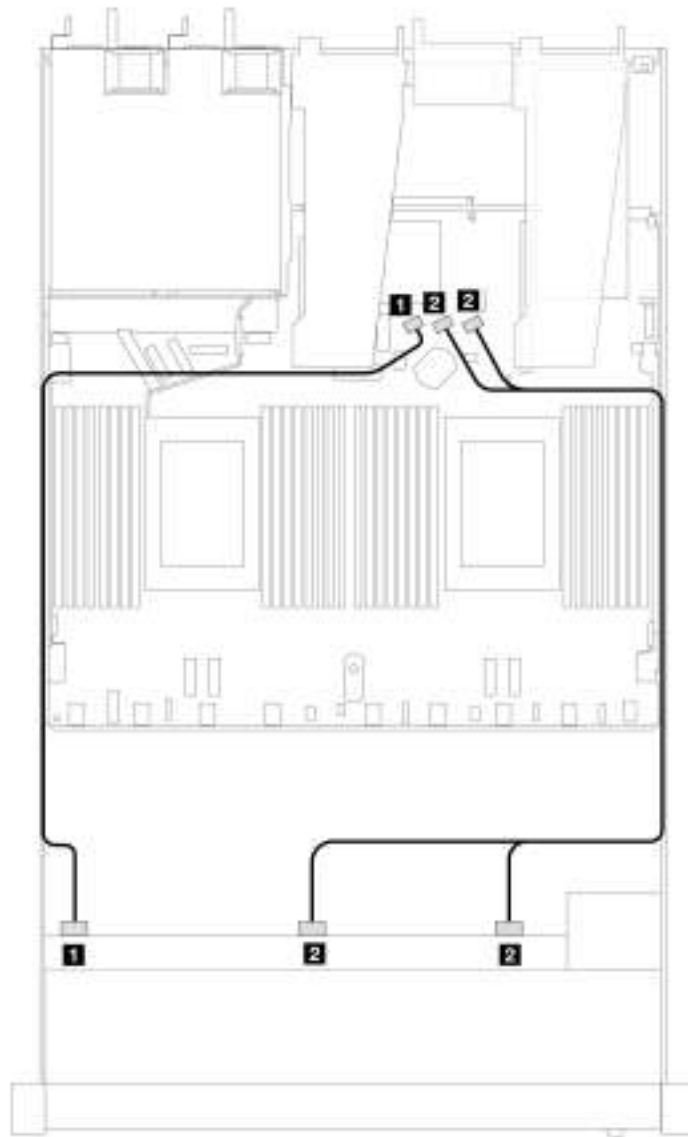


Figure 335. Cable routing for onboard configuration of 10 x 2.5 SAS/SATA front drives

Table 142. Mapping between one front AnyBay backplane and processor board for onboard configuration

Backplane	From	To
Front BP (SAS)	1 SAS 0	1 SATA 0
	2 SAS 1, SAS 2	2 SATA 1, SATA 2

### Cable routing with an SFF HBA/RAID adapter

The following tables show the mapping relationship between backplane connectors and a 16i SFF HBA/RAID adapter (Gen 3 or Gen 4).



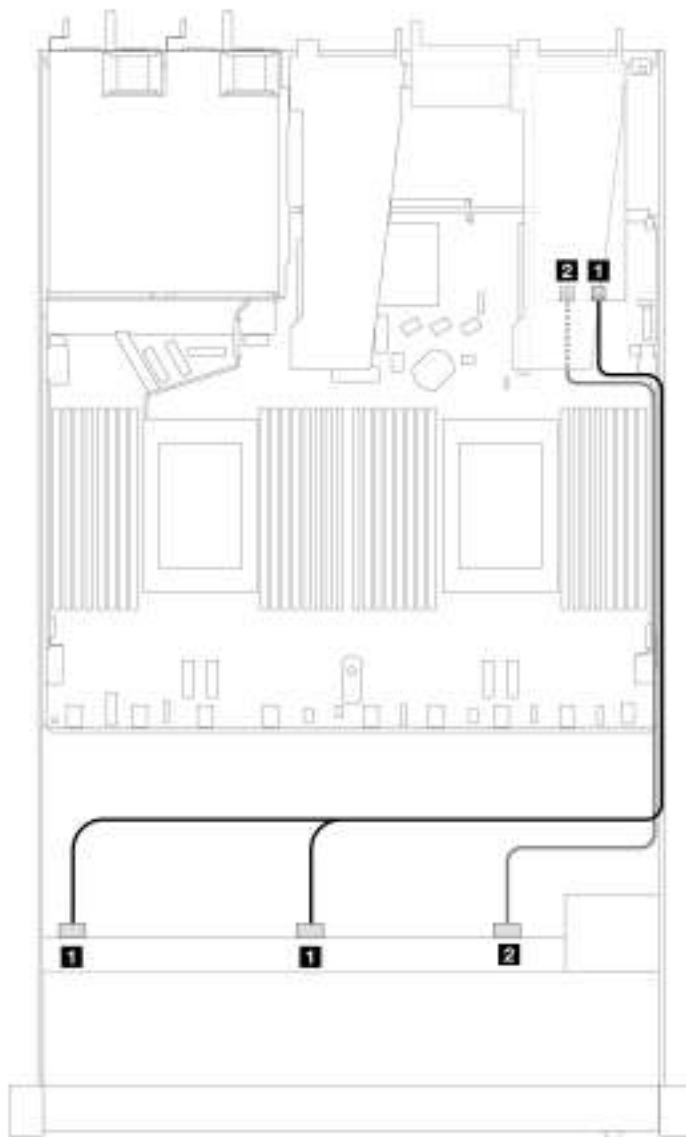


Figure 336. Cable routing for 10 front SAS/SATA drives bays with a 16i SFF RAID adapter (Gen 4)

Table 143. Mapping between one front AnyBay backplane and an SFF HBA/RAID adapter

Backplane	From	To
Front BP (SAS)	1 SAS 0, SAS 1	1 C0
	2 SAS 2	2 C1

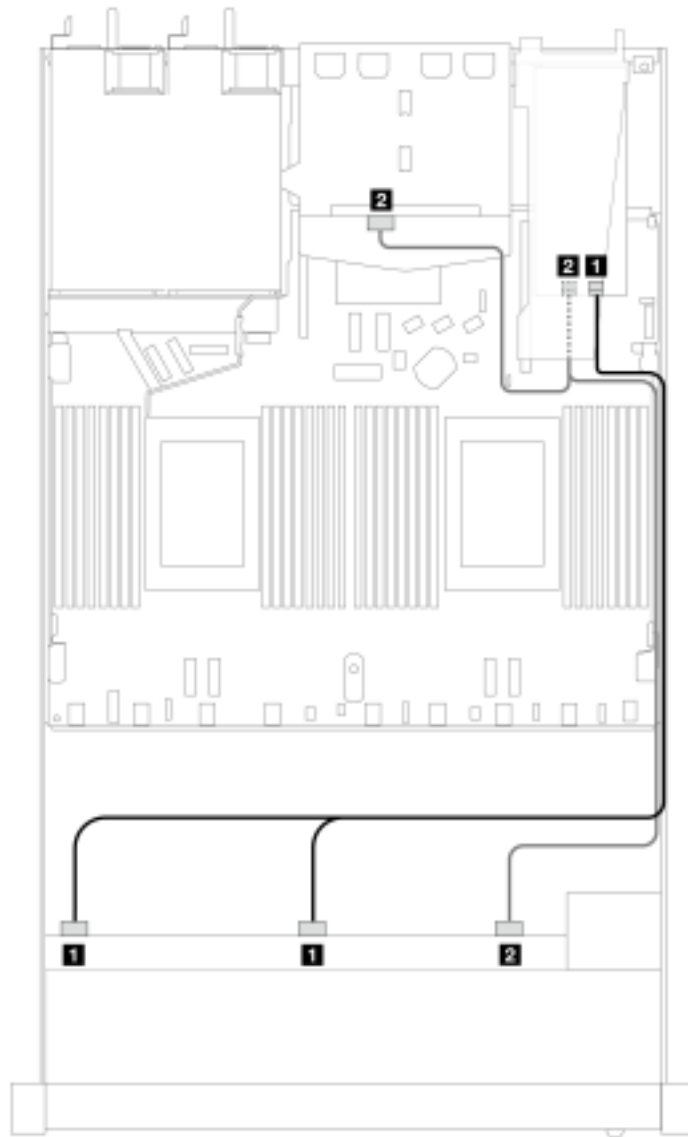


Figure 337. Cable routing for 10 front SAS/SATA drives bays and a 16i SFF RAID adapter (Gen 4) with 2 x 2.5 rear SAS/SATA drives installed

Table 144. Mapping between one front AnyBay and one rear SAS/SATA backplanes and an SFF HBA/RAID adapter

Backplane	From	To
Front BP (SAS)	1 SAS 0, SAS 1	1 C0
Rear BP (SAS)	2 SAS 2 (front), SAS (rear)	2 C1

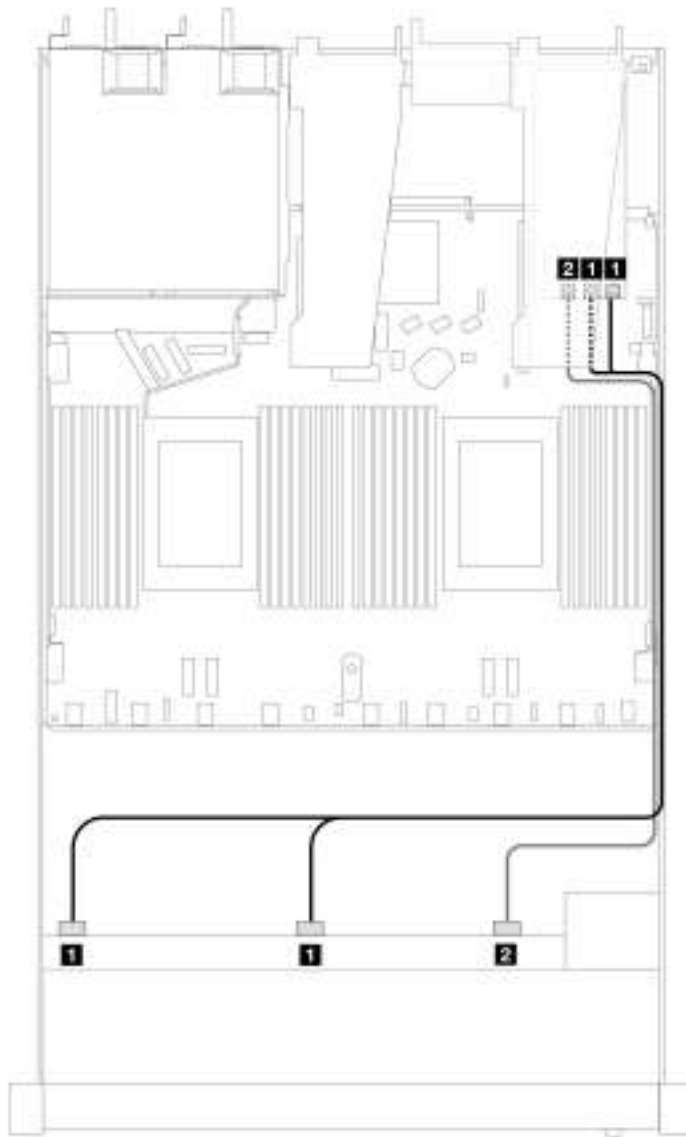


Figure 338. Cable routing for 10 front SAS/SATA drives bays with a 16i SFF RAID adapter (Gen 3)

Table 145. Mapping between one front AnyBay backplane and an SFF HBA/RAID adapter

Backplane	From	To
Front BP (SAS)	1 SAS 0, SAS 1	1 C0, C1
	2 SAS 2	2 C2

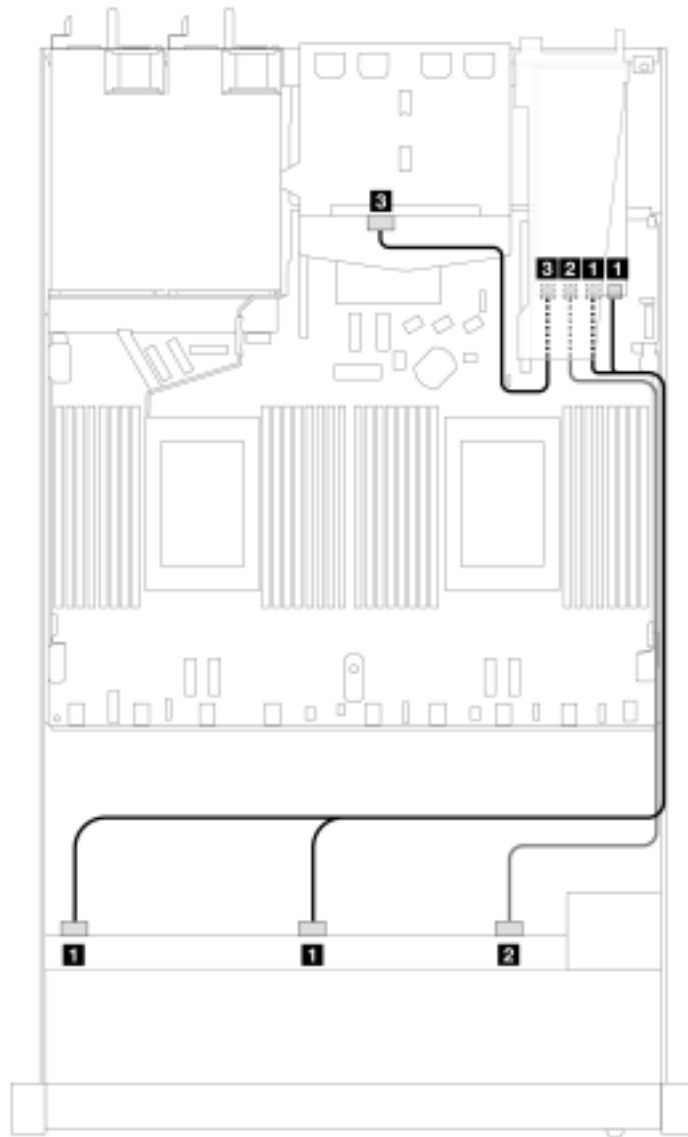


Figure 339. Cable routing for 10 front SAS/SATA drives bays and a 16i SFF RAID adapter (Gen 3) with 2 x 2.5 rear SAS/SATA drives installed

Table 146. Mapping between one front AnyBay and one rear SAS/SATA backplanes and an SFF HBA/RAID adapter

Backplane	From	To
Front BP (SAS)	1 SAS 0, SAS 1	1 C0, C1
	2 SAS 2	2 C2
Rear BP (SAS)	3 SAS	3 C3

### Cable routing with a CFF RAID adapter

The following tables show the mapping relationship between backplane connectors and a 16i CFF RAID adapter (Gen 3 or Gen 4).

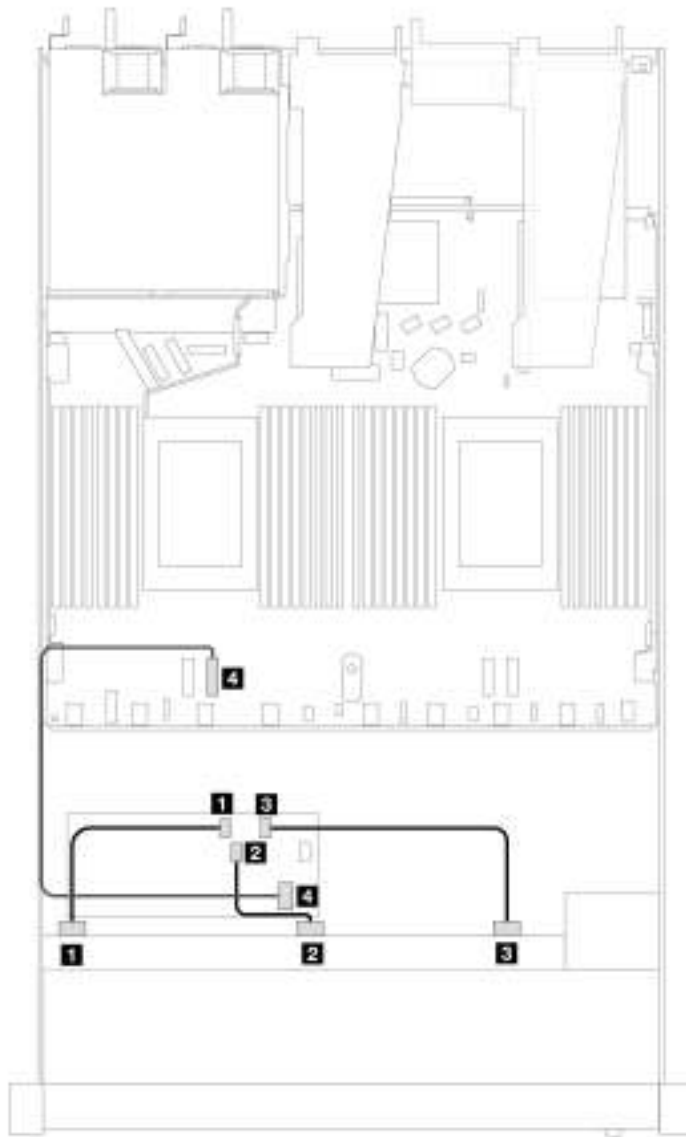


Figure 340. Cable routing for 10 front SAS/SATA drives bays with a 16i CFF RAID adapter (Gen 3 or Gen 4)

Table 147. Mapping between one front SAS/SATA backplane and a CFF RAID adapter

Backplane/adapter	From	To
Front backplane	1 SAS 0	1 C0
	2 SAS 1	2 C1
	3 SAS 2	3 C2
CFF RAID adapter	4 MB input	4 PCIe 3

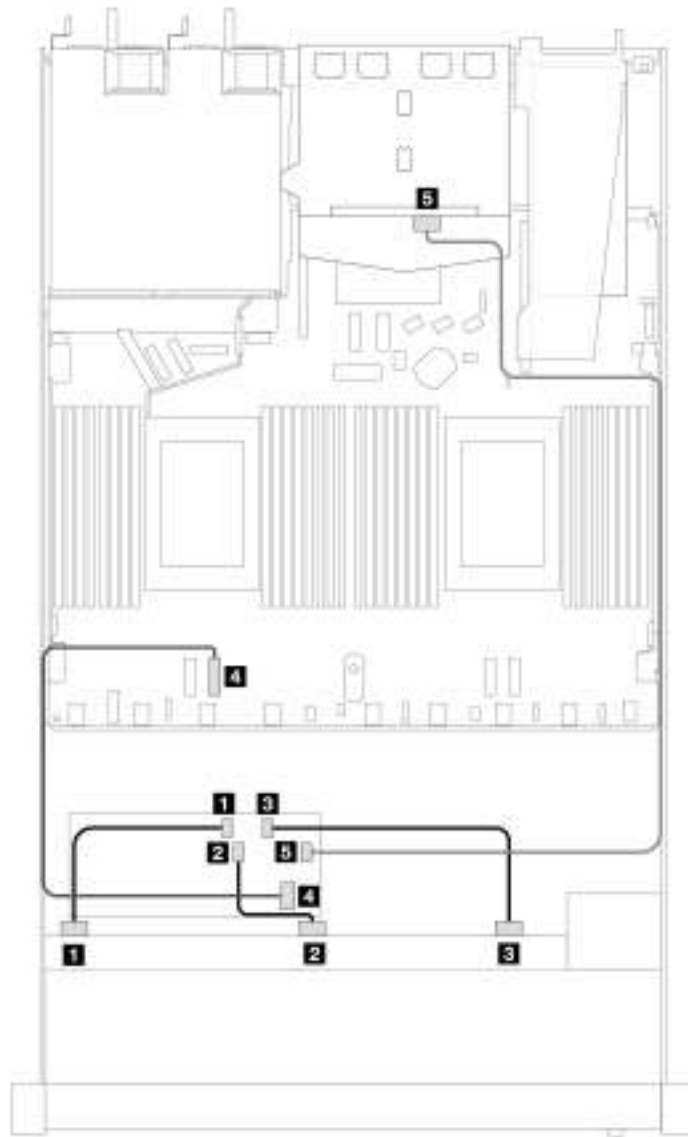


Figure 341. Cable routing for 10 front SAS/SATA drives bays and a 16i CFF RAID adapter (Gen 3 or Gen 4) with 2 x 2.5 rear SAS/SATA drives installed

Table 148. Mapping between one front AnyBay and one rear SAS/SATA backplane and a CFF RAID adapter

Backplane/adapter	From	To
Front backplane	<b>1</b> SAS 0	<b>1</b> C0
	<b>2</b> SAS 1	<b>2</b> C1
	<b>3</b> SAS 2	<b>3</b> C2
CFF RAID adapter	<b>4</b> MB input	<b>4</b> PCIe 3
	<b>5</b> C3	<b>5</b> SAS (rear)

### 10 x 2.5" Anybay backplane (Gen 4)

Use this section to understand the alternatives that a 10 x 2.5" AnyBay backplane (Gen 4) offers.

With a 10 x 2.5" AnyBay backplane (Gen 4), following front drive combinations are supported:

**10 x 2.5" AnyBay**

See this section to understand the cable routing of 10 front AnyBay drives with the 10 x 2.5" AnyBay backplane (Gen 4) installed.

To connect cables for a 7mm drive backplane, refer to [“7mm drive backplane” on page 270](#).

To connect power cables for a backplane for standard 2.5-inch or 3.5-inch drives, refer to [“Cable routing for backplane power” on page 274](#).

To connect cables for M.2 drives, refer to [“M.2 drive backplane” on page 267](#).

**Cable routing with an SFF HBA/RAID adapter**

The following tables show the mapping relationship between backplane connectors and an SFF HBA/RAID adapter (Gen 3 or Gen 4).

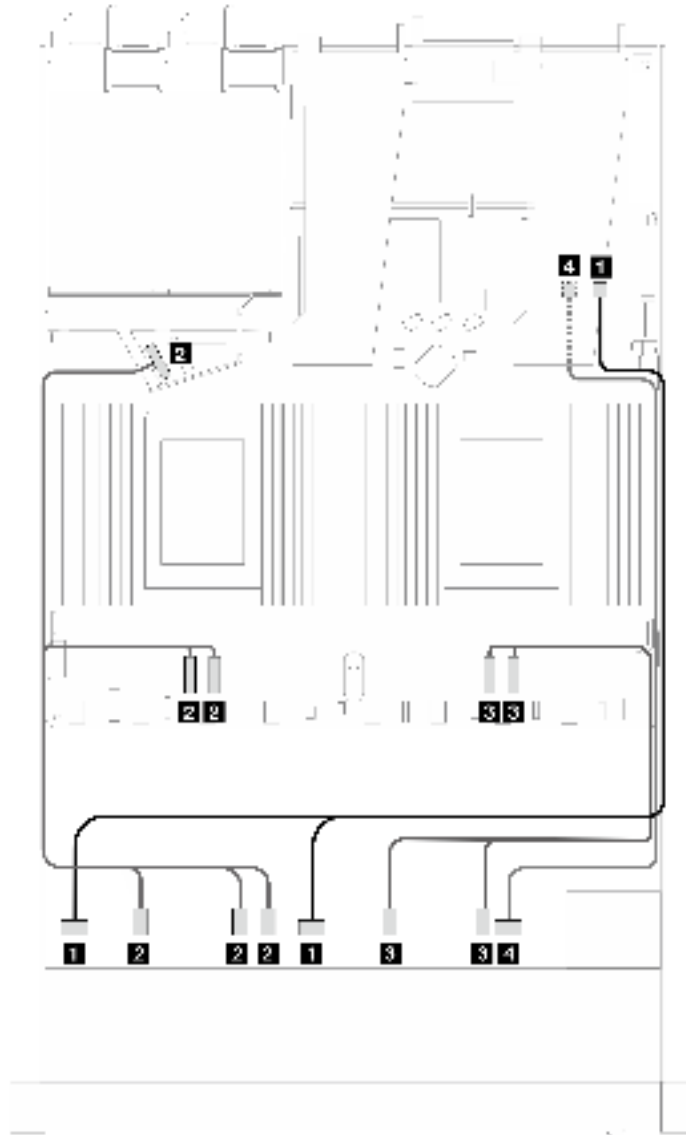


Figure 342. Cable routing for 10 AnyBay drives with a 16i SFF RAID adapter (Gen 4)

Table 149. Mapping between one front AnyBay backplane and an SFF HBA/RAID adapter

Backplane	From	To
Front BP (SAS)	1 SAS 0, SAS 1	1 C0
Front BP (NVMe)	2 NVMe 2-3, 0-1, 4-5	2 PCIe 3, 4, 5
	3 NVMe 8-9, 6-7	3 PCIe 1, 2
Front BP (SAS)	4 SAS 2	4 C1



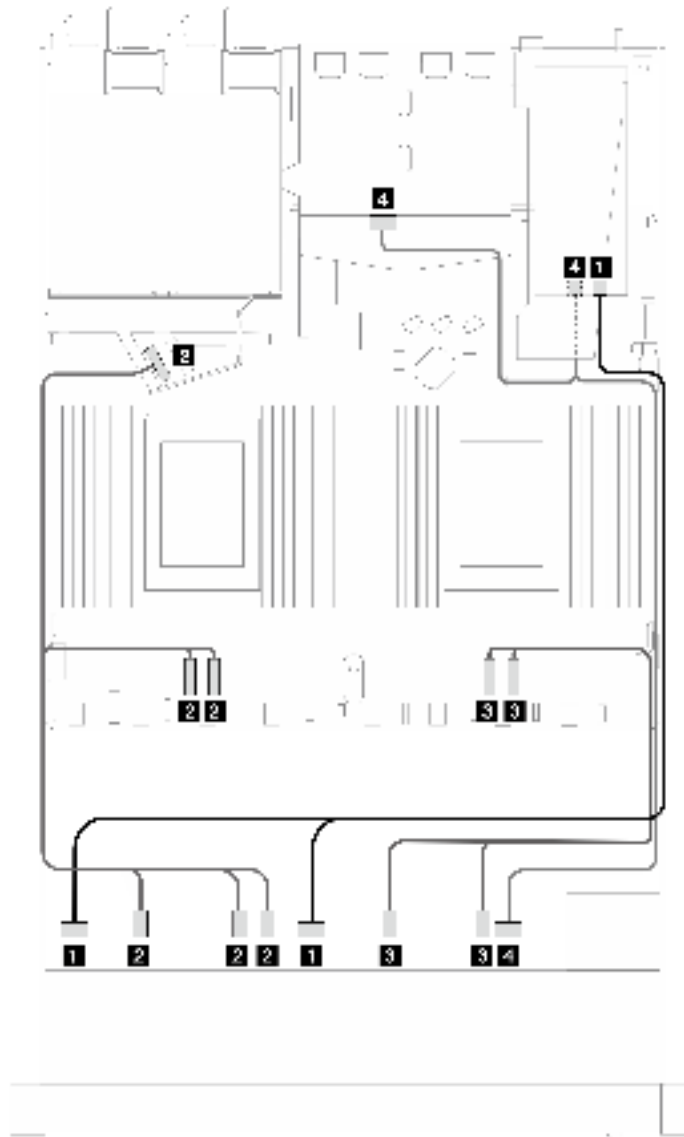


Figure 343. Cable routing for 10 front AnyBay drives and 2 rear SAS/SATA drives with a 16i SFF RAID adapter (Gen 4)

Table 150. Mapping between one front AnyBay and one rear SAS/SATA backplanes and an SFF HBA/RAID adapter

Backplane	From	To
Front BP (SAS)	1 SAS 0, SAS 1	1 C0
Front BP (NVMe)	2 NVMe 2-3, 0-1, 4-5	2 PCIe 3, 4, 5
	3 NVMe 8-9, 6-7	3 PCIe 1, 2
Front and rear BP (SAS)	4 SAS 2 (front), SAS (rear)	4 C1

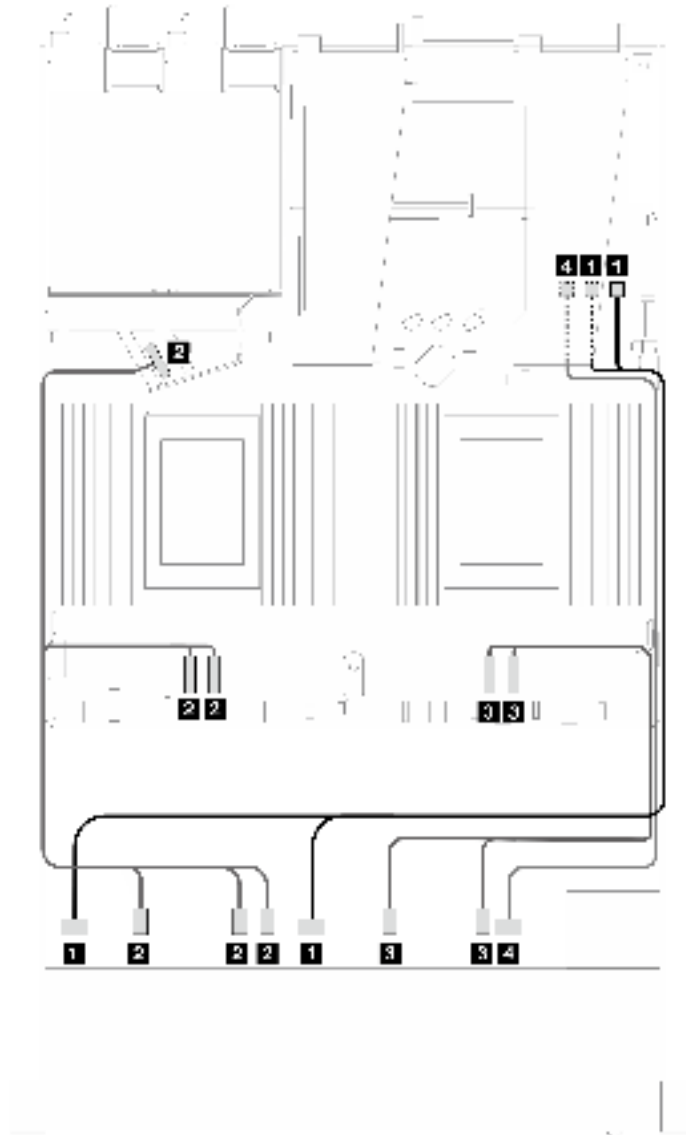


Figure 344. Cable routing for 10 AnyBay drives with a 16i SFF RAID adapter (Gen 3)

Table 151. Mapping between one front AnyBay backplane and an SFF HBA/RAID adapter

Backplane	From	To
Front BP (SAS)	1 SAS 0, SAS 1	1 C0, C1
Front BP (NVMe)	2 NVMe 2-3, 0-1, 4-5	2 PCIe 3, 4, 5
	3 NVMe 8-9, 6-7	3 PCIe 1, 2
Front BP (SAS)	4 SAS 2	4 C2

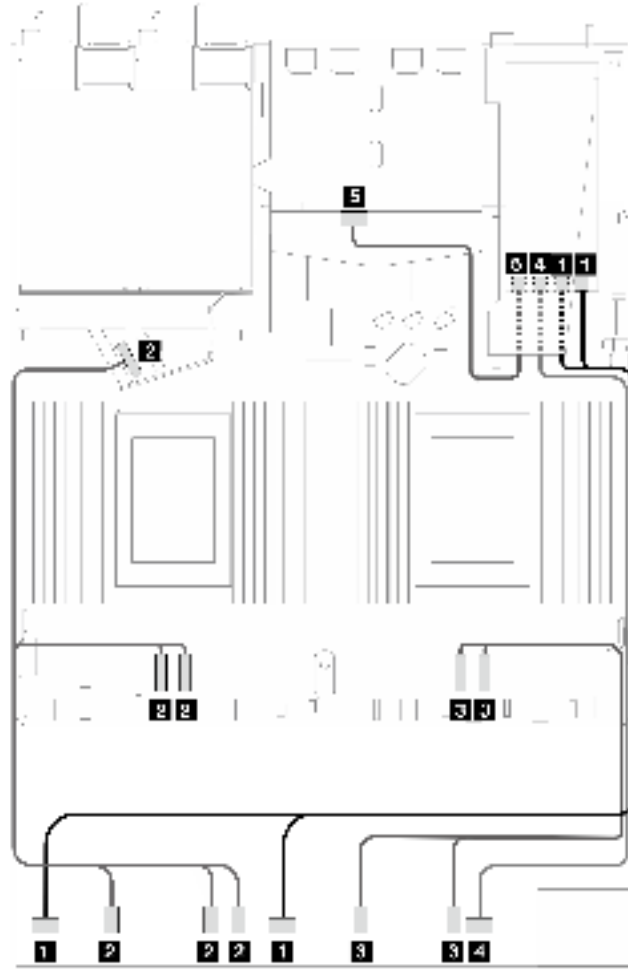


Figure 345. Cable routing for 10 front AnyBay drives and 2 rear SAS/SATA drives with a 16i SFF RAID adapter (Gen 3)

Table 152. Mapping between one front AnyBay and one rear SAS/SATA backplanes and an SFF HBA/RAID adapter

Backplane	From	To
Front BP (SAS)	1 SAS 0, SAS 1	1 C0, C1
Front BP (NVMe)	2 NVMe 2-3, 0-1, 4-5	2 PCIe 3, 4, 5
	3 NVMe 8-9, 6-7	3 PCIe 1, 2
Front and rear BP (SAS)	4 SAS 2 (front)	4 C2
Rear BP (SAS)	5 SAS (rear)	5 C3

### 10 x 2.5" NVMe

Use this section to understand the cable routing of 10 NVMe front drives.

To connect power cables for a backplane for standard 2.5-inch or 3.5-inch drives, refer to [“Cable routing for backplane power”](#) on page 274.

To connect cables for M.2 drives, refer to [“M.2 drive backplane”](#) on page 267.

### Cable routing for onboard configuration

The following illustrations and tables show the mapping relationship between backplane connectors and processor board connectors for onboard configuration.

The following figure illustrates the cable routing for the configuration of 10 front SAS/SATA drives bays. Connections between connectors: **1** ↔ **1**, **2** ↔ **2**, **3** ↔ **3**, ... **n** ↔ **n**.

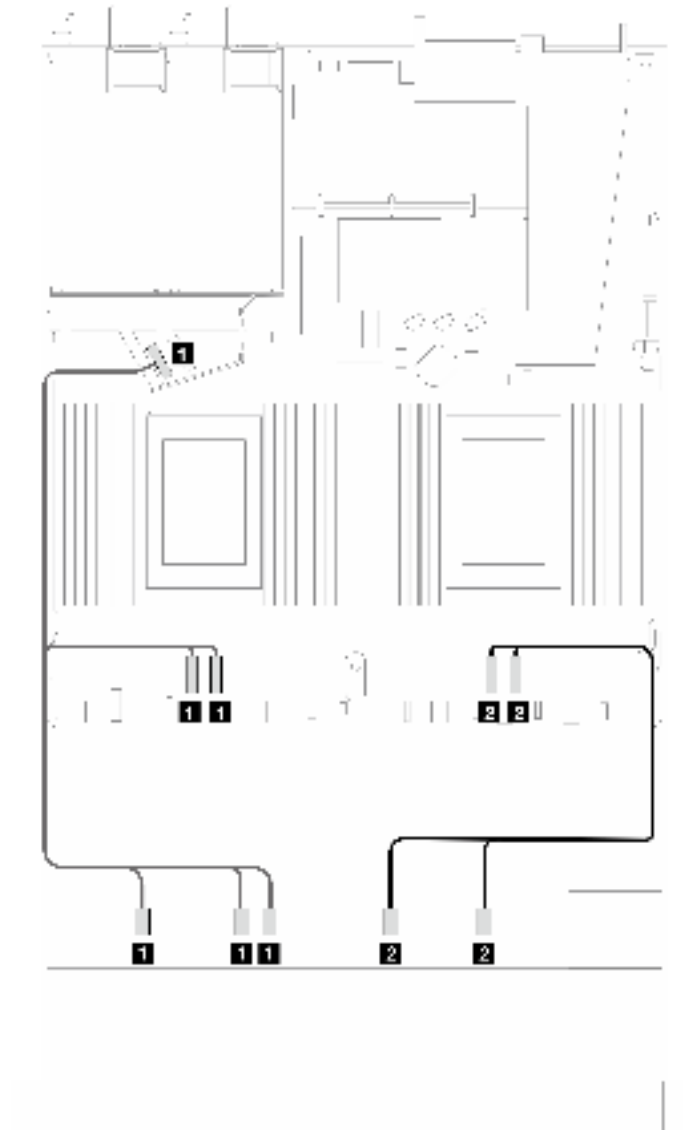


Figure 346. Cable routing for onboard configuration of 10 x 2.5 NVMe front drives

Table 153. Mapping between one front AnyBay backplane and processor board for onboard configuration

Backplane	From	To
Front BP (NVMe)	1 NVMe 2-3, NVMe 0-1, NVMe 4-5	1 PCIe 3, PCIe 4, PCIe 5
	2 NVMe 8-9, NVMe 6-7	2 PCIe 1, PCIe 2

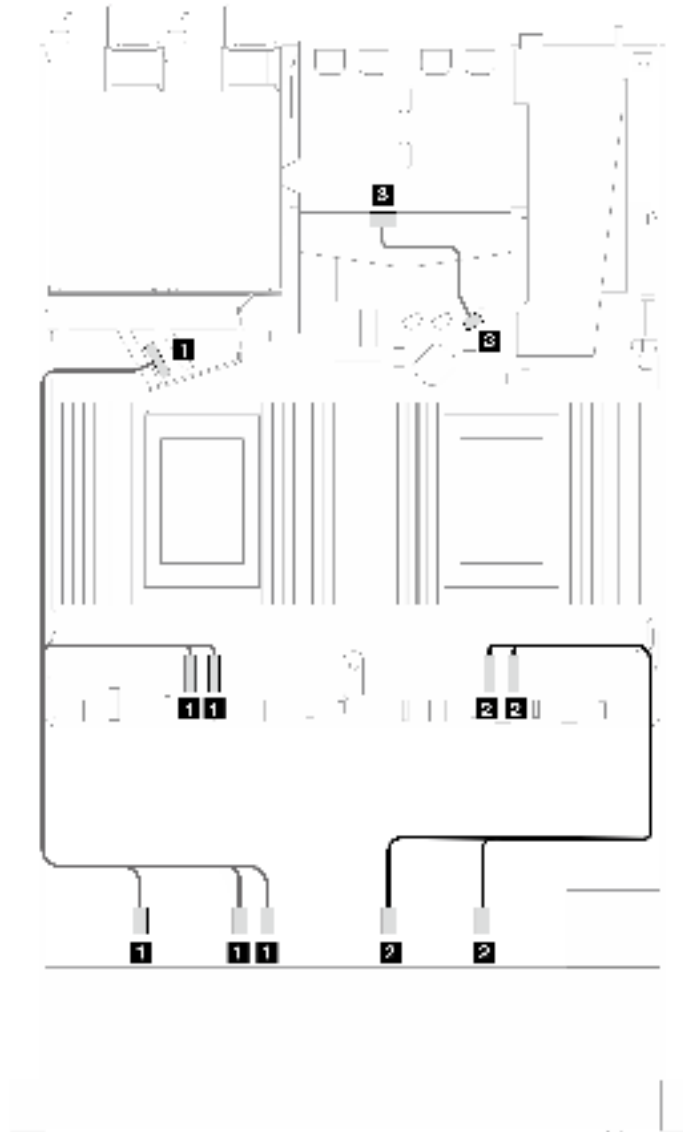


Figure 347. Cable routing for onboard configuration of 10 x 2.5 NVMe front drives with 2 x 2.5 rear SAS/SATA drives installed

Table 154. Mapping between one front AnyBay and one rear SAS/SATA backplanes and processor board for onboard configuration

Backplane	From	To
Front BP (NVMe)	1 NVMe 2–3, NVMe 0–1, NVMe 4–5	1 PCIe 3, PCIe 4, PCIe 5
	2 NVMe 8–9, NVMe 6–7	2 PCIe 1, PCIe 2
Rear BP (SAS)	3 SAS (rear)	3 SATA 2

### 10 x 2.5" Anybay backplane (Gen 5)

Use this section to understand the alternatives that a 10 x 2.5" AnyBay backplane (Gen 5) offers.

With a 10 x 2.5" AnyBay backplane (Gen 5), following front drive combinations are supported:

#### 6 x 2.5" SAS/SATA + 4 x 2.5" AnyBay (Gen 5)

See this section to understand the cable routing of six front SAS/SATA drives and four front AnyBay drives with 10 x 2.5" backplane (Gen 5) installed.

To connect cables for a 7mm drive backplane, refer to [“7mm drive backplane” on page 270](#).

To connect cables for M.2 drives, refer to [“M.2 drive backplane” on page 267](#).

To connect cables for rear NVMe drives, refer to [“Rear NVMe backplane cable routing with 10 x 2.5" AnyBay backplane \(Gen 5\) installed” on page 273](#).

To connect signal cables for a backplane for standard six front SAS/SATA drives and four front AnyBay drives, refer to the following cable routing scenarios depending on your server configuration:

- [“Cable routing for onboard configuration” on page 412](#)
- [“Cable routing with an SFF HBA/RAID adapter” on page 413](#)
- [“Cable routing with a CFF HBA/RAID adapter” on page 417](#)

#### Cable routing for onboard configuration

The following illustration and table show the mapping relationship between backplane connectors and processor board connectors for onboard configuration.

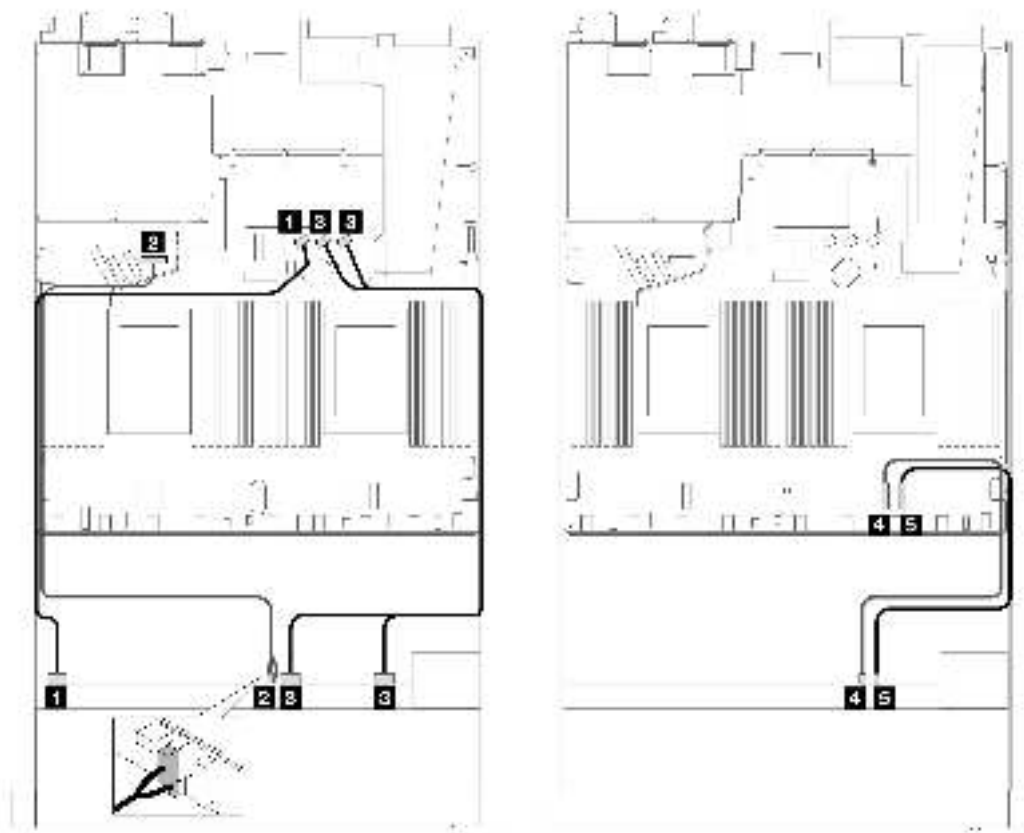


Figure 348. Cable routing for onboard configuration of 6 x 2.5'' SAS/SATA front drives and 4 x 2.5'' AnyBay front drives

Table 155. Mapping between one front AnyBay backplane and processor board for onboard configuration

Backplane	From	To
Front BP (SAS)	1 SAS 0–3	1 SATA 0
Front BP (power)	2 Power and sideband <sup>Note</sup>	2 Power port for front BP
Front BP (SAS)	3 SAS 4–7, 8–9	3 SATA 1, 2
Front BP (NVMe)	4 NVMe 6–7	4 PCIe 2
	5 NVMe 8–9	5 PCIe 1

**Note:** Different from the 10 x 2.5'' Anybay backplane (Gen 4), the new Gen 5 backplane has two connectors, power and sideband, for power connection. The two connectors are placed closely, make sure that the two are connected. Use the illustration above for guidance.

#### Cable routing with an SFF HBA/RAID adapter

The following tables show the mapping relationship between backplane connectors and a 16i SFF RAID adapter (Gen 3 or Gen 4).

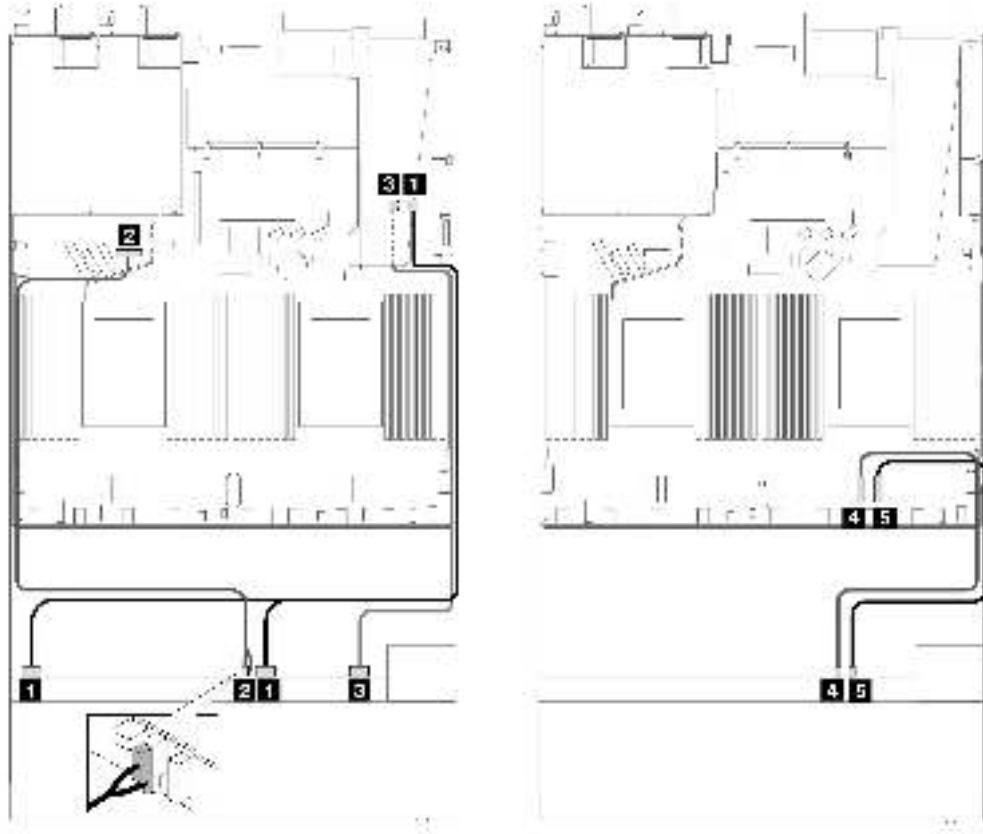


Figure 349. Cable routing for six front SAS/SATA drives and four front AnyBay drives bays with a 16i SFF RAID adapter (Gen 4)

Table 156. Mapping between one front AnyBay backplane and an SFF RAID adapter

Backplane	From	To
Front BP (SAS)	1 SAS 0–3, 4–7	1 C0
Front BP (power)	2 Power and sideband	2 Power port for front BP
Front BP (SAS)	3 SAS 8–9	3 C1
Front BP (NVMe)	4 NVMe 6–7	4 PCIe 2
	5 NVMe 8–9	5 PCIe 1



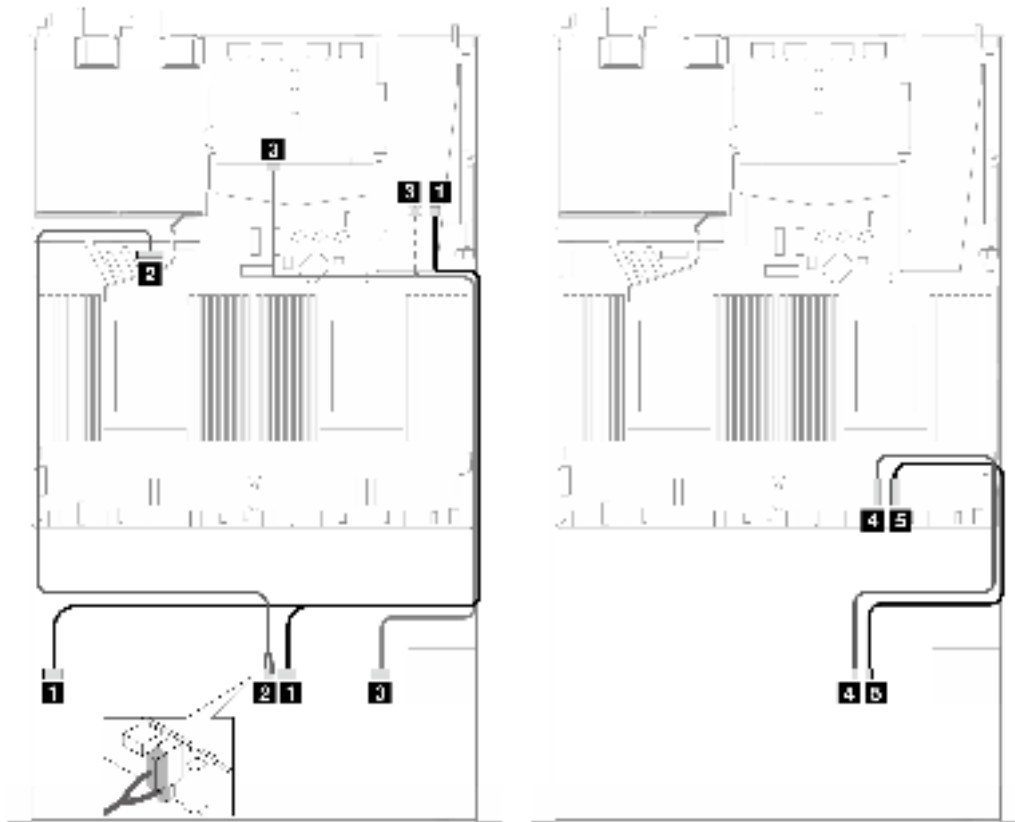


Figure 350. Cable routing for six front SAS/SATA drives and four front AnyBay drives bays and a 16i SFF RAID adapter (Gen 4) with two rear SAS/SATA drives installed

Table 157. Mapping between one front AnyBay and one rear SAS/SATA backplanes and an SFF RAID adapter

Backplane	From	To
Front BP (SAS)	1 SAS 0-3, 4-7	1 C0
Front BP (power)	2 Power and sideband	2 Power port for front BP
Front and rear BP (SAS)	3 SAS 8-9, SAS (rear)	3 C1
Front BP (NVMe)	4 NVMe 6-7	4 PCIe 2
	5 NVMe 8-9	5 PCIe 1

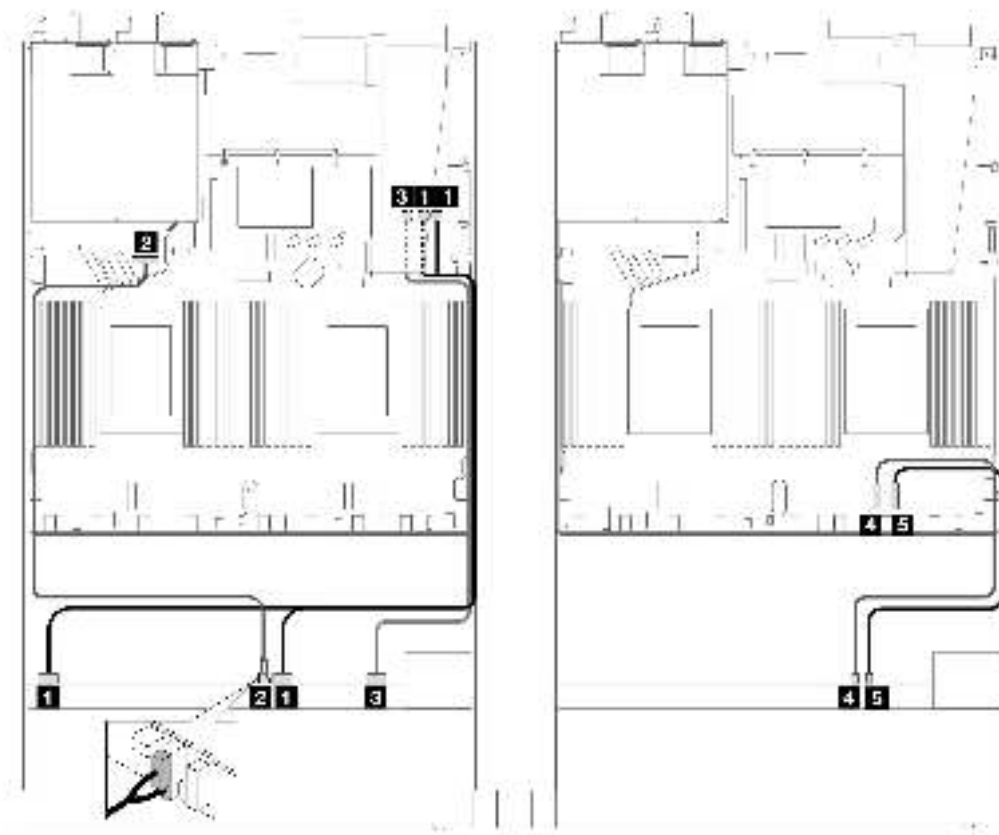


Figure 351. Cable routing for six front SAS/SATA drives and four front AnyBay drives bays with a 16i SFF RAID adapter (Gen 3)

Table 158. Mapping between one front AnyBay backplane and an SFF RAID adapter

Backplane	From	To
Front BP (SAS)	1 SAS 0–3, 4–7	1 C0, C1
Front BP (power)	2 Power and sideband	2 Power port for front BP
Front BP (SAS)	3 SAS 8–9	3 C2
Front BP (NVMe)	4 NVMe 6–7	4 PCIe 2
	5 NVMe 8–9	5 PCIe 1

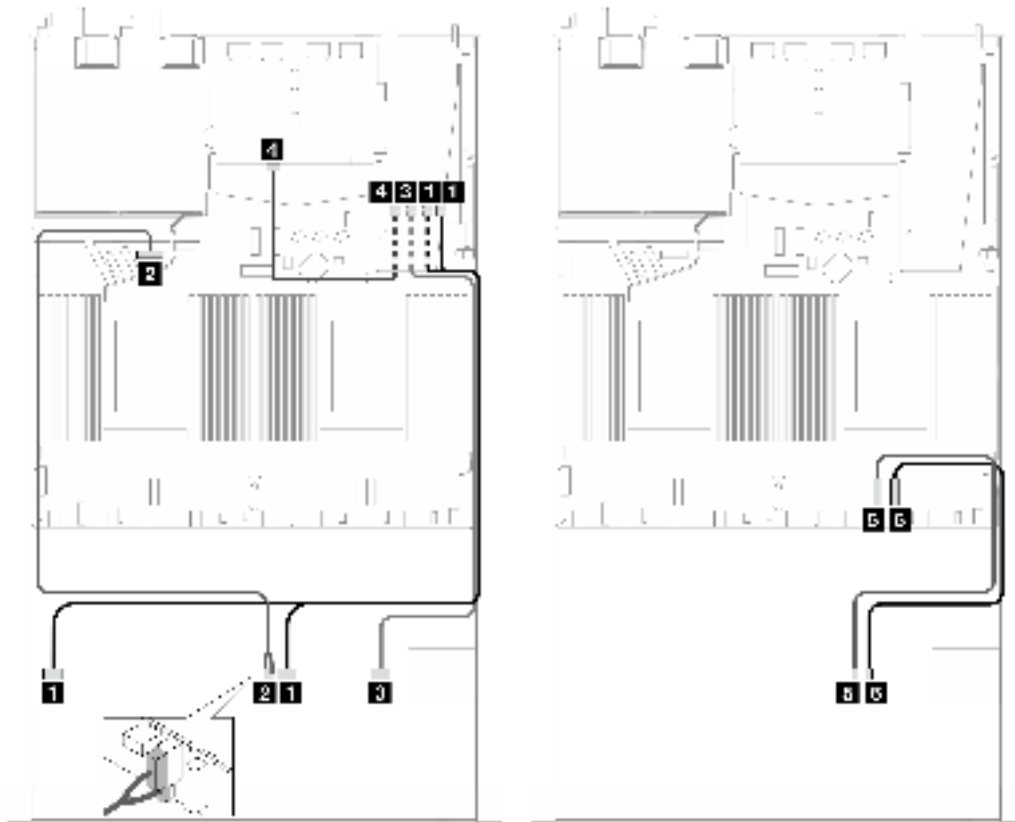


Figure 352. Cable routing for six front SAS/SATA drives and four front AnyBay drives bays and a 16i SFF RAID adapter (Gen 3) with two rear SAS/SATA drives installed

Table 159. Mapping between one front AnyBay and one rear SAS/SATA backplanes and an SFF RAID adapter

Backplane	From	To
Front BP (SAS)	1 SAS 0–3, 4–7	1 C0
Front BP (power)	2 Power and sideband	2 Power port for front BP
Front BP (SAS)	3 SAS 8–9	3 C1
Rear BP (SAS)	4 SAS (rear)	4 C2
Front BP (NVMe)	5 NVMe 6–7	5 PCIe 2
	6 NVMe 8–9	6 PCIe 1

### Cable routing with a CFF HBA/RAID adapter

The following tables show the mapping relationship between backplane connectors and a CFF HBA/RAID adapter.

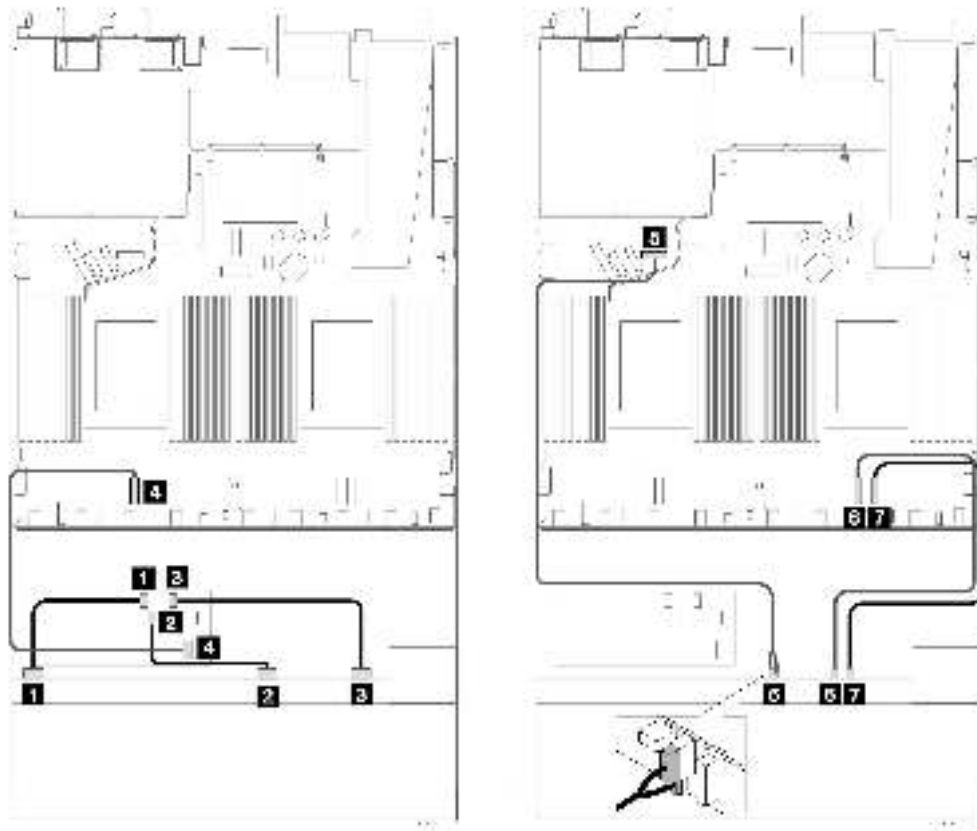


Figure 353. Cable routing for six front SAS/SATA and four front AnyBay drives with a 16i CFF HBA/RAID adapter (Gen 4)

Table 160. Mapping between one front AnyBay backplane and a CFF HBA/RAID adapter

Backplane/adapter	From	To
Front BP (SAS)	<b>1</b> SAS 0–3	<b>1</b> C0
	<b>2</b> SAS 4–7	<b>2</b> C1
	<b>3</b> SAS 8–9	<b>3</b> C2
CFF RAID adapter	<b>4</b> MB input	<b>4</b> PCIe 3
Front BP (power)	<b>5</b> Power and sideband	<b>5</b> Power port for front BP
Front BP (NVMe)	<b>6</b> NVMe 6–7	<b>6</b> PCIe 2
	<b>7</b> NVMe 8–9	<b>7</b> PCIe 1

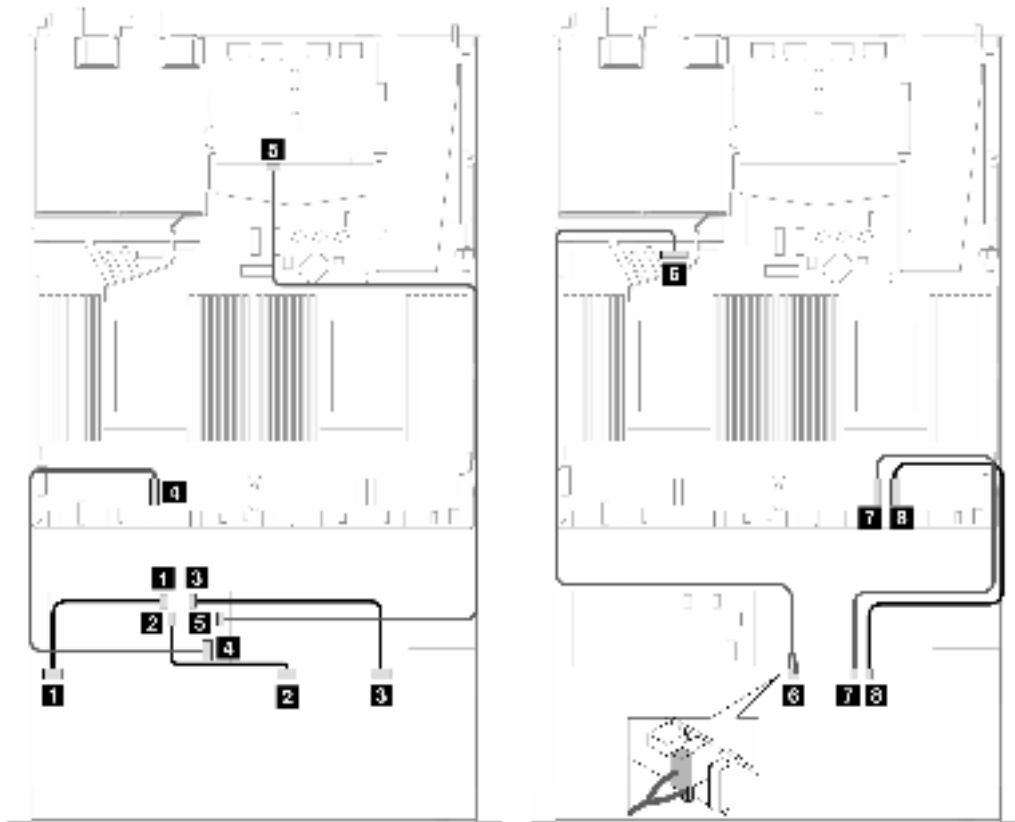


Figure 354. Cable routing for six front SAS/SATA and four front AnyBay drives with a 16i CFF HBA/RAID adapter (Gen 4) and two rear SAS/SATA drives installed

Table 161. Mapping between one front AnyBay and one rear SAS/SATA backplane and a CFF HBA/RAID adapter

Backplane/adapter	From	To
Front BP (SAS)	1 SAS 0–3	1 C0
	2 SAS 4–7	2 C1
	3 SAS 8–9	3 C2
CFF RAID adapter	4 MB input	4 PCIe 3
	5 C3	5 SAS (rear)
Front BP (power)	6 Power and sideband	6 Power port for front BP
Front BP (NVMe)	7 NVMe 6–7	7 PCIe 2
	8 NVMe 8–9	8 PCIe 1

### 6 x 2.5" SAS/SATA + 2 x 2.5" AnyBay + 2 x 2.5" NVMe (Gen 5)

See this section to understand the cable routing of six front SAS/SATA drives, two front AnyBay drives and two front NVMe drives with the 10 x 2.5" AnyBay backplane (Gen 5) installed.

To connect cables for a 7mm drive backplane, refer to [“7mm drive backplane” on page 270](#).

To connect cables for M.2 drives, refer to [“M.2 drive backplane” on page 267](#).

To connect cables for rear NVMe drives, refer to [“Rear NVMe backplane cable routing with 10 x 2.5” AnyBay backplane \(Gen 5\) installed” on page 273.](#)

To connect signal cables for a backplane for standard six front SAS/SATA drives, two AnyBay drives and two front NVMe drives, refer to the following cable routing scenarios depending on your server configuration:

- [“Cable routing for onboard configuration” on page 420](#)
- [“Cable routing with an SFF HBA/RAID adapter” on page 421](#)
- [“Cable routing with a CFF HBA/RAID adapter” on page 422](#)

### Cable routing for onboard configuration

The following tables show the mapping relationship between backplane connectors and processor board connectors for onboard configuration.

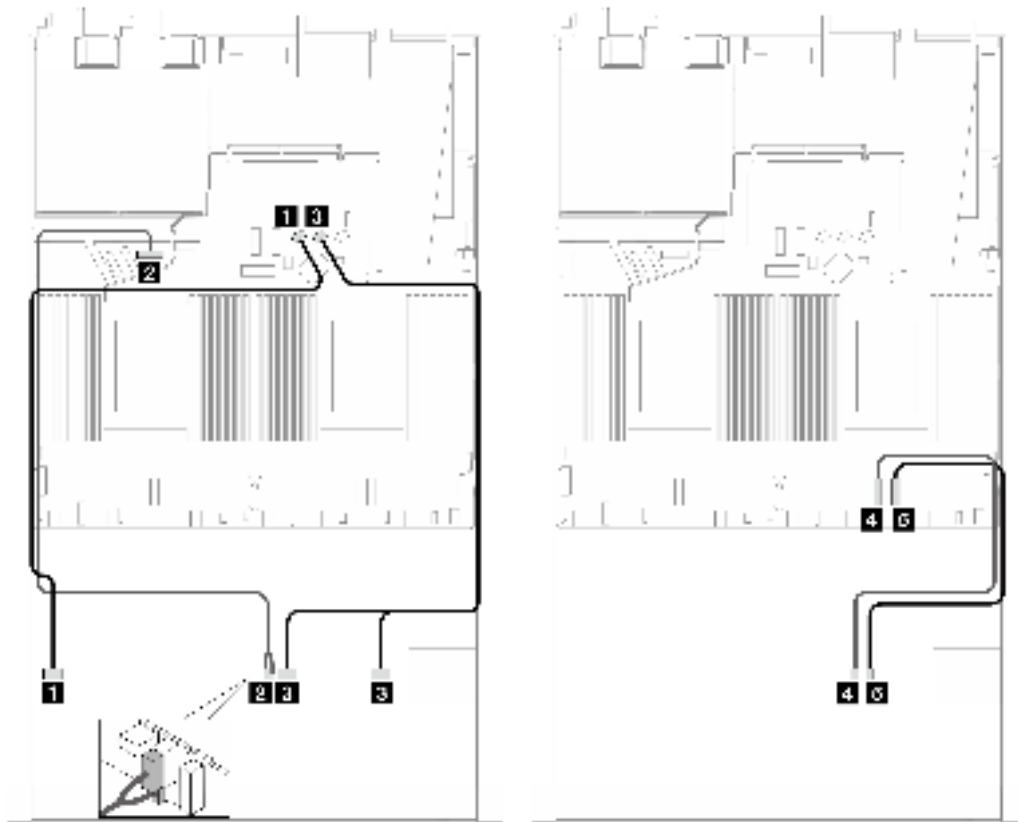


Figure 355. Cable routing for onboard configuration of six SAS/SATA drives and two AnyBay and two NVMe front drives bays

Table 162. Mapping between one front AnyBay backplane and processor board for onboard configuration

Backplane	From	To
Front BP (SAS)	<b>1</b> SAS 0–3	<b>1</b> SATA 0
Front BP (power)	<b>2</b> Power and sideband	<b>2</b> Power port for front BP
Front BP (SAS)	<b>3</b> SAS 4–7, 8–9	<b>3</b> SATA 1
Front BP (NVMe)	<b>4</b> NVMe 6–7	<b>4</b> PCIe 2

Table 162. Mapping between one front AnyBay backplane and processor board for onboard configuration (continued)

Backplane	From	To
	5 NVMe 8–9	5 PCIe 1

### Cable routing with an SFF HBA/RAID adapter

The following tables show the mapping relationship between backplane connectors and an SFF HBA/RAID adapter.

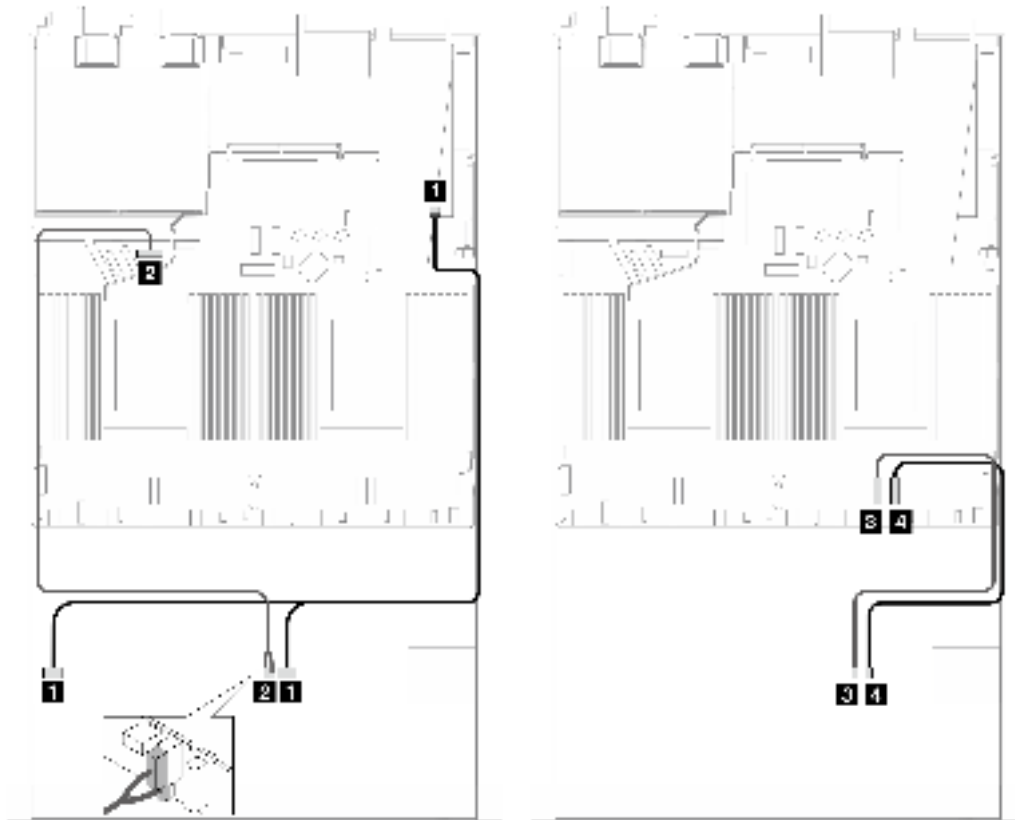


Figure 356. Cable routing for six SAS/SATA drives and two AnyBay drives and two NVMe front drive bays with a 16i SFF RAID adapter (Gen 4)

Table 163. Mapping between one front AnyBay backplane and an SFF HBA/RAID adapter

Backplane	From	To
Front BP (SAS)	1 SAS 0–3, 4–7	1 C0
Front BP (power)	2 Power and sideband	2 Power port for front BP
Front BP (NVMe)	3 NVMe 6–7	3 PCIe 2
	4 NVMe 8–9	4 PCIe 1

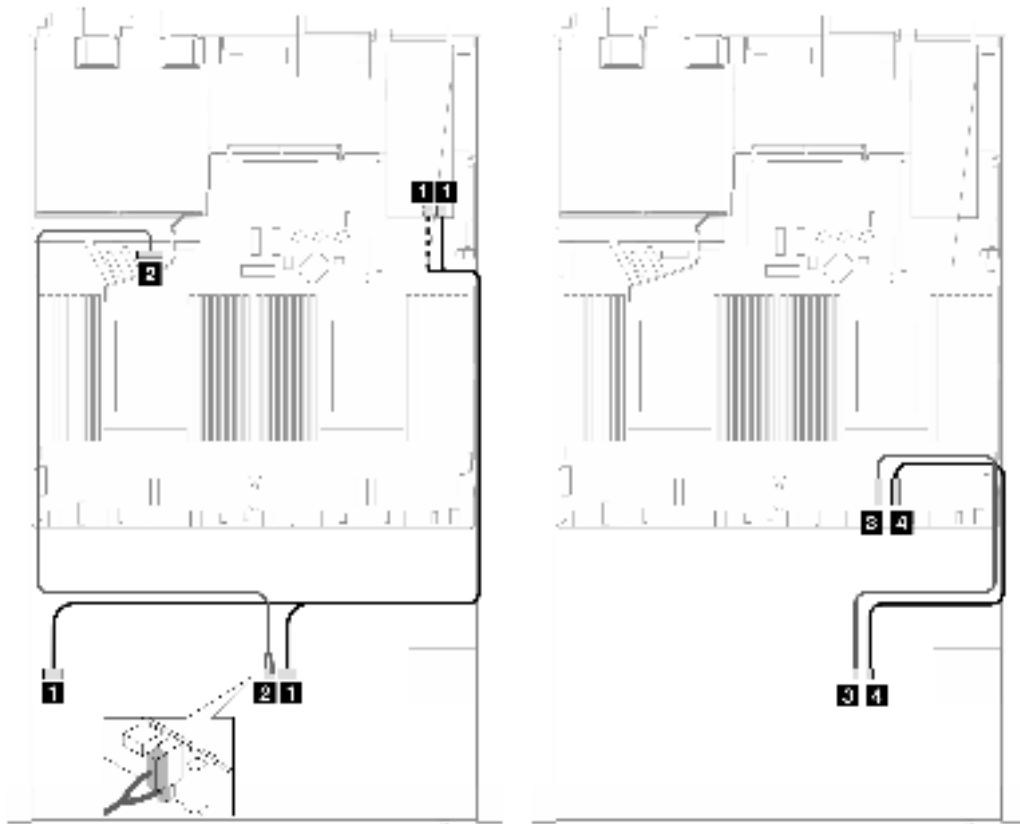


Figure 357. Cable routing for six SAS/SATA drives and two AnyBay drives and two NVMe front drive bays with a 16i SFF RAID adapter (Gen 3)

Table 164. Mapping between one front AnyBay backplane and an SFF HBA/RAID adapter

Backplane	From	To
Front BP (SAS)	1 SAS 0–3, 4–7	1 C0, C1
Front BP (power)	2 Power and sideband	2 Power port for front BP
Front BP (NVMe)	3 NVMe 6–7	3 PCIe 2
	4 NVMe 8–9	4 PCIe 1

### Cable routing with a CFF HBA/RAID adapter

The following tables show the mapping relationship between backplane connectors and a 16i CFF HBA/RAID adapter (Gen 3 or Gen 4).



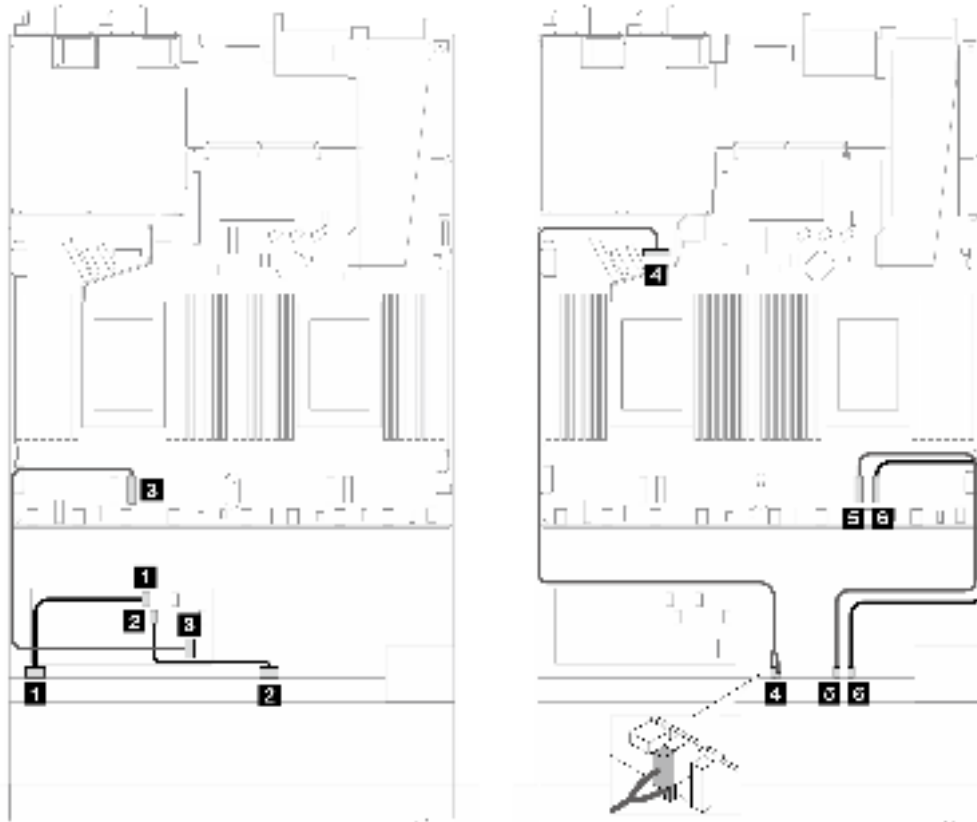


Figure 358. Cable routing for six SAS/SATA drives and two AnyBay drives and two NVMe front drive bays with a 16i CFF HBA/RAID adapter (Gen 3 or Gen 4)

Table 165. Mapping between one front SAS/SATA backplane and a CFF RAID adapter

Backplane/adapter	From	To
Front BP (SAS)	1 SAS 0–3	1 C0
	2 SAS 4–7	2 C1
CFF RAID adapter	3 MB input	3 PCIe 3
Front BP (power)	4 Power and sideband	4 Power port for front BP
Front BP (NVMe)	5 NVMe 6–7	5 PCIe 2
	6 NVMe 8–9	6 PCIe 1

### 10 x 2.5" AnyBay (Gen 5)

See this section to understand the cable routing of 10 front AnyBay drives with 10 x 2.5" backplane (Gen 5) installed.

To connect cables for a 7mm drive backplane, refer to [“7mm drive backplane” on page 270](#).

To connect cables for M.2 drives, refer to [“M.2 drive backplane” on page 267](#).

To connect cables for rear NVMe drives, refer to [“Rear NVMe backplane cable routing with 10 x 2.5" AnyBay backplane \(Gen 5\) installed” on page 273](#).

To connect signal cables for a backplane for standard 10 front front AnyBay drives, refer to the following cable routing scenarios depending on your server configuration:

- “Cable routing for onboard configuration” on page 424
- “Cable routing with an SFF HBA/RAID adapter” on page 425

### Cable routing for onboard configuration

The following tables show the mapping relationship between backplane and processor board connectors for onboard configuration.

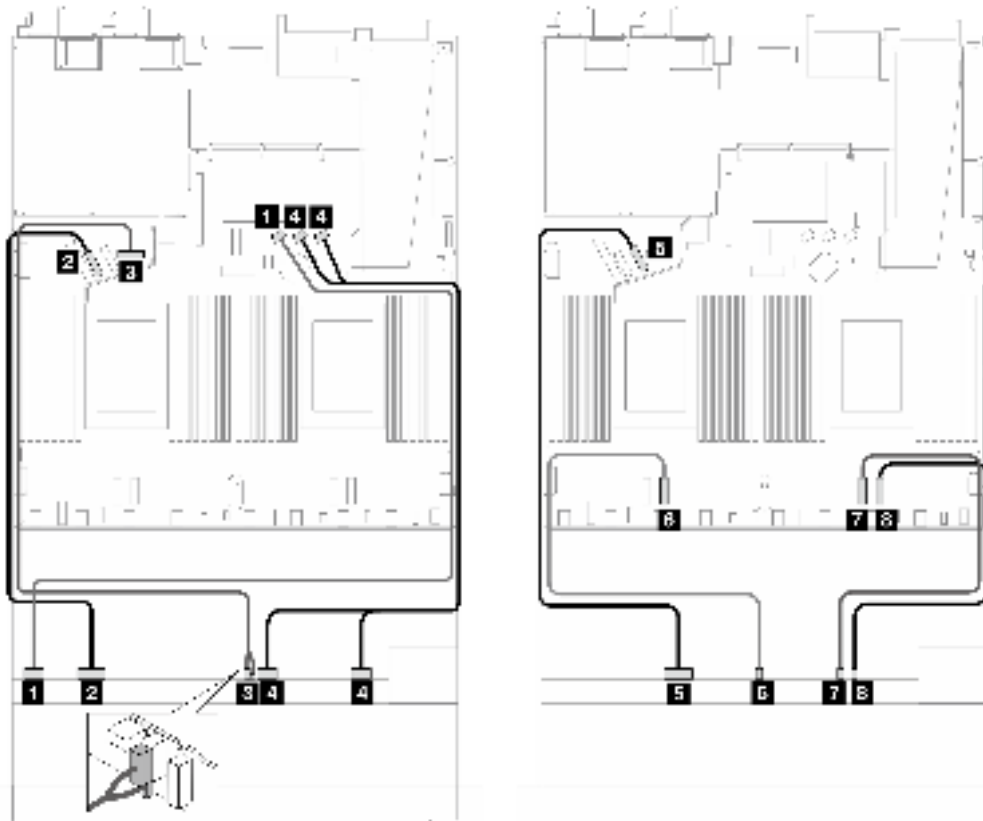


Figure 359. Cable routing for onboard configuration of 10 x 2.5'' AnyBay front drives

Table 166. Mapping between one front AnyBay backplane and processor board for onboard configuration

Backplane	From	To
Front BP (SAS)	1 SAS 0–3	1 SATA 0
Front BP (NVMe)	2 NVMe 0–1	2 PCIe 5
Front BP (power)	3 Power and sideband	3 Power port for front BP
Front BP (SAS)	4 SAS 4–7, 8–9	4 SATA 1, 2
Front BP (NVMe)	5 NVMe 2–3	5 PCIe 6
	6 NVMe 4–5	6 PCIe 3
	7 NVMe 6–7	7 PCIe 2
	8 NVMe 8–9	8 PCIe 1

### Cable routing with an SFF HBA/RAID adapter

The following tables show the mapping relationship between backplane connectors and an SFF HBA/RAID adapter (Gen 3 or Gen 4).

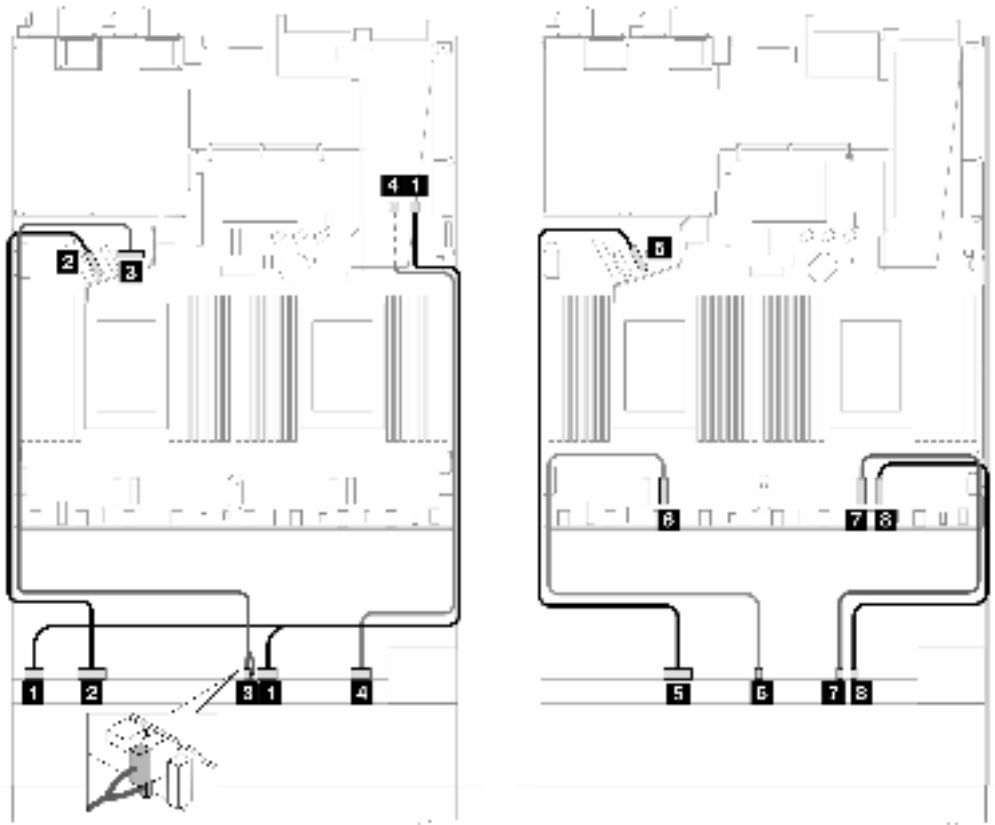


Figure 360. Cable routing for 10 front AnyBay drives with a 16i SFF RAID adapter (Gen 4)

Table 167. Mapping between one front AnyBay backplane and a Gen 4 SFF HBA/RAID adapter

Backplane	From	To
Front BP (SAS)	1 SAS 0–3, 4–7	1 C0
Front BP (NVMe)	2 NVMe 0–1	2 PCIe 5
Front BP (power)	3 Power and sideband	3 Power port for front BP
Front BP (SAS)	4 SAS 8–9	4 C1
Front BP (NVMe)	5 NVMe 2–3	5 PCIe 6
	6 NVMe 4–5	6 PCIe 3
	7 NVMe 6–7	7 PCIe 2
	8 NVMe 8–9	8 PCIe 1

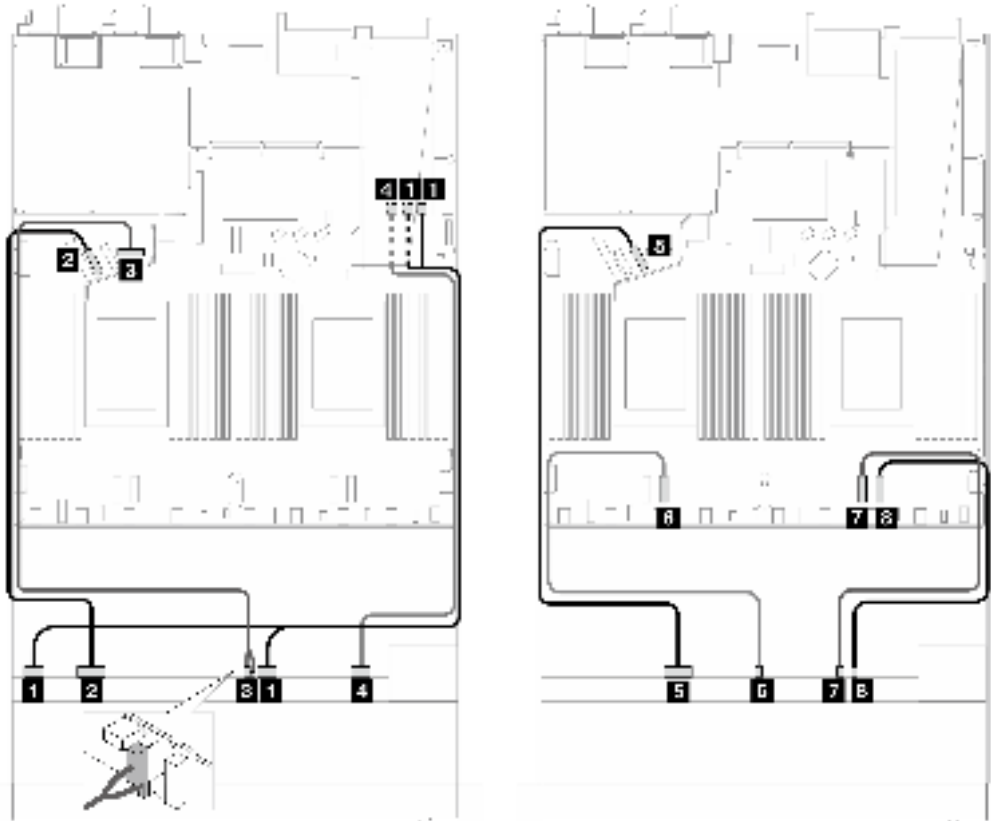


Figure 361. Cable routing for 10 AnyBay drives with a 16i SFF RAID adapter (Gen 3)

Table 168. Mapping between one front AnyBay backplane and an SFF HBA/RAID adapter

Backplane	From	To
Front BP (SAS)	1 SAS 0–3, 4–7	1 C0, C1
Front BP (NVMe)	2 NVMe 0–1	2 PCIe 5
Front BP (power)	3 Power and sideband	3 Power port for front BP
Front BP (SAS)	4 SAS 8–9	4 C2
Front BP (NVMe)	5 NVMe 2–3	5 PCIe 6
	6 NVMe 4–5	6 PCIe 3
	7 NVMe 6–7	7 PCIe 2
	8 NVMe 8–9	8 PCIe 1

### 10 x 2.5" NVMe (Gen 5)

See this section to understand the cable routing of 10 front NVMe drives with 10 x 2.5" backplane (Gen 5) installed.

To connect cables for a 7mm drive backplane, refer to [“7mm drive backplane” on page 270](#).

To connect cables for M.2 drives, refer to [“M.2 drive backplane” on page 267](#).

## Cable routing for onboard configuration

The following table shows the mapping relationship between backplane connectors and system board connectors for onboard configuration.

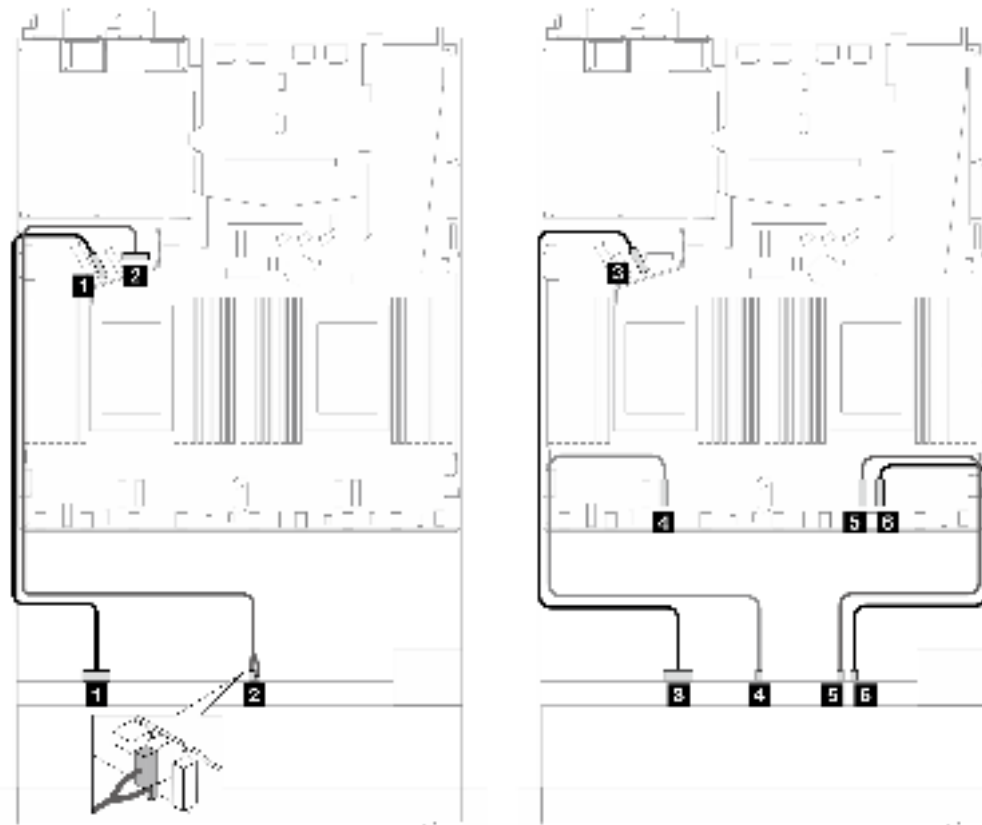


Figure 362. Cable routing for onboard configuration of 10 x 2.5'' NVMe front drives

Table 169. Mapping between one front AnyBay backplane and processor board for onboard configuration

Backplane	From	To
Front BP (NVMe)	1 NVMe 0–1	1 PCIe 5
Front BP (power)	2 Power and sideband	2 Power port for front BP
Front BP (NVMe)	3 NVMe 2–3	3 PCIe 6
	4 NVMe 4–5	4 PCIe 3
	5 NVMe 6–7	5 PCIe 2
	6 NVMe 8–9	6 PCIe 1

### 12 x 2.5'' NVMe (Gen 5)

See this section to understand the cable routing of 12 front NVMe drives with 10 x 2.5'' backplane (Gen 5) installed.

To connect cables for a 7mm drive backplane, refer to [“7mm drive backplane” on page 270](#).

To connect cables for M.2 drives, refer to [“M.2 drive backplane” on page 267](#).

## Cable routing for onboard configuration

The following table shows the mapping relationship between backplane connectors and system board connectors for onboard configuration.

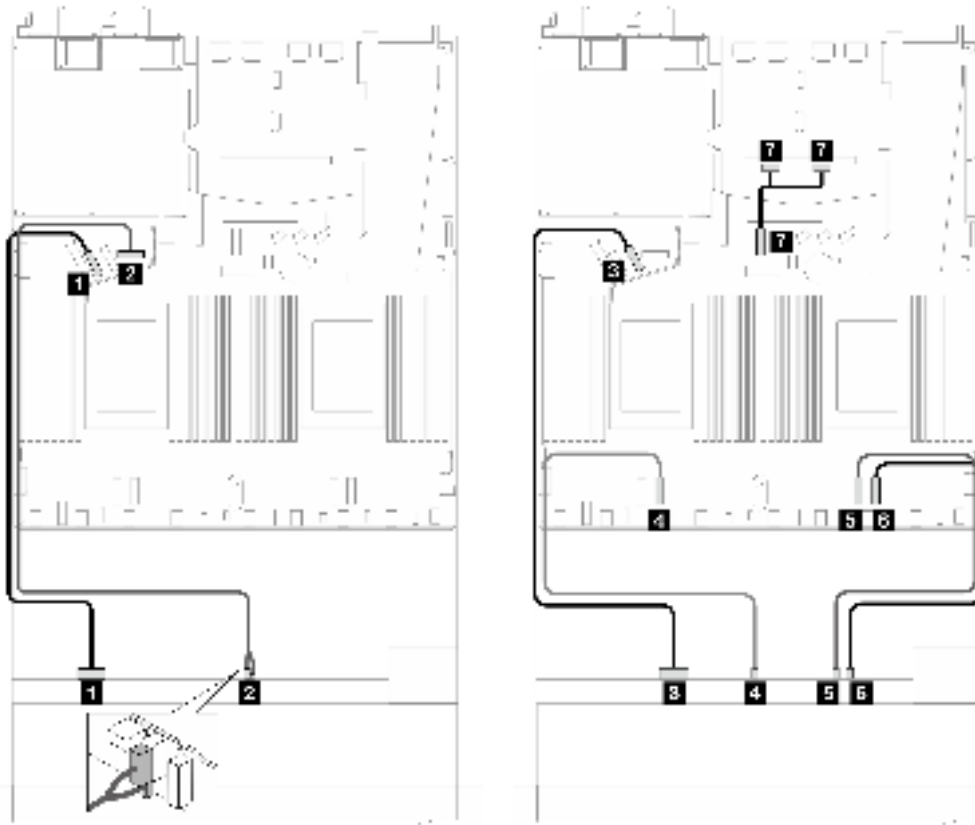


Figure 363. Cable routing for onboard configuration of 12 x 2.5'' NVMe front drives

Table 170. Mapping between one front AnyBay backplane and processor board for onboard configuration

Backplane	From	To
Front BP (NVMe)	1 NVMe 0–1	1 PCIe 5
Front BP (power)	2 Power and sideband	2 Power port for front BP
Front BP (NVMe)	3 NVMe 2–3	3 PCIe 6
	4 NVMe 4–5	4 PCIe 3
	5 NVMe 6–7	5 PCIe 2
	6 NVMe 8–9	6 PCIe 1
Rear BP (NVMe)	7 NVMe 0, 1(rear)	7 PCIe 7

## 16-EDSFF drive backplane

Use this section to understand the backplane cable routing for server model with 16 E1.S EDSFF front drives.

The following table shows the mapping relationship between backplane, re-timer adapter and processor board connectors.

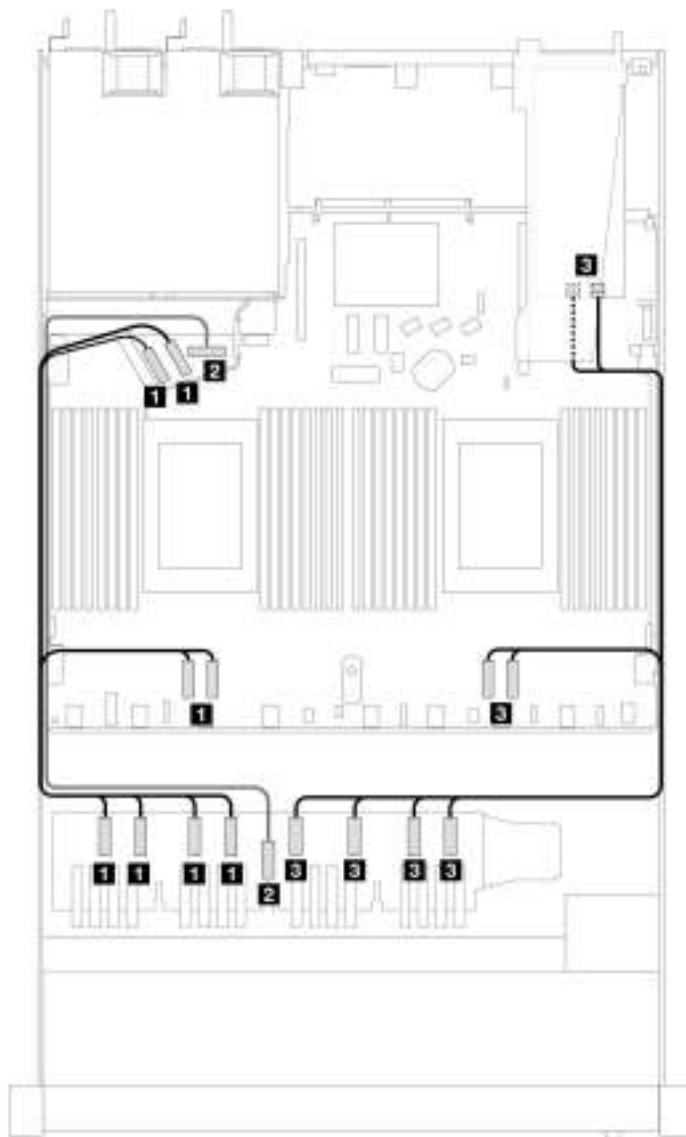


Table 171. Mapping between one front AnyBay backplane and a re-timer adapter with onboard connectors

From	To
<b>1</b> EDSFF 0-1	<b>1</b> PCIe 6
<b>1</b> EDSFF 2-3	<b>1</b> PCIe 5
<b>1</b> EDSFF 4-5	<b>1</b> PCIe 4
<b>1</b> EDSFF 6-7	<b>1</b> PCIe 3
<b>2</b> Power	<b>2</b> Front backplane power port on the processor board
<b>3</b> EDSFF 8-9	<b>3</b> C1
<b>3</b> EDSFF 10-11	<b>3</b> C0
<b>3</b> EDSFF 12-13	<b>3</b> PCIe 2
<b>3</b> EDSFF 14-15	<b>3</b> PCIe 1





---

## Chapter 7. System configuration

Complete these procedures to configure your system.

---

### Set the network connection for the Lenovo XClarity Controller

Before you can access the Lenovo XClarity Controller over your network, you need to specify how Lenovo XClarity Controller will connect to the network. Depending on how the network connection is implemented, you might need to specify a static IP address as well.

The following methods are available to set the network connection for the Lenovo XClarity Controller if you are not using DHCP:

- If a monitor is attached to the server, you can use Lenovo XClarity Provisioning Manager to set the network connection.

Complete the following steps to connect the Lenovo XClarity Controller to the network using the Lenovo XClarity Provisioning Manager.

1. Start the server.
2. Press the key specified in the on-screen instructions to display the Lenovo XClarity Provisioning Manager interface. (For more information, see the “Startup” section in the LXPM documentation compatible with your server at [https://sysmgt.lenovofiles.com/help/topic/lxpm\\_frontend/lxpm\\_product\\_page.html](https://sysmgt.lenovofiles.com/help/topic/lxpm_frontend/lxpm_product_page.html).)
3. Go to **LXPM → UEFI Setup → BMC Settings** to specify how the Lenovo XClarity Controller will connect to the network.
  - If you choose a static IP connection, make sure that you specify an IPv4 or IPv6 address that is available on the network.
  - If you choose a DHCP connection, make sure that the MAC address for the server has been configured in the DHCP server.
4. Click **OK** to apply the setting and wait for two to three minutes.
5. Use an IPv4 or IPv6 address to connect Lenovo XClarity Controller.

**Important:** The Lenovo XClarity Controller is set initially with a user name of USERID and password of PASSWORD (with a zero, not the letter O). This default user setting has Supervisor access. It is required to change this user name and password during your initial configuration for enhanced security.

- If no monitor is attached to the server, you can set the network connection through the Lenovo XClarity Controller interface. Connect an Ethernet cable from your laptop to XCC system management port on your server. For the location of the XCC system management port, see [Chapter 2 “Server components” on page 19](#).

**Note:** Make sure that you modify the IP settings on the laptop so that it is on the same network as the server default settings.

The default IPv4 address and the IPv6 Link Local Address (LLA) is provided on the Lenovo XClarity Controller Network Access label that is affixed to the Pull Out Information Tab. See [“Identify the server and access the Lenovo XClarity Controller” on page 47](#).

- If you are using the Lenovo XClarity Administrator Mobile app from a mobile device, you can connect to the Lenovo XClarity Controller through the Lenovo XClarity Controller USB connector on the server. For the location of the Lenovo XClarity Controller USB connector, see [Chapter 2 “Server components” on page 19](#).

**Note:** The Lenovo XClarity Controller USB connector mode must be set to manage the Lenovo XClarity Controller (instead of normal USB mode). To switch from normal mode to Lenovo XClarity Controller management mode, hold the ID button on the server for at least 3 seconds until its LED flashes slowly (once every couple of seconds). See [Chapter 2 “Server components” on page 19](#) for the location of the ID button.

To connect using the Lenovo XClarity Administrator Mobile app:

1. Connect the USB cable of your mobile device to the Lenovo XClarity Controller USB connector on the server.
2. On your mobile device, enable USB tethering.
3. On your mobile device, launch the Lenovo XClarity Administrator mobile app.
4. If automatic discovery is disabled, click **Discovery** on the USB Discovery page to connect to the Lenovo XClarity Controller.

For more information about using the Lenovo XClarity Administrator Mobile app, see:

[http://sysmgt.lenovofiles.com/help/topic/com.lenovo.lxca.doc/lxca\\_usemobileapp.html](http://sysmgt.lenovofiles.com/help/topic/com.lenovo.lxca.doc/lxca_usemobileapp.html)

---

## Set front USB port for Lenovo XClarity Controller connection

Before you can access the Lenovo XClarity Controller through the front USB port, you need to configure the USB port for Lenovo XClarity Controller connection.

### Server support

To see if your server supports accessing Lenovo XClarity Controller through the front USB port, check one of the following:

- Refer to [Chapter 2 “Server components” on page 19](#).



- If there is a wrench icon on the USB port of your server, you can set the USB port to connect to Lenovo XClarity Controller. It is also the only USB port that supports USB automation update of the firmware and RoT security module.

### Setting the USB port for Lenovo XClarity Controller connection

You can switch the USB port between normal and Lenovo XClarity Controller management operation by performing one of the following steps.

- Hold the ID button for at least 3 second until its LED flashes slowly (once every couple of seconds). See [Chapter 2 “Server components” on page 19](#) for ID button location.
- From the Lenovo XClarity Controller management controller CLI, run the `usbfp` command. For information about using the Lenovo XClarity Controller CLI, see the “Command-line interface” section in the XCC documentation compatible with your server at [https://sysmgt.lenovofiles.com/help/topic/lxcc\\_frontend/lxcc\\_overview.html](https://sysmgt.lenovofiles.com/help/topic/lxcc_frontend/lxcc_overview.html).
- From the Lenovo XClarity Controller management controller web interface, click **BMC Configuration** → **Network** → **Front Panel USB Port Manager**. For information about Lenovo XClarity Controller web interface functions, see the “Description of XClarity Controller functions on web interface” section in the XCC documentation compatible with your server at [https://sysmgt.lenovofiles.com/help/topic/lxcc\\_frontend/lxcc\\_overview.html](https://sysmgt.lenovofiles.com/help/topic/lxcc_frontend/lxcc_overview.html).

### Checking USB port current setting

You can also check the current setting of the USB port using the Lenovo XClarity Controller management controller CLI (usbfp command) or the Lenovo XClarity Controller management controller web interface ( **BMC Configuration → Network → Front Panel USB Port Manager**). See the “Command-line interface” and “Description of XClarity Controller functions on web interface” sections in the XCC documentation compatible with your server at [https://sysmgmt.lenovofiles.com/help/topic/ixcc\\_frontend/ixcc\\_overview.html](https://sysmgmt.lenovofiles.com/help/topic/ixcc_frontend/ixcc_overview.html).

---

## Update the firmware

Several options are available to update the firmware for the server.

You can use the tools listed here to update the most current firmware for your server and the devices that are installed in the server.

- Best practices related to updating firmware is available at the following site:
  - <https://lenovopress.lenovo.com/lp0656-lenovo-thinksystem-firmware-and-driver-update-best-practices>
- The latest firmware can be found at the following site:
  - <https://datacentersupport.lenovo.com/products/servers/thinksystem/sr630v3/7d72/downloads/driver-list/>
- You can subscribe to product notification to stay up to date on firmware updates:
  - <https://datacentersupport.lenovo.com/solutions/ht509500>

### Static Bundles (Service Packs)

Lenovo typically releases firmware in bundles called Static Bundles (Service Packs). To ensure that all of the firmware updates are compatible, you should update all firmware at the same time. If you are updating firmware for both the Lenovo XClarity Controller and UEFI, update the firmware for Lenovo XClarity Controller first.

### Update method terminology

- **In-band update.** The installation or update is performed using a tool or application within an operating system that is executing on the server’s core CPU.
- **Out-of-band update.** The installation or update is performed by the Lenovo XClarity Controller collecting the update and then directing the update to the target subsystem or device. Out-of-band updates have no dependency on an operating system executing on the core CPU. However, most out-of-band operations do require the server to be in the S0 (Working) power state.
- **On-Target update.** The installation or update is initiated from an installed operating system executing on the target server itself.
- **Off-Target update.** The installation or update is initiated from a computing device interacting directly with the server’s Lenovo XClarity Controller.
- **Static Bundles (Service Packs).** Static Bundles (Service Packs) are bundled updates designed and tested to provide the interdependent level of functionality, performance, and compatibility. Static Bundles (Service Packs) are server machine-type specific and are built (with firmware and device driver updates) to support specific Windows Server, Red Hat Enterprise Linux (RHEL) and SUSE Linux Enterprise Server (SLES) operating system distributions. Machine-type-specific firmware-only Static Bundles (Service Packs) are also available.

### Firmware updating tools

See the following table to determine the best Lenovo tool to use for installing and setting up the firmware:

Tool	Update Methods Supported	Core System Firmware Updates	I/O Devices Firmware Updates	Drive Firmware Updates	Graphical user interface	Command line interface	Supports Static Bundles (Service Packs)
<b>Lenovo XClarity Provisioning Manager (LXPM)</b>	In-band <sup>2</sup> On-Target	√			√		
<b>Lenovo XClarity Controller (XCC)</b>	In-band <sup>4</sup> Out-of-band Off-Target	√	Selected I/O devices	√ <sup>3</sup>	√		√
<b>Lenovo XClarity Essentials OneCLI (OneCLI)</b>	In-band Out-of-band On-Target Off-Target	√	All I/O devices	√ <sup>3</sup>		√	√
<b>Lenovo XClarity Essentials UpdateXpress (LXCE)</b>	In-band Out-of-band On-Target Off-Target	√	All I/O devices		√		√
<b>Lenovo XClarity Essentials Bootable Media Creator (BoMC)</b>	In-band Out-of-band Off-Target	√	All I/O devices		√ (BoMC application)	√ (BoMC application)	√
<b>Lenovo XClarity Administrator (LXCA)</b>	In-band <sup>1</sup> Out-of-band <sup>2</sup> Off-Target	√	All I/O devices		√		√
<b>Lenovo XClarity Integrator (LXCI) for VMware vCenter</b>	Out-of-band Off-Target	√	Selected I/O devices		√		
<b>Lenovo XClarity Integrator (LXCI) for Microsoft Windows Admin Center</b>	In-band Out-of-band On-Target Off-Target	√	All I/O devices		√		√

Tool	Update Methods Supported	Core System Firmware Updates	I/O Devices Firmware Updates	Drive Firmware Updates	Graphical user interface	Command line interface	Supports Static Bundles (Service Packs)
<b>Lenovo XClarity Integrator (LXCI) for Microsoft System Center Configuration Manager</b>	In-band On-Target	√	All I/O devices		√		√
<b>Notes:</b> <ol style="list-style-type: none"> <li>For I/O firmware updates.</li> <li>For BMC and UEFI firmware updates.</li> <li>Drive firmware update is only supported by the tools and methods below: <ul style="list-style-type: none"> <li>XCC Bare Metal Update (BMU): In-band, and requires system reboot.</li> <li>Lenovo XClarity Essentials OneCLI: <ul style="list-style-type: none"> <li>For drives supported by ThinkSystem V2 and V3 products (legacy drives): In-band, and does not require system reboot.</li> <li>For drives supported only by ThinkSystem V3 products (new drives): Staging to XCC and complete the update with XCC BMU (In-band, and requires system reboot.).</li> </ul> </li> </ul> </li> <li>Bare Metal Update (BMU) only.</li> </ol>							

- **Lenovo XClarity Provisioning Manager**

From Lenovo XClarity Provisioning Manager, you can update the Lenovo XClarity Controller firmware, the UEFI firmware, and the Lenovo XClarity Provisioning Manager software.

**Note:** By default, the Lenovo XClarity Provisioning Manager Graphical User Interface is displayed when you start the server and press the key specified in the on-screen instructions. If you have changed that default to be the text-based system setup, you can bring up the Graphical User Interface from the text-based system setup interface.

For additional information about using Lenovo XClarity Provisioning Manager to update firmware, see:

“Firmware Update” section in the LXPM documentation compatible with your server at [https://sysmgt.lenovofiles.com/help/topic/lxpm\\_frontend/lxpm\\_product\\_page.html](https://sysmgt.lenovofiles.com/help/topic/lxpm_frontend/lxpm_product_page.html)

- **Lenovo XClarity Controller**

If you need to install a specific update, you can use the Lenovo XClarity Controller interface for a specific server.

**Notes:**

- To perform an in-band update through Windows or Linux, the operating system driver must be installed and the Ethernet-over-USB (sometimes called LAN over USB) interface must be enabled.

For additional information about configuring Ethernet over USB, see:

“Configuring Ethernet over USB” section in the XCC documentation version compatible with your server at [https://sysmgt.lenovofiles.com/help/topic/lxcc\\_frontend/lxcc\\_overview.html](https://sysmgt.lenovofiles.com/help/topic/lxcc_frontend/lxcc_overview.html)

- If you update firmware through the Lenovo XClarity Controller, make sure that you have downloaded and installed the latest device drivers for the operating system that is running on the server.

For additional information about using Lenovo XClarity Controller to update firmware, see:

“Updating Server Firmware” section in the XCC documentation compatible with your server at [https://sysmgt.lenovofiles.com/help/topic/lxcc\\_frontend/lxcc\\_overview.html](https://sysmgt.lenovofiles.com/help/topic/lxcc_frontend/lxcc_overview.html)

- **Lenovo XClarity Essentials OneCLI**

Lenovo XClarity Essentials OneCLI is a collection of command line applications that can be used to manage Lenovo servers. Its update application can be used to update firmware and device drivers for your servers. The update can be performed within the host operating system of the server (in-band) or remotely through the BMC of the server (out-of-band).

For additional information about using Lenovo XClarity Essentials OneCLI to update firmware, see:

[http://sysmgt.lenovofiles.com/help/topic/toolstr\\_cli\\_lenovo/onecli\\_c\\_update.html](http://sysmgt.lenovofiles.com/help/topic/toolstr_cli_lenovo/onecli_c_update.html)

- **Lenovo XClarity Essentials UpdateXpress**

Lenovo XClarity Essentials UpdateXpress provides most of OneCLI update functions through a graphical user interface (GUI). It can be used to acquire and deploy Static Bundle update packages and individual updates. Static Bundle contain firmware and device driver updates for Microsoft Windows and for Linux.

You can obtain Lenovo XClarity Essentials UpdateXpress from the following location:

<https://datacentersupport.lenovo.com/solutions/lnvo-xpress>

- **Lenovo XClarity Essentials Bootable Media Creator**

You can use Lenovo XClarity Essentials Bootable Media Creator to create bootable media that is suitable for firmware updates, VPD updates, inventory and FFDC collection, advanced system configuration, FoD Keys management, secure erase, RAID configuration, and diagnostics on supported servers.

You can obtain Lenovo XClarity Essentials BoMC from the following location:

<https://datacentersupport.lenovo.com/solutions/lnvo-bomc>

- **Lenovo XClarity Administrator**

If you are managing multiple servers using the Lenovo XClarity Administrator, you can update firmware for all managed servers through that interface. Firmware management is simplified by assigning firmware-compliance policies to managed endpoints. When you create and assign a compliance policy to managed endpoints, Lenovo XClarity Administrator monitors changes to the inventory for those endpoints and flags any endpoints that are out of compliance.

For additional information about using Lenovo XClarity Administrator to update firmware, see:

[http://sysmgt.lenovofiles.com/help/topic/com.lenovo.lxca.doc/update\\_fw.html](http://sysmgt.lenovofiles.com/help/topic/com.lenovo.lxca.doc/update_fw.html)

- **Lenovo XClarity Integrator offerings**

Lenovo XClarity Integrator offerings can integrate management features of Lenovo XClarity Administrator and your server with software used in a certain deployment infrastructure, such as VMware vCenter, Microsoft Admin Center, or Microsoft System Center.

For additional information about using Lenovo XClarity Integrator to update firmware, see:

[https://sysmgt.lenovofiles.com/help/topic/lxci/lxci\\_product\\_page.html](https://sysmgt.lenovofiles.com/help/topic/lxci/lxci_product_page.html)

---

## Configure the firmware

Several options are available to install and set up the firmware for the server.

**Important:** Lenovo does not recommend setting option ROMs to **Legacy**, but you can conduct this setting if necessary. Note that this setting prevents UEFI drivers for the slot devices from loading, which may cause negative side effects to Lenovo software, such as LXCA, OneCLI, and XCC. These side effects include but are not limited to the inability to determine adapter card details, such as model name and firmware levels. For

example, "ThinkSystem RAID 930-16i 4GB Flash" may be displayed as "Adapter 06:00:00". In some cases, the functionality on a specific PCIe adapter may not be enabled properly.

- **Lenovo XClarity Provisioning Manager (LXPM)**

From Lenovo XClarity Provisioning Manager, you can configure the UEFI settings for your server.

**Notes:** The Lenovo XClarity Provisioning Manager provides a Graphical User Interface to configure a server. The text-based interface to system configuration (the Setup Utility) is also available. From Lenovo XClarity Provisioning Manager, you can choose to restart the server and access the text-based interface. In addition, you can choose to make the text-based interface the default interface that is displayed when you start LXPM. To do this, go to **Lenovo XClarity Provisioning Manager → UEFI Setup → System Settings → <F1>Start Control → Text Setup**. To start the server with Graphic User Interface, select **Auto** or **Tool Suite**.

See the following documentations for more information:

- Search for the LXPM documentation version compatible with your server at [https://sysmgt.lenovofiles.com/help/topic/lxpm\\_frontend/lxpm\\_product\\_page.html](https://sysmgt.lenovofiles.com/help/topic/lxpm_frontend/lxpm_product_page.html)
- *UEFI User Guide* at <https://pubs.lenovo.com/uefi-overview/>

- **Lenovo XClarity Essentials OneCLI**

You can use the config application and commands to view the current system configuration settings and make changes to Lenovo XClarity Controller and UEFI. The saved configuration information can be used to replicate or restore other systems.

For information about configuring the server using Lenovo XClarity Essentials OneCLI, see:

[http://sysmgt.lenovofiles.com/help/topic/toolsctr\\_cli\\_lenovo/onecli\\_c\\_settings\\_info\\_commands.html](http://sysmgt.lenovofiles.com/help/topic/toolsctr_cli_lenovo/onecli_c_settings_info_commands.html)

- **Lenovo XClarity Administrator**

You can quickly provision and pre-provision all of your servers using a consistent configuration. Configuration settings (such as local storage, I/O adapters, boot settings, firmware, ports, and Lenovo XClarity Controller and UEFI settings) are saved as a server pattern that can be applied to one or more managed servers. When the server patterns are updated, the changes are automatically deployed to the applied servers.

Specific details about updating firmware using Lenovo XClarity Administrator are available at:

[http://sysmgt.lenovofiles.com/help/topic/com.lenovo.lxca.doc/server\\_configuring.html](http://sysmgt.lenovofiles.com/help/topic/com.lenovo.lxca.doc/server_configuring.html)

- **Lenovo XClarity Controller**

You can configure the management processor for the server through the Lenovo XClarity Controller Web interface, the command-line interface, or Redfish API.

For information about configuring the server using Lenovo XClarity Controller, see:

“Configuring the Server” section in the XCC documentation compatible with your server at [https://sysmgt.lenovofiles.com/help/topic/lxcc\\_frontend/lxcc\\_overview.html](https://sysmgt.lenovofiles.com/help/topic/lxcc_frontend/lxcc_overview.html)

---

## Enable Software Guard Extensions (SGX)

Intel® Software Guard Extensions (Intel® SGX) operates under the assumption that the security perimeter includes only the internals of the CPU package, and leaves the DRAM untrusted.

Make sure to refer to “[Memory module installation rules and order](#)” on page 56, which specifies whether your sever supports SGX and lists the memory module population sequence for SGX configuration.

Complete the following steps to enable SGX.

- Step 1. Restart the system. Before the operating system starts up, press the key specified in the on-screen instructions to enter the Setup Utility. (For more information, see the “Startup” section in the LXPM documentation compatible with your server at [https://sysmgt.lenovofiles.com/help/topic/lxpm\\_frontend/lxpm\\_product\\_page.html](https://sysmgt.lenovofiles.com/help/topic/lxpm_frontend/lxpm_product_page.html).)
- Step 2. Go to **System settings** → **Processors** → **UMA-Based Clustering** and disable the option.
- Step 3. Go to **System settings** → **Processors** → **Total Memory Encryption (TME)** and enable the option.
- Step 4. Save the changes, then go to **System settings** → **Processors** → **SW Guard Extension (SGX)** and enable the option.

---

## RAID configuration

Using a Redundant Array of Independent Disks (RAID) to store data remains one of the most common and cost-efficient methods to increase server's storage performance, availability, and capacity.

RAID increases performance by allowing multiple drives to process I/O requests simultaneously. RAID can also prevent data loss in case of a drive failure by reconstructing (or rebuilding) the missing data from the failed drive using the data from the remaining drives.

RAID array (also known as RAID drive group) is a group of multiple physical drives that uses a certain common method to distribute data across the drives. A virtual drive (also known as virtual disk or logical drive) is a partition in the drive group that is made up of contiguous data segments on the drives. Virtual drive is presented up to the host operating system as a physical disk that can be partitioned to create OS logical drives or volumes.

An introduction to RAID is available at the following Lenovo Press website:

<https://lenovopress.lenovo.com/lp0578-lenovo-raid-introduction>

Detailed information about RAID management tools and resources is available at the following Lenovo Press website:

<https://lenovopress.lenovo.com/lp0579-lenovo-raid-management-tools-and-resources>

### Notes:

- Before setting up RAID for NVMe drives, follow the below steps to enable VROC:
  1. Restart the system. Before the operating system starts up, press the key specified in the on-screen instructions to enter the Setup Utility. (For more information, see the “Startup” section in the LXPM documentation compatible with your server at [https://sysmgt.lenovofiles.com/help/topic/lxpm\\_frontend/lxpm\\_product\\_page.html](https://sysmgt.lenovofiles.com/help/topic/lxpm_frontend/lxpm_product_page.html).)
  2. Go to **System settings** → **Devices and I/O Ports** → **Intel VMD** and enable the option.
  3. Save the changes and reboot the system.
- VROC Intel-SSD-Only supports RAID levels 0, 1, 5, and 10 with Intel NVMe drives.
- VROC Premium requires an activation key and supports RAID levels 0, 1, 5, and 10 with non-Intel NVMe drives. For more information about acquiring and installing the activation key, see <https://fod.lenovo.com/lkms>.

---

## Deploy the operating system

Several options are available to deploy an operating system on the server.



## Available operating systems

- Microsoft Windows Server
- VMware ESXi
- Red Hat Enterprise Linux
- SUSE Linux Enterprise Server
- Canonical Ubuntu

Complete list of available operating systems: <https://lenovopress.lenovo.com/osig>.

## Tool-based deployment

### • Multi-server

Available tools:

- Lenovo XClarity Administrator  
[http://sysmgt.lenovofiles.com/help/topic/com.lenovo.lxca.doc/compute\\_node\\_image\\_deployment.html](http://sysmgt.lenovofiles.com/help/topic/com.lenovo.lxca.doc/compute_node_image_deployment.html)
- Lenovo XClarity Essentials OneCLI  
[http://sysmgt.lenovofiles.com/help/topic/toolsctr\\_cli\\_lenovo/onecli\\_r\\_uxspi\\_proxy\\_tool.html](http://sysmgt.lenovofiles.com/help/topic/toolsctr_cli_lenovo/onecli_r_uxspi_proxy_tool.html)
- Lenovo XClarity Integrator deployment pack for SCCM (for Windows operating system only)  
[https://sysmgt.lenovofiles.com/help/topic/com.lenovo.lxci\\_deploypack\\_sccm.doc/dpsccm\\_c\\_endtoend\\_deploy\\_scenario.html](https://sysmgt.lenovofiles.com/help/topic/com.lenovo.lxci_deploypack_sccm.doc/dpsccm_c_endtoend_deploy_scenario.html)

### • Single-server

Available tools:

- Lenovo XClarity Provisioning Manager  
“OS Installation” section in the LXPM documentation compatible with your server at [https://sysmgt.lenovofiles.com/help/topic/lxpm\\_frontend/lxpm\\_product\\_page.html](https://sysmgt.lenovofiles.com/help/topic/lxpm_frontend/lxpm_product_page.html)
- Lenovo XClarity Essentials OneCLI  
[http://sysmgt.lenovofiles.com/help/topic/toolsctr\\_cli\\_lenovo/onecli\\_r\\_uxspi\\_proxy\\_tool.html](http://sysmgt.lenovofiles.com/help/topic/toolsctr_cli_lenovo/onecli_r_uxspi_proxy_tool.html)
- Lenovo XClarity Integrator deployment pack for SCCM (for Windows operating system only)  
[https://sysmgt.lenovofiles.com/help/topic/com.lenovo.lxci\\_deploypack\\_sccm.doc/dpsccm\\_c\\_endtoend\\_deploy\\_scenario.html](https://sysmgt.lenovofiles.com/help/topic/com.lenovo.lxci_deploypack_sccm.doc/dpsccm_c_endtoend_deploy_scenario.html)

## Manual deployment

If you cannot access the above tools, follow the instructions below, download the corresponding OS *Installation Guide*, and deploy the operating system manually by referring to the guide.

1. Go to <https://datacentersupport.lenovo.com/solutions/server-os>.
2. Select an operating system from the navigation pane and click **Resources**.
3. Locate the “OS Install Guides” area and click the installation instructions. Then, follow the instructions to complete the operation system deployment task.

---

## Back up the server configuration

After setting up the server or making changes to the configuration, it is a good practice to make a complete backup of the server configuration.

Make sure that you create backups for the following server components:

- **Management processor**

You can back up the management processor configuration through the Lenovo XClarity Controller interface. For details about backing up the management processor configuration, see:

“Backing up the BMC configuration” section in the XCC documentation compatible with your server at [https://sysmgt.lenovofiles.com/help/topic/lxcc\\_frontend/lxcc\\_overview.html](https://sysmgt.lenovofiles.com/help/topic/lxcc_frontend/lxcc_overview.html).

Alternatively, you can use the `save` command from Lenovo XClarity Essentials OneCLI to create a backup of all configuration settings. For more information about the `save` command, see:

[http://sysmgt.lenovofiles.com/help/topic/toolsctr\\_cli\\_lenovo/onecli\\_r\\_save\\_command.html](http://sysmgt.lenovofiles.com/help/topic/toolsctr_cli_lenovo/onecli_r_save_command.html)

- **Operating system**

Use your backup methods to back up the operating system and user data for the server.

---

## Chapter 8. Problem determination

Use the information in this section to isolate and resolve issues that you might encounter while using your server.

Lenovo servers can be configured to automatically notify Lenovo Support if certain events are generated. You can configure automatic notification, also known as Call Home, from management applications, such as the Lenovo XClarity Administrator. If you configure automatic problem notification, Lenovo Support is automatically alerted whenever a server encounters a potentially significant event.

To isolate a problem, you should typically begin with the event log of the application that is managing the server:

- If you are managing the server from the Lenovo XClarity Administrator, begin with the Lenovo XClarity Administrator event log.
- If you are using some other management application, begin with the Lenovo XClarity Controller event log.

### Web resources

- **Tech tips**

Lenovo continually updates the support website with the latest tips and techniques that you can use to solve issues that your server might encounter. These Tech Tips (also called retain tips or service bulletins) provide procedures to work around issues or solve problems related to the operation of your server.

To find the Tech Tips available for your server:

1. Go to <http://datacentersupport.lenovo.com>, and input the model name or machine type of your server in the search bar to navigate to the support page.
2. Click on **How To's** from the navigation pane.
3. Click **Article Type** → **Solution** from the drop-down menu.

Follow the on-screen instructions to choose the category for the problem that you are having.

- **Lenovo Data Center Forum**

- Check [https://forums.lenovo.com/t5/Datacenter-Systems/ct-p/sv\\_eg](https://forums.lenovo.com/t5/Datacenter-Systems/ct-p/sv_eg) to see if someone else has encountered a similar problem.

---

## Event logs

An *alert* is a message or other indication that signals an event or an impending event. Alerts are generated by the Lenovo XClarity Controller or by UEFI in the servers. These alerts are stored in the Lenovo XClarity Controller Event Log. If the server is managed by the Chassis Management Module 2 or by the Lenovo XClarity Administrator, alerts are automatically forwarded to those management applications.

**Note:** For a listing of events, including user actions that might need to be performed to recover from an event, see the *Messages and Codes Reference*, which is available at [https://thinksystem.lenovofiles.com/help/topic/SR630V3/pdf\\_files.html](https://thinksystem.lenovofiles.com/help/topic/SR630V3/pdf_files.html).

### Lenovo XClarity Administrator event log

If you are using Lenovo XClarity Administrator to manage server, network, and storage hardware, you can view the events from all managed devices through the XClarity Administrator.

## Logs

Severity	Serviceability	Date and Time	System	Event	System Type	Source Date
Warning	Support	Jan 30, 2017, 7:49:07 AM	Chassis114:...	Node Node 08 device	Chassis	Jan 30, 20
Warning	Support	Jan 30, 2017, 7:49:07 AM	Chassis114:...	Node Node 02 device	Chassis	Jan 30, 20
Warning	User	Jan 30, 2017, 7:49:07 AM	Chassis114:...	I/O module IO Module	Chassis	Jan 30, 20
Warning	User	Jan 30, 2017, 7:49:07 AM	Chassis114:...	Node Node 08 incom	Chassis	Jan 30, 20

Figure 364. Lenovo XClarity Administrator event log

For more information about working with events from XClarity Administrator, see:

[http://sysmgt.lenovofiles.com/help/topic/com.lenovo.lxca.doc/events\\_vieweventlog.html](http://sysmgt.lenovofiles.com/help/topic/com.lenovo.lxca.doc/events_vieweventlog.html)

### Lenovo XClarity Controller event log

The Lenovo XClarity Controller monitors the physical state of the server and its components using sensors that measure internal physical variables such as temperature, power-supply voltages, fan speeds, and component status. The Lenovo XClarity Controller provides various interfaces to systems management software and to system administrators and users to enable remote management and control of a server.

The Lenovo XClarity Controller monitors all components of the server and posts events in the Lenovo XClarity Controller event log.

Severity	Source	Event ID	Message	Date
Warning	System	2016010200000000	Power supply control & Log: The controller is not working properly. Power supply 15 104 134 100	01/30/2015 08:11:34 AM
Warning	System	2016010200000000	Power supply control & Log: The controller is not working properly. Power supply 15 100 134 100	01/30/2015 08:11:34 AM
Warning	System	2016010200000000	Power supply control & Log: The controller is not working properly. Power supply 15 101 134 100	01/30/2015 08:11:34 AM
Warning	System	2016010200000000	Power supply control & Log: The controller is not working properly. Power supply 15 106 134 100	01/30/2015 08:11:34 AM

Figure 365. Lenovo XClarity Controller event log

For more information about accessing the Lenovo XClarity Controller event log, see:

“Viewing Event Logs” section in the XCC documentation compatible with your server at [https://sysmgt.lenovofiles.com/help/topic/lxccc\\_frontend/lxccc\\_overview.html](https://sysmgt.lenovofiles.com/help/topic/lxccc_frontend/lxccc_overview.html).

## Troubleshooting by system LEDs and diagnostics display

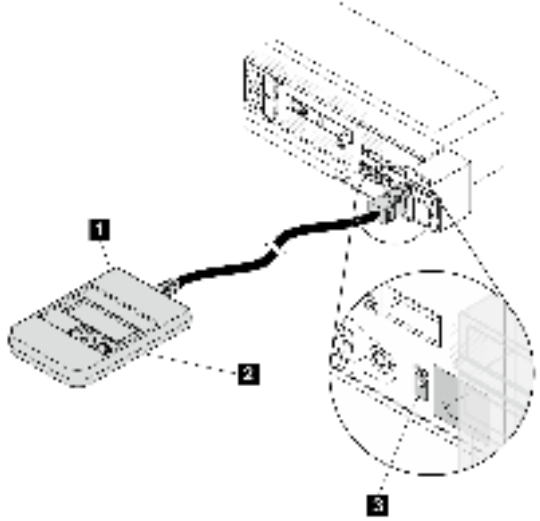
See the following section for information on available system LEDs and diagnostics display.

### External diagnostics handset

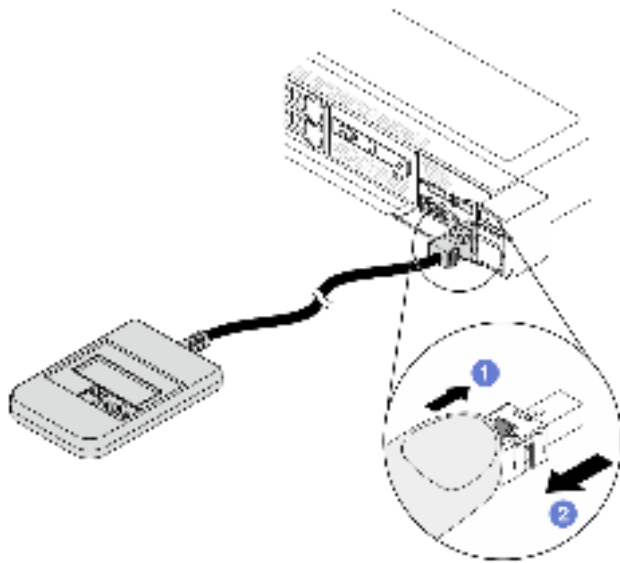
The external LCD diagnostics handset is an external device that is connected to the server with a cable, and it allows quick access to system information such as errors, system status, firmware, network, and health information.

**Note:** The external diagnostics handset is an optional part that needs to be purchased separately.

#### Location of the external diagnostics handset

Location	Callouts
<p>The external diagnostics handset is connected to the server with an external cable.</p> 	<p><b>1</b> External diagnostics handset</p> <p><b>2</b> Magnetic bottom With this component, the diagnostic handset can be attached to the top or side of the rack with hands spared for service tasks.</p> <p><b>3</b> External diagnostics connector This connector is located on the front of the server, and is used to connect an external diagnostics handset.</p>

**Note:** When unplugging the external handset, see the following instructions:



- 1 Press the plastic clip on the plug forward.
- 2 Hold the clip and remove the cable from the connector.

### Display panel overview

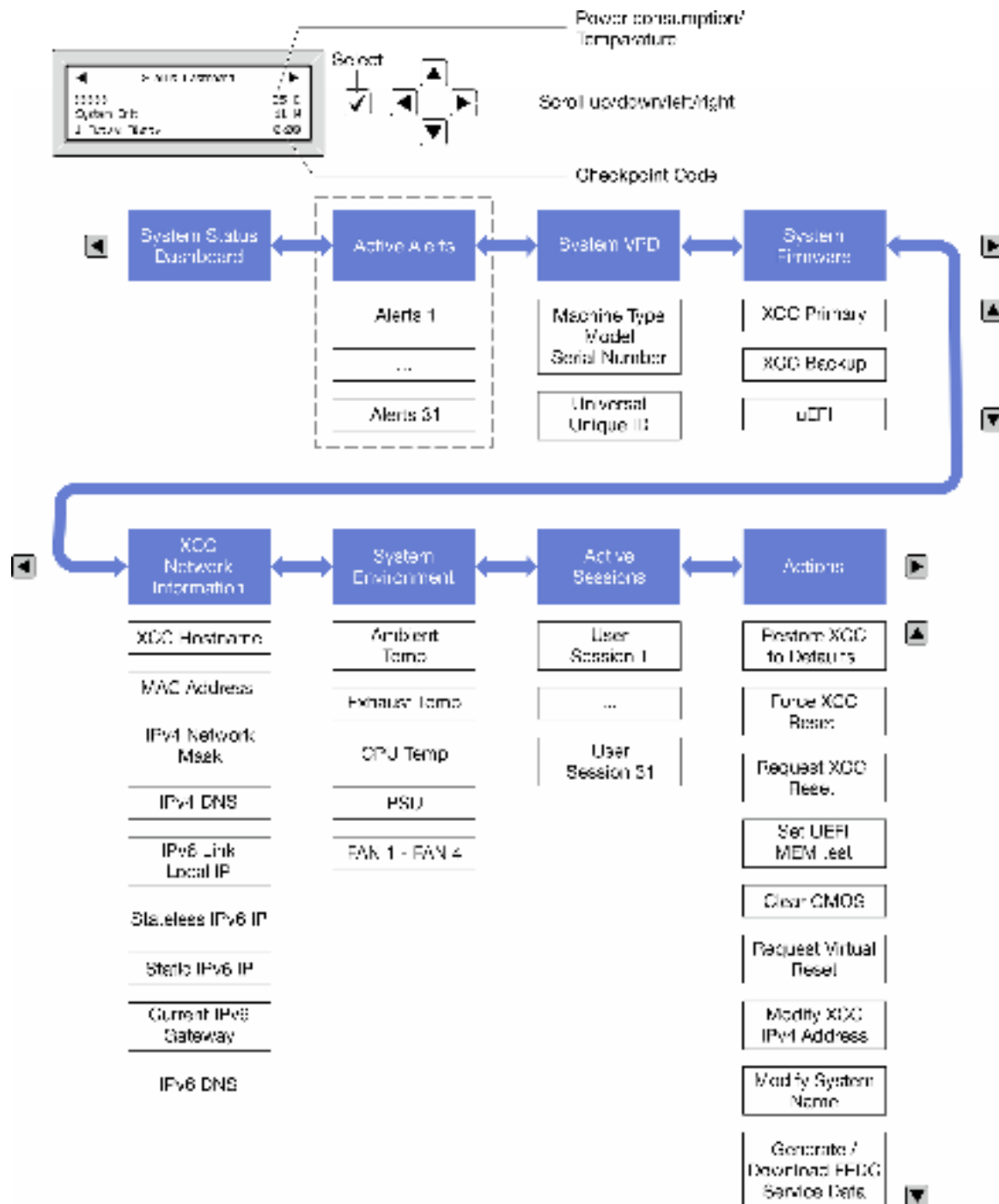
The diagnostics device consists of an LCD display and 5 navigation buttons.

	<p><b>1</b> LCD display</p> <p><b>2</b> Scroll buttons (up/down/left/right) Press the scroll buttons to locate and select system information.</p> <p><b>3</b> Select button Press the select button to select from the options in the menu.</p>
--	---

### Option flow diagram

The external diagnostics handset displays various system information. Navigate through the options with the scroll keys.

Depending on the model, the options and entries on the LCD display might be different.




### Full menu list

Following is the list of available options. Switch between an option and the subordinate information entries with the select button, and switch among options or information entries with the scroll buttons.

Depending on the model, the options and entries on the LCD display might be different.

### Home Menu (System Status Dashboard)

Home Menu	Example
<ul style="list-style-type: none"> <li>1 System name</li> <li>2 System status</li> <li>3 Active alert quantity</li> <li>4 Temperature</li> <li>5 Power consumption</li> <li>6 Checkpoint code</li> </ul>	

### Active Alerts

Sub Menu	Example
<p>Home screen: Active error quantity</p> <p><b>Note:</b> The “Active Alerts” menu displays only the quantity of active errors. If no errors occur, the “Active Alerts” menu will not be available during navigation.</p>	<p>1 Active Alerts</p>
<p>Details screen:</p> <ul style="list-style-type: none"> <li>• Error message ID (Type: Error/Warning/Information)</li> <li>• Occurrence time</li> <li>• Possible sources of the error</li> </ul>	<p>Active Alerts: 1</p> <p>Press ▼ to view alert details</p> <p>FQXSPPU009N(Error)</p> <p>04/07/2020 02:37:39 PM</p> <p>CPU 1 Status:</p> <p>Configuration Error</p>

### System VPD Information

Sub Menu	Example
<ul style="list-style-type: none"> <li>• Machine type and serial number</li> <li>• Universal Unique ID (UUID)</li> </ul>	<p>Machine Type: xxxx</p> <p>Serial Num: xxxxxx</p> <p>Universal Unique ID: XXXXXXXXXXXXXXXXXXXXXXXXXXXX</p>



## System Firmware

Sub Menu	Example
XCC Primary <ul style="list-style-type: none"> <li>Firmware level (status)</li> <li>Build ID</li> <li>Version number</li> <li>Release date</li> </ul>	XCC Primary (Active) Build: DVI399T Version: 4.07 Date: 2020-04-07
XCC Backup <ul style="list-style-type: none"> <li>Firmware level (status)</li> <li>Build ID</li> <li>Version number</li> <li>Release date</li> </ul>	XCC Backup (Active) Build: D8BT05I Version: 1.00 Date: 2019-12-30
UEFI <ul style="list-style-type: none"> <li>Firmware level (status)</li> <li>Build ID</li> <li>Version number</li> <li>Release date</li> </ul>	UEFI (Inactive) Build: DOE101P Version: 1.00 Date: 2019-12-26

## XCC Network Information

Sub Menu	Example
<ul style="list-style-type: none"> <li>XCC hostname</li> <li>MAC address</li> <li>IPv4 Network Mask</li> <li>IPv4 DNS</li> <li>IPv6 Link Local IP</li> <li>Stateless IPv6 IP</li> <li>Static IPv6 IP</li> <li>Current IPv6 Gateway</li> <li>IPv6 DNS</li> </ul> <p><b>Note:</b> Only the MAC address that is currently in use is displayed (extension or shared).</p>	XCC Network Information XCC Hostname: XCC-xxxx-SN MAC Address: xx:xx:xx:xx:xx:xx IPv4 IP: xx.xx.xx.xx IPv4 Network Mask: x.x.x.x IPv4 Default Gateway: x.x.x.x

## System Environmental Information

Sub Menu	Example
<ul style="list-style-type: none"> <li>• Ambient temperature</li> <li>• Exhaust temperature</li> <li>• CPU temperature</li> <li>• PSU status</li> <li>• Spinning speed of fans by RPM</li> </ul>	Ambient Temp: 24 C Exhaust Temp: 30 C CPU1 Temp: 50 C PSU1: Vin= 213 w Inlet= 26 C FAN1 Front: 21000 RPM FAN2 Front: 21000 RPM FAN3 Front: 21000 RPM FAN4 Front: 21000 RPM

## Active Sessions

Sub Menu	Example
Quantity of active sessions	Active User Sessions: 1

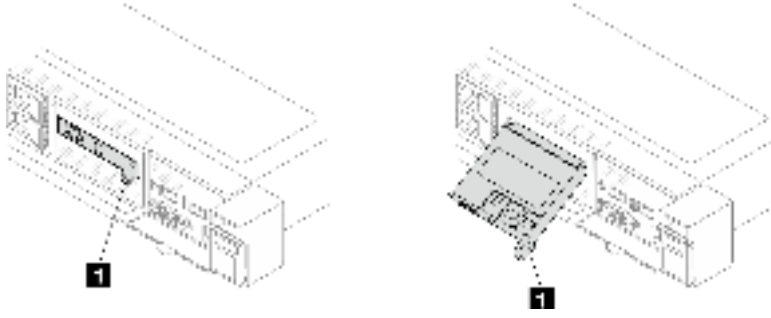
## Actions

Sub Menu	Example
Several quick actions are available: <ul style="list-style-type: none"> <li>• Restore XCC to Defaults</li> <li>• Force XCC Reset</li> <li>• Request XCC Reset</li> <li>• Set UEFI Memory Test</li> <li>• Clear CMOS</li> <li>• Request Virtual Reseat</li> <li>• Modify XCC Static IPv4 Address/Net mask/Gateway</li> <li>• Modify System Name</li> <li>• Generate/Download FFDC Service Data</li> </ul>	Request XCC Reset? This will request the BMC to reboot itself. Hold $\sqrt{\quad}$ for 3 seconds

## Integrated diagnostics panel

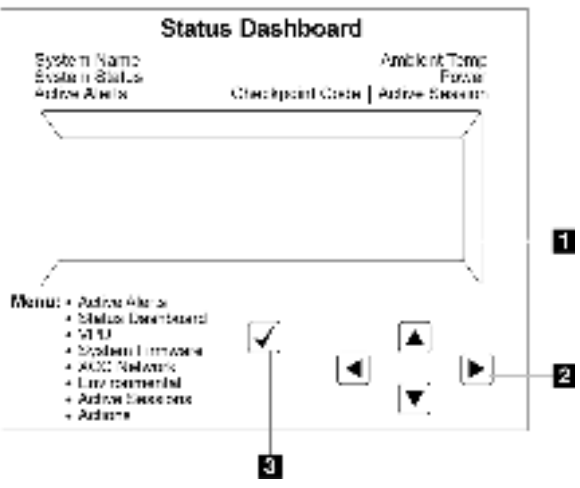
The integrated diagnostics panel is attached to the front of the server, while it allows quick access to system information such as errors, system status, firmware, network, and health information.

## Location of the integrated diagnostics panel

<p><b>Location</b></p>	<p>The integrated diagnostics panel is attached to the front of the server.</p> 
<p><b>Callout</b></p>	<p><b>1</b> The handle with which the panel can be pulled out from the server.</p> <p><b>Notes:</b></p> <ul style="list-style-type: none"> <li>• The panel can be pushed in or pulled out regardless of the system power status.</li> <li>• When pulling it out, do it gently to avoid damage.</li> </ul>

## Display panel overview

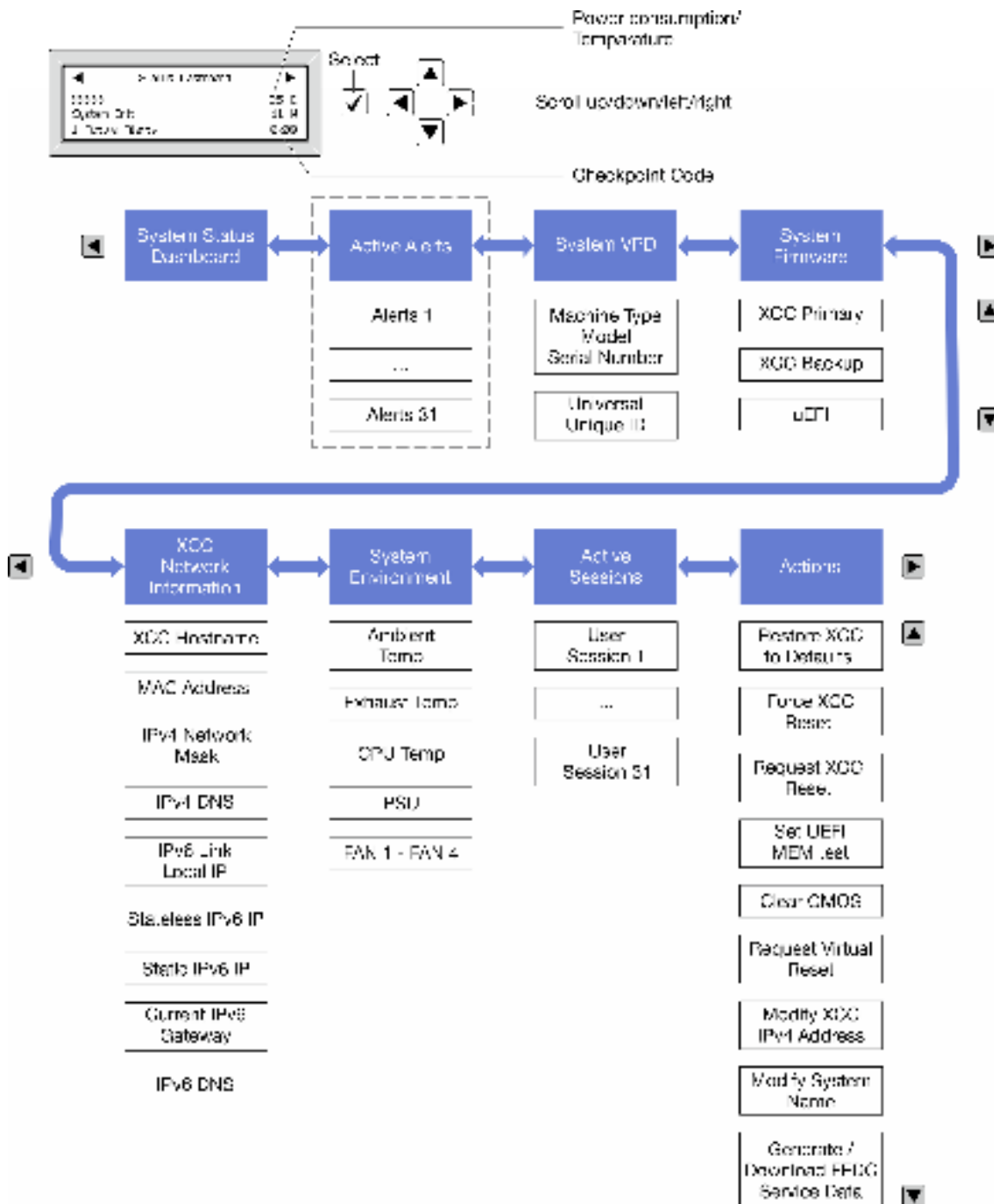
The diagnostics device consists of an LCD display and 5 navigation buttons.

	<p><b>1</b> LCD display</p> <p><b>2</b> Scroll buttons (up/down/left/right) Press the scroll buttons to locate and select system information.</p> <p><b>3</b> Select button Press the select button to select from the options in the menu.</p>
--	---

## Option flow diagram

The external diagnostics handset displays various system information. Navigate through the options with the scroll keys.

Depending on the model, the options and entries on the LCD display might be different.




### Full menu list

Following is the list of available options. Switch between an option and the subordinate information entries with the select button, and switch among options or information entries with the scroll buttons.

Depending on the model, the options and entries on the LCD display might be different.

### Home Menu (System Status Dashboard)

Home Menu	Example
<ul style="list-style-type: none"> <li>1 System name</li> <li>2 System status</li> <li>3 Active alert quantity</li> <li>4 Temperature</li> <li>5 Power consumption</li> <li>6 Checkpoint code</li> </ul>	

### Active Alerts

Sub Menu	Example
Home screen: Active error quantity <b>Note:</b> The “Active Alerts” menu displays only the quantity of active errors. If no errors occur, the “Active Alerts” menu will not be available during navigation.	1 Active Alerts
Details screen: <ul style="list-style-type: none"> <li>• Error message ID (Type: Error/Warning/Information)</li> <li>• Occurrence time</li> <li>• Possible sources of the error</li> </ul>	Active Alerts: 1 Press ▼ to view alert details FQXSPPU009N(Error) 04/07/2020 02:37:39 PM CPU 1 Status: Configuration Error

### System VPD Information

Sub Menu	Example
<ul style="list-style-type: none"> <li>• Machine type and serial number</li> <li>• Universal Unique ID (UUID)</li> </ul>	Machine Type: xxxx Serial Num: xxxxxx Universal Unique ID: xxxxxxxxxxxxxxxxxxxxxxxxxxxxxxxx

## System Firmware

Sub Menu	Example
XCC Primary <ul style="list-style-type: none"> <li>Firmware level (status)</li> <li>Build ID</li> <li>Version number</li> <li>Release date</li> </ul>	XCC Primary (Active) Build: DVI399T Version: 4.07 Date: 2020-04-07
XCC Backup <ul style="list-style-type: none"> <li>Firmware level (status)</li> <li>Build ID</li> <li>Version number</li> <li>Release date</li> </ul>	XCC Backup (Active) Build: D8BT05I Version: 1.00 Date: 2019-12-30
UEFI <ul style="list-style-type: none"> <li>Firmware level (status)</li> <li>Build ID</li> <li>Version number</li> <li>Release date</li> </ul>	UEFI (Inactive) Build: D0E101P Version: 1.00 Date: 2019-12-26

## XCC Network Information

Sub Menu	Example
<ul style="list-style-type: none"> <li>XCC hostname</li> <li>MAC address</li> <li>IPv4 Network Mask</li> <li>IPv4 DNS</li> <li>IPv6 Link Local IP</li> <li>Stateless IPv6 IP</li> <li>Static IPv6 IP</li> <li>Current IPv6 Gateway</li> <li>IPv6 DNS</li> </ul> <p><b>Note:</b> Only the MAC address that is currently in use is displayed (extension or shared).</p>	XCC Network Information XCC Hostname: XCC-xxxx-SN MAC Address: xx:xx:xx:xx:xx:xx IPv4 IP: xx.xx.xx.xx IPv4 Network Mask: x.x.x.x IPv4 Default Gateway: x.x.x.x

## System Environmental Information

Sub Menu	Example
<ul style="list-style-type: none"> <li>• Ambient temperature</li> <li>• Exhaust temperature</li> <li>• CPU temperature</li> <li>• PSU status</li> <li>• Spinning speed of fans by RPM</li> </ul>	Ambient Temp: 24 C Exhaust Temp: 30 C CPU1 Temp: 50 C PSU1: Vin= 213 w Inlet= 26 C FAN1 Front: 21000 RPM FAN2 Front: 21000 RPM FAN3 Front: 21000 RPM FAN4 Front: 21000 RPM

## Active Sessions

Sub Menu	Example
Quantity of active sessions	Active User Sessions: 1

## Actions

Sub Menu	Example
Several quick actions are available: <ul style="list-style-type: none"> <li>• Restore XCC to Defaults</li> <li>• Force XCC Reset</li> <li>• Request XCC Reset</li> <li>• Set UEFI Memory Test</li> <li>• Clear CMOS</li> <li>• Request Virtual Reseat</li> <li>• Modify XCC Static IPv4 Address/Net mask/Gateway</li> <li>• Modify System Name</li> <li>• Generate/Download FFDC Service Data</li> </ul>	Request XCC Reset? This will request the BMC to reboot itself. Hold √ for 3 seconds

## LEDs and buttons on the front operator panel

The front operator panel of the server provides controls, connectors, and LEDs.

**Note:** Diagnostics panel with an LCD display is available for some models. For details, see [“Integrated diagnostics panel” on page 448](#) and [“External diagnostics handset” on page 443](#).

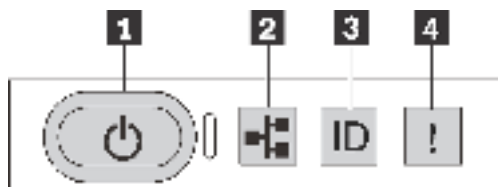


Figure 366. Diagnostics panel

## 1 Power button with power status LED

You can press the power button to power on the server when you finish setting up the server. You also can hold the power button for several seconds to power off the server if you cannot shut down the server from the operating system. The power status LED helps you determine the current power status.

Status	Color	Description
Solid on	Green	The server is on and running.
Slow blinking (about one flash per second)	Green	The server is off and is ready to be powered on (standby state).
Fast blinking (about four flashes per second)	Green	<ul style="list-style-type: none"><li>The server is off, but the XClarity Controller is initializing, and the server is not ready to be powered on.</li><li>System-board-assembly power has failed.</li></ul>
Off	None	There is no ac power applied to the server.

## 2 Network activity LED

Compatibility of the NIC adapter and the network activity LED

NIC adapter	Network activity LED
OCP module	Support
PCIe NIC adapter	Not support

When an OCP module is installed, the network activity LED on the front I/O assembly helps you identify the network connectivity and activity. If no OCP module is installed, this LED is off.

Status	Color	Description
On	Green	The server is connected to a network.
Blinking	Green	The network is connected and active.
Off	None	The server is disconnected from the network. <b>Note:</b> If the network activity LED is off when an OCP module is installed, check the network ports in the rear of your server to determine which port is disconnected.

## 3 System ID button with system ID LED

Use this system ID button and the blue system ID LED to visually locate the server. A system ID LED is also located on the rear of the server. Each time you press the system ID button, the state of both the system ID LEDs changes. The LEDs can be changed to on, blinking, or off. You can also use the Lenovo XClarity Controller or a remote management program to change the state of the system ID LEDs to assist in visually locating the server among other servers.

If the XClarity Controller USB connector is set to have both the USB 2.0 function and XClarity Controller management function, you can press the system ID button for three seconds to switch between the two functions.

## 4 System error LED



The system error LED helps you to determine if there are any system errors.

Status	Color	Description	Action
On	Amber	<p>An error has been detected on the server. Causes might include but are not limited to the following errors:</p> <ul style="list-style-type: none"> <li>• The temperature of the server reached the non-critical temperature threshold.</li> <li>• The voltage of the server reached the non-critical voltage threshold.</li> <li>• A fan has been detected to be running at low speed.</li> <li>• A hot-swap fan has been removed.</li> <li>• The power supply has a critical error.</li> <li>• The power supply is not connected to the power.</li> <li>• A processor error.</li> <li>• A system I/O board or processor board error.</li> <li>• Abnormal status is detected on the liquid assisted cooling module (LACM).</li> </ul>	<ul style="list-style-type: none"> <li>• Check the Lenovo XClarity Controller event log and the system event log to determine the exact cause of the error.</li> <li>• Check if additional LEDs in the server are lit. It will direct you to the error source. See <a href="#">“Troubleshooting by system LEDs and diagnostics display”</a> on page 443.</li> <li>• Save the log if necessary.</li> </ul> <p><b>Note:</b> For server models with LACM installed, it is required to open the top cover to check the LED status of the liquid detection sensor module. For more instructions, see <a href="#">“The LED on the liquid detection sensor module”</a> on page 463.</p>
Off	None	The server is off or the server is on and is working correctly.	None.

## LEDs on drives

This topic provides information on drive LEDs.

Each drive comes with an activity LED and a status LED. Different colors and speeds indicate different activities or status of the drive. The following illustrations and tables describe the problems that are indicated by the activity LED and the status LED.

- [“LEDs on hard disk drives or solid-state drives”](#) on page 455
- [“LEDs on EDSFF drives”](#) on page 456

### LEDs on hard disk drives or solid-state drives

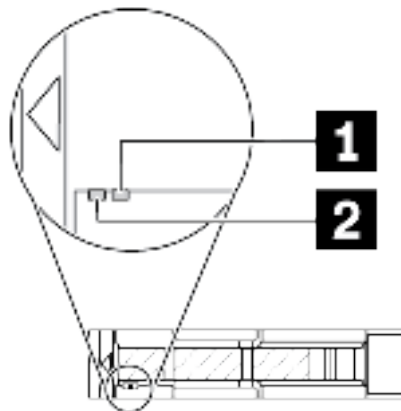


Figure 367. LEDs on hard disk drives or solid-state drives

Drive LED	Status	Description
<b>1</b> Drive status LED (right)	Solid yellow	The drive has an error.
	Blinking yellow (blinking slowly, about one flash per second)	The drive is being rebuilt.
	Blinking yellow (blinking rapidly, about four flashes per second)	The RAID adapter is locating the drive.
<b>2</b> Drive activity LED (left)	Solid green	The drive is powered but not active.
	Blinking green	The drive is active.

### LEDs on EDSFF drives

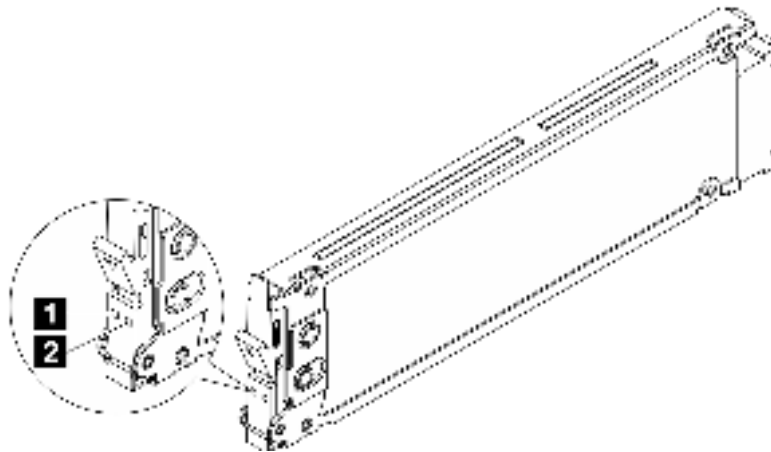


Figure 368. LEDs on EDSFF drives

Drive LED	Status	Description
<b>1</b> Drive activity LED	Solid green	The drive is powered but not active.
	Blinking green (about four flashed per second)	The drive is active.
	Off	The drive is not powered.
<b>2</b> Drive status LED	Solid amber	The drive has an error.
	Blinking amber (blinking slowly, about one flash per second)	The drive is being rebuilt.
	Blinking amber (blinking rapidly, about four flashes per second)	The RAID adapter is locating the drive.

### LEDs on the Firmware and RoT Security Module

The following illustrations show the light-emitting diodes (LEDs) on the ThinkSystem V3 Firmware and Root of Trust Security Module (Firmware and RoT Security Module).

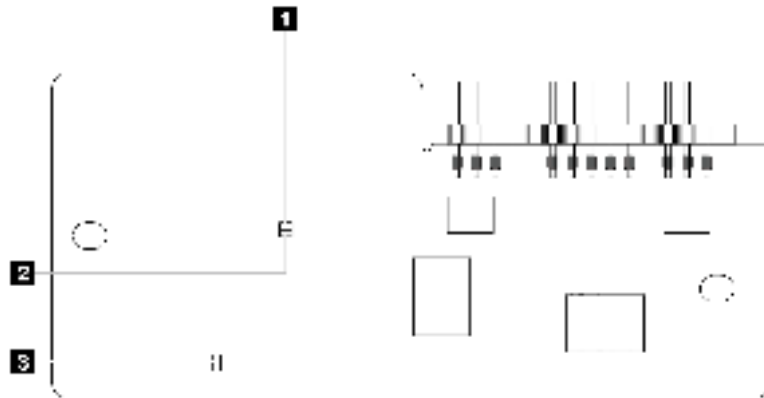


Figure 369. LEDs on the Firmware and RoT Security Module

<b>1</b> AP0 LED (Green)	<b>2</b> AP1 LED (Green)	<b>3</b> Fatal Error LED (Amber)
--------------------------	--------------------------	----------------------------------

Table 172. LEDs description

Scenario	AP0 LED	AP1 LED	Fatal Error LED	FPGA heart-beat LED <sup>note</sup>	XCC heart-beat LED <sup>note</sup>	Actions
RoT security module fatal firmware failure	Off	Off	On	N/A	N/A	Replace the Firmware and RoT Security Module.
	Blink	N/A	On	N/A	N/A	Replace the Firmware and RoT Security Module.
	Blink	N/A	On	On	N/A	Replace the Firmware and RoT Security Module.
No system power (FPGA heartbeat LED off)	Off	Off	Off	Off	Off	If the AC power is on, but the system board assembly does not have power, then: <ol style="list-style-type: none"> <li>1. Check the power supply unit (PSU) or power interposer board (PIB) if any. If the PSU or PIB has any error, replace it.</li> <li>2. If the PSU or PIB is good, do the following:               <ol style="list-style-type: none"> <li>a. Replace the system I/O board.</li> <li>b. Replace the processor board.</li> </ol> </li> </ol>
XCC firmware recoverable error	Blink	N/A	Off	N/A	N/A	Information only. No action is required.
XCC firmware is recovered from error	Blink	N/A	Off	N/A	N/A	Information only. No action is required.
UEFI firmware authentication failure	N/A	Blink	Off	N/A	N/A	Information only. No action is required.

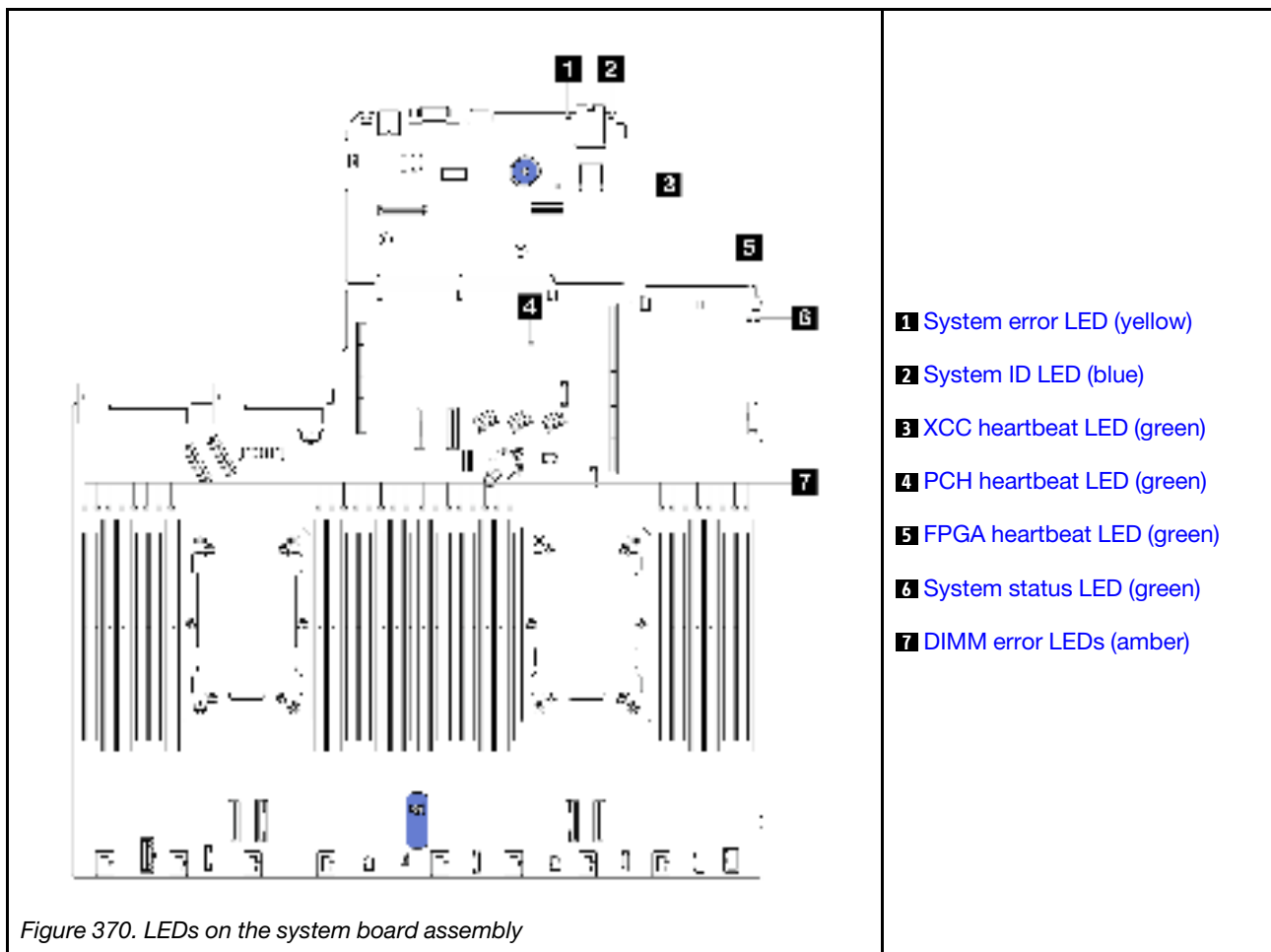
Table 172. LEDs description (continued)

Scenario	AP0 LED	AP1 LED	Fatal Error LED	FPGA heart-beat LED <sup>note</sup>	XCC heart-beat LED <sup>note</sup>	Actions
UEFI firmware is recovered from authentication failure	N/A	On	Off	N/A	N/A	Information only. No action is required.
System is OK (FPGA heartbeat LED is On)	On	On	Off	On	On	Information only. No action is required.

**Note:** For locations of the FPGA LED and XCC heartbeat LED, see “LEDs on the system board assembly” on page 458.

## LEDs on the system board assembly

The following illustrations show the light-emitting diodes (LEDs) on the system board assembly.



## Descriptions of LEDs on the system board assembly

<b>1 System error LED (yellow)</b>	
Description	When this yellow LED is lit, another one or more LEDs in the server might also be lit to direct you to the error source.
Action	Check system logs or internal error LEDs to identify the failed part. For more information, see <a href="#">“LEDs and buttons on the front operator panel” on page 453</a> .

<b>2 System ID LED (blue)</b>	
Description	The front system ID LED helps you locate the server.
Action	Each time you press the system ID button, the state of both system ID LEDs changes, and the state can be on, blinking, or off.

<b>3 XCC heartbeat LED (green)</b>	
Description	<p>The XCC heartbeat LED helps you identify the XCC status.</p> <ul style="list-style-type: none"> <li>Blinking (about one flash per second) : XCC is working normally.</li> <li>Blinking at other speeds or always on: XCC is at the initial phase or is working abnormally.</li> <li>Off: XCC is not working.</li> </ul>
Action	<ul style="list-style-type: none"> <li>If the XCC heartbeat LED is always off or always on, do the following: <ul style="list-style-type: none"> <li>If XCC cannot be accessed: <ol style="list-style-type: none"> <li>Re-plug the power cord.</li> <li>Check and ensure that the system I/O board and the Firmware and RoT Security Module are installed correctly. (Trained technicians only) Reinstall them if needed.</li> <li>(Trained technicians only) Replace the Firmware and RoT Security Module.</li> <li>(Trained technicians only) Replace the system I/O board.</li> </ol> </li> <li>If XCC can be accessed, replace the system I/O board.</li> </ul> </li> <li>If the XCC heartbeat LED is always blinking fast over 5 minutes, do the following: <ol style="list-style-type: none"> <li>Re-plug the power cord.</li> <li>Check and ensure that the system I/O board and the Firmware and RoT Security Module are installed correctly. (Trained technicians only) Reinstall them if needed.</li> <li>(Trained technicians only) Replace the Firmware and RoT Security Module.</li> <li>(Trained technicians only) Replace the system I/O board.</li> </ol> </li> <li>If the XCC heartbeat LED is always blinking slow over 5 minutes, do the following: <ol style="list-style-type: none"> <li>Re-plug the power cord.</li> <li>Check and ensure that the system I/O board and the Firmware and RoT Security Module are installed correctly. (Trained technicians only) Reinstall them if needed.</li> <li>If the problem remains, contact Lenovo Support.</li> </ol> </li> </ul>

#### 4 PCH heartbeat LED (green)

Description	<p>The PCH heartbeat LED helps you identify the PCH status.</p> <ul style="list-style-type: none"><li>• Blinking (about one flash per second): system ME is working normally.</li><li>• Off: system ME is not working.</li></ul>
Action	<p>If the PCH heartbeat LED is always off or always on, do the following:</p> <ol style="list-style-type: none"><li>1. Check and ensure that the system I/O board and the Firmware and RoT Security Module are installed correctly. (Trained technicians only) Reinstall them if needed.</li><li>2. Make sure the UEFI firmware has been flashed to the corresponding platform version.</li><li>3. Update UEFI and XCC firmware to the latest version.</li><li>4. Check if there is an ME error event triggered in system event log. If yes, and the above actions are done, replace the Firmware and RoT Security Module.</li><li>5. (Trained technicians only) If it is still not working, replace the processor board.</li></ol>

#### 5 FPGA heartbeat LED (green)

Description	<p>The FPGA heartbeat LED helps you identify the FPGA status.</p> <ul style="list-style-type: none"><li>• Blinking (about one flash per second): FPGA is working normally.</li><li>• On or off: FPGA is not working.</li></ul>
Action	<p>If FPGA heartbeat LED is always off or always on, do the following:</p> <ol style="list-style-type: none"><li>1. Replace the processor board.</li><li>2. If the problem remains, contact Lenovo Support.</li></ol>

#### 6 System status LED (green)

Description	<p>The system status LED indicates the working status of the system.</p> <ul style="list-style-type: none"><li>• Fast blinking (about four flashes per second): Power fault or is waiting for XCC power permission ready.</li><li>• Slow blinking (about one flash per second): Power off and is ready to be powered on (standby state).</li><li>• On: Power on.</li></ul>
Action	<ul style="list-style-type: none"><li>• If the system status LED is blinking fast over 5 minutes and cannot power on, check the XCC heartbeat LED and follow the <a href="#">actions for the XCC heartbeat LED</a>.</li><li>• If the system status LED remains off or is blinking fast (about four flashes per second) and the system error LED on the front panel is on (yellow), the system is in a power fault status. Do the following:<ol style="list-style-type: none"><li>1. Re-plug the power cord.</li><li>2. Remove installed adapters/devices, one at a time, until you reach the minimal configuration for debugging.</li><li>3. (Trained technicians only) If the problem remains, capture FFDC log, and replace the processor board.</li><li>4. If the problem still remains, contact Lenovo Support.</li></ol></li></ul>

#### 7 DIMM error LEDs (amber)

Description	<p>When a memory module error LED is lit, it indicates that the corresponding memory module has failed.</p>
Action	<p>For more information, see <a href="#">“Memory problems” on page 471</a>.</p>

## Rear LEDs

This topic provides an overview of the LEDs on the rear of the server.

### Rear LEDs of the server

The following illustration shows the LEDs on the rear view of server model with two PCIe slots and a two-bay 7mm drive cage. The LEDs on the rear view of other server models are the same.



Figure 371. Rear LEDs overview

Callout	LED
<b>1 2</b>	<a href="#">“LEDs on the XCC system management port” on page 462</a>
<b>3 4 5</b>	<a href="#">“LEDs on the power supply unit” on page 461</a>
<b>6 7</b>	<a href="#">Rear system LEDs</a>

### LEDs on the power supply unit

This topic provides information about various power supply unit LED status and corresponding action suggestions.

The following minimal configuration is required for the server to start:

- One processor in processor socket 1
- One memory module in slot 7
- One power supply unit
- One HDD/SSD drive, one M.2 drive, or one 7mm drive (if OS is needed for debugging)
- Six system fans (with one processor)

The following table describes the problems that are indicated by various combinations of the power-supply unit LEDs and the power-on LED and suggested actions to correct the detected problems.

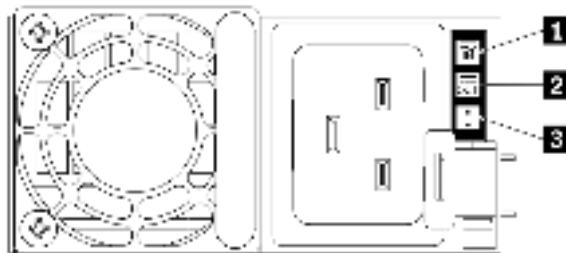


Figure 372. LEDs on the power supply unit

LED	Description
<b>1</b> Input status	<p>The input status LED can be in one of the following states:</p> <ul style="list-style-type: none"> <li>• Off: The power supply unit is disconnected from the input power source.</li> <li>• Green: The power supply unit is connected to the input power source.</li> </ul>
<b>2</b> Output status	<p>The output status LED can be in one of the following states:</p> <ul style="list-style-type: none"> <li>• Off: The server is powered off, or the power supply unit is not working properly. If the server is powered on but the output status LED is off, replace the power supply unit.</li> <li>• Slow blinking green (about one flash every two seconds): The power supply unit is in cold redundancy active mode.</li> <li>• Fast blinking green (about 2 flashes each second): The power supply unit is in cold redundancy sleep mode.</li> <li>• Green: The server is on and the power supply unit is working normally.</li> </ul> <p>Zero-output mode can be disabled via Setup utility or Lenovo XClarity Controller web interface. If you disable zero-output mode, both power supplies will be in the active state.</p> <ul style="list-style-type: none"> <li>• Start the Setup utility, go to <b>System Settings → Power → Zero Output</b> and select <b>Disable</b>. If you disable zero-output mode, both power supplies will be in the active state.</li> <li>• Log in to the Lenovo XClarity Controller web interface, choose <b>Server Configuration → Power Policy</b>, disable <b>Zero Output Mode</b>, and then click <b>Apply</b>.</li> </ul>
<b>3</b> Fault LED	<ul style="list-style-type: none"> <li>• Off: The power supply unit is working normally.</li> <li>• Yellow: The power supply unit may have failed. Dump the FFDC log from the system and contact Lenovo back end support team for PSU data log reviewing.</li> </ul>

## LEDs on the XCC system management port

This topic provides information on LEDs of XCC system management port.

The following table describes the problems that are indicated by LEDs on XCC system management port.

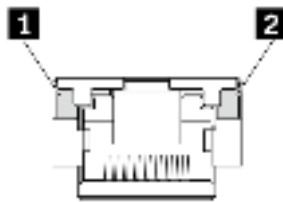


Figure 373. LEDs on the XCC system management port

LED	Description
<b>1</b> XCC system management port (1 GB RJ-45) Ethernet port link LED	<p>Use this green LED to distinguish the network connectivity status:</p> <ul style="list-style-type: none"> <li>• Off: The network link is disconnected.</li> <li>• Green: The network link is established.</li> </ul>
<b>2</b> XCC system management port (1 GB RJ-45) Ethernet port activity LED	<p>Use this green LED to distinguish the network activity status:</p> <ul style="list-style-type: none"> <li>• Off: The server is disconnected from a LAN.</li> <li>• Green: The network is connected and active.</li> </ul>



## The LED on the liquid detection sensor module

This topic provides information about the LED on the liquid cooling leak detection module.

The liquid detection sensor module on the Liquid Assisted Cooling Module (LACM) comes with one LED. The following illustration shows the LED on the module.

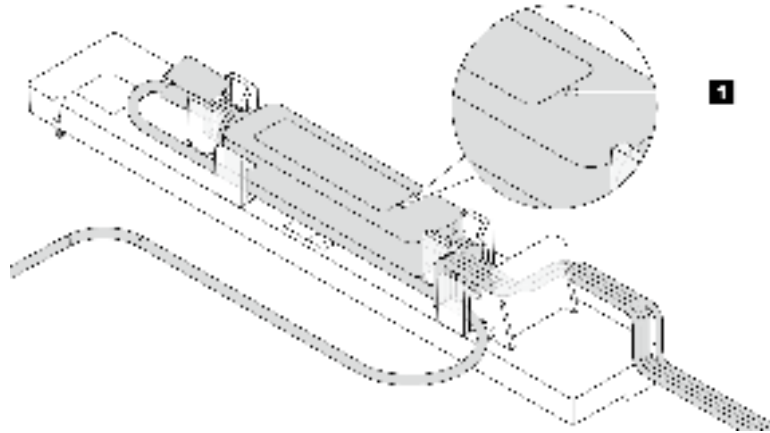


Figure 374. Leak detection LED

The following table describes the status that are indicated by liquid detection sensor module LED.

<b>1 Liquid detection sensor LED</b>		
<b>Status</b>	<b>Description</b>	<b>Action</b>
Solid green	No coolant leakage detected.	No action required.
Blinking green	Abnormal status detected.	<ol style="list-style-type: none"><li>1. Check for green coolant leakage around the radiator, liquid pipes and pumps.</li><li>2. If coolant leakage found, turn off the power and remove the LACM.</li><li>3. Contact Lenovo Support.</li></ol>

## General problem determination procedures

Use the information in this section to resolve problems if the event log does not contain specific errors or the server is inoperative.

If you are not sure about the cause of a problem and the power supplies are working correctly, complete the following steps to attempt to resolve the problem:

1. Power off the server.
2. Make sure that the server is cabled correctly.
3. Remove or disconnect the following devices if applicable, one at a time, until you find the failure. Power on and configure the server each time you remove or disconnect a device.
  - Any external devices.
  - Surge-suppressor device (on the server).
  - Printer, mouse, and non-Lenovo devices.
  - Each adapter.

- Hard disk drives.
- Memory modules until you reach the minimal configuration for debugging that is supported for the server.

To determine the minimal configuration for your server, see “Minimal configuration for debugging” in [“Technical specifications” on page 4](#).

#### 4. Power on the server.

If the problem is solved when you remove an adapter from the server, but the problem recurs when you install the same adapter again, suspect the adapter. If the problem recurs when you replace the adapter with a different one, try a different PCIe slot.

If the problem appears to be a networking problem and the server passes all system tests, suspect a network cabling problem that is external to the server.

## Resolving suspected power problems

Power problems can be difficult to solve. For example, a short circuit can exist anywhere on any of the power distribution buses. Usually, a short circuit will cause the power subsystem to shut down because of an overcurrent condition.

Complete the following steps to diagnose and resolve a suspected power problem.

Step 1. Check the event log and resolve any errors related to the power.

**Note:** Start with the event log of the application that is managing the server. For more information about event logs, see [“Event logs” on page 441](#).

Step 2. Check for short circuits, for example, if a loose screw is causing a short circuit on a circuit board.

Step 3. Remove the adapters and disconnect the cables and power cords to all internal and external devices until the server is at the minimal configuration for debugging that is required for the server to start. To determine the minimal configuration for your server, see “Minimal configuration for debugging” in [“Technical specifications” on page 4](#).

Step 4. Reconnect all AC power cords and turn on the server. If the server starts successfully, reseal the adapters and devices one at a time until the problem is isolated.

If the server does not start from the minimal configuration, replace the components in the minimal configuration one at a time until the problem is isolated.

## Resolving suspected Ethernet controller problems

The method that you use to test the Ethernet controller depends on which operating system you are using. See the operating-system documentation for information about Ethernet controllers, and see the Ethernet controller device-driver readme file.

Complete the following steps to attempt to resolve suspected problems with the Ethernet controller.

Step 1. Make sure that the correct device drivers, which come with the server are installed and that they are at the latest level.

Step 2. Make sure that the Ethernet cable is installed correctly.

- The cable must be securely attached at all connections. If the cable is attached but the problem remains, try a different cable.
- If you set the Ethernet controller to operate at 100 Mbps or 1000 Mbps, you must use Category 5 cabling.

- Step 3. Determine whether the hub supports auto-negotiation. If it does not, try configuring the integrated Ethernet controller manually to match the speed and duplex mode of the hub.
- Step 4. Check the Ethernet controller LEDs on the server. These LEDs indicate whether there is a problem with the connector, cable, or hub.

Ethernet controller LED locations are specified in [“System LEDs and diagnostics display” on page 40](#).

- The Ethernet link status LED is lit when the Ethernet controller receives a link pulse from the hub. If the LED is off, there might be a defective connector or cable or a problem with the hub.
- The Ethernet transmit/receive activity LED is lit when the Ethernet controller sends or receives data over the Ethernet network. If the Ethernet transmit/receive activity is off, make sure that the hub and network are operating and that the correct device drivers are installed.

- Step 5. Check the Network activity LED on the server. The Network activity LED is lit when data is active on the Ethernet network. If the Network activity LED is off, make sure that the hub and network are operating and that the correct device drivers are installed.

Network activity LED location is specified in [“System LEDs and diagnostics display” on page 40](#).

- Step 6. Check for operating-system-specific causes of the problem, and also make sure that the operating system drivers are installed correctly.
- Step 7. Make sure that the device drivers on the client and server are using the same protocol.

If the Ethernet controller still cannot connect to the network but the hardware appears to be working, the network administrator must investigate other possible causes of the error.

---

## Troubleshooting by symptom

Use this information to find solutions to problems that have identifiable symptoms.

To use the symptom-based troubleshooting information in this section, complete the following steps:

1. Check the event log of the application that is managing the server and follow the suggested actions to resolve any event codes.
  - If you are managing the server from the Lenovo XClarity Administrator, begin with the Lenovo XClarity Administrator event log.
  - If you are using some other management application, begin with the Lenovo XClarity Controller event log.

For more information about event logs (see [“Event logs” on page 441](#)).

2. Review this section to find the symptoms that you are experiencing and follow the suggested actions to resolve the issue.
3. If the problem persists, contact support (see [“Contacting Support” on page 489](#)).

## Coolant leak problems

Use this information to resolve coolant leak problems with the Liquid Assisted Cooling Module (LACM).

### Options to identify coolant leaks

Coolant leaks can be identified through the following practices:

- If the server is on remote maintenance,
  - A Lenovo XClarity Controller event shows:

FOXPUN0019M: Sensor Liquid Leak has transitioned to critical from a less severe state.



- Lenovo XClarity Controller has defined lots of system conditions as IPMI sensors. Users can use IPMI commands to check system running status. Here are examples of executing ipmitool, an open-source common tool which follows Intel’s IPMI standard. Check for coolant leakage status with command lines as shown.

```

system@lenovo-server:~$ ipmitool -C 17 -I lanplus -H 10.132.229.164 -U USERID -P ***** sel elist
- 1 | 12/26/2022 | 10:38:17 | Event Logging Disabled SEL Fullness | Log area reset/cleared | Asserted
- 3 | 12/26/2022 | 10:38:32 | Cooling Device Liquid Leak | Transition to Critical from less severe | Asserted
  
```

The event logs shown with the parameter sel elist.

```

system@lenovo-server:~$ ipmitool -C 17 -I lanplus -H 10.132.229.164 -U USERID -P ***** sdr elist |grep "Liquid Leak"
- Liquid Leak | EAh | ok | 30.1 | Transition to Critical from less severe
  
```

Liquid Leak | EAh | ok | 30.1 | Transition to Critical from less severe

The status of all sensors can be fetched with the parameter sdr elist. If coolant leakage happens, the log above will show up.

- If the server is within reach, and the amber LED is lit on the front operator panel, potential coolant leaks may have occurred. It is required to open the top cover to check the LED status of the liquid detection sensor module. See [“LEDs and buttons on the front operator panel” on page 453](#) and [“The LED on the liquid detection sensor module” on page 463](#) for more details.

### Steps to resolve coolant leaks

If the LED on the liquid detection sensor module is blinking green, follow the procedures to get help.

1. Check for green coolant leakage around the radiator, coolant pipes and pumps.
2. If green coolant found, power off the server and remove the LACM.
3. Clean up the coolant from any components in the chassis. Inspect the server for any signs of moisture in sockets or gaps.
4. Contact Lenovo Support.

## Hard disk drive problems

Use this information to resolve issues related to the hard disk drives.

- “Server cannot identify a hard drive” on page 467
- “Multiple hard drives fail” on page 468
- “Multiple hard drives are offline” on page 468
- “A replacement hard disk drive does not rebuild” on page 468
- “Green hard disk drive activity LED does not represent actual state of associated drive” on page 468
- “Yellow hard disk drive status LED does not represent actual state of associated drive” on page 468
- “U.3 NVMe drive can be detected in NVMe connection, but cannot be detected in Tri-mode” on page 469

### Server cannot identify a hard drive

Complete the following steps until the problem is solved.

1. Observe the target yellow hard disk drive status LED. If the LED is lit, it indicates a drive fault.
2. If the status LED is lit, remove the drive from the bay, wait for 45 seconds, and reinsert the drive. Make sure that the drive assembly connects to the hard disk drive backplane.
3. Observe the target green hard disk drive activity LED and the yellow status LED and perform corresponding operations in different situations:
  - If the green activity LED is flashing and the yellow status LED is not lit, the drive is identified by the controller and is working correctly. Run the diagnostics tests for the hard disk drives. When you start a server and press the key according to the on-screen instructions, the LXPM interface is displayed by default. (For more information, see the “Startup” section in the LXPM documentation compatible with your server at [https://sysmgt.lenovofiles.com/help/topic/lxpm\\_frontend/lxpm\\_product\\_page.html](https://sysmgt.lenovofiles.com/help/topic/lxpm_frontend/lxpm_product_page.html).) From the Diagnostic page, click **Run Diagnostic → Disk Drive Test**.
  - If the green activity LED is flashing and the yellow status LED is flashing slowly, the drive is identified by the controller and is rebuilding.
  - If neither LED is lit or flashing, check whether the hard disk drive backplane is correctly seated. For details, go to step 4.
  - If the green activity LED is flashing and the yellow status LED is lit, replace the drive.
4. Make sure that the hard disk drive backplane is correctly seated. When it is correctly seated, the drive assemblies correctly connect to the backplane without curving or causing movement of the backplane.
5. Reseat the backplane power cable and repeat steps 1 through 3.
6. Reseat the backplane signal cable and repeat steps 1 through 3.
7. Suspect the backplane signal cable or the backplane:
  - Replace the affected backplane signal cable.
  - Replace the affected backplane.
8. Run the diagnostics tests for the hard disk drives. When you start a server and press F1, the LXPM interface is displayed by default. (For more information, see the “Startup” section in the LXPM documentation compatible with your server at [https://sysmgt.lenovofiles.com/help/topic/lxpm\\_frontend/lxpm\\_product\\_page.html](https://sysmgt.lenovofiles.com/help/topic/lxpm_frontend/lxpm_product_page.html).) You can perform hard drive diagnostics from this interface. From the Diagnostic page, click **Run Diagnostic → Disk Drive Test**.

Based on those tests:

- If the backplane passes the test but the drives are not recognized, replace the backplane signal cable and run the tests again.
- Replace the backplane.

- If the adapter fails the test, disconnect the backplane signal cable from the adapter and run the tests again.
- If the adapter fails the test, replace the adapter.

### **Multiple hard drives fail**

Complete the following steps until the problem is solved:

- View the Lenovo XClarity Controller event log for events related to power supplies or vibration issues and resolve those events.
- Make sure that the device drivers and firmware for the hard disk drive and server are at the latest level.

**Important:** Some cluster solutions require specific code levels or coordinated code updates. If the device is part of a cluster solution, verify that the latest level of code is supported for the cluster solution before you update the code.

### **Multiple hard drives are offline**

Complete the following steps until the problem is solved:

- View the Lenovo XClarity Controller event log for events related to power supplies or vibration issues and resolve those events.
- View the storage subsystem log for events related to the storage subsystem and resolve those events.

### **A replacement hard disk drive does not rebuild**

Complete the following steps until the problem is solved:

1. Make sure that the hard disk drive is recognized by the adapter (the green hard disk drive activity LED is flashing).
2. Review the SAS/SATA RAID adapter documentation to determine the correct configuration parameters and settings.

### **Green hard disk drive activity LED does not represent actual state of associated drive**

Complete the following steps until the problem is solved:

1. If the green hard disk drive activity LED does not flash when the drive is in use, run the diagnostics tests for the hard disk drives. When you start a server and press F1, the LXPM interface is displayed by default. (For more information, see the “Startup” section in the LXPM documentation compatible with your server at [https://sysmgt.lenovofiles.com/help/topic/lxpm\\_frontend/lxpm\\_product\\_page.html](https://sysmgt.lenovofiles.com/help/topic/lxpm_frontend/lxpm_product_page.html).) You can perform hard drive diagnostics from this interface. From the Diagnostic page, click **Run Diagnostic → Disk Drive Test**
2. If the drive passes the test, replace the backplane.
3. If the drive fails the test, replace the drive.

### **Yellow hard disk drive status LED does not represent actual state of associated drive**


Complete the following steps until the problem is solved:

1. Turn off the server.
2. Reseat the SAS/SATA adapter.
3. Reseat the backplane signal cable and backplane power cable.
4. Reseat the hard disk drive.
5. Power on the server and observe the activity of the hard disk drive LEDs.

### U.3 NVMe drive can be detected in NVMe connection, but cannot be detected in Tri-mode

In Tri-mode, NVMe drives are connected via a PCIe x1 link to the controller. To support Tri-mode with U.3 NVMe drives, **U.3 x1 mode** must be enabled for the selected drive slots on the backplane through the XCC Web GUI. By default, the backplane setting is **U.2 x4 mode**.

Complete the following steps to enable **U.3 x1 mode**:

1. Log into the XCC Web GUI, and choose **Storage** → **Detail** from the navigation tree on the left.
2. In the window that is displayed, click the icon  next to **Backplane**.
3. In the dialog box that is displayed, select the target drive slots and click **Apply**.
4. Do a DC power cycle to make the setting take effect.

## Intermittent problems

Use this information to solve intermittent problems.

- “Intermittent external device problems” on page 469
- “Intermittent KVM problems” on page 469
- “Intermittent unexpected reboots” on page 470

### Intermittent external device problems

Complete the following steps until the problem is solved.

1. Update the UEFI and XCC firmware to the latest versions.
2. Make sure that the correct device drivers are installed. See the manufacturer's website for documentation.
3. For a USB device:
  - a. Make sure that the device is configured correctly.

Restart the server and press F1 to display the LXPM system setup interface. For more information, see the “Startup” section in the LXPM documentation compatible with your server at [https://sysmgmt.lenovofiles.com/help/topic/lxpm\\_frontend/lxpm\\_product\\_page.html](https://sysmgmt.lenovofiles.com/help/topic/lxpm_frontend/lxpm_product_page.html). Then, click **System Settings** → **Devices and I/O Ports** → **USB Configuration**.
  - b. Connect the device to another port. If using a USB hub, remove the hub and connect the device directly to the server. Make sure that the device is configured correctly for the port.

### Intermittent KVM problems

Complete the following steps until the problem is solved.

#### Video problems:

1. Make sure that all cables and the console breakout cable are properly connected and secure.
2. Make sure that the monitor is working properly by testing it on another server.
3. Test the console breakout cable on a working server to ensure that it is operating properly. Replace the console breakout cable if it is defective.

#### Keyboard problems:

Make sure that all cables and the console breakout cable are properly connected and secure.

#### Mouse problems:

Make sure that all cables and the console breakout cable are properly connected and secure.

### Intermittent unexpected reboots

**Note:** Some uncorrectable errors require that the server reboot so that it can disable a device, such as a memory DIMM or a processor to allow the machine to boot up properly.

1. If the reset occurs during POST and the POST watchdog timer is enabled, make sure that sufficient time is allowed in the watchdog timeout value (POST Watchdog Timer).

To check the POST watchdog time, restart the server and press F1 to display the LXPM system setup interface. For more information, see the “Startup” section in the LXPM documentation compatible with your server at [https://sysmgt.lenovofiles.com/help/topic/lxpm\\_frontend/lxpm\\_product\\_page.html](https://sysmgt.lenovofiles.com/help/topic/lxpm_frontend/lxpm_product_page.html). Then, click **BMC Settings → POST Watchdog Timer**.

2. If the reset occurs after the operating system starts, enter the operating system when the system operates normally and set up operating system kernel dump process (Windows and Linux base operating systems will be using different method). Enter the UEFI setup menus and disable the feature, or disable it with the following OneCli command.

```
OneCli.exe config set SystemRecovery.RebootSystemOnNMI Disable --bmc XCC_USER:XCC_PASSWORD@XCC_IPAddress
```

3. See the management controller event log to check for an event code that indicates a reboot. See “[Event logs](#)” on page 441 for information about viewing the event log. If you are using Linux base operating system, then capture all logs back to Lenovo support for further investigation.

## Keyboard, mouse, KVM switch or USB-device problems

Use this information to solve problems related to a keyboard, mouse, KVM switch or USB-device problems.

- “[All or some keys on the keyboard do not work](#)” on page 470
- “[Mouse does not work](#)” on page 470
- “[KVM switch problems](#)” on page 471
- “[USB-device does not work](#)” on page 471

### All or some keys on the keyboard do not work

1. Make sure that:
  - The keyboard cable is securely connected.
  - The server and the monitor are turned on.
2. If you are using a USB keyboard, run the Setup utility and enable keyboardless operation.
3. If you are using a USB keyboard and it is connected to a USB hub, disconnect the keyboard from the hub and connect it directly to the server.
4. Replace the keyboard.

### Mouse does not work

1. Make sure that:
  - The mouse cable is securely connected to the server.
  - The mouse device drivers are installed correctly.
  - The server and the monitor are turned on.
  - The mouse option is enabled in the Setup utility.
2. If you are using a USB mouse and it is connected to a USB hub, disconnect the mouse from the hub and connect it directly to the server.
3. Replace the mouse.



## KVM switch problems

1. Make sure that the KVM switch is supported by your server.
2. Make sure that the KVM switch is powered on correctly.
3. If the keyboard, mouse or monitor can be operated normally with direct connection to the server, then replace the KVM switch.

## USB-device does not work

1. Make sure that:
  - The correct USB device driver is installed.
  - The operating system supports USB devices.
2. Make sure that the USB configuration options are set correctly in system setup.

Restart the server and press the key according to the on-screen instructions to display the LXPM system setup interface. For more information, see the “Startup” section in the LXPM documentation compatible with your server at [https://sysmgt.lenovofiles.com/help/topic/lxpm\\_frontend/lxpm\\_product\\_page.html](https://sysmgt.lenovofiles.com/help/topic/lxpm_frontend/lxpm_product_page.html). Then, click **System Settings → Devices and I/O Ports → USB Configuration**.

3. If you are using a USB hub, disconnect the USB device from the hub and connect it directly to the server.

## Memory problems

See this section to resolve issues related to memory.

- “Multiple memory modules in a channel identified as failing” on page 471
- “Displayed system memory is less than installed physical memory” on page 472
- “Invalid memory population detected” on page 472

### Multiple memory modules in a channel identified as failing

**Note:** Each time you install or remove a memory module, you must disconnect the server from the power source; then, wait 10 seconds before restarting the server.

Complete the following procedure to solve the problem.

1. Reseat the memory modules; then, restart the server.
2. Remove the highest-numbered memory module of those that are identified and replace it with an identical known good memory module; then, restart the server. Repeat as necessary. If the failures continue after all identified memory modules are replaced, go to step 4.
3. Return the removed memory modules, one at a time, to their original connectors, restarting the server after each memory module, until a memory module fails. Replace each failing memory module with an identical known good memory module, restarting the server after each memory module replacement. Repeat step 3 until you have tested all removed memory modules.
4. Replace the highest-numbered memory module of those identified; then, restart the server. Repeat as necessary.
5. Reverse the memory modules between the channels (of the same processor), and then restart the server. If the problem is related to a memory module, replace the failing memory module.
6. (Trained technicians only) Install the failing memory module into a memory module connector for processor 2 (if installed) to verify that the problem is not the processor or the memory module connector.
7. (Trained technicians only) Replace the system board.

## Displayed system memory is less than installed physical memory

Complete the following procedure to solve the problem.

**Note:** Each time you install or remove a memory module, you must disconnect the server from the power source; then, wait 10 seconds before restarting the server.

1. Make sure that:
  - No error LEDs are lit. See [“System LEDs and diagnostics display” on page 40](#).
  - No memory module error LEDs are lit on the system board.
  - Memory mirrored channel does not account for the discrepancy.
  - The memory modules are seated correctly.
  - You have installed the correct type of memory module (see [“Memory module installation rules and order” on page 56](#) for requirements).
  - After changing or replacing a memory module, memory configuration is updated accordingly in the Setup Utility.
  - All banks of memory are enabled. The server might have automatically disabled a memory bank when it detected a problem, or a memory bank might have been manually disabled.
  - There is no memory mismatch when the server is at the minimum memory configuration.
2. Reseat the memory modules, and then restart the server.
3. Check the POST error log:
  - If a memory module was disabled by a systems-management interrupt (SMI), replace the memory module.
  - If a memory module was disabled by the user or by POST, reseat the memory module; then, run the Setup Utility and enable the memory module.
4. Run memory diagnostics. When you start a server and press the key according to the on-screen instructions, the LXPM interface is displayed by default. For more information, see the “Startup” section in the LXPM documentation compatible with your server at [https://sysmgt.lenovofiles.com/help/topic/lxpm\\_frontend/lxpm\\_product\\_page.html](https://sysmgt.lenovofiles.com/help/topic/lxpm_frontend/lxpm_product_page.html). You can perform memory diagnostics with this interface. From the Diagnostic page, go to **Run Diagnostic → Memory Test → Advanced Memory Test**.
5. Reverse the modules between the channels (of the same processor), and then restart the server. If the problem is related to a memory module, replace the failing memory module.
6. Re-enable all memory modules using the Setup Utility, and then restart the server.
7. (Trained technicians only) Install the failing memory module into a memory module connector for processor 2 (if installed) to verify that the problem is not the processor or the memory module connector.
8. (Trained technicians only) Replace the system board.

## Invalid memory population detected

If this warning message appears, complete the following steps:

Invalid memory population (unsupported DIMM population) detected. Please verify memory configuration is valid.

1. See [“Memory module installation rules and order” on page 56](#) to make sure the present memory module population sequence is supported.
2. If the present sequence is indeed supported, see if any of the modules is displayed as “disabled” in Setup Utility.
3. Reseat the module that is displayed as “disabled,” and reboot the system.
4. If the problem persists, replace the memory module.

## Monitor and video problems

Use this information to solve problems related to a monitor or video.

- [“Incorrect characters are displayed” on page 473](#)
- [“Screen is blank” on page 473](#)
- [“Screen goes blank when you start some application programs” on page 473](#)
- [“The monitor has screen jitter, or the screen image is wavy, unreadable, rolling, or distorted” on page 473](#)
- [“The wrong characters appear on the screen” on page 474](#)

### Incorrect characters are displayed

Complete the following steps:

1. Verify that the language and locality settings are correct for the keyboard and operating system.
2. If the wrong language is displayed, update the server firmware to the latest level. See [“Update the firmware” on page 433](#).

### Screen is blank

**Note:** Make sure that the expected boot mode has not been changed from the UEFI to Legacy or vice versa.

1. If the server is attached to a KVM switch, bypass the KVM switch to eliminate it as a possible cause of the problem: connect the monitor cable directly to the correct connector on the rear of the server.
2. The management controller remote presence function is disabled if you install an optional video adapter. To use the management controller remote presence function, remove the optional video adapter.
3. If the server is installed with the graphical adapters while turning on the server, the Lenovo logo is displayed on the screen after approximately 3 minutes. This is normal operation while the system loads.
4. Make sure that:
  - The server is turned on and there is power supplied to the server.
  - The monitor cables are connected correctly.
  - The monitor is turned on and the brightness and contrast controls are adjusted correctly.
5. Make sure that the correct server is controlling the monitor, if applicable.
6. Make sure that the video output is not affected by corrupted server firmware; See [“Update the firmware” on page 433](#).
7. If the problem remains, contact Lenovo Support.

### Screen goes blank when you start some application programs

1. Make sure that:
  - The application program is not setting a display mode that is higher than the capability of the monitor.
  - You installed the necessary device drivers for the application.

### The monitor has screen jitter, or the screen image is wavy, unreadable, rolling, or distorted

1. If the monitor self-tests show that the monitor is working correctly, consider the location of the monitor. Magnetic fields around other devices (such as transformers, appliances, fluorescents, and other monitors) can cause screen jitter or wavy, unreadable, rolling, or distorted screen images. If this happens, turn off the monitor.

**Attention:** Moving a color monitor while it is turned on might cause screen discoloration.

Move the device and the monitor at least 305 mm (12 in.) apart, and turn on the monitor.

**Notes:**

- a. To prevent diskette drive read/write errors, make sure that the distance between the monitor and any external diskette drive is at least 76 mm (3 in.).
  - b. Non-Lenovo monitor cables might cause unpredictable problems.
2. Reseat the monitor cable.
  3. Replace the components listed in step 2 one at a time, in the order shown, restarting the server each time:
    - a. Monitor cable
    - b. Video adapter (if one is installed)
    - c. Monitor
    - d. (Trained technicians only) System board.

### The wrong characters appear on the screen

Complete the following steps until the problem is solved:

1. Verify that the language and locality settings are correct for the keyboard and operating system.
2. If the wrong language is displayed, update the server firmware to the latest level. See [“Update the firmware” on page 433](#).

## Observable problems

Use this information to solve observable problems.

- [“Server hangs during the UEFI boot process” on page 474](#)
- [“The server immediately displays the POST Event Viewer when it is turned on” on page 475](#)
- [“Server is unresponsive \(POST is complete and operating system is running\)” on page 475](#)
- [“Server is unresponsive \(POST failed and cannot start System Setup\)” on page 475](#)
- [“Voltage planar fault is displayed in the event log” on page 476](#)
- [“Unusual smell” on page 476](#)
- [“Server seems to be running hot” on page 476](#)
- [“Cannot enter legacy mode after installing a new adapter” on page 476](#)
- [“Cracked parts or cracked chassis” on page 477](#)

### Server hangs during the UEFI boot process

If the system hangs during the UEFI boot process with the message UEFI: DXE INIT on the display, make sure that Option ROMs were not configured with a setting of **Legacy**. You can remotely view the current settings for Option ROMs by running the following command using the Lenovo XClarity Essentials OneCLI:

```
onecli config show EnableDisableAdapterOptionROMSupport --bmc xcc_userid:xcc_password@xcc_ipaddress
```

To recover a system that hangs during the boot process with Legacy Option ROM settings, see the following Tech Tip:

<https://datacentersupport.lenovo.com/solutions/ht506118>

If legacy Option ROMs must be used, do not set slot Option ROMs to **Legacy** on the Devices and I/O Ports menu. Instead, set slot Option ROMs to **Auto** (the default setting), and set the System Boot Mode to **Legacy Mode**. Legacy option ROMs will be invoked shortly before the system boots.

### **The server immediately displays the POST Event Viewer when it is turned on**

Complete the following steps until the problem is solved.

1. Correct any errors that are indicated by the system LEDs and diagnostics display.
2. Make sure that the server supports all the processors and that the processors match in speed and cache size.

You can view processor details from system setup.

To determine if the processor is supported for the server, see <https://serverproven.lenovo.com>.

3. (Trained technicians only) Make sure that processor 1 is seated correctly.
4. (Trained technicians only) Remove processor 2 and restart the server.
5. Replace the following components one at a time, in the order shown, restarting the server each time:
  - a. (Trained technicians only) Processor
  - b. (Trained technicians only) System board

### **Server is unresponsive (POST is complete and operating system is running)**

Complete the following steps until the problem is solved.

- If you are in the same location as the compute node, complete the following steps:
  1. If you are using a KVM connection, make sure that the connection is operating correctly. Otherwise, make sure that the keyboard and mouse are operating correctly.
  2. If possible, log in to the compute node and verify that all applications are running (no applications are hung).
  3. Restart the compute node.
  4. If the problem remains, make sure that any new software has been installed and configured correctly.
  5. Contact your place of purchase of the software or your software provider.
- If you are accessing the compute node from a remote location, complete the following steps:
  1. Make sure that all applications are running (no applications are hung).
  2. Attempt to log out of the system and log back in.
  3. Validate the network access by pinging or running a trace route to the compute node from a command line.
    - a. If you are unable to get a response during a ping test, attempt to ping another compute node in the enclosure to determine whether it is a connection problem or compute node problem.
    - b. Run a trace route to determine where the connection breaks down. Attempt to resolve a connection issue with either the VPN or the point at which the connection breaks down.
  4. Restart the compute node remotely through the management interface.
  5. If the problem remains, verify that any new software has been installed and configured correctly.
  6. Contact your place of purchase of the software or your software provider.

### **Server is unresponsive (POST failed and cannot start System Setup)**

Configuration changes, such as added devices or adapter firmware updates, and firmware or application code problems can cause the server to fail POST (the power-on self-test).

If this occurs, the server responds in either of the following ways:

- The server restarts automatically and attempts POST again.
- The server hangs, and you must manually restart the server for the server to attempt POST again.

After a specified number of consecutive attempts (automatic or manual), the server reverts to the default UEFI configuration and starts System Setup so that you can make the necessary corrections to the configuration and restart the server. If the server is unable to successfully complete POST with the default configuration, there might be a problem with the system board.

You can specify the number of consecutive restart attempts in System Setup. Restart the server and press the key according to the on-screen instructions to display the LXPM system setup interface. For more information, see the “Startup” section in the LXPM documentation compatible with your server at [https://sysmgmt.lenovofiles.com/help/topic/lxpm\\_frontend/lxpm\\_product\\_page.html](https://sysmgmt.lenovofiles.com/help/topic/lxpm_frontend/lxpm_product_page.html). Then, click **System Settings** → **Recovery and RAS** → **POST Attempts** → **POST Attempts Limit**. Available options are 3, 6, 9, and disable.

### **Voltage planar fault is displayed in the event log**

Complete the following steps until the problem is solved.

1. Revert the system to the minimum configuration. See “[Specifications](#)” on page 3 for the minimally required number of processors and DIMMs.
2. Restart the system.
  - If the system restarts, add each of the removed items one at a time and restart the system each time until the error occurs. Replace the item for which the error occurs.
  - If the system does not restart, suspect the system board.

### **Unusual smell**

Complete the following steps until the problem is solved.

1. An unusual smell might be coming from newly installed equipment.
2. If the problem remains, contact Lenovo Support.

### **Server seems to be running hot**

Complete the following steps until the problem is solved.

Multiple compute nodes or chassis:

1. Make sure that the room temperature is within the specified range (see “[Specifications](#)” on page 3).
2. Make sure that the fans are installed correctly.
3. Update the UEFI and XCC to the latest versions.
4. Make sure that the fillers in the server are installed correctly (see [Chapter 5 “Hardware replacement procedures” on page 51](#) for detailed installation procedures).
5. Use the IPMI command to ramp up the fan speed to the full fan speed to see whether the issue can be resolved.

**Note:** The IPMI raw command should only be used by trained technicians and the each system has its own specific IPMI raw command.
6. Check the management processor event log for rising temperature events. If there are no events, the compute node is running within normal operating temperatures. Note that you can expect some variation in temperature.

### **Cannot enter legacy mode after installing a new adapter**

Complete the following procedure to solve the problem.

1. Go to **UEFI Setup** → **Devices and I/O Ports** → **Set Option ROM Execution Order**.
2. Move the RAID adapter with operation system installed to the top of the list.
3. Select **Save**.

4. Reboot the system and auto boot to operation system.

### **Cracked parts or cracked chassis**

Contact Lenovo Support.

## **Optional-device problems**

Use this information to solve problems related to optional devices.

- [“External USB device is not recognized” on page 477](#)
- [“PCIe adapter is not recognized or is not functioning” on page 477](#)
- [“Insufficient PCIe resources are detected.” on page 477](#)
- [“A Lenovo optional device that was just installed does not work.” on page 478](#)
- [“A Lenovo optional device that worked previously does not work now” on page 478](#)

### **External USB device is not recognized**

Complete the following steps until the problem is resolved:

1. Update the UEFI firmware to the latest version.
2. Make sure that the proper drivers are installed on the compute node. See the product documentation for the USB device for information about device drivers.
3. Use the Setup utility to make sure that the device is configured correctly.
4. If the USB device is plugged into a hub or the console breakout cable, unplug the device and plug it directly into the USB port on the front of the compute node.

### **PCIe adapter is not recognized or is not functioning**

Complete the following steps until the problem is resolved:

1. Update the UEFI firmware to the latest version.
2. Check the event log and resolve any issues related to the device.
3. Validate that the device is supported for the server (see <https://serverproven.lenovo.com>). Make sure that the firmware level on the device is at the latest supported level and update the firmware if applicable.
4. Make sure that the adapter is installed in a correct slot.
5. Make sure that the proper device drivers are installed for the device.
6. Resolve any resource conflicts if running legacy mode (UEFI). Check legacy ROM boot orders and modify the UEFI setting for MM config base.

**Note:** Ensure that you modify the ROM boot order associated with the PCIe adapter to the first execution order.

7. Check <http://datacentersupport.lenovo.com> for any tech tips (also known as retain tips or service bulletins) that might be related to the adapter.
8. Ensure any adapter external connections are correct and that the connectors are not physically damaged.
9. Make sure that the PCIe adapter is installed with the supported operating system.

### **Insufficient PCIe resources are detected.**

If you see an error message stating “Insufficient PCI Resources Detected,” complete the following steps until the problem is resolved:

1. Press Enter to access System Setup Utility.

2. Select **System Settings → Devices and I/O Ports → MM Config Base**; then, modify the setting to increase the device resources. For example, modify 3 GB to 2 GB or modify 2 GB to 1 GB.
3. Save the settings and restart the system.
4. If the error recurs with the highest device resource setting (1GB), shutdown the system and remove some PCIe devices; then, power on the system.
5. If the reboot failed, repeat step 1 to step 4.
6. If the error recurs, press Enter to access System Setup Utility.
7. Select **System Settings → Devices and I/O Ports → PCI 64-Bit Resource Allocation**, then; modify the setting from **Auto** to **Enable**.
8. If the Boot Device does not support MMIO above 4GB for Legacy Boot, use UEFI Boot Mode or remove/disable some PCIe devices.
9. DC cycle the system and ensure the system is enter UEFI boot menu or the operating system; then, capture the FFDC log.
10. Contact Lenovo technical support.

#### **A Lenovo optional device that was just installed does not work.**

1. Make sure that:
  - The device is supported for the server (see <https://serverproven.lenovo.com>).
  - You followed the installation instructions that came with the device and the device is installed correctly.
  - You have not loosened any other installed devices or cables.
  - You updated the configuration information in system setup. When you start a server and press the key according to the on-screen instructions to display the Setup Utility. For more information, see the “Startup” section in the LXPM documentation compatible with your server at [https://sysmgt.lenovofiles.com/help/topic/ixpm\\_frontend/ixpm\\_product\\_page.html](https://sysmgt.lenovofiles.com/help/topic/ixpm_frontend/ixpm_product_page.html). Whenever memory or any other device is changed, you must update the configuration.
2. Reseat the device that you have just installed.
3. Replace the device that you have just installed.
4. Reseat the cable connection and check there is no physical damage to the cable.
5. If there is any cable damages, then replace the cable.

#### **A Lenovo optional device that worked previously does not work now**

1. Make sure that all of the cable connections for the device are secure.
2. If the device comes with test instructions, use those instructions to test the device.
3. Reseat the cable connection and check if any physical parts have been damaged.
4. Replace the cable.
5. Reseat the failing device.
6. Replace the failing device.

## **Performance problems**

Use this information to solve performance problems.

- [“Network performance” on page 478](#)
- [“Operating system performance” on page 479](#)

### **Network performance**

Complete the following steps until the problem is solved:



1. Isolate which network is operating slowly (such as storage, data, and management). You might find it helpful to use ping tools or operating-system tools such as task manager or resource manager.
2. Check for traffic congestion on the network.
3. Update the NIC device driver, or the storage device controller device driver.
4. Use the traffic-diagnostic tools that are provided by the IO-module manufacturer.

### Operating system performance

Complete the following steps until the problem is solved:

1. If you have recently made changes to the compute node (for example updated device drivers or installed software applications) remove the changes.
2. Check for any networking issues.
3. Check the operating system logs for performance related errors.
4. Check for events related to high temperatures and power issues as the compute node might be throttled to help with cooling. If it is throttled, reduce the workload on the compute node to help improve performance.
5. Check for events related to disabled DIMMs. If you do not have enough memory for the application workload, your operating system will have poor performance.
6. Ensure that the workload is not too high for the configuration.

### Power on and power off problems

Use this information to resolve issues when powering on or powering off the server.

- [“The power button does not work \(server does not start\)” on page 479](#)
- [“Server does not power on” on page 480](#)
- [“Server does not power off” on page 480](#)

#### The power button does not work (server does not start)

**Note:** After the server is connected to AC power, it will take one to three minutes for XCC to initialize. The power button does not work during the initialization.

Complete the following steps until the problem is resolved:

1. Make sure that the power button on the server is working correctly:
  - a. Disconnect the server power cords.
  - b. Reconnect the server power cords.
  - c. Reconnect the front operator panel cable, and then repeat steps 1a and 1b.
    - If the server starts, reseal the front operator panel.
    - If the problem remains, replace the front operator panel.
2. Make sure that:
  - The power cords are correctly connected to the server and to a working electrical outlet.
  - The LEDs on the power supply units work normally.
  - The power button LED is lit on and flash slowly.
  - The button-push force is sufficient and the button shows release response after pushed.
3. If the power button LED does not light on or flash correctly, reseal all the power supply units and make sure that the power input status LED is lit on.
4. If you have just installed an optional device, remove it, and restart the server.

5. If the issue is still observed or without power button LED lit on, implement the minimum configuration to check whether any specific components have locked the power permission. Replace power supply units and check the power button function after installing each unit.
6. If all procedures are tried and the issue cannot be resolved, collect the failure information with system logs captured and contact Lenovo Support.

### **Server does not power on**

Complete the following steps until the problem is resolved:

1. Check the event logs for any events related to the server not powering on.
2. Check for any LEDs that are blinking amber or yellow.
3. Check the system status LED on the system board (system board assembly). See [“LEDs on the system board assembly” on page 458](#).
4. Check if the power input status LED is off or the yellow LED is lit on the power supply unit.
5. Do the AC cycle to the system, that is, power off the power supply units and re-power them on.
6. Remove the CMOS battery for at least ten seconds, then, reinstall the CMOS battery.
7. Try to power on the system by IPMI command through XCC or by the power button.
8. Implement the minimum configuration (one processor, one DIMM and one PSU without any adapter or any drive installed).
9. Reseat all power supply units and make sure that the power input status LED on the power supply unit is lit.
10. Replace power supply units and check the power button function after installing each unit.
11. If the issue cannot be resolved by all attempts above, call service to review the issue symptoms and see whether the system board (system board assembly) replacement is necessary.

### **Server does not power off**

Complete the following steps until the problem is resolved:

1. Determine whether you are using an Advanced Configuration and Power Interface (ACPI) or a non-ACPI operating system. If you are using a non-ACPI operating system, complete the following steps:
  - a. Press Ctrl+Alt+Delete.
  - b. Turn off the server by pressing the power button on the front operator panel and holding it down for 5 seconds.
  - c. Restart the server.
  - d. If the server fails POST and the power-control button does not work, disconnect the power cord for 20 seconds; then, reconnect the power cord and restart the server.
2. If the problem remains or if you are using an ACPI-aware operating system, suspect the system board (system board assembly).

## **Power problems**

Use this information to resolve issues related to power.

### **System error LED is on and event log "Power supply has lost input" is displayed**

To resolve the problem, ensure that:

1. The power supply unit is properly connected to a power cord.
2. The power cord is connected to a properly grounded electrical outlet for the server.
3. Make sure that the AC source of the power supply unit is stable within the supported range.

4. Swap power supply units to see that the issue follows which power supply unit, if the issue follows one power supply unit, then place the failing one.
5. Review the event logs and identify problem category, follow the event log actions and fix the problem.

## Serial-device problems

Use this information to solve problems with serial ports or devices.

- [“Number of displayed serial ports is less than the number of installed serial ports” on page 481](#)
- [“Serial device does not work” on page 481](#)

### Number of displayed serial ports is less than the number of installed serial ports

Complete the following steps until the problem is solved.

1. Make sure that:
  - Each port is assigned a unique address in the Setup utility and none of the serial ports is disabled.
  - The serial-port adapter (if one is present) is seated correctly.
2. Reseat the serial port adapter.
3. Replace the serial port adapter.

### Serial device does not work

1. Make sure that:
  - The device is compatible with the server.
  - The serial port is enabled and is assigned a unique address.
  - The device is connected to the correct connector (see [“System-board-assembly connectors” on page 36](#)).
2. Reseat the following components:
  - a. Failing serial device.
  - b. Serial cable.
3. Replace the following components:
  - a. Failing serial device.
  - b. Serial cable.
4. (Trained technician only) Replace the system board.

## Software problems

Use this information to solve software problems.

1. To determine whether the problem is caused by the software, make sure that:
  - The server has the minimum memory that is needed to use the software. For memory requirements, see the information that comes with the software.

**Note:** If you have just installed an adapter or memory, the server might have a memory-address conflict.

- The software is designed to operate on the server.
  - Other software works on the server.
  - The software works on another server.
2. If you receive any error messages while you use the software, see the information that comes with the software for a description of the messages and suggested solutions to the problem.

3. Contact your place of purchase of the software.

---

## Appendix A. Hardware disassembling for recycle

Follow the instructions in this section to recycle components with compliance with local laws or regulations.

---

### Disassemble the system board assembly for recycle



Follow the instructions in this section to disassemble the system board assembly before recycling.

Before disassembling the system board assembly:

1. Remove the system board assembly from the server. See [“Remove the processor board” on page 233](#).
2. Refer to local environmental, waste or disposal regulations to ensure compliance.

Step 1. Remove the following component as illustrated:

Table 173. Screw type

Screw type	Quantity	Tool type
	12	PH2 screwdriver
	5	

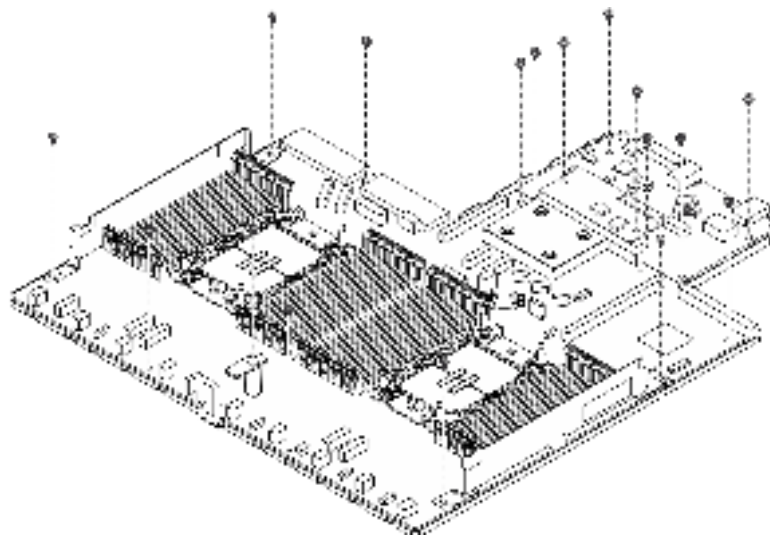


Figure 375. Disassembling the system board assembly

Step 2. Remove the following component as illustrated:

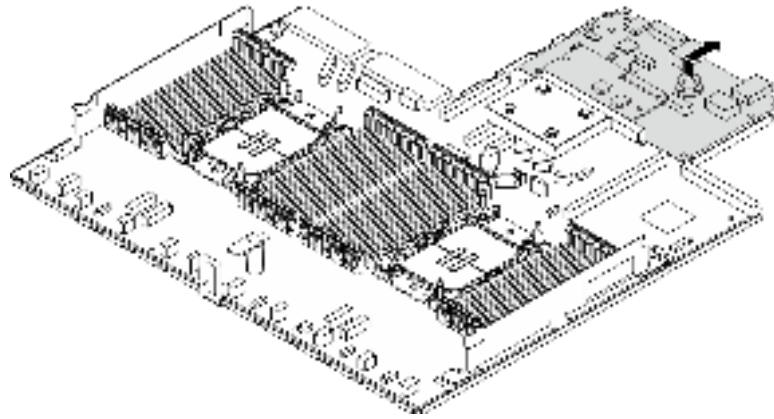


Figure 376. Disassembling the IO board

**Note:** To prevent the contact of the IO board from damage, pinch and lift the plunger on the IO board upward a little and pull out the IO board outward. During the entire pulling action, ensure that the IO board remains as horizontal as possible.

Step 3. Remove the following component as illustrated:

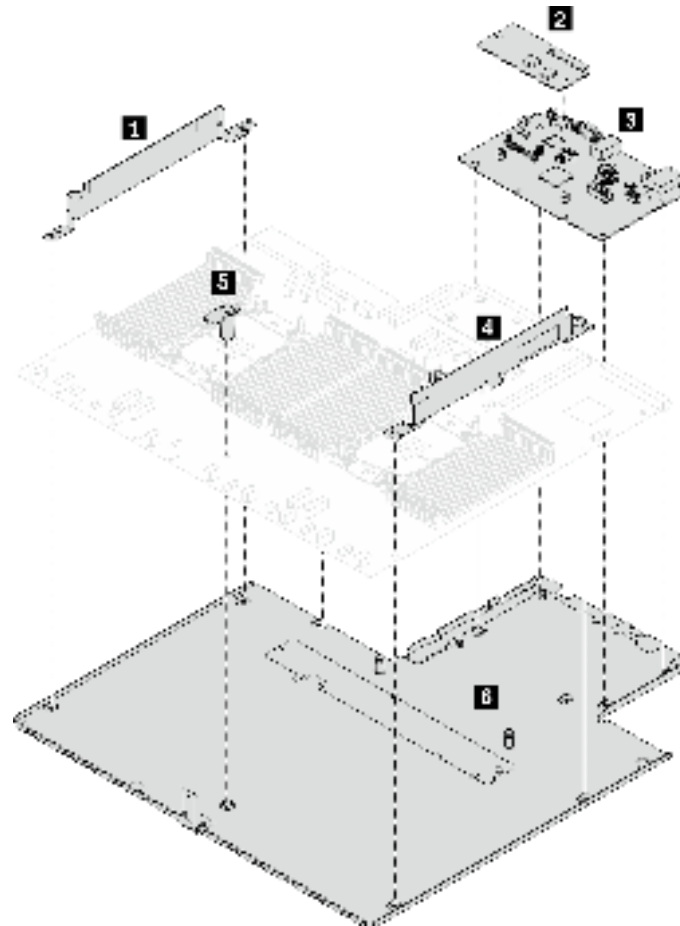


Figure 377. Disassembling the system board assembly

Separate following parts from the system board assembly:

- **1** Cable wall (left)
- **2** Firmware and RoT Security Module
- **3** System I/O board
- **4** Cable wall (right)
- **5** Handle
- **6** Supporting metal sheet

Separate the system board assembly from the supporting sheet metal.

After disassembling the system board assembly, recycle the units in compliance with local regulations.





---

## Appendix B. Getting help and technical assistance

If you need help, service, or technical assistance or just want more information about Lenovo products, you will find a wide variety of sources available from Lenovo to assist you.

On the World Wide Web, up-to-date information about Lenovo systems, optional devices, services, and support are available at:

<http://datacentersupport.lenovo.com>

**Note:** IBM is Lenovo's preferred service provider for ThinkSystem

---

### Before you call

Before you call, there are several steps that you can take to try and solve the problem yourself. If you decide that you do need to call for assistance, gather the information that will be needed by the service technician to more quickly resolve your problem.

#### Attempt to resolve the problem yourself

You can solve many problems without outside assistance by following the troubleshooting procedures that Lenovo provides in the online help or in the Lenovo product documentation. The online help also describes the diagnostic tests that you can perform. The documentation for most systems, operating systems, and programs contains troubleshooting procedures and explanations of error messages and error codes. If you suspect a software problem, see the documentation for the operating system or program.

You can find the product documentation for your ThinkSystem products at the following location:

<https://pubs.lenovo.com/>

You can take these steps to try to solve the problem yourself:

- Check all cables to make sure that they are connected.
- Check the power switches to make sure that the system and any optional devices are turned on.
- Check for updated software, firmware, and operating-system device drivers for your Lenovo product. (See the following links) The Lenovo Warranty terms and conditions state that you, the owner of the Lenovo product, are responsible for maintaining and updating all software and firmware for the product (unless it is covered by an additional maintenance contract). Your service technician will request that you upgrade your software and firmware if the problem has a documented solution within a software upgrade.
  - Drivers and software downloads
    - <https://datacentersupport.lenovo.com/products/servers/thinksystem/sr630v3/7d72/downloads/driver-list/>
  - Operating system support center
    - <https://datacentersupport.lenovo.com/solutions/server-os>
  - Operating system installing instructions
    - <https://pubs.lenovo.com/#os-installation>
- If you have installed new hardware or software in your environment, check <https://serverproven.lenovo.com> to make sure that the hardware and software are supported by your product.
- Refer to [Chapter 8 “Problem determination” on page 441](#) for instructions on isolating and solving issues.

- Go to <http://datacentersupport.lenovo.com> and check for information to help you solve the problem.

To find the Tech Tips available for your server:

1. Go to <http://datacentersupport.lenovo.com>, and input the model name or machine type of your server in the search bar to navigate to the support page.
2. Click on **How To's** from the navigation pane.
3. Click **Article Type** → **Solution** from the drop-down menu.

Follow the on-screen instructions to choose the category for the problem that you are having.

- Check Lenovo Data Center Forum at [https://forums.lenovo.com/t5/Datacenter-Systems/ct-p/sv\\_eg](https://forums.lenovo.com/t5/Datacenter-Systems/ct-p/sv_eg) to see if someone else has encountered a similar problem.

### Gathering information needed to call Support

If you require warranty service for your Lenovo product, the service technicians will be able to assist you more efficiently if you prepare the appropriate information before you call. You can also go to <http://datacentersupport.lenovo.com/warrantylookup> for more information about your product warranty.

Gather the following information to provide to the service technician. This data will help the service technician quickly provide a solution to your problem and ensure that you receive the level of service for which you might have contracted.

- Hardware and Software Maintenance agreement contract numbers, if applicable
- Machine type number (Lenovo 4-digit machine identifier). Machine type number can be found on the ID label, see “[Identify the server and access the Lenovo XClarity Controller](#)” on page 47.
- Model number
- Serial number
- Current system UEFI and firmware levels
- Other pertinent information such as error messages and logs

As an alternative to calling Lenovo Support, you can go to <https://support.lenovo.com/servicerequest> to submit an Electronic Service Request. Submitting an Electronic Service Request will start the process of determining a solution to your problem by making the pertinent information available to the service technicians. The Lenovo service technicians can start working on your solution as soon as you have completed and submitted an Electronic Service Request.

---

## Collecting service data

To clearly identify the root cause of a server issue or at the request of Lenovo Support, you might need collect service data that can be used for further analysis. Service data includes information such as event logs and hardware inventory.

Service data can be collected through the following tools:

- **Lenovo XClarity Provisioning Manager**

Use the Collect Service Data function of Lenovo XClarity Provisioning Manager to collect system service data. You can collect existing system log data or run a new diagnostic to collect new data.

- **Lenovo XClarity Controller**

You can use the Lenovo XClarity Controller web interface or the CLI to collect service data for the server. The file can be saved and sent to Lenovo Support.

- For more information about using the web interface to collect service data, see the “Backing up the BMC configuration” section in the XCC documentation compatible with your server at [https://sysmgt.lenovofiles.com/help/topic/lxcc\\_frontend/lxcc\\_overview.html](https://sysmgt.lenovofiles.com/help/topic/lxcc_frontend/lxcc_overview.html).
- For more information about using the CLI to collect service data, see the “XCC `ffdc` command” section in the XCC documentation compatible with your server at [https://sysmgt.lenovofiles.com/help/topic/lxcc\\_frontend/lxcc\\_overview.html](https://sysmgt.lenovofiles.com/help/topic/lxcc_frontend/lxcc_overview.html).

- **Lenovo XClarity Administrator**

Lenovo XClarity Administrator can be set up to collect and send diagnostic files automatically to Lenovo Support when certain serviceable events occur in Lenovo XClarity Administrator and the managed endpoints. You can choose to send diagnostic files to Lenovo Support using Call Home or to another service provider using SFTP. You can also manually collect diagnostic files, open a problem record, and send diagnostic files to the Lenovo Support.

You can find more information about setting up automatic problem notification within the Lenovo XClarity Administrator at [http://sysmgt.lenovofiles.com/help/topic/com.lenovo.lxca.doc/admin\\_setupcallhome.html](http://sysmgt.lenovofiles.com/help/topic/com.lenovo.lxca.doc/admin_setupcallhome.html).

- **Lenovo XClarity Essentials OneCLI**

Lenovo XClarity Essentials OneCLI has inventory application to collect service data. It can run both in-band and out-of-band. When running in-band within the host operating system on the server, OneCLI can collect information about the operating system, such as the operating system event log, in addition to the hardware service data.

To obtain service data, you can run the `getinfor` command. For more information about running the `getinfor`, see [http://sysmgt.lenovofiles.com/help/topic/toolsctr\\_cli\\_lenovo/onecli\\_r\\_getinfor\\_command.html](http://sysmgt.lenovofiles.com/help/topic/toolsctr_cli_lenovo/onecli_r_getinfor_command.html).

---

## Contacting Support

You can contact Support to obtain help for your issue.

You can receive hardware service through a Lenovo Authorized Service Provider. To locate a service provider authorized by Lenovo to provide warranty service, go to <https://datacentersupport.lenovo.com/serviceprovider> and use filter searching for different countries. For Lenovo support telephone numbers, see <https://datacentersupport.lenovo.com/supportphonenumber> for your region support details.



---

## Appendix C. Documents and supports

This section provides handy documents, driver and firmware downloads, and support resources.

---

### Documents download

This section provides introduction and download link for handy documents.

#### Documents

- **Rail Installation Guides**
  - Rail installation in a rack
- **User Guide**
  - Complete overview, system configuration, hardware components replacing, and troubleshooting.  
Selected chapters from *User Guide*:
    - **System Configuration Guide** : Server overview, components identification, system LEDs and diagnostics display, product unboxing, setting up and configuring the server.
    - **Hardware Maintenance Guide** : Installing hardware components, cable routing, and troubleshooting.
- **Messages and Codes Reference**
  - XClarity Controller, LXPM, and uEFI events
- **UEFI Manual**
  - UEFI setting introduction

---

### Support websites

This section provides driver and firmware downloads and support resources.



---

## Appendix D. Notices

Lenovo may not offer the products, services, or features discussed in this document in all countries. Consult your local Lenovo representative for information on the products and services currently available in your area.

Any reference to a Lenovo product, program, or service is not intended to state or imply that only that Lenovo product, program, or service may be used. Any functionally equivalent product, program, or service that does not infringe any Lenovo intellectual property right may be used instead. However, it is the user's responsibility to evaluate and verify the operation of any other product, program, or service.

Lenovo may have patents or pending patent applications covering subject matter described in this document. The furnishing of this document is not an offer and does not provide a license under any patents or patent applications. You can send inquiries in writing to the following:

*Lenovo (United States), Inc.  
8001 Development Drive  
Morrisville, NC 27560  
U.S.A.  
Attention: Lenovo Director of Licensing*

LENOVO PROVIDES THIS PUBLICATION "AS IS" WITHOUT WARRANTY OF ANY KIND, EITHER EXPRESS OR IMPLIED, INCLUDING, BUT NOT LIMITED TO, THE IMPLIED WARRANTIES OF NON-INFRINGEMENT, MERCHANTABILITY OR FITNESS FOR A PARTICULAR PURPOSE. Some jurisdictions do not allow disclaimer of express or implied warranties in certain transactions, therefore, this statement may not apply to you.

This information could include technical inaccuracies or typographical errors. Changes are periodically made to the information herein; these changes will be incorporated in new editions of the publication. Lenovo may make improvements and/or changes in the product(s) and/or the program(s) described in this publication at any time without notice.

The products described in this document are not intended for use in implantation or other life support applications where malfunction may result in injury or death to persons. The information contained in this document does not affect or change Lenovo product specifications or warranties. Nothing in this document shall operate as an express or implied license or indemnity under the intellectual property rights of Lenovo or third parties. All information contained in this document was obtained in specific environments and is presented as an illustration. The result obtained in other operating environments may vary.

Lenovo may use or distribute any of the information you supply in any way it believes appropriate without incurring any obligation to you.

Any references in this publication to non-Lenovo Web sites are provided for convenience only and do not in any manner serve as an endorsement of those Web sites. The materials at those Web sites are not part of the materials for this Lenovo product, and use of those Web sites is at your own risk.

Any performance data contained herein was determined in a controlled environment. Therefore, the result obtained in other operating environments may vary significantly. Some measurements may have been made on development-level systems and there is no guarantee that these measurements will be the same on generally available systems. Furthermore, some measurements may have been estimated through extrapolation. Actual results may vary. Users of this document should verify the applicable data for their specific environment.

---

## Trademarks

LENOVO and THINKSYSTEM are trademarks of Lenovo.

All other trademarks are the property of their respective owners.

---

## Important notes

Processor speed indicates the internal clock speed of the processor; other factors also affect application performance.

CD or DVD drive speed is the variable read rate. Actual speeds vary and are often less than the possible maximum.

When referring to processor storage, real and virtual storage, or channel volume, KB stands for 1 024 bytes, MB stands for 1 048 576 bytes, and GB stands for 1 073 741 824 bytes.

When referring to hard disk drive capacity or communications volume, MB stands for 1 000 000 bytes, and GB stands for 1 000 000 000 bytes. Total user-accessible capacity can vary depending on operating environments.

Maximum internal hard disk drive capacities assume the replacement of any standard hard disk drives and population of all hard-disk-drive bays with the largest currently supported drives that are available from Lenovo.

Maximum memory might require replacement of the standard memory with an optional memory module.

Each solid-state memory cell has an intrinsic, finite number of write cycles that the cell can incur. Therefore, a solid-state device has a maximum number of write cycles that it can be subjected to, expressed as total bytes written (TBW). A device that has exceeded this limit might fail to respond to system-generated commands or might be incapable of being written to. Lenovo is not responsible for replacement of a device that has exceeded its maximum guaranteed number of program/erase cycles, as documented in the Official Published Specifications for the device.

Lenovo makes no representations or warranties with respect to non-Lenovo products. Support (if any) for the non-Lenovo products is provided by the third party, not Lenovo.

Some software might differ from its retail version (if available) and might not include user manuals or all program functionality.

---

## Electronic emission notices

When you attach a monitor to the equipment, you must use the designated monitor cable and any interference suppression devices that are supplied with the monitor.

Additional electronic emissions notices are available at:

[https://pubs.lenovo.com/important\\_notices/](https://pubs.lenovo.com/important_notices/)



## Taiwan Region BSMI RoHS declaration

單元 Unit	限制物質及其化學符號 Restricted substances and its chemical symbols					
	鉛Lead (Pb)	汞Mercury (Hg)	鎘Cadmium (Cd)	六價鉻Hexavalent chromium (Cr <sup>6+</sup> )	多溴聯苯Polybrominated biphenyls (PBB)	多溴二苯醚Polybrominated diphenyl ethers (PBDE)
機架	○	○	○	○	○	○
外部蓋板	○	○	○	○	○	○
機殼組零件	-	○	○	○	○	○
空氣傳動設備	-	○	○	○	○	○
冷卻組零件	-	○	○	○	○	○
內存模組	-	○	○	○	○	○
處理器模組	-	○	○	○	○	○
電源組零件	-	○	○	○	○	○
電源供應器	-	○	○	○	○	○
儲備設備	-	○	○	○	○	○
印刷電路板	-	○	○	○	○	○

備考1: "超出0.1 wt%"及"超出0.01 wt%"係指該項物質之百分比含量超出百分比含量基準值。  
 Note1: "exceeding 0.1wt%" and "exceeding 0.01 wt%" indicate that the percentage content of the restricted substance exceeds the reference percentage value of presence condition.

備考2: "○"係指該項限制物質之百分比含量未超出百分比含量基準值。  
 Note2: "○" indicates that the percentage content of the restricted substance does not exceed the percentage of reference value of presence.

備考3: "-"係指該項限制物質為排除項目。  
 Note3: The "-" indicates that the restricted substance corresponds to the exemption.

## Taiwan Region import and export contact information

Contacts are available for Taiwan Region import and export information.

委製商/進口商名稱: 台灣聯想環球科技股份有限公司  
 進口商地址: 台北市南港區三重路 66 號 8 樓  
 進口商電話: 0800-000-702





**Lenovo**