

Europe, Middle East

ENGLISH

FRANÇAIS

DEUTSCH

NEDERLANDS

ITALIANO

ESPAÑOL

PORTUGUÊS

РУССКИЙ

ČESTINA

TÜRKÇE

POLSKI

SVENSKA

SUOMI

SLOVENCINA

MAGYAR

עברית

العربية

North America/

Norteamérica

ENGLISH

FRANÇAIS

ESPAÑOL

Latin America/

América Latina

ENGLISH

ESPAÑOL

PORTUGUÊS

Asia Pacific

日本語

简体中文

繁體中文

한국어

ENGLISH

THRUSTMASTER®

VIPER TQS

THROTTLE QUADRANT SYSTEM

THRUSTMASTER®

VIPER TQS

THROTTLE QUADRANT SYSTEM

For PC (Windows 10/11)

User Manual



Carefully read the instructions provided in this manual **before** installing the product, **before** any use of the product and **before** any maintenance. Be sure to follow the safety instructions. Failure to follow these instructions may result in accidents and/or damage. Keep this manual so that you can refer to the instructions in the future.

TABLE OF CONTENTS

1.	BOX CONTENTS	5
2.	VIPER TQS FEATURES	6
3.	MAPPING OF BUTTONS AND AXES.....	8
4.	INFORMATION ABOUT USING VIPER TQS...	10
5.	ADJUSTING THE FRICTION.....	11
6.	INSTALLATION ON A SUPPORT	12
7.	INSTALLING VIPER PANEL*	17
8.	INSTALLATION ON PC.....	20
9.	CUT OFF AND AFTERBURNER DETENTS	23
10.	T.A.R.G.E.T ADVANCED PROGRAMMING SOFTWARE.....	26
11.	FAQ AND TECHNICAL SUPPORT	28



Rev up your engines and fly into the danger zone with the iconic throttle quadrant system from the U.S. Air Force's VIPER — the world's most widely-used modern fighter aircraft!

Take your cockpit to the next level with the unique ergonomics of a 1:1 scale HOTAS replica featuring a metal handle, plus realistic buttons and detents.

This manual will help you install and use your VIPER TQS under the best conditions. Before taking off, make sure to carefully read all of these instructions and warnings: they will help you get the most enjoyment out of your product.



Updating the firmware

In order for VIPER TQS to function properly in video games, you must update its firmware.

To carry out the update, please visit

<https://support.thrustmaster.com/product/viper-tqs/>

Select **Firmware**, then follow the instructions — including the downloading and installation procedure.



1. Box contents

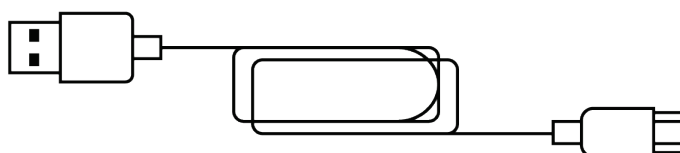
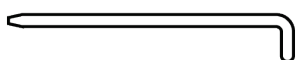
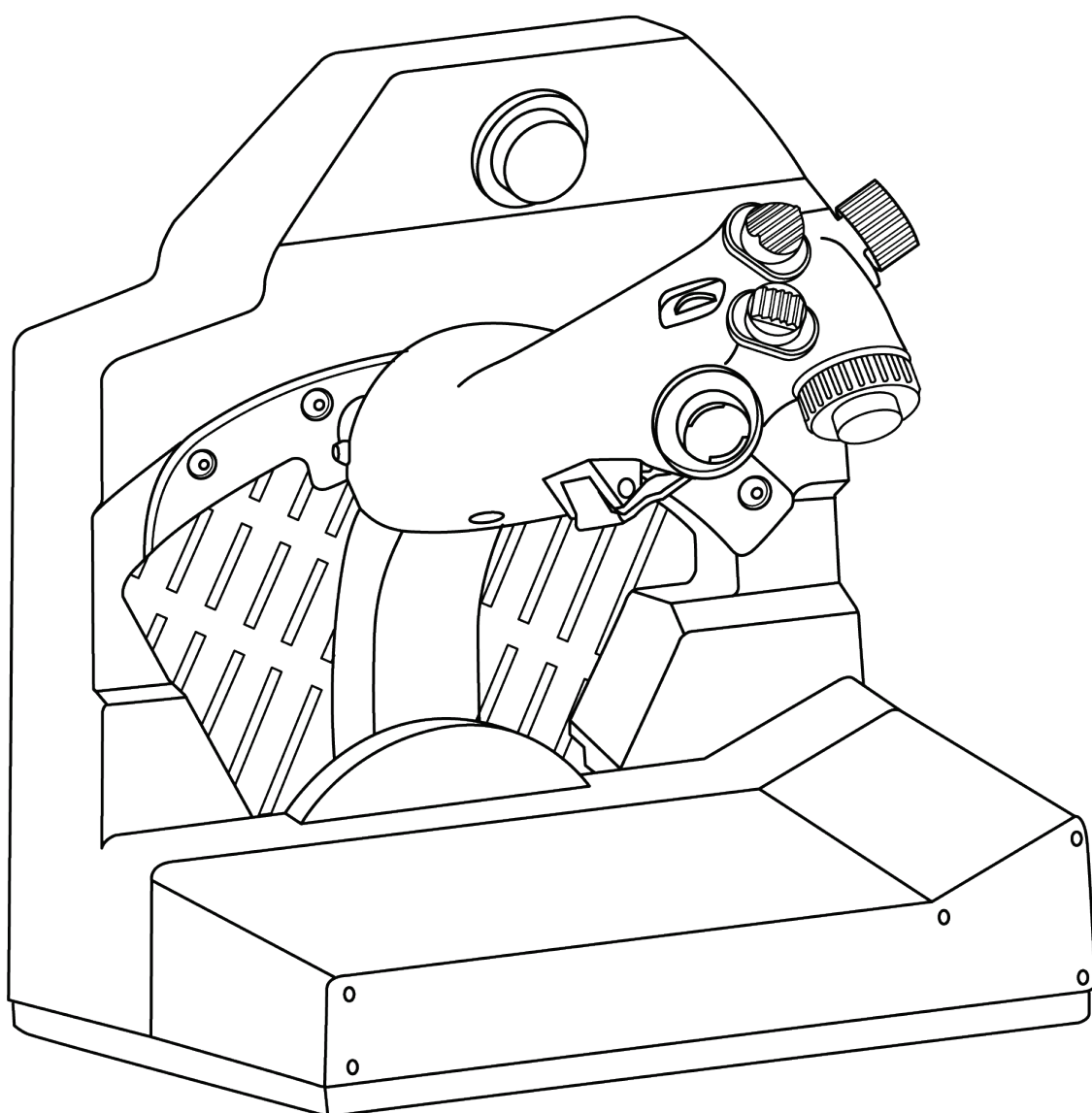



2. VIPER TQS features

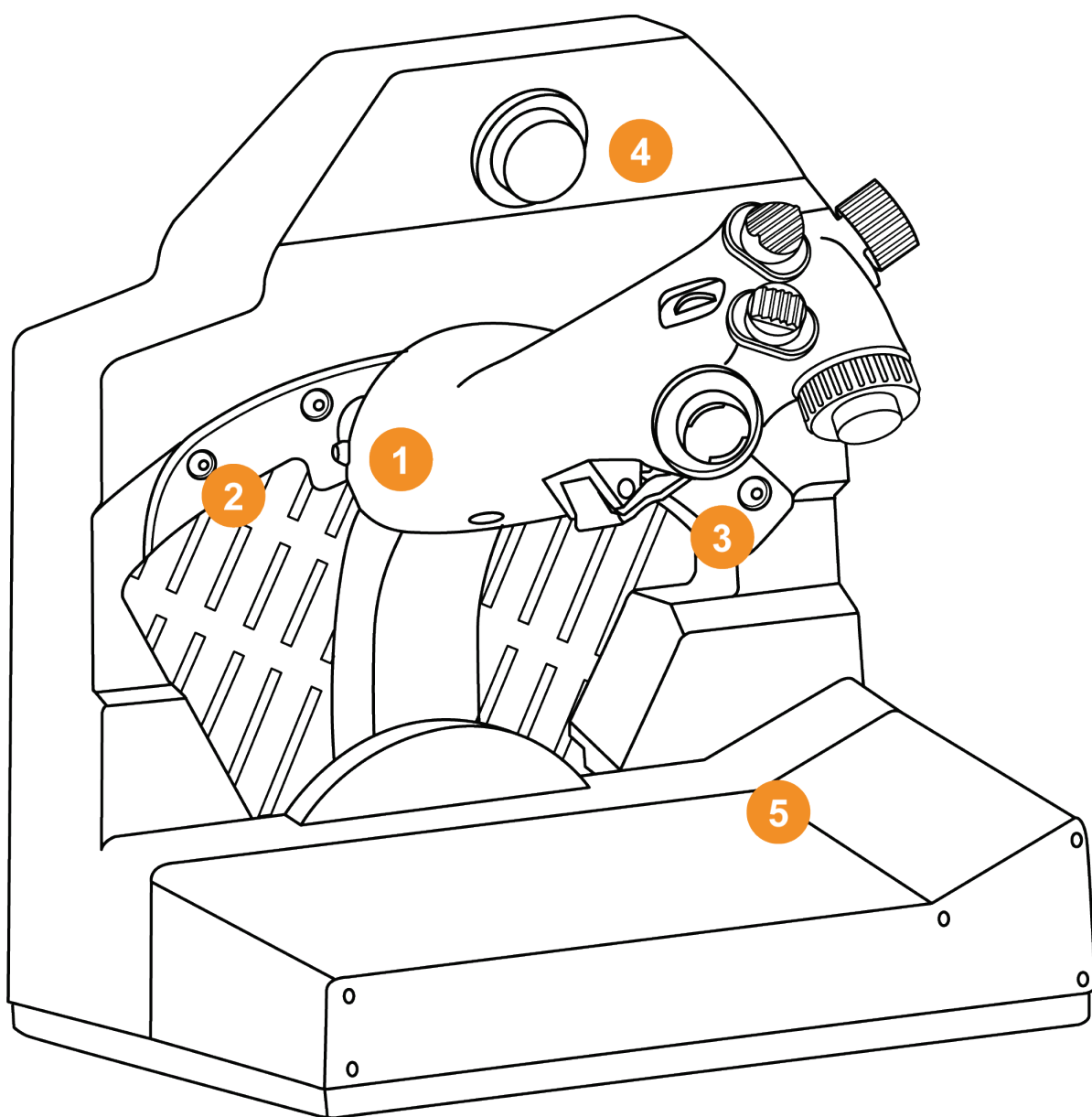

1. Handle

2. Cut Off stop

3. Afterburner stop

4. CHAFF/FLARE slap switch

5. Clip for mission map

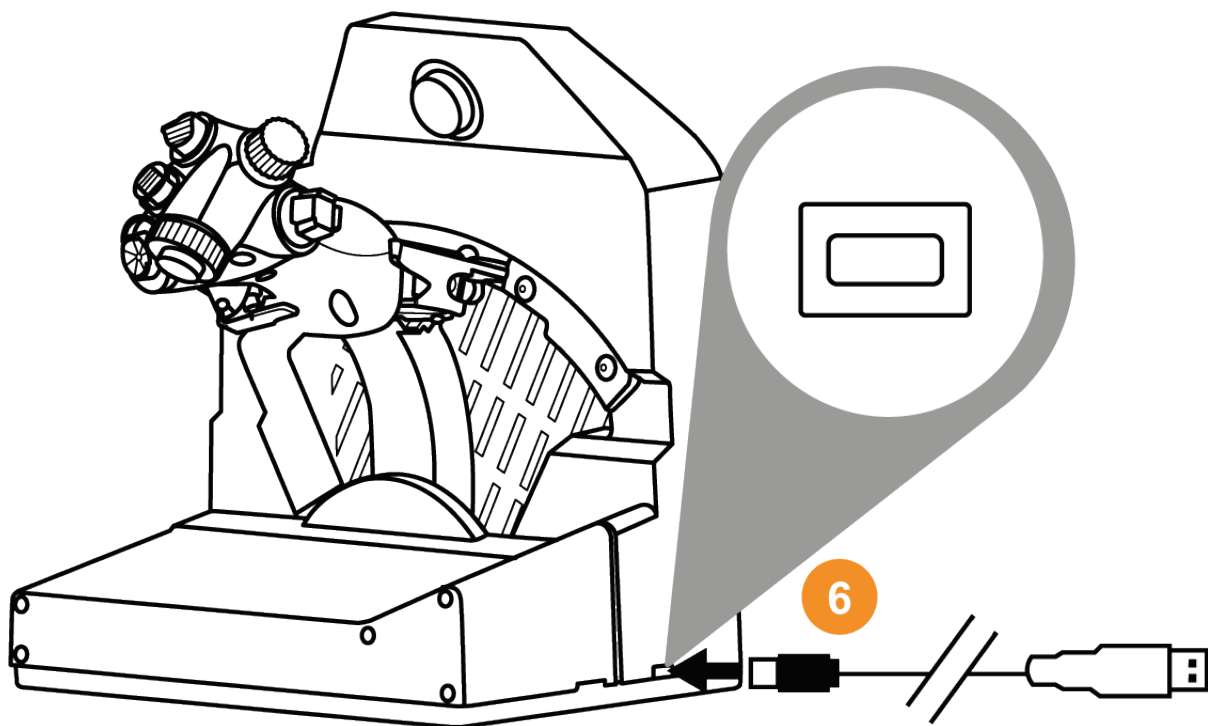

6. USB connector (type C)

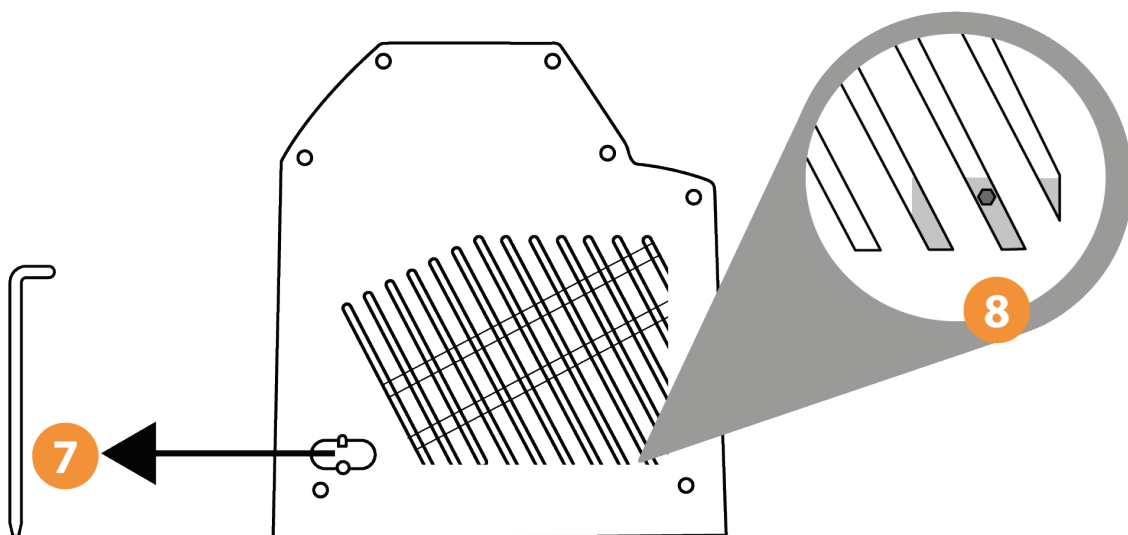

7. Friction adjustment tool location

8. Throttle friction adjustment access point



3. Mapping of buttons and axes

VIPER TQS handle: mapping of the 19 buttons and 5 axes in mode A (without virtual buttons)

A 1 → 19

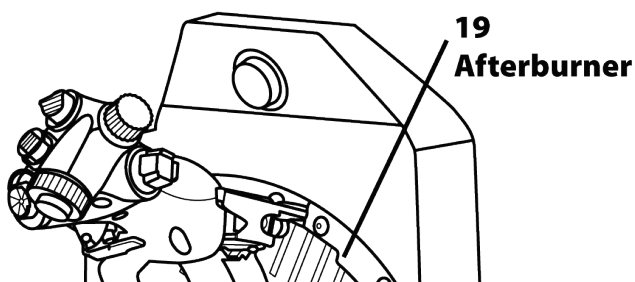
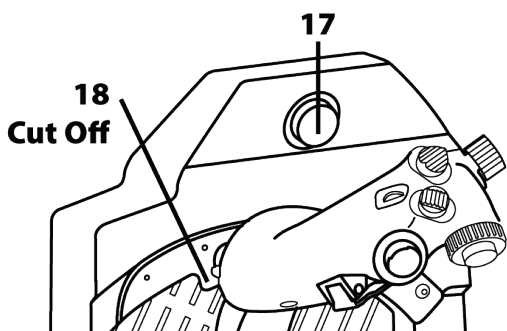
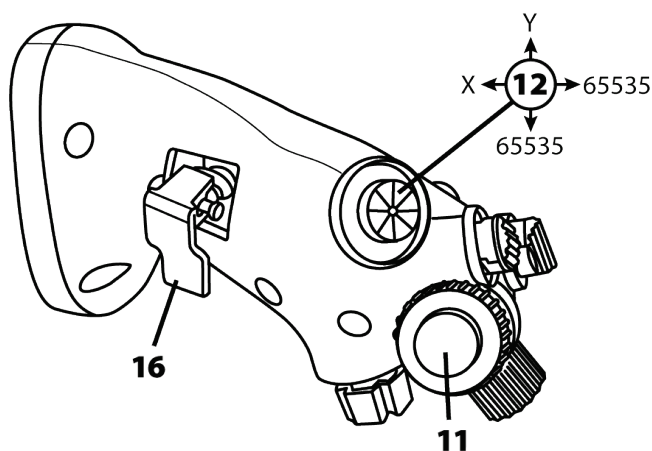
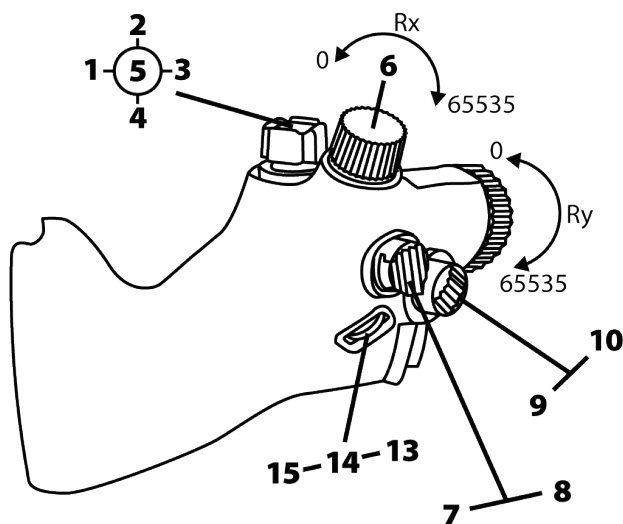



Mode B: with virtual buttons

B 1 → 21

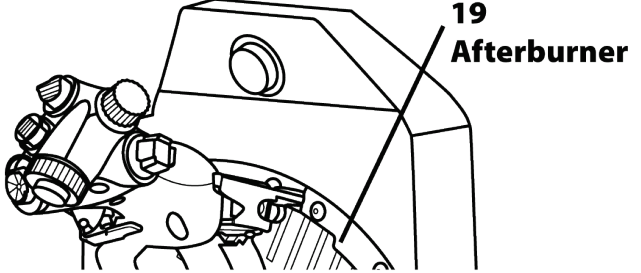
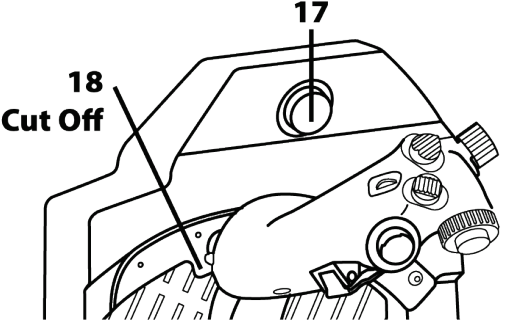
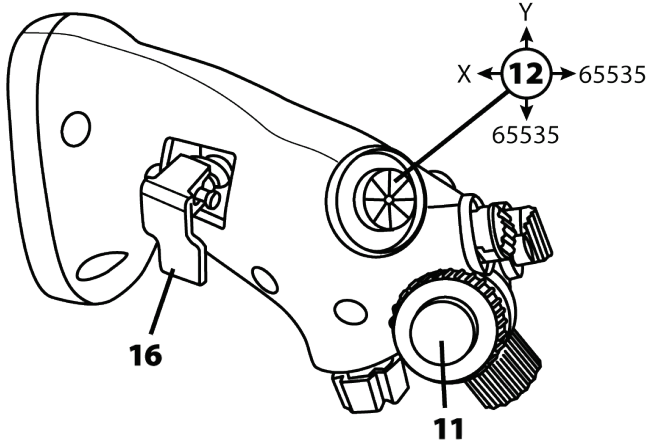
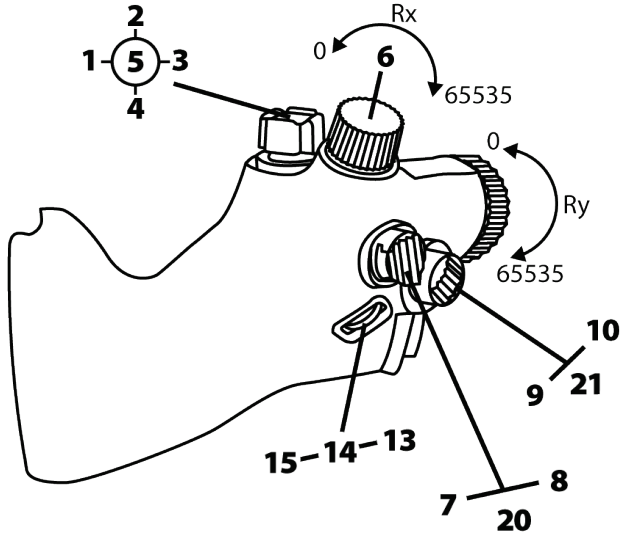



4. Information about using VIPER TQS



Pinch hazard

Never place your fingers in the stop areas when you are using the handle.

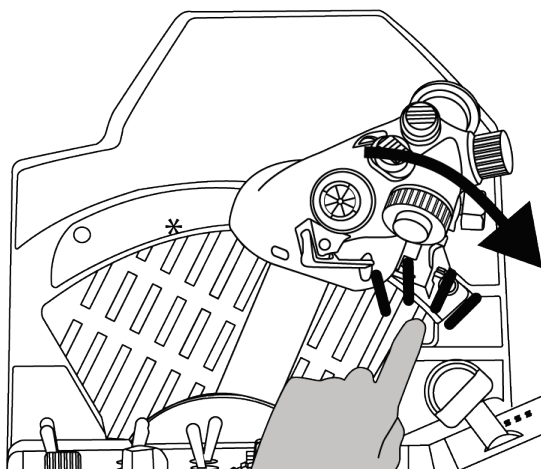
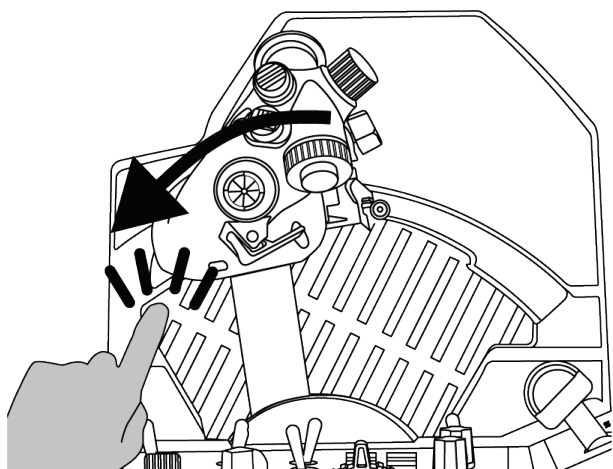
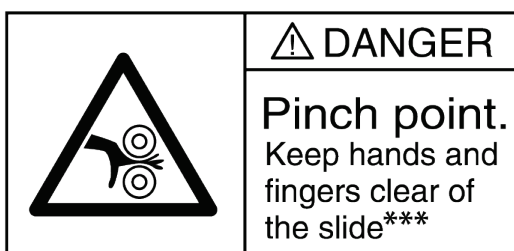



5. Adjusting the friction

You can adjust the friction of your VIPER TQS throttle quadrant to your own personal preference by using the tool included on the side of VIPER TQS. Please note, however, that optimal throttle friction has been set by default at the factory.

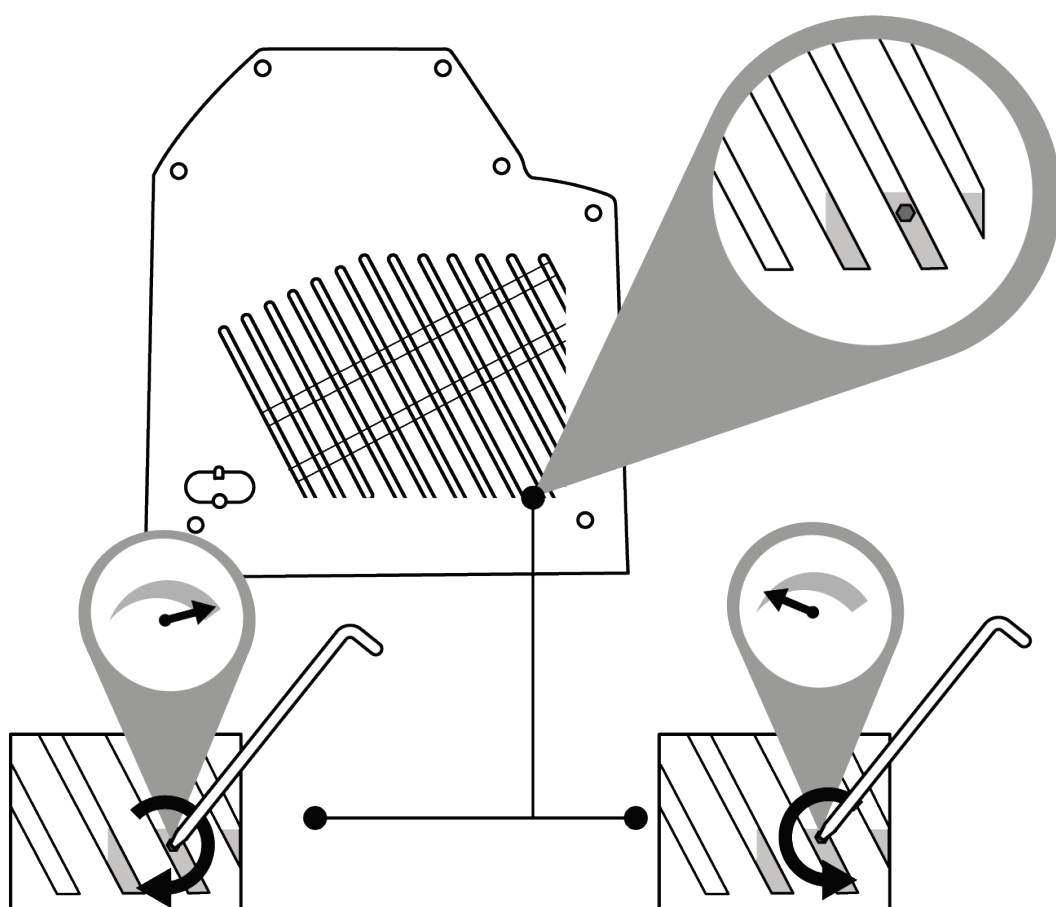

In order to avoid damaging the friction system, be sure not to overtighten the adjustment screw.

Also, be sure not to completely untighten the adjustment screw: by doing so, you run the risk that the throttle will no longer be able to stay in position.



6. Installation on a support



VIPER TQS can be installed on different types of supports. Most cockpits and supports available on the market are already compatible with similar Thrustmaster products (i.e. HOTAS Warthog).

Please keep in mind that VIPER TQS features a powerful lever effect, and must therefore be firmly attached.

Attach the base to your support using suitable M6 screws (not included), so as not to damage the handle.

A complete VIPER TQS blueprint is available at <https://support.thrustmaster.com/product/viper-tqs/>



Before each use, make sure that VIPER TQS is still properly attached to the support, according to the instructions specified by the manufacturer.

Be sure to take into account the material that your support is made of, and ensure that it is possible to safely attach the product to it. VIPER TQS must be used on a desk made of a solid material (i.e. MDF or wood), without any hollow or glass components.



Mounting blueprint dimensions (in mm)

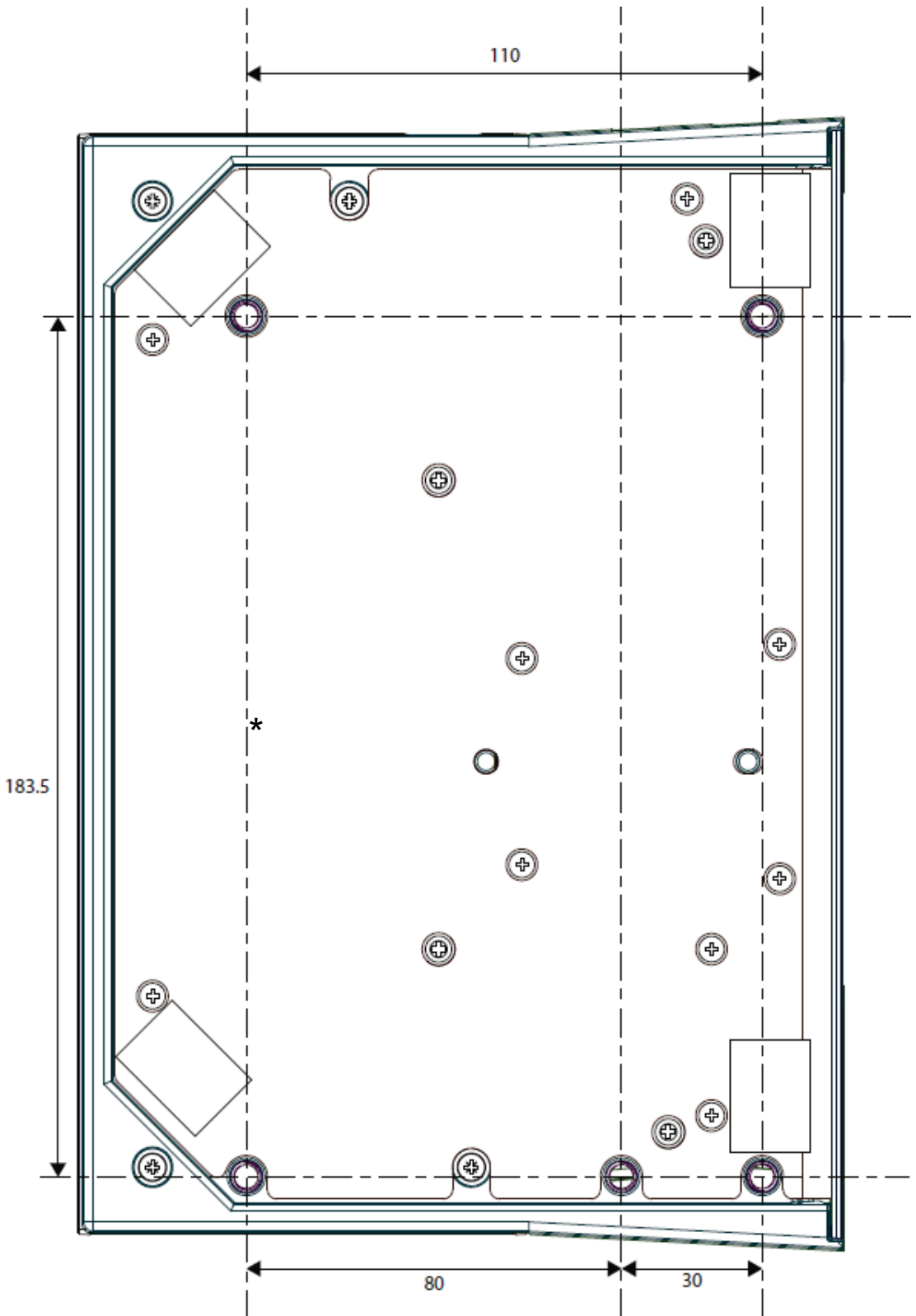

You can download the mounting blueprint from <https://support.thrustmaster.com/product/viper-tqs/>, then print it out and use it on your support in order to prepare the drill holes.



*Installation using TM Flying Desk Mount**

TM Flying Desk Mount is a metal mounting system featuring a clamping screw, improving the ergonomics and piloting position when using your device. This system is designed for use with desks and tables from 0.6–2.0 inches / 15–50 mm thick.

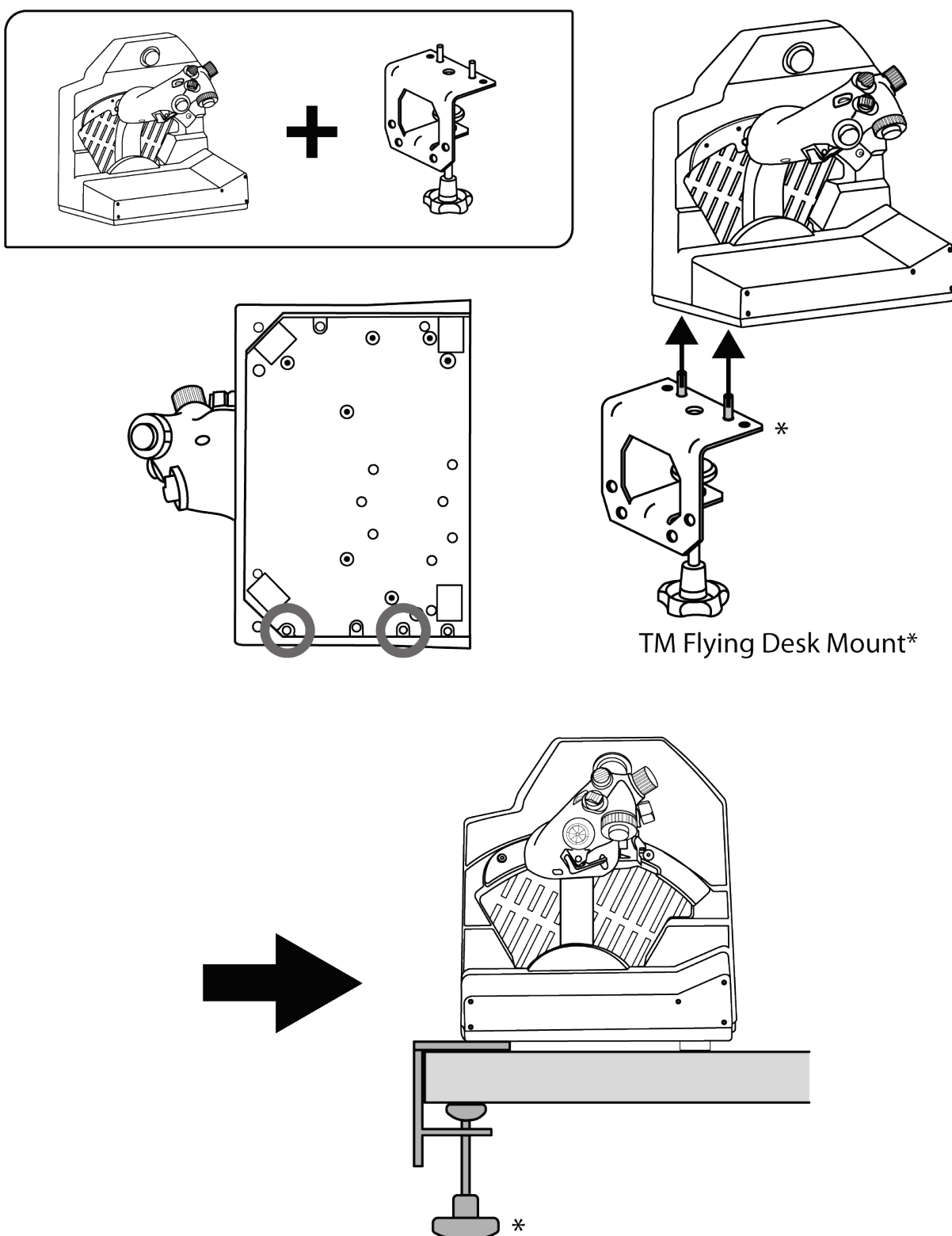

**Sold separately*



Installation using TM Flying Clamp*

TM Flying Clamp is a height-adjustable support designed by Thrustmaster for its flight simulation accessories. This mounting system features two clamping screws allowing it to be adjusted for use with desks and tables from 0.6–1.8 inches / 15–45 mm thick.

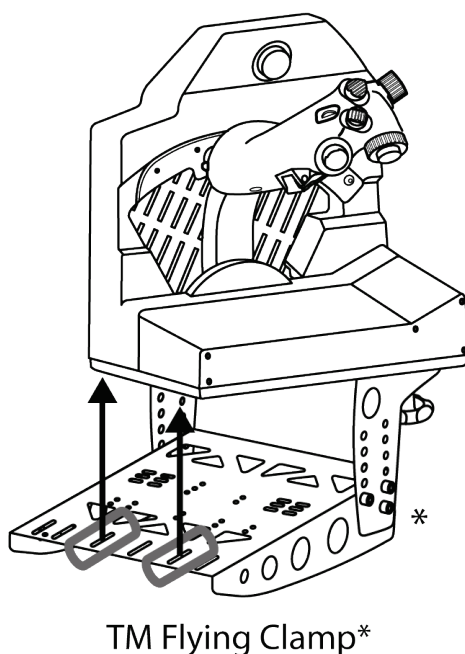
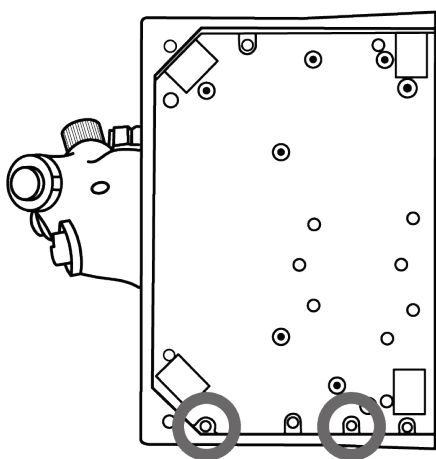
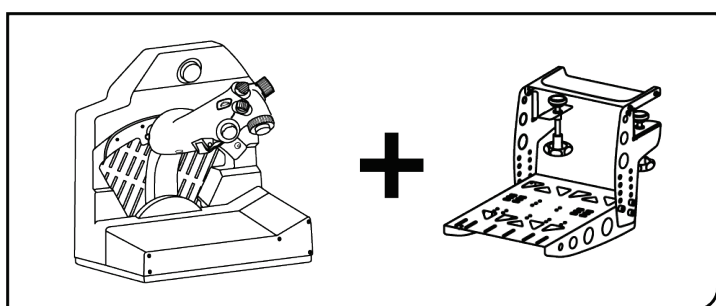

TM Flying Clamp*

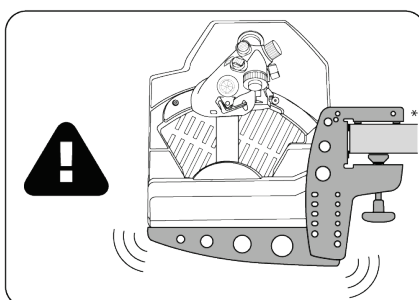
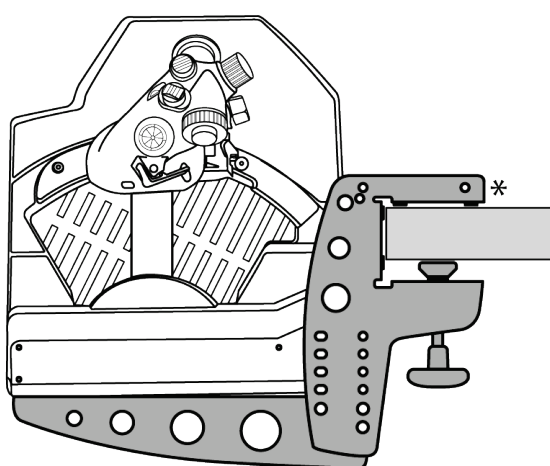
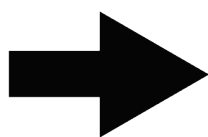

*Sold separately



Please note that the heavy weight of VIPER TQS may result in unwanted movements of the mounting system.



7. Installing VIPER PANEL*

**Sold separately. VIPER PANEL is included with VIPER TQS Mission Pack.*

VIPER PANEL is a control panel that lets you expand your flight/combat capabilities with a total of 43 buttons and 1 axis — all of which are programmable via the T.A.R.G.E.T software. VIPER PANEL is a complement to VIPER TQS.

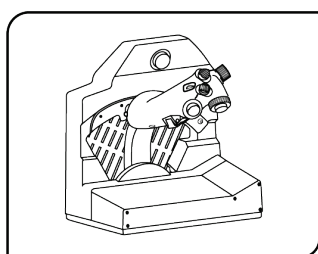

1

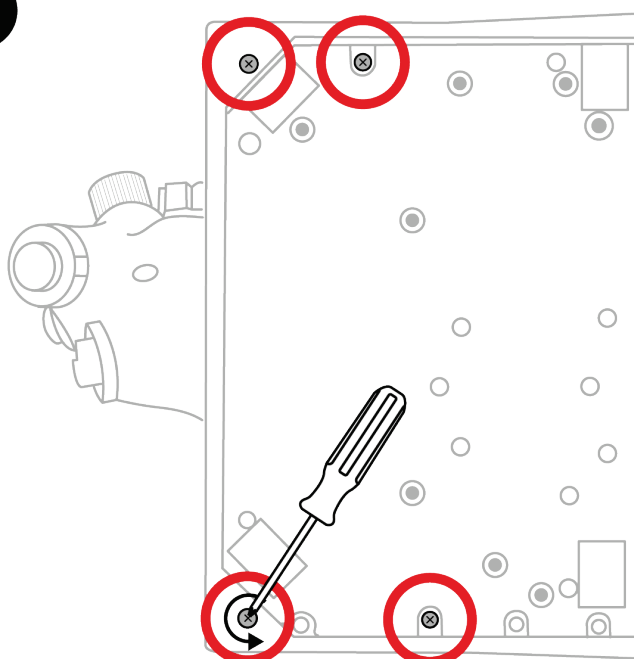

2

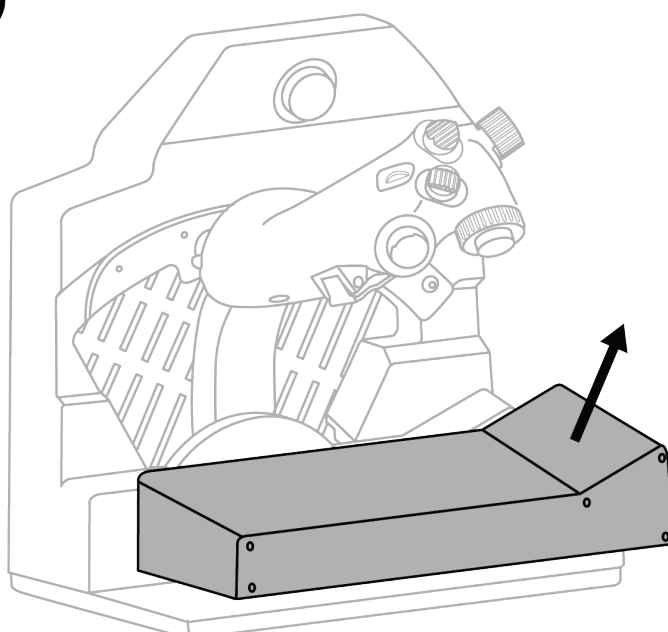

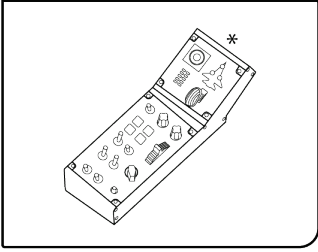

3

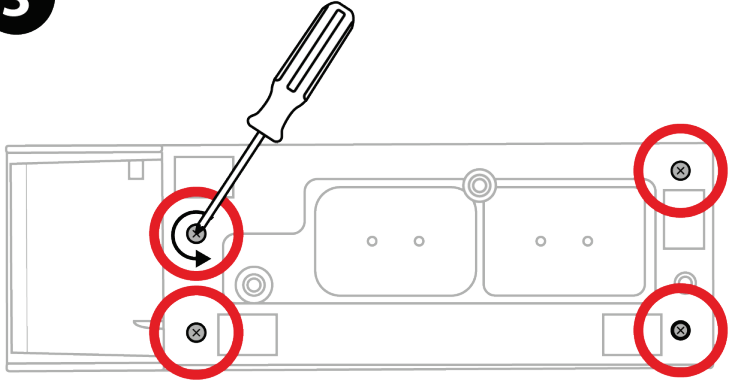

4

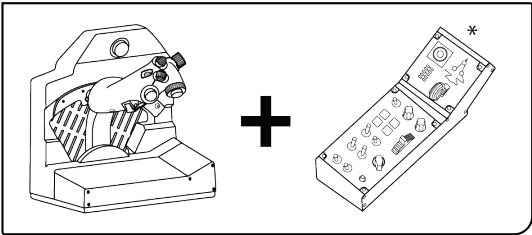
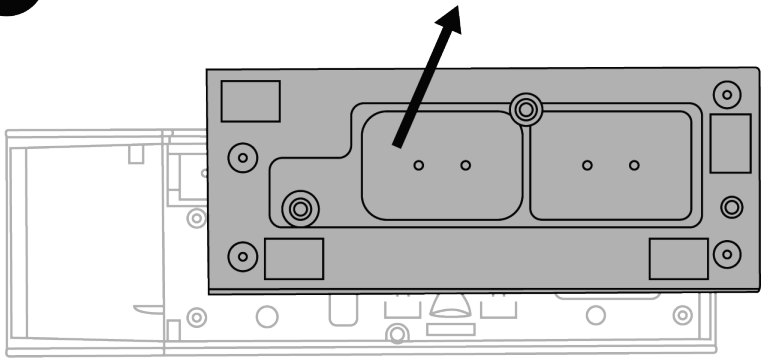

5

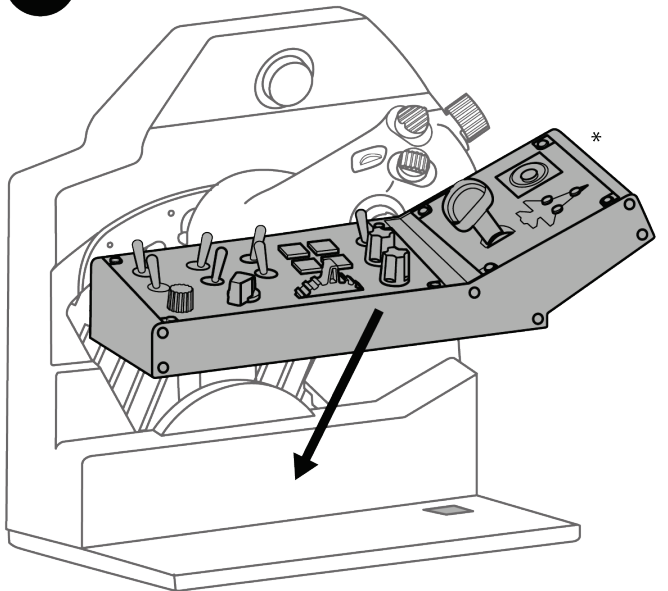



6

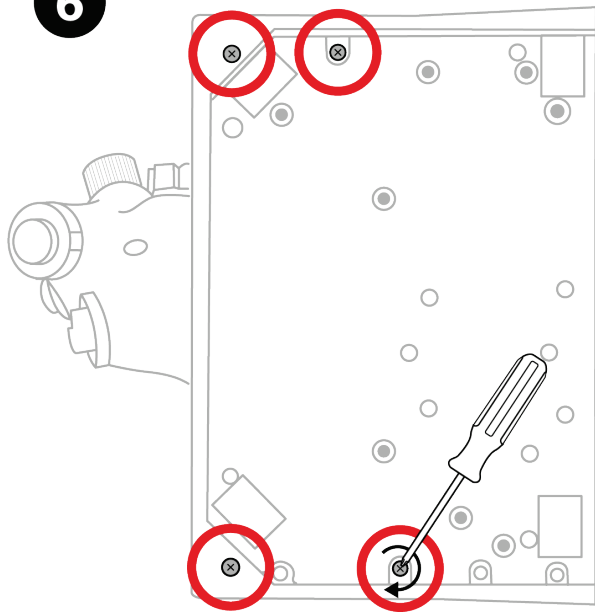

7

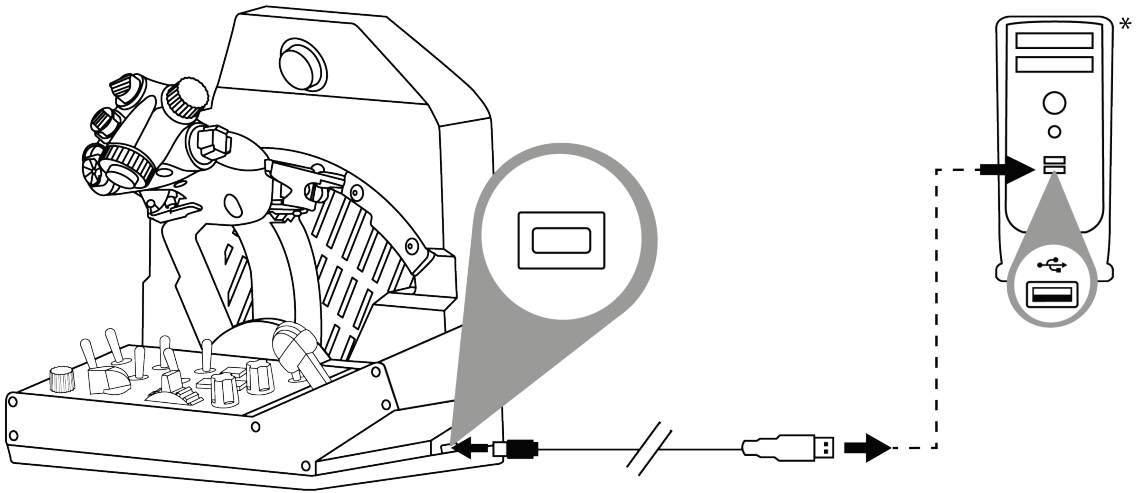

**Not included*



8. Installation on PC

1



Please visit

<https://support.thrustmaster.com/product/viper-tqs/>.

2

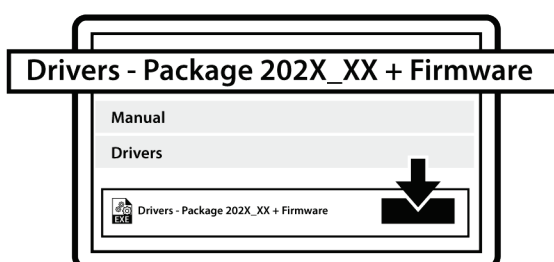

Download and install the PC driver and its customized interface for the Windows Control Panel.

3

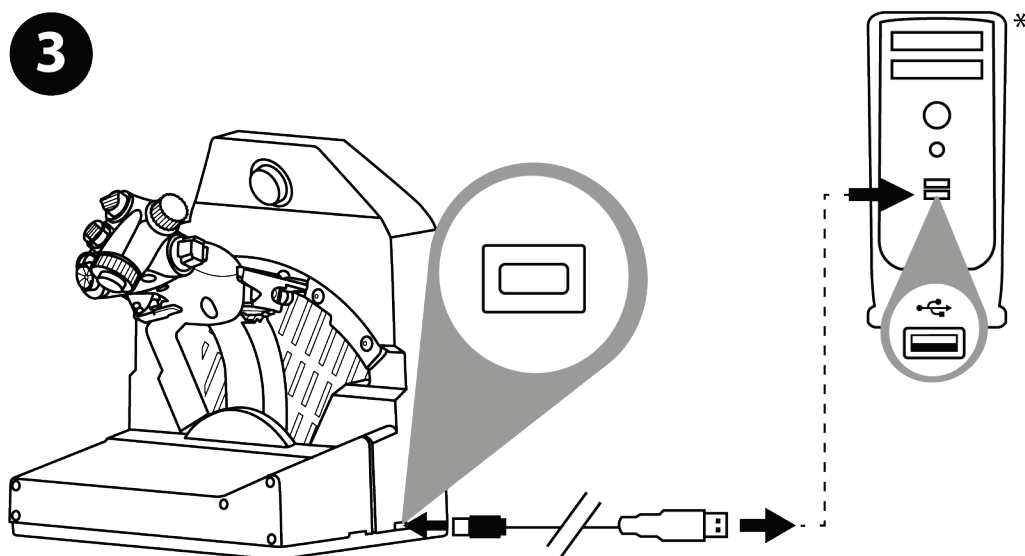

Once the PC driver has been installed, connect the USB connector to one of your PC's USB ports.

**Not included*



④ To access the Control Panel, select **Start / All apps / Thrustmaster / Control Panel** or **Control Panel** (in Windows 10).

The **Game Controllers** dialog box is displayed. The accessory appears onscreen with the name **VIPER TQS** and **OK** status.

⑤ In the **Game Controllers** dialog box, click **Properties** to test and view all functions.

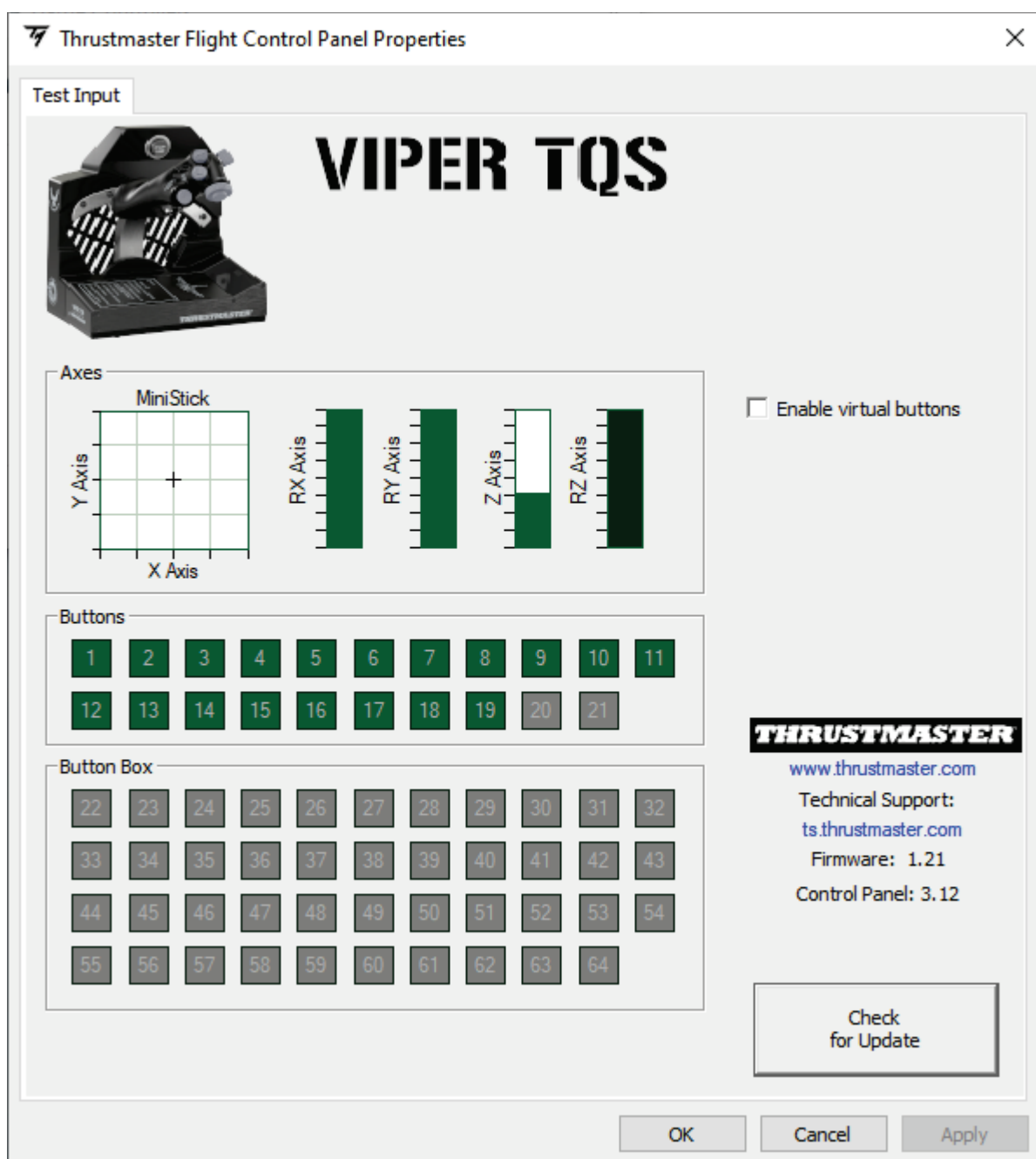



Enable virtual buttons (Enable virtual buttons):

This function lets you enable or disable the virtual buttons on the handle (buttons 20 and 21). Click **Apply** (Apply) once you have selected the mode that you want to use.

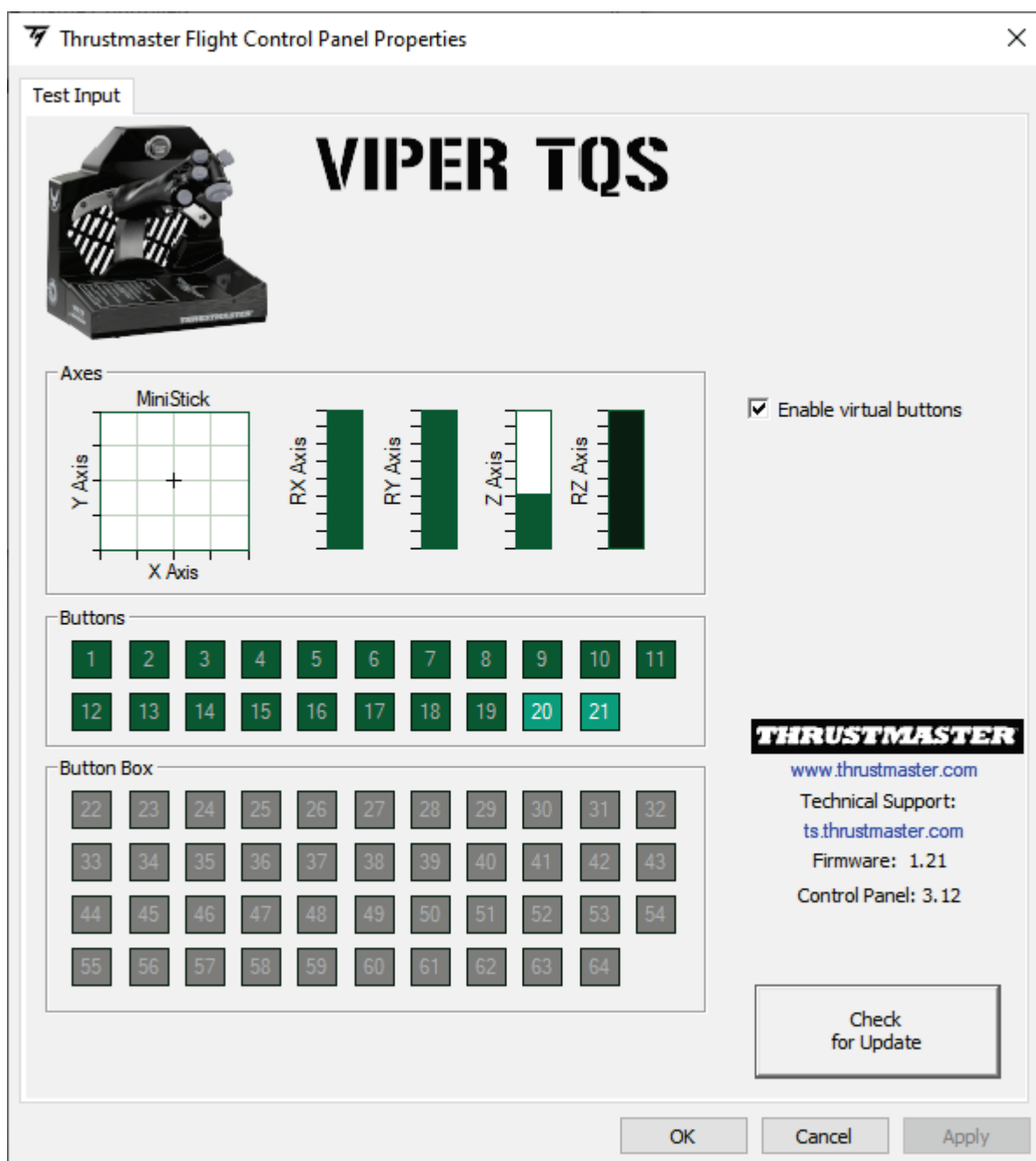

The virtual buttons are disabled by default on VIPER TQS.



9. CUT OFF and AFTERBURNER detents

The VIPER TQS throttle quadrant features a realistic system of CUT OFF and AFTERBURNER detents (the Afterburner module is removable).

CUT OFF

After having positioned the throttle at the IDLE stop, press the “engine cut-off unlocking” trigger **1** to lift up the handle in order to get over the stop **2**, then put the handle in the OFF position **3**.

To turn the engines back on, carry out this procedure in reverse.

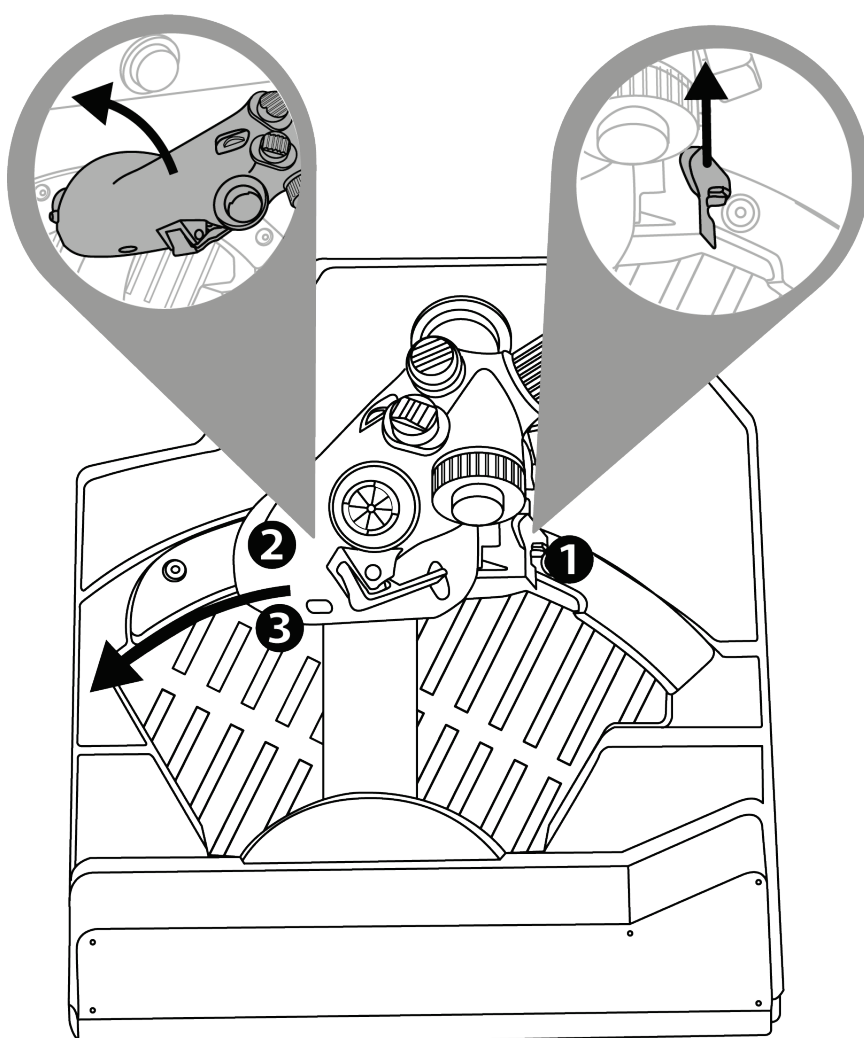



AFTERBURNER

Move the throttle to the stop **1** and lift it up **2** in order to get over the stop and engage the afterburner **3**.

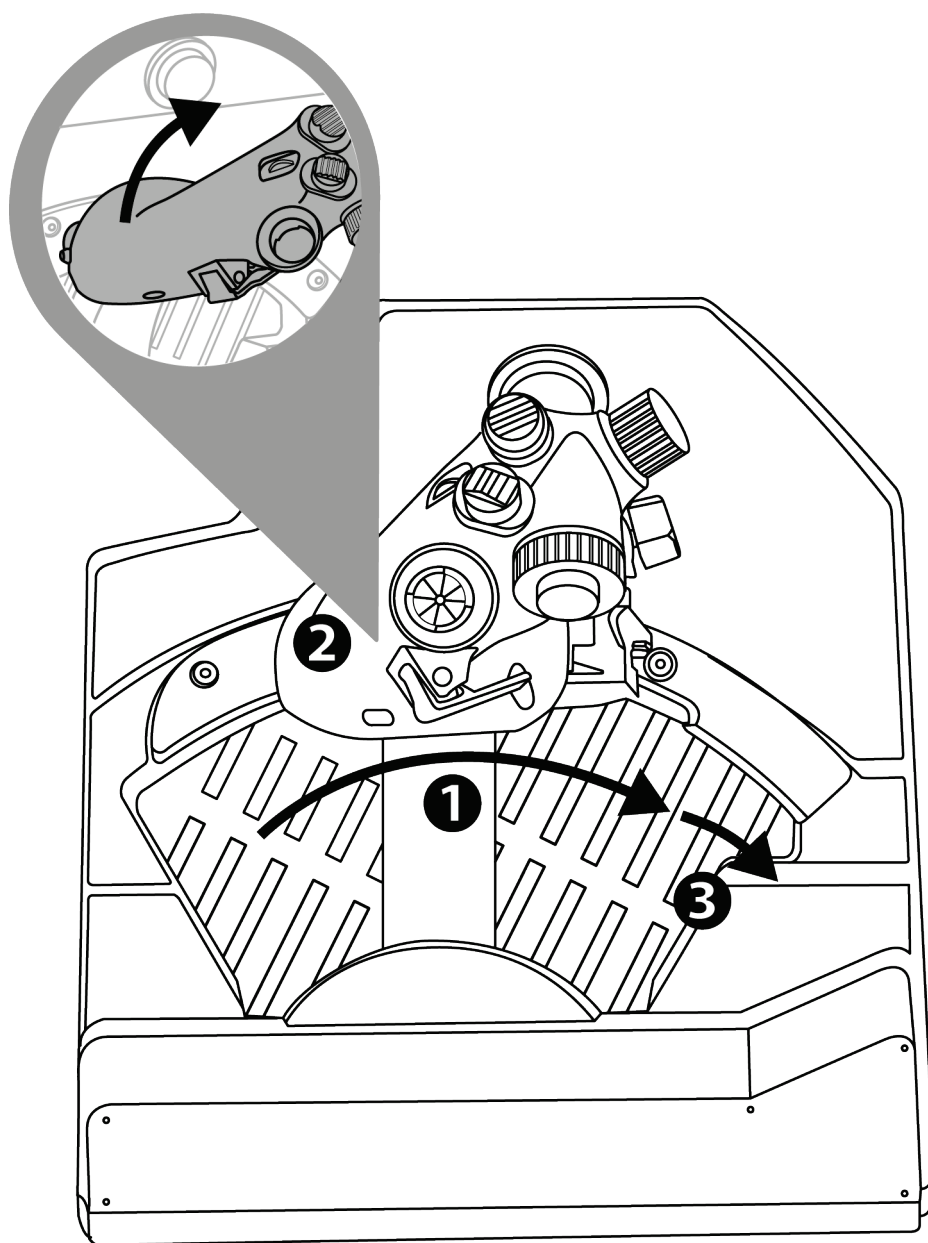



Uninstalling the AFTERBURNER stop

The stop of the Afterburner module is positioned at 80% of the value of the axis.

If you need 100% of the throttle's travel without a stop (for a particular simulator), you can remove the Afterburner module and its stop by unscrewing the module's two screws using an Allen key (not included).

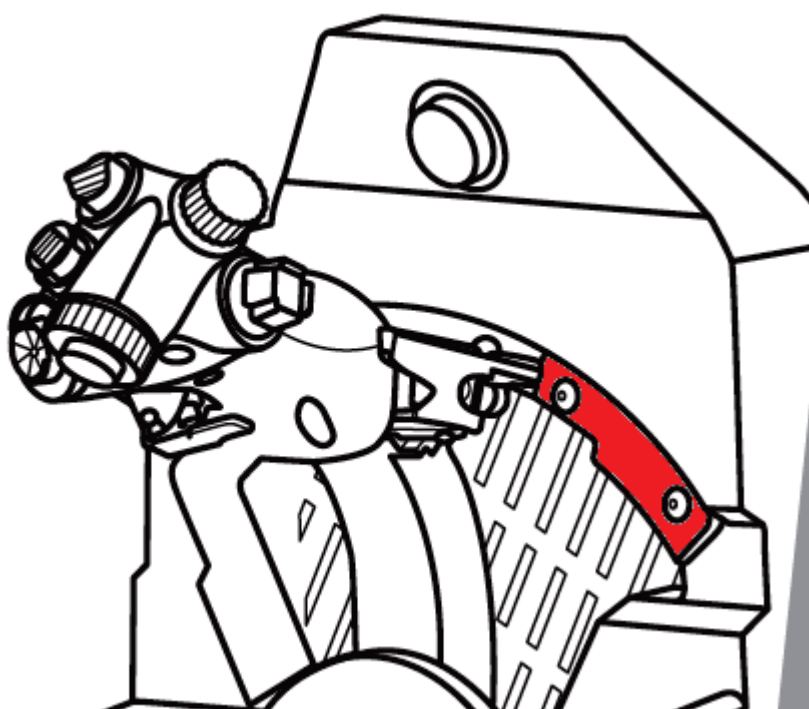



10. T.A.R.G.E.T advanced programming software



Please visit

<https://support.thrustmaster.com/product/viper-tqs/>.

In the **Software** section, download and install the T.A.R.G.E.T advanced programming software.



Main features of T.A.R.G.E.T

- Different possible configurations for the axes.
- Different possible programming levels: Basic, Advanced and Script.
- Use of the Drag and Drop principle.
- Ability to combine the VIPER TQS throttle quadrant with various Thrustmaster joysticks (HOTAS Cougar, HOTAS Warthog, T.16000M, MFD Cougar Pack, all of which are also compatible with T.A.R.G.E.T), allowing them to be recognized as a single USB device.
- Access to advanced profiles created by the Thrustmaster community.



11. FAQ and technical support

Do you have questions regarding VIPER TQS, or are you experiencing technical problems? If so, visit the Thrustmaster technical support website:

<https://support.thrustmaster.com/product/viper-tqs/>.



THRUSTMASTER®

VIPER TQS

THROTTLE QUADRANT SYSTEM

Pour PC (Windows 10/11)

Manuel de l'utilisateur



Lisez attentivement les instructions fournies dans ce manuel **avant** d'installer le produit, **avant** toute utilisation et **avant** tout entretien. Conformez-vous aux consignes de sécurité. Le non-respect de ces instructions peut causer des accidents et/ou des dommages. Conservez ce manuel pour toute consultation ultérieure des instructions.

TABLE DES MATIÈRES

1.	CONTENU DE LA BOÎTE.....	5
2.	CARACTÉRISTIQUES DE LA TQS	6
3.	MAPPING DES BOUTONS ET DES AXES ..	8
5.	INFORMATIONS LIÉES À L'UTILISATION DE LA TQS	10
6.	AJUSTEMENT DE LA FRICTION	11
7.	INSTALLATION SUR UN SUPPORT.....	12
8.	INSTALLATION DU VIPER PANEL*	17
9.	INSTALLATION SUR PC.....	20
10.	DÉTENTE CUTOFF ET AFTERBURNER.....	23
11.	LOGICIEL DE PROGRAMMATION AVANCÉE T.A.R.G.E.T	26
12.	FAQ ET SUPPORT TECHNIQUE	28



Faites rugir votre moteur et montez dans la zone de danger avec l'emblématique poignée du VIPER de l'U.S. Air Force, le chasseur à réaction moderne le plus utilisé au monde !

Passez votre cockpit au niveau supérieur avec l'ergonomie unique d'une réplique HOTAS à l'échelle 1/1 dotée d'une poignée en métal et de boutons et détentes réalistes.

Ce manuel va vous aider à installer et utiliser dans les meilleures conditions votre VIPER TQS. Avant de décoller, lisez attentivement les instructions et les avertissements, ils vous aideront à tirer le maximum de plaisir de votre produit.



Mise à jour du firmware

Pour que la VIPER TQS fonctionne correctement avec les jeux vidéo, il est impératif de mettre à jour le firmware.

Pour effectuer la mise à jour, allez sur

<https://support.thrustmaster.com/product/viper-tqs>

Sélectionnez **Firmware** et suivez les instructions et la procédure de téléchargement et d'installation.



1. Contenu de la boîte

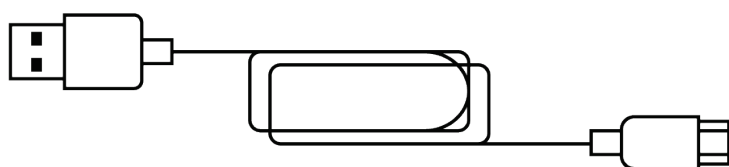
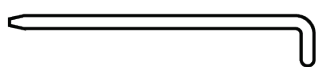
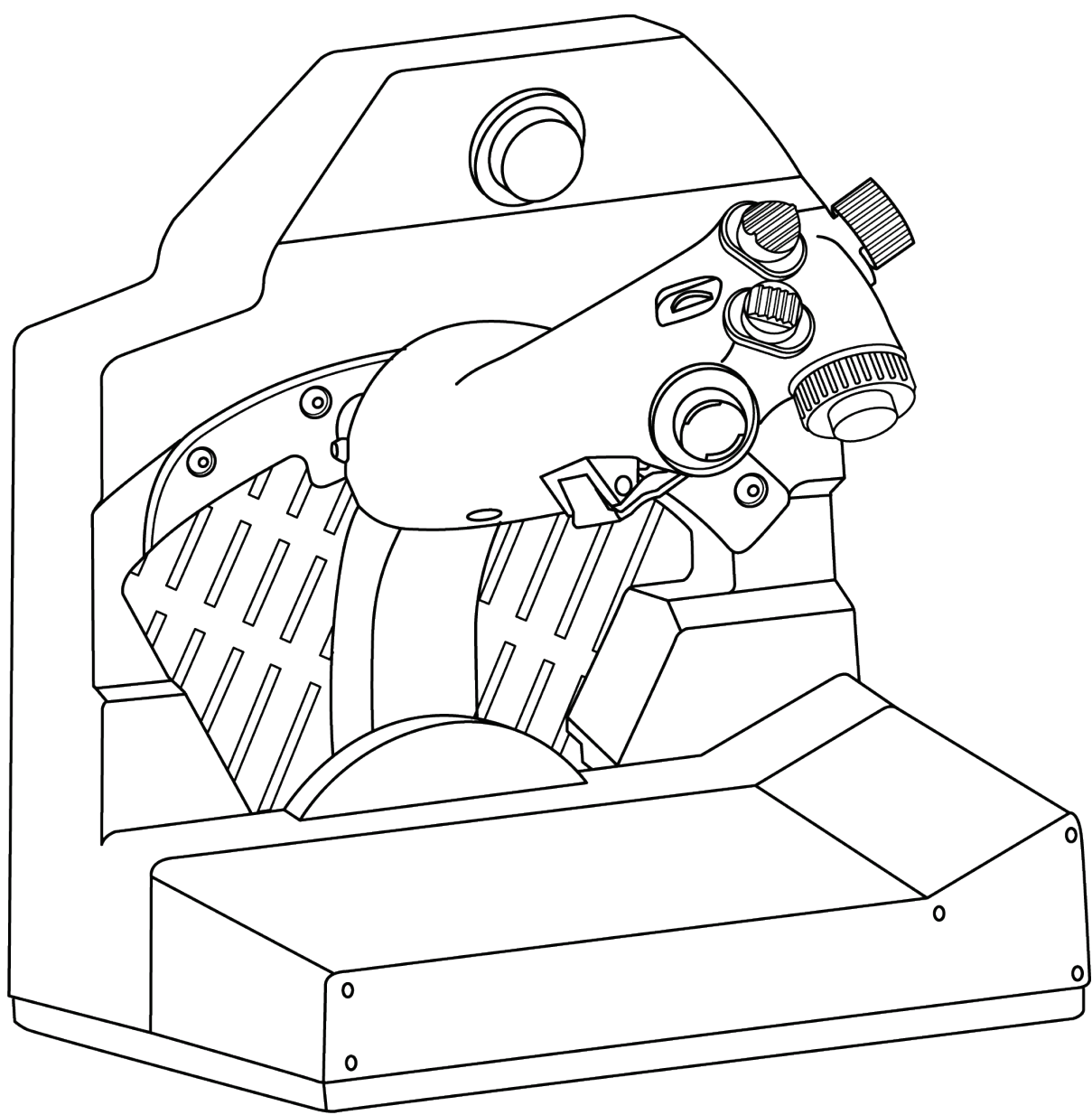



2. Caractéristiques de la TQS

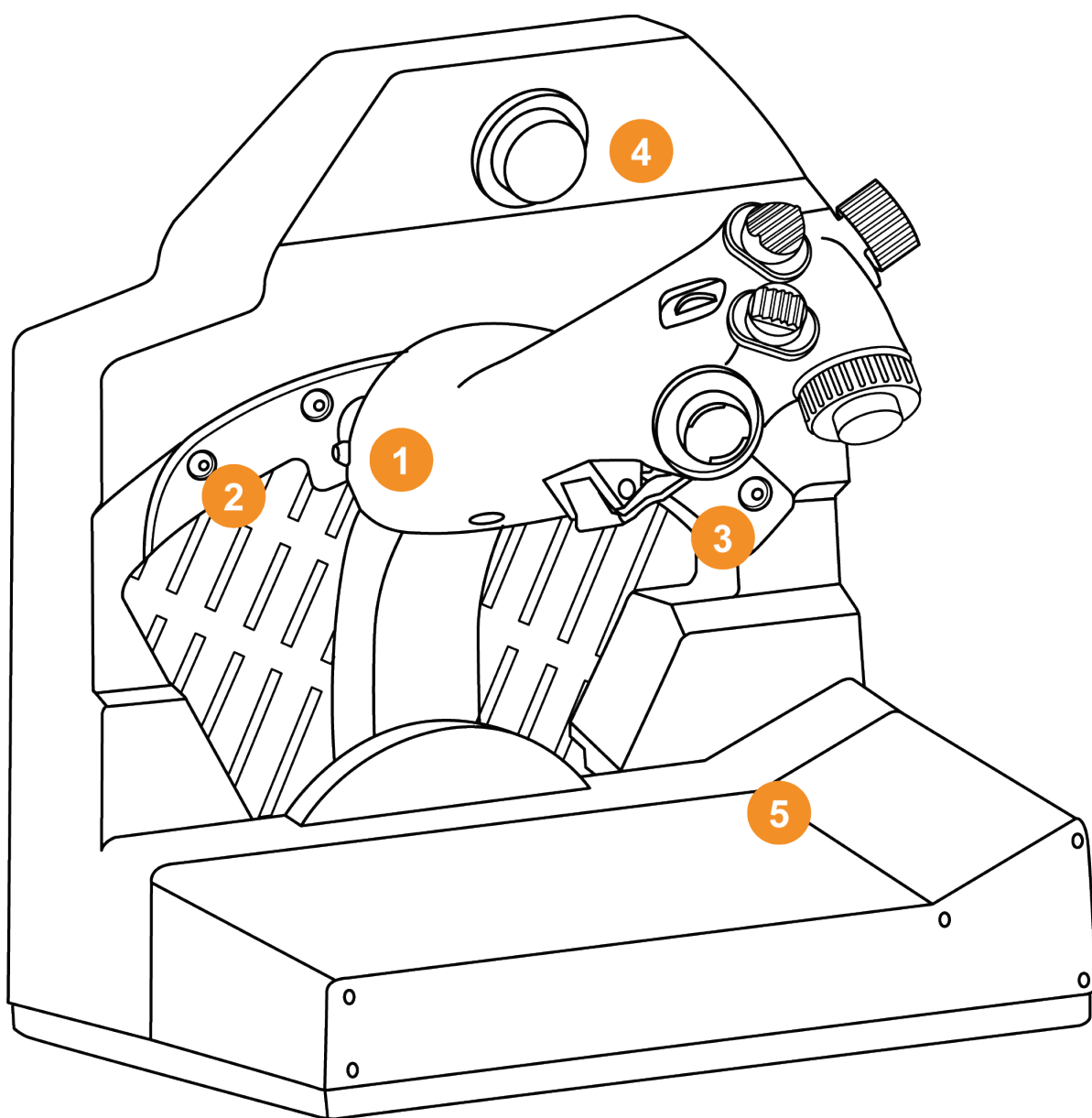

1. Poignée

2. Butée Cut off

3. Butée Afterburner

4. Bouton Chaff flare

5. Pince pour carte de mission

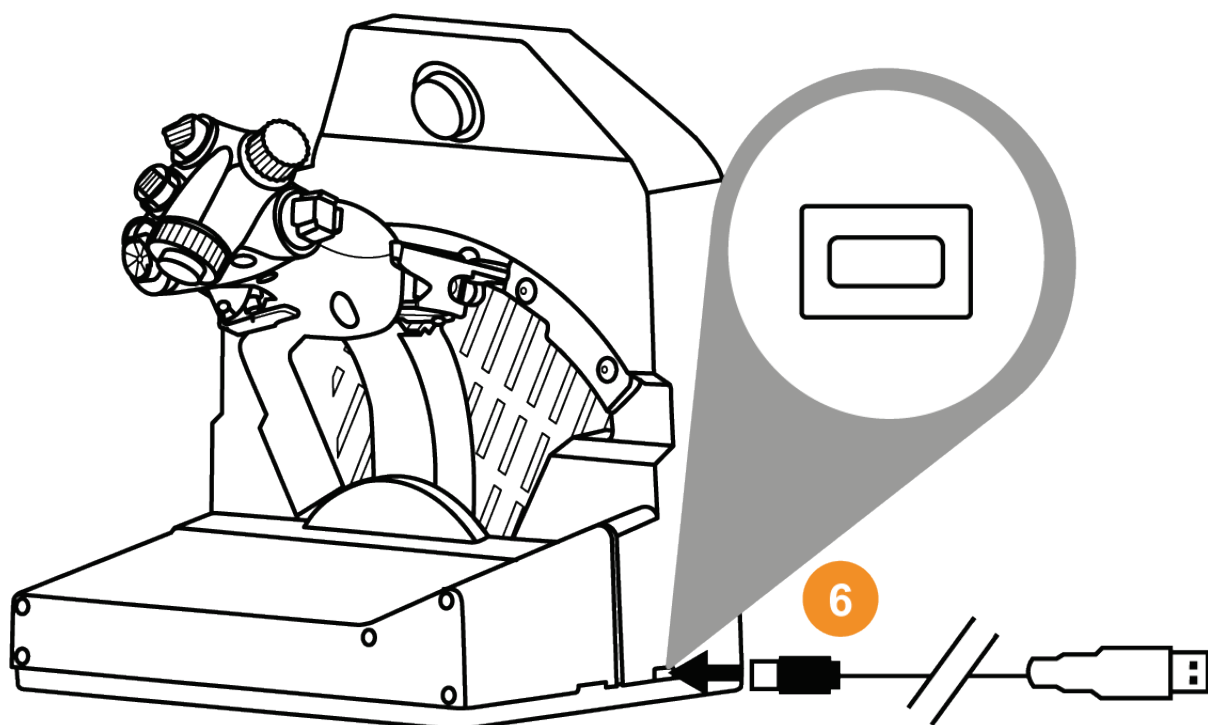

6. Connecteur USB type C

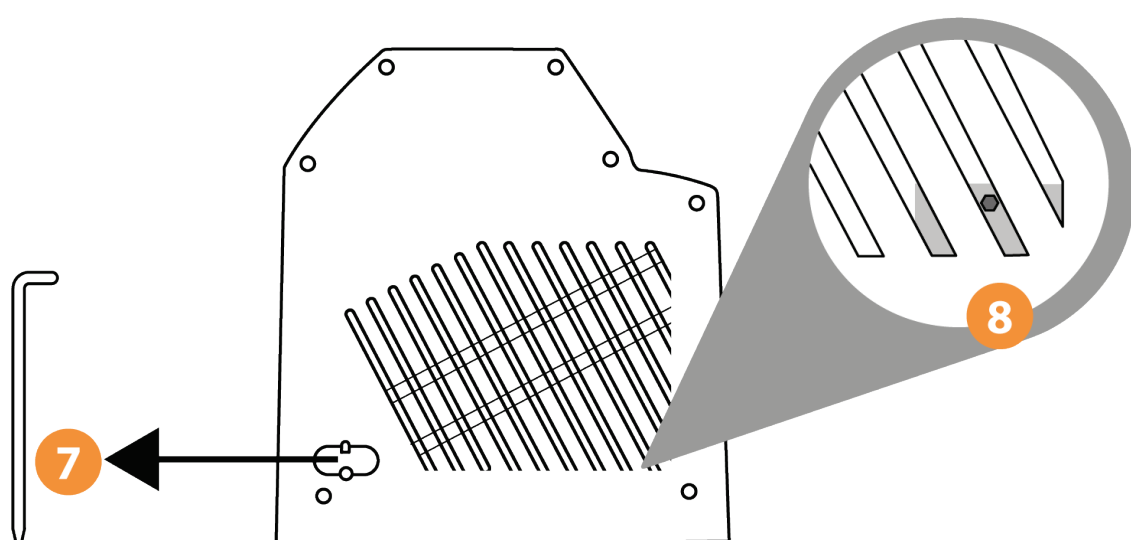

7. Emplacement outil pour ajustement friction

8. Accès ajustement friction manette



3. Mapping des boutons et des axes

Poignée VIPER TQS : mapping des 19 boutons et 5 axes en mode A (sans boutons virtuels)

A 1 → 19

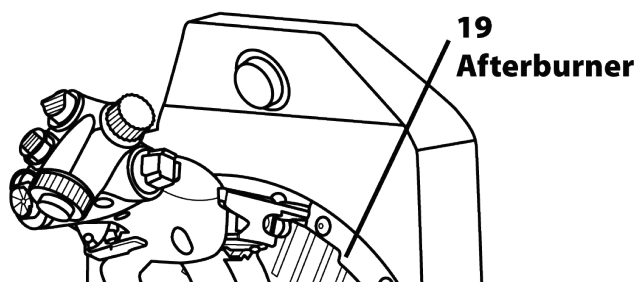
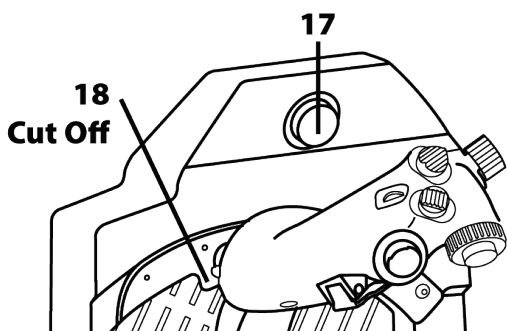
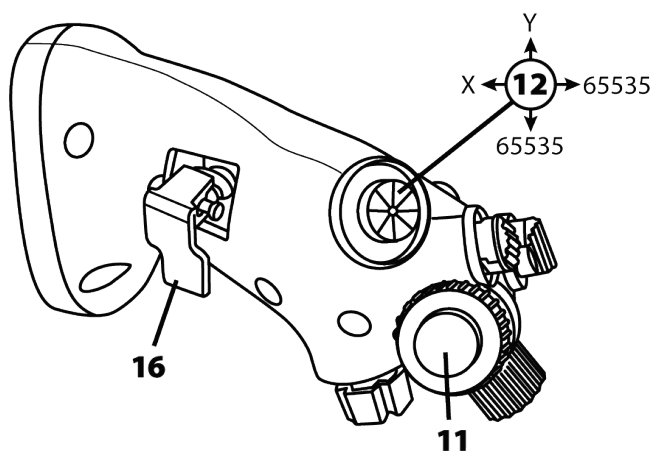
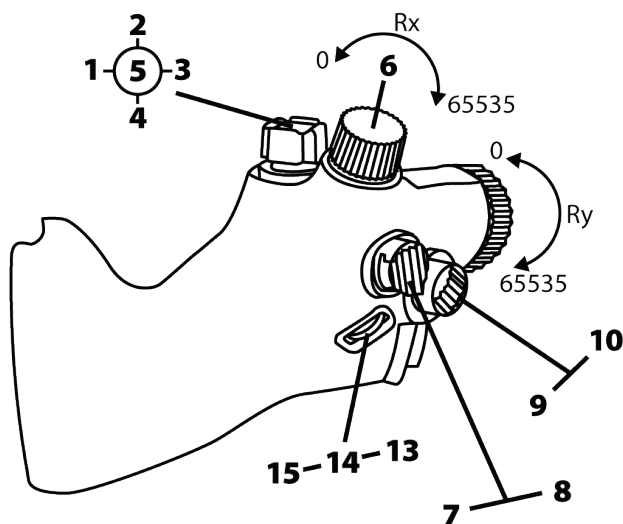



Mode B : avec boutons virtuels

B 1 → 21

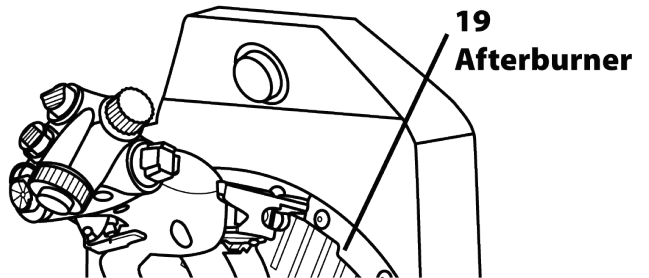
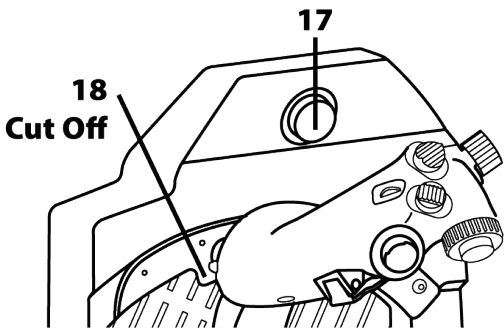
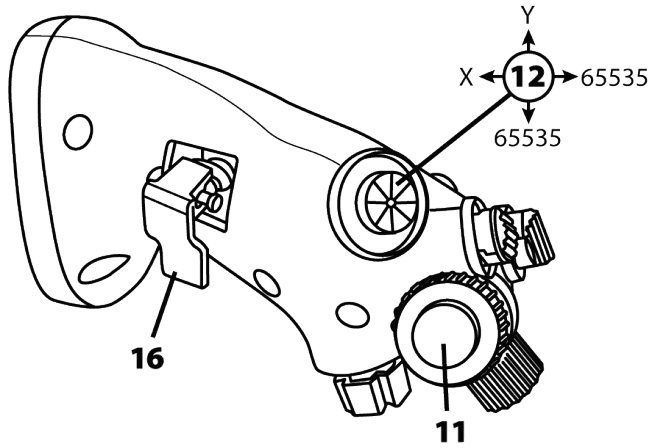
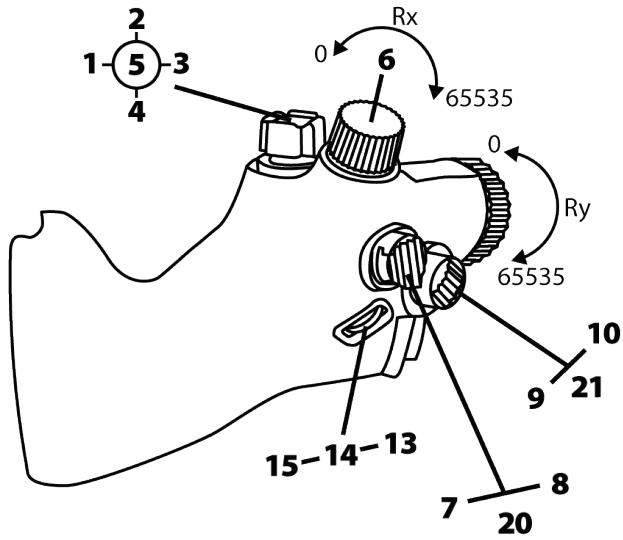



4. Informations liées à l'utilisation de la TQS



Risque de pincement

Ne placez pas vos doigts dans les espaces de butée lorsque vous utilisez la poignée.

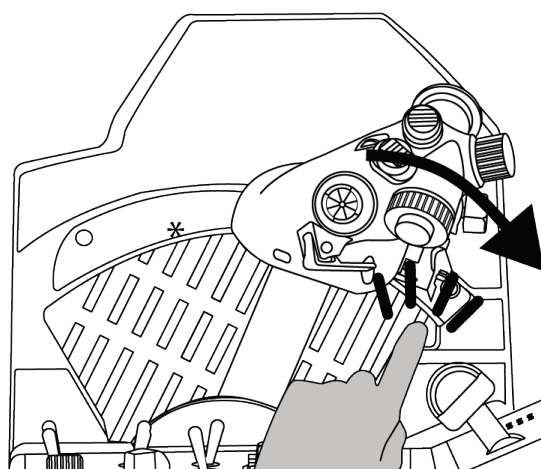
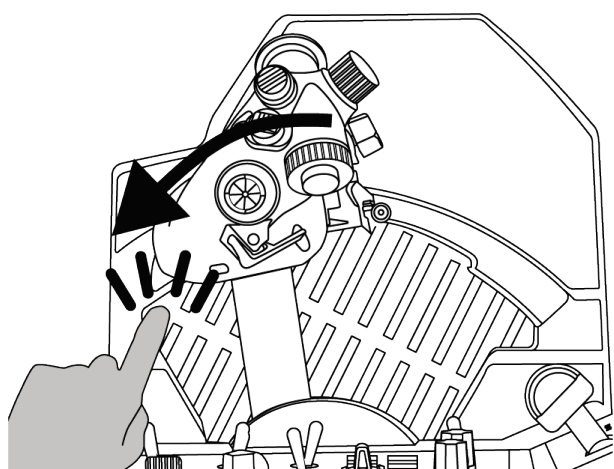
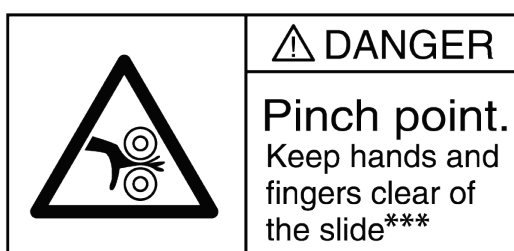



5. Ajustement de la friction

Personnalisez la friction du bloc manette de votre VIPER TQS selon votre convenance en utilisant l'outil inclus sur le côté de la VIPER TQS. Une friction optimale de la manette des gaz est réglée par défaut en usine.

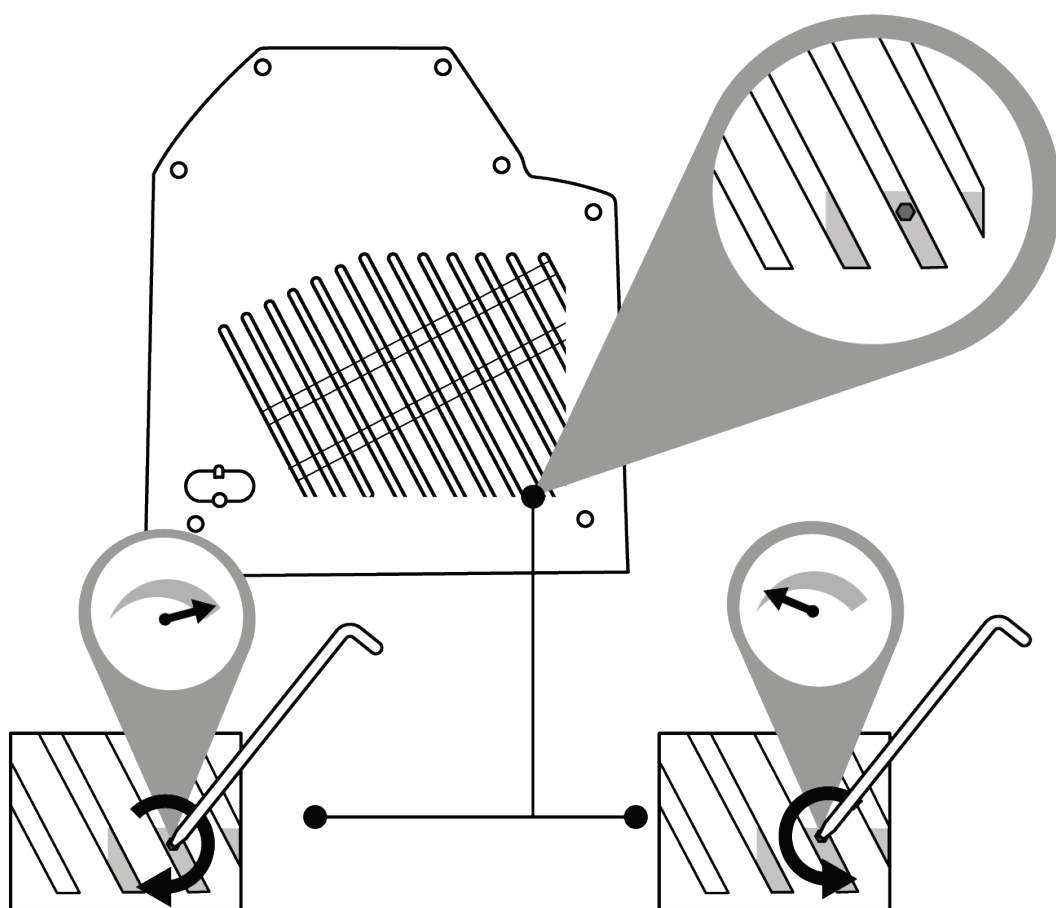

Pour éviter d'endommager le système de friction, ne serrez pas trop fort la vis d'ajustement.

Ne dévissez pas complètement la vis d'ajustement au risque de voir la manette ne plus rester en position.



7. Installation sur un support



Il est possible d'installer la VIPER TQS sur différents types de supports. La plupart des cockpits ou supports disponibles sur le marché sont déjà compatibles avec les produits Thrustmaster similaires (Hotas Warthog).

Gardez en mémoire que la VIPER TQS dispose d'un puissant effet de levier et doit donc être solidement fixée.

Fixez la base sur votre support à l'aide de vis M6 adaptées (non fournies), afin de pas endommager la poignée.

Un plan complet de la VIPER TQS est disponible sur <https://support.thrustmaster.com/product/viper-tqs-mission-pack/>



Avant chaque utilisation, vérifiez que la VIPER TQS est toujours correctement fixée au support, conformément aux instructions spécifiées par le fabricant.

Prenez en compte le matériau de votre support pour vous assurer qu'il est possible d'y monter un produit.

La VIPER TQS doit donc être utilisée sur un bureau composé d'un matériau solide, à savoir du MDF ou du bois, et sans éléments creux ou de verre.



Dimensions du plan de montage (en mm)

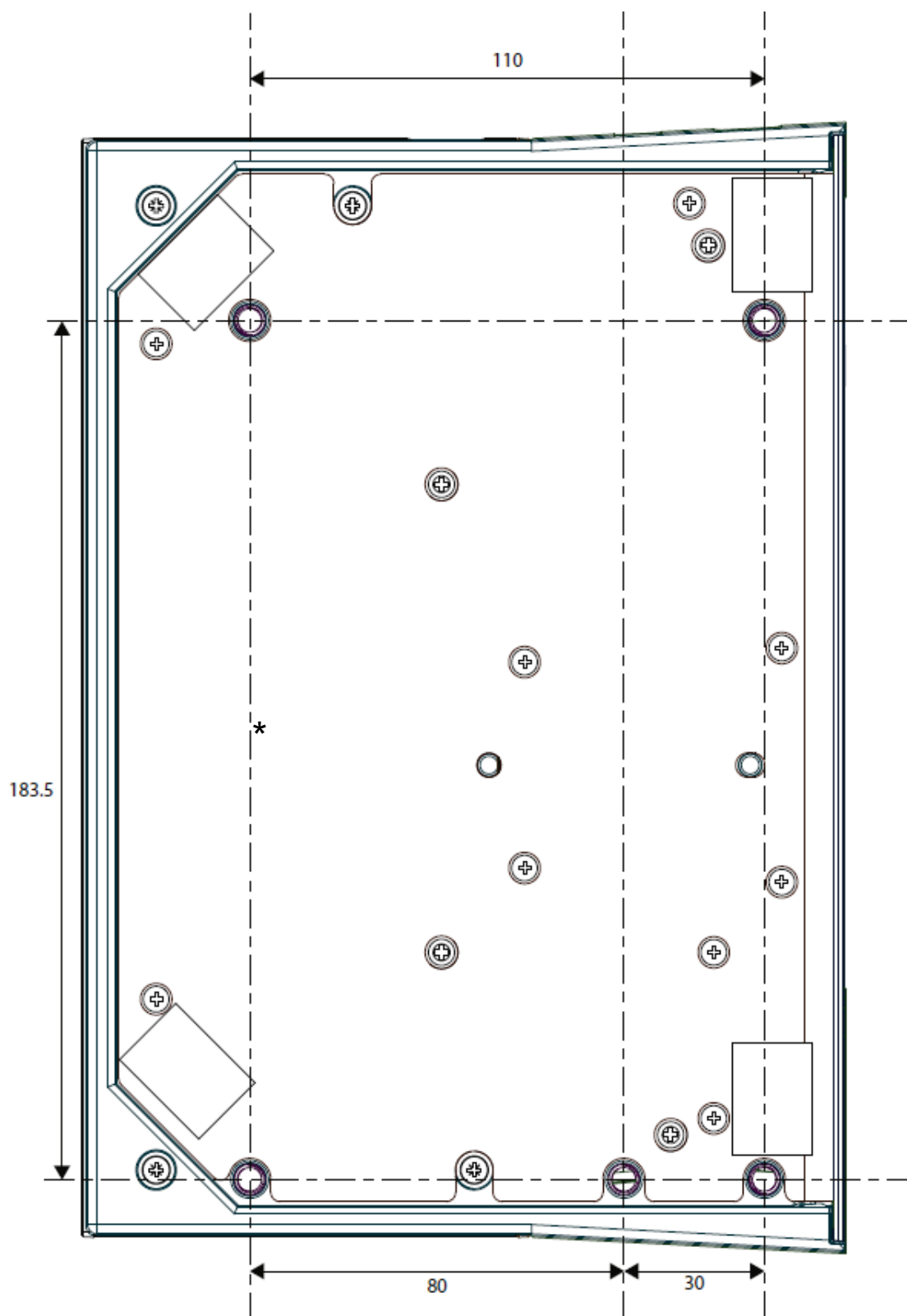

Vous pouvez télécharger le plan de montage depuis <https://support.thrustmaster.com/product/viper-tqs-mission-pack/>, l'imprimer et le reporter sur votre support pour préparer les perçages.



*Installation à l'aide du TM Flying Desk Mount**

Le TM Flying Desk Mount est un système de fixation en métal avec vis de serrage, améliorant l'ergonomie et la position de pilotage lors de l'utilisation de son périphérique. Ce système est conçu pour les bureaux/tables de 15 à 50 mm d'épaisseur.

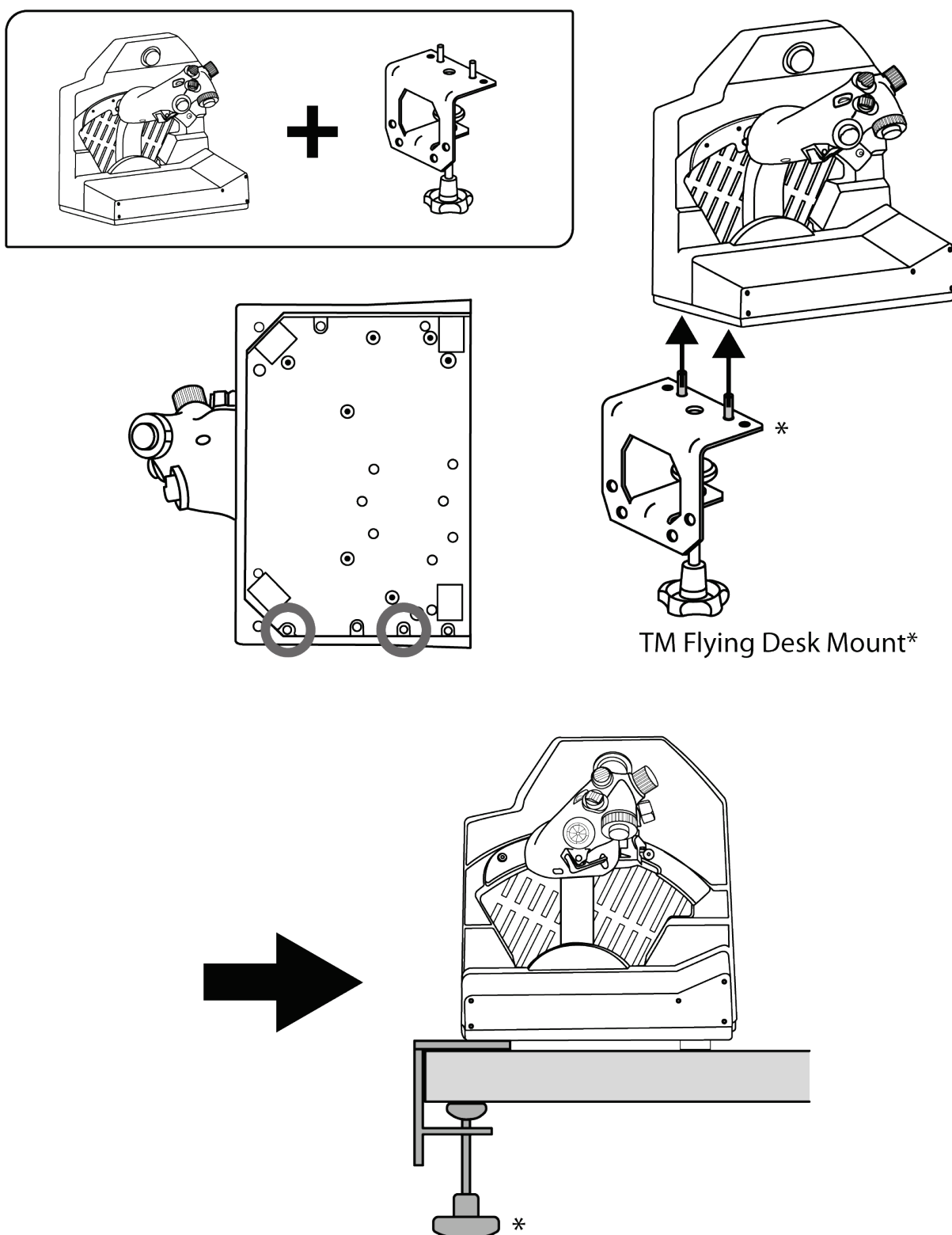

**Vendu séparément*



Installation à l'aide du TM Flying Clamp*

Le TM Flying Clamp est un support réglable en hauteur conçu par Thrustmaster pour ses accessoires de simulation aérienne. Le système de fixation à double molette de serrage permet d'ajuster la prise pour les bureaux/tables de 15 et 45 mm d'épaisseur.

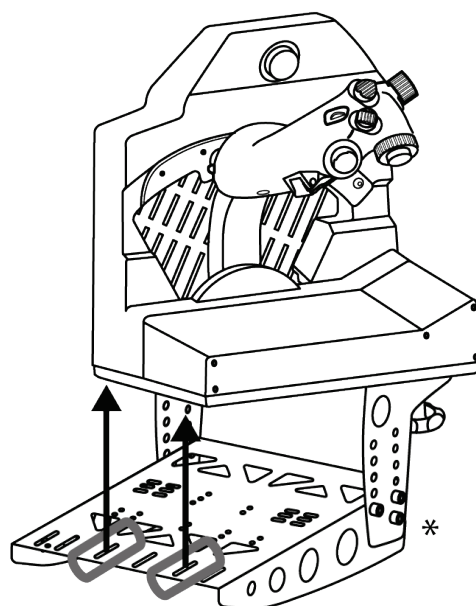
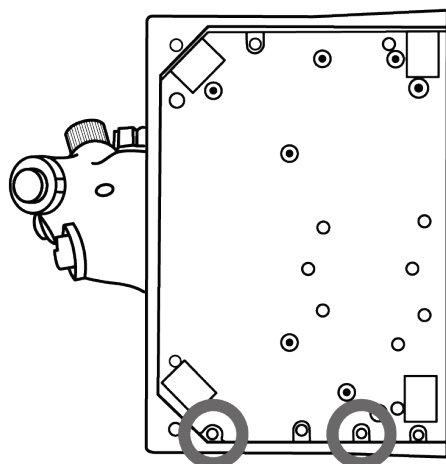
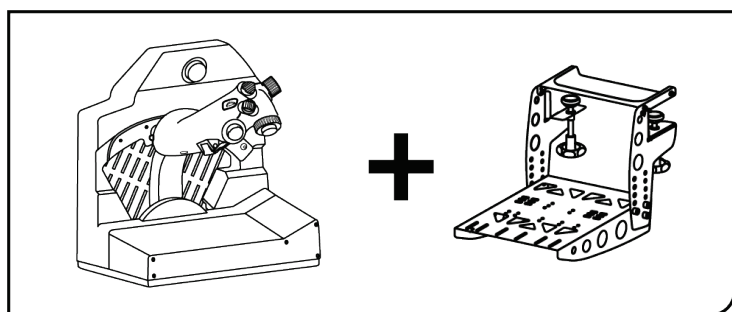

TM Flying Clamp*

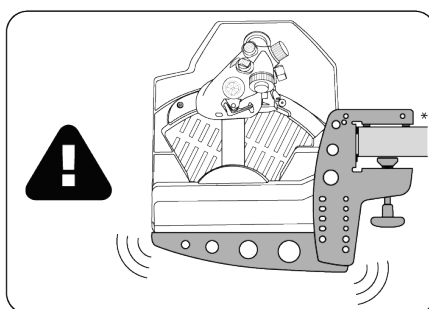
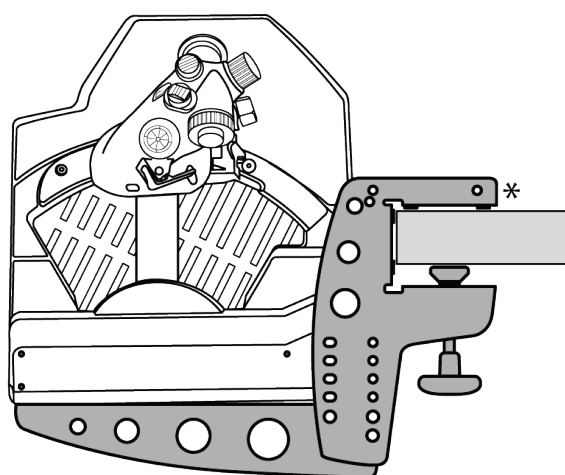
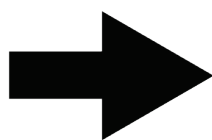

**Vendu séparément*



Le poids élevé de la VIPER TQS peut induire des mouvements parasites du système de fixation.



7. Installation du VIPER PANEL*

**Vendu séparément. Le Viper Panel est inclus avec le VIPER TQS Mission Pack.*

Le VIPER PANEL est un panneau de commandes qui permet d'étendre vos capacités de vol/combat avec un total de 43 boutons et 1 axe programmables via le logiciel T.A.R.G.E.T., qui vient compléter la VIPER TQS.

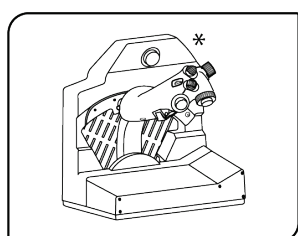

1

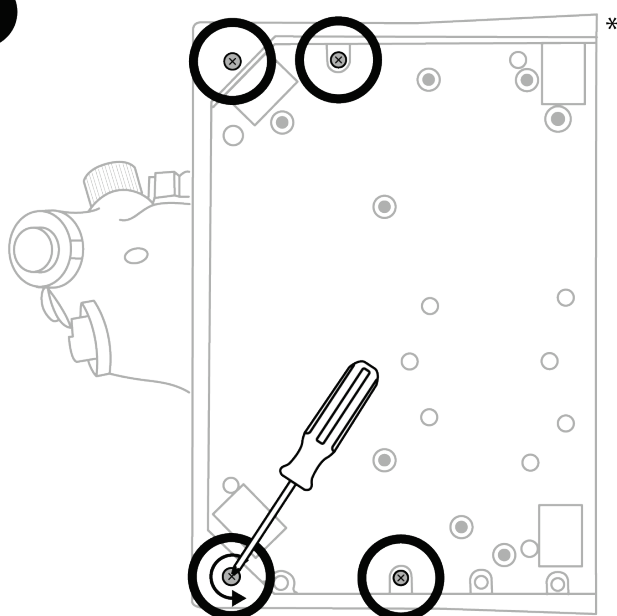

2

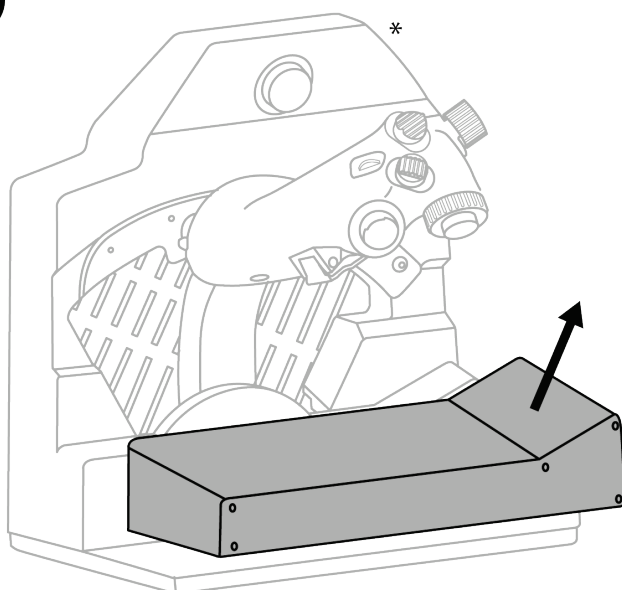

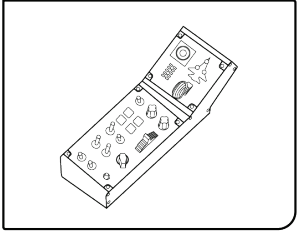

3

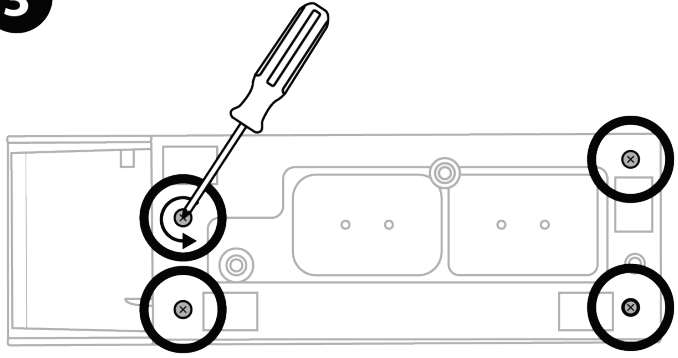

4

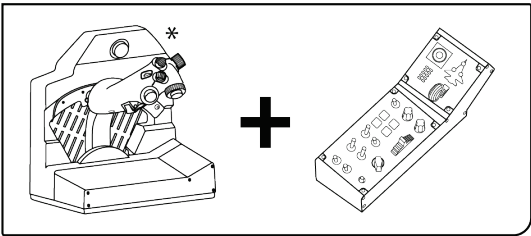
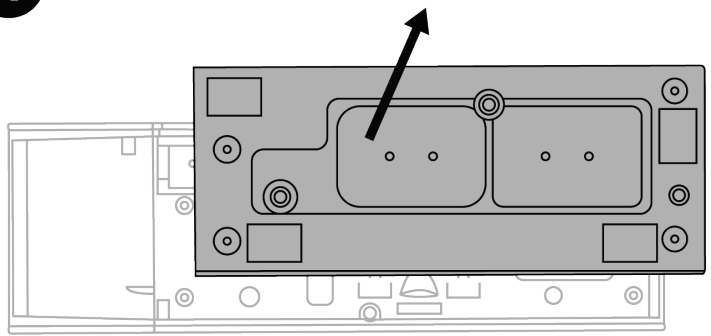

5

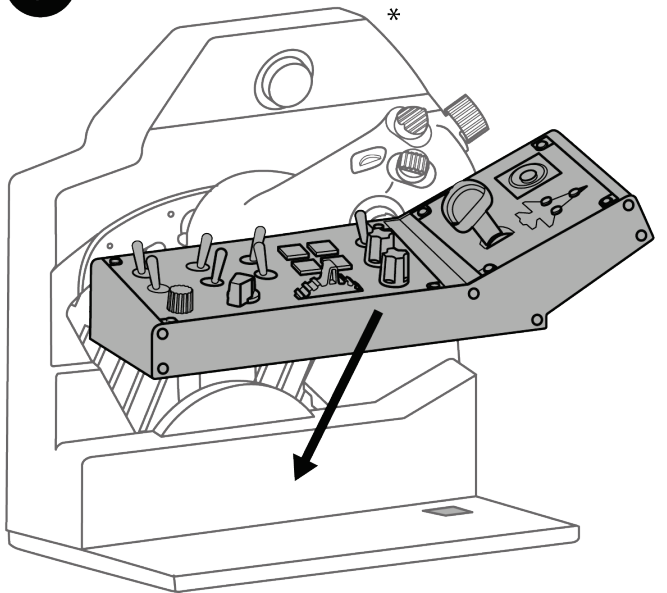

6

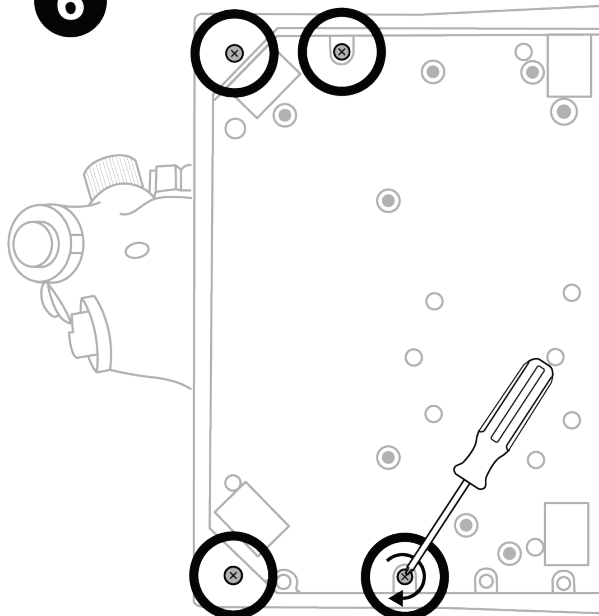



7

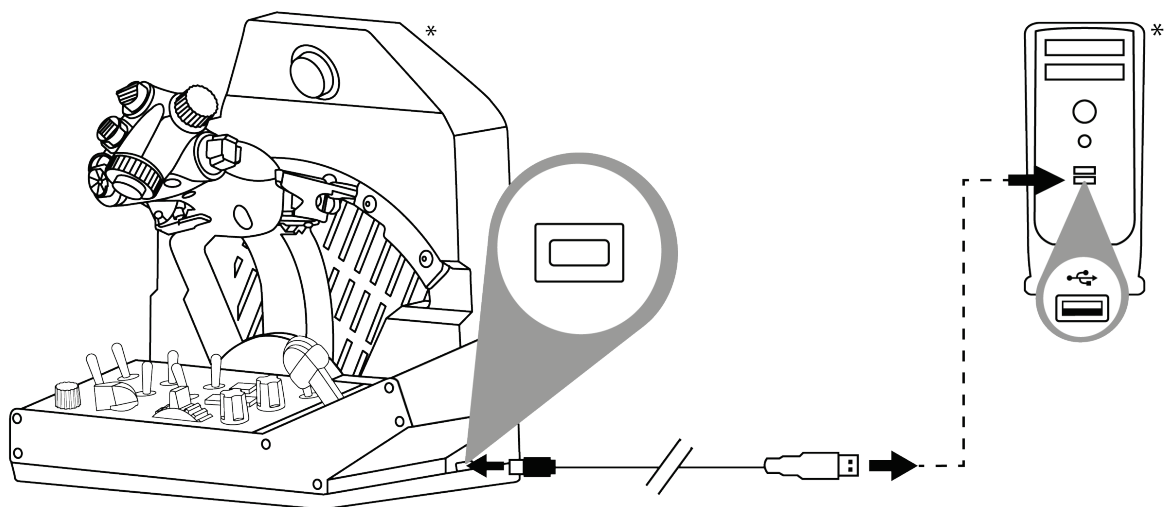

**Non fourni*



8. Installation sur PC

1



Allez sur

<https://support.thrustmaster.com/product/viper-tqs/>.

2

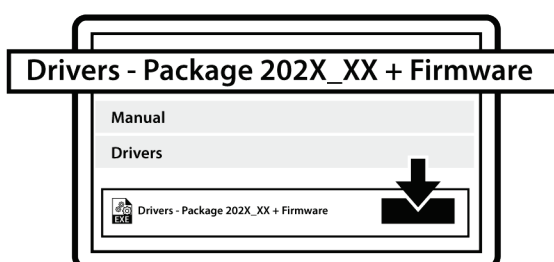

Téléchargez et installez le pilote PC et son Interface personnalisée du Control Panel Windows

3

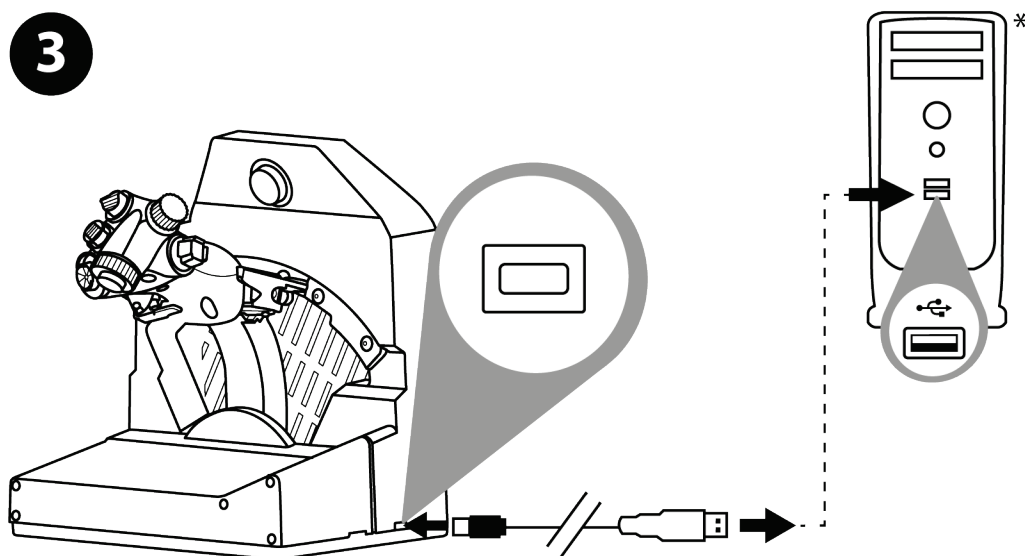

Une fois le pilote PC installé, branchez le connecteur USB sur l'un des ports USB de votre PC.

**Non fourni*



④ Pour accéder au Control Panel, sélectionnez Démarrer / Applications / Thrustmaster / Control Panel ou Panneau de configuration (sous Windows 10).

La boîte de dialogue Contrôleurs de jeu s'affiche. L'accessoire apparaît à l'écran sous le nom **VIPER TQS** et l'état **OK**.

⑤ Dans la boîte de dialogue **Contrôleurs de jeu**, cliquez sur **Propriétés** pour tester et visualiser l'ensemble des fonctions.

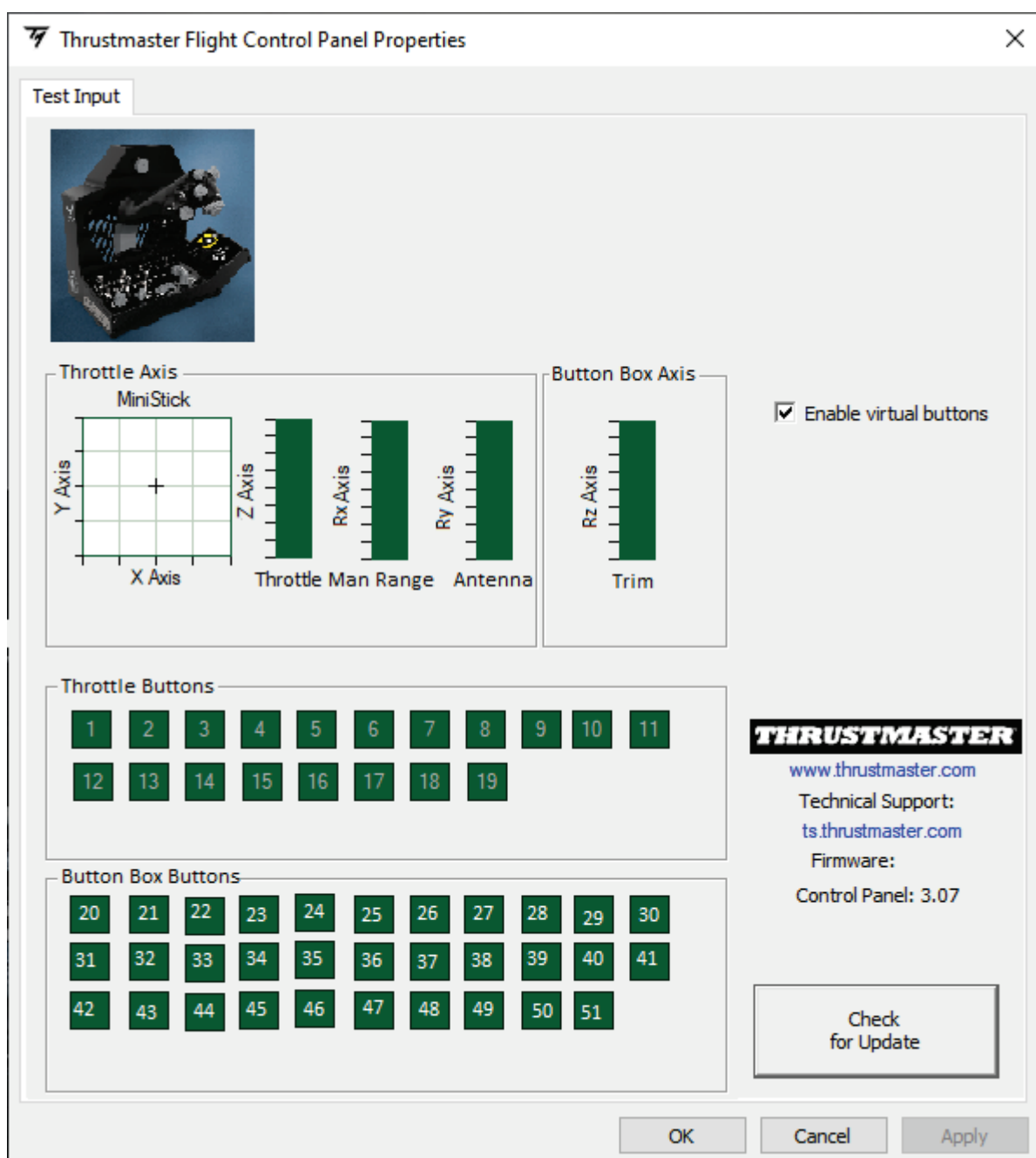



Enable virtual buttons (Activer les boutons virtuels) :

Cette fonction permet d'activer ou de désactiver les boutons virtuels présents sur la poignée (boutons 20 et 21). Cliquez sur Apply (Appliquer) après avoir sélectionné le mode souhaité.



Les boutons virtuels sont désactivés par défaut sur la VIPER TQS.



9. Détente CUTOFF et AFTERBURNER

Le bloc manette VIPER TQS possède un système de détente CUT OFF et AFTERBURNER réaliste (le module Afterburner est amovible).

CUT OFF

Après avoir positionné la manette des gaz sur la butée IDLE, appuyez sur la gâchette "déverrouillage coupure moteur" **1** pour soulever la poignée afin de dépasser la butée **2**, puis ramenez-la en position OFF **3**.

Pour rallumer les moteurs, effectuez la manipulation en sens inverse.

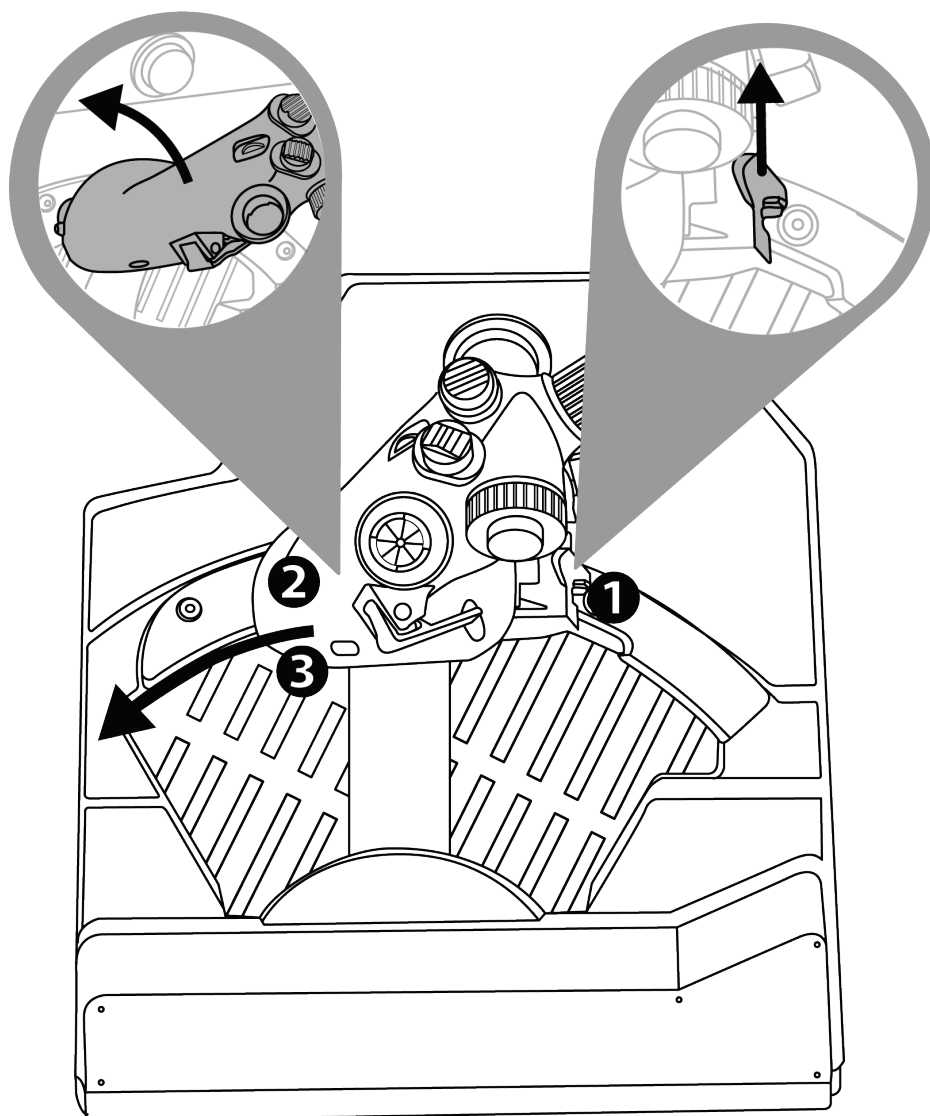



AFTERBURNER

Amenez la manette des gaz à la butée **1** puis soulevez-la **2** afin de dépasser la butée et déclencher la postcombustion **3**.

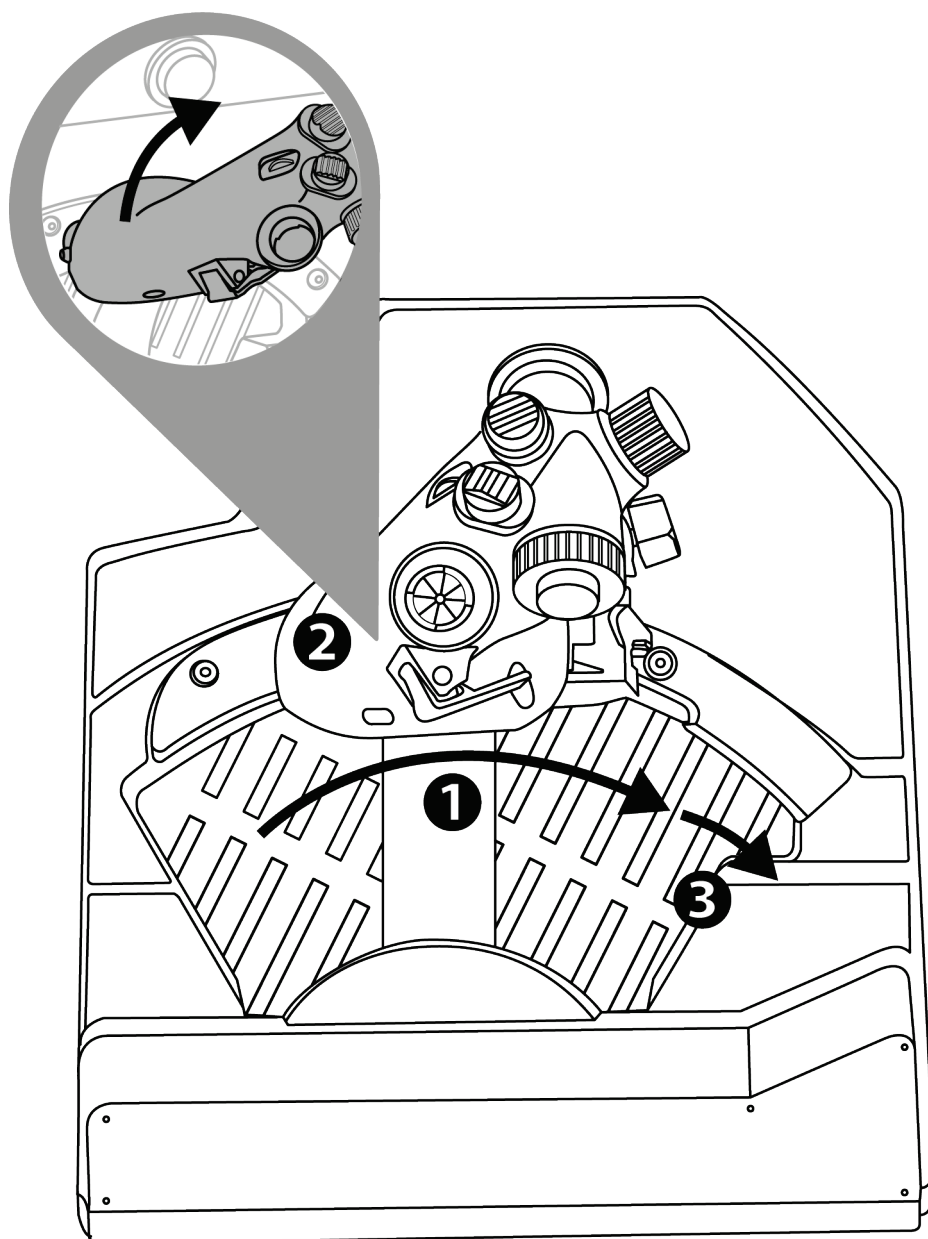



Désinstaller la butée AFTERBURNER

La butée du module Afterburner est positionnée à 80% de la valeur de l'axe.

Si vous avez besoin de 100% de la course de la manette des gaz sans butée pour un simulateur particulier, vous pouvez retirer le module Afterburner et sa butée en dévissant les deux vis du module à l'aide d'une clé Allen (non fournie).

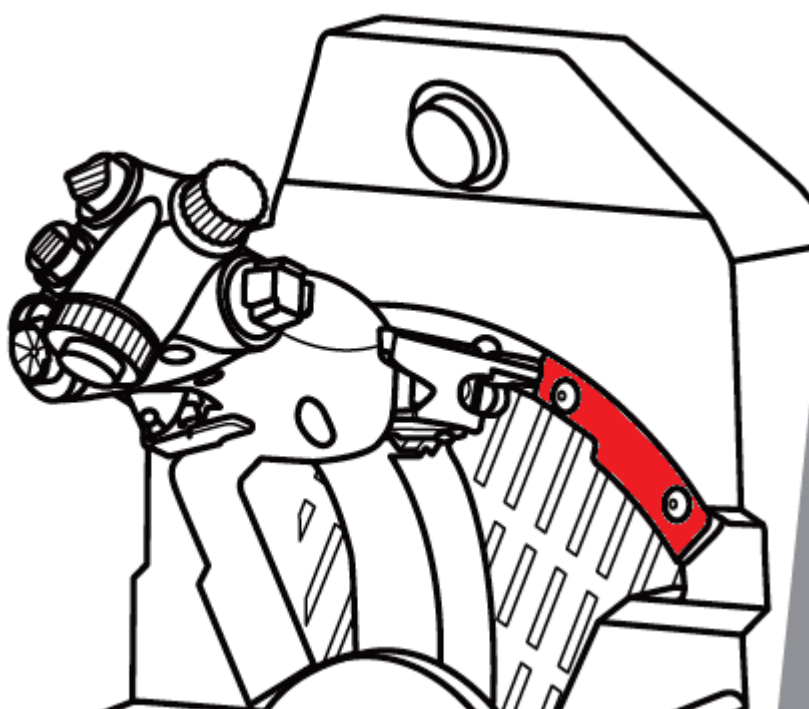



10. Logiciel de programmation avancée T.A.R.G.E.T



Allez sur

<https://support.thrustmaster.com/product/viper-tqs/>

Dans la rubrique Logiciel, téléchargez et installez le logiciel de programmation avancée T.A.R.G.E.T.



Principales caractéristiques de T.A.R.G.E.T

- Diverses configurations possibles des axes.
- Plusieurs niveaux de programmation possibles : Basic, Advanced et Script.
- Utilisation du principe Drag and Drop.
- Fusion possible du bloc manette VIPER TQS avec les autres joysticks Thrustmaster (Hotas Cougar, Hotas Warthog, T.16000M, MFD Cougar Pack, également compatibles avec T.A.R.G.E.T) permettant la reconnaissance d'un seul périphérique USB.
- Accès aux profils avancés créés par la communauté Thrustmaster.



11. FAQ et support technique

Vous avez des questions ou vous rencontrez des problèmes techniques concernant la VIPER TQS ? Consultez le site du support technique Thrustmaster : <https://support.thrustmaster.com/product/viper-tqs/>.



THRUSTMASTER®

VIPER TQS

THROTTLE QUADRANT SYSTEM

Für PC (Windows 10/11)

Benutzerhandbuch



Lesen Sie die Anweisungen in diesem Benutzerhandbuch **sorgfältig durch**, **bevor** Sie das Produkt installieren, **bevor** Sie es benutzen und **bevor** Sie es warten. Beachten Sie unbedingt die Sicherheitsanweisungen. Die Nichtbeachtung dieser Anweisungen kann zu Unfällen und/oder Schäden führen. Bewahren Sie dieses Benutzerhandbuch auf, damit Sie auch in Zukunft darin nachschlagen können.

VERPACKUNGSGEHALT

1.	VERPACKUNGSGEHALT	5
2.	FUNKTIONEN DES VIPER TQS	6
3.	BELEGUNG DER TASTEN UND ACHSEN	8
4.	INFORMATIONEN ZUR BENUTZUNG DES VIPER TQS	10
5.	EINSTELLUNG DER FRIKTION	11
6.	ANBRINGUNG AUF EINER HALTERUNG	12
7.	MONTAGE DES <i>VIPER PANEL</i> *	17
8.	INSTALLATION AUF PC.....	20
9.	CUT OFF UND AFTERBURNER-RASTEN.....	23
10.	ERWEITERTE PROGRAMMIERSOFTWARE T.A.R.G.E.T.....	26
11.	FAQ UND TECHNISCHER SUPPORT	28



Lassen Sie Ihre Triebwerke aufheulen und fliegen Sie in die Dangerzone mit dem kultigen Schubhebel-Quadranten der VIPER der U.S. Air Force – dem weltweit meistgenutzten modernen Kampfflugzeug!

Bringen Sie Ihr Cockpit mit der einzigartigen Ergonomie einer HOTAS-Replika im Maßstab 1:1, die über einen Metallgriff sowie realistische Tasten und Rasten verfügt, auf ein neues Niveau.

Diese Anleitung hilft Ihnen, Ihr VIPER TQS unter den besten Bedingungen zu installieren und zu benutzen. Bevor Sie loslegen, lesen Sie bitte alle Anweisungen und Warnhinweise sorgfältig durch: Sie werden Ihnen helfen, Ihr Produkt optimal zu nutzen.



Aktualisierung der Firmware

Damit die Funktion des VIPER TQS in Videospielen gewährleistet ist, müssen Sie die Firmware aktualisieren.

Zur Durchführung der Aktualisierung, besuchen Sie bitte

<https://support.thrustmaster.com/product/viper-tqs/>

Wählen Sie **Firmware** und folgen Sie dann den Anweisungen – einschließlich des Download- und Installationsvorgangs.



1. Verpackungsinhalt

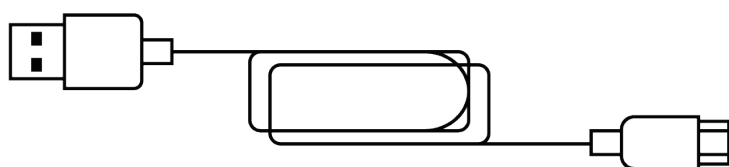
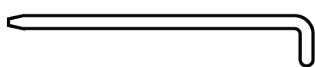
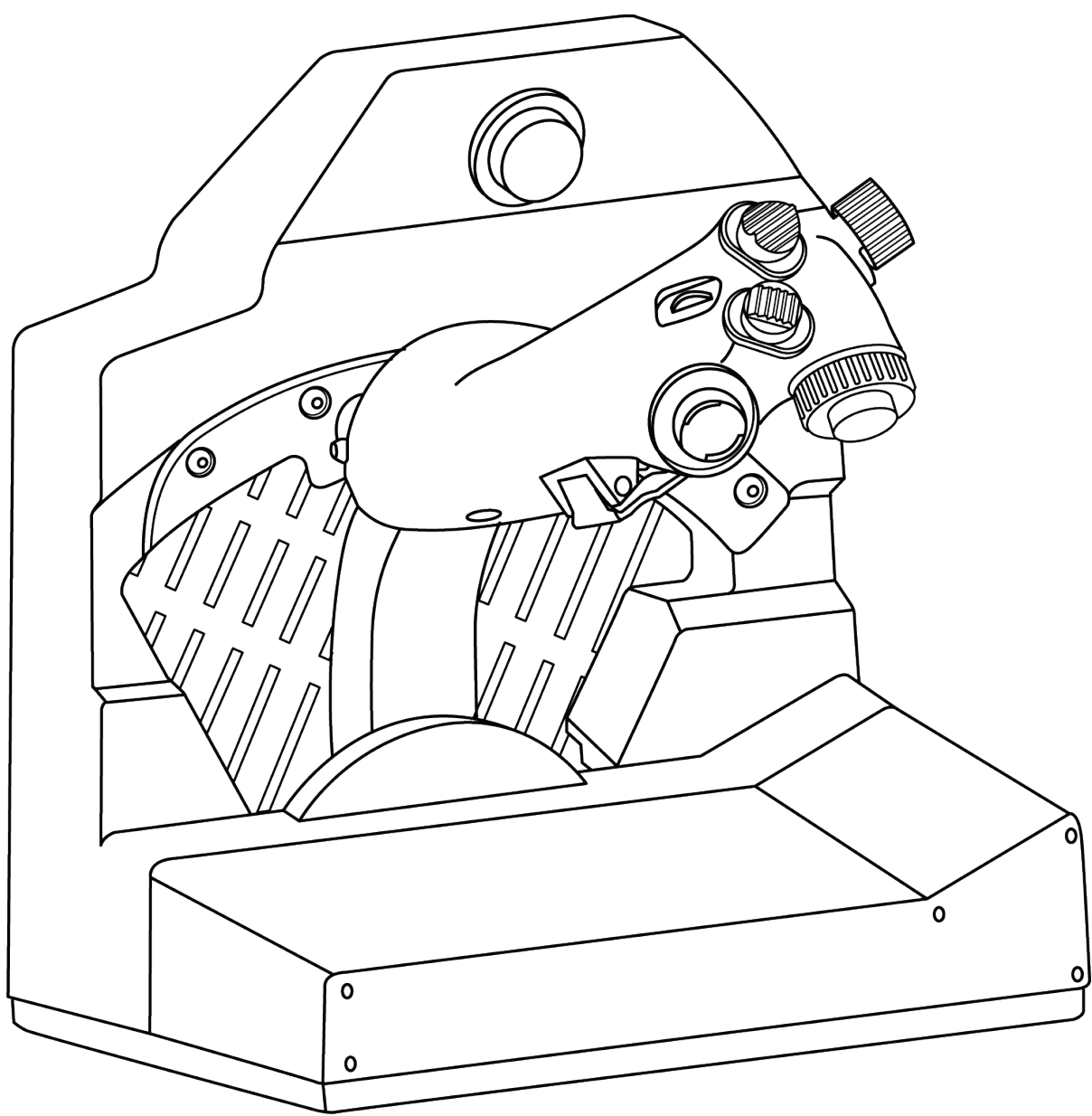



2. Funktionen des VIPER TQS

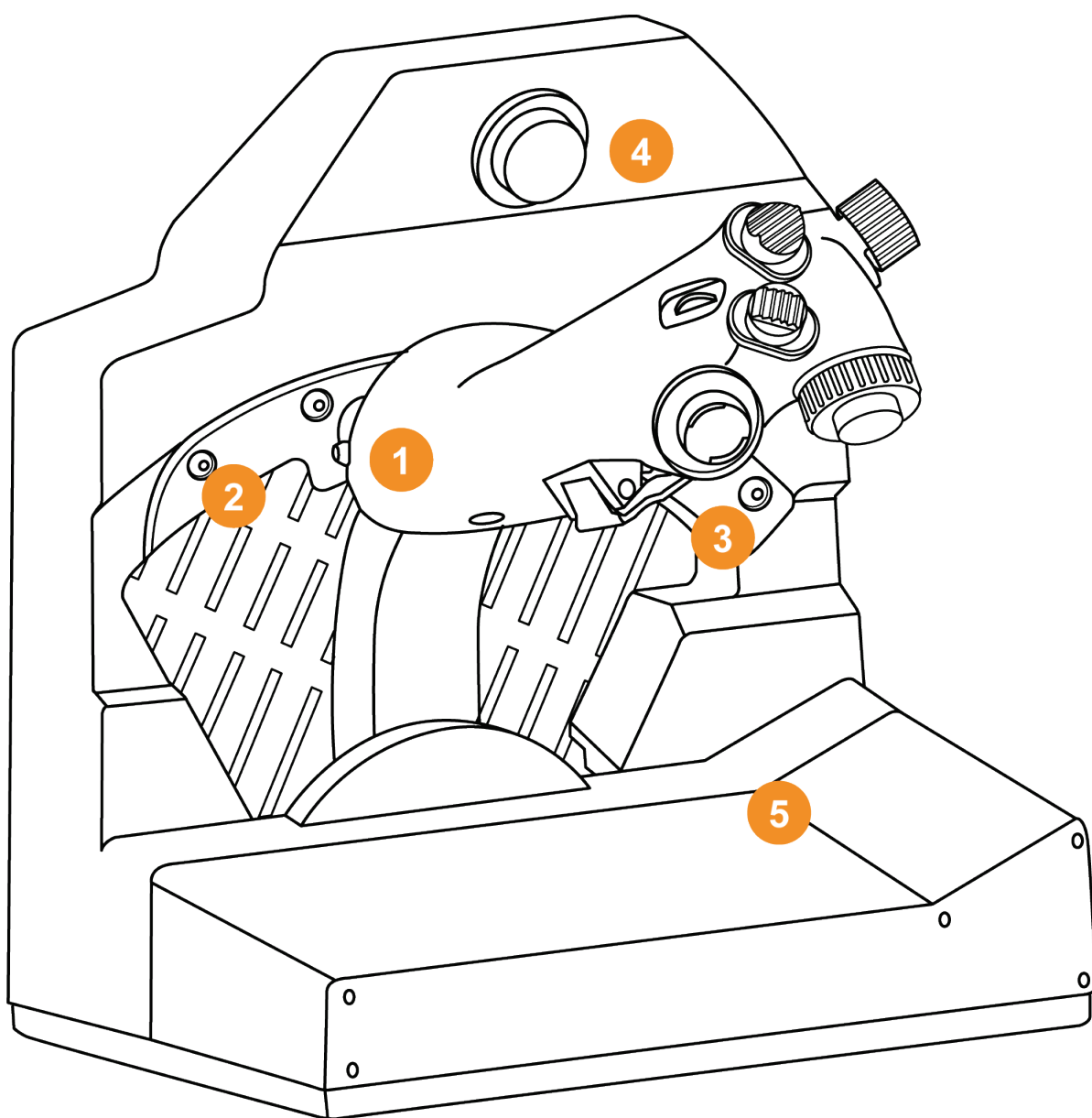

1. Griff

2. Cut Off-Anschlag

3. Afterburner-Anschlag

4. CHAFF/FLARE-Druckschalter

5. Halteclip für Einsatzplan

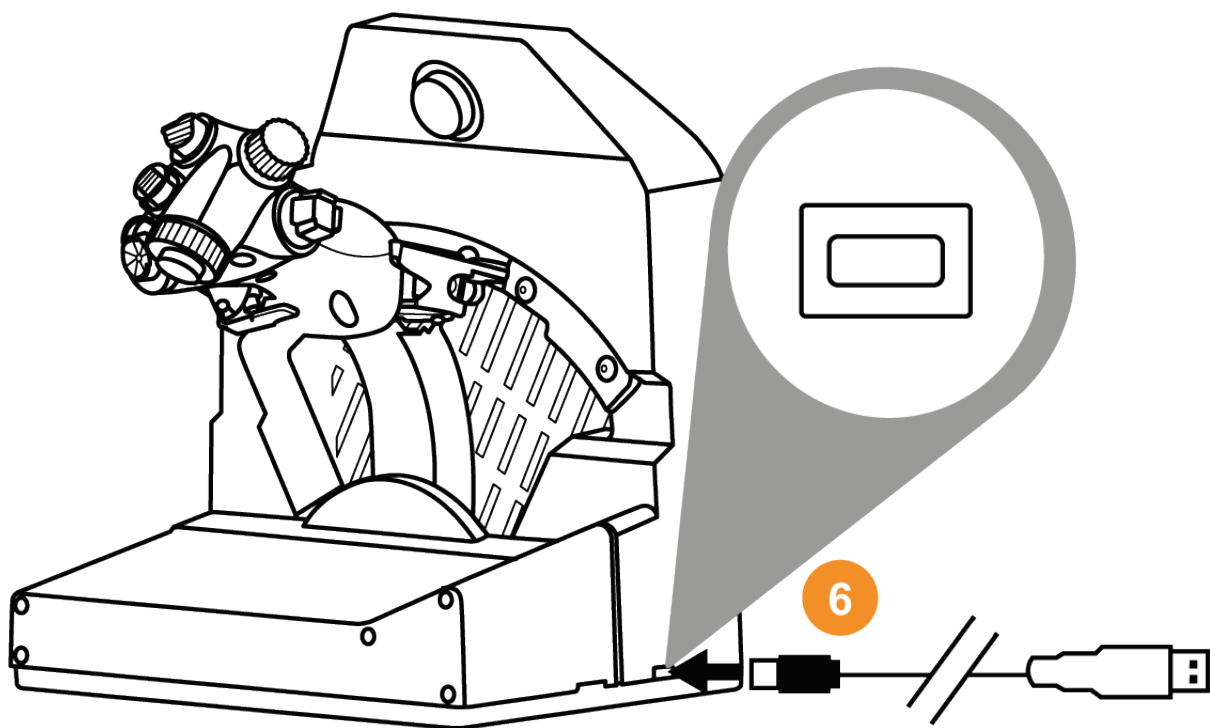

6. USB-Anschluss (Typ C)

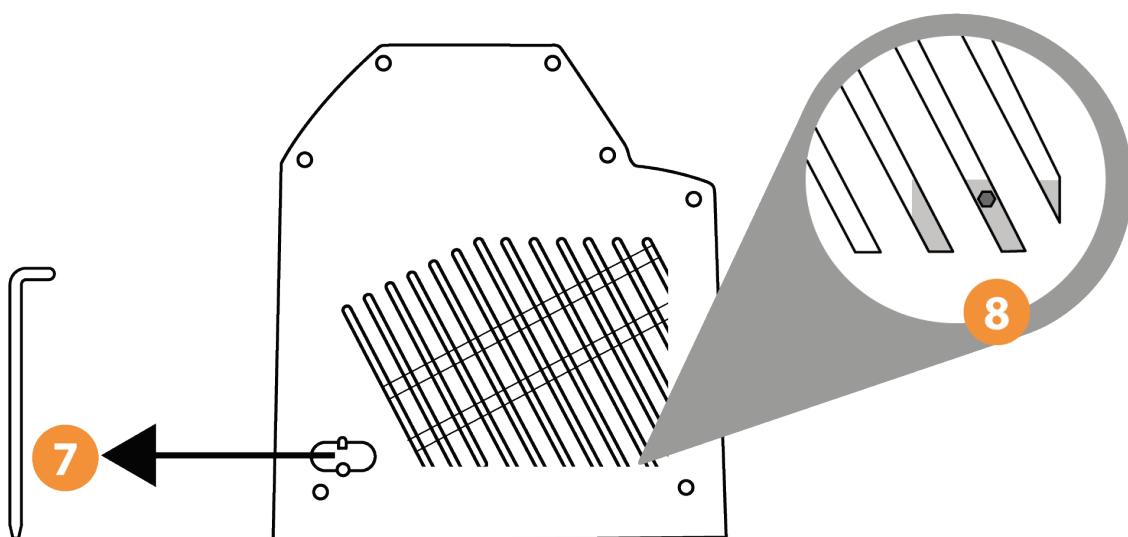

7. Position des Friktionseinstellwerkzeugs

8. Zugangspunkt für die Einstellung der Schubhebelfriktion



3. Belegung der Tasten und Achsen

Griff des VIPER TQS: Belegung der 19 Tasten und 5 Achsen im Modus A (ohne virtuelle Tasten)

A 1 → 19

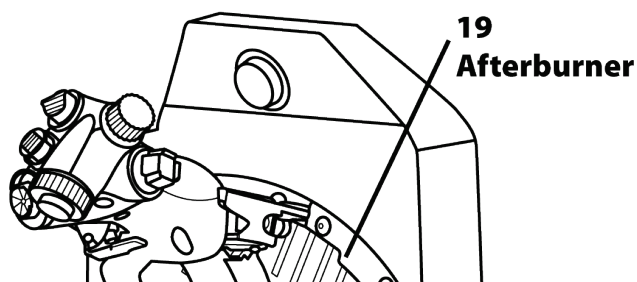
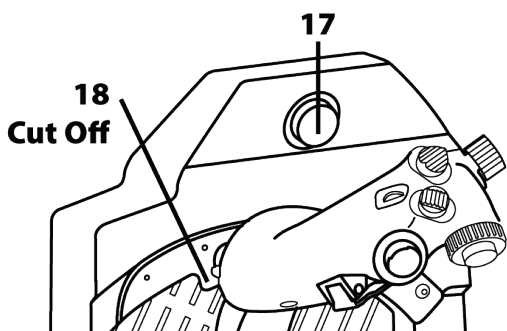
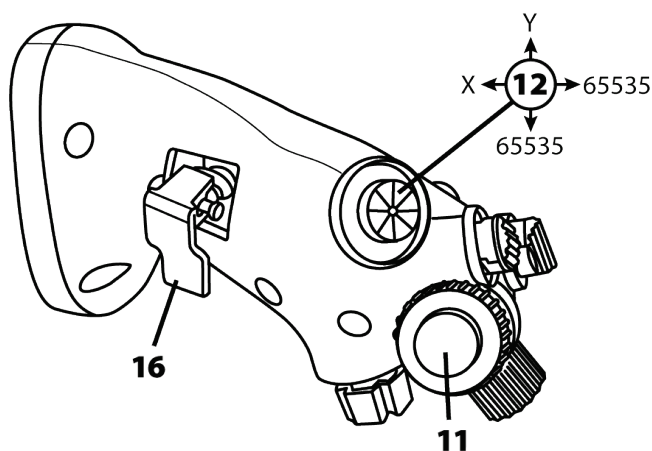
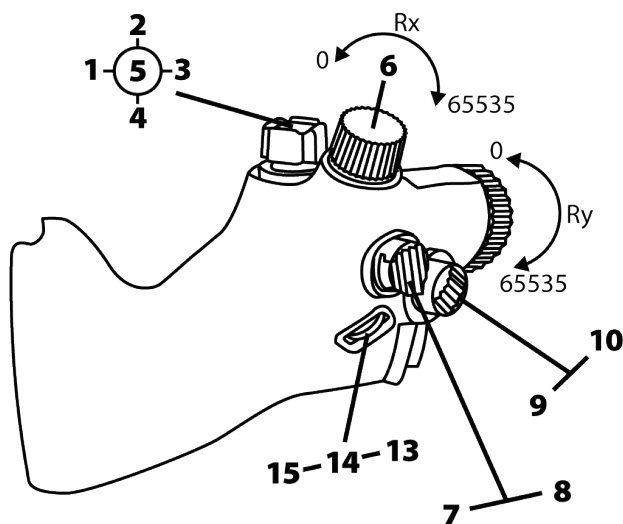



Modus B: mit virtuellen Tasten

B 1 → 21

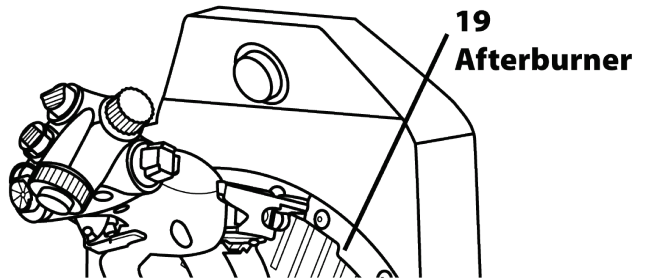
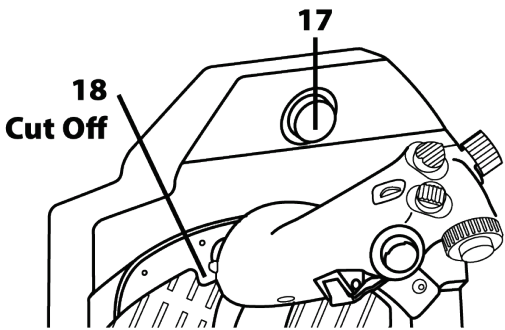
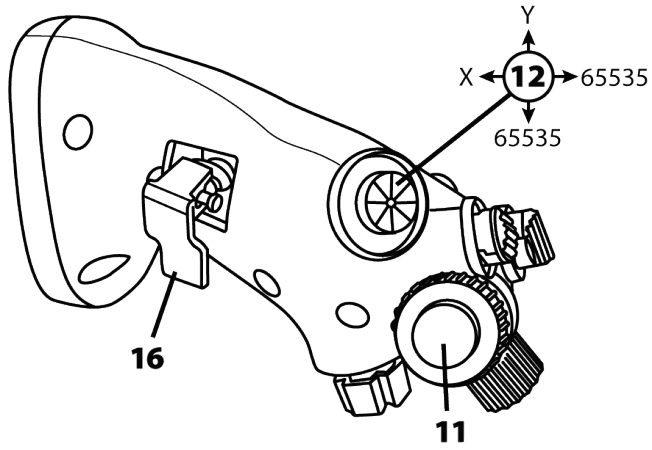
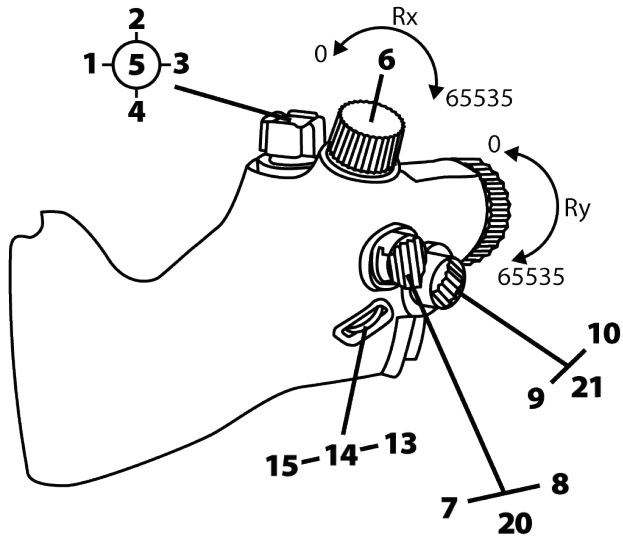



4. Informationen zur Benutzung des VIPER TQS



Einklemmgefahr

Stecken Sie Ihre Finger niemals in die Anschlagbereiche, wenn Sie den Griff benutzen.

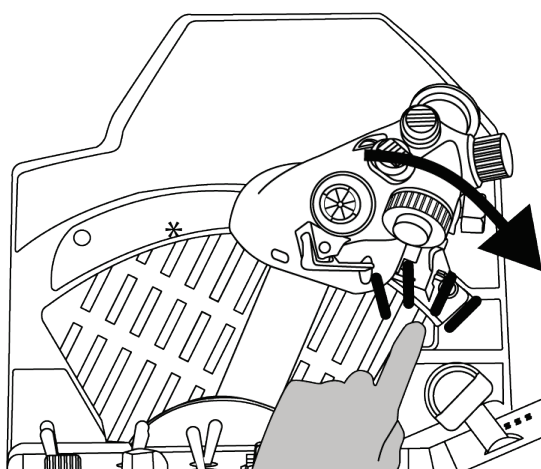
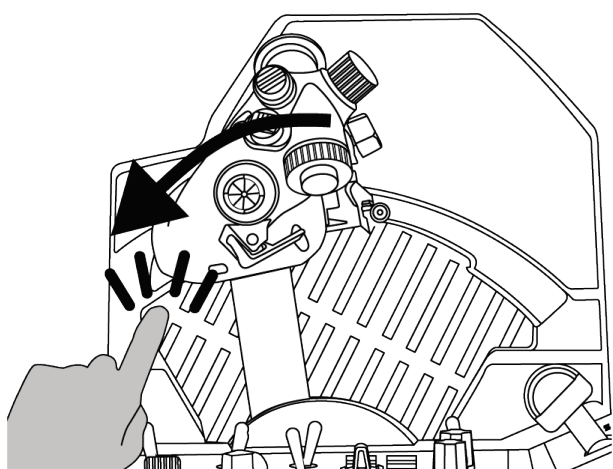
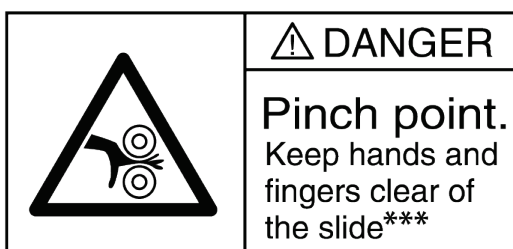



4. Einstellung der Friktion

Sie können die Friktion Ihres VIPER TQS-Schubhebelquadranten mit Hilfe des seitlich am VIPER TQS angebrachten Werkzeugs nach Ihren persönlichen Bedürfnissen einstellen. Bitte beachten Sie jedoch, dass die optimale Friktion des Schubhebels bereits ab Werk voreingestellt ist.

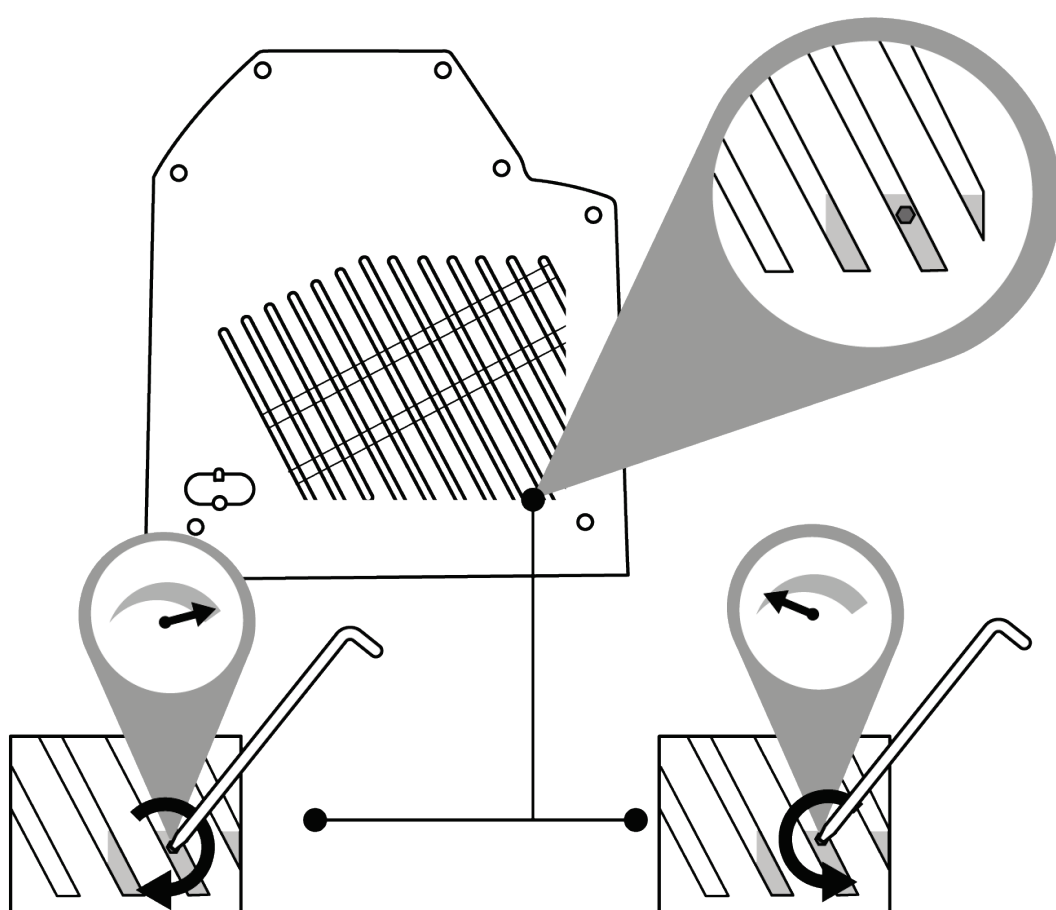

Um eine Beschädigung des Friktionssystems zu vermeiden, darf die Einstellschraube nicht zu fest angezogen werden.

Achten Sie auch darauf, dass Sie die Einstellschraube nicht ganz lösen, da sonst die Gefahr besteht, dass der Schubhebel nicht mehr in der richtigen Position bleibt.



6. Anbringung auf einer Halterung



Das VIPER TQS kann auf verschiedenen Arten von Halterungen montiert werden. Die meisten auf dem Markt erhältlichen Cockpits und Halterungen sind bereits mit ähnlichen Thrustmaster-Produkten (z. B. HOTAS Warthog) kompatibel.

Bitte beachten Sie, dass das VIPER TQS über einen starken Hebeleffekt verfügt und daher fest angebracht werden muss.

Befestigen Sie die Basis mit geeigneten M6-Schrauben (nicht im Lieferumfang enthalten) an Ihrer Halterung, damit der Griff nicht beschädigt wird. Eine ausführliche Bauanleitung zum VIPER TQS finden Sie unter

<https://support.thrustmaster.com/product/viper-tqs/>



Vergewissern Sie sich vor jedem Gebrauch, dass das VIPER TQS gemäß den Anweisungen des Herstellers ordnungsgemäß an der Halterung befestigt ist.

Berücksichtigen Sie das Material Ihrer Halterung und stellen Sie sicher, dass das Produkt sicher daran befestigt werden kann. Das VIPER TQS muss auf einem Schreibtisch aus massivem Material (z.B. MDF oder Holz) ohne Hohlkörper oder Glasteile verwendet werden.



Bauplan mit Abmessungen für die Montage (in mm)

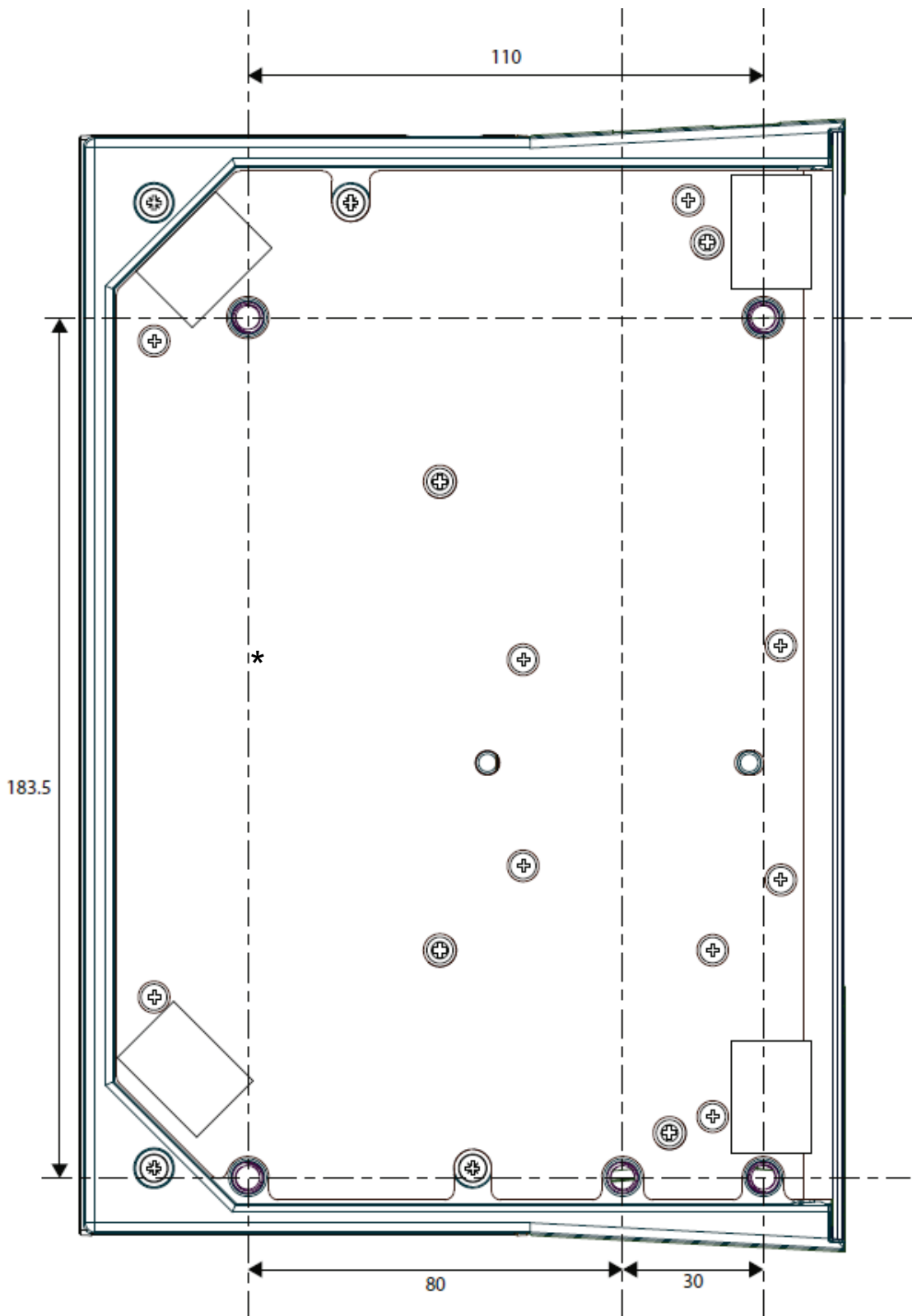

Sie können den Bauplan für die Montage von <https://support.thrustmaster.com/product/viper-tqs/> herunterladen, ausdrucken und zur Vorbereitung der Bohrlöcher auf Ihrer Halterung verwenden.



Montage mit dem TM Flying Desk Mount*

Das TM Flying Desk Mount ist ein Befestigungssystem aus Metall mit einer Schraubklemme, dass die Ergonomie und die Position bei der Bedienung des Geräts verbessert. Dieses System ist für die Verwendung mit Schreibtischen und Tischen von 15 bis 50 mm Dicke konzipiert.

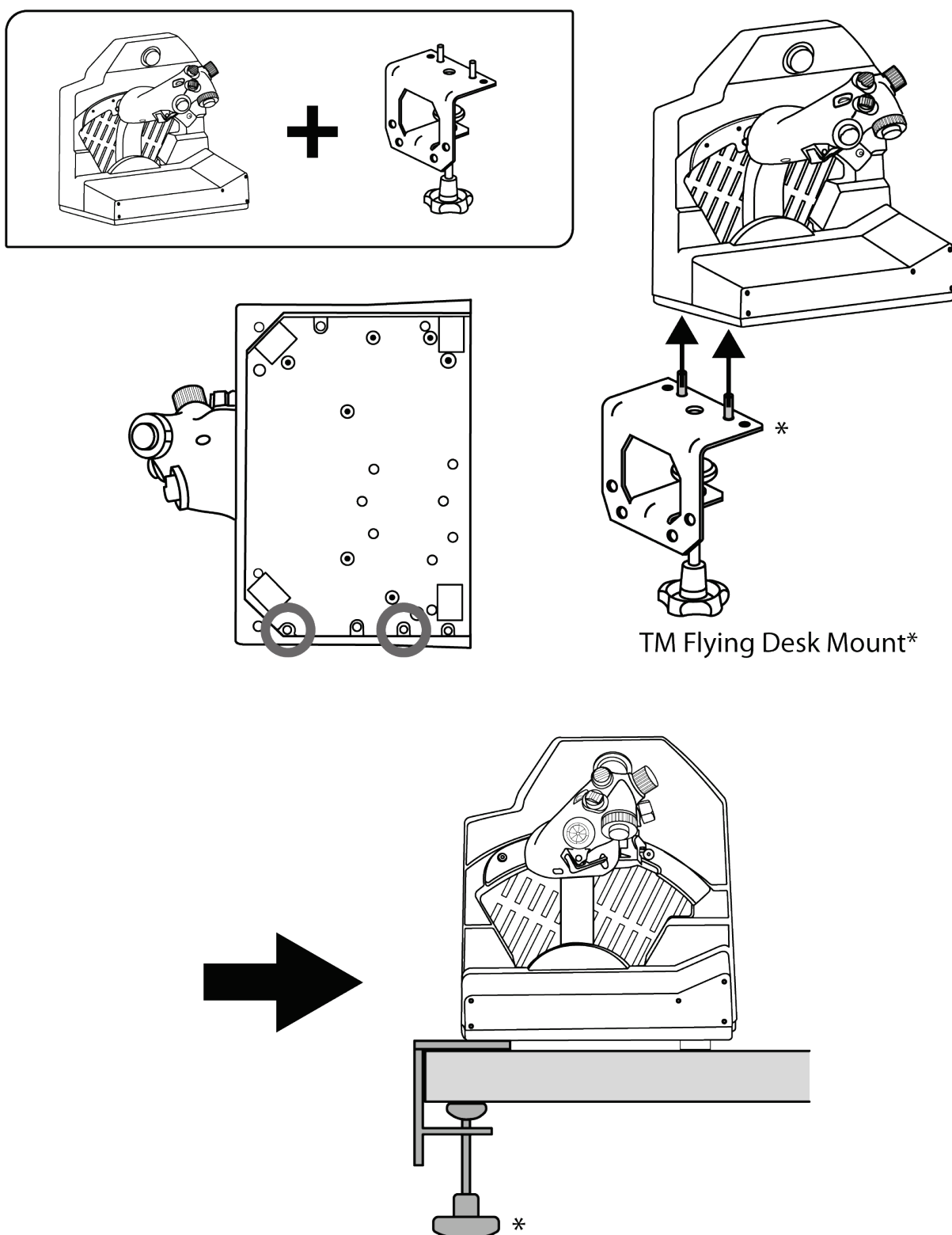

*Separat erhältlich



Montage mit der TM Flying Clamp*

Die TM Flying Clamp ist eine höhenverstellbare Halterung, die von Thrustmaster für sein Flugsimulationszubehör entwickelt wurde. Dieses Befestigungssystem verfügt über zwei Schraubklemmen, mit denen es für die Verwendung auf Tischen mit einer Dicke von 15 bis 45 mm angepasst werden kann.

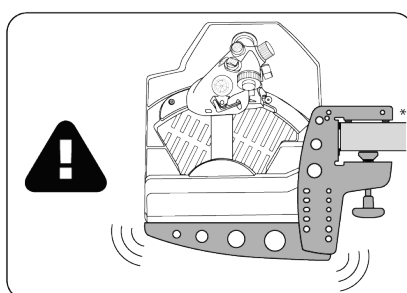
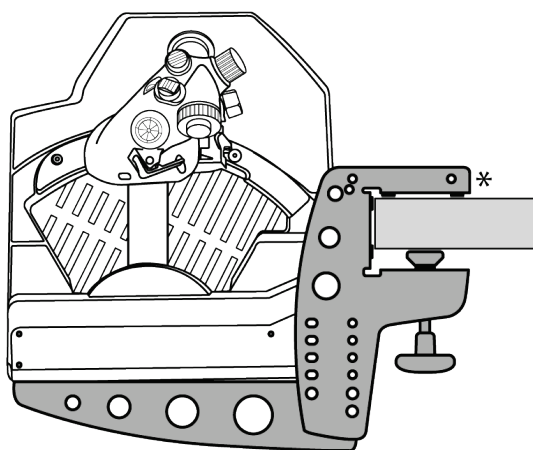
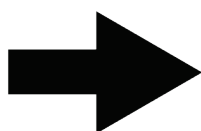
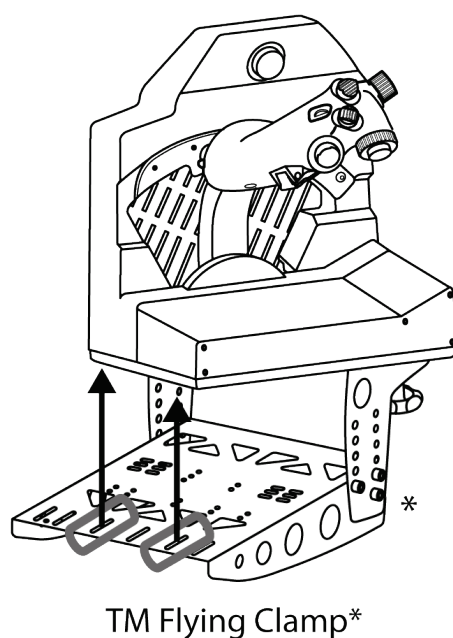
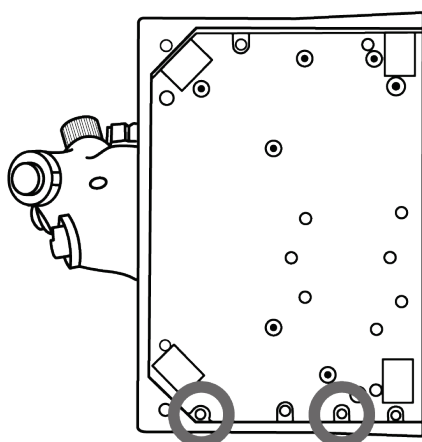
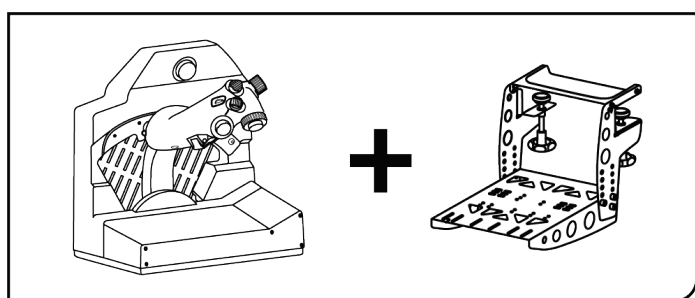

*Separat erhältlich



Bitte beachten Sie, dass das hohe Gewicht des VIPER TQS zu unerwünschten Bewegungen des Befestigungssystems führen kann.



7. Montage des *VIPER PANEL**

*Separat erhältlich. Das VIPER PANEL gehört zum Lieferumfang des VIPER TQS Mission Pack.

Das VIPER PANEL ist ein Steuerpanel, mit dem Sie Ihre Flug- und Kampffähigkeiten mit insgesamt 43 Tasten und 1 Achse erweitern können, die alle über die T.A.R.G.E.T-Software programmierbar sind. VIPER PANEL ist eine Erweiterung zum VIPER TQS.

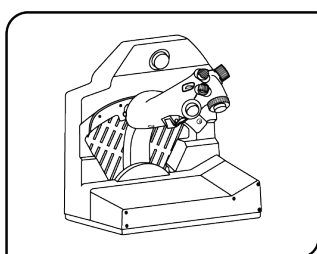

1

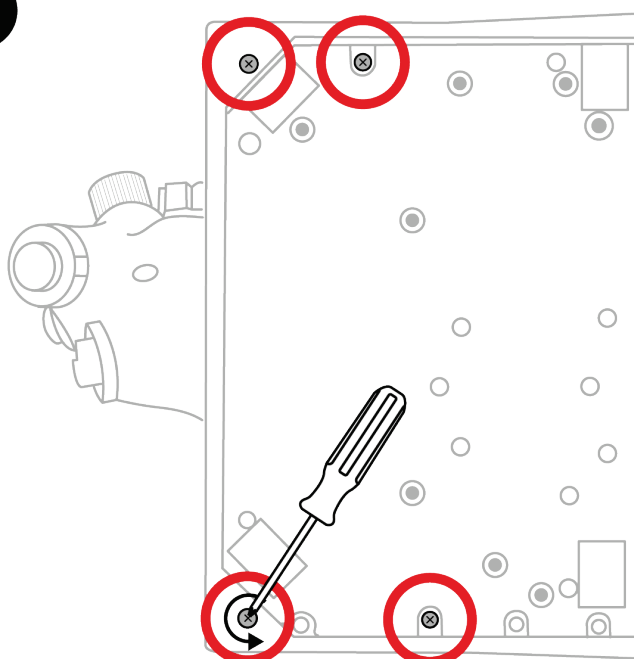

2

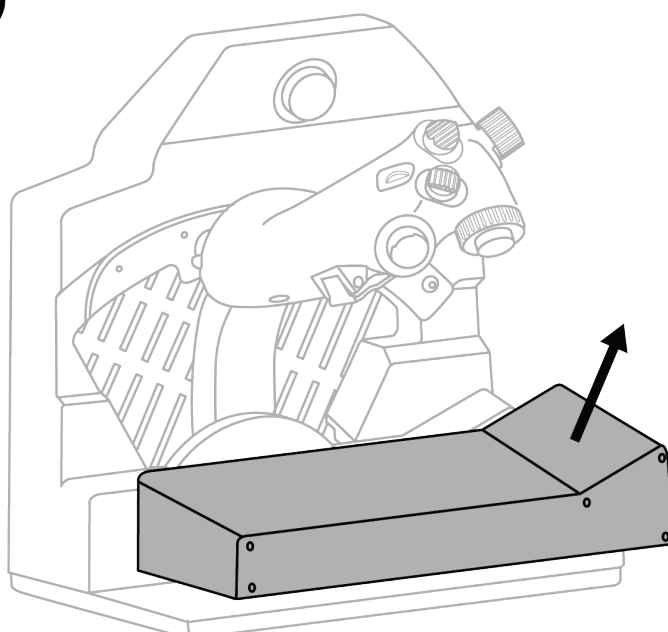

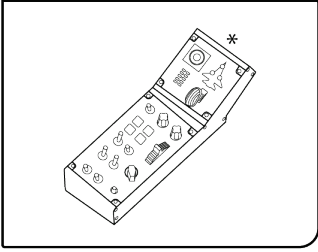

3

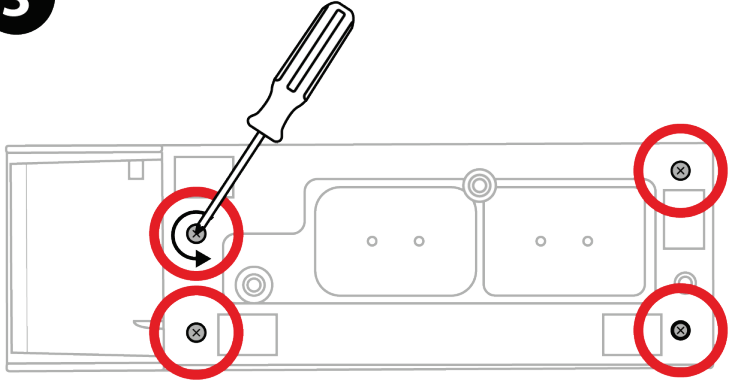

4

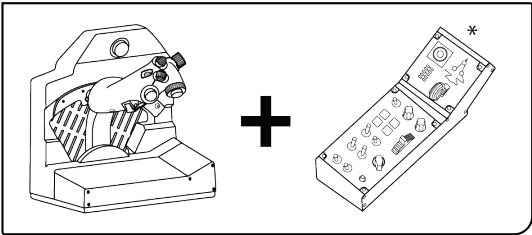
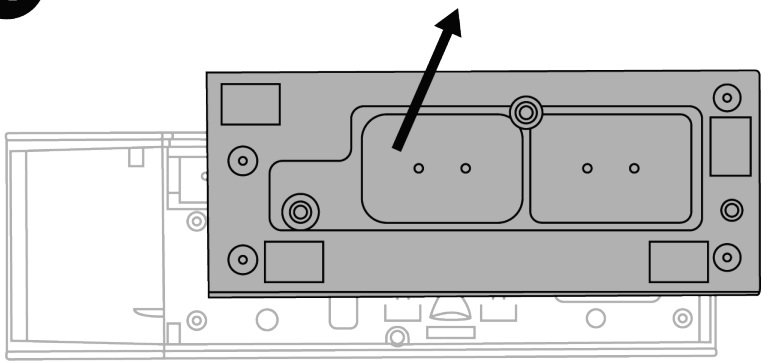

5

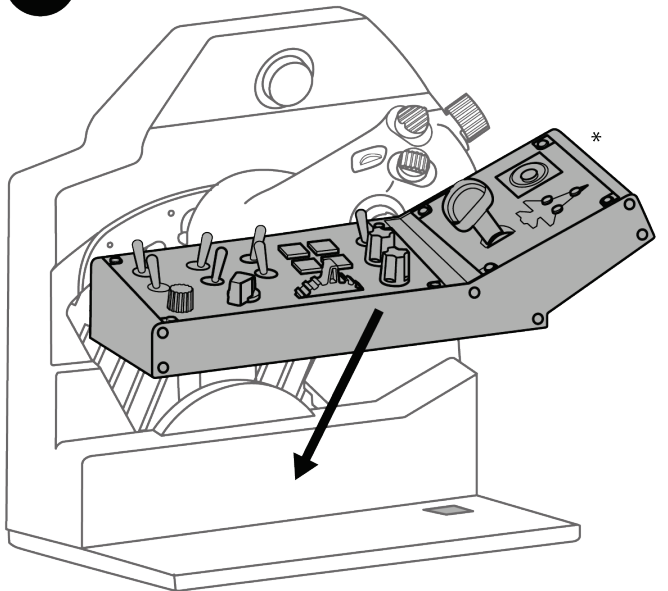



6

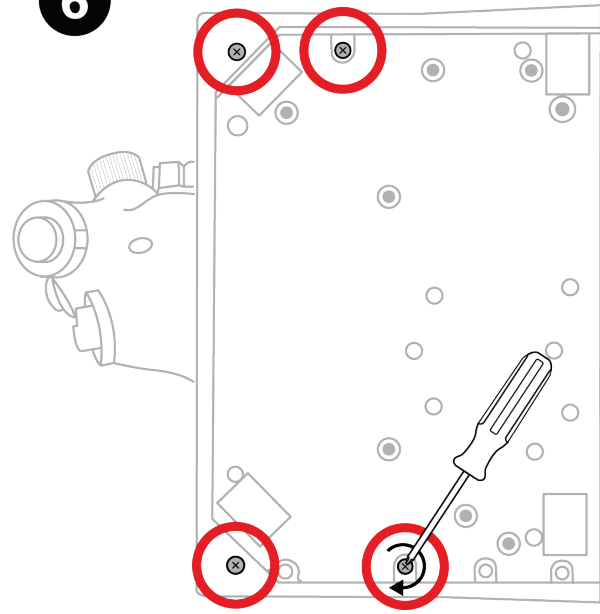

7

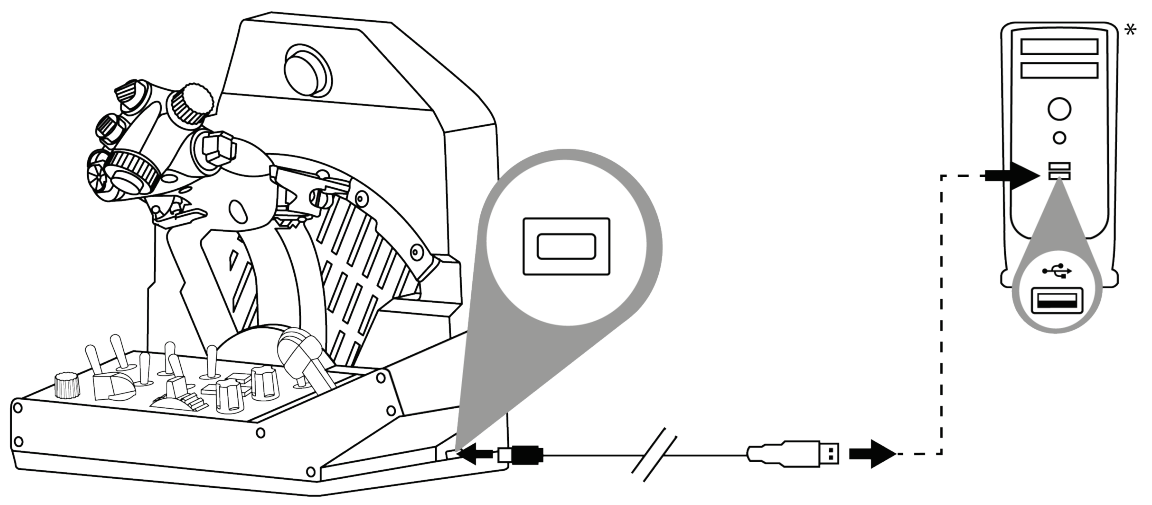

**Nicht im Lieferumfang enthalten*



8. Installation auf PC

1



Bitte besuchen Sie

<https://support.thrustmaster.com/product/viper-tqs/>.

2

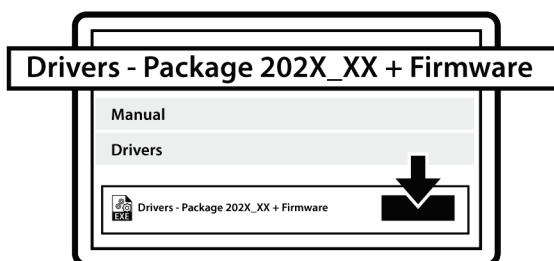

Laden Sie den PC-Treiber und seine spezielle Schnittstelle für die Windows-Systemsteuerung herunter und installieren Sie ihn.

3

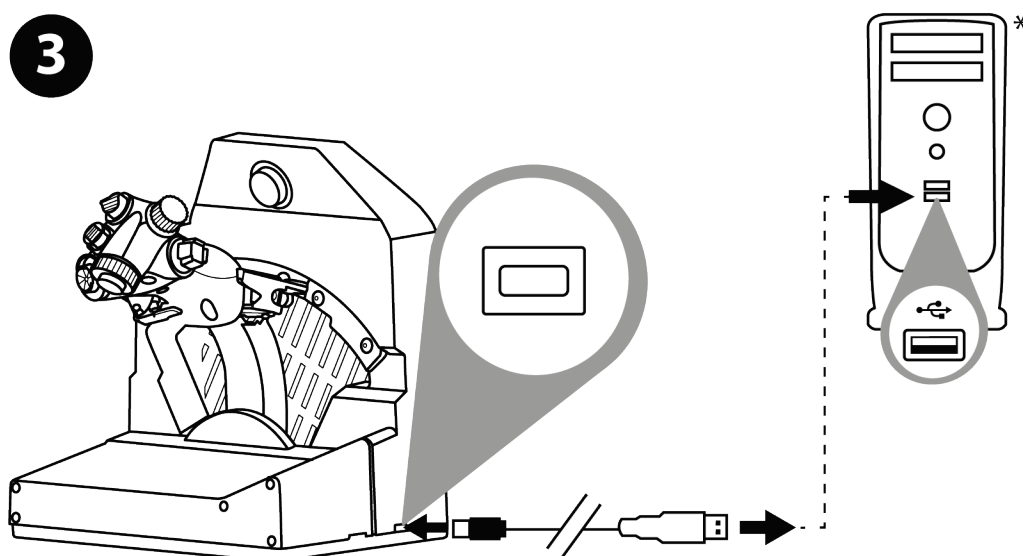

Sobald der PC-Treiber installiert ist, schließen Sie den USB-Stecker an einen der USB-Anschlüsse Ihres PCs an.

**Nicht im Lieferumfang enthalten*



④ Um auf die Systemsteuerung zuzugreifen, wählen Sie **Start / Alle Apps / Thrustmaster / Control Panel** oder **Systemsteuerung** (in Windows 10).

Das Dialogfeld **Gamecontroller** wird angezeigt. Das Zubehör wird auf dem Bildschirm mit dem Namen **VIPER TQS** und dem Status **OK** angezeigt.

⑤ Klicken Sie im Dialogfeld **Gamecontroller** auf **Eigenschaften**, um alle Funktionen zu testen und anzuzeigen.

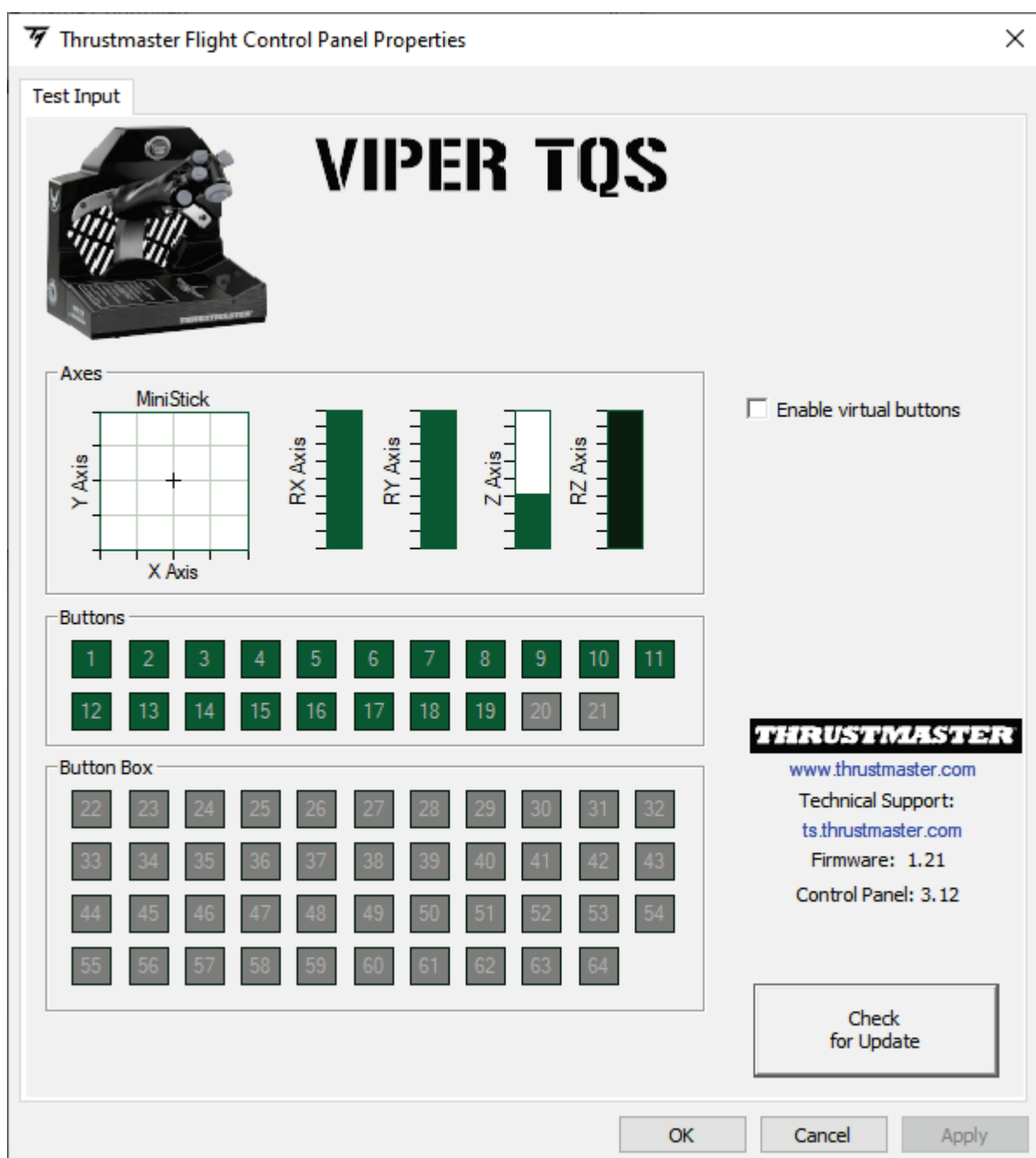



Enable virtual buttons (Virtuelle Tasten aktivieren):

Mit dieser Funktion können Sie die virtuellen Tasten am Griff (Tasten 20 und 21) aktivieren oder deaktivieren. Klicken Sie auf **Apply** (Übernehmen), sobald Sie den gewünschten Modus ausgewählt haben.

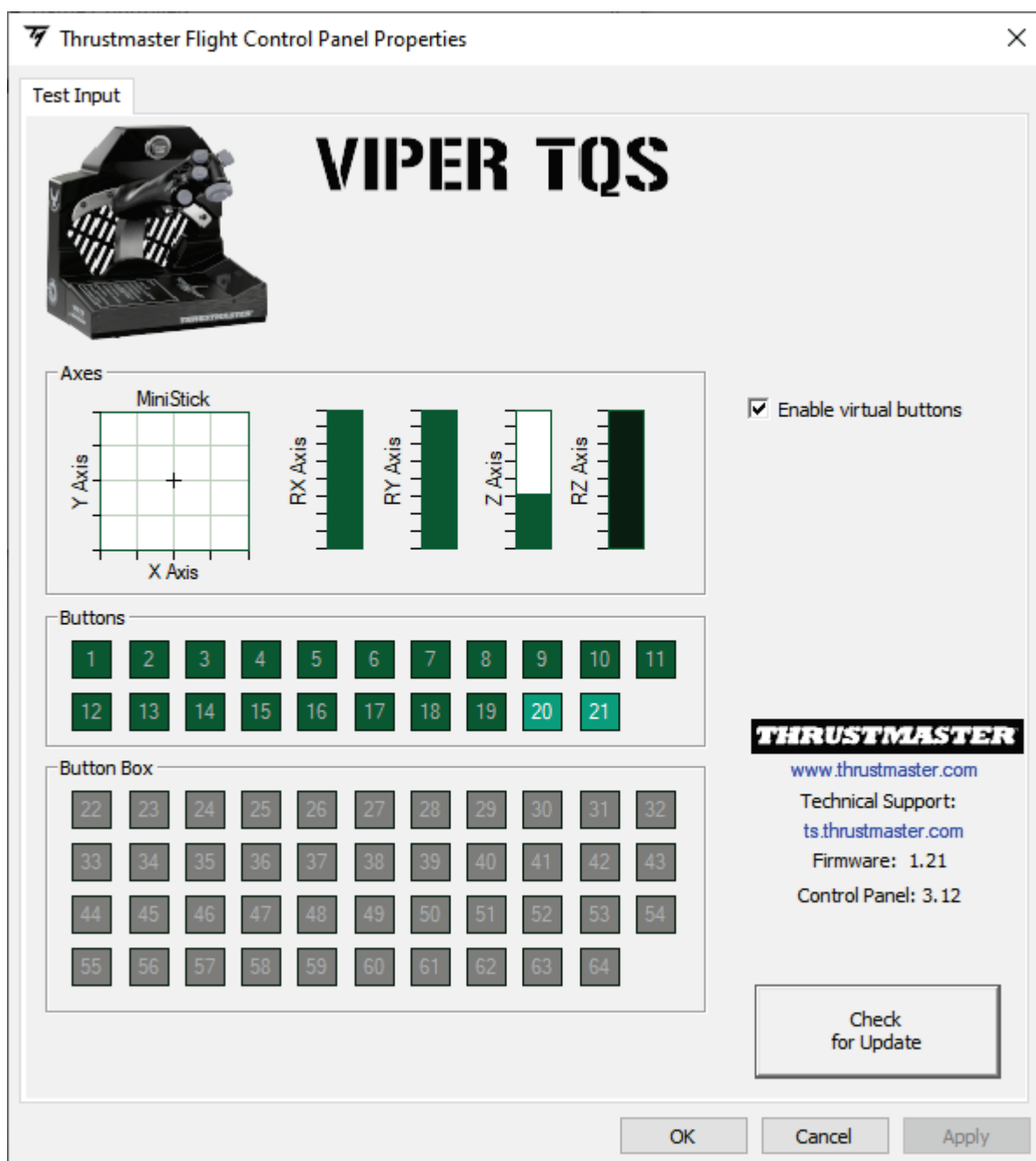

Die virtuellen Tasten sind bei dem VIPER TQS standardmäßig deaktiviert.



9. CUT OFF und AFTERBURNER-Rasten

Der Schubhebelquadrant des VIPER TQS verfügt über ein realitätsnahes System von CUT OFF- und AFTERBURNER-Rasten (das Afterburner-Modul ist abnehmbar).

CUT OFF

Nachdem Sie den Schubhebel am IDLE-Anschlag positioniert haben, drücken Sie den Trigger für die "Entriegelung der Triebwerkabschaltung" **1**, um den Griff anzuheben und über den Anschlag **2** zu gelangen.

Danach stellen Sie den Griff in die Position OFF **3**.

Um die Triebwerke wieder einzuschalten, führen Sie diesen Vorgang in umgekehrter Reihenfolge durch.

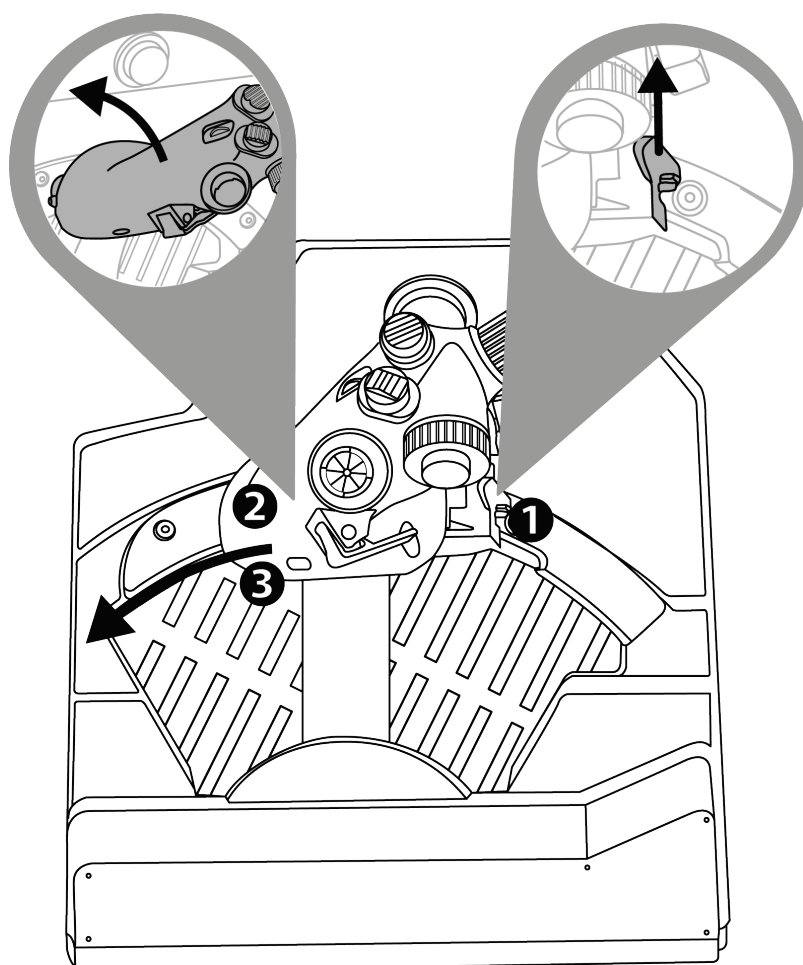



AFTERBURNER

Bewegen Sie den Schubhebel bis zum Anschlag **1** und heben Sie ihn an **2**, um über den Anschlag zu kommen und den Nachbrenner **3** einzuschalten.

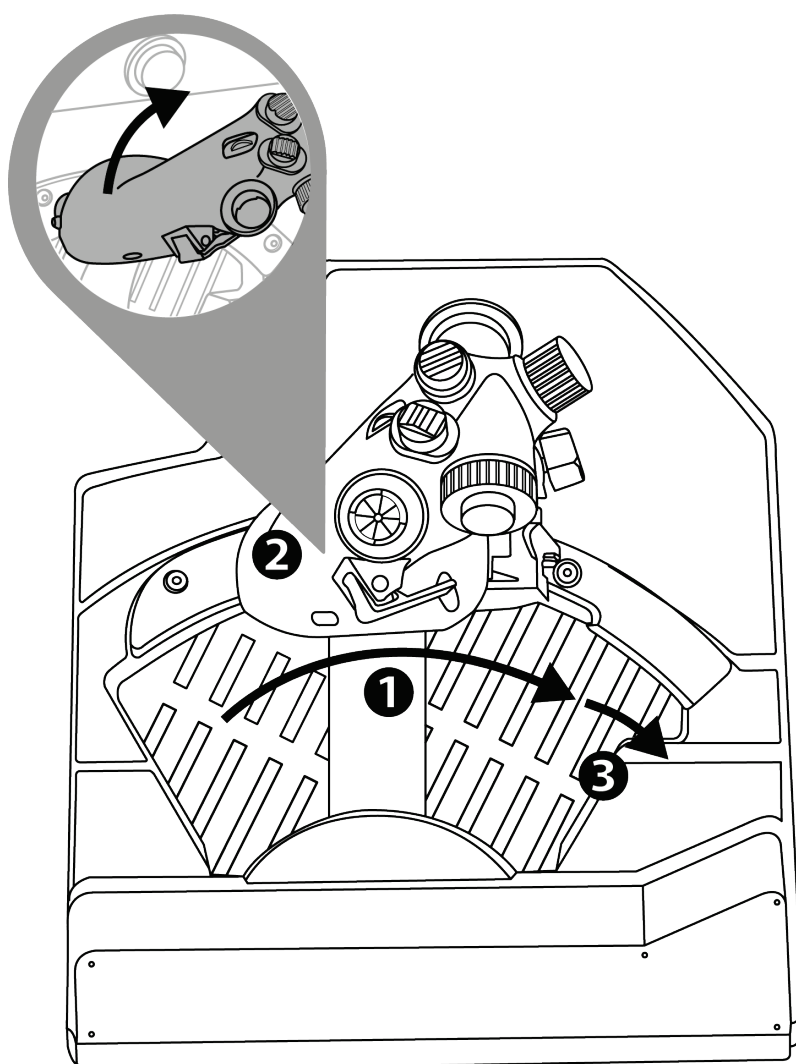



Demontage des AFTERBURNER- Anschlags

Der Anschlag des Afterburner-Moduls befindet sich bei 80 % des Wertes der Achse.

Wenn Sie 100 % des Schubhebelwegs ohne Anschlag wünschen (für einen bestimmten Simulator), können Sie das Afterburner-Modul und seinen Anschlag entfernen, indem Sie die beiden Schrauben des Moduls mit einem Inbusschlüssel (nicht im Lieferumfang enthalten) herausdrehen.

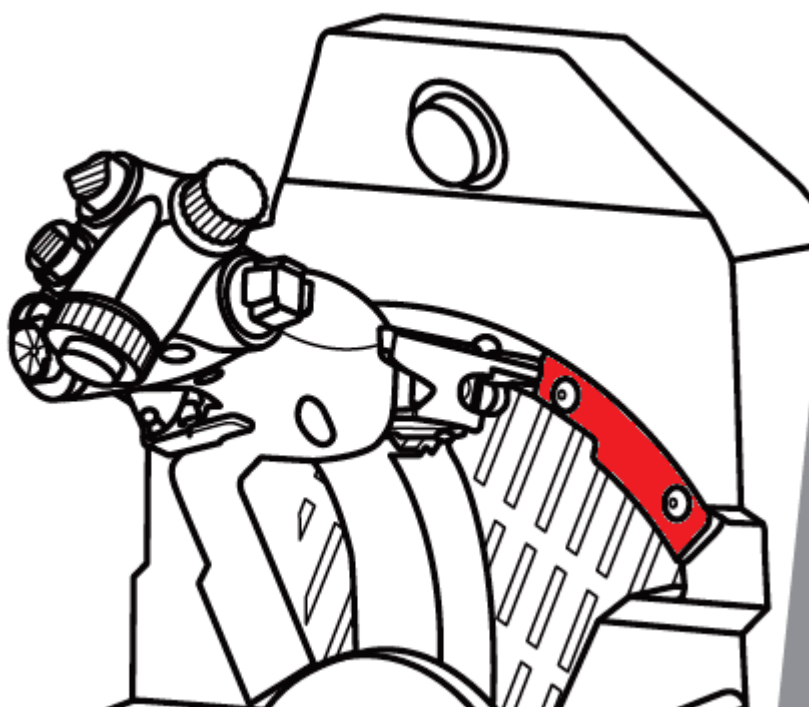



10. Erweiterte Programmiersoftware

T.A.R.G.E.T



Bitte besuchen Sie

<https://support.thrustmaster.com/product/viper-tqs/>.

Laden Sie im Bereich **Software** die erweiterte Programmiersoftware T.A.R.G.E.T herunter und installieren Sie diese.



Hauptmerkmale von T.A.R.G.E.T

- Verschiedene Konfigurationsmöglichkeiten für die Achsen.
- Verschiedene Programmierstufen: Basic, Advanced und Script.
- Verwendung des Drag-and-Drop-Prinzips.
- Möglichkeit der Kombination des VIPER TQS-Schubhebels mit verschiedenen Thrustmaster-Joysticks (HOTAS Cougar, HOTAS Warthog, T.16000M, MFD Cougar Pack, die alle auch mit T.A.R.G.E.T kompatibel sind), so dass sie als ein einziges USB-Gerät erkannt werden.
- Zugriff auf erweiterte Profile, die von der Thrustmaster-Community erstellt wurden.



11. FAQ und technischer Support

Haben Sie Fragen zum VIPER TQS oder haben Sie technische Probleme? Dann besuchen Sie bitte die Website des technischen Supports von Thrustmaster:

<https://support.thrustmaster.com/product/viper-tqs/>.



THRUSTMASTER®

VIPER TQS

THROTTLE QUADRANT SYSTEM

Voor de PC (Windows 10/11)

Handleiding



Lees zorgvuldig de instructies in deze handleiding **voordat** u het product installeert, **voordat** u het product gebruikt en **voordat** u onderhoud uitvoert. Volg de veiligheidsvoorschriften. Als u deze instructies niet opvolgt, bestaat de kans op ongelukken en/of schade. Bewaar deze handleiding zodat u de instructies in de toekomst kunt raadplegen.

INHOUDSOPGAVE

1.	INHOUD VAN DE VERPAKKING.....	5
2.	VIPER TQS-VOORZIENINGEN	6
3.	TOEWIJZEN VAN KNOPPEN EN ASSEN.....	8
4.	INFORMATIE OVER HET GEBRUIK VAN DE VIPER TQS	10
5.	DE FRICTIE AANPASSEN	11
6.	INSTALLATIE OP EEN STEUN.....	12
7.	INSTALLATIE VAN HET VIPER PANEL*	17
8.	INSTALLATIE OP DE PC	20
9.	CUT OFF- EN AFTERBURNER-STANDEN.....	23
10.	T.A.R.G.E.T GEAVANCEERDE PROGRAMMEERSOFTWARE.....	26
11.	FAQ EN TECHNISCHE ONDERSTEUNING .	28



Zet de motoren op maximale stuwkracht en vlieg de gevarenzone in met het iconische throttle-quadrant-systeem van de U.S. Air Force VIPER, 's werelds meest gebruikte moderne gevechtsvliegtuig.

Breng uw cockpit naar een hoger niveau met de unieke ergonomie van een HOTAS-replica op schaal 1:1 met een metalen greep en realistische knoppen en standen.

Deze handleiding helpt u bij het installeren en bij het onder de best mogelijke omstandigheden gebruiken van uw VIPER TQS. Lees, voordat u het luchtruim kiest, zorgvuldig alle instructies en waarschuwingen: ze helpen u het meeste plezier uit uw product te halen.



De firmware bijwerken

Om ervoor te zorgen dat de VIPER TQS goed functioneert in games, moet u de firmware bijwerken naar de meest recente versie.

Voor het bijwerken van de firmware gaat u naar

<https://support.thrustmaster.com/product/viper-tqs/>

Selecteer **Firmware** en volg de instructies inclusief de procedure voor het downloaden en installeren.



1. Inhoud van de verpakking

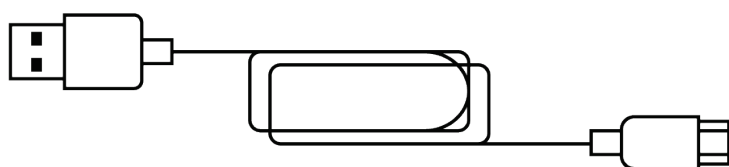
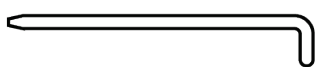
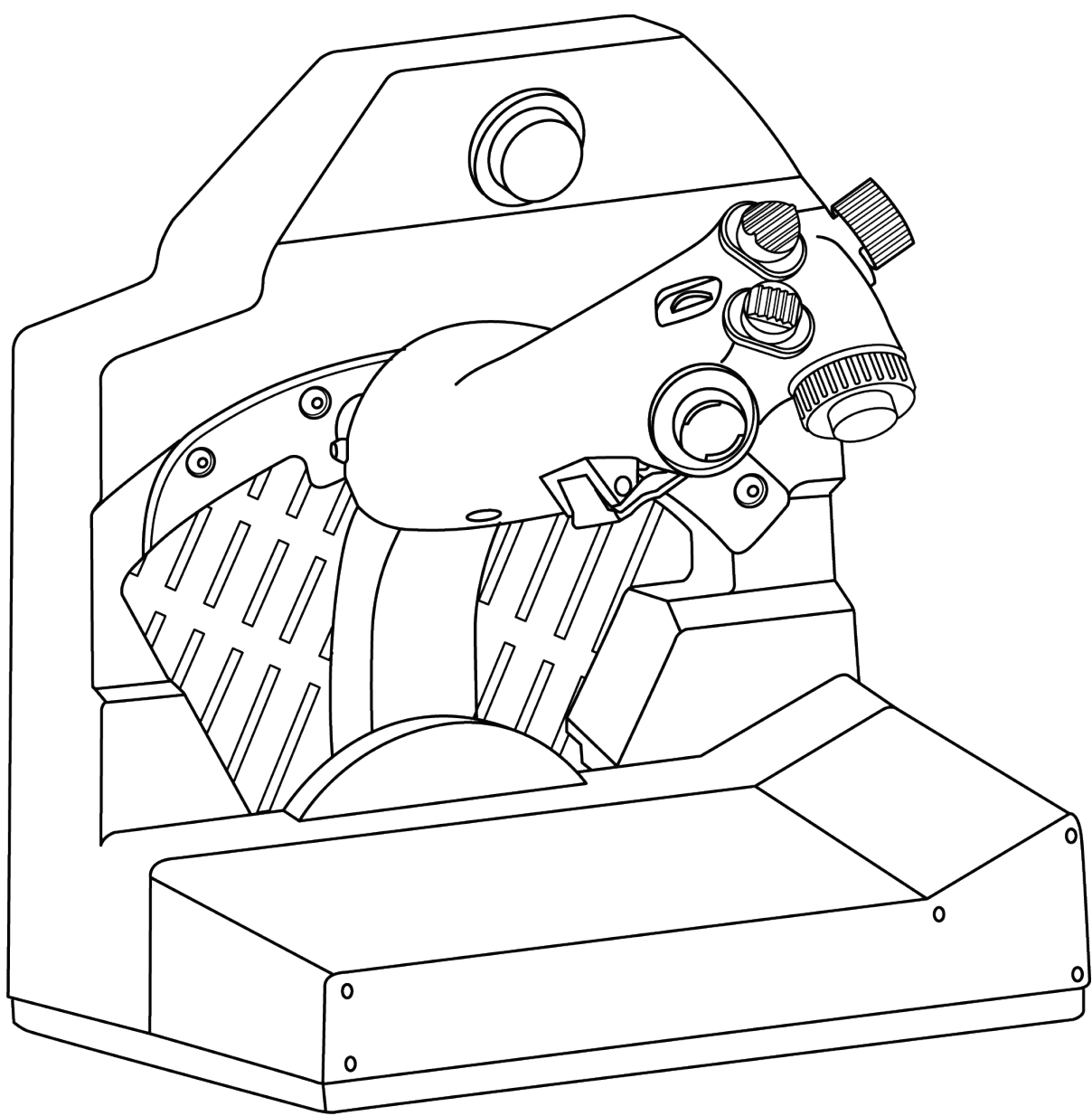



2. VIPER TQS-voorzieningen

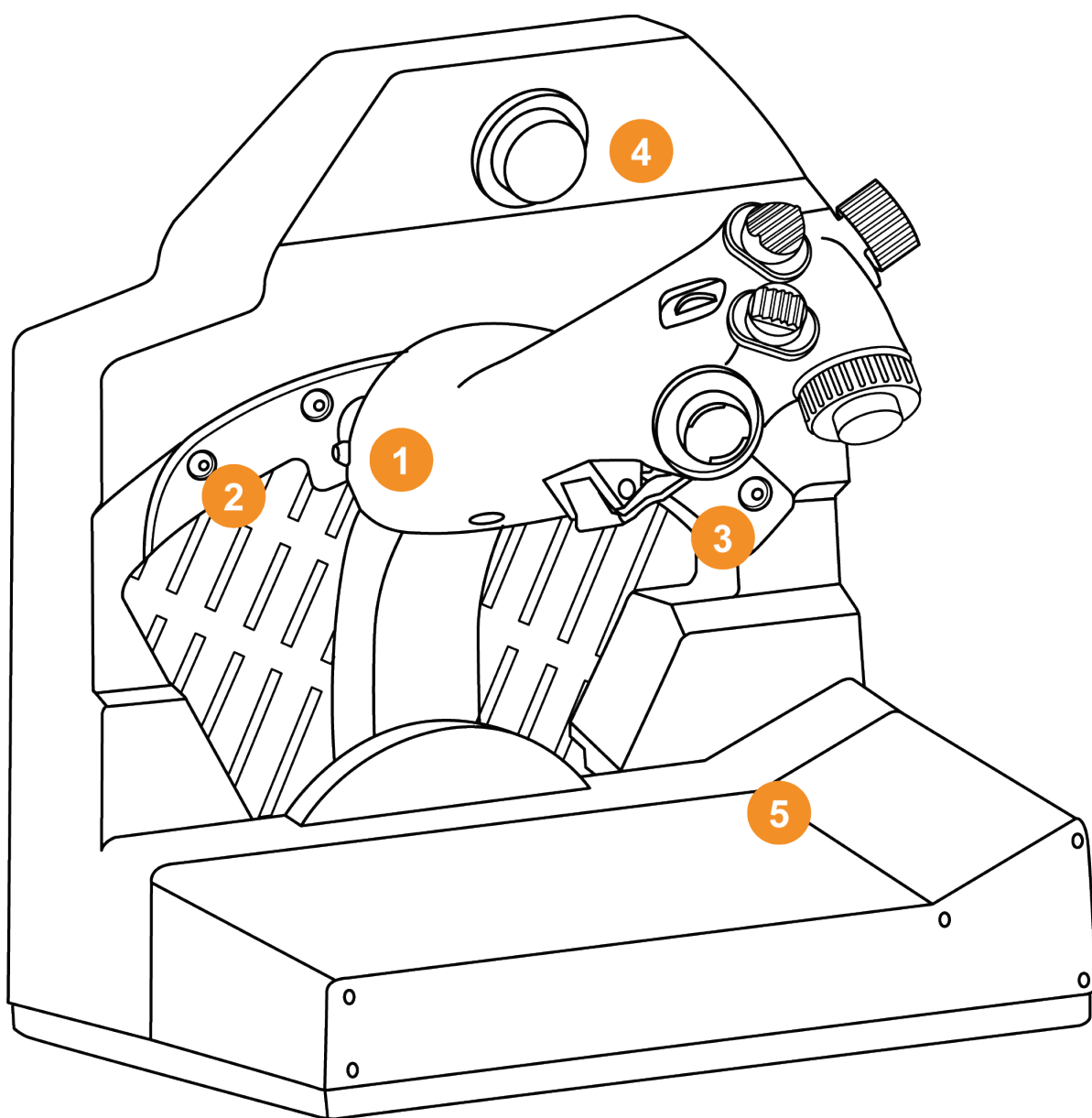

1. Greep

2. Cut Off-stop

3. Afterburner-stop

4. CHAFF/FLARE-slap-schakelaar

5. Clip voor missiekaart

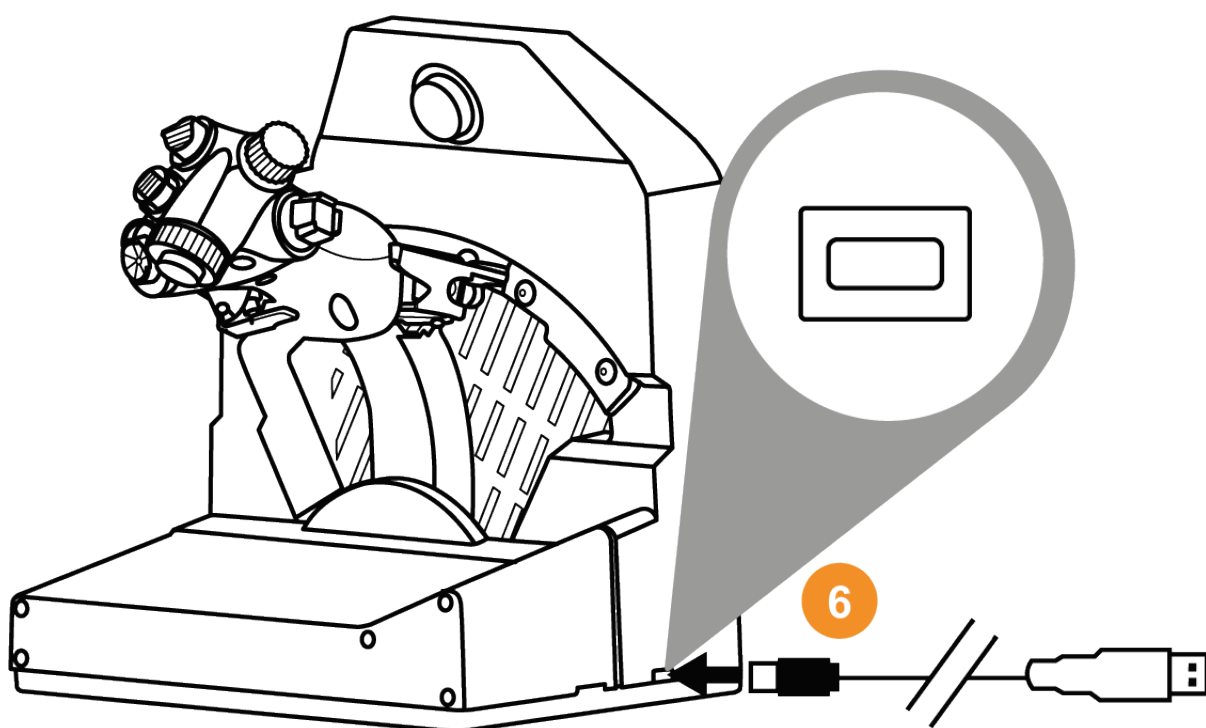

6. USB-connector (type C)

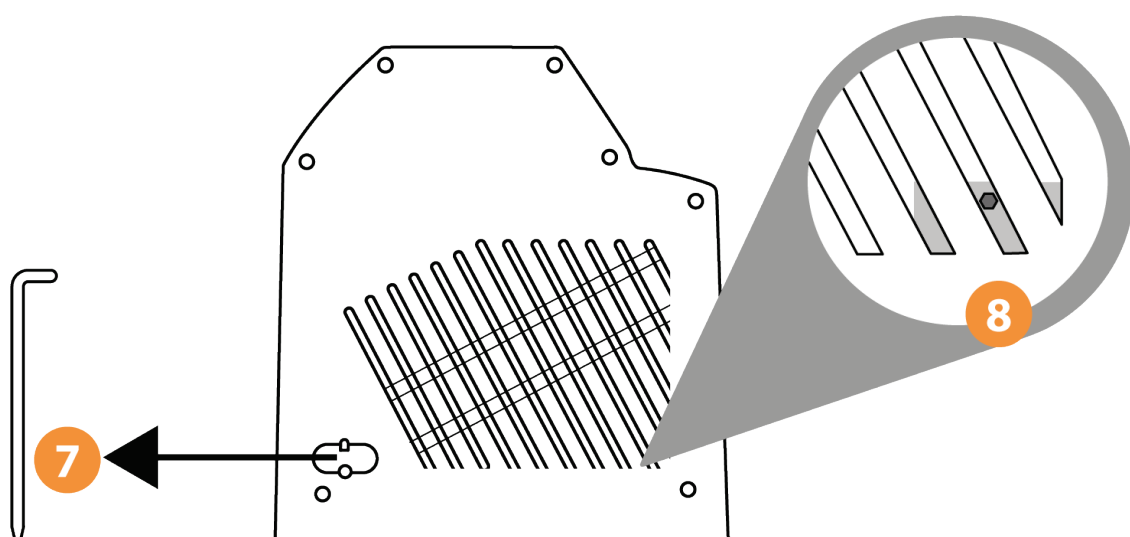

7. Locatie frictieafstel-tool

8. Toegangspunt afstellen throttle-frictie



3. Toewijzen van knoppen en assen

VIPER TQS-greep: toewijzen van de 19 knoppen en 5 assen in modus A (zonder virtuele knoppen)

A 1 → 19

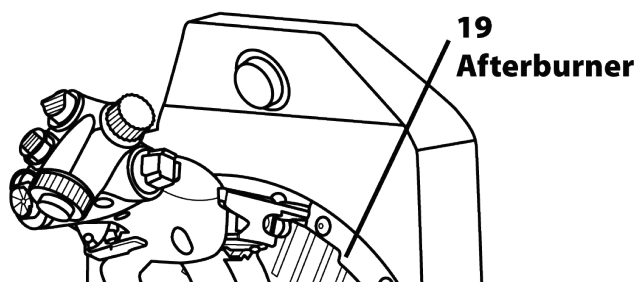
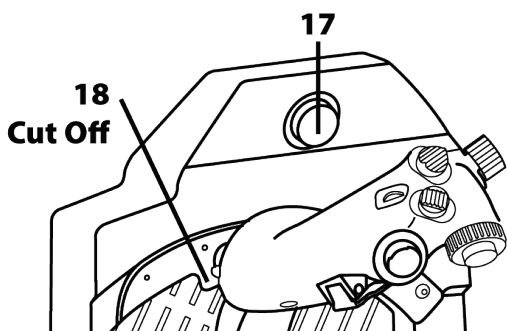
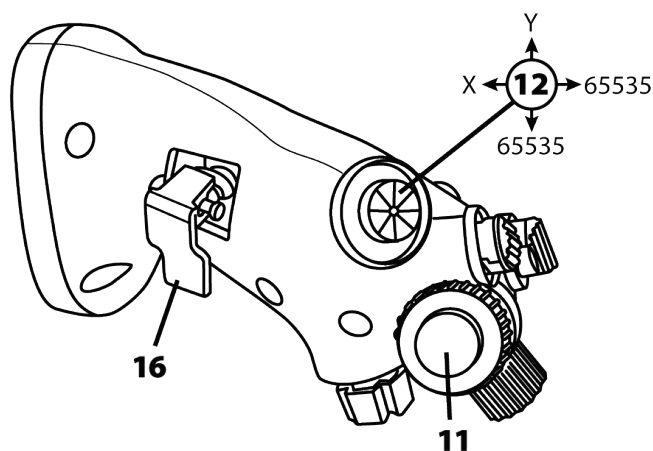
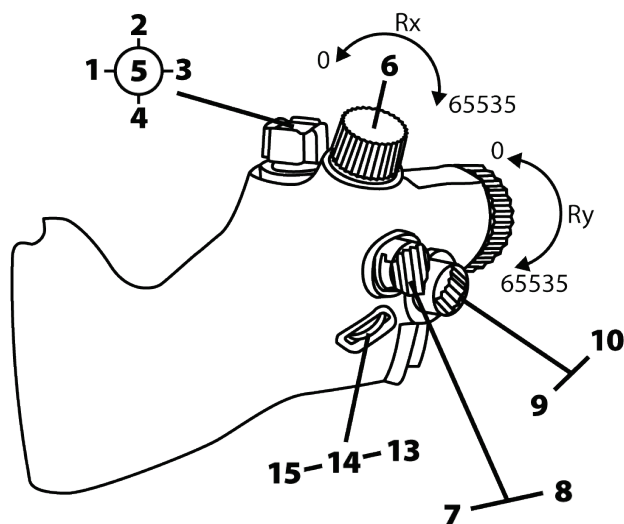



Modus B: met virtuele knoppen

B 1 → 21

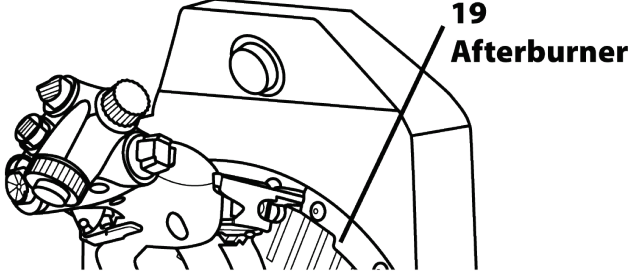
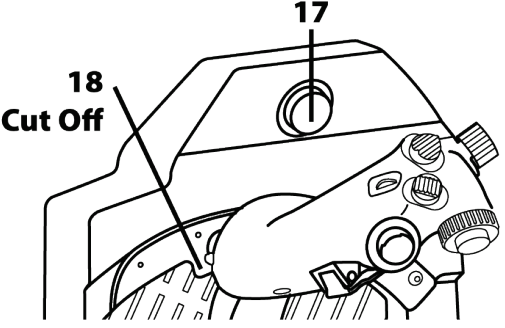
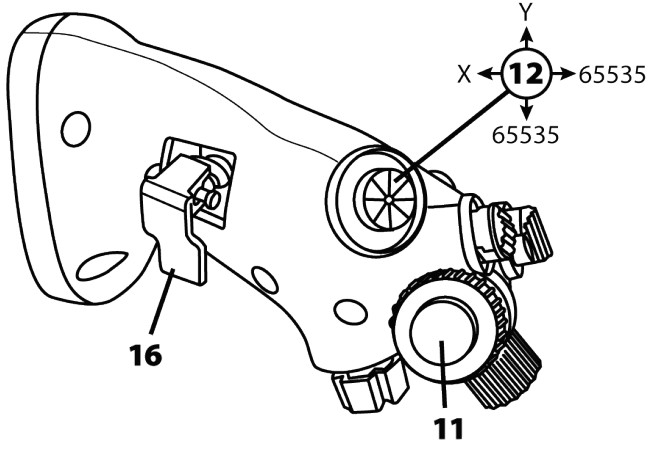
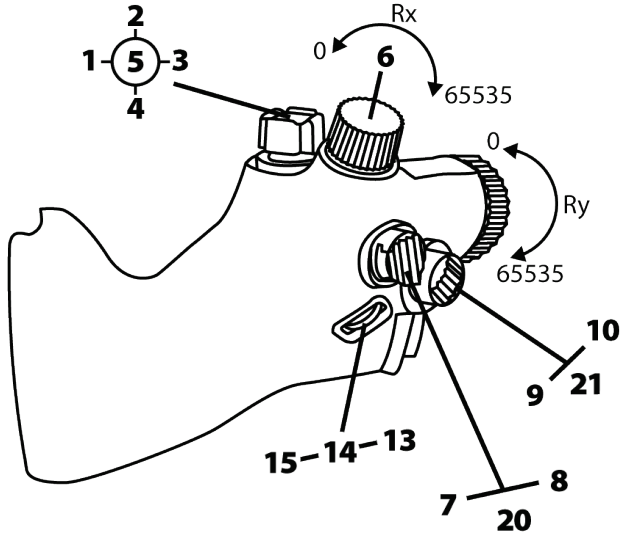



4. Informatie over het gebruik van de VIPER TQS



Gevaar op beknelling

Plaats uw vingers nooit in de buurt van de stops wanneer u de greep gebruikt.

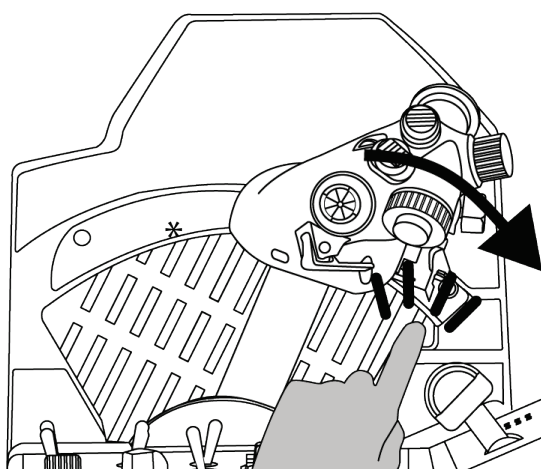
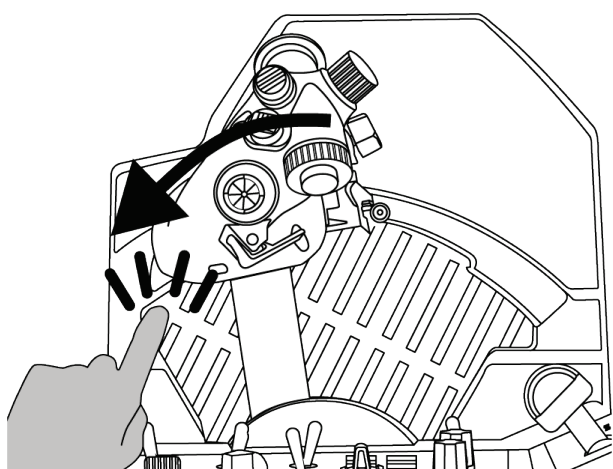
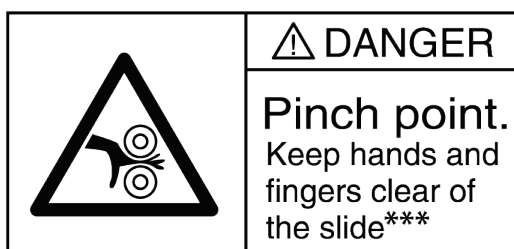



5. De frictie aanpassen

U kunt de frictie van uw VIPER TQS-throttle-quadrant aanpassen aan uw eigen voorkeur met behulp van de tool aan de zijkant van de VIPER TQS. Houd er echter rekening mee dat optimale throttlefrictie al is ingesteld in de fabriek.

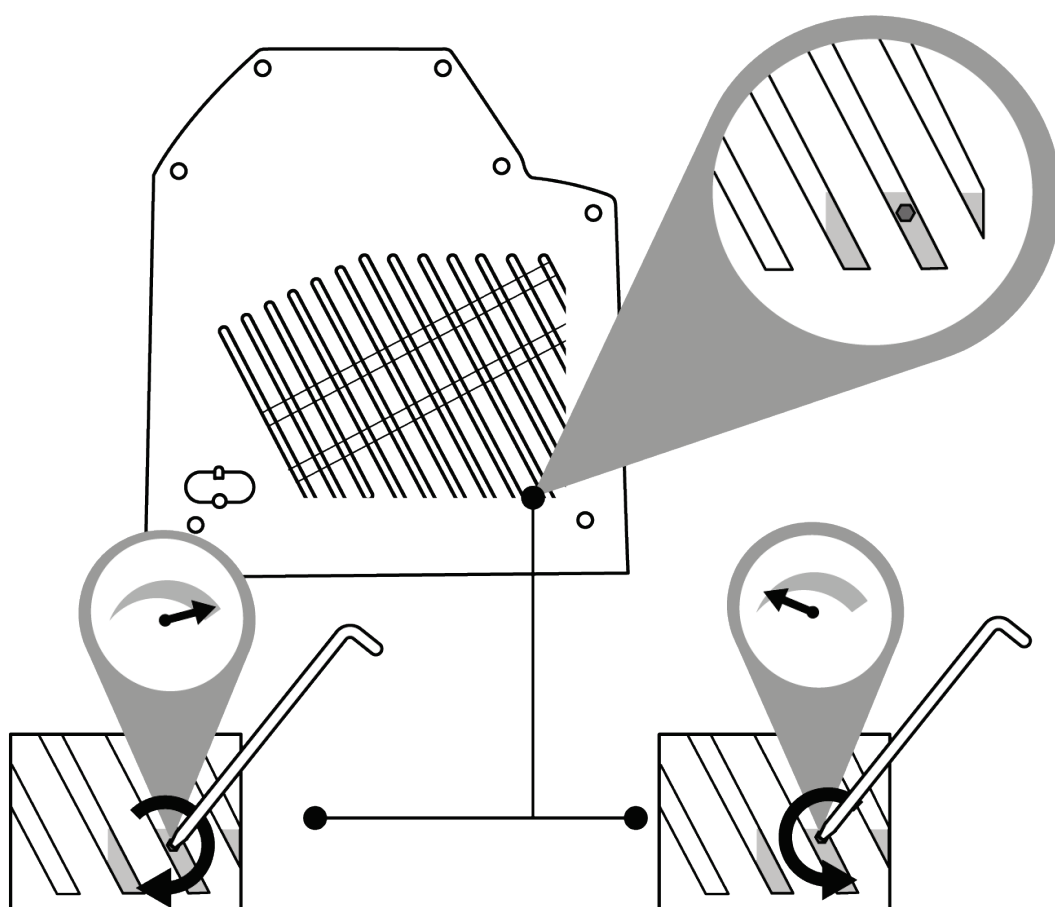

Draai de stelbout niet te strak aan om schade aan het frictiesysteem te voorkomen.

Draai de stelbout ook niet helemaal los: als u dit toch doet, bestaat de kans dat de throttle instabiel wordt.



6. Installatie op een steun



De VIPER TQS kan op verschillende soorten steunen worden geïnstalleerd. De meeste cockpits en steunen die te koop zijn, zijn al compatibel met vergelijkbare Thrustmaster-producten zoals de HOTAS Warthog.

Houd er rekening mee dat de VIPER TQS een krachtig hefboomeffect heeft en daarom stevig moet worden bevestigd.

Bevestig de voet aan de steun met behulp van vier geschikte M6-bouten (niet meegeleverd) zodat de greep niet beschadigd raakt.

Een volledig VIPER TQS-schema is beschikbaar op <https://support.thrustmaster.com/product/viper-tqs/>



Controleer voor elk gebruik of de VIPER TQS nog steeds correct aan de steun is bevestigd, volgens de instructies van de fabrikant.

Houd rekening met het materiaal waarvan uw steun is gemaakt en zorg ervoor dat het product veilig aan dat materiaal kan worden bevestigd. De VIPER TQS moet worden gebruikt op een tafel, werkblad of bureau gemaakt van een stevig materiaal (bijvoorbeeld MDF of hout), zonder holle of glazen delen.



Montagemal-afmetingen (in mm)

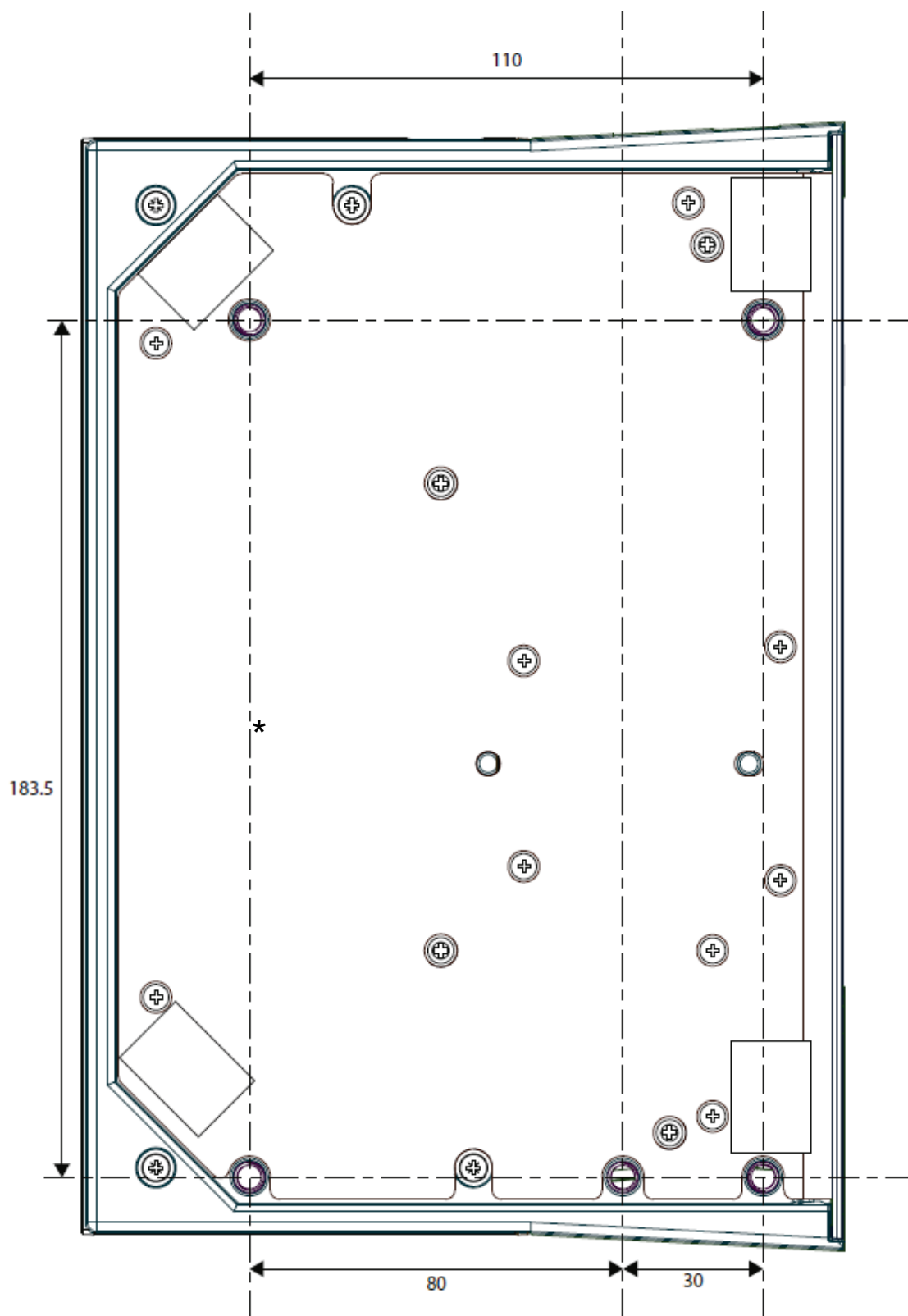

U kunt de montagemal downloaden van <https://support.thrustmaster.com/product/viper-tqs/>, afdrukken en gebruiken op uw steun om de boorgaten voor te bereiden.



*Installatie met behulp van de TM Flying Desk Mount**

De TM Flying Desk Mount is een metalen bevestigingssysteem met een klemschroef, waardoor de ergonomie en bedieningspositie van uw apparaat worden verbeterd. Dit systeem is ontworpen voor gebruik met bureaus, werkbladen en tafels van 15–50 mm dik.

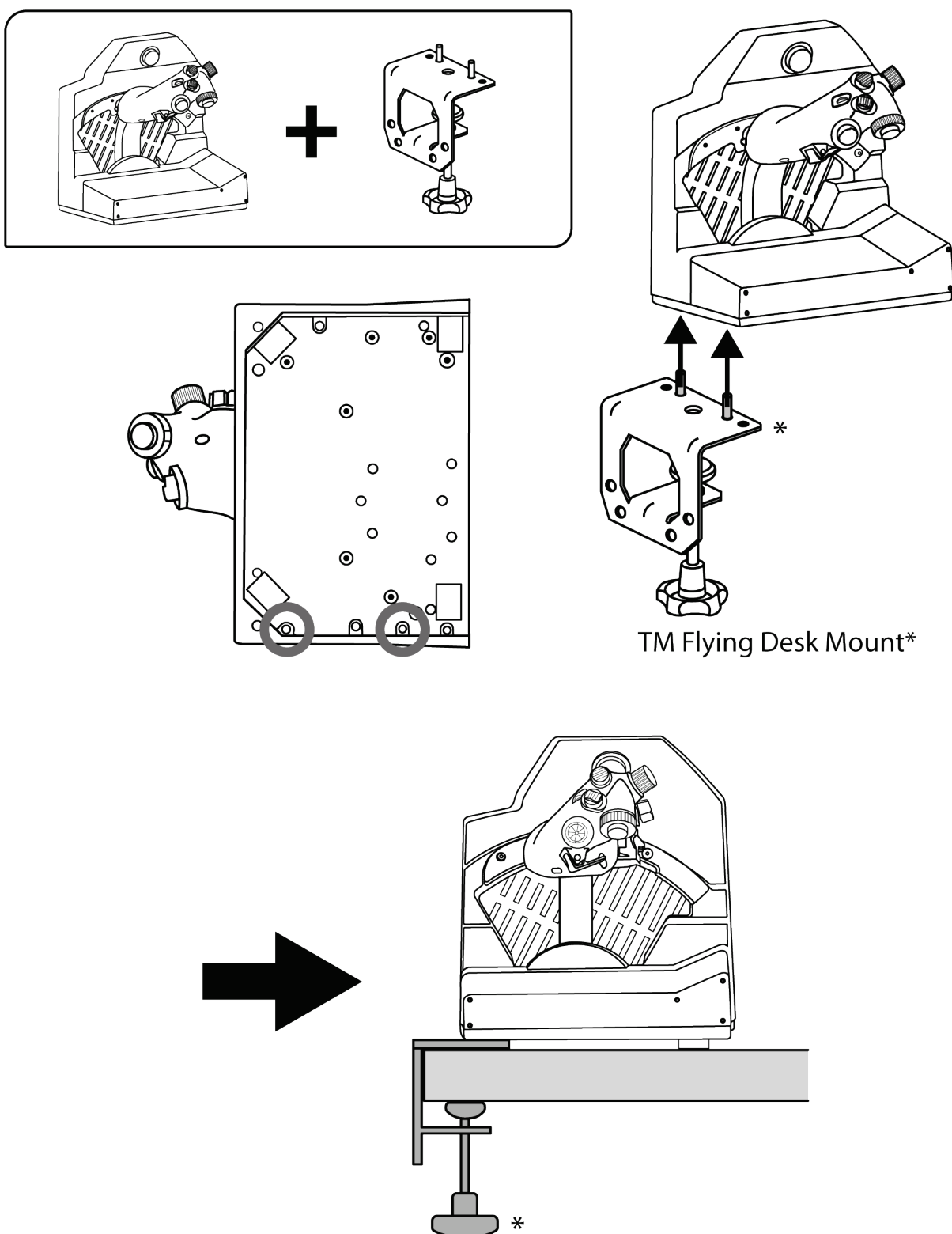

**Wordt apart verkocht*



*Installatie met behulp van de TM Flying Clamp**

De TM Flying Clamp is een in de hoogte verstelbare steun die door Thrustmaster is ontworpen voor haar flightsim-accessoires. Dit bevestigingssysteem heeft twee klembouten waarmee het kan worden ingesteld voor gebruik met bureaus, werkbladen en tafels van 15–45 mm dik.

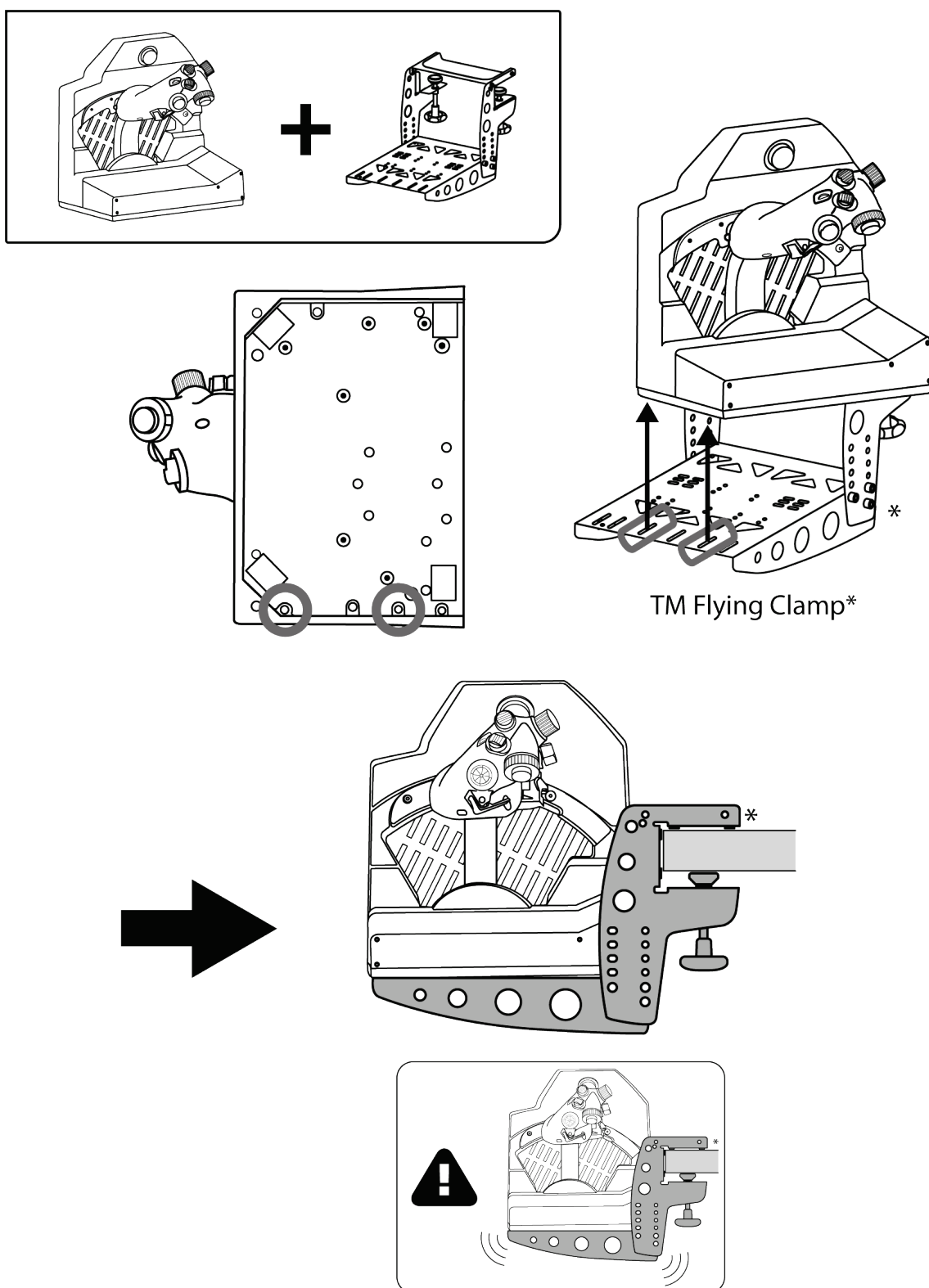

**Wordt apart verkocht*



Houd er rekening mee dat het hoge gewicht van de VIPER TQS kan leiden tot ongewenste bewegingen van het bevestigingssysteem.



7. Installatie van het VIPER PANEL*

* *Wordt apart verkocht Het VIPER PANEL wordt meegeleverd met de VIPER TQS Mission Pack.*

Het VIPER PANEL is een bedieningspaneel waarmee u uw vlucht-/gevechtsmogelijkheden kunt uitbreiden met een totaal van 43 knoppen en 1 as die alle programmeerbaar zijn via de T.A.R.G.E.T.-software. Het VIPER PANEL is een aanvulling op de VIPER TQS.

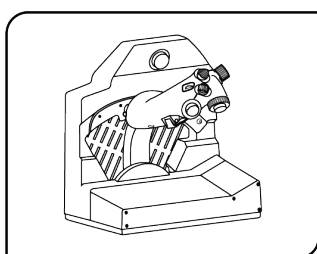

1

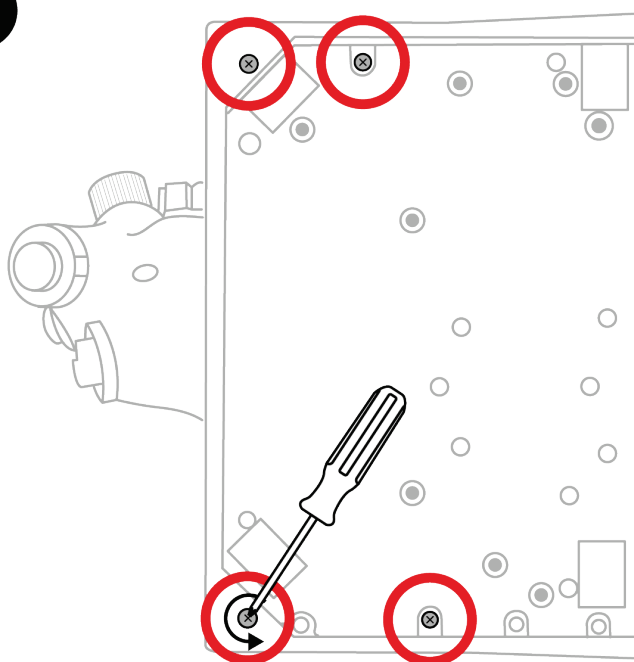

2

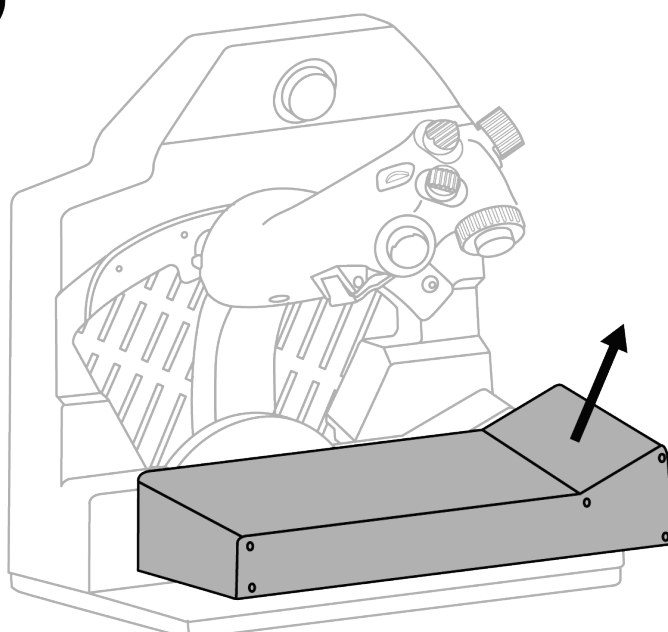

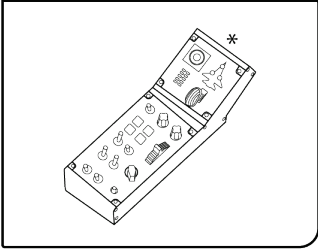

3

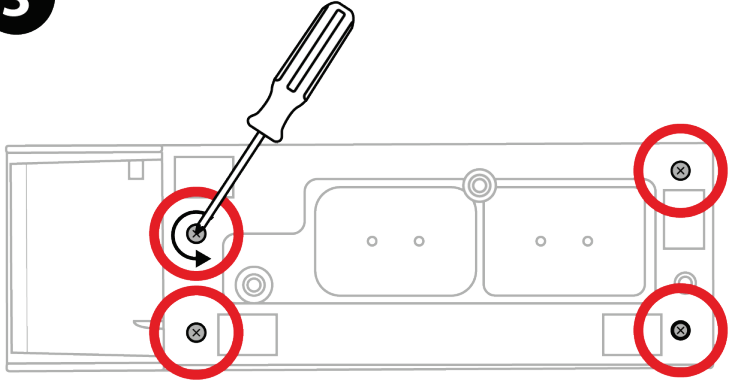

4

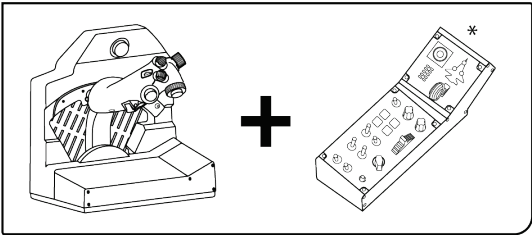
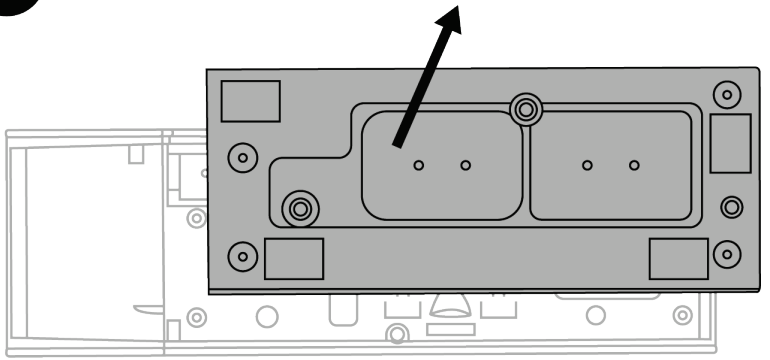

5

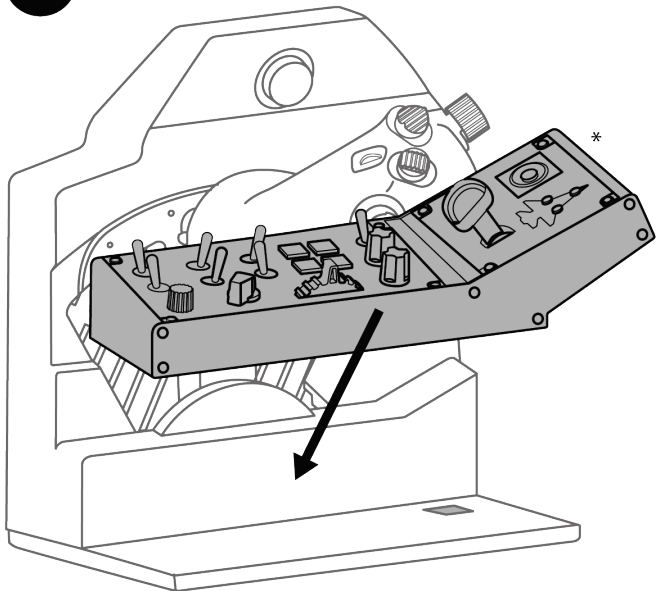



6

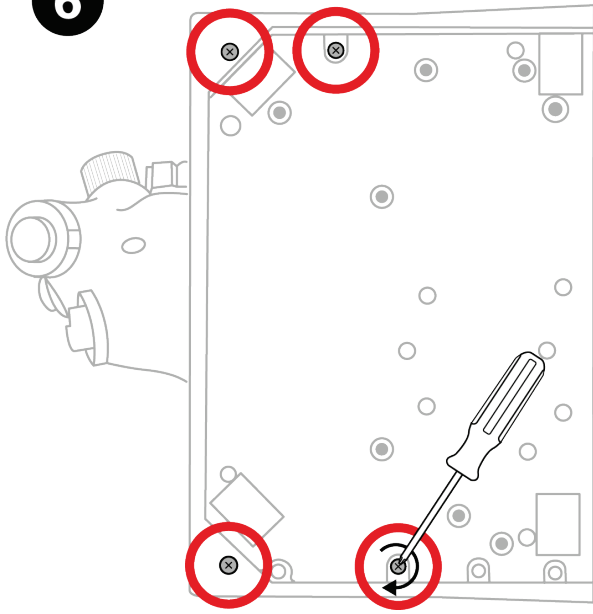

7

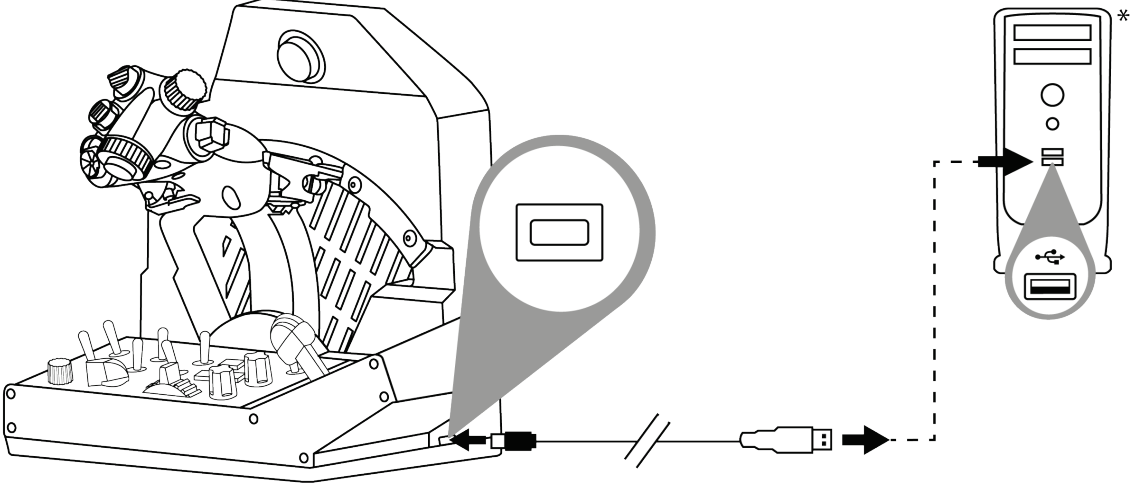

**Niet meegeleverd*



8. Installatie op de PC

1



Ga naar

<https://support.thrustmaster.com/product/viper-tqs/>

2

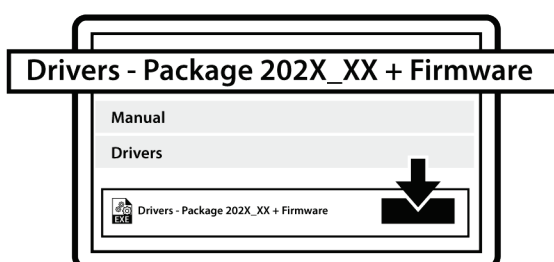

Download en installeer de PC-driver en de speciaal aangepaste interface voor het Windows-configuratiescherm.

3

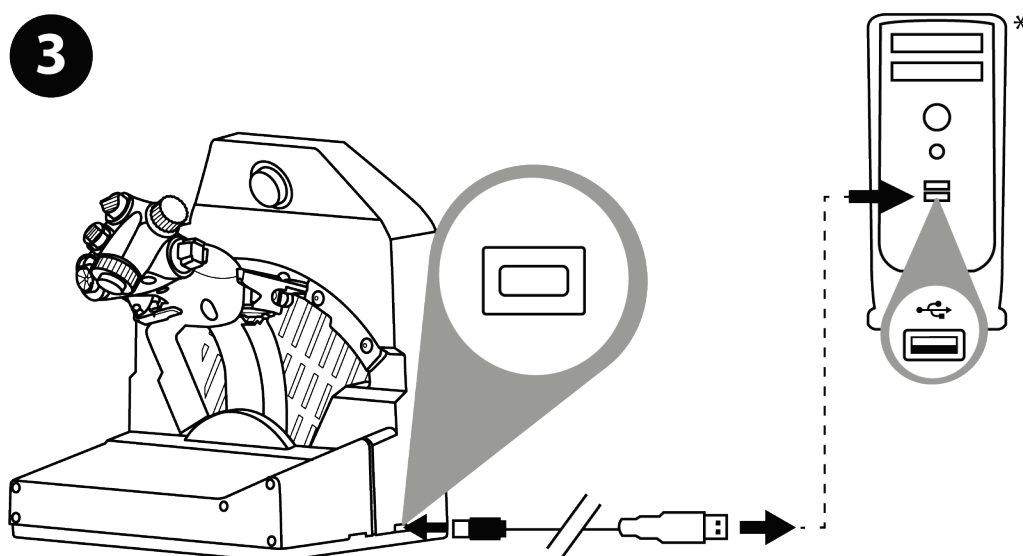

Sluit, nadat de PC-driver is geïnstalleerd, de USB-connector aan op een van de USB-poorten van uw PC.

**Niet meegeleverd*



④ Voor toegang tot het Control Panel, gaat u naar **Start / Thrustmaster / Control Panel** of **Configuratiescherm** (in Windows 10).

Het dialoogvenster **Spelbesturingen** wordt weergegeven. Het apparaat wordt in het venster weergegeven met de naam **Viper TQS** en de status **OK**.

⑤ Klik op **Eigenschappen** in het dialoogvenster **Spelbesturingen** om alle functies te bekijken en te testen.

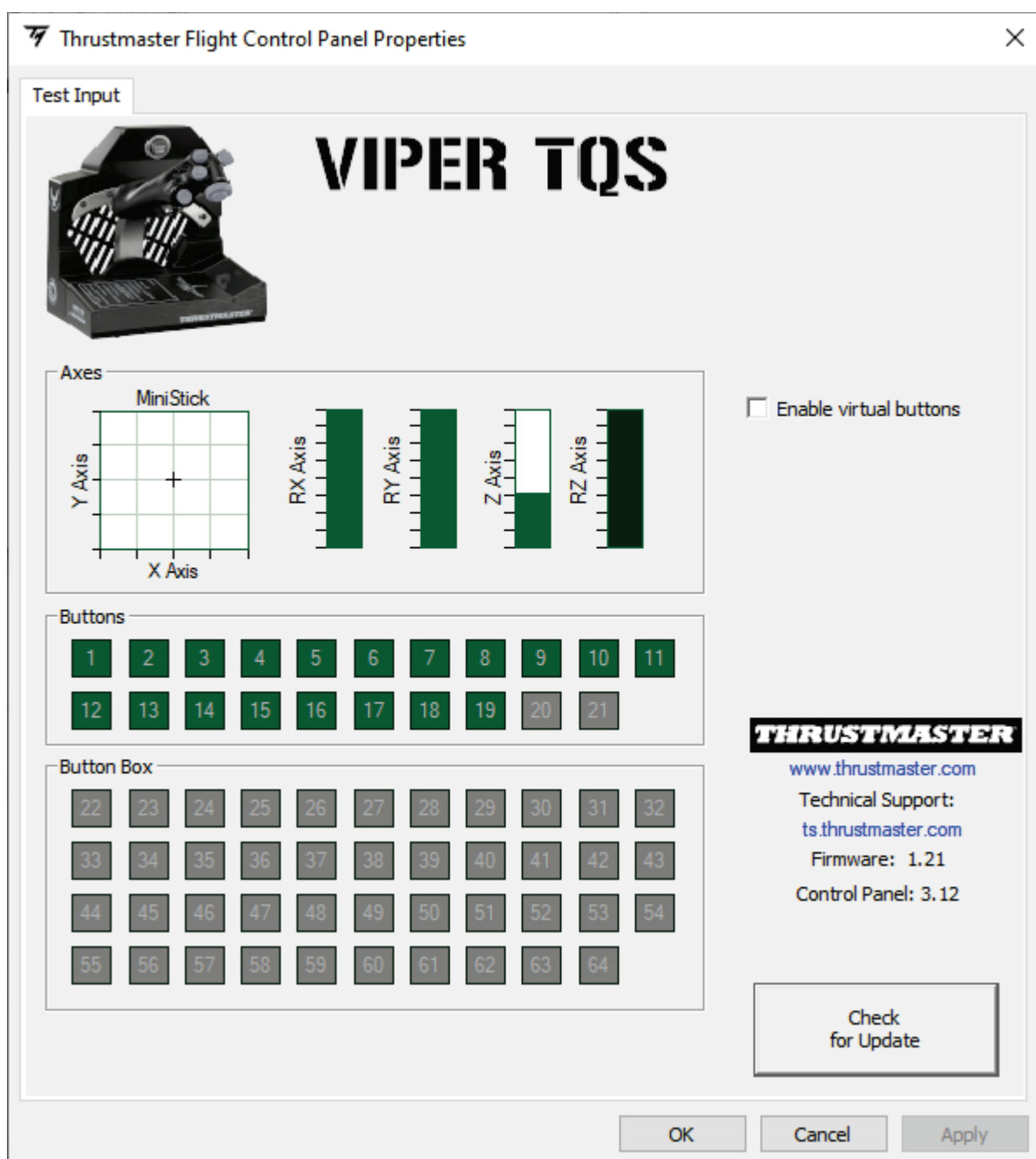



Enable virtual buttons (Virtuele knoppen inschakelen):

Met deze functie kunt u de virtuele knoppen op de greep (knop 20 en 21) in- of uitschakelen. Klik op **Apply** (Toepassen) nadat u de modus hebt geselecteerd die u wilt gebruiken.

Thrustmaster Flight Control Panel Properties

Test Input

VIPER TQS

Enable virtual buttons

Buttons

1	2	3	4	5	6	7	8	9	10	11
12	13	14	15	16	17	18	19	20	21	

Button Box

22	23	24	25	26	27	28	29	30	31	32
33	34	35	36	37	38	39	40	41	42	43
44	45	46	47	48	49	50	51	52	53	54
55	56	57	58	59	60	61	62	63	64	

Check for Update

OK Cancel Apply



De virtuele knoppen zijn standaard uitgeschakeld op de VIPER TQS.



9. CUT OFF- en AFTERBURNER-standen

De VIPER TQS-throttle-quadrant beschikt over een realistisch systeem van CUT OFF- en AFTERBURNER-standen (de Afterburner-module is verwijderbaar).

CUT OFF

Zet de throttle in de IDLE-stop, druk op de pal "motoruitschakeling ontgrendelen" **1** om de greep over de stop te tillen **2** en zet de greep vervolgens in de OFF-stand **3**.

Om de motoren weer aan te zetten, voert u deze procedure uit in omgekeerde volgorde.

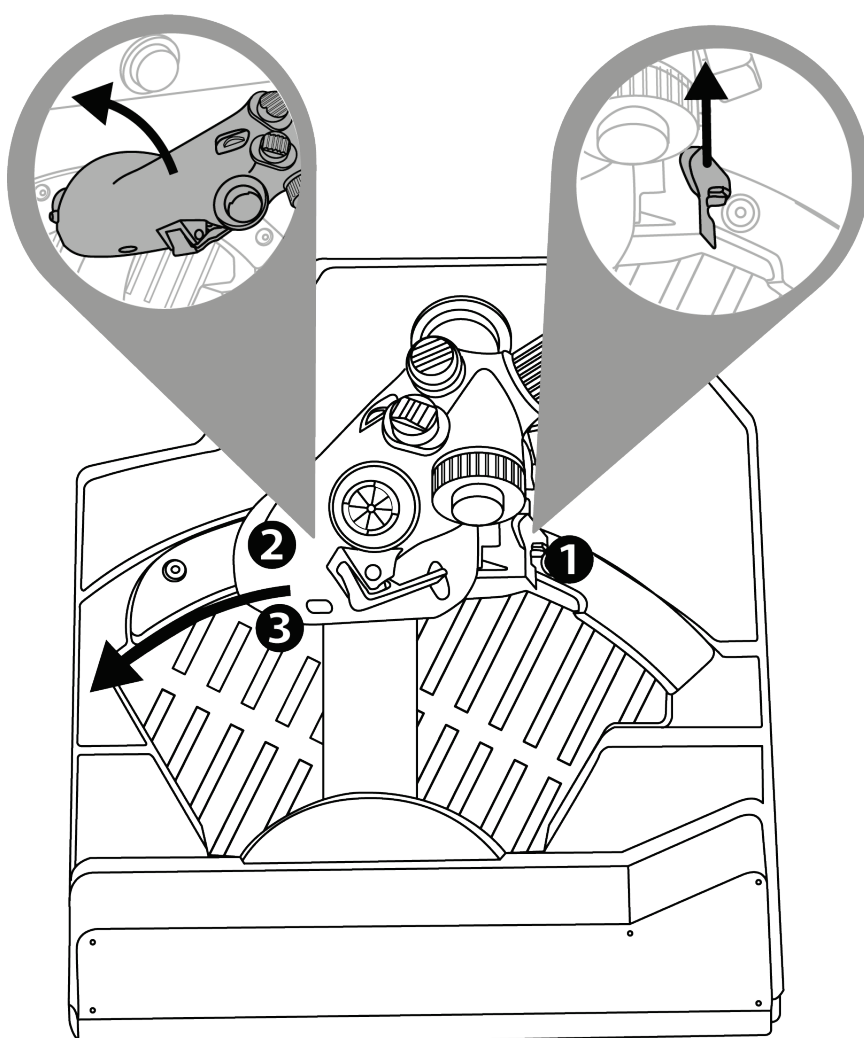



AFTERBURNER

Beweeg de throttle naar de stop **1** en til deze op **2** om over de stop te tillen en de naverbrander **3** in te schakelen.

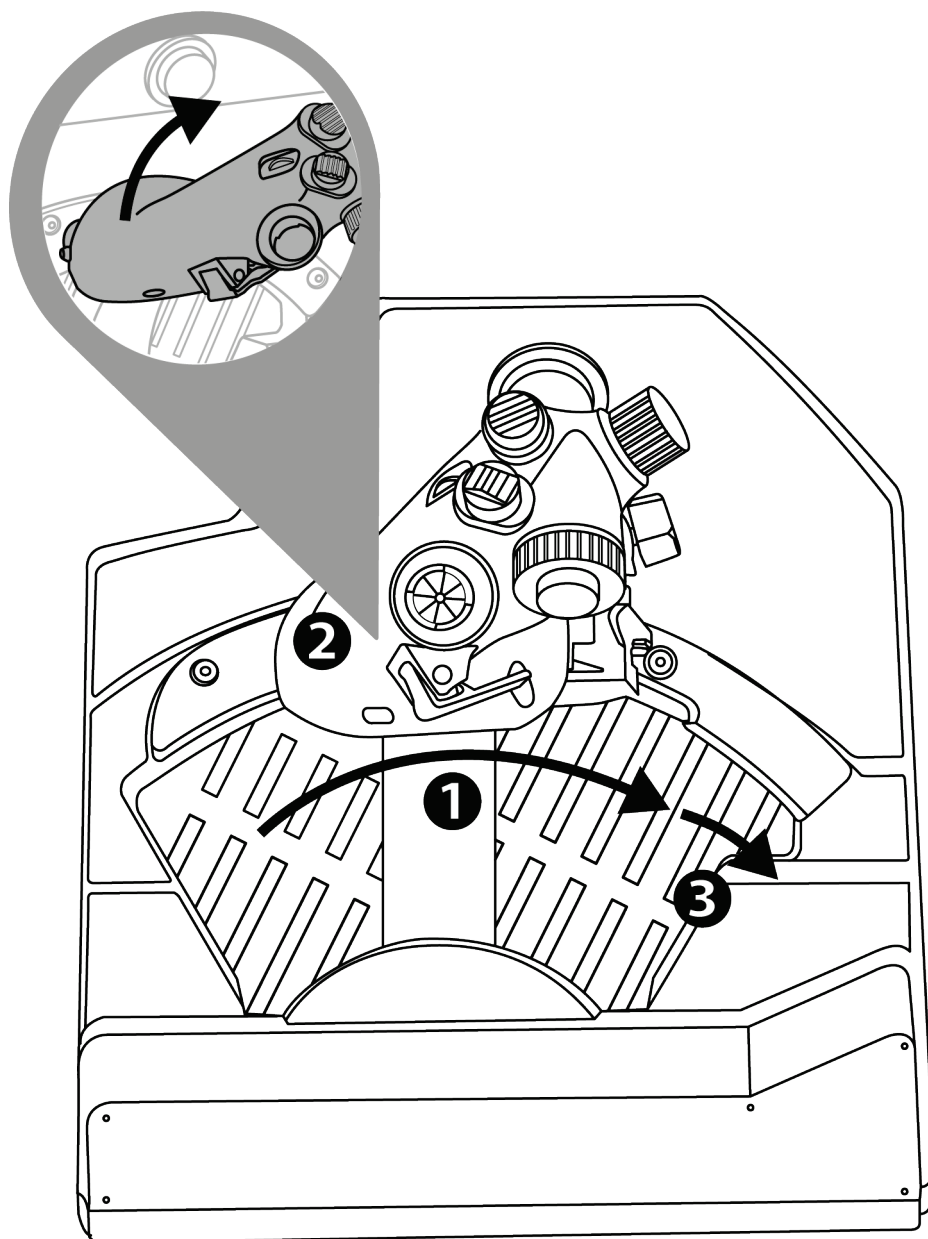



De AFTERBURNER-stop verwijderen

De stop van de Afterburner-module bevindt zich op 80% van de waarde van de as.

Als u de maximale gebruikslengte van de throttle nodig hebt zonder stop (voor een bepaalde simulator), kunt u de Afterburner-module en de stop ervan verwijderen door de twee bouten van de module los te draaien met behulp van een inbussleutel (niet meegeleverd).

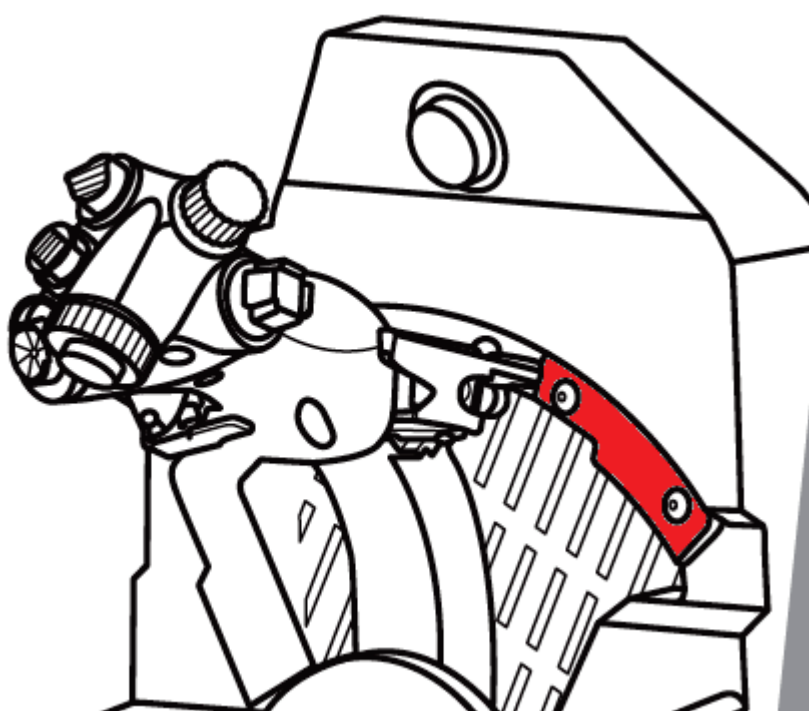



10. T.A.R.G.E.T geavanceerde programmeersoftware



Ga naar

<https://support.thrustmaster.com/product/viper-tqs/>

Ga naar de sectie **Software** en download en installeer de geavanceerde T.A.R.G.E.T-programmeersoftware.



Belangrijkste kenmerken van T.A.R.G.E.T

- Verschillende mogelijke configuraties voor de assen.
- Verschillende mogelijke programmeerniveaus: Basic, Advanced en Script.
- Gebruik van Drag & Drop.
- De mogelijkheid om de VIPER TQS-throttle-quadrant te combineren met andere Thrustmaster-joysticks (HOTAS Cougar, HOTAS Warthog, T.16000M, MFD Cougar Pack die alle compatibel zijn met T.A.R.G.E.T) waardoor ze herkend worden als één enkel USB-apparaat.
- Toegang tot geavanceerde profielen gemaakt door de Thrustmaster-community.



11. FAQ en technische ondersteuning

Hebt u vragen over de VIPER TQS of komt u technische problemen tegen? Ga dan naar de website voor technische ondersteuning van Thrustmaster:

<https://support.thrustmaster.com/product/viper-tqs/>.



THRUSTMASTER®

VIPER TQS

THROTTLE QUADRANT SYSTEM

Per PC (Windows 10/11)

Manuale d'uso



Leggi attentamente le istruzioni riportate nel presente manuale **prima** di installare il prodotto, **prima** di qualsiasi uso del prodotto e **prima** di qualsiasi intervento di manutenzione. Assicurati di rispettare le istruzioni sulla sicurezza: il mancato rispetto di tali istruzioni potrebbe causare incidenti e/o danni. Conserva questo manuale in modo tale da poterne consultare le istruzioni in futuro.

INDICE

2.	CARATTERISTICHE DEL VIPER TQS	6
3.	MAPPATURA DI PULSANTI E ASSI.....	8
4.	INFORMAZIONI SULL'USO DEL VIPER TQS	10
5.	REGOLAZIONE DELLA RESISTENZA.....	11
6.	INSTALLAZIONE SU UN SUPPORTO	12
7.	INSTALLAZIONE DEL VIPER PANEL*	17
8.	INSTALLAZIONE SU PC.....	20
9.	BLOCCHI CUT OFF E AFTERBURNER	23
10.	SOFTWARE DI PROGRAMMAZIONE AVANZATA T.A.R.G.E.T	26
11.	FAQ E ASSISTENZA TECNICA	28



Accendi i tuoi motori e vola nella zona di pericolo con l'iconico sistema quadrante manetta del VIPER della U.S. Air Force: il moderno aereo da caccia più utilizzato al mondo!

Alza il livello del tuo abitacolo grazie alle esclusive ergonomie di un HOTAS replica in scala 1:1, caratterizzato da un'impugnatura in metallo oltre a pulsanti e blocchi realistici.

Questo manuale ti aiuterà a installare e utilizzare al meglio il tuo VIPER TQS. Prima di decollare, assicurati di aver letto con attenzione tutti i presenti avvisi e istruzioni: ti aiuteranno a divertirti al massimo utilizzando il tuo prodotto.



Aggiornamento del firmware

Affinché il VIPER TQS funzioni correttamente nei videogiochi, dovrai aggiornarne il firmware.

Per eseguire l'aggiornamento, visita la pagina:

<https://support.thrustmaster.com/product/viper-tqs/>

Seleziona **Firmware** e segui le istruzioni, comprese le procedure di download e installazione.



1. Contenuto della confezione

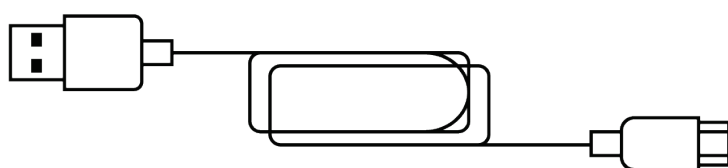
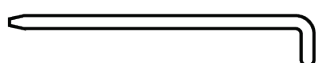
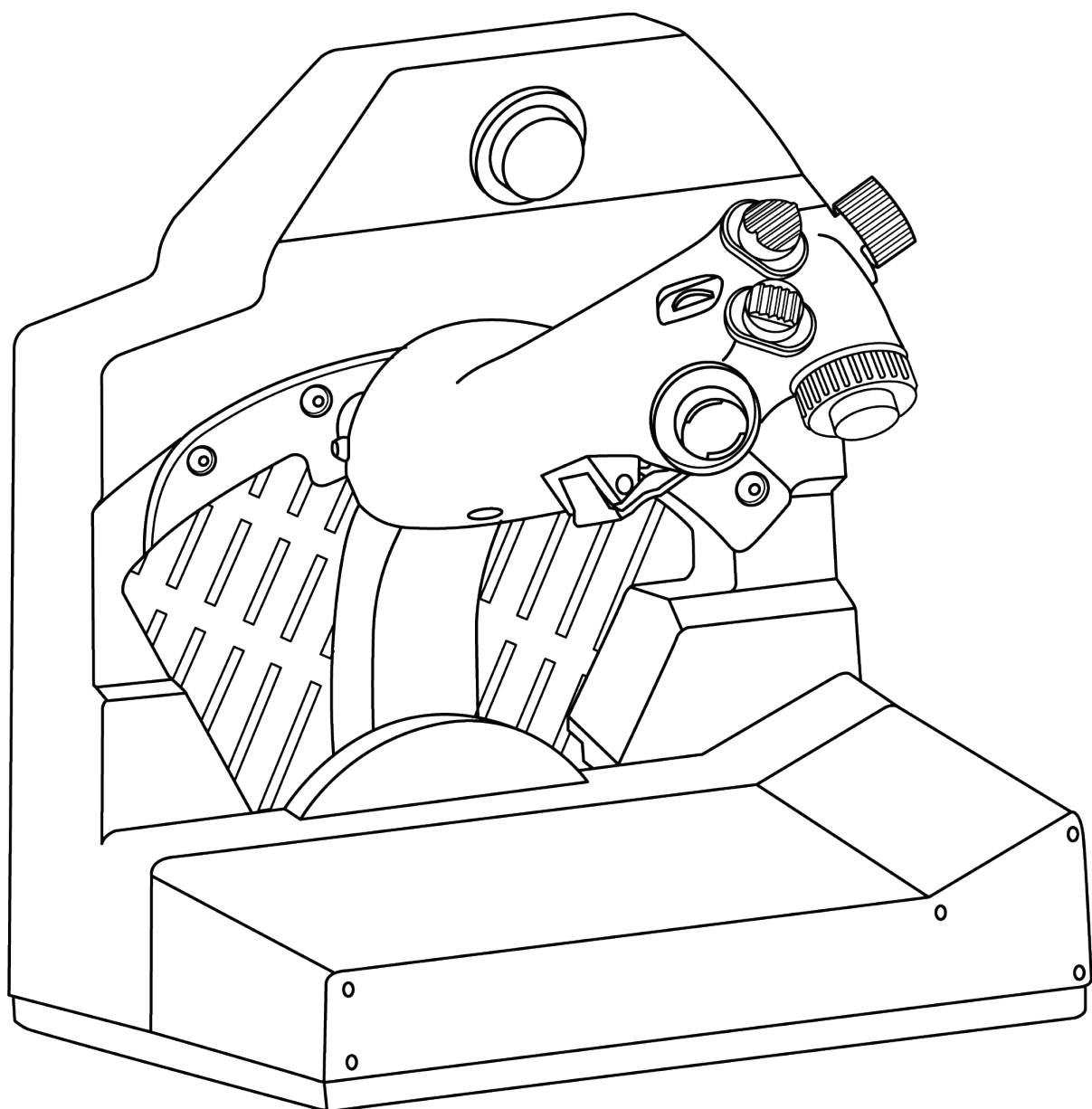



2. Caratteristiche del VIPER TQS

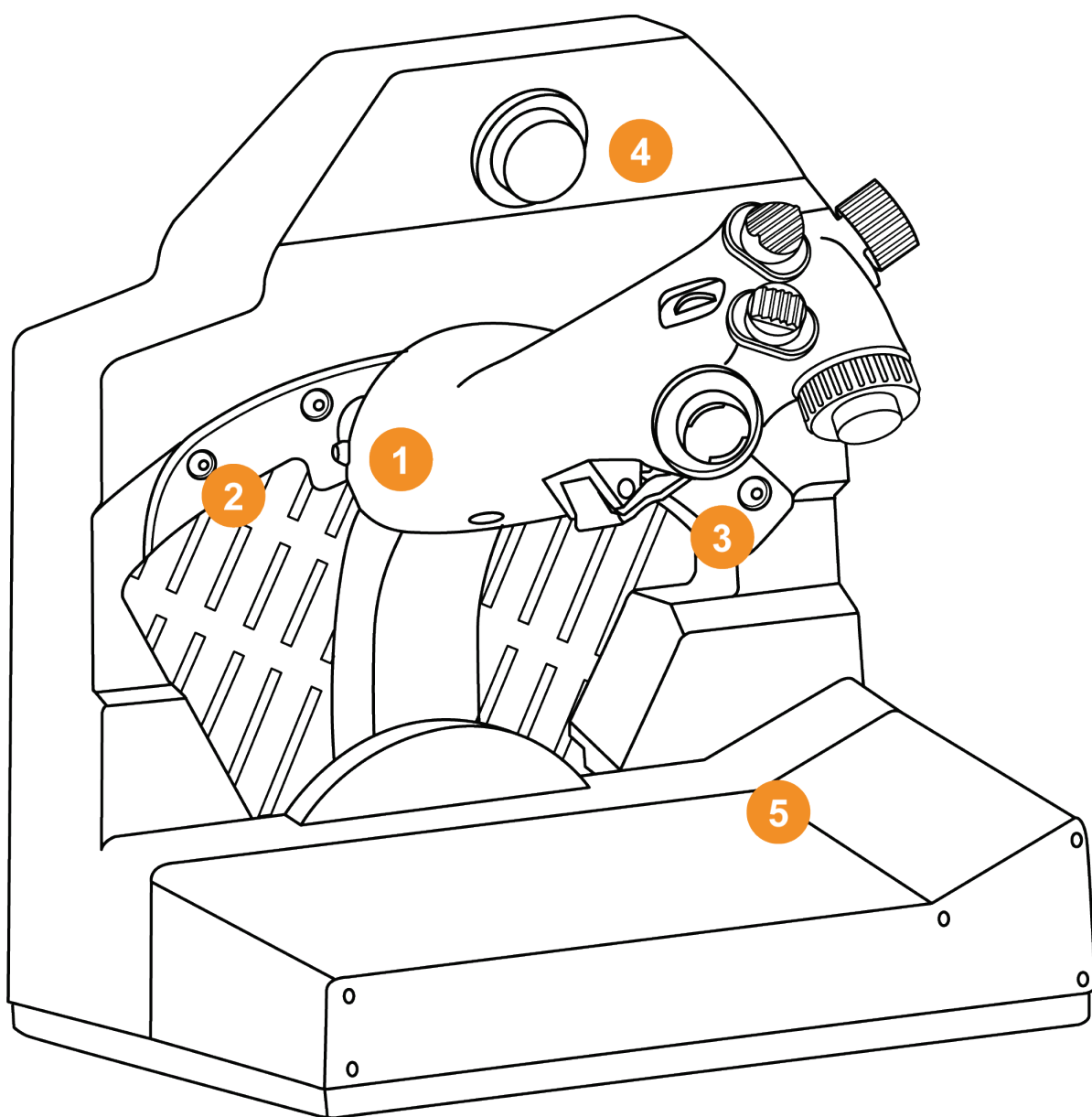

1. Impugnatura

2. Blocco Cut Off

3. Blocco Afterburner

4. Pulsante immediato CHAFF/FLARE

5. Clip per mappa della missione

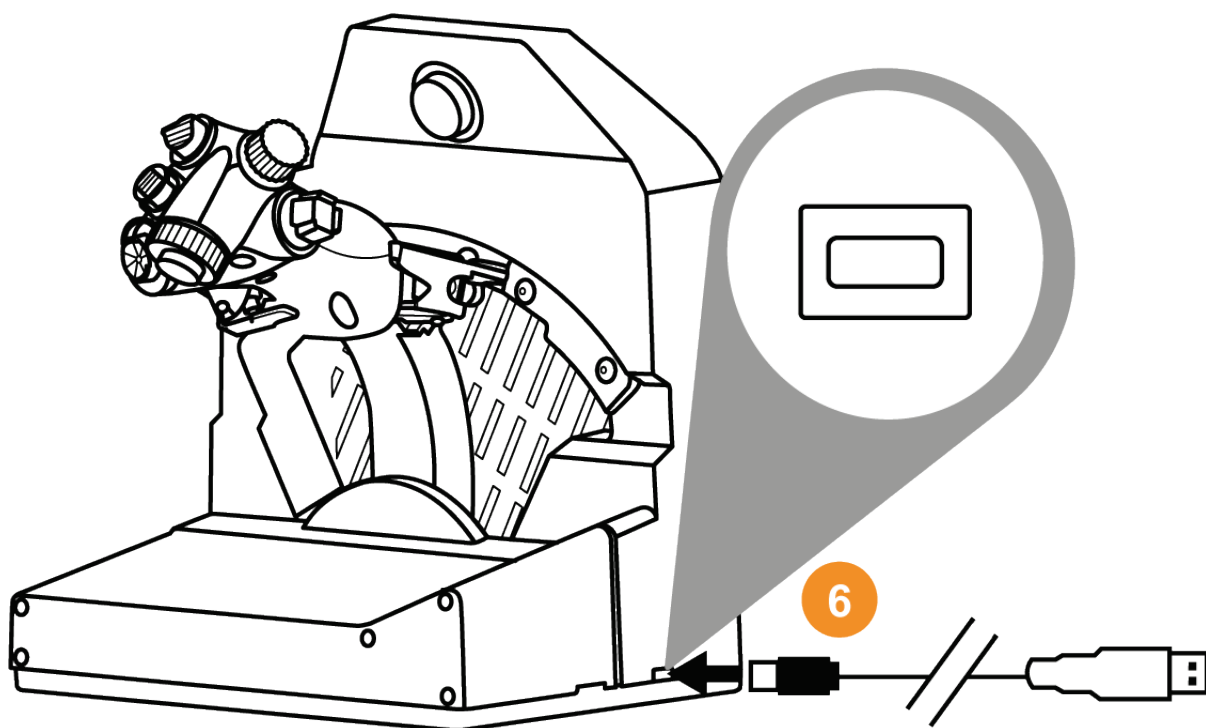

6. Connettore USB (tipo C)

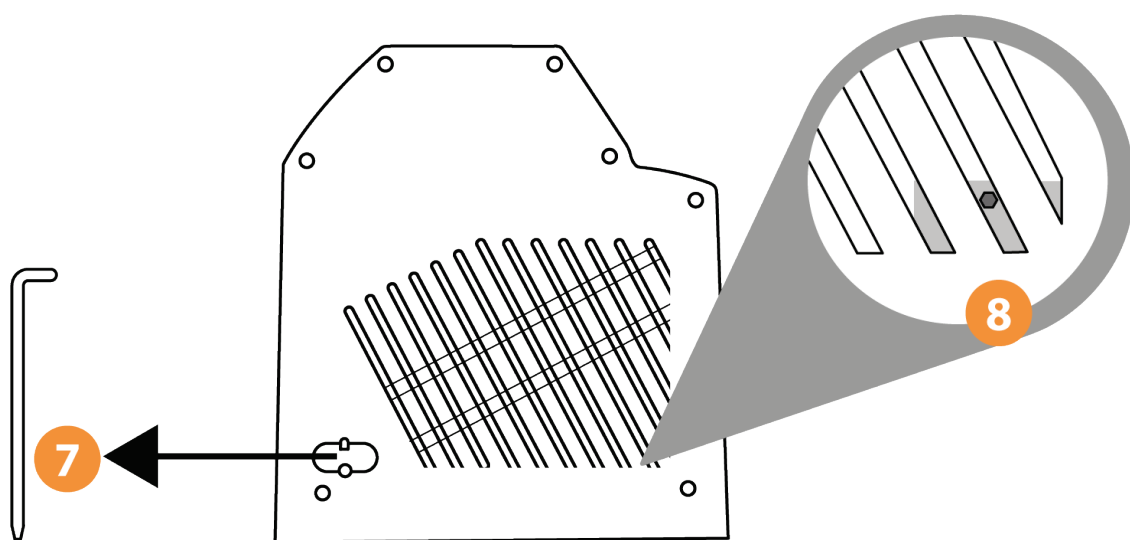

7. Posizione dello strumento per la regolazione della resistenza

8. Punto di accesso per la regolazione della resistenza della manetta



3. Mappatura di pulsanti e assi

Impugnatura VIPER TQS: mappatura dei 19 pulsanti e 5 assi in modalità A (senza pulsanti virtuali)

A 1 → 19

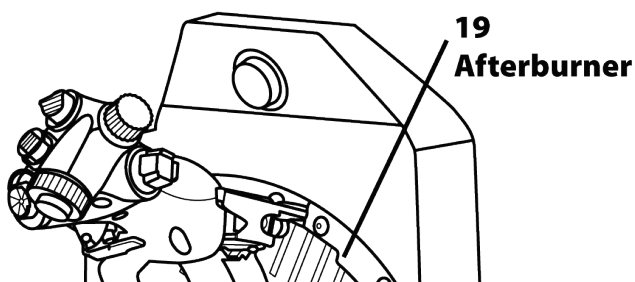
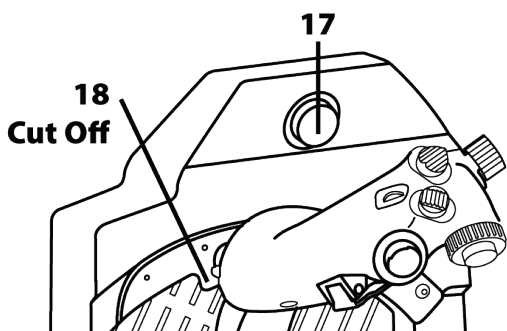
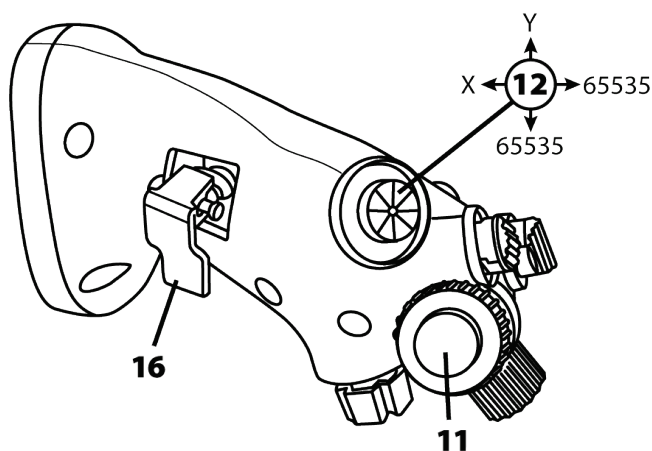
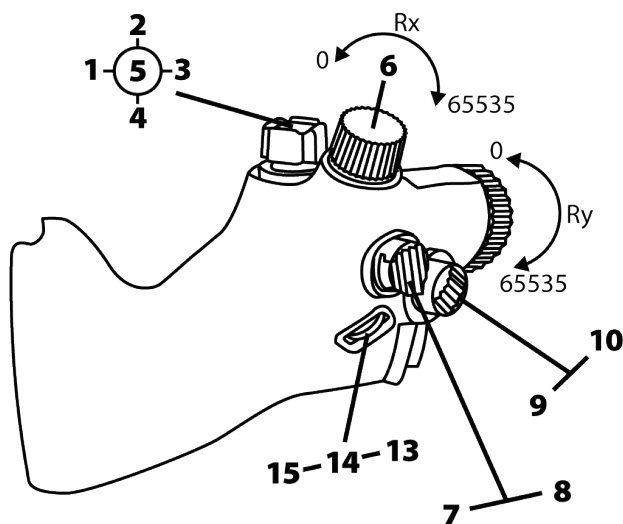



Modalità B: con pulsanti virtuali

B 1 → 21

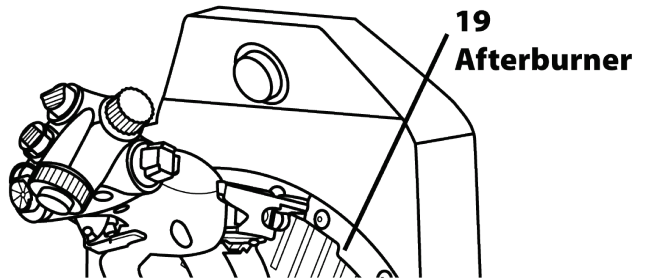
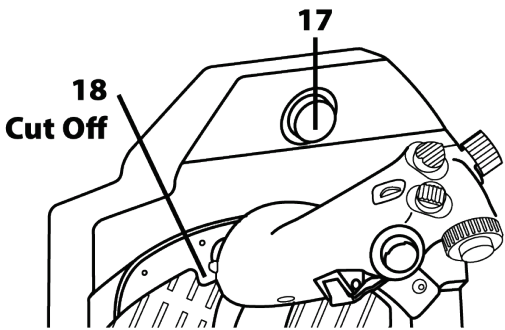
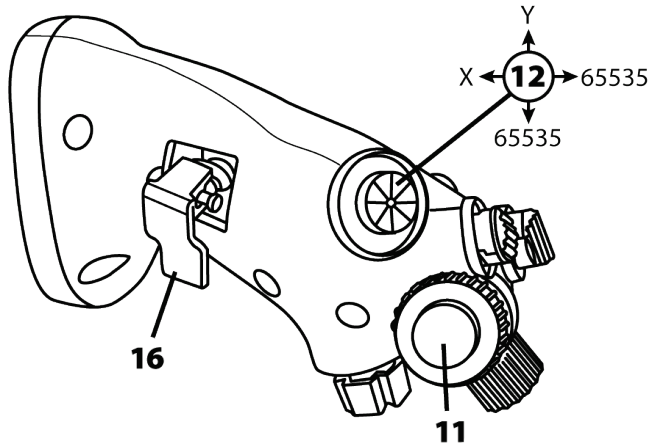
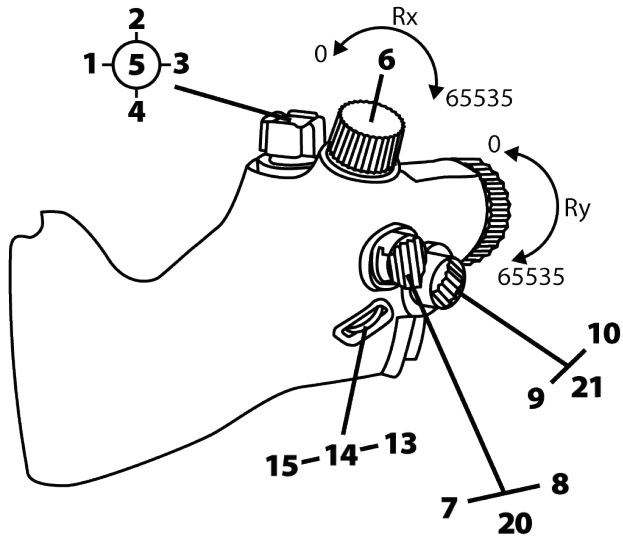



4. Informazioni sull'uso del VIPER TQS



Rischio schiacciamento

Quando utilizzi l'impugnatura, non lasciare mai le tue dita nelle aree di blocco.

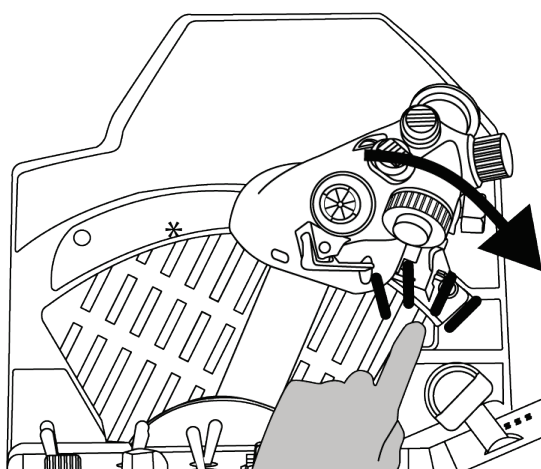
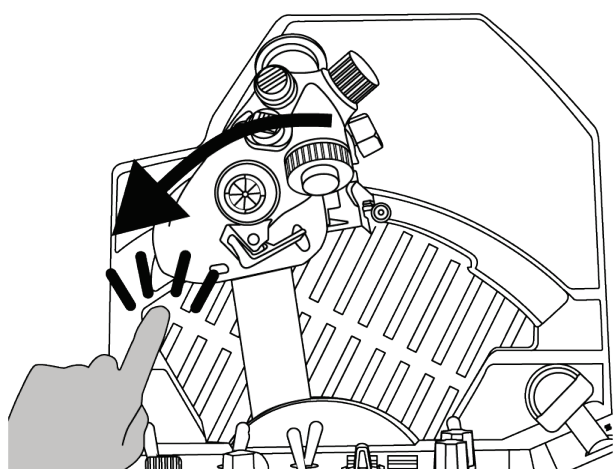
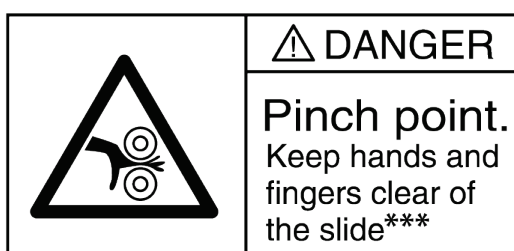



4. Regolazione della resistenza

Puoi regolare la resistenza del tuo quadrante manetta VIPER TQS in base ai tuoi gusti personali, utilizzando l'apposito strumento presente sul fianco del VIPER TQS. Tuttavia, è bene ricordare che la resistenza della manetta è stata preimpostata al livello ottimale al momento della fabbricazione.

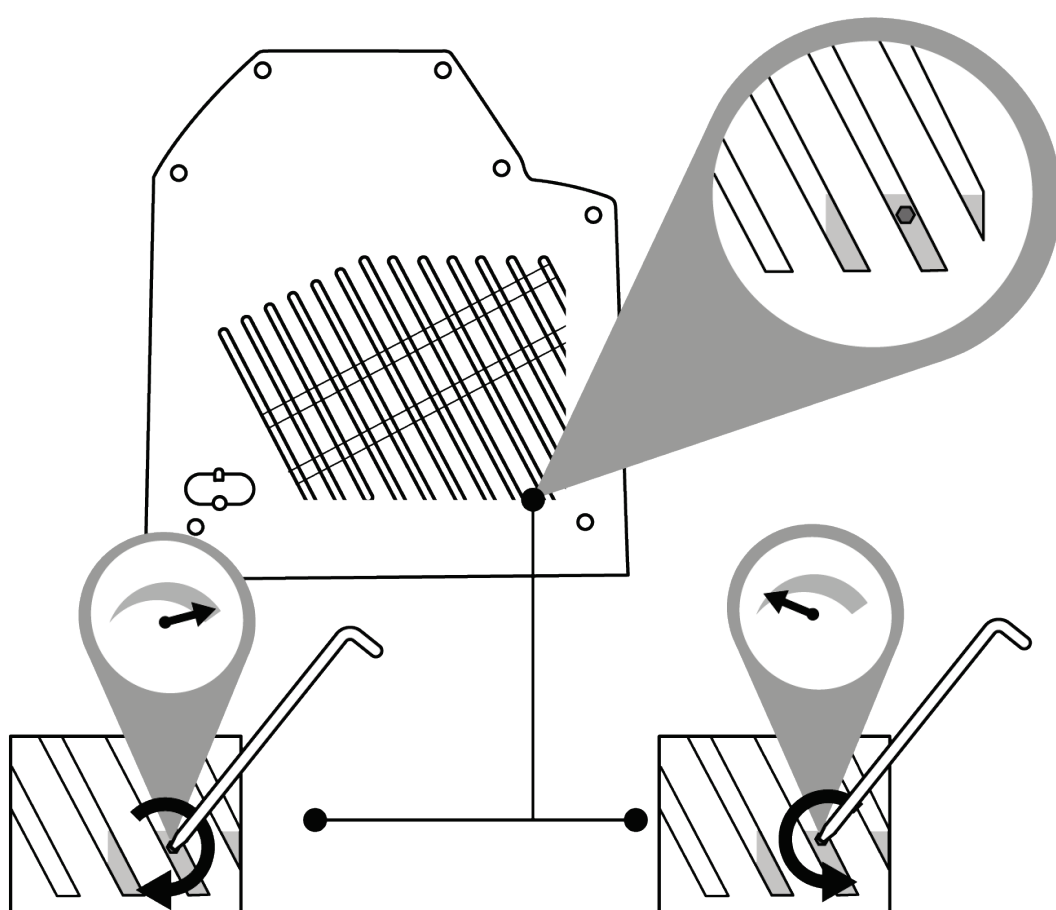

Per non danneggiare il meccanismo della resistenza, assicurati di non stringere troppo la vite di regolazione.

Inoltre, assicurati di non allentare troppo la vite di regolazione, altrimenti rischieresti che la manetta non riesca più a rimanere in posizione.



6. Installazione su un supporto



VIPER TQS può essere installato su diversi tipi di supporti. La maggior parte degli abitacoli e dei supporti disponibili sul mercato sono già compatibili con prodotti Thrustmaster simili (ovvero HOTAS Warthog).

Tieni ben presente che il VIPER TQS è caratterizzato da un potente effetto leva e dovrà essere, pertanto, ben fissato.

Per non danneggiare l'impugnatura, fissa la base al tuo supporto utilizzando apposite viti M6 (non incluse).

Uno schema completo del VIPER TQS è disponibile alla pagina:

<https://support.thrustmaster.com/product/viper-tqs/>



Prima di ogni utilizzo, verifica che il VIPER TQS risulti sempre ben fissato al supporto, rispettando le istruzioni fornite dal produttore.

Tieni sempre ben presente il materiale di cui è fatto il tuo supporto e assicurati che sia possibile fissarvi il prodotto in totale sicurezza. Il VIPER TQS deve essere utilizzato su ripiani in materiale solido (ovvero MDF o legno), privi di parti vuote o in vetro.



Dimensioni schema di montaggio (in mm)

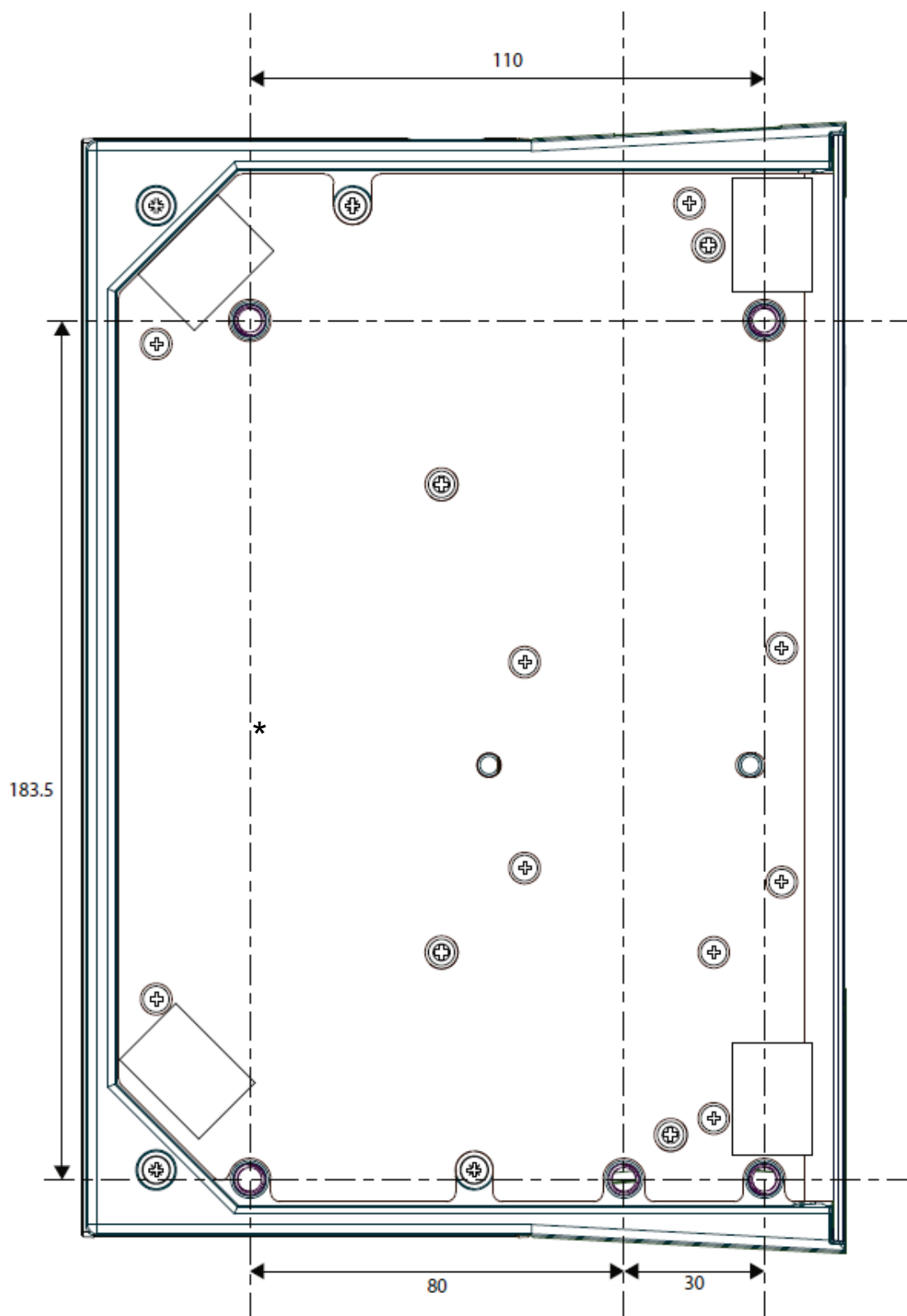

Puoi scaricare lo schema di montaggio dalla pagina:
<https://support.thrustmaster.com/product/viper-tqs/>, per poi stamparlo e utilizzarlo sul tuo supporto per preparare i relativi fori.



Installazione utilizzando il TM Flying Desk Mount*

Il TM Flying Desk Mount è un sistema di montaggio in metallo dotato di una morsa di fissaggio, che migliora le ergonomie e la posizione di pilotaggio nell'uso della tua periferica. Questo sistema è stato concepito per scrivanie e tavoli da 15 a 50 mm di spessore.

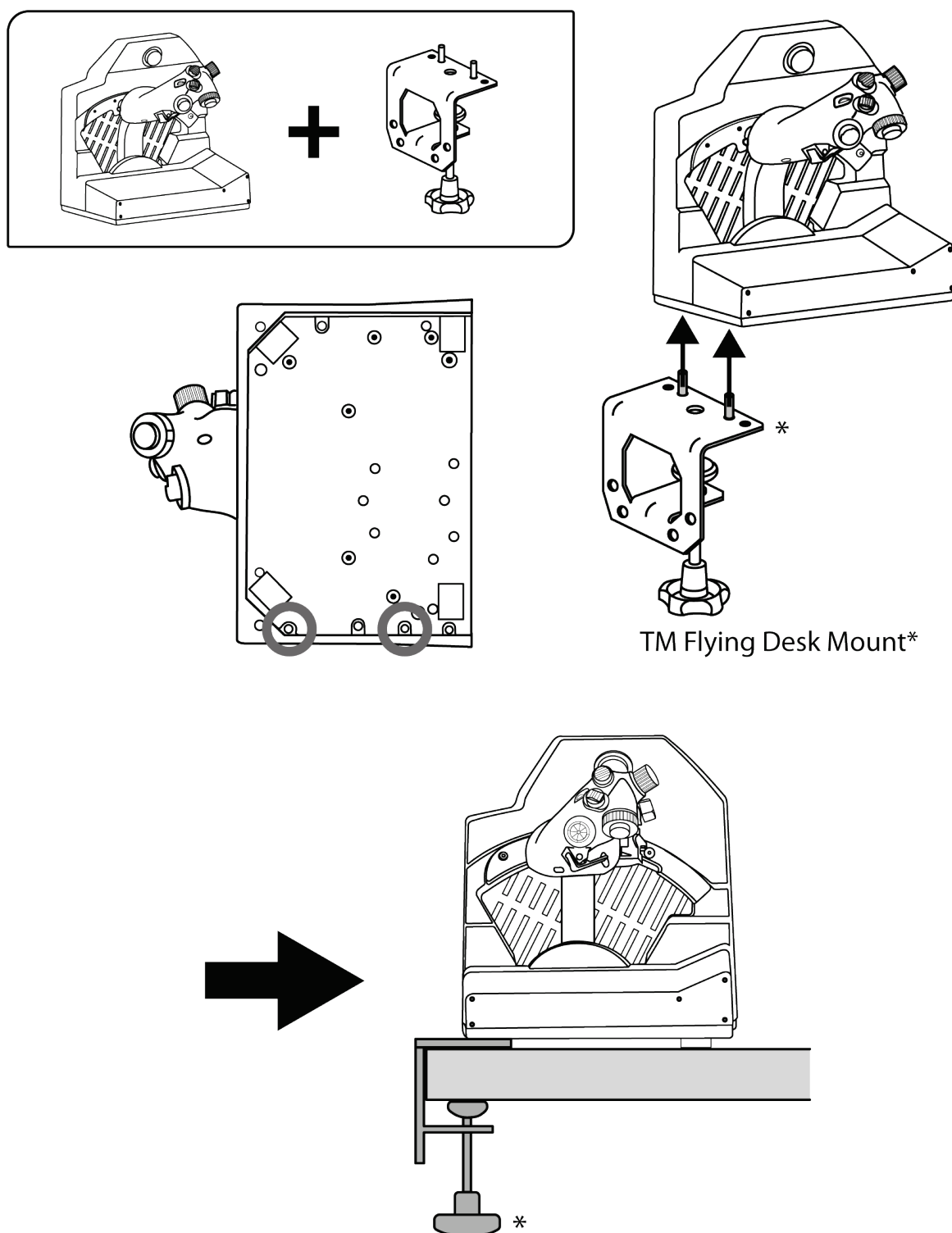

** Venduto separatamente*



Installazione utilizzando il TM Flying Clamp*

TM Flying Clamp è un supporto ad altezza regolabile progettato da Thrustmaster per i suoi accessori dedicati alle simulazioni di volo. Questo sistema di montaggio è dotato di due viti di fissaggio a morsa, che lo rendono utilizzabile con tavoli e scrivanie da 15 a 45 mm di spessore.

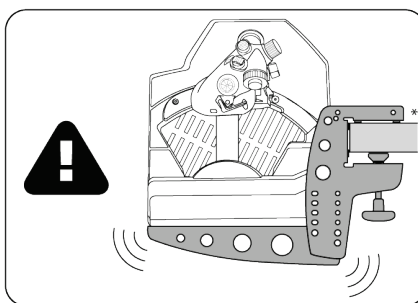
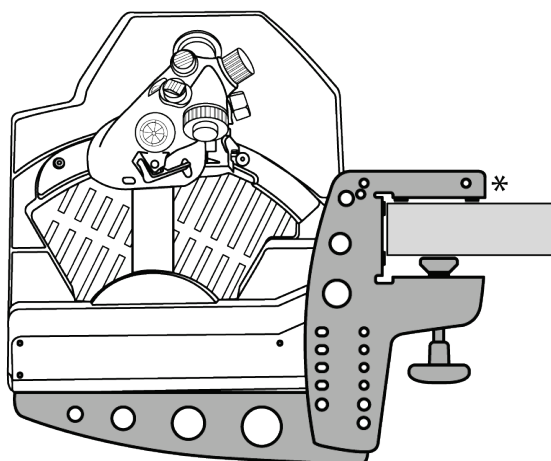
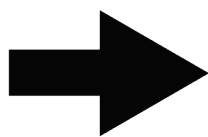
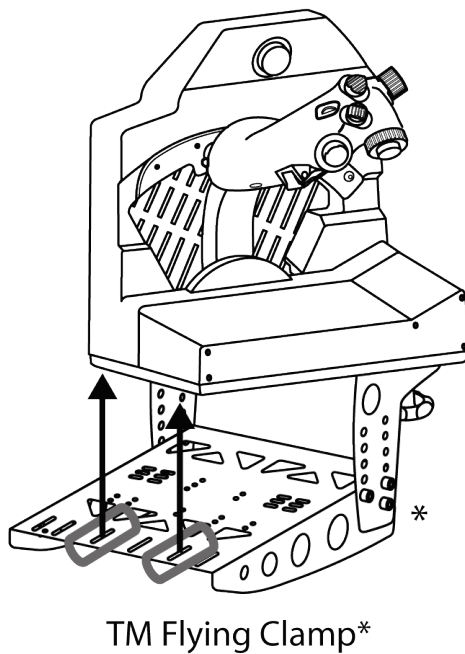
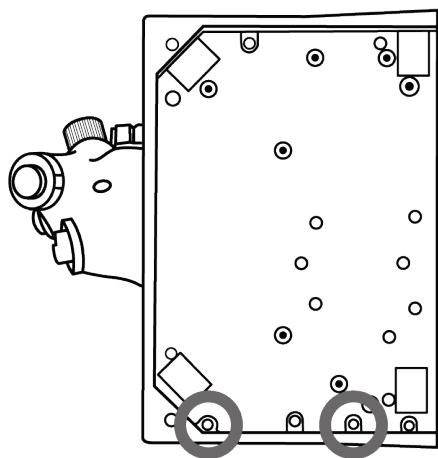
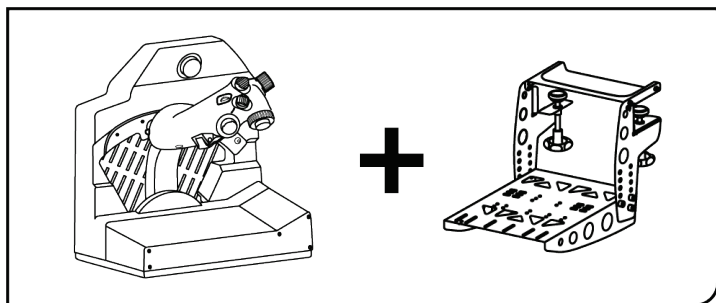

* *Venduto separatamente*



Tieni ben presente che il peso notevole del VIPER TQS potrebbe causare movimenti imprevisti del sistema di montaggio.



7. Installazione del VIPER PANEL*

**Venduto separatamente. Il VIPER PANEL è incluso nel VIPER TQS Mission Pack.*

Il VIPER PANEL è un pannello di controllo che ti permette di espandere le tue capacità di volo/combattimento, con un totale di 43 pulsanti e un asse — tutti programmabili tramite il software T.A.R.G.E.T. Il VIPER PANEL è un complemento del VIPER TQS.

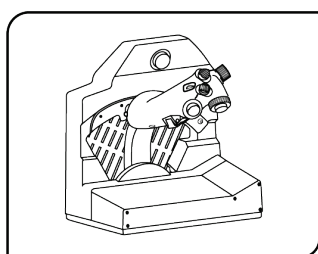

1

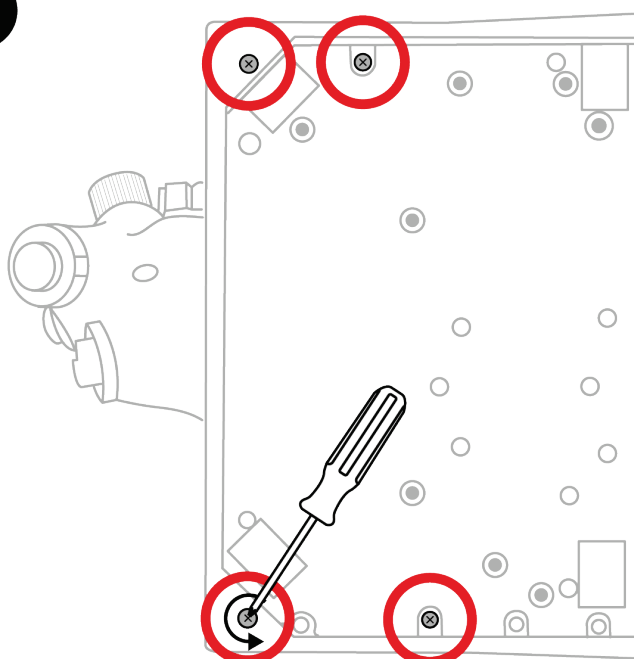

2

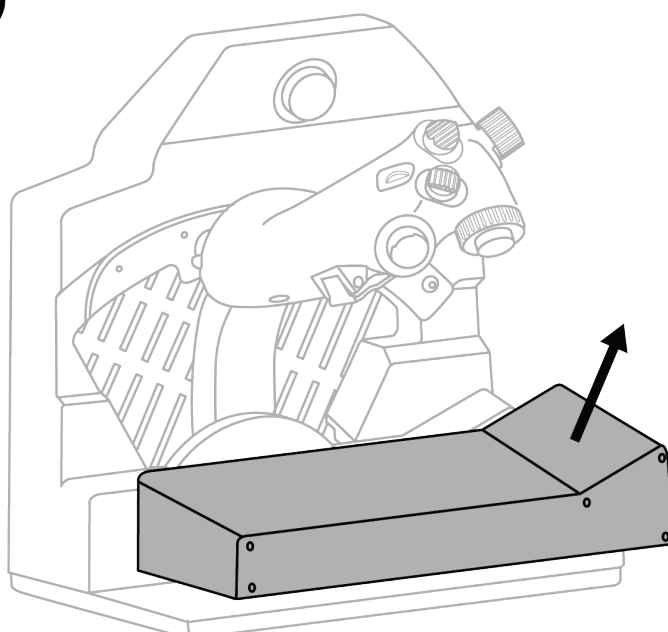

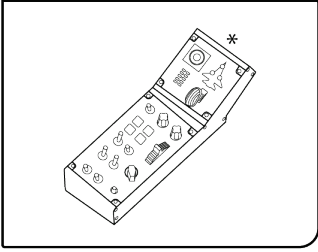

3

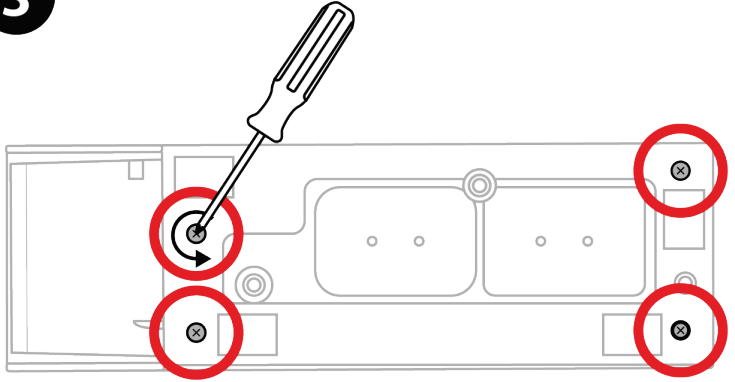

4

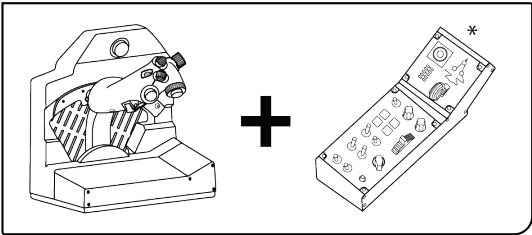
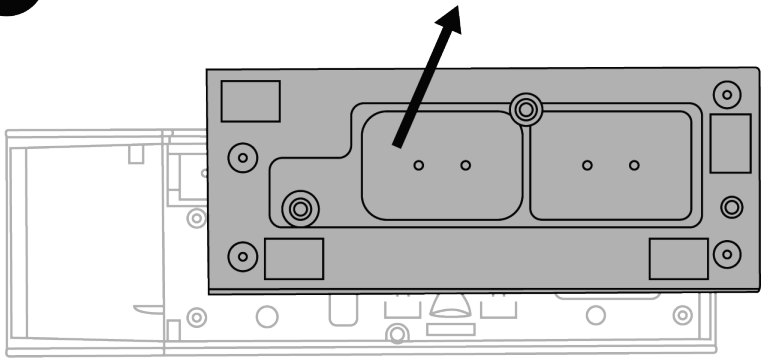

5

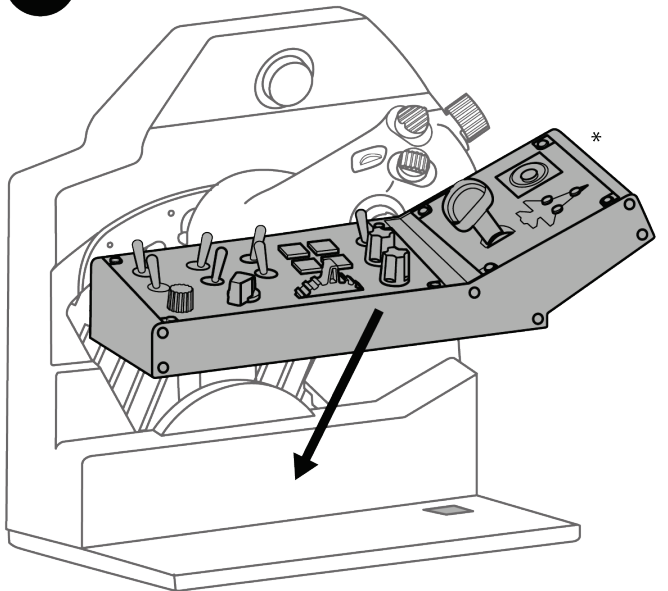



6

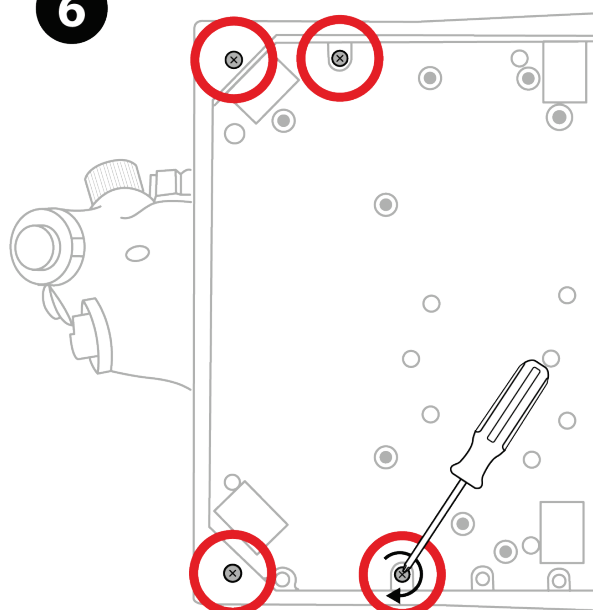

7

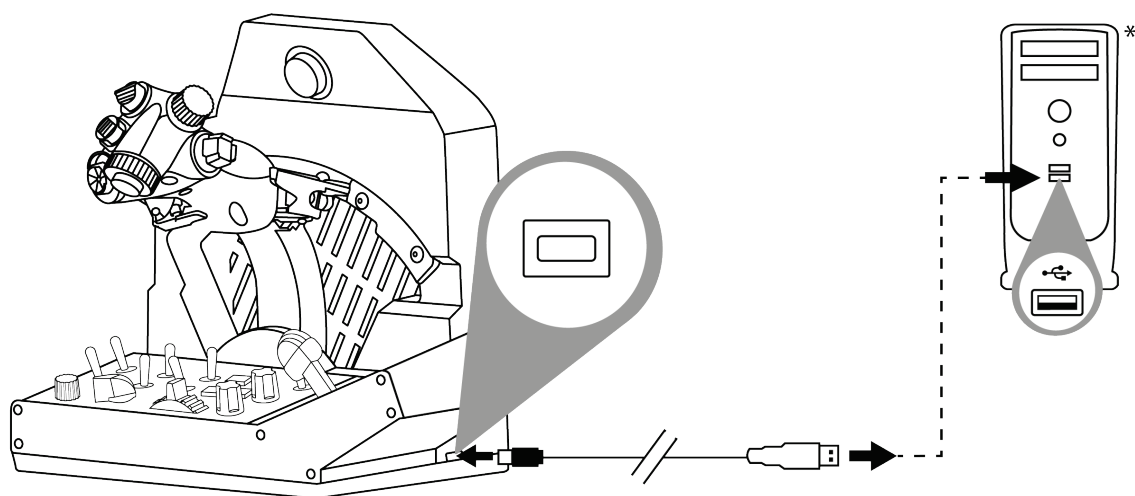

**Non incluso*



8. Installazione su PC

1



Visita la pagina:

<https://support.thrustmaster.com/product/viper-tqs/>.

2

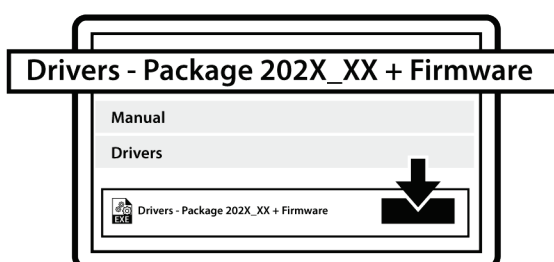

Scarica e installa i driver per PC e la relativa interfaccia personalizzata per il Pannello di Controllo di Windows.

3

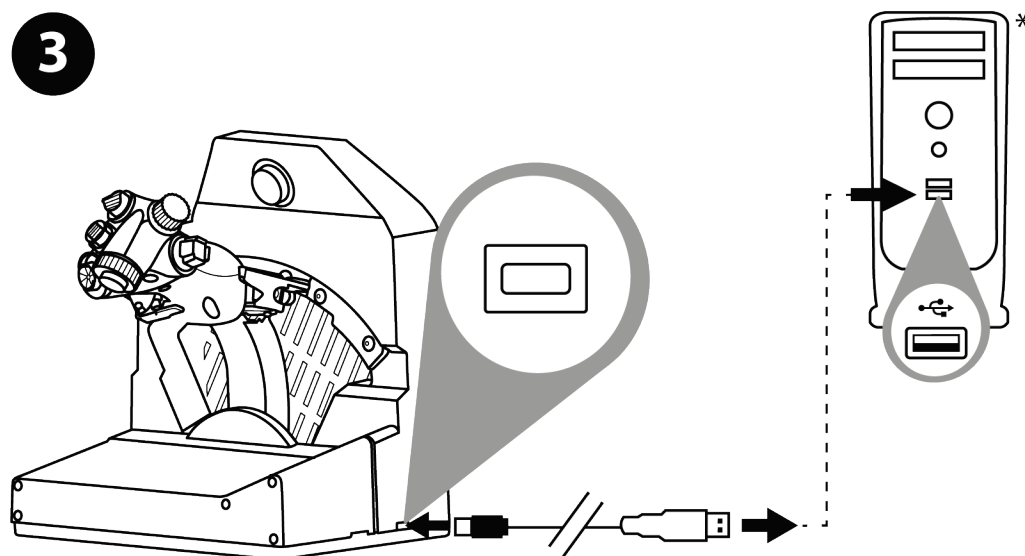

Una volta installati i driver per PC, collega il connettore USB a una porta USB del tuo PC.

* *Non incluso*



④ Per accedere al Control Panel, seleziona **Start** / **Tutte le app** / **Thrustmaster** / **Control Panel** oppure **Pannello di controllo** (in Windows 10).

Apparirà la finestra **Periferiche di gioco**. Sullo schermo comparirà l'accessorio col nome **VIPER TQS** e lo stato **OK**.

⑤ Nella finestra di dialogo **Periferiche di gioco**, clicca su **Proprietà** per testare e visualizzare tutte le funzioni.

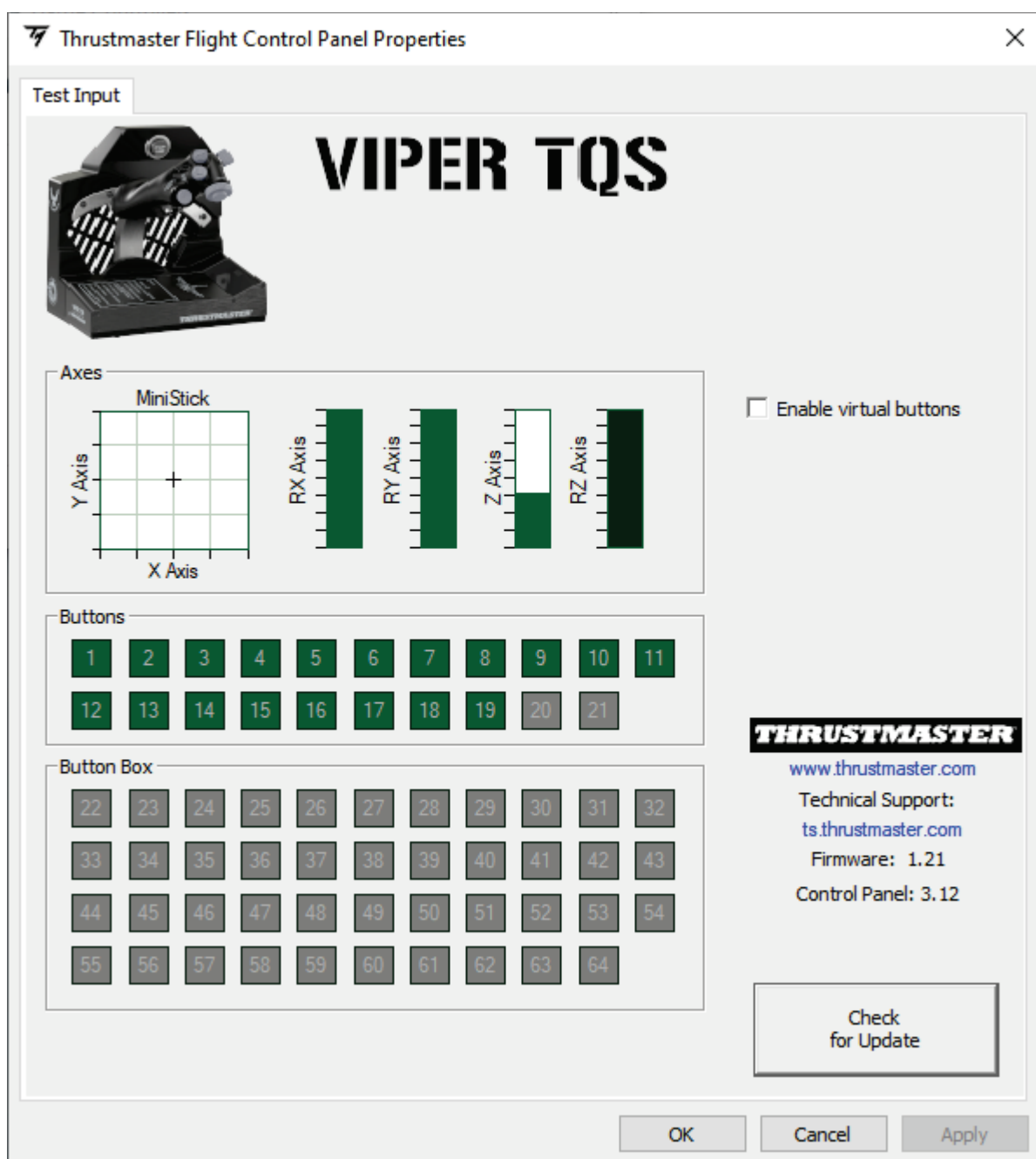



Enable virtual buttons (Attiva pulsanti virtuali):

Questa funzione ti permette di attivare o disattivare i pulsanti virtuali sull'impugnatura (pulsanti 20 e 21). Dopo aver scelto la modalità che desideri utilizzare, clicca su **Apply** (Applica).

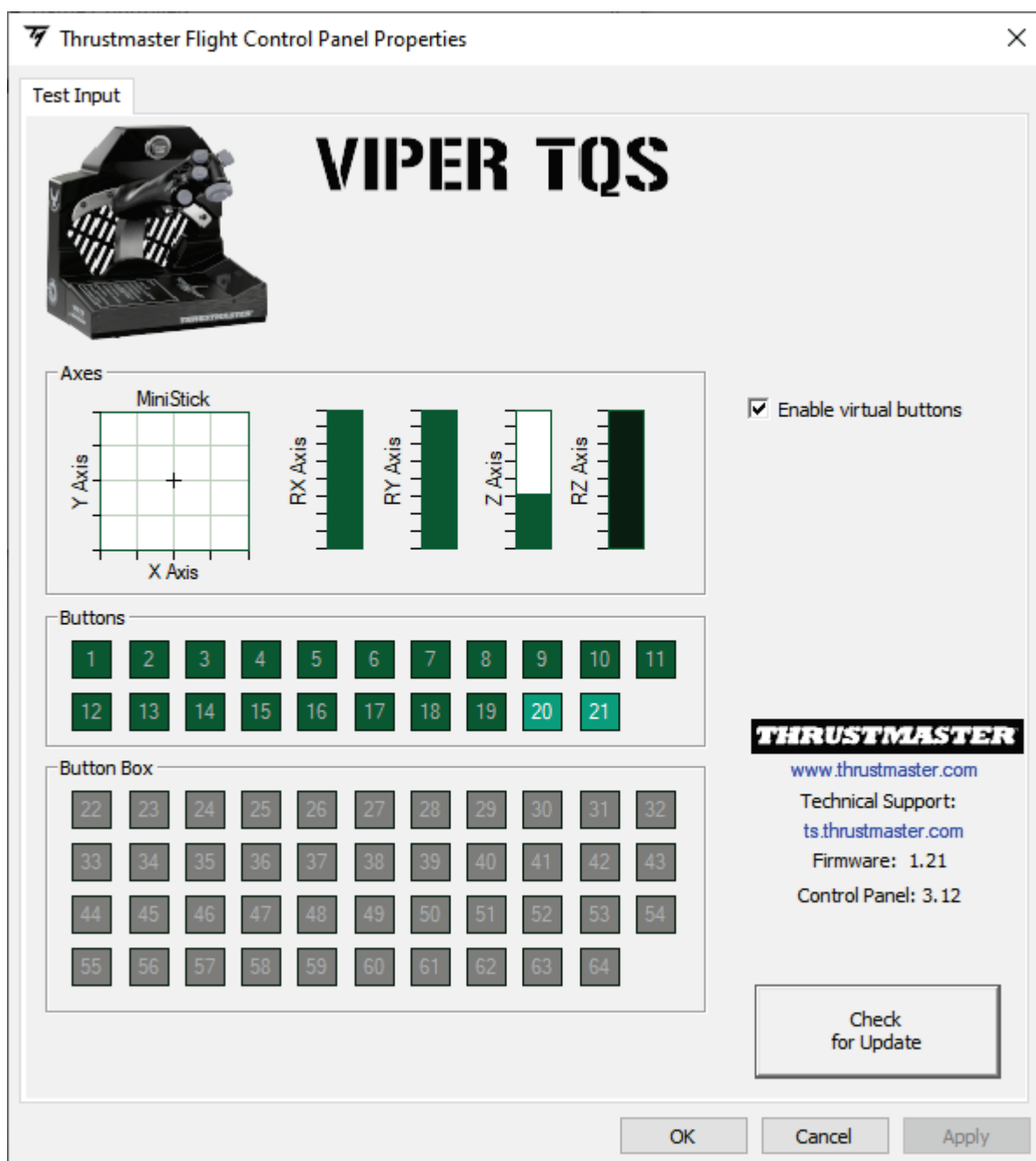

Per default, i pulsanti virtuali del VIPER TQS sono disattivati.



9. Blocchi CUT OFF e AFTERBURNER

Il quadrante manetta VIPER TQS è dotato di un realistico sistema di blocchi CUT OFF e AFTERBURNER (il modulo Afterburner è rimuovibile).

CUT OFF

Dopo aver posizionato la manetta sulla posizione di blocco IDLE, premi la levetta di “sblocco cut-off motori”

- ➊ per sollevare l'impugnatura e andare oltre il blocco
- ➋, quindi porta l'impugnatura in posizione OFF ➌.

Per riaccendere i motori, esegui questa procedura al contrario.

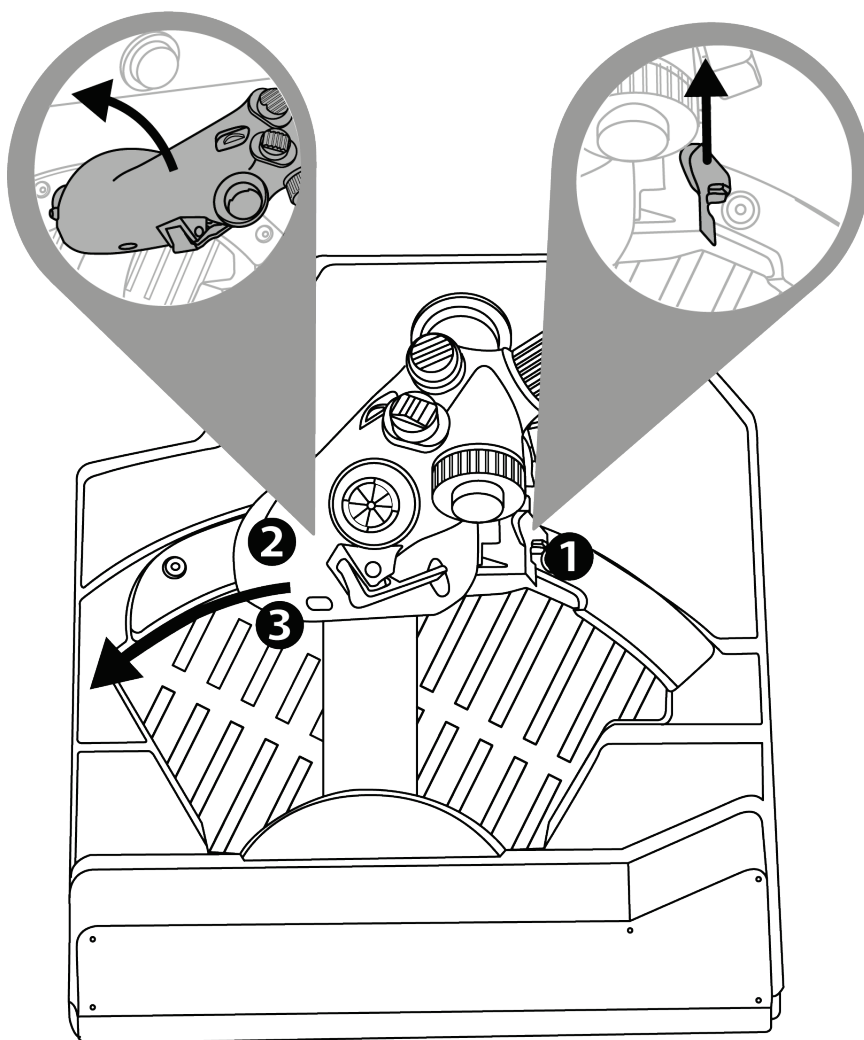



AFTERBURNER

Muovi la manetta fino al blocco **1** e sollevala **2** per andare oltre il blocco e attivare i postbruciatori **3**.

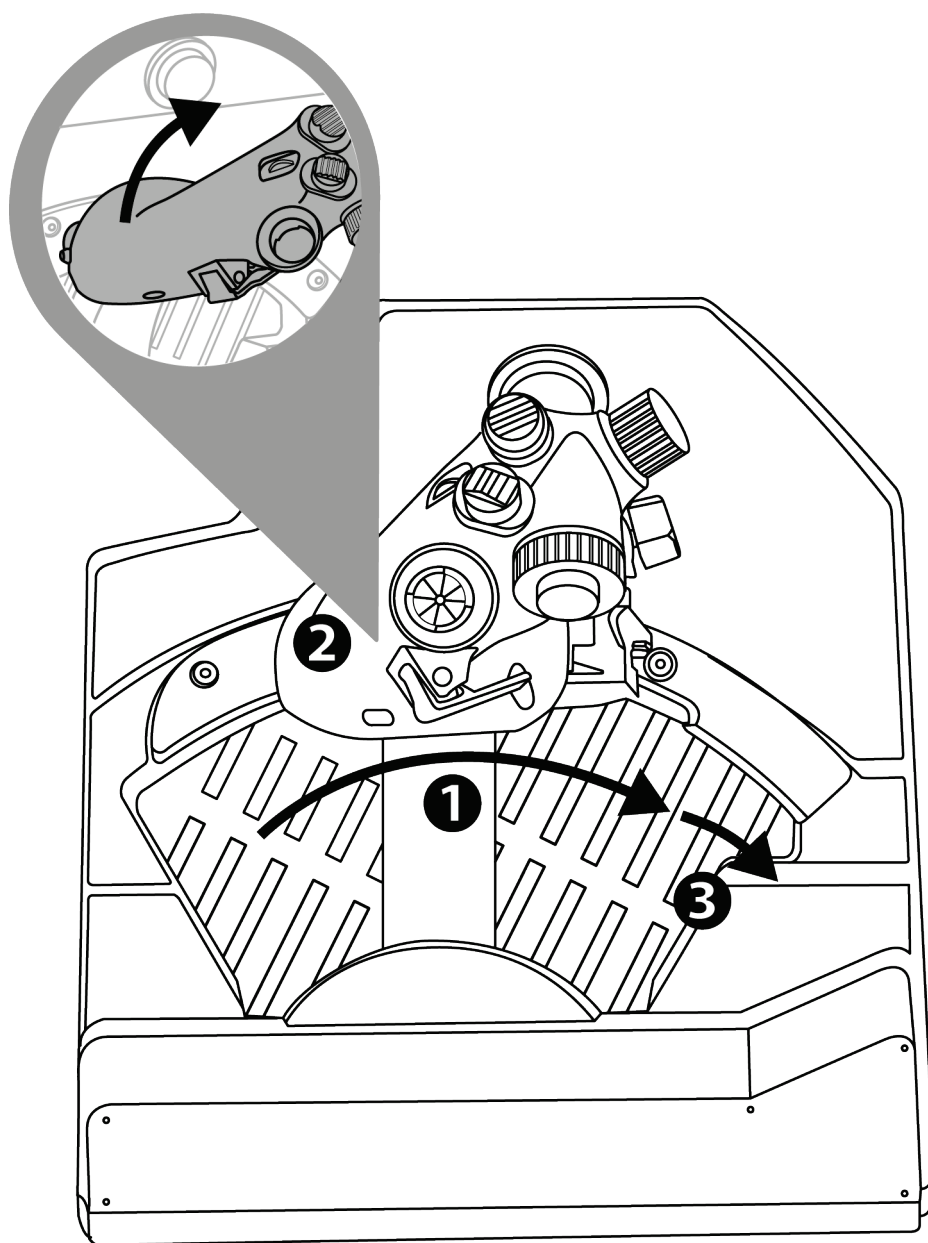



Disinstallare il blocco AFTERBURNER

Il blocco del modulo Afterburner è posizionato in corrispondenza dell'80% del valore dell'asse.

Qualora avessi bisogno del 100% della corsa della manetta, senza blocchi (per uno specifico simulatore), puoi rimuovere il modulo Afterburner e i relativi blocchi svitando le due viti del modulo utilizzando una chiave a brugola (non inclusa).

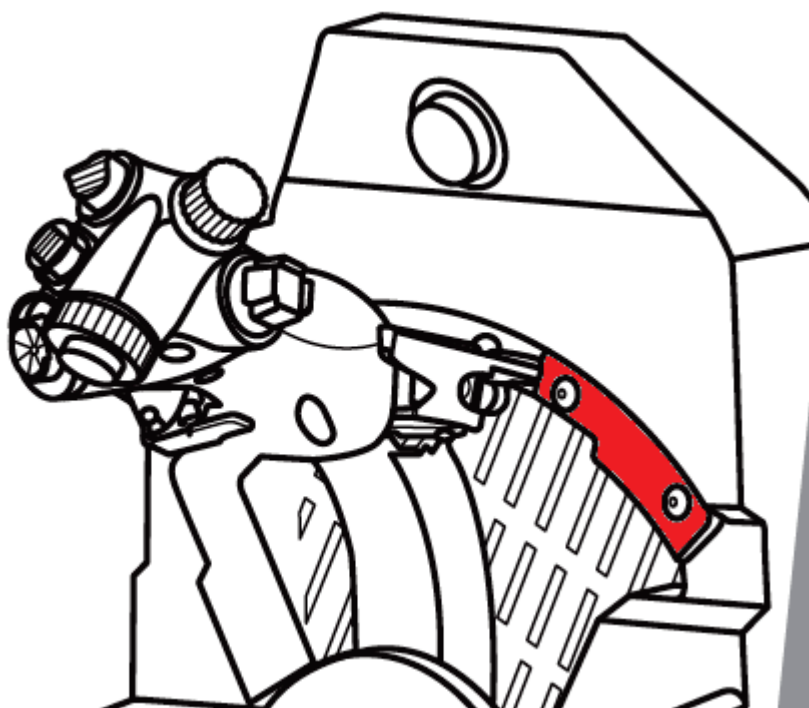



10. Software di programmazione avanzata T.A.R.G.E.T



Visita la pagina:

<https://support.thrustmaster.com/product/viper-tqs/>.

Nella sezione **Software**, scarica e installa il software di programmazione avanzata T.A.R.G.E.T.



Caratteristiche principali di T.A.R.G.E.T

- Diverse configurazioni possibili per gli assi.
- Diversi livelli di programmazione disponibili: Basic, Advanced e Script.
- Uso del principio del Drag and Drop.
- Possibilità di combinare il quadrante manetta VIPER TQS con svariati joystick Thrustmaster (HOTAS Cougar, HOTAS Warthog, T.16000M, MFD Cougar Pack, tutti compatibili anche con T.A.R.G.E.T), in modo tale che vengano riconosciuti come un'unica periferica USB.
- Accesso a profili avanzati creati dalla community Thrustmaster.



11. FAQ e assistenza tecnica

Hai qualche domanda riguardante il VIPER TQS o stai riscontrando dei problemi tecnici? Se così fosse, visita il sito web di assistenza tecnica Thrustmaster:

<https://support.thrustmaster.com/product/viper-tqs/>.



THRUSTMASTER®

VIPER TQS

THROTTLE QUADRANT SYSTEM

Para PC (Windows 10/11)

Manual del usuario



Lee atentamente las instrucciones proporcionadas en este manual **antes de** instalar el producto, **antes de** cualquier uso del producto y **antes de** cualquier mantenimiento. Asegúrate de seguir las instrucciones de seguridad. El incumplimiento de estas instrucciones puede resultar en accidentes y/o daños. Conserva este manual para poder consultar las instrucciones en el futuro.

TABLA DE CONTENIDO

1.	CONTENIDO DE LA CAJA.....	5
2.	CARACTERÍSTICAS DEL VIPER TQS	6
3.	MAPEADO DE BOTONES Y EJES	8
4.	INFORMACIÓN SOBRE EL USO DEL VIPER TQS	10
5.	AJUSTE DE LA FRICCIÓN.....	11
6.	INSTALACIÓN SOBRE UN SOPORTE.....	12
7.	INSTALACIÓN DE VIPER PANEL*	17
8.	INSTALACIÓN EN PC.....	20
9.	RETENES DE CUT OFF Y AFTERBURNER.	23
10.	SOFTWARE DE PROGRAMACIÓN AVANZADA T.A.R.G.E.T.....	26
11.	PREGUNTAS FRECUENTES Y SOPORTE TÉCNICO.....	28



Acelera tus motores y vuela hacia la zona de peligro con el icónico sistema de cuadrante del acelerador del VIPER de la Fuerza Aérea de EE. UU., ¡el caza moderno más usado en el mundo!

Aumenta el nivel de tu cabina con la ergonomía única de una réplica HOTAS a escala 1:1 que incorpora una palanca metálica, además de botones y retenes realistas.

Este manual te ayudará a instalar y usar tu VIPER TQS en las mejores condiciones. Antes de despegar, asegúrate de leer detenidamente todas estas instrucciones y advertencias: te ayudarán a disfrutar al máximo de tu producto.



Actualización del firmware

Para que el VIPER TQS funcione correctamente en los videojuegos, debes actualizar su firmware.

Para realizar la actualización, visita

<https://support.thrustmaster.com/product/viper-tqs/>

Selecciona **Firmware** y después sigue las instrucciones, incluido el procedimiento de descarga e instalación.



1. Contenido de la caja

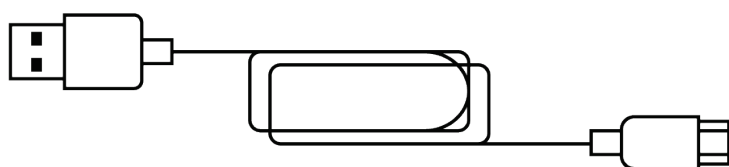
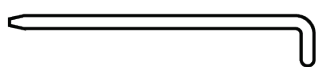
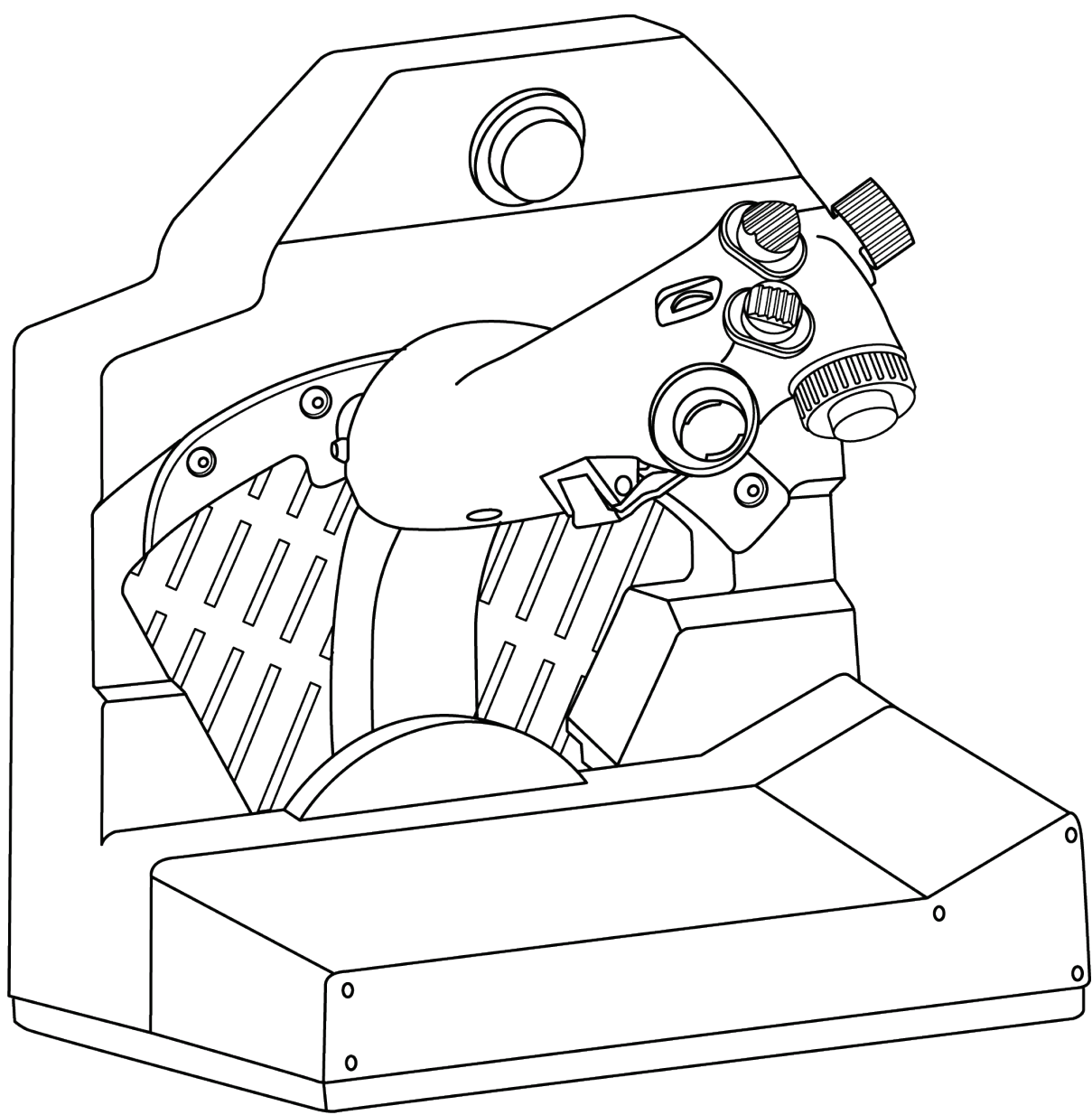



2. Características del VIPER TQS

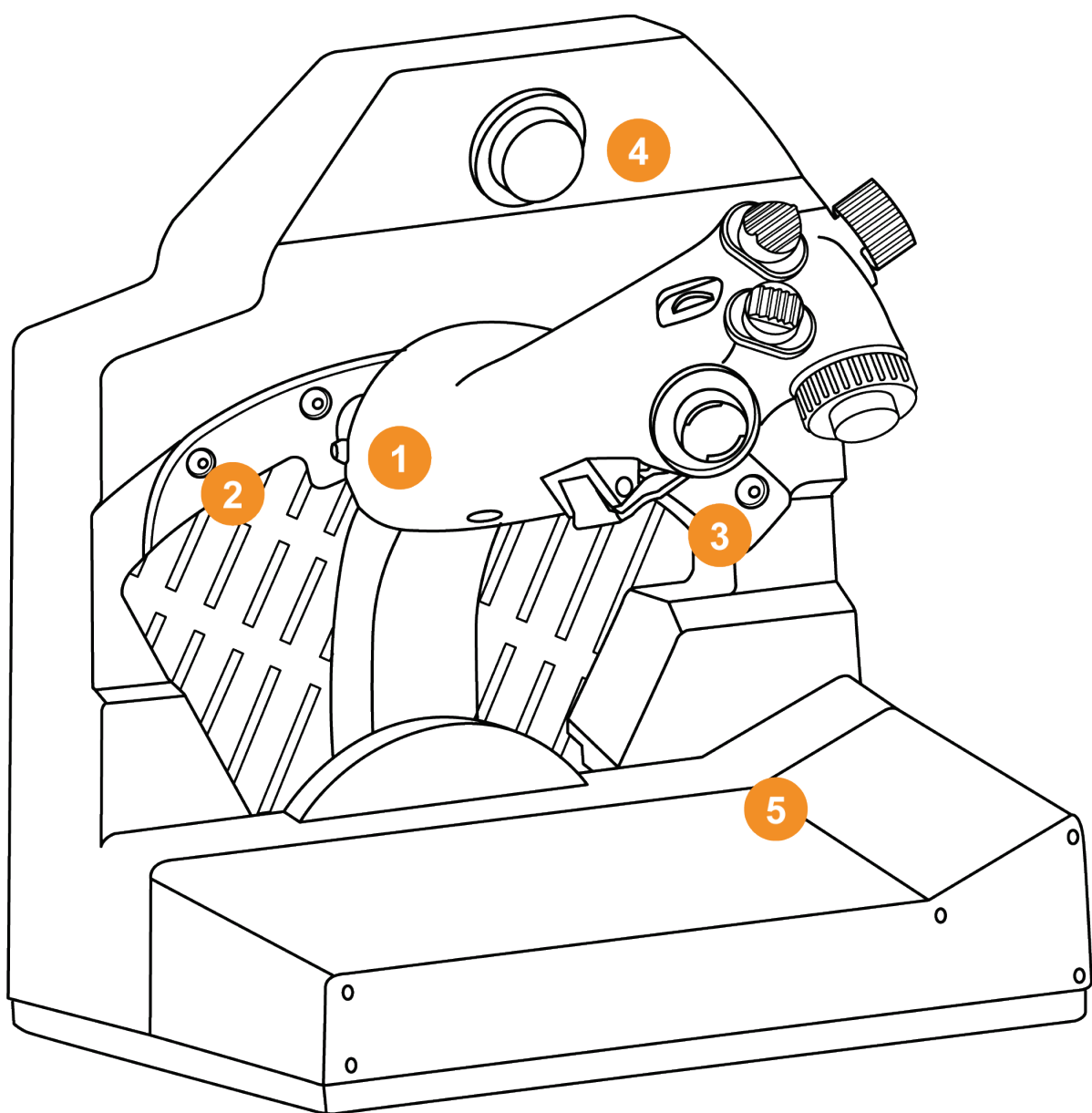

1. Palanca

2. Tope de Cut Off

3. Tope de Afterburner

4. Interruptor rápido CHAFF/FLARE

5. Clip para el mapa de la misión

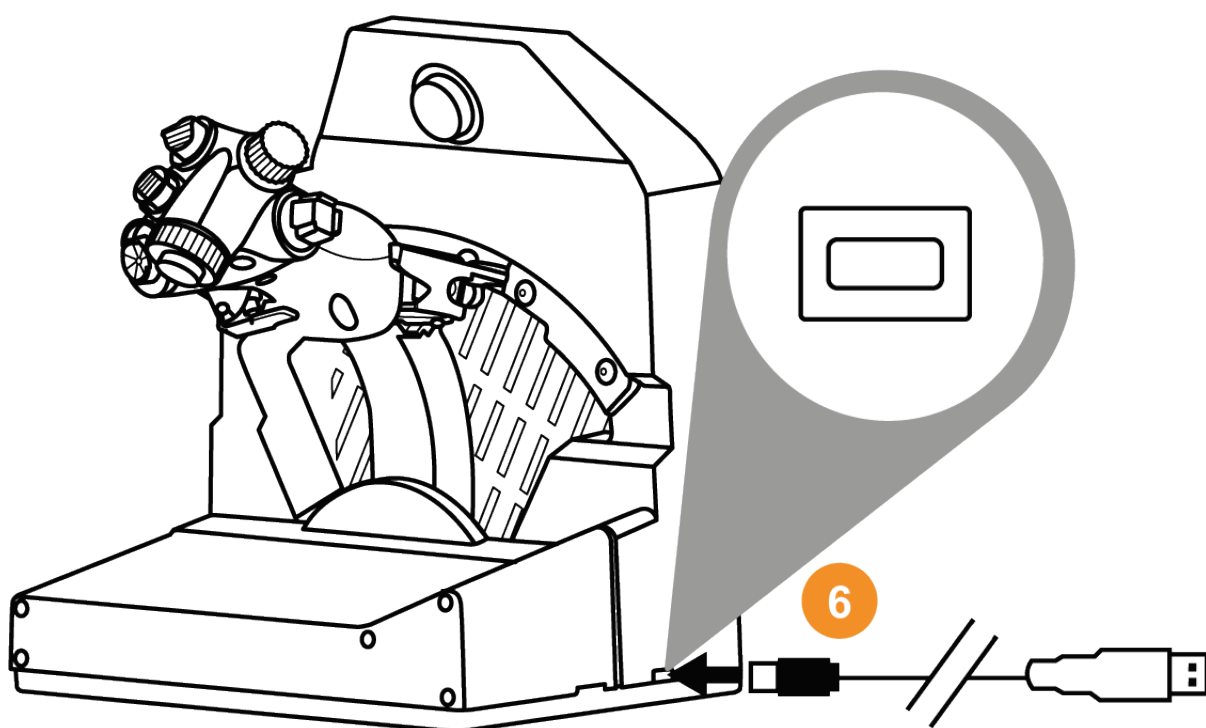

6. Conector USB (tipo C)

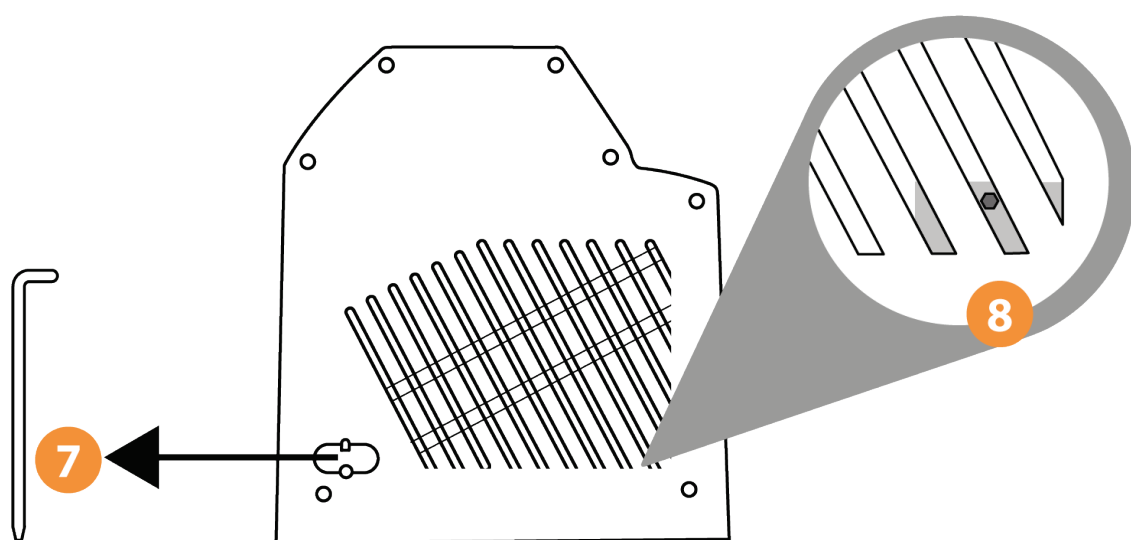

7. Ubicación de la herramienta de ajuste de fricción

8. Punto de acceso de ajuste de fricción del acelerador



3. Mapeado de botones y ejes

Palanca de VIPER TQS: mapeado de los 19 botones y 5 ejes en modo A (sin botones virtuales)

A 1 → 19

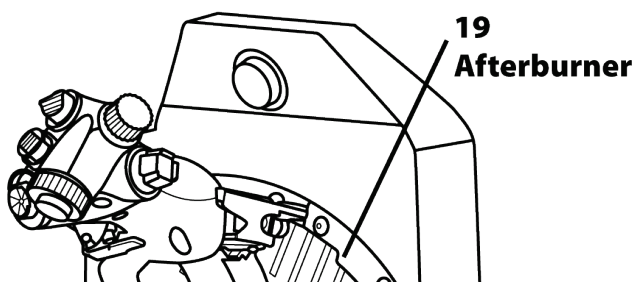
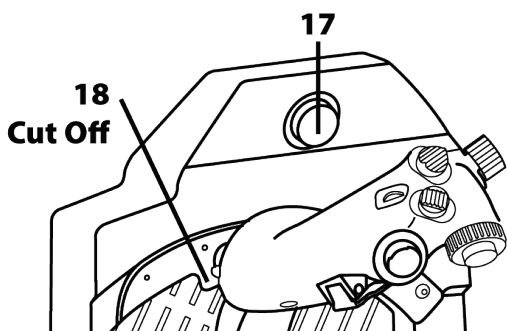
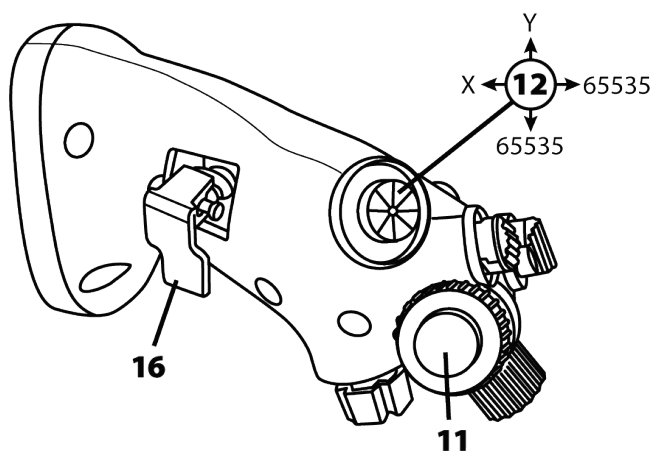
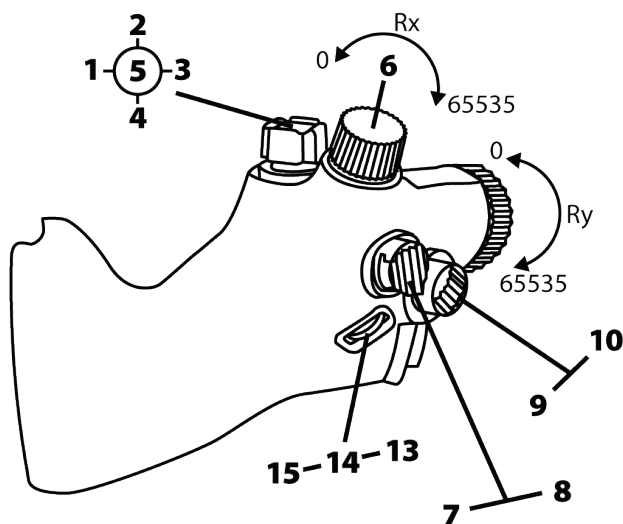



Modo B: con botones virtuales

B 1 → 21

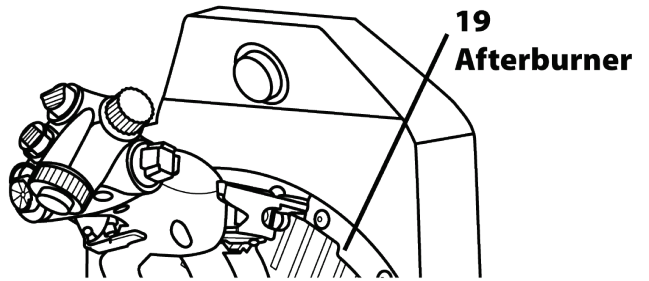
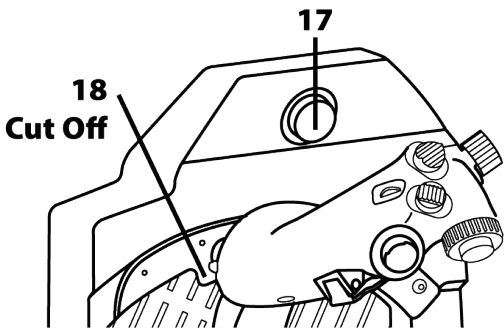
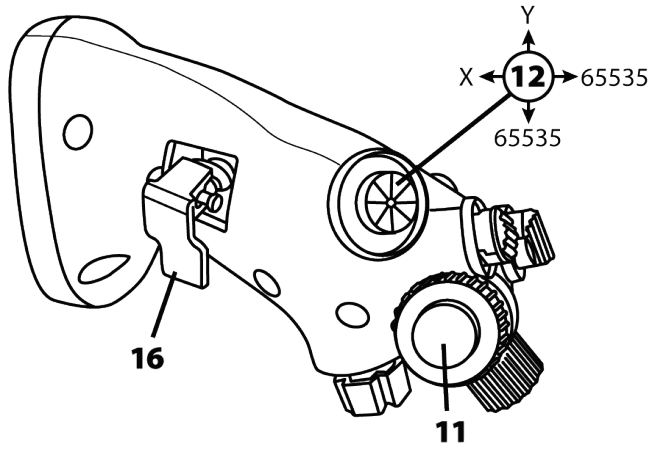
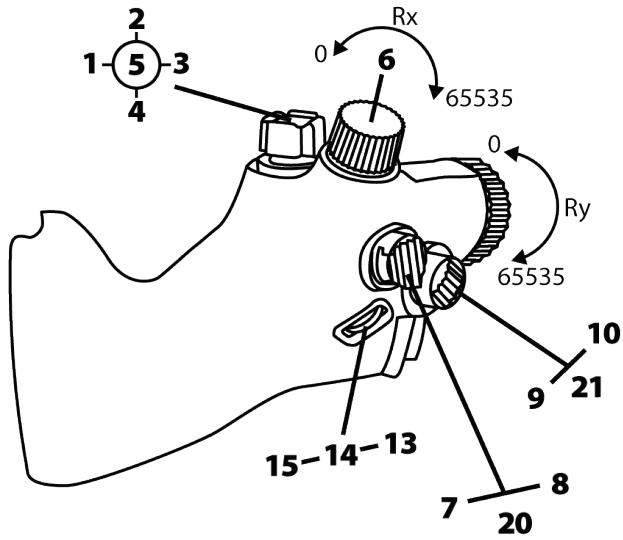



4. Información sobre el uso del VIPER TQS



Peligro de pellizcarse

No pongas nunca los dedos en las áreas de tope cuando estés usando la palanca.

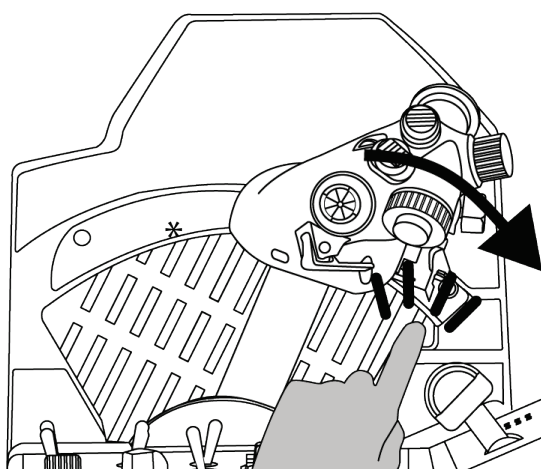
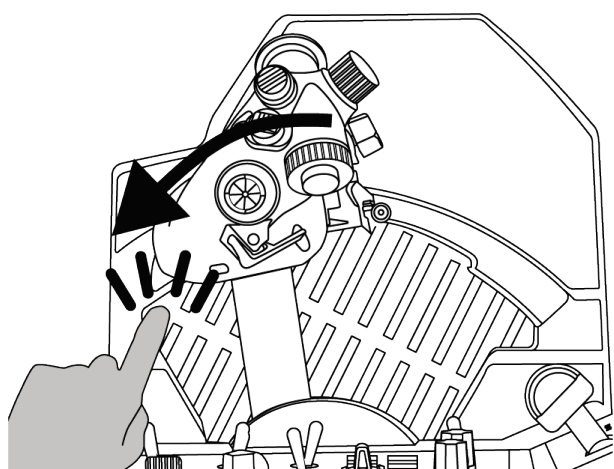
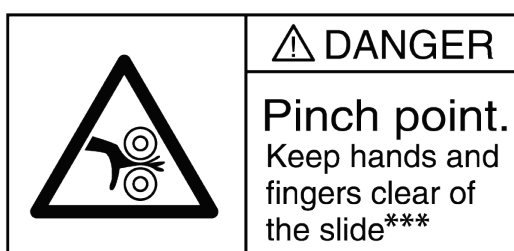



5. Ajuste de la fricción

Puedes ajustar la fricción de tu cuadrante del acelerador VIPER TQS según tus preferencias personales usando la herramienta incluida en el lateral del VIPER TQS. Ten en cuenta, sin embargo, que la fricción óptima del acelerador se ha configurado de forma predeterminada en la fábrica.

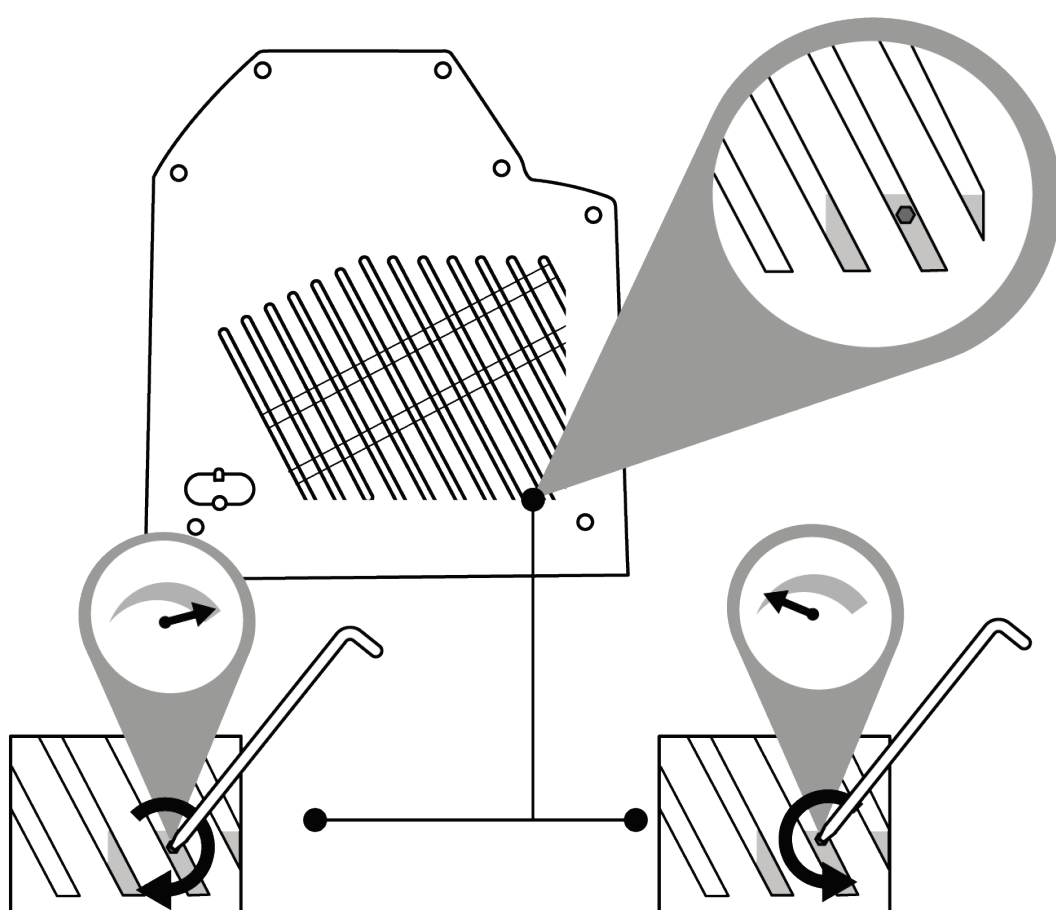

Para evitar dañar el sistema de fricción, asegúrate de no apretar en exceso el tornillo de ajuste.

Además, asegúrate de no aflojar por completo el tornillo de ajuste: de hacerlo, corres el riesgo de que el acelerador ya no pueda permanecer en su posición.



6. Instalación sobre un soporte



El VIPER TQS se puede instalar en diferentes tipos de soportes. La mayoría de las cabinas y los soportes disponibles en el mercado ya son compatibles con productos Thrustmaster similares (p. ej. HOTAS Warthog).

Ten en cuenta que el VIPER TQS presenta un potente efecto de palanca y, por lo tanto, debe estar firmemente sujeto.

Fija la base a tu soporte con tornillos M6 adecuados (no incluidos), para no dañar la palanca.

Un plano completo del VIPER TQS está disponible en <https://support.thrustmaster.com/product/viper-tqs/>



Antes de cada uso, asegúrate de que el VIPER TQS todavía esté correctamente sujeto al soporte, de acuerdo con las instrucciones especificadas por el fabricante.

Asegúrate de tener en cuenta el material del que está hecho tu soporte y cerciórate de que sea posible fijar el producto de forma segura. El VIPER TQS debe usarse en un escritorio hecho de un material sólido (es decir, MDF o madera), sin ningún componente hueco o de vidrio.



Dimensiones del plano de montaje (en mm)

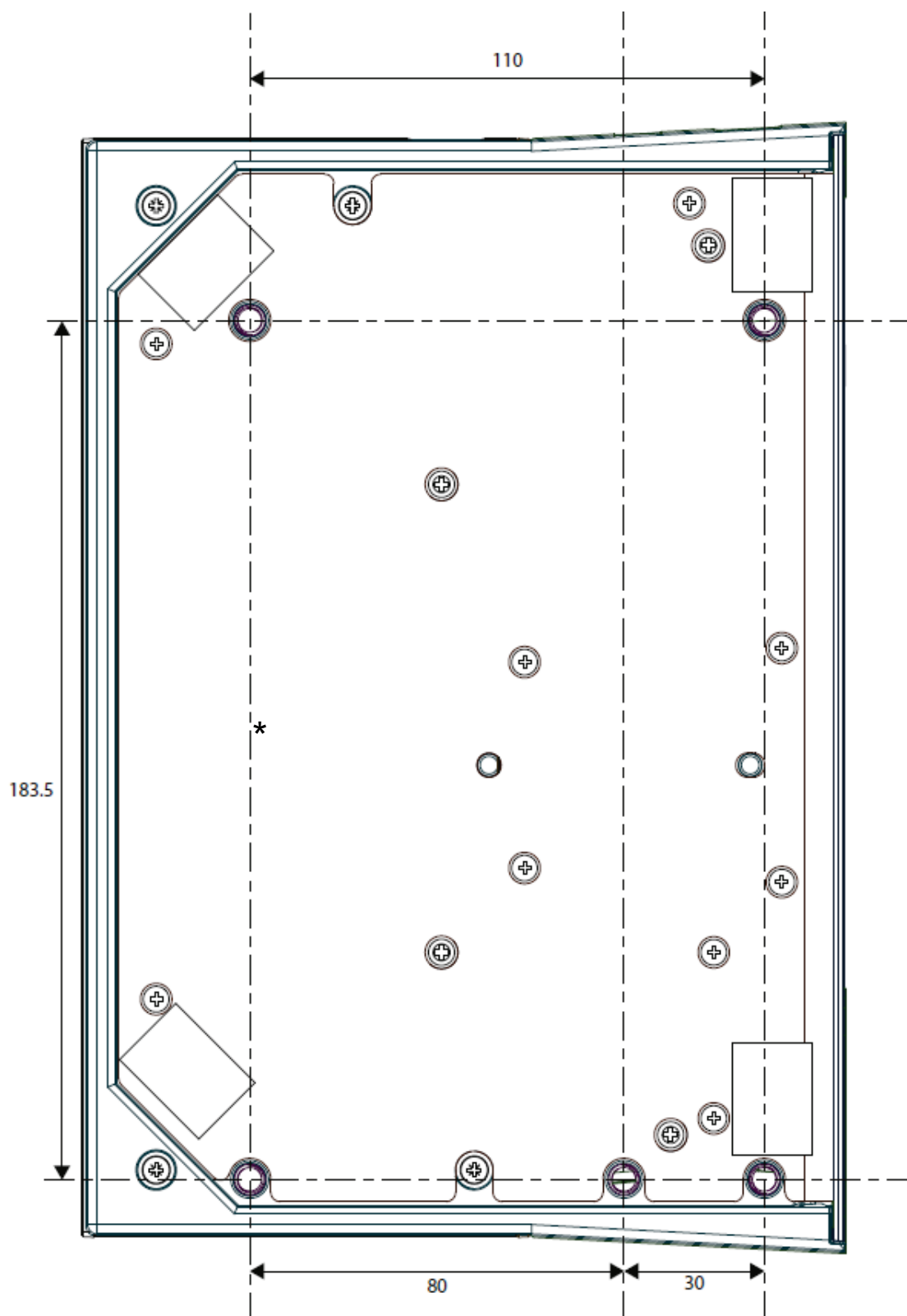

Puedes descargar el plano de montaje desde <https://support.thrustmaster.com/product/viper-tqs/>, luego imprimirlo y usarlo en tu soporte para preparar los agujeros de perforación.



Instalación usando TM Flying Desk Mount*

El TM Flying Desk Mount es un sistema de montaje metálico con un tornillo de sujeción, que mejora la ergonomía y la posición de pilotaje al usar tu dispositivo. Este sistema está diseñado para usarse con escritorios y mesas de 15 a 50 mm de grosor.

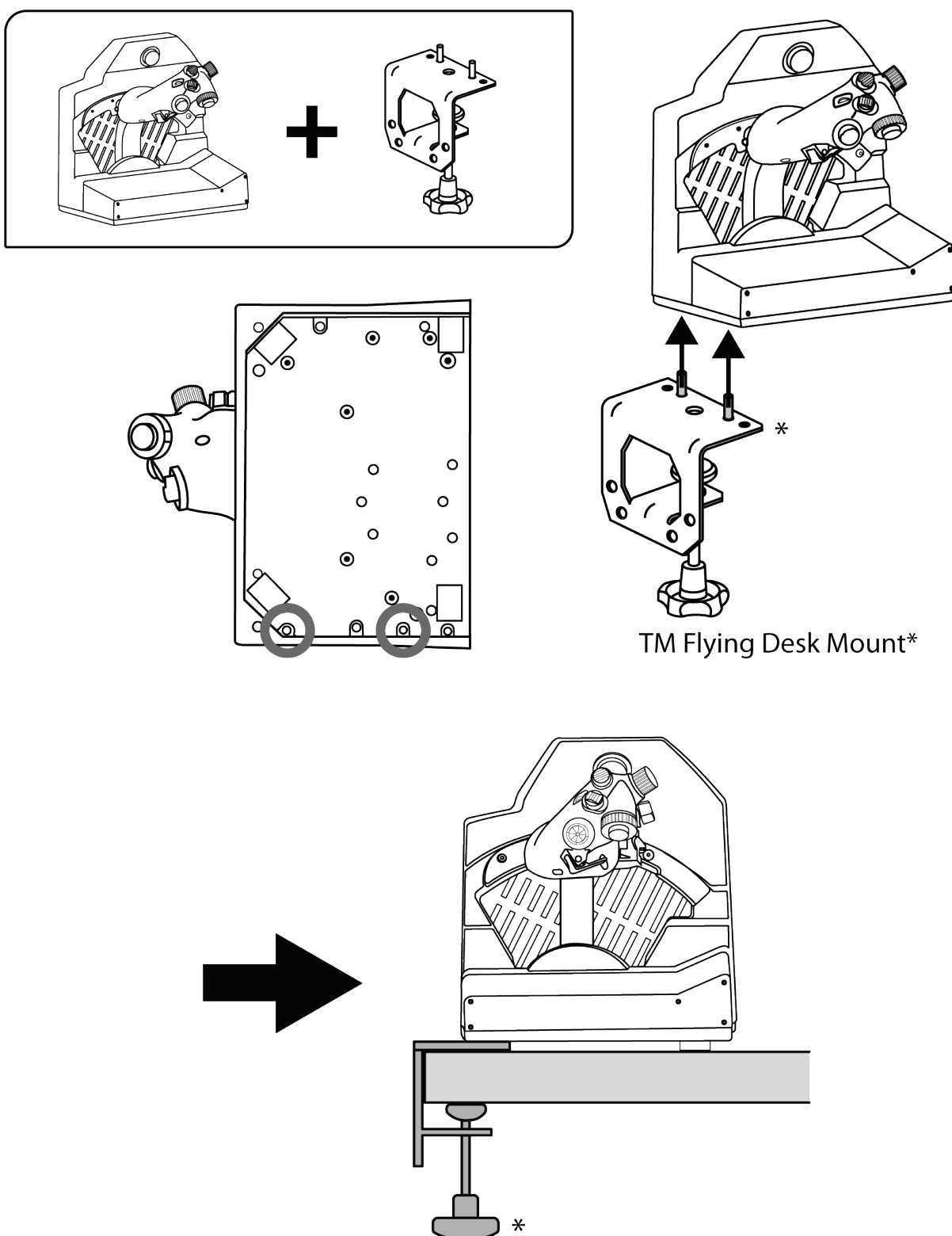

*Se vende por separado



Instalación con TM Flying Clamp*

El TM Flying Clamp es un soporte de altura ajustable diseñado por Thrustmaster para sus accesorios de simulación de vuelo. Este sistema de montaje cuenta con dos tornillos de sujeción que permiten ajustarlo para su uso con escritorios y mesas de 15 a 45 mm de grosor.

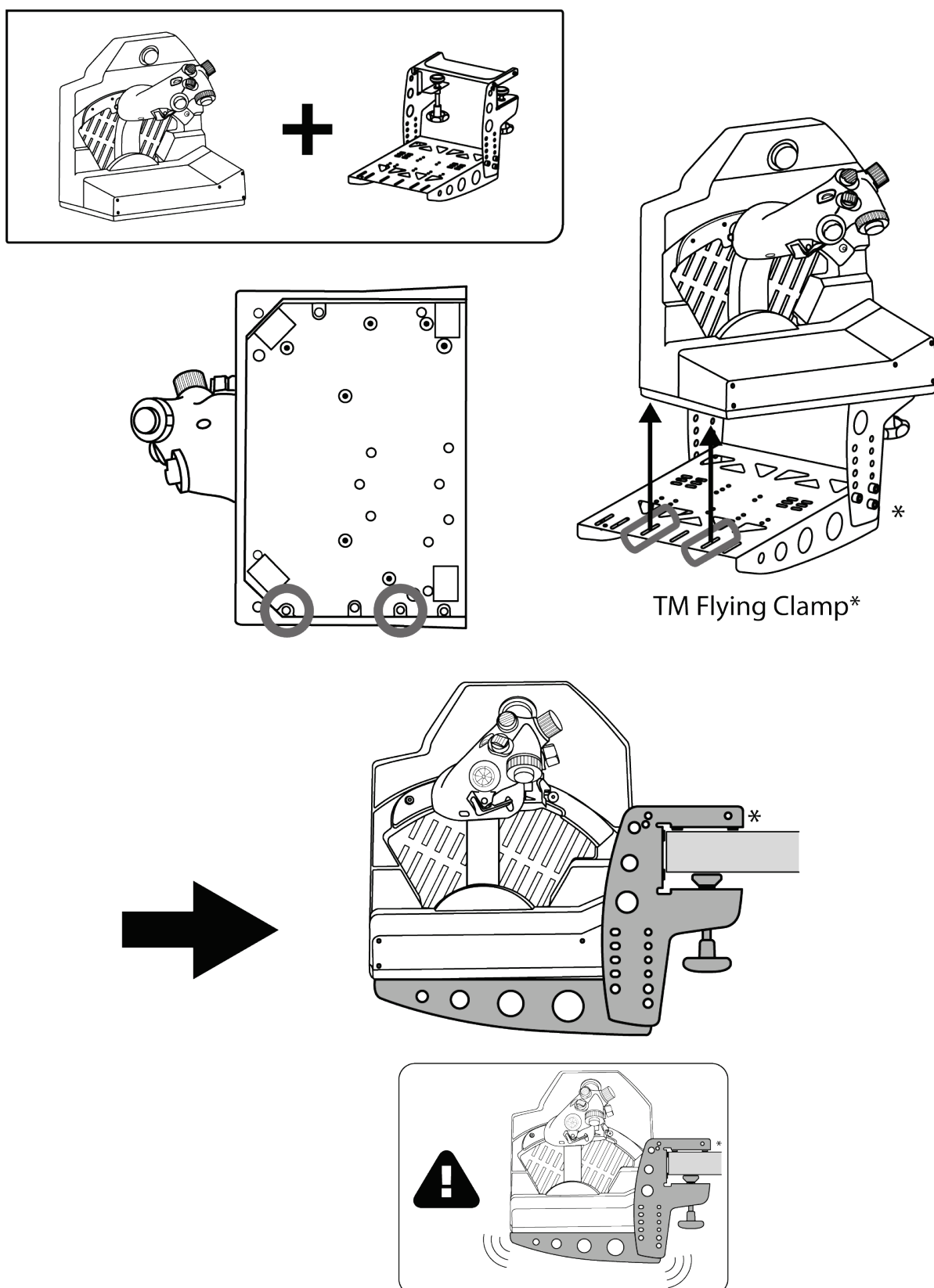

*Se vende por separado



Ten en cuenta que el gran peso del VIPER TQS puede provocar movimientos no deseados del sistema de montaje.



7. Instalación de VIPER PANEL*

**Se vende por separado. El VIPER PANEL se incluye en el VIPER TQS Mission Pack.*

El VIPER PANEL es un panel de control que te permite expandir tus capacidades de vuelo/combate con un total de 43 botones y 1 eje, todos programables a través del software T.A.R.G.E.T. El VIPER PANEL es un complemento del VIPER TQS.

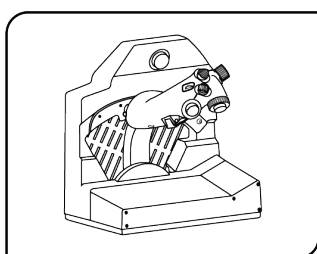

1

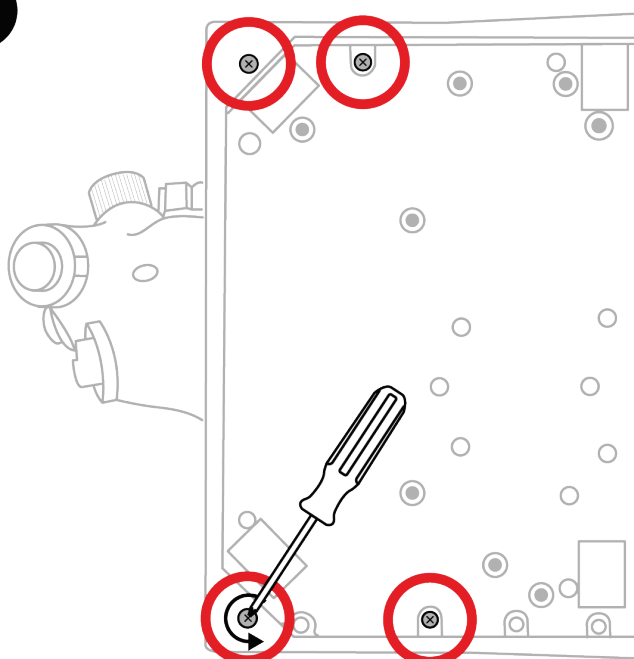

2

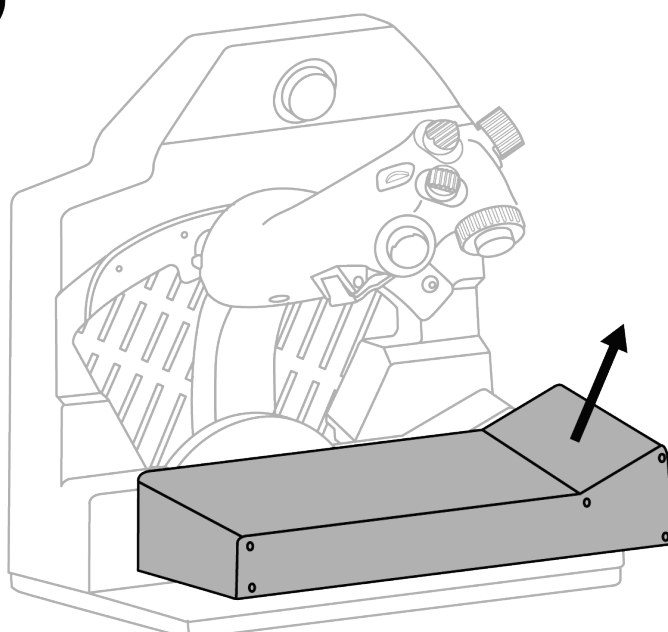

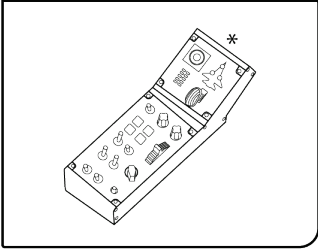

3

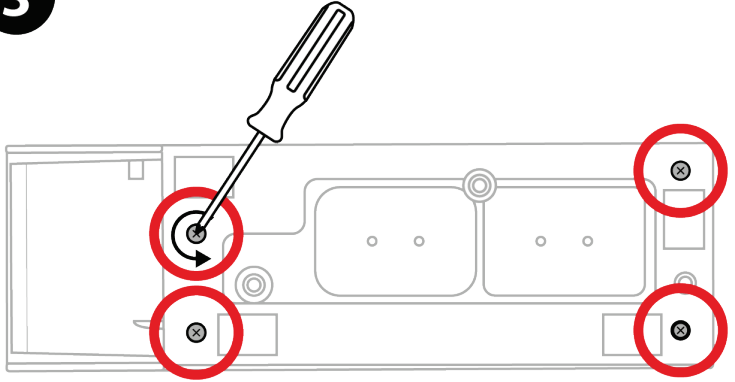

4

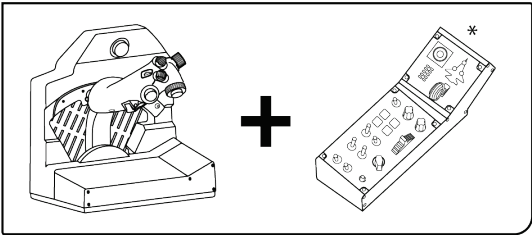
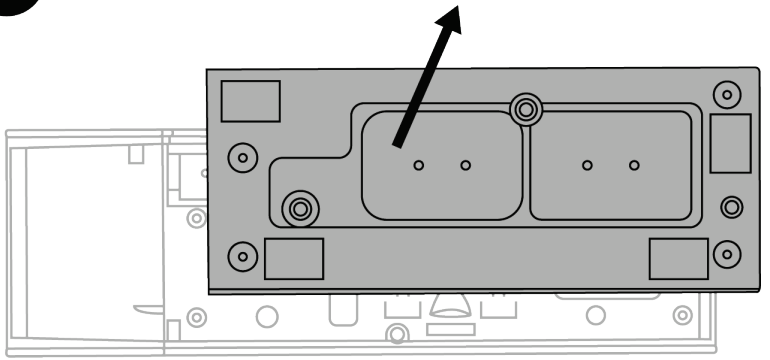

5

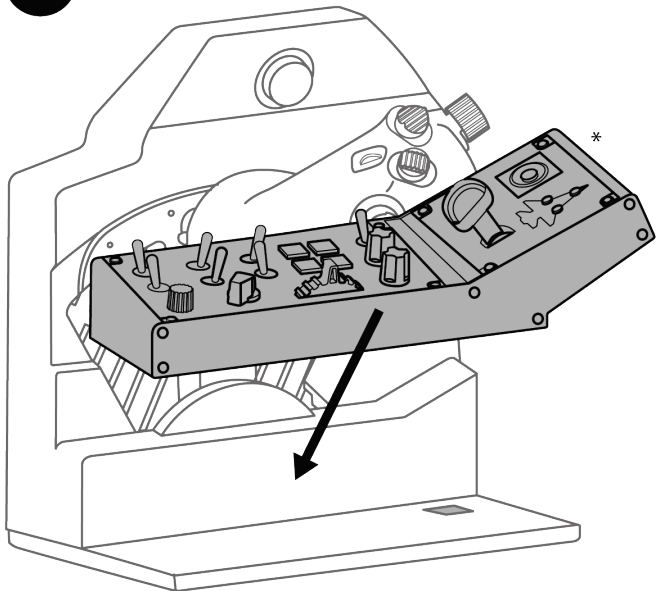



6

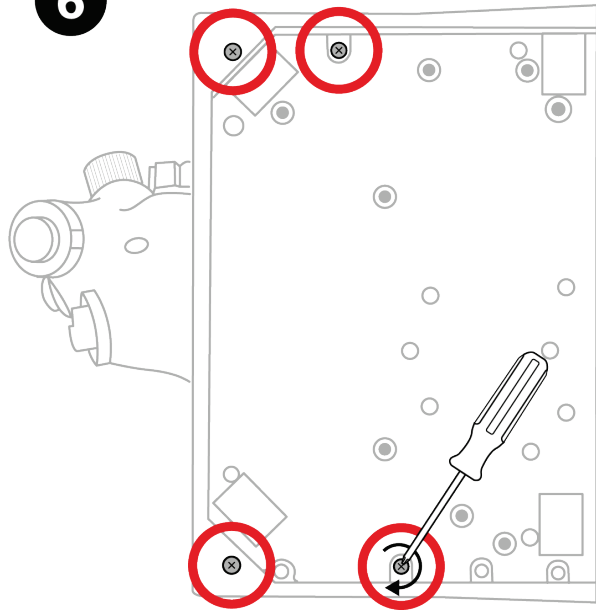

7

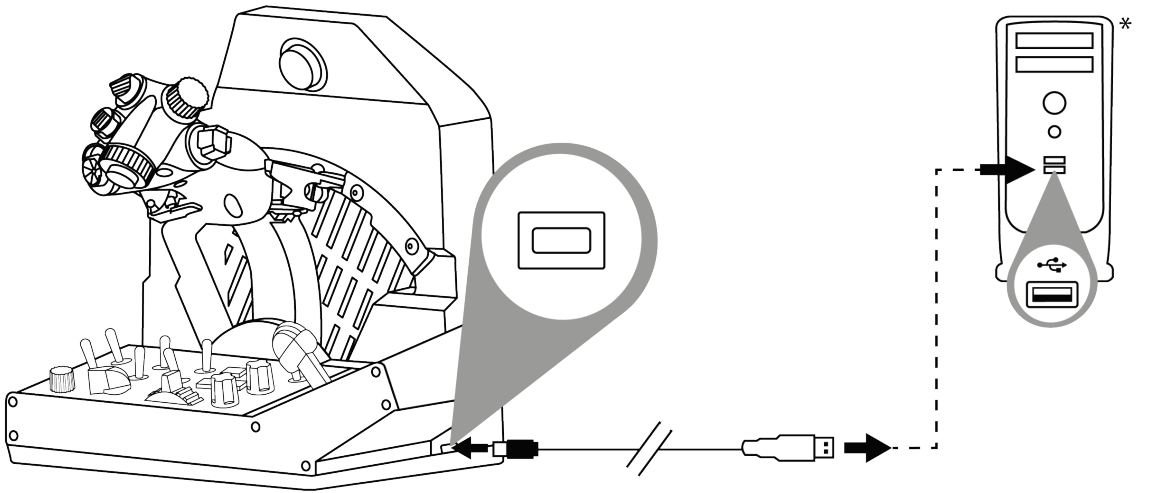

**No incluido*



8. Instalación en PC

1



Visita

<https://support.thrustmaster.com/product/viper-tqs/>.

2

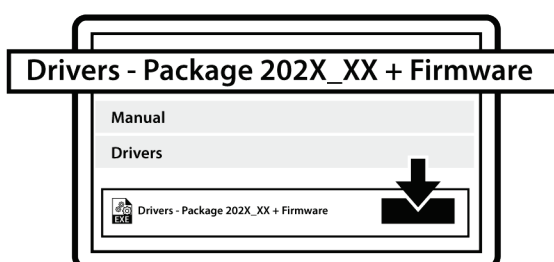

Descarga e instala el controlador de PC y su interfaz personalizada para el Panel de control de Windows.

3

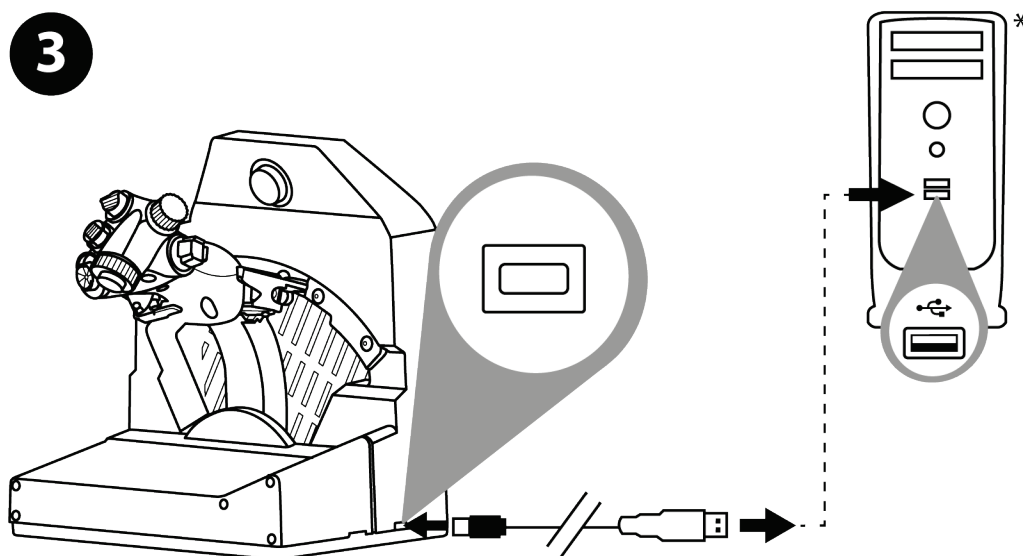

Una vez que se haya instalado el controlador de PC, conecta el conector USB a uno de los puertos USB de tu PC.

**No incluido*



④ Para acceder al Panel de control, selecciona **Inicio / Todas las aplicaciones / Thrustmaster / Control Panel** o **Panel de control** (en Windows 10).

Se muestra el cuadro de diálogo **Dispositivos de juego**. El accesorio aparece en pantalla con el nombre **VIPER TQS** y el estado **OK**.

⑤ En el cuadro de diálogo **Dispositivos de juego**, haz clic en **Propiedades** para probar y ver todas las funciones.

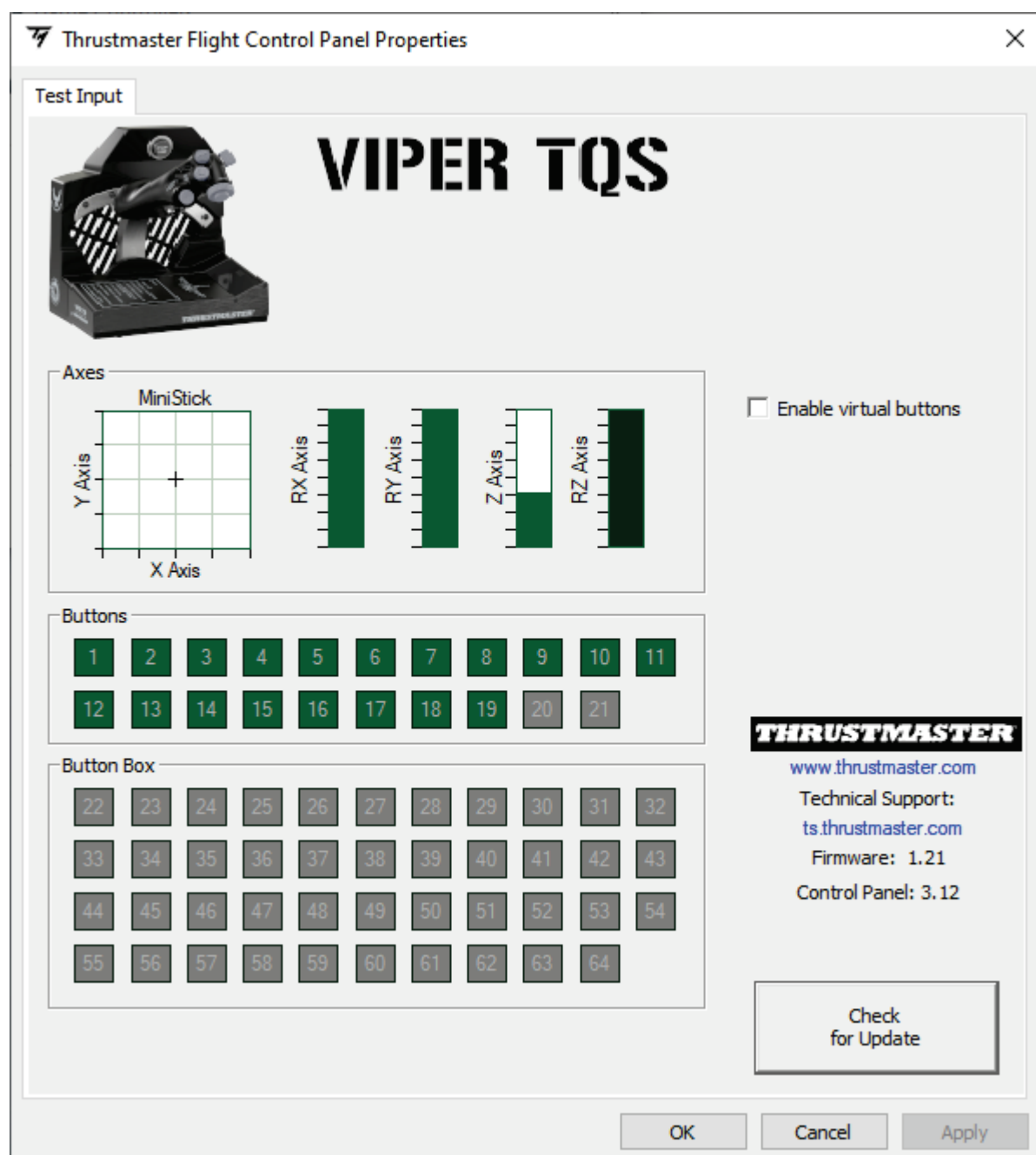



Enable virtual buttons (Habilitar botones virtuales):

Esta función te permite habilitar o deshabilitar los botones virtuales en la palanca (botones 20 y 21). Haz clic en **Apply** (Aplicar) una vez que hayas seleccionado el modo que deseas usar.

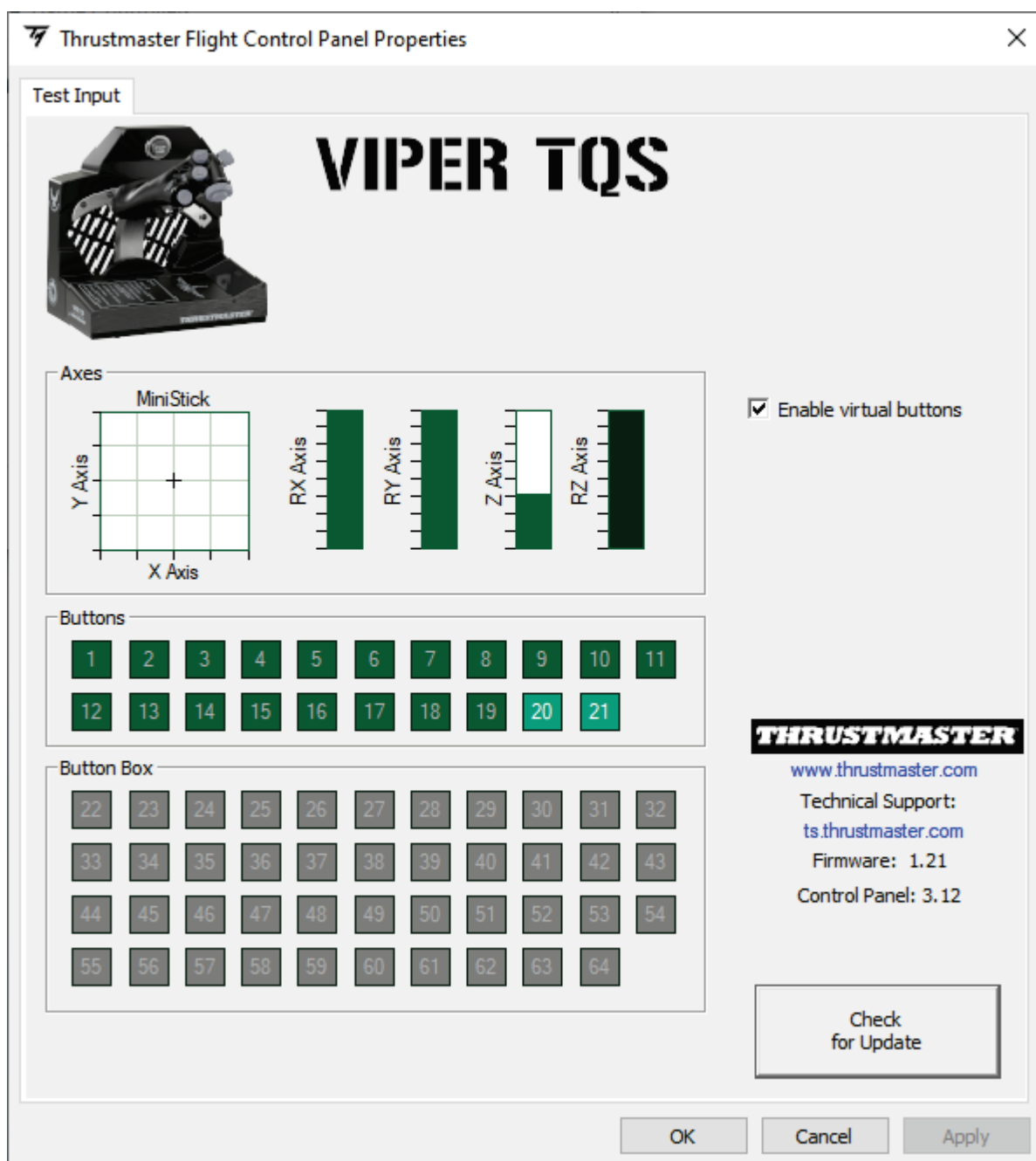

Los botones virtuales están deshabilitados por defecto en el **VIPER TQS**.



9. Retenes de CUT OFF y AFTERBURNER

El cuadrante del acelerador VIPER TQS presenta un sistema realista de retenes de CUT OFF y AFTERBURNER (el módulo Afterburner es extraíble).

CUT OFF

Después de haber colocado el acelerador en el tope IDLE, presiona el gatillo de "desbloqueo de corte del motor" **1** para levantar la palanca para superar el tope **2**, luego coloca la palanca en la posición OFF **3**.

Para volver a encender los motores, realiza este procedimiento a la inversa.

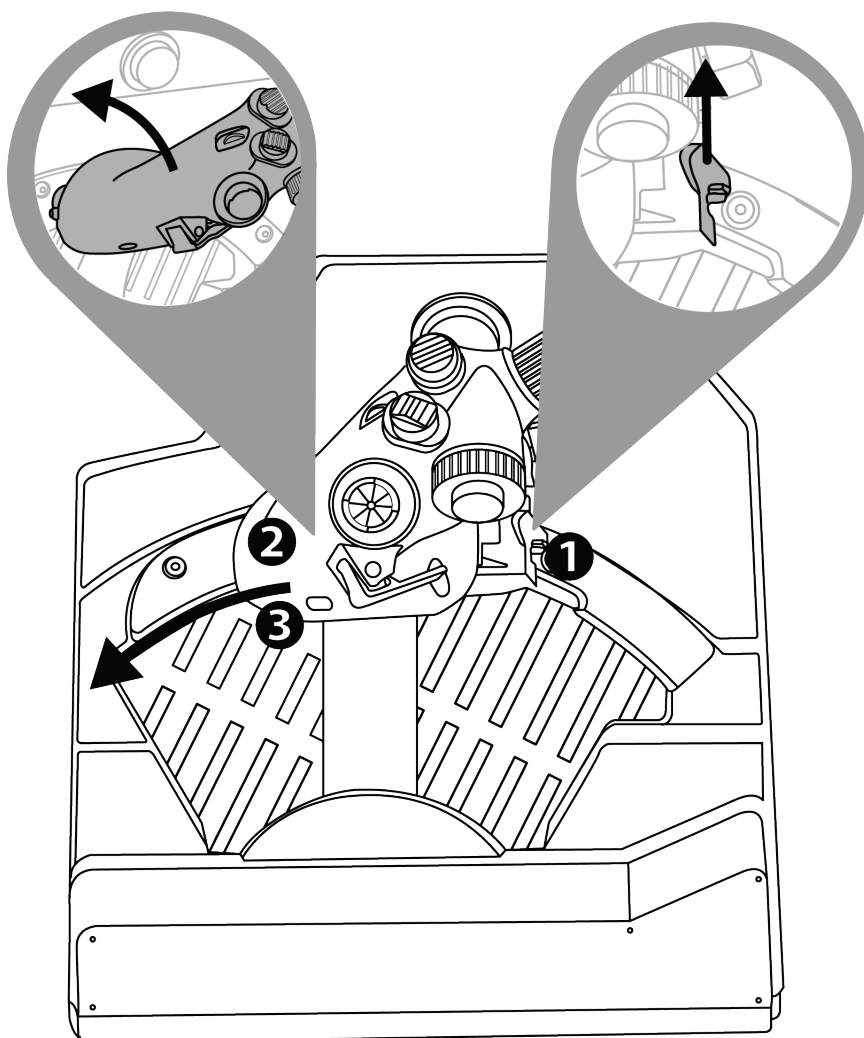



AFTERBURNER

Mueve el acelerador hasta el tope **1** y levántalo **2** para superar el tope y activar la postcombustión **3**.

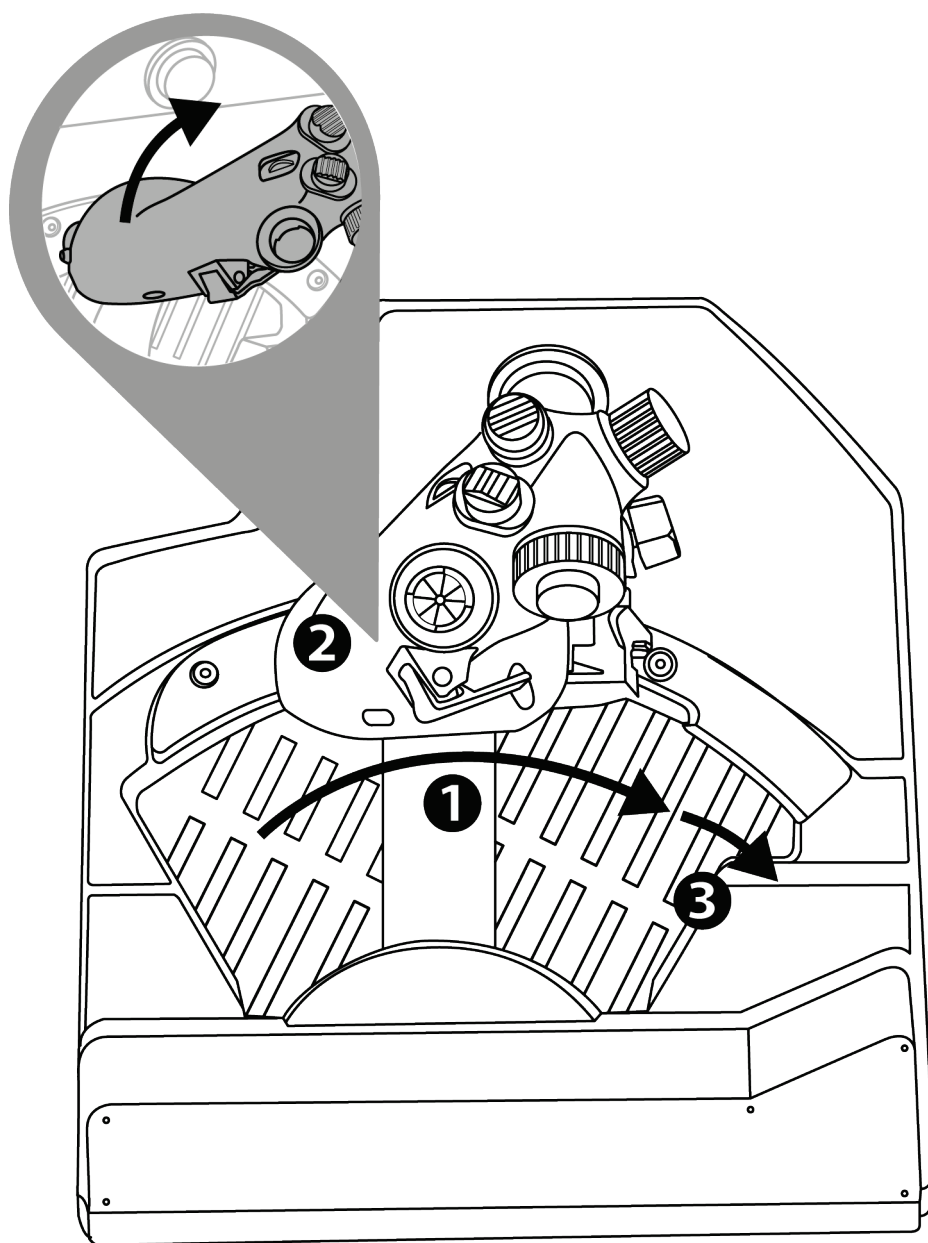



Desinstalación del tope de AFTERBURNER

El tope del módulo Afterburner está colocado al 80% del valor del eje.

Si necesitas el 100% del recorrido del acelerador sin tope (para un simulador en particular), puedes quitar el módulo Afterburner y su tope desatornillando los dos tornillos del módulo con una llave Allen (no incluida).

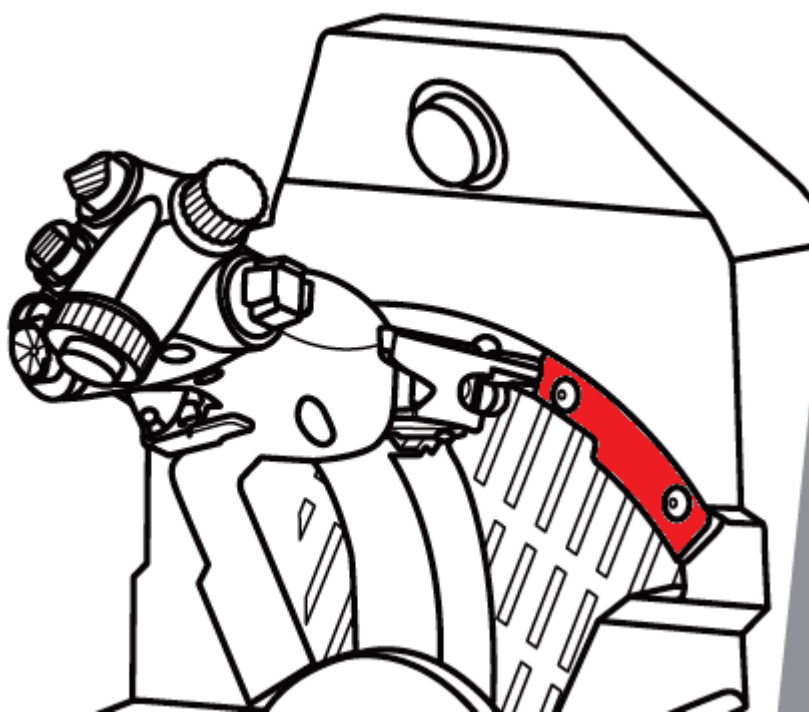



10. Software de programación avanzada T.A.R.G.E.T



Visita

<https://support.thrustmaster.com/product/viper-tqs/>.

En la sección **Software**, descarga e instala el software de programación avanzada T.A.R.G.E.T.



Características principales de T.A.R.G.E.T

- Distintas configuraciones posibles de los ejes.
- Diferentes niveles de programación posibles: Basic, Advanced y Script.
- Uso del principio de Arrastrar y Soltar.
- Capacidad de combinar el cuadrante del acelerador VIPER TQS con diversos joysticks de Thrustmaster (HOTAS Cougar, HOTAS Warthog, T.16000M, MFD Cougar Pack, también compatibles con T.A.R.G.E.T), que les permiten ser reconocidos como un único dispositivo USB.
- Acceso a perfiles avanzados creados por la comunidad de Thrustmaster.



11. Preguntas frecuentes y soporte técnico

¿Tienes preguntas sobre el VIPER TQS o tienes problemas técnicos? Si es así, visita el sitio web de soporte técnico de Thrustmaster:

<https://support.thrustmaster.com/product/viper-tqs/>.



THRUSTMASTER®

VIPER TQS

THROTTLE QUADRANT SYSTEM

Para PC (Windows 10/11)

Manual do Utilizador



Leia atentamente as instruções fornecidas neste manual **antes** de instalar o produto, **antes** de qualquer utilização do produto e **antes** de realizar qualquer manutenção. Siga as instruções de segurança. O incumprimento destas instruções pode resultar em acidentes e/ou danos. Guarde este manual para poder consultar as instruções no futuro.

ÍNDICE

1.	CONTEÚDO DA EMBALAGEM	5
2.	CARACTERÍSTICAS DO VIPER TQS.....	6
3.	MAPEAMENTO DE BOTÕES E EIXOS.....	8
4.	INFORMAÇÃO ACERCA DA UTILIZAÇÃO DO VIPER TQS	10
5.	AJUSTAR A FRICÇÃO	11
6.	INSTALAÇÃO NUM SUPORTE	12
7.	INSTALAR O VIPER PANEL*	17
8.	INSTALAÇÃO NO PC	20
9.	DETENTORES CUT OFF E AFTERBURNER .	23
10.	SOFTWARE DE PROGRAMAÇÃO AVANÇADA T.A.R.G.E.T.....	26
11.	PERGUNTAS FREQUENTES E SUPORTE TÉCNICO	28



Acelere a fundo e voe até à zona de perigo com o emblemático sistema de quadrante de potência do VIPER da U.S. Air Force – o avião de caça moderno mais amplamente utilizado do mundo!

Suba o seu cockpit de nível com a ergonomia exclusiva de uma réplica do HOTAS à escala 1:1 dotada de um manípulo de metal, além de botões e detentores realistas.

Este manual irá ajudá-lo(a) a instalar e utilizar o seu VIPER TQS nas melhores condições. Antes de descolar, leia atentamente todas estas instruções e avisos: eles irão ajudá-lo(a) a desfrutar ao máximo do seu produto.



Atualizar o firmware

Para que o VIPER TQS funcione corretamente nos videojogos, deve atualizar o respetivo firmware.

Para proceder à atualização, vá até

<https://support.thrustmaster.com/product/viper-tqs/>

Selecione **Firmware** e siga as instruções, incluindo o procedimento de transferência e instalação.



1. Conteúdo da embalagem

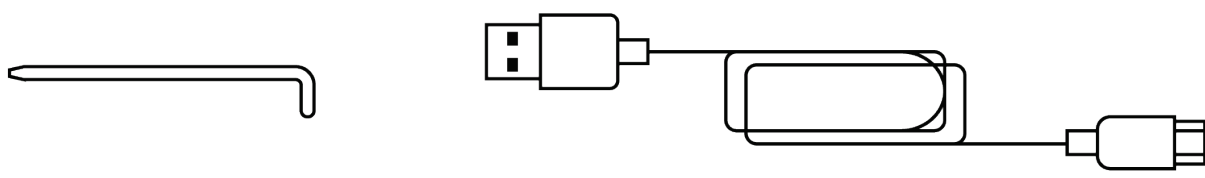
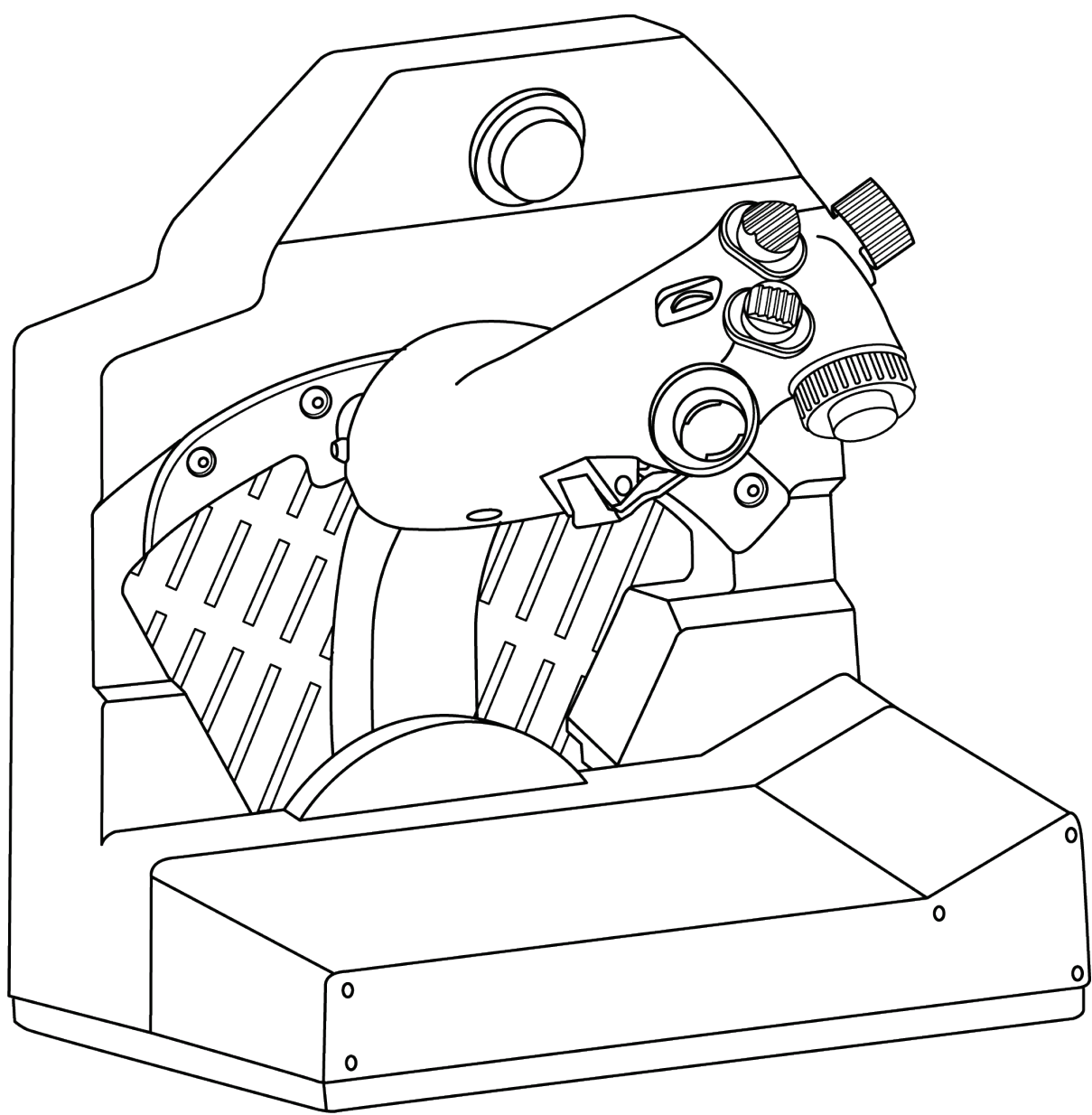



2. Características do VIPER TQS

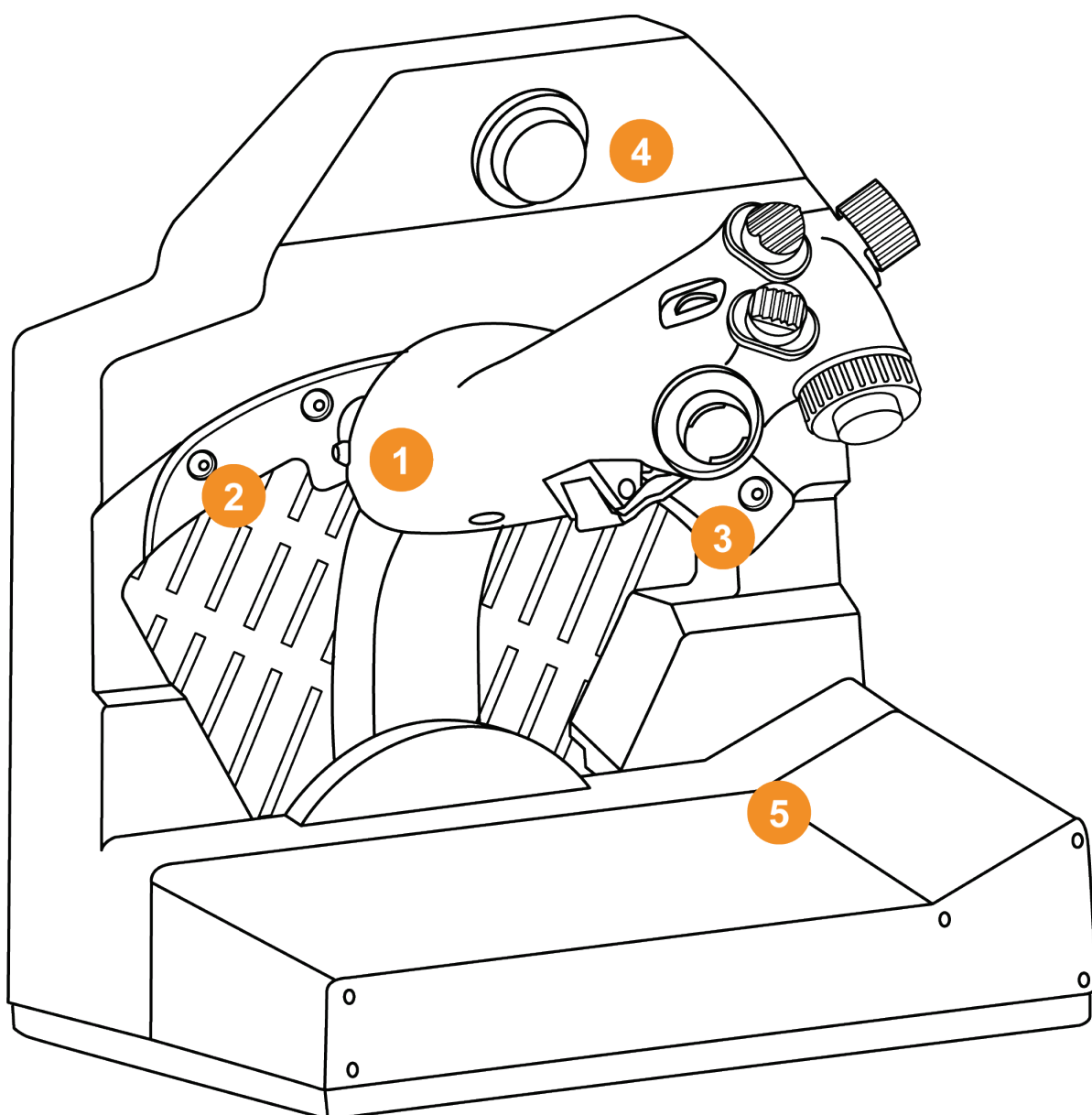

1. Manípulo

2. Batente Cut Off

3. Batente Afterburner

4. Interruptor de palmada CHAFF/FLARE

5. Grampo para o mapa da missão

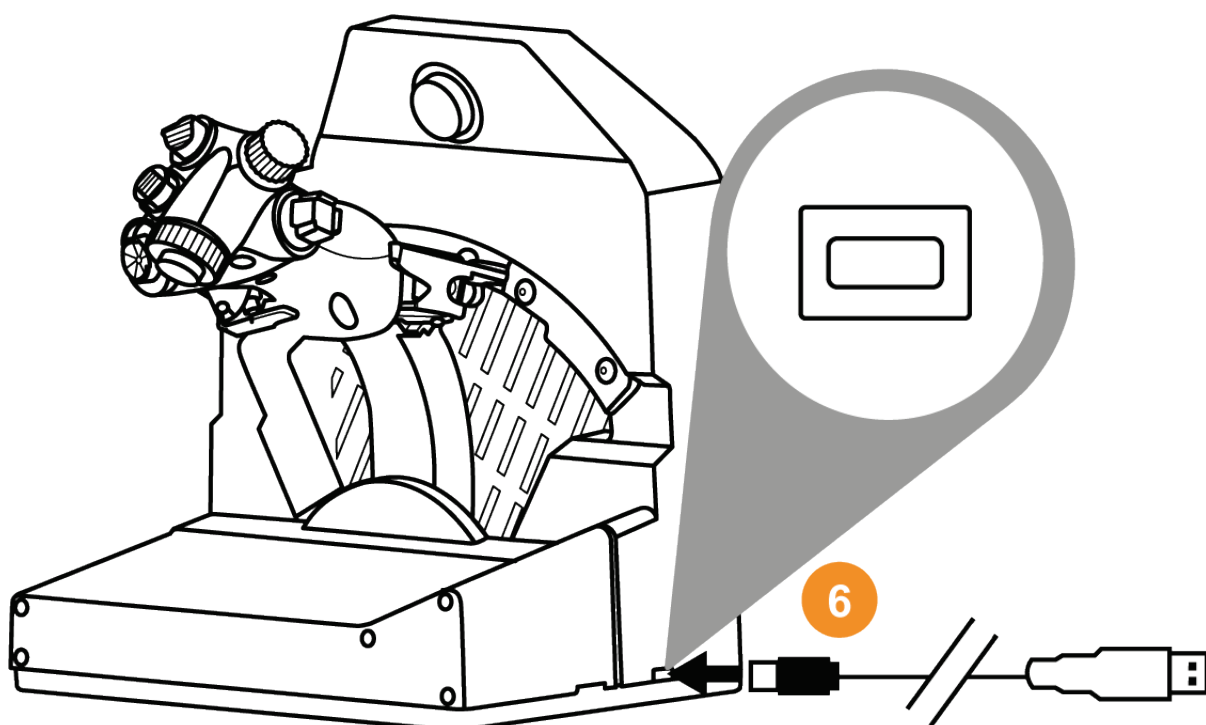

6. Conector USB (tipo C)

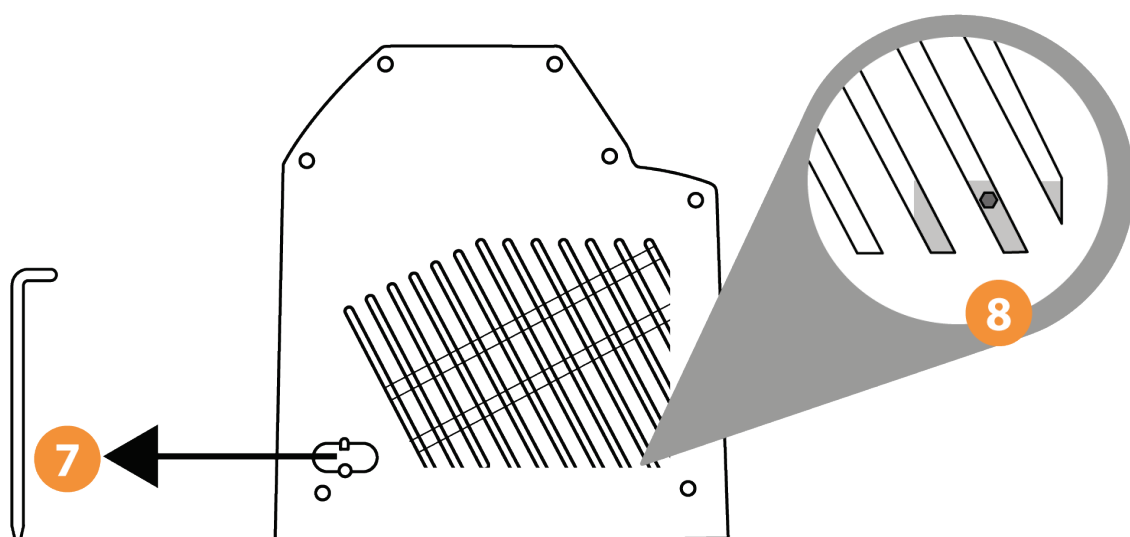

7. Localização da ferramenta de ajuste da fricção

8. Ponto de acesso ao ajuste da fricção da alavanca de potência



3. Mapeamento de botões e eixos

Manípulo do VIPER TQS: mapeamento dos 19 botões e 5 eixos no modo A (sem botões virtuais)

A 1 → 19

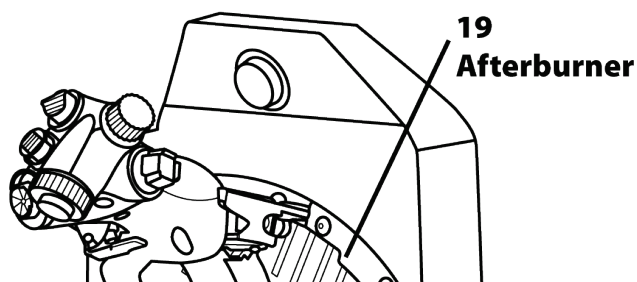
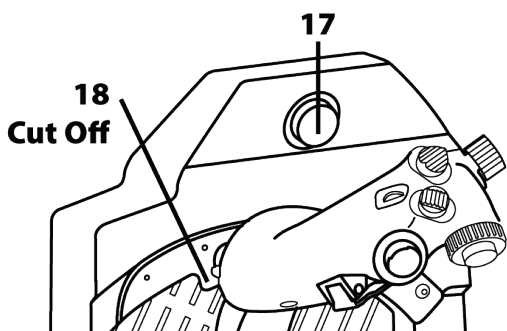
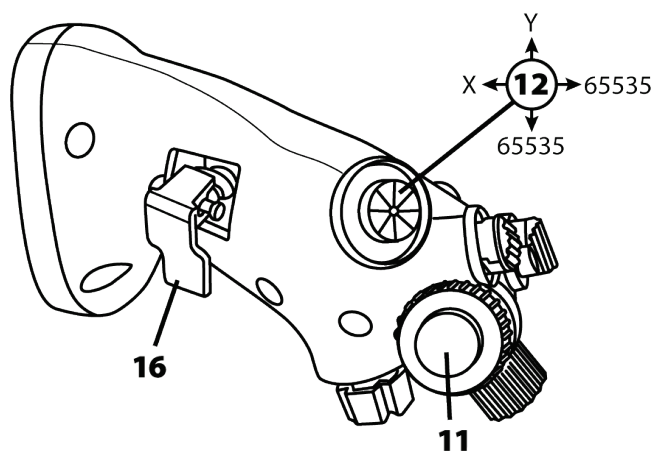
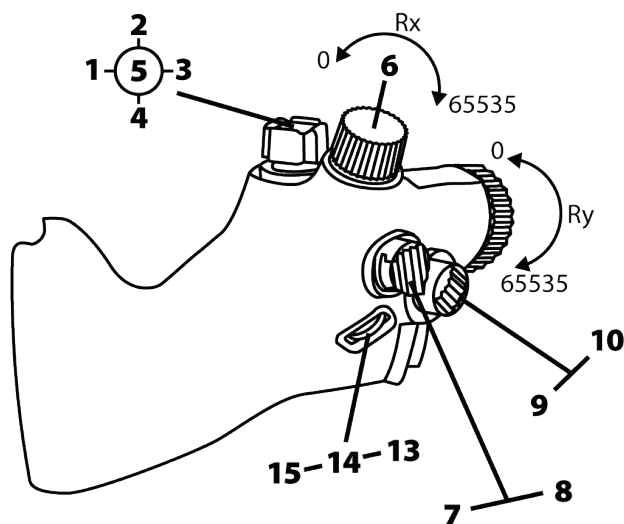



Modo B: com botões virtuais

B 1 → 21

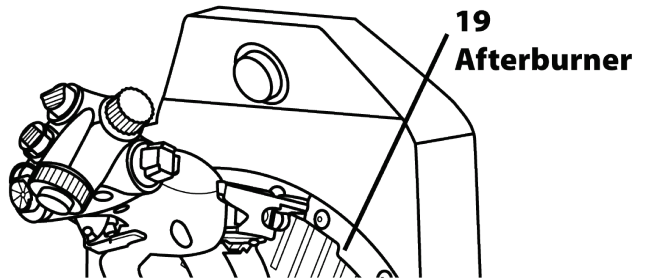
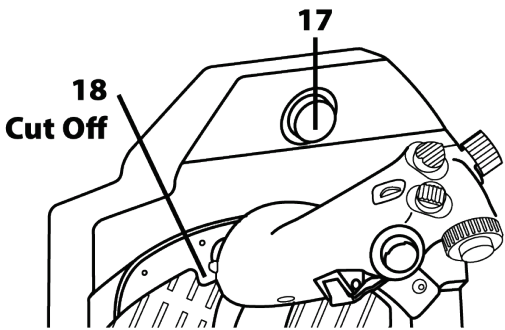
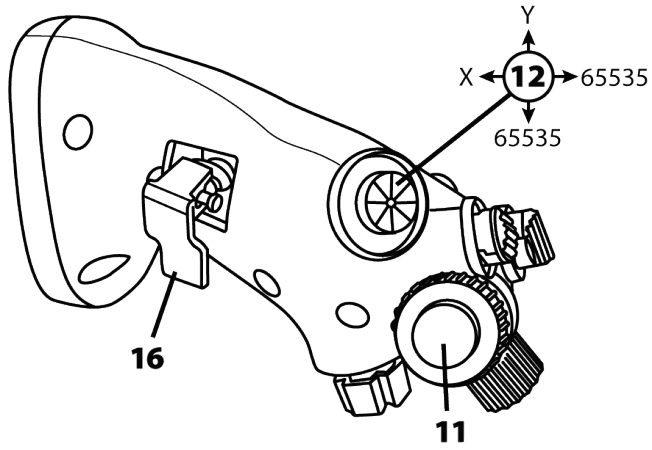
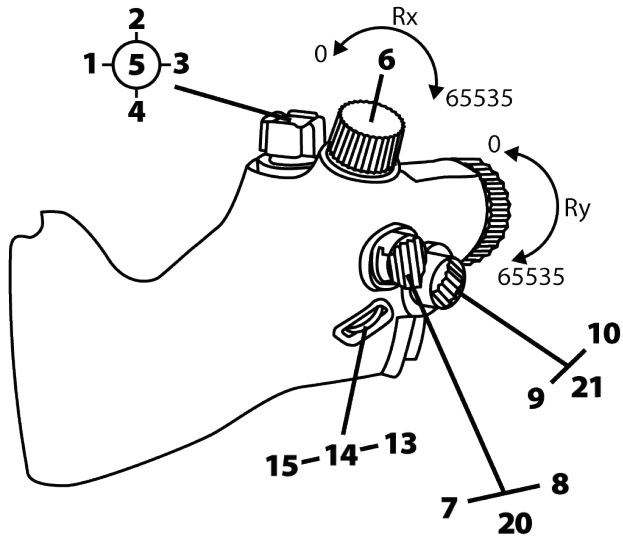



4. Informação acerca da utilização do VIPER TQS



Perigo de entalamento

Nunca coloque os dedos nas áreas dos batentes quando estiver a utilizar o manípulo.

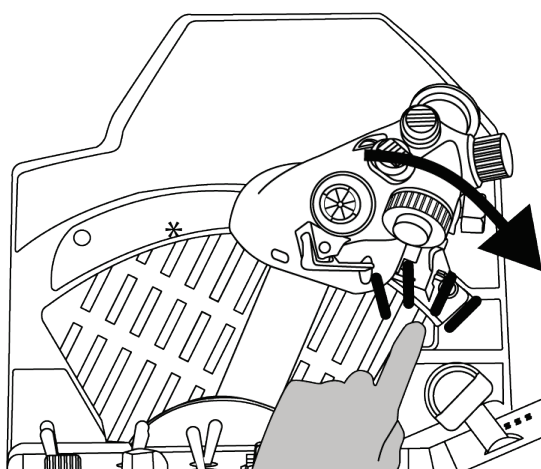
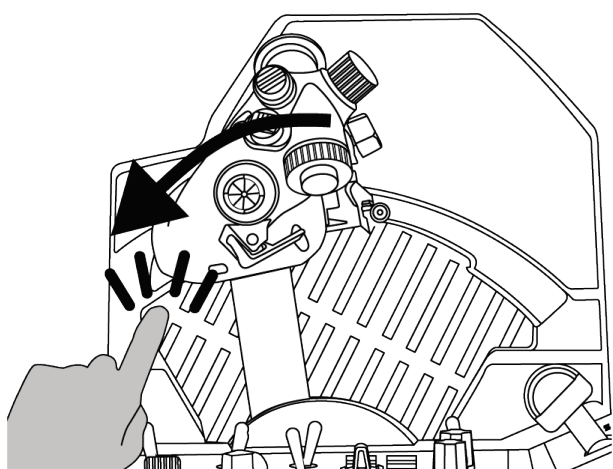
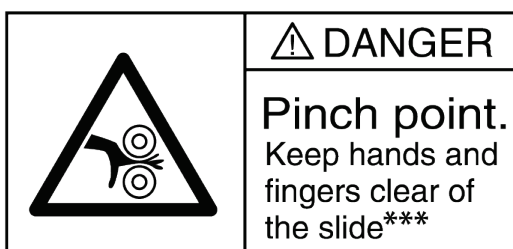



5. Ajustar a fricção

Pode ajustar a fricção do quadrante de potência do seu VIPER TQS de acordo com a sua preferência pessoal utilizando a ferramenta incluída na parte lateral do VIPER TQS. Note, contudo, que a fricção ótima da alavanca de potência foi predefinida na fábrica.

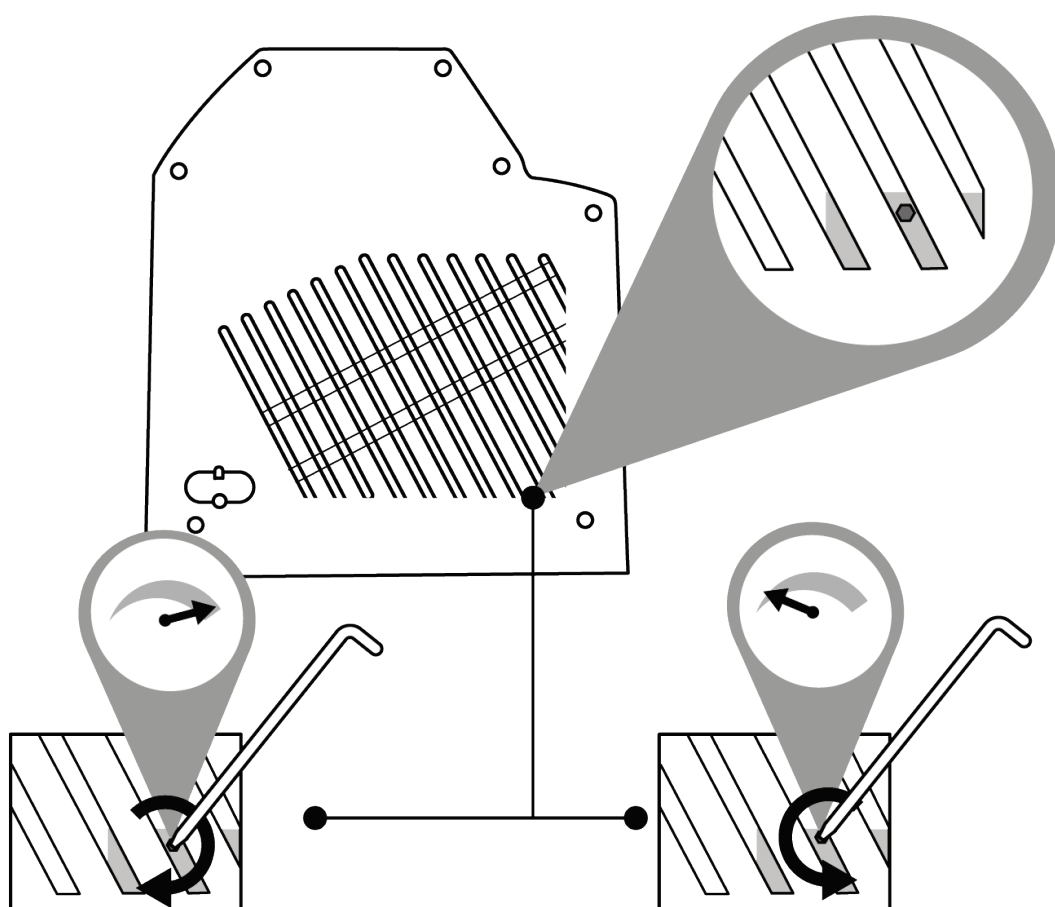

De modo a evitar danificar o sistema de fricção, não aperte excessivamente o parafuso de ajuste.

Além disso, não desaperte completamente o parafuso de ajuste: ao fazê-lo, corre o risco de a alavanca de potência deixar de conseguir manter-se na posição.



6. Instalação num suporte



O VIPER TQS pode ser instalado em diferentes tipos de suportes. A maioria dos cockpits e suportes disponíveis no mercado já são compatíveis com produtos Thrustmaster semelhantes (ou seja, o HOTAS Warthog).

Lembre-se de que o VIPER TQS possui um efeito de alavanca potente, pelo que deve estar fixado firmemente. Fixe a base ao suporte utilizando parafusos M6 adequados (não incluídos), de modo a não danificar o manípulo. Um esquema completo do VIPER TQS está disponível em <https://support.thrustmaster.com/product/viper-tqs/>



Antes de cada utilização, certifique-se de que o **VIPER TQS** continua fixado corretamente ao suporte, de acordo com as instruções especificadas pelo fabricante. Tenha em consideração o material do suporte e certifique-se de que é possível fixar em segurança o produto ao mesmo. O **VIPER TQS** deve ser utilizado numa secretária em material sólido (ou seja, MDF ou madeira), sem quaisquer componentes ocos ou de vidro.



Dimensões do esquema de montagem (em mm)

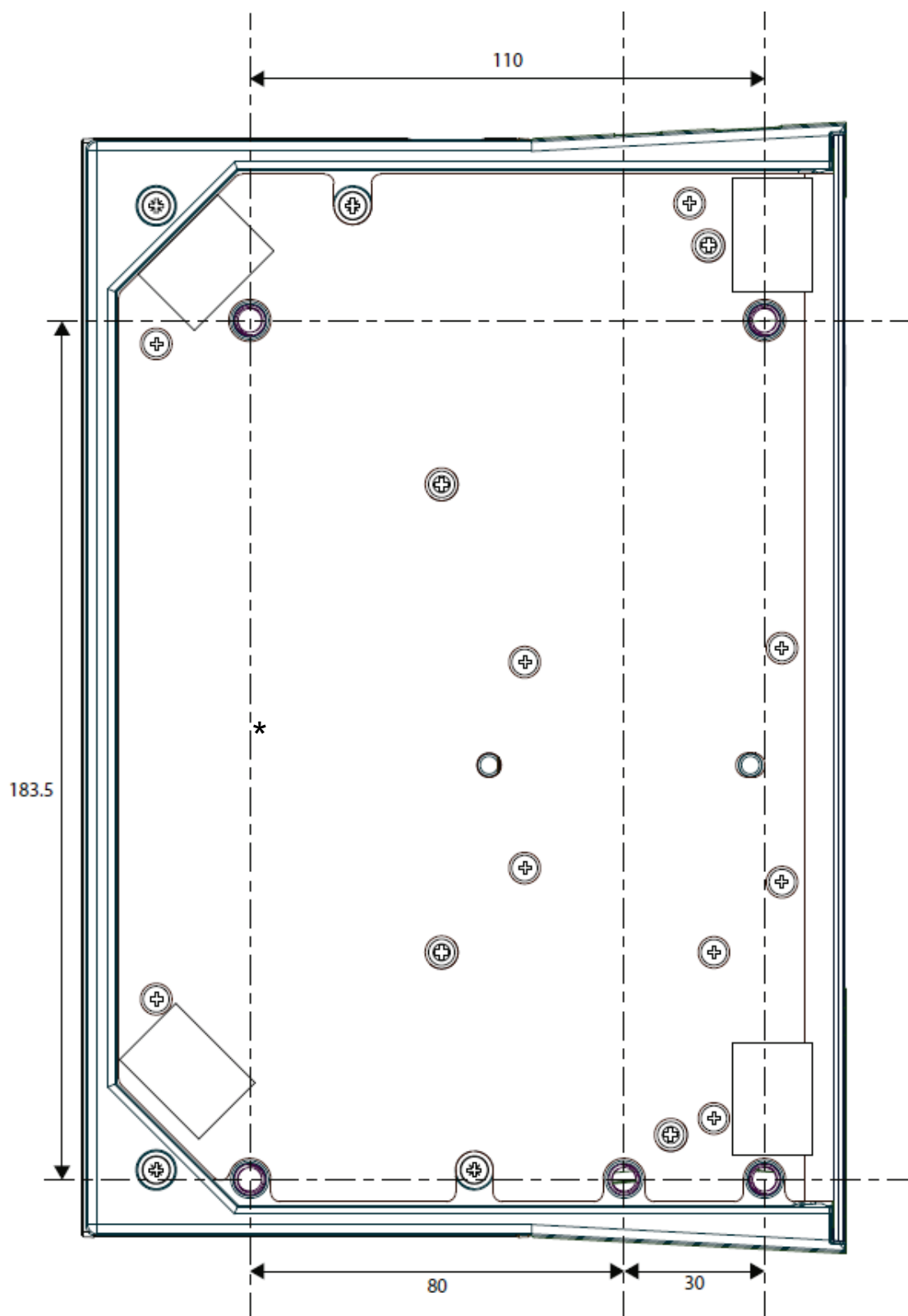

Pode transferir o esquema de montagem de <https://support.thrustmaster.com/product/viper-tqs/> e em seguida imprimi-lo e utilizá-lo no seu suporte a fim de preparar os orifícios de perfuração.



Instalação utilizando o TM Flying Desk Mount*

O TM Flying Desk Mount é um sistema de montagem de metal dotado de um parafuso de fixação, melhorando a ergonomia e a posição de pilotagem ao utilizar o dispositivo. Este sistema está concebido para a utilização com secretárias e mesas com 15 a 50 mm de espessura.

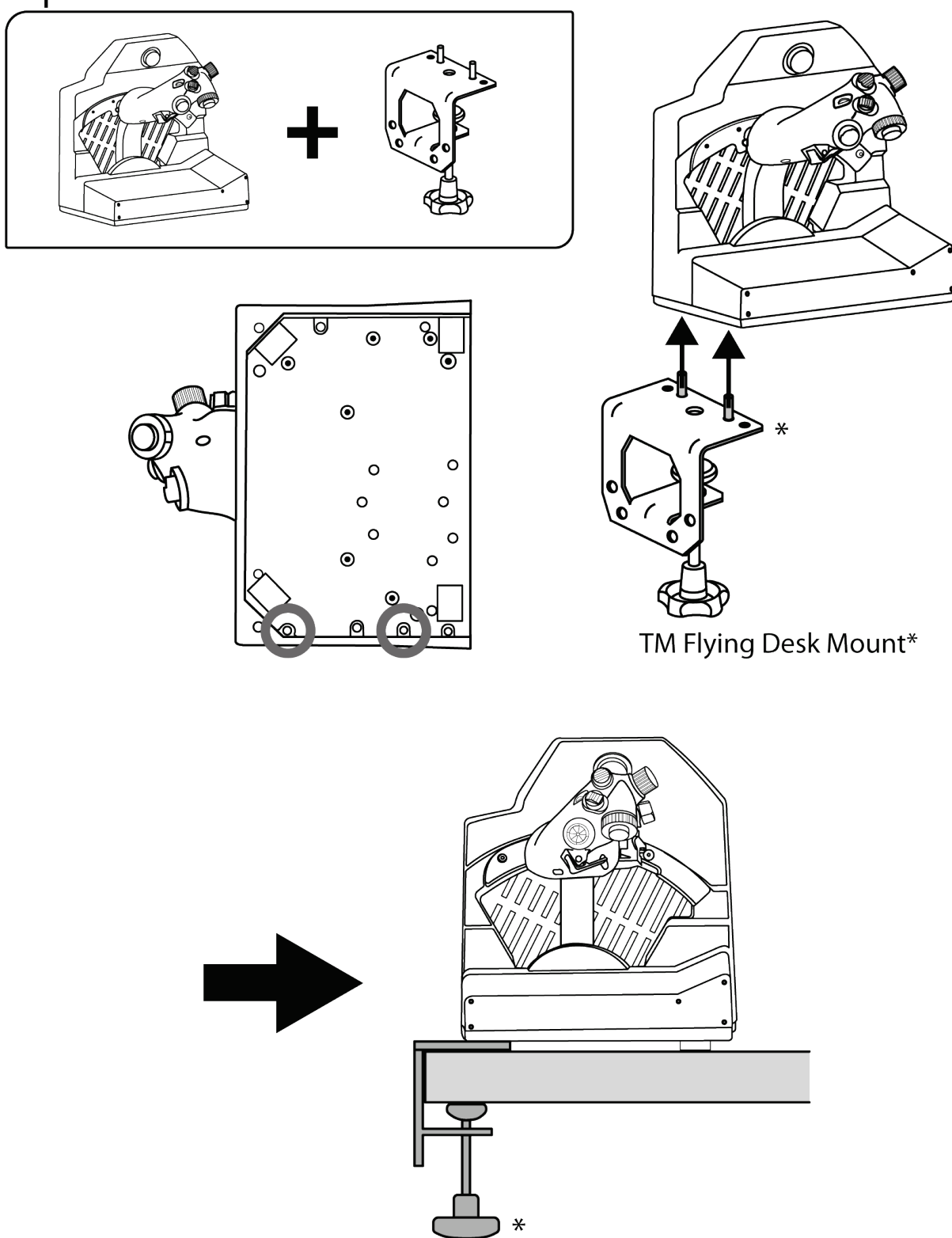

* Vendido à parte



Instalação utilizando o TM Flying Clamp*

O TM Flying Clamp é um suporte ajustável em altura concebido pela Thrustmaster para os respetivos acessórios de simulação de voo. Este sistema de montagem possui dois parafusos de fixação, que permitem ajustá-lo para a utilização com secretárias e mesas com 15 a 45 mm de espessura.

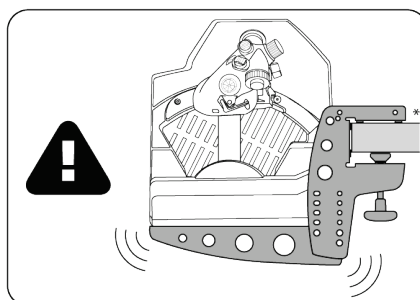
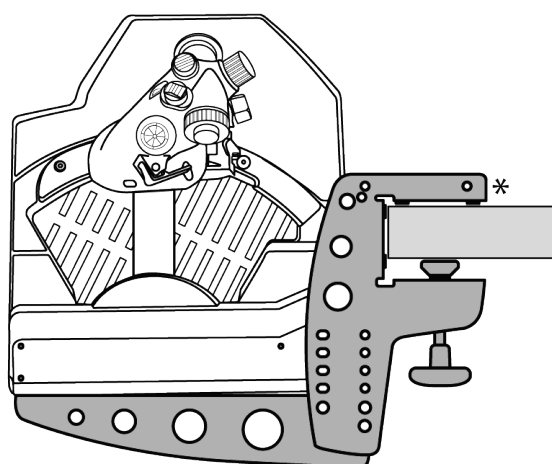
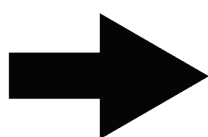
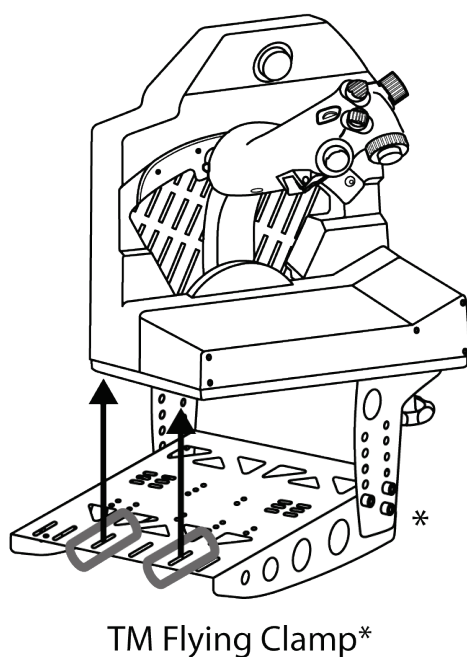
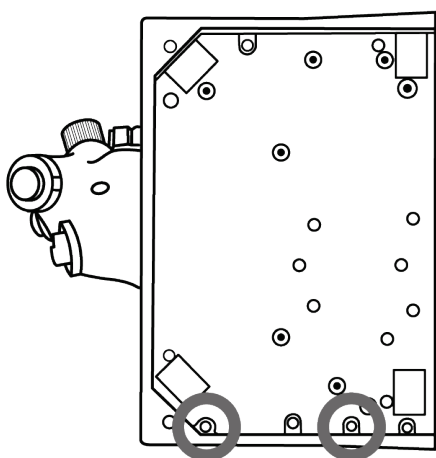
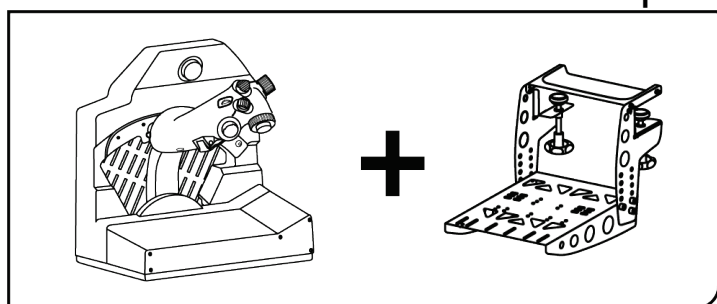

* Vendido à parte



Note que o peso elevado do VIPER TQS pode causar movimentos indesejados do sistema de montagem.



7. Instalar o VIPER PANEL*

* Vendido à parte O VIPER PANEL é incluído com o VIPER TQS Mission Pack.

O VIPER PANEL é um painel de controlo que lhe permite expandir as suas capacidades de voo/combate com um total de 43 botões e 1 eixo, os quais são todos programáveis através do software T.A.R.G.E.T. O VIPER PANEL é um complemento do VIPER TQS.

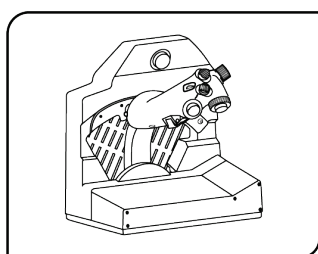

1

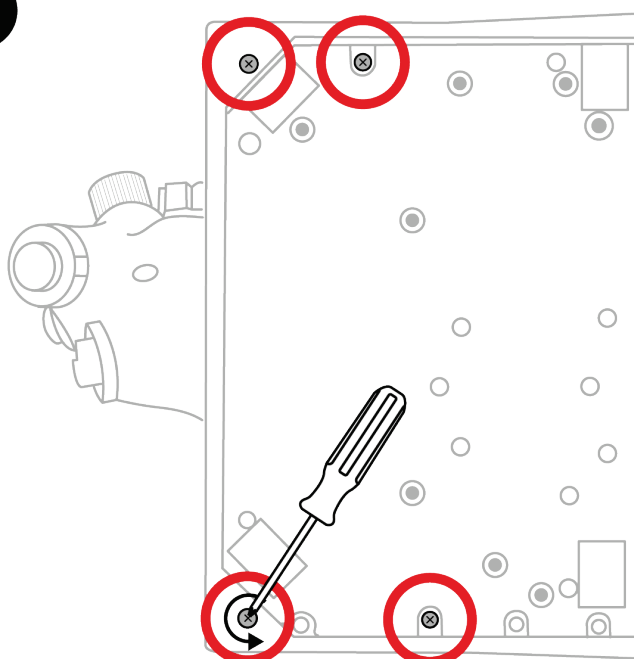

2

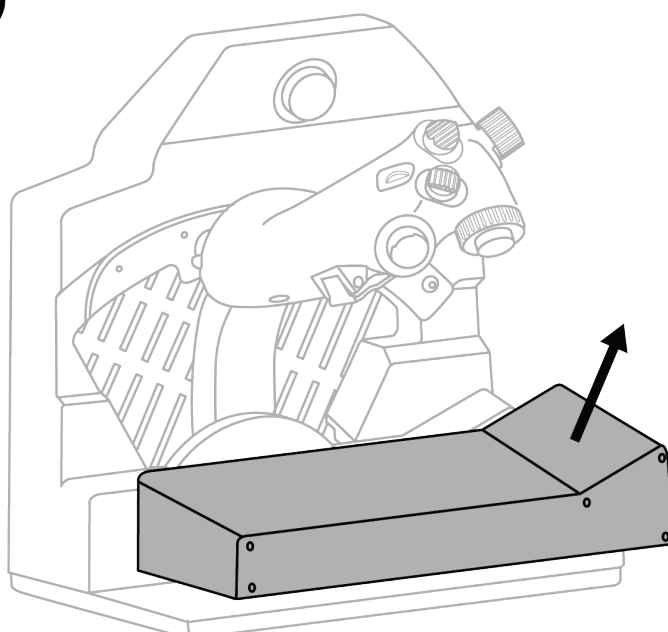

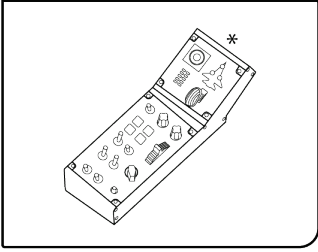

3

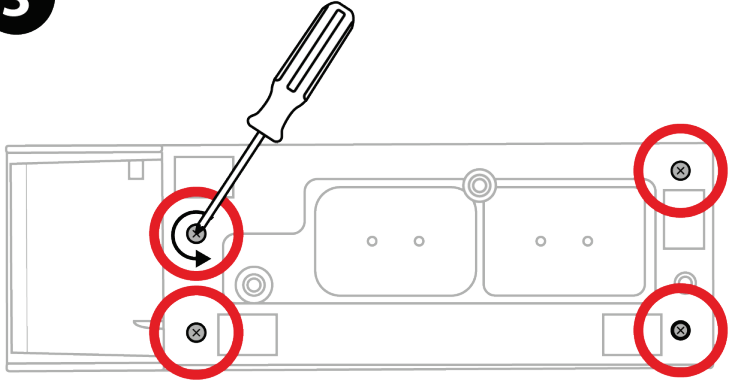

4

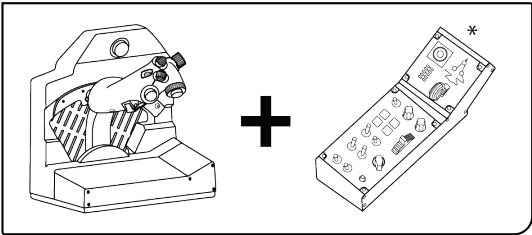
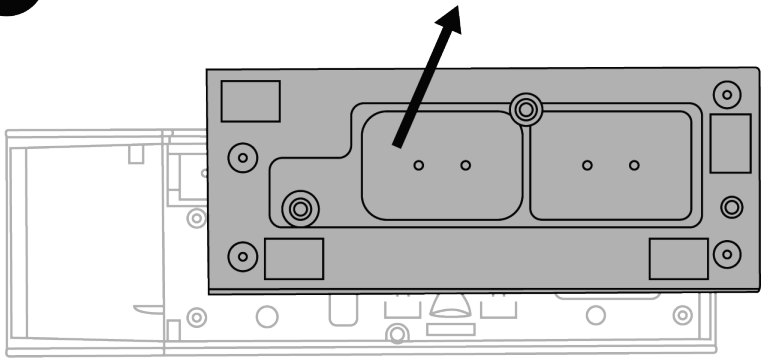

5

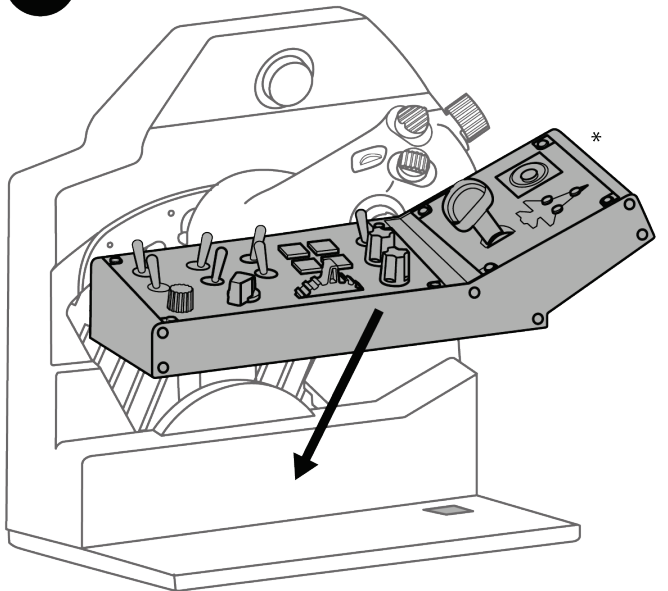



6

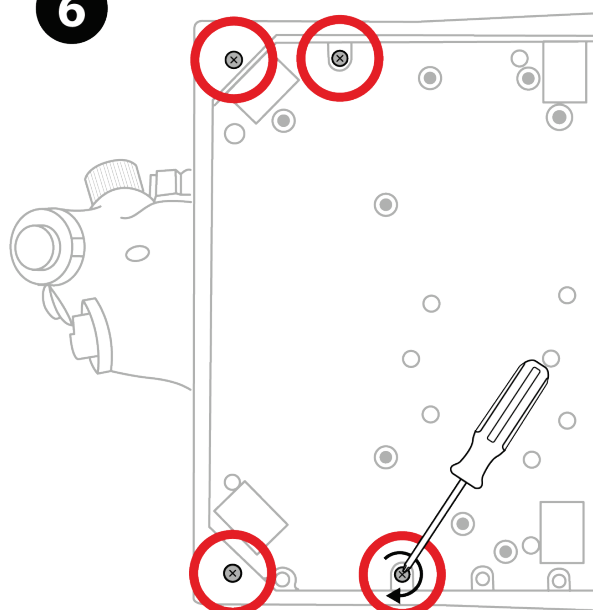

7

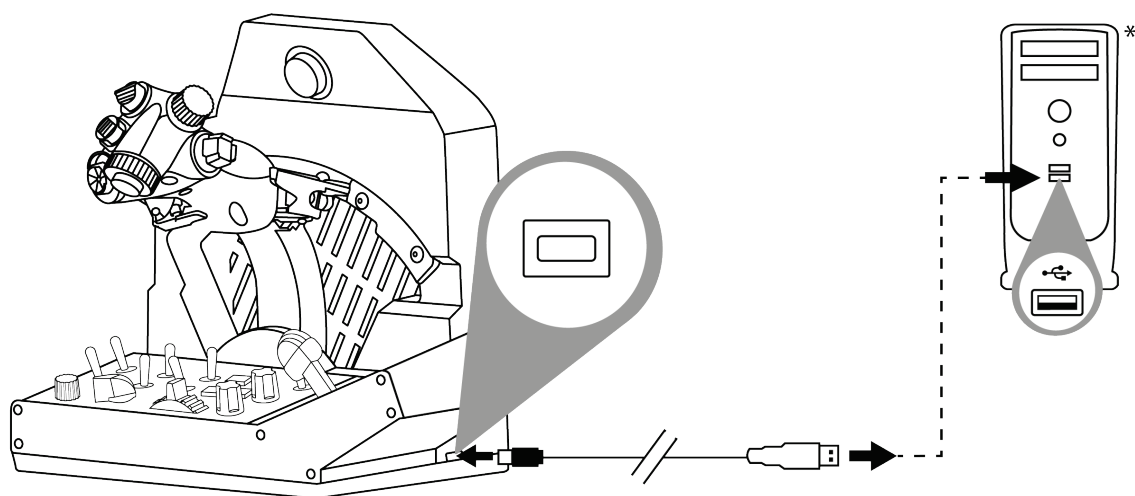

* Não incluído



8. Instalação no PC

1



Vá até

<https://support.thrustmaster.com/product/viper-tqs/>.

2

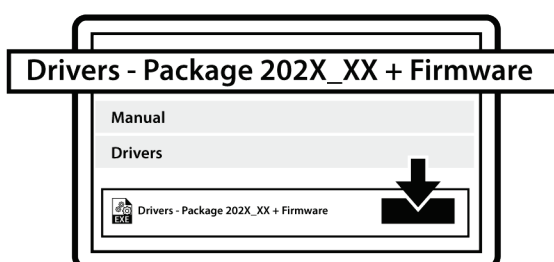

Transfira e instale o controlador para o PC e a respetiva interface personalizada para o Painel de Controlo do Windows.

3

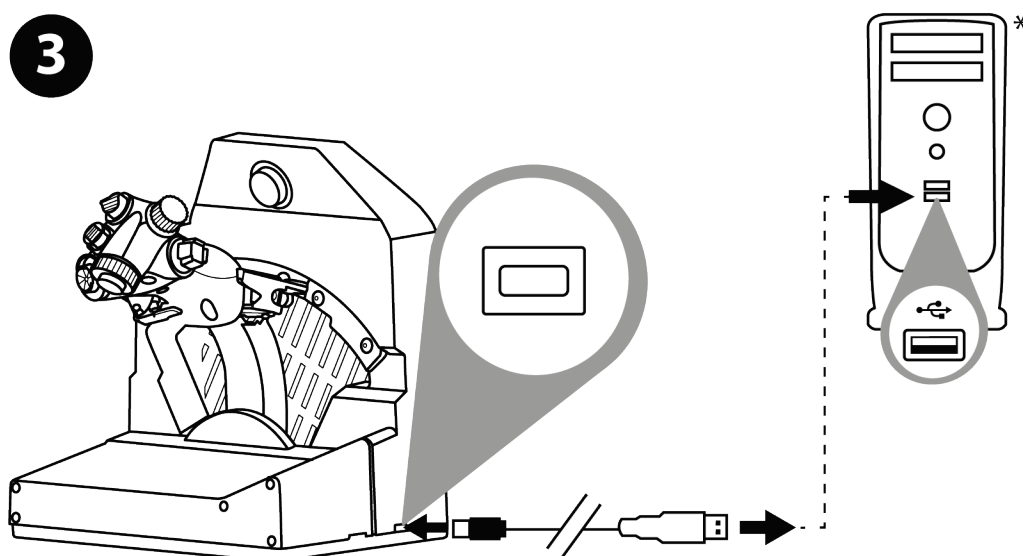

Quando o controlador para o PC estiver instalado, ligue o conector USB a uma das portas USB do PC.

* Não incluído



④ Para aceder ao Control Panel, seleccione **Iniciar / Todas as aplicações / Thrustmaster / Control Panel** ou **Painel de Controlo** (no Windows 10).

É apresentada a caixa de diálogo **Controladores de jogos**. O acessório fica visível no ecrã com o nome **VIPER TQS** e o estado **OK**.

⑤ Na caixa de diálogo **Controladores de jogos**, clique em **Propriedades** para testar e ver todas as funções.

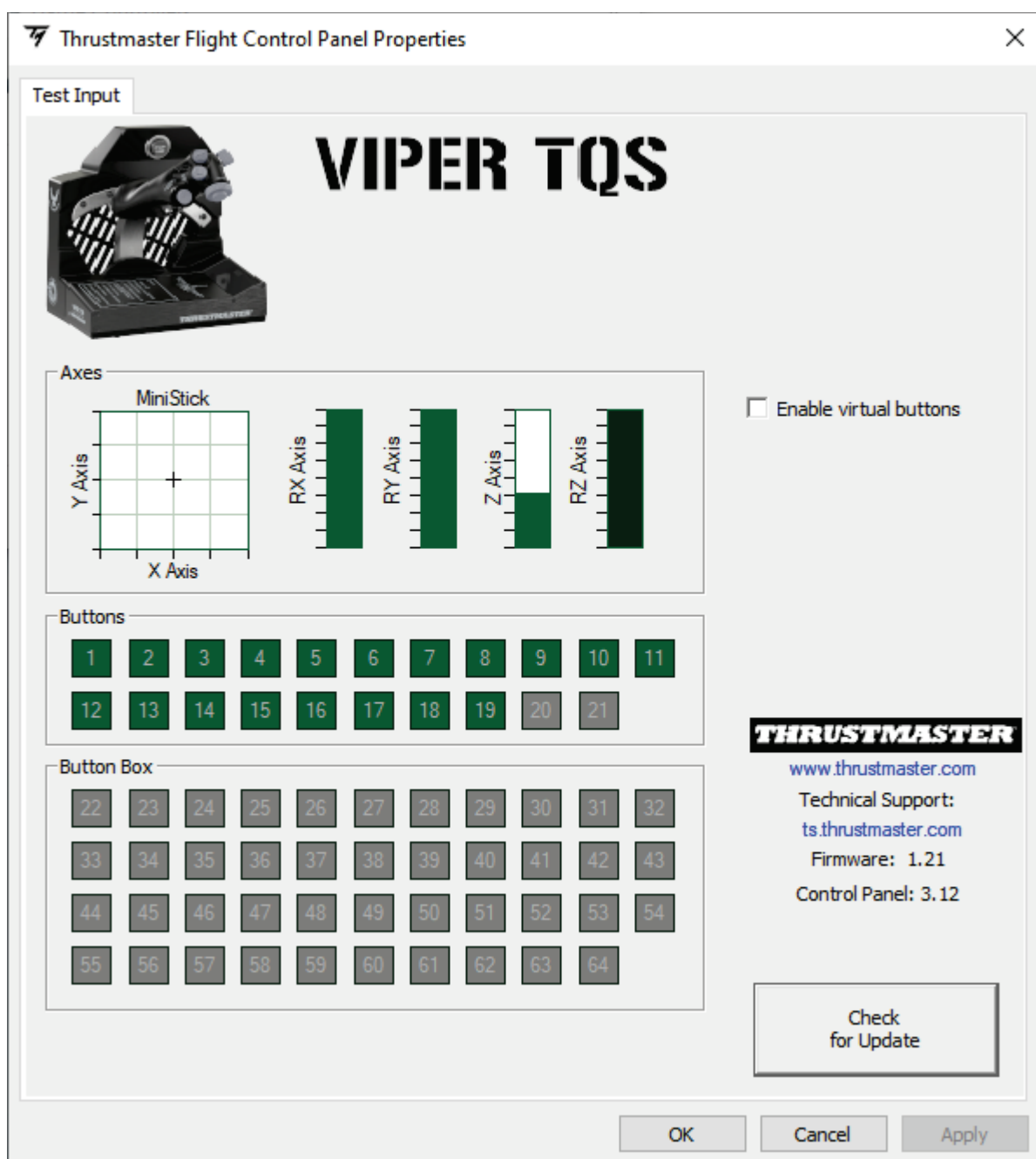



Enable virtual buttons (Ativar botões virtuais):

Esta função permite-lhe ativar ou desativar os botões virtuais no manípulo (botões 20 e 21). Clique em **Apply** (Aplicar) depois de seleccionar o modo que pretende utilizar.

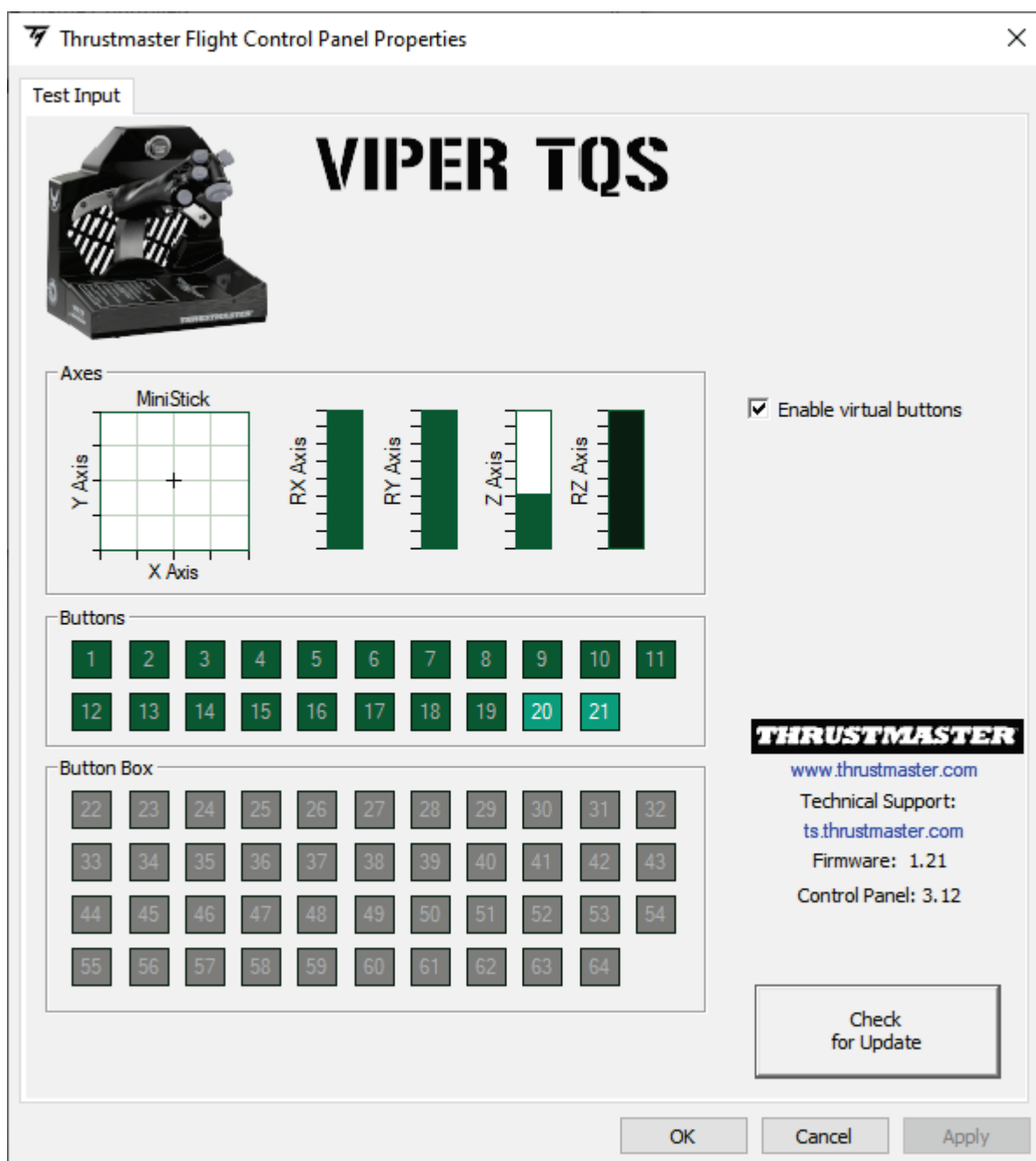

Os botões virtuais estão desativados por predefinição no VIPER TQS.



9. Detentores CUT OFF e AFTERBURNER

O quadrante de potência VIPER TQS possui um sistema realista de detentores CUT OFF e AFTERBURNER (o módulo Afterburner é amovível).

CUT OFF

Depois de posicionar a alavanca de potência no batente IDLE, prima o gatilho de “desbloqueio do corte do motor”

1 para subir o manípulo a fim de passar por cima do batente **2** e, em seguida, coloque o manípulo na posição OFF **3**. Para ligar novamente os motores, execute este procedimento pela ordem inversa.

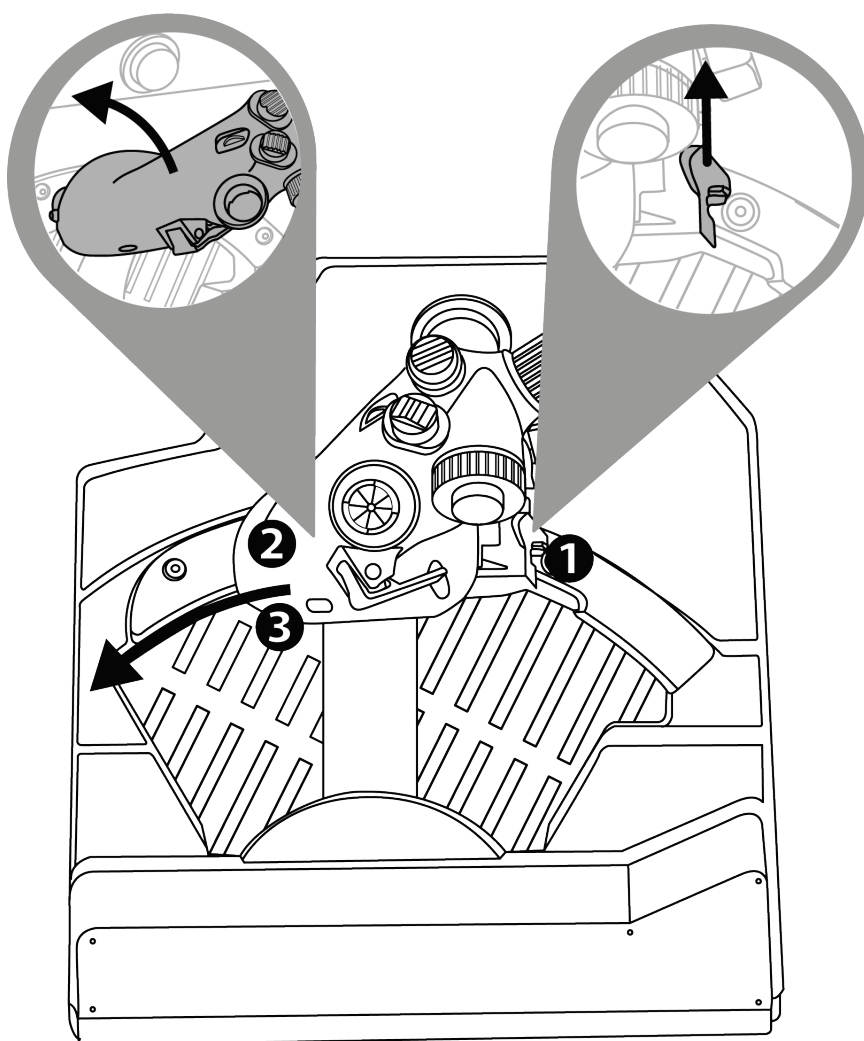



AFTERBURNER

Mova a alavanca de potência para o batente **1** e suba-a **2** a fim de passar por cima do batente e acionar o pós-combustor **3**.

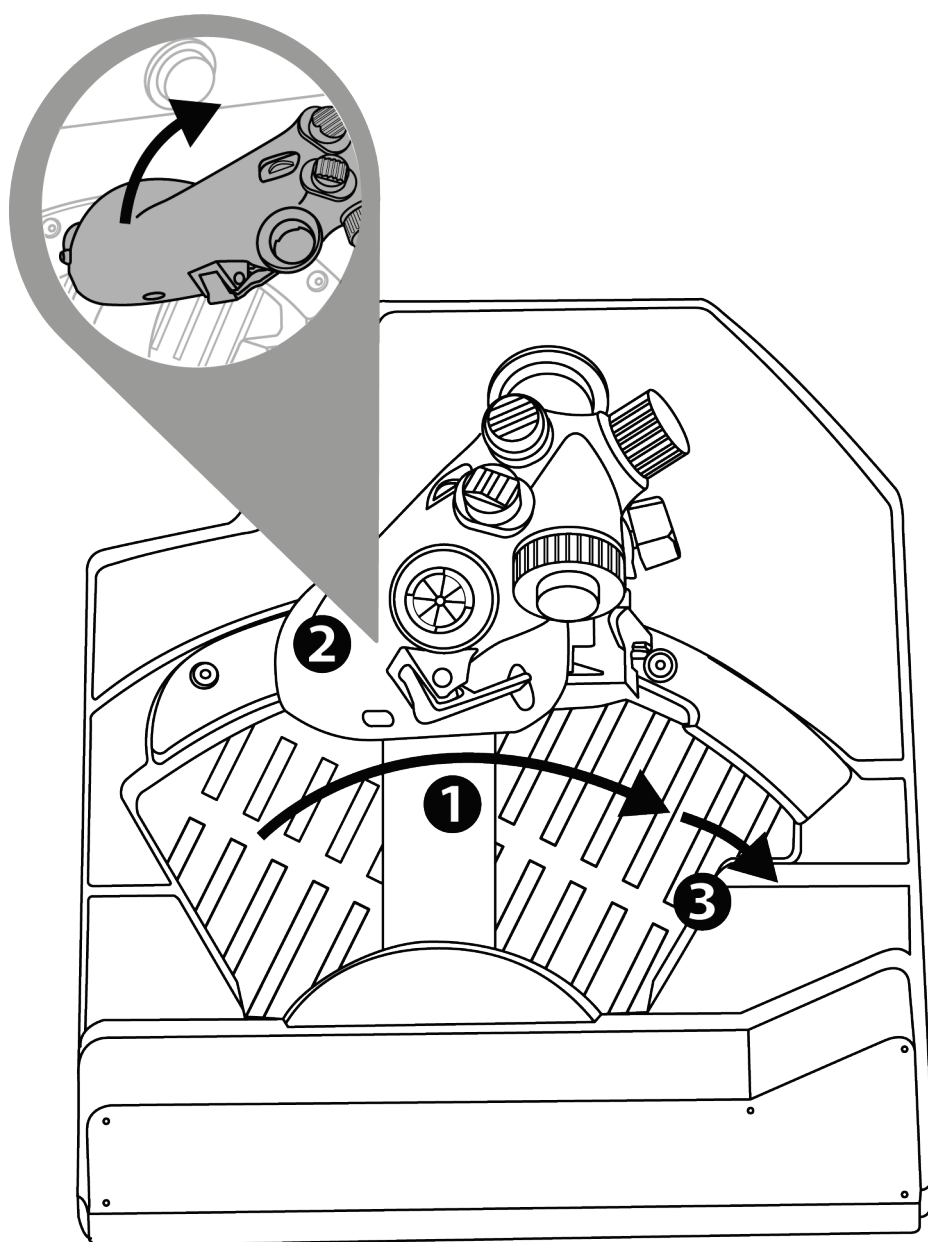



Desinstalar o batente AFTERBURNER

O batente do módulo Afterburner está posicionado a 80% do valor do eixo.

Se necessitar de 100% do curso da alavanca de potência sem um batente (para um simulador específico), pode remover o módulo Afterburner e o respectivo batente desapertando os dois parafusos do módulo com uma chave sextavada (não incluída).

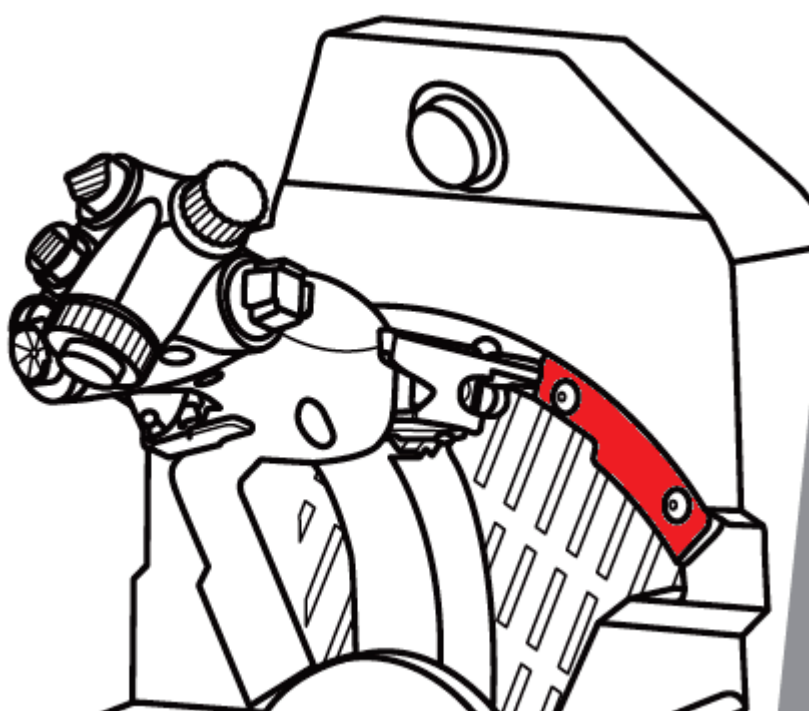



10. Software de programação avançada T.A.R.G.E.T



Vá até

<https://support.thrustmaster.com/product/viper-tqs/>.

Na secção **Software**, transfira e instale o software de programação avançada T.A.R.G.E.T.



Principais características do software

T.A.R.G.E.T

- Diferentes configurações possíveis dos eixos.
- Diferentes níveis de programação possíveis: Basic, Advanced e Script.
- Utilização do princípio de arrastar e largar.
- Capacidade para combinar o quadrante de potência VIPER TQS com vários joysticks Thrustmaster (HOTAS Cougar, HOTAS Warthog, T.16000M, MFD Cougar Pack, os quais são todos igualmente compatíveis com o software T.A.R.G.E.T), permitindo que sejam reconhecidos como um único dispositivo USB.
- Acesso a perfis avançados criados pela comunidade Thrustmaster.



11. Perguntas frequentes e suporte técnico

Tem alguma questão relativamente ao VIPER TQS, ou deparou-se com problemas técnicos? Se for o caso, visite o sítio Web de suporte técnico da Thrustmaster:

<https://support.thrustmaster.com/product/viper-tqs/>.



THRUSTMASTER®

VIPER TQS

THROTTLE QUADRANT SYSTEM

PC (Windows 10/11)

Руководство пользователя



Внимательно прочитайте инструкции, содержащиеся в данном руководстве, перед установкой, перед любым использованием продукта и перед любым техническим обслуживанием. Обязательно соблюдайте правила техники безопасности. Несоблюдение техники безопасности может привести к несчастным случаям или повреждениям. Сохраните это руководство, чтобы иметь возможность обратиться к инструкциям в будущем.

ОГЛАВЛЕНИЕ

1.	СОДЕРЖИМОЕ КОРОБКИ.....	5
2.	VIPER TQS — ОПИСАНИЕ УСТРОЙСТВА.....	6
3.	ФУНКЦИИ КНОПОК И ОСЕЙ.....	8
4.	ИНФОРМАЦИЯ ОБ ИСПОЛЬЗОВАНИИ VIPER TQS	10
5.	РЕГУЛИРОВКА ТРЕНИЯ.....	11
6.	УСТАНОВКА НА ОПОРЕ.....	12
7.	УСТАНОВКА VIPER PANEL*	17
8.	ПОДКЛЮЧЕНИЕ К РС.....	20
9.	ФИКСАТОРЫ CUT OFF И AFTERBURNER..	23
10.	РАСШИРЕННОЕ ПО ДЛЯ ПРОГРАММИРОВАНИЯ T.A.R.G.E.T	26
11.	ЧАСТО ЗАДАВАЕМЫЕ ВОПРОСЫ И ТЕХНИЧЕСКАЯ ПОДДЕРЖКА.....	28



Запустите свои двигатели и отправляйтесь в опасную зону, управляя своим самолетом с помощью копии легендарного блока рычагов, которым оснащались самолеты VIPER ВВС США — самые распространенные в мире современные истребители.

Поднимите свой кокпит на новый уровень благодаря уникальной эргономике реплики HOTAS в масштабе 1:1 с металлической рукояткой, а также реалистичными кнопками и фиксаторами.

Данное руководство поможет вам установить и использовать VIPER TQS наилучшим образом. Перед взлетом обязательно внимательно прочитайте все инструкции и предупреждения: они помогут вам получить максимальное удовольствие от использования устройства.



Обновление прошивки

Чтобы VIPER TQS правильно функционировал в видеоиграх, необходимо обновить его прошивку.

Чтобы выполнить обновление, зайдите на сайт

<https://support.thrustmaster.com/product/viper-tqs/>

Выберите **Firmware** (Прошивка) и следуйте инструкциям, включая процедуру загрузки и установки.



1. Содержимое коробки

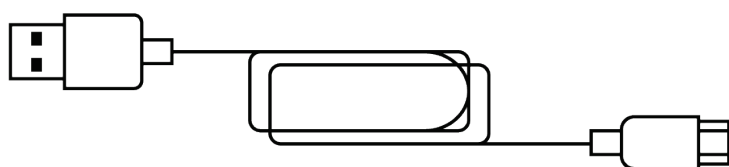
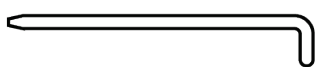
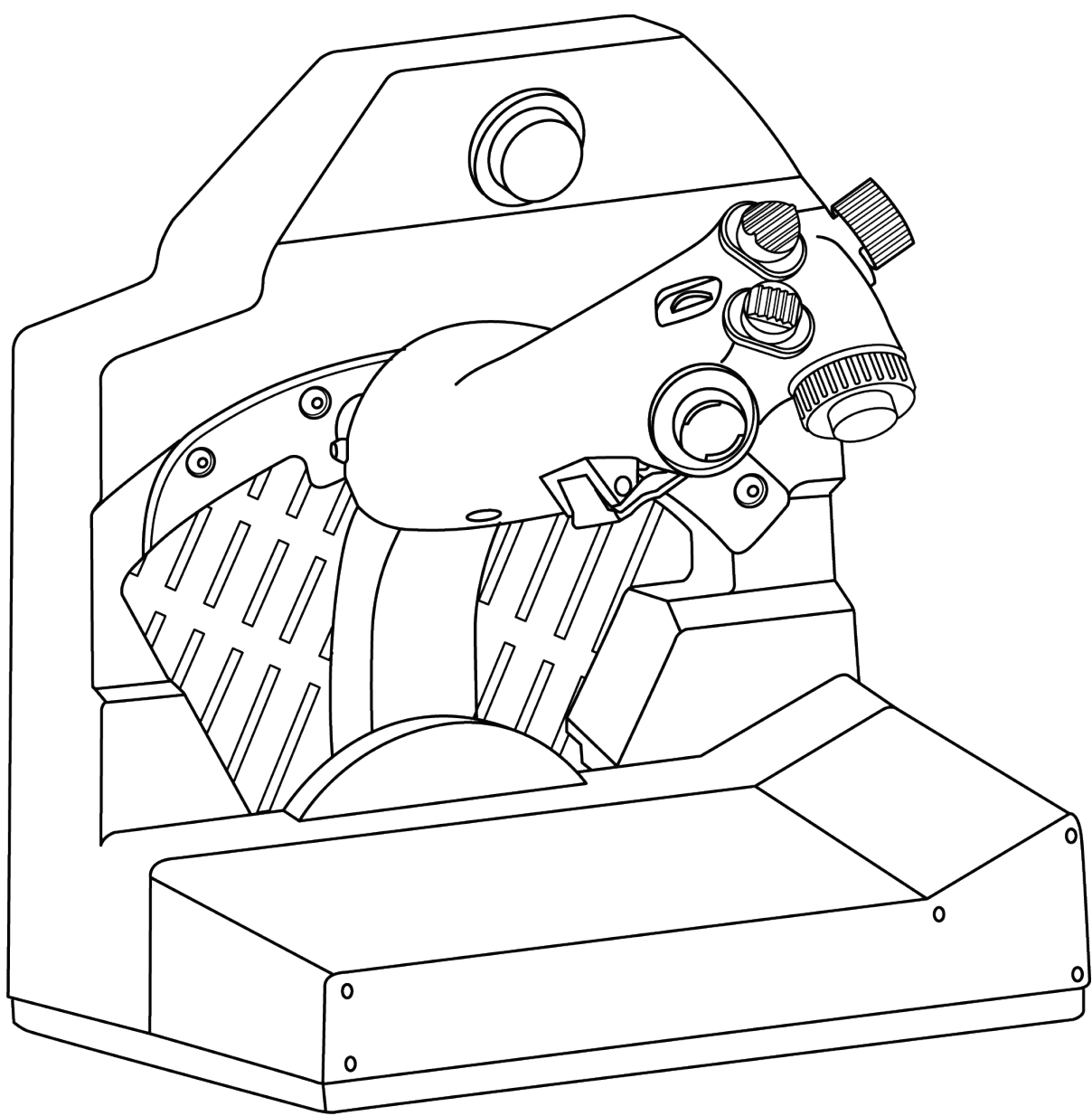



2. VIPER

TQS —

описание

устройства

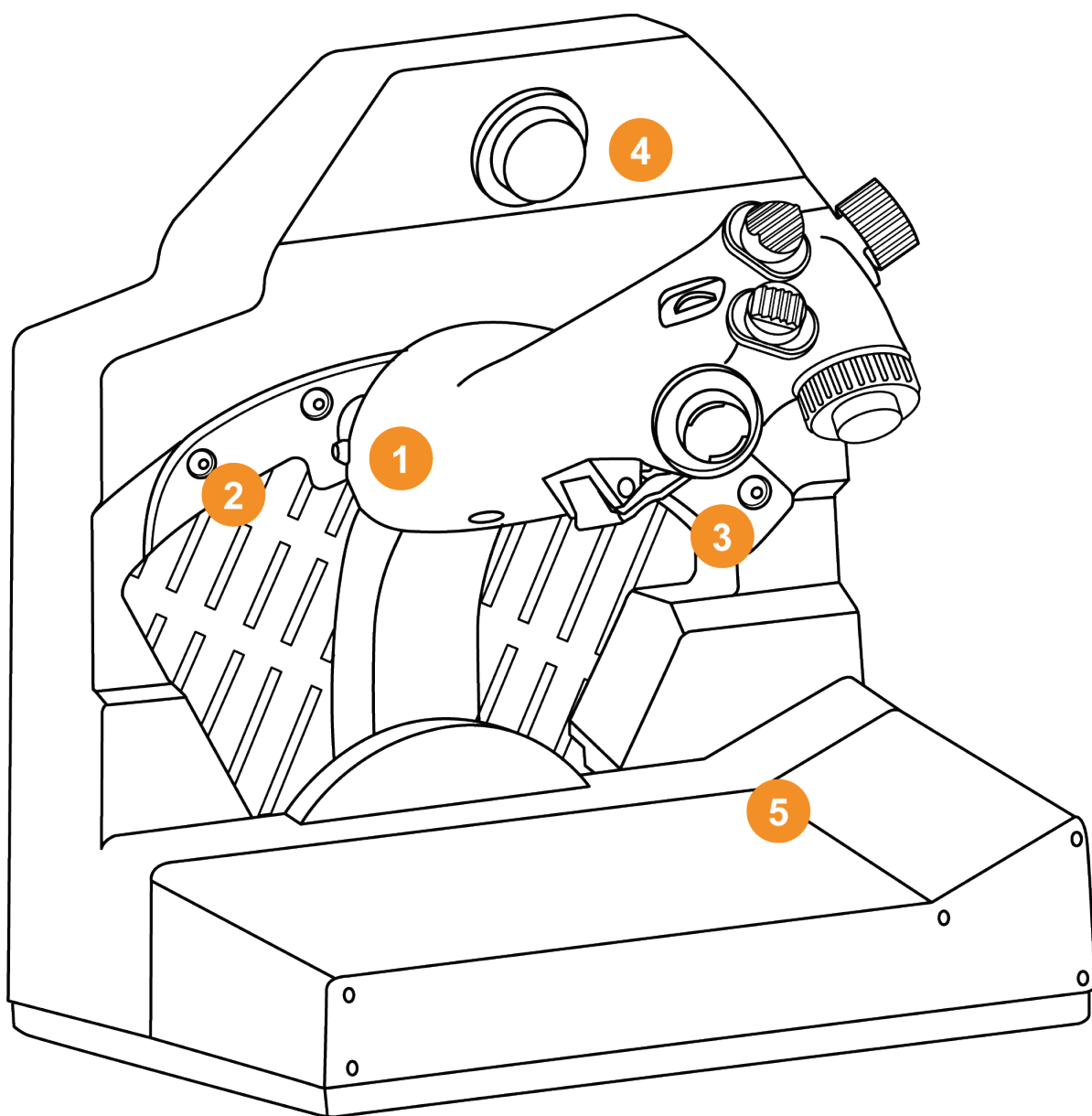

1. Рукоятка

2. Стопор Cut off

3. Стопор Afterburner

4. CHAFF/FLARE переключатель-хлопушка

5. Зажим для карты миссии

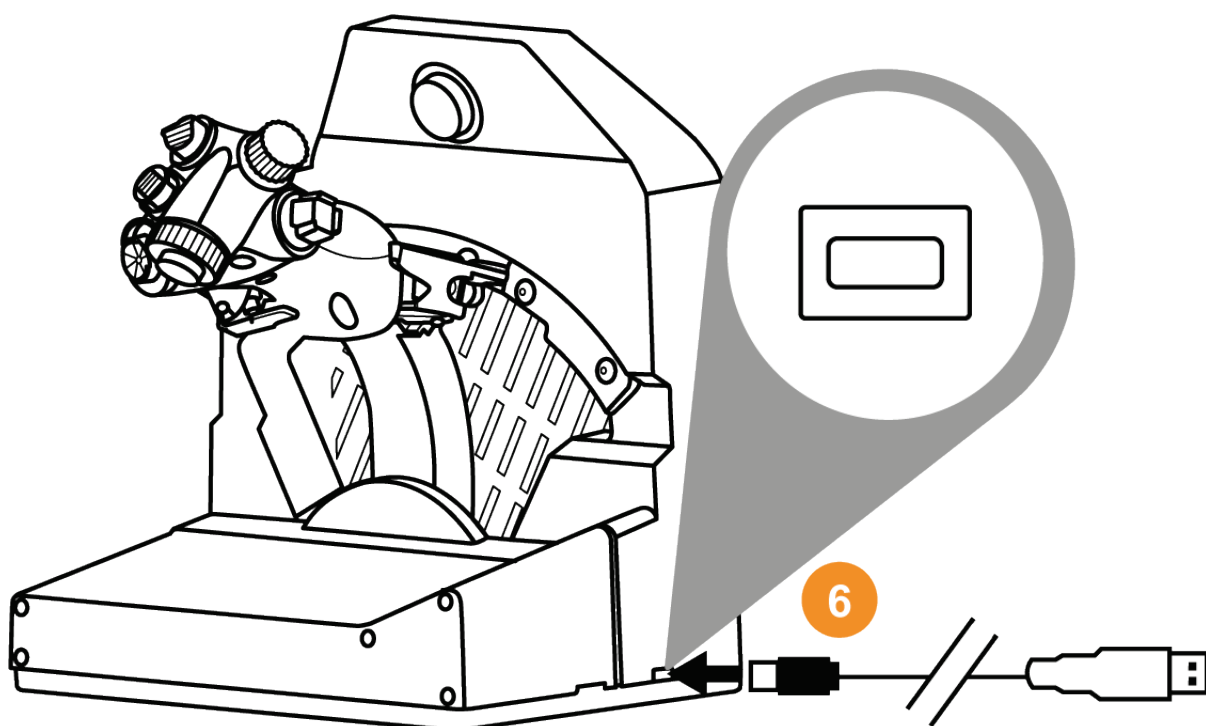

6. USB-разъем (Type-C)

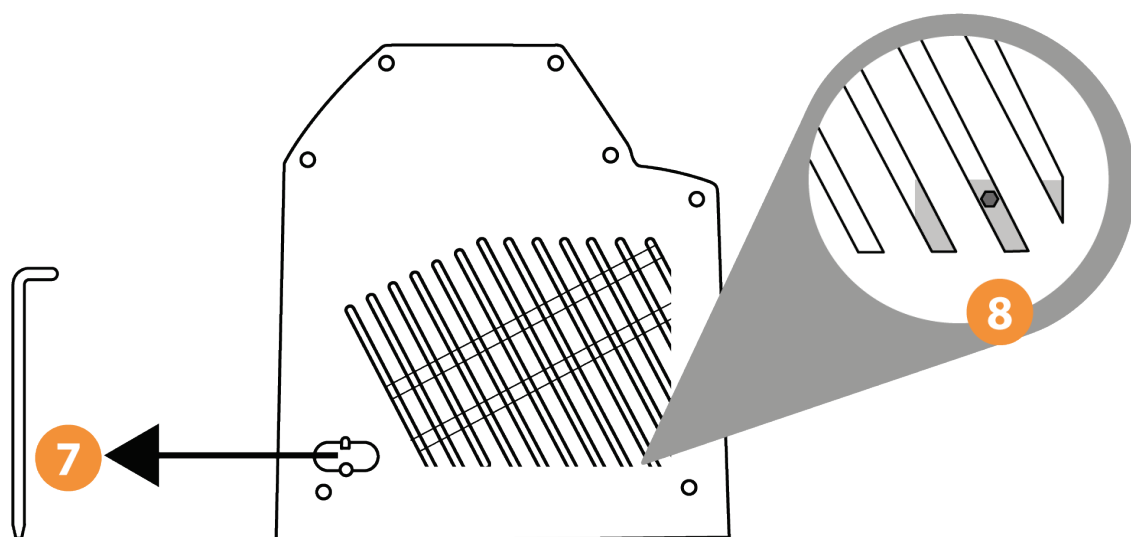

7. Расположение инструмента для регулировки силы трения

8. Точка доступа к регулировке силы трения



3. Функции кнопок и осей

Рукоятка VIPER TQS: функции 19 кнопок и 5 осей в режиме А (без виртуальных кнопок)

A 1 → 19

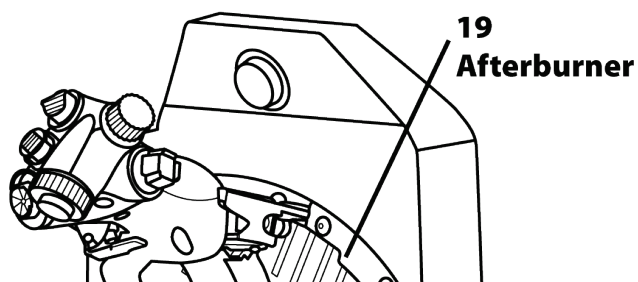
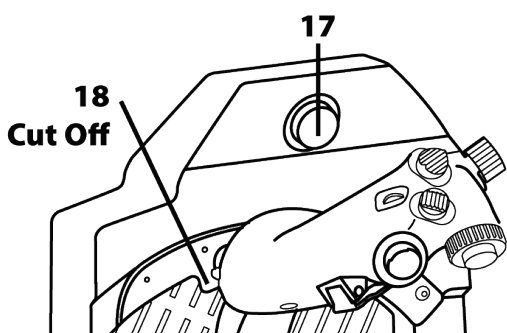
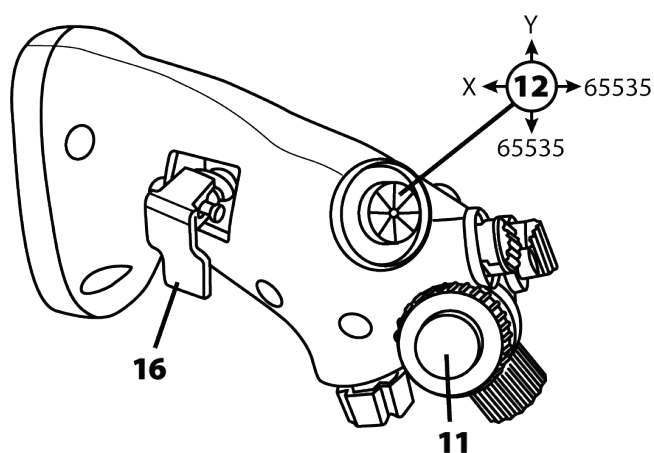
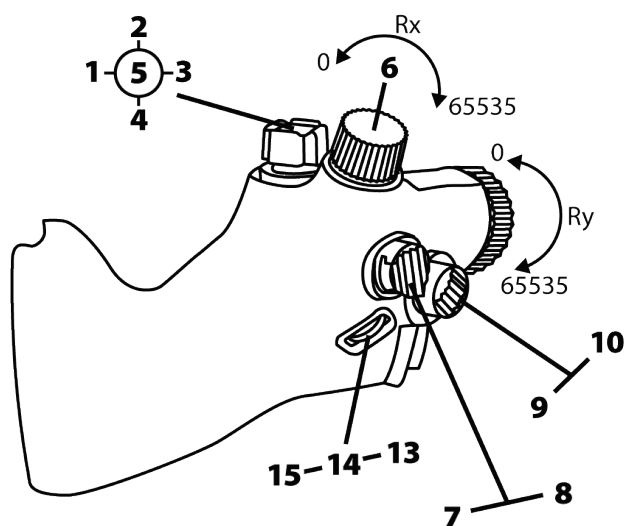



Режим В: с виртуальными кнопками

В 1→21

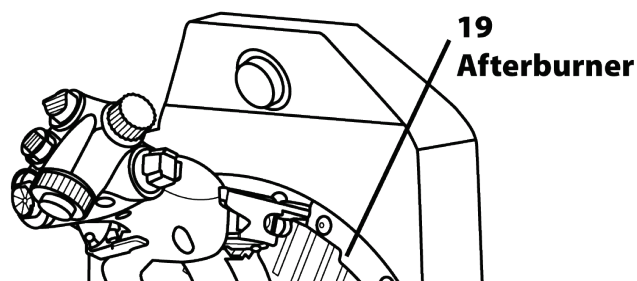
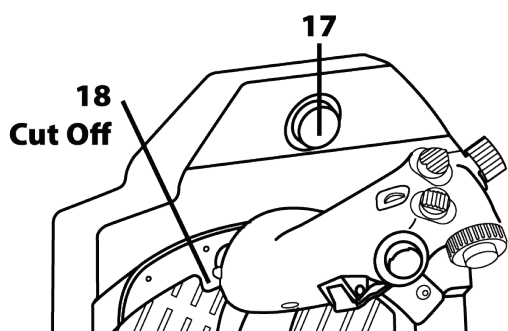
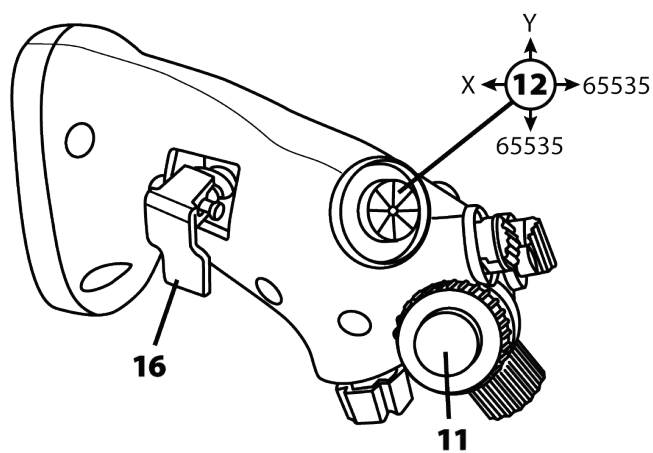
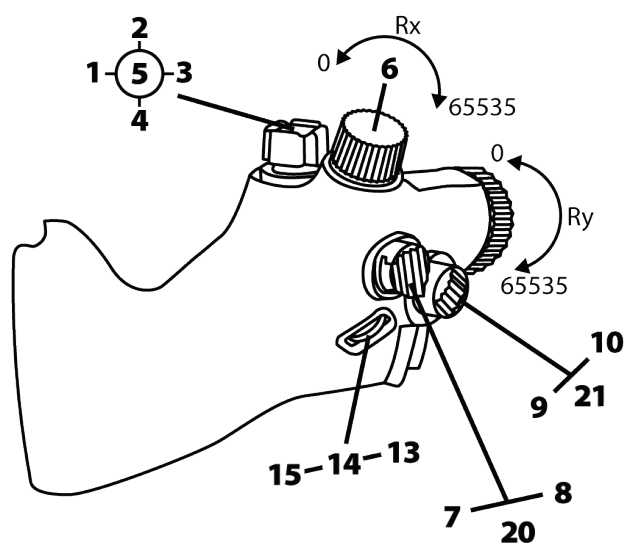



4. Информация об использовании VIPER TQS



Опасность защемления

Никогда не помещайте пальцы в зоны упора при использовании рукоятки.

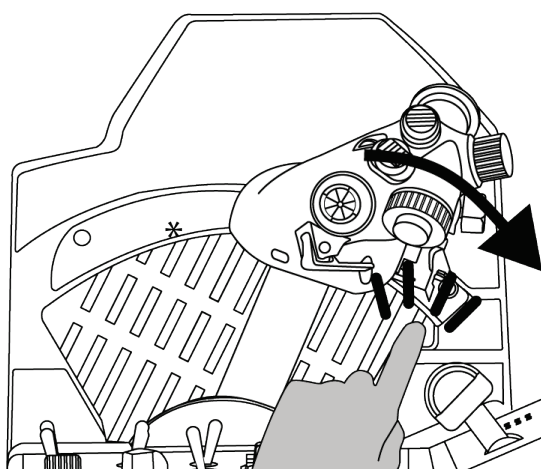
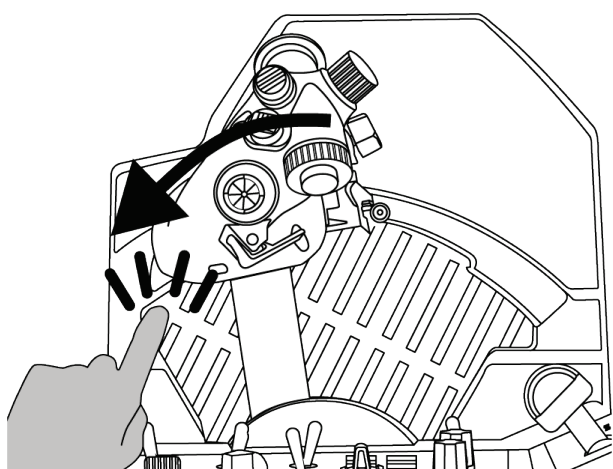
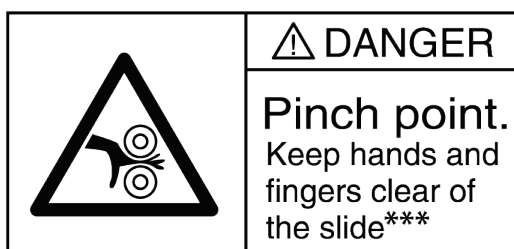



5. Регулировка трения

Вы можете отрегулировать трение в блоке рычагов VIPER TQS в соответствии с вашими личными предпочтениями с помощью инструмента, входящего в комплект поставки VIPER TQS. Однако обратите внимание, что оптимальное трение рычага установлено по умолчанию на заводе.

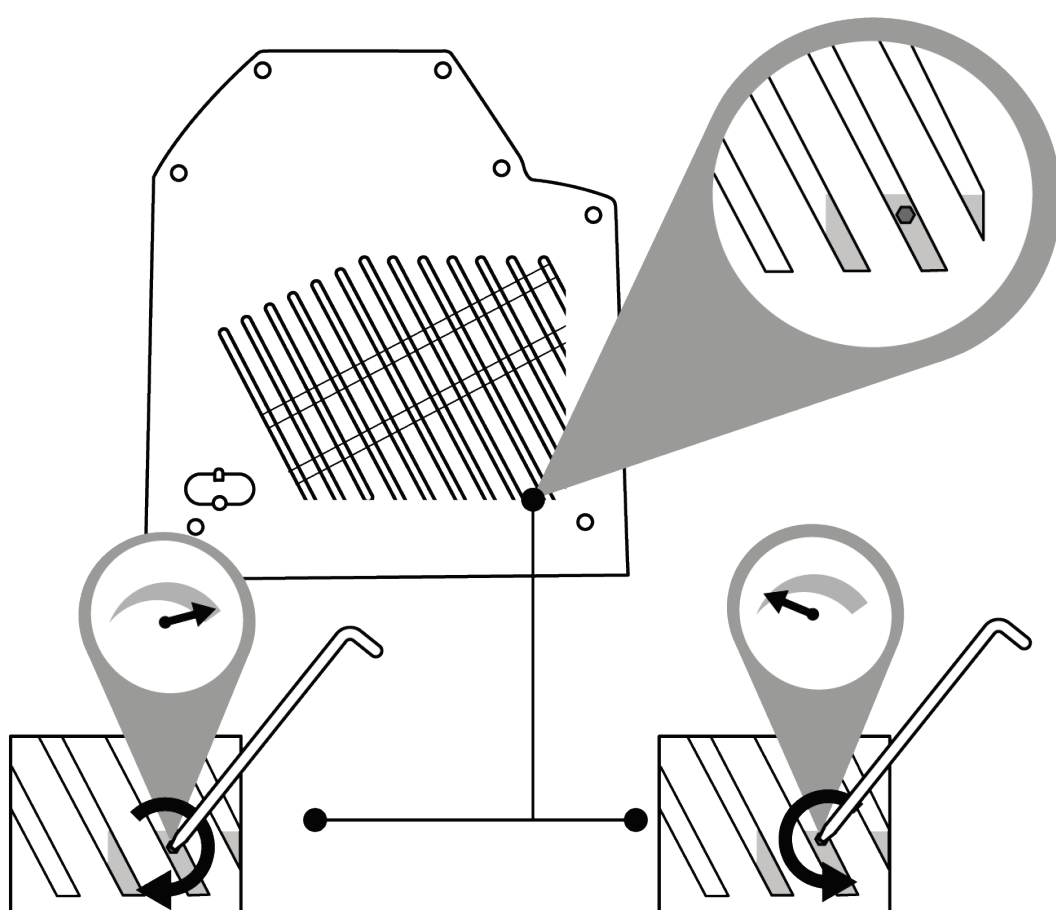

Чтобы не повредить систему трения, не затягивайте регулировочный винт слишком сильно. Кроме того, не выкручивайте регулировочный винт полностью: это может привести к тому, что рукоятка перестанет фиксироваться в нужном положении.



6. Установка на опоре



VIPER TQS можно устанавливать на различные типы опор. Большинство имеющихся на рынке кокпитов и опор совместимы с аналогичными продуктами Thrustmaster (например, HOTAS Warthog).

Следует помнить, что VIPER TQS обладает мощным рычажным эффектом и поэтому должен быть прочно закреплен. Прикрепите базу к опоре с помощью подходящих винтов М6 так, чтобы не повредить рукоятку. (Винты в комплект не входят.)

Подробный чертеж VIPER TQS можно найти на сайте <https://support.thrustmaster.com/product/viper-tqs/>



Перед каждым использованием убедитесь, что VIPER TQS по-прежнему правильно закреплен на опоре в соответствии с инструкциями, указанными производителем.

Обязательно учитывайте материал, из которого сделана ваша опора, и убедитесь, что к нему можно надежно прикрепить устройство. Столешница, на которой вы крепите VIPER TQS, должна быть сделана из цельного куска материала (например, МДФ или дерева), без полостей или стеклянных элементов.



Размеры монтажного чертежа (в мм)

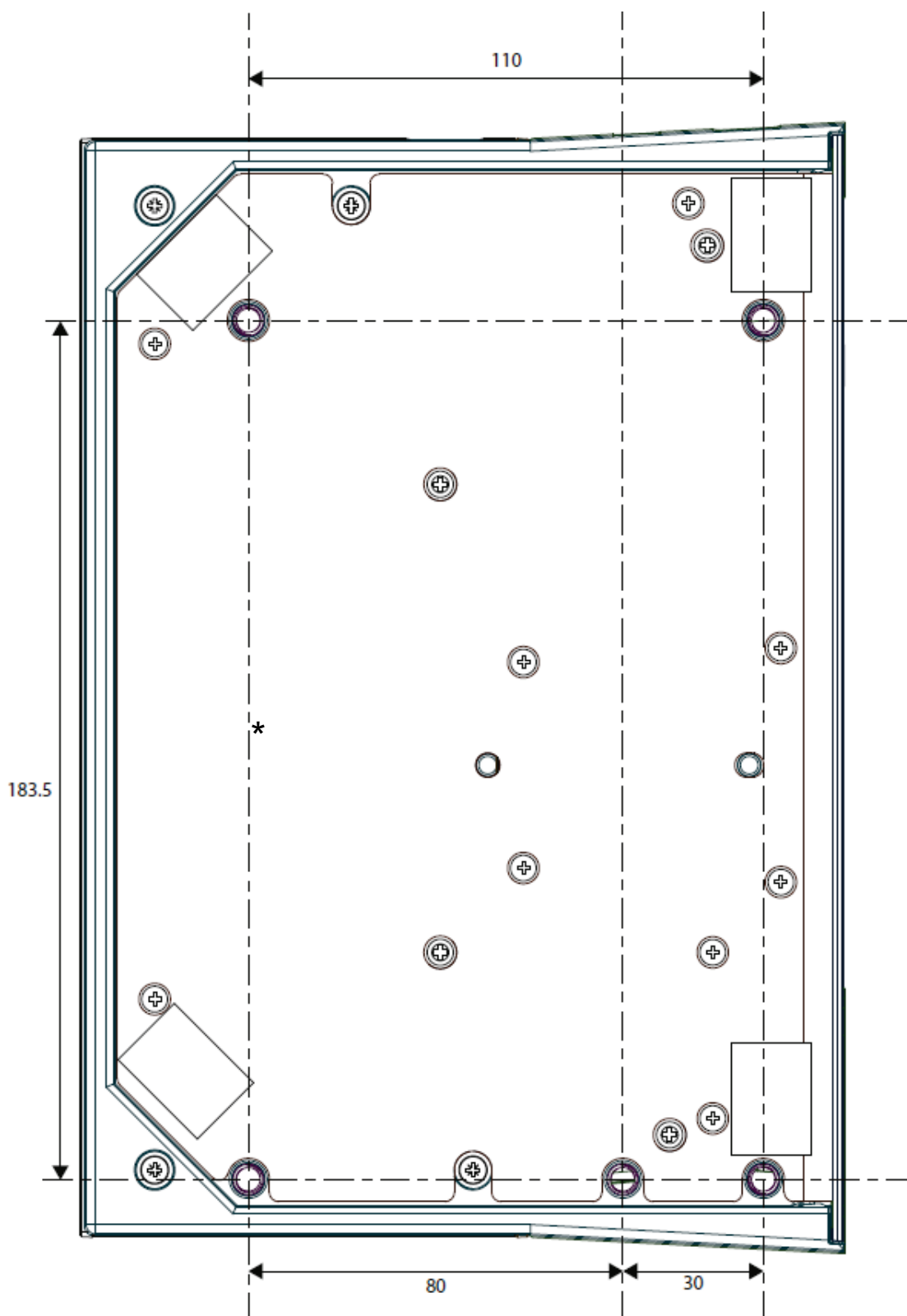

Вы можете скачать монтажную схему с сайта <https://support.thrustmaster.com/product/viper-tqs/>, затем распечатать ее и приложить к опоре для подготовки отверстий.



Установка с помощью TM Flying Desk Mount*

TM Flying Desk Mount — это металлическая система крепления с зажимным винтом, улучшающая эргономику и положение пилота при использовании устройства. Эта система предназначена для крепления к столешнице толщиной 15-50 мм.

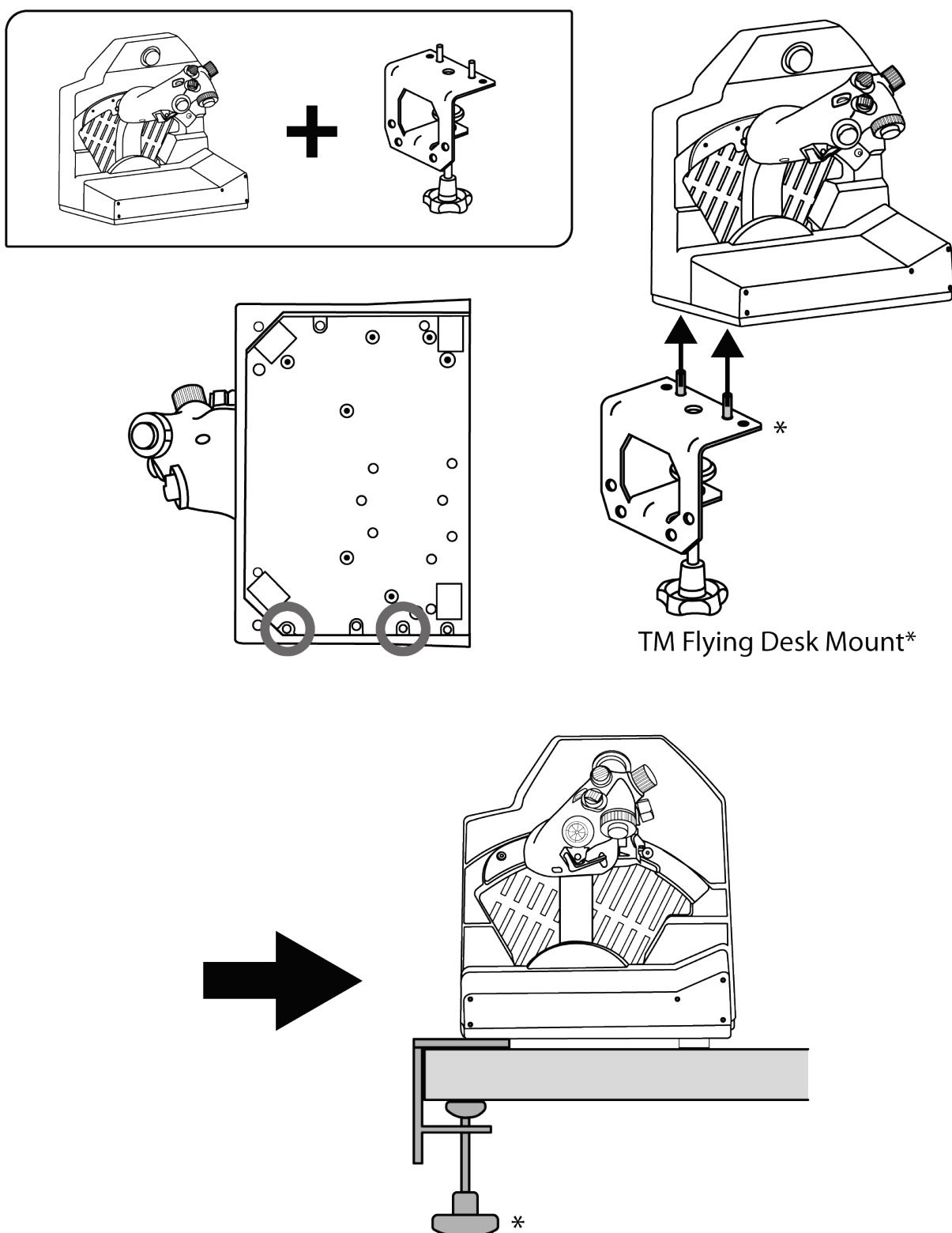

* Продается отдельно



Установка с использованием TM Flying Clamp*

TM Flying Clamp — это регулируемая по высоте опора, разработанная компанией Thrustmaster для своих аксессуаров для моделирования полетов. Эта монтажная система имеет два зажимных винта, что позволяет регулировать ее и крепить к столешнице толщиной от 15 до 45 мм.

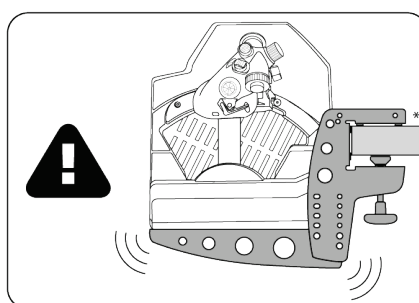
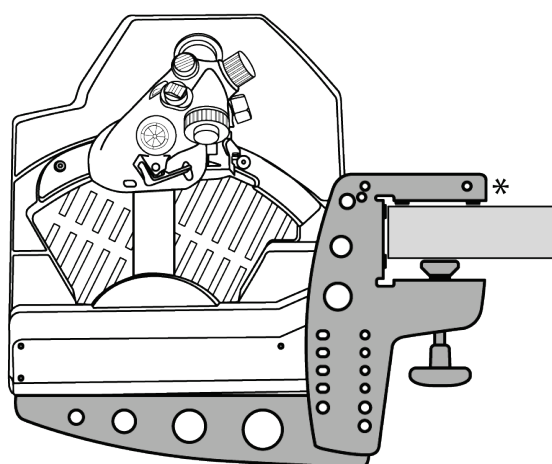
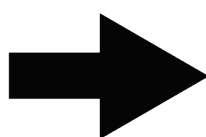
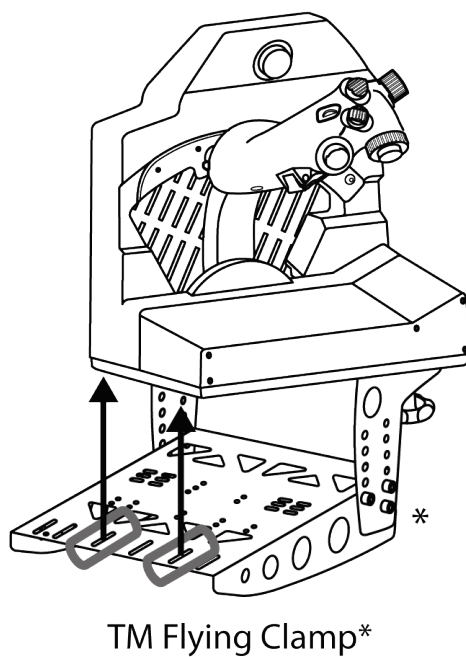
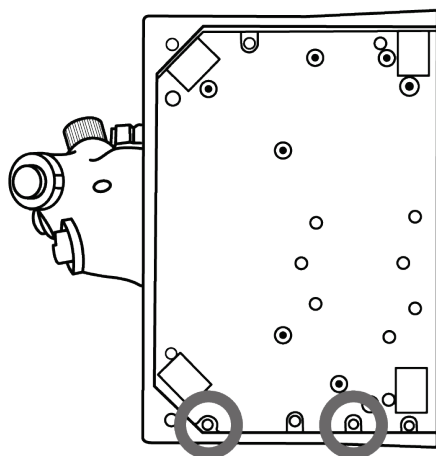
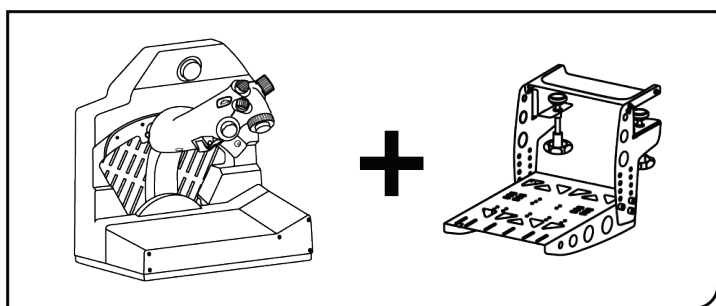

* Продается отдельно



Обратите внимание, что большой вес VIPER TQS может привести к нежелательным движениям монтажной системы.



7. Установка VIPER PANEL*

* Продается отдельно VIPER PANEL входит в комплект VIPER TQS Mission Pack.

VIPER PANEL — это панель управления, позволяющая расширить возможности полета и боя с помощью 43 кнопок и 1 оси — все они программируются с помощью программного обеспечения T.A.R.G.E.T. VIPER PANEL является дополнением к VIPER TQS.

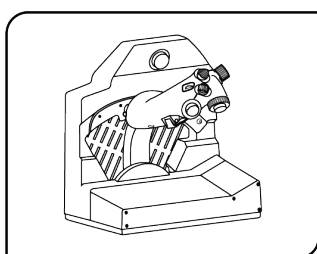

1

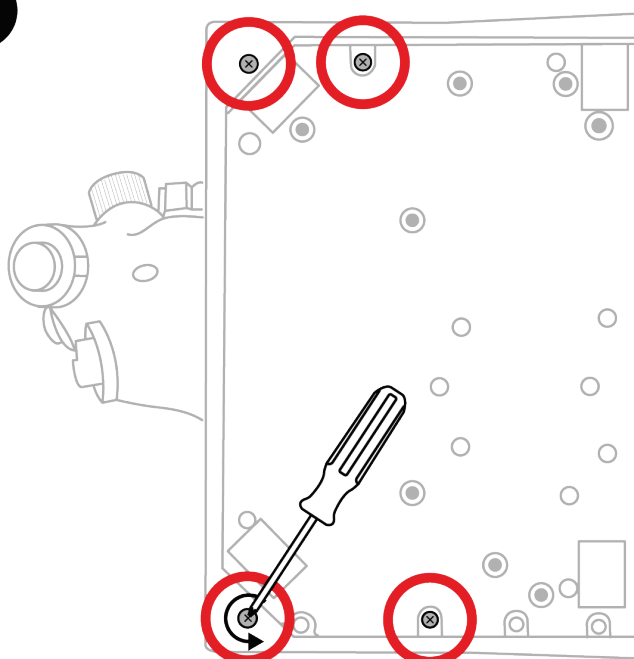

2

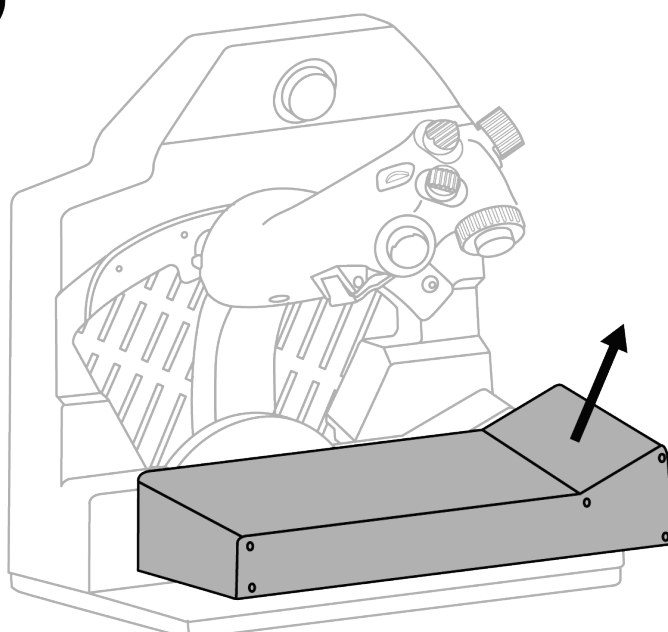

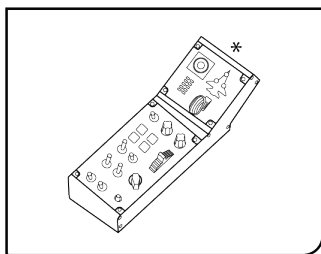

3

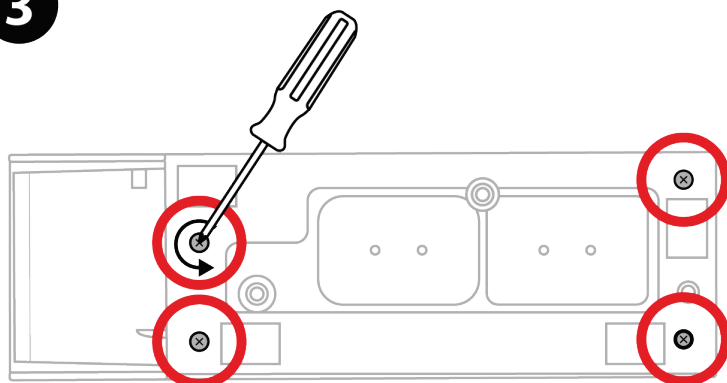

4

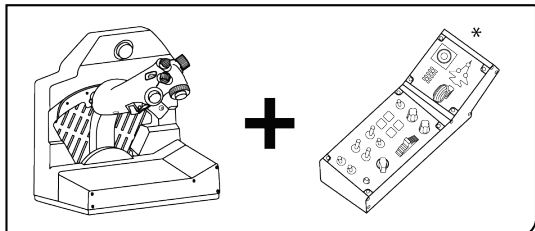
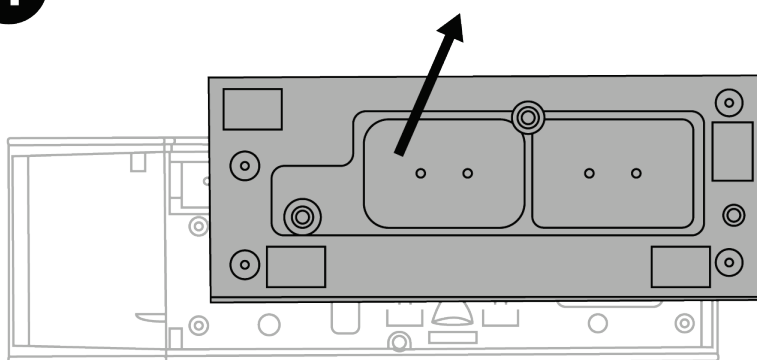

5

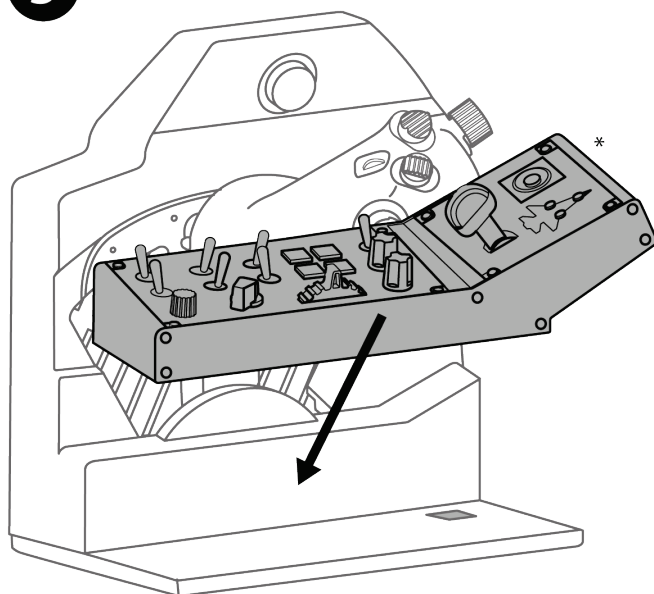



6

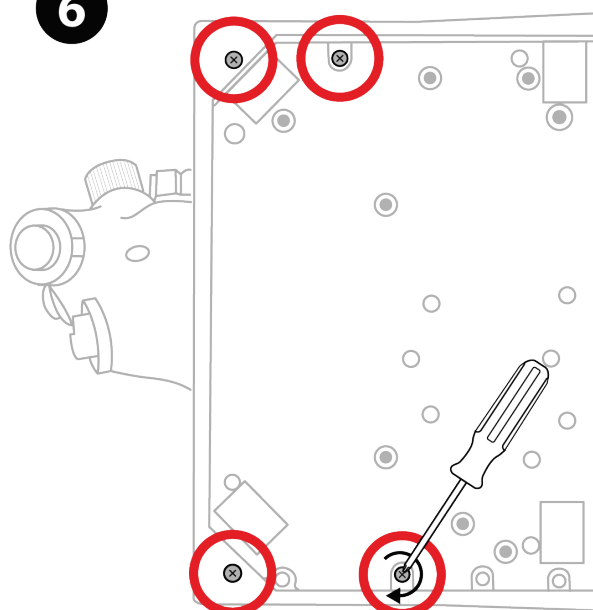

7

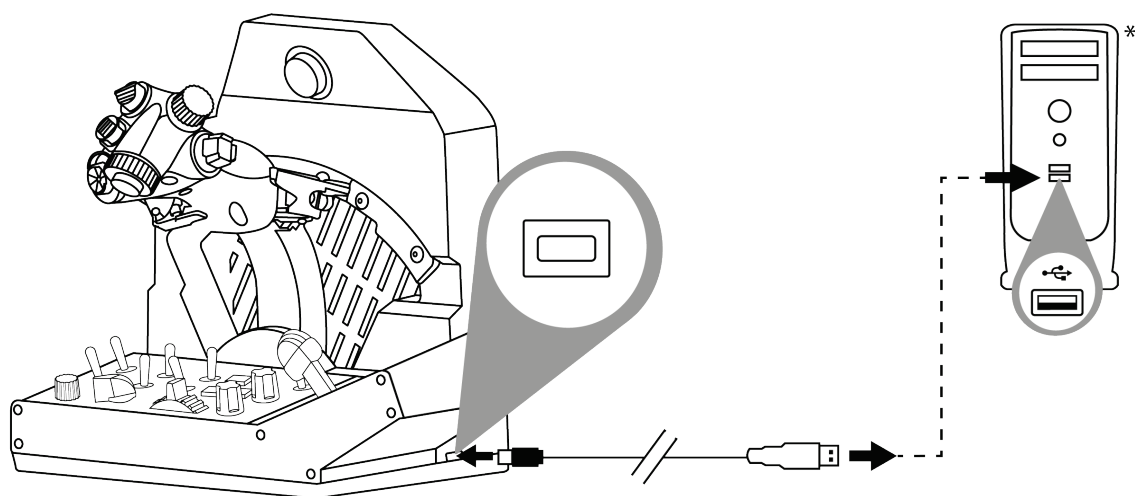

* В комплект не входит



8. Подключение к PC

1



Перейдите на веб-сайт

<https://support.thrustmaster.com/product/viper-tqs/>.

2

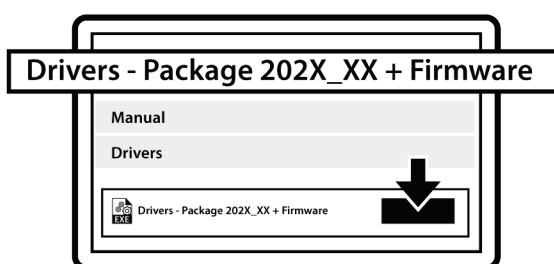

Скачайте и установите драйвер для PC, добавляющий специальный интерфейс в панель управления Windows.

3

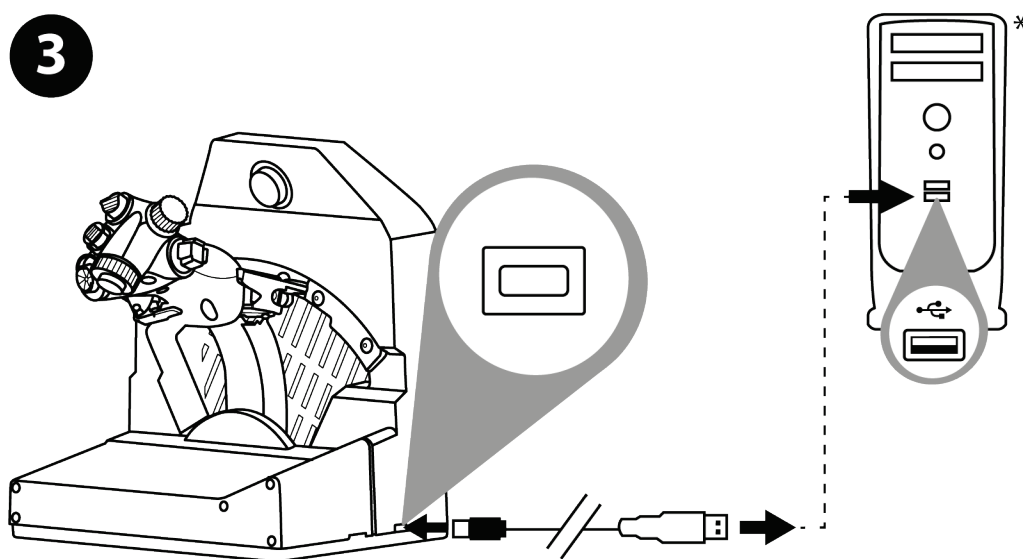

После установки драйвера подключите USB-кабель устройства к USB-порту компьютера.

* В комплект не входит



④ Для доступа к Control Panel нажмите **Пуск / Все приложения / Thrustmaster / Control Panel** или **Панель управления** (в Windows 10).

Откроется окно **Игровые устройства**. Аксессуар будет отображаться на экране с названием **VIPER TQS** и статусом **OK**.

⑤ В окне **Игровые устройства** щелкните **Свойства** для просмотра и проверки всех характеристик устройства.

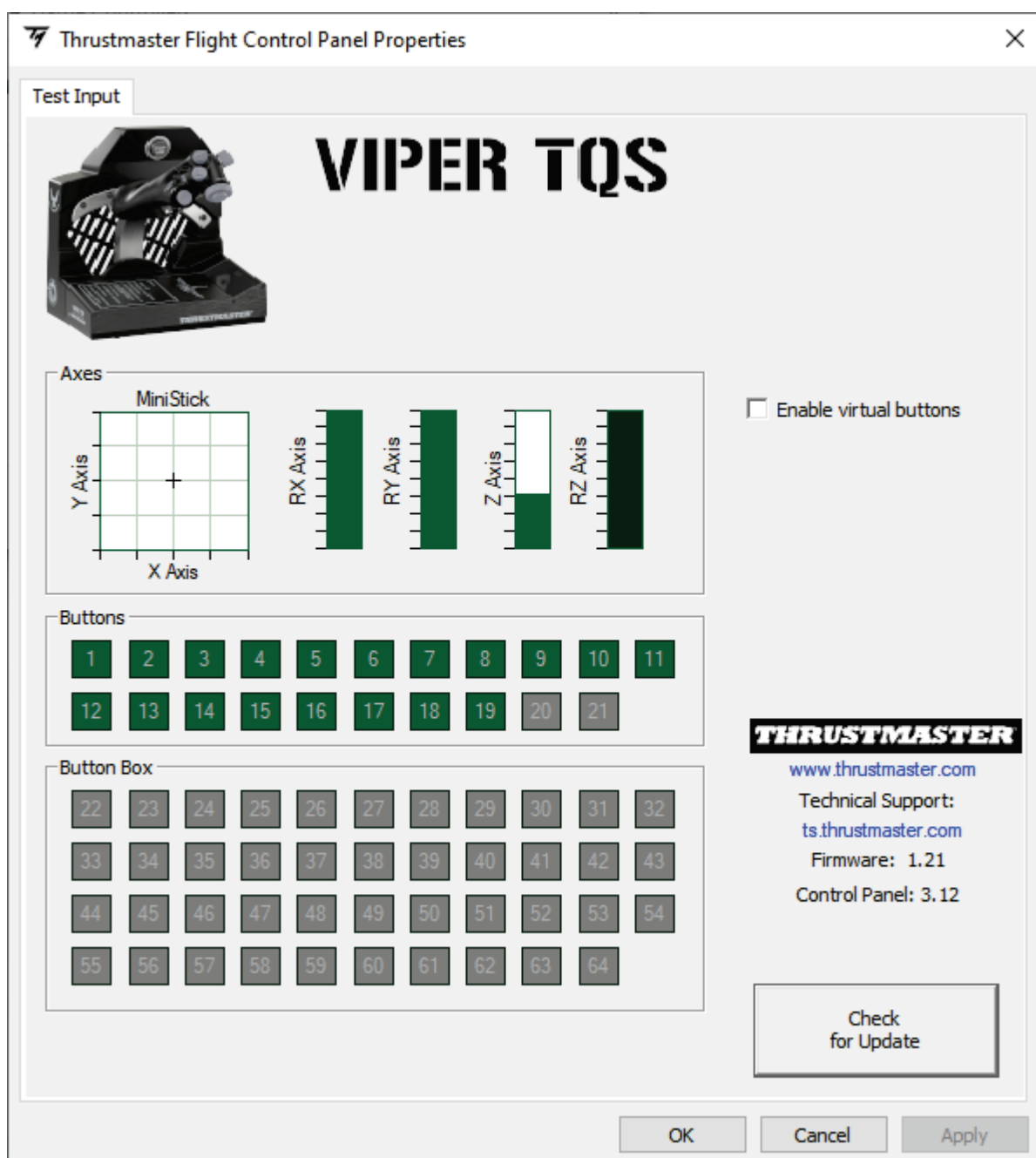



Enable virtual buttons (Включить виртуальные кнопки)

Эта функция позволяет включить или выключить виртуальные кнопки на ручке (кнопки 20 и 21). Выбрав нужный режим, нажмите **Apply** (Применить).

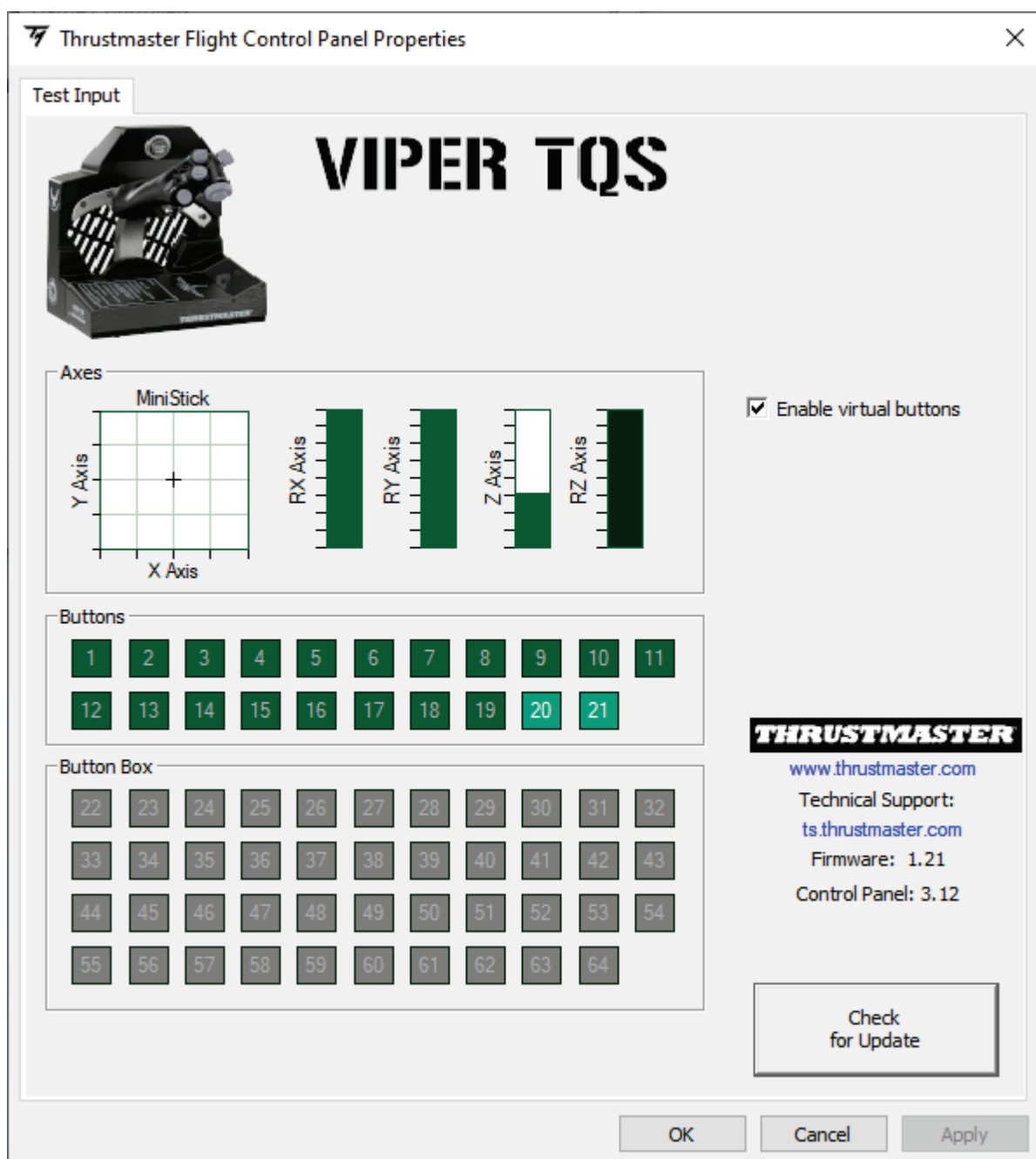

По умолчанию в VIPER TQS виртуальные кнопки отключены.



9. Фиксаторы CUT OFF и AFTERBURNER

Блок рычагов VIPER TQS имеет реалистичную систему фиксаторов CUT OFF и AFTERBURNER (модуль Afterburner съемный).

CUT OFF

Установив рычаг в положение IDLE, нажмите на кнопку разблокировки отключения двигателей **1**, чтобы поднять рукоятку вверх для преодоления упора **2**, затем переведите рукоятку в положение OFF **3**.

Чтобы снова включить двигатели, выполните эту процедуру в обратном порядке.

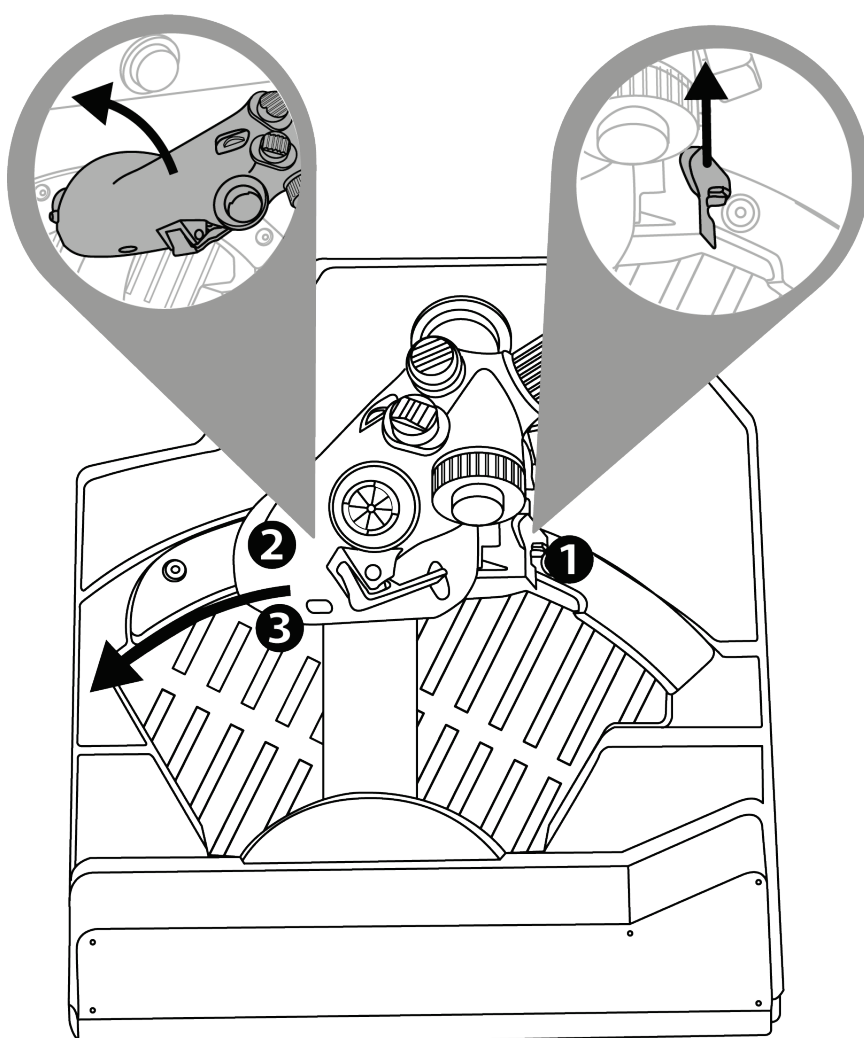



AFTERBURNER

Переместите рычаг до упора **1** и поднимите рукоятку вверх **2**, чтобы преодолеть упор и включить форсажную камеру **3**.

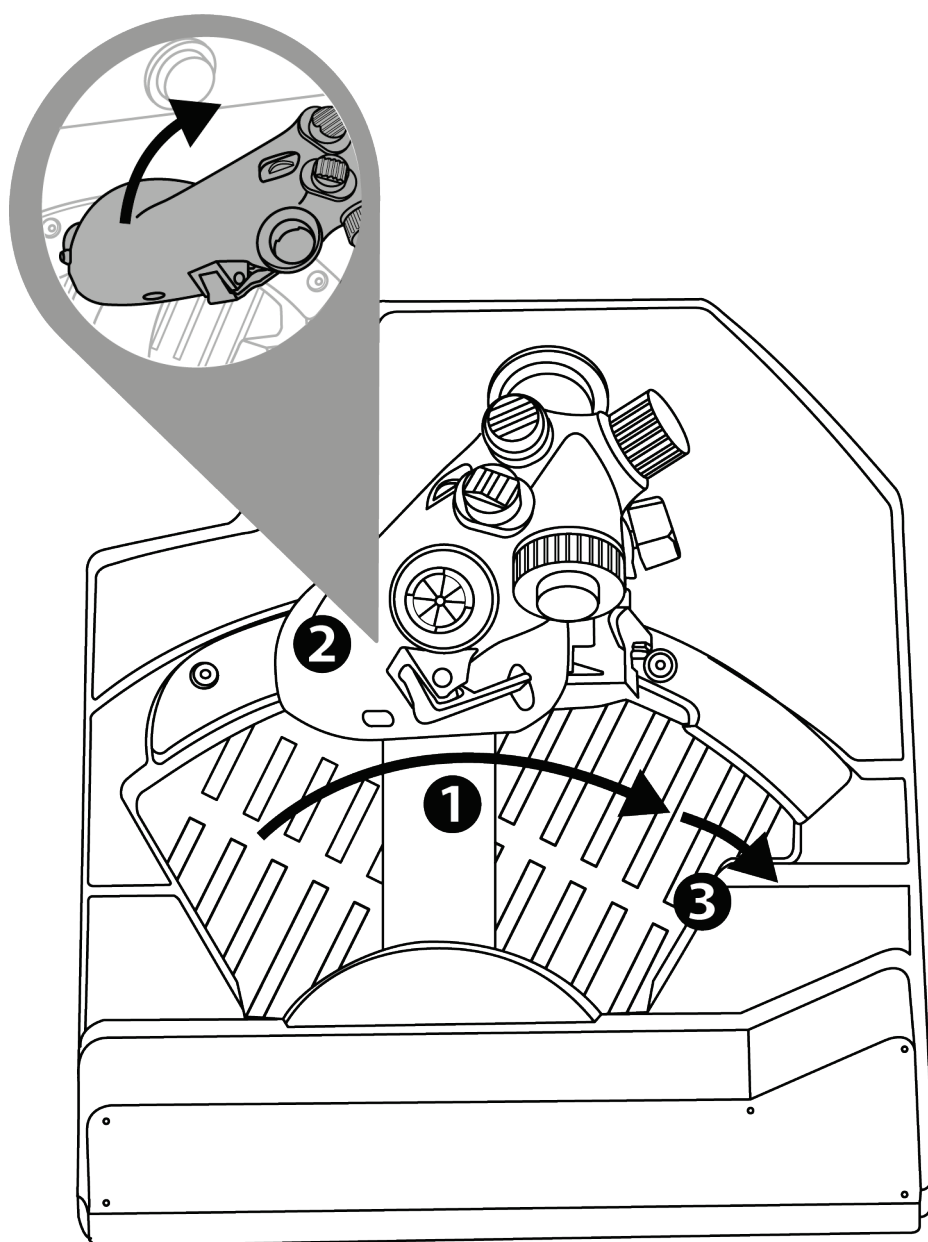



Демонтаж стопора AFTERBURNER

Стопор модуля Afterburner расположен на 80% от значения оси.

Если вам нужно 100% хода рычага (для конкретного симулятора), вы можете снять модуль Afterburner и его стопор, открутив два винта модуля с помощью шестигранного ключа (не входит в комплект).

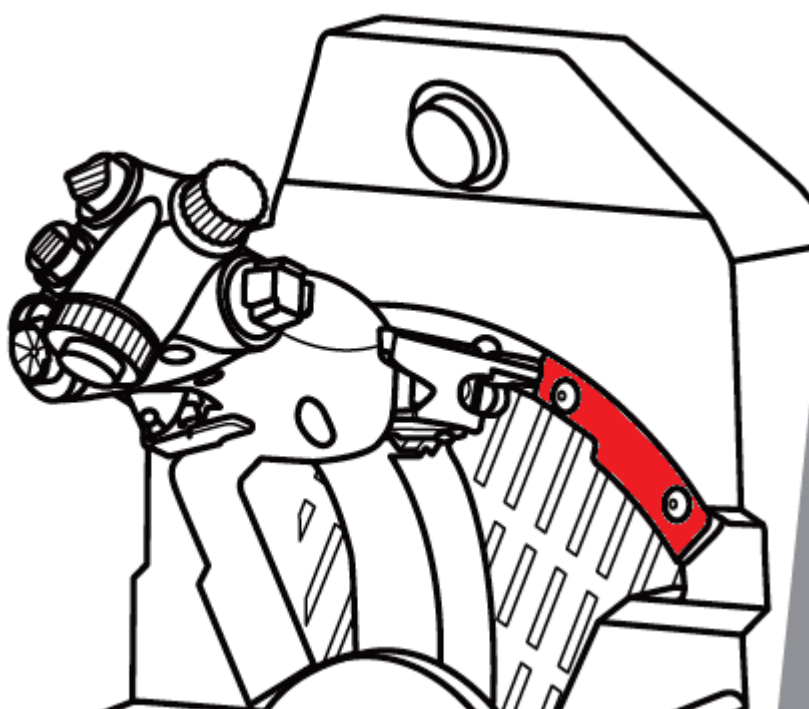



10. Расширенное ПО для программирования T.A.R.G.E.T



Перейдите на веб-сайт

<https://support.thrustmaster.com/product/viper-tqs/>.

В разделе **Software** (Программное обеспечение) скачайте и установите расширенное ПО для программирования T.A.R.G.E.T.



Основные особенности программы

T.A.R.G.E.T

- Различные возможные конфигурации для осей.
- Различные возможные уровни программирования: Basic, Advanced и Script.
- Поддержка метода перетягивания.
- Возможность комбинирования блока рычагов VIPER TQS с различными джойстиками Thrustmaster (HOTAS Cougar, HOTAS Warthog, T.16000M, MFD Cougar Pack, каждый из которых также совместим с программой T.A.R.G.E.T), благодаря чему они распознаются как одно USB-устройство.
- Доступ к расширенным профилям, созданным пользователями сообщества Thrustmaster.



11. Часто задаваемые вопросы и техническая поддержка

У вас есть вопросы по VIPER TQS или возникли технические проблемы? Посетите веб-сайт технической поддержки Thrustmaster:

<https://support.thrustmaster.com/product/viper-tqs/>.



THRUSTMASTER®

VIPER TQS

THROTTLE QUADRANT SYSTEM

Pro PC (Windows 10/11)

Uživatelský manuál



Před instalací výrobku, **před** jakýmkoli použitím výrobku a **před** jakoukoli údržbou si **pečlivě přečtete** pokyny uvedené v této příručce. Nezapomeňte dodržovat bezpečnostní pokyny. Nedodržení těchto pokynů může mít za následek nehody a/nebo poškození. Tento návod si uschovejte, abyste se k němu mohli v budoucnu vrátit.

OBSAH

1.	OBSAH BALENÍ	5
2.	VIPER TQS VLASTNOSTI.....	6
3.	MAPOVÁNÍ TLAČÍTEK A OS	8
4.	INFORMACE O POUŽÍVÁNÍ VIPER TQS.....	10
5.	NASTAVENÍ TŘENÍ.....	11
6.	INSTALACE NA PODPĚRU.....	12
6.	INSTALACE VIPER PANEL *	17
7.	INSTALACE NA PC	20
7.	CUT OFF A AFTERBURNER DETENTY	23
8.	T.A.R.G.E.T POKROČILÝ PROGRAMOVACÍ SOFTWARE.....	26
9.	ČASTO KLADENÉ DOTAZY A TECHNICKÁ PODPORA	28



Nažhavte motory a vletněte do nebezpečné zóny s ikonickým systémem kvadrantu ovládání tahu motoru z letounu VIPER amerického letectva - nejrozšířenějšího moderního stíhacího letounu na světě!

Posuňte svůj kokpit na vyšší úroveň díky jedinečné ergonomii repliky systému HOTAS v měřítku 1:1 s kovovou rukojetí a realistickými tlačítky a detenty.

Tato příručka vám pomůže nainstalovat a používat zařízení VIPER TQS za nejlepších podmínek. Než odstartujete, nezapomeňte si pečlivě přečíst všechny tyto pokyny a upozornění: pomohou vám získat z vašeho výrobku co nejvíce radosti.



Aktualizace firmwaru

Aby zařízení VIPER TQS správně fungovalo ve videohráčích, je třeba aktualizovat jeho firmware.

Chcete-li provést aktualizaci, navštivte prosím

<https://support.thrustmaster.com/product/viper-tqs/>

Vyberte **Firmware** a postupujte podle pokynů - včetně postupu stahování a instalace.



1. Obsah balení

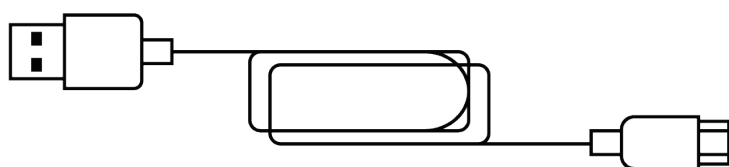
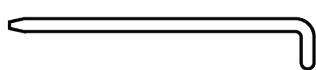
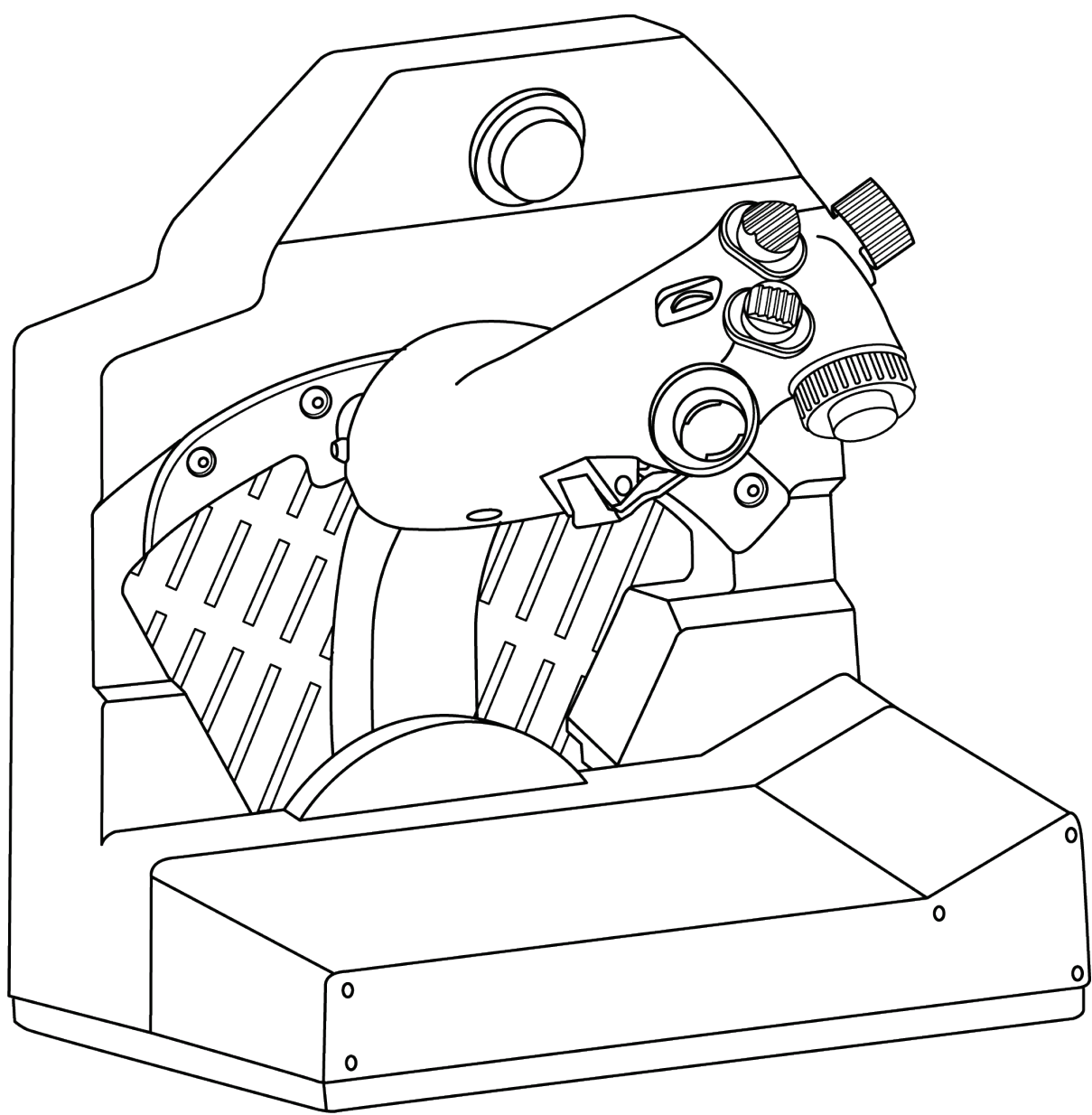



2. VIPER TQS vlastnosti

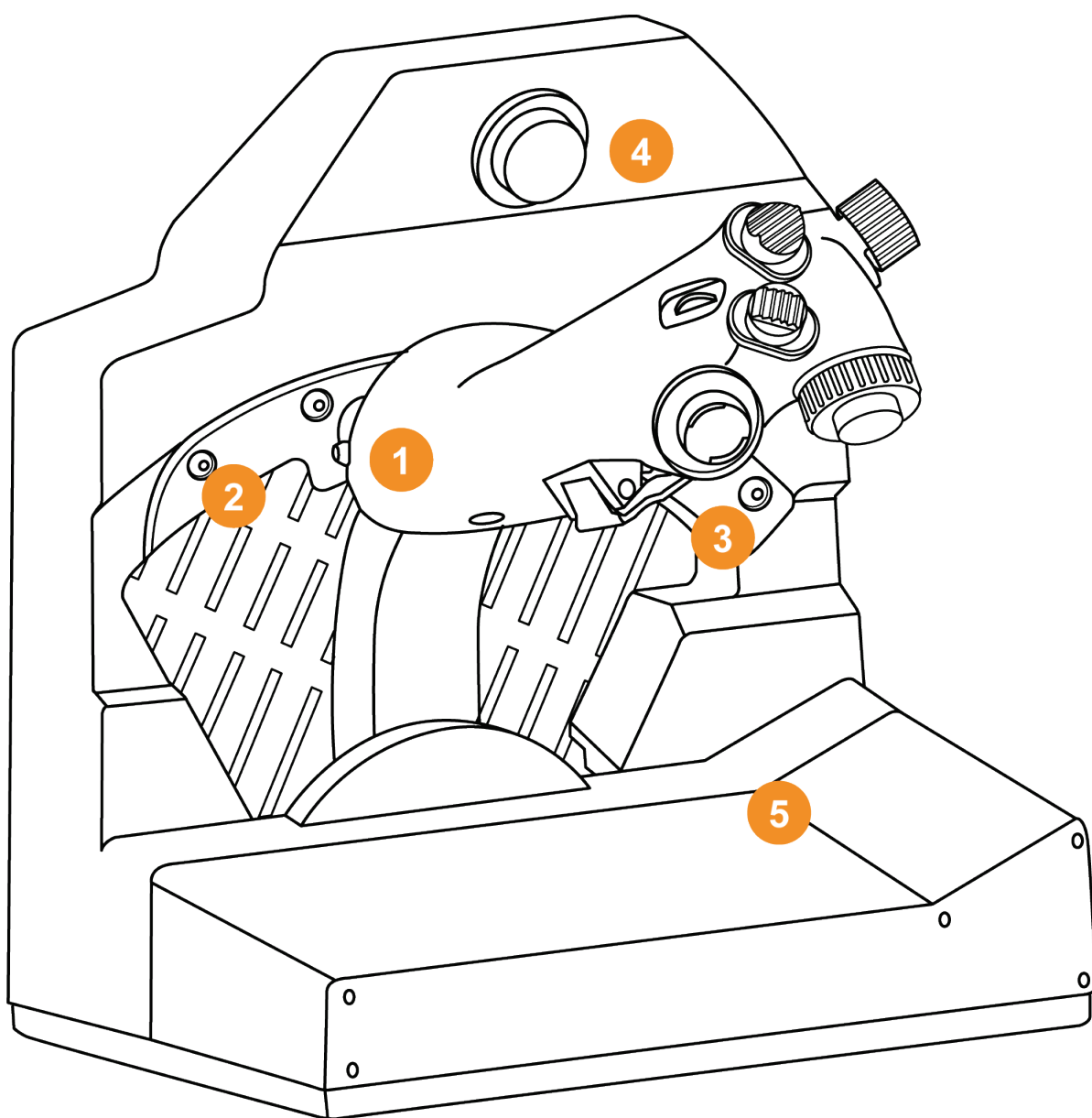

1. Páka

2. Zarážka Cut Off

3. Zarážka Afterburner

4. CHAFF/FLARE přepínač

5. Klip pro mapu mise

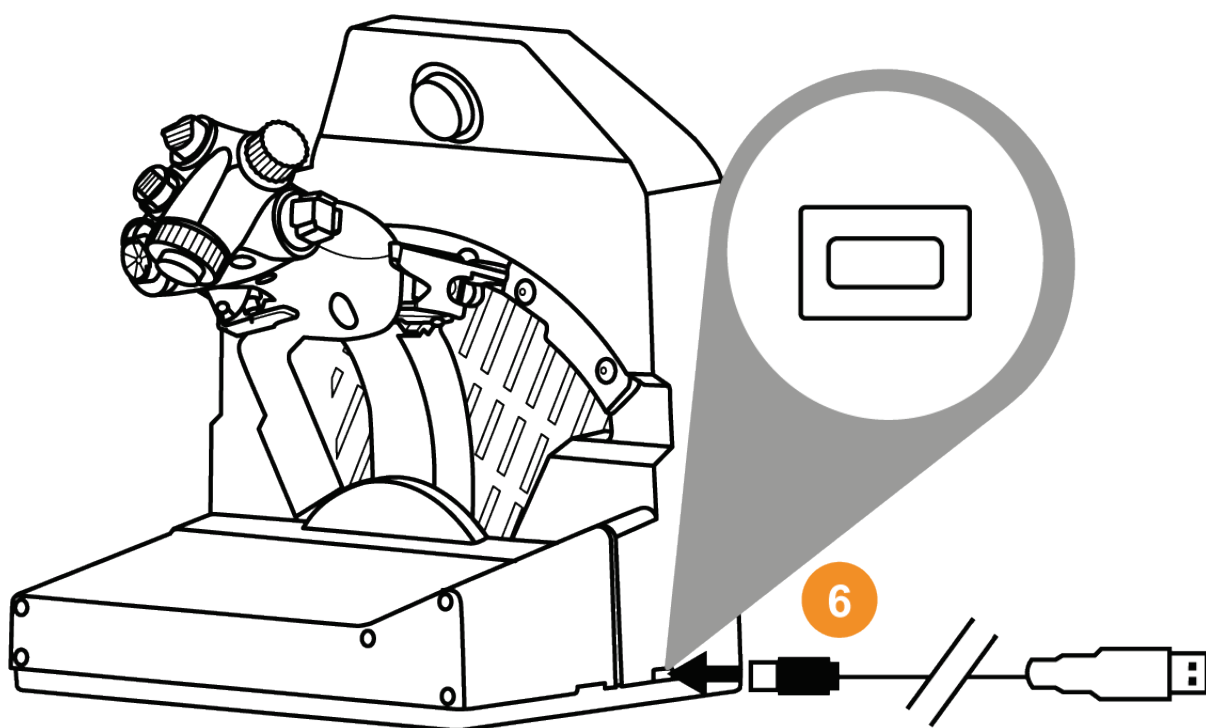

6. USB konektor (typ C)

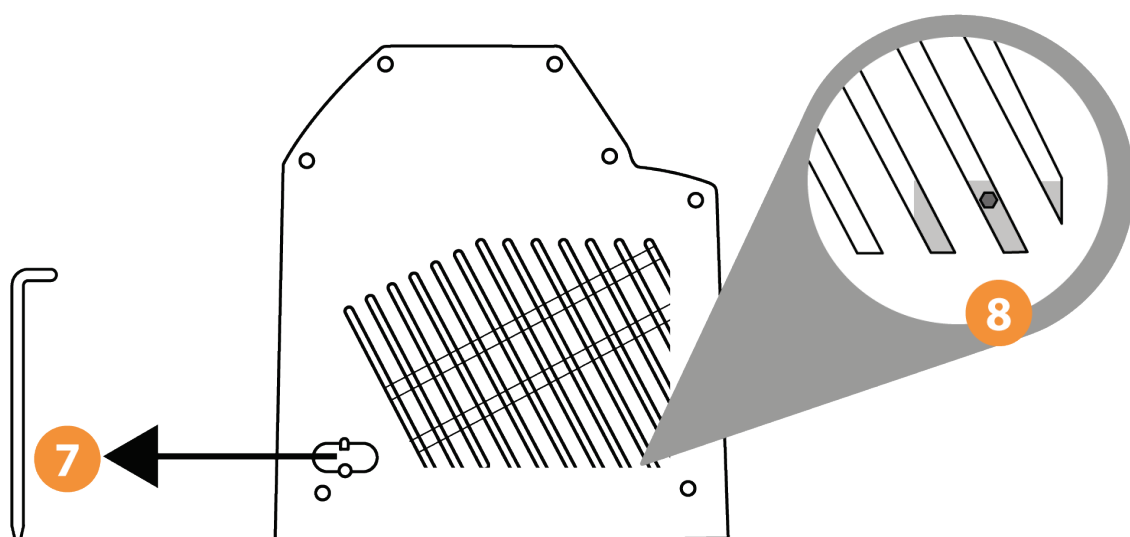

7. Umístění nástroje pro nastavení tření

8. Přístup k nastavení tření plynové páky



3. Mapování tlačítek a os

VIPER TQS páka: mapování 19 tlačítek a 5 os v režimu A (bez virtuálních tlačítek)

A 1 → 19

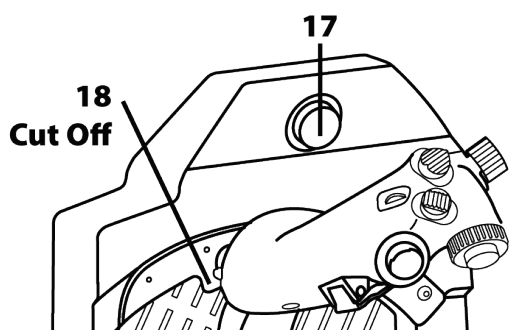
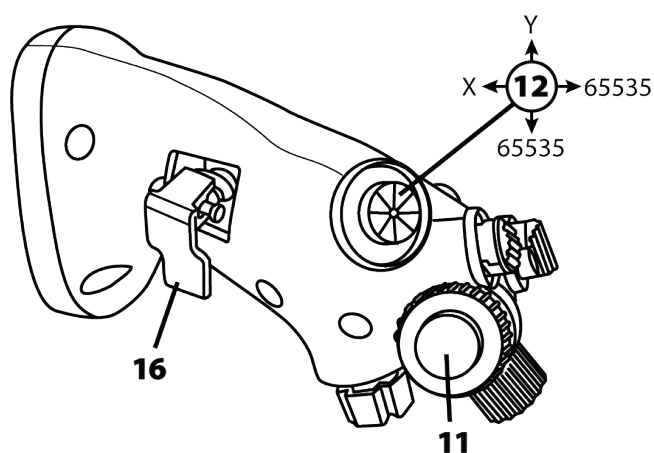
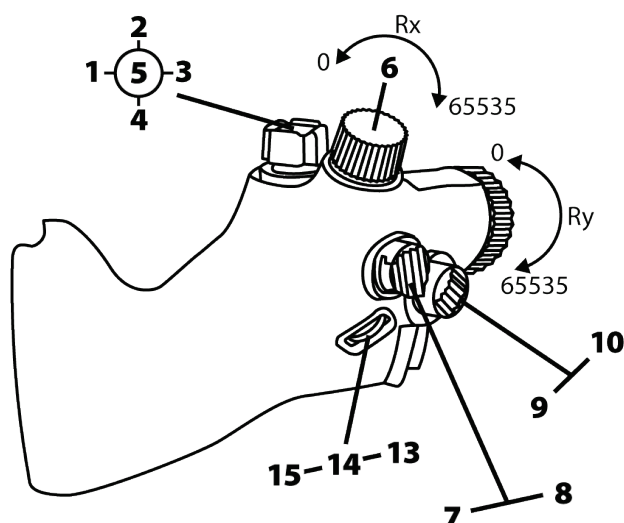



Režim B: s virtuálními tlačítky

B 1 → 21

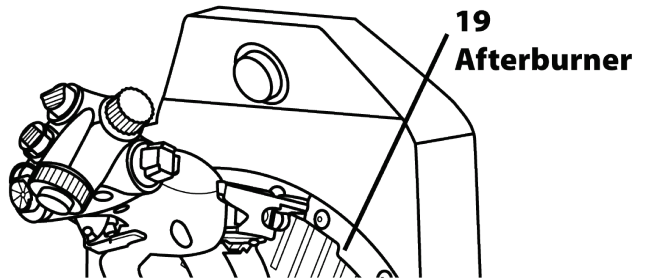
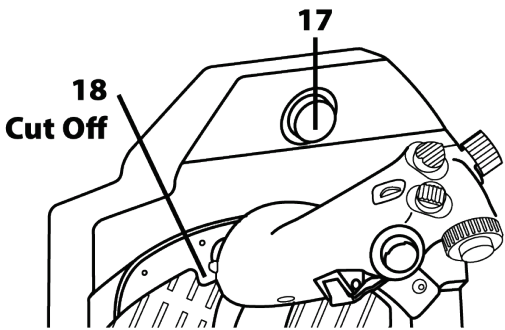
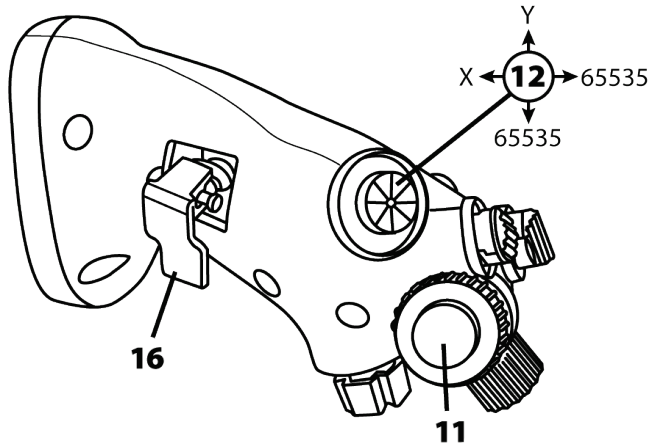
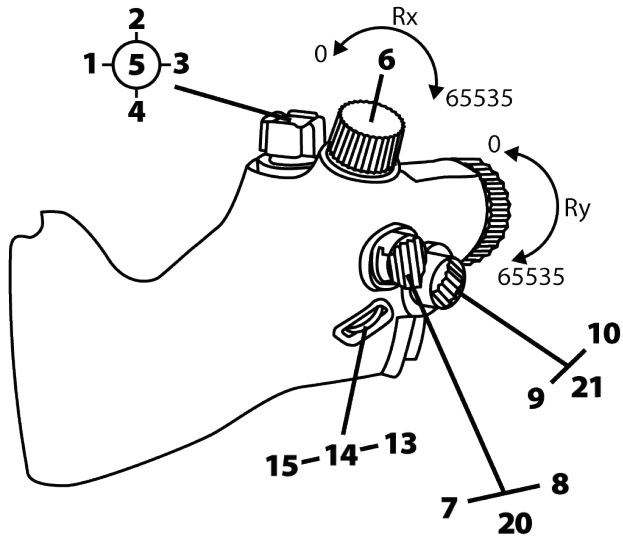



4. Informace o používání VIPER TQS



Nebezpečí skřípnutí

Při používání páky nikdy nevkládejte prsty do oblastí dorazů.

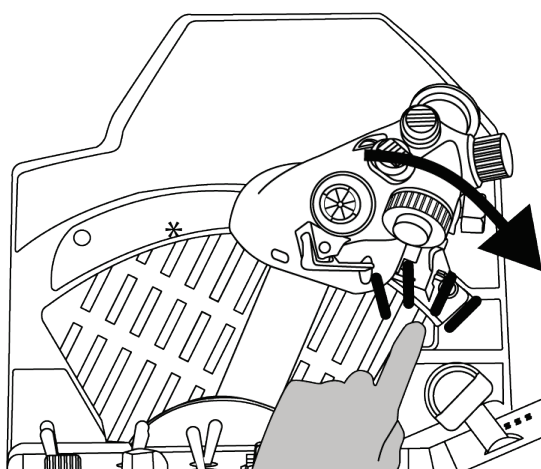
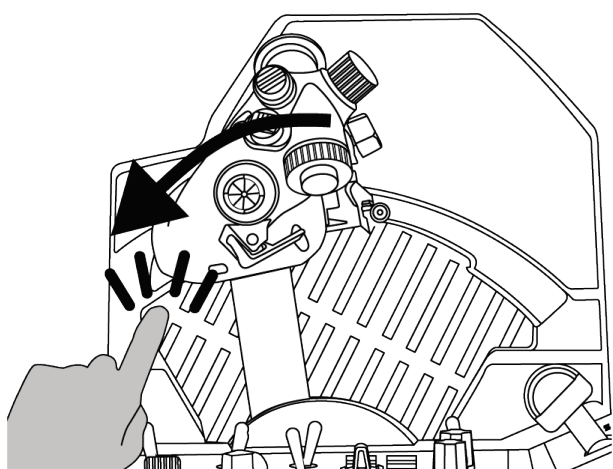
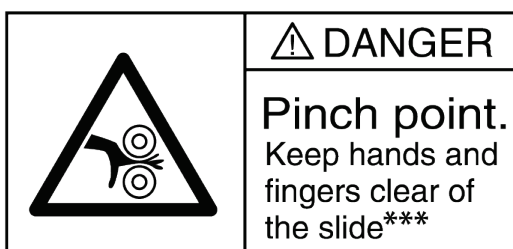



4. Nastavení tření

Tření kvadrantu ovládání tahu motoru VIPER TQS si můžete nastavit podle vlastních preferencí pomocí nástroje, který je součástí balení na boku VIPER TQS. Mějte však na paměti, že optimální tření škrticí klapky bylo nastaveno standardně z výroby.

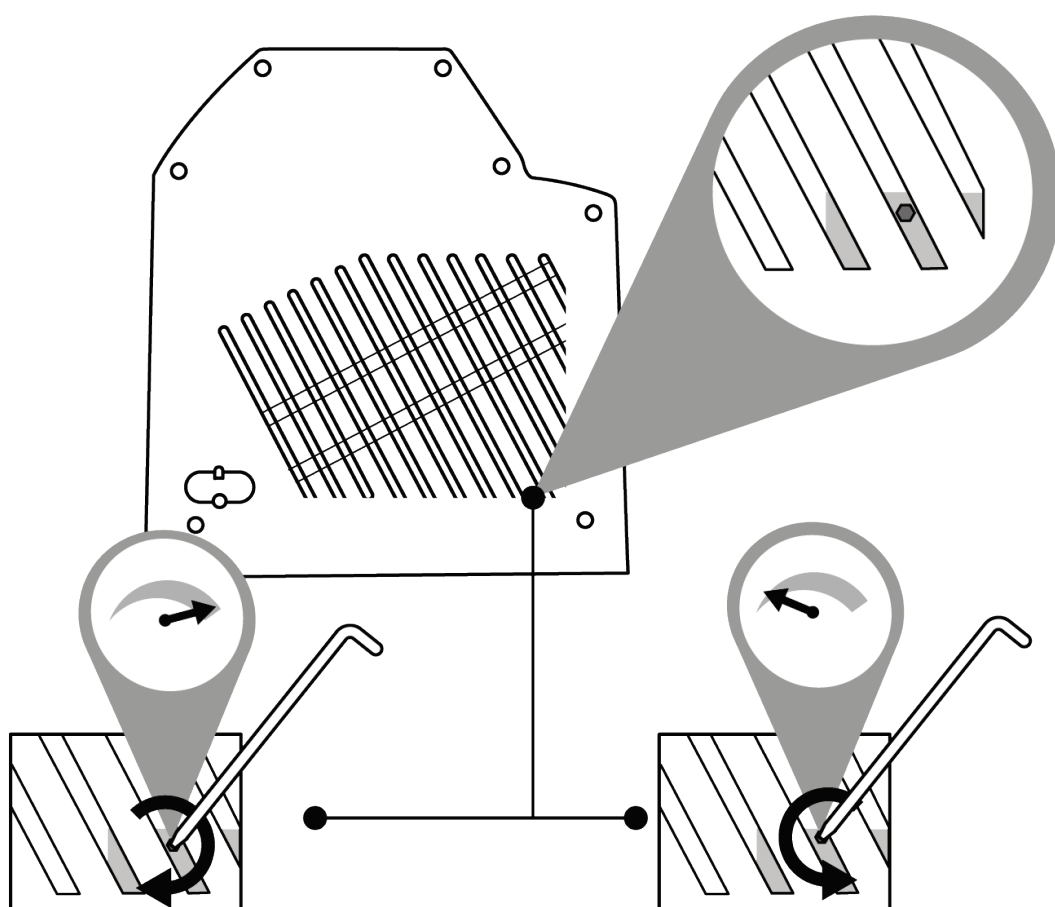

Aby nedošlo k poškození třecího systému, dbejte na to, abyste seřizovací šroub příliš neutáhli.

Dbejte také na to, abyste seřizovací šroub zcela neutáhli: tím se vystavujete riziku, že škrticí klapka již nebude moci zůstat v dané poloze.



6. Instalace na podpěru



System VIPER TQS lze instalovat na různé typy podpěr. Většina kokpitů a podpěr dostupných na trhu je již kompatibilní s podobnými produkty Thrustmaster (tj. HOTAS Warthog).

Mějte na paměti, že systém VIPER TQS má silný pákový efekt, a proto musí být pevně připevněn.

Připevněte základnu k podpěře pomocí vhodných šroubů M6 (nejsou součástí balení), aby nedošlo k poškození páky.

Kompletní plán systému VIPER TQS je k dispozici na adrese

<https://support.thrustmaster.com/product/viper-tqs/>



Před každým použitím se ujistěte, že je zařízení VIPER TQS stále správně připevněno k podpěře podle pokynů výrobce.

Nezapomeňte vzít v úvahu materiál, ze kterého je vaše podpěra vyrobena, a ujistěte se, že je možné k ní výrobek bezpečně připevnit. System VIPER TQS musí být použit na stole z pevného materiálu (např. MDF nebo dřeva) bez dutých nebo skleněných součástí.



Rozměry montážního plánu (v mm)

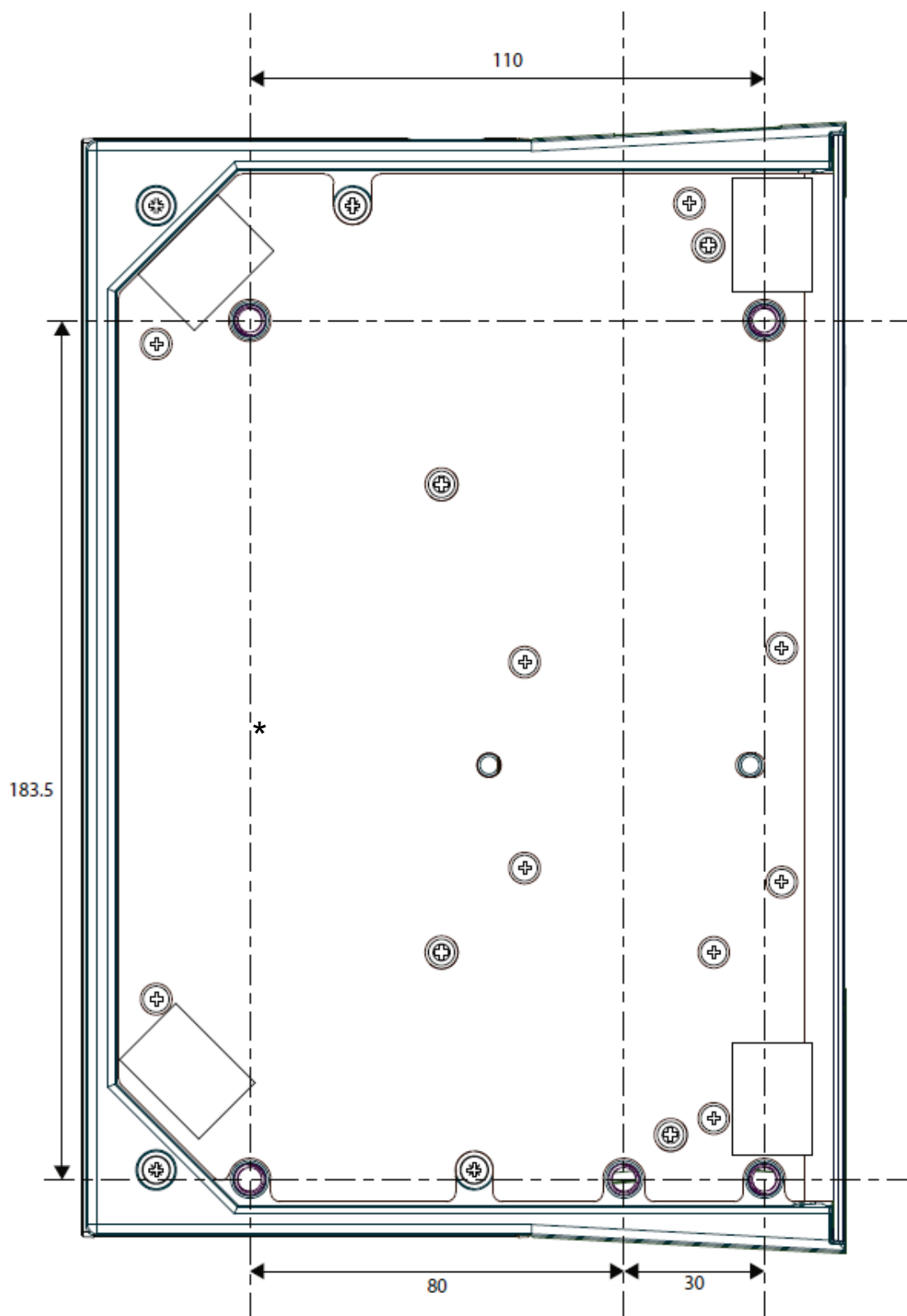

Montážní plán si můžete stáhnout ze stránek <https://support.thrustmaster.com/product/viper-tqs/>, pak si jej vytiskněte a použijte na podložce, abyste připravili otvory pro vrtání.



Instalace za použití TM Flying Desk Mount*

TM Flying Desk Mount je kovový montážní systém s upínacím šroubem, který zlepšuje ergonomii a pilotní polohu při používání zařízení. Tento systém je určen pro použití se stoly o tloušťce 15-50 mm.

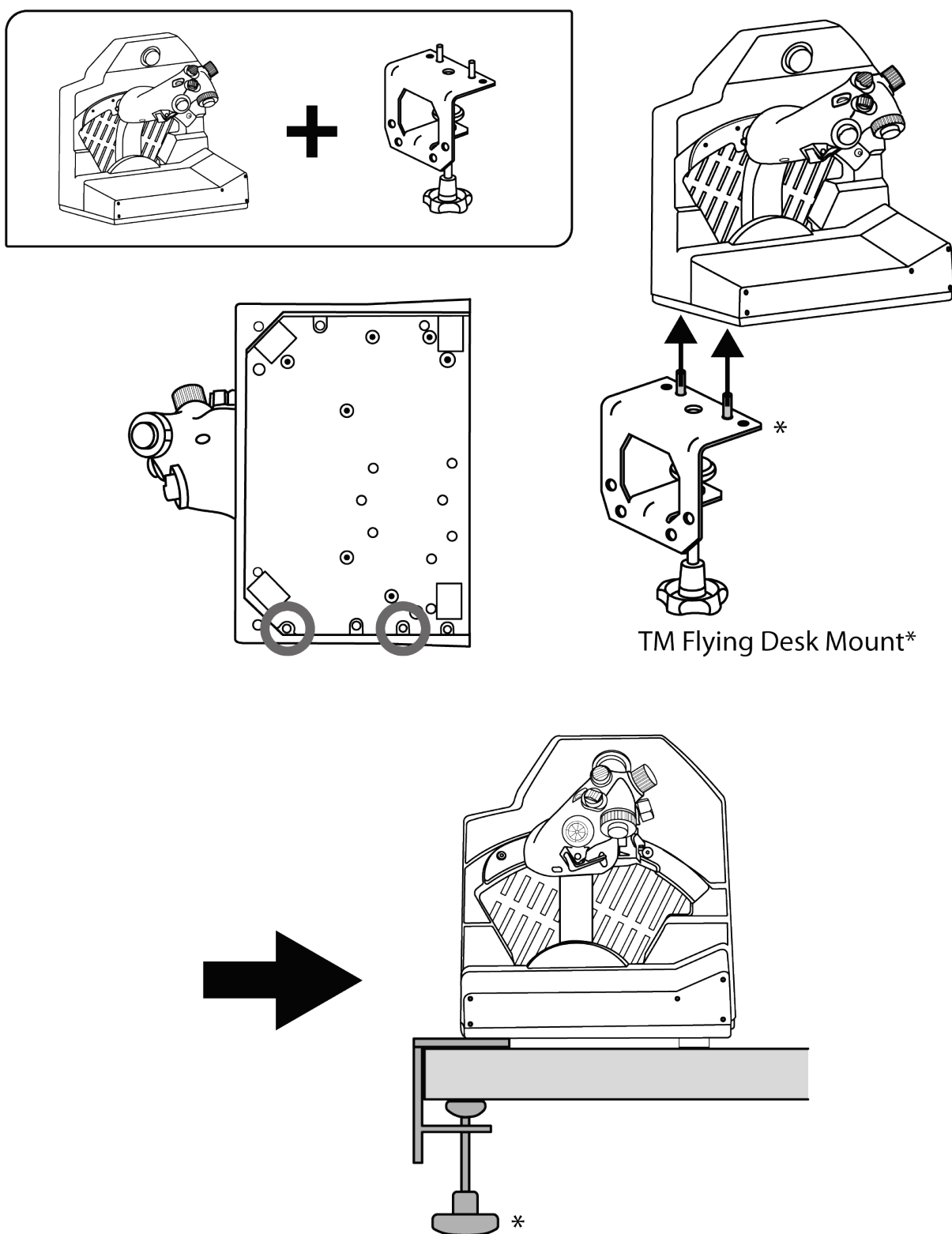

* Prodává se samostatně



Instalace za použití TM Flying Clamp*

TM Flying Clamp je výškově nastavitelná podpěra navržená společností Thrustmaster pro její příslušenství pro letecké simulace. Tento montážní systém je vybaven dvěma upínacími šrouby, které umožňují jeho nastavení pro použití se stoly a deskami o tloušťce 15-45 mm.

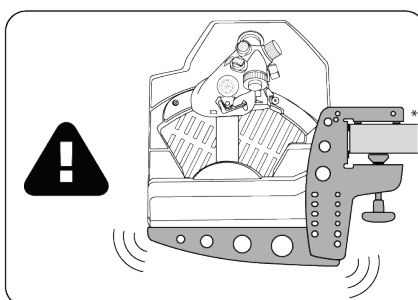
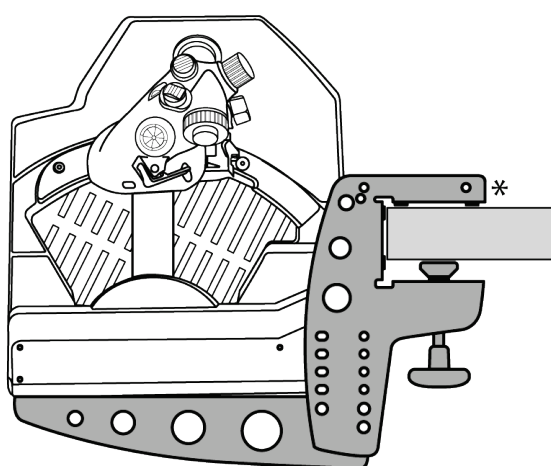
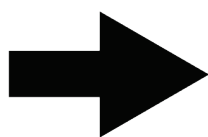
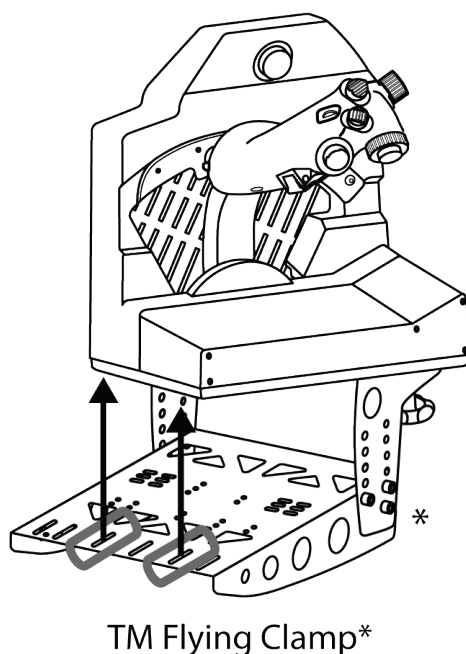
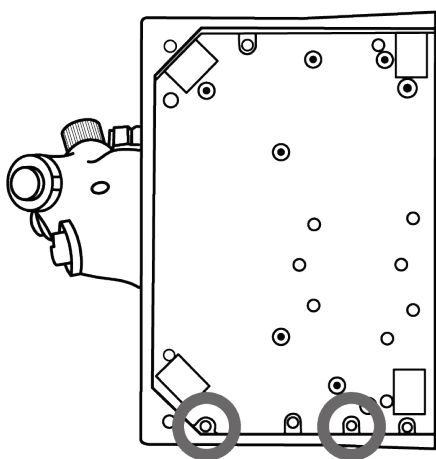
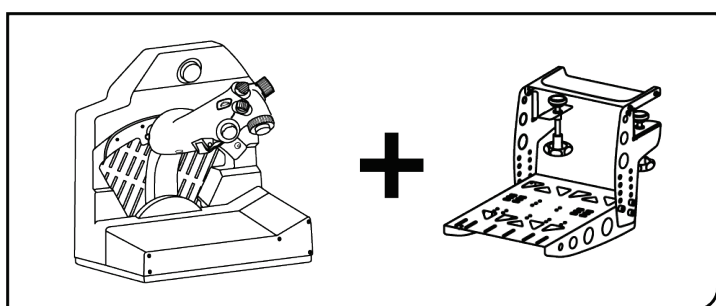

* Prodává se samostatně



Upozorňujeme, že velká hmotnost systému VIPER TQS může způsobit nežádoucí pohyby montážního systému.



6. Instalace VIPER PANEL*

**Prodává se samostatně. VIPER PANEL je součástí balíčku VIPER TQS Mission Pack.*

VIPER PANEL je ovládací panel, který vám umožní rozšířit vaše letové/bojové možnosti o celkem 43 tlačítek a 1 osu - všechny jsou programovatelné pomocí softwaru T.A.R.G.E.T. VIPER PANEL je doplňkem k VIPER TQS.

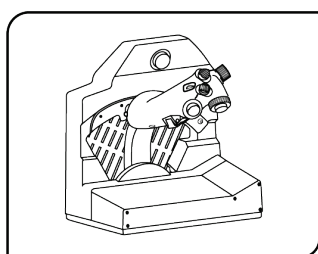

1

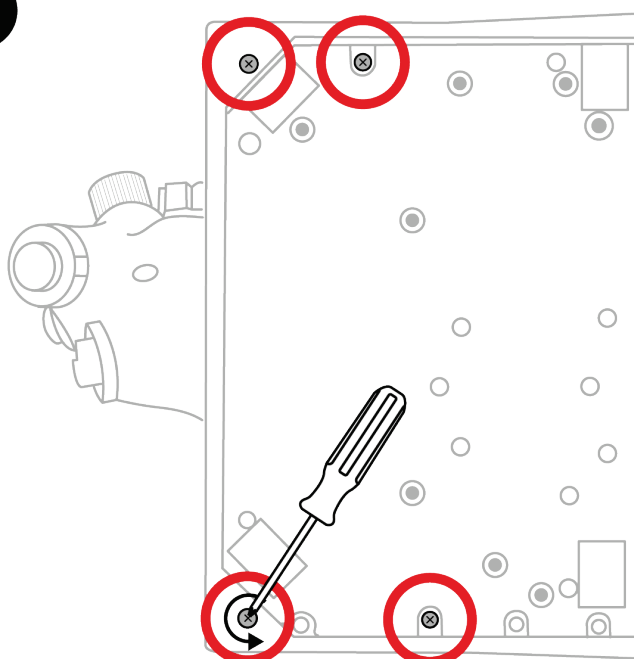

2

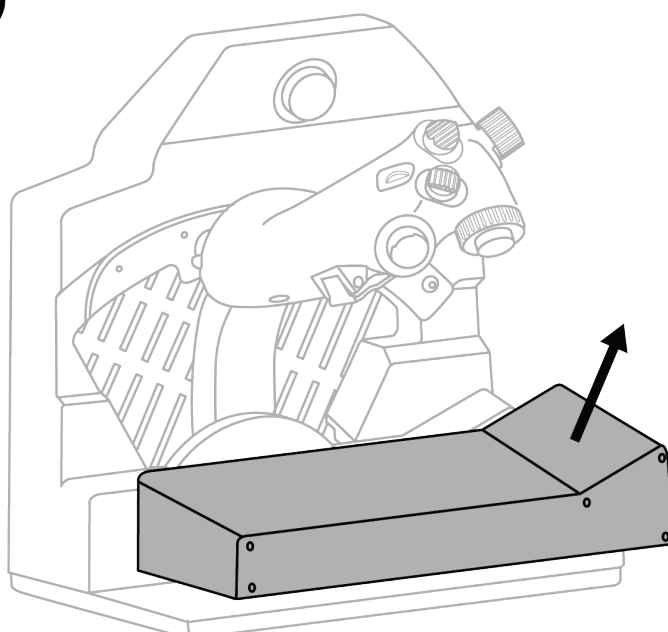

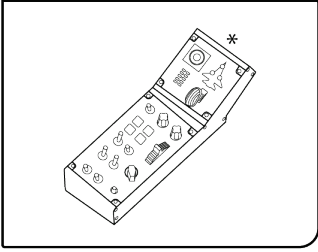

3

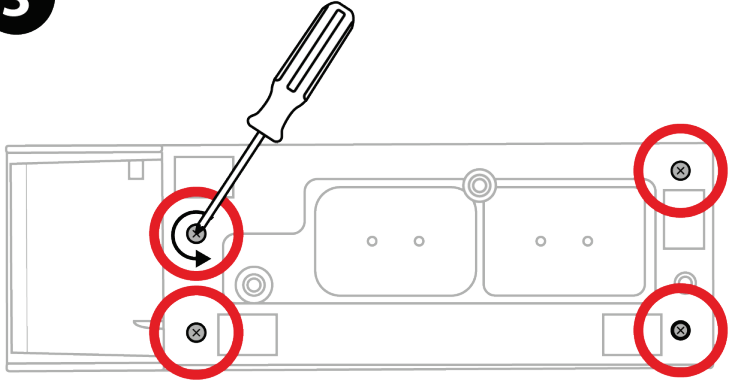

4

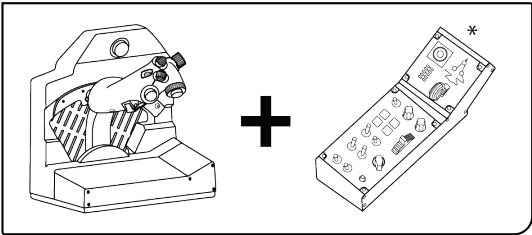
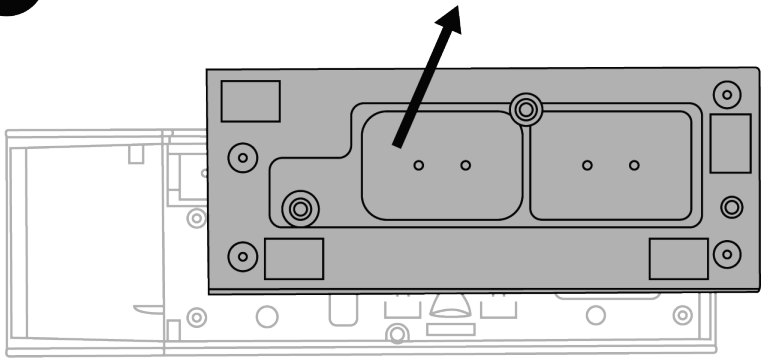

5

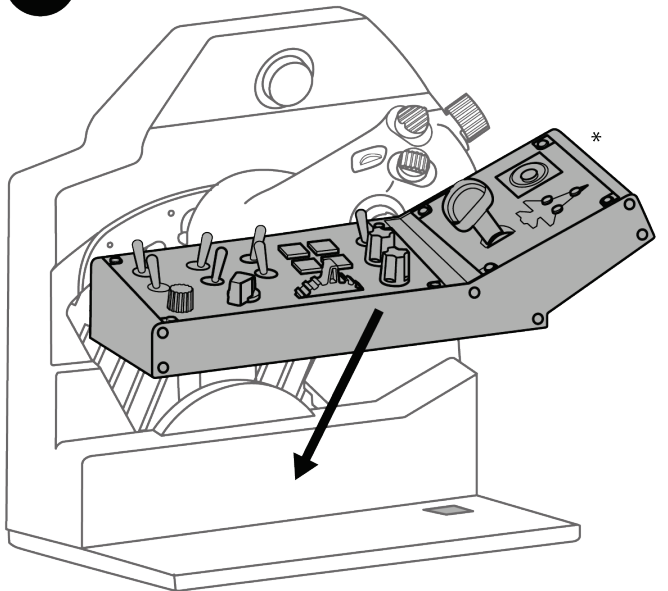



6

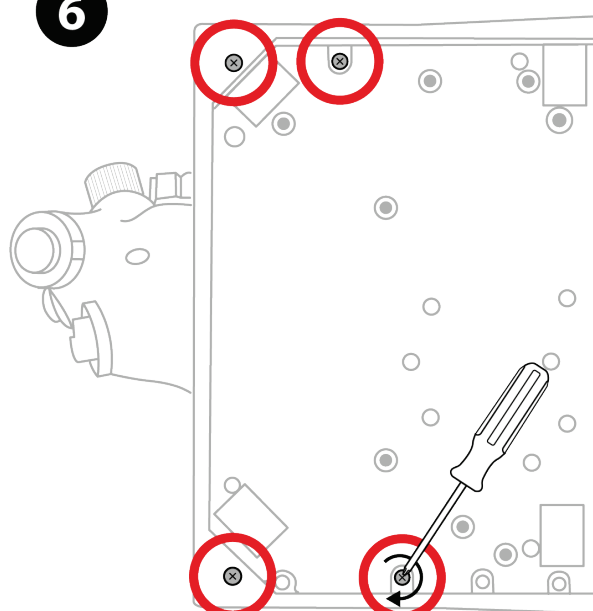

7

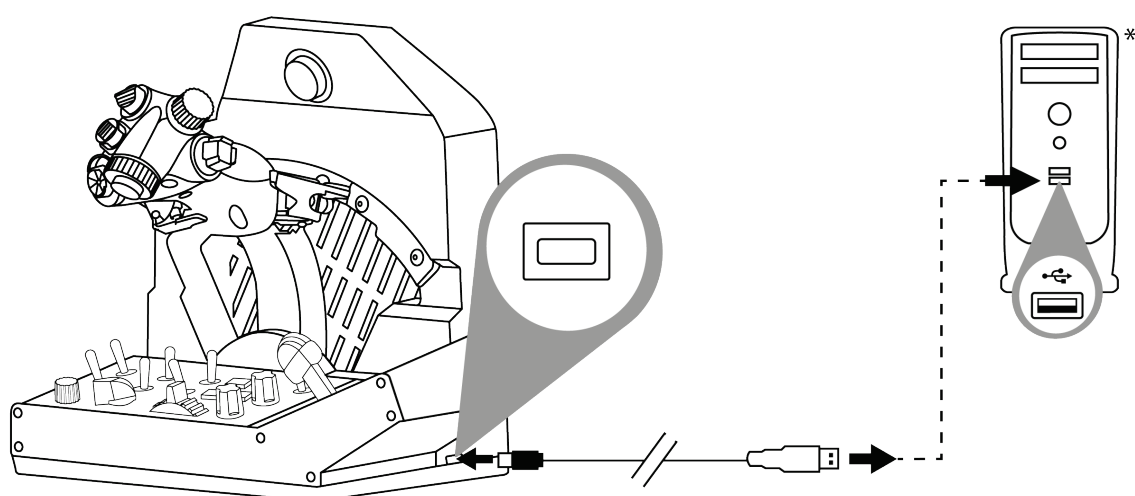

**Není součástí*



7. Instalace na PC

1



Navštivte prosím

<https://support.thrustmaster.com/product/viper-tqs/>.

2

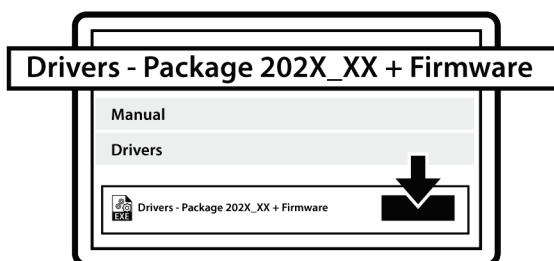

Stáhněte a nainstalujte ovladač počítače a jeho přizpůsobené rozhraní pro Ovládací panely systému Windows.

3

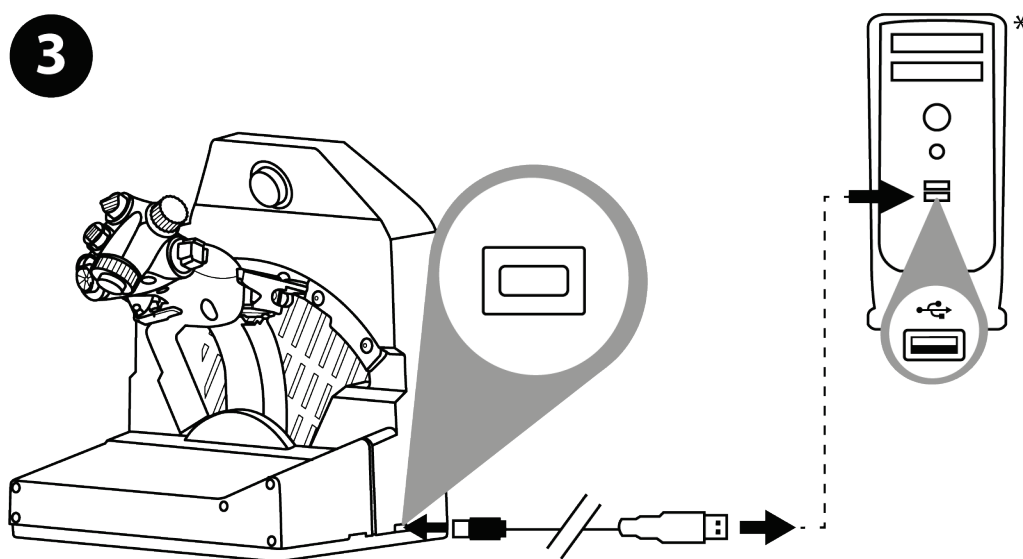

Po instalaci ovladače počítače připojte konektor USB k jednomu z portů USB počítače.

**Není součástí*



④ Chcete-li vstoupit do složky Control Panel, vyberte **Start / Aplikace / Thrustmaster / Control Panel** nebo **Ovládací panely** (ve Windows 10).

Zobrazí se dialogové okno **Herní ovladače**. Na obrazovce se zobrazí příslušenství s názvem **VIPER TQS** a stavem **OK**.

⑤ V dialogovém okně **Herní ovladače** klikněte na tlačítko **Vlastnosti** a otestujte a zobrazte všechny funkce.

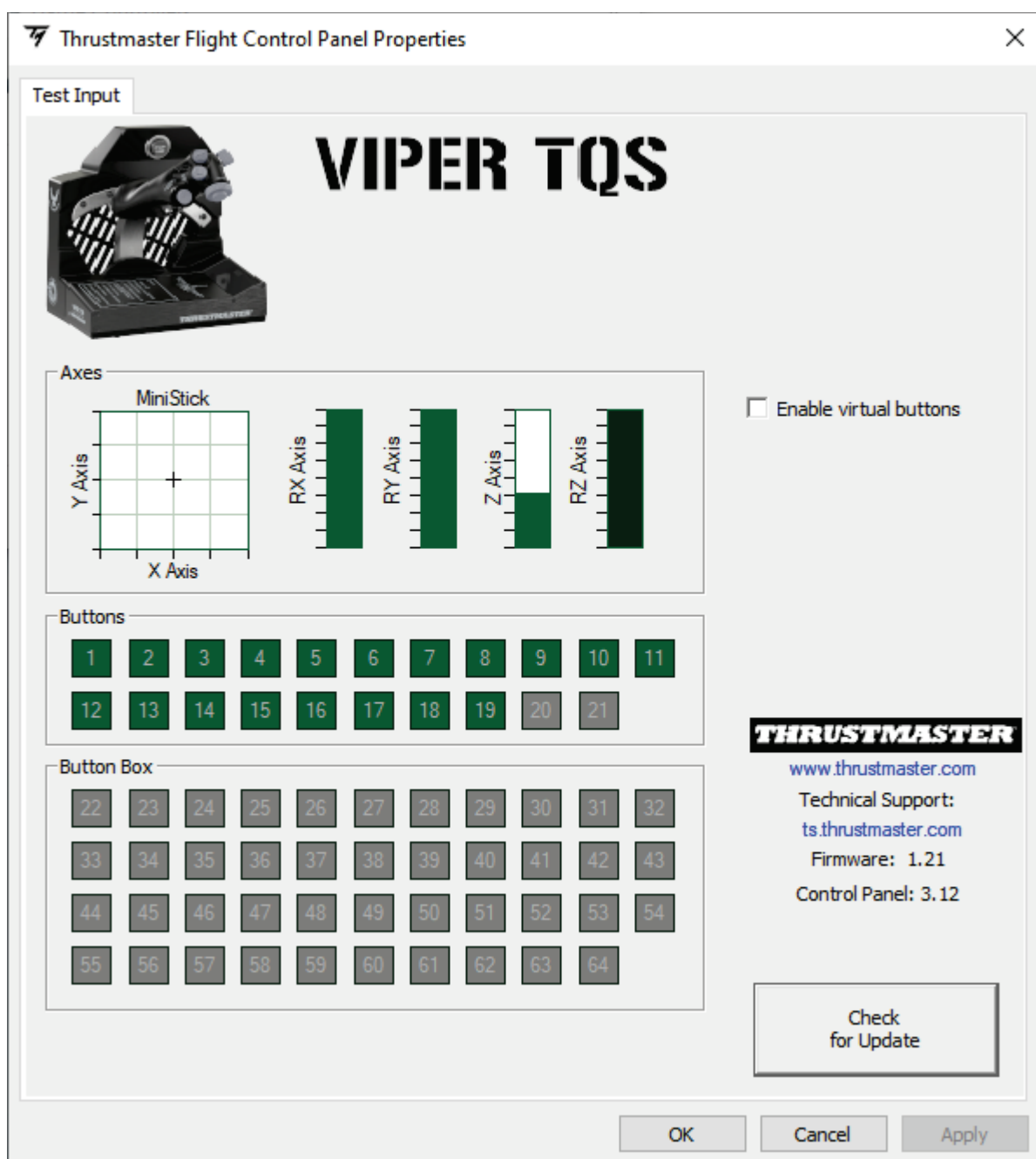



Enable virtual buttons (Povolit virtuální tlačítka):

Tato funkce umožňuje zapnout nebo vypnout virtuální tlačítka na páce (tlačítka 20 a 21). Po výběru režimu, který chcete použít, klikněte na tlačítko **Apply** (Použít).

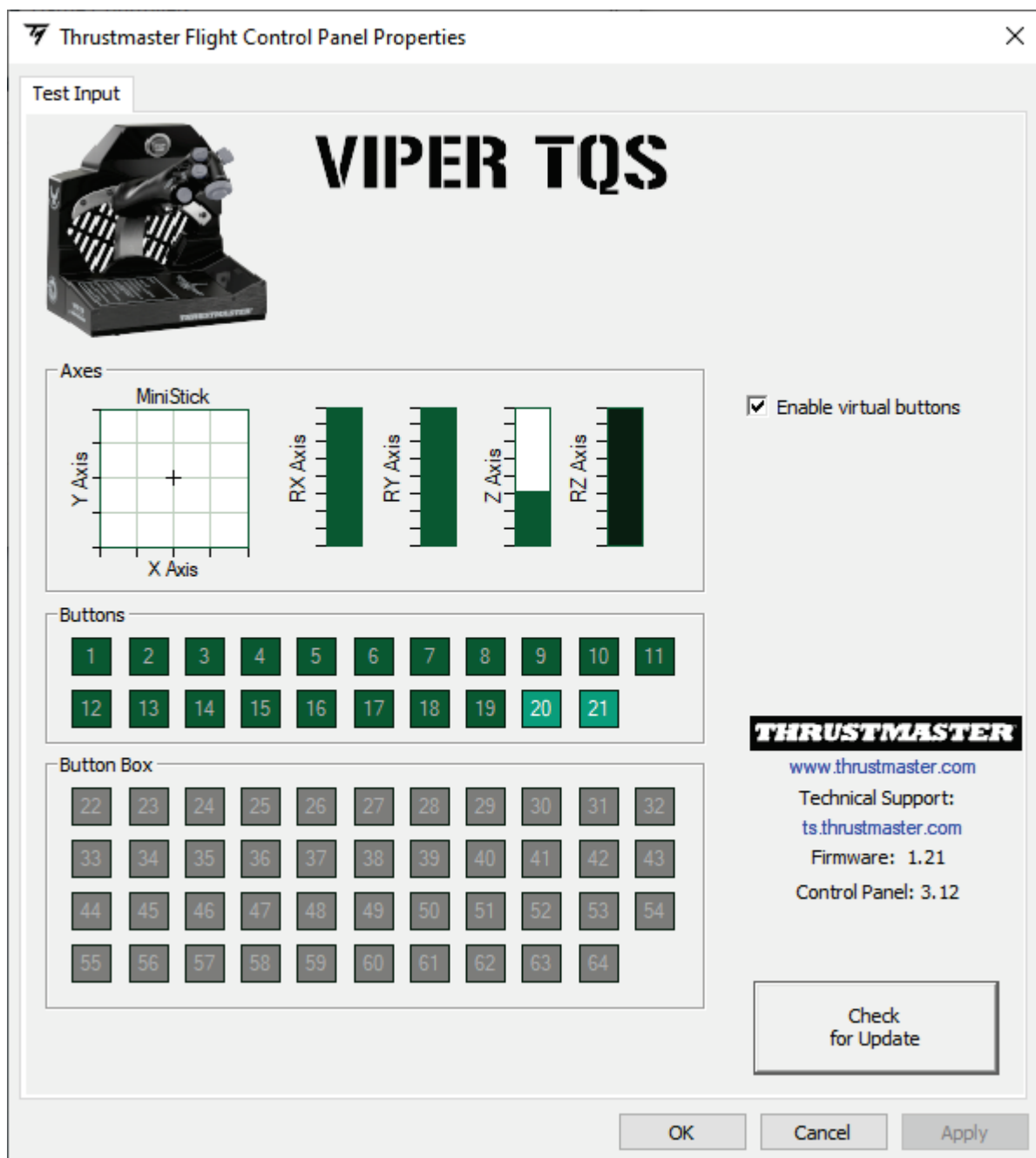

Virtuální tlačítka jsou v systému VIPER TQS ve výchozím nastavení vypnuta.



7. CUT OFF a AFTERBURNER detenty

Kvadrant ovládání tahu motoru VIPER TQS je vybaven realistickým systémem zážek CUT OFF a AFTERBURNER (modul Afterburner je odnímatelný).

CUT OFF

Po nastavení plynu na doraz IDLE stiskněte spoušť "odblokování vypnutí motoru" **1**, abyste zvedli páku a dostali se přes doraz **2**, poté dejte páku do polohy OFF **3**.

Pro opětovné zapnutí motorů proveďte tento postup v opačném pořadí.

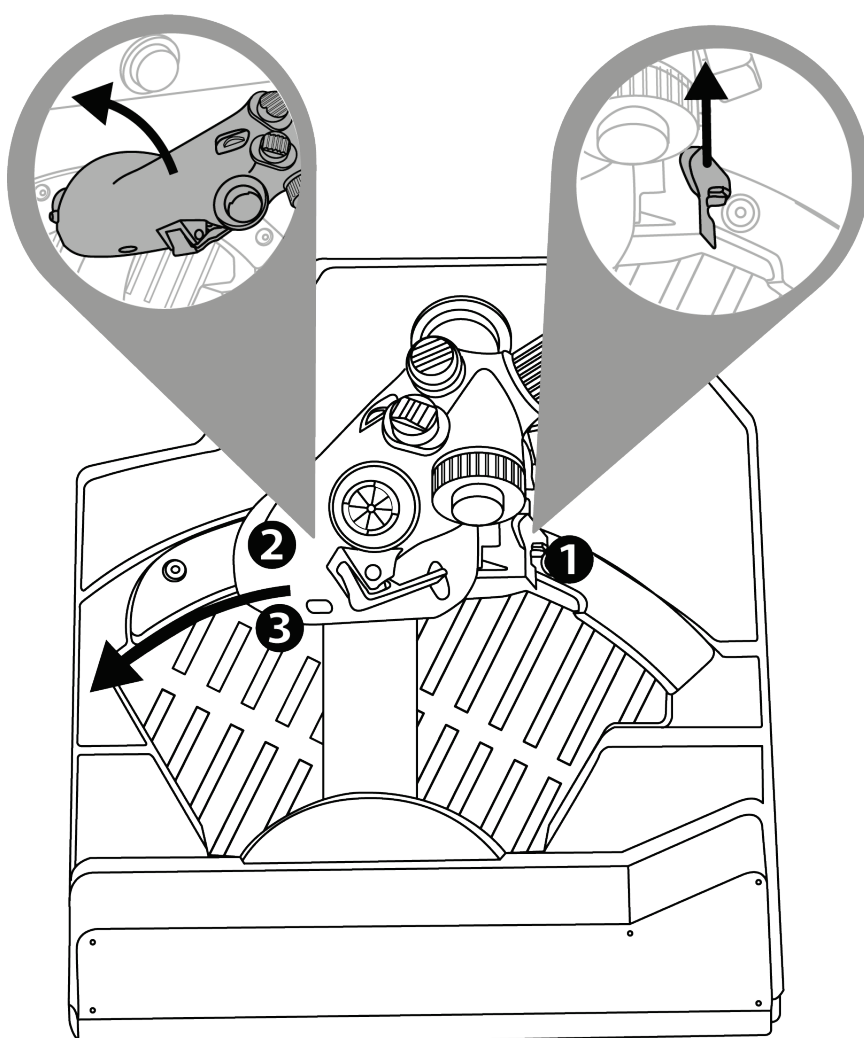



AFTERBURNER

Přesuňte plynovou páku na doraz **1** a zvedněte ji nahoru **2**, abyste se dostali přes doraz a zapnuli přídatné spalování **3**.

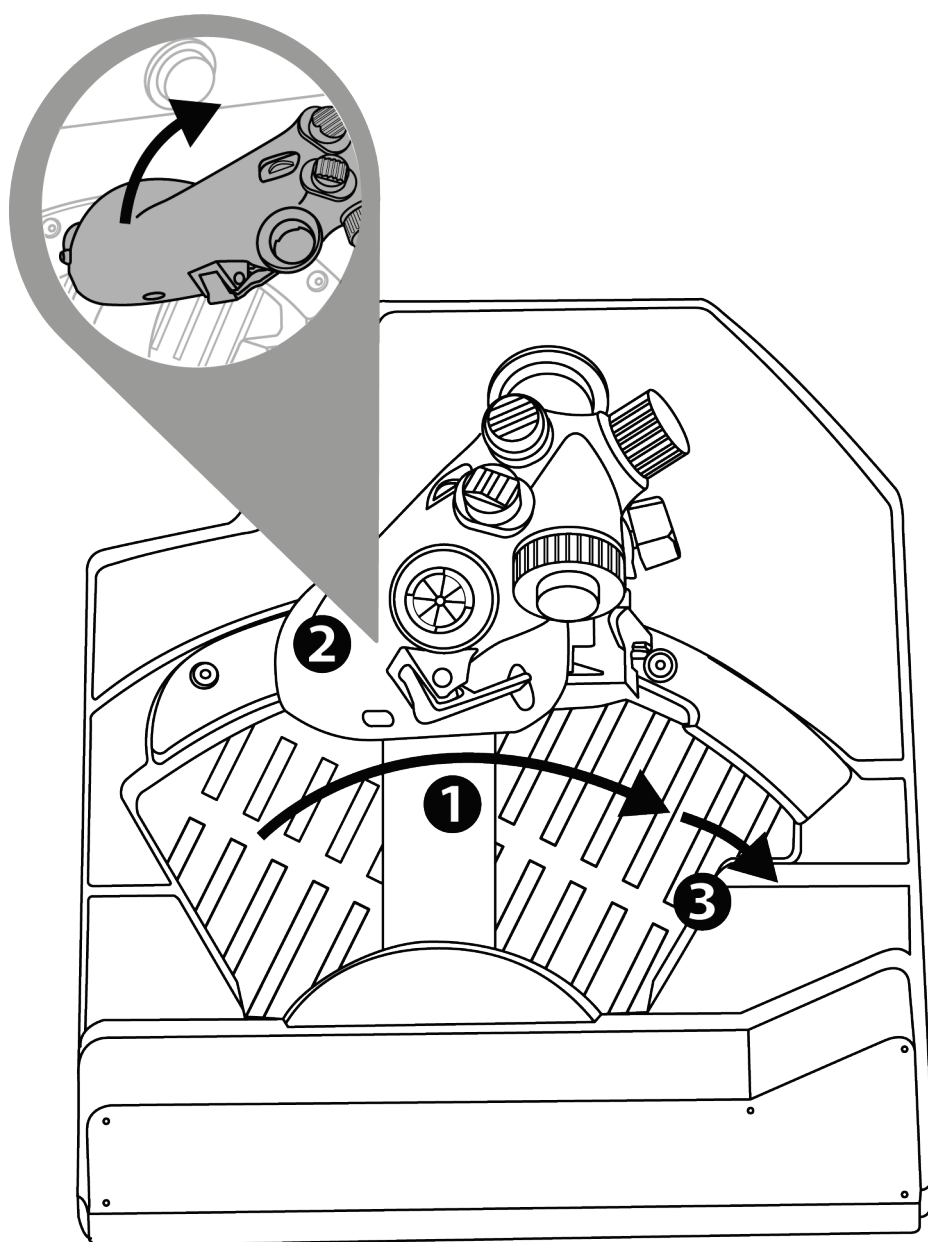



Odinstalování zářky AFTERBURNER

Zarážka modulu Afterburner je umístěna na 80 % hodnoty osy.

Pokud potřebujete 100 % dráhy plynu bez dorazu (pro konkrétní simulátor), můžete modul Afterburner a jeho doraz vyjmout vyšroubováním dvou šroubů modulu pomocí imbusového klíče (není součástí dodávky).

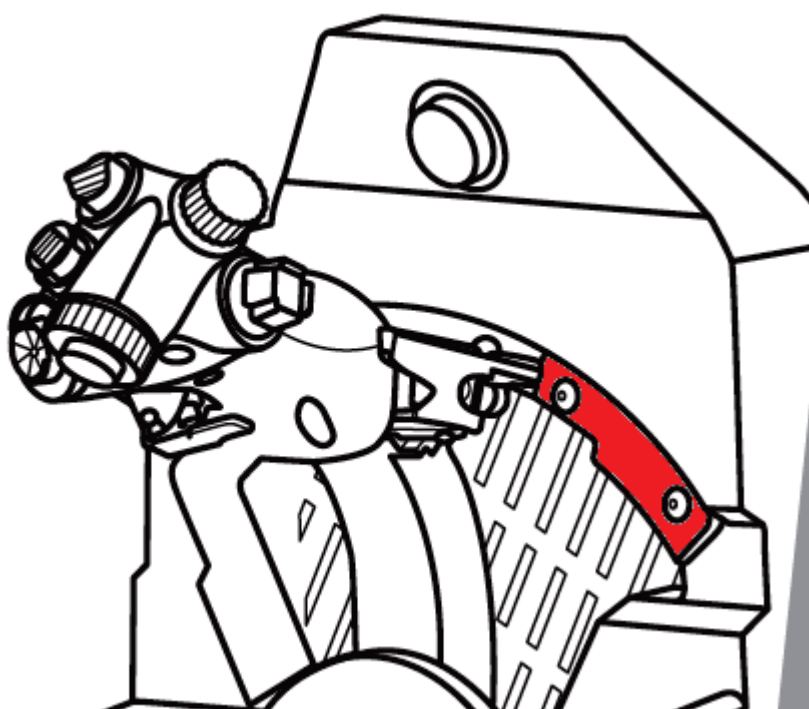



8. T.A.R.G.E.T pokročilý programovací software



Navštivte prosím

<https://support.thrustmaster.com/product/viper-tqs/>.

V sekci **Software** stáhněte a nainstalujte software pro pokročilé programování T.A.R.G.E.T.



Hlavní vlastnosti T.A.R.G.E.T

- Různé možné konfigurace os.
- Různé možné úrovně programování: Basic, Advanced a Script.
- Použití principu Drag and Drop.
- Možnost kombinovat kvadrant ovládání tahu motoru VIPER TQS s různými joysticky Thrustmaster (HOTAS Cougar, HOTAS Warthog, T.16000M, MFD Cougar Pack, které jsou rovněž kompatibilní s T.A.R.G.E.T), což umožňuje jejich rozpoznání jako jediného zařízení USB.
- Přístup k pokročilým profilům vytvořeným komunitou Thrustmaster.



9. Často kladené dotazy a technická podpora

Máte dotazy týkající se VIPER TQS nebo se potýkáte s technickými problémy? Pokud ano, navštivte webové stránky technické podpory společnosti Thrustmaster:

<https://support.thrustmaster.com/product/viper-tqs/>.



THRUSTMASTER®

VIPER TQS **THROTTLE QUADRANT SYSTEM**

PC (Windows 10/11) için

Kullanıcı Kılavuzu



Ürünü monte etmeden **önce**, ürünün her türlü kullanımından **önce** ve tüm bakımlardan **önce** bu kılavuzda verilen talimatları **dikkatlice okuyun**. Güvenli talimatlarına mutlaka uyun. Bu talimatlara uyulmaması kazalara ve/veya hasara neden olabilir. Gelecekte talimatlara başvurabilmek için bu kılavuzu muhafaza edin.

İÇİNDEKİLER

1.	KUTU İÇERİĞİ	5
2.	VIPER TQS ÖZELLİKLERİ	6
3.	DÜĞME VE EKSEN EŞLEŞTİRME	8
4.	VIPER TQS KULLANIMI HAKKINDA BİLGİ	10
5.	SÜRTÜNMENİN AYARLANMASI.....	11
6.	BİR DESTEĞE MONTE ETME	12
7.	VIPER PANEL* KURULUMU	17
8.	PC'DE KURULUM.....	20
9.	CUT OFF VE AFTERBURNER KONUMLARI .	23
10.	T.A.R.G.E.T GELİŞMİŞ PROGRAMLAMA YAZILIMI.....	26
11.	SSS VE TEKNİK DESTEK.....	28



ABD Hava Kuvvetleri'ne ait dünyanın en yaygın kullanılan modern savaş uçağı VIPER'dan alınan ikonik gaz kolu kadranı sistemi ile motorlarına gaz verip tehlike bölgesine dalın!

Metal kol, artı gerçekçi düğmeler ve konumlar içeren 1:1 ölçekli HOTAS replikasının eşsiz ergonomisi ile kokpitinize seviye atlatın.

Bu kılavuz, VIPER TQS'i en iyi koşullarda monte edip kullanmanıza yardımcı olacaktır. Kalkış yapmadan önce tüm bu talimatları ve uyarıları mutlaka dikkatlice okuyun: Ürününüzden en üst düzeyde yararlanmanıza yardımcı olacaktır.



Donanım yazılımını güncelleme

VIPER TQS'in video oyunlarında düzgün çalışması için donanım yazılımını güncellemeniz gerekir.

Güncellemeyi gerçekleştirmek için lütfen şu adresi ziyaret edin:

<https://support.thrustmaster.com/product/viper-tqs/>

Firmware (Donanım yazılımı) ögesini seçin, ardından indirme ve yükleme prosedürü dahil talimatları izleyin.



1. Kutu içeriđi

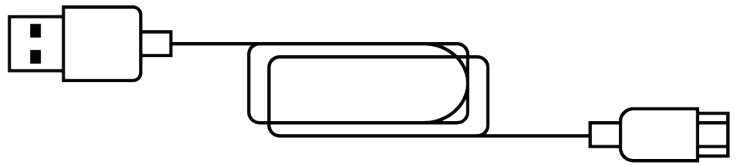
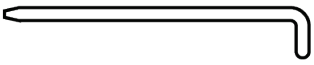
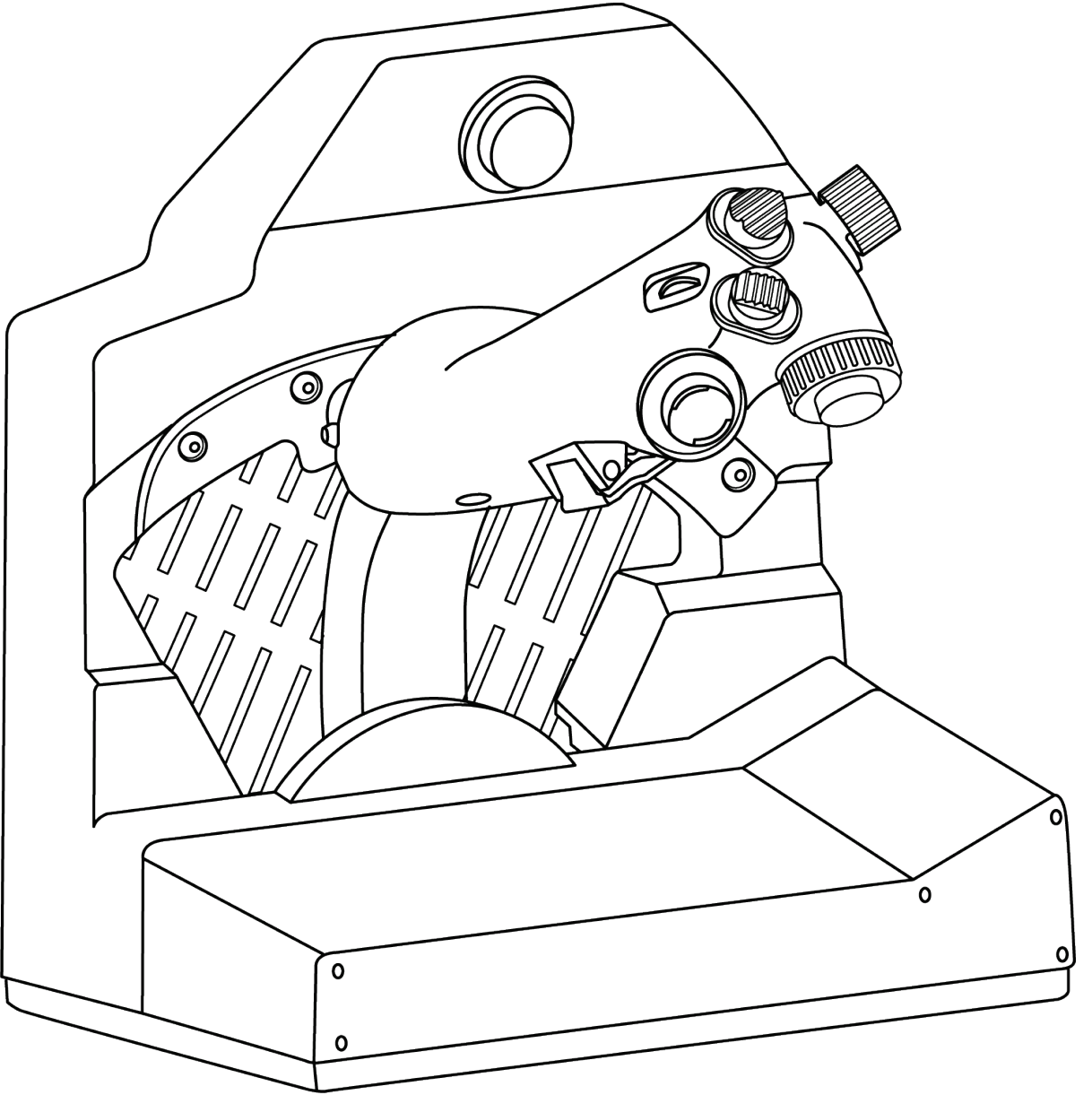



2. VIPER TQS özellikleri

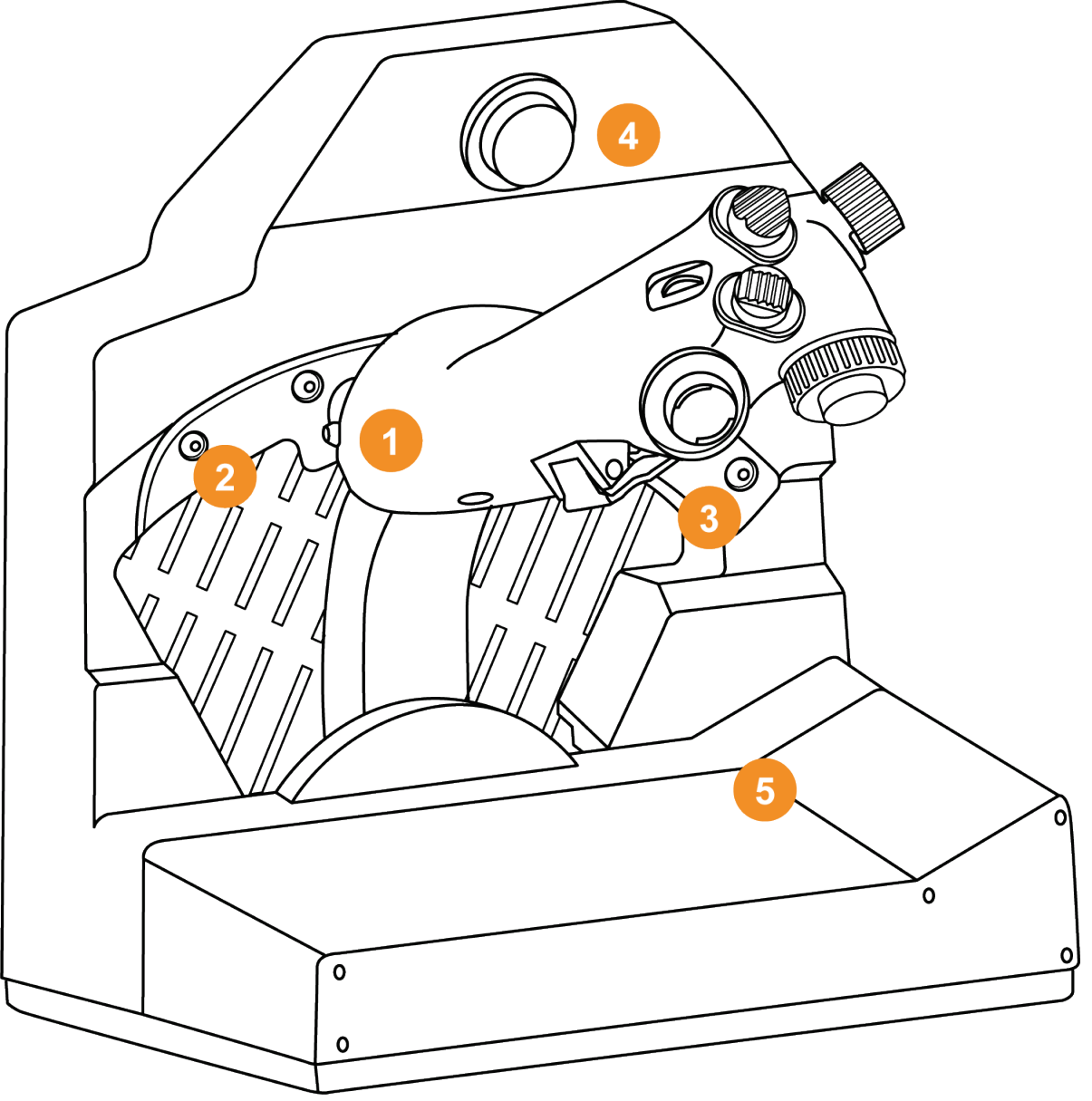

1. Kol

2. Cut Off durdurucusu

3. Afterburner durdurucusu

4. CHAFF/FLARE vurmali düğmesi

5. Görev haritası klipsi

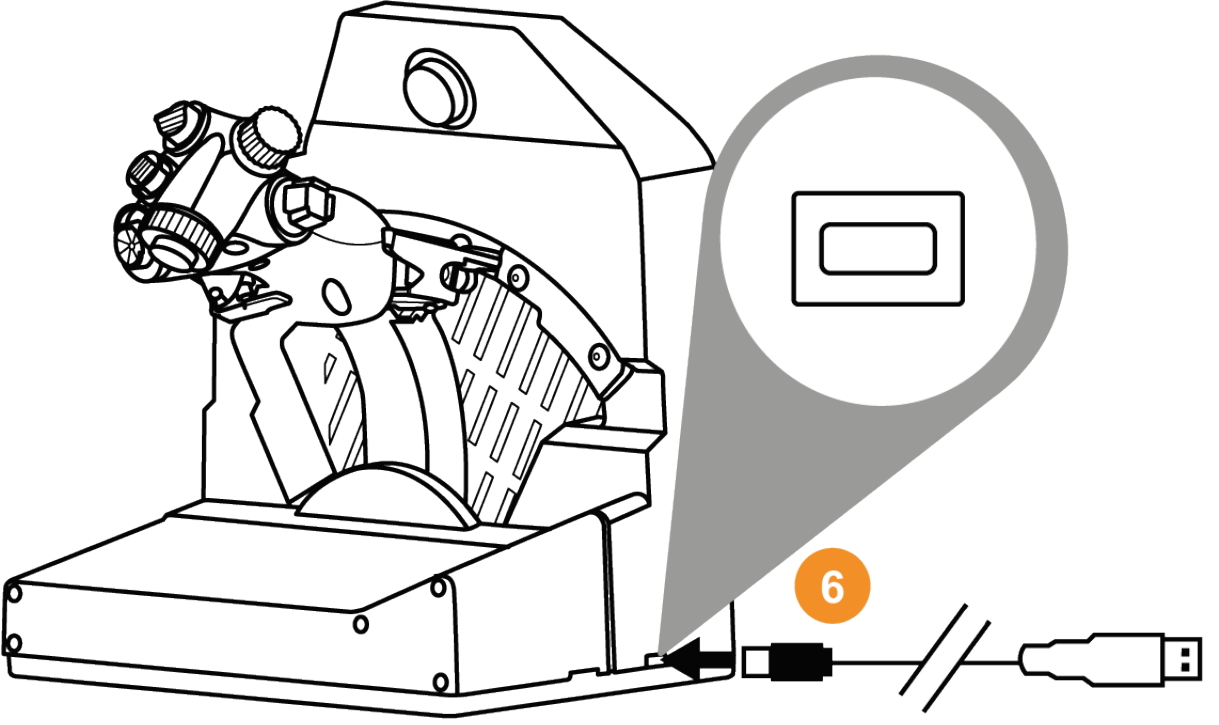

6. USB konektörü (tip C)

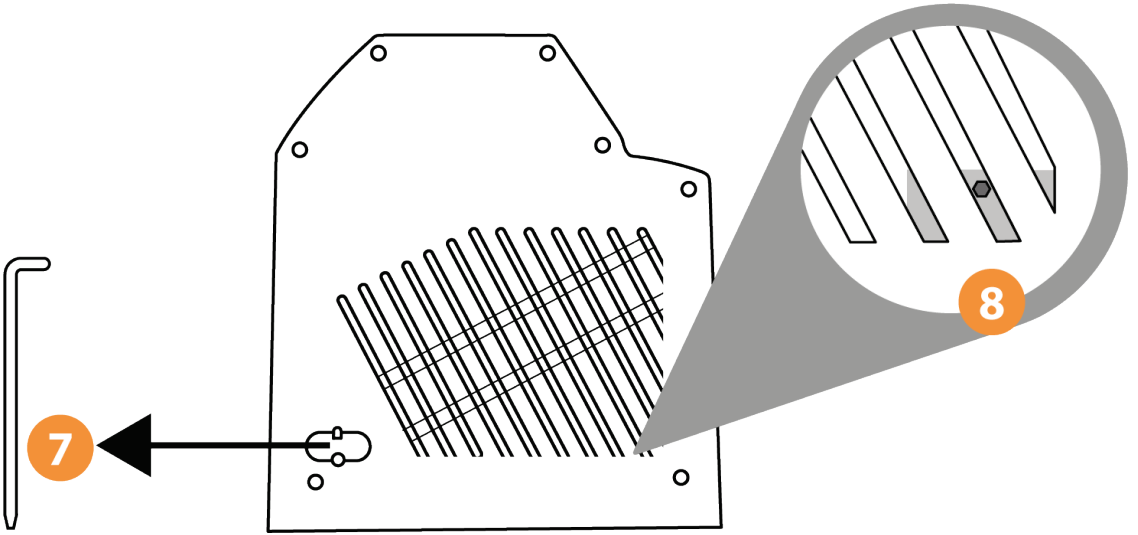

7. Sürtünme ayarı aleti yeri

8. Gaz kolu sürtünme ayarı erişim noktası



3. Düğme ve eksen eşleştirme

VIPER TQS kolu: mod A'da 19 düğme ve 5 eksen eşlemesi (sanal düğmeler hariç)

A 1 → 19

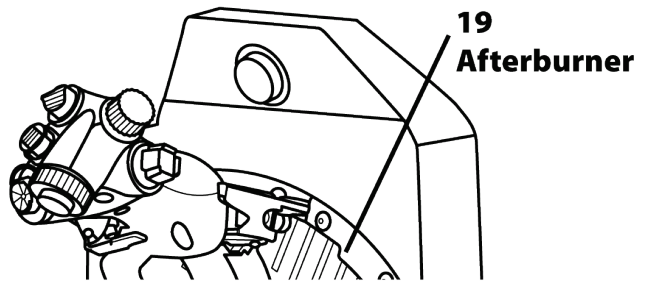
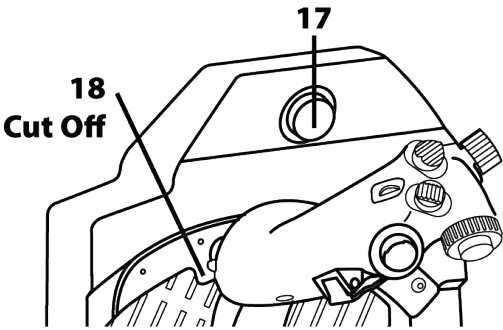
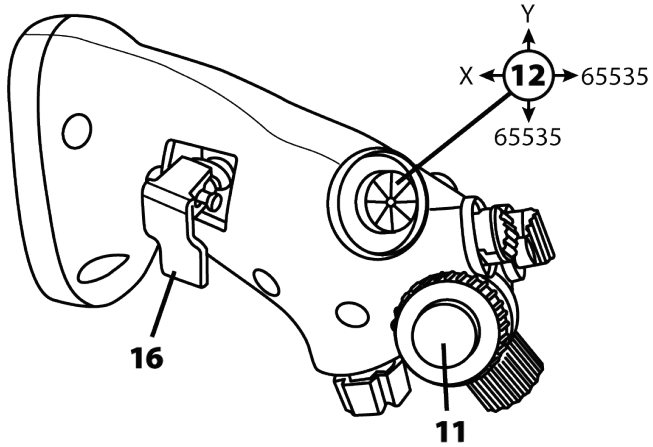
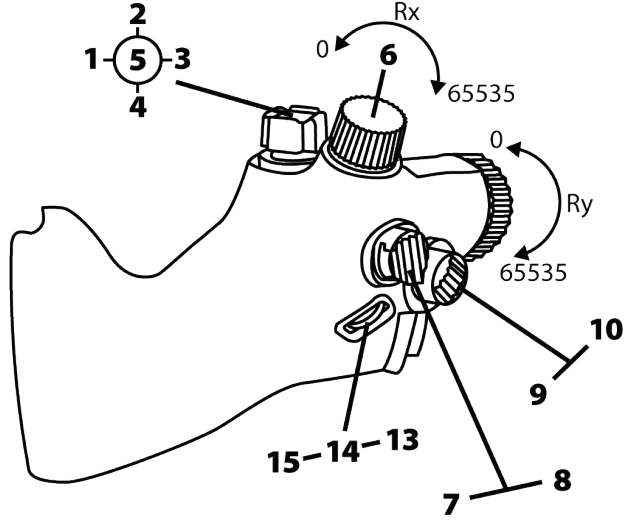



Mod B: sanal düğmelerle

B 1 → 21

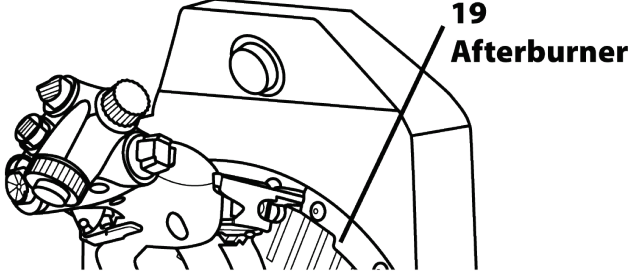
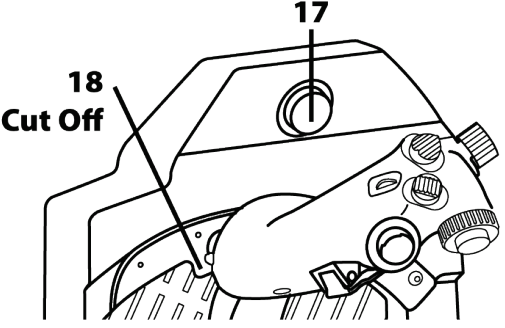
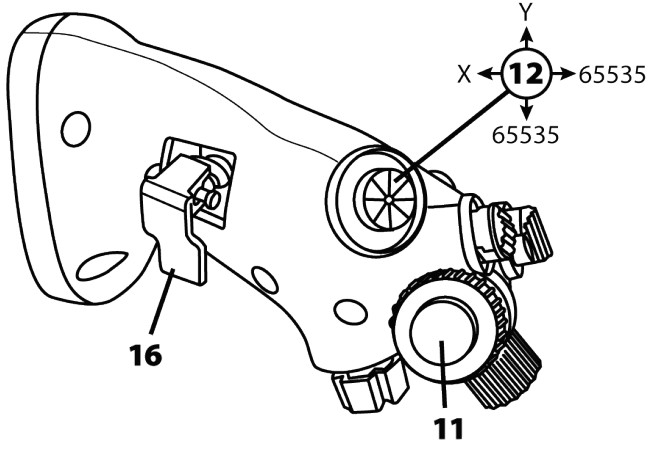
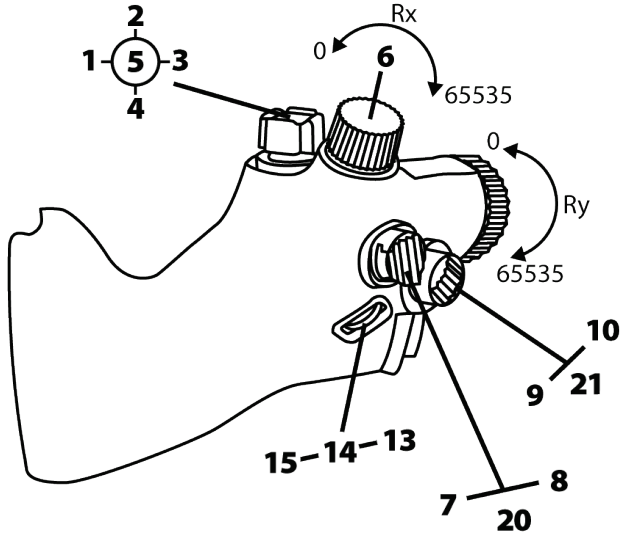



4. VIPER TQS kullanımı hakkında bilgi



Sıkışma tehlikesi

Kolu kullanırken parmaklarınızı asla durdurucu alanlarının içine koymayın.

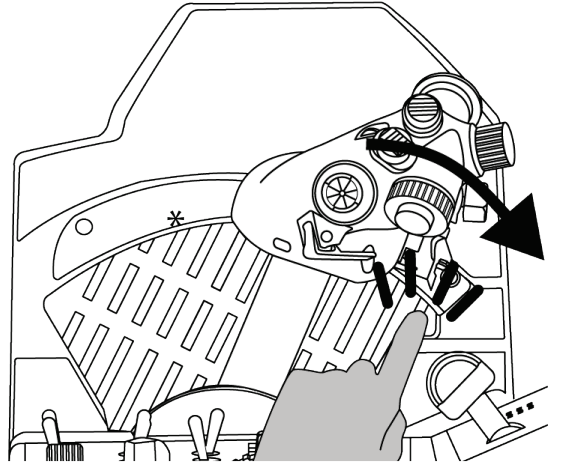
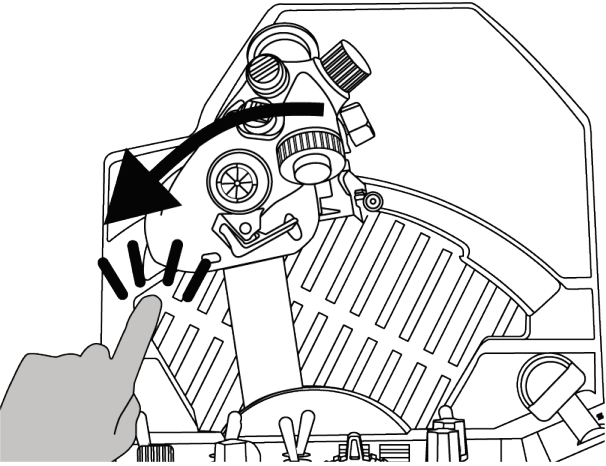
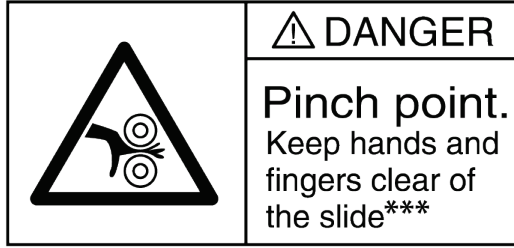



5. Sürtünmenin ayarlanması

VIPER TQS gaz kolu kadranının sürtünmesini, VIPER TQS'in yan tarafında bulunan aleti kullanarak kendi kişisel tercihinize göre ayarlayabilirsiniz. Bununla birlikte ideal gaz kolu sürtünmesinin fabrikada varsayılan olarak ayarlandığını lütfen unutmayın.

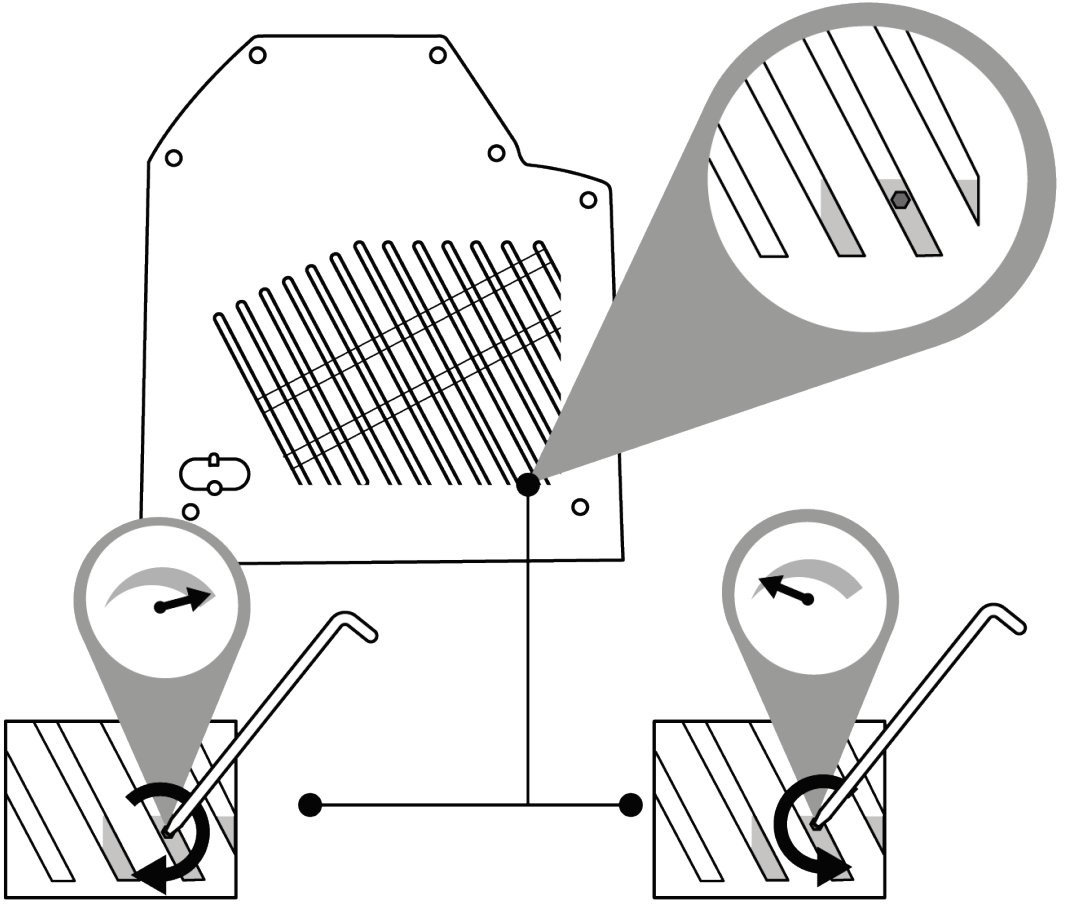

Sürtünme sisteminin zarar görmesini engellemek için ayar vidasını çok sıkılamaya dikkat edin.

Ayrıca, ayar vidasını tamamen gevşetmemeye özen gösterin: Böyle yaparsanız gaz kolunun artık yerinde duramaması riskiyle karşı karşıya kalırsınız.



6. Bir desteğe monte etme



VIPER TQS farklı tipte desteklere monte edilebilir. Piyasada mevcut çoğu kokpit ve destek, benzer Thrustmaster ürünleriyle (HOTAS Warthog gibi) zaten uyumludur.

VIPER TQS'in güçlü bir kol efektine sahip olduğunu ve bu nedenle sıkıca takılması gerektiğini lütfen aklınızdan çıkarmayın.

Tabanı desteğinize uygun M6 vidalar (ürünle verilmez) kullanarak kola hasar vermeyecek şekilde takın.

Tam bir VIPER TQS planı için bkz.:
<https://support.thrustmaster.com/product/viper-tqs/>



Her kullanımdan önce VIPER TQS'in, üreticinin belirttiği talimatlara göre desteğe hala düzgün bir şekilde takılı olduğunu kontrol edin.

Desteğinizin yapıldığı malzemeyi mutlaka dikkate alın ve ürünü desteğe güvenli bir şekilde takmanın mümkün olduğundan emin olun. VIPER TQS içi boş veya cam bileşen içermeyen katı malzemedan (MDF veya ahşap) yapılmış bir masada/sırada kullanılmalıdır.



Montaj planı boyutları (mm)

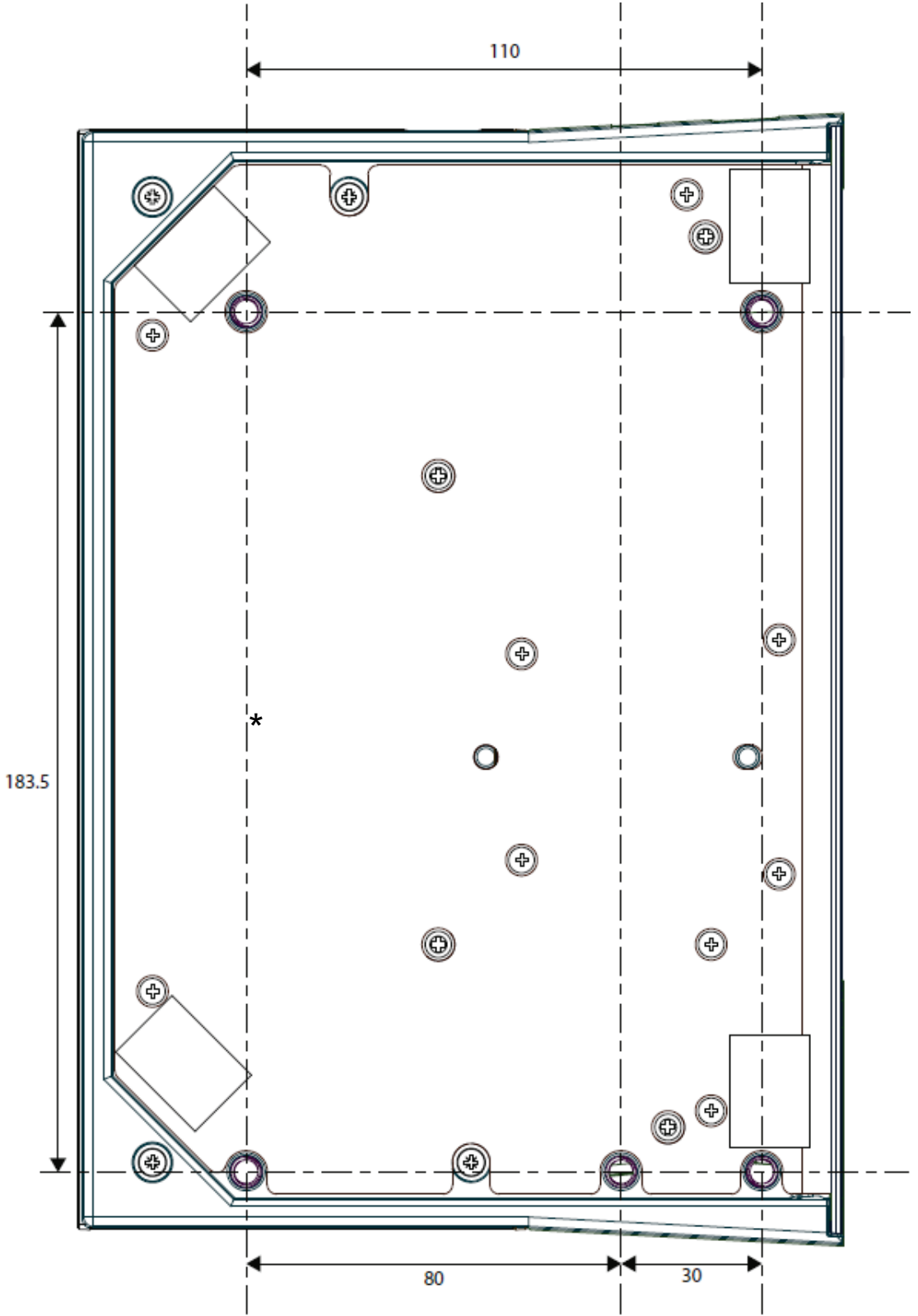

Montaj planını şu adresten indirebilir:

<https://support.thrustmaster.com/product/viper-tqs/>

ve daha sonra yazdırarak matkap deliklerini

hazırlamak için desteğinizin üzerinde kullanabilirsiniz.



TM Flying Desk Mount* kullanarak kurulum

TM Flying Desk Mount, bir sabitleme vidası içeren metal bir montaj sistemi olup cihazınızı kullanırken ergonomi ve pilotaj pozisyonunu iyileştirir. Bu sistem 15-50 mm kalınlığındaki masalar ve sıralar ile kullanım için tasarlanmıştır.

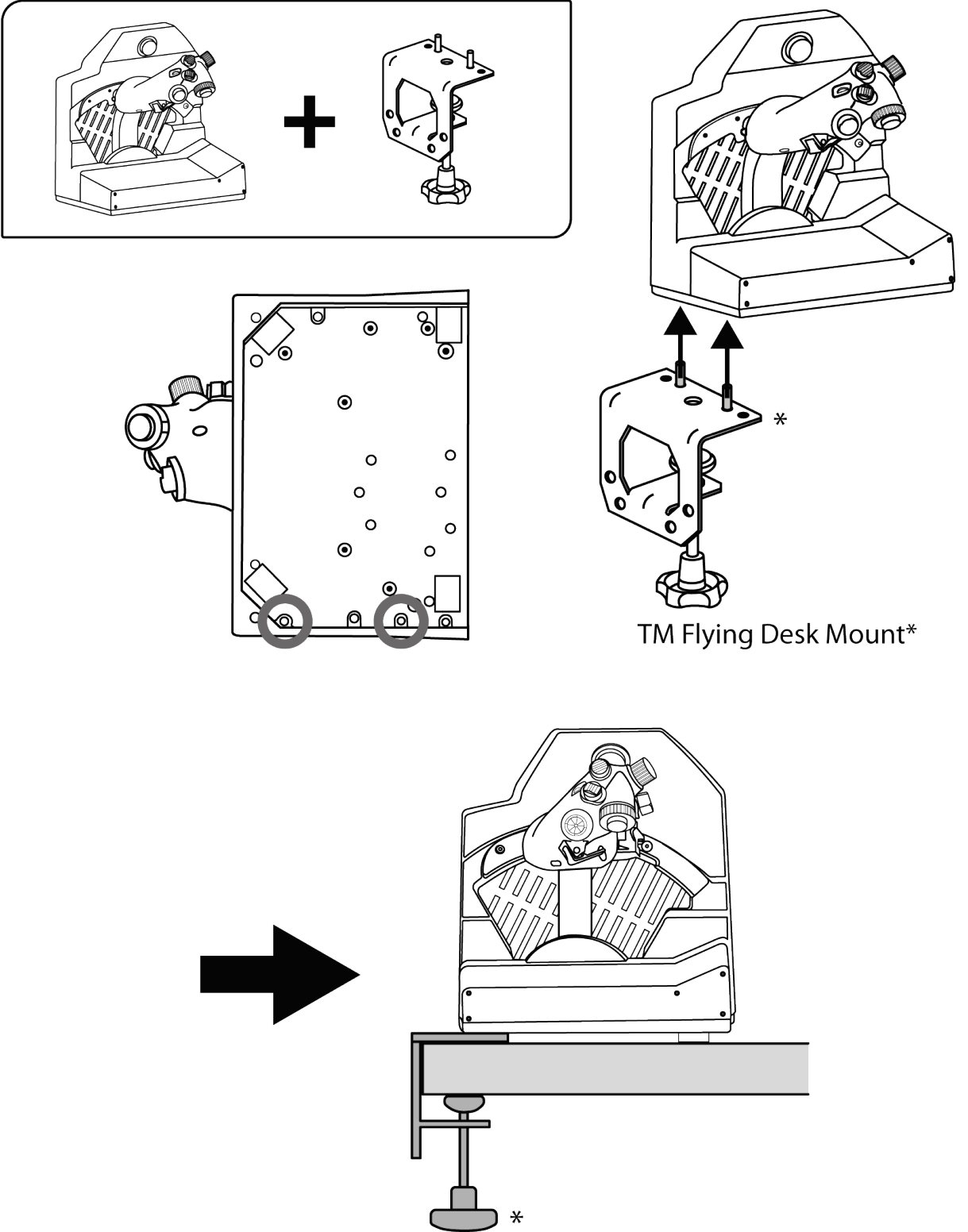

*Ayrı olarak satılır



TM Flying Clamp* kullanarak kurulum

TM Flying Clamp, Thrustmaster tarafından kendi uçuş simülasyonu aksesuarları için tasarlanmış yüksekliği ayarlanabilir bir destektir. Bu montaj sistemi iki sabitleme vidası içermekte olup 15-45 mm kalınlığındaki masa ve sıralarda kullanım için ayarlanmasını sağlar.

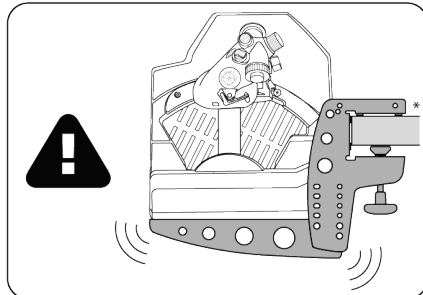
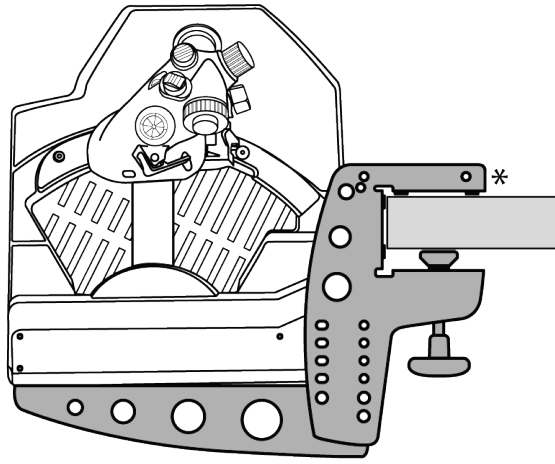
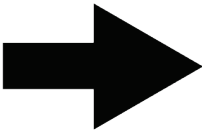
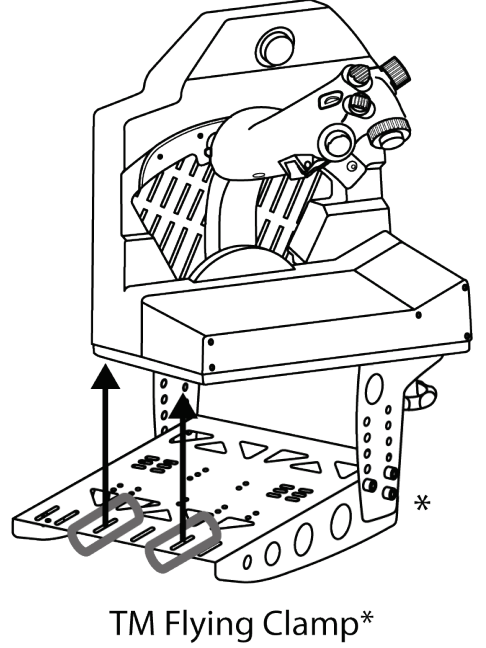
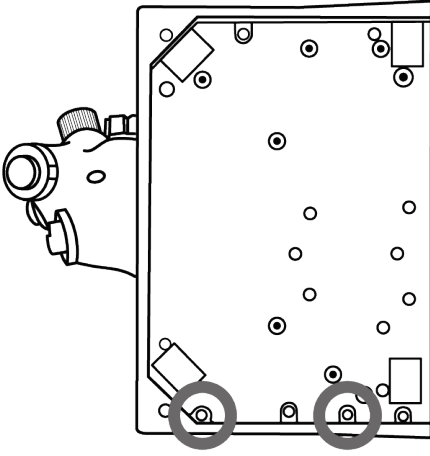
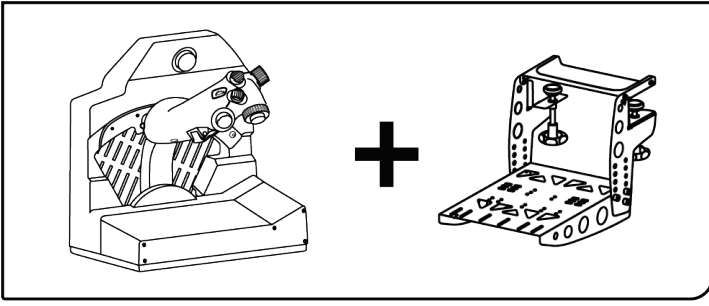

*Ayrı olarak satılır



VIPER TQS'in ağırlığının montaj sisteminde istenmeyen hareketlere neden olabileceğini lütfen unutmayın.



7. VIPER PANEL* kurulumu

**Ayrı olarak satılır. VIPER PANEL, VIPER TQS Mission Pack ile birlikte verilir.*

VIPER PANEL, tamamı T.A.R.G.E.T yazılımı üzerinden programlanabilir toplam 43 düğme ve 1 eksenle uçuş/savaş kabiliyetlerinizi artırmanızı sağlayan bir kumanda panelidir. VIPER PANEL, VIPER TQS'i tamamlayan bir parçadır.

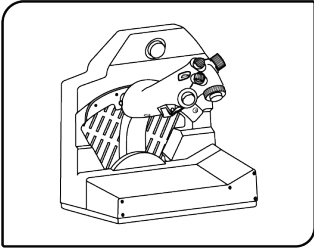

1

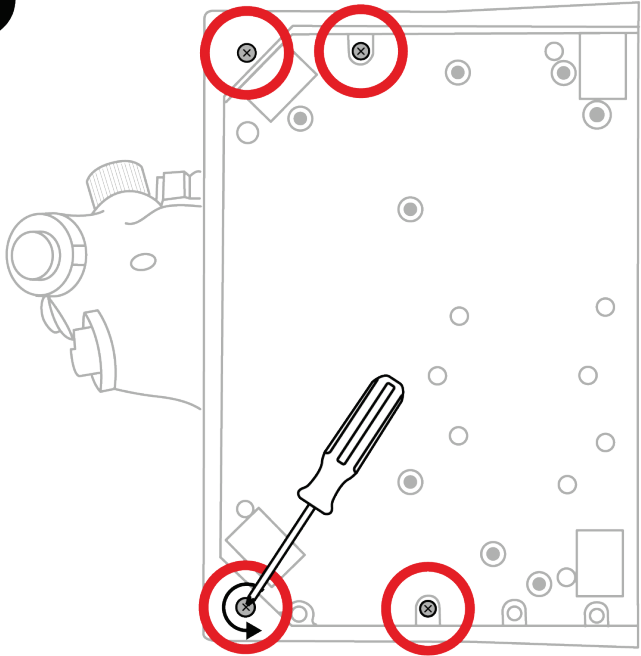

2

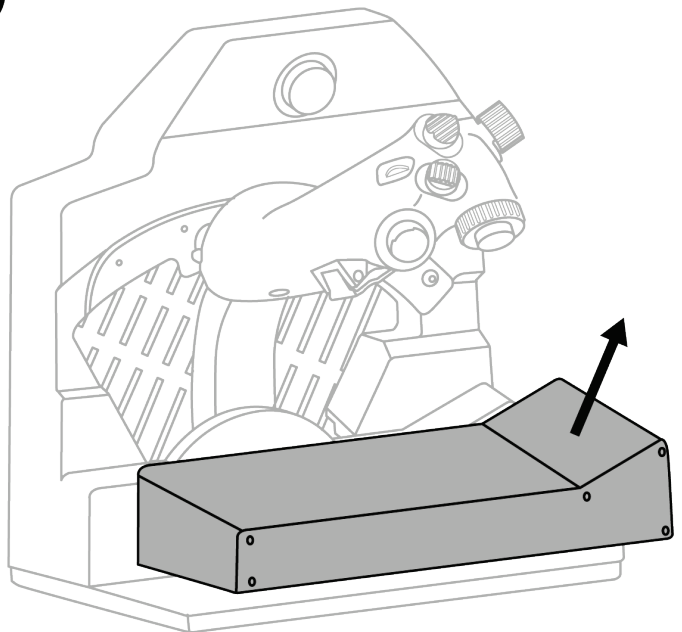

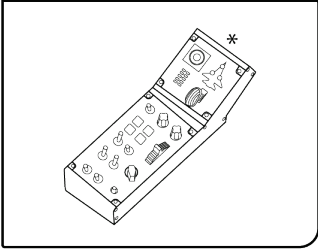

3

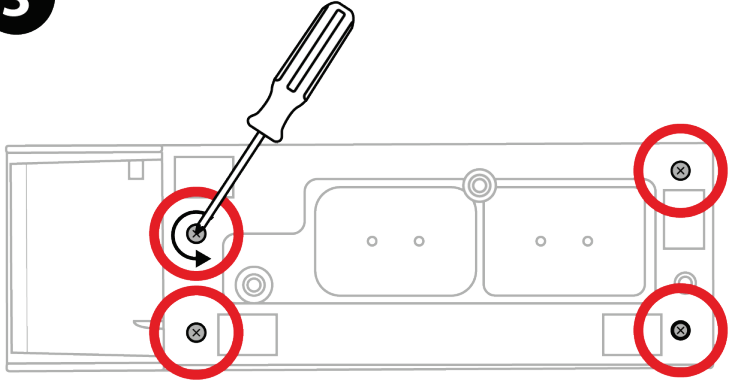

4

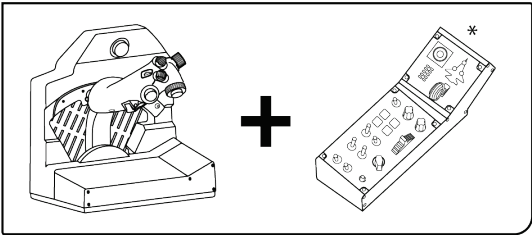
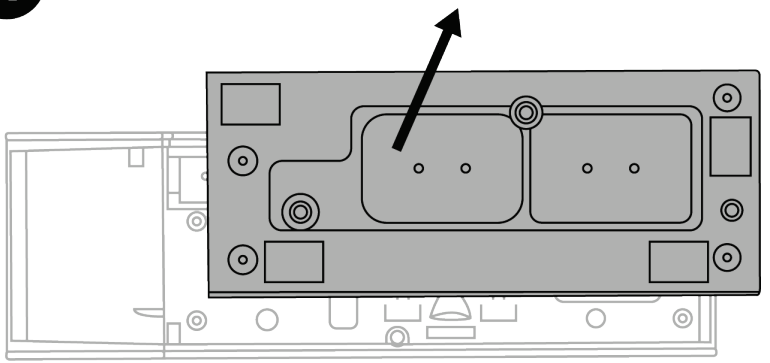

5

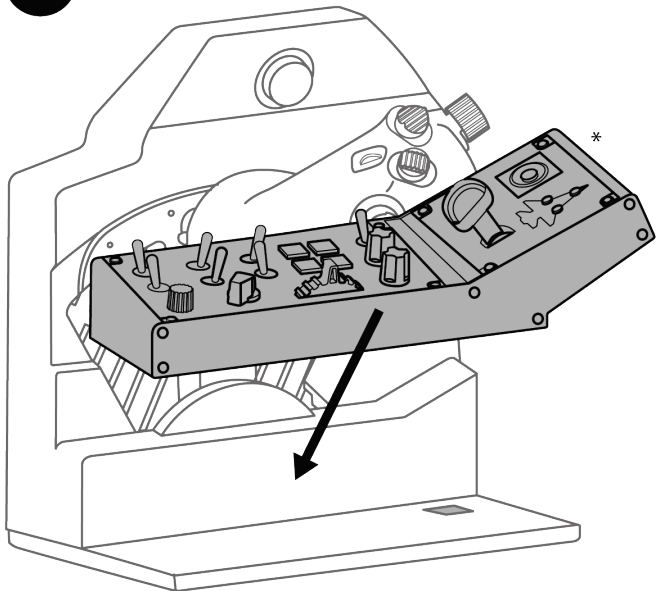



6

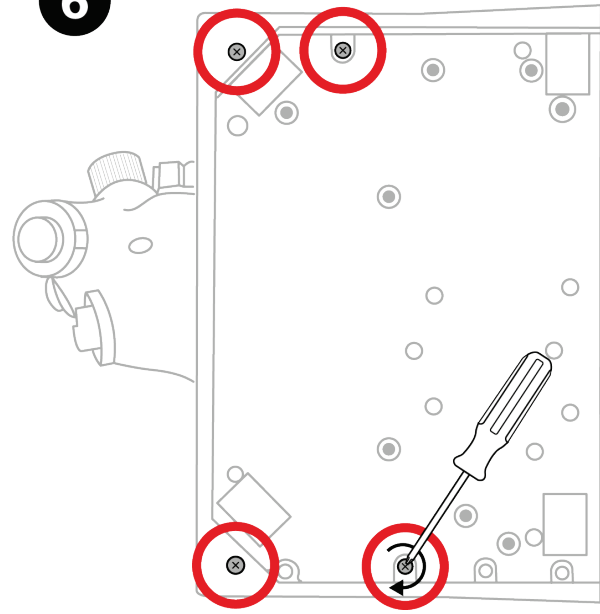

7

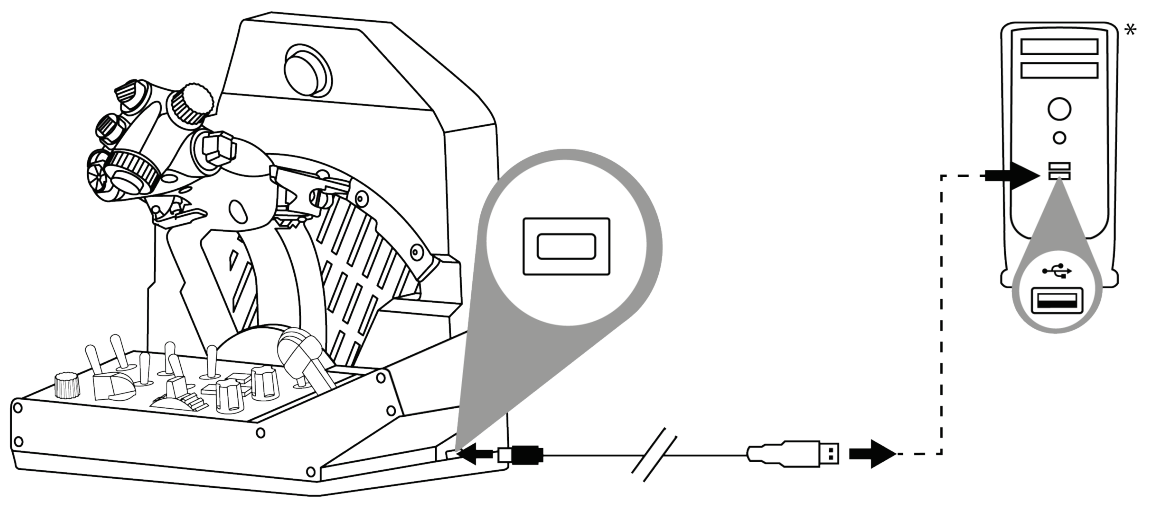

*Ürünle verilmez



8. PC'de Kurulum

1



Lütfen şu adresi ziyaret edin:

<https://support.thrustmaster.com/product/viper-tqs/>.

2

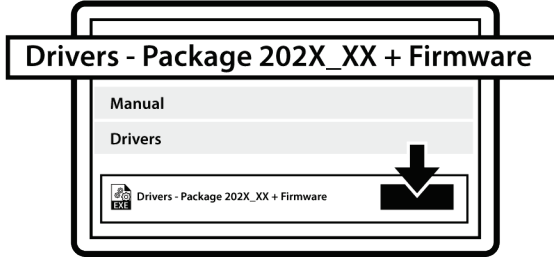

PC sürücüsünü ve Windows Denetim Masası için özel arayüzünü indirip yükleyin.

3

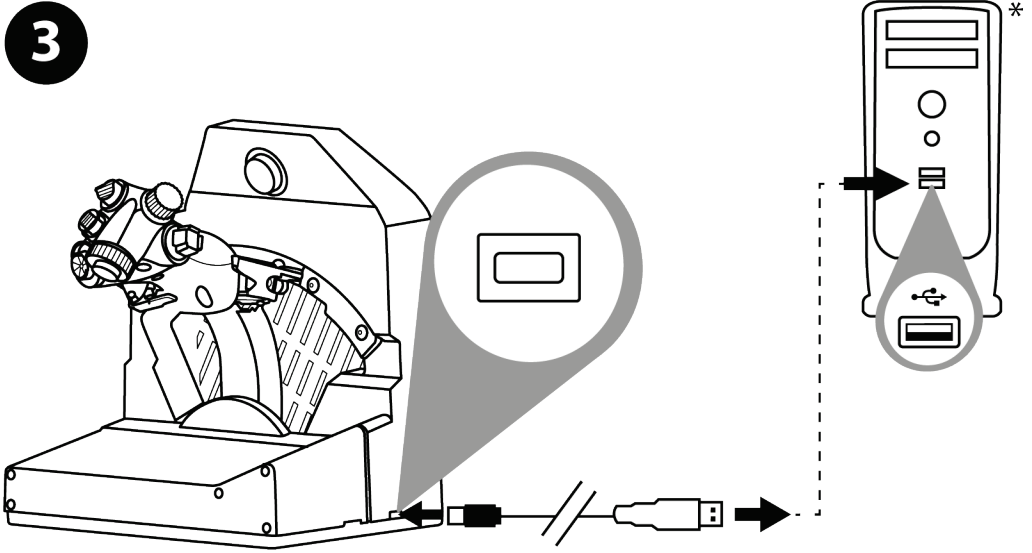

PC sürücüsünü yükledikten sonra USB konektörünü PC'nizin USB bağlantı noktalarından birine bağlayın.

*Ürünle verilmez



④ Control Panel'e erişmek için **Başlat / Tüm uygulamalar / Thrustmaster / Control Panel veya Denetim Masası'nı** (Windows 10'da) seçin.

Oyun Kumandaları iletişim kutusu açılır. Aksesuar ekranda **VIPER TQS** adıyla ve durumu **OK** olarak gösterilir.

⑤ Tüm fonksiyonları test etmek ve görmek için **Oyun Kumandaları** iletişim kutusunda **Özellikler**'e tıklayın.

Thrustmaster Flight Control Panel Properties

Test Input

VIPER TQS

MiniStick

Y Axis

X Axis

RX Axis

RY Axis

Z Axis

RZ Axis

Enable virtual buttons

THRUSTMASTER

www.thrustmaster.com

Technical Support:
ts.thrustmaster.com

Firmware: 1.21

Control Panel: 3.12

Check for Update

OK Cancel Apply



Enable virtual buttons (Sanal düğmeleri etkinleştir):

Bu fonksiyon, kolda mevcut sanal düğmeleri (20 ve 21 no'lu düğmeler) devreye alıp devreden çıkarmanızı sağlar. Kullanmak istediğiniz modu seçip **Apply** (Uygula) düğmesine tıklayın.

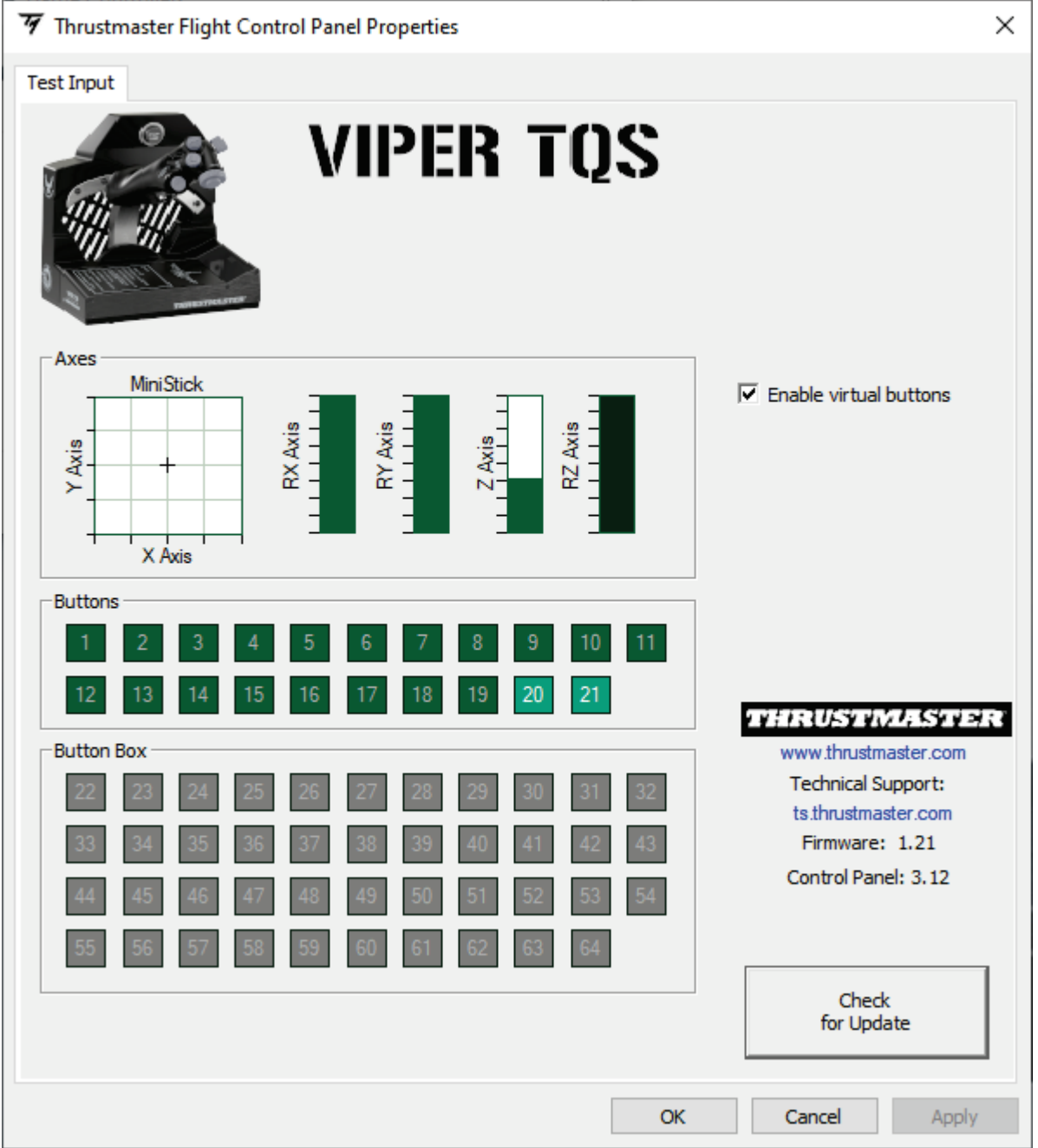

Sanal düğmeler, **VIPER TQS**'te varsayılan olarak devre dışıdır.



9. CUT OFF ve AFTERBURNER konumları

VIPER TQS gaz kolu kadranında gerçekçi bir CUT OFF ve AFTERBURNER konumları sistemi vardır (Afterburner modülü çıkarılabilir).

CUT OFF

Gaz kolunu IDLE durdurucusu konumuna aldıktan sonra “motoru kapatma kilidini açma” tetiğine **1** basarak durdurucuyu **2** geçmek için kolu yukarı kaldırın, ardından kolu OFF konumuna **3** alın.

Motorları tekrar açmak için bu prosedürü tersinden uygulayın.

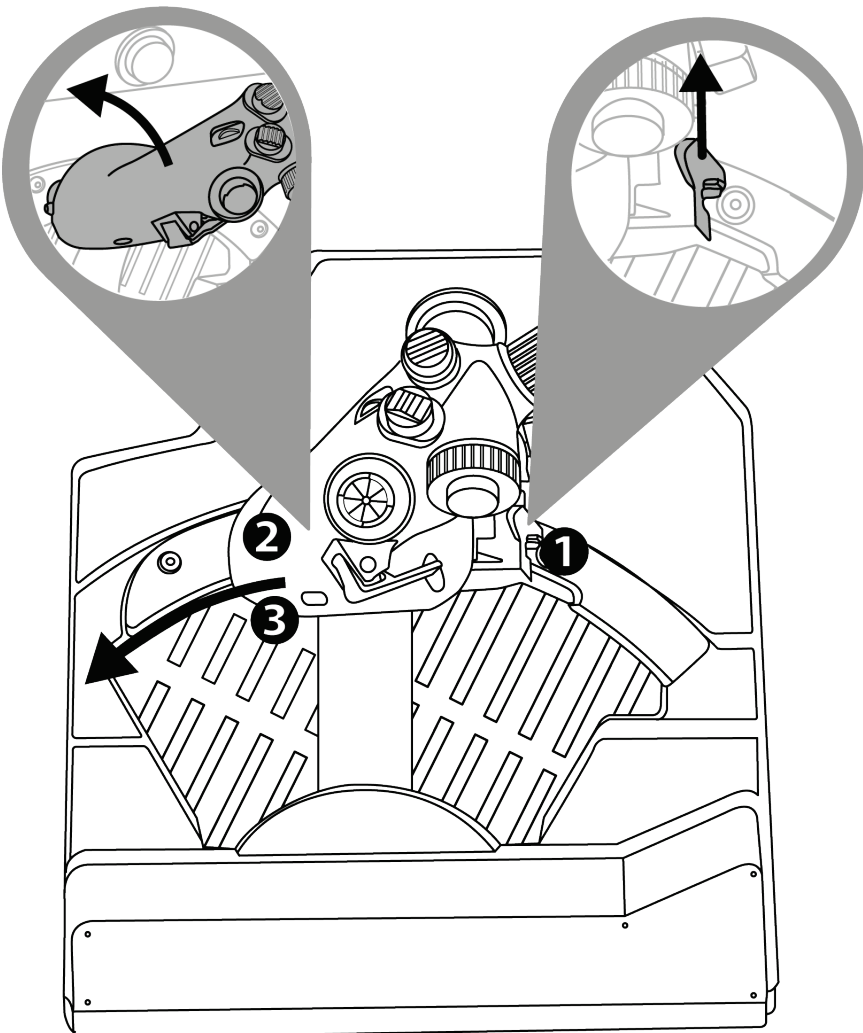



AFTERBURNER

Gaz kolunu durdurucuya **1** alın ve yukarı kaldırarak **2** durdurucuyu geçin ve afterburner'ı **3** devreye alın.

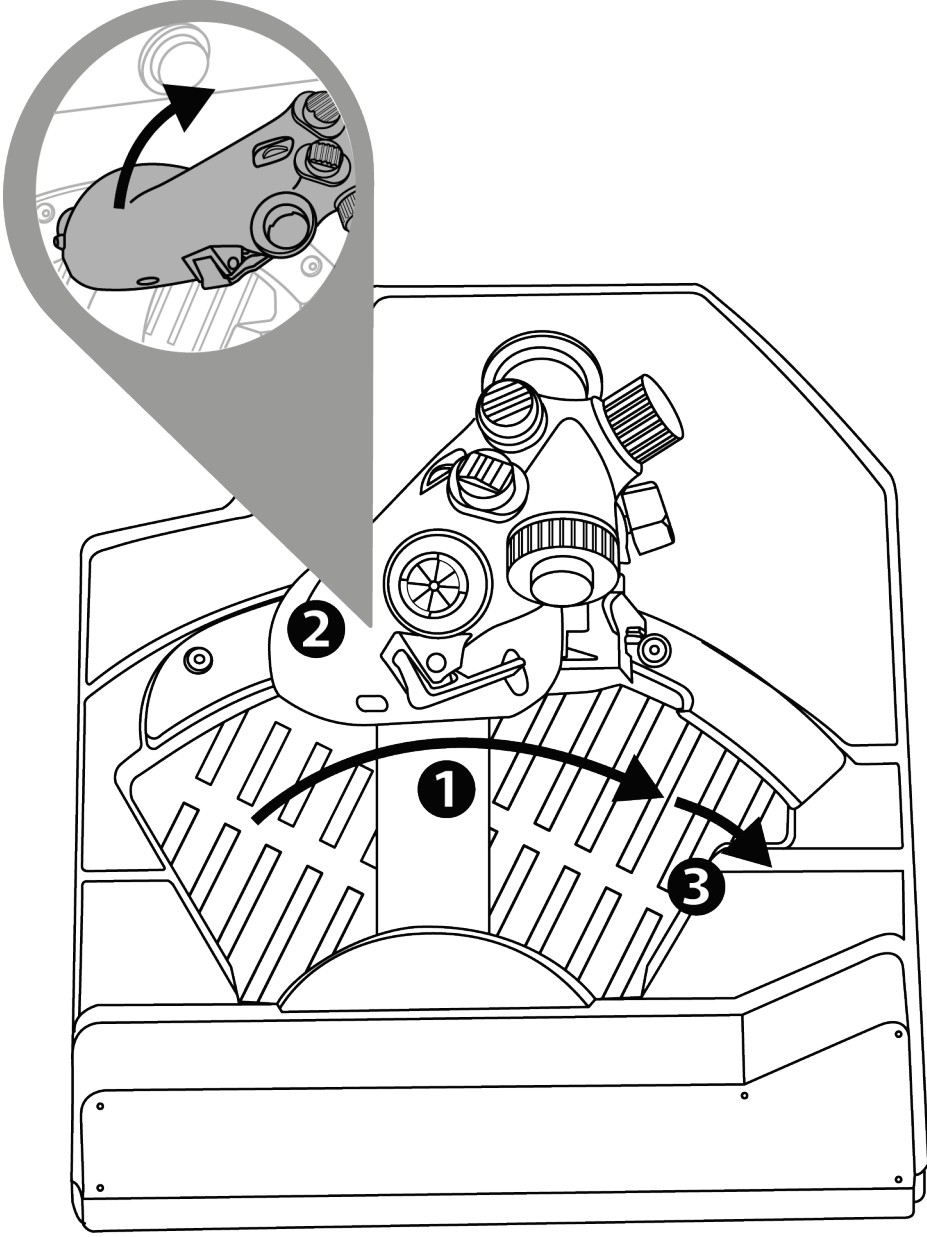



AFTERBURNER durdurucusunun sökülmesi

Afterburner modülünün durdurucusu, eksen değerinin %80'ine konumlandırılmıştır.

(Belirli bir simülatörde) bir durdurucu olmadan gaz kolu hareket aralığının %100'üne ihtiyaç duyarsanız bir alyan anahtarı (ürünle verilmez) kullanarak modülün iki vidasını sökmek suretiyle Afterburner modülü ve durdurucusunu çıkarabilirsiniz.

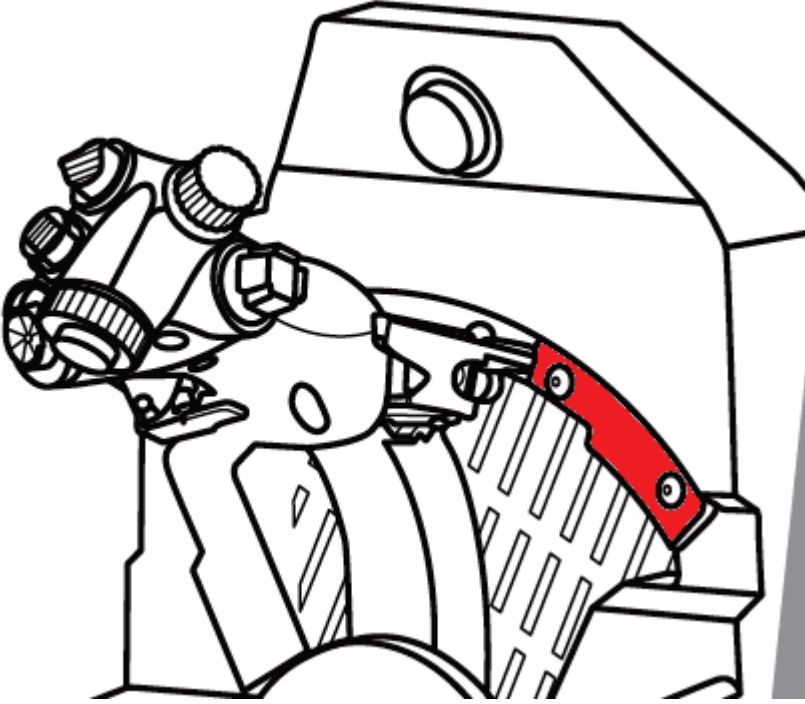



10. T.A.R.G.E.T gelişmiş programlama yazılımı



Lütfen şu adresi ziyaret edin:

<https://support.thrustmaster.com/product/viper-tqs/>.

Software (Yazılım) kısmından T.A.R.G.E.T gelişmiş programlama yazılımını indirerek yükleyin.



T.A.R.G.E.T'in ana özellikleri

- Eksenler için farklı konfigürasyon imkanı.
- Çeşitli programlama düzeyleri: Basic, Advanced ve Script.
- Sürükle ve Bırak ilkesi kullanımı.
- VIPER TQS gaz kolu kadranını çeşitli Thrustmaster joystick'lerle (HOTAS Cougar, HOTAS Warthog, T.16000M, MFD Cougar Pack, hepsi aynı zamanda T.A.R.G.E.T ile uyumludur) birleştirerek tek bir USB cihazı olarak algılanma imkanı.
- Thrustmaster topluluğu tarafından oluşturulan gelişmiş profillere ulaşma.



11. SSS ve teknik destek

VIPER TQS ile ilgili sorularınız mı var veya teknik sorunlarla mı karşılaştınız? Öyleyse Thrustmaster teknik destek web sitesini ziyaret edin:

<https://support.thrustmaster.com/product/viper-tqs/>.



THRUSTMASTER®

VIPER TQS

THROTTLE QUADRANT SYSTEM

Dla PC (Windows 10/11)

Instrukcja obsługi



Przed zainstalowaniem urządzenia, **przed** każdym jego użyciem i **przed** wykonaniem jakichkolwiek czynności konserwacyjnych **uważnie przeczytaj** wskazówki zawarte w niniejszej instrukcji. Koniecznie przestrzegaj wskazówek dotyczących bezpieczeństwa. Nieprzestrzeganie tych wskazówek może prowadzić do wypadków i/lub uszkodzeń. Zachowaj tę instrukcję do ewentualnego użycia w przyszłości.

SPIS TREŚCI

1.	ZAWARTOŚĆ OPAKOWANIA.....	5
2.	VIPER TQS — ELEMENTY	6
3.	MAPOWANIE PRZYCISKÓW I OSI.....	8
4.	INFORMACJE O KORZYSTANIU Z URZĄDZENIA VIPER TQS.....	10
5.	REGULOWANIE OPORU	11
6.	INSTALACJA NA PODPORZE.....	12
7.	INSTALOWANIE PULPITU VIPER PANEL*	17
8.	INSTALACJA NA KOMPUTERZE PC	20
9.	ZAPADKI CUT OFF I AFTERBURNER.....	23
10.	ZAAWANSOWANA APLIKACJA DO PROGRAMOWANIA T.A.R.G.E.T.....	26
11.	CZĘSTO ZADAWANE PYTANIA I POMOC TECHNICZNA	28



Zwiększ moc silników i śmiało wleć w strefę zagrożenia ze słynnym blokiem przepustnicy samolotu U.S. Air Force VIPER — najczęściej używanego nowoczesnego samolotu myśliwskiego na świecie!

Przenieś swój kokpit na nowy, wyższy poziom dzięki wyjątkowej ergonomii, jaką zapewnia pełnowymiarowa replika układu HOTAS obejmująca metalowy uchwyt oraz realistyczne przyciski i zapadki.

Niniejsza instrukcja pomoże Ci w optymalnej instalacji i eksploatacji urządzenia VIPER TQS. Zanim wzbijesz się w przestworza, uważnie zapoznaj się ze wszystkimi przedstawionymi tu wskazówkami i ostrzeżeniami, które pomogą Ci czerpać maksymalną przyjemność z użytkowania urządzenia.



Aktualizowanie oprogramowania sprzętowego

Aby urządzenie VIPER TQS działało prawidłowo w grach wideo, należy zaktualizować jego oprogramowanie sprzętowe.

Aby wykonać aktualizację, wejdź na stronę:

<https://support.thrustmaster.com/product/viper-tqs/>

Wybierz **Firmware** (Oprogramowanie sprzętowe), a następnie wykonaj instrukcje obejmujące procedurę pobierania oraz instalacji.



1. Zawartość opakowania

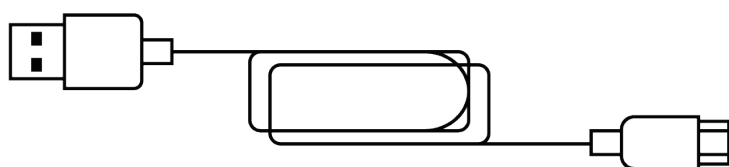
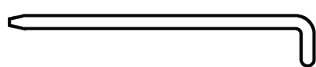
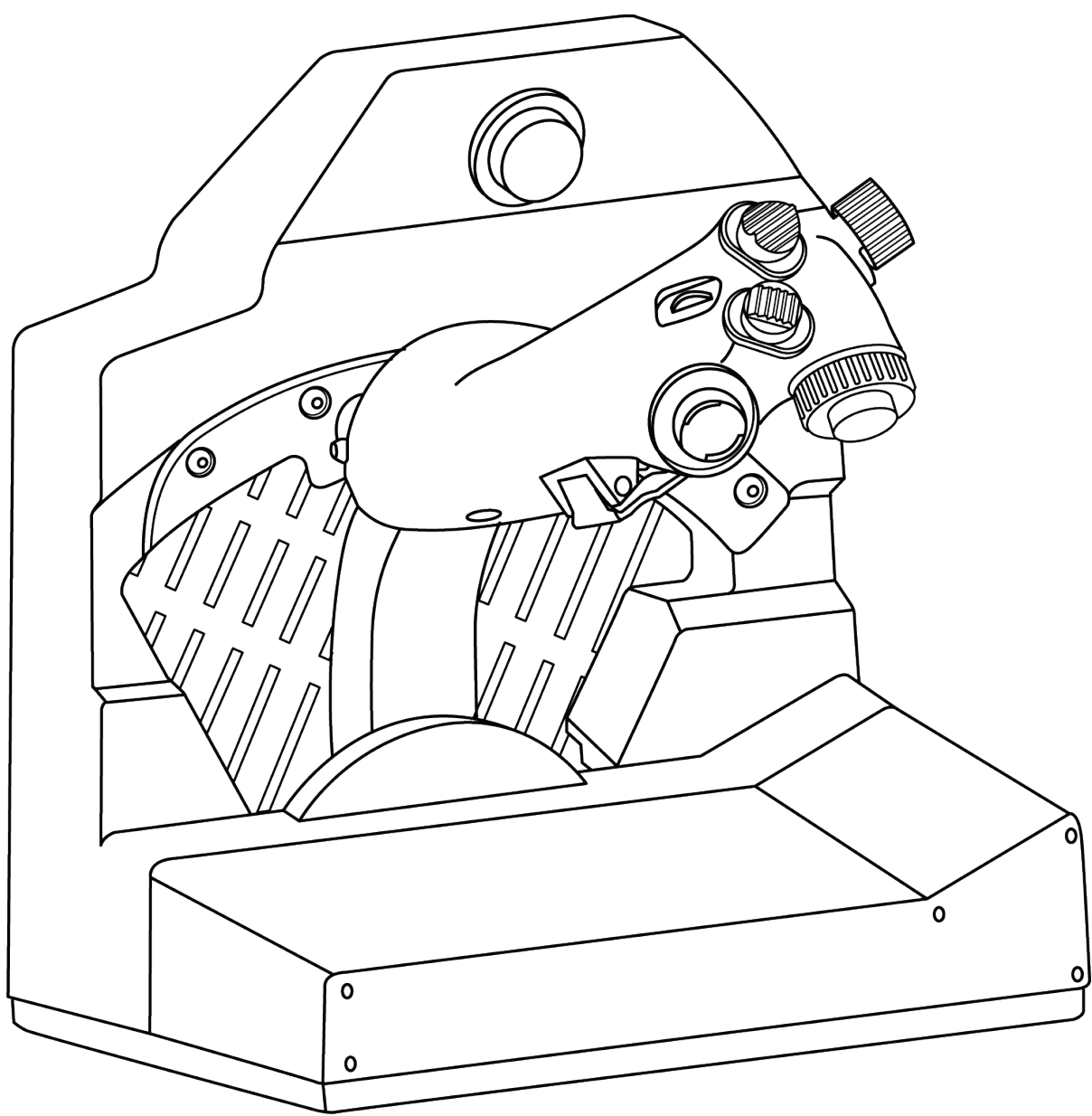



2. VIPER TQS — elementy

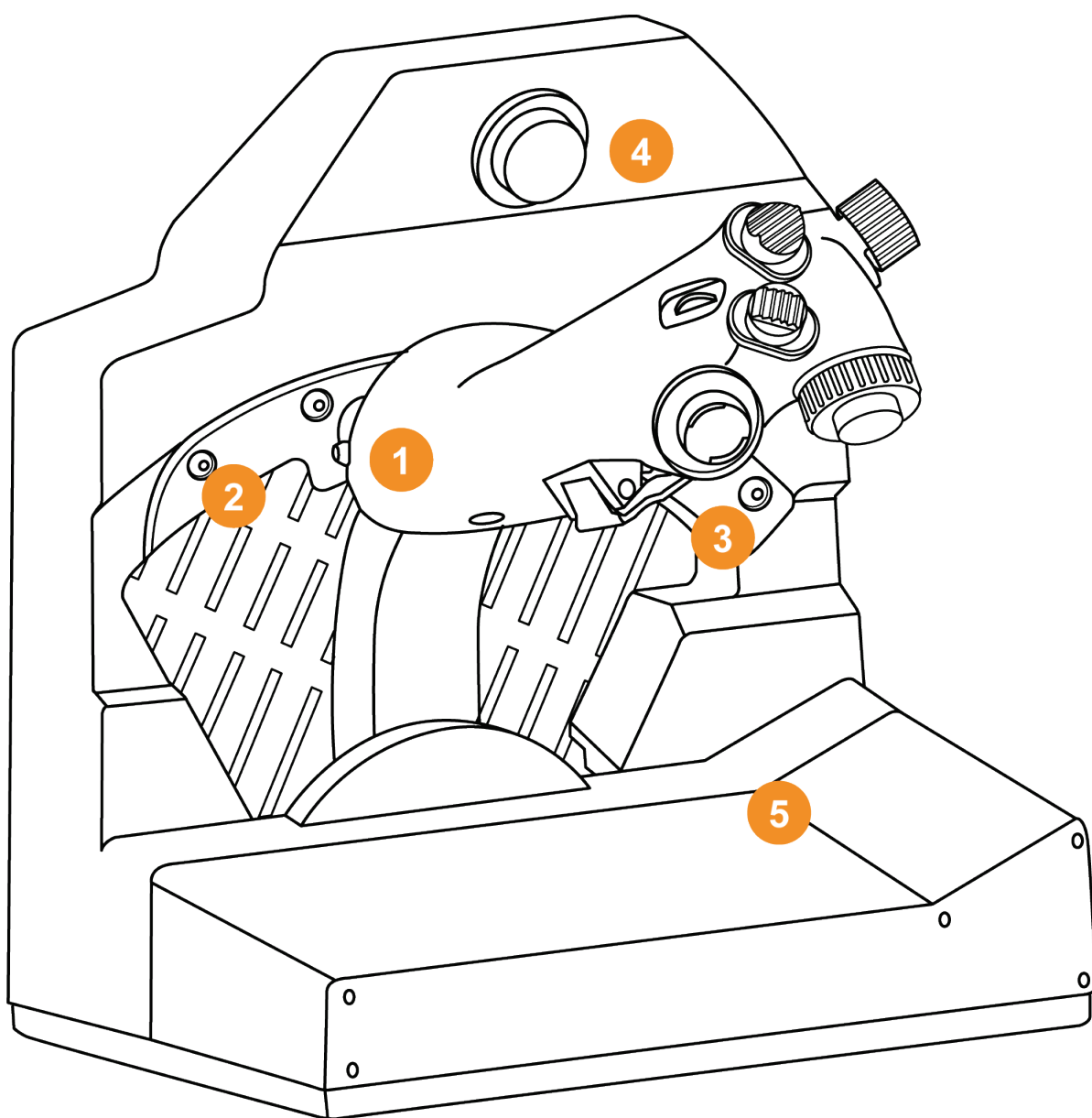

1. Uchwyt

2. Ogranicznik Cut Off

3. Ogranicznik Afterburner

4. Przycisk CHAFF/FLARE

5. Uchwyt na mapę misji

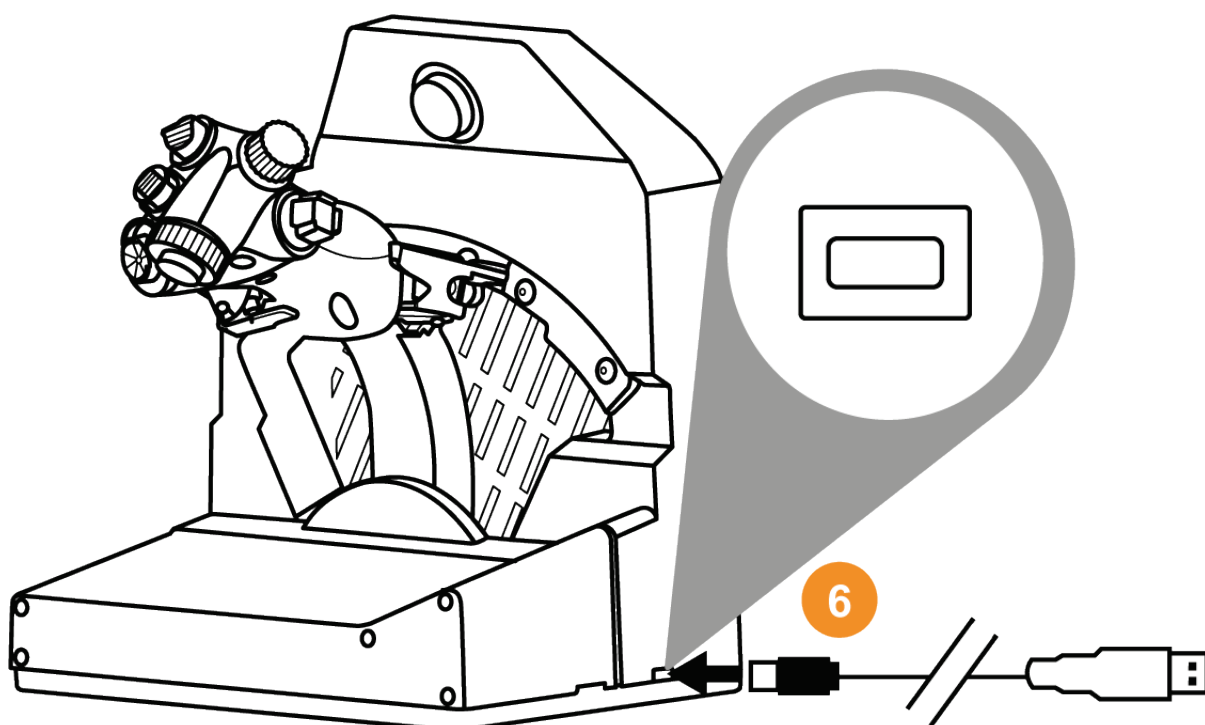

6. Złącze USB (typ C)

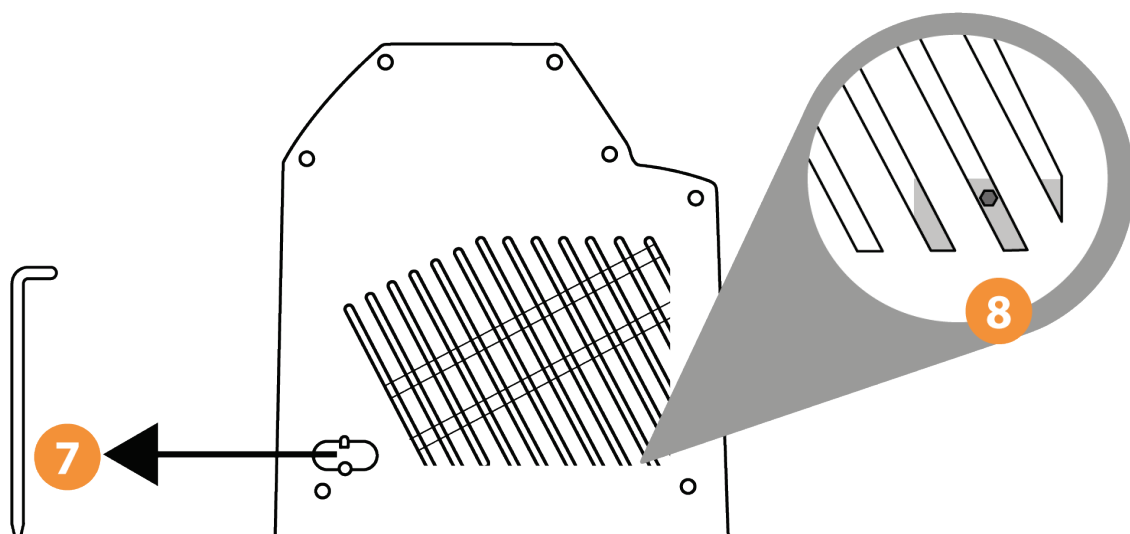

7. Lokalizacja narzędzia do regulacji oporu

8. Punkt dostępu do regulacji oporu przepustnicy



3. Mapowanie przycisków i osi

Uchwyt urządzenia VIPER TQS: mapowanie 19 przycisków i 5 osi w trybie A (bez przycisków wirtualnych)

A 1 → 19

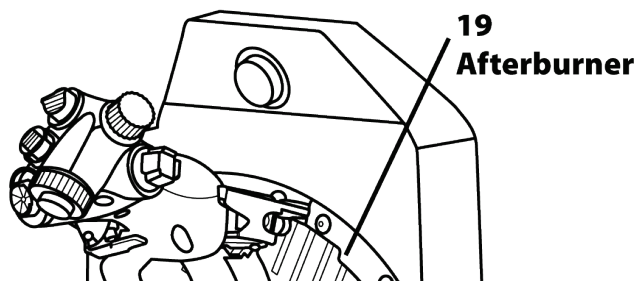
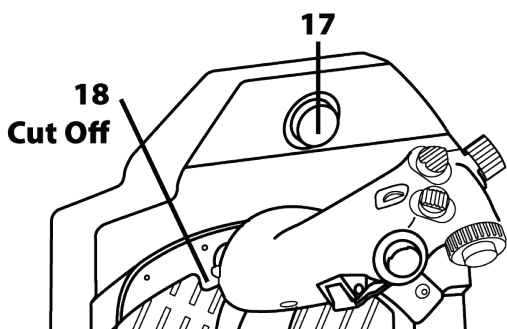
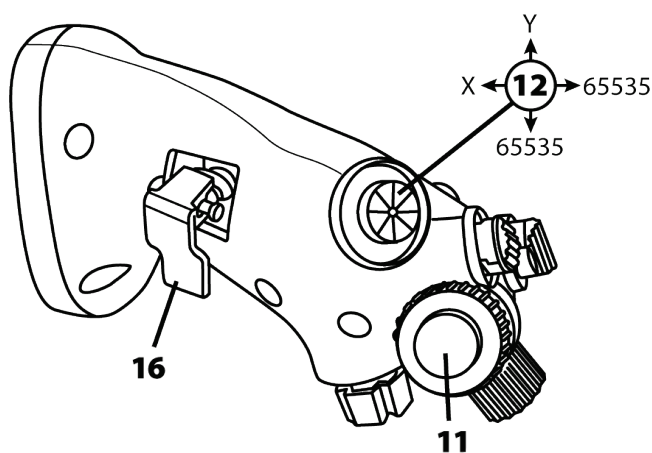
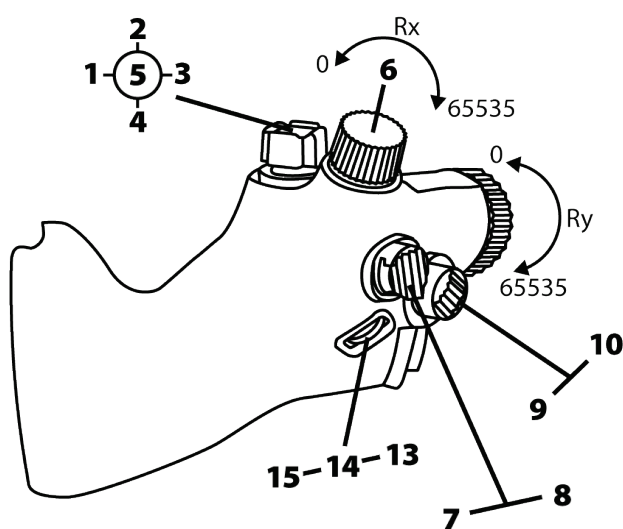



Tryb B: z przyciskami wirtualnymi

B 1 → 21

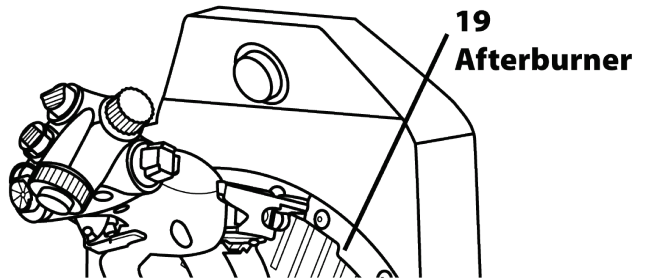
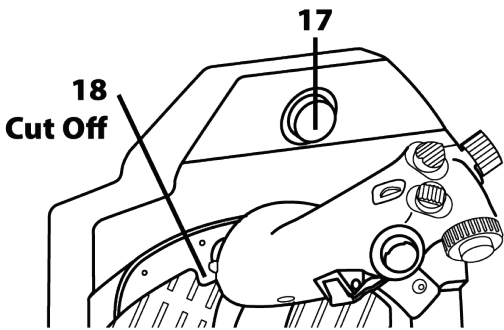
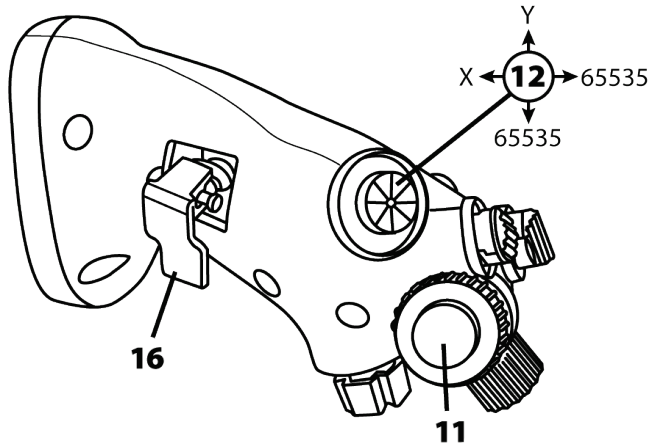
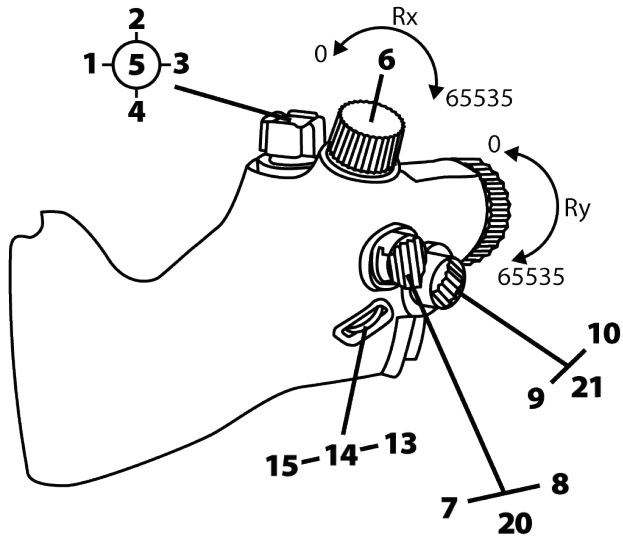



4. Informacje o korzystaniu z urządzenia VIPER TQS



Ryzyko przytrzaśnięcia

Podczas korzystania z uchwytu nigdy nie umieszczaj palców w strefach ograniczników.

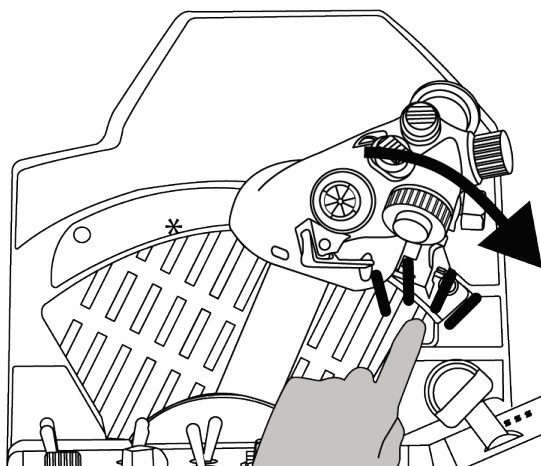
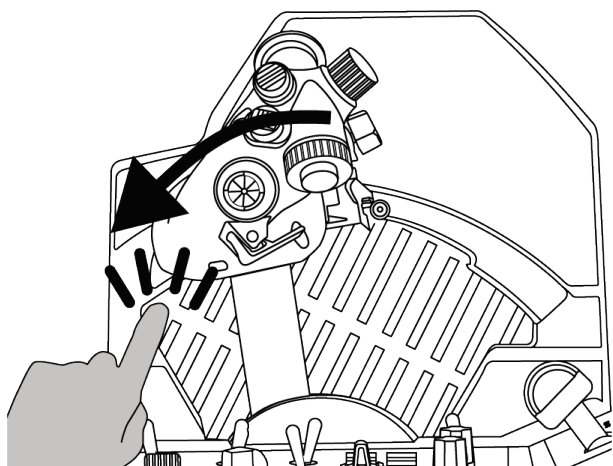
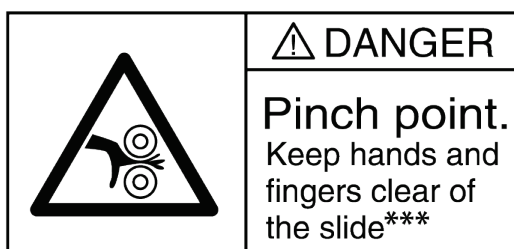



5. Regulowanie oporu

Opór bloku przepustnicy VIPER TQS można wyregulować zgodnie z osobistymi preferencjami, korzystając z narzędzia umieszczonego z boku urządzenia. Zwracamy jednak uwagę, że fabrycznie ustawiony opór przepustnicy jest optymalny.

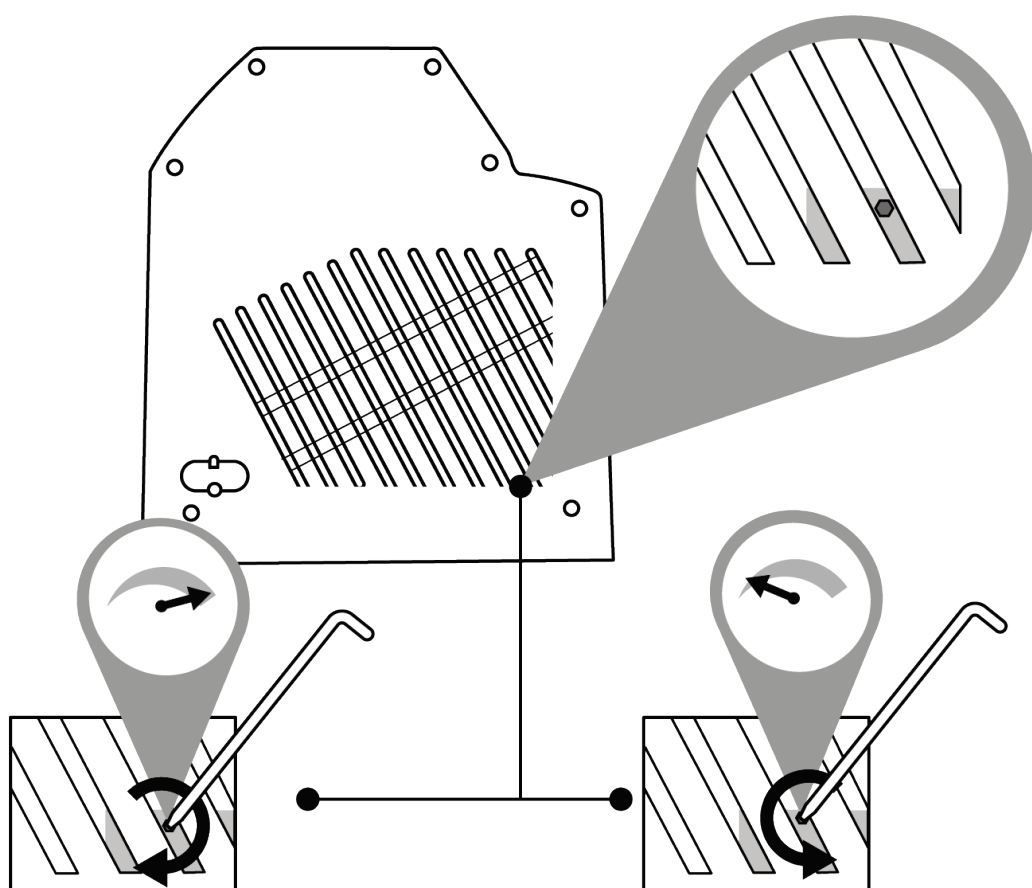

Aby nie uszkodzić układu regulacji oporu, nie dokręcaj śruby regulacyjnej zbyt mocno.

Pilnuj także, aby całkowicie nie odkręcić śruby regulacyjnej, ponieważ grozi to sytuacją, w której dźwignia przepustnicy nie będzie w stanie utrzymać się w ustawionym położeniu.



6. Instalacja na podporze



Urządzenie VIPER TQS można instalować na różnego rodzaju podporach. Większość kokpitów i podpór dostępnych na rynku jest już zgodna z podobnymi produktami Thrustmaster (np. HOTAS Warthog).

Pamiętaj, że urządzenie VIPER TQS cechuje się silnym efektem dźwigni i dlatego wymaga solidnego zamocowania.

Przymocuj podstawę do podpory za pomocą odpowiednich śrub M6 (do nabycia osobno), aby nie uszkodzić uchwytu.

Pełny schemat przeznaczony dla urządzenia VIPER TQS jest dostępny na stronie

<https://support.thrustmaster.com/product/viper-tqs/>



Przed każdym użyciem sprawdź, czy urządzenie VIPER TQS jest wciąż prawidłowo przymocowane do podpory zgodnie ze wskazówkami przekazanymi przez producenta. Koniecznie weź pod uwagę materiał, z którego jest wykonana podpora, i upewnij się, że można do niego solidnie zamocować urządzenie. Urządzenia VIPER TQS należy używać na biurku wykonanym z lekkiego materiału (np. płyty MDF lub drewna) niezawierającego wydrążeń ani elementów szklanych.



Wymiary schematu mocowania (w mm)

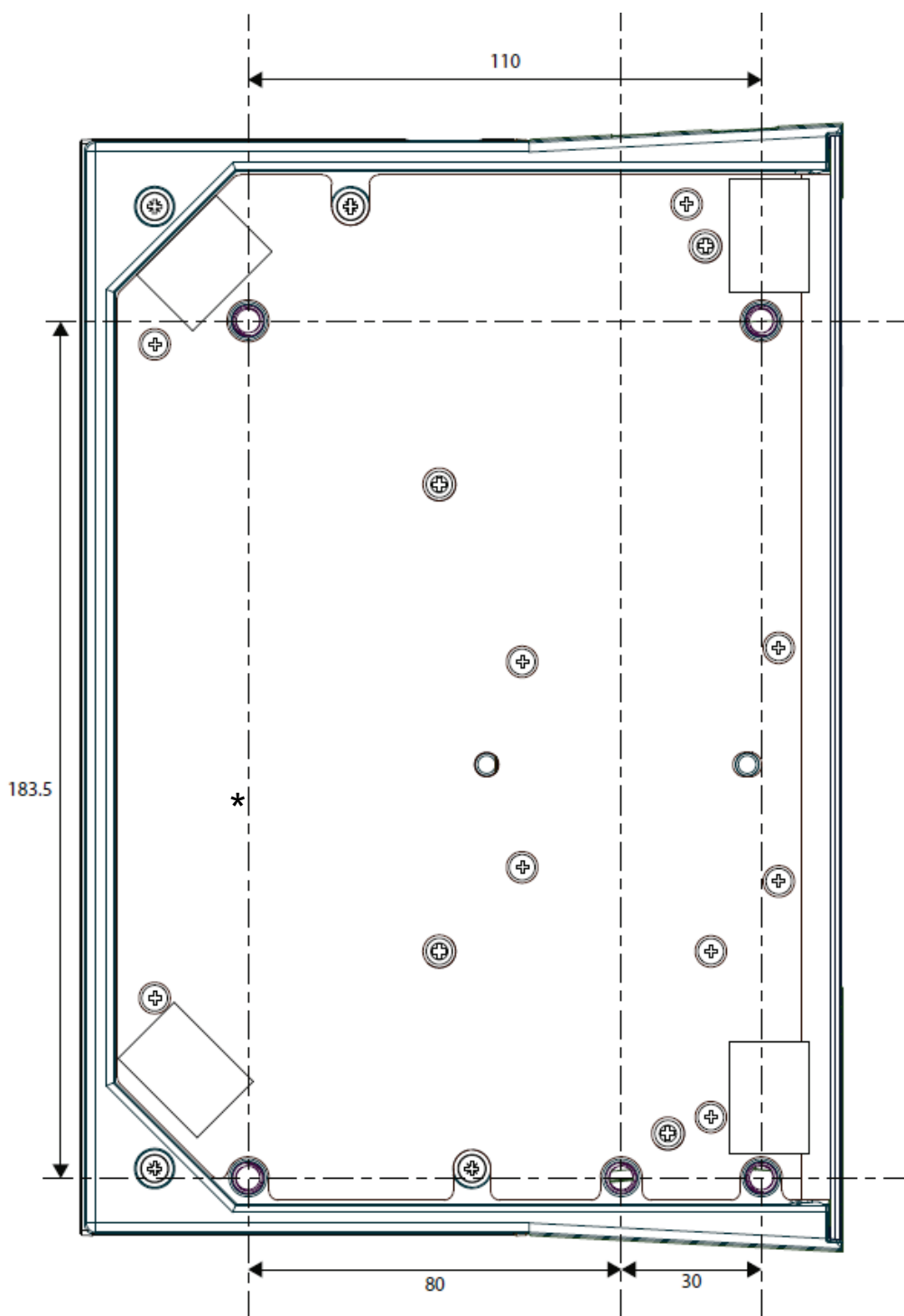

Schemat mocowania możesz pobrać ze strony <https://support.thrustmaster.com/product/viper-tqs/>, a następnie możesz go wydrukować i użyć na podporze w celu wywiercenia otworów.



Instalacja za pomocą zacisku *TM Flying Desk Mount**

TM Flying Desk Mount to metalowy system mocowania ze śrubą zaciskową, który polepsza ergonomię i pozycję pilota podczas korzystania z urządzenia. System ten jest przeznaczony do biurków i stołów o grubości 15–50 mm.

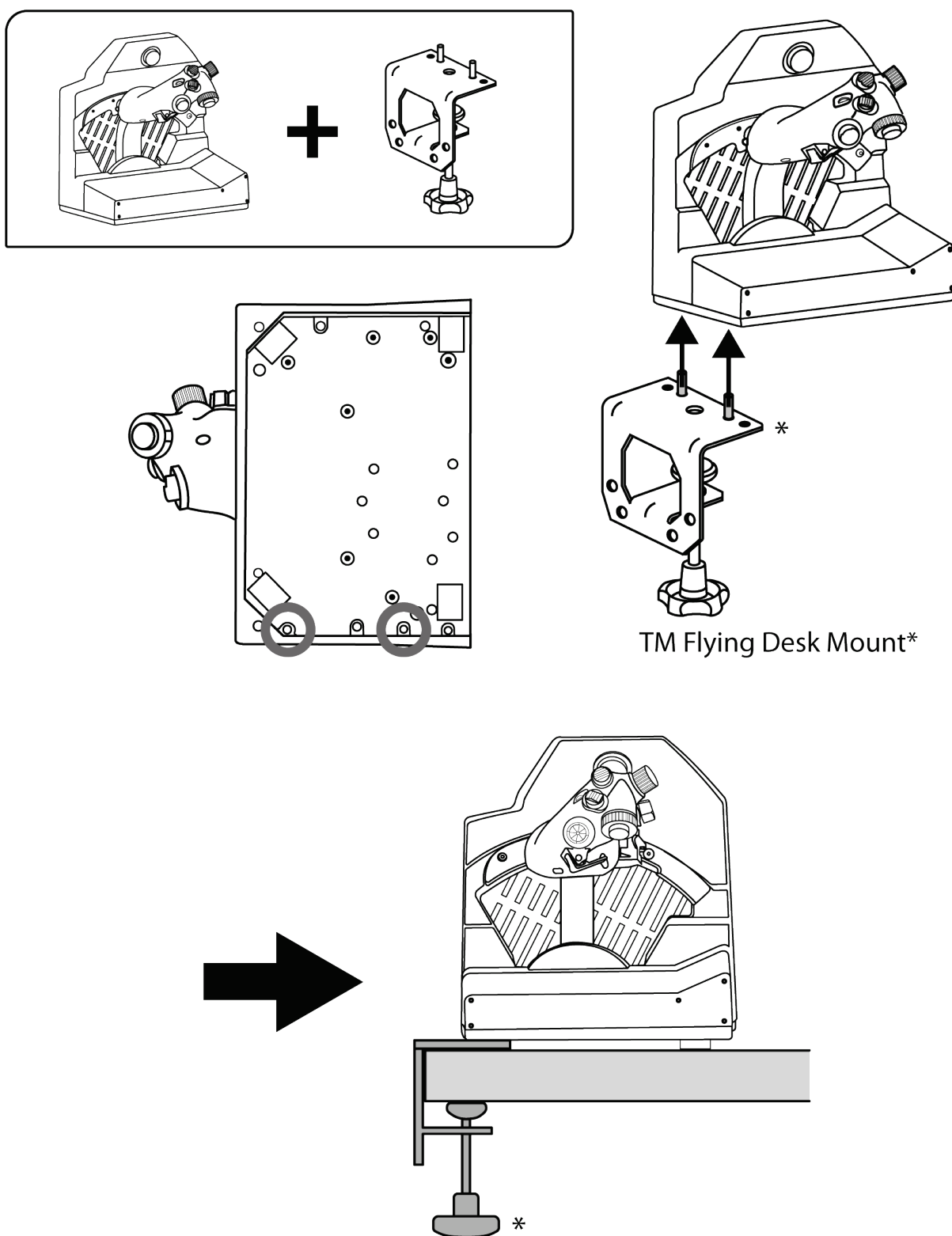

* *Do nabycia osobno*



Instalacja za pomocą zacisku *TM Flying Clamp**

TM Flying Clamp to podpora o regulowanej wysokości, którą firma Thrustmaster zaprojektowała z myślą o swoich akcesoriach do symulacji lotu. Urządzenie jest wyposażone w dwie śruby zaciskowe, które umożliwiają jego używanie na biurkach i stołach o grubości 15–45 mm.

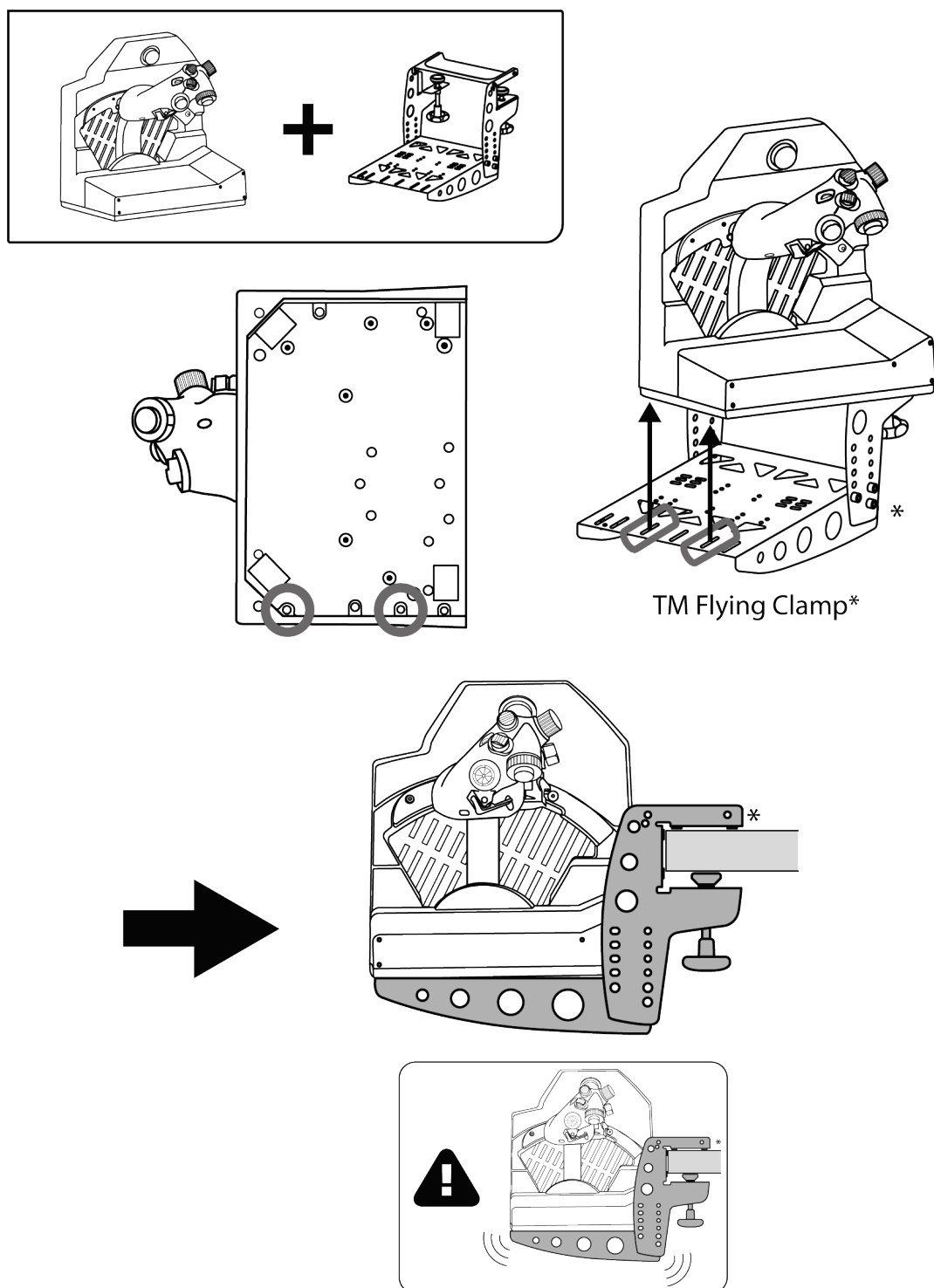

* Do nabycia osobno



Zwróć uwagę, że duża waga urządzenia VIPER TQS może spowodować niepożądane ruchy systemu mocowania.



7. Instalowanie pulpitu VIPER PANEL*

**Do nabycia osobno. VIPER PANEL wchodzi w skład zestawu VIPER TQS Mission Pack.*

VIPER PANEL to pulpit sterowniczy, który zwiększa możliwości pilotażu i walki powietrznej dzięki 43 przyciskom i 1 osi — w całości programowalnym przy użyciu aplikacji T.A.R.G.E.T. VIPER PANEL jest uzupełnieniem urządzenia VIPER TQS.

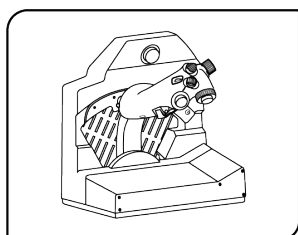

1

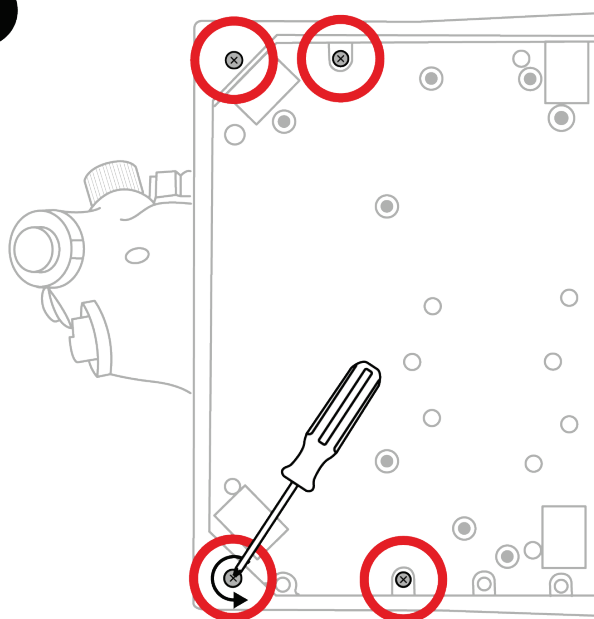

2

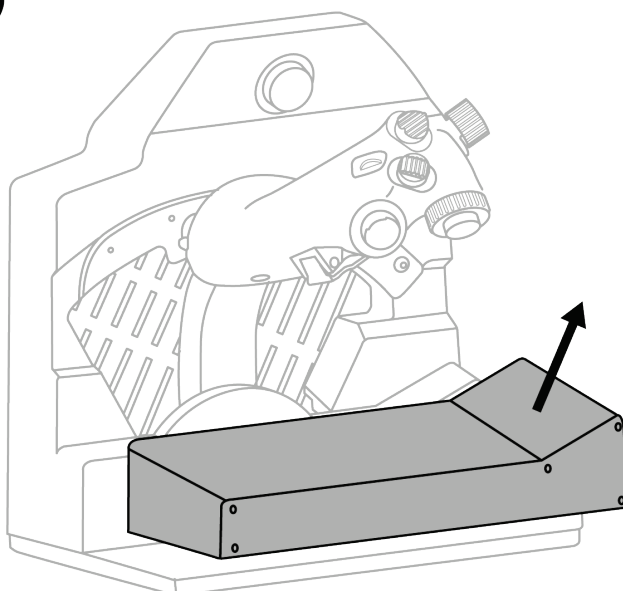

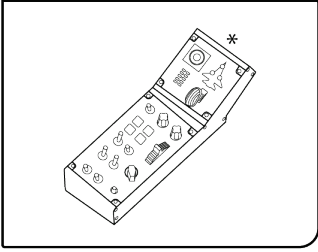

3

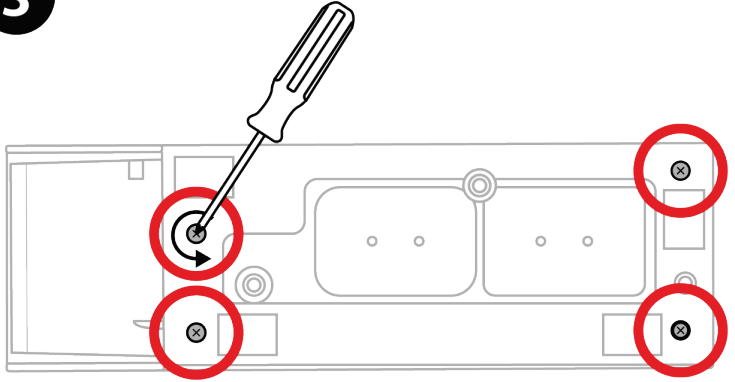

4

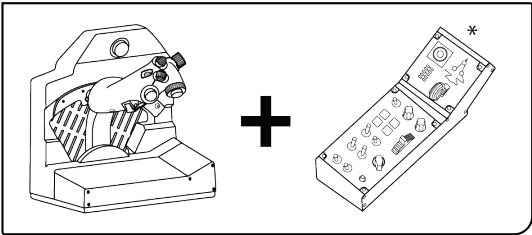
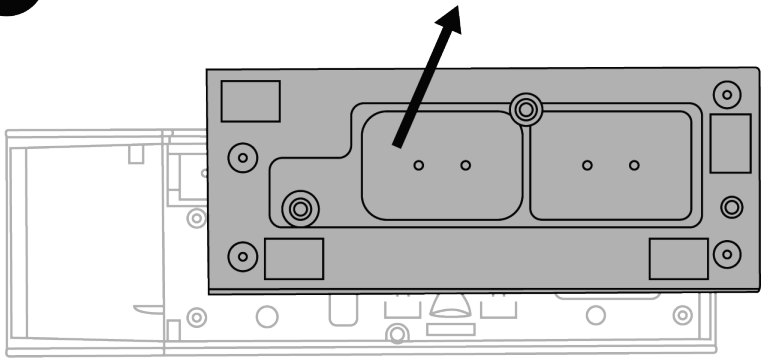

5

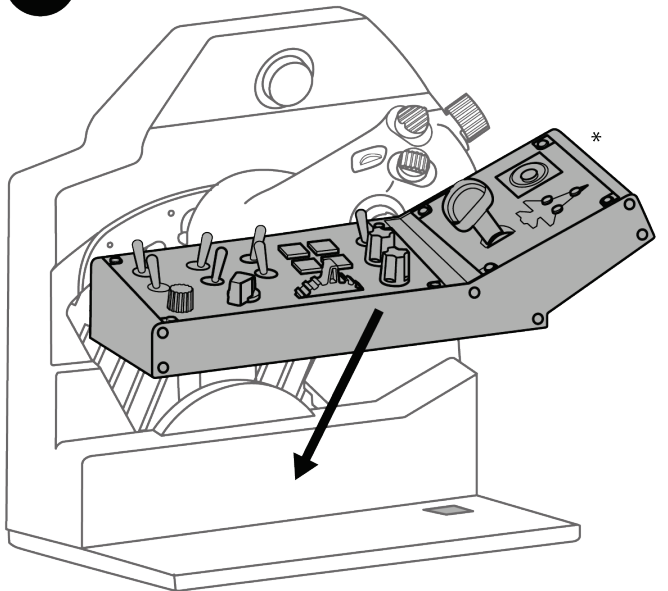



6

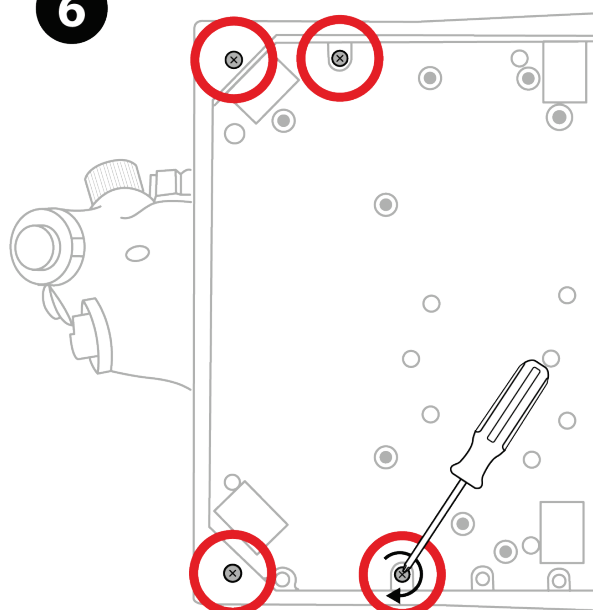

7

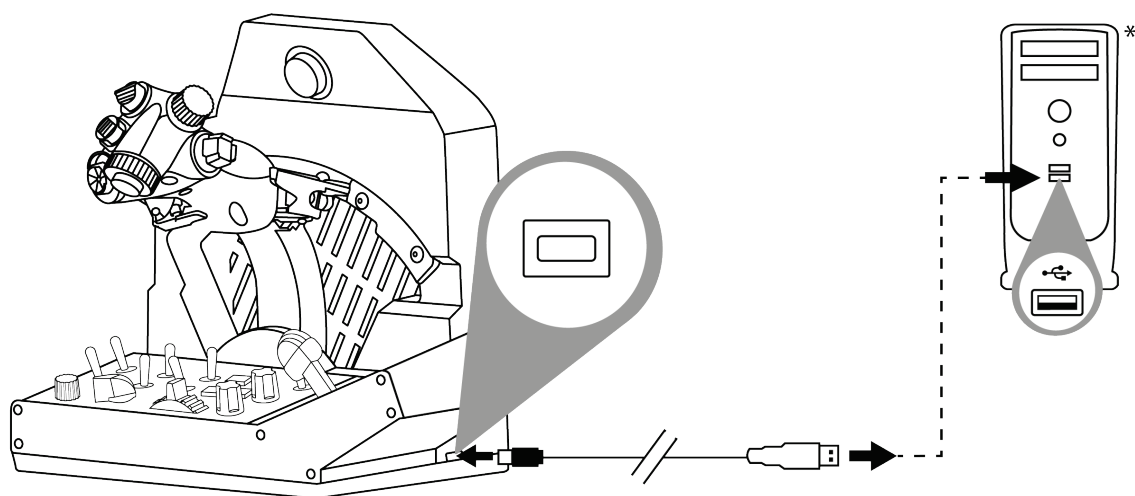

**Do nabycia osobno*



8. Instalacja na komputerze PC

1



Wejdź na stronę

<https://support.thrustmaster.com/product/viper-tqs/>.

2

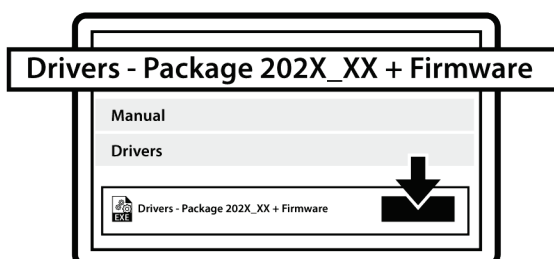

Pobierz i zainstaluj sterownik dla komputera PC i jego specjalny interfejs przeznaczony do Panelu sterowania systemu Windows.

3

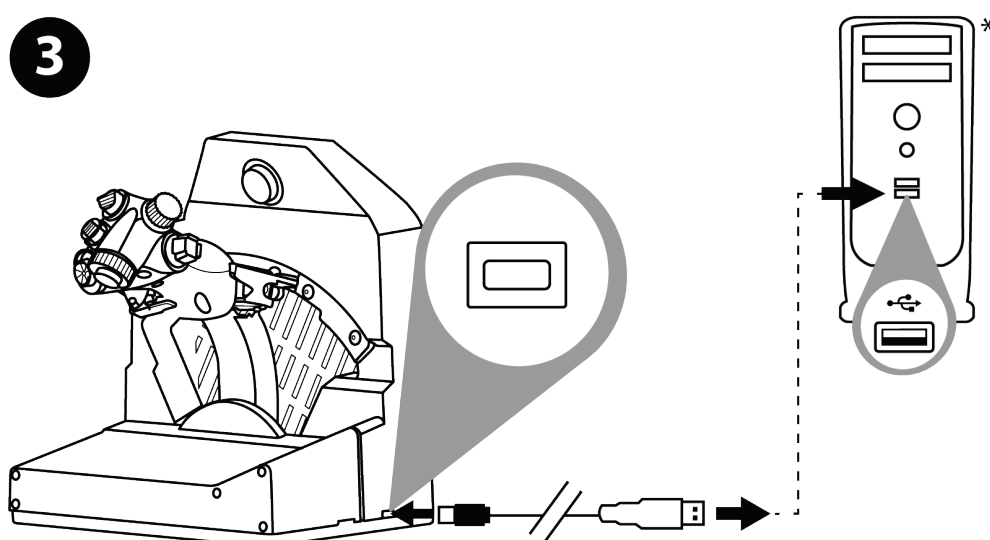

Po zainstalowaniu sterownika na komputerze PC podłącz złącze USB do jednego z portów USB komputera.

**Do nabycia osobno*



4 Aby wyświetlić okno Control Panel, wybierz **Start / Wszystkie aplikacje / Thrustmaster / Control Panel** lub **Panel sterowania** (w systemie Windows 10).

Wyświetli się okno dialogowe **Kontrolery gier**. Akcesorium będzie widoczne na ekranie pod nazwą **VIPER TQS** i ze stanem **OK**.

5 W oknie dialogowym **Kontrolery gier** kliknij **Właściwości**, aby przetestować i wyświetlić wszystkie funkcje.

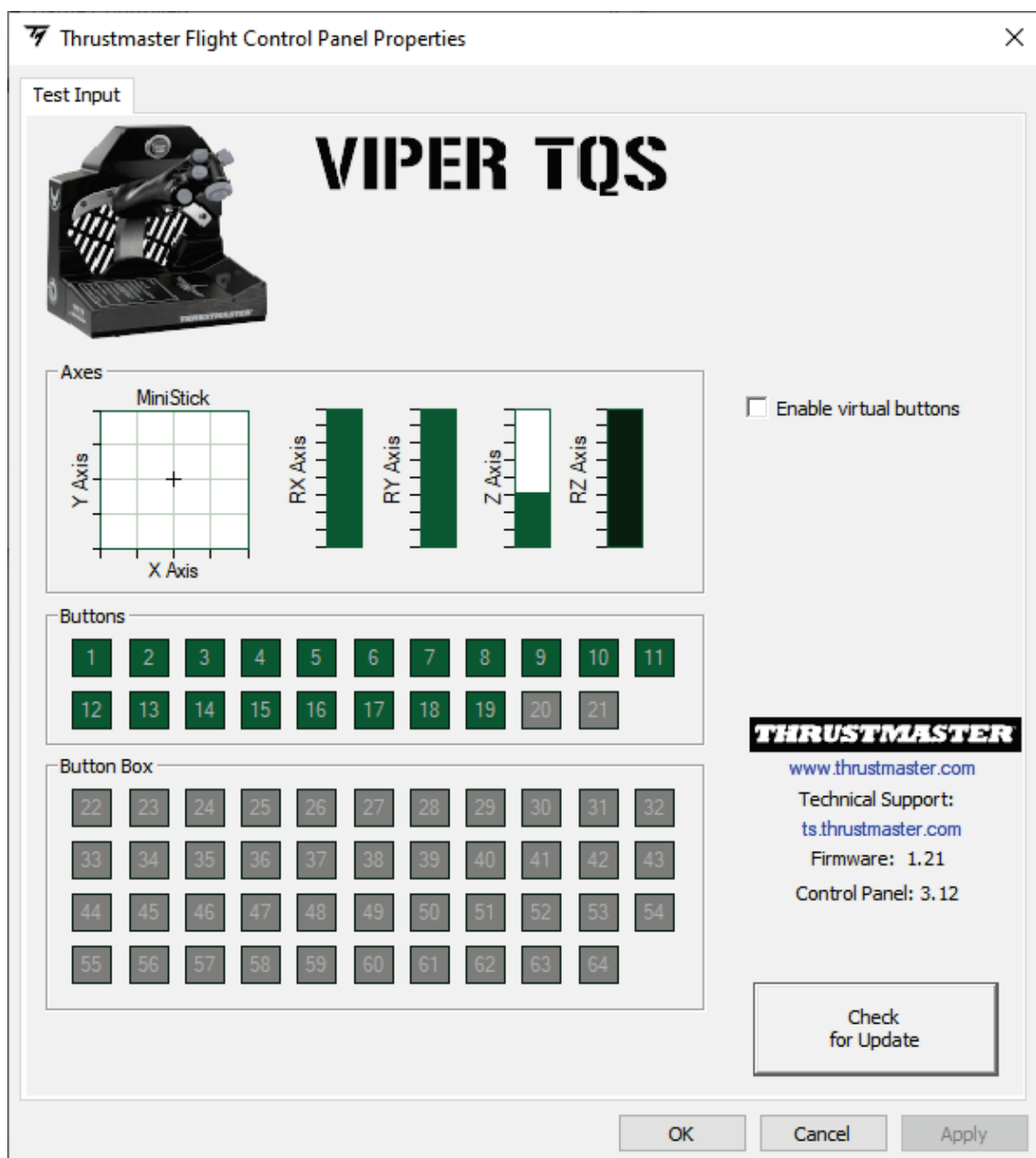



Enable virtual buttons (Włącz przyciski wirtualne):

Ta funkcja umożliwia włączenie lub wyłączenie przycisków wirtualnych na uchwycie (przyciski 20 i 21). Po wybraniu trybu, z którego chcesz korzystać, kliknij **Apply** (Zastosuj).

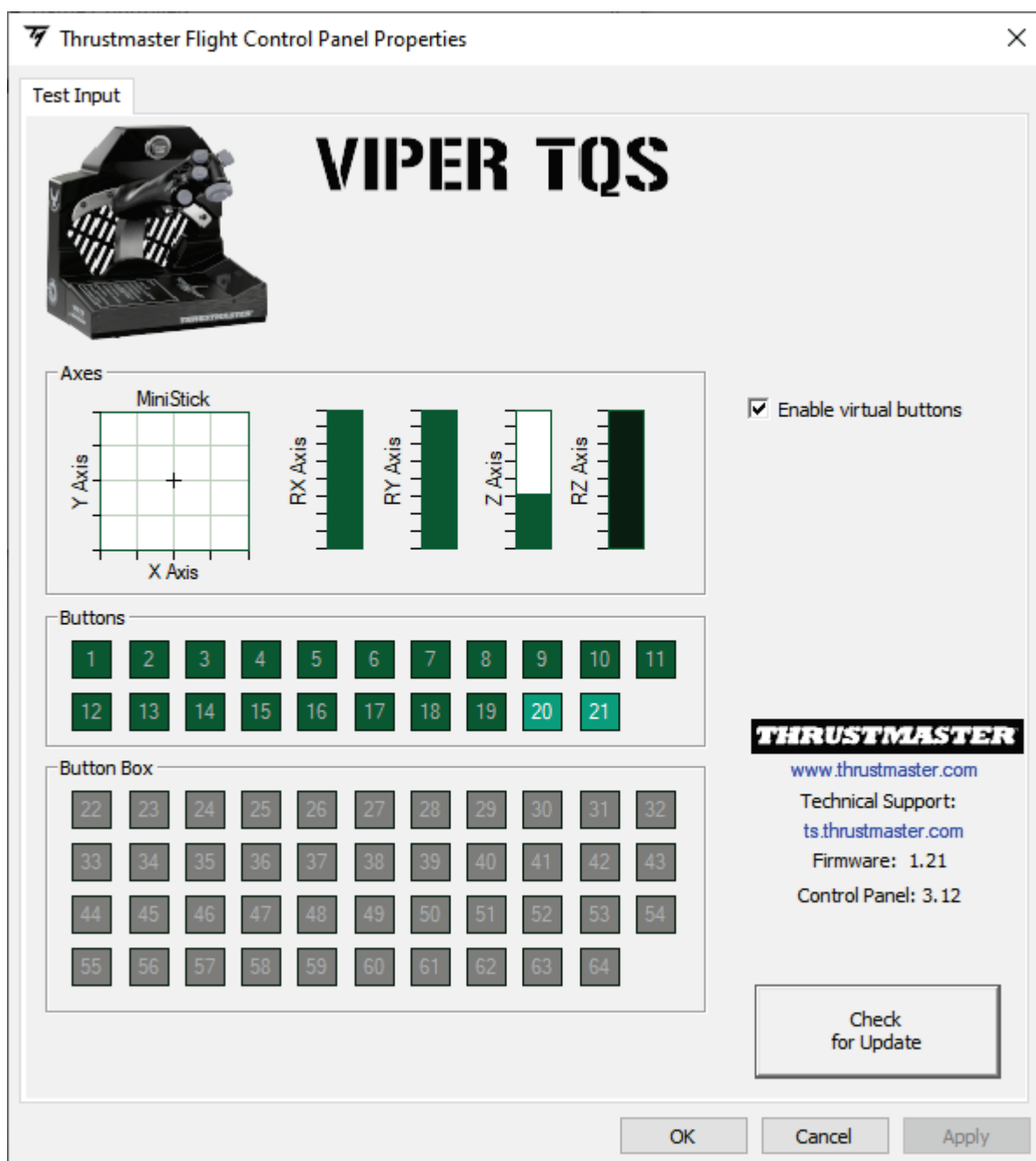

W urządzeniu VIPER TQS przyciski wirtualne domyślnie są wyłączone.



9. Zapadki CUT OFF i AFTERBURNER

Blok przepustnicy VIPER TQS jest wyposażony w realistyczny układ zapadek CUT OFF i AFTERBURNER (moduł Afterburner można zdemontować).

CUT OFF

Po ustawieniu dźwigni przepustnicy na ograniczniku IDLE naciśnij spust odblokowujący możliwość wyłączenia silników **1**, aby unieść uchwyt i przesunąć go nad ogranicznikiem **2**, a następnie ustawić uchwyt w położeniu OFF **3**.

Aby ponownie włączyć silniki, wykonaj tę procedurę w odwrotnej kolejności.

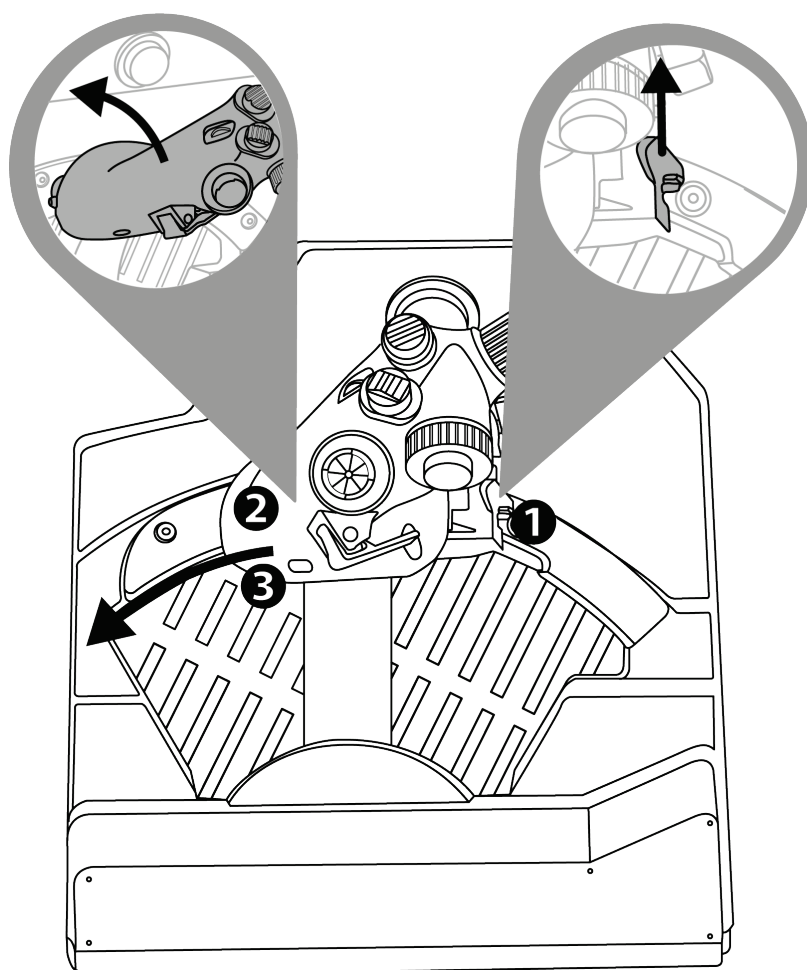



AFTERBURNER

Przesuń dźwignię przepustnicy do ogranicznika **1**
i unieś uchwyt **2**, aby przesunąć go nad ogranicznikiem
i włączyć dopalacz **3**.

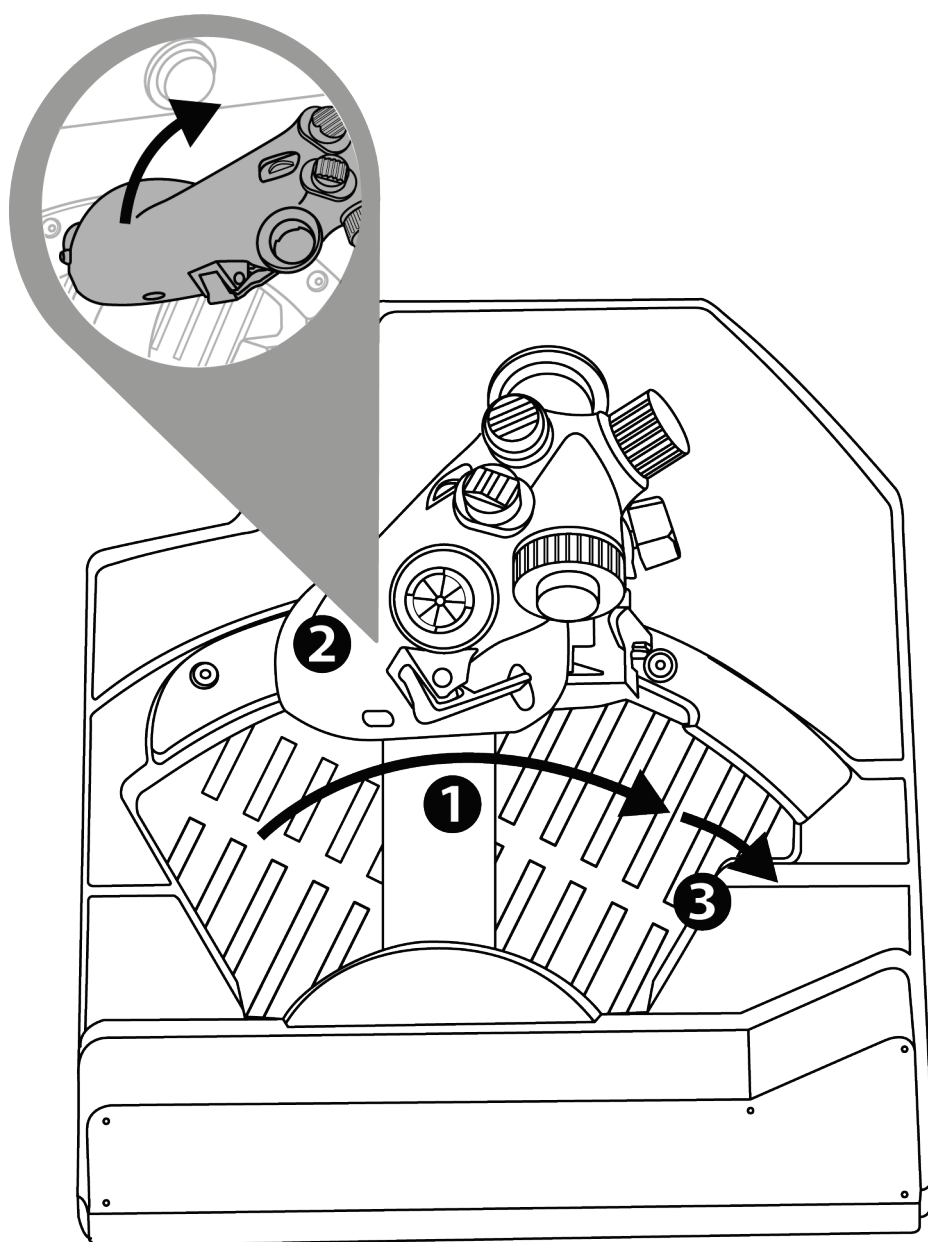



Demontowanie ogranicznika

AFTERBURNER

Ogranicznik modułu Afterburner znajduje się w 80% zakresie ruchu osi.

Jeśli potrzebujesz 100% zakresu przesuwu dźwigni przepustnicy bez jego ograniczania (np. w określonym symulatorze), możesz zdemontować moduł Afterburner i jego ogranicznik, wykręcając dwie śruby modułu kluczem imbusowym (do nabycia osobno).

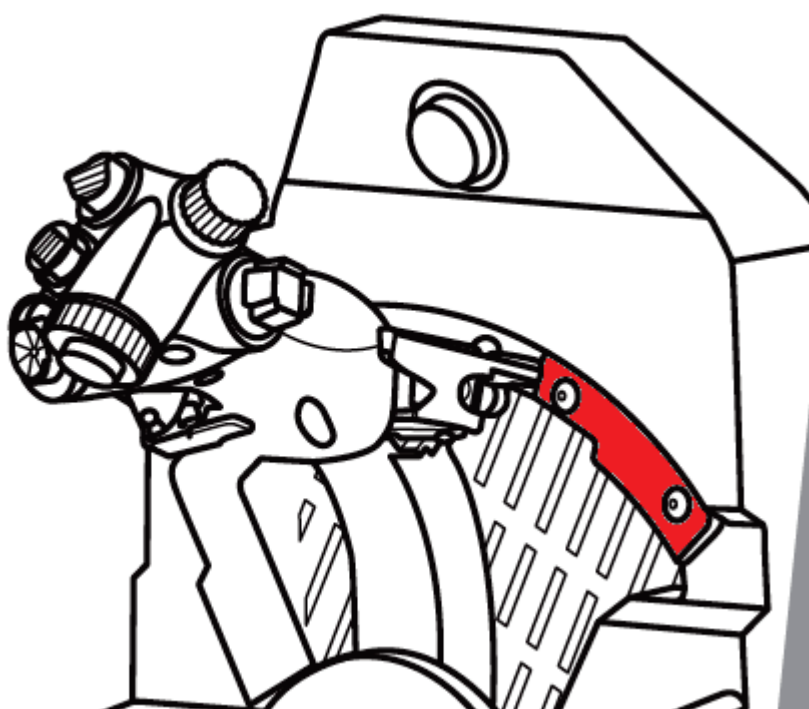



10. Zaawansowana aplikacja do programowania T.A.R.G.E.T.



Wejdź na stronę

<https://support.thrustmaster.com/product/viper-tqs/>.

Z sekcji **Software** (Oprogramowanie) pobierz i zainstaluj zaawansowaną aplikację do programowania T.A.R.G.E.T.



Główne cechy i funkcje aplikacji

T.A.R.G.E.T

- Różne konfiguracje osi
- Różne poziomy programowania: Basic, Advanced i Script
- Korzystanie z techniki przeciągania i upuszczania
- Możliwość łączenia bloku przepustnicy VIPER TQS z różnymi joystickami Thrustmaster (HOTAS Cougar, HOTAS Warthog, T.16000M, MFD Cougar Pack — również zgodnymi z aplikacją T.A.R.G.E.T), dzięki czemu są one rozpoznawane jako jedno urządzenie USB
- Dostęp do zaawansowanych profili tworzonych przez członków społeczności Thrustmaster



11. Często zadawane pytania i pomoc techniczna

Masz pytania dotyczące urządzenia VIPER TQS lub napotykasz problemy techniczne? Jeśli tak, wejdź na stronę pomocy technicznej Thrustmaster:

<https://support.thrustmaster.com/product/viper-tqs/>.



THRUSTMASTER®

VIPER TQS

THROTTLE QUADRANT SYSTEM

PC 用 (Windows 10/11)

ユーザーズマニュアル



本製品を取り付ける前、使用する前、およびメンテナンスする前に、このマニュアルに記載されている指示をよくお読みください。安全に関する注意事項を必ず守ってください。これらの指示に従わない場合、事故や破損の原因となります。このマニュアルは、後で参照できるように保管しておいてください。

目次

1.	パッケージ内容.....	5
2.	VIPER TQS の特長.....	6
3.	ボタンと軸のマッピング	8
4.	VIPER TQS の使用に関する情報.....	10
5.	摩擦の調整	11
6.	サポートへの取り付け.....	12
7.	VIPER PANEL の取り付け	17
8.	PC で使用する.....	20
9.	CUT OFF および AFTERBURNER デイテント	23
10.	T.A.R.G.E.T 高機能プログラミングソフトウェア	26
11.	FAQ とテクニカルサポート	28



世界で最も多く使用されている米国空軍の戦闘機
VIPER のアイコンックなスロットルクアドラントを駆使し、
エンジンを始動して危険地帯へと飛び込もう！

金属製のハンドルとリアル感あふれるボタンおよびデ
ィテントを備えた、人間工学デザインの 1:1 スケール
HOTAS レプリカが、あなたのコックピットを次のレベル
に引き上げます。

このマニュアルは、VIPER TQS を最適な条件で設置
および使用するのに役立ちます。離陸の前に、説明書
と警告をよく読んでください。これらの情報は、製品の
楽しさを最大限に引き出すために役立ちます。



ファームウェアのアップデート

VIPER TQS をビデオゲームで正しく機能させるためには、ファームウェアをアップデートする必要があります。

アップデートを実行するには、以下のサイトにアクセスしてください:

<https://support.thrustmaster.com/product/viper-tqs/>

[Firmware] (ファームウェア)を選択し、ダウンロードおよびセットアップ手順にしたがってください。



1. パッケージ内容

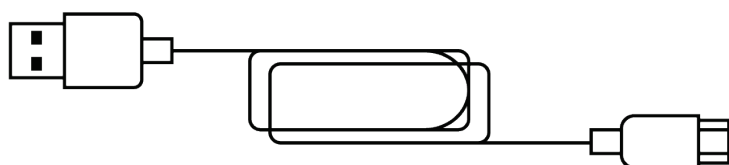
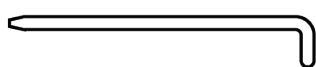
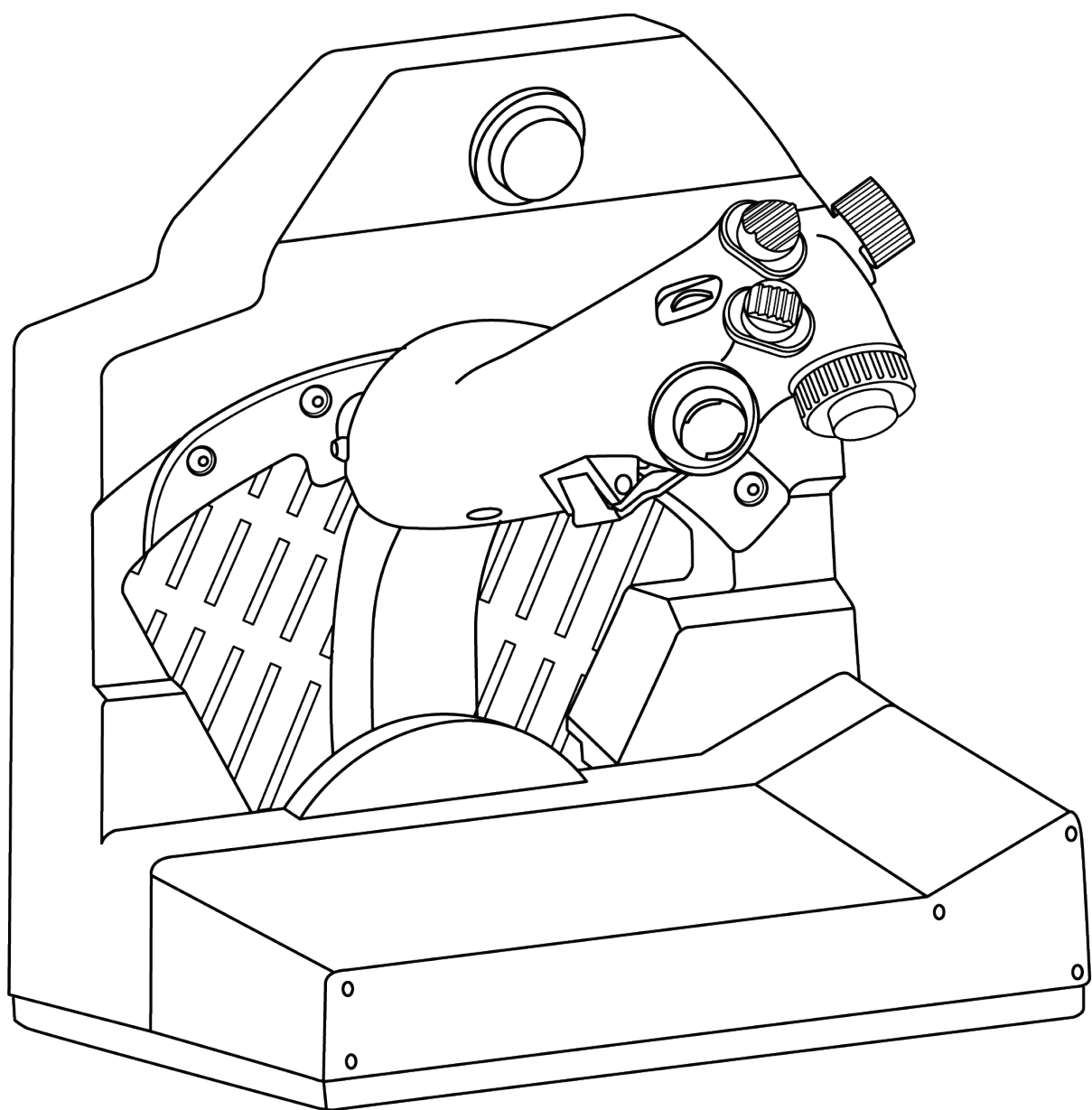



2. VIPER TQS の特長

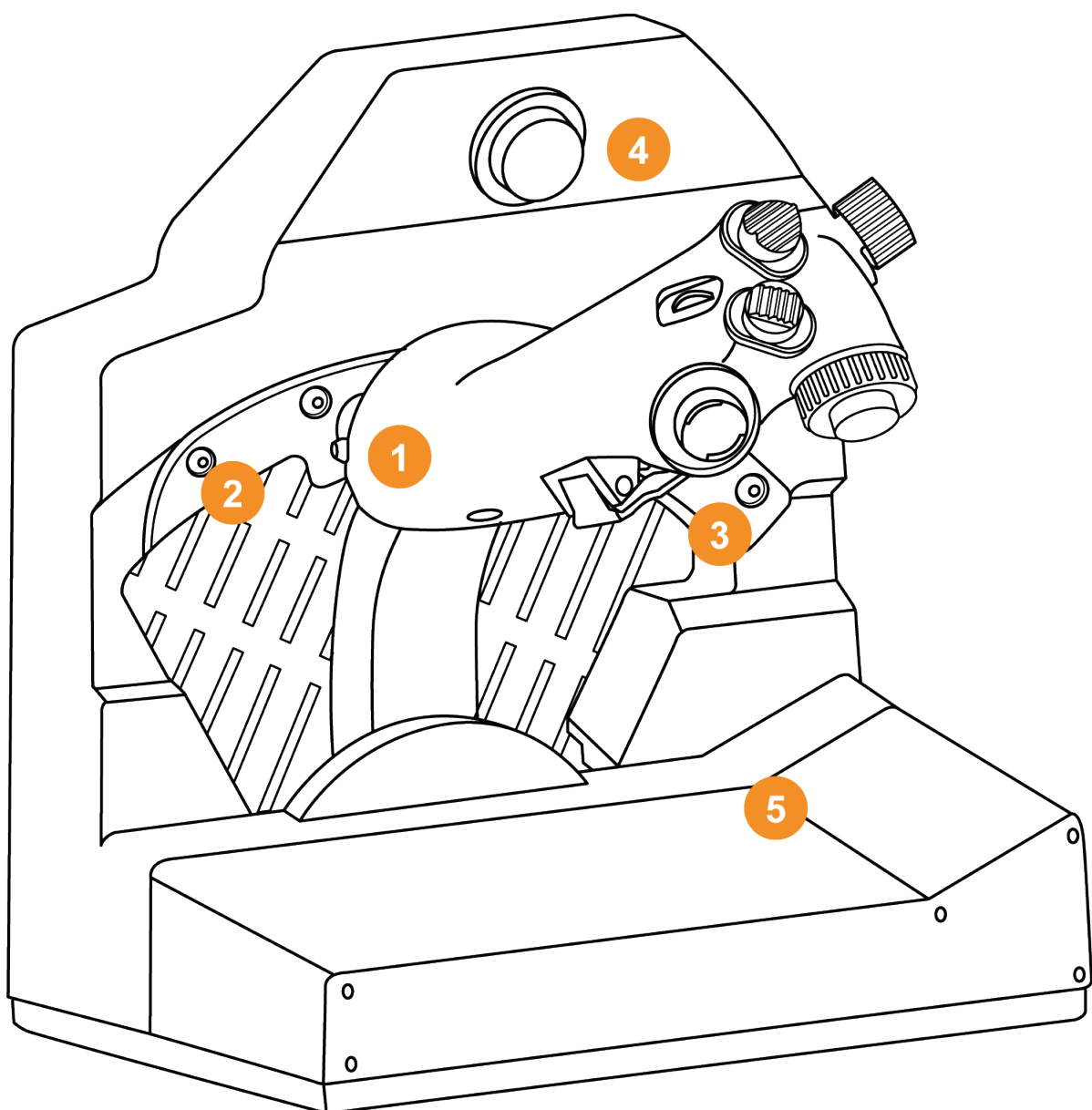

1. ハンドル

2. Cut Off 終端ストップ

3. アフターバーナーストップ

4. CHAFF/FLARE スラップスイッチ

5. ミッションマップ用クリップ

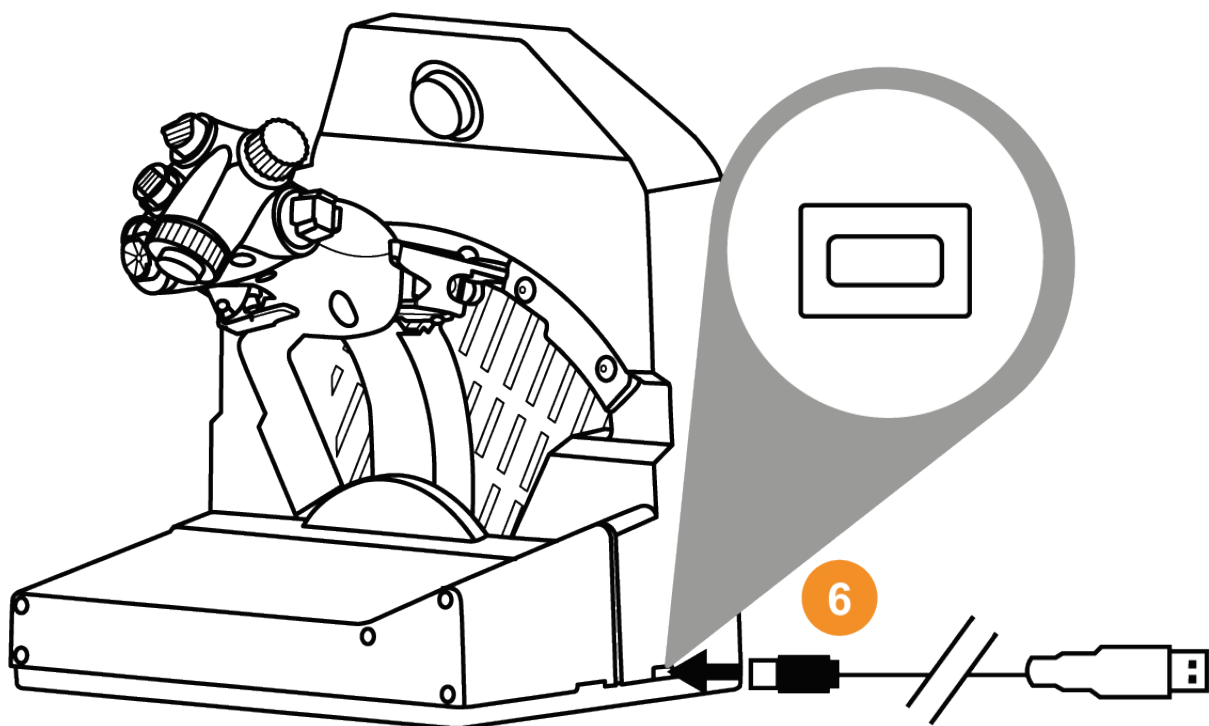

6. USB コネクター (タイプ C)

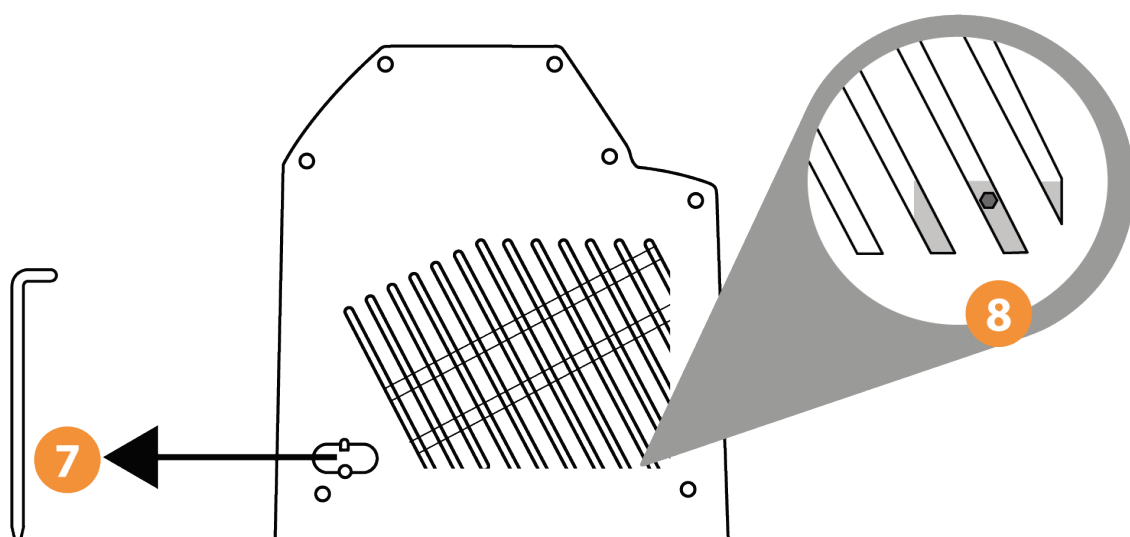

7. 摩擦調整ツールの位置

8. スロットル摩擦調整用アクセスポイント



3. ボタンと軸のマッピング

VIPER TQS ハンドル: モード A (仮想ボタンなし) の 19 個のボタンと 5 軸のマッピング

A 1→19

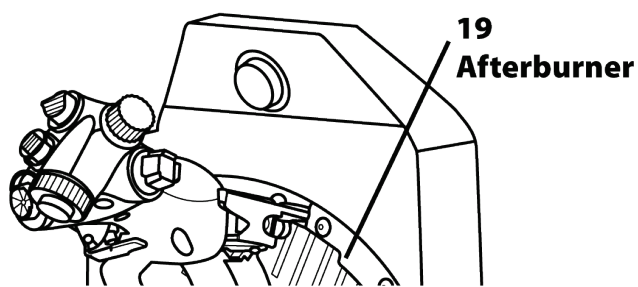
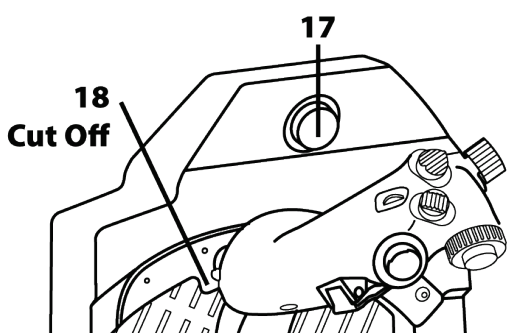
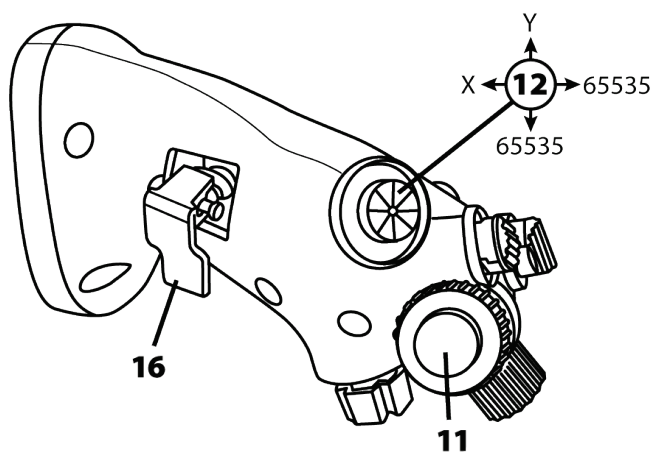
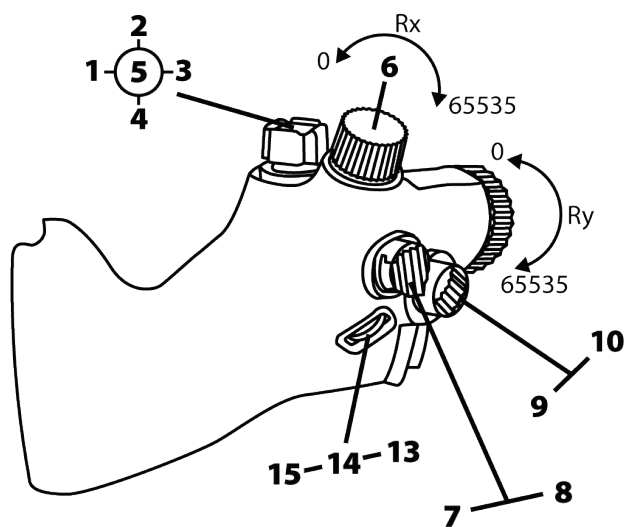



モード B: 仮想ボタンあり

B 1→21

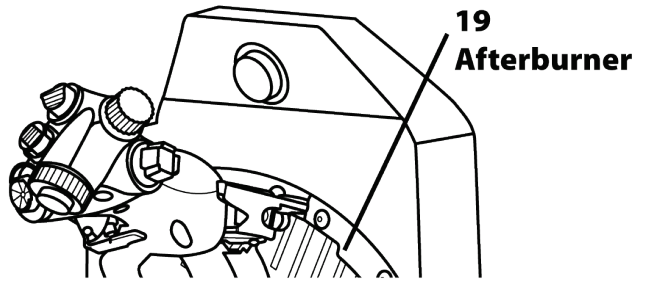
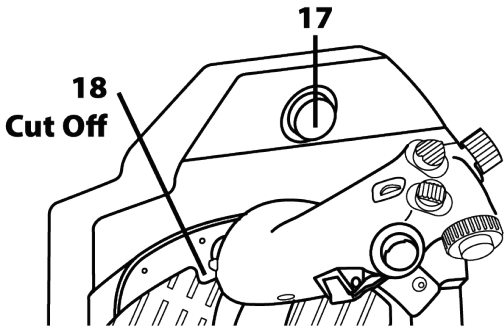
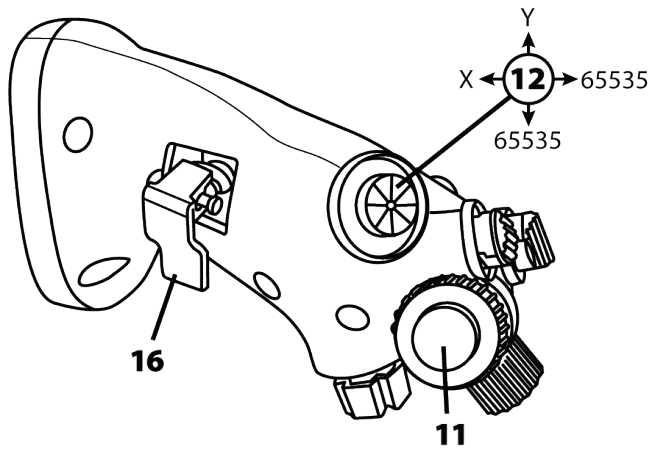
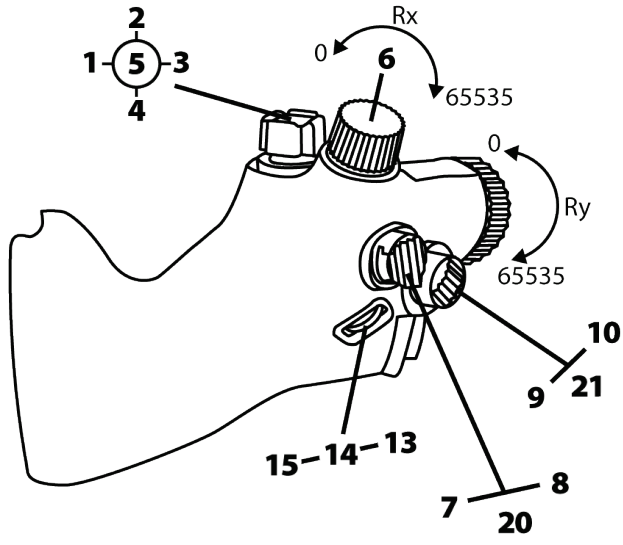



4. VIPER TQS の使用に関する情報



挟まれ危険

ハンドルの使用時には、可動域の終端部に絶対に指を入れないでください。

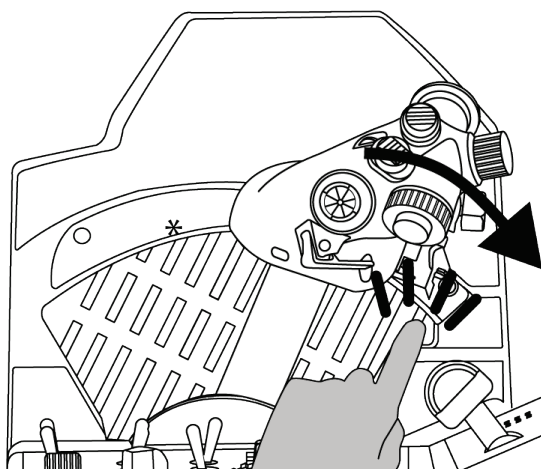
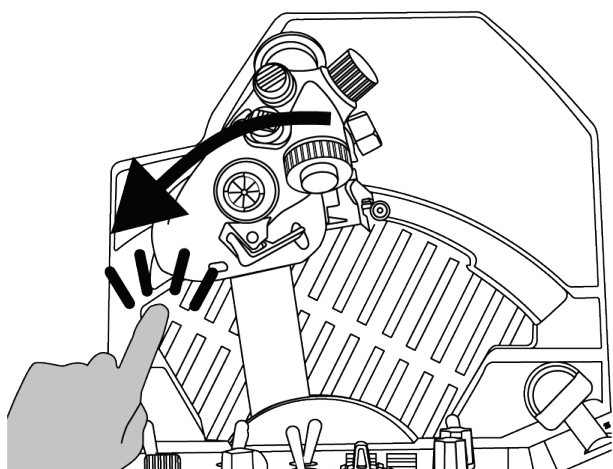
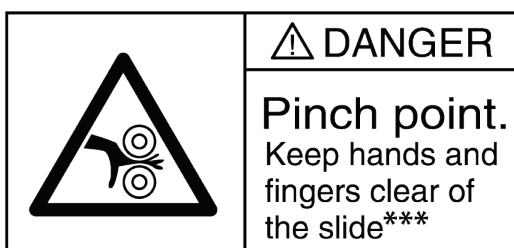



5. 摩擦の調整

VIPER TQS のサイドに付属しているツールを使って、VIPER TQS のスロットルクアドラントの摩擦を好みに調整することができます。ただし、工場出荷時にあらかじめ最適なスロットル摩擦が設定されている点にご留意ください。

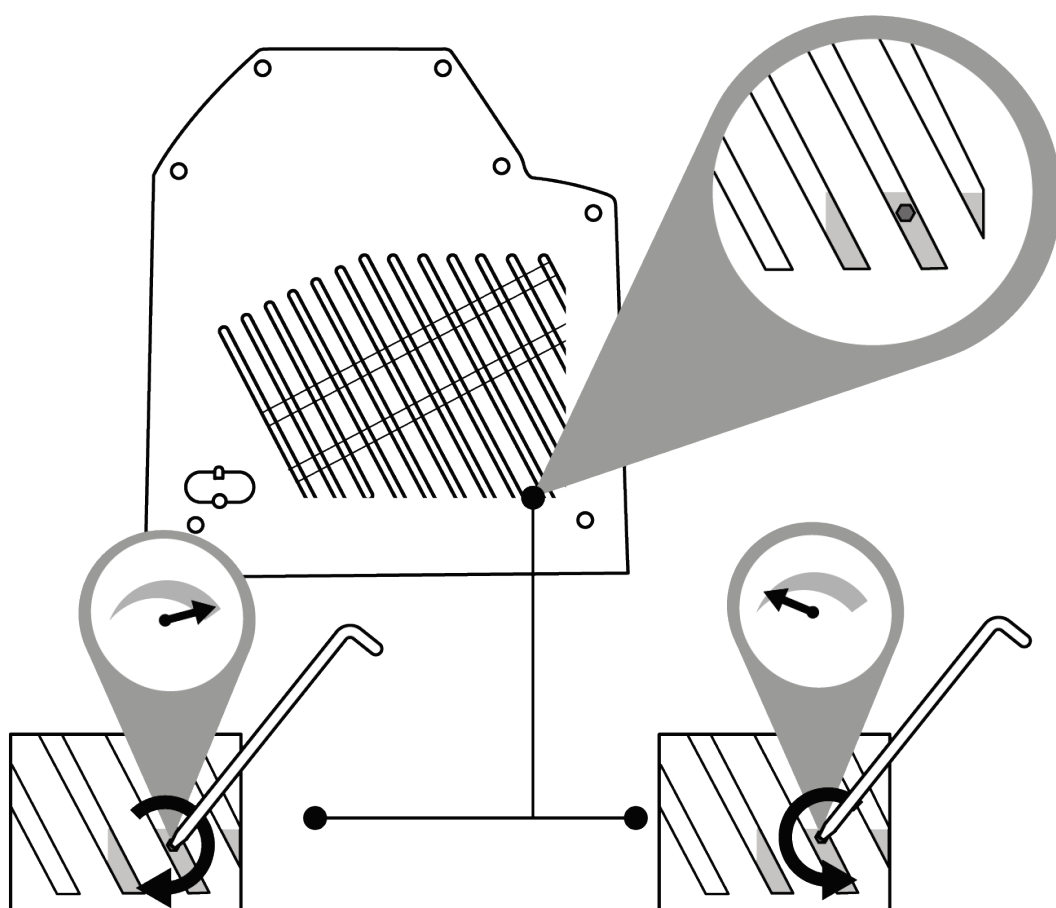

摩擦システムの損傷を防ぐため、調整ねじを締めすぎないように注意してください。

また、調整ねじを完全に外してしまうと、スロットルが所定の位置に留まらなくなるリスクがありますので注意してください。



6. サポートへの取り付け



VIPER TQS は、さまざまなタイプのサポートに取り付けることができます。市販されているほとんどのコックピットとサポートは、すでに類似 Thrustmaster 製品 (HOTAS Warthog) と互換性があります。

VIPER TQS には強いテコの力がかかるため、必ずしっかりと固定する必要があります。

ハンドルを損傷しないように注意しながら、適切な M6 ねじ (別売) でベースをサポートに取り付けます。

VIPER TQS の完全な設計図は <https://support.thrustmaster.com/product/viper-tqs/> でご覧いただけます。



毎回使用する前に、製造元の指定する指示に従って VIPER TQS がサポートに正しく取り付けられていることを確認してください。

サポートの材質を考慮し、製品を安全に取り付けられるようにしてください。VIPER TQS は、中空またはガラス部品のない、固体素材 (MDF または木材) で製のデスクで必ず使用する必要があります。



取り付け設計図寸法 (単位: mm)

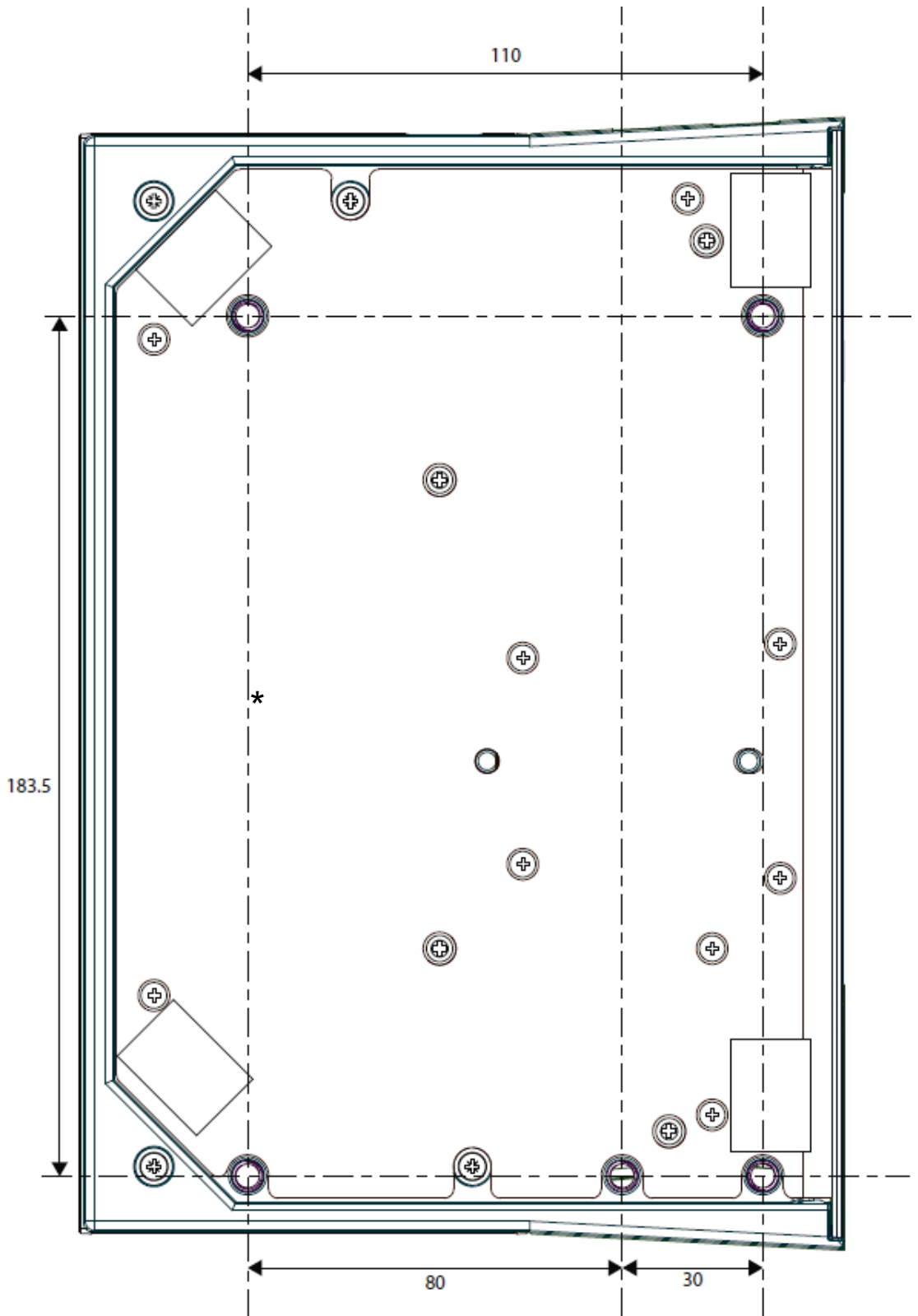

<https://support.thrustmaster.com/product/viper-tqs/> から取り付け設計図をダウンロードし、印刷してサポートに重ねて使用することで、ドリル穴を簡単に開けることができます。



TM Flying Desk Mount* を使用した取り付け

TM Flying Desk Mount は、クランプねじを備えた金属製のマウントシステムで、デバイス使用時のエルゴノミクスと操縦姿勢を改善するためのものです。このシステムは、厚さ 15~50mm のデスクやテーブルで使用できるように設計されています。

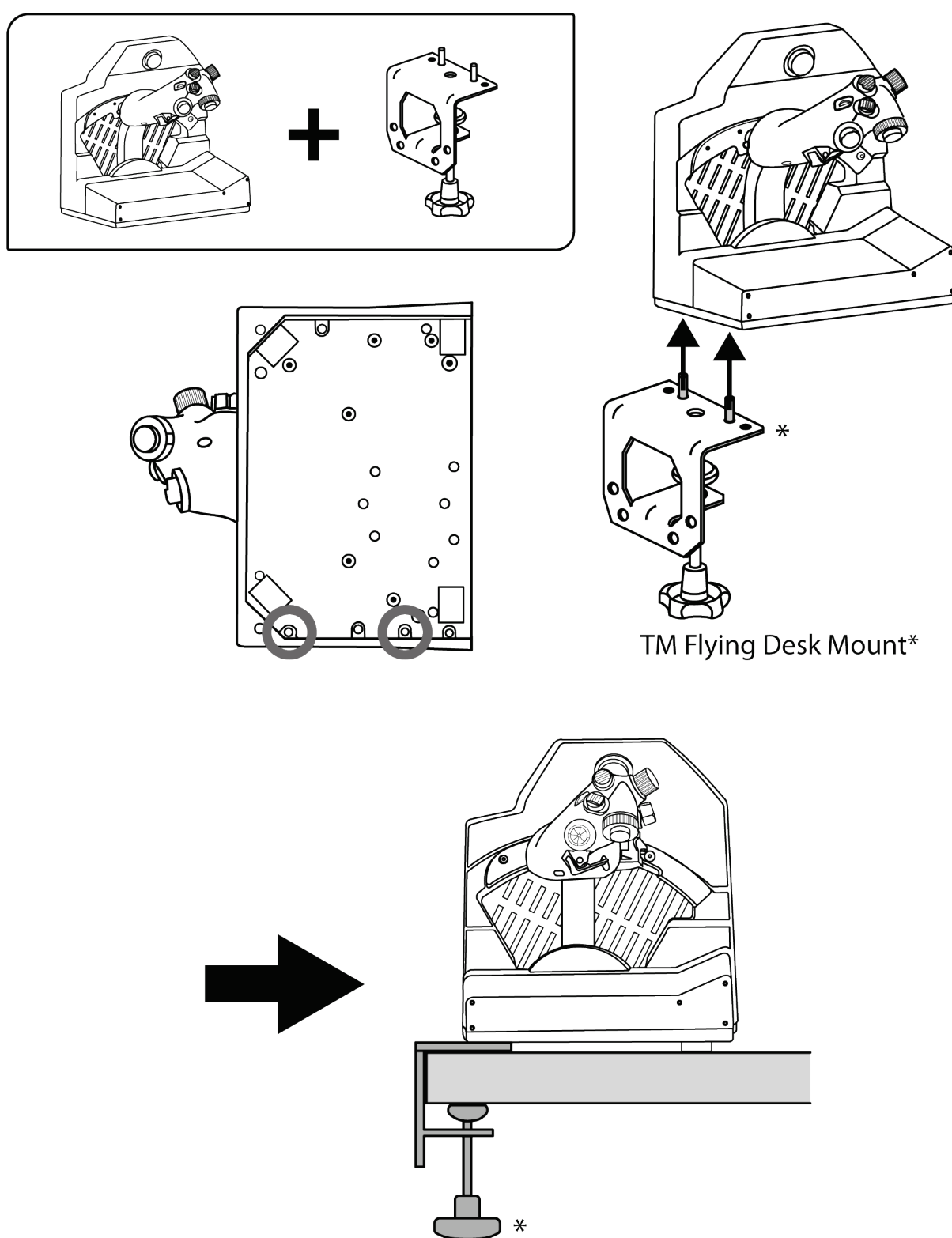

*別売品



TM Flying Clamp* を使用した取り付け

TM Flying Clamp は、Thrustmaster がフライトシミュレーター用アクセサリ向けに設計した高さ調節可能なサポートです。このマウントシステムは、2 つのクランプねじを備えており、厚さ 15~45mm のデスクやテーブルで使用するために調整することが可能です。

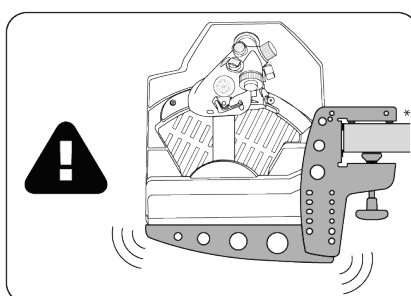
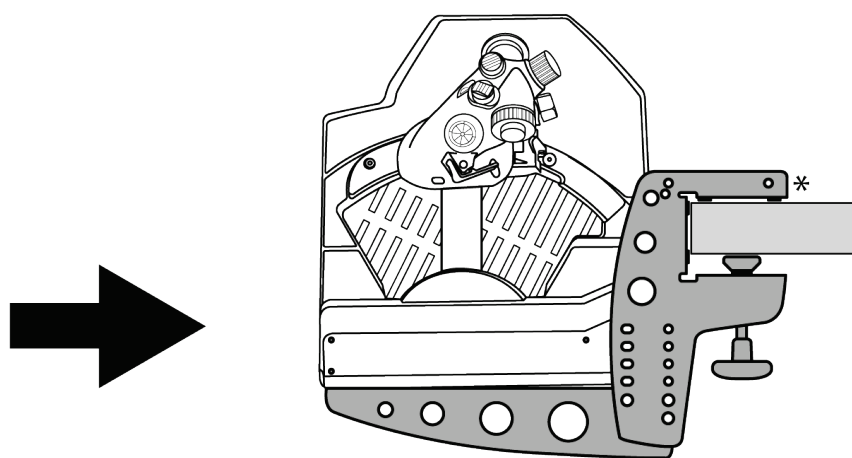
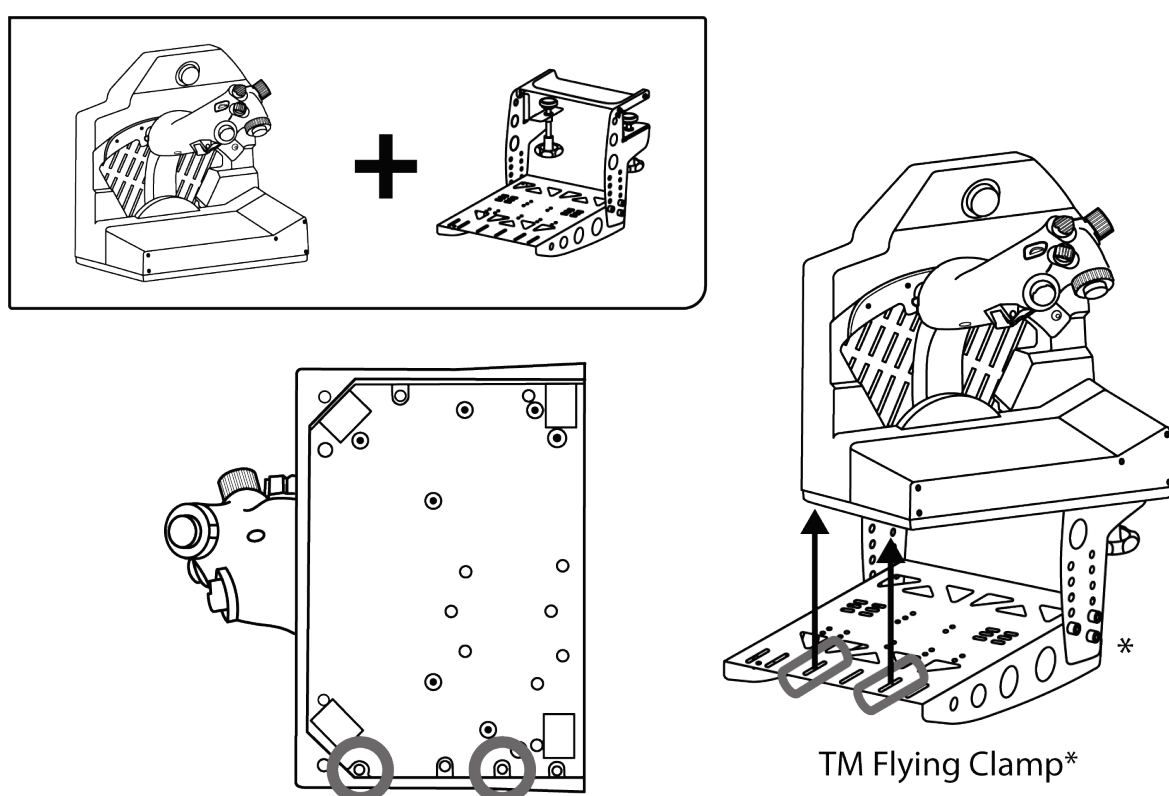

*別売品



VIPER TQS の重量により、マウントシステムが望ましくない動きをする可能性がある点に注意してください。



7. VIPER PANEL の取り付け

*別売。VIPER PANEL は VIPER TQS Mission Pack に含まれています。

VIPER PANEL は、T.A.R.G.E.T ソフトウェアによってプログラミング可能な 43 個のボタンと 1 本の軸を備えた、フライト/戦闘能力を拡張できるコントロールパネルです。VIPER PANEL は、VIPER TQS を補完する製品です。

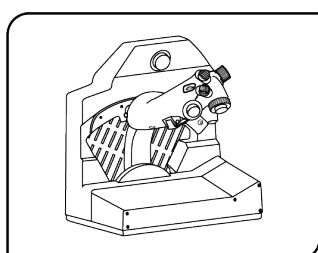

1

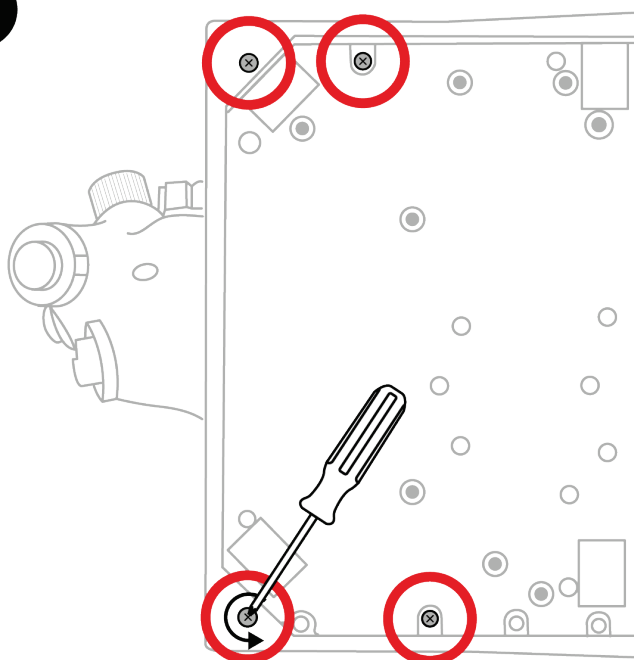

2

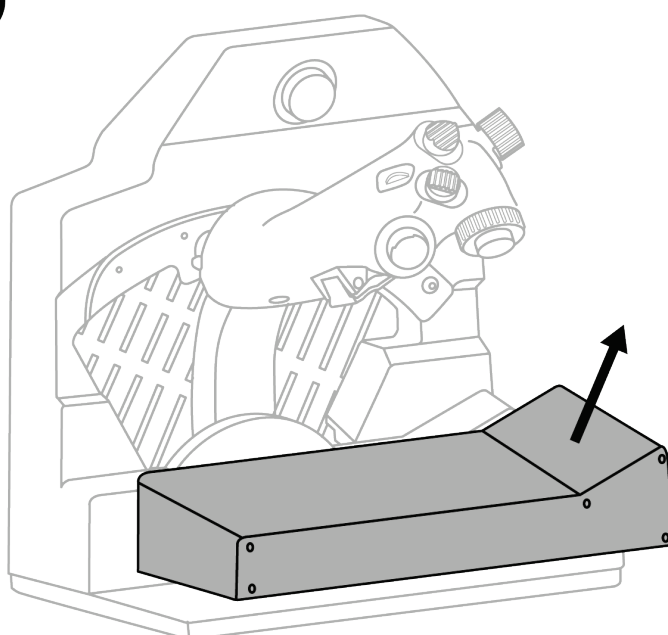

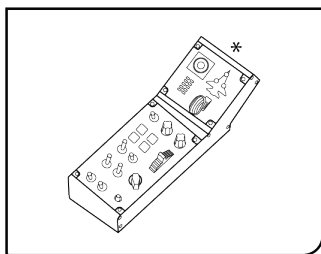

3

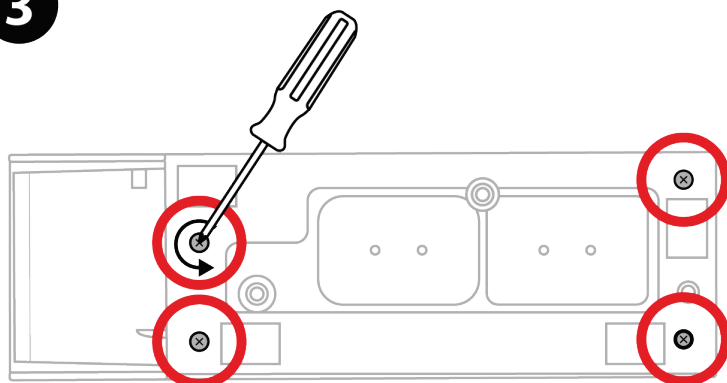

4

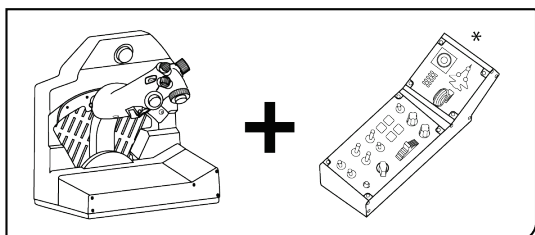
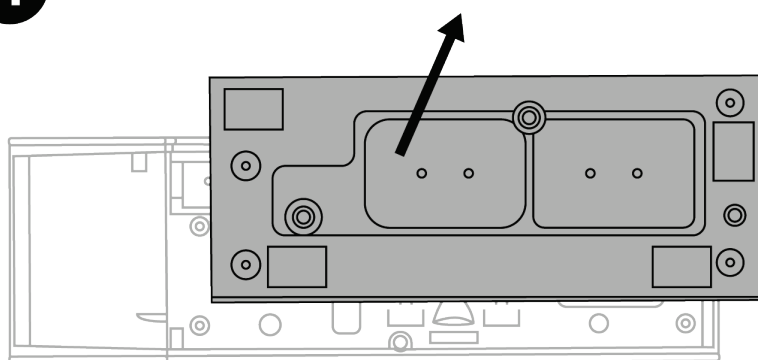

5

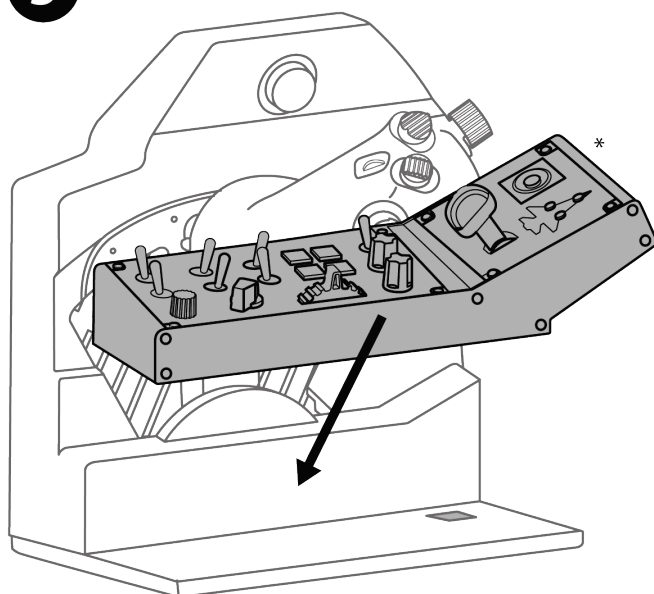



6

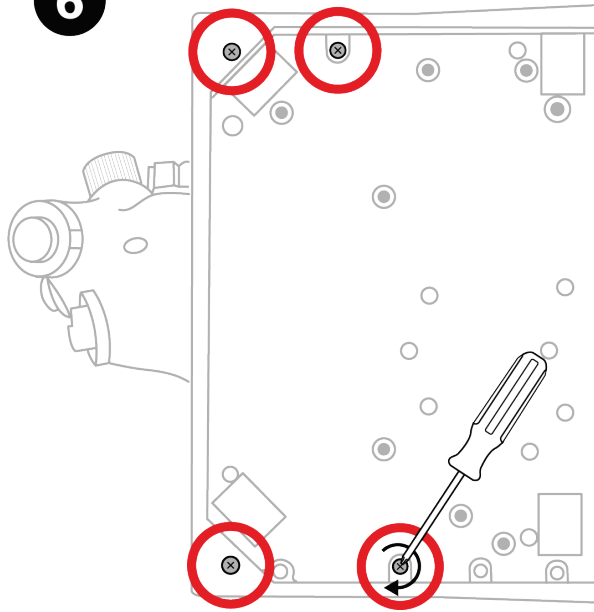

7

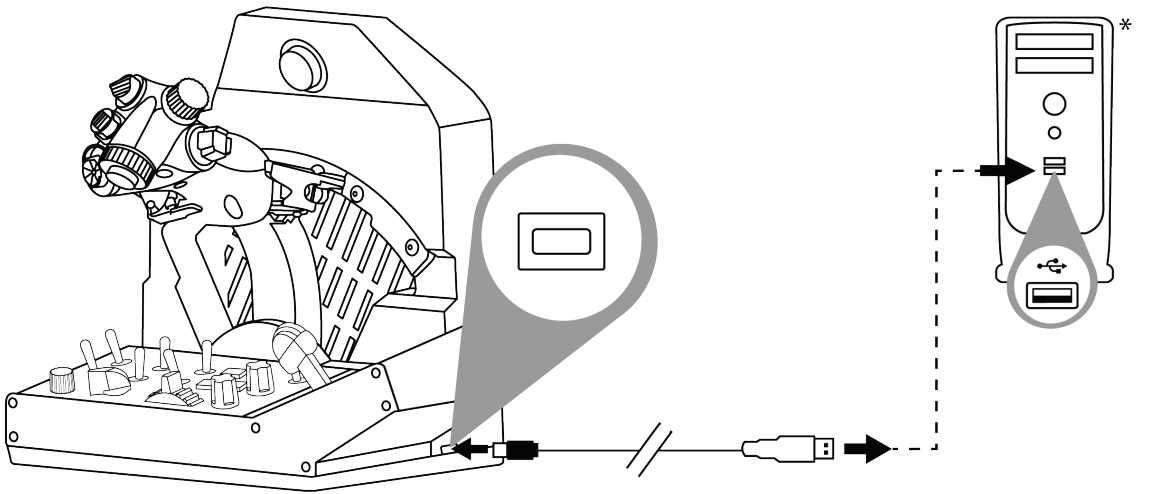

*付属していません



8. PC で使用する

1



<https://support.thrustmaster.com/product/viper-tqs/> にアクセスしてください。

2

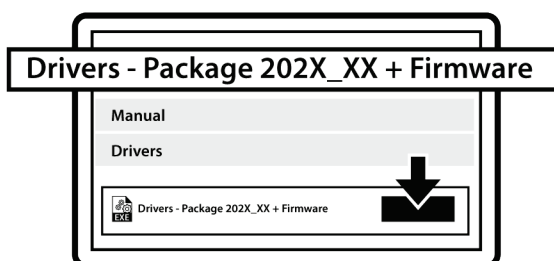

PC 用ドライバと、Windows コントロールパネル用のカスタムインターフェイスをダウンロードしてインストールします。

3

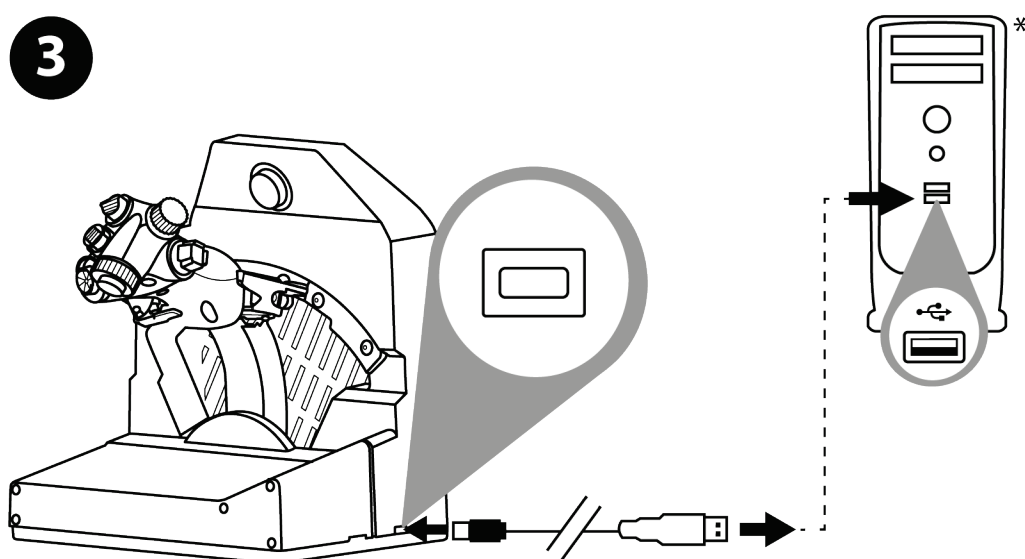

PC ドライバがインストールされたら、USB コネクタを、PC の USB ポートに接続します。

**付属していません*



④ Control Panel にアクセスするには、[スタート] / [すべてのアプリ] / [Thrustmaster] / [Control Panel] または [コントロール パネル] を選択します (Windows 10 の場合)。

「ゲーム コントローラー」ダイアログボックスが表示されます。デバイスは画面上に VIPER TQS という名前で OK ステータスとともに表示されます。

⑤ 「ゲーム コントローラー」ダイアログボックスで「プロパティ」をクリックして、すべての機能を表示・テストします。

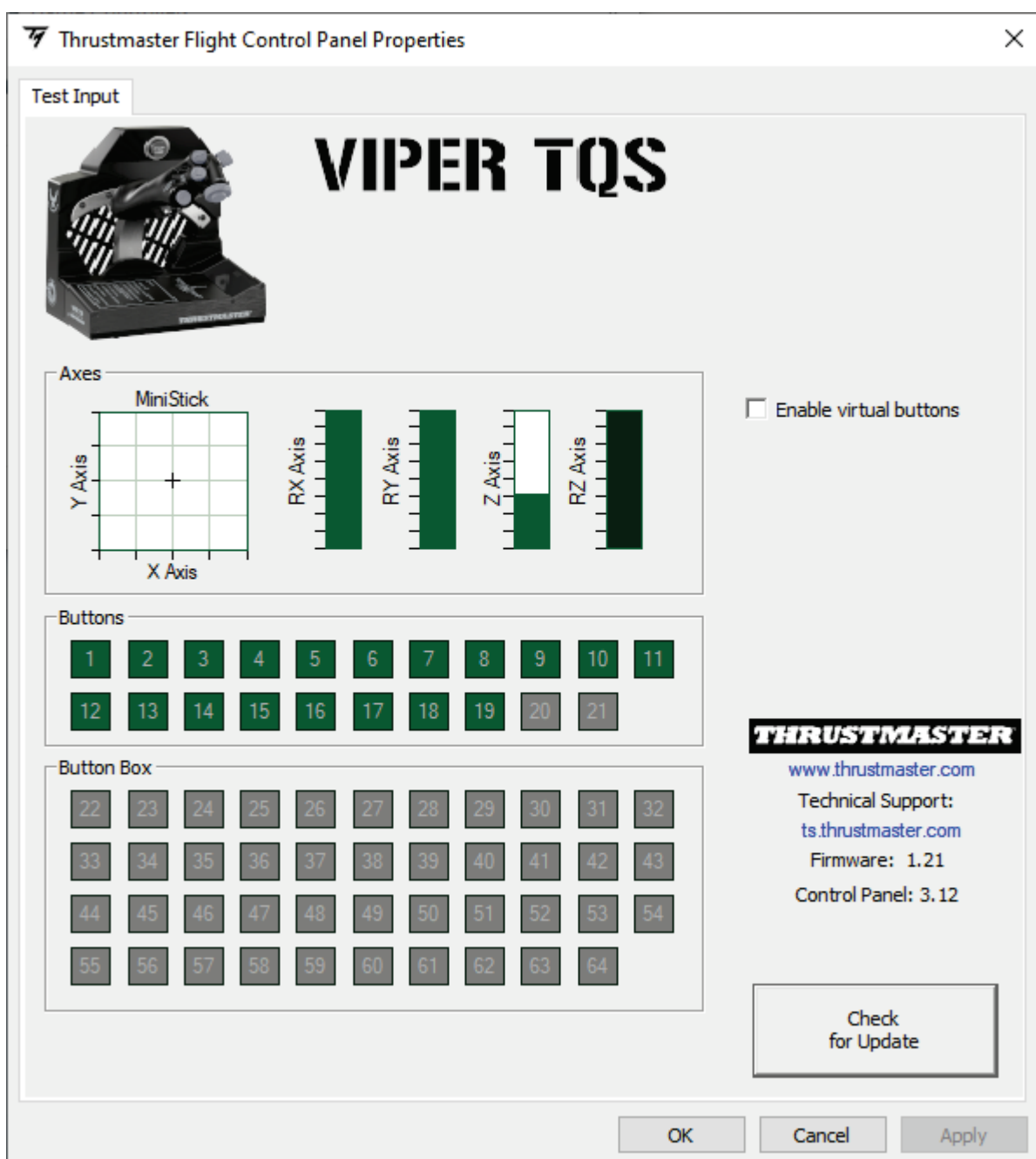



Enable virtual buttons (仮想ボタンを有効にする):

ハンドルの仮想ボタン (ボタン 20 と 21) を有効/無効にする機能です。使用したいモードを選択したら、[Apply] (適用) をクリックします。

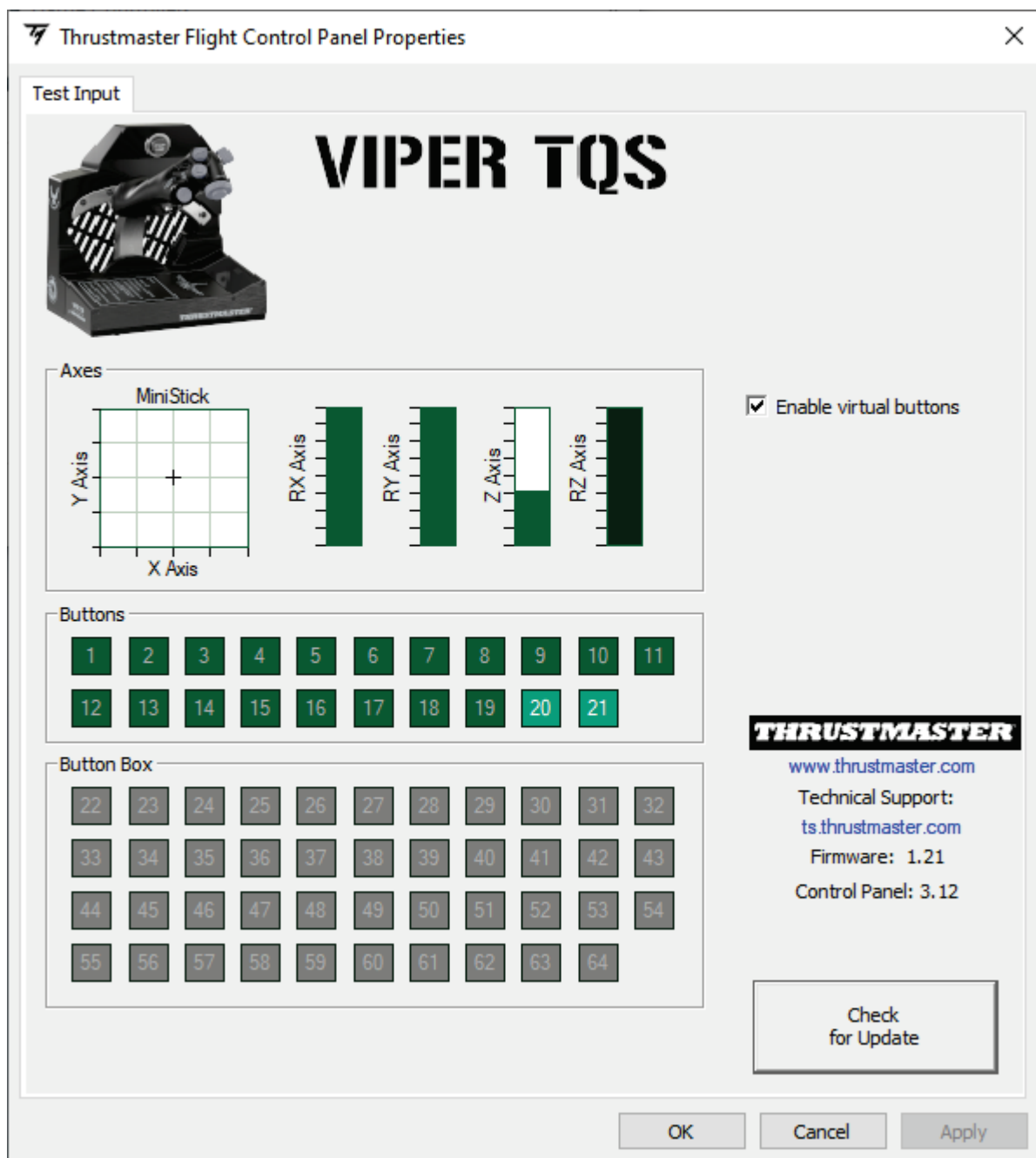

VIPER TQS では、仮想ボタンはデフォルトで無効になっています。



9.CUT OFF および AFTERBURNER ディテント

VIPER TQS スロットルクアドラントには、CUT OFF と AFTERBURNER ディテントのリアル感あふれるシステムが採用されています (Afterburner モジュールは取り外し可能)。

CUT OFF

スロットルを IDLE 終端ストップに動かした後、「エンジンカットオフロック解除」トリガー①を押してハンドルを持ち上げ、終端②を越えたら、ハンドルを OFF の位置③に動かします。

エンジンを再稼働させるには、この手順を逆に実行します。

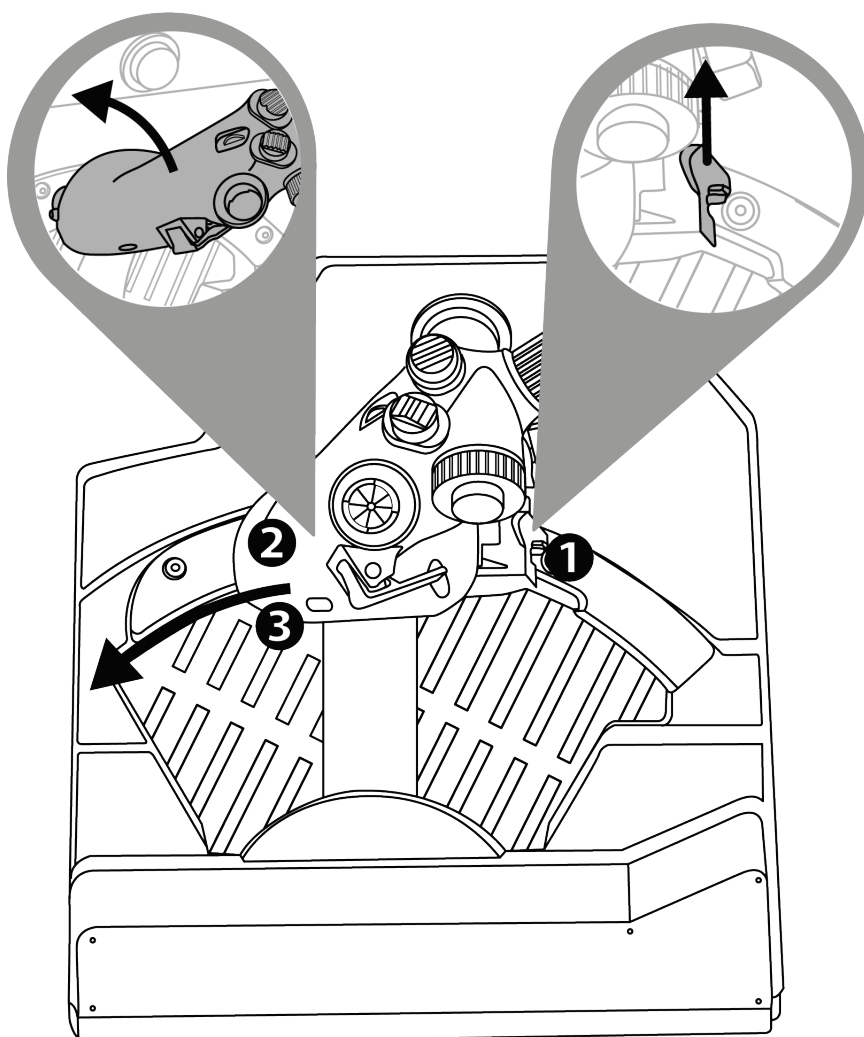



AFTERBURNER

スロットルを可動域の終端**①**まで動かし、終端を越えてアフターバーナー**③**を作動させるために、スロットルを持ち上げます**②**。

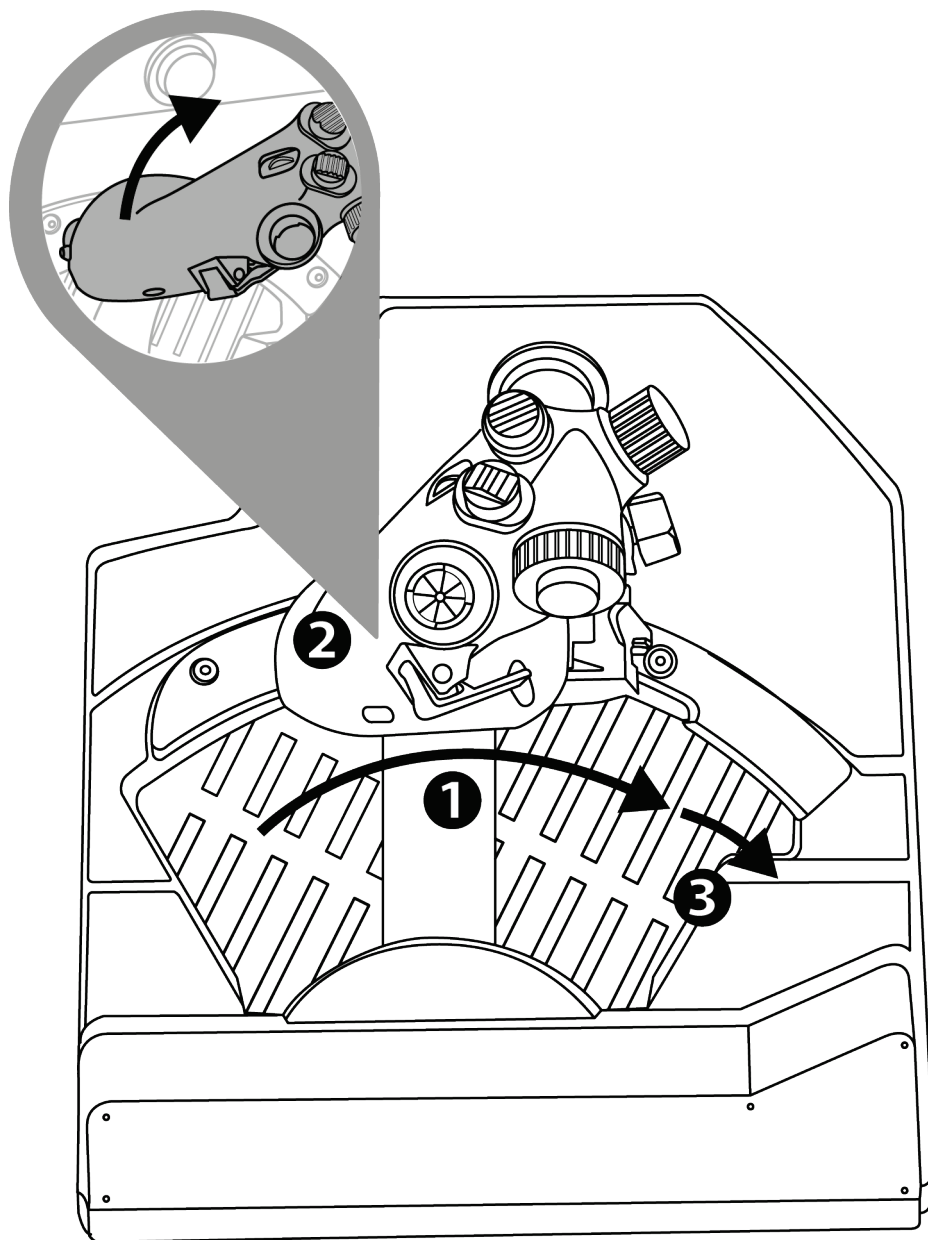



AFTERBURNER 終端ストップを取り外す

Afterburner モジュールの可動域の終端は、軸の値の 80% に位置します。

(特定のシミュレーターなどで) 終端なしの 100% 可動域がスロットルに必要な場合、六角レンチ (別売) を使ってモジュールの 2 つのねじを外すと、Afterburner モジュールとその可動域の終端を取り除くことができます。

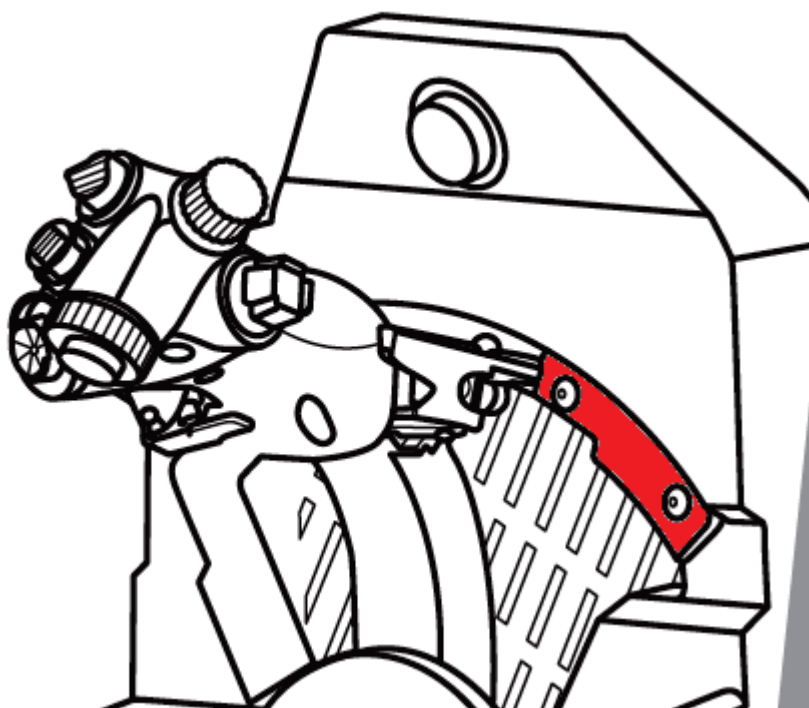



10. T.A.R.G.E.T 高機能プログラミングソフトウェア



<https://support.thrustmaster.com/product/viper-tqs/> にアクセスしてください。

Software (ソフトウェア)」セクションで、T.A.R.G.E.T 高機能プログラミングソフトウェアをダウンロードし、インストールします。



T.A.R.G.E.T の主な特長:

- 軸の多彩な設定が可能。
- 異なるプログラミングレベルを搭載: Basic、Advanced、Script。
- ドラッグアンドドロップで操作可能。
- VIPER TQS スロットルクアドラントを他の Thrustmaster ジョイスティック (T.A.R.G.E.T と互換性のある HOTAS Cougar、HOTAS Warthog、T.16000M、および MFD Cougar Pack) と組み合わせて、1 台の USB デバイスとして認識させることが可能。
- Thrustmaster コミュニティのメンバーらによって作成された高度なプロファイルへのアクセス。



11. FAQ とテクニカルサポート

VIPER TQS についてご質問がおありですか、それとも技術的な問題が発生していますか？そのような場合は、Thrustmaster テクニカルサポートのウェブサイトアクセスしてください:

<https://support.thrustmaster.com/product/viper-tqs/>.



THRUSTMASTER®

VIPER TQS

THROTTLE QUADRANT SYSTEM

PC (Windows 10/11) 版

用户手册



在安装本产品之前、在以任何方式使用本产品之前以及对其执行任何维护之前，请仔细阅读本手册提供的说明。请务必遵守安全说明。不遵守这些说明可能导致事故和/或损坏。请保留本手册，以便您日后查阅说明。

目录

1.	包装清单.....	5
2.	VIPER TQS 配备	6
3.	按钮和轴的映射.....	8
4.	有关使用 VIPER TQS 的信息.....	10
5.	调节摩擦力.....	11
6.	安装到支架上.....	12
7.	安装 VIPER PANEL*	17
8.	安装到 PC 上.....	20
9.	CUT OFF 和 AFTERBURNER 止动器.....	23
10.	T.A.R.G.E.T 高级编程软件.....	26
11.	常见问题解答和技术支持.....	28



借助来自美国空军部的 **VIPER**（世界上使用最广泛的现代战斗机）的标志性节流阀弧座加速飞行，深入虎穴！

独特的 1:1 比例人体工学复刻版 **HOTAS** 配备金属手柄和逼真的按钮与止动器，让您的驾驶舱再上一个台阶。

本手册将帮助您安装 **VIPER TQS** 并让其运行在最佳条件下。在开始起飞之前，请仔细阅读以下所有说明和警告：它们将帮助您尽情享受您的产品。



更新固件

要使 VIPER TQS 能在视频游戏中正常工作，您必须更新其固件。

要执行更新，请访问

<https://support.thrustmaster.com/product/viper-tqs/>

选择 **Firmware** (固件)，然后按照说明（包括下载和安装程序）进行操作。



1. 包装清单

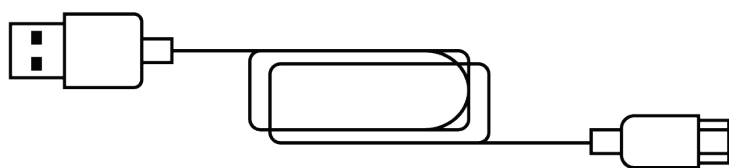
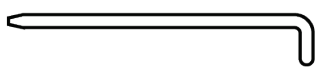
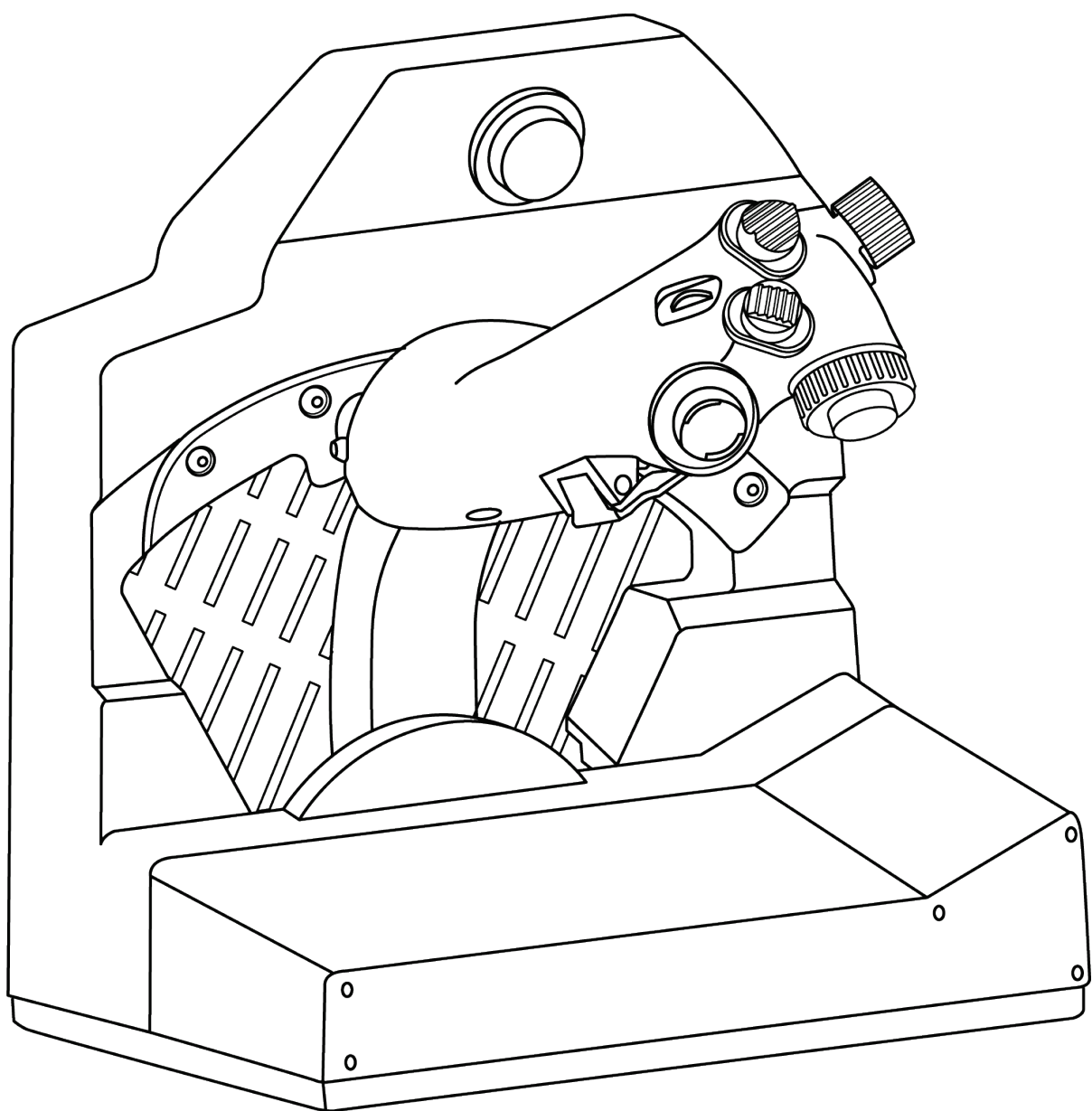



2. VIPER TQS 配备

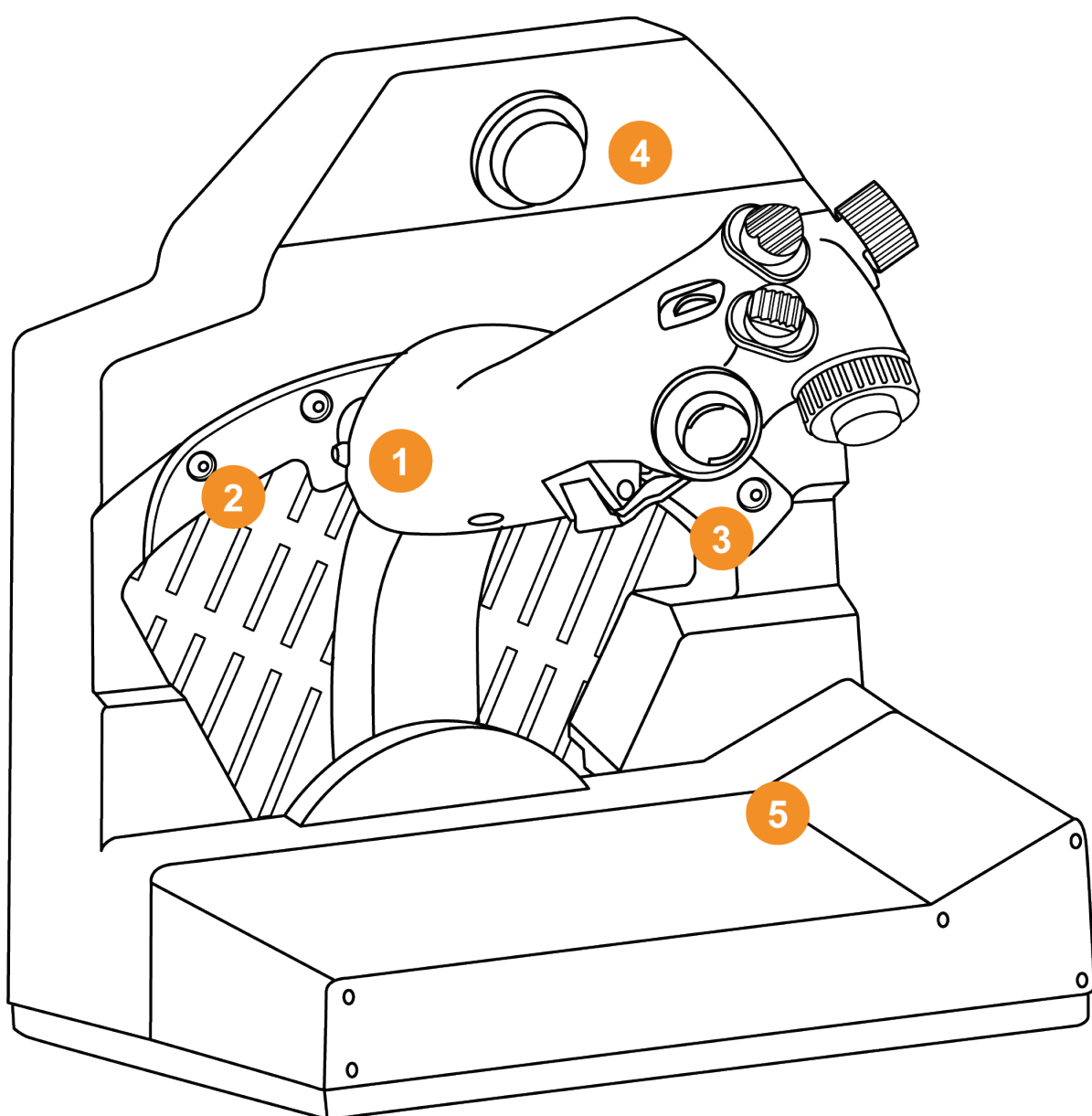

1. 手柄

2. **Cut Off** 限位器

3. 后燃器限位器

4. **CHAFF/FLARE** 拍击按钮

5. 任务地图夹

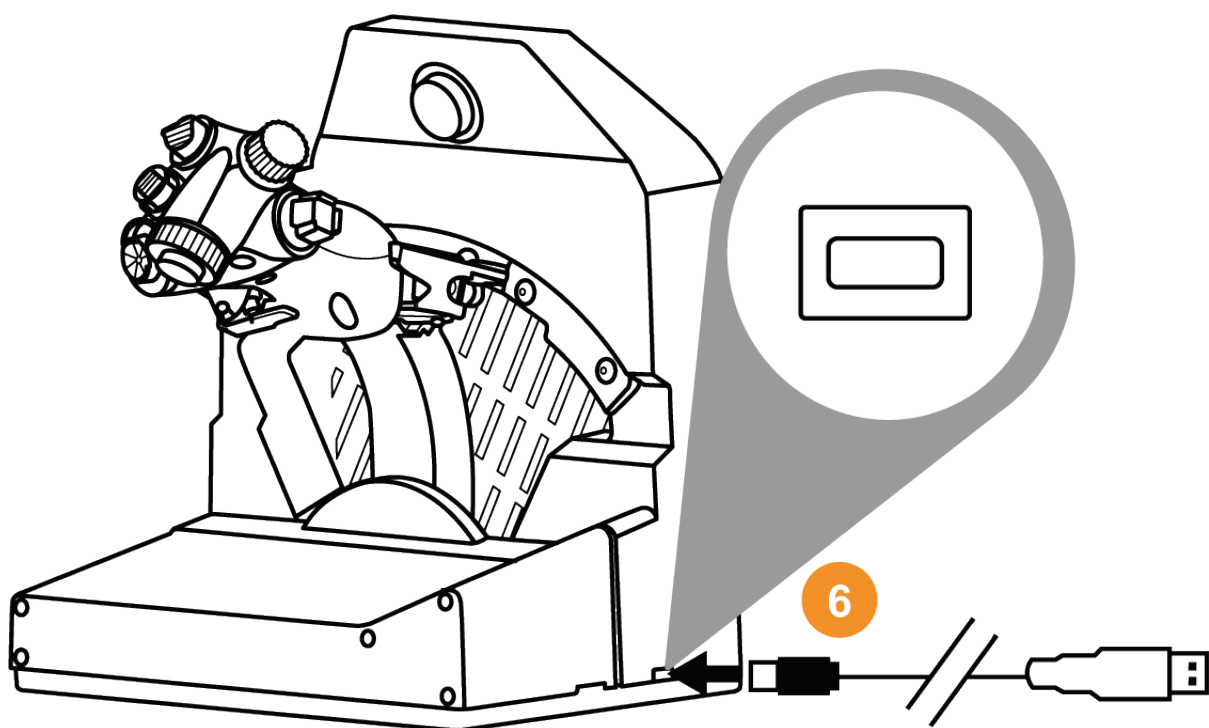

6. USB 接口 (type C)

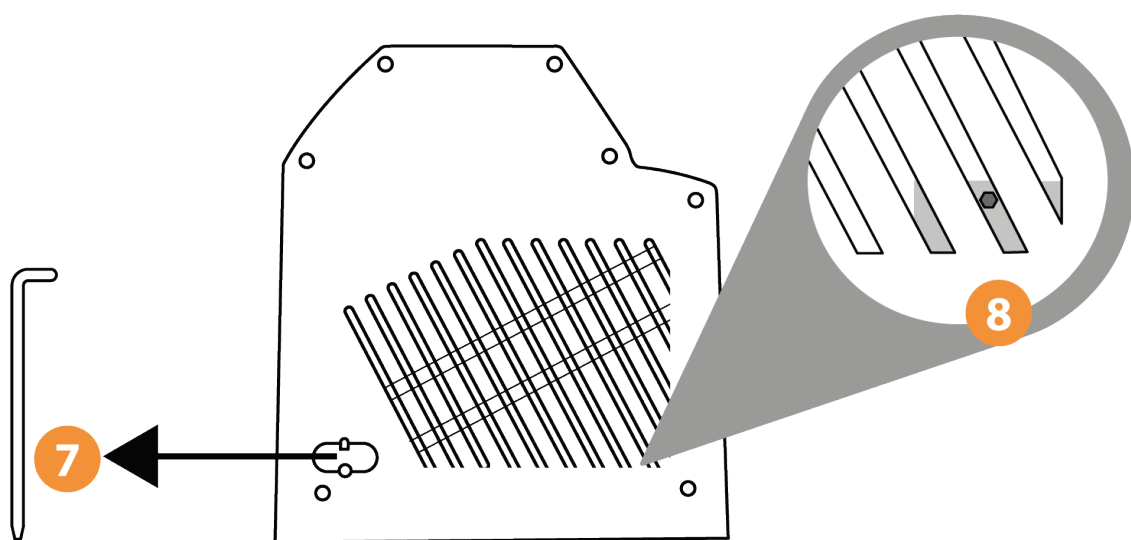

7. 摩擦力调节工具位置

8. 节流阀摩擦力调节操作点



3. 按钮和轴的映射

VIPER TQS 手柄：19 个按钮和 5 个轴在模式 A（不含虚拟按钮）下的映射

A 1→19

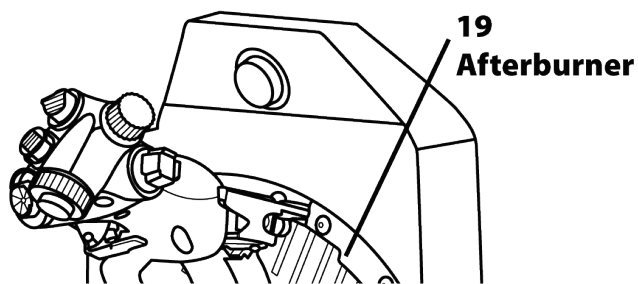
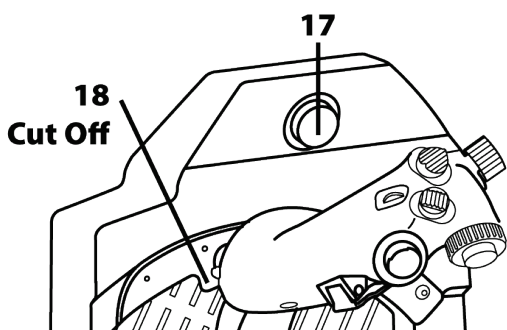
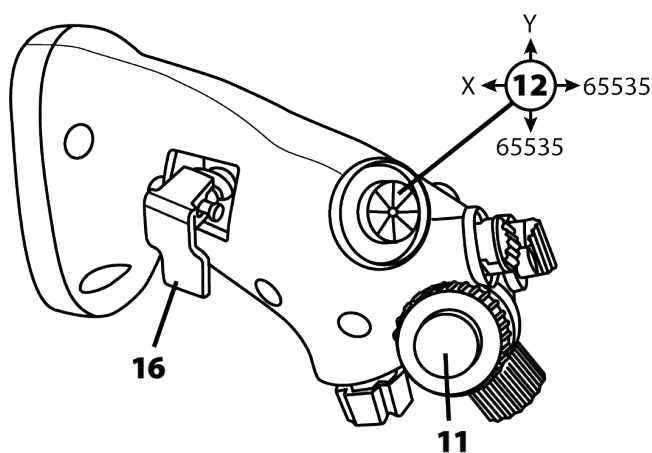
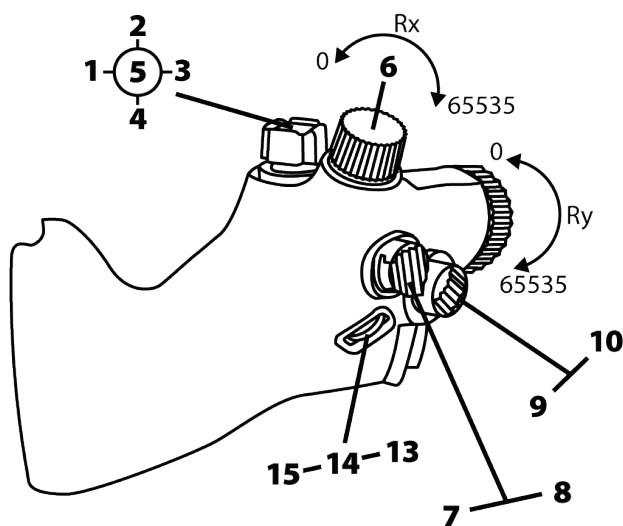



模式 B: 含虚拟按钮

B 1→21

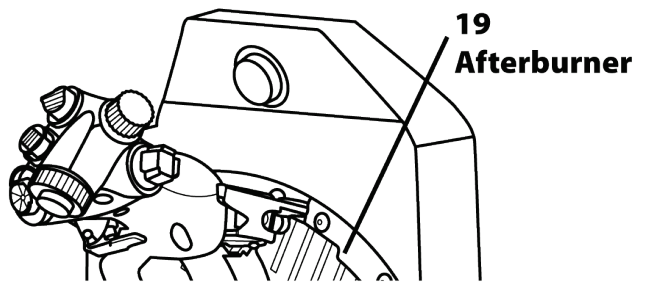
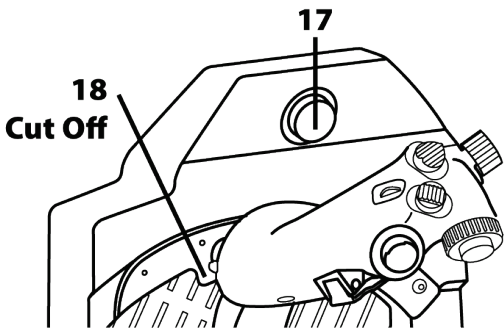
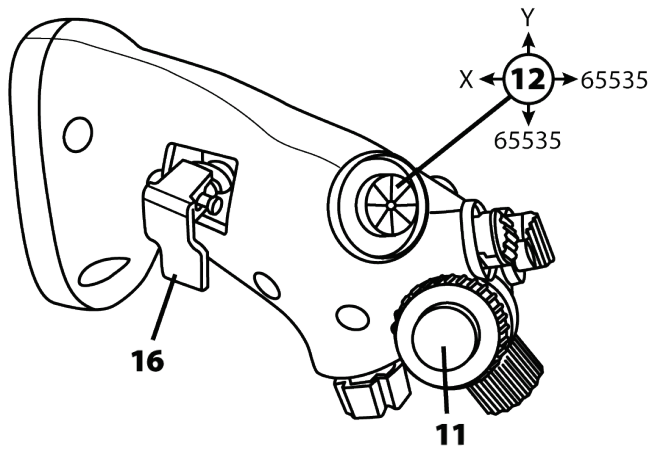
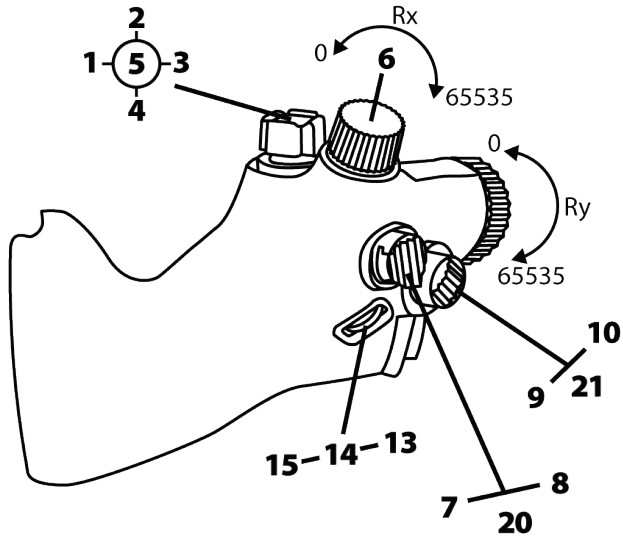



4. 有关使用 VIPER TQS 的信息



夹伤危险

在使用手柄时，切勿将手指置于禁止区域。

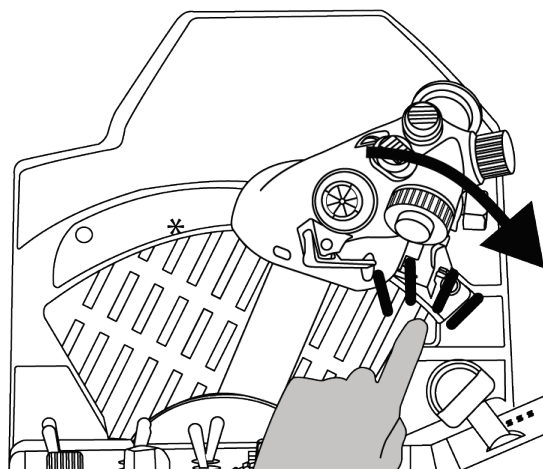
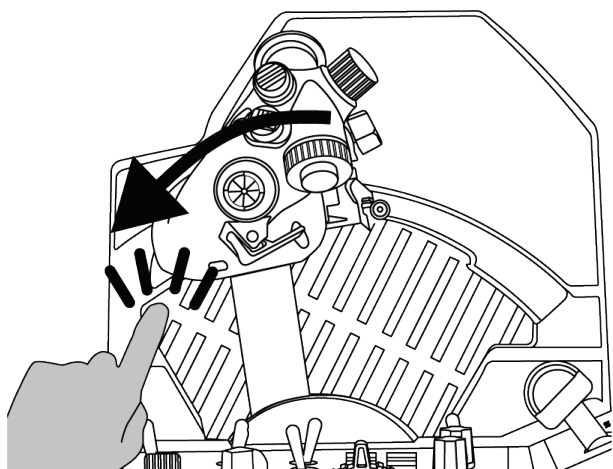
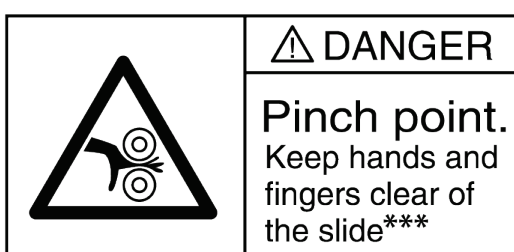



5. 调节摩擦力

您可以使用 VIPER TQS 侧面附带的工具，根据您自己的喜好调节 VIPER TQS 节流阀弧座的摩擦力。然而，请注意，出厂时已默认设置为最佳的节流阀摩擦力。

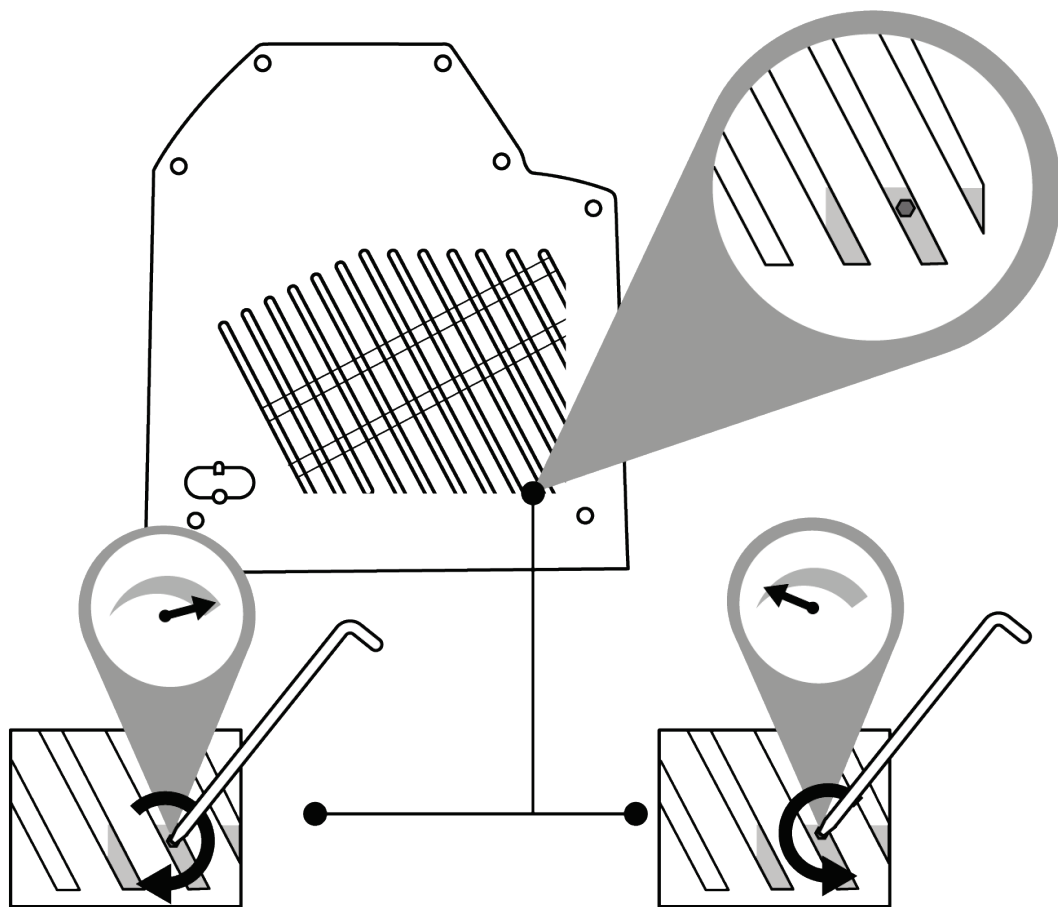

为避免损坏摩擦力系统，请小心操作，不要过度拧紧调节螺丝。

此外，切勿完全拧松调节螺丝，否则，可能存在这样的风险：节流阀无法再固定在正确的位置上。



6. 安装到支架上



VIPER TQS 可以安装在不同类型的支架上。大多数市售驾驶舱和支架均已兼容类似的 Thrustmaster（图马思特）产品（如 HOTAS Warthog）。

请切记：VIPER TQS 带有强大的杠杆效应，因此，必须连接必须牢固。

请使用合适的 M6 螺丝（不随附）将底座连接到您的支架上，以免损坏手柄。

完整的 VIPER TQS 设计图详见 <https://support.thrustmaster.com/product/viper-tqs/>



在每次使用之前，请确保 VIPER TQS 仍然按照制造商规定的说明正确连接到支架上。

务必考虑支架的制作材料，确保本产品可以安全地连接到该支架。VIPER TQS 必须在坚固材料（如中密度纤维板或木材）制成且没有任何中空或玻璃组件的桌面上使用。



安装图纸尺寸（单位：mm）

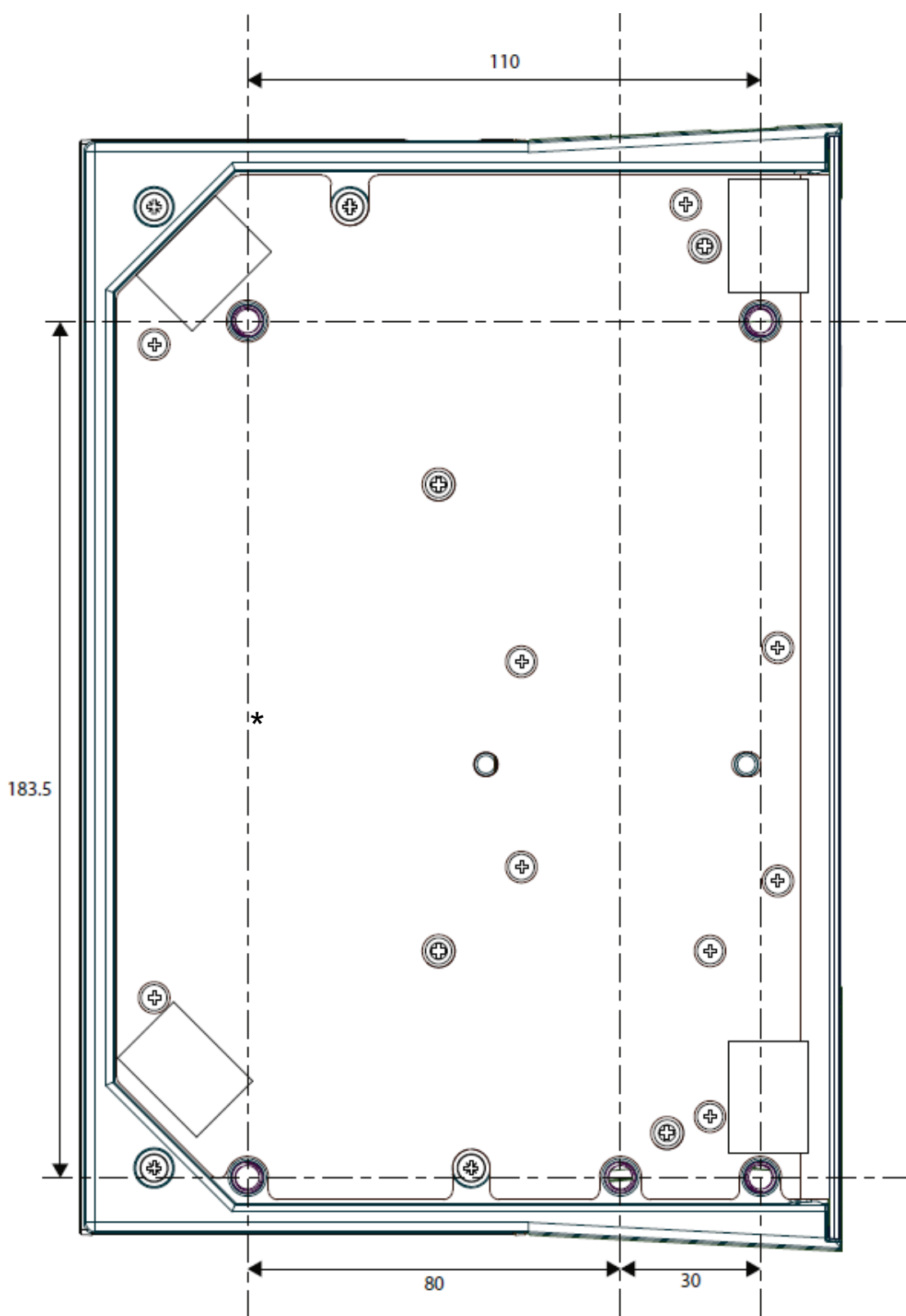

您可以从

<https://support.thrustmaster.com/product/viper-tqs/> 下载安装图纸，然后打印出来并用在您的支架上，以做好钻孔准备。



使用 *TM Flying Desk Mount* 进行安装*

TM Flying Desk Mount 是一款金属安装系统，其带有一个夹紧螺丝，可改善使用设备时的人体工学体验和驾驶位置。该系统设计用于厚度为 15 到 50 mm 的桌面和台面。

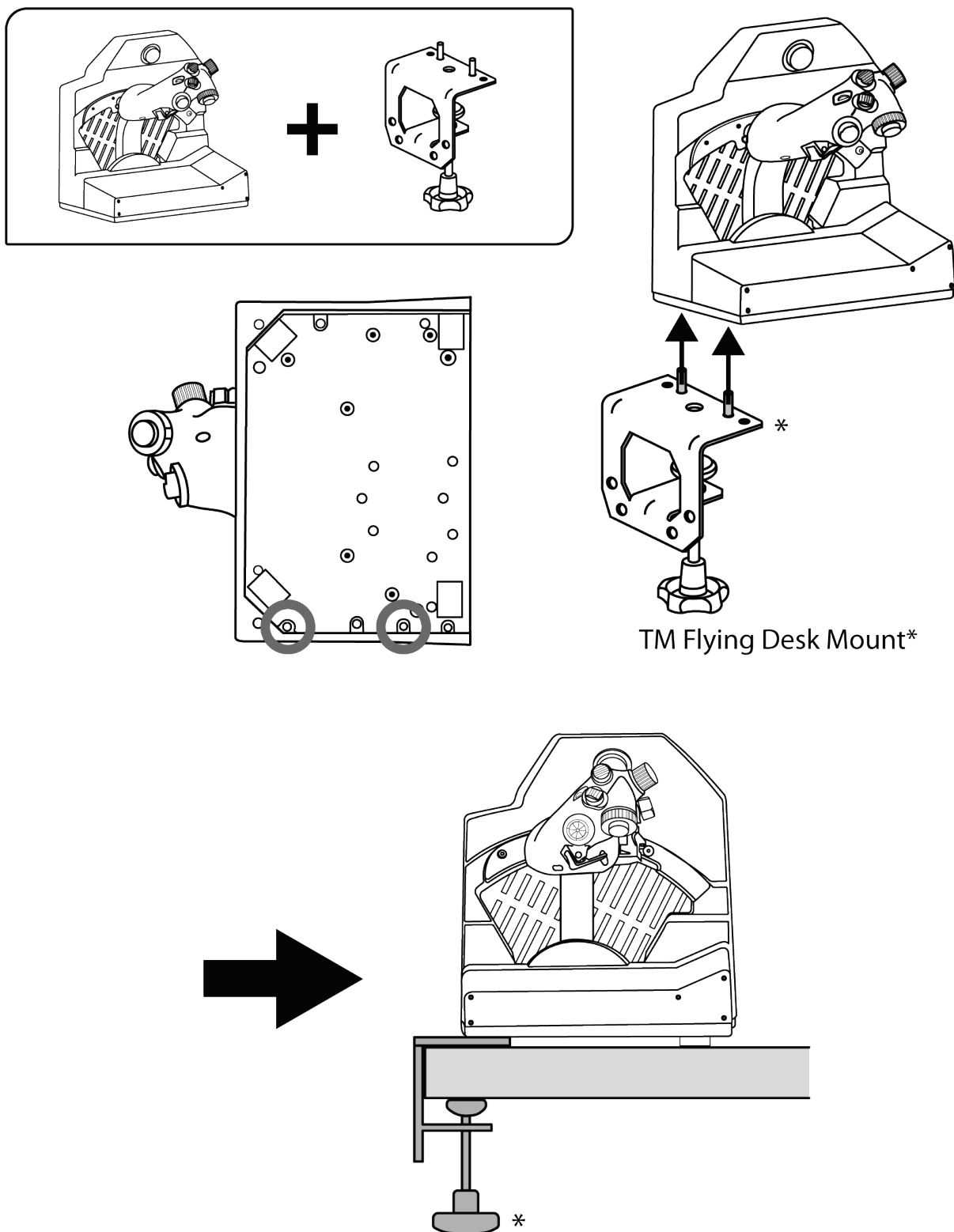

* 另售



使用 *TM Flying Clamp** 进行安装

TM Flying Clamp 是一款可调节高度的支架，由 Thrustmaster（图马思特）为其飞行模拟配件设计。该安装系统带有两个夹紧螺丝，可进行调节，以便用于厚度为 15 到 45 mm 的桌面和台面。

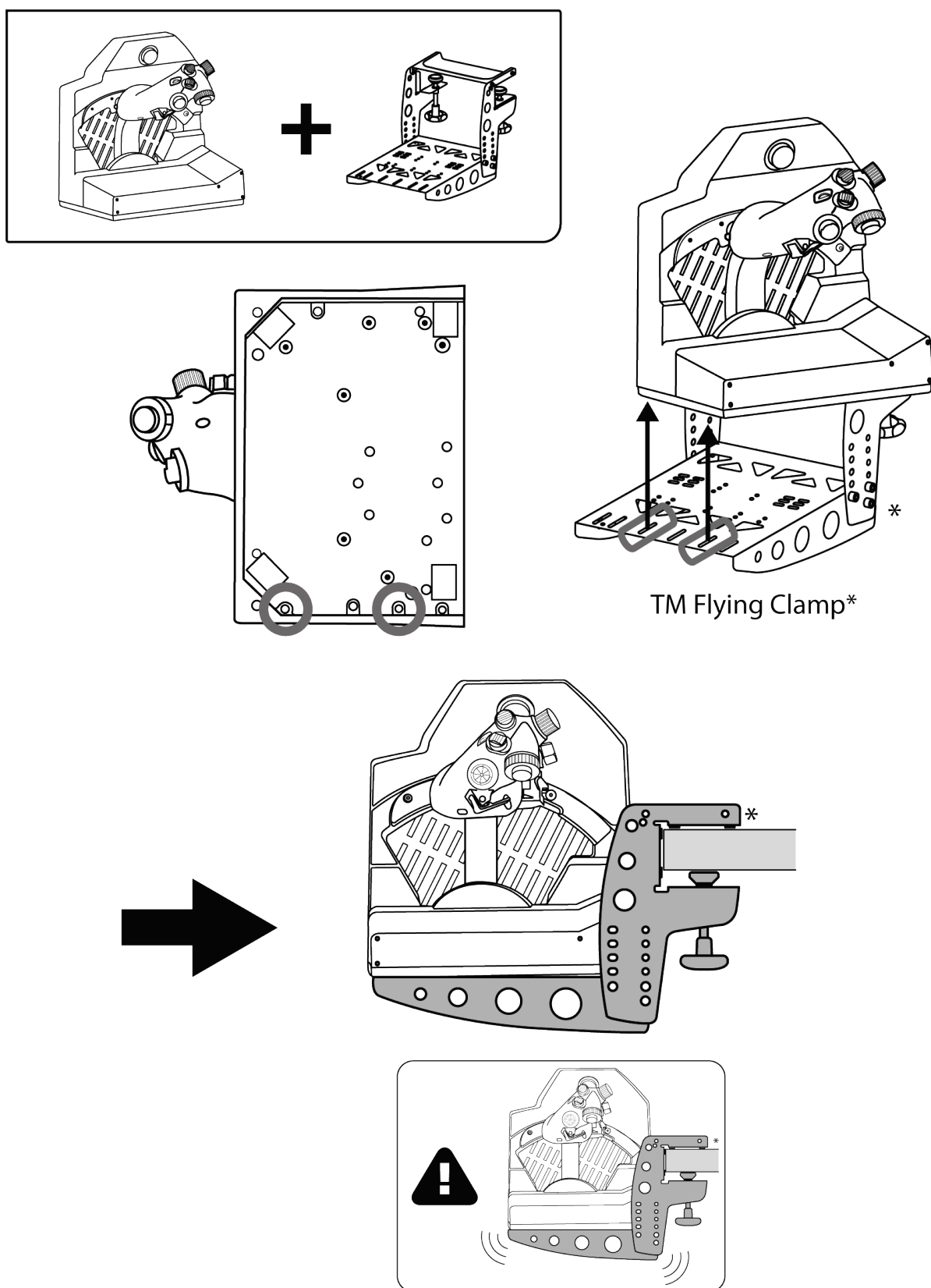

* 另售



请注意，VIPER TQS 很重，可能导致安装系统的意外移动。



7. 安装 VIPER PANEL*

* 另售。VIPER PANEL 包含在 VIPER TQS Mission Pack 中。

VIPER PANEL 是一款控制面板，其提供总共 43 个按钮和 1 个轴，所有这些控件均可通过 T.A.R.G.E.T 软件进行编程，让您能够拓展飞行/战斗功能。VIPER PANEL 是 VIPER TQS 的加装配件。

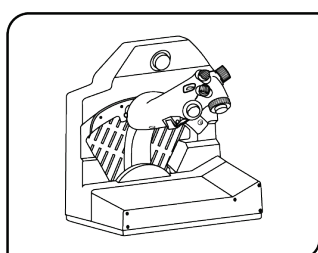

1

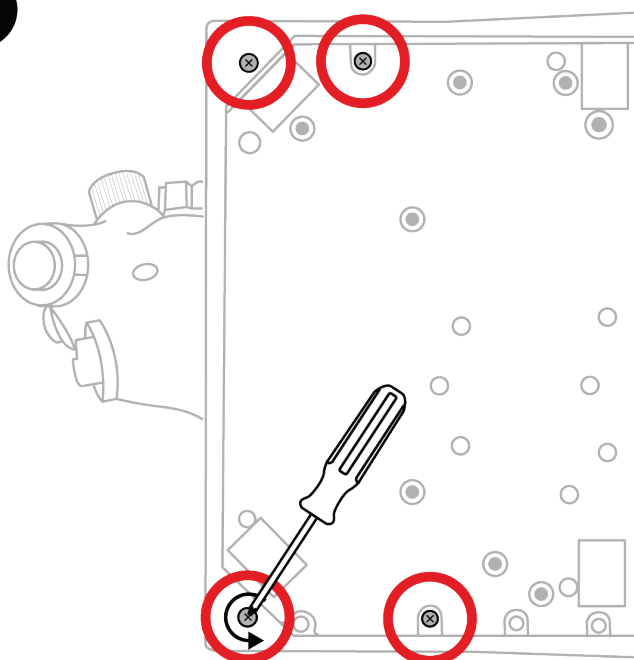

2

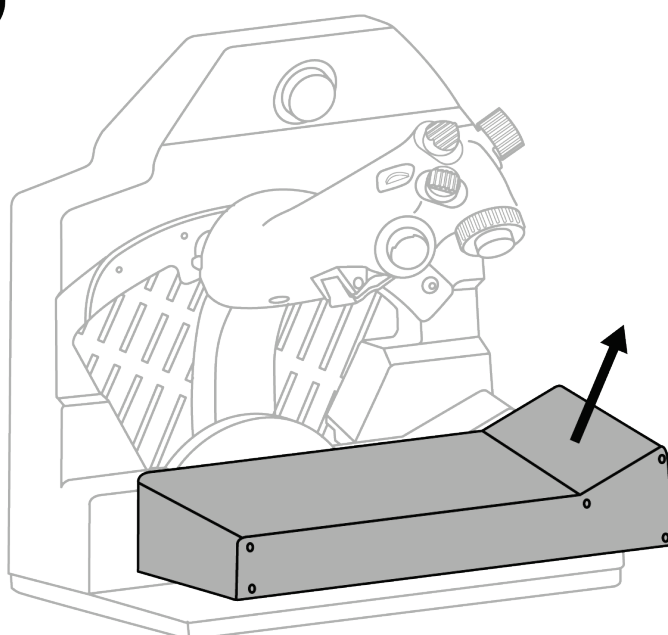

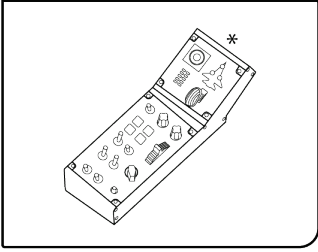

3

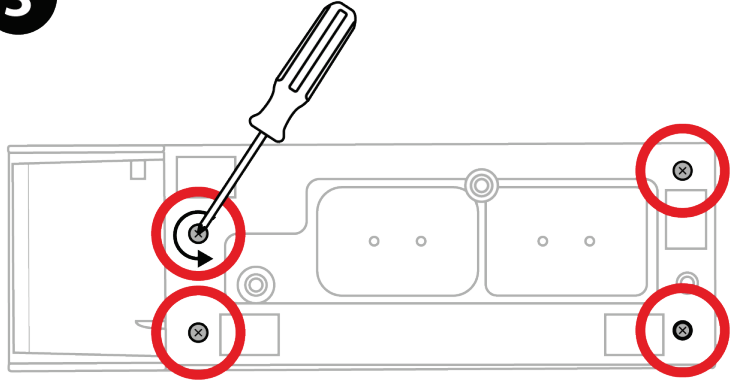

4

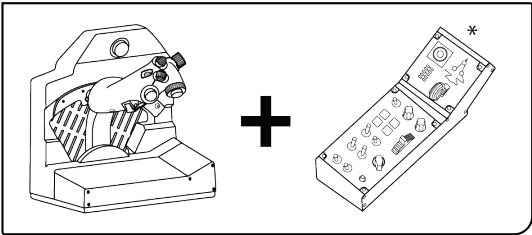
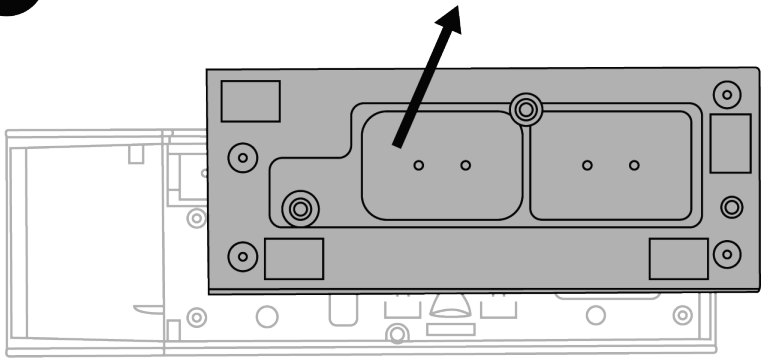

5

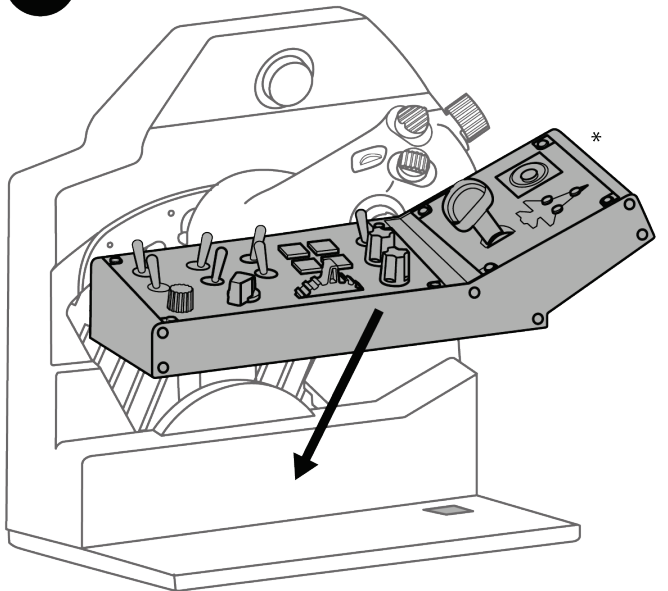



6

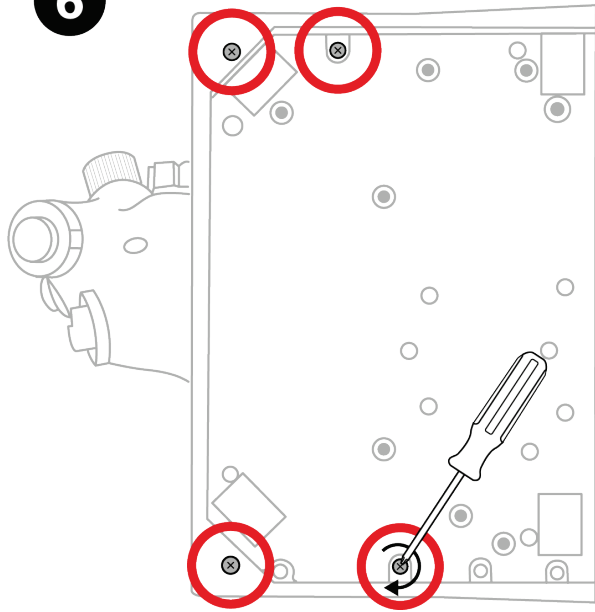

7

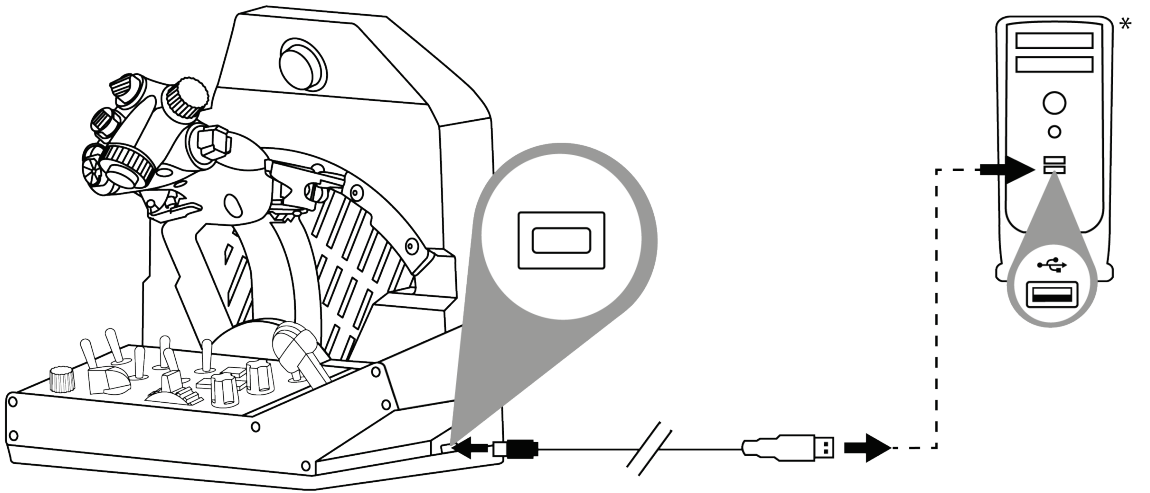

* 未提供



8. 安装到 PC 上

1



请访问

<https://support.thrustmaster.com/product/viper-tqs/>。

2

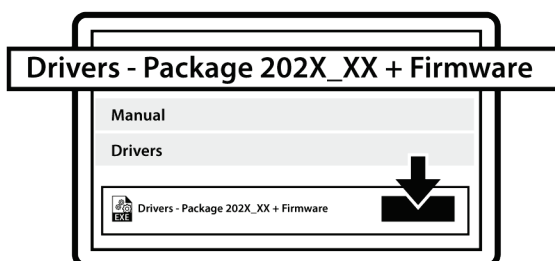

下载并安装 PC 驱动程序及其基于 Windows 控制面板的自定义界面。

3

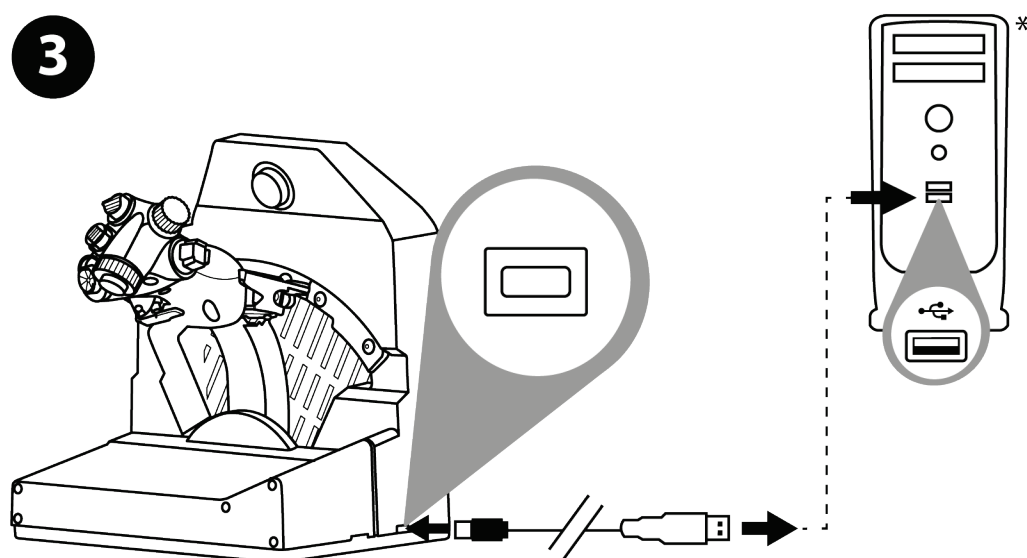

安装 PC 驱动程序之后，将 USB 接头连接到 PC 上的某个 USB 端口。

* 未提供



④ 要访问 Control Panel，请选择开始 / 所有应用 / **Thrustmaster / Control Panel** 或控制面板（在 Windows 10 中）。

此时将显示**游戏控制器**对话框。该附件将出现在屏幕上，其名称显示为 **VIPER TQS**，状态为 **OK**。

⑤ 在**游戏控制器**对话框中，单击**属性**可测试和查看所有功能。

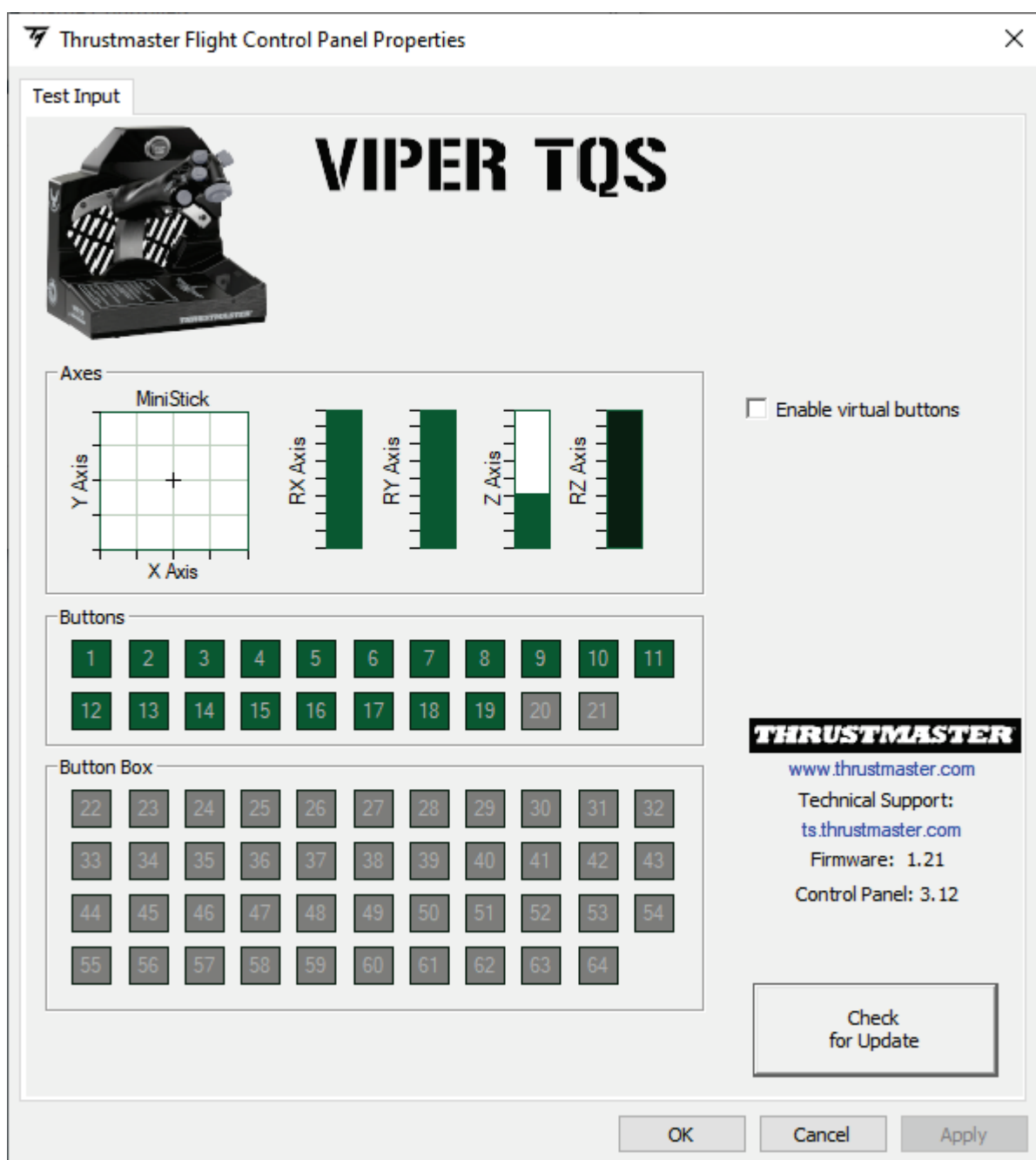



Enable virtual buttons (启用虚拟按钮):

此功能允许您启用或禁用手柄上的虚拟按钮（按钮 20 至 21）。在选择您要使用的模式之后，单击 **Apply** (应用)。

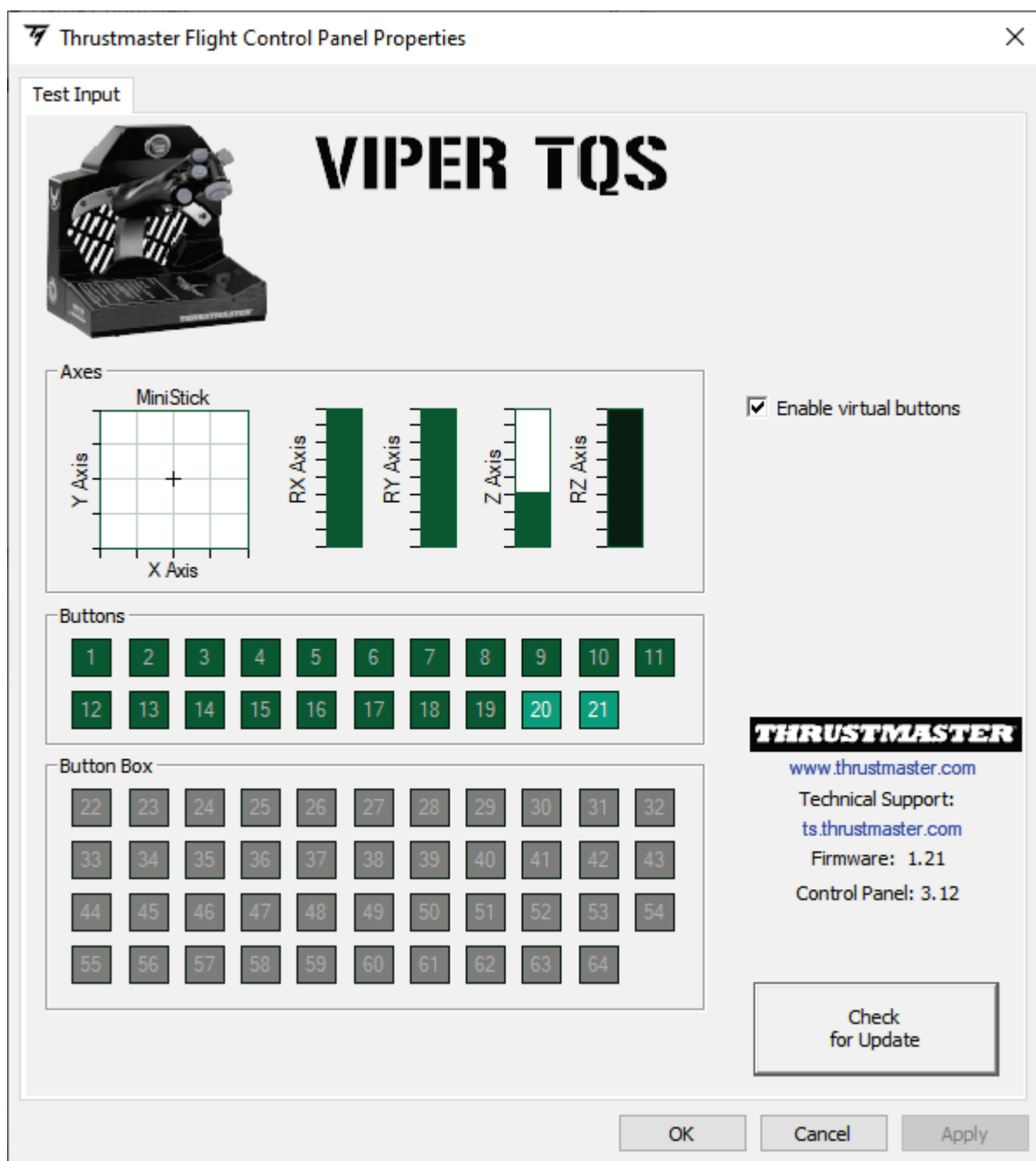

默认情况下，会禁用 VIPER TQS 上的虚拟按钮。



9. CUT OFF 和 AFTERBURNER 止动器

VIPER TQS 节流阀弧座配备逼真的 CUT OFF 和 AFTERBURNER 止动器（Afterburner 模块可拆卸）系统。

CUT OFF

在将节流阀置于 IDLE 限位器后，按下“引擎切断解锁”扳机 **1**，以抬升手柄，使之越过限位器 **2**，然后将手柄置于 OFF 位置 **3**。

要重新打开引擎，请倒序执行上述程序。

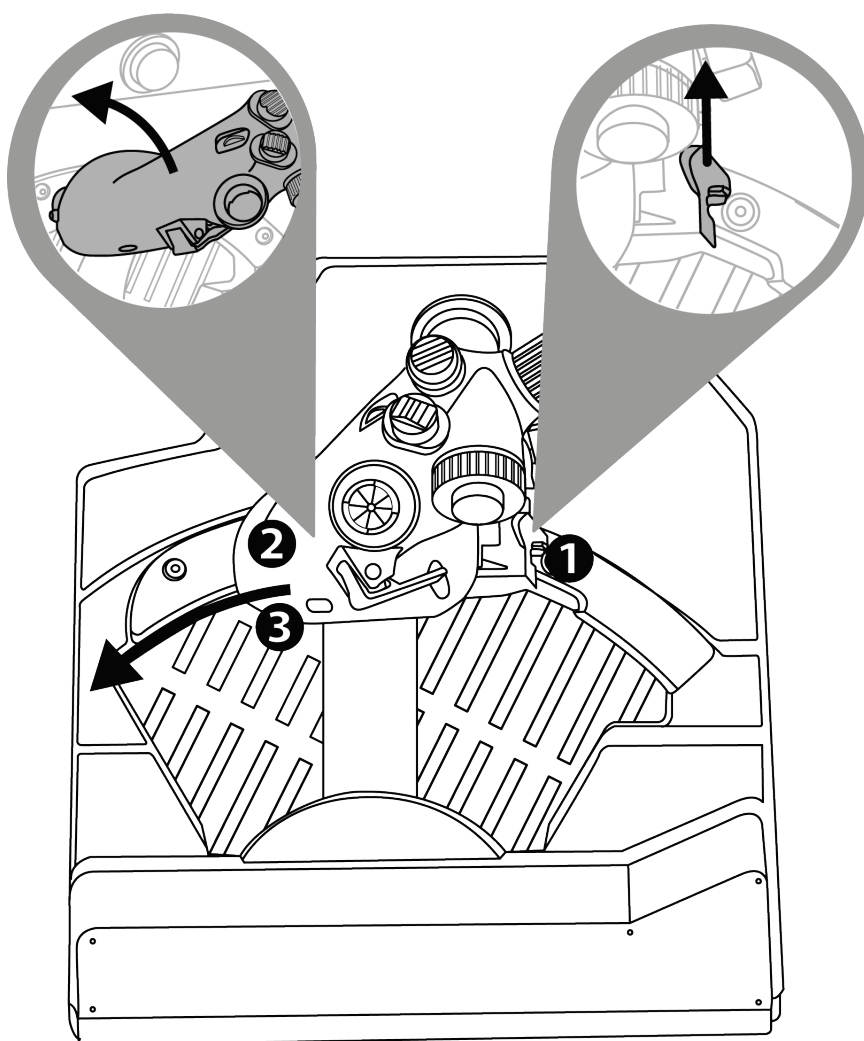



AFTERBURNER

将节流阀移动到限位器 **1** 并抬升 **2**，以越过限位器，啮合后燃器 **3**。

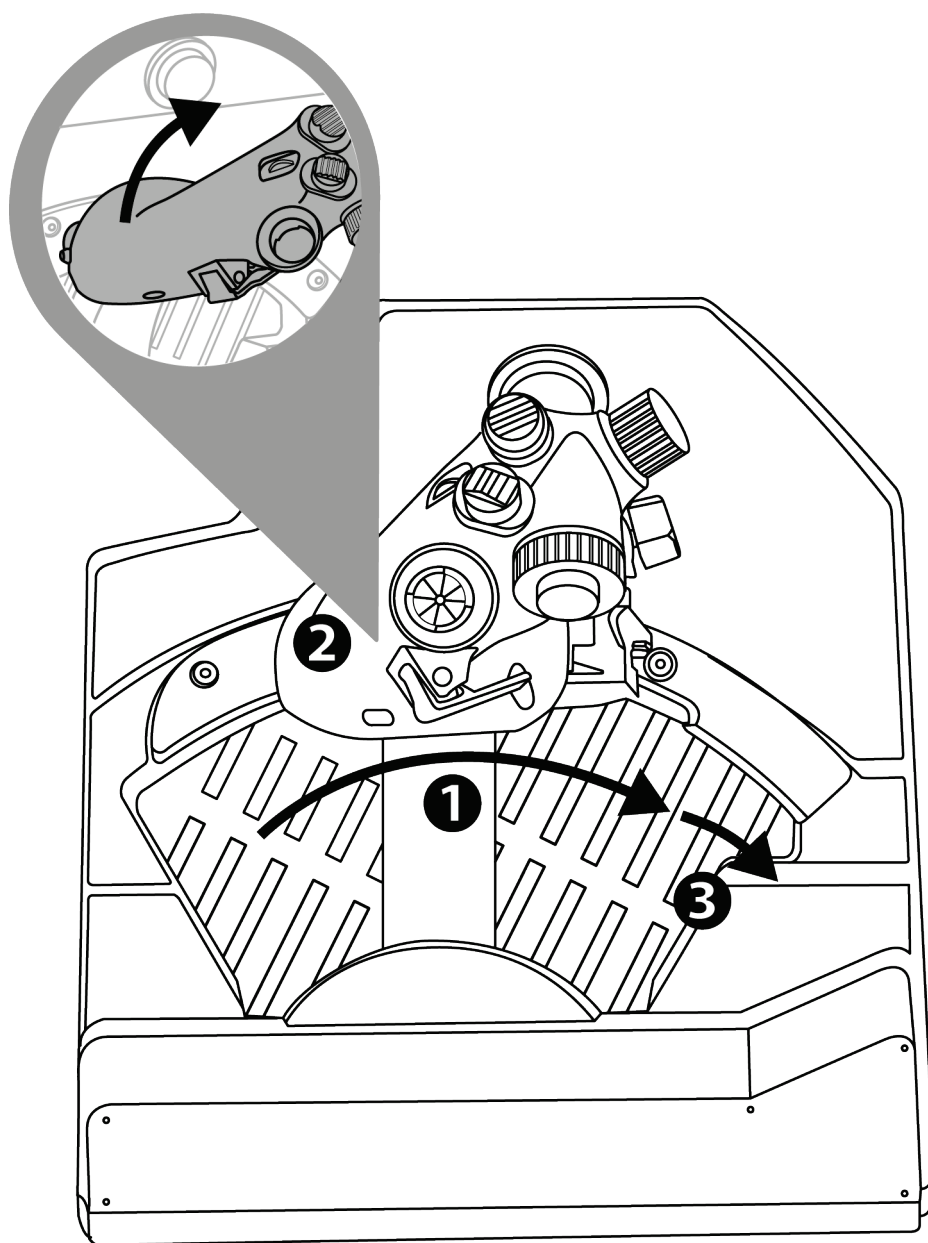



拆卸 AFTERBURNER 限位器

Afterburner 模块的限位器位于轴的 80% 处。

如果您需要不带限位器的 100% 节流阀行程（针对特殊的模拟器），您可以通过使用内六角扳手（未随附）拧松该模块的两个螺丝，拆卸 Afterburner 模块及其限位器。

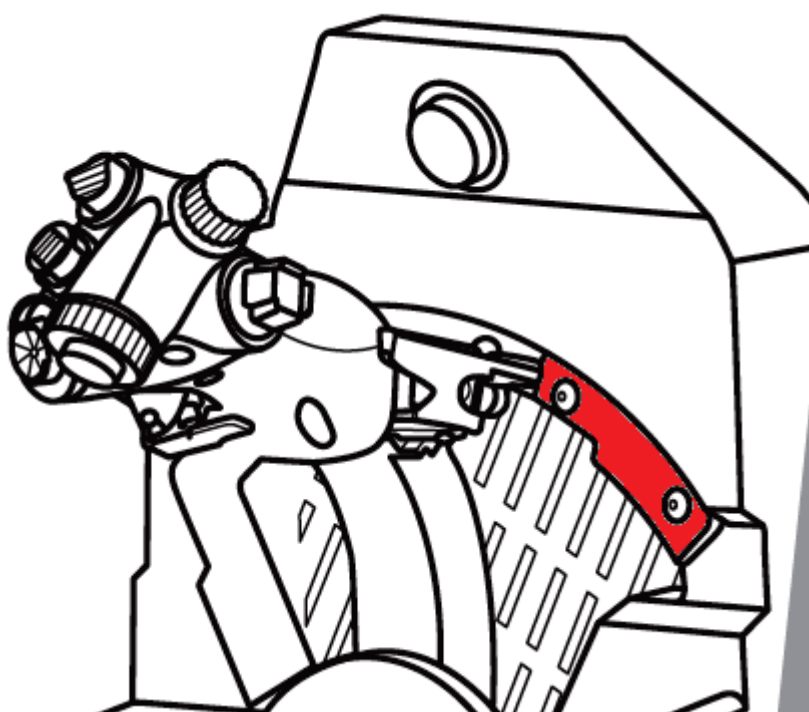



10. T.A.R.G.E.T 高级编程软件



请访问

<https://support.thrustmaster.com/product/viper-tqs/>。

在 **Software** (软件) 部分，下载并安装 T.A.R.G.E.T 高级编程软件。



T.A.R.G.E.T 的主要功能

- 支持不同的轴配置。
- 支持不同级别的编程设置：Basic、Advanced 与 Script。
- 采用“拖放”原则。
- 可将 VIPER TQS 节流阀弧座与各种 Thrustmaster（图马思特）摇杆（HOTAS Cougar、HOTAS Warthog、T.16000M 和 MFD Cougar Pack，所有这些设备也兼容 T.A.R.G.E.T）结合在一起，从而被识别为单个 USB 设备。
- 可访问由 Thrustmaster（图马思特）社区创建的高级配置文件。



11. 常见问题解答和技术支持

您对 VIPER TQS 是否有任何疑问，或者您是否遇到任何技术问题？若有的话，请访问 Thrustmaster（图马思特）技术支持网站：

<https://support.thrustmaster.com/product/viper-tqs/>.



THRUSTMASTER®

VIPER TQS

THROTTLE QUADRANT SYSTEM

PC (Windows 10/11) 版

使用者手冊



在安裝本產品之前、在以任何方式使用本產品之前以及對其執行任何維護之前，請仔細閱讀本手冊提供的說明。請務必遵守安全說明。不遵守這些說明可能導致事故和/或損壞。請保留本手冊，以便您日後查閱說明。

目錄

1.	包裝清單.....	5
2.	VIPER TQS 配備.....	6
3.	按鈕和軸的對應.....	8
4.	有關使用 VIPER TQS 的信息.....	10
5.	調節摩擦力.....	11
6.	安裝到支架上.....	12
7.	安裝 VIPER PANEL*.....	17
8.	安裝到 PC 上.....	20
9.	CUT OFF 和 AFTERBURNER 止動器.....	23
10.	T.A.R.G.E.T 進階編程軟體.....	26
11.	常見問題解答和技術支援.....	28



借助來自美國空軍部的 **VIPER**（世界上使用最廣泛的現代戰鬥機）的標誌性節流閥弧座加速飛行，深入虎穴！

獨特的 **1:1** 比例人體工學複刻版 **HOTAS** 配備金屬手柄和逼真的按鈕與止動器，讓您的駕駛艙再上一個臺階。

本手冊將輔助您安裝 **VIPER TQS** 並讓其運作在最佳條件下。在開始起飛之前，請仔細閱讀以下所有說明和警告：它們將助力您盡情享受您的產品。



更新韌體

要使 VIPER TQS 能在視訊遊戲中正常工作，您必須更新其韌體。

要執行更新，請瀏覽

<https://support.thrustmaster.com/product/viper-tqs/>

選取 **Firmware** (韌體)，然後按照說明（包括下載和安裝程式）進行操作。



1. 包裝清單

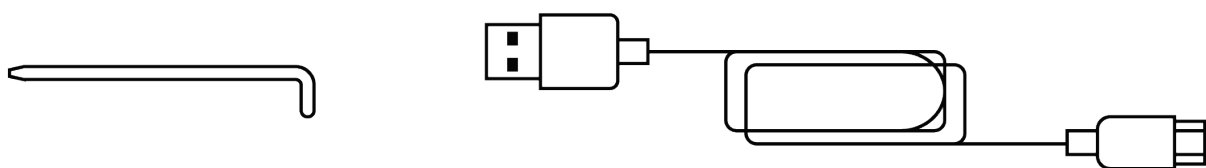
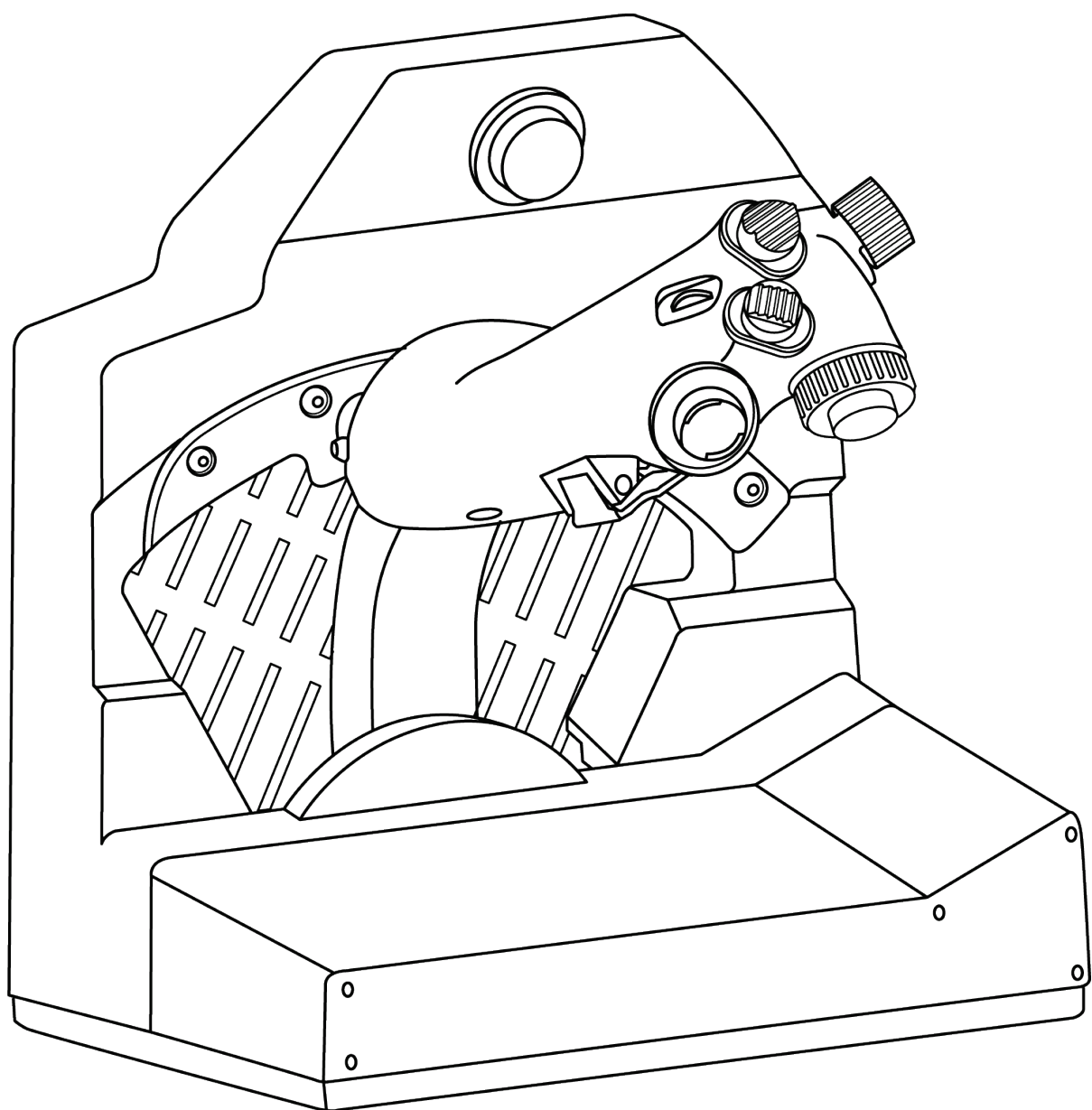



2. VIPER TQS 配備

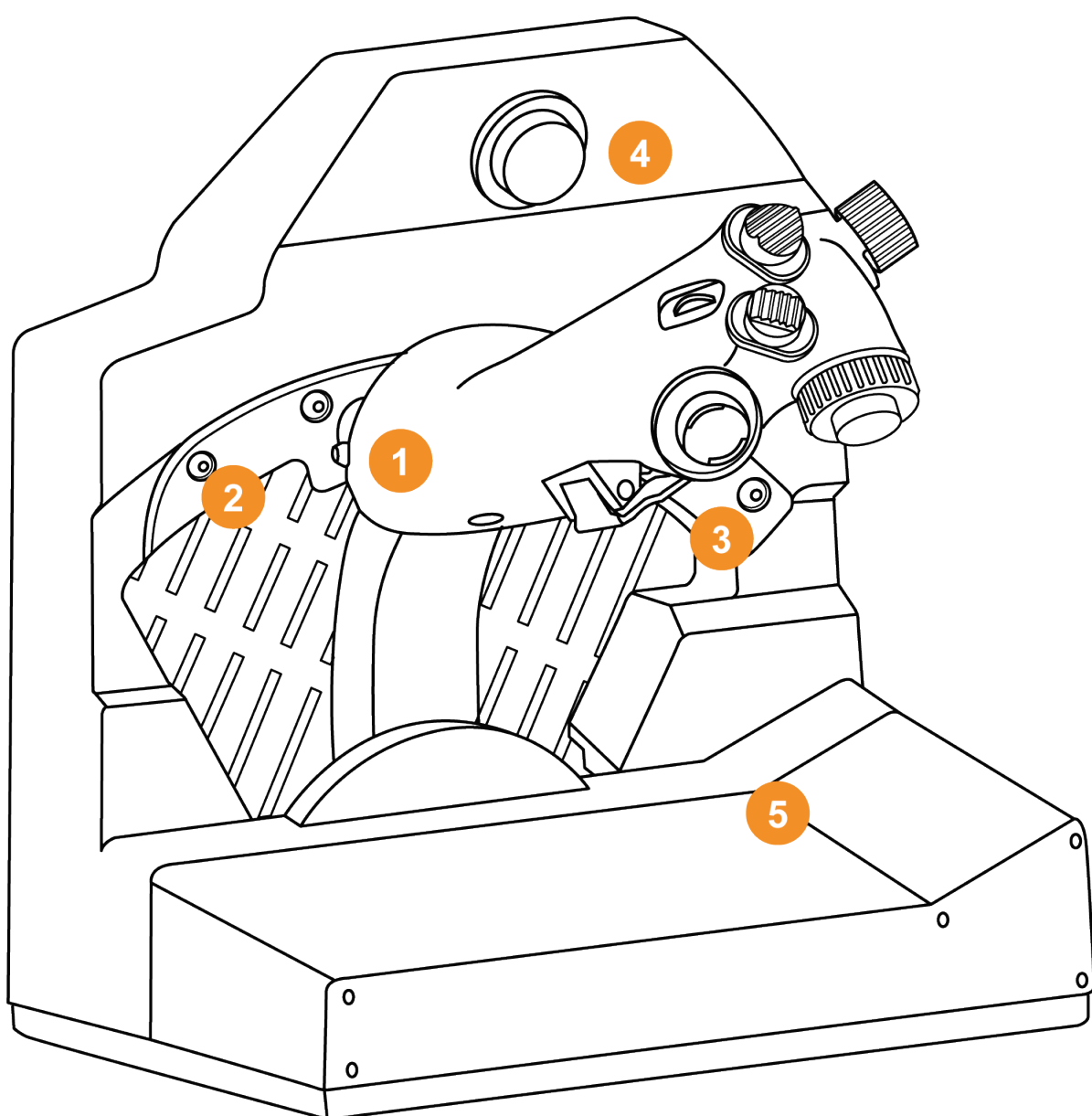

1. 手柄

2. **Cut Off** 限位器

3. 後燃器限位器

4. **CHAFF/FLARE** 拍擊按鈕

5. 任務地圖夾

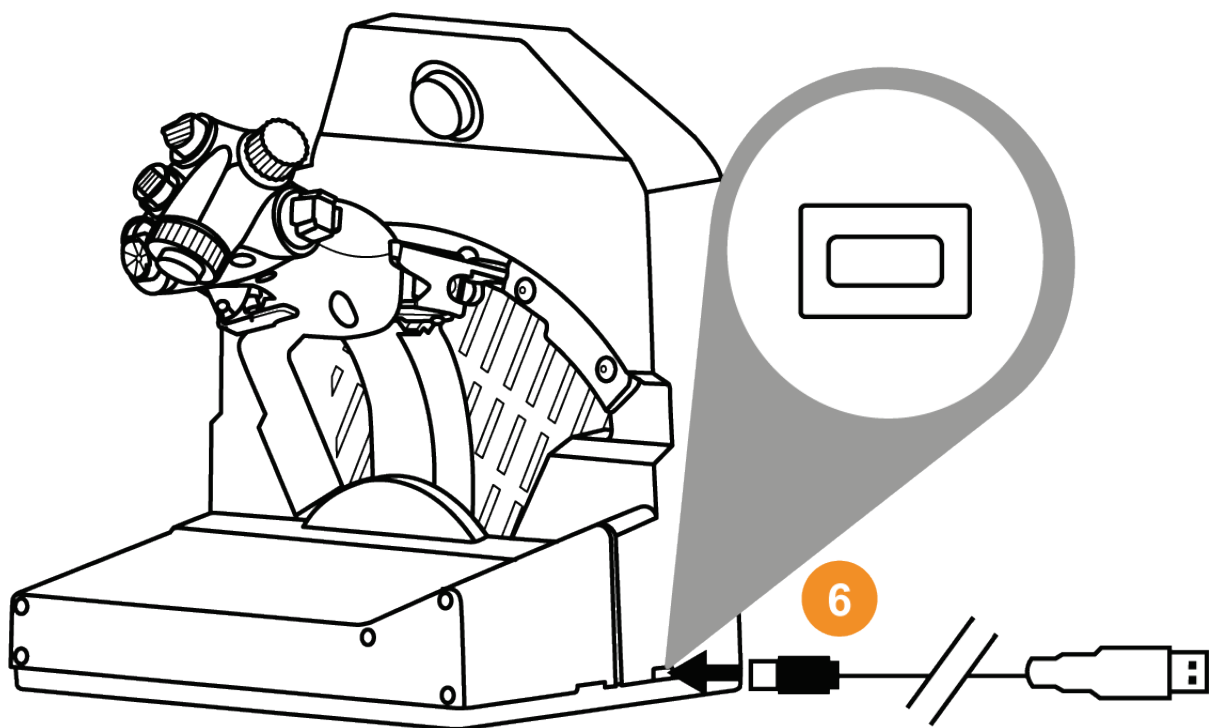

6. USB 介面 (type C)

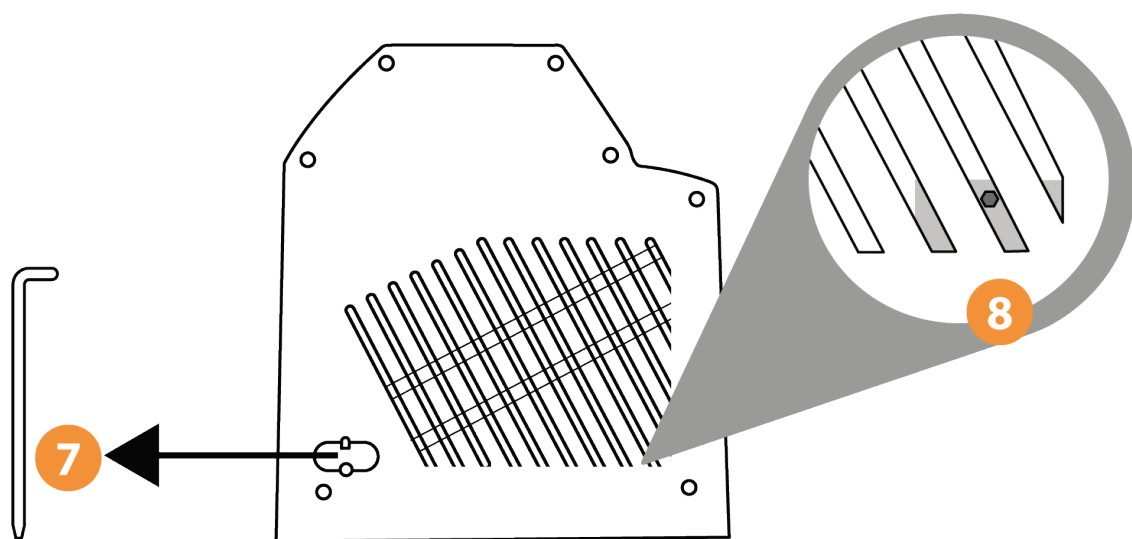

7. 摩擦力調節工具位置

8. 節流閥摩擦力調節操作點



3. 按鈕和軸的對應

VIPER TQS 手柄：19 個按鈕和 5 個軸在模式 A（不含虛擬按鈕）下的對應

A 1→19

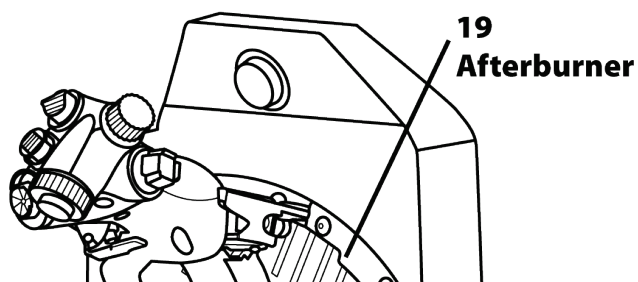
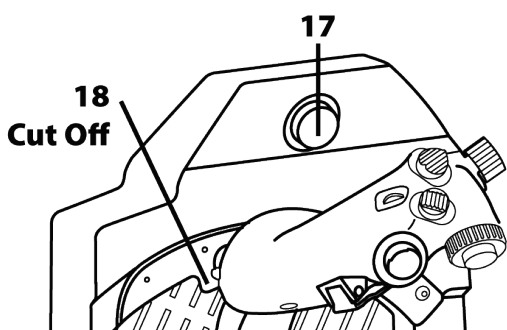
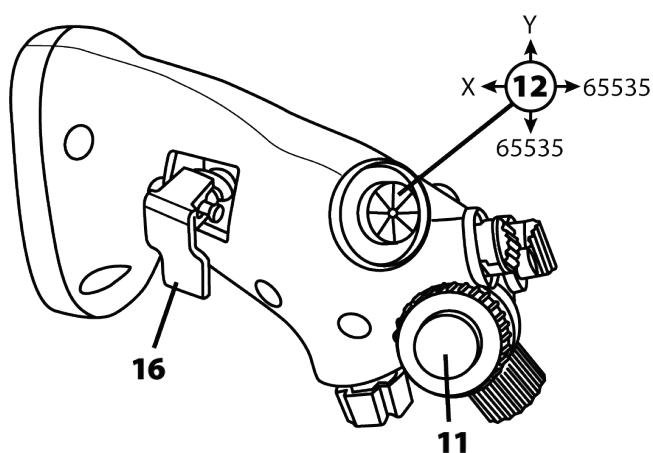
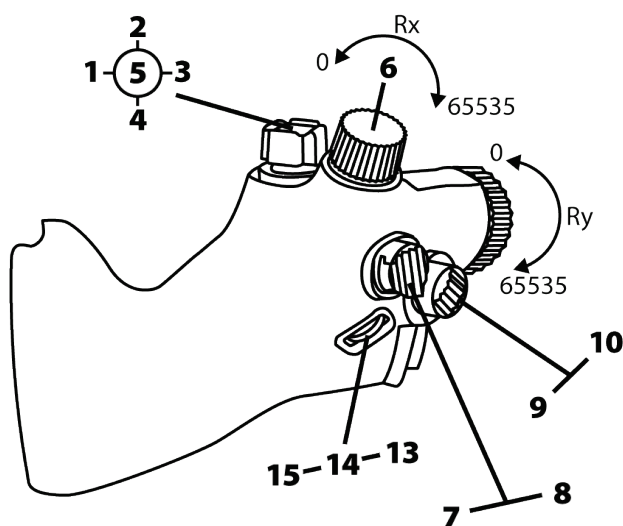



模式 B：含虛擬按鈕

B 1→21

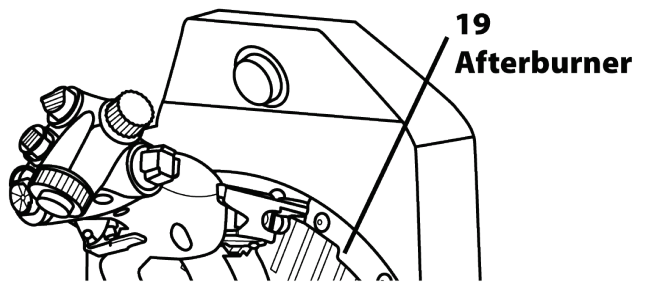
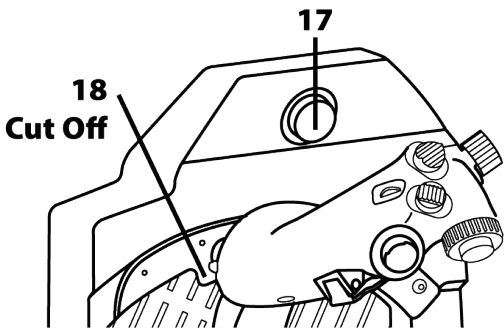
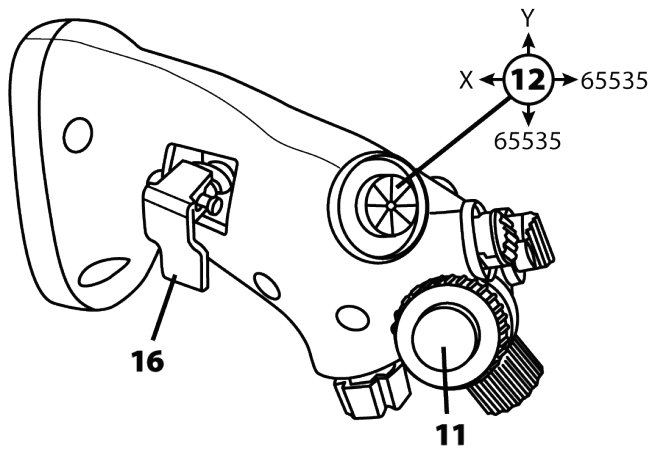
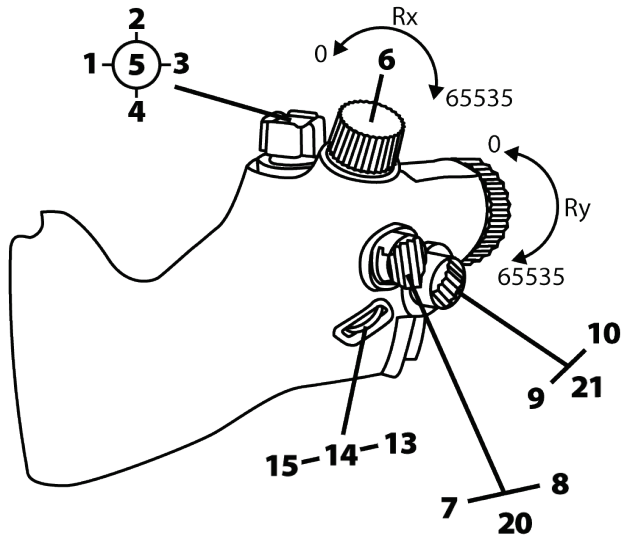



4. 有關使用 VIPER TQS 的信息



夾傷危險

在使用手柄時，切勿將手指置於禁止區域。

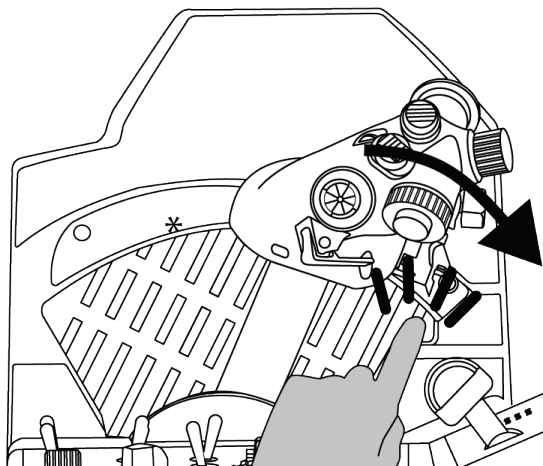
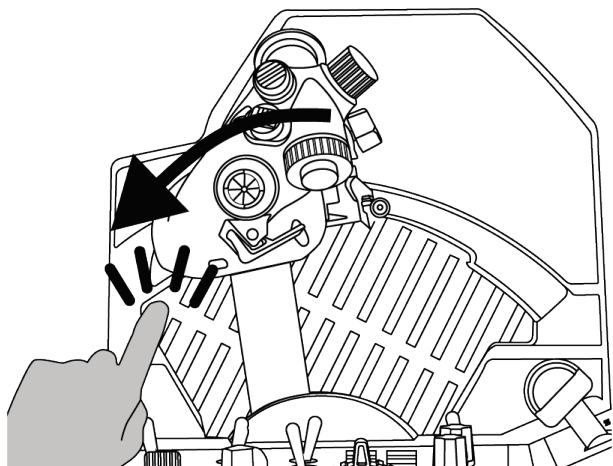
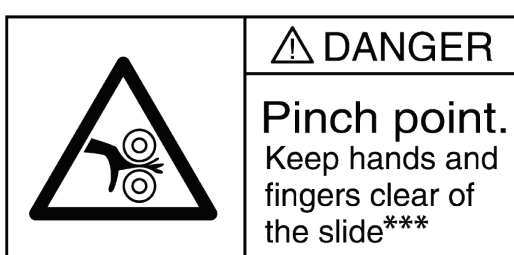



5. 調節摩擦力

您可以使用 VIPER TQS 側面附帶的工具，根據您自己的喜好調節 VIPER TQS 節流閥弧座的摩擦力。然而，請注意，出廠時已預設為最佳的節流閥摩擦力。

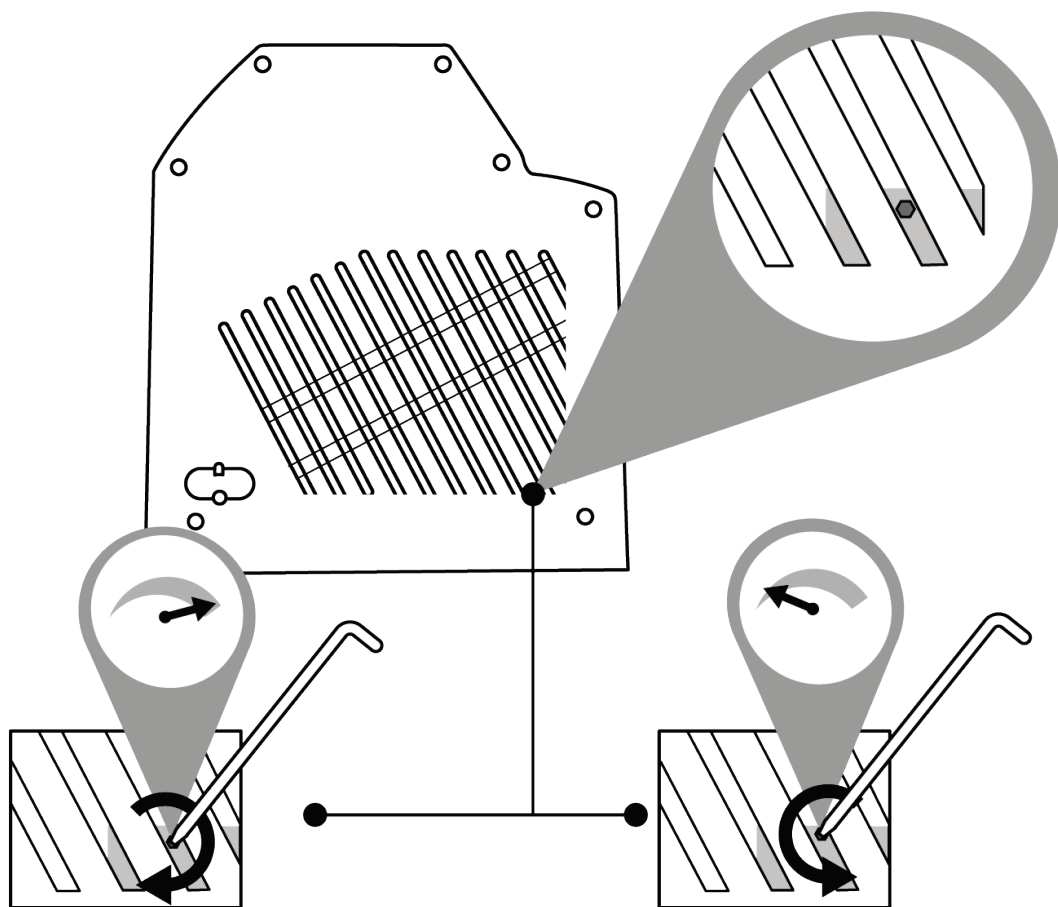

為避免損壞摩擦力系統，請小心操作，不要過度擰緊調節螺絲。

此外，切勿完全擰松調節螺絲，否則，可能存在這樣的風險：節流閥無法再固定在正確的位置上。



6. 安裝到支架上



VIPER TQS 可以安裝在不同類型的支架上。大多數市售駕駛艙和支架均已相容於類似的 Thrustmaster（圖馬思特）產品（如 HOTAS Warthog）。

請切記：VIPER TQS 帶有強大的杠杆效應，因此，必須連接必須牢固。

請使用合適的 M6 螺絲（不隨附）將底座連接到您的支架上，以免損壞手柄。

完整的 VIPER TQS 設計圖詳見 <https://support.thrustmaster.com/product/viper-tqs/>



在每次使用之前，請確保 VIPER TQS 仍然按照製造商規定的說明正確連接到支架上。

務必考慮支架的製作材料，確保本產品可以安全地連接到該支架。VIPER TQS 必須在堅固材料（如中密度纖維板或木材）製成且沒有任何中空或玻璃元件的桌面上使用。



安裝圖紙尺寸（單位：mm）

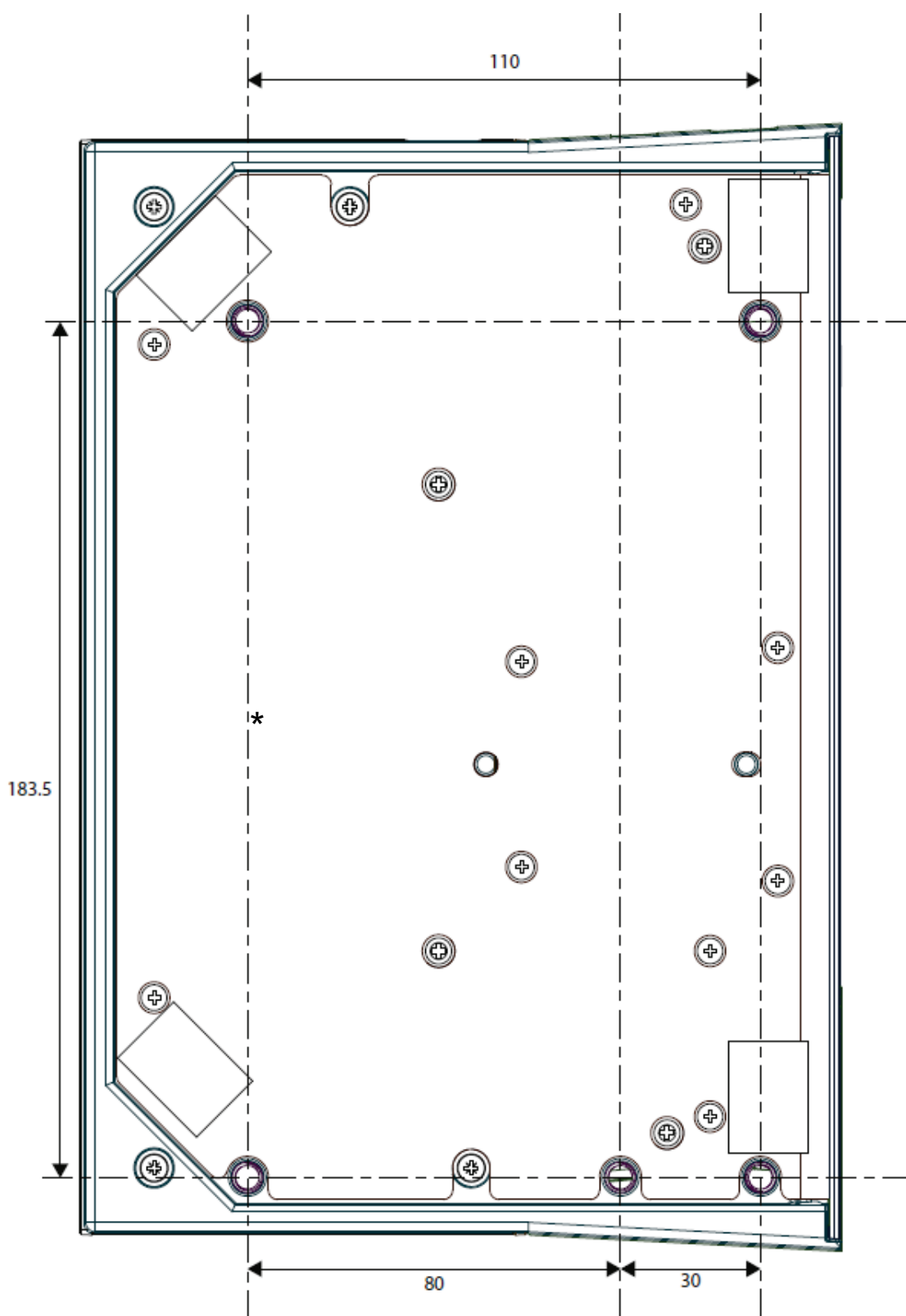

您可以從

<https://support.thrustmaster.com/product/viper-tqs/>

下載安裝圖紙，然後列印出來並用在您的支架上，以做好鑽孔準備。



使用 *TM Flying Desk Mount* 進行安裝*

TM Flying Desk Mount 是一款金屬安裝系統，其帶有一個夾緊螺絲，可改善使用裝置時的人體工學體驗和駕駛位置。該系統設計用於厚度為 15 到 50 mm 的桌面和檯面。

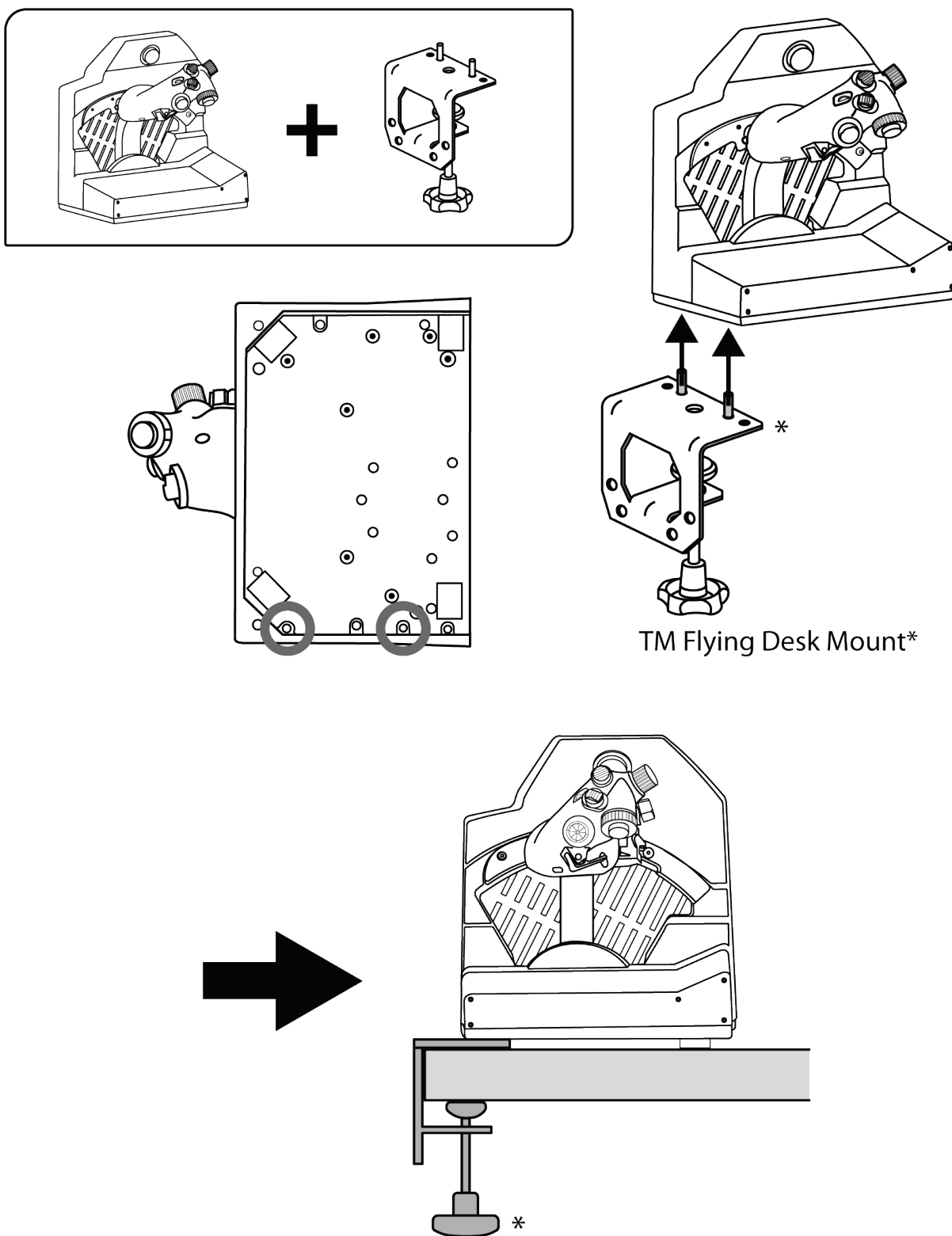

* 另售



使用 *TM Flying Clamp** 進行安裝

TM Flying Clamp 是一款可調節高度的支架，由 Thrustmaster（圖馬思特）為其飛行模擬配件設計。該安裝系統帶有兩個夾緊螺絲，可進行調節，以使用於厚度為 15 到 45 mm 的桌面和檯面。

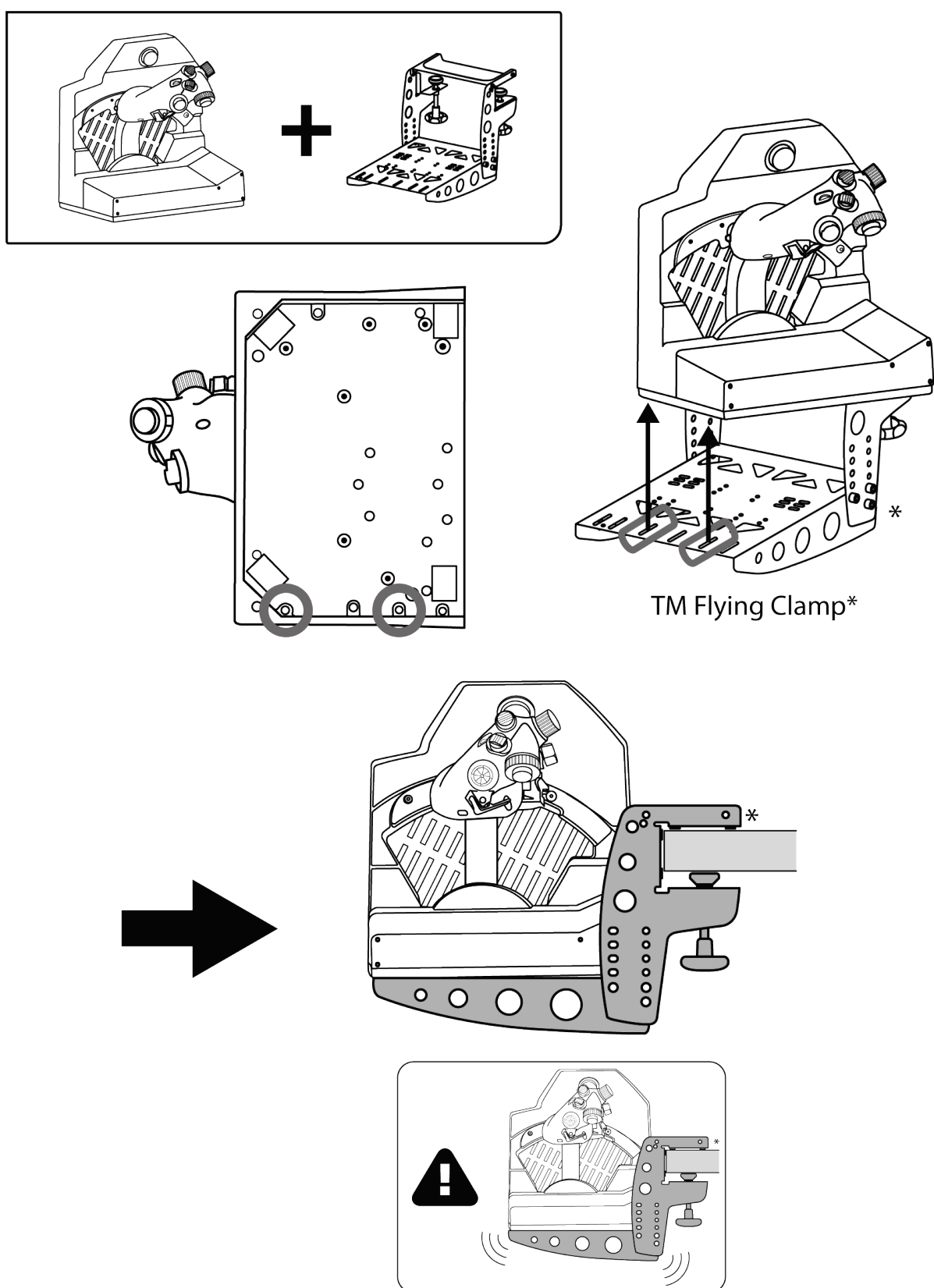

* 另售



請注意，VIPER TQS 很重，可能導致安裝系統的意外移動。



7. 安裝 VIPER PANEL*

* 另售。VIPER PANEL 包含在 VIPER TQS Mission Pack 中。

VIPER PANEL 是一款控制台，其提供總共 43 個按鈕和 1 個軸，所有這些控制項均可透過 T.A.R.G.E.T 軟體進行編程，讓您能夠拓展飛行/戰鬥功能。VIPER PANEL 是 VIPER TQS 的加裝配件。

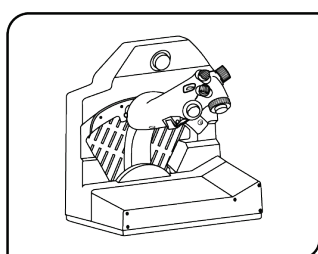

1

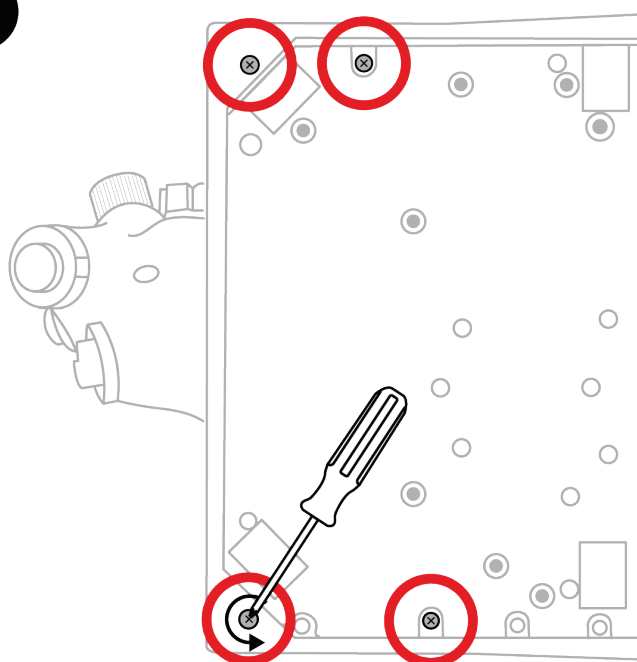

2

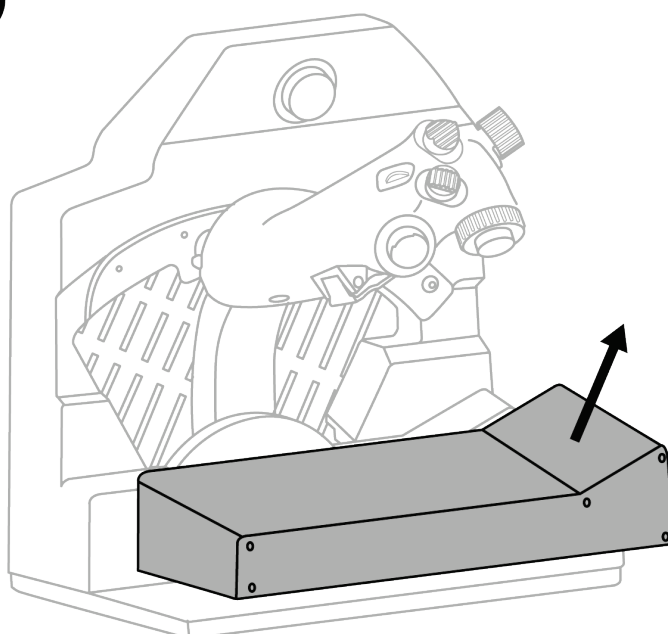

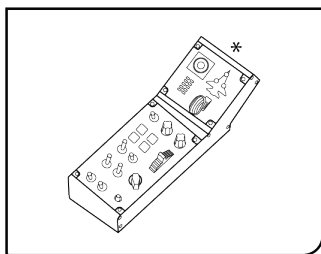

3

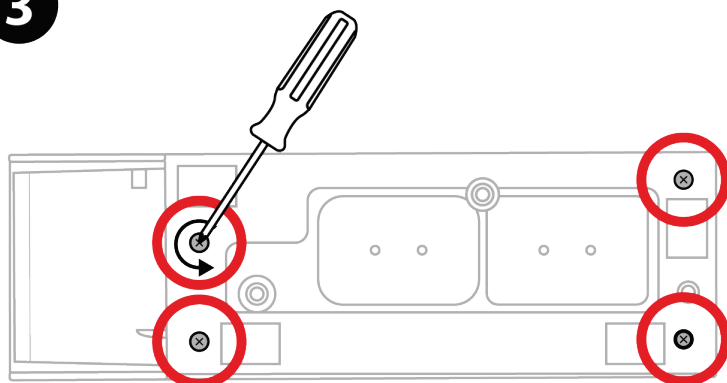

4

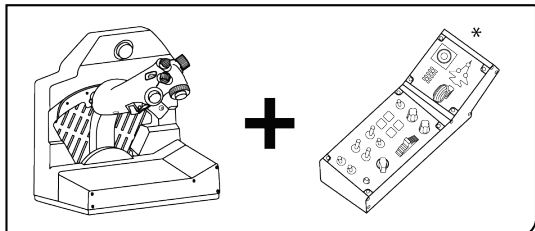
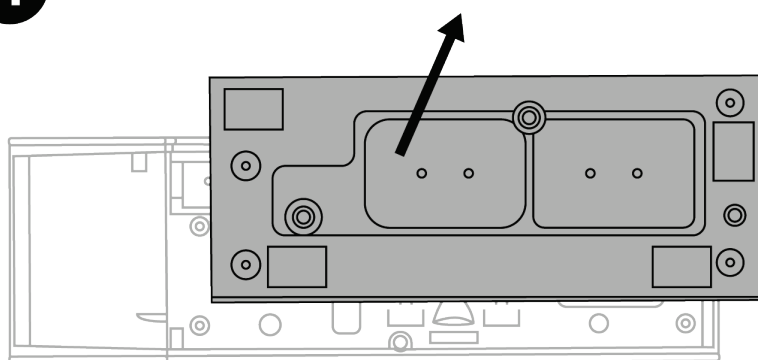

5

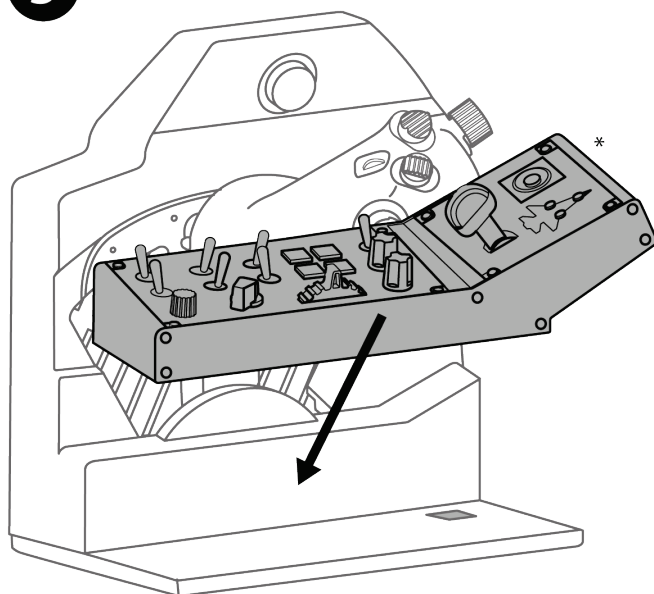



6

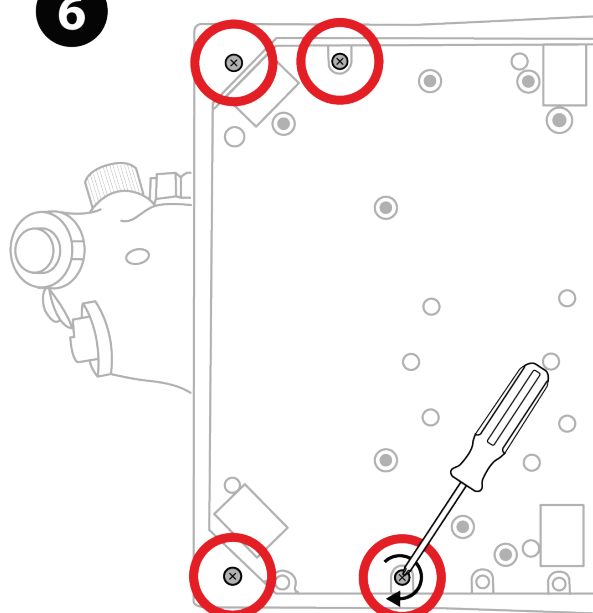

7

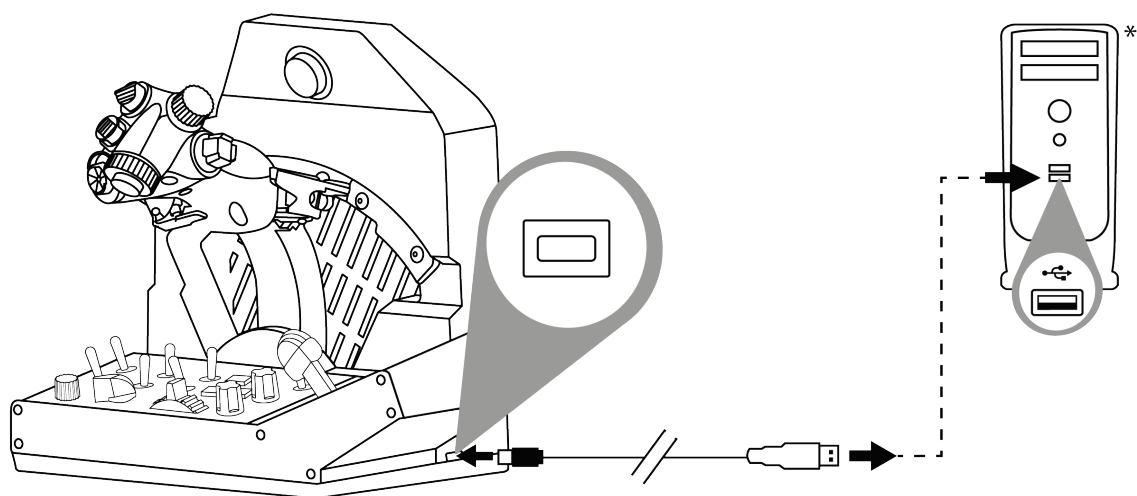

* 未提供



8. 安裝到 PC 上

1



請瀏覽

<https://support.thrustmaster.com/product/viper-tqs/>。

2

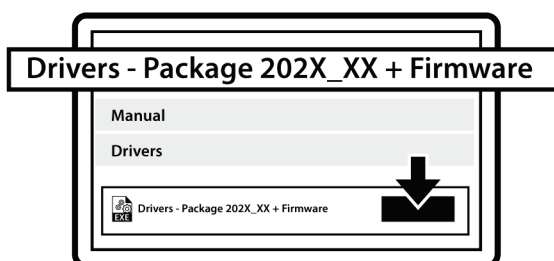

下載並安裝 PC 驅動程式及其基於 Windows 控制台的自訂介面。

3

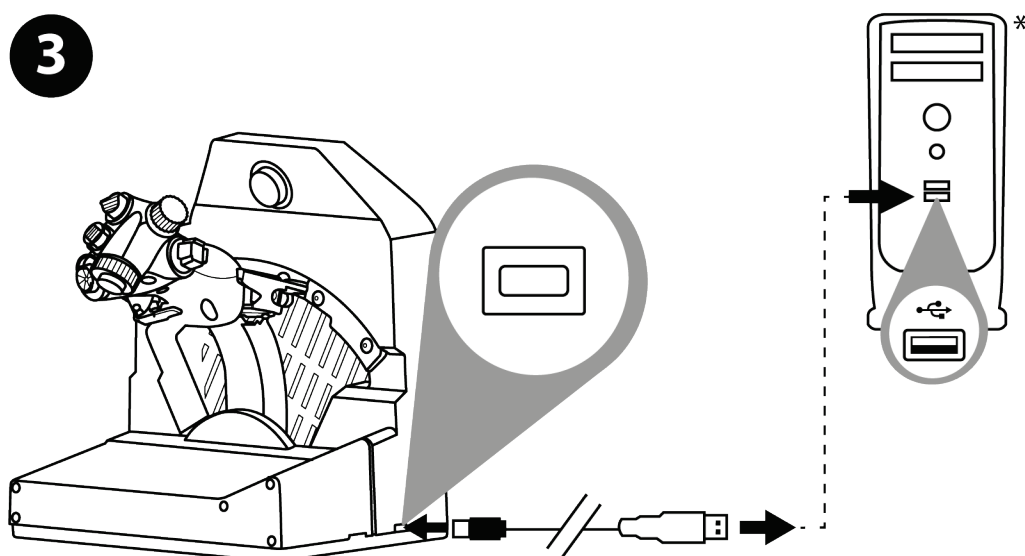

安裝 PC 驅動程式之後，將 USB 介面連接到 PC 上的某個 USB 埠。

* 未提供



④ 要存取 Control Panel，請選取開始 / 所有應用 / **Thrustmaster / Control Panel** 或控制台（在 Windows 10 中）。

此時將顯示**遊戲控制器**對話方塊。該附件將出現在螢幕上，其名稱顯示為 **VIPER TQS**，狀態為 **OK**。

⑤ 在**遊戲控制器**對話方塊中，按一下內容可測試和檢視所有功能。

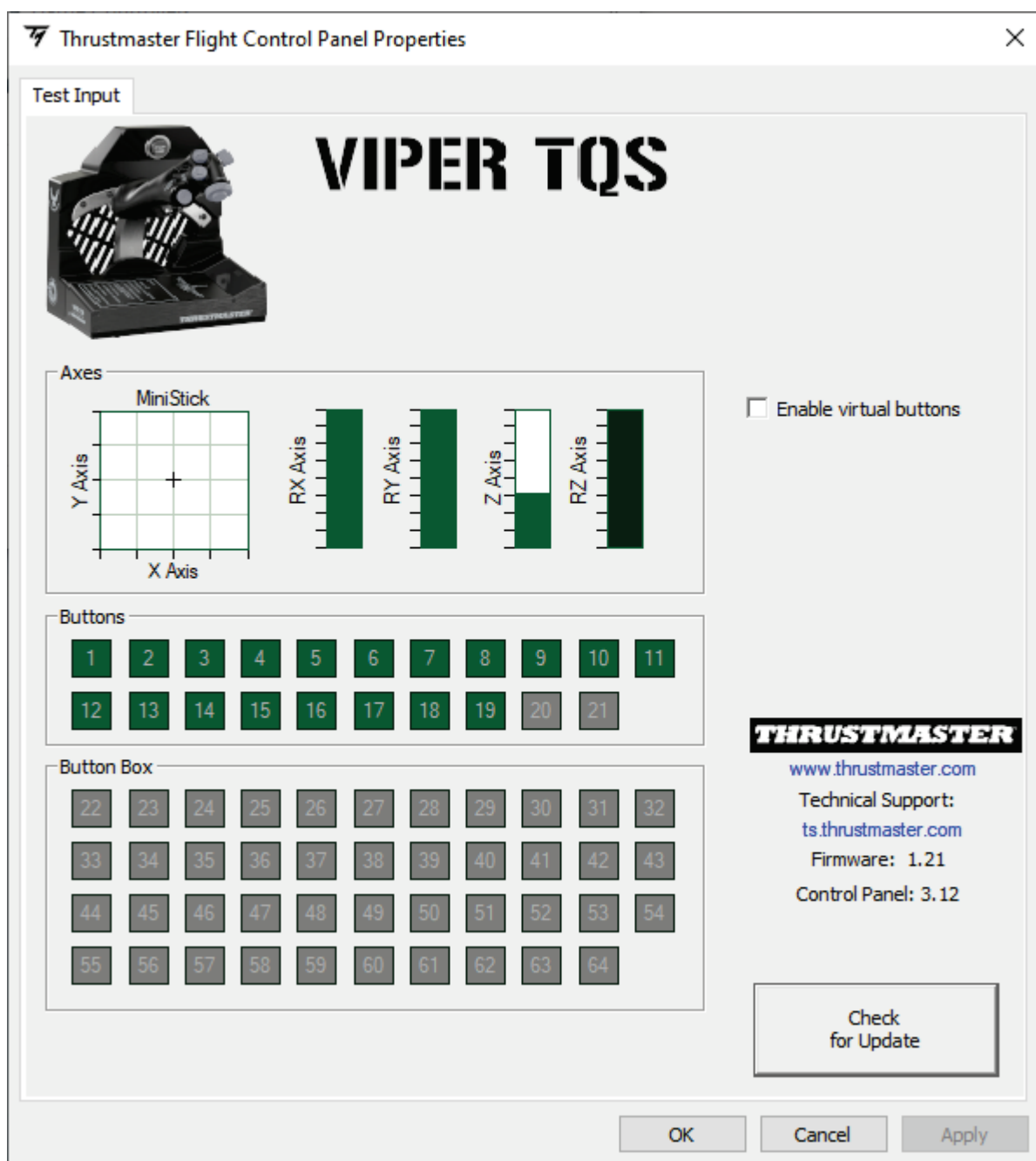



Enable virtual buttons (啟用虛擬按鈕)：

此功能允許您啟用或停用手柄上的虛擬按鈕（按鈕 20 至 21）。在選取您要使用的模式之後，按一下 **Apply** (應用)。

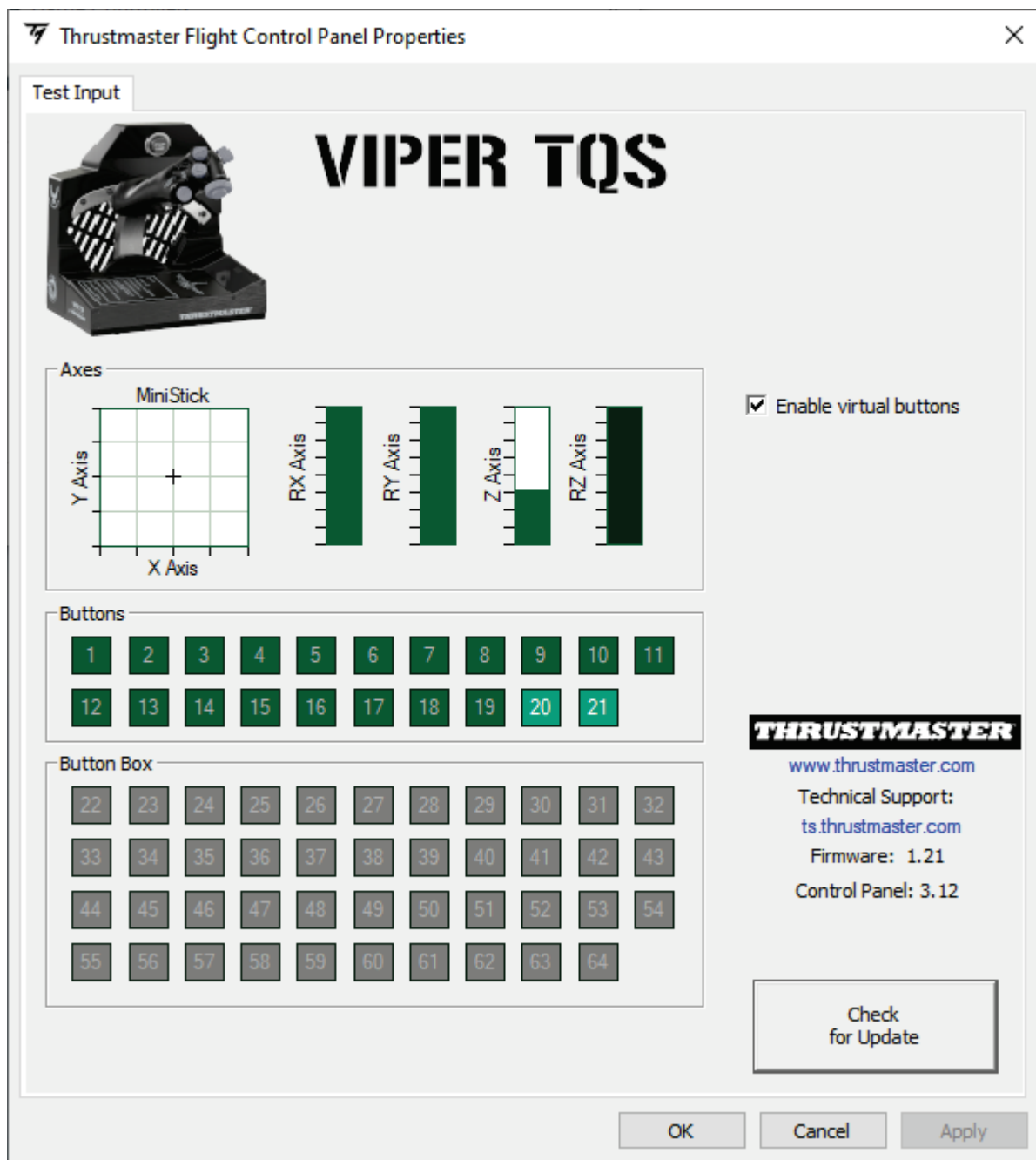

預設情況下，會停用 VIPER TQS 上的虛擬按鈕。



9. CUT OFF 和 AFTERBURNER 止動器

VIPER TQS 節流閥弧座配備逼真的 CUT OFF 和 AFTERBURNER 止動器（Afterburner 模組可拆卸）系統。

CUT OFF

在將節流閥置於 IDLE 限位器後，按下「引擎切斷解鎖」扳機 **1**，以抬升手柄，使之越過限位器 **2**，然後將手柄置於 OFF 位置 **3**。

要重新開啟引擎，請倒序執行上述程式。

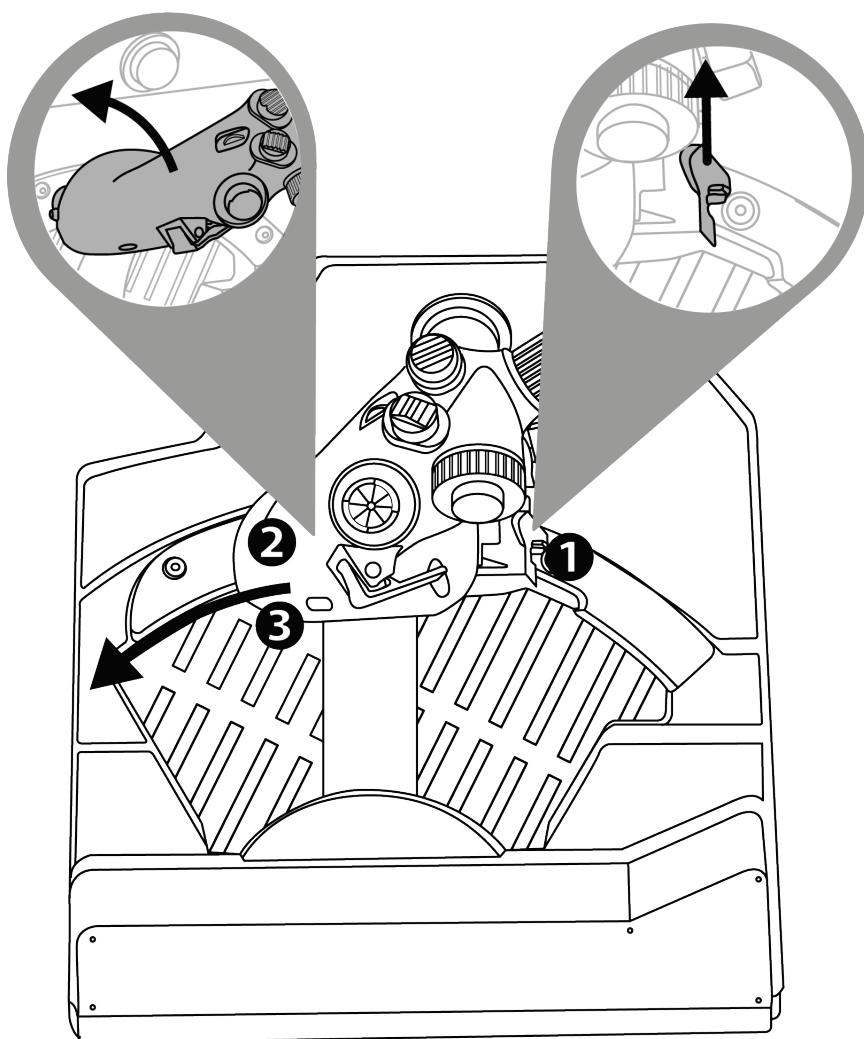



AFTERBURNER

將節流閥移動到限位器 **1** 並抬升 **2**，以越過限位器，
嚙合後燃器 **3**。

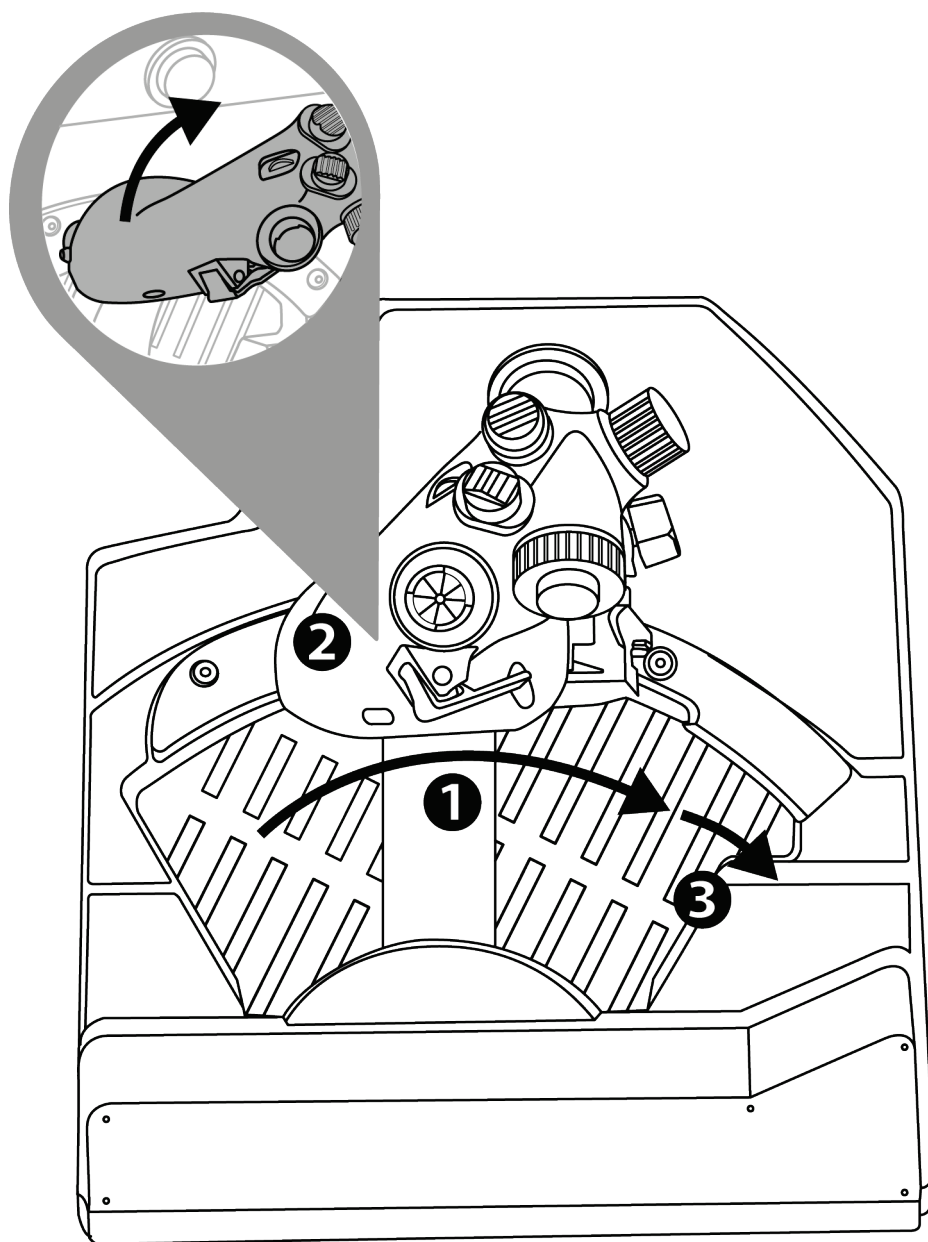



拆卸 **AFTERBURNER** 限位器

Afterburner 模組的限位器位於軸的 80% 處。

如果您需要不帶限位器的 100% 節流閥行程（針對特殊的模擬器），您可以透過使用內六角扳手（未隨附）擰松該模組的兩個螺絲，拆卸 Afterburner 模組及其限位器。

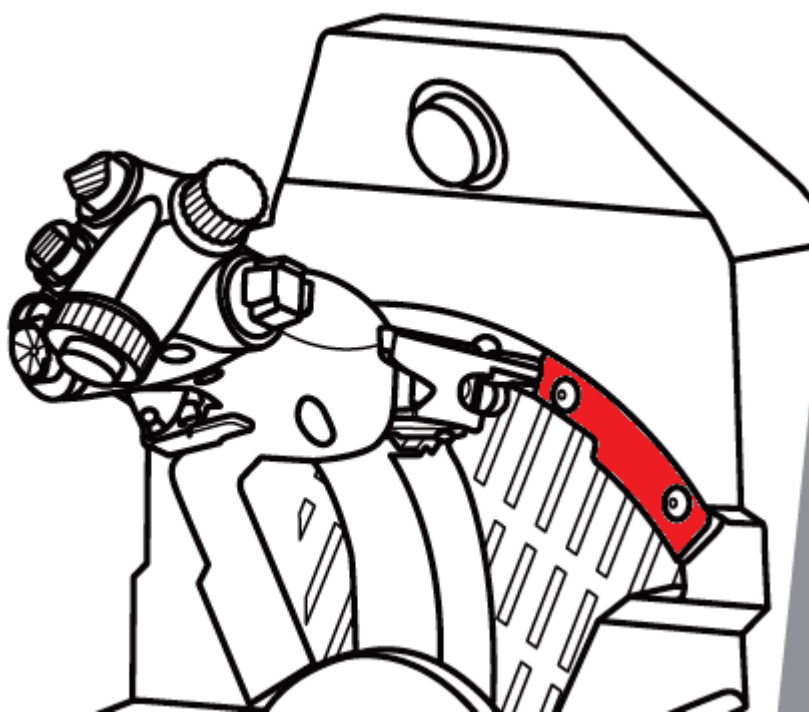



10. T.A.R.G.E.T 進階編程軟體



請瀏覽

<https://support.thrustmaster.com/product/viper-tqs/>。

在 **Software** (軟體) 部分，下載並安裝 T.A.R.G.E.T 進階編程軟體。



T.A.R.G.E.T 的主要功能

- 支援不同的軸設定。
- 支援不同級別的編程設定：Basic、Advanced 與 Script。
- 採用「拖放」原則。
- 可將 VIPER TQS 節流閥弧座與各種 Thrustmaster（圖馬思特）搖桿（HOTAS Cougar、HOTAS Warthog、T.16000M 和 MFD Cougar Pack，所有這些裝置也相容於 T.A.R.G.E.T）結合在一起，從而被識別為單個 USB 裝置。
- 可存取由 Thrustmaster（圖馬思特）社群建立的進階設定檔。



11. 常見問題解答和技術支援

您對 VIPER TQS 是否有任何疑問，或者您是否遇到任何技術問題？若有的話，請瀏覽 Thrustmaster（圖馬思特）技術支援網站：

<https://support.thrustmaster.com/product/viper-tqs/>.



THRUSTMASTER®

VIPER TQS **THROTTLE QUADRANT SYSTEM**

PC 용(Windows 10/11)

사용설명서



제품을 설치하기 **전**, 제품을 사용하기 **전**, 그리고
유지보수 하기 **전에** 본 설명서에 제공된 지침을 **주의**
깊게 읽으십시오. 안전 지침을 따르십시오. 이러한
지침을 따르지 않으면 사고가 나거나 제품이 손상될 수
있습니다. 나중에 지침을 참조할 수 있도록 본
설명서를 보관하십시오.

목차

1.	포장 내용물	5
2.	VIPER TQS 기능	6
3.	버튼 및 축 매핑	8
4.	VIPER TQS 사용 정보	10
5.	마찰 조절하기	11
6.	지지대에 설치	12
7.	VIPER PANEL* 설치하기	17
8.	PC 에 설치	20
9.	CUT OFF 및 AFTERBURNER 멈춤쇠	23
10.	T.A.R.G.E.T 고급 프로그래밍 소프트웨어	26
11.	자주 묻는 질문들과 기술 지원	28



미 공군의 VIPER(세계에서 가장 널리 사용되는 현대식 전투기)의 상징적인 스로틀 퀴드런트를 이용하여 엔진 회전수를 높이고 위험 지대로 비행하십시오!

금속 손잡이에 현실감 있는 버튼과 멈춤쇠로 꾸며져 있고 독특한 인체공학적 요소가 가미된 1:1 비율의 HOTAS 레플리카로 조종석의 수준을 한 단계 더 높이십시오.

이 설명서는 VIPER TQS 를 최상의 조건에서 설치하고 사용하는 데 도움이 될 것입니다. 이륙 전에 이 지침과 경고 내용을 잘 읽으십시오. 제품을 최대한 즐길 수 있도록 도와줄 것입니다.



펌웨어 업데이트

비디오 게임을 하면서 VIPER TQS 가 올바르게 작동하기 위해서는 펌웨어를 업데이트해야 합니다.

업데이트를 실행하려면 다음 사이트를 방문하십시오.

<https://support.thrustmaster.com/product/viper-tqs/>

Firmware(펌웨어)를 선택한 후, 다운로드 및 설치 절차를 포함한 지침을 따르십시오.



1. 포장 내용물

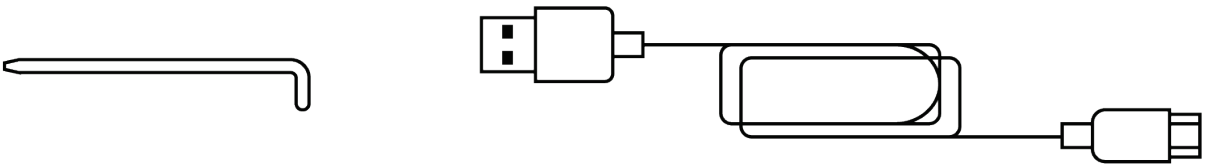
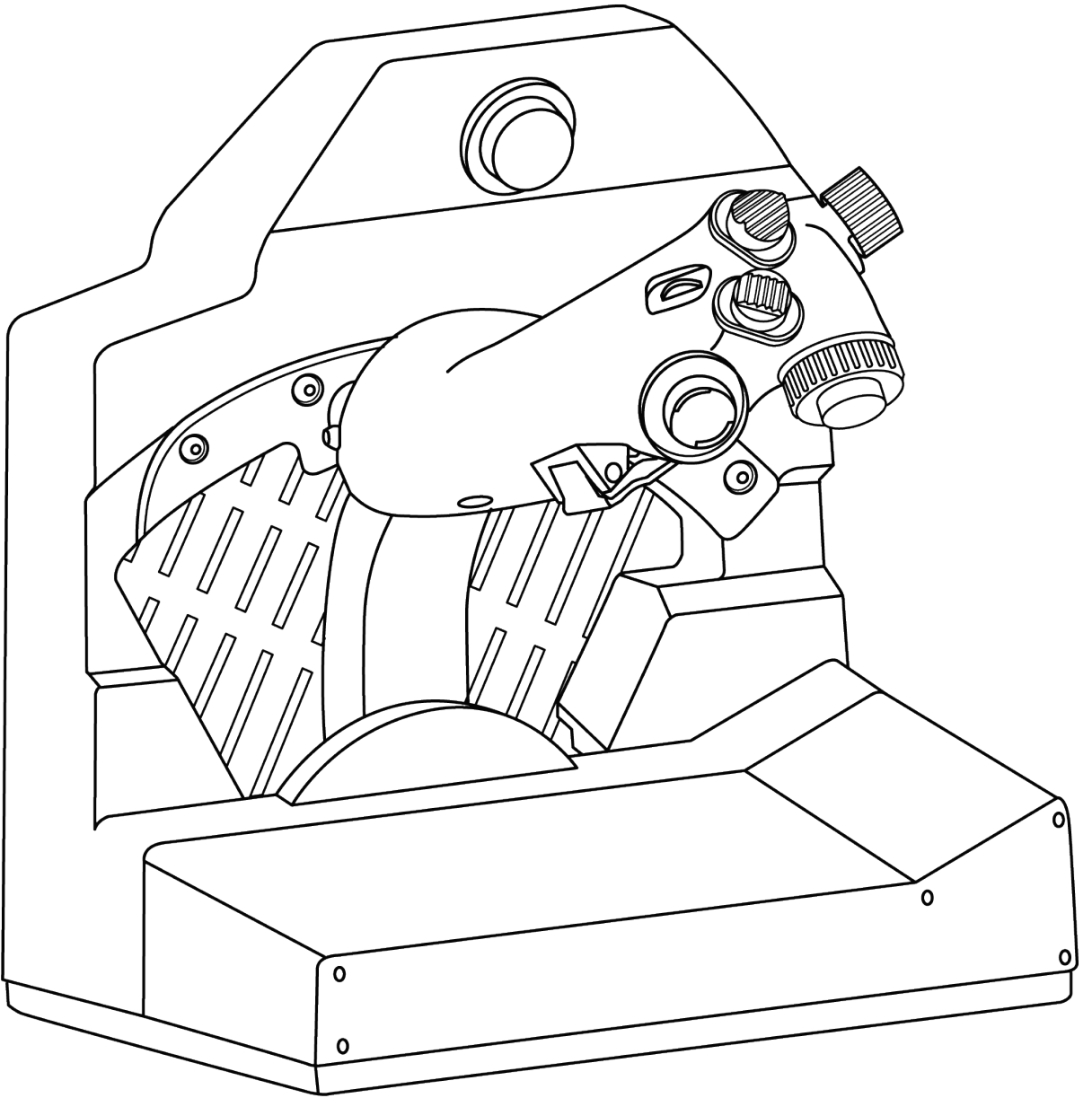



2. VIPER TQS 기능

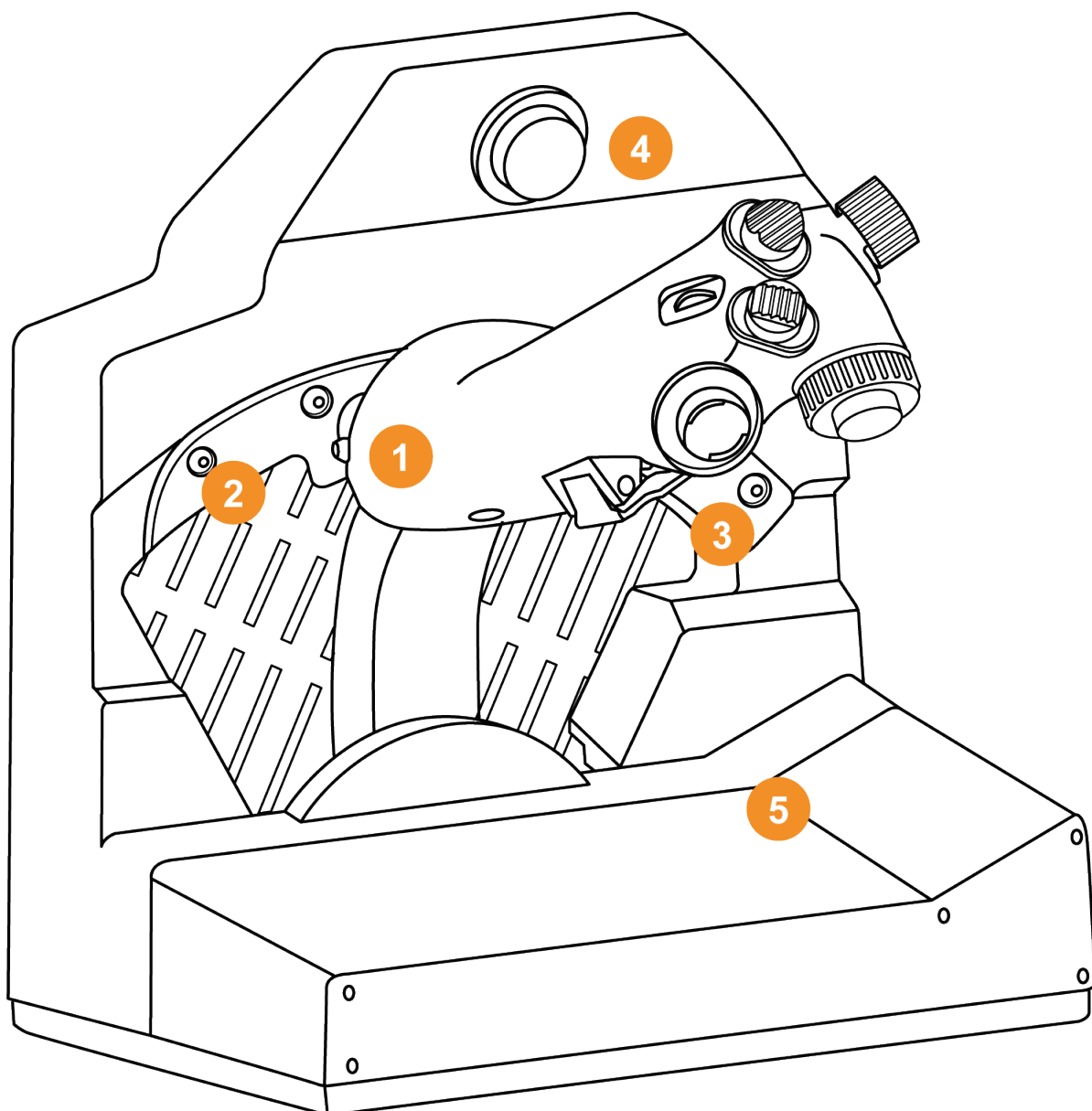

1. 핸들

2. Cut Off 포인트

3. Afterburner 포인트

4. CHAFF/FLARE 슬랩 스위치

5. 임무 지도용 클립

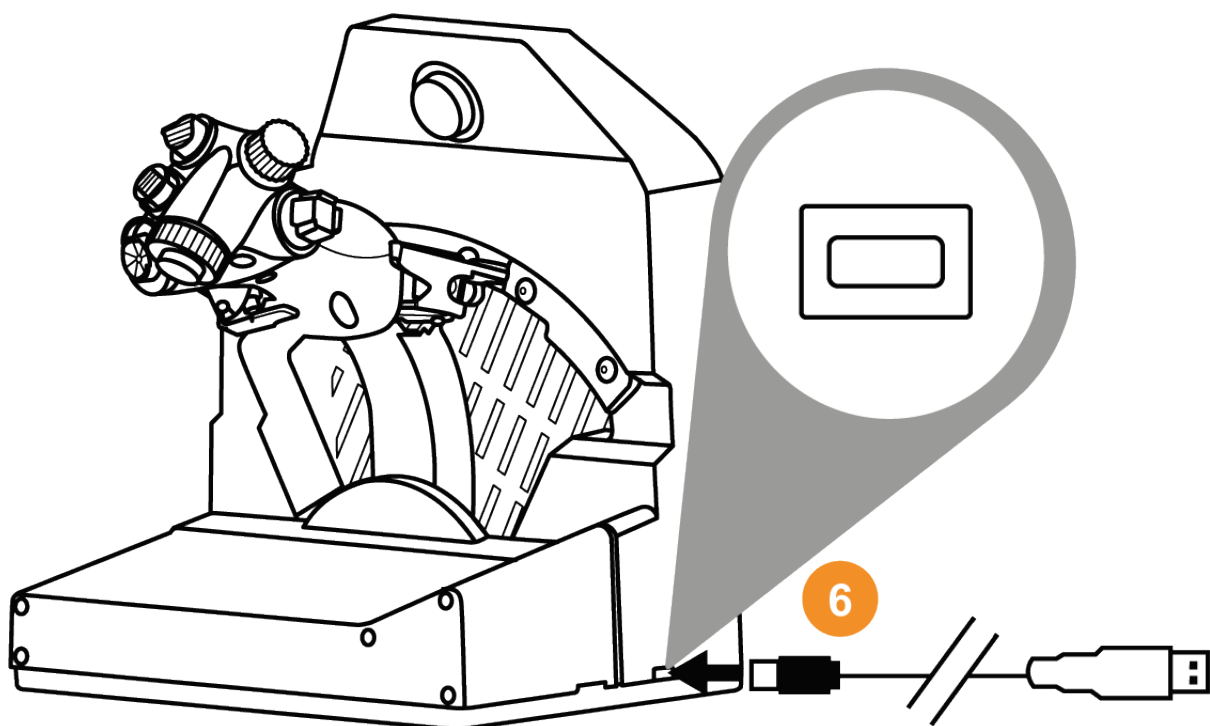

6. USB 커넥터(타입 C)

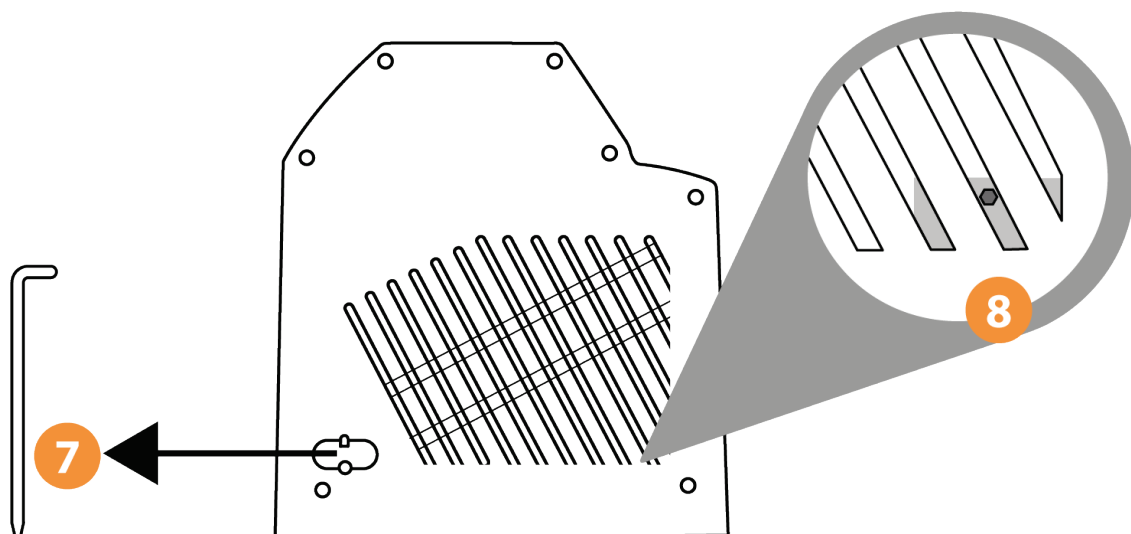

7. 마찰 조절 도구 위치

8. 스톱 슬롯 마찰 조절 접근 포인트



3. 버튼 및 축 매핑

VIPER TQS 핸들: 모드 A의 경우 버튼 19개와 축 5개로 매핑(가상 버튼 없음)

A 1→19

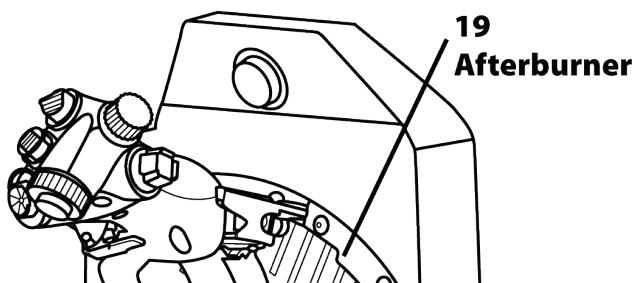
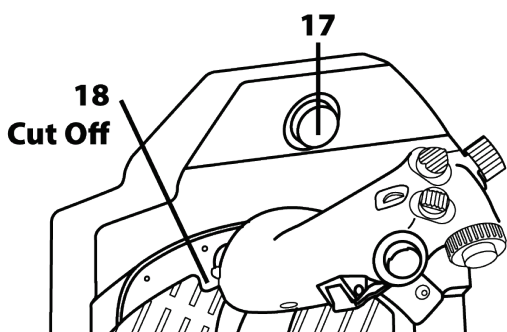
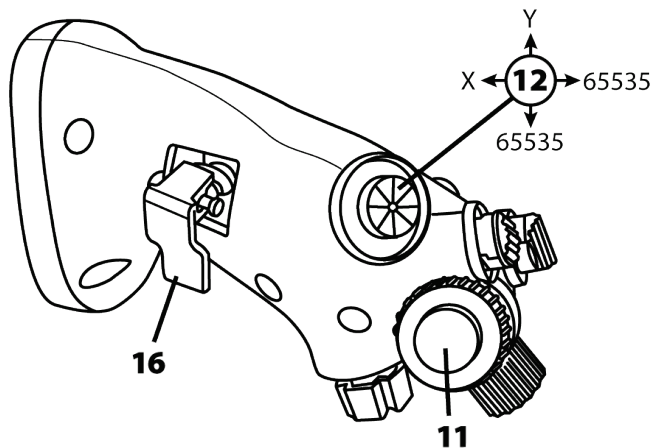
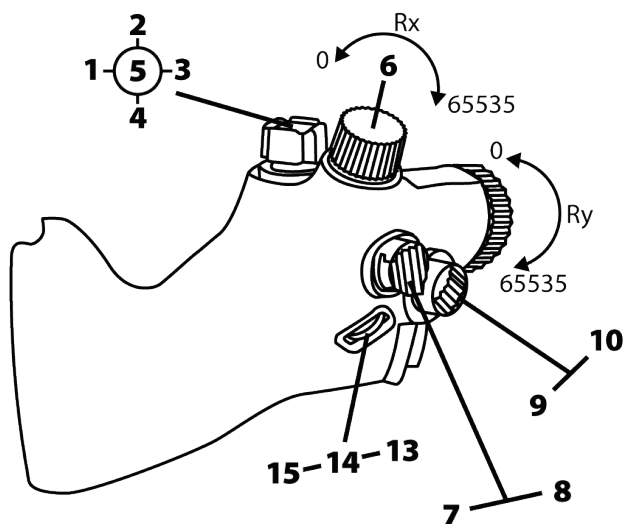



모드 B: 가상 버튼 포함

B 1→21

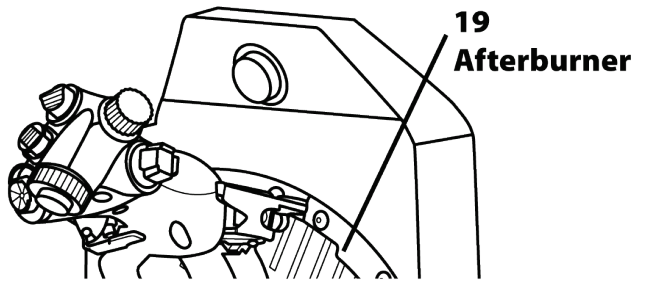
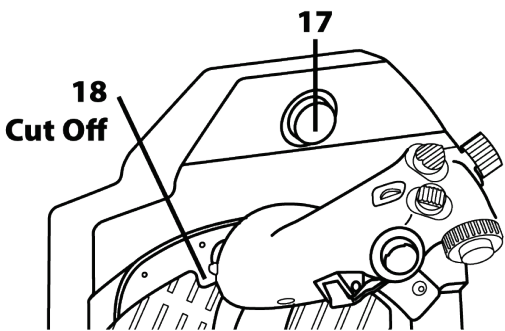
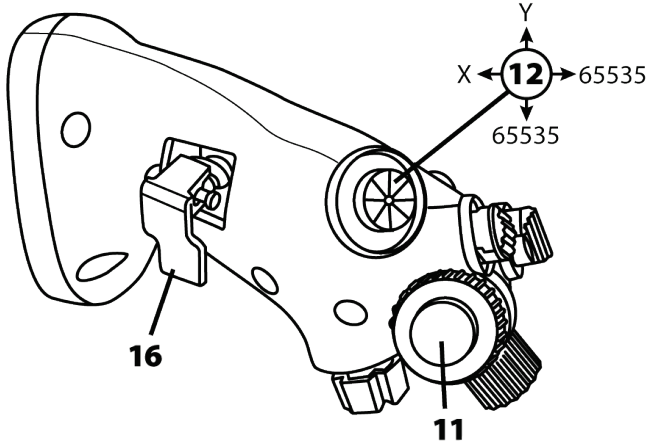
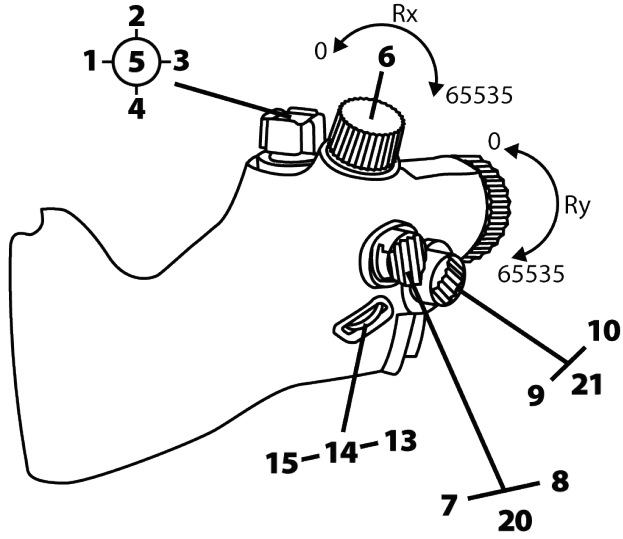



4. VIPER TQS 사용 정보



끼임 위험

핸들 사용 시 절대 멈춤부(포인트)에 손가락을 두지 마십시오.

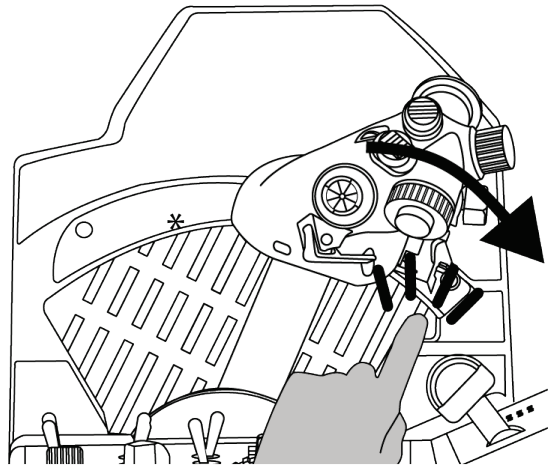
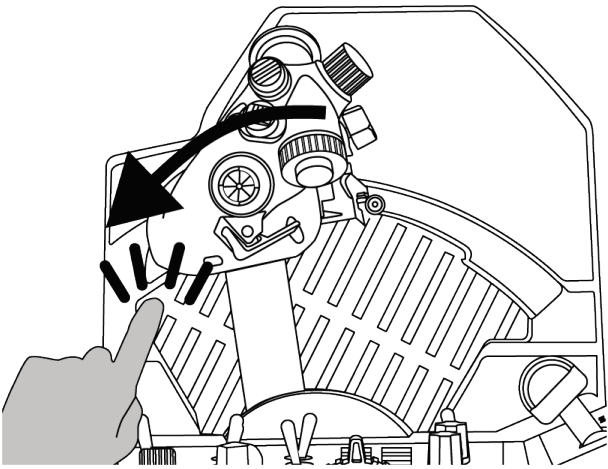
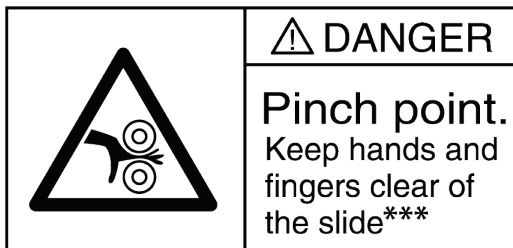



5. 마찰 조절하기

VIPER TQS의 측면에 들어 있는 도구를 사용하여 VIPER TQS 스톱 쿼드런트의 마찰력을 원하는 대로 조절할 수 있습니다. 단, 제품 출하 시 최적의 스톱 마찰로 설정하여 출하된다는 점에 유의하십시오.

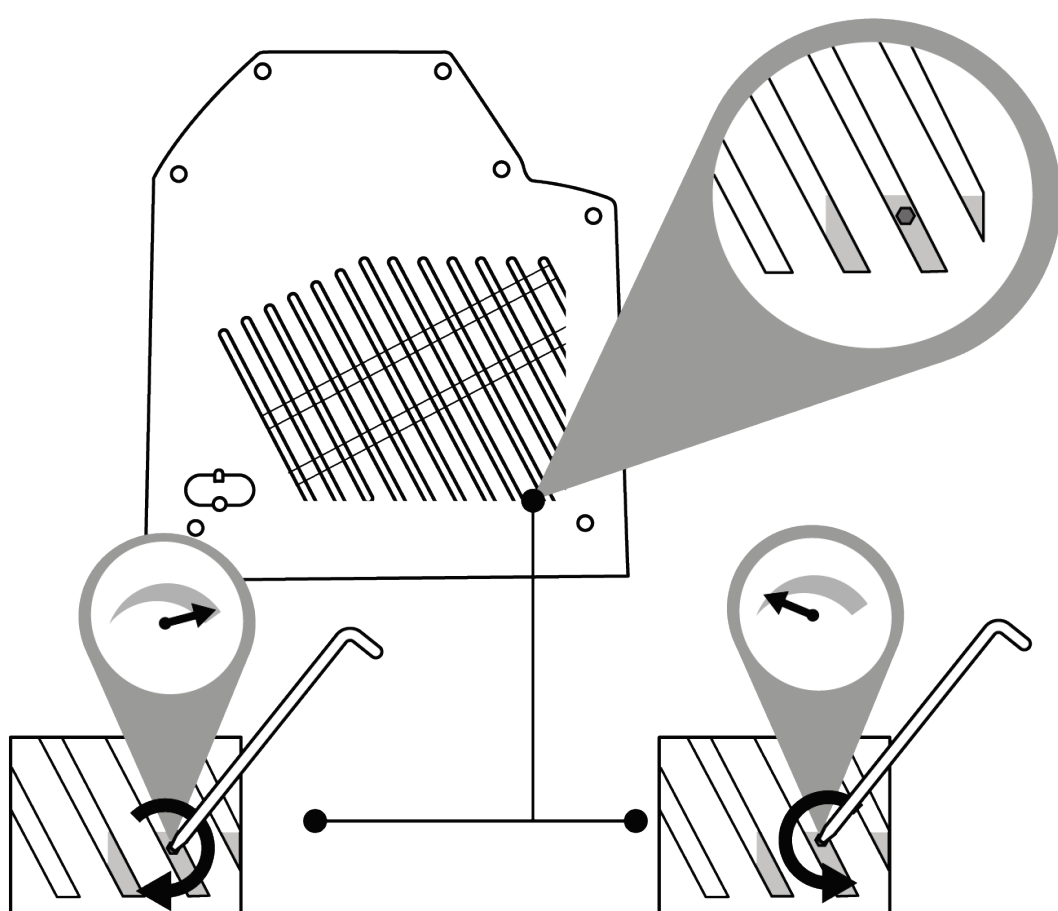

마찰 시스템의 손상을 방지하기 위해, 조정 나사를 과하게 조이지 마십시오.

그리고 조절 나사를 완전히 풀지 않도록 하십시오. 완전히 풀 경우 스톱틀이 더 이상 특정 위치에 머물러 있지 않게 될 수 있습니다.



6. 지지대에 설치



VIPER TQS 는 여러 가지 유형의 지지대에 설치할 수 있습니다. 시중에 판매되는 대부분의 조종석과 지지대는 유사한 Thrustmaster 제품들(즉, HOTAS Warthog)과 이미 호환이 됩니다.

VIPER TQS 는 강력한 레버 효과를 발휘하므로 단단히 부착해야 한다는 점을 명심하십시오.

핸들이 손상되지 않도록 적절한 M6 나사(미포함)를 사용하여 베이스를 지지대에 부착합니다.

VIPER TQS 의 전체 도면은 다음 주소에서 확인할 수 있습니다.

<https://support.thrustmaster.com/product/viper-tqs/>



사용하기 전에 항상 VIPER TQS 가 제조사의 지침에 따라 지지대에 적절하게 부착되어 있는지 확인하십시오.

지지대가 어떤 소재로 되어 있는지를 꼭 확인하여 제품을 지지대에 안전하게 부착할 수 있도록 하십시오. VIPER TQS 는 빈 구성품 없이 단단한 재질(예: MDF 또는 나무)로 만들어진 데스크 위에서 사용해야 합니다.



장착 도면 치수(단위: mm)

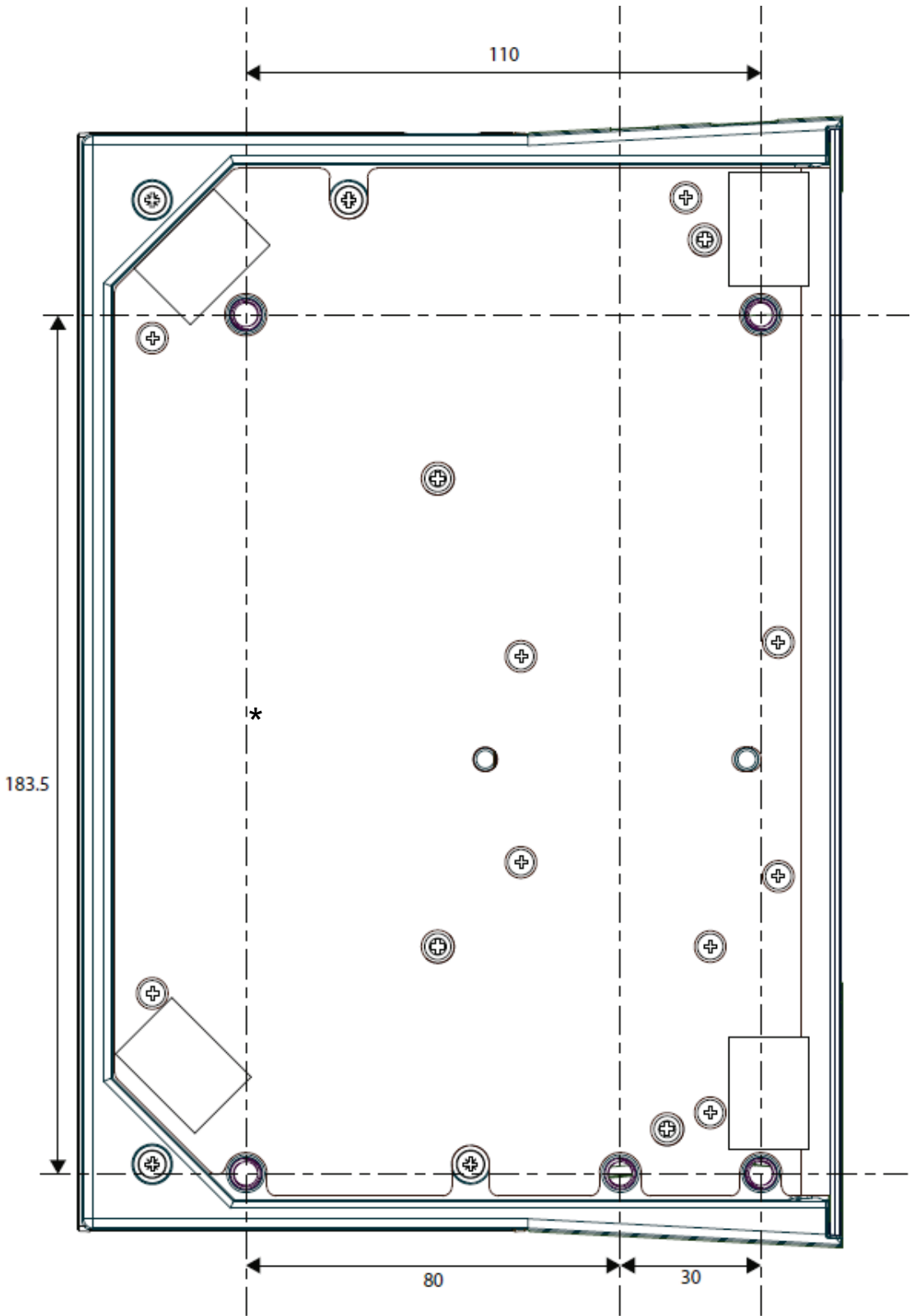

다음 [https://support.thrustmaster.com/product/viper-](https://support.thrustmaster.com/product/viper-tqs/)

[tqs/](https://support.thrustmaster.com/product/viper-tqs/)에서 장착 도면을 다운로드하여 인쇄할 수 있으며 드릴

구멍을 만들 때 지지대 위에 도면을 놓고 사용할 수 있습니다.



TM Flying Desk Mount*를 사용하여 설치

TM Flying Desk Mount 는 클램핑 나사가 적용된 금속 장착 시스템으로, 장치를 사용할 때 인체공학적 특성과 조종 자세를 개선해줍니다. 이 시스템은 두께가 15~50mm 인 책상이나 탁자에 사용하도록 설계되었습니다.

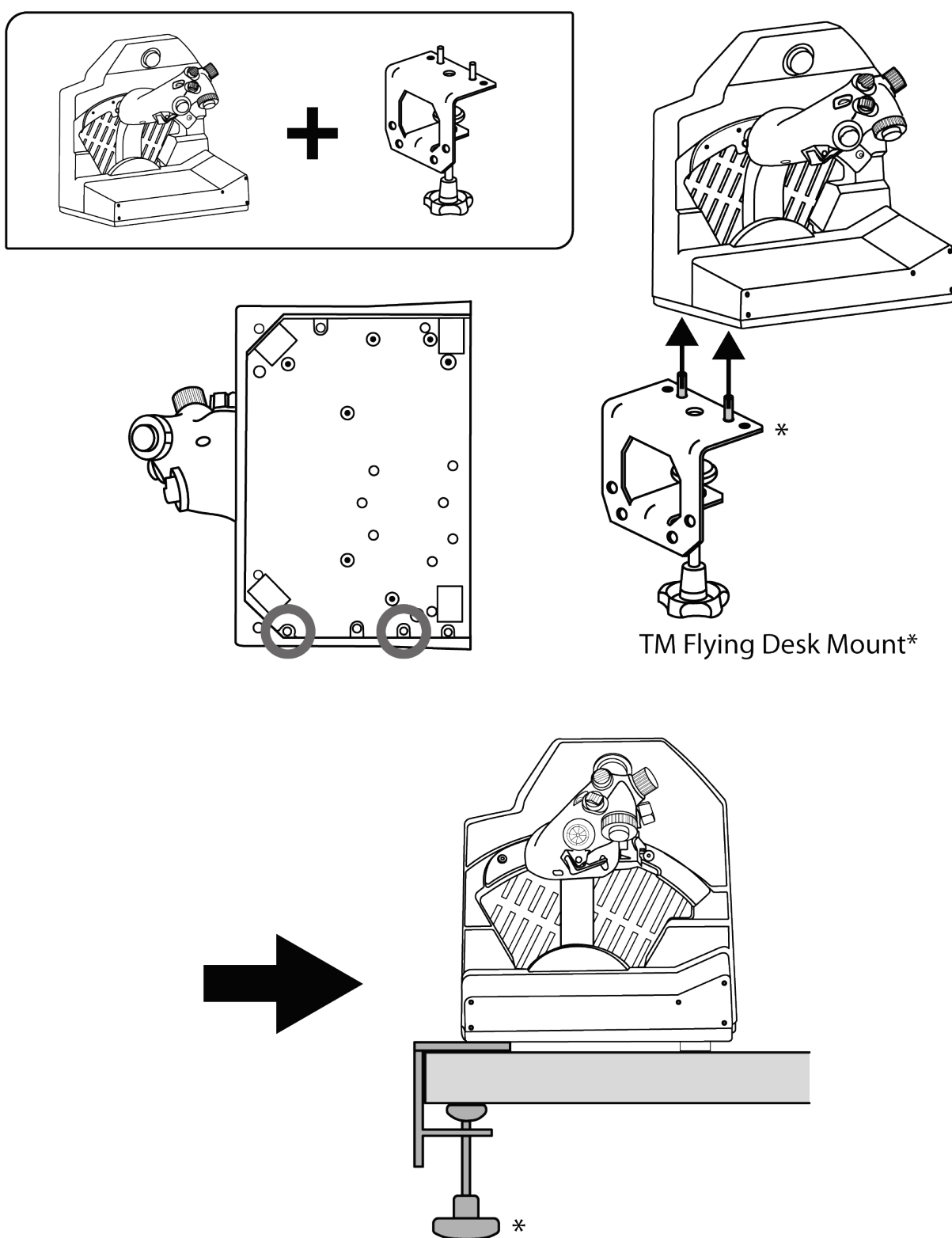

* 별도 판매



TM Flying Clamp*를 사용하여 설치

TM Flying Clamp 는 비행 시뮬레이션 액세서리를 위해 Thrustmaster 에서 설계한 높이 조절 지지대입니다. 이 장착 시스템에는 클램핑 나사가 두 개 있어서 두께가 15~45mm 인 책상과 탁자에서 사용할 수 있도록 조절이 가능합니다.

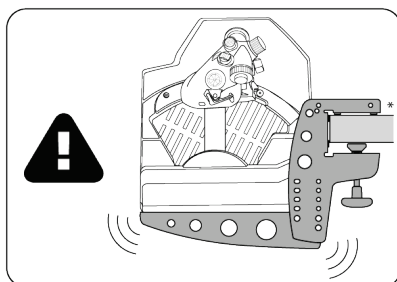
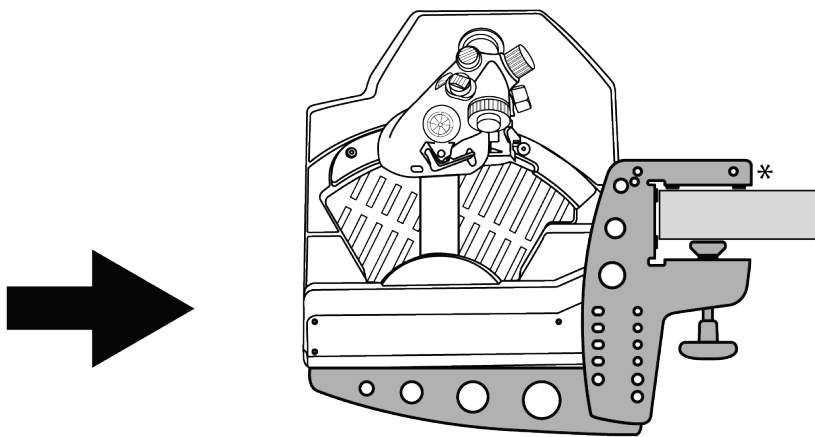
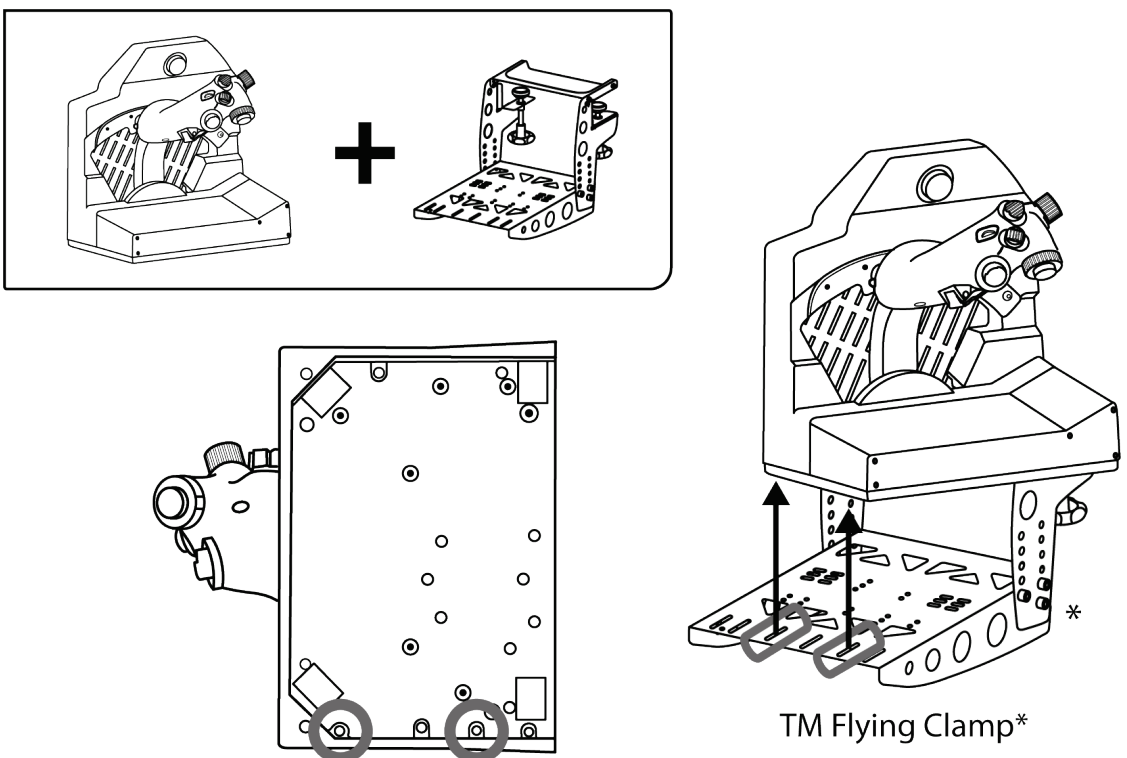

* 별도 판매



VIPER TQS 의 무게 때문에 장착 시스템이 의도치 않게 움직일 수 있다는 점에 유의하십시오.



7. VIPER PANEL* 설치하기

*별도 판매. VIPER PANEL 은 VIPER TQS Mission Pack 에 포함되어 있습니다.

VIPER PANEL 은 총 43 개의 버튼과 1 개의 축으로 전투 능력을 확대할 수 있게 해주는 계기판으로, 이 모든 것을 T.A.R.G.E.T 소프트웨어를 통해 프로그램할 수 있습니다. VIPER PANEL 은 VIPER TQS 의 보조 도구입니다.

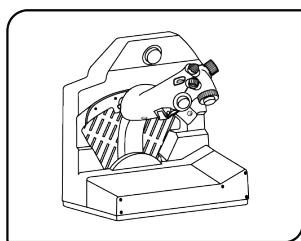

1

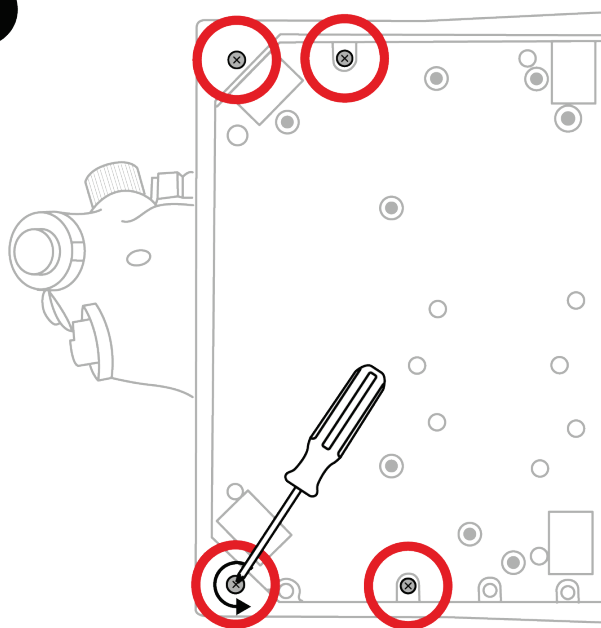

2

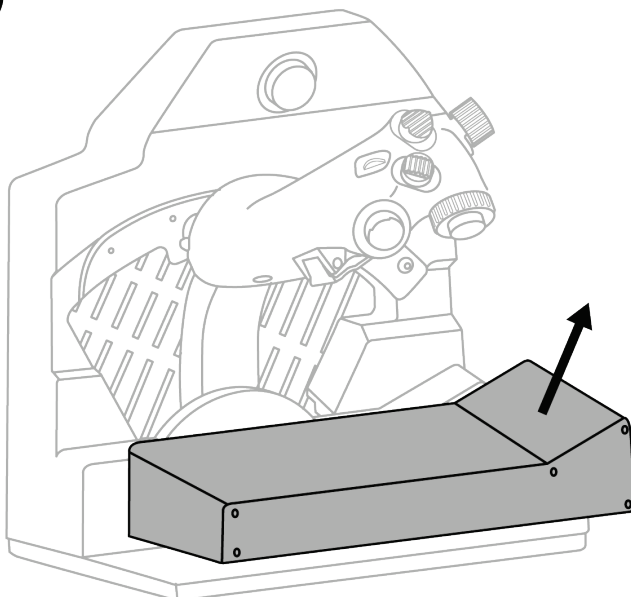

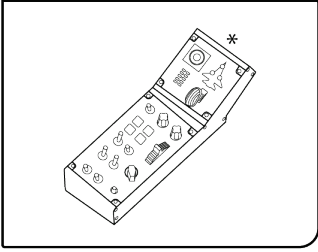

3

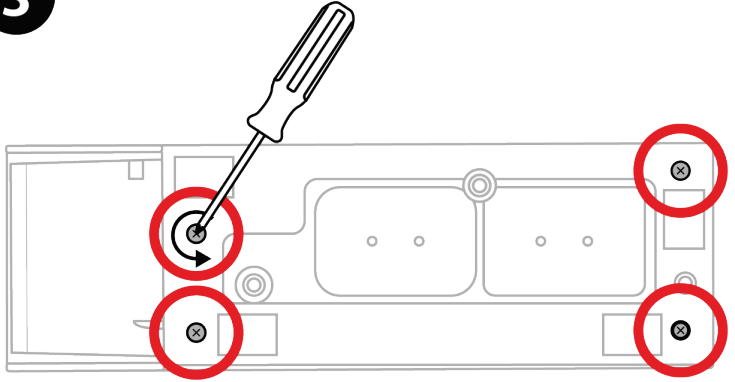

4

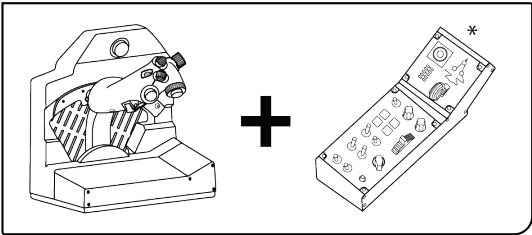
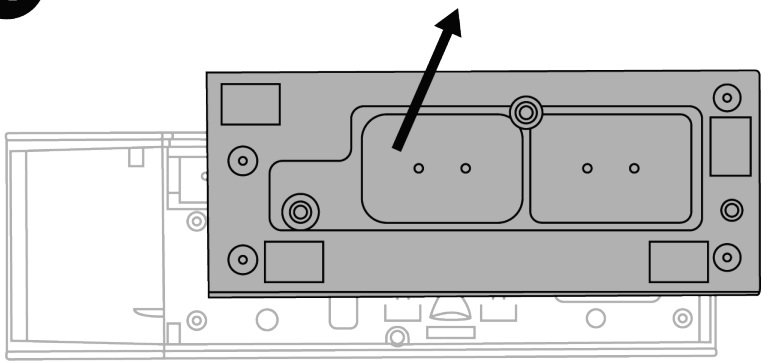

5

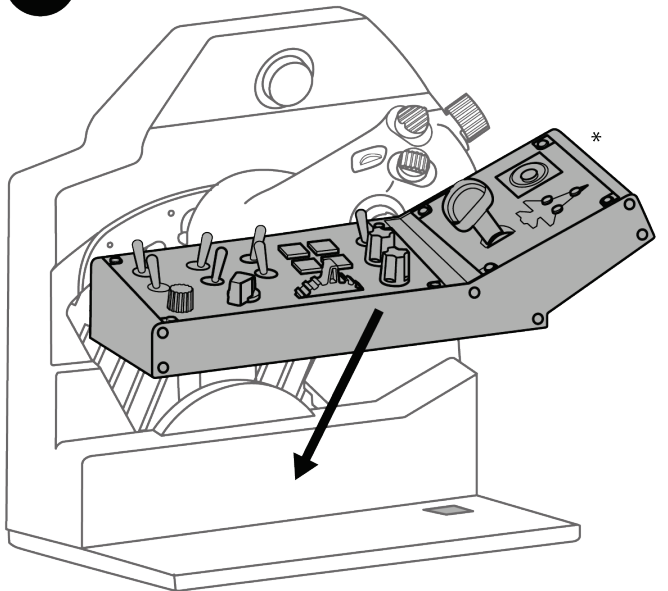



6

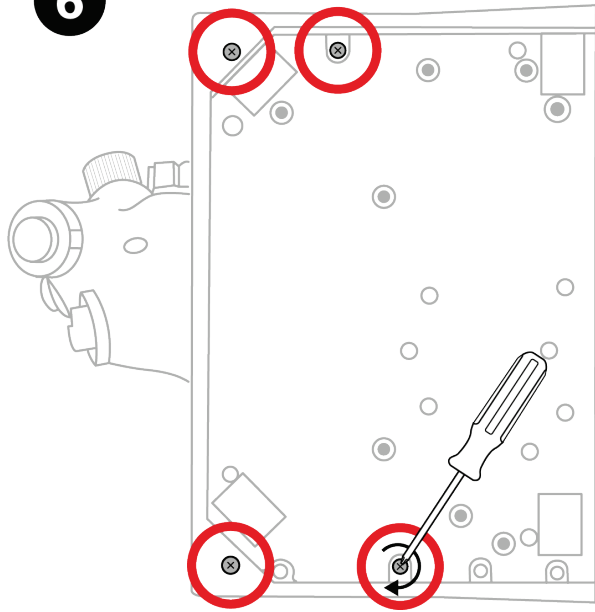

7

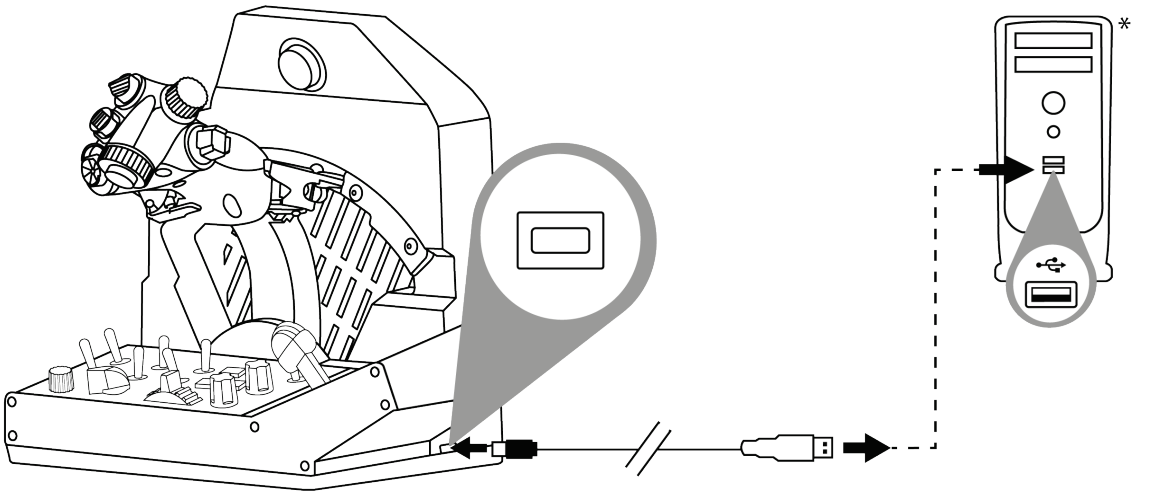

*미포함



8. PC 에 설치

1



<https://support.thrustmaster.com/product/viper-tqs/>을 방문해 주십시오.

2

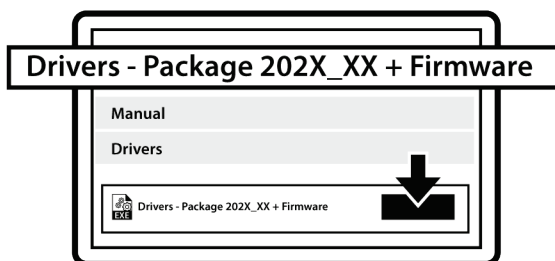

PC 드라이버와 Windows 제어판용 맞춤형 인터페이스를 다운로드 및 설치합니다.

3

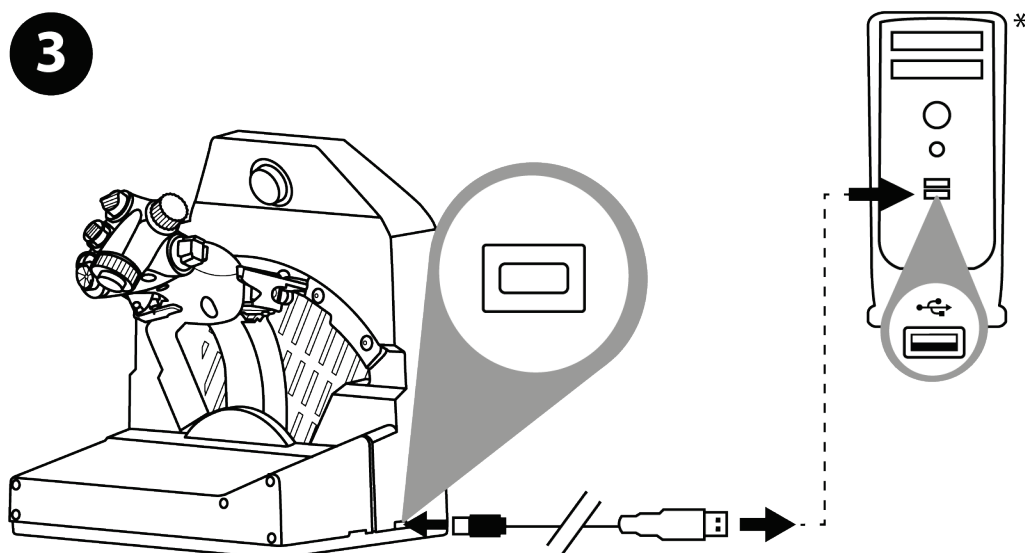

PC 드라이버가 설치되었으면 USB 커넥터를 PC의 USB 포트에 연결합니다.

*미포함



④ Control Panel 로 이동하려면 시작 / 모든 앱 / Thrustmaster / Control Panel 또는 계기판(Windows 10)을 선택합니다.

게임 컨트롤러 대화 상자가 표시됩니다. **VIPER TQS** 이라는 액세서리 이름이 **OK** 상태로 표시됩니다.

⑤ 게임 컨트롤러 대화 박스에서 속성을 클릭하여 모든 기능을 테스트 및 확인합니다.

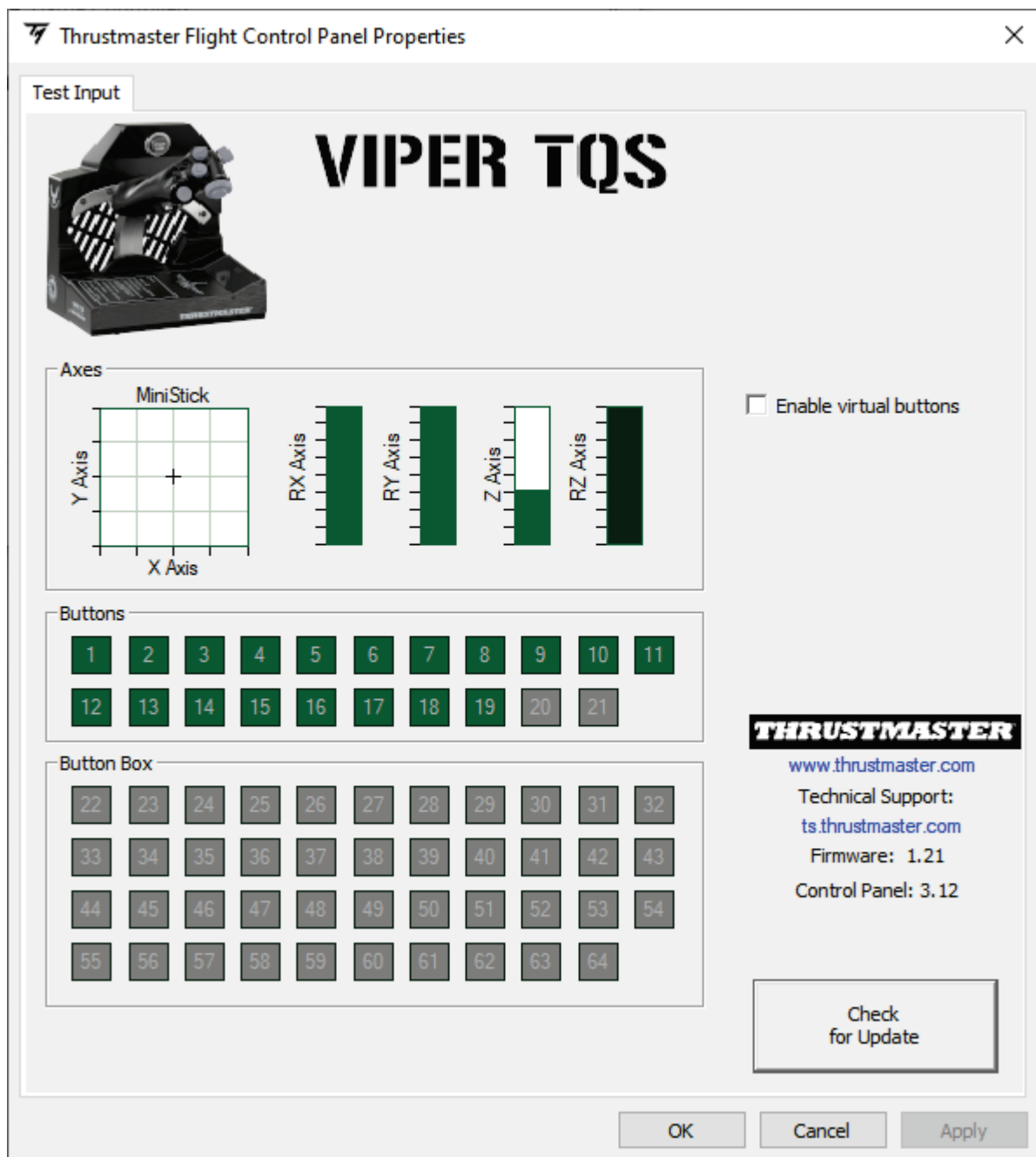



Enable virtual buttons (가상 버튼 활성화):

이 기능을 이용하여 핸들에 있는 가상 버튼(버튼 20 과 21)을 활성화하거나 비활성화할 수 있습니다. 사용하려는 모드를 선택한 후 **Apply**(적용)를 클릭합니다.

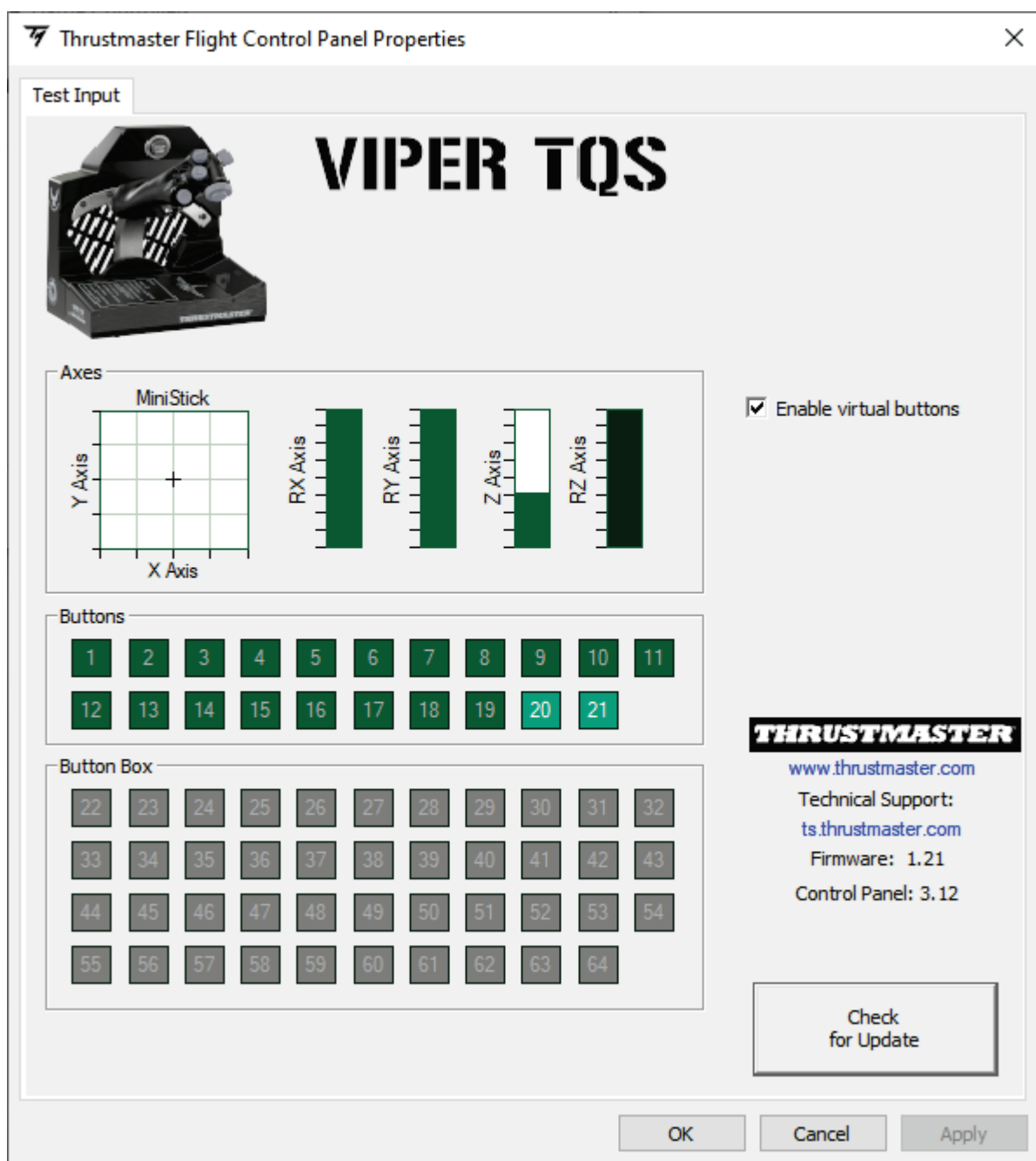

가상 버튼은 VIPER TQS 에서 기본적으로 비활성화되어 있습니다.



9. CUT OFF 및 AFTERBURNER

멈춤쇠

VIPER TQS 스로틀 쿼드런트는 CUT OFF 및 AFTERBURNER 멈춤쇠가 실제와 유사하게 적용되어 있습니다(Afterburner 모듈은 탈착이 가능함).

CUT OFF

스로틀을 IDLE 포인트에 놓은 후, “엔진 차단 잠금해제” 레버

①을 누르고 핸들을 들어올려 포인트 ②를 지난 다음, 핸들을 OFF 위치 ③에 놓습니다.

엔진을 다시 작동시키려면 이 과정을 역순으로 수행합니다.

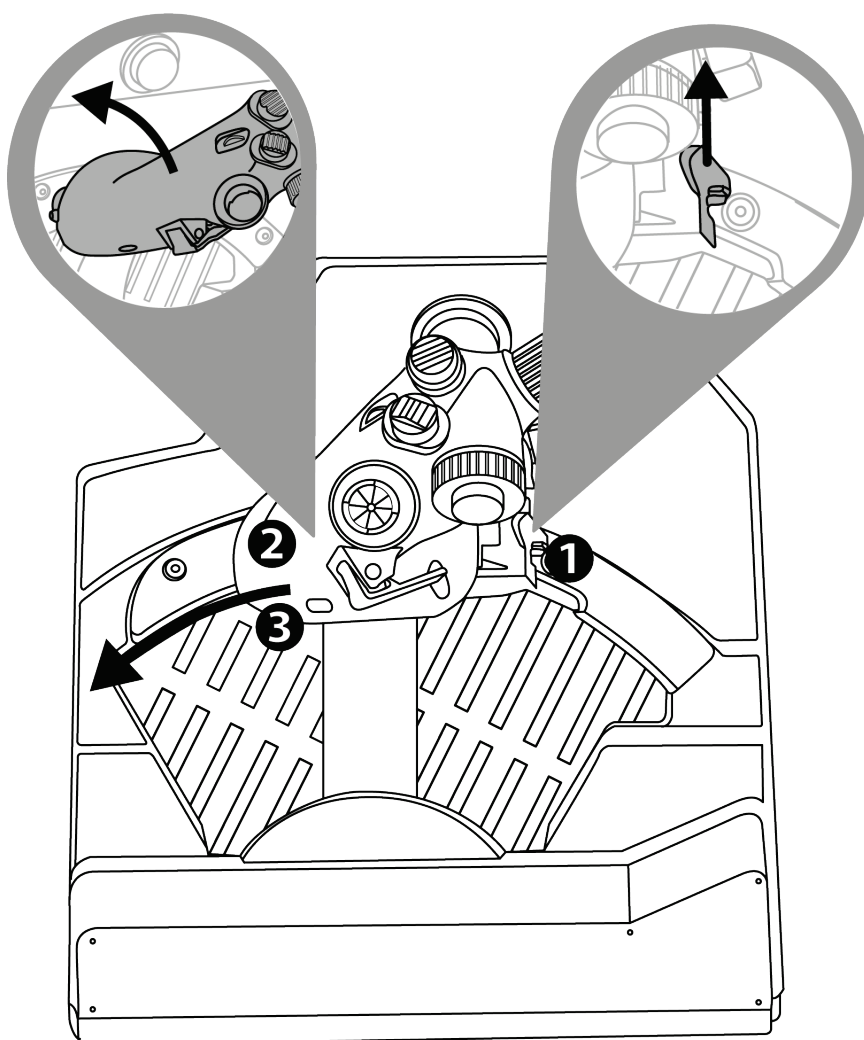



AFTERBURNER

스로틀을 포인트 ①로 옮기고 들어올려 ② 포인트를 지난 후 애프터버너 ③을 작동시킵니다.

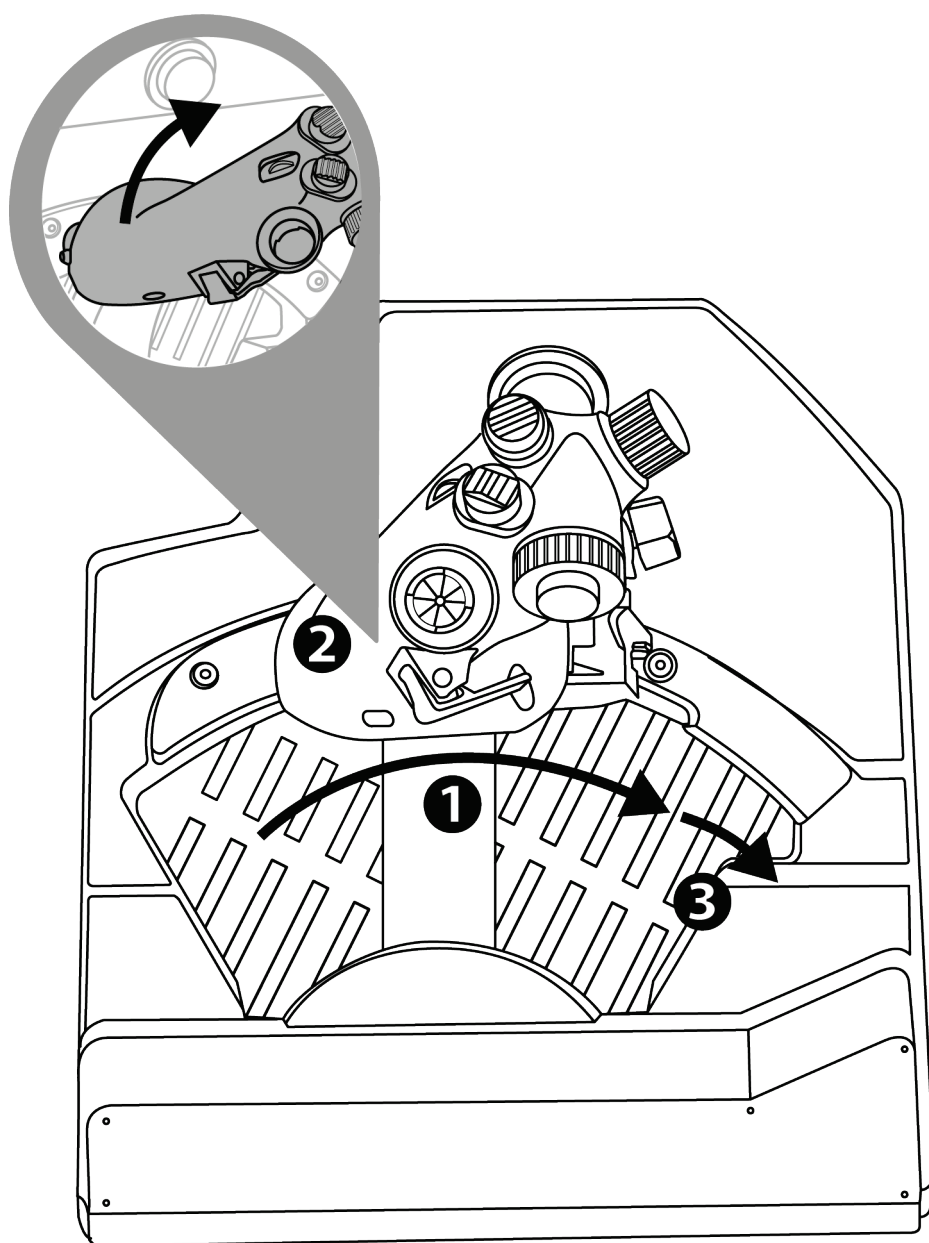



AFTERBURNER 포인트 탈거하기

Afterburner 모듈의 포인트(멈춤부)는 축의 값에서 80% 지점에 위치하고 있습니다.

멈춤부 없이 스로틀 유격을 100% 사용해야 할 경우(특정 시뮬레이터의 경우), 앨런 키(미포함)를 사용하여 모듈의 나사 두 개를 풀어서 Afterburner 모듈과 그 포인트를 탈거할 수 있습니다.

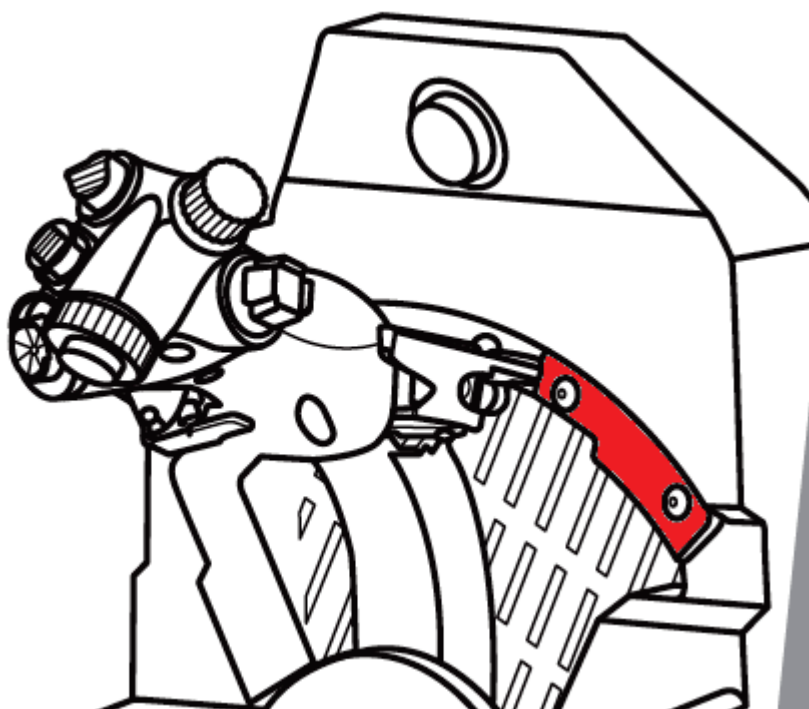



10. T.A.R.G.E.T 고급 프로그래밍

소프트웨어



<https://support.thrustmaster.com/product/viper-tqs/>을 방문해 주십시오.

Software(소프트웨어) 섹션에서 T.A.R.G.E.T 고급 프로그래밍 소프트웨어를 다운로드하여 설치하십시오.



T.A.R.G.E.T 의 주요 기능:

- 축을 각각 다르게 구성할 수 있습니다.
- 프로그래밍 수준 차별화 가능: Basic, Advanced, Script.
- 드래그 앤 드롭 원리 사용.
- VIPER TQS 스톱틀 쿼드런트와 여러 가지 Thrustmaster 조이스틱(HOTAS Cougar, HOTAS Warthog, T.16000M, MFD Cougar Pack, 이 모든 기기가 T.A.R.G.E.T 과 호환 가능)을 결합하여 하나의 USB 장치로 인식하도록 할 수 있습니다.
- Thrustmaster 커뮤니티가 생성하는 고급 프로파일에 접근합니다.



11. 자주 묻는 질문들과 기술 지원

VIPER TQS 에 관한 질문이 있거나 기술적 문제를 겪고 계신가요? 그런 경우에는 Thrustmaster 기술 지원 웹사이트를 방문하시기 바랍니다.

<https://support.thrustmaster.com/product/viper-tqs/>.



THRUSTMASTER®

VIPER TQS

THROTTLE QUADRANT SYSTEM

لأجهزة الكمبيوتر (Windows 10/11)

دليل المستخدم



اقرأ التعليمات الواردة في هذا الدليل قراءة متأنية وذلك قبل تركيب المنتج وقبل أي استعمال له وقبل إجراء أي صيانة له. وتأكد من اتباع تعليمات السلامة. إذ قد يؤدي عدم اتباع هذه التعليمات إلى وقوع حوادث و/أو أضرار. لذلك، احتفظ بهذا الدليل لكي تتمكن من الرجوع إلى التعليمات في المستقبل.

جدول المحتويات

1. محتويات الصندوق 5
2. VIPER TQS - الميزات 6
3. تعيين الأزرار والمحاور 8
4. معلومات حول استخدام VIPER TQS 10
5. ضبط الاحتكاك 11
6. التركيب على حامل 12
7. تركيب VIPER PANEL* 17
8. التثبيت على أجهزة الكمبيوتر 20
9. AFTERBURNER و CUT OFF - الحابست 23
10. برنامج البرمجة المتقدمة T.A.R.G.E.T 26
11. الأسئلة الشائعة والدعم الفني 28

قم بزيادة سرعة المحركات والطيران إلى منطقة الخطر باستخدام نظام ربعية الخائق الرائع من الولايات المتحدة. VIPER التابعة للقوات الجوية — الطائرة المقاتلة الحديثة الأكثر استخدامًا في العالم!

ارتق بقمرة القيادة الخاصة بك إلى المستوى التالي من خلال التصميمات الهندسية الفريدة لنسخة طبق الأصل من HOTAS بمقياس 1:1 تتميز بمقبض معدني، بالإضافة إلى أزرار وحابسات واقعية.

سيساعدك هذا الدليل على تركيب VIPER TQS واستخدامه في ظل أفضل الظروف. قبل الإقلاع، تأكد من قراءة كل هذه التعليمات والتحذيرات قراءة متأنية: فهي ستساعدك على تحقيق أقصى قدر من المتعة عند استخدام المنتج.



تحديث البرنامج الثابت

لكي يعمل VIPER TQS بصورة صحيحة في ألعاب الفيديو، يجب عليك تحديث البرنامج الثابت الخاص به.

لإجراء التحديث، يُرجى زيارة

<https://support.thrustmaster.com/product/viper-tqs/>

حدد **Firmware** (البرنامج الثابت)، واتبع التعليمات — بما فيها إجراء التنزيل والتنصيب.



1. محتويات الصندوق

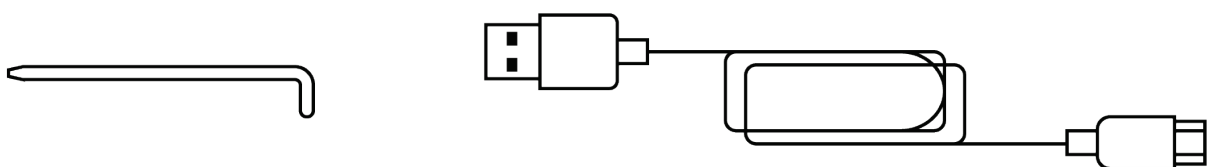
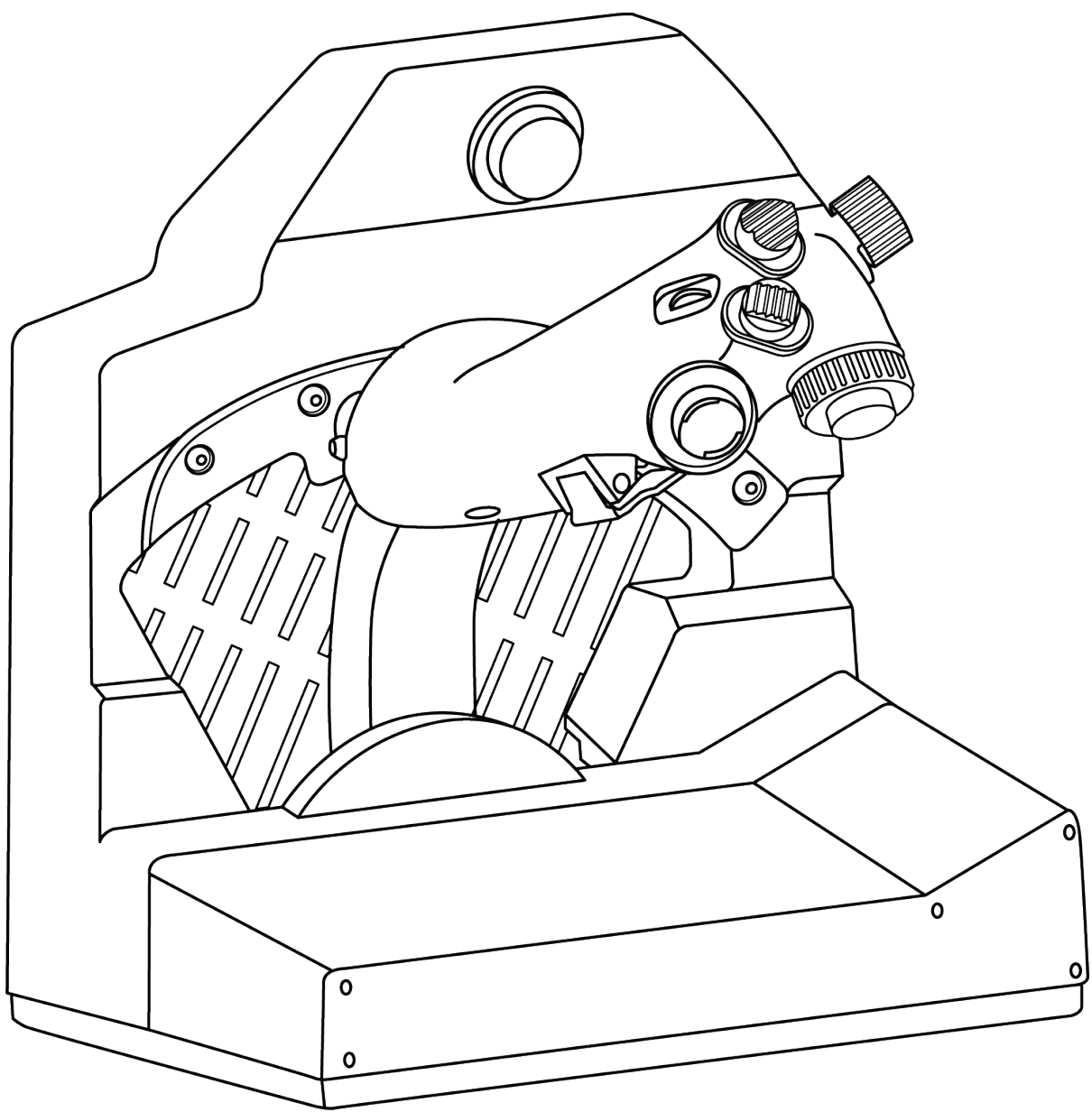



2. VIPER TQS - الميزات

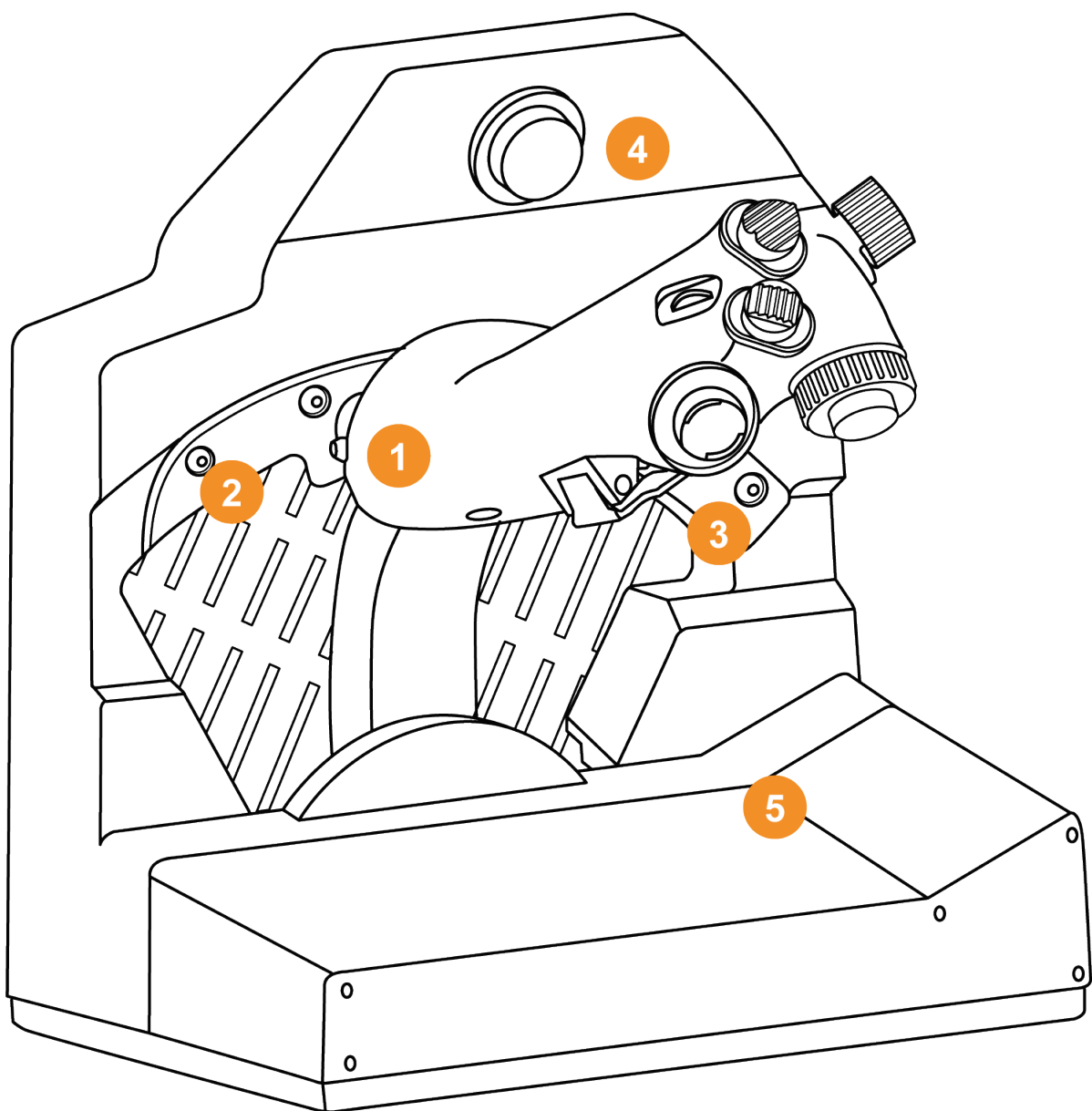

1. المقبض

2. نقطة توقف Cut Off

3. نقطة توقف Afterburner

4. مفتاح الضغط FLARE/CHAFF

5. مشبك لخريطة المهمة

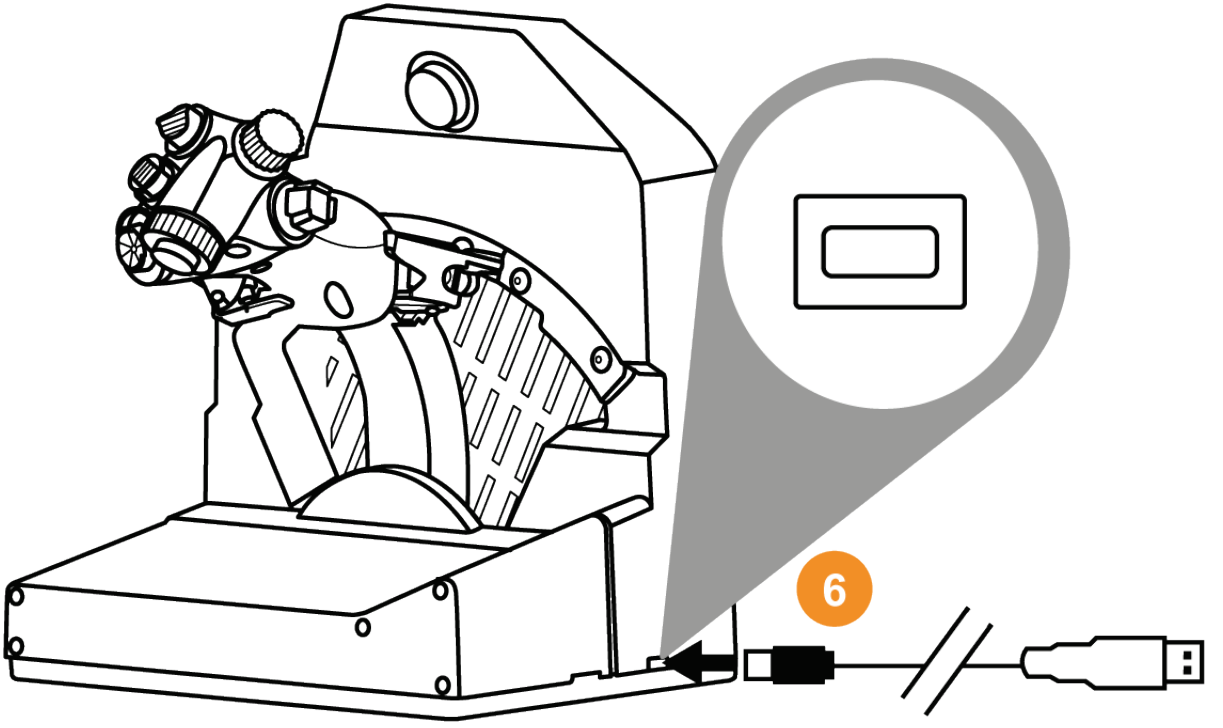

6. موصل USB (من النوع C)

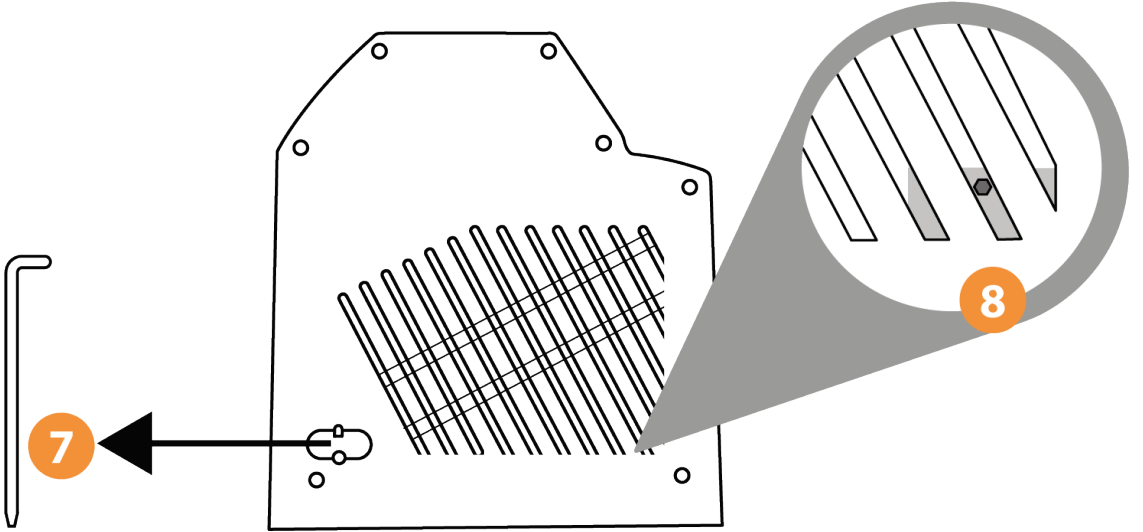

7. موقع أداة ضبط الاحتكاك

8. نقطة وصول ضبط احتكاك الخانق

3. تعيين الأزرار والمحاور

مقبض VIPER TQS: تعيين 19 زرًا و5 محاور في الوضع A (من دون أزرار افتراضية)

A 1→19

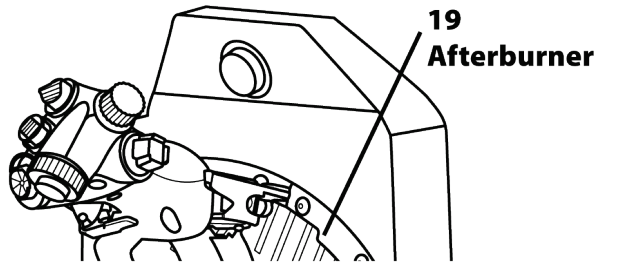
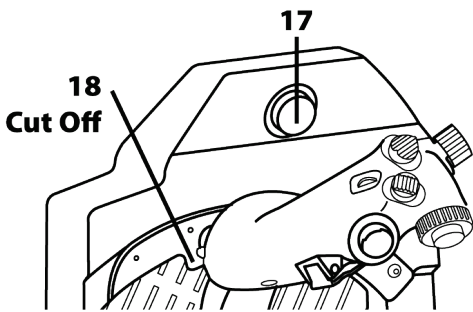
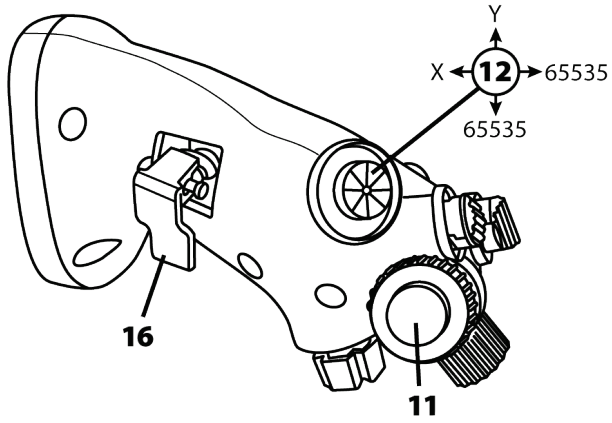
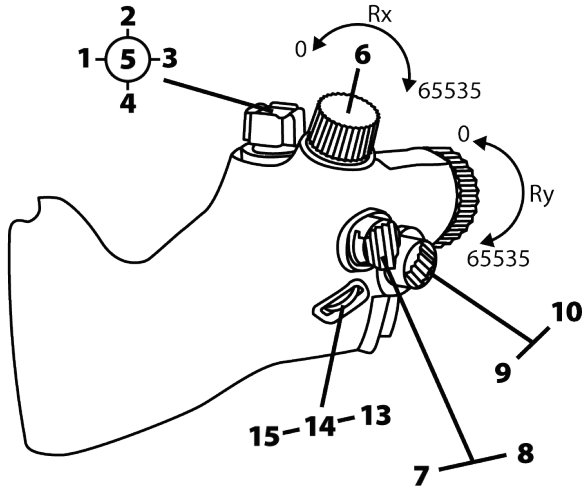



الوضع B: مع أضرار افتراضية

B 1 → 21

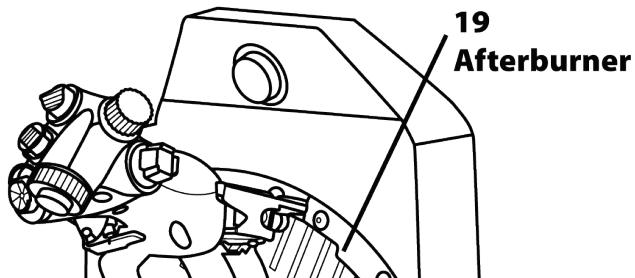
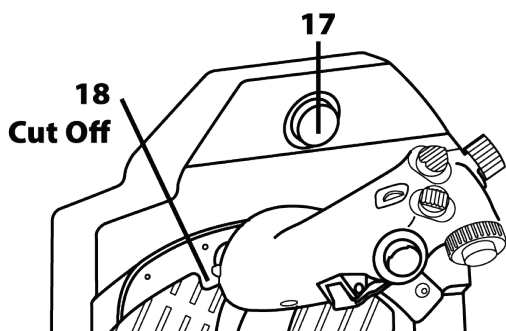
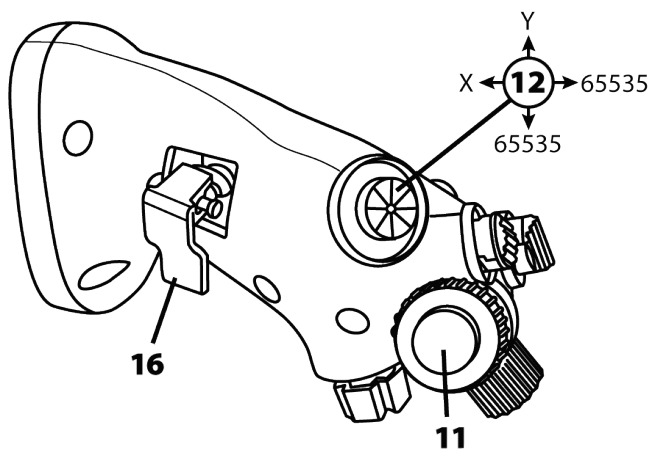
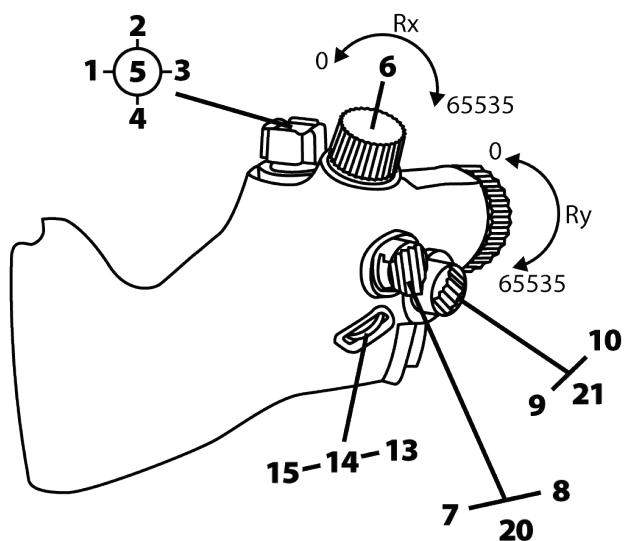

4. معلومات حول استخدام VIPER TQS



خطر التعرض للقرص

لا تضع أصابعك في مناطق التوقف عند استخدام المقبض.



⚠ DANGER

Pinch point.
Keep hands and
fingers clear of
the slide***

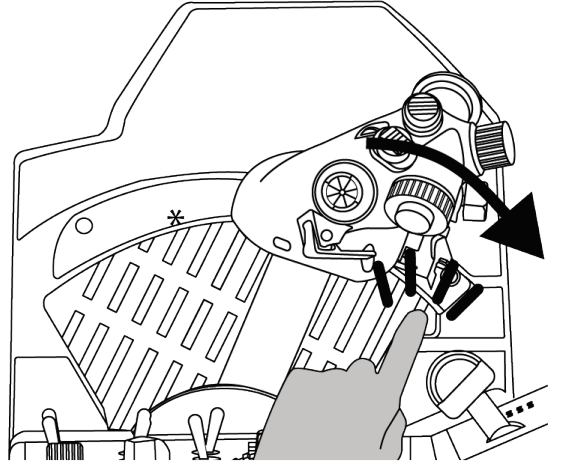
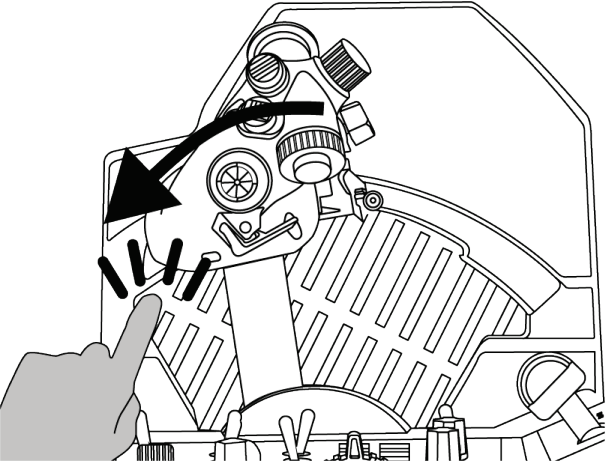

5. ضبط الاحتكاك

يمكنك ضبط احتكاك ربعية الخانق VIPER TQS وفقاً لتفضيلاتك الشخصية باستخدام الأداة المضمنة على جانب VIPER TQS. لكن يُرجى ملاحظة أنه تم تعيين الاحتكاك الأمثل للخانق افتراضياً في المصنع.

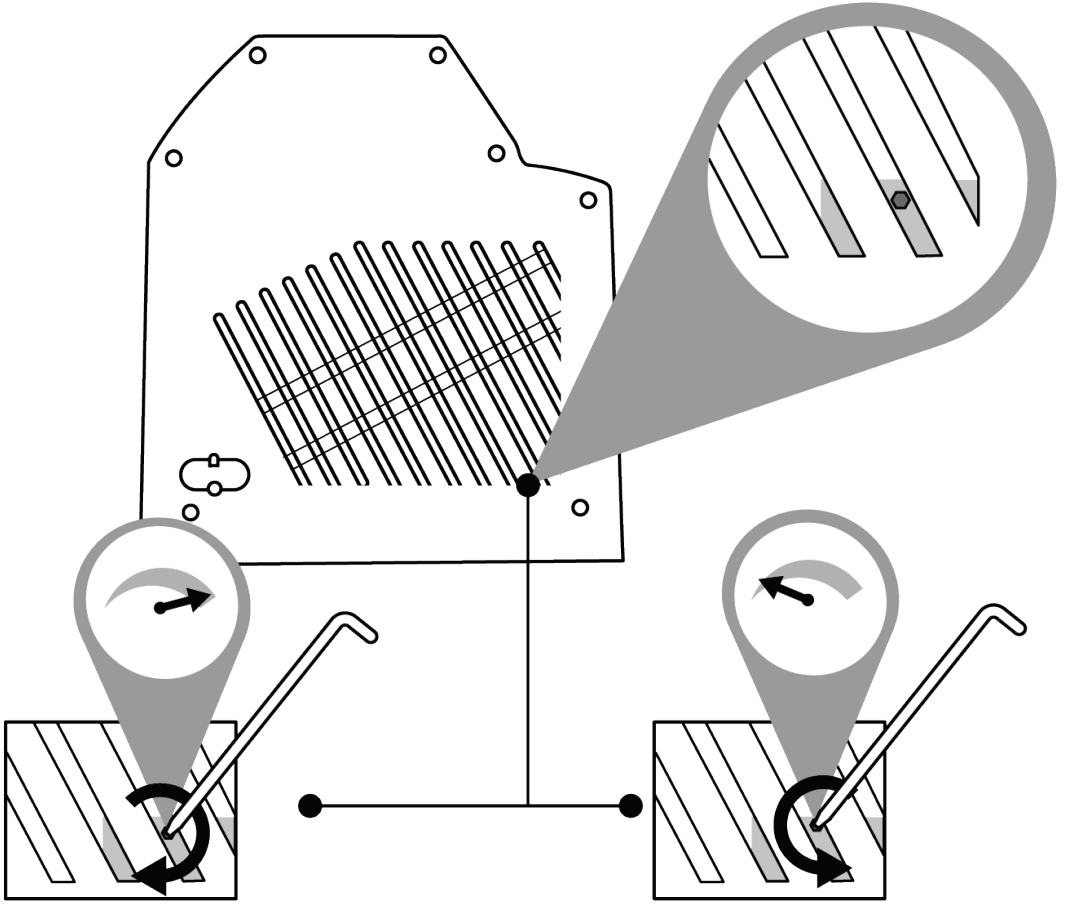

لتجنب إتلاف نظام الاحتكاك، تأكد من عدم المبالغة في ربط برغي الضبط. تأكد أيضاً من عدم فك برغي الضبط تماماً، لأنه إذا قمت بذلك، فأنت تخاطر بالألا يتمكن الخانق من البقاء في موضعه بعد الآن.

6. التركيب على حامل



يمكن تركيب VIPER TQS على أنواع مختلفة من الدعامات. وتتوافق معظم قمرات القيادة والدعامات المتوفرة في السوق بالفعل مع منتجات Thrustmaster المماثلة (مثل HOTAS Warthog). يُرجى الانتباه إلى أن VIPER TQS يتميز بتأثير ذراع قوي، ومن ثمَّ يجب تثبيته بإحكام.

تُثبت القاعدة بالدعامة الخاصة بك باستخدام براغي M6 مناسبة (غير مُرفقة) حتى لا تتلف المقبض.

يتوفر مخطط VIPER TQS الكامل على

<https://support.thrustmaster.com/product/viper-tqs/>



قبل كل استخدام، تأكد من أن VIPER TQS لا يزال مثبتًا بالدعامة بصورة صحيحة، وفقًا للتعليمات المحددة من قبل الشركة المصنّعة. تأكد من مراعاة المواد التي تتكون منها الدعامة الخاصة بك، وتأكد من إمكانية تثبيت المنتج بها بأمان. يجب استخدام VIPER TQS على مكتب مصنوع من مادة صلبة (مثل خشب ليفي متوسط الكثافة أو خشب عادي)، من دون أي مكونات مجوفة أو زجاجية.



أبعاد مخطط التركيب (بوحدة قياس مم)

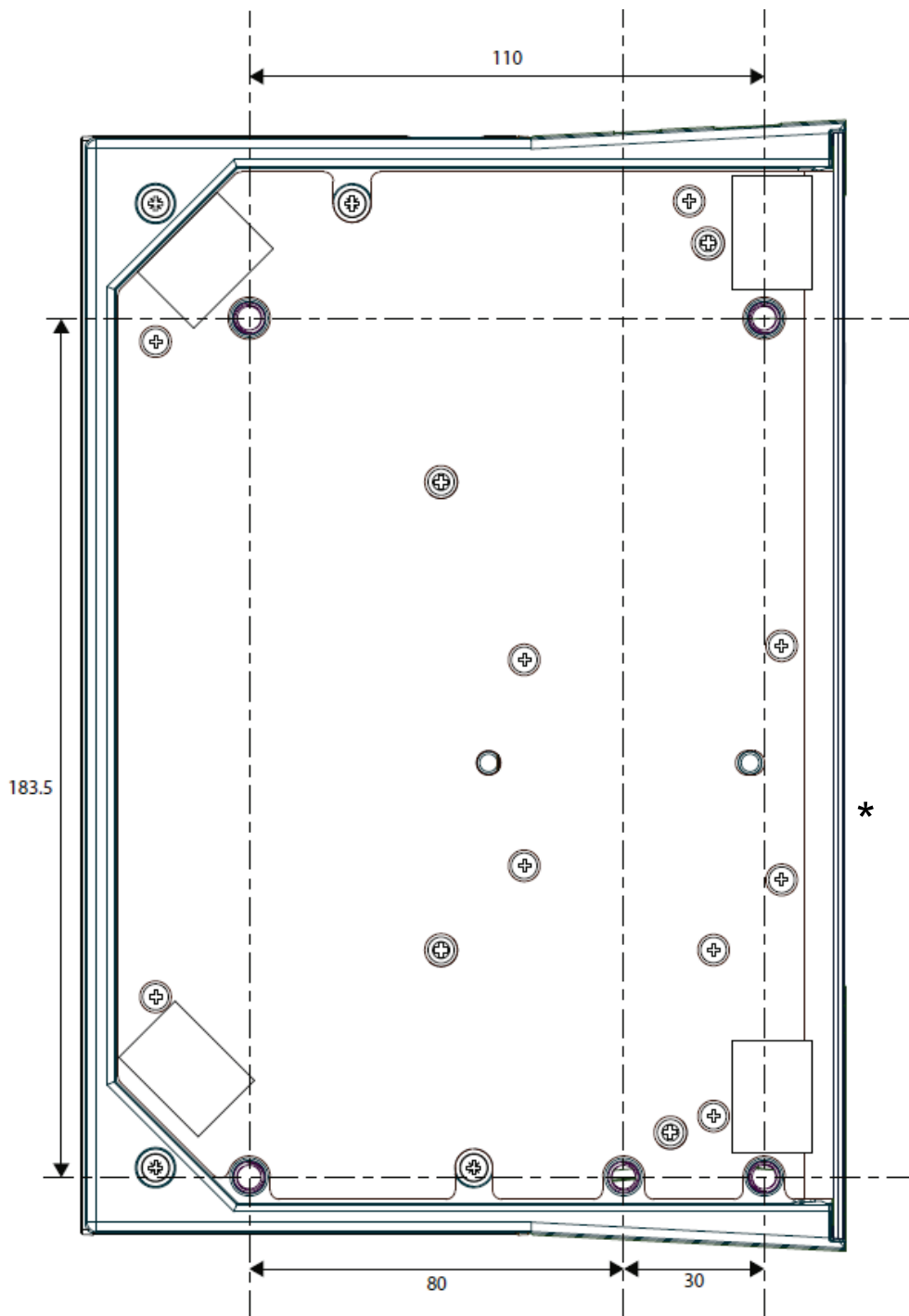

يمكنك تنزيل مخطط التركيب من

<https://support.thrustmaster.com/product/viper-tqs/>

، ثم طباعته واستخدامه على الدعامة الخاصة بك لإعداد ثقب الحفر.

التركيب باستخدام *TM Flying Desk Mount**

يُعد TM Flying Desk Mount نظام تركيب معدنيًا يتميز ببرغي تثبيت لتحسين التصميمات الهندسية وموضع القيادة عند استخدام جهازك. تم تصميم هذا النظام للاستخدام مع مكاتب وطاولات بسُمك يتراوح بين 15 و 50 مم.

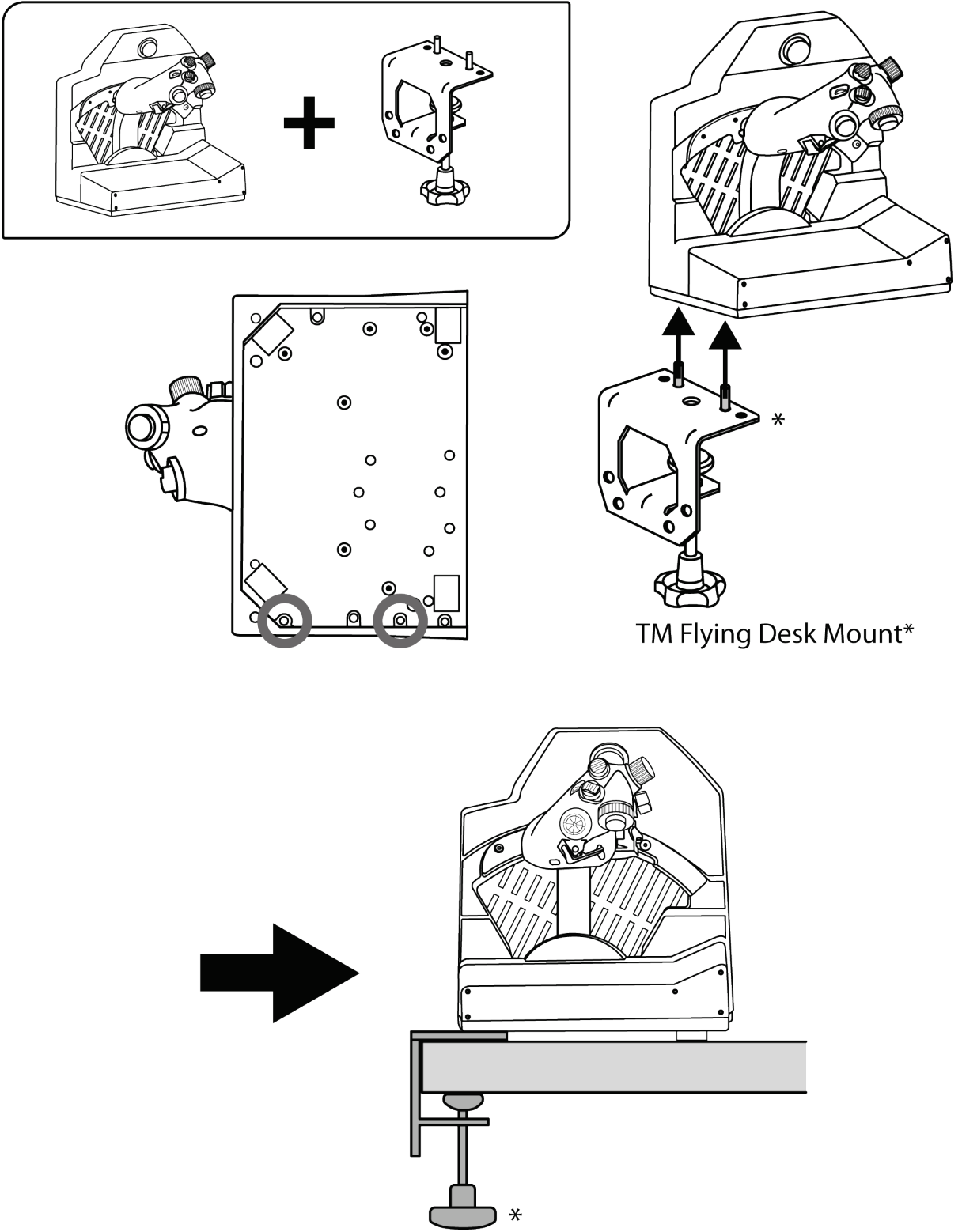

* يُباع منفصلاً

التركيب باستخدام *TM Flying Clamp**

يُعد TM Flying Clamp دعامة يمكن ضبط ارتفاعها تم تصميمها بواسطة Thrustmaster لمحاكاة الطيران الخاصة بها. ويتميز نظام التركيب هذا باثنين من براغي التثبيت التي تسمح بتعديله للاستخدام مع المكاتب والطاولات بسُمك يتراوح بين 15 و45 مم.

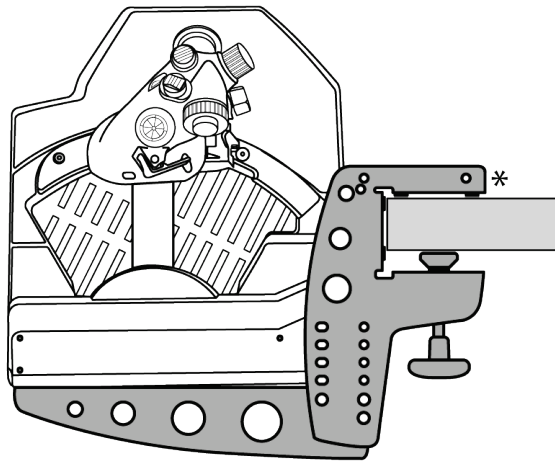
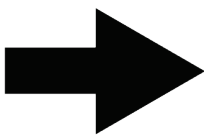
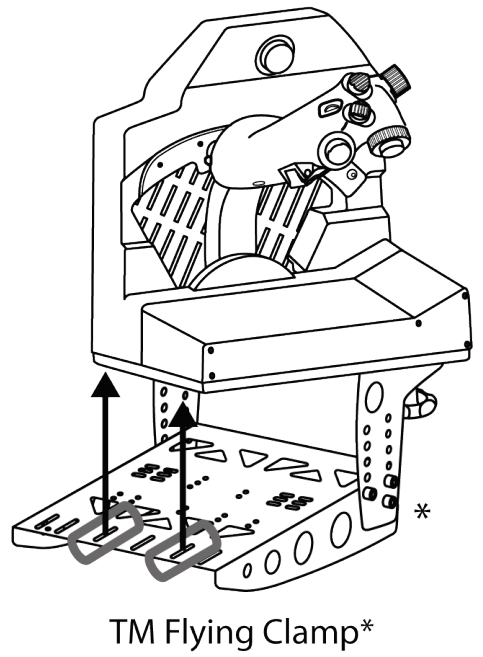
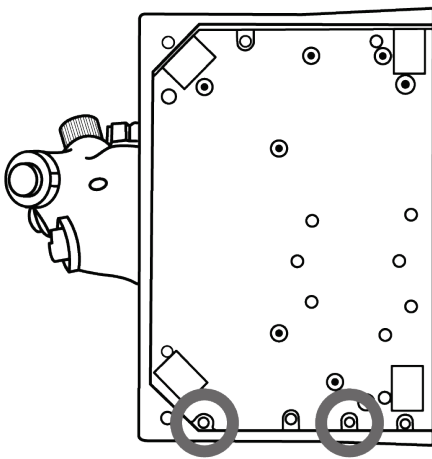
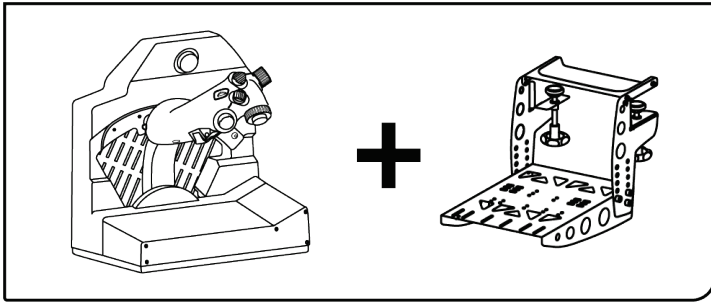

* يُباع منفصلاً



يُرجى ملاحظة أن وزن VIPER TQS الثقيل قد يؤدي إلى حركات غير مرغوب فيها لنظام التركيب.



7. تركيب VIPER PANEL*

*يُباع منفصلاً. يتم تضمين VIPER PANEL مع VIPER TQS Mission Pack.

تُعد VIPER PANEL لوحة تحكم تتيح لك تعزيز قدرات الطيران/القتال لديك بإجمالي 43 زرًا ومحور واحد — وكلها قابلة للبرمجة عبر برنامج T.A.R.G.E.T. كما أن VIPER PANEL تُكمل VIPER TQS.

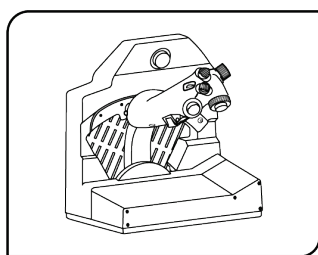

1

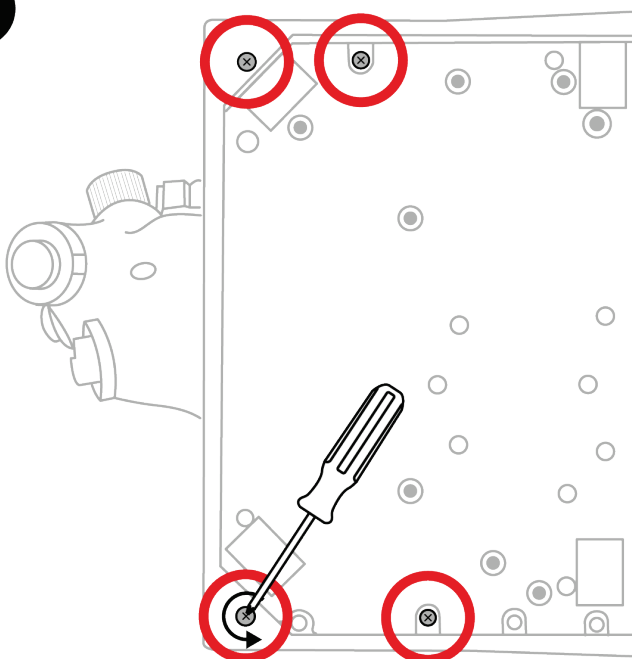

2

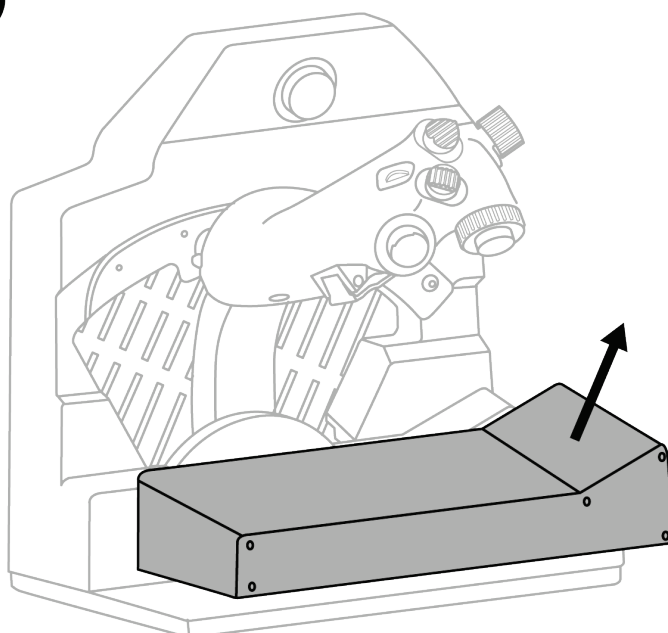

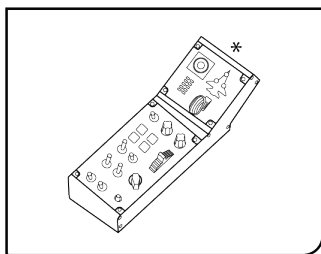

3

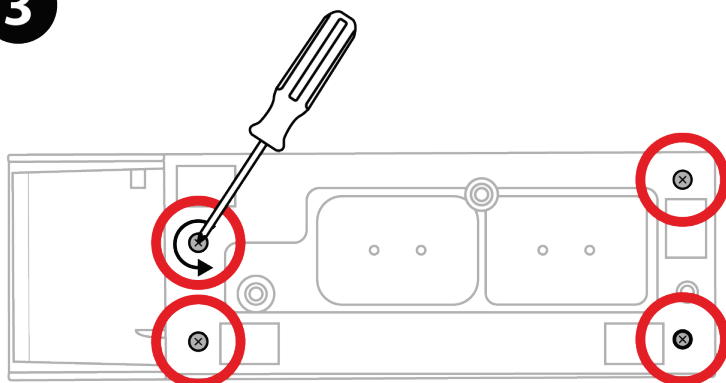

4

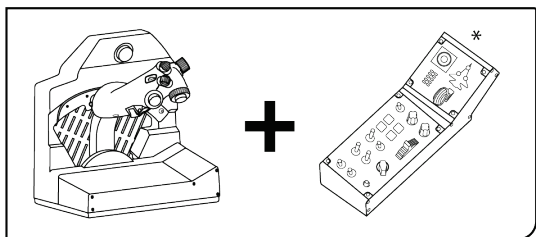
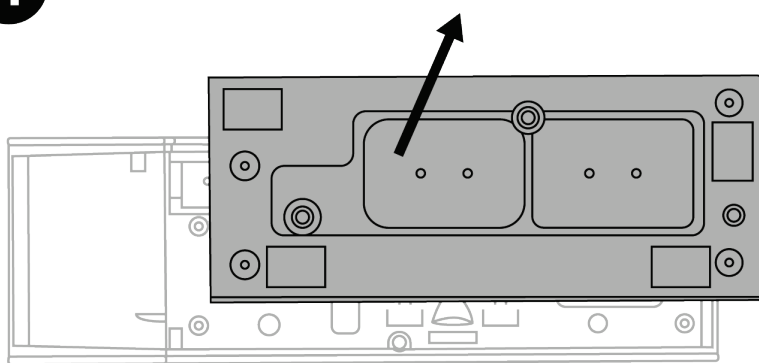

5

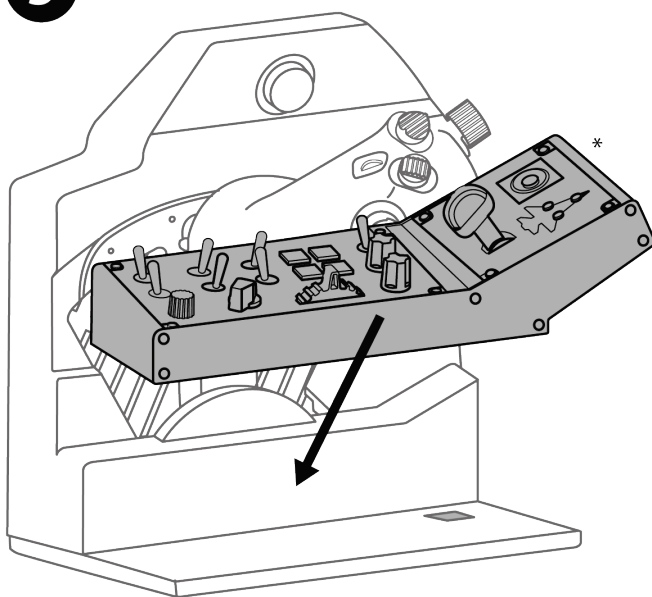



6

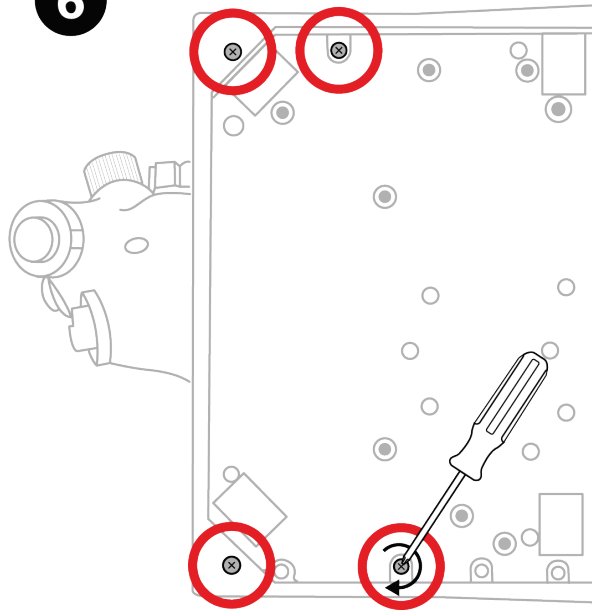

7

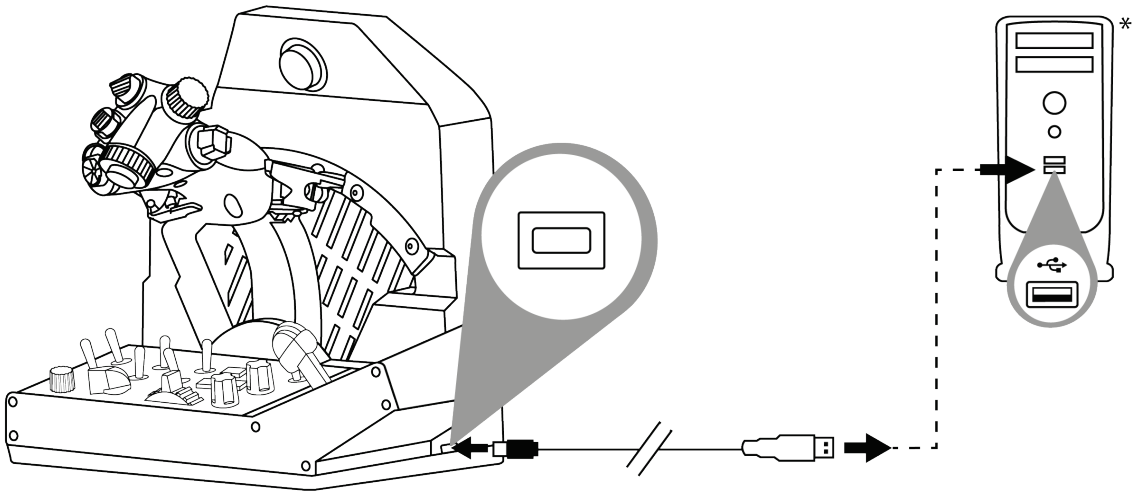

* غير مرفقة

8. التثبيت على أجهزة الكمبيوتر

1



يُرجى زيارة الموقع الإلكتروني

<https://support.thrustmaster.com/product/viper-tqs/>

2

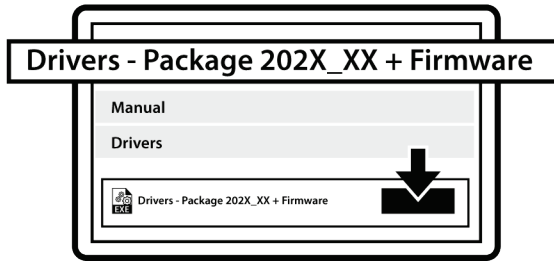

قم بتنزيل وتثبيت برنامج التشغيل الخاص بأجهزة الكمبيوتر وواجهته المخصصة للوحة التحكم في نظام التشغيل Windows.

3

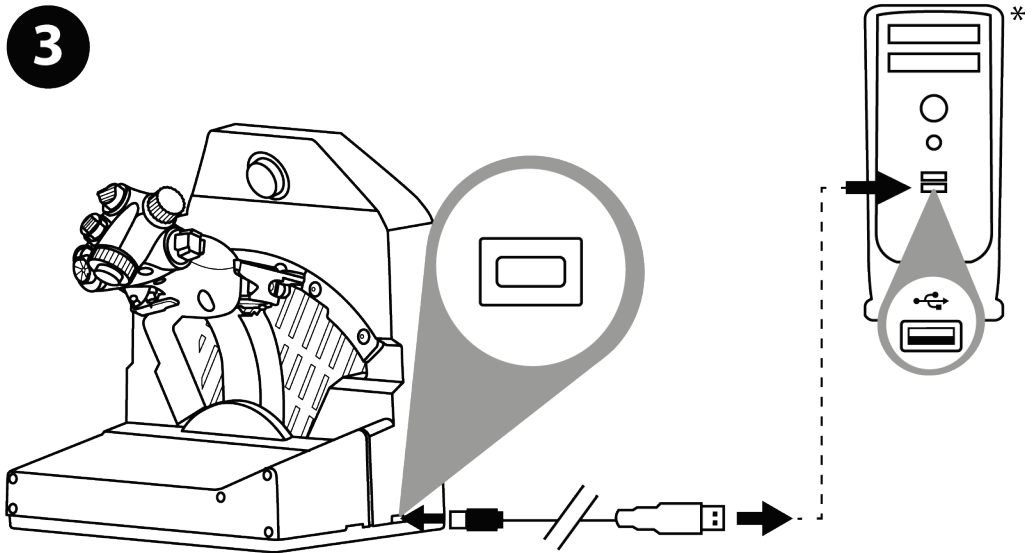

بمجرد تثبيت برنامج التشغيل الخاص بأجهزة الكمبيوتر، قم بتوصيل موصل USB في أحد منافذ USB الموجودة في جهاز الكمبيوتر.

* غير مرفقة

4 للوصول إلى Control Panel، حدد بدء / كل التطبيقات /
Control Panel / Thrustmaster أو لوحة التحكم (في Windows
10).

يتم عندئذ عرض مربع الحوار وحدات التحكم بالألعاب. ويظهر الملحق على
الشاشة باسم VIPER TQS وتظهر الحالة OK.

5 في مربع الحوار وحدات التحكم بالألعاب، انقر فوق الخصائص لعرض كل
الوظائف واختبارها.

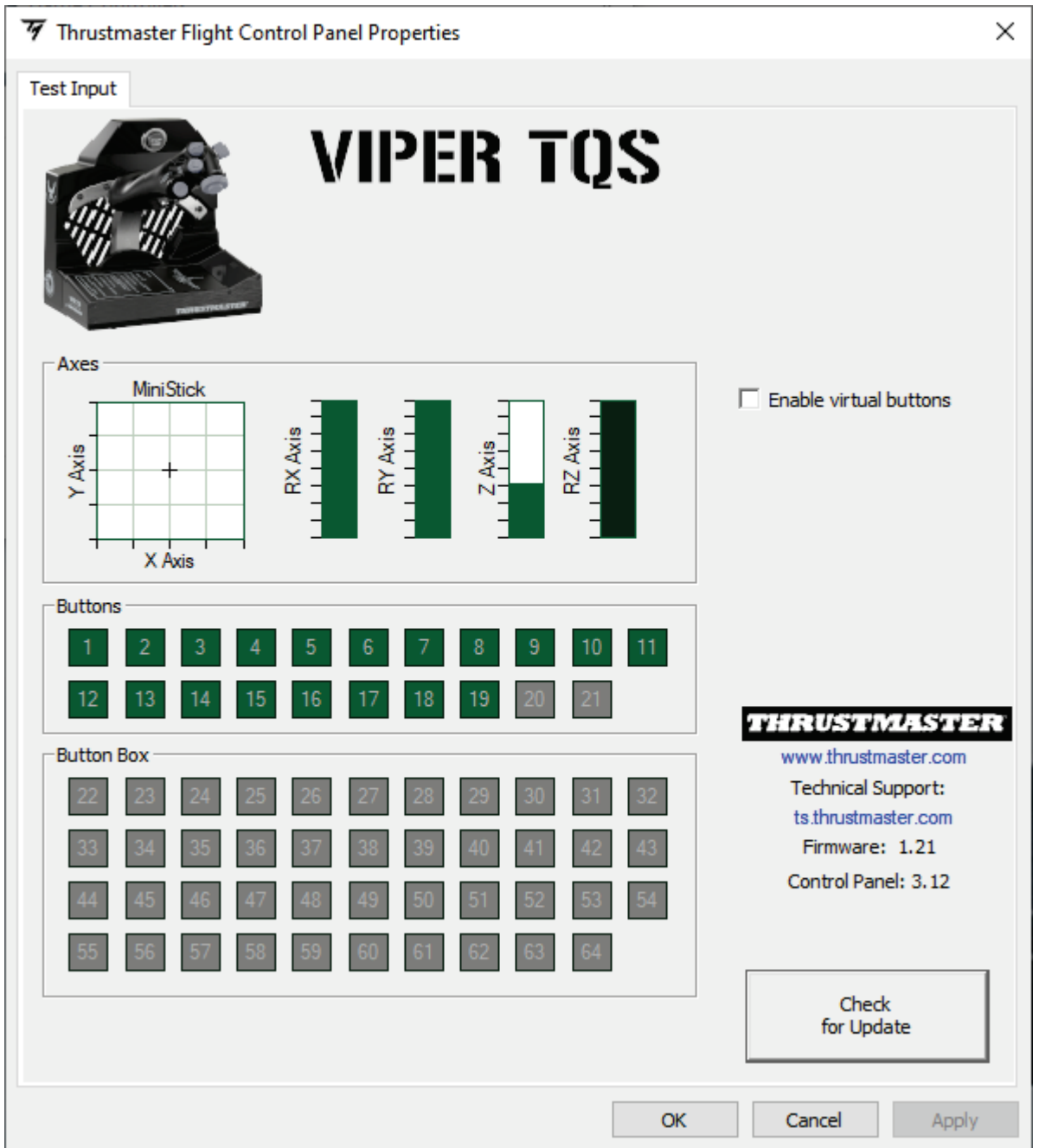

Enable virtual buttons (تمكين الأزرار الافتراضية):

تتيح لك هذه الوظيفة تمكين الأزرار الافتراضية أو تعطيلها على المقبض (الزر 20 والزر 21). انقر فوق **Apply** (تطبيق) بمجرد تحديد الوضع الذي تريد استخدامه.

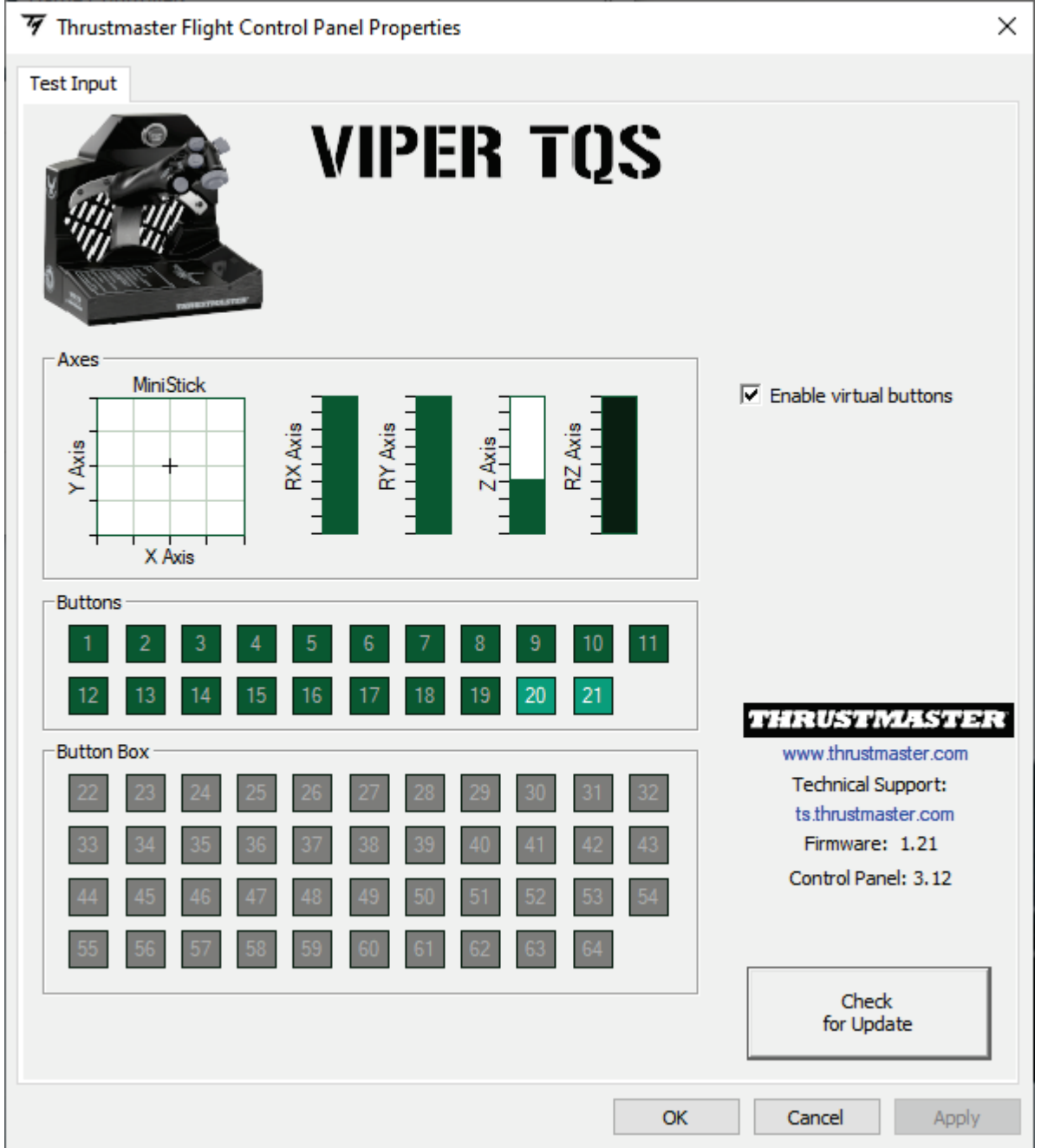

يتم تعطيل الأزرار الافتراضية بشكل افتراضي في VIPER TQS.



- AFTERBURNER و CUT OFF .9

الحابسات

تتميز ربعية الخانق VIPER TQS بنظام واقعي لحابسات CUT OFF وAFTERBURNER (تُعد وحدة Afterburner قابلة للإزالة).

CUT OFF

بعد وضع الخانق عند نقطة توقف IDLE، اضغط على زناد "فتح قطع المحرك"
1 لرفع المقبض من أجل تجاوز نقطة التوقف 2، ثم ضع المقبض في وضع
3 OFF.

لإعادة تشغيل المحركات، قم بتنفيذ هذا الإجراء عكسيًا.



AFTERBURNER

حرك الخانق إلى نقطة التوقف ① وارفعه ② من أجل تجاوز نقطة التوقف وتشغيل حاقن الوقود ③.

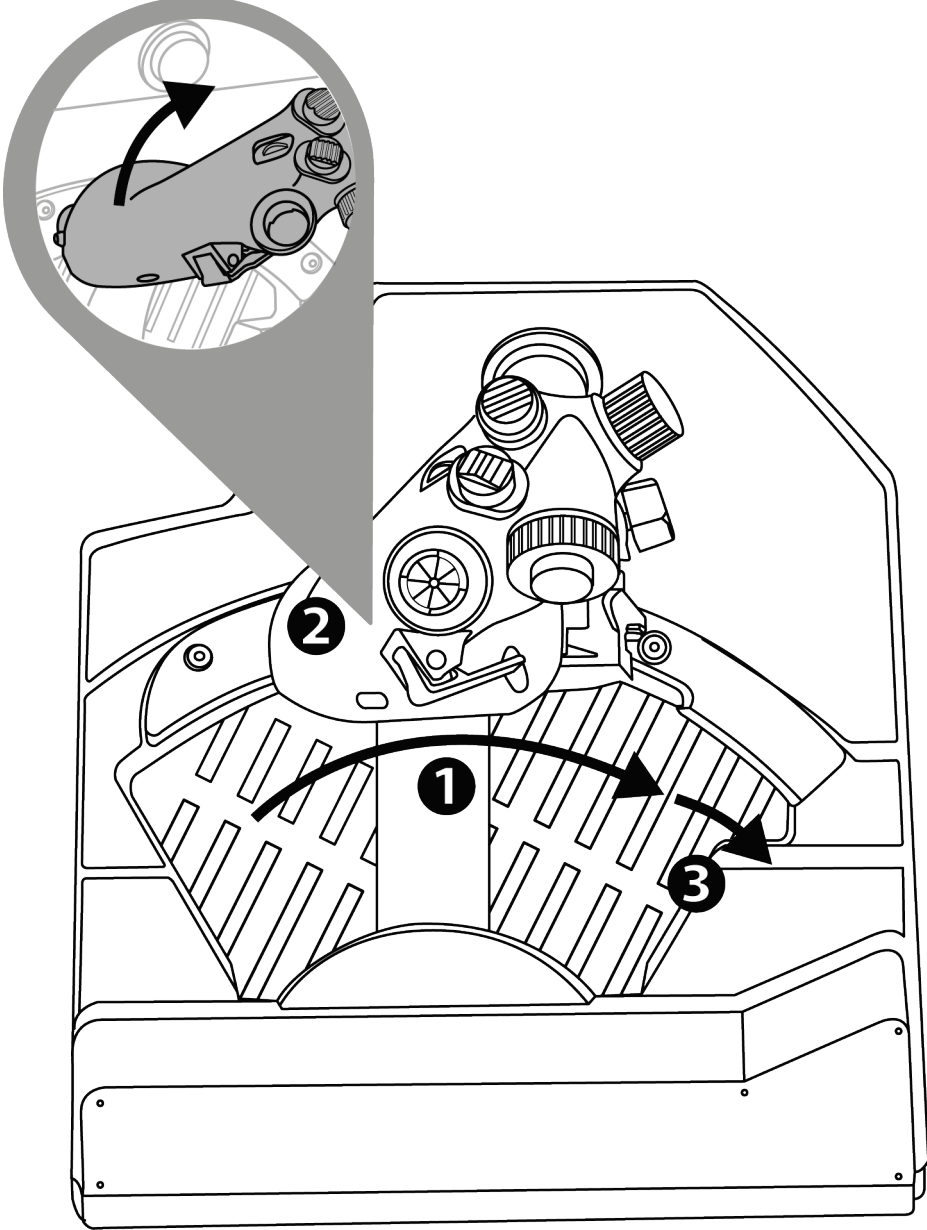

إلغاء تركيب نقطة توقف **AFTERBURNER**

يتم وضع نقطة توقف وحدة Afterburner عند 80% من قيمة المحور. إذا كنت بحاجة إلى 100% من حركة الخانق من دون نقطة توقف (لجهاز محاكاة معين)، فيمكنك إزالة وحدة Afterburner ونقطة التوقف الخاصة بها عن طريق فك اثنين من براغي الوحدة باستخدام مفتاح ألن (غير مرفق).

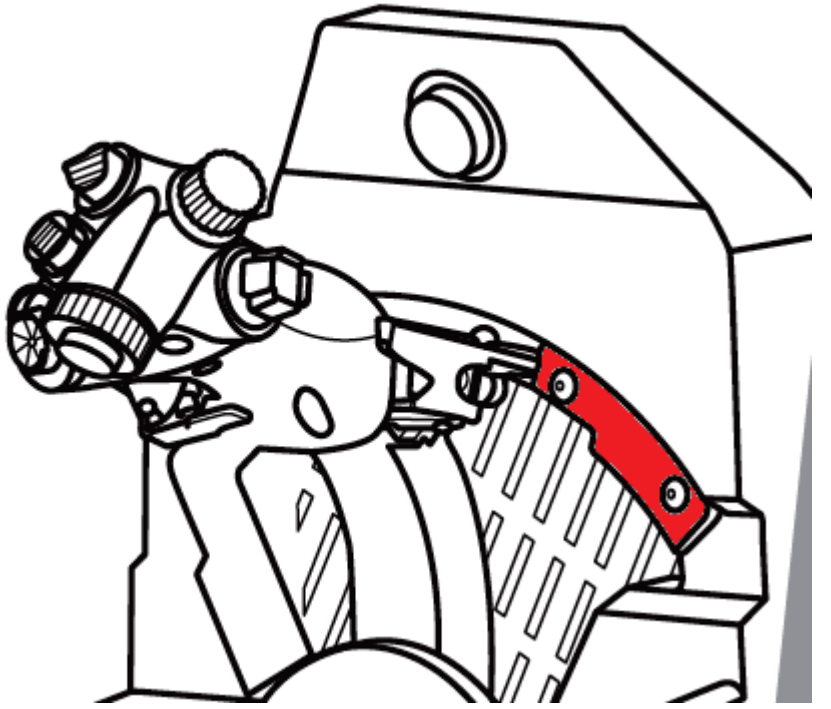



10. برنامج البرمجة المتقدمة T.A.R.G.E.T



يُرجى زيارة الموقع الإلكتروني

[./https://support.thrustmaster.com/product/viper-tqs](https://support.thrustmaster.com/product/viper-tqs)

في قسم **Software** (البرنامج)، قم بتنزيل برنامج البرمجة المتقدمة
T.A.R.G.E.T وتثبيته.



الميزات الرئيسية لبرنامج T.A.R.G.E.T

- تكوينات ممكنة مختلفة للمحاور.
- مستويات برمجة ممكنة مختلفة: Basic و Advanced و Script.
- استخدام مبدأ السحب والإفلات.
- إمكانية دمج رابعة الخانق VIPER TQS مع أذرع تحكم Thrustmaster متنوعة (HOTAS Cougar، و HOTAS، و Warthog، و T.16000M، و MFD Cougar Pack، علمًا بأن هذه الأذرع جميعها متوافقة أيضًا مع برنامج البرمجة المتقدمة T.A.R.G.E.T)، وهذا يسمح بالتعرف عليها كجهاز USB واحد.
- الوصول إلى ملفات التعريف المتقدمة التي يتم إنشاؤها بواسطة مجتمع Thrustmaster.



11. الأسئلة الشائعة والدعم الفني

هل لديك أسئلة بخصوص VIPER TQS، أو هل تواجه مشكلات فنية؟ إذا كان الأمر كذلك، فنفضل بزيارة الموقع الإلكتروني للدعم الفني لشركة Thrustmaster:

<https://support.thrustmaster.com/product/viper-tqs/>



THRUSTMASTER®

VIPER TQS

THROTTLE QUADRANT SYSTEM

För PC (Windows 10/11)

Användarmanual



Läs noggrant igenom instruktionerna i denna manual **innan** du installerar produkten, **innan** produkten används och **innan** underhåll utförs på den. Var noga med att följa säkerhetsinstruktionerna. Att inte följa instruktionerna kan leda till olyckor och/eller skada. Behåll denna manual så att du kan läsa instruktionerna även i framtiden.

INNEHÅLLSFÖRTECKNING

1.	INNEHÅLL I FÖRPACKNINGEN.....	5
2.	VIPER TQS - FUNKTIONER.....	6
3.	MAPPNING AV KNAPPAR OCH AXLAR	8
4.	ANVÄNDNINGSGENOMGÅNG FÖR VIPER TQS	10
5.	JUSTERA FRIKTIONEN	11
6.	INSTALLATION PÅ ETT STÖD.....	12
7.	INSTALLERA VIPER PANEL*	17
8.	INSTALLATION PÅ PC.....	20
9.	CUT OFF- OCH AFTERBURNER-SPÄRRAR.	23
10.	AVANCERADE PROGRAMMERINGS- PROGRAMMET T.A.R.G.E.T	26
11.	VANLIGA FRÅGOR OCH TEKNISK SUPPORT	28



Varva upp motorerna och flyg in i farozonen med det ikoniska gasreglagekvadrantsystemet från det amerikanska flygvapnets VIPER – världens mest utbrett använda moderna stridsflygplan!

Ta din cockpit till nästa nivå med den unika ergonomin av en HOTAS-replika i verklig storlek med metallhandtag och realistiska knappar och spärrar.

Denna manual hjälper dig att installera och använda din VIPER TQS med så bra förutsättningar som möjligt. Läs noggrant igenom alla dessa instruktioner och varningar innan du lyfter: de hjälper dig att få ut så mycket som möjligt av din produkt.



Uppdatera firmwären

För att VIPER TQS ska fungera ordentligt i spel måste du uppdatera dess firmware.

Uppdatera genom att gå till

<https://support.thrustmaster.com/product/viper-tqs/>

Välj **Firmware** (Firmware) och följ instruktionerna – inklusive hur man laddar ner och installerar.



1. Innehåll i förpackningen

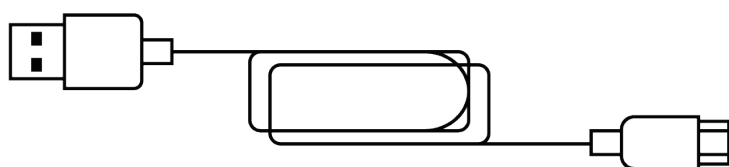
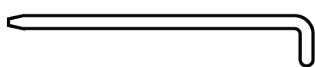
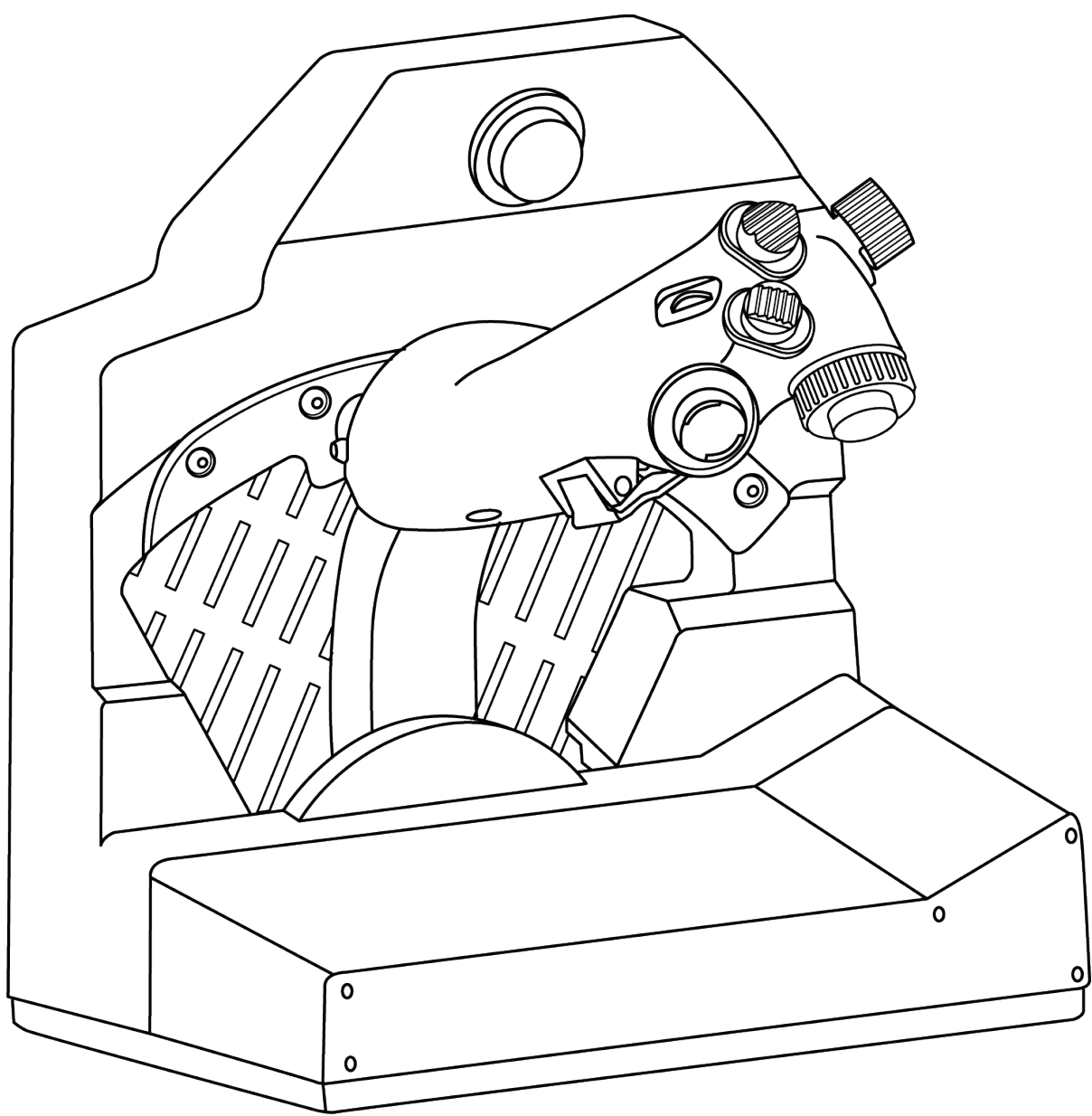



2. VIPER TQS - Funktioner

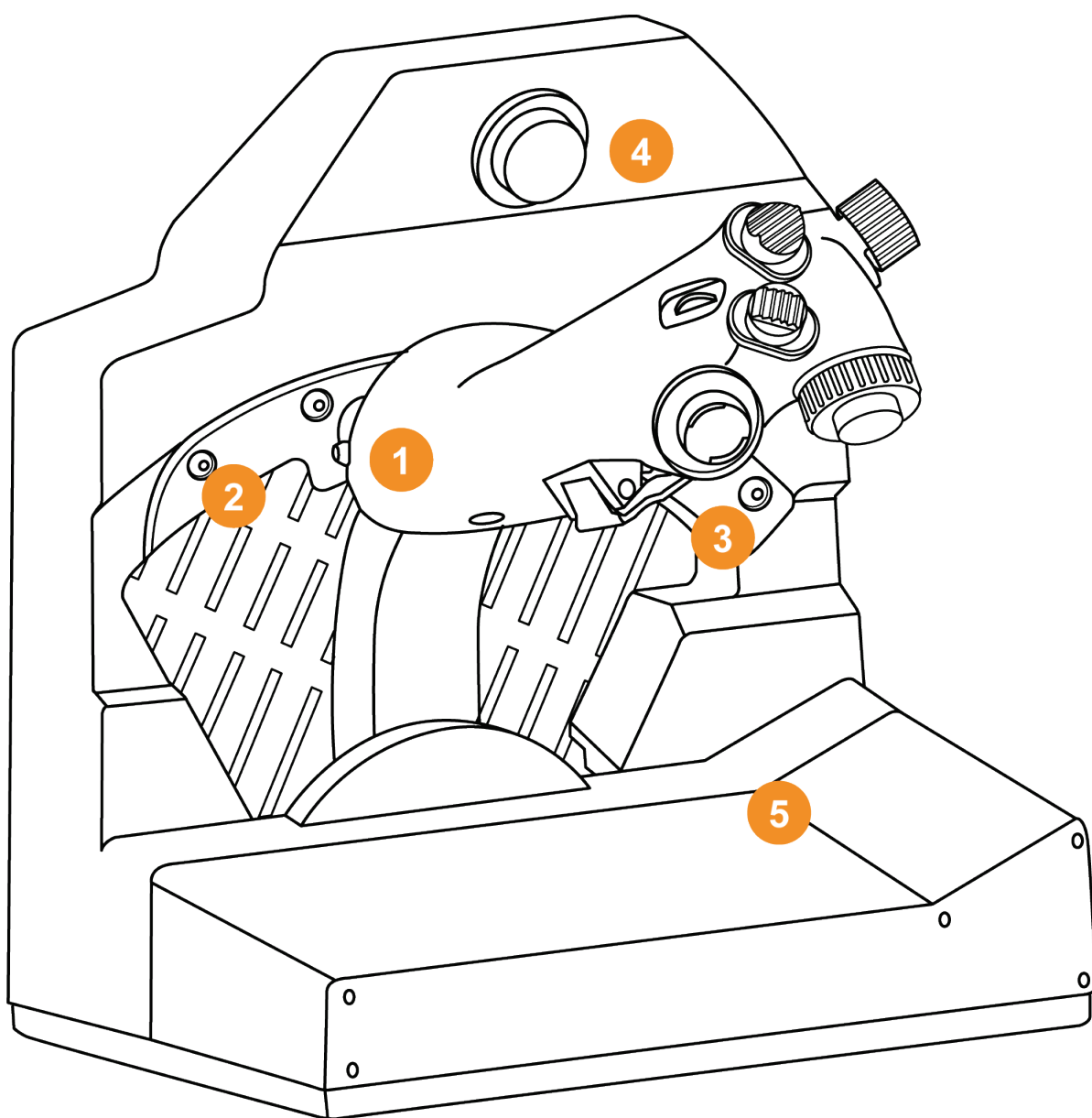

1. Handtag

2. Cut Off-spärr

3. Afterburner-spärr

4. CHAFF/FLARE-knapp

5. Klämma för uppdragskarta

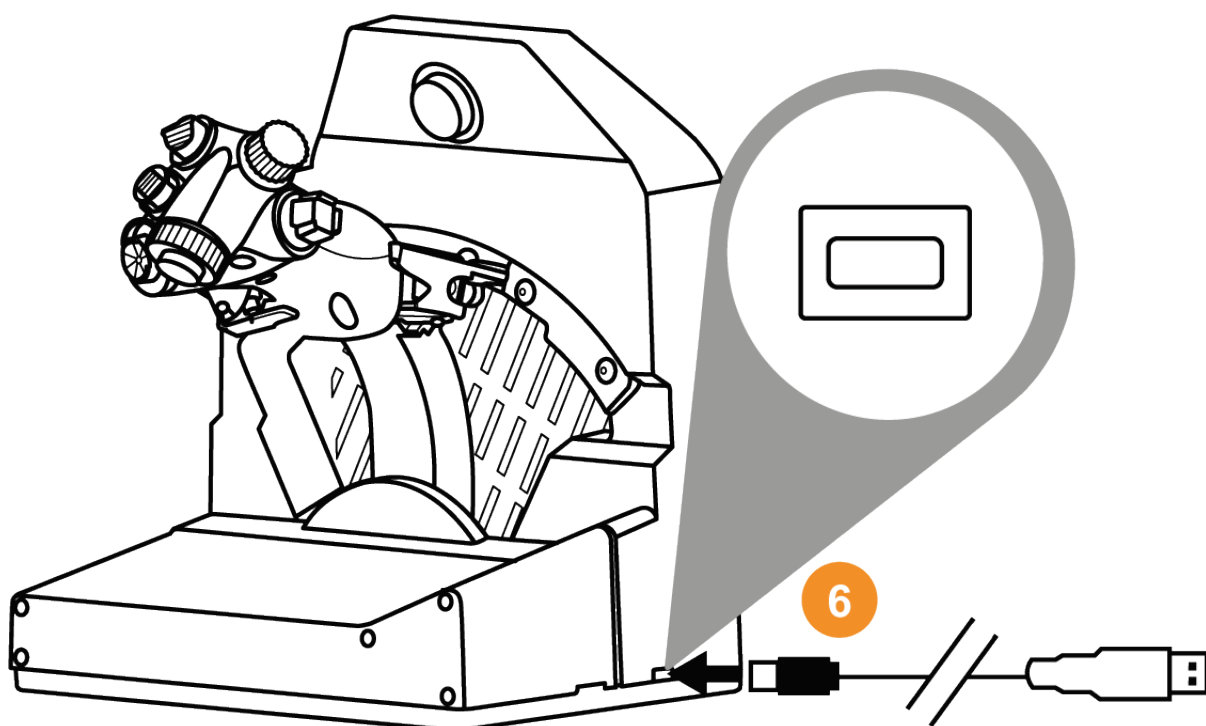

6. USB-C-kontakt

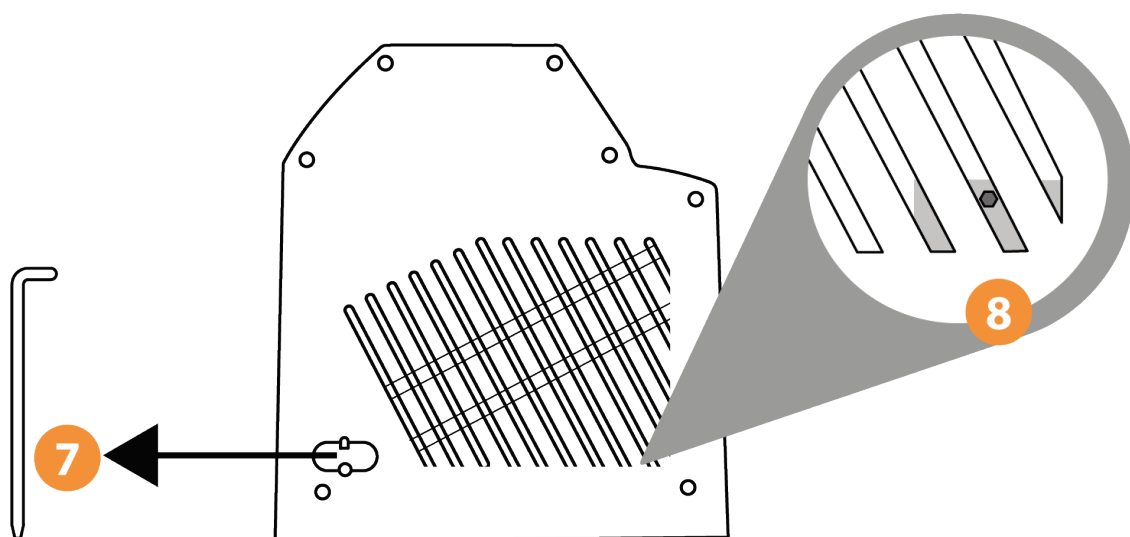

7. Friktionsjusteringsverktyg

8. Åtkomstpunkt för justering av gasreglagets friktion



3. Mappning av knappar och axlar

VIPER TQS-handtaget: mappning av de 19 knapparna och fem axlarna i läge A (utan virtuella knappar)

A 1 → 19

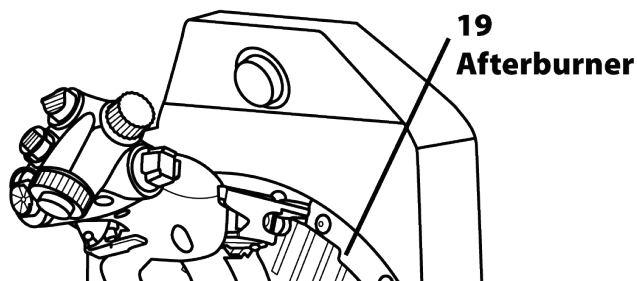
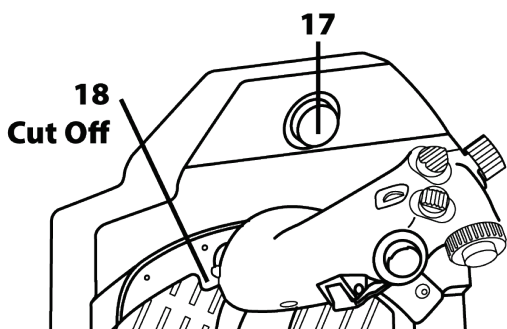
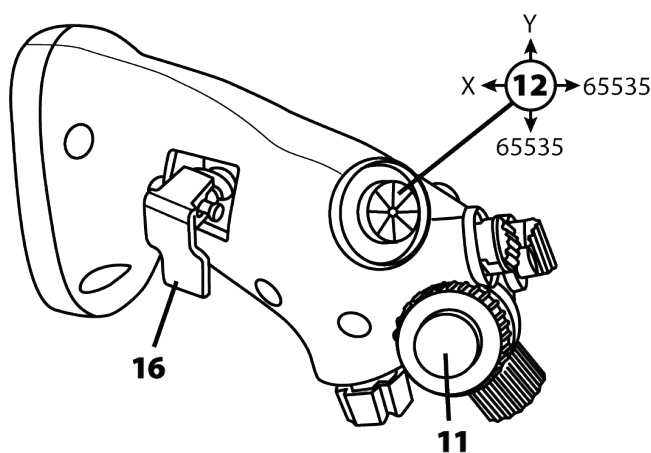
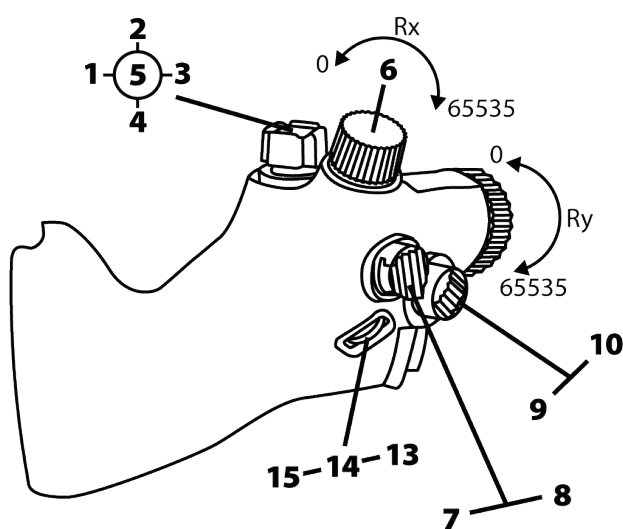



Läge B: med virtuella knappar

B 1 → 21

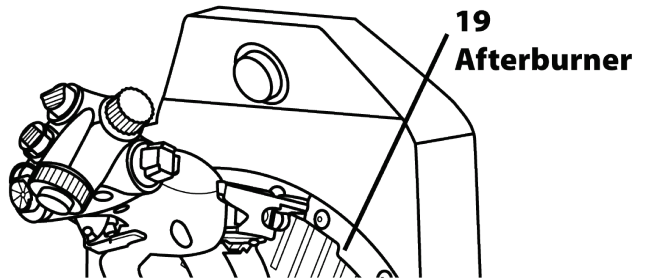
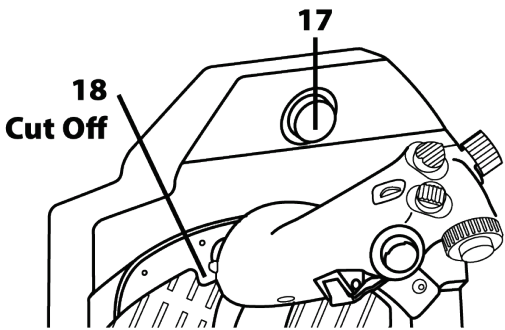
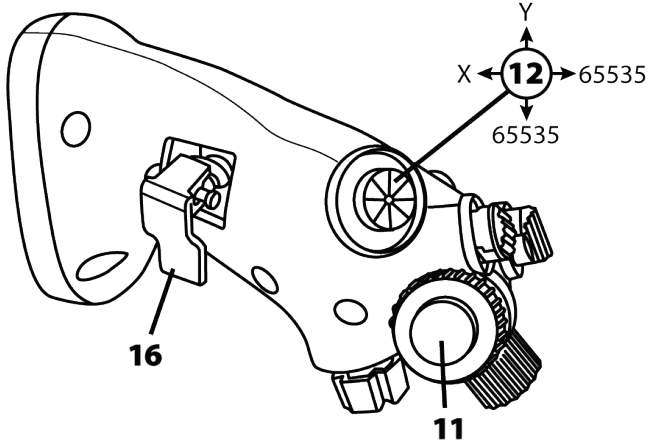
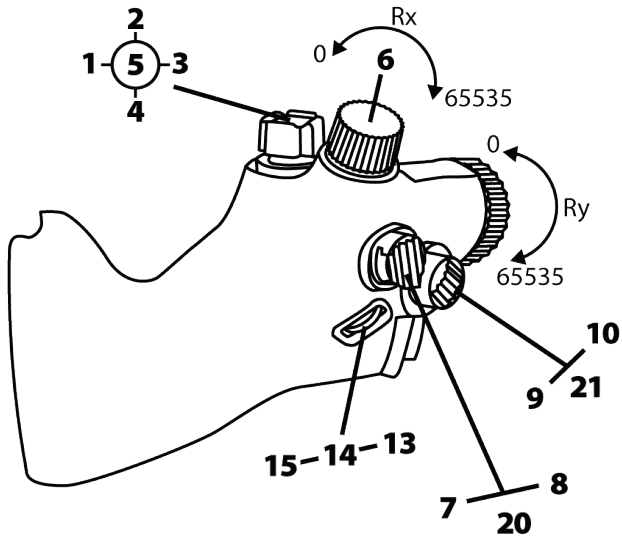



4. Användningsinformation

för

VIPER TQS



Klämrisk

Ha aldrig fingrarna i spärrområdena när du använder handtaget.

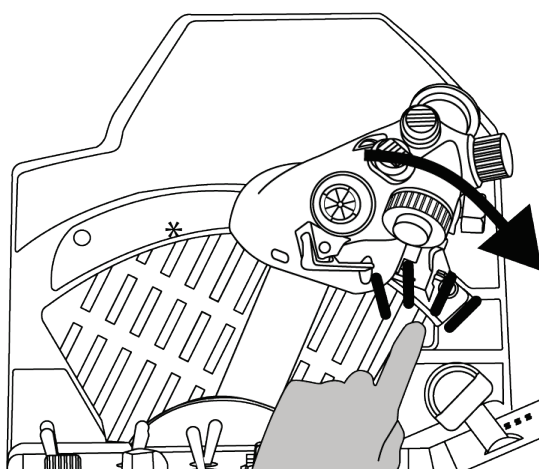
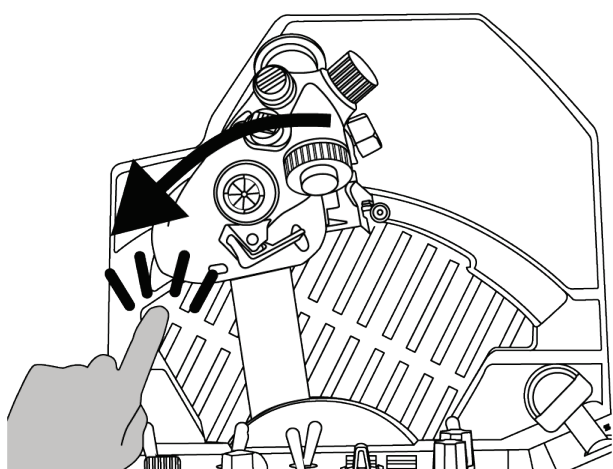
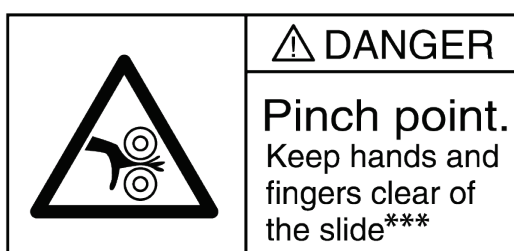



5. Justera friktionen

Du kan justera friktionen på gasreglagekvadranten VIPER TQS efter eget tycke med hjälp av verktyget som sitter på sidan av VIPER TQS. Observera dock att den optimala gasreglagefriktionen redan är fabriksinställd som standard.

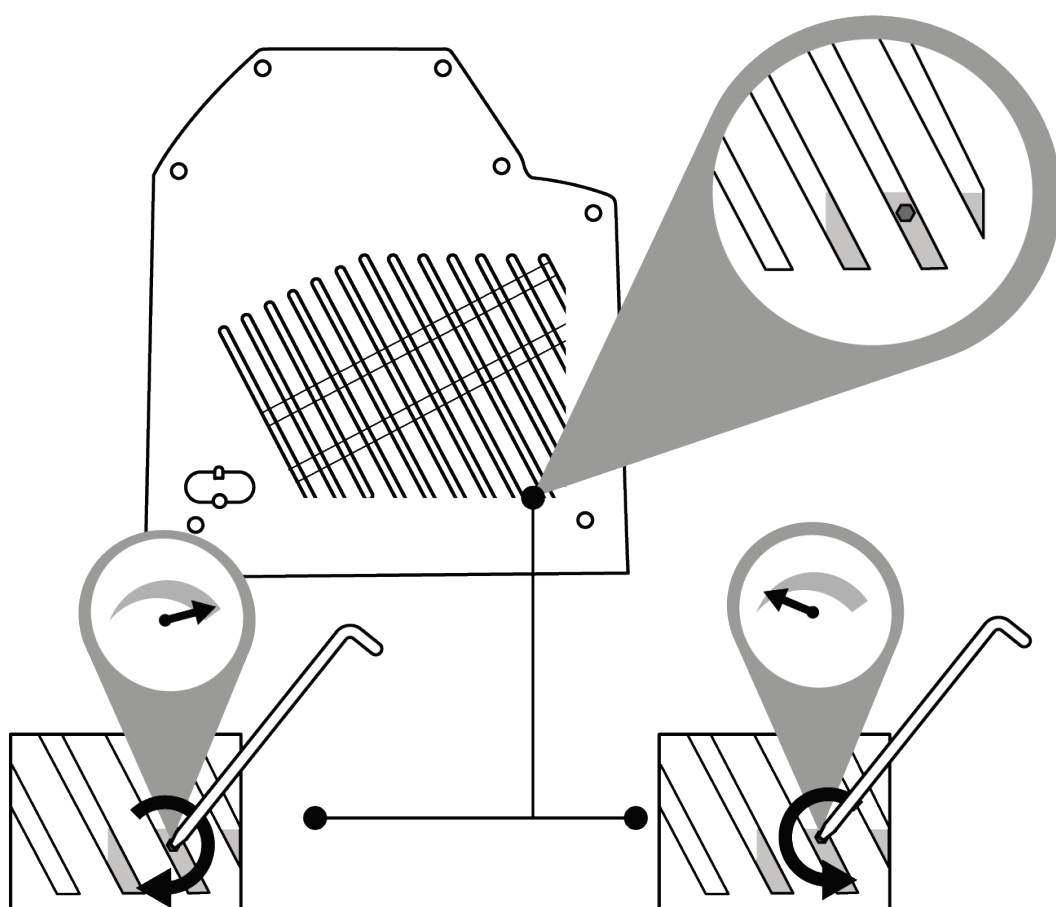

Var försiktig så du inte drar åt justeringsskruven för mycket och skadar friktionssystemet.

Tänk också på att inte skruva loss justeringsskruven helt och hållet eftersom det kan göra att gasreglaget inte längre kan sitta kvar.



6. Installation på ett stöd



VIPER TQS kan installeras på olika typer av stöd. De flesta cockpits och stöd som finns på marknaden är redan kompatibla med liknande Thrustmaster-produkter (som HOTAS Warthog).

Tänk på att VIPER TQS har en kraftfull hävstångseffekt och måste därför sitta fast ordentligt.

Montera basen på ditt stöd med lämpliga M6-skruvar (ingår ej) för att inte skada handtaget.

En komplett VIPER TQS-ritning finns på <https://support.thrustmaster.com/product/viper-tqs/>



Kontrollera varje gång innan du använder VIPER TQS att den sitter ordentligt fast på stödet enligt tillverkarens instruktioner.

Ta hänsyn till materialet som stödet är gjort av och försäkra dig om att det är säkert att montera produkten på det. VIPER TQS måste användas på ett bord gjort av ett solitt material (som MDF eller trä) utan ihåliga komponenter eller komponenter gjorda av glas.



Mått på monteringsritningen (i mm)

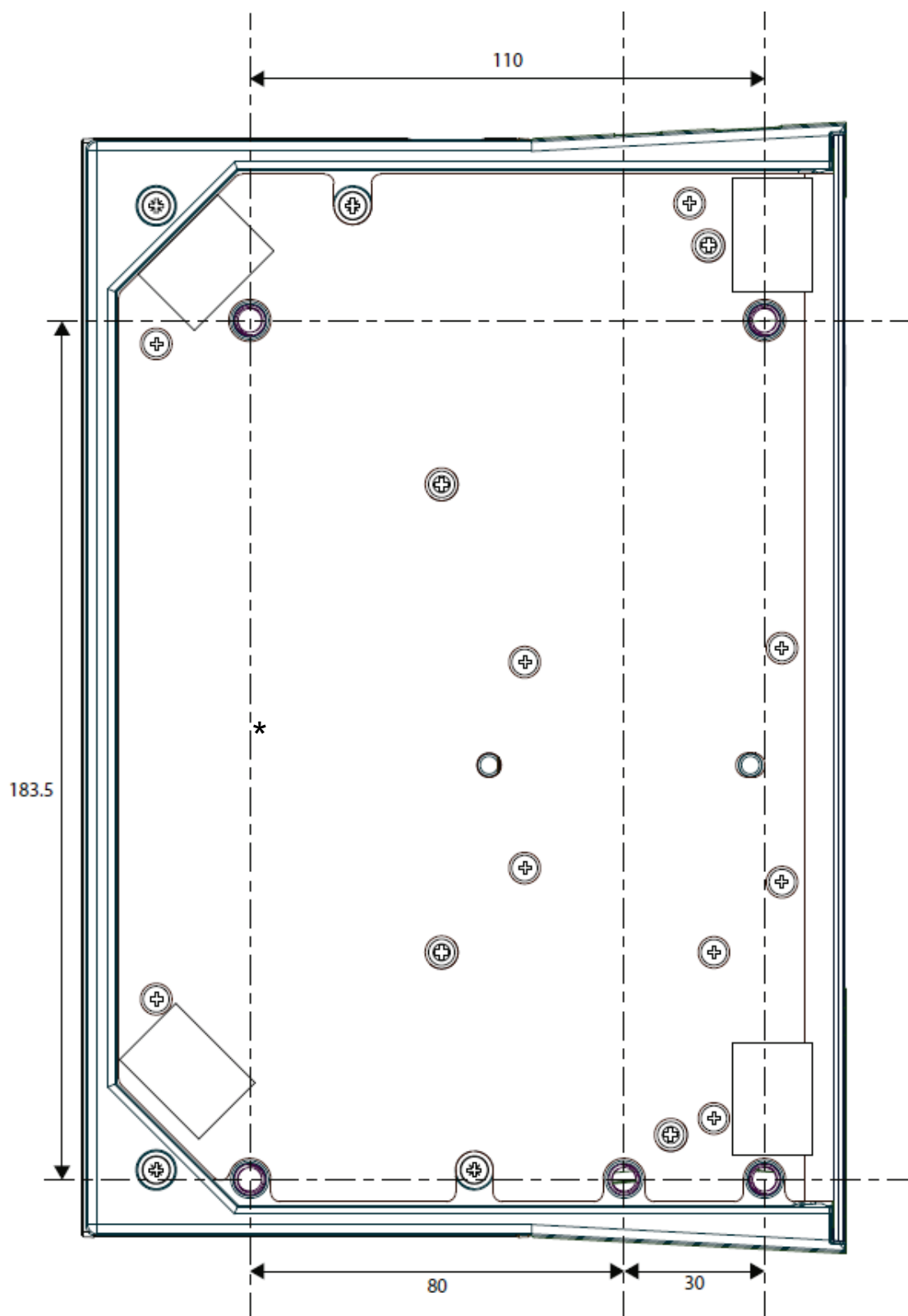

Du kan ladda ner monteringsritningen från <https://support.thrustmaster.com/product/viper-tqs/>, skriva ut den och använd den på ditt stöd för att förbereda borrhålen.



*Installation med TM Flying Desk Mount**

TM Flying Desk Mount är ett monteringsystem i metall med en klämskruv som förbättrar ergonomin och din position som pilot när du använder enheten. Detta system är gjort för att användas på skrivbord och bord som har en tjocklek på 15 - 50 mm.

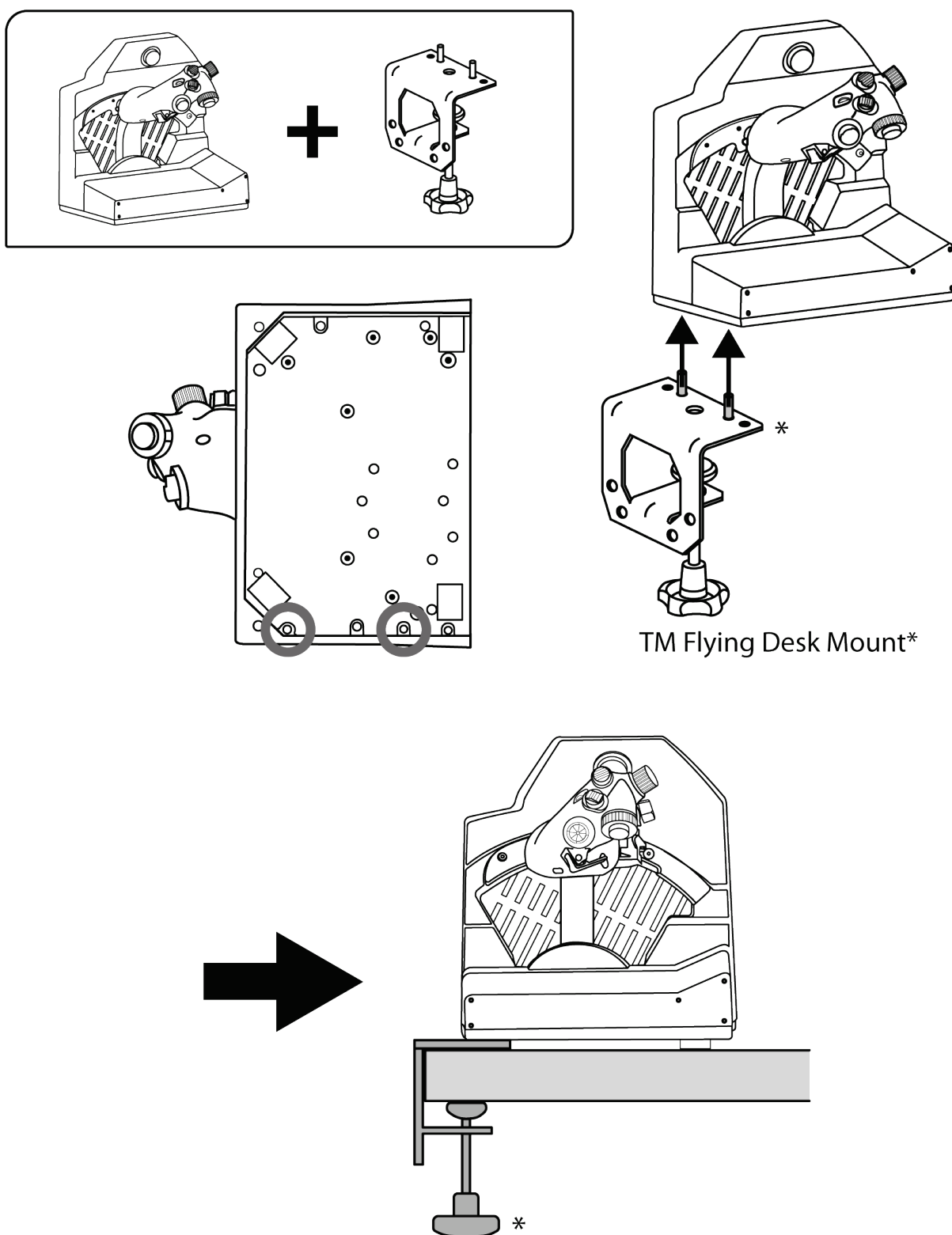

**Säljs separat*



Installation med TM Flying Clamp*

TM Flying Clamp är ett höjjusterbart stöd som Thrustmaster har designat för dess flygsimulatortillbehör. Detta monteringsystem har två klämskruvar som gör att det kan användas på skrivbord och bord som har en tjocklek på 15 - 45 mm.

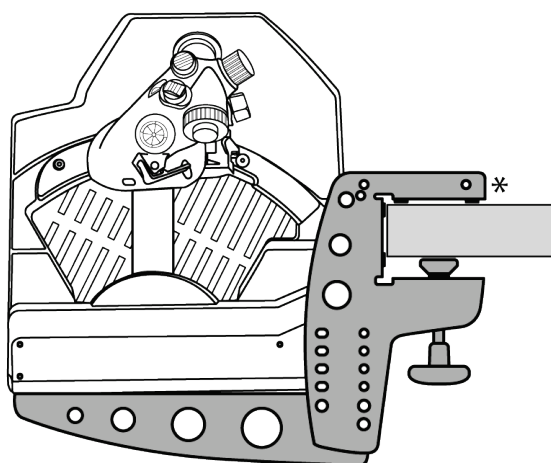
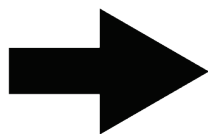
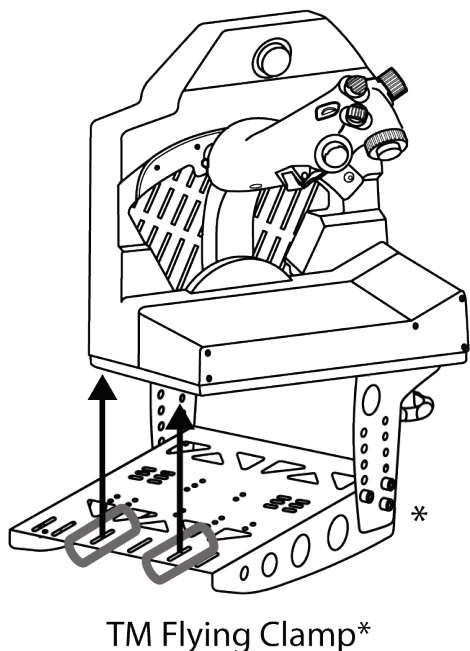
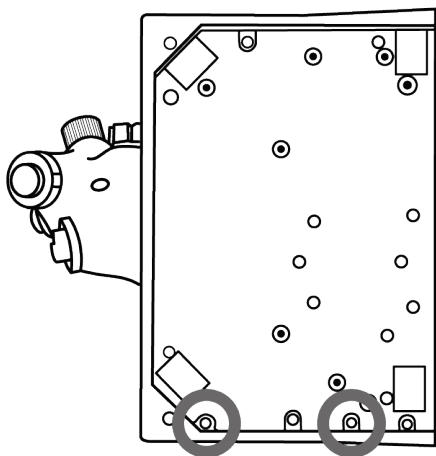
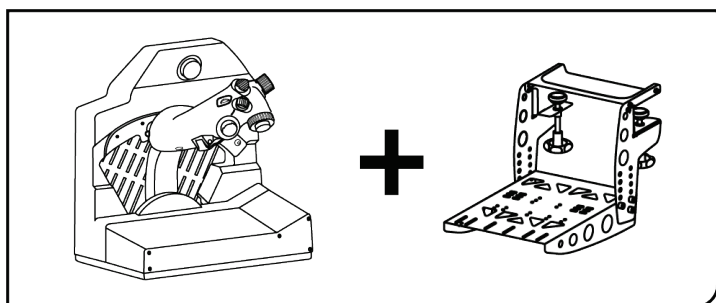

*Säljs separat



Observera att VIPER TQS tunga vikt kan göra att monteringsystemet rör sig på oönskat sätt.



7. Installera VIPER PANEL*

*Säljs separat. VIPER PANEL medföljer VIPER TQS Mission Pack.

VIPER PANEL är en kontrollpanel som utökar din flyg- och stridsförmåga med totalt 43 knappar och en axel – allt programmerbart via programvaran T.A.R.G.E.T. VIPER PANEL är ett komplement till VIPER TQS.

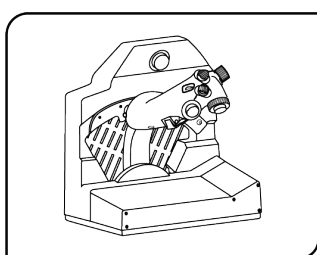

1

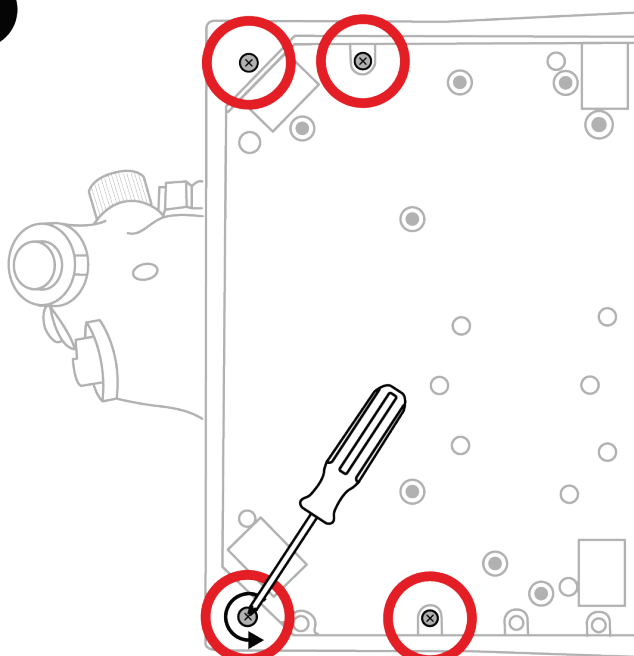

2

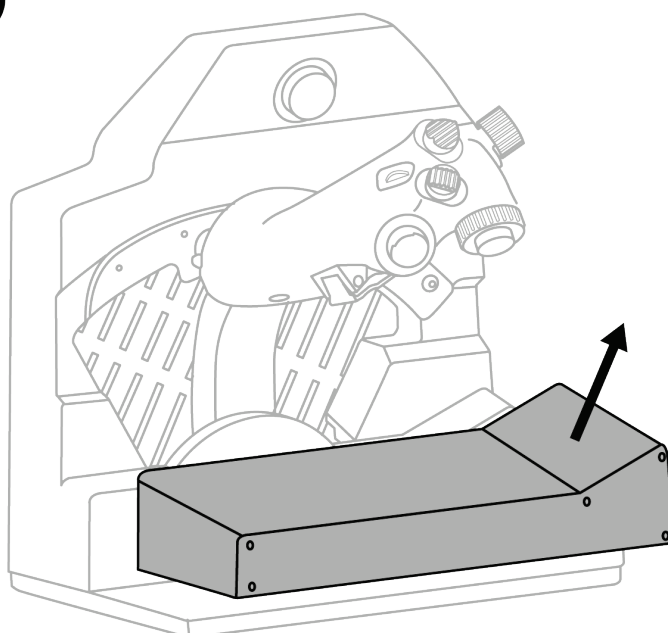

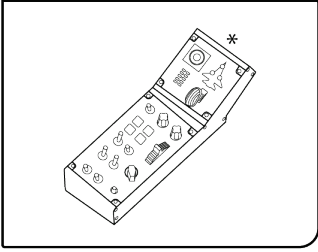

3

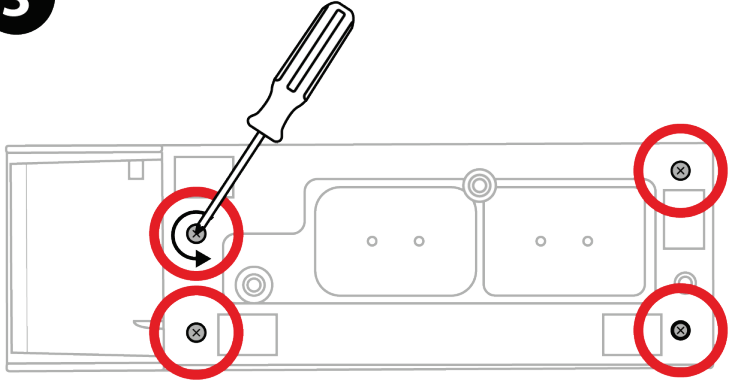

4

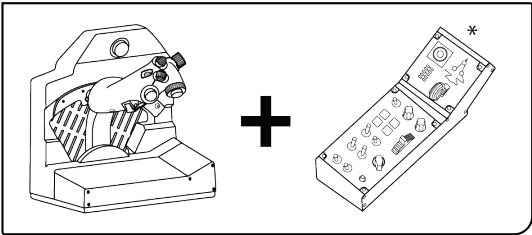
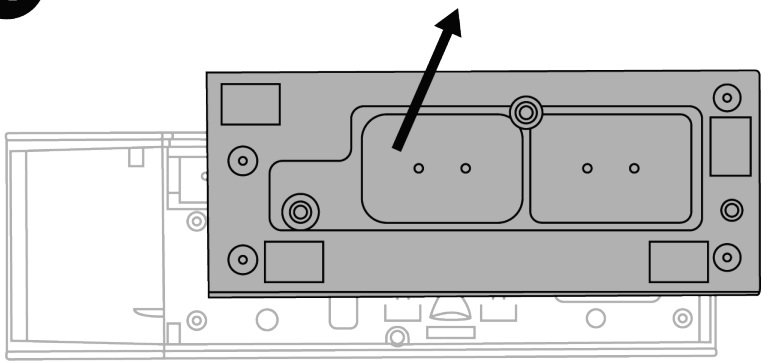

5

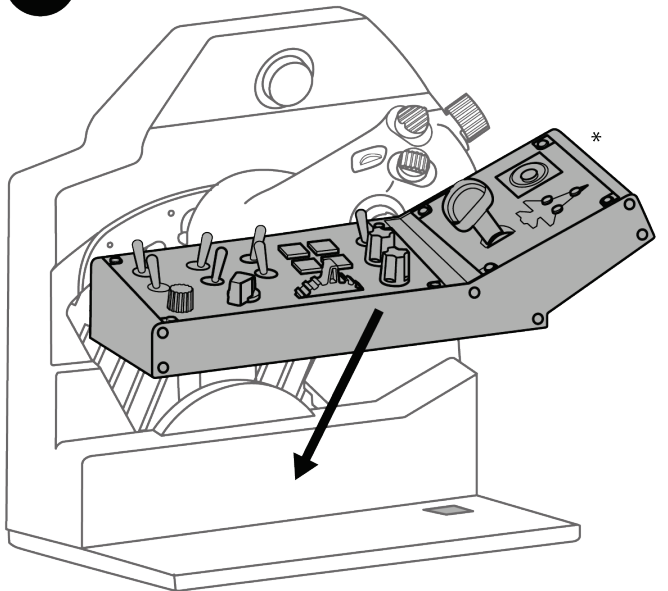



6

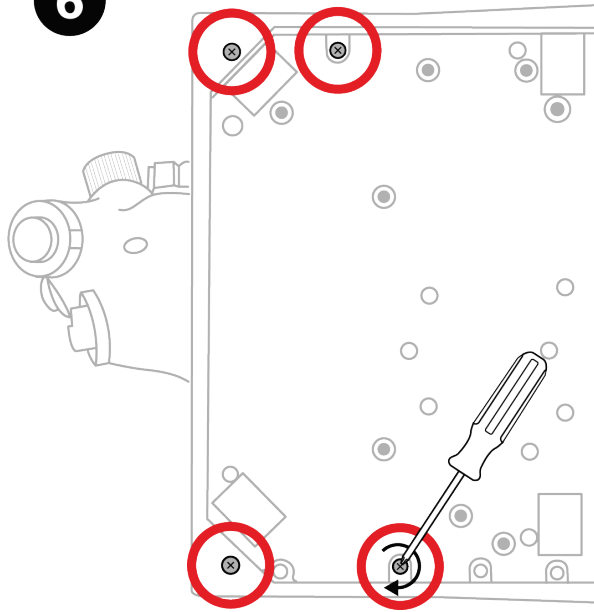

7

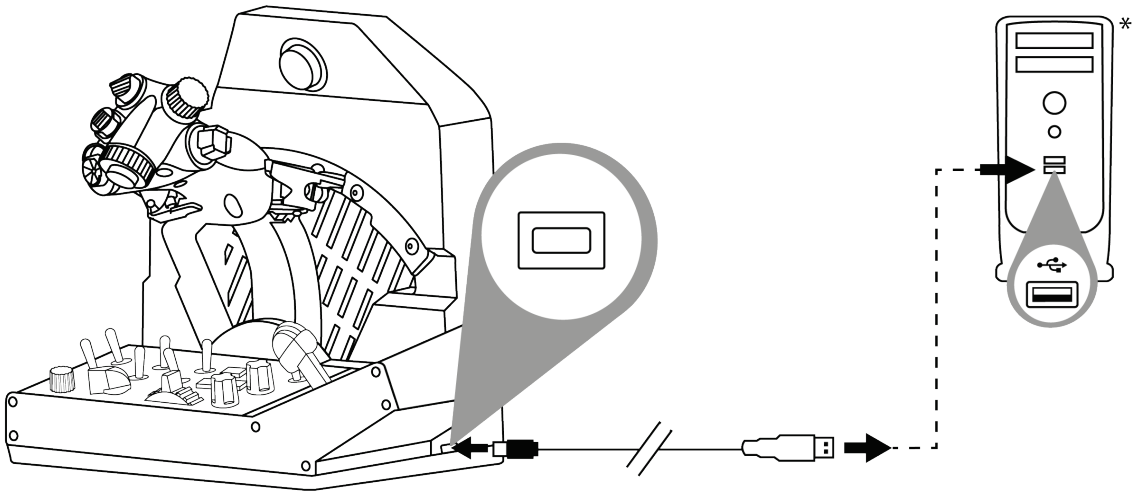

**Ingår ej*



8. Installation på PC

1



Gå till

<https://support.thrustmaster.com/product/viper-tqs/>.

2

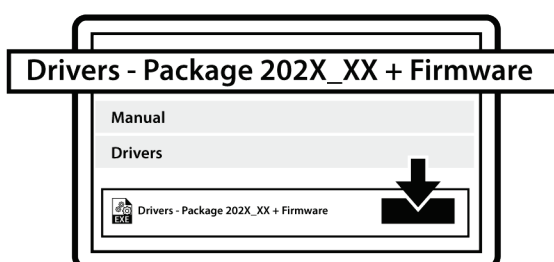

Ladda ner och installera PC-drivrutinen och dess anpassade gränssnitt för Kontrollpanelen i Windows.

3

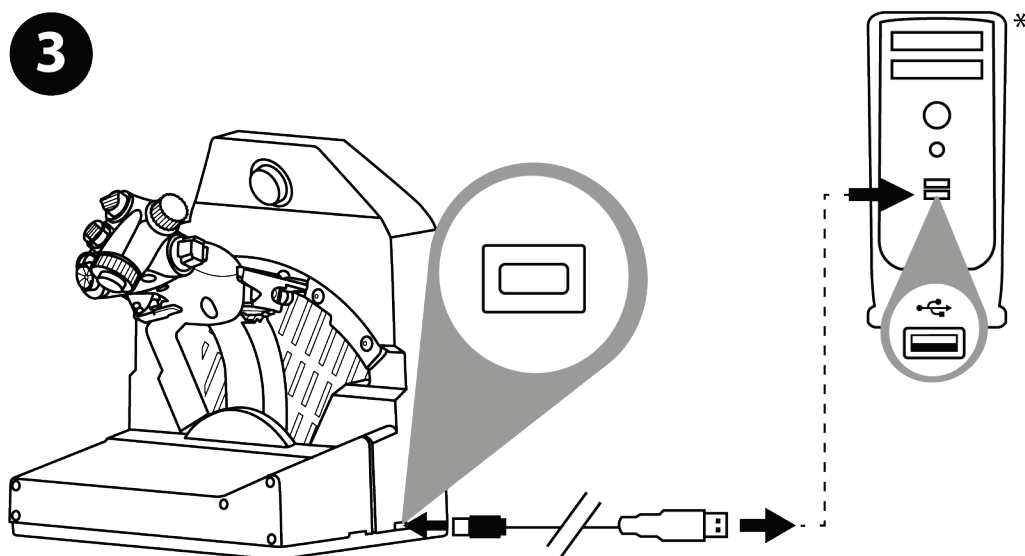

När PC-drivrutinen har installerats ansluter du USB-kontakten till någon av USB-portarna på din PC.

**Ingår ej*



④ Öppna Control Panel genom att välja **Start / Alla appar / Thrustmaster / Control Panel** eller **Kontrollpanelen** (i Windows 10).

Dialogrutan **Spelkontroller** visas. Tillbehöret visas på skärmen under namnet **VIPER TQS** och med statusen **OK**.

⑤ Klicka på **Egenskaper** i dialogrutan **Spelkontroller** för att testa och visa alla funktioner.

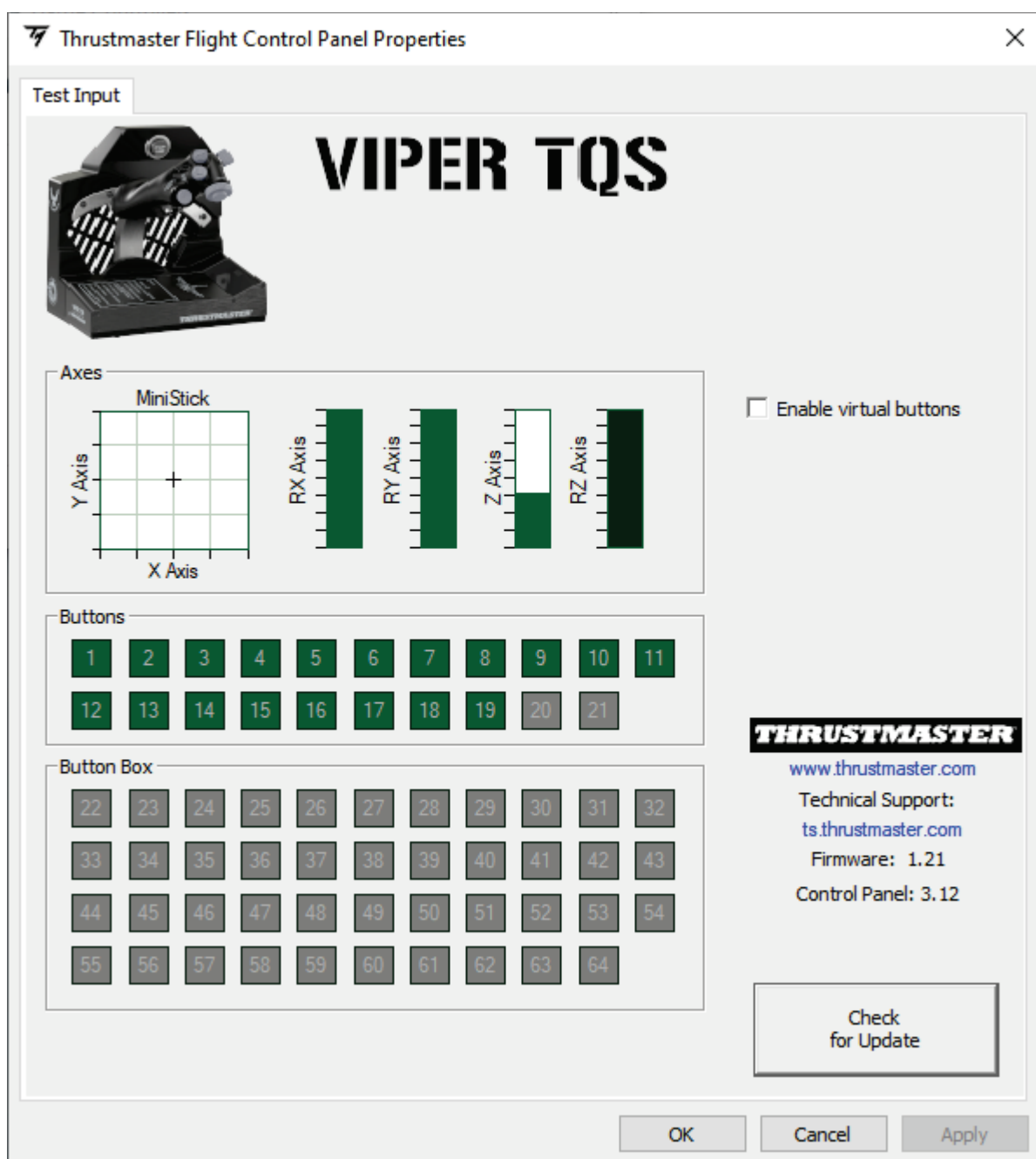



Enable virtual buttons (Aktivera virtuella knappar):

Med denna funktion kan du aktivera eller inaktivera de virtuella knapparna på handtaget (knapp 20 och 21). Klicka på **Apply** (Verkställ) när du har valt vilket läge du vill använda.

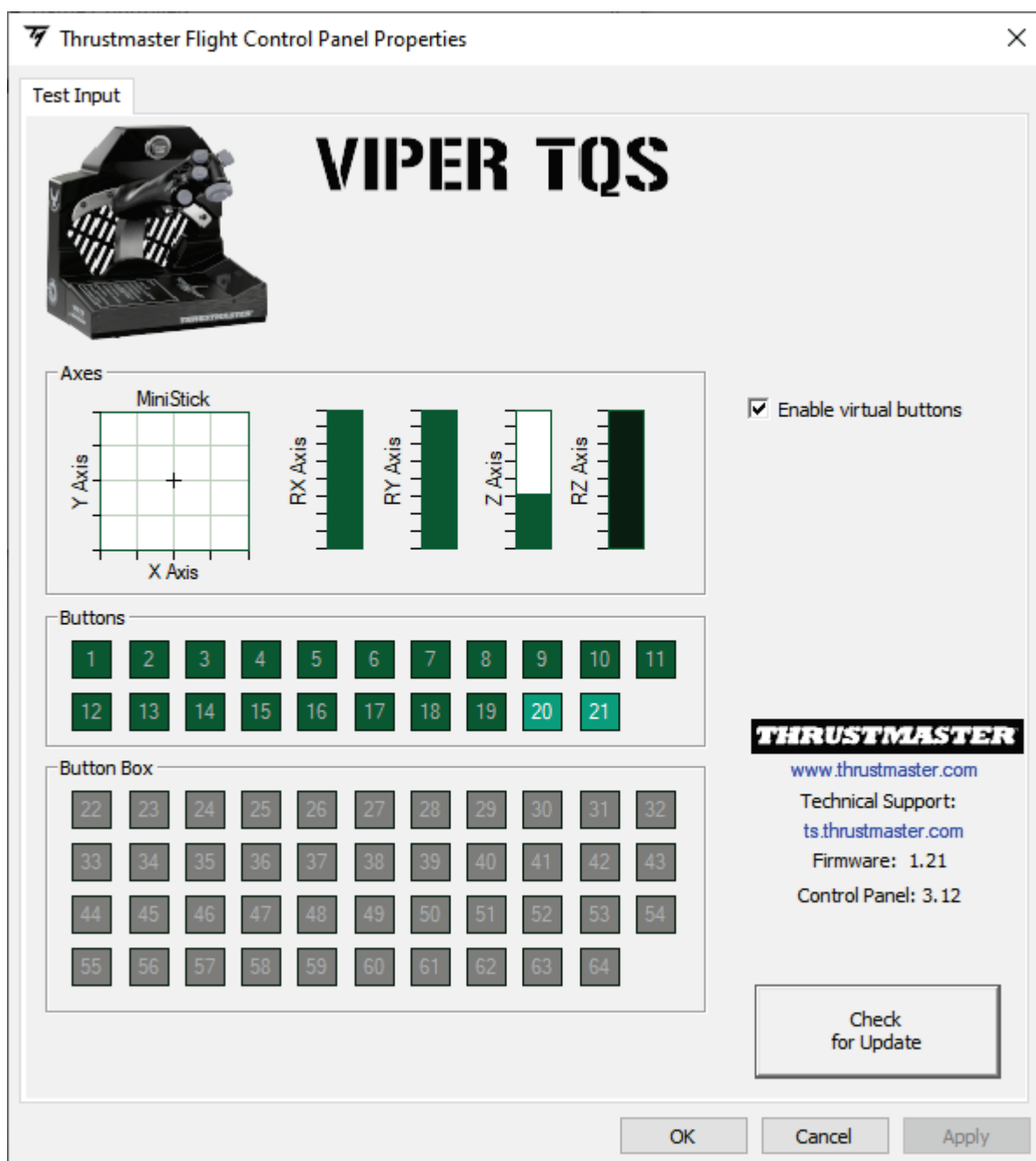

De virtuella knapparna är inaktiverade som standard på VIPER TQS.



9. CUT OFF- och AFTERBURNER-spärrar

Gasreglagekvadranten VIPER TQS har ett realistiskt system med CUT OFF- och AFTERBURNER-spärrar (Afterburner-modulen är löstagbar).

CUT OFF

När du har positionerat gasreglaget vid IDLE-spärren trycker du på "upplåsning av motoravstängning"-avtryckaren **1** för att lyfta upp handtaget och komma över spärren **2**. Sätt sedan handtaget i OFF-läge **3**.

Gör om proceduren i omvänd ordning för att slå på motorerna igen.

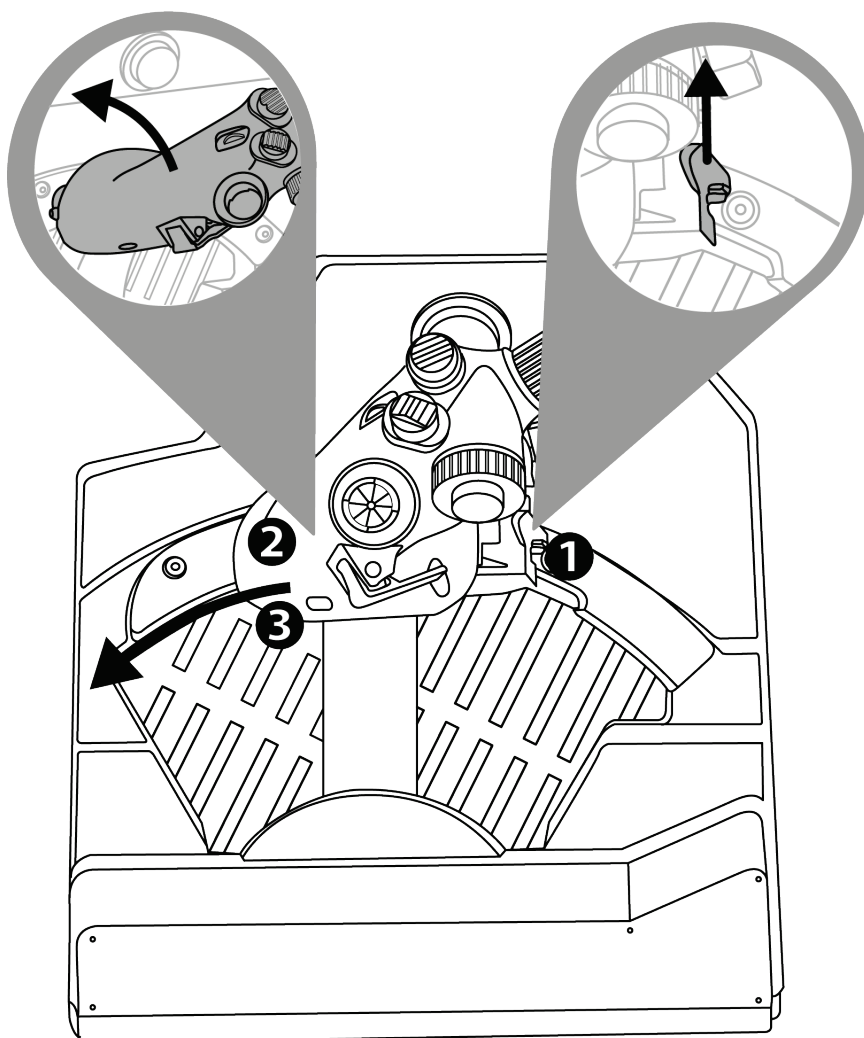



AFTERBURNER

För gasreglaget till spärren **1** och lyft upp den **2** för att komma över spärren och aktivera efterbrännaren **3**.

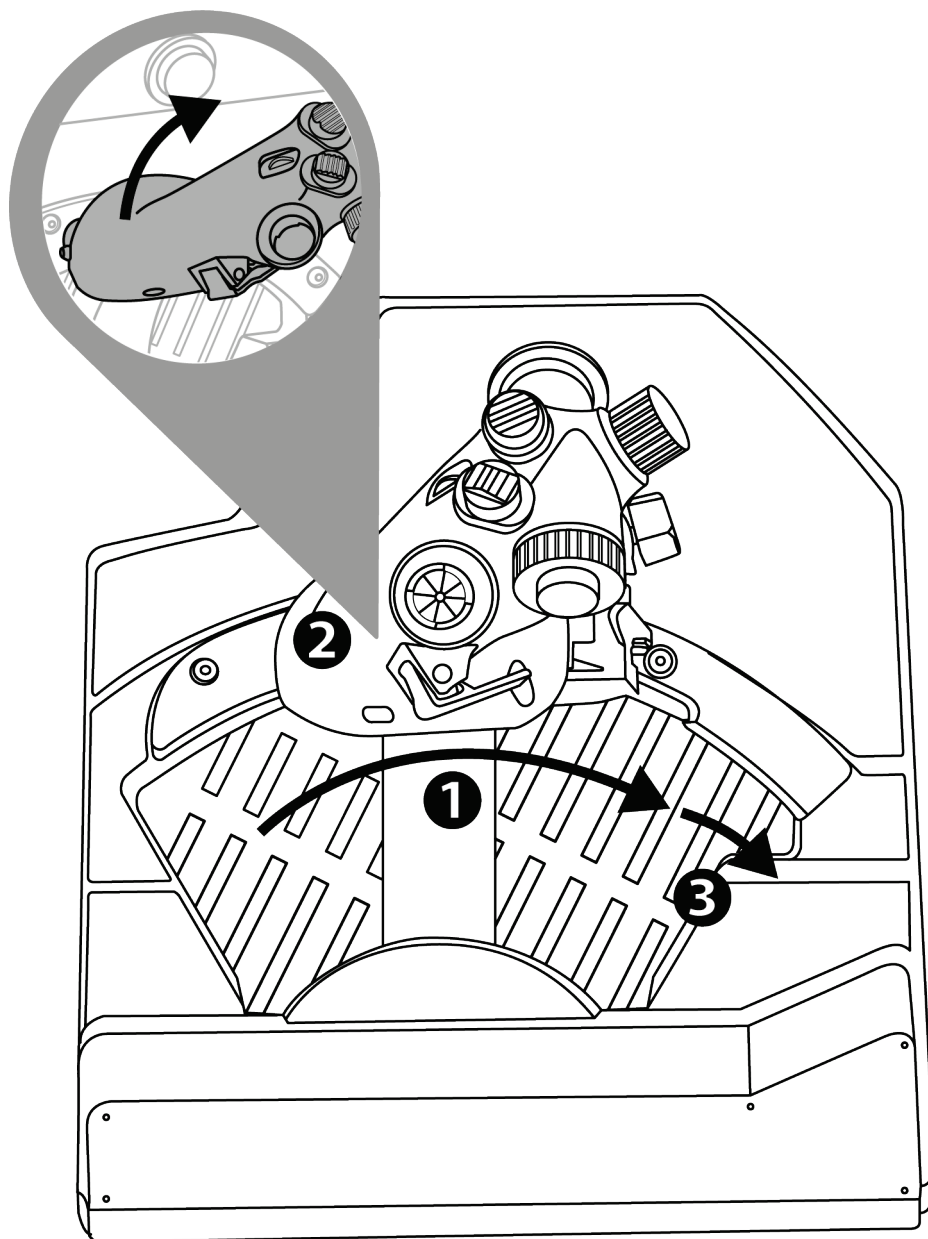



Avinstallera AFTERBURNER-spärren

Afterburner-modulens spärr är placerad vid 80 % av axelns värde.

Om du behöver 100 % av gasreglaget rörelseområde utan någon spärr (för en viss simulator) kan du ta bort Afterburner-modulen och dess spärr genom att skruva loss modulens två skruvar med en insexnyckel (ingår ej).

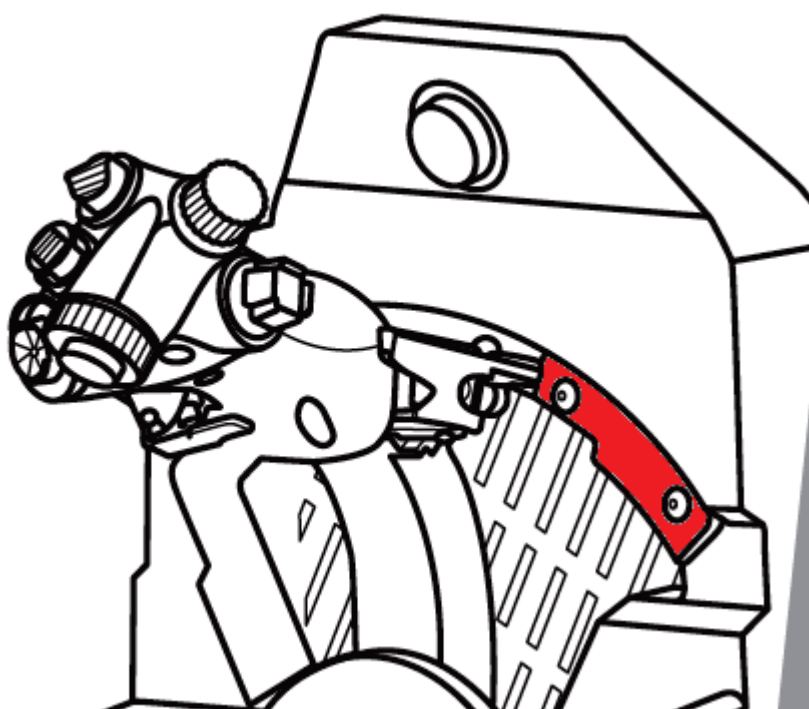



10. Avancerade programmeringsprogrammet T.A.R.G.E.T



Gå till

<https://support.thrustmaster.com/product/viper-tqs/>.

Ladda ner och installera det avancerade programmeringsprogrammet T.A.R.G.E.T under **Software** (Programvara).



T.A.R.G.E.T - Huvudfunktioner

- Olika möjliga konfigurationer för axlarna.
- Olika möjliga programmeringsnivåer: Basic, Advanced och Script.
- Använder sig av dra och släpp-principen.
- Möjligt att kombinera gasreglagekvadranten VIPER TQS med olika joystickar från Thrustmaster (HOTAS Cougar, HOTAS Warthog, T.16000M, MFD Cougar Pack – alla dessa är även kompatibla med T.A.R.G.E.T) så att de kan kännas igen som en enda USB-enhet.
- Tillgång till avancerade profiler som skapats av Thrustmasters community.



11. Vanliga frågor och teknisk support

Har du frågor om VIPER TQS eller upplever du tekniska problem? Besök i så fall Thrustmasters tekniska support sida:

<https://support.thrustmaster.com/product/viper-tqs/>.



THRUSTMASTER®

VIPER TQS

THROTTLE QUADRANT SYSTEM

PC (Windows 10/11)

Käyttöohje



Lue huolella tästä käyttöohjeesta löytyvät ohjeet, **ennen kuin** asennat tuotteen, **ennen kuin** käytät tuotetta ja **ennen kuin** suoritat mitään huoltoa. Muista noudattaa turvallisuusohjeita. Näiden ohjeiden noudattamattomuus voi johtaa onnettomuuksiin ja/tai vahinkoihin. Pidä tämä käyttöohje tallessa, jotta voit tarkistaa ohjeita myöhemmin.

SISÄLLYSLUETTELO

1.	LAATIKON SISÄLTÖ	5
2.	VIPER TQS -OMINAISUUDET	6
3.	PAINIKKEIDEN JA AKSELIEN MÄÄRITTÄMINEN.....	8
4.	TIETOA VIPER TQS:N KÄYTÖSTÄ.....	10
5.	LIKEVASTUKSEN SÄÄTÄMINEN.....	11
6.	TUKIASENNUS	12
7.	VIPER PANELIN ASENTAMINEN*	17
8.	ASENNUS PC-TIETOKONEELLE	20
9.	CUT OFFIN JA AFTERBURNERIN PYKÄLÄT	23
10.	EDISTYNYT T.A.R.G.E.T- OHJELMOINTIOHJELMISTO	26
11.	UKK JA TEKNINEN TUKI.....	28



Käynnistä moottorit ja lennä vaaran vyöhykkeelle Yhdysvaltojen ilmavoimien VIPERIN kuuluisalla tehovipujärjestelmällä – kyseessä on maailman laajimmin käytetty nykyaikainen hävittäjä!

Vie ohjaamo seuraavalle tasolle täyden skaalan HOTAS-replikan ainutlaatuisella ergonomialla. Mukana tulee metallikahva sekä realistiset painikkeet ja pykälät.

Tämä käyttöohje auttaa asentamaan VIPER TQS -tehovipuyksikön ja käyttämään sitä parhaissa olosuhteissa. Ennen kuin nouset ilmaan, muista lukea kaikki nämä ohjeet ja varoitukset huolella: ne auttavat ottamaan kaiken nautinnon irti tuotteesta.



Laiteohjelmiston päivittäminen

Sinun on päivitettävä VIPER TQS:n laiteohjelmisto, jotta se toimii kunnolla videopeleissä.

Suorita päivitys käymällä osoitteessa

<https://support.thrustmaster.com/product/viper-tqs/>

Valitse **Firmware** (Laiteohjelmisto) ja seuraa sitten ohjeita, mukaan lukien lataus- ja asennustoimenpiteitä.



1. Laatikon sisältö

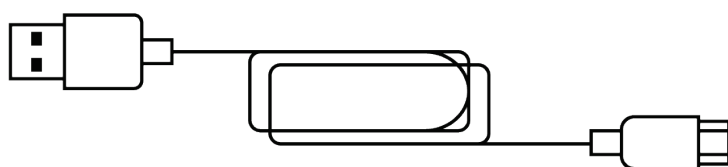
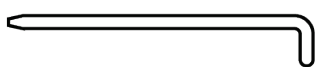
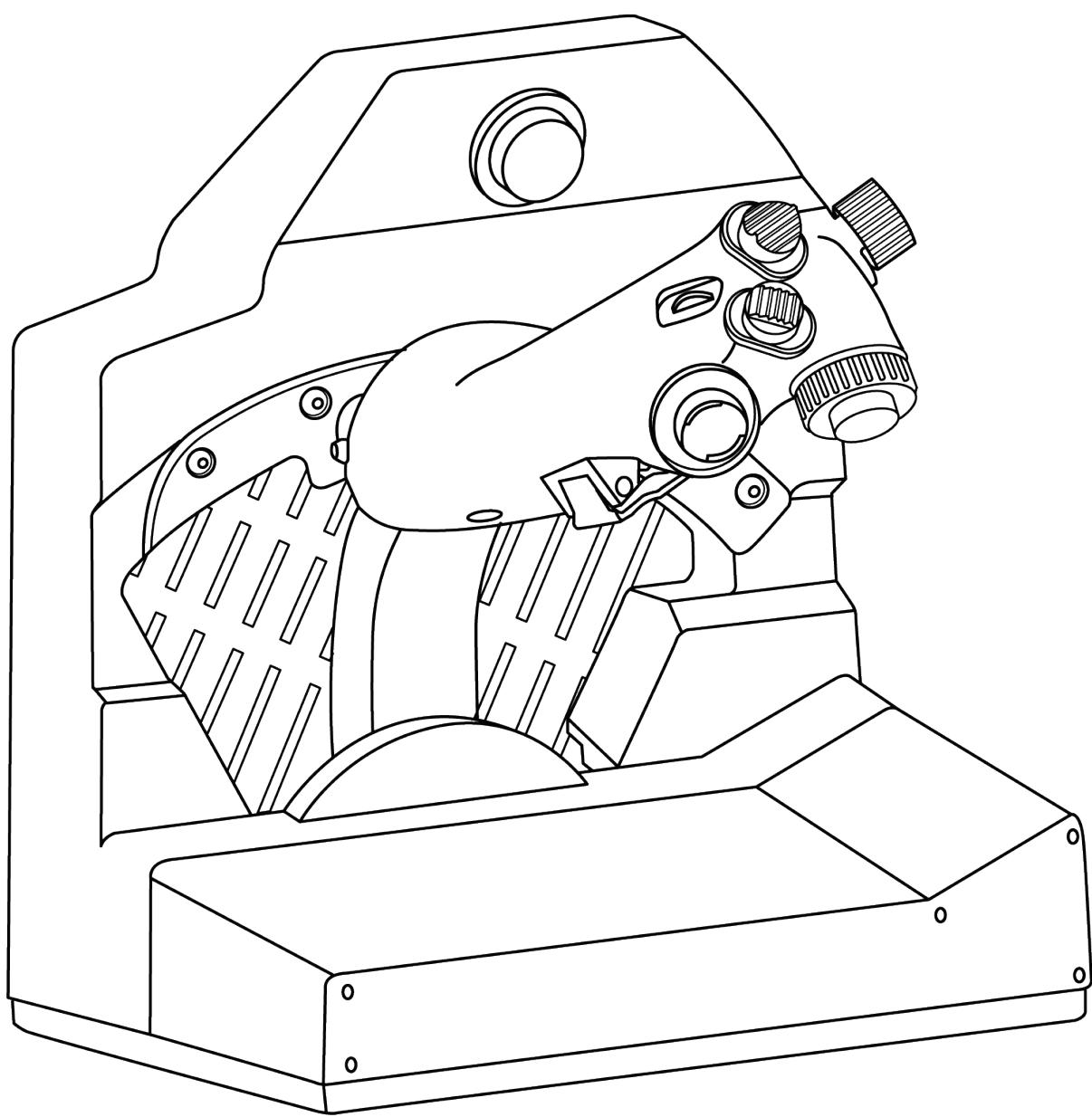



2. VIPER TQS -ominaisuudet

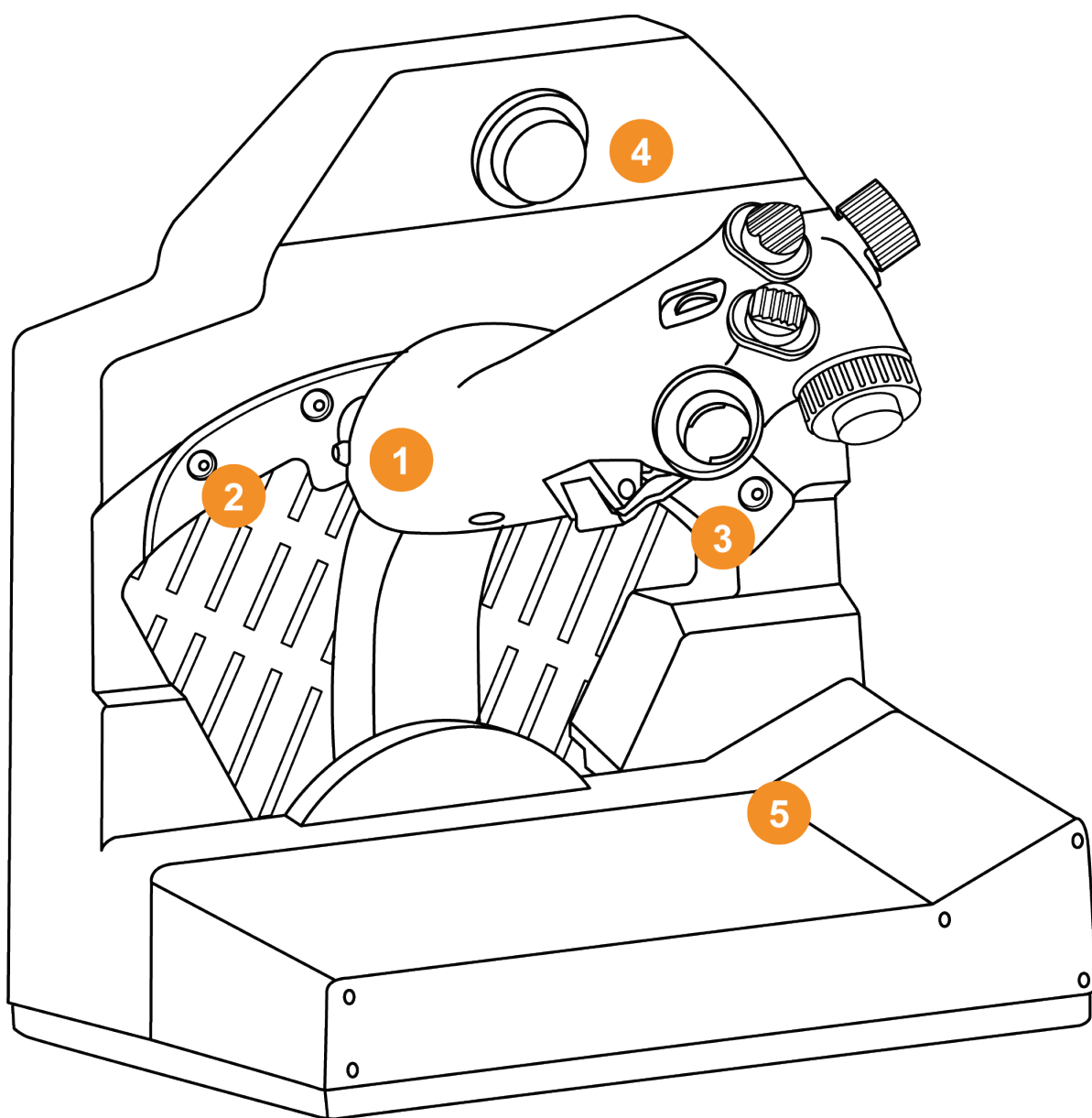

1. Kahva

2. Cut Off -pykälä

3. Afterburner-pykälä

4. CHAFF/FLARE-pikapainike

5. Kiinnitin tehtäväkarttaa varten

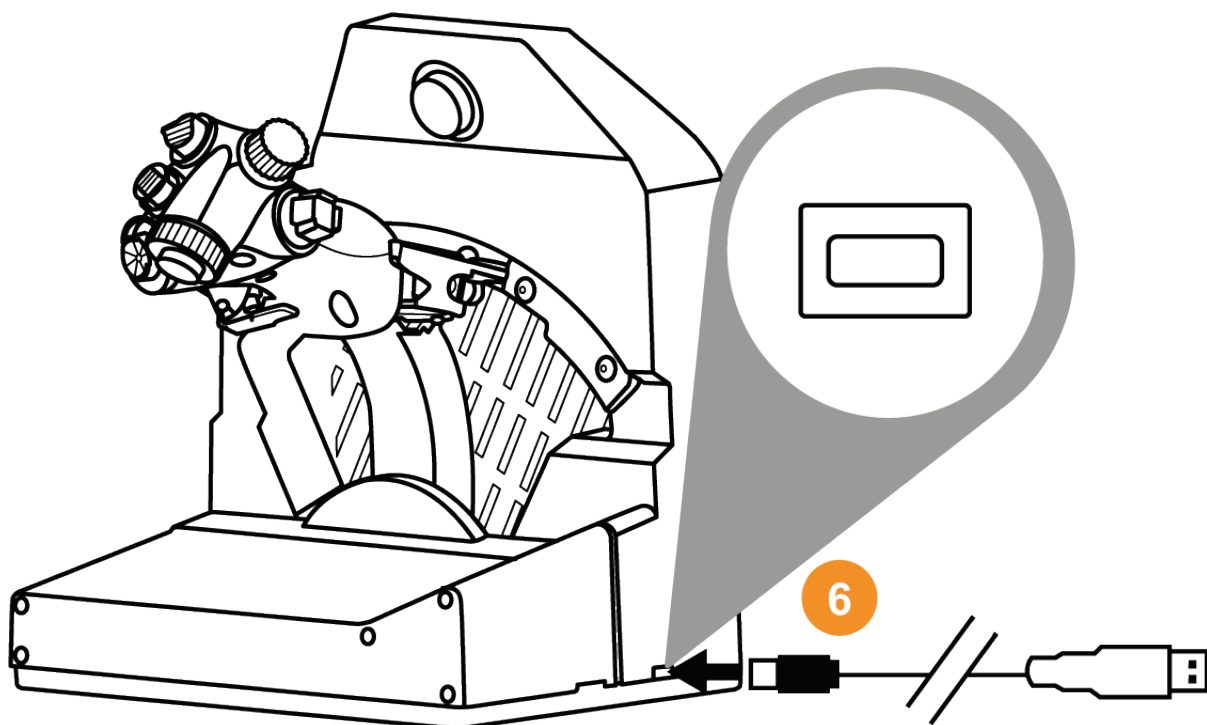

6. USB-liitin (type C)

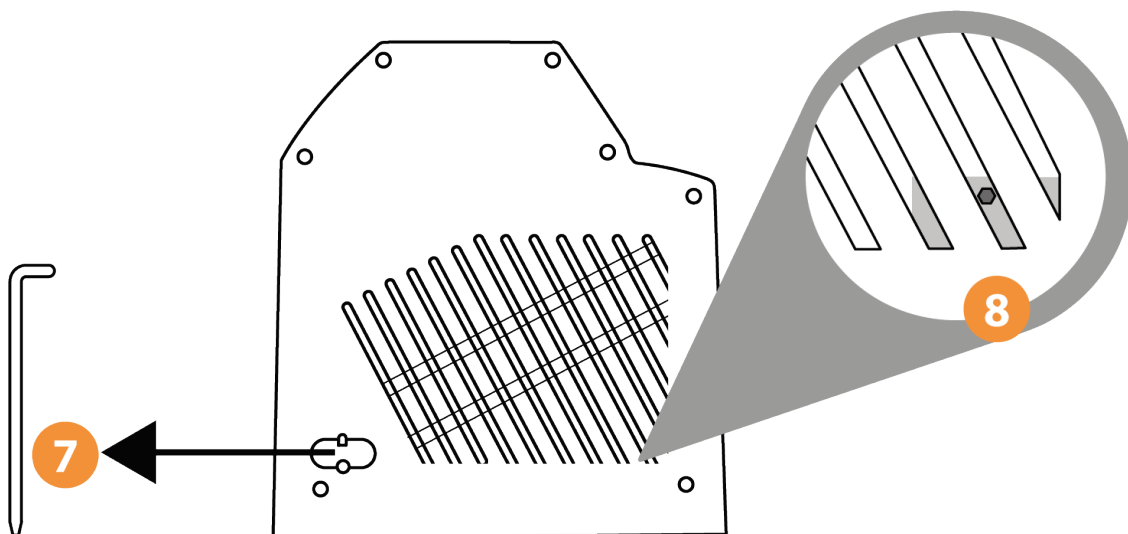

7. Liikevastuksen säätötyökalun paikka

8. Kahvan liikevastuksen säätöpiste



3. Painikkeiden ja akselien määrittäminen

VIPER TQS -kahva: 19 painikkeen ja 5 akselin määrittäminen A-tilassa (ilman virtuaalipainikkeita)

A 1 → 19

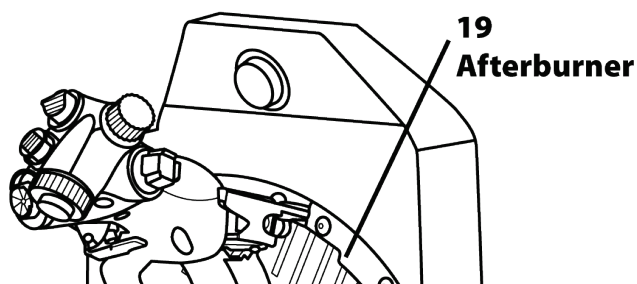
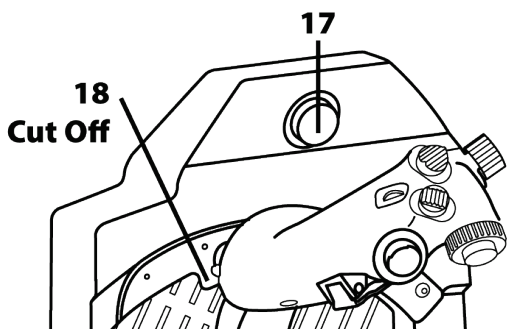
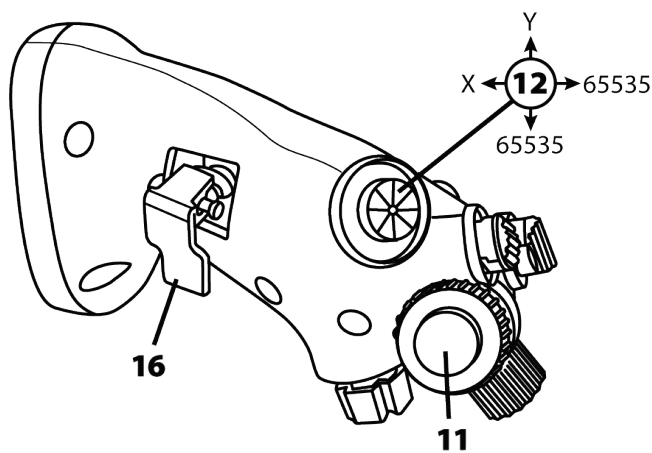
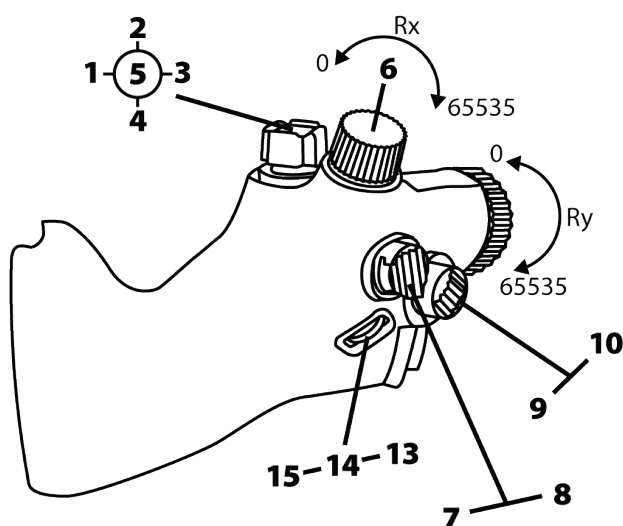



B-tila: virtuaalipainikkeilla

B 1 → 21

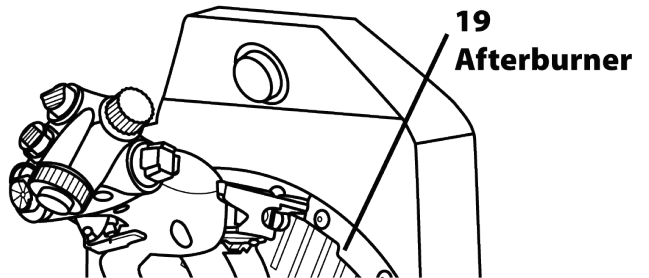
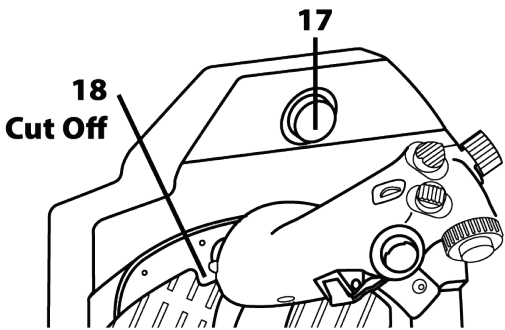
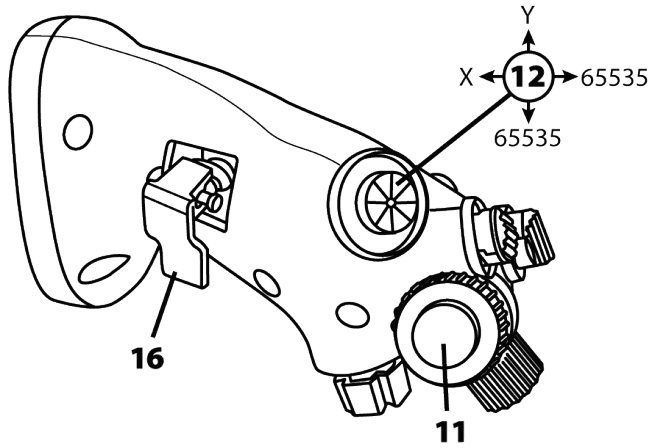
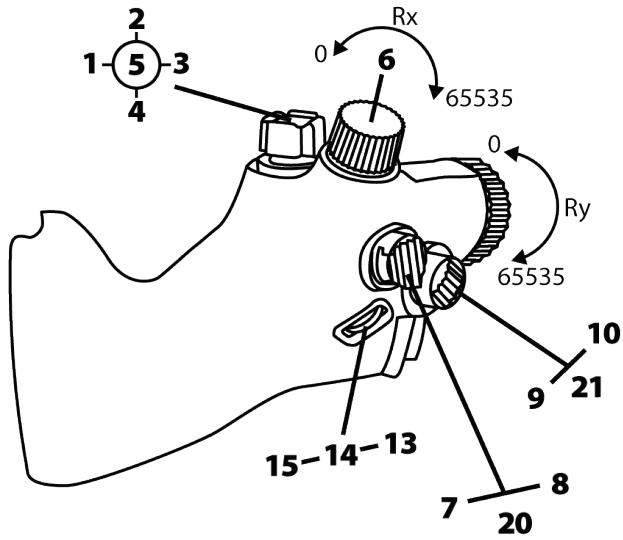



4. Tietoa VIPER TQS:n käytöstä



Nipistysvaara

Älä ikinä aseta sormiasi pykäläalueille, kun kahva on käytössä.

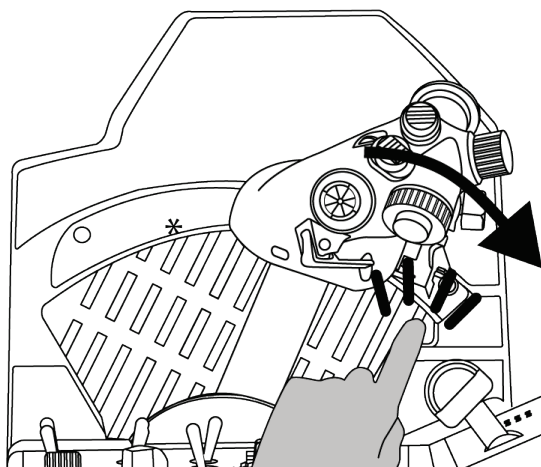
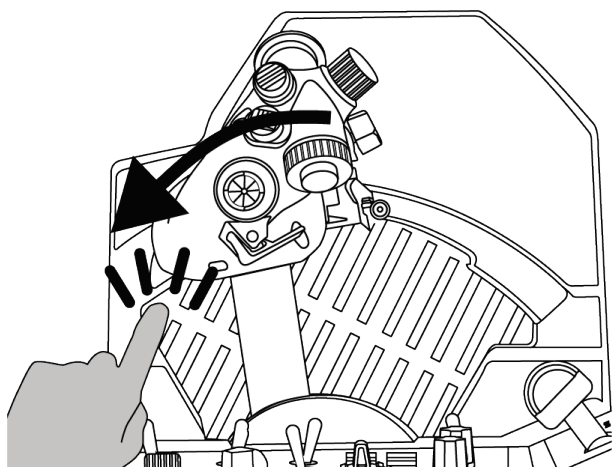
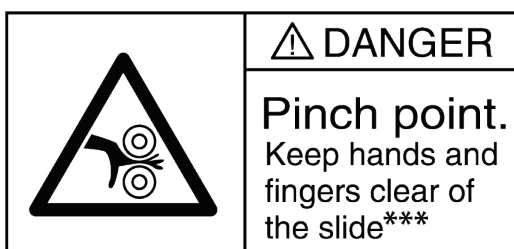



5. Liikevastuksen säätäminen

Voit säätää VIPER TQS -tehovipuyksikön liikevastuksen haluamaksesi käyttämällä VIPER TQS:n kyljestä löytyvää työkalua. Ota kuitenkin huomioon, että optimaalinen liikevastus on asetettu tehtaalla.

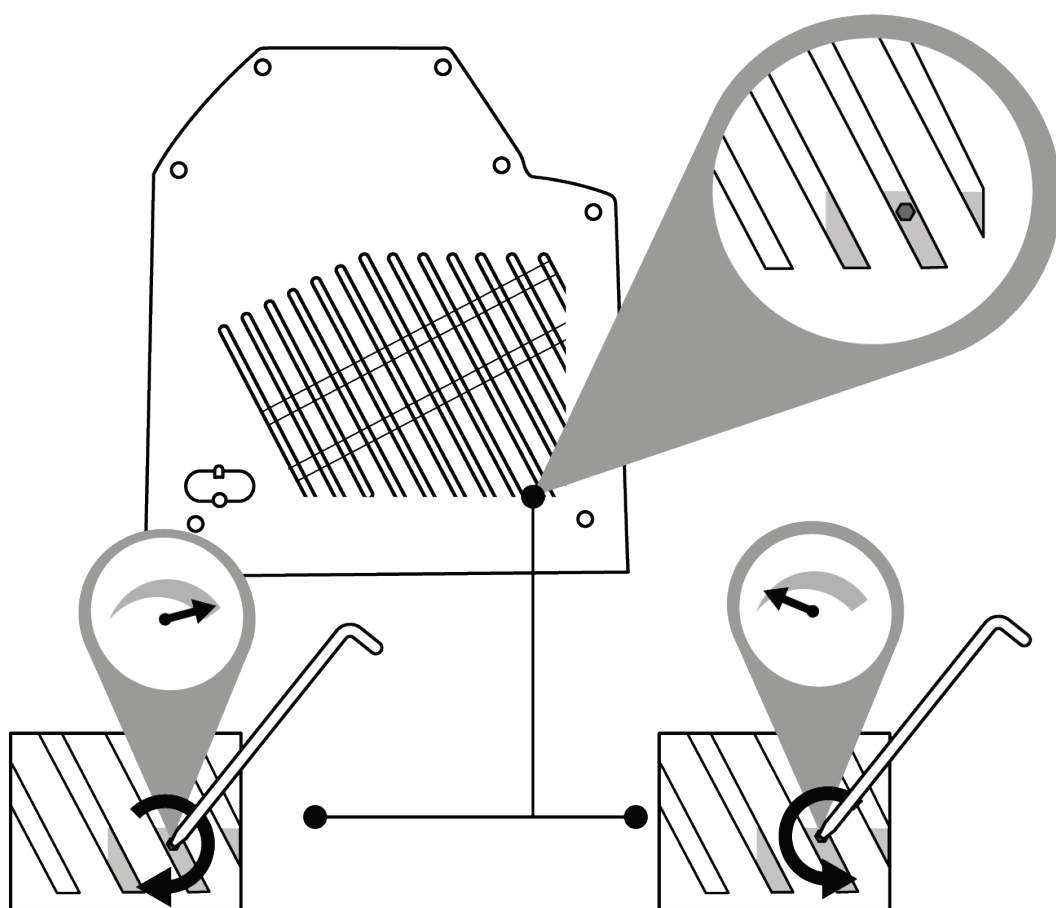

Välttääksesi liikevastusjärjestelmän vahingoittamista varo, ettet kiristä säätöruuveja liikaa.

Varmista myös, ettet avaa säätöruuveja täysin: silloin on vaarana, ettei tehovipu pysy enää paikoillaan.



6. Tukiasennus



VIPER TQS:n voi asentaa erilaisiin tukiin. Useimmat markkinoilta löytyvät ohjaamot ja tuet ovat jo yhteensopivia vastaavien Thrustmaster-tuotteiden kanssa (esim. HOTAS Warthog).

Ota huomioon, että VIPER TQS sisältää voimakkaan viputehosteen, ja se on sen vuoksi kiinnitettävä tukevasti.

Kiinnitä jalusta tukeen käyttämällä sopivia M6-ruuveja (ei mukana), jotta et vahingoita kahvaa.

Täydet VIPER TQS -piirustukset löytyvät osoitteesta <https://support.thrustmaster.com/product/viper-tqs/>



Varmista ennen jokaista käyttökertaa, että VIPER TQS on edelleen kiinnitetty kunnolla valmistajan antamien ohjeiden mukaisesti.

Ota huomioon tuessa käytetty materiaali ja varmista, että siihen on turvallista kiinnittää tämä tuote. VIPER TQS on asetettava pöydälle, joka on valmistettu kiinteästä materiaalista (esim. MDF tai puu) ilman onttoja tai lasisia osia.



Kiinnityspiirustusten mitat (mm)

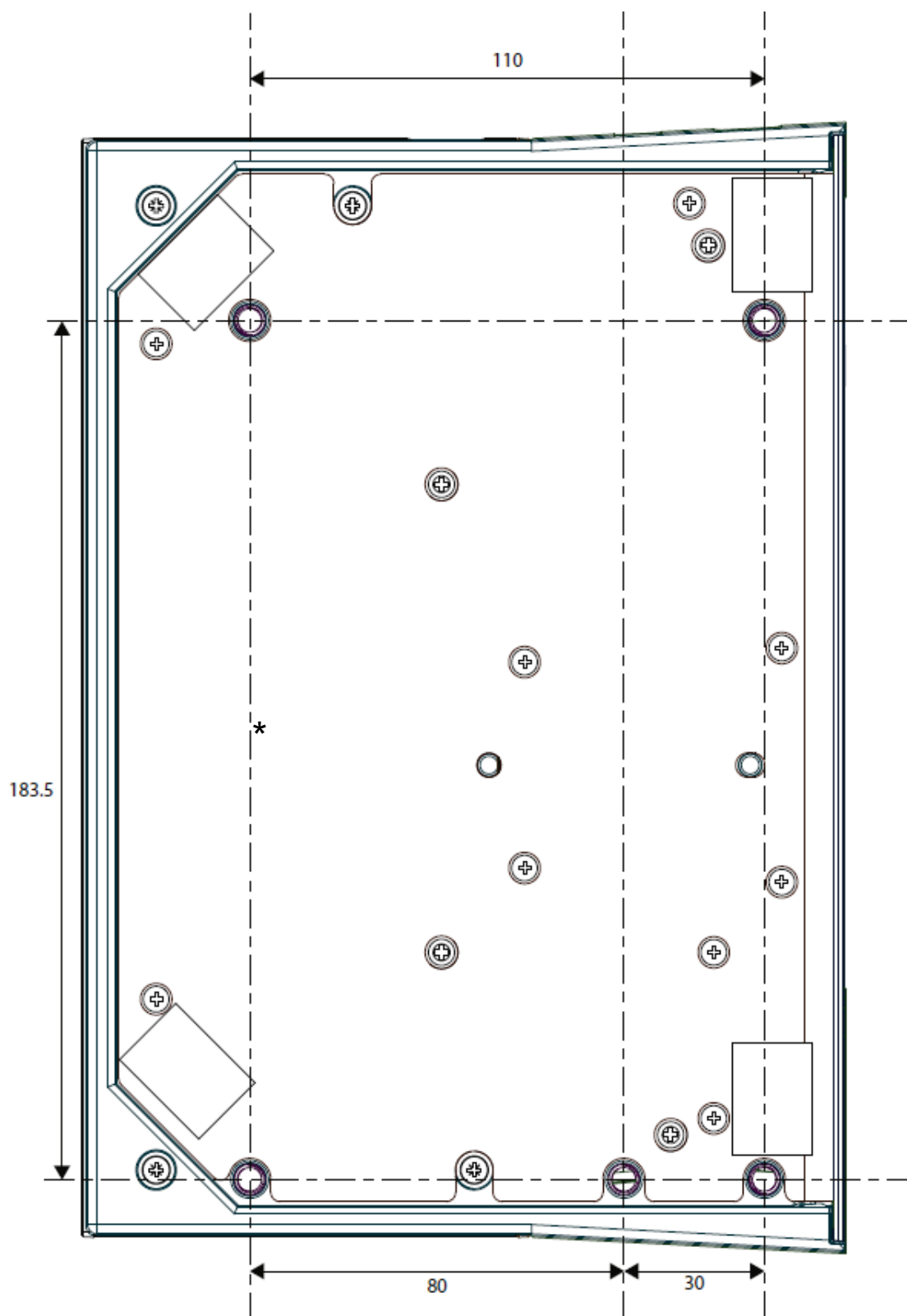

Voit ladata kiinnityspiirustukset osoitteesta

[https://support.thrustmaster.com/product/viper-](https://support.thrustmaster.com/product/viper-tqs/)

[tqs/](https://support.thrustmaster.com/product/viper-tqs/), tulostaa ne ja käyttää niitä tuen kanssa, jotta voit määrittää ja valmistella porauspaikat.



Asennus *TM Flying Desk Mount* - kiinnikettä* käyttämällä

TM Flying Desk Mount on metallista valmistettu kiinnitysjärjestelmä, joka sisältää kiinnitysruuvien, mikä parantaa ergonomiaa ja lentoasentoa laitetta käytettäessä. Tämä järjestelmä on suunniteltu 15–50 mm paksuilla pöydillä käytettäväksi.

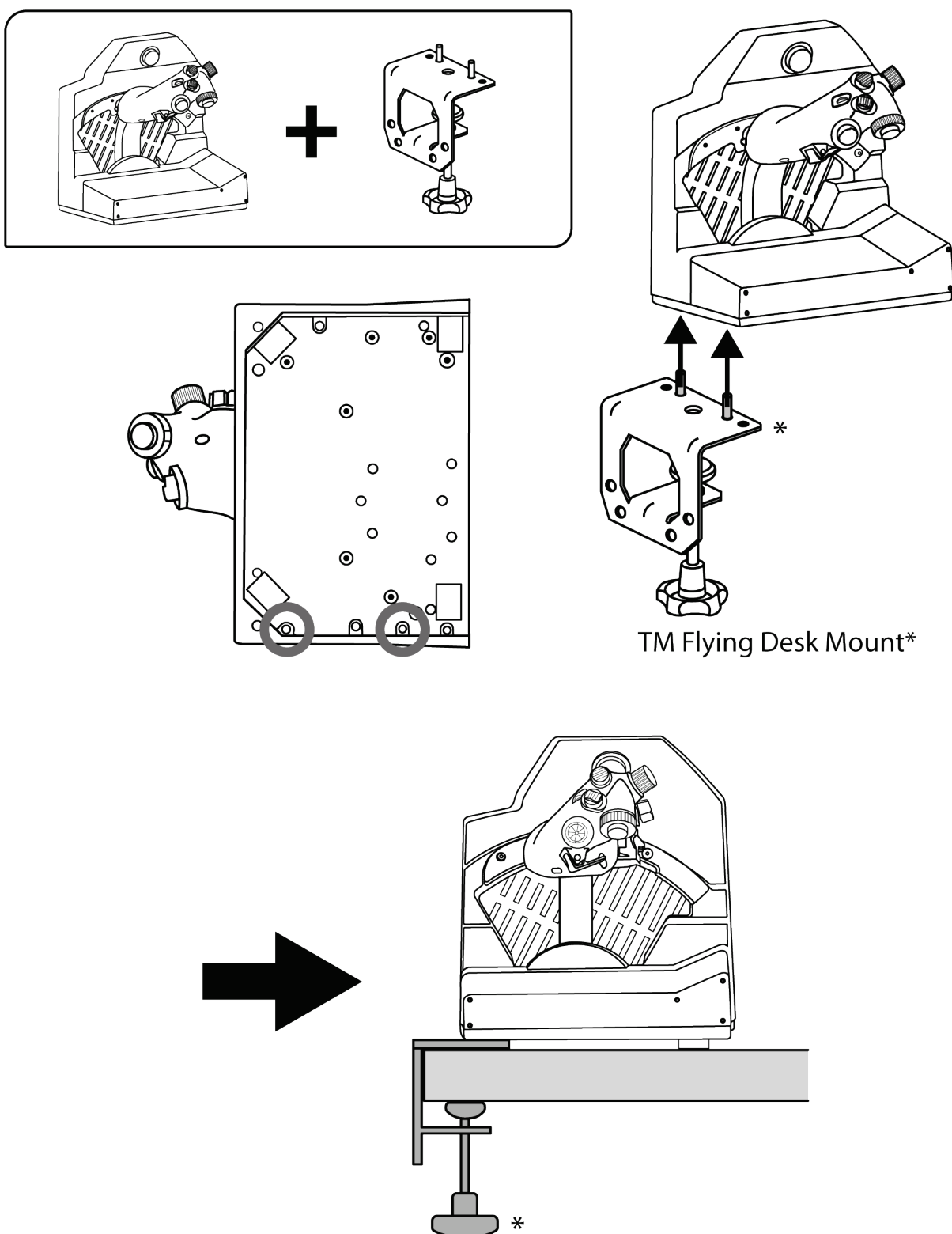

* Myydään erikseen.



Asennus TM Flying Clamp -kiinnikettä* käyttämällä

TM Flying Clamp on Thrustmasterin suunnittelema lentosimulaattorien lisävarustetuki, jonka korkeutta voi säätää. Tämä kiinnitysjärjestelmä sisältää kaksi kiinnitysruuvia, joiden avulla sitä voi käyttää 15–45 mm paksuilla pöydillä.

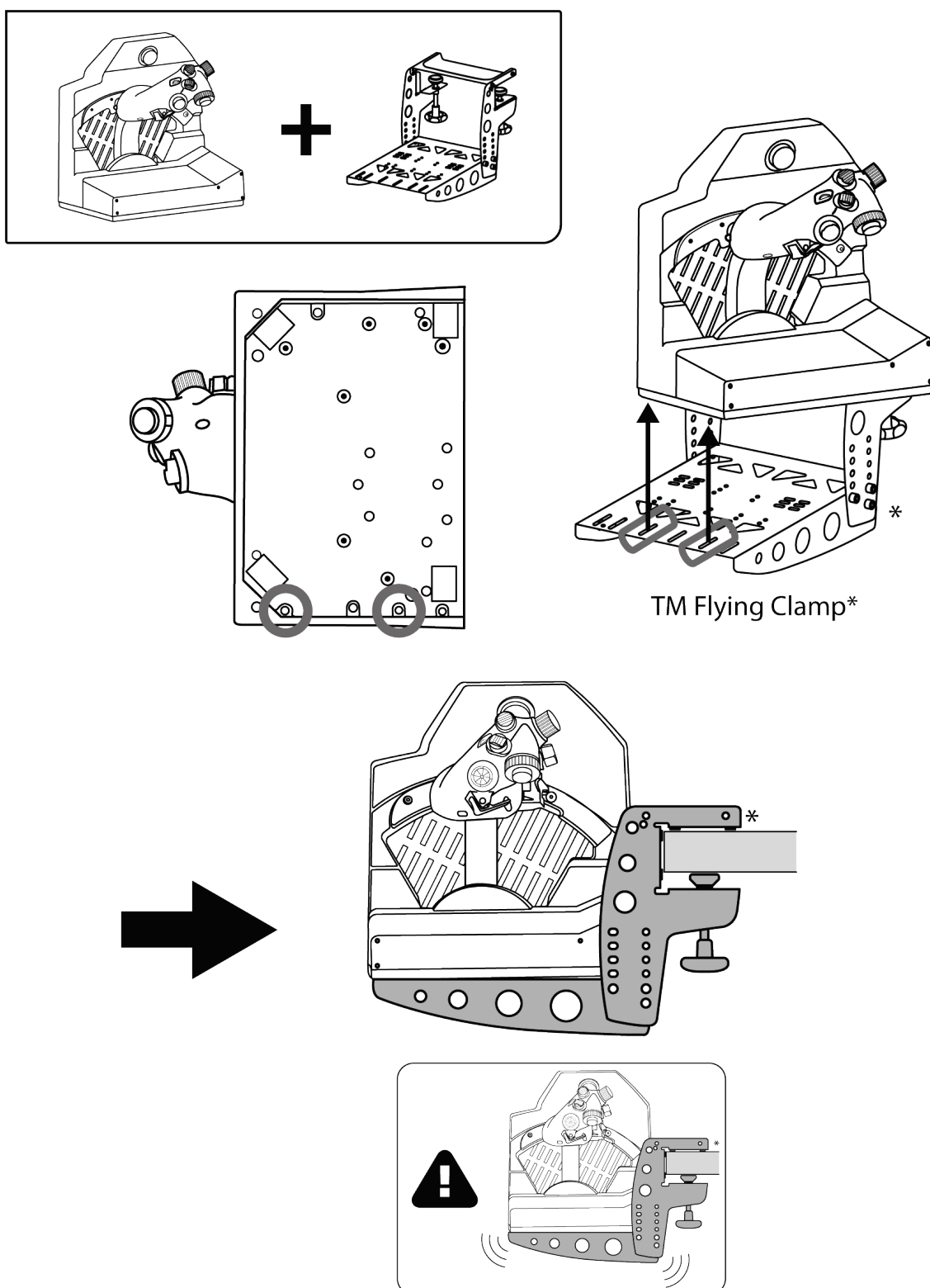

* Myydään erikseen.



Ota huomioon, että VIPER TQS:n raskas paino saattaa johtaa kiinnitysjärjestelmän ikäviin liikkeisiin.



7. VIPER PANELIN asentaminen*

* Myydään erikseen. VIPER PANEL sisältyy VIPER TQS Mission Packiin.

VIPER PANEL on ohjauspaneeli, joka sallii lento-/taistelukapasiteetin laajentamisen yhteensä 43 painikkeella ja 1 akselilla – kaikkia niistä voi ohjelmoida T.A.R.G.E.T-ohjelmistolla. VIPER PANEL on oiva lisä VIPER TQS -yksikölle.

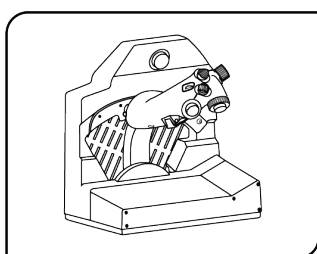

1

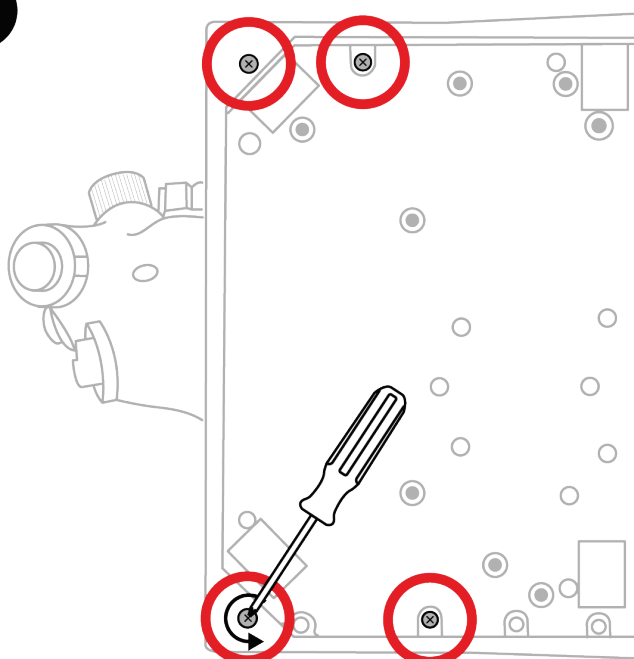

2

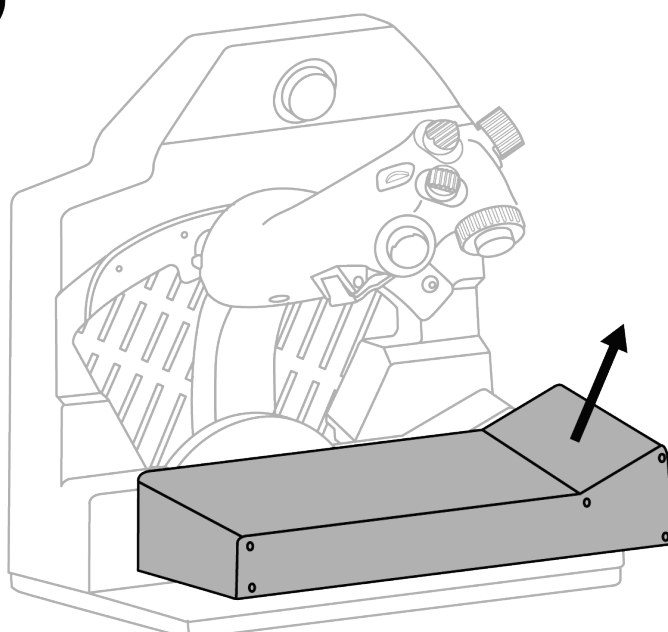

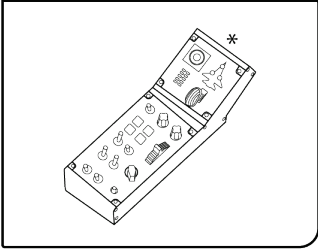

3

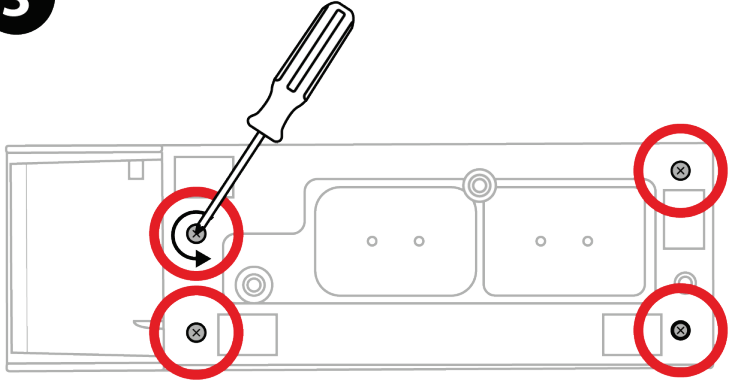

4

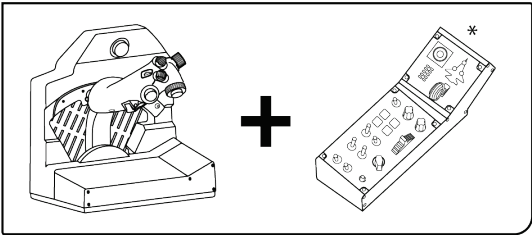
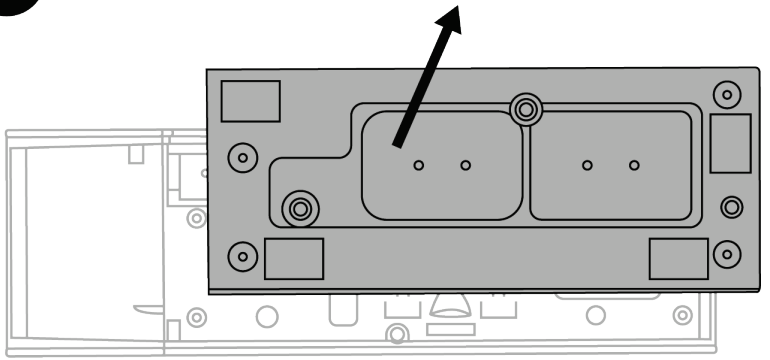

5

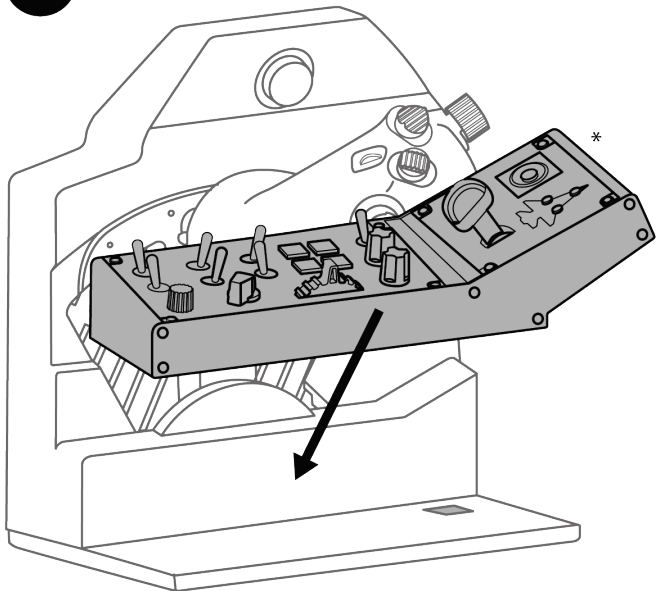



6

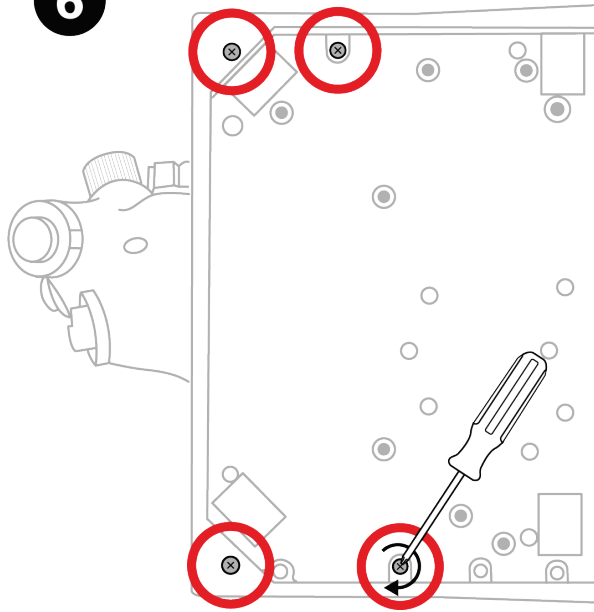

7

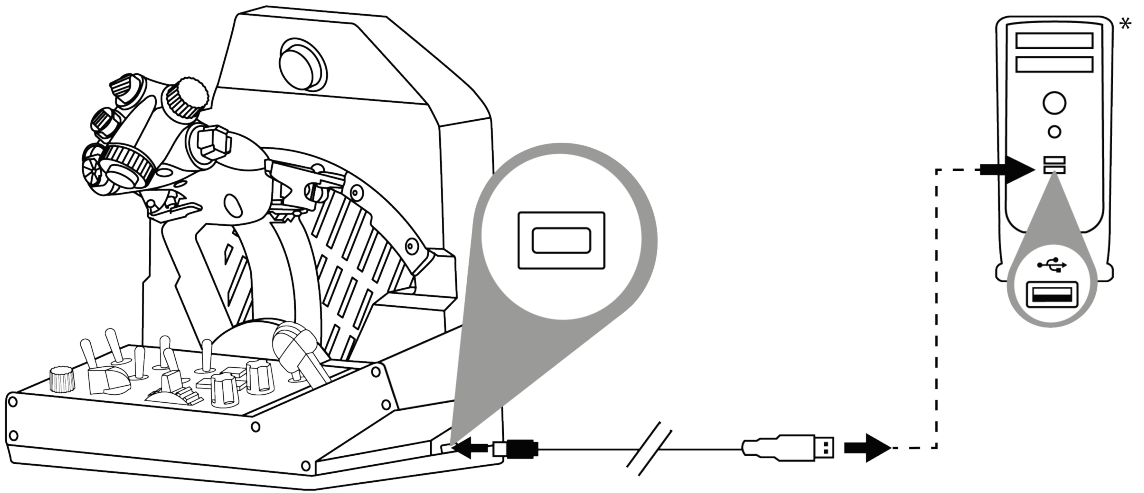

* Ei tule mukana.



8. Asennus PC-tietokoneelle

1



Käy osoitteessa

<https://support.thrustmaster.com/product/viper-tqs/>.

2

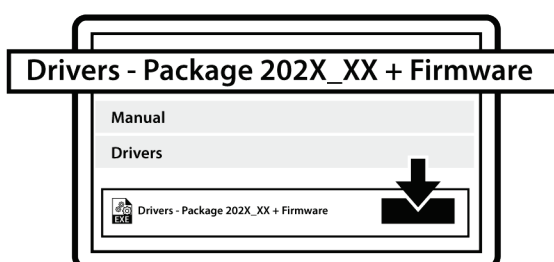

Lataa ja asenna tietokoneen ajuri sekä sen erillinen käyttöliittymä Windowsin ohjauspaneelia varten.

3

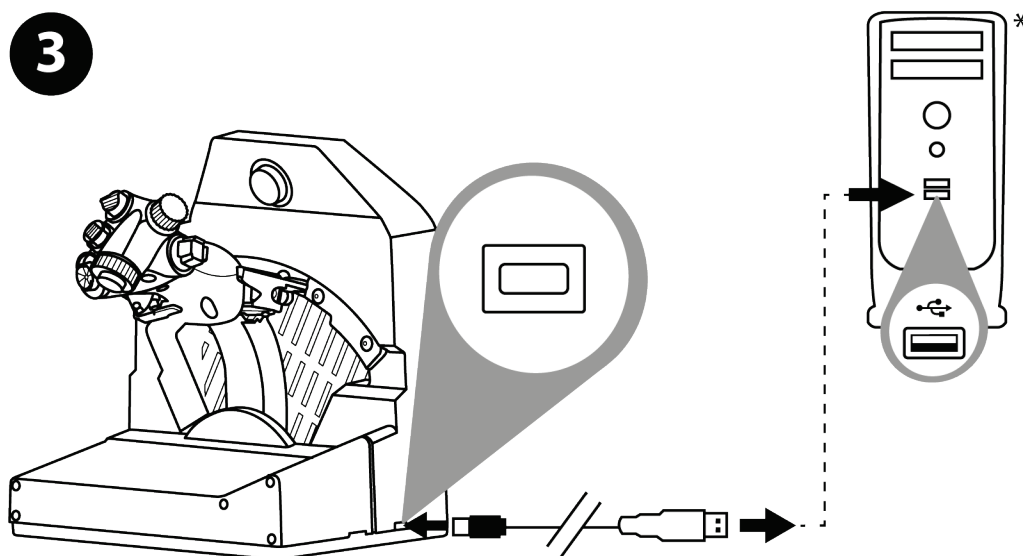

Kun tietokoneen ajuri on asennettu, yhdistä USB-liitin yhteen tietokoneen USB-porteista.

* *Ei tule mukana.*



④ Avaa Control Panel, valitse **Aloita / Kaikki sovellukset / Thrustmaster / Control Panel** tai **Ohjauspaneeli** (Windows 10:ssä).

Peliohjaimet-ikkuna ilmestyy ruudulle. Lisälaite näkyy ruudulla nimellä **VIPER TQS** ja sen status on **OK**.

⑤ Napsauta **Peliohjaimet**-ikkunassa kohtaa **Ominaisuudet** testataksesi ja nähdäksesi kaikki toiminnot.

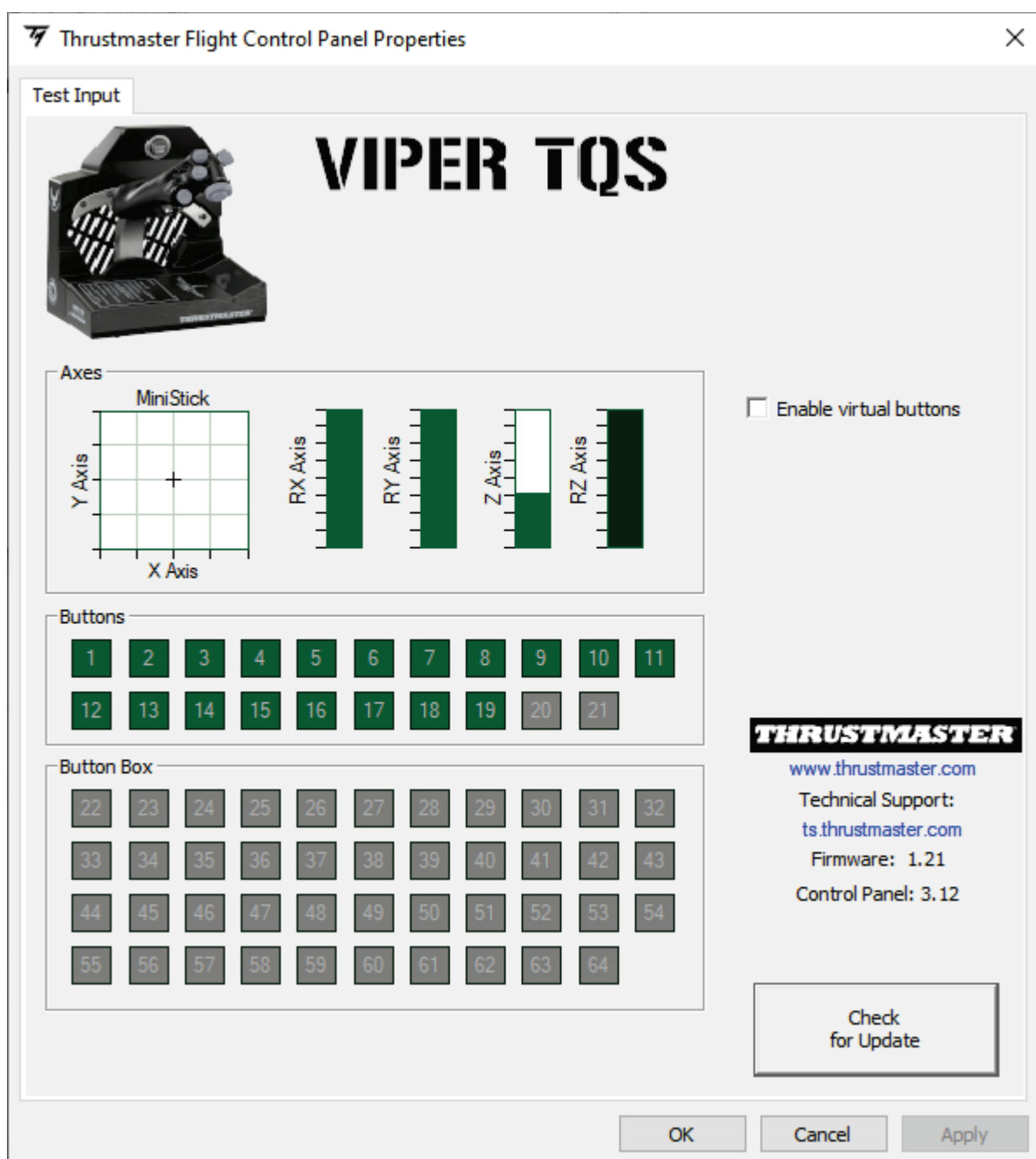



Enable virtual buttons (Ota virtuaalipainikkeet käyttöön):

Tämä toiminto sallii kahvan virtuaalipainikkeiden käyttöön ottamisen tai käytöstä poistamisen (painikkeet 20–21). Napsauta **Apply** (Käytä), kun olet valinnut käytettävän tilan.

Thrustmaster Flight Control Panel Properties

Test Input

VIPER TQS

Enable virtual buttons

Buttons

1	2	3	4	5	6	7	8	9	10	11
12	13	14	15	16	17	18	19	20	21	

Button Box

22	23	24	25	26	27	28	29	30	31	32
33	34	35	36	37	38	39	40	41	42	43
44	45	46	47	48	49	50	51	52	53	54
55	56	57	58	59	60	61	62	63	64	

Check for Update

OK Cancel Apply



VIPER TQS:n virtuaalipainikkeet ovat oletusarvoisesti poissa käytöstä.



9. CUT OFFIN ja AFTERBURNERIN pykälät

VIPER TQS -tehovipuyksikkö sisältää realistiset CUT OFF- ja AFTERBURNER-pykälät (Afterburner-moduuli on poistettavissa).

CUT OFF

Kun tehovipu on IDLE-pykälän kohdalla, paina ”avaa moottorin sammutus” -liipaisinta **1**, jotta voit nostaa kahvan pykälän yli **2** ja asettaa kahvan OFF-asentoon **3**.

Käynnistä moottorit uudelleen toistamalla prosessi käänteisenä.

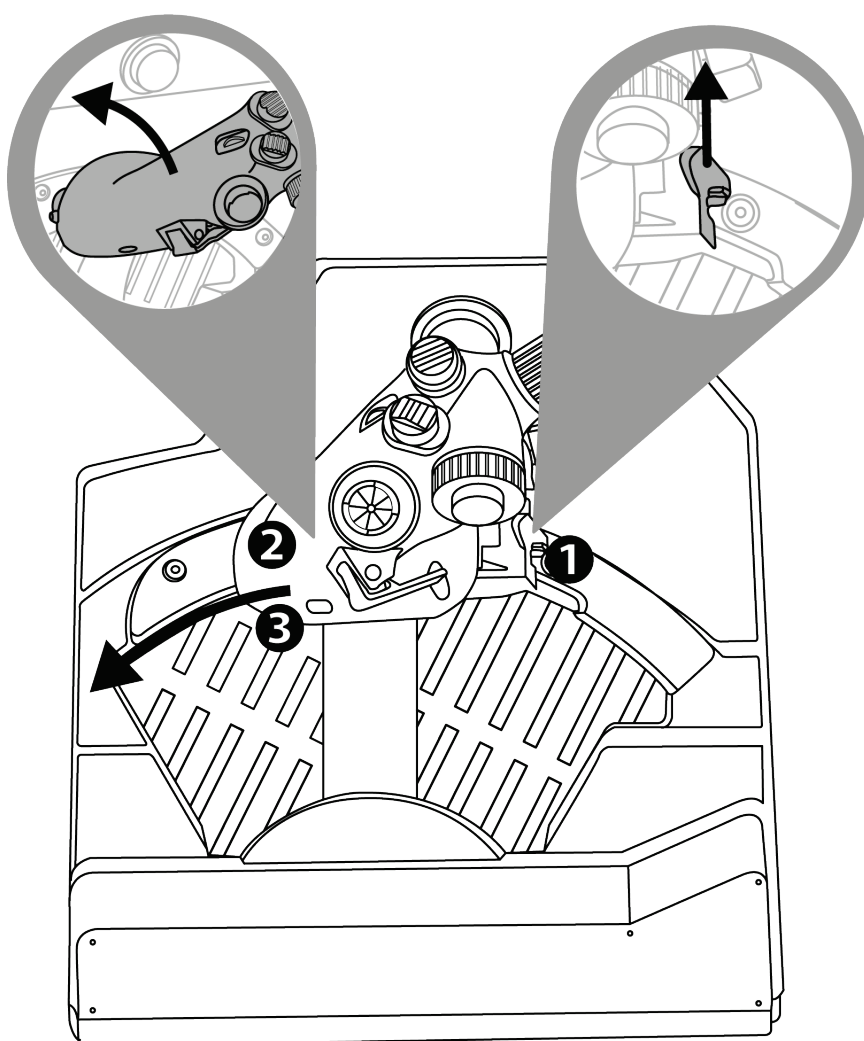



AFTERBURNER

Liikuta tehovipu pykälän kohdalle **1** ja nosta kahva **2** pykälän yli, niin käynnistät jälkipolttimen **3**.

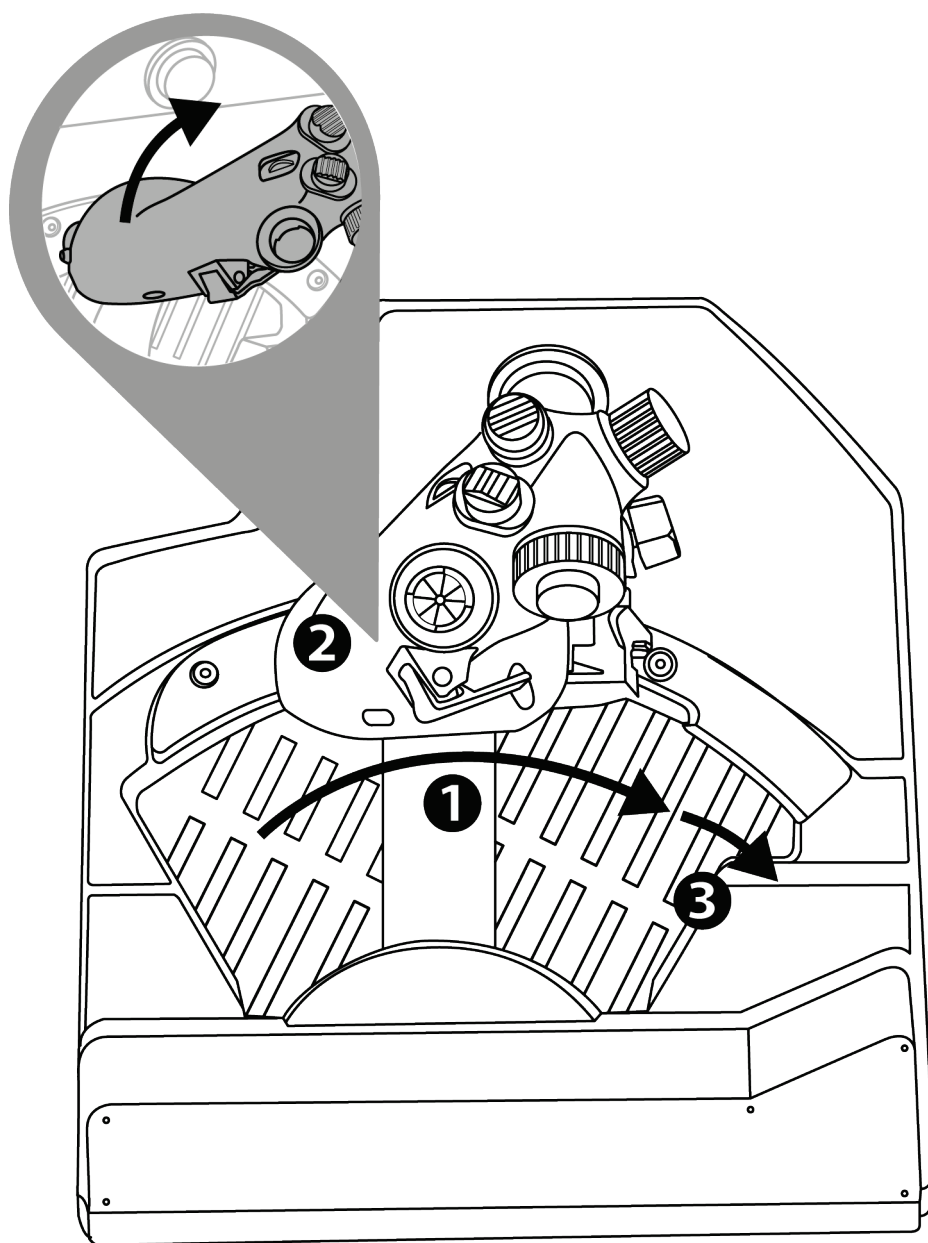



AFTERBURNER-pykälän poistaminen

Afterburner-moduulin pykälä on asetettu akselilla 80 %:in kohdalle.

Jos tarvitset koko akselin käyttöäsi ilman pykälää (tietyssä simulaattorissa), voit poistaa Afterburner-moduulin ja sen pykälän ruuvaamalla irti moduulin kaksi ruuvia kuusiokoloavaimella (ei mukana).

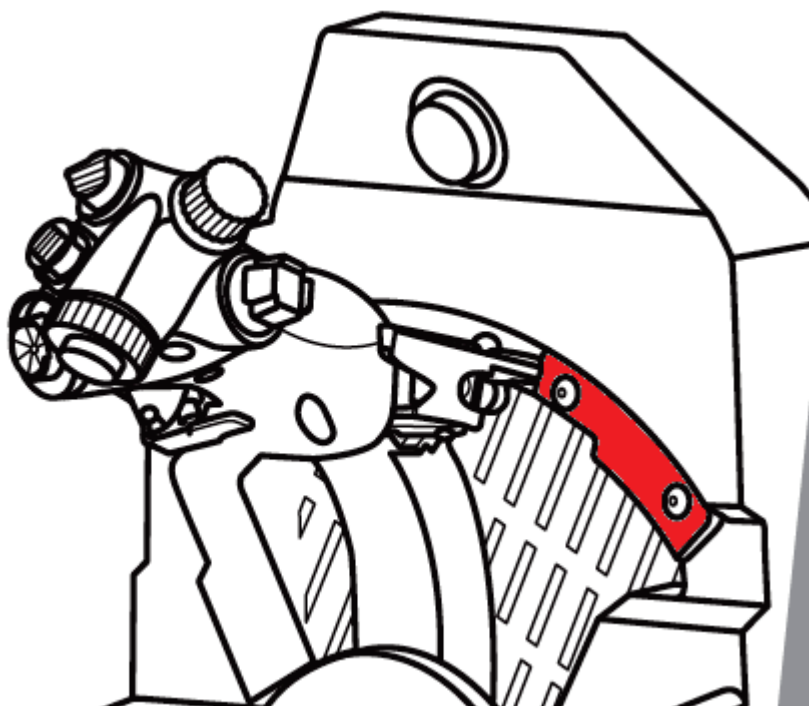



10. Edistynyt T.A.R.G.E.T- ohjelmointiohjelmisto



Käy osoitteessa

<https://support.thrustmaster.com/product/viper-tqs/>.

Lataa **Software** (Ohjelmisto) -osiosta edistynyt T.A.R.G.E.T-ohjelmointiohjelmisto ja asenna se.



T.A.R.G.E.T – pääominaisuudet

- Eri akselimäärityksiä.
- Eri ohjelmointitasoja: Basic, Advanced ja Script.
- Käyttää Drag & Drop -periaatetta.
- Yhdistä VIPER TQS -tehoviipuyksikkö eri Thrustmaster-lentosauvoihin (HOTAS Cougar, HOTAS Warthog, T.16000M ja MFD Cougar Pack, joista kaikki ovat myös T.A.R.G.E.T-yhteensopivia), mikä sallii niiden tunnistamisen yhtenä USB-laitteena.
- Pääsy Thrustmaster-yhteisön luomiin edistyneisiin profiileihin.



11. UKK ja tekninen tuki

Onko sinulla kysymyksiä VIPER TQS -yksiköstä tai kärsitkö teknisistä ongelmista? Mikäli näin on, vieraile Thrustmasterin teknisen tuen sivustolla:

<https://support.thrustmaster.com/product/viper-tqs/>.



THRUSTMASTER®

VIPER TQS

THROTTLE QUADRANT SYSTEM

Pre PC (Windows 10/11)

Návod na použitie



Pred inštaláciou produktu, **pred** akýmkoľvek použitím produktu a **pred** akoukoľvek údržbou si **pozorne prečítajte** pokyny uvedené v tomto návode. Bezpodmienečne dodržiavajte bezpečnostné pokyny. Nedodržanie týchto pokynov môže viesť k nehodám a/alebo škodám. Uschovajte si tento návod, aby ste si ho mohli v budúcnosti prečítať.

OBSAH

1.	OBSAH BALENIA.....	5
2.	FUNKCIE VIPER TQS	6
3.	MAPOVANIE TLAČIDIEL A OSÍ	8
4.	INFORMÁCIE O POUŽÍVANÍ VIPER TQS.....	10
5.	NASTAVENIE TRENIA.....	11
6.	INŠTALÁCIA NA PODPERU	12
7.	INŠTALÁCIA VIPER PANEL *	17
8.	INŠTALÁCIA NA PC	20
9.	ZARÁŽKY CUT OFF A AFTERBURNER	23
10.	POKROČILÝ PROGRAMOVACÍ SOFTVÉR T.A.R.G.E.T.....	26
11.	ČASTO KLADENÉ OTÁZKY A TECHNICKÁ PODPORA	28



Naštartujte svoje motory a vyleťte do nebezpečnej zóny s ikonickým systémom plynového kvadrantu z lietadla VIPER od U.S. Air Force – najpoužívanejšieho moderného bojového lietadla na svete!

Posuňte svoj kokpit na vyššiu úroveň s jedinečnou ergonómiou repliky HOTAS v mierke 1:1 s kovovou rukoväťou a realistickými tlačidlami a zarážkami.

Tento návod vám pomôže nainštalovať a používať váš VIPER TQS za najlepších podmienok. Pred vzlietnutím si pozorne prečítajte všetky tieto pokyny a varovania: pomôžu vám získať maximálny pôžitok z vášho produktu



Aktualizácia firmvéru

Aby VIPER TQS správne fungoval vo videohrách, musíte aktualizovať jeho firmvér.

Ak chcete vykonať aktualizáciu, navštívte stránku

<https://support.thrustmaster.com/product/viper-tqs/>

Vyberte **Firmware** (Firmvér) a potom postupujte podľa pokynov – vrátane postupu sťahovania a inštalácie.



1. Obsah balenia

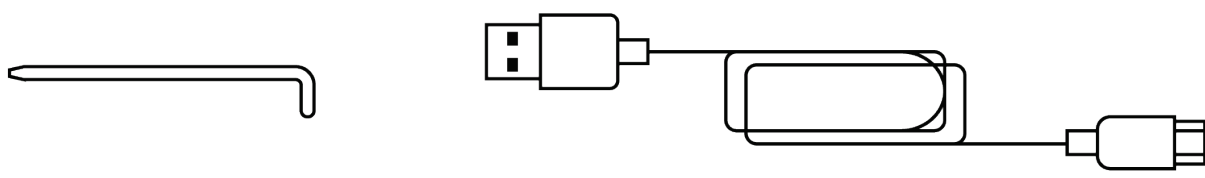
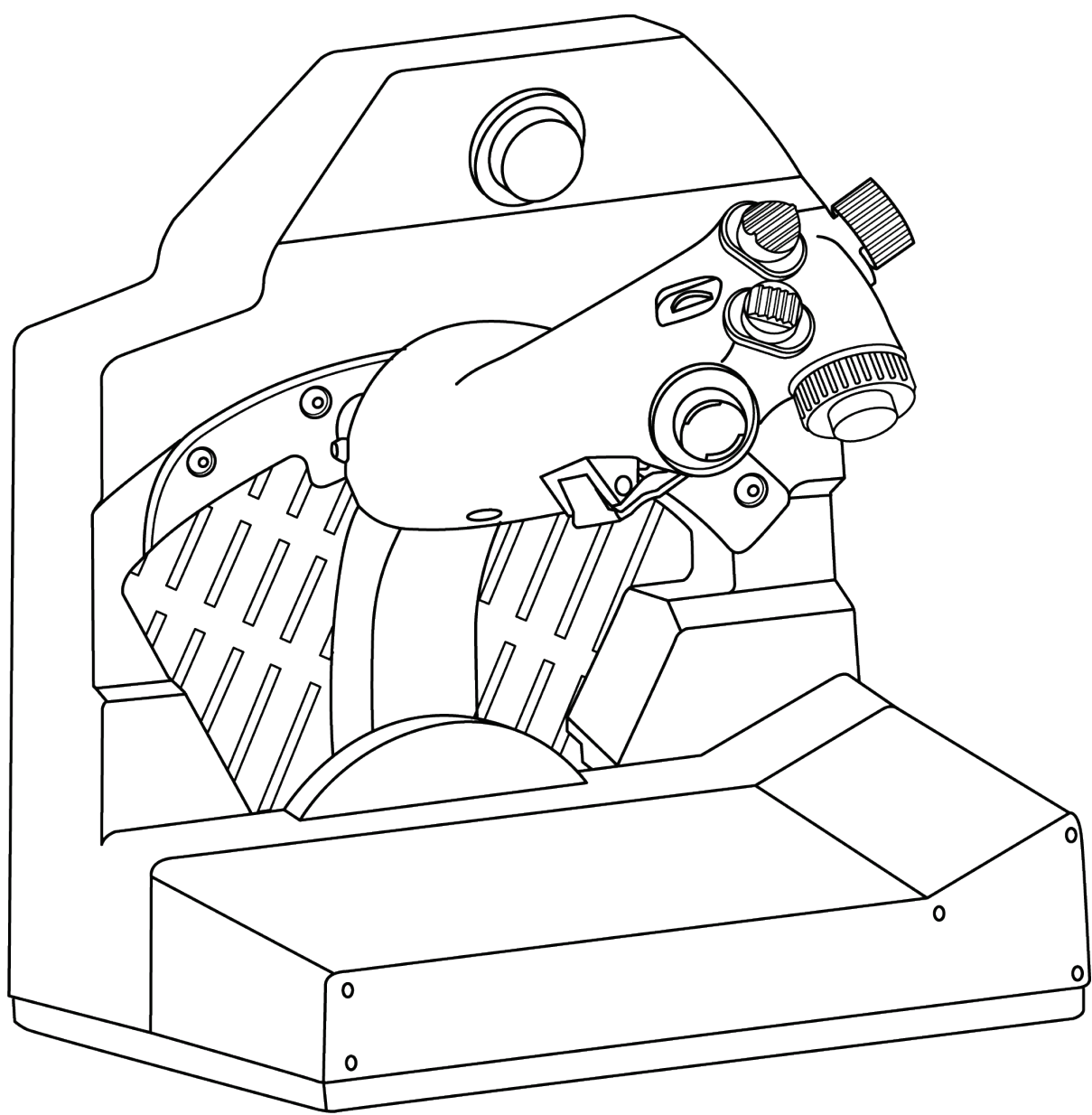



2. Funkcie VIPER TQS

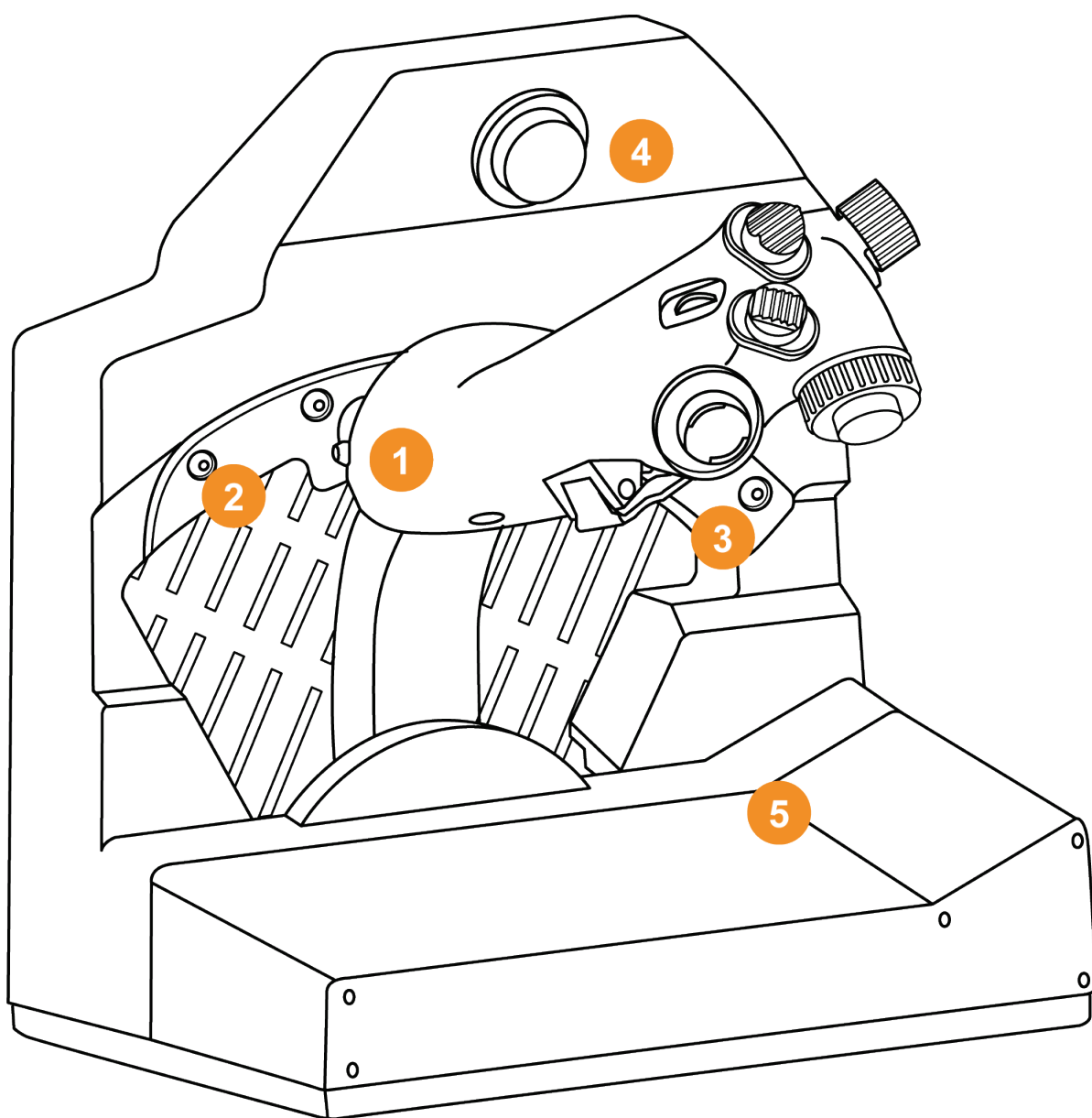

1. Rukovät'

2. Zarážka Cut Off

3. Zarážka Afterburner

4. Spínač CHAFF/FLARE

5. Klip pre mapu misie

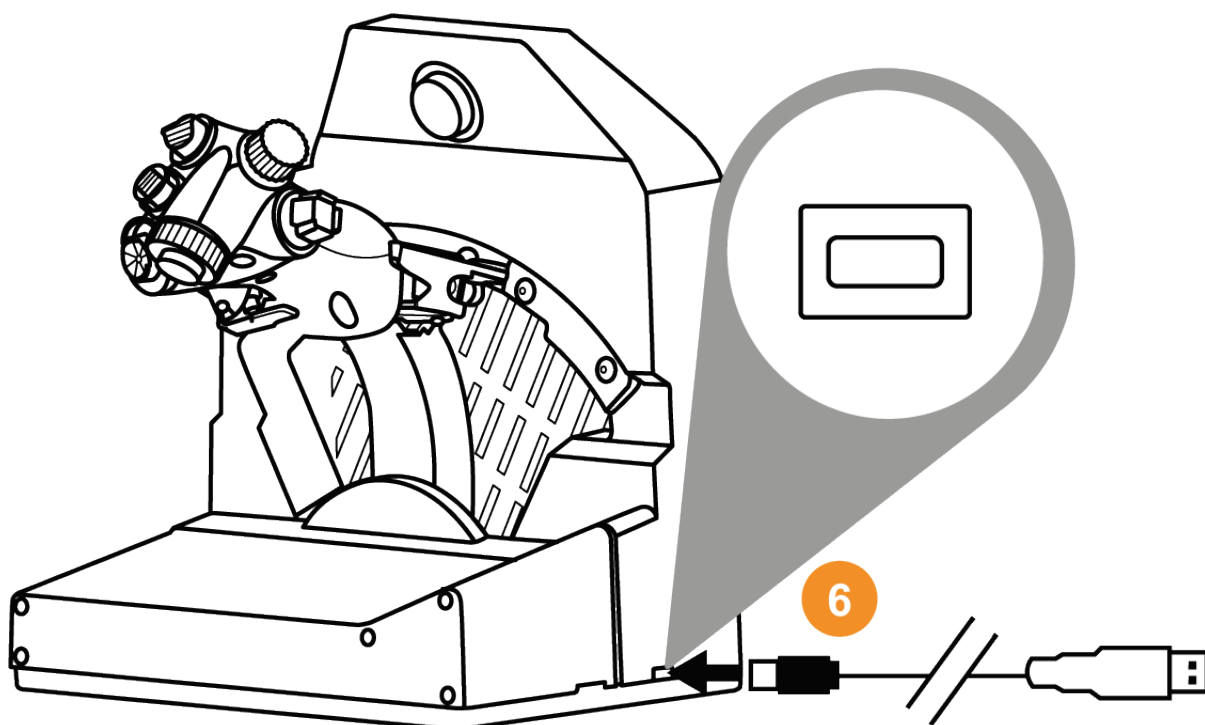

6. USB konektor (typ C)

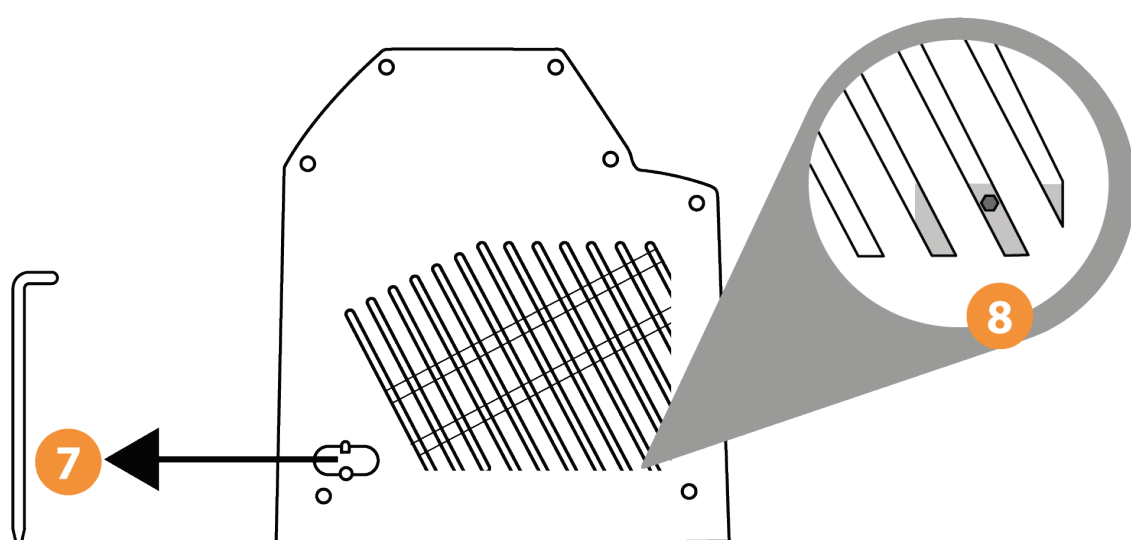

7. Umiestnenie nástroja na nastavenie trenia

8. Prístupový bod nastavenia trenia škrtiacej klapky



3. Mapovanie tlačidiel a osí

Rukoväť VIPER TQS: mapovanie 19 tlačidiel a 5 osí v režime A (bez virtuálnych tlačidiel)

A 1 → 19

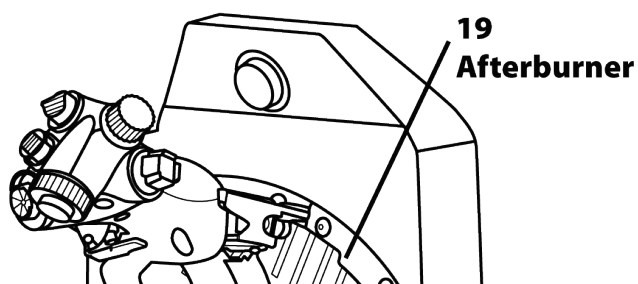
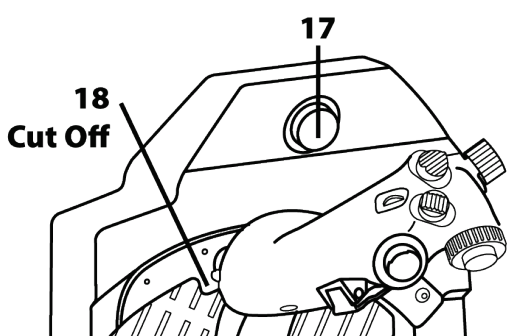
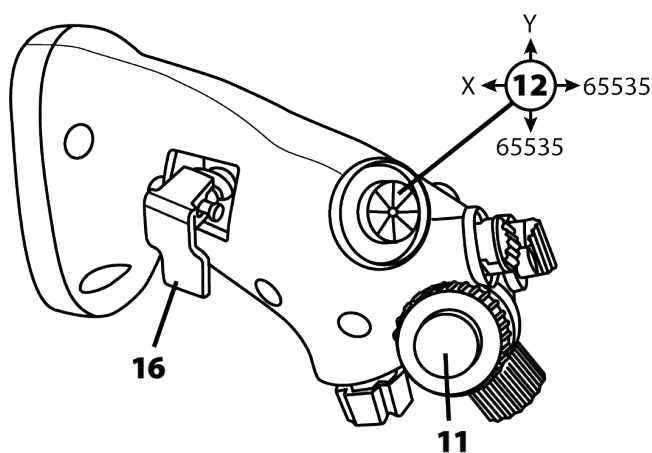
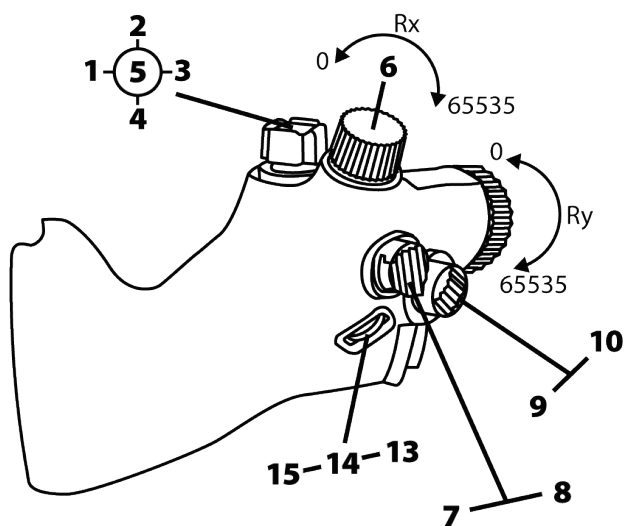



Režim B: s virtuálnymi tlačidlami

B 1 → 21

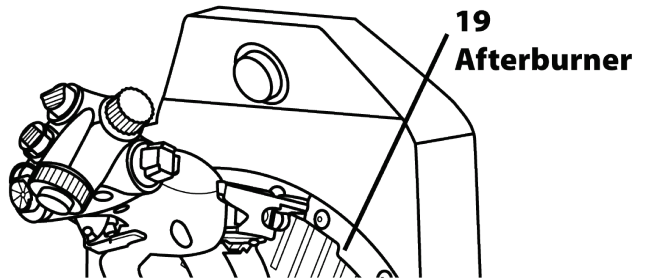
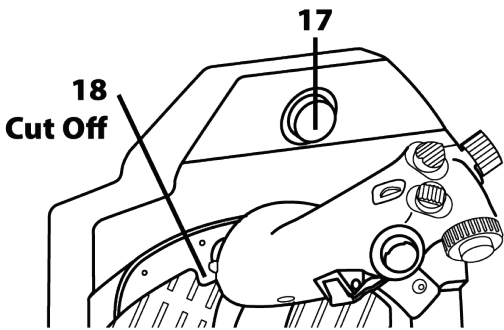
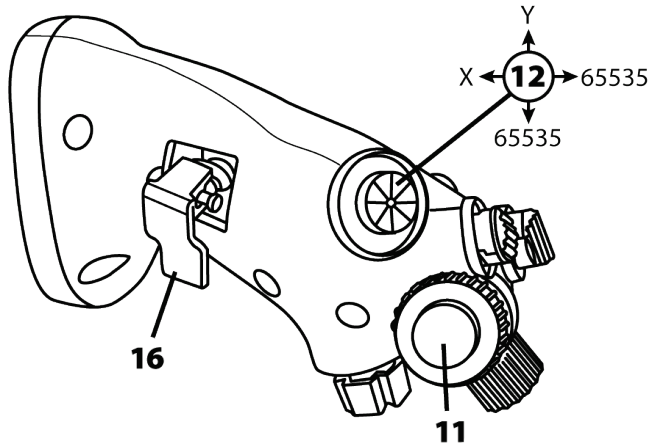
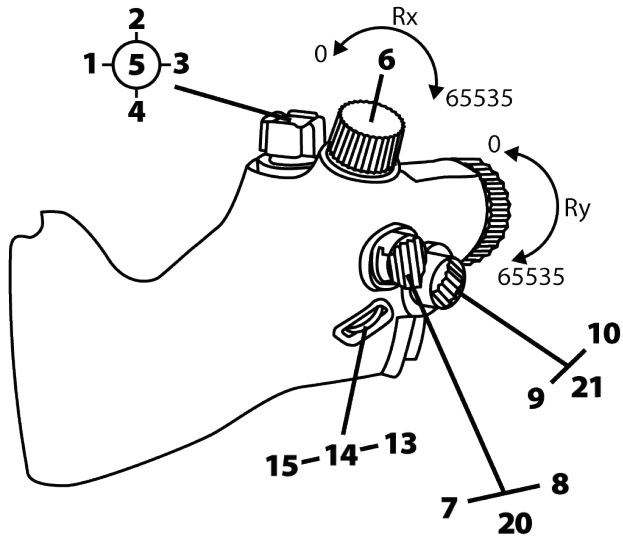



4. Informácie o používaní VIPER TQS



Nebezpečenstvo priškripania

Pri používaní rukoväte nikdy nedávajte prsty do oblasti zarážok.

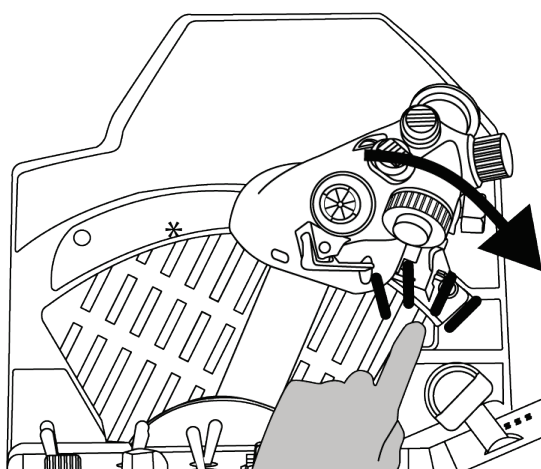
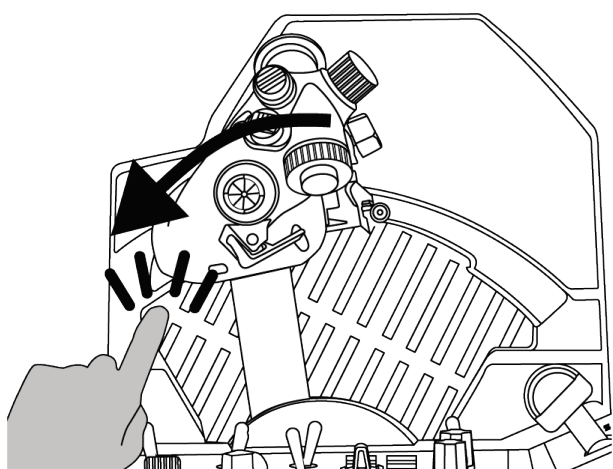
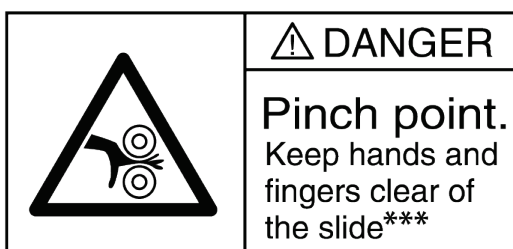



4. Nastavenie trenia

Pomocou nástroja na boku VIPER TQS môžete upraviť trenie vášho plynového kvadrantu VIPER TQS podľa vašich osobných preferencií. Upozorňujeme však, že optimálne trenie plynovej páky bolo predvolene nastavené z výroby.

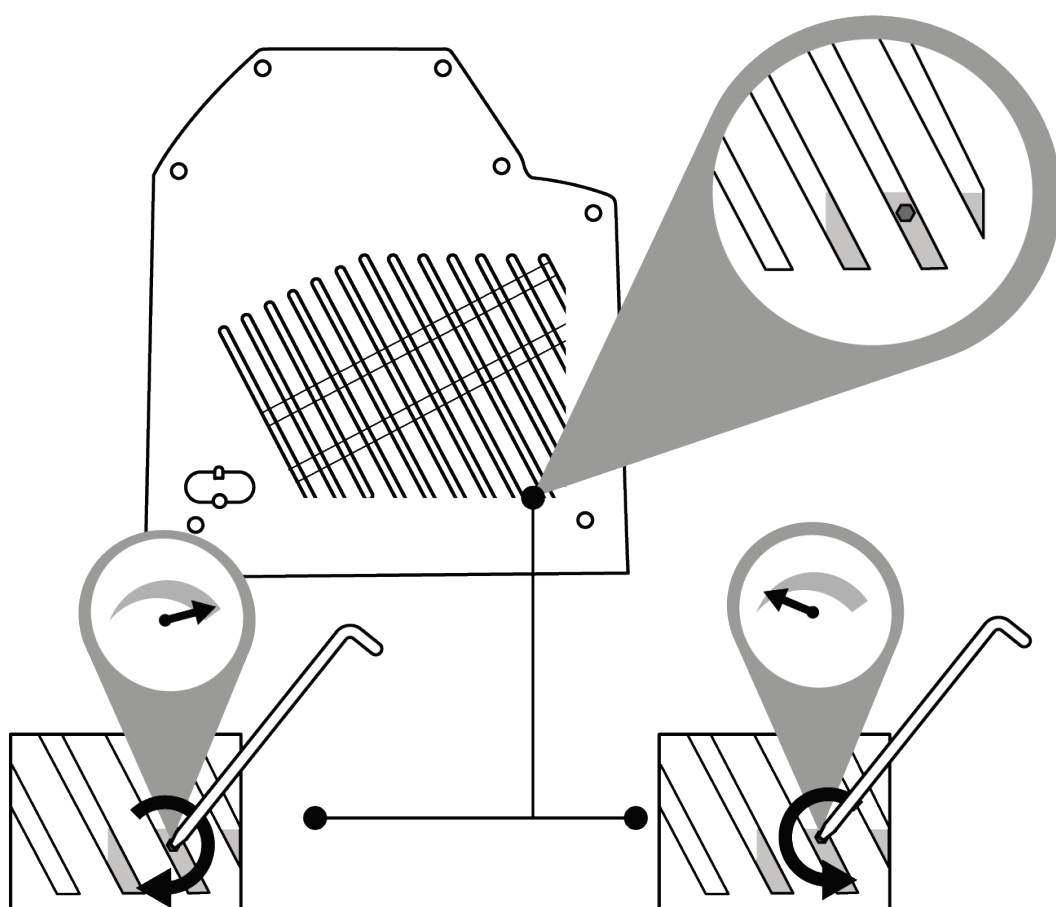

Aby ste predišli poškodeniu trecieho systému dbajte na to, aby ste nastavovaciu skrutku príliš neutiahli.

Taktiež dbajte na to, aby ste nastavovaciu skrutku úplne neuvolnili: riskujete tým, že plynová páka už nebude môcť zostať na svojom mieste.



6. Inštalácia na podperu



VIPER TQS je možné inštalovať na rôzne typy podpier. Väčšina kokpitov a podpier dostupných na trhu je už kompatibilná s podobnými produktmi Thrustmaster (t.j. HOTAS Warthog).

Majte na pamäti, že VIPER TQS má silný pákový efekt, a preto musí byť pevne pripevnený.

Pripevnite základňu k podpere pomocou vhodných skrutiek M6 (nie sú súčasťou balenia), aby ste nepoškodili rukoväť.

Kompletný plán VIPER TQS je k dispozícii na <https://support.thrustmaster.com/product/viper-tqs/>



Pred každým použitím sa presvedčte, že VIPER TQS je stále správne pripevnený k podpere podľa návodu špecifikovaného výrobcom.

Nezabudnite vziať do úvahy materiál, z ktorého je vaša podpera vyrobená a uistite sa, že je možné na ňu produkt bezpečne pripevniť. VIPER TQS je nutné použiť na doske vyrobenej z masívneho materiálu (t.j. MDF alebo dreva), bez akýchkoľvek dutých alebo sklenených komponentov.



Rozmery montážneho plánu (v mm)

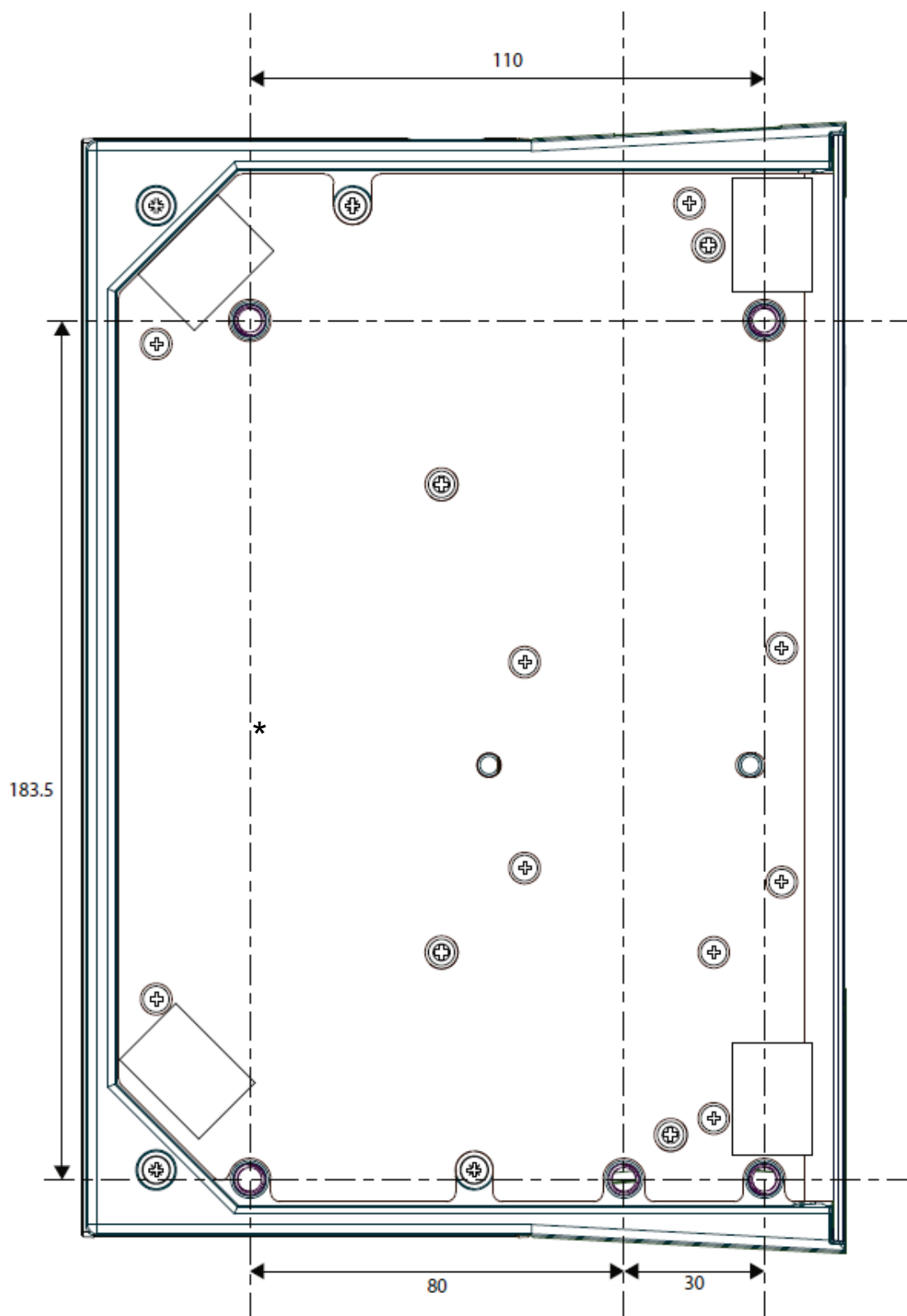

Montážny plán si môžete stiahnuť z

[https://support.thrustmaster.com/product/viper-](https://support.thrustmaster.com/product/viper-tqs/)

[tqs/](https://support.thrustmaster.com/product/viper-tqs/), potom ho vytlačiť a použiť na svojej podpere na prípravu dier.



Inštalácia použitím TM Flying Desk Mount*

TM Flying Desk Mount je kovový montážny systém s upínacou skrutkou, ktorý zlepšuje ergonómiu a polohu pilotovania pri používaní vášho zariadenia. Tento systém je určený na použitie so stolmi a pevnými povrchmi s hrúbkou 15–50 mm.

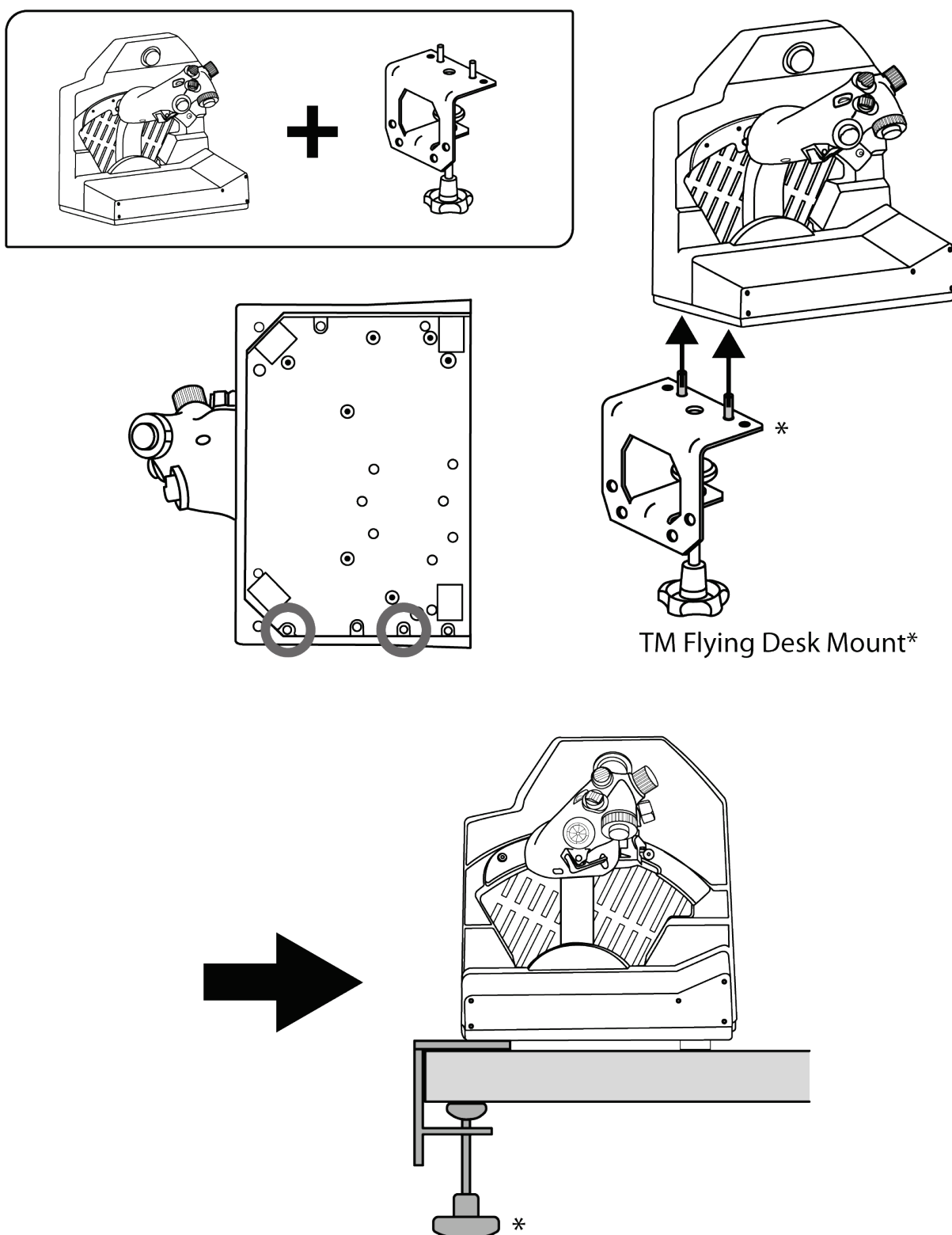

* Predávané samostatne



*Inštalácia použitím TM Flying Clamp**

TM Flying Clamp je výškovo nastaviteľná podpera navrhnutá od Thrustmaster pre jej príslušenstvo na simuláciu letu. Tento montážny systém obsahuje dve upínacie skrutky, ktoré umožňujú jeho použitie so stolmi a pevnými povrchmi s hrúbkou 15-45 mm.

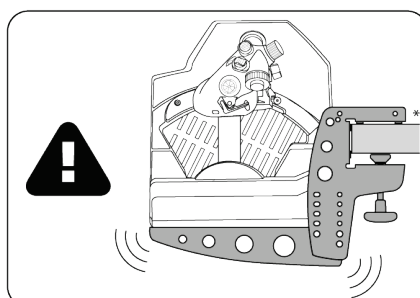
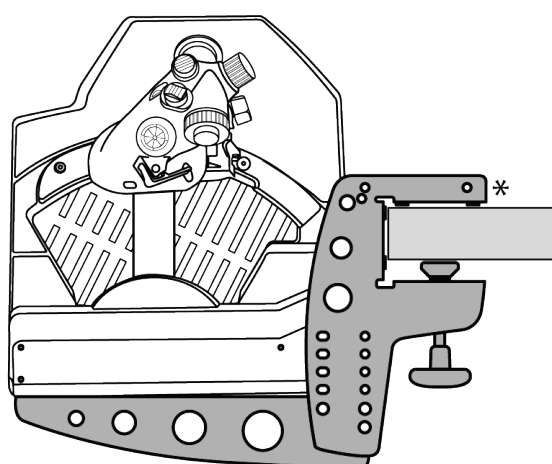
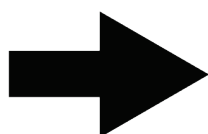
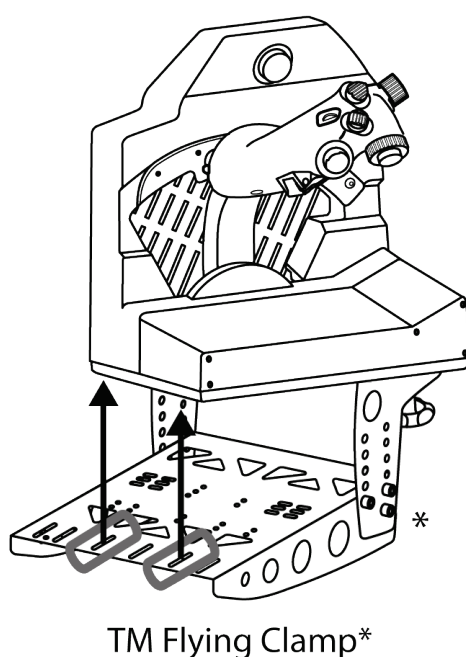
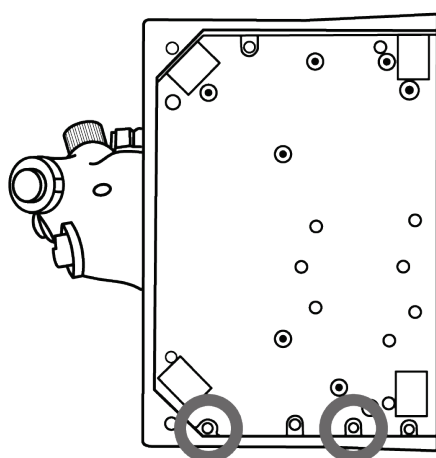
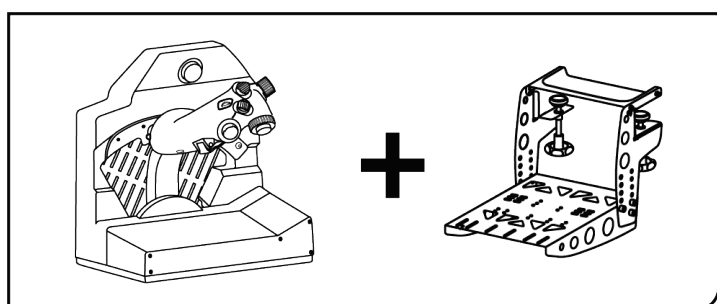

* Predávané samostatne



Prosím vezmite do úvahy, že veľká hmotnosť VIPER TQS môže viesť k nežiaducim pohybom montážneho systému.



7. Inštalácia VIPER PANEL*

*Predávané samostatne. VIPER PANEL je súčasťou VIPER TQS Mission Pack.

VIPER PANEL je ovládací panel, ktorý vám umožní rozšíriť vaše letové/bojové schopnosti s celkom 43 tlačidlami a 1 osou – všetky sú programovateľné pomocou softvéru T.A.R.G.E.T. VIPER PANEL je doplnkom VIPER TQS.

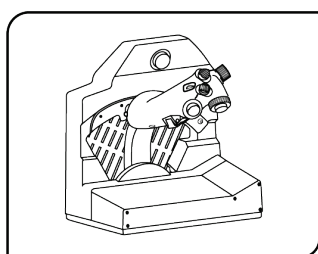

1

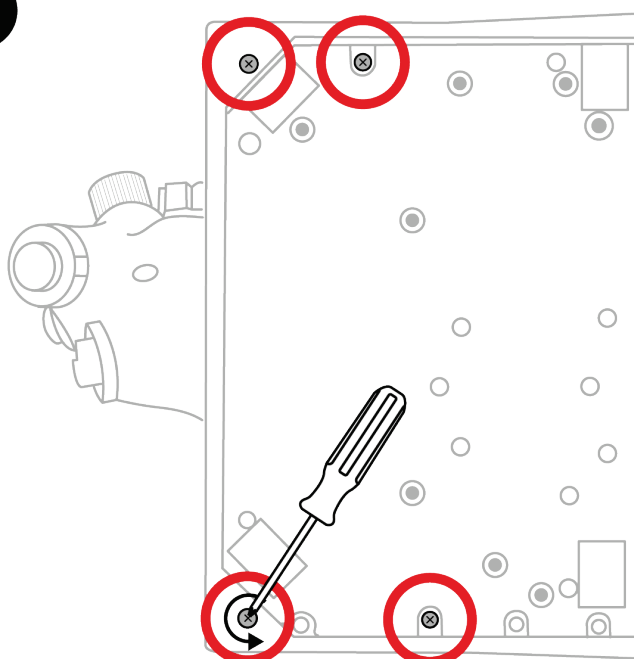

2

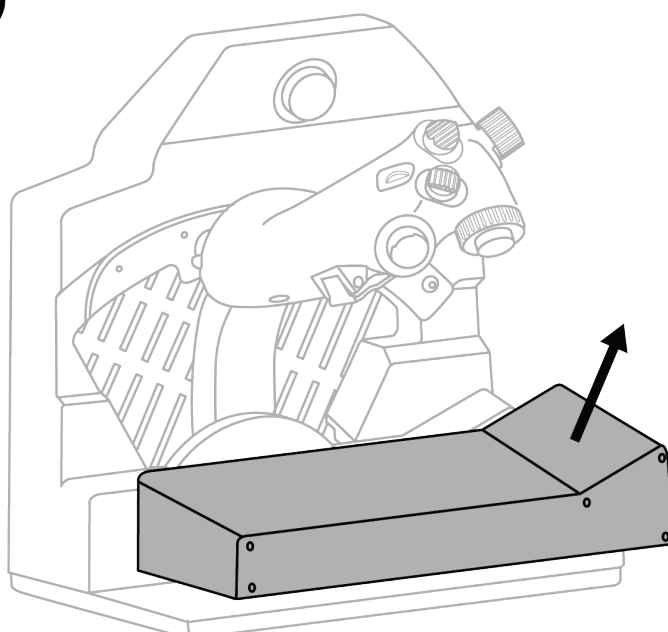

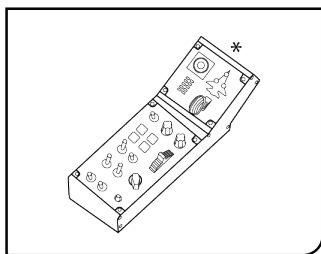

3

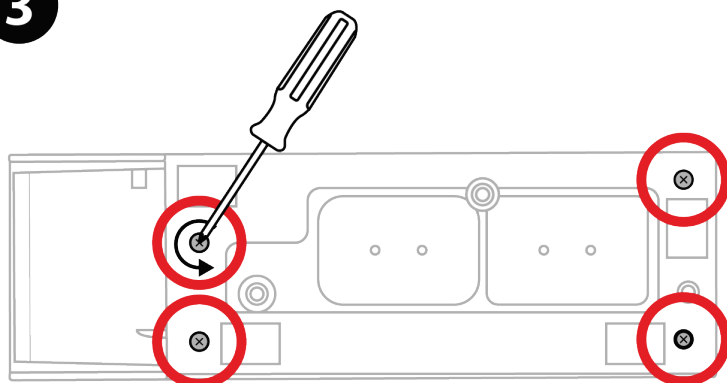

4

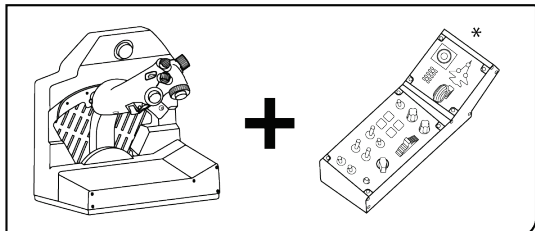
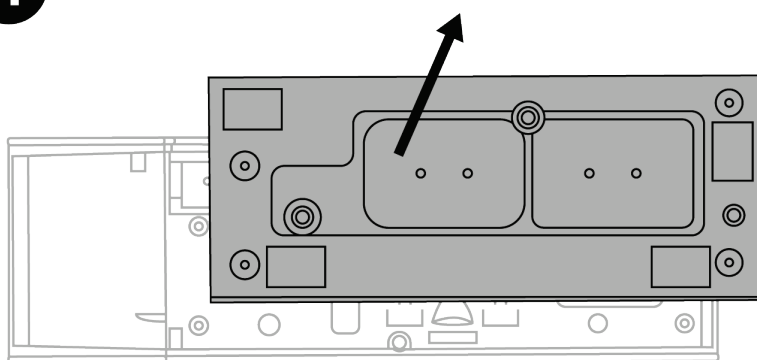

5

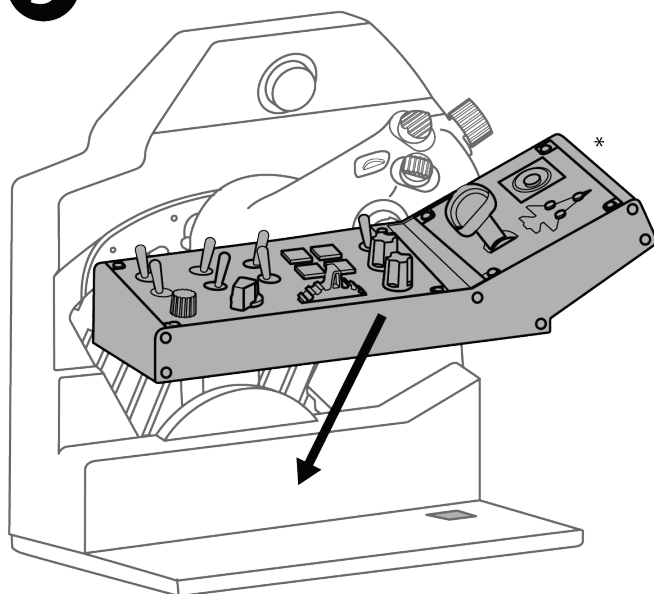



6

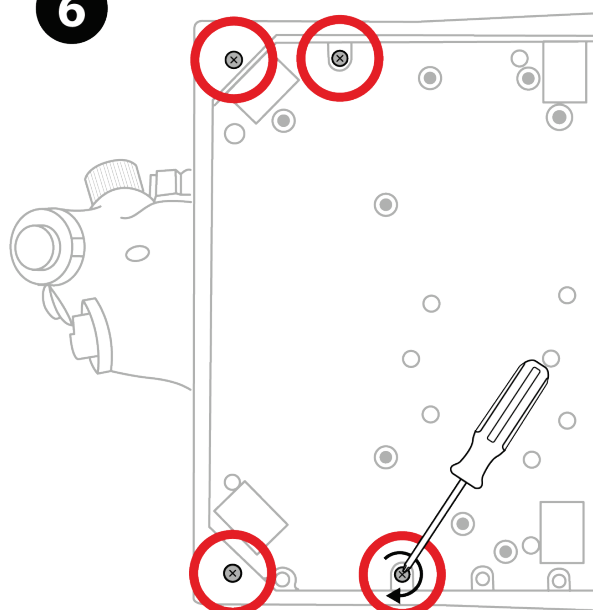

7

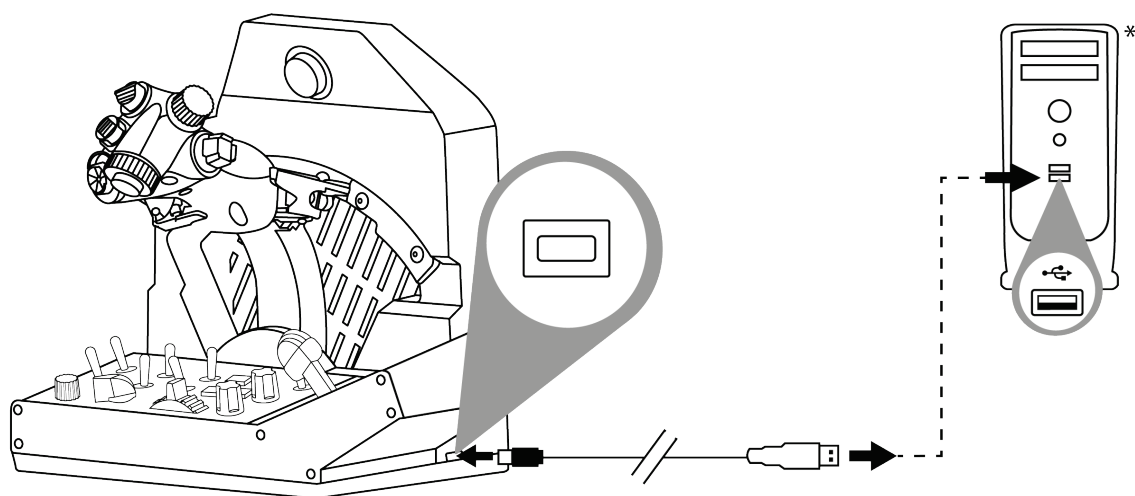

**Nie je súčasťou balenia*



8. Inštalácia na PC

1



Prosím navštívte

<https://support.thrustmaster.com/product/viper-tqs/>.

2

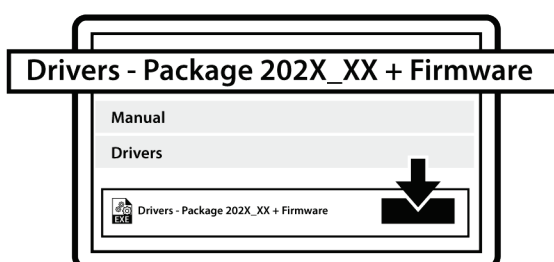

Stiahnite a nainštalujte PC ovládač a jeho prispôsobené rozhranie pre Ovládací Panel Windows.

3

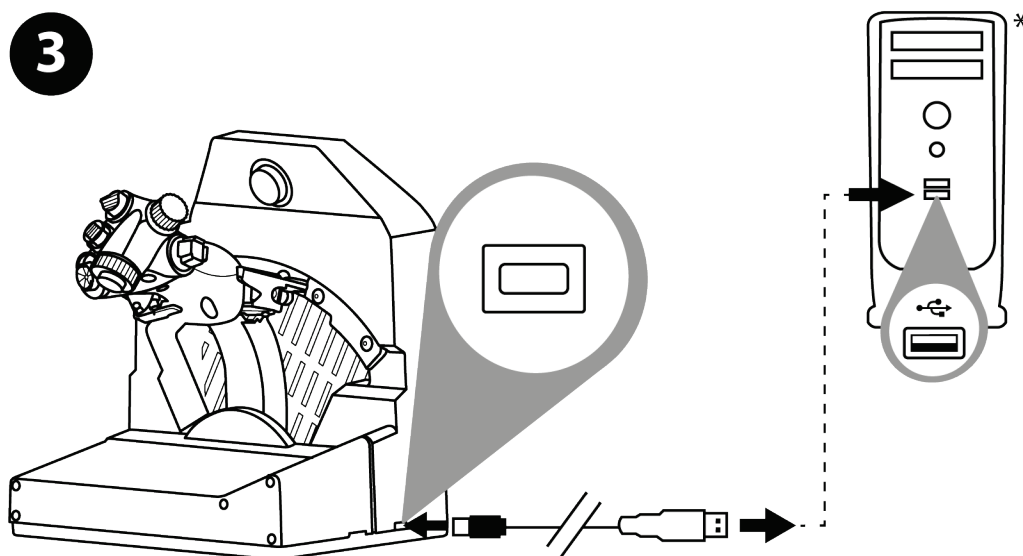

Po nainštalovaní PC ovládača pripojte USB konektor k jednému z USB portov vášho PC.

* Nie je súčasťou balenia



④ Na prístup k oknu Control Panel, vyberte **Štart / Všetky aplikácie / Thrustmaster / Control Panel** alebo **Ovládací panel** (vo Windows 10).

Zobrazí sa dialógové okno **Herné ovládače**. Príslušenstvo sa zobrazí na obrazovke s názvom **VIPER TQS** a stavom **OK**.

⑤ V dialógovom okne **Herné ovládače** kliknite na **Vlastnosti**, aby ste otestovali a zobrazili všetky funkcie.

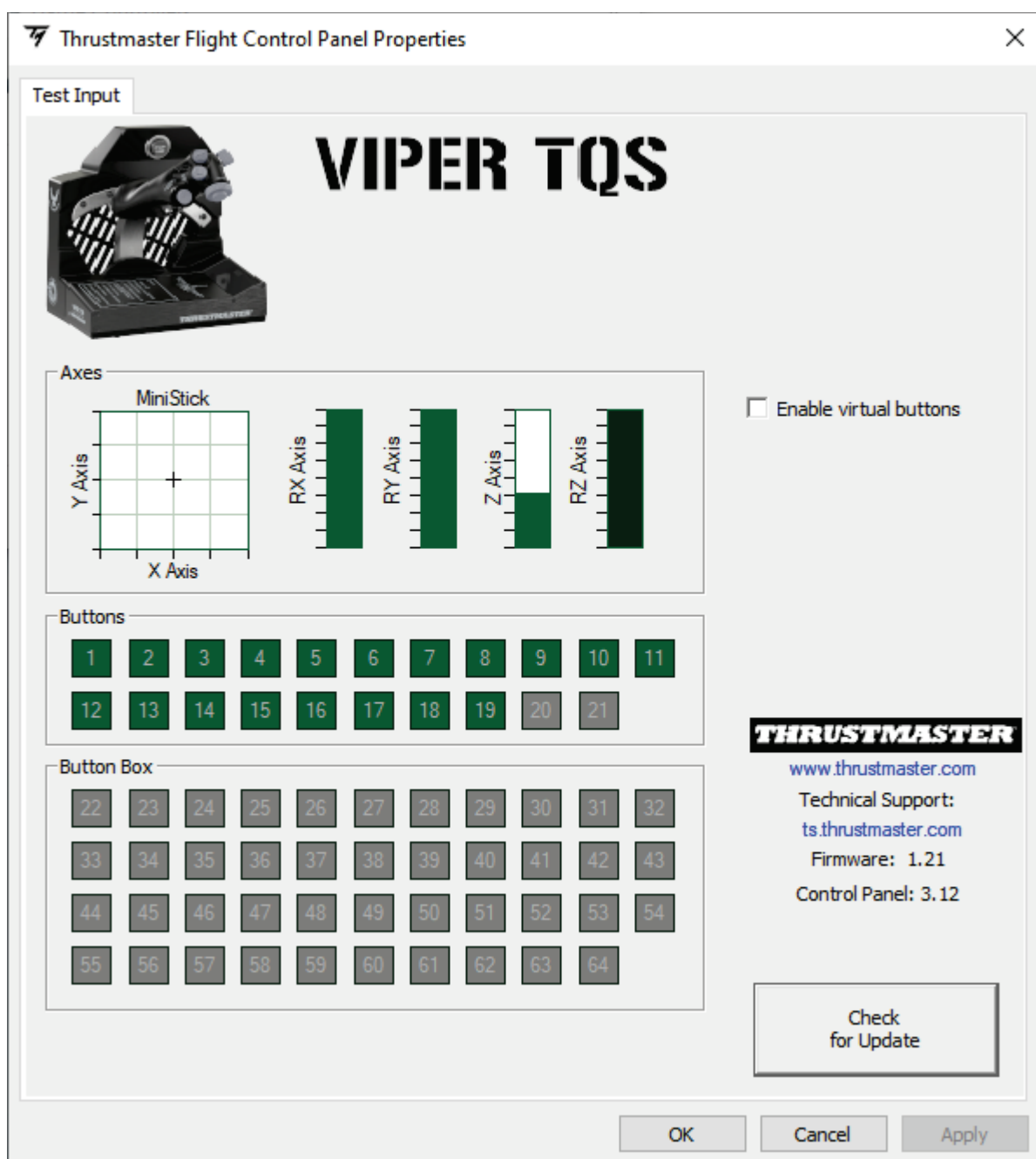



Enable virtual buttons (Povoliť virtuálne tlačidlá):

Táto funkcia vám umožňuje povoliť alebo zakázať virtuálne tlačidlá na rukoväti (tlačidlá 20 a 21). Po výbere režimu, ktorý chcete použiť, kliknite na tlačidlo **Apply** (Použiť).

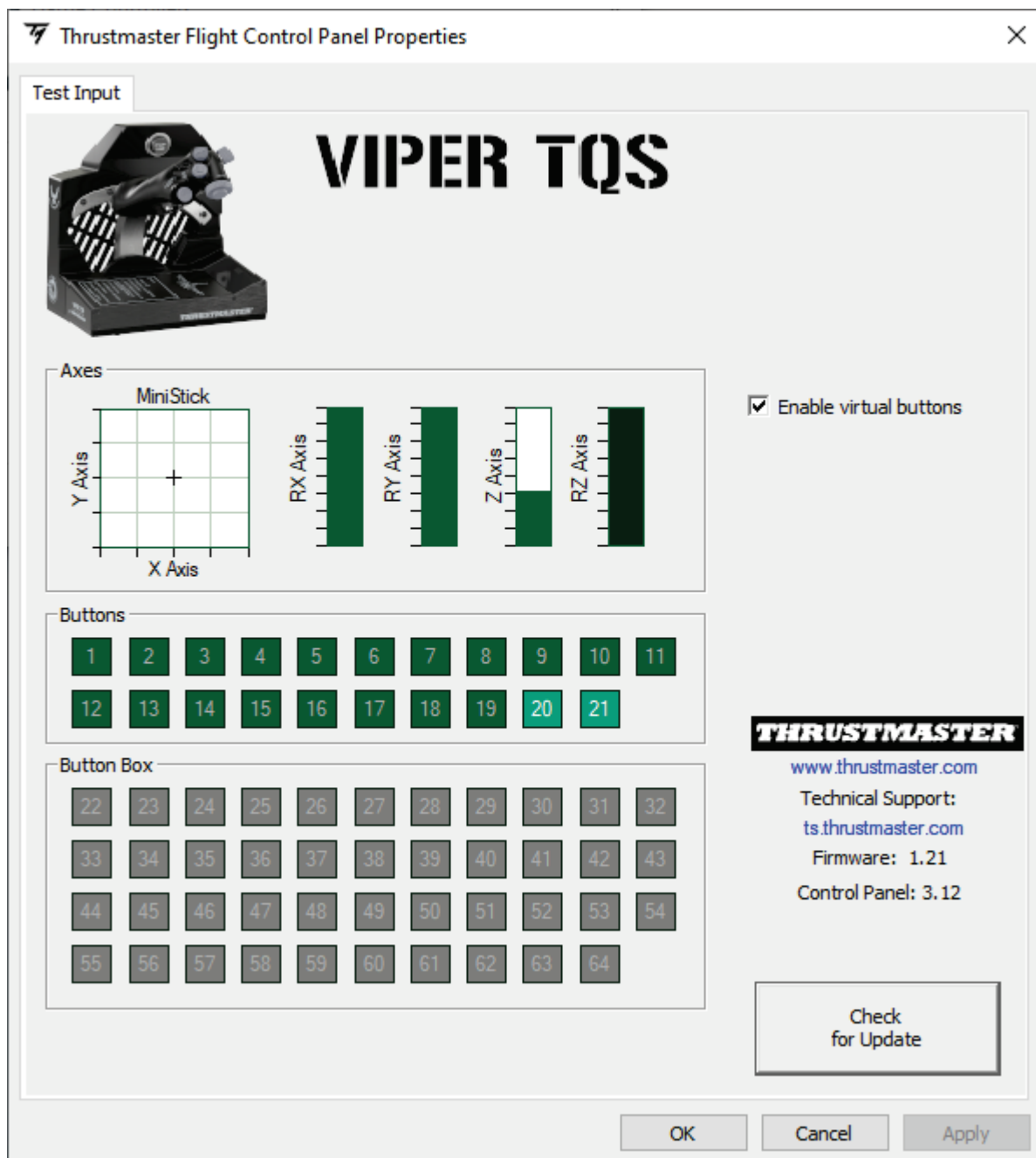

Virtuálne tlačidlá sú na VIPER TQS predvolene vypnuté.



9. Zarážky CUT OFF a AFTERBURNER

Kvadrant plynovej páky VIPER TQS obsahuje realistický systém zárážok CUT OFF a AFTERBURNER (modul Afterburner je odnímateľný).

CUT OFF

Po umiestnení plynovej páky na doraz zárážky IDLE stlačte spúšť „odblokovanie vypnutia motora“ **1** aby ste zdvihli rukoväť a dostali sa tak cez doraz **2** a potom dajte rukoväť do polohy OFF **3**.

Ak chcete motory znova zapnúť, vykonajte tento postup v opačnom poradí.

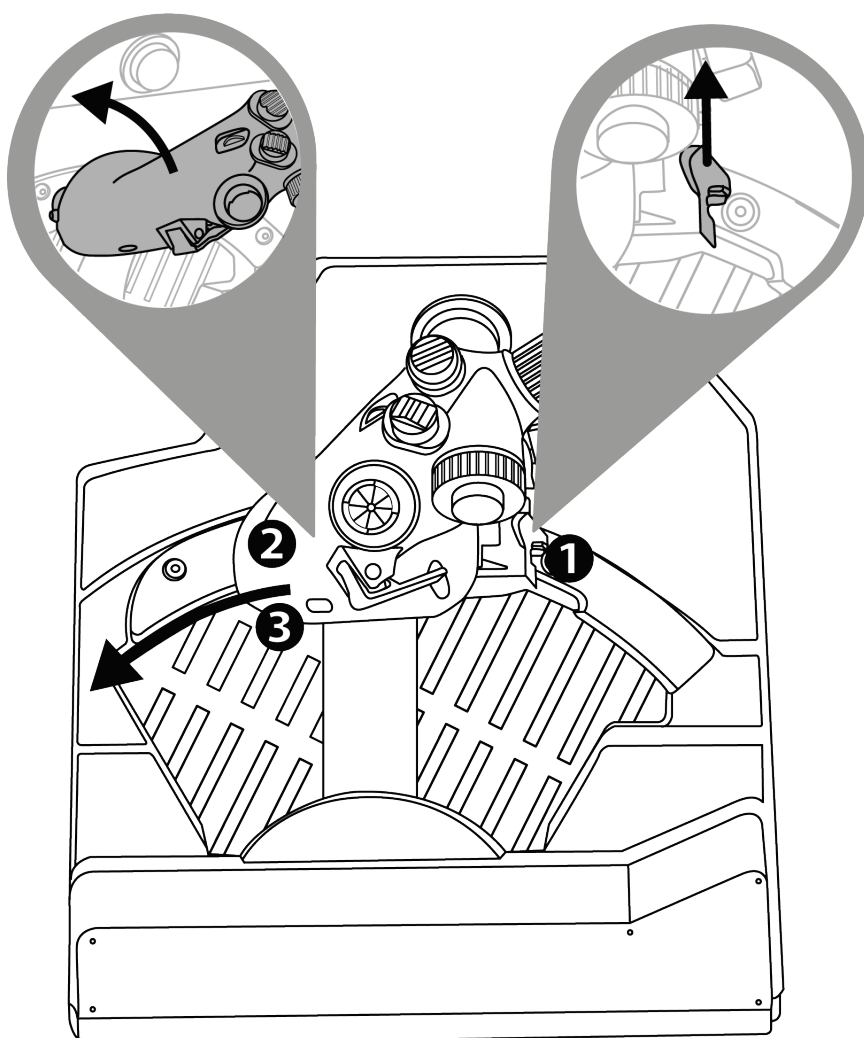



AFTERBURNER

Posuňte plynovú páku na doraz zarážky **1** a zdvihnite ju **2**, aby ste sa dostali cez doraz a zapli prídavné spaľovanie **3**.

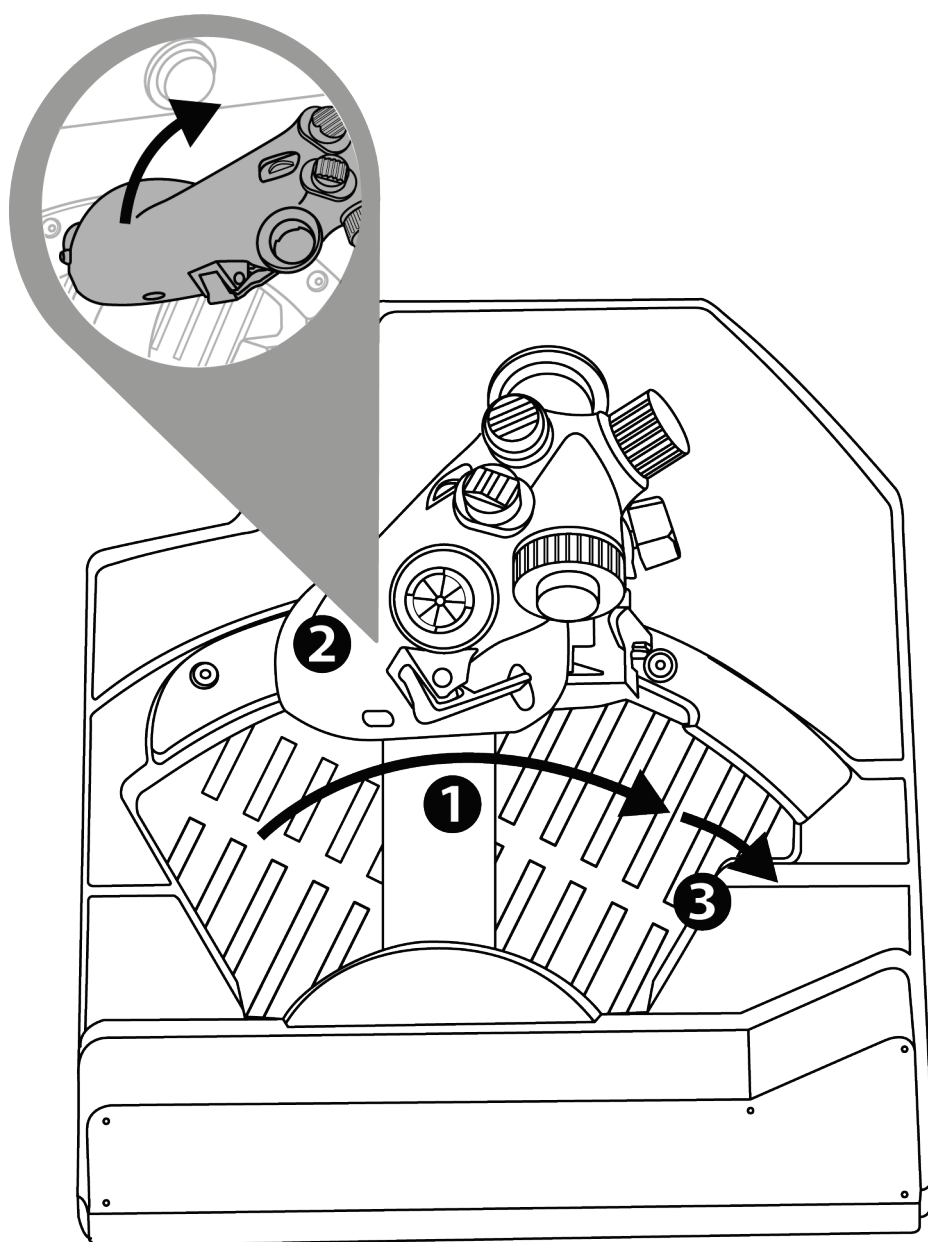



Odinštalovanie zarážky

AFTERBURNER

Doraz modulu Afterburner je umiestnený na 80 % hodnoty osi.

Ak potrebujete 100 % rozsahu plynu bez zastavenia (pre konkrétny simulátor), môžete odstrániť modul Afterburner a jeho zarážku odskrutkovaním dvoch skrutiek modulu pomocou imbusového kľúča (nie je súčasťou balenia).

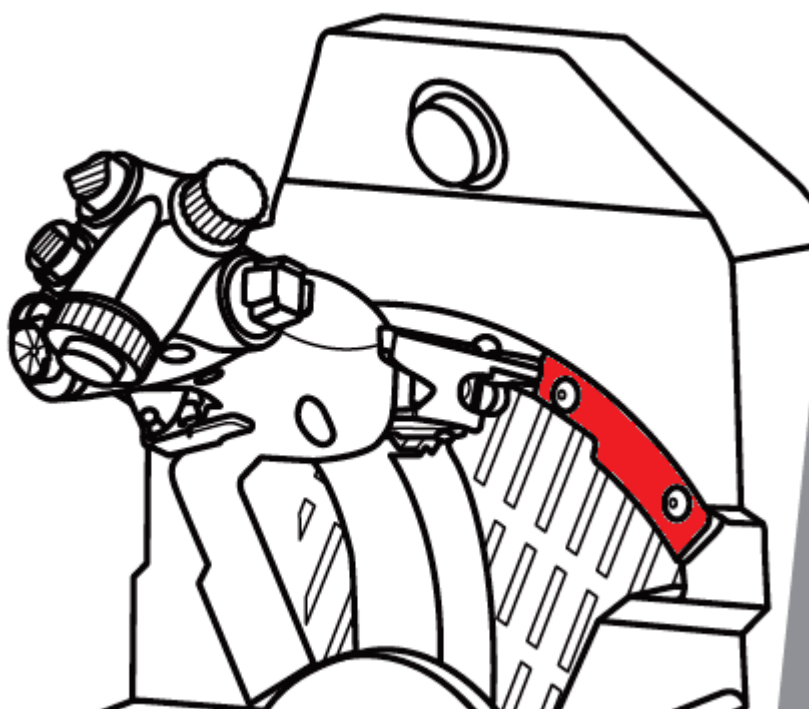



10. Pokročilý programovací softvér

T.A.R.G.E.T



Navštívte

<https://support.thrustmaster.com/product/viper-tqs/>.

V sekcii **Software** (Softvér) si stiahnite a nainštalujte pokročilý programovací softvér T.A.R.G.E.T.



Hlavné vlastnosti T.A.R.G.E.T

- Rôzne možné konfigurácie osí.
- Rôzne možné úrovne programovania: Basic, Advanced a Script.
- Použitie princípu Drag and Drop.
- Schopnosť kombinovať plynový kvadrant VIPER TQS s rôznymi joystickmi Thrustmaster (HOTAS Cougar, HOTAS Warthog, T.16000M, MFD Cougar Pack, z ktorých všetky sú tiež kompatibilné s T.A.R.G.E.T), čo umožňuje ich rozpoznanie ako jedno USB zariadenie.
- Prístup k pokročilým profilom vytvoreným komunitou Thrustmaster.



11. Často kladené otázky a technická podpora

Máte otázky týkajúce sa VIPER TQS alebo máte technické problémy? Ak áno, navštívte webovú stránku technickej podpory Thrustmaster:

<https://support.thrustmaster.com/product/viper-tqs/>.



THRUSTMASTER®

VIPER TQS

THROTTLE QUADRANT SYSTEM

PC-hez (Windows 10/11)

Használati útmutató



A termék telepítése **előtt**, használata **előtt** és karbantartása **előtt** **figyelmesen olvassa** el a jelen útmutatóban található utasításokat. Feltétlenül tartsa be a biztonsági utasításokat. Az utasítások figyelmen kívül hagyása baleseteket és/vagy károkat okozhat. Őrizze meg ezt a használati útmutatót, hogy a jövőben hivatkozhatson az utasításokra.

TARTALOMJEGYZÉK

1.	DOBOZ TARTALMA	5
2.	VIPER TQS JELLEMZŐK.....	6
3.	GOMBOK ÉS TENGELYEK MEGFELELŐI.....	8
4.	A VIPER TQS HASZNÁLATÁVAL KAPCSOLATOS TUDNIVALÓK	10
5.	A SÚRLÓDÁS BEÁLLÍTÁSA.....	11
6.	TARTÓRA SZERELÉS.....	12
7.	A VIPER PANEL* SZERELÉSE.....	17
8.	TELEPÍTÉS PC-RE	20
9.	CUT OFF ÉS AFTERBURNER ÜTKÖZŐK (MÓDVÁLTÓK).....	23
10.	T.A.R.G.E.T KORSZERŰ PROGRAMOZÁSI SZOFTVER	26
11.	GYIK ÉS TECHNIKAI TÁMOGATÁS	28



Pörgesd fel a motorokat és repülj a veszélyzónába az amerikai légierő VIPER-jének - a világ legszélesebb körben használt modern vadászrepülőgépeének ikonikus quadrant gázkaros rendszerével!

Emeld a pilótafülkét a következő szintre az 1:1 méretarányú HOTAS replika egyedülálló ergonómiájával, amely fém markolattal, valamint valóságos gombokkal és ütközőkkel rendelkezik.

Ez az útmutató segít a VIPER TQS telepítésében és a legjobb feltételek melletti használatában. Felszállás előtt, olvassa el figyelmesen az összes utasítást és figyelmeztetést: így tud a termék használata maximális élményt nyújtani.



A firmware frissítése

Ahhoz, hogy a VIPER TQS megfelelően működjön a videójátékokban, frissítenie kell a firmware-t.

A frissítéshez látogasson el a

<https://support.thrustmaster.com/product/viper-tqs/> weboldalra.

Válassza a **Firmware-t** (Firmware), majd kövesse az utasításokat - beleértve a letöltési és telepítési eljárást is.



1. Doboz tartalma

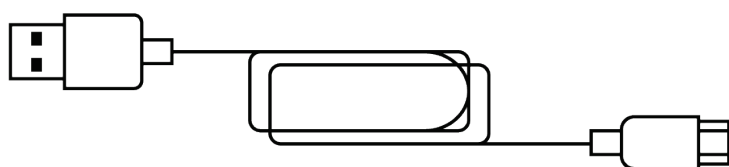
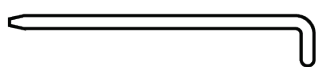
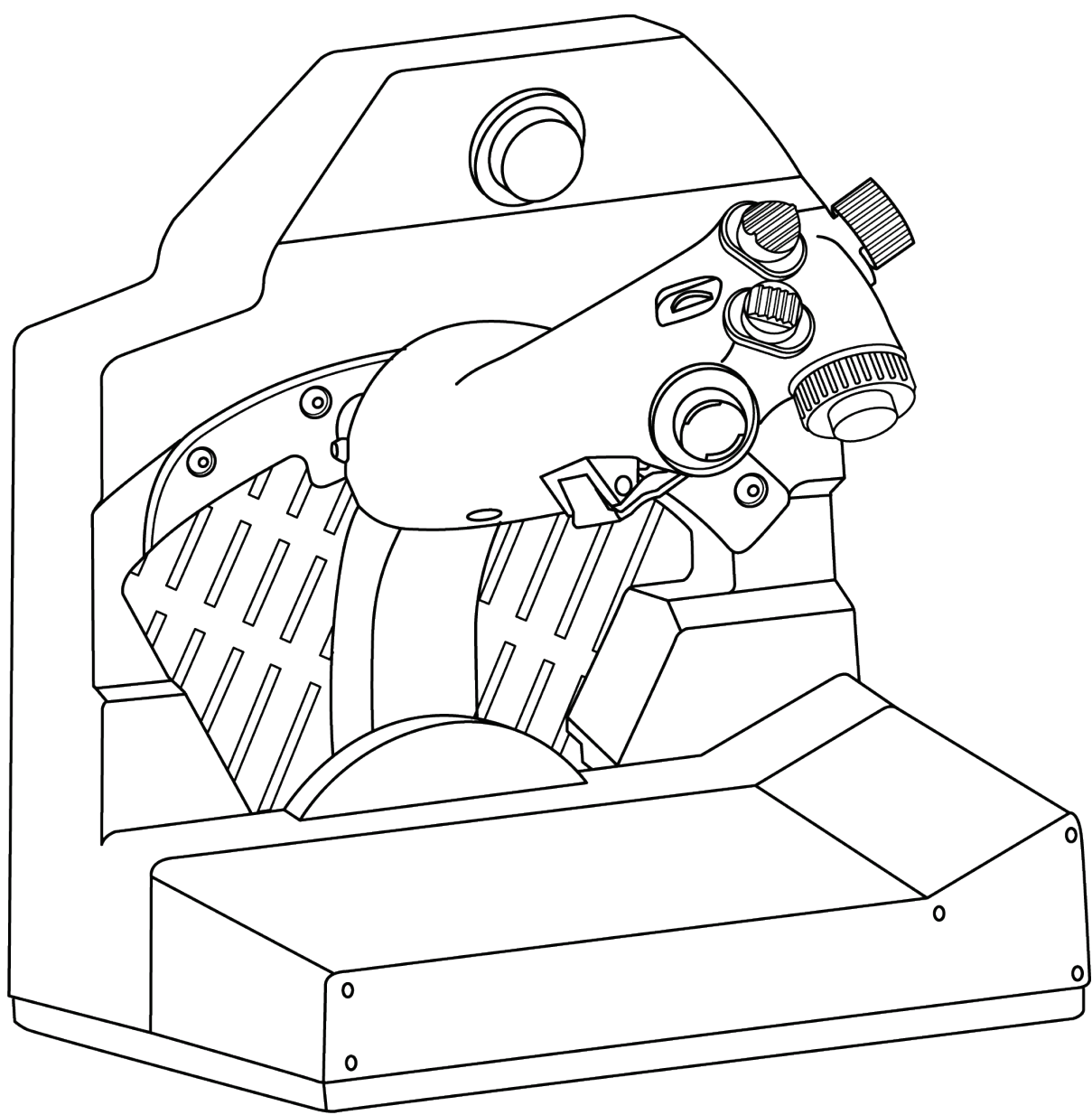



2. VIPER TQS jellemzők

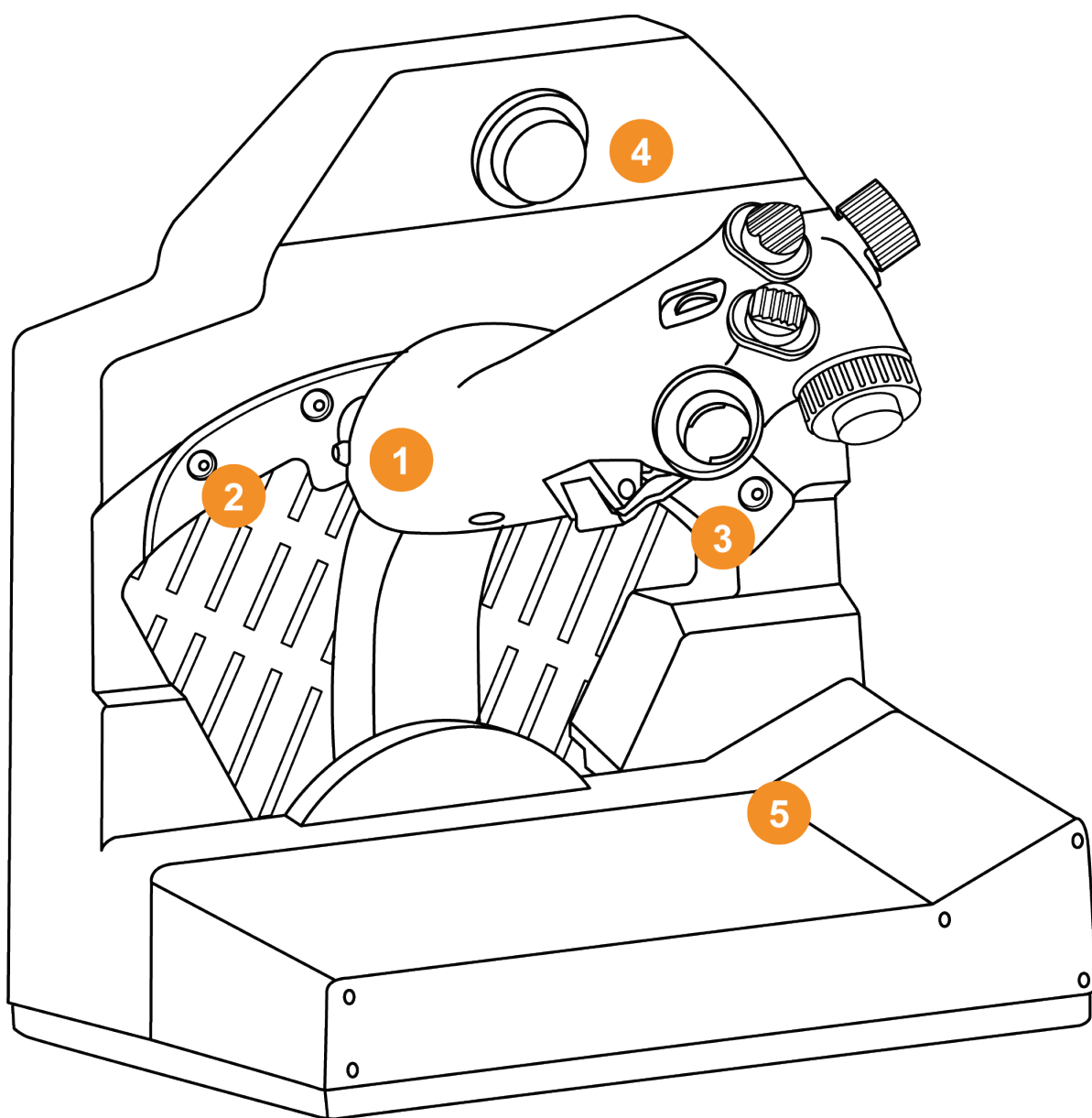

1. Markolat

2. Cut Off ütköző

3. Afterburner ütköző

4. CHAFF/FLARE kapcsológomb

5. Küldetéstérkép rögzítő

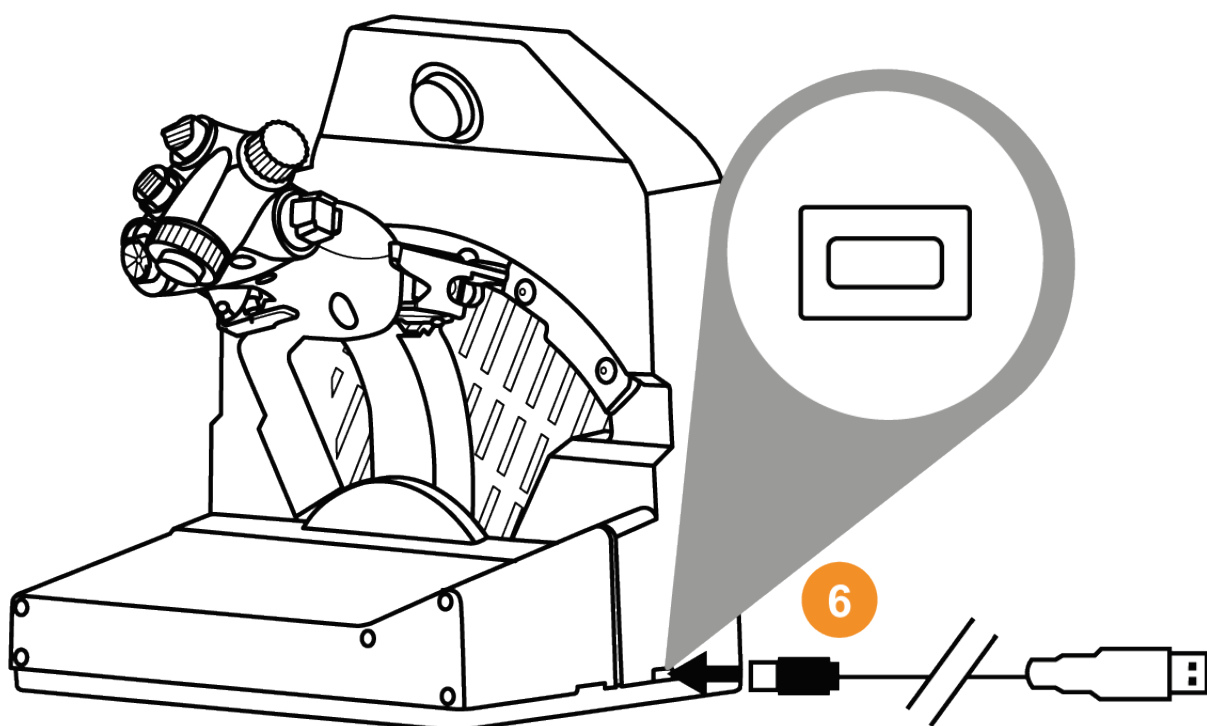

6. USB csatlakozó (C típusú)

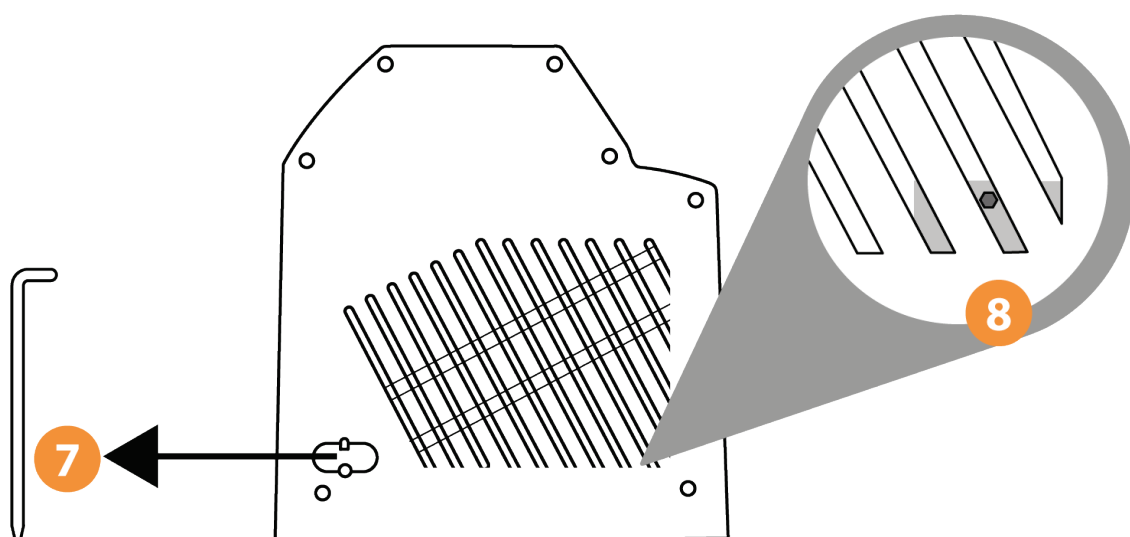

7. A súrlódásbeállító eszköz helye

8. Gázkar súrlódásbeállító hozzáférési pont



3. Gombok és tengelyek megfelelői

VIPER TQS markolat: a 19 gomb és 5 tengely kiosztása A módban (virtuális gombok nélkül)

A 1 → 19

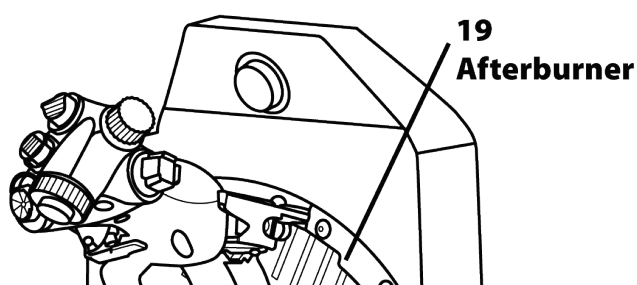
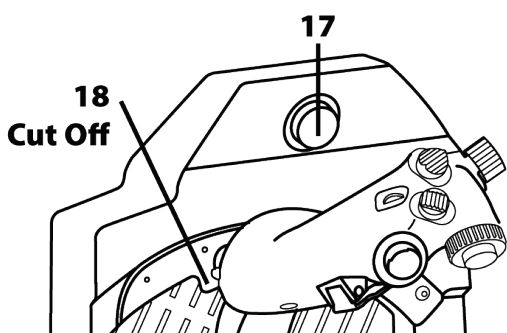
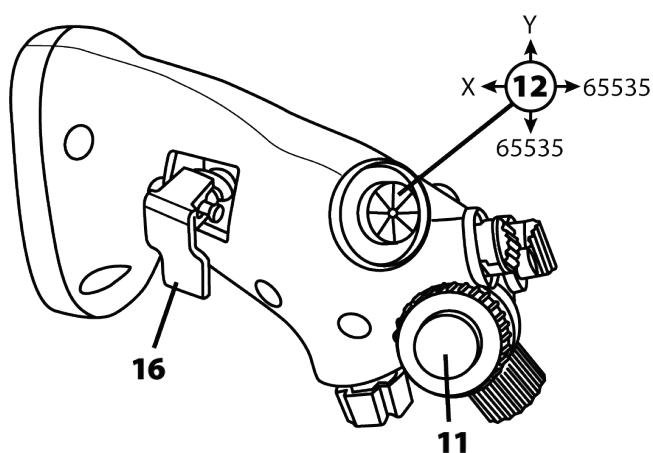
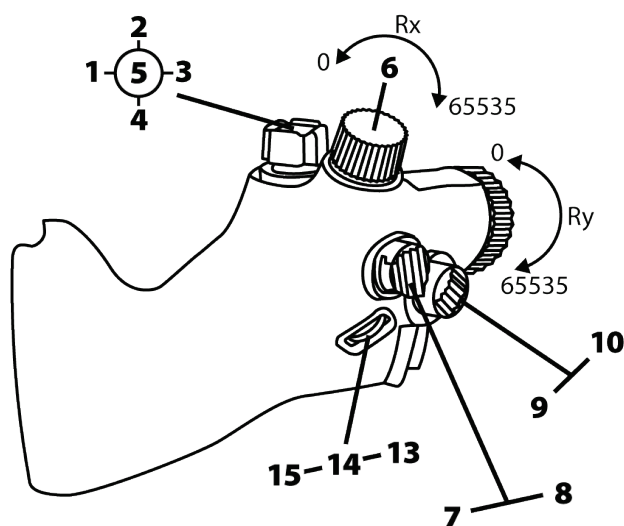



B mód: virtuális gombokkal

B 1 → 21

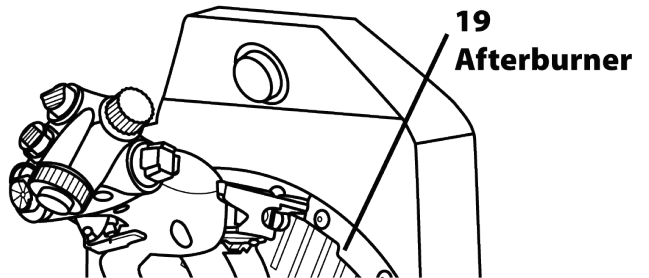
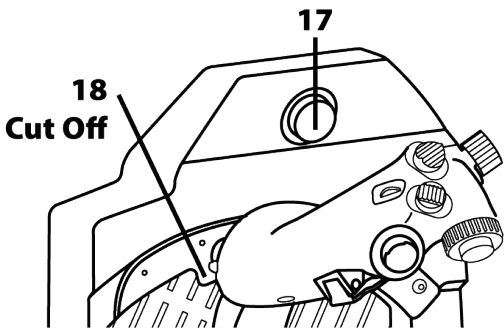
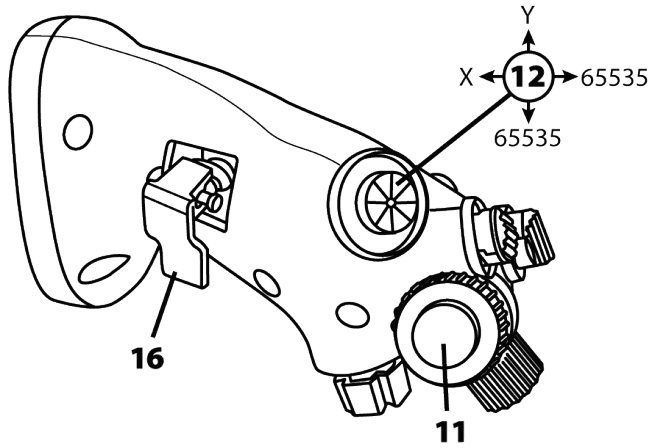
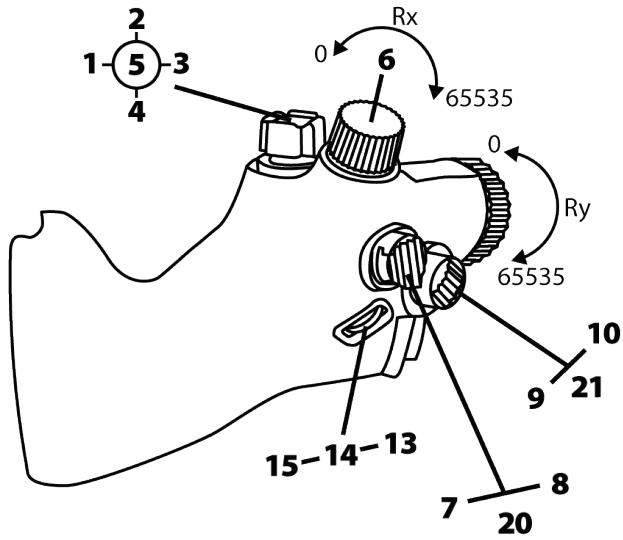



4. A VIPER TQS használatával kapcsolatos tudnivalók



Becsípődés veszély

A markolat használatakor soha ne tegye az ujjait az ütköző területekre.

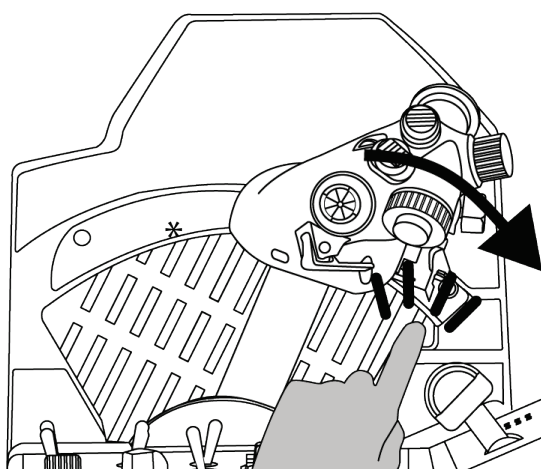
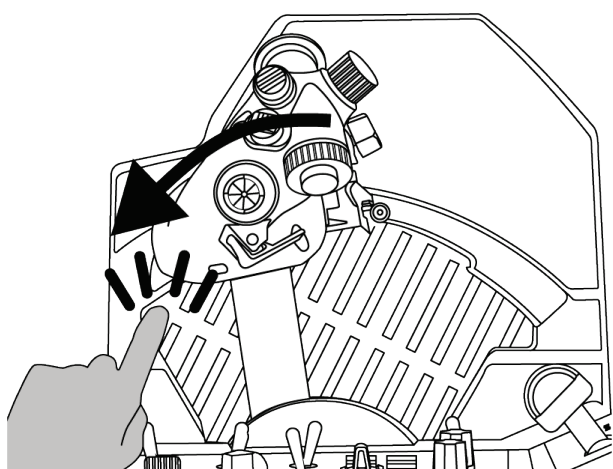
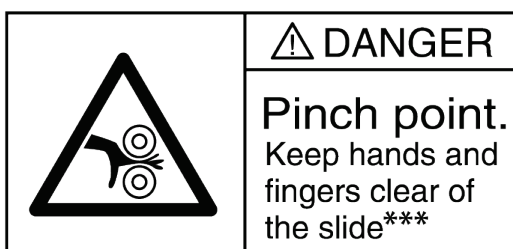



4. A súrlódás beállítása

A VIPER TQS quadrant gázkar súrlódását a VIPER TQS oldalán található eszközzel, a saját preferenciája szerint állíthatja be. Felhívjuk azonban a figyelmét, hogy az optimális gázkar súrlódás alapértelmezettként, gyárilag be van állítva.

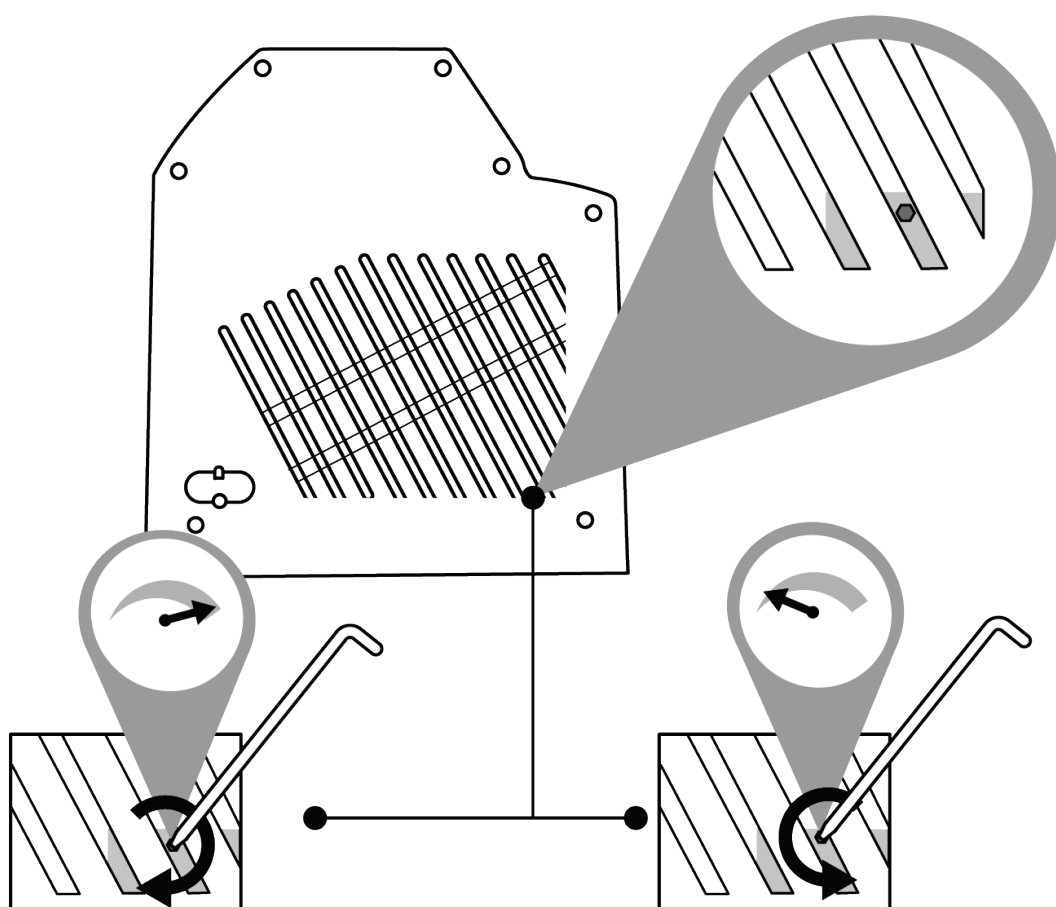

A súrlódási rendszer károsodásának elkerülése érdekében ügyeljen arra, hogy ne húzza túl a beállítócsavart. Ügyeljen arra, hogy ne lazítsa ki teljesen a beállítócsavart: ezzel azt kockáztatja, hogy a gázkar többé nem marad a helyén.



6. Tartóra szerelés



A VIPER TQS különböző típusú tartókra szerelhető. A piacon kapható legtöbb pilótafülke és tartó már kompatibilis a hasonló Thrustmaster termékekkel (pl. HOTAS Warthog).

Kérjük, tartsa szem előtt, hogy a VIPER TQS erős vezérlőkar hatással rendelkezik, ezért szilárdan kell rögzíteni. Rögzítse az alapot a tartóhoz a megfelelő M6-os csavarokkal (nem tartalmazza), a markolat sérülése nélkül.

A teljes VIPER TQS tervrajz itt elérhető el <https://support.thrustmaster.com/product/viper-tqs/>



Minden használat előtt győződjön meg arról, hogy a VIPER TQS a gyártó által megadott utasításoknak megfelelően van-e rögzítve a tartóra.

Mindenképpen vegye figyelembe, hogy milyen anyagból készült a tartó, és győződjön meg arról, hogy a termék biztonságosan rögzíthető-e rá. A VIPER TQS-t tömör anyagból (pl. MDF vagy fa) készült, üreges vagy üveg alkatrészek nélküli asztalon kell használni.



Szerelési rajz méretei (mm-ben)

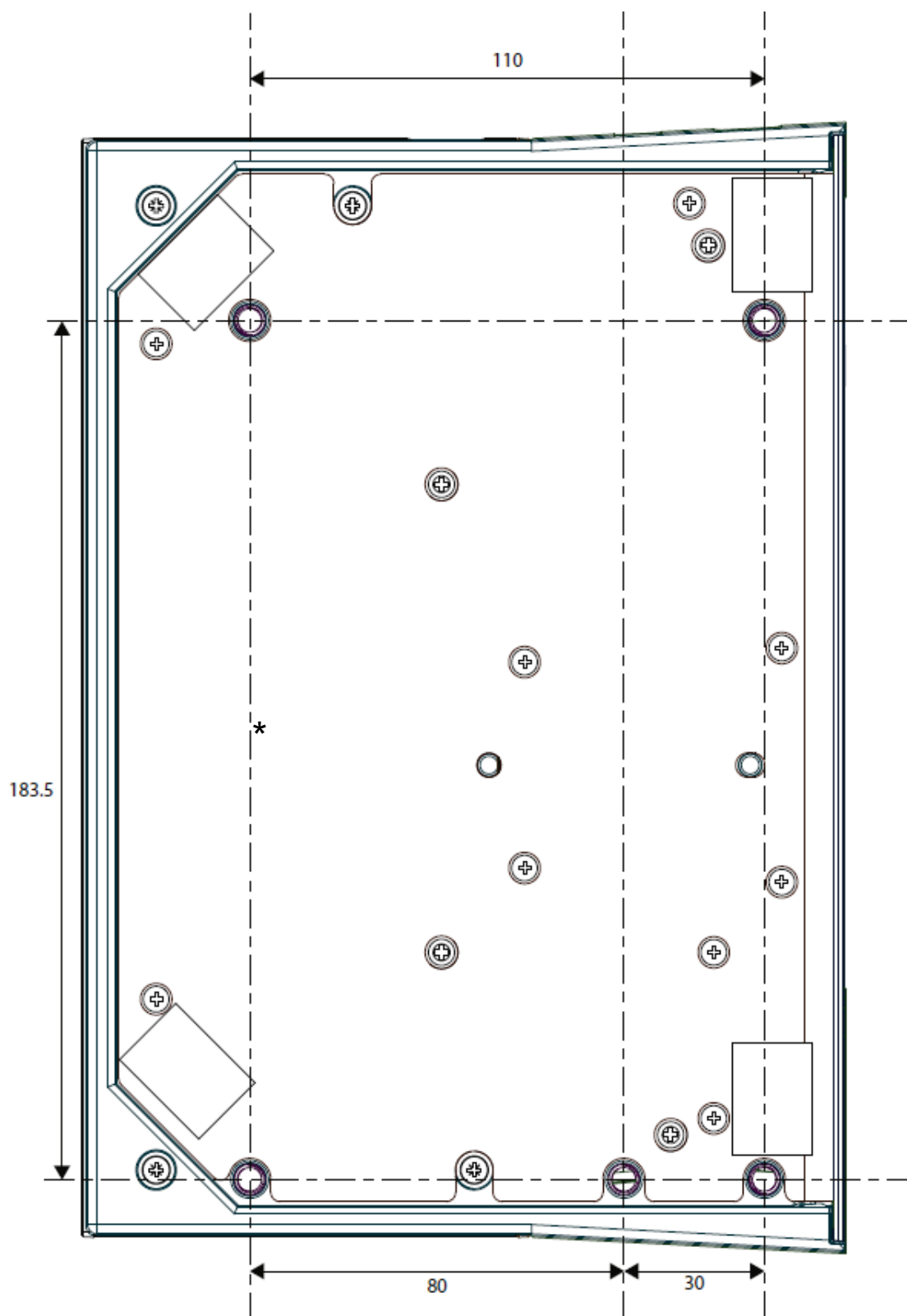

A szerelési rajzot a

<https://support.thrustmaster.com/product/viper-tqs/> weboldalról töltheti le, majd nyomtassa ki, és használja a tartón a fúrólukak előkészítéséhez.



Rögzítés a *TM Flying Desk Mount** használatával

A TM Flying Desk Mount egy fém rögzítőrendszer, amely rögzítőcsavarral rendelkezik, és javítja az ergonómiát és a vezetési pozíciót a készülék használata közben. A rendszert 15-50 mm vastagságú íróasztalokhoz és asztalokhoz tervezték.

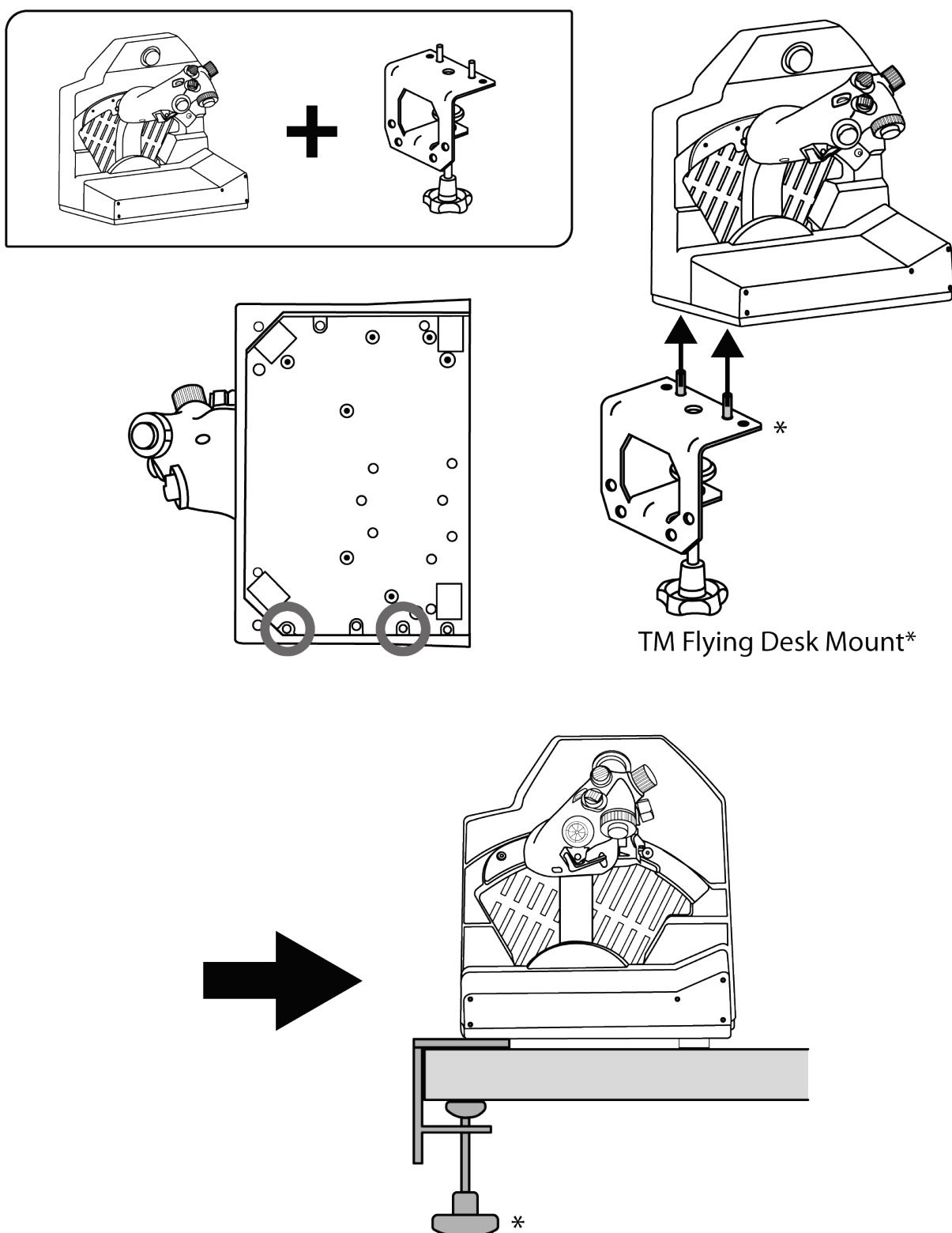

**Külön kapható*



Rögzítés a *TM Flying Clamp**-el

A *TM Flying Clamp*, a Thrustmaster által repülésszimulációs kiegészítőkhez tervezett, állítható magasságú tartó. A rögzítőrendszer két rögzítőcsavarral rendelkezik, melyekkel 15-45 mm vastagságú íróasztalokhoz és asztalokhoz lehet beállítani.

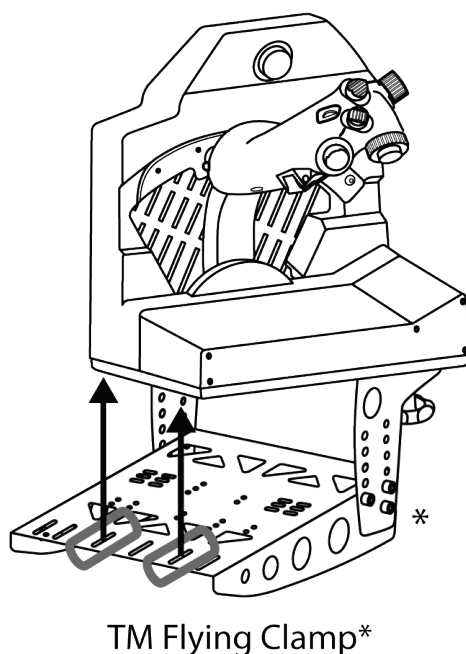
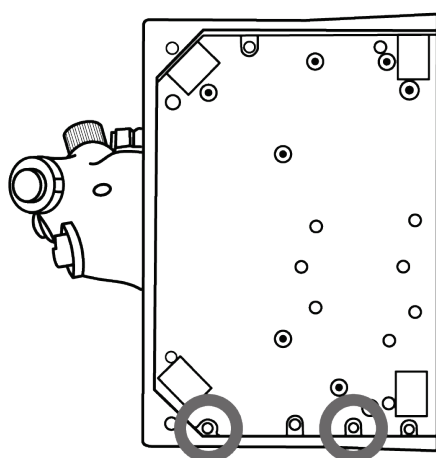
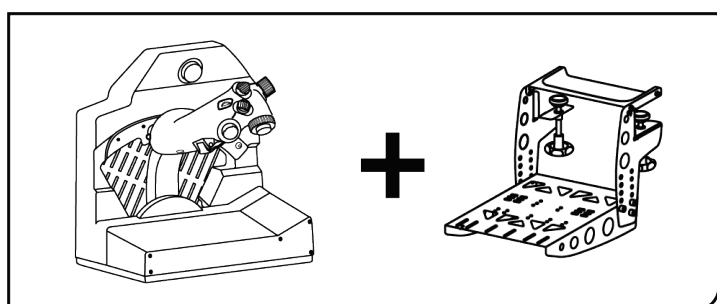

*TM Flying Clamp**

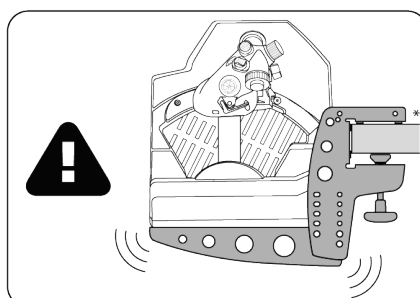
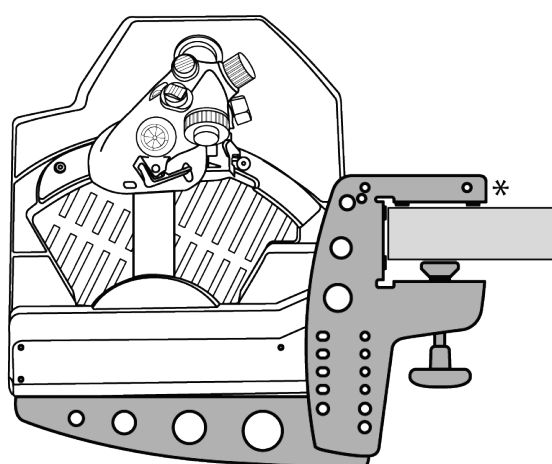
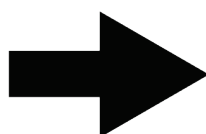

*Külön kapható



Felhívjuk figyelmét, hogy a VIPER TQS nagy súlya a rögzítőrendszer nem kívánt mozgását eredményezheti.



7. A VIPER PANEL* szerelése

*Külön kapható. A VIPER PANEL megtalálható a VIPER TQS Mission Pack-ben.

A VIPER PANEL egy olyan vezérlőpanel, amellyel kiegészítheti a repülési/harci képességeit összesen 43 gombbal és 1 tengellyel - ezek mindegyike a T.A.R.G.E.T szoftveren keresztül programozható. A VIPER PANEL a VIPER TQS kiegészítője.

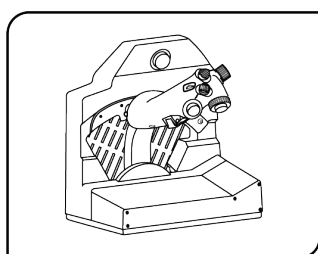

1

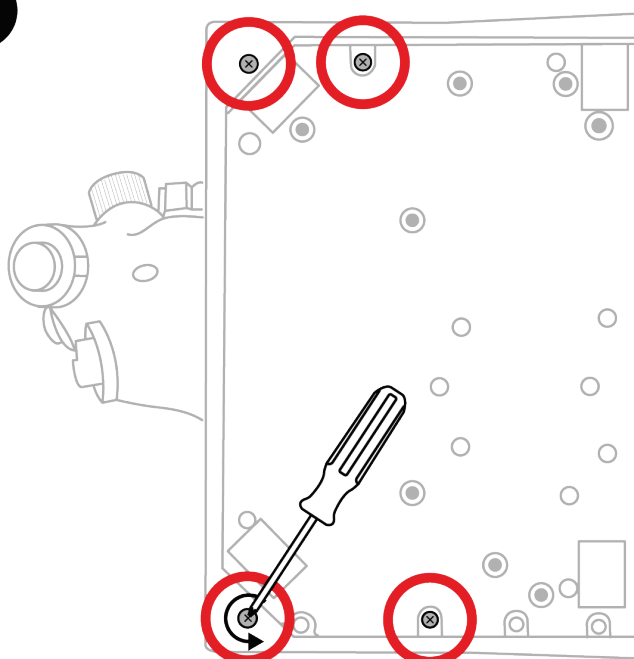

2

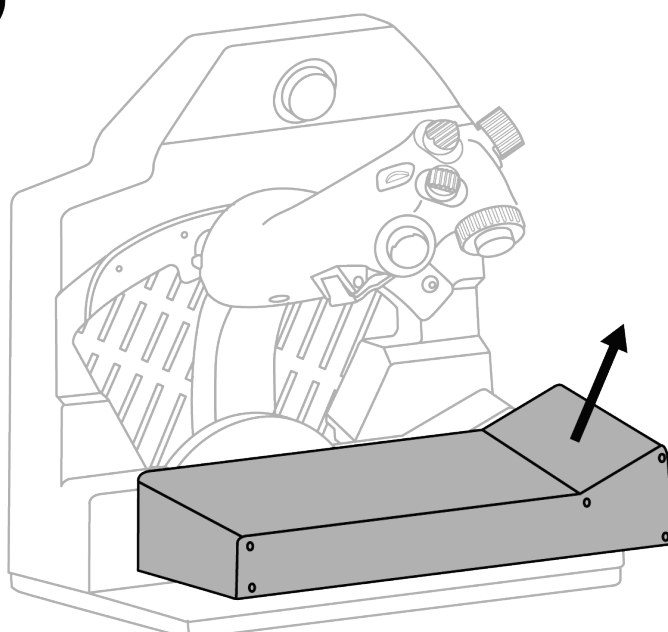

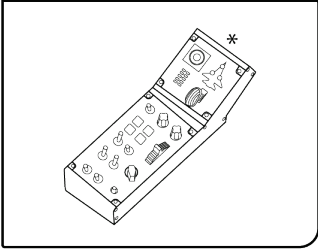

3

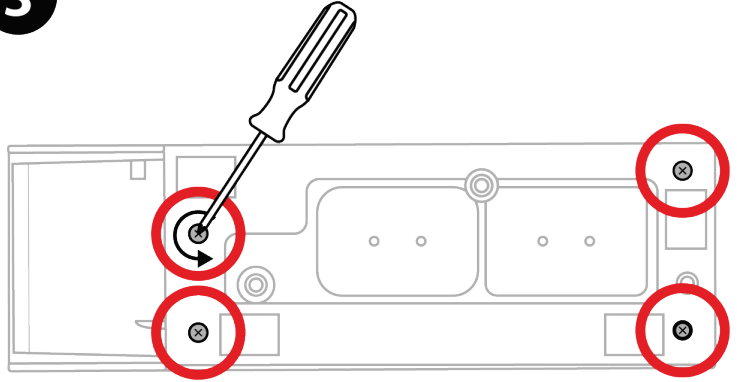

4

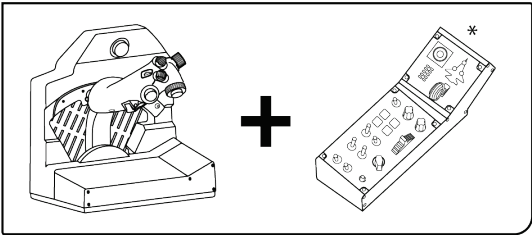
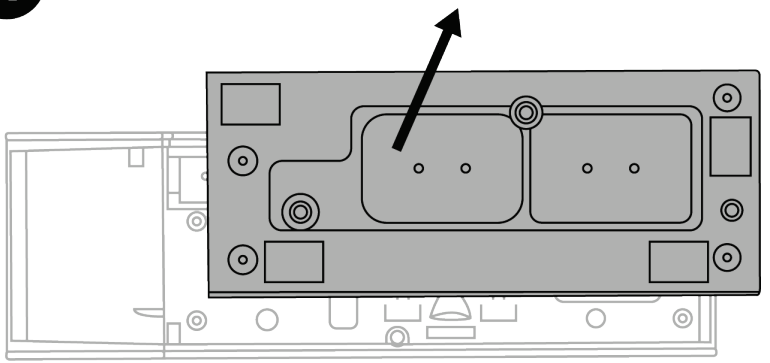

5

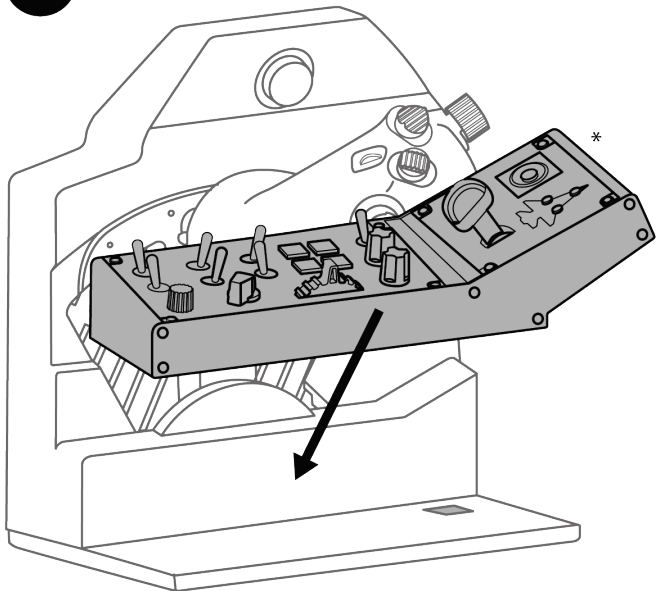



6

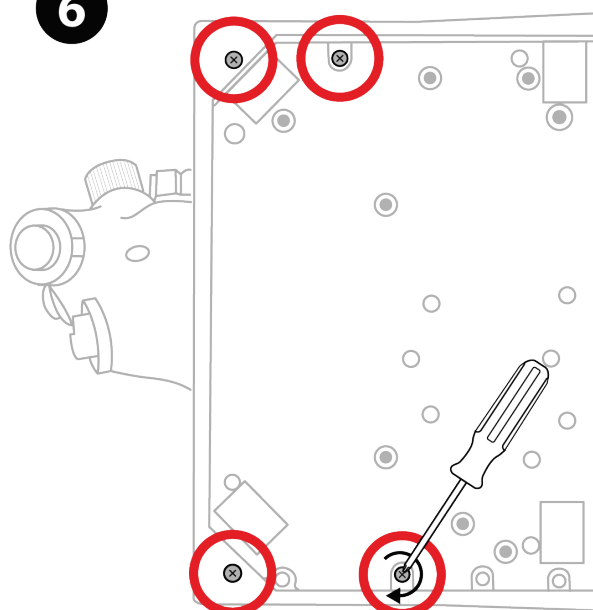

7

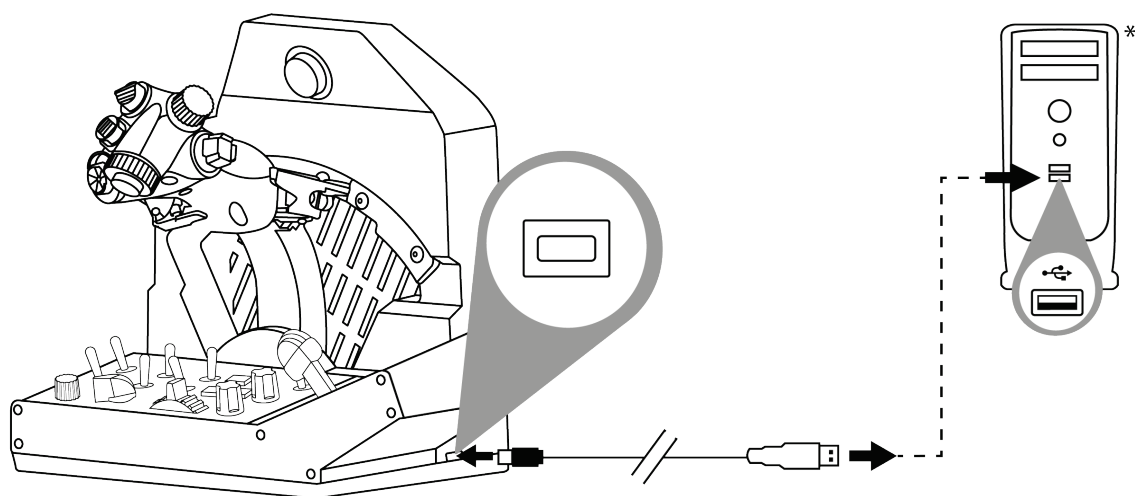

**Nem tartalmazza*



8. Telepítés PC-re

1



Látogasson el a

<https://support.thrustmaster.com/product/viper-tqs/> weboldalra.

2

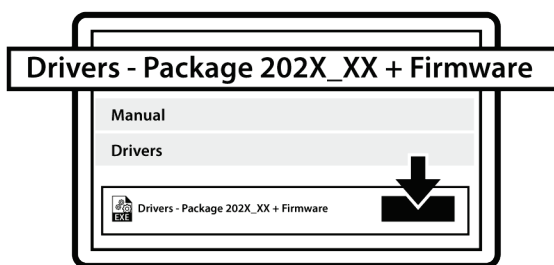

Töltse le és telepítse a PC illesztőprogramot és annak testreszabott felületét a Windows Vezérlőpulthoz.

3

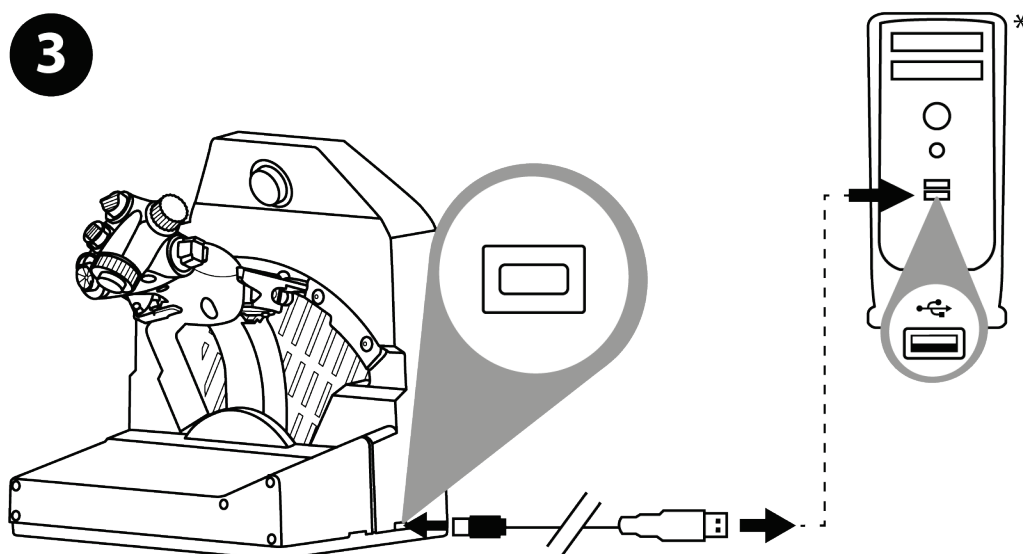

A PC illesztőprogram telepítése után csatlakoztassa az USB csatlakozót a számítógép egyik USB portjához.

**Nem tartalmazza*



④ A Control Panel eléréséhez: **Start / Minden alkalmazás / Thrustmaster / Control Panel-t** vagy **Vezérlőpult-ot** (Windows 10-ben).

Megjelenik a **Játékvezérlők** párbeszédpanel. A kiegészítő **VIPER TQS** névvel és **OK** állapottal jelenik meg a képernyőn.

⑤ A **Játékvezérlők** párbeszédpanelben, kattintson a **Tulajdonságokra** az összes funkció teszteléséhez és megtekintéséhez.

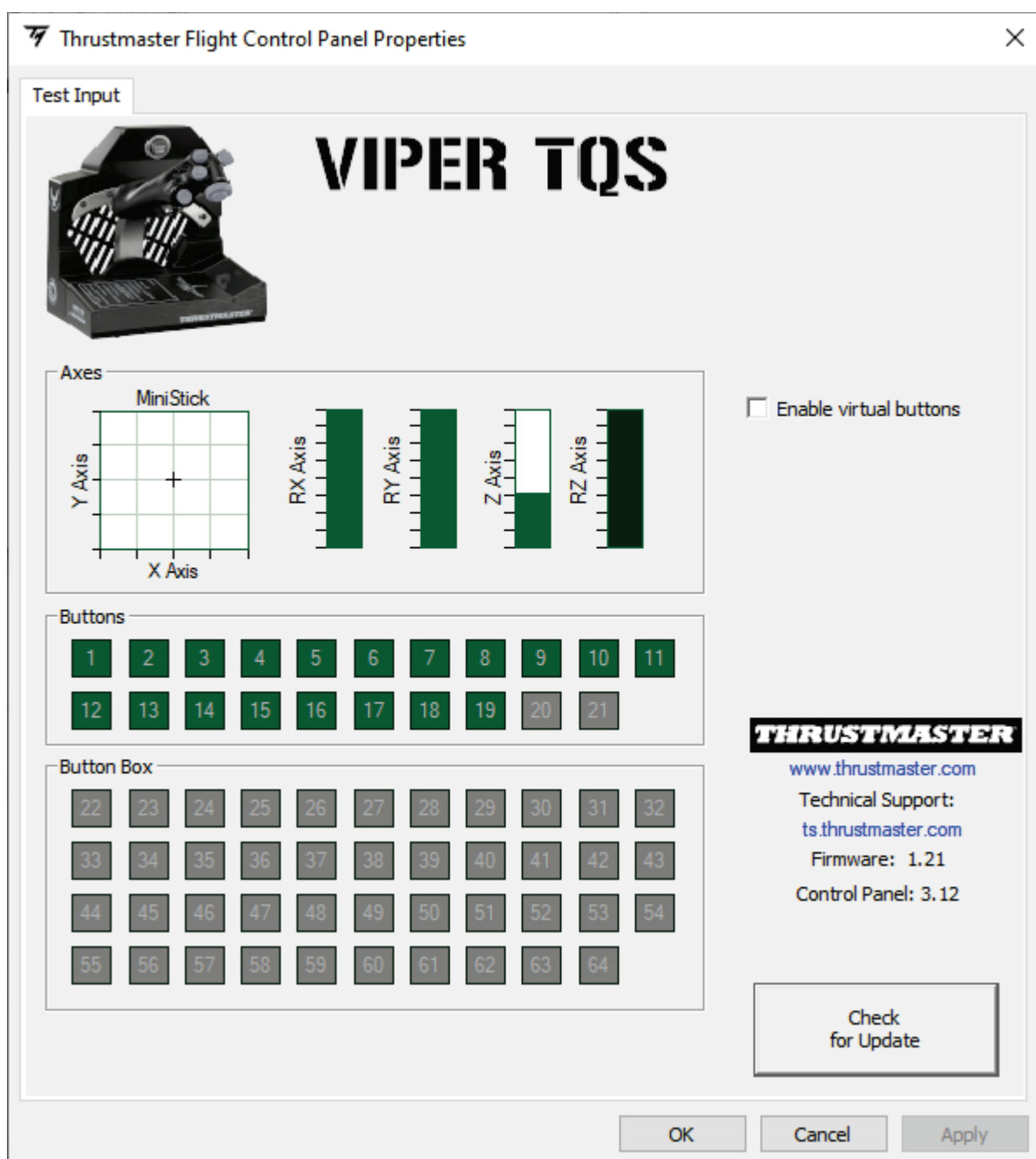



Enable virtual buttons (Virtuális gombok engedélyezése):

Ezzel a funkcióval engedélyezheti vagy letilthatja a virtuális gombokat a markolaton (20 és 21-es gomb). Kattintson az **Apply** (Alkalmaz) gombra, miután kiválasztotta a használni kívánt módot.

Thrustmaster Flight Control Panel Properties

Test Input

VIPER TQS

Enable virtual buttons

Buttons

Button Box

Check for Update

OK Cancel Apply



A virtuális gombok alapértelmezétként le vannak tiltva a VIPER TQS-en.



9. CUT OFF és AFTERBURNER ütközők (módváltók)

A VIPER TQS quadrant gázkar a CUT OFF és AFTERBURNER módváltók valóságú rendszerével rendelkezik (az Afterburner modul kivehető).

CUT OFF

Miután a gázkart az IDLE ütközéséhez állította, nyomja meg a "motor leállításának feloldása" ravaszt **1** a markolat felemeléséhez, hogy átjusson az ütközőn **2**, majd tegye a markolatot OFF állásba **3**.

A motorok visszakapcsolásához végezze el ezt az eljárást fordítva.

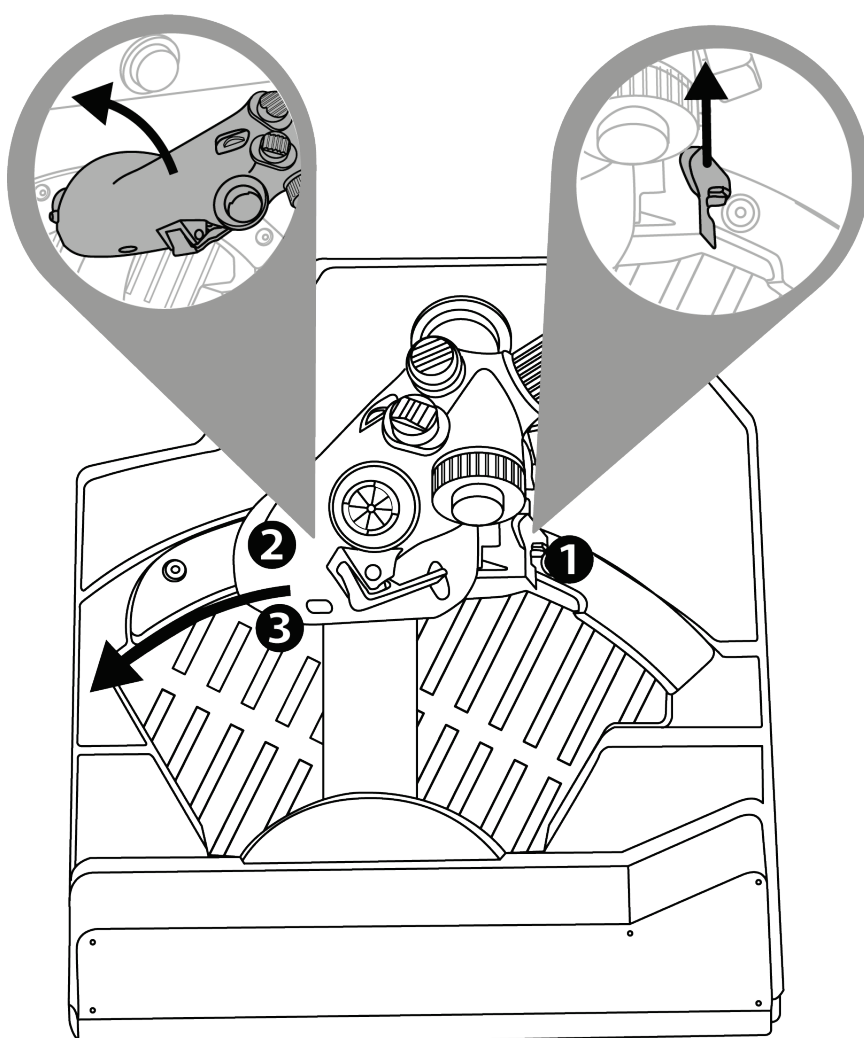



AFTERBURNER

Vigye a gázkart az ütközőig **1** és emelje fel **2**, hogy az ütköző fölé kerüljön és bekapcsolja az utánégetőt **3**.

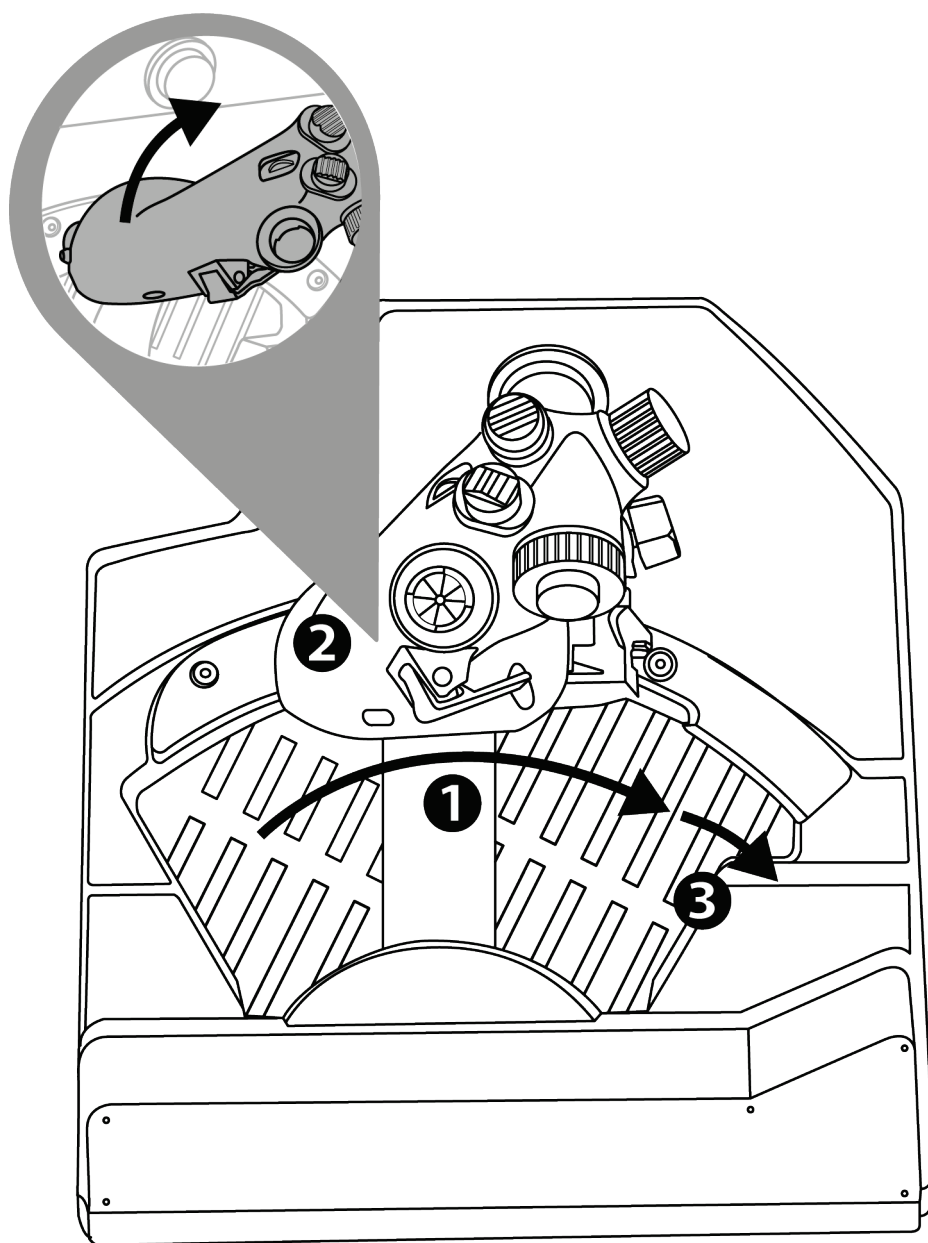



Az AFTERBURNER ütköző eltávolítása

Az Afterburner modul ütközője a tengely értékének 80%-nál van elhelyezve.

Ha a gázkar 100%-os mozgására van szüksége ütköző nélkül (egy adott szimulátorhoz), akkor az Afterburner modult és annak ütközőjét eltávolíthatja a modul két csavarjának imbuszkulcs segítségével történő kicsavarásával (nem tartalmazza).

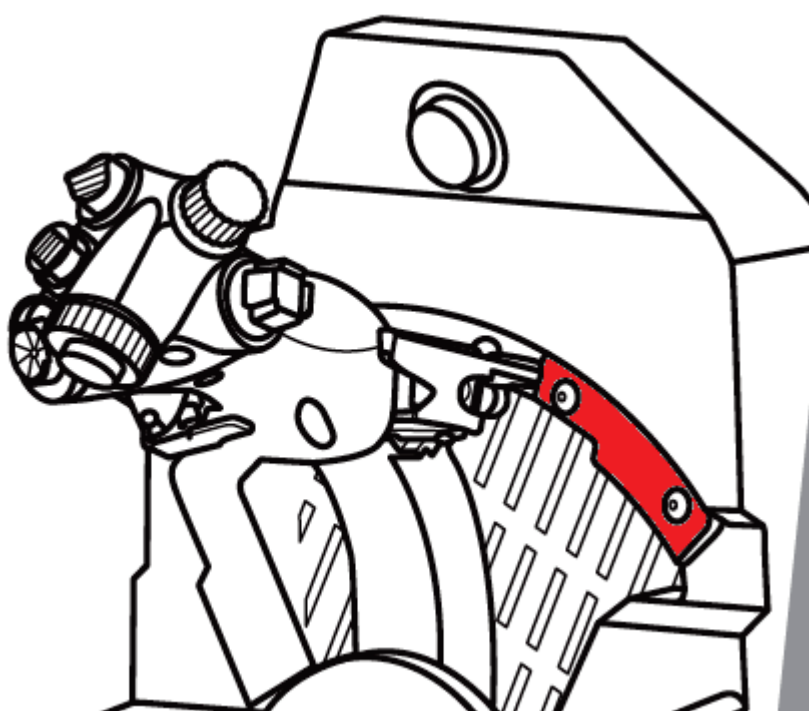



10. T.A.R.G.E.T korszerű programozási szoftver



Látogasson el a

<https://support.thrustmaster.com/product/viper-tqs/>
weboldalra.

A **Software** (Szoftver) résznél, töltsse le és telepítse a T.A.R.G.E.T korszerű programozási szoftvert.



A T.A.R.G.E.T főbb jellemzői

- A tengelyek különböző lehetséges konfigurációi.
- Különböző lehetséges programozási szintek: Basic, Advanced és Script.
- „Fogd meg és húzd, ahova kell” elv használata.
- Lehetőség a VIPER TQS quadrant gázkar kombinálására a különböző Thrustmaster joystickokkal (HOTAS Cougar, HOTAS Warthog, T.16000M, MFD Cougar Pack, amelyek mindegyike kompatibilis a T.A.R.G.E.T-el is), így egyetlen USB eszközként ismerhetők fel.
- Hozzáférés a Thrustmaster közösség által létrehozott haladó profilokhoz.



11. GYIK és technikai támogatás

Kérdése van a VIPER TQS-el kapcsolatban, vagy technikai problémái vannak? Ha igen, látogasson el a Thrustmaster műszaki támogatási weboldalára: <https://support.thrustmaster.com/product/viper-tqs/>.



THRUSTMASTER®

VIPER TQS **THROTTLE QUADRANT SYSTEM**

למחשב (Windows 10/11)

מדריך למשתמש



יש לקרוא בתשומת לב את ההוראות שבמדריך זה לפני התקנת המוצר, לפני השימוש בו ולפני כל פעולת תחזוקה. יש להקפיד לפעול בהתאם להנחיות הבטיחות. אי הקפדה על הנחיות אלו עלולה לגרום תאונות ו/או נזק. יש לשמור את המדריך לשימוש חוזר בעתיד.

תוכן העניינים

5.....	תוכן האריזה	1.
6.....	התכונות של VIPER TQS	2.
8.....	מיפוי לחצנים וצירים	3.
10.....	מידע על השימוש ב-VIPER TQS	4.
11.....	התאמת החיכוך	5.
12.....	התקנה על תושבת	6.
17.....	ההתקנה של VIPER PANEL*	7.
20.....	התקנה במחשב	8.
23.....	מעצורי AFTERBURNER- / CUT OFF	9.
26.....	תוכנת T.A.R.G.E.T לתכנות מתקדם	10.
28.....	שאלות נפוצות ותמיכה טכנית	11.



לחמם מנועים ולטוס לאזור הסכנה עם מערכת המצערת
האיקונית של ה-VIPER מחיל האוויר האמריקני - מטוס
הקרוב המודרני הנפוץ ביותר בעולם!
לקחת את הרמה של תא הטייס שלך לשלב הבא עם
הארגונומיה הייחודית של העתק HOTAS בקנה מידה 1:1,
כולל ידית מתכת, בתוספת לחצנים ומעצורים ראליסטיים.

מדריך זה יעזור להתקין את VIPER TQS ולהשתמש בו
בתנאים הטובים ביותר. לפני ההמראה, חשוב לקרוא היטב
את כל ההוראות והאזהרות האלה: הן יעזרו ליהנות כמה
שיותר מהמוצר.



עדכון הקושחה

כדי לשמור על תפקוד תקין של VIPER TQS במשחקי וידאו, חובה לעדכן את הקושחה שלו.

כדי לבצע את העדכון, נא לבקר באתר

<https://support.thrustmaster.com/product/viper-tqs/>

יש לבחור באפשרות **Firmware** (קושחה) ולפעול בהתאם להוראות, כולל תהליך ההורדה וההתקנה.



1. תוכן האריזה

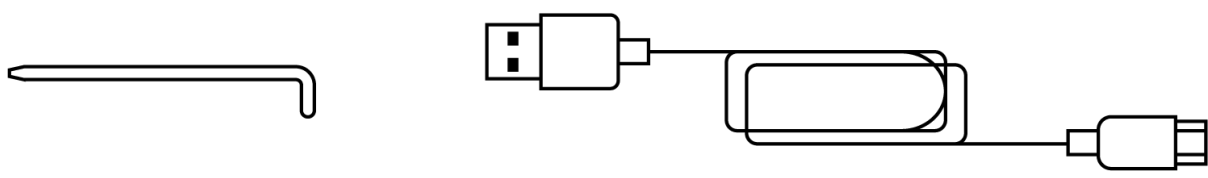
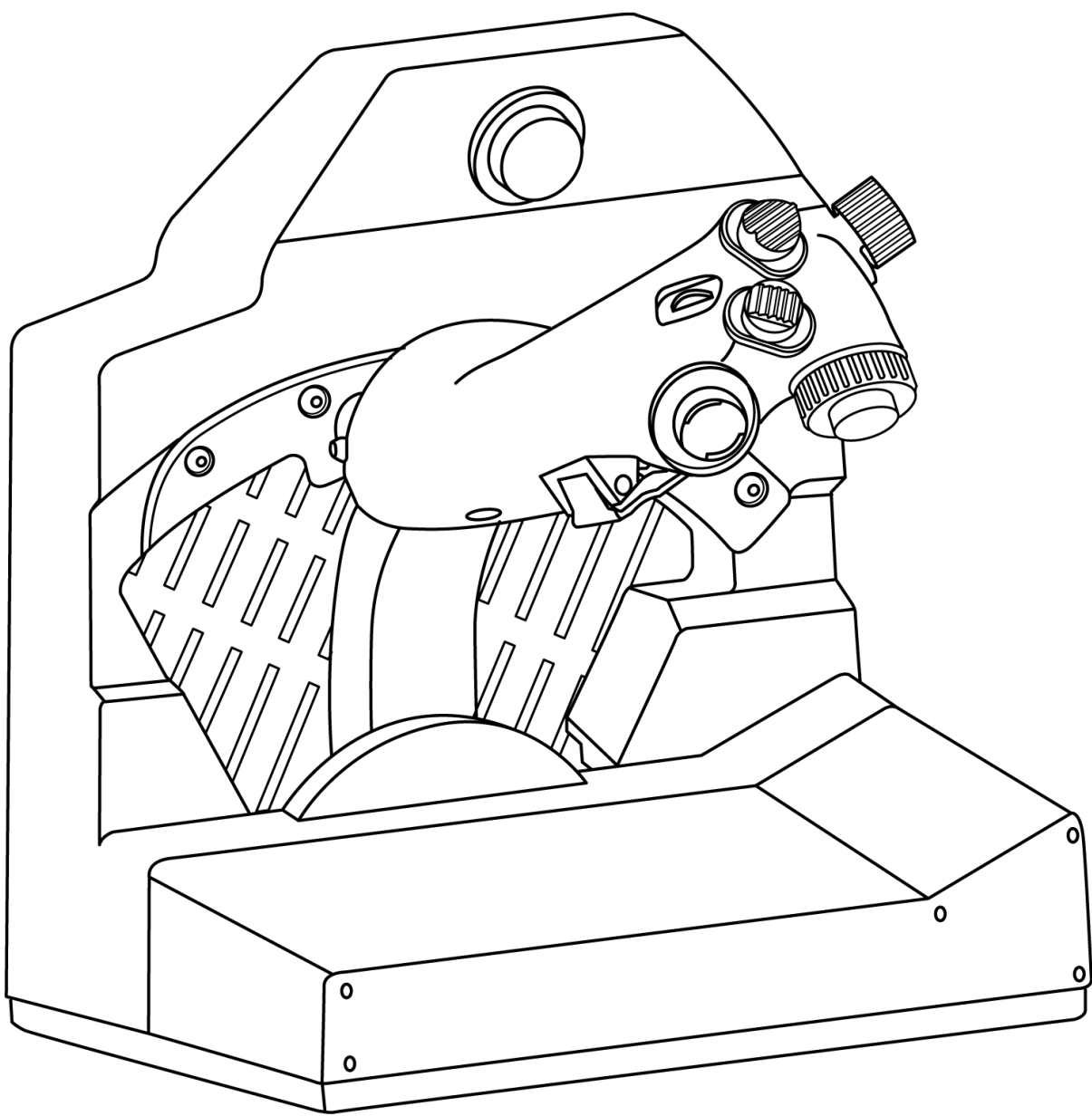



2. התכונות של VIPER TQS

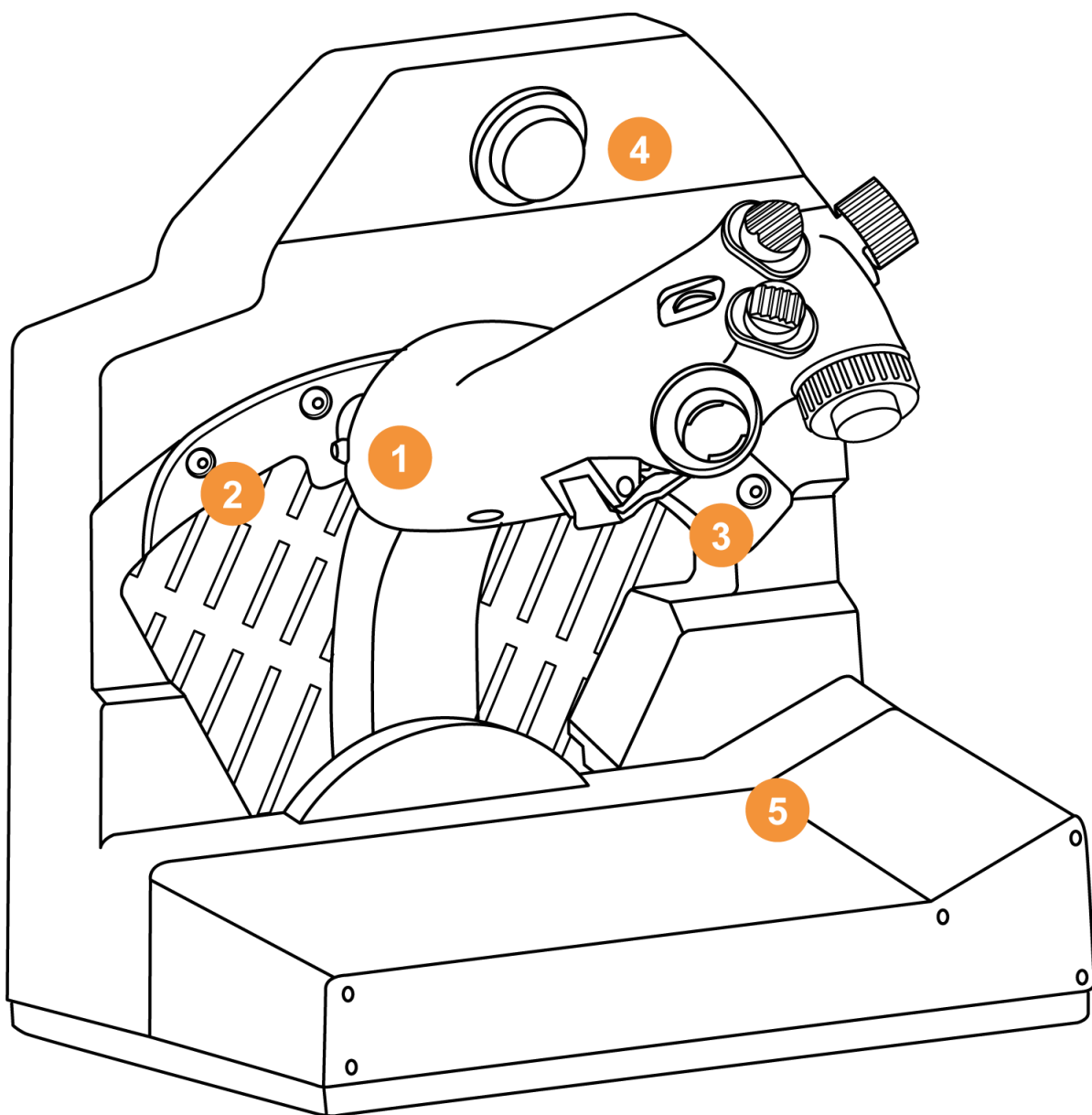

1. ידית

2. מעצור Cut Off

3. מעצור Afterburner

4. מתג FLARE / CHAFF

5. תפסן מפת משימה

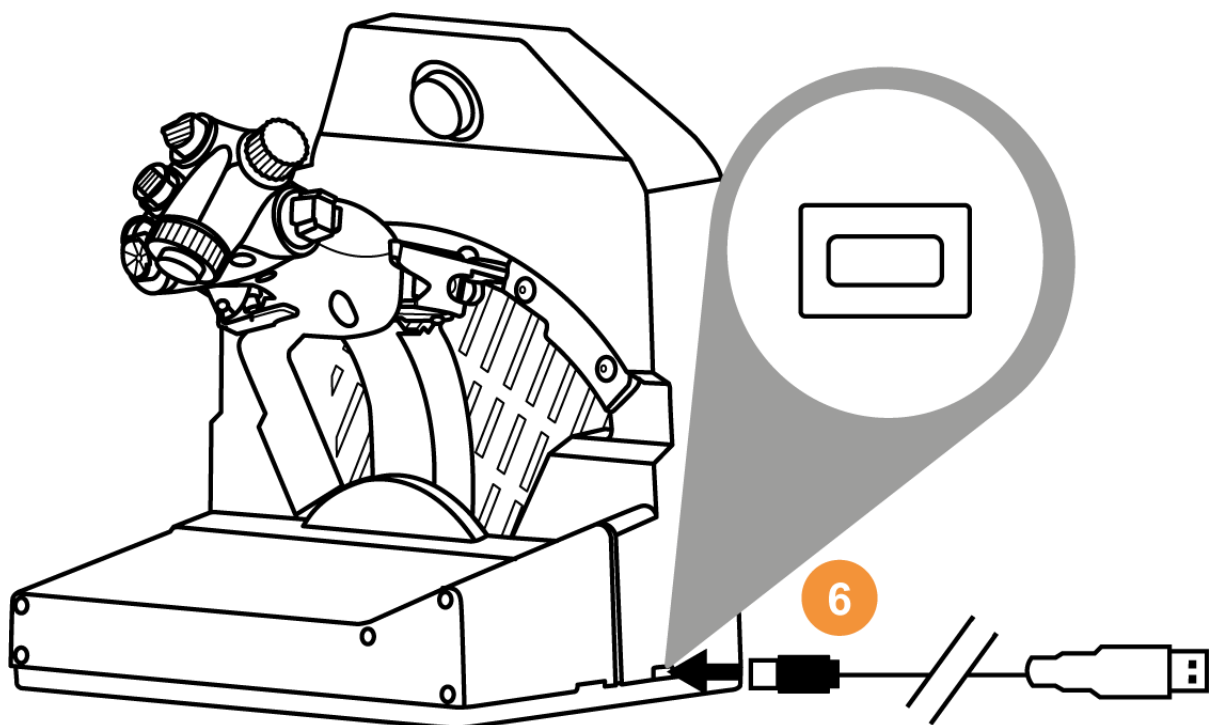

6. מחבר USB (סוג C)

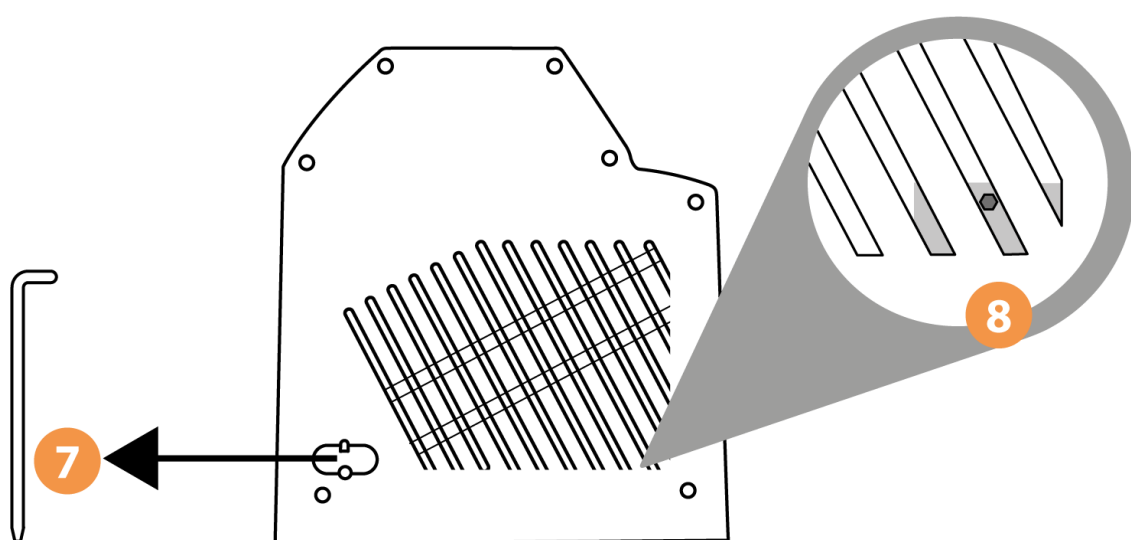

7. המיקום של כלי כוונן החיכוך

8. נקודת גישה לכוונן חיכוך מצערת



3. מיפוי לחצנים וצירים

ידית VIPER TQS: מיפוי של 19 הלחצנים וחמישה צירים במצב A (ללא לחצנים וירטואליים)

A 1 → 19

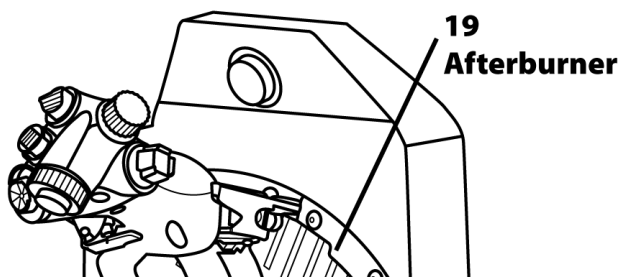
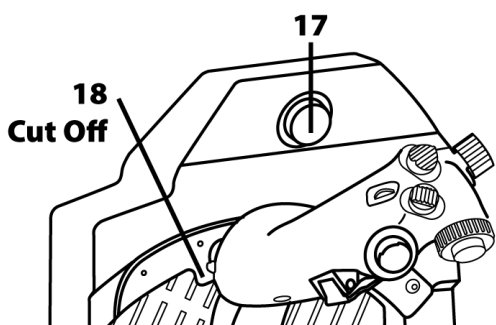
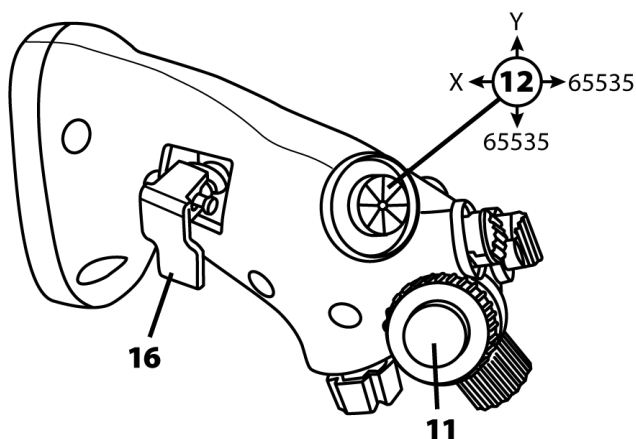
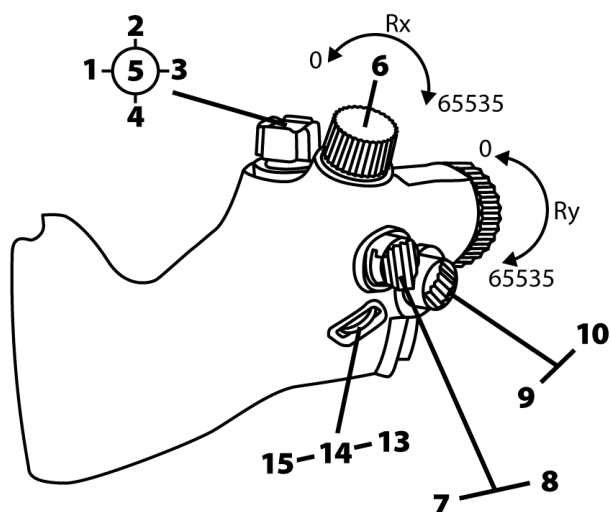

מצב B: עם לחצנים וירטואליים

B 1→21

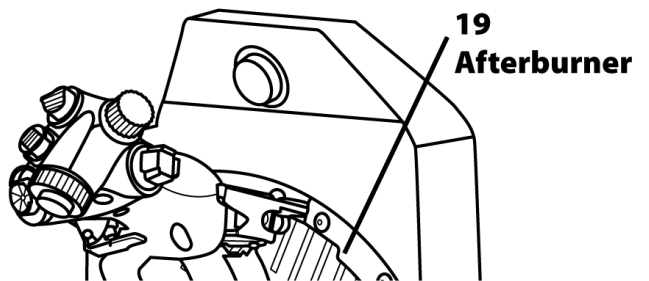
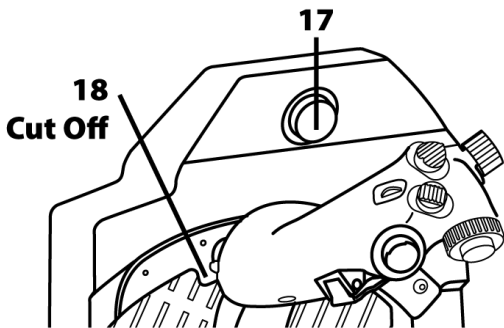
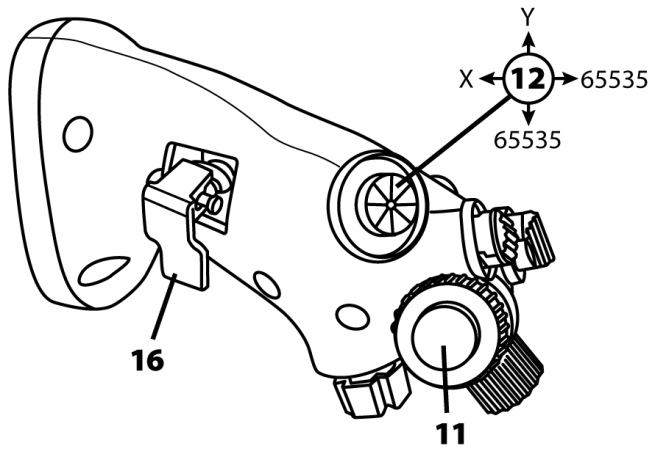
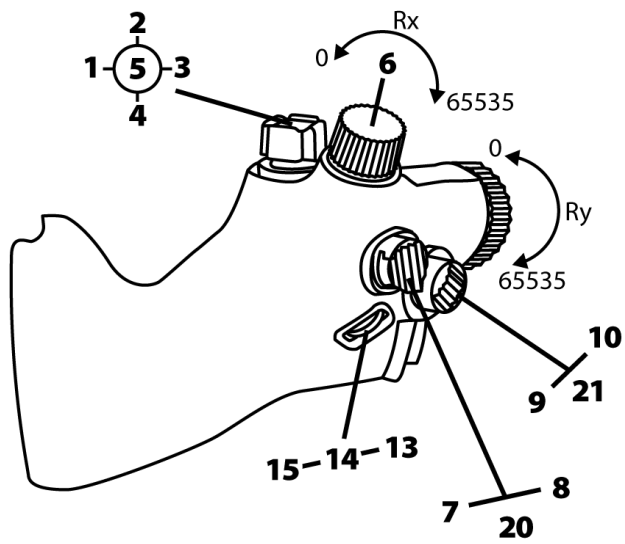



4. מידע על השימוש ב-VIPER TQS



סכנת צביטה

אסור להניח את האצבעות באזורי העצירה בעת השימוש בידיה.

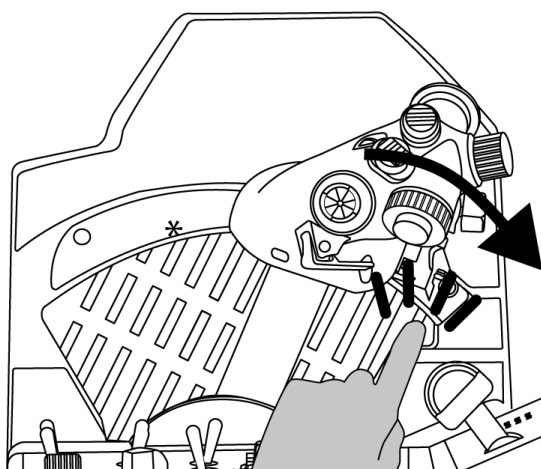
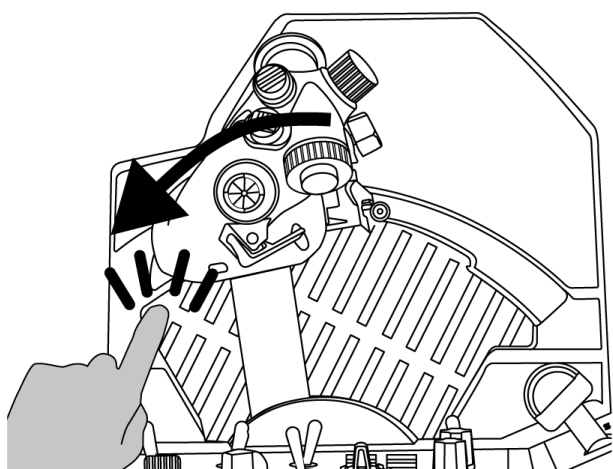
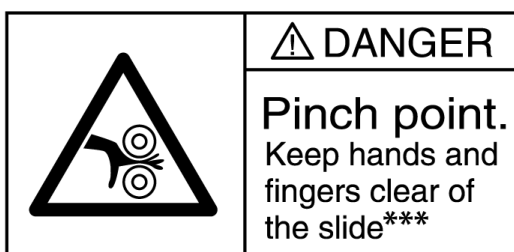



5. התאמת החיכוך

ניתן להתאים את החיכוך של מצערת VIPER TQS להעדפתך האישית באמצעות הכלול בצד של VIPER TQS. עם זאת, יש לשים לב כי ברירת המחדל שנקבעה במפעל תואמת לחיכוך המצערת האופטימלי.

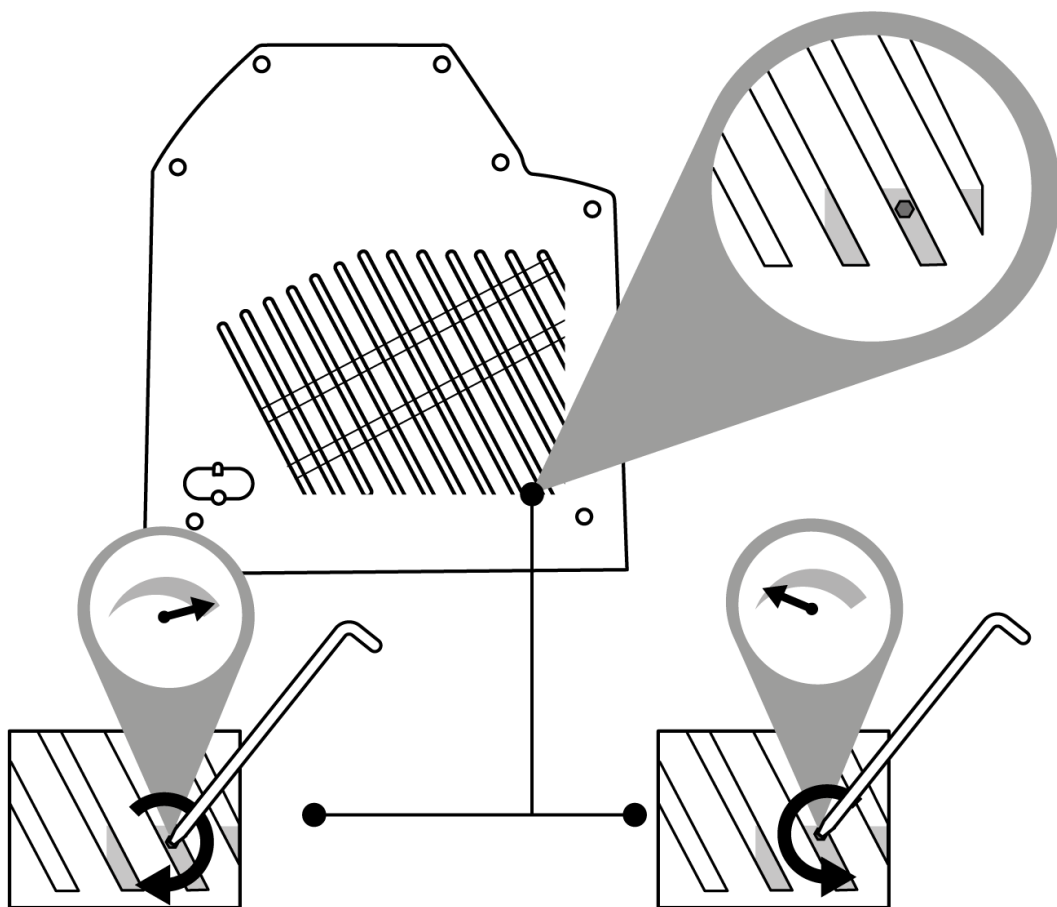

כדי למנוע נזק למערכת החיכוך, יש לוודא שבורג הכוונון אינו מהודק יתר על המידה. יש להקפיד גם שלא לשחרר לחלוטין את בורג הכוונון: אם הוא משוחרר לחלוטין, קיים סיכום שהמצערת לא תוכל יותר להישאר במקומה.

6. התקנה על תושבת



ניתן להתקין את VIPER TQS על תושבות מסוגים שונים. רוב תאי הטייס והתושבות הזמינים בשוק כיום תואמים למוצרים דומים של Thrustmaster (למשל Warthog HOTAS). יש לזכור ש-VIPER TQS כוללת אפקט מנוף עוצמתי, ולכן יש לחבר אותה היטב למקומה.

יש לחבר את הבסיס לתושבת באמצעות ארבעה בורגי M6 מתאימים (לא כלולים), כדי למנוע נזק לידיית.

A שרטוט מלא של VIPER TQS זמין בכתובת

<https://support.thrustmaster.com/product/viper-tqs/>



לפני כל שימוש, יש לוודא ש-VIPER TQS עדיין מחוברת היטב לתושבת, לפי ההוראות שציין היצרן.

יש להקפיד להתחשב בחומר שממנו עשויה התושבת, ולוודא שניתן לחבר אליה את המוצר בצורה בטוחה. יש להשתמש ב-VIPER TQS על שולחן עשוי מחומר מוצק (למשל, MDF או עץ), ללא חלקים חלולים או מזכוכית.



שרטוט מידות הרכבה (במ"מ)

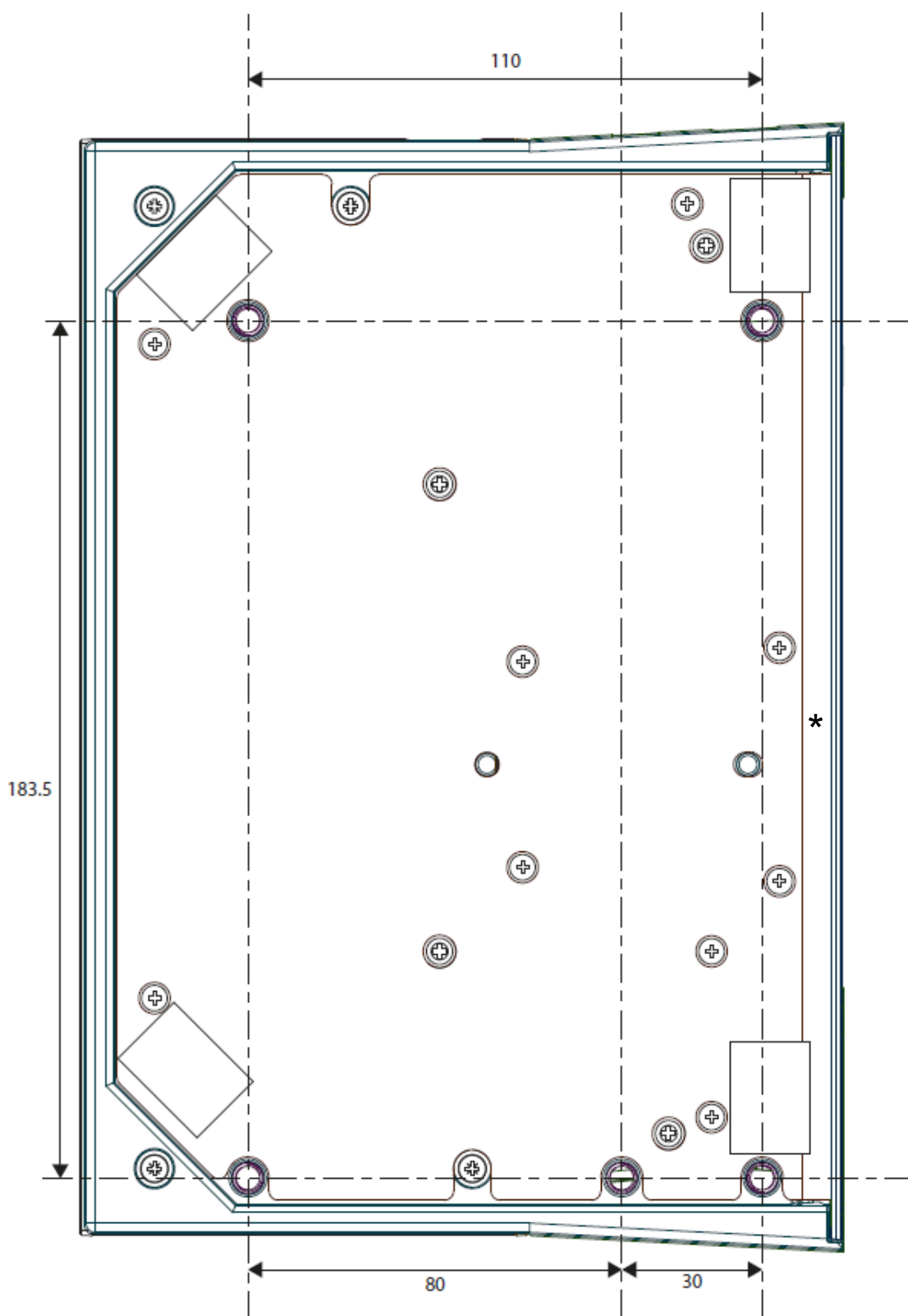

ניתן להוריד את השרטוט מ-

<https://support.thrustmaster.com/product/viper->

[tqs/](https://support.thrustmaster.com/product/viper-), ולאחר מכן להדפיסו ולהיעזר בעת הכנת חורי הקידוח.



התקנה באמצעות *TM Flying Desk Mount*

TM Flying Desk Mount היא מערכת הרכבה מתכתית הכוללת בורג הידוק, לשיפור הארגונומיה ומיקום הטייס בזמן השימוש במכשיר. מערכת זו מיועדת לשימוש עם שולחנות ועמדות עבודה בעובי 15-50 מ"מ.

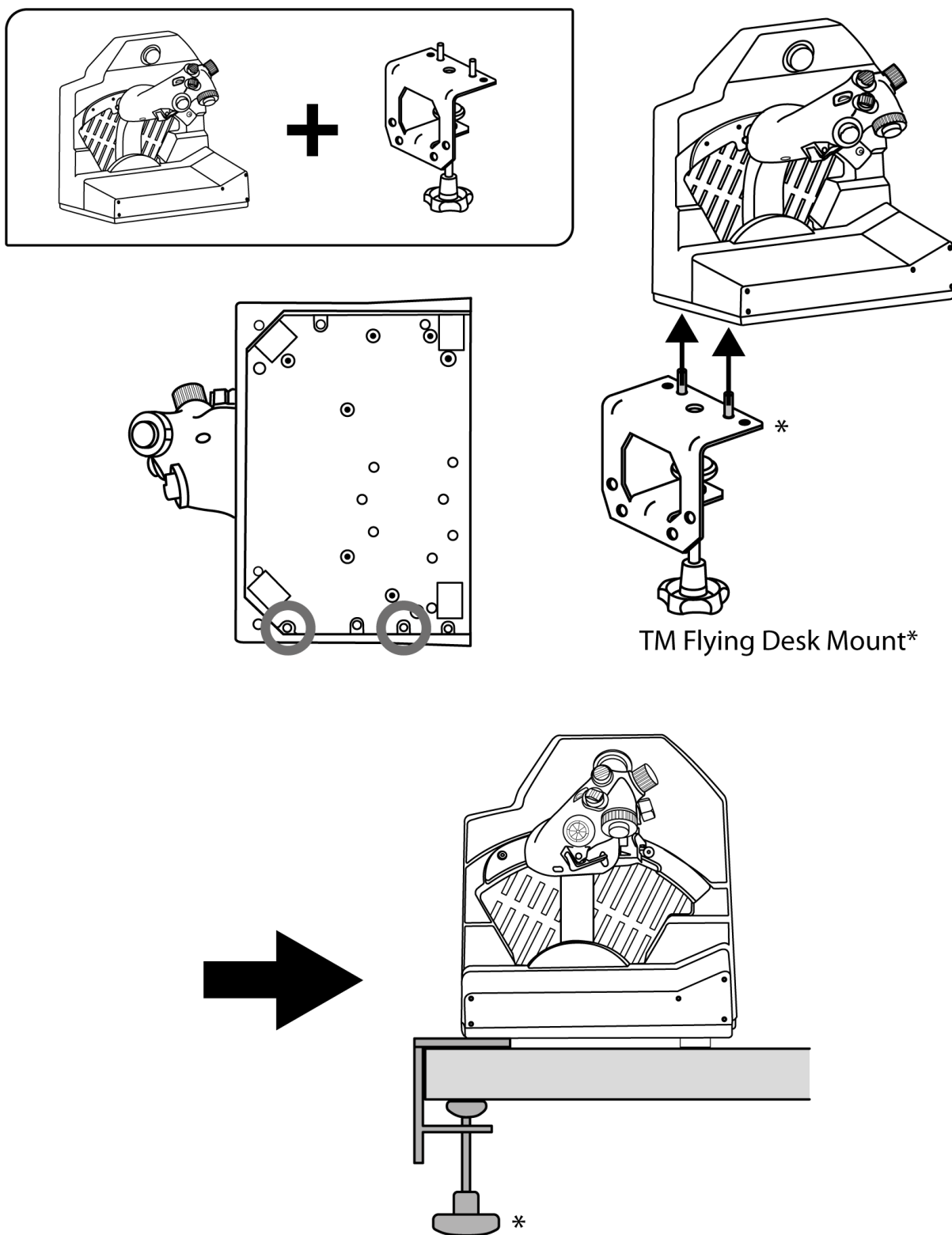

נמכר בנפרד*



התקנה באמצעות TM Flying Clamp

TM Flying Clamp היא תושבת עם גובה מתכוונן, ש-Thrustmaster עיצבה עבור האביזרים של החברה להדמיות טיסה. מערכת הרכבה זו כוללת שני בורגי הידוק המאפשרים להתאים אותה לשימוש עם עמדות עבודה ושולחנות בעובי 15-45 מ"מ.

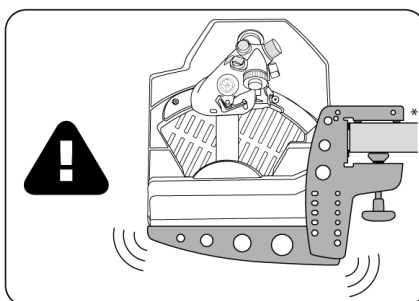
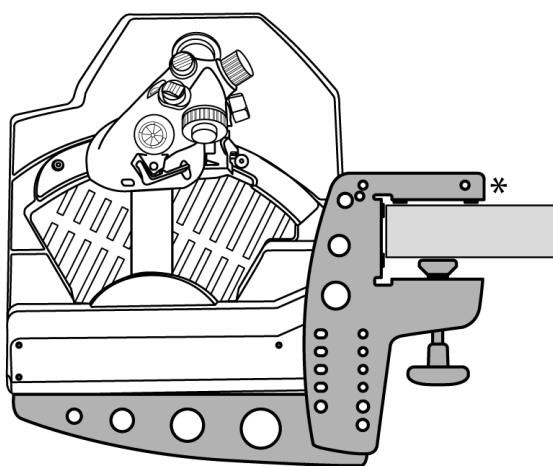
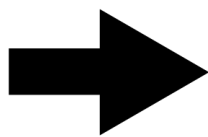
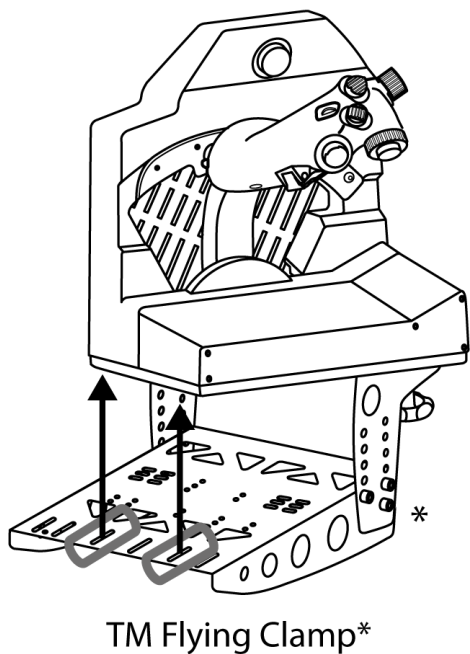
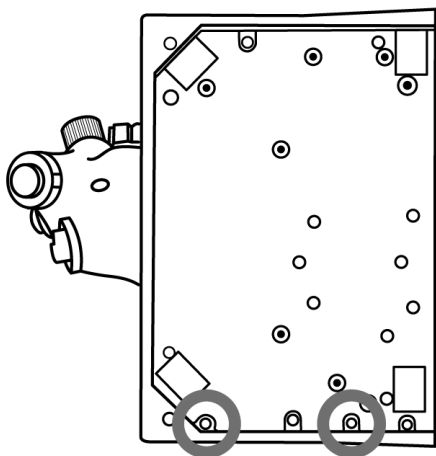
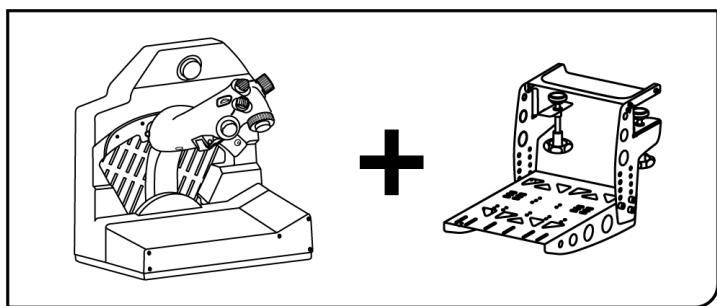

* נמכר בנפרד



יש לשים לב שמשקלה הכבד של VIPER TQS עלול לגרום
תנועות בלתי רצויות של מערכת ההרכבה.



7. ההתקנה של VIPER PANEL*

*נמכר בנפרד. VIPER PANEL כלול ב- VIPER TQS Mission Pack.

VIPER PANEL הוא לוח בקרה המאפשר להרחיב את יכולות הטיסה/הקרב עם 43 לחצנים בסך הכול וציר אחד - וכולם ניתנים לתכנות באמצעות תוכנת T.A.R.G.E.T. VIPER PANEL הוא מוצר משלים של VIPER TQS.

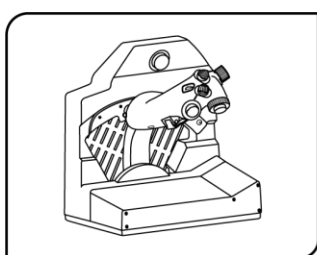

1

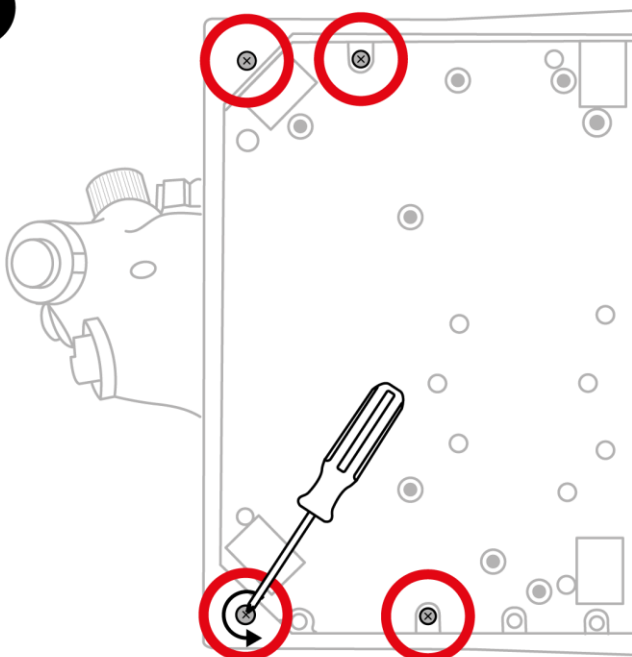

2

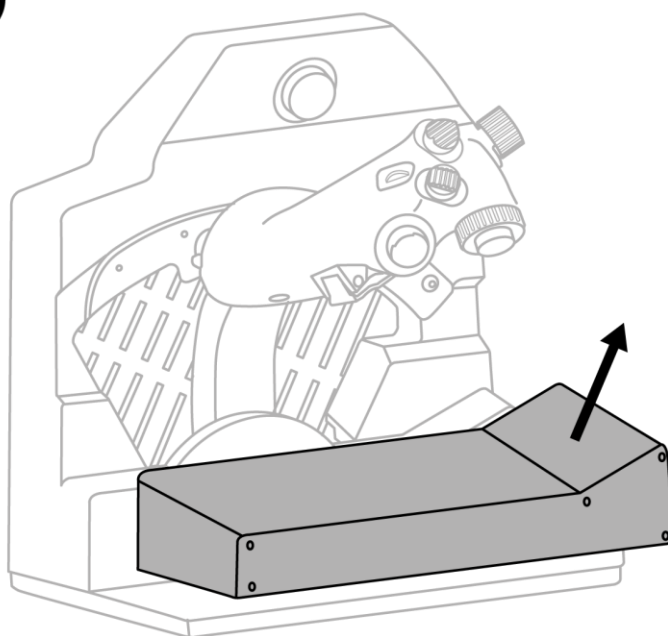

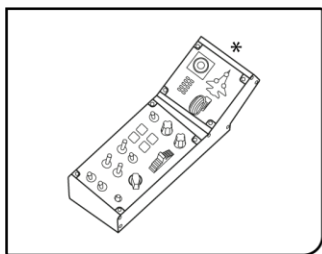

3

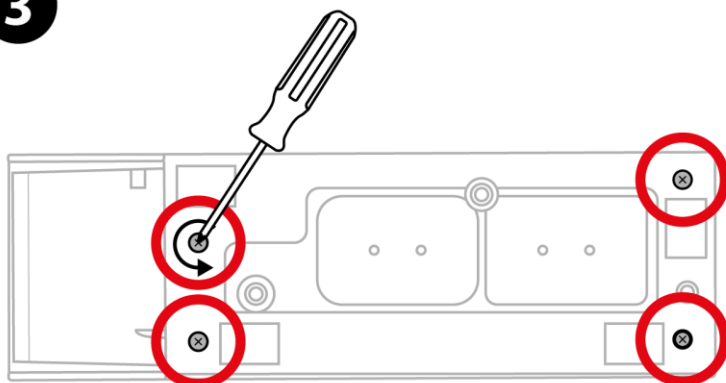

4

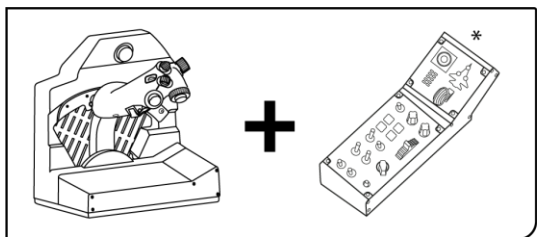
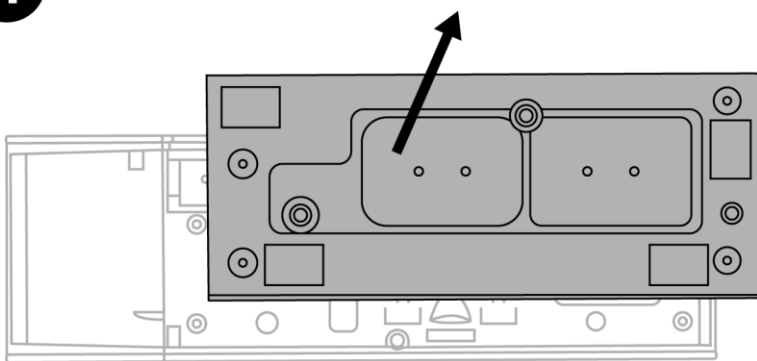

5

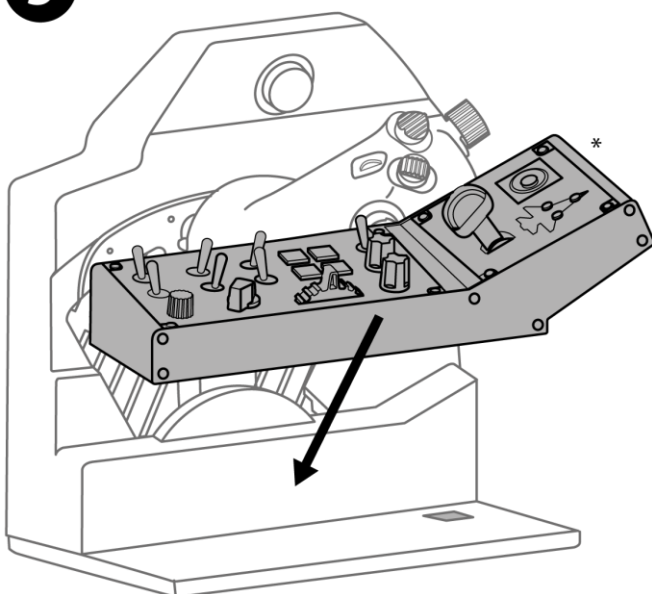



6

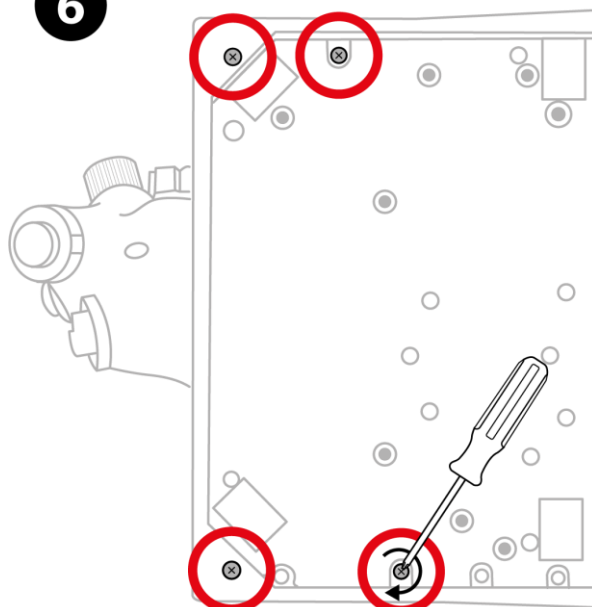

7

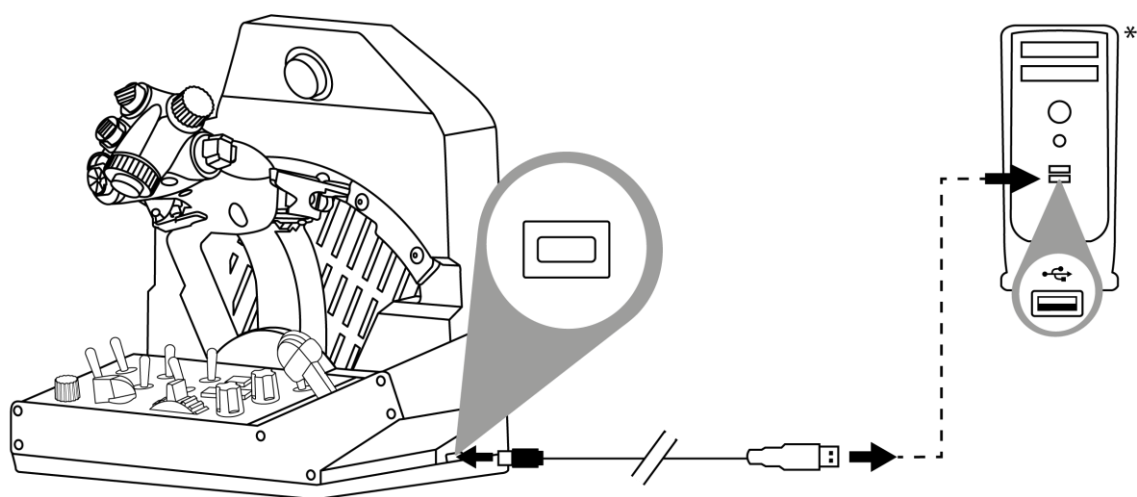

*לא כלול



8. התקנה במחשב

1



בקר בכתובת

<https://support.thrustmaster.com/product/viper-tqs/>

2

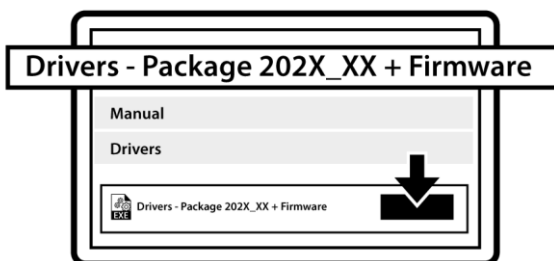

יש להוריד ולהתקין את מנהל ההתקן ל-PC ואת הממשק המותאם ללוח הבקרה של Windows.

3

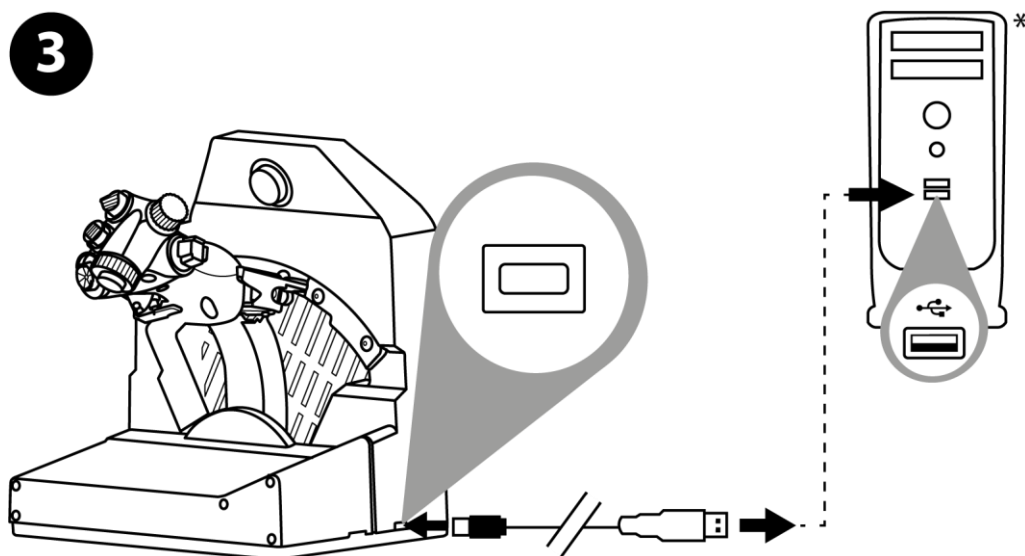

לאחר התקנה של מנהל ההתקן במחשב האישי, יש לחבר את מחבר ה-USB אל אחת מיציאות ה-USB של המחשב.

*לא כלול



④ כדי לגשת אל Control Panel, יש לבחור באפשרות התחל/ כל האפליקציות/Thrustmaster/Control Panel או באפשרות לוח הבקרה (ב-10 Windows).

תיבת הדו-שיח בקרי משחק תוצג. האביזר מופיע במסך עם השם VIPER TQS והסטטוס OK.

⑤ בתיבת הדו-שיח בקרי משחק, לחץ על מאפיינים כדי לבדוק ולהציג את כל התפקודים.

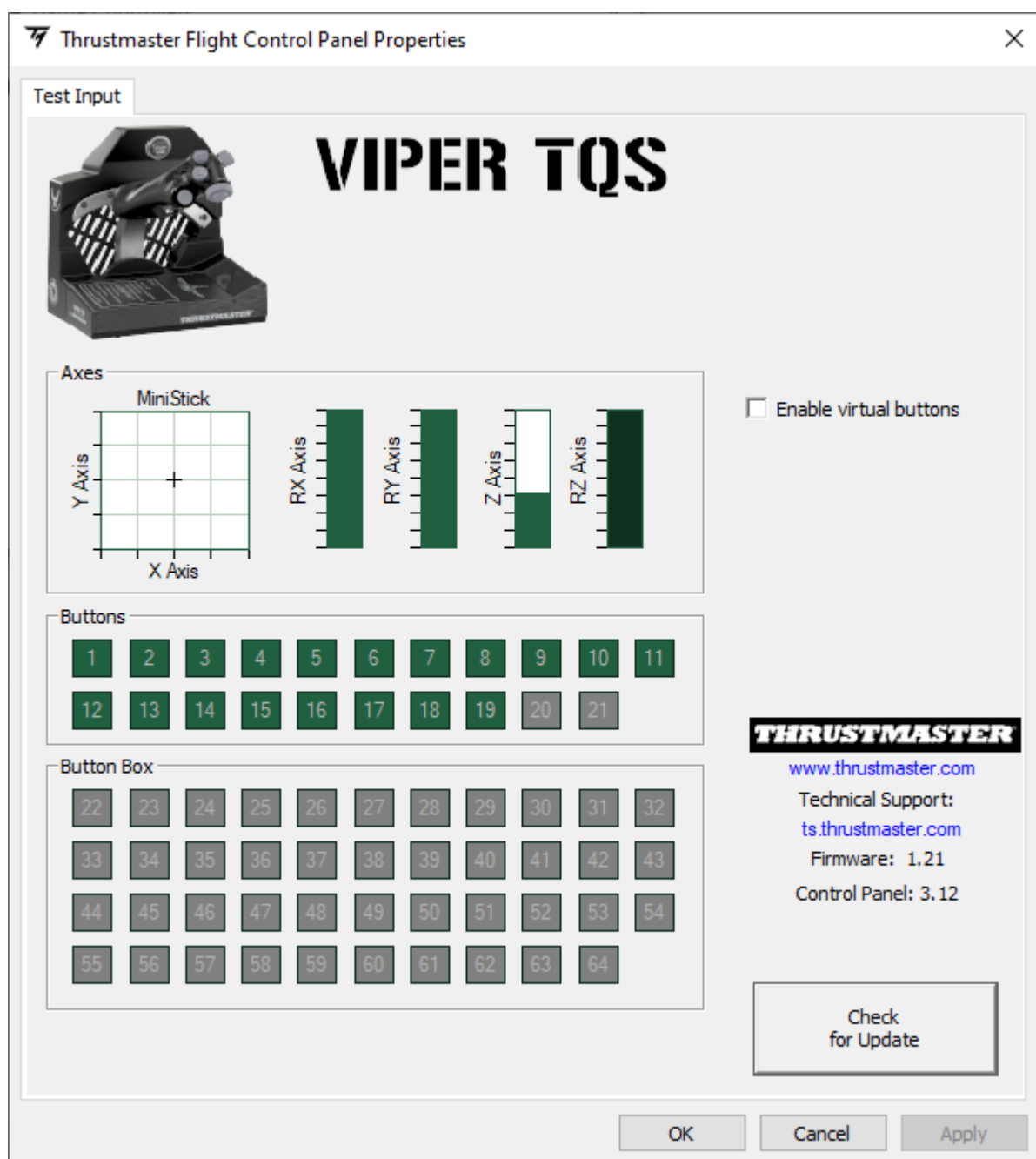



Enable virtual buttons (הפעל לחצנים וירטואליים):

הפונקציה מאפשרת להפעיל או להשבית את הלחצנים הווירטואליים על הידית (הלחצנים 20 ו-21). לאחר בחירת המצב הרצוי, יש ללחוץ על **Apply** (החל).

Thrustmaster Flight Control Panel Properties

Test Input

VIPER TQS

Enable virtual buttons

Buttons

1	2	3	4	5	6	7	8	9	10	11
12	13	14	15	16	17	18	19	20	21	

Button Box

22	23	24	25	26	27	28	29	30	31	32
33	34	35	36	37	38	39	40	41	42	43
44	45	46	47	48	49	50	51	52	53	54
55	56	57	58	59	60	61	62	63	64	

Check for Update

OK Cancel Apply



כברירת מחדל, הלחצנים הווירטואליים מושבתים ב- VIPER TQS.



9. מעצורי CUT OFF ו-AFTERBURNER

מצערת VIPER TQS כוללת מערכת ראליסטית של מעצורי CUT OFF ו-AFTERBURNER (אפשר להסיר את המודול Afterburner).

CUT OFF

לאחר הצבת המצערת במעצור IDLE, לחץ על ההדק "ביטול נעילה של ניתוק המנוע" ❶ כדי להרים את הידית ולעבור את המעצור ❷, ואז העבר את הידית למצב OFF ❸. כדי להפעיל שוב את המנועים, בצע הליך זה בסדר הפוך.

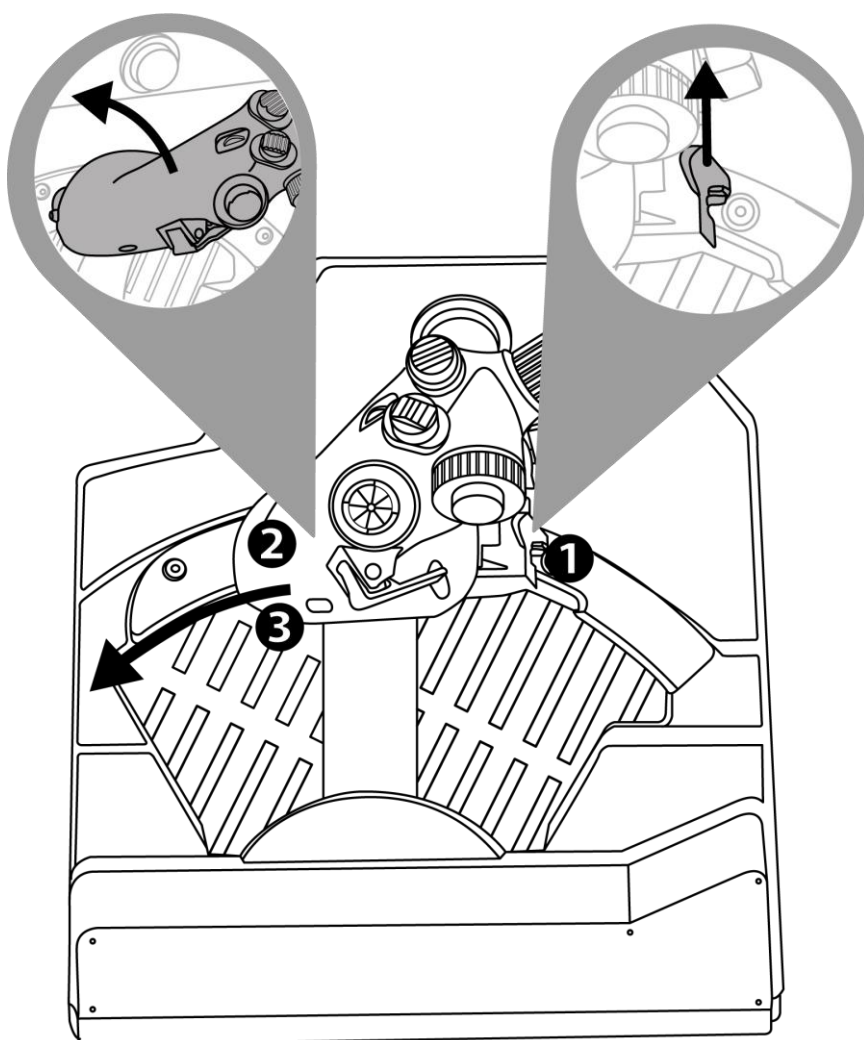



AFTERBURNER

העבר את המצערת למעצור **1**, והרם אותה **2** כדי לעבור את המעצור ולהפעיל את המבער **3**.

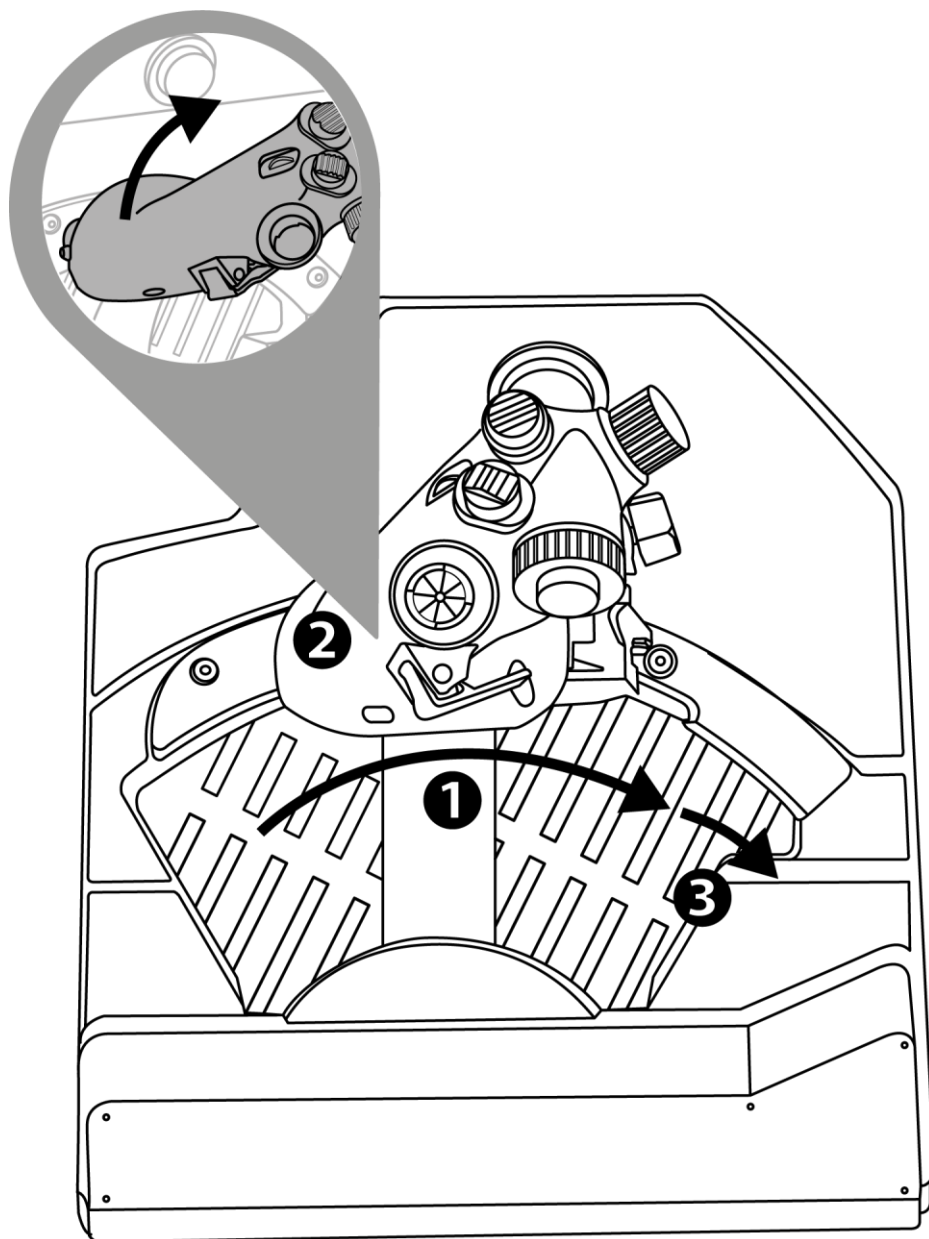



הסרת ההתקנה של המעצור **AFTERBURNER**

המעצור של המודול Afterburner נמצא ב-80% מערך הציר. אם צריך 100% ממהלך המצערת בלי עצירה (עבור סימולטור מסוים), אפשר להסיר את המודול Afterburner ואת העצירה שלו לאחר שחרור של שניים מהברגים של המודול באמצעות מפתח אלן (לא כלול).

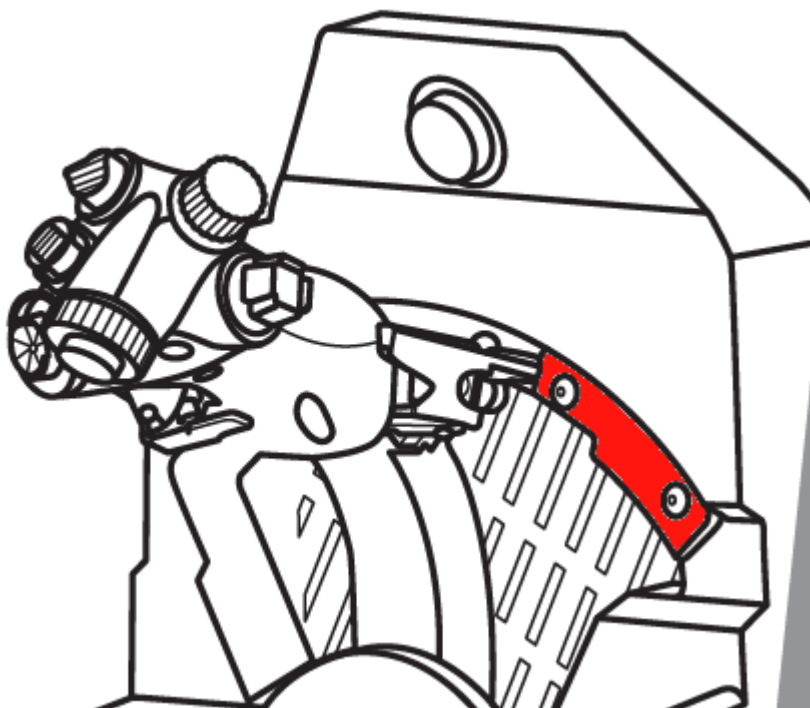



10. תוכנת T.A.R.G.E.T לתכנות מתקדם



בקר בכתובת

<https://support.thrustmaster.com/product/viper-tqs/>

במקטע **Software** (תוכנה), יש להוריד ולהתקין את תוכנת T.A.R.G.E.T לתכנות מתקדם.



T.A.R.G.E.T עיקריות של

- אפשרות להגדרות תצורה שונות של הצירים.
- אפשרות לרמות תכנות שונות: Basic (בסיסי), Advanced (מתקדם) ו-Script (סקריפט).
- שימוש בשיטת 'גרור ושחרר'.
- אפשרות לשלב את מצערת VIPER TQS עם ג'ויסטיקים שונים מבית Thrustmaster (HOTAS Cougar, HOTAS Warthog, T.16000M, MFD Cougar Pack, שגם הם תואמים ל- T.A.R.G.E.T), מה שמאפשר לזהות אותם כמכשיר USB אחד.
- גישה לפרופילים מתקדמים שנוצרו על ידי קהילת Thrustmaster.



11. שאלות נפוצות ותמיכה טכנית

יש לך שאלות על VIPER TQS, או שנתקלת בבעיות טכניות? אם כן, אפשר לבקר באתר התמיכה הטכנית של Thrustmaster: <https://support.thrustmaster.com/product/viper-tqs/>

