

Dell G15 5535

Owner's Manual



Notes, cautions, and warnings

 **NOTE:** A NOTE indicates important information that helps you make better use of your product.

 **CAUTION:** A CAUTION indicates either potential damage to hardware or loss of data and tells you how to avoid the problem.

 **WARNING:** A WARNING indicates a potential for property damage, personal injury, or death.

Chapter 1: Views of Dell G15 5535	7
Right	7
Left	7
Top	8
Front	8
Bottom	10
Back	10
Service Tag	11
Chapter 2: Set up your Dell G15 5535	12
Chapter 3: Specifications of Dell G15 5535	14
Dimensions and weight	14
Processor	14
Chipset	15
Operating system	15
Memory	15
External ports	16
Internal slots	16
Ethernet	16
Wireless module	17
Audio	17
Storage	18
Keyboard	18
Keyboard shortcuts	18
Camera	20
Touchpad	21
Power adapter	21
Battery	22
Display	23
GPU—Integrated	24
GPU—Discrete	24
Operating and storage environment	24
ComfortView Plus	25
Chapter 4: Working inside your computer	26
Safety instructions	26
Before working inside your computer	26
Safety precautions	27
Electrostatic discharge—ESD protection	27
ESD field service kit	28
Transporting sensitive components	29
After working inside your computer	29
BitLocker	29

Recommended tools.....	29
Screw list.....	29
Major components of Dell G15 5535.....	31
Chapter 5: Removing and installing Customer Replaceable Units (CRUs).....	34
Base cover.....	34
Removing the base cover.....	34
Installing the base cover.....	37
Solid-state drive.....	39
Removing the solid-state drive	39
Installing the solid-state drive.....	40
Procedure to move the M.2 solid-state drive screw mount for solid-state drive slot 2.....	42
Wireless card.....	43
Removing the wireless card.....	43
Installing the wireless card.....	44
Memory.....	46
Removing the memory module.....	46
Installing the memory module.....	46
Speakers.....	47
Removing the speakers.....	47
Installing the speakers.....	48
Rear cover.....	49
Removing the rear cover.....	49
Installing the rear cover.....	50
Chapter 6: Removing and installing Field Replaceable Units (FRUs).....	52
Battery.....	52
Rechargeable Li-ion battery precautions.....	52
Removing the battery.....	52
Installing the battery.....	54
Touchpad.....	55
Removing the touchpad.....	55
Installing the touchpad.....	56
Display assembly.....	57
Removing the display assembly.....	57
Installing the display assembly.....	60
Keyboard-controller board.....	63
Removing the keyboard-controller board.....	63
Installing the keyboard-controller board.....	63
Power-adaptor port.....	64
Removing the power-adaptor port.....	64
Installing the power-adaptor port.....	65
System board.....	66
Removing the system board (Single-color keyboard).....	66
Installing the system board (Single-color keyboard).....	69
Removing the system board (Four-zone keyboard).....	72
Installing the system board (Four-zone keyboard).....	75
USB board.....	78
Removing the USB board.....	78

Installing the USB board.....	79
Ethernet and audio board.....	80
Removing the ethernet and audio board.....	80
Installing the ethernet and audio board.....	81
Fan and heat-sink assembly.....	82
Removing the fan and heat-sink assembly	82
Installing the fan and heat-sink assembly	83
Power-button assembly.....	84
Removing the power button.....	84
Installing the power button.....	85
Palm-rest and keyboard assembly.....	86
Removing the palm-rest and keyboard assembly.....	86
Installing the palm-rest and keyboard assembly.....	87
Chapter 7: Software.....	89
Operating system.....	89
Drivers and downloads.....	89
Chapter 8: Technology and components.....	90
Chapter 9: BIOS Setup.....	91
Entering BIOS setup program.....	91
Navigation keys.....	91
F12 One Time Boot menu.....	91
System setup options.....	92
Updating the BIOS.....	98
Updating the BIOS in Windows.....	98
Updating the BIOS using the USB drive in Windows.....	99
Updating the BIOS in Linux and Ubuntu.....	99
Updating the BIOS from the F12 One Time Boot menu.....	99
System and setup password.....	100
Assigning a System Setup password.....	100
Deleting or changing an existing system setup password.....	100
Clearing CMOS settings.....	101
Clearing BIOS (System Setup) and System passwords.....	101
Chapter 10: Troubleshooting.....	102
Handling swollen rechargeable Li-ion batteries.....	102
Locate the Service Tag or Express Service Code of your Dell computer	102
Dell SupportAssist Pre-boot System Performance Check diagnostics.....	103
Running the SupportAssist Pre-Boot System Performance Check.....	103
Built-in self-test (BIST).....	103
M-BIST.....	103
LCD Power rail test (L-BIST).....	104
LCD Built-in Self-Test (BIST).....	104
System-diagnostic lights.....	105
Recovering the operating system.....	106
Real-Time Clock (RTC Reset).....	106
Backup media and recovery options.....	106

Wi-Fi power cycle.....106
Drain residual flea power (perform hard reset).....107

Chapter 11: Getting help and contacting Dell..... 108

Views of Dell G15 5535

Right

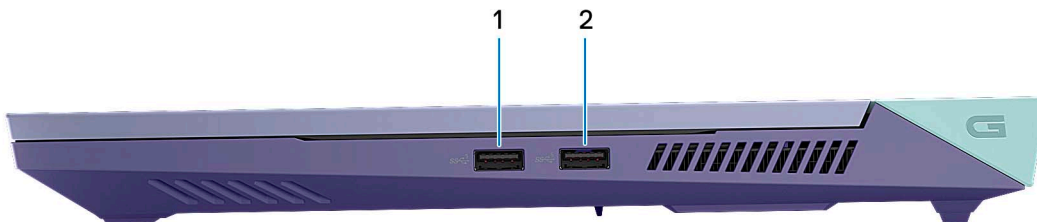

1. USB 3.2 Gen 1 ports (2)

Connect devices such as external storage devices and printers. Provides data transfer speeds up to 5 Gbps.

Left

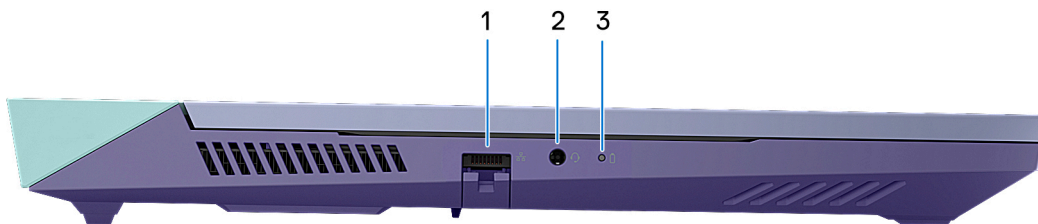

1. Network port

Connect an Ethernet (RJ45) cable from a router or a broadband modem for network or Internet access.

2. Universal audio jack

Connect audio-output devices such as speakers, amplifiers, and so on.

3. Battery-status light

Indicates the battery-charge status.

Solid amber—Battery charge is low.

Blinking amber—Battery charge is critical.

Off—Battery is fully charged.

Top

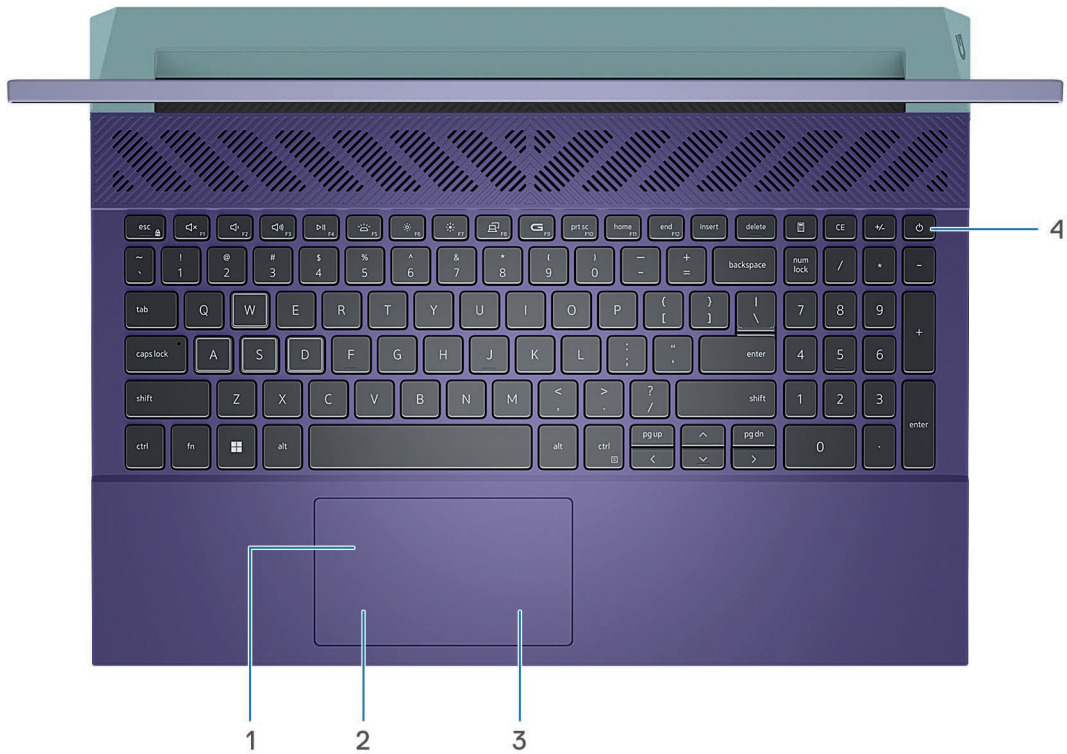

1. Touchpad

Move your finger on the touchpad to move the mouse pointer. Tap to left-click and two fingers tap to right-click.

2. Left-click area

Press to left-click.

3. Right-click area

Press to right-click.

4. Power button

Press to turn on the computer if it is turned off, in sleep state, or in hibernate state.

When the computer is turned on, press the power button to put the computer into sleep state; press and hold the power button for 10 seconds to force shut-down the computer.

NOTE: You can customize the power-button behavior in Windows. For more information, see *Me and My Dell* at www.dell.com/support/manuals.

Front

CAUTION: The maximum operating angle for the display-panel hinge is 135 degrees.



1. Camera

Enables you to video chat, capture photos, and record videos.

2. Camera-status light

Turns on when the camera is in use.

3. Microphone

Provides digital sound input for audio recording, voice calls, and so on.

Bottom

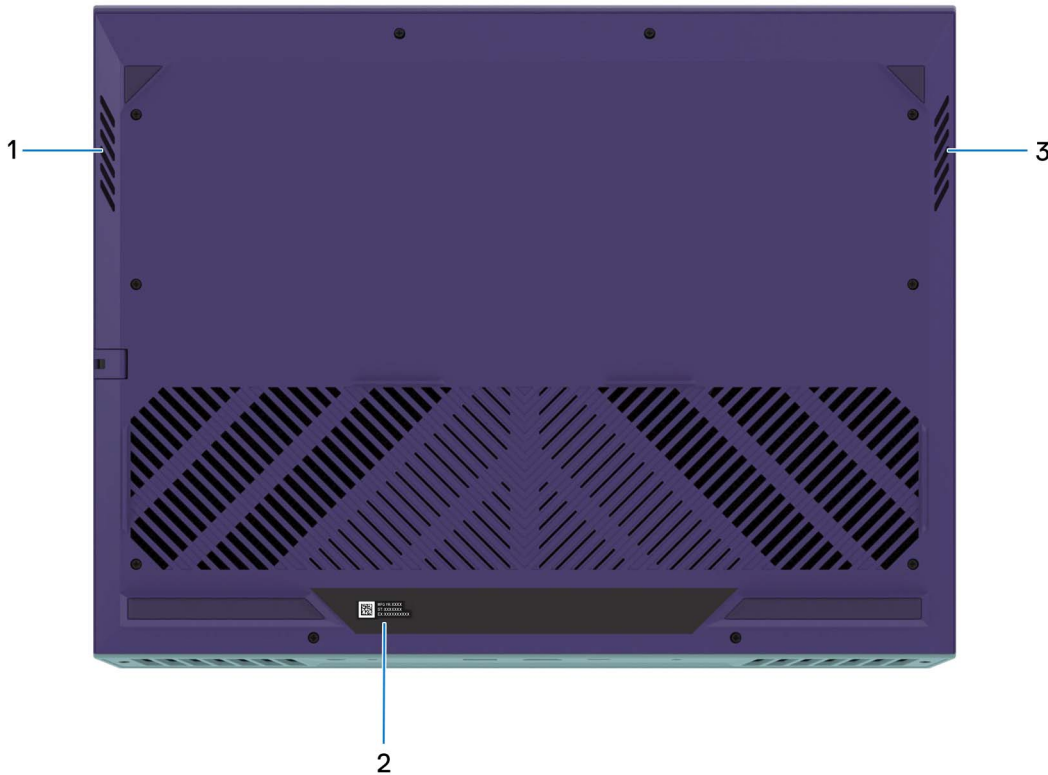

1. Left speaker

Provides audio output.

2. Service Tag label

The Service Tag is a unique alphanumeric identifier that enables Dell service technicians to identify the hardware components in your computer and access warranty information.

3. Right speaker

Provides audio output.

Back

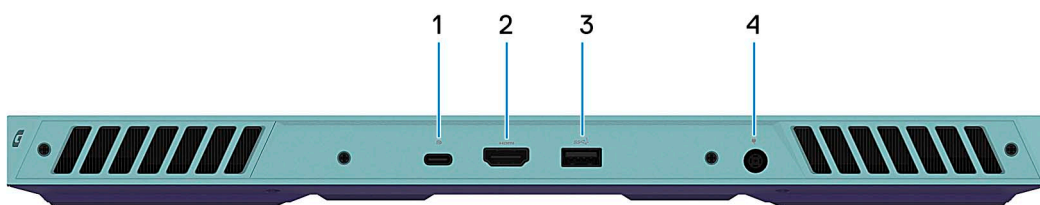

1. USB 3.2 Gen 2 (Type-C) port with DisplayPort

Connect devices such as external storage devices, printers, and external displays. Provides data transfer rate of up to 10 Gbps.

Supports DisplayPort 1.4 and also enables you to connect an external display using a display adapter.

NOTE: A USB Type-C to DisplayPort adapter (sold separately) is required to connect a DisplayPort device.

2. HDMI port

Connect to a TV, external display or another HDMI-in enabled device. Provides video and audio output.

3. USB 3.2 Gen 1 port

Connect devices such as external storage devices and printers. Provides data transfer speeds up to 5 Gbps.

4. Power-adaptor port

Connect a power adapter to provide power to your computer and charge the battery.

Service Tag

The service tag is a unique alphanumeric identifier that allows Dell service technicians to identify the hardware components in your computer and access warranty information.



Set up your Dell G15 5535

About this task

NOTE: The images in this document may differ from your computer depending on the configuration you ordered.

Steps

1. Connect the power adapter and press the power button.



NOTE: The battery may go into power-saving mode during shipment to conserve charge on the battery. Ensure that the power adapter is connected to your computer when it is turned on for the first time.

2. Finish Windows setup.

Follow the on-screen instructions to complete the setup. When setting up, Dell recommends that you:





- Connect to a network for Windows updates.

NOTE: If connecting to a secured wireless network, enter the password for the wireless network access when prompted.

- If connected to the Internet, sign in with or create a Microsoft account. If not connected to the Internet, create an offline account.
- On the **Support and Protection** screen, enter your contact details.

3. Locate and use Dell apps from the Windows Start menu—Recommended.

Table 1. Locate Dell apps

Resources	Description
	<p>My Dell</p> <p>Centralized location for key Dell applications, help articles, and other important information about your computer. It also notifies you about the warranty status, recommended accessories, and software updates if available.</p>
	<p>SupportAssist</p> <p>SupportAssist proactively and predictively identifies hardware and software issues on your computer and automates the engagement process with Dell Technical support. It addresses performance and stabilization issues, prevents security threats, monitors, and detects hardware failures. For more information, see <i>SupportAssist for Home PCs User's Guide</i> at www.dell.com/serviceabilitytools. Click SupportAssist and then, click SupportAssist for Home PCs.</p> <p>NOTE: In SupportAssist, click the warranty expiry date to renew or upgrade your warranty.</p>
	<p>Dell Update</p> <p>Updates your computer with critical fixes and latest device drivers as they become available. For more information on using Dell Update, search in the Knowledge Base Resource at www.dell.com/support.</p>
	<p>Dell Digital Delivery</p> <p>Download software applications, which are purchased but not preinstalled on your computer. For more information on using Dell Digital Delivery, search in the Knowledge Base Resource at www.dell.com/support.</p>

Specifications of Dell G15 5535

Dimensions and weight

The following table lists the height, width, depth, and weight of your Dell G15 5535.

Table 2. Dimensions and weight

Description	Values
Height:	
Front height	21.28 mm (0.84 in.)
Rear height	26.15 mm (1.03 in.)
Width	357.26 mm (14.07 in.)
Depth	274.52 mm (10.81 in.)
Weight  NOTE: The weight of your computer depends on the configuration that is ordered and manufacturing variability.	2.97 kg (6.55 lb)

Processor

The following table lists the details of the processors that are supported for your Dell G15 5535.

Table 3. Processor

Description	Option one	Option two
Processor type	AMD Ryzen 5 7640HS	AMD Ryzen 7 7840HS
Processor wattage	54 W	54 W
Processor core count	6	8
Processor thread count	12	16
Processor speed	Up to 5 GHz	Up to 5.10 GHz
Processor cache	22 MB	24 MB
Integrated graphics	AMD Radeon Graphics	AMD Radeon Graphics

Chipset

The following table lists the details of the chipset that is supported for your Dell G15 5535.

Table 4. Chipset

Description	Values
Chipset	Integrated in the processor
Processor	<ul style="list-style-type: none">• AMD Ryzen 5 7640HS• AMD Ryzen 7 7840HS
DRAM bus width	64-bit
Flash EPROM	32 MB
PCIe bus	Up to Gen4

Operating system

Your Dell G15 5535 supports the following operating systems:

- Windows 11 Home, 64-bit
- Windows 11 Pro, 64-bit

Memory

The following table lists the memory specifications of your Dell G15 5535.

Table 5. Memory specifications

Description	Values
Memory slots	Two SODIMMs
Memory type	DDR5
Memory speed	<ul style="list-style-type: none">• 4800 MT/s• 5600 MT/s
Maximum memory configuration	32 GB
Minimum memory configuration	8 GB
Memory size per slot	<ul style="list-style-type: none">• 8 GB• 16 GB
Memory configurations supported	<ul style="list-style-type: none">• 8 GB, 1 x 8 GB, DDR5, 4800 MT/s• 16 GB, 2 x 8 GB, dual-channel DDR5, 4800 MT/s• 16 GB, 1 x 16 GB, DDR5, 4800 MT/s• 32 GB, 2 x 16 GB, dual-channel DDR5, 4800 MT/s• 8 GB, 1 x 8 GB, DDR5, 5600 MT/s• 16 GB, 2 x 8 GB, dual-channel DDR5, 5600 MT/s• 16 GB, 1 x 16 GB, DDR5, 5600 MT/s• 32 GB, 2 x 16 GB, dual-channel DDR5, 5600 MT/s

External ports

The following table lists the external ports of your Dell G15 5535.

Table 6. External ports

Description	Values
Network port	One RJ-45 port
USB ports	<ul style="list-style-type: none">• Three USB 3.2 Gen 1 ports• One USB 3.2 Gen 2 (Type-C) port with DisplayPort
Audio port	One universal audio jack
Video port	One HDMI 2.1 port i NOTE: The HDMI port supports resolution of up to 8K at 60 Hz with DSC.
Media-card reader	Not supported
Power-adaptor port	One 7.40 mm x 5.10 mm power-adaptor port
Security-cable slot	Not supported

Internal slots

The following table lists the internal slots of your Dell G15 5535.

Table 7. Internal slots

Description	Values
M.2	<ul style="list-style-type: none">• One M.2 2230 slot for WiFi and Bluetooth combo card• Two M.2 2230/2280 slots for solid-state drives i NOTE: To learn more about the features of different types of M.2 cards, search in the Knowledge Base Resource at www.dell.com/support .

Ethernet

The following table lists the wired Ethernet Local Area Network (LAN) specifications of your Dell G15 5535.

Table 8. Ethernet specifications

Description	Values
Model number	Realtek RTL8111H PCI-e Gigabit ethernet controller
Transfer rate	10/100/1000 Mbps

Wireless module

The following table lists the Wireless Local Area Network (WLAN) module that is supported on your Dell G15 5535.

Table 9. Wireless module specifications

Description	Values
Model number	MediaTek MT7921
Transfer rate	Up to 1200 Mbps
Frequency bands supported	2.4 GHz/5 GHz
Wireless standards	<ul style="list-style-type: none"> • WiFi 802.11a/b/g • Wi-Fi 4 (WiFi 802.11n) • Wi-Fi 5 (WiFi 802.11ac) • Wi-Fi 6 (WiFi 802.11ax)
Encryption	<ul style="list-style-type: none"> • 64-bit/128-bit WEP • AES-CCMP • TKIP
Bluetooth wireless card	Bluetooth 5.3
	 NOTE: The version of the Bluetooth wireless card may vary depending on the operating system that is installed on your computer.

Audio

The following table lists the audio specifications of your Dell G15 5535.

Table 10. Audio specifications

Description	Values	
Audio controller	Realtek ALC3204	
Stereo conversion	Supported	
Internal audio interface	High definition audio	
External audio interface	One universal audio jack	
Number of speakers	2	
Internal-speaker amplifier	Supported	
External volume controls	Keyboard shortcut controls	
Speaker output:		
	Average speaker output	2 x 2 W = 4 W
	Peak speaker output	2 x 2.50 W = 5 W
Subwoofer output	Not supported	
Microphone	One microphone in the camera assembly	

Storage

This section lists the storage options on your Dell G15 5535.

Your Dell G15 5535 supports one of the following storage configurations:

- One M.2 2230 or M.2 2280 solid-state drive
- Two M.2 2230 or M.2 2280 solid-state drives

The primary drive of your Dell G15 5535 is installed in solid-state drive slot one.

Table 11. Storage specifications

Storage type	Interface type	Capacity
M.2 2230 solid-state drive	PCIe NVMe Gen4 x4, up to 64 Gbps	Up to 1 TB
M.2 2280 solid-state drive	PCIe NVMe Gen4 x4, up to 64 Gbps	Up to 2 TB

Keyboard

The following table lists the keyboard specifications of your Dell G15 5535.

Table 12. Keyboard specifications

Description	Values
Keyboard type	<ul style="list-style-type: none">• Single-color backlit (white) keyboard• Single-color backlit (hot coral) keyboard• 4-zone RGB backlit keyboard
Keyboard layout	QWERTY
Number of keys	<ul style="list-style-type: none">• United States and Canada: 101 keys• United Kingdom: 102 keys• Japan: 105 keys
Keyboard size	X=18.70 mm key pitch Y=18.05 mm key pitch
Keyboard shortcuts	<p>Some keys on your keyboard have two symbols on them. These keys can be used to type alternate characters or to perform secondary functions. To type the alternate character, press Shift and the desired key. To perform secondary functions, press Fn and the desired key.</p> <p>NOTE: You can define the primary behavior of the function keys (F1–F12) changing Function Key Behavior in BIOS setup program.</p> <p>For more information, see Keyboard shortcuts.</p>

Keyboard shortcuts

NOTE: Keyboard characters may differ depending on the keyboard language configuration. Keys used for shortcuts remain the same across all language configurations.





































Some keys on your keyboard have two symbols on them. These keys can be used to type alternate characters or to perform secondary functions. The symbol shown on the lower part of the key refers to the character that is typed out when the key is pressed. If you press **Shift** and the key, the symbol shown on the upper part of the key is typed out. For example, if you press **2**, **2** is typed out; if you press **Shift + 2**, **@** is typed out.

The keys **F1** to **F12** at the top row of the keyboard are function keys for multi-media control, as indicated by the icon at the bottom of the key. Press the function key to invoke the task represented by the icon. For example, pressing **F1** mutes the audio (refer to the table below).

However, if the function keys **F1** to **F12** are needed for specific software applications, multi-media functionality can be disabled by pressing **fn + Esc**. Subsequently, multi-media control can be invoked by pressing **fn** and the respective function key. For example, mute audio by pressing **fn + F1**.

























i **NOTE:** You can also define the primary behavior of the function keys (**F1** to **F12**) by changing **Function Key Behavior** in the BIOS setup program.

Table 13. List of keyboard shortcuts

Function key	Redefined key (for multimedia control)	Behavior
	 + 	Mute audio
	 + 	Decrease volume
	 + 	Increase volume
	 + 	Play/Pause
	 + 	Toggle keyboard backlight (optional)
	 + 	Decrease brightness
	 + 	Increase brightness
	 + 	Switch to external display
	 + 	Search/G key (optional)
	 + 	Print screen
	 + 	Home
	 + 	End

The **Fn** key is also used with selected keys on the keyboard to invoke other secondary functions.

Table 14. List of keyboard shortcuts

Function key	Behavior
 + 	Turn off/on wireless
 + 	Pause/Break
 + 	Insert
 + 	Sleep
 + 	Toggle between power and battery-status light/hard-drive activity light
 + 	System request
 + 	Open application menu
 + 	Toggle fn-key lock
 + 	Page up
 + 	Page down
 + 	Home
 + 	End

Camera

The following table lists the camera specifications of your Dell G15 5535.

Table 15. Camera specifications

Description	Values
Number of cameras	One
Camera type	HD RGB camera
Camera location	Front camera
Camera sensor type	CMOS sensor technology

Table 15. Camera specifications (continued)

Description		Values
Camera resolution:		
	Still image	0.92 megapixel
	Video	1280 x 720 (HD) at 30 fps
Diagonal viewing angle:		78.60 degrees

Touchpad

The following table lists the touchpad specifications of your Dell G15 5535.

Table 16. Touchpad specifications

Description		Values
Touchpad resolution:		
	Horizontal	1229
	Vertical	689
Touchpad dimensions:		
	Horizontal	105 mm (4.13 in.)
	Vertical	60 mm (2.36 in.)
Touchpad gestures		For more information about touchpad gestures available on Windows, see the Microsoft Knowledge Base article at support.microsoft.com .

Power adapter

The following table lists the power adapter specifications of your Dell G15 5535.

Table 17. Power adapter specifications

Description	Option one	Option two
Type	240 W	330 W
Connector dimensions:		
	External diameter	7.40 mm
	Internal diameter	5.10 mm
Power-adapter dimensions:		
	Height	25.40 mm (1 in.)
	Width	100 mm (3.94 in.)
	Depth	200 mm (7.87 in.)
Input voltage	100 VAC–240 VAC	100 VAC–240 VAC

Table 17. Power adapter specifications (continued)

Description		Option one	Option two
Input frequency		50 Hz–60 Hz	50 Hz–60 Hz
Input current (maximum)		3.50 A	4.40 A
Output current (continuous)		12.31 A	16.92 A
Rated output voltage		19.50 VDC	19.50 VDC
Temperature range:			
	Operating	0°C to 40°C (32°F to 104°F)	0°C to 40°C (32°F to 104°F)
	Storage	-40°C to 70°C (-40°F to 158°F)	-40°C to 70°C (-40°F to 158°F)
 CAUTION: Operating and storage temperature ranges may differ among components, so operating or storing the device outside these ranges may impact the performance of specific components.			

Battery

The following table lists the battery specifications of your Dell G15 5535.

Table 18. Battery specifications

Description		Option one	Option two
Battery type		3-cell, 56 Wh, Lithium-ion, ExpressCharge Boost	6-cell, 86 Wh, Lithium-ion, ExpressCharge Boost
Battery voltage		11.40 VDC	11.40 VDC
Battery weight (maximum)		0.26 kg (0.57 lb)	0.34 kg (0.75 lb)
Battery dimensions:			
	Height	77.70 mm (3.06 in.)	77.70 mm (3.06 in.)
	Width	295.20 mm (11.62 in.)	295.20 mm (11.62 in.)
	Depth	7.56 mm (0.30 in.)	7.56 mm (0.30 in.)
Temperature range:			
	Operating	0°C to 50°C (32°F to 149°F)	0°C to 50°C (32°F to 122°F)
	Storage	-20°C to 65°C (-4°F to 149°F)	-20°C to 65°C (-4°F to 149°F)
Battery operating time		Varies depending on operating conditions and can significantly reduce under certain power-intensive conditions.	Varies depending on operating conditions and can significantly reduce under certain power-intensive conditions.
Battery charging time (approximate)  NOTE: Control the charging time, duration, start and end time, and so on, using the Dell Power Manager application. For more information about Dell Power Manager, search		3 hours (when the computer is off)	3 hours (when the computer is off)

Table 18. Battery specifications (continued)

Description	Option one	Option two
in the Knowledge Base Resource at www.dell.com/support .		
Coin-cell battery	Not supported	Not supported
<p>⚠ CAUTION: Operating and storage temperature ranges may differ among components, so operating or storing the device outside these ranges may impact the performance of specific components.</p> <p>⚠ CAUTION: Dell Technologies recommends that you charge the battery regularly for optimal power consumption. If your battery charge is depleted, connect the power adapter, turn on your computer, and then restart your computer to reduce the power consumption.</p>		

Display

The following table lists the display specifications of your Dell G15 5535.

Table 19. Display specifications

Description	Option one	Option two	Option three	Option four	
Display type	Full High Definition (FHD)	Full High Definition (FHD), ComfortView Plus	Full High Definition (FHD), ComfortView Plus	Quad High Definition (QHD), ComfortView Plus	
Display-panel technology	Wide-Viewing Angle (WVA)	Wide-Viewing Angle (WVA)	Wide-Viewing Angle (WVA)	Wide-Viewing Angle (WVA)	
Display-panel dimensions (active area):					
	Height	193.59 mm (7.62 in.)	193.59 mm (7.62 in.)	193.59 mm (7.62 in.)	193.59 mm (7.62 in.)
	Width	344.16 mm (13.55 in.)	344.16 mm (13.55 in.)	344.16 mm (13.55 in.)	344.16 mm (13.55 in.)
	Diagonal	395 mm (15.55 in.)	395 mm (15.55 in.)	395 mm (15.55 in.)	395 mm (15.55 in.)
Display-panel native resolution	1920 x 1080	1920 x 1080	1920 x 1080	2560 x 1440	
Luminance (typical)	250 nits	300 nits	300 nits	400 nits	
Megapixels	2.07	2.07	2.07	3.68	
Color gamut	45% NTSC (typical)	100% sRGB (typical)	100% sRGB (typical)	99% DCI-P3 (typical)	
Pixels Per Inch (PPI)	141	141	141	188	
Contrast ratio	<ul style="list-style-type: none"> 600:1 (minimum) 800:1 (typical) 	<ul style="list-style-type: none"> 800:1 (minimum) 1000:1 (typical) 	<ul style="list-style-type: none"> 800:1 (minimum) 1000:1 (typical) 	<ul style="list-style-type: none"> 800:1 (minimum) 1000:1 (typical) 	
Response time	<ul style="list-style-type: none"> Tr+Tf: 25 ms (typical) Tr+Tf: 35 ms (maximum) 	<ul style="list-style-type: none"> GtG with Overdrive: 3 ms (typical) 	<ul style="list-style-type: none"> GtG with Overdrive: 1 ms (typical) 	<ul style="list-style-type: none"> GtG with Overdrive: 2 ms (typical) 	

Table 19. Display specifications (continued)

Description	Option one	Option two	Option three	Option four
		<ul style="list-style-type: none"> GtG without Overdrive: 8 ms (typical) 		
Refresh rate	120 Hz	165 Hz	360 Hz	240 Hz
Horizontal view angle	+/- 85 degrees (typical)	+/- 85 degrees (typical)	+/- 85 degrees (typical)	+/- 85 degrees (typical)
Vertical view angle	+/- 85 degrees (typical)	+/- 85 degrees (typical)	+/- 85 degrees (typical)	+/- 85 degrees (typical)
Pixel pitch	0.17925 x 0.17925 mm	0.17925 x 0.17925 mm	0.17925 x 0.17925 mm	0.13446 x 0.13446 mm
Power consumption (maximum)	4.60 W	6 W	7.6 W	8.55 W
Anti-glare vs glossy finish	Anti-glare	Anti-glare	Anti-glare	Anti-glare
Touch options	No	No	No	No

GPU—Integrated

The following table lists the specifications of the integrated Graphics Processing Unit (GPU) supported by your Dell G15 5535.

Table 20. GPU—Integrated

Controller	Memory size	Processor
AMD Radeon Graphics	Shared system memory	<ul style="list-style-type: none"> AMD Ryzen 5 7640HS AMD Ryzen 7 7840HS

GPU—Discrete

The following table lists the specifications of the discrete Graphics Processing Unit (GPU) supported by your Dell G15 5535.

Table 21. GPU—Discrete

Controller	Memory size	Memory type
NVIDIA GeForce RTX 3050	6 GB	GDDR6
NVIDIA GeForce RTX 4050	6 GB	GDDR6
NVIDIA GeForce RTX 4060	8 GB	GDDR6

Operating and storage environment

This table lists the operating and storage specifications of your Dell G15 5535.

Airborne contaminant level: G1 as defined by ISA-S71.04-1985

Table 22. Computer environment

Description	Operating	Storage
Temperature range	0°C to 35°C (32°F to 95°F)	-40°C to 65°C (-40°F to 149°F)
Relative humidity (maximum)	10% to 90% (non-condensing)	0% to 95% (non-condensing)
Vibration (maximum)*	0.66 GRMS	1.30 GRMS
Shock (maximum)	110 G†	160 G†
Altitude range	-15.2 m to 3048 m (-49.87 ft to 10000 ft)	-15.2 m to 10668 m (-49.87 ft to 35000 ft)
 CAUTION: Operating and storage temperature ranges may differ among components, so operating or storing the device outside these ranges may impact the performance of specific components.		

* Measured using a random vibration spectrum that simulates the user environment.

† Measured using a 2 ms half-sine pulse.

ComfortView Plus

 **WARNING: Prolonged exposure to blue light from the display may lead to long-term effects such as eye strain, eye fatigue, or damage to the eyes.**

Blue light is a color in the light spectrum which has a short wavelength and high energy. Chronic exposure to blue light, particularly from digital sources, may disrupt sleep patterns and cause long-term effects such as eye strain, eye fatigue, or damage to the eyes.

The display on this computer is designed to minimize blue light and complies with TÜV Rheinland's requirement for low blue light displays.

Low blue light mode is enabled at the factory, so no further configuration is necessary.











To reduce the risk of eye strain, it is also recommended that you:

- Position the display at a comfortable viewing distance between 20 and 28 inches (50 cm and 70 cm) from your eyes.
- Blink frequently to moisten your eyes, wet your eyes with water, or apply suitable eye drops.
- Look away from your display, and gaze at a distant object at 20 ft (609.60 cm) away for at least 20 seconds during each break.
- Take an extended break for 20 minutes every two hours.

Working inside your computer

Safety instructions

Use the following safety guidelines to protect your computer from potential damage and to ensure your personal safety. Unless otherwise noted, each procedure in this document assumes that you have read the safety information that shipped with your computer.

-  **WARNING:** Before working inside your computer, read the safety information that is shipped with your computer. For more safety best practices, see the Regulatory Compliance home page at www.dell.com/regulatory_compliance.
-  **WARNING:** Disconnect your computer from all power sources before opening the computer cover or panels. After you finish working inside the computer, replace all covers, panels, and screws before connecting your computer to an electrical outlet.
-  **CAUTION:** To avoid damaging the computer, ensure that the work surface is flat, dry, and clean.
-  **CAUTION:** To avoid damaging the components and cards, handle them by their edges, and avoid touching the pins and the contacts.
-  **CAUTION:** You should only perform troubleshooting and repairs as authorized or directed by the Dell technical assistance team. Damage due to servicing that is not authorized by Dell is not covered by your warranty. See the safety instructions that is shipped with the product or at www.dell.com/regulatory_compliance.
-  **CAUTION:** Before touching anything inside your computer, ground yourself by touching an unpainted metal surface, such as the metal at the back of the computer. While you work, periodically touch an unpainted metal surface to dissipate static electricity which could harm internal components.
-  **CAUTION:** When you disconnect a cable, pull it by its connector or its pull tab, not the cable itself. Some cables have connectors with locking tabs or thumbscrews that you must disengage before disconnecting the cable. When disconnecting cables, keep them evenly aligned to avoid bending the connector pins. When connecting cables, ensure that the ports and the connectors are correctly oriented and aligned.
-  **CAUTION:** Press and eject any installed card from the media-card reader.
-  **CAUTION:** Exercise caution when handling rechargeable Li-ion batteries in laptops. Swollen batteries should not be used and should be replaced and disposed properly.
-  **NOTE:** The color of your computer and certain components may appear differently than shown in this document.

Before working inside your computer

About this task

-  **NOTE:** The images in this document may differ from your computer depending on the configuration you ordered.

Steps

1. Save and close all open files and exit all open applications.
2. Shut down your computer. For Windows operating system, click **Start** >  **Power** > **Shut down**.

 **NOTE:** If you are using a different operating system, see the documentation of your operating system for shut-down instructions.

3. Disconnect your computer and all attached devices from their electrical outlets.
4. Disconnect all attached network devices and peripherals, such as keyboard, mouse, and monitor from your computer.

 **CAUTION:** To disconnect a network cable, first unplug the cable from your computer and then unplug the cable from the network device.

5. Remove any media card and optical disc from your computer, if applicable.

Safety precautions

The safety precautions chapter details the primary steps to be taken before performing any disassembly instructions.

Observe the following safety precautions before you perform any installation or break or fix procedures involving disassembly or reassembly:

- Turn off the computer and all attached peripherals.
- Disconnect the computer and all attached peripherals from AC power.
- Disconnect all network cables, telephone, and telecommunications lines from the computer.
- Use an ESD field service kit when working inside any to avoid electrostatic discharge (ESD) damage.
- After removing any computer component, carefully place the removed component on an anti-static mat.
- Wear shoes with non-conductive rubber soles to reduce the chance of getting electrocuted.

Standby power

Dell products with standby power must be unplugged before you open the case. Systems that incorporate standby power are powered while turned off. The internal power enables the computer to be remotely turned on (Wake-on-LAN) and suspended into a sleep mode and has other advanced power management features.

Unplugging, pressing, and holding the power button for 15 seconds should discharge residual power in the system board.

Bonding

Bonding is a method for connecting two or more grounding conductors to the same electrical potential. This is done by using a field service electrostatic discharge (ESD) kit. When connecting a bonding wire, ensure that it is connected to bare metal and never to a painted or nonmetal surface. The wrist strap should be secure and in full contact with your skin, and ensure that you remove all jewelry such as watches, bracelets, or rings prior to bonding yourself and the equipment.

Electrostatic discharge—ESD protection

ESD is a major concern when you handle electronic components, especially sensitive components such as expansion cards, processors, memory DIMMs, and system boards. Slight charges can damage circuits in ways that may not be obvious, such as intermittent problems or a shortened product life span. As the industry pushes for lower power requirements and increased density, ESD protection is an increasing concern.

Due to the increased density of semiconductors used in recent Dell products, the sensitivity to static damage is now higher than in previous Dell products. For this reason, some previously approved methods of handling parts are no longer applicable.

Two recognized types of ESD damage are catastrophic and intermittent failures.

- **Catastrophic** – Catastrophic failures represent approximately 20 percent of ESD-related failures. The damage causes an immediate and complete loss of device functionality. An example of catastrophic failure is a memory DIMM that has received a static shock and immediately generates a "No POST/No Video" symptom with a beep code that is emitted for missing or nonfunctional memory.
- **Intermittent** – Intermittent failures represent approximately 80 percent of ESD-related failures. The high rate of intermittent failures means that most of the time when damage occurs, it is not immediately recognizable. The DIMM receives a static shock, but the tracing is merely weakened and does not immediately produce outward symptoms that are related to the damage. The weakened trace may take weeks or months to melt, and in the meantime may cause degradation of memory integrity, intermittent memory errors, and so on.

The more difficult type of damage to recognize and troubleshoot is the intermittent (also called latent or "walking wounded") failure.

Perform the following steps to prevent ESD damage:

- Use a wired ESD wrist strap that is properly grounded. The use of wireless anti-static straps is no longer allowed; they do not provide adequate protection. Touching the chassis before handling parts does not ensure adequate ESD protection on parts with increased sensitivity to ESD damage.
- Handle all static-sensitive components in a static-safe area. If possible, use anti-static floor pads and workbench pads.
- When unpacking a static-sensitive component from its shipping carton, do not remove the component from the anti-static packing material until you are ready to install the component. Before unwrapping the anti-static packaging, ensure that you discharge static electricity from your body.
- Before transporting a static-sensitive component, place it in an anti-static container or packaging.

ESD field service kit

The unmonitored Field Service kit is the most commonly used service kit. Each Field Service kit includes three main components: anti-static mat, wrist strap, and bonding wire.

Components of an ESD field service kit

The components of an ESD field service kit are:

- **Anti-Static Mat** – The anti-static mat is dissipative and parts can be placed on it during service procedures. When using an anti-static mat, your wrist strap should be snug and the bonding wire should be connected to the mat and to any bare metal on the computer being worked on. Once deployed properly, service parts can be removed from the ESD bag and placed directly on the mat. ESD-sensitive items are safe in your hand, on the ESD mat, in the computer, or inside a bag.
- **Wrist Strap and Bonding Wire** – The wrist strap and bonding wire can be either directly connected between your wrist and bare metal on the hardware if the ESD mat is not required, or connected to the anti-static mat to protect hardware that is temporarily placed on the mat. The physical connection of the wrist strap and bonding wire between your skin, the ESD mat, and the hardware is known as bonding. Use only Field Service kits with a wrist strap, mat, and bonding wire. Never use wireless wrist straps. Always be aware that the internal wires of a wrist strap are prone to damage from normal wear and tear, and must be checked regularly with a wrist strap tester in order to avoid accidental ESD hardware damage. It is recommended to test the wrist strap and bonding wire at least once per week.
- **ESD Wrist Strap Tester** – The wires inside an ESD strap are prone to damage over time. When using an unmonitored kit, it is a best practice to regularly test the strap prior to each service call, and at a minimum, test once per week. A wrist strap tester is the best method for doing this test. If you do not have your own wrist strap tester, check with your regional office to find out if they have one. To perform the test, plug the wrist-strap's bonding-wire into the tester while it is strapped to your wrist and push the button to test. A green LED is lit if the test is successful; a red LED is lit and an alarm sounds if the test fails.
- **Insulator Elements** – It is critical to keep ESD sensitive devices, such as plastic heat sink casings, away from internal parts that are insulators and often highly charged.
- **Working Environment** – Before deploying the ESD Field Service kit, assess the situation at the customer location. For example, deploying the kit for a server environment is different than for a desktop or laptop environment. Servers are typically installed in a rack within a data center; desktops or laptops are typically placed on office desks or cubicles. Always look for a large open flat work area that is free of clutter and large enough to deploy the ESD kit with additional space to accommodate the type of computer that is being repaired. The workspace should also be free of insulators that can cause an ESD event. On the work area, insulators such as Styrofoam and other plastics should always be moved at least 12 inches or 30 centimeters away from sensitive parts before physically handling any hardware components.
- **ESD Packaging** – All ESD-sensitive devices must be shipped and received in static-safe packaging. Metal, static-shielded bags are preferred. However, you should always return the damaged part using the same ESD bag and packaging that the new part arrived in. The ESD bag should be folded over and taped shut and all the same foam packing material should be used in the original box that the new part arrived in. ESD-sensitive devices should be removed from packaging only at an ESD-protected work surface, and parts should never be placed on top of the ESD bag because only the inside the bag is shielded. Always place parts in your hand, on the ESD mat, in the computer, or inside an anti-static bag.
- **Transporting Sensitive Components** – When transporting ESD sensitive components such as replacement parts or parts to be returned to Dell, it is critical to place these parts in anti-static bags for safe transport.

ESD protection summary

It is recommended to use the traditional wired ESD grounding wrist strap and protective anti-static mat always when servicing Dell products. In addition, it is critical to keep sensitive parts separate from all insulator parts while performing service and that they use anti-static bags for transporting sensitive components.

Transporting sensitive components

When transporting ESD sensitive components such as replacement parts or parts to be returned to Dell, it is critical to place these parts in anti-static bags for safe transport.

After working inside your computer

About this task

 **CAUTION:** Leaving stray or loose screws inside your computer may severely damage your computer.

Steps

1. Replace all screws and ensure that no stray screws remain inside your computer.
2. Connect any external devices, peripherals, or cables you removed before working on your computer.
3. Replace any media cards, discs, or any other parts that you removed before working on your computer.
4. Connect your computer and all attached devices to their electrical outlets.
5. Turn on your computer.

BitLocker

 **CAUTION:** If BitLocker is not suspended before updating the BIOS, the next time you reboot the system it will not recognize the BitLocker key. You will then be prompted to enter the recovery key to progress, and the system will ask for the recovery key on each reboot. If the recovery key is not known, this can result in data loss or an unnecessary operating system reinstall. For more information about this subject, see Knowledge Article: [updating the BIOS on Dell systems with BitLocker enabled](#).

The installation of the following components triggers BitLocker:

- Hard disk drive or solid-state drive
- System board

Recommended tools

The procedures in this document may require the following tools:

- Phillips screwdriver #0
- Phillips screwdriver #1
- Plastic scribe

Screw list

 **NOTE:** When removing screws from a component, it is recommended to note the screw type, the quantity of screws, and then place them in a screw storage box. This is to ensure that the correct number of screws and correct screw type is restored when the component is replaced.

 **NOTE:** Some computers have magnetic surfaces. Ensure that the screws are not left attached to such surfaces when replacing a component.

NOTE: Screw color may vary with the configuration ordered.

Table 23. Screw list























Component	Screw type	Quantity	Screw image
Base cover	M2x5	6	
Battery	M2x4	4	
Solid-state drive (SSD slot 1)	M2x4	2	
Solid-state drive (SSD slot 2)	M2x4	2	
Wireless card	M2x4	1	
Touchpad bracket	M2x2	3	
Touchpad	M2x2	4	
Rear cover	M2x4	2	
Rear cover	M2x5	4	
Display hinges	M2.5x4	8	
Keyboard-controller board	M2x2	1	
Power-adaptor port	M2x5	2	
System board	M2x5	7	
System board	M2x3	2	
System board	M2x4	1	
USB board	M2x4	2	
USB board	M2x3	1	
Ethernet and audio board	M2x4	2	

Table 23. Screw list (continued)

Component	Screw type	Quantity	Screw image
Ethernet and audio board	M2x3	1	
Left fan (fan and heat-sink assembly)	M2x4	1	
Fan and heat-sink assembly	M2x4	6	
Power-button board bracket	M2x2	2	
Power button	M2x2	1	

Major components of Dell G15 5535

The following image shows the major components of Dell G15 5535.

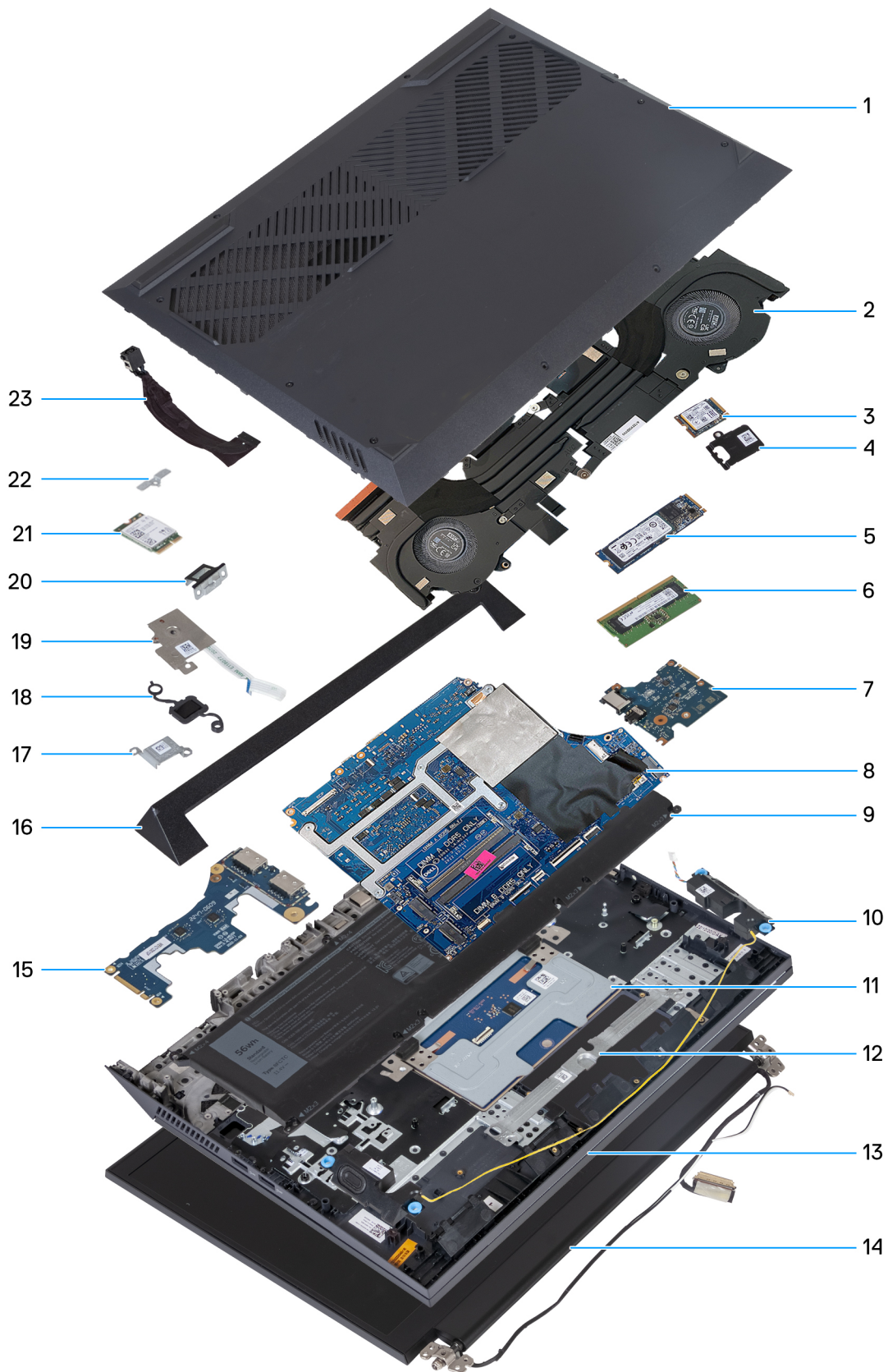

- | | |
|-----------------------------|---|
| 1. Base cover | 2. Fan and heat-sink assembly |
| 3. M.2 solid-state drive | 4. M.2 solid-state drive thermal shield |
| 5. M.2 solid-state drive | 6. Memory module |
| 7. Ethernet and audio board | 8. System board |

- 9. Battery
- 11. Touchpad
- 13. Palm-rest and keyboard assembly
- 15. USB board
- 17. Power-adaptor port bracket
- 19. Power-button board
- 21. Wireless card
- 23. Power-adaptor port

- 10. Speakers
- 12. Touchpad bracket
- 14. Display assembly
- 16. Rear cover
- 18. Power button
- 20. USB Type-C port bracket
- 22. Wireless-card bracket

 **NOTE:** Dell provides a list of components and their part numbers for the original system configuration purchased. These parts are available according to warranty coverages purchased by the customer. Contact your Dell sales representative for purchase options.

Removing and installing Customer Replaceable Units (CRUs)

The replaceable components in this chapter are Customer Replaceable Units (CRUs).

 **CAUTION:** Customers can replace only the Customer Replaceable Units (CRUs) following the safety precautions and replacement procedures.

 **NOTE:** The images in this document may differ from your computer depending on the configuration you ordered.

Base cover

Removing the base cover

Prerequisites

1. Follow the procedure in [Before working inside your computer](#).

About this task

The following images indicate the location of the base cover and provide a visual representation of the removal procedure.



6x
M2x5



4x

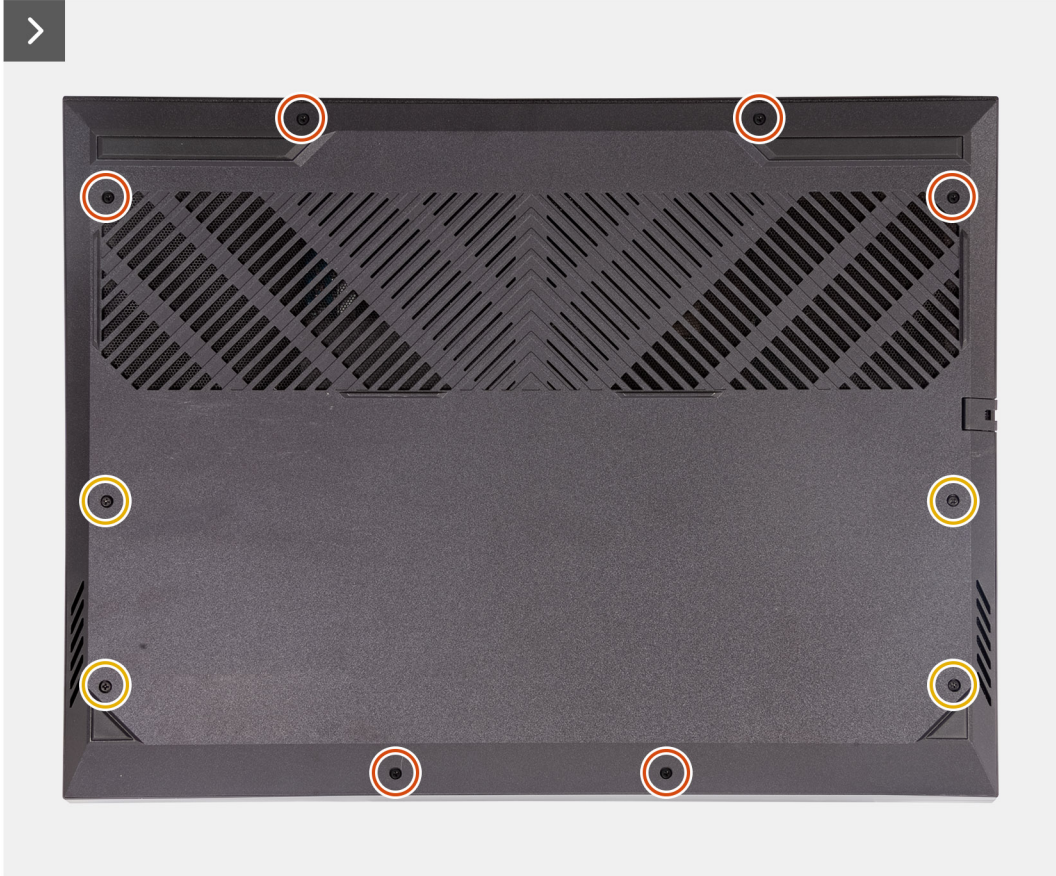

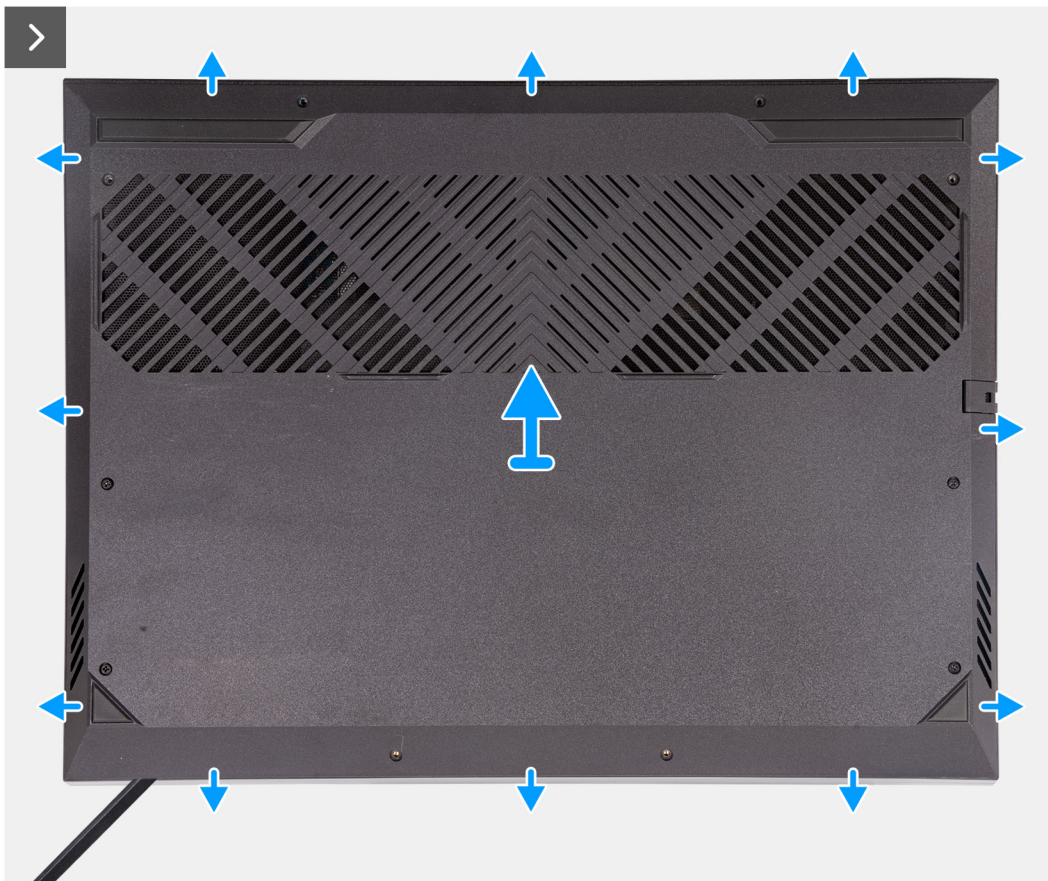

Steps

1. Remove the six screws (M2x5) that secure the base cover to the palm-rest and keyboard assembly.
2. Loosen the four captive screws that secure the base cover to the palm-rest and keyboard assembly.
 - NOTE:** Loosening the two captive screws that are located in the front of the computer creates a gap which can be used to pry and lift the base cover off the palm-rest and keyboard assembly.
3. Starting from the gap created at the left-bottom corner, pry open the base cover. Work your way around the bottom edge and bottom-right corner of the base cover.
4. Lift the base cover off the palm-rest and keyboard assembly.
 - NOTE:** The following steps are applicable only if you want to further remove any other component from your computer.
5. Peel the tape that secures the battery cable to the battery.
6. Using the pull tab, disconnect the battery cable from the system board.

7. Turn your computer over and press the power button for 20 seconds to drain the flea power.

Installing the base cover

Prerequisites

If you are replacing a component, remove the existing component before performing the installation procedure.

About this task

The following images indicate the location of the base cover and provide a visual representation of the installation procedure.

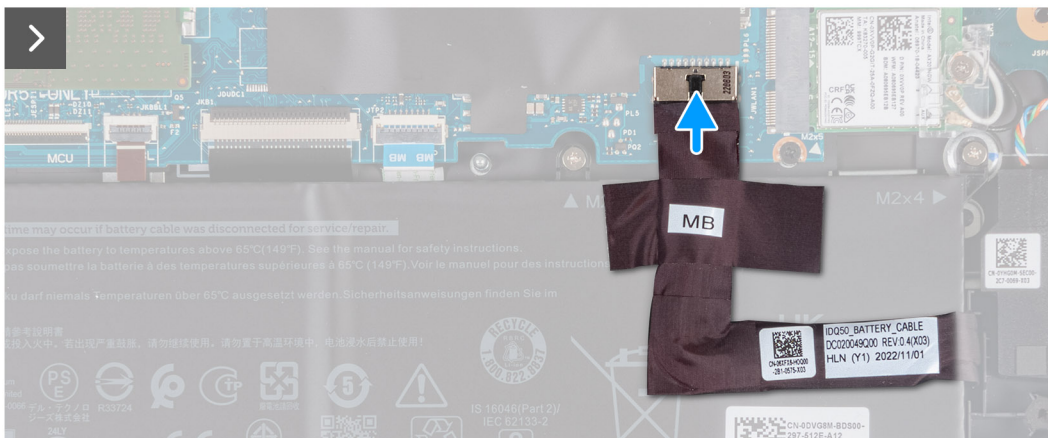
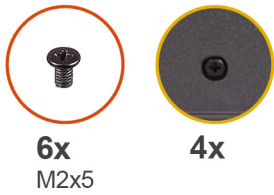

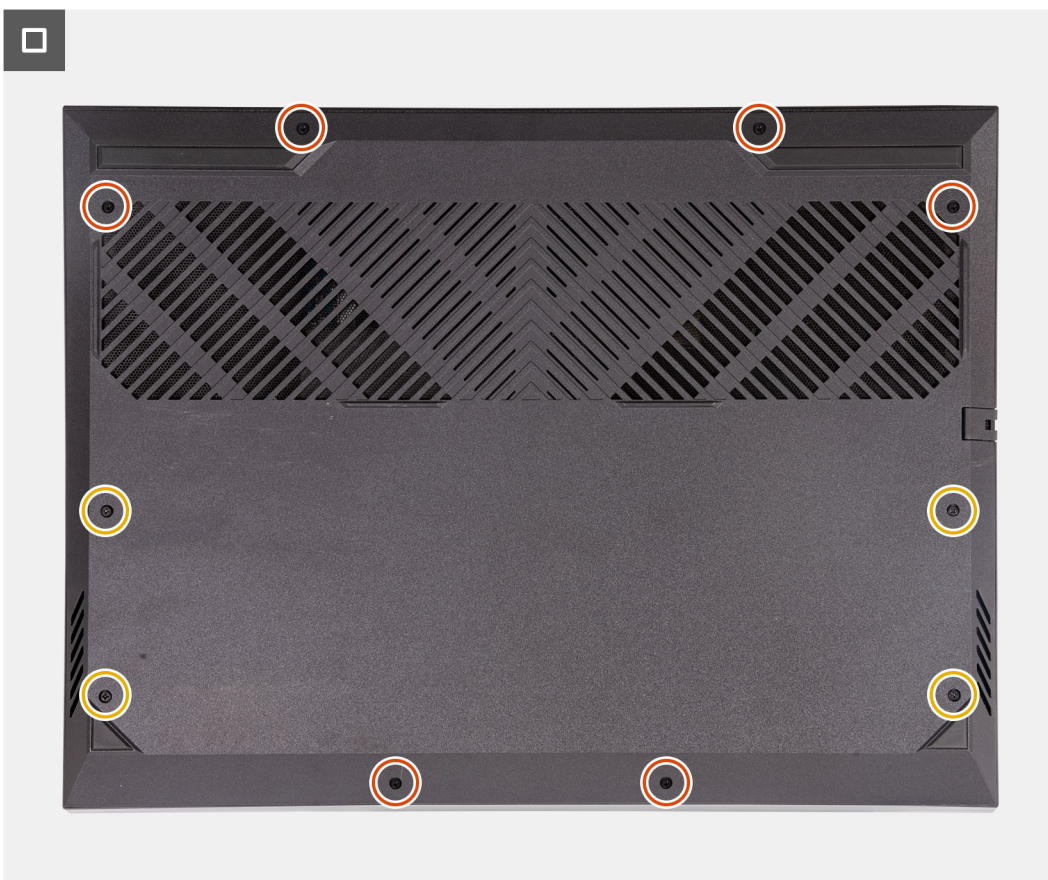
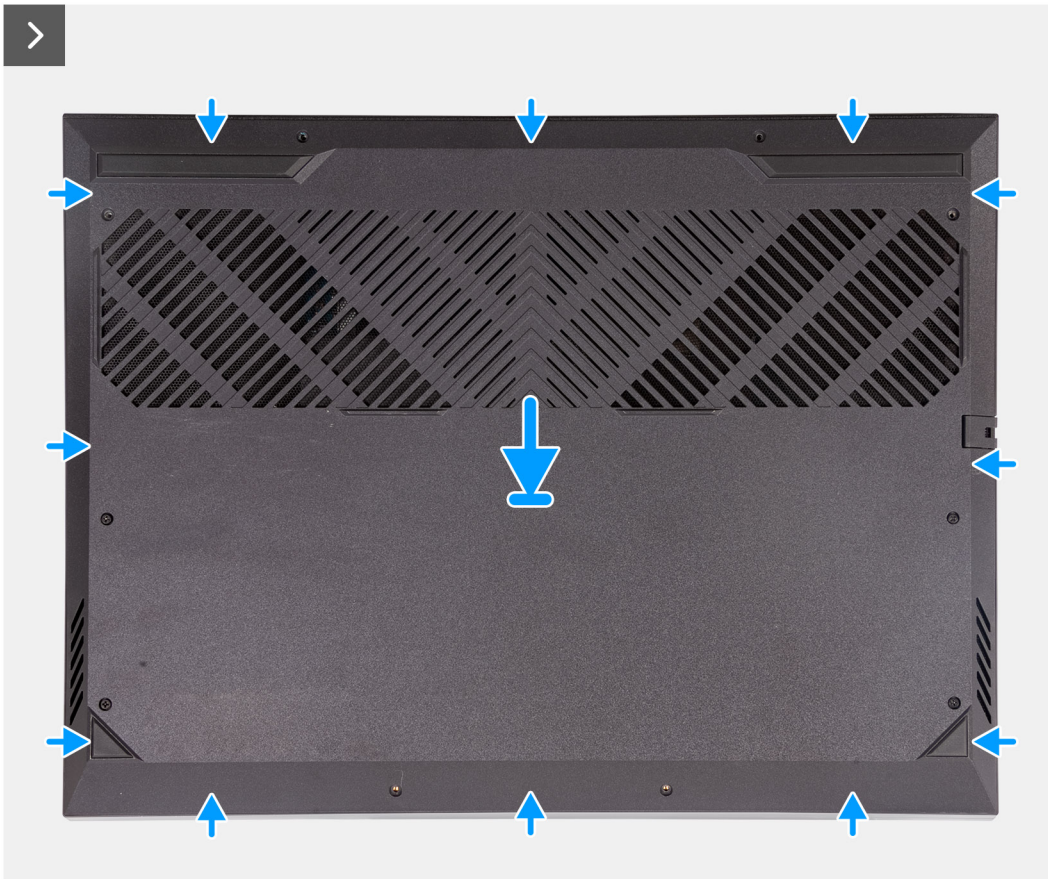

Steps

1. Connect the battery cable to the system board, if the battery cable had been previously disconnected.
2. Adhere the tape that secures the battery cable to the battery.
3. Align the screw holes on the base cover with the screw holes on the palm-rest and keyboard assembly, and then snap the base cover into place.
4. Replace the six screws (M2x5) that secure the base cover to the palm-rest and keyboard assembly.
5. Tighten the four captive screws that secure the base cover to the palm-rest and keyboard assembly.

Next steps

1. Follow the procedure in [After working inside your computer](#).

Solid-state drive

Removing the solid-state drive

Prerequisites

1. Follow the procedure in [Before working inside your computer](#).
2. Remove the [base cover](#).

About this task

 **NOTE:** Your computer has two M.2 solid-state drive slots, both located on the system board adjacent to the left fan. The procedure to remove a solid-state drive from slot 1 and slot 2 are exactly the same.

 **NOTE:** Depending on the configuration ordered, a 2230 or 2280 solid-state drive may be installed in your computer.

The following image(s) indicates the location of M.2 2230 solid-state drive or the M.2 2280 solid-state drive and provides a visual representation of their respective removal procedures.

Removing the M.2 2230 solid-state drive

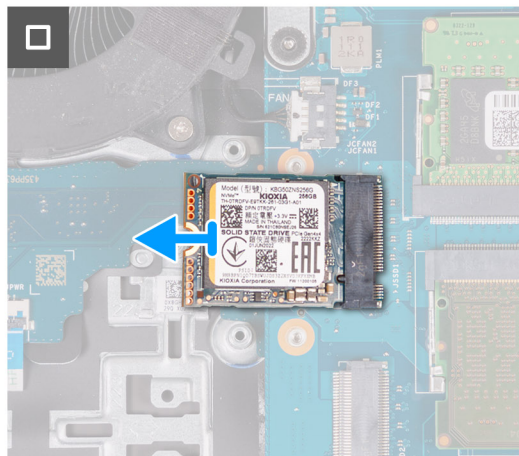
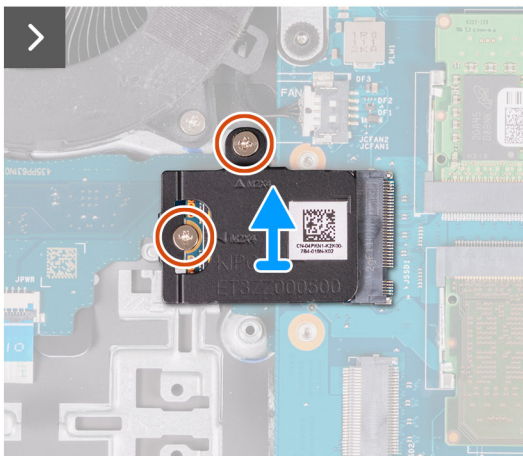
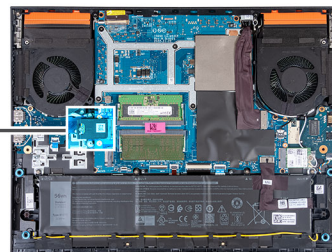

Removing the M.2 2280 solid-state drive



2x
M2x4

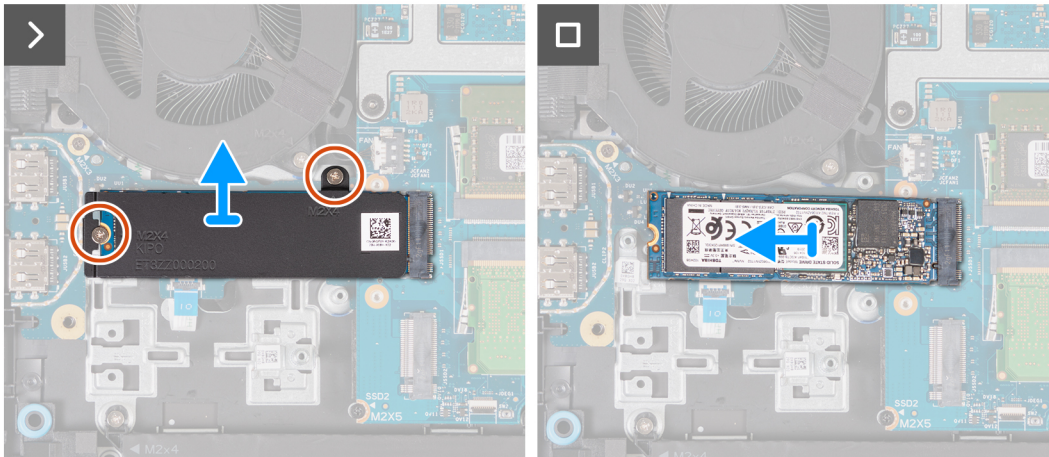
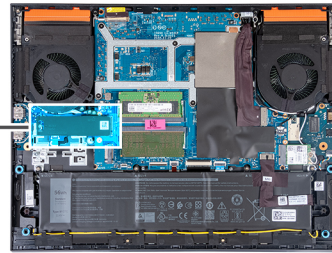

Steps

1. Remove the two screws (M2x4) that secure the thermal shield to the solid-state drive and the system board.
2. Lift the thermal shield off the palm-rest and keyboard assembly.
3. Slide and lift the solid-state drive off the M.2 slot on the system board.

Installing the solid-state drive

Prerequisites

If you are replacing a component, remove the existing component before performing the installation procedure.

About this task

NOTE: Your computer has two M.2 solid-state drive slots, both located on the system board next to the left fan. The procedure to remove a solid-state drive from slot 1 and slot 2 are exactly the same.

NOTE:

A M.2 2230 or 2280 solid-state drive may be installed into both slot 1 and 2.

If you are installing a solid-state drive into **slot 2** by yourself, only a **M.2 2280 SSD**, paired with a **Dell thermal shield** is recommended. Depending on the previously installed configuration, the solid-state drive screw mount may have to be moved to facilitate the installation of the new M.2 2280 solid-state drive.

The following image(s) indicates the location of the M.2 2230 solid-state drive or the M.2 2280 solid-state drive and provides a visual representation of their respective installation procedures.

Installing the M.2 2230 solid-state drive



2x
M2x4

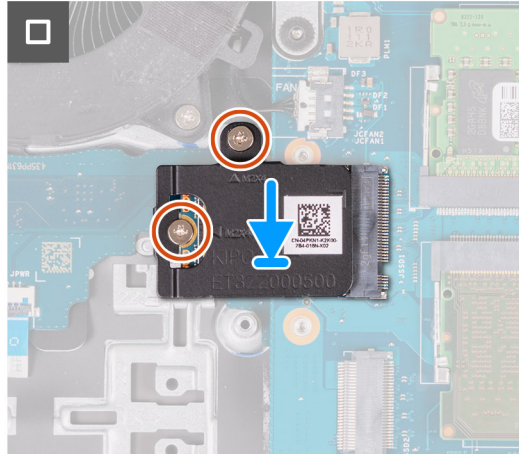
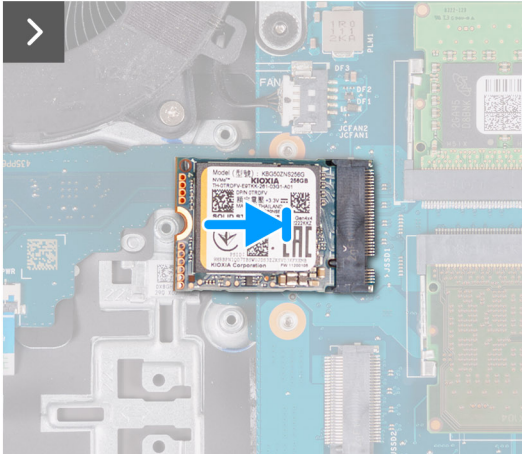
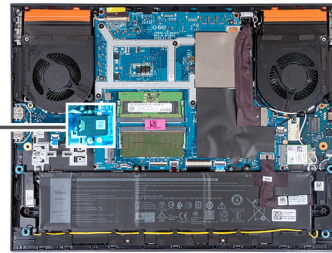

Installing the M.2 2280 solid-state drive



2x
M2x4

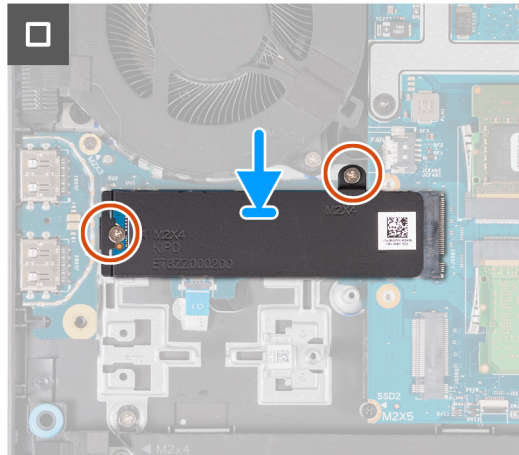
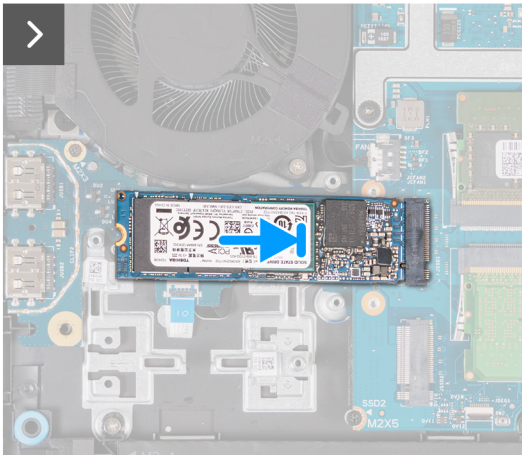
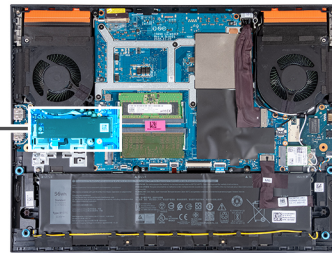

Steps

1. Align the notch on the solid-state drive with the tab on the M.2 card slot.
2. Slide the solid-state drive into the M.2 card slot.
3. Place the thermal shield on the solid-state drive.
4. Align the screw holes on the thermal shield with the screw holes on the solid-state drive and system board.
5. Replace the two screws (M2x4) that secure the thermal shield to the solid-state drive and the system board.

Next steps

1. Install the [base cover](#).
2. Follow the procedure in [After working inside your computer](#).

Procedure to move the M.2 solid-state drive screw mount for solid-state drive slot 2

About this task

NOTE: Both M.2 solid-state drive slots on this computer support the following solid-state drive configurations:

- M.2 2230 solid-state drive
- M.2 2280 solid-state drive

NOTE: Depending on the configuration ordered, a M.2 2230 or 2280 solid-state drive may be installed into both slot 1 and 2. If you are installing a solid-state drive into **slot 2** by yourself, only a **M.2 2280 SSD**, paired with a **Dell thermal shield** is recommended.

If you are replacing the solid-state drive of a different form factor other than the one removed, perform the following procedure to move the location of the solid-state drive screw mount.

Steps

1. Push the solid-state drive screw mount outwards to remove it from the screw-mount slot of the palm-rest and keyboard assembly.
2. Rotate the solid-state drive screw mount 180 degrees and slide it into the **M.2 2280** screw-mount slot.

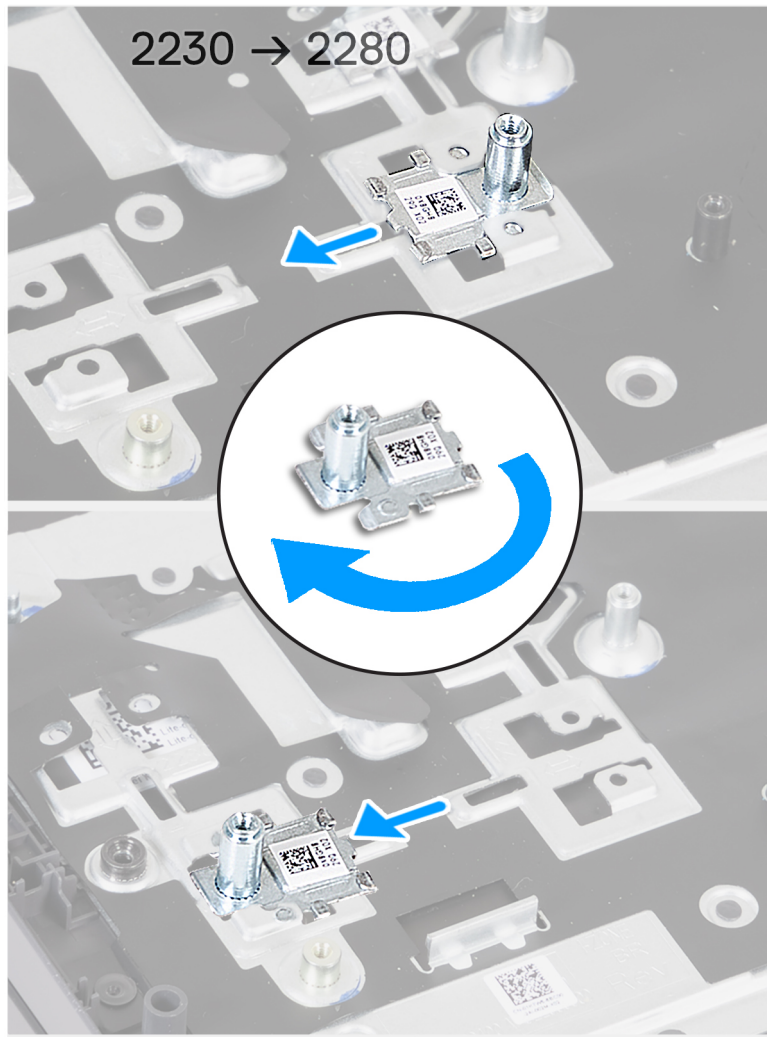

Figure 1. Changing 2280 to 2230

3. To install the solid-state drive, see [installing solid-state drive](#).

Wireless card

Removing the wireless card

Prerequisites

1. Follow the procedure in [Before working inside your computer](#).
2. Remove the [base cover](#).

About this task

The following image indicates the location of the wireless card and provides a visual representation of the removal procedure.



1x
M2x4

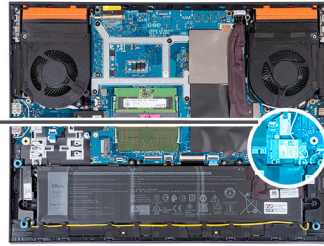

Steps

1. Remove the screw (M2x4) that secures the wireless card to the system board.
2. Lift the bracket off the wireless card.
3. Disconnect the antenna cables from the wireless card.
4. Slide and remove the wireless card from the M.2 wireless card slot.

Installing the wireless card

Prerequisites

If you are replacing a component, remove the existing component before performing the installation procedure.

About this task

The following image indicates the location of the wireless card and provides a visual representation of the installation procedure.



1x
M2x4

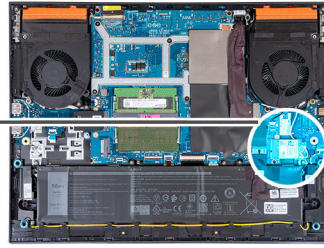

Steps

1. Connect the antenna cables to the wireless card.

The following table provides the antenna-cable color scheme for the wireless card supported by your computer.

Table 24. Antenna-cable color scheme

Connectors on the wireless card	Antenna-cable color
Main (white triangle)	White
Auxiliary (black triangle)	Black

2. Align the notch on the wireless card with the tab on the M.2 wireless card slot and insert the wireless card at an angle into the M.2 card slot.
3. Place and align the wireless-card bracket on the wireless card.
4. Replace the screw (M2x4) that secures the wireless card to the system board.

Next steps

1. Install the [base cover](#).
2. Follow the procedure in [After working inside your computer](#).

Memory

Removing the memory module

Prerequisites

1. Follow the procedure in [Before working inside your computer](#).
2. Remove the [base cover](#).

About this task

The following image indicates the location of the memory modules and provides a visual representation of the removal procedure.

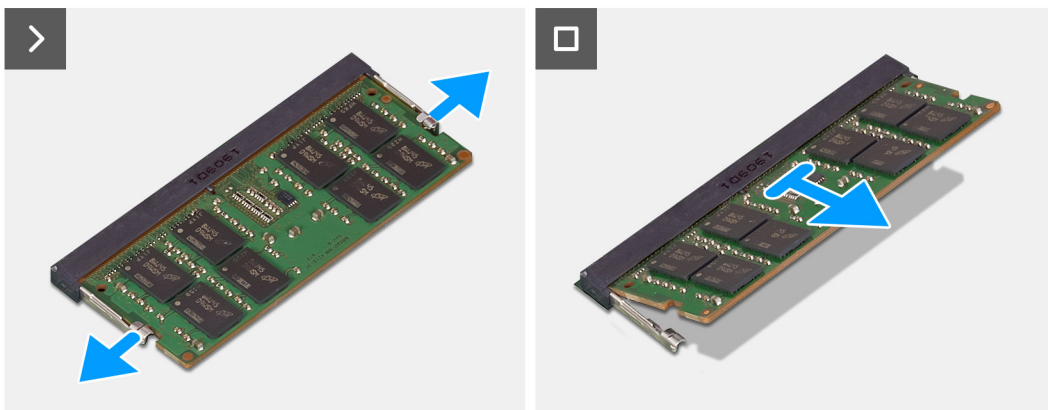
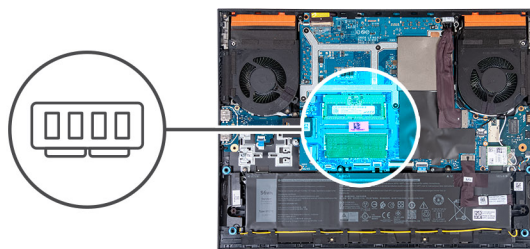

Steps

1. Use your fingertips to carefully spread apart the securing-clips on each end of the memory-module slot until the memory module pops up.
2. Remove the memory module from the memory-module slot.

i **NOTE:** Repeat step 1 and step 2 if there is a second memory module installed on your computer.

Installing the memory module

Prerequisites

If you are replacing a component, remove the existing component before performing the installation procedure.

About this task

The following image indicates the location of the memory module and provides a visual representation of the installation procedure.

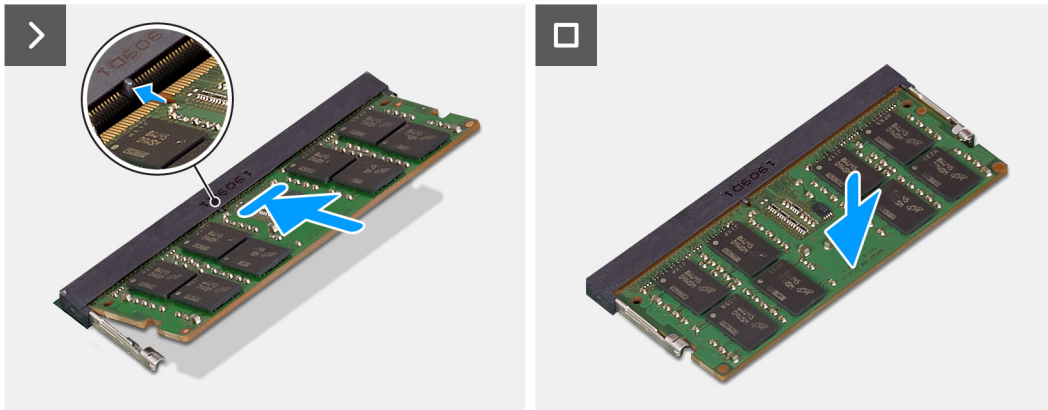
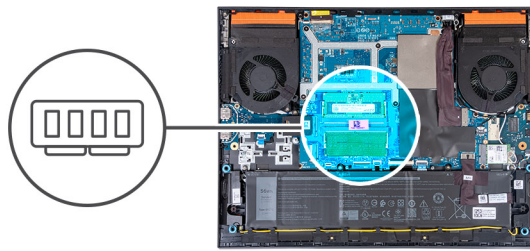

Steps

1. Align the notch on the memory module with the tab on the memory-module slot.
2. Slide the memory module into the memory-module slot.
3. Press the memory module down until it clicks into place.

i **NOTE:** If you do not hear the click, remove the memory module and reinstall it.

i **NOTE:** Repeat step 1 to step 3 to install a second memory module into your computer, if applicable.

Next steps

1. Install the [base cover](#).
2. Follow the procedure in [After working inside your computer](#).

Speakers

Removing the speakers

Prerequisites

1. Follow the procedure in [Before working inside your computer](#).
2. Remove the [base cover](#).

About this task

The following image indicates the location of the speakers and provides a visual representation of the removal procedure.

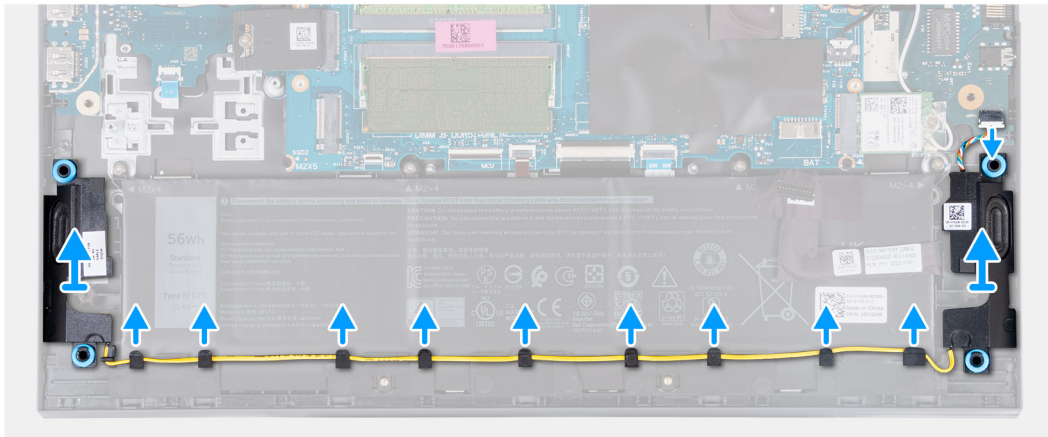
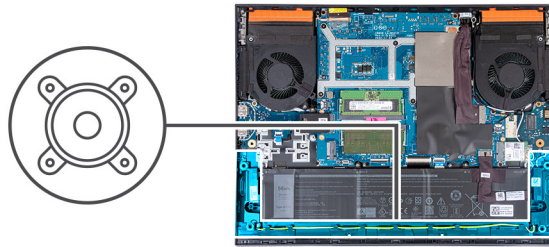

Steps

1. Disconnect the speaker cable from the ethernet and audio board.
2. Remove the speaker cable from the routing guides on the palm-rest and keyboard assembly.
3. Lift the speakers, along with its cable, off the palm-rest and keyboard assembly.

Installing the speakers

Prerequisites

If you are replacing a component, remove the existing component before performing the installation procedure.

About this task

The following image indicates the location of the speakers and provides a visual representation of the installation procedure.

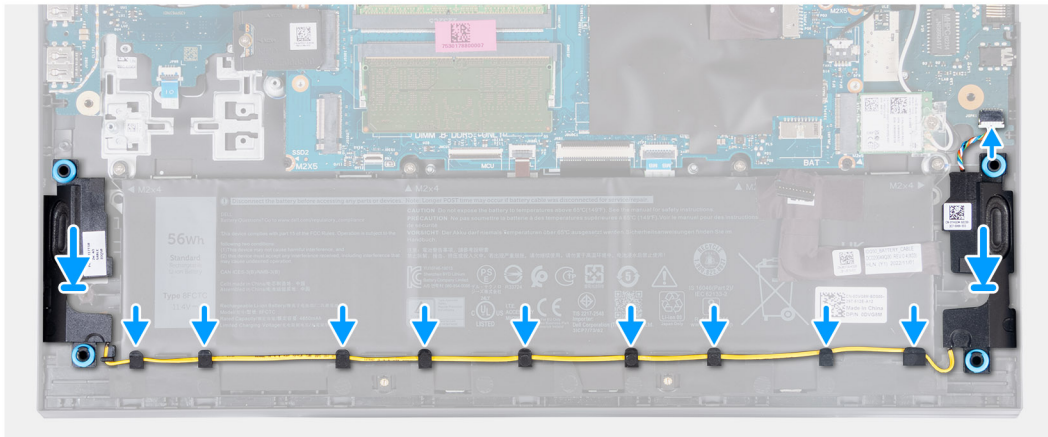
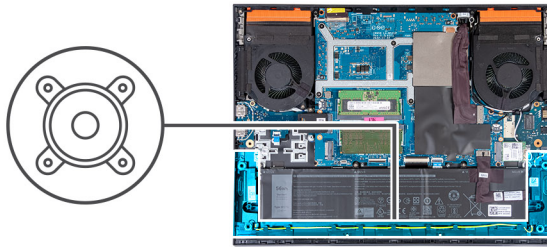

Steps

1. Using the alignment posts and rubber grommets, place the speakers in the slots on the palm-rest and keyboard assembly
i **NOTE:** If the rubber grommets are pushed out of the speakers when removing the speakers, push them back in place before replacing the speakers.
2. Connect the speaker cable to the ethernet and audio board.
3. Route the speaker cable through the routing guides on the palm-rest and keyboard assembly.

Next steps

1. Install the [base cover](#).
2. Follow the procedure in [After working inside your computer](#).

Rear cover

Removing the rear cover

Prerequisites

1. Follow the procedure in [Before working inside your computer](#).
2. Remove the [base cover](#).

About this task

The following image indicates the location of the rear cover and provides a visual representation of the removal procedure.

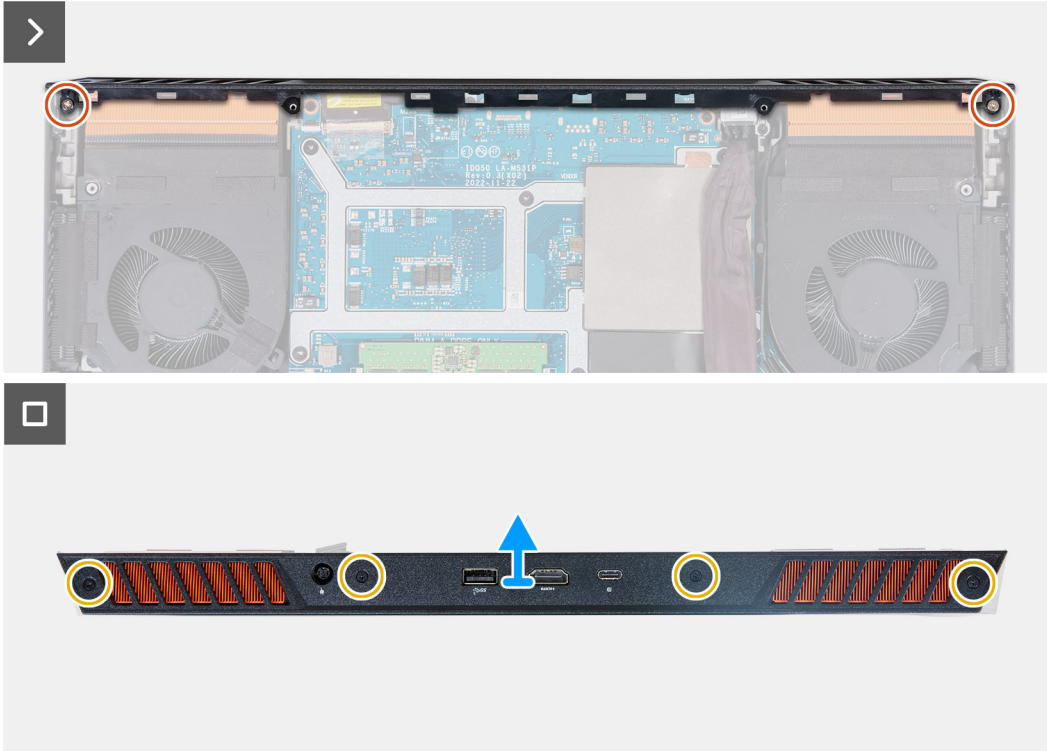
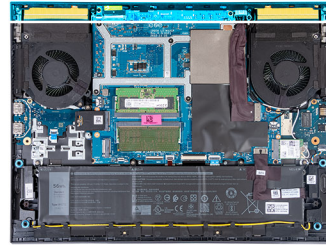
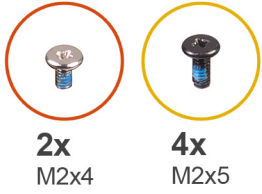

Steps

1. Remove the two screws (M2x4) that secure the rear cover to the system board.
2. Remove the four screws (M2x5) that secure the rear cover to the palm-rest and keyboard assembly.
3. Turn the laptop over and grip both edges of the laptop, with the thumbs placed at the bottom edge of the rear cover, near the air vents.
4. Use both thumbs to push the rear cover away from cooling fans, and lift the rear cover off the palm-rest and keyboard assembly.

Installing the rear cover

Prerequisites

If you are replacing a component, remove the existing component before performing the installation procedure.

About this task

The following image indicates the location of the rear cover and provides a visual representation of the installation procedure.

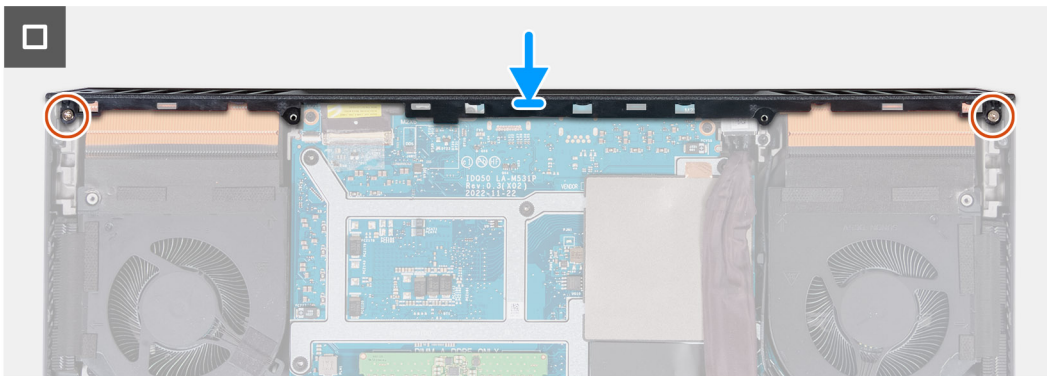
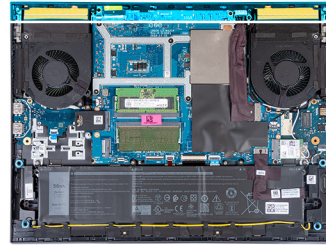
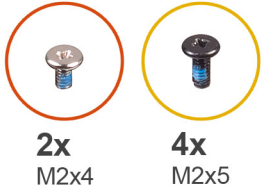

Steps

1. Slide the rear cover towards the system board till it snaps into place.
2. Align the screw holes on the rear cover with the screw holes on the palm-rest and keyboard assembly.
3. Replace the four screws (M2x5) that secure the rear cover to the system board.
4. Replace the two screws (M2x4) that secure the rear cover to the palm-rest and keyboard assembly.

Next steps

1. Install the [base cover](#).
2. Follow the procedure in [After working inside your computer](#).

Removing and installing Field Replaceable Units (FRUs)

The replaceable components in this chapter are Field Replaceable Units (FRUs).

CAUTION: The information in this removing and installing FRUs section is intended for authorized service technicians only.

CAUTION: To avoid any potential damage to the component or loss of data, ensure that an authorized service technician replaces the Field Replaceable Units (FRUs).

CAUTION: Dell Technologies recommends that this set of repairs, if needed, to be conducted by trained technical repair specialists.

CAUTION: As a reminder, your warranty does not cover damages that may occur during the courses of FRU repairs that are not authorized by Dell Technologies.

NOTE: The images in this document may differ from your computer depending on the configuration you ordered.

Battery

Rechargeable Li-ion battery precautions

CAUTION:

- Exercise caution when handling rechargeable Li-ion batteries.
- Discharge the battery completely before removing it. Disconnect the AC power adapter from the computer and operate the computer solely on battery power—the battery is fully discharged when the computer no longer turns on when the power button is pressed.
- Do not crush, drop, mutilate, or penetrate the battery with foreign objects.
- Do not expose the battery to high temperatures, or disassemble battery packs and cells.
- Do not apply pressure to the surface of the battery.
- Do not bend the battery.
- Do not use tools of any kind to pry on or against the battery.
- Ensure any screws during the servicing of this product are not lost or misplaced, to prevent accidental puncture or damage to the battery and other computer components.
- If the battery gets stuck inside your computer as a result of swelling, do not try to release it as puncturing, bending, or crushing a rechargeable Li-ion battery can be dangerous. In such an instance, contact Dell technical support for assistance. See www.dell.com/contactdell.
- Always purchase genuine batteries from www.dell.com or authorized Dell partners and resellers.
- Swollen batteries should not be used and should be replaced and disposed properly. For guidelines on how to handle and replace swollen rechargeable Li-ion batteries, see [Handling swollen rechargeable Li-ion batteries](#).

Removing the battery

Prerequisites

1. Follow the procedure in [Before working inside your computer](#).

2. Remove the [base cover](#).

About this task

The following image indicates the location of the battery and provides a visual representation of the removal procedure.

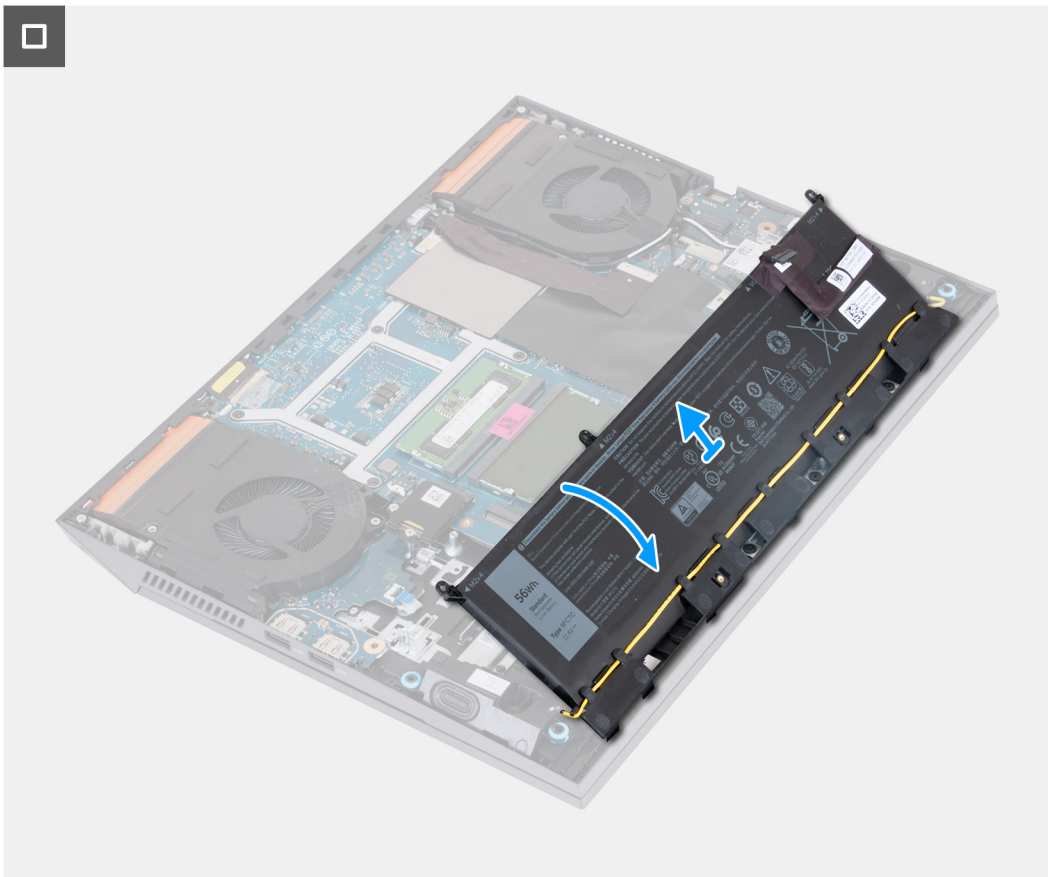
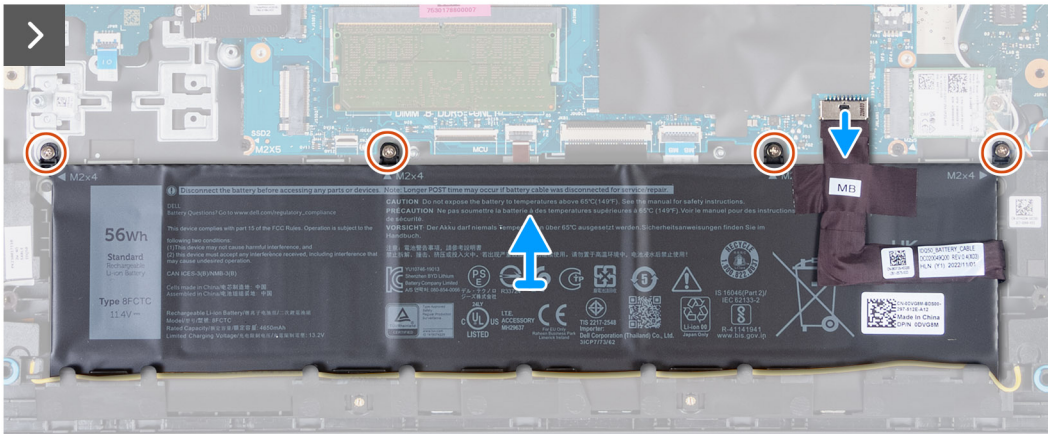
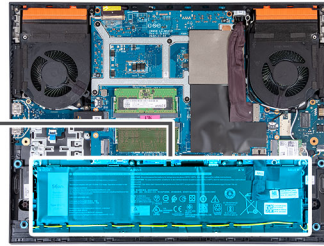
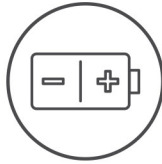

Steps

1. Using the pull tab, disconnect the battery cable from the system board, if it is not previously disconnected.
2. Remove the four screws (M2x4) that secure the battery to the palm-rest and keyboard assembly.
3. Lift the battery at a 45 degree angle and remove it from the palm-rest and keyboard assembly.

Installing the battery

Prerequisites

If you are replacing a component, remove the existing component before performing the installation procedure.

About this task

The following image indicates the location of the battery and provides a visual representation of the installation procedure.



4x
M2x4

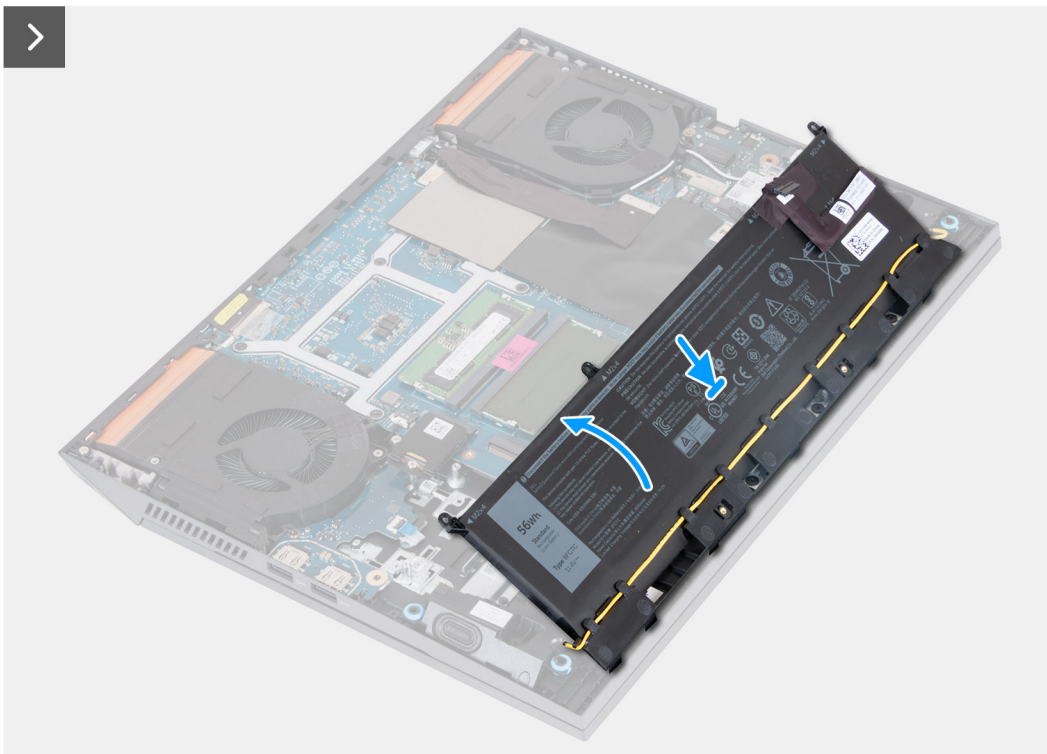
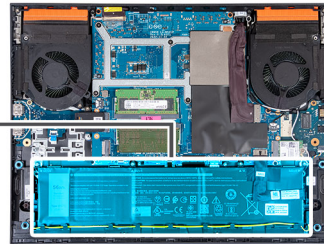
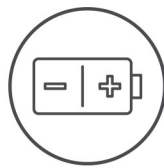

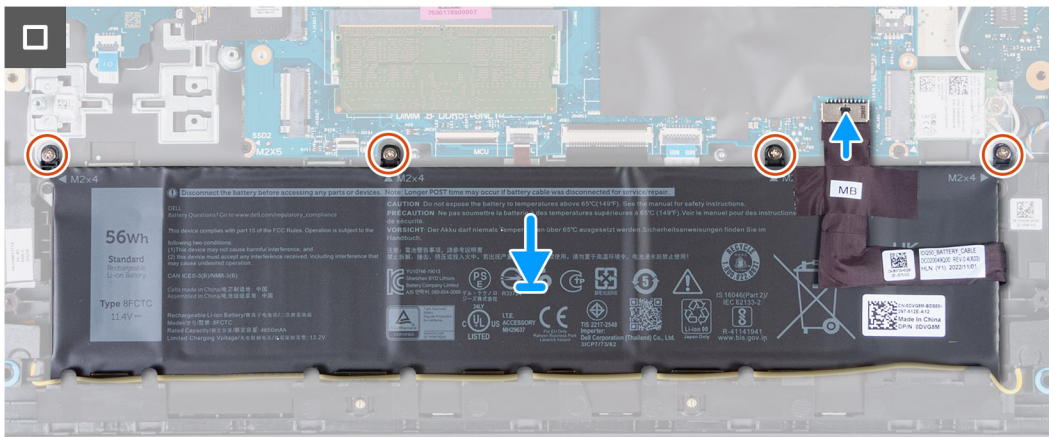

Steps

1. At a 45 degree angle, slide the battery into the slot on the palm-rest and keyboard assembly.
2. Align the screw holes on the battery with the screw holes on the palm-rest and keyboard assembly.
3. Replace the four screws (M2x4) that secure the battery to the palm-rest and keyboard assembly.
4. Connect the battery cable to the system board.
5. Adhere the tape to secure the battery cable to the system board.

Next steps

1. Install the [base cover](#).
2. Follow the procedure in [After working inside your computer](#).

Touchpad

Removing the touchpad

Prerequisites

1. Follow the procedure in [Before working inside your computer](#).
2. Remove the [base cover](#).
3. Remove the [battery](#).

About this task

The following image indicates the location of the touchpad and provides a visual representation of the removal procedure.



7x
M2x2

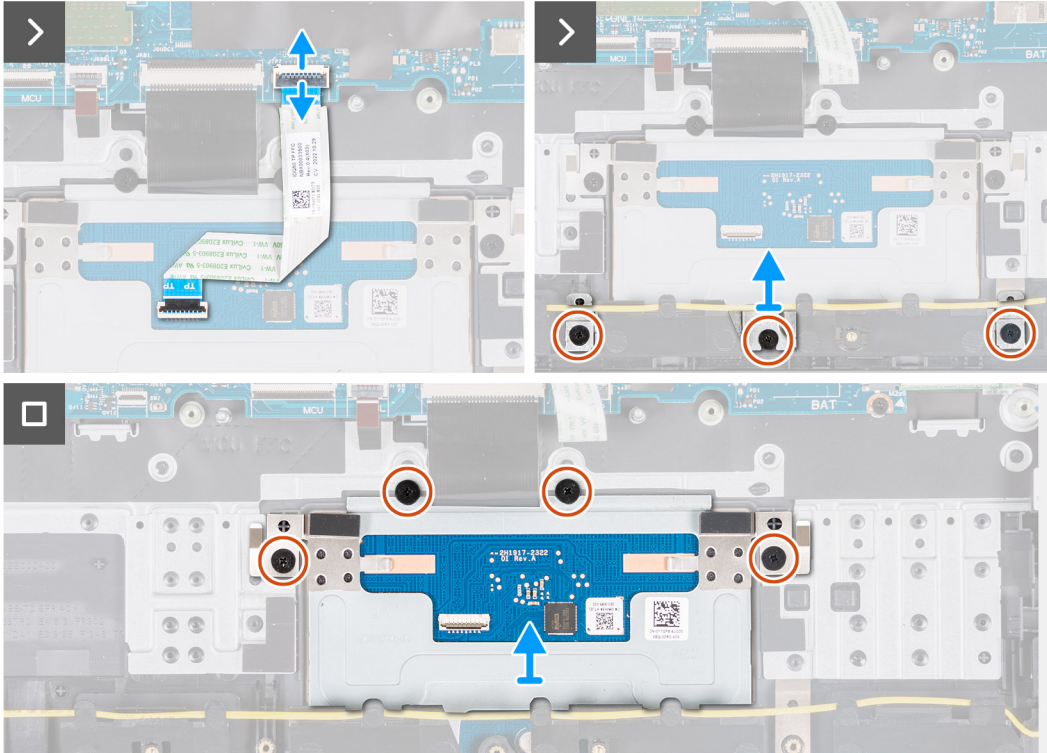
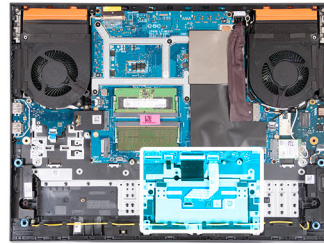

Steps

1. Open the latch and disconnect the touchpad cable from the system board.
2. Remove the three (M2x2) screws that secure the touchpad bracket to the palm-rest and keyboard assembly.
3. Lift the touchpad bracket off the touchpad.
4. Remove the four (M2x2) screws that secure the touchpad to the palm-rest and keyboard assembly.
5. Lift the touchpad off the palm-rest and keyboard assembly.

Installing the touchpad

Prerequisites

If you are replacing a component, remove the existing component before performing the installation procedure.

About this task

The following image indicates the location of the touchpad and provides a visual representation of the installation procedure.



7x
M2x2

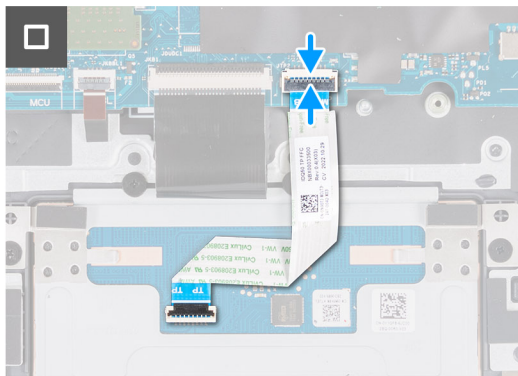
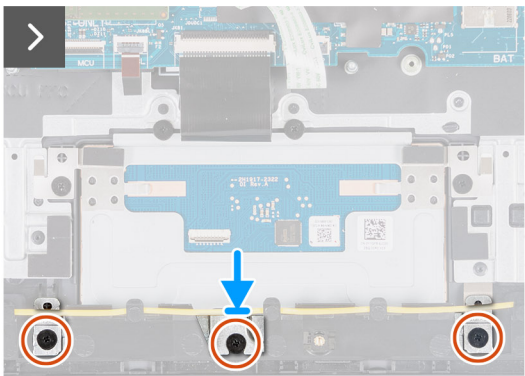
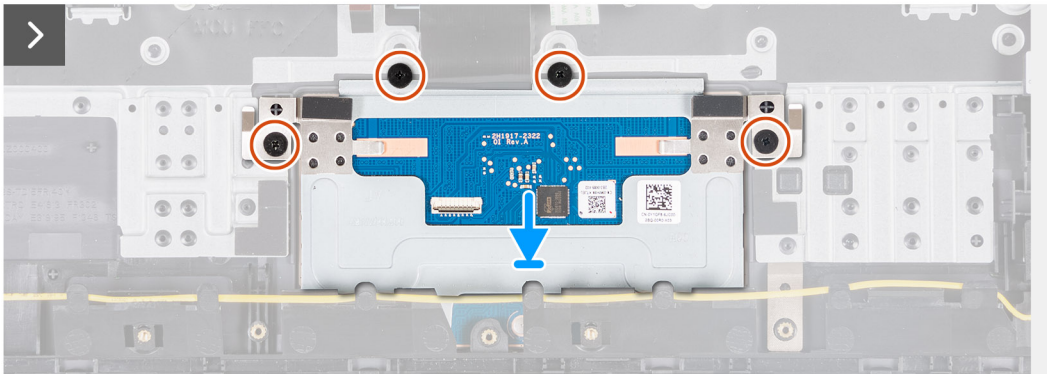
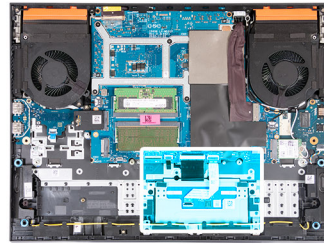

Steps

1. Align and place the touchpad into the slot on the palm-rest and keyboard assembly.
2. Replace the four (M2x2) screws that secure the touchpad to the palm-rest and keyboard assembly.
3. Align and place the touchpad bracket into the slot on the palm-rest and keyboard assembly.
4. Replace the three (M2x2) screws that secure the touchpad bracket to the palm-rest and keyboard assembly.
5. Connect the touchpad cable to the system board and close the latch.

Next steps

1. Install the [battery](#).
2. Install the [base cover](#).
3. Follow the procedure in [After working inside your computer](#).

Display assembly

Removing the display assembly

Prerequisites

1. Follow the procedure in [Before working inside your computer](#).
2. Remove the [base cover](#).
3. Remove the [rear cover](#).

About this task

The following images indicate the location of the display assembly and provide a visual representation of the removal procedure.



8x
M2.5x4

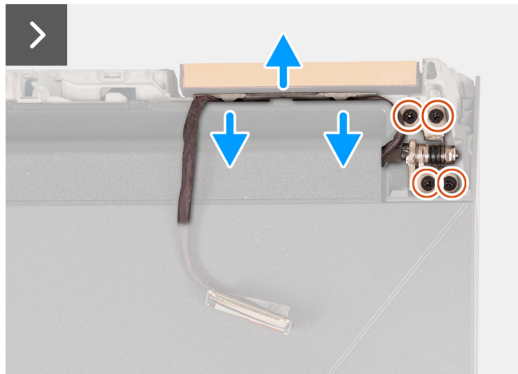
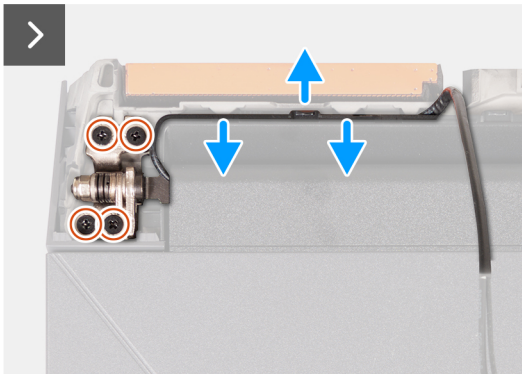
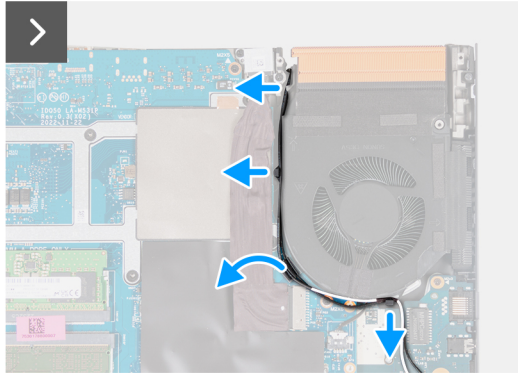
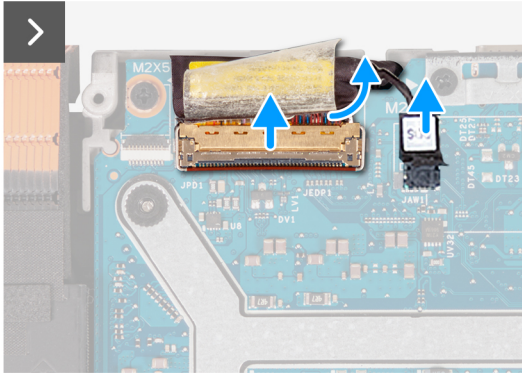
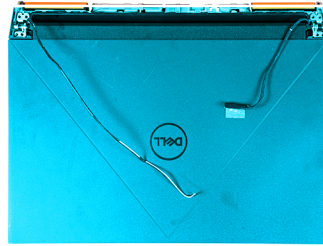

Steps

1. Peel that tape that secures the display-cable latch to the system board.
2. Open the latch and disconnect the display cable from the system board.
3. Disconnect the dynamic-display switch (DDS) cable from the system board.

 **NOTE:** This step is applicable only for computers that are shipped with a 165 Hz or 240 Hz display.

4. Remove the antenna cables from the routing guides on the right fan.
5. Turn the computer over and place the computer on a clean and flat surface.
6. Remove the four screws (M2.5x4) that secure the left display-assembly hinge to the palm-rest and keyboard assembly.
7. Remove the antenna cables from the routing guides along the left edge of the palm-rest and keyboard assembly.
8. Remove the four screws (M2.5x4) that secure the right display-assembly hinge to the palm-rest and keyboard assembly.
9. Remove the display cable from the routing guides along the right edge of the palm-rest and keyboard assembly.
10. Gently lift the display assembly from the palm-rest and keyboard assembly.

Installing the display assembly

Prerequisites

If you are replacing a component, remove the existing component before performing the installation procedure.

About this task

The following image indicates the location of the display assembly and provides a visual representation of the installation procedure.



8x
M2.5x4

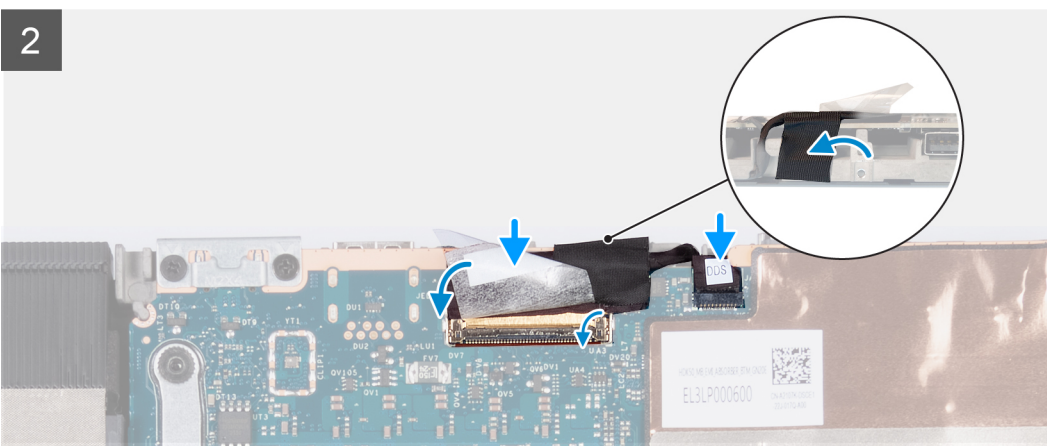
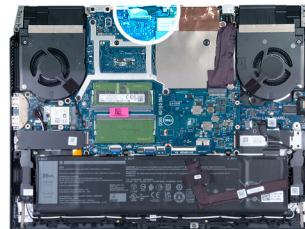
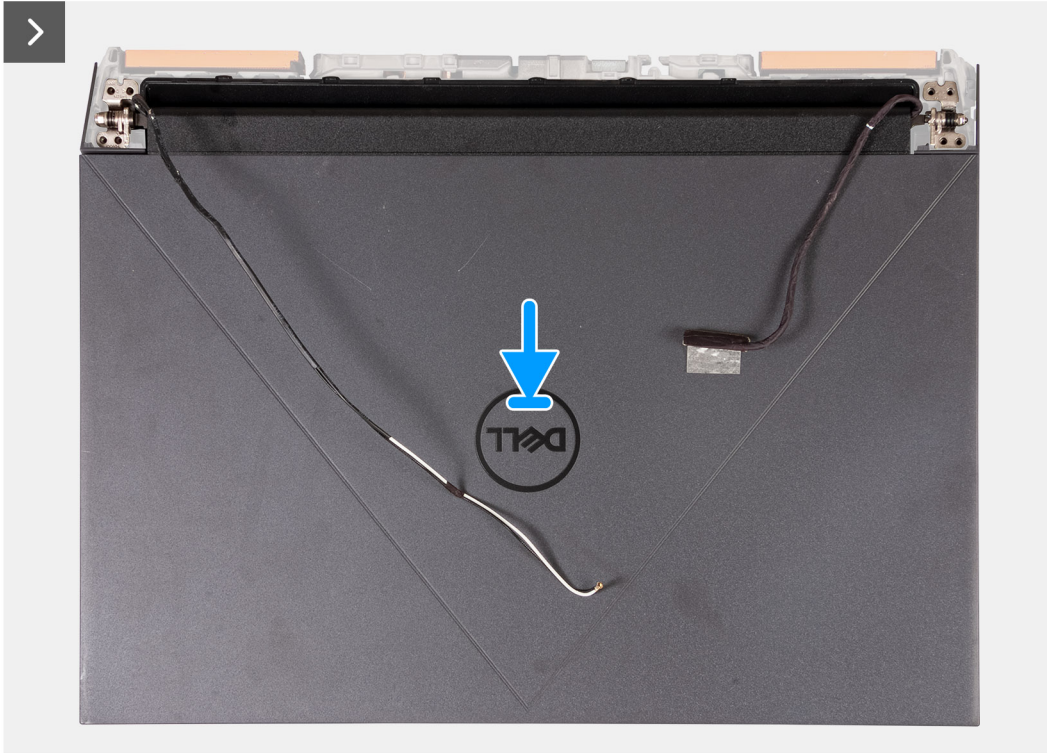
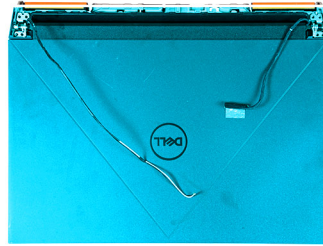

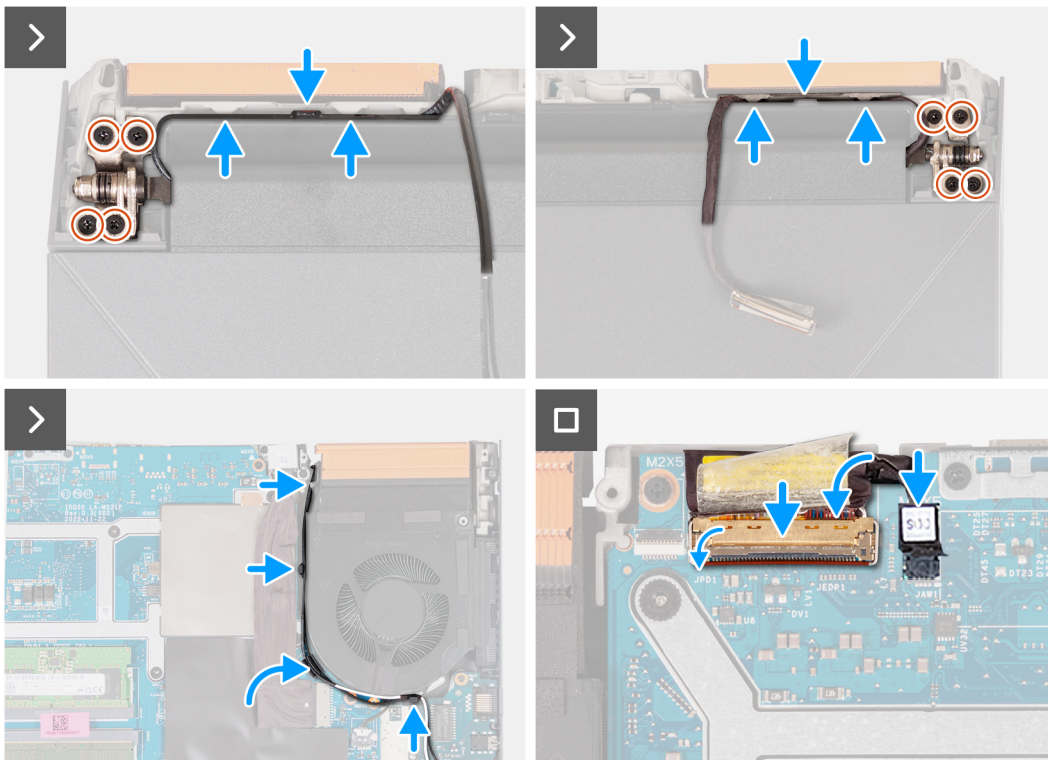

Steps

1. Place the display assembly on the palm-rest and keyboard assembly.
2. Align the screw holes on the display hinges with screw holes on the palm-rest and keyboard assembly.
3. Replace the four screws (M2.5x4) that secure the left display-assembly hinge to the palm-rest and keyboard assembly.
4. Route the antenna cables through the routing guides along the left edge of the palm-rest and keyboard assembly and into the opening to the right of the power-adaptor port.
5. Replace the four screws (M2.5x4) that secure the right display-assembly hinge to the palm-rest and keyboard assembly.
6. Route the display cable through the routing guides along the right edge of the palm-rest and keyboard assembly and into the opening at the edge of the right heat-sink.
7. Turn the computer over and place the computer on a clean and flat surface.
8. Route the antenna cables through the routing guides on the fan.
9. Connect the display cable to the connector on the system board and close the latch.
10. Adhere the tape that secures the display-cable connector latch to the system board.
11. Connect the dynamic-display switch (DDS) cable to the system board.

i **NOTE:** This step is applicable only for computers shipped with a 165 Hz or 240 Hz display.

Next steps

1. Install the [rear cover](#).
2. Install the [base cover](#).
3. Follow the procedure in [After working inside your computer](#).

Keyboard-controller board

Removing the keyboard-controller board

Prerequisites

1. Remove the [base cover](#).
2. Remove the [battery](#).

About this task

 **NOTE:** The keyboard-controller board is only required for computers that are shipped with a 4-zone keyboard.



1x
M2x2

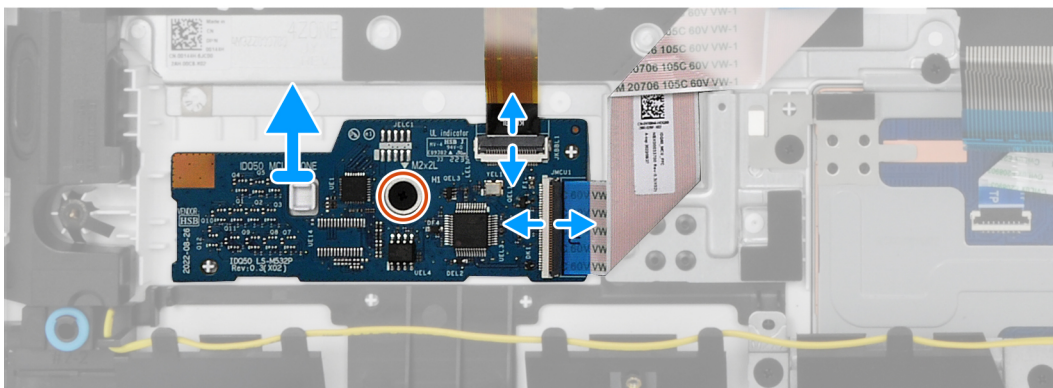
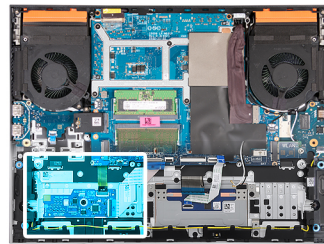

Steps

1. Open the latch and disconnect the keyboard-backlight cable from the keyboard-controller board.
2. Open the latch and disconnect the keyboard-controller board cable from the keyboard-controller board.
3. Remove the screw (M2x2) that secures the keyboard-controller board to the palm-rest and keyboard assembly.
4. Lift the keyboard-controller board off the palm-rest and keyboard assembly.

Installing the keyboard-controller board

Prerequisites

If you are replacing a component, remove the existing component before performing the installation process.

About this task

 **NOTE:** The keyboard-controller board is only required for computers that are shipped with a 4-zone keyboard.



1x
M2x2

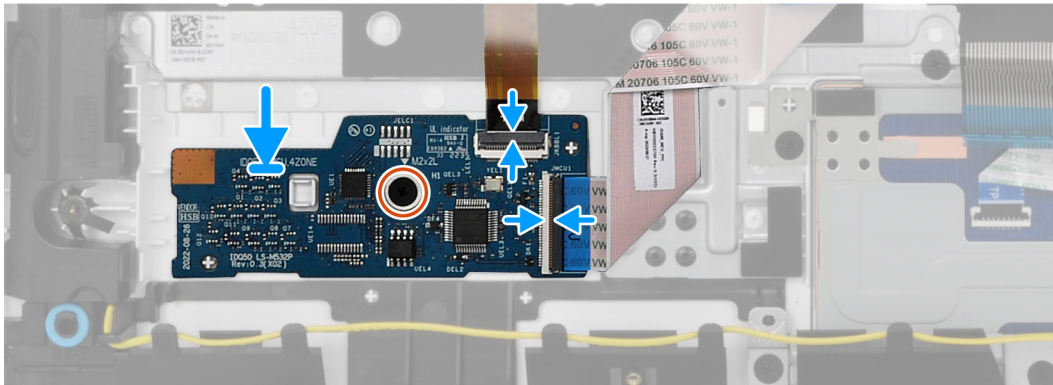
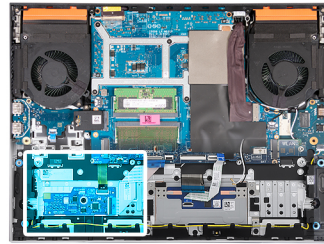

Steps

1. Using the alignment posts, place the keyboard-controller board into the slot on the palm-rest and keyboard assembly.
2. Replace the screw (M2x2) that secures the keyboard-controller board to the palm-rest and keyboard assembly.
3. Connect the keyboard-controller board cable to the keyboard-controller board and close the latch.
4. Connect the keyboard-backlight cable to the keyboard-controller board and close the latch.

Next steps

1. Install the [battery](#).
2. Install the [base cover](#).
3. Follow the procedure in [After working inside your computer](#).

Power-adapter port

Removing the power-adapter port

Prerequisites

1. Follow the procedure in [Before working inside your computer](#).
2. Remove the [base cover](#).
3. Remove the [rear cover](#).

About this task

The following image indicates the location of the power-adapter port and provides a visual representation of the removal procedure.



2x
M2x5

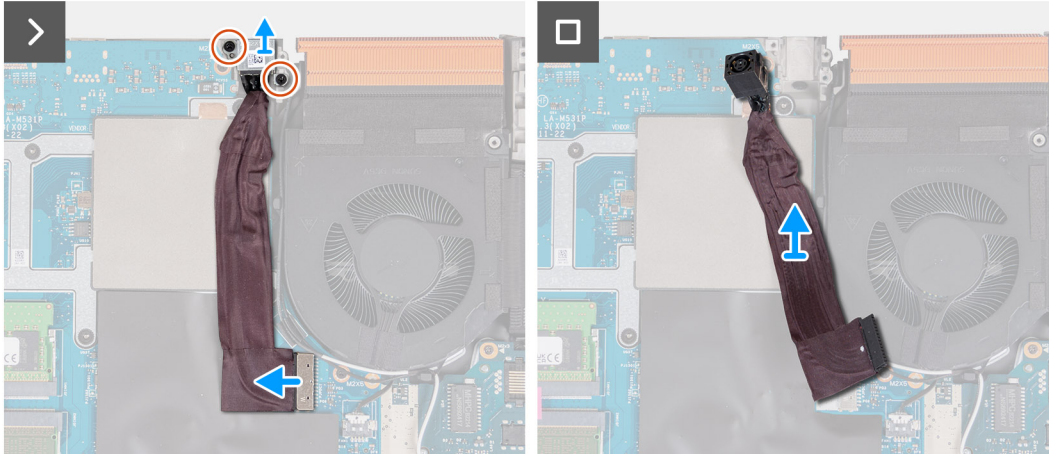
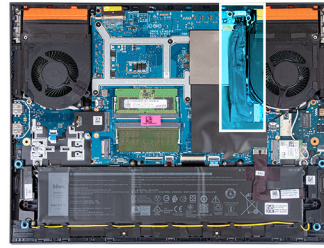

Steps

1. Remove the two screws (M2x5) that secure the power-adapter port bracket to the palm-rest and keyboard assembly.
2. Lift the power-adapter port-bracket off the power-adapter port.
3. Peel the power-adapter port cable off the system board.
4. Disconnect the power-adapter port-cable from the system board.
5. Lift the power-adapter port and its cable off the palm-rest and keyboard assembly.

Installing the power-adapter port

Prerequisites

If you are replacing a component, remove the existing component before performing the installation procedure.

About this task

The following image indicates the location of the power-adapter port and provides a visual representation of the installation procedure.



2x
M2x5

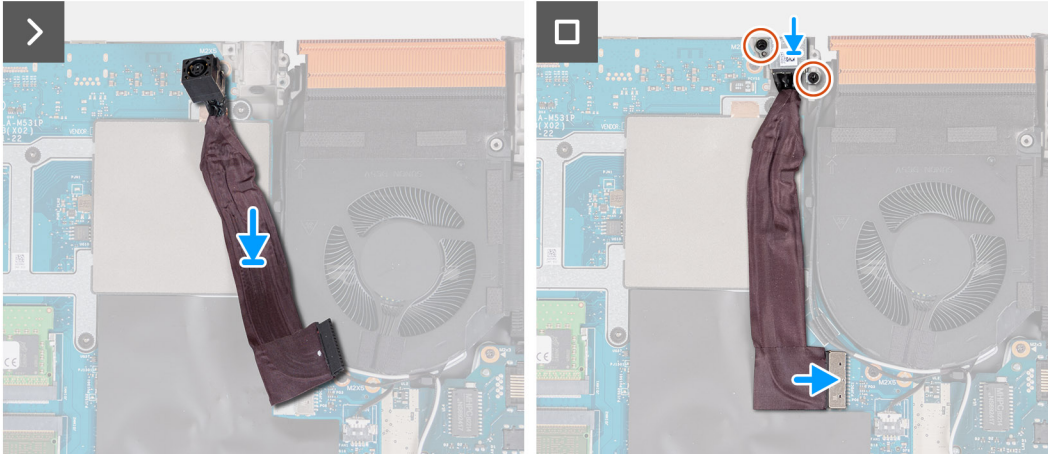
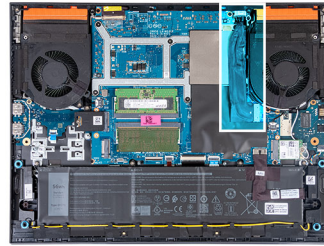

Steps

1. Adhere the power-adapter port cable on the system board and place the power-adapter port into the slot.
2. Place the power-adapter port bracket on the power-adapter port and align the screw holes on the power-adapter port bracket to the screw holes on the palm-rest and keyboard assembly.
3. Replace the two screws (M2x5) that secure the power-adapter port bracket to the palm-rest and keyboard assembly.
4. Connect the power-adapter port cable to the system board.

Next steps

1. Install the [rear cover](#).
2. Install the [base cover](#).
3. Follow the procedure in [After working inside your computer](#).

System board

Removing the system board (Single-color keyboard)

 **NOTE:** This system board is only required for computers that are shipped with a single-color keyboard.

Prerequisites

1. Follow the procedure in [Before working inside your computer](#).
2. Remove the [base cover](#).
3. Remove the [battery](#).
4. Remove the [rear cover](#).
5. Remove the [solid-state drive](#).
6. Remove the [wireless card](#).
7. Remove the [memory module](#).

About this task

CAUTION: Before removing the system board, give sufficient time for the heat sink to cool down to avoid injury.

NOTE: Replacing the system board removes any changes that you have made to the BIOS using the BIOS setup program. Make the appropriate changes again after you replace the system board.

The following image indicates the connectors on your system-board assembly.

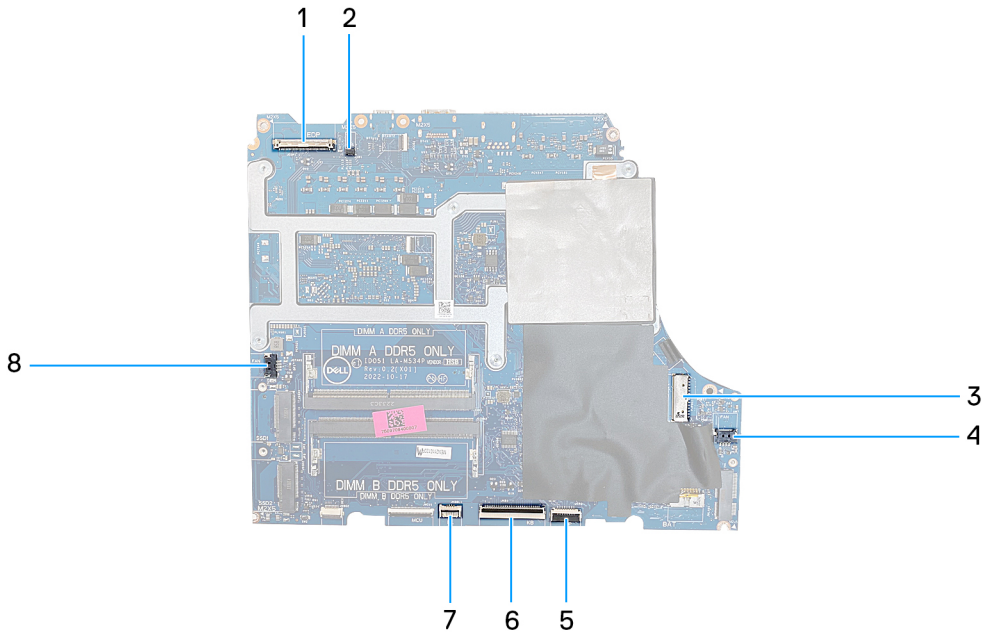

- 1. Display cable
- 2. Dynamic-display switch (DDS) cable (applicable to computers with a 165 Hz or 240 Hz display)
- 3. Power-adaptor port cable
- 4. Right-fan cable
- 5. Touchpad cable
- 6. Keyboard cable
- 7. Keyboard-backlight cable
- 8. Keyboard-controller board cable (optional)
- 9. Left-fan cable

The following image indicates the location of the system board and provides a visual representation of the removal procedure.

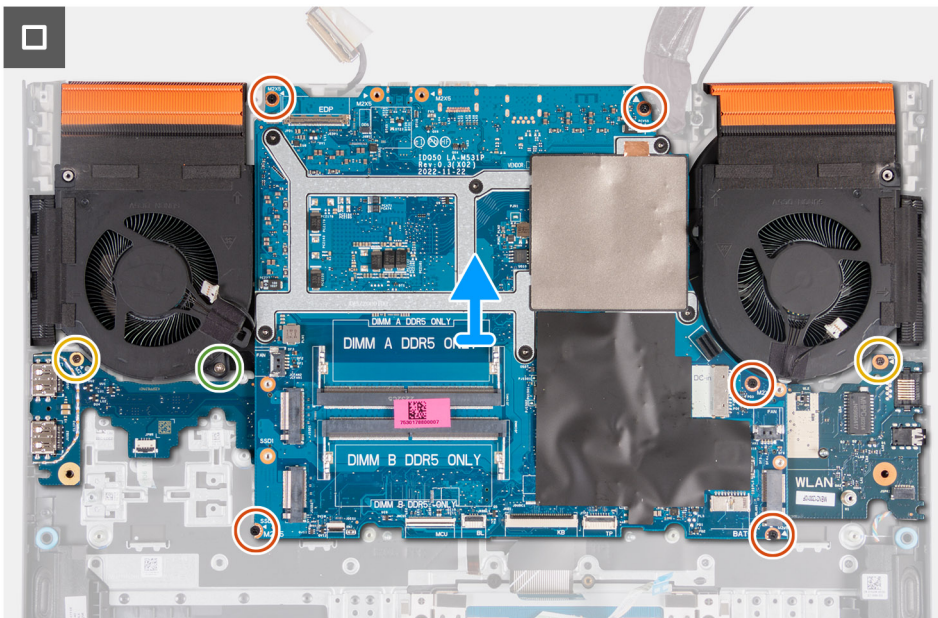
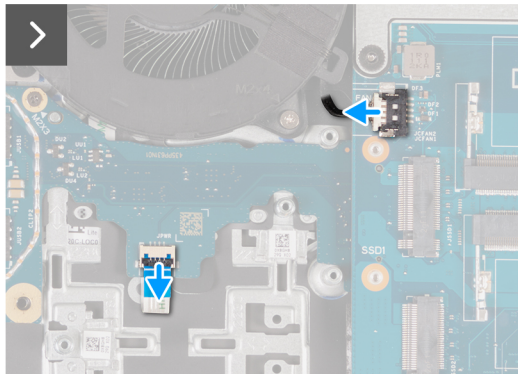
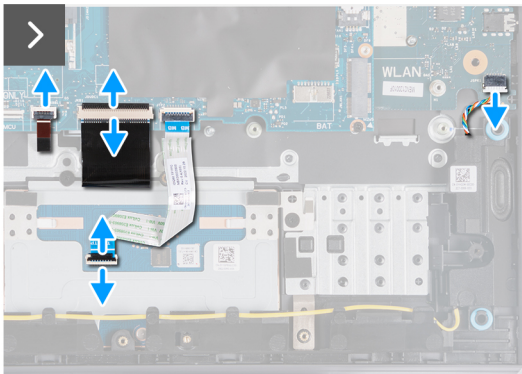
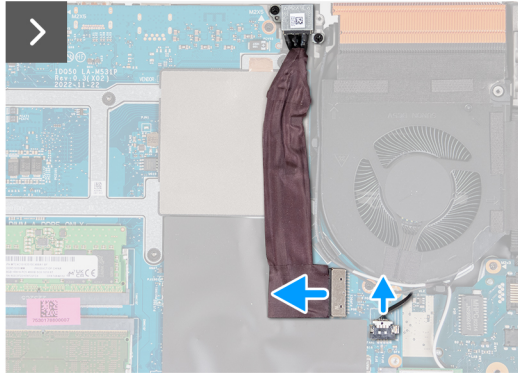
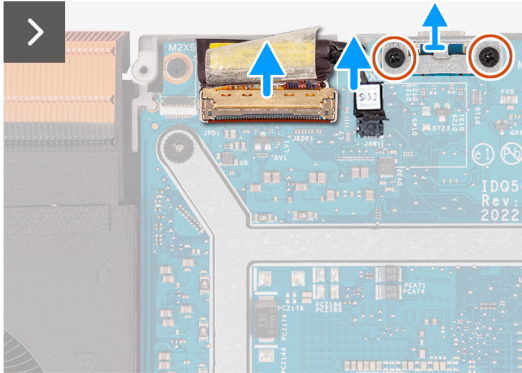
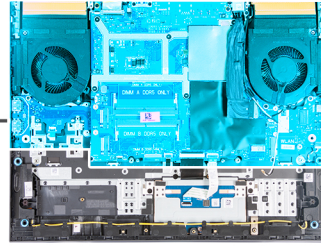

Steps

1. Peel the tape that secures the display-cable connector latch to the system board.
2. Open the latch and disconnect the display cable from the system board.
3. Disconnect the dynamic-display switch (DDS) cable from the system board.

NOTE: This step is applicable only for computers that are shipped with a 165 Hz or 240 Hz display.

4. Remove the two (M2x5) screws that secure the USB Type-C bracket to the system board and lift the bracket off the system board.
5. Disconnect the power-adaptor port cable from the system board.
6. Peel the power-adaptor port cable off the system board.
7. Disconnect the right-fan cable from the system board.
8. Disconnect the speaker cable from the system board.
9. Open the latch and disconnect the touchpad cable from the system board.
10. Open the latch and disconnect the keyboard cable from the system board.
11. Open the latch and disconnect the keyboard-backlight cable from the system board.
12. Disconnect the left-fan cable from the system board.
13. Open the latch and disconnect the power-button board cable from the USB board.
14. Remove the five screws (M2x5) that secure the system board to the palm-rest and keyboard assembly.
15. Remove the screw (M2x3) that secures the USB board to the palm-rest and keyboard assembly.
16. Remove the screw (M2x3) that secures the ethernet and audio board to the palm-rest and keyboard assembly.
17. Remove the screw (M2x4) that secures the left fan to the palm-rest and keyboard assembly.
18. Lift the system-board assembly off the palm-rest and keyboard assembly.

NOTE: Ensure that you lift the system board from the upper left and right sides of the heat sink.

19. Place the system-board assembly on a clean and flat surface.
20. Turn the system-board assembly over and remove the [ethernet and audio board](#), [USB board](#), and [fan and heat-sink assembly](#).

Installing the system board (Single-color keyboard)

NOTE: This system board is only required for computers that are shipped with a single-color keyboard.

Prerequisites

If you are replacing a component, remove the existing component before performing the installation procedure.

NOTE: Replacing the system board removes any changes that you have made to the BIOS using the BIOS setup program. Make the appropriate changes again after you replace the system board.

About this task

The following image indicates the connectors on your system board.

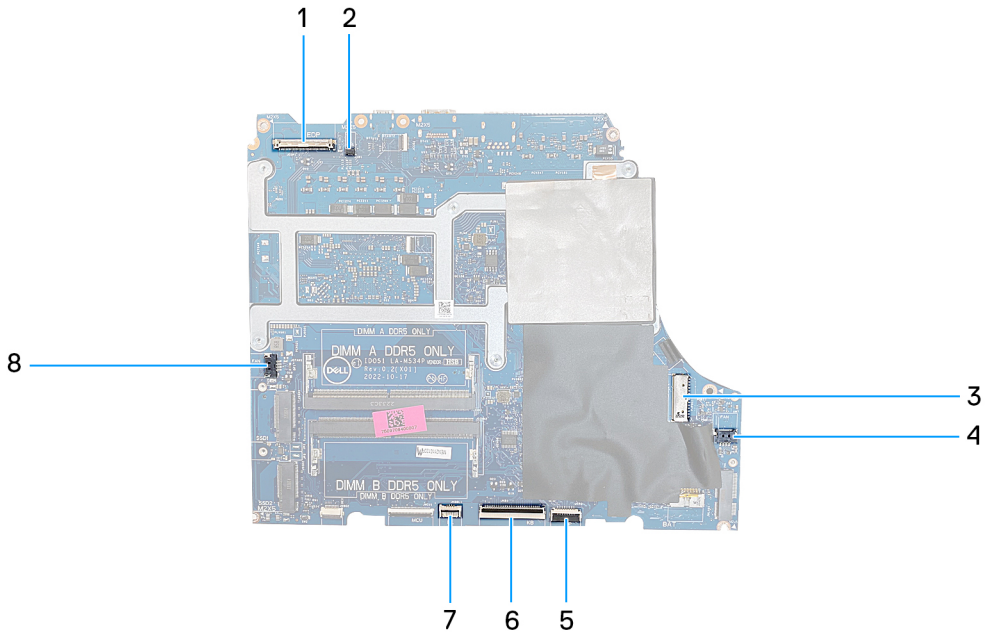

1. Display cable
2. Dynamic-display switch (DDS) cable
3. Power-adapter port cable
4. Right-fan cable
5. Touchpad cable
6. Keyboard cable
7. Keyboard-backlight cable
8. Keyboard-controller board cable (optional)
9. Left-fan cable

The following image indicates the location of the system board and provides a visual representation of the installation procedure.

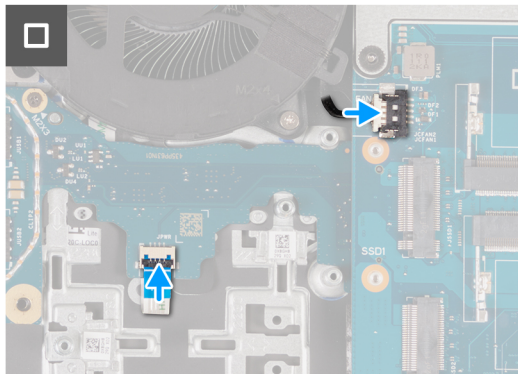
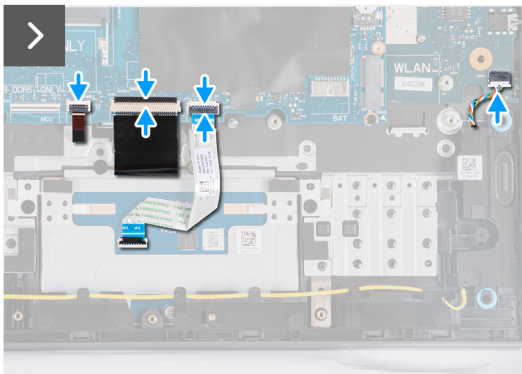
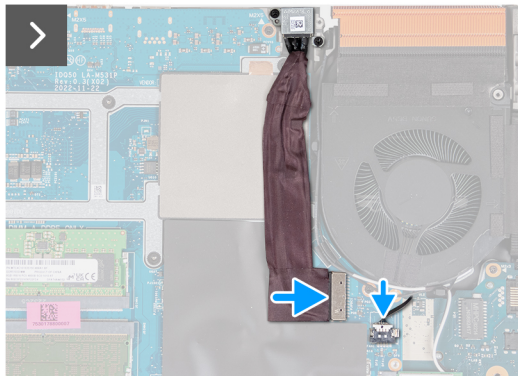
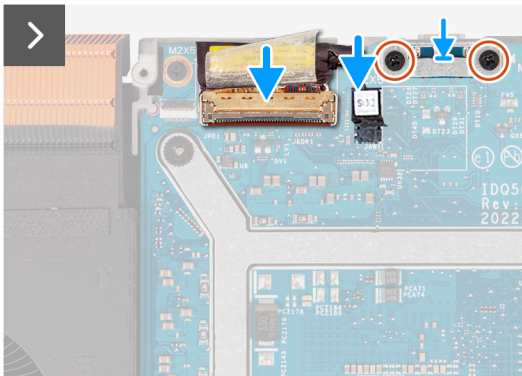
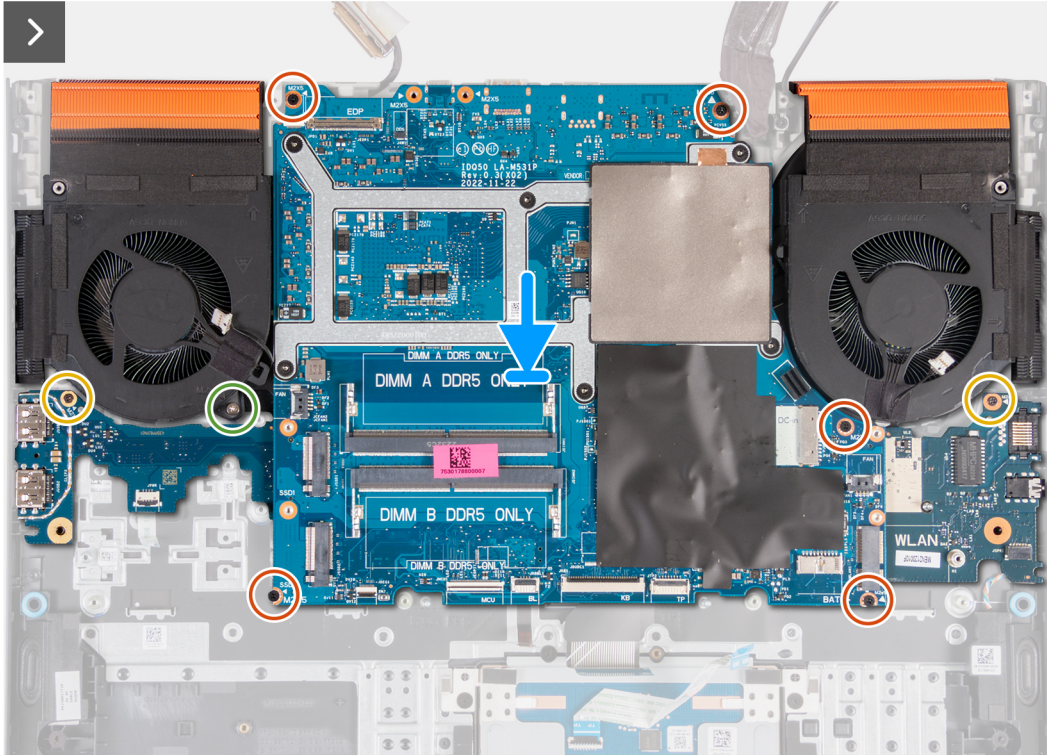
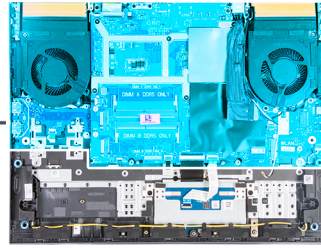

Steps

1. Place the system board on a clean and flat surface.
2. Install the [ethernet and audio board](#), [USB board](#), and [fan and heat-sink assembly](#).
3. Turn the system board over.
4. Using the alignment posts, place the system board on the palm-rest and keyboard assembly, ensuring that the heat sink is aligned against the top edge of the palm-rest and keyboard assembly.
5. Align the screw holes on the system board with the screw holes on the palm-rest and keyboard assembly.
6. Replace the five screws (M2x5) that secure the system board to the palm-rest and keyboard assembly.
7. Replace the screw (M2x3) that secures the USB board to the palm-rest and keyboard assembly.
8. Replace the screw (M2x3) that secures the ethernet and audio board to the palm-rest and keyboard assembly.
9. Replace the screw (M2x4) that secures the left fan to the palm-rest and keyboard assembly.
10. Align the screw holes on the USB Type-C bracket with the screw holes on the system board.
11. Replace the two screws (M2x5) that secure the USB Type-C bracket to the system board.
12. Connect the DDS (Dynamic Display Switch) cable to the system board.

 **NOTE:** This step is applicable only for computers that are shipped with a 165 Hz or 240 Hz display.

13. Connect the display cable to the system board and close the latch.
14. Adhere the tape that secures the display-cable connector latch to the system board.
15. Connect the power-adaptor port cable to the system board.
16. Adhere the power-adaptor port cable on the system board.
17. With both hands, use your fingertips to push the right-fan cable into its connector on the system board.

 **CAUTION:** Connecting the cable with the incorrect side facing upwards will cause damage to the connector and the system board. Ensure that the black dot on the cable is facing upwards before connecting the cable.

18. Connect the speaker cable to the system board.
19. Connect the touchpad cable to the system board and close the latch.
20. Connect the keyboard cable to the system board and close the latch.
21. Connect the keyboard-backlight cable to the keyboard-controller board and close the latch.
22. Connect the power-button board cable to the USB board and close the latch.
23. With both hands, use your fingertips to push the left-fan cable into its connector on the system board.

 **CAUTION:** Connecting the cable with the incorrect side facing upwards will cause damage to the connector and the system board. Ensure that the black dot on the cable is facing upwards before connecting the cable.

Next steps

1. Install the [memory module](#).
2. Install the [wireless card](#).
3. Install the [solid-state drive](#).
4. Install the [rear cover](#).
5. Install the [battery](#).
6. Install the [base cover](#).
7. Follow the procedure in [After working inside your computer](#).

Removing the system board (Four-zone keyboard)

 **NOTE:** This system board is only required for computers that are shipped with a four-zone keyboard.

Prerequisites

1. Follow the procedure in [Before working inside your computer](#).
2. Remove the [base cover](#).
3. Remove the [battery](#).

4. Remove the [rear cover](#).
5. Remove the [solid-state drive](#).
6. Remove the [wireless card](#).
7. Remove the [memory module](#).

About this task

CAUTION: Before removing the system board, give sufficient time for the heat sink to cool down to avoid injury.

NOTE: Replacing the system board removes any changes that you have made to the BIOS using the BIOS setup program. Make the appropriate changes again after you replace the system board.

The following image indicates the connectors on your system-board assembly.

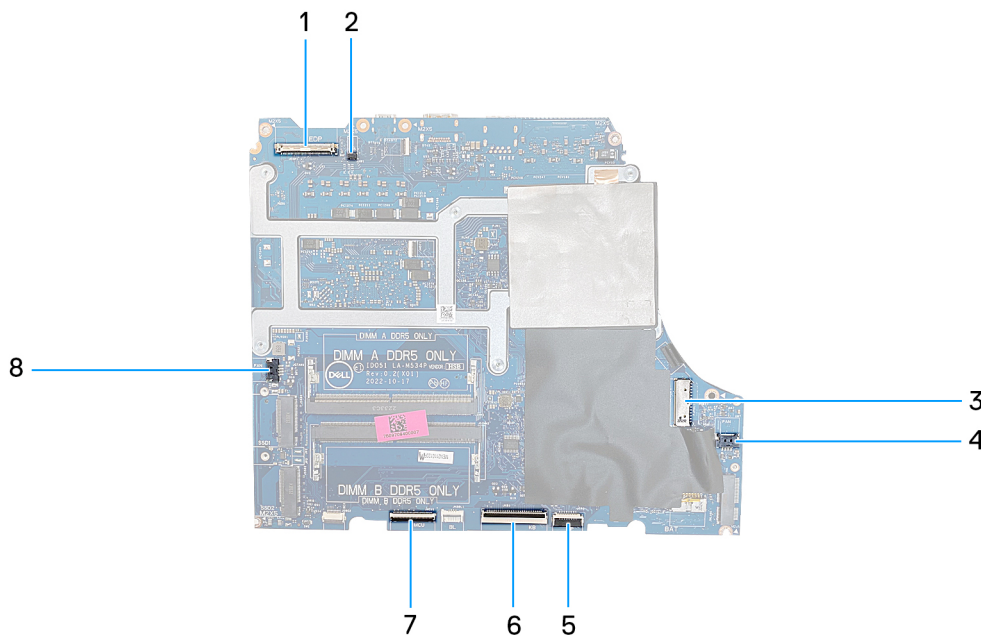

1. Display cable
2. Dynamic-display switch (DDS) cable
3. Power-adaptor port cable
4. Right-fan cable
5. Touchpad cable
6. Keyboard cable
7. Keyboard-controller board cable
8. Left-fan cable

The following image indicates the location of the system board and provides a visual representation of the removal procedure.

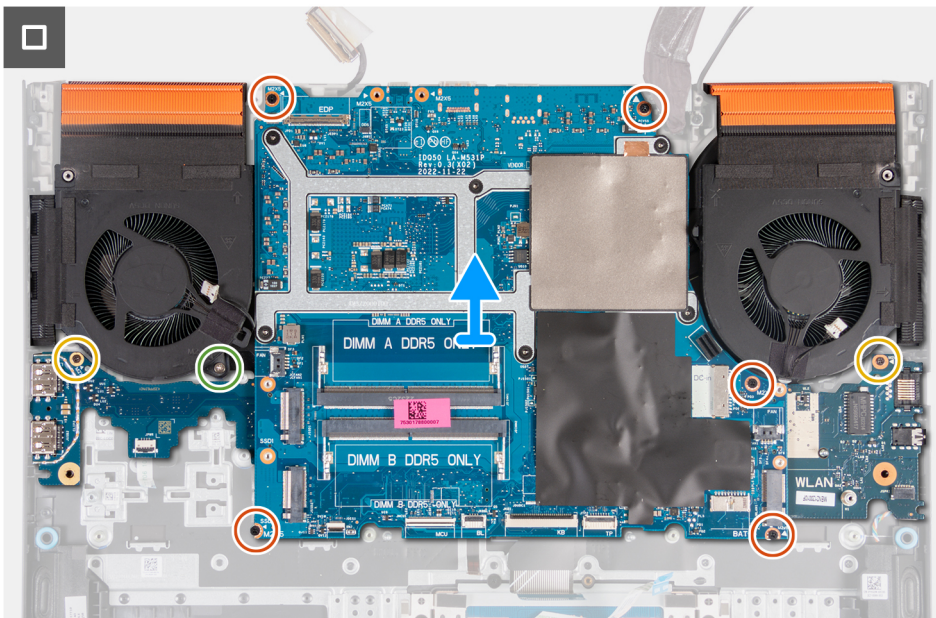
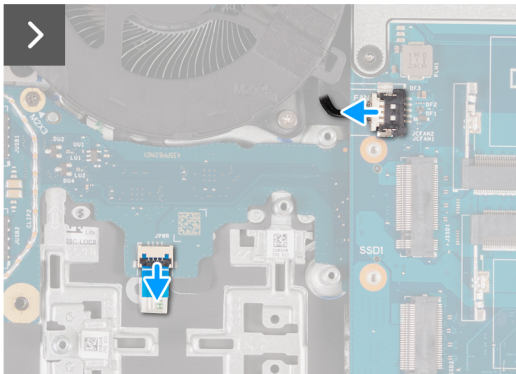
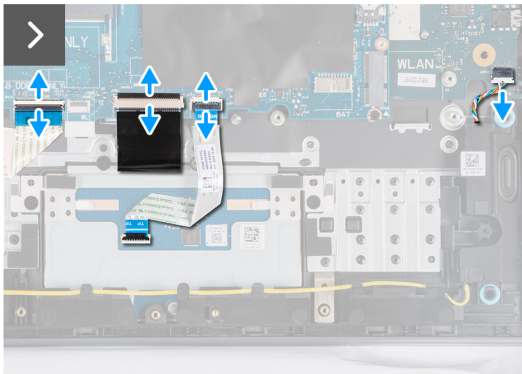
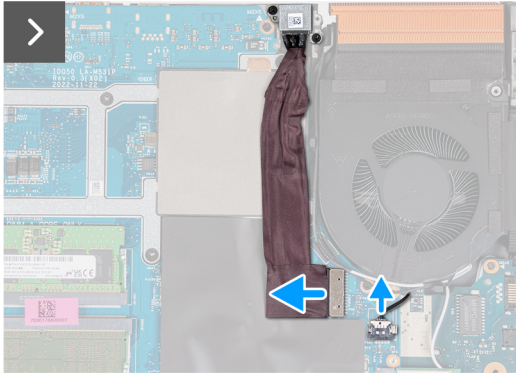
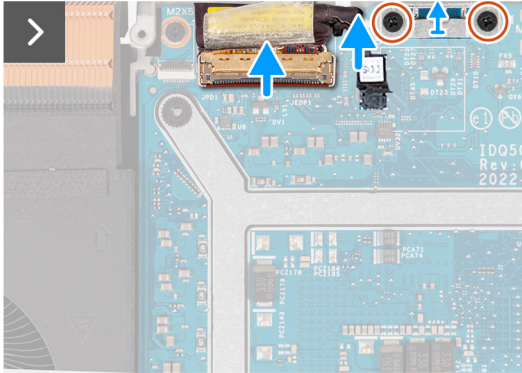
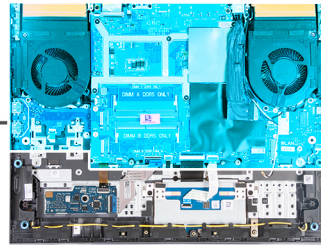

Steps

1. Peel the tape that secures the display-cable connector latch to the system board.
2. Open the latch and disconnect the display cable from the system board.
3. Disconnect the dynamic-display switch (DDS) cable from the system board.

NOTE: This step is applicable only for computers that are shipped with a 165 Hz or 240 Hz display.

4. Remove the two (M2x5) screws that secure the USB Type-C bracket to the system board and lift the bracket off the system board.
5. Disconnect the power-adapter port cable from the system board.
6. Peel the power-adapter port cable off the system board.
7. Disconnect the right-fan cable from the system board.
8. Disconnect the speaker cable from the system board.
9. Open the latch and disconnect the touchpad cable from the system board.
10. Open the latch and disconnect the keyboard cable from the system board.
11. Open the latch and disconnect the keyboard-backlight cable from the keyboard-controller board.
12. Open the latch and disconnect the keyboard-controller board cable from the system board.
13. Disconnect the left-fan cable from the system board.
14. Open the latch and disconnect the power-button board cable from the USB board.
15. Remove the five screws (M2x5) that secure the system board to the palm-rest and keyboard assembly.
16. Remove the screw (M2x3) that secures the USB board to the palm-rest and keyboard assembly.
17. Remove the screw (M2x3) that secures the ethernet and audio board to the palm-rest and keyboard assembly.
18. Remove the screw (M2x4) that secures the left fan to the palm-rest and keyboard assembly.
19. Lift the system-board assembly off the palm-rest and keyboard assembly.

NOTE: Ensure that you lift the system board from the upper left and right sides of the heat sink.

20. Place the system-board assembly on a clean and flat surface.
21. Turn the system-board assembly over and remove the [ethernet and audio board](#), [USB board](#), and [fan and heat-sink assembly](#).

Installing the system board (Four-zone keyboard)

NOTE: This system board is only required for computers that are shipped with a four-zone keyboard.

Prerequisites

If you are replacing a component, remove the existing component before performing the installation procedure.

NOTE: Replacing the system board removes any changes that you have made to the BIOS using the BIOS setup program. Make the appropriate changes again after you replace the system board.

About this task

The following image indicates the connectors on your system board.

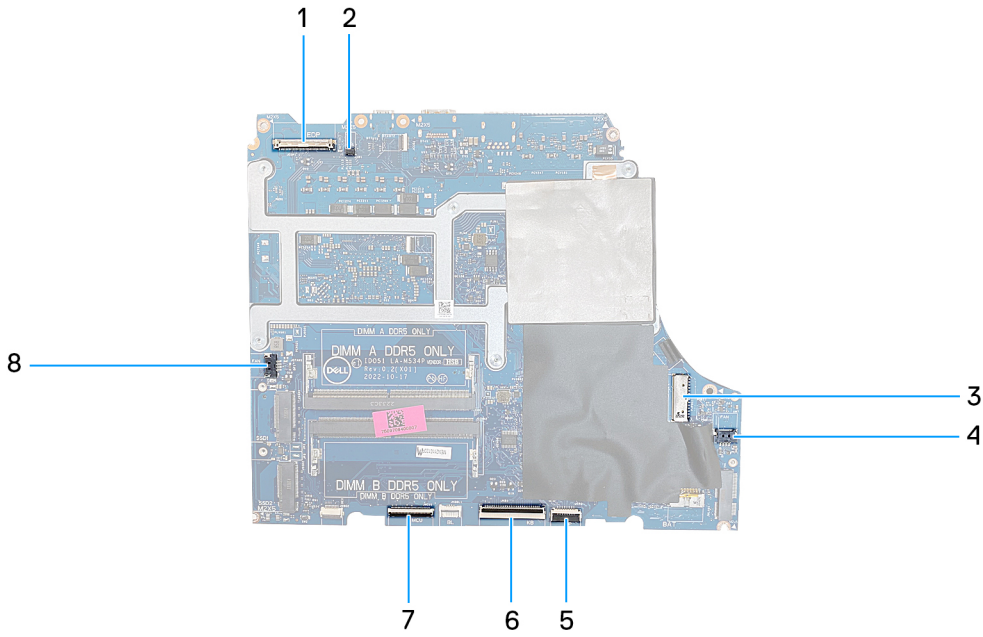

1. Display cable
2. Dynamic-display switch (DDS) cable
3. Power-adapter port cable
4. Right-fan cable
5. Touchpad cable
6. Keyboard cable
7. Keyboard-controller board cable
8. Left-fan cable

The following image indicates the location of the system board and provides a visual representation of the installation procedure.

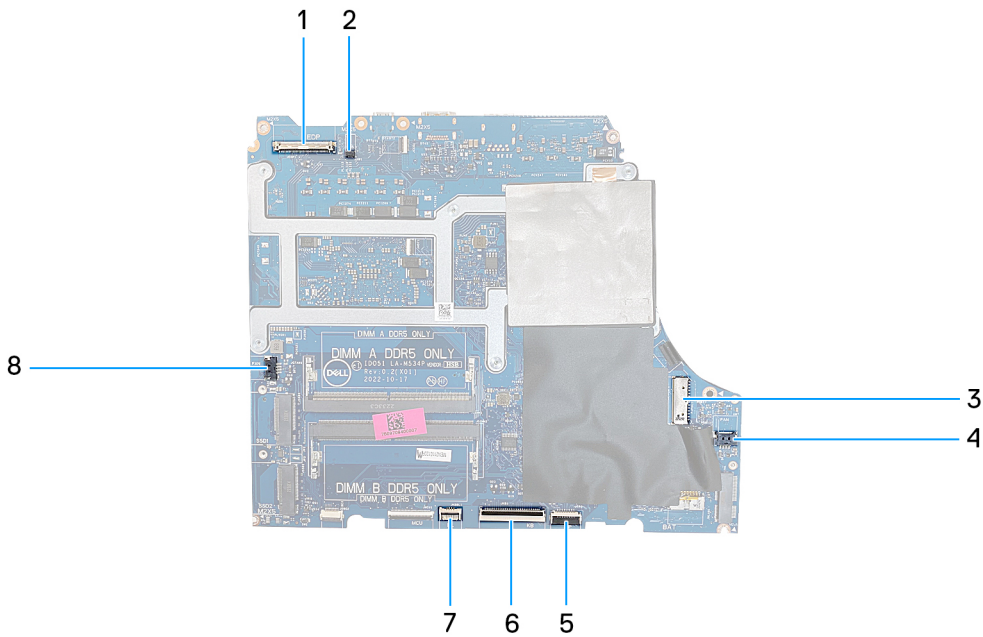



Steps

1. Place the system board on a clean and flat surface.
2. Install the [ethernet and audio board](#), [USB board](#), and [fan and heat-sink assembly](#).
3. Turn the system board over.
4. Using the alignment posts, place the system board on the palm-rest and keyboard assembly, ensuring that the heat sink is aligned against the top edge of the palm-rest and keyboard assembly.
5. Align the screw holes on the system board with the screw holes on the palm-rest and keyboard assembly.
6. Replace the five screws (M2x5) that secure the system board to the palm-rest and keyboard assembly.
7. Replace the screw (M2x3) that secures the USB board to the palm-rest and keyboard assembly.
8. Replace the screw (M2x3) that secures the ethernet and audio board to the palm-rest and keyboard assembly.
9. Replace the screw (M2x4) that secures the left fan to the palm-rest and keyboard assembly.
10. Align the screw holes on the USB Type-C bracket with the screw holes on the system board.
11. Replace the two screws (M2x5) that secure the USB Type-C bracket to the system board.
12. Connect the DDS (Dynamic Display Switch) cable to the system board.

NOTE: This step is applicable only for computers that are shipped with a 165 Hz or 240 Hz display.

13. Connect the display cable to the system board and close the latch.
14. Adhere the tape that secures the display-cable connector latch to the system board.
15. Connect the power-adapter port cable to the system board.
16. Adhere the power-adapter port cable on the system board.
17. With both hands, use your fingertips to push the right-fan cable into its connector on the system board.

CAUTION: Connecting the cable with the incorrect side facing upwards will cause damage to the connector and the system board. Ensure that the black dot on the cable is facing upwards before connecting the cable.

18. Connect the speaker cable to the system board.
19. Connect the touchpad cable to the system board and close the latch.
20. Connect the keyboard cable to the system board and close the latch.
21. Connect the keyboard-backlight cable to the keyboard-controller board and close the latch.
22. Connect the keyboard-controller board cable to the system board and close the latch.

23. Connect the power-button board cable to the USB board and close the latch.
24. With both hands, use your fingertips to push the left-fan cable into its connector on the system board.

 **CAUTION:** Connecting the cable with the incorrect side facing upwards will cause damage to the connector and the system board. Ensure that the black dot on the cable is facing upwards before connecting the cable.

Next steps

1. Install the [memory module](#).
2. Install the [wireless card](#).
3. Install the [solid-state drive](#).
4. Install the [rear cover](#).
5. Install the [battery](#).
6. Install the [base cover](#).
7. Follow the procedure in [After working inside your computer](#).

USB board

Removing the USB board

Prerequisites

1. Follow the procedure in [Before working inside your computer](#).
2. Remove the [base cover](#).
3. Remove the [battery](#).
4. Remove the [rear cover](#).
5. Remove the [solid-state drive](#).
6. Remove the [wireless card](#).
7. Remove the [memory module](#).
8. Remove the [system board](#).

 **NOTE:** The system board can be removed as an assembly with the fan and heat-sink assembly, ethernet and audio board, and USB board attached.

About this task

The following image indicates the location of the USB board and provides a visual representation of the removal procedure.



2x
M2x4

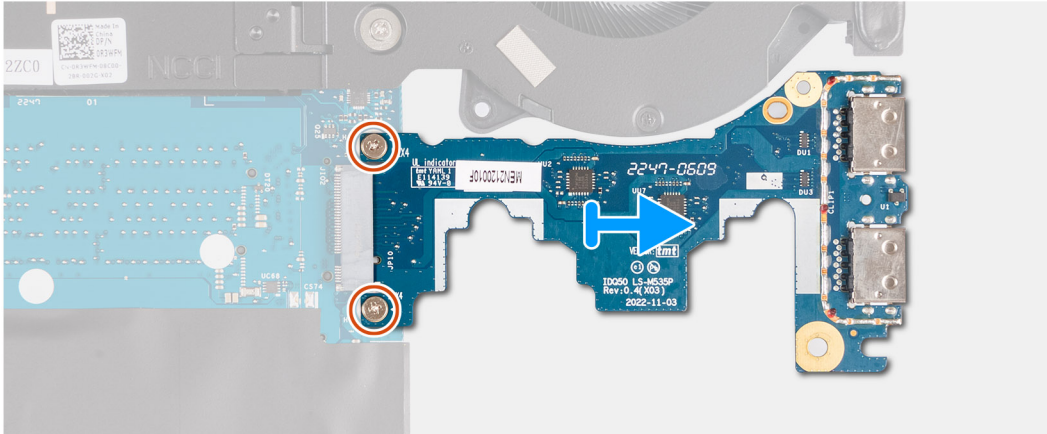
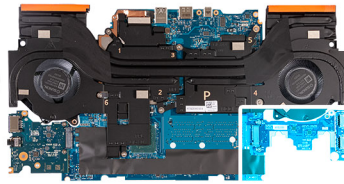

Steps

1. Turn the system-board assembly over.
2. Remove the two screws (M2x4) that secure the USB board to the system-board assembly.
3. Disconnect and remove USB board from the system-board assembly.

Installing the USB board

Prerequisites

If you are replacing a component, remove the existing component before performing the installation procedure.

About this task

The following image indicates the location of the USB board and provides a visual representation of the installation procedure.



2x
M2x4

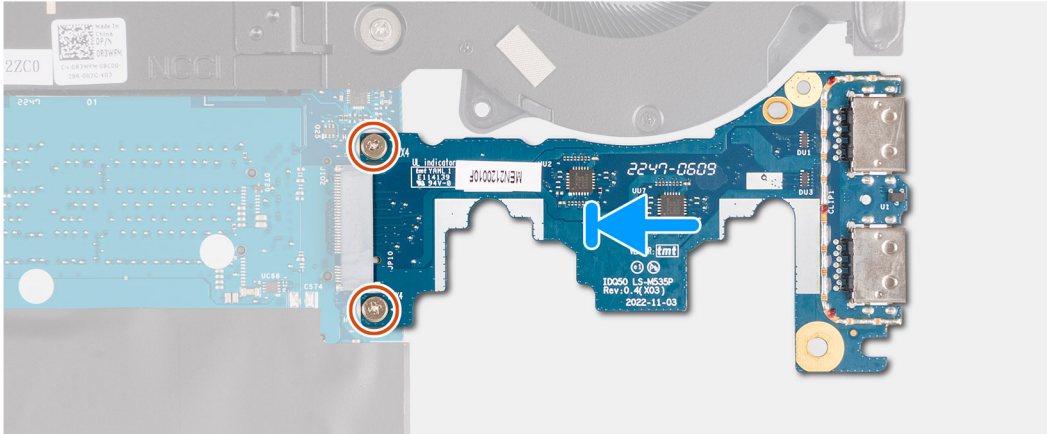
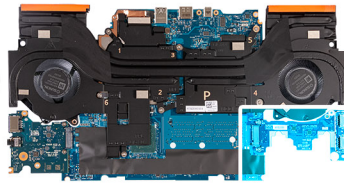

Steps

1. Slide the USB board into the M.2 card slot on the system board and align the screw holes on the USB board to the screw holes on the system board.
2. Replace the two screws (M2x4) that secure the USB board to the system board.
3. Turn the system-board assembly over.

Next steps

1. Install the [system board](#).
2. Install the [memory module](#).
3. Install the [wireless card](#).
4. Install the [solid-state drive](#).
5. Install the [rear cover](#).
6. Install the [battery](#).
7. Install the [base cover](#).
8. Follow the procedure in [After working inside your computer](#).

Ethernet and audio board

Removing the ethernet and audio board

Prerequisites

About this task

The following image indicates the location of the ethernet and audio board and provides a visual representation of the removal procedure.

1. Follow the procedure in [Before working inside your computer](#).
2. Remove the [base cover](#).
3. Remove the [battery](#).
4. Remove the [rear cover](#).

5. Remove the [solid-state drive](#).
6. Remove the [wireless card](#).
7. Remove the [memory module](#).
8. Remove the [system board](#).

NOTE: The system board can be removed as an assembly with the fan and heat-sink assembly, ethernet and audio board, and USB board attached.



2x
M2x4

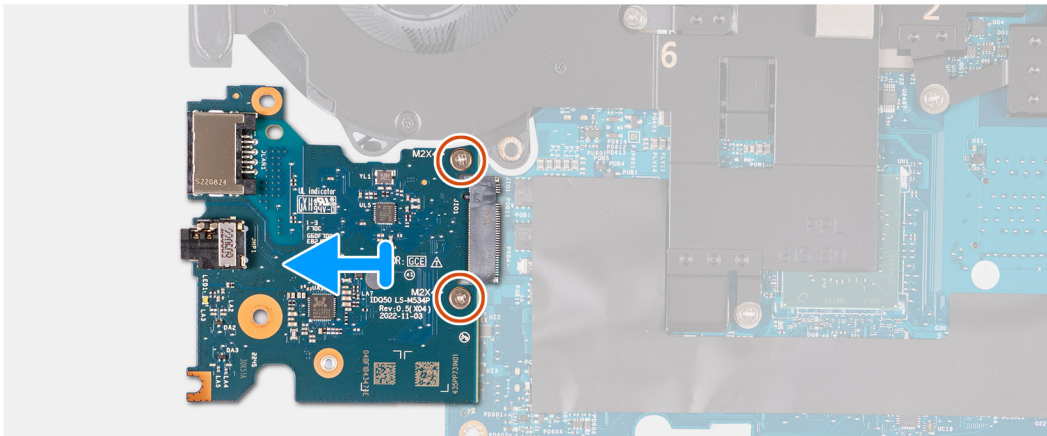
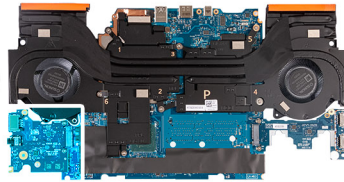

Steps

1. Turn the system-board assembly over.
2. Remove the two screws (M2x4) that secure the ethernet and audio board to the system board.
3. Disconnect and remove the ethernet and audio board from the system board.

Installing the ethernet and audio board

Prerequisites

If you are replacing a component, remove the existing component before performing the installation procedure.

About this task

The following image indicates the location of the ethernet and audio board and provides a visual representation of the installation procedure.



2x
M2x4

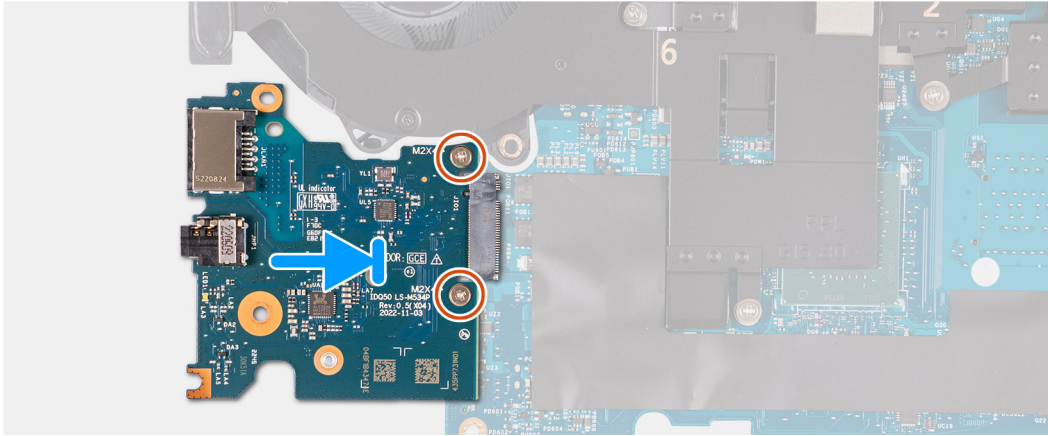
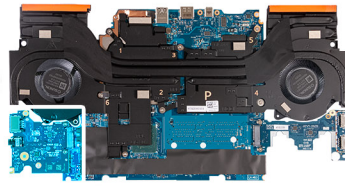

Steps

1. Slide the ethernet and audio board into the M.2 card slot on the system board.
2. Align the screw holes on the ethernet and audio board to the screw holes on the system board.
3. Replace the two screws (M2x4) that secure the ethernet and audio board to the system board.
4. Turn the system-board assembly over.

Next steps

1. Install the [system board](#).
2. Install the [memory module](#).
3. Install the [wireless card](#).
4. Install the [solid-state drive](#).
5. Install the [rear cover](#).
6. Install the [battery](#).
7. Install the [base cover](#).
8. Follow the procedure in [After working inside your computer](#).

Fan and heat-sink assembly

Removing the fan and heat-sink assembly

Prerequisites

1. Follow the procedure in [Before working inside your computer](#).

CAUTION: For maximum cooling of the processor, do not touch the heat transfer areas on the heat sink. The oils in your skin can reduce the heat transfer capability of the thermal grease.

NOTE: The heat sink may become hot during normal operation. Allow sufficient time for the heat sink to cool before you touch it.

2. Remove the [base cover](#).
3. Remove the [battery](#).
4. Remove the [rear cover](#).

5. Remove the [solid-state drive](#).
6. Remove the [wireless card](#).
7. Remove the [memory module](#).
8. Remove the [system board](#).

i **NOTE:** The system board can be removed as an assembly with the fan and heat-sink assembly, ethernet and audio board, and USB board attached.

About this task

The following image indicates the location of the fan and heat-sink assembly and provides a visual representation of the removal procedure.

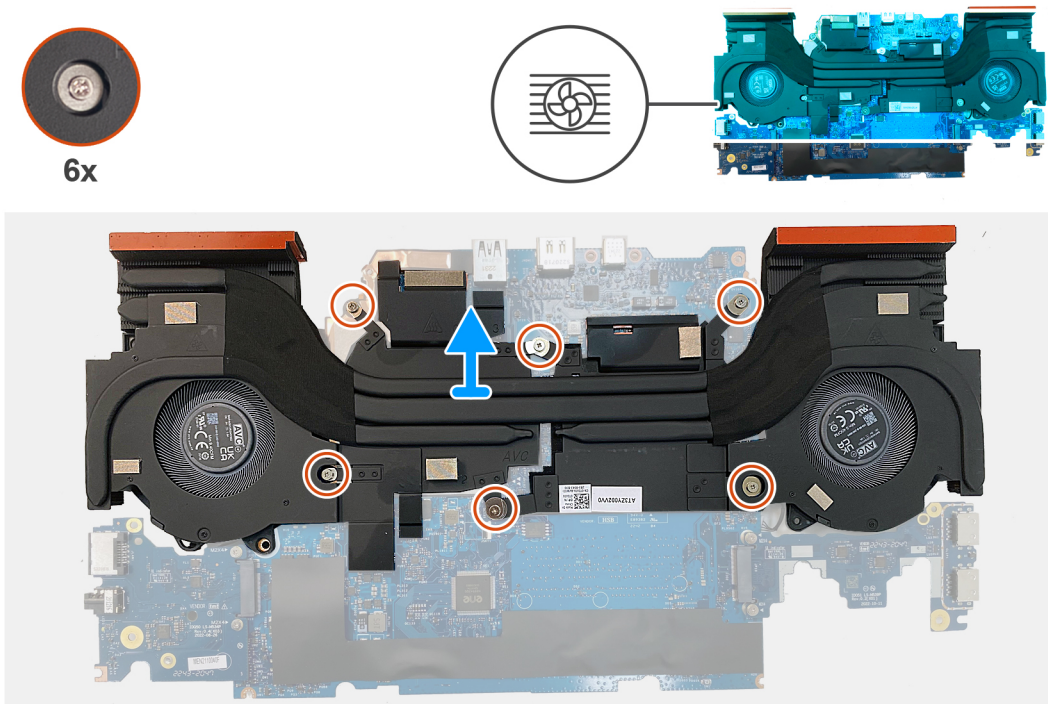

Steps

1. Turn the system-board assembly over.
2. In sequential order (1>2>3>4>5>6), remove the six screws that secure the fan and heat-sink assembly to the system-board assembly.
3. Lift the fan and heat-sink assembly off the system-board assembly.

Installing the fan and heat-sink assembly

Prerequisites

If you are replacing a component, remove the existing component before performing the installation procedure.

About this task

The following image indicates the location of the fan and heat-sink assembly and provides a visual representation of the installation procedure.

i **NOTE:** If either the system board or the heat sink is replaced, use the thermal pad that is provided in the kit to ensure that thermal conductivity is achieved.



6x

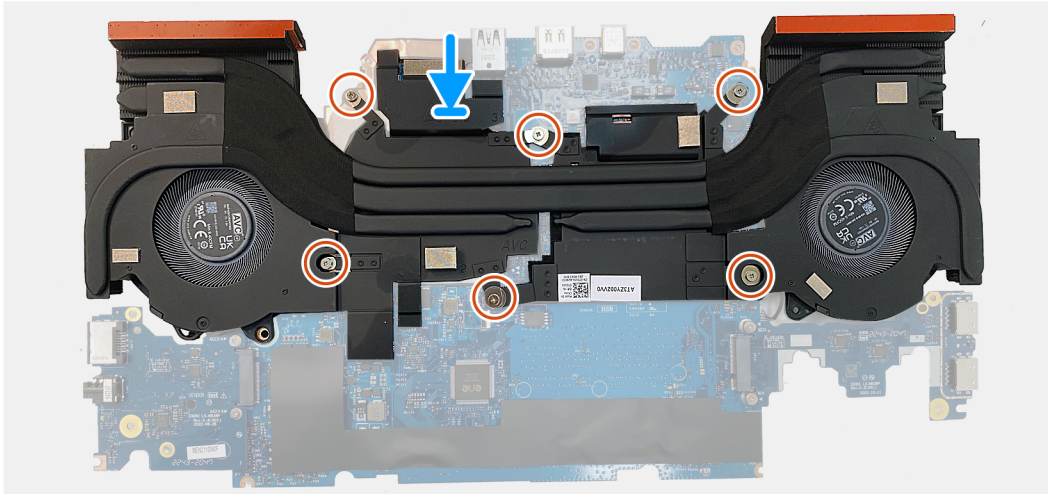
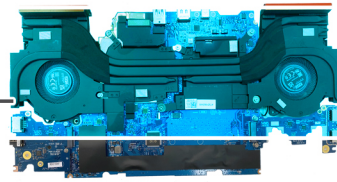

Steps

1. Place the fan and heat-sink assembly on the system board and align the screw holes on the fan and heat-sink assembly with the screw holes on the system board.
2. In reverse sequential order (6>5>4>3>2>1), replace the six screws that secure the fan and heat-sink assembly to the system board.
3. Turn the system-board assembly over.

Next steps

1. Install the [system board](#).
2. Install the [memory module](#).
3. Install the [wireless card](#).
4. Install the [solid-state drive](#).
5. Install the [rear cover](#).
6. Install the [battery](#).
7. Install the [base cover](#).
8. Follow the procedure in [After working inside your computer](#).

Power-button assembly

Removing the power button

Prerequisites

1. Follow the procedure in [Before working inside your computer](#).
2. Remove the [base cover](#).
3. Remove the [battery](#).
4. Remove the [rear cover](#).
5. Remove the [solid-state drive](#).
6. Remove the [wireless card](#).

7. Remove the [memory module](#).
8. Remove the [system board](#).

NOTE: The system board can be removed as an assembly with the fan and heat-sink assembly, ethernet and audio board, and USB board attached.

About this task

The following images indicate the location of the power button and provide a visual representation of the removal procedure.



3x
M2x2

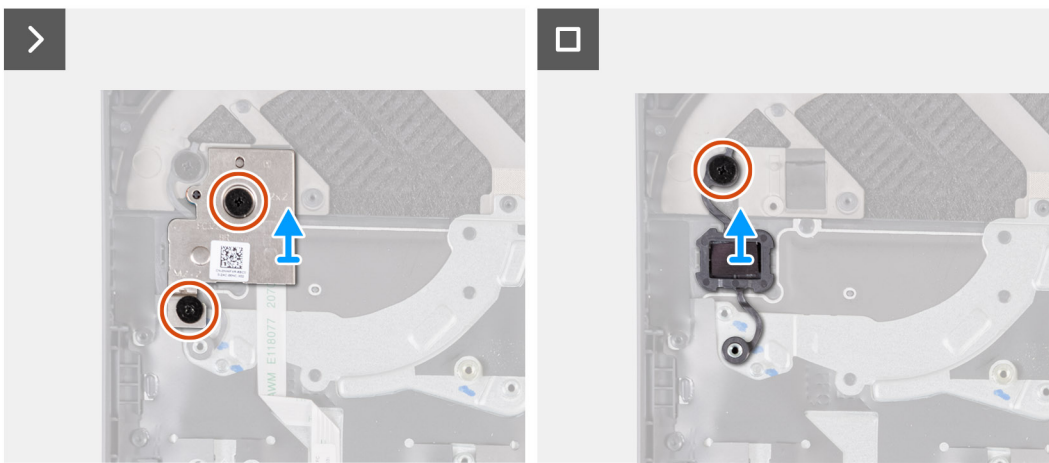
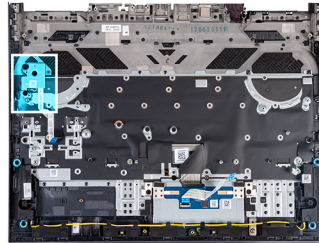

Steps

1. Remove the two screws (M2x2) that secure the power-button board assembly to the palm-rest and keyboard assembly.
2. Lift the power-button board assembly off the palm-rest and keyboard assembly.
3. Remove the screw (M2x2) that secures the power button to the palm-rest and keyboard assembly.
4. Lift the power button off the palm-rest and keyboard assembly.

Installing the power button

Prerequisites

If you are replacing a component, remove the existing component before performing the installation procedure.

About this task

The following image indicates the location of the power button and provides a visual representation of the installation procedure.



3x
M2x2

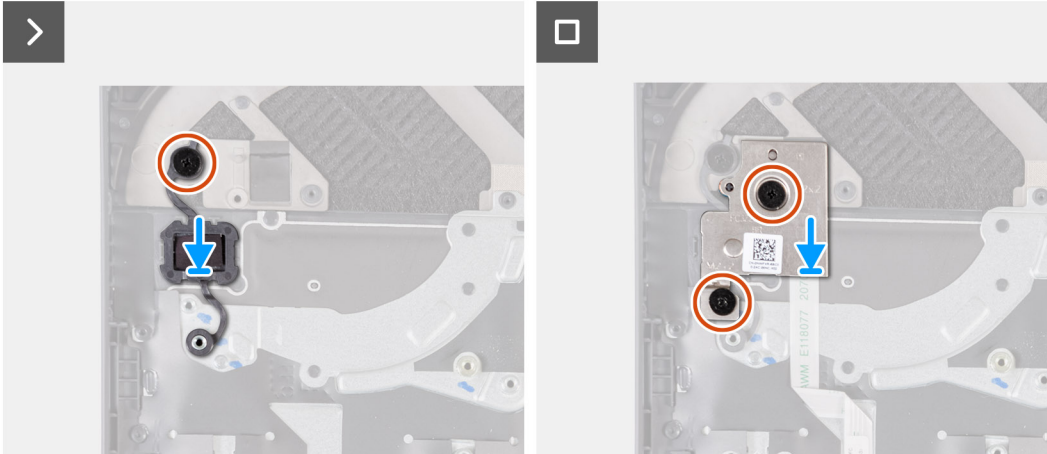
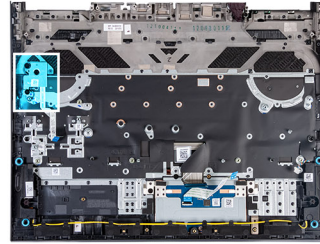

Steps

1. Place the power button on the slot on the palm-rest and keyboard assembly.
2. Replace the screw (M2x2) that secures the power button to the palm-rest and keyboard assembly.
3. Align the screw holes on the power-button board assembly with the screw holes on the palm-rest and keyboard assembly.
4. Replace the two screws (M2x2) that secure the power-button board assembly to the palm-rest and keyboard assembly.

Next steps

1. Install the [system board](#).
2. Install the [memory module](#).
3. Install the [wireless card](#).
4. Install the [solid-state drive](#).
5. Install the [rear cover](#).
6. Install the [battery](#).
7. Install the [base cover](#).
8. Follow the procedure in [After working inside your computer](#).

Palm-rest and keyboard assembly

Removing the palm-rest and keyboard assembly

Prerequisites

1. Follow the procedure in [Before working inside your computer](#).
2. Remove the [base cover](#).
3. Remove the [battery](#).
4. Remove the [rear cover](#).
5. Remove the [touchpad](#).
6. Remove the [display assembly](#).
7. Remove the [solid-state drive](#).
8. Remove the [wireless card](#).

9. Remove the [memory module](#).
10. Remove the [speakers](#).
11. Remove the [power-adapter port](#).
12. Remove the [system board](#).

i **NOTE:** The system board can be removed as an assembly with the fan and heat-sink assembly, ethernet and audio board, and USB board attached.

13. Remove the [keyboard-controller board](#), if applicable.
14. Remove the [power-button assembly](#).

About this task

Performing the steps in the pre-requisites leaves us with the palm-rest and keyboard assembly.

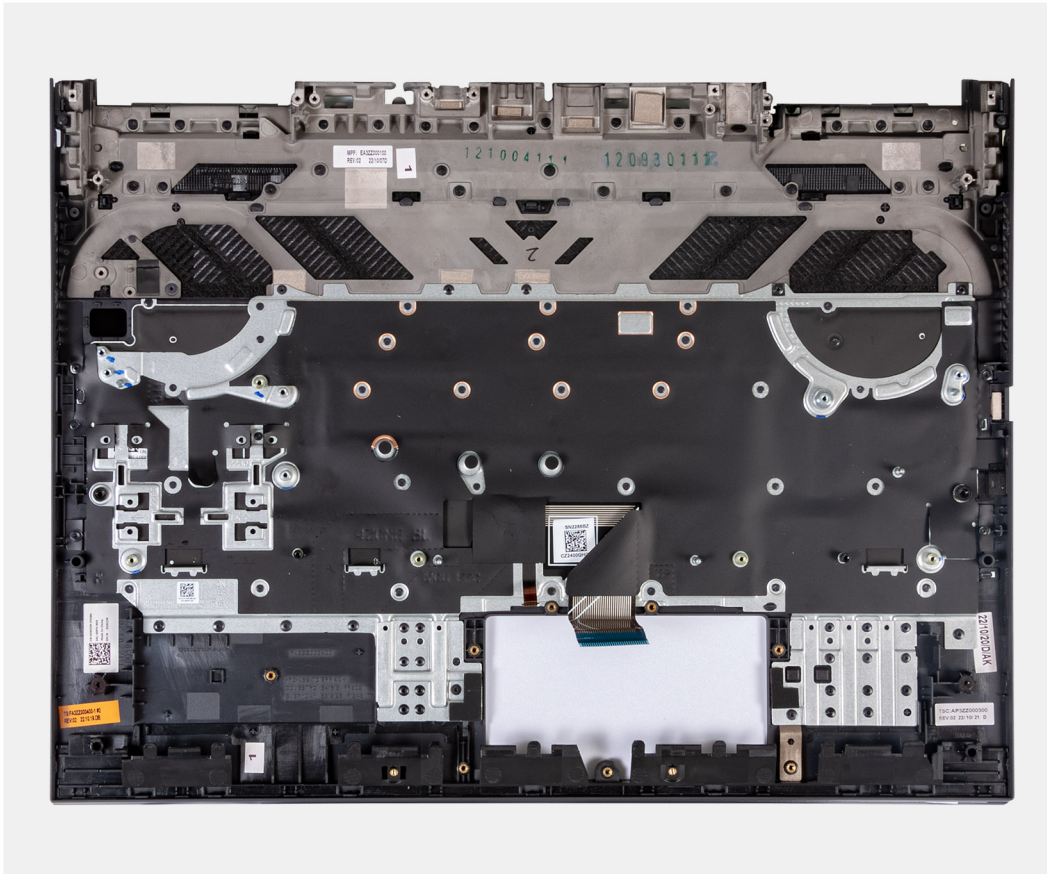

i **NOTE:** To replace the palm-rest and keyboard assembly, remove the solid-state drive screw mount from the existing palm-rest and keyboard assembly and transfer it to the replacement palm-rest and keyboard assembly.

Installing the palm-rest and keyboard assembly

Prerequisites

If you are replacing a component, remove the existing component before performing the installation procedure.

About this task

Place the palm-rest and keyboard assembly on a flat surface.

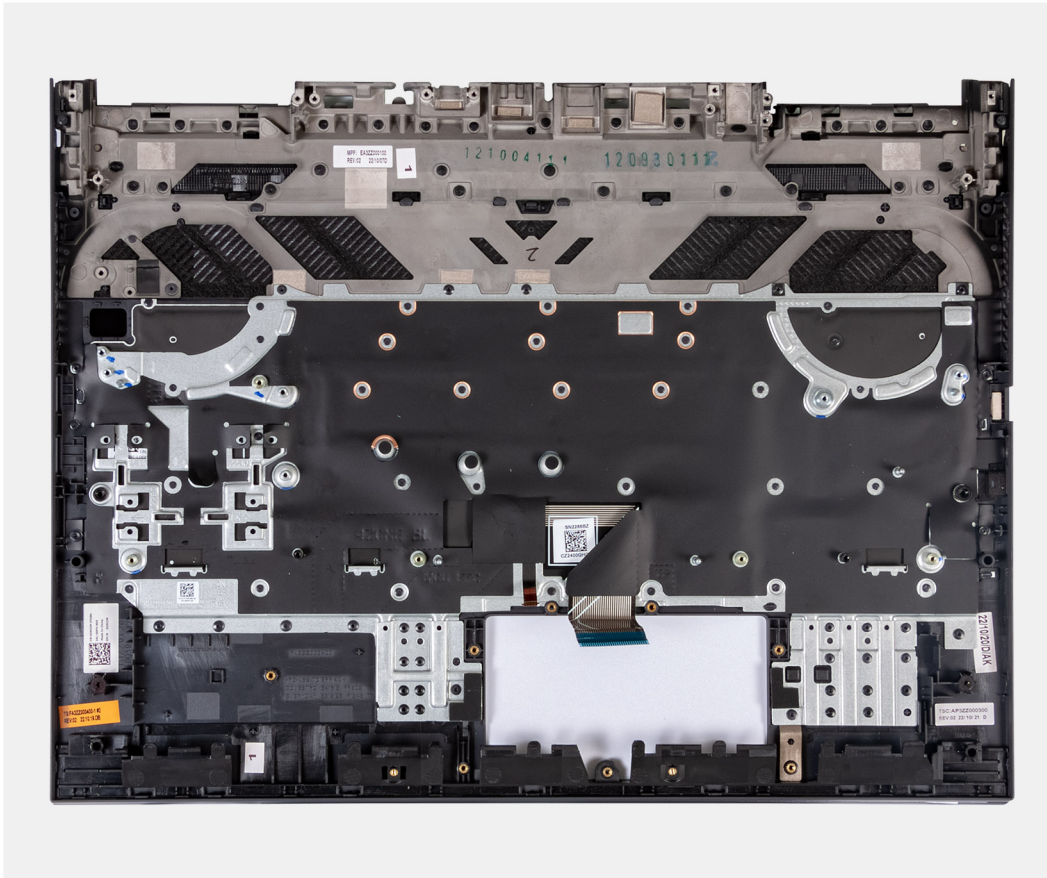

NOTE: To replace the palm-rest and keyboard assembly, remove the solid-state drive screw mount from the existing palm-rest and keyboard assembly and transfer it to the replacement palm-rest and keyboard assembly.

Next steps

1. Install the [power-button assembly](#).
2. Install the [system board](#).
NOTE: The system board can be installed as an assembly with the fan and heat-sink assembly, ethernet and audio board, and USB board attached.
3. Install the [keyboard-controller board](#), if applicable.
4. Install the [power-adapter port](#).
5. Install the [speakers](#).
6. Install the [memory module](#).
7. Install the [wireless card](#).
8. Install the [solid-state drive](#).
9. Install the [display assembly](#).
10. Install the [touchpad](#).
11. Install the [rear cover](#).
12. Install the [battery](#).
13. Install the [base cover](#).
14. Follow the procedure in [After working inside your computer](#).

Software

This chapter details the supported operating systems along with instructions on how to install the drivers.

Operating system

Your Dell G15 5535 supports the following operating systems:

- Windows 11 Home, 64-bit
- Windows 11 Pro, 64-bit

Drivers and downloads

When troubleshooting, downloading, or installing drivers, it is recommended that you read the Dell Knowledge Base article, Drivers and Downloads FAQs [000123347](#).

Technology and components

 **NOTE:** Instructions that are provided in the following section are applicable on computers that are shipped with the Windows operating system. Windows is factory-installed with this computer.

BIOS Setup

CAUTION: Unless you are an expert computer user, do not change the settings in the BIOS Setup. Certain changes can make your computer work incorrectly.

NOTE: Depending on the computer and its installed devices, the items that are listed in this section may or may not be displayed.

NOTE: Before you change the settings in BIOS Setup, it is recommended that you note down the original settings for future reference.

Use BIOS Setup for the following purposes:

- Get information about the hardware installed in your computer, such as the amount of RAM and the size of the hard drive.
- Change the system configuration information.
- Set or change a user-selectable option, such as the user password, type of hard drive installed, and enabling or disabling base devices.

Entering BIOS setup program

About this task

Turn on (or restart) your computer and press F2 immediately.

Navigation keys

NOTE: For most of the System Setup options, changes that you make are recorded but do not take effect until you restart the computer.

Table 25. Navigation keys

Keys	Navigation
Up arrow	Moves to the previous field.
Down arrow	Moves to the next field.
Enter	Selects a value in the selected field (if applicable) or follow the link in the field.
Spacebar	Expands or collapses a drop-down list, if applicable.
Tab	Moves to the next focus area. NOTE: For the standard graphics browser only.
Esc	Moves to the previous page until you view the main screen. Pressing Esc in the main screen displays a message that prompts you to save any unsaved changes and restarts the computer.

F12 One Time Boot menu

To enter the One Time Boot menu, turn on your computer, and then press F12 immediately.

NOTE: It is recommended to shut down the computer, if it is on.

The F12 One Time Boot menu displays the devices that you can boot from including the diagnostic option. The boot menu options are:

- Removable Drive (if available)
- STXXXX Drive (if available)
- **i** **NOTE:** XXX denotes the SATA drive number.
- Optical Drive (if available)
- SATA Hard Drive (if available)
- Diagnostics

The boot sequence screen also displays the option to access System Setup.

System setup options

i **NOTE:** Depending on your computer and its installed devices, the items that are listed in this section may or may not appear.

Table 26. System setup options—Main menu

Main	
System Time	Displays the current time in HH:MM:SS format.
System Date	Displays the current date in MM/DD/YYYY format.
BIOS Version	Displays the BIOS version.
Product Name	Displays the model number of your computer.
Service Tag	Displays the service tag of your computer.
Asset Tag	Displays the asset tag of your computer.
CPU Type	Displays the processor type.
CPU Speed	Displays the processor speed.
CPU ID	Displays the processor identification code.
CPU Cache	
L1 Cache	Displays the processor L1 cache size.
L2 Cache	Displays the processor L2 cache size.
L3 Cache	Displays the processor L3 cache size.
M.2 PCIe SSD-1	Displays the M.2 PCIe SSD device information of the computer.
M.2 PCIe SSD-2	Displays the M.2 PCIe SSD device information of the computer.
AC Adapter Type	Displays the type of AC adapter.
System Memory	Displays the size of memory installed.
Memory Speed	Displays the speed of memory.
Keyboard Type	Displays the type of keyboard installed on the computer.

Table 27. System setup options—Advance menu

Advanced	
Virtualization	Enables or disables the Virtualization technology. By default, the Virtualization option is enabled.
VT for Direct I/O	Enables or disables the computer to perform Virtualization Technology for Direct I/O.

Table 27. System setup options—Advance menu (continued)

Advanced	
USB Emulation	<p>By default, the VT for Direct I/O option is enabled.</p> <p>Enables or disables the USB emulation feature. This feature defines how the BIOS, in the absence of a USB-aware operating system, handles USB devices. USB emulation is always enabled during POST.</p> <p>i NOTE: You cannot boot any type of USB device (floppy, hard drive, or memory key) when this option is off.</p> <p>By default, the USB Emulation option is enabled.</p>
SATA/NVMe Operation mode	<p>Allows you to configure the operating mode of the integrated SATA/NVMe storage drive controller.</p> <p>By default, the AHCI option is selected.</p>
Adapter Warnings	<p>Allows you to choose if the computer should display warning messages when you use AC adapters that are not supported by your computer.</p> <p>By default, the Adapter Warnings option is enabled.</p>
Function Key Behavior	<p>Allows you to set function key or multimedia key as the default function key behavior.</p> <p>By default, the Multimedia key option is selected.</p>
Keyboard Illumination	<p>Selects the operating mode of the keyboard illumination feature.</p> <p>By default, the Bright option is selected.</p>
Keyboard Backlight with AC	<p>Selects the timeout value for the keyboard backlight when an AC adapter is plugged into the computer.</p> <p>By default, the Keyboard Backlight with AC value is set to 1 minute.</p>
Keyboard Backlight with Battery	<p>Selects the timeout value for the keyboard backlight when the computer is running on battery power. Default: 1 minute</p> <p>By default, the Keyboard Backlight with Battery value is set to 1 minute.</p>
Battery Health	<p>Displays the battery health.</p>
External USB Ports	<p>Enables or disables the external USB ports.</p> <p>By default, the External USB Ports are enabled.</p>
Enable Audio	<p>Enables or disables the integrated audio controller.</p> <p>By default, this option is enabled.</p>
Microphone	<p>Enables or disables the microphone.</p> <p>By default, the Microphone is enabled.</p>
Camera	<p>Enables or disables the camera.</p> <p>By default, the Camera is enabled.</p>
Secure Digital (SD) Card	<p>Enables or disables the SD card reader.</p> <p>By default, this option is enabled.</p>
Battery Charge Configuration	<p>Set the battery charge settings with a preselected custom charge start and stop.</p> <p>By default, the Adaptive option is selected.</p>

Table 27. System setup options—Advance menu (continued)

Advanced	
Advanced Battery Charge Configuration	<p>Enable Advance Battery Charge Configuration from the beginning of the day to a specified work period.</p> <p>By default, the Advanced Battery Charge Configuration option is disabled.</p>
IPv4 HTTP Support	<p>Enables or disables IPv4 HTTP Boot Support in the system.</p> <p>By default, the IPv4 HTTP Support option is disabled.</p>
IPv6 HTTP Support	<p>Enables or disables IPv6 HTTP Boot Support in the system.</p> <p>By default, the IPv6 HTTP Support option is disabled.</p>
Power Option	
Power on LID open	<p>Enables or disables the computer to power up from the off state whenever the lid is opened.</p> <p>By default, the Power on LID open option is enabled.</p>
Maintenance	
Data Wipe on next boot	<p>Enables or disables data wipe on the next boot.</p> <p>Default: Disabled</p> <p>By default, the Power on LID open option is disabled.</p>
BIOS Recovery from Hard Drive	<p>Enables the user to recover from certain corrupted BIOS conditions from a recovery file on the user primary hard drive or an external USB key.</p>
BIOS Auto-Recovery	<p>Enables BIOS to automatically recover BIOS without user actions.</p> <p>Default: Disabled</p> <p>By default, the BIOS Auto-Recovery option is disabled.</p>
SupportAssist System Resolution	
Auto OS Recovery Threshold	<p>Controls the automatic boot flow for SupportAssist System Resolution Console and for the Dell OS Recovery tool.</p> <p>By default, the Auto OS Recovery Threshold value is set to 2.</p>
SupportAssist OS Recovery	<p>Enables or disables the boot flow for the SupportAssist OS Recovery tool in the even of certain system errors.</p> <p>By default, the SupportAssist OS Recovery option is disabled.</p>

Table 28. System setup options—Security menu

Security	
Admin Password	<p>The Administrator Password prevents unauthorized access to the BIOS Setup options. Once the administrator password is set, the BIOS setup options can only be modified after providing the correct password.</p> <p>The following rules and dependencies apply to the Administrator Password -</p> <ul style="list-style-type: none"> • The administrator password cannot be set if system and/or internal hard drive passwords are previously set. • The administrator password can be used in place of the system and/or internal hard drive passwords.

Table 28. System setup options—Security menu (continued)

Security	
System Password	<ul style="list-style-type: none"> • When set, the administrator password must be provided during a firmware update. • Clearing the administrator password also clears the system password (if set). <p>Dell Technologies recommends using an administrator password to prevent unauthorized changes to BIOS setup options.</p> <p>The System Password prevents the system from booting to an operating system without entering the correct password.</p> <p>The following rules and dependencies apply when the System Password is used -</p> <ul style="list-style-type: none"> • The computer shuts down when idle for approximately 10 minutes at the system password prompt. • The computer shuts down after three incorrect attempts to enter the system password. • The computer shuts down when the Esc key is pressed at the System Password prompt. • The system password is not prompted when the computer resumes from standby mode. <p>Dell Technologies recommends using the system password in situations where it is likely that a system may be lost or stolen.</p>
Asset tag	Set your system's Asset Tag.
Password Change	<p>Allows you to permit or deny system password or HDD password changes.</p> <p>By default, Password Change is permitted.</p>
Allow Non-Admin Password Changes	<p>The Allow Non-Admin Password Changes option in BIOS setup allows an end user to set or change the system or hard drive passwords without entering the administrator password. This gives an administrator control over the BIOS settings but enables an end user to provide their own password.</p> <p>By default, the Allow Non-Admin Password Changes option is disabled.</p> <p>For additional security, Dell Technologies recommends keeping the Allow Non-Admin Password Changes option disabled.</p>
Non-Admin Setup Changes	<p>The Non-Admin Setup Changes option allows an end user to configure the wireless devices without requiring the administrator password.</p> <p>By default, the Non-Admin Setup Changes option is disabled.</p> <p>For additional security, Dell Technologies recommends keeping the Non-Admin Setup Changes option disabled.</p>
Absolute	<p>Enables, disables, or permanently disables the BIOS module interface of the optional Absolute Persistence Module service from Absolute software.</p> <p>By default, the Absolute option is enabled.</p> <p>For additional security, Dell Technologies recommends keeping the Absolute option enabled.</p>

Table 28. System setup options—Security menu (continued)





Security	
	<p> WARNING: The 'Permanently Disabled' option can only be selected once. When 'Permanently Disabled' is selected, Absolute Persistence cannot be re-enabled. No further changes to the Enable/Disable states are allowed.</p> <p> NOTE: The Enable/Disable options are unavailable while the computer is in the activated state.</p> <p> NOTE: When the Absolute features are activated, the Absolute integration cannot be disabled from the BIOS setup screen.</p>
Absolute Status	Displays Absolute status.
Windows SMM Security Mitigations Table (WSMT)	<p>Enables or disables additional UEFI SMM Security Mitigation protections. This option uses the Windows SMM Security Mitigations Table (WSMT) to confirm to the operating system that security best practices have been implemented by the UEFI firmware.</p> <p>By default, the SMM Security Mitigation option is enabled.</p> <p>For additional security, Dell Technologies recommends keeping the SMM Security Mitigation option enabled unless you have a specific application which is not compatible.</p> <p> NOTE: This feature may cause compatibility issues or loss of functionality with some legacy tools and applications.</p>
Trusted Platform Module (TPM)	<p>Trusted Platform Module (TPM) is a security device that stores computer-generated keys for encryption and features such as BitLocker, Virtual Secure Mode, remote Attestation.</p> <p>By default, the Trusted Platform Module (TPM) option is enabled.</p> <p>For additional security, Dell Technologies recommends keeping Trusted Platform Module (TPM) enabled to allow these security technologies to fully function.</p>
PPI Bypass for Clear Command	<p>Allows you to control the TPM Physical Presence Interface (PPI). When enabled, this setting will allow the OS to skip BIOS PPI user prompts when issuing the Clear command. Changes to this setting take effect immediately.</p> <p>By default, the PPI Bypass for Clear Command option is disabled.</p> <p>For additional security, Dell Technologies recommends keeping the PPI Bypass for Clear Commands option disabled.</p>
Enable Pre-Boot DMA Support	<p>Allows you to control the Pre-Boot DMA protection for both internal and external ports. This option does not directly enable DMA protection in the operating system.</p> <p> NOTE: This option is not available when the virtualization setting for IOMMU is disabled (VT-d/AMD Vi).</p>

Table 28. System setup options—Security menu (continued)

Security	
Enable OS Kernel DMA Support	<p>By default, the Enable Pre-Boot DMA Support option is enabled.</p> <p>For additional security, Dell Technologies recommends keeping the Enable Pre-Boot DMA Support option enabled.</p> <p>i NOTE: This option is provided only for compatibility purposes, since some older hardware is not DMA capable.</p> <p>Allows you to control the Kernel DMA protection for both internal and external ports. This option does not directly enable DMA protection in the operating system. For operating systems that support DMA protection, this setting indicates to the operating system that the BIOS supports the feature.</p> <p>i NOTE: This option is not available when the virtualization setting for IOMMU is disabled (VT-d/AMD Vi).</p> <p>By default, the Enable OS Kernel DMA Support option is enabled.</p> <p>i NOTE: This option is provided only for compatibility purposes, since some older hardware is not DMA capable.</p>
UEFI Firmware Capsule Updates	<p>Enables or disables BIOS updates through UEFI capsule update packages.</p> <p>By default, the UEFI Firmware Capsule Updates option is enabled.</p>
Secure Boot	
Secure Boot Database	Displays the status of secure boot database.
Secure Boot Status	Displays the status of secure boot.
Secure Boot Mode	Displays the mode of secure boot.
User Customized Security	Displays the status of presence of user customized security.
Secure Boot	<p>Enables the computer to boot using only validated boot software.</p> <p>By default, the Enable Secure Boot option is enabled.</p> <p>For additional security, Dell Technologies recommends keeping the Secure Boot option enabled to ensure that the UEFI firmware validates the operating system during the boot process.</p> <p>i NOTE: For Secure Boot to be enabled, the computer is required to be in UEFI boot mode and the Enable Legacy Option ROMs option is required to be turned off.</p>
Select Secure Mode	<p>Enables or disables the Secure Boot operation mode.</p> <p>By default, the Deployed Mode is selected.</p> <p>i NOTE: Deployed Mode should be selected for normal operation of Secure Boot.</p>
Expert Key Management	

Table 28. System setup options—Security menu (continued)

Security	
Enable Custom Mode	Enables or disables the keys in the PK, KEK, db, and dbx security key databases to be modified. By default, the Enable Custom Mode option is disabled.
Custom Mode Key Management	Selects the custom values for expert key management. By default, the PK option is selected.

Table 29. System setup options—Boot menu

Boot	
File Browser Add Boot Option	Allows you to add the boot options.
Windows Boot Manager	Display boot options in Windows
UEFI Boot	Enables or disables UEFI boot. By default, the UEFI Boot option is disabled.

Table 30. System setup options—Exit menu

Exit	
Exit Saving Changes	Allows you to exit system setup and save your changes.
Save Change Without Exit	Allows you to save your changes without exiting the BIOS setup.
Exit Discarding Changes	Allows you to exit the BIOS setup without saving the changes.
Load Optimal Defaults	Allows you to restore default values for all system setup options.
Discard Changes	Allows you to load previous values for all system setup options.

Updating the BIOS

Updating the BIOS in Windows

Steps

1. Go to www.dell.com/support.
2. Click **Product support**. In the **Search support** box, enter the Service Tag of your computer, and then click **Search**.
 **NOTE:** If you do not have the Service Tag, use the SupportAssist feature to automatically identify your computer. You can also use the product ID or manually browse for your computer model.
3. Click **Drivers & Downloads**. Expand **Find drivers**.
4. Select the operating system installed on your computer.
5. In the **Category** drop-down list, select **BIOS**.
6. Select the latest version of BIOS, and click **Download** to download the BIOS file for your computer.
7. After the download is complete, browse the folder where you saved the BIOS update file.
8. Double-click the BIOS update file icon and follow the on-screen instructions.
 For more information about how to update the system BIOS, search in the Knowledge Base Resource at www.dell.com/support.

Updating the BIOS using the USB drive in Windows

Steps

1. Follow the procedure from step 1 to step 6 in [Updating the BIOS in Windows](#) to download the latest BIOS setup program file.
2. Create a bootable USB drive. For more information, search the Knowledge Base Resource at www.dell.com/support.
3. Copy the BIOS setup program file to the bootable USB drive.
4. Connect the bootable USB drive to the computer that needs the BIOS update.
5. Restart the computer and press **F12**.
6. Select the USB drive from the **One Time Boot Menu**.
7. Type the BIOS setup program filename and press **Enter**.
The **BIOS Update Utility** appears.
8. Follow the on-screen instructions to complete the BIOS update.

Updating the BIOS in Linux and Ubuntu

To update the system BIOS on a computer that is installed with Linux or Ubuntu, see the knowledge base article [000131486](#) at www.dell.com/support.

Updating the BIOS from the F12 One Time Boot menu

Update your computer BIOS using the BIOS update.exe file that is copied to a FAT32 USB drive and booting from the F12 **One Time Boot** menu.

About this task

BIOS Update

You can run the BIOS update file from Windows using a bootable USB drive or you can also update the BIOS from the F12 **One Time Boot** menu on the computer.

Most of the Dell computers built after 2012 have this capability, and you can confirm by booting your computer to the F12 **One Time Boot** Menu to see if BIOS FLASH UPDATE is listed as a boot option for your computer. If the option is listed, then the BIOS supports this BIOS update option.

 **NOTE:** Only computers with the BIOS Flash Update option in the F12 **One Time Boot** menu can use this function.

Updating from the One Time Boot menu

To update your BIOS from the F12 **One Time Boot** menu, you need the following:

- USB drive formatted to the FAT32 file system (key does not have to be bootable)
- BIOS executable file that you downloaded from the Dell Support website and copied to the root of the USB drive
- AC power adapter that is connected to the computer
- Functional computer battery to flash the BIOS

Perform the following steps to perform the BIOS update flash process from the F12 menu:

 **CAUTION:** Do not turn off the computer during the BIOS update process. The computer may not boot if you turn off your computer.

Steps

1. From a turn off state, insert the USB drive where you copied the flash into a USB port of the computer.
2. Turn on the computer and press F12 to access the **One Time Boot** Menu, select BIOS Update using the mouse or arrow keys then press Enter.
The flash BIOS menu is displayed.
3. Click **Flash from file**.
4. Select an external USB device.
5. Select the file and double-click the flash target file, and then click **Submit**.
6. Click **Update BIOS**. The computer restarts to flash the BIOS.

7. The computer will restart after the BIOS update is completed.

System and setup password

Table 31. System and setup password

Password type	Description
System password	Password that you must enter to log in to your system.
Setup password	Password that you must enter to access and make changes to the BIOS settings of your computer.

You can create a system password and a setup password to secure your computer.

 **CAUTION:** The password features provide a basic level of security for the data on your computer.

 **CAUTION:** Anyone can access the data that is stored on your computer, when not locked and left unattended.

 **NOTE:** System and setup password feature is disabled.

Assigning a System Setup password

Prerequisites

You can assign a new System or Admin Password only when the status is in **Not Set**.

About this task

To enter BIOS System Setup, press F2 immediately after a power-on or reboot.

Steps

1. In the **System BIOS** or **System Setup** screen, select **Security** and press Enter.
The **Security** screen is visible.
2. Select **System/Admin Password** and create a password in the **Enter the new password** field.
Use the following guidelines to assign the system password:
 - A password can have up to 32 characters.
 - At least one special character: "(! " # \$ % & ' * + , - . / : ; < = > ? @ [\] ^ _ ` { | })"
 - Numbers 0 to 9.
 - Upper case letters from A to Z.
 - Lower case letters from a to z.
3. Type the system password that you entered earlier in the **Confirm new password** field and click **OK**.
4. Press Esc and save the changes as prompted by the message.
5. Press Y to save the changes.
The computer restarts.

Deleting or changing an existing system setup password

Prerequisites

Ensure that the **Password Status** is Unlocked (in the System Setup) before attempting to delete or change the existing System and/or Setup password. You cannot delete or change an existing System or Setup password, if the **Password Status** is Locked.

About this task

To enter the System Setup, press F2 immediately after a power-on or reboot.

Steps

1. In the **System BIOS** or **System Setup** screen, select **System Security** and press Enter. The **System Security** screen is displayed.
2. In the **System Security** screen, verify that the Password Status is **Unlocked**.
3. Select **System Password**, update, or delete the existing system password, and press Enter or Tab.
4. Select **Setup Password**, update, or delete the existing setup password, and press Enter or Tab.
 **NOTE:** If you change the System and/or Setup password, reenter the new password when prompted. If you delete the System and/or Setup password, confirm the deletion when prompted.
5. Press Esc. A message prompts you to save the changes.
6. Press Y to save the changes and exit from System Setup. The computer restarts.

Clearing CMOS settings

About this task

 **CAUTION:** Clearing CMOS settings will reset the BIOS settings on your computer.

Steps

1. Remove the [base cover](#).
2. Disconnect the battery cable from the system board.
3. Wait for one minute.
4. Connect the battery cable to the system board.
5. Replace the [base cover](#).

Clearing BIOS (System Setup) and System passwords

About this task

To clear the system or BIOS passwords, contact Dell technical support as described at www.dell.com/contactdell.

 **NOTE:** For information about how to reset Windows or application passwords, see the documentation accompanying Windows or your application.

Troubleshooting

Handling swollen rechargeable Li-ion batteries

Like most laptops, Dell laptops use Lithium-ion batteries. One type of Lithium-ion battery is the rechargeable Li-ion battery. Rechargeable Li-ion batteries have increased in popularity in recent years and have become standard in the electronics industry due to customer preferences for a slim form factor (especially with newer ultra-thin laptops) and long battery life. Inherent to rechargeable Li-ion battery technology is the potential for swelling of the battery cells.

A swollen battery may impact the performance of the laptop. To prevent possible further damage to the device enclosure or internal components leading to malfunction, discontinue the use of the laptop and discharge it by disconnecting the AC adapter and letting the battery drain.

Swollen batteries should not be used and should be replaced and disposed of properly. We recommend contacting Dell product support for options to replace a swollen battery under the terms of the applicable warranty or service contract, including options for replacement by a Dell authorized service technician.

The guidelines for handling and replacing rechargeable Li-ion batteries are as follows:

- Exercise caution when handling rechargeable Li-ion batteries.
- Discharge the battery before removing it from the system. To discharge the battery, unplug the AC adapter from the system and operate the system only on battery power. When the system will no longer turn on when the power button is pressed, the battery is fully discharged.
- Do not crush, drop, mutilate, or penetrate the battery with foreign objects.
- Do not expose the battery to high temperatures, or disassemble battery packs and cells.
- Do not apply pressure to the surface of the battery.
- Do not bend the battery.
- Do not use tools of any type to pry on or against the battery.
- If a battery gets stuck in a device as a result of swelling, do not try to free it as puncturing, bending, or crushing a battery can be dangerous.
- Do not attempt to reassemble a damaged or swollen battery into a laptop.
- Swollen batteries that are covered under warranty should be returned to Dell in an approved shipping container (provided by Dell)—this is to comply with transportation regulations. Swollen batteries that are not covered under warranty should be disposed of at an approved recycling center. Contact Dell product support at <https://www.dell.com/support> for assistance and further instructions.
- Using a non-Dell or incompatible battery may increase the risk of fire or explosion. Replace the battery only with a compatible battery purchased from Dell that is designed to work with your Dell computer. Do not use a battery from other computers with your computer. Always purchase genuine batteries from <https://www.dell.com> or otherwise directly from Dell.

Rechargeable Li-ion batteries can swell for various reasons such as age, number of charge cycles, or exposure to high heat. For more information about how to improve the performance and lifespan of the laptop battery and to minimize the possibility of occurrence of the issue, search Dell Laptop Battery in the Knowledge Base Resource at www.dell.com/support.

Locate the Service Tag or Express Service Code of your Dell computer

Your Dell computer is uniquely identified with a Service Tag or Express Service Code. To view relevant support resources for your Dell computer, we recommend entering the Service Tag or Express Service Code at www.dell.com/support.

For more information about how to find the Service Tag for your computer, see [Locate the Service Tag on your computer](#).

Dell SupportAssist Pre-boot System Performance Check diagnostics

About this task

SupportAssist diagnostics (also known as system diagnostics) performs a complete check of your hardware. The Dell SupportAssist Pre-boot System Performance Check diagnostics is embedded with the BIOS and launched by the BIOS internally. The embedded system diagnostics provides options for particular devices or device groups allowing you to:

- Run tests automatically or in an interactive mode.
- Repeat the tests.
- Display or save test results.
- Run thorough tests to introduce additional test options to provide extra information about one or more failed devices.
- View status messages that inform you the tests are completed successfully.
- View error messages that inform you of problems encountered during testing.

 **NOTE:** Some tests for specific devices require user interaction. Always ensure that you are present at the computer terminal when the diagnostic tests are performed.

For more information, see the knowledge base article [000180971](#).

Running the SupportAssist Pre-Boot System Performance Check

Steps

1. Turn on your computer.
2. As the computer boots, press the F12 key as the Dell logo appears.
3. On the boot menu screen, select the **Diagnostics** option.
4. Click the arrow at the bottom left corner.
Diagnostics front page is displayed.
5. Click the arrow in the lower-right corner to go to the page listing.
The items that are detected are listed.
6. To run a diagnostic test on a specific device, press Esc and click **Yes** to stop the diagnostic test.
7. Select the device from the left pane and click **Run Tests**.
8. If there are any issues, error codes are displayed.
Note the error code and validation number and contact Dell.

Built-in self-test (BIST)

M-BIST

M-BIST (Built In Self-Test) is the system board built-in self-test diagnostics tool that improves the diagnostics accuracy of system board Embedded Controller (EC) failures.

 **NOTE:** M-BIST can be manually initiated before Power On Self-Test (POST).

How to run M-BIST

 **NOTE:** M-BIST must be initiated on the computer from a power-off state that is either connected to AC power or with a battery only.

1. Press and hold both the **M** key on the keyboard and the **power button** to initiate M-BIST.
2. The battery indicator LED may exhibit two states:
 - a. OFF: No fault was detected with the system board.
 - b. AMBER: Amber indicates a problem with the system board.

- If there is a failure with the system board, the battery status LED flashes one of the following error codes for 30 seconds:

Table 32. LED error codes

Blinking Pattern		Possible Problem
Amber	White	
2	1	CPU Failure
2	8	LCD Power Rail Failure
1	1	TPM Detection Failure
2	4	Memory/RAM failure

- If there is no failure with the system board, the LCD cycles through the solid color screens that are described in the LCD-BIST section for 30 seconds and then turn off.

LCD Power rail test (L-BIST)

L-BIST is an enhancement to the single LED error code diagnostics and is automatically initiated during POST. L-BIST will check the LCD power rail. If there is no power being supplied to the LCD (that is if the L-BIST circuit fails), the battery status LED flashes either an error code [2,8] or an error code [2,7].

NOTE: If L-BIST fails, LCD-BIST cannot function as no power will be supplied to the LCD.

How to invoke the L-BIST Test:

- Press the power button to start the computer.
- If the computer does not start up normally, look at the battery status LED:
 - If the battery status LED flashes an error code [2,7], the display cable may not be connected properly.
 - If the battery status LED flashes an error code [2,8], there is a failure on the LCD power rail of the system board, hence there is no power that is supplied to the LCD.
- For cases, when a [2,7] error code is shown, check to see if the display cable is properly connected.
- For cases when a [2,8] error code is shown, replace the system board.

LCD Built-in Self-Test (BIST)

Dell laptops have a built-in diagnostic tool that helps you determine if the screen abnormality you are experiencing is an inherent problem with the LCD (screen) of the Dell laptop or with the video card (GPU) and computer settings.

When you notice screen abnormalities like flickering, distortion, clarity issues, fuzzy or blurry image, horizontal or vertical lines, color fade and so on, it is always a good practice to isolate the LCD (screen) by running the Built-In Self-Test (BIST).

How to invoke the LCD BIST Test

- Power off the Dell laptop.
- Disconnect any peripherals that are connected to the laptop. Connect only the AC adapter (charger) to the laptop.
- Ensure that the LCD (screen) is clean (no dust particles on the surface of the screen).
- Press and hold the **D** key and **Power on** the laptop to enter LCD built-in self-test (BIST) mode. Continue to hold the D key until the computer boots up.
- The screen displays solid colors and change colors on the entire screen to white, black, red, green, and blue twice.
- Then it displays the colors white, black, and red.
- Carefully inspect the screen for abnormalities (any lines, fuzzy color, or distortion on the screen).
- At the end of the last solid color (red), the computer shuts down.

NOTE: Dell SupportAssist Preboot diagnostics upon launch initiates an LCD BIST first, expecting a user intervention to confirm functionality of the LCD.

System-diagnostic lights

Battery-status light

Indicates the power and battery-charge status.

Solid white — Power adapter is connected and the battery has more than 5 percent charge.

Amber — Computer is running on battery and the battery has less than 5 percent charge.

Off

- Power adapter is connected, and the battery is fully charged.
- Computer is running on battery, and the battery has more than 5 percent charge.
- Computer is in sleep state, hibernation, or turned off.

The battery-status light blinks amber along with beep codes indicating failures.

For example, the battery-status light blinks amber two times followed by a pause, and then blinks white three times followed by a pause. This 2,3 pattern continues until the computer is turned off indicating no memory or RAM is detected.

The following table shows different power and battery-status light patterns and associated problems.

Table 33. System diagnostic lights

Blinking pattern		Problem description
Amber	White	
1	1	TPM detection failure
1	2	Unrecoverable SPI Flash Failure
1	3	Short in hinge cable tripped OCP1
1	4	Short in hinge cable tripped OCP2
1	5	EC unable to program i-Fuse
1	6	Generic catch-all for ungraceful EC code flow errors
1	7	Non-RPMC Flash on Boot Guard fused system
2	1	CPU failure
2	2	System board failure (included BIOS corruption or ROM error)
2	3	No memory/RAM detected
2	4	Memory/RAM failure
2	5	Invalid memory installed
2	6	System board/Chipset Error
2	7	LCD failure (SBIOS message)
2	8	LCD failure (EC detection of power rail failure)
3	1	CMOS battery failure
3	2	PCI or Video card/chip failure
3	3	BIOS recovery image not found
3	4	BIOS recovery image found but invalid
3	5	Power rail failure
3	6	Flash corruption detected by SBIOS.

Table 33. System diagnostic lights (continued)

Blinking pattern		Problem description
Amber	White	
3	7	Timeout waiting on ME to reply to HECI message.

NOTE: Blinking 3-3-3 LEDs on Lock LED (Caps-Lock or Num-Lock), Power button LED (without Fingerprint reader), and Diagnostic LED indicates failure to provide input during LCD panel test on Dell SupportAssist Pre-boot System Performance. Check diagnostics.

Camera status light: Indicates whether the camera is in use.

- Solid white — Camera is in use.
- Off — Camera is not in use.

Caps Lock status light: Indicates whether Caps Lock is enabled or disabled.

- Solid white — Caps Lock enabled.
- Off — Caps Lock disabled.

Recovering the operating system

When your computer is unable to boot to the operating system even after repeated attempts, it automatically starts Dell SupportAssist OS Recovery.

Dell SupportAssist OS Recovery is a stand-alone tool that is preinstalled in all Dell computers that are installed with the Windows operating system. It consists of tools to diagnose and troubleshoot issues that may occur before your computer boots to the operating system. It enables you to diagnose hardware issues, repair your computer, back up your files, or restore your computer to its factory state.

You can also download it from the Dell Support website to troubleshoot and fix your computer when it fails to boot into their primary operating system due to software or hardware failures.

For more information about the Dell SupportAssist OS Recovery, see *Dell SupportAssist OS Recovery User's Guide* at www.dell.com/serviceabilitytools. Click **SupportAssist** and then, click **SupportAssist OS Recovery**.

Real-Time Clock (RTC Reset)

The Real Time Clock (RTC) reset function allows you or the service technician to recover Dell computers from No POST/No Power/No Boot situations. The legacy jumper enabled RTC reset has been retired on these models.

Start the RTC reset with the computer powered off and connected to AC power. Press and hold the power button for thirty to thirty five (30-35) seconds

. The computer RTC Reset occurs after you release the power button.

Backup media and recovery options

It is recommended to create a recovery drive to troubleshoot and fix problems that may occur with Windows. Dell proposes multiple options for recovering the Windows operating system on your Dell computer. For more information, see [Dell Windows Backup Media and Recovery Options](#).

Wi-Fi power cycle

About this task

If your computer is unable to access the Internet due to Wi-Fi connectivity issues a Wi-Fi power cycle procedure may be performed. The following procedure provides the instructions on how to conduct a Wi-Fi power cycle:

 **NOTE:** Some Internet Service Providers (ISPs) provide a modem or router combo device.

Steps

1. Turn off your computer.
2. Turn off the modem.
3. Turn off the wireless router.
4. Wait for 30 seconds.
5. Turn on the wireless router.
6. Turn on the modem.
7. Turn on your computer.

Drain residual flea power (perform hard reset)

About this task

Flea power is the residual static electricity that remains in the computer even after it has been powered off and the battery is removed.

For your safety, and to protect the sensitive electronic components in your computer, you are requested to drain residual flea power before removing or replacing any components in your computer.

Draining residual flea power, also known as a performing a "hard reset", is also a common troubleshooting step if your computer does not turn on or boot into the operating system.

Procedure to drain residual flea power (perform a hard reset)

Steps

1. Turn off your computer.
2. Disconnect the power adapter from your computer.
3. Remove the base cover.
4. Remove the battery.
5. Press and hold the power button for 20 seconds to drain the flea power.
6. Install the battery.
7. Install the base cover.
8. Connect the power adapter to your computer.
9. Turn on your computer.



 **NOTE:** For more information about performing a hard reset, search in the Knowledge Base Resource at www.dell.com/support.

Getting help and contacting Dell

Self-help resources

You can get information and help on Dell products and services using these self-help resources:

Table 34. Self-help resources

Self-help resources	Resource location
Information about Dell products and services	www.dell.com
My Dell app	 <p>Figure 2. My Dell app</p>
Tips	 <p>Figure 3. Tips</p>
Contact Support	In Windows search, type <code>Contact Support</code> , and press Enter.
Online help for operating system	www.dell.com/support/windows www.dell.com/support/linux
Access top solutions, diagnostics, drivers and downloads, and learn more about your computer through videos, manuals, and documents.	<p>Your Dell computer is uniquely identified by a Service Tag or Express Service Code. To view relevant support resources for your Dell computer, enter the Service Tag or Express Service Code at www.dell.com/support.</p> <p>For more information about how to find the Service Tag for your computer, see Locate the Service Tag on your computer.</p>
Dell knowledge base articles	<ol style="list-style-type: none"> 1. Go to www.dell.com/support. 2. On the menu bar at the top of the Support page, select Support > Knowledge Base. 3. In the Search field on the Knowledge Base page, type the keyword, topic, or model number, and then click or tap the search icon to view the related articles.

Contacting Dell

To contact Dell for sales, technical support, or customer service issues, see www.dell.com/contactdell.

 **NOTE:** Availability varies by country/region and product, and some services may not be available in your country/region.

 **NOTE:** If you do not have an active Internet connection, you can find contact information about your purchase invoice, packing slip, bill, or Dell product catalog.