

SolidKVM SK01

2-Port Dual Monitors DisplayPort™ 1.2 USB KVM Switch w/ Audio & Mic
True Transparent USB Emulation Technology



User Manual

Y10P011-B1

INTRODUCTION

The SolidKVM SK10 Dual Monitors DP1.2 KVM Switch has been meticulously crafted to streamline the experience of sharing dual monitors or flat panel displays among two or two multimedia computers equipped with dual-head DP displays. With this innovative solution, you can exercise complete control over two dual-head PCs using just one keyboard, one mouse, and your dual monitors. Notably, this dual monitor DP KVM switch supports resolutions up to 4090 x 2160 (4K) at an impressive 60Hz, ensuring your display preferences are met with utmost convenience.

Distinguished by our cutting-edge TTU Emulation Technology, integrated into a state-of-the-art ASIC chip, the SolidKVM SK10 Dual Monitors DP USB KVM switch exhibits remarkable adaptability to cater to the diverse functional demands of advanced keyboards and mice. Additionally, it offers a rich 2-channel stereo sound experience, akin to a theater-grade audio setup, and incorporates audio and microphone switching capabilities, guaranteeing uninterrupted multimedia immersion during KVM switching activities. This KVM switch extends its versatility by providing support for both PC and Mac platforms, thus accommodating a wide range of users and system preferences.

PACKAGE INCLUDES

- SolidKVM SK10 Switch Unit x 1
- DC 12V Power Adapter x 1
- Quick Installation Guide x 1
- USB Type-B male to USB Type-A male cable x 2
- 2-in-1 Audio cable w/ Audio & Mic. 3.5mm phone plugs x 2
- DisplayPort male to male cable x 4

FRONT & REAR PANEL OVERVIEW

FRONT PANEL:

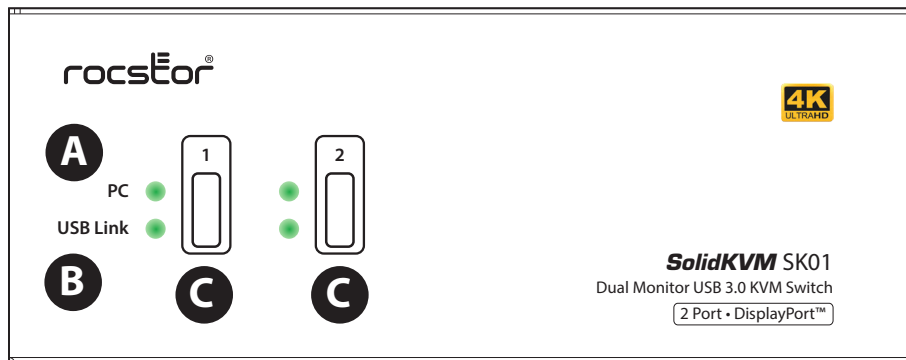

REAR PANEL:

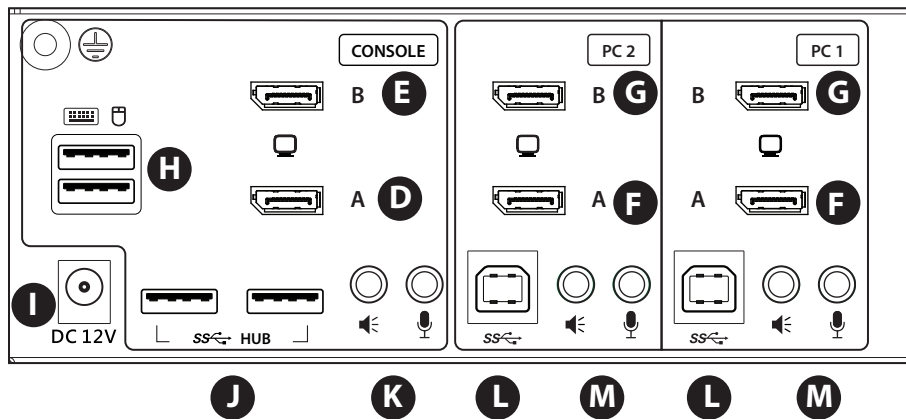

| No. | Item |
|-------|---|
| A. | 2 x Green LEDs for Indicating Active PC-port |
| B. | 2 x Red LEDs for USB Hub Status Monitoring |
| C. | 2 x Port-selection Buttons |
| D./E. | 2 x Console Video-port (DP 1.2) respectively for monitors A/B |
| F./G. | 4 x PC Video-port (DP 1.2) respectively for display outputs A/B |
| H. | 2 x Console USB 1.1 Type-A Ports for Keyboard/Mouse |
| I. | 1 x DC 12V Ø2.1mm Power Jack |
| J. | 2 x USB 3.0 Type-A Device Ports |
| K. | 2 x Console Audio/Mic. 3.5mm Phone Jacks |
| L. | 2 x PC USB 3.0 Type-B Ports for PC Data Link |
| M. | 4 x PC Audio/Mic. 3.5mm Phone Jacks |
| N. | 1 x Grounding Terminal w/ Screw |

CONNECTION DIAGRAM

The connection diagrams illustrated below are only references for SolidKVM S10 Switch, actual applications may vary. All illustrated computer, accessories and monitors are not included in the package.

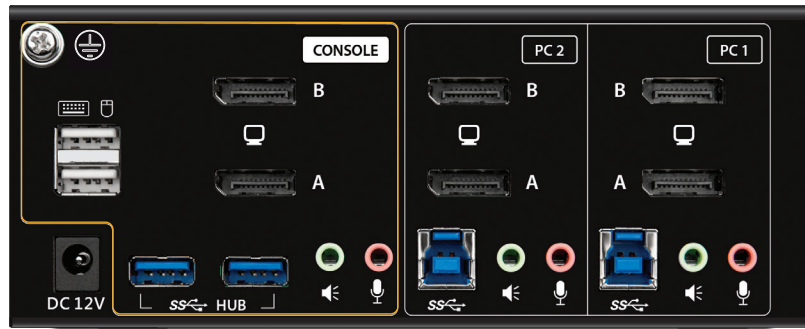

INSTALLATION

1. Power up your KVM Switch by connecting the external power adapter to its power jack **I**.
2. Connect the shared USB keyboard **H**, mouse **H**, dual monitor **A/B D - E** and Audio/Mic. jacks **K** to corresponding ports on the console section of the KVM switch rear panel.

*KEYBOARD HOTKEY WILL ONLY BE DETECTED
AS THE KEYBOARD IS CONNECTED TO THIS
DEDICATED USB PORT*

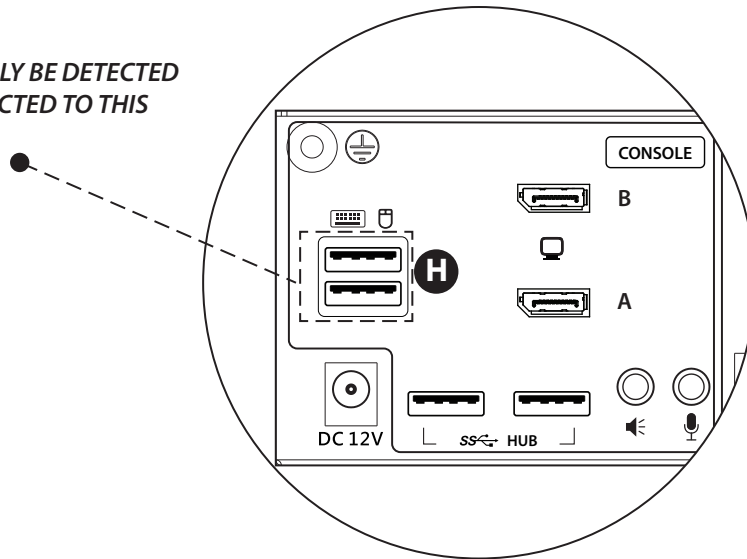

3. In a KVM PC port, connect the USB 3.0 ports **L**, dual DP display outputs **A/B F - G** and Audio/Mic. jacks **M** to one PC, using one USB Type-B cable, two DP cables and one 2-in-1 Audio/Mic. cable.
4. Connect your USB devices to the USB 3.0 hub ports **J** (on the rear panel). Power on PCs connected to the KVM switch. Now you can enjoy the KVM port switching operation over the connected PCs.

There are two ways to operate SolidKVM SK10 switch, please carefully read the instructions as below.

1. Front-panel Buttons

The front-panel buttons allow you a direct control of KVM port switching operation. Simply press a desired button to switch to its corresponding KVM PC port (Note: The USB hub port and Audio/ Mic. port can be set as going along or not going along with the KVM PC port switching, depending on if they are bound with the PC port switching). By default, PC port switching, USB hub port and Audio/ Mic. port switching are bound together.

2. Keyboard Hotkeys

Each keyboard hotkey consists of at least three keystrokes: See the Hotkey Reference Sheet as shown on the next page. Keyboard Hotkey = [ScrLk]*, [ScrLk]*, Command key(s) Two consecutive [ScrLk] keystrokes constitute a hotkey preceding sequence which is user-definable and can be substituted by [Caps Lock], [Esc], [F12], or [Num Lock] keys. For users who want to use a different hotkey preceding sequence other than two consecutive [ScrLk] keystrokes, following are steps to configure it.

(1) Hit [ScrLk], [ScrLk], [H], then two beeps will signal readiness for setting a new hotkey preceding sequence. Alternatively, you may also press and hold down the far right front-panel button (Button 2 for AP-532P/Button 4 for AP-534P) till you hear two beeps, then release it.

(2) Next, hit a desired key from the above user-definable keys and you'll hear a beep for the change confirmation. Now you can use your new hotkey preceding sequence to execute your hotkey operations.

Note 1: Each interval between two individual keystrokes should be less than 2 seconds. Otherwise, the hotkey input will be deemed as an invalid one. See the following examples.



Note 2: Following figures a and b illustrate different display outcomes when performing port-switching. Users may determine a preferred H.P.D. state for each ports according to their application needs.

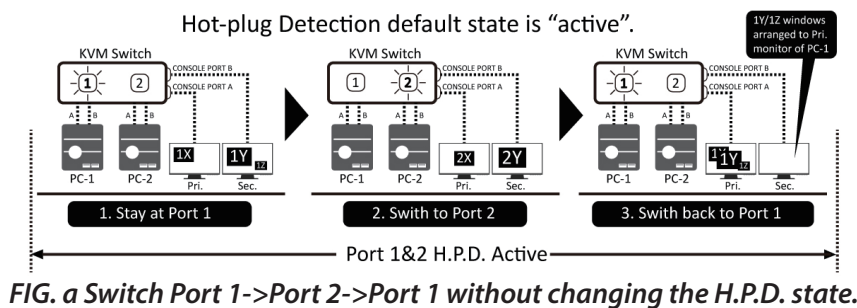
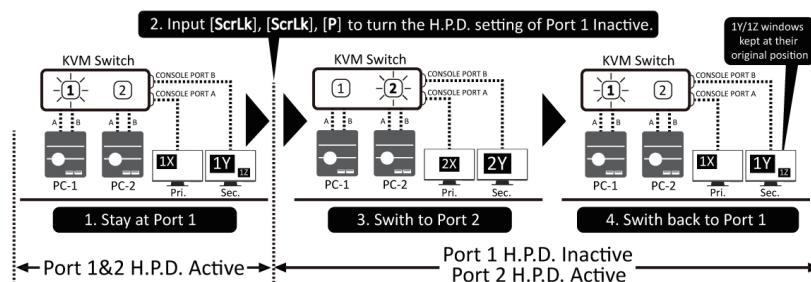

FIG. a Switch Port 1->Port 2->Port 1 without changing the H.P.D. state.



* Note: Each KVM port has its two states (Active/Inactive) of H.P.D. setting which can be toggled with the above keyboard hotkey [ScrLk], [ScrLk], [P].

FIG. b Change the H.P.D. state of Port 1 & switch Port 1->Port 2->Port 1.

HOTKEY REFERENCE SHEET

| Command | Hotkeys (*1) | Front-Panel Button | Description |
|--|--|---|--|
| PC Port Selection | [ScrLk], [ScrLk], [a] a = 1~2/1~4 for PC port numbers 1~2/1~4 | Press a specific button to select a corresponding PC port you want to switch to. | Select an active PC Port. (PC Port Selection/Hub Port Selection/Audio&Mic. Port Selection functions are bound together by factory default.) |
| Hub Port Selection (*2) | [ScrLk], [ScrLk], [F _x] F _x = F1~F2/F1~F4 (F _x is a function key) for Hub port numbers 1~2/1~4 | The Hub port LED will not switch along with the selected PC port once the PC port Selection/Hub port Selection functions are not bound together.) | Select an active USB Hub Ports. (PC Port Selection/Hub Port Selection functions are bound together by factory default.) |
| Audio&Mic. Port Selection (*4) | [ScrLk], [ScrLk], [F _y] F _y = F5~F6/F5~F8 (F _y is a function key) for Audio&Mic. port numbers 1~2/1~4 | | Select an active Audio&Mic. Port. (PC Port Selection/Audio& Mic. Port Selection functions are bound together by factory default.) |
| Reset hotkeys | [ScrLk], [ScrLk], [R] | | Resume all hotkey settings to factory default. |
| Toggle DP Display Hot-plug Detection State (*5) | [ScrLk], [ScrLk], [P] | | Each KVM port has its two states (Active/Inactive) of Hot-plug Detection setting. This hotkey toggles between two states of the H.P.D. for DP display. It is designed for user's determination on the DP display outcome according to their applications. The default setting of the H.P.D. state is active. |
| Bind PC port Selection and Hub port Selection functions (*2) | [ScrLk], [ScrLk], [Z] | | Enable binding of PC Port Selection and Hub Port Selection functions. |
| Unbind PC port Selection and Hub port Selection functions (*2) | [ScrLk], [ScrLk], [X] | | Disable the binding of PC Port Selection and Hub Port Selection functions. |
| Bind PC port Selection and Audio&Mic. port Selection functions (*4) | [ScrLk], [ScrLk], [Q] | | Enable the binding of PC Port Selection and Audio&Mic. Port Selection functions. |
| Unbind PC port Selection and Audio&Mic. port Selection functions (*4) | [ScrLk], [ScrLk], [W] | | Disable the binding of PC Port Selection and Audio&Mic. Port Selection functions |
| Switch to the Lower-number PC port (*2) (*3) | [ScrLk], [ScrLk], [↑] (Up arrow key) | Press a corresponding button for PC Port Selection. | Select the previous PC port number, i.e. [2->1->4->3->2->...] |
| Switch to the Higher-number PC port (*2) (*3) | [ScrLk], [ScrLk], [↓] (Down arrow key) | Press a corresponding button for PC Port Selection. | Select the next PC port number, i.e. [2->3->4->1->2->...] |
| Switch to the last selected PC port | [ScrLk], [ScrLk], [←] (Backspace key) | Press a corresponding button for PC Port Selection. | Toggle switching between the last selected PC port and the current PC port |
| Beep Sound ON/OFF (Factory default = ON) | [ScrLk], [ScrLk], [B] | | Toggle turning ON/OFF the beep sound. |
| Change Hotkey Preceding Sequence (*1) | [ScrLk], [ScrLk], [H], [k] k=[Caps Lock]/[Esc]/[F12]/[Num Lock]/[Scroll Lock] | Press and hold the far right button (Button 2/4) till you hear two beeps, release it then press the [k] key. | Change the hotkey preceding sequence from 5 key options. |
| Enable Auto-scan monitoring over 2/4 PC ports and program the delay time (Factory default: 10 seconds) | n=1~6 1 → 10" (default); 2 → 20"; 3 → 30"; 4 → 40"; 5 → 50"; 6 → 60" | | Circularly and sequentially monitoring the screens of all PC ports with a programmable delay time ranging from 10 to 60 seconds. |
| Stop PC port Auto-scan monitoring | Press any keys on the keyboard | Press any front-panel buttons. | Terminate the PC port Auto-scan monitoring. |
| Stop Autocan | Press any button | | Terminate autocan activity |

*All the hotkey settings will be stored even after the power is gone.

*1. The USB keyboard hotkeys allows you a faster and extensive control for your KVM switching operation in addition to the front-panel button. If you want a different hotkey preceding sequence other than two consecutive [ScrLk] keystrokes by default, you can refer to the above reference sheet to make the change.

*2. When the PC Port Selection and Hub Port Selection functions are bound together by the hotkeys: [ScrLk], [ScrLk], [Z], each PC port and Hub port will be switched synchronously. To release the binding, use the hotkeys: [ScrLk], [ScrLk], [X].

*3. If you are currently viewing PC port 3, for example, pressing [ScrLk], [ScrLk], [↑] will switch the KVM connection to PC Port 2; pressing [ScrLk], [ScrLk], [↓] will switch the KVM connection to PC Port 4.

*4. When the PC Port Selection and Audio&Mic. Port Selection functions are bound together by the hotkeys [ScrLk], [ScrLk], [Q], each PC port and Audio&Mic. port will be switched synchronously. To release the bind use the hotkeys: [ScrLk], [ScrLk], [W].

*5. In some applications, users would like the DP display not to perform Hot-plug Detection everytime when switch the KVM port back-and-forth. The keyboard hotkey [ScrLk], [ScrLk], [P] can be used to turn the H.P.T inactive to disable the H.P.D. operation for a specific KVM port. To return to the default state of said specific KVM port, input this hotkey again to toggle to active state. (Please also see [Note 2, Chapter 6 OPERATION.](#))

WARRANTY INFORMATION

This product is backed by a (3) three-year warranty. Rocstor warrants its products against defects in materials and workmanship for the periods noted, following the initial date of purchase. During this period, the products may be returned for repair, or replacement with equivalent products at our discretion. The warranty covers parts and labor costs only. Rocstor does not warrant its products from defects or damages arising from misuse, abuse, alteration, or normal wear and tear.

Limitation of Liability

In no event shall the liability of Rocstor, Inc. and Rocstor (or their officers, directors, employees or agents) for any damages (whether direct or indirect, special, punitive, incidental, consequential, or otherwise), loss of profits, loss of business, or any pecuniary loss, arising out of or related to the use of the product exceed the actual price paid for the product. Some states do not allow the exclusion or limitation of incidental or consequential damages. If such laws apply, the limitations or exclusions contained in this statement may not apply to you.

SUPPORT

Technical support is available to all the registered users of Rocstor products.

Technical Support / RMA

Hours: 9:00 am - 5:00 pm PST

Monday to Friday (except holidays)

Tell: +1 (818) 727-7000 (National and international)

Fax: +1 (818) 875-0002

Email: support@Rocstor.com

FCC / CC STATMENT

FCC Statement:

This equipment has been tested and found to comply with the regulations for a Class B digital device, pursuant to Part 15 of the FCC Rules. These limits are designed to provide reasonable protection against harmful interference when the equipment is operated in a commercial environment. This equipment generates, uses, and can radiate radio frequency energy and, if not installed and used in accordance with this Quick Installation Guide, may cause harmful interference to radio communications. Operation of this equipment in a residential area is likely to cause harmful interference in which case, the user will be required to correct the interference at his/her own expense.

CE Statement:

This is a Class B product in a domestic environment, this product may cause radio interference, in which case the user may be required to take adequate measures.

© [2023] Rocstor Inc. All rights reserved.

This packaging design and its contents are protected by copyright laws and international treaties. Unauthorized reproduction, distribution, or use of this design, in whole or in part, without the express written consent of Rocstor Inc. is strictly prohibited and may result in legal action.

Rocstor Inc. reserves the right to enforce its intellectual property rights to the fullest extent permitted by law.

For more information about Rocstor Inc. and our products, please visit our website at [www.rocstor.com].

Mac and Windows are registered trademarks of Apple Inc. and Microsoft Corporation, respectively. Linux is a registered trademark of Linus Torvalds. USB and DisplayPort are trademarks of the USB Implementers Forum and the Video Electronics Standards Association, respectively. These trademarks are used for reference purposes only and are not affiliated with or endorsed by Rocstor Inc.

