



# **Microsoft Surface Laptop 6 for Business Service Guide**

## *Disclaimer of Warranties and Limitation of Damages*

All information, content, materials, and products made available in or in conjunction with this Guide are provided by Microsoft on “as-is” and “as available” basis, unless otherwise specified by Microsoft in writing. Microsoft makes no representations or warranties of any kind, express or implied, as to the information, content, materials, and products included or otherwise made available to you or accompanying this Guide unless specified in writing. You expressly agree that your use of the information, content, materials, and product in or accompanying this Guide is at your sole risk.

To the fullest extent permissible by law, Microsoft disclaims all warranties, express or implied, including but not limited to implied warranties of merchantability and fitness for a particular purpose. To the fullest extent permissible by law, Microsoft shall not be liable for damages of any kind arising from the use of information, content, materials, or product made available in or in conjunction with this Guide, including but not limited to direct, indirect, incidental, consequential, and/or punitive damages unless otherwise specified in writing.

### *Notice*

Microsoft and its suppliers may have patents, patent applications, trademarks, copyrights, trade secrets and/or other intellectual property rights covering subject matter in this document. Microsoft’s furnishing of this document to recipient does not grant or imply any license to any patents, trademarks, copyrights, trade secrets or other intellectual property rights, and recipient’s permitted use of any such intellectual property rights, if any, is solely governed by the Agreements.

This document and the information it contains are subject to change without notice. You can find the latest information on Surface device servicing and repair at <https://aka.ms/surfaceservicing> . Always consult the most up-to-date information available before performing device service or repair.

©2024 Microsoft Corporation. All rights reserved.

Document Part Number: M1309602

<b>Rev</b>	<b>Date</b>	<b>Changes Made</b>
A	04/09/2024	Initial Release

## Table of Contents

Introduction.....	6
Device Identity Information .....	6
General Information, Precautions, and Warnings .....	7
Tools.....	7
General Safety Precautions .....	9
Electro-Static Discharge (ESD) Prevention.....	9
Repair-Specific Precautions and Warnings .....	10
Battery Safety.....	10
Battery Warning Label.....	12
Lithium-Ion Battery Inspection .....	12
Handling Used, Damaged, or Defective Lithium-Ion Batteries .....	12
Actions to take in case of a Thermal Event .....	13
Report Battery Thermal Events to Microsoft .....	13
Illustrated Service Parts List .....	15
Software Tools – Diagnostic, Calibration, and Troubleshooting .....	20
Genuine Microsoft Replacement Parts .....	20
General Support.....	20
Software Tools .....	20
Calibration and Authentication .....	20
Hardware Troubleshooting Approach.....	21
Component Removal and Replacement Procedures .....	21
Prerequisite Steps (All Repairs) .....	21
Fet Replacement Process .....	22
Keyboard Replacement Process .....	24
Thermal Module Replacement Process .....	29
Storage (rSSD) Replacement Process.....	39
Speaker Replacement Process .....	44
Display Assembly Replacement Process.....	50
Surface Connect Replacement Process .....	60
Motherboard Module Replacement Process.....	66
Audio Jack Replacement Process.....	82
Battery Replacement Process .....	89

Enclosure Replacement Process .....96  
Environmental Compliance Requirements..... 101

## Introduction

This Service Guide provides instructions for repairing Microsoft Surface devices using genuine Microsoft parts. It is intended for technically inclined individuals with the knowledge, experience, and specialized tools required to repair Microsoft devices.

**IMPORTANT:** Read this Guide in its entirety before starting any repairs. If at any point you are unsure or uncomfortable about performing the repairs, as detailed in this Guide, **DO NOT** proceed. Contact Microsoft for additional support options.

**⚠ WARNING:** Failure to follow the instructions in this Guide; use of non-Microsoft (non-genuine), incompatible, or modified replacement parts; and/or failure to use proper tools could result in serious personal injury, death, and/or damage to the product or other property.

## Device Identity Information

Supported Models –

- Surface Laptop 6 for Business

Support Link – [Link](#)

The model and serial number for Surface Laptops are on the bottom center closest to the Display hinge point.

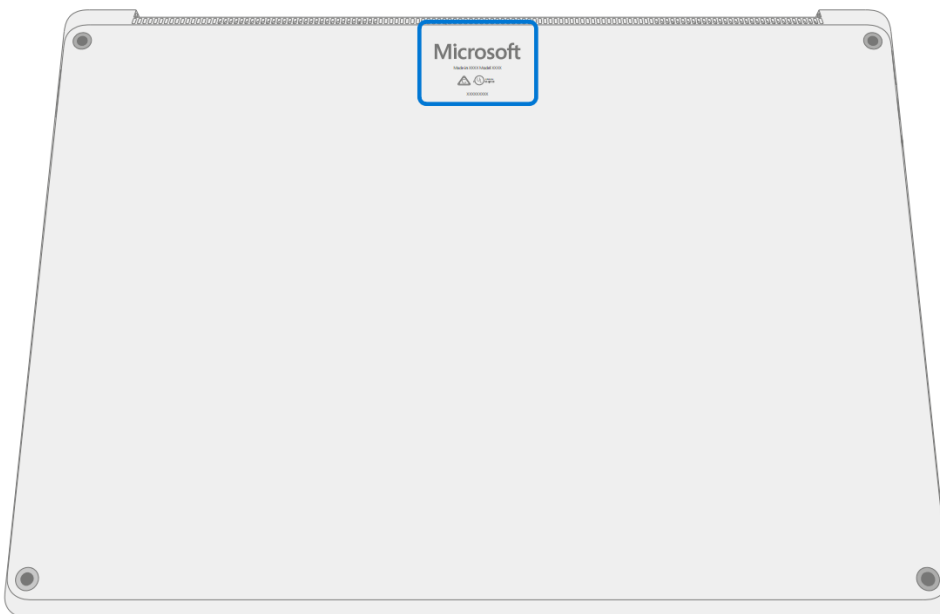

## General Information, Precautions, and Warnings





### Tools

This section documents the tools recommended or required by Microsoft to successfully complete a repair on a Surface device. Microsoft Service Tools (recommended and required) are sold by iFixit in partnership with Microsoft. Items under Electronic Repair Hardware and Tools can be commonly purchased from electronic repair retailers. Lastly, items under standard tools and misc. items on this list can be commonly purchased from consumer retailers.

#### Required Microsoft Service Tools

<a href="#">ESD-safe Surface Battery Cover - iFixit</a>	 A rectangular, light-colored, flexible ESD-safe surface battery cover.
---	---

#### Required Electronic Service Tools

Anti-static Wrist Strap (1 MOhm resistance)	 An anti-static wrist strap with a blue connector and a black cord.
ESD-safe mat or benchtop	 A roll of black ESD-safe mat or benchtop material.
Nylon Spudger/Probing Tool	 A long, thin, black nylon spudger/probing tool.
Plastic Opening Pick	 A blue, triangular plastic opening pick.
Plastic Opening Tool	 A blue, curved plastic opening tool.

ESD-safe Tweezers	
Plastic Card Tool	

### Required Standard Tools and Misc Items

- 3IP Torx-Plus Driver
- 5IP Torx-Plus Driver
- 6IP Torx-Plus Driver
- Metal Tweezers
- USB 3.0 Thumb drive – 16 GB minimum storage
- Isopropyl alcohol dispenser bottle (use 70% IPA)
- Cleaning swabs
- Microfiber Cloth
- Lint free cleaning cloth
- 4 Gallon Bucket
- 2.0 Gallons Sand, Clean
- 65W Microsoft Surface Power Supply
- 0.1mm Thickness Gauge
- 0.15mm Thickness Gauge



## General Safety Precautions

▲ Always observe the following general safety precautions:

- Opening and/or repairing any electronic device can present a risk of electric shock, fire, serious personal injury, death, damage to the device or other property, and/or other hazards. Exercise caution when undertaking the repair activities described in this Guide. The repair activities identified in this Guide should only be undertaken by technically inclined individuals with the knowledge, experience, and specialized tools required to repair Microsoft devices.
- Improper use or handling of devices or their batteries may result in fire or explosion. Only open the enclosure on a device as outlined in this Guide.
- Do not heat, puncture, mutilate, or dispose of devices or their batteries in fire. Do not leave or charge devices in direct sunlight or expose devices or their batteries to temperatures outside the recommended operating range of 0°C to 60°C/32°F to 140°F for an extended period. Doing so can result in battery failure, electric shock, fire, serious personal injury, death, and/or damage to the device or other property.
- We recommend wearing protective eyewear and gloves when disassembling/re-assembling a device.
- Clean your work surface regularly to remove debris and abrasive particles.
- While working on devices, avoid the use of clothing accessories such as bracelets, rings, or watches that can cause electrical shorts and/or damage the battery.
- As you remove each subassembly from the device, place the subassembly (and all accompanying screws) away from the work area to prevent damage to the device or to the subassembly.
- If battery damage (e.g., leaking, expansion, folds or other) is discovered during device repair or if the battery is impacted or damaged during replacement, **DO NOT** proceed. Refer to the [Actions to take in case of a Thermal Event](#) section or contact Microsoft directly for proper device disposition.

For additional product safety information relevant to Microsoft Surface devices, see [aka.ms/surface-safety](https://aka.ms/surface-safety) or the Surface app. To open the Surface app, select the Start button, enter Surface into the search box, then select the Surface app.

## Electro-Static Discharge (ESD) Prevention

- Review and follow the general guidelines and ESD prevention steps in this Guide prior to beginning work.
- Ensure your work surface is level/flat and covered with ESD-safe, soft, non-marring material.
- Before opening a device, always wear an anti-static wrist strap and confirm your work area is properly grounded to protect vulnerable electronics from electrostatic discharge (ESD).
- Parts removed from a device during the repair process should be stored in ESD-safe bags and packaged for return or recycling in the same packaging that the new replacement part came in.

## Repair-Specific Precautions and Warnings

- For Autopilot managed Surface Products refer to the following guidelines posted [here](#).

**⚠ WARNING:** Before opening a device, ensure it is powered off and disconnected from its power source. Disconnect the device charger or power cord from mains power.

- For devices with rechargeable lithium-ion batteries that power on, fully discharge the battery before beginning repair. To expedite the battery discharge process:
  - Disconnect the charger from the device.
  - Increase Display brightness to the highest level.
  - Turn on wi-fi and Bluetooth.
  - Open the Camera app in Windows.
  - Play music or video files from a local drive or streaming service.
- Operate the device in this mode until the battery is fully discharged and the device powers off.
- Review the General Safety Precautions and Battery Safety Sections of this Guide before beginning work.

**⚠ WARNING:** For Surface devices where the battery is affixed to the back cover, place the back cover with the battery in a location where it will be protected from possible punctures, impacts, crushing, or drops during the repair process. Refer to the [Battery Safety](#) section in this guide for more information.

**⚠ WARNING:** During all activities (excluding feet-only replacement) check to ensure that no loose articles are on the back cover or remain inside the device before reassembling it.

**IMPORTANT:** Remove the rSSD (removable Solid-State Drive), or short the appropriate jumper on the PCBA, whenever the Keyboard is removed from device. rSSD removal or shorting of the jumper, disconnects the battery from all device logical components for safety purposes. Refer to the instructions in the repair workflow you are performing for directions on the appropriate scenarios to perform these actions.

**IMPORTANT:** Whenever the rSSD has been removed, powering on the device requires that the rSSD and Keyboard are installed.

**IMPORTANT:** The serial number for this device is located on its original chassis. To keep track of the device's serial number, please [record](#) it using waterproof ink, on a sticker or label, and apply the sticker or label to an easily accessible area on the device's exterior. The serial number cannot be added permanently to a replacement part. Microsoft may have provided a label for this use in the replacement part's packaging.

## Battery Safety

- This device contains a built-in, lithium-ion rechargeable battery. Battery safety is a significant concern when repairing a device.
- For optimum compatibility, performance, and safety, we recommend using genuine Microsoft replacement parts available on [Microsoft.com](#) and other online part retailers such as iFixit. Use of non-Microsoft (non-genuine), incompatible, reused, or modified batteries; improper battery installation; improper handling or storage of batteries; and/or failure to follow the instructions in this Guide could cause battery overheating, expansion, venting, leaking, or a thermal event which could result in fire, serious personal injury, death, data loss, or damage to the device or other property damage.

- Before beginning device repair, ensure your workspace is free of flammable debris or materials, has adequate ventilation, and that you have a fire suppressant device (example: fire blanket, container of sand, Class B fire extinguisher) within easy reach or you are within 20 feet of a fireproof enclosure. Fireproof enclosures should be kept free of combustible or flammable materials.

**⚠ WARNING**: It is recommended that an ESD-safe battery cover be placed across the device to protect the battery from any physical contact or accidental damage whenever Display is removed for internal repairs. Ensure corners of cover are always aligned with the corners of the device while battery is exposed. If battery cover is misaligned during activities in any way, re-align before continuing work.

- Use personal protective equipment (PPE) when handling damaged, venting, or hot battery packs.
- Use the following best practices when handling batteries:
  - Always fully discharge batteries by running an application such as video playback with the device unplugged. If the device does not function while unplugged, you may leave out this step.
  - Do not puncture, impact, strike, bend, or crush the battery or a device containing a battery.
  - Keep your workspace clear of debris, extra tools, and sharp objects.
  - Exercise caution when using sharp tools near the battery to avoid impacting or poking the battery.
  - Do not leave loose screws or small parts inside the device.
  - Avoid using tools that conduct electricity.
  - Do not drop or throw a lithium-ion battery.
  - Do not expose the battery to excessive heat, sunlight, or temperatures outside the battery's normal operating range (0°C to 60°C) / (32°F to 140°F)
  - Ensure you handle, recycle, and/or dispose of used or damaged batteries in accordance with local laws and regulations. Follow Handling Used, Damaged or Defective Li-ion Batteries below.
- If device repair cannot be completed immediately and the device needs to be stored temporarily before restarting the repair
  - Select a storage location and process that follows the battery safety precautions in this Guide.
  - Avoid exposing the device to environmental conditions and objects that could damage the battery pack.
  - Reinspect the battery pack as outlined in this Guide prior to restarting repair and installing the new battery pack.

## Battery Warning Label

**⚠ WARNING:** Please note that the battery bears the following warning label. Please heed the information provided on the label.



**Battery is replaceable by trained personnel; replacement must follow Microsoft procedure**  
**See <http://aka.ms/surface-safety> for important information.**

- Risk of fire or burning – contact Microsoft for assistance
- Do not modify battery, its wiring, or connectors
- Do not short circuit, bend, dent, crush, or puncture battery
- Do not dispose of battery in fire or expose to high temperatures (+140°F/60°C)



## Lithium-Ion Battery Inspection

Upon device opening, we recommend that you visually inspect the battery for signs of damage. Factors to consider when inspecting the battery include, but are not limited to:

- Evidence of leaking or venting
- Visible signs of physical or mechanical damage, such as:
  - Expansion or swelling. In expanded or swollen batteries, the soft pouch encasing the cell pulls away from the inner material and appears baggy, loose, or puffy.
  - Discoloration of the battery casing.
  - Odor, smell, or visible corrosion. Leaked battery electrolyte smells like nail polish remover (acetone).
  - Dents along the battery cell edges or on the top surface.
  - Surface scratches that have exposed the aluminum beneath the black coating layer on the battery.
  - Loose or damaged wires.
  - Known misuse or abuse.

Any battery exhibiting the signs listed above must be replaced. Consult the [Battery Replacement Process](#) section of this document for battery replacement instructions.

## Handling Used, Damaged, or Defective Lithium-Ion Batteries

- **DO NOT** dispose of used lithium-ion batteries, whether damaged or not, in household or commercial garbage or recycling bins.

**⚠ WARNING:** **DO NOT SHIP DAMAGED OR DEFECTIVE BATTERIES ALONE OR INSIDE DEVICES.**  
Damaged or defective batteries and devices containing damaged or defective batteries require special packaging and handling.

Prior to transport:

- Follow all instructions provided by your local e-waste recycling or household hazardous waste collection provider.
- Place the device or battery in individual, non-metallic inner packaging, such as a zip-to-close plastic bag, that completely encloses the device or battery.
- Surround the inner packaging with non-combustible, electrically non-conductive, absorbent cushioning material.
- Each damaged battery or device containing a damaged battery should be packed individually in its own carton and that carton should be clearly marked as containing a damaged battery.

For more information on industry practices concerning damaged, defective, or recalled batteries, please see [PHMSA Lithium-Battery-Recycling-Safety-Advisory](#).

Undamaged, used lithium batteries can be sent to e-waste recycling or household hazardous waste collection points for processing. Please see <https://www.microsoft.com/en-us/legal/compliance/recycling> for more information.

## Actions to take in case of a Thermal Event

- **DO NOT** use water. Immediately smother the battery or device with clean, dry sand, a fire blanket, or an appropriate (Class B) fire extinguisher. If using sand, dump the sand all at once until the device is completely covered.
- Contact local fire authorities if further assistance is needed.
- Exit the work area and ventilate it until it is clear of smoke.
- Wait at least 2 hours before attempting to touch the device.
- Dispose of the damaged battery or device in accordance with local environmental or e-waste laws and guidelines.

## Report Battery Thermal Events to Microsoft

A thermal event is a rapid chemical chain reaction that can occur inside a battery cell. During a thermal event, the energy stored inside the battery is released suddenly, resulting in heating and/or smoke and, in some instances, fire or flame. A battery thermal event can be triggered by physical damage to the battery (including during replacement/repair), improper storage, or exposure to temperatures outside of the battery's operating range.

Act immediately if you see any of the following symptoms of a battery thermal event:

- Smoke, soot, sparks, or flame emitted by the battery or from a device containing a battery.
- The battery pouch suddenly expands in size.
- A popping or hissing noise from the battery or a device containing a battery.

## Stop Repair and Contact Microsoft

If any Microsoft device visually exhibits any of the following symptoms, cease all further repair efforts and contact Microsoft Surface Customer Support to report and obtain next steps:

- Any burned or melted components, traces, or plastic parts on the outside of the device, or which otherwise exhibits heat damage, including charring seen in charging and other ports.
  - Any burned or melted components, traces, or plastic parts on the inside of the device, or which otherwise exhibits heat damage.
  - Any accessories exhibiting melting or heat damage that are included with the Microsoft device, such as power supplies, keyboards, mice, cables, charging connectors, etc.
  - Any devices that exhibit a case that has separated apart or opened for reasons other than impact damage from dropping, evidence of tampering, or separation caused by a malfunctioning battery.
  - Any other finding that may constitute a safety hazard to the user, such as sharp edges on plastics.
- Microsoft Surface Customer Support will ask you to provide the following information:
- The model and serial number of the affected Microsoft Surface device and/or accessory(ies).
  - A brief description of the damage found.
  - Clear photographs depicting the symptoms observed.

## Illustrated Service Parts List

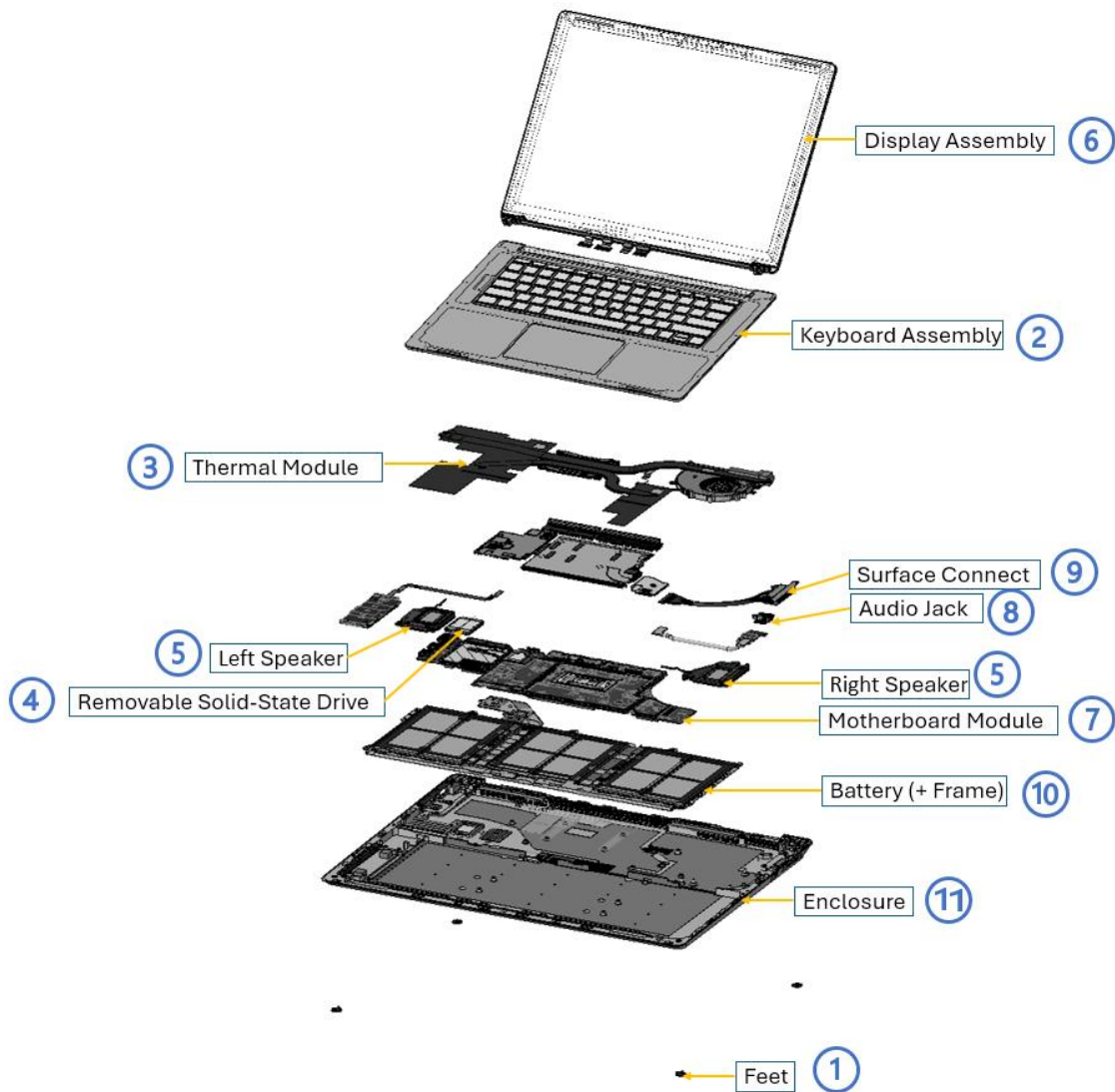







**IMPORTANT:** Repair workflows may require multiple parts to be ordered to complete the repair successfully. Please check the Required Components section in each repair workflow to ensure you have all required parts before beginning your repair.



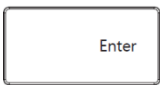
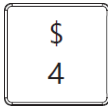
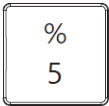

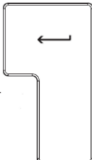

Item	Component	SKU Part No.
<b>1</b>	<b>Feet</b>	
	Platinum	D0V-00002
	Black	D0V-00001
<b>2</b>	<b>Keyboard Assembly (includes touchpad)</b>	
	13-inch Platinum America/Asia	D0M-00001
	13-inch Black America/Asia	D0M-00019
	13-inch Platinum Austria/Germany	D0M-00023
	13-inch Black Austria/Germany	D0M-00005
	13-inch Platinum BH/KW/OM/QA/SA/AE	D0M-00031
	13-inch Black BH/KW/OM/QA/SA/AE	D0M-00013
	13-inch Platinum Belgium	D0M-00024
	13-inch Black Belgium	D0M-00006
	13-inch Platinum Canada	D0M-00020
	13-inch Black Canada	D0M-00002
	13-inch Platinum DK/FI/NO/SE	D0M-00027
	13-inch Black DK/FI/NO/SE	D0M-00009
	13-inch Platinum EMEA	D0M-00025
	13-inch Black EMEA	D0M-00007
	13-inch Platinum France	D0M-00022
	13-inch Black France	D0M-00004
	13-inch Platinum Italy	D0M-00028
	13-inch Black Italy	D0M-00010
	13-inch Platinum Japan	D0M-00035
	13-inch Black Japan	D0M-00017
	13-inch Platinum Korea	D0M-00033
	13-inch Black Korea	D0M-00015
	13-inch Platinum Mexico	D0M-00036
	13-inch Black Mexico	D0M-00018
	13-inch Platinum Portugal	D0M-00029
	13-inch Black Portugal	D0M-00011
	13-inch Platinum Spain	D0M-00030
	13-inch Black Spain	D0M-00012
	13-inch Platinum Switzerland/Luxembourg	D0M-00026
	13-inch Black Switzerland/Luxembourg	D0M-00008
	13-inch Platinum Taiwan	D0M-00034
	13-inch Black Taiwan	D0M-00016
	13-inch Platinum Thailand	D0M-00032
	13-inch Black Thailand	D0M-00014
	13-inch Platinum UK/Ireland	D0M-00021
	13-inch Black UK/Ireland	D0M-00003
	15-inch Platinum America/Asia	D0N-00002
	15-inch Black America/Asia	D0N-00020
	15-inch Platinum Austria/Germany	D0N-00024
	15-inch Black Austria/Germany	D0N-00006
	15-inch Platinum BH/KW/OM/QA/SA/AE	D0N-00032
	15-inch Black BH/KW/OM/QA/SA/AE	D0N-00014
	15-inch Platinum Belgium	D0N-00025
	15-inch Black Belgium	D0N-00007
	15-inch Platinum Canada	D0N-00021

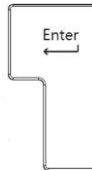
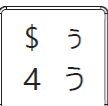
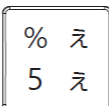
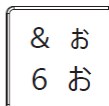
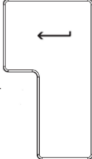
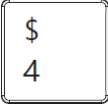
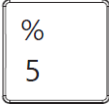
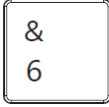

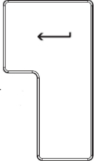
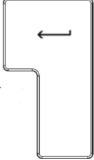
	15-inch Black Canada	D0N-00003
	15-inch Platinum DK/FI/NO/SE	D0N-00028
	15-inch Black DK/FI/NO/SE	D0N-00010
	15-inch Platinum EMEA	D0N-00026
	15-inch Black EMEA	D0N-00008
	15-inch Platinum France	D0N-00023
	15-inch Black France	D0N-00005
	15-inch Platinum Italy	D0N-00029
	15-inch Black Italy	D0N-00011
	15-inch Platinum Japan	D0N-00036
	15-inch Black Japan	D0N-00018
	15-inch Platinum Korea	D0N-00034
	15-inch Black Korea	D0N-00016
	15-inch Platinum Mexico	D0N-00037
	15-inch Black Mexico	D0N-00019
	15-inch Platinum Portugal	D0N-00030
	15-inch Black Portugal	D0N-00012
	15-inch Platinum Spain	D0N-00031
	15-inch Black Spain	D0N-00013
	15-inch Platinum Switzerland/Luxembourg	D0N-00027
	15-inch Black Switzerland/Luxembourg	D0N-00009
	15-inch Platinum Taiwan	D0N-00035
	15-inch Black Taiwan	D0N-00017
	15-inch Platinum Thailand	D0N-00033
	15-inch Black Thailand	D0N-00015
	15-inch Platinum UK/Ireland	D0N-00022
	15-inch Black UK/Ireland	D0N-00004
<b>3</b>	<b>Thermal Module</b>	
	13-inch Thermal Module	D0X-00001
	15-inch Thermal Module	D0X-00002
<b>4</b>	<b>Removable Solid-State Drive</b>	
	13-inch 256GB rSSD	E0P-00001
	13-inch 512GB rSSD	E0Q-00001
	13-inch 1TB rSSD	E0R-00001
	15-inch 256GB rSSD	E0P-00002
	15-inch 512GB rSSD	E0Q-00002
	15-inch 1TB rSSD	E0R-00002
<b>5</b>	<b>Speakers</b>	
	13-inch Speakers	D0Y-00001
	15-inch Speakers	D0Y-00002
<b>6</b>	<b>Display Assembly (includes camera)</b>	
	13-inch Platinum Display Assembly	D0I-00002
	13-inch Black Display Assembly	D0I-00001
	15-inch Platinum Display Assembly	D0J-00002
	15-inch Black Display Assembly	D0J-00001
<b>7</b>	<b>Motherboard Module ( includes main processor and main memory)</b>	
	13-inch Intel i5/8GB	C0C-00001
	13-inch Intel i5/16GB	C0D-00001
	13-inch Intel i5/32GB	C0F-00001
	13-inch Intel i7/16GB	C0G-00001

	13-inch Intel i7/32GB	C0H-00001
	13-inch Intel i7/64GB	C0I-00001
	15-inch Intel i5/8GB	C0J-00001
	15-inch Intel i5/16GB	C0K-00001
	15-inch Intel i7/16GB	C0L-00001
	15-inch Intel i7/32GB	C0M-00001
	15-inch Intel i7/64GB	C0N-00001
<b>8</b>	<b>Audio Jack</b>	
	13-inch Audio Jack	D0S-00001
	15-inch Audio Jack	D0U-00001
<b>9</b>	<b>Surface Connect</b>	
	13-inch Surface Connect	D0W-00001
	15-inch Surface Connect	D0W-00002
<b>10</b>	<b>Battery</b>	
	13-inch Battery	B0Y-00001
	15-inch Battery	B0Z-00001
<b>11</b>	<b>Enclosure</b>	
	13-inch Platinum	C0V-00002
	13-inch Black	C0V-00001
	15-inch Platinum	C0W-00003
	15-inch Black	C0W-00002

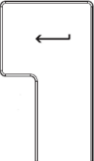
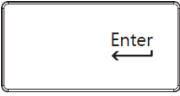
<u>Description</u>	<u>Enter Key</u>	<u>"4,5,6" Keys</u>
104 English, US		  
105 Canadian, Bilingual		  
109 Japan		  
105 Austria/Germany		  

105 Belgium AZERTY		<table border="1"> <tr> <td>4 ' {</td> <td>5 ( [</td> <td>6 § ^</td> </tr> </table>	4 ' {	5 ( [	6 § ^
4 ' {	5 ( [	6 § ^			
105 Nordic Denmark, Finland, Norway, Sweden		<table border="1"> <tr> <td>¤ 4 \$</td> <td>% 5</td> <td>&amp; 6</td> </tr> </table>	¤ 4 \$	% 5	& 6
¤ 4 \$	% 5	& 6			
105 French		<table border="1"> <tr> <td>4 ' {</td> <td>5 ( [</td> <td>6 -  </td> </tr> </table>	4 ' {	5 ( [	6 -
4 ' {	5 ( [	6 -			
105 English, UK Ireland		<table border="1"> <tr> <td>\$ 4 €</td> <td>% 5</td> <td>^ 6</td> </tr> </table>	\$ 4 €	% 5	^ 6
\$ 4 €	% 5	^ 6			
<u>Description</u>	<u>Enter Key</u>	<u>"4,5,6" Keys</u>			
105 Italy		<table border="1"> <tr> <td>\$ 4</td> <td>% 5 €</td> <td>&amp; 6</td> </tr> </table>	\$ 4	% 5 €	& 6
\$ 4	% 5 €	& 6			
105 Switzerland, Luxembourg		<table border="1"> <tr> <td>ç 4 °</td> <td>% 5 §</td> <td>&amp; 6 ¬</td> </tr> </table>	ç 4 °	% 5 §	& 6 ¬
ç 4 °	% 5 §	& 6 ¬			
104 English, International Netherlands		<table border="1"> <tr> <td>\$ 4</td> <td>% 5 €</td> <td>^ 6</td> </tr> </table>	\$ 4	% 5 €	^ 6
\$ 4	% 5 €	^ 6			
105 Portuguese		<table border="1"> <tr> <td>\$ 4 §</td> <td>% 5 €</td> <td>&amp; 6</td> </tr> </table>	\$ 4 §	% 5 €	& 6
\$ 4 §	% 5 €	& 6			

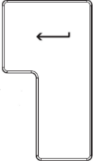
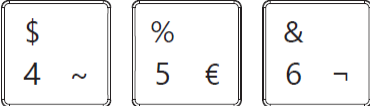
105 Spanish, European		
-----------------------	---	---

## Software Tools – Diagnostic, Calibration, and Troubleshooting

This section covers the software tools required to support a Surface device thru problem discovery and resolution.

### Genuine Microsoft Replacement Parts

- Genuine Microsoft replacement parts can be obtained directly from Microsoft on [Microsoft.com](https://www.microsoft.com).
- Genuine Microsoft replacement parts are also available on the partner sites below:
  - [iFixit](https://www.ifixit.com)

### General Support

- For general Surface support, visit [www.support.microsoft.com](https://www.support.microsoft.com)
- To troubleshoot device feature/function problems or learn more about Surface Laptops visit <https://support.microsoft.com/surface> .
- If you'd like to learn more about Windows, visit <https://support.microsoft.com/windows>
- To learn more about the accessibility features of the Surface Laptop, go to the online user guide at [aka.ms/Windows-Accessibility](https://aka.ms/Windows-Accessibility)

### Software Tools

- How To: [Update Surface device firmware and OS](#)
- How To: [Surface Tools Video](#)
- How To: [Surface Diagnostic Toolkit User Guide](#)
- Download: [Surface drivers and firmware](#)
- Download: [Surface Diagnostic Toolkit \(SDT\)](#)
- Download: [Surface Data Eraser](#)
- Download: [Surface Imaging Tools](#)

### Calibration and Authentication

Specific components require additional software calibration or authentication after completing the installation of the component before the part will function to full capability. The specific steps will be called out in the pertinent repair workflows.

#### Impacted Parts

- **Display Assembly (TDM) –**
  - Pre-installation – requires a pre-installation repair workflow, completed in SDT, to put the device into repair mode.

- Post-installation – requires a post-installation workflow, completed in SDT, to calibrate the Display to the correct settings.
- **Battery –**
  - Pre-installation - requires a pre-installation repair workflow, completed in SDT, to put the device into repair mode.
  - Post-installation – requires a post-installation authentication workflow, completed in SDT, to authenticate the new battery as a valid Microsoft part.
- **Motherboard Module (PCBA) –**
  - Post-installation - requires a post-installation workflow for Display Assembly and an authentication for Battery, completed in SDT, to calibrate the Display to the correct settings with the new board and ensure the battery is detected as an authentic part.

## Hardware Troubleshooting Approach

Microsoft recommends the following approach for troubleshooting Surface devices:

1. Update device to the latest Operating System and Driver/Firmware versions using Windows Update.

**Important:** Ensuring your device is fully up to date is important for ensuring the issue you are experiencing is not fixed by a software update prior to conducting a hardware repair.

2. Utilize the Surface Diagnostic Toolkit (SDT) after confirming the device is fully updated to confirm the hardware fault is still present prior to repair.
3. After the repair is completed, run the Surface Diagnostic Toolkit (SDT) to validate the original hardware fault is resolved.
  - a. If the issue is still being experienced, it is recommended to reimage the device using a Surface Recovery Image (BMR) to return the device to a known OS/FW state. Additional repairs should only be carried out if the issue persists after re-imaging the device.

## Component Removal and Replacement Procedures

### Prerequisite Steps (All Repairs)

Steps outlined in this section should be conducted prior to starting any repair on a Surface device.

- **Power off device** – Ensure the device is powered off completely and the battery has been fully discharged. Refer to the [Repair-Specific Precautions and Warnings section](#) for details. Once discharged, the device should be disconnected from all power sources.
- **ESD Prevention** – Ensure ESD prevention steps and general guidelines are followed prior to opening the device. Refer to the [ESD Prevention section](#) for details.
- **Position Device** – To prevent damage to the device, ensure the device is placed on a clean surface free of debris.

## Feet Replacement Process

### Preliminary Requirements

**Important:** Be sure to follow all special (bolded) notes of caution within each process section.

### Required Tools

- ESD-Safe Tweezers
- Nylon Spudger/Probing Tool
- Isopropyl Alcohol (70% IPA)
- Cleaning Swabs
- Soft ESD-safe mat
- Microfiber Cloth

### Primary Components

- Feet (Refer to [Illustrated Service Parts List](#))
  - 5 x M1.6x2.4 5IP Screws

### Additional Components (Ordered Separately)

- None

### Procedure – Removal (Feet)

1. **Position device** - Place the device with bottom facing up.
2. **Remove front feet** - Using the Nylon Spudger, pry up the front foot from the front divot and then peel to remove. Repeat for the other foot.

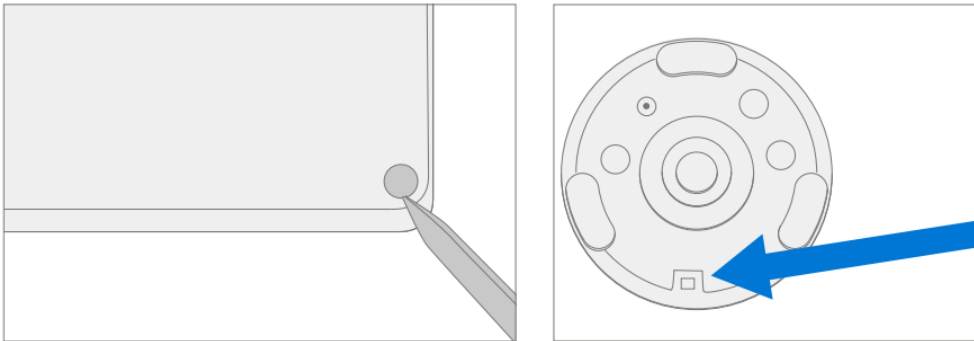

3. **Remove back feet** - Using the Nylon Spudger, pry up the back from the back divot and then peel to remove. Repeat for the other foot.

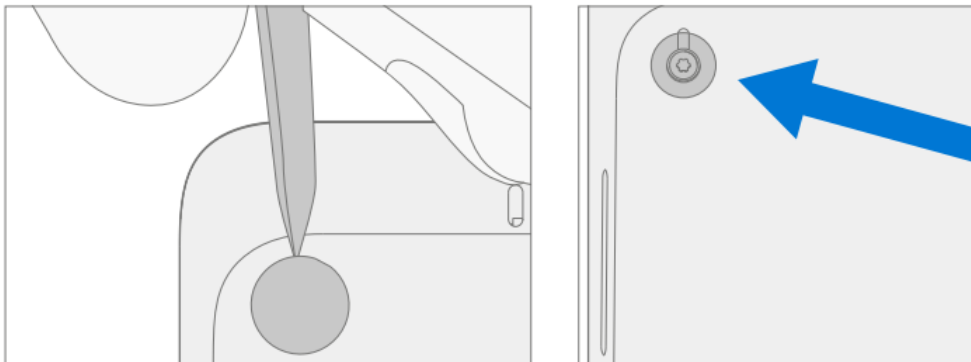

4. **Cleaning** – using the Nylon Spudger, clean off any remaining glue residue on the feet and foot wells including any remaining adhesive tape.
5. **Cleaning** – Take a cleaning swab and dip it in the Isopropyl Alcohol. Use the cleaning swab to clean the residual glue from the foot wells on the bottom of the device.

**Procedure – Installation (Feet)**

1. **Position device** - Place the device with bottom facing up.

**Important:** Feet must be replaced with new feet after removal.

2. **Applying new front feet** – Remove the liners to the adhesive on the bottom of each foot and align with the holes in the chassis. Repeat the process for the remaining front foot.

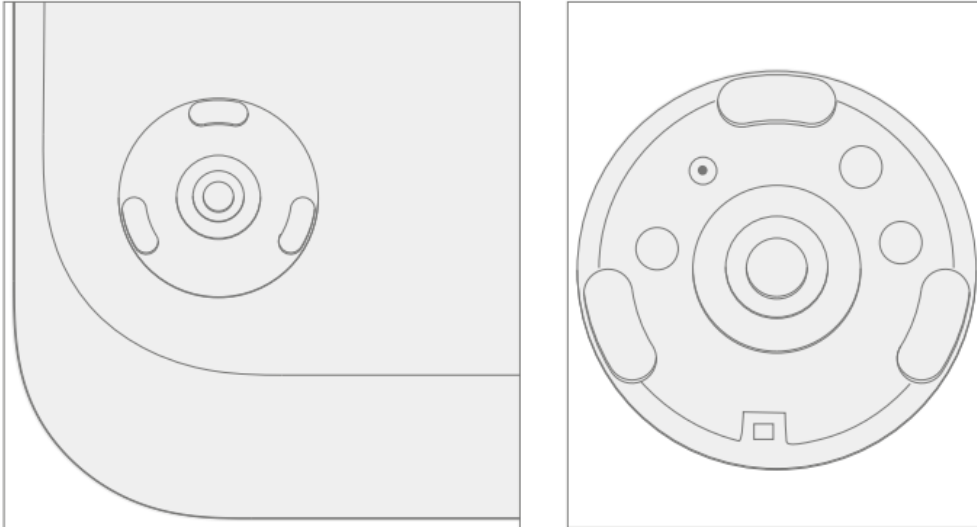

3. **Applying new back feet** - Remove the liners to the adhesive on the bottom of each foot and align with the screw hole on the chassis. Repeat the same steps for the remaining back foot.

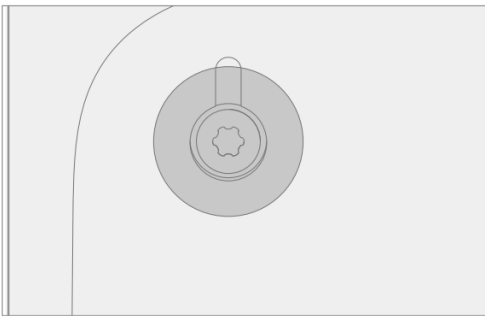

4. **Securing new feet** – Press down on each foot firmly for 30 seconds to engage the adhesive and secure the foot.

# Keyboard Replacement Process

## Preliminary Requirements

**Important:** Be sure to follow all special (bolded) notes of caution within each process section.

- See [Prerequisite Steps \(All Repairs\)](#) section before beginning repair.

## Required Tools

- Surface Battery Cover (M1214771-001)
- ESD-Safe Tweezers
- Metal Tweezers
- Plastic card tool
- USB drive with SDT
- Anti-static wrist strap (1 MOhm resistance)
- Nylon Spudger/Probing Tool
- Isopropyl Alcohol (70% IPA)
- Cleaning Swabs
- 3IP (Torx-plus) Driver
- Surface Power Supply
- Soft ESD-safe mat
- Microfiber Cloth

## Primary Components

- Keyboard (Refer to [Illustrated Service Parts List](#))
  - 4 x M1.6x2.4 3IP Screws (Keyboard Assembly) 
    - P/N: 13N4 – 0FN1V21

## Additional Components (Ordered Separately)

- Feet (Refer to [Illustrated Service Parts List](#))

## Procedure – Removal (Keyboard)

1. **Position device** - Place the device with bottom facing up.
2. **Remove Feet** – Refer to [Procedure – Removal \(Feet\)](#) for steps to remove the feet.
3. **Remove Screws** – Using a 3IP (Torx-plus) screwdriver, remove the four screws from under the four feet on the device.



4. **Reverse Device** – Turn device over so that top of device is facing up.



5. **Open Device** – Open screen to approximately 110-degrees.



**CAUTION:** Take care to prevent the keyboard power button from getting pressed during this step. If the power button is accidentally pressed and the device powers on, shut down the device as normal thru the OS Start menu before continuing with repair.

6. **Separate keyboard from device** – Grasp the back of the keyboard, by the Display and pull directly up. Keyboard should lift free from device.



7. **Disconnect Keyboard** – While holding the keyboard at a ~45-degree angle, use a Nylon Spudger to disconnect the keyboard connector from the motherboard.

**Important:** It is recommended to have a Surface Battery Cover (M1214771-001) placed across the device to protect the battery from any accidental damage during repair. Ensure the corners of the cover are always aligned with the corners of the device during repair. If the battery cover is misaligned during the repair, re-align before continuing repair activities.

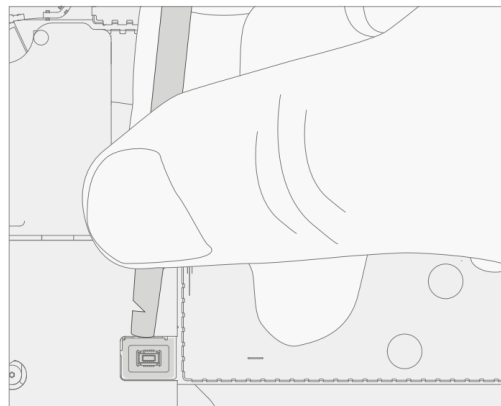
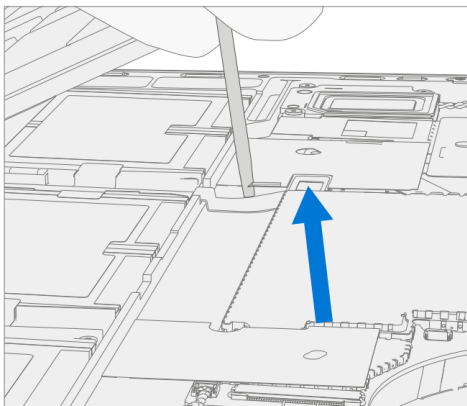

**CAUTION:** When removed from the device, please put the keyboard in a safe place with the key and trackpad side down and the connector facing up to avoid bending/creasing the connector's cable. Be sure the key and trackpad side of the keyboard is protected from cosmetic damage by placing on a clean, soft surface.

8. **Short jumper** – Using metal tweezers, touch the two parts of the battery icon as shown below for a few seconds. This will shut down the connection to the battery and prevent power on during repair. The LED located next to it will turn off if it was previously lit.

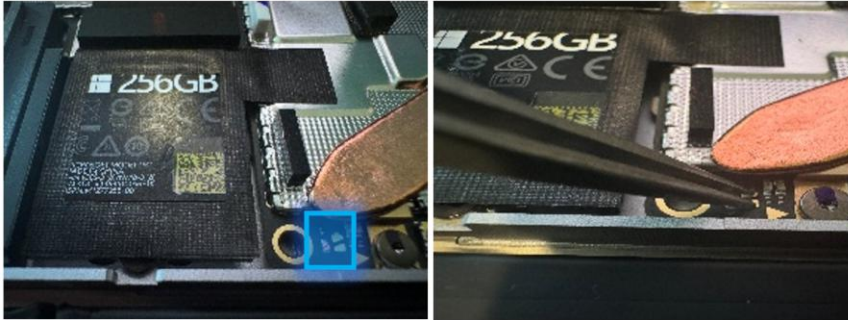

9. **Remove TIM (Thermal Interface Material) from keyboard and rSSD** – Using a plastic spudger, gently scrape away any remaining TIM from the bottom of the keyboard and rSSD. Any residue material should be removed using IPA and a cleaning swab.

**Important:** If you are only replacing the Keyboard Assembly, retain the TIM removed in Step 9 to be re-applied on the replacement Keyboard Assembly.



**Important:** Prior to completing the disassembly section, ensure all screws are accounted for and that no screws have been left in the disassembly area.

#### Procedure – Installation (Keyboard)

**Important:** Verify the condition of the Liquid Damage Indicator (LDI) inside the audio jack. Using a bright light, illuminate the interior of the audio jack port. If the indicator is any color other than white, then liquids have entered the device. In these scenarios, a whole unit replacement is necessary to ensure device functionality.

1. **Replace TIM on Keyboard (only if reusing the same keyboard)** – Place new TIM on Keyboard in the same position as previous TIM, and remove the protective film on the TIM.



2. **Apply Thermal Interface Material (TIM) to rSSD** – Apply a thermal pad to the rSSD approximately as shown in the image below.

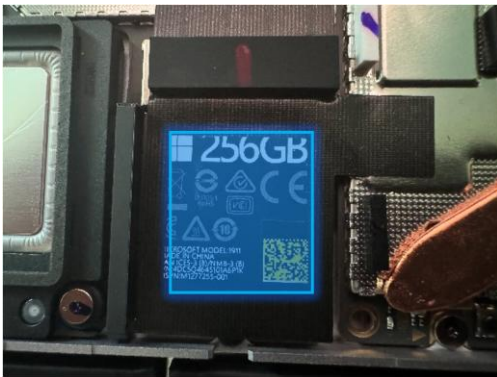

3. **Remove tape from the new keyboard connector** – Tape secures the keyboard connector during shipping. Remove this tape before continuing with assembling the device.
4. **Connect Keyboard** – While holding the keyboard at a 45-degree angle, use your hand to align the keyboard connector with the connector on the motherboard. Gently push the connector into place. Ensure the connector is attached completely with no gaps or looseness.

**CAUTION:** Ensure the keyboard connector's ribbon cable does not get folded or creased during installation. Cable should sit in the device using the same bend with which it was shipped.

5. **Protect the screw holes** - to prevent stripping of the screw holes while fastening the Keyboard Assembly to the Enclosure in the next step, place 2 pieces of printer paper on the left and right hinge area in-between the Display and the Keyboard.



6. **Align keyboard with chassis** - Place the keyboard on top of chassis and press down on the Keyboard Assembly with both hands as indicated in the photo below. Inspect all sides of the device and verify there are no discernable gaps between keyboard and the device enclosure when viewed from the side.



**CAUTION:** Before installing the keyboard, inspect the internal area for loose screws or debris, paying special attention to the magnetic areas around the chassis and the battery.

7. **Close Display and invert device** - with Display closed, turn over the device so that the bottom of the chassis is facing up.
8. **Install new chassis screws** - Using a 3IP (Torx-plus) screwdriver, install (1) new chassis screw (  ) in each corner (4 total). Turn all screws until just snug and seated, and then turn another 45-degrees (1/8<sup>th</sup> turn) to fully fasten.



9. **Power on device** - Carefully place device screen side up. Connect device to a power supply, open Display, and power on to the Windows desktop screen.
10. **Run the Surface Diagnostic Toolkit (SDT)** - Run SDT's full diagnostic test to ensure device functions as expected.
11. **Power down device** - Power down device using the OS start menu. Once powered down, invert device so that the bottom chassis is facing up.
12. **Install Feet** - Refer to [Procedure - Installation \(Feet\)](#) for instructions on installing the feet on the device

# Thermal Module Replacement Process

## Preliminary Requirements

**Important:** Be sure to follow all special (bolded) notes of caution within each process section.

- See [Prerequisite Steps \(All Repairs\)](#) section before beginning repair.

## Required Tools

- Surface Battery Cover (M1214771-001)
- USB drive with SDT
- ESD-Safe Tweezers
- Metal Tweezers
- Anti-static wrist strap (1 MOhm resistance)
- Nylon Spudger/Probing Tool
- Isopropyl Alcohol (70% IPA)
- Cleaning Swabs
- 3IP (Torx-plus) Driver
- 5IP (Torx-plus) Driver
- Surface Power Supply
- Soft ESD-safe mat
- Microfiber Cloth
- Metal Tweezers

## Primary Components

- Thermal Module (Refer to [Illustrated Service Parts List](#))
  - 1 x SOC Thermal Pad
  - 1 x Shield Lid
  - 1 x Antenna Cable Tape
  - 1 x Conductive Tape Sponge
  - 1 x Conductive Tape
  - 1 x Lid Tape
  - 1 x SSD Thermal Pad
  - 1 x Mylar
  - 5 x M1.2x3.3 3IP screws (Thermal Module) **Ⓜ3IP-3**
    - P/N: 13N4-1EN0L01
  - 2 x M1.2x2.3 3IP screws (Thermal Module) **Ⓜ3IP-1**
    - P/N: 13N4-0FN1V21
  - 4-6 x M1.2x1.7 3IP screws (Thermal Module) **Ⓜ3IP-2**
    - P/N: 13N4-0FN2P12
  - 2 x M1.2x2.0 3IP screws (Thermal Module: 13" only) **Ⓜ3IP-4**
    - P/N: 13N4-1EN0X02
  - 4 x M1.6x2.4 3IP Screws (Keyboard Assembly) **Ⓜ3IP**
    - P/N: 13N4 – 0FN1V21

## Additional Components (Ordered Separately)

- Feet (Refer to [Illustrated Service Parts List](#))

### Procedure – Removal (Thermal Module)

1. **Position device** - Place the device with bottom facing up.
2. **Remove Feet** – Refer to [Procedure – Removal \(Feet\)](#) for steps to remove the feet.
3. **Remove Keyboard** – Refer to [Procedure – Removal \(Keyboard\)](#) for steps to remove the keyboard.
4. **Remove Conductive Tape** – Pressing the thermal graphite sheet with your left hand, gently remove the Conductive Tape starting from the lower right.

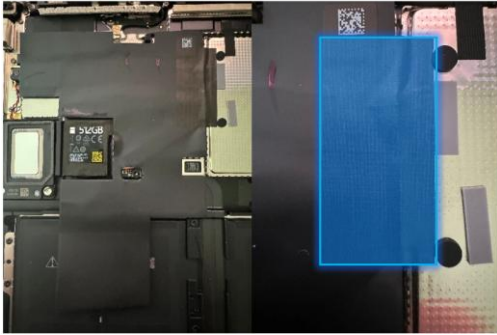

**CAUTION:** If you are removing the Thermal Module for another repair and will be re-using, ensure no damage is present on the graphite sheeting after removal. If there is damage (bubbling, hole, tear, wrinkling, etc.) on the graphite sheet then the Thermal Module will need to be replaced.

5. **Remove Graphite Sheet** – Carefully lift and remove the black graphite sheet to expose the Motherboard.

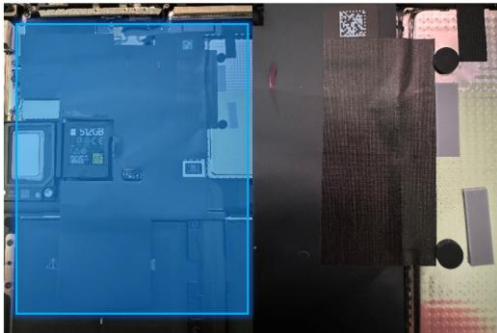

6. **Short jumper** – Using metal tweezers, touch the two parts of the battery icon as shown below for a few seconds. This will shut down the connection to the battery and prevent power on during repair. The LED located next to it will turn off if it was previously lit.

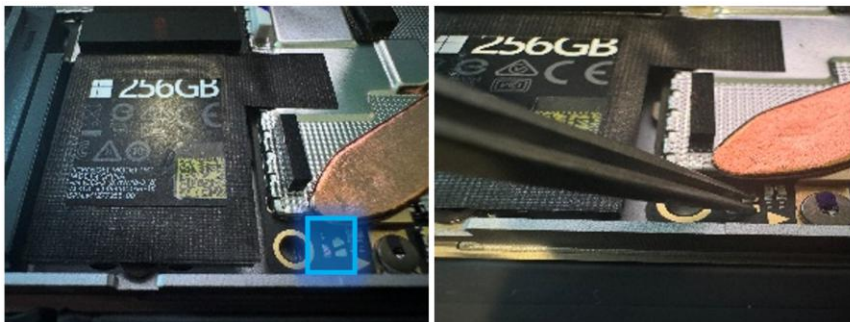

7. **Remove Screws** – this step differs slightly from the 13” and 15” models. See the marked sections below for instructions for your device’s size.

- a) **Screw Removal on 13"** - Using a 3IP (Torx-plus) driver remove the 5 screws securing the Thermal Module + Fan to the chassis.

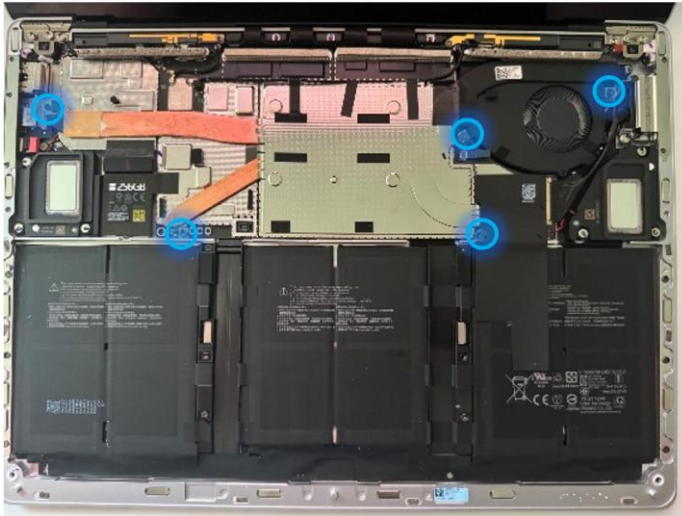

- b) **Screw Removal on 15"** – Using a 3IP (Torx-plus) driver remove the 6 screws securing the Thermal Module + Fan to the chassis.

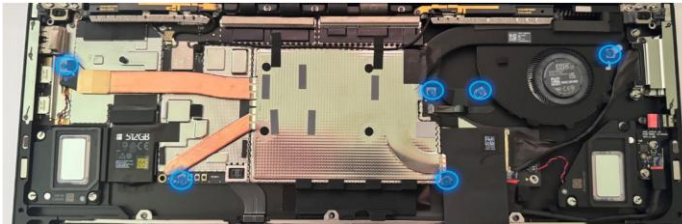

8. **Remove Antennae Cable tape** – carefully remove the two pieces of black antennae tape from the thermal module.

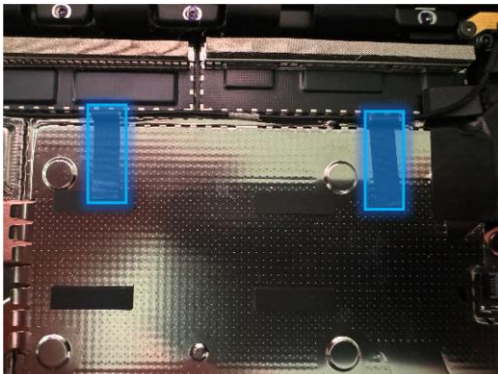

9. **Remove and reposition the right antenna** – Using a Nylon spudger, remove the buckle of the right antenna. Place the antenna in the position shown in the second picture to avoid hitting the antenna connector.

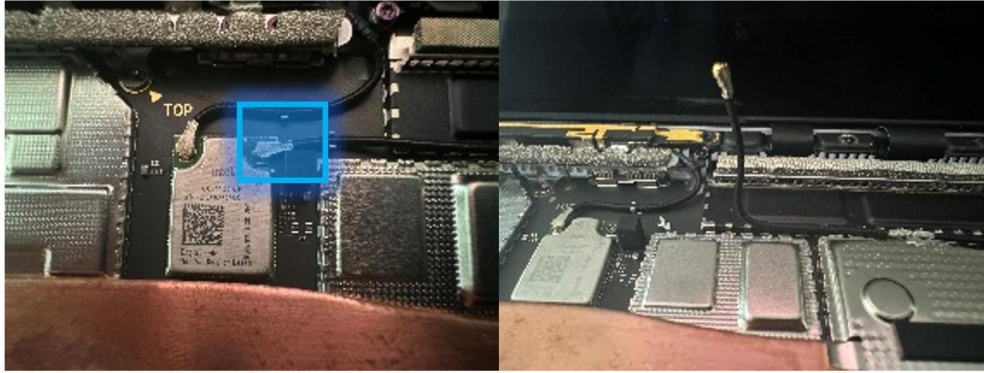

**CAUTION:** Connectors on the Wi-Fi module are very fragile. Do not attempt to remove with your fingers. If the connector is damaged, motherboard must be replaced. The nearby foams are also very delicate – take care not to damage or remove them. DO NOT use metal tools for this process.

10. **Remove Tape Sponge** – Carefully remove the Tape Sponge from the thermal module.

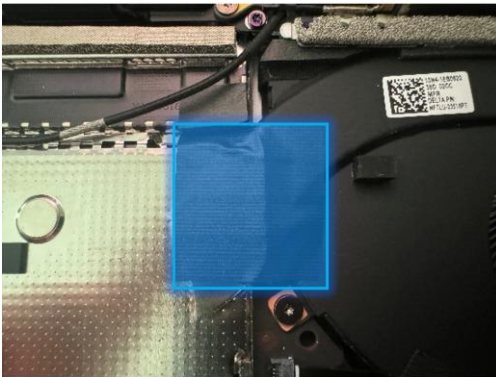

11. **Remove the Mylar (15" only)** - Using ESD-Tweezers, gently peel off the mylar from the left to right.

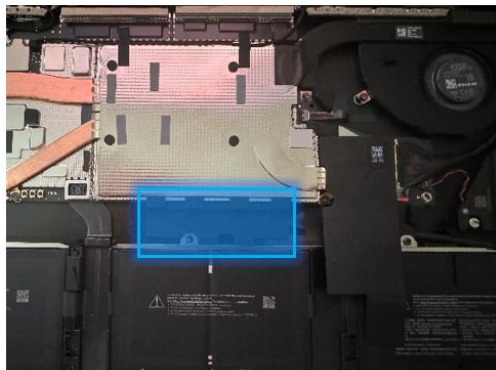

12. **Remove the fan connector** – Using a Nylon Spudger, lift the locking tab on the fan connector and gently pull the fan cable out of the connector.



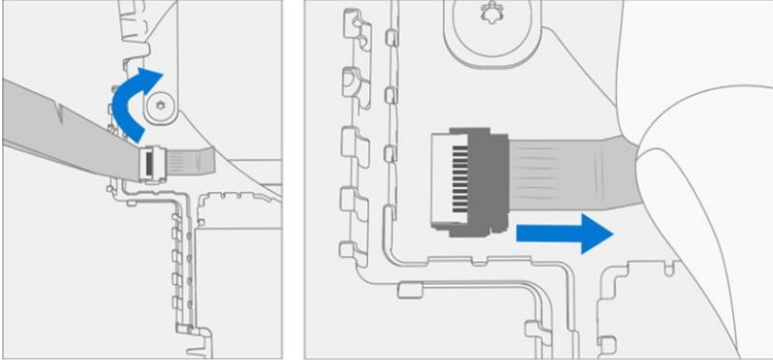

**CAUTION:** The fan connectors are delicate, so use extra care in the removal process. If the connector on the motherboard side is damaged, the motherboard will require replacement.

- 13. Remove the Lid Tape** – Using the flat end of the Nylon Spudger, insert from the lower right corner of the Lid Tape, and lift to allow removal by hand.

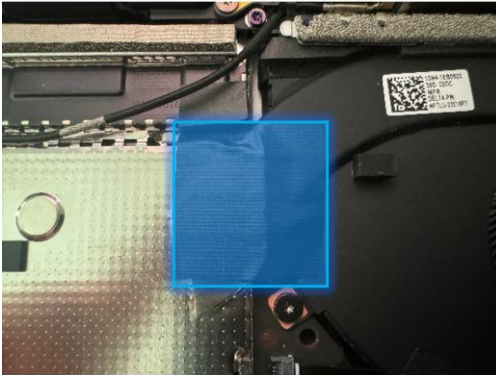

- 14. Remove thermal module shield** – Using ESD-safe Tweezers, work around the right-side of the thermal shield, gently prying it up. Once the right side is separated from the retention frame underneath the shield, gently pull up using fingers.

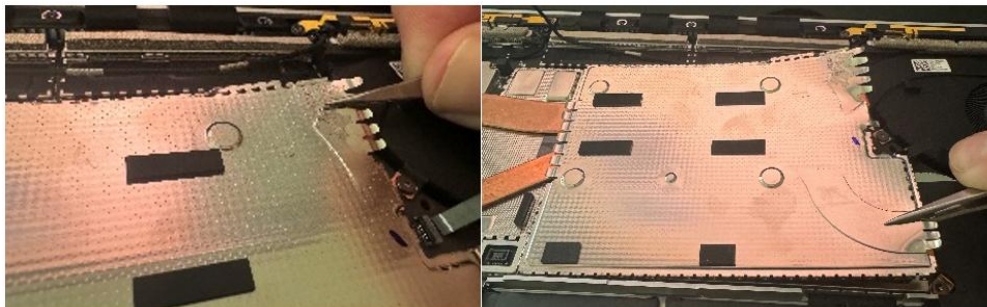

- 15. Remove socket screws** – Using a 3IP (Torx-Plus) driver, remove the 4 socket screws securing the Thermal Module + Fan to the motherboard.

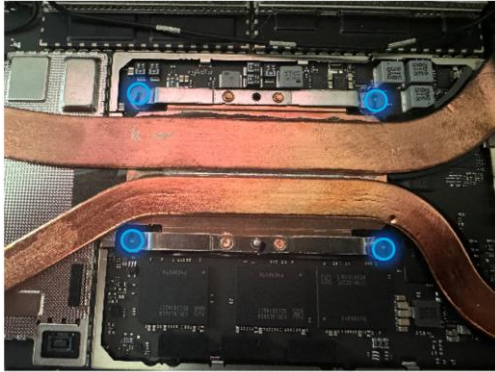

16. **Remove thermal module** – Using a Nylon Spudger, gently work under the edge of the thermal module to break the seal with the Thermal Interface Material (TIM) underneath. Gently lift out the thermal module, and place face down on a clean surface.
17. **Clean residual Thermal Interface Material from PCBA** – Using a Nylon Spudger gently scrape off left over TIM from the SOC. Use a cleaning swab soaked in Isopropyl Alcohol to completely remove any residual material from the board or any other surface to avoid damage to the Motherboard. Finally, allow the surface to dry completely before moving forward.

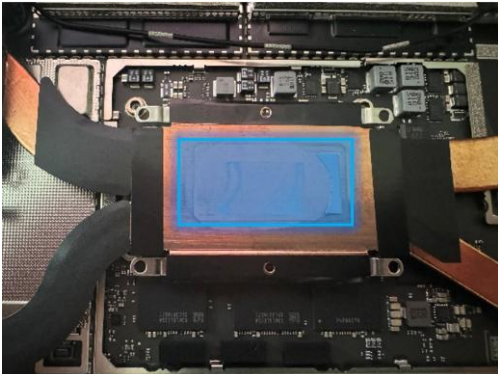

18. **Clean residual Thermal Interface Material from Thermal Module (Part Re-use Only)** – Using a Nylon Spudger gently scrape off left over TIM from the PCBA. Use a cleaning swab soaked in Isopropyl Alcohol to completely remove any residual material from the board. Finally, wipe the surface dry with a Microfiber cloth.
19. **Apply new Thermal Interface Material to Thermal Module (Part Re-use Only)** – Take 1 piece of new Thermal Interface Material and attach it to the bottom of the Thermal Module in the same place as the prior material was applied. Gently press on the Thermal Interface Material and remove the release paper.

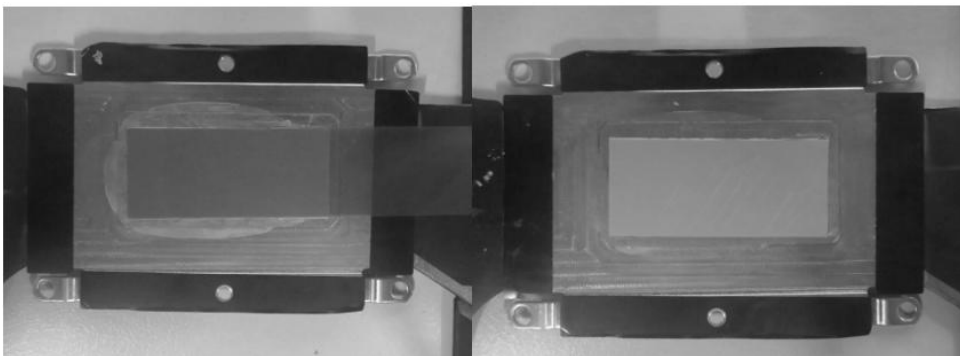

### Procedure – Installation (Thermal Module)

1. **Install Thermal Module** - Place new thermal module + fan into the device. Ensure the screw holes are aligned with the chassis points.

**Important:** Limit Thermal Module movement once the Thermal Module is placed in the device. Excessive movement may damage the Thermal Interface Material requiring replacement of the Thermal Interface Material.

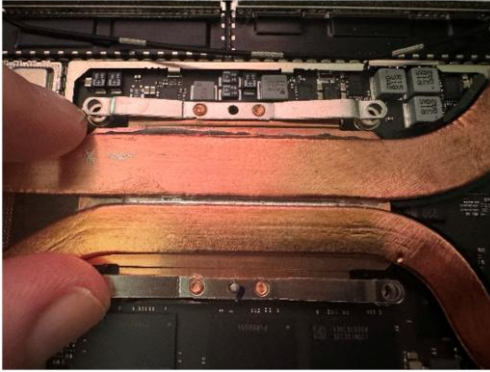

2. **Install socket screws** - Using a 3IP (Torx-plus) drive, install the 4 new socket screws in each corner tensioner. Turn each screw until just snug and seated. Once all screws are installed, turn each screw another 45 degrees (1/8 turn) to fully fasten.

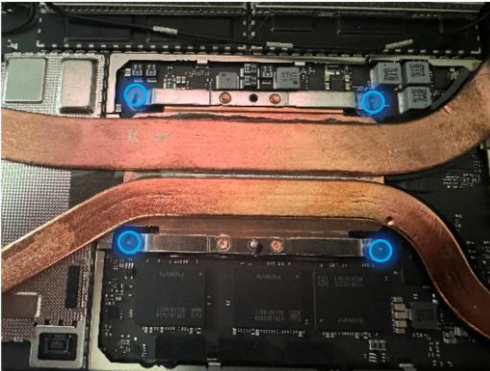

3. **Install Screws** – this step differs slightly from the 13” and 15” models. See the marked sections below for instructions for your device’s size.
  - a) **Screw Installation on 13”** - Using a 3IP (Torx-plus) driver install the 5 screws securing the Thermal Module + Fan to the chassis.

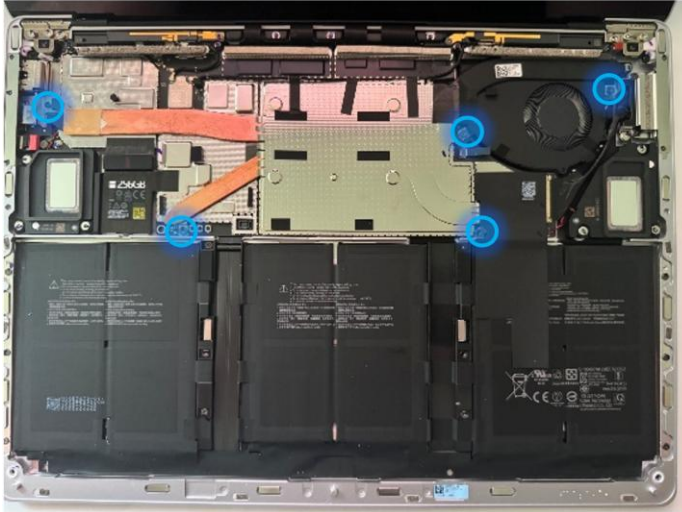

b) **Screw Installation on 15”** – Using a 3IP (Torx-plus) driver install the 6 screws securing the Thermal Module + Fan to the chassis.

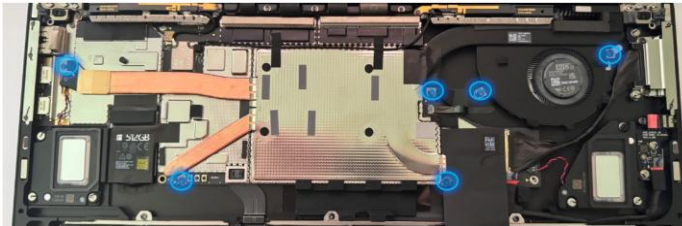

4. **Install thermal module shield** - Align the shield around the retention frame and press down on the upper left corner. Work around the outer edge of the shield. As the shield seats properly, you should hear clicking.

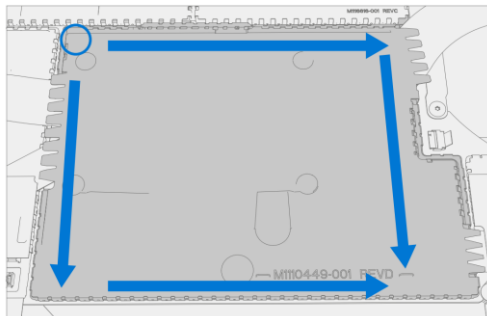

5. **Apply Mylar Tape** – Place new Mylar Tape so that it aligns with the edge of the bottom of the QR code as shown in the image below. Press firmly to apply.

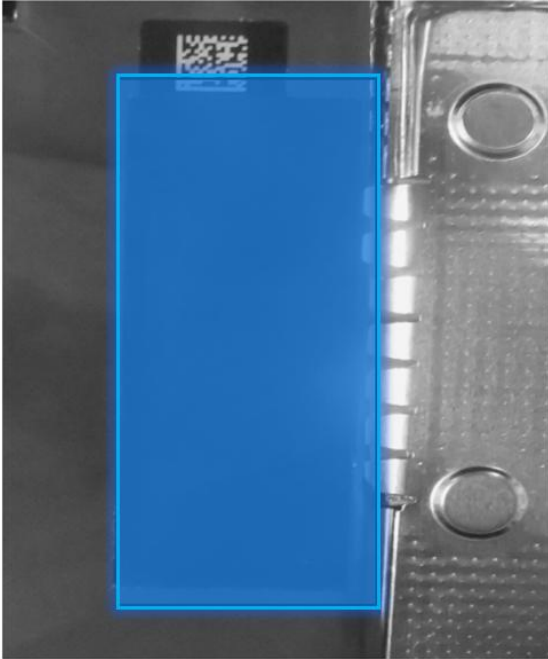

6. **Apply Lid Tape** - Place new Lid Tape so that it is aligned with the cover edge of the shield lid. Press firmly to apply.

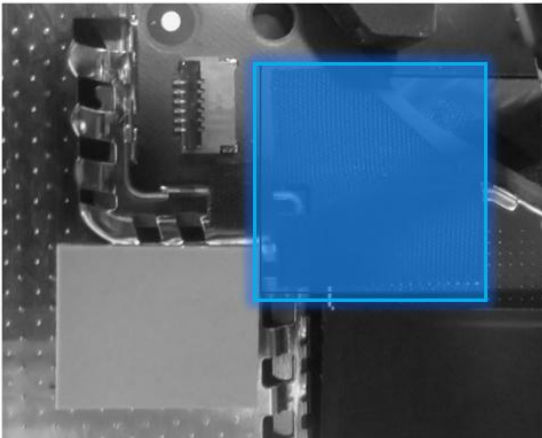

7. **Install fan connector** - Reconnect the fan cable to the connector on the PCBA. Press the locking tab down to complete the connection.

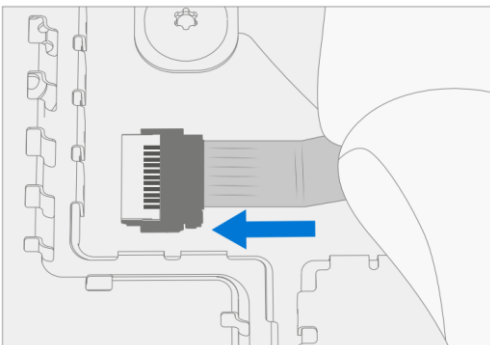

8. **Attach Rubber (15" model only)** - Attach a new Rubber piece. Press firmly to apply.

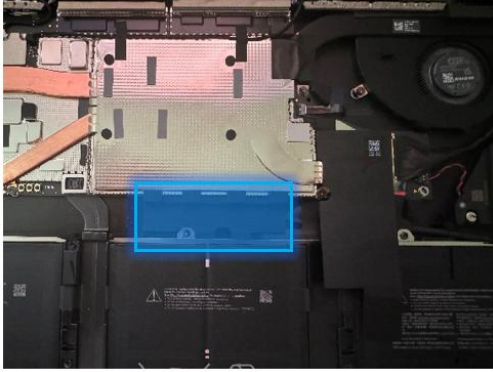

9. **Attach Tape Sponge** - Attach a new Tape Sponge. Press firmly to apply.

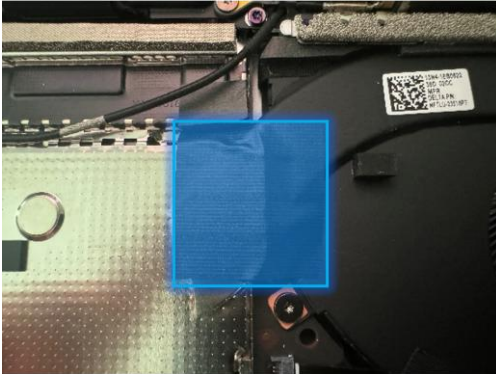

10. **Reposition and secure the right antenna** – Reposition the black antennae cable and gently secure it, using the flat end of a Nylon Spudger or Finger, to the antennae connector on the motherboard.

11. **Attach Antennae Cable Tape** - Carefully place two pieces of antennae cable tape as shown in the photo. The Antennae cable must be placed over and above the sponge and cannot be routed around it.

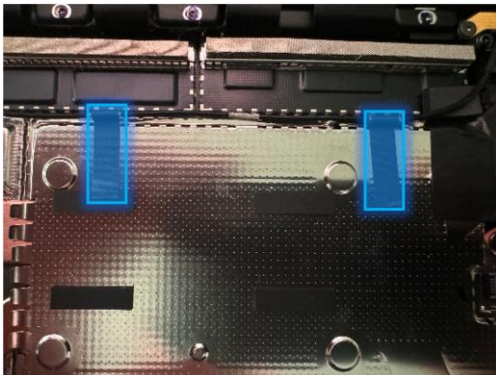

12. **Install rSSD** – Refer to [Procedure – Installation \(rSSD\)](#) for steps to install the rSSD.
13. **Install Keyboard** – Refer to [Procedure – Installation \(Keyboard\)](#) for steps to install the Keyboard.
14. **Power on Device** – Carefully reposition the device so that it is top side up. Connect the device to a power supply, open the Display, and power on to the Windows Desktop.
15. **Run the Surface Diagnostic Toolkit (SDT)** – Run all diagnostics to ensure the device is functioning as expected before moving forward.
16. **Install Feet** – Refer to [Procedure – Installation \(Feet\)](#) for steps to install Feet.

# Storage (rSSD) Replacement Process

## Preliminary Requirements

**Important:** Be sure to follow all special (bolded) notes of caution within each process section.

- See [Prerequisite Steps \(All Repairs\)](#) section before beginning repair.

## Required Tools

- Surface Battery Cover (M1214771-001)
- USB Drive with SDT and BMR Image
- ESD-Safe Tweezers
- Anti-static wrist strap (1 MOhm resistance)
- Nylon Spudger/Probing Tool
- Isopropyl Alcohol (70% IPA)
- Cleaning Swabs
- 3IP (Torx-plus) Driver
- 5IP (Torx-plus) Driver
- Surface Power Supply
- Soft ESD-safe mat
- Microfiber Cloth

## Primary Components

- rSSD (Refer to [Illustrated Service Parts List](#))
  - 1 x SSD Conductive Tape
  - 1 x SSD Top Rubber
  - 1 x SSD Thermal Pad
  - 1 x SOC Thermal Pad
  - 1 x Shield Lid
  - 2 x Antenna Cable Tape
  - 1 x Conductive Tape Sponge
  - 1 x Conductive Tape
  - 1 x Lid Tape
  - 2 x M1.6x2.0 5 IP screws (rSSD) **5IP**
    - P/N: 13N4-1EN0L01
  - 5 x M1.2x3.3 3IP screws (Thermal Module) **3IP-3**
    - P/N: 13N4-1EN0L01
  - 2 x M1.2x2.3 3IP screws (Thermal Module) **3IP-1**
    - P/N: 13N4-0FN1V21
  - 4-6 x M1.2x1.7 3IP screws (Thermal Module) **3IP-2**
    - P/N: 13N4-0FN2P12
  - 2 x M1.2x2.0 3IP screws (Thermal Module: 13" only) **3IP-4**
    - P/N: 13N4-1EN0X02
  - 4 x M1.6x2.4 3IP Screws (Keyboard Assembly) **3IP**
    - P/N: 13N4 – 0FN1V21

## Additional Components (Ordered Separately)

- Feet (Refer to [Illustrated Service Parts List](#))

### Procedure – Removal (rSSD)

1. **Remove Feet** – Refer to [Procedure – Removal \(Feet\)](#) for steps to remove the feet.
2. **Remove Keyboard** – Refer to [Procedure – Removal \(Keyboard\)](#) for steps to remove the keyboard.
3. **Remove Thermal Module** – Refer to [Procedure – Removal \(Thermal Module\)](#) for steps to remove the Thermal Module.
4. **Remove Thermal Interface Material (TIM) from rSSD** – Use a Nylon spudger to gently scrape away any remaining TIM for the rSSD. Remaining residual can be removed with a cleaning swab soaked in Isopropyl Alcohol.
5. **Remove SSD rubber and conductive tape from the top of the rSSD enclosure-** using ESD-Safe tweezers, gently remove the rSSD rubber from the top of the rSSD. Next, remove the conductive tape from the top of the rSSD.

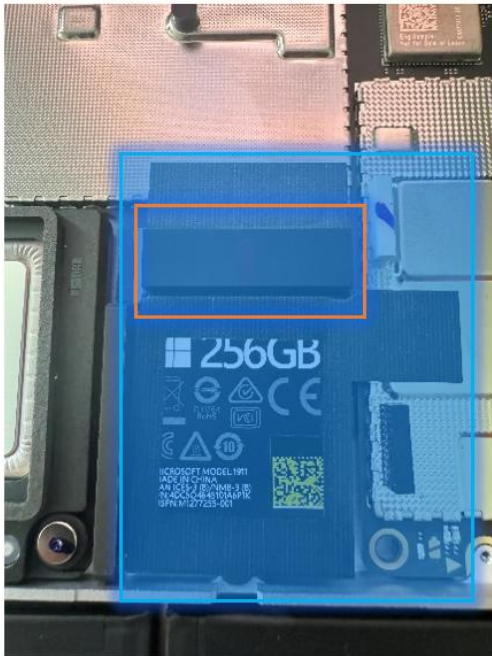

6. **Remove rSSD screw** – Using a 5IP (Torx-plus) driver, remove the screw securing the rSSD.





7. **Remove rSSD** – The rSSD should lift upwards to ~15-degrees after the screw is removed. Carefully grab the sides of the rSSD case and pull it out of the mainboard socket while maintaining the ~15-degree angle.

#### Procedure – Installation (rSSD)

1. **Insert rSSD** – Insert the connector end of the rSSD into the receptacle on the motherboard at a ~15-degree angle. Using a Nylon Spudger, push the drive into the receptacle to make clearance for the rSSD screw to be installed.

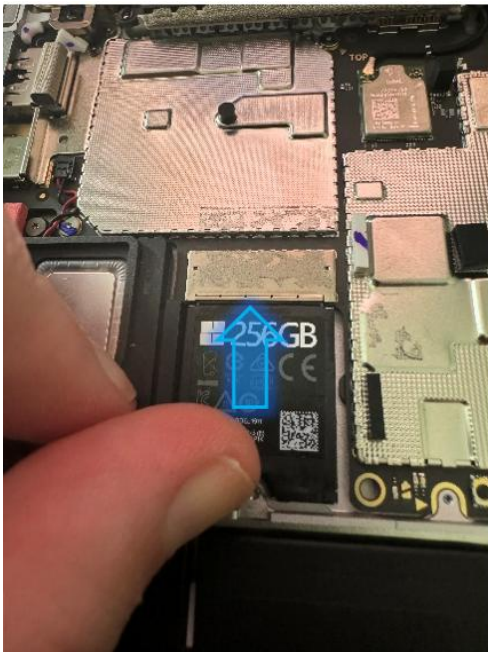

2. **Install new rSSD screw** – Using a 5IP (Torx-plus) screwdriver, install the rSSD screw. Turn the screw until just snug and seated, and then turn another 45 degrees (1/8 turn) to fully fasten.



3. **Install new SSD conductive tape and rubber around rSSD** – Using ESD-Safe Tweezers, gently apply a new set of conductive tapes around the rSSD.

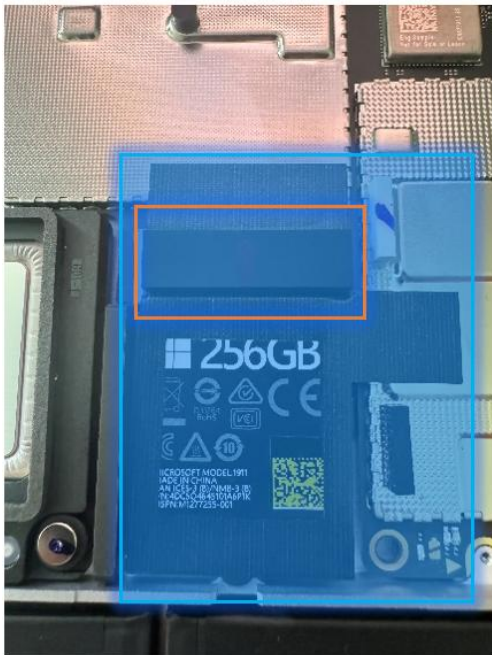

4. **Apply Thermal Interface Material (TIM)** – Apply a thermal pad to the rSSD approximately as shown in the image below.

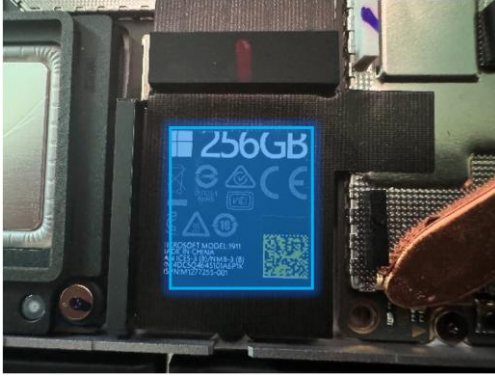

5. **Connect Keyboard** – Connect keyboard as detailed in the [Procedure – Installation \(Keyboard\)](#) section, but do not install chassis screws before step 9 is completed.
6. **Power on device** – Carefully place the device with the screen side facing up. Connect the device to a power supply and open the Display.
7. **Image the device** – Reinstall the operating system and all drivers/firmware by using a USB-drive containing the latest Surface BMR for your model. Please see [the Software Tools – Diagnostic, Calibration, and Troubleshooting](#) section for links to instructions on how to get the latest image and install it.
8. **Run the Surface Diagnostic Toolkit (SDT)** – With Windows installed and sitting at the desktop, insert the USB drive containing SDT and launch the program. Run all diagnostics to ensure the device is functioning as expected before moving forward.
9. **Install the Keyboard fully** – Install the chassis screws to fully attach the keyboard to the chassis as detailed in the [Procedure – Installation \(Keyboard\)](#) section.
10. **Install Feet** – Refer to the [Procedure – Installation \(Feet\)](#) section for instructions.

# Speaker Replacement Process

## Preliminary Requirements







**Important:** Be sure to follow all special (bolded) notes of caution within each process section.

- See [Prerequisite Steps \(All Repairs\)](#) section before beginning repair.

## Required Tools

- Surface Battery Cover (M1214771-001)
- ESD-Safe Tweezers
- USB drive with SDT
- Anti-static wrist strap (1 MOhm resistance)
- Nylon Spudger/Probing Tool
- Isopropyl Alcohol (70% IPA)
- Cleaning Swabs
- 3IP (Torx-plus) Driver
- 5IP (Torx-plus) Driver
- Surface Power Supply
- Soft ESD-safe mat
- Microfiber Cloth

## Primary Components

- Speaker (Refer to [Illustrated Service Parts List](#))
  - 1 x Left Speaker
  - 1 x Right Speaker
  - 1 x Speaker Screw Rubber D
  - 1 x Speaker Screw Rubber T
  - 1 x SSD Thermal Pad
  - 1 x SOC Thermal Pad
  - 1 x Shield Lid
  - 2 x Antenna Cable Tape
  - 1 x Conductive Tape Sponge
  - 1 x Conductive Tape
  - 1 x Lid Tape
  - 7 x M1.2x0.25 3IP screws (Speakers)  **3IP**
    - P/N: 13E5-2TN3V21
  - 5 x M1.2x3.3 3IP screws (Thermal Module)  **3IP-3**
    - P/N: 13N4-1EN0L01
  - 2 x M1.2x2.3 3IP screws (Thermal Module)  **3IP-1**
    - P/N: 13N4-0FN1V21
  - 4-6 x M1.2x1.7 3IP screws (Thermal Module)  **3IP-2**
    - P/N: 13N4-0FN2P12
  - 2 x M1.2x2.0 3IP screws (Thermal Module: 13" only)  **3IP-4**
    - P/N: 13N4-1EN0X02
  - 4 x M1.6x2.4 3IP Screws (Keyboard Assembly)  **3IP**
    - P/N: 13N4 – 0FN1V21

## Additional Components (Ordered Separately)

- Feet (Refer to [Illustrated Service Parts List](#))

### Procedure – Removal (Speakers)

1. **Position device** - Place the device with bottom facing up.
2. **Remove Feet** – Refer to [Procedure – Removal \(Feet\)](#) for steps to remove the feet.
3. **Remove Keyboard** – Refer to [Procedure – Removal \(Keyboard\)](#) for steps to remove the keyboard.
4. **Remove Thermal Module** – Refer to [Procedure – Removal \(Thermal Module\)](#) for steps to remove the Thermal Module.
5. **Remove Speaker Screw Rubber**- this step differs from the 13” and 15” models slightly. See the marked sections below for instructions for your device’s size.
  - a) **Speaker Rubber removal for 13” model** – Using ESD-Safe Tweezers, remove the two Speaker Screw Rubbers from each speaker as shown in the photo below.

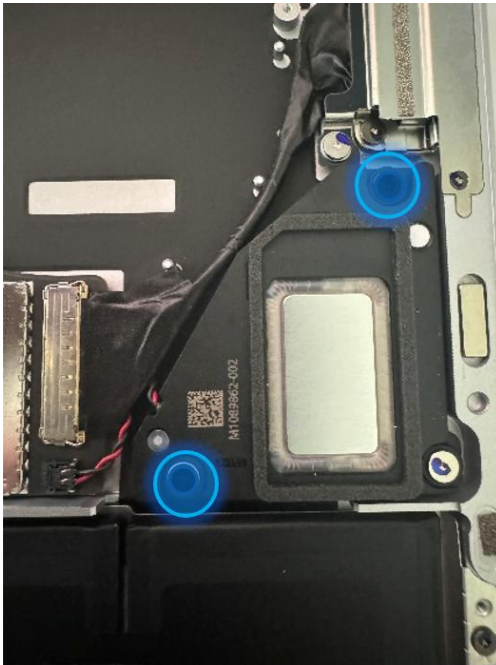

- b) **Speaker Rubber removal for 15” model** - Using ESD-Safe Tweezers, remove the singular Speaker Screw Rubbers from each speaker as shown in the photo below.

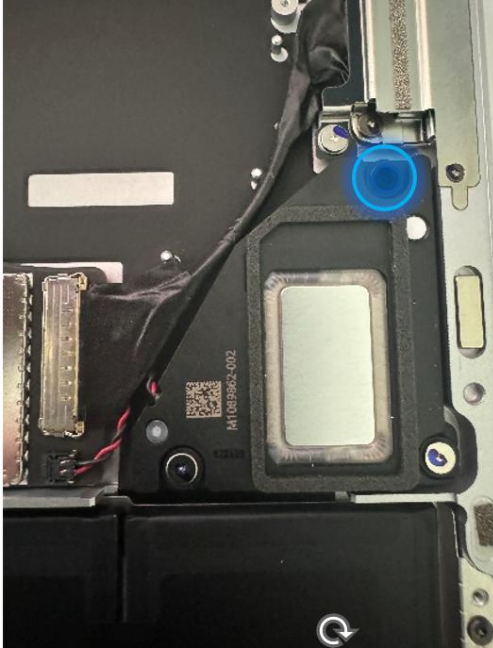

6. **Remove the left speaker** – Using a 3IP (Torx-plus) driver, remove the 3 screws securing the left speaker to the chassis. Disconnect the speaker from the motherboard using a Nylon Spudger, by carefully lifting the cable up from the motherboard. Remove the left speaker.

**CAUTION:** DO NOT attempt to pull the cable out. The cable slots into the connector from the top and should be gently lifted out of the chassis.

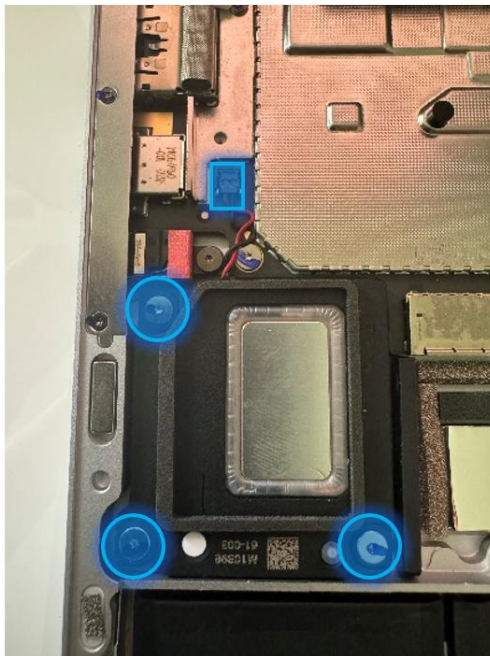

7. **Remove the right speaker** - Using a 3IP (Torx-plus) driver, remove the 3 screws securing the left speaker to the chassis. Disconnect the speaker from the motherboard using a Nylon Spudger, by lifting the cable up from the motherboard. Remove the right speaker.

**CAUTION:** DO NOT attempt to pull the cable out. The cable slots into the connector from the top and should be gently lifted out of the chassis.

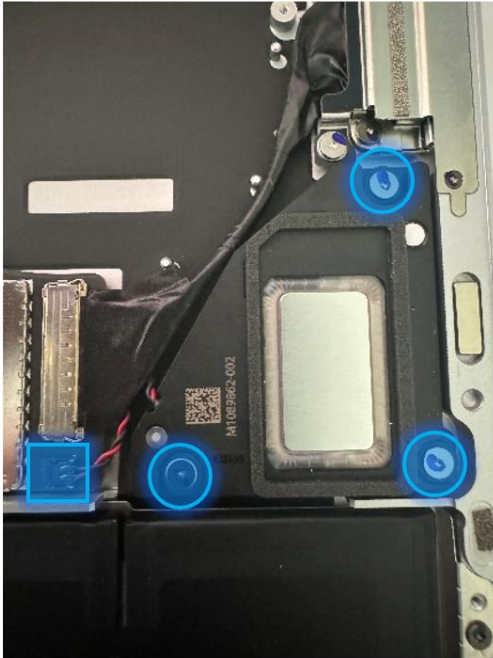

#### **Procedure – Installation (Speakers)**

1. **Install the left speaker** – Place the left speaker in the chassis. Using a 3IP (Torx-plus) driver, install the 3 screws securing the left speaker to the chassis until finger tight. Then turn each screw an additional ~45 degrees (1/8 turn) to fully fasten. Gently connect the speaker cable to the motherboard using a Nylon Spudger or your finger.

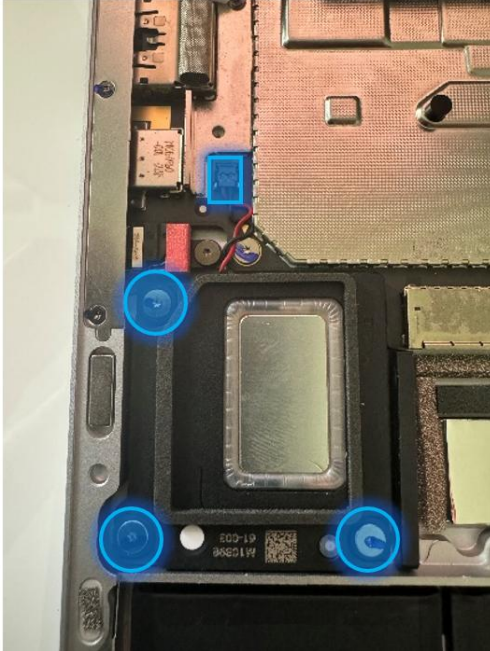

2. **Install audio cable (15" model only)** – Locate the audio connector next to the left speaker and insert the cable connector into the connector on the Motherboard Module. Apply included protective film to the back of each connector. Press firmly with your hands to secure the connection.

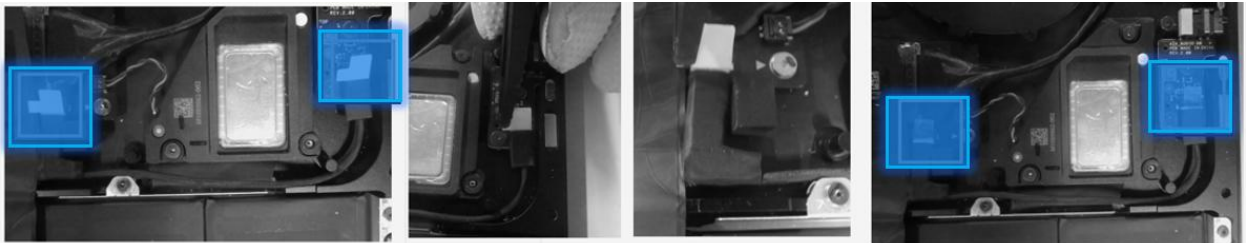

3. **Install the right speaker** – Place the right speaker in the chassis. Using a 3IP (Torx-plus) driver, install the 3 screws securing the left speaker to the chassis until finger tight. Then turn each screw an additional ~45 degrees (1/8 turn) to fully fasten. Gently connect the speaker cable to the motherboard using a Nylon Spudger or your finger.



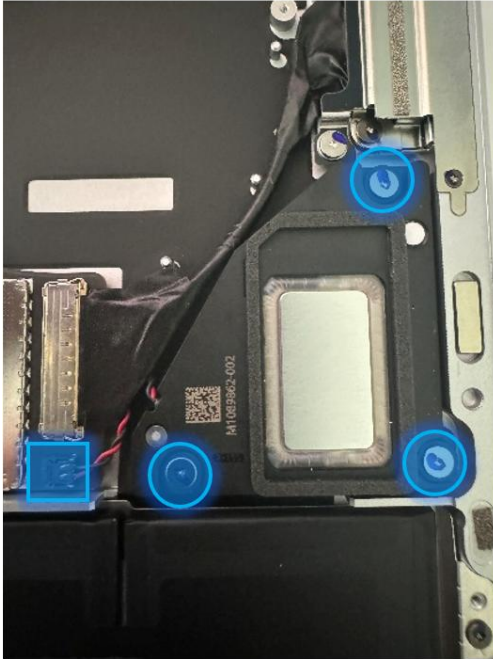

4. **Install Keyboard** – Refer to [Procedure – Installation \(Keyboard\)](#) for steps to install the keyboard.
5. **Power on Device** – Carefully reposition the device so that it is top side up. Connect the device to a power supply, open the Display, and power on to the Windows Desktop.
6. **Run the Surface Diagnostic Toolkit (SDT)** – Run all diagnostics to ensure the device is functioning as expected before moving forward.
7. **Install Feet** – Refer to [Procedure – Installation \(Feet\)](#) for steps to install Feet.

# Display Assembly Replacement Process

## Preliminary Requirements

**Important:** Be sure to follow all special (bolded) notes of caution within each process section.

**Important:** If replacing both the Motherboard Module and the Display Assembly – complete the Motherboard Module replacement prior to performing the Display Assembly Replacement to ensure proper part operation.

## Required Tools

- Surface Battery Cover (M1214771-001)
- ESD-Safe Tweezers
- Metal Tweezers
- USB drive with SDT
- Anti-static wrist strap (1 MOhm resistance)
- Nylon Spudger/Probing Tool
- Isopropyl Alcohol (70% IPA)
- Cleaning Swabs
- 3IP (Torx-plus) Driver
- 6IP (Torx-plus) Driver
- Surface Power Supply
- Soft ESD-safe mat
- Microfiber Cloth
- 0.1mm thickness gauge
- 0.15mm thickness gauge
- Metal Tweezers

## Primary Components

- Display Assembly (Refer to [Illustrated Service Parts List](#))
  - 1 x Hinge Rubber L
  - 1 x Hinge Rubber R
  - 1 x Shield Lid T1
  - 1 x Shield Lid T2
  - 1 x RF Lid Wall T1
  - 1 x RF Lid Wall T2
  - 2 x Antenna Cable Tape
  - 1 x Conductive Tape Sponge
  - 1 x SSD Thermal Pad
  - 7 x M2.0x5.2 6IP screws (Display – Hinge screws) **6IP**
    - P/N: 13N4-1EN0Y02
  - 3 x M2.0x4.65 3IP screws (Display – Hinge TPU rubber screws) **3IP**
    - P/N: 13N4-1EN0R01
  - 4 x M1.6x2.4 3IP Screws (Keyboard Assembly) **3IP**
    - P/N: 13N4 – 0FN1V21

## Additional Components (Ordered Separately)

- Feet (Refer to [Illustrated Service Parts List](#))

## Procedure – Preparation (Display Assembly)

**Important:** This section is only for instances where you are replacing the Display. If the Display is being re-used, then this section is not required. If Display is unusable due to damage or fault, connect an external monitor to the device to perform these steps.

1. **Connect USB** – Connect USB with the Surface Diagnostic Toolkit (SDT) loaded to an available USB port on the device under repair.
2. **Power on device** – Connect a power supply to the device. Press the power button on the device to power the device on. Allow it to boot to the Windows Desktop before continuing.
3. **Launch SDT** – From the Windows Desktop, use Windows Explorer to navigate to the USB drive. Select the SDT executable (.exe) to launch the Surface Diagnostic Toolkit.
4. **Run Touch Display Setup** – From the SDT launch screen, select **Repair** from the drop-down menu. Next, select **Repair Setup and Validation** to enter the selection screen. Run the **Touch Display (Setup)** tool to prepare your device for Display replacement. Follow all on-screen instructions and allow the device to shut down when prompted. Disconnect the Power Supply and remove the USB drive before proceeding forward.

## Procedure – Removal (Display Assembly)

1. **Position device** - Place the device with bottom facing up.
2. **Remove Feet** – Refer to [Procedure – Removal \(Feet\)](#) for steps to remove the feet.
3. **Remove Keyboard** – Refer to [Procedure – Removal \(Keyboard\)](#) for steps to remove the keyboard.
4. **Short jumper** – Using metal tweezers, touch the two parts of the battery icon as shown below for a few seconds. This will shut down the connection to the battery and prevent power on during repair. The LED located next to it will turn off if it was previously lit.

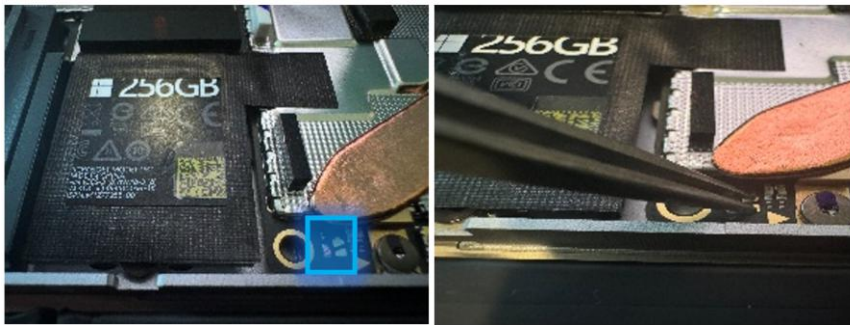

5. **Remove Hinge Rubber** – Using ESD-Safe Tweezers, carefully remove the 3 pieces of rubber from around the hinges as identified in the photo below (red boxes). Ensure you do not remove the 2 pieces of rubber near them (green arrows).

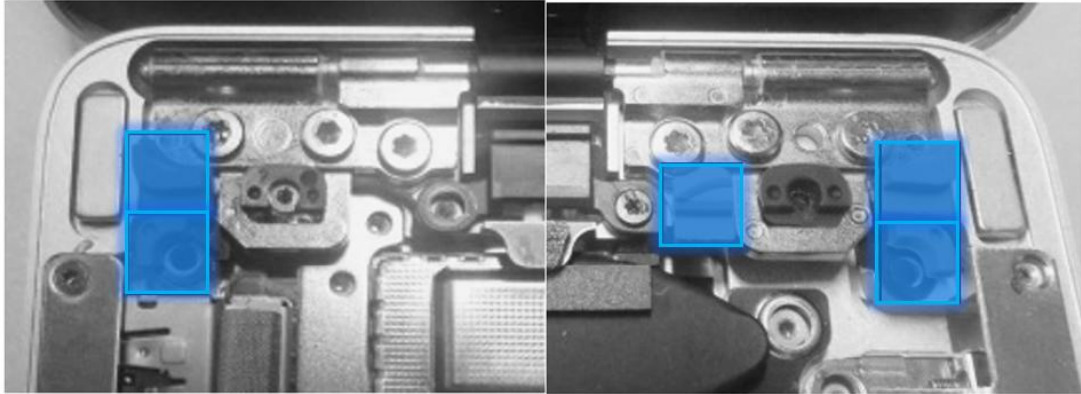

6. **Remove Hinge TPU Rubber** – Use a 3IP screwdriver to remove the 2 pieces of Hinge TPU Rubber from the device.



7. **Remove the Tape Sponge** – Using ESD-Safe Tweezers, carefully remove the tape sponge from the Thermal Module.

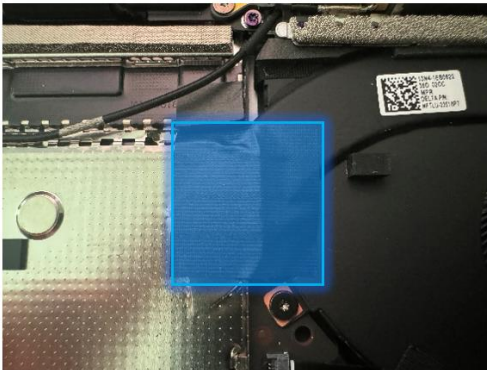

8. **Remove the left and right RF Wall** – Using a Nylon Spudger, remove the left and right RF Walls from the device.

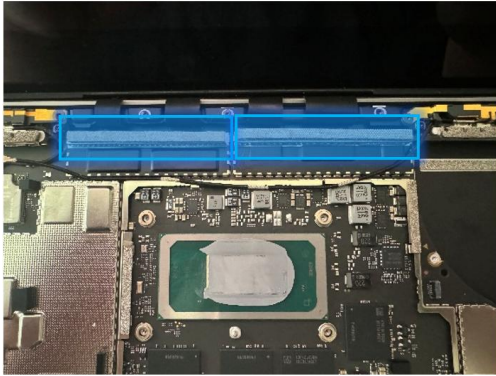

9. **Remove and reposition the right antenna** – Using a Nylon spudger, remove the buckle of the right antenna. Place the antenna in the position show in the second picture to avoid hitting the antenna connector.

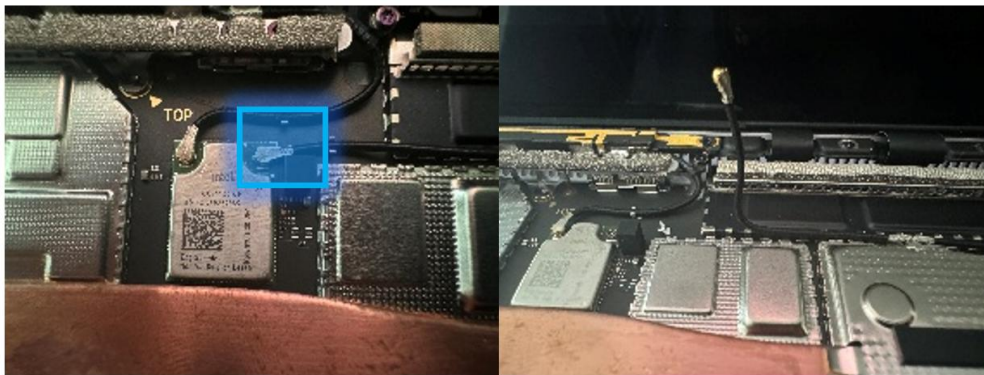

**CAUTION:** Connectors on the Wi-Fi module are very fragile. Do not attempt to remove with your fingers. If the connector is damaged, motherboard must be replaced. The nearby foams are also very delicate – take care not to damage or remove them. DO NOT use metal tools for this process.

10. **Remove the antennae cable tape** – Using ESD-Safe Tweezers, remove the 2 pieces of black antennae cable tape from the device.

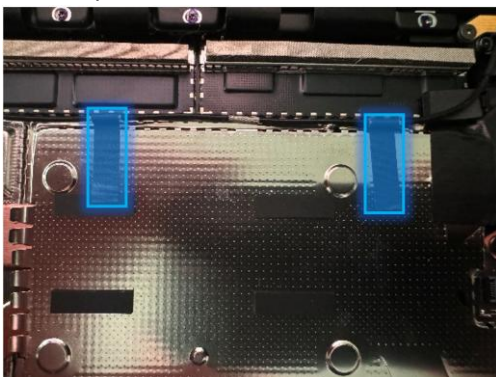

11. **Remove connector shielding** - Using a pair of ESD-Safe Tweezers, remove the Display FPC shields. The right shield is pried up from the lower left corner, while the left shield is pried up from the lower right corner. Fold the shields up and remove them in parallel.

**CAUTION:** When removing the connector shields, ensure only to remove the black shields and not the silver shield retainers. The nearby foams are very delicate. Take additional care not to damage or remove them.

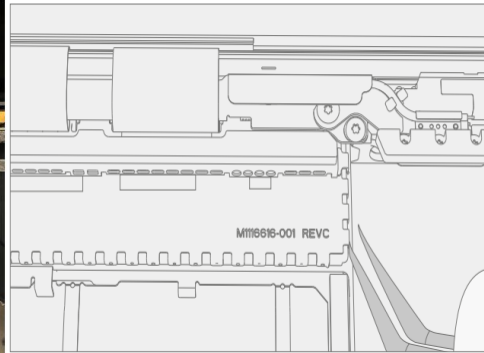
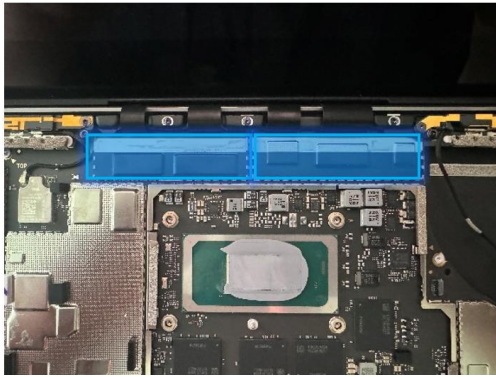

12. **Disconnect the Display connectors** - Using a Nylon Spudger, remove the Display connectors one by one in the order detailed in the photo below. Connectors in position 1, 2, 3 are disconnected from the lower right corner. The connector in the #4 position is disconnected at a 90-degree angle from the lower left corner.

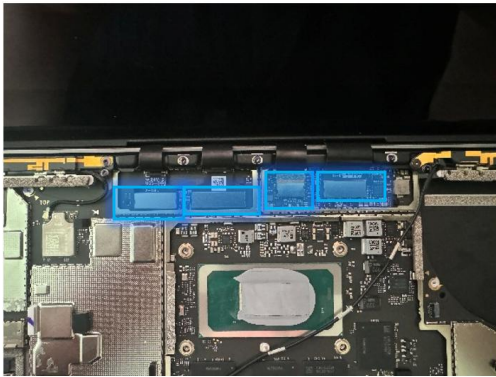

13. **Remove the hinge screws** - Holding the Display Assembly with one hand, use a 6IP (Torx-plus) driver, remove the 3 hinge screws on each hinge.

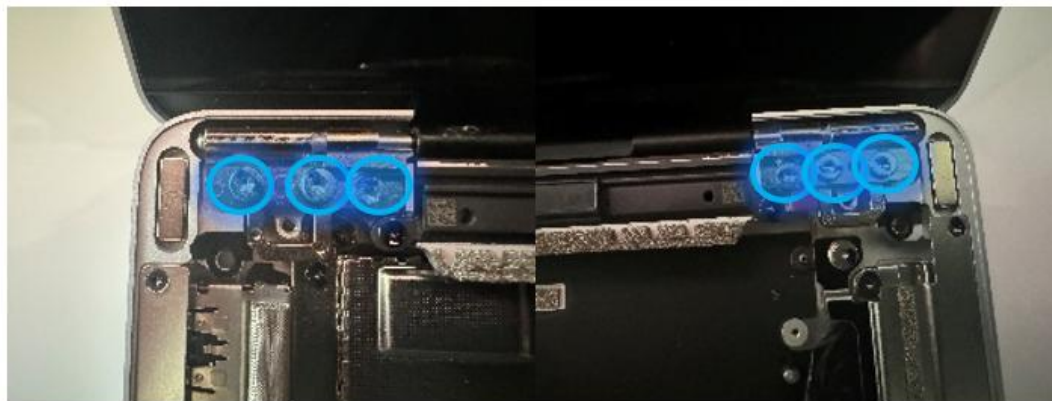

14. **Remove the Display** – Using two hands, lift the Display away from the chassis and set aside on a soft, clean surface free of debris that may damage the Display.

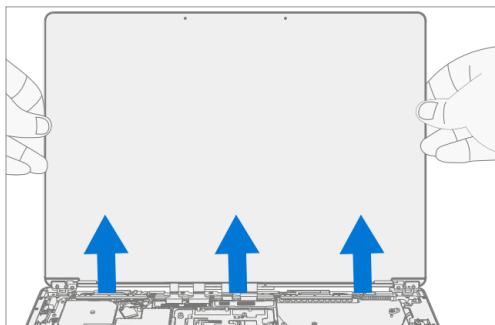

15. **Clean rubber residue** - Using a cleaning swab soaked in Isopropyl Alcohol, clean any residual rubber residue from the chassis where the hinges were previously attached.

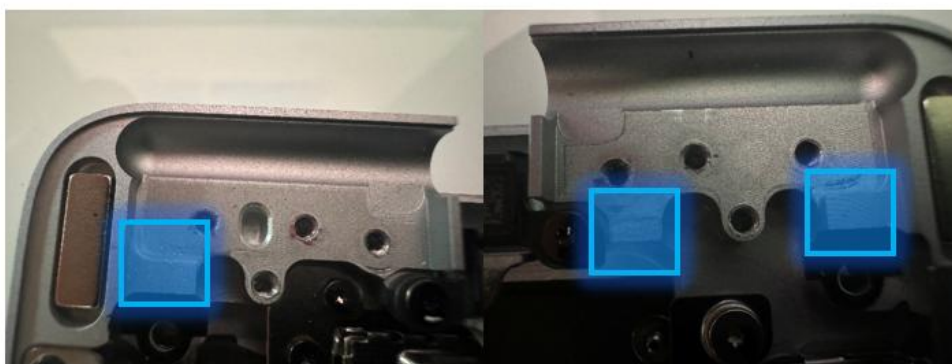

#### Procedure – Installation (Display)

1. **Position hinges** - Place the backside of the replacement Display module on the ESD safe workbench. Adjust both hinges until they are approximately set to 90 degrees.

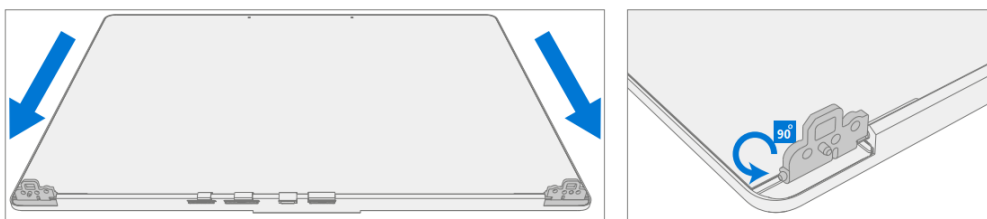

2. **Install Display module onto chassis** – While holding the Display with both hands, carefully align the hinges so they fit into the pockets on each side of the chassis.

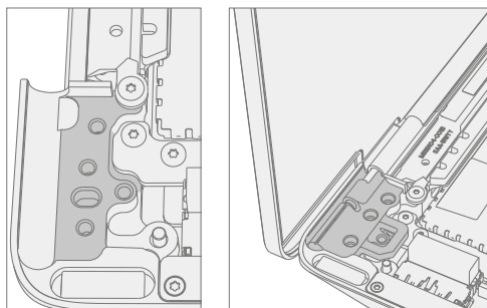

3. **Pre-fasten the hinge screws** – Using a 6IP (Torx-plus) drivers, assemble the 3 left and 3 right hinge screws in the order shown. Tighten each screw until just snug.

**Important:** Ensure each screw can be inserted at a 90-degree angle. If any of the 6 hinge screws cannot be inserted at 90-degrees, re-check hinge alignment with Enclosure before continuing.

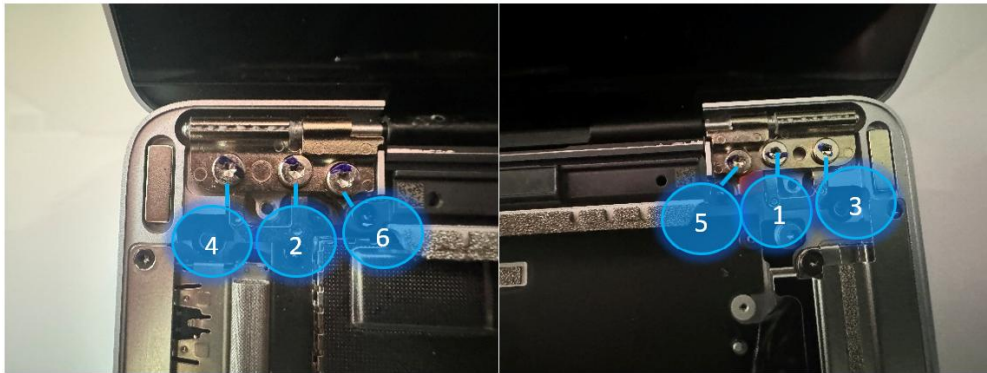

**4. Hinge alignment –**

- a. Loosen all 6 hinge screws 90 degrees (1/4<sup>th</sup> turn).
- b. Carefully close Display.
- c. Using a 0.1mm plastic thickness gauge, verify the gauge can slide easily in the hinge gap.

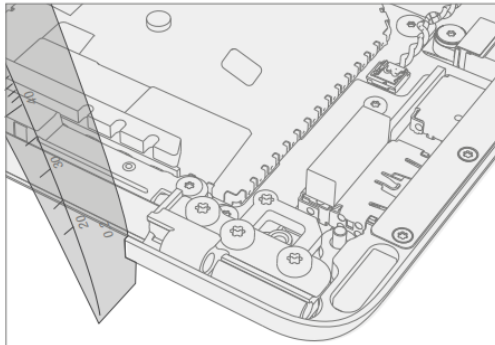

- d. Open the lid and tighten 1 screw on each hinge until snug, then turn an additional 90 degrees (1/4<sup>th</sup> turn) and re-check alignment with the 0.1mm plastic thickness gauge.
  - e. Repeat steps b thru d on each of the 5 remaining hinge screws.
- 5. Install new hinge rubber –** Using ESD-Safe Tweezers, place 3 pcs of rubber on the areas shown below. There are different rubber pieces for 13” and 15” devices so ensure yours match the ones in the photo for your device.
- a. 13” Devices:

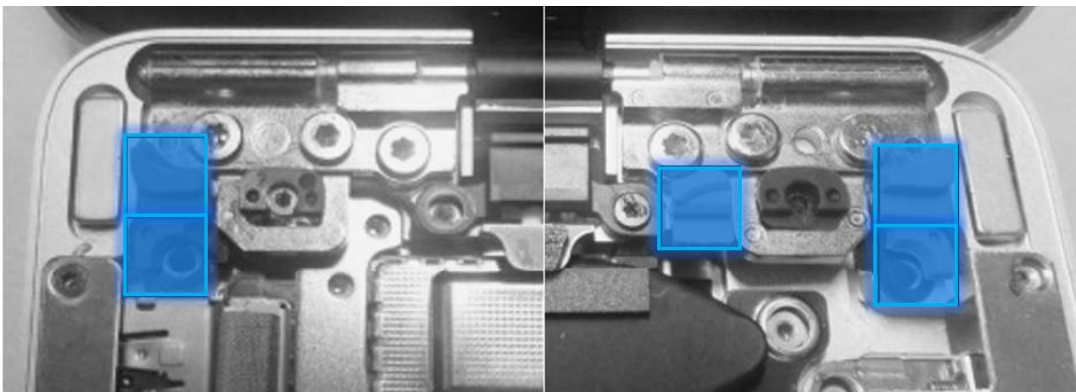



**Important:** When installing the hinge rubber, ensure the protruding edge on the rubber piece is fitted into the narrow gap between the hinge and the device chassis.

b. 15" Devices:

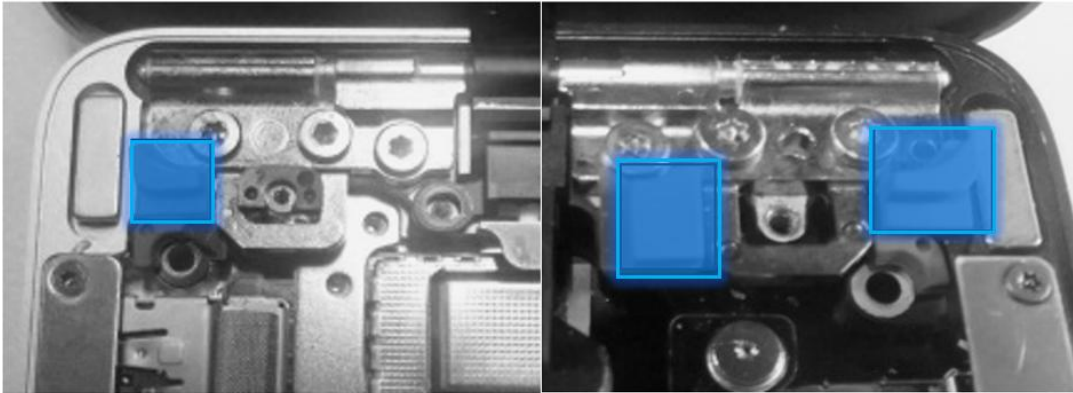

6. **Install new hinge TPU rubber** – Using ESD-Safe Tweezers, place 1 piece of TPU rubber on both the left and right hinges. Use a 3IP (Torx-plus) driver to tighten a screw into each of the two TPU rubbers so that the screw head is not higher than the TPU surface.



7. **Connect the Display cables** - Carefully connect the 4 Display cables to the connectors on the PCBA. Perform a visual inspection to ensure all are fully connected before moving forward.

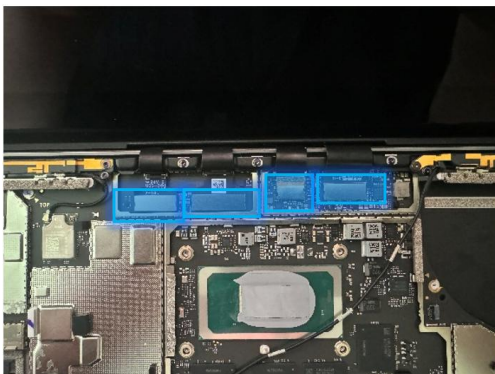

8. **Install connector shielding** – Using a pair of ESD-Tweezers, slide the Display cable shields into place. Once the shields are properly positioned, use your finger to press them into place.
9. **Install the RF lid wall** - place the 2 RF lid wall pieces on the connector shields as shown in the photo below and press firmly to apply.

**Important:** The RF lids come in two design: T1 and T2. T1 is the shorter and T2 is the longer lid. For both lids, the side with holes should face away from the Display.

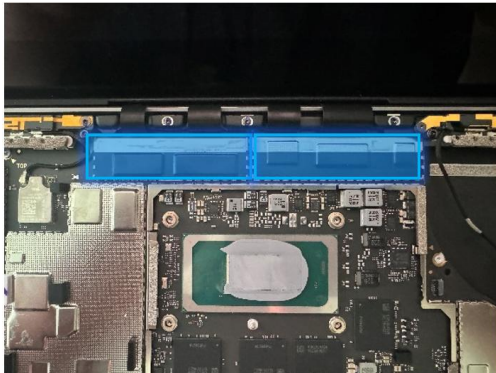

10. **Install the tape sponge** – Please a new tape sponge and press firmly with both hands to apply.

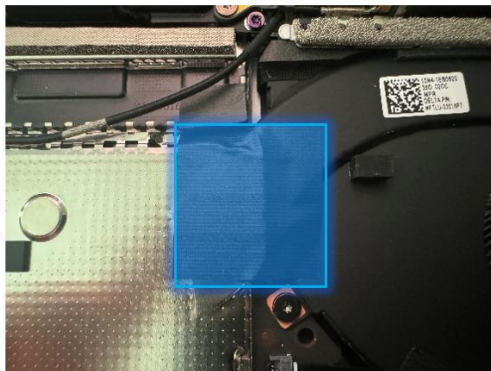

11. **Install antenna** – Using your fingers, gently move the black Wi-Fi antenna into place above the connector on the Wi-Fi module and press to apply with fingers or the flat end of a Nylon Spudger. The cable should route around and in front of the RF lid walls.

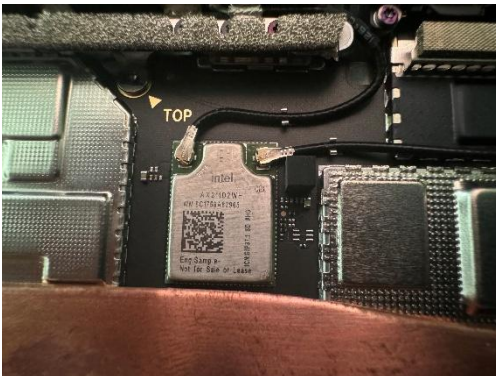

**CAUTION:** the connectors on the Wi-Fi module are very fragile. If the connector is damaged, the Motherboard Module will need to be replaced.

12. **Install the antenna cable tape** - Apply 2 pieces of antenna cable tape to the locations outlined in the photo below to secure the antenna cable to the thermal module shield.

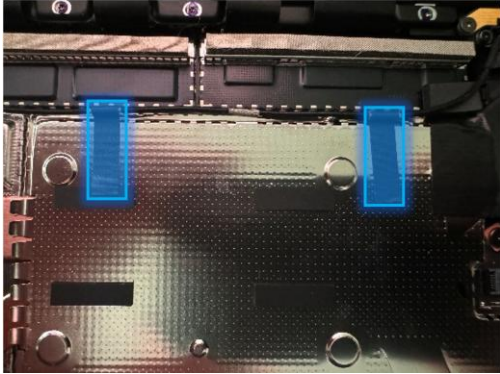

13. **Install Keyboard** – Refer to [Procedure – Installation \(Keyboard\)](#) for steps to install the keyboard.
14. **Power on Device** – Carefully reposition the device so that it is top side up. Connect the device to a power supply, open the Display, and power on to the Windows Desktop.

#### Procedure – Finalize (Display Assembly)

**Important:** This section is only for instances where you are replacing the Display. If the Display is being re-used, then this section is not required. If Display is unusable due to damage or fault, connect an external monitor to the device to perform these steps.

1. **Connect USB** – Connect USB with the Surface Diagnostic Toolkit (SDT) loaded to an available USB port on the device under repair.
2. **Launch SDT** – From the Windows Desktop, use Windows Explorer to navigate to the USB drive. Select the SDT executable (.exe) to launch the Surface Diagnostic Toolkit.
3. **Run Touch Display Calibration** – From the SDT launch screen, select **Repair** from the drop-down menu. Next, select **Repair Setup and Validation** to enter the selection screen. Run the **Touch Display (Calibration)** tool to calibrate your new Display. Follow all on-screen instructions and allow the device to restart when prompted.

**Important:** If the calibration fails, reboot the device, and attempt again. If the failure continues, then the Display may be faulty and require replacement.

4. **Launch SDT** – Once the device has rebooted and is at the Windows Desktop, use Windows Explorer to navigate to the USB drive. Select the SDT executable (.exe) to launch the Surface Diagnostic Toolkit.
5. **Run the Surface Diagnostic Toolkit (SDT)** – Run all diagnostics to ensure the device is functioning as expected before moving forward.
6. **Install Feet** – Refer to [Procedure – Installation \(Feet\)](#) for steps to install Feet.

# Surface Connect Replacement Process

## Preliminary Requirements

**Important:** Be sure to follow all special (bolded) notes of caution within each process section.

## Required Tools

- Surface Battery Cover (M1214771-001)
- ESD-Safe Tweezers
- Metal Tweezers
- USB drive with SDT
- Anti-static wrist strap (1 MOhm resistance)
- Nylon Spudger/Probing Tool
- Isopropyl Alcohol (70% IPA)
- Cleaning Swabs
- 3IP (Torx-plus) Driver
- Surface Power Supply
- Soft ESD-safe mat
- Microfiber Cloth
- Metal Tweezers

## Primary Components

- Surface Connect (Refer to [Illustrated Service Parts List](#))
  - 1 x Surface Connect Cable
  - 1 x SSD Thermal Pad
  - 3 x M1.2x1.4 3IP screws (Surface Connect – Iron Plate) **3IP-3**
    - P/N: 13N4-0FN1U12
  - 3 x M1.2x2.2 3IP screws (Surface Connect – Iron Plate) **3IP-2**
    - P/N: 13N4-1EN0J02
  - 3 x M1.2x2.4 3IP screws (Surface Connect – SL Cable) **3IP-1**
    - P/N: 13N4-0FN2K12
  - 4 x M1.6x2.4 3IP screws (Keyboard Assembly) **3IP**
    - P/N: 13N4 – 0FN1V21

## Additional Components (Ordered Separately)

- Feet (Refer to [Illustrated Service Parts List](#))

## Procedure – Removal (Surface Connect)

1. **Position device** - Place the device with bottom facing up.
2. **Remove Feet** – Refer to [Procedure – Removal \(Feet\)](#) for steps to remove the feet.
3. **Remove Keyboard** – Refer to [Procedure – Removal \(Keyboard\)](#) for steps to remove the keyboard.
4. **Short jumper** – Using metal tweezers, touch the two parts of the battery icon as shown below for a few seconds. This will shut down the connection to the battery and prevent power on during repair. The LED located next to it will turn off if it was previously lit.

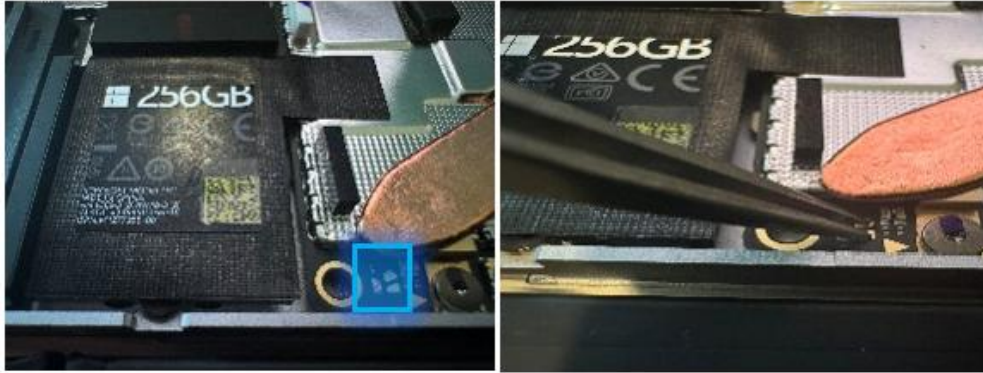

5. **Disconnect the Surflink connector from the Motherboard Module** – Located below the cooling fan, carefully pull back the thermal graphite to expose the Surflink cable on the motherboard. Lift the cable connector handle and delicately pull to the right to disengage the cable from the connector.

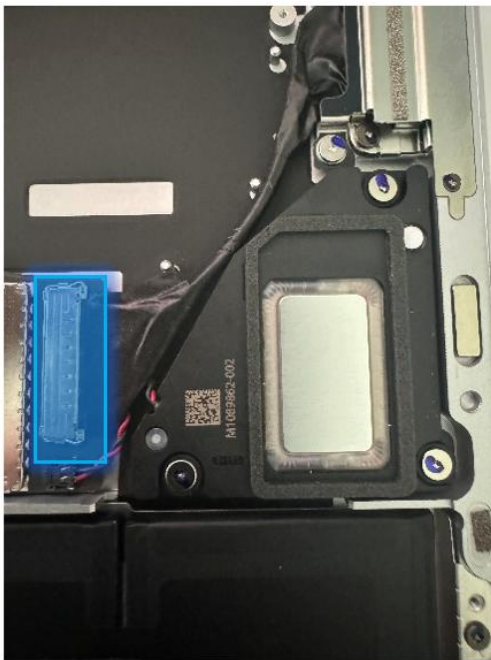

6. **Remove bracket** – Using a 3IP (Torx-plus) driver, remove the 4 bracket screws securing the bracket to the chassis. Remove the bracket.



7. **Remove Surface Connect Screws** – Using a 3IP (Torx-plus) driver, remove the 2 SurfLink screws securing the Surface Connect to the chassis.

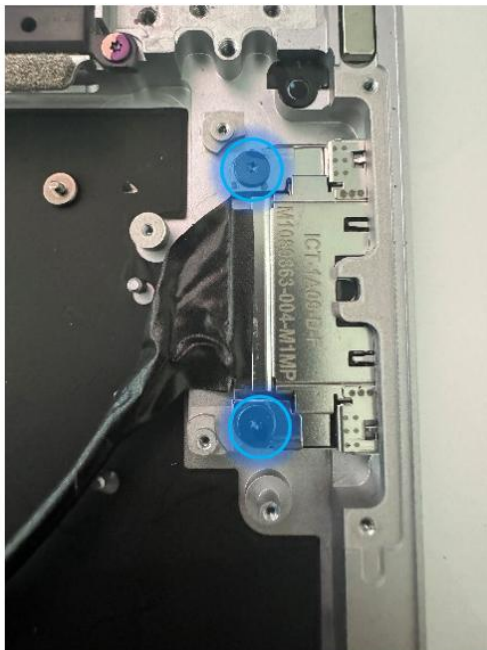

8. **Remove Surface Connect** – Remove the Surface Connect from the chassis.



#### Procedure – Installation (Surface Connect)

1. **Install Surface Connect** – Place the Surface Connect into the chassis. Ensure the chassis posts net into the Surface Connect slot.

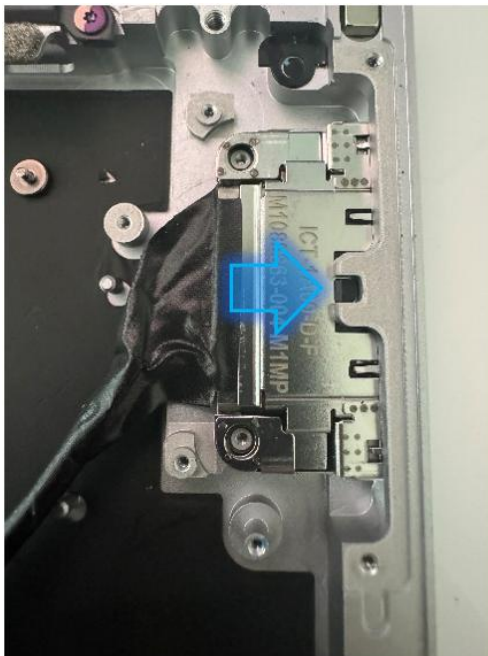

2. **Install new SurfLink Screws** – Using a 3IP (Torx-plus) driver, install 2 new SurfLink screws. Turn all screws until just snug and seated, and then turn each another 45-degree (1/8<sup>th</sup> turn) until fully fastened.

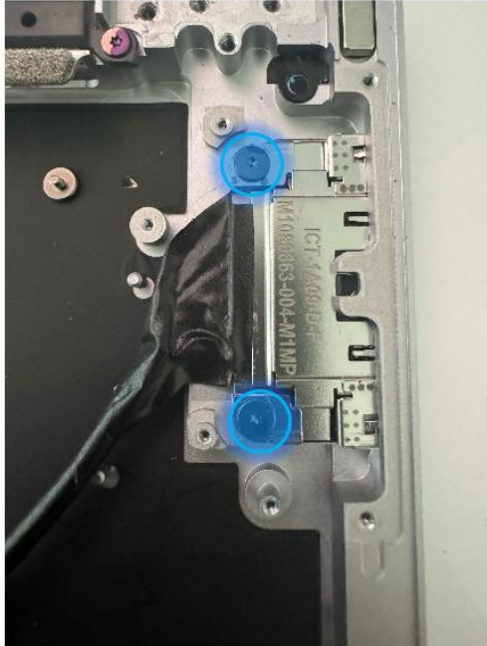

3. **Reconnect the Surflink connector to the Motherboard Module** – Located below the cooling fan, carefully pull back the thermal graphite to expose the Surflink connector on the motherboard. Insert the Surflink cable into the connector on the motherboard and press down on the locking cover to fully secure the cable. Carefully reinstall the graphite sheet into its original position.

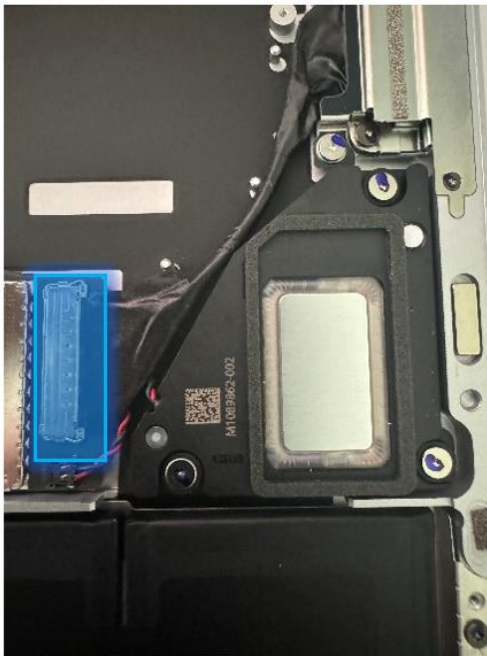

4. **Install bracket** – Place the Surflink bracket over the Surflink. Using a 3IP (Torx-plus) driver install 4 new Bracket Screws. Turn all screws until they are just snug and seated, then turn each another 45-degrees (1/8<sup>th</sup> turn) or until fully fastened.





5. **Install Keyboard** – Refer to [Procedure – Installation \(Keyboard\)](#) for steps to install the keyboard.
6. **Power on Device** – Carefully reposition the device so that it is top side up. Connect the device to a power supply, open the Display, and power on to the Windows Desktop.
7. **Launch SDT** – Once the device has rebooted and is at the Windows Desktop, use Windows Explorer to navigate to the USB drive. Select the SDT executable (.exe) to launch the Surface Diagnostic Toolkit.
8. **Run the Surface Diagnostic Toolkit (SDT)** – Run all diagnostics to ensure the device is functioning as expected before moving forward.
9. **Install Feet** – Refer to [Procedure – Installation \(Feet\)](#) for steps to install the feet.

# Motherboard Module Replacement Process

## Preliminary Requirements

**Important:** Be sure to follow all special (bolded) notes of caution within each process section.

**Important:** If replacing both the Motherboard Module and the Display Assembly – complete the Motherboard Module replacement prior to performing the Display Assembly Replacement to ensure proper part operation.

## Required Tools

- Surface Battery Cover (M1214771-001)
- ESD-Safe Tweezers
- USB drive with SDT
- Anti-static wrist strap (1 MOhm resistance)
- Nylon Spudger/Probing Tool
- Isopropyl Alcohol (70% IPA)
- Cleaning Swabs
- 3IP (Torx-plus) Driver
- 5IP (Torx-plus) Driver
- 6IP (Torx-plus) Driver
- Surface Power Supply
- Soft ESD-safe mat
- Microfiber Cloth
- Metal Tweezers

## Primary Components

- Motherboard Module (Refer to [Illustrated Service Parts List](#))
  - 1 x PCB Screw Top
  - 1 x Shield Lid T4
  - 1 x Shield Lid T7
  - 1 x rSSD Stiffener
  - 1 x Hinge Rubber L
  - 1 x Hinge Rubber R
  - 1 x Shield Lid T1
  - 1 x Shield Lid T2
  - 1 x RF Lid T1
  - 1 x RF Lid T2
  - 1 x Foam Baffle
  - 1 x Hinge Sticker
  - 1 x USBA RF Foam
  - 1 x SOC Thermal Pad
  - 1 x Shield Lid T3
  - 2 x Antenna Cable Tape
  - 1 x Conductive Tape
  - 1 x Conductive Tape Sponge

- 1 x T4 Lid Tape
- 1 x SSD Conductive Tape
- 1 x SSD Top Rubber
- 1 x SSD Thermal Pad
- 2 x M1.2x3.0 3IP screws (Left Antenna PCB) **Ⓢ3IP-1**
  - P/N: 13N4-0FN3K02
- 2 x M1.6x2.3 3IP screws (Left Antenna PCB) **Ⓢ3IP-3**
  - P/N: 13N4-1EN0E01
- 5 x M1.2x1.6 3IP screws (Left Antenna PCB) **Ⓢ3IP-2**
  - P/N: 13N4-1EN0F02
- 2 x M1.6x2.0 5 IP screws (rSSD) **■5IP**
  - P/N: 13N4-1EN0L01
- 7 x M2.0x5.2 6IP screws (Display – Hinge screws) **▣6IP**
  - P/N: 13N4-1EN0Y02
- 3 x M2.0x4.65 3IP screws (Display – Hinge TPU rubber screws) **▣3IP**
  - P/N: 13N4-1EN0R01
- 7 x M1.2x1.4 3IP screws (Surface Connect – Iron Plate/Motherboard) **⚡3IP-3 #3IP-3**
  - P/N: 13N4-0FN1U12
- 4 x M1.2x2.2 3IP screws (Surface Connect – Iron Plate/Motherboard – Iron Piece) **⚡3IP-2 #3IP-2**
  - P/N: 13N4-1EN0J02
- 3 x M1.2x2.4 3IP screws (Surface Connect – SL Cable) **⚡3IP-1**
  - P/N: 13N4-0FN2K12
- 4 x M1.2x0.25 3IP screws (Left Speaker) **🔊3IP**
  - P/N: 13E5-2TN3V21
- 5 x M1.2x3.3 3IP screws (Thermal Module) **Ⓢ3IP-3**
  - P/N: 13N4-1EN0L01
- 4 x M1.2x2.3 3IP screws (Thermal Module/Motherboard – USB Bracket) **Ⓢ3IP-1 #3IP-1**
  - P/N: 13N4-0FN1V21
- 4-6 x M1.2x1.7 3IP screws (Thermal Module) **Ⓢ3IP-2**
  - P/N: 13N4-0FN2P12
- 2 x M1.2x2.0 3IP screws (Thermal Module: 13” only) **Ⓢ3IP-4**
  - P/N: 13N4-1EN0X02
- 4 x M1.6x2.4 3IP Screws (Keyboard Assembly) **⌨3IP**
  - P/N: 13N4 – 0FN1V21

#### Additional Components (Ordered Separately)

- Feet (Refer to [Illustrated Service Parts List](#))

#### Procedure – Removal (Motherboard Module)

1. **Position device** - Place the device with bottom facing up.
2. **Remove Feet** – Refer to [Procedure – Removal \(Feet\)](#) for steps to remove the feet.
3. **Remove Keyboard** – Refer to [Procedure – Removal \(Keyboard\)](#) for steps to remove the keyboard.
4. **Remove Thermal Module** – Refer to [Procedure – Removal \(Thermal Module\)](#) for steps to remove the Thermal Module.

5. **Remove Surface Connect** - Refer to [Procedure – Removal \(Surface Connect\)](#) for steps to remove the Surface Connect.
6. **Remove rSSD** – Refer to [Procedure – Removal \(rSSD\)](#) for steps to remove the rSSD.
7. **Remove Speakers** – Refer to [Procedure – Removal \(Speakers\)](#) for steps to remove the Speakers.
8. **Remove Display** – Refer to [Procedure – Removal \(Display Assembly\)](#) for steps to remove the Display.
9. **Remove Hinge Sticker** - Position the device on its end so that the hinge recesses are facing up towards you. Remove the hinge sticker from between the hinge recesses.



10. **Remove Foam** – Locate the foam directly above the Wi-Fi module. Using ESD-Safe Tweezers, carefully remove the thin layer of foam.

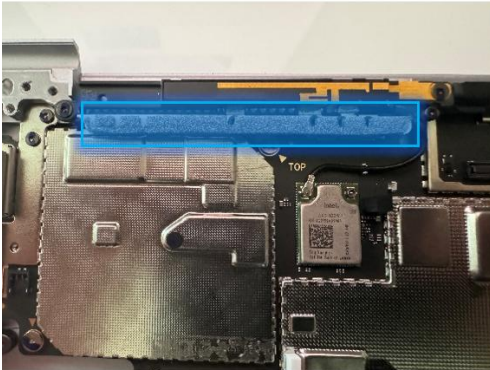

11. **Remove and reposition the right antenna** – Using a Nylon spudger, unplug the buckle of the right antenna. Place the antenna in the position shown in the second picture to avoid hitting the antenna connector.

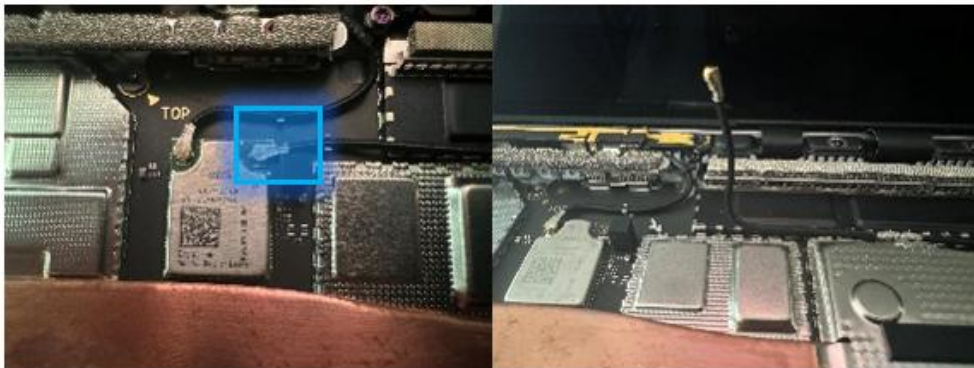

12. **Remove Surface Connect connector from Motherboard** - Carefully lift the thermal graphite sheet (no more than a 140 degree angle) and remove the Surface Connect connector from the Motherboard.

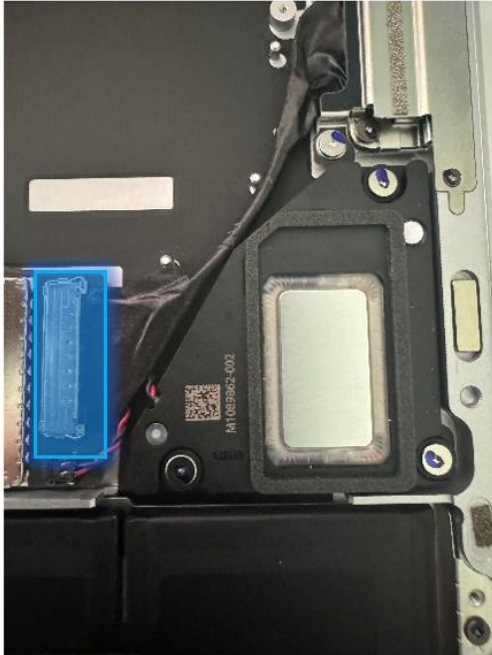

- 13. Remove the left antennae** – Using a 3IP (Torx-plus) driver to remove the 6 screws on the left antennae located directly above the Wi-Fi module. Using a Nylon Spudger, disconnect the left antenna. Remove the antennae from the chassis.

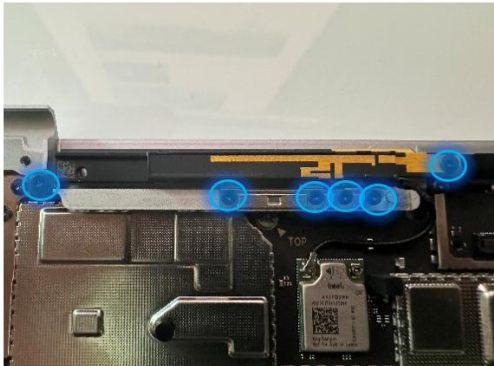

- 14. Remove audio cable (15" model only)** – Locate the audio cable next to the left speaker and lift the tape from the connector. Pulling back on the tape to remove the audio cable from the connector.

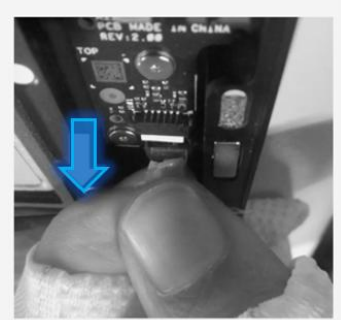
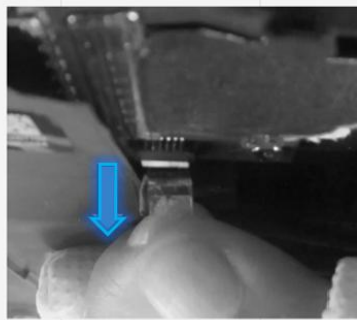
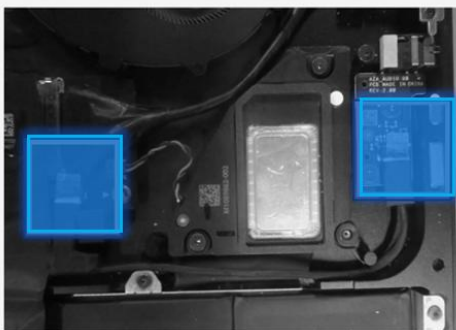

- 15. Remove the USB Bracket** – Locate the USB bracket near the USB ports and follow the directions below based on the model you are repairing as there are differences.

- a) **Remove USB Bracket (13")** – Use a 3IP (Torx-plus) driver to remove the 2 screws securing the USB bracket to the chassis. Lift the bracket and remove from the device.

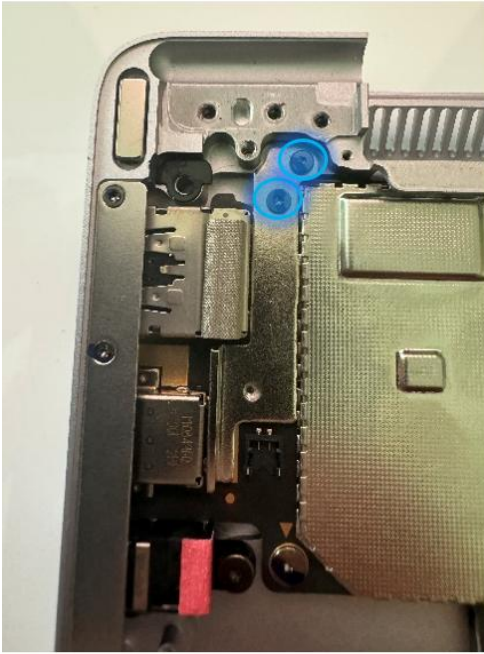

- b) **Remove USB Bracket (15")** – Use a 3IP (Torx-plus) driver to remove the 3 screws securing the USB bracket to the chassis. Lift the bracket and remove from the device.

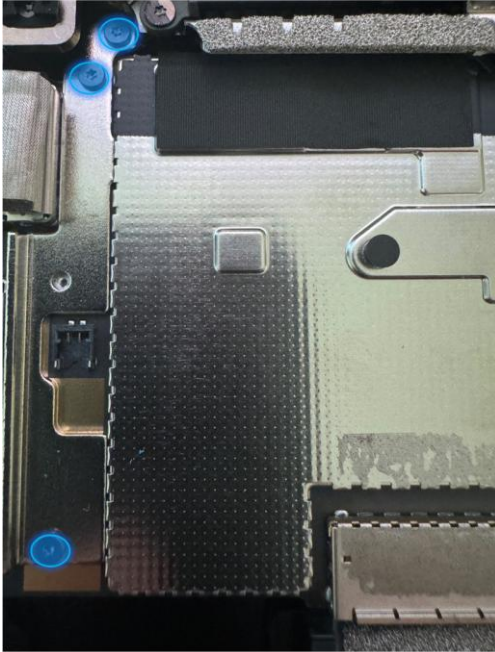

16. **Remove the retention clip** – Locate the metal retention clip directly above the USB ports. Using a 3IP (Torx-plus) driver, remove the 3 screws securing the retention clip to the chassis. Lift the retention clip and remove from the device.

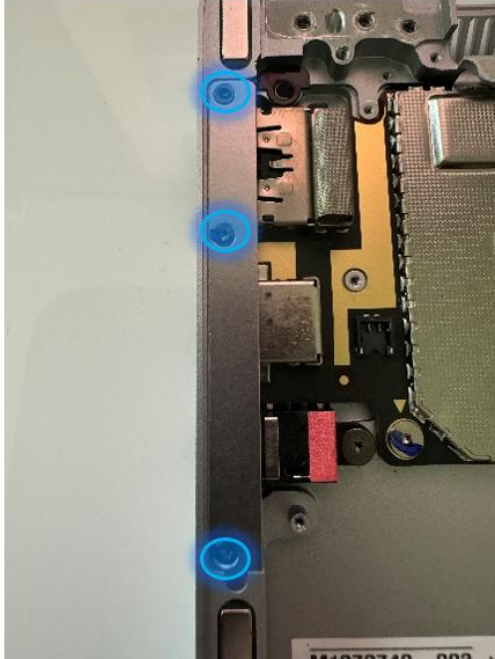

17. Using ESD-Safe Tweezers, work your way around the two metallic shield lids until you can lift them from the device.

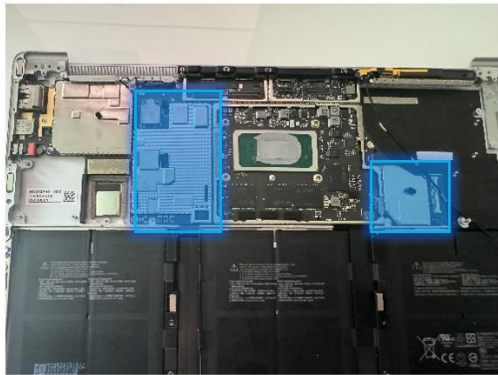

18. **Remove Thermal Interface Material residue** – Using the flat end of a Nylon Spudger, carefully remove any Thermal Interface Material from the chip under the larger left shield.

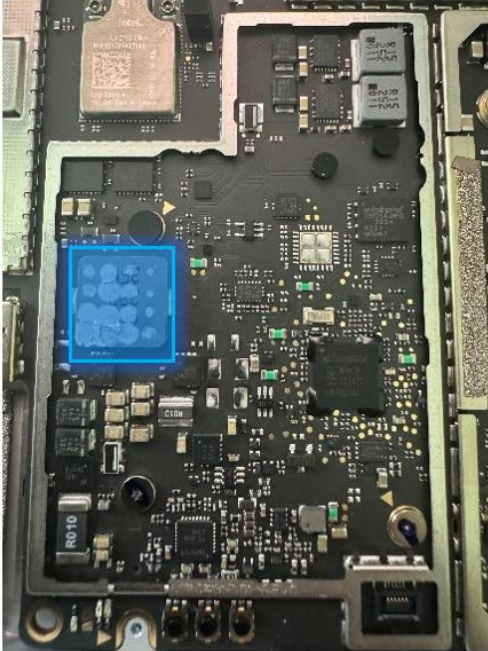

19. **Remove Rubber Cap** – Using a Nylon Spudger, carefully remove the rubber cap as identified in the photo below.



20. **Remove Fan Rubber (15" only)** – Using ESD-Safe Tweezers, locate and remove the rubber block located near the fan.



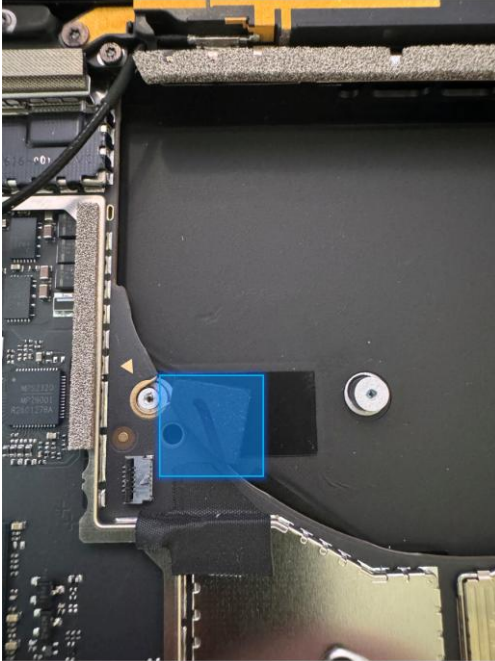

21. **Remove rSSD Stiffener** – Using ESD-Safe Tweezers, locate and remove the rSSD Stiffener located directly next to the rSSD connector.

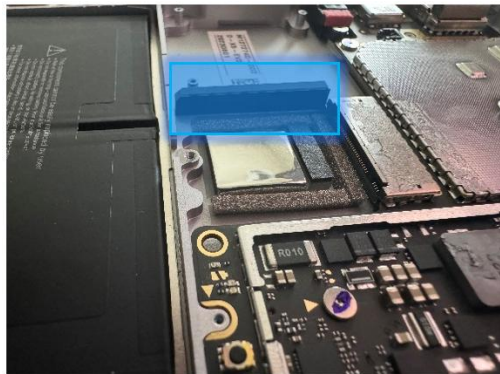

22. **Remove Motherboard Shields** – Using ESD-Safe Tweezes, remove the two metal shields identified in the image below to expose the Motherboard screws.



23. **Remove Motherboard Module screws** – Using a 3IP (Torx-plus) driver, remove the 6 screws securing the Motherboard Module to the chassis. Please see the sections below for exact locations as placement differs by device model.
  - a) **Remove Motherboard Module screws (13")** –

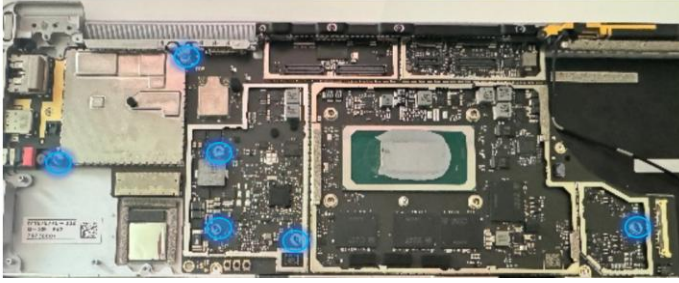

b) **Remove Motherboard Module screws (15")** –

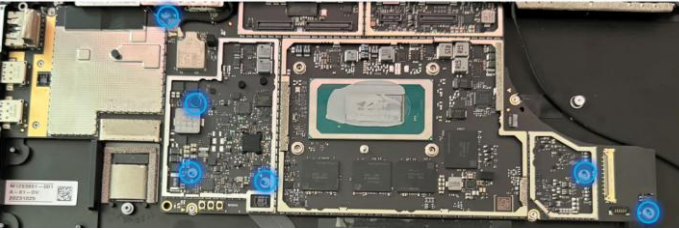

24. **Remove Motherboard Module** – Grab the right-hand side of the motherboard and lift until it is just off the chassis standoffs. Gently rotate the board towards you and pull gently to the right. A wiggling motion will be required to loosen the top of the board from the chassis. Once clear, lift the motherboard out of the chassis and place on an ESD-Safe mat.

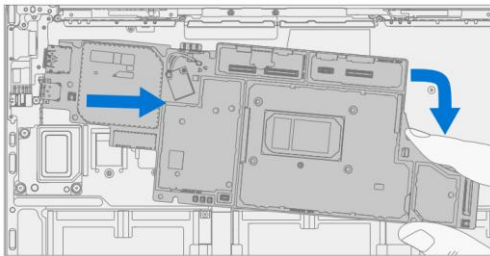

**Important:** Do not remove the acetate cloth on the upper left lid of the Motherboard Module if re-using the Motherboard Module. It is also unnecessary in replacement scenarios as the new Motherboard Module will have the acetate cloth pre-applied.

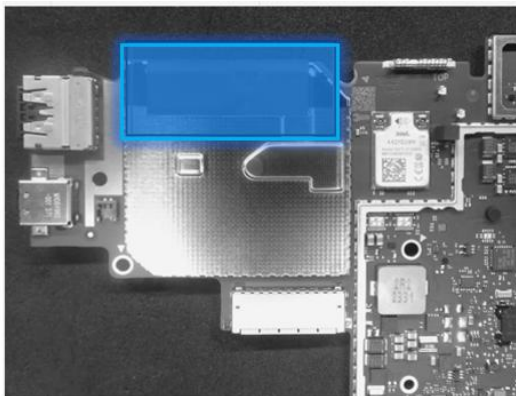

**Procedure – Installation (Motherboard Module)**

1. **Insert Motherboard Module** – While holding the right-hand side of the motherboard, insert the USB ports into the left-hand side of the chassis. Once inserted, rotate the board down and into the chassis.



2. **Install Motherboard Module screws** – Using a 3IP (Torx-plus) driver, install the 6 screws securing the Motherboard Module to the chassis. Please see the sections below for exact locations as placement differs by device model.

- a) **Install Motherboard Module screws (13")** –

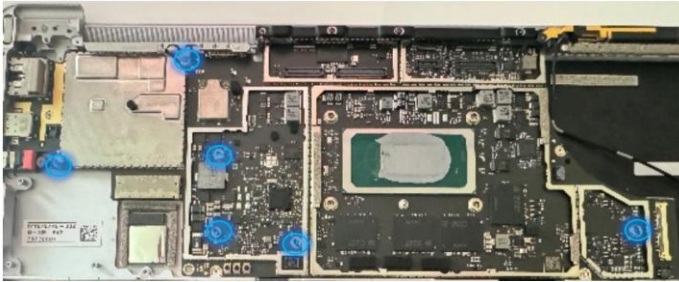

- b) **Install Motherboard Module screws (15")** –

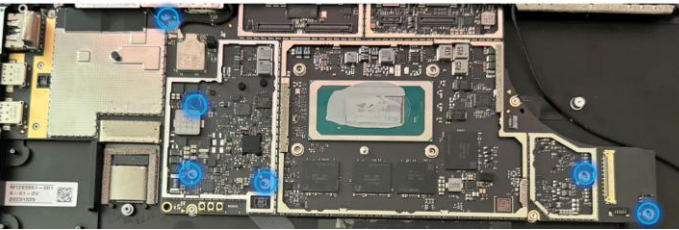

3. **Install Rubber Cap** – Using a Nylon Spudger, carefully apply the rubber cap as identified in the photo below.



4. **Install Shield Lids** – Using ESD-Safe Tweezers, install the 2 Shield Lids to the Motherboard Module in the positions indicated.

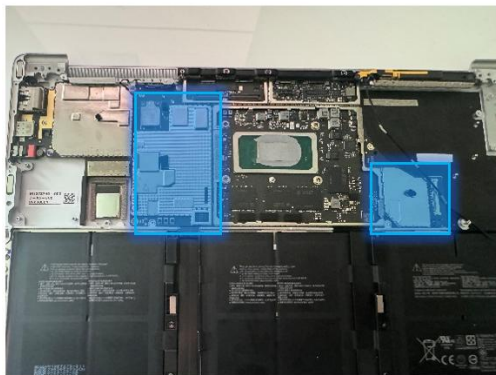

5. **Install Fan Rubber (15" only)** – Using ESD-Safe Tweezers, locate and install the rubber block located near the fan.

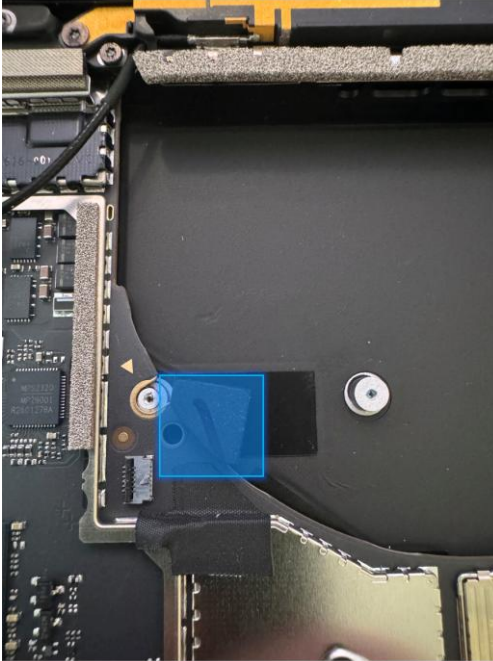

6. **Install the retention clip** – Locate the metal retention clip directly above the USB ports. Using a 3IP (Torx-plus) driver, install the 3 screws securing the retention clip to the chassis.

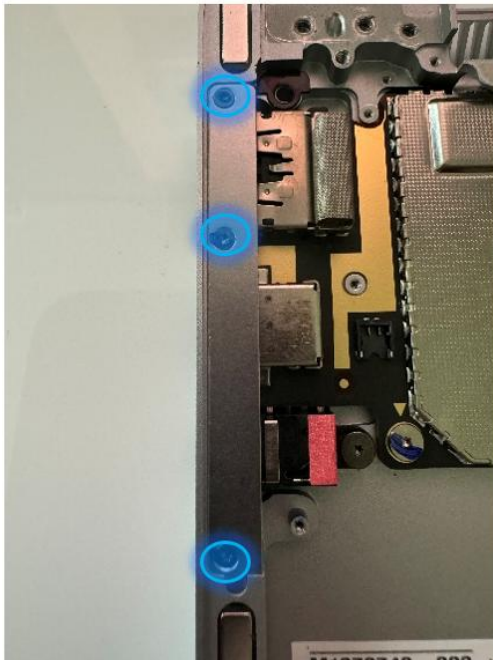

7. **Install the USB Bracket** – Locate the USB ports and follow the directions below based on the model you are repairing as there are differences.
  - a) **Install USB Bracket (13")** – Use a 3IP (Torx-plus) driver to install the 2 screws securing the USB bracket to the chassis.

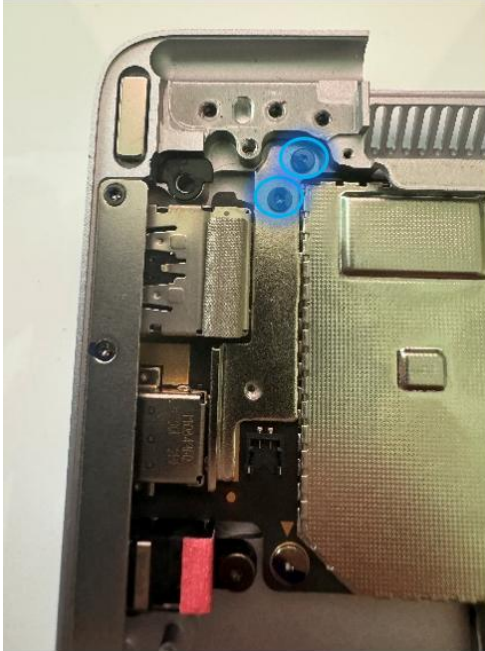

- b) **Install USB Bracket (15")** – Use a 3IP (Torx-plus) driver to install the 3 screws securing the USB bracket to the chassis.

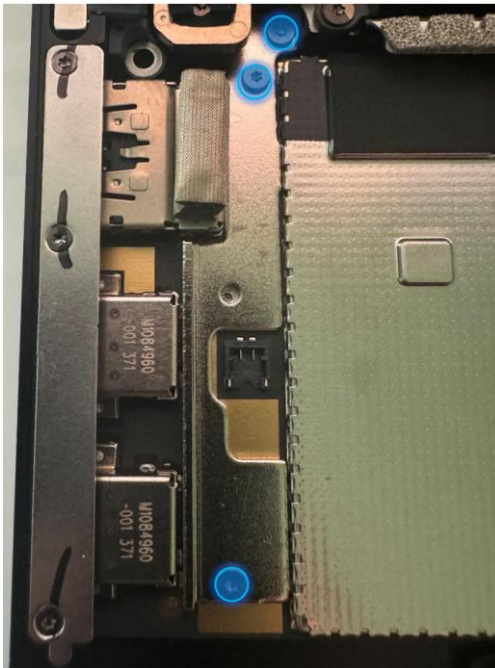

8. **Install the Surface Connect Connector to Motherboard** – Carefully lift the graphite sheet and insert the Surface Connect Connector to the Motherboard.

**CAUTION:** If the graphite sheet is damaged in any way, the entire Thermal Module will need to be replaced.

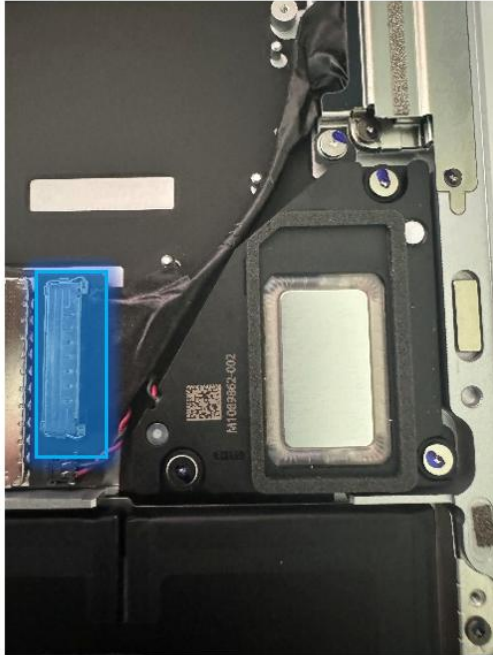

9. **Install audio cable (15" model only)** – Locate the audio connector next to the right speaker. Take 1 piece of new Audio cable and insert an end into both the connector on the Motherboard and the connector on the Audio Board. Make sure the red line mark is aligned with the black connector with no gap. Using a pair of ESD-safe tweezers, remove the protective film on the back of the FPC and place an FPC on each connector. Press firmly with your hands to complete the application.

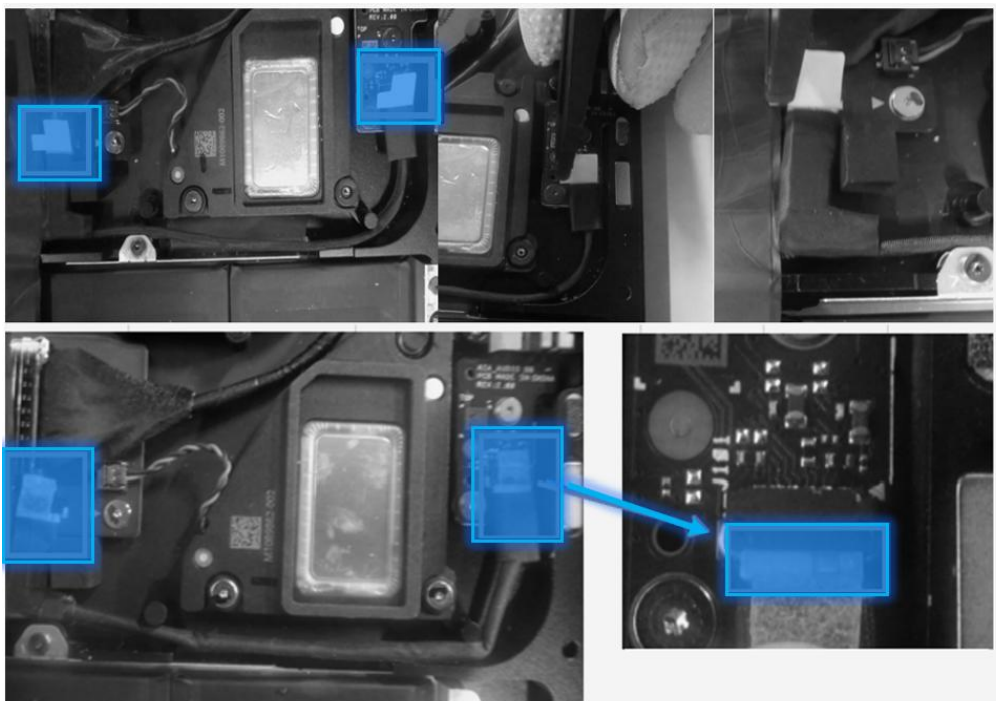

10. **Install RF Foam** – Locate the Shield Lid near the USB ports. In the upper left corner, install 1 piece of RF Foam as Displayed in the photo below.

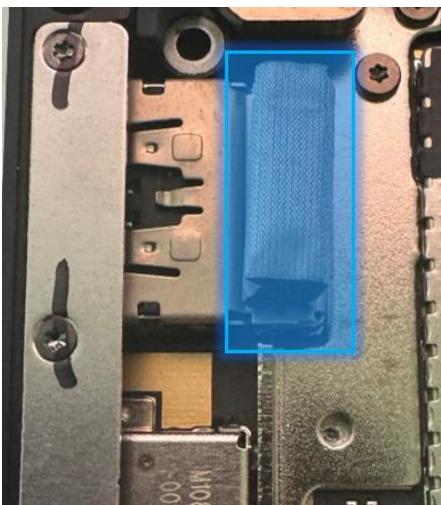

11. **Install the left antennae** – Using a 3IP (Torx-plus) driver, install the 6 screws on the left antennae located directly above the Wi-Fi module. Different screws are utilized for specific locations as identified in the image below.

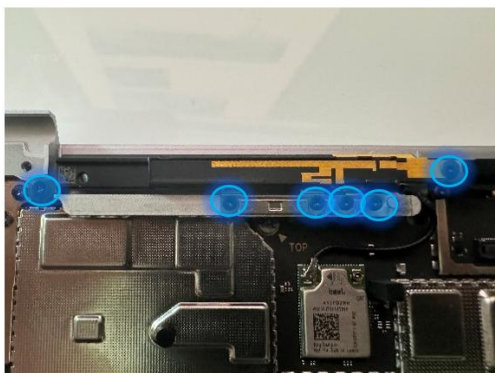

12. **Install Foam** – Locate the area directly above the Wi-Fi module as identified in the photo below. Using ESD-Safe Tweezers, carefully apply the foam.

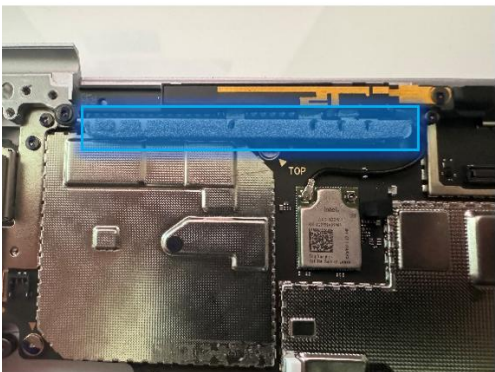

13. **Connect the Antenna Buckle** – Using your fingers or the flat end of a Nylon Spudger, reattach the left antenna cable to the Wi-Fi Module. Carefully apply pressure when aligned to establish the connection.





14. **Install Speakers** – Refer to [Procedure – Installation \(Speaker\)](#) for steps to install the Speakers.
15. **Install Hinge Sticker** – Position the device on its end so that the hinge recesses are facing up towards you. Install the hinge sticker between the hinge recesses. Press firmly with the flat end of a Nylon Spudger to secure. Remove the protective film and reapply pressure with the Nylon Spudger to ensure the sticker is secure.



16. **Install Display** – Refer to [Procedure – Installation \(Display Assembly\)](#) for steps to install the Display.
17. **Install rSSD** – Refer to [Procedure – Installation \(rSSD\)](#) for steps to install the rSSD.
18. **Install Surface Connect** – Refer to [Procedure – Installation \(Surface Connect\)](#) for steps to install the Surface Connect.
19. **Install Thermal Module** – Refer to [Procedure – Installation \(Thermal Module\)](#) for steps to install the Thermal Module.
20. **Install Keyboard** – Refer to [Procedure – Installation \(Keyboard\)](#) for steps to install the keyboard.

#### Procedure – Finalize (Motherboard Module)

**Important:** If replacing both the Motherboard Module and the Display Assembly – complete the Motherboard Module replacement prior to performing the Display Assembly Replacement to ensure proper part operation.

1. **Power on Device** – Connect a Power Supply to the device and power it on until it reaches the Windows Desktop.
2. **Connect USB** – Connect USB with the Surface Diagnostic Toolkit (SDT) loaded to an available USB port on the device under repair.
3. **Launch SDT** – From the Windows Desktop, use Windows Explorer to navigate to the USB drive. Select the SDT executable (.exe) to launch the Surface Diagnostic Toolkit.
4. **Run Touch Display Calibration** – From the SDT launch screen, select **Repair** from the drop-down menu. Next, select **Repair Setup and Validation** to enter the selection screen. Run the **Touch Display (Calibration)** tool to calibrate your new Display. Follow all on-screen instructions and allow the device to restart when prompted.

**Important:** If the calibration fails, reboot the device, and attempt again. If the failure continues, then the Display may be faulty and require replacement.

5. **Allow the Battery to charge** – With the device connected to a power supply, allow the battery to charge until the battery icon in Windows reads at least 50% remaining battery charge.

6. **Launch SDT** – Once the device has rebooted and is at the Windows Desktop, use Windows Explorer to navigate to the USB drive. Select the SDT executable (.exe) to launch the Surface Diagnostic Toolkit.
7. **Run Battery Authentication** – From the SDT launch screen, select **Repair** from the drop-down menu. Next, select **Repair Setup and Validation** to enter the selection screen. Select the **Battery Repair (Validation)** tool to ensure the battery is detected as properly authenticated. If the battery reads anything other than authenticated, run the Validation tool in its entirety.

**Important:** Battery authentication requires a stable internet connection and the latest version of the [Surface Management Extension](#). If the battery validation tool fails or is not detected properly, install the Surface Management Extension, reboot the device, and try again with a new internet connection. If failures continue, reach out to Microsoft Support.

8. **Run the Surface Diagnostic Toolkit (SDT)** – Run all diagnostics to ensure the device is functioning as expected before moving forward.
9. **Install Feet** – Refer to [Procedure – Installation \(Feet\)](#) for steps to install Feet.

## Audio Jack Replacement Process

### Preliminary Requirements

**Important:** Be sure to follow all special (bolded) notes of caution within each process section.

**Important:** The removal process differs greatly between the 13” and 15” models. Please ensure you are looking at the correct section for the device you are servicing.

### Required Tools

- Surface Battery Cover (M1214771-001)
- ESD-Safe Tweezers
- Metal Tweezers
- USB drive with SDT
- Anti-static wrist strap (1 MOhm resistance)
- Nylon Spudger/Probing Tool
- Isopropyl Alcohol (70% IPA)
- Cleaning Swabs
- 3IP (Torx-plus) Driver
- 5IP (Torx-plus) Driver
- 6IP (Torx-plus) Driver
- Surface Power Supply
- Soft ESD-safe mat
- Microfiber Cloth
- Headphones with 2.55mm connector
- Metal Tweezers

### Primary Components

- Audio Jack (Refer to [Illustrated Service Parts List](#))
  - 1 x PCB Screw Top
  - 1 x Shield Lid T4
  - 1 x Shield Lid T7
  - 1 x rSSD Stiffener
  - 1 x Hinge Rubber L
  - 1 x Hinge Rubber R
  - 1 x Shield Lid T1
  - 1 x Shield Lid T2
  - 1 x RF Lid T1
  - 1 x RF Lid T2
  - 1 x Foam Baffle
  - 1 x Hinge Sticker
  - 1 x USBA RF Foam
  - 1 x SOC Thermal Pad
  - 1 x Shield Lid T3
  - 2 x Antenna Cable Tape
  - 1 x Conductive Tape
  - 1 x Conductive Tape Sponge
  - 1 x T4 Lid Tape
  - 1 x SSD Conductive Tape
  - 1 x SSD Top Rubber

- 1 x SSD Thermal Pad
- 2 x M1.2x3.0 3IP screws (Left Antenna PCB) (🌀)3IP-1
  - P/N: 13N4-0FN3K02
- 2 x M1.6x2.3 3IP screws (Left Antenna PCB) (🌀)3IP-3
  - P/N: 13N4-1EN0E01
- 5 x M1.2x1.6 3IP screws (Left Antenna PCB) (🌀)3IP-2
  - P/N: 13N4-1EN0F02
- 2 x M1.6x2.0 5 IP screws (rSSD) 🗄️5IP
  - P/N: 13N4-1EN0L01
- 7 x M2.0x5.2 6IP screws (Display – Hinge screws) 🗄️6IP
  - P/N: 13N4-1EN0Y02
- 3 x M2.0x4.65 3IP screws (Display – Hinge TPU rubber screws) 🗄️3IP
  - P/N: 13N4-1EN0R01
- 10 x M1.2x1.4 3IP screws (Surface Connect – Iron Plate/Motherboard) ⚡3IP-3 🗄️3IP-3
  - P/N: 13N4-0FN1U12
- 4 x M1.2x2.2 3IP screws (Surface Connect – Iron Plate/Motherboard – Iron Piece) ⚡3IP-2 🗄️3IP-2
  - P/N: 13N4-1EN0J02
- 3 x M1.2x2.4 3IP screws (Surface Connect – SL Cable) ⚡3IP-1
  - P/N: 13N4-0FN2K12
- 4 x M1.2x0.25 3IP screws (Left Speaker) 🗣️3IP
  - P/N: 13E5-2TN3V21
- 5 x M1.2x3.3 3IP screws (Thermal Module) 🗄️3IP-3
  - P/N: 13N4-1EN0L01
- 4 x M1.2x2.3 3IP screws (Thermal Module/Motherboard – USB Bracket) 🗄️3IP-1 🗄️3IP-1
  - P/N: 13N4-0FN1V21
- 6-8 x M1.2x1.7 3IP screws (Thermal Module) 🗄️3IP-2 🗄️3IP-1
  - P/N: 13N4-0FN2P12
- 2 x M1.2x2.0 3IP screws (Thermal Module: 13” only) 🗄️3IP-4
  - P/N: 13N4-1EN0X02
- 4 x M1.6x2.4 3IP Screws (Keyboard Assembly) 🗄️3IP
  - P/N: 13N4 – 0FN1V21

#### Additional Components (Ordered Separately)

- Feet (Refer to [Illustrated Service Parts List](#))

#### Procedure – Removal (Audio Jack) 13” Model

1. **Position device** - Place the device with bottom facing up.
2. **Remove Feet** – Refer to [Procedure – Removal \(Feet\)](#) for steps to remove the feet.
3. **Remove Keyboard** – Refer to [Procedure – Removal \(Keyboard\)](#) for steps to remove the keyboard.
4. **Remove Thermal Module** – Refer to [Procedure – Removal \(Thermal Module\)](#) for steps to remove the Thermal Module.
5. **Remove Surface Connect** - Refer to [Procedure – Removal \(Surface Connect\)](#) for steps to remove the Surface Connect.
6. **Remove rSSD** – Refer to [Procedure – Removal \(rSSD\)](#) for steps to remove the rSSD.
7. **Remove Speakers** – Refer to [Procedure – Removal \(Speakers\)](#) for steps to remove the Speakers.
8. **Remove Display** – Refer to [Procedure – Removal \(Display Assembly\)](#) for steps to remove the Display.

9. **Remove Motherboard Module** – Refer to [Procedure – Removal \(Motherboard Module\)](#) for steps to remove the Motherboard Module.
10. **Remove Audio Jack** – Using a 3IP (Torx-Plus) remove the audio screw. Lift the Audio Jack out of the chassis.



**Procedure – Removal (Audio Jack) 15” Model**

1. **Position device** - Place the device with bottom facing up.
2. **Remove Feet** – Refer to [Procedure – Removal \(Feet\)](#) for steps to remove the feet.
3. **Remove Keyboard** – Refer to [Procedure – Removal \(Keyboard\)](#) for steps to remove the keyboard.
4. **Short jumper** – Using metal tweezers, touch the two parts of the battery icon as shown below for a few seconds. This will shut down the connection to the battery and prevent power on during repair. The LED located next to it will turn off if it was previously lit.

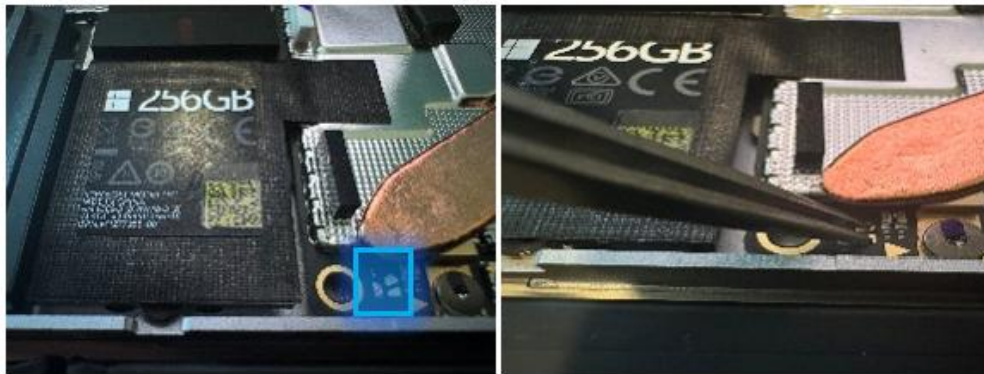

5. **Remove audio cable**– Locate the audio cable next to the left speaker and lift the tape from the connector. Pulling back on the tape to remove the audio cable from the connector.

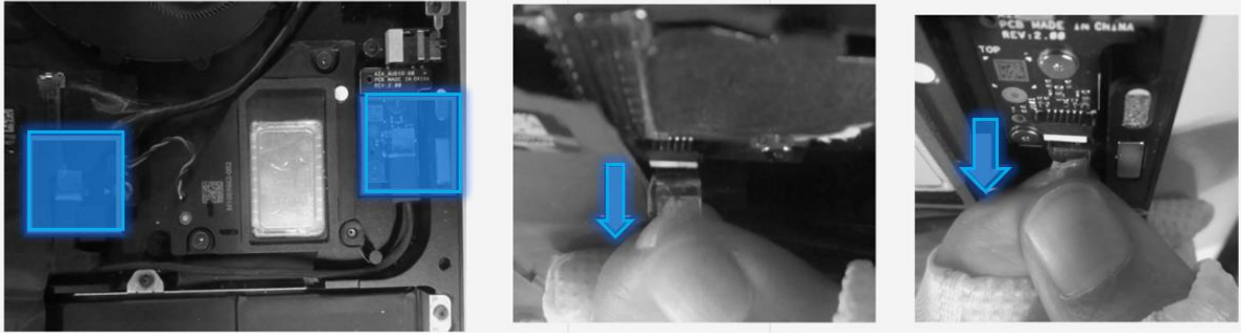

6. **Remove the Audio Board** – Using a 3IP (Torx-plus) driver, remove the 2 audio board screws and the 1 Audio Jack screw. Once removed, lift the Audio Board out of the chassis.



7. **Remove the Audio Jack** – Lift the Audio Jack out of the chassis.

#### Procedure – Installation (Audio Jack) 13” Model

1. **Install Audio Jack** - Place Audio Jack into chassis, aligning the rear hole with the chassis riser to ensure part alignment.
2. **Install Audio screw** – Using a 3IP screwdriver, fasten the audio screw to the screw hole on the rear of the Audio Jack. Turn screw until just snug, and then turn another 45-degree (1/8<sup>th</sup>) turn to fully fasten.



3. **Install Motherboard Module** – Refer to [Procedure – Installation \(Motherboard Module\)](#) for steps to install the Motherboard Module.
4. **Install Speakers** – Refer to [Procedure – Installation \(Speakers\)](#) for steps to install the Speakers.
5. **Install Display** – Refer to [Procedure – Installation \(Display Assembly\)](#) for steps to install the Display.
6. **Install rSSD** – Refer to [Procedure – Installation \(rSSD\)](#) for steps to install the rSSD.
7. **Install Surface Connect** – Refer to [Procedure – Installation \(Surface Connect\)](#) for steps to install the Surface Connect.
8. **Install Thermal Module** – Refer to [Procedure – Installation \(Thermal Module\)](#) for steps to install the Thermal Module.
9. **Install Keyboard** – Refer to [Procedure – Installation \(Keyboard\)](#) for steps to install the keyboard.
10. **Connect USB** – Connect USB with the Surface Diagnostic Toolkit (SDT) loaded to an available USB port on the device under repair.
11. **Launch SDT** – From the Windows Desktop, use Windows Explorer to navigate to the USB drive. Select the SDT executable (.exe) to launch the Surface Diagnostic Toolkit.
12. **Run the Surface Diagnostic Toolkit (SDT)** – Run all diagnostics to ensure the device is functioning as expected before moving forward.
13. **Install Feet** – Refer to [Procedure – Installation \(Feet\)](#) for steps to install Feet.

#### **Procedure – Installation (Audio Jack) 15” Model**

1. **Install Audio Jack** – Align the Audio Jack with the chassis riser so that the port is aligned with the exterior access. Use a 3IP (Torx-plus) driver to fasten the audio screw until just snug. Turn an additional 45 degrees (1/8<sup>th</sup> turn) to fully secure.

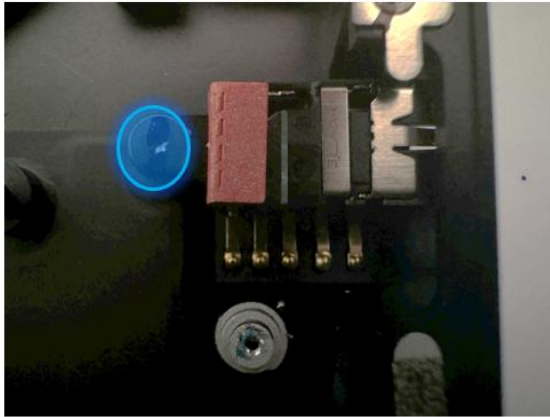

2. **Install the Audio Board** – Insert the Audio Board over the Audio Jack. Using a 3IP (Torx-plus) driver to fasten the audio board screws (labeled 2 in the photo) until snug. Turn each screw an additional 45 degrees (1/8<sup>th</sup> turn) to fully secure.



3. **Install a new Audio Cable** – Take 1 new Audio cable and insert the connectors into the Motherboard Module and Audio board. Using ESD-Safe Tweezers, peel off the protective film on the back of each connector. Press firmly on each connector to ensure connection.

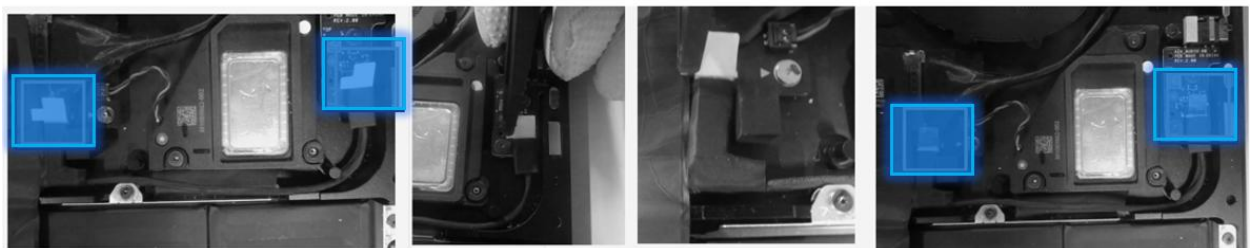



4. **Install Keyboard** – Refer to [Procedure – Installation \(Keyboard\)](#) for steps to install the keyboard.
5. **Connect USB** – Connect USB with the Surface Diagnostic Toolkit (SDT) loaded to an available USB port on the device under repair.
6. **Launch SDT** – From the Windows Desktop, use Windows Explorer to navigate to the USB drive. Select the SDT executable (.exe) to launch the Surface Diagnostic Toolkit.
7. **Run the Surface Diagnostic Toolkit (SDT)** – Run all diagnostics to ensure the device is functioning as expected before moving forward.
8. **Install Feet** – Refer to [Procedure – Installation \(Feet\)](#) for steps to install Feet.

## Battery Replacement Process

### Preliminary Requirements



















**Important:** Be sure to follow all special (bolded) notes of caution within each process section.

### Required Tools

- ESD-Safe Tweezers
- USB drive with SDT
- Anti-static wrist strap (1 MOhm resistance)
- Nylon Spudger/Probing Tool
- Isopropyl Alcohol (70% IPA)
- Cleaning Swabs
- 3IP (Torx-plus) Driver
- 5IP (Torx-plus) Driver
- 6IP (Torx-plus) Driver
- Surface Power Supply
- Soft ESD-safe mat
- Microfiber Cloth
- Bucket (4 gallon)
- Clean, dry, untreated sand (2.0 gallon)

### Primary Components

- Battery (Refer to [Illustrated Service Parts List](#))
  - 1 x Battery FPC Conductive Tape
  - 1 x Battery FPC PSA
  - 1 x PCB Screw Top
  - 1 x Shield Lid T4
  - 1 x Shield Lid T7
  - 1 x rSSD Stiffener
  - 1 x Hinge Rubber L
  - 1 x Hinge Rubber R
  - 1 x Shield Lid T1
  - 1 x Shield Lid T2
  - 1 x RF Lid T1
  - 1 x RF Lid T2
  - 1 x Foam Baffle
  - 1 x Hinge Sticker
  - 1 x USBA RF Foam

- 1 x SOC Thermal Pad
- 1 x Shield Lid T3
- 2 x Antenna Cable Tape
- 1 x Conductive Tape
- 1 x Conductive Tape Sponge
- 1 x T4 Lid Tape
- 1 x SSD Conductive Tape
- 1 x SSD Top Rubber
- 1 x SSD Thermal Pad
- 13 – 16 M1.6x2.7 3IP screws (Battery)  **3IP**
  - P/N: 13N4-1EN0D01
- 2 x M1.2x3.0 3IP screws (Left Antenna PCB)  **3IP-1**
  - P/N: 13N4-0FN3K02
- 2 x M1.6x2.3 3IP screws (Left Antenna PCB)  **3IP-3**
  - P/N: 13N4-1EN0E01
- 5 x M1.2x1.6 3IP screws (Left Antenna PCB)  **3IP-2**
  - P/N: 13N4-1EN0F02
- 2 x M1.6x2.0 5 IP screws (rSSD)  **5IP**
  - P/N: 13N4-1EN0L01
- 7 x M2.0x5.2 6IP screws (Display – Hinge screws)  **6IP**
  - P/N: 13N4-1EN0Y02
- 3 x M2.0x4.65 3IP screws (Display – Hinge TPU rubber screws)  **3IP**
  - P/N: 13N4-1EN0R01
- 7 x M1.2x1.4 3IP screws (Surface Connect – Iron Plate/Motherboard)  **3IP-3**  **3IP-3**
  - P/N: 13N4-0FN1U12
- 4 x M1.2x2.2 3IP screws (Surface Connect – Iron Plate/Motherboard – Iron Piece)  **3IP-2**  **3IP-2**
  - P/N: 13N4-1EN0J02
- 3 x M1.2x2.4 3IP screws (Surface Connect – SL Cable)  **3IP-1**
  - P/N: 13N4-0FN2K12
- 4 x M1.2x0.25 3IP screws (Left Speaker)  **3IP**
  - P/N: 13E5-2TN3V21
- 5 x M1.2x3.3 3IP screws (Thermal Module)  **3IP-3**
  - P/N: 13N4-1EN0L01
- 4 x M1.2x2.3 3IP screws (Thermal Module/Motherboard – USB Bracket)  **3IP-1**  **3IP-1**
  - P/N: 13N4-0FN1V21
- 4-6 x M1.2x1.7 3IP screws (Thermal Module)  **3IP-2**
  - P/N: 13N4-0FN2P12
- 2 x M1.2x2.0 3IP screws (Thermal Module: 13” only)  **3IP-3**
  - P/N: 13N4-1EN0X02
- 4 x M1.6x2.4 3IP Screws (Keyboard Assembly)  **3IP**
  - P/N: 13N4 – 0FN1V21

#### Additional Components (Ordered Separately)

- Feet (Refer to [Illustrated Service Parts List](#))

#### Procedure – Preparation (Battery)

**Important:** This section is only for instances where you are replacing the battery. If the battery is being re-used, then this section is not required.

1. **Connect USB** – Connect USB with the Surface Diagnostic Toolkit (SDT) loaded to an available USB port on the device under repair.
2. **Power on device** – Connect a power supply to the device. Press the power button on the device to power the device on. Allow it to boot to the Windows Desktop before continuing.
3. **Launch SDT** – From the Windows Desktop, use Windows Explorer to navigate to the USB drive. Select the SDT executable (.exe) to launch the Surface Diagnostic Toolkit.
4. **Run Battery Repair (Setup)** – From the SDT launch screen, select **Repair** from the drop-down menu. Next, select **Repair Setup and Validation** to enter the selection screen. Run the **Battery Repair (Setup)** to put your device into repair mode. Follow all on-screen instructions and allow the device to shut down when prompted. Disconnect the Power Supply and remove the USB drive before proceeding forward.

#### **Procedure – Removal (Battery)**

1. **Position device** - Place the device with bottom facing up.
2. **Remove Feet** – Refer to [Procedure – Removal \(Feet\)](#) for steps to remove the feet.
3. **Remove Keyboard** – Refer to [Procedure – Removal \(Keyboard\)](#) for steps to remove the keyboard.
4. **Remove Thermal Module** – Refer to [Procedure – Removal \(Thermal Module\)](#) for steps to remove the Thermal Module.
5. **Remove Surface Connect** - Refer to [Procedure – Removal \(Surface Connect\)](#) for steps to remove the Surface Connect.
6. **Remove rSSD** – Refer to [Procedure – Removal \(rSSD\)](#) for steps to remove the rSSD.
7. **Remove Speakers** – Refer to [Procedure – Removal \(Speakers\)](#) for steps to remove the Speakers.
8. **Remove Display** – Refer to [Procedure – Removal \(Display Assembly\)](#) for steps to remove the Display.
9. **Remove Motherboard Module** – Refer to [Procedure – Removal \(Motherboard Module\)](#) for steps to remove the Motherboard Module.

**Important:** Place the battery somewhere where the battery cannot accidentally be contacted or damaged. **DO NOT** place anything on top of the battery.

**Important:** When disposing of the battery, ensure you are recycling according to local laws.

**Important:** The Motherboard Module and Battery are extremely sensitive to ESD and can be easily damaged. It is critical that you ensure proper grounding before performing any work on these parts.

**WARNING:** In the instance of a battery event, submerge the entire device in a 4-gallon bucket filled with 2 gallons of clean sand. Ensure the entire device is submerged. **DO NOT** attempt to pick up the device.

10. **Remove Battery Screws** – Using a 3IP (Torx-plus) driver, remove the battery screws according to the sections below for the size of device you are servicing.
  - a) **Remove Battery Screws (13")** – Remove 12 screws from around the battery. See the photo below for locations.



- b) **Remove Battery Screws (15")** – Remove 15 screws from around the battery. See the photo below for locations.

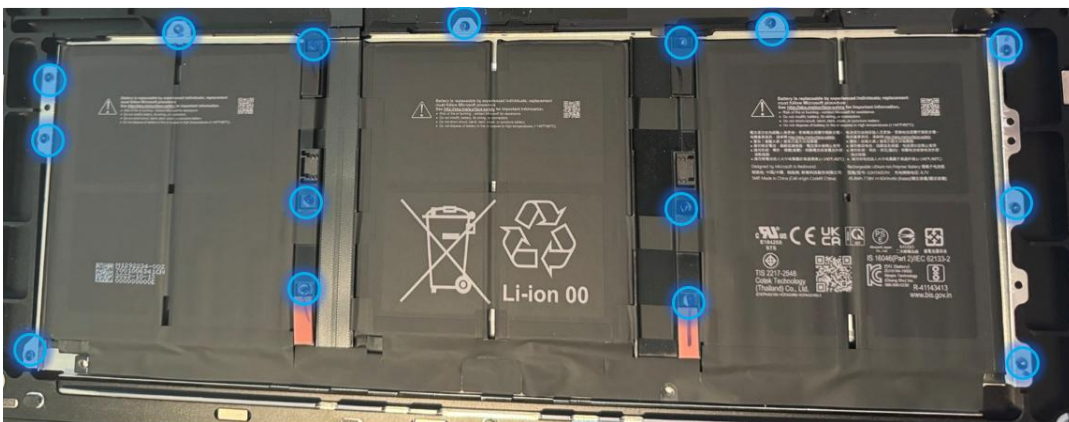

11. **Remove Battery FPC** – Using a Nylon Spudger, carefully lift the Battery FPC to disconnect it from the Enclosure. Lift from the device chassis.

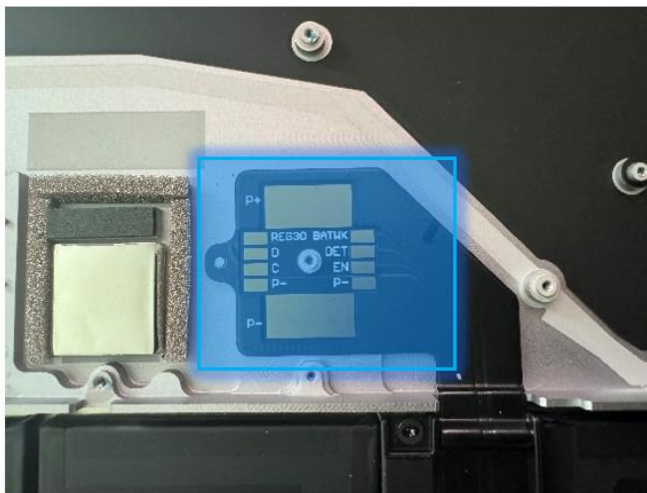

12. **Remove Battery** – Carefully lift Battery from the device chassis. Place the battery on a clean ESD-Safe mat free of any items that may damage the battery in any way.
13. **Remove the Battery FPC Contact Tape** – Remove the Battery FPC Contact tape from where the Battery FPC previously was. Use a cleaning swab soaked in Isopropyl Alcohol to clean the area of any residual material.



14. **Apply a new Battery FPC Contact Tape** – Once the area has been cleaned and allowed to dry completely, apply 1 piece of new Battery FPC Contact Tape to the chassis according to the positioning hole. Remove the film covering the tape.

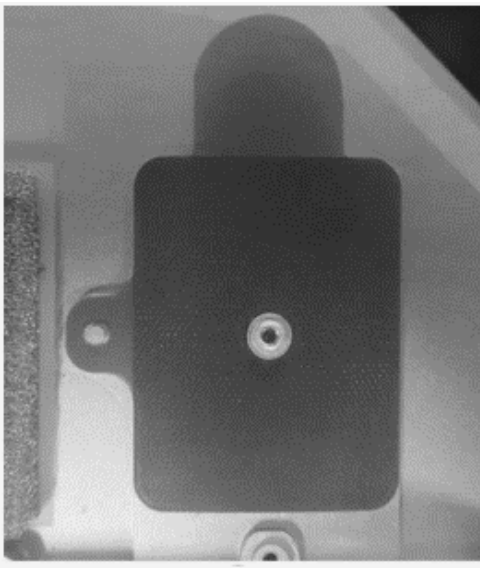

15. **Inspect Battery FPC PSA (Battery Reuse)** – If you are planning to re-use the same battery, inspect the Battery FPC PSA on the bottom of the Battery FPC. If it is damaged or has wrinkling, it will need to be removed. The area will need to be cleaned with a cleaning swab soaked in Isopropyl Alcohol and allowed to completely dry. Once dry, place 1 piece of new Battery FPC PSA to the Battery FPC so that the holes align, and no wrinkles or deformations are present.

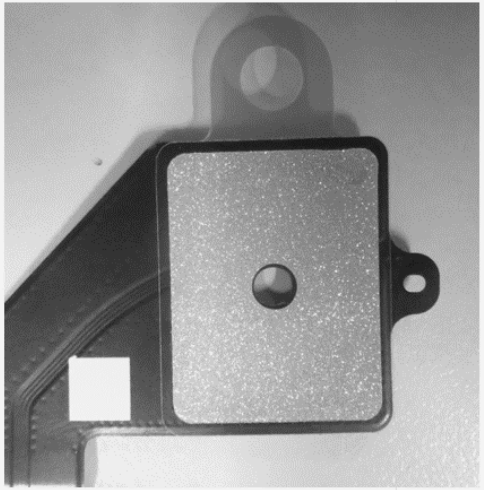

**Procedure – Installation (Battery)**

1. **Install Battery** – Holding the Battery with both hands, place the battery into the device chassis so that it aligns with the positioning pins on the chassis.

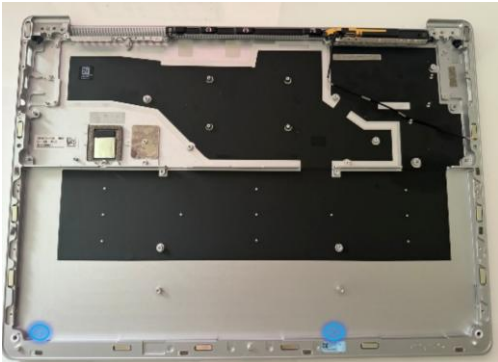

2. **Install Battery FPC** – Remove the liner on the Battery FPC and attach it to the chassis in accordance with the positioning holes.

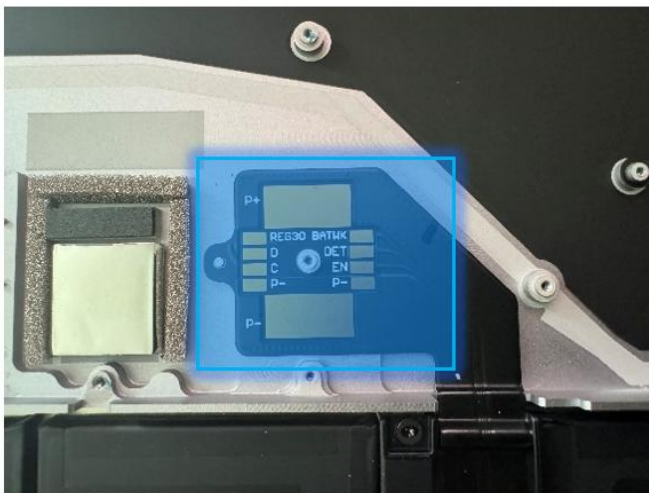

3. **Install Battery Screws** – Using a 3IP (Torx-plus) driver, install the battery screws according to the sections below for the size of device you are servicing.

- a) **Install Battery Screws (13”)** – Install 12 screws around the battery. See the photo below for locations.



- b) **Install Battery Screws (15”)** – Install 15 screws around the battery. See the photo below for locations.

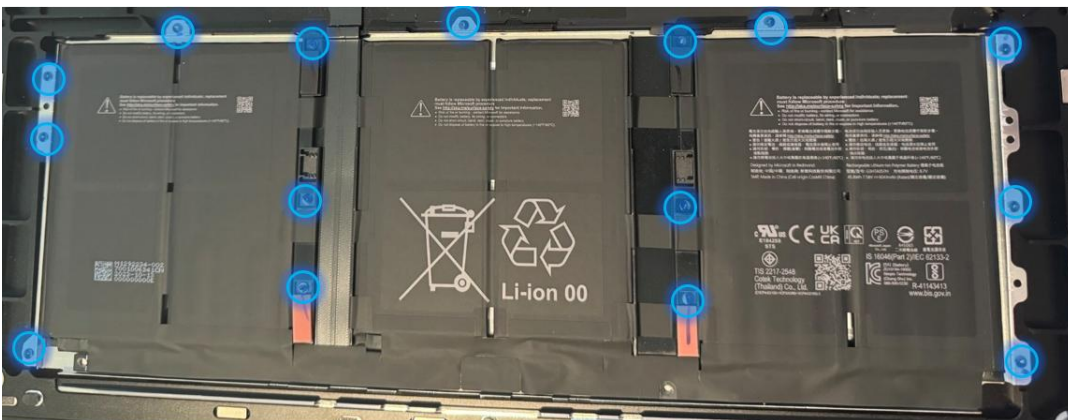

4. **Install Motherboard Module** – Refer to [Procedure – Installation \(Motherboard Module\)](#) for steps to install the Motherboard Module.
5. **Install Speakers** – Refer to [Procedure – Installation \(Speakers\)](#) for steps to install the Speakers.
6. **Install Display** – Refer to [Procedure – Installation \(Display Assembly\)](#) for steps to install the Display.
7. **Install rSSD** – Refer to [Procedure – Installation \(rSSD\)](#) for steps to install the rSSD.
8. **Install Surface Connect** – Refer to [Procedure – Installation \(Surface Connect\)](#) for steps to install the Surface Connect.
9. **Install Thermal Module** – Refer to [Procedure – Installation \(Thermal Module\)](#) for steps to install the Thermal Module.
10. **Install Keyboard** – Refer to [Procedure – Installation \(Keyboard\)](#) for steps to install the keyboard.

#### **Procedure – Finalize (Battery)**

1. **Power on Device** – Connect a Power Supply to the device and power it on until it reaches the Windows Desktop.
2. **Connect USB** – Connect USB with the Surface Diagnostic Toolkit (SDT) loaded to an available USB port on the device under repair.
3. **Launch SDT** – From the Windows Desktop, use Windows Explorer to navigate to the USB drive. Select the SDT executable (.exe) to launch the Surface Diagnostic Toolkit.

4. **Allow the Battery to charge** – With the device connected to a power supply, allow the battery to charge until the battery icon in Windows reads at least 50% remaining battery charge.
5. **Run Battery Authentication** – From the SDT launch screen, select **Repair** from the drop-down menu. Next, select **Repair Setup and Validation** to enter the selection screen. Select the **Battery Repair (Validation)** tool and follow the on-screen prompts until a successful authentication is completed.

**Important:** Battery authentication requires a stable internet connection and the latest version of the [Surface Management Extension](#). If the battery validation tool fails or is not detected properly, install the Surface Management Extension, reboot the device, and try again with a new internet connection. If failures continue, reach out to Microsoft Support.

6. **Run the Surface Diagnostic Toolkit (SDT)** – Run all diagnostics to ensure the device is functioning as expected before moving forward.
7. **Install Feet** – Refer to [Procedure – Installation \(Feet\)](#) for steps to install Feet.

## Enclosure Replacement Process

### Preliminary Requirements

**Important:** Be sure to follow all special (bolded) notes of caution within each process section.

**Important:** The serial number for this device is located on its original chassis. To keep track of the device's serial number, please [record](#) it using waterproof ink, on a sticker or label, and apply the sticker or label to an easily accessible area on the device's exterior. The serial number cannot be added permanently to a replacement part. Microsoft may have provided a label for this use in the replacement part's packaging.

### Required Tools



- ESD-Safe Tweezers
- USB drive with SDT
- Anti-static wrist strap (1 MOhm resistance)
- Nylon Spudger/Probing Tool
- Isopropyl Alcohol (70% IPA)
- Cleaning Swabs
- 3IP (Torx-plus) Driver
- 5IP (Torx-plus) Driver
- 6IP (Torx-plus) Driver
- Surface Power Supply
- Soft ESD-safe mat
- Microfiber Cloth
- Bucket (4 gallon)
- Clean, dry, untreated sand (2.0 gallon)

### Primary Components

- Enclosure (Refer to [Illustrated Service Parts List](#))
  - 1 x Battery FPC Conductive Tape
  - 1 x Battery FPC PSA
  - 1 x PCB Screw Top
  - 1 x Shield Lid T4

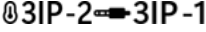

- 1 x Shield Lid T7
- 1 x rSSD Stiffener
- 1 x Hinge Rubber L
- 1 x Hinge Rubber R
- 1 x Shield Lid T1
- 1 x Shield Lid T2
- 1 x RF Lid T1
- 1 x RF Lid T2
- 1 x Foam Baffle
- 1 x Hinge Sticker
- 1 x USBA RF Foam
- 1 x SOC Thermal Pad
- 1 x Shield Lid T3
- 2 x Antenna Cable Tape
- 1 x Conductive Tape
- 1 x Conductive Tape Sponge
- 1 x T4 Lid Tape
- 1 x SSD Conductive Tape
- 1 x SSD Top Rubber
- 1 x SSD Thermal Pad
- 13 – 16 M1.6x2.7 3IP screws (Battery) **☐3IP**
  - P/N: 13N4-1EN0D01
- 2 x M1.2x3.0 3IP screws (Left Antenna PCB) **Ⓢ3IP-1**
  - P/N: 13N4-0FN3K02
- 2 x M1.6x2.3 3IP screws (Left Antenna PCB) **Ⓢ3IP-3**
  - P/N: 13N4-1EN0E01
- 5 x M1.2x1.6 3IP screws (Left Antenna PCB) **Ⓢ3IP-2**
  - P/N: 13N4-1EN0F02
- 2 x M1.6x2.0 5 IP screws (rSSD) **■5IP**
  - P/N: 13N4-1EN0L01
- 7 x M2.0x5.2 6IP screws (Display – Hinge screws) **☐6IP**
  - P/N: 13N4-1EN0Y02
- 3 x M2.0x4.65 3IP screws (Display – Hinge TPU rubber screws) **☐3IP**
  - P/N: 13N4-1EN0R01
- 10 x M1.2x1.4 3IP screws (Surface Connect – Iron Plate/Motherboard) **⚡3IP-3 #3IP-3**  
**☐3IP-2**
  - P/N: 13N4-0FN1U12
- 4 x M1.2x2.2 3IP screws (Surface Connect – Iron Plate/Motherboard – Iron Piece)  
**⚡3IP-2 #3IP-2**
  - P/N: 13N4-1EN0J02
- 3 x M1.2x2.4 3IP screws (Surface Connect – SL Cable) **⚡3IP-1**
  - P/N: 13N4-0FN2K12
- 4 x M1.2x0.25 3IP screws (Left Speaker) **Ⓢ3IP**
  - P/N: 13E5-2TN3V21
- 5 x M1.2x3.3 3IP screws (Thermal Module) **Ⓢ3IP-3**
  - P/N: 13N4-1EN0L01
- 4 x M1.2x2.3 3IP screws (Thermal Module/Motherboard – USB Bracket) **Ⓢ3IP-1 #3IP-1**
  - P/N: 13N4-0FN1V21

- 6-8 x M1.2x1.7 3IP screws (Thermal Module) 
  - P/N: 13N4-0FN2P12
- 2 x M1.2x2.0 3IP screws (Thermal Module: 13" only) 
  - P/N: 13N4-1EN0X02
- 4 x M1.6x2.4 3IP Screws (Keyboard Assembly) 
  - P/N: 13N4 – 0FN1V21

#### Additional Components (Ordered Separately)

- Feet (Refer to [Illustrated Service Parts List](#))

#### Procedure – Removal (Enclosure)

1. **Position device** - Place the device with bottom facing up.
2. **Remove Feet** – Refer to [Procedure – Removal \(Feet\)](#) for steps to remove the feet.
3. **Remove Keyboard** – Refer to [Procedure – Removal \(Keyboard\)](#) for steps to remove the keyboard.
4. **Remove Thermal Module** – Refer to [Procedure – Removal \(Thermal Module\)](#) for steps to remove the Thermal Module.
5. **Remove Surface Connect** - Refer to [Procedure – Removal \(Surface Connect\)](#) for steps to remove the Surface Connect.
6. **Remove rSSD** – Refer to [Procedure – Removal \(rSSD\)](#) for steps to remove the rSSD.
7. **Remove Speakers** – Refer to [Procedure – Removal \(Speakers\)](#) for steps to remove the Speakers.
8. **Remove Display** – Refer to [Procedure – Removal \(Display Assembly\)](#) for steps to remove the Display.
9. **Remove Motherboard Module** – Refer to [Procedure – Removal \(Motherboard Module\)](#) for steps to remove the Motherboard Module.
10. **Remove Audio Jack** – Refer to [Procedure – Removal \(Audio Jack\)](#) for steps to remove the Audio Jack.
11. **Remove Battery** – Refer to [Procedure – Removal \(Battery\)](#) for steps to remove the Battery.

#### Procedure – Removal (Enclosure)

1. **Inspect Battery FPC PSA (Battery Reuse)** – If you are planning to re-use the same battery, inspect the Battery FPC PSA on the bottom of the Battery FPC. If it is damaged or has wrinkling, it will need to be removed. The area will need to be cleaned with a cleaning swab soaked in Isopropyl Alcohol and allowed to completely dry. Once dry, place 1 piece of new Battery FPC PSA to the Battery FPC so that the holes align, and no wrinkles or deformations are present.

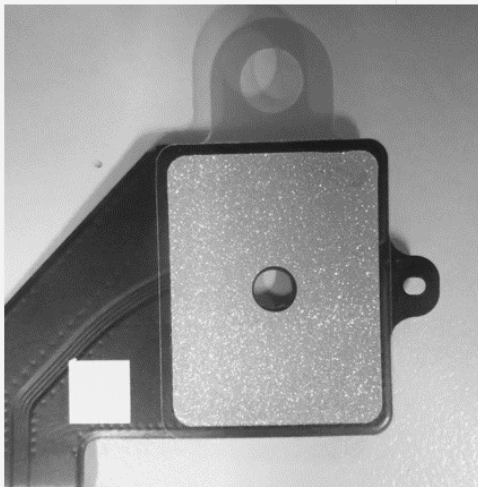

2. **Install Battery** – Refer to [Procedure – Installation \(Battery\)](#) for steps to install the Battery.

3. **Install Audio Jack** – Refer to [Procedure – Installation \(Audio Jack\)](#) for steps to install the Audio Jack.
4. **Install Motherboard Module** – Refer to [Procedure – Installation \(Motherboard Module\)](#) for steps to install the Motherboard Module.
5. **Install Speakers** – Refer to [Procedure – Installation \(Speakers\)](#) for steps to install the Speakers.
6. **Install Surface Connect** – Refer to [Procedure – Installation \(Surface Connect\)](#) for steps to install the Surface Connect.
7. **Install rSSD** – Refer to [Procedure – Installation \(rSSD\)](#) for steps to install the rSSD.
8. **Install Thermal Module** – Refer to [Procedure – Installation \(Thermal Module\)](#) for steps to install the Thermal Module.
9. **Install Lid Top Rubber (15” Model Only)** - Apply 1 piece of Lid Top Rubber to the Right Speaker as indicated in the image below.

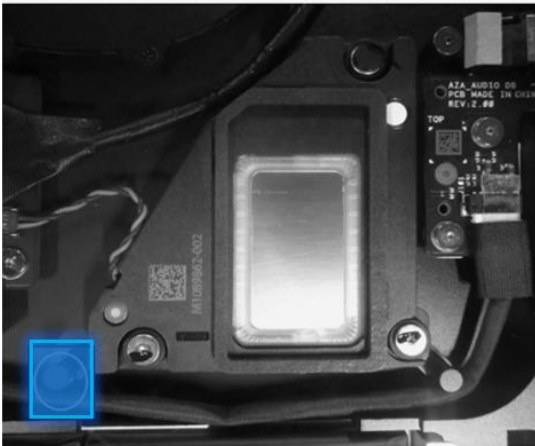

10. **Install Right Speaker Rubber** – Apply 1 piece of Speaker Rubber to the Right Speaker as indicated in the image below.



11. **Install Display** – Refer to [Procedure – Installation \(Display Assembly\)](#) for steps to install the Display.
12. **Install Keyboard** – Refer to [Procedure – Installation \(Keyboard\)](#) for steps to install the keyboard.
13. **Power on Device** – Connect a Power Supply to the device and power it on until it reaches the Windows Desktop.
14. **Connect USB** – Connect USB with the Surface Diagnostic Toolkit (SDT) loaded to an available USB port on the device under repair.
15. **Launch SDT** – From the Windows Desktop, use Windows Explorer to navigate to the USB drive. Select the SDT executable (.exe) to launch the Surface Diagnostic Toolkit.

16. **Run the Surface Diagnostic Toolkit (SDT)** – Run all diagnostics to ensure the device is functioning as expected before moving forward.
17. **Install Feet** – Refer to [Procedure – Installation \(Feet\)](#) for steps to install Feet.

## Environmental Compliance Requirements

All waste electrical and electronic equipment (WEEE), waste electronic components, waste batteries, and electronic waste residuals must be managed according to applicable laws and regulations. and H09117, “Conformance Standards for Environmentally Sound Management of Waste Electrical and Electronic Equipment (WEEE)” which is available at this link: <https://www.microsoft.com/en-pk/download/details.aspx?id=11691> . In case of questions, please contact [AskECT@microsoft.com](mailto:AskECT@microsoft.com) .

©2024 Microsoft.