

Dynamic Arm Wall Mount

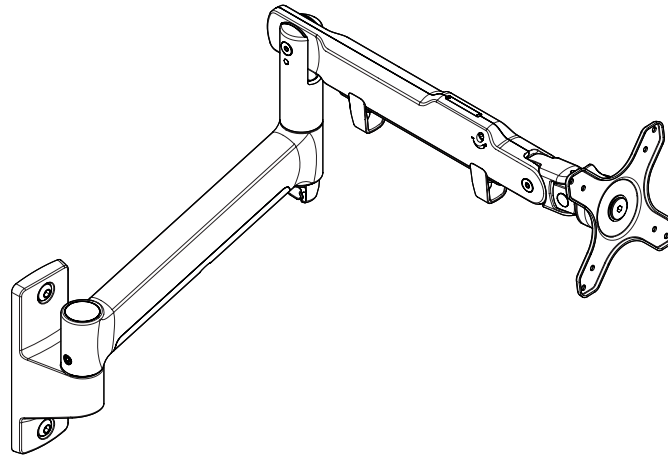

COMPONENT CHECKLIST

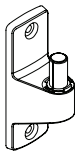

A
Single Wall
Bracket
(x1)

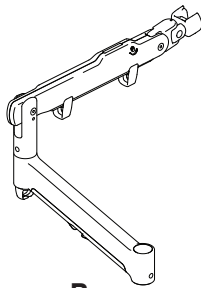

B
Dynamic
Monitor Arm
(x1)

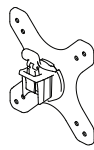

C
VESA
Head
(x1)



D
Screw
M8x70mm
(x2)



E
Washer
(x2)



F
Spacer
(x4)



G
Screw
M4x25mm
(x4)



H
Screw
M4x16mm
(x4)



I
Screw
M4x12mm
(x4)



J
Security
Screw
(x1)



K
4mm
Hex Key
(x1)

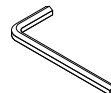

L
6mm
Hex Key
(x1)

Wall

REQUIRED TOOLS

- Phillips head screwdriver
- Power drill
- Suitable drill bit
- Driver bit for selected wall fasteners
- Stud finder
- Spirit level

WEIGHT RANGE

Flat Monitor
0 - 9kg (0 - 20lb)

Curved Monitor
0 - 6kg (0 - 13.5lbs)

IMPORTANT INFORMATION

- ! Please ensure this product is installed as per these installation instructions.
- ! Do not remove or throw away the plastic sleeve on wall bracket and arm links.
- ! The manufacturer accepts no responsibility for incorrect installation.
- ! Failure to install this product correctly may cause serious injury/death during or following installation.
- ! This product is not suitable for outdoor use.
- ! Do not use this product for mobile applications.
- ! This product should only be installed by professional installers of good mechanical aptitude, who have experience with building construction, and fully understand these instructions and the consequences of incorrect installation.
- ! Supplied wall fasteners are for timber stud wall constructions **only**. For other wall constructions, such as masonry, alternative suitable wall fasteners should be sourced by the installer.
- ! To safely achieve the full capacity of this product, wall fasteners must have a pull-out (tension) force rating of at least 100kg (1000N) **per** fastener. This rating must include a safety factor.
- ! Professional installer to ensure adequate structural capacity of wall (including appropriate safety factor) to support total weight of all equipment being mounted.
- ! Drilling into electrical wires can cause death - use appropriate equipment and caution when drilling holes in walls to avoid electrical cables, water pipes and gas pipes. Do not drill into structures unless you have established it's safe to do so.
- ! Curved monitors, deep devices (such as all-in-one PCs), VESA mounted accessories (such as mini PC brackets and mounts), and offset VESA locations exert additional leverage that can exceed the capacity of the mount even though the monitor weight may be within the stated range. Please contact Atdec if you would like further information.

1. Mount the Wall Bracket to the Wall

Using the Single Wall Bracket as a template, mark the two fixing hole positions for drilling.

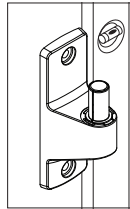
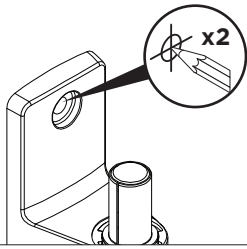

NOTE: Wall bracket must be level. Verify using a quality spirit level tool positioned along the side edge of the wall bracket.

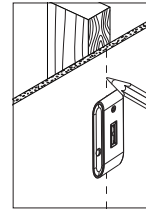

NOTE: On a timber stud wall, use a good quality stud finder to position mounting fasteners in the centre of studs.

Timber Stud

NOTE: Thickness of sheeting and cladding over the timber stud, including plaster board, should not exceed 15mm ($\frac{5}{8}$ ").

NOTE:

- Alternative wall constructions, such as masonry, will require different fasteners than what is supplied with the product.
- Selection and sourcing of alternative wall mounting fasteners is the responsibility of the installer. See 'Important Information' above for more details.

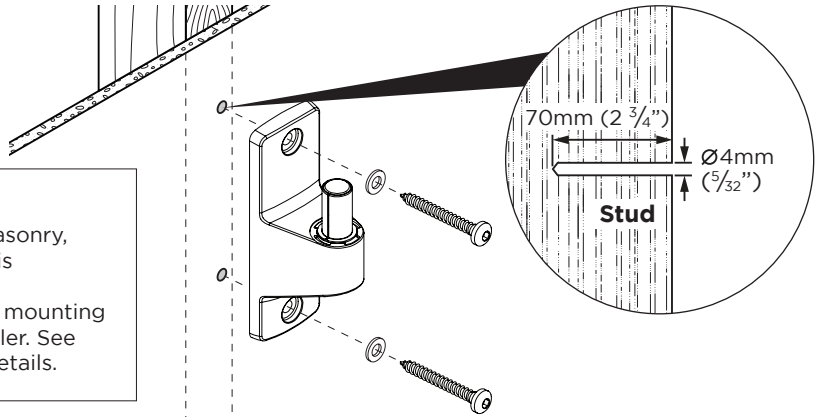

2. (Optional) Set arm rotation to 360°

Note rotation is set to 180° by default. This will protect the wall by preventing the arm swinging into it.

2.1 Remove plastic sleeve from wall bracket

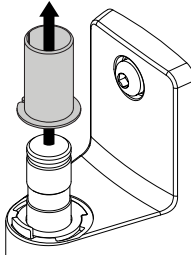

2.2 Remove rotation ring.

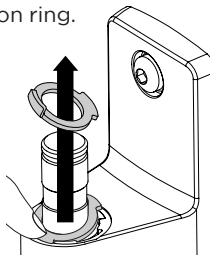

2.3 Place rotation ring in desired position and **replace** plastic sleeve.

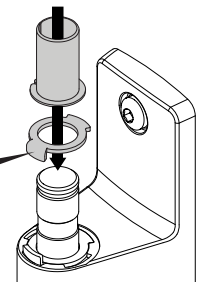
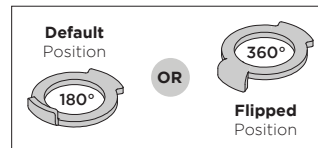

3. Fit arm to Single Wall Bracket

3.1 Push arm onto the wall bracket shaft. Ensure grub screw is retracted before doing so.

NOTE: Ensure plastic sleeve is on shaft before fitting arm.

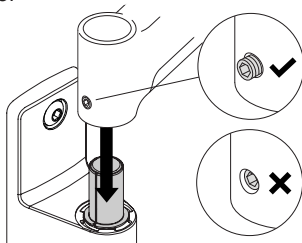

3.2 Ensure arm is fully pushed onto bracket

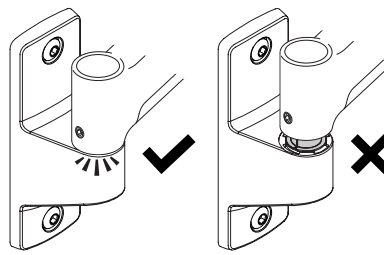

3.3 Tighten the set screw with 4mm Hex Key to secure the arm in place.

NOTE: Check the joint rotation is smooth after tightening.

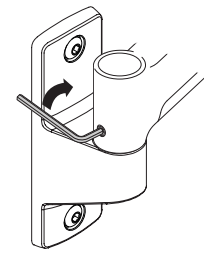

4. Attach VESA head to monitor

4.1 Check VESA mounting compatibility.

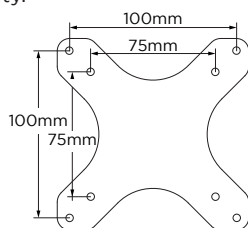

NOTE: For other sizes, use a suitable adaptor plate (sold separately).

4.2 Attach VESA head onto monitor with provided screws.

NOTE: Spacers may be required for curved, recessed or uneven monitor surfaces.

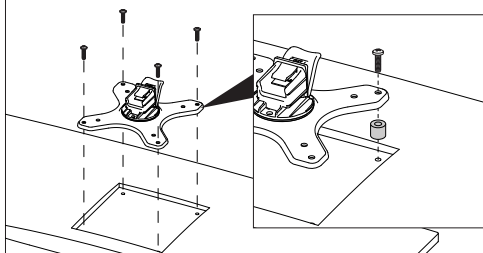

NOTE: Be sure to use a screw length that suits the monitor.

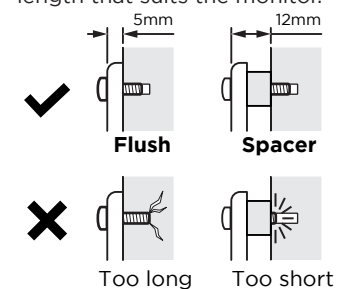

5. Mount monitor

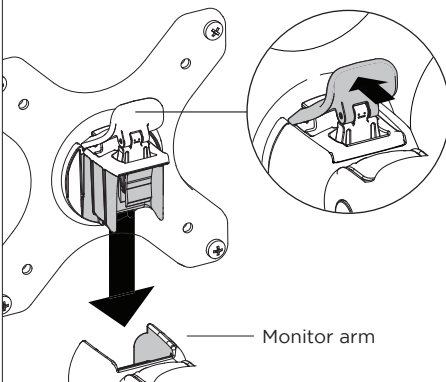
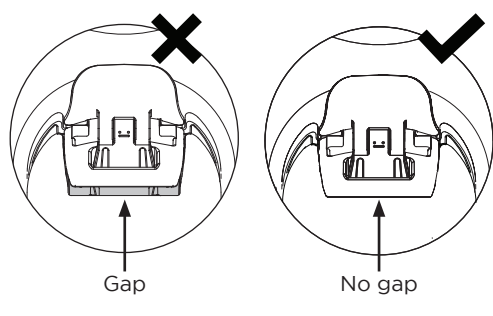
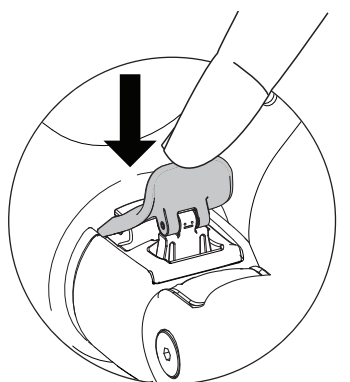
<p>5.1 Insert VESA head into the monitor arm.</p>  <p>Monitor arm</p>	<p>5.2 Ensure that the VESA head sits flush within the monitor arm. There should be no gap.</p>  <p>Gap</p> <p>No gap</p>	<p>5.3 Push the lever down to secure it to the arm assembly.</p> 
--	---	---

6. Adjust tilt tension & Install security screw

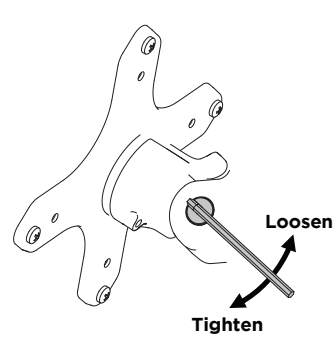
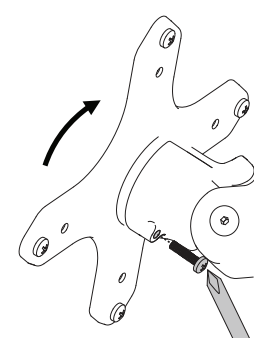
<p>6.1 Use the provided Hex Key to adjust the tilt tension until the monitor holds in a vertical position at the end of the arm.</p>  <p>Loosen</p> <p>Tighten</p> <p>NOTE: Support monitor while adjusting</p>	<p>6.2 (OPTIONAL) To install the optional security screw tilt the head upwards.</p> 
---	--

7. Adjust arm tension

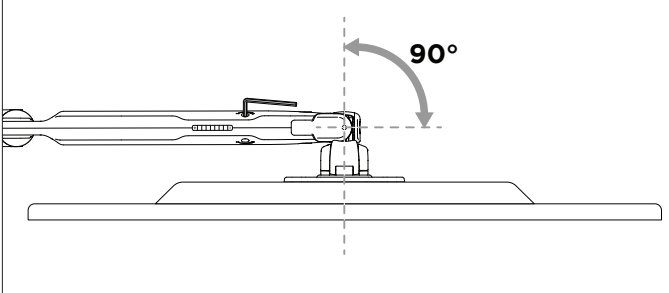
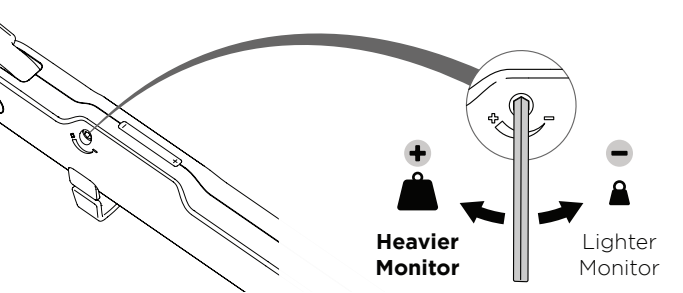
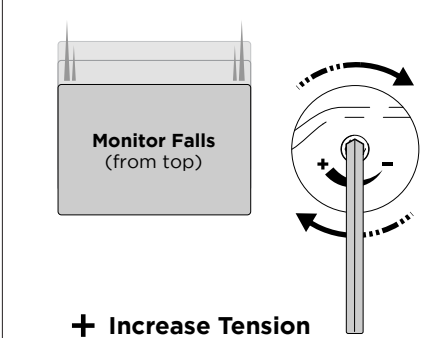
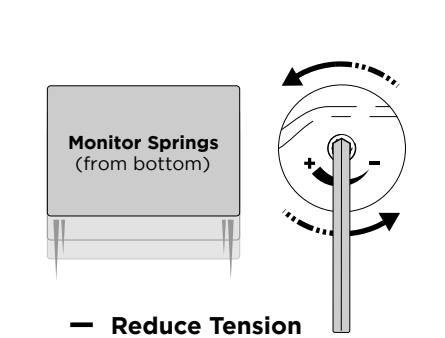
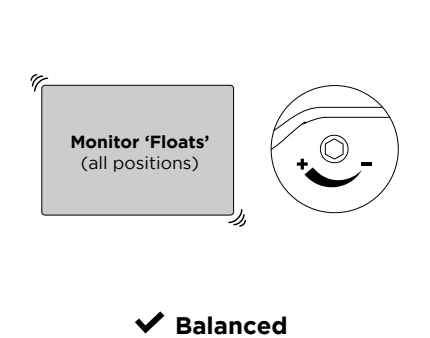
<p>7.1 To accurately set the tension of the arm, position the monitor at 90 degrees</p>  <p>90°</p>	<p>7.2 Use the allen key to adjust the arm tension to the weight of the monitor. Follow steps 7.3 to 7.5 to set the tension.</p>  <p>Heavier Monitor</p> <p>Lighter Monitor</p>	
<p>7.3 If the monitor sags or falls down, increase the arm tension by rotating the screw clockwise.</p>  <p>Monitor Falls (from top)</p> <p>+ Increase Tension</p>	<p>7.4 If the monitor springs upwards from the bottom position, decrease the arm tension by rotating the screw anti-clockwise.</p>  <p>Monitor Springs (from bottom)</p> <p>- Reduce Tension</p>	<p>7.5 If the monitor floats or hovers in all positions the arm tension is balanced and does not require further adjustment.</p>  <p>Monitor 'Floats' (all positions)</p> <p>✓ Balanced</p>

8. Tension gauge

When installing multiple monitors of a similar weight, use the tension gauge to make installation faster.

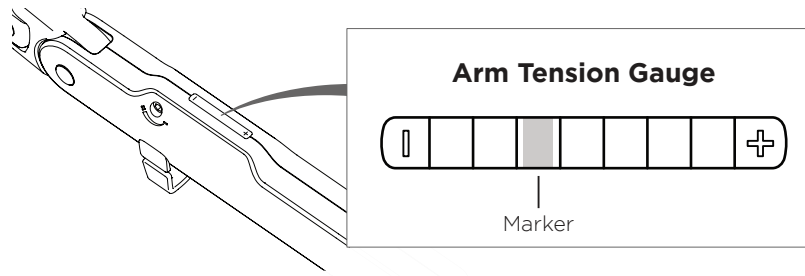

1. Set up one monitor and record the position of the marker on the gauge.
2. When installing subsequent monitors, pre-tension the arm to the recorded amount, then fine-tune the tension by following steps **7.3** to **7.5**.

9. Cable management

9.1 Plug cables into the monitor and route the cables down the arm using the cable hooks and clips.

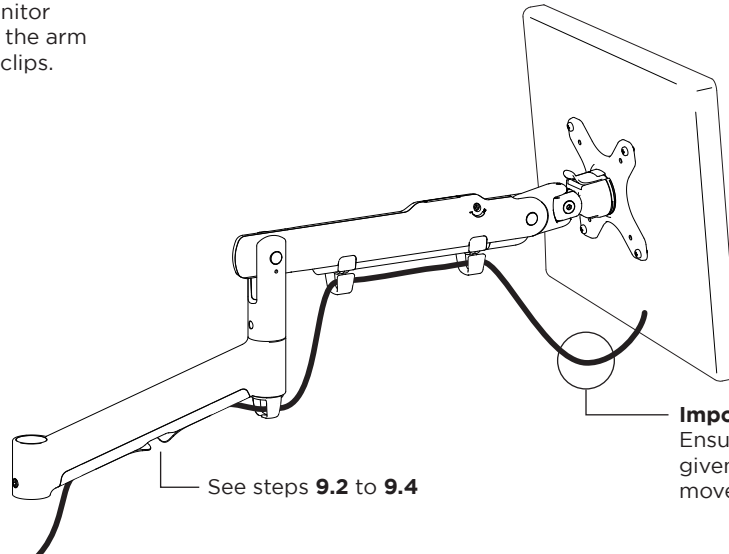

9.2 Wedge cable into the central gap and slide it down the arm.

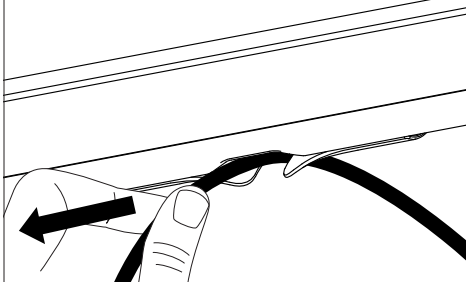

9.3 The cable should slip into the arm cavity

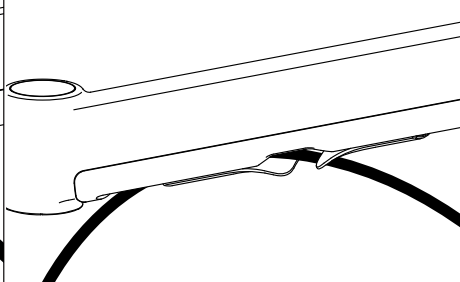

9.4 Slide the remaining loose cable from the central gap up the arm.

