

**HPE MSA 1060/2060/2062
Quick Start Instructions**

Abstract

This document is for the person who installs, administers, and troubleshoots servers and storage systems. HPE assumes that you are qualified in servicing and installing computer equipment, and are trained in recognizing hazards in products and hazardous energy levels.

© Copyright 2020 Hewlett Packard Enterprise Development LP

Part Number: R0Q73-90026
Published: October 2020
Edition: 2



Prepare for the installation

- To help with the planning, installation, and configuration processes, and to ensure that all environmental requirements are met, see *HPE MSA 1060/2060/2062 Installation Guide*. See *HPE MSA 1060/2060/2062 Storage Management Guide* for system configuration, available at <https://www.hpe.com/info/MSAdocs>.
- Confirm that the devices you plan to connect and their installed firmware and software versions are compatible. See the HPE Single Point of Connectivity Knowledge (SPOCK) website <http://www.hpe.com/storage/spock> for the latest support information.
- For product specifications, see the MSA QuickSpecs at www.hpe.com/support/MSA1060QuickSpecs, www.hpe.com/support/MSA2060QuickSpecs, or www.hpe.com/support/MSA2062QuickSpecs.

Install the rail kit into the rack

Required tools: T25 Torx screwdriver.

Remove the rack mounting rail kit from the plastic bag and examine for damage.

Install the rail kit for the controller enclosure:

- Determine the "U" position for installing the enclosure in the rack.
- At the rack front**, engage the rail with the front column. (Labels denote the **FRONT RIGHT** and **FRONT LEFT** of the rails.)

Align the front of the rail with the chosen "U" position, and then push the rail toward the front column until the guide pins are through the rack holes.
- At the rack rear**, engage the rail with the rear column.

Align the rear of the rail with the chosen "U" position, and then expand the rail to align and connect to the rear column.
- Secure the front and rear of the rail assembly to the rack columns using four M5 12 mm T25 Torx (long-flat) shoulder screws. Insert screws in the top and bottom holes of the rail, and then tighten the screws with a 19-in-lbs torque.

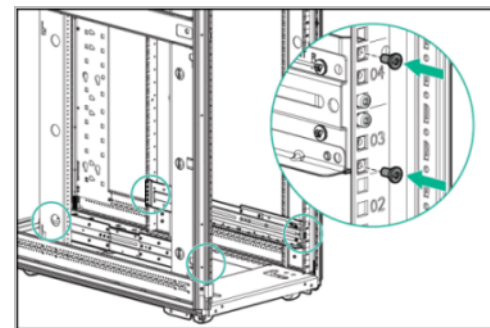

- HPE recommends installing the middle support bracket. The bracket is supported in all HPE racks but may not align in a third-

party rack. Align the bracket with the top holes of the rails, insert four M5 10 mm T25 Torx screws (short-round), and tighten.

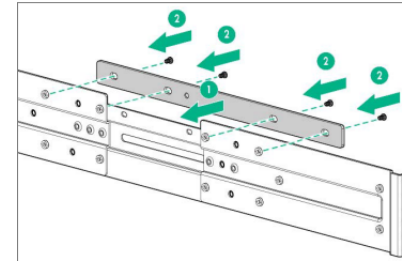

- Repeat step 1 through step 5 for the other rail.

Install the enclosures into the rack

WARNING: At least two people are needed to lift a fully populated MSA controller enclosure or expansion enclosure into the rack.

NOTE: For enclosures using small form pluggable SFP transceivers that are not preinstalled, install the SFPs.

- Lift the controller enclosure and align it with the installed rack rails, ensuring that the enclosure remains level, and slide the controller enclosure onto the rack rails.
- Remove the hubcaps, install the front enclosure M5, 12mm, T25 Torx screws, then replace the hubcaps.

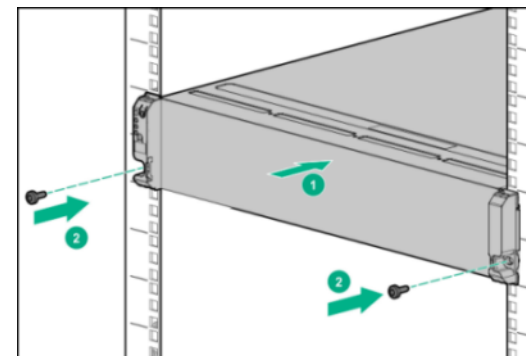

- Install the controller enclosure M5 5mm, Pan Head T25 Torx screws in the rear to secure the enclosure to the rack and rails, as shown in the following illustration:

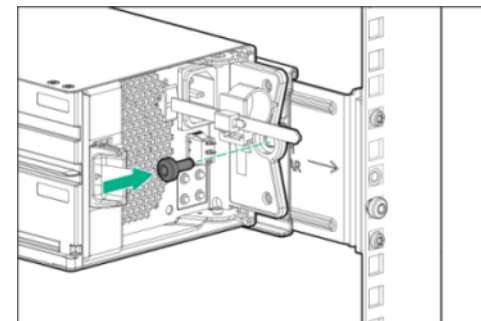

- If you have drives to install, remove the air management sleds (blanks) and install the drives as follows:

IMPORTANT: Each drive bay must have a drive or air management sled installed.

- Prepare the drive by pressing the drive latch (1) and pivoting the release lever (2) to the full open position.

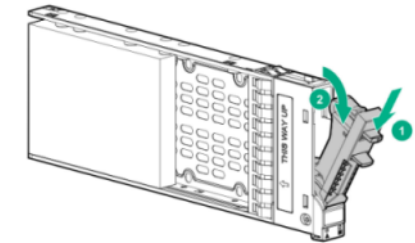

- Insert the drive into the drive enclosure (1), sliding the drive into the drive enclosure as far as it will go. As the drive meets the backplane, the release lever (2) automatically begins to rotate closed.
- Press firmly on the release lever to ensure that the drive is fully seated.

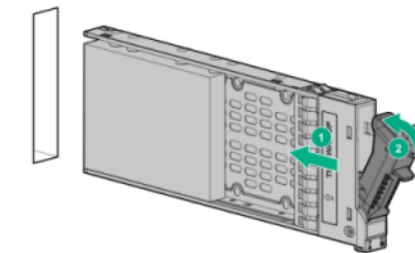

After the controller enclosure is fully secured into the rack, repeat the rail kit and enclosure installation steps for all expansion enclosures.

Attach the optional bezels

MSA 1060/2060/2062 controller and expansion enclosures provide an optional, removable bezel designed to cover the front-facing portion of the enclosure during operation. The enclosure bezel covers the disk modules and attaches to the left and right hubcaps.

- Hook the right end of the bezel onto the hubcap of the enclosure (1).
- Pinch and hold the release latch, then insert the left end of the bezel (2) into the securing slot (3) until the release latch snaps into place.

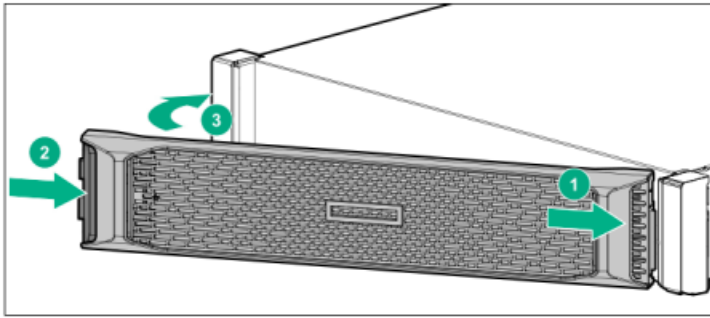

Connect controller enclosure to expansion enclosures

If expansion enclosures are included in your system, connect SAS cables employing a straight-through cabling plan. Two Mini-SAS HD to Mini-SAS HD cables are required for each expansion enclosure.

Expansion enclosure connection guidelines

- Cables longer than those supplied with the expansion enclosure must be purchased separately.
- The maximum length cable supported for connecting expansion enclosures is 2m (6.56 ft).
- The MSA 1060 supports a maximum of four enclosures (one MSA 1060 controller enclosure and up to three expansion enclosures). The MSA 2060/2062 supports a maximum of 10 enclosures (one MSA 2060/2062 controller enclosure and up to nine expansion enclosures).

The following illustration shows the straight-through cabling scheme:

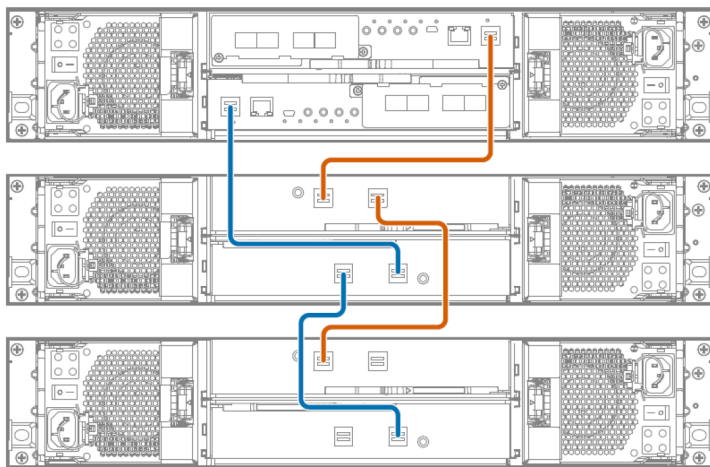

For more information on cable configuration, see the *HPE MSA 1060/2060/2062 Installation Guide*.

Connect power cords and power on devices

IMPORTANT: Power cords must be approved for use in your country/region and must be rated for the product, voltage, and current marked on the electrical ratings label of the product.

1. Ensure that power switches for all enclosures are in the **Off** position.
2. Connect power cords from the power distribution units (PDUs) to separate external power sources.
3. Connect the power supply modules in the controller enclosure and all attached expansion enclosures to the PDUs, and secure power cords to the enclosures using the retaining clips that are attached to the power supplies in the enclosures.
4. Apply power to all expansion enclosures by turning the power switches to the **On** position and wait two minutes to ensure that all disks in the expansion enclosures are powered up.
5. Apply power to the controller enclosure by turning the power switch to the **On** position and allow up to five minutes for the controller enclosure to power on.
6. Observe the LEDs on the front and the rear of the controller enclosure and all expansion enclosures and confirm that all components are powered on and functioning properly.

Controller module LEDs (rear view):

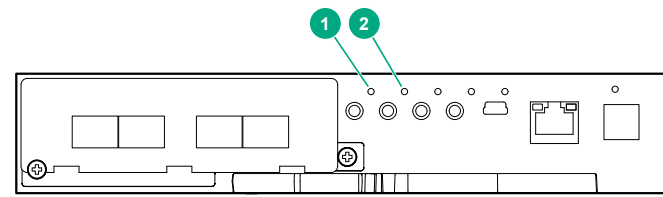

If LED 1 or 2 indicates either of the following states, identify and correct the issue before continuing.

LED	Description	Color	Definition
1	FRU OK	Off	The controller module is not okay or is powered off.
2	Fault	Amber	A fault has been detected or a service action is required.

Expansion enclosure I/O module LEDs (rear view):

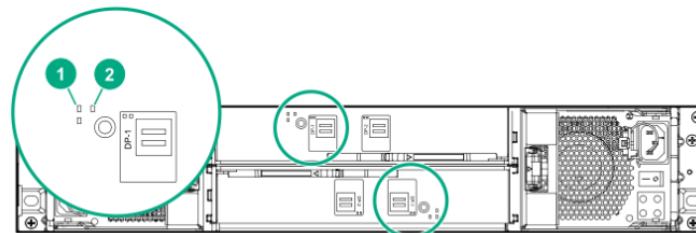

If LED 1 or 2 indicates either of the following states, identify and correct the issue before continuing.

LED	Description	Color	Definition
1	Fault	Amber	A fault has been detected or a service action is required.

Table Continued

LED	Description	Color	Definition
2	FRU OK	Off	The I/O module is not okay or powered off.

For a complete list of controller module and I/O module LED descriptions, see *HPE MSA 1060/2060/2062 Installation Guide*.

Identify or set the IP address of each controller

To complete the installation, create storage, and manage your system, you must connect to one of the two controller's network ports using the controller's IP address. Obtain or set the IP addresses using one of the following methods:

Method 1: Default address

If the network management ports are connected and DHCP is not enabled on your network, use the default address of either 10.0.0.2 for controller A or 10.0.0.3 for controller B. Access system management either with an SSH client or using a browser through HTTPS to the Storage Management Utility (SMU).

Method 2: DHCP assigned

If the network management ports are connected and DHCP is enabled on your network, obtain the DHCP-assigned IP addresses using one of the following methods:

- Connect the CLI USB cable to either controller enclosure CLI port and issue the `show network-parameters` CLI command (for IPv4) or `show ipv6-network-parameters` CLI command (for IPv6).
- Look in the DHCP server pool of leased addresses for two IP addresses assigned to "HPE MSA StoragexxxxxY". "xxxxxx" is the last six characters of the enclosure WWID and "Y" is A or B, signifying the controller.
- Use a ping broadcast from the local subnet to identify the device through the Address Resolution Protocol (ARP) table of the host.

```
ping <broadcast address>
arp -a
```

Look for a MAC Address starting with '00:C0:FF'. The subsequent numbers in the MAC Address are unique to each controller.

If you cannot connect to the management interfaces through the network, verify that the management network ports of the controllers are connected, or set the management network port IP addresses manually.

Method 3: Manually assigned

Use the provided CLI USB cable to assign static IP addresses to the controller modules:

1. Obtain an IP address, subnet mask, and gateway address for controllers A and B from your network administrator.

2. Use the provided CLI USB cable to connect controller A to a USB port on a host computer.
3. Start a terminal emulator and connect to controller A.
4. Press **Enter** to display the CLI.
5. To log in to the system for the first time, enter the user name **setup** and follow the onscreen directions to create a user account to manage the system.
6. Use the `set network-parameters` command (for IPv4) or `set ipv6-network-parameters` (for IPv6) to set the IP values for both network ports.
7. Verify the new IP addresses by using the following commands: `show network-parameters` (for IPv4) or `show ipv6-network-parameters` (for IPv6).
8. Use the `ping` command from both the system command line and the management host to verify network connectivity.

Connect the MSA Controllers to data hosts

Direct-connect and switch-connect environments are supported. See the SPOCK website at: www.hpe.com/storage/spock

- No host interface cables are shipped with HPE MSA systems. For a list of cables available from HPE, see the HPE MSA QuickSpecs. For cabling examples, including connecting directly to a server, see the installation guide.
- In direct-connect deployments, connect each host to the same port number on both HPE MSA controllers (that is, connect host to ports A1 and B1).
- In switch-connect deployments, connect an HPE MSA Controller A port and the corresponding HPE MSA Controller B port to one switch, and connect a second HPE MSA Controller A port and the corresponding HPE MSA Controller B port to a separate switch.

Complete system installation using the Storage Management Utility (SMU)

1. Open a web browser and enter the `https://<IP-address>` of one of the controller module's network ports in the address field (that is, one of the IP addresses identified or set after powering on the array).
2. To sign in to the SMU for the first time, use the valid system user credentials that were created using the CLI setup command, or create a new user and password using the SMU if you did not create system user credentials previously.
3. Complete the setup wizard by following the onscreen instructions.