



Security Slim Spring Arm w/ USB Ports

PAD-SSMAE

INSTRUCTION - MANUAL

CONTENTS:

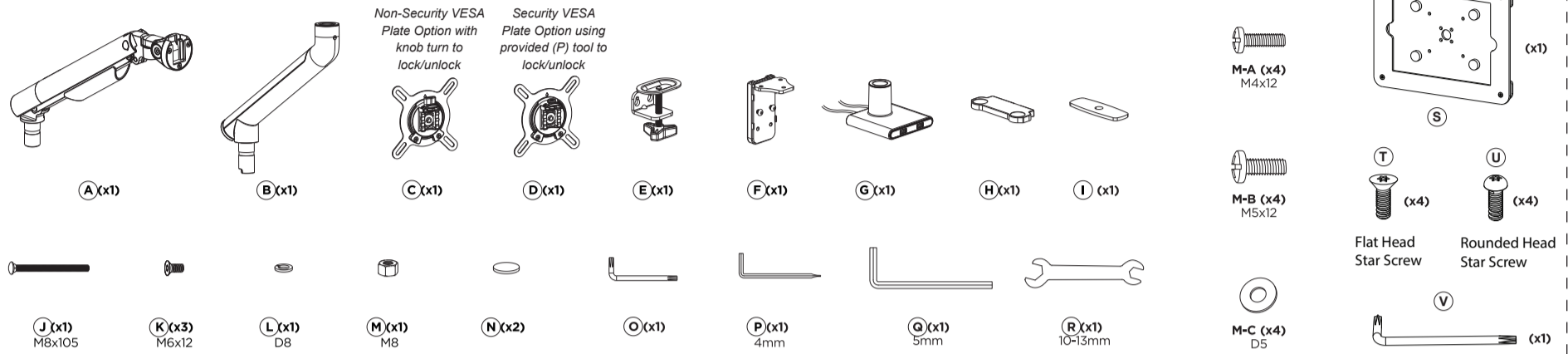

INSTALLATIONS:

1 PRE-SETUP

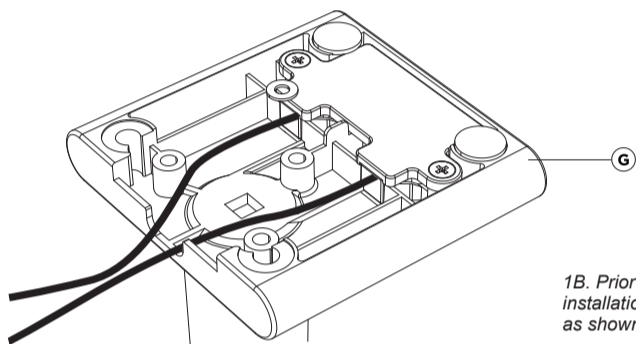

1B. Prior to beginning the grommet or clamp installation - press the USB cables into the groove as shown to properly setup.

VESA Compatible
75x75 100x100

32" MAX
FLAT/CURVED

2-9kg
4.4-19.8lbs
RATED

2 SETTING UP CLAMP MOUNT OPTION

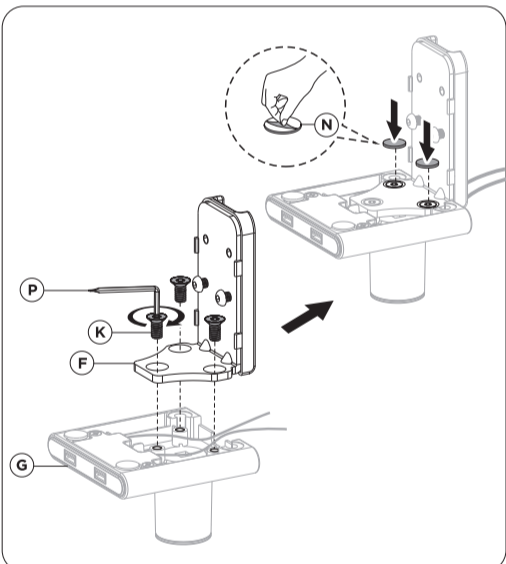

2A. Align L-shape component (F) with base of clamp mount as shown above. Rotate in screws (K) through using provided tool (P) until securely tightened. Afterwards peel off sticker back of padding (N) and place firmly on the screws (K).

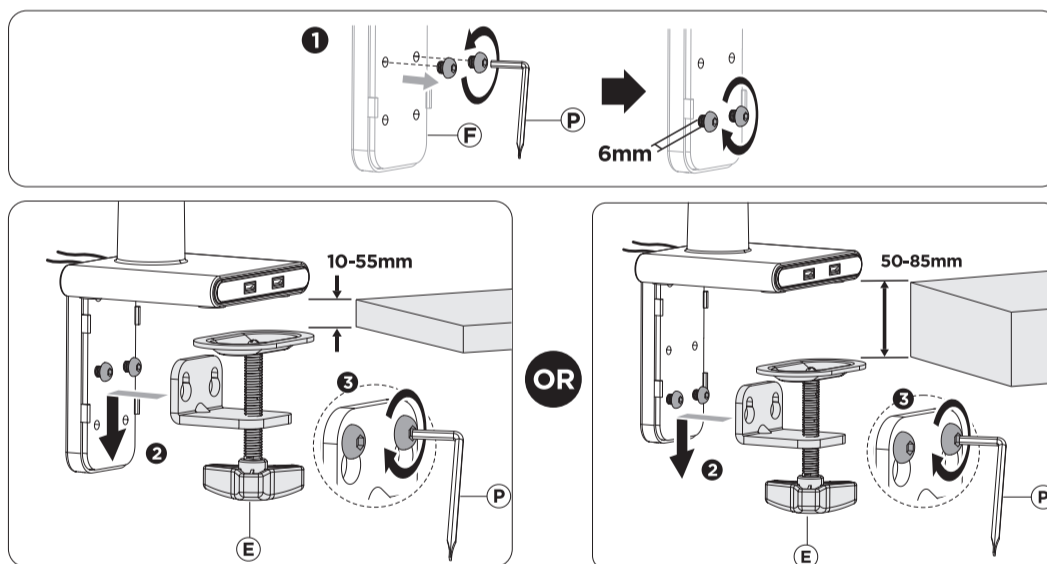

2B. Identify the overall thickness of the surface the clamp will be mounting on. If the thickness is in the 10-55mm range, you will be using the higher setting on the L-shape bracket of the base. If the thickness is in the 50-85mm range, you will be using the lower setting. Rotate in the screws (F) of the bracket until halfway in leaving some space. Hook on the knob component (E). After hooked on, use the provided tool (P) and securely tighten the screws (F) until securely fastened.

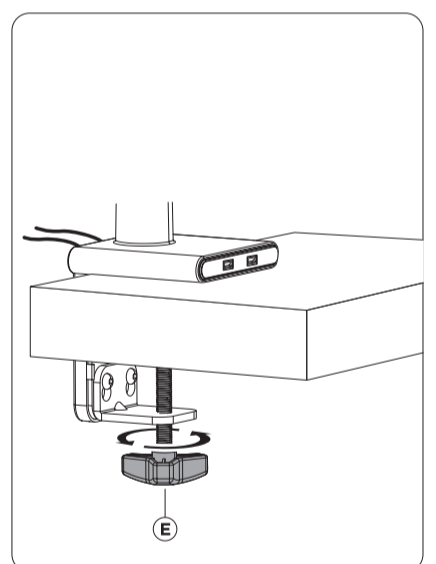

2C. Rotate knob (E) until securely tightened to fasten clamp to surface.

3 SETTING UP GROMMET MOUNT OPTION

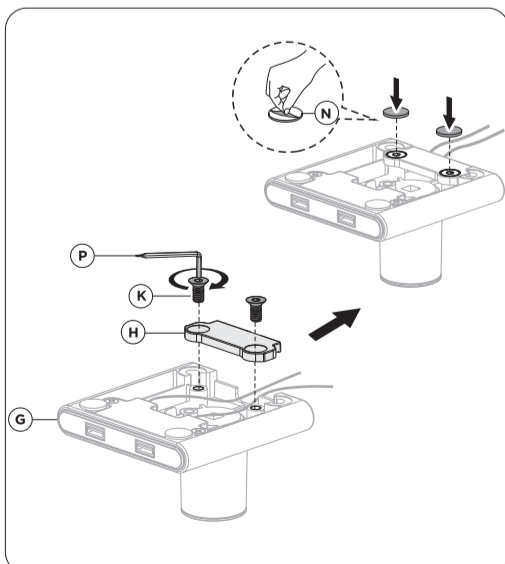

3A. Align base (G) with component (H). Rotate in screws (K) with provided tool (P) until securely tightened. After, locate base pads and remove backing. Place adhesive side of pads on the screws as illustrated above.

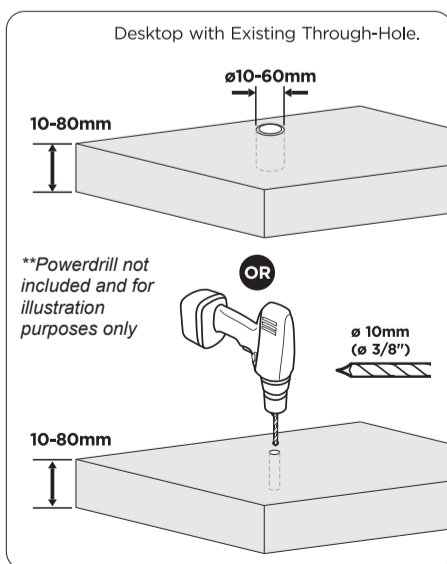

3B. Using drill (not included), drill a 10mm diameter hole for the grommet mount installation. If existing hole is available, make sure diameter is in the 10-60mm range prior to setup for proper installation.

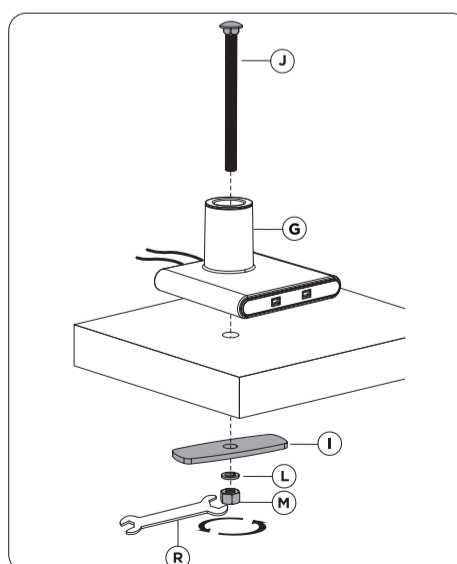

3C. Align base (G) with pre-drilled hole and insert long screw (J) through the base and hole. From below insert grommet mount components (I, L, M) onto the long screw. Using fingers initially, rotate all the grommet components until tightly fastened. Using provided wrench tool (R), rotate hex nut (M) until securely tightened.

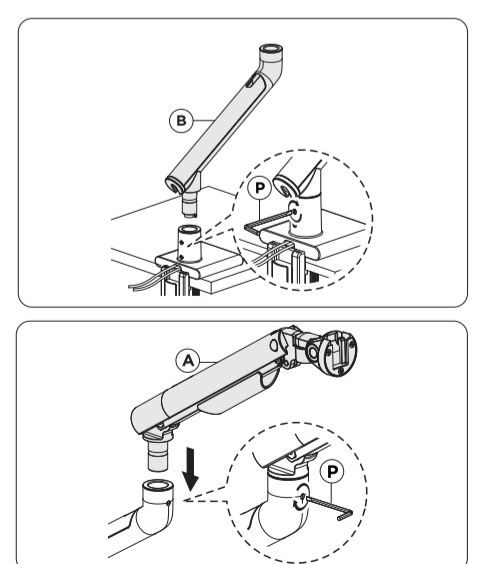

3D. Take the bottom part of the clamp arm (B) and insert the bottom connector into the base (G) as illustrated above. Then tighten with provided tool (P) until securely fastened. Then take the top part of clamp arm (A) and insert into top connector part of the bottom arm. Tighten joint with provided tool (P) as illustrated.

4 SETTING UP VESA MOUNT & VESA CONNECTION

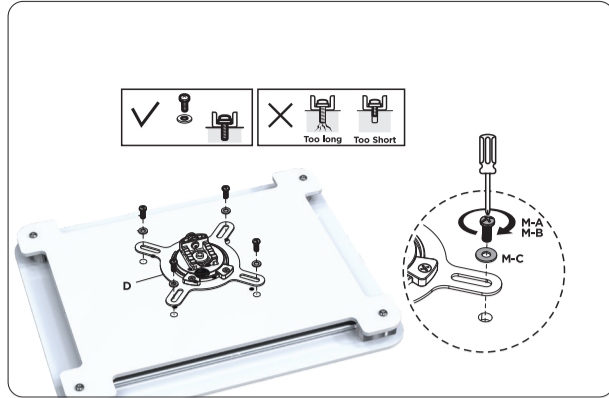

4A. Pending thickness of VESA compatible device, use provided screws M-A or M-B along with washer (M-C) as shown above. Longer screws for thicker monitor / devices. Load capacity of 19.8 lbs and 32" screen max. Decide which VESA plate to use. If you want to have a security VESA plate, select that particular VESA(D). If you want to go with the non-security version, selection that particular VESA (C). Align VESA holes of VESA plate (C or D) with device and rotate in screws using screwdriver (not included) until securely tightened.

WHEN USING SECURITY VESA PLATE (D)

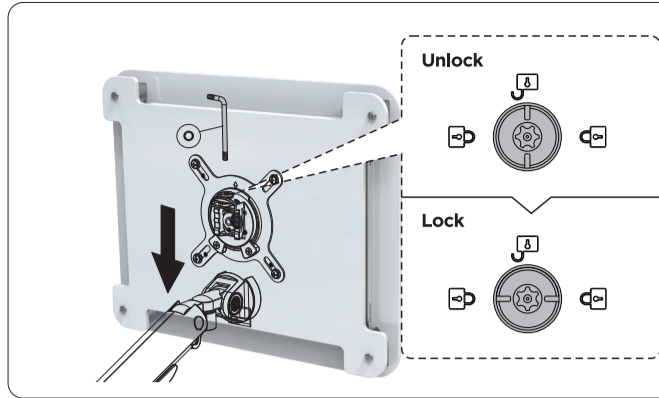

4B. Combine device with VESA plate attached with rest of clamp by sliding in at the grooves at the joint.

Afterwards, using provided tool (O), rotate key component to the locked position to securely connect everything in place. Make sure to unlock joint when needing to remove monitor.

OR WHEN USING NON-SECURITY VESA PLATE (C)

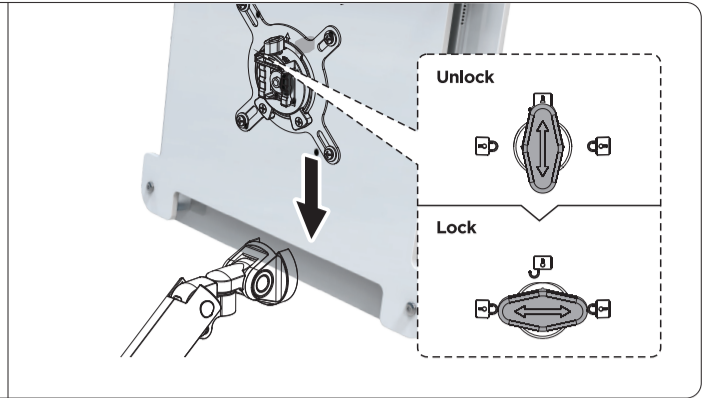

4C. Combine device with VESA plate attached with rest of clamp by sliding in at the grooves at the joint.

Afterwards, simply rotate knob to the locked position to secure the connection. And rotate to the unlocked position when needing to remove VESA plate and monitor together.

5 ARM ADJUSTABILITY

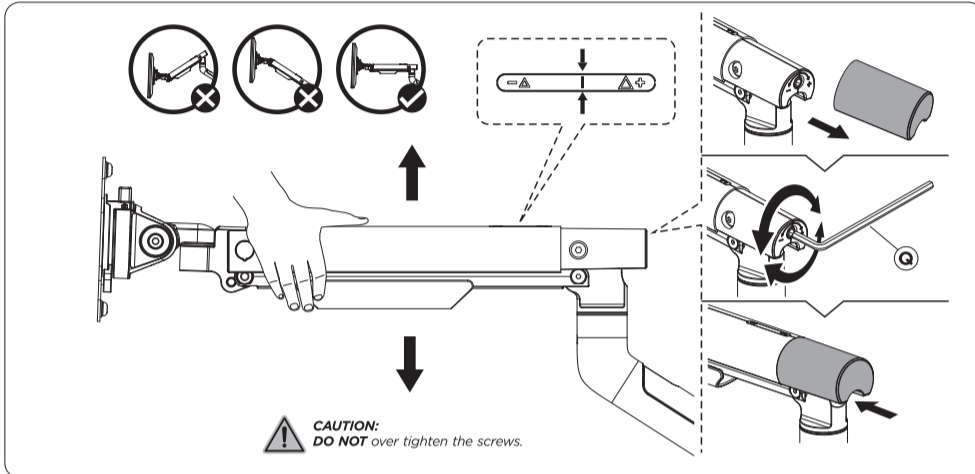

5A. To properly balance the arms with monitors mounted, adjust the spring tension using the provided allen key. Position it in the horizontal position and firmly hold the arm as shown. Tight the screw to fix it in the horizontal position.

If the arm **drops**, turn the adjustment screw clockwise until it stays in a horizontal position.

If the arm **rises**, turn the adjustment screw counter-clockwise until it stays in a horizontal position.

5B. To adjust the arm to the desired height and configuration, remove the back joint cover as shown. Then using provided tool (Q), rotate to loosen and firmly push/pull arm into position, then rotate screw opposite direction to tighten.

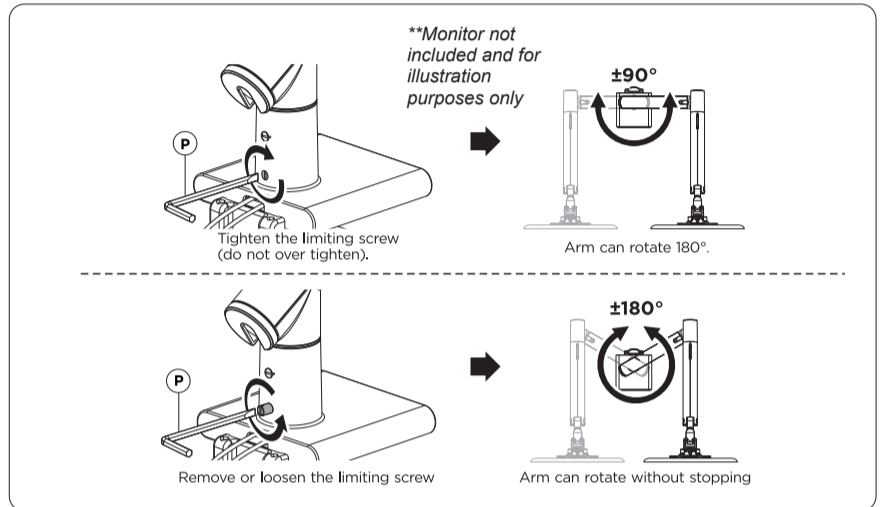

5C. When making swivel adjustments to the arm, use provided tool (P) at the joint above the mount as shown above. Loosen to allow for swivel rotation as shown. Then rotate clockwise to tighten again once desired rotation has been set for preferred setup.

6 CABLE ROUTING / CABLE MANAGEMENT

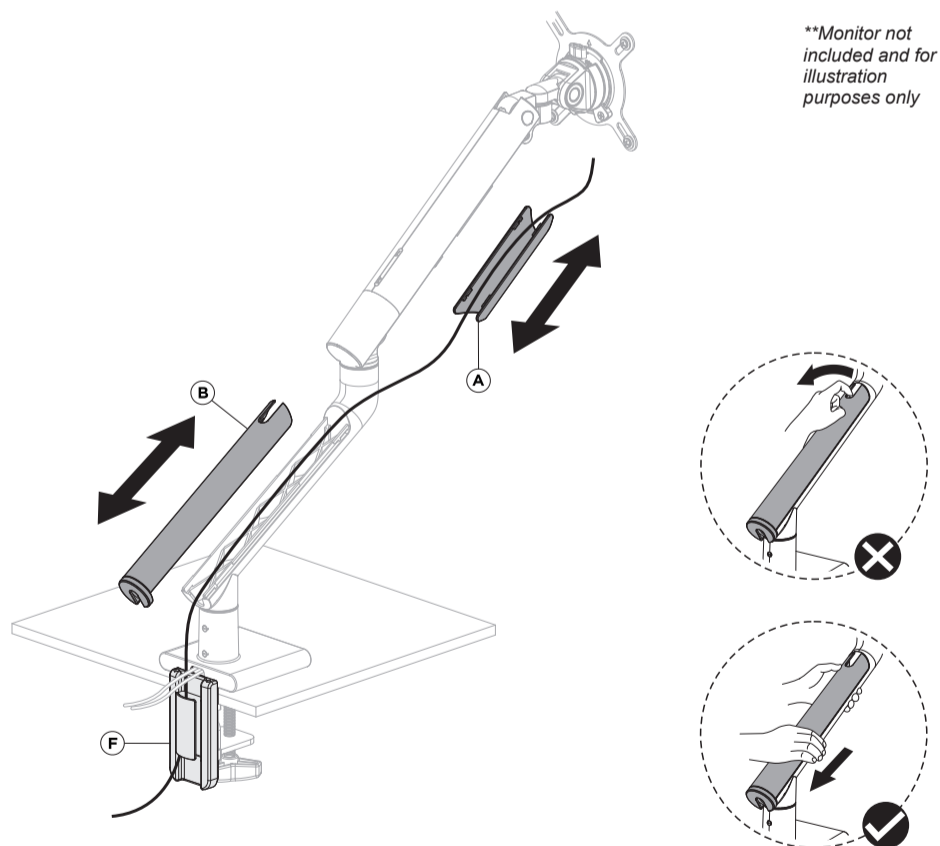

6A. Identify the (3) components needed for cable routing. There is a clipped tray at the upper arm (A), a cover piece at the lower arm (B) and then a hook at the base L-Bracket(F). Remove the clipped tray at the upper arm and then slide off the cover for the lower arm. Plug one end of the cable to your device as shown above. Fish the cord under the upper arm, then clip on the tray. Then continue to fish the cord to the lower arm through the arm. Re-cover the channel with the cover piece Lastly hook the wire onto L-Bracket back (F) and then continue fishing the cord towards the outlet or power source.

7 JOINT ADJUSTMENTS

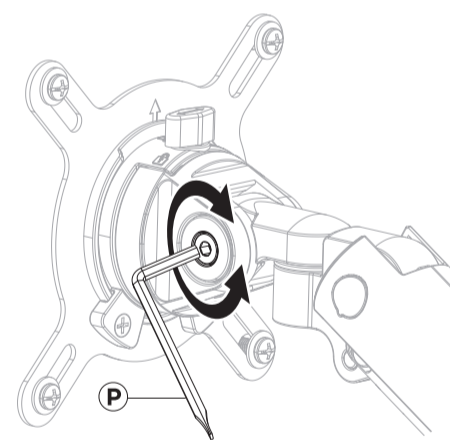

7A. Loosen the joint (as shown) behind the VESA plate using provided tool (P). When loose, tilt up and down or rotate portrait / landscape for preferred viewing angles and setup. When done, tighten screw again until securely fastened.

8 TOOL HOLDER ORGANIZER

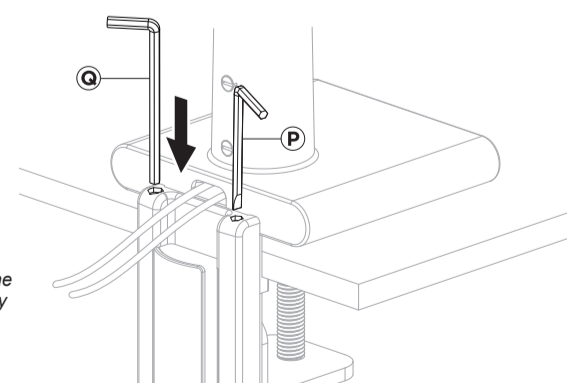

8A. When fully finished with setup, place the provided tools (Q, P) in the tool organizer (F) as shown for easy clamp angle and orientation adjustments when needed.

9 Removing Enclosure Top

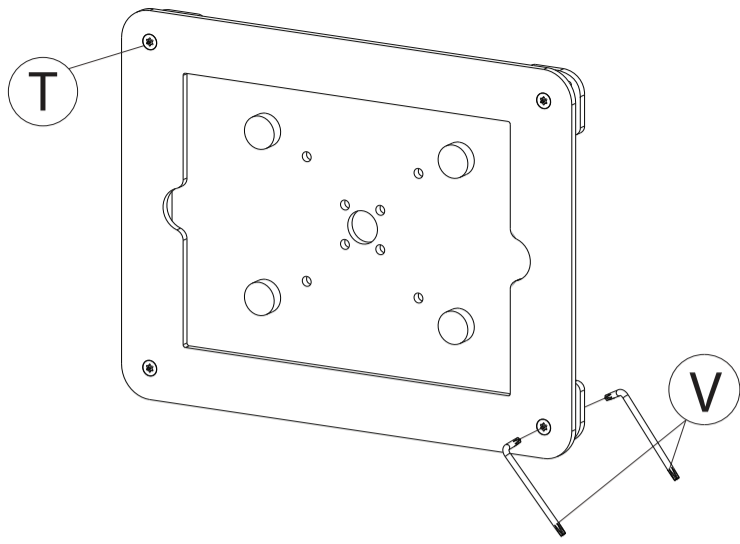

9A. Align the security star keys x2 (V) and insert it one in the front screw (T) and one in the Back screw (U) as shown.

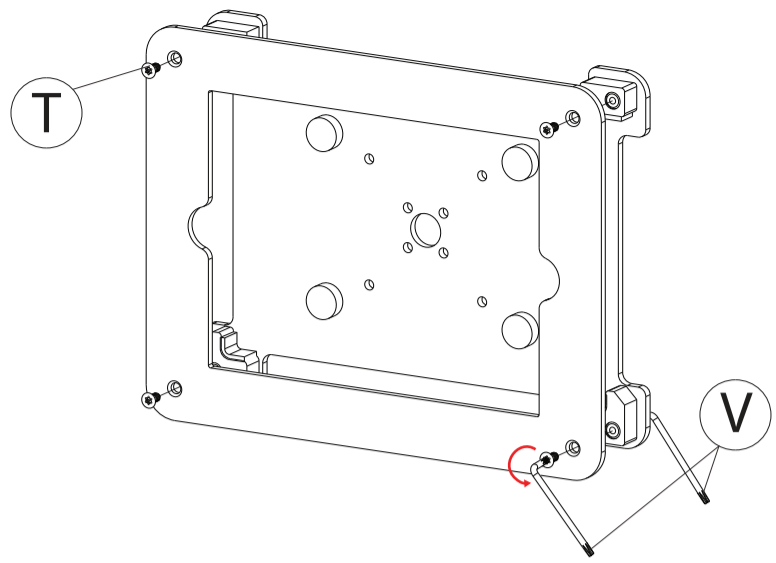

9B. While holding the back security star key (V) tight in place. Turn the front security star key (V) counter clock-wise until all 4 Screws on both sides (T+U) are unscrewed.

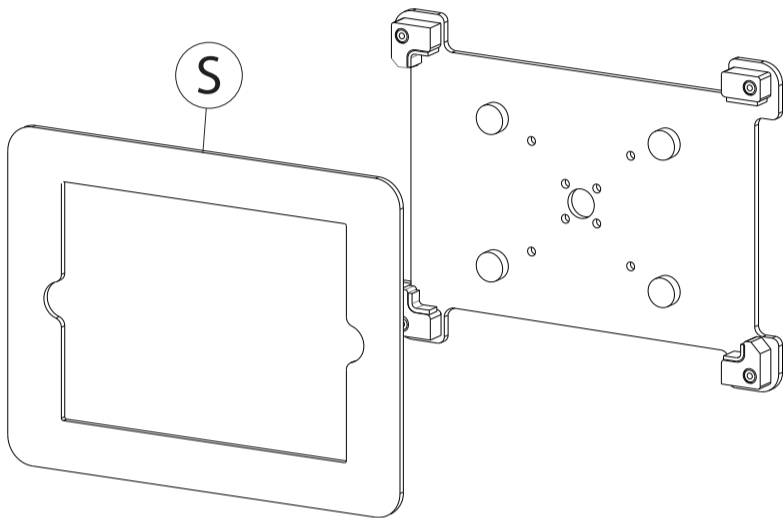

9C. Separate front part of enclosure (A) as shown.

10 Inserting the Tablet

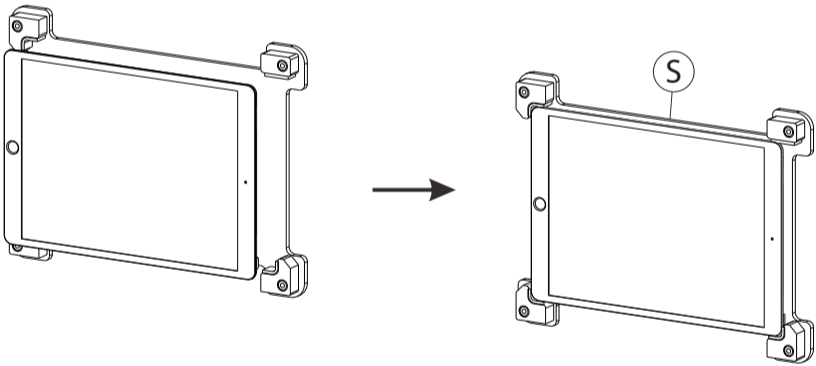

10A. Using one of the compatible listed tablets, insert into the foam adapters for a secure and tight fit. Insert tablet in back part of enclosure (S) as shown. Watch out orientation of tablet.

11 Re-assemble Enclosure

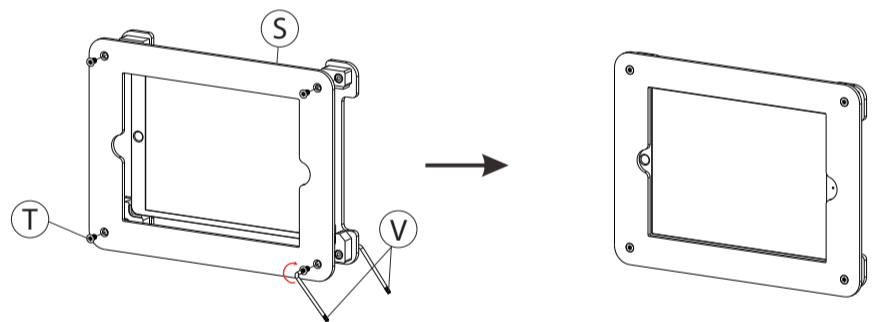

11A. Take the detached enclosure top (S), align the corner holes with the bottom portion. Then use the provided security star key (V), turn in clock-wise the star screws (T and U) until securely tightened while holding the security star key (V) on the other side with your other hand. Screw in until securely tightened.

12 Rotation Adjustability



12A. Can install the enclosure in surface either portrait or landscape mode as needed.