



Premium Locking Floor Stand Kiosk with Enclosed Printer Storage & Cable Management

PAD-PARAFP

INSTRUCTION - MANUAL

CONTENTS:

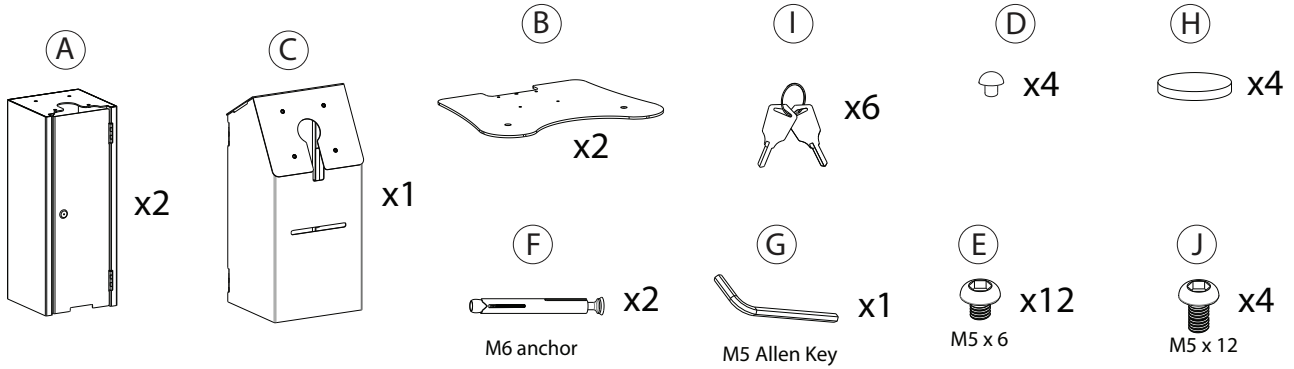

INSTALLATION:

1. Assembling base

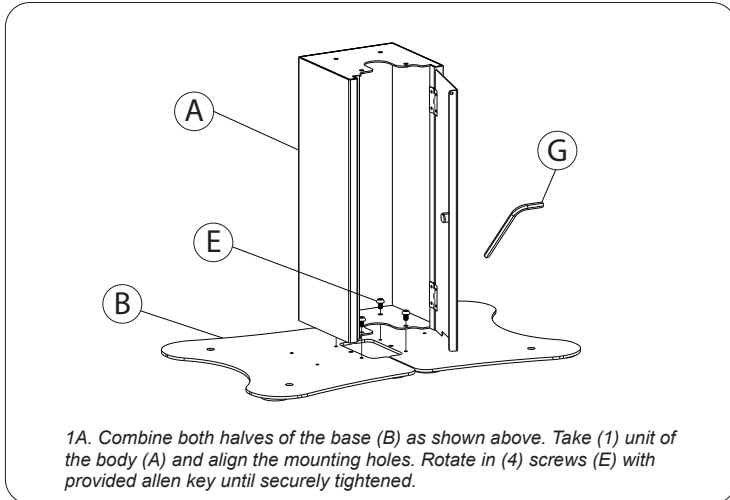

2. Attaching Base Pads

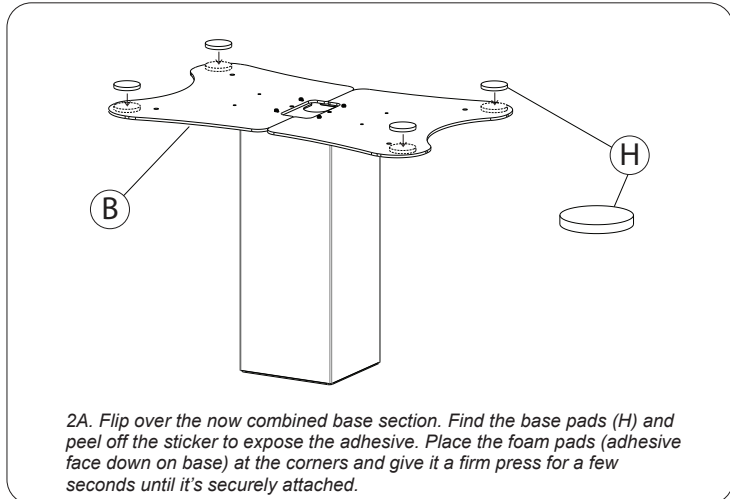

3. Assembling Body Segments

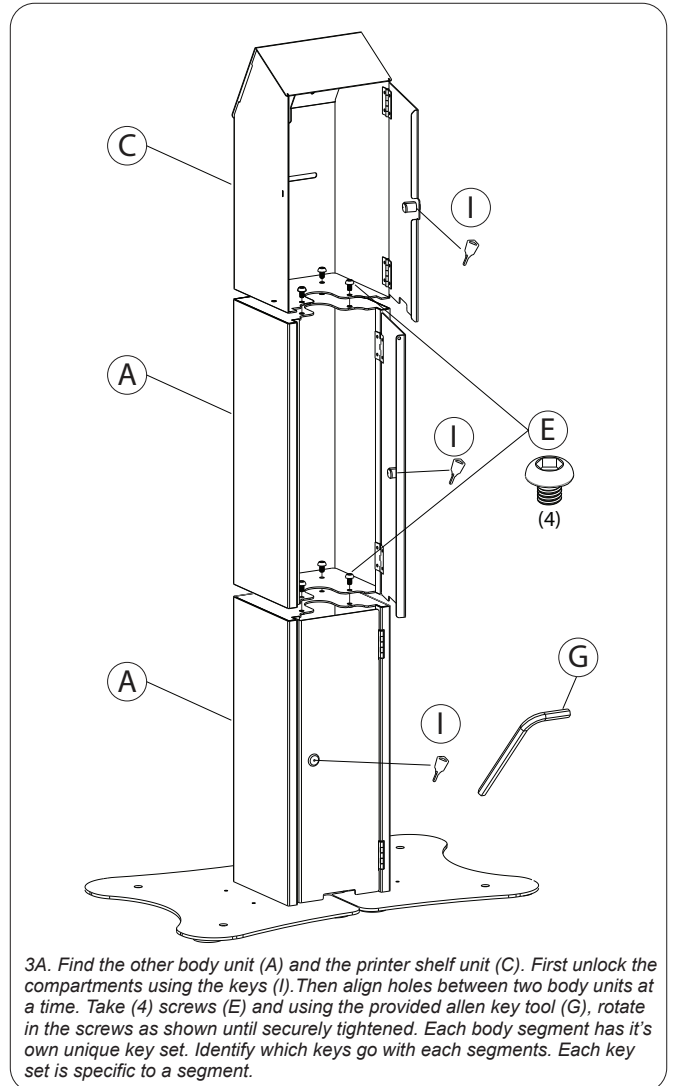

4. (Optional) Anchoring Base to Floor

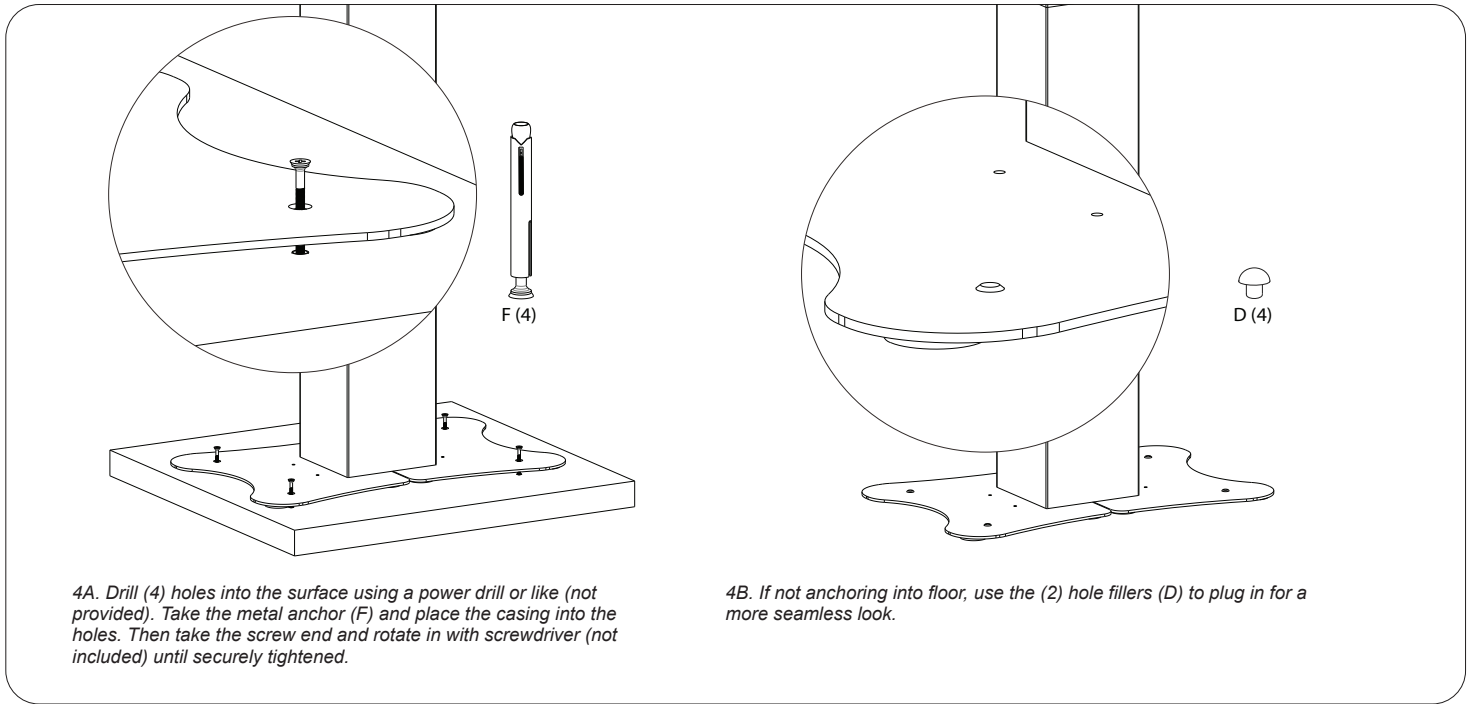

Assembling Enclosure to Printer Shelf Component

Align the VESA holes of the enclosure to that of the printer shelf component (C). Rotate in screws (J) from above using provided allen key tool (G) as shown until securely tightened.

**Tablet and enclosure shown for illustration, NOT INCLUDED.

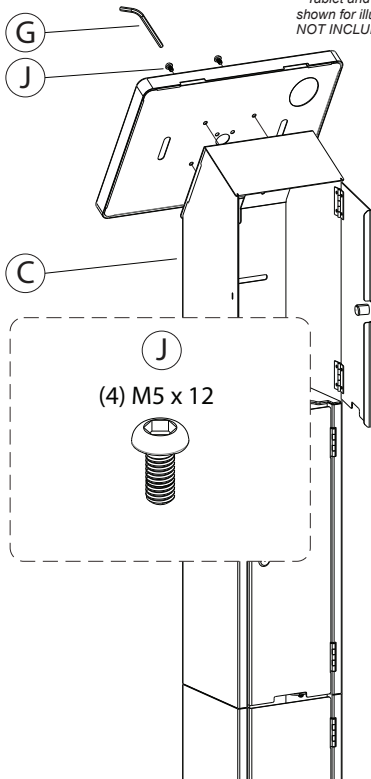

Assembling Monitor to Printer Shelf Component

Align the VESA holes of the monitor to that of the printer shelf component (C). Rotate in screws (J) from behind using provided allen key tool (G) as shown until securely tightened.

**Monitor shown for illustration only, NOT INCLUDED.

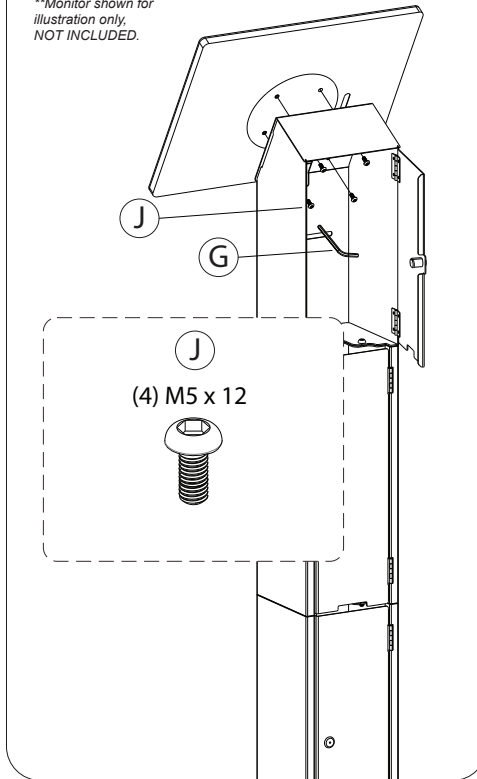

Cable Routing Cable Management

**Monitor shown for illustration only, NOT INCLUDED.

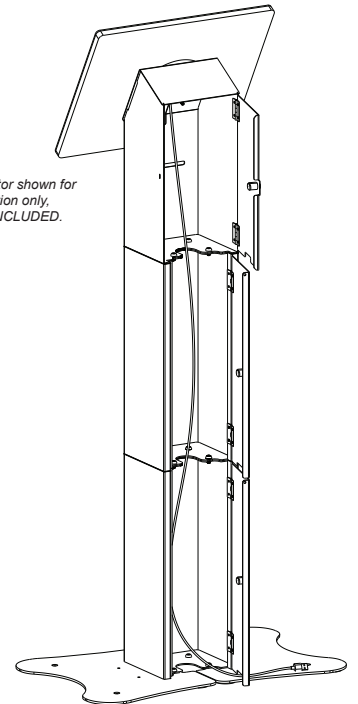

Unlock all (3) body unit storage compartments using the correct key for each section. Fish the cables through as shown and out the opening at the very bottom as needed.