

**MIDDLE  
ATLANTIC®**

A brand of **legrand**



**NOTE:** Free standing and floor-to-wall models shown.

**forum**<sup>™</sup>  
COLLABORATION SUITE

## **XL Display Stand for Single and Dual Displays**

Instruction Sheet

100-00087 Rev B



## TABLE OF CONTENTS

Important Safety Instructions.....	3 - 8
Weight Ratings.....	9
Supplied Components and Hardware.....	9 - 11
Required Tools.....	11
Introduction.....	12
Removing the Panels from Your Display Stand.....	12
Attaching the Display Stand to Your Wall (Floor-To-Wall Models Only).....	13 - 15
Removing the Doors from Your Display Stand.....	15 - 16
Repositioning the 10" Lever Lock Plate.....	17
Using Top Small Device Storage and Bottom Rackmount Bays.....	18
Determining the Default Height from the Floor to the Bottom of Your Display.....	19
Customizing the Height from the Floor to the Bottom of Your Display.....	20
Attaching Horizontal Brackets, Extrusion, and Making Adjustments.....	20 - 21
Attaching Shroud Brackets and Making Adjustments .....	22 - 24
Attaching End Caps to the Horizontal Extrusion.....	24
Selecting the Correct Interface Bracket Hardware for Your Display.....	24
Attaching Interface Brackets to the Back of Your Display.....	25 - 26
Leveling Your Display Stand (Free-Standing Models Only) .....	26
Hanging Your Display.....	27
Re-attaching the Panels from Your Display Stand.....	27
Re-attaching the Doors from Your Display Stand.....	28
Warranty.....	28

## IMPORTANT SAFETY INSTRUCTIONS - EN

- Read these instructions.
- Heed all warnings.
- Clean only with dry cloth.
- Keep these instructions.
- Follow all instructions.
- Only use attachments/accessories specified by the manufacturer.



**DANGER HAZARDOUS VOLTAGE:** The lightning flash with the arrowhead symbol, within an equilateral triangle is intended to alert the user to the presence of uninsulated dangerous voltage within the product's enclosure that may be of sufficient magnitude to constitute a risk of electric shock to persons.



**WARNING:** A warning alerts you to a situation that could result in serious personal injury or death.



**CAUTION:** A caution alerts you to a situation that may result in minor personal injury or damage to the product and/or property.



**WARNING:** Middle Atlantic Products, electrical systems conform to and should be properly grounded in compliance with requirements of the current National Electrical Code or codes administered by local authorities. All electrical products may present a possible shock or fire hazard if improperly installed or used. Electrical products may bear the mark of a Nationally Recognized Testing Laboratory (NRTL) and should be installed in conformance with current local and/or the National Electrical Code.



**WARNING:** Failure to read, understand and follow the following information can result in serious personal injury, damage to the equipment or voiding of the warranty. It is the responsibility of the Installer/User to ensure that this product is loaded according to specifications.



**WARNING:** Risk of Electric Shock: Connect the device to a properly grounded outlet only. Do not defeat the safety purpose of the polarized or grounding-type plug. A polarized plug has two blades with one wider than the other. A grounding type plug has two blades and a third grounding prong. The wide blade or the third prong is provided for your safety. If the provided plug does not fit into your outlet, consult an electrician for replacement of the obsolete outlet.



**WARNING:** The apparatus shall not be exposed to dripping or splashing and that no objects filled with liquids, such as vases, shall be placed on the apparatus.



**WARNING:** To reduce the risk of burns, fire, electric shock, or injury to persons:

- Unplug from outlet before putting on or taking off parts.
- Close supervision is necessary when this device is used by, or near children, invalids, or disabled persons.
- Use this device only for its intended use as described in these instructions. Do not use attachments not recommended by the manufacturer.
- Never operate the device if it has a damaged cord or plug, if it is not working properly, if it has been dropped or damaged, or dropped into water. Return the device to a service center for examination and repair.
- Protect the power cord from being walked on or pinched particularly at plugs, convenience receptacles, and the point where they exit from the apparatus.
- Keep the cord away from heated surfaces.
- Never drop or insert any object into any opening.
- Do not use outdoors.
- Do not operate where aerosol (spray) products are being used or where oxygen is being administered.
- To disconnect, turn all controls to the off position, then remove plug from outlet.



**CAUTION:** Do not plug into another relocatable power tap



**CAUTION:** Do not plug into another relocatable power tap.



**CAUTION:** A caution alerts you to a situation that may result in minor personal injury or damage to the product and/or property.

## IMPORTANT SAFETY INSTRUCTIONS - EN (CONTINUED)

### Safety Instructions: Rack Mount

**Elevated Operating Ambient:** If installed in a closed or multi-unit rack assembly, the operating ambient temperature of the rack environment may be greater than room ambient. Therefore, consideration should be given to installing the equipment in an environment compatible with the maximum ambient temperature (T<sub>ma</sub>) specified by the manufacturer.

**Reduced Air Flow:** Installation of the equipment in a rack should be such that the amount of air flow required for safe operation of the equipment is not compromised.

**Mechanical Loading:** Mounting of the equipment in the rack should be such that a hazardous condition is not achieved due to uneven mechanical loading.

**Circuit Overloading:** Consideration should be given to the connection of the equipment to the supply circuit and the effect that overloading of the circuit might have on overcurrent protection and supply wiring. Appropriate consideration of equipment nameplate ratings should be used when addressing this concern.

**Reliable Earthing:** Reliable earthing of rack-mounting equipment should be maintained. Particular attention should be given to supply connections other than direct connections to the branch circuit (e.g. use of power strips).

**Disconnect Device (Pluggable Equipment):** The socket-outlet shall be installed near the equipment and shall be easily accessible.

When using electrical products, basic precautions should always be followed, including the following:

- Read and follow all instructions before using.
- There are no user-serviceable components within this device. Removal of the cover from this device may present a shock hazard, and void the warranty.
- The mains plug is used as your disconnect device. This device shall remain readily operable.
- Unplug this apparatus during lightning storms or when unused for long periods of time.
- Do not overload the wall outlet where this device is being connected. Do not overload this device. Ensure the total load to this device does not exceed that which is listed in the specifications section of this manual.
- Ensure this device is connected to a properly grounded AC power source. Ensure the device is plugged into a source providing the required 120V. Do not use a plug adapter that defeats the ground pin of the AC plug.

## WASTE ELECTRICAL AND ELECTRONIC EQUIPMENT (WEEE) DIRECTIVE



Correct disposal of this product: This symbol indicates that this product must not be disposed of with household waste, according to the WEEE Directive (2012/19/EU) and your national law. This product should be taken to a collection center licensed for the recycling of waste electrical and electronic equipment (EEE). The mishandling of of this type of waste could have a possible negative impact on the environment and human health due to potentially hazardous substances that are generally associated with EEE. At the same time, your cooperation in the correct disposal of this product will contribute to the efficient use of natural resources. For more information about where you can take your waste equipment for recycling, please contact your local city office or your household waste collection service.

## INSTRUCCIONES DE SEGURIDAD IMPORTANTES - ES

- Lea estas instrucciones.
- Preste atención a todas las advertencias.
- Limpie solamente con un paño seco.
- Guarda estas instrucciones.
- Siga todas las instrucciones
- Utilice únicamente accesorios especificados por el fabricante.

### UNDERSTANDING SAFETY SYMBOLS



**PELIGRO VOLTAJE PELIGROSO:** El rayo con el símbolo de punta de flecha dentro de un triángulo equilátero alerta al usuario de la presencia de voltaje peligroso no aislado dentro del producto que puede ser de suficiente magnitud como para constituir un riesgo de descarga eléctrica para las personas.



**ADVERTENCIA:** Una advertencia lo alerta sobre una situación que podría ocasionar lesiones personales graves o la muerte.



**PRECAUCIÓN:** Una precaución lo alerta sobre una situación que puede ocasionar lesiones personales menores o daños al producto o a la propiedad.



**PELIGRO VOLTAJE PELIGROSO:** Para reducir el riesgo de descarga eléctrica: Desenchufe siempre este dispositivo de la toma de corriente antes de limpiarlo.



**ADVERTENCIA:** Si no lee, comprende y sigue la siguiente información, puede ocasionar lesiones personales graves, daños al equipo o anulación de la garantía. Es responsabilidad del instalador/usuario asegurarse de que este producto se carga según las especificaciones.



**ADVERTENCIA:** Riesgo de descarga eléctrica: Conecte el dispositivo únicamente a una toma de corriente con conexión a tierra. No rechace el propósito de seguridad del enchufe polarizado o con toma de tierra. Un enchufe polarizado tiene dos cuchillas con una más ancha que la otra. Un enchufe con toma de tierra tiene dos cuchillas y una tercera a tierra. La cuchilla ancha o la tercera clavija se proporcionan para su seguridad. Si el enchufe suministrado no encaja en su tomacorriente, consulte a un electricista para reemplazar la toma de corriente obsoleta.



**ADVERTENCIA:** El aparato no debe exponerse a goteos o salpicaduras y no debe colocarse sobre el aparato ningún objeto lleno de líquidos, como jarrones.



**ADVERTENCIA:** Para reducir el riesgo de quemaduras, incendios, descargas eléctricas o lesiones a personas:

- Desenchufe de la toma de corriente antes de poner o quitar piezas.
- Es necesaria una estrecha supervisión cuando este dispositivo sea utilizado por, o cerca de niños, inválidos o personas discapacitadas.
- Use este dispositivo solo para su uso previsto como se describe en estas instrucciones. No use accesorios no recomendados por el fabricante.
- Nunca opere el dispositivo si tiene un cable o enchufe dañado, si no funciona correctamente, si se ha caído o dañado, o si se ha caído al agua. Devuelva el dispositivo a un centro de servicio para su examen y reparación.
- Proteja el cable de alimentación de ser pisado o pellizcado, especialmente en los enchufes, receptáculos de conveniencia y el punto donde salen del aparato.
- Mantenga el cable alejado de superficies calientes.
- Nunca deje caer ni inserte ningún objeto en ninguna abertura.
- No lo use al aire libre.
- No opere donde se usan productos en aerosol (spray) o donde se administra oxígeno.
- Para desconectar, coloque todos los controles en la posición de apagado, luego retire el enchufe de la toma de corriente.



**PRECAUCIÓN:** No lo conecte a otro tomacorriente de energía reubicable.



**PRECAUCIÓN:** La toma de corriente debe instalarse cerca del equipo y debe ser de fácil acceso.



**PRECAUCIÓN:** Cualquier instalación eléctrica debe realizarse de acuerdo con los códigos eléctricos nacionales y locales.

## INSTRUCCIONES DE SEGURIDAD IMPORTANTES - ES (CONTINUACION)

**Instrucciones de seguridad:** montaje en rack

**Ambiente de operación elevado:** si se instala en un ensamblaje de bastidor cerrado o de varias unidades, la temperatura ambiente de funcionamiento del entorno del bastidor puede ser mayor que el ambiente ambiental. Por lo tanto, se debe considerar la instalación del equipo en un entorno compatible con la temperatura ambiente máxima (Tma) especificada por el fabricante.

**Flujo de aire reducido:** La instalación del equipo en un bastidor debe ser tal que la cantidad de flujo de aire requerida para la operación segura del equipo no se vea comprometida.

**Carga mecánica:** El montaje del equipo en el rack debe ser tal que no se alcance una condición peligrosa debido a una carga mecánica desigual.

**Sobrecarga del circuito:** Se debe considerar la conexión del equipo al circuito de alimentación y el efecto que la sobrecarga del circuito pueda tener sobre la protección de sobrecorriente y el cableado de alimentación. Se debe considerar la consideración apropiada de las clasificaciones de la placa de identificación del equipo al abordar esta preocupación.

**Conexión a tierra confiable:** Se debe mantener la conexión a tierra confiable del equipo de montaje en bastidor. Se debe prestar especial atención a las conexiones de suministro distintas de las conexiones directas al circuito derivado (por ejemplo, el uso de regletas de enchufes).

**Dispositivo de desconexión (equipo enchufable):** La toma de corriente debe instalarse cerca del equipo y debe ser de fácil acceso.

Al usar productos eléctricos, siempre se deben seguir precauciones básicas, que incluyen las siguientes:

- Lea y siga todas las instrucciones antes de usar.
- No hay componentes que el usuario pueda reparar en este dispositivo. La extracción de la cubierta de este dispositivo puede presentar un riesgo de electrocución y anular la garantía.
- El enchufe de red se usa como su dispositivo de desconexión. Este dispositivo debe permanecer fácilmente operable.
- Desconecte este aparato durante tormentas eléctricas o cuando no se use por largos períodos de tiempo.
- No sobrecargue el tomacorriente donde se está conectando este dispositivo. No sobrecargue este dispositivo. Asegúrese de que la carga total de este dispositivo no exceda la que se detalla en la sección de especificaciones de este manual.
- Asegúrese de que este dispositivo esté conectado a una fuente de alimentación de CA debidamente conectada a tierra. Asegúrese de que el dispositivo esté enchufado en una fuente que proporcione los 120 voltios necesarios. No use un adaptador de enchufe que derrote la clavija de tierra del enchufe de CA.

## DIRECTIVA SOBRE RESIDUOS DE APARATOS ELÉCTRICOS Y ELECTRÓNICOS (WEEE)



Eliminación correcta de este producto: este símbolo indica que este producto no debe desecharse con la basura doméstica, de acuerdo con la Directiva WEEE (2012/19/EU) y legislación nacional. Este producto debe llevarse a un centro de recolección con licencia para el reciclaje de residuos de equipos eléctricos y electrónicos (EEE). El mal manejo de este tipo de residuos podría tener un posible impacto negativo en el medio ambiente y la salud humana debido a sustancias potencialmente peligrosas que generalmente están asociadas con EEE. Al mismo tiempo, su cooperación en la eliminación correcta de este producto contribuirá al uso eficiente de los recursos naturales. Para obtener más información sobre dónde puede llevar su equipo de desechos para reciclar, comuníquese con la oficina local de la ciudad o con el servicio de recolección de desechos domésticos.

## INSTRUCTIONS DE SÉCURITÉ IMPORTANTES - FR

- Lire ces instructions.
- Respectez tous les avertissements.
- Nettoyer uniquement avec un chiffon sec.
- Conservez ces instructions.
- Suivez toutes les instructions
- N'utilisez que des accessoires spécifiés par le fabricant.

### COMPRENDRE LES SYMBOLES DE SÉCURITÉ



**DANGER TENSION DANGEREUSE:** Le symbole de la pointe de flèche, dans un triangle équilatéral, est destiné à alerter l'utilisateur sur la présence de tension dangereuse non isolée dans l'enceinte du produit qui peut être d'une ampleur suffisante pour constituer un risque d'électrocution.



**AVERTISSEMENT:** Un avertissement vous avertit d'une situation pouvant entraîner des blessures graves ou la mort.



**ATTENTION:** Une attention vous avertit d'une situation pouvant entraîner des blessures mineures ou des dommages au produit et/ou à la propriété.



**AVERTISSEMENT:** Les produits Middle Atlantic, les systèmes électriques sont conformes et doivent être correctement mis à la terre conformément aux exigences du Code national de l'électricité en vigueur ou aux codes administrés par les autorités locales. Tous les produits électriques peuvent présenter un risque d'électrocution ou d'incendie s'ils sont mal installés ou utilisés. Les produits électriques peuvent porter la marque d'un laboratoire d'essais reconnu au niveau national (NRTL) et doivent être installés conformément au code électrique local et/ou national en vigueur.



**AVERTISSEMENT:** Refus de lire, comprendre et suivre la renseignements suivants peut traduire par de graves blessures, des dommages à l'équipement ou invalider la garantie. Il est la responsabilité de l'installateur / utilisateur de s'assurer que ce produit est chargé conformément aux spécifications.



**AVERTISSEMENT:** Risque de choc électrique: Brancher le meuble uniquement à une prise correctement mise à la terre. Ne pas détériorer le dispositif de sécurité de la fiche polarisée ou de la fiche de terre. Une fiche polarisée possède deux broches, dont l'une plus large que l'autre. Une fiche de type terre possède deux broches et une troisième de mise à la terre. La broche large ou la troisième fiche sont fournies pour des raisons de sécurité. Si la fiche fournie n'entre pas dans votre prise de courant, veuillez faire appel à un électricien pour remplacer la prise obsolète.



**AVERTISSEMENT:** L'appareil ne doit pas être exposé à des éclaboussures et aucun objet rempli de liquide, comme des vases, ne doit être placé sur l'appareil.



**AVERTISSEMENT:** Pour réduire les risques de brûlures, d'incendie, de choc électrique ou de blessures:

- Débrancher de la prise électrique avant d'installer ou de retirer des pièces.
- Surveiller étroitement ce meuble s'il est utilisé par ou à proximité d'un enfant, d'une personne invalide ou handicapée.
- N'utiliser ce meuble que pour l'usage auquel il est destiné, tel que décrit dans la présente fiche d'instructions. Ne pas utiliser d'accessoires non recommandés par le fabricant.
- Ne jamais utiliser ce meuble si le cordon ou la prise est endommagé, s'il ne fonctionne pas correctement, s'il est tombé ou est endommagé, ou s'il est tombé dans l'eau. Renvoyer le meuble à un centre de service après-vente pour qu'il soit examiné et réparé.
- Le cordon d'alimentation doit être placé de manière à éviter qu'il soit piétiné ou pincé, notamment au niveau des prises, des réceptacles et à la sortie de l'appareil.
- Garder le cordon d'alimentation loin des surfaces chauffées.
- Ne jamais faire tomber ou introduire un objet dans une ouverture.
- Ne pas utiliser en extérieur.
- Ne pas utiliser dans des lieux où des produits aérosols sont utilisés ou à proximité d'une source d'oxygène.
- Pour débrancher, placer tous les boutons en position off, puis retirer la fiche de la prise électrique.



**ATTENTION:** Ne branchez pas dans une autre puissance robinet relocalisable.



**ATTENTION:** La prise de courant doit être installée près de l'équipement et doit être facilement accessible.



**ATTENTION:** Toute installation électrique doit être effectuée conformément aux codes électriques nationaux et locaux.

## INSTRUCTIONS DE SÉCURITÉ IMPORTANTES - FR (CONTINUER)

**Consignes de sécurité:** montage en rack

**Température de fonctionnement élevée:** Si installé dans un rack fermé ou à unités multiples, la température ambiante de fonctionnement de l'environnement du rack peut être supérieure à ambiante de la pièce. Par conséquent, il faudrait envisager d'installer l'équipement dans un environnement compatible avec la température ambiante maximale (T<sub>ma</sub>) spécifiée par le constructeur.

**Réduction Air accréditives:** Installation de l'équipement dans un rack doit être telle que la quantité de flux d'air nécessaire au bon fonctionnement de l'équipement ne soit pas compromise.

**Chargement mécanique:** Le montage de l'équipement dans le rack doit être telle qu'une condition dangereuse ne lié à un chargement mécanique irrégulier.

**Surcharge des circuits:** Il faudrait envisager à la connexion de l'équipement au circuit d'alimentation et l'effet que la surcharge du circuit pourrait avoir sur la protection contre les surintensités et le câblage d'alimentation. Examen approprié des équipements évaluations de la plaque signalétique doit être utilisée pour traiter de cette préoccupation.

**Mise à la terre fiable:** Fiable mise à la terre de l'équipement de montage en rack doit être maintenue. Une attention particulière devrait être accordée aux connexions d'alimentation autres que les connexions directes vers le circuit de dérivation (par exemple de l'utilisation de bandes de puissance).

**Appareil Disconnect (Équipement Pluggable):** La prise de courant doit être installée à proximité du matériel et doit être facilement accessible.

Lors de l'utilisation des produits électriques, des précautions de base doivent toujours être respectées, y compris les suivantes:

- Lire et suivre toutes les instructions avant l'utilisation du matériel.
- Il n'y a pas de composants réparables par l'utilisateur au sein de cet appareil. Retrait de la couverture de cet appareil peut présenter un danger d'électrocution et annuler la garantie.
- La fiche secteur est utilisée comme sectionneur de courant. Ce dispositif doit rester en état de marche.
- Débrancher cet appareil pendant les orages ou s'il n'est pas utilisé pendant de longues périodes.
- Ne surchargez pas le réceptacle de mur ou le circuit qui fournit l'énergie à ce appareil. Ne pas surcharger cette appareil. S'assurer que la charge totale à cet appareil ne dépasse pas celle qui est répertoriée dans la section des spécifications de ce manuel.
- Assurez-vous cet appareil est connecté à une source d'alimentation C/A avec mise à la terre. Assurez-vous cet appareil est branché sur une source d'alimentation fournissant les nécessaires 120V. Ne pas utiliser un adaptateur qui contrecarre la broche de terre de la prise du cordon d'alimentation.

## DIRECTIVE SUR LES DÉCHETS D'ÉQUIPEMENTS ÉLECTRIQUES ET ÉLECTRONIQUES (WEEE)



Élimination correcte de ce produit: Ce symbole indique que ce produit ne doit pas être éliminé avec les ordures ménagères, conformément à la directive WEEE (2012/19/EU) et à votre législation nationale. Ce produit doit être déposé dans un centre de collecte agréé pour le recyclage des déchets d'équipements électriques et électroniques (EEE). La mauvaise manipulation de ce type de déchets pourrait avoir un impact négatif possible sur l'environnement et la santé humaine en raison de substances potentiellement dangereuses généralement associées aux EEE. Dans le même temps, votre coopération dans l'élimination correcte de ce produit contribuera à une utilisation efficace des ressources naturelles. Pour plus d'informations sur les lieux de recyclage de vos équipements usagés, veuillez contacter votre mairie ou votre service de collecte des ordures ménagères.



# WEIGHT RATINGS

Item	Weight Rating
Chief Fusion Fixed Display Mount Attached to the Forum Collaboration Suite Display Stand (Free Standing or Floor-to-Wall)	150 lbs. (68 kg) Maximum Total Rated Load <b>NOTE:</b> The combined maximum total rated load of the mount installed on the stand must not exceed the total rated load indicated. This includes the mounting of any additional camera, soundbar/audio, and AV accessories on the stand or mount.
Display Stand's Bottom Rackmount Storage	50 lbs. (23 kg) Maximum Total Rated Load Per Bay
Display Stand's Top Small Device Storage	30 lbs. (14 kg) Maximum Total Rated Load
Single Display Size of up to 100"	150 lbs. (68 kg) Maximum Total Rated Load Per Display <b>NOTE:</b> For Jupiter 105" and Jupiter 81" displays only, the maximum total rated load per display is 225 lbs. (102 kg).
Double Display Size of up to 75"	300 lbs. (136 kg) Maximum Total Rated Load Per Display



**WARNING:** This product is intended for use only with the products and maximum weights indicated. Use with other products or products heavier than the maximum weights indicated may result in instability causing possible injury. Total equipment weight must not exceed the amounts indicated on the previous table.

**ADVERTENCIA:** Este producto está destinado a ser utilizado solo con los productos y pesos máximos indicados. El uso con otros productos o productos más pesados que el peso máximo indicado puede causar inestabilidad que puede causar lesiones. El peso total del equipo no deberá superar las cantidades indicadas en el cuadro anterior.

**AVERTISSEMENT:** Ce produit est destiné à être utilisé uniquement avec les produits et les poids maximum indiqués. L'utilisation avec d'autres produits ou produits plus lourds que le poids maximum indiqué peut entraîner une instabilité pouvant causer des blessures. Le poids total de l'équipement ne doit pas dépasser les quantités indiquées dans le tableau précédent.

## SUPPLIED COMPONENTS AND HARDWARE

If any pieces are missing or damaged, please report it immediately to Technical Support at [av.support@legrand.com](mailto:av.support@legrand.com) or (866) 977-3901.

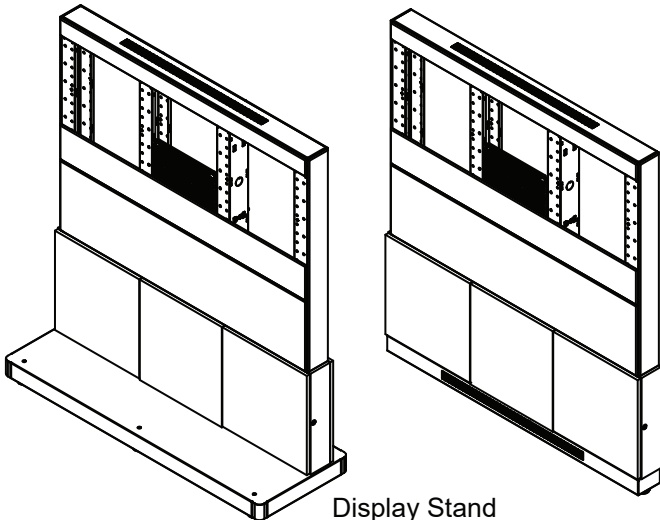

**Display Stand**  
**NOTE:** Free Standing and Floor-to-Wall models, respectively.

A

### (2x) CHIEF GRADE 5 TOGGLER KIT (Model Number: FCAT1)

**NOTE:** Floor-to-Wall Display Stand Models Only

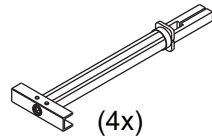

(4x)  
**SNAPTOGGLE®**  
Anchor  
B

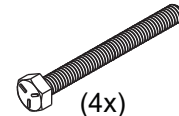

(4x)  
1/4"-20 x 2 1/2"  
Hex Head Bolt  
C



(4x)  
1/4"-20 Washer  
D

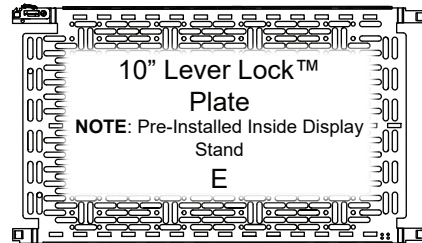

10" Lever Lock™  
Plate  
**NOTE:** Pre-Installed Inside Display Stand  
E

(2x)  
Securing Rivet  
F

### FOR FREE STANDING DISPLAY STAND ONLY



(6x)  
5/8" Dome Plug  
**NOTE:** If Free-Standing display stand is purchased.  
G

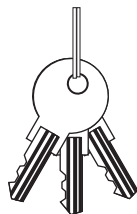

Rear Door Keys  
Spare Set Part Number  
(500-00828)  
H

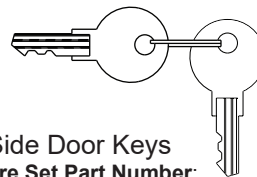

Side Door Keys  
Spare Set Part Number:  
(500-01173)  
J



(20x)  
Washer  
K

# SUPPLIED COMPONENTS AND HARDWARE (CONTINUED)

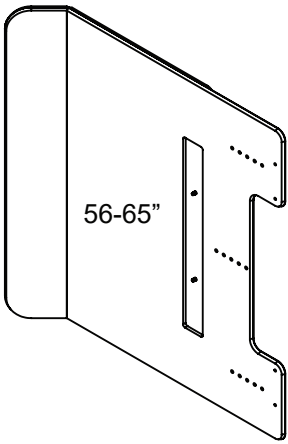

Dual Display Sizes
50-55"
56-65"
66-75"
Single Display Sizes
70-75"
76-85"
86-100"
Jupiter 81" ®
Jupiter 105" ®

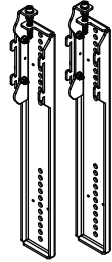

Shroud Interface Bracket Pair  
**NOTE:** Only the 75" dual display shroud kit contains (2x) bracket pairs.

M

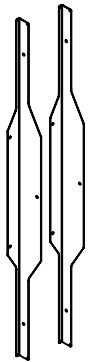

Rear Shroud Bracket Pair

N

Shroud Pairs

**NOTE:** Left shroud is shown for a 56-65" Dual Display.

L



Horizontal Extrusion

P

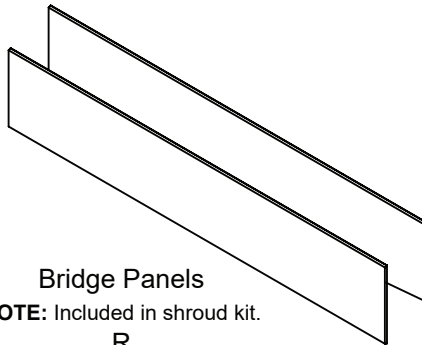

Bridge Panels

**NOTE:** Included in shroud kit.

R



(8x)  
 12 x 5/8"  
 Phillips Head Sheet  
 Metal Screw

S

Single or Dual Display	Qty.
Single	1 Extrusion
Dual	2 Extrusions

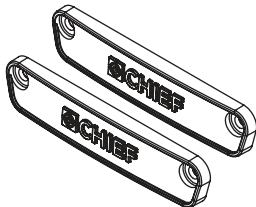

Extrusion End Cap Pair

T



(4x)  
 1/4-20 x 1/2"  
 Pan Head Phillips Thread  
 Tapping End Cap Screws

U



(4x)  
 5/16"-18  
 Hex Nut

V

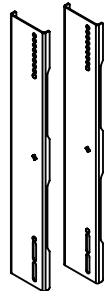

Adapter Bracket Pair  
**NOTE:** For Jupiter 105" displays only.

W

## CONNECTING BRACKET KIT (FOR DUAL DISPLAY STAND ONLY, IF PURCHASED)

(Model Number: FMSHC1)

**NOTE:** Quantity listed per hardware bag.

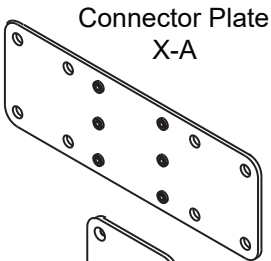

Connector Plate  
 X-A

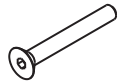

(6x)  
 10-24 x 1-1/2"  
 Flat Head Cap  
 Screw  
 X-B



(8x)  
 5/16 x 5/8"  
 Button Head  
 Cap Screw  
 X-C

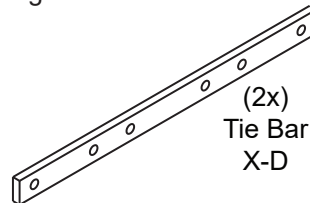

(2x)  
 Tie Bar  
 X-D

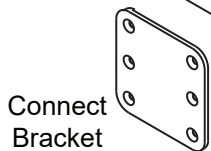

Connect  
 Bracket  
 X-E



(8x)  
 5/16"  
 Split Washer  
 X-F



(8x)  
 Friction  
 Washer  
 X-G

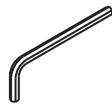

3/16"  
 Hex Key  
 X-H

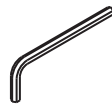

1/8"  
 Hex Key  
 X-J



(18x)  
 1/4"-20  
 Flange Nut  
 Y

## SUPPLIED COMPONENTS AND HARDWARE (CONTINUED)



Display Interface Pair  
Z

Single or Dual Display	Qty.
Single Display	1 Pair
Dual Display	2 Pairs

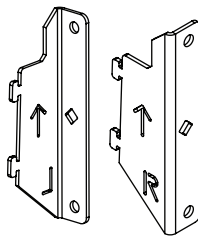

Horizontal Extrusion Bracket Pair  
AA

Number of Extrusions	Qty. (L and R)
1 Extrusion	2 Brackets (1 of ea.)
2 Extrusions	4 Brackets (2 of ea.)

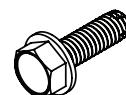

(8x)  
5/16-18 x 1"  
Machine Screw  
AB



(8x)  
5/16"-18  
Flange Nut  
AC

## DISPLAY INTERFACE PAIR HARDWARE

**NOTE:** Two sets of the following interface hardware (9900-002248) are provided for dual display installations.



(4x)  
M4 x 12mm  
Pan Head Screw  
IP-A



(4x)  
M4 x 20mm  
Pan Head Screw  
IP-A



(4x)  
M4 x 25mm  
Pan Head Screw  
IP-A



(4x)  
M5 x 12mm  
Pan Head Screw  
IP-A



(4x)  
M5 x 20mm  
Pan Head Screw  
IP-A



(4x)  
M5 x 25mm  
Pan Head Screw  
IP-A



(4x)  
M6 x 12mm  
Pan Head Screw  
IP-G

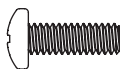

(4x)  
M6 x 20mm  
Pan Head Screw  
IP-A



(4x)  
M6 x 25mm  
Pan Head Screw  
IP-A



(4x)  
M8 x 12mm  
Pan Head Screw  
IP-A

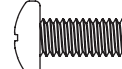

(4x)  
M8 x 20mm  
Pan Head Screw  
IP-A



(4x)  
M8 x 30mm  
Pan Head Screw  
IP-A



(8x)  
Spacer  
IP-B



(4x)  
Washer  
IP-C

### NOTE:

- To order more hardware, contact support at [av.support@legrand.com](mailto:av.support@legrand.com) or (866) 977-3901.
- Additional hardware is included that may not be required for your installation.

## REQUIRED TOOLS

- Protective Eyewear
- Pencil
- Electric Drill
- 1/2" Drill Bit
- 3/32" Drill Bit
- Level
- Socket wrench
- 5/16" Socket
- 7/16" Socket
- 1/2" Socket
- #2 Philips Screwdriver
- #2 Philips Bit
- Mini Ratchet
- Stubby #2 Phillips Screwdriver



**WARNING:** Use tools with caution and follow all necessary safety protocols.

**ADVERTENCIA:** Utilice las herramientas con precaución y siga todos los protocolos de seguridad necesarios.

**AVERTISSEMENT:** Utiliser des outils avec prudence et suivre tous les protocoles de sécurité nécessaires.

## INTRODUCTION

### NOTE:

- Please take the time to carefully unpack and inspect all of the products you ordered and save this instruction sheet for future use.
- Maintenance and care information is provided in Care and Cleaning of Products (I-00788) and Unpacking and Handling Precautions (I-00787) for your convenience.
- All documents may be accessed at [www.legrandav.com](http://www.legrandav.com).

Your Forum™ collaboration suite configuration may include a free-standing XL display stand, a floor-to-wall XL display stand, and/or a table equipped with optional Wiremold ModPower™ modular power units (table and ModPower units sold separately).

Use the topics in this instruction sheet in order of appearance to attach the floor-to-wall XL display stand to your wall (if applicable), the configuration of brackets and panels, and attaching your display(s) (not provided) to your display stand.

If you purchased a Forum™ Collaboration Suite Display Stand for Single Displays (100-00066) or a Forum™ Collaboration Suite Table Option (100-00086), please refer to those respective instruction sheets provided with your product or download them anytime from our website.

For more information, refer to the following Forum™ Collaboration Suite product page at [www.legrandav.com](http://www.legrandav.com):

[https://www.legrandav.com/Products/Technical\\_Furniture/Collaboration/Forum\\_Collaboration\\_Suite](https://www.legrandav.com/Products/Technical_Furniture/Collaboration/Forum_Collaboration_Suite)

## REMOVING THE PANELS FROM YOUR DISPLAY STAND

1. Carefully tug at the magnetic sides of the front panels to remove from the display stand frame (A) and set aside for re-installation. (**FIGURE A**)
2. Carefully lift up the side panel to unhook it from the display stand frame and set aside for re-installation.

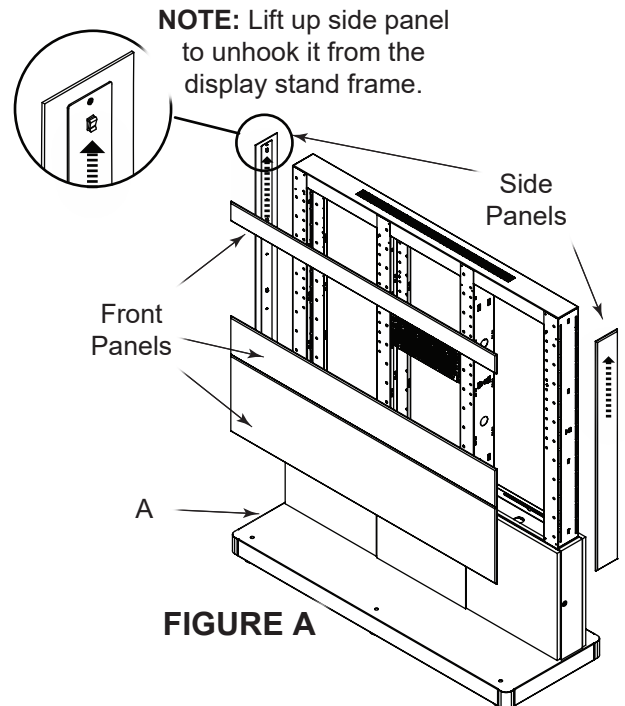
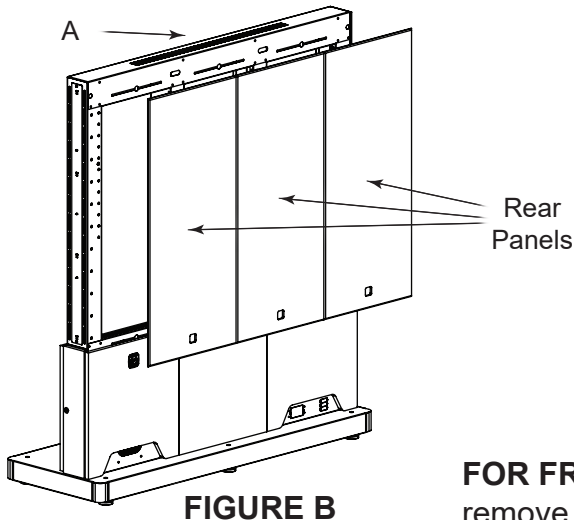

**FOR FREE-STANDING MODELS ONLY:** Repeat step 1 to remove rear panels from your display stand. (**FIGURE B**)

## ATTACHING THE DISPLAY STAND TO YOUR WALL (FLOOR-TO-WALL MODELS ONLY)



**WARNING:** This procedure requires at least one additional person.

**ADVERTENCIA:** Este procedimiento requiere al menos una persona adicional.

**AVERTISSEMENT:** Cette procédure nécessite au moins une personne supplémentaire.

1. Carefully team lift your display stand (A) and place it on its feet against your desired mounting wall.



**WARNING:** The display stand must always bear its weight on its feet when wall mounted.

**ADVERTENCIA:** El soporte de visualización siempre debe soportar su peso en los pies cuando se monta en la pared.

**AVERTISSEMENT:** Le présentoir doit toujours supporter son poids sur ses pieds lorsqu'il est fixé au mur.

**NOTE:** Consider power receptacles on the wall and power requirements when positioning your display stand.

2. Use a pencil to draw horizontal lines on your wall from the center of the top and bottom keyhole slots (shaded) of the display stand. **(FIGURE C)**
3. With the display stand still on the wall, mark your desired keyhole slot drilling locations along top and bottom keyhole slot lines (drawn during previous step) as shown.
4. Carefully team lift your display stand away from the wall.

**NOTE:**

- If securing to a wall with steel or wood studs, use a pencil and a stud finder to align your keyhole slot drilling locations along top and bottom keyhole slot lines (drawn during step 2) to hit the studs.
- If you are not securing your display stand into steel studs using the provided SNAPTOGGLE® anchors (B), and instead are going into wood studs, you must provide your own lag bolt hardware that meets the appropriate weight ratings specified in “Weight Ratings” on page 9.
- If you are not securing your display stand into cinderblocks using the provided SNAPTOGGLE anchors (B), and instead are going into a solid concrete wall, you must also provide your own concrete anchor hardware meeting the appropriate weight ratings specified.

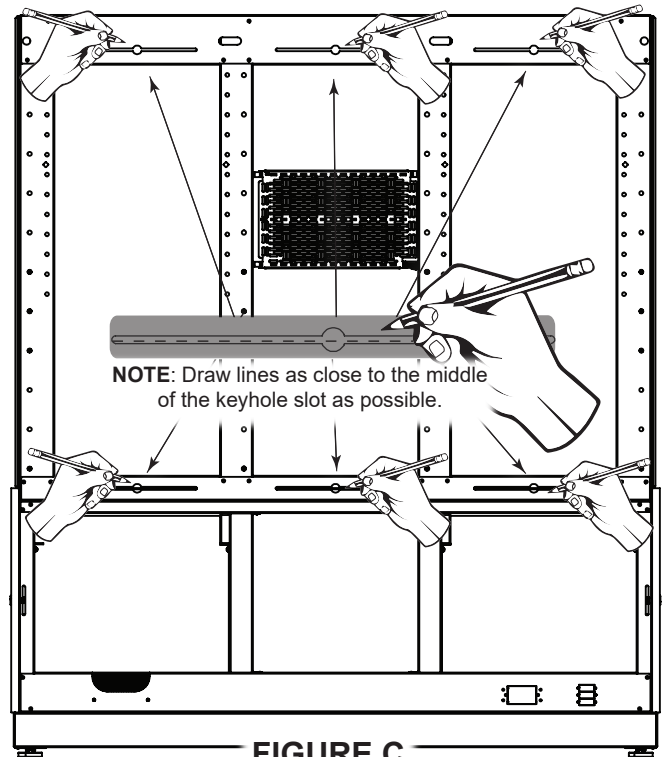

**FIGURE C**



**WARNING:** Customer-provided mounting hardware must be used on all four keyhole slot locations when securing the display stand to any wall type and the unit must be set on the ground.

**ADVERTENCIA:** El material de montaje proporcionado por el cliente debe utilizarse en las cuatro ranuras de los orificios de bloqueo al fijar el soporte de pantalla a cualquier tipo de pared y la unidad debe colocarse en el suelo.

**AVERTISSEMENT:** Le matériel de montage fourni par le client doit être utilisé sur les quatre emplacements des trous de serrure lors de la fixation du support d'affichage à tout type de mur et l'unité doit être placée sur le sol.

## ATTACHING THE DISPLAY STAND TO YOUR WALL (IF PURCHASED, CONTINUED)



**WARNING:** When securing to a wall with steel or wood studs, your mounting hardware must hit the stud through both top and bottom keyhole slot locations on at least one side of your display stand for proper support.

**ADVERTENCIA:** Al asegurar a una pared con de acero o madera estructuras, su hardware de montaje debe fijarse al material a través de ambos lugares de ranura de ojo de cerradura superior e inferior en al menos un lado de su soporte de pantalla para un soporte suficiente.

**AVERTISSEMENT:** Lors de la fixation à un mur avec des montants en acier ou en bois, votre matériel de montage doit toucher le montant à travers les emplacements des fentes en trou de serrure supérieur et inférieur sur au moins un côté de votre présentoir pour un support approprié.

5. The remaining sections of this topic show you how to attach the display stand to your specific wall type as follows:

- “Attaching the Display Stand to a Wall With Steel Studs or Cinderblocks” on page 14.
- “Attaching the Display Stand to a Wall With Wood Studs” on page 15.
- “Attaching the Display Stand to a Solid Concrete Wall” on page 15.

**NOTE:** If your installation requires additional measurements and details, refer to the technical specification (120-00027) at [www.legrandav.com](http://www.legrandav.com).

### Attaching the Display Stand to a Wall With Steel Studs or Cinderblocks

**NOTE:** Adjust torque on power driver to the “drill” setting.

1. Use electric drill and ½” drill bit to drill holes in all the marked keyhole slot locations. You must hit wall studs (where applicable) in top and bottom keyhole slots on at least one side of the display stand for proper support.

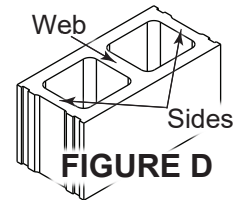

**NOTE:** If securing to cinderblocks, avoid drilling into webs and sides as shown. (FIGURE D)

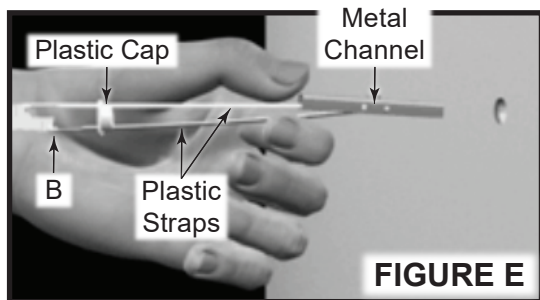

2. Insert SNAPTOGGLE® anchor (B) into a hole by holding the metal channel flat alongside the plastic straps and sliding the channel through the hole as shown. (FIGURE E)

3. Make the plastic strap handles even to force the metal channel perpendicular to the entire anchor. (FIGURE F)

4. Secure the anchor by firmly sliding the plastic cap along the straps until the flange of the cap is flush with the wall.

5. Snap off plastic straps from the anchor by carefully bending them toward the wall. (FIGURE G)

6. Repeat steps 2 - 5 to insert SNAPTOGGLE anchors (B) into all of your keyhole slot location holes drilled during step 1.

**NOTE:** Adjust torque on power driver to lightest setting and only increase as necessary.

7. Team lift the display stand and place it against your mounting wall aligning keyhole slots with the prepared holes and anchors.

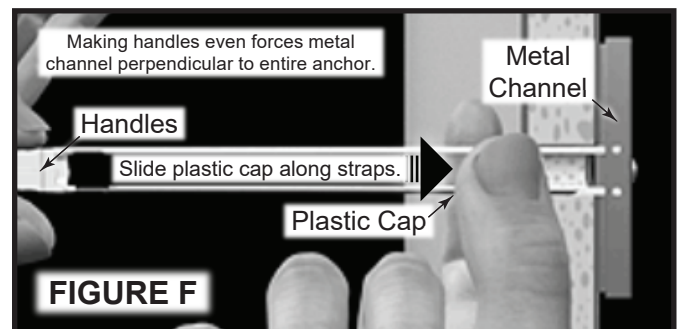

## ATTACHING THE DISPLAY STAND TO YOUR WALL (IF PURCHASED, CONTINUED)

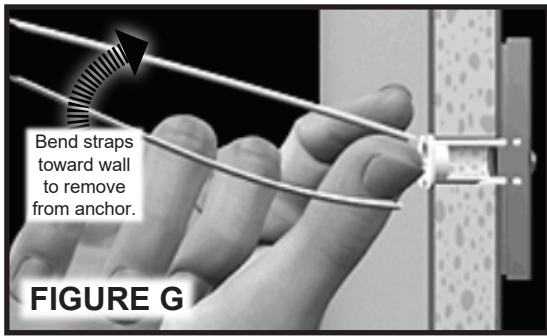

8. Place a level on the top center of your display stand and make any final adjustments to the leveling feet (by carefully team tilting the display stand) as necessary.
9. Use electric drill, 7/16" socket, (4x) 1/4"-20 x 2 1/2" bolts (C) and (4x) 1/4"-20 washers (D) through keyhole slots and into the anchors to secure the stand to your wall.

### Attaching the Display Stand to a Wall With Wood Studs

**NOTE:** Adjust torque on power driver to the "drill" setting.

1. Use protective eyewear, electric drill, and 3/32" drill bit to drill holes in all the marked keyhole slot locations. You must hit wall studs in top and bottom keyhole slots on at least one side of the display stand for proper support.

**NOTE:** Adjust torque on electric drill to lightest setting and only increase as necessary.

2. Team lift the display stand and place it against your mounting wall aligning keyhole slots with the prepared holes and anchors.
3. Place a level on the top center of your display stand and make any final adjustments to the leveling feet (by carefully team tilting the display stand) as necessary.
4. Use electric drill, 7/16" socket, (6x) 1/4" x 2 1/2" lag bolts (C, not provided), and (6x) 1/4"-20 washers (D) through keyhole slots and into the drilled holes to secure the stand to your wall.

### Attaching the Display Stand to a Solid Concrete Wall

**NOTE:** When securing your display stand (A) to a solid concrete wall, you must provide your own concrete anchors that support the weight ratings specified in "Weight Ratings" on page 9.

Secure your display stand (A) to a solid concrete wall by using a procedure similar to "Securing the Display Stand to a Wall With Steel Studs or Cinderblocks" on page 14.

## REMOVING THE DOORS FROM YOUR DISPLAY STAND

1. Use side door keys (J) to unlock the outer doors from the lower bay. (**FIGURE H**)

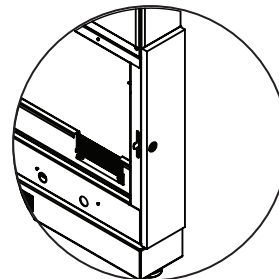
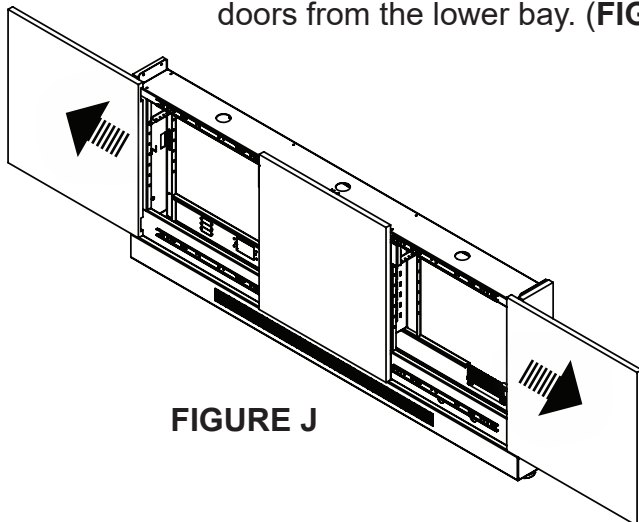

**NOTE:**  
Door locks are located on side of display stand. Right door lock shown.

2. Carefully push outer doors into the open position as shown. (**FIGURE J**)

**NOTE:** Middle door cannot be removed until outer doors are removed or opened.

## REMOVING THE DOORS FROM YOUR DISPLAY STAND (CONTINUED)

3. Push the the sliding rail outward while pressing the release lever until it is exposed. (**FIGURE K**)

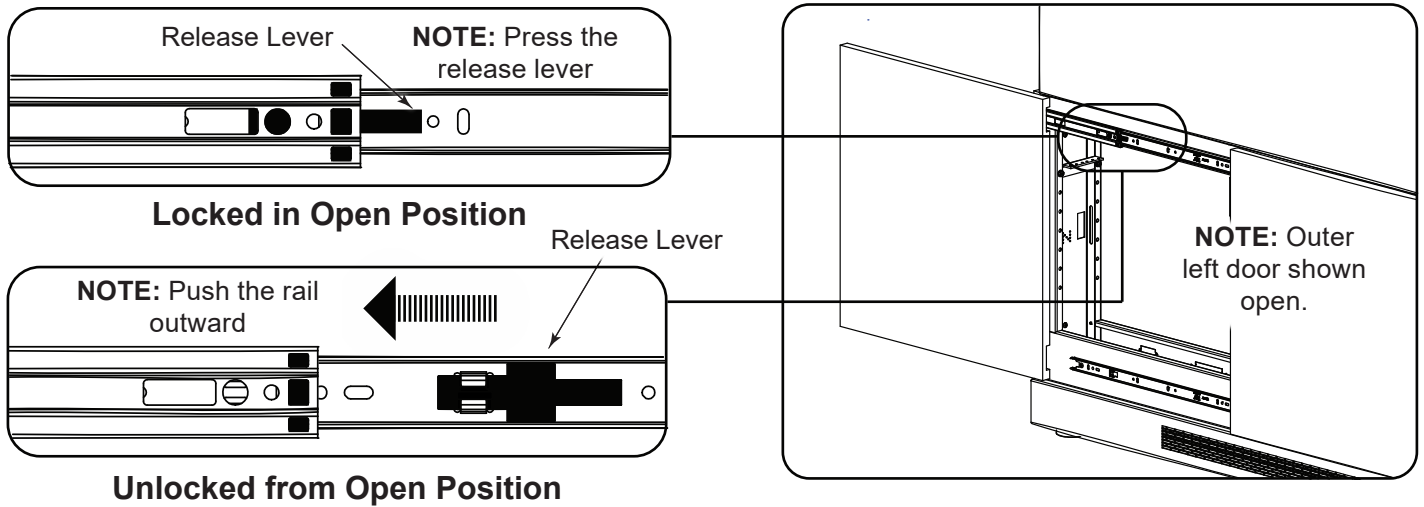

**FIGURE K**

4. Pull and lift to remove the door completely from the sliding rail and set aside for re-installation.

5. Repeat steps 3 and 4 for the other outer door.

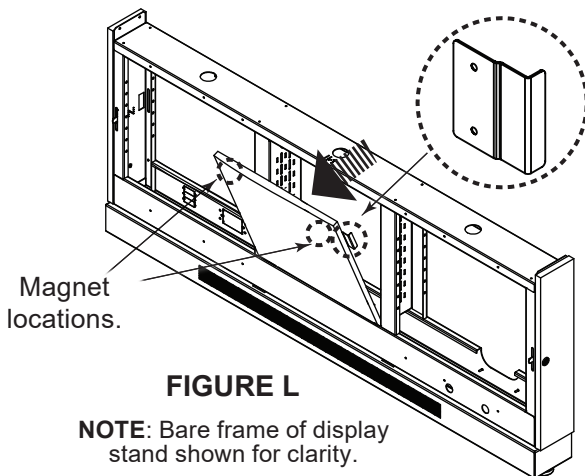

**FIGURE L**

**NOTE:** Secured with magnets, the middle door remains in place after removing the outer doors.

6. Pull the middle front door to remove it and set aside for re-installation. (**FIGURE L**)

**FREE STANDING DISPLAY STAND ONLY:** A separate set of 3 door keys (H) provided for the rear doors.

7. Use a rear door key (H) to unlock each door (left, middle, and right).

8. Pull the latch until the door opens as shown. (**FIGURE M**)

9. Lift up the door to remove it and set aside for re-installation. Repeat the previous two steps to remove the remaining doors.

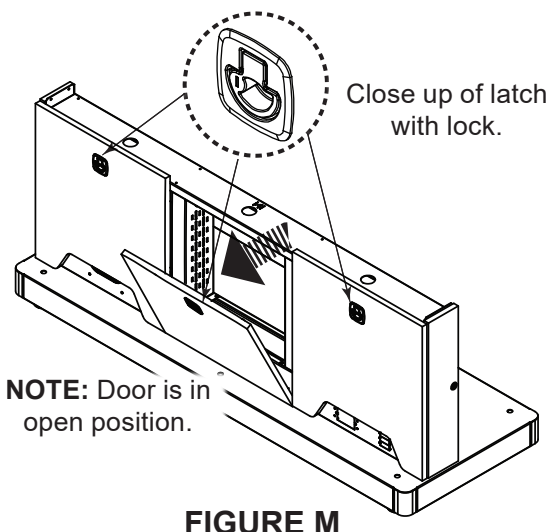

**FIGURE M**



## REPOSITIONING THE 10" LEVER LOCK PLATE

### NOTE:

- One 10" Lever Lock plate (E) is pre-installed inside of the display stand. For more information, contact support at [av.support@legrand.com](mailto:av.support@legrand.com) or (866) 977-3901.
- This topic shows how to reposition your pre-installed 10" Lever Lock (E), if needed.

1. Press the clip and lift the same side of the 10" plate from the display stand column. (**FIGURE P**)
2. Reverse the steps (inserting the 10" plate tabs on the on the side without the clip first) to re-install the 10" plate to a new location inside the display stand, if desired.

### NOTE:

- There are 4x mounting positions available for the three upper columns on the front and rear side of the display stand. (**FIGURE N**)
- The bottom-middle bay has (3x) mounting positions available for one Lever Lock plate in three different locations (first, second, and third column).

3. Insert securing rivets (F) on the tab beneath the clip of the 10" plate to lock it in place.

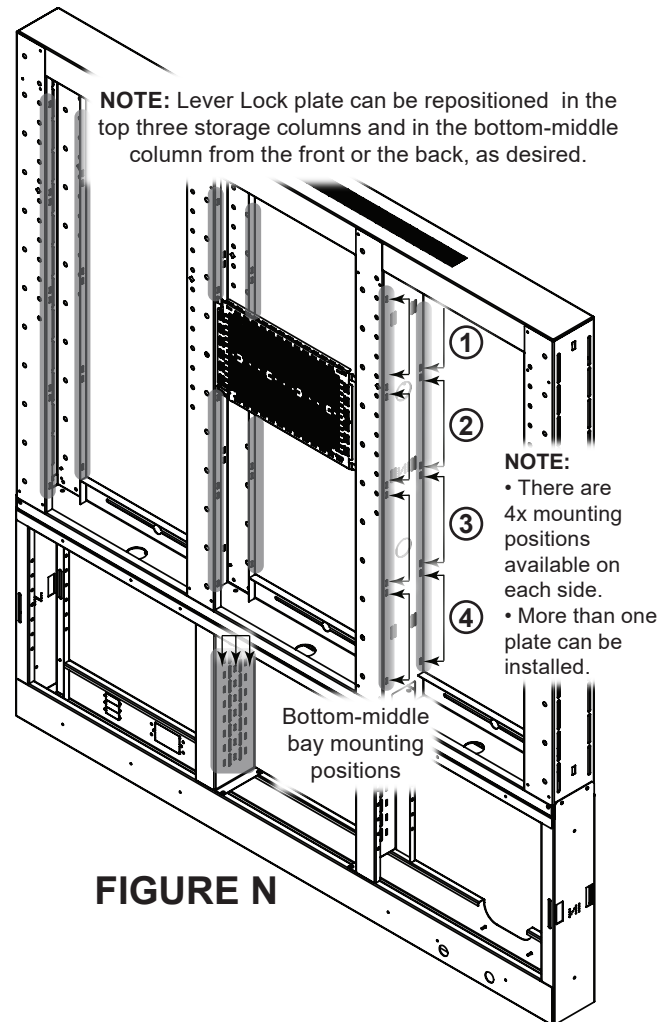

**FIGURE N**

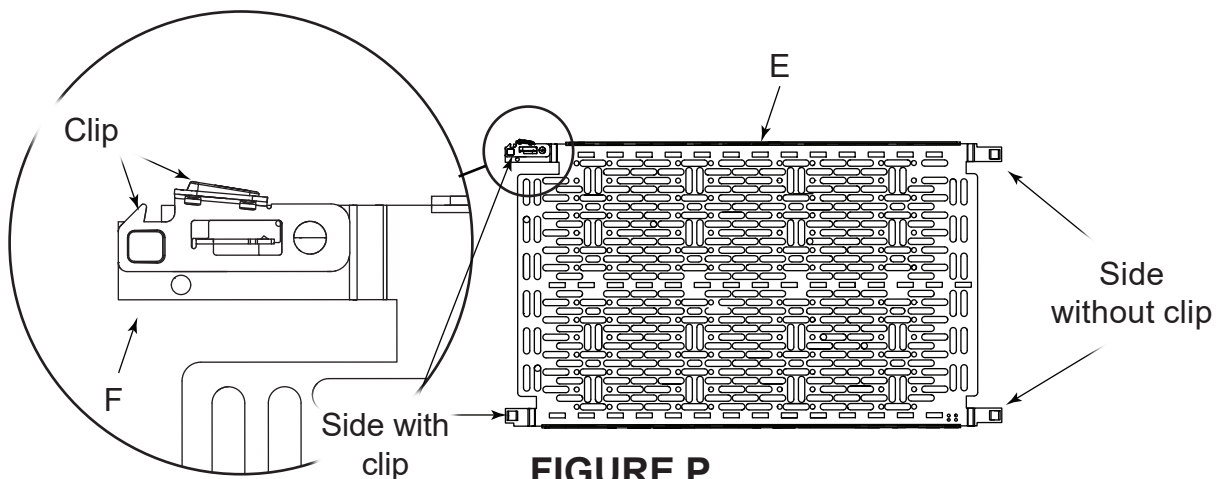

**TIP:** If necessary, you can remove the securing rivet by pushing its tip end out of the hole with a small screwdriver, and then pulling by hand at the rivet's head.

## USING TOP SMALL DEVICE STORAGE AND BOTTOM RACKMOUNT BAYS

1. After installing your equipment, run cabling using openings between the top small device storage columns and the bottom rackmount bays, if needed.

**FLOOR-TO-WALL DISPLAY STANDS ONLY:** Load components into the top small device storage columns and bottom bays at this point in the overall installation and configuration process because access to these areas is more difficult after re-installing the front panel and mounting your display.

**NOTE:**

- Bottom-outside bays on all display stand models includes 2RU rackrail pairs for device storage that may be re-positioned in 7 vertical 1.5" (38mm) increments.
  - Adjust torque on electric drill to lightest setting and only increase as necessary.
2. Use electric drill and a 5/16" socket to remove the 10-32 nuts, reposition the rackrail brackets to the same height, and re-install the nuts as necessary. **(FIGURE R)**

3. Attach devices to the rackrail using a #2 Phillips screwdriver and rack screws (not provided).

**NOTE:** If you are installing equipment to higher rackrail positions in the outer bottom bays, use a short, stubby #2 Phillips screwdriver or a mini ratchet wrench with a #2 Phillips bit to tighten rack screws (not provided). **(FIGURE S)**

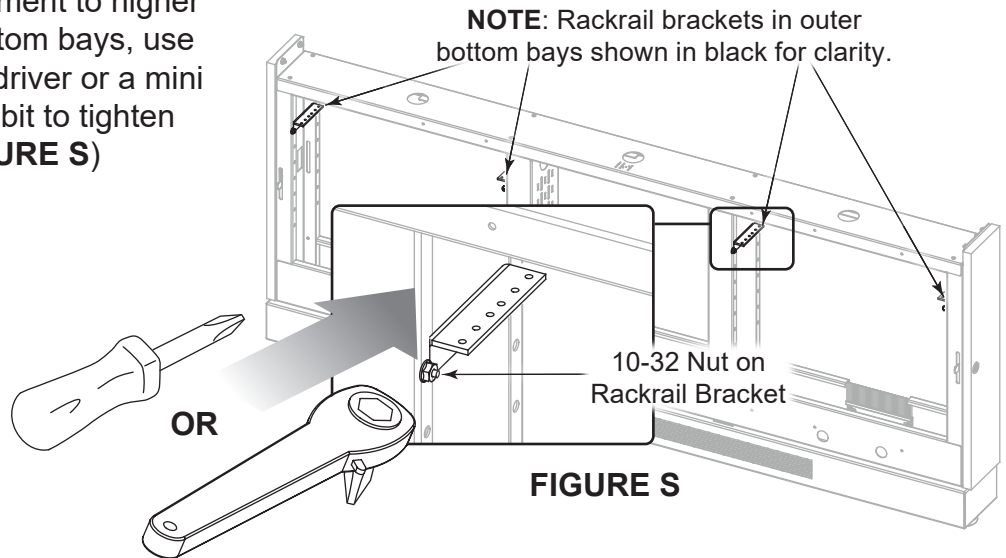
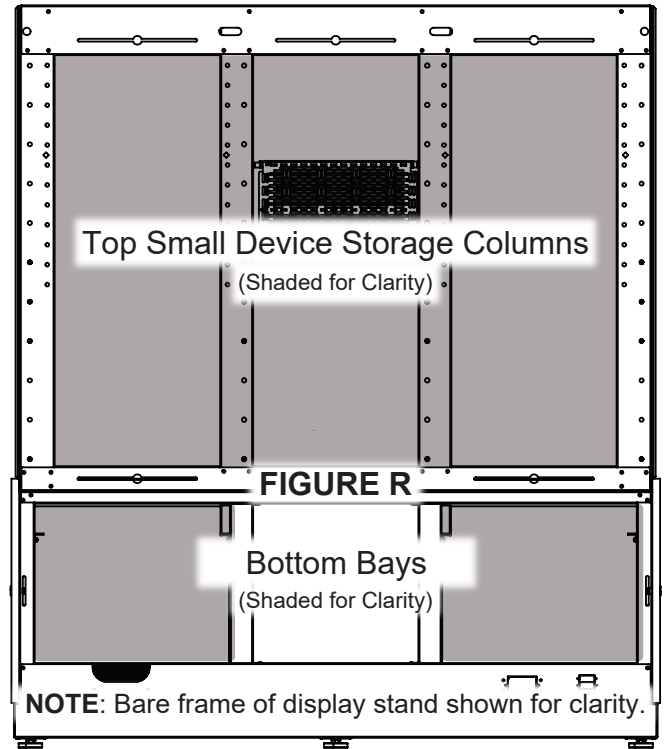

## DETERMINING THE DEFAULT HEIGHT FROM THE FLOOR TO THE BOTTOM OF YOUR DISPLAY

Use the following steps to determine the height from the floor to the bottom edge of your display when mounted on your display stand.

1. Locate the diamond-shaped holes punched into each column of the top small device storage area of your display stand as shown. (FIGURE T)

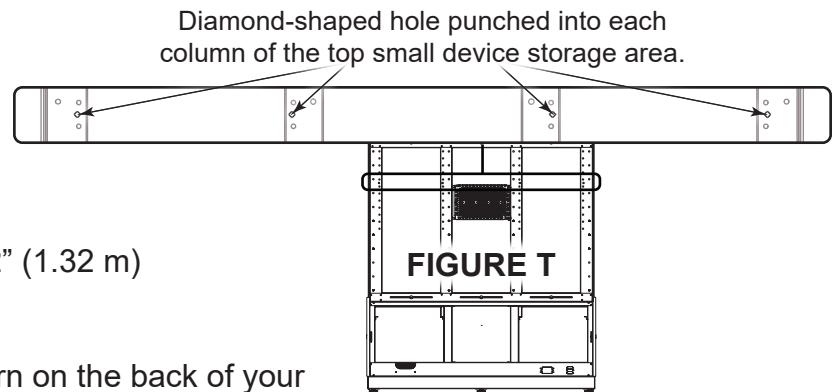

**NOTE:** The diamond holes are located 52" (1.32 m) from the floor.

2. Confirm the location of the VESA pattern on the back of your display (display not provided).

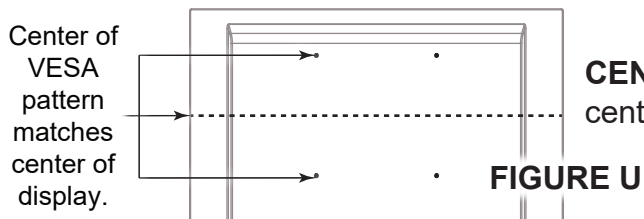

**CENTERED VESA PATTERN:** VESA patterns are often centered on the back of displays. (FIGURE U)

**OFFSET VESA PATTERN:** Sometimes, VESA patterns are offset below the center of displays. If the VESA pattern on the back of your display is offset, measure the difference between the center of the pattern and the center of your display. (FIGURE V)

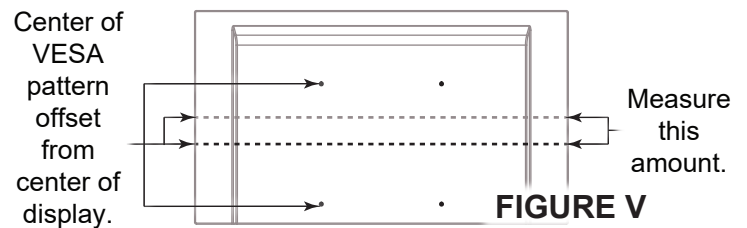

3. Use the data from the previous steps to subtract  $\frac{1}{2}$  the height of your display (if VESA is centered) or  $\frac{1}{2}$  the height of your display and the offset (if applicable) from the 52" (1.32 m) height level. The result is the height from the floor to bottom edge of your display.

Formula if VESA pattern centered on back of display:

$$52'' (1.32 m) - \frac{1}{2} \text{ Height of Your Display} = ?$$

$$52'' (1.32 m) - \frac{1}{2} \text{ Height of Your Display} - \text{VESA Offset Amount} = ?$$

## CUSTOMIZING THE HEIGHT FROM THE FLOOR TO THE BOTTOM OF YOUR DISPLAY

Use the following step to customize the height from the floor to the bottom edge of your display using the default height calculated in the previous topic.

- Use the default height calculated to determine how much higher or lower you would like the bottom edge of your display in 2" (50.8 mm) increments.

**NOTE:** Hole sets for customizing the height of your display are shown. **(FIGURE W)**

**NOTE:** Hole sets shown are spaced in 2" (50.8 mm) increments.

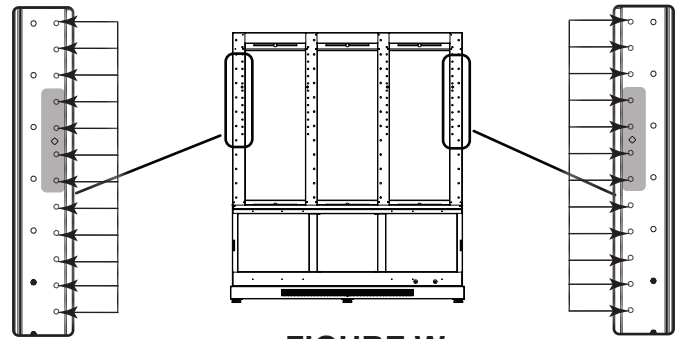

**FIGURE W**

## ATTACHING HORIZONTAL BRACKETS, EXTRUSION, AND MAKING ADJUSTMENTS

Based on the desired bottom edge of your display, plan to install all of your horizontal extrusion brackets (AA) to higher or lower hole sets from where the diamond holes on the brackets and the display stand align.

**NOTE:** The hole sets shown for the brackets are spaced vertically in 2" (50.8 mm) increments. **(FIGURE X)**

**TIP:** Refer to dimension specifications provided with your display.

1. Attach all horizontal extrusion brackets (AA) at the same level higher or lower than diamond holes by 2" (50.8 mm) increments on the display stand.

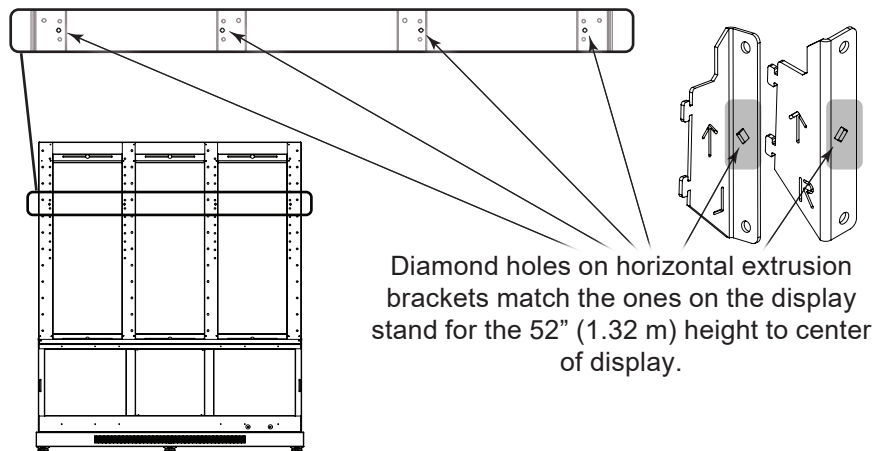

Diamond holes on horizontal extrusion brackets match the ones on the display stand for the 52" (1.32 m) height to center of display.

**FIGURE X**

**NOTE:** Back view of upper frame shown.

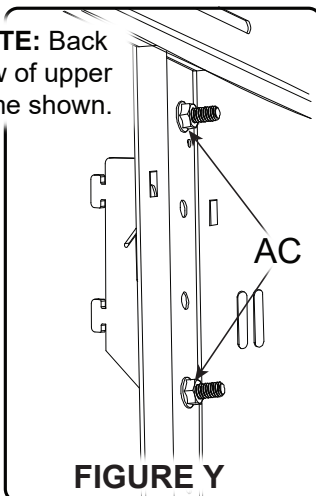

**FIGURE Y**

2. By hand, put (2x) 5/16-18 x 1" machine screws (AB) through keyhole slots where the horizontal extrusion bracket (AA) and the desired hole set on display stand (determined from the previous topic) align, and thread (2x) 5/16"-18 hex nuts (AC) onto the screws as shown. Do not tighten. **(FIGURE Y)**
3. Repeat the process to attach the remaining brackets, all at the same hole set height, onto your display stand.

## ATTACHING HORIZONTAL BRACKETS, EXTRUSION, AND MAKING ADJUSTMENTS (CONT.)

- Slide horizontal extrusion (P) into interlock tabs found on horizontal extrusion brackets (AA, positioned loosely), as shown. **(FIGURE Z)**

**NOTE:** For dual and Jupiter 105" display installations, make sure to attach both extrusions at this point.

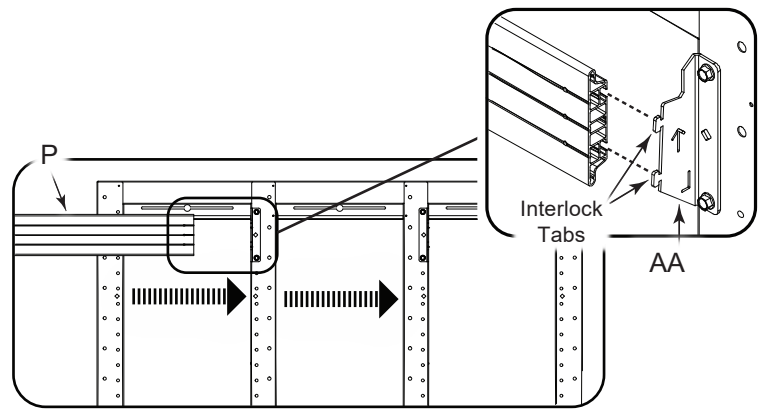

**FIGURE Z**

**FOR SINGLE DISPLAY INSTALLATIONS (EXCEPT JUPITER 105''):** Proceed to the final step.

**FOR DUAL DISPLAY AND SINGLE JUPITER 105" DISPLAY INSTALLATIONS:**

- Refer to corresponding "Chief Fusion Modular Mounting Rails, Connectors and End Cap Kits" installation instructions for the Connecting Bracket kit (FMSHC1) at [www.legrandav.com](http://www.legrandav.com). The connecting bracket kit installation instruction provides details for the coupling of (2x) horizontal extrusions (P).

**NOTE:** For floor to wall models, reach behind the horizontal extrusion (P) to tighten the connecting bracket.

**TIP:** Use a short, stubby #2 Phillips screwdriver or a mini ratchet wrench with a #2 Phillips bit, if necessary.

- While referencing the Chief Fusion Modular Mounting Rails, Connectors and End Cap Kits installation instruction, use hex key and 10-24 x 1-1/2" flat head cap screw to secure the connect bracket to front of mounting rail. **(FIGURE AA)**

- Use 3/16" hex key, 5/16 x 5/8" button head cap screw, 5/16" split washer, and friction washers to fasten connector plate. **(FIGURE AB)**

- Use 1/8" hex key and 10-24 x 1-1/2" flat head cap screw to secure the connect bracket to front of second section of mounting rail.

- Repeat Step 7 to fasten connector plate and completely secure it to the connect plate.

- Use socket wrench and 1/2" socket to tighten machine screws and nuts (previously tightened by hand) to the horizontal extrusion brackets (AA).

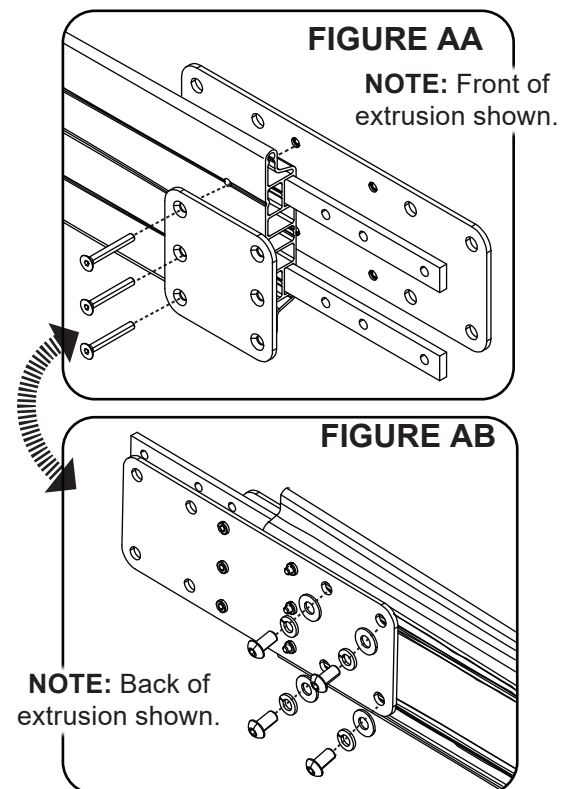

## ATTACHING SHROUD BRACKETS AND MAKING ADJUSTMENTS

Based on the desired height of your horizontal extrusion and the number of your displays, plan to prep and install the shrouds at the same level.

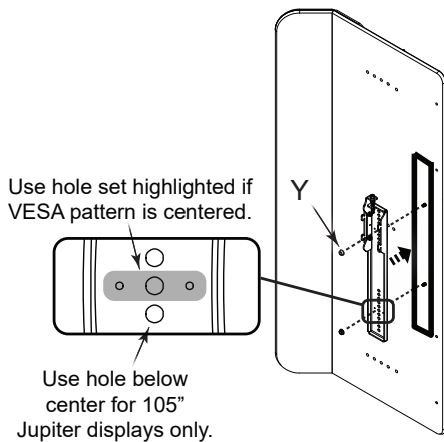

**FIGURE AC**

**NOTE:** Attach shroud interface bracket (M) and rear shroud bracket (N) to have a fully prepped shroud before mounting it on the display stand.

1. Attach shroud interface bracket (M) to front of shroud before securing the hardware.

**CENTERED VESA PATTERN:** Use the marked hole set shown. (FIGURE AC)

**OFFSET VESA PATTERN:**

- Take the offset amount from page 19 and use the holes for that distance below the marked hole set shown.
- For Jupiter 105" displays only, use hole below centered hole set.

2. By hand, screw (2x) ¼"-20 flange nuts (Y) onto (2x) studs located on the front of shroud, to secure the shroud interface bracket (M) to the shroud (L).

**FOR JUPITER DISPLAYS:** Hole pattern on shroud may vary.

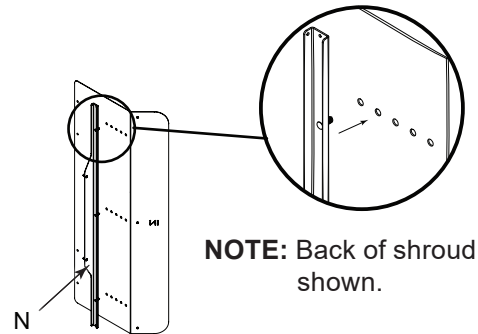

**FIGURE AD**

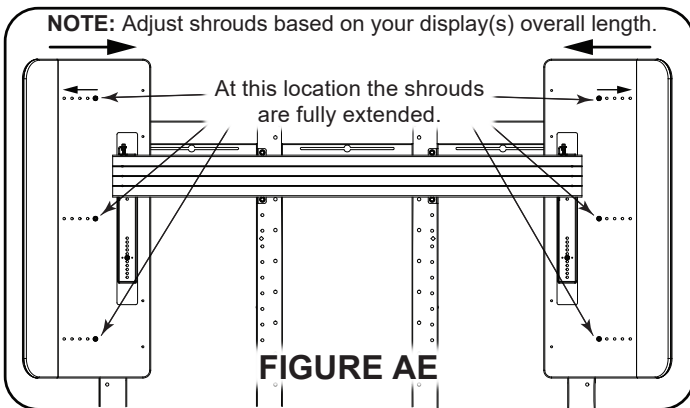

**FIGURE AE**

3. Attach side containing (3x) rear shroud bracket (N) studs to the (3x) corresponding keyholes located on back of shroud (L). (FIGURE AD)

**TIP:** For large display sizes use innermost hole set and for smaller display sizes use outermost hole set, as shown. (FIGURE AE)

4. By hand, tighten (3x) ¼"-20 flange nuts (Y) onto studs located on the front of shroud.

5. Repeat the previous steps to assemble brackets on the second shroud before mounting them on the display stand.

**NOTE:**

- Procedure is similar for dual display installations.
- Ensure both shrouds are fully prepped before attaching them to the display stand.



**WARNING:** This procedure requires at least one additional person.

**ADVERTENCIA:** Este procedimiento requiere al menos una persona adicional.

**AVERTISSEMENT:** Cette procédure nécessite au moins une personne supplémentaire.

## ATTACHING SHROUD BRACKETS AND MAKING ADJUSTMENTS (CONTINUED)

**NOTE:** Attach shroud (L) to the display stand at the same level of your desired height, which was established in previous topics.

- Carefully team lift shroud and slide interlock tabs located on shroud interface bracket (M) into the (2x) channels found on the back end of the horizontal extrusion (P). (**FIGURE AF**)

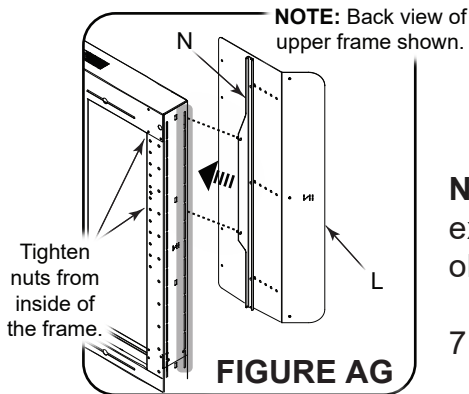
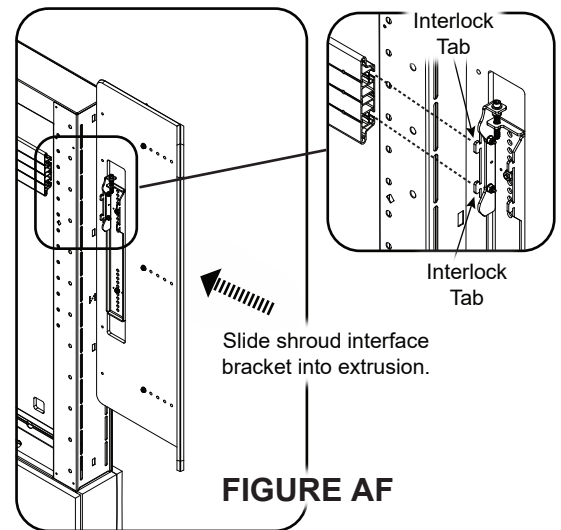

**NOTE:** As one person slides the interlock tabs into the horizontal extrusion, have another person align rear shroud bracket studs with obround holes (shaded for clarity) on the side of frame. (**FIGURE AG**)

- By hand, tighten (2x)  $\frac{1}{4}$ "-20 flange nuts (Y) onto (2x) rear shroud bracket studs from the inside of the frame.

- At this point, make any desired adjustments to the shroud height or width based on your display dimensions. (**FIGURE AH**)

**NOTE:**

- Adjust torque on electric drill to lightest setting and only increase as necessary.
- Return to steps 2 and 5 to secure hardware previously tightened by hand.

- Use an electric drill and  $\frac{7}{16}$ " socket to tighten  $\frac{1}{4}$ "-20 flange nuts (Y) to secure the shroud interface bracket (M) to shroud (L). Do not overtighten.

- Use an electric drill and a  $\frac{7}{16}$ " socket to tighten  $\frac{1}{4}$ "-20 flange nuts (Y) to secure the rear shroud bracket (N) to the display stand (A). Do not overtighten.

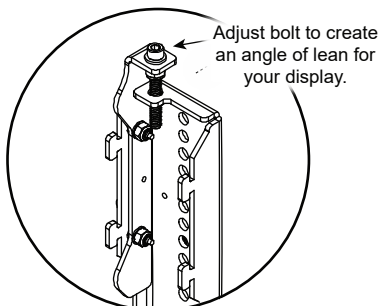
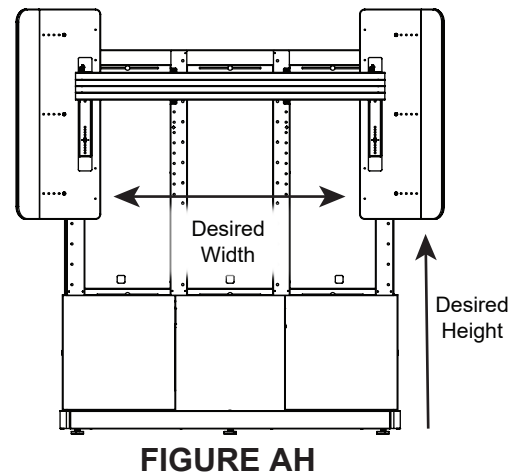

**NOTE:** The shroud interface bracket (M) is designed to create a small angle of lean for your display.

- Use a  $\frac{3}{16}$ " hex key to adjust the angle of lean, if necessary. (**FIGURE AJ**)

## ATTACHING SHROUD BRACKETS AND MAKING ADJUSTMENTS (CONTINUED)

**NOTE:** Once shrouds are fixed to your display stand, proceed to attaching front and bridge panels.

12. Attach front panels, previously removed in “Removing the Panels from Your Display Stand” on page 12, behind shroud.

13. Attach bridge panels (R) behind shroud (L).

**NOTE:** Position bridge panels to cover any gaps that may be visible. (**FIGURE AK**)

14. Use a #2 Phillips screwdriver and (8x) 12 x  $\frac{5}{8}$ " sheet metal screws (S) to secure bridge and shroud panels. Do not overtighten.

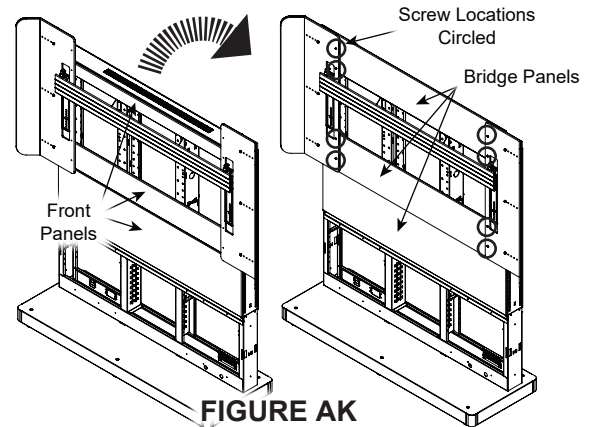

**FIGURE AK**

## ATTACHING END CAPS TO HORIZONTAL EXTRUSION

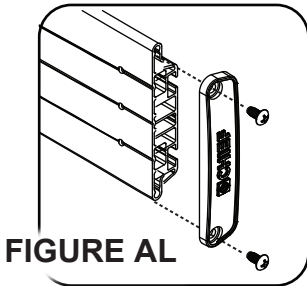

**FIGURE AL**

**NOTE:** Verify the torque on your electric drill is on the lightest setting and only increase as necessary.

- Use electric drill, #2 Phillips bit, extrusion end caps (T) and (4x)  $\frac{1}{4}$ "-20 x  $\frac{1}{2}$ " end cap screws (U) to attach an end cap on each end of the horizontal extrusion (P). (**FIGURE AL**)

## SELECTING THE CORRECT INTERFACE BRACKET HARDWARE FOR YOUR DISPLAY

**NOTE:** The interface hardware kit provided includes different pan head screws (IP-A) to accommodate the threaded inserts on the back of most displays. This topic helps you select the correct size pan head screw length for your display.

1. Use a toothpick or small straw as a thread depth indicator and insert it into a threaded insert on the back of your display.
2. With the toothpick or straw fully inserted, use a pencil to mark it at  $\frac{1}{8}$ " above the surface as shown. (**FIGURE AM**)

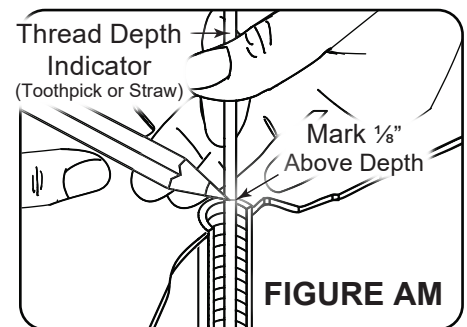

**FIGURE AM**

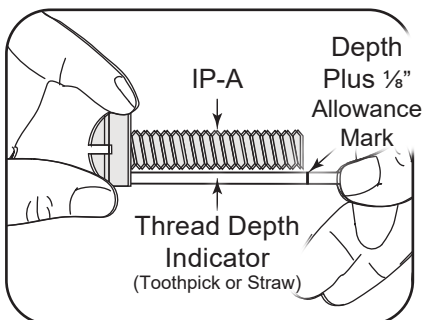

**FIGURE AN**

3. Select a pan head screw (IP-A) size that is shorter in length than the  $\frac{1}{8}$ " mark you made on your thread depth indicator. (**FIGURE AN**)



**CAUTION:** Only use screws shorter than the  $\frac{1}{8}$ " mark or damage to the display may occur.

**PRECAUCIÓN:** Solo puede haber tornillos más cortos que la marca  $\frac{1}{8}$ " o puede haber daños en la pantalla.

**ATTENTION:** N'utilisez que des vis plus courtes que la marque  $\frac{1}{8}$ " ou vous risquez d'endommager l'écran.



## ATTACHING INTERFACE BRACKETS TO THE BACK OF YOUR DISPLAY

**NOTE:** Install any additional accessories you may have purchased (camera mounts, sound bars and other audio products available from Legrand or other providers) before mounting your display.

Before proceeding, refer to the instructions provided with your accessory for the proper installation order.

1. Carefully place your display facedown onto an appropriate work surface.

**NOTE:** Center the display interface brackets (Z) on your display so they do not extend past the top or bottom.

2. Determine the correct size pan head screws for attaching the interface brackets to your display. For more information, see the previous topic.

3. Determine if spacers (IP-B) are required when attaching the interface brackets to the back of your display.

**NOTE:** Adjust torque on electric drill to lightest setting and only increase as necessary.

4. Use electric drill, #2 Phillips bit, (4x) spacers (IP-B, if required), (4x) washers (IP-C), and (4x) correct length pan head screws to attach the interface brackets to the back of your display as shown. **(FIGURE AP)**

**NOTE:**

- Spacers may be needed between the interface bracket and display for clearance and added depth.
- The hardware used must be assembled in the arranged order shown in this topic.
- A minimum of (2x) pan head screws, washers, and spacers (if spacers required) must be used on each interface bracket.

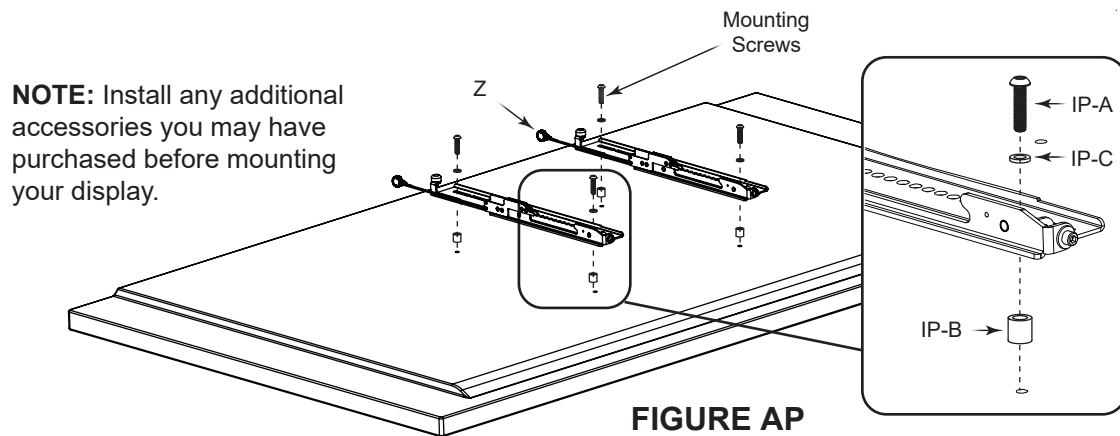

**FOR DUAL DISPLAY INSTALLATIONS:** Repeat the previous steps to attach the display interface brackets (Z) to the back of your second display.

## ATTACHING INTERFACE BRACKETS TO THE BACK OF YOUR DISPLAY (CONTINUED)

**FOR SINGLE JUPITER 105" DISPLAY INSTALLATIONS:** Assemble interface and adapter brackets prior to attaching it to your display.

**NOTE:** Adjust torque on electric drill to lightest setting and only increase as necessary.

5. Use socket wrench, (4x) and (4x) 5/16"-18 hex nuts (V) to attach the adapter bracket (W) to the interface bracket (Z) as shown. **(FIGURE AR)**

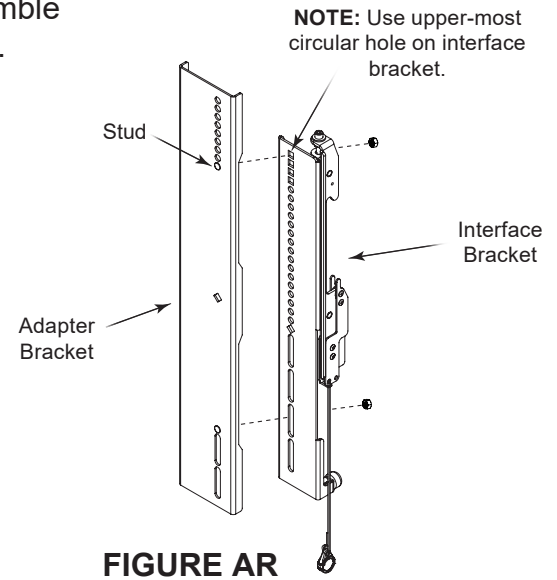
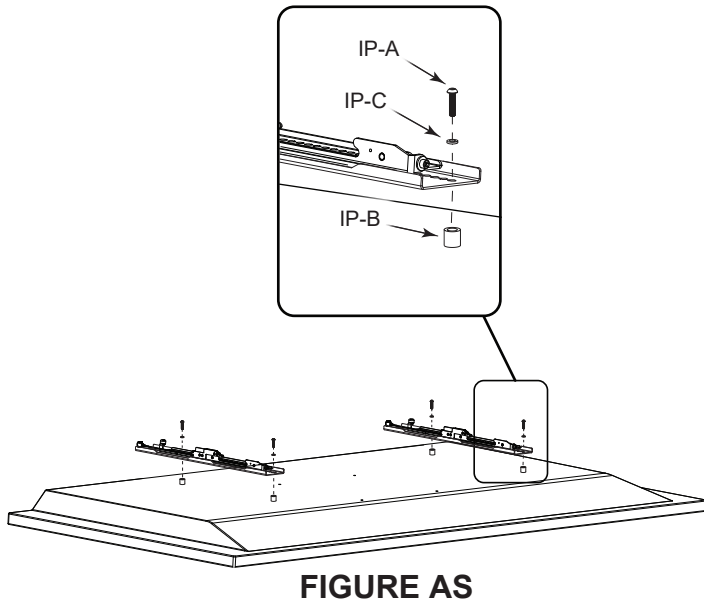

6. Use electric drill, #2 Phillips bit, (4x) spacers (IP-B), (4x) washers (IP-C), and (4x) pan head screws (IP-A) to attach the assembled bracket to the back of your display as shown. **(FIGURE AS)**

## LEVELING YOUR DISPLAY STAND (FREE-STANDING MODELS ONLY)

### NOTE:

- Leveling mounts are provided in case the level of your display stand requires adjusting. **(FIGURE AT)**
- The following topic provides information on how to re-adjust the leveling mounts for your model.

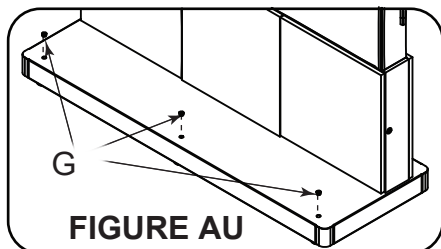
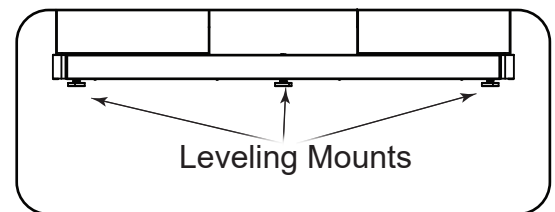

1. Use a socket wrench and 5/16" socket to re-adjust the level of your display stand.

**NOTE:** Reach the leveling mount from the top surface of base.

2. Use (6x) 5/8" dome plugs (G) to cover holes exposing the leveling mounts as shown. **(FIGURE AU)**

## HANGING YOUR DISPLAY



**WARNING:** This procedure requires at least one additional person.

**ADVERTENCIA:** Este procedimiento requiere al menos una persona adicional.

**AVERTISSEMENT:** Cette procédure nécessite au moins une personne supplémentaire.

1. With at least one other person, carefully lift your display slightly above your horizontal extrusion (P). (**FIGURE AV**)
2. Slowly lower the display while ensuring top interface bracket hooks fully engage onto the top of the horizontal extrusion (P).



**WARNING:** Do not release your display until certain the top hook of each interface bracket is securely seated on the upper edge of your horizontal extrusion.

**ADVERTENCIA:** No suelte la pantalla hasta que el gancho superior de cada soporte de interfaz esté firmemente sentado en el borde superior de la extrusión horizontal.

**AVERTISSEMENT:** Non rilasciare il display fino a quando il gancio superiore di ogni staffa di interfaccia non è fissato saldamente sul bordo superiore dell'estrusione orizzontale

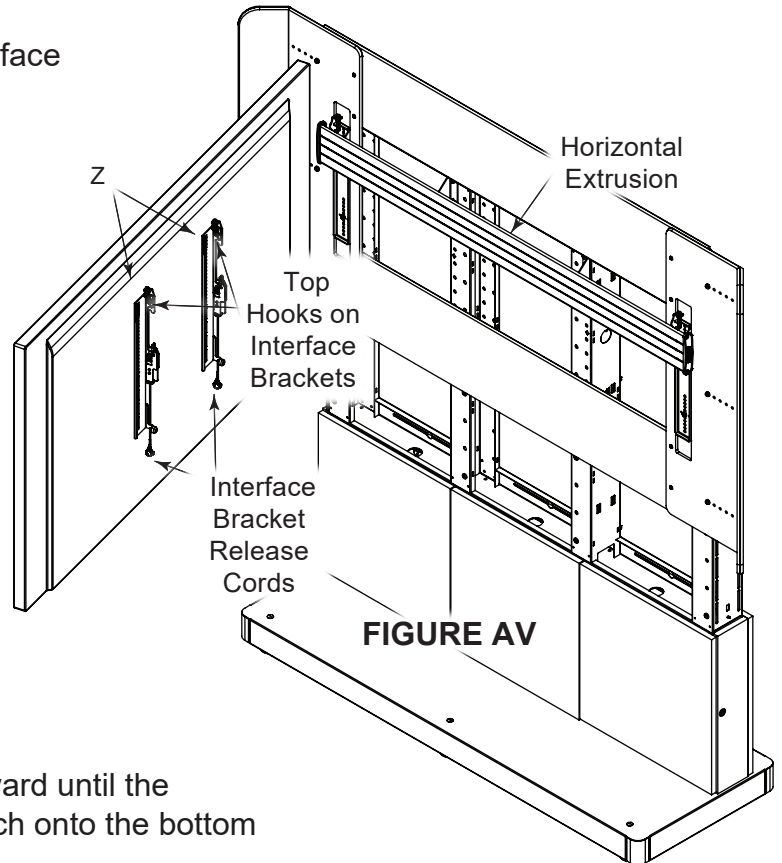

3. Carefully bring the lower side of the display forward until the lower jaws of the interface brackets securely latch onto the bottom edge of the horizontal extrusion.

**NOTE:** Remove your display by pulling both release cord rings down while pulling bottom of the display away and then team lift it off the horizontal extrusion.

**TIP:** Store release cords behind your display by attaching the magnetic rings to the metal interface brackets.

## RE-ATTACHING THE PANELS TO YOUR DISPLAY STAND

### NOTE:

- Any indentations made to the acoustic felt (PET) material of the front or side panel may be removed by applying steam.
- Remove dust and debris from panels with a clean, soft, lint-free cloth or vacuum.
- Bleach and cleaning agents are not recommended, as they may discolor the material.
- Carefully re-install both front and side panels by reversing the steps in “Removing the Panels from Your Display Stand” on page 12.

**FOR FREE-STANDING MODELS:** Re-install back panels by reversing the steps in “Removing the Panels from Your Display Stand” on page 12.

## RE-ATTACHING THE DOORS TO YOUR DISPLAY STAND

1. Align outer and inner sliding rails before pushing doors inward. **(FIGURE AW)**

**NOTE:** If sliding rails are misaligned, the door may fall off or not close properly.

2. Push doors inward.

**NOTE:** The door is secured when the release lever, inner and outer sliding rails are locked, as shown. **(FIGURE AX)**

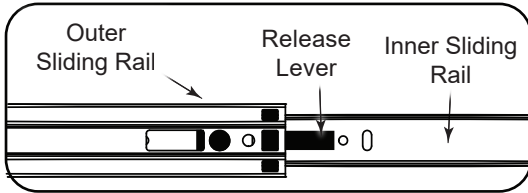

**FIGURE AX**

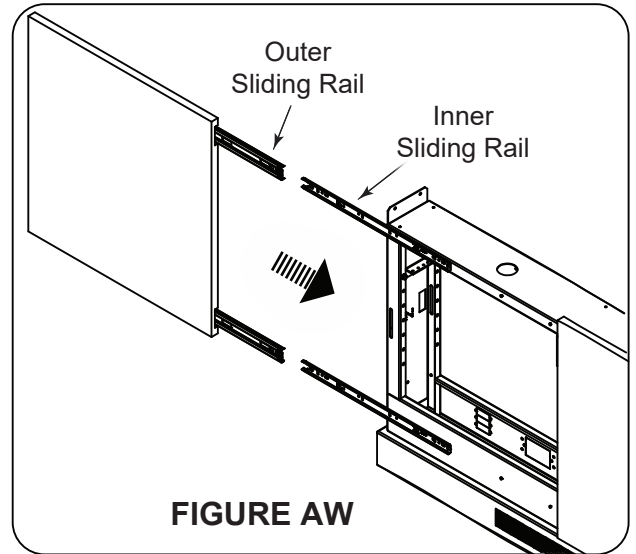

**FIGURE AW**

## WARRANTY

For warranty information, refer to [www.legrandav.com/policies/warranty\\_information](http://www.legrandav.com/policies/warranty_information).

### Contacting Corporate Headquarters

P: (866) 977-3901 | F: (877) 894-6918 | [www.legrandav.com](http://www.legrandav.com) | [av.support@legrand.com](mailto:av.support@legrand.com)

### Contacting Middle Atlantic Canada

P: (888) 766-9770 | F: (888) 599-5009 | [ca.middleatlantic.com](http://ca.middleatlantic.com) | [av.canada.customerservice@legrand.com](mailto:av.canada.customerservice@legrand.com)

### Contacting Middle Atlantic Europe, Middle East, and Africa (EMEA) Technical Support

P: +31 495-726-003 | [av.emea.middleatlantic.support@legrand.com](mailto:av.emea.middleatlantic.support@legrand.com)

#### United States (US)

Legrand | AV Headquarters  
6436 City West Parkway  
Eden Prairie, MN, 55344, USA

#### European Union (EU)

Legrand AV Netherlands  
B.V. Franklinstraat 14 6003  
DK, Weert, Netherlands

#### United Kingdom (UK)

Starline Holding Technology Ltd.  
(Authorized Representative)  
Unit C, Island Rd.  
Reading RG2, 0RP- UK

At Legrand AV Inc. we are always listening. Your comments are welcome.

Legrand AV is an ISO 9001 and ISO 14001 Registered Company.

# MIDDLE ATLANTIC®

A brand of  **legrand®**