



User's Manual

Motorcycle Dashcam

DrivePro™ 20

Version 1.0

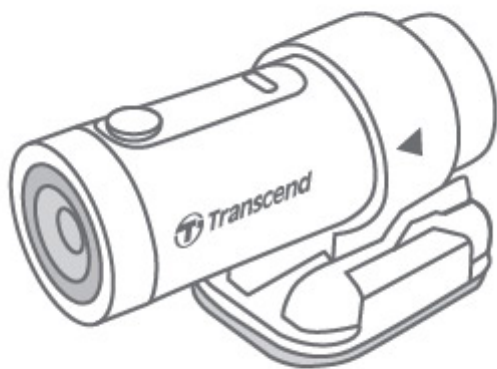

Table of Contents

- **1. Package Contents**
- **2. System Requirements**
- **3. Getting Started**
 - **3-1 Overview**
 - **3-2 Inserting a microSD Memory Card**
 - **3-3 Mounting the DrivePro**
 - **3-4 Charging**
 - **3-5 Operation**
 - **3-6 LED Indicator**
- **4. Recording Videos**
 - **4-1 Normal Recording**
 - **4-2 Emergency Recording**
 - **Automatic Emergency Recording:**
- **5. Using the DrivePro App**
 - **5-1 Connecting to DrivePro App**
 - **5-2 App Settings**
- **6. Using the DrivePro Toolbox**
 - **6-1 Toolbox Interface & Operation**
 - **6-1-1 Interface**
 - **6-1-2 Import Files and Review Snapshots (A)**
 - **6-1-3 Video Editing, Snapshots, and Tools (B)**
 - **6-1-4 Video Trimming**
 - **6-1-5 Preference Settings (C)**
 - **6-2 Transferring Files To A Computer**
- **7. Troubleshooting**
- **8. Safety Cautions**
- **9. Specifications**
- **10. Legal Compliance**
 - **10-1 EU Compliance Statement**
 - **10-2 Recycling & Environmental Protection**
 - **10-3 Federal Communications Commission (FCC) Statement**
 - **10-4 Two-Year Limited Warranty**
 - **10-5 GNU General Public License (GPL) Disclosure**
 - **10-6 End-User License Agreement (EULA)**
 - **10-7 Eurasian Conformity Mark (EAC)**

1. Package Contents

The DrivePro 20 dashcam package includes the following items:

- DrivePro 20
 - Camera holder
 - Adhesive mounting base
 - 32GB microSD card
 - Quick Start Guide
 - micro USB to USB Type-A power cable
-

2. System Requirements

Desktop or Notebook computer together with a microSD card reader or an adapter.

DrivePro Toolbox supports the following operating systems:

- Windows® 7
- Windows® 8
- Windows® 8.1
- Windows® 10
- macOS 10.11 or later

System requirements for using DrivePro App on a mobile device:



3. Getting Started

3-1 Overview

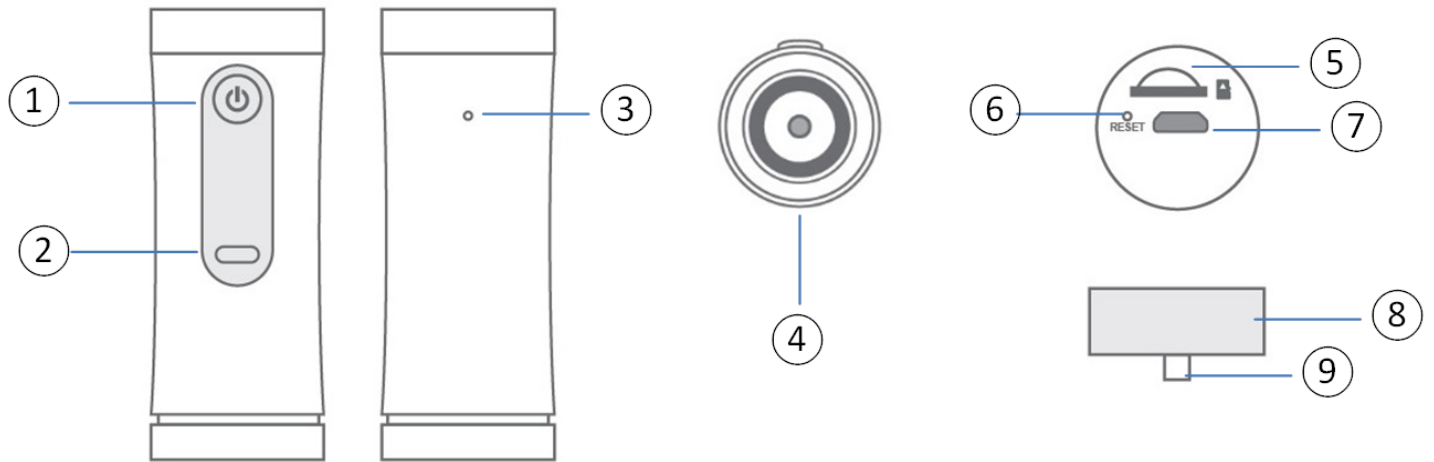

① Power Button	④ Lens	⑦ micro USB Port
② LED Indicator	⑤ microSD Card Slot	⑧ Protective Case
③ Microphone	⑥ Reset Button	⑨ Lanyard Hole

3-2 Inserting a microSD Memory Card

A microSD memory card is required before recording. Please use a microSD memory card with 32GB, 64GB, 128GB or 256GB capacity (Class 10 or above).

1. Rotate protective case anti-clockwise until loose.
2. Insert a microSD memory card into the appropriate card slot.
3. To remove, push to remove the memory card out of the slot.

"NOTE"

- Always format new memory cards in the DrivePro before using them for the first time. Formatting will erase all data on the memory card.
- Make sure the allocation Unit Size of the microSD card is 32 KB or larger; if not, the DrivePro may not work properly.

"WARNING"

- Do not remove the memory card during a shutdown to avoid damages to the memory card and loss of recorded videos. DrivePro 20 can support FAT32 and exFAT file format, but not NTFS.

The following table shows approximate recording time according to capacity and resolution (for reference only):

Frame Rate \ Capacity	32GB	64GB	128GB	256GB
Full HD 1080P 60 fps	2.5 hr	5 hr	10.5 hr	22 hr
Full HD 1080P 30 fps	3.5 hr	7 hr	14 hr	29 hr
HD 720P 60fps	5.5 hr	11 hr	21.5 hr	45 hr
HD 720P 30fps	8.5 hr	17 hr	34.5 hr	70 hr

3-3 Mounting the DrivePro

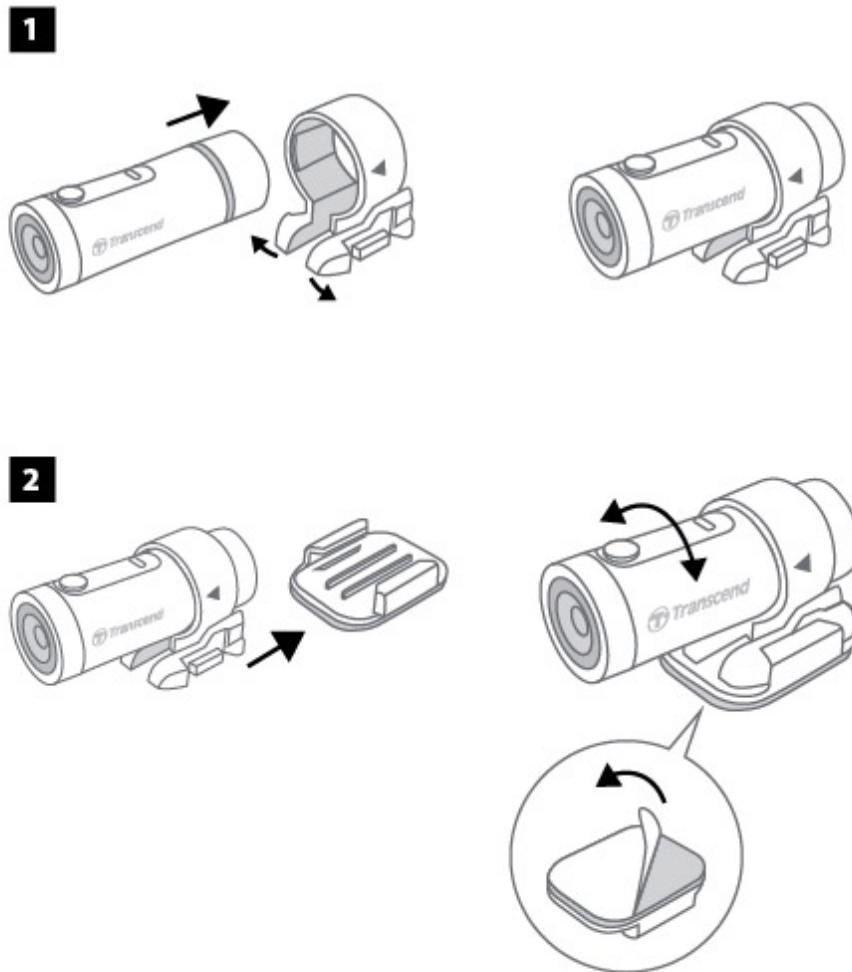

"NOTE"

- Installation surface should first be cleaned and dried so 3M adhesive pad can be firmly attached. Avoid uneven surfaces.
- Allow at least 24 hours for the mount to properly adhere to the surface.
- To separate mount and holder, press the holder and push it forward.
- The arrow symbol on the camera holder should point towards the lens.

3-4 Charging

1. Rotate protective case anti-clockwise until loose.
2. Connect micro USB end of the USB power cable to the device and the Type-A end to a charging device with 5V power output.
3. LED light will turn solid orange while charging, and turn off automatically when fully charged.



"NOTE"

- The ideal temperature for charging is 10°C-40°C and the output power supply of DC 5V/2A.

3-5 Operation

Status	Operation	Vibration
Turn on/off dashcam	Long press Power Button for 3 s	Vibration-short
Turn on/off Wi-Fi	Press Power Button once	Vibration-short
Reset to default	In recording mode, long press Power Button for 10 s	Vibration-long
Low battery	--	Vibrate twice every 30 s
Disk error	--	Vibrate twice every 5 s and turn off after 180 s

3-6 LED Indicator

LED	Status	Description
Red	Flashing Flashing quickly Flashing quickly twice every interval Solid	Recording/Firmware Upgrade Emergency Recording/Formatting Low Battery Power Saving Mode/Disk Error/Connecting to Computer
Blue	Flashing	Recording and Wi-Fi On
Orange	Solid	Charging



"WARNING"

All files will be deleted when the dashcam is reset to default.

4. Recording Videos

4-1 Normal Recording

By default, one video file is saved for every 1 minute of recording. To adjust the recording length, please refer to the Settings section in this manual. When DrivePro 20 is fully charged, recording in 1080/60fps can last for 2.5 hours, while recording in 1080/30fps can last 3 hours. The actual recording time differs according to the recording condition.

When the DrivePro is idle for 5 minutes, power saving mode will be activated. The DrivePro will be turned off automatically after another 5 minutes.

"NOTE"

- DrivePro 20 has loop recording function. The earliest videos will be overwritten by new footage.

4-2 Emergency Recording

30% of the storage space will be saved for emergency video files. Video files recorded in emergency mode are protected from being overwritten.

Automatic Emergency Recording:

During video recording, the DrivePro will automatically activate Emergency Recording mode when detecting a collision. G-Sensor sensitivity can be adjusted or disabled in the **Settings** menu.

"NOTE"

- If the G-Sensor sensitivity is set to "High", even minor shocks will activate Emergency Recording mode.
- If the G-Sensor sensitivity is set to "Low", only significant shocks will activate Emergency Recording mode.
- In the Power Saving Mode, recording is off.

5. Using the DrivePro App

5-1 Connecting to DrivePro App

After downloading and installing the DrivePro App from the Google Play or App Store,











1. Tap Settings > Wi-Fi from your mobile device.
2. Select the Wi-Fi network with DP 20 in the SSID. (password is 12345678)
3. Tap the DrivePro icon on the home screen of your mobile device to use the App.
4. Click the links below for detailed operation guidance.
 - o [iOS](#)
 - o [Android](#)





5-2 App Settings

In the **Settings**, modify video and device configurations.

Video		
Icon	Feature	Function/Option
	Resolution	Set the resolution/quality for video recording.
		1080P 60fps(FHD) (default) / 1080P 30fps(FHD) / 720P 60fps(HD) / 720P 30 fps(HD)
	Exposure Value	Adjust exposure composition value to lighten or darken the preview screen.
		+2.0 / +1.5 / +1.0 / +0.5 / 0 (default) / -0.5 / -1.0 / -1.5 / -2.0
	Microphone	Turn on/off the microphone during video recording.
		Disable (default) / Enable

	Video Length	Set the recording length of each recorded video file.
		1 min (default) / 3 mins / 5 mins
	Light Frequency	Select the appropriate frequency to avoid flashing A/C light.
		50Hz (default) / 60Hz
Video Stamp		
Icon	Feature	Function/Option
	Video Stamp	Display the current time of the video being recorded.
		Disable / Enable (default)
	Date / Time Format	Set the current date, time, format and time zone.
Device		
Icon	Feature	Function/Option
	G-Sensor	Adjust the sensitivity of the G-Sensor.
		Disable / Low (default) / Medium / High
	SSID	Set Wi-Fi name
	Password	Set Wi-Fi password
	Power Management	Turn on/off the power saving mode. If no vibration is detected in 10 minutes, the dashcam will turn off automatically.
		Disable / Enable (default)
	Noise Cancellation	Reduce wind noise when wind strikes the surface of the microphone.
		Disable / Enable (default)
System		
Icon	Feature	Function/Option
	Time Synchronized	Synchronize the DrivePro's system time to that of your smart device's.
	Memory	Check the capacity of the microSD card.

	Capacity	
	Format Card	Format the microSD memory card.
	Upgrade Firmware	Keep your DrivePro up-to-date with the latest version downloaded from the Transcend website. https://www.transcend-info.com/Support/service .



"NOTE"

The firmware upgrade will take about 1-2 minutes. Please do not turn off the DrivePro while upgrading. The DrivePro will restart automatically after the upgrade is completed.



"WARNING"

NEVER remove the power cord or the microSD memory card while the firmware is being upgraded. If the DrivePro cannot be turned on due to firmware upgrade failure, please contact Transcend customer service for technical support.

6-1-2 Import Files and Review Snapshots (A)

When connecting the DrivePro to a Windows computer, the DrivePro Toolbox will automatically ask users whether to import the videos in the DrivePro.

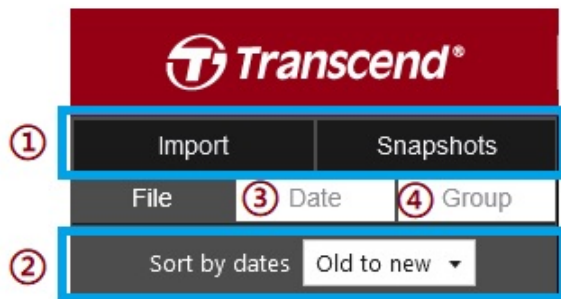

① Tap **Import** to select the video files you wish to import; Tap **Snapshots** to open snapshot files.



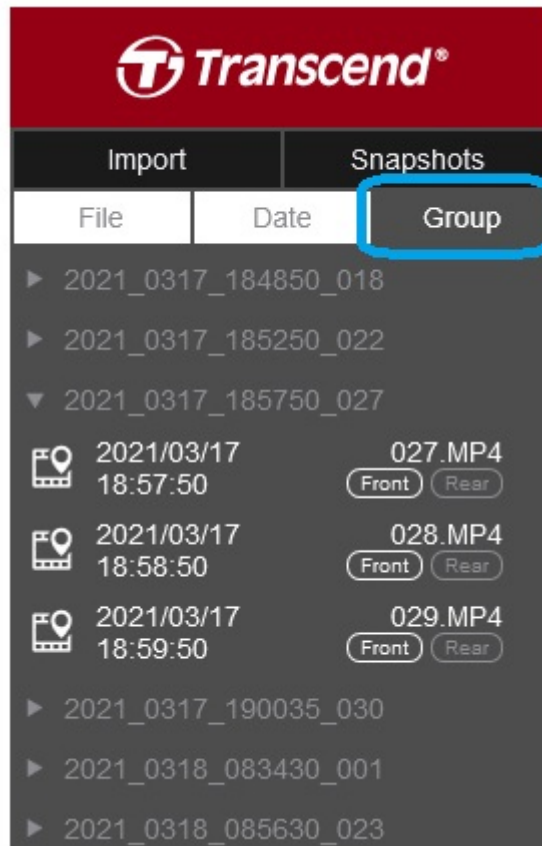
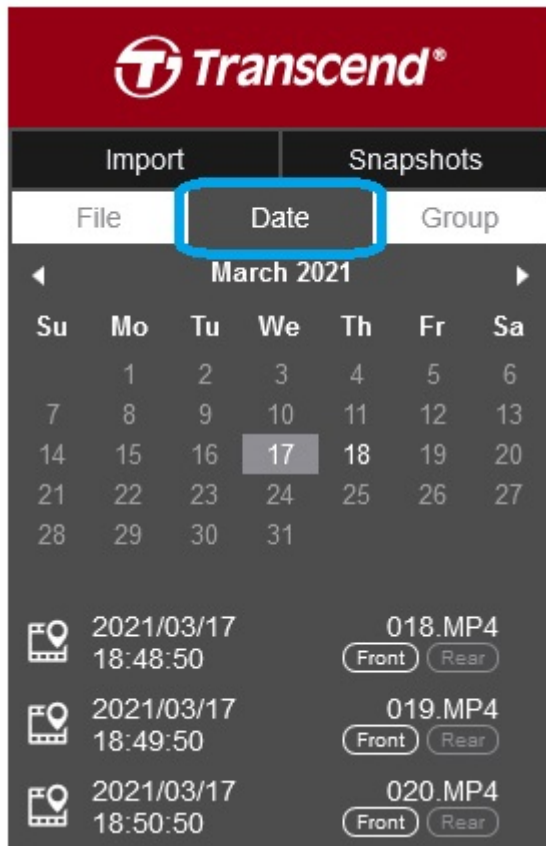

② Sort videos by recording dates, either from old to new or new to old.

③ Select **Date** to broadcast the videos recorded on a specific day.

④ Select **Group**, the videos will be grouped by recording date.



6-1-3 Video Editing, Snapshots, and Tools (B)

Video		
Icon	Feature	Description
	Snapshot	Capture and save the snapshots in the video
	Trim	Trim your video
	Sound	Turn on/off the sound
	Full Screen	Play video in full screen

6-1-4 Video Trimming

Step 1: Enable clip mode

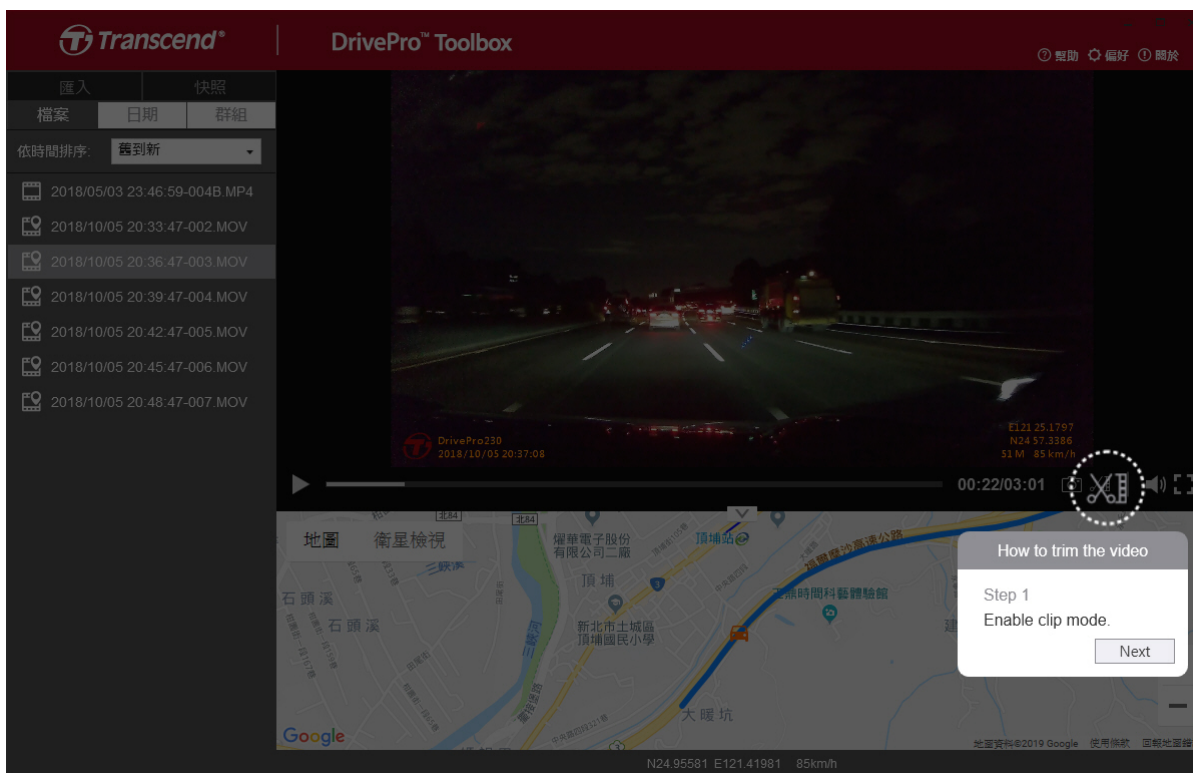

Step 2: Specify the beginning of video clip

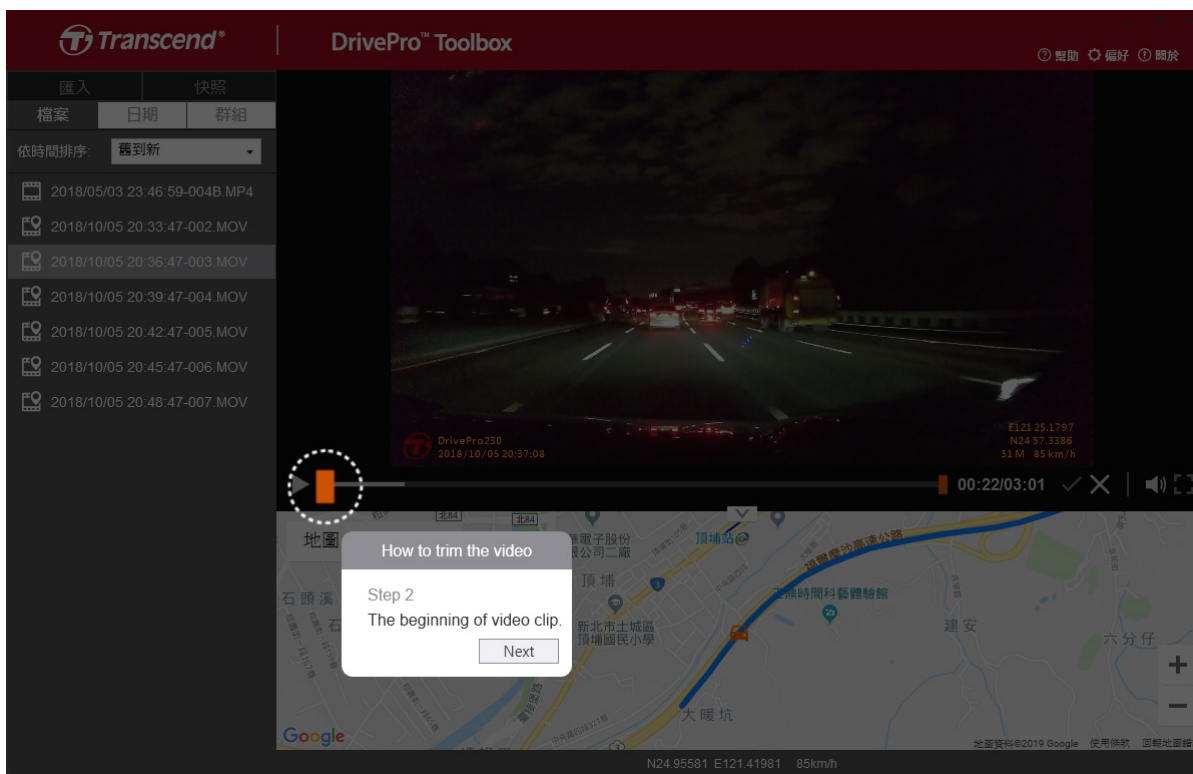

Step 3: Specify the end of video clip

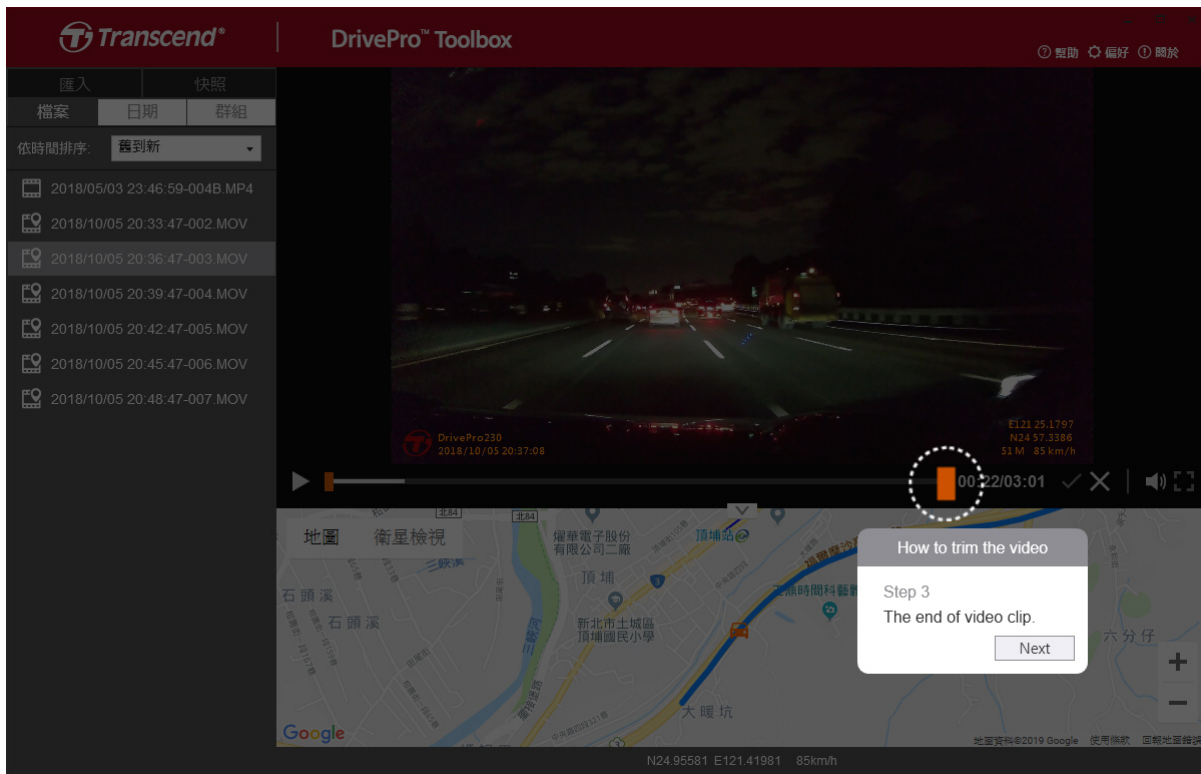

Step 4: Save the video clip

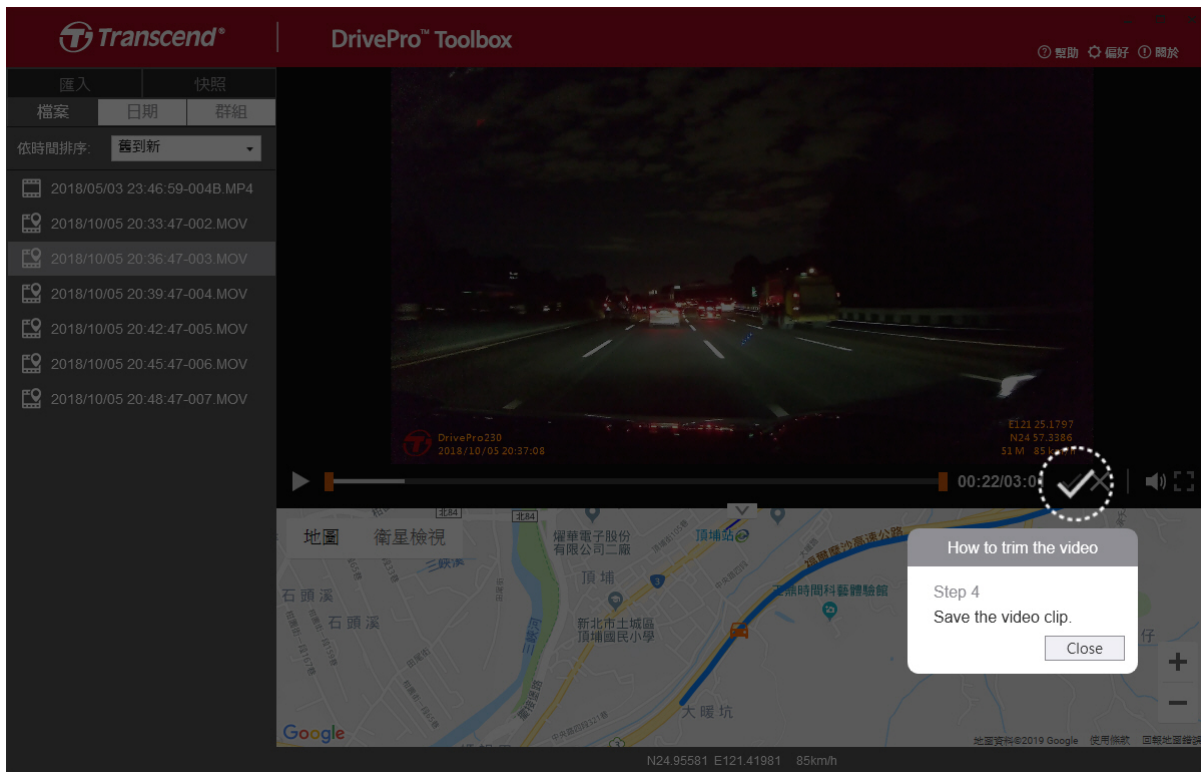

6-1-5 Preference Settings (C)

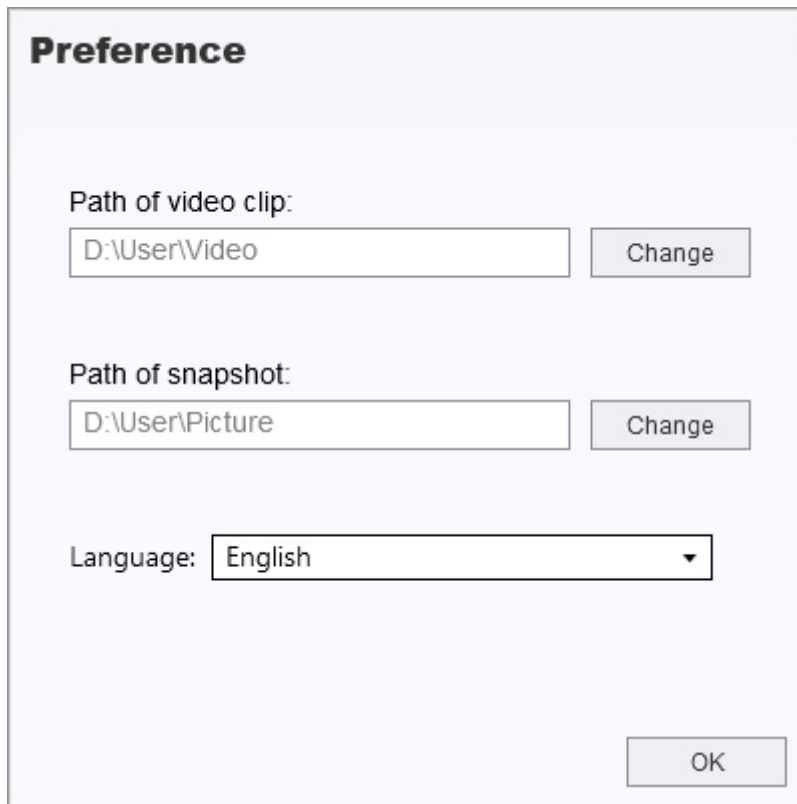

The image shows a 'Preference' dialog box with a light blue background. At the top, the title 'Preference' is displayed in bold. Below the title, there are three settings sections. The first section is 'Path of video clip:', which includes a text input field containing 'D:\User\Video' and a 'Change' button to its right. The second section is 'Path of snapshot:', which includes a text input field containing 'D:\User\Picture' and a 'Change' button to its right. The third section is 'Language:', which includes a dropdown menu currently showing 'English' with a downward-pointing arrow. At the bottom right of the dialog box, there is an 'OK' button.

Tap **Preference** to change the saving routes of the videos/photos and the language settings.

6-2 Transferring Files To A Computer

Option 1:

Take the microSD memory card out of the DrivePro, and insert it into a compatible card reader to transfer files to a computer.

Option 2:

1. Insert the microSD memory card into the DrivePro.
2. Plug the small end of a USB cable into the USB port located on the right-hand side of the DrivePro.
3. Plug the large end of the cable into an available USB port on your computer. The DrivePro will display the following screen when connected to a computer.



"WARNING"

- DrivePro 20 package contains a USB cable.
- To prevent data loss, always follow the proper removal procedures when disconnecting the DrivePro from your computer.

- When the DrivePro is connected to a computer, it can only be used for transferring files. The DrivePro's features are not available at this time. Please disconnect your DrivePro from the computer to resume normal function.
- **NEVER** use the "format" or "initialize disk" function while the DrivePro is connected to your computer, even if prompted to do so.

7. Troubleshooting

If a problem occurs with your DrivePro, please first check the instructions listed below before sending your DrivePro for repair. If you cannot find an ideal solution to your question below, please consult your dealer, service center, or local Transcend branch office for further help. You can also visit the Transcend website for FAQ and Technical Support services (<https://www.transcend-info.com/Support>). For any hardware issues, please refer to the DrivePro User's Manual.

My computer operating system cannot detect my DrivePro

Please check the followings:

1. Is your DrivePro properly connected to the USB port? If not, unplug and connect it again. Make sure that both ends of the USB cables are properly connected as shown in the User's Manual.
2. Is your DrivePro connected to the Mac keyboard? If yes, try to plug it in an available USB port on your Mac Desktop directly.
3. Is the computer's USB ports enabled? If not, refer to the user's manual of your computer (or motherboard) to enable them.

None of the DrivePro buttons are responding (hangs / lags / stalls)

Try unplugging the car adapter from your DrivePro, and reconnecting it to your DrivePro again.

8. Safety Cautions

These usage and safety guidelines are **IMPORTANT!** Please follow them carefully to ensure your own personal safety, and help protect your DrivePro from potential damages.

1. General use

- For your safety, do not operate the DrivePro, or use the DrivePro App while driving.
- Avoid placing the DrivePro in an extreme temperature environment.
- Do not use the DrivePro in an environment with strong magnetic fields or excessive vibration.
- Only use the adapter provided by Transcend. Other car adapters may not compatible with the DrivePro.

2. Mounting location

- Never place the DrivePro where the driver's view is obstructed.

3. Data backup

- **Transcend does NOT take any responsibility for data loss or damage during operation.** We strongly advise that you regularly back up data in your memory card to a computer or other storage medium.
- To ensure high-speed USB 2.0 data transfer rates when connecting your DrivePro to a computer, please check if the computer is installed with correct USB drivers. If you are not sure how to check this, please refer to the User's Manual of the computer or motherboard for USB driver information.

4. IP (Ingress Protection) 68 rating

- DrivePro 20 is backed by an international standard rating of IP68, able to withstand dust, dirt, splash or spray. Its protection against intrusions of solid objects/liquid does not mean invincible. The protection level may decrease as the device is used. Damages caused by a liquid are not covered in the warranty service.
- Do not immerse DrivePro 20 in water or use it in a high-humidity environment.
- Do not use DrivePro 20 in high-temperature, high-humidity environments, such as SPA, sauna, steam room, or shower room.
- Make sure the charging cable is dry before charging.
- Malfunctions or damages due to improper usage are not covered by the limited warranty service.

"WARNING"



DrivePro 20 is not resistant to liquid when the protective case is not tightened.

9. Specifications

DrivePro 20	
Dimensions	90.2mm x 30mm x 30mm
Weight	74g (2.6oz)
Connect Interface	USB2.0
Memory Card Supported	microSD, 32GB/64GB/128GB/256GB memory card (Class 10 or above)
Wi-Fi	802.11b/g/n
Lens	F/2.8, 140° (diagonal)
Video Formats	MP4 (H.264: up to 1920x1080 60fps)
Resolution / Frame Rate	Full HD (1920 x 1080) 30/60fps HD (1280 x 720) 30/60fps
Operating Temperature	-10°C (14°F) ~ 60°C (140°F)
Storage Temperature	-30°C(-22°F) ~ 70°C (158°F)
Battery	Li-Polymer 1140mAh (2.5 hr)
Power Supply	Input DC5V / 2A
IP Rating	IP68
Certification	CE, FCC, BSMI, KC, NCC, MIC, EAC, RCM, UKCA
Warranty	2 years

DrivePro 20	
Note	
<p>In addition to the bundled microSD card, we recommend Transcend's High Endurance microSD cards or MLC-based memory cards to ensure the best recording performance.</p> <ul style="list-style-type: none">● 32GB/64GB High Endurance microSDHC card (TS32GUSDHC10V/TS64GUSDXC10V)● 64GB/128/256GB High Endurance microSDXC 350V card (TS64GUSD350V/TS128GUSD350V/TS256GUSD350V)	

10. Legal Compliance

10-1 EU Compliance Statement

Transcend Information hereby declares that all CE marked Transcend products incorporating radio equipment functionality are in compliance with Directive 2014/53/EU.

The full text of the EU declaration of conformity is available at the following internet address:

www.transcend-info.com/eu_compliance



Frequency:
2400-2483.5MHz

Maximum transmit power:
< 100mW

10-2 Recycling & Environmental Protection



Recycling the Product (WEEE): Your product is designed and manufactured with high quality materials and components, which can be recycled and reused. When you see the crossed-out wheel bin symbol attached to a product, it means that the product is covered by the European Directive 2002/96/EC:



Never dispose of your product with other household waste. Please inform yourself about the local rules on the separate collection of electrical and electronic products. The correct disposal of your old product helps prevent potentially negative consequences on the environment and human health.



Battery Disposal: Your product contains a built-in rechargeable battery covered by the European Directive 2006/66/EC, which cannot be disposed of with normal household waste. Please inform yourself about the local rules on the separate collection of batteries. The correct disposal of batteries helps prevent potentially negative consequences on the environment and human health.

For products with non-exchangeable built-in batteries: The removal of (or the attempt to remove) the battery invalidates the warranty. This procedure is only to be performed at the end of the product's life.



CAUTION

RISK OF EXPLOSION IF BATTERY IS REPLACED BY AN INCORRECT TYPE.
DISPOSE OF USED BATTERIES ACCORDING TO THE INSTRUCTIONS.

廢電池請回收

10-3 Federal Communications Commission (FCC) Statement

This device complies with Part 15 FCC Rules. Operation is subject to the following two conditions: (1) This device may not cause harmful interference. (2) This device must accept any interference received including interference that may cause undesired operation.

This Equipment has been tested and found to comply with the limits for a Class B digital device, pursuant to Part 15 of the FCC rules. These limits are designed to provide reasonable protection against harmful interference in a residential installation. This equipment generates, uses and can radiate radio frequency energy and, if not installed and used in accordance with the instructions, may cause harmful interference to radio communications. However, there is no guarantee that interference will not occur in a particular installation. If this equipment does cause harmful interference to radio or television reception, which can be determined by turning the equipment off and on, the user is encouraged to try to correct the interference by one or more of the following measures:

- Reorient or relocate the receiving antenna.
- Increase the separation between the equipment and receiver.
- Connect the equipment into an outlet on a circuit different from that to which the receiver is connected.
- Consult the dealer or an experienced radio/TV technician for help.

RF Exposure Statement:

This equipment complies with FCC RF radiation exposure limits set forth for an uncontrolled environment. This equipment should be installed and operated with a minimum distance of 5mm between the radiator and your body.

You are cautioned that changes or modifications not expressly approved by the part responsible for compliance could void the user's authority to operate the equipment.

This Transmitter must not be co-located or operating in conjunction with any other antenna or transmitter.

10-4 Two-Year Limited Warranty

Please visit www.transcend-info.com/warranty to view the Transcend Warranty Policy. By using the product, you agree that you accept the terms of the Transcend Warranty Policy, which may be amended from time to time.

10-5 GNU General Public License (GPL) Disclosure

Firmware incorporated into this product and/or software used for this product may include third party copyrighted software pursuant to the license terms specified as below (“Licensed Software” defined as follows),

1. GNU General Public License (GPL), the terms of which is currently available at <http://www.gnu.org/licenses/gpl.html>
2. GNU Lesser General Public License (LGPL), the terms of which is currently available at <http://www.gnu.org/copyleft/lesser.html> ; and/or
3. Code Project Open License (CPOL), the terms of which is currently available at <http://www.codeproject.com/info/cpol10.aspx>

In accordance with the such license terms, if applicable: 1) the source code for the Licensed Software may be downloaded at no charge or obtained on CD for a nominal charge by calling Customer Support within three (3) years of the date of purchase; 2) you may copy, re-distribute and/or modify the Licensed Software under the terms of the above license terms or any later version; 3) the Licensed Software is distributed WITHOUT ANY WARRANTY, without even implied warranty of MERCHANTABILITY or FITNESS FOR A PARTICULAR PURPOSE. The entire risk as to the quality and performance of the Licensed Software is with you. Transcend does not provide any support for the Licensed Software. The above license terms will control solely with respect to the open source components. In the event that this manual conflicts with the requirements of the above one or more terms with respect to the use of the corresponding open source components, Customer agrees to be bound by such one or more license terms.

10-6 End-User License Agreement (EULA)

1. Generally.

Transcend Information, Inc. ("Transcend") is willing to grant the following license to install or use the software and/or firmware (“Licensed Software”) pursuant to this End-User License Agreement (“Agreement”), whether provided separately or associated with a Transcend product (“Product”), to the original purchaser of the Product upon or with which the Licensed Software was installed or associated as of the time of purchase ("Customer") only if Customer accepts all of the terms and conditions of this Agreement. PLEASE READ THESE TERMS CAREFULLY. USING THE SOFTWARE WILL CONSTITUTE CUSTOMER'S ACCEPTANCE OF THE TERMS AND CONDITIONS OF THIS AGREEMENT. IF YOU DO NOT AGREE TO THE TERMS AND CONDITIONS OF THIS AGREEMENT, DO NOT INSTALL OR USE THE LICENSED SOFTWARE.

2. License Grant.

Transcend grants to Customer a personal, non-exclusive, non-transferable, non-distributable, non-assignable, non-sublicensable license to install and use the Licensed Software on the Product in accordance with the terms and conditions of this Agreement.

3. Intellectual Property Rights.

As between Transcend and Customer, the copyright and all other intellectual property rights in the Licensed Software are the property of Transcend or its supplier(s) or licensor(s). Any rights not expressly granted in this License are reserved to Transcend.

4. License Limitations.

Customer may not, and may not authorize or permit any third party to: (a) use the Licensed Software for any purpose other than in connection with the Product or in a manner inconsistent with the design or documentations of the Licensed Software; (b) license, distribute, lease, rent, lend, transfer, assign or otherwise dispose of the Licensed Software or use the Licensed Software in any commercial hosted or service bureau environment; (c) reverse engineer, decompile, disassemble or attempt to discover the source code for or any trade secrets related to the Licensed Software, except and only to the extent that such activity is expressly permitted by applicable law notwithstanding this limitation; (d) adapt, modify, alter, translate or create any derivative works of the Licensed Software; (e) remove, alter or obscure any copyright notice or other proprietary rights notice on the Licensed Software or Product; or (f) circumvent or attempt to circumvent any methods employed by Transcend to control access to the components, features or functions of the Product or Licensed Software.

5. Copying.

Customer may not copy the Licensed Software except that one copy of any separate software component of the Licensed Software may be made to the extent that such copying is necessary for Customer's own backup purposes.

6. Disclaimer.

TRANSCEND MAKES NO WARRANTY AND REPRESENTATIONS ABOUT THE SUITABILITY, RELIABILITY, AVAILABILITY, TIMELINESS, LACK OF VIRUSES OR OTHER HARMFUL COMPONENTS AND ACCURACY OF THE INFORMATION, LICENSED SOFTWARE, PRODUCTS, SERVICES AND RELATED GRAPHICS CONTAINED WITHIN THE LICENSED SOFTWARE FOR ANY PURPOSE. ALL SUCH INFORMATION, LICENSED SOFTWARE, PRODUCTS, SERVICES AND RELATED GRAPHICS ARE PROVIDED "AS IS" WITHOUT WARRANTY OF ANY KIND. TRANSCEND HEREBY DISCLAIMS ALL WARRANTIES AND CONDITIONS WITH REGARD TO THIS INFORMATION, LICENSED SOFTWARE, PRODUCTS, SERVICES AND RELATED GRAPHICS, INCLUDING ALL IMPLIED WARRANTIES AND CONDITIONS OF MERCHANTABILITY, FITNESS FOR A PARTICULAR PURPOSE, WORKMANLIKE EFFORT, TITLE, AND NON-INFRINGEMENT. IN NO EVENT SHALL TRANSCEND BE LIABLE FOR ANY DIRECT, INDIRECT, PUNITIVE, INCIDENTAL, SPECIAL, CONSEQUENTIAL DAMAGES OR ANY DAMAGES WHATSOEVER INCLUDING, WITHOUT LIMITATION, DAMAGES FOR LOSS OF USE, DATA OR PROFITS, ARISING OUT OF OR IN ANY WAY CONNECTION WITH THE USE, PERFORMANCE OR ACCURACY OF THE LICENSED SOFTWARE OR WITH THE DELAY OR INABILITY TO USE THE LICENSED SOFTWARE, OR THE PRODUCT WITH WHICH THE LICENSED SOFTWARE IS ASSOCIATED, WHETHER BASED ON CONTRACT, TORT, NEGLIGENCE, STRICT LIABILITY OR OTHERWISE, EVEN IF TRANSCEND HAS BEEN ADVISED OF THE POSSIBILITY OF SUCH

DAMAGES.

7. Limitation of Liability.

IN ANY CASE, TRANSCEND 'S LIABILITY ARISING OUT OF OR IN CONNECTION WITH THIS AGREEMENT WILL BE LIMITED TO THE TOTAL AMOUNT ACTUALLY AND ORIGINALLY PAID AT RETAIL BY CUSTOMER FOR THE PRODUCT. The foregoing Disclaimer and Limitation of Liability will apply to the maximum extent permitted by applicable law. Some jurisdictions do not allow the exclusion or limitation of incidental or consequential damages, so the exclusions and limitations set forth above may not apply.

8. Privacy.

Transcend may collect, process and use your personal information and/or non-personal information through Firebase Analytics or otherwise. Learn more details about Transcend's Privacy Policy: <https://www.transcend-info.com/Legal/?no=1>. Learn about what and why personal information and/or non-personal information would be collected when you use the Licensed Software: <https://www.transcend-info.com/Legal/?no=18>

9. Termination.

Transcend may, in addition to any other remedies available to Transcend, terminate this Agreement immediately if Customer breaches any of its obligations under this Agreement.

10. Miscellaneous.

(a) This Agreement constitutes the entire agreement between Transcend and Customer concerning the subject matter hereof, and it may only be modified by a written amendment signed by an authorized executive of Transcend. (b) Except to the extent applicable law, if any, provides otherwise, this Agreement will be governed by the law of the Republic of China, excluding its conflict of law provisions. (c) If any part of this Agreement is held invalid or unenforceable, and the remaining portions will remain in full force and effect. (d) A waiver by either party of any term or condition of this Agreement or any breach thereof, in any one instance, will not waive such term or condition or any subsequent breach thereof. (e) Transcend may assign its rights under this Agreement without condition. (f) This Agreement will be binding upon and will inure to the benefit of the parties, their successors and permitted assigns.

10-7 Eurasian Conformity Mark (EAC)

