

Installation Guide Smart-UPS™ On-Line APCRBC152/APCRBC141

Safety Messages

Read the instructions carefully to become familiar with the equipment before trying to install, operate, service or maintain it. The following special messages may appear throughout this manual or on the equipment to warn of potential hazards or to call attention to information that clarifies or simplifies a procedure.



The addition of this symbol to a Danger or Warning safety label indicates that an electrical hazard exists which will result in personal injury if the instructions are not followed.



This is the safety alert symbol. It is used to alert you to potential personal injury hazards. Obey all safety messages that follow this symbol to avoid possible injury or death.

CAUTION

CAUTION indicates a potentially hazardous situation which, if not avoided, **can result in** minor or moderate injury.

CAUTION

CAUTION addresses practices not related to physical injury including certain environmental hazards, potential damage or loss of data.



Safety and General Information

**Inspect the package contents upon receipt.
Notify the carrier and dealer if there is any damage.**

- Adhere to all local and national electrical codes.
- Always recycle used batteries.
For information on recycling used battery modules, refer to the Battery Disposal Information sheet included with the replacement battery module.
- Recycle the package materials or save them for reuse.

Battery safety

- Before installing or replacing the batteries, remove jewelry such as wristwatches and rings.
High short circuit current through conductive materials could cause severe burns.
- Do not dispose of batteries by burning them. The batteries may explode.
- Do not open or mutilate batteries. Released electrolyte is harmful to the skin and eyes, and may be toxic.

Replace Battery Modules

⚠ CAUTION

DAMAGE TO EQUIPMENT OR PERSONNEL

- The equipment is heavy. Each APCRBC152 battery module weighs 15.3 kg (33.7 lb) and each APCRBC141 battery module weighs 11.7 kg (25.8 lb).
- Always practice safe lifting techniques adequate for the weight of the equipment.
- Adhere to all local and national electrical codes.
- Use the battery model handle to slide the battery modules in and out of the UPS and external battery pack (XLBP).
- Do not use the handle to lift or carry the battery module.
- When replacing the battery modules, replace with the same type of battery modules.

Failure to follow these instructions can result in equipment damage and minor or moderate injury.

Note: The batteries will charge to 90% capacity in the first three hours of operation on utility power. Do not expect full runtime capability during this initial charge period.

Battery Module	UPS	XLBP
APCRBC152	SRT3000XLx/SRT3000RMLx	SRT96BP/SRT96RMBP
APCRBC141	SRT2200XLx/SRT2200RMLx	SRT72BP/SRT72RMBP

SRT2200XLx/SRT2200RMLx/SRT3000XLx/SRT3000RMLx UPS models

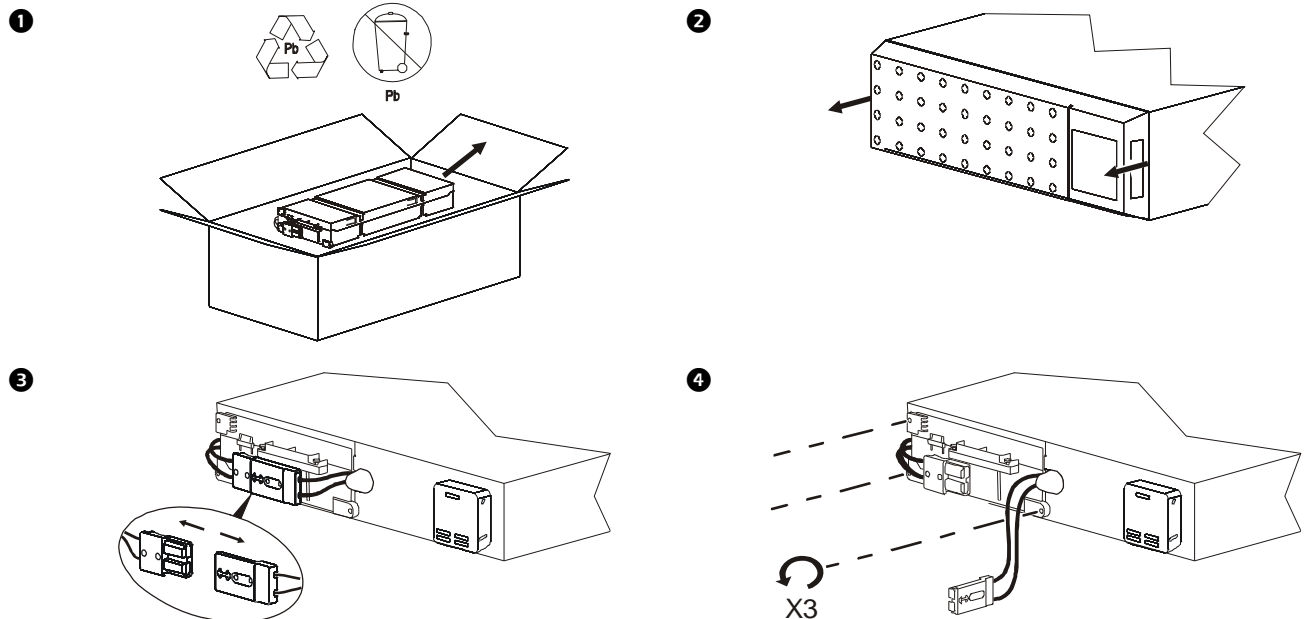

5 APCRBC141

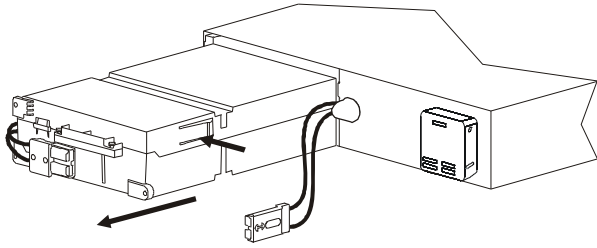

APCRBC152

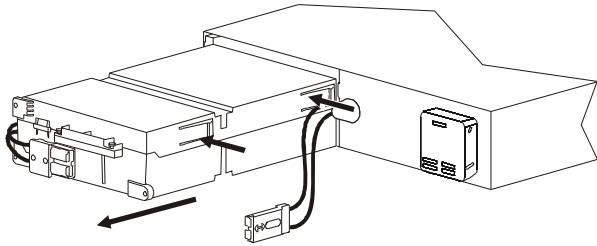

6

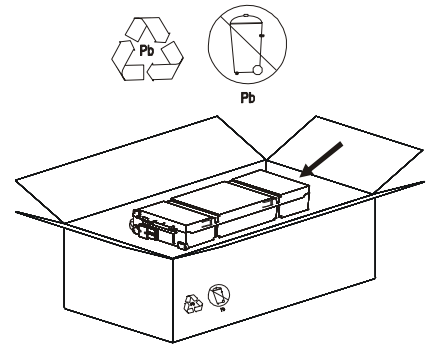

7 APCRBC141

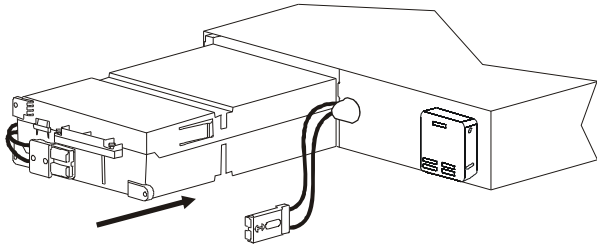

APCRBC152

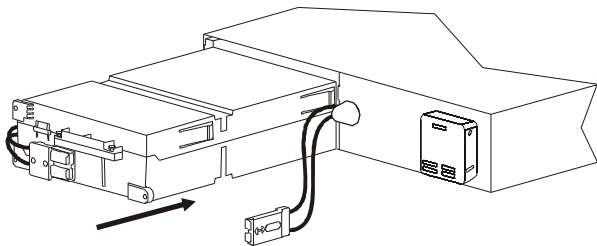

8

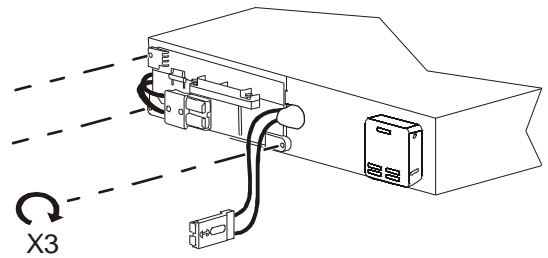

9

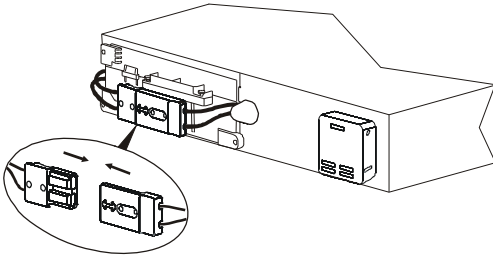

10

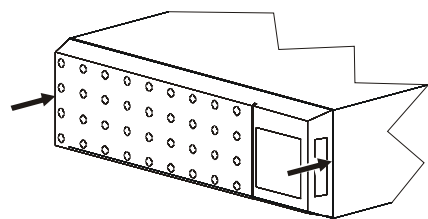

SRT72BP/SRT72RMBP/SRT96BP/SRT96RMBP External battery packs

1

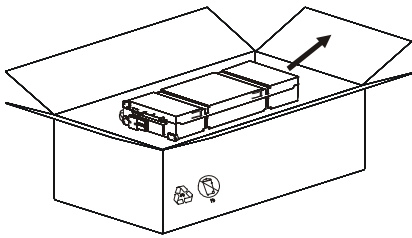
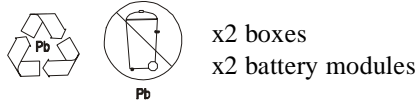

2

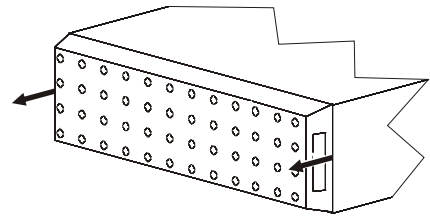

3

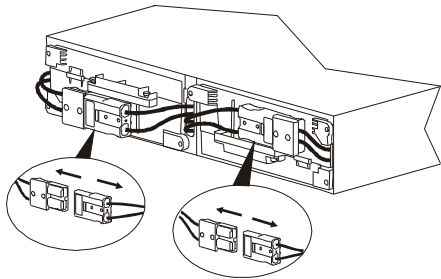

4

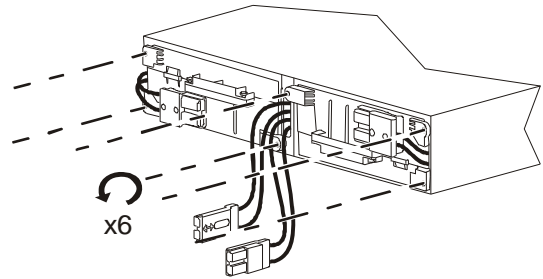

5

APCRBC141

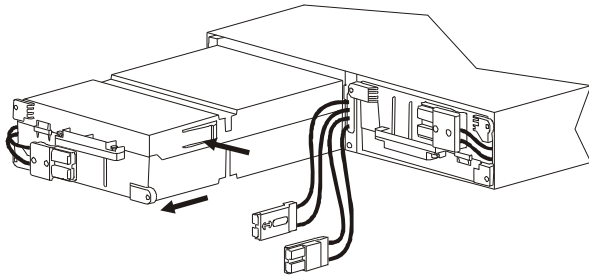

6

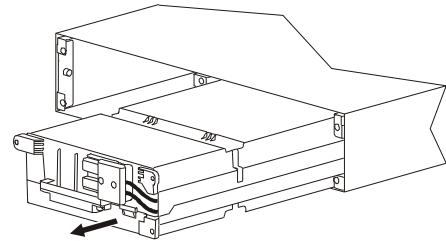

APCRBC152

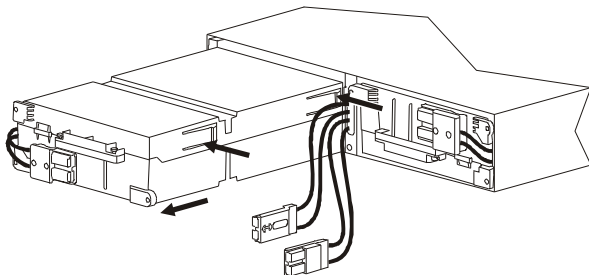

7



8

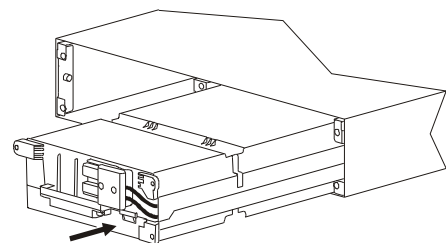

9 APCRBC141

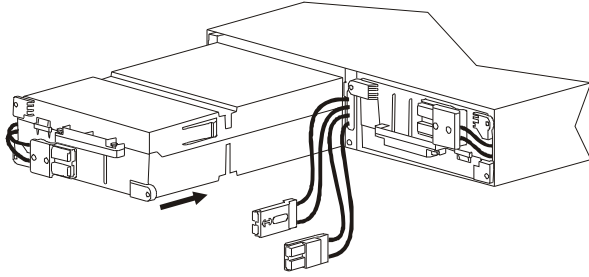

10

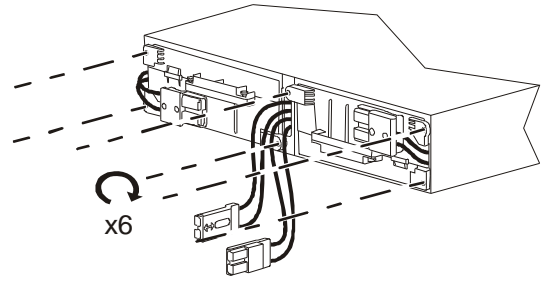

APCRBC152

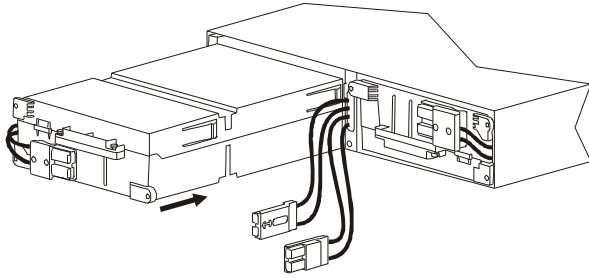

11

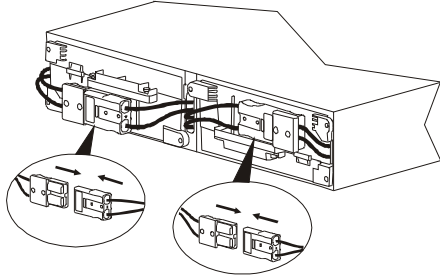

12

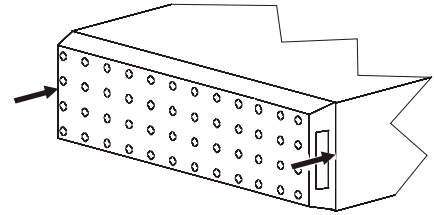

Reset Battery Installation Date

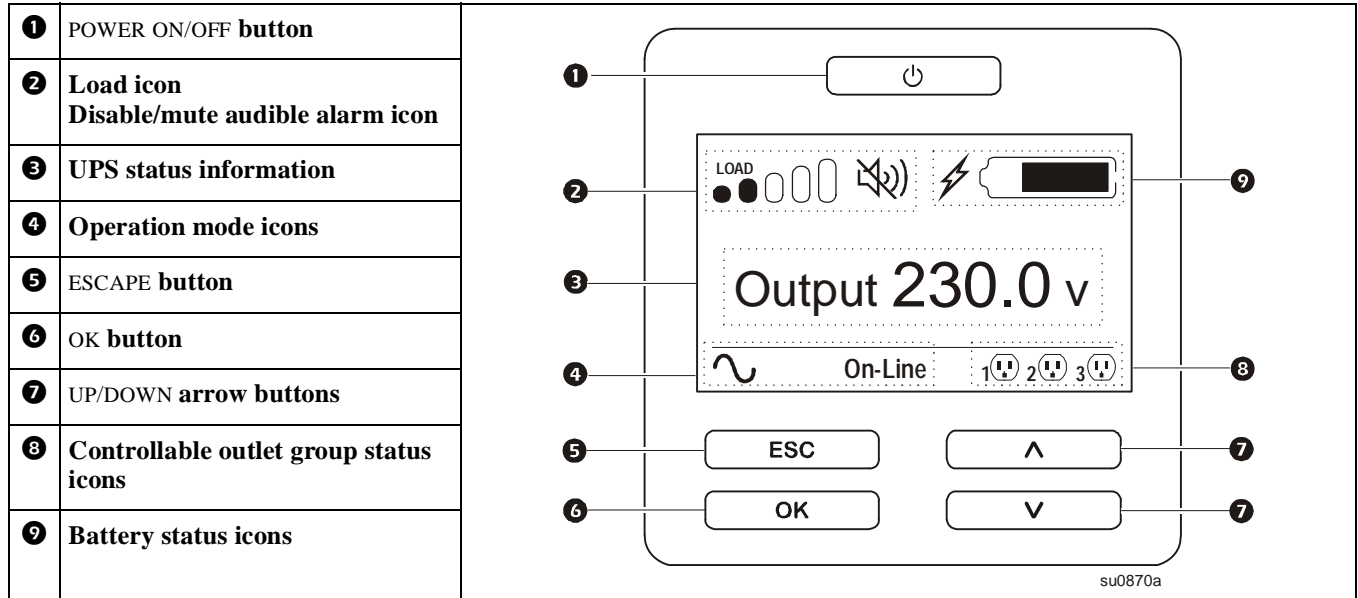

The battery installation date will appear on the display interface within two minutes of battery installation. If the installation date does not appear on the display interface, use the UP/DOWN arrow buttons to navigate to the **Config Menu > Battery** and enter the correct **Installation Date**.

When the replacement battery cartridge (RBC), is charged to full capacity, perform a **Self Test** and a **Runtime Calibration Test**.

Installationsanleitung Smart-UPS™ On-Line APCRBC152/APCRBC141

Sicherheitshinweise

Lesen Sie die Anweisungen sorgfältig, um sich mit dem Gerät vertraut zu machen, bevor Sie es installieren, in Betrieb nehmen oder warten. Die folgenden Sonderhinweise können in dieser Anleitung oder auf dem Gerät angegeben sein, um vor potenziellen Gefahren zu warnen oder die Aufmerksamkeit auf Informationen zu lenken, die einen Vorgang erläutern oder vereinfachen.



Die Ergänzung dieses Symbols zu einem Sicherheitsaufkleber für Gefahren- oder Warnhinweise deutet darauf hin, dass eine Stromschlaggefahr besteht, die bei Nichtbeachtung der Anweisungen zu Personenschäden führen kann.



Dieses Symbol beschreibt eine Sicherheitswarnung. Es warnt Sie in Bezug auf potenzielle Gefahren für Personenschäden. Beachten Sie alle Sicherheitshinweise, die auf dieses Symbol folgen, um schwere oder tödliche Verletzungen zu verhindern.

⚠ VORSICHT

VORSICHT weist auf eine potenzielle Gefahrensituation hin, die bei Nichtbeachtung **zu** leichten bis mittelschweren Verletzungen führen kann.

VORSICHT

VORSICHT beschreibt Verfahren, die sich nicht auf körperliche Verletzungen beziehen, unter anderem bestimmte Gefahren in der Umgebung, potenzielle Beschädigung oder Datenverlust.



Sicherheits- und allgemeine Informationen

**Überprüfen Sie nach Erhalt den Verpackungsinhalt.
Benachrichtigen Sie bei Beschädigung den Frachtführer und Händler.**

- Befolgen Sie alle örtlichen und nationalen elektrischen Vorschriften.
- Führen Sie gebrauchte Akkus stets dem Recycling zu.
Informationen zum Recycling von gebrauchten Akkumodulen entnehmen Sie dem Informationsblatt zur Akku-Entsorgung, das dem Ersatzakku-Modul beiliegt.
- Recyceln Sie die Verpackungsmaterialien oder bewahren Sie sie für die Wiederverwendung auf.

Akkusicherheit

- Nehmen Sie vor dem Installieren oder Austauschen von Akkus Schmuck wie Armbanduhren oder Ringe ab. Hoher Kurzschlussstrom durch leitendes Material könnte schwere Verbrennungen verursachen.
- Versuchen Sie nicht, die Akkus durch Verbrennen zu entsorgen. Die Akkus können explodieren.
- Öffnen Sie die Akkus nicht und beschädigen Sie sie nicht. Freigesetzte Elektrolyte schädigen die Haut und Augen und können toxisch sein.

Austauschen der Akkumodule

⚠ VORSICHT

SCHÄDEN AN GERÄTEN ODER PERSONEN

- Das Gerät ist schwer. Jedes Akkumodul APCRBC152 wiegt 15,3 kg und jedes Akkumodul APCRBC141 wiegt 11,7 kg.
- Praktizieren Sie immer sichere Verfahren zum Anheben passend zum Gewicht des Geräts.
- Befolgen Sie alle örtlichen und nationalen elektrischen Vorschriften.
- Halten Sie die Akkumodule beim Einschieben in die sowie beim Herausziehen aus der USV oder dem externen Akku (XLBP) am Griff fest.
- Benutzen Sie den Griff nicht zum Anheben oder Tragen des Akkumoduls.
- Ersetzen Sie Akkumodule beim Austausch nur durch Akkumodule desselben Typs.

Die Nichtbeachtung dieser Anweisungen kann zu Schäden am Gerät und leichten bis mittelschweren Verletzungen führen.

Hinweis: Die Akkus werden in den ersten drei Stunden des Netzstrombetriebs auf 90 % der Kapazität geladen. Gehen Sie während des ersten Ladevorgangs nicht von der vollen Laufzeitkapazität aus.

Akkumodul	USV	XLBP
APCRBC152	SRT3000XLx/SRT3000RMLx	SRT96BP/SRT96RMBP
APCRBC141	SRT2200XLx/SRT2200RMLx	SRT72BP/SRT72RMBP

SRT2200XLx/SRT2200RMLx/SRT3000XLx/SRT3000RMLx – USV-Modelle

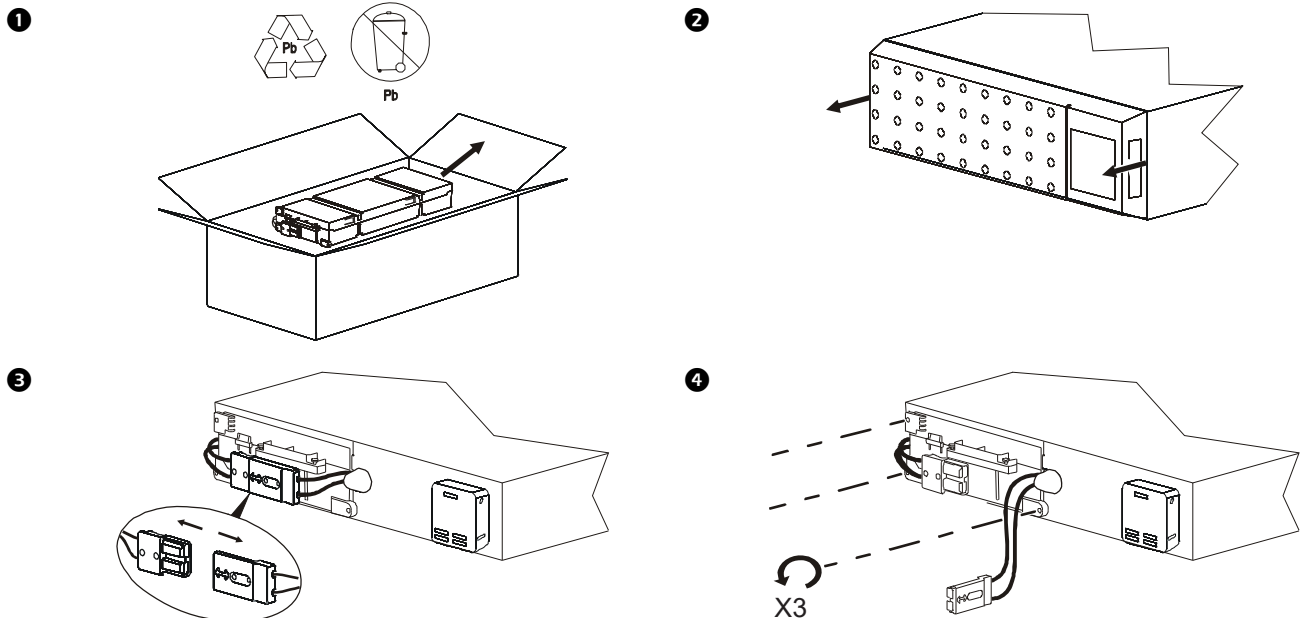

5 APCRBC141

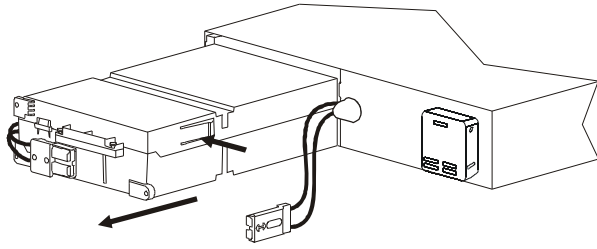

APCRBC152

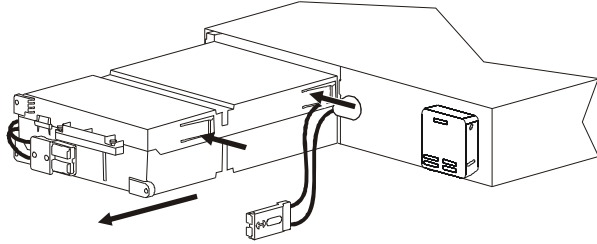

7 APCRBC141

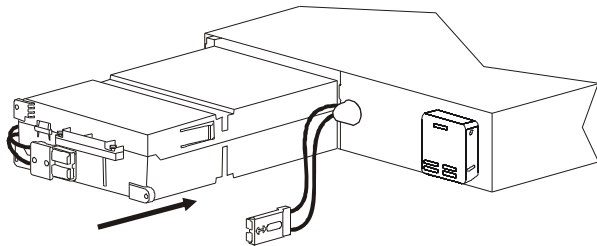

APCRBC152

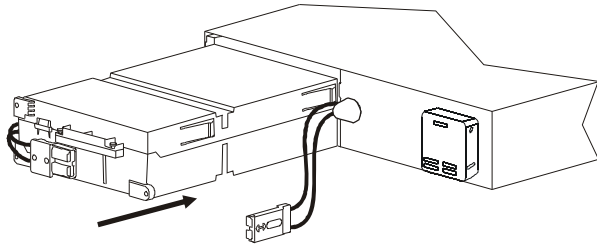

9

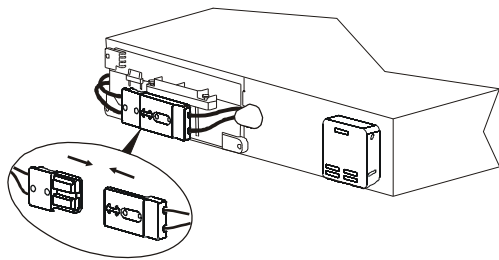

6

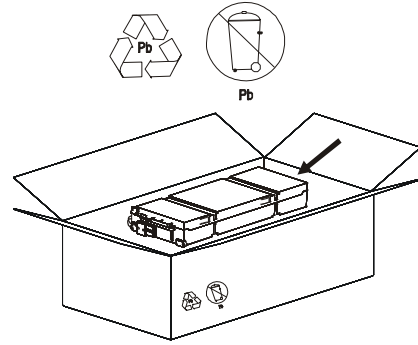

8

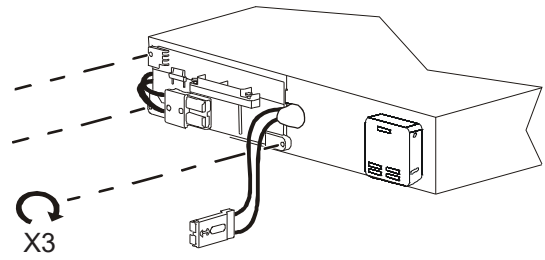

10

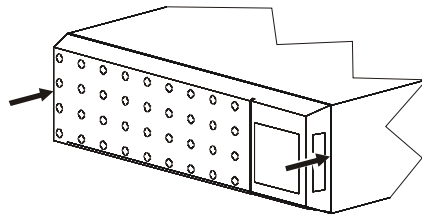

SRT72BP/SRT72RMBP/SRT96BP/SRT96RMBP – externe Akkus

1

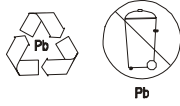

x2 Gehäuse
x2 Akkumodule

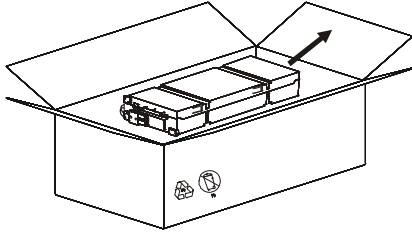

2

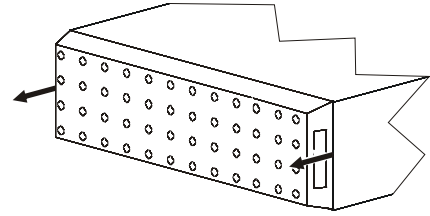

3

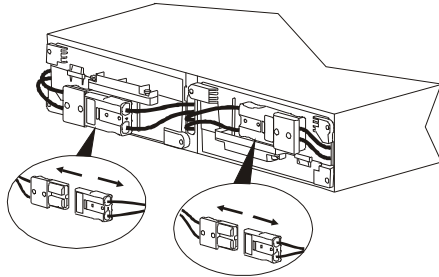

4

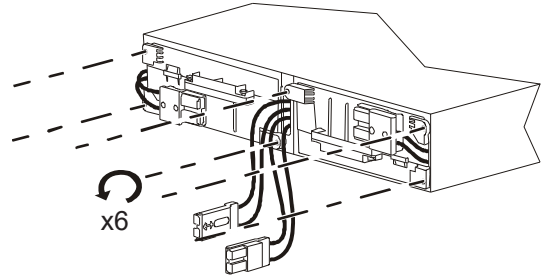

5

APCRBC141

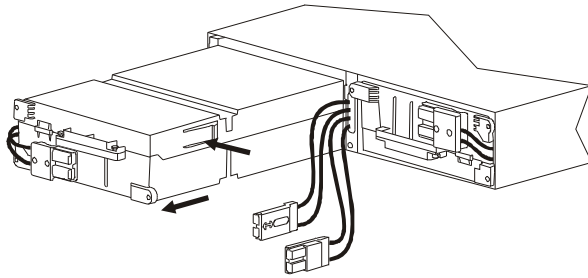

6

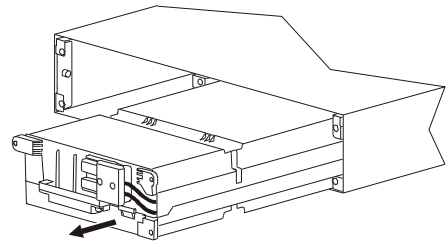

APCRBC152

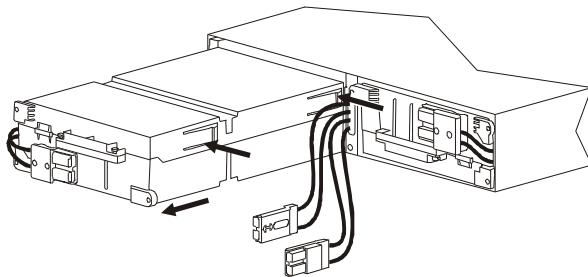

7

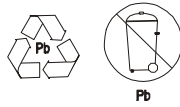

8

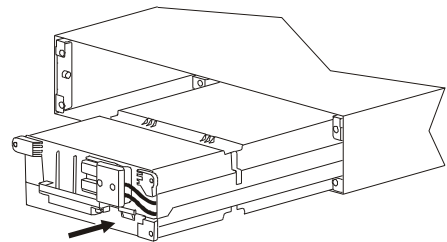

9 APCRBC141

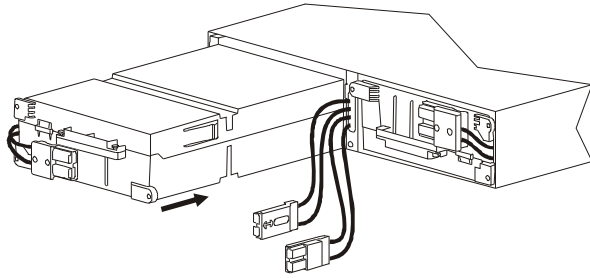

10

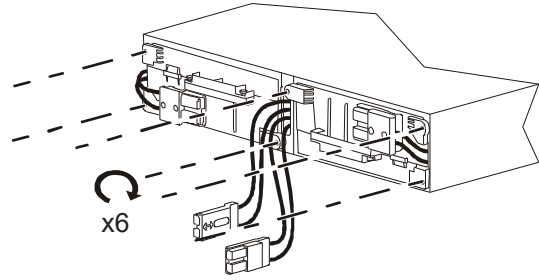

APCRBC152

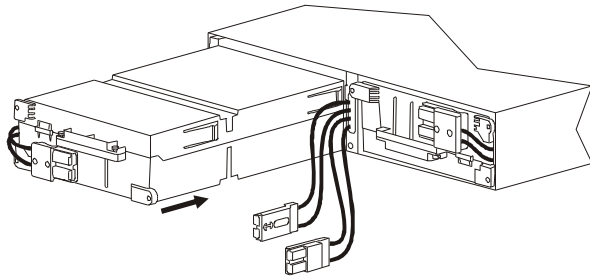

11

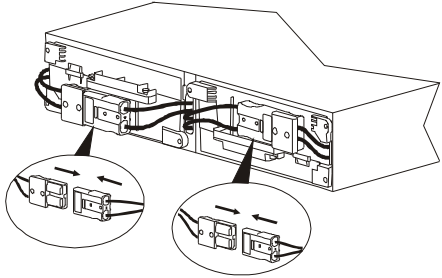

12

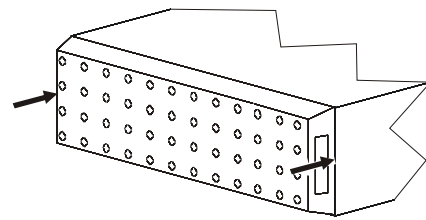

Datum der Akkuinstallation zurücksetzen

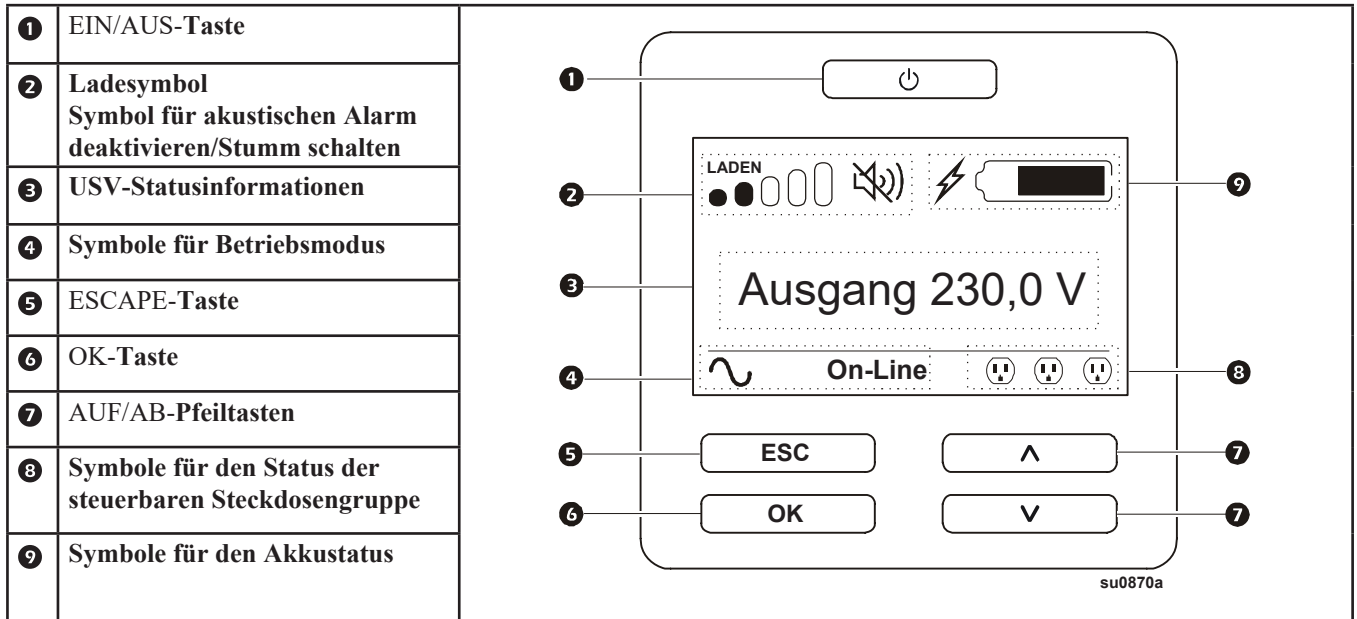

Das Datum der Akkuinstallation wird innerhalb von zwei Minuten nach der Akkuinstallation auf der Displayoberfläche angezeigt. Wird das Installationsdatum nicht auf der Displayoberfläche angezeigt, nutzen Sie die AUF/AB-Pfeiltasten, um zu **Config Menu (Konfig.-Menü) > Battery (Akku)** zu navigieren und geben Sie das korrekte **Installation Date (Installationsdatum)** ein.

Wenn die Ersatzakkukartusche (RBC) auf die volle Kapazität geladen ist, führen Sie einen **Self Test (Selbsttest)** und einen **Runtime Calibration Test (Laufzeitkalibrierungstest)** durch.

Guía de instalación del SAI Smart-UPS™ On-Line APCRBC152/APCRBC141

Mensajes de seguridad

Lea atentamente las instrucciones para familiarizarse con el equipo antes de intentar instalarlo, ponerlo en funcionamiento, o realizar reparaciones o mantenimiento. Los siguientes mensajes especiales pueden aparecer en este manual o en el equipo para advertir de posibles peligros o para llamar la atención sobre información que aclara o simplifica un procedimiento.



La incorporación de este símbolo en una etiqueta de Peligro o Advertencia indica que existe un peligro eléctrico que provocará lesiones personales si no se siguen las instrucciones.



Este es el símbolo de alerta de seguridad. Se utiliza para alertarle de posibles riesgos de lesiones personales. Obedezca todos los mensajes de seguridad que sigan a este símbolo para evitar posibles lesiones o la muerte.

⚠PRECAUCIÓN

PRECAUCIÓN indica una situación potencialmente peligrosa que, si no se evita, **puede provocar** lesiones leves o moderadas.

PRECAUCIÓN

PRECAUCIÓN se refiere a prácticas no relacionadas con las lesiones físicas, incluidos ciertos riesgos medioambientales, daños potenciales o pérdida de datos.



Información general y de seguridad

Inspeccione el contenido del paquete al recibirlo.

En caso de que haya algún daño, notifíquelo al transportista y a su distribuidor.

- Respete todos los códigos de instalación eléctrica locales y nacionales.
- Recicle siempre las baterías usadas.
Si desea obtener información sobre el reciclaje de módulos de baterías usados, consulte la hoja de información sobre la eliminación de baterías que se incluye con el módulo de baterías de repuesto.
- Recicle los materiales de embalaje o guárdelos para volver a utilizarlos.

Medidas de seguridad relativas a la batería

- Antes de instalar o sustituir la batería, quítese las joyas, como relojes de pulsera y anillos.
La corriente de cortocircuito elevada que circula a través de los materiales conductores puede provocar quemaduras graves.
- No intente desechar las baterías quemándolas. Las baterías podrían explotar.
- No abra ni golpee las baterías. El electrolito liberado es perjudicial para la piel y los ojos, y puede ser tóxico.

Sustitución de los módulos de la batería

⚠ RECAUCIÓN

DAÑOS AL EQUIPO O AL PERSONAL

- El equipo es pesado. Cada módulo de batería APCRBC152 tiene un peso de 15,3 kg (33,7 lb) y cada módulo de batería APCRBC141 tiene un peso de 11,7 kg (25,8 lb).
- Practique siempre técnicas de levantamiento seguras y adecuadas al peso del equipo.
- Respete todos los códigos de instalación eléctrica locales y nacionales.
- Utilice el mango del modelo de batería para deslizar los módulos de batería dentro y fuera del SAI y del paquete de baterías externas (XLBP).
- No utilice el mango para levantar o transportar el módulo de la batería.
- Al sustituir los módulos de batería, sustitúyalos por el mismo tipo de módulos de batería.

En caso de no seguir estas instrucciones se pueden producir daños en el equipo y lesiones leves o moderadas.

Nota: Las baterías se cargarán al 90 % de su capacidad en las primeras tres horas de funcionamiento conectadas a la red eléctrica. No espere una capacidad de funcionamiento completa durante este período de carga inicial.

Módulo de batería	SAI	XLBP
APCRBC152	SRT3000XLx/SRT3000RMXLx	SRT96BP/SRT96RMBP
APCRBC141	SRT2200XLx/SRT2200RMXLx	SRT72BP/SRT72RMBP

Modelos SAI SRT2200XLx/SRT2200RMXLx/SRT3000XLx/SRT3000RMXLx

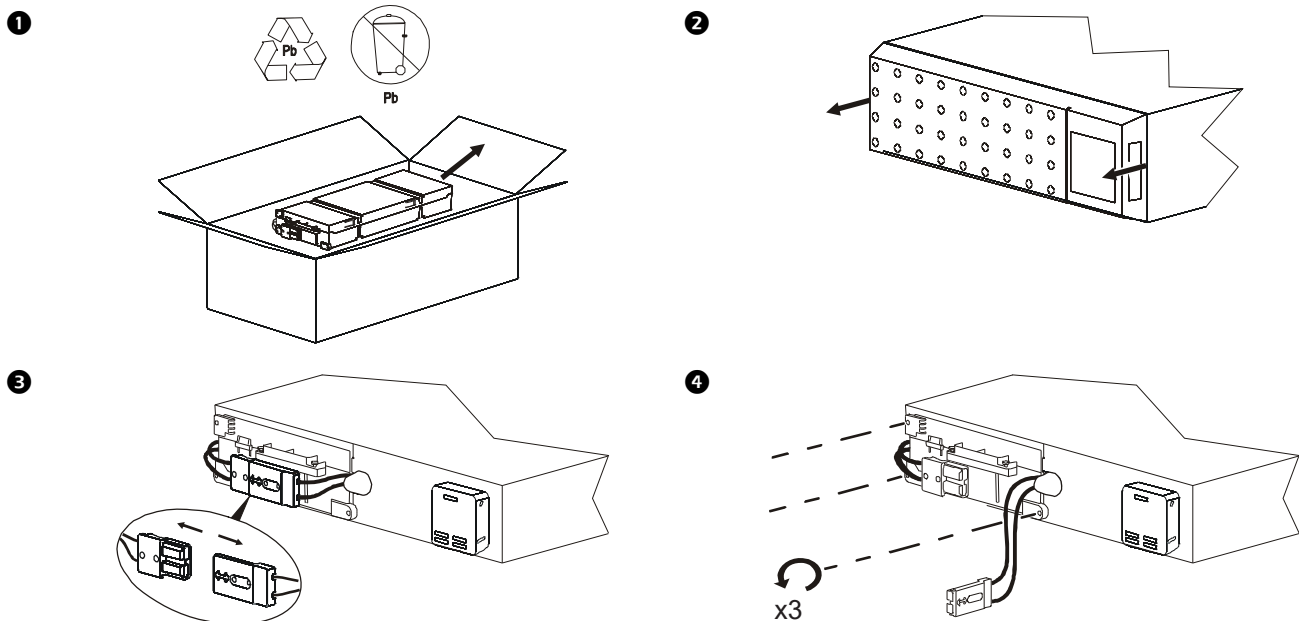

5 APCRBC141

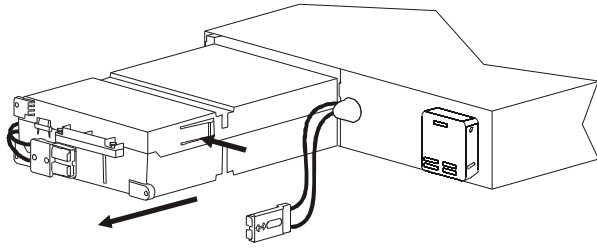

APCRBC152

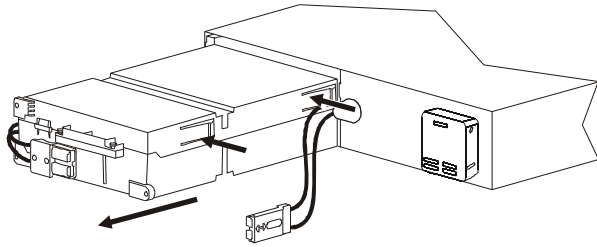

7 APCRBC141

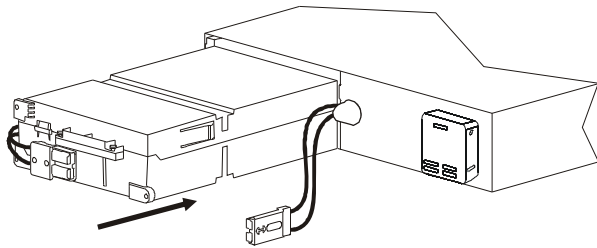

APCRBC152

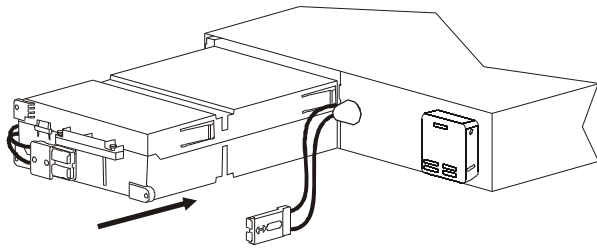

9

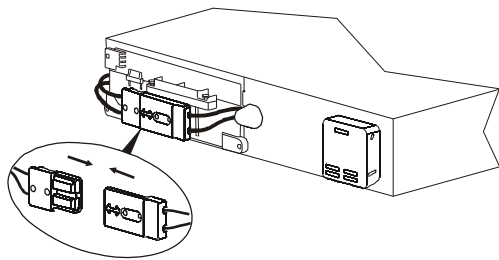

6

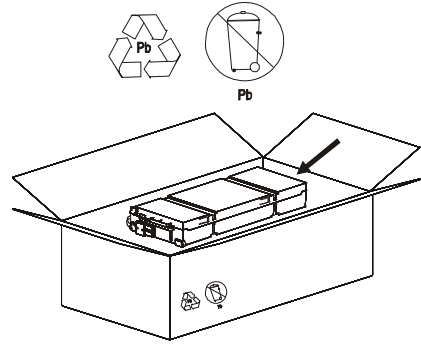

8

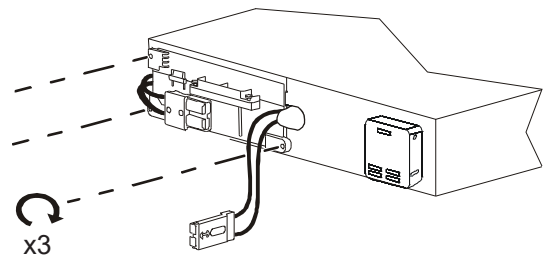

10

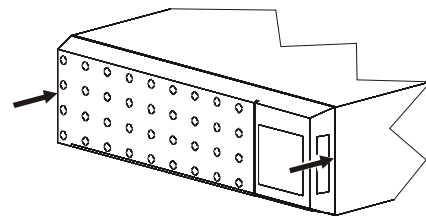

Paquetes de baterías externos SRT72BP/SRT72RMBP/SRT96BP/SRT96RMBP

1

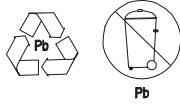

x2 cajas
x2 módulos de batería

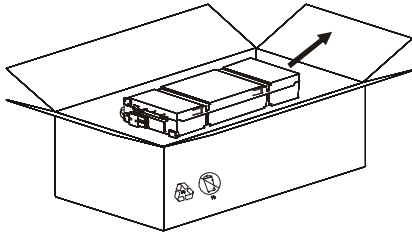

2

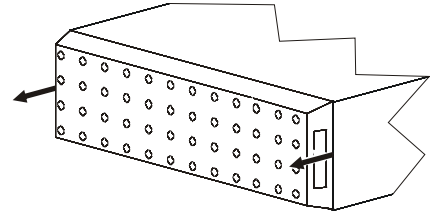

3

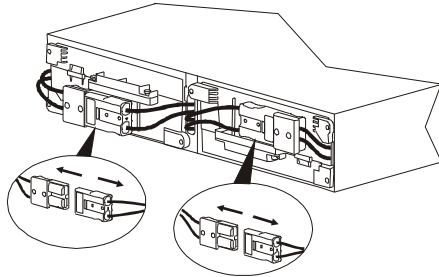

4

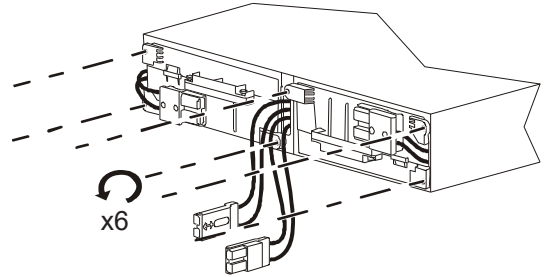

5

APCRBC141

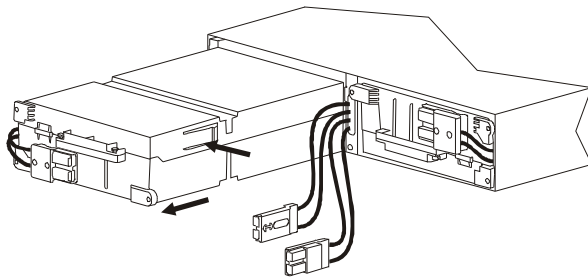

6

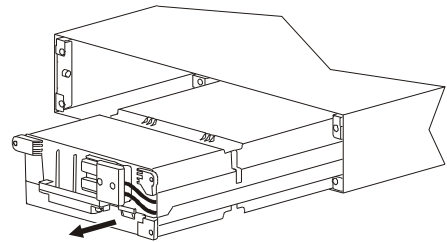

APCRBC152

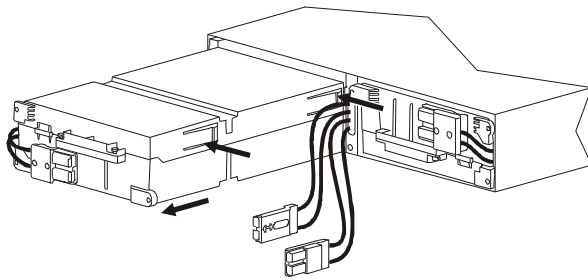

7



8

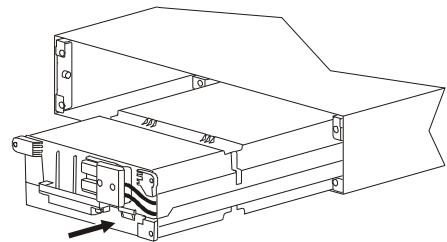

9 APCRBC141

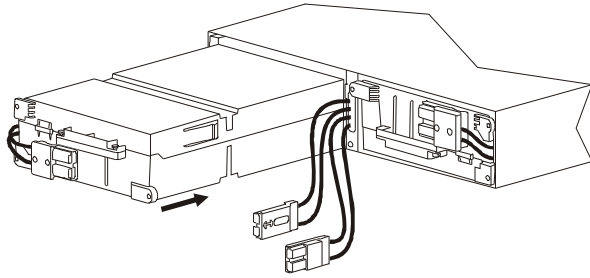

10

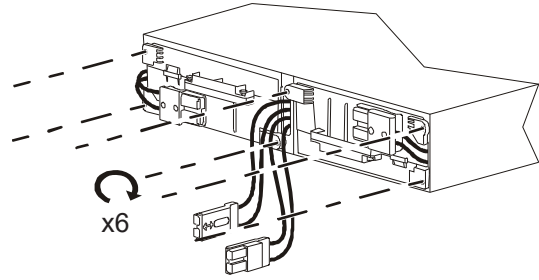

APCRBC152

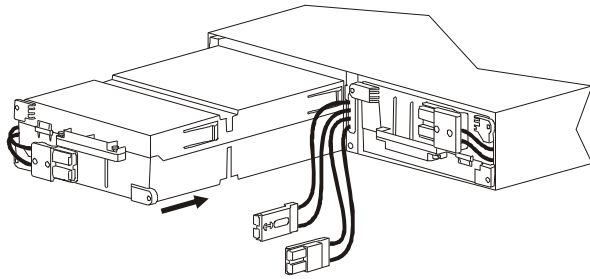

11

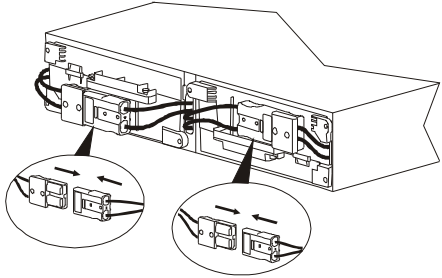

12

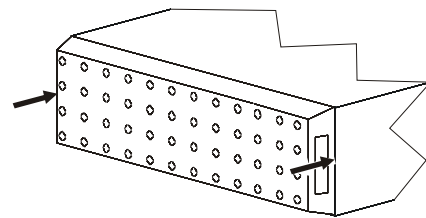

Restablecimiento de la fecha de instalación de la batería

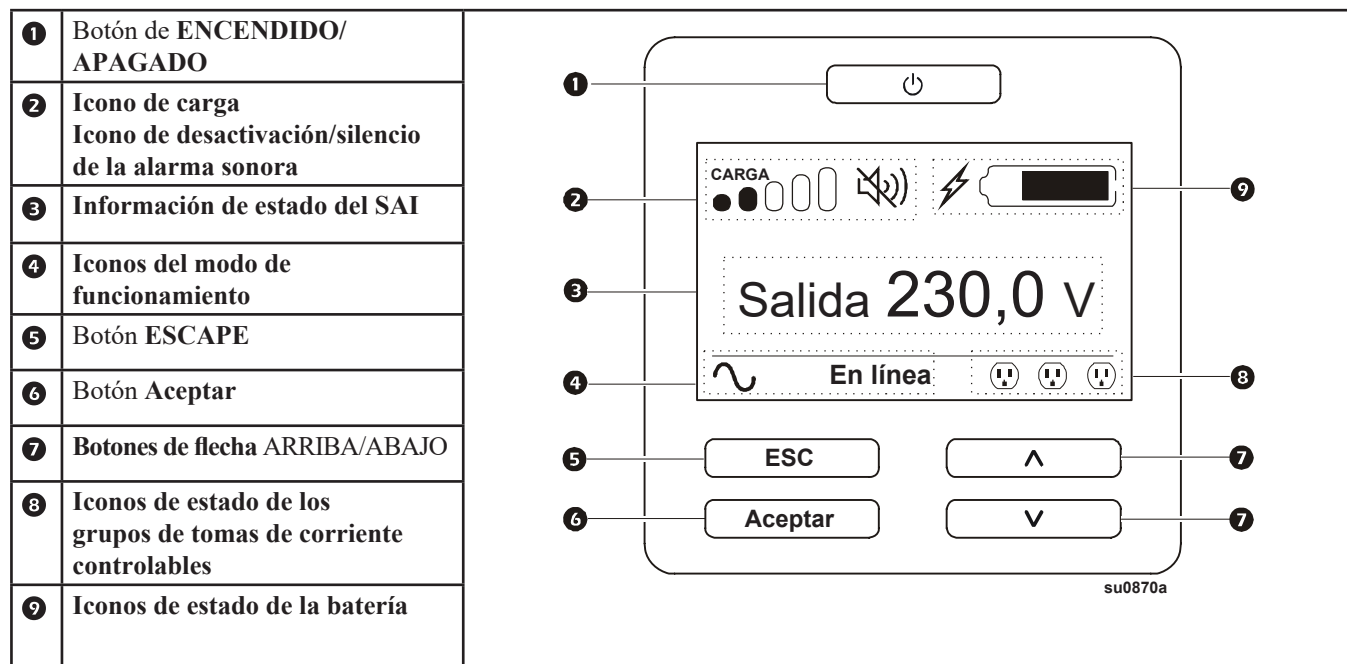

La fecha de instalación de la batería aparecerá en la interfaz de la pantalla en un plazo de dos minutos tras la instalación de la batería. Si la fecha de instalación no aparece en la interfaz de la pantalla, utilice los botones de flecha ARRIBA/ABAJO para navegar hasta el **menú Configuración > Batería** e introduzca la **Fecha de instalación** correcta.

Cuando el cartucho de la batería de repuesto (RBC), esté cargado al máximo de su capacidad, realice una **Autocomprobación** y una **Prueba de calibración en tiempo de ejecución**.

Guide d'installation Smart-UPS™ On-Line APCRBC152/APCRBC141

Messages de sécurité

Lisez attentivement les instructions pour vous familiariser avec l'équipement avant de procéder à son installation, son utilisation, sa réparation ou son entretien. Ce manuel ou l'équipement peuvent comporter les messages spéciaux suivants pour signaler des risques potentiels ou attirer l'attention sur des informations qui clarifient ou simplifient une procédure.



L'ajout de ce symbole à une étiquette de sécurité de type Danger ou Avertissement indique qu'il existe un risque électrique qui peut entraîner des blessures corporelles si les instructions ne sont pas suivies.



C'est le symbole d'alerte de sécurité. Il est utilisé pour vous avertir des risques potentiels de blessures corporelles. Respectez tous les messages de sécurité qui suivent ce symbole pour éviter tout risque de blessure ou de décès.

ATTENTION

ATTENTION indique une situation potentiellement dangereuse qui, si elle n'est pas évitée, **peut entraîner** des blessures mineures ou modérées.

ATTENTION

ATTENTION concerne des pratiques qui ne présentent pas de risque de blessure physique, mais plutôt certains risques de pollution de l'environnement, de dommages potentiels ou de perte de données.



Informations générales et de sécurité

**Inspectez le contenu du paquet dès sa réception.
Informez le transporteur et le revendeur de tout dommage.**

- Respectez tous les codes locaux et nationaux en matière d'électricité.
- Recyclez toujours les batteries usagées.
Pour plus d'informations sur le recyclage des modules de batteries usagés, reportez-vous à la fiche d'information sur l'élimination des batteries accompagnant le module de batteries de rechange.
- Recyclez les matériaux d'emballage ou conservez-les pour les réutiliser.

Sécurité des batteries

- Avant d'installer ou de remplacer les batteries, retirez les bijoux tels que les montres-bracelets et les bagues. Le passage d'un fort courant de court-circuit à travers des matériaux conducteurs peut provoquer de graves brûlures.
- N'éliminez pas les batteries en les brûlant. Elles risquent d'exploser.
- N'ouvrez ni n'abîmez les batteries. L'électrolyte libéré est dangereux pour la peau et les yeux, et peut être toxique.

Remplacement des modules de batteries

⚠ ATTENTION

RISQUE DE DOMMAGES À L'ÉQUIPEMENT OU DE BLESSURES AU PERSONNEL

- L'équipement est lourd. Chaque module de batteries APCRBC152 pèse 15,3 kg (33,7 lb) et chaque module de batteries APCRBC141 pèse 11,7 kg (25,8 lb).
- Utilisez toujours des techniques de levage sécuritaires et adaptées au poids de l'équipement.
- Respectez tous les codes locaux et nationaux en matière d'électricité.
- Pour introduire les modules de batteries dans l'onduleur et le bloc-batterie externe (XLBP) et les en retirer, utilisez les poignées desdits modules.
- N'utilisez pas la poignée pour soulever ou transporter le module de batteries.
- Lorsque vous remplacez les modules de batteries, remplacez-les par des modules de batteries du même type.

Le non-respect de ces instructions peut entraîner des dommages matériels et des blessures mineures ou modérées.

Remarque : Les batteries se chargeront jusqu'à 90 % de leur capacité dans les trois premières heures de fonctionnement sur le réseau d'alimentation électrique. Ne vous attendez pas à une capacité de fonctionnement complète pendant cette période de charge initiale.

Module de batteries	Onduleur	XLBP
APCRBC152	SRT3000XLx/SRT3000RMLx	SRT96BP/SRT96RMBP
APCRBC141	SRT2200XLx/SRT2200RMLx	SRT72BP/SRT72RMBP

Modèles d'onduleur SRT2200XLx/SRT2200RMLx/SRT3000XLx/SRT3000RMLx

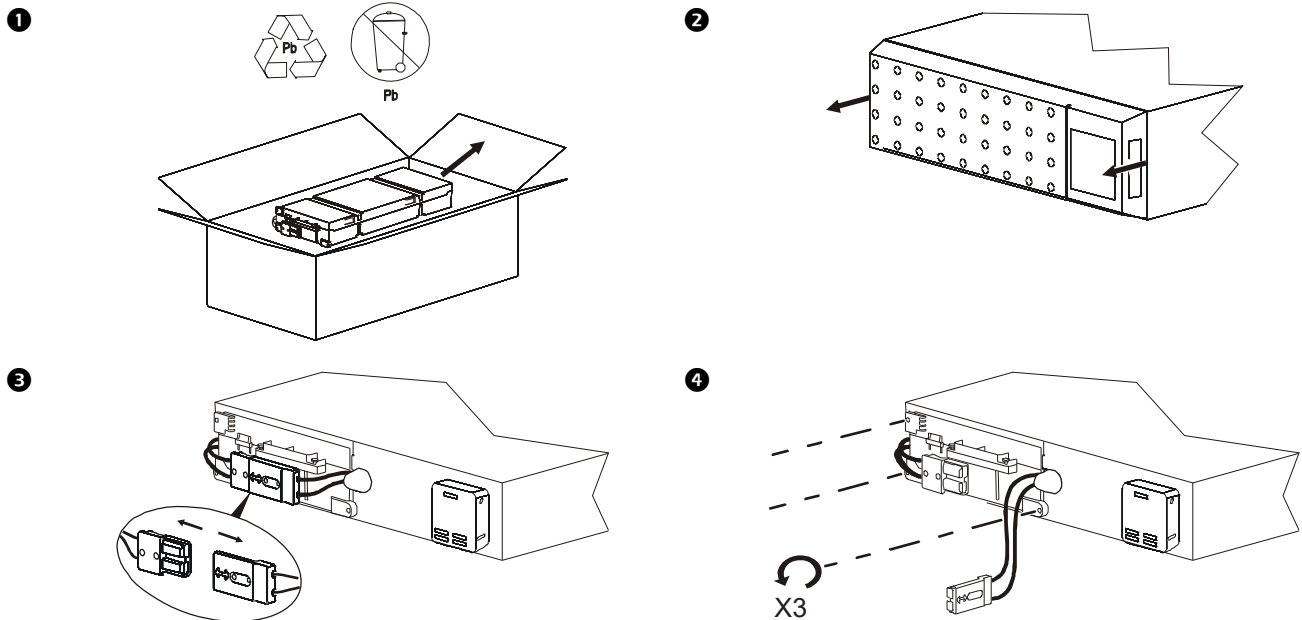

5 APCRBC141

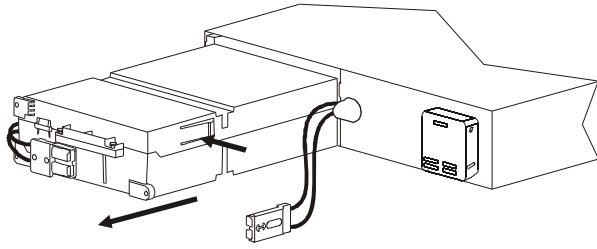

APCRBC152

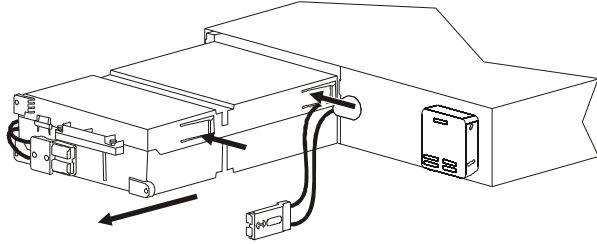

7 APCRBC141

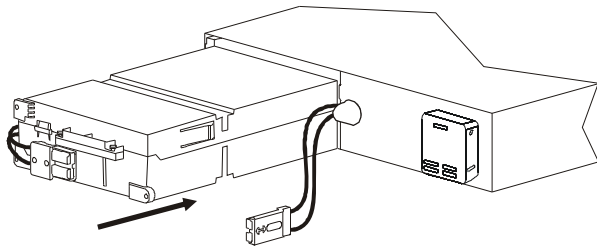

APCRBC152

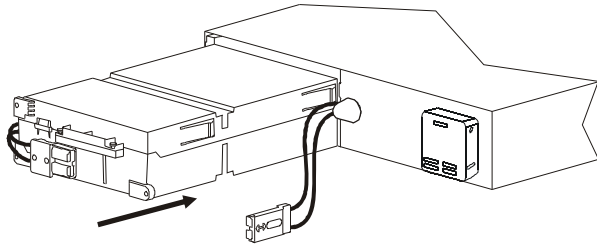

9

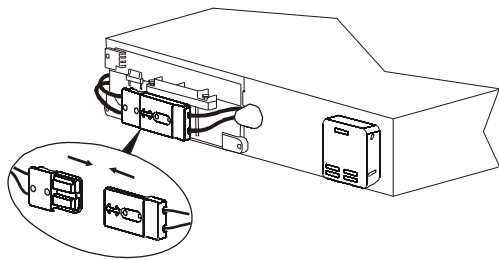

6

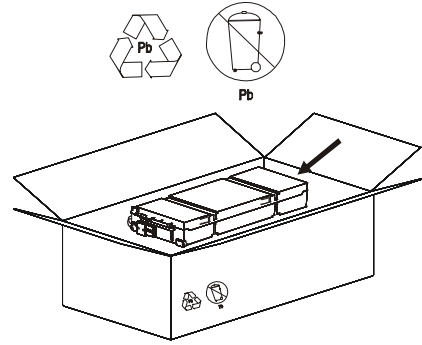

8

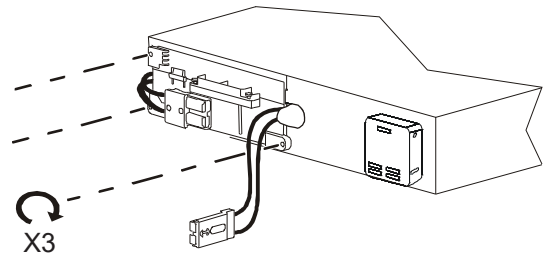

10

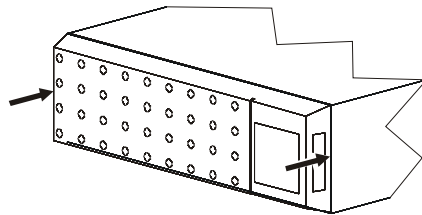

Blocs-batteries externes SRT72BP/SRT72RMBP/SRT96BP/SRT96RMBP

1

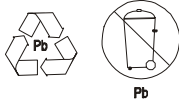

Boîtier x2
Module de batteries x2

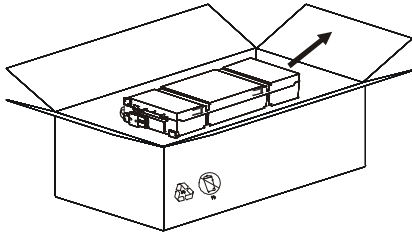

2

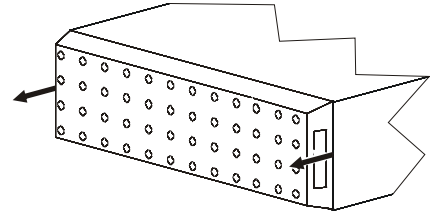

3

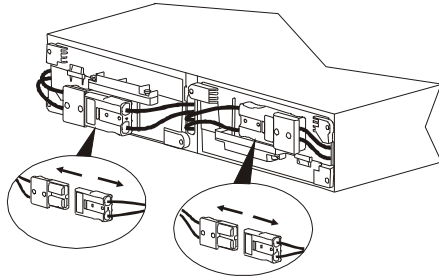

4

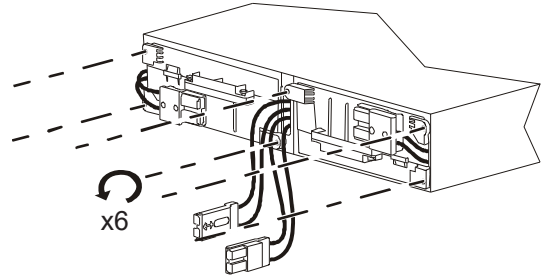

5

APCRBC141

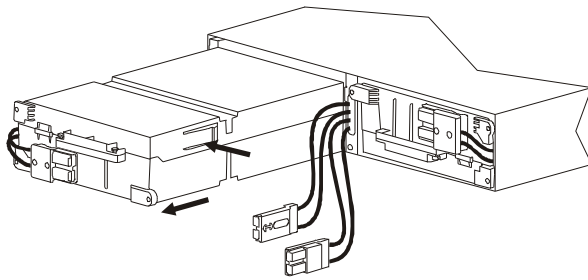

6

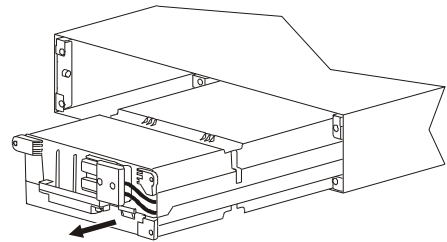

APCRBC152

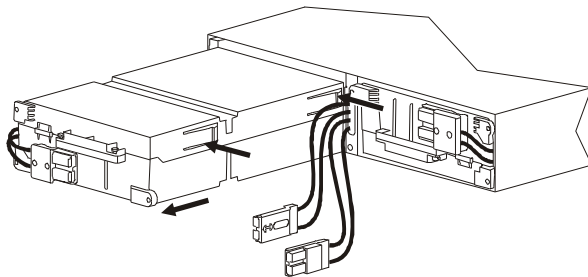

7



8

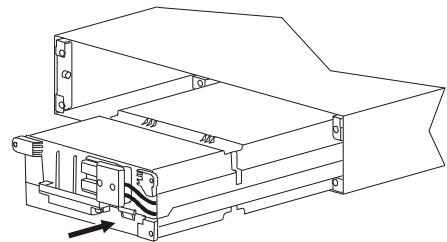

9 APCRBC141

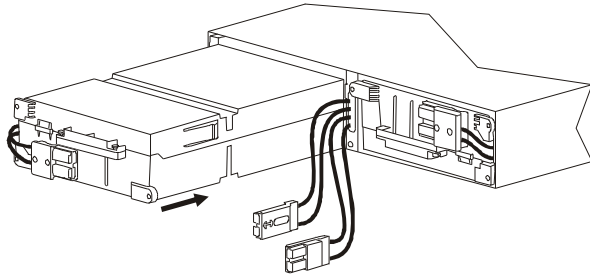

10

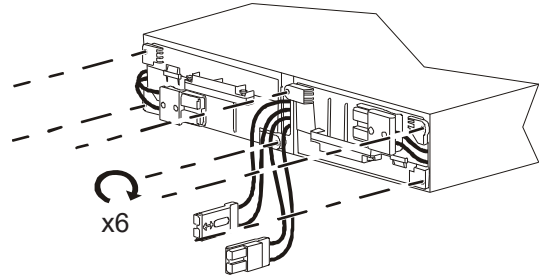

APCRBC152

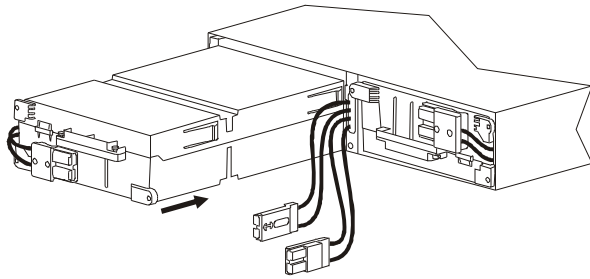

11

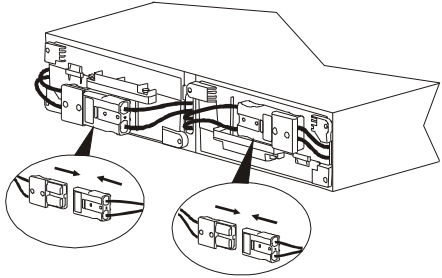

12

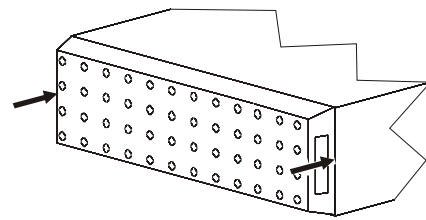

Réinitialisation de la date d'installation de la batterie

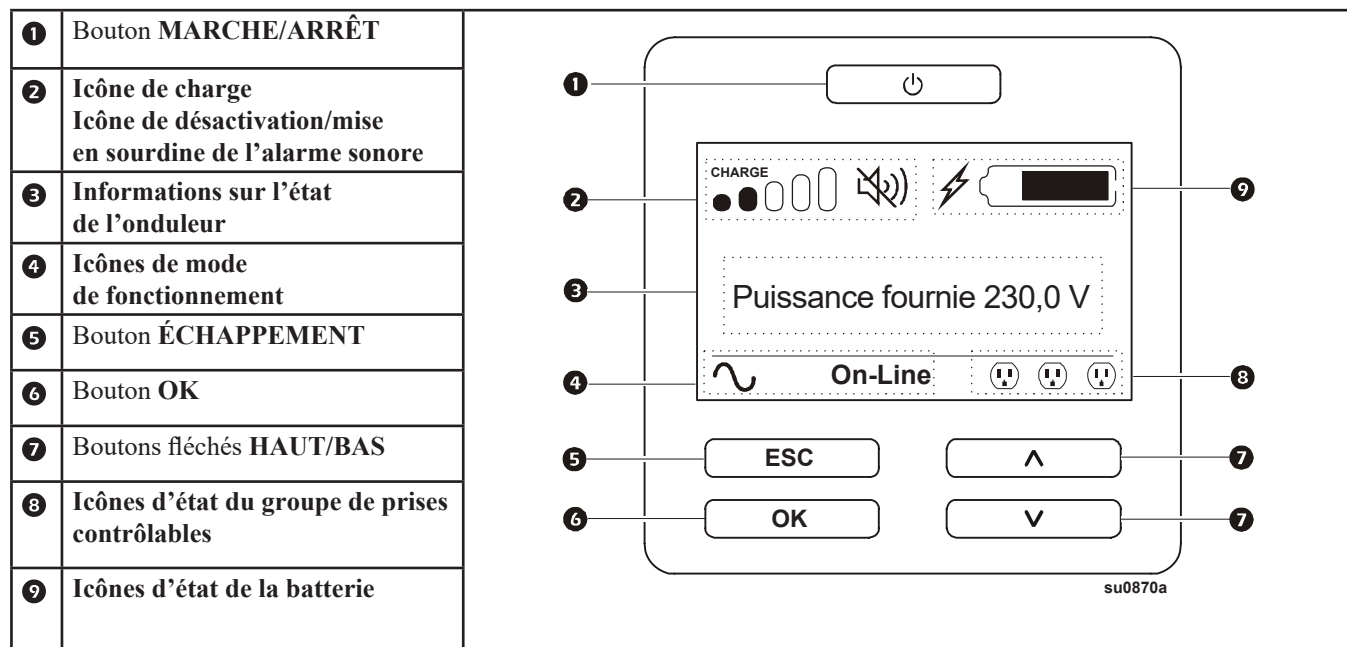

La date d'installation de la batterie apparaît sur l'interface d'affichage dans les deux minutes suivant l'installation de la batterie. Si la date d'installation n'apparaît pas sur l'interface d'affichage, utilisez les boutons fléchés HAUT/BAS pour accéder au **menu Config > Batterie et saisissez la Date d'installation** correcte.

Lorsque la cartouche de batterie de rechange (RBC) est chargée à pleine capacité, effectuez un **Autotest** et un **Test d'étalonnage d'autonomie**.

Guida all'installazione di Smart-UPS™ On-Line APCRBC152/APCRBC141

Messaggi relativi alla sicurezza

Leggere attentamente le istruzioni per acquisire dimestichezza con l'apparecchiatura prima di provare a installarla, metterla in funzione, eseguire l'assistenza o la manutenzione. Potrebbero essere presenti i seguenti messaggi speciali nel manuale o sull'apparecchiatura per avvertire l'utente dei potenziali pericoli o per richiamarne l'attenzione su informazioni che chiariscono o semplificano una procedura.



L'aggiunta di questo simbolo a un'etichetta di sicurezza di Pericolo o Avvertenza indica che è presente un pericolo elettrico che potrebbe provocare lesioni personali se non si seguono le istruzioni.



Questo è il simbolo d'allarme per la sicurezza. Viene utilizzato per avvisare l'utente di potenziali pericoli relativi a lesioni personali. Rispettare tutti i messaggi di sicurezza che seguono questo simbolo per evitare lesioni gravi o morte.

ATTENZIONE

ATTENZIONE indica una situazione potenzialmente pericolosa che, se non viene evitata, **può provocare** lesioni minori o moderate.

AVVISO

AVVISO si riferisce a pratiche non correlate a lesioni fisiche, compresi alcuni rischi ambientali, potenziali danni o perdita di dati.



Informazioni di carattere generale e per la sicurezza

**Ispezionare il contenuto della confezione alla consegna.
Comunicare a corriere e rifornitore eventuali danni.**

- Rispettare tutte le normative elettriche locali e nazionali.
- Riciclare sempre le batterie usate.
Per maggiori informazioni su come riciclare i moduli batteria, consultare il foglio informativo sullo smaltimento delle batterie in dotazione con il modulo batteria sostitutivo.
- Riciclare i materiali di imballaggio o conservarli per un eventuale riutilizzo.

Sicurezza della batteria

- Prima di installare o sostituire le batterie, rimuovere gioielli come orologi da polso e anelli.
Un'elevata corrente di cortocircuito che attraversa materiali conduttori può provocare gravi ustioni.
- Non smaltire le batterie bruciandole: potrebbero esplodere.
- Non aprire o danneggiare le batterie. Il rilascio di elettroliti è dannoso per pelle e occhi e può essere tossico.

Sostituire moduli batteria

ATTENZIONE

DANNI ALL'APPARECCHIATURA O AL PERSONALE

- L'attrezzatura è pesante. Ogni modulo batteria APCRBC152 pesa 15,3 kg (33,7 lb) e ogni modulo batteria APCRBC141 pesa 11,7 kg (25,8 lb).
- Adottare sempre tecniche di sollevamento sicure e adeguate al peso dell'apparecchiatura.
- Rispettare tutte le normative elettriche locali e nazionali.
- Utilizzare la maniglia del modulo batteria per far scorrere i moduli batteria all'interno e all'esterno dell'UPS e del pacco batterie esterno (XLBP).
- Non utilizzare la maniglia per sollevare o trasportare il modulo batteria.
- Durante la sostituzione dei moduli batteria, utilizzare un modulo batteria dello stesso tipo.

La mancata osservanza di queste istruzioni potrebbe provocare danni all'apparecchiatura e lesioni minori o moderate.

Nota: Le batterie si caricano al 90% della capacità durante le prime tre ore di funzionamento con alimentazione elettrica. Non aspettarsi la piena capacità di funzionamento della batteria durante questo periodo iniziale di carica.

Modulo batteria	UPS	XLBP
APCRBC152	SRT3000XLx/SRT3000RMLx	SRT96BP/SRT96RMBP
APCRBC141	SRT2200XLx/SRT2200RMLx	SRT72BP/SRT72RMBP

Modelli di UPS SRT2200XLx/SRT2200RMLx/SRT3000XLx/SRT3000RMLx

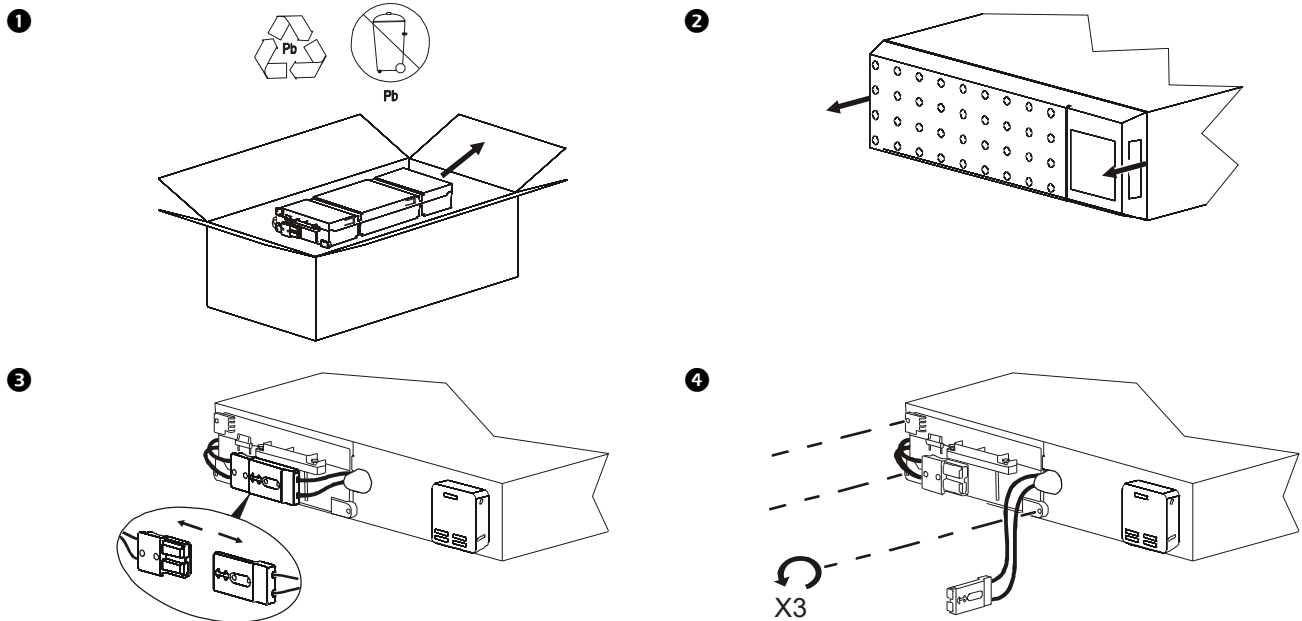

5 APCRBC141

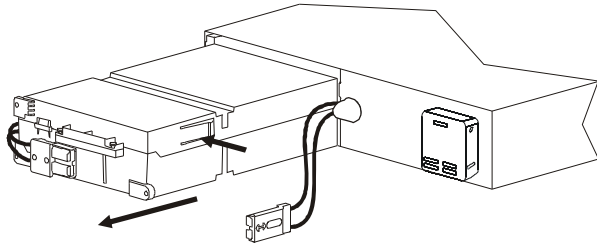

APCRBC152

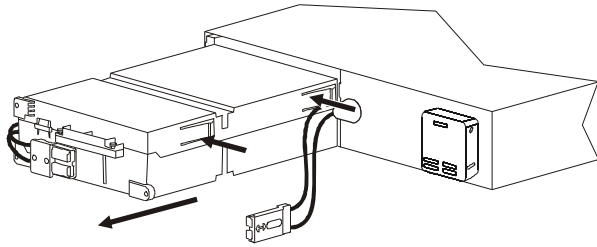

7 APCRBC141

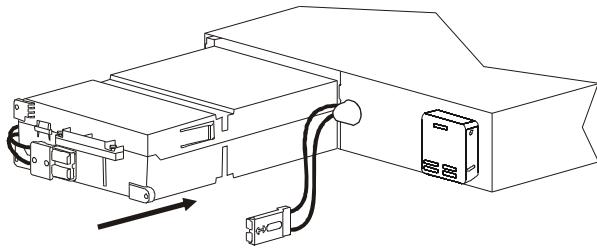

APCRBC152

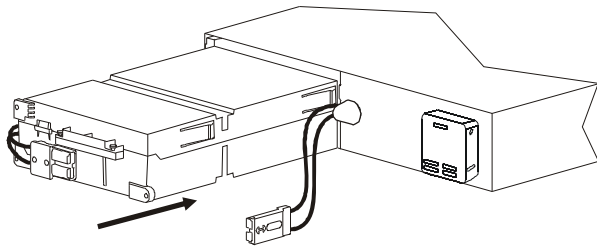

9

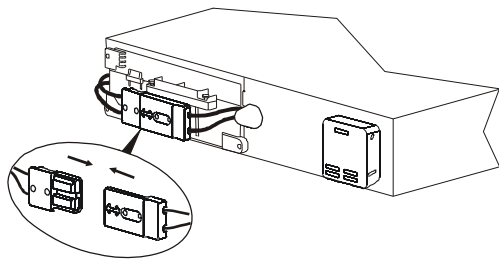

6

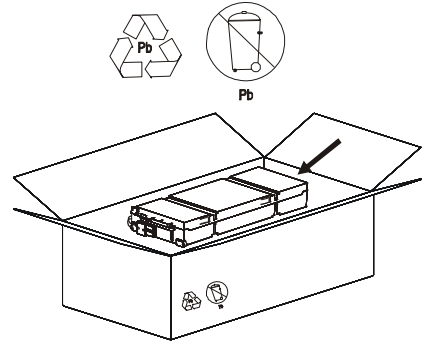

8

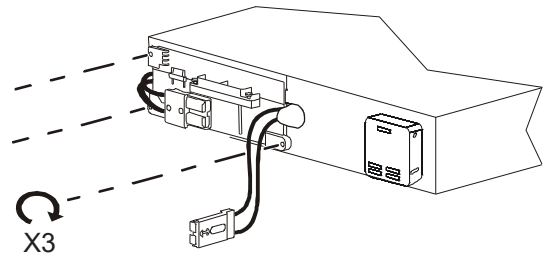

10

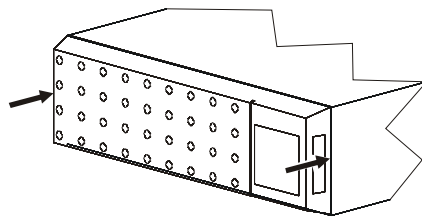

Pacchi batterie esterni SRT72BP/SRT72RMBP/SRT96BP/SRT96RMBP

1

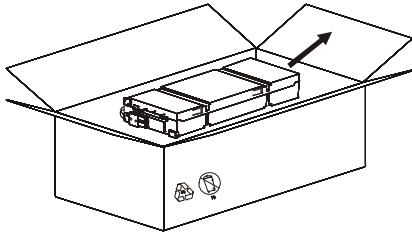
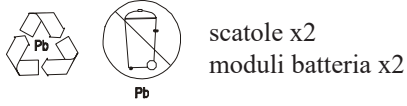

2

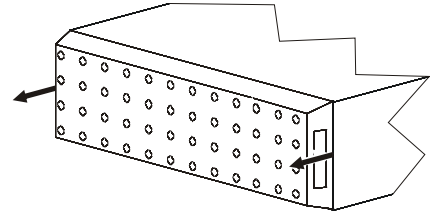

3

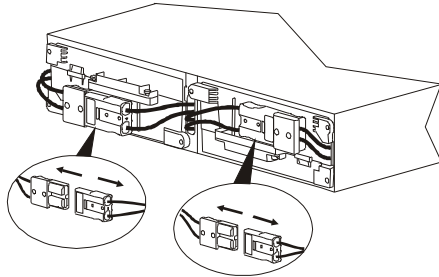

4

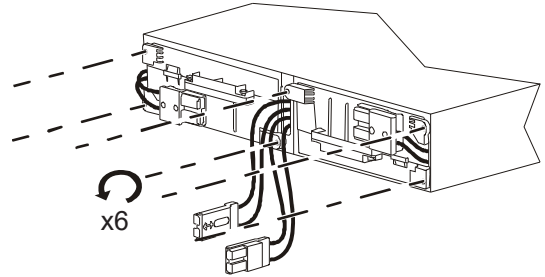

5

APCRBC141

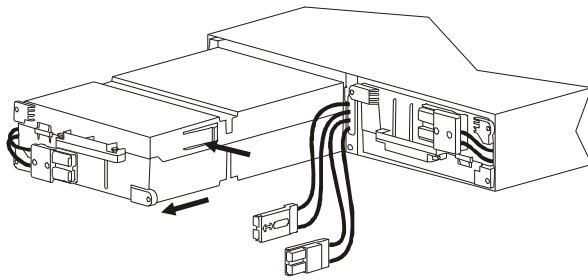

6

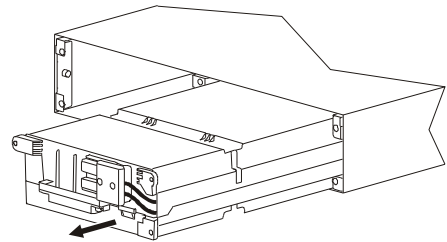

APCRBC152

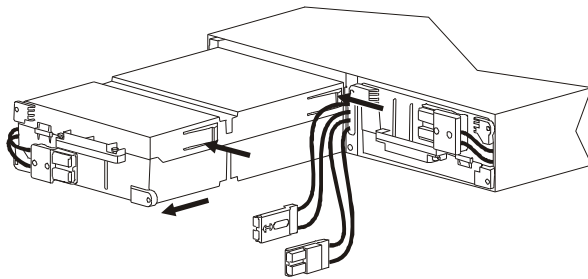

7

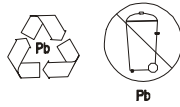

8

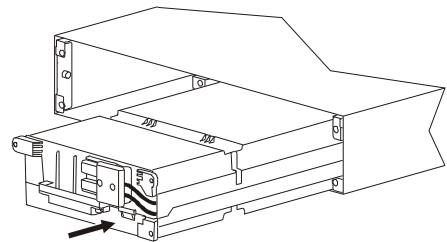

9 APCRBC141

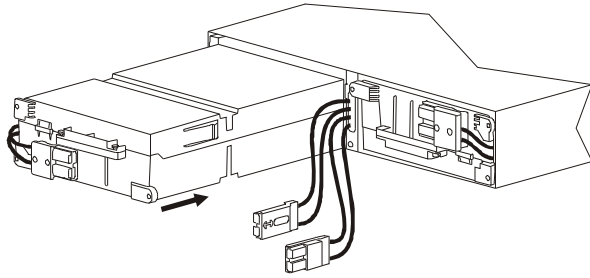

10

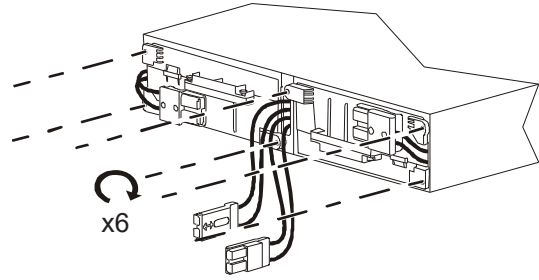

APCRBC152

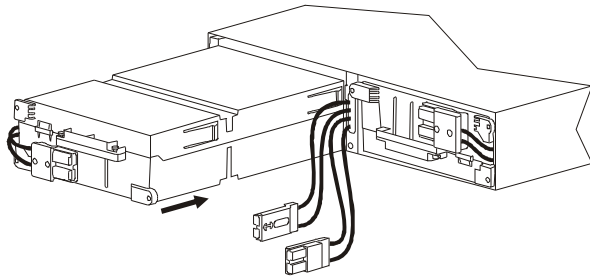

11

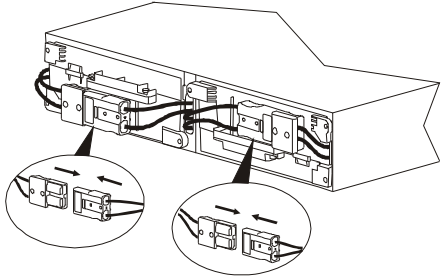

12

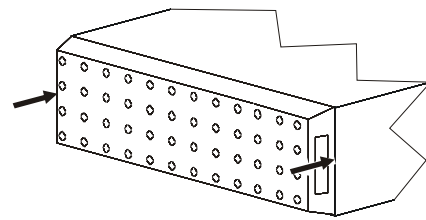

Ripristinare la data di installazione della batteria

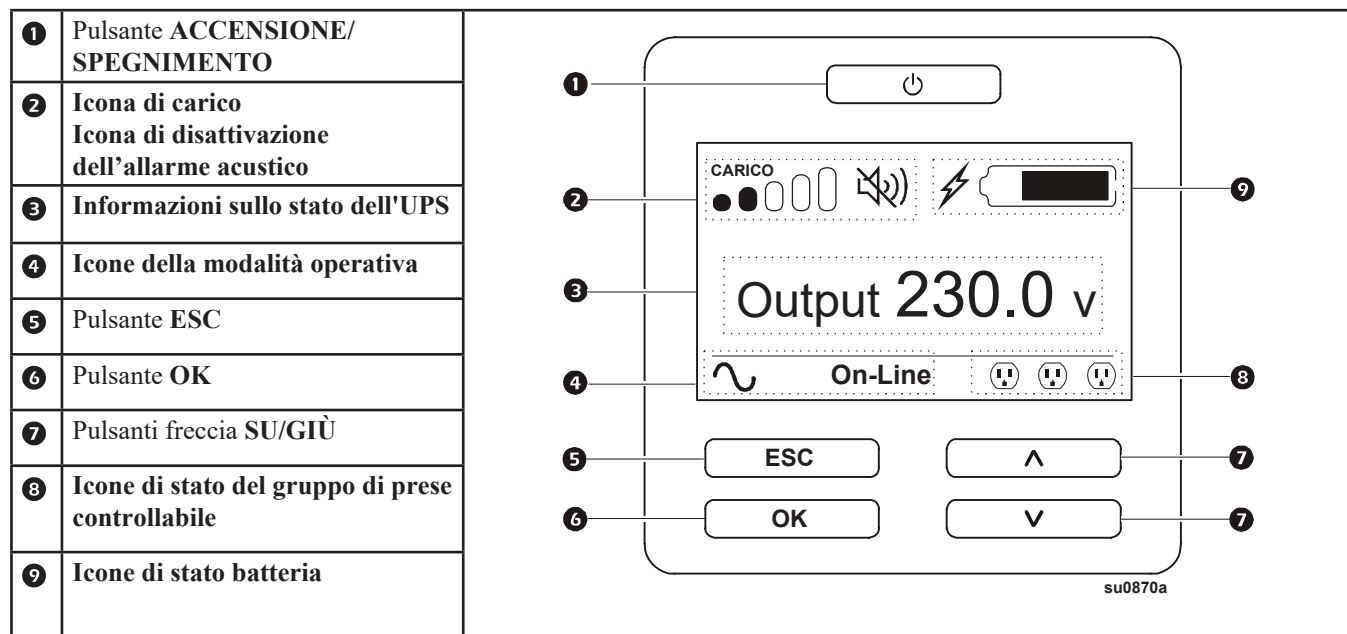

La data di installazione della batteria apparirà sull'interfaccia del display entro due minuti dall'installazione. Se la data di installazione non appare sull'interfaccia del display, utilizzare i pulsanti freccia SU/GIÙ per navigare nel **menu di configurazione > Batteria** e inserire la **Data di installazione** corretta.

Quando la batteria di ricambio (RBC) viene caricata alla sua piena capacità, eseguire un **Auto test** e un **Test di calibrazione dell'autonomia**.