

Titan T2000

Owner's Manual



Dell PowerVault ME5 Series Storage System

Owner's Manual



Notes, cautions, and warnings

 **NOTE:** A NOTE indicates important information that helps you make better use of your product.

 **CAUTION:** A CAUTION indicates either potential damage to hardware or loss of data and tells you how to avoid the problem.

 **WARNING:** A WARNING indicates a potential for property damage, personal injury, or death.

About this guide.....	5
Chapter 1: Storage system hardware.....	6
Locate the service tag.....	6
Enclosure configurations.....	6
Upgrading to dual-controller configuration.....	7
Removing the second controller.....	7
Enclosure management.....	7
Operation.....	8
Enclosure variants.....	10
2U enclosure core product.....	11
2U enclosure front panel.....	12
2U enclosure rear panel.....	12
5U84 enclosure core product.....	14
5U84 enclosure front panel.....	15
5U84 enclosure rear panel.....	15
5U84 enclosure chassis.....	18
5U84 enclosure drawers.....	18
Operators (Ops) panel LEDs.....	20
2U enclosure Ops panel.....	20
5U enclosure Ops panel.....	21
Controller modules.....	21
12 Gb/s controller module LEDs.....	22
Cache status LED details.....	24
Controller failure when a single-controller is operational.....	25
Chapter 2: Troubleshooting and problem solving.....	26
Fault isolation methodology.....	26
Options available for performing basic steps.....	26
Performing basic steps.....	27
Host I/O.....	28
2U enclosure LEDs.....	28
2U enclosure Ops panel.....	28
2U enclosure PCM LEDs.....	29
2U enclosure Ops panel LEDs.....	29
2U enclosure disk drive carrier module LEDs.....	30
IO Module LEDs.....	31
12 Gb/s controller module LEDs.....	32
5U84 enclosure LEDs.....	34
5U enclosure Ops panel.....	34
ME5084 PSU LEDs.....	35
ME5084 FCM LEDs.....	35
ME5084 Ops panel LEDs.....	35
ME5084 drawer LEDs.....	36

ME5084 DDIC LEDs.....	36
5U84 controller module and IOM LEDs	37
Initial start-up problems.....	37
Troubleshooting 2U enclosures.....	37
Troubleshooting 5U enclosures.....	39
If the enclosure does not initialize.....	40
Correcting enclosure IDs.....	40
Troubleshooting hardware faults.....	40
Chapter 3: Module removal and replacement.....	43
ESD precautions.....	43
Dealing with hardware faults.....	44
Firmware updates.....	44
Partner firmware update.....	44
Installing a firmware bundle.....	45
Activating a firmware bundle.....	45
Shutting down attached hosts.....	45
Shutting down a controller module.....	45
Using the PowerVault Manager.....	45
Using the CLI.....	46
Verifying component failure.....	46
Customer-replaceable units (CRUs).....	46
Attach or remove the front bezel of a 2U enclosure.....	47
Replacing a drive carrier module in a 2U enclosure.....	48
Replacing a DDIC in a 5U enclosure.....	52
Replacing a controller module or IOM	60
Replacing a power cooling module (PCM) in a 2U enclosure.....	65
Replacing a power supply unit (PSU) in a 5U enclosure.....	66
Replacing a fan cooling module (FCM) in a 5U enclosure.....	68
Completing the component installation process.....	69
Verifying component operation.....	70
Using LEDs.....	70
Using management interfaces.....	70
Performing updates in PowerVault Manager after replacing an FC or SAS HBA.....	71
Chapter 4: Events and event messages.....	72
Event descriptions.....	72
Events.....	73
Appendix A: Connecting to the CLI.....	134
Micro-USB device connection.....	134
Microsoft Windows drivers.....	135
Linux drivers.....	135
Appendix B: Technical specifications.....	136
Appendix C: Standards and regulations.....	140

This guide describes the features and technical specifications of ME5 Series storage systems.

Audience

The information provided in this guide is intended for storage or network administrators and deployment personnel.

Related publications

The following documentation provides additional information about ME5 Series storage systems:

- Dell PowerVault ME5 Series Administrator's Guide
- Dell PowerVault ME5 Series ME5012 and ME5024 Getting Started Guide
- Dell PowerVault ME5 Series ME5084 Getting Started Guide
- Dell PowerVault ME5 Series Deployment Guide

Storage system hardware

This chapter describes the front-end and back-end components of ME5 Series enclosures.

Some of the modules within the enclosure are replaceable as described in [Module removal and replacement](#). The types of modules and other components that can be replaced are defined below:

- CRU: Customer-replaceable Unit
- FRU: Field-replaceable Unit (requires service expertise)

The terms CRU and FRU are used throughout this document.

This document might contain third-party content that is not under the control of Dell. The language in the third-party content might be inconsistent with the current guidelines for Dell content. Dell reserves the right to update this document after the content is updated by the relevant third parties.

Topics:

- [Locate the service tag](#)
- [Enclosure configurations](#)
- [Enclosure management](#)
- [Operation](#)
- [Enclosure variants](#)
- [2U enclosure core product](#)
- [5U84 enclosure core product](#)
- [5U84 enclosure chassis](#)
- [Operators \(Ops\) panel LEDs](#)
- [Controller modules](#)

Locate the service tag

ME5 Series storage systems are identified by a unique Service Tag and Express Service Code.

The Service Tag and Express Service Code can be found on the front of the system by pulling out the information tag. Alternatively, the information might be on a sticker on the back of the storage system chassis. This information is used to route support calls to appropriate personnel.

i **NOTE:** Quick Resource Locator (QRL):

- The QRL code contains information unique to your system. It can be found on the information tag and the *Setting Up Your Dell PowerVault ME5 Series Storage System* document provided with your ME5 Series enclosure.
- Scan the QRL to get immediate access to your system information, using your smart phone or tablet.

Enclosure configurations

The storage system supports three controller enclosure configurations.

- The 2U12 controller enclosure holds up to 12 low profile 3.5" form factor disk drives in a horizontal orientation.
- The 2U24 controller enclosure holds up to 24 low profile 2.5" form factor disk drives in a vertical orientation.
- The 5U84 controller enclosure holds up to 84 low profile 3.5" form factor disk drives in a vertical orientation within a disk drawer. The 5U84 controller enclosure contains two drawers that each hold 42 disks. If 2.5" disks are used, a 3.5" adapter is required.

The 2U12 and 2U24 enclosures support single or dual-controller module configurations, but the 5U84 enclosure only supports a dual-controller module configuration. If a partner controller module fails, the storage system fails over and runs on a single controller module until the redundancy is restored. For 2U enclosures, a controller module must be installed in slot A, and a

controller module or a controller module blank must be installed in slot B to ensure sufficient airflow through the enclosure during operation. For 5U84 enclosures, a controller module must be installed in both slot A and slot B.

These same 2U and 5U chassis form factors are used for the supported expansion enclosures; but with I/O modules instead of controller modules.

Upgrading to dual-controller configuration

You can upgrade a 2U single-controller module configuration by adding a second controller module in slot B.

Controller module B can be added while controller module A continues to process host I/O requirements. However, we recommend scheduling configuration changes during a maintenance window with low or no I/O activity.

Data is not impacted when a controller module B is inserted into the enclosure, but we recommended doing a complete data backup before proceeding.

NOTE:

- When a controller module B is inserted, the redundancy setting is automatically changed from `Single Controller` to `Active-Active ULP` (Unified LUN Presentation). No manual changes are necessary.
- If PFU (partner firmware upgrade) is enabled, when you add controller module B, the system automatically updates the firmware on second controller module to match the firmware version on the first controller module.

1. Type the following CLI command to confirm that redundancy is configured as `Single Controller Mode`:

```
show advanced-settings
```

This step confirms that controller module A does not report controller module B as missing.

2. Remove the controller blank from slot B.
3. Grasp the controller module with both hands, and with the latch in the open position, orient the module and align it for insertion into slot B.
4. Ensuring that the controller module is level, slide it into the enclosure as far as it will go. A controller module that is only partially seated will prevent optimal performance of the controller enclosure. Verify that the controller module is fully seated before continuing.
5. Set the module in position by manually closing the latch. You should hear a click as the latch handle engages and secures the controller module to its connector on the back of the midplane.
6. Connect the cables.
7. Map the host ports on controller module B.

Removing the second controller

To remove controller module B and revert back to a single-controller configuration:

1. Shut down controller module B using PowerVault Manager or the CLI.
2. Remove the controller module from the enclosure.
3. Type the following CLI command to change the redundancy settings to `Single Controller Mode`:

```
#set advanced-settings single-controller
```

4. Install a controller module blank in slot B.

Enclosure management

The enclosure is mechanically and electrically compliant with the Storage Bridge Bay (SBB) v 2.1 specification.

SBB modules actively manage the enclosure. Each module has a SAS expander with its own storage enclosure processor (SEP) that provides a SES target for a host to interface using the ANSI SES (SCSI Enclosure Services) standard. If one of these modules fails, the other module continues to operate.

Management interfaces

When the hardware installation is complete, use the PowerVault Manager to configure, monitor, and manage the storage system. The controller module also supports a command-line interface (CLI) for command line entry and scripting. For details, see the *Dell PowerVault ME5 Series Storage System CLI Guide* for your system.

Operation

CAUTION: Operating an enclosure with CRU modules disrupts the airflow, and prevents the enclosure from cooling sufficiently. All the slots in an enclosure must contain modules while the enclosure is in use, including drive carrier blanks in empty drive slots for 2U enclosures.

- Read the module bay caution label affixed to the controller modules being replaced.
- Replace a defective power cooling module (PCM) with a fully operational PCM within 24 hours. Do not remove a defective PCM unless you have a replacement model of the correct type ready for insertion.
- Disconnect power from a PCM or power supply unit (PSU) to be replaced before removing the PCM or PSU.
- Read the hazardous voltage warning label that is affixed to PCMs.

CAUTION: 5U84 enclosures only

- To prevent overturning, drawer interlocks stop users from opening both drawers simultaneously. Do not attempt to force open a drawer when the other drawer in the enclosure is already open. In a rack containing more than one 5U84 enclosure, do not open more than one drawer per rack at a time.
- Read the hot surface label that is affixed to the drawer. Operating temperatures inside enclosure drawers can reach 60°C. Take care when opening drawers and removing DDICs.
- Due to product acoustics, ear protection should be worn during prolonged exposure to the product in operation.
- Do not use open drawers to support any other objects or equipment.

NOTE: See [Enclosure variants](#) for details about enclosure options.

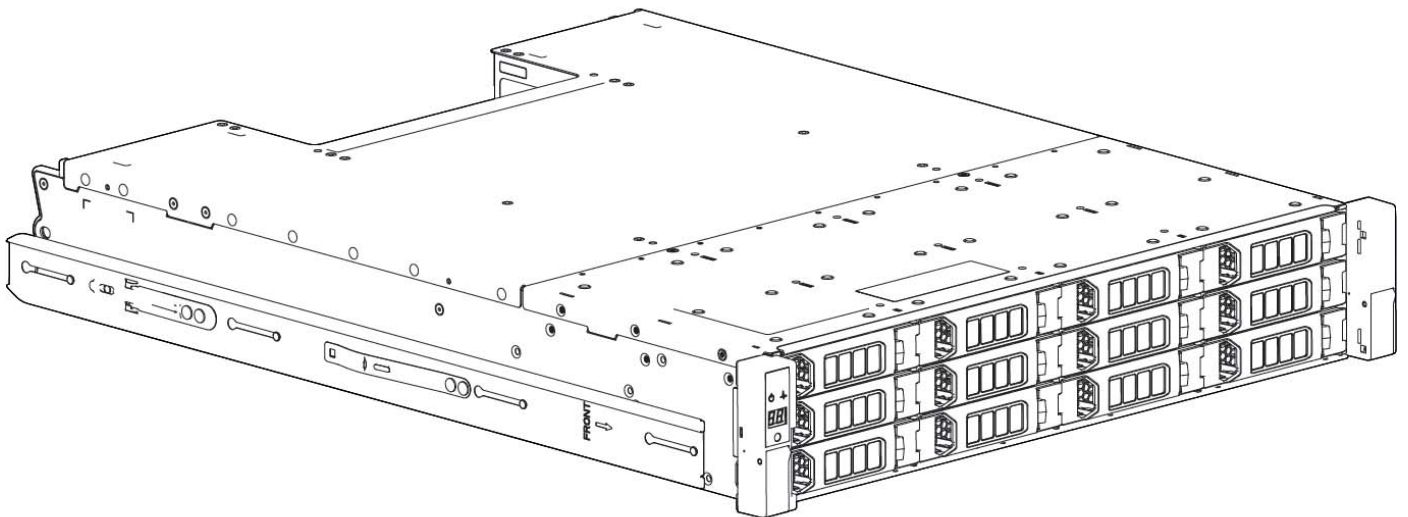

Figure 1. 2U12 enclosure system—front orientation

The 2U12 controller enclosure is equipped with dual-controllers.

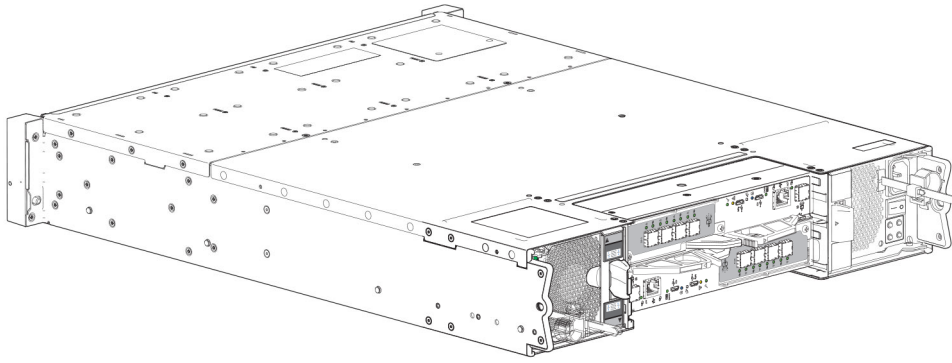

Figure 2. 2U12 enclosure system—rear orientation

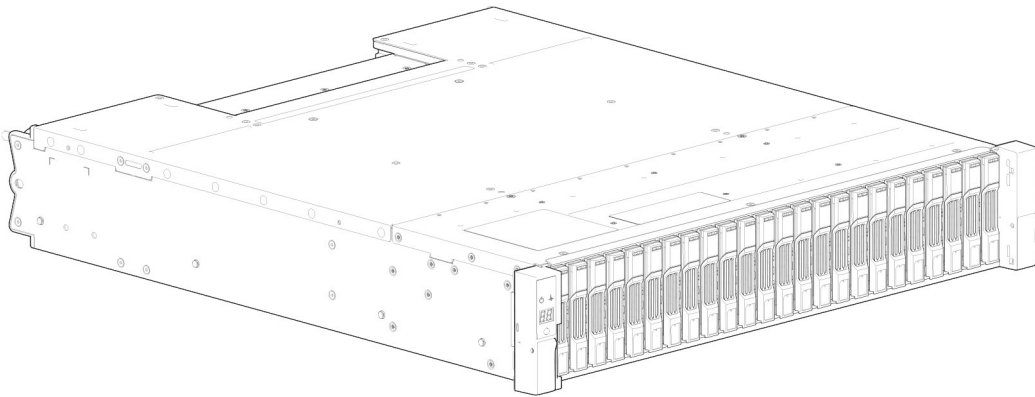

Figure 3. 2U24 enclosure system—front orientation

The 2U24 controller enclosure is equipped with dual-controllers.

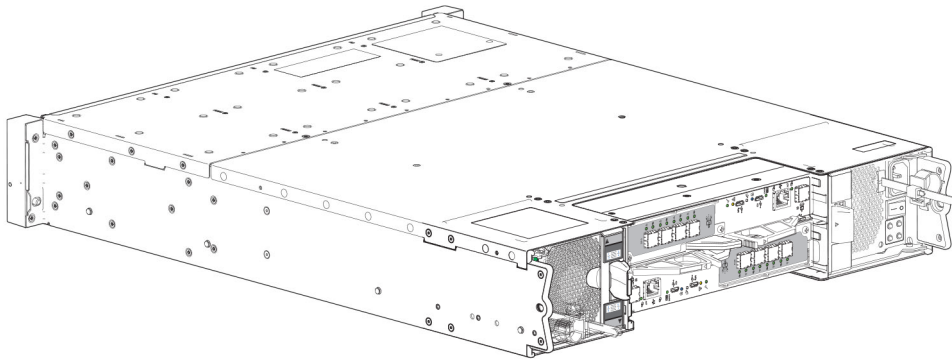

Figure 4. 2U24 enclosure system—rear orientation

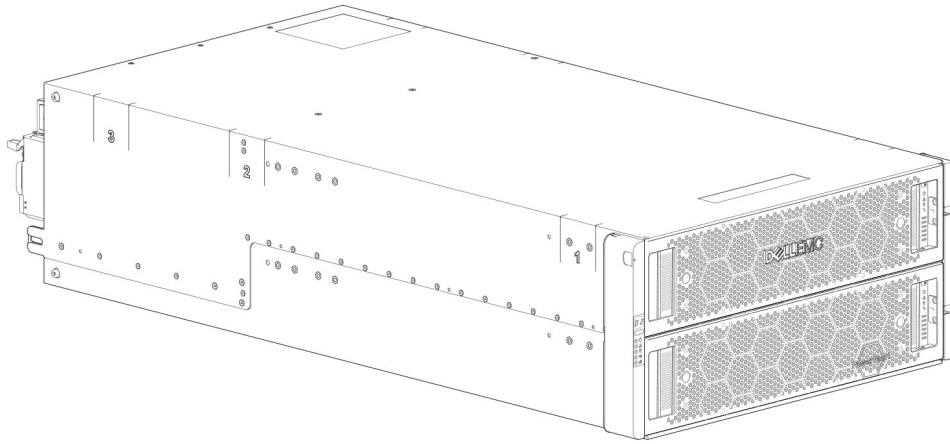

Figure 5. 5U84 enclosure system—front orientation

The 5U84 controller enclosure is equipped with dual-controllers.

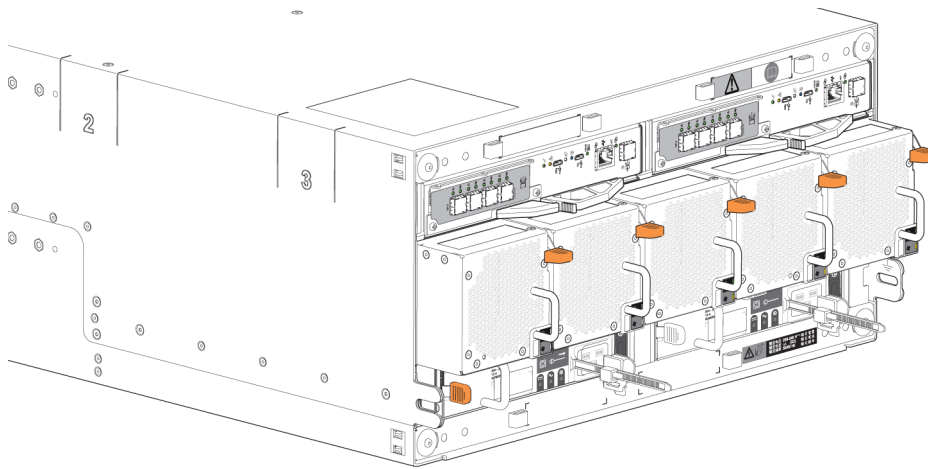

Figure 6. 5U84 enclosure system—rear orientation

Enclosure variants

The 2U chassis can be configured as a controller enclosure ME5012/ME5024, or an expansion enclosure ME412/ME424. The 5U chassis can be configured as a controller enclosure ME5084 or an expansion enclosure ME484.

NOTE: The key components of 2U and 5U enclosures are described in the following sections.

Although many CRUs differ between the form factors, the controller modules and IOMs are common to 2U12, 2U24, and 5U84 chassis. The controller modules and IOMs are introduced in [2U enclosure core product](#) and cross-referenced from [5U84 enclosure core product](#).

2U12

2U12 enclosures consist of 12 LFF (Large Form Factor) disk drives.

Table 1. 2U12 enclosure variants

Product	Configuration	PCMs ¹	Controller modules and IOMs ^{2,3}
ME5012	12 Gb/s direct dock SAS drives	2	2
	12 Gb/s direct dock SAS drives	2	1

Table 1. 2U12 enclosure variants (continued)

Product	Configuration	PCMs ¹	Controller modules and IOMs ^{2,3}
ME412	12 Gb/s direct dock SAS drives	2	2

¹ The redundant PCMs must be compatible modules of the same type.

² The supported controller modules are 4-port FC SFP+, 4-port iSCSI SFP28, 4-port 10Gbase-T iSCSI, 4-port mini-SAS HD. The supported IOMs are used in expansion enclosures for adding additional storage.

³ In single-controller module configurations, the controller module is installed into slot A, and a controller blank is installed in slot B.

2U24

2U24 enclosures consist of 24 SFF (Small Form Factor) disk drives.

Table 2. 2U24 enclosure variants

Product	Configuration	PCMs ¹	Controller modules or IOMs ^{2,3}
ME5024	12 Gb/s direct dock SAS drives	2	2
	12 Gb/s direct dock SAS drives	2	1
ME424	12 Gb/s direct dock SAS drives	2	2

¹ The redundant PCMs must be compatible modules of the same type.

² The supported controller modules are 4-port FC SFP+, 4-port iSCSI SFP28, 4-port 10Gbase-T iSCSI, 4-port mini-SAS HD. The supported IOMs are used in expansion enclosures for adding additional storage.

³ In single-controller module configurations, the controller module is installed in slot A, and a controller module blank is installed in slot B.

5U84

5U84 enclosures consist of 84 LFF, or 84 SFF disk drives held in two 42-slot drawers.

Table 3. 5U84 enclosure variants

Product	Configuration	PSUs ¹	FCMs ²	Controller modules or IOMs ³
ME5084	12 Gb/s direct dock SAS drives	2	5	2
ME484	12 Gb/s direct dock SAS drives	2	5	2

¹ The redundant PCMs must be compatible modules of the same type (both AC).

² The fan control module (FCM) is a separate CRU (not integrated into a PCM).

³ The supported controller modules are 4-port FC SFP+, 4-port iSCSI SFP28, 4-port 10Gbase-T iSCSI, 4-port mini-SAS HD. The supported IOMs are used in expansion enclosures for adding additional storage.

2U enclosure core product

The design concept is based on an enclosure subsystem together with a set of plug-in modules.

The following figures show component locations—together with CRU slot indexing—relative to 2U enclosure front and rear panels.

2U enclosure front panel

In the following figures, integers on disks indicate drive slot numbering sequence.

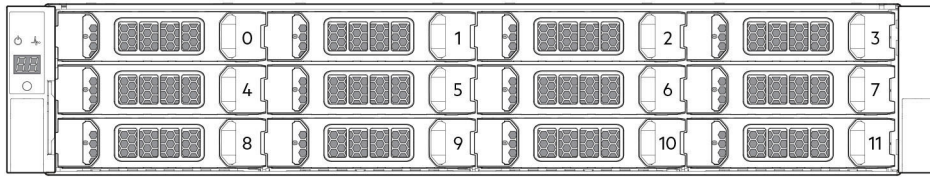

Figure 7. 2U12 enclosure system—front panel components

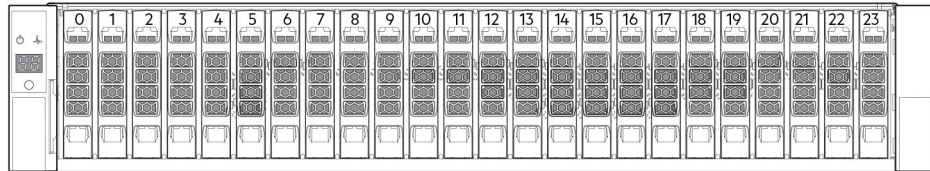

Figure 8. 2U24 enclosure system—front panel components

i NOTE:

- For information about enclosure front panel LEDs, see [2U enclosure Ops panel](#).
- For information about disk LEDs for LFF and SFF disk modules, see [Using LEDs](#) on page 70.
- For information about the optional 2U enclosure front bezel, see [Attach or remove the front bezel of a 2U enclosure](#).

2U enclosure rear panel

The controller modules and IOMs use alphabetic designators, and the Power Cooling Modules (PCMs) use numeric designators to identify the slots in a 2U enclosure.

There are two redundant controller modules that use a series of LEDs to reflect host connectivity status. You can monitor the LEDs from the rear panel area to determine system status.

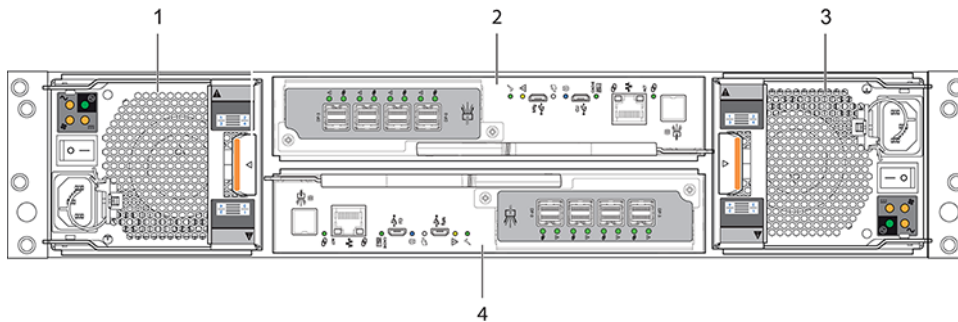

Figure 9. 2U controller enclosure—rear panel components

1. PCM 0
2. Controller module A
3. PCM 1
4. Controller module B

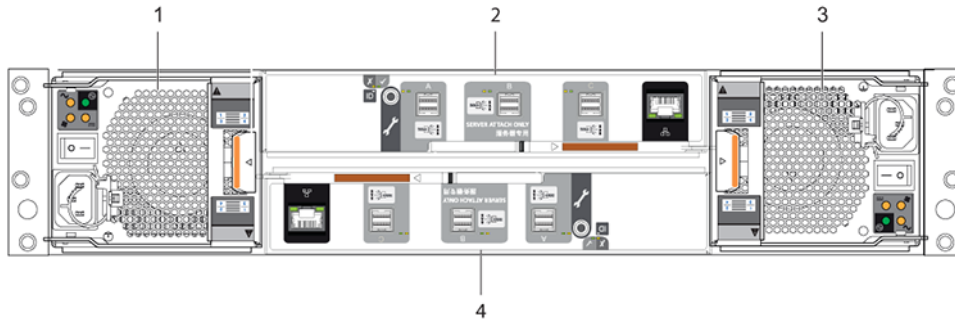

Figure 10. 2U expansion enclosure—rear panel components

- 1. PCM 0
- 2. IOM A
- 3. PCM 1
- 4. IOM B

2U enclosure rear panel components

This section describes the controller module, expansion enclosure IOM, and power cooling module components for 2U enclosures.

Controller module

The top slot for holding controller modules is designated slot A, and the bottom slot is designated slot B. The face plate details of the controller modules show a module aligned for use in slot A. In this orientation, the controller module latch is shown at the bottom of the module and it is in a closed/locked position. See [12 Gb/s controller module LEDs](#)

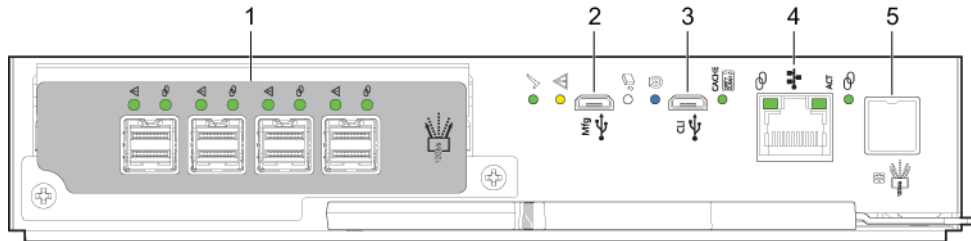

Figure 11. Controller module details

- 1. Host ports
- 2. USB serial port (service only)
- 3. USB serial port (CLI)
- 4. Ethernet port for management network
- 5. SAS expansion port

Expansion enclosure IOM

The following figure shows the IOM used in supported expansion enclosures for adding storage. Ports A/B/C ship configured with 12 Gb/s mini-SAS HD (SFF-8644) external connectors. See [I/O Module LEDs](#) for a description of LED behavior.

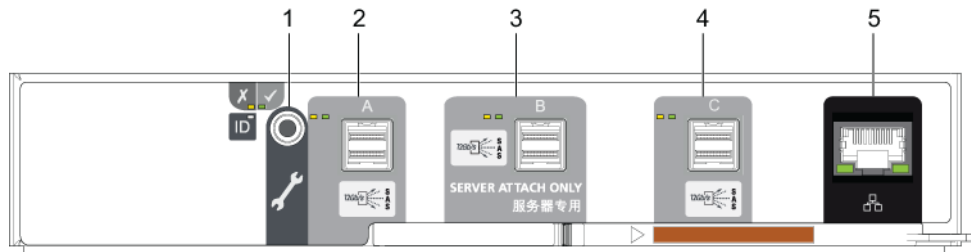

Figure 12. Expansion enclosure IOM details

- 1. 3.5 mm serial port (service only)
- 2. SAS expansion port A
- 3. SAS expansion port B (disabled)
- 4. SAS expansion port C
- 5. Ethernet port (disabled)

Power cooling module

The following figure shows the power cooling module (PCM) used in controller enclosures and optional expansion enclosures. The PCM includes integrated cooling fans. The example shows a PCM oriented for use in the left PCM slot of the enclosure rear panel.

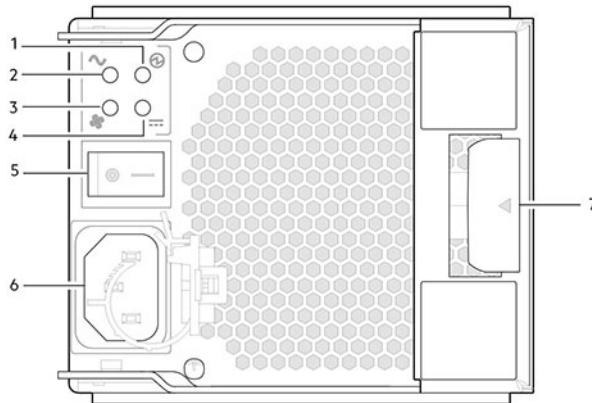

Figure 13. Power cooling module (PCM)

- | | |
|--|---------------------------------------|
| 1. PCM OK LED (Green) | 2. AC Fail LED (Amber/blinking amber) |
| 3. Fan Fail LED (Amber/blinking amber) | 4. DC Fail LED (Amber/blinking amber) |
| 5. On/Off switch | 6. Power connector |
| 7. Release latch | |

LED behavior:

- If any of the PCM LEDs are illuminated amber, a module fault condition or failure has occurred.
- For a detailed description of PCM LED behavior, see [2U enclosure PCM LEDs](#).

5U84 enclosure core product

The following figures show component locations and CRU slot indexing on the 5U84 enclosure front panel with drawers, and on the rear panel.

The 5U84 supports up to 84 DDIC modules populated within two drawers (42 DDICs per drawer; 14 DDICs per row).

i NOTE:

- The 5U84 does not ship with DDICs installed. DDICs ship in a separate container, and must be installed into the enclosure drawers during product installation and setup.
- To ensure sufficient circulation and cooling throughout the enclosure, all PSU slots, cooling module slots, and IOM slots must contain a functioning CRU. Do not replace a faulty CRU until the replacement is available and in hand.

5U84 enclosure front panel

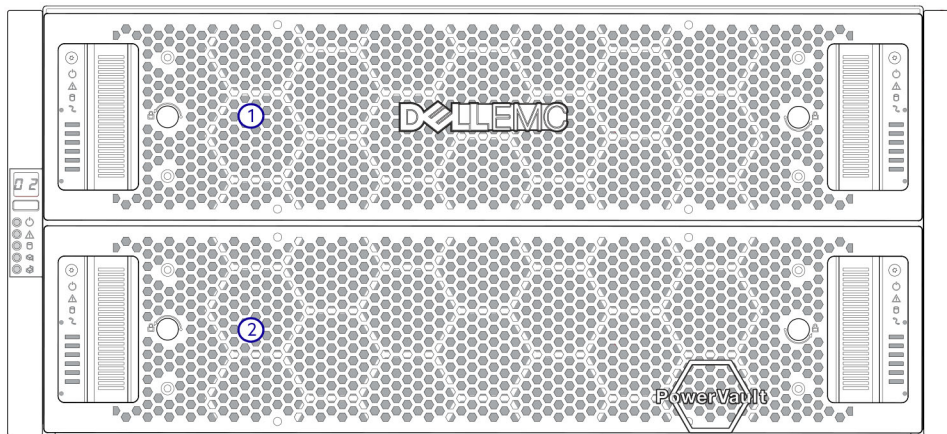

Figure 14. 5U84 enclosure—front panel components

1. 5U84 enclosure drawer (slot 0 = top drawer)
2. 5U84 enclosure drawer (slot 1 = bottom drawer)

This figure shows a plan view of an enclosure drawer that is accessed from the enclosure front panel. The conceptual graphics are simplified for clarity.

NOTE: See [ME5084 DDIC LEDs](#) for 5U84 (LFF disks) DDIC LED behavior.

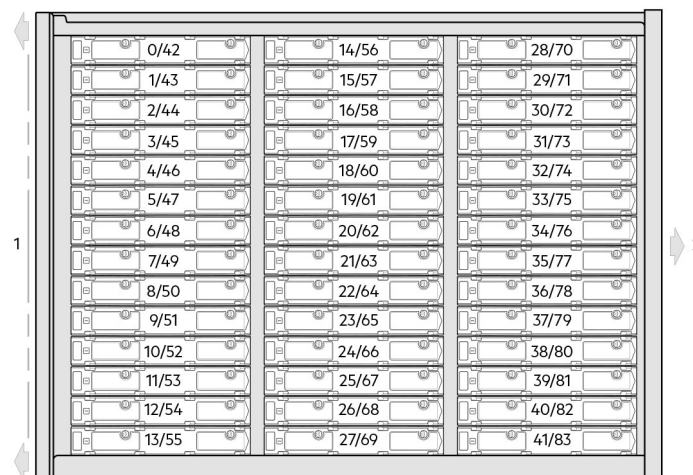

Figure 15. 5U84 enclosure system - plan view of drawer

1. Drawer front panel (shown as an edge in plan view)
2. Direction into the enclosure drawer slot (slot 0 or 1)

5U84 enclosure rear panel

The controller modules and IOMs use alphabetic designators, and the Power Supply Units (PSUs) and Fan Control Modules (FCMs) use numeric designators to identify the slots in a 5U84 enclosure.

NOTE: Controller modules, IOMs, PSUs, and FCMs are available as CRUs.

5U84 controller enclosures support dual-controller module configuration only. If a partner controller module fails, the controller fails over and runs on a single controller module until the redundancy is restored. Both controller module slots must be occupied to ensure sufficient airflow through the controller during operation.

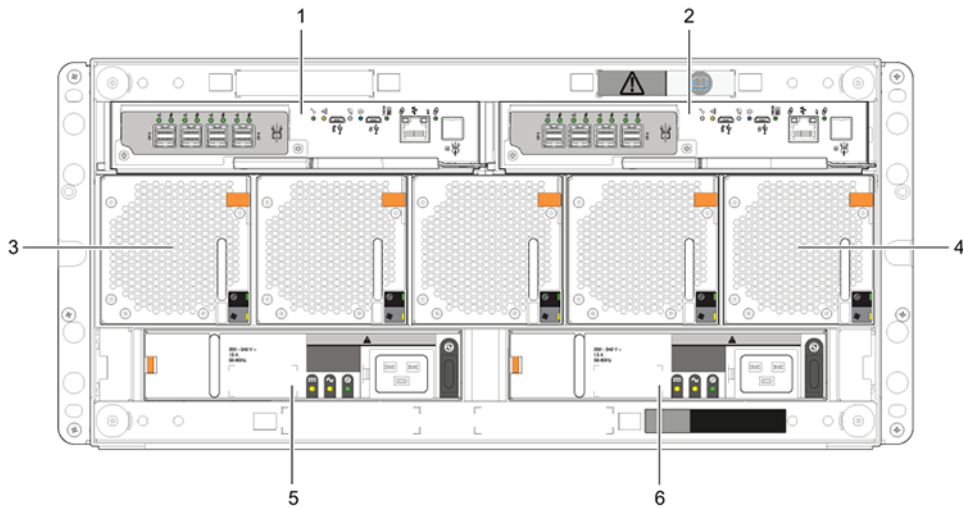

Figure 16. 5U84 controller enclosure—rear panel components

- | | |
|------------------------|------------------------|
| 1. Controller module A | 2. Controller module B |
| 3. FCM 0 | 4. FCM 4 |
| 5. PSU 0 | 6. PSU 1 |

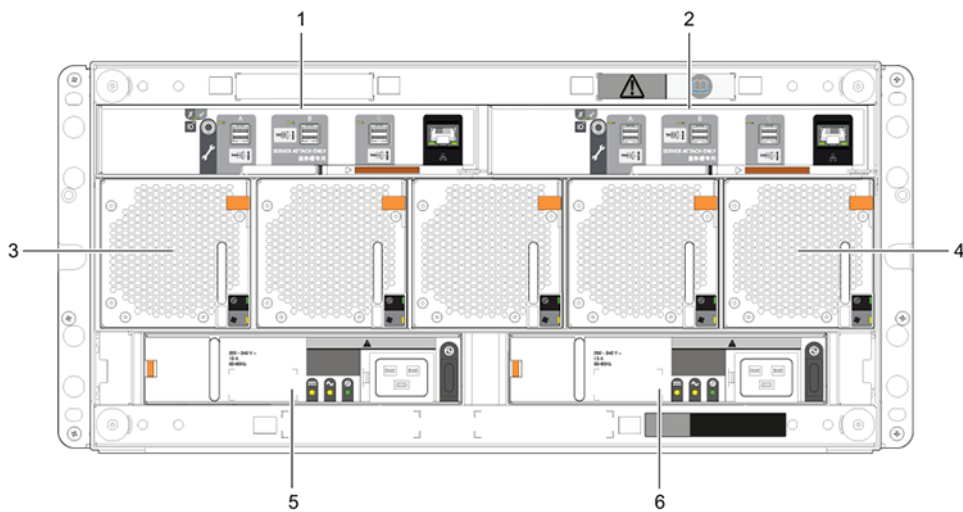

Figure 17. 5U84 expansion enclosure—rear panel components

- | | |
|----------|----------|
| 1. IOM A | 2. IOM B |
| 3. FCM 0 | 4. FCM 4 |
| 5. PSU 0 | 6. PSU 1 |

5U84 rear panel components

This section describes the rear-panel controller modules, expansion module, power supply module, and fan cooling module.

Controller modules

The 5U84 controller enclosure uses the same controller modules that are used by 2U12 and 2U24 enclosures.

The top slot for holding controller modules is designated slot A, and the bottom slot is designated slot B. The face plate details of the controller modules show a module aligned for use in slot A. In this orientation, the controller module latch is shown at the bottom of the module and it is in a closed/locked position. See [12 Gb/s controller module LEDs](#) for information about the indicators on the controller module.

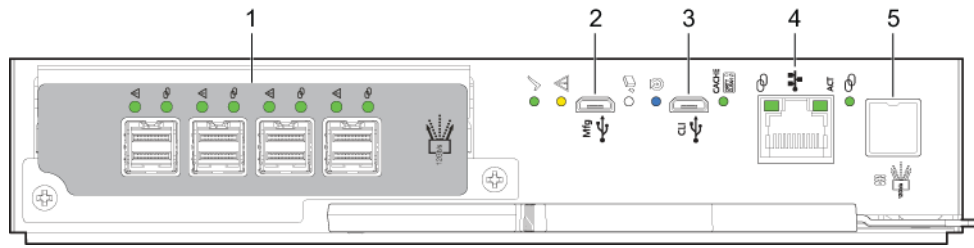

Figure 18. Controller module details

- | | |
|--------------------------|---|
| 1. Host ports | 2. USB serial port (service only) |
| 3. USB serial port (CLI) | 4. Ethernet port for management network |
| 5. SAS expansion port | |

Expansion module

The 5U84 expansion enclosure uses the same IOMs that are used by 2U12 and 2U24 enclosures.

The following figure shows the IOM used in supported expansion enclosures for adding storage. Ports A/B/C ship configured with 12 Gb/s mini-SAS HD (SFF-8644) external connectors. See [I/O Module LEDs](#) for information about indicators on the enclosure.

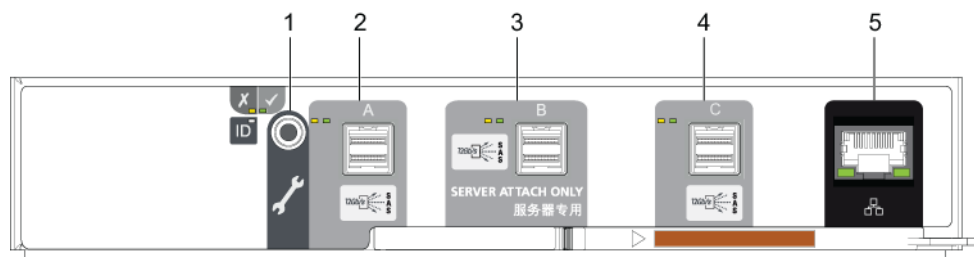

Figure 19. Expansion enclosure IOM details

- | | |
|--------------------------------------|-------------------------|
| 1. 3.5 mm serial port (service only) | 2. SAS expansion port A |
| 3. SAS expansion port B (disabled) | 4. SAS expansion port C |
| 5. Ethernet port (disabled) | |

Power supply module

This figure shows the power supply unit that is used in 5U controller enclosures and optional 5U84 expansion enclosures.

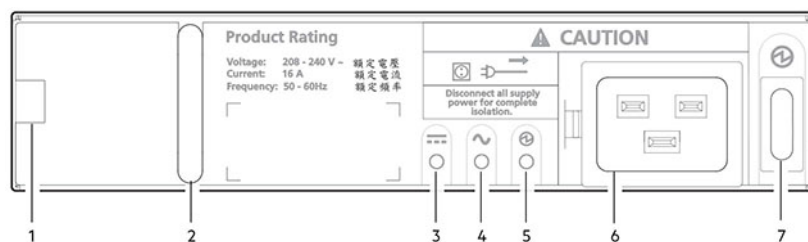

Figure 20. Power supply unit (PSU)

- | | |
|---|---------------------------------------|
| 1. Module release latch | 2. Handle |
| 3. PSU Fault LED (Amber/blinking amber) | 4. AC Fail LED (Amber/blinking amber) |
| 5. Power OK LED (Green) | 6. Power connect |
| 7. Power switch | |

LED behavior:

- If any of the PSU LEDs are illuminated amber, a module fault condition or failure has occurred.
- For a detailed description of PSU LEDs, see [ME5084 LEDs](#).

The 5U84 enclosures use separate CRU modules for power supply and cooling/circulation, respectively. The power supply module provides the enclosure with power connection and a power switch. The fan cooling module is smaller than the PCM, and five of them are used within the 5U enclosure to provide sufficient airflow throughout the enclosure.

Fan cooling module

The following figure shows the fan cooling module (FCM) used in 5U controller enclosures and optional 5U expansion enclosures.

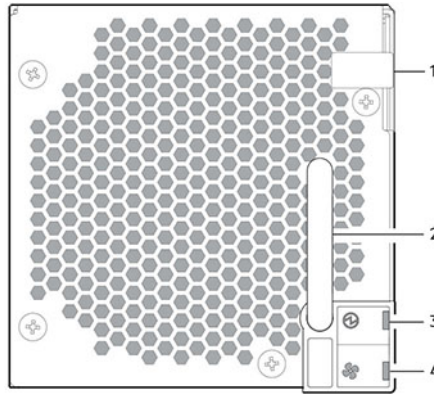

Figure 21. Fan cooling module (FCM)

- | | |
|--------------------------|---|
| 1. Module release latch | 2. Handle |
| 3. Module OK LED (Green) | 4. Fan Fault LED (Amber/blinking amber) |

LED behavior:

- If any of the FCM LEDs are illuminated amber, a module fault condition or failure has occurred.
- For a detailed description of FCM LEDs, see [ME5084 FCM LEDs](#).

5U84 enclosure chassis

The 5U84 enclosure includes the following features:

- 5U84 chassis configured with up to 84 LFF disks in DDICs.
- 5U84 chassis configured with SFF disks in 2.5" to 3.5" hybrid driver carrier adapter.
- 5U84 empty chassis with midplane, module runner system, and drawers.

The chassis has a 19-inch rack mounting that enables it to be installed onto standard 19-inch racks and uses five EIA units of rack space (8.75").

At the front of the enclosure, two drawers can be opened and closed. Each drawer provides access to 42 slots for Disk Drive in Carrier (DDIC) modules. DDICs are top mounted into the drawers. The front of the enclosure also provides enclosure status LEDs and drawer status/activity LEDs.

The rear of the enclosure provides access to rear panel CRUs:

- Two controller modules or IOMs
- Two PSUs
- Five FCMs

5U84 enclosure drawers

Each enclosure drawer contains 42 slots, each of which can accept a single DDIC containing a 3.5" LFF disk drive or a 2.5" SFF disk drive with an adapter.

Opening a drawer does not interrupt the functioning of the storage system, and DDICs can be hot-swapped while the enclosure is in operation. However, drawers must not be left open for longer than two minutes, or airflow and cooling will be compromised.

NOTE: During normal operation, drawers should be closed to ensure proper airflow and cooling within the enclosure.

A drawer is designed to support its own weight, plus the weight of installed DDICs, when fully opened.

CAUTION: The sideplanes on the enclosure drawers are not hot swappable or customer serviceable.

Safety features

- To prevent the rack from tipping, slide only one enclosure out of the rack at a time.
- The drawer locks into place when fully opened and extended. To reduce finger pinching hazards, two latches must be released before the drawer can be pushed back into the drawer slot within the enclosure.

Each drawer can be locked shut by turning both anti-tamper locks clockwise using a screwdriver with a Torx T20 bit (included in your shipment). The anti-tamper locks are symmetrically placed on the left and right sides of the drawer bezel. Drawer status and activity LEDs can be monitored by two drawer LEDs panels located next to the two drawer-pull pockets located on the left and right side of each drawer.

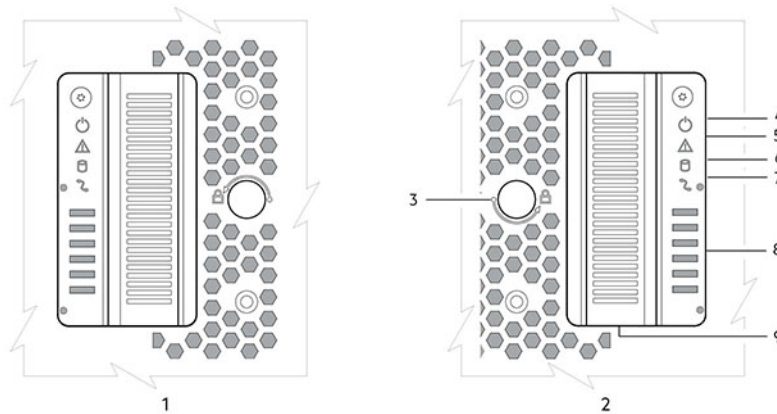

Figure 22. Drawer bezel details

- | | |
|-----------------------|----------------------------|
| 1. Left side | 2. Right side |
| 3. Anti-tamper lock | 4. Sideplane OK/Power Good |
| 5. Drawer fault | 6. Logical fault |
| 7. Cable fault | 8. Drawer activity |
| 9. Drawer pull handle | |

NOTE: For descriptions of drawer LED behavior, see [ME5084 drawer LEDs](#).

Operators (Ops) panel LEDs

Each ME5 Series enclosure features an Operators (Ops) panel located on the chassis left ear flange. This section describes the Ops panel for 2U and 5U enclosures.

2U enclosure Ops panel

The front of the enclosure has an Ops panel that is located on the left ear flange of the 2U chassis. The Ops panel is a part of the enclosure chassis, but is not replaceable on-site.

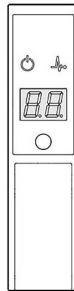





Figure 23. Ops panel LEDs—2U enclosure front panel

Table 4. Ops panel functions—2U enclosure front panel

Indicator	Description	Color	Status
	System power	Green	On steady: at least one PCM is supplying power Off: system not operating regardless of AC present
	Status/Health	Blue	On steady: system is powered on and controller is ready Blinking (2 Hz): Enclosure management is busy (for example, when booting or performing a firmware update)
		Amber	On steady: module fault present (may be associated with a Fault LED on a controller module, IOM, or PCM) Blinking: logical fault (2 s on, 1 s off)
	Unit identification display (UID)	Green	Dual seven-segment display that shows the numerical position of the enclosure in the cabling sequence. The UID is also called the enclosure ID. The controller enclosure ID is 0.
	Identity	Blue	Blinking (0.25 Hz): system ID locator is activated to assist in locating the chassis within a data center. Off: Normal state

5U enclosure Ops panel

The front of the enclosure has an Ops panel that is located on the left ear flange of the 5U chassis. The Ops panel is part of the enclosure chassis, but is not replaceable on-site.



Figure 24. Ops panel LEDs—5U enclosure front panel

Table 5. Ops panel functions – 5U enclosure front panel

Indicator	Description	Color	Status
	Unit Identification Display (UID)	Green	Dual seven-segment display that shows the numerical position of the enclosure in the cabling sequence. The UID is also called the enclosure ID. The controller enclosure ID is 0.
	System Power On/Standby	Green	On steady: system power is available (operational)
		Amber	Constant amber: system in standby (not operational)
	Module Fault	Amber	Constant or blinking: system hardware fault. The module fault LED may be associated with a Fault LED on a controller module, IOM, PSU, FCM, DDIC, or drawer.
	Logical status LED	Amber	Constant or blinking: fault present from something other than the enclosure management system. The logical status LED may be initiated from the controller module or an external HBA. The indication is typically associated with a DDIC and LEDs at each disk position within the drawer, which help to identify the DDIC affected.
	Top Drawer Fault	Amber	Constant or blinking: fault present in drive, cable, or sideplane (drawer 0)
	Bottom Drawer Fault	Amber	Constant or blinking: fault present in drive, cable, or sideplane (drawer 10)

Controller modules

This section describes the controller modules used in 12 Gb/s storage enclosures. They are mechanically and electrically compliant to the latest SBB v2.1 specification.

The following figure shows a 4-port SAS controller module aligned for use in the top slot located on the 2U enclosure rear panel. The controller module is also properly aligned for use in either slot located on the 5U84 enclosure rear panel.

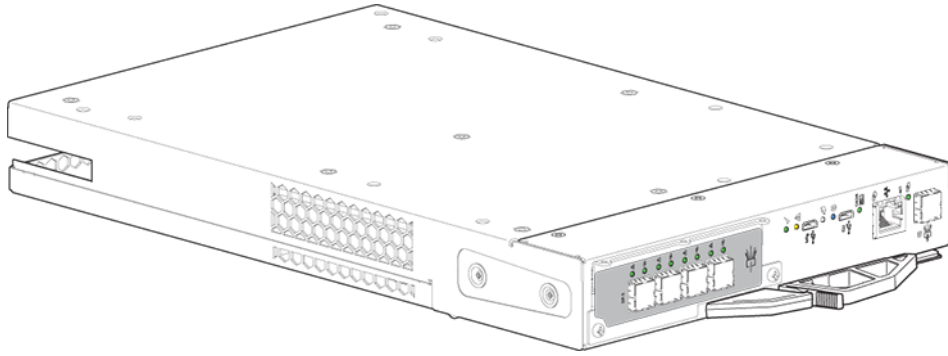

Figure 25. Controller module – rear orientation

Each controller module maintains VPD (Vital Product Data) in EEPROM devices. In a dual-controller module system, controller modules are interconnected by SBB-defined I2C buses on the midplane. In this way, the SBB module can discover the type and capabilities of the partner SBB module, and vice versa, within the enclosure.

12 Gb/s controller module LEDs

The diagrams with tables that immediately follow provide descriptions for the different controller modules that can be installed into the rear panel of the controller enclosures.

NOTE: Consider the following when viewing the controller module diagrams on the following pages:

- In each diagram, the controller module is oriented for insertion into the top slot (A) of 2U enclosures. When oriented for use in the bottom slot (B) of 2U enclosures, the controller module labels appear upside down.
- In each diagram, the controller module is oriented for insertion into either slot of 5U84 enclosures.
- Alternatively, you can configure the 2U controller enclosure with a single controller module. Install the controller module in slot A, and install a blank plate in slot B.

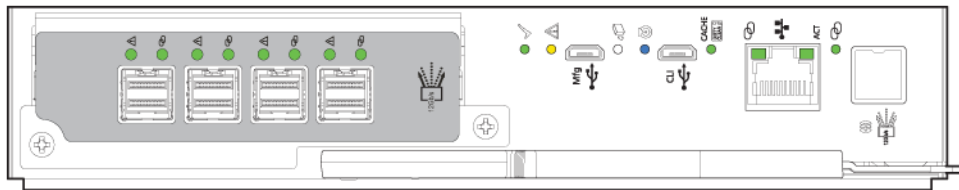





Figure 26. ME5 Series controller module

Table 6. Common controller module LEDs

LED	Description	Color	Status
✓	Hardware normal	Green	On—Controller module is functioning properly
			Flashing—Part of standby sequence as the controller module comes online
			Off—Controller module power is off, controller module is offline, or controller module has a fault condition
⚠	Hardware fault	Amber	On—Controller module hardware fault
			Off—Controller module functioning properly
🗑️	OK to remove	White	On—Ready for removal, the cache is clear
			Off—Do not remove the controller module, cache still contains unwritten data
🔍	Identify	Blue	On—Unit identification (UID) is active
			Off—Normal state, UID is not active

Table 6. Common controller module LEDs (continued)

LED	Description	Color	Status
	Cache status	Green	On—Cache contains unwritten data, controller module is functioning properly
			Fast flash (1s:1s)—Cache is active, cache flush in progress
			Slow flash (3s: 1s)—Cache self-refresh in progress after cache flush
			Off—Cache is clear or system is coming online
	Ethernet management port speed	Amber	On—1000Base-T negotiated rate
			Off—10/100Base-T negotiated rate
ACT	Ethernet management port link activity	Green	On—Ethernet link is up
			Off—Ethernet link is down
	12 Gb/s SAS expansion port status	Green	On—Connected, link is up
		Green or amber	Flashing—Link activity
		Amber	On—Connected, partial link is up
		None	Off—Not connected or link is down

The following figure shows the host port LEDs on a 32Gb/s Fibre Channel controller module:

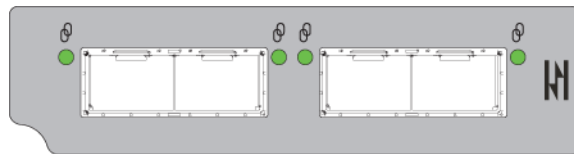



Figure 27. 32Gb/s Fibre Channel ports

LED	Description	Color	Status
	Fibre Channel link activity	Green	On—Connected, link is up
			Flashing—Link activity
			Off—Not connected or link is down

The following figure shows the host port LEDs on a 25 GbE iSCSI controller module:

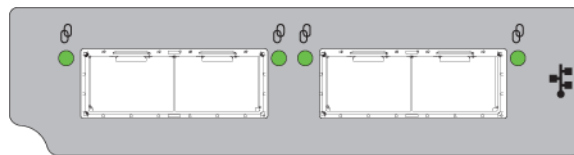



Figure 28. 25 GbE iSCSI ports

LED	Description	Color	Status
	iSCSI link activity	Green	On—Connected, link is up
			Flashing—Link activity
			Off—Not connected or link is down

The following figure shows host port LEDs on a 10Gbase-T iSCSI controller module:



Figure 29. 10Gbase-T iSCSI ports

LED	Description	Color	Status
	iSCSI 10Gbase-T link speed	Green	On—10GbE link speed
		Amber	On—1GbE link speed
		None	Off—Not connected or link is down
ACT	iSCSI 10Gbase-T link activity	Green	On—Connected, link is up
		Flashing	Link activity
		Off	Not connected or link is down

The following figure shows the host port LEDs on a 12 Gb/s SAS controller module:



Figure 30. 12 Gb/s SAS ports

LED	Description	Color	Status
	SAS port status	Green	On—Connected, link is up
		Green or amber	Flashing—Link activity
		Amber	On—Connected, partial link is up
		None	Off—Not connected or link is down

Cache status LED details

This section describes the behavior of the LEDs during powering on and off and cache status behavior.

Power on/off behavior

During power on, discrete sequencing for power on display states of internal components is reflected by blinking patterns displayed by the Cache Status LED.

Table 7. Cache Status LED – power on behavior

Item	Display states reported by Cache Status LED during power on sequence							
	0	1	2	3	4	5	6	7
Component	VP	SC	SAS BE	ASIC	Host	Boot	Normal	Reset
Blink pattern	On 1/Off 7	On 2/Off 6	On 3/Off 5	On 4/Off 4	On 5/Off 3	On 6/Off 2	Solid/On	Steady

Once the enclosure has completed the power on sequence, the Cache Status LED displays Solid/On (Normal), before assuming the operating state for cache purposes.

Cache status behavior

If the LED is blinking evenly, a cache flush is in progress. When a controller module loses power and write cache is dirty (contains data that has not been written to disk), the supercapacitor pack provides backup power to flush (copy) data from write cache to memory. When cache flush is complete, the cache transitions into self-refresh mode.

If the LED is blinking momentarily slowly, the cache is in a self-refresh mode. In self-refresh mode, if primary power is restored before the backup power is depleted (3–30 minutes, depending on various factors), the system boots, finds data preserved in cache, and writes it to disk. This means the system can be operational within 30 seconds, and before the typical host I/O time-out of 60 seconds, at which point system failure would cause host-application failure. If primary power is restored after the backup power is depleted, the system boots and restores data to cache from the system eMMC, which can take about 90 seconds. The cache flush and self-refresh mechanism is an important data protection feature; essentially four copies of user data are preserved: one in controller cache and one in the eMMC of each controller. The Cache Status LED illuminates solid green during the boot-up process. This behavior indicates the cache is logging all Power On Self Tests (POSTs), which will be flushed to the eMMC the next time the controller shuts down.

NOTE:

If the Cache Status LED illuminates solid green—and you wish to shut down the controller—do so from the user interface, so unwritten data can be flushed to eMMC.

Controller failure when a single-controller is operational

The following information applies to 2U and 5U dual-controller enclosures when one of the controllers is down and the other controller fails.

Cache memory is flushed to eMMC in the case of a controller failure or power loss. During the process of writing to eMMC, only the components needed to write the contents of the cache to the eMMC are powered by the supercapacitor. After the cache is copied to eMMC, the remaining power left in the supercapacitor is used to refresh the cache memory. While the cache is being maintained by the supercapacitor, the Cache Status LED blinks at a rate of 1/10 second on and 9/10 second off.

Cache status LED – corrective action

If the controller has failed or does not start, check if the Cache status LED is on or blinking.

Table 8. LEDs: Rear panel Cache Status

Status	Action
Cache status LED status is off, and the controller does not boot.	If the problem persists, replace the controller module.
Cache status LED is off, and the controller boots.	The system has flushed data to disks. If the problem persists, replace the controller module.
Cache status LED blinks at a 1:10 rate - 1 Hz, and the controller does not boot.	You may need to replace the controller module.
Cache status LED blinks at a 1:10 rate - 1 Hz, and the controller boots.	The system is flushing data to CompactFlash. If the problem persists, replace the controller module.
Cache status LED blinks at a 1:1 rate - 2 Hz, and the controller does not boot.	You may need to replace the controller module.
Cache status LED blinks at a 1:1 rate - 1 Hz, and the controller boots.	The system is in self-refresh mode. If the problem persists, replace the controller module.

Troubleshooting and problem solving

These procedures are intended to be used only during initial configuration for verifying that hardware setup is successful. They are not intended to be used as troubleshooting procedures for configured systems using production data and I/O.

 **NOTE:** For further troubleshooting help after setup, and when data is present, see Dell.com/support.

Topics:

- [Fault isolation methodology](#)
- [2U enclosure LEDs](#)
- [5U84 enclosure LEDs](#)
- [Initial start-up problems](#)

Fault isolation methodology

ME5 Series Storage Systems provide many ways to isolate faults. This section presents the basic methodology that is used to locate faults within a storage system, and to identify the pertinent CRUs affected.

Use the PowerVault Manager to configure and provision the system upon completing the hardware installation. Configure and enable event notification to be notified when a problem occurs that is at or above the configured severity. See the *Dell PowerVault ME5 Series Storage System Administrator's Guide* for more information.

When you receive an event notification, follow the recommended actions in the notification message to resolve the problem. In addition, see the following topics for troubleshooting guidance:

- [Options available for performing basic steps](#)
- [Performing basic steps](#)
- [Host I/O](#)

Cabling systems to replicate volumes is another important fault isolation consideration related to initial system installation. See the *ME5 Series Storage Systems Deployment Guide* for more information about troubleshooting during initial setup.

Options available for performing basic steps

When performing fault isolation and troubleshooting steps, select the option or options that best suit your site environment.

Use of any option is not mutually exclusive to the use of another option. You can use the PowerVault Manager to check the health icons/values for the system, or to examine a problem component. If you discover a problem, either the PowerVault Manager or the CLI provides recommended-action text online. Options for performing basic steps are listed according to frequency of use:

- Use the PowerVault Manager
- Use the CLI
- Monitor event notification
- View the enclosure LEDs

Use the PowerVault Manager

The PowerVault Manager uses health icons to show OK, Degraded, Fault, or Unknown status for the system and its components. The PowerVault Manager enables you to monitor the health of the system and its components. If any component has a problem, the system health is in a Degraded, Fault, or Unknown state. Use the PowerVault Manager to find each component that has a problem. Follow actions in the Recommendation field for the component to resolve the problem.

Use the CLI

As an alternative to using the PowerVault Manager, you can run the `show system` CLI command to view the health of the system and its components. If any component has a problem, the system health is in a Degraded, Fault, or Unknown state, and those components are listed as Unhealthy Components. Follow the recommended actions in the component Health Recommendation field to resolve the problem.

Monitor event notification

With event notification configured and enabled, you can view event logs to monitor the health of the system and its components. If a message tells you to check whether an event has been logged, or to view information about an event, use the PowerVault Manager or the CLI. Using the PowerVault Manager, view the event log and then click the event message to see detail about that event. Using the CLI, run the `show events detail` command to see the detail for an event.

View the enclosure LEDs

You can view the LEDs on the hardware to identify component status. If a problem prevents access to the PowerVault Manager or the CLI, viewing the enclosure LEDs is the only option available. However, monitoring/management is often done at a management console using storage management interfaces, rather than relying on line-of-sight to LEDs of racked hardware components.

Performing basic steps

You can use any of the available options that are described in the previous sections to perform the basic steps comprising the fault isolation methodology.

Gather fault information

When a fault occurs, gather as much information as possible. Doing so helps determine the correct action that is needed to remedy the fault.

Begin by reviewing the reported fault:

- Is the fault related to an internal data path or an external data path?
- Is the fault related to a hardware component such as a disk drive module, controller module, or power supply unit?

By isolating the fault to one of the components within the storage system, you are able determine the necessary corrective action more quickly.

Determine where the fault is occurring

When a fault occurs, the Module Fault LED illuminates. Check the LEDs on the back of the enclosure to narrow the fault to a CRU, connection, or both. The LEDs also help you identify the location of a CRU reporting a fault.

Use the PowerVault Manager to verify any faults found while viewing the LEDs. If the LEDs cannot be viewed due to the location of the system, use the PowerVault Manager to determine where the fault is occurring . This web-application provides you with a visual representation of the system and where the fault is occurring. The PowerVault Manager also provides more detailed information about CRUs, data, and faults.

Review the event logs

The event logs record all system events. Each event has a numeric code that identifies the type of event that occurred, and has one of the following severities:

- Critical – A failure occurred that may cause a controller to shut down. Correct the problem immediately.
- Error – A failure occurred that may affect data integrity or system stability. Correct the problem as soon as possible.
- Warning – A problem occurred that may affect system stability, but not data integrity. Evaluate the problem and correct it if necessary.

- Informational – A configuration or state change occurred, or a problem occurred that the system corrected. No immediate action is required.

The event logs record all system events. Review the logs to identify fault and cause of the failure. For example, a host could lose connectivity to a disk group if a user changes channel settings without taking the storage resources that are assigned to it into consideration. In addition, the type of fault can help you isolate the problem to either hardware or software.

Isolate the fault

Occasionally, it might become necessary to isolate a fault. This is true with data paths, due to the number of components comprising the data path. For example, if a host-side data error occurs, it could be caused by any of the components in the data path: controller module, cable, or data host.

Host I/O

When troubleshooting disk drive and connectivity faults, stop I/O to the affected disk groups from all hosts as a data protection precaution.

As an extra data protection precaution, it is helpful to conduct regularly scheduled backups of your data.

2U enclosure LEDs

Use the LEDs on the 2U enclosure to help troubleshoot initial start-up problems.

2U enclosure Ops panel

The front of the enclosure has an Ops panel that is located on the left ear flange of the 2U chassis. The Ops panel is a part of the enclosure chassis, but is not replaceable on-site.

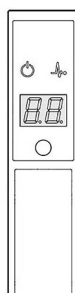

Figure 31. Ops panel LEDs—2U enclosure front panel

Table 9. Ops panel functions—2U enclosure front panel





Indicator	Description	Color	Status
	System power	Green	On steady: at least one PCM is supplying power Off: system not operating regardless of AC present
	Status/Health	Blue	On steady: system is powered on and controller is ready Blinking (2 Hz): Enclosure management is busy (for example, when booting or performing a firmware update)
		Amber	On steady: module fault present (may be associated with a Fault LED on a controller module, IOM, or PCM) Blinking: logical fault (2 s on, 1 s off)

Table 9. Ops panel functions—2U enclosure front panel (continued)

Indicator	Description	Color	Status
	Unit identification display (UID)	Green	Dual seven-segment display that shows the numerical position of the enclosure in the cabling sequence. The UID is also called the enclosure ID. The controller enclosure ID is 0.
	Identity	Blue	Blinking (0.25 Hz): system ID locator is activated to assist in locating the chassis within a data center. Off: Normal state

2U enclosure PCM LEDs

Under normal conditions, the power cooling module (PCM) OK LEDs will be a constant green.

Table 10. PCM LED states

PCM OK (Green)	Fan Fail (Amber)	AC Fail (Amber)	DC Fail (Amber)	Status
Off	Off	Off	Off	No AC power on any PCM
Off	Off	On	On	No AC power on this PCM only
On	Off	Off	Off	AC present; PCM working correctly
On	Off	Off	On	PCM fan speed is outside acceptable limits
Off	On	Off	Off	PCM fan has failed
Off	On	On	On	PCM fault (above temperature, above voltage, above current)
Off	Blinking	Blinking	Blinking	PCM firmware download is in progress

2U enclosure Ops panel LEDs

The Ops panel displays the aggregated status of all the modules. The following table describes the Ops panel LED states.

Table 11. Ops panel LED states

System Power (Green/Amber)	Module Fault (Amber)	Identity (Blue)	LED display	Associated LEDs /Alarms	Status
On	Off	Off	--	--	5V standby power present, overall power failed or switched off
On	On	On	On	--	Ops panel power on (5s) test state
On	Off	Off	--	--	Power on, all functions good
On	On	--	--	PCM fault LEDs, fan fault LEDs	Any PCM fault, fan fault, above or below temperature
On	On	--	--	SBB module LEDs	Any SBB module fault
On	On	--	--	No module LEDs	Enclosure logical fault
On	Blink	--	--	Module status LED on SBB module	Unknown (invalid or mixed) SBB module type installed, I ² C bus failure (inter-SBB communications). EBOD VPD configuration error
On	Blink	--	--	PCM fault LEDs, fan fault LEDs	Unknown (invalid or mixed) PCM type installed or I ² C bus failure (PCM communications)

Table 11. Ops panel LED states (continued)

System Power (Green/Amber)	Module Fault (Amber)	Identity (Blue)	LED display	Associated LEDs /Alarms	Status
--	--	--	Blink	--	Enclosure identification or invalid ID selected

Actions:

- If the Ops panel Module Fault LED is on, check the module LEDs on the enclosure rear panel to narrow the fault to a CRU, a connection, or both.
- Check the event log for specific information regarding the fault, and follow any Recommended Actions.
- If installing an IOM CRU:
 - Remove and reinstall the IOM.
 - Check the event log for errors.
- If the CRU Fault LED is on, a fault condition is detected.
 - Restart this controller from the partner controller using the PowerVault Manager or CLI.
 - If the restart does not resolve the fault, remove the IOM and reinsert it.

2U enclosure disk drive carrier module LEDs

Disk drive status is monitored by a green LED and an amber LED mounted on the front of each drive carrier module, as shown in the following figure.

The drive module LEDs are identified in the figure, and the LED behavior is described in the table following the figure.

- In normal operation, the green LED are on, and flicker as the drive operates.
- In normal operation the amber LED will be:
 - Off if there is no drive present.
 - Off as the drive operates.
 - On if there is a drive fault.

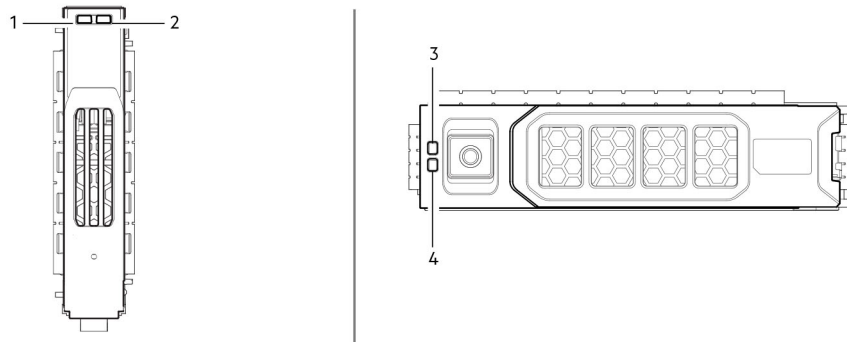

Figure 32. LEDs: Drive carrier LEDs (SFF and LFF modules) used in 2U enclosures

- | | |
|----------------------|----------------------|
| 1. Disk Activity LED | 2. Disk Fault LED |
| 3. Disk Fault LED | 4. Disk Activity LED |

Table 12. Drive carrier LED states

Activity LED (Green)	Fault LED (Amber)	Status/condition*
Off	Off	Off (disk module/enclosure)
Off	Off	Not present
Blink off with activity	Blinking: 1s on /1s off	Identify
<ul style="list-style-type: none"> • 1 down: Blink with activity • 2 down: Off 	On	Drive link (PHY lane) down
On	On	Fault (leftover/failed/locked-out)

Table 12. Drive carrier LED states (continued)





Activity LED (Green)	Fault LED (Amber)	Status/condition*
Blink off with activity	Off	Available
Blink off with activity	Off	Storage system: Initializing
Blink off with activity	Off	Storage system: Fault-tolerant
Blink off with activity	Off	Storage system: Degraded (not critical)
Blink off with activity	Blinking: 3s on/ 1s off	Storage system: Degraded (critical)
On	Off	Storage system: Quarantined
Blink off with activity	Blinking: 3s on/ 1s off	Storage system: Offline (dequarantined)
Blink off with activity	Off	Storage system: Reconstruction
Blink off with activity	Off	Processing I/O (whether from host or internal activity)

*If multiple conditions occur simultaneously, the LED state behaves as indicated by the condition listed earliest in the table, as rows are read from top to bottom.

IO Module LEDs

IOM status is monitored by the LEDs located on the face plate. The following table describes LED behaviors for expansion enclosure IOMs.

Table 13. Expansion enclosure IOM LEDs

LED	Description	Color	Status
	Module fault	Amber	On <ul style="list-style-type: none"> Ops panel undergoing 5s test Rear panel area module fault: IOM, fan, PSU, when paired with module fault LED Drive module hardware fault, paired with drive fault LED
			Flashing <ul style="list-style-type: none"> Unknown, invalid, or mixed module type, such as drive module or PSU Vital product data (VPD) configuration error or I2C bus failure
			Off—IOM functioning properly
	Power on or standby	Green	On—IOM power is on
		Amber	On—Part of standby sequence as IOM comes online
		None	Off—IOM power is off
	Unit identification (UID)	White	On—UID active to locate or identify for service activity
			Off—UID not active
	12 Gb/s SAS port	Green	On—Connected, link is up
			Off—Not connected or link is down
		Amber	On—Critical SAS cable fault
			Fast flash (1s:1s)—SAS UID active
			Slow flash (3s:1s)—Non-critical SAS cable fault
Off—SAS expansion port functioning properly			
	Ethernet port	---	Ethernet port is disabled

12 Gb/s controller module LEDs

The diagrams with tables that immediately follow provide descriptions for the different controller modules that can be installed into the rear panel of the controller enclosures.

NOTE: Consider the following when viewing the controller module diagrams on the following pages:

- In each diagram, the controller module is oriented for insertion into the top slot (A) of 2U enclosures. When oriented for use in the bottom slot (B) of 2U enclosures, the controller module labels appear upside down.
- In each diagram, the controller module is oriented for insertion into either slot of 5U84 enclosures.
- Alternatively, you can configure the 2U controller enclosure with a single controller module. Install the controller module in slot A, and install a blank plate in slot B.

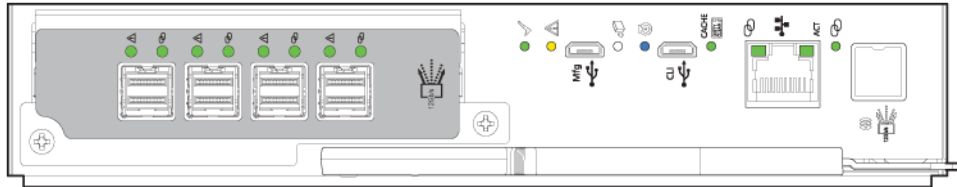

Figure 33. ME5 Series controller module

Table 14. Common controller module LEDs

LED	Description	Color	Status
✓	Hardware normal	Green	On—Controller module is functioning properly
			Flashing—Part of standby sequence as the controller module comes online
			Off—Controller module power is off, controller module is offline, or controller module has a fault condition
⚠	Hardware fault	Amber	On—Controller module hardware fault
			Off—Controller module functioning properly
🗑️	OK to remove	White	On—Ready for removal, the cache is clear
			Off—Do not remove the controller module, cache still contains unwritten data
🔄	Identify	Blue	On—Unit identification (UID) is active
			Off—Normal state, UID is not active
CACHE	Cache status	Green	On—Cache contains unwritten data, controller module is functioning properly
			Fast flash (1s:1s)—Cache is active, cache flush in progress
			Slow flash (3s: 1s)—Cache self-refresh in progress after cache flush
			Off—Cache is clear or system is coming online
🔗	Ethernet management port speed	Amber	On—1000Base-T negotiated rate
			Off—10/100Base-T negotiated rate
ACT	Ethernet management port link activity	Green	On—Ethernet link is up
			Off—Ethernet link is down
🔗	12 Gb/s SAS expansion port status	Green	On—Connected, link is up
		Green or amber	Flashing—Link activity
		Amber	On—Connected, partial link is up

Table 14. Common controller module LEDs (continued)

LED	Description	Color	Status
		None	Off—Not connected or link is down

The following figure shows the host port LEDs on a 32Gb/s Fibre Channel controller module:

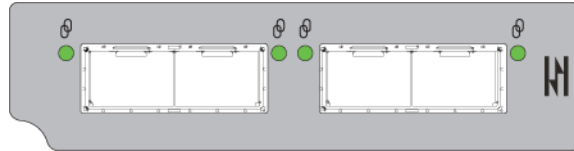

Figure 34. 32Gb/s Fibre Channel ports

LED	Description	Color	Status
🔗	Fibre Channel link activity	Green	On—Connected, link is up
			Flashing—Link activity
			Off—Not connected or link is down

The following figure shows the host port LEDs on a 25 GbE iSCSI controller module:

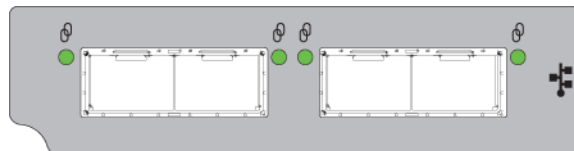

Figure 35. 25 GbE iSCSI ports

LED	Description	Color	Status
🔗	iSCSI link activity	Green	On—Connected, link is up
			Flashing—Link activity
			Off—Not connected or link is down

The following figure shows host port LEDs on a 10Gbase-T iSCSI controller module:



Figure 36. 10Gbase-T iSCSI ports

LED	Description	Color	Status
🔗	iSCSI 10Gbase-T link speed	Green	On—10GbE link speed
		Amber	On—1GbE link speed
		None	Off—Not connected or link is down
ACT	iSCSI 10Gbase-T link activity	Green	On—Connected, link is up
			Flashing—Link activity
			Off—Not connected or link is down

The following figure shows the host port LEDs on a 12 Gb/s SAS controller module:



Figure 37. 12 Gb/s SAS ports

LED	Description	Color	Status
	SAS port status	Green	On—Connected, link is up
		Green or amber	Flashing—Link activity
		Amber	On—Connected, partial link is up
		None	Off—Not connected or link is down

5U84 enclosure LEDs

When the 5U84 enclosure is powered on, all LEDs turn on for a short period to ensure that they are working.

NOTE: This behavior does not indicate a fault unless LEDs remain lit after several seconds.

5U enclosure Ops panel

The front of the enclosure has an Ops panel that is located on the left ear flange of the 5U chassis. The Ops panel is part of the enclosure chassis, but is not replaceable on-site.

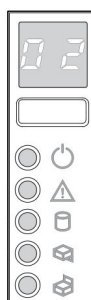



Figure 38. Ops panel LEDs—5U enclosure front panel

Table 15. Ops panel functions – 5U enclosure front panel

Indicator	Description	Color	Status
	Unit Identification Display (UID)	Green	Dual seven-segment display that shows the numerical position of the enclosure in the cabling sequence. The UID is also called the enclosure ID. The controller enclosure ID is 0.
	System Power On/Standby	Green	On steady: system power is available (operational)
		Amber	Constant amber: system in standby (not operational)
	Module Fault	Amber	Constant or blinking: system hardware fault. The module fault LED may be associated with a Fault LED on a controller module, IOM, PSU, FCM, DDIC, or drawer.
	Logical status LED	Amber	Constant or blinking: fault present from something other than the enclosure management system. The logical status LED may be initiated from the controller module or an external HBA. The indication is typically associated with a DDIC and LEDs at each disk position within the drawer, which help to identify the DDIC affected.

Table 15. Ops panel functions – 5U enclosure front panel (continued)

Indicator	Description	Color	Status
	Top Drawer Fault	Amber	Constant or blinking: fault present in drive, cable, or sideplane (drawer 0)
	Bottom Drawer Fault	Amber	Constant or blinking: fault present in drive, cable, or sideplane (drawer 10)

ME5084 PSU LEDs

The following table describes the LED states for the PSU:

Table 16. PSU LED states

CRU Fail (Amber)	AC Missing (Amber)	Power (Green)	Status
On	Off	Off	No AC power to either PSU
On	On	Off	PSU present, but not supplying power or PSU alert state. (usually due to critical temperature)
Off	Off	On	Mains AC present, switch on. This PSU is providing power.
Off	Off	Blinking	AC power present, PSU in standby (other PSU is providing power).
Blinking	Blinking	Off	PSU firmware download in progress
Off	On	Off	AC power missing, PSU in standby (other PSU is providing power).
On	On	On	Firmware has lost communication with the PSU module.
On	--	Off	PSU has failed. Follow the procedure in Replacing a PSU .

ME5084 FCM LEDs

The following table describes the LEDs on the Fan Cooling Module (FCM) faceplate:

Table 17. FCM LED states

LED	Status/description
Module OK	Constant green indicates that the FCM is working correctly. Off indicates the fan module has failed. Follow the procedure in Replacing a fan cooling module
Fan Fault	Amber indicates the fan module has failed. Follow the procedure in Replacing a fan cooling module .

ME5084 Ops panel LEDs

The Ops panel displays the aggregated status of all the modules.

Table 18. Ops panel LED states

LED	Status/description
Unit ID display	Usually shows the ID number for the enclosure, but can be used for other purposes, for example, blinking to locate enclosure.
Power On/ Standby	Amber if the system is in standby. Green if the system has full power.

Table 18. Ops panel LED states (continued)

LED	Status/description
Module Fault	Amber indicates a fault in a controller module, IOM, PSU, or FCM. Check the drawer LEDs for indication of a disk fault.
Logical status	Amber indicates a fault from something other than firmware (usually a disk, an HBA, or an internal or external RAID controller). Check the drawer LEDs for indication of a disk fault. See ME5084 drawer LEDs on page 36.
Drawer 0 Fault	Amber indicates a disk, cable, or sideplane fault in drawer 0. Open the drawer and check DDICs for faults.
Drawer 1 Fault	Amber indicates a disk, cable, or sideplane fault in drawer 1. Open the drawer and check DDICs for faults.

CAUTION: The sideplanes on the enclosure drawers are not hot swappable or customer serviceable.

ME5084 drawer LEDs

The following table describes the LEDs on the drawers:

Table 19. Drawer LED states

LED	Status/description
Sideplane OK/Power Good	Green if the sideplane is working and there are no power problems.
Drawer Fault	Amber if a drawer component has failed. If the failed component is a disk, the LED on the failed DDIC will light amber. Follow the procedure in Replacing a DDIC in a 5U enclosure on page 52. If the disks are OK, contact your service provider to identify the cause of the failure, and resolve the problem. CAUTION: The sideplanes on the enclosure drawers are not hot swappable or customer serviceable.
Logical Fault	Amber (solid) indicates a disk fault. Amber (blinking) indicates that one or more storage systems are in an impacted state.
Cable Fault	Amber indicates the cabling between the drawer and the back of the enclosure has failed. Contact your service provider to resolve the problem.
Activity Bar Graph	Displays the amount of data I/O from zero segments lit (no I/O) to all six segments lit (maximum I/O).

ME5084 DDIC LEDs

The DDIC supports LFF 3.5" and SFF 2.5" disks. The following figure shows the top panel of the DDIC as viewed when the disk is aligned for insertion into a drawer slot.

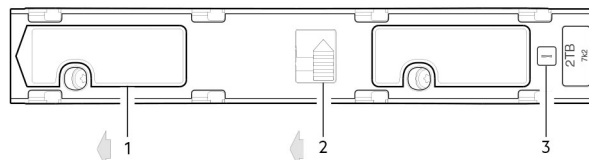

Figure 39. LEDs: DDIC – 5U enclosure disk slot in drawer

1. Slide latch (slides left)
2. Latch button (shown in the locked position)
3. Drive Fault LED

Table 20. DDIC LED states

Fault LED (Amber)	Status/description*
Off	Off (disk module/enclosure)
Off	Not present
Blinking: 1s on/1s off	Identify
Any links down: On	Drive link (PHY lane) down
On	Fault (leftover/failed/locked-out)
Off	Available
Off	Storage system: Initializing
Off	Storage system: Fault-tolerant
Off	Storage system: Degraded (non-critical)
Blinking: 3s on/1s off	Storage system: Degraded (critical)
Off	Storage system: Quarantined
Blinking: 3s on/1s off	Storage system: Offline (dequarantined)
Off	Storage system: Reconstruction
Off	Processing I/O (whether from host or internal activity)
*If multiple conditions occur simultaneously, the LED state will behave as indicated by the condition listed earliest in the table, as rows are read from top to bottom.	

Each DDIC has a single Drive Fault LED. A disk drive fault is indicated if the Drive Fault LED is lit amber. In the event of a disk failure, replace the DDIC.

5U84 controller module and IOM LEDs

Controller module and IOM CRUs are common to the 2U and 5U84 enclosures.

- For information about controller module LEDs, see [12 Gb/s controller module LEDs](#).
- For information about IOM LEDs, see [IO Module LEDs](#).

Initial start-up problems

The following sections describe how to troubleshoot initial start-up problems.

Troubleshooting 2U enclosures

Common problems that may occur with your 2U enclosure system.

The Module Fault LED on the Ops panel lights amber to indicate a fault for the problems listed in the following table:

 **NOTE:** All alarms also report through SES.

Table 21. Troubleshooting 2U alarm conditions

Status	Severity	Alarm
PCM alert – loss of DC power from a single PCM	Fault – loss of redundancy	S1
PCM fan fail	Fault – loss of redundancy	S1
SBB module detected PCM fault	Fault	S1
PCM removed	Configuration error	None

Table 21. Troubleshooting 2U alarm conditions (continued)

Status	Severity	Alarm
Enclosure configuration error (VPD)	Fault – critical	S1
Low warning temperature alert	Warning	S1
High warning temperature alert	Warning	S1
Over-temperature alarm	Fault – critical	S4
I ² C bus failure	Fault – loss of redundancy	S1
Ops panel communication error (I ² C)	Fault – critical	S1
RAID error	Fault – critical	S1
SBB interface module fault	Fault – critical	S1
SBB interface module removed	Warning	None
Drive power control fault	Warning – no loss of disk power	S1
Drive power control fault	Fault – critical – loss of disk power	S1
Drive removed	Warning	None
Insufficient power available	Warning	None

PCM faults

Table 22. PCM recommended actions

Symptom	Cause	Recommended action
Ops panel Module Fault LED is amber	Any power fault	Verify AC mains connections to PCM are live
Fan Fail LED is illuminated on PCM	Fan failure	Replace PCM

Thermal monitoring and control

The storage enclosure system uses extensive thermal monitoring and takes a number of actions to ensure component temperatures are kept low, and to also minimize acoustic noise. Air flow is from the front to the back of the enclosure.

Table 23. Thermal monitoring recommended actions

Symptom	Cause	Recommended action
<p>If the ambient air is below 25°C (77°F), and the fans are observed to increase in speed, then some restriction on airflow may be causing additional internal temperature rise.</p> <p>NOTE: This is not a fault condition.</p>	<p>The first stage in the thermal control process is for the fans to automatically increase in speed when a thermal threshold is reached. This may be caused by higher ambient temperatures in the local environment, and may be perfectly normal.</p> <p>NOTE: This threshold changes according to the number of disks and power supplies installed.</p>	<ol style="list-style-type: none"> 1. Check the installation for any airflow restrictions at either the front or back of the enclosure. A minimum gap of 25 mm (1") at the front and 50 mm (2") at the rear is recommended. 2. Check for restrictions due to dust build-up. Clean as appropriate. 3. Check for excessive re-circulation of heated air from rear to front. Use of the enclosure in a fully enclosed rack is not recommended. 4. Verify that all blank modules are in place. 5. Reduce the ambient temperature.

Thermal alarm

Table 24. Thermal alarm recommended actions

Symptom	Cause	Recommended action
<ol style="list-style-type: none"> Ops panel Module Fault LED is amber. Fan Fail LED is illuminated on one or more PCMs. 	Internal temperature exceeds a preset threshold for the enclosure.	<ol style="list-style-type: none"> Verify that the local ambient environment temperature is within the acceptable range. Check the installation for any airflow restrictions at either the front or back of the enclosure. A minimum gap of 25 mm (1") at the front and 50 mm (2") at the rear is recommended. Check for restrictions due to dust build-up. Clean as appropriate. Check for excessive re-circulation of heated air from rear to front. Use of the enclosure in a fully enclosed rack is not recommended. If possible, shut down the enclosure and investigate the problem before continuing.

Troubleshooting 5U enclosures

Common problems that may occur with your 5U enclosure system.

The Module Fault LED on the Ops panel lights amber to indicate a fault for the problems listed in the following table:



 **NOTE:** All alarms also report through SES.

Table 25. 5U alarm conditions

Status	Severity
PSU alert – loss of DC power from a single PSU	Fault – loss of redundancy
Cooling module fan failure	Fault – loss of redundancy
SBB I/O module detected PSU fault	Fault
PSU removed	Configuration error
Enclosure configuration error (VPD)	Fault – critical
Low temperature warning	Warning
High temperature warning	Warning
Over-temperature alarm	Fault – critical
Under-temperature alarm	Fault – critical
I ² C bus failure	Fault – loss of redundancy
Ops panel communication error (I ² C)	Fault – critical
RAID error	Fault – critical
SBB I/O module fault	Fault – critical
SBB I/O module removed	Warning
Drive power control fault	Warning – no loss of drive power
Drive power control fault	Fault – critical – loss of drive power
Insufficient power available	Warning

 **NOTE:** Use the PowerVault Manager to monitor the storage system event logs for information about enclosure-related events, and to determine any necessary recommended actions.

Thermal considerations

Thermal sensors in the 5U84 enclosure and its components monitor the thermal health of the storage system.

NOTE:

- Exceeding the limits of critical values will activate the over-temperature alarm.
- For information about 5U84 enclosure alarm notification, see [5U alarm conditions](#).

If the enclosure does not initialize

It may take up to two minutes for all enclosures to initialize.

If an enclosure does not initialize:

- Perform a rescan
- Power cycle the system
- Make sure that the power cord is properly connected, and check the power source to which it is connected
- Check the event log for errors

Correcting enclosure IDs

When installing a system with expansion enclosures attached, the enclosure IDs might not agree with the physical cabling order. This issue occurs if the controller was previously attached to enclosures in a different configuration, and the controller attempts to preserve the previous enclosure IDs.

To correct this condition, ensure that both controllers are up, and perform a rescan using the PowerVault Manager or the CLI. The rescan reorders the enclosures, but it can take up to two minutes to correct the enclosure IDs.

NOTE: Reordering expansion enclosure IDs only applies to dual-controller mode. If only one controller is available, due to a controller failure, a manual rescan does not reorder the expansion enclosure IDs.

1. To perform a rescan using the PowerVault Manager:
 - a. Verify that both controllers are operating normally.
 - b. Select **Maintenance > Hardware**.
 - c. Select **Actions > Rescan All Disks**
 - d. Click **Rescan**.
2. To perform a rescan using the CLI, type the following command:

```
rescan
```

Troubleshooting hardware faults

Make sure that you have a replacement module of the same type before removing any faulty module.

NOTE: If the enclosure system is powered up and you remove any module, replace it immediately. If the system is used with any modules missing for more than a few seconds, the enclosures can overheat, causing power failure and potential data loss. Such action can invalidate the product warranty.

NOTE: Observe applicable/conventional ESD precautions when handling modules and components. Avoid contact with midplane components, module connectors, leads, pins, and exposed circuitry.

Isolating a host-side connection fault

During normal operation, when a controller module host port is connected to a data host, the port host link status/link activity LED is green. If there is I/O activity, the host activity LED blinks green. If data hosts are having trouble accessing the storage system, but you cannot locate a specific fault or access the event logs, use the following procedures. These procedures require scheduled downtime.

NOTE: Do not perform more than one step at a time. Changing more than one variable at a time can complicate the troubleshooting process.

Host-side connection troubleshooting featuring 10Gbase-T and SAS host ports

The following procedure applies to ME5 Series controller enclosures employing external connectors in the host interface ports. The external connectors include 10Gbase-T connectors in iSCSI host ports and 12 Gb SFF-8644 connectors in the HD mini-SAS host ports.

1. Halt all I/O to the storage system.
2. Check the host activity LED.
If there is activity, stop all applications that access the storage system.
3. Check the Cache Status LED to verify that the controller cached data is flushed to the disk drives.
 - Solid – Cache contains data yet to be written to the disk.
 - Blinking – Cache data is being written to the controller module.
 - Flashing at 1/10 second on and 9/10 second off – Cache is being refreshed by the supercapacitor.
 - Off – Cache is clean (no unwritten data).
4. Remove the host cable and inspect for damage.
5. Reseat the host cable.
Is the host link status LED on?
 - Yes – Monitor the status to ensure that there is no intermittent error present. If the fault occurs again, clean the connections to ensure that a dirty connector is not interfering with the data path.
 - No – Proceed to the next step.
6. Move the host cable to a port with a known good link status.
This step isolates the problem to the external data path (host cable and host-side devices) or to the controller module port.
Is the host link status LED on?
 - Yes – You now know that the host cable and host-side devices are functioning properly. Return the cable to the original port. If the link status LED remains off, you have isolated the fault to the controller module port. Replace the controller module.
 - No – Proceed to the next step.
7. Verify that the switch, if any, is operating properly. If possible, test with another port.
8. Verify that the HBA is fully seated, and that the PCI slot is powered on and operational.
9. Replace the HBA with a known good HBA, or move the host side cable to a known good HBA.
Is the host link status LED on?
 - Yes – You have isolated the fault to the HBA. Replace the HBA.
 - No – It is likely that the controller module needs to be replaced.
10. Move the host cable back to its original port.
Is the host link status LED on?
 - Yes – Monitor the connection for a period of time. It may be an intermittent problem, which can occur with damaged cables and HBAs.
 - No – The controller module port has failed. Replace the controller module.

Isolating a controller module expansion port connection fault

During normal operation, when a controller module expansion port is connected to an expansion enclosure, the expansion port status LED is green. If the expansion port LED is off, the link is down.

Use the following procedure to isolate the fault. This procedure requires scheduled downtime.

i **NOTE:** Do not perform more than one step at a time. Changing more than one variable at a time can complicate the troubleshooting process.

1. Halt all I/O to the storage system.
2. Check the host activity LED.
If there is activity, stop all applications that access the storage system.
3. Check the Cache Status LED to verify that the controller cached data is flushed to the disk drives.
 - Solid – Cache contains data yet to be written to the disk.

- Blinking – Cache data is being written to the controller module.
 - Flashing at 1/10 second on and 9/10 second off – Cache is being refreshed by the supercapacitor.
 - Off – Cache is clean (no unwritten data).
4. Remove expansion cable and inspect for damage.
 5. Reseat the expansion cable.

Is the expansion port status LED on?

 - Yes – Monitor the status to ensure that there is no intermittent error present. If the fault occurs again, clean the connections to ensure that a dirty connector is not interfering with the data path.
 - No – Proceed to the next step.
 6. Move the expansion cable to a port on the controller enclosure with a known good link status.

This step isolates the problem to the expansion cable or to the controller module expansion port.

Is the expansion port status LED on?

 - Yes – You now know that the expansion cable is good. Return the cable to the original port. If the expansion port status LED remains off, you have isolated the fault to the controller module expansion port. Replace the controller module.
 - No – Proceed to the next step.
 7. Move the expansion cable back to the original port on the controller enclosure.
 8. Move the expansion cable on the expansion enclosure to a known good port on the expansion enclosure.

Is the host link status LED on?

 - Yes – You have isolated the problem to the expansion enclosure port. Replace the IOM in the expansion enclosure.
 - No – Proceed to the next step.
 9. Replace the cable with a known good cable, ensuring the cable is attached to the original ports used by the previous cable.

Is the host link status LED on?

 - Yes – Replace the original cable. The fault has been isolated.
 - No – It is likely that the controller module must be replaced.

Module removal and replacement

This chapter provides procedures for replacing CRUs (customer-replaceable units), including precautions, removal instructions, installation instructions, and verification of successful installation. Each procedure addresses a specific task.

Topics:

- [ESD precautions](#)
- [Dealing with hardware faults](#)
- [Firmware updates](#)
- [Shutting down attached hosts](#)
- [Shutting down a controller module](#)
- [Verifying component failure](#)
- [Customer-replaceable units \(CRUs\)](#)
- [Verifying component operation](#)
- [Performing updates in PowerVault Manager after replacing an FC or SAS HBA](#)

ESD precautions

Before you begin any of the procedures, review the following precautions and preventive measures.

Preventing electrostatic discharge

To prevent electrostatic discharge (ESD) from damaging the system, be aware of the precautions to consider when setting up the system or handling parts. A discharge of static electricity from a finger or other conductor may damage system boards or other static-sensitive devices. This type of damage may reduce the life expectancy of the device.

CAUTION: Parts can be damaged by electrostatic discharge. Follow these precautions:

- **Avoid hand contact by transporting and storing products in static-safe containers.**
- **Keep electrostatic-sensitive parts in their containers until they arrive at static-protected workstations.**
- **Place parts in a static-protected area before removing them from their containers.**
- **Avoid touching pins, leads, or circuitry.**
- **Always be properly grounded when touching a static-sensitive component or assembly.**
- **Remove clutter (plastic, vinyl, foam) from the static-protected workstation.**

Grounding methods to prevent electrostatic discharge

Several methods are used for grounding. Adhere to the following precautions when handling or installing electrostatic-sensitive parts.

CAUTION: Parts can be damaged by electrostatic discharge. Use proper anti-static protection:

- **Keep the replacement CRU in the ESD bag until needed; and when removing a CRU from the enclosure, immediately place it in the ESD bag and anti-static packaging.**
- **Wear an ESD wrist strap connected by a ground cord to a grounded workstation or unpainted surface of the computer chassis. Wrist straps are flexible straps with a minimum of 1 megohm (± 10 percent) resistance in the ground cords. To provide proper ground, wear the strap snug against the skin.**
- **If an ESD wrist strap is unavailable, touch an unpainted surface of the chassis before handling the component.**

- **Use heel straps, toe straps, or boot straps at standing workstations. Wear the straps on both feet when standing on conductive floors or dissipating floor mats.**
- **Use conductive field service tools.**
- **Use a portable field service kit with a folding static-dissipating work mat.**

If you do not have any of the suggested equipment for proper grounding, have an authorized technician install the part. For more information about static electricity or assistance with product installation, contact customer support. For additional information, see www.dell.com/support.

Dealing with hardware faults

Ensure that you have obtained a replacement module of the same type before removing any faulty module.

CAUTION:

- **If the enclosure system is powered up and you remove any module, replace it immediately. If the enclosure system operates for too long with a module removed, the enclosures can overheat, causing power failure and potential data loss. Such use may invalidate the warranty.**
- **Observe applicable/conventional ESD precautions when handling modules and components as described in [ESD precautions](#). Avoid contact with midplane components, module connectors, leads, pins, and exposed circuitry.**

Firmware updates

After installing the hardware and powering on the storage system components for the first time, verify that the controller modules, expansion modules, and disk drives are using the current firmware release. Periodically, ensure that the firmware versions used in the enclosure modules are compatible.

Partner firmware update

Partner firmware update (PFU) is enabled on the system by default. With PFU enabled, when you update firmware on one controller or replace a controller, the system automatically updates the partner controller. Disable PFU only if requested by a service technician. Use the PowerVault Manager or CLI to change the PFU setting.

For a dual-controller system, the partner firmware update (PFU) setting (**Settings > System > Properties > Firmware Properties**) controls how updates impact the partner controller:

- **Automatic**—PFU is enabled (the default). When you activate controller module firmware on one controller, the firmware is automatically copied over and activated on the partner controller first, and then activated on the current controller. PFU provides for updating expansion module firmware in similar fashion.
- **Manual**—PFU is disabled. When you update controller module or enclosure IOM firmware on one controller, you must log into the partner controller and manually perform the same updates.

When a controller module is installed into an enclosure at the factory, the enclosure midplane serial number and firmware-update timestamp are recorded for each firmware component in controller flash memory, and will not be erased when the configuration is changed or is reset to defaults. These two pieces of data are not present in controller modules that are not factory-installed and are used as replacements.

Updating controller firmware with the PFU option enabled ensures that the same firmware version is installed in both controller modules. PFU uses the following algorithm to determine which controller module will update its partner:

- If both controllers are running the same firmware version, no change is made.
- The controller installed first will send its configuration and settings to the partner controller. Similarly, if a controller is replaced, it will receive configuration information from the partner controller. In both cases, subsequent firmware update behavior for both controllers is determined by the system's unified PFU setting
- If both controllers were already installed in the system, then the controller with firmware installed first will send its configuration and settings to the partner controller.
- If both controllers are newly installed, then controller A is transferred to controller B.

Installing a firmware bundle

In the PowerVault Manager, use the **Maintenance > Firmware > System** tab to install firmware bundles obtained from Dell and then activate a particular bundle.

Review the following points before updating system firmware:

- Firmware update typically takes 5 minutes for a controller with current CPLD firmware, or up to 20 minutes for a controller with downlevel CPLD firmware. Expand the firmware row to view the CPLD version (**Maintenance > Firmware**).
- If the Storage Controller cannot be updated, the update operation is canceled. Verify that you specified the correct firmware file and repeat the update. Run the `check_firmware-upgrade-health` CLI command to determine if any problems need to be resolved before attempting to update the firmware. If this problem persists, contact technical support.
- When firmware update on the local controller is complete, the Management Controller restarts. Until the restart is complete, sign-in pages say that the system is currently unavailable. When this message is cleared, you may sign in again.
- If PFU is enabled, the amount of time required for updating both controllers is less than 10 minutes.
- If PFU is enabled for the system (**Settings > System > Properties > Firmware Properties > Partner Firmware Update** check box), after firmware update has completed on both controllers, check the system health. If the system health is Degraded and the health reason indicates that the firmware version is incorrect, verify that you specified the correct firmware file and repeat the update. If this problem persists, contact technical support.

If PFU is disabled, you must locate, install, and activate compatible firmware on the replacement expansion module.

1. Download the firmware from Dell.com.
2. Go to **Maintenance > Firmware > System**.
3. Click, **Browse For File** and navigate to the downloaded firmware bundle.
4. Follow the on-screen directions to install the firmware.

Activating a firmware bundle

After a firmware bundle is available to the system, activate the firmware to complete the firmware update.

1. Go to **Maintenance > Firmware > System** and click its **Activate this Version** link to display the Activate Firmware dialog.
2. Follow the on-screen directions to start the activation.

As part of the activation process the system performs these steps: check bundle integrity, check system health, update firmware on the partner controller module, restart the partner controller module, update firmware on the local controller module, and restart the local controller module. After the local controller module has restarted, the PowerVault Manager login screen is displayed. Log back in and go to the **Maintenance > Firmware** panel and verify that the new firmware is active on the system. An alert will also be generated to inform you that the firmware has been upgraded.

If firmware activation fails, go to **Maintenance > Support > Collect Logs** and fill in the necessary fields and collect the logs. Such logs will be needed for any support request generated by this failure.

Shutting down attached hosts

To replace modules in a 2U controller enclosure that has one controller module, you must shut down all of the attached hosts before shutting down the controller module.

Shutting down a controller module

Shutting down the controller module in an enclosure ensures that a proper failover sequence is used, which includes stopping all I/O operations and writing any data in write cache to disk. Perform a shut down before you remove a controller module from an enclosure, or before you power off an enclosure for maintenance, repair, or a move.

Using the PowerVault Manager

1. Sign-in to the PowerVault Manager.
2. Go to **Maintenance > Hardware**.
3. Under **Enclosure > Actions** select **Restart/Shutdown System**.

The Controller Restart and Shut Down panel opens.

4. Select the Shut Down operation.
5. Select the controller module to shut down: **A**, **B**, or **both**.
6. Click **Apply**. A confirmation panel appears.
7. Click **Yes** to continue; otherwise, click **No**. If you clicked **Yes**, a message describes shutdown activity.

NOTE:

- If an iSCSI port is connected to a Microsoft Windows host, the following event is recorded in the Windows event log: Initiator failed to connect to the target.
- See the *Dell PowerVault ME5 Series Storage System Administrator's Guide* for additional information.

Using the CLI

1. Log-in to the CLI.
2. In your dual-controller system, verify that the partner controller is online by running the command: `show controllers`
3. Shut down the failed controller—A or B—by running the command: `shutdown a` or `shutdown b`
The blue OK to Remove LED (back of enclosure) illuminates to indicate that the controller module can be safely removed.
4. Illuminate the white Identify LED of the enclosure that contains the controller module to remove by running the command:
`set led enclosure 0 on`

The Display LED on the Ops panel located on the enclosure left ear will be blinking green when the `set led enclosure 0 on` command is invoked.

NOTE: See the *Dell PowerVault ME5 Series Storage System CLI Guide* for additional information.

Verifying component failure

Select from the following methods to verify component failure:

- Use the PowerVault Manager to check the health icons/values of the system and its components to either ensure that everything is okay, or to drill down to a problem component. The PowerVault Manager uses health icons to show OK, Degraded, Fault, or Unknown status for the system and its components. If you discover a problem component, follow the actions in its Recommendation field to resolve the problem.
- As an alternative to using the PowerVault Manager, you can run the CLI `show system` command to view the health of the system and its components. If any component has a problem, the system health will be `Degraded`, `Fault`, or `Unknown`. If you discover a problem component, follow the actions in its Health Recommendations field to resolve the problem.
- Monitor event notification — With event notification configured and enabled, use the PowerVault Manager to view the event log, or run the CLI `show events detail` command to see details for events.
- Check Fault LED (back of enclosure on controller module or IOM face plate): Amber = Fault condition.
- Check that the OK LED (back of enclosure) is off.

Customer-replaceable units (CRUs)

The following tables describe the types of ME5 Series controller enclosures:

NOTE: See [2U enclosure core product](#) on page 11 and [5U84 enclosure core product](#) on page 14 for views of controller module and IOM CRUs used in the different enclosure form factors supported by ME5 Series storage systems.

Table 26. ME5 Series 2U controller enclosure models

Model	Description	Form factor	Drives
ME5012	Fibre Channel (32 Gb/s) SFP	2U12	Up to 12 3.5" (LFF) drives
ME5012	iSCSI (25 GbE) SFP	2U12	Up to 12 3.5" (LFF) drives
ME5012	iSCSI 10Gbase-T (10 Gb/s or 1 Gb/s) ¹	2U12	Up to 12 3.5" (LFF) drives
ME5012	Mini-SAS HD (12 Gb/s) ²	2U12	Up to 12 3.5" (LFF) drives

Table 26. ME5 Series 2U controller enclosure models (continued)

Model	Description	Form factor	Drives
ME5024	Fibre Channel (32 Gb/s) SFP	2U24	Up to 24 2.5" (SFF) drives
ME5024	iSCSI (25 GbE) SFP	2U24	Up to 24 2.5" (SFF) drives
ME5024	iSCSI 10Gbase-T (10 Gb/s or 1 Gb/s) ¹	2U24	Up to 24 2.5" (SFF) drives
ME5024	Mini-SAS HD (12 Gb/s) ²	2U24	Up to 24 2.5" (SFF) drives

¹ This model supports 10 Gb/s or 1 Gb/s speeds (used for iSCSI host connections).

² This model uses SFF-8644 connectors and qualified cable options for host connections.

Table 27. ME5 Series high-density 5U controller enclosure models

Model	Description	Form factor	Drives
ME5084	Fibre Channel (32 Gb/s) SFP	5U84	Up to 84 2.5" (SFF) or 3.5" (LFF) drives
ME5084	iSCSI (25 GbE) SFP ¹	5U84	Up to 84 2.5" (SFF) or 3.5" (LFF) drives
ME5084	iSCSI 10Gbase-T (10 Gb/s or 1 Gb/s) ¹	5U84	Up to 84 2.5" (SFF) or 3.5" (LFF) drives
ME5084	Mini-SAS HD (12 Gb/s) ²	5U84	Up to 84 2.5" (SFF) or 3.5" (LFF) drives

¹ This model supports 10 Gb/s or 1 Gb/s speeds (used for iSCSI host connection).

² This model uses SFF-8644 connectors and qualified cable options for host connection.

Attach or remove the front bezel of a 2U enclosure

The following figure shows a partial view of a 2U12 enclosure:

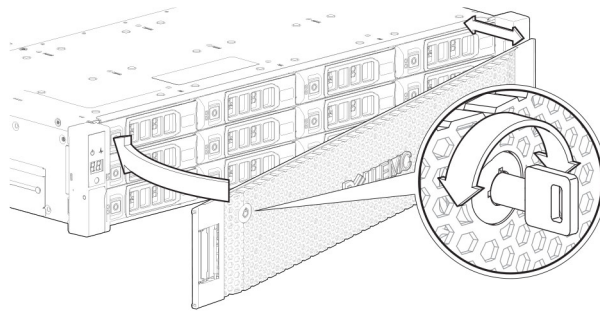

Figure 40. Attaching or removing the 2U enclosure front bezel

To attach the front bezel to the 2U enclosure:

1. Locate the bezel, and while grasping it with your hands, face the front panel of the 2U12 or 2U24 enclosure.
2. Hook the right end of the bezel onto the right ear cover of the storage system.
3. Insert the left end of the bezel into the securing slot until the release latch snaps in place.
4. Secure the bezel with the keylock.

To remove the bezel from the 2U enclosure, reverse the order of the preceding steps.

NOTE: See [Enclosure variants](#) for details about various enclosure options.

Replacing a drive carrier module in a 2U enclosure

The section describes how to replace a drive carrier module in a 2U enclosure.

A drive carrier module consists of a disk drive that is installed in a carrier module. Drive carrier modules are hot-swappable, which means they can be replaced without halting I/O to the disk groups, or powering off the enclosure. The new disk drive must be of the same type of drive and contain a capacity equal to or greater than the drive being replaced. Otherwise, the storage system cannot use the new disk drive to reconstruct the disk group.

⚠ CAUTION:

- **Removing a drive carrier module impacts the airflow and cooling ability of the enclosure. If the internal temperature exceeds acceptable limits, the enclosure may overheat and automatically shut down or restart.**
- **When removing a drive carrier module, wait 30 seconds after unseating the drive carrier module to allow the disk drive to stop spinning.**

ℹ NOTE:

- Familiarize yourself with full disk encryption (FDE) considerations relative to disk drive installation and replacement.
- When moving FDE-capable disk drives for a disk group, stop I/O to the disk group before removing the drive carrier modules. Import the keys for the disk drives so that the drive content becomes available. See the *Dell PowerVault ME5 Series Storage System Administrator's Guide* or *Dell PowerVault ME5 Series Storage System CLI Guide* for more information.

Before you begin any of the procedures, see the [ESD precautions](#) on page 43.

Replacing an LFF drive carrier module

The replacement procedures for LFF drive carrier modules are the same for SFF modules, except that the LFF drive carrier modules are mounted horizontally.

Removing an LFF drive carrier module

Perform the following steps to remove an LFF drive carrier module from a 2U enclosure:

1. Press the latch on the drive module carrier to open the handle.

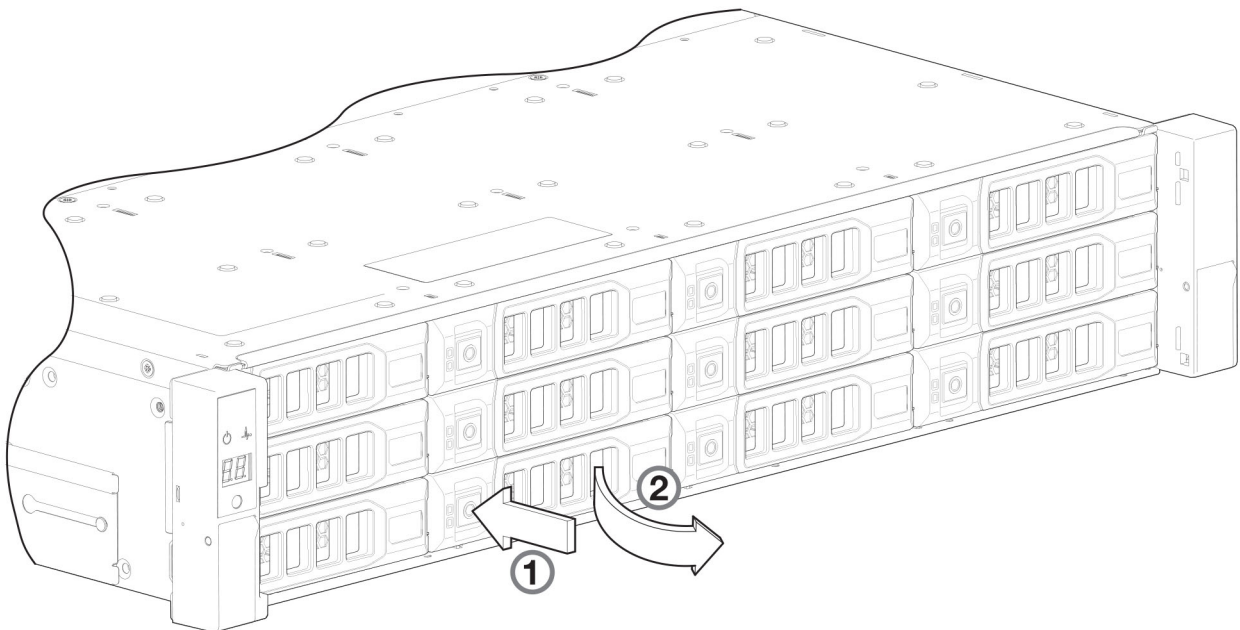

Figure 41. Removing an LFF drive carrier module (1 of 2)

2. Gently move the drive carrier module approximately 25 mm (1 in.), and then wait 30 seconds for the drive to spin down.

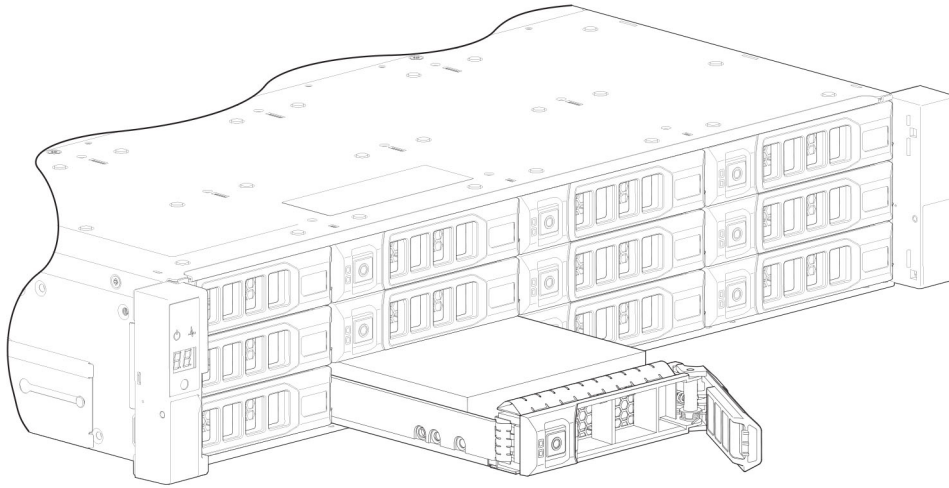

Figure 42. Removing an LFF drive carrier module (2 of 2)

3. Remove the drive carrier module from the drive slot.

CAUTION: To ensure optimal cooling throughout the enclosure, blank drive carrier modules must be installed in all unused drive slots.

Installing an LFF drive carrier module

Perform the following steps to install an LFF drive carrier module in a 2U enclosure:

1. Press the latch on the drive module carrier to open the handle.

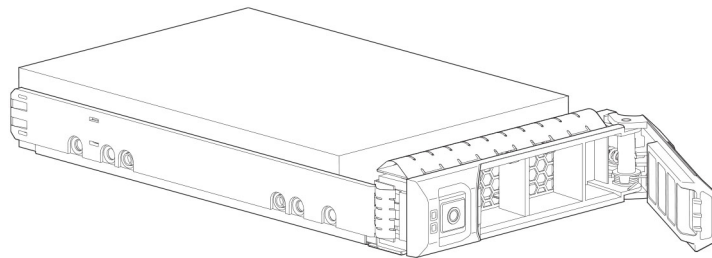

Figure 43. LFF drive carrier module in open position

2. Insert the drive carrier module into the enclosure.
3. Gently slide the drive carrier module into the enclosure until it stops moving.



Figure 44. Installing an LFF drive carrier module (1 of 2)

4. Push the drive carrier module further into the enclosure until the latch handle starts to engage.

5. Continue to push firmly until the latch handle fully engages. You should hear a click as the latch handle engages and holds the handle closed.

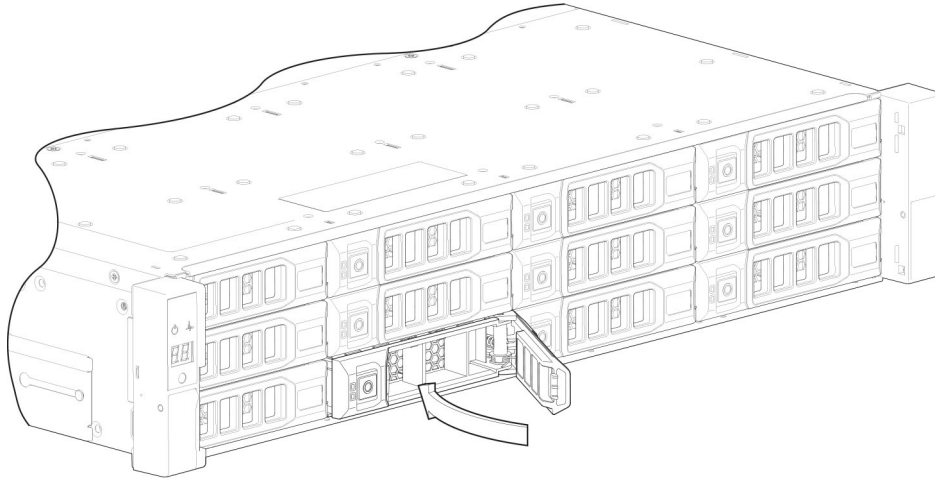

Figure 45. Installing an LFF drive carrier module (2 of 2)

6. Use the PowerVault Manager or CLI to verify the following:
 - Health of the new disk drive is OK
 - Green Disk Activity LED is on/blinking
 - Ops panel states show no amber module faults

Replacing an SFF drive carrier module

The replacement procedures for SFF drive carrier modules are the same for LFF modules, except that the SFF drive carrier modules are mounted vertically.

Removing an SFF drive carrier module

Perform the following steps to remove an SFF drive carrier module from a 2U enclosure:

1. Press the latch on the drive module carrier to open the handle.

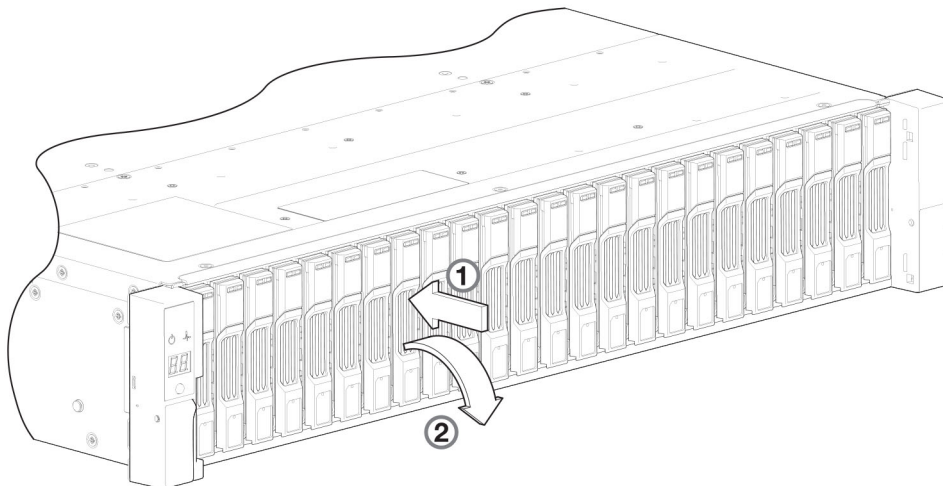

Figure 46. Removing an SFF drive module carrier (1 of 2)

2. Gently move the drive carrier module approximately 25 mm (1 in.), and then wait 30 seconds for the drive to spin down.

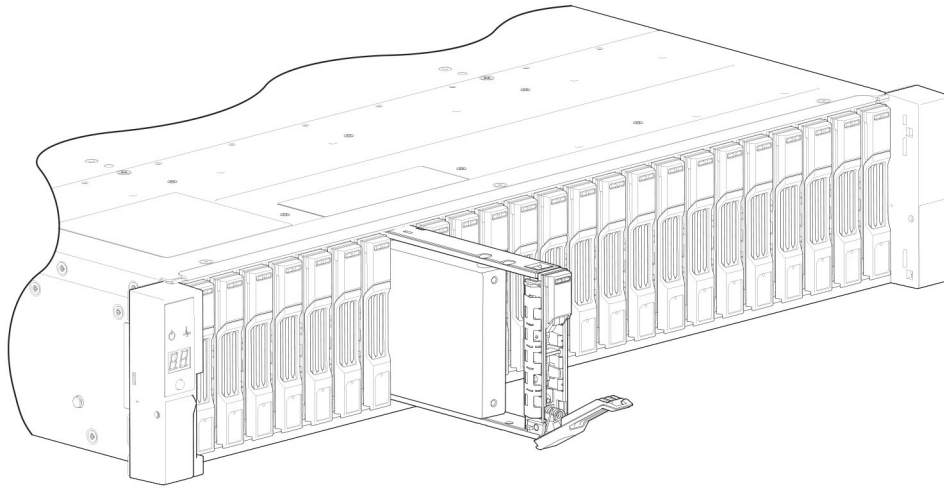

Figure 47. Removing an SFF drive module carrier (2 of 2)

3. Remove the drive carrier module from the drive slot.

CAUTION: To ensure optimal cooling throughout the enclosure, blank drive carrier modules must be installed in all unused drive slots.

Installing an SFF drive carrier module

Perform the following steps to install an SFF drive carrier module in a 2U enclosure:

1. Press the latch on the drive module carrier to open the handle.

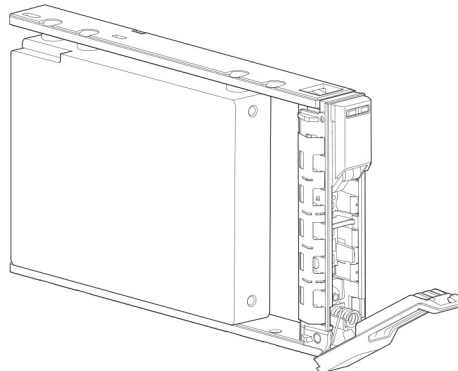

Figure 48. SFF drive carrier module in open position

2. Insert the drive carrier module into the enclosure.
3. Gently slide the drive carrier module into the enclosure until it stops moving.

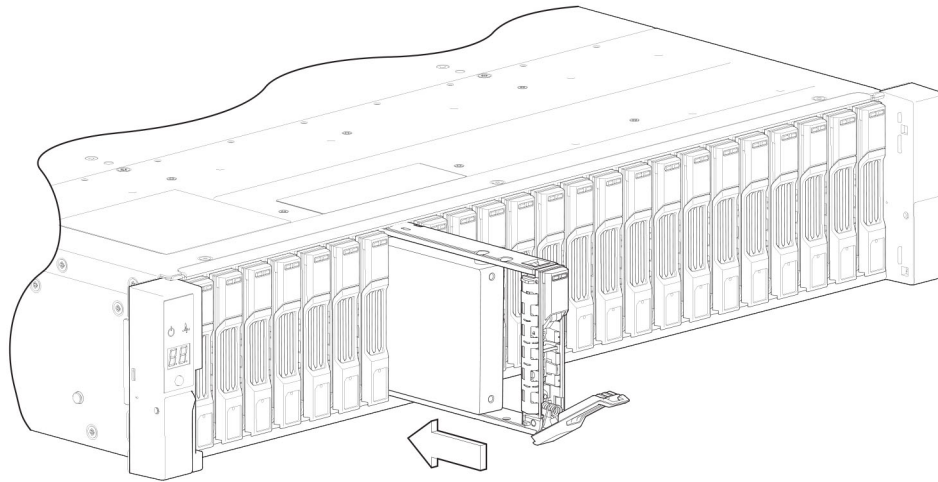

Figure 49. Installing an SFF drive carrier module (1 of 2)

4. Push the drive carrier module further into the enclosure until the latch handle starts to engage.
5. Continue to push firmly until the latch handle fully engages. You should hear a click as the latch handle engages and holds the handle closed.

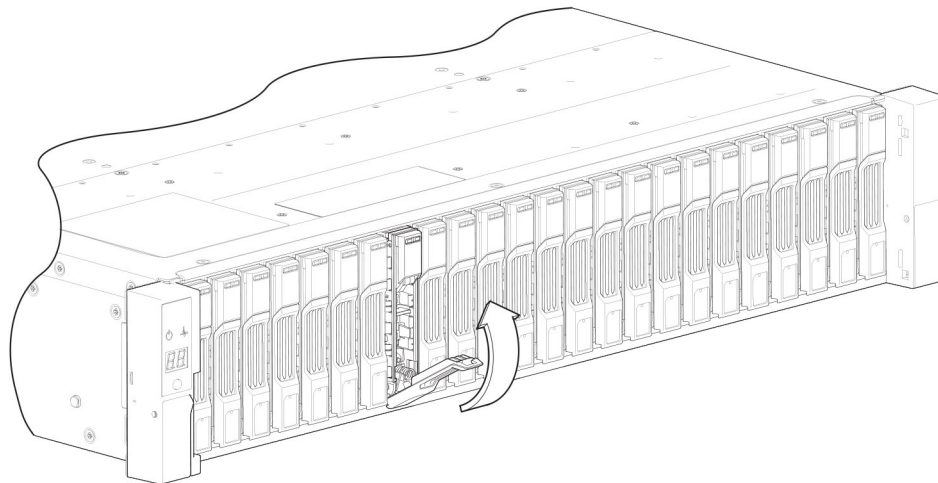

Figure 50. Installing an SFF drive carrier module (2 of 2)

6. Use the PowerVault Manager or CLI to verify the following:
 - Health of the new disk drive is OK
 - Green Disk Activity LED is on/blinking
 - Ops panel states show no amber module faults

Replacing a blank drive carrier module

Ensure optimal cooling throughout the enclosure by installing blank drive carrier modules into all unused drive slots.

To remove a blank drive carrier module, press the latch on the module and pull the module out of the drive slot.

To install a blank drive carrier module, insert the module into the drive slot and push the module into the drive slot to secure it in place.

Replacing a DDIC in a 5U enclosure

The section describes how to replace a Disk Drive in Carrier (DDIC) in a 5U enclosure.

A DDIC consists of a disk drive that is installed in a carrier module. DDICs are hot-swappable, which means they can be replaced without halting I/O to the disk groups, or powering off the enclosure. The new disk drive must be of the same type of drive and

contain a capacity equal to or greater than the drive being replaced. Otherwise, the storage system cannot use the new disk drive to reconstruct the disk group.

CAUTION:

- **Removing a DDIC impacts the airflow and cooling ability of the enclosure. If the internal temperature exceeds acceptable limits, the enclosure may overheat and automatically shut down or restart.**
- **When removing a DDIC, wait 30 seconds after unlocking the DDIC from its seated position to allow the disk drive to stop spinning.**

NOTE:

- Familiarize yourself with full disk encryption (FDE) considerations relative to disk drive installation and replacement.
- When moving FDE-capable disk drives for a disk group, stop I/O to the disk group before removing the DDICs. Import the keys for the disk drives so that the drive content becomes available. See the *Dell PowerVault ME5 Series Storage System Administrator's Guide* or *Dell PowerVault ME5 Series Storage System CLI Guide* for more information.

Before you begin any of the procedures, see the [ESD precautions](#) on page 43.

Installing a replacement 2.5" disk drive into a DDIC

Each replacement disk drive is shipped with a new disk drive in carrier (DDIC).

Install the replacement disk drive in the DDIC before opening the drawer of the enclosure to remove the failed drive.

1. Install the 2.5" replacement disk drive into the 3.5" mounting bracket.

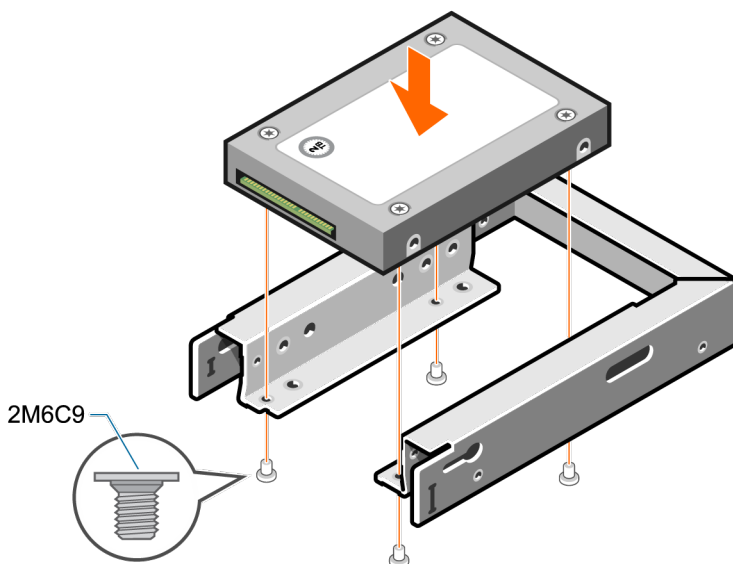

2. Insert the SAS connector into the SAS interface on the disk drive.

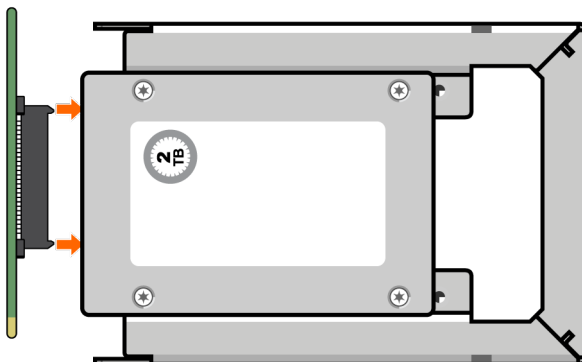

3. Insert the 3.5" mounting bracket with the 2.5" disk drive into the lower assembly.

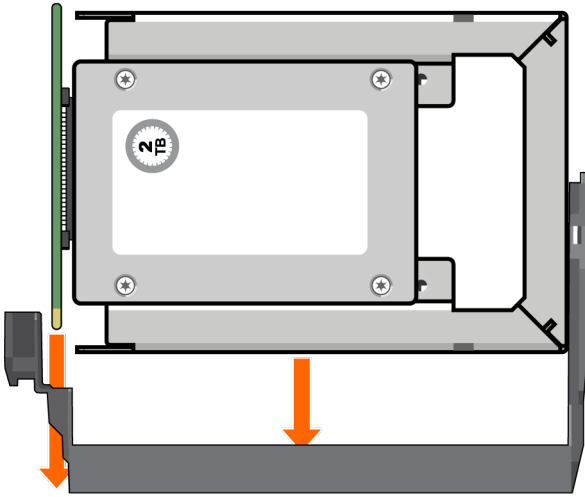

4. Remove the protective film from the upper assembly of the DDIC.
5. Slide the upper assembly of the DDIC onto the mounting bracket with the 2.5" disk drive

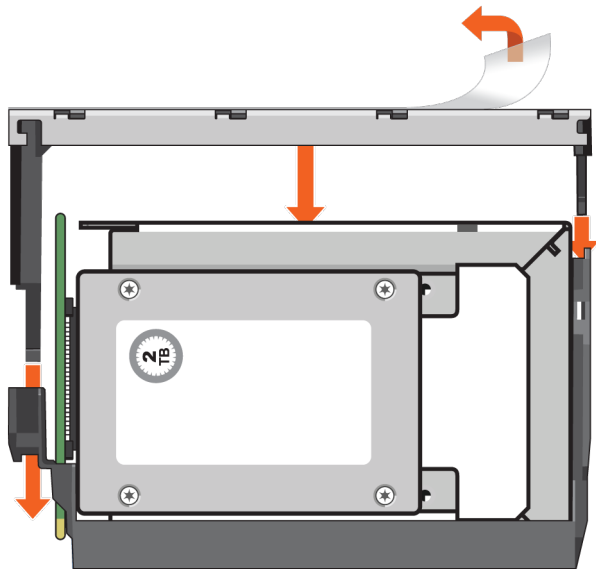

6. Secure the upper assembly to the mounting bracket using the supplied screws.

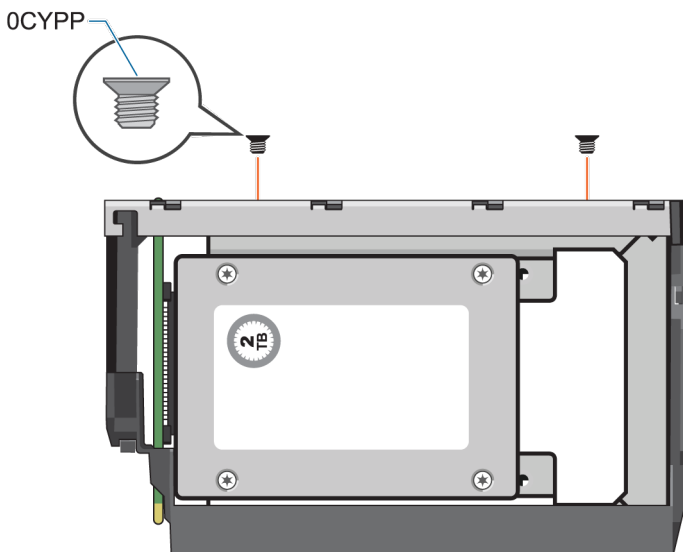

7. Attach the appropriate drive size label to the label location on top of the upper assembly.

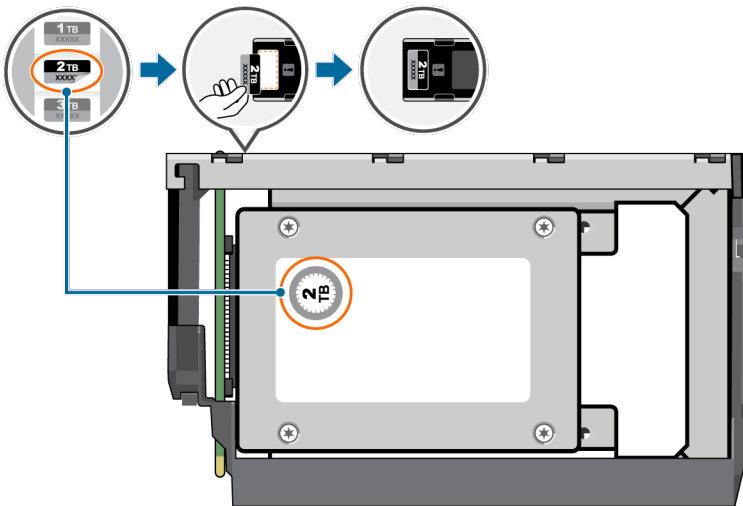

Installing a replacement 3.5" disk drive into a DDIC

Each replacement disk drive is shipped with a new disk drive in carrier (DDIC).

Install the replacement disk drive in the DDIC before opening the drawer of the enclosure to remove the failed drive.

1. Insert the SAS connector into the SAS interface on the disk drive.

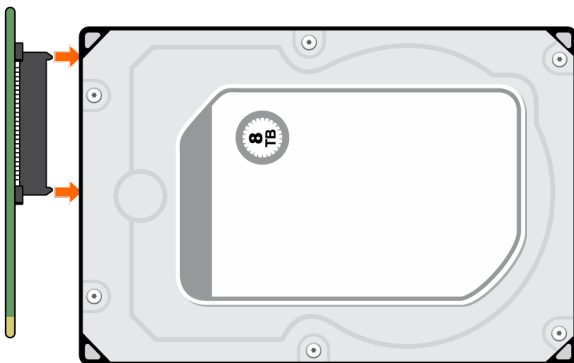

2. Slide the disk drive into the lower assembly of the DDIC.

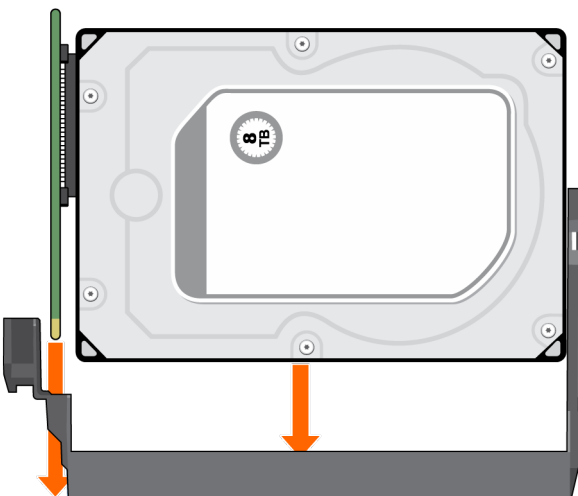

3. Remove the protective film from the upper assembly of the DDIC.

4. Slide the upper assembly of the DDIC onto the disk drive.

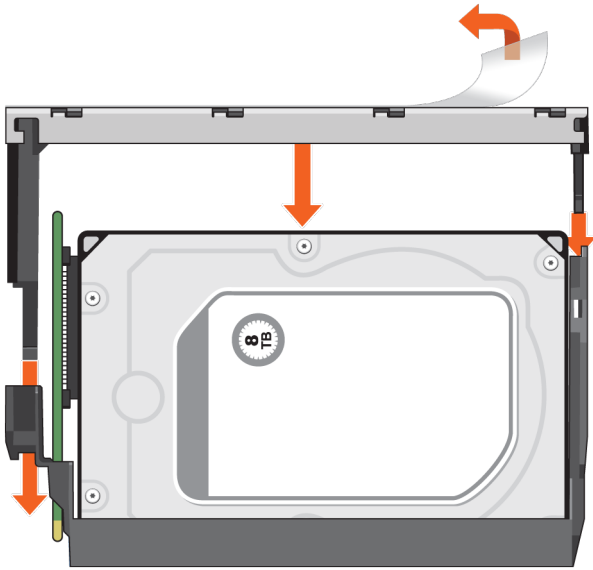

5. Secure the upper assembly to the disk drive using the supplied screws.

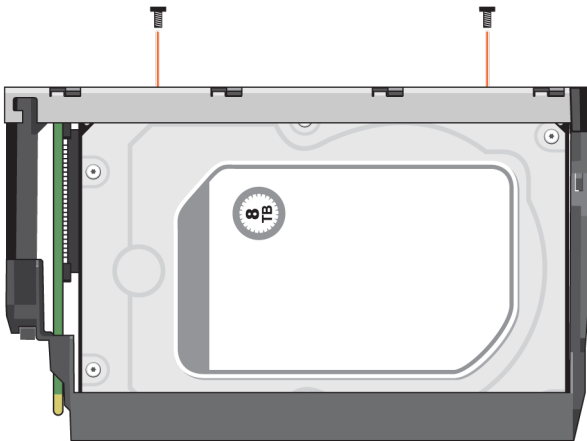

6. Attach the appropriate drive size label to the label location on top of the upper assembly.

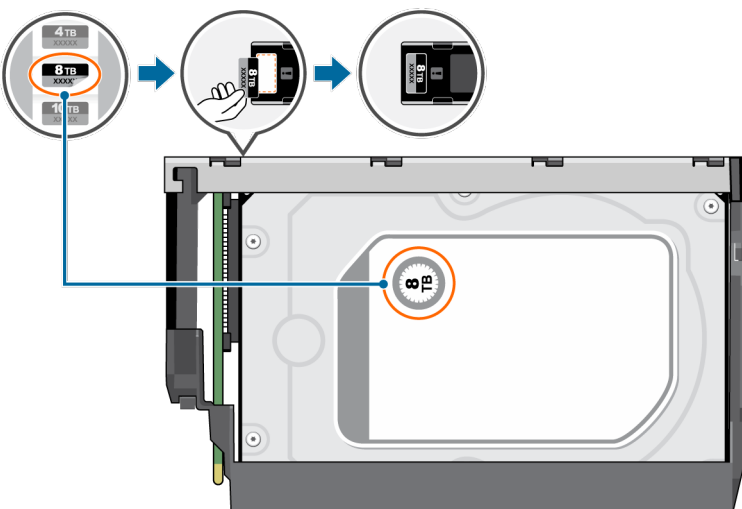

Accessing the drawers of a 5U84 chassis

The replacement procedure for DDICs must be completed within two minutes of opening a drawer.

Opening a drawer

1. Verify that the anti-tamper locks are not engaged. The red arrows on the locks point inwards if the locks are disengaged as shown in the following figure. If necessary, unlock them by rotating counter-clockwise using a Torx T20 bit.

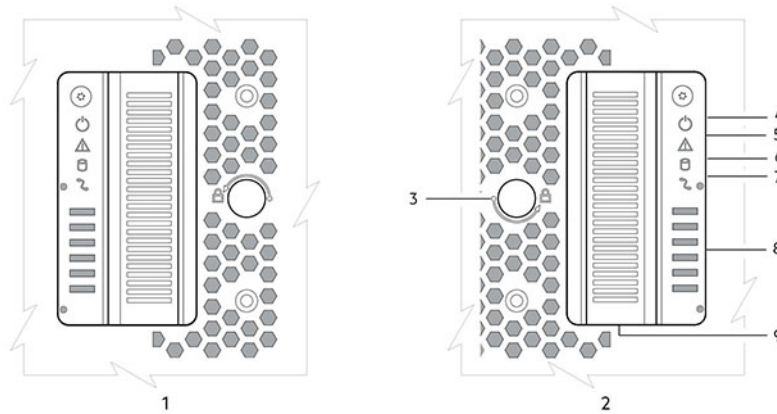

Figure 51. Drawer front panel details

- | | |
|---|-------------------------|
| 1 | Left side |
| 2 | Right side |
| 3 | Anti-tamper lock |
| 4 | Sideplane OK/Power Good |
| 5 | Drawer Fault |
| 6 | Logical Fault |
| 7 | Cable Fault |
| 8 | Drawer Activity |
| 9 | Drawer pull handle |

2. Push the drawer latches inward and hold them as shown in the following figure.

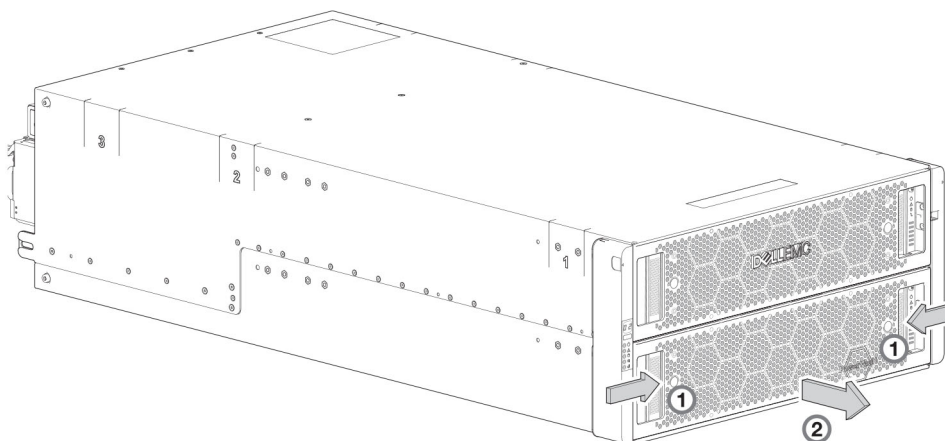

Figure 52. Opening a drawer (1 of 2)

3. Pull the drawer outward until it locks at the drawer stops as shown in the following figure. The drawer is shown empty, which is how the enclosure is delivered. A drawer slide rail latch detail is inset.

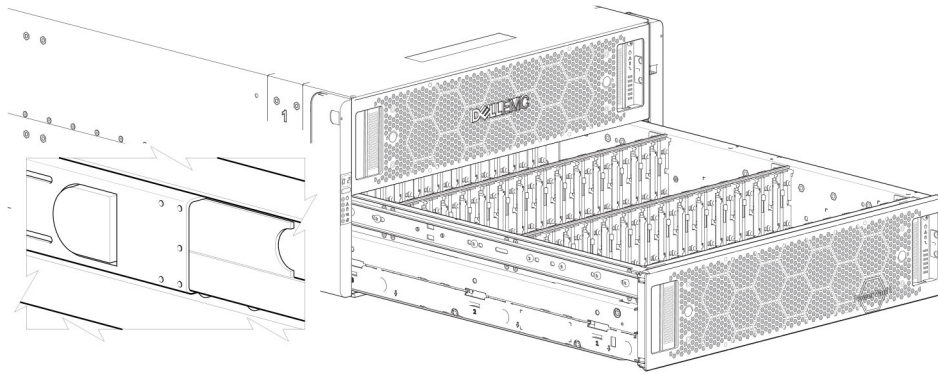

Figure 53. Opening a drawer (2 of 2)

NOTE: The drawer must not remain open for more than two minutes while the enclosure is powered on.

Closing a drawer

1. Press and hold the black latches on the sides of the open drawer in each extended top rail. The previous diagram shows a magnified detail of a slide latch, which resides on the left and right drawer rails.
2. Push the drawer in slightly.
3. Release the drawer latches.
4. Push the drawer all the way into the enclosure, making sure that it clicks home.

Removing a DDIC from a 5U enclosure

Remove a DDIC only if a replacement DDIC is available.

NOTE: Closing a drawer with one or more DDICs missing can potentially cause cooling problems. See [Populating drawers](#).

1. Determine which drawer contains the disk drive to remove.
 - If the disk drive has failed, a fault LED is lit on the front panel of the affected drawer.
 - If the disk drive has failed, the Drive Fault LED on the DDIC is lit amber.
2. Open the drawer that contains the DDIC to remove.
3. Unlock the DDIC from its seated position in the slot by pushing the latch button in the direction shown in the following figure:

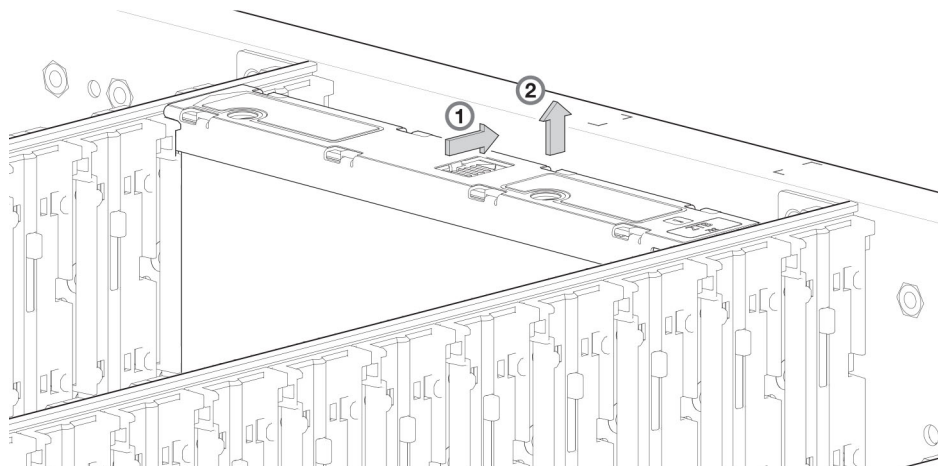

Figure 54. Removing a DDIC (1 of 2)

4. Pull the DDIC upwards and out of the drawer slot.

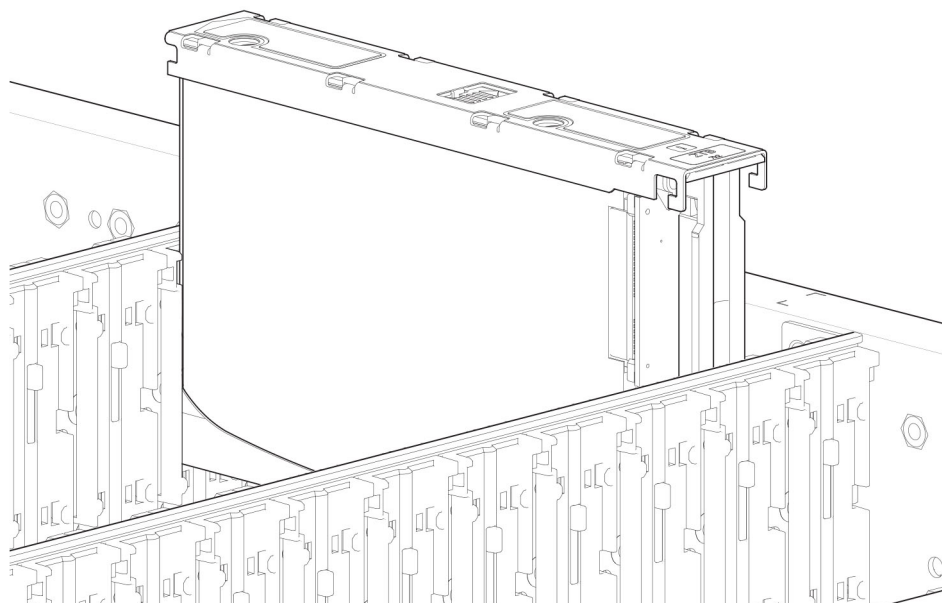

Figure 55. Removing a DDIC (2 of 2)

Installing a DDIC in a 5U enclosure

Failed disk drives must be replaced with approved disk drives. Contact your service provider for details.

1. Align the DDIC with the target drive slot and insert it into the drive slot.
2. Lower the DDIC into the drive slot.
 - a. Push the DDIC downwards and hold it down.
 - b. Move the slide latch in the direction shown in the following figure:

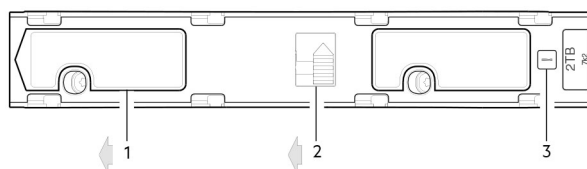

Figure 56. Installing a DDIC

1. Slide latch (slides left)
 2. Latch button (shown in locked position)
 3. Drive Fault LED
3. Verify the following:
 - a. The latch button is in the locked position.
 - b. The Drive Fault LED is not lit.
 4. Close the drawer.

Populating drawers

The general guidelines for populating a drawer with DDICs are provided in the *Dell PowerVault ME5 Series Storage System Deployment Guide*. Additional guidelines are provided for replacing disk drives in previously populated drawers, or populating enclosures delivered with the half-populated enclosure configuration option.

Preparation

Disk drives are shipped in expansion packages of 42 drives. Customers with multiple enclosures may spread the 42 disk drives of an expansion package across multiple enclosures, provided that the DDICs are installed 14 at a time to completely fill empty rows. The installation pattern providing the best airflow and thermal performance is described in this section.

The drawers must be populated with DDICs in whole rows. Each drawer contains 3 rows of 14 DDICs. Rules and assumptions are listed:

- The minimum number of DDICs in an enclosure is 28.
- The number of rows must not differ by more than 1 between the top and bottom drawers.
- The rows should be populated from the front of the drawer to the rear of the drawer
- If a second expansion package of disk drives is shipped to a customer, the disk drives of the second expansion package must match the disk drives that were originally shipped with the 5U84 enclosure. Both groups of disk drives must share the same model type and capacity.

NOTE: Part numbers for expansion packages are not listed because they change over time when disk drives ship with new firmware, or new disk drive models become available. Contact your account manager for part numbers.

- If the two groups of disk drives have different firmware, all disk drives must be updated with current/compatible firmware. See the *Dell PowerVault ME5 Series Storage System Administrator's Guide* or online help for additional information about updating firmware.

Installation guidelines

The recommended order for partially populating disk drives in the 5U84 enclosure optimizes the airflow through the chassis. [5U84 enclosure-plan view of drawer](#) shows the location and indexing of drawers accessed from the enclosure front panel.

The 5U84 ships with drawers installed in the chassis. However, to avoid shock and vibration issues during transit, the enclosure does not ship with DDICs installed in the drawers. An enclosure is configured with either 42 disk drives (half-populated) or 84 disk drives (fully populated) for customer delivery. If half-populated, the rows containing disk drives should be populated with a full complement of DDICs (no blank slots in the row). The following list identifies rows in drawers that should contain DDICs when the enclosure is configured as half-populated:

- Top drawer–front row
- Top drawer–middle row
- Bottom drawer–front row

If additional disk drives are incrementally installed into a half-populated enclosure, the DDICs must be added one complete row at a time (no blank slots in row) in the sequence listed:

- Bottom drawer–middle row
- Top drawer–back row
- Bottom drawer–back row

Replacing a controller module or IOM

This section provides procedures for removing and installing a controller module or IOM in a 2U or 5U enclosure.

The 2U enclosures support single or dual-controller module configurations. The 5U84 enclosures support only dual-controller module configurations.

If a controller module fails, the controller will fail over and run on a single controller module until the redundancy is restored. For 2U enclosures, a controller module must be installed in slot A, and either a controller module or controller blank must be installed in slot B to ensure sufficient air flow through the enclosure during operation. For 5U84 enclosures, a controller module must be installed in both slots.

In a dual-controller module configuration, controller modules and IOMs are hot-swappable, which means you can replace one module without halting I/O to disk groups, or powering off the enclosure. In this case, the second controller module takes over operation of the storage system until you install the new module.

You might need to replace a controller module or IOM when:

- The Fault LED is illuminated
- Health status reporting in the PowerVault Manager indicates a problem with the module
- Events in the PowerVault Manager indicate a problem with the module
- Troubleshooting indicates a problem with the module

The figure in the following sections show controller module replacement for the top slot (A) of the enclosure. To replace a controller module or IOM in the bottom slot (B), rotate the module 180° so that it properly aligns with its connectors on the back of the midplane.

Replacing a controller module in a dual-controller module enclosure

When two controller modules are installed in an enclosure, the controller modules must be the same model type.

Removing a controller module from an operational enclosure changes the air flow within the enclosure. Leave the controller modules in the enclosure until you are ready to install a replacement controller module.

CAUTION: When a controller module is removed from a 2U enclosure, it must be replaced within five minutes to prevent the enclosure from overheating. When a controller module is removed from a 5U enclosure, it must be replaced within seven minutes to prevent the enclosure from overheating.

Follow these guidelines when replacing one controller module in an operational enclosure:

1. Record the controller module settings in PowerVault Manager before replacing the controller modules.
2. Remove the controller module from the enclosure.
3. Install the replacement controller module in the enclosure.
4. Wait 30 minutes, and then use the PowerVault Manager or CLI to check the system status and event logs to verify that the system is stable.

NOTE: If the Partner Firmware Update (PFU) feature is not enabled, update the firmware on the replacement controller module.

Follow these guidelines when replacing both controller modules in an operational enclosure:

1. Record the controller module settings in PowerVault Manager before replacing the controller modules.
2. Remove one controller module from the enclosure.
3. Install the replacement controller module in the enclosure.
4. Wait 30 minutes, and then use the PowerVault Manager or CLI to check the system status and event logs to verify that the system is stable.

NOTE: If the Partner Firmware Update (PFU) feature is not enabled, update the firmware on the replacement controller module. For more information updating the firmware, see the *Dell PowerVault ME5 Series Storage System Administrator's Guide*.

5. Remove the second controller module from the enclosure.
6. Install the replacement controller module in the enclosure.
7. Wait 30 minutes, and then use the PowerVault Manager or CLI to check the system status and event logs to verify that the system is stable.

NOTE: If the Partner Firmware Update (PFU) feature is not enabled, update the firmware on the replacement controller module. For more information updating the firmware, see the *Dell PowerVault ME5 Series Storage System Administrator's Guide*.

Removing a controller module from a dual-controller module enclosure

Perform the following steps to remove a controller module from a dual-controller module enclosure:

Before you begin any procedure, see [ESD precautions](#).

NOTE:

- You may hot-swap a single controller module in an operational enclosure, provided you first shut down the controller module using the PowerVault Manager or the CLI.
- Do not remove a faulty controller module unless its replacement is on-hand. All controller modules must be in place when the system is in operation.

1. Verify that you have successfully shut down the controller module using the PowerVault Manager or the CLI.
2. Locate the enclosure with a Unit identification (UID) LED that is lit.
3. Within the enclosure, locate the controller module to remove and make sure that the **OK to remove** LED is lit.
4. Disconnect any cables connected to the controller module.
Label each cable to facilitate re-connection to the replacement controller module.

5. Grasp the module latch between the thumb and forefinger, and squeeze the flange and handle together to release the latch handle, and swing the latch handle out to release the controller module from its seated position.
6. Swing the latch handle open, then grip the latch handle and slide the controller module forward from the slot.

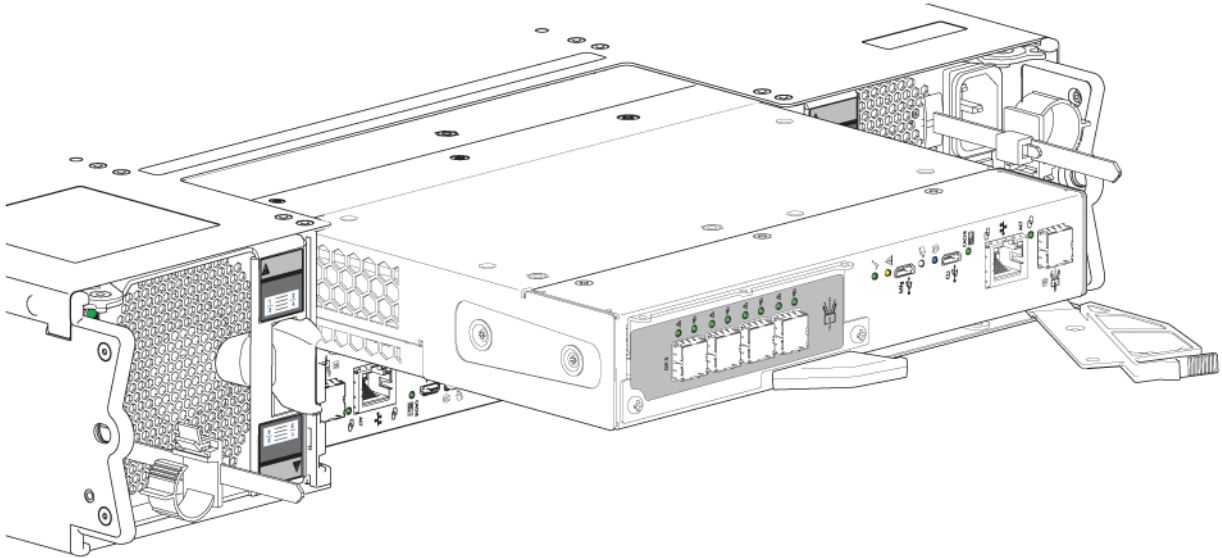

Figure 57. Removing a controller module from an enclosure

NOTE: This figure shows a 4-port SAS controller module. However, all of the controller modules use the same latching mechanism.

7. Place both hands on the controller module, and pull it straight out of the enclosure such that the controller module remains level during removal.

Installing a replacement controller module in a dual-controller module enclosure

Perform the following steps to install a replacement controller module in a dual-controller module enclosure:

Before you begin any procedure, see [ESD precautions](#).

1. Examine the replacement controller module for damage, and closely inspect the interface connector. Do not install the replacement controller module if the pins are bent.
2. Grasp the controller module using both hands, and with the latch in the open position, orient the controller module and align it for insertion into the target slot.

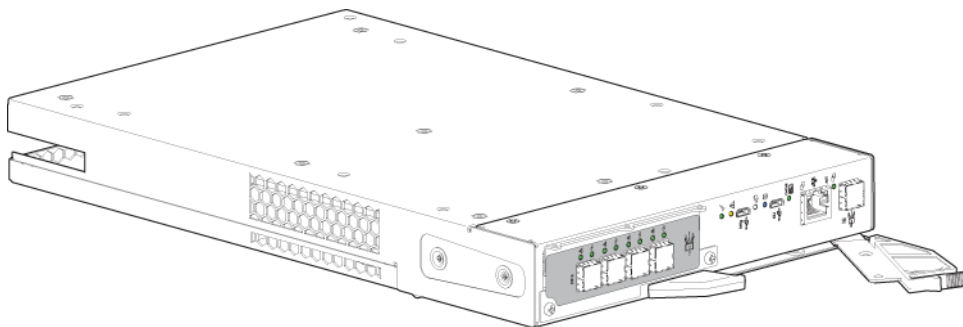

Figure 58. Installing a controller module

NOTE: This figure shows a 4-port SAS controller module. However, all of the controller modules use the same latching mechanism.

3. Ensuring that the controller module is level, slide it into the enclosure until it stops. A controller module that is only partially seated will prevent optimal performance of the controller enclosure. Verify that the controller module is fully seated before continuing.
4. Secure the controller module in position by manually closing the latch.

You should hear a click as the latch handle engages and secures the controller module to its connector on the back of the midplane.

5. Reconnect the cables to the controller module.

CAUTION: If passive copper cables are connected to the controller module, the cable must not have a connection to a common ground/earth point.

6. Update the firmware on the replacement controller module to the same version as the other controller module.

NOTE: In a dual-controller module system on which the partner firmware update is enabled, the system automatically updates the firmware on a replacement controller module.

Replacing a controller module in a single-controller module enclosure

Follow these guidelines when replacing a controller module in a single-controller module enclosure:

1. If the controller module is still operational, record the IP addresses and settings of the storage system in the System Information Worksheet, which is located in the *Dell PowerVault ME5 Series Storage System Deployment Guide*.
2. Use the PowerVault Manager or CLI to shut down the storage system.
3. Remove the controller module from the storage system enclosure.
4. Install the replacement controller module in the storage system enclosure and configure the replacement controller module.

Removing a controller module from a single-controller module enclosure

Perform the following steps to remove a controller module from a single-controller module enclosure:

Before you begin any procedure, see [ESD precautions](#).

1. Shut down the storage system using PowerVault Manager or the CLI.
2. Disconnect any cables connected to the controller module.
Label each cable to facilitate re-connection to the replacement controller module.
3. Grasp the module latch between the thumb and forefinger, and squeeze the flange and handle together to release the latch handle, and swing the latch handle out to release the controller module from its seated position.
4. Swing the latch handle open, then grip the latch handle and slide the controller module forward from the slot.

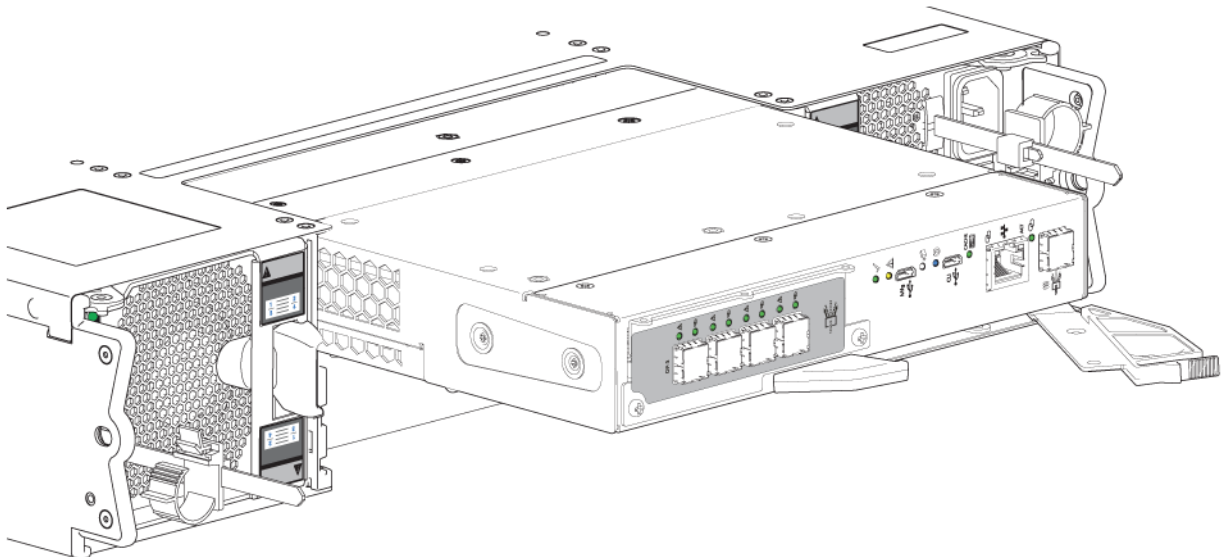

Figure 59. Removing a controller module from an enclosure

NOTE: This figure shows a 4-port SAS controller module. However, all of the controller modules use the same latching mechanism.

5. Place both hands on the controller module, and pull it straight out of the enclosure such that the controller module remains level during removal.

Installing and configure a replacement controller module in a single-controller module enclosure

Perform the following steps to install and configure a replacement controller module in a single-controller module enclosure:

Before you begin any procedure, see [ESD precautions](#).

NOTE: For instructions on performing the following steps, see the *Dell PowerVault ME5 Series Storage System Deployment Guide*.

1. Examine the controller module for damage, and closely inspect the interface connector. Do not install the controller module if the pins are bent.
2. With the latch in the open position, grasp the controller module using both hands and align it for insertion into the target slot.
3. Ensuring that the controller module is level, slide it into the enclosure until it stops.
A controller module that is only partially seated prevents optimal performance of the controller enclosure. Verify that the controller module is fully seated before continuing.
4. Secure the controller module in position by manually closing the latch.
You should hear a click as the latch handle engages and secures the controller module to its connector on the back of the midplane.
5. Reconnect the cables to the controller module.

CAUTION: If passive copper cables are connected to the controller module, the cable must not have a connection to a common ground point.

6. Update the firmware on the controller module to the same version of the firmware that was on the failed controller module.
7. Configure the system settings and perform storage setup.

CAUTION: If the disk groups go into quarantine mode during the storage setup, contact technical support before proceeding to the next step.

8. Reconfigure the connections to the host systems and remap the volumes.
9. Set up replications between storage systems.

Removing an IOM

Before you begin any procedure, see [ESD precautions](#).

NOTE: Considerations for removing IOM:

- Expansion enclosures are equipped with two IOMs. You may hot-swap a single IOM in an operational enclosure.
- If replacing both IOMs, and the expansion enclosure is online, you can hot-swap the IOM in slot "A", and then hot-swap the IOM slot "B", verifying each module is recognized by the controller.
- Do not remove a faulty IOM unless its replacement is on-hand. All IOMs must be in place when the system is in operation.

1. Locate the expansion enclosure containing the IOM that must be replaced. On the enclosure front panel, check for an amber fault condition on the enclosure Ops panel. On the enclosure rear panel, look for amber illumination of the IOM Fault LED.
2. Disconnect any cables connected to the IOM.
Label each cable to facilitate re-connection to the replacement IOM.
3. Grasp the module latch between the thumb and forefinger, and squeeze the flange and handle together to release the latch handle, and swing the latch handle out to release the IOM from its seated position.

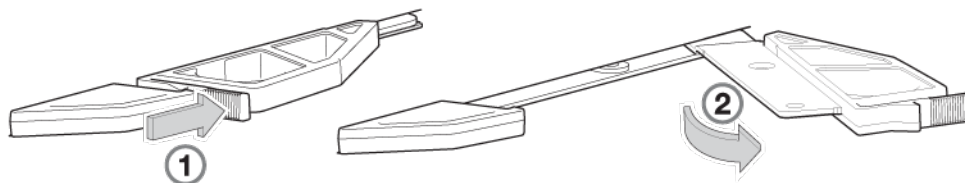

Figure 60. Open module latch

4. Swing the latch handle open, then grip the latch handle and ease the IOM forward from the slot.

5. Place both hands on the IOM body, and pull it straight out of the enclosure such that the IOM remains level during removal.

Installing an IOM

Before you begin any procedure, see [ESD precautions](#).

1. Examine the IOM for damage, and closely inspect the interface connector. Do not install the IOM if the pins are bent.
2. Grasp the IOM using both hands, and with the latch in the open position, orient the IOM and align it for insertion into the target slot.
3. Ensuring that the IOM is level, slide it into the enclosure as far as it will go.
An IOM that is only partially seated will prevent optimal performance of the expansion enclosure. Verify that the IOM is fully seated before continuing.
4. Secure the IOM in position by manually closing the latch.

You should hear a click as the latch handle engages and secures the IOM to its connector on the back of the midplane.

5. Reconnect the cables.

Replacing a power cooling module (PCM) in a 2U enclosure

This section provides procedures for removing and installing a PCM in a 2U enclosure.

The images in the PCM removal and installation procedures show rear panel views of the 2U enclosure.

A single PCM is sufficient to maintain operation of the enclosure. You need not halt operations and completely power-off the enclosure when replacing only one PCM; however, a complete orderly shutdown is required if replacing both units simultaneously.

CAUTION: Do not remove the cover from the PCM due to danger from electric shock inside. Return the PCM to your supplier for repair.

Before you begin any of the procedures, see the [ESD precautions](#).

NOTE: The figures show PCM module replacement within the right slot as you view the enclosure rear panel. To replace a PCM in the left slot, rotate the module 180° so that it properly aligns with its connectors on the back of the midplane.

Removing a power cooling module

CAUTION: Removing a power supply unit significantly disrupts the enclosure's airflow. Do not remove a power cooling module until you have received the replacement module on-hand. It is important that all slots are filled when the enclosure is in operation.

Before removing the power cooling module, disconnect the power from the power cooling module by either the mains switch (where present) or by physically removing the power source in order to ensure your system has warning of imminent power shutdown. Ensure that you correctly identify the faulty power cooling module before beginning the procedure.

1. Stop all I/O from hosts to the enclosure.
NOTE: This step is not required for hot-swapping. However, it is required when replacing both power cooling module at once.
2. Use management software to shut down any other system components necessary.
NOTE: This step is not required for hot-swapping. However, it is required when replacing both power cooling module at once.
3. Turn off the faulty power cooling module, and disconnect the power supply cable.
4. If replacing a single power cooling module using hot-swap, proceed to step 6.
5. If replacing both power cooling module, verify that the enclosure was shut down using management interfaces, and that the enclosure is powered off.
6. Verify that the power cable is disconnected.
7. Grasp the latch and the side of the power cooling module handle between thumb and forefinger, squeeze together and open the handle to release the power cooling module and pull it half way out of the enclosure.

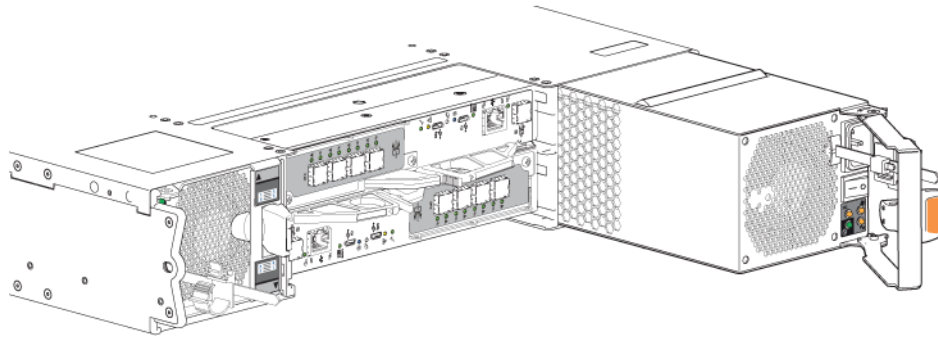

Figure 61. Removing a power cooling module

NOTE: This figure shows a controller enclosure with two 4-port SAS controller modules. However, this procedure applies to all 2U controller enclosures and expansion enclosures.

8. Grip the handle and pull the power cooling module out of the enclosure, taking care to support the base of the module with both hands as you remove it from the enclosure.
9. If you are replacing two power cooling modules, repeat steps 5 through 8.

Installing a power cooling module

Handle the power cooling module carefully, and avoid damaging the connector pins. Do not install the power cooling module if any pins appear to be bent.

1. Check for damage, especially to all module connectors.
2. Move the handle on the power cooling module to the open position.

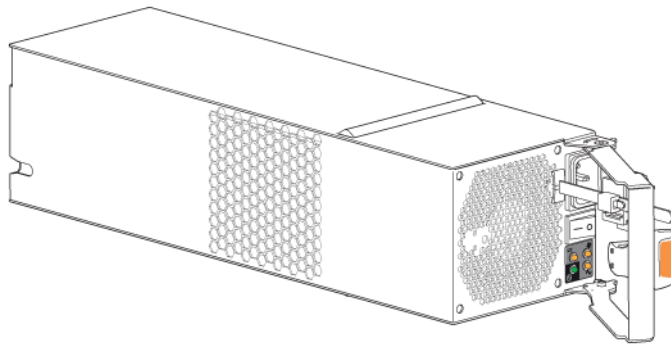

Figure 62. Installing a power cooling module

3. Slide the module into the enclosure, taking care to support the base and weight of the module with both hands.
4. Close the power cooling module handle to secure the PCM. You should hear a click as the latch handle engages and secures the power cooling module to its connector on the back of the midplane.
5. Connect the power cable to the power source and the power cooling module.
6. Using the management interfaces (the PowerVault Manager or CLI), verify whether the health of the new PCM is OK. Verify that the green PCM OK LED is on/blinking per [PCM LED states](#) on page 29. Verify that cooling fans are spinning with no fail states. Verify that Ops panel states show no amber module faults.
7. If replacing two power cooling module, repeat steps 1 through 5.

Replacing a power supply unit (PSU) in a 5U enclosure

This section provides procedures for removing and installing a PSU in a 5U enclosure.

The images in the PSU removal and installation procedures show rear panel views of the 5U enclosure.

Before you begin any procedure, see [ESD precautions](#).

Removing a power supply unit

Before removing the power supply unit (PSU), disconnect the power from the PSU by either the mains switch (where present) or by physically removing the power source in order to ensure your system has warning of imminent power shutdown. Make sure that you correctly identify the faulty PSU before beginning the procedure.

CAUTION: Removing a power supply unit significantly disrupts the enclosure's airflow. Do not remove the PSU until you have received the replacement module. It is important that all slots in the enclosure are filled while it is in operation.

1. Stop all I/O from hosts to the enclosure.
 - NOTE:** This step is not required for hot-swapping. However, it is required when replacing both PSUs at once.
2. Use management software to shut down any other system components necessary.
 - NOTE:** This step is not required for hot-swapping. However, it is required when replacing both PSUs at once.
3. Verify the Power OK LED is lit, then switch off the faulty PSU, and disconnect the power supply cable.
4. If replacing a single PSU via hot-swap, proceed to step 6.
5. If replacing both PSUs, verify that the enclosure was shut down using management interfaces, and that the enclosure is powered off.
6. Verify that the power cable is disconnected.
7. Push the release latch to the right and hold it in place.
8. With your other hand, grasp the handle and pull the PSU outward.

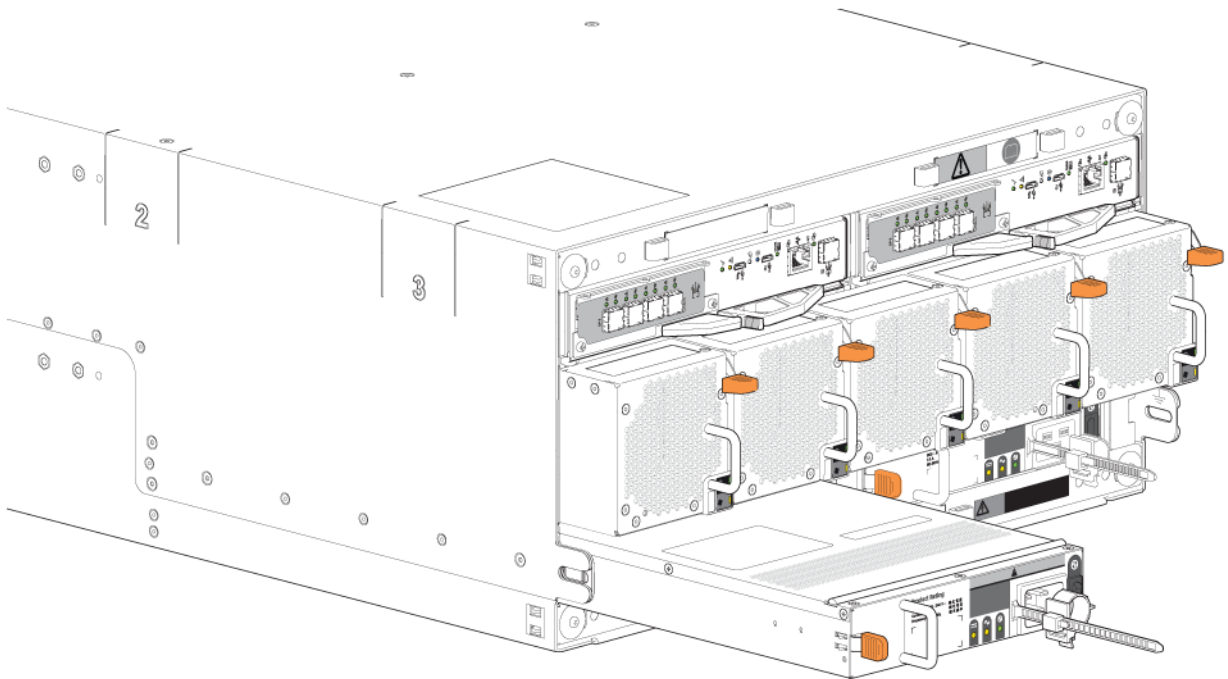

Figure 63. Removing a PSU

9. While supporting the PSU with both hands, remove it from the enclosure.
10. If replacing both PSUs, repeat steps 5 through 9.
 - NOTE:** The PSU slot must not be empty for more than 2 minutes while the enclosure is powered.

Installing a power supply unit

If replacing both (power supply units) PSUs, the enclosure must be powered off via an orderly shutdown using the management interfaces.

1. Make sure power switch on the PSU is in the Off position.
2. Orient the PSU for insertion into the target slot on the enclosure rear panel.

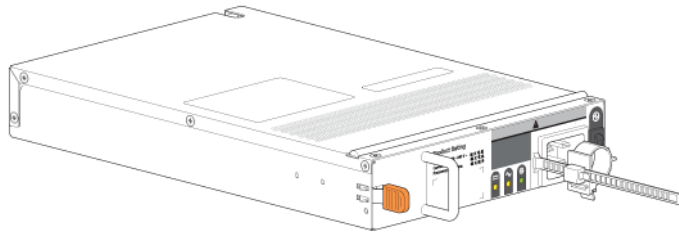

Figure 64. Install a PSU

3. Slide the PSU into the slot until the latch clicks home.
4. Connect the AC power cord.
5. Move the power switch on the PSU to the On position.
6. Wait for the Power OK LED on the newly inserted PSU to illuminate green..
 - If the Power OK LED does not illuminate, verify that the PSU is properly inserted and seated in the slot.
 - If properly seated, the module may be defective. Check the PowerVault Manager and the event logs for more information.
 - Using the management interfaces (the PowerVault Manager or CLI), determine if the health of the new PSU is OK. Verify that the Power OK LED is green, and that the Ops panel states show no amber module faults.
7. If replacing both PSUs, repeat steps 1 through 6.

Replacing a fan cooling module (FCM) in a 5U enclosure

This section provides procedures for removing and installing an FCM in a 5U enclosure.

The images in the FCM removal and installation procedures show rear panel views of the 5U enclosure.

Before you begin any procedure, see [ESD precautions](#).

Removing a fan cooling module

You can change all fan cooling modules as long as they are removed and inserted one at a time. We recommend that you shut down the unit before removing two or more fans.

CAUTION: Removing a fan cooling module significantly disrupts the enclosure's airflow. Do not remove the FCM until you have received the replacement module. It is important that all slots are filled when the enclosure is in operation.

1. Identify the fan cooling module (FCM) to be removed. If the FCM module has failed, the Fan Fault LED will illuminate amber. .
2. Push the release latch down and hold it in place.
3. With your other hand, grasp the handle and pull the FCM outward.

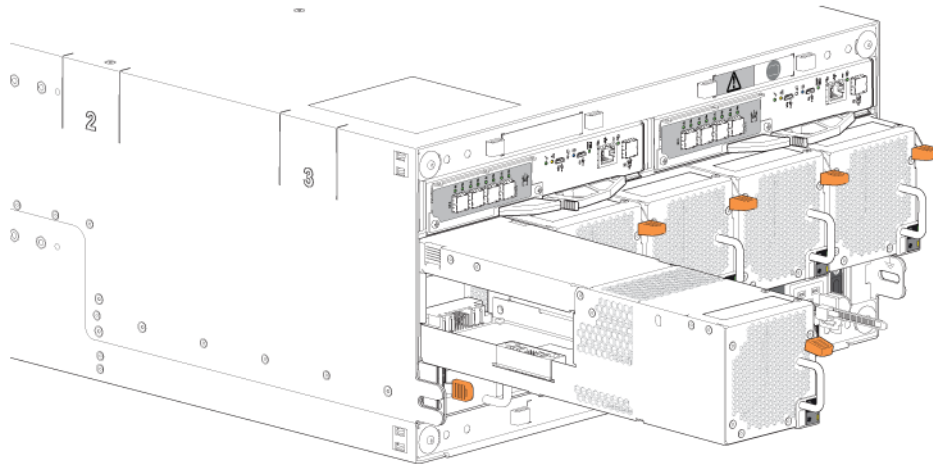

Figure 65. Removing an FCM

4. While supporting the FCM with both hands, remove it from the enclosure.

Installing a fan cooling module

You can hotswap the replacement of a single fan cooling module. However, if you are replacing multiple fan cooling module, the enclosure must be powered off using an orderly shutdown using the management interfaces.

1. Orient the fan cooling module (FCM) for insertion into the target slot on the enclosure rear panel.

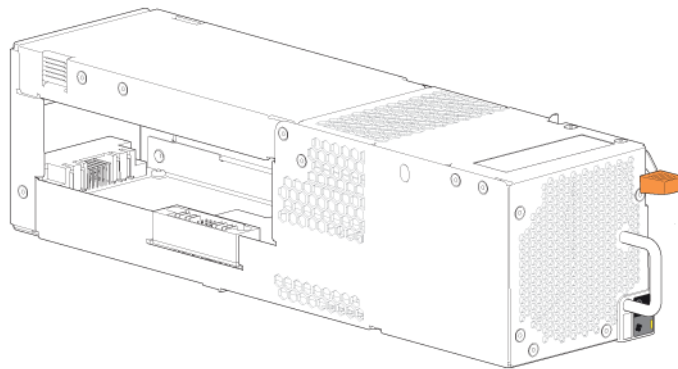

Figure 66. Installing an FCM

2. Slide the FCM into the slot until the latch clicks home.
The enclosure should automatically detect and make use of the new module.
3. Wait for the Module OK LED on the newly inserted FCM to illuminate green.
 - If the Module OK LED does not illuminate, verify that the FCM is properly inserted and seated in the slot.
 - If properly seated, the module may be defective. Check the PowerVault Manager and the event logs for more information.
 - Using the management interfaces (the PowerVault Manager or CLI), determine if the health of the new FCM is OK. Verify that the Module OK LED is green, and that the Ops panel states show no amber module faults.
4. If replacing multiple FCMs, repeat steps 1 through 3.

Completing the component installation process

This section provides a procedure for ensuring that the components installed in the replacement controller enclosure chassis function properly.

1. Reconnect data cables between devices, as needed, to return to the original cabling configuration:
 - Between cascaded storage enclosures.
 - Between the controller and peripheral or SAN devices.

- Between the controller enclosure and the host.
2. Reconnect power cables to the storage enclosures.

Verifying component operation

1. Restart system devices by moving the power switch on the power supply to the On position in the following sequence:
 - a. Expansion enclosures first.
 - b. Controller enclosure next.
 - c. Data host last (if powered down for maintenance purposes).Allow time for each device to complete its Power On Self Tests (POST) before proceeding.
2. If you are unable to connect the storage system, ping the management IP addresses for both controller modules. If the pings fail, check if the management IP addresses are set on the controller modules. If the IP address are not set, enter the management IP address of both controller modules.
3. If the controller modules contain iSCSI ports, ping the IP address of the iSCSI ports. If the pings fail, check if IP addresses are set on the iSCSI ports of the controller modules. If the IP address are not set, enter the IP address of the iSCSI ports on both controller modules.
4. Perform a rescan to force a fresh discovery of all expansion enclosures connected to the controller enclosure. This step clears the internal SAS layout information, reassigns enclosure IDs, and ensures the enclosures are displayed in the proper order. Use the CLI or PowerVault Manager to perform the rescan:

To perform a rescan using the CLI, enter the following command: `rescan`

To perform a rescan using the PowerVault Manager:

 - a. Verify that both controllers are operating normally.
 - b. In the System topic, select **Action > Rescan Disk Channels**.
 - c. Select **Rescan**.

Using LEDs

This section describes the LEDs used to verify component operation. These LEDs are located on the enclosure front and rear panels.

1. Verify front panel LEDs. Front panel LEDs reside on the Ops panel located on the left ear flange. Disk LEDs are located on the carrier modules.
 - Verify that the System Power On/Standby LED is illuminated green, and that the Module Fault LED is not illuminated
 - Verify that the enclosure ID LED located on the left ear is illuminated green.
 - Verify that the disk module's LED is green or blinking green, and is not amber.
2. Verify rear panel LEDs. Rear panel LEDs are located on controller module, IOM, and PCM face plates.
 - For controller modules and IOMs, verify that the OK LED is illuminated green, indicating that the module has completed initializing, and is online.
 - For PCMs, verify that the PCM OK LED is illuminated green on each PCM.

Using management interfaces

In addition to viewing LEDs as previously described, you can use management interfaces to monitor the health status of the system and its components, provided you have configured and provisioned the system, and enabled event notification.

Select from the following methods to verify component operation:

- Use the PowerVault Manager to check the health icons/values of the system and its components, or to drill down to a problem component. The PowerVault Manager uses health icons to show OK, Degraded, Fault, or Unknown status for the system and its components. If you discover a problem component, follow the actions in its Recommendation field to resolve the problem.
- As an alternative to using the PowerVault Manager, you can run the `show system` command in the CLI to view the health of the system and its components. If any component has a problem, the system health will be `Degraded`, `Fault`, or `Unknown`. If you discover a problem component, follow the actions in its Health Recommendations field to resolve the problem.

- Monitor event notification — With event notification configured and enabled, you can view event logs to monitor the health of the system and its components. If a message recommends that you check whether an event has been logged, or to view information about an event in the log, you can do so using the PowerVault Manager or the CLI. Using the PowerVault Manager, view the event log and then hover over the event message to see detail about that event. Using the CLI, run the `show events detail` command with additional parameters to filter the output to see the detail for an event. See the CLI Reference Guide for more information about command parameters and syntax.

Performing updates in PowerVault Manager after replacing an FC or SAS HBA

After replacing an FC or SAS HBA in an attached host, perform the following tasks:

1. For an FC HBA, update the zoning if a switch is used, then update the host/initiator grouping in PowerVault Manager.
2. For a SAS HBA, update the host/initiator grouping in PowerVault Manager.

For details about managing hosts and host groups in PowerVault Manager, see the *Dell PowerVault ME5 Series Storage System Administrator's Guide*.

Events and event messages

When an event occurs in a storage system, an event message is recorded in the system event log. Depending on the event notification settings of the system, the event message can also be sent to users using email, and to host-based applications using SNMP.

i **NOTE:** A best practice is to enable notifications to be sent for events having a severity Warning and higher.

Each event has a numeric code that identifies the type of event that occurred, and has one of the following severities:

- **Critical:** A failure occurred that might cause a controller to shut down. Correct the problem *immediately*.
- **Error:** A failure occurred that might affect data integrity or system stability. Correct the problem as soon as possible.
- **Warning:** A problem occurred that might affect system stability but not data integrity. Evaluate the problem and correct it if necessary.
- **Informational:** A configuration or state change occurred, or a problem occurred that the system corrected. No immediate action is required. In this document, this severity is abbreviated as "Info."
- **Resolved:** The condition that caused an event to be logged has been resolved.

An event message might specify an associated error code or reason code, which provides additional detail for technical support. Error codes and reason codes are outside the scope of this guide.

Topics:

- [Event descriptions](#)
- [Events](#)

Event descriptions

This section describes the event messages that may be reported during system operation and specifies any actions recommended in response to an event.

Depending on your system model and firmware version, some events described in this document may not apply to your system. The event descriptions should be considered as explanations of events that you do see. They should not be considered as descriptions of events that you should have seen but did not. In such cases those events probably do not apply to your system.

In this section:

- The term *disk group* refers to either a vdisk for linear storage or a virtual disk group for virtual storage.
- The term *pool* refers to either a single vdisk for linear storage or a virtual pool for virtual storage.

Events

Table 28. Event descriptions and recommended actions

Number	Severity	Description/Recommended actions
1	Critical	<p>This event severity has the following variants:</p> <ol style="list-style-type: none"> The disk group is online and cannot tolerate another disk failure, and no spare of the proper size and type is present to automatically reconstruct the disk group. <ul style="list-style-type: none"> If the indicated disk group is RAID 6, it is operating with degraded health due to the failure of two disks. If the indicated disk group is not RAID 6, it is operating with degraded health due to the failure of one disk. <p>For linear disk groups, if an available disk of the proper type and size is present and the dynamic spares feature is enabled, that disk is used to automatically reconstruct the disk group and event 37 is logged.</p> The disk group is online and cannot tolerate another disk failure. If the indicated disk group is RAID 6, it is operating with degraded health due to the failure of two disks. If the indicated disk group is not RAID 6, it is operating with degraded health due to the failure of one disk. <p>Recommended actions:</p> <ul style="list-style-type: none"> If event 37 was not logged, a spare of the proper type and size was not available for reconstruction. Replace the failed disk with one of the same type and the same or greater capacity and, if necessary, designate it as a spare. Confirm this by checking that events 9 and 37 are logged. Otherwise, reconstruction automatically started and event 37 was logged. Replace the failed disk and configure the replacement as a dedicated (linear only) or global spare for future use. For continued optimum I/O performance, the replacement disk should have the same or better performance. Confirm that all failed disks have been replaced and that there are sufficient spare disks configured for future use.
	Warning	<p>The disk group is online but cannot tolerate another disk failure.</p> <ul style="list-style-type: none"> If the indicated disk group is RAID 6, it is operating with degraded health due to the failure of two disks. If the indicated disk group is not RAID 6, it is operating with degraded health due to the failure of one disk. <p>A dedicated spare or global spare of the proper size and type is being used to automatically reconstruct the disk group. Events 9 and 37 are logged to indicate this.</p> <p>Recommended actions:</p> <ul style="list-style-type: none"> If event 37 was not logged, a spare of the proper type and size was not available for reconstruction. Replace the failed disk with one of the same type and the same or greater capacity and, if necessary, designate it as a spare. Confirm this by checking that events 9 and 37 are logged. Otherwise, reconstruction automatically started and event 37 was logged. Replace the failed disk and configure the replacement as a dedicated (linear only) or global spare for future use. For continued optimum I/O performance, the replacement disk should have the same or better performance. Confirm that all failed disks have been replaced and that there are sufficient spare disks configured for future use.
3	Error	<p>The indicated disk group went offline.</p> <p>One disk failed for RAID 0 or NRAID, three disks failed for RAID 6, or two disks failed for other RAID levels. The disk group cannot be reconstructed. This is not a normal status for a disk group unless you have done a manual dequarantine.</p> <p>For virtual disk groups in the Performance tier, when a disk failure occurs the data in the disk group that uses that disk will be automatically migrated to another available disk group if space is available, so no user data is lost. Data will be lost only if multiple disk failures occur in rapid succession so there is not enough time to migrate the data, or if there is insufficient space to fit the data in another tier, or if failed disks are not replaced promptly by the user.</p>

Table 28. Event descriptions and recommended actions (continued)

Number	Severity	Description/Recommended actions
		<p>Recommended actions:</p> <ul style="list-style-type: none"> ● The CLI <code>trust</code> command might be able to recover some of the data in the disk group. See the CLI help for the trust command. Contact technical support for help to determine if the trust operation applies to your situation and for help to perform it. ● If you choose to not use the trust command, perform these steps: <ul style="list-style-type: none"> ○ Replace the failed disk or disks. (Look for event 8 in the event log to determine which disks failed and for advice on replacing them.) ○ Delete the disk group (CLI <code>remove disk-groups</code> command). ○ Re-create the disk group (CLI <code>add disk-group</code> command). <p>To prevent this problem in the future, use a fault-tolerant RAID level, configure one or more disks as spare disks, and replace failed disks promptly.</p>
4	Info.	<p>The indicated disk had a bad block which was corrected.</p> <p>Recommended actions:</p> <ul style="list-style-type: none"> ● Monitor the error trend and whether the number of errors approaches the total number of bad-block replacements available.
6	Warning	<p>A failure occurred during initialization of the indicated disk group. This was probably caused by the failure of a disk drive. The initialization may have completed but the disk group probably has a status of FTDN (fault tolerant with a down disk), CRIT (critical), or OFFL (offline), depending on the RAID level and the number of disks that failed.</p> <p>Recommended actions:</p> <ul style="list-style-type: none"> ● Look for another event logged at approximately the same time that indicates a disk failure, such as event 55, 58, or 412. Follow the recommended actions for that event.
	Info.	<p>Either:</p> <ul style="list-style-type: none"> ● Disk group creation completed successfully. ● Disk group creation failed immediately. The user was given immediate feedback that it failed at the time they attempted to add the disk group. <p>Recommended actions:</p> <ul style="list-style-type: none"> ● No action is required.
7	Error	<p>In a testing environment, a controller diagnostic failed and reports a product-specific diagnostic code.</p> <p>Recommended actions:</p> <ul style="list-style-type: none"> ● Perform failure analysis.
8	Warning	<p>One of the following conditions has occurred:</p> <ul style="list-style-type: none"> ● A disk that was part of a disk group is down. The indicated disk in the indicated disk group failed and the disk group probably has a status of FTDN (fault tolerant with a down disk), CRIT (critical), or OFFL (offline), depending on the RAID level and the number of disks that failed. If a spare is present and the disk group is not offline, the controller automatically uses the spare to reconstruct the disk group. Subsequent events indicate the changes that happen to the disk group. When the problem is resolved, event 9 is logged. ● Reconstruction of a disk group failed. The indicated disk was being used as the target disk for reconstructing the indicated disk group. While the disk group was reconstructing, another disk in the disk group failed and the status of the disk group went to OFFL (offline). The indicated disk has a status of LEFTOVR (leftover). ● An SSD that was part of a disk group has reported that it has no life remaining. The indicated disk in the indicated disk group failed and the disk group probably has a status of FTDN (fault tolerant with a down disk), CRIT (critical), or OFFL (offline), depending on the RAID level and the number of disks that failed. If a spare is present and the disk group is not offline, the controller automatically uses the spare to reconstruct the disk group. Subsequent events indicate the changes that happen to the disk group. When the problem is resolved, event 9 is logged. <p>Recommended actions:</p> <ul style="list-style-type: none"> ● If a disk that was part of a disk group is down:

Table 28. Event descriptions and recommended actions (continued)

Number	Severity	Description/Recommended actions
		<ul style="list-style-type: none"> ○ If the indicated disk failed for one of these reasons—excessive media errors, imminent disk failure, possible hardware failure, disk is not supported, too many controller-recoverable errors, illegal request, due to being degraded, or due to being too slow—replace the disk with one of the same type (SSD, enterprise SAS, or midline SAS) and the same or greater capacity. For continued optimum I/O performance, the replacement disk should have performance that is the same as or better than the one it is replacing. ○ If the indicated disk failed because a user forced the disk out of the disk group, RAID-6 initialization failed, or for an unknown reason: <ul style="list-style-type: none"> ▪ If the associated disk group is offline or quarantined, contact technical support. ▪ Otherwise, clear the disk’s metadata to reuse the disk. ○ If the indicated disk failed because a previously detected disk is no longer present: <ul style="list-style-type: none"> ▪ Reinsert the disk or insert a replacement disk of the same type (SSD, enterprise SAS, or midline SAS) and the same or greater capacity as the one that was in the slot. For continued optimum I/O performance, the replacement disk should have performance that is the same as or better than the one it is replacing. ▪ If the disk then has a status of leftover (LEFTOVR), clear the metadata to reuse the disk. ▪ If the associated disk group is offline or quarantined, contact technical support. ● If reconstruction of a disk group failed: <ul style="list-style-type: none"> ○ If the associated disk group is online, clear the indicated disk's metadata so that the disk can be re-used. ○ If the associated disk group is offline, the CLI <code>trust</code> command may be able to recover some or all of the data in the disk group. However, trusting a partially reconstructed disk may lead to data corruption. See the CLI help for the <code>trust</code> command. Contact technical support for help to determine if the trust operation applies to your situation and for help to perform it. ● If the associated disk group is offline and you do not want to use the trust command, perform these steps: <ul style="list-style-type: none"> ○ Delete the disk group (CLI <code>remove disk-groups</code> command). ○ Clear the indicated disk’s metadata so the disk can be re-used (CLI <code>clear disk-metadata</code> command). ○ Replace the failed disk or disks. (Look for other instances of event 8 in the event log to determine which disks failed). ○ Re-create the disk group (CLI <code>add disk-group</code> command). ● If an SSD that was part of a disk group has reported that it has no life remaining, replace the disk with one of the same type and the same or greater capacity. For continued optimum I/O performance, the replacement disk should have performance that is the same as or better than the one it is replacing.
9	Info.	<p>The indicated spare disk has been used in the indicated disk group to bring it back to a fault-tolerant status.</p> <p>Disk group reconstruction starts automatically. This event indicates that a problem reported by event 8 is resolved.</p> <p>Recommended actions:</p> <ul style="list-style-type: none"> ● No action is required.
16	Info.	<p>The indicated disk has been designated a global spare.</p> <p>Recommended actions:</p> <ul style="list-style-type: none"> ● No action is required.
18	Error	<p>Disk group reconstruction completed with errors.</p> <p>When a disk fails, reconstruction is performed using a spare disk. However, this operation failed. Some of the data in the other disk(s) in the disk group is unreadable (uncorrectable media error), so part of the data cannot be reconstructed.</p> <p>Recommended actions:</p> <ul style="list-style-type: none"> ● If you do not have a backup copy of the data, take a backup.

Table 28. Event descriptions and recommended actions (continued)

Number	Severity	Description/Recommended actions
		<ul style="list-style-type: none"> Look for another event logged at approximately the same time that indicates a disk failure, such as event 8, 55, 58, or 412. Follow the recommended actions for that event.
	Info.	<p>Disk group reconstruction completed.</p> <p>For the ADAPT disk group that completed partially, either there is no available spare space, or the spare space cannot be used because of ADAPT fault-tolerant requirements.</p> <p>Recommended actions:</p> <ul style="list-style-type: none"> No action is required.
19	Info.	<p>A rescan has completed.</p> <p>Recommended actions:</p> <ul style="list-style-type: none"> No action is required.
20	Info.	<p>Storage Controller firmware update has completed.</p> <p>Recommended actions:</p> <ul style="list-style-type: none"> No action is required.
21	Error	<p>Disk group verification completed. Errors were found but not corrected.</p> <p>Recommended actions:</p> <ul style="list-style-type: none"> No action is required.
	Warning	<p>Disk group verification did not complete because of an internally detected condition such as a failed disk. If a disk fails, data may be at risk.</p> <p>Recommended actions:</p> <ul style="list-style-type: none"> Resolve any non-disk hardware problems, such as a cooling problem or a faulty controller module, expansion module, or power supply. Check whether any disks in the disk group have logged SMART events or unrecoverable read errors. <ul style="list-style-type: none"> If so, and the disk group is a non-fault-tolerant RAID level (RAID 0 or non-RAID), copy the data to a different disk group and replace the faulty disks. If so, and the disk group is a fault-tolerant RAID level, check the current state of the disk group. If it is not FTOL then back up the data as data may be at risk. If it is FTOL then replace the indicated disk. If more than one disk in the same disk group has logged a SMART event, back up the data and replace each disk one at a time. In virtual storage it may be possible to remove the affected disk group, which will drain its data to another disk group, and then re-add the disk group.
	Info.	<p>Disk group verification failed immediately, was aborted by a user, or succeeded.</p> <p>Recommended actions:</p> <ul style="list-style-type: none"> No action is required.
23	Info.	<p>Disk group creation has started.</p> <p>Recommended actions:</p> <ul style="list-style-type: none"> No action is required.
25	Info.	<p>Disk group statistics were reset.</p> <p>Recommended actions:</p> <ul style="list-style-type: none"> No action is required.
28	Info.	<p>Controller parameters have been changed.</p> <p>This event is logged when general configuration changes are made. For example, utility priority, remote notification settings, user interface passwords, and network port IP values. This event is not logged when changes are made to disk group or volume configuration.</p> <p>Recommended actions:</p>

Table 28. Event descriptions and recommended actions (continued)

Number	Severity	Description/Recommended actions
		<ul style="list-style-type: none"> No action is required.
31	Info.	<p>The indicated disk is no longer designated as a spare.</p> <p>Recommended actions:</p> <ul style="list-style-type: none"> No action is required.
32	Info.	<p>Disk group verification has started.</p> <p>Recommended actions:</p> <ul style="list-style-type: none"> No action is required.
33	Info.	<p>Controller time/date has been changed.</p> <p>This event is logged before the change happens, so the timestamp of the event shows the old time. This event may occur often if NTP is enabled.</p> <p>Recommended actions:</p> <ul style="list-style-type: none"> No action is required.
34	Info.	<p>The controller configuration has been restored to factory defaults.</p> <p>Recommended actions:</p> <ul style="list-style-type: none"> No action is required.
35	Info.	<p>A disk group job was aborted.</p> <p>Recommended actions:</p> <ul style="list-style-type: none"> No action is required.
37	Info.	<p>Disk group reconstruction has started. When complete, event 18 is logged.</p> <p>Recommended actions:</p> <ul style="list-style-type: none"> No action is required.
39	Warning	<p>The sensors monitored a temperature or voltage in the warning range. When the problem is resolved, event 47 is logged for the component that logged event 39.</p> <p>If the event refers to a disk sensor, disk behavior may be unpredictable in this temperature range.</p> <p>Check the event log to determine if more than one disk has reported this event.</p> <ul style="list-style-type: none"> If multiple disks report this condition there could be a problem in the environment. If one disk reports this condition, there could be a problem in the environment or the disk has failed. <p>Recommended actions:</p> <ul style="list-style-type: none"> Check that the storage system's fans are running. Check that the ambient temperature is not too warm. The controller enclosure operating range is 5°C to 35°C (41°F to 95°F). The expansion enclosure operating range is 5°C to 40°C (41°F to 104°F). Check for any obstructions to the airflow. Check that there is a module or blank plate in every module slot in the enclosure. If none of these explanations apply, replace the disk or controller module that logged the error.
40	Error	<p>The sensors monitored a temperature or voltage in the failure range. When the problem is resolved, event 47 is logged for the component that logged event 40.</p> <p>Recommended actions:</p> <ul style="list-style-type: none"> Check that the storage system's fans are running. Check that the ambient temperature is not too warm. The controller enclosure operating range is 5°C to 35°C (41°F to 95°F). The expansion enclosure operating range is 5°C to 40°C (41°F to 104°F). Check for any obstructions to the airflow.

Table 28. Event descriptions and recommended actions (continued)

Number	Severity	Description/Recommended actions
		<ul style="list-style-type: none"> • Check that there is a module or blank plate in every module slot in the enclosure. • If none of these explanations apply, replace the disk or controller module that logged the error.
41	Info.	<p>The indicated disk has been designated a spare for the indicated disk group.</p> <p>Recommended actions:</p> <ul style="list-style-type: none"> • No action is required.
43	Info.	<p>The indicated disk group has been deleted.</p> <p>Recommended actions:</p> <ul style="list-style-type: none"> • No action is required.
44	Warning	<p>The controller contains cache data for the indicated volume but the corresponding disk group is not online.</p> <p>Recommended actions:</p> <ul style="list-style-type: none"> • Determine the reason that the disks comprising the disk group are not online. • If an enclosure is down, determine corrective action. • If the disk group is no longer needed, you can clear the orphan data. This will result in lost data. • If the disk group is missing and was not intentionally removed, see Troubleshooting and problem solving.
47	Info.	<p>An error detected by the sensors has been cleared. This event indicates that a problem reported by event 39, 40, or 524 is resolved.</p> <p>Recommended actions:</p> <ul style="list-style-type: none"> • No action is required.
48	Info.	<p>The indicated disk group has been renamed.</p> <p>Recommended actions:</p> <ul style="list-style-type: none"> • No action is required.
49	Info.	<p>A lengthy SCSI maintenance command has completed. (This typically occurs during disk firmware update.)</p> <p>Recommended actions:</p> <ul style="list-style-type: none"> • No action is required.
50	Error	<p>A correctable ECC error occurred in cache memory more than 10 times during a 24-hour period, indicating a probable hardware fault.</p> <p>Recommended actions:</p> <ul style="list-style-type: none"> • Replace the controller module that logged this event.
	Warning	<p>A correctable ECC error occurred in cache memory.</p> <p>This event is logged with Warning severity to provide information that may be useful to technical support, but no action is required now. It will be logged with Error severity if it is necessary to replace the controller module.</p> <p>Recommended actions:</p> <ul style="list-style-type: none"> • No action is required.
51	Error	<p>An uncorrectable ECC error occurred in cache memory more than once during a 48-hour period, indicating a probable hardware fault.</p> <p>Recommended actions:</p> <ul style="list-style-type: none"> • Replace the controller module that logged this event.
	Warning	<p>An uncorrectable ECC error occurred in cache memory.</p>

Table 28. Event descriptions and recommended actions (continued)

Number	Severity	Description/Recommended actions
		<p>This event is logged with Warning severity to provide information that may be useful to technical support, but no action is required now. It will be logged with Error severity if it is necessary to replace the controller module.</p> <p>Recommended actions:</p> <ul style="list-style-type: none"> • No action is required.
52	Info.	<p>Disk group expansion has started.</p> <p>This operation can take days, or weeks in some cases, to complete. Allow adequate time for the expansion to complete.</p> <p>When complete, event 53 is logged.</p> <p>Recommended actions:</p> <ul style="list-style-type: none"> • No action is required.
53	Warning	<p>Too many errors occurred during disk group expansion to allow the expansion to continue.</p> <p>Recommended actions:</p> <ul style="list-style-type: none"> • If the expansion failed because of a disk problem, replace the disk with one of the same type (SSD, enterprise SAS, or midline SAS) and the same or greater capacity. For continued optimum I/O performance, the replacement disk should have performance that is the same as or better than the one it is replacing. If disk group reconstruction starts, wait for it to complete and then retry the expansion.
	Info.	<p>Disk group expansion either completed, failed immediately, or was aborted by a user.</p> <p>Recommended actions:</p> <ul style="list-style-type: none"> • If the expansion failed because of a disk problem, replace the disk with one of the same type (SSD, enterprise SAS, or midline SAS) and the same or greater capacity. For continued optimum I/O performance, the replacement disk should have performance that is the same as or better than the one it is replacing. If disk group reconstruction starts, wait for it to complete and then retry the expansion.
55	Warning	<p>The indicated disk reported a SMART event.</p> <p>A SMART event indicates impending disk failure.</p> <p>Recommended actions:</p> <ul style="list-style-type: none"> • Resolve any non-disk hardware problems, especially a cooling problem or a faulty power supply. • If the disk is in a disk group that uses a non-fault-tolerant RAID level (RAID 0 or non-RAID), copy the data to a different disk group and replace the faulty disk. • If the disk is in a disk group that uses a fault-tolerant RAID level, check the current state of the disk group. If it is not FTOL then back up the data as data may be at risk. If it is FTOL then replace the indicated disk. If more than one disk in the same disk group has logged a SMART event, back up the data and replace each disk one at a time. In virtual storage it may be possible to remove the affected disk group, which will drain its data to another disk group, and then re-add the disk group.
56	Info.	<p>A controller has powered up or restarted.</p> <p>Recommended actions:</p> <ul style="list-style-type: none"> • No action is required.
58	Error	<p>A disk drive detected a serious error, such as a parity error or disk hardware failure.</p> <p>Recommended actions:</p> <ul style="list-style-type: none"> • Replace the failed disk with one of the same type (SSD, enterprise SAS, or midline SAS) and the same or greater capacity. For continued optimum I/O performance, the replacement disk should have performance that is the same as or better than the one it is replacing.
	Warning	<p>A disk drive reset itself due to an internal logic error.</p> <p>Recommended actions:</p>

Table 28. Event descriptions and recommended actions (continued)

Number	Severity	Description/Recommended actions
		<ul style="list-style-type: none"> The first time this event is logged with Warning severity, if the indicated disk is not running the latest firmware, update the disk firmware. If this event is logged with Warning severity for the same disk more than five times in one week, and the indicated disk is running the latest firmware, replace the disk with one of the same type (SSD, enterprise SAS, or midline SAS) and the same or greater capacity. For continued optimum I/O performance, the replacement disk should have performance that is the same as or better than the one it is replacing.
	Info.	<p>A disk drive reported an event.</p> <p>Recommended actions:</p> <ul style="list-style-type: none"> No action is required.
59	Warning	<p>The controller detected a parity event while communicating with the indicated SCSI device. The event was detected by the controller, not the disk.</p> <p>Recommended actions:</p> <ul style="list-style-type: none"> If the event indicates that a disk or an expansion module is bad, replace the indicated device.
	Info.	<p>The controller detected a non-parity error while communicating with the indicated SCSI device. The error was detected by the controller, not the disk.</p> <p>Recommended actions:</p> <ul style="list-style-type: none"> No action is required.
61	Error	<p>The controller reset a disk channel to recover from a communication error. This event is logged to identify an error trend over time.</p> <p>Recommended actions:</p> <ul style="list-style-type: none"> If the controller recovers, no action is required. View other logged events to determine other action to take.
62	Warning	<p>The indicated dedicated spare disk or global spare disk has failed.</p> <p>Recommended actions:</p> <ul style="list-style-type: none"> Replace the disk with one of the same type (SSD, enterprise SAS, or midline SAS) and the same or greater capacity. For continued optimum I/O performance, the replacement disk should have performance that is the same as or better than the one it is replacing. If the failed disk was a global spare, configure the new disk as a global spare. If the failed disk was a dedicated spare, configure the new disk as a dedicated spare for the same disk group.
65	Error	<p>An uncorrectable ECC error occurred in cache memory on startup.</p> <p>The controller is automatically restarted and its cache data are restored from the partner controller's cache.</p> <p>Recommended actions:</p> <ul style="list-style-type: none"> Replace the controller module that logged this event.
68	Info.	<p>The controller that logged this event is shut down, or both controllers are shut down.</p> <p>Recommended actions:</p> <ul style="list-style-type: none"> No action is required.
71	Info.	<p>The controller has started or completed failing over.</p> <p>Recommended actions:</p> <ul style="list-style-type: none"> No action is required.
72	Info.	<p>After failover, recovery has either started or completed.</p> <p>Recommended actions:</p> <ul style="list-style-type: none"> No action is required.

Table 28. Event descriptions and recommended actions (continued)

Number	Severity	Description/Recommended actions
73	Info.	The two controllers are communicating with each other and cache redundancy is enabled. Recommended actions: <ul style="list-style-type: none"> • No action is required.
74	Info.	The FC loop ID for the indicated disk group was changed to be consistent with the IDs of other disk groups. This can occur when disks that constitute a disk group are inserted from an enclosure having a different FC loop ID. This event is also logged by the new owning controller after disk group ownership is changed. Recommended actions: <ul style="list-style-type: none"> • No action is required.
75	Info.	The indicated volume's LUN (logical unit number) has been unassigned because it conflicts with LUNs assigned to other volumes. This can happen when disks containing data for a mapped volume have been moved from one storage system to another. Recommended actions: <ul style="list-style-type: none"> • If you want hosts to access the volume data in the inserted disks, map the volume with a different LUN.
76	Info.	The controller is using default configuration settings. This event occurs on the first power up, and might occur after a firmware update. Recommended actions: <ul style="list-style-type: none"> • If you have just performed a firmware update and your system requires special configuration settings, you must make those configuration changes before your system will operate as before.
77	Info.	The cache was initialized as a result of power up or failover. Recommended actions: <ul style="list-style-type: none"> • No action is required.
78	Warning	The controller could not use an assigned spare for a disk group because the spare's capacity is too small. This occurs when a disk in the disk group fails, there is no dedicated spare available and all global spares are too small or, if the dynamic spares feature is enabled, all global spares and available disks are too small, or if there is no spare of the correct type. There may be more than one failed disk in the system. Recommended actions: <ul style="list-style-type: none"> • Replace each failed disk with one of the same type (SSD, enterprise SAS, or midline SAS) and the same or greater capacity. For continued optimum I/O performance, the replacement disk should have performance that is the same as or better than the one it is replacing. • Configure disks as dedicated spares or global spares. <ul style="list-style-type: none"> ○ For a dedicated spare, the disk must be of the same type as the other disks in the disk group and at least as large as the smallest-capacity disk in the disk group, and it should have the same or better performance. ○ For a global spare, it is best to choose a disk that is as big as or bigger than the largest disk of its type in the system and of equal or greater performance. If the system contains a mix of disk types (SSD, enterprise SAS, or midline SAS), there should be at least one global spare of each type (unless dedicated spares are used to protect every disk group of a given type).
79	Info.	A trust operation has completed for the indicated disk group. Recommended actions: <ul style="list-style-type: none"> • Be sure to complete the trust procedure as documented in the CLI help for the <code>trust</code> command.
80	Info.	The controller enabled or disabled the indicated parameters for one or more disks.

Table 28. Event descriptions and recommended actions (continued)

Number	Severity	Description/Recommended actions
		<p>Recommended actions:</p> <ul style="list-style-type: none"> • No action is required.
81	Info.	<p>The current controller has unkilld the partner controller. The other controller will restart.</p> <p>Recommended actions:</p> <ul style="list-style-type: none"> • No action is required.
83	Info.	<p>The partner controller is changing state (shutting down or restarting).</p> <p>Recommended actions:</p> <ul style="list-style-type: none"> • No action is required.
84	Warning	<p>The current controller that logged this event forced the partner controller to fail over.</p> <p>Recommended actions:</p> <ul style="list-style-type: none"> • Download the debug logs from your storage system and contact technical support. A service technician can use the debug logs to determine the problem.
86	Info.	<p>Host-port or disk-channel parameters have been changed.</p> <p>Recommended actions:</p> <ul style="list-style-type: none"> • No action is required.
87	Warning	<p>The mirrored configuration retrieved by this controller from the partner controller has a bad cyclic redundancy check (CRC). The local flash configuration will be used instead.</p> <p>Recommended actions:</p> <ul style="list-style-type: none"> • Restore the default configuration by using the <code>restore defaults</code> command, as described in the CLI Reference Guide.
88	Warning	<p>The mirrored configuration retrieved by this controller from the partner controller is corrupt. The local flash configuration will be used instead.</p> <p>Recommended actions:</p> <ul style="list-style-type: none"> • Restore the default configuration by using the <code>restore defaults</code> command, as described in the CLI Reference Guide.
89	Warning	<p>The mirrored configuration retrieved by this controller from the partner controller has a configuration level that is too high for the firmware in this controller to process. The local flash configuration will be used instead.</p> <p>Recommended actions:</p> <ul style="list-style-type: none"> • The current controller that logged this event probably has down-level firmware. Update the firmware in the down-level controller. Both controllers should have the same firmware versions. <p>When the problem is resolved, event 20 is logged.</p>
90	Info.	<p>The partner controller does not have a mirrored configuration image for the current controller, so the current controller's local flash configuration is being used.</p> <p>This event is expected if the other controller is new or its configuration has been changed.</p> <p>Recommended actions:</p> <ul style="list-style-type: none"> • No action is required.
91	Error	<p>In a testing environment, the diagnostic that checks hardware reset signals between controllers in Active-Active mode failed.</p> <p>Recommended actions:</p> <ul style="list-style-type: none"> • Perform failure analysis.

Table 28. Event descriptions and recommended actions (continued)

Number	Severity	Description/Recommended actions
95	Error	Both controllers in an Active-Active configuration have the same serial number. Non-unique serial numbers can cause system problems. For example, WWNs are determined by serial number. Recommended actions: <ul style="list-style-type: none"> Remove one of the controller modules and insert a replacement, then return the removed module to be reprogrammed.
96	Info.	Pending configuration changes that take effect at startup were ignored because customer data might be present in cache. Recommended actions: <ul style="list-style-type: none"> If the requested configuration changes did not occur, make the changes again and then use a user-interface command to shut down the Storage Controller and then restart it.
103	Info.	The name has been changed for the indicated volume. Recommended actions: <ul style="list-style-type: none"> No action is required.
104	Info.	The size has been changed for the indicated volume. Recommended actions: <ul style="list-style-type: none"> No action is required.
105	Info.	The default LUN (logical unit number) has been changed for the indicated volume. Recommended actions: <ul style="list-style-type: none"> No action is required.
106	Info.	The indicated volume has been added to the indicated pool. Recommended actions: <ul style="list-style-type: none"> No action is required.
107	Error	A serious error has been detected by the controller. In a single-controller configuration, the controller will restart automatically. In an Active-Active configuration, the partner controller will kill the controller that experienced the error. Recommended actions: <ul style="list-style-type: none"> Download the debug logs from your storage system and contact technical support. A service technician can use the debug logs to determine the problem.
108	Info.	The indicated volume has been deleted from the indicated pool. Recommended actions: <ul style="list-style-type: none"> No action is required.
109	Info.	The statistics for the indicated volume have been reset. Recommended actions: <ul style="list-style-type: none"> No action is required.
110	Info.	Ownership of the indicated disk group has been given to the other controller. Recommended actions: <ul style="list-style-type: none"> No action is required.
111	Info.	The link for the indicated host port is up. This event indicates that a problem reported by event 112 is resolved. For a system with FC ports, this event also appears after loop initialization Recommended actions: <ul style="list-style-type: none"> No action is required.

Table 28. Event descriptions and recommended actions (continued)

Number	Severity	Description/Recommended actions
112	Warning	The link for the indicated host port has unexpectedly gone down. This can affect host mappings. Recommended actions: <ul style="list-style-type: none"> • Look for corresponding event 111 and monitor excessive transitions indicating a host-connectivity or switch problem. If this event occurs more than 8 times per hour, it should be investigated. • This event is probably caused by equipment outside of the storage system, such as faulty cabling or a faulty switch. • If the problem is not outside of the storage system, replace the controller module that logged this event.
	Info.	The link for the indicated host port has gone down because the controller is starting up. Recommended actions: <ul style="list-style-type: none"> • No action is required.
114	Info.	The link for the indicated disk-channel port is down. Note that events 114 and 211 are logged whenever a user-requested rescan occurs and do not indicate an error. Recommended actions: <ul style="list-style-type: none"> • Look for corresponding event 211 and monitor excessive transitions indicating disk problems. If more than 8 transitions occur per hour, see Troubleshooting and problem solving.
116	Error	After a recovery, the partner controller was killed while mirroring write-back cache data to the controller that logged this event. The controller that logged this event restarted to avoid losing the data in the partner controller's cache, but if the other controller does not restart successfully, the data will be lost. Recommended actions: <ul style="list-style-type: none"> • To determine if data might have been lost, check whether this event was immediately followed by event 56 (Storage Controller booted up), closely followed by event 71 (failover started). The failover indicates that the restart did not succeed.
117	Warning	This controller module detected or generated an error on the indicated host channel. Recommended actions: <ul style="list-style-type: none"> • Restart the Storage Controller that logged this event. • If more errors are detected, check the connectivity between the controller and the attached host. • If more errors are generated, shut down the Storage Controller and replace the controller module.
118	Info.	Cache parameters have been changed for the indicated volume. Recommended actions: <ul style="list-style-type: none"> • No action is required.
127	Warning	The controller has detected an invalid disk dual-port connection. This event indicates that a controller host port is connected to an expansion port, instead of to a port on a host or a switch. Recommended actions: <ul style="list-style-type: none"> • Disconnect the host port and expansion port from each other and connect them to the proper devices.
136	Warning	Errors detected on the indicated disk channel have caused the controller to mark the channel as degraded. Recommended actions: <ul style="list-style-type: none"> • Determine the source of the errors on the indicated disk channel and replace the faulty hardware. <p>When the problem is resolved, event 189 is logged.</p>
139	Info.	The Management Controller (MC) has powered up or restarted.

Table 28. Event descriptions and recommended actions (continued)

Number	Severity	Description/Recommended actions
		<p>Recommended actions:</p> <ul style="list-style-type: none"> • No action is required.
140	Info.	<p>The Management Controller is about to restart.</p> <p>Recommended actions:</p> <ul style="list-style-type: none"> • No action is required.
141	Info.	<p>This event is logged when the IP address used for management of the system has been changed by a user or by a DHCP server (if DHCP is enabled). This event is also logged during power up or failover recovery, even when the address has not changed.</p> <p>Recommended actions:</p> <ul style="list-style-type: none"> • No action is required.
152	Warning	<p>The Management Controller (MC) has not communicated with the Storage Controller (SC) for 15 minutes and may have failed.</p> <p>This event is initially logged as Informational severity. If the problem persists, this event is logged a second time as Warning severity and the MC is automatically restarted in an attempt to recover from the problem. Event 156 is then logged.</p> <p>Recommended actions:</p> <ul style="list-style-type: none"> • If this event is logged only one time as Warning severity, no action is required. • If this event is logged more than one time as Warning severity, do the following: <ul style="list-style-type: none"> ○ Check the version of the controller firmware and update to the latest firmware if needed. ○ If the latest firmware is already installed, the controller module that logged this event probably has a hardware fault. Replace the module. • If you are not able to access the management interfaces of the controller that logged this event, do the following: <ul style="list-style-type: none"> ○ Shut down that controller and reseal the module. ○ If you are then able to access the management interfaces, check the version of the controller firmware and update to the latest firmware if needed. ○ If the problem recurs, replace the module.
	Info.	<p>The Management Controller (MC) has not communicated with the Storage Controller (SC) for 160 seconds.</p> <p>If communication is restored in less than 15 minutes, event 153 is logged. If the problem persists, this event is logged a second time as Warning severity.</p> <p> NOTE: It is normal for this event to be logged as Informational severity during firmware update.</p> <p>Recommended actions:</p> <ul style="list-style-type: none"> • Check the version of the controller firmware and update to the latest firmware if needed. • If the latest firmware is already installed, no action is required.
153	Info.	<p>The Management Controller (MC) has re-established communication with the Storage Controller (SC).</p> <p>Recommended actions:</p> <ul style="list-style-type: none"> • No action is required.
156	Warning	<p>The Management Controller (MC) has been restarted from the Storage Controller (SC) for the purpose of error recovery.</p> <p>Recommended actions:</p> <ul style="list-style-type: none"> • See the recommended actions for event 152, which is logged at approximately the same time.
	Info.	<p>The Management Controller (MC) has been restarted from the Storage Controller (SC) in a normal case, such as when initiated by a user.</p>

Table 28. Event descriptions and recommended actions (continued)

Number	Severity	Description/Recommended actions
		<p>Recommended actions:</p> <ul style="list-style-type: none"> • No action is required.
157	Error	<p>A failure occurred when trying to write to the Storage Controller (SC) flash chip.</p> <p>Recommended actions:</p> <ul style="list-style-type: none"> • Replace the controller module that logged this event.
158	Error	<p>A correctable ECC error occurred in Storage Controller CPU memory more than once during a 12-hour period, indicating a probable hardware fault.</p> <p>Recommended actions:</p> <ul style="list-style-type: none"> • Replace the controller module that logged this event.
	Warning	<p>A correctable ECC error occurred in Storage Controller CPU memory.</p> <p>This event is logged with Warning severity to provide information that may be useful to technical support, but no action is required now. It will be logged with Error severity if it is necessary to replace the controller module.</p> <p>Recommended actions:</p> <ul style="list-style-type: none"> • No action is required.
161	Info.	<p>One or more enclosures do not have a valid path to an enclosure management processor (EMP). All enclosure EMPs are disabled.</p> <p>Recommended actions:</p> <ul style="list-style-type: none"> • Download the debug logs from your storage system and contact technical support. A service technician can use the debug logs to determine the problem.
162	Warning	<p>The host WWNs (node and port) previously presented by this controller module are unknown. In a dual-controller system this event has two possible causes:</p> <ul style="list-style-type: none"> • One or both controller modules have been replaced or moved while the system was powered off. • One or both controller modules have had their flash configuration cleared (this is where the previously used WWNs are stored). <p>The controller module recovers from this situation by generating a WWN based on its own serial number.</p> <p>Recommended actions:</p> <ul style="list-style-type: none"> • If the controller module was replaced or someone reprogrammed its FRU ID data, verify the WWN information for this controller module on all hosts that access it.
163	Warning	<p>The host WWNs (node and port) previously presented by the partner controller module, which is currently offline, are unknown.</p> <p>This event has two possible causes:\</p> <ul style="list-style-type: none"> • The online controller module reporting the event was replaced or moved while the system was powered off. • The online controller module had its flash configuration (where previously used WWNs are stored) cleared. <p>The online controller module recovers from this situation by generating a WWN based on its own serial number for the other controller module.</p> <p>Recommended actions:</p> <ul style="list-style-type: none"> • If the controller module was replaced or someone reprogrammed its FRU ID data, verify the WWN information for the other controller module on all hosts that access it.
166	Warning	<p>The RAID metadata level of the two controllers does not match, which indicates that the controllers have different firmware levels.</p> <p>Usually, the controller at the higher firmware level can read metadata written by a controller at a lower firmware level. The reverse is typically not true. Therefore, if the controller at the</p>

Table 28. Event descriptions and recommended actions (continued)

Number	Severity	Description/Recommended actions
		<p>higher firmware level failed, the surviving controller at the lower firmware level cannot read the metadata in disks that have failed over.</p> <p>Recommended actions:</p> <ul style="list-style-type: none"> ● If this occurs after a firmware update, it indicates that the metadata format changed, which is rare. Update the controller with the lower firmware level to match the firmware level in the other controller.
167	Warning	<p>A diagnostic test at controller bootup detected an abnormal operation, which might require a power cycle to correct.</p> <p>Recommended actions:</p> <ul style="list-style-type: none"> ● Download the debug logs from your storage system and contact technical support. A service technician can use the debug logs to determine the problem.
170	Info.	<p>The last rescan detected that the indicated enclosure was added to the system.</p> <p>Recommended actions:</p> <ul style="list-style-type: none"> ● No action is required.
171	Info.	<p>The last rescan detected that the indicated enclosure was removed from the system.</p> <p>Recommended actions:</p> <ul style="list-style-type: none"> ● No action is required.
172	Error or Warning	<p>The indicated disk group was quarantined for one of the following reasons:</p> <ul style="list-style-type: none"> ● Not all of its disks are accessible. While the disk group is quarantined, in linear storage any attempt to access its volumes in the disk group from a host will fail. In virtual storage, all volumes in the pool will be forced read-only. If all of the disks become accessible, the disk group will be dequarantined automatically with a resulting status of FTOL. If not all of the disks become accessible but enough become accessible to allow reading from and writing to the disk group, it will be dequarantined automatically with a resulting status of FTDN or CRIT. If a spare disk is available, reconstruction will begin automatically. When the disk group has been removed from quarantine, event 173 is logged. For a more detailed discussion of quarantine, see the SMC or CLI documentation. <p>CAUTION:</p> <ul style="list-style-type: none"> ○ Avoid using the manual dequarantine operation as a recovery method when event 172 is logged because this causes data recovery to be more difficult or impossible. ○ If you clear unwritten cache data while a disk group is quarantined or offline, that data will be permanently lost. <ul style="list-style-type: none"> ● It contains data in a format that is not supported by this system. The controller does not support linear disk groups. <p>Recommended actions:</p> <ul style="list-style-type: none"> ● If the disk group was quarantined because not all of its disks are accessible: <ul style="list-style-type: none"> ○ If event 173 has subsequently been logged for the indicated disk group, no action is required. The disk group has already been removed from quarantine. ○ Otherwise, perform the following actions: <ul style="list-style-type: none"> ■ Check that all enclosures are powered on. ■ Check that all disks and I/O modules in every enclosure are fully seated in their slots and that their latches are locked. ■ Reseat any disks in the quarantined disk group that are reported as missing or failed in the user interface. (Do NOT remove and reinsert disks that are not members of the disk group that is quarantined.) ■ Check that the SAS expansion cables are connected between each enclosure in the storage system and that they are fully seated. (Do NOT remove and reinsert the cables because this can cause problems with additional disk groups.) ■ Check that no disks have been removed from the system unintentionally.

Table 28. Event descriptions and recommended actions (continued)

Number	Severity	Description/Recommended actions
		<ul style="list-style-type: none"> ▪ Check for other events that indicate faults in the system and follow the recommended actions for those events. But, if the event indicates a failed disk and the recommended action is to replace the disk, do NOT replace the disk at this time because it may be needed later for data recovery. ▪ If the disk group is still quarantined after performing the steps, shut down both controllers and then power down the entire storage system. Power it back up, beginning with any disk enclosures (expansion enclosures), then the controller enclosure. ▪ If the disk group is still quarantined after performing these recommended actions, contact technical support. • If the disk group was quarantined because it contains data in a format that is not supported by this system: <ul style="list-style-type: none"> ○ Recover full support and manageability of the quarantined disk groups and volumes by replacing your controllers with controllers that support this type of disk group. ○ If you are sure that the data on this disk group is not needed, simply remove the disk group, and thus the volumes, using the currently installed controllers.
173	Info.	<p>The indicated disk group has been removed from quarantine.</p> <p>Recommended actions:</p> <ul style="list-style-type: none"> • No action is required.
174	Info.	<p>Enclosure or disk firmware update has succeeded, been aborted by a user, or failed.</p> <p>If the firmware update fails, the user will be notified about the problem immediately and should take care of the problem at that time, so even when there is a failure, this event is logged as Informational severity.</p> <p>Recommended actions:</p> <ul style="list-style-type: none"> • No action is required.
175	Info.	<p>The network-port Ethernet link has changed status (up or down) for the indicated controller.</p> <p>Recommended actions:</p> <ul style="list-style-type: none"> • If this event is logged indicating the network port is up shortly after the Management Controller (MC) has booted up (event 139), no action is required. • Otherwise, monitor occurrences of this event for an error trend. If this event occurs more than 8 times per hour, it should be investigated. <ul style="list-style-type: none"> ○ This event is probably caused by equipment outside of the storage system, such as faulty cabling or a faulty Ethernet switch. ○ If this event is being logged by only one controller in a dual-controller system, swap the Ethernet cables between the two controllers. This will show whether the problem is outside or inside the storage system. ○ If the problem is not outside of the storage system, replace the controller module that logged this event.
176	Info.	<p>The error statistics for the indicated disk have been reset.</p> <p>Recommended actions:</p> <ul style="list-style-type: none"> • No action is required.
177	Info.	<p>Cache data was purged for the indicated missing volume.</p> <p>Recommended actions:</p> <ul style="list-style-type: none"> • No action is required.
181	Info.	<p>One or more configuration parameters associated with the Management Controller (MC) have been changed, such as configuration for SNMP, SMI-S, email notification, and system strings (system name, system location, etc.).</p> <p>Recommended actions:</p> <ul style="list-style-type: none"> • No action is required.

Table 28. Event descriptions and recommended actions (continued)

Number	Severity	Description/Recommended actions
182	Info.	<p>All disk channels have been paused. I/O will not be performed on the disks until all channels are unpaused.</p> <p>Recommended actions:</p> <ul style="list-style-type: none"> • If this event occurs in relation to disk firmware update, no action is required. When the condition is cleared, event 183 is logged. • If this event occurs and you are not performing disk firmware update, see Troubleshooting and problem solving.
183	Info.	<p>All disk channels have been unpaused, meaning that I/O can resume. An unpaused initiates a rescan, which when complete is logged as event 19.</p> <p>This event indicates that the pause reported by event 182 has ended.</p> <p>Recommended actions:</p> <ul style="list-style-type: none"> • No action is required.
185	Info.	<p>An enclosure management processor (EMP) write command has completed.</p> <p>Recommended actions:</p> <ul style="list-style-type: none"> • No action is required.
186	Info.	<p>Enclosure parameters have been changed by a user.</p> <p>Recommended actions:</p> <ul style="list-style-type: none"> • No action is required.
187	Info.	<p>The write-back cache has been enabled.</p> <p>Event 188 is the corresponding event that is logged when write-back cache is disabled.</p> <p>Recommended actions:</p> <ul style="list-style-type: none"> • No action is required.
188	Info.	<p>Write-back cache has been disabled.</p> <p>Event 187 is the corresponding event that is logged when write-back cache is disabled.</p> <p>Recommended actions:</p> <ul style="list-style-type: none"> • No action is required.
189	Info.	<p>A disk channel that was previously degraded or failed is now healthy.</p> <p>Recommended actions:</p> <ul style="list-style-type: none"> • No action is required.
190	Info.	<p>The controller module's supercapacitor pack has started charging.</p> <p>This change met a condition to trigger the auto-write-through feature, which has disabled write-back cache and put the system in write-through mode. When the fault is resolved, event 191 is logged to indicate that write-back mode has been restored.</p> <p>Recommended actions:</p> <ul style="list-style-type: none"> • If event 191 is not logged within 5 minutes after this event, the supercapacitor has probably failed and the controller module should be replaced.
191	Info.	<p>The auto-write-through trigger event that caused event 190 to be logged has been resolved.</p> <p>Recommended actions:</p> <ul style="list-style-type: none"> • No action is required.
192	Info.	<p>The controller module's temperature has exceeded the normal operating range.</p> <p>This change met a condition to trigger the auto-write-through feature, which has disabled write-back cache and put the system in write-through mode. When the fault is resolved, event 193 is logged to indicate that write-back mode has been restored.</p> <p>Recommended actions:</p>

Table 28. Event descriptions and recommended actions (continued)

Number	Severity	Description/Recommended actions
		<ul style="list-style-type: none"> If event 193 has not been logged since this event was logged, the over-temperature condition probably still exists and should be investigated. Another over-temperature event was probably logged at approximately the same time as this event (such as event 39, 40, 168, 307, 469, 476, or 477). See the recommended actions for that event.
193	Info.	<p>The auto-write-through trigger event that caused event 192 to be logged has been resolved.</p> <p>Recommended actions:</p> <ul style="list-style-type: none"> No action is required.
194	Info.	<p>The Storage Controller in the partner controller module is not up.</p> <p>This indicates that a trigger condition has occurred that has caused the auto-write-through feature to disable write-back cache and put the system in write-through mode. When the fault is resolved, event 195 is logged to indicate that write-back mode has been restored.</p> <p>Recommended actions:</p> <ul style="list-style-type: none"> If event 195 has not been logged since this event was logged, the other Storage Controller is probably still down and the cause should be investigated. Other events were probably logged at approximately the same time as this event. See the recommended actions for those events.
195	Info.	<p>The auto-write-through trigger event that caused event 194 to be logged has been resolved.</p> <p>Recommended actions:</p> <ul style="list-style-type: none"> No action is required.
198	Info.	<p>A power supply has failed.</p> <p>This indicates that a trigger condition has occurred that has caused the auto-write-through feature to disable write-back cache and put the system in write-through mode. When the fault is resolved, event 199 is logged to indicate that write-back mode has been restored.</p> <p>Recommended actions:</p> <ul style="list-style-type: none"> If event 199 has not been logged since this event was logged, the power supply probably does not have a health of OK and the cause should be investigated. Another power-supply event was probably logged at approximately the same time as this event (such as event 168). See the recommended actions for that event.
199	Info.	<p>The auto-write-through trigger event that caused event 198 to be logged has been resolved.</p> <p>Recommended actions:</p> <ul style="list-style-type: none"> No action is required.
200	Info.	<p>A fan has failed.</p> <p>This indicates that a trigger condition has occurred that has caused the auto-write-through feature to disable write-back cache and put the system in write-through mode. When the fault is resolved, event 201 is logged to indicate that write-back mode has been restored.</p> <p>Recommended actions:</p> <ul style="list-style-type: none"> If event 201 has not been logged since this event was logged, the fan probably does not have a health of OK and the cause should be investigated. Another fan event was probably logged at approximately the same time as this event (such as event 168). See the recommended actions for that event.
201	Info.	<p>The auto-write-through trigger event that caused event 200 to be logged has been resolved.</p> <p>Recommended actions:</p> <ul style="list-style-type: none"> No action is required.
202	Info.	<p>An auto-write-through trigger condition has been cleared, causing write-back cache to be re-enabled. The environmental change is also logged at approximately the same time as this event (event 191, 193, 195, 199, 201, and 241.)</p> <p>Recommended actions:</p>

Table 28. Event descriptions and recommended actions (continued)

Number	Severity	Description/Recommended actions
		<ul style="list-style-type: none"> No action is required.
203	Warning	<p>An environmental change occurred that allows write-back cache to be enabled, but the auto-write-back preference is not set. The environmental change is also logged at approximately the same time as this event (event 191, 193, 195, 199, 201, or 241).</p> <p>Recommended actions:</p> <ul style="list-style-type: none"> Manually enable write-back cache.
204	Error	<p>An error occurred with either the NV device itself or the transport mechanism. The system may attempt to recover itself.</p> <p>The eMMC is used for backing up unwritten cache data when a controller goes down unexpectedly, such as when a power failure occurs. This event is generated when the Storage Controller (SC) detects a problem with the eMMC as it is booting up.</p> <p>Recommended actions:</p> <ul style="list-style-type: none"> Restart the Storage Controller that logged this event. If this event is logged again, shut down the Storage Controller and replace the eMMC. If this event is logged again, shut down the Storage Controller and replace the controller module.
	Warning	<p>The system has started and found an issue with the NV device. The system will attempt to recover itself.</p> <p>The eMMC is used for backing up unwritten cache data when a controller goes down unexpectedly, such as when a power failure occurs. This event is generated when the Storage Controller (SC) detects a problem with the eMMC as it is booting up.</p> <p>Recommended actions:</p> <ul style="list-style-type: none"> Restart the Storage Controller that logged this event. If this event is logged again, shut down the Storage Controller and replace the controller module.
	Info.	<p>The system has come up normally and the NV device is in a normal expected state. This event will be logged as an Error or Warning event if any user action is required.</p> <p>Recommended actions:</p> <ul style="list-style-type: none"> No action is required.
205	Info.	<p>The indicated volume has been mapped or unmapped.</p> <p>Recommended actions:</p> <ul style="list-style-type: none"> No action is required.
206	Info.	<p>Disk group scrub has started.</p> <p>The scrub checks disks in the disk group for the following types of errors:</p> <ul style="list-style-type: none"> Data parity errors for a RAID 3, 5, 6, or 50 disk group. Mirror verify errors for a RAID 1 or RAID 10 disk group. Media errors for all RAID levels including RAID 0 and non-RAID disk groups. <p>When errors are detected, they are automatically corrected.</p> <p>When the scrub is complete, event 207 is logged.</p> <p>Recommended actions:</p> <ul style="list-style-type: none"> No action is required.
207	Error	<p>Disk group scrub completed and found an excessive number of errors in the indicated disk group. This event is logged as Error severity when more than 100 parity or mirror mismatches are found and corrected during a scrub or when 1 to 99 parity or mirror mismatches are found and corrected during each of 10 separate scrubs of the same disk group.</p>

Table 28. Event descriptions and recommended actions (continued)

Number	Severity	Description/Recommended actions
		<p>For non-fault-tolerant RAID levels (RAID 0 and non-RAID), media errors may indicate loss of data.</p> <p>Recommended actions:</p> <ul style="list-style-type: none"> ● Resolve any non-disk hardware problems, such as a cooling problem or a faulty controller module, expansion module, or power supply. ● Check whether any disks in the disk group have logged SMART events or unrecoverable read errors. <ul style="list-style-type: none"> ○ If so, and the disk group is a non-fault-tolerant RAID level (RAID 0 or non-RAID), copy the data to a different disk group and replace the faulty disks. ○ If so, and the disk group is a fault-tolerant RAID level, check the current state of the disk group. If it is not FTOL then back up the data as data may be at risk. If it is FTOL then replace the indicated disk. If more than one disk in the same disk group has logged a SMART event, back up the data and replace each disk one at a time. In virtual storage it may be possible to remove the affected disk group, which will drain its data to another disk group, and then re-add the disk group.
	Warning	<p>Disk group scrub did not complete because of an internally detected condition such as a failed disk. If a disk fails, data may be at risk.</p> <p>Recommended actions:</p> <ul style="list-style-type: none"> ● Resolve any non-disk hardware problems, such as a cooling problem or a faulty controller module, expansion module, or power supply. <ul style="list-style-type: none"> ○ If so, and the disk group is a non-fault-tolerant RAID level (RAID 0 or non-RAID), copy the data to a different disk group and replace the faulty disks. ○ If so, and the disk group is a fault-tolerant RAID level, check the current state of the disk group. If it is not FTOL then back up the data as data may be at risk. If it is FTOL then replace the indicated disk. If more than one disk in the same disk group has logged a SMART event, back up the data and replace each disk one at a time. In virtual storage it may be possible to remove the affected disk group, which will drain its data to another disk group, and then re-add the disk group.
	Info.	<p>Disk group scrub completed or was aborted by a user.</p> <p>This event is logged as Informational severity when fewer than 100 parity or mirror mismatches are found and corrected during a scrub.</p> <p>For non-fault-tolerant RAID levels (RAID 0 and non-RAID), media errors may indicate loss of data.</p> <p>Recommended actions:</p> <ul style="list-style-type: none"> ● No action is required.
208	Info.	<p>A scrub-disk job has started for the indicated disk. The result will be logged with event 209.</p> <p>Recommended actions:</p> <ul style="list-style-type: none"> ● No action is required.
209	Error	<p>A scrub-disk job logged with event 208 has completed and found one or more media errors, SMART events, or hard (non-media) errors. If this disk is used in a non-fault-tolerant disk group, data may have been lost.</p> <p>Recommended actions:</p> <ul style="list-style-type: none"> ● Replace the disk with one of the same type (SSD, enterprise SAS, or midline SAS) and the same or greater capacity. For continued optimum I/O performance, the replacement disk should have performance that is the same as or better than the one it is replacing.
	Warning	<p>A scrub-disk job logged with event 208 has been aborted by a user, or has reassigned a disk block. These bad-block replacements are reported as "other errors". If this disk is used in a non-fault-tolerant disk group, data may have been lost.</p> <p>Recommended actions:</p>

Table 28. Event descriptions and recommended actions (continued)

Number	Severity	Description/Recommended actions
		<ul style="list-style-type: none"> Monitor the error trend and whether the number of errors approaches the total number of bad-block replacements available.
	Info.	<p>A scrub-disk job logged with event 208 has completed and found no errors, or a disk being scrubbed (with no errors found) has been added to a disk group, or a user has aborted the job.</p> <p>Recommended actions:</p> <ul style="list-style-type: none"> No action is required.
210	Info.	<p>All snapshots have been deleted for the indicated parent volume when using virtual storage.</p> <p>Recommended actions:</p> <ul style="list-style-type: none"> No action is required.
211	Warning	<p>SAS topology has changed. No elements are detected in the SAS map. The message specifies the number of elements in the SAS map, the number of expanders detected, the number of expansion levels on the native (local controller) side and on the partner (partner controller) side, and the number of device PHYs.</p> <p>Recommended actions:</p> <ul style="list-style-type: none"> Perform a rescan to repopulate the SAS map. If a rescan does not resolve the problem, then shut down and restart both Storage Controllers. If the problem persists, see Troubleshooting and problem solving.
	Info.	<p>SAS topology has changed. The number of SAS expanders has increased or decreased. The message specifies the number of elements in the SAS map, the number of expanders detected, the number of expansion levels on the native (local controller) side and on the partner (partner controller) side, and the number of device PHYs.</p> <p>Recommended actions:</p> <ul style="list-style-type: none"> No action is required.
214	Info.	<p>The creation of snapshots is complete. The number of snapshots is indicated. Additional events give more information for each snapshot.</p> <p>Recommended actions:</p> <ul style="list-style-type: none"> No action is required.
216	Info.	<p>An uncommitted snapshot has been deleted. Removal of the indicated snapshot completed successfully.</p> <p>Recommended actions:</p> <ul style="list-style-type: none"> No action is required.
217	Error	<p>A supercapacitor failure occurred in the controller.</p> <p>Recommended actions:</p> <ul style="list-style-type: none"> Replace the controller module that logged this event.
218	Warning	<p>The supercapacitor pack is near end of life.</p> <p>Recommended actions:</p> <ul style="list-style-type: none"> Replace the controller module reporting this event.
219	Info.	<p>Utility priority has been changed by a user.</p> <p>Recommended actions:</p> <ul style="list-style-type: none"> No action is required.
220	Info.	<p>Roll back of data in the indicated volume to data in the indicated snapshot has been started by a user.</p> <p>Recommended actions:</p>

Table 28. Event descriptions and recommended actions (continued)

Number	Severity	Description/Recommended actions
		<ul style="list-style-type: none"> No action is required.
221	Info.	Snapshot reset has completed. Recommended actions: <ul style="list-style-type: none"> No action is required.
224	Info.	Roll back of data in the indicated volume to data in the indicated snapshot has completed. Recommended actions: <ul style="list-style-type: none"> No action is required.
232	Warning	The maximum number of enclosures allowed for the current configuration has been exceeded. The platform does not support the number of enclosures that are configured. The enclosure indicated by this event has been removed from the configuration. Recommended actions: <ul style="list-style-type: none"> Reconfigure the system.
233	Warning	The indicated disk type is invalid and is not allowed in the current configuration. All disks of the disallowed type have been removed from the configuration. Recommended actions: <ul style="list-style-type: none"> Replace the disallowed disks with ones that are supported.
235	Error	An enclosure management processor (EMP) detected a serious error. Recommended actions: <ul style="list-style-type: none"> Replace the indicated controller module or expansion module.
	Info.	An enclosure management processor (EMP) reported an event. Recommended actions: <ul style="list-style-type: none"> No action is required.
236	Error	A special shutdown operation has started. These special shutdown types indicate an incompatible feature. Recommended actions: <ul style="list-style-type: none"> Replace the indicated controller module with one that supports the indicated feature.
	Info.	A special shutdown operation has started. These special shutdown types are used as part of the firmware-update process. Recommended actions: <ul style="list-style-type: none"> No action is required.
237	Error	A firmware update attempt was aborted because of either general system health issues, or unwritable cache data that would be lost during a firmware update. Recommended actions: <ul style="list-style-type: none"> Resolve before retrying a firmware update. For health issues, issue the CLI <code>show system</code> command to determine the specific health issues. For unwritten cache data, use the CLI <code>show unwritable-cache</code> command
	Info.	A firmware update has started and is in progress. This event provides details of the steps in a firmware-update operation that may be of interest if you have problems updating firmware. Recommended actions: <ul style="list-style-type: none"> No action is required.
238	Warning	An attempt to install a licensed feature failed due to an invalid license. Recommended actions:

Table 28. Event descriptions and recommended actions (continued)

Number	Severity	Description/Recommended actions
		<ul style="list-style-type: none"> Check the license for what is allowed for the platform, make corrections as appropriate, and reinstall.
239	Warning	<p>A timeout occurred while flushing the eMMC.</p> <p>Recommended actions:</p> <ul style="list-style-type: none"> Restart the Storage Controller that logged this event. If this event is logged again, shut down the Storage Controller and replace the eMMC.
240	Warning	<p>A failure occurred while flushing the eMMC.</p> <p>Recommended actions:</p> <ul style="list-style-type: none"> Restart the Storage Controller that logged this event. If this event is logged again, shut down the Storage Controller and replace the eMMC. If this event is logged again, shut down the Storage Controller and replace the controller module.
241	Info.	<p>The auto-write-through trigger event that caused event 242 to be logged has been resolved.</p> <p>Recommended actions:</p> <ul style="list-style-type: none"> No action is required.
242	Error	<p>The eMMC card in the controller module has failed.</p> <p>This change met a condition to trigger the auto-write-through feature, which has disabled write-back cache and put the system in write-through mode. When the fault is resolved, event 241 is logged to indicate that write-back mode has been restored.</p> <p>Recommended actions:</p> <ul style="list-style-type: none"> If event 241 has not been logged since this event was logged, the eMMC probably does not have health of OK and the cause should be investigated. Another eMMC event was probably logged at approximately the same time as this event (such as event 239, 240, or 481). See the recommended actions for that event.
243	Info.	<p>A new controller enclosure has been detected. This happens when a controller module is moved from one enclosure to another and the controller detects that the midplane WWN is different from the WWN it has in its local flash.</p> <p>Recommended actions:</p> <ul style="list-style-type: none"> No action is required.
245	Info.	<p>An existing disk channel target device is not responding to SCSI discovery commands.</p> <p>Recommended actions:</p> <ul style="list-style-type: none"> Check the indicated target device for bad hardware or bad cable, then initiate a rescan.
246	Warning	<p>The coin battery is not present, is not properly seated, or has reached end-of-life.</p> <p>The battery provides backup power for the real-time (date/time) clock. In the event of a power failure, the date and time will revert to 1980-01-01 00:00:00.</p> <p>Recommended actions:</p> <ul style="list-style-type: none"> Replace the controller module that logged this event.
247	Warning	<p>The FRU ID SEEPROM for the indicated field replaceable unit (FRU) cannot be read. FRU ID data might not be programmed.</p> <p>FRU ID data includes the worldwide name, serial numbers, firmware and hardware versions, branding information, etc. This event is logged once each time a Storage Controller (SC) is started for each FRU that is not programmed.</p> <p>Recommended actions:</p> <ul style="list-style-type: none"> Return the FRU to have its FRU ID data reprogrammed.
248	Info.	<p>A valid feature license was successfully installed. See event 249 for details about each licensed feature.</p>

Table 28. Event descriptions and recommended actions (continued)

Number	Severity	Description/Recommended actions
		<p>Recommended actions:</p> <ul style="list-style-type: none"> • No action is required.
249	Info.	<p>After a valid license is installed, this event is logged for each licensed feature to show the new license value for that feature. The event specifies whether the feature is licensed, whether the license is temporary, and whether the temporary license is expired.</p> <p>Recommended actions:</p> <ul style="list-style-type: none"> • No action is required.
250	Warning	<p>A license could not be installed.</p> <p>The license is invalid or specifies a feature that is not supported on your product.</p> <p>Recommended actions:</p> <ul style="list-style-type: none"> • Review the readme file that came with the license. Verify that you are trying to install the license in the system that the license was generated for.
251	Info.	<p>A volume-copy operation has started for the indicated source volume.</p> <p>Do not mount either volume until the copy is complete (as indicated by event 268).</p> <p>Recommended actions:</p> <ul style="list-style-type: none"> • No action is required.
253	Info.	<p>A license was uninstalled.</p> <p>Recommended actions:</p> <ul style="list-style-type: none"> • No action is required.
255	Info.	<p>The PBCs across controllers do not match as PBC from controller A and PBC from controller B are from different vendors.</p> <p>This may limit the available configurations.</p> <p>Recommended actions:</p> <ul style="list-style-type: none"> • No action is required.
257	Info.	<p>The indicated snapshot has been prepared and committed and is ready for use.</p> <p>Recommended actions:</p> <ul style="list-style-type: none"> • No action is required.
259	Info.	<p>In-band CAPI commands have been disabled.</p> <p>Recommended actions:</p> <ul style="list-style-type: none"> • No action is required.
260	Info.	<p>In-band CAPI commands have been enabled.</p> <p>Recommended actions:</p> <ul style="list-style-type: none"> • No action is required.
261	Info.	<p>In-band SES commands have been disabled.</p> <p>Recommended actions:</p> <ul style="list-style-type: none"> • No action is required.
262	Info.	<p>In-band SES commands have been enabled.</p> <p>Recommended actions:</p> <ul style="list-style-type: none"> • No action is required.
263	Warning	<p>The indicated spare disk is missing. Either it was removed or it is not responding.</p> <p>Recommended actions:</p>

Table 28. Event descriptions and recommended actions (continued)

Number	Severity	Description/Recommended actions
		<ul style="list-style-type: none"> Replace the disk with one of the same type (SSD, enterprise SAS, or midline SAS) and the same or greater capacity. Configure the disk as a spare.
266	Info.	<p>A volume-copy operation for the indicated master volume has been aborted by a user.</p> <p>Recommended actions:</p> <ul style="list-style-type: none"> No action is required.
267	Error	<p>A volume-copy operation completed with a failure.</p> <p>This event has two variants:</p> <ol style="list-style-type: none"> If the source volume is a master volume, you can remount it. If the source volume is a snapshot, do not remount it until the copy is complete (as indicated by event 268). Possible causes are the pool running out of available space and crossing the high threshold, volumes being unavailable, or general I/O errors. <p>Recommended actions:</p> <ul style="list-style-type: none"> For variant 1: No action is required. For variant 2: Look for other events logged at approximately the same time that indicate a pool space or volume failure. Follow the recommended actions for those events.
268	Info.	<p>A volume-copy operation for the indicated volume has completed.</p> <p>Recommended actions:</p> <ul style="list-style-type: none"> No action is required.
269	Error	<p>A partner firmware update operation could not be performed.</p> <p>This event has these variants:</p> <ol style="list-style-type: none"> System health is insufficient to support firmware partner update. System has unwritable cache data present. Unable to determine if unwritable cache data is present. Incompatible firmware versions in the controller modules. Incompatible firmware is present in the system. <p>Recommended actions:</p> <ul style="list-style-type: none"> For variant 1, 2, or 3: You must resolve this condition before the firmware update will proceed. Log into the system and run the <code>show system</code> command to identify unhealthy components and find recommendations for restoring system health. The <code>check firmware-upgrade-health</code> command can be used to verify that the system is ready for firmware upgrade. For unwritten cache data, use the CLI <code>show unwritable-cache</code> command. For variant 4: This feature can be manually re-enabled after both controller modules are running compatible firmware. For variant 5: The controller modules should be updated to the latest version of firmware.
	Info.	<p>A partner firmware update operation has started. This operation is used to copy firmware from one controller to the other to bring both controllers up to the same version of firmware.</p> <p>Recommended actions:</p> <ul style="list-style-type: none"> No action is required.
270	Warning	<p>Either there was a problem reading or writing the persistent IP data from the FRU ID SEEPROM, or invalid data were read from the FRU ID SEEPROM.</p> <p>Recommended actions:</p> <ul style="list-style-type: none"> Check the IP settings (including iSCSI host-port IP settings for an iSCSI system), and update them if they are incorrect.
271	Info.	<p>The storage system could not get a valid serial number from the FRU ID SEEPROM on the controller, either because it could not read the FRU ID data, or because the data in it is not valid</p>

Table 28. Event descriptions and recommended actions (continued)

Number	Severity	Description/Recommended actions
		<p>or has not been programmed. Therefore, the MAC address is derived by using the controller serial number from flash. This event is only logged one time during bootup.</p> <p>Recommended actions:</p> <ul style="list-style-type: none"> ● No action is required.
273	Info.	<p>PHY fault isolation has been enabled or disabled by a user for the indicated enclosure and controller module.</p> <p>Recommended actions:</p> <ul style="list-style-type: none"> ● No action is required.
274	Warning	<p>The indicated PHY has been disabled, either automatically or by a user. Drive PHYs are automatically disabled for empty disk slots or if a problem is detected. The following reasons indicate a likely hardware fault:</p> <ul style="list-style-type: none"> ● Disabled because of error count interrupts ● Disabled because of excessive PHY change counts ● PHY is ready but did not pass COMINIT <p>Recommended actions:</p> <ul style="list-style-type: none"> ● If none of the preceding reasons apply, no action is required. ● If any of the preceding reasons are indicated and the event occurs shortly after the storage system is powered up, do the following: <ul style="list-style-type: none"> ○ Shut down the Storage Controllers. Then turn off the power for the indicated enclosure wait a few seconds, and turn it back on. ○ If the problem recurs and the event message identifies a disk slot, replace the disk in that slot. ○ If the problem recurs and the event message identifies a module, do the following: <ul style="list-style-type: none"> ■ If the indicated PHY type is Egress, replace the cable in the module's egress port ■ If the indicated PHY type is Ingress, replace the cable in the module's ingress port ■ For other indicated PHY types or if replacing the cable does not fix the problem, replace the indicated module. ○ If the problem persists, check for other events that may indicate faulty hardware, such as an event indicating an over-temperature condition or power supply fault, and follow the recommended actions for those events. ○ If the problem persists, the fault may be in the enclosure midplane. Replace the chassis FRU. ● If any of the preceding reasons are indicated and this event is logged shortly after a failover, user-initiated rescan, or restart, do the following: <ul style="list-style-type: none"> ○ If the event message identifies a disk slot, reseal the disk in that slot. ○ If the problem persists after reseating the disk, replace the disk. ○ If the event message identifies a module, do the following: <ul style="list-style-type: none"> ■ If the indicated PHY type is Egress, replace the cable in the module's egress port. ■ If the indicated PHY type is Ingress, replace the cable in the module's ingress port. ■ For other indicated PHY types or if replacing the cable does not fix the problem, replace the indicated module. ○ If the problem persists, check for other events that may indicate faulty hardware, such as an event indicating an over-temperature condition or power supply fault, and follow the recommended actions for those events. ○ If the problem persists, the fault may be in the enclosure midplane. Replace the chassis FRU.
275	Info.	<p>The indicated PHY has been enabled.</p> <p>Recommended actions:</p> <ul style="list-style-type: none"> ● No action is required.
298	Warning	<p>The real-time clock (RTC) setting on the controller is invalid.</p>

Table 28. Event descriptions and recommended actions (continued)

Number	Severity	Description/Recommended actions
		<p>This event will most commonly occur after a power loss if the real-time clock battery has failed. The time may have been set to a time that is up to 5 minutes before the power loss occurred, or it may have been reset to 1980-01-01 00:00:00.</p> <p>Recommended actions:</p> <ul style="list-style-type: none"> • Check the system date and time. If either is incorrect, set them to the correct date and time. • Also look for event 246 and follow the recommended action for that event. <p>When the problem is resolved, event 299 is logged.</p>
299	Info.	<p>The RTC setting on the controller was successfully recovered.</p> <p>This event will most commonly occur after an unexpected power loss.</p> <p>Recommended actions:</p> <ul style="list-style-type: none"> • No action is required, but if event 246 is also logged, follow the recommended action for that event.
300	Info.	<p>CPU frequency has changed to high.</p> <p>Recommended actions:</p> <ul style="list-style-type: none"> • No action is required.
301	Info.	<p>CPU frequency has changed to low.</p> <p>Recommended actions:</p> <ul style="list-style-type: none"> • No action is required.
302	Info.	<p>DDR memory clock frequency has changed to high.</p> <p>Recommended actions:</p> <ul style="list-style-type: none"> • No action is required.
303	Info.	<p>DDR memory clock frequency has changed to low.</p> <p>Recommended actions:</p> <ul style="list-style-type: none"> • No action is required.
304	Info.	<p>The controller has detected I²C errors that may have been fully recovered.</p> <p>Recommended actions:</p> <ul style="list-style-type: none"> • No action is required.
305	Info.	<p>A serial number in Storage Controller (SC) flash memory was found to be invalid when compared to the serial number in the controller-module or midplane FRU ID SEEPROM. The valid serial number has been recovered automatically.</p> <p>Recommended actions:</p> <ul style="list-style-type: none"> • No action is required.
306	Info.	<p>The controller-module serial number in Storage Controller (SC) flash memory was found to be invalid when compared to the serial number in the controller-module FRU ID SEEPROM. The valid serial number has been recovered automatically.</p> <p>Recommended actions:</p> <ul style="list-style-type: none"> • No action is required.
307	Critical	<p>A temperature sensor on a controller FRU detected an over-temperature condition that caused the controller to shut down.</p> <p>Recommended actions:</p> <ul style="list-style-type: none"> • Check that the storage system's fans are running. • Check that the ambient temperature is not too warm. The controller enclosure operating range is 5°C to 35°C (41°F to 95°F). The expansion enclosure operating range is 5°C to 40°C (41°F to 104°F).

Table 28. Event descriptions and recommended actions (continued)

Number	Severity	Description/Recommended actions
		<ul style="list-style-type: none"> • Check for any obstructions to the airflow. • Check that there is a module or blank plate in every module slot in the enclosure. <p>If the problem persists, replace the controller module that logged the error.</p>
309	Info.	<p>Normally when the Management Controller (MC) is started, the IP settings are obtained from the midplane FRU ID EEPROM where it persists. If the system is unable to write it to the EEPROM the last time it changed, a flag is set in flash memory. This flag is checked during startup, and if set, this event is logged and the IP data that is in the EEPROM is used by the controller module.</p> <p>The IP settings of the Management Controller (MC) may be incorrect after a controller module is swapped or the storage enclosure chassis is replaced.</p> <ul style="list-style-type: none"> • If a controller module is swapped, the IP settings in the flash memory of the replacement controller module may be used. • If the storage enclosure chassis is replaced, the IP settings are lost and they must be reentered on both controller modules. <p>Recommended actions:</p> <ul style="list-style-type: none"> • No action is required.
310	Info.	<p>After a rescan, back-end discovery and initialization of data for at least one EMP (Enclosure Management Processor) has completed. This event is not logged again when processing completes for other EMPs in the system.</p> <p>Recommended actions:</p> <ul style="list-style-type: none"> • No action is required.
311	Info.	<p>This event is logged when a user initiates a ping of a host using the iSCSI interface.</p> <p>Recommended actions:</p> <ul style="list-style-type: none"> • If the ping operation failed, check connectivity between the storage system and the remote host.
313	Error	<p>The indicated controller module has failed. This event can be ignored for a single-controller configuration.</p> <p>Recommended actions:</p> <ul style="list-style-type: none"> • If this is a dual-controller system, replace the failed controller module. The module's Fault/Service Required LED will be illuminated (not blinking).
314	Error	<p>The indicated FRU has failed or is not operating correctly. This event follows some other FRU-specific event indicating a problem.</p> <p>Recommended actions:</p> <ul style="list-style-type: none"> • To determine whether the FRU needs to be replaced, see the topic about verifying component failure in your product's Hardware Installation and Maintenance Guide.
315	Critical	<p>This IOM is incompatible with the enclosure in which it is inserted.</p> <p>Recommended actions:</p> <ul style="list-style-type: none"> • Replace this IOM with an IOM that is compatible with this enclosure.
317	Error	<p>A serious error has been detected on the Storage Controller disk interface. The controller will be killed by its partner.</p> <p>Recommended actions:</p> <ul style="list-style-type: none"> • Visually trace the cabling between the controller modules and expansion modules. • If the cabling is OK, replace the controller module that logged this event. • If the problem recurs, replace the expansion module that is connected to the controller module.
319	Warning	<p>The indicated available disk has failed.</p>

Table 28. Event descriptions and recommended actions (continued)

Number	Severity	Description/Recommended actions
		<p>Recommended actions:</p> <ul style="list-style-type: none"> ● Replace the disk with one of the same type (SSD, enterprise SAS, or midline SAS) and the same or greater capacity. For continued optimum I/O performance, the replacement disk should have performance that is the same as or better than the one it is replacing.
322	Warning	<p>The controller has an older Storage Controller (SC) version than the version used to create the CHAP authentication database in the controller’s flash memory.</p> <p>The CHAP database cannot be read or updated. However, new records can be added, which will replace the existing database with a new database using the latest known version number.</p> <p>Recommended actions:</p> <ul style="list-style-type: none"> ● Upgrade the controller firmware to a version whose SC is compatible with the indicated database version. <ul style="list-style-type: none"> ○ If no records were added, the database becomes accessible and remains intact. ○ If records were added, the database becomes accessible but contains only the new records.
352	Info.	<p>Expander Controller (EC) assert data or stack-dump data are available.</p> <p>Recommended actions:</p> <ul style="list-style-type: none"> ● No action is required.
353	Info.	<p>Expander Controller (EC) assert data and stack-dump data have been cleared.</p> <p>Recommended actions:</p> <ul style="list-style-type: none"> ● No action is required.
354	Warning	<p>SAS topology has changed on a host port. At least one PHY has gone down. For example, the SAS cable connecting a controller host port to a host has been disconnected.</p> <p>Recommended actions:</p> <ul style="list-style-type: none"> ● Check the cable connection between the indicated port and the host. ● Monitor the log to see if the problem persists.
	Info.	<p>SAS topology has changed on a host port. At least one PHY has become active. For example, the SAS cable connecting a controller host port to a host has been connected.</p> <p>Recommended actions:</p> <ul style="list-style-type: none"> ● No action is required.
355	Warning	<p>The debug button on the faceplate was stuck on during boot up.</p> <p>Recommended actions:</p> <ul style="list-style-type: none"> ● If the button remains stuck, replace the controller module.
356	Warning	<p>This event can only result from tests that are run in the manufacturing environment.</p> <p>Recommended actions:</p> <ul style="list-style-type: none"> ● Follow the manufacturing process.
357	Warning	<p>This event can only result from tests that are run in the manufacturing environment.</p> <p>Recommended actions:</p> <ul style="list-style-type: none"> ● Follow the manufacturing process.
358	Critical	<p>All PHYs are down for the indicated disk channel. The system is degraded and is not fault tolerant because all disks are in a single-ported state.</p> <p> NOTE: ME5 Series systems support only dual-ported disks.</p> <p>Recommended actions:</p> <ul style="list-style-type: none"> ● Turn off the power for the controller enclosure, wait a few seconds, and turn it back on.

Table 28. Event descriptions and recommended actions (continued)

Number	Severity	Description/Recommended actions
		<ul style="list-style-type: none"> • If event 359 has been logged for the indicated channel, indicating the condition no longer exists, no further action is required. • If the condition persists, this indicates a hardware problem in one of the controller modules or in the controller enclosure midplane. For help identifying which FRU to replace, see Troubleshooting and problem solving.
	Warning	<p>Some, but not all, PHYs are down for the indicated disk channel.</p> <p>Recommended actions:</p> <ul style="list-style-type: none"> • Monitor the log to see whether the condition persists. • If event 359 has been logged for the indicated channel, indicating the condition no longer exists, no further action is required. • If the condition persists, this indicates a hardware problem in one of the controller modules or in the controller enclosure midplane. For help identifying which FRU to replace, see Troubleshooting and problem solving.
359	Info.	<p>All PHYs that were down for the indicated disk channel have recovered and are now up.</p> <p>Recommended actions:</p> <ul style="list-style-type: none"> • No action is required.
360	Info.	<p>The speed of the indicated disk PHY was renegotiated.</p> <p>Recommended actions:</p> <ul style="list-style-type: none"> • No action is required.
361	Critical, Error, or Warning	<p>The scheduler experienced a problem with the indicated schedule.</p> <p>Recommended actions:</p> <ul style="list-style-type: none"> • Take appropriate action based on the indicated problem.
	Info.	<p>A scheduled task was initiated.</p> <p>Recommended actions:</p> <ul style="list-style-type: none"> • No action is required.
362	Critical, Error, or Warning	<p>The scheduler experienced a problem with the indicated task.</p> <p>Recommended actions:</p> <ul style="list-style-type: none"> • Take appropriate action based on the indicated problem.
	Info.	<p>The scheduler experienced a problem with the indicated task.</p> <p>Recommended actions:</p> <ul style="list-style-type: none"> • No action is required.
363	Error	<p>When the Management Controller (MC) is restarted, firmware versions that are currently installed are compared against those in the bundle that was most recently installed. When firmware is updated, it is important that all components are successfully updated or the system may not work correctly. Components checked include the CPLD, Expander Controller (EC), Storage Controller (SC), and MC.</p> <p>Recommended actions:</p> <ul style="list-style-type: none"> • Reinstall the firmware bundle.
	Info.	<p>When the Management Controller (MC) is restarted, firmware versions that are currently installed are compared against those in the bundle that was most recently installed. If the versions match, this event is logged as Informational severity. Components checked include the CPLD, Expander Controller (EC), Storage Controller (SC), and MC.</p> <p>Recommended actions:</p> <ul style="list-style-type: none"> • No action is required.
364	Info.	<p>The broadcast bus is running as generation 1.</p>

Table 28. Event descriptions and recommended actions (continued)

Number	Severity	Description/Recommended actions
		<p>Recommended actions:</p> <ul style="list-style-type: none"> • No action is required.
365	Error	<p>An uncorrectable ECC error occurred in Storage Controller CPU memory more than once, indicating a probable hardware fault.</p> <p>Recommended actions:</p> <ul style="list-style-type: none"> • Replace the controller module that logged this event.
	Warning	<p>An uncorrectable ECC error occurred in Storage Controller CPU memory.</p> <p>This event is logged with Warning severity to provide information that may be useful to technical support, but no action is required now. It will be logged with Error severity if it is necessary to replace the controller module.</p> <p>Recommended actions:</p> <ul style="list-style-type: none"> • No action is required.
400	Info.	<p>The indicated log has filled to a level at which it needs to be transferred to a log-collection system.</p> <p>Recommended actions:</p> <ul style="list-style-type: none"> • No action is required.
401	Warning	<p>The indicated log has filled to a level at which diagnostic data will be lost if not transferred to a log-collection system.</p> <p>Recommended actions:</p> <ul style="list-style-type: none"> • Transfer the log file to the log-collection system.
402	Error	<p>The indicated log has wrapped and has started to overwrite its oldest diagnostic data.</p> <p>Recommended actions:</p> <ul style="list-style-type: none"> • Investigate why the log-collection system is not transferring the logs before they are overwritten. For example, you might have enabled managed logs without configuring a destination to send logs to.
412	Warning	<p>One disk in the indicated RAID-6 disk group failed. The disk group is online but has a status of FTDN (fault tolerant with a down disk).</p> <p>If a dedicated spare (linear only) or global spare of the proper type and size is present, that spare is used to automatically reconstruct the disk group. Events 9 and 37 are logged to indicate this. If no usable spare disk is present, but an available disk of the proper type and size is present and the dynamic spares feature is enabled, that disk is used to automatically reconstruct the disk group and event 37 is logged.</p> <p>Recommended actions:</p> <p>RAID-6:</p> <ul style="list-style-type: none"> • If event 37 was not logged, a spare of the proper type and size was not available for reconstruction. Replace the failed disk with one of the same type and the same or greater capacity and, if necessary, designate it as a spare. Confirm this by checking that events 9 and 37 are logged. • Otherwise, reconstruction automatically started and event 37 was logged. Replace the failed disk and configure the replacement as a dedicated spare (linear only) or global spare for future use. • For continued optimum I/O performance, the replacement disk should have the same or better performance. • Confirm that all failed disks have been replaced and that there are sufficient spare disks configured for future use. <p>ADAPT:</p>

Table 28. Event descriptions and recommended actions (continued)

Number	Severity	Description/Recommended actions
		<ul style="list-style-type: none"> • If event 37 was not logged, spare space was not available for reconstruction. Replace the failed disk with one of the same type and the same or greater capacity. Reconstruction should start and event 37 should be logged automatically. • For continued optimum I/O performance, the replacement disk should have the same or better performance. • Confirm that all failed disks have been replaced for future fault tolerance.
442	Warning	<p>Power-On Self Test (POST) diagnostics detected a hardware error in a UART chip.</p> <p>Recommended actions:</p> <ul style="list-style-type: none"> • Replace the controller module that logged this event.
443	Error	<p>The firmware for the indicated enclosure is not supported in this configuration.</p> <p>The firmware for the indicated enclosure does not support this enclosure for use as an expansion chassis. Its firmware supports this enclosure only as a direct attached JBOD.</p> <p>Recommended actions:</p> <ul style="list-style-type: none"> • Replace the indicated enclosure. It is not supported.
454	Info.	<p>A user changed the drive-spin-down delay for the indicated disk group to the indicated value.</p> <p>Recommended actions:</p> <ul style="list-style-type: none"> • No action is required.
455	Warning	<p>The controller detected that the configured host-port link speed exceeded the capability of an FC SFP. The speed has been automatically reduced to the maximum value supported by all hardware components in the data path.</p> <p>Recommended actions:</p> <ul style="list-style-type: none"> • Replace the SFP in the indicated port with an SFP that supports a higher speed.
456	Warning	<p>The system IQN was generated from the default OUI because the controllers could not read the OUI from the midplane FRU ID data during startup. If the IQN is wrong for the system branding, iSCSI hosts might be unable to access the system.</p> <p>Recommended actions:</p> <ul style="list-style-type: none"> • If event 270 with status code 0 is logged at approximately the same time, restart the Storage Controllers.
457	Info.	<p>The indicated virtual pool was created.</p> <p>Recommended actions:</p> <ul style="list-style-type: none"> • No action is required.
458	Info.	<p>Disk groups were added to the indicated virtual pool.</p> <p>Recommended actions:</p> <ul style="list-style-type: none"> • No action is required.
459	Info.	<p>Removal of the indicated disk groups was started.</p> <p>When this operation is complete, event 470 is logged.</p> <p>Recommended actions:</p> <ul style="list-style-type: none"> • No action is required.
460	Error	<p>The indicated disk group is missing from the indicated virtual pool.</p> <p>This might be caused by missing disk drives or unconnected or powered-off enclosures</p> <p>Recommended actions:</p> <ul style="list-style-type: none"> • Ensure that all disks are installed and all enclosures are connected and powered on. When the problem is resolved, event 461 is logged.
461	Info.	<p>The indicated disk group that was missing from the indicated virtual pool was recovered.</p>

Table 28. Event descriptions and recommended actions (continued)

Number	Severity	Description/Recommended actions
		<p>This event indicates that a problem reported by event 460 is resolved.</p> <p>Recommended actions:</p> <ul style="list-style-type: none"> • No action is required.
462	Error	<p>The indicated virtual pool reached its storage limit.</p> <p>There are three thresholds, two of which are user-settable. The third and highest setting is set automatically by the controller and cannot be changed. This event is logged with Warning severity if the high threshold is exceeded and the virtual pool is overcommitted. Overcommitted means that the total committed size of all virtual volumes exceeds the physical space in the virtual pool. If the storage usage drops below a threshold, event 463 is logged.</p> <p>Recommended actions:</p> <ul style="list-style-type: none"> • You should immediately take steps to reduce storage usage or add capacity.
	Warning	<p>The indicated virtual pool exceeded its high threshold for allocated pages, and the virtual pool is overcommitted.</p> <p>There are three thresholds, two of which are user-settable. The third and highest setting is set automatically by the controller and cannot be changed. This event is logged with Warning severity if the high threshold is exceeded and the virtual pool is overcommitted. Overcommitted means that the total committed size of all virtual volumes exceeds the physical space in the virtual pool. If the storage usage drops below a threshold, event 463 is logged.</p> <p>Recommended actions:</p> <ul style="list-style-type: none"> • You should immediately take steps to reduce storage usage or add capacity.
	Info.	<p>The indicated virtual pool exceeded one of its thresholds for allocated pages.</p> <p>There are three thresholds, two of which are user-settable. The third and highest setting is set automatically by the controller and cannot be changed. This event is logged with Warning severity if the high threshold is exceeded and the virtual pool is overcommitted. Overcommitted means that the total committed size of all virtual volumes exceeds the physical space in the virtual pool. If the storage usage drops below a threshold, event 463 is logged.</p> <p>Recommended actions:</p> <ul style="list-style-type: none"> • No action is required for the low and mid thresholds. However, you may want to determine if your storage usage is growing at a rate that will result in the high threshold being crossed in the near future. If this will occur, either take steps to reduce storage usage or purchase additional capacity. • If the high threshold is crossed, you should promptly take steps to reduce storage usage or add capacity.
463	Info.	<p>The indicated virtual pool has dropped below one of its thresholds for allocated pages.</p> <p>This event indicates that a condition reported by event 462 is no longer applicable.</p> <p>Recommended actions:</p> <ul style="list-style-type: none"> • No action is required.
464	Warning	<p>A user inserted an unsupported cable or SFP into the indicated controller host port.</p> <p>Recommended actions:</p> <ul style="list-style-type: none"> • Replace the cable or SFP with a supported type.
465	Info.	<p>A user removed an unsupported cable or SFP from the indicated controller host port.</p> <p>Recommended actions:</p> <ul style="list-style-type: none"> • No action is required.
466	Info.	<p>The indicated virtual pool was deleted.</p> <p>Recommended actions:</p> <ul style="list-style-type: none"> • No action is required.

Table 28. Event descriptions and recommended actions (continued)

Number	Severity	Description/Recommended actions
467	Info.	<p>Addition of the indicated disk group completed successfully.</p> <p>Recommended actions:</p> <ul style="list-style-type: none"> • No action is required.
468	Info.	<p>FPGA temperature has returned to the normal operating range and the speed of buses connecting the FPGA to downstream adapters has been restored. The speed was reduced to compensate for an FPGA over-temperature condition.</p> <p>This event indicates that a problem reported by event 469 is resolved.</p> <p>Recommended actions:</p> <ul style="list-style-type: none"> • No action is required.
469	Warning	<p>The speed of buses connecting the FPGA to downstream adapters has been reduced to compensate for an FPGA over-temperature condition.</p> <p>The storage system is operational but I/O performance is reduced.</p> <p>Recommended actions:</p> <ul style="list-style-type: none"> • Check that the storage system’s fans are running. • Check that the ambient temperature is not too warm. The controller enclosure operating range is 5°C to 35°C (41°F to 95°F). The expansion enclosure operating range is 5°C to 40°C (41°F to 104°F). • Check for any obstructions to the airflow. • Check that there is a module or blank plate in every module slot in the enclosure. • If none of these recommended actions resolve the issue, replace the controller module that logged the error. <p>When the problem is resolved, event 468 is logged.</p>
470	Warning	<p>Removal of the indicated disk groups completed with failure.</p> <p>Removal of disk groups can fail for several reasons, and the specific reason for this failure is included with the event. Removal most often fails because there is no longer room in the remaining pool space to move data pages off of the disks in the disk group.</p> <p>Recommended actions:</p> <ul style="list-style-type: none"> • Resolve the issue specified by the error messaging included with this event and re-issue the request to remove the disk group.
	Info.	<p>Removal of the indicated disk groups completed successfully.</p> <p>Recommended actions:</p> <ul style="list-style-type: none"> • No action is required.
473	Info.	<p>The indicated volume is using more than its threshold percentage of its virtual pool.</p> <p>This is an indication that the storage usage crossed the threshold for this volume. If the storage usage drops below the threshold, event 474 is logged.</p> <p>Recommended actions:</p> <ul style="list-style-type: none"> • No action is required. How this information is utilized is left to the discretion of the user.
474	Info.	<p>The indicated volume is no longer using more than its threshold percentage of its virtual pool.</p> <p>This event indicates that the condition reported by event 473 is no longer applicable.</p> <p>Recommended actions:</p> <ul style="list-style-type: none"> • No action is required.
476	Warning	<p>The CPU temperature exceeded the safe range so the CPU entered its self-protection state. IOPS were reduced.</p> <p>The storage system is operational but I/O performance is reduced.</p> <p>Recommended actions:</p>

Table 28. Event descriptions and recommended actions (continued)

Number	Severity	Description/Recommended actions
		<ul style="list-style-type: none"> • Check that the storage system's fans are running. • Check that the ambient temperature is not too warm. The controller enclosure operating range is 5°C to 35°C (41°F to 95°F). The expansion enclosure operating range is 5°C to 40°C (41°F to 104°F). • Check for any obstructions to the airflow. • Check that there is a module or blank plate in every module slot in the enclosure. • If none of these recommended actions resolve the issue, replace the controller module that logged the error. <p>When the problem is resolved, event 478 is logged.</p>
477	Info.	<p>The CPU temperature exceeded the normal range so the CPU speed was reduced. IOPS were reduced.</p> <p>The storage system is operational but I/O performance is reduced.</p> <p>Recommended actions:</p> <ul style="list-style-type: none"> • Check that the storage system's fans are running. • Check that the ambient temperature is not too warm. The controller enclosure operating range is 5°C to 35°C (41°F to 95°F). The expansion enclosure operating range is 5°C to 40°C (41°F to 104°F). • Check for any obstructions to the airflow. • Check that there is a module or blank plate in every module slot in the enclosure. • If none of these recommended actions resolve the issue, replace the controller module that logged the error. <p>When the problem is resolved, event 478 is logged.</p>
478	Info.	<p>A problem reported by event 476 or 477 is resolved.</p> <p>Recommended actions:</p> <ul style="list-style-type: none"> • No action is required.
479	Error	<p>The controller reporting this event was unable to flush data to or restore data from non-volatile memory.</p> <p>This mostly likely indicates a eMMC failure, but it could be caused by some other problem with the controller module. The Storage Controller that logged this event will be killed by its partner controller, which will use its own copy of the data to perform the flush or restore operation.</p> <p>Recommended actions:</p> <ul style="list-style-type: none"> • If this is the first time this event has been logged, restart the killed Storage Controller. • If this event is then logged again, replace the eMMC. • If this event is then logged again, shut down the Storage Controller and replace the controller module.
480	Error	<p>An IP address conflict was detected for the indicated iSCSI port of the storage system. The indicated IP address is already in use.</p> <p>Recommended actions:</p> <ul style="list-style-type: none"> • Contact your data-network administrator to help resolve the IP address conflict.
481	Error	<p>The periodic monitor of eMMC hardware detected an error. The controller was put in write-through mode, which reduces I/O performance.</p> <p>Recommended actions:</p> <ul style="list-style-type: none"> • Restart the Storage Controller that logged this event. • If this event is logged again, shut down the Storage Controller and replace the eMMC. • If this event is logged again, shut down the Storage Controller and replace the controller module.
482	Warning	<p>One of the PCIe buses is running with fewer lanes than it should.</p> <p>This event is the result of a hardware problem that has caused the controller to use fewer lanes. The system works with fewer lanes, but I/O performance is degraded.</p>

Table 28. Event descriptions and recommended actions (continued)

Number	Severity	Description/Recommended actions
		<p>Recommended actions:</p> <ul style="list-style-type: none"> • Replace the controller module that logged this event.
483	Error	<p>An invalid expansion-module connection was detected for the indicated disk channel. An egress port is connected to an egress port, or an ingress port is connected to an incorrect egress port.</p> <p>Recommended actions:</p> <ul style="list-style-type: none"> • Visually trace the cabling between enclosures and correct the cabling.
484	Warning	<p>No compatible spares are available to reconstruct this disk group if it experiences a disk failure. Only disk groups that have dedicated or suitable global spares will start reconstruction automatically.</p> <p>This situation puts data at increased risk because it will require user action to configure a disk as a dedicated or global spare before reconstruction can begin on the indicated disk group if a disk in that disk group fails in the future.</p> <p>If the last global spare has been deleted or used for reconstruction, ALL disk groups that do not have at least one dedicated or global spare are at increased risk. Note that even though there may be global spares still available, they cannot be used for reconstruction of a disk group if that disk group uses larger-capacity disks or a different type of disk. Therefore, this event may be logged even when there are unused global spares. If the dynamic spares feature is enabled, this event will be logged even if there is an available disk that may be used for reconstruction.</p> <p>Recommended actions:</p> <ul style="list-style-type: none"> • Configure disks as dedicated spares or global spares. <ul style="list-style-type: none"> ○ For a dedicated spare, the disk must be of the same type as the other disks in the linear disk group and at least as large as the smallest-capacity disk in the linear disk group, and it should have the same or better performance. ○ For a global spare, it is best to choose a disk that is as big as or bigger than the largest disk of its type in the system and of equal or greater performance. If the system contains a mix of disk types (SSD, enterprise SAS, or midline SAS), there should be at least one global spare of each type (unless dedicated spares are used to protect every disk group of a given type, which will only apply to a linear storage configuration).
485	Warning	<p>The indicated disk group was quarantined to prevent writing invalid data that may exist in the controller that logged this event.</p> <p>This event is logged to report that the indicated disk group has been put in the quarantined offline state (status of QTOF) to prevent loss of data. The controller that logged this event has detected (using information saved in the disk group metadata) that it may contain outdated data that should not be written to the disk group. Data may be lost if you do not follow the recommended actions carefully. This situation is typically caused by removal of a controller module without shutting it down first, then inserting a different controller module in its place. To avoid having this problem occur in the future, always shut down the Storage Controller in a controller module before removing it. This situation may also be caused by failure of the eMMC card, as indicated by event 204.</p> <p>Recommended actions:</p> <ul style="list-style-type: none"> • If event 204 is logged, follow the recommended actions for event 204. • If event 204 is NOT logged, perform the following recommended actions: <ul style="list-style-type: none"> ○ If event 486 is not logged at approximately the same time as event 485, reinsert the removed controller module, shut it down, then remove it again. ○ If events 485 and 486 are both logged at approximately the same time, wait at least 5 minutes for the automatic recovery process to complete. Then sign in and confirm that both controller modules are operational. (You can determine if the controllers are operational with the CLI show controllers command or with the SMC.) In most cases, the system will come back up and no further action is required. If both controller modules do not become operational in 5 minutes, data may have been lost. If both controllers are not operational, follow this recovery process: <ul style="list-style-type: none"> ▪ Remove the controller module that first logged event 486.

Table 28. Event descriptions and recommended actions (continued)

Number	Severity	Description/Recommended actions
		<ul style="list-style-type: none"> ▪ Turn off the power for the controller enclosure, wait a few seconds, then turn it back on. ▪ Wait for the controller module to restart, then sign in again. ▪ Check the status of the disk groups. If any of the disk groups have a status of quarantined offline (QTOF), dequarantine those disk groups. ▪ Reinsert the previously removed controller module. It should now restart successfully
486	Warning	<p>A recovery process was initiated to prevent writing invalid data that may exist in the controller that logged this event.</p> <p>The controller that logged this event has detected (using information saved in the disk group metadata) that it may contain outdated data that should not be written to the disk groups. The controller will log this event, restart the partner controller, wait 10 seconds, then kill itself. The partner controller will then unkill this controller and mirror the correct cache data to it. This procedure will, in most cases, allow all data to be correctly written without any loss of data and without writing any outdated data.</p> <p>Recommended actions:</p> <ul style="list-style-type: none"> • Wait at least 5 minutes for the automatic recovery process to complete. Then sign in and confirm that both controller modules are operational. (You can determine if the controllers are operational with the CLI <code>show redundancy-mode</code> command.) In most cases, the system will come back up and no action is required. • If both controller modules do not become operational in 5 minutes, see the recommended actions for event 485, which will be logged at approximately the same time.
487	Info.	<p>Historical performance statistics were reset.</p> <p>Recommended actions:</p> <ul style="list-style-type: none"> • No action is required.
488	Info.	<p>Creation of a volume group started.</p> <p>Recommended actions:</p> <ul style="list-style-type: none"> • No action is required.
489	Info.	<p>Creation of a volume group completed.</p> <p>Recommended actions:</p> <ul style="list-style-type: none"> • No action is required.
490	Info.	<p>Creation of a volume group failed.</p> <p>Recommended actions:</p> <ul style="list-style-type: none"> • No action is required.
491	Info.	<p>Creation of a volume group started.</p> <p>Recommended actions:</p> <ul style="list-style-type: none"> • No action is required.
492	Info.	<p>The volumes in a volume group were ungrouped.</p> <p>Recommended actions:</p> <ul style="list-style-type: none"> • No action is required.
493	Info.	<p>A volume group was modified.</p> <p>Recommended actions:</p> <ul style="list-style-type: none"> • No action is required.
495	Warning	<p>The algorithm for best-path routing selected the alternate path to the indicated disk because the I/O error count on the primary path reached its threshold.</p>

Table 28. Event descriptions and recommended actions (continued)

Number	Severity	Description/Recommended actions
		<p>The controller that logs this event indicates which channel (path) has the problem. For example, if the B controller logs the problem, the problem is in the chain of cables and expansion modules connected to the B controller module.</p> <p>Recommended actions:</p> <ul style="list-style-type: none"> • If this event is consistently logged for only one disk in an enclosure, perform the following actions: <ul style="list-style-type: none"> ○ Replace the disk. ○ If that does not resolve the problem, the fault is probably in the enclosure midplane. Replace the chassis FRU for the indicated enclosure. • If this event is logged for more than one disk in an enclosure or disks in multiple enclosures, perform the following actions: <ul style="list-style-type: none"> ○ Check for disconnected SAS cables in the bad path. If no cables are disconnected, replace the cable connecting to the ingress port in the most-upstream enclosure with reported failures. If that does not resolve the problem, replace other cables in the bad path, one at a time until the problem is resolved. ○ If that does not resolve the problem, replace the expansion modules that are in the bad path. Begin with the most-upstream module that is in an enclosure with reported failures. If that does not resolve the problem, replace other expansion modules (and the controller module) upstream of the affected enclosure(s), one at a time until the problem is resolved. ○ If that does not resolve the problem, the fault is probably in the enclosure midplane. Replace the chassis FRU of the most-upstream enclosure with reported failures. If that does not resolve the problem and there is more than one enclosure with reported failures, replace the chassis FRU of the other enclosures with reported failures until the problem is resolved.
496	Warning	<p>An unsupported disk type was found.</p> <p>Recommended actions:</p> <ul style="list-style-type: none"> • Replace the disk with a supported type.
	Warning	<p>An unsupported disk vendor was found.</p> <p>Recommended actions:</p> <ul style="list-style-type: none"> • Replace the disk with a disk that is supported by your system vendor.
501	Error	<p>The enclosure hardware is not compatible with the I/O module firmware.</p> <p>The Expander Controller firmware detected an incompatibility with the midplane type. As a preventive measure, disk access was disabled in the enclosure.</p> <p>Recommended actions:</p> <ul style="list-style-type: none"> • If using a supported enclosure, update the storage system to the latest firmware. If using an unsupported enclosure, replace the unsupported enclosure with a supported one.
502	Warning	<p>The indicated SSD has 5% or less of its life remaining.</p> <p>This event will be logged again as the device approaches and reaches its end of life.</p> <p>Recommended actions:</p> <ul style="list-style-type: none"> • Be sure you have a spare SSD of the same type and capacity available. • If a spare is available, replace the SSD now.
	Info.	<p>The indicated SSD has 20% or less of its life remaining.</p> <p>This event will be logged again with a severity of Warning as the SSD further approaches its end of life.</p> <p>Recommended actions:</p> <ul style="list-style-type: none"> • Obtain a replacement SSD of the same type and capacity if you do not already have one available.

Table 28. Event descriptions and recommended actions (continued)

Number	Severity	Description/Recommended actions
503	Info.	<p>The Intelligent BackEnd Error Monitor (IBEEM) has discovered that continuous errors are being reported for the indicated PHY.</p> <p>IBEEM logged this event after monitoring the PHY for 30 minutes.</p> <p>Recommended actions:</p> <ul style="list-style-type: none"> • No action is required.
504	Info.	<p>Service debug access to the system has been enabled or disabled by a user. Allowing service debug access may have security implications. After the diagnosis is complete you may want to disallow such access.</p> <p>Recommended actions:</p> <ul style="list-style-type: none"> • No action is required.
505	Warning	<p>The indicated virtual pool was created with a size smaller than 500 GB, which can lead to unpredictable behavior.</p> <p>The storage system may not perform correctly.</p> <p>Recommended actions:</p> <ul style="list-style-type: none"> • Add disk groups to the virtual pool to increase the size of the pool.
506	Info.	<p>Addition of the indicated disk group was started.</p> <p>When this operation is complete, event 467 is logged.</p> <p>Recommended actions:</p> <ul style="list-style-type: none"> • No action is required.
507	Info.	<p>The link speed of the indicated disk does not match the link speed that the enclosure is capable of.</p> <p>This event is logged when the auto-negotiated link speed is less than the maximum speed that the enclosure supports. The disk is functional, but I/O performance is reduced. This event may be logged for one disk channel or for both disk channels.</p> <p>Recommended actions:</p> <ul style="list-style-type: none"> • If the disk is a member of a non-fault-tolerant disk group (RAID 0 or non-RAID), move the data to a different disk group. • Replace the disk with one of the same type (SSD, enterprise SAS, or midline SAS) and the same or greater capacity. For continued optimum I/O performance, the replacement disk should have performance that is the same as or better than the one it is replacing.
508	Error	<p>The indicated virtual pool went offline. All of its volumes also went offline.</p> <p>All data in the virtual pool has been lost. This condition can be caused by corrupt or inaccessible virtual pool metadata.</p> <p>Recommended actions:</p> <ul style="list-style-type: none"> • Check for other events that indicate faults in the system and follow the recommended actions for those events. • Re-create the virtual pool. • Restore the data from a backup, if available.
509	Error	<p>The metadata volume for the indicated virtual pool went offline. Volume mappings and persistent reservations are inaccessible or lost.</p> <p>Recommended actions:</p> <ul style="list-style-type: none"> • Check for other events that indicate faults in the system and follow the recommended actions for those events. • Create new mappings for the volumes. Persistent reservations will be restored by host systems automatically.
510	Info.	<p>The FDE lock key has been set or changed by a user.</p>

Table 28. Event descriptions and recommended actions (continued)

Number	Severity	Description/Recommended actions
		<p>Recommended actions:</p> <ul style="list-style-type: none"> • Be sure to record the lock key passphrase and the new lock ID.
511	Info.	<p>The FDE import lock key has been set by a user.</p> <p>This is normally used to import into the system an FDE disk that was locked by another system.</p> <p>Recommended actions:</p> <ul style="list-style-type: none"> • Ensure that the imported disks are integrated into the system.
512	Info.	<p>The system was set to the FDE secured state by a user.</p> <p>Full Disk Encryption is now enabled. Disks removed from this system will not be readable unless they are imported into another system.</p> <p>Recommended actions:</p> <ul style="list-style-type: none"> • No action is required.
513	Info.	<p>The system was set to the FDE repurposed state by a user.</p> <p>All disks have been repurposed and set to their initial factory states. FDE is no longer enabled on the system.</p> <p>Recommended actions:</p> <ul style="list-style-type: none"> • No action is required.
514	Info.	<p>The FDE lock key and import key were cleared by a user.</p> <p>I/O operations may continue as long as the system is not restarted.</p> <p>Recommended actions:</p> <ul style="list-style-type: none"> • If the system is restarted and access to data is intended, the lock key must be reinstated.
515	Info.	<p>An FDE disk was repurposed by a user.</p> <p>The disk was reset to its original factory state.</p> <p>Recommended actions:</p> <ul style="list-style-type: none"> • No action is required.
516	Error	<p>An FDE disk has been placed in the unavailable state.</p> <p>The related event message 518, which indicates that a disk operation failed, may provide additional information.</p> <p>Recommended actions:</p> <ul style="list-style-type: none"> • See the recommended action specified in the event message.
517	Info.	<p>A disk that was formerly in the FDE unavailable state is no longer unavailable.</p> <p>The disk has returned to normal operations.</p> <p>Recommended actions:</p> <ul style="list-style-type: none"> • No action is required.
518	Error	<p>An FDE disk operation has failed.</p> <p>This event provides detail about the operation that failed.</p> <p>Recommended actions:</p> <ul style="list-style-type: none"> • The disk may need to be removed, imported, repurposed, or replaced.
519	Error	<p>The system changed to the Full Disk Encryption degraded state.</p> <p>Typically a disk-related condition has occurred.</p> <p>Recommended actions:</p> <ul style="list-style-type: none"> • One or more disks may need to be removed, imported, repurposed, or replaced.

Table 28. Event descriptions and recommended actions (continued)

Number	Severity	Description/Recommended actions
520	Info.	<p>The system that was in the Full Disk Encryption degraded state is no longer degraded. The system has returned to normal operations.</p> <p>Recommended actions:</p> <ul style="list-style-type: none"> • No action is required.
521	Error	<p>An error occurred while accessing the midplane SEEPROM to store or fetch Full Disk Encryption keys.</p> <p>The midplane memory is used to store the FDE lock key.</p> <p>Recommended actions:</p> <ul style="list-style-type: none"> • The midplane may need to be replaced if the error persists.
522	Warning	<p>A scrub-disk-group job encountered an error at the indicated logical block address.</p> <p>The event message always includes the disk group name and the logical block address of the error within that disk group. If the block with an error falls within the LBA range used by a volume, the event message also includes the volume name and the LBA within that volume.</p> <p>Recommended actions:</p> <ul style="list-style-type: none"> • Examine event 207 that was logged previously to this event. Follow the recommended actions for that event.
523	Info.	<p>This event provides additional details associated with a scrub-disk-group job, expanding on the information in event 206, 207, or 522.</p> <p>Recommended actions:</p> <ul style="list-style-type: none"> • Follow the recommended actions for the associated event.
524	Error	<p>A temperature or voltage sensor reached a critical threshold.</p> <p>A sensor monitored a temperature or voltage in the critical range. When the problem is resolved, event 47 is logged for the component that logged event 524.</p> <p>If the event refers to a disk sensor, disk behavior may be unpredictable in this temperature range.</p> <p>Check the event log to determine if more than one disk has reported this event.</p> <ul style="list-style-type: none"> • If multiple disks report this condition there could be a problem in the environment. • If one disk reports this condition, there could be a problem in the environment or the disk has failed. <p>Recommended actions:</p> <ul style="list-style-type: none"> • Check that the storage system's fans are running. • Check that the ambient temperature is not too warm. The controller enclosure operating range is 5°C to 35°C (41°F to 95°F). The expansion enclosure operating range is 5°C to 40°C (41°F to 104°F). • Check for any obstructions to the airflow. • Check that there is a module or blank plate in every module slot in the enclosure. • If none of these recommended actions resolve the issue, replace the disk or controller module that logged the error.
525	Info.	<p>A drawer has been stopped by a user.</p> <p>The drawer has powered down and may be safely removed. A rescan must complete before the updated drawer information will be available.</p> <p>Recommended actions:</p> <ul style="list-style-type: none"> • Restart the drawer using the <code>start drawer</code> command, or remove the drawer for replacement.
526	Info.	<p>A drawer has been started by a user.</p>

Table 28. Event descriptions and recommended actions (continued)

Number	Severity	Description/Recommended actions
		<p>The drawer has powered up. Disks in the drawer may take a few minutes to spin up. A rescan must complete before the updated drawer information will be available.</p> <p>Recommended actions:</p> <ul style="list-style-type: none"> • No action is required.
527	Error	<p>Expander Controller (EC) firmware is incompatible with the enclosure.</p> <p>As a preventative measure, the Expander Controller (EC) disabled all PHYs and reported the short enclosure status page in the supported diagnostic list.</p> <p>Recommended actions:</p> <ul style="list-style-type: none"> • Upgrade the controller module to the latest supported bundle version.
528	Error	<p>Expander Controller firmware detected that the partner Expander Controller (EC) firmware is incompatible with the enclosure.</p> <p>As a preventative measure, the Expander Controller (EC) disabled all PHYs and reported the short enclosure status page in the supported diagnostic list.</p> <p>Recommended actions:</p> <ul style="list-style-type: none"> • Upgrade the partner controller module to the latest supported bundle version.
529	Error	<p>The local Expander Controller (EC) is incompatible with the enclosure.</p> <p>As a preventative measure, the Expander Controller (EC) disabled all PHYs and reported the short enclosure status page in the supported diagnostic list.</p> <p>Recommended actions:</p> <ul style="list-style-type: none"> • Replace the controller module with one that is compatible with the enclosure.
530	Error	<p>The local Expander Controller (EC) firmware detected a level of incompatibility with the partner Expander Controller (EC). This incompatibility could be due to unsupported hardware or firmware.</p> <p>As a preventative measure, the local Expander Controller (EC) is holding the partner Expander Controller (EC) in a reset loop.</p> <p>Recommended actions:</p> <ul style="list-style-type: none"> • Remove the partner controller module from the enclosure. Boot the partner controller module in single-controller mode in a separate enclosure (without the controller module that reported this event). Load the latest compatible bundle version. If the version fails to load, replace the partner controller module.
533	Error	<p>This event provides details about the result of the MC test of the indicated component.</p> <p>If the test succeeded, the message says the component is present and operational. If the test failed, the message says the component is unavailable.</p> <p>Recommended actions:</p> <ul style="list-style-type: none"> • If the event indicates the test failed, replace the controller module that logged this event.
	Info.	<p>This event provides details about the result of the MC test of the indicated component.</p> <p>Recommended actions:</p> <ul style="list-style-type: none"> • No action is required.
539	Info.	<p>For the indicated disk group, which was corrupted, the 'recreate' step of the group recovery was not successful or the 'recreate' step of the disk group recovery succeeded.</p> <p>Recommended actions:</p> <ul style="list-style-type: none"> • Verify that expected volumes have been recovered. • If the expected volumes were not recovered, the "recover volume" command may be used. • After verifying volume recovery, complete disk group recovery by running the 'recover disk-group complete' command.

Table 28. Event descriptions and recommended actions (continued)

Number	Severity	Description/Recommended actions
540	Info.	<p>The indicated volume, which was corrupted, has been recovered.</p> <p>Recommended actions:</p> <ul style="list-style-type: none"> • After verifying volume recovery, complete disk group recovery by running the 'recover disk-group complete' command.
541	Info.	<p>For the indicated disk group, which was corrupted, the 'complete' step of the disk group recovery succeeded.</p> <p>Recommended actions:</p> <ul style="list-style-type: none"> • No action is required.
544	Info.	<p>A disk group scrub operation exceeded its duration goal by 20%.</p> <p>The system will attempt to meet the scrub duration goals by adjusting system resources, but factors such as the amount of data or abnormally high host activity may cause scrub operations to exceed the requested duration.</p> <p>Recommended actions:</p> <ul style="list-style-type: none"> • If this event occurs repeatedly, the scrub duration goal should be increased to increase the likelihood that the goal can be met.
545	Warning	<p>A controller module is connected to a legacy enclosure midplane, resulting in degraded performance.</p> <p>Recommended actions:</p> <ul style="list-style-type: none"> • To achieve better performance, replace the enclosure's legacy chassis FRU with the latest version of the FRU.
546	Error	<p>The controller that logged this event killed the partner controller which has an incompatible host port configuration.</p> <p>Recommended actions:</p> <ul style="list-style-type: none"> • Replace the killed controller module with a controller module that has the same host port configuration as the surviving controller module.
548	Warning	<p>Disk group reconstruction failed.</p> <p>When a disk fails, reconstruction is performed using a spare disk. In this case, the reconstruction operation failed because unreadable data (uncorrectable media error) exists in at least one other disk in the disk group. Because of this, a portion of the data cannot be reconstructed.</p> <p>Recommended actions:</p> <ul style="list-style-type: none"> • If you do not have a backup copy of the data in the disk group, make a backup. • Note the configuration of the disk group, such as its size and host mappings. • Look for another event logged at approximately the same time that indicates a disk failure, such as event 8, 55, 58, or 412. Follow the recommended actions for that event. • Remove the disk group. • Re-add the disk group. • Restore the data from the backup to a new disk group.
549	Critical	<p>The indicated controller module detected that it recovered from an internal processor fault.</p> <p>Recommended actions:</p> <ul style="list-style-type: none"> • Replace the controller module.
550	Critical	<p>The read data path between the Storage Controller and the disk drives was detected to be unreliable. The Storage Controller took action to correct this.</p> <p>Recommended actions:</p> <ul style="list-style-type: none"> • Replace the controller.
551	Error	<p>An EMP reported one of the following for a power supply unit (PSU):</p> <ul style="list-style-type: none"> • The PSU is unable to communicate with the EMP.

Table 28. Event descriptions and recommended actions (continued)

Number	Severity	Description/Recommended actions
		<ul style="list-style-type: none"> ● The PSU in an enclosure does not have power supplied to it or has a hardware failure. ● The PSU is running with corrupted firmware. <p>Recommended actions:</p> <ul style="list-style-type: none"> ● If the EMP is unable to communicate with the indicated PSU: <ul style="list-style-type: none"> ○ Wait for at least 10 minutes and check if the error resolves. ○ If the error persists, check that all modules in the enclosure are fully seated in their slots and that their latches, if any, are locked. ○ If this does not resolve the issue, note down the PSU. Ensure the partner PSU is not degraded. If the partner PSU is degraded, contact technical support. ○ If the partner PSU is not degraded, remove and reinsert the indicated PSU.. ○ If this does not resolve the issue, the indicated FRU has probably failed and should be replaced. ● If one of the PSUs in an enclosure does not have power supplied to it or has a hardware failure: <ul style="list-style-type: none"> ○ Check that the indicated PSU is fully seated in its slot and that the PSU's latches, if any, are locked. ○ Check that each PSU has its switch turned on (if equipped with a switch). ○ Check that each power cable is firmly plugged into both the PSU and a functional electrical outlet. ○ If none of these recommended actions resolve the issue, the indicated PSU has probably failed and should be replaced. ● If a PSU is running with corrupted firmware: <ul style="list-style-type: none"> ○ The indicated PSU has failed and should be replaced. <p>When the problem is resolved, an event with the same code will be logged with Resolved severity.</p>
	Warning	<p>An EMP reported that a power supply unit (PSU) has been uninstalled.</p> <p>Recommended actions:</p> <ul style="list-style-type: none"> ● Check that the indicated PSU is in the indicated enclosure. ● If the PSU is not in the enclosure, install a PSU immediately. ● If the PSU is in the enclosure, ensure that the power supply is fully seated in its slot and that its latch is locked. ● If none of these recommended actions resolves the issue, the indicated FRU has failed and should be replaced. <p>When the problem is resolved, an event with the same code will be logged with Resolved severity.</p>
	Resolved	<p>A SES alert for a power supply in the indicated enclosure has been resolved.</p> <p>Recommended actions:</p> <ul style="list-style-type: none"> ● No action is required.
552	Error	<p>An EMP reported an alert condition.</p> <ul style="list-style-type: none"> ● A hardware failure has been detected and all fans in the indicated FRU have failed. ● The fan is unable to communicate with the EMP. <p>Recommended actions:</p> <ul style="list-style-type: none"> ● If a hardware failure has been detected and all fans in the indicated FRU have failed. <ul style="list-style-type: none"> ○ Inspect the system health information to determine which FRU contains the affected fans. Event 551 or 558 should give further information on the containing FRUs. ○ Replace the containing FRUs. ● If the fan is unable to communicate with the EMP. <ul style="list-style-type: none"> ○ Wait for at least 10 minutes and check if the error resolves. ○ If the error persists, check that all modules in the enclosure are fully seated in their slots and that their latches, if any, are locked. ○ If this does not resolve the issue, note down the FRU. Ensure the partner FRU is not degraded. If the partner FRU is degraded, contact technical support.

Table 28. Event descriptions and recommended actions (continued)

Number	Severity	Description/Recommended actions
		<ul style="list-style-type: none"> ○ If the partner FRU is not degraded, remove and reinsert the indicated FRU. ○ If these recommended actions do not resolve the issue, the indicated FRU has probably failed and should be replaced <p>When the problem is resolved, an event with the same code will be logged with Resolved severity.</p>
	Warning	<p>An EMP reported one of the following:</p> <ul style="list-style-type: none"> ● A fan in the indicated FRU has been uninstalled. ● A fan in the indicated FRU has failed and fan redundancy for the FRU has been lost. <p>Recommended actions:</p> <ul style="list-style-type: none"> ● If a fan in the indicated FRU has been uninstalled: <ul style="list-style-type: none"> ○ Check that the indicated FRU is in the indicated enclosure. ○ If the FRU is not in the enclosure, install the appropriate FRU immediately. ○ If the FRU is in the enclosure, ensure that the FRU is fully seated in its slot and that its latch is locked. ○ If these recommended actions do not resolve the issue, the indicated FRU has failed and should be replaced. ● If a fan in the indicated FRU has failed and fan redundancy for the FRU has been lost: <ul style="list-style-type: none"> ○ The indicated FRU has failed and should be replaced. <p>When the problem is resolved, an event with the same code will be logged with Resolved severity.</p>
	Resolved	<p>A SES alert for a fan in the indicated enclosure has been resolved.</p> <p>Recommended actions:</p> <ul style="list-style-type: none"> ● No action is required.
553	Error	<p>A temperature sensor reported an alert condition.</p> <ul style="list-style-type: none"> ● A temperature sensor is outside critical temperature threshold in the indicated FRU. ● The temperature sensor is not able to communicate with the EMP. <p>Recommended actions:</p> <ul style="list-style-type: none"> ● If temperature sensor is outside critical temperature threshold in the indicated FRU. <ul style="list-style-type: none"> ○ Check that the ambient temperature is not too warm. For the normal operating range, see your product's Hardware Installation and Maintenance Guide. ○ Check for any obstructions to the airflow. ○ Check that all modules in the enclosure are fully seated in their slots and that their latches, if any, are locked. ○ Check that all fans in the enclosure are running. ○ Check that there is a module or blank plate in every module slot in the enclosure. ○ If none of these recommended actions resolve the issue, the indicated FRU has probably failed and should be replaced. ● The temperature sensor is not able to communicate with the EMP. <ul style="list-style-type: none"> ○ Wait for at least 10 minutes and check if the error resolves. ○ If the error persists, check that all modules in the enclosure are fully seated in their slots and that their latches, if any, are locked. ○ If this does not resolve the issue, note down the FRU. Ensure the partner FRU is not degraded. If the partner FRU is degraded, contact technical support. ○ For all FRU types except the enclosure, if the partner FRU is not degraded, remove and reinsert the indicated FRU. ○ If the indicated FRU is the enclosure, set up a preventive maintenance window and power cycle the enclosure at that time. ○ If these recommended actions do not resolve the issue, the indicated FRU has probably failed and should be replaced. <p>When the problem is resolved, an event with the same code will be logged with Resolved severity.</p>

Table 28. Event descriptions and recommended actions (continued)

Number	Severity	Description/Recommended actions
	Warning	<p>A temperature sensor is not within normal operating temperature thresholds but is within safe operating limits; or, a temperature sensor has been uninstalled.</p> <p>Recommended actions:</p> <ul style="list-style-type: none"> ● If a temperature sensor has exceeded the normal operating range but is within safe operating limits. <ul style="list-style-type: none"> ○ Check that the ambient temperature is not too warm. For the normal operating range, see your product's Hardware Installation and Maintenance Guide. ○ Check for any obstructions to the airflow. ● If a temperature sensor has been uninstalled: <ul style="list-style-type: none"> ○ Check that the indicated FRU is in the indicated enclosure. ● If the FRU is not in the enclosure, install the FRU immediately. ● If the FRU is in the enclosure, ensure that the FRU is fully seated in its slot and that its latches, if any, are locked. <p>When the problem is resolved, an event with the same code will be logged with Resolved severity.</p>
	Resolved	<p>A SES alert for a temperature sensor in the indicated enclosure has been resolved.</p> <p>Recommended actions:</p> <ul style="list-style-type: none"> ● No action is required.
554	Error	<p>A voltage sensor reported an alert condition.</p> <ul style="list-style-type: none"> ● A voltage sensor is outside a critical voltage threshold in the indicated FRU. ● A voltage sensor is not able to communicate with the EMP. <p>Recommended actions:</p> <ul style="list-style-type: none"> ● If a voltage sensor is outside a critical voltage threshold in the indicated FRU: <ul style="list-style-type: none"> ○ Check that all modules in the enclosure are fully seated in their slots and that their latches, if any, are locked. ○ If this does not resolve the issue, the indicated FRU has probably failed and should be replaced. ● If the voltage sensor is not able to communicate with the EMP: <ul style="list-style-type: none"> ○ Wait for at least 10 minutes and check if the error resolves. ○ If the error persists, check that all modules in the enclosure are fully seated in their slots and that their latches, if any, are locked. ○ If this does not resolve the issue, ensure the partner FRU is not degraded. If the partner FRU is degraded, contact technical support. ○ For all FRU types except the enclosure, if the partner FRU is not degraded, remove and reinsert the indicated FRU. ○ If the indicated FRU is the enclosure, set up a preventive maintenance window and power cycle the enclosure at that time. ○ If these recommended actions do not resolve the issue, the indicated FRU has probably failed and should be replaced. <p>When the problem is resolved, an event with the same code will be logged with Resolved severity.</p>
	Warning	<p>A voltage sensor is not within the normal operating range but is within safe operating limits; or, a voltage sensor has been removed.</p> <p>Recommended actions:</p> <ul style="list-style-type: none"> ● If a voltage sensor has exceeded the normal operating range but is within safe operating limits: <ul style="list-style-type: none"> ○ Check that all modules in the enclosure are fully seated in their slots and that their latches are locked. ○ If this does not resolve the issue, the indicated FRU has probably failed and should be replaced. ● If a voltage sensor has been removed:

Table 28. Event descriptions and recommended actions (continued)

Number	Severity	Description/Recommended actions
		<ul style="list-style-type: none"> ○ Check that the indicated FRU is in the indicated enclosure. ○ If the FRU is not in the enclosure, install the FRU immediately. ○ If the FRU is in the enclosure, ensure that the FRU is fully seated in its slot and that its latches are locked. ○ If these recommended actions do not resolve the issue, the indicated FRU has probably failed and should be replaced. <p>When the problem is resolved, an event with the same code will be logged with Resolved severity.</p>
	Resolved	<p>A SES alert for a voltage sensor in the indicated enclosure has been resolved.</p> <p>Recommended actions:</p> <ul style="list-style-type: none"> ● No action is required.
555	Error	<p>The local Expander Controller firmware has detected a level of incompatibility with the partner Expander Controller firmware or hardware. As a preventive measure, the local Expander Controller may disable all the PHYs.</p> <p>Recommended actions:</p> <ul style="list-style-type: none"> ● Check that both the Expander Controllers have the correct firmware revision. ● If both Expander Controllers have different firmware versions, upgrade the partner controller module to the appropriate firmware that is compatible with the enclosure. ● If these recommended actions do not resolve the issue, replace the partner controller module. <p>When the problem is resolved, an event with the same code will be logged with Resolved severity.</p>
	Warning	<p>An expander in a controller module, expansion module, or drawer is mated but is not responding; or, an expander in an expansion module has been removed.</p> <p>Recommended actions:</p> <ul style="list-style-type: none"> ● Check that the indicated FRU is in the indicated enclosure. ● If the FRU is not in the enclosure, install the appropriate FRU immediately. ● If the FRU is in the enclosure, ensure that the FRU is fully seated in its slot and that its latches, if any, are locked. ● If these recommended actions do not resolve the issue, the indicated FRU has failed and should be replaced. <p>When the problem is resolved, an event with the same code will be logged with Resolved severity.</p>
	Resolved	<p>A SES alert for an expander in the indicated enclosure has been resolved.</p> <p>Recommended actions:</p> <ul style="list-style-type: none"> ● No action is required.
556	Error	<p>An alert condition was detected on a root expander or drawer expander element.</p> <p>Recommended actions:</p> <ul style="list-style-type: none"> ● Replace the module that contains the indicated expander. This could be an IOM, sideplane or a drawer. Contact technical support for replacement of the module containing the drawer expander. <p>⚠ CAUTION: The sideplanes on the enclosure drawers are not hot swappable or customer serviceable.</p> <ul style="list-style-type: none"> ● If these recommended actions do not resolve the issue, contact technical support. The enclosure must be replaced. <p>When the problem is resolved, an event with the same code will be logged with Resolved severity.</p>
	Warning	<p>An alert condition was detected on a root expander or drawer expander element.</p> <p>Recommended actions:</p>

Table 28. Event descriptions and recommended actions (continued)

Number	Severity	Description/Recommended actions
		<ul style="list-style-type: none"> If uninstalled, the expander associated with the sideplane or drawer will have to be installed. Contact technical support. Otherwise, replace the module that contains the indicated expander. This could be a sideplane or a drawer. Contact technical support for replacement of the module containing the drawer expander. <p>⚠ CAUTION: The sideplanes on the enclosure drawers are not hot swappable or customer serviceable.</p> <ul style="list-style-type: none"> If these recommended actions do not resolve the issue, contact technical support. The enclosure must be replaced. <p>When the problem is resolved, an event with the same code will be logged with Resolved severity.</p>
	Resolved	<p>A SES alert for an expander in the indicated enclosure has been resolved.</p> <p>Recommended actions:</p> <ul style="list-style-type: none"> No action is required.
557	Error	<p>An Enclosure Management Processor (EMP) reported an alert condition on a current sensor.</p> <ul style="list-style-type: none"> The EMP is unable to communicate with the indicated current sensor. The current sensor is outside critical threshold values. <p>Recommended actions:</p> <ul style="list-style-type: none"> If the EMP is unable to communicate with the indicated current sensor: <ul style="list-style-type: none"> Wait for at least 10 minutes and check if the error resolves. If the error persists, check that all modules in the enclosure are fully seated in their slots and that their latches, if any, are locked. If this does not resolve the issue, ensure the partner FRU is not degraded. If the partner FRU is degraded, contact technical support. For all FRU types except the enclosure, if the partner FRU is not degraded, remove and reinsert the indicated FRU. If the indicated FRU is the enclosure, set up a preventive maintenance window and power cycle the enclosure at that time. If these recommended actions do not resolve the issue, the indicated FRU has probably failed and should be replaced. If the current sensor is outside critical threshold values: <ul style="list-style-type: none"> Check that all modules in the enclosure are fully seated in their slots and that their latches, if any, are locked. If these recommended actions do not resolve the issue, the indicated FRU has probably failed and should be replaced. <p>When the problem is resolved, an event with the same code will be logged with Resolved severity.</p>
	Warning	<p>An Enclosure Management Processor (EMP) reported an alert condition on a current sensor.</p> <ul style="list-style-type: none"> A current sensor is outside the defined warning threshold values. A current sensor has been uninstalled. <p>Recommended actions:</p> <ul style="list-style-type: none"> If a current sensor has exceeded the defined warning threshold values: <ul style="list-style-type: none"> Check that all modules in the enclosure are fully seated in their slots and that their latches, if any are locked. If this does not resolve the issue, the indicated FRU has probably failed and should be replaced. If a current sensor has been uninstalled: <ul style="list-style-type: none"> Check that the indicated FRU is in the indicated enclosure. If the FRU is not in the enclosure, install the FRU immediately. If the FRU is in the enclosure, ensure that the FRU is fully seated in its slot and that its latches, if any, are locked. If these recommended actions do not resolve the issue, the indicated FRU has probably failed and should be replaced.

Table 28. Event descriptions and recommended actions (continued)

Number	Severity	Description/Recommended actions
		When the problem is resolved, an event with the same code will be logged with Resolved severity.
	Resolved	A SES alert for a current sensor in the indicated enclosure has been resolved. Recommended actions: <ul style="list-style-type: none"> • No action is required.
562	Info.	Virtual pool statistics have been reset. Recommended actions: <ul style="list-style-type: none"> • No action is required.
563	Info.	A disk has been restarted. Recommended actions: <ul style="list-style-type: none"> • No action is required.
565	Warning	One of the PCIe buses is running at less than optimal speed. This event is the result of a hardware problem that has caused the controller to run slower than expected. The system works, but I/O performance is degraded. Recommended actions: <ul style="list-style-type: none"> • Restart the controller that logged the event. If the problem persists, replace the controller module.
566	Info.	One of the DDR ports has been busy for at least 5 minutes. This event is the result of a speed compensation while handling short data blocks. The system is operational but I/O performance is degraded. Recommended actions: <ul style="list-style-type: none"> • No action is required.
568	Info.	A disk group has mixed physical sector size disks (for example 512n and 512e disks in the same disk group). This event is the result of the user selecting disks with sector formats that do not match or a global spare replacement with a different sector format than the disk group. This could result in degraded performance for some workloads. Recommended actions: <ul style="list-style-type: none"> • No action is required.
569	Warning	A SAS host cable mismatch has been detected for port. The indicated alternate PHYs have been disabled. For example, a fan-out cable is connected to a controller module host port but the port is configured to use standard SAS cables, or vice versa. Recommended actions: <ul style="list-style-type: none"> • To use the connected cable, use the CLI 'set host-parameters' command to configure ports to use the proper cable type. • Otherwise, replace the cable with the type of cable that the port is configured to use. • When the problem is resolved, an event with the same code will be logged with Resolved severity.
	Resolved	A previously detected SAS host cable mismatch has been resolved for port. The proper cable type has been connected. Recommended actions: <ul style="list-style-type: none"> • No action is required.
571	Error	Allocated snapshot space exceeded the configured percentage limit of the virtual pool.

Table 28. Event descriptions and recommended actions (continued)

Number	Severity	Description/Recommended actions
		<p>If the snapshot space limit policy is set to delete snapshots, the system will begin to delete snapshots according to the snapshot retention priority setting until the snapshot space usage drops below the configured limit. Otherwise, the system will begin to use general pool space for snapshots until snapshots are manually deleted. If the storage usage drops below a threshold, event 572 is logged.</p> <p>Recommended actions:</p> <ul style="list-style-type: none"> • If the snapshot space limit policy is set to notify only, you should immediately take steps to reduce snapshot space usage or add storage capacity. • If the snapshot space policy is set to delete, the system will reduce snapshot space automatically, or log event 573 if no snapshots can be deleted.
	Warning	<p>Allocated snapshot space exceeded the high snapshot space threshold.</p> <p>The high threshold setting indicates that the pool is nearly out of snapshot space. The threshold settings are intended to indicate that the pool is using a significant portion of configured snapshot space and should be monitored. If the storage usage drops below any threshold, event 572 is logged.</p> <p>Recommended actions:</p> <ul style="list-style-type: none"> • Reduce the snapshot space usage by deleting snapshots that are no longer needed.
	Info.	<p>Allocated snapshot space exceeded either the low or middle snapshot space threshold.</p> <p>The threshold settings are intended to indicate that the pool is using a significant portion of configured snapshot space and should be monitored. If the storage usage drops below any threshold, event 572 is logged.</p> <p>Recommended actions:</p> <ul style="list-style-type: none"> • Reduce the snapshot space usage by deleting snapshots that are no longer needed.
572	Info.	<p>The indicated virtual pool has dropped below one of its snapshot space thresholds.</p> <p>This event indicates that a condition reported by event 571 is no longer applicable.</p> <p>Recommended actions:</p> <ul style="list-style-type: none"> • No action is required.
573	Warning	<p>Allocated snapshot space for a virtual pool cannot be reduced because no snapshots are deletable.</p> <p>Allocated snapshots cannot be automatically deleted if their retention priority is set to never-delete. Snapshots must also be at the leaf end of a snapshot tree in order to be considered deletable. This event is logged when no snapshots in the pool pass these constraints.</p> <p>Recommended actions:</p> <ul style="list-style-type: none"> • Manually delete snapshots to reduce allocated snapshot space.
574	Info.	<p>A peer connection was created.</p> <p>Recommended actions:</p> <ul style="list-style-type: none"> • No action is required.
575	Info.	<p>A peer connection was deleted.</p> <p>Recommended actions:</p> <ul style="list-style-type: none"> • No action is required.
576	Info.	<p>A replication set was created, or a replication set failed to be created.</p> <p>Recommended actions:</p> <ul style="list-style-type: none"> • No action is required.
577	Error	<p>A replication set failed to be deleted.</p> <p>Recommended actions:</p>

Table 28. Event descriptions and recommended actions (continued)

Number	Severity	Description/Recommended actions
		<ul style="list-style-type: none"> No action is required.
	Info.	<p>A replication set was deleted.</p> <p>Recommended actions:</p> <ul style="list-style-type: none"> No action is required.
578	Error	<p>A replication failed to start.</p> <p>The replication was unsuccessful due to the condition specified within the event. Reasons for replication failure include but are not limited to shutdown of the secondary system, a loss of communication across the peer connection (which may be due to CHAP configuration changes), or a pool out-of-space condition.</p> <p>Recommended actions:</p> <ul style="list-style-type: none"> Resolve the issue specified by the error message included with this event.
	Info.	<p>A replication was started.</p> <p>Recommended actions:</p> <ul style="list-style-type: none"> No action is required.
579	Warning	<p>A replication completed with failure.</p> <p>The replication was unsuccessful due to the condition specified within the event. Reasons for replication failure include but are not limited to shutdown of the secondary system, a loss of communication across the peer connection (which may be due to CHAP configuration changes), or a pool out of space condition.</p> <p>Recommended actions:</p> <ul style="list-style-type: none"> Resolve the issue specified by the error message included with this event.
	Info.	<p>A replication completed successfully.</p> <p>Recommended actions:</p> <ul style="list-style-type: none"> No action is required.
580	Info.	<p>A replication was aborted.</p> <p>Recommended actions:</p> <ul style="list-style-type: none"> No action is required.
581	Warning	<p>A replication was suspended internally by the system.</p> <p>The system will suspend the replication internally if it detects an error condition in the replication set and replications cannot continue for any reason. This includes but is not limited to shutdown of the secondary system, a loss of communication across the peer connection (which may be due to CHAP configuration changes), or a pool out-of-space condition.</p> <p>Recommended actions:</p> <ul style="list-style-type: none"> The replication will automatically resume once the condition described in this event is cleared.
	Info.	<p>A replication was suspended by the user.</p> <p>Recommended actions:</p> <ul style="list-style-type: none"> No action is required.
582	Info.	<p>A replication has queued behind the active replication.</p> <p>Recommended actions:</p> <ul style="list-style-type: none"> No action is required.
583	Error	<p>The replication set was not reversed due to a failure.</p>

Table 28. Event descriptions and recommended actions (continued)

Number	Severity	Description/Recommended actions
		<p>During the Failback Restore operation, the replication direction for a replication set was not reversed due to a failure.</p> <p>Recommended actions:</p> <ul style="list-style-type: none"> ● If an issue with the peer connection was reported, check that appropriate interface cables are connected to the host ports defined in the peer connection. ● If the appropriate cables are connected, check the cables and any network switches for problems. ● Otherwise, check the peer connection for invalid configuration.
	Info.	<p>The replication direction for a replication set was reversed. Secondary is now primary. Primary is now secondary.</p> <p>During the Failback Restore operation, the replication direction for a replication set was reversed.</p> <p>Recommended actions:</p> <ul style="list-style-type: none"> ● No action is required.
584	Info.	<p>A peer connection was modified.</p> <p>Recommended actions:</p> <ul style="list-style-type: none"> ● No action is required.
585	Info.	<p>A replication set was modified.</p> <p>Recommended actions:</p> <ul style="list-style-type: none"> ● No action is required.
586	Error	<p>Resuming the replication was unsuccessful due to the condition specified within the event. Reasons for replication failure include but are not limited to shutdown of the secondary system, a loss of communication across the peer connection (which may be due to CHAP configuration changes), or a pool out-of-space condition.</p> <p>Recommended actions:</p> <ul style="list-style-type: none"> ● Resolve the issue specified by the error message included with this event.
	Info.	<p>A replication was resumed.</p> <p>Recommended actions:</p> <ul style="list-style-type: none"> ● No action is required.
587	Info.	<p>A pending replication was removed from the queue.</p> <p>Recommended actions:</p> <ul style="list-style-type: none"> ● No action is required.
588	Info.	<p>A replication set was failed over.</p> <p>During the Failback Restore operation, a replication set was failed over</p> <p>Recommended actions:</p> <ul style="list-style-type: none"> ● No action is required.
589	Info.	<p>A replication set completed the Failback No Restore operation or failed to complete the Failback No Restore operation.</p> <p>Recommended actions:</p> <ul style="list-style-type: none"> ● No action is required.
590	Error	<p>A disk group has been quarantined.</p> <p>This condition resulted from a controller flush/restore failure.</p> <p>Recommended actions:</p>

Table 28. Event descriptions and recommended actions (continued)

Number	Severity	Description/Recommended actions
		<ul style="list-style-type: none"> ● To restore the disk group, use the CLI <code>dequarantine</code> command to dequarantine the disk group. If more than one disk group is quarantined you must individually dequarantine each disk group, whether it is fault tolerant or not. When dequarantine is complete, the disk group will return to the state it was in before being quarantined. For example, if the disk group was reconstructing before being quarantined, the disk group will resume reconstructing where it stopped ● For a linear disk group, if you want to find where parity is incorrect, use the CLI <code>scrub vdisk</code> command with the <code>fix</code> parameter disabled. This step is optional and not required to fix data integrity issues ● For a fault tolerant disk group, run either <code>scrub disk-groups</code> for a virtual disk group or <code>scrub vdisk</code> with the <code>fix</code> parameter enabled for a linear disk group. This step will make the parity consistent with the existing user data, and is required to fix data integrity issues. ● For a reconstructing disk group, let reconstruction finish, then run either <code>scrub disk-groups</code> for a virtual disk group or <code>scrub vdisk</code> with the <code>fix</code> parameter enabled for a linear disk group. This step will make the parity consistent with the existing user data, and is required to fix data integrity issues. ● Restore the data to the disk group from a backup copy.
593	Info.	<p>A PCIe bus has transitioned to a different speed.</p> <p>Recommended actions:</p> <ul style="list-style-type: none"> ● No action is required.
594	Info.	<p>The indicated disk in the indicated disk group is missing and the disk group is quarantined. While the disk group is quarantined, in linear storage any attempt to access its volumes from a host will fail. In virtual storage, all volumes in the pool will be forced read-only. If all of the disks become accessible, the disk group will be dequarantined automatically with a resulting status of FTOL. If not all of the disks become accessible but enough become accessible to allow reading from and writing to the disk group, it will be dequarantined automatically with a resulting status of FTDN or CRIT. If a spare disk is available, reconstruction will begin automatically. When the disk group has been removed from quarantine, event 173 is logged. For a more detailed discussion of dequarantine, see the PowerVault Manager or CLI documentation.</p> <p>⚠ CAUTION:</p> <ul style="list-style-type: none"> ● Avoid using the manual dequarantine operation as a recovery method when event 172 is logged because this causes data recovery to be more difficult or impossible. ● If you clear unwritten cache data while a disk group is quarantined or offline, that data will be permanently lost. <p>Recommended actions:</p> <ul style="list-style-type: none"> ● If event 173 has subsequently been logged for the indicated disk group, no action is required. The disk group has already been removed from quarantine. ● Otherwise, perform the following actions: <ul style="list-style-type: none"> ○ Check that all enclosures are powered on. ○ Check that all disks and I/O modules in every enclosure are fully seated in their slots and that their latches are locked. ○ Reseat any disks in the quarantined disk group that are reported as missing or failed in the user interface. (Do NOT remove and reinsert disks that are not members of the disk group that is quarantined.) ○ Check that the SAS expansion cables are connected between each enclosure in the storage system and that they are fully seated. (Do NOT remove and reinsert the cables because this can cause problems with additional disk groups.) ○ Check that no disks have been removed from the system unintentionally. ○ Check for other events that indicate faults in the system and follow the recommended actions for those events. But, if the event indicates a failed disk and the recommended action is to replace the disk, do NOT replace the disk at this time because it may be needed later for data recovery.

Table 28. Event descriptions and recommended actions (continued)

Number	Severity	Description/Recommended actions
		<ul style="list-style-type: none"> ○ If the disk group is still quarantined after performing the preceding steps, shut down both controllers and then power down the entire storage system. Power it back up, beginning with any disk enclosures (expansion enclosures), then the controller enclosure. ○ If the disk group is still quarantined after performing the preceding steps, contact technical support.
595	Info.	<p>This event reports the serial number of each controller module in this system.</p> <p>Recommended actions:</p> <ul style="list-style-type: none"> ● No action is required.
596	Warning	<p>Enclosure fault protection has been compromised for the indicated disk group.</p> <p>To replace the failed disk, the system was unable to find a spare that met requirements to minimize the risk of data loss in the event of enclosure failure, so the system had to select a spare that did not meet the requirements. For a RAID-6 disk group, this means that more than two member disks are in the same enclosure. For other RAID levels, this means that more than one member disk is in the same enclosure.</p> <p>Recommended actions:</p> <ul style="list-style-type: none"> ● Replace the indicated failed disk in the indicated enclosure to restore enclosure fault protection.
597	Warning	<p>Drawer fault protection has been compromised for the indicated disk group.</p> <p>To replace the failed disk, the system was unable to find a spare that met requirements to minimize the risk of data loss in the event of drawer failure, so the system had to select a spare that did not meet the requirements. For a RAID-6 disk group, this means that more than two member disks are in the same drawer. For other RAID levels, this means that more than one member disk is in the same drawer.</p> <p>Recommended actions:</p> <ul style="list-style-type: none"> ● Replace the indicated failed disk in the indicated enclosure to restore drawer fault protection.
598	Warning, Info.	<p>Drive has failed a performance measurement.</p> <p>Recommended actions:</p> <ul style="list-style-type: none"> ● Monitor the disk.
599	Error	<p>The firmware has yet to retrieve Enclosure Power control status.</p> <p>The Enclosure Power element provides enclosure level power control. This could occur shortly after a reboot or module insertion. It should only be treated as an error if it persists for more than 30 seconds after a reset.</p> <p>Recommended actions:</p> <ul style="list-style-type: none"> ● Contact technical support. ● When the problem is resolved, an event with the same code will be logged with Resolved severity.
	Warning, Resolved	<p>The firmware has yet to retrieve Enclosure Power control status.</p> <p>The Enclosure Power element provides enclosure level power control.</p> <p>Recommended actions:</p> <ul style="list-style-type: none"> ● No action is required.
602	Error, Warning	<p>An alert condition was detected on a Midplane Interconnect element.</p> <p>The Midplane Interconnect element reports status associated with the interface between the SBB I/O module and the midplane. This is typically some form of communication problem on the midplane interconnect.</p> <p>Recommended actions:</p> <ul style="list-style-type: none"> ● Contact technical support. Provide logs to technical support personnel for analysis.

Table 28. Event descriptions and recommended actions (continued)

Number	Severity	Description/Recommended actions
	Resolved	<ul style="list-style-type: none"> • When the problem is resolved, an event with the same code will be logged with Resolved severity. <p>A previous Warning or Error condition for the Midplane Interconnect element has been resolved. The Midplane Interconnect element reports status associated with the interface between the SBB I/O module and the midplane.</p> <p>Recommended actions:</p> <ul style="list-style-type: none"> • No action is required.
603	Error, Warning	<p>An alert condition for a SAS Connector element has been detected.</p> <p>The SAS Connector element report status information for both external and internal SAS port connectors.</p> <p>Recommended actions:</p> <ul style="list-style-type: none"> • Contact technical support. • When the problem is resolved, an event with the same code will be logged with Resolved severity.
	Info., Resolved	<p>An alert condition for a SAS Connector element has been detected.</p> <p>The SAS Connector element report status information for both external and internal SAS port connectors.</p> <p>Recommended actions:</p> <ul style="list-style-type: none"> • No action is required.
604	Warning	<p>A replication snapshot was attempted and failed.</p> <p>A replication-set has been configured to retain snapshots of the volume. An error is possible if the snapshot fails.</p> <p>Recommended actions:</p> <ul style="list-style-type: none"> • Monitor the health of the local system, the replication-set, the volume, and the peer-connection. A full storage pool may be the cause of this fault. <ul style="list-style-type: none"> ○ Check the peer-connection system health and state. ○ Ensure that the Maximum Licensable Snapshots limit (shown by the CLI <code>show license</code> command) was not exceeded.
605	Warning	<p>Inactive processing core.</p> <p>The controller module has multiple processing cores. The system has enough active cores to operate but performance is degraded.</p> <p>Recommended actions:</p> <ul style="list-style-type: none"> • Attempt to restart all the processing cores as follows: <ul style="list-style-type: none"> ○ Shut down the controller module that logged this event. ○ Remove the controller module, wait 30 seconds, and then reinsert the controller module. • If this event is logged again, contact technical support.
606	Error	<p>A controller contains unwritten cache data for a volume, and its supercapacitor has failed to charge.</p> <p>Due to the supercapacitor failure, if the controller loses power, it will not have backup power to flush the unwritten data from cache to eMMC.</p> <p>Recommended actions:</p> <ul style="list-style-type: none"> • Verify that the cache-write policy is write-through for all volumes. • Contact technical support for information about replacing the controller module.
607	Warning	<p>The local controller is rebooting the other controller.</p> <p>Recommended actions:</p>

Table 28. Event descriptions and recommended actions (continued)

Number	Severity	Description/Recommended actions
		<ul style="list-style-type: none"> No action is required.
608	Error	<p>A back-end cabling error was detected.</p> <p>Recommended actions:</p> <ul style="list-style-type: none"> If the message says both controllers are connected with a undefined error type, one of the cables is incorrectly connected to a controller egress port forming a loop in the SAS topology. Check back-end cabling from each controller egress port to determine the incorrect connection. If the message says controller egress ports are connected to each other, one of the cables is incorrectly connected to a controller egress port forming a loop in the SAS topology. Check back-end cabling and make sure that SAS cables are connected to the correct ports for the port specified. If the message says an EBOD loop has been created, one of the cables is incorrectly connected to an expansion enclosure egress port forming a loop in the SAS topology. Check back-end cabling and make sure that SAS cables are connected to the correct ports for the port specified. If the message says a cable is connected to the middle port but that port is not supported, check back-end cabling and make sure that SAS cables are connected to the correct ports for the port specified. Move the cable from the middle port of the IOM to the left or right port, as appropriate.
609	Error	<p>An alert condition was detected on a door lock element. The door lock element reports status associated with the enclosure drawer. The drawer has been reporting as open for a long period of time. This may reduce cooling, potentially causing the enclosure to overheat.</p> <p>Recommended actions:</p> <ul style="list-style-type: none"> Check that the drawer is fully closed and latched. <p>When the problem is resolved, an event with the same code will be logged with Resolved severity.</p>
	Info.	<p>An alert condition was detected on a door lock element. The door lock element reports status associated with the enclosure drawer. The drawer sensor is reporting uninstalled.</p> <p>Recommended actions:</p> <ul style="list-style-type: none"> No action is required.
	Resolved	<p>A previous Informational or Error condition for the door lock element has been resolved.</p> <p>Recommended actions:</p> <ul style="list-style-type: none"> No action is required.
610	Error	<p>An alert condition was detected on a sideplane element.</p> <p>Recommended actions:</p> <ul style="list-style-type: none"> Check the drawer that the indicated sideplane is fully closed and latched. <p>⚠ CAUTION: The sideplanes on the enclosure drawers are not hot swappable or customer serviceable.</p> <ul style="list-style-type: none"> If this does not resolve the issue, contact technical support. The enclosure must be replaced.
	Warning	<p>An alert condition was detected on a sideplane element.</p> <p>Recommended actions:</p> <ul style="list-style-type: none"> The sideplane associated with the drawer must be installed. Contact technical support. <p>⚠ CAUTION: The sideplanes on the enclosure drawers are not hot swappable or customer serviceable.</p>
	Resolved	<p>A previous Warning or Error condition for the sideplane element has been resolved.</p> <p>Recommended actions:</p> <ul style="list-style-type: none"> No action is required.
611	Error	<p>Email notification failed due to either:</p>

Table 28. Event descriptions and recommended actions (continued)

Number	Severity	Description/Recommended actions
		<ul style="list-style-type: none"> An unreachable SMTP server or a difference between the sender and SMTP server domains. Improper configuration. <p>Recommended actions:</p> <ul style="list-style-type: none"> Verify the configured parameters and ask the recipients to confirm that they received the message.
	Info.	<p>Email notification sent successfully. Please ask the recipients to confirm that they received the message.</p> <p>Recommended actions:</p> <ul style="list-style-type: none"> Verify the configured parameters and ask the recipients to confirm that they received the message.
612	Info.	<p>An alert condition was detected on an internal chassis SAS connector.</p> <p>The event message specifies the location of the internal SAS connector in the chassis.</p> <p>Recommended actions:</p> <ul style="list-style-type: none"> No action is required.
613	Error	<p>An alert condition was detected on an IOM.</p> <p>Recommended actions:</p> <ul style="list-style-type: none"> Either install the indicated IOM or attempt to reseal it. If the problem persists, replace the IOM.
	Warning	<p>An alert condition was detected on an IOM.</p> <p>Recommended actions:</p> <ul style="list-style-type: none"> If uninstalled, install the indicated IOM otherwise attempt to reseal it. If the problem persists, replace the IOM.
	Info.	<p>An IOM was uninstalled.</p> <p>Recommended actions:</p> <ul style="list-style-type: none"> No action is required.
	Resolved	<p>A previous Warning or Error condition for the IOM has been resolved.</p> <p>Recommended actions:</p> <ul style="list-style-type: none"> No action is required.
614	Info.	<p>Cleared the degraded state of the indicated disk.</p> <p>Recommended actions:</p> <ul style="list-style-type: none"> No action is required.
615	Info.	<p>A rebalance operation for an ADAPT disk group has started.</p> <p>Recommended actions:</p> <ul style="list-style-type: none"> No action is required.
616	Warning	<p>A rebalance operation for an ADAPT disk group has completed partially.</p> <p>Recommended actions:</p> <ul style="list-style-type: none"> No action is required.
	Info.	<p>A rebalance operation for an ADAPT disk group has completed.</p> <p>Recommended actions:</p> <ul style="list-style-type: none"> No action is required.
617	Warning	<p>The spare capacity goal is not met.</p>

Table 28. Event descriptions and recommended actions (continued)

Number	Severity	Description/Recommended actions
		<p>This event indicates that the available space in the system is insufficient to provide the level of full fault tolerance that is specified by the target spare capacity. Spare capacity availability can be influenced by operations that require available space in the system, such as reconstructing data from a failed disk.</p> <p>Recommended actions:</p> <ul style="list-style-type: none"> • Add disks to the disk group, or replace any disks that may have failed. The system will automatically increase the spare capacity to meet the requirements placed on the system by the target spare capacity.
618	Resolved	<p>The spare capacity goal is met.</p> <p>Recommended actions:</p> <ul style="list-style-type: none"> • No action is required.
619	Info.	<p>The controller has been injected with a fault to introduce a broadcast receiver (BR) link error.</p> <p>Recommended actions:</p> <ul style="list-style-type: none"> • No action is required.
620	Error	<p>Expander zoning is enabled, which may limit disk access.</p> <p>Disk access will change depending on the port used to connect to the expander.</p> <p>Recommended actions:</p> <ul style="list-style-type: none"> • Load a valid firmware bundle to disable zoning.
	Resolved	<p>Expander zoning has been disabled for the indicated enclosure.</p> <p>Recommended actions:</p> <ul style="list-style-type: none"> • No action is required.
621	Info.	<p>Degraded ADAPT rebalance operation started. This operation takes fault tolerant stripe zones and makes them degraded so critical stripe zones can be made degraded.</p> <p>Recommended actions:</p> <ul style="list-style-type: none"> • No action is required.
622	Info.	<p>Degraded ADAPT rebalance operation completed. This operation takes fault tolerant stripe zones and makes them degraded so critical stripe zones can be made degraded.</p> <p>Recommended actions:</p> <ul style="list-style-type: none"> • No action is required.
623	Info.	<p>Management Controller configuration parameters were set.</p> <p>One or more configuration parameters associated with the Management Controller (MC) have been changed, such as configuration for SNMP, SMI-S (not supported on the ME5084), email notification, and system strings (system name, system location, etc.).</p> <p>Recommended actions:</p> <ul style="list-style-type: none"> • No action is required.
626	Info.	<p>Detected an unsupported TPID (midplane Type ID).</p> <p>Recommended actions:</p> <ul style="list-style-type: none"> • No action is required.
628	Error	<p>A firmware mismatch has been identified for the expansion enclosure.</p> <p>A firmware mismatch could result from attaching an enclosure configured as a JBOD (instead of an EBOD) or installing a new IOM FRU with incompatible firmware.</p> <p>Recommended actions:</p> <ul style="list-style-type: none"> • Update the firmware to the appropriate level for connecting your expansion enclosures to the controller enclosure.

Table 28. Event descriptions and recommended actions (continued)

Number	Severity	Description/Recommended actions
		<ul style="list-style-type: none"> If you receive this event when no new enclosures or IOMs have been added, please contact support.
630	Info	<p>A disk has started a remanufacture/rebuild operation. The operation will result in reduced capacity. Do not replace the disk until the remanufacture/rebuild operation is complete. This operation can take a long time, and the completion is indicated by event 631.</p> <p>Recommended actions:</p> <ul style="list-style-type: none"> No action is required.
631	Warning	<p>A remanufacture/rebuild operation failed. The disk should be replaced.</p> <p>Recommended actions:</p> <ul style="list-style-type: none"> Replace the disk with one of the same type and the same or greater capacity. For continued optimum I/O performance, the replacement disk should have performance that is the same as or better than the disk it is replacing.
	Info	<p>A disk remanufacture/rebuild operation completed successfully.</p> <p>Recommended actions:</p> <ul style="list-style-type: none"> No action is required.
632	Error	<p>A flush restore failure occurred. An integrity check failed on data restored from cache.</p> <p>Recommended actions:</p> <ul style="list-style-type: none"> o Allow time for the partner controller to recover the data and unkill the controller.
635	Warning	<p>An I/O controller PHY setting was changed by a user.</p> <p>Recommended actions:</p> <ul style="list-style-type: none"> No action is required.
636	Error	<p>The other controller killed this controller for an unknown reason. The system will automatically recover.</p> <p>Recommended actions:</p> <ul style="list-style-type: none"> Collect the logs and contact technical support for further action.
637	Error	<p>The other controller killed this controller because it stopped responding via the inter-controller heartbeat. The system will automatically recover.</p> <p>Recommended actions:</p> <ul style="list-style-type: none"> Collect the logs and contact technical support for further action.
638	Error	<p>This is an illegal access to memory by the CPU. The system will automatically recover.</p> <p>Recommended actions:</p> <ul style="list-style-type: none"> Collect the logs and contact technical support for further action.
639	Error	<p>Access violation in the software. The system will automatically recover.</p> <p>Recommended actions:</p> <ul style="list-style-type: none"> Collect the logs and contact technical support for further action.
640	Error	<p>The software attempted to divide by 0. The system will automatically recover.</p> <p>Recommended actions:</p> <ul style="list-style-type: none"> Collect the logs and contact technical support for further action.
641	Error	<p>Detected an Assert or OSM debug error. The system will automatically recover.</p> <p>Recommended actions:</p> <ul style="list-style-type: none"> Collect the logs and contact technical support for further action.
642	Error	<p>Detected a PCI fault error. The system will automatically recover.</p>

Table 28. Event descriptions and recommended actions (continued)

Number	Severity	Description/Recommended actions
		<p>Recommended actions:</p> <ul style="list-style-type: none"> Collect the logs and contact technical support for further action.
643	Error	<p>Detected a non-maskable interrupt fault error. The system will automatically recover.</p> <p>Recommended actions:</p> <ul style="list-style-type: none"> Collect the logs and contact technical support for further action.
644	Error	<p>Unable to upload firmware to the system because the encryption or bundle signature is invalid.</p> <p>Recommended actions:</p> <ul style="list-style-type: none"> Verify that you are using the correct firmware bundle.
	Warning	<p>Unable to upload firmware to the system because the firmware bundle is using an outdated format.</p> <p>Recommended actions:</p> <ul style="list-style-type: none"> Verify that you are using the correct firmware bundle.
	Info.	<p>Successfully uploaded firmware to the system.</p> <p>Recommended actions:</p> <ul style="list-style-type: none"> No action is required.
645	Critical	<p>Could not retrieve valid FRU data. Recommended actions:</p> <ul style="list-style-type: none"> Collect the logs and contact technical support for further action.
646	Info.	<p>Indicates any of the following changes to SupportAssist:</p> <ul style="list-style-type: none"> State changed Contact information changed Proxy settings changed or cleared Operation mode changed Settings changed <p>Recommended actions:</p> <ul style="list-style-type: none"> No action is required.
647	Error	<p>This Storage Controller is restarting due to an internal error.</p> <p>This Storage Controller experienced a management-interface hang and will restart to recover.</p> <p>Recommended actions:</p> <ul style="list-style-type: none"> Collect the logs and contact technical support for further action.
648	Error	<p>Failed to upload SupportAssist logs or CloudIQ configuration or performance data.</p> <p>Recommended actions:</p> <ul style="list-style-type: none"> No action is required.
649	Warning	<p>A controller firmware update is available for your system.</p> <p>Recommended actions:</p> <ul style="list-style-type: none"> Go to https://dell.com/support, enter your service tag and download the update. You can then use the Update Firmware function in PowerVault Manager to perform the update.
650	Warning	<p>A disk firmware update is available for your system.</p> <p>Recommended actions:</p> <ul style="list-style-type: none"> Go to https://dell.com/support, enter your service tag and download the update. You can then use the Update Firmware function in PowerVault Manager to perform the update.
655	Info.	<p>SupportAssist telemetry send failed/succeeded. (Payload type: CloudIQ Config)</p> <p>Recommended actions:</p>

Table 28. Event descriptions and recommended actions (continued)

Number	Severity	Description/Recommended actions
		<ul style="list-style-type: none"><li data-bbox="435 271 703 300">• No action is required.

Connecting to the CLI

You can access the CLI using a micro USB cable and terminal emulation software.

1. Connect a micro USB cable from a computer to the CLI port on controller module A .
2. Start a terminal emulator and configure the following display settings and the connection settings:

Table 29. Terminal emulator display settings

Parameter	Value
Terminal emulation mode	VT-100 or ANSI (for color support)
Font	Terminal
Translations	None
Columns	80

Table 30. Terminal emulator connection settings

Parameter	Value
Connector	COM3 (for example) ^{1,2}
Baud rate	115,200
Data bits	8
Parity	None
Stop bits	1
Flow control	None

¹ Your computer configuration determines which COM port is used for the Disk Array USB Port.

² Verify the appropriate COM port for use with the CLI.

3. If necessary, press Enter to display login prompt.
 - a. Type the user name of a user with the manage role at the login prompt and press Enter.
 - b. Type the password for the user at the Password prompt and press Enter.

Topics:

- [Micro-USB device connection](#)

Micro-USB device connection

The following sections describe the connection to the micro-USB port:

Emulated serial port

When a computer is connected to a controller module using a micro-USB cable, the controller presents an emulated serial port to the computer. The name of the emulated serial port is displayed using a *customer vendor ID* and *product ID*. Serial port configuration is unnecessary.

NOTE: Certain operating systems require a device driver or special mode of operation to enable proper functioning of the USB CLI port. See also [Device driver/special operation mode](#).

Supported host applications

The following terminal emulator applications can be used to communicate with an ME5 Series controller module:

Table 31. Supported terminal emulator applications

Application	Operating system
PuTTY	Microsoft Windows (all versions)
Minicom	Linux (all versions)

Command-line interface

When the computer detects a connection to the emulated serial port, the controller awaits input of characters from the computer using the command-line interface. To see the CLI prompt, you must press Enter.

 **NOTE:** Directly cabling to the micro-USB port is considered an out-of-band connection. The connection to the micro-USB port is outside of the normal data paths to the controller enclosure.

Device driver/special operation mode

Certain operating systems require a device driver or special mode of operation. The following table displays the product and vendor identification information that is required for certain operating systems:

Table 32. USB identification code

USB identification code type	Code
USB Vendor ID	0x210C
USB Product ID	0xA4A7

Microsoft Windows drivers

Windows Server 2016 and later operating systems provide a native USB serial driver that supports the micro-USB port.

Linux drivers

Linux operating systems do not require the installation of an ME5 Series USB driver. However, certain parameters must be provided during driver loading to enable recognition of the micro-USB port on an ME5 Series controller module.

Type the following command to load the Linux device driver with the parameters that are required to recognize the micro-USB port:

```
# modprobe usbserial vendor=0x210c product=0xa4a7 use_acm=1
```

 **NOTE:** Optionally, this information can be incorporated into the `/etc/modules.conf` file.

Technical specifications

Enclosure dimensions

Table 33. 2U12 and 2U24 enclosure dimensions

Specification	mm	inches
Height	87.9 mm	3.46 in
Width	483 mm	19.01 in
Depth (2U12)	618.7 mm	24.36 in
Depth (2U24)	547.8 mm	21.56 in

NOTE:

- The 2U12 enclosure uses 3.5" LFF disks.
- The 2U24 enclosure uses 2.5" SFF disks.

Table 34. 5U84 enclosure dimensions

Specification	mm	inches
Height	222.3 mm	8.75 in
Width	483 mm	19.01 in
Depth	981 mm	38.62 in

NOTE: The 5U84 uses 3.5" LFF disks in the DDIC carrier. It can also use 2.5" SFF disks with 3.5" adapter in the DDIC.

Enclosure weights

Table 35. 2U12, 2U24, and 5U84 enclosure weights

CRU/component	2U12 (kg/lb)	2U24 (kg/lb)	5U84 (kg/lb)
Storage enclosure (empty)	4.8/10.56	4.8/10.56	64/141
Disk drive carrier	0.9/1.98	0.3/0.66	0.8/1.8
Blank disk drive carrier	0.05/0.11	0.05/0.11	—
Power Cooling Module (PCM)	3.5/7.7	3.5/7.7	—
Power Supply Unit (PSU)	—	—	2.7/6
Fan Cooling Module (FCM)	—	—	1.4/3
SBB controller module (maximum weight)	2.6/5.8	2.6/5.8	2.6/5.8
SBB expansion module	1.5/3.3	1.5/3.3	1.5/3.3
RBOD enclosure (fully populated with modules: maximum weight)	32/71	30/66	135/298

Table 35. 2U12, 2U24, and 5U84 enclosure weights (continued)

CRU/component	2U12 (kg/lb)	2U24 (kg/lb)	5U84 (kg/lb)
EBOD enclosure (fully populated with modules: maximum weight)	28/62	25/55	130/287

NOTE:

- Weights shown are nominal, and subject to variances.
- Weights may vary due to different controller modules, IOMs, and power supplies; and differing calibrations between scales.
- Weights may also vary due to the number and type of disk drives (SAS or SSD) installed.

Environmental requirements

Table 36. Ambient temperature and humidity

Specification	Temperature range	Relative humidity	Max. Wet Bulb
Operating	<ul style="list-style-type: none"> • RBOD: 5°C to 35°C (41°F to 95°F) • EBOD: 5°C to 40°C (41°F to 104°F) 	20% to 80% non-condensing	28°C
Non-operating (shipping)	-40°C to +70°C (-40°F to +158°F)	5% to 100% non-precipitating	29°C

Table 37. Additional environmental requirements

Specification	Measurement/description
Airflow	<ul style="list-style-type: none"> • System must be operated with low pressure rear exhaust installation. • Back pressure created by rack doors and obstacles not to exceed 5Pa (~0.5 mm H₂O)
Altitude, operating	<ul style="list-style-type: none"> • 2U enclosures: 0 to 3,000 meters (0 to 10,000 feet) • Maximum operating temperature is de-rated by 5°C above 2,133 meters (7,000 feet)
	<ul style="list-style-type: none"> • 5U84 enclosures: -100 to 3,000 meters (-330 to 10,000 feet) • Maximum operating temperature is de-rated by 1°C above 900 meters (3,000 feet)
Altitude, non-operating	-100 to 12,192 meters (-330 to 40,000 feet)
Shock, operating	5.0 g, 10 ms, ½ sine pulses, Y-axis
Shock, non-operating	2U enclosures: 30.0 g, 10 ms, ½ sine pulses
	5U84 enclosures: 30.0 g, 10 ms, ½ sine pulses (Z-axis); 20.0 g, 10 ms, ½ sine pulses (X- and Y-axes)
Vibration, operating	0.21 G _{rms} 5 Hz to 500 Hz random
Vibration, non-operating	1.04 G _{rms} 2 Hz to 200 Hz random
Vibration, relocation	0.3 G _{rms} 2 Hz to 200 Hz 0.4 decades per minute
Acoustics	Operating sound power
	<ul style="list-style-type: none"> • 2U enclosures: ≤ L_{WAd} 6.6 Bels (re 1 pW) @ 23°C • 5U84 enclosures: ≤ L_{WAd} 8.0 Bels (re 1 pW) @ 23°C
Orientation and mounting	19" rack mount (2 EIA units; 5 EIA units)

Power cooling module

Specifications for the PCM are provided in the following table.

Table 38. 2U Power cooling module specifications

Specification	Measurement/description	
Dimensions (size)	84.3 mm high x 104.5 mm wide x 340.8 mm long <ul style="list-style-type: none"> X-axis length: 104.5 mm (4.11 in) Y-axis length: 84.3 mm (3.32 in) Z-axis length: 340.8 mm (37.03) 	
Maximum output power	580 W	
Voltage range	100–200 VAC rated	
Frequency	50/60 Hz	
Voltage range selection	Auto-ranging: 90–264 VAC, 47–63 Hz	
Maximum inrush current	20A	
Power factor correction	≥ 95% @ nominal input voltage	
Efficiency	115 VAC/60 Hz	230 VAC/50 Hz
	> 80% @ 10% load	> 80% @ 10% load
	> 87% @ 20% load	> 88% @ 20% load
	> 90% @ 50% load	> 92% @ 50% load
	> 87% @ 100% load	> 88% @ 100% load
	> 85% @ surge	> 85% @ surge
Harmonics	Meets EN61000-3-2	
Output	+5 V @ 42A, +12 V @ 38A, +5 V standby voltage @ 2.7A	
Operating temperature	0°C to 57°C (32°F to +135°F)	
Hot pluggable	Yes	
Switches and LEDs	AC mains switch and four status indicator LEDs	
Enclosure cooling	Dual axial cooling fans with variable fan speed control	

Power supply unit

Table 39. 5U84 Power supply unit specifications

Specification	Measurement/description
Maximum output power	2,214 W maximum continuous output power at high line voltage
Voltage	<ul style="list-style-type: none"> +12 V at 183 A (2,196 W) +5 V standby voltage at 2.7 A
Voltage range	200–240 VAC rated
Frequency	50/60 Hz
Power factor correction	≥ 95% @ 100% load
Efficiency	<ul style="list-style-type: none"> 82% @ 10% load 90% @ 20% load 94% @ 50% load

Table 39. 5U84 Power supply unit specifications (continued)

Specification	Measurement/description
	<ul style="list-style-type: none">• 91% @ 100% load
Holdup time	5 ms from ACOKn high to rails out of regulation (see SBB v2 specification)
Main inlet connector	IEC60320 C20 with cable retention
Weight	3 kg (6.6 lb)
Cooling fans	Two stacked fans: 80 mm x 80 mm x 38 mm (3.1 in. x 3.15 in. x 1.45 in.)

Standards and regulations

Potential for radio frequency interference

USA Federal Communications Commission (FCC)

i NOTE: This equipment has been tested and found to comply with the limits for a class A digital device, pursuant to Part 15 of the FCC rules. These limits are designed to provide reasonable protection against harmful interference when the equipment is operated in a commercial environment. This equipment generates, uses, and can radiate radio frequency energy, and if not installed and used in accordance with the instruction manual, may cause harmful interference to radio communications. Operation of this equipment in a residential area is likely to cause harmful interference, in which case the user will be required to correct the interference at his or her expense.

Properly shielded and grounded cables and connectors must be used in order to meet FCC emission limits. The supplier is not responsible for any radio or television interference caused by using other than recommended cables and connectors or by unauthorized changes or modifications to this equipment. Unauthorized changes or modifications could void the user's authority to operate the equipment.

This device complies with Part 15 of the FCC Rules. Operation is subject to the following two conditions: (1) this device may not cause harmful interference, and (2) this device must accept any interference received, including interference that may cause undesired operation.

European regulations

This equipment complies with European Regulations EN 55022 Class A: Limits and Methods of Measurement of Radio Disturbance Characteristics of Information Technology Equipment and EN50082-1: Generic Immunity.

This product is not suitable for use at visual display workplaces according to §2 of the Workplace Regulations.

Safety compliance

Table 40. Safety compliance standards

System product type approval	Standard
Safety compliance	UL 60950-1
	UL 62368-1
	IEC 60950-1
	IEC 62368-1
	EN 60950-1
	EN 62368-1

Electromagnetic compatibility (EMC) compliance

Table 41. EMC compliance standards

System product type approval	Standards
Conducted emissions limit levels	CFR47 Part 15B Class A
	EN 55032
	CISPR Class A
Radiated emissions limit levels	CFR47 Part 15B Class A
	EN 55032
	CISPR Class A
Harmonics and flicker	EN 61000-3-2/3
Immunity limit levels	EN 55024

AC power cable specifications

Table 42. United States of America – Must be NRTL Listed (National Recognized Test Laboratory – e.g., UL)

Chassis form factor	2U12/2U24	5U84
Cable type	SV or SVT, 18 AWG minimum, 3 conductor, 2.0 M max length	SJT or SVT, 12 AWG minimum, 3 conductor
Plug (AC source)	<ul style="list-style-type: none"> NEMA 5–15P grounding-type attachment plug rated 120V, 10A IEC 320, C14, 250V, 10A 	<ul style="list-style-type: none"> IEC 320, C20, 250V, 20A A suitable plug rated 250V, 20A
Socket	IEC 320, C13, 250V, 10A	IEC 320, C19, 250V, 20A

Table 43. Europe and others – General requirements

Chassis form factor	2U12/2U24	5U84
Cable type	Harmonized, H05VV-F-3G1.0	Harmonized, H05VV-F-3G2.5
Plug (AC source)	<ul style="list-style-type: none"> IEC 320, C14, 250V, 10A A suitable plug rated 250V, 16A 	<ul style="list-style-type: none"> IEC 320, C20, 250V, 16A A suitable plug rated 250V, 16A
Socket	IEC 320, C13, 250V, 10A	IEC 320, C19, 250V, 16A

NOTE: The plug and the complete power cable assembly must meet the standards appropriate to the country, and must have safety approvals acceptable in that country.

Recycling of Waste Electrical and Electronic Equipment (WEEE)

At the end of the product's life, all scrap/waste electrical and electronic equipment should be recycled in accordance with national regulations applicable to the handling of hazardous/toxic electrical and electronic waste materials.

Contact your supplier for a copy of the Recycling Procedures applicable to your country.

NOTE: Observe all applicable safety precautions detailed in the preceding chapters (weight restrictions, handling batteries and lasers, and so on) when dismantling and disposing of this equipment.