



## **Hardware Installation Guide for Cisco 8800 Series Routers**

**First Published:** 2019-11-07

**Last Modified:** 2023-11-30

### **Americas Headquarters**

Cisco Systems, Inc.  
170 West Tasman Drive  
San Jose, CA 95134-1706  
USA  
<http://www.cisco.com>  
Tel: 408 526-4000  
800 553-NETS (6387)  
Fax: 408 527-0883

THE SPECIFICATIONS AND INFORMATION REGARDING THE PRODUCTS IN THIS MANUAL ARE SUBJECT TO CHANGE WITHOUT NOTICE. ALL STATEMENTS, INFORMATION, AND RECOMMENDATIONS IN THIS MANUAL ARE BELIEVED TO BE ACCURATE BUT ARE PRESENTED WITHOUT WARRANTY OF ANY KIND, EXPRESS OR IMPLIED. USERS MUST TAKE FULL RESPONSIBILITY FOR THEIR APPLICATION OF ANY PRODUCTS.

THE SOFTWARE LICENSE AND LIMITED WARRANTY FOR THE ACCOMPANYING PRODUCT ARE SET FORTH IN THE INFORMATION PACKET THAT SHIPPED WITH THE PRODUCT AND ARE INCORPORATED HEREIN BY THIS REFERENCE. IF YOU ARE UNABLE TO LOCATE THE SOFTWARE LICENSE OR LIMITED WARRANTY, CONTACT YOUR CISCO REPRESENTATIVE FOR A COPY.

The Cisco implementation of TCP header compression is an adaptation of a program developed by the University of California, Berkeley (UCB) as part of UCB's public domain version of the UNIX operating system. All rights reserved. Copyright © 1981, Regents of the University of California.

NOTWITHSTANDING ANY OTHER WARRANTY HEREIN, ALL DOCUMENT FILES AND SOFTWARE OF THESE SUPPLIERS ARE PROVIDED "AS IS" WITH ALL FAULTS. CISCO AND THE ABOVE-NAMED SUPPLIERS DISCLAIM ALL WARRANTIES, EXPRESSED OR IMPLIED, INCLUDING, WITHOUT LIMITATION, THOSE OF MERCHANTABILITY, FITNESS FOR A PARTICULAR PURPOSE AND NON-INFRINGEMENT OR ARISING FROM A COURSE OF DEALING, USAGE, OR TRADE PRACTICE.

IN NO EVENT SHALL CISCO OR ITS SUPPLIERS BE LIABLE FOR ANY INDIRECT, SPECIAL, CONSEQUENTIAL, OR INCIDENTAL DAMAGES, INCLUDING, WITHOUT LIMITATION, LOST PROFITS OR LOSS OR DAMAGE TO DATA ARISING OUT OF THE USE OR INABILITY TO USE THIS MANUAL, EVEN IF CISCO OR ITS SUPPLIERS HAVE BEEN ADVISED OF THE POSSIBILITY OF SUCH DAMAGES.

Any Internet Protocol (IP) addresses and phone numbers used in this document are not intended to be actual addresses and phone numbers. Any examples, command display output, network topology diagrams, and other figures included in the document are shown for illustrative purposes only. Any use of actual IP addresses or phone numbers in illustrative content is unintentional and coincidental.

All printed copies and duplicate soft copies of this document are considered uncontrolled. See the current online version for the latest version.

Cisco has more than 200 offices worldwide. Addresses and phone numbers are listed on the Cisco website at [www.cisco.com/go/offices](http://www.cisco.com/go/offices).

Cisco and the Cisco logo are trademarks or registered trademarks of Cisco and/or its affiliates in the U.S. and other countries. To view a list of Cisco trademarks, go to this URL: <https://www.cisco.com/c/en/us/about/legal/trademarks.html>. Third-party trademarks mentioned are the property of their respective owners. The use of the word partner does not imply a partnership relationship between Cisco and any other company. (1721R)

© 2019–2021 Cisco Systems, Inc. All rights reserved.



## CONTENTS

---

### CHAPTER 1

<b>Cisco 8800 Series Routers Overview</b>	<b>1</b>
Cisco 8800 Series Routers	2
Line Card Overview	4
Route Processor Card Overview	9
Fabric Card Overview	11
Temperature and Physical Specifications	12
Weight and Power Consumption	12
Airflow Direction	13
Maximum Power Available to the Router	13
Supported Optics	17

---

### CHAPTER 2

<b>Prepare for Installation</b>	<b>19</b>
Safety Guidelines	20
Compliance and Safety Information	20
Laser Safety	22
Energy Hazard	22
Preventing Electrostatic Discharge Damage	22
Cautions and Regulatory Compliance Statements for NEBS	23
Installation Guidelines	23
Procure Tools and Equipment	24
Rack Mount and Accessory Kits	25
Prepare Your Location	25
Prepare Yourself	26
Prepare Rack for Chassis Installation	27
Clearance Requirements	28

---

<b>CHAPTER 3</b>	<b>Unpack and Install the Chassis</b>	<b>31</b>
	Unpack the Chassis	31
	Install Bottom-Support Rails	36
	Transfer Chassis to a Mechanical Lifting Device	37
	Mount Chassis Into the Rack	39
	Locate and Ground the Chassis	51
	Install Cable Management on a Chassis	57
	Attach Front Door to Chassis	68
	Ground the Front Door	72

---

<b>CHAPTER 4</b>	<b>Powering on the Router</b>	<b>75</b>
	Power Module Overview	75
	Connect DC Power Supply to Power Source	78
	Connect HVAC/HVDC Power Supply to Power Source	81
	Power Supply Power Cord Specifications	84

---

<b>CHAPTER 5</b>	<b>Connect Router to the Network</b>	<b>99</b>
	Connecting a Console to the Router	99
	Connect the Management Interface	100
	Transceivers, Connectors, and Cables	101
	Transceiver and Cable Specifications	101
	RJ-45 Connectors	101
	Install and Remove SFP28 and SFP+ Modules	102
	Bale Clasp SFP28 or SFP+ Module	103
	Install a Bale Clasp SFP28 or SFP+ Module	103
	Remove a Bale Clasp SFP28 or SFP+ Module	104
	Using the Optical Transceiver Extraction Tool	105
	Install and Remove QSFP Transceiver Modules	109
	Required Tools and Equipment	110
	Installing the Transceiver Module	111
	Attach the Optical Network Cable	113
	Removing the Transceiver Module	114
	Connect Interface Ports	116



Connect a Fiber-Optic Port to the Network	116
Disconnect Optical Ports from the Network	116
Maintain Transceivers and Optical Cables	116
Create the Initial Router Configuration	116
Verify Chassis Installation	118
Set Fabric Bandwidth Threshold	125

---

**CHAPTER 6**
**Replace Chassis Components 127**

Replace Chassis Door Foam Air Filters	127
Provision of Grace Period Before Route Processor Shutdown from Ejector Lever	129
Replace a Route Processor Card	130
Replace the 8800-RP Card	130
Install a New 8800-RP Card	133
Replace the 8800-RP2 Card	135
Install an 8800-RP2 Card	138
Migrating from RP1 to RP2 Card	140
Replace a Line Card	142
Replace or Install a Line Card - Ejector Levers with Buttons	142
Replace or Install a Line Card - Ejector Levers with Latches	150
Replace a Fan Tray	156
Remove Fan Tray	157
Install Fan Tray	157
Replace Fabric Card	159
Remove a Fabric Card	160
Install a Fabric Card	162
Migrate from 8808-FC1-G to 8808-FC1 Card	168
Replace Power Supply Components	168
Install Power Shelf Bezel	169
Replace DC Power Module	172
Disconnect DC Power	173
Reconnect DC Power	173
Replace HVAC and HVDC Power Module	174

---

**CHAPTER 7**
**LEDs 177**

Chassis LED 177

Port Status LEDs 177

Power Supply LEDs 178

Fan Tray LEDs 179

    Temperature Warning Label 180

Route Processor Card LEDs 181

Fabric Card LEDs 184

Line Card LEDs 185



## CHAPTER 1

# Cisco 8800 Series Routers Overview

**Table 1: Feature History Table**

Hardware	Release Information	Description
Cisco 8804	Release 7.3.2	This release introduces Cisco 8804, a 4-slot 10 RU (rack unit) modular router that provides 57.6 Tbps of network bandwidth. For more information, see the Cisco 8800 section in the Datasheet <a href="#">here</a> .

The Cisco 8800 series routers include:

- The Cisco 8818 is a 33-RU router that supports distributed forwarding across multiple field replaceable units (FRUs).
- The Cisco 8812 is a 21-RU router that supports distributed forwarding across multiple field replaceable units (FRUs).
- The Cisco 8808 is a 16-RU router that supports distributed forwarding across multiple field replaceable units (FRUs).
- The Cisco 8804 is a 10-RU router that supports distributed forwarding across multiple field replaceable units (FRUs).
- [Cisco 8800 Series Routers, on page 2](#)
- [Line Card Overview, on page 4](#)
- [Route Processor Card Overview, on page 9](#)
- [Fabric Card Overview, on page 11](#)
- [Temperature and Physical Specifications, on page 12](#)
- [Weight and Power Consumption, on page 12](#)
- [Airflow Direction, on page 13](#)
- [Maximum Power Available to the Router, on page 13](#)
- [Supported Optics, on page 17](#)

# Cisco 8800 Series Routers

**Table 2: Feature History Table**

Feature Name	Release	Description
PSU4.8KW-DC100 power supply for Cisco 8804 and 8808 routers.	Release 7.3.2	<p>This feature introduces support for the 4.8 KW power supply for 48V 100A DC (DC100) on the Cisco 8804 and 8808 routers.</p> <p>The power supply accepts a nominal input voltage of 48V 100A DC, with an operational tolerance range of -40 to -75 VDC.</p>

The following table describes the Cisco 8818 router components, and the supported quantity.

**Table 3: Cisco 8818 Router Components**

Component	Quantity
Line cards	18
Route Processors	2
Fabric Cards	8
Fan trays	4
Power trays	6
Power supplies	HVAC/HVDC—18 (3 per tray) DC60—24 (4 per tray) DC100—24 (4 per tray)

The following table describes the Cisco 8812 router components, and the supported quantity.

**Table 4: Cisco 8812 Router Components**

Component	Quantity
Line cards	12
Route Processors	2
Fabric Cards	8
Fan trays	4
Power trays	3

Component	Quantity
Power supplies	HVAC/HVDC—9 (3 per tray) DC60—12 (4 per tray) DC100—12 (4 per tray)

The following table describes the Cisco 8808 router components, and the supported quantity.

**Table 5: Cisco 8808 Router Components**

Component	Quantity
Line cards	8
Route Processors	2
Fabric Cards	8
Fan trays	4
Power trays	3
Power supplies	HVAC/HVDC—9 (3 per tray) DC60—12 (4 per tray) DC100—12 (4 per tray)

The following table describes the Cisco 8804 router components, and the supported quantity.

**Table 6: Cisco 8804 Router Components**

Component	Quantity
Line cards	4
Route Processors	2
Fabric Cards	8
Fan trays	4
Power trays	2
Power supplies	HVAC/HVDC—6 (3 per tray) DC60—8 (4 per tray) DC100—8 (4 per tray)

# Line Card Overview

*Table 7: Feature History Table*

Feature Name	Release	Description
88-LC0-36FH-M with MACsec, based on Q200 Silicon Chip	Release 7.3.15	<p>The Cisco 8800 modular chassis support the Cisco 8800 36x400 GE QSFP56-DD Line Card (88-LC0-36FH-M).</p> <p>The 88-LC0-36FH-M line card is Q200 silicon chip-based, and MACsec-capable, providing 14.4 Tbps of throughput with line rate MACsec on all ports.</p> <p>The line card provides up to 144 ports of 100 GE via breakout and support QSFP+, QSFP28, and QSFP28-DD modules.</p> <p>88-LC0-36FH-M line card is supported on Cisco 8808 and Cisco 8818 modular chassis.</p>
88-LC0-36FH without MACsec, based on Q200 Silicon Chip	Release 7.3.15	<p>The Cisco 8800 modular chassis support the Cisco 8800 36x400 GE QSFP56-DD Line Card (88-LC0-36FH).</p> <p>88-LC0-36FH line card is Q200 silicon chip-based, providing 14.4 Tbps of throughput line rate without MACsec on all ports.</p> <p>The line card provides up to 144 ports of 100 GE via breakout and support QSFP+, QSFP28, and QSFP28-DD modules.</p> <p>88-LC0-36FH line card is supported on Cisco 8808 and Cisco 8818 modular chassis.</p>

Feature Name	Release	Description
88-LC0-34H14FH, based on Q200 Silicon Chip	Release 7.5.1 and Release 7.3.3	<p>This release introduces a 48-port combo line card that provides 9 Tbps of throughput. The 88-LC0-34H14FH line card is Q200 silicon chip-based and comprises 34 ports of 100 GbE (QSFP28) and 14 ports of 400 GbE (QSFP-DD). Sixteen 100 GbE ports are MACsec capable. 100 GbE ports support 4x10/25 GbE breakout, and 400 GbE ports support 4x100 GbE, 2x100 GbE, and 4x10/25 GbE breakout.</p> <p>The 88-LC0-34H14FH line card is supported on Cisco 8800 series modular chassis.</p> <p>For more information on this line card, see the <a href="#">Cisco 8000 Series Routers Data Sheet</a>.</p>

Feature Name	Release	Description
88-LC0-34H14FH-O Line Card based on the Q200 Silicon Chip	Release 7.5.2	<p>This release introduces the Q200 silicon chip-based 88-LC0-34H14FH-O line card with these highlights:</p> <ul style="list-style-type: none"> <li>• A 48-port combination line card providing 9 Tbps of throughput.</li> <li>• Thirty-four ports of 100 GbE (QSFP28) and 14 ports of 400 GbE (QSFP-DD).</li> <li>• Sixteen 100 GbE ports are MACsec capable.</li> <li>• 100 GbE ports support 4x10/25 GbE breakout.</li> <li>• 400 GbE ports support 4x100 GbE, 2x100 GbE, and 4x10/25 GbE breakout.</li> <li>• Supports Cisco-qualified open-source network operating systems, such as SONiC (Software for Open Networking in the Cloud).</li> </ul> <p>See the <a href="#">Cisco 8000 Series Routers Data Sheet</a> for more information on this line card. The details available for 88-LC0-34H14FH line card in the datasheet are also applicable to 88-LC0-34H14FH-O line card.</p>



Feature Name	Release	Description
88-LC1-36EH based on P100 Silicon One Chip	Release 24.2.1	<p>This release introduces the P100 silicon one chip-based 88-LC1-36EH line card with these highlights:</p> <ul style="list-style-type: none"> <li>• A 36-port combination line card providing 28.8 Tbps of throughput.</li> <li>• Thirty-six ports of 800 GbE.</li> <li>• 800 GbE ports support 400 (QSFP-DD56), 2x400 (QSFP-DD800), 2x400 (QDD-2X400G-FR), 8x100 (QDD-8X100G-FR), 4x100 (QSFP-DD56) 2X100 (QDD-2X100-LR4-S), 4x10/40 (QSFP+) GbE breakout.</li> </ul> <p>The 88-LC1-36EH Line Card is supported on Cisco 8808 modular chassis with 8800-RP2 route processors and 8808-FC1 fabric cards.</p> <p>See the <a href="#">Cisco 8000 Series Routers Data Sheet</a> for more information on this line card.</p>

Cisco 8800 Series Routers support the following line cards:

**Table 8: Supported Line Cards and Transceivers**

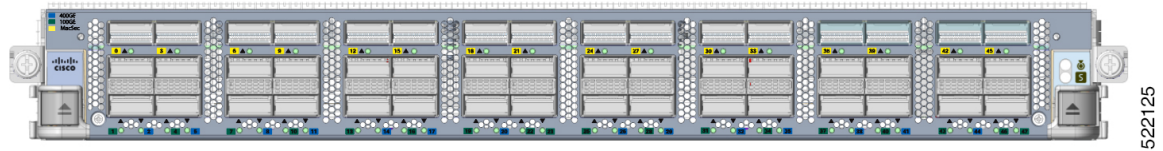
Line Card PIDs	Transceivers
8800-LC-48H	QSFP28 / QSFP+
8800-LC-36FH	QSFP56-DD / QSFP28 / QSFP+
88-LC0-36FH	QSFP56-DD / QSFP28 / QSFP+
88-LC0-36FH-M	QSFP56-DD / QSFP28 / QSFP+
88-LC1-36EH	QSFP-DD

88-LC0-36FH and 88-LC0-36FH-M line cards are compatible with Q100 and Q200 silicon based fabric cards.

### 88-LC0-34H14FH and 88-LC0-34H14FH-O Line Card

The following image explains the port configuration details of the 88-LC0-34H14FH and 88-LC0-34H14FH-O line card:

**Figure 1: 88-LC0-34H14FH and 88-LC0-34H14FH-O Line Card**



**Table 9: Port Description**

Port Color	Description
Blue	Fourteen 400 GbE QSFP-DD ports. These ports support 4x100 GbE, 2x100 GbE, and 4x10/25 GbE breakout.
Green	Eighteen 100 GbE QSFP28 ports. These ports support 4x10/25 GbE breakout.
Yellow	Sixteen 100 GbE QSFP28 MACsec-capable ports. These ports support 4x10/25 GbE breakout.

### 88-LC1-36EH Performance Optimized Line Card

The P100 silicon one chip-based 88-LC1-36EH Performance Optimized Line Card supports the following:

- Thirty-six ports of 800 GbE providing 28.8 Tbps of throughput..
- The 800 GbE ports support 400, 2x400, 8x100, 4x100, 2X100 and 4x10/40 GbE breakout.
- The 400Gbe breakout uses QSFP-DD56 optics
- The 2x400GbE breakout uses QDD-2X400G-FR or QSFP-DD800 optics.
- The 8x100GbE breakout uses QDD-8X100G-FR optics.
- The 4X100GbE breakout uses QSFP-DD56 optics.
- The 2X100GbE breakout uses QDD-2X100-LR4-S optics.
- The 4x10/40GbE breakout uses QSFP+ optics.

The 88-LC1-36EH Line Card is supported on Cisco 8808 modular chassis with 8800-RP2 route processors and 8808-FC1 fabric cards.

The following image explains the port configuration details of the 88-LC1-36EH Line Card:

Figure 2: 88-LC1-36EH Line Card

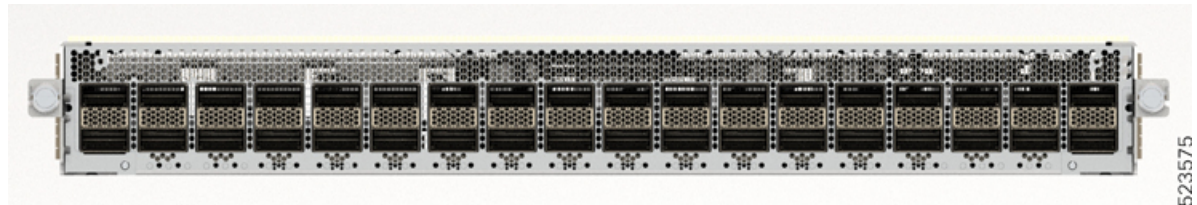


Table 10: Port Description

Port	Description
All	Thirty-six 800 GbE QSFP-DD800 ports. These ports support 400, 2x400, 8x100, 4x100, 2X100, 4x10/40 GbE breakout.

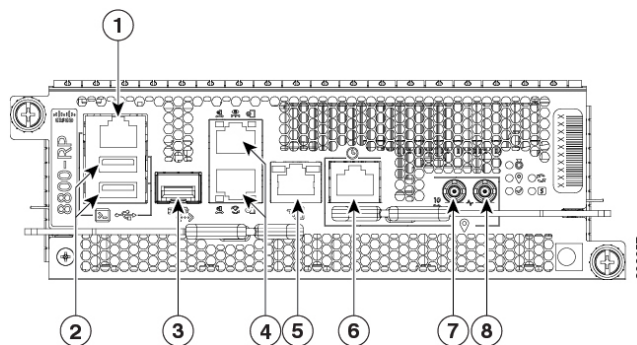
## Route Processor Card Overview

Table 11: Feature History Table

Hardware	Release Information	Description
Route Processor Card 8800-RP2	Release 7.11.1	This release introduces support for a new route processor card, 8800-RP2, on Cisco 8800 Series routers. It provides a capacity of 8-core x86 CPU at 2.7GHz with 64GB RAM. For more information, see the Cisco 8800 section in the Datasheet <a href="#">here</a> .

Route Processor cards (8800-RP and 8800-RP2) manage all routing operations on the Cisco 8800 Series Routers.

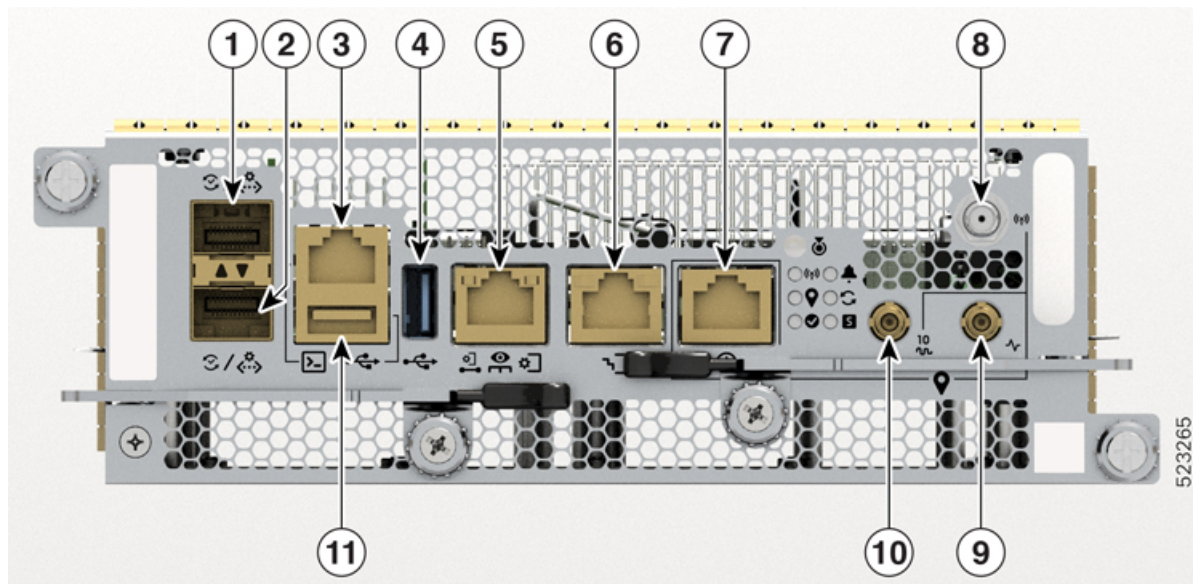
Figure 3: Route Processor - 8800-RP



1	Console RS-232 Serial Port RJ45	5	SyncE BITS/DTI/J.211
---	---------------------------------	---	----------------------

2	USB Port Type-A (2-ports). Port A gets detected ahead of Port B. Top: Port B Bottom: Port A	6	G.703 Time-of-Day (TOD)
3	Control Plane Expansion SFP/SFP+ port	7	1.0/2.3 50 ohm connector for 10 MHz, input, and output
4	Top: Management Ethernet (10/100/1000-Mbps) RJ-45 (Copper) port LAN. Bottom: IEEE 1588 Precision Time Protocol (PTP)	8	1.0/2.3 50 ohm connector for 1 PPS, input, and output

Figure 4: Route Processor - 8800-RP2



1	Control Plane Expansion SFP/SFP+ Port	7	G.703 Time-of-Day (TOD)
2	IEEE 1588 Precision Time Protocol (PTP) Port	8	GNSS Port
3	Console RS-232 Serial Port RJ45	9	1.0/2.3 50 ohm connector for 1 PPS, input, and output
4	USB Port Type-A.	10	1.0/2.3 50 ohm connector for 10 MHz, input, and output
5	Top: Management Ethernet (10/100/1000-Mbps) RJ-45 (Copper) Port LAN. Bottom: IEEE 1588 Precision Time Protocol (PTP)	11	USB Port Type-B. Port A gets detected ahead of Port B.

6	SyncE BITS/DTI/J.211		
---	----------------------	--	--

## Fabric Card Overview

**Table 12: Feature History Table**

Feature Name	Release	Description
8808-FC1 Fabric Card based on F100 Silicon Chip	Release 24.2.1	<p>The Cisco 8808 Series Routers support the Cisco 8808 fabric card (8808-FC1).</p> <p>The 8808-FC1 fabric card is based on Silicon One F100 ASIC. The 8808-FC1 fabric card provides 36 Tbps of switching capacity between the eight line cards. Because of the higher switching capacity, this fabric card offer benefits, such as faster communication, lower latency, and ability to manage higher data flows.</p> <p>The fabric card supports 8FC and 5FC modes.</p>
8808-FC1-G Fabric Card based on G100 Silicon Chip	Release 7.11.1	<p>The Cisco 8808 modular chassis supports the Cisco 8808 fabric card (8808-FC1-G).</p> <p>The 8808-FC1-G fabric card is based on Silicon One G100 ASIC. The 8808-FC1-G fabric card provides 35.4 Tbps of switching capacity per line card. The fabric card supports 8FC and 5FC modes.</p>
8804-FC0 Fabric Card based on Q200 Silicon Chip	Release 7.3.16	<p>The Cisco 8804 modular chassis supports the Cisco 8804 fabric card (8804-FC0).</p> <p>The 8804-FC0 fabric card is Q200 silicon chip-based providing 9.6 Tbps. The fabric card supports 8FC and 5FC modes.</p>
8818-FC0 Fabric Card based on Q200 Silicon Chip	Release 7.3.16	<p>The Cisco 8818 modular chassis supports the Cisco 8818 fabric card (8818-FC0).</p> <p>The 8818-FC0 fabric card is Q200 silicon chip-based providing 43.2 Tbps. The fabric card supports 8FC and 5FC modes.</p>
8808-FC0 Fabric Card based on Q200 Silicon Chip	Release 7.3.15	<p>The Cisco 8808 modular chassis supports the Cisco 8808 fabric card (8808-FC0).</p> <p>The 8808-FC0 fabric card is Q200 silicon chip-based providing 21.6 Tbps. The fabric card supports 8FC and 5FC modes.</p>

The Cisco 8800 series routers are powered by the Cisco Silicon One Q200, Q100, G100, and F100 series processors. The following table lists the fabric cards, supported routers, and the ASIC that the fabric cards are based on.

ASIC	Fabric Card	Supported Router
Q100 Silicon	8818-FC	Cisco 8808
	8812-FC	Cisco 8812
	8808-FC	Cisco 8808
Q200 Silicon	8804-FC0	Cisco 8804
	8808-FC0	Cisco 8808
	8818-FC0	Cisco 8818
G100 Silicon	8808-FC1-G <b>Note</b> The 8808-FC1-G fabric card cannot be used in the router that has 8800-LC-48H and 8800-LC-36FH line cards installed.	Cisco 8808
F100	8808-FC1	Cisco 8808



**Caution** The system doesn't support a mix of the following:

- Q100 Silicon based fabric cards
- Q200 Silicon based fabric cards
- G100 based fabric cards
- F100 based fabric cards

Attempting to mix Q100, Q200, G100, and F100 Silicon based fabric cards in a system could result in an equipment failure.

## Temperature and Physical Specifications

For temperature and physical specifications, refer to the *Physical characteristics* table in the [Cisco 8000 Series Routers Data Sheet](#).

## Weight and Power Consumption

For weight and power consumption, refer to the *Physical characteristics* table in the [Cisco 8000 Series Routers Data Sheet](#).

## Airflow Direction

The airflow through the fan trays and power supplies on the Cisco 8800 series routers are from front to back (port side intake).

To ensure proper airflow for the router in your facility, position the router with its air intake on a cold aisle and the air exhaust on a hot aisle.

## Maximum Power Available to the Router

The maximum power available for operations depends on the input power from your power source, the number and output capabilities of your power supplies, and the power redundancy mode that you use.

The following table lists the amount of power available for Cisco 8800 series routers from all available power trays.

**Table 13: Maximum Power Available for a Router with HVAC/HVDC Power Supplies**

Total Power Supply	Combined Mode in Watts (No redundancy)	N+1 Redundancy Mode in Watts (with Single Supply Loss)	Total Power Tray
1	6,300	—	1
2	12,600	6,300	
3	18,900	12,600	
4	25,200	18,900	2 <sup>1</sup>
5	31,500	25,200	
6	37,800	31,500	
7	44,100	37,800	3 <sup>2</sup>
8	50,400	44,100	
9	56,700	50,400	
10	63,000	56,700	4 <sup>3</sup>
11	69,300	63,000	
12	75,600	69,300	
13	81,900	75,600	5 <sup>3</sup>
14	88,200	81,900	
15	94,500	88,200	

Total Power Supply	Combined Mode in Watts (No redundancy)	N+1 Redundancy Mode in Watts (with Single Supply Loss)	Total Power Tray
16	100,800	94,500	6 <sup>3</sup>
17	107,100	100,800	
18	113,400	107,100	



- Note**
- <sup>1</sup> Cisco 8804 router supports 2 power trays.
  - <sup>2</sup> Cisco 8808 and Cisco 8812 routers support 3 power trays.
  - <sup>3</sup> Power Tray 4, 5 and 6 are applicable for Cisco 8818 Router.

**Table 14: Maximum Power Available for a Router with DC60 Power Supplies (or DC100 Power Supplies in 60A Mode)**

Total Power Supply	Combined Mode in Watts (No redundancy)	N+1 Redundancy Mode in Watts (with Single Supply Loss)	N+N Redundancy Mode in Watts (with Feed Loss)	Total Power Tray
1	4,400	—	2,200	1
2	8,800	4,400	4,400	
3	13,200	8,800	6,600	
4	17,600	13,200	8,800	
5	22,000	17,600	11,000	2 <sup>1</sup>
6	26,400	22,000	13,200	
7	30,800	26,400	15,400	
8	35,200	30,800	17,600	
9	39,600	35,200	19,800	3 <sup>2</sup>
10	44,000	39,600	22,000	
11	48,400	44,000	24,200	
12	52,800	48,400	26,400	



- Note**
- <sup>1</sup> Cisco 8804 router supports 2 power trays.
  - <sup>2</sup> Cisco 8808 and Cisco 8812 routers support 3 power trays.



Total Power Supply	Combined Mode in Watts (No redundancy)	N+1 Redundancy Mode in Watts (with Single Supply Loss)	N+N Redundancy Mode in Watts (with Feed Loss)	Total Power Tray
13	57,200	52,800	28,600	4 <sup>3</sup>
14	61,600	57,200	30,800	
15	66,000	61,600	33,000	
16	70,400	66,000	35,200	
17	74,800	70,400	37,400	5 <sup>3</sup>
18	79,200	74,800	39,600	
19	83,600	79,200	41,800	
20	88,000	83,600	44,000	
21	92,400	88,000	46,200	6 <sup>3</sup>
22	96,800	92,400	48,400	
23	101,200	96,800	50,600	
24	105,600	101,200	52,800	



**Note** <sup>3</sup> Power Tray 4, 5 and 6 are applicable for Cisco 8818 Router.

**Table 15: Maximum Power Available for a Router with DC100 Power Supplies**

Total Power Supply	Combined Mode in Watts (No redundancy)	N+1 Redundancy Mode in Watts (with Single Supply Loss)	N+N Redundancy Mode in Watts (with Feed Loss)	Total Power Tray
1	4,800	—	2,400	1
2	9,600	4,800	4,800	
3	14,400	9,600	7,200	
4	19,200	14,400	9,600	
5	24,000	19,200	12,000	2 <sup>1</sup>
6	28,800	24,000	14,400	
7	33,600	28,800	16,800	
8	38,400	33,600	19,200	

Total Power Supply	Combined Mode in Watts (No redundancy)	N+1 Redundancy Mode in Watts (with Single Supply Loss)	N+N Redundancy Mode in Watts (with Feed Loss)	Total Power Tray
9	43,200	38,400	21,600	3 <sup>2</sup>
10	48,000	43,200	24,000	
11	52,800	48,000	26,400	
12	57,600	52,800	28,800	



- Note**
- <sup>1</sup> Cisco 8804 router supports 2 power trays.
  - <sup>2</sup> Cisco 8808 and Cisco 8812 routers support 3 power trays.

Total Power Supply	Combined Mode in Watts (No redundancy)	N+1 Redundancy Mode in Watts (with Single Supply Loss)	N+N Redundancy Mode in Watts (with Feed Loss)	Total Power Tray
13	62,400	57,600	31,200	4 <sup>3</sup>
14	67,200	62,400	33,600	
15	72,000	67,200	36,000	
16	76,800	72,000	38,400	
17	81,600	76,800	40,800	5 <sup>3</sup>
18	86,400	81,600	43,200	
19	91,200	86,400	45,600	
20	96,000	91,200	48,000	
21	10,0800	96,000	50,400	6 <sup>3</sup>
22	105,600	10,0800	52,800	
23	110,400	105,600	55,200	
24	115,200	110,400	57,600	



- Note** <sup>3</sup> Power Tray 4, 5 and 6 are applicable for Cisco 8818 Router.

# Supported Optics



---

**Note** To determine which transceivers and cables are supported by this router, refer to the Transceiver Module Group (TMG) Compatibility Matrix Tool:

<https://tmgmatrix.cisco.com>

- For QSFP-DD data sheets, refer to the [Cisco 400G QSFP-DD Cable and Transceiver Modules Data Sheet](#).
  - For QSFP28 data sheets, refer to the [Cisco 100GBASE QSFP-100G Modules Data Sheet](#).
  - For QSFP+ data sheets, refer to the [Cisco 40GBASE QSFP Modules Data Sheet](#).
-





## CHAPTER 2

# Prepare for Installation



**Note** The images in this chapter are only for representational purposes, unless specified otherwise. The chassis' actual appearance and size may vary.



**Warning** **Statement 1071**—Warning Definition

### IMPORTANT SAFETY INSTRUCTIONS

Before you work on any equipment, be aware of the hazards involved with electrical circuitry and be familiar with standard practices for preventing accidents. Read the installation instructions before using, installing, or connecting the system to the power source. Use the statement number at the beginning of each warning statement to locate its translation in the translated safety warnings for this device.

SAVE THESE INSTRUCTIONS



- [Safety Guidelines, on page 20](#)
- [Compliance and Safety Information, on page 20](#)
- [Laser Safety, on page 22](#)
- [Energy Hazard, on page 22](#)
- [Preventing Electrostatic Discharge Damage, on page 22](#)
- [Cautions and Regulatory Compliance Statements for NEBS, on page 23](#)
- [Installation Guidelines, on page 23](#)
- [Procure Tools and Equipment, on page 24](#)
- [Prepare Your Location , on page 25](#)
- [Prepare Yourself , on page 26](#)
- [Prepare Rack for Chassis Installation, on page 27](#)
- [Clearance Requirements, on page 28](#)

# Safety Guidelines

Before you perform any procedure in this document, review the safety guidelines in this section to avoid injuring yourself or damaging the equipment. The following guidelines are for your safety and to protect the equipment. Because the guidelines do not include all hazards, be constantly alert.

- Keep the work area clear, smoke and dust-free during and after installation. Do not allow dirt or debris to enter into any laser-based components.
- Do not wear loose clothing, jewelry, or other items that could get caught in the router or other associated components.
- Cisco equipment operates safely when used in accordance with its specifications and product-usage instructions.
- Be sure to power down a fixed configuration PDU or modular configuration power shelf before removing it from the chassis.
- If potentially hazardous conditions exist, do not work alone.
- Take care when connecting multiple units to the supply circuit so that wiring is not overloaded.
- This equipment must be grounded. Never defeat the ground conductor or operate the equipment in the absence of a suitably installed ground conductor. Contact the appropriate electrical inspection authority or an electrician if you are uncertain about whether suitable grounding is available.
- When installing or replacing the unit, the ground connection must always be made first and disconnected last.
- To prevent personal injury or damage to the chassis, never attempt to lift or tilt the chassis using the handles on modules (such as power supplies, fans, or cards); these types of handles are not designed to support the weight of the unit.
- Hazardous voltage or energy is present on the backplane when the system is operating. Use caution when servicing.
- The rack stabilizing mechanism must be in place, or the rack must be bolted to the floor before you slide out the unit for servicing. Failure to stabilize the rack may cause the rack to tip over.

## Compliance and Safety Information

The Cisco 8000 Series Routers are designed to meet the regulatory compliance and safety approval requirements. For detailed safety information, see [Regulatory Compliance and Safety Information—Cisco 8000 Series Routers](#).



---

**Warning Statement 1089**—Instructed and Skilled Person Definitions

An instructed person is someone who has been instructed and trained by a skilled person and takes the necessary precautions when working with equipment.

A skilled person or qualified personnel is someone who has training or experience in the equipment technology and understands potential hazards when working with equipment.

There are no serviceable parts inside. To avoid risk of electric shock, do not open.

---



---

**Warning Statement 9001**—Product Disposal

Ultimate disposal of this product should be handled according to all national laws and regulations.

---



---

**Warning Statement 1074**—Comply with Local and National Electrical Codes

To reduce risk of electric shock or fire, installation of the equipment must comply with local and national electrical codes.

---



---

**Warning Statement 1090**—Installation by Skilled Person

Only a skilled person should be allowed to install, replace, or service this equipment. See statement 1089 for the definition of a skilled person.

There are no serviceable parts inside. To avoid risk of electric shock, do not open.

---



---

**Warning Statement 1091**—Installation by an Instructed Person

Only an instructed person or skilled person should be allowed to install, replace, or service this equipment. See statement 1089 for the definition of an instructed or skilled person.

There are no serviceable parts inside. To avoid risk of electric shock, do not open.

---



---

**Warning Statement 1029**—Blank Faceplates and Cover Panels

Blank faceplates and cover panels serve three important functions: they reduce the risk of electric shock and fire, they contain electromagnetic interference (EMI) that might disrupt other equipment, and they direct the flow of cooling air through the chassis. Do not operate the system unless all cards, faceplates, front covers, and rear covers are in place.

---

## Laser Safety



---

**Warning** **Statement 1051**—Laser Radiation

Invisible laser radiation may be emitted from disconnected fibers or connectors. Do not stare into beams or view directly with optical instruments.

---



---

**Warning** **Statement 1055**—Class 1/1M Laser

Invisible laser radiation is present. Do not expose to users of telescopic optics. This applies to Class 1/1M laser products.



---

**Warning** **Statement 1255**—Laser Compliance Statement

Pluggable optical modules comply with IEC 60825-1 Ed. 3 and 21 CFR 1040.10 and 1040.11 with or without exception for conformance with IEC 60825-1 Ed. 3 as described in Laser Notice No. 56, dated May 8, 2019.

---

## Energy Hazard

The routers can be configured for a DC power source. Do not touch terminals while they are live. Observe the following warning to prevent injury.



---

**Warning** **Statement 1086**—Replace Cover on Power Terminals

Hazardous voltage or energy may be present on power terminals. To reduce the risk of electric shock, make sure the power terminal cover is in place when the power terminal is not being serviced. Be sure uninsulated conductors are not accessible when the cover is in place.

---

## Preventing Electrostatic Discharge Damage

Many router components can be damaged by static electricity. Not exercising the proper electrostatic discharge (ESD) precautions can result in intermittent or complete component failures. To minimize the potential for ESD damage, always use an ESD-preventive antistatic wrist strap (or ankle strap) and ensure that it makes adequate skin contact.





**Note** Check the resistance value of the ESD-preventive strap periodically. The measurement should be 1–10 megohms.

Before you perform any of the procedures in this guide, attach an ESD-preventive strap to your wrist and connect the leash to the chassis.

## Cautions and Regulatory Compliance Statements for NEBS

The NEBS-GR-1089-CORE regulatory compliance statements and requirements are discussed in this section.



**Warning** The intrabuilding port(s) of the equipment or subassembly, which is the management Ethernet port, must use shielded intrabuilding cabling/wiring that is grounded at both ends. Statement 7003



**Warning** The intrabuilding port(s) of the equipment or subassembly, which is the management Ethernet port, must not be metallically connected to interfaces that connect to the OSP or its wiring. These interfaces are designed for use as intrabuilding interfaces only (Type 2 or Type 4 ports as described in GR-1089-CORE) and require isolation from the exposed OSP cabling. The addition of Primary Protectors is not sufficient protection in order to connect these interfaces metallically to OSP wiring. Statement 7005



**Warning** This equipment shall be connected to AC mains provided with a surge protective device (SPD) at the service equipment complying with NFPA 70, the National Electrical Code (NEC). Statement 7012



**Warning** This equipment is suitable for installations utilizing the Common Bonding Network (CBN). Statement 7013



**Warning** This equipment is suitable for installation in Network Telecommunications Facilities. Statement 8015



**Warning** This equipment is suitable for installation in locations where the NEC applies. Statement 8016

## Installation Guidelines

Before installing the chassis, ensure that the following guidelines are met:

- Site is properly prepared so that there is sufficient room for installation and maintenance.

- Operating environment is within the ranges that are listed in Environment and Physical specifications. For more details on environmental requirements, see [Cisco 8000 Series Routers Data Sheet](#).
- Chassis is mounted at the bottom of the rack if it is the only unit in the rack.
- When mounting the chassis in a partially filled rack, load the rack from the bottom to the top with the heaviest component at the bottom of the rack.
- If the rack is provided with stabilizing devices, install the stabilizers before mounting or servicing the chassis in the rack.
- Airflow around the chassis and through the vents is unrestricted.
- Cabling is away from sources of electrical noise, such as radios, power lines, and fluorescent lighting fixtures. Make sure that the cabling is safely away from other devices that might damage the cables.
- Each port must match the wave-length specifications on each end of the cable, and the cable must not exceed the stipulated cable length.



---

**Note** Cisco 8000 Series Routers function in operating temperatures of up to 40°C at sea level. For every 300 meters (1000 ft), the maximum temperature is reduced by 1°C. For more details on environmental requirements, see [Cisco 8000 Series Routers Data Sheet](#).

---

## Procure Tools and Equipment

Obtain these necessary tools and equipment for installing the chassis:

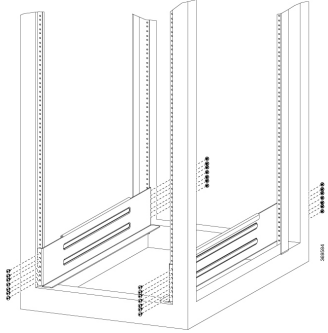

- Number 1 and number 2 Phillips screwdrivers with torque capability to rack-mount the chassis.
- 3/16-inch flat-blade screwdriver.
- Tape measure and level.
- ESD wrist strap or other grounding device.
- Antistatic mat or antistatic foam.
- Two-hole ground lug (1).
- Grounding cable (2 AWG recommended), sized according to local and national installation requirements; the required length depends on the proximity of the switch to proper grounding facilities.
- Crimping tool for lug.
- Wire-stripping tool.
- A maximum of 70 rack mount screws can be used based on your rack selection.

## Rack Mount and Accessory Kits

### Router Accessory Kit

Router accessory kit (8800-INSTKIT) includes the following:

**Table 16: Router Accessory Kit**

Illustration	Description	Quantity
	Rack mount rails: <ul style="list-style-type: none"> <li>• Support rails are non-adjustable</li> <li>• Set the vertical support rack rails at 32" pitch</li> </ul>	1
	Ground lug kit <ul style="list-style-type: none"> <li>• Two-hole lug (1)</li> <li>• 1/4"-20 Phillips pan-head screws (2)</li> </ul>	1

### More Hardware Components

If you purchased this product through a Cisco reseller, you might receive more contents in your kit, such as documentation, hardware, and power cables.

The shipped cables depend on your specification when placing an order. See the *Power Supply Power Cord Specifications* section for information on the available power cords.

If you notice any discrepancies or damage, send the following information to your customer service representative by email:

- Invoice number of the shipper (see the packing slip)
- Model and serial number of the missing or damaged unit
- Description of the problem and how it affects the installation
- Photos of the damage to external packaging, internal packaging, and product

## Prepare Your Location

This section illustrates how the building that houses the chassis must be properly grounded to the earth ground.

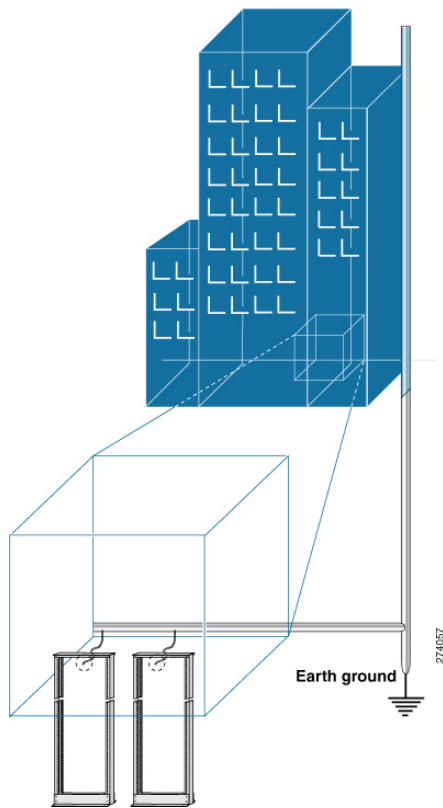


**Note** Unless specified otherwise, the image is only for representational purposes. The rack's actual appearance and size may vary.



**Note** This image is only for representational purposes. Your grounding requirement depends on your building.

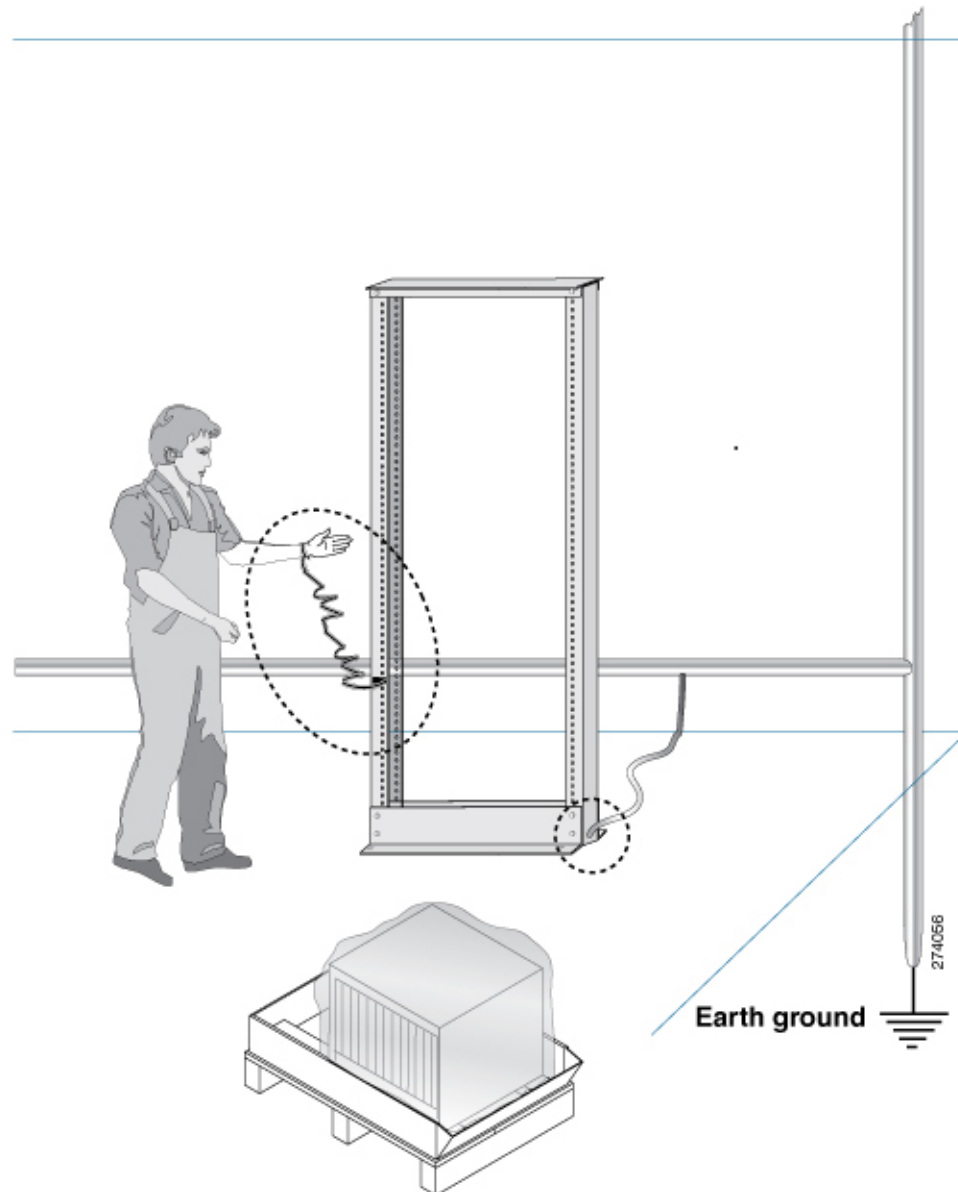
**Figure 5: Building with Rack Room Connected to Earth Ground**



## Prepare Yourself

This section illustrates how to prepare yourself before removing the chassis from the sealed antistatic bag. The figures show how to cuff the ESD strap around the wrist and the ground cord that connects the cuff to the ground. ESD wrist straps are the primary means of controlling static charge on personnel.

*Figure 6: Wearing the ESD Strap*



## Prepare Rack for Chassis Installation

Install the Cisco 8800 Series Routers on a standard 19 inch, Electronic Industries Alliance (EIA) rack with mounting rails that conform to English universal hole spacing according to Section 1 of the ANSI/EIA-310-D-1992 standard.

The spacing between the posts of the rack must be (EIA-310-D-1992 19-inch rack compatible) wide enough to accommodate the width of the chassis.

Before you move the chassis or mount the chassis into the rack, we recommend that you do the following:

**Procedure**

**Step 1** Place the rack at the location where you plan to install the chassis.

**Step 2** (Optional) Secure the rack to the floor.

To bolt the rack to the floor, a floor bolt kit (also called an anchor embedment kit) is required. For information on bolting the rack to the floor, consult a company that specializes in floor mounting kits (such as Hilti; see [Hilti.com](http://Hilti.com) for details). Make sure that floor mounting bolts are accessible, especially if annual retorquing of bolts is required.

**Note** Ensure that the rack in which the chassis is being installed is grounded to earth ground.

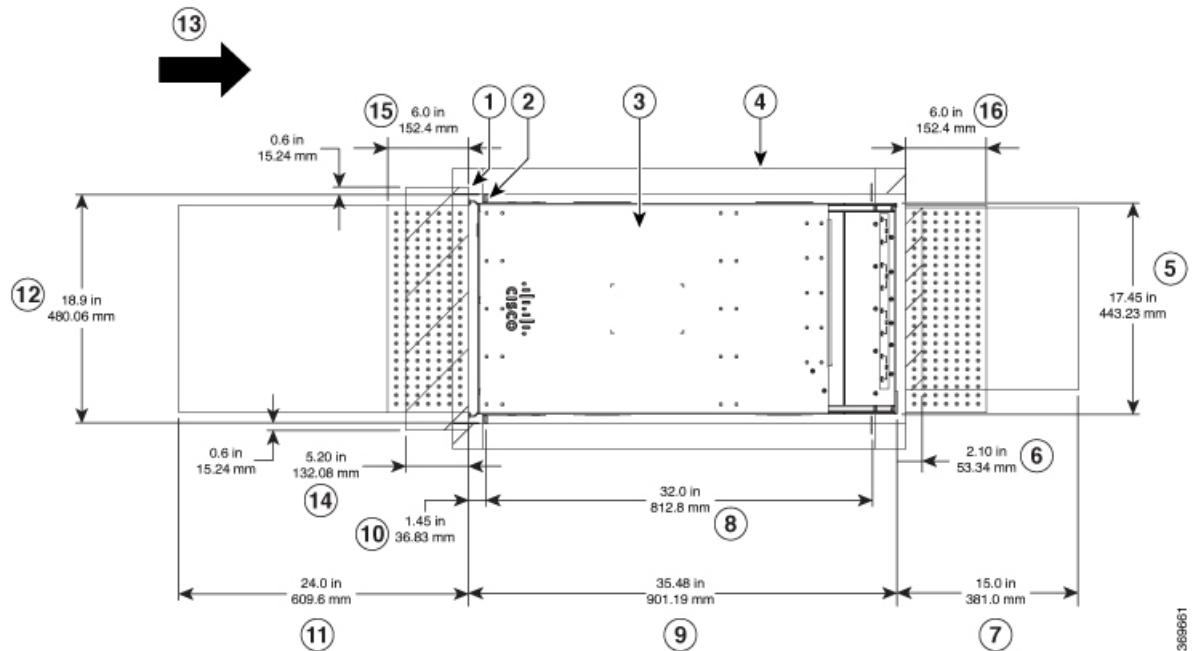
# Clearance Requirements

To ensure adequate airflow, we recommend that you maintain a minimum of 6 in. (15.24 cm) front and rear clearance for air intake/exhaust.

If the router is installed in a perforated door cabinet, maintain a minimum of 6 in. (15.24 cm) from the inside of the door. The front and rear doors of the cabinet must be perforated with a minimum open area of 70%.

Following figure shows the clearances required for installation of Cisco 8800 Series Routers.

**Figure 7: Clearances Required Around the Chassis**

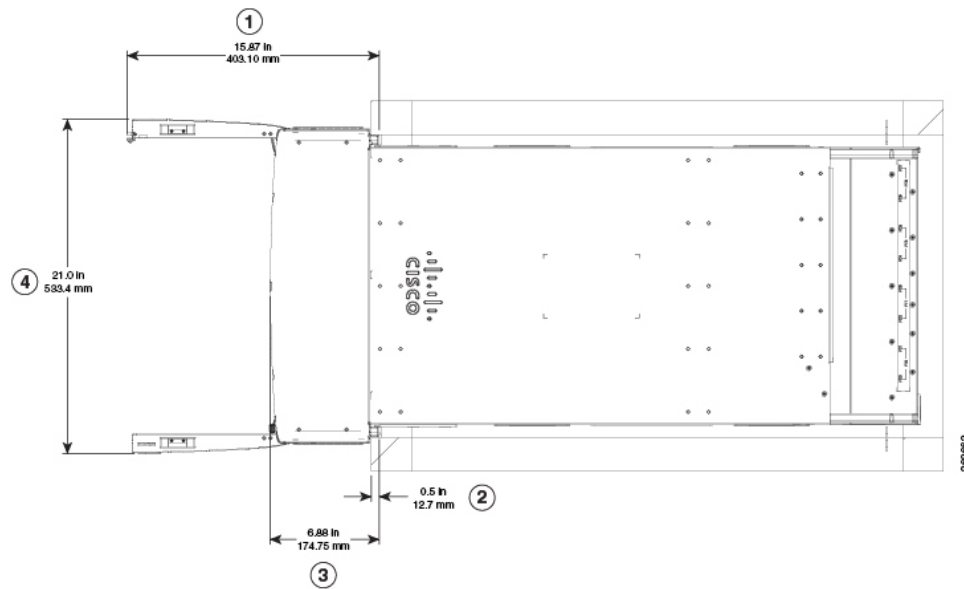


1	Vertical rack post	9	Chassis depth
---	--------------------	---	---------------

2	Vertical rack rail	10	Depth from the vertical rack rail to the front of the chassis
3	Chassis	11	Front service area for the line card replacement
4	Outside of the rack (no clearance required)	12	Front chassis width
5	Rear chassis width	13	Airflow direction
6	Clearance required for the fan tray handle at the rear	14	Clearance for line card ejector levers
7	Rear service area for the fan tray and fabric card replacement	15	Clearance required in front of the chassis for air intake
8	Mounting depth of rack vertical rails	16	Clearance required in rear of the chassis for air exhaust

Following figure shows the clearances required for the cable management of Cisco 8800 Series Routers.

**Figure 8: Clearances Required Around the Chassis Door**



(1) Overall door width on side (in an open position)	(3) Depth of cable management
(2) Maximum vertical rack rail setback, when filters are installed on the chassis	(4) Overall door depth on front (in an open position)







## CHAPTER 3

# Unpack and Install the Chassis

---



---

**Note** The images in this chapter are only for representation purposes, unless specified otherwise. The chassis' actual appearance and size may vary.

---

- [Unpack the Chassis, on page 31](#)
- [Install Bottom-Support Rails, on page 36](#)
- [Transfer Chassis to a Mechanical Lifting Device, on page 37](#)
- [Mount Chassis Into the Rack, on page 39](#)
- [Install Cable Management on a Chassis , on page 57](#)
- [Attach Front Door to Chassis, on page 68](#)

## Unpack the Chassis



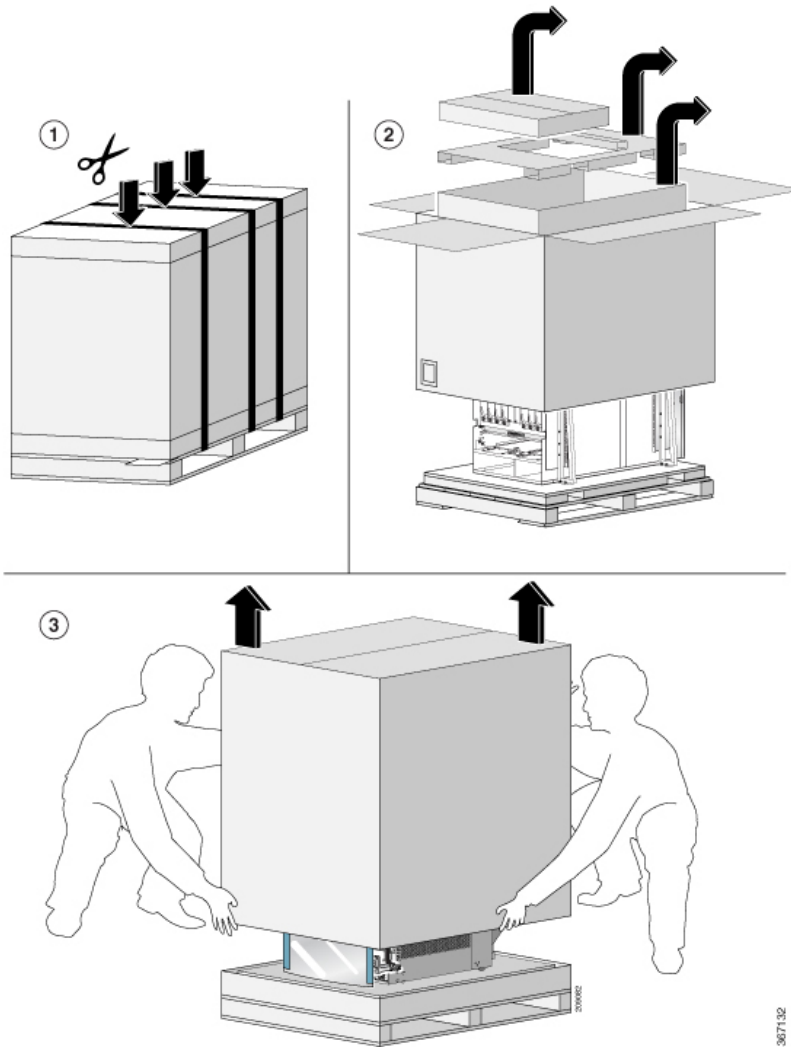
---

**Tip** Be sure to save the packaging in case you need to return any of the components products.

---

Ensure that there is sufficient room around the chassis pallet for unpacking. For information about the chassis dimensions and clearance requirements see, *Clearance Requirements*.

Carefully move the pallet containing the chassis to the staging area where you plan on unpacking it.



367132

Figure 9: Remove Shipping Brackets from 8818 Chassis

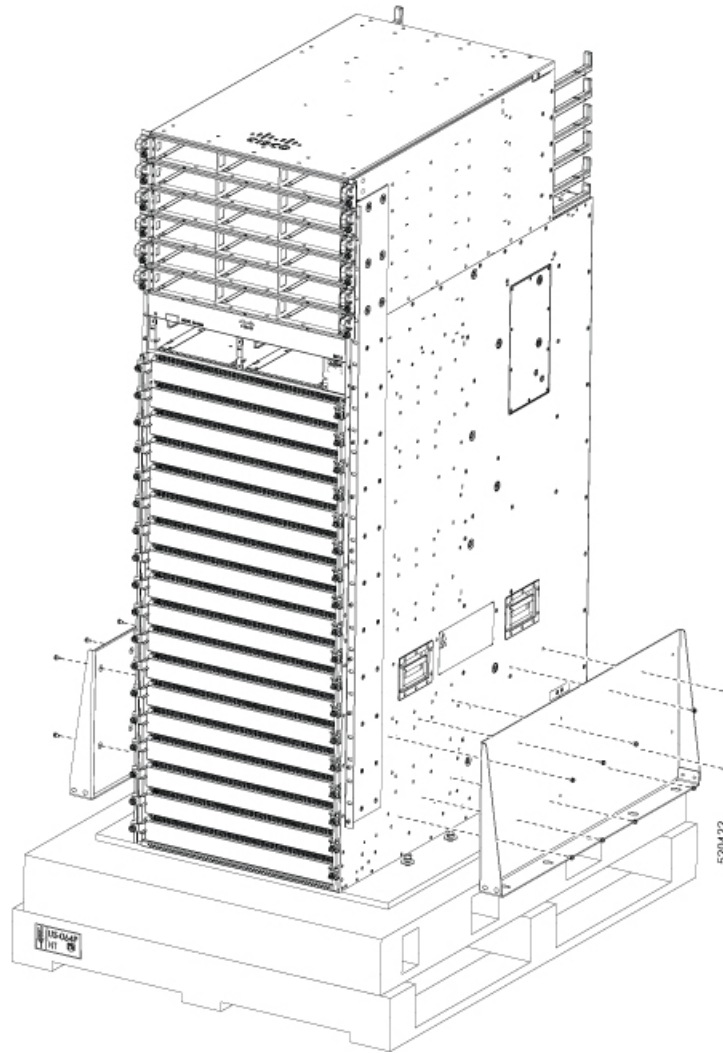
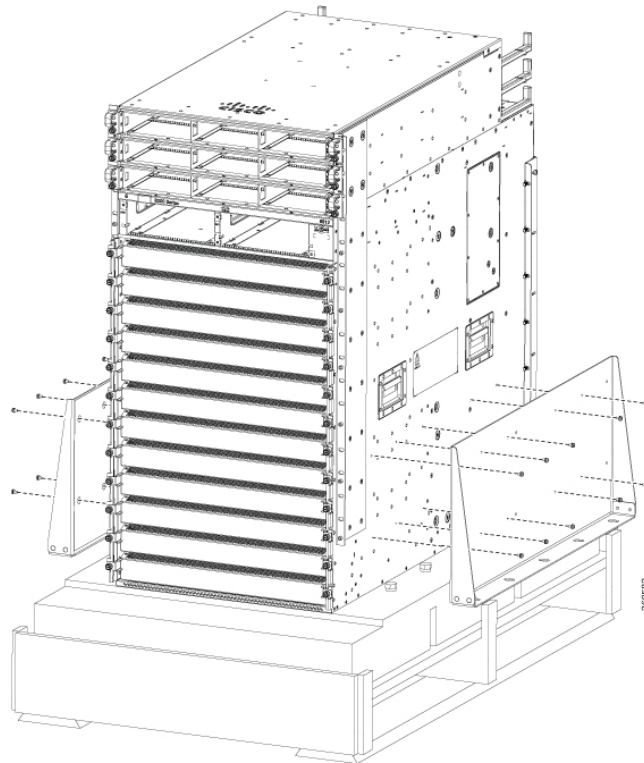


Figure 10: Remove Shipping Brackets from 8812 Chassis



*Figure 11: Remove Shipping Brackets from 8808 Chassis*

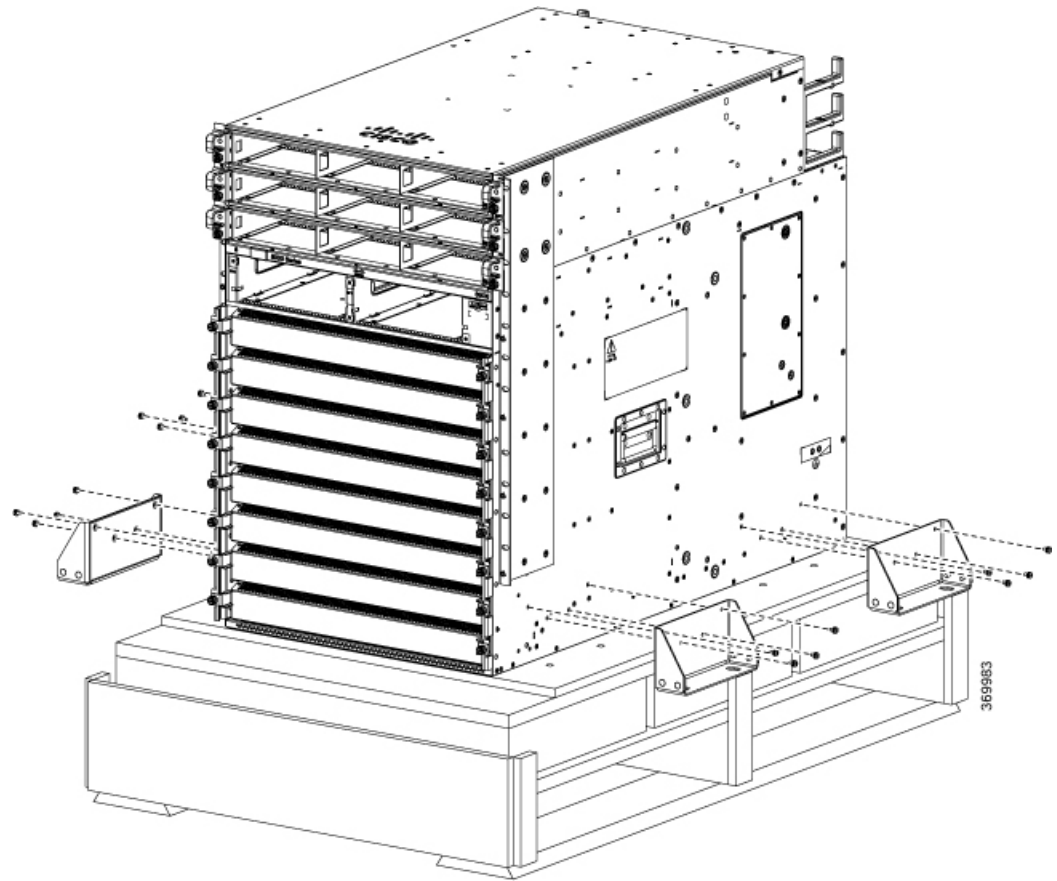
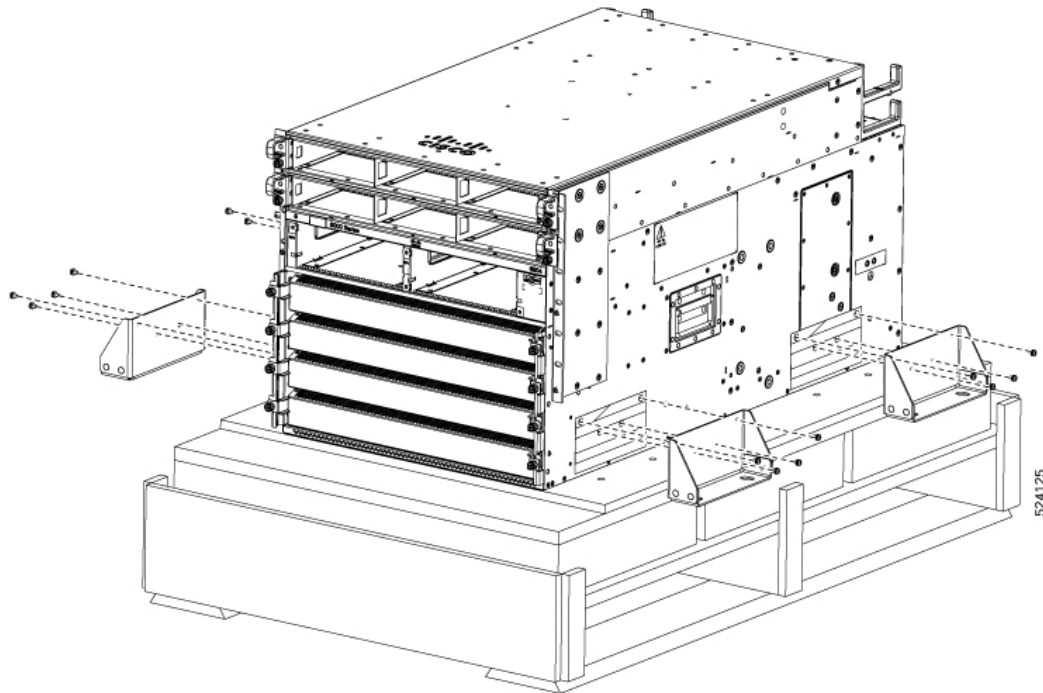


Figure 12: Remove Shipping Brackets from 8804 Chassis



Remove the shipping brackets:

- 20 x M4 screws from the 8818 chassis
- 20 x M4 screws from the 8812 chassis
- 16 x M4 screws from the 8808 chassis
- 16 x M4 screws from the 8804 chassis

To make the chassis weigh less for moving, remove the following module and place them where their connectors will not be damaged:

- Fan trays

Leave the chassis on the pallet until you are ready to move and install the chassis in a rack.

## Install Bottom-Support Rails

The bottom-support rails support the weight of the router chassis in the rack. To maximize the stability of the rack, you must attach these rails at the lowest possible rack unit (RU).

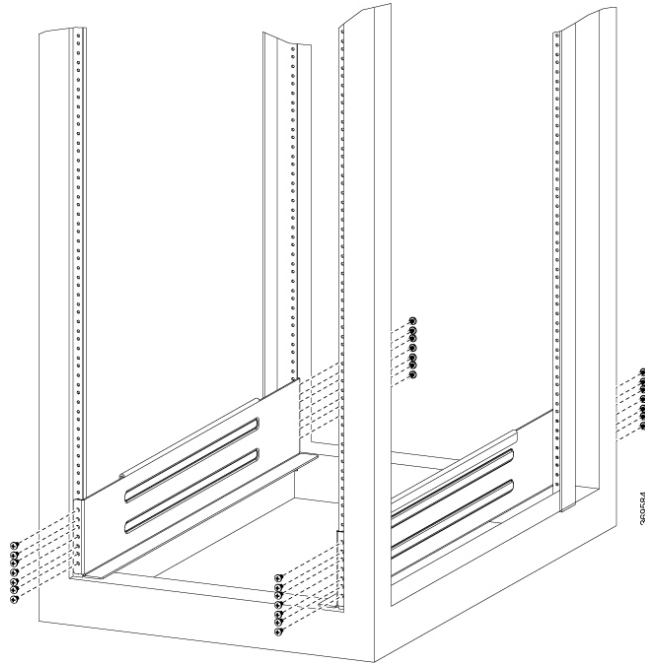
### Procedure

- Step 1** Position the vertical rack rails at 32" depth to match with the length of the bottom-support rails. Check spacing considerations.

- Maintain at least 21 RU (36.75 inches [93.34 cm]) for 8812 chassis and 16 RU (28 inches [71.12 cm]) for 8808 chassis of vertical space above support rails.
- Use 8800-ADJ-RAIL for an L-type rail kit and use 8800-RAIL-KIT for a U-type rail kit.

**Step 2** Attach the bottom-support rail to the rack using a Phillips torque screwdriver on M6 x 19 mm or 12–24 x 3/4 inch screws for each end of the rail (as shown in the following figure) and tighten each screw to 40 in-lbs (4.5 N-m) of torque.

**Figure 13: Attach Bottom-Support Rails to a Rack**



**Note** Use at least three screws on each end of each bottom-support rail.

**Step 3** Repeat Steps 1 and 2 to attach the other bottom-support rail to the rack.

**Note** Make sure that the two bottom-support rails are level with one another. If they are not level, adjust the higher rail down to the level of the lower rail.

#### What to do next

Mount the chassis into the rack.

## Transfer Chassis to a Mechanical Lifting Device

#### Procedure

**Step 1** Place the mechanical lifting device in front of the chassis on the pallet (or on Line Card side) as shown.

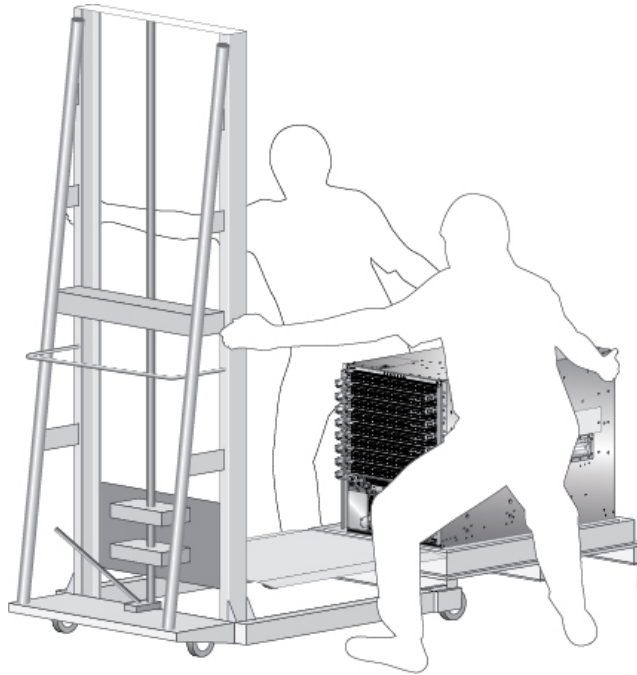
**Figure 14:** *Align the Lifting Device in Front of the Chassis on the Pallet*



- Step 2** Prepare to use the mechanical lifting device by placing a piece of cardboard on the surface of the lift (to prevent scratching).
- Step 3** With at least two or three people move the chassis carefully from the pallet onto the lifting device as shown.



**Figure 15: Move the Chassis on to the Lifting Device**



---

#### What to do next

After moving the chassis to the room or area where you will install it, begin the procedure to mount the chassis into the rack.

## Mount Chassis Into the Rack

To accommodate equipment racks with different mounting hole patterns, the chassis mounting brackets have groups of screw holes on either side. The mounting holes in the chassis mounting brackets are spaced so that one mounting hole in each hole group aligns with a corresponding hole in the equipment rack. By using the corresponding mounting hole (in the same hole group) on the opposite side of the chassis, you can level the chassis in the rack.



---

#### Note

- To lift the chassis, use a mechanical lift. Do not use the handles on the side of the chassis. Use the side handles for only repositioning the chassis after it is already on the mechanical lift or in the rack or cabinet.
  - Do not remove the blanks during rack installation.
-

## Procedure

- Step 1** Using your mechanical lift, raise the chassis so that it is in level with or not more than 1/4 inch [0.635cm] above the rails.
- Step 2** Push the chassis all the way onto the rack so that the vertical mounting brackets on the front of the chassis come in contact with the vertical mounting rails on the rack.
- Step 3** Use screws provided with the rack to secure the chassis with the vertical mounting rails on the rack.

*Figure 16: Attach 8818 Chassis to Rack - Front*

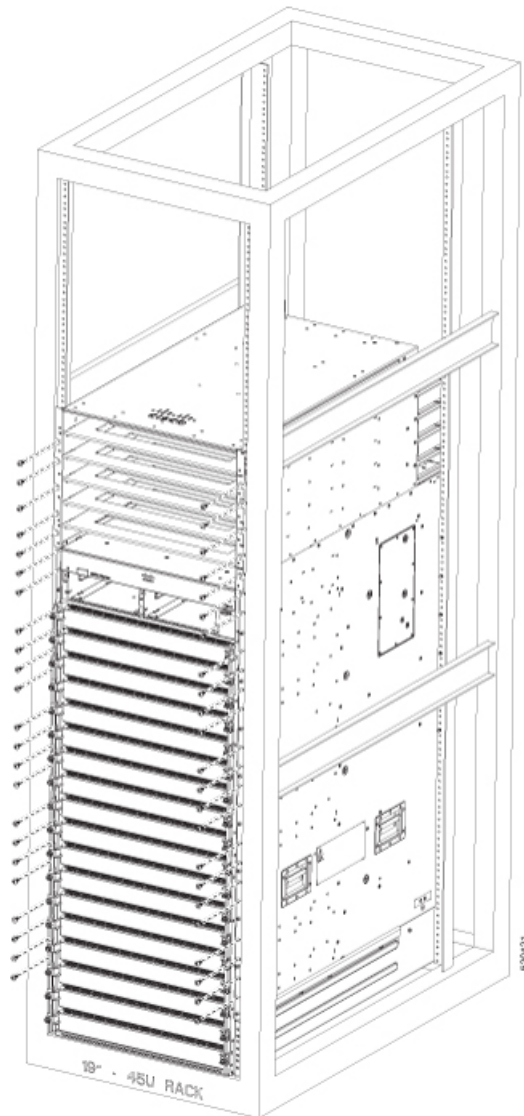
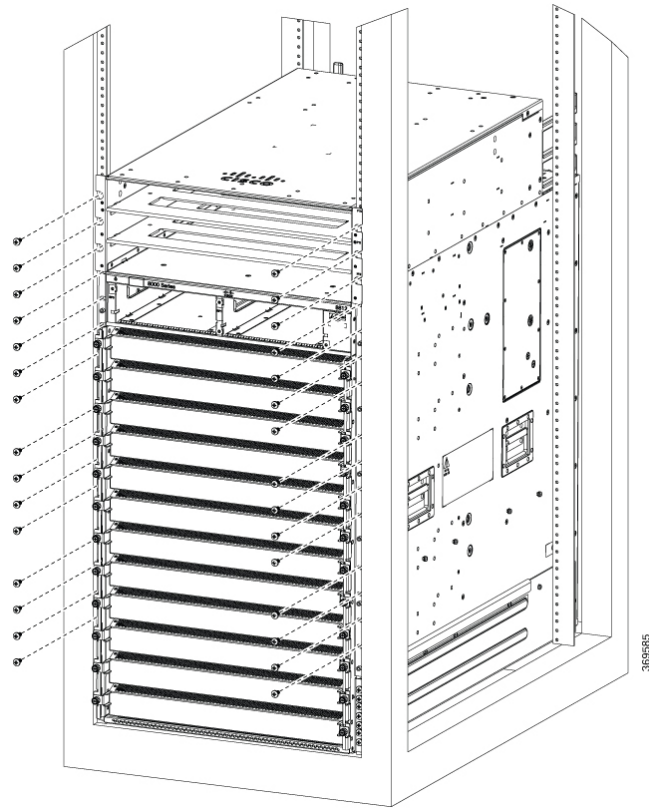


Figure 17: Attach 8812 Chassis to Rack - Front



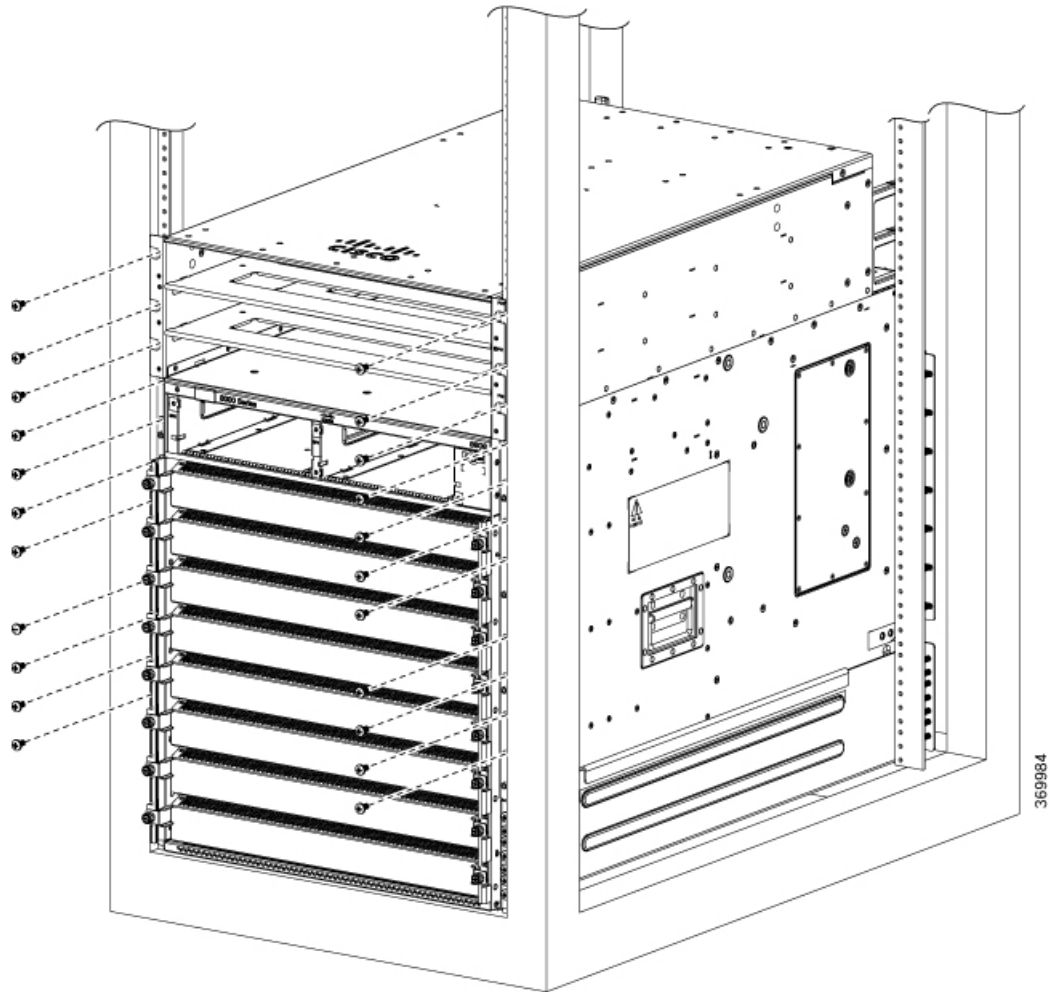
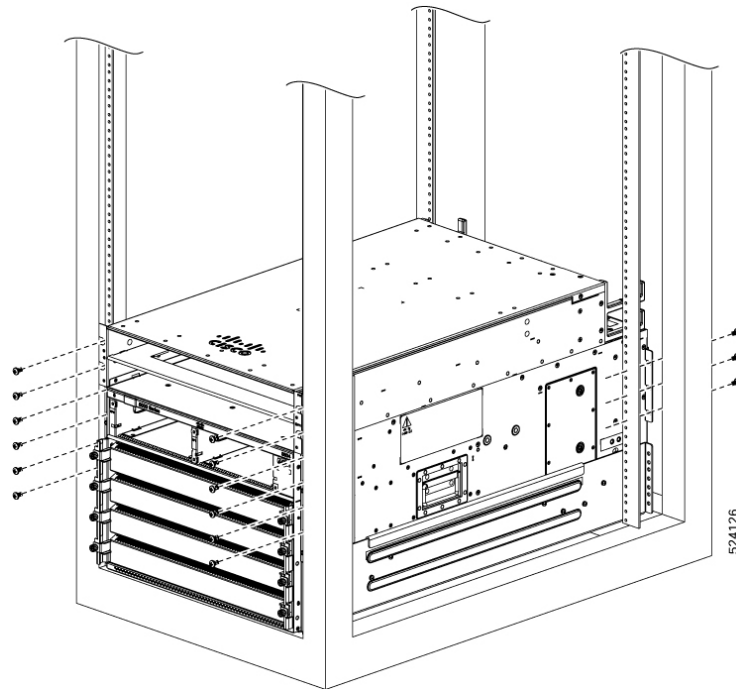
*Figure 18: Attach 8808 Chassis to Rack - Front*

Figure 19: Attach 8804 Chassis to Rack - Front



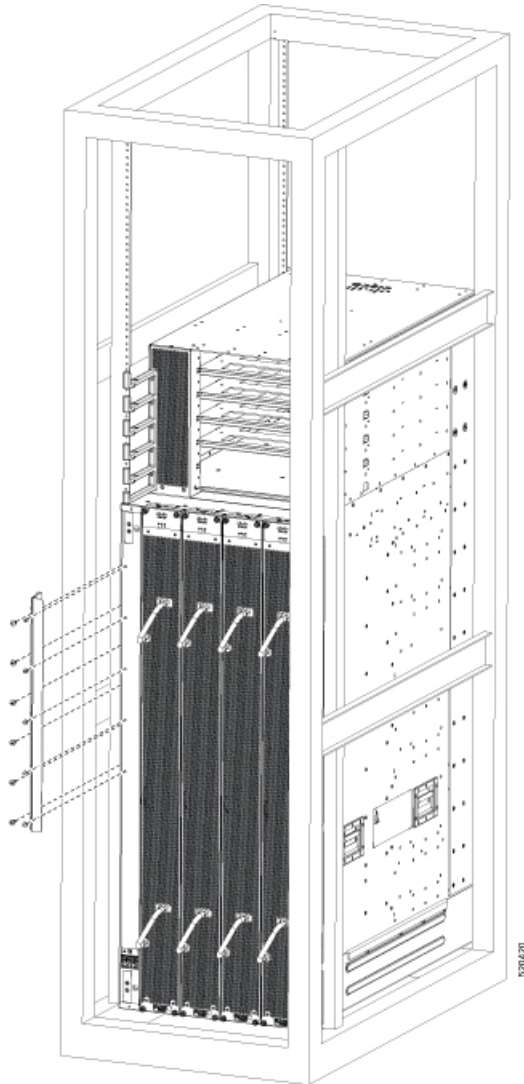
**Note** You should remove the power shelf to facilitate attaching chassis to the rack.

Table 17: Screws Required to Secure the Cisco 8800 Chassis to the Rack

Chassis	Screws for Front	Screws for Rear
Cisco 8818	46	17
Cisco 8812	30	12
Cisco 8808	22	14
Cisco 8804	12	10

**Step 4** Use the screws provided with the rack to attach the chassis rear rails.

*Figure 20: Attach 8818 Chassis to Rack - Rear Left View*



8204520

Figure 21: Attach 8818 Chassis to Rack - Rear Right View

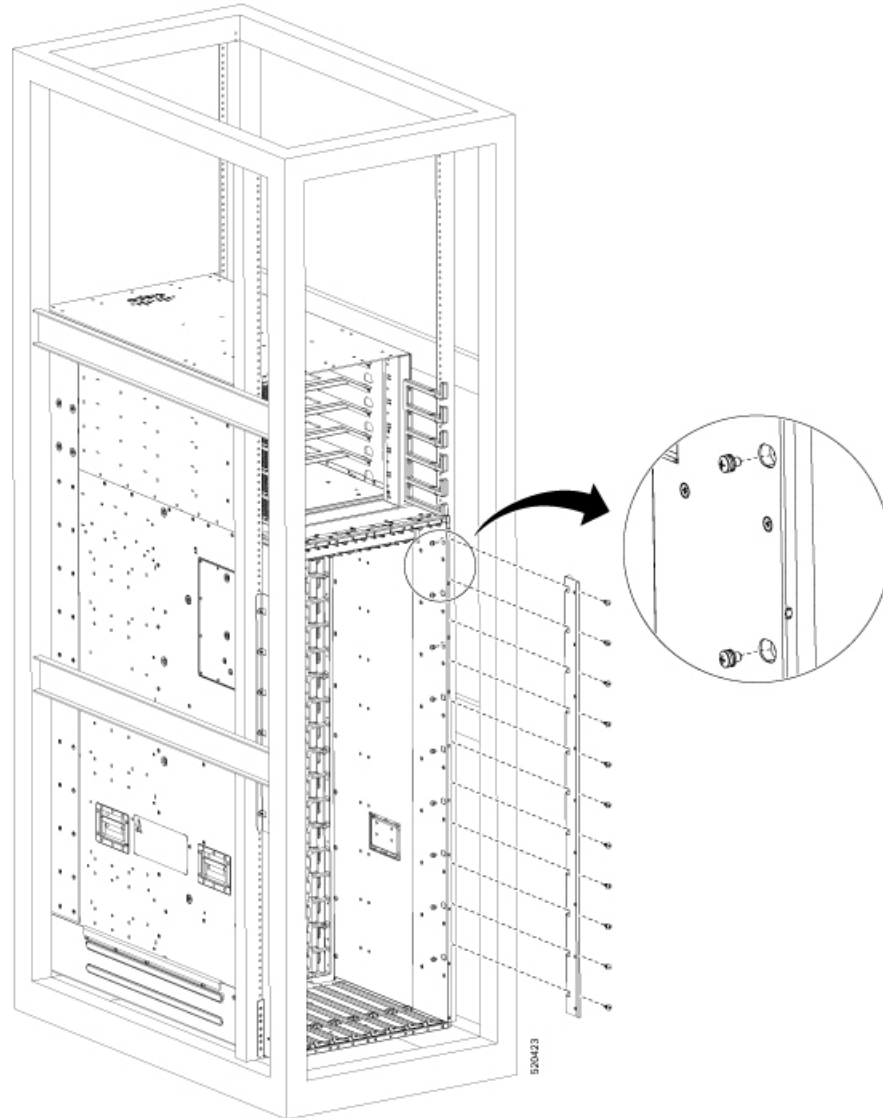


Figure 22: Attach 8812 Chassis to Rack - Rear Left View

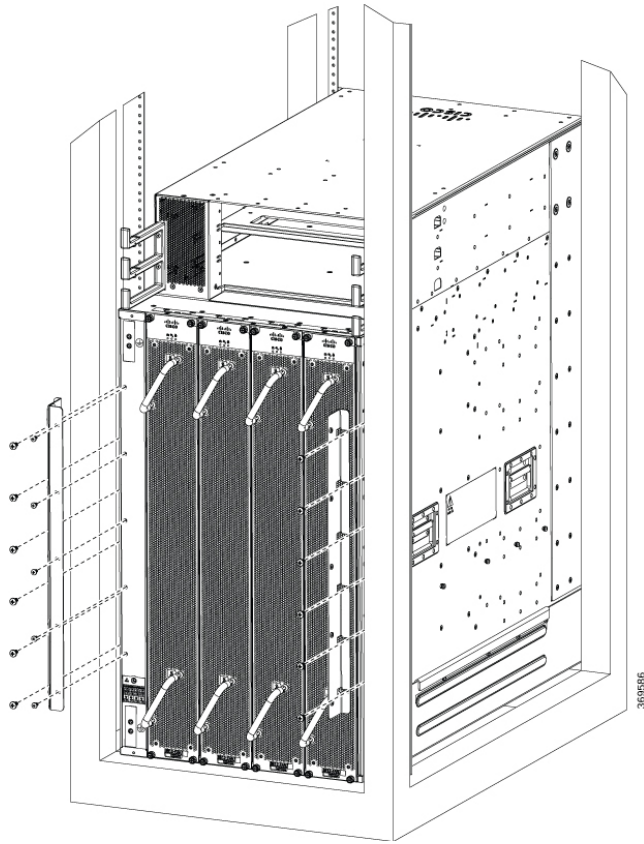
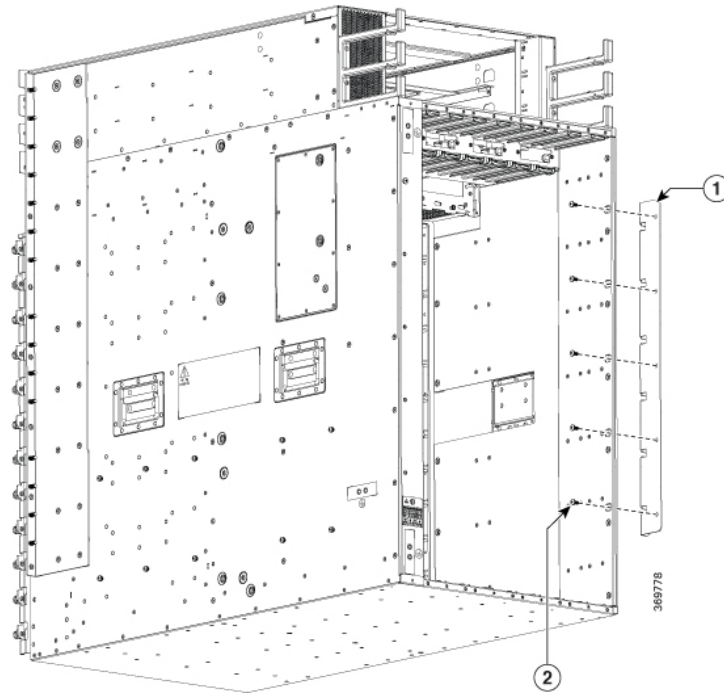




Figure 23: Attach 8812 Chassis to Rack - Rear Right View



1	Rear right rack mounting bracket.	2	Install screws from inside the chassis to the rack with a torque of 26 in-lbs (2.93 N-m) of torque.
---	-----------------------------------	---	---

Figure 24: Attach 8808 Chassis to Rack - Rear Left View

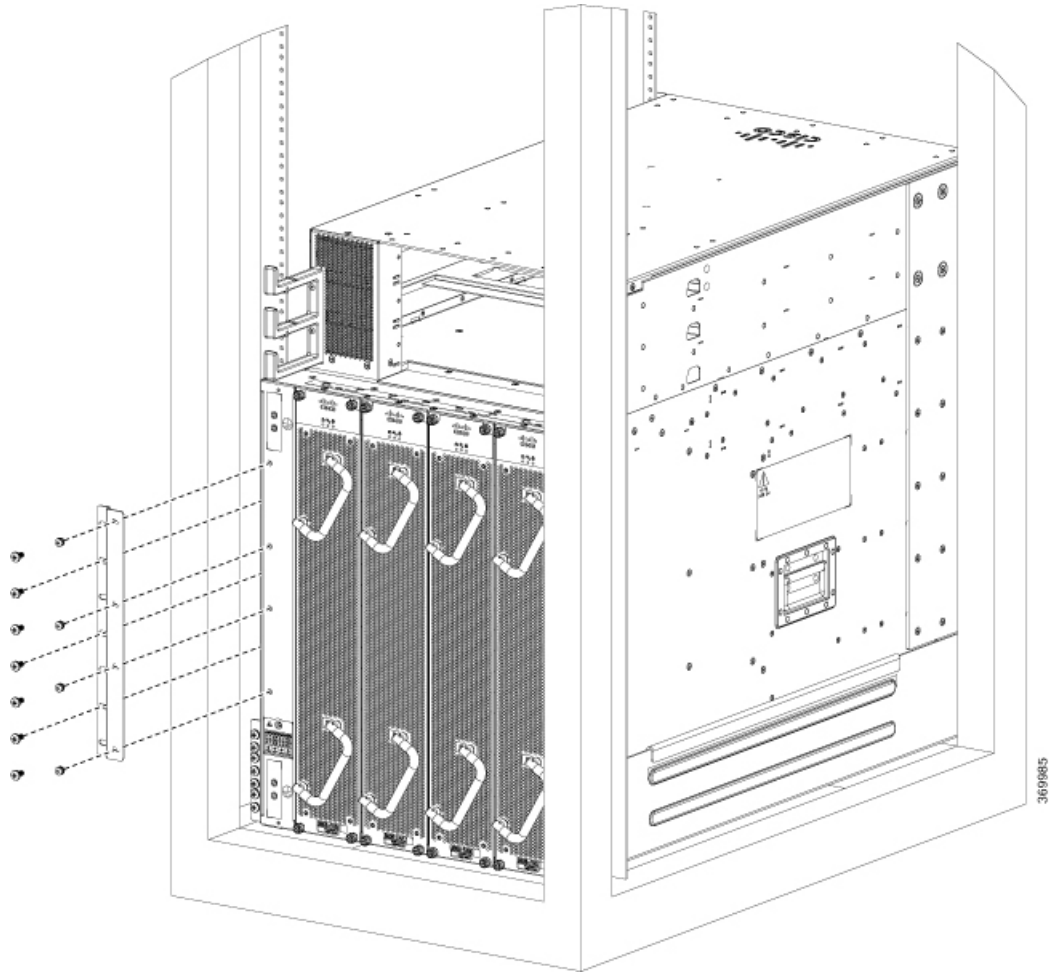
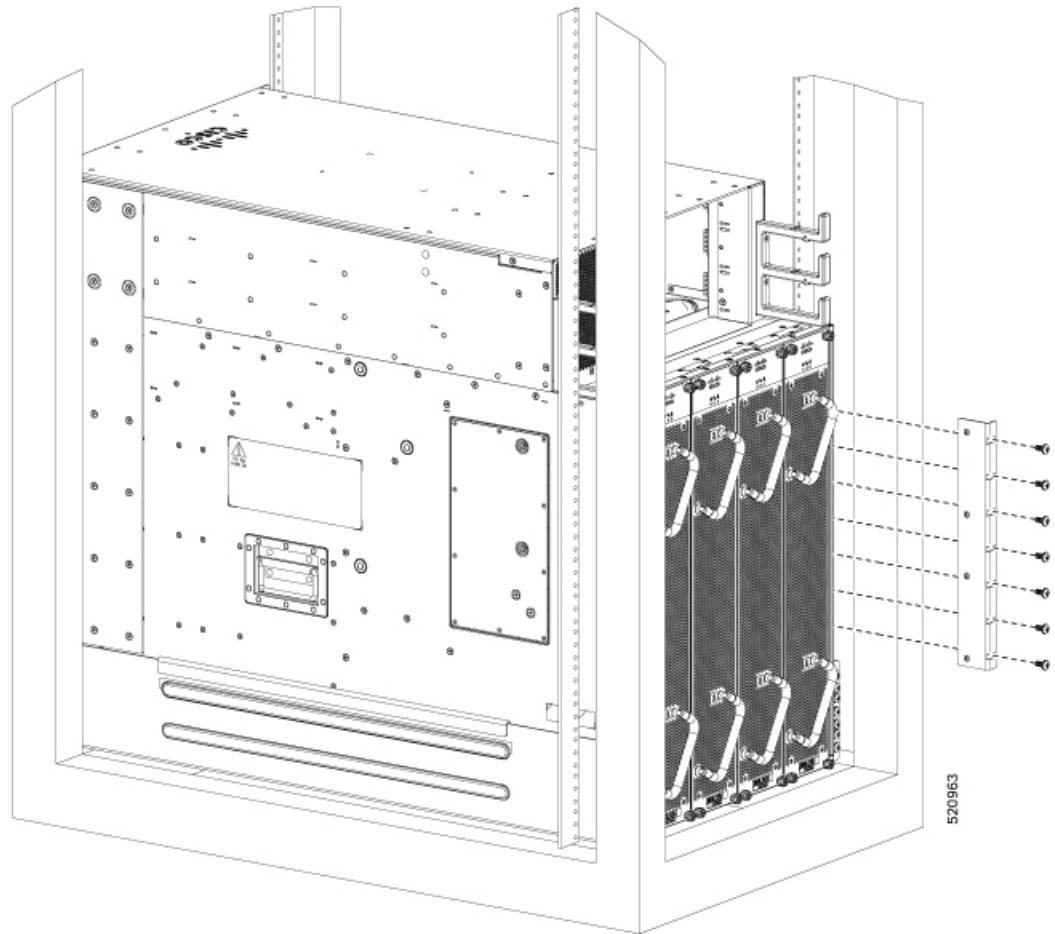
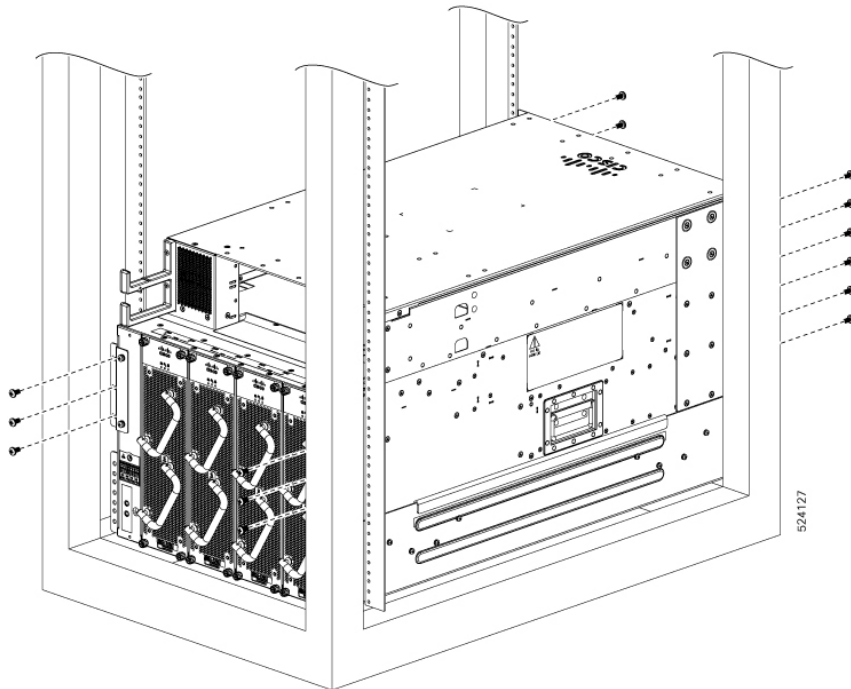


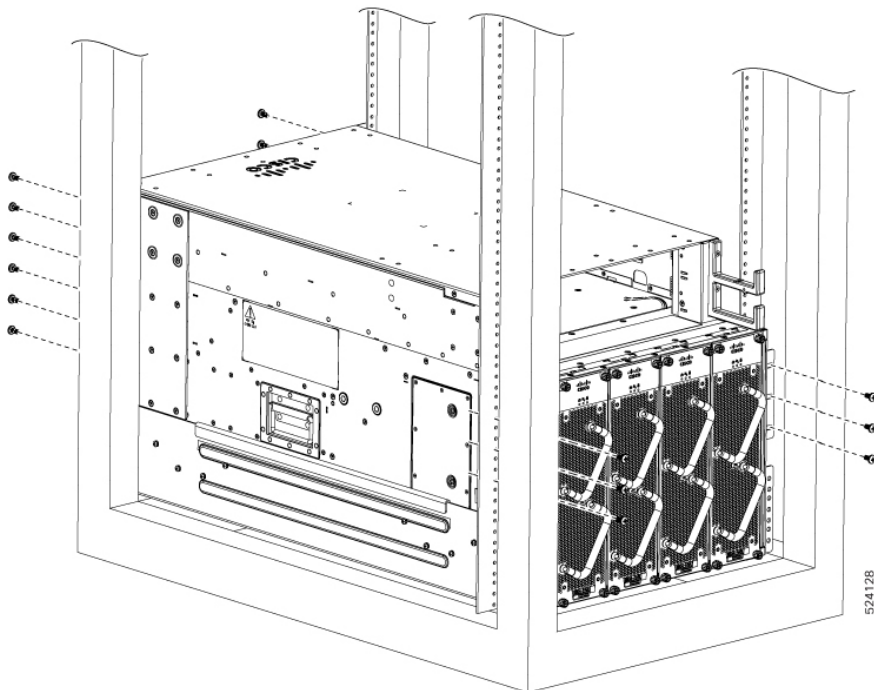
Figure 25: Attach 8808 Chassis to Rack - Rear Right View



**Figure 26: Attach 8804 Chassis to Rack - Rear Left View**



**Figure 27: Attach 8804 Chassis to Rack - Rear Right View**



**Note** We provide 10-32 screws to secure the left and right bracket. The screws to attach bracket to rack come from rack supplier.

---

#### **What to do next**

Connect the chassis to the ground at your facility.

## **Locate and Ground the Chassis**

### **Procedure**

---

- Step 1** Locate the chassis grounding receptacles on your router chassis.  
You can locate them at the following position:
- At the left side panel, lower section towards the rear

Figure 28: Chassis Ground Receptacles on Cisco 8818 Chassis

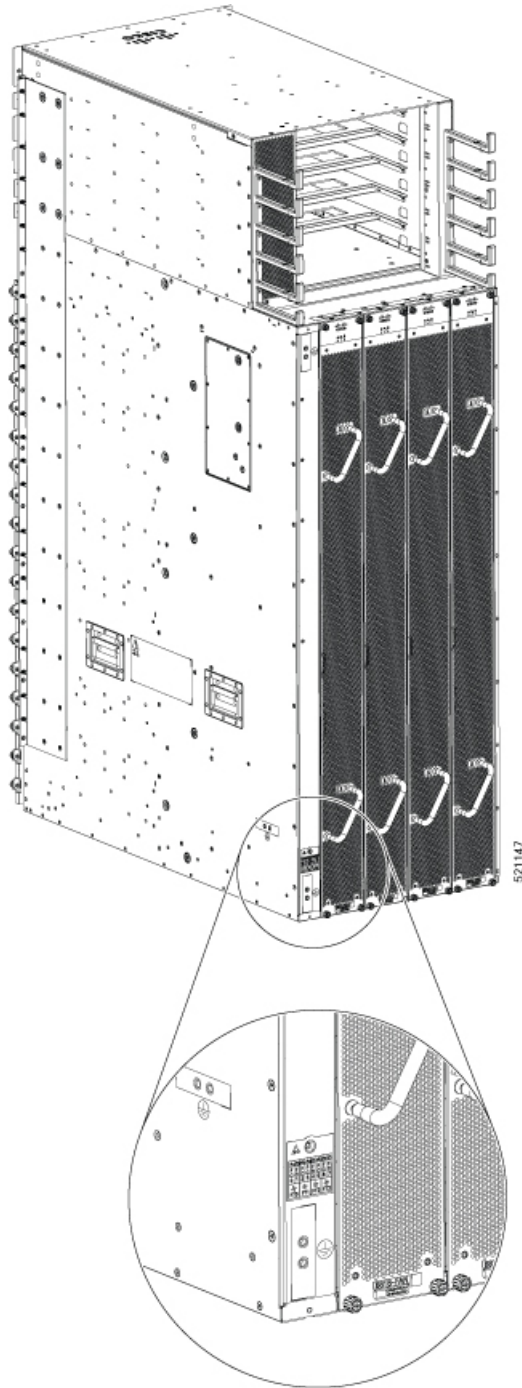


Figure 29: Chassis Ground Receptacles on Cisco 8812 Chassis

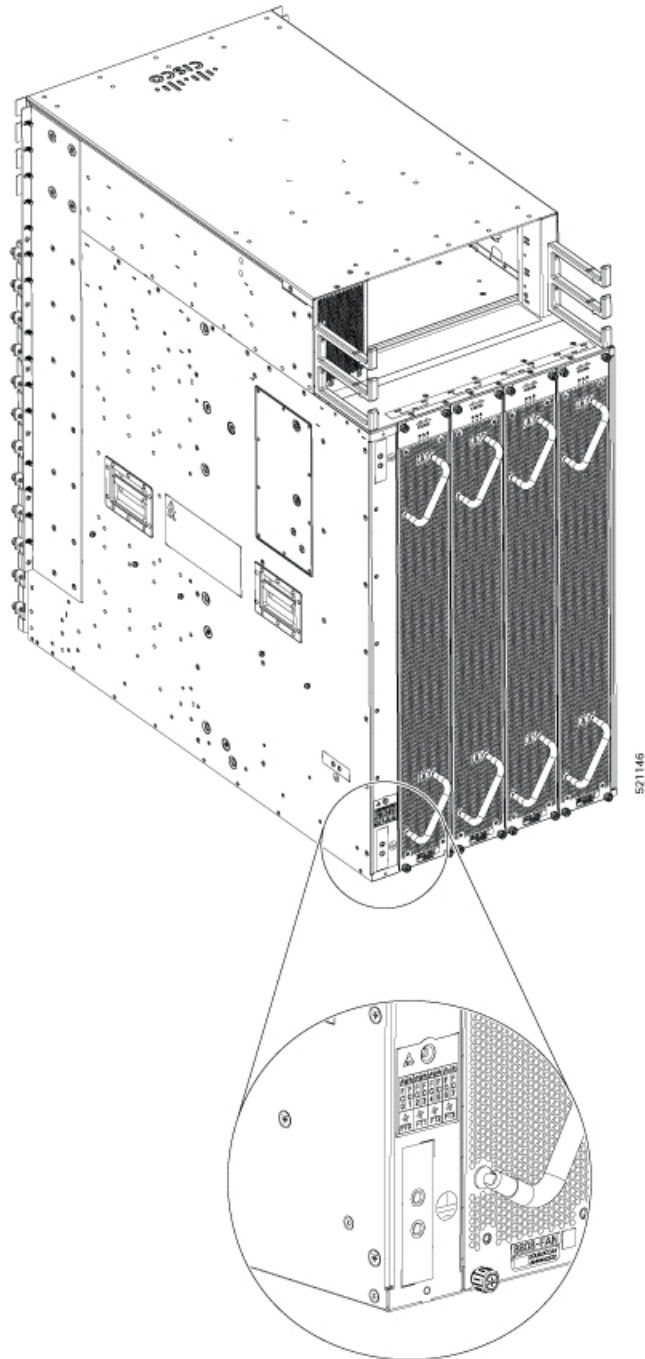
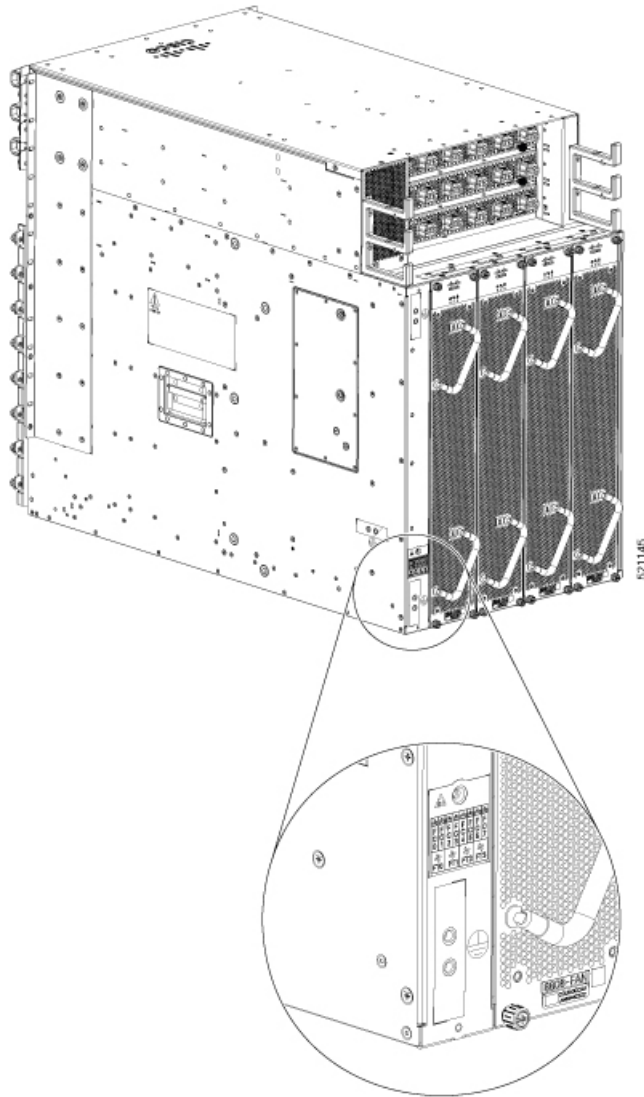
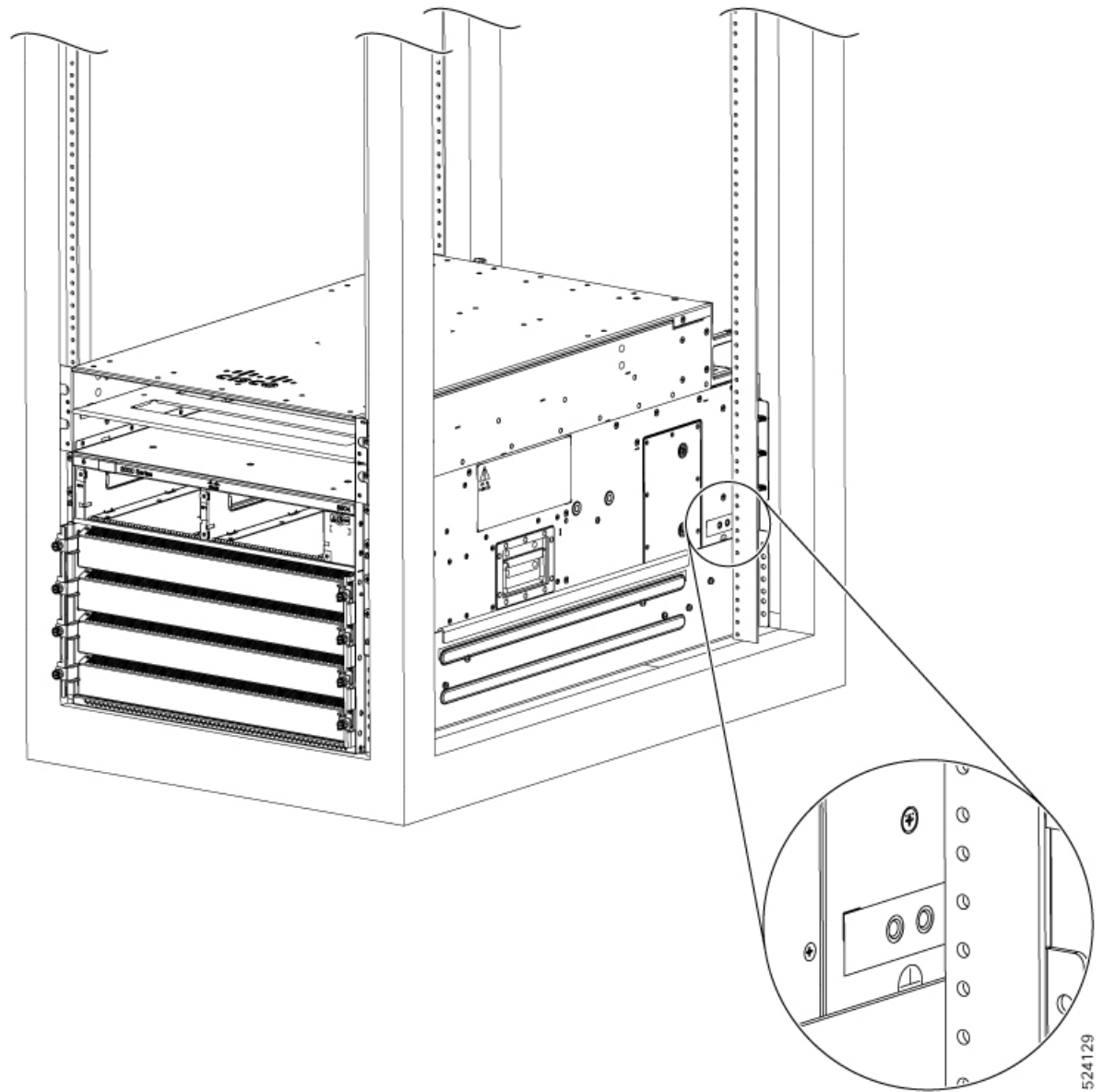


Figure 30: Chassis Ground Receptacles on Cisco 8808 Chassis



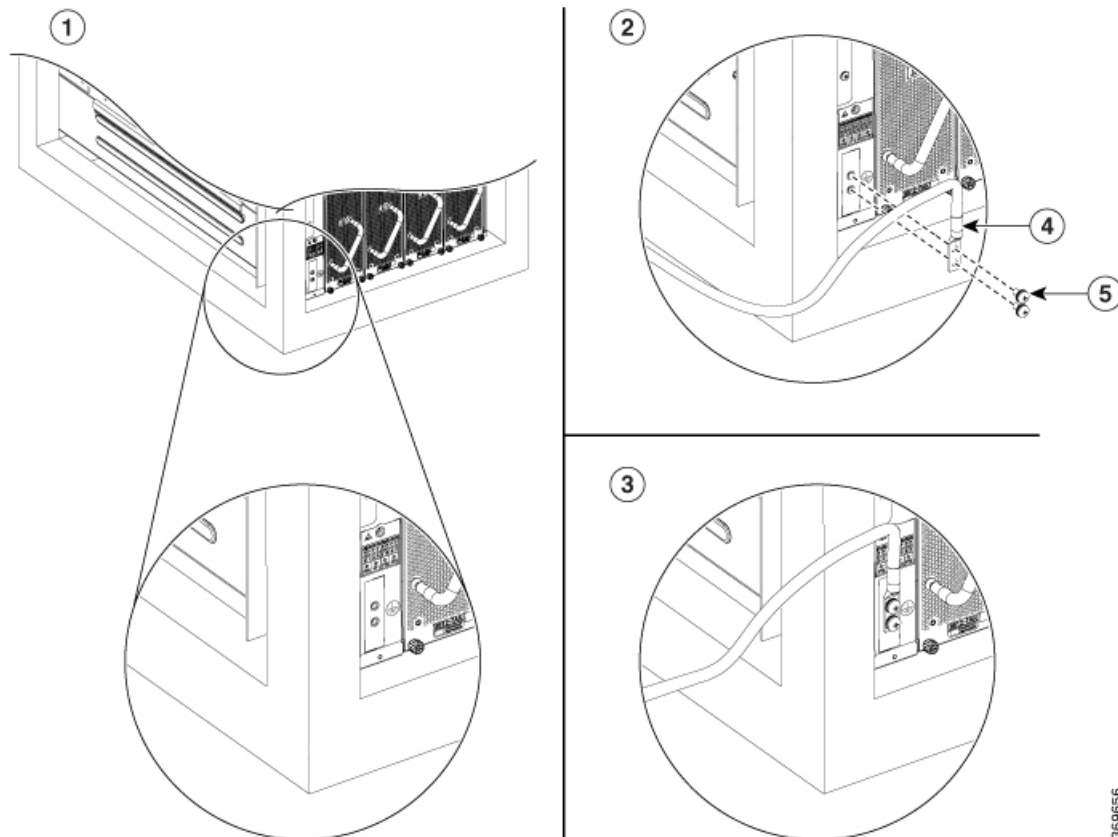


*Figure 31: Chassis Ground Receptacles on Cisco 8804 Chassis*



- Step 2** Use the wire stripper to strip one end of the 2-AWG wire approximately 0.75 inches (19.05 mm).
- Step 3** Insert the 2-AWG wire into the wire receptacle on the grounding lug.

Figure 32: Ground the Chassis



1	Locate ground	4	Align the lug holes
2	Prepare lug	5	Tighten the screws
3	Ground the chassis		

- Step 4** Use the crimping tool to carefully crimp the wire receptacle around the wire; this step is required to ensure a proper mechanical connection.
- Step 5** Insert the two screws through the holes in the grounding lug. Ensure that the grounding lug does not interfere with other router hardware components.
- Step 6** Use the Phillips screwdriver to carefully tighten the screws to 60 in-lbs 6.7 (N-m) of torque until the grounding lug is held firmly to the chassis. Do not overtighten the screws.
- Step 7** Connect the opposite end of the grounding wire to the appropriate grounding point at your site to ensure an adequate chassis ground.

#### What to do next

Attach the chassis doors.

# Install Cable Management on a Chassis

## Before you begin

The chassis must be installed and secured to the rack.

Required tools and equipment:

- Phillips screwdriver with a torque capability (customer supplied)
- Cable management brackets (8818-CBLMGMT, 8812-CBLMGMT, 8808-CBLMGMT, or 8804-CBLMGMT).



---

**Note** The cable management assembly is shipped with the chassis.

---

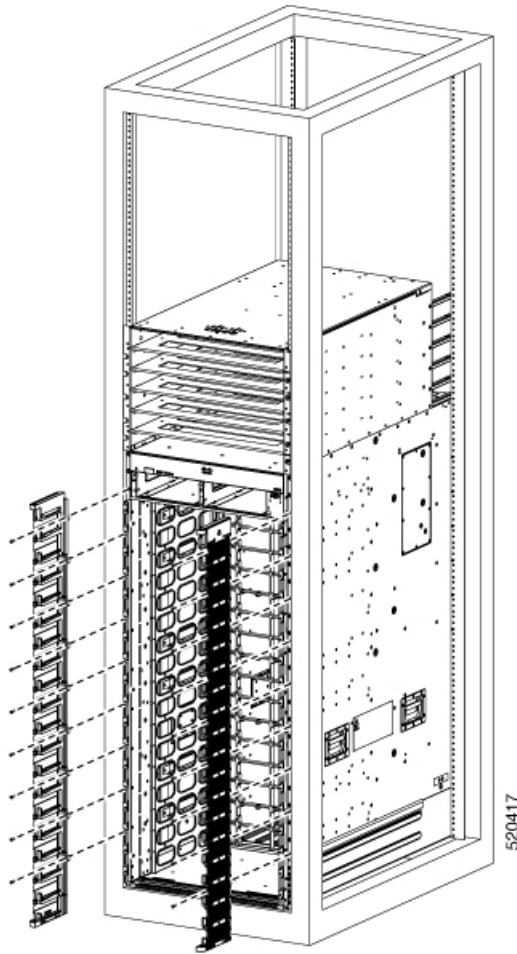
## Procedure

---

### Step 1

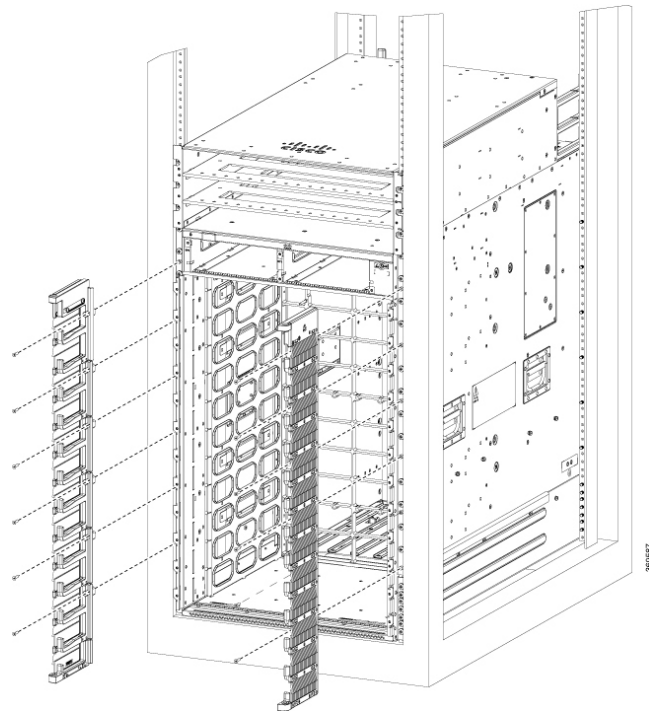
Position one of the cable management brackets on the vertical mounting bracket so that the screw holes are aligned.

Figure 33: Cable Management Brackets for 8818 Chassis

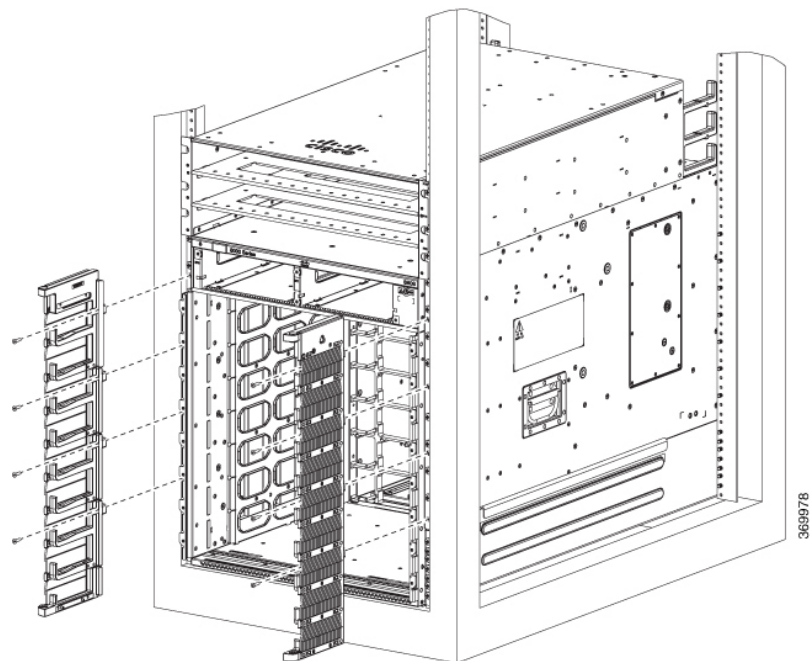


520417

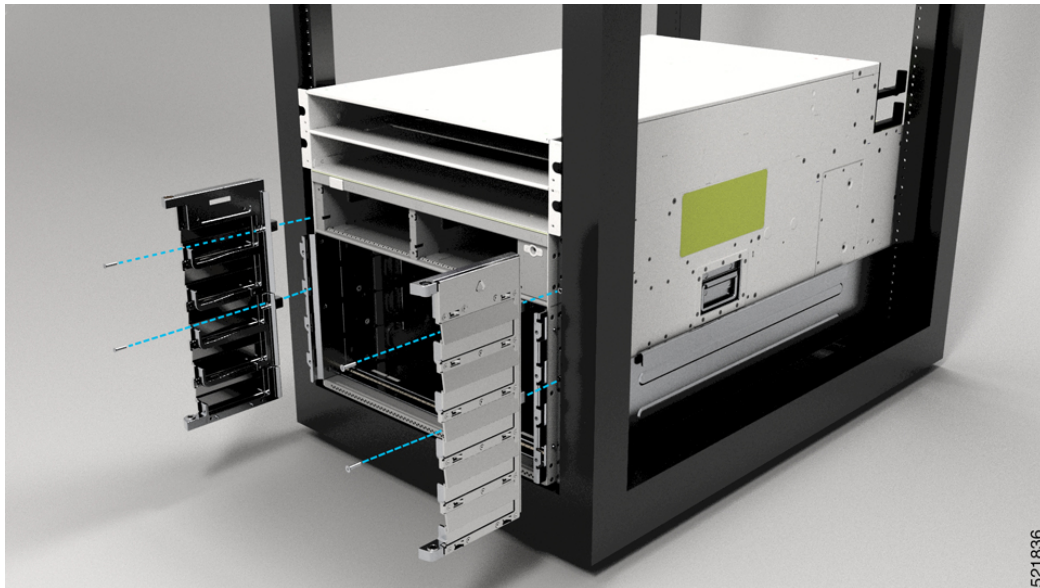
**Figure 34: Cable Management Brackets for 8812 Chassis**



**Figure 35: Cable Management Brackets for 8808 Chassis**

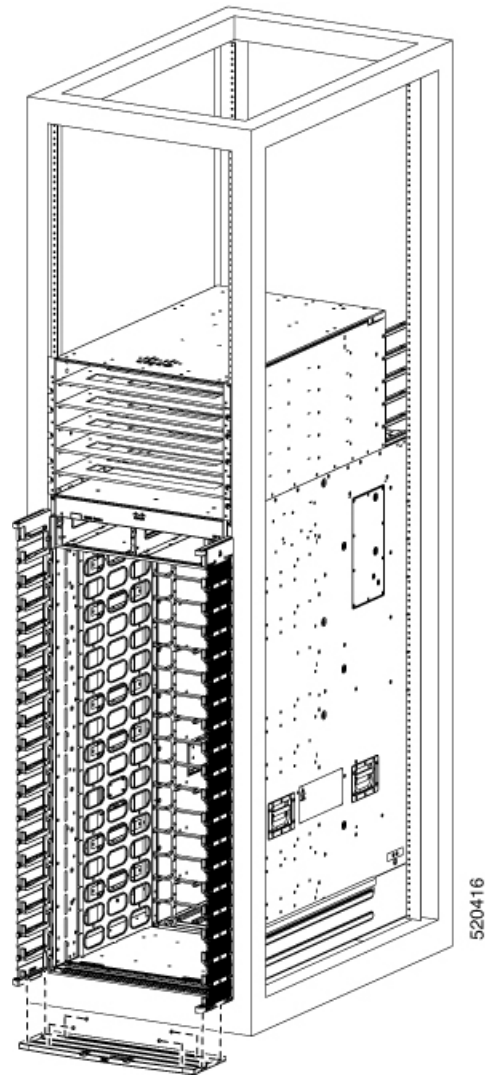


**Figure 36: Cable Management Brackets for 8804 Chassis**

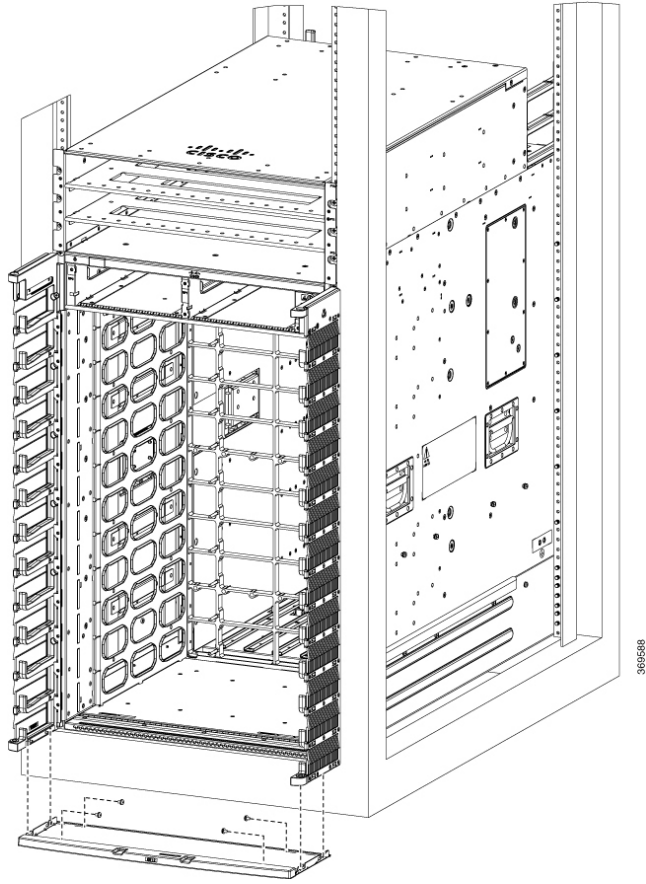


- Step 2** Secure the left and right cable management brackets to the chassis vertical mounting brackets with M4 x 18-mm screws, flat-head Phillips screws (use all screws provided in the kit). Insert one screw at the top and one at the bottom, likewise add more screws in this sequence. The number of screws may vary based on the chassis.
- Note** Do not fully tighten the screws until the cable management brackets, bottom cover, and top hood are installed.
- Step 3** Repeat Steps 1 and 2 to attach the other cable management bracket to the vertical mounting bracket on the opposite side of the chassis.
- Step 4** Remove the power shelf bezel from the chassis and proceed with bottom cover and top hood installation.
- Step 5** Position the bottom cover, with its brackets pointing up, to the bottom of the two side cable management bracket screw holes.

Figure 37: Bottom Cover for 8818 Chassis

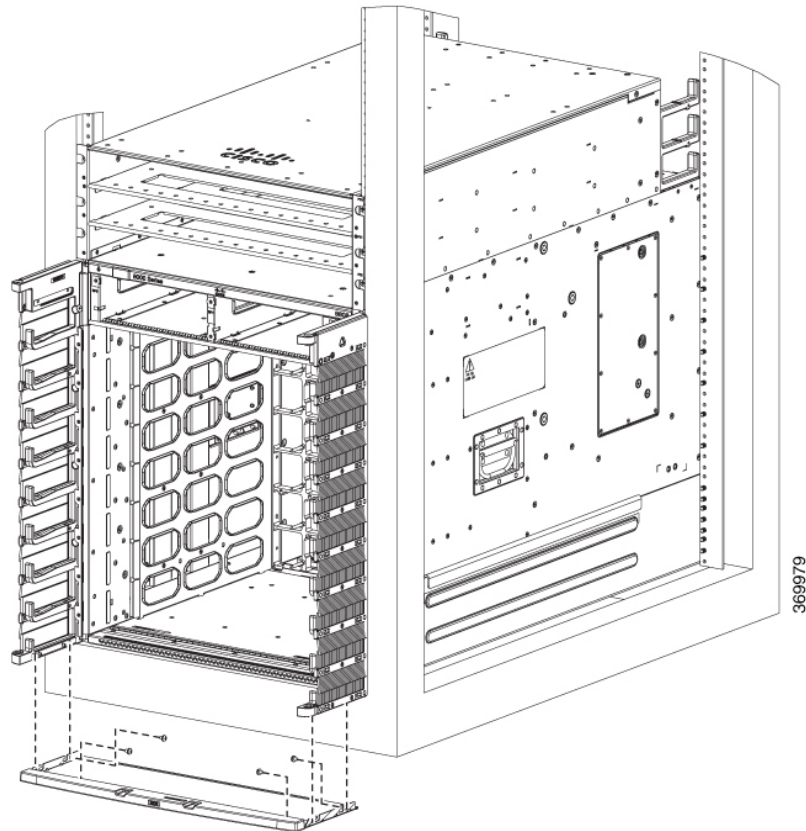


520416

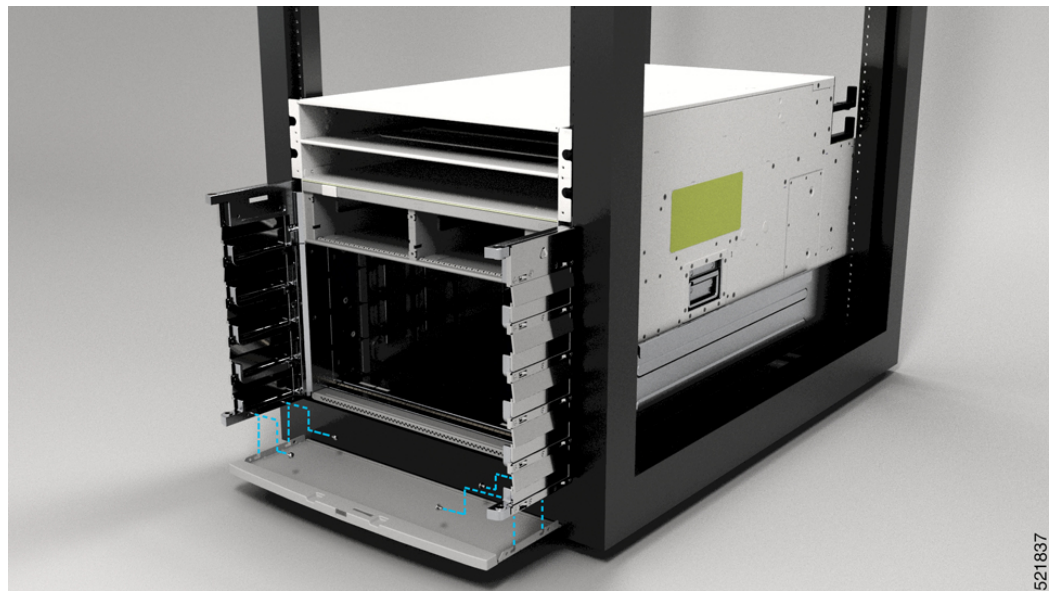
**Figure 38: Bottom Cover for 8812 Chassis**



**Figure 39: Bottom Cover for 8808 Chassis**



**Figure 40: Bottom Cover for 8804 Chassis**

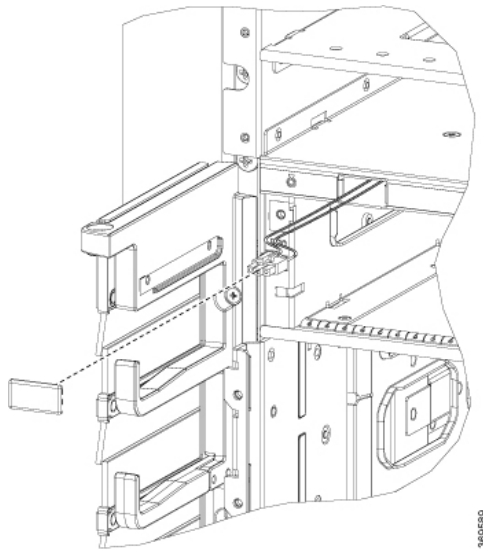


**Step 6**

Secure the bottom cover to the cable management brackets by using four M4 x 6 mm pan-head Phillips screws. Tighten each screw to 11.5 to 15 in-lb (1.3 to 1.7 N·m) of torque.

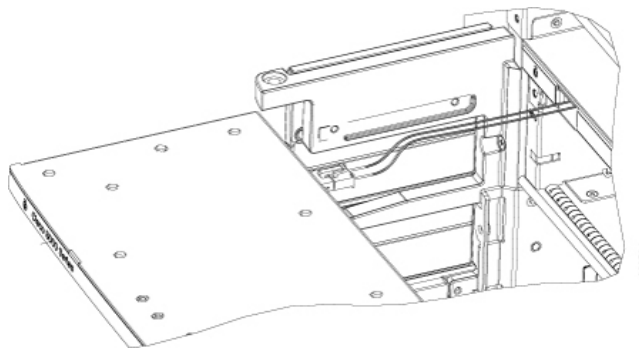
**Step 7** Before you install the top hood, remove the connector cap from the alarm cable.

**Figure 41: Remove Connector Cap**



**Step 8** Connect the alarm cable to the top hood.

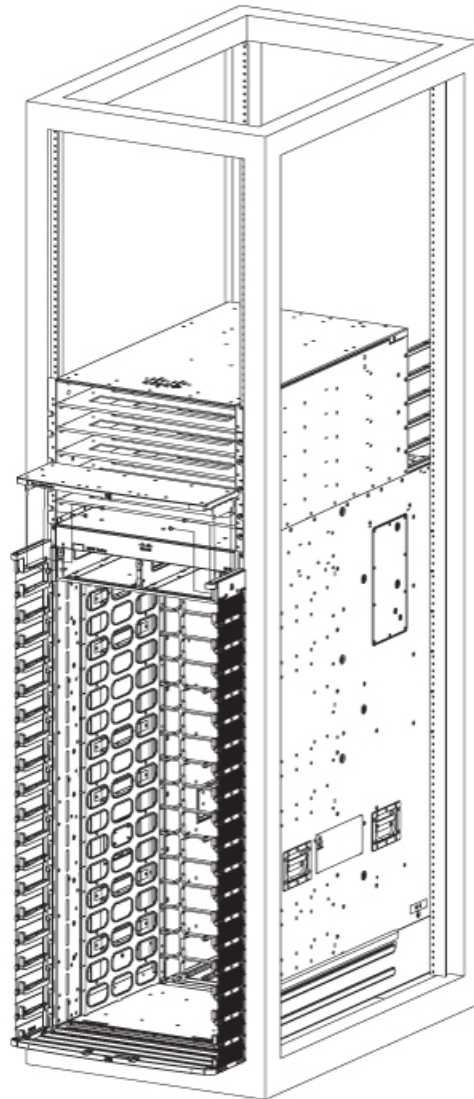
**Figure 42: Connect Alarm Cable**



**Note** Door open alarm is supported in the chassis.

**Step 9** Position the top hood, with its brackets pointing down, above the cable management bracket screw holes.

Figure 43: Top Hood for 8818 Chassis



520424

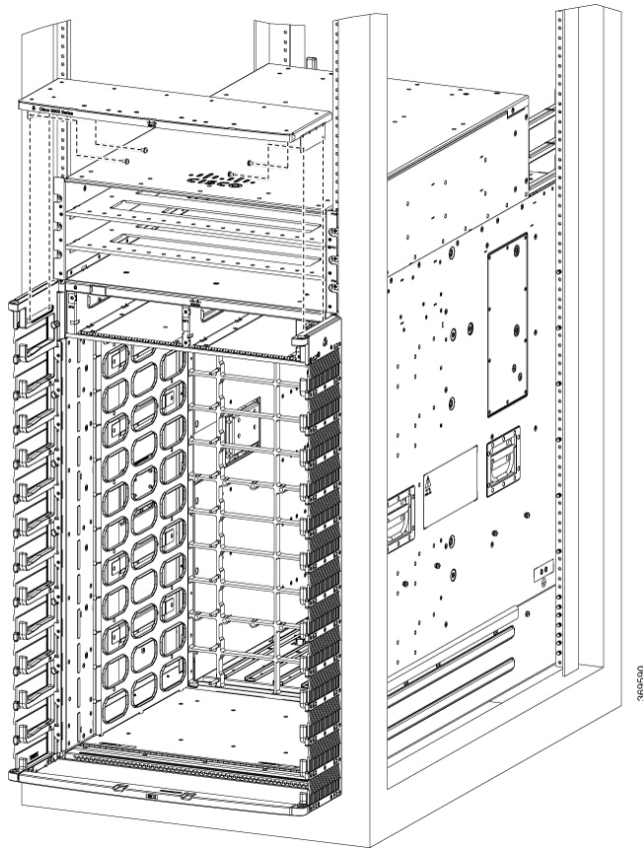
**Figure 44: Top Hood for 8812 Chassis**

Figure 45: Top Hood for 8808 Chassis

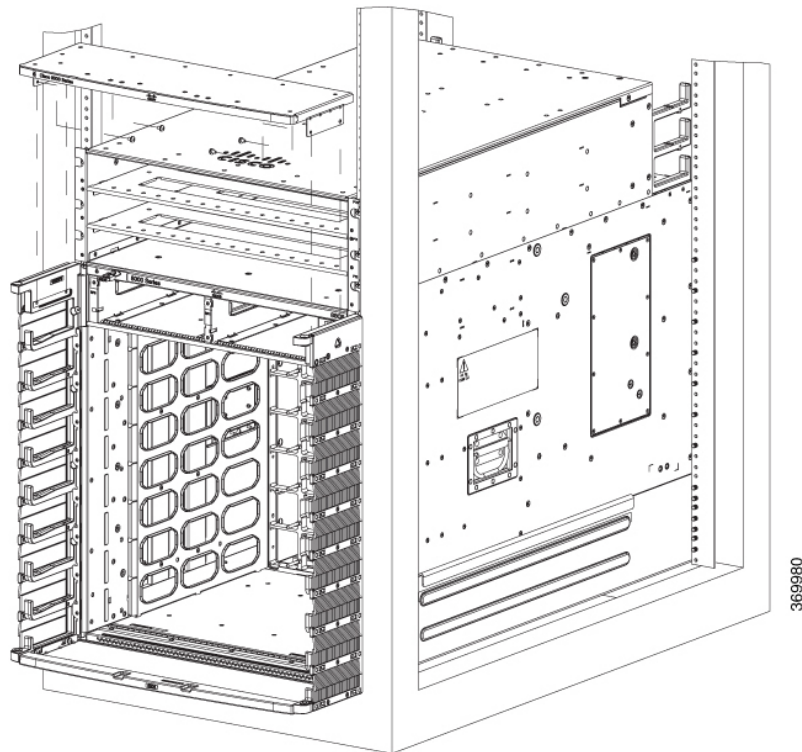
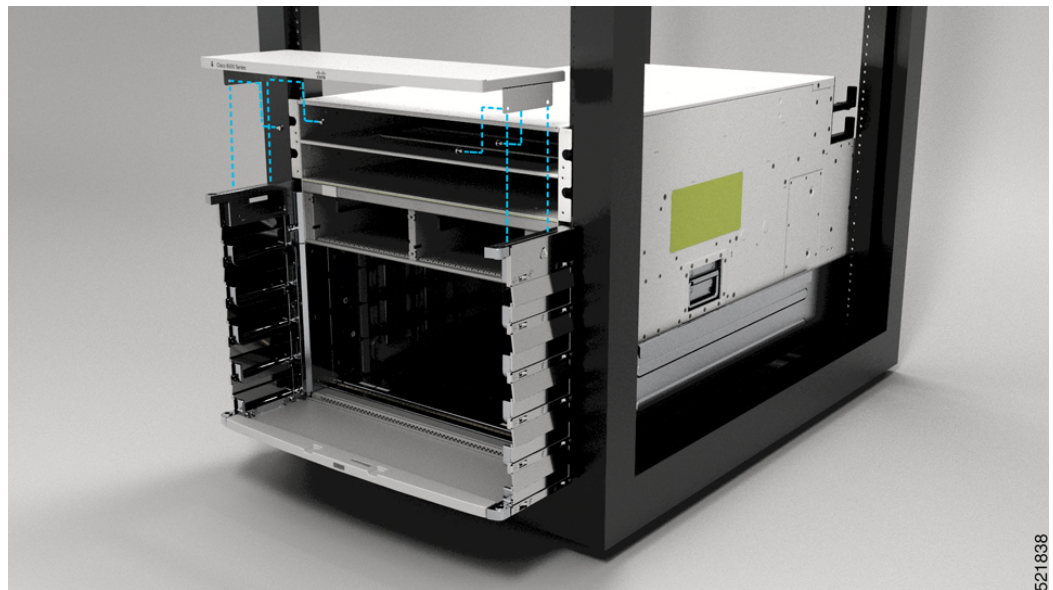


Figure 46: Top Hood for 8804 Chassis



**Step 10**

Secure the top hood with the cable management brackets by using four M4 x 6 mm pan-head Phillips screws. Tighten each screw to 11.5 to 15 in-lb (1.3 to 1.7 N·m) of torque.

- Step 11** Tighten the cable management brackets screws to 11.5 to 15 in-lb (1.3 to 1.7Nm) of torque after completing the bottom cover, and top hood installation.
- 

## Attach Front Door to Chassis

### Before you begin

Before you can attach the front door to the chassis, you must attach the cable management brackets, bottom plate, and top hood onto the chassis.

Required tools and equipment:

- Phillips screwdriver with a torque capability (customer supplied)
- Door kit (8818-KIT, 8812-KIT, 8808-KIT, or 8804-KIT)



---

**Note** The door kit is optional.

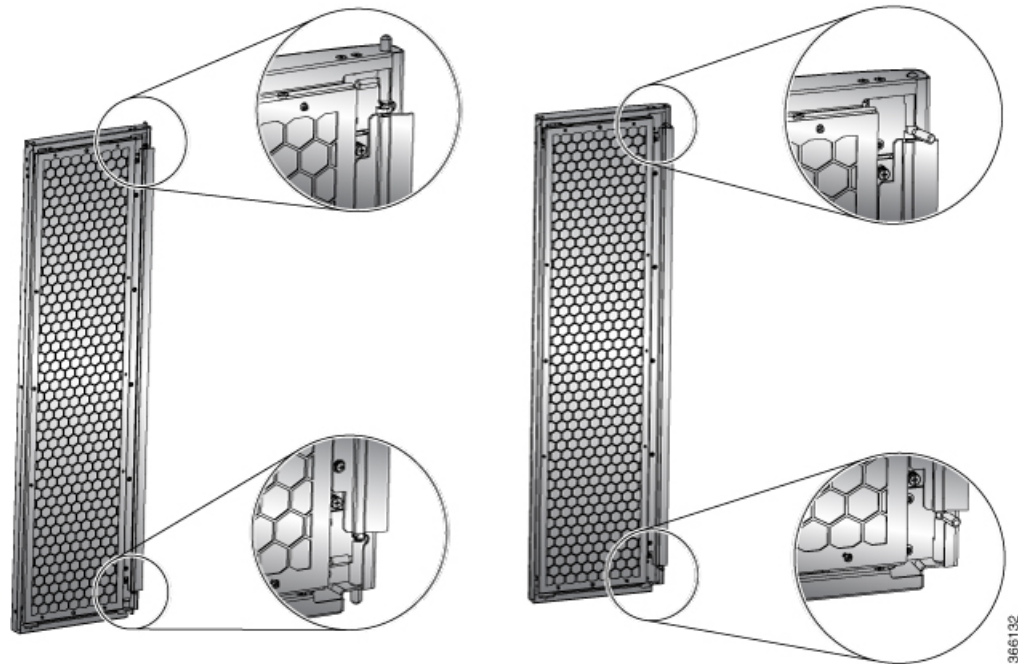
---

### Procedure

---

- Step 1** Remove the power shelf bezel from the chassis, if already installed.  
This is to ease the installation of chassis doors.
- Step 2** On the back side (open side) of one door, pull in on two protruding spring pins so that the pins are held inside the door frame.

Figure 47: Front Door Pins



- Step 3** Align the spring pin to hole in the bottom plate and release the spring pin, so that they insert into the bottom hole.

*Figure 48: Attach Front Door to 8818 Chassis*

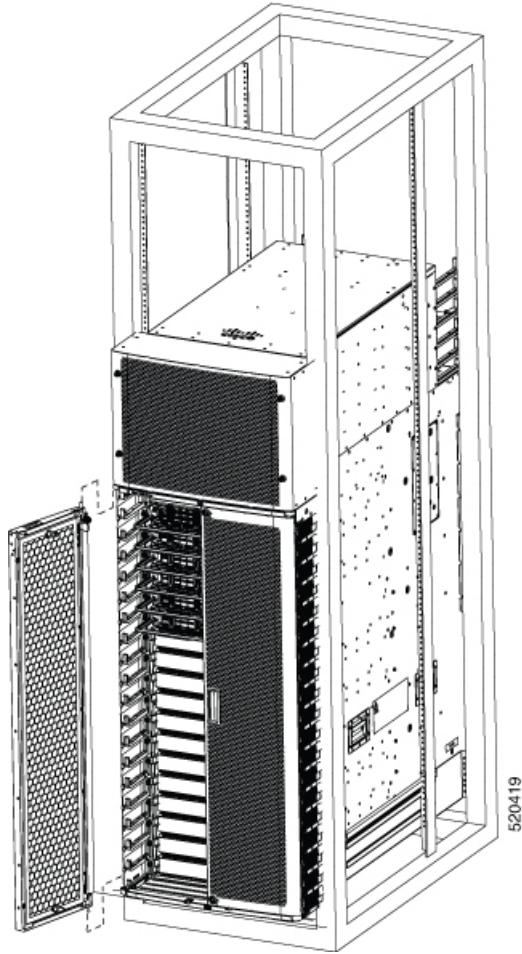




Figure 49: Attach Front Door to 8812 Chassis

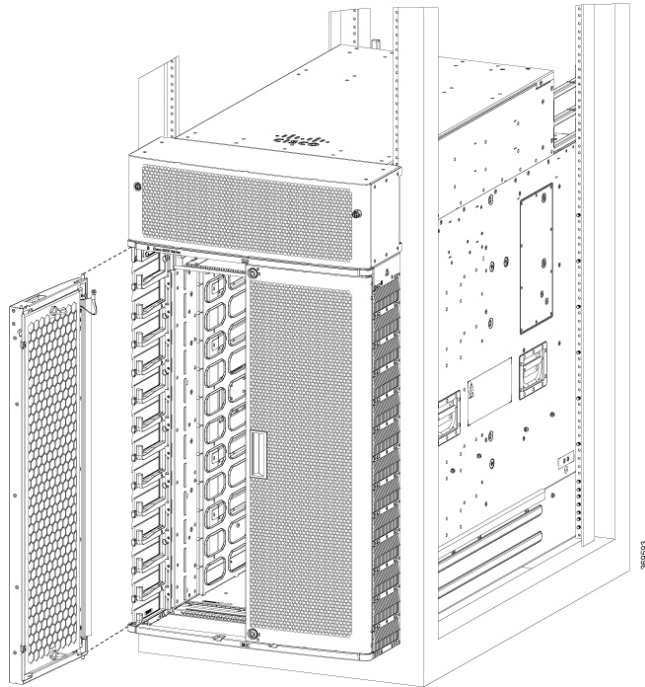


Figure 50: Attach Front Door to 8808 Chassis

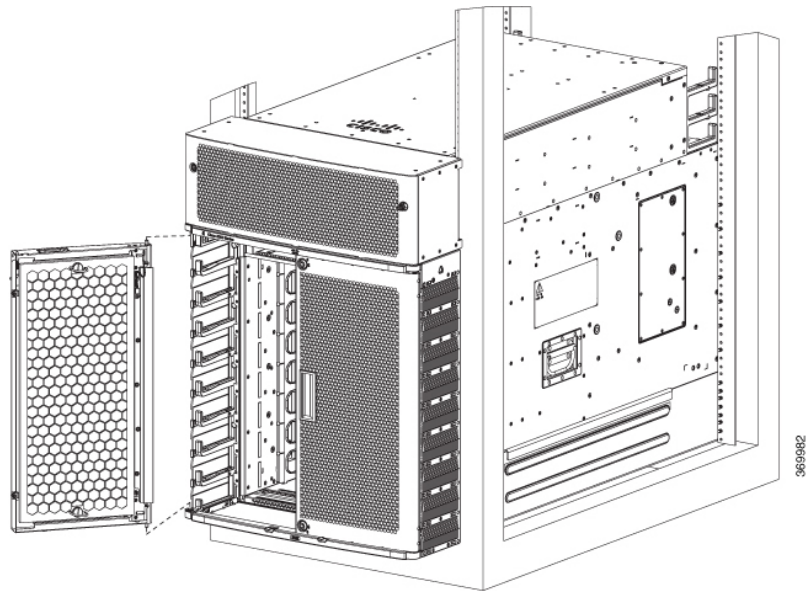
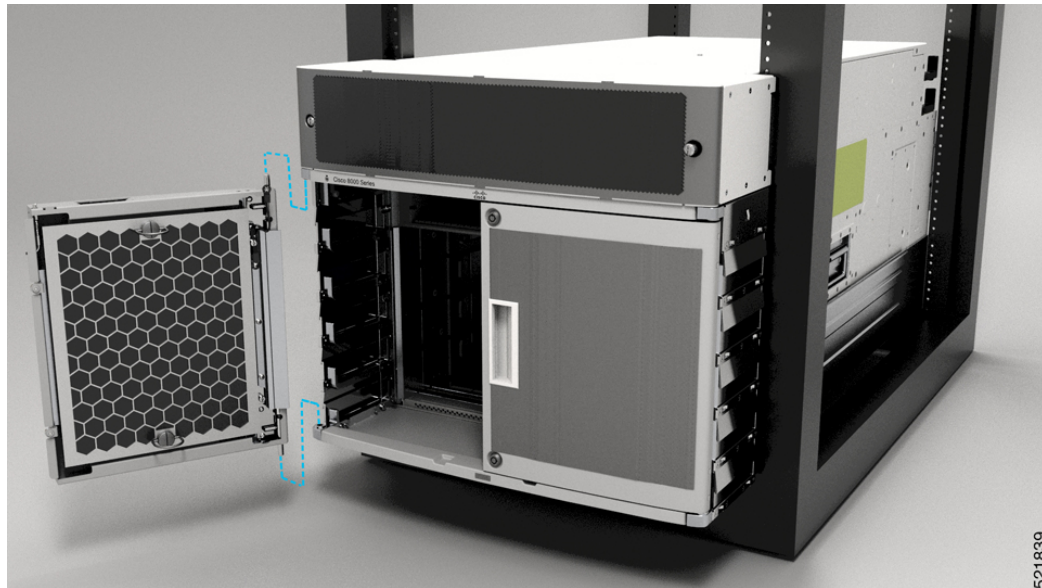


Figure 51: Attach Front Door to 8804 Chassis



- Step 4** Now align the spring pin to hole in the top hood and release the spring pin.
- Step 5** Ensure the pins are properly inserted into the holes so that the door can freely swing on the spring pins.
- Step 6** Repeat Steps 2–5 to install the other front door.
- Step 7** Ground the front door.

For information on grounding the front door, see [Ground the Front Door, on page 72](#).

- Step 8** Replace the power supply bezel and secure it with the provided jackscrews.

For information on replacing the power supply bezel, see [Install Power Shelf Bezel, on page 169](#).

**Note** Install the following modules, if you had them removed from the chassis while mounting into the rack.

- Fan trays

For more information on replacing components, see [Replace a Fan Tray](#).

## Ground the Front Door



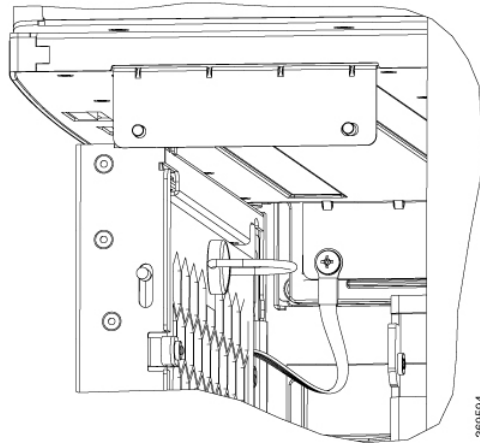
**Note** To comply with GR-1089, you have to bond the front doors to the ground port on the chassis using the ground braid.

## Procedure

---

- Step 1** Install the grounding cable towards the side of the front door.
- Step 2** Apply the star ring terminal end of the grounding cable to the front door. Tighten the screw to 11.5 to 15 in-lb (1.3 to 1.7 N-m) of torque to provide proper bonding.

**Figure 52: Ground Cable to Chassis**



**Note** Fasten the ground straps on both the doors to the chassis.

- Step 3** Connect the other round terminal of the grounding cable to the ground port on the cable management bracket on either left or right side of the chassis. Use the front hole of the bracket that connects the top cover to the cable management bracket. Tighten the M4 screw to 11.5 to 15 in-lb (1.3 to 1.7 N-m) of torque.
- Step 4** Repeat Steps 1–3 to install the grounding cable to the other front door.
- Step 5** Close and lock the front door.
- 

## What to do next

Continue to power on the router.





## CHAPTER 4

# Powering on the Router

This chapter describes how to connect the power modules in the chassis and to power on the router.

- [Power Module Overview](#), on page 75
- [Connect DC Power Supply to Power Source](#), on page 78
- [Connect HVAC/HVDC Power Supply to Power Source](#), on page 81
- [Power Supply Power Cord Specifications](#), on page 84

## Power Module Overview

*Table 18: Feature History Table*

Feature Name	Release	Description
60A support on the PSU4.8KW-DC100 (DC100) power supply	Release 7.3.2	This feature allows you to operate the 4.8 KW power supply for 48V 100A DC with 48V 60A.  By default, the power module accepts 100A. To change the power mode to 60A, a toggle switch is provided in the power tray.

You can install an AC or a DC power module in the chassis. Ensure all power connection wiring conforms to the rules and regulations in the National Electrical Code (NEC) as well as local codes.

Each chassis has a power assembly shelf that supports the following number of power trays:

- Cisco 8818 chassis supports up six power trays
- Cisco 8812 and 8808 chassis supports up to three power trays
- Cisco 8804 router contains two power trays

Each power tray supports up to three AC power modules or four DC power modules.



**Note** Use only one kind of power tray and power module in the chassis.



**Note** Use only the same capacity power module in the chassis. Do not mix different capacity power modules.

### High-Voltage AC / DC Power Supplies

HVAC/HVDC power modules operate in the input range of 180 VAC to 305 VAC (nominal input level of 200 to 240 VAC, 277 VAC) and 192 to 400 VDC (nominal 240 VDC, 380 VDC).

- PSU6.3KW-20A-HV: Each 6.3 KW, 20A power module can supply up to 6.3 KW to the power tray when it's supplied by two feeds (A and B). It can supply up to 3.15 KW with only one feed.
- PSU6.3KW-HV: Each 6.3 KW, 30A power module can supply up to 6.3 KW to the power tray when it's supplied by two feeds (A and B). It can supply up to 4.8 KW with only one feed.

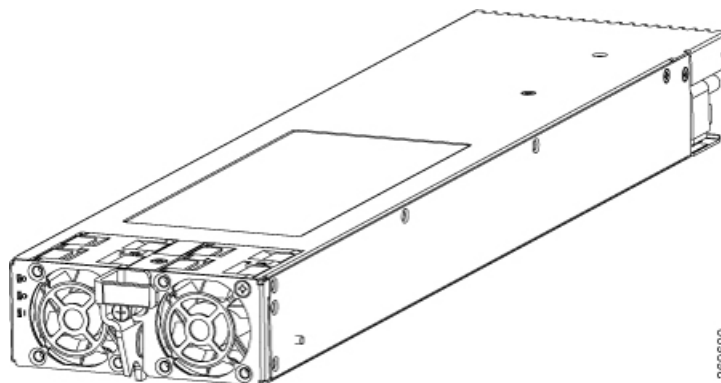
### DC Power Supplies

There are two types of DC power modules supported on Cisco 8800 router series:

- PWR-4.4KW-DC-V3: The 4.4KW power supply accepts a nominal input voltage of 48V 60A DC, with an operational tolerance range of -40 to -72 VDC.

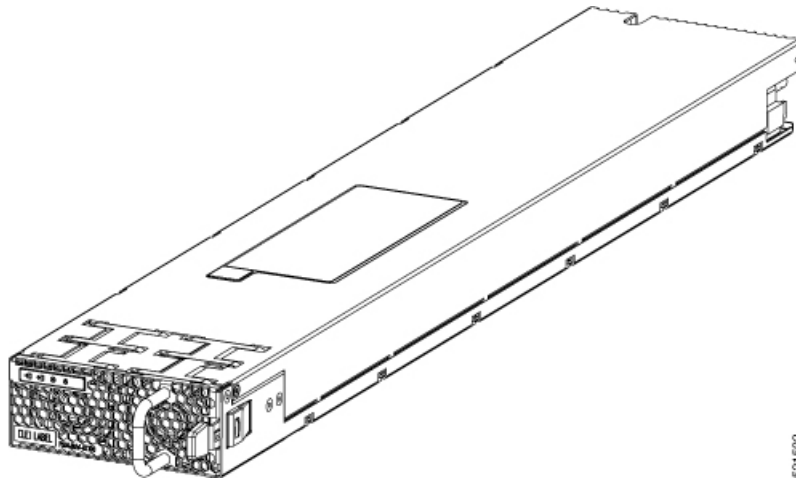
Each 4.4 KW, 60A power module can supply up to 4.4 KW to the power tray when it's supplied by two feeds (A and B). It can supply up to 2.2 KW with only one feed.

**Figure 53: PWR-4.4KW-DC-V3**



- PSU4.8KW-DC100: The 4.8KW power supply accepts a nominal input voltage of 48V 100A DC, with an operational tolerance range of -40 to -75 VDC.

Figure 54: PSU4.8KW-DC100



The PSU4.8KW-DC100 power module can also be configured to accept voltage of 48V 60A. By default, the power module accepts 100A. To change the power mode to 60A, a power mode switch is provided in the power tray. The power mode switch is located in the left-hand side on the power tray.

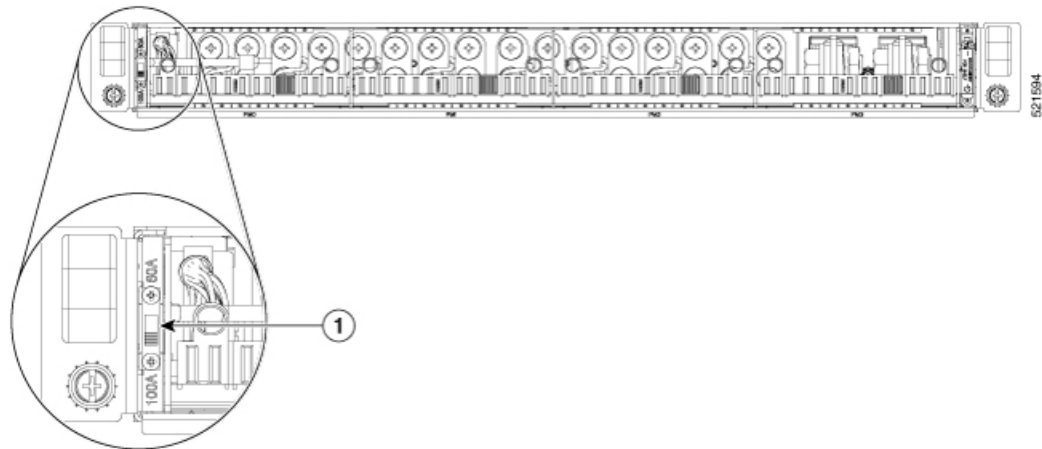


**Note** The power mode switch must be in the same position for all power trays installed in the chassis, either 60A or 100A mode.

When the power mode switch is configured for 100A mode, each power module can supply up to 4.8 KW to the power tray when it's supplied by two feeds (A and B). In 100A mode, it can supply up to 3.5 KW with only one feed.

When the power mode switch is configured for 60A mode, each power module can supply up to 4.4 KW to the power tray when it's supplied by two feeds (A and B). In 60A mode, it can supply up to 2.2 KW with only one feed.

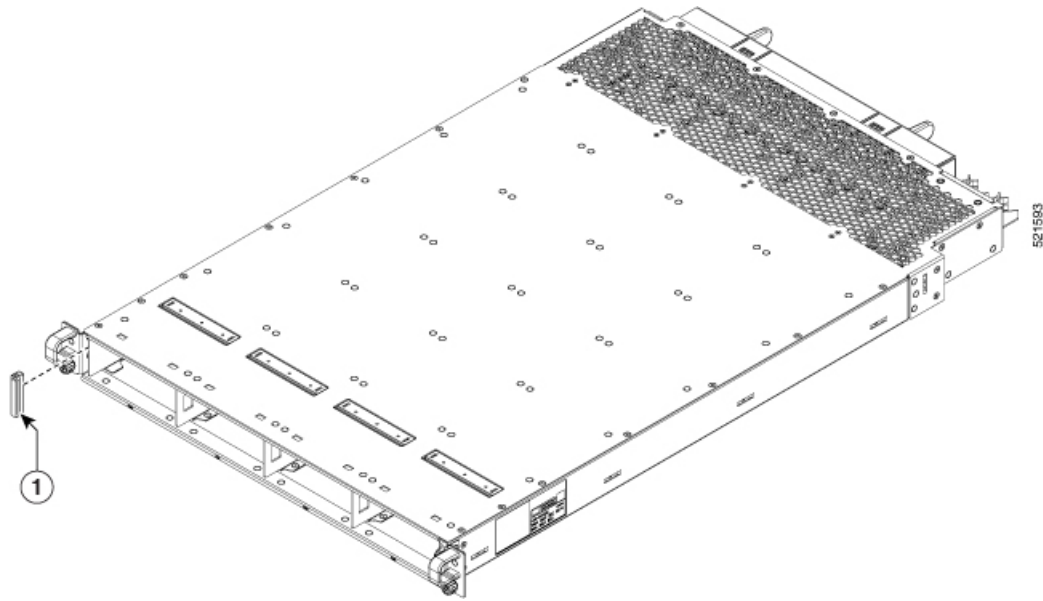
Figure 55: Power Mode Switch on the Power Tray



1	Power mode switch.
---	--------------------

A plug cover is also provided to block the access to the power mode switch as shown in the below figure:

**Figure 56: Power Mode Switch Cover**



1

Power mode switch cover.

## Connect DC Power Supply to Power Source

This section contains the procedures to connect the DC source power cables to a DC-powered router.

For DC power cables, we recommend that you use 60A-rated, high-strand-count copper wire cables (#6 AWG or #4 AWG), or 100A-rated high-strand-count copper wire cables (#2 AWG). The length of the cables depends on your router location from the source power. DC power cables are not available from Cisco, but they are available from any commercial cable vendor.

You must terminate DC power cables using cable lugs at the power tray end. Ensure that the lugs are right-angle dual-hole and that they fit over to allow quarter inch screws at 0.625-inch (15.88-mm) centers. For #4 AWG cable, use Panduit part number LCD4-14AF-L or equivalent; for #6 AWG, use Panduit part number LCD6-14AF-L or equivalent; for #2 AWG cables, use Panduit part number LCD2-14AF-Q or equivalent.

If you are not using power redundancy or are using n+1 power redundancy, you can connect all the power supplies in the chassis to the same power grid on the rear end of each power tray. If you are using n+n power redundancy, connect one redundant grid to one of the power supply inputs and the other redundant grid to the other power supply input on the back of the power tray as shown for each power supply.

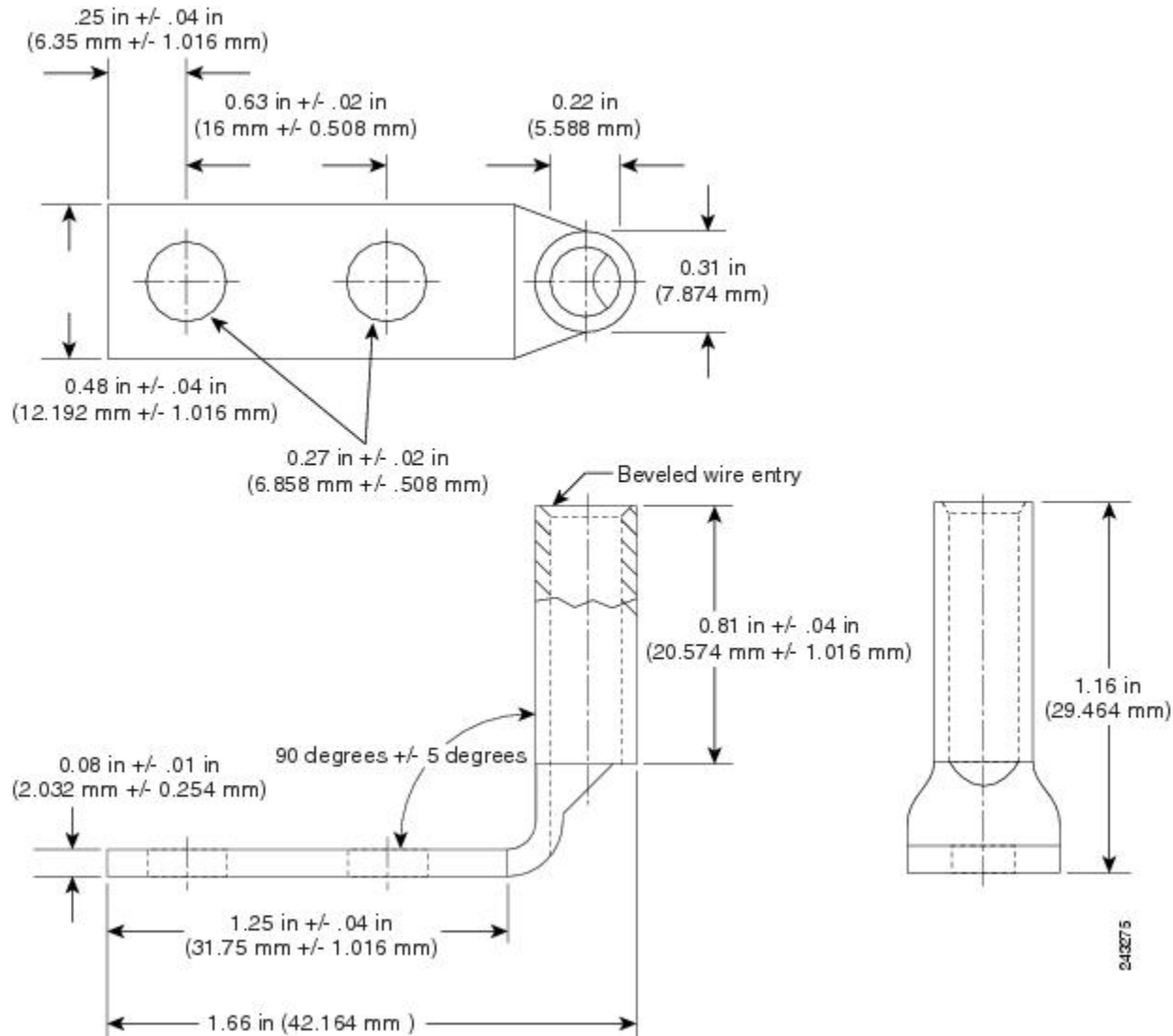
The color coding of source DC power cable leads depends on the color coding of the site DC power source. Ensure that power source cables are connected to the power module with the proper positive (+) and negative (-) polarity:

- After powering on the router, you should see an LED (for each input) light up green on each power shelf. If LEDs light up red that indicates that the polarity is incorrect.

This figure shows the lug type required for DC input cable connections.



Figure 57: Typical DC Power Cable Lug



**Caution** DC power modules contain circuitry to create a fault condition on the power module if the power module detects a reverse polarity condition. No damage should occur from reverse polarity, but ensure to correct a reverse-polarity condition immediately.



**Note** The length of the cables depends on the location of your router in relation to the source of DC power. These cables and the cable lugs that are used to attach the cables to the router chassis are not available from Cisco Systems. They are available from any commercial cable vendor.



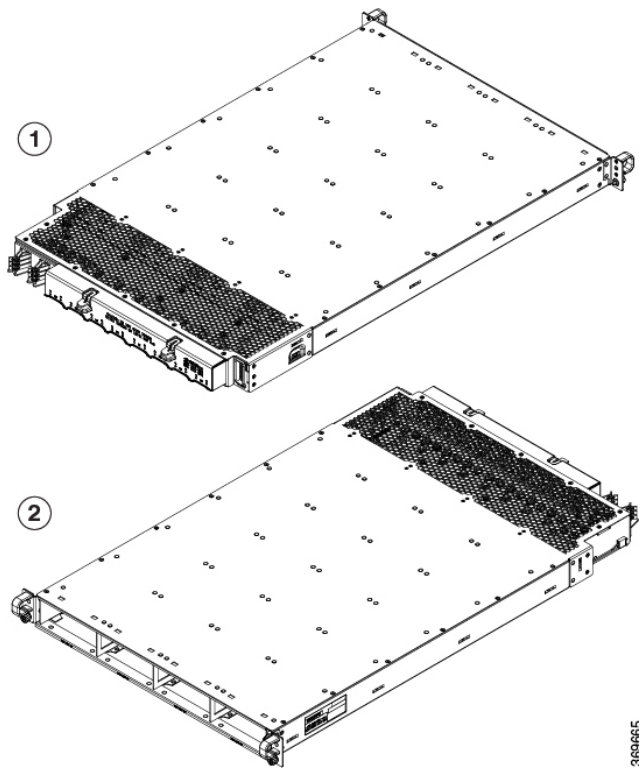
**Caution** To ensure that power remains off while you are performing this procedure, lock-out/tag-out the DC circuit breaker switch in the off (0) position until you are ready to turn it on.

Follow these steps to connect the DC source power cables to a DC power tray:

**Procedure**

**Step 1** Verify that the power tray switch is set to the STANDBY (0) position.

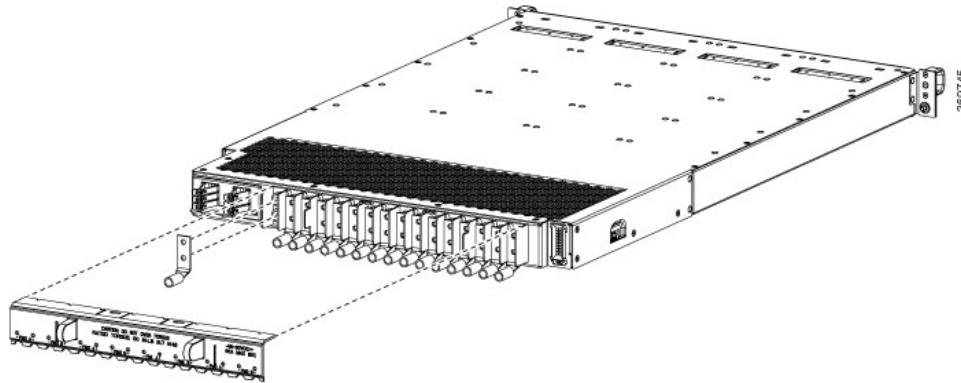
*Figure 58: DC Power Tray*



1	Rear	2	Front
---	------	---	-------

**Step 2** Remove the clear plastic safety covers that fit over the DC power connection terminal studs.

Figure 59: DC Power Connection



**Step 3** Connect the DC power cables in the following order.

- a) Positive cables first.
- b) Negative cables last.

**Step 4** Repeat Step 3 for the other power modules installed in the tray.

**Caution** To prevent injury and damage to the equipment, always attach the ground and source DC power cable lugs to power tray terminals in the following order: (1) positive (+) to positive (+), (2) negative (–) to negative (–).

**Caution** Do not overtighten the nuts that secure the DC power cables to the power tray terminals. Using the 7/16 hex socket and torque wrench the nuts should be tightened to a torque of 45–50 in-lb.

**Step 5** Replace the clear plastic safety covers over the connection terminal studs.

**Step 6** Turn on the switch of the power shelf to turn on the system.

## Connect HVAC/HVDC Power Supply to Power Source

The HVAC/HVDC power supply has 2 redundant input power lines. It can provide a power output of 6.3 kW from each input power line with 2 inputs operating, or provide 4.8 kW (30A) or 3.15 kW (20A) output from either input with one input operating. The HVAC/HVDC power supply provides  $n+n$  or  $n+x$  line redundancy mode in a single power supply for the Cisco 8800 Series Routers.

The HVAC/HVDC power supply accepts a maximum of 305VAC or 400VDC input power.

If you are not using power redundancy or are using  $n+1$  power redundancy, you can connect all the power supplies in the chassis to the same power grid on the rear end of each power tray. If you are using  $n+n$  power redundancy, connect one redundant grid to one of the power supply inputs and the other redundant grid to the other power supply input on the back of the power tray as shown for each power supply.

### Before you begin

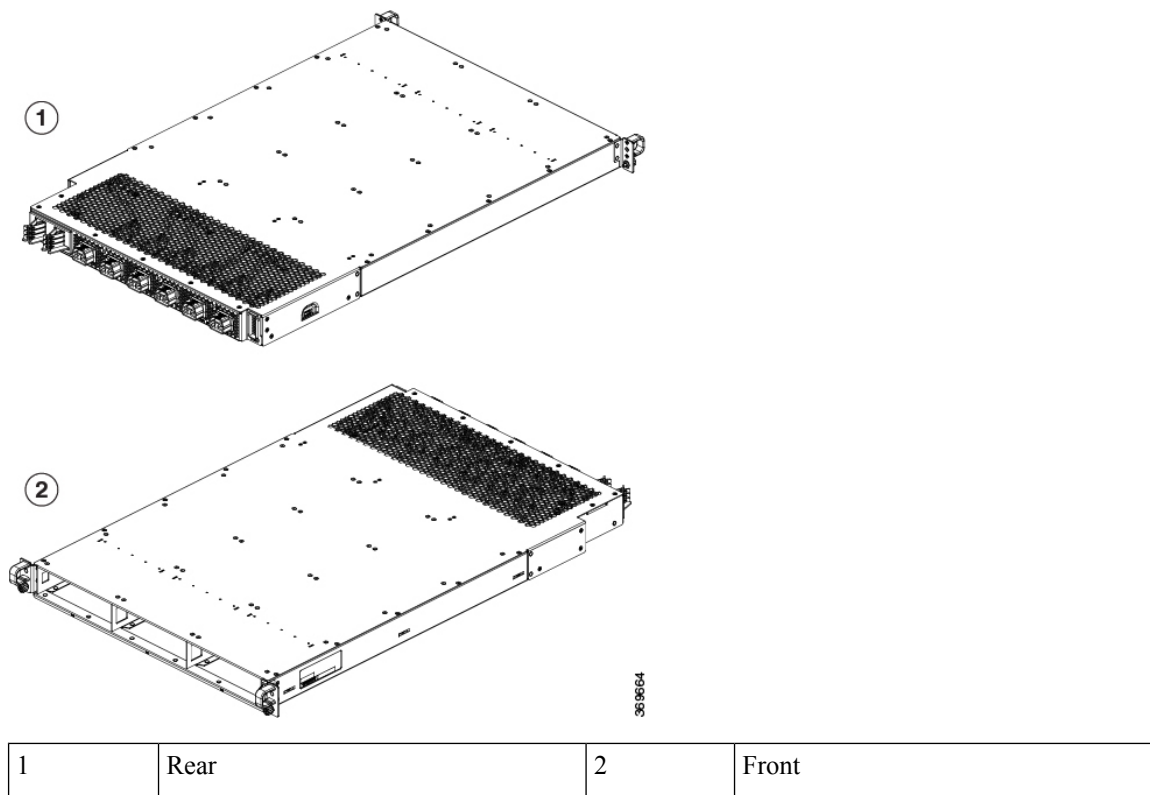
- Turn off the power source at its circuit breaker.
- Check that the power switch is set to the STANDBY (0) position on the power tray.
- PSU6.3KW-HV: The HVAC or HVDC power sources are rated for 30A maximum input current.

- PSU6.3KW-20A-HV: The HVAC or HVDC power sources are rated for 20A maximum input current.

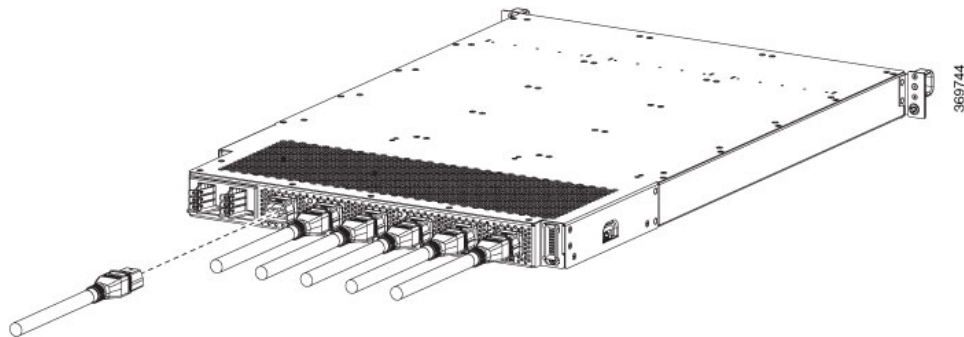
**Procedure**

- Step 1** Choose your power supply (HVAC or HVDC) and use a Saf-D-Grid power cable to connect to the power supply tray.
- Step 2** For HVAC input, connect a Saf-D-Grid AC power cable to the Saf-D-Grid receptacle.

*Figure 60: HV Power Tray*



*Figure 61: HVAC Power Connection*



- Step 3** For HVDC input, connect a Saf-D-Grid DC cable to a Saf-D-Grid receptacle, otherwise:

- a) Connect the ground terminal ring on the power cable to the ground terminal on the DC power source and secure it in place with a nut tightened to the appropriate torque setting for the terminal post.
- b) Connect the negative terminal ring on the power cable to the negative (-) terminal on the DC power source and secure it in place with a nut tightened to the appropriate torque setting for the terminal post.
- c) Connect the positive terminal ring on the power cable to the positive (+) terminal on the DC power source and secure it in place with a nut tightened to the appropriate torque setting for the terminal post.

**Step 4** Verify that the Saf-D-Grid plug is plugged in completely to secure the built-in retaining latch.

**Step 5** Turn on the circuit breaker for the HVAC or HVDC power source circuit.

**Note** If you use both inputs, the IN LED of the power supply is green. If you use only one input, the IN LED is blinking green.

**Step 6** Turn on the switch of the power shelf to turn on the system.

### What to do next

Use the **power-mgmt redundancy-num-pms** *number* command in config mode to convert the power module redundancy from  $n+1$  to  $n+x$ , specifying the number of redundant power modules that you want to configure. The total number of functioning power modules in the system is at least  $x$  number more than the number of power modules that are needed to support the power required for all the cards in the system. The range is 0–11; 0 means that no power redundancy is required.

```
RP/0/RP0/CPU0:ios# config
RP/0/RP0/CPU0:ios(config)# power-mgmt redundancy-num-pms 2
RP/0/RP0/CPU0:ios(config)# commit
Tue Sep 24 09:03:22.889 UTC
Commit complete.
```

Use the **hw-module attention-led location0/PM** *number* command in config mode to enable and use the **no** form of the command to disable the ID LED on the specified power supply.

```
RP/0/RP0/CPU0:ios# config
RP/0/RP0/CPU0:ios(config)# hw-module attention-led location 0/PT0-PM0
RP/0/RP0/CPU0:ios(config)# commit
RP/0/RP0/CPU0:ios(config)# end
RP/0/RP0/CPU0:ios# show led location 0/PT0-PM0
```

```
=====
Location      Led Name      Mode           Color
=====
0/PT0-PM0
      Attention  OPERATIONAL    BLINKING BLUE
      Fault      OPERATIONAL    OFF
      Input      OPERATIONAL    GREEN
      Output     OPERATIONAL    GREEN
```

# Power Supply Power Cord Specifications



**Note** Always use the Saf-D-Grid connector toward the router.

**Table 19: 30A HVAC/HVDC Cables for PSU6.3KW-HV**

Locale	Part Number	Cisco Part Number (CPN)	Power Cord Set Rating	Connector Part Number	Power Cord Illustration
AUSTRALIA/NEW ZEALAND	CAB-AC-32A-ANZ	37-101007-01	32A, 250VAC	Saf-D-Grid 3-5958P4 to Hubbell C332P6S Plug	Refer the figure in <a href="#">30A HVAC/HVDC Cable Illustrations</a>
SWITZERLAND	CAB-AC-32A-CHE	37-101007-01	32A, 250VAC	Saf-D-Grid 3-5958P4 to Hubbell C332P6S Plug	Refer the figure in <a href="#">30A HVAC/HVDC Cable Illustrations</a>
ITALY	CAB-AC-32A-ITA	37-101007-01	32A, 250VAC	Saf-D-Grid 3-5958P4 to Hubbell C332P6S Plug	Refer the figure in <a href="#">30A HVAC/HVDC Cable Illustrations</a>
SOUTH AFRICA	CAB-AC-32A-ZAF	37-101007-01	32A, 250VAC	Saf-D-Grid 3-5958P4 to Hubbell C332P6S Plug	Refer the figure in <a href="#">30A HVAC/HVDC Cable Illustrations</a>
BRAZIL	CAB-AC-32A-BRZ	37-101007-01	32A, 250VAC	Saf-D-Grid 3-5958P4 to Hubbell C332P6S Plug	Refer the figure in <a href="#">30A HVAC/HVDC Cable Illustrations</a>
ISRAEL	CAB-AC-32A-ISR	37-101007-01	32A, 250VAC	Saf-D-Grid 3-5958P4 to Hubbell C332P6S Plug	Refer the figure in <a href="#">30A HVAC/HVDC Cable Illustrations</a>
ARGENTINA	CAB-AC-32A-ARG	37-101007-01	32A, 250VAC	Saf-D-Grid 3-5958P4 to Hubbell C332P6S Plug	Refer the figure in <a href="#">30A HVAC/HVDC Cable Illustrations</a>
INDIA	CAB-AC-32A-IND	37-101007-01	32A, 250VAC	Saf-D-Grid 3-5958P4 to Hubbell C332P6S Plug	Refer the figure in <a href="#">30A HVAC/HVDC Cable Illustrations</a>
NORTH AMERICA	CAB-AC-30A-US1	37-101008-01	30A, 250VAC	Saf-D-Grid 3-5958P4 to VOLEX 174606	Refer the figure in <a href="#">30A HVAC/HVDC Cable Illustrations</a>
NORTH AMERICA	CAB-AC-30A-US2	37-101009-01	30A, 250VAC	Saf-D-Grid 3-5958P4 to VOLEX 174606	Refer the figure in <a href="#">30A HVAC/HVDC Cable Illustrations</a>

Locale	Part Number	Cisco Part Number (CPN)	Power Cord Set Rating	Connector Part Number	Power Cord Illustration
NORTH AMERICA	CAB-DC-30A-US1	37-101014-01	30A, 400VDC	Saf-D-Grid 3-5958P4 to Saf-D-Grid 3-5958P4	Refer the figure in <a href="#">30A HVAC/HVDC Cable Illustrations</a>
NORTH AMERICA	CAB-DC-30A-US2	37-101016-01	30A, 400VDC	Saf-D-Grid 3-5958P4 to Saf-D-Grid 3-5958P4	Refer the figure in <a href="#">30A HVAC/HVDC Cable Illustrations</a>
NORTH AMERICA	CAB-AC-30A-US3	37-101013-01	30A, 277VAC	Saf-D-Grid 3-5958P4 to HBL2631	Refer the figure in <a href="#">30A HVAC/HVDC Cable Illustrations</a>
NORTH AMERICA	CAB-AC-30A-US4	37-101018-01	30A, 300VAC	Saf-D-Grid 3-5958P4 to Saf-D-Grid 3-6074P30	Refer the figure in <a href="#">30A HVAC/HVDC Cable Illustrations</a>
IEC/EU	CAB-AC-32A-EU	37-101019-01	32A, 300VAC	Saf-D-Grid 3-5958P4 to Saf-D-Grid 3-6074P30	Refer the figure in <a href="#">30A HVAC/HVDC Cable Illustrations</a>
IEC/EU	CAB-DC-32A-EU1	37-101015-01	32A, 400VDC	Saf-D-Grid 3-5958P4 to Saf-D-Grid 3-5958P4	Refer the figure in <a href="#">30A HVAC/HVDC Cable Illustrations</a>
IEC/EU	CAB-DC-32A-EU2	37-101017-01	32A, 400VDC	Saf-D-Grid 3-5958P4 to Saf-D-Grid 3-5958P4	Refer the figure in <a href="#">30A HVAC/HVDC Cable Illustrations</a>
CHINA	CAB-AC-32A-CHN	37-101010-01	32A, 250VAC	-	Refer the figure in <a href="#">30A HVAC/HVDC Cable Illustrations</a>
KOREA	CAB-AC-32A-KOR	37-101012-01	32A, 250VAC	-	Refer the figure in <a href="#">30A HVAC/HVDC Cable Illustrations</a>

### 30A HVAC/HVDC Cable Illustrations

**Figure 62: CAB-AC-32A-ANZ, CAB-AC-32A-CHE, CAB-AC-32A-ITA, CAB-AC-32A-BRZ, CAB-AC-32A-ZAF, CAB-AC-32A-ISR, CAB-AC-32A-IND, CAB-AC-32A-ARG Power Cord and Plugs for Standard AC Power Supply**

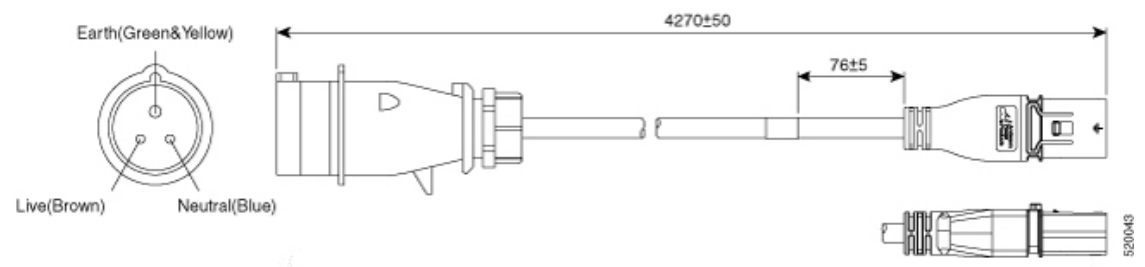


Figure 63: CAB-AC-30A-US1 Power Cord and Plugs for Standard AC Power Supply

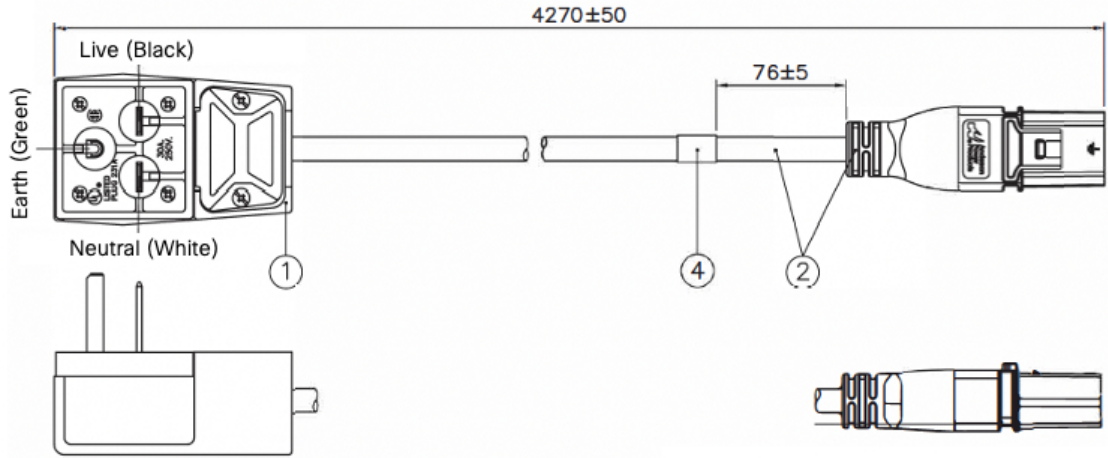


Figure 64: CAB-AC-30A-US2 Power Cord and Plugs for Standard AC Power Supply

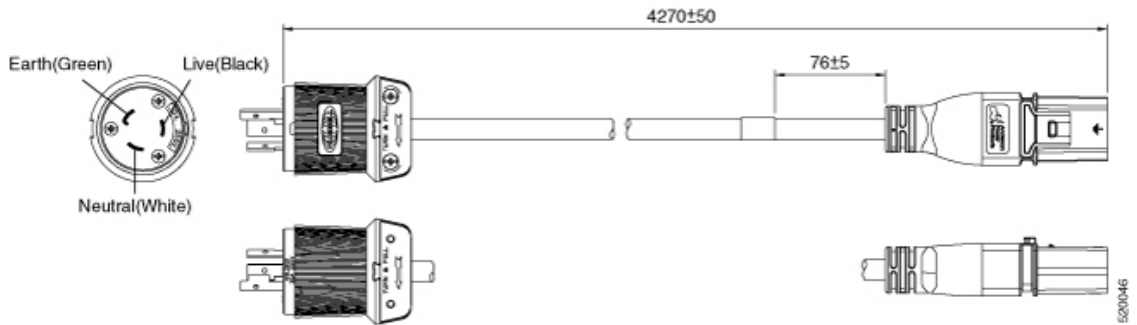


Figure 65: CAB-DC-30A-US1 Power Cord and Plugs for HVDC Power Supply

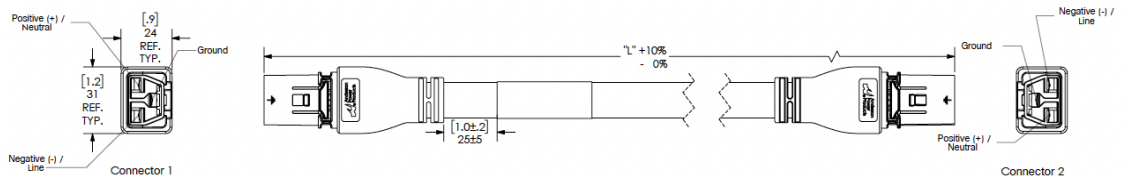


Figure 66: CAB-DC-30A-US2 Power Cord and Plugs for HVDC Power Supply

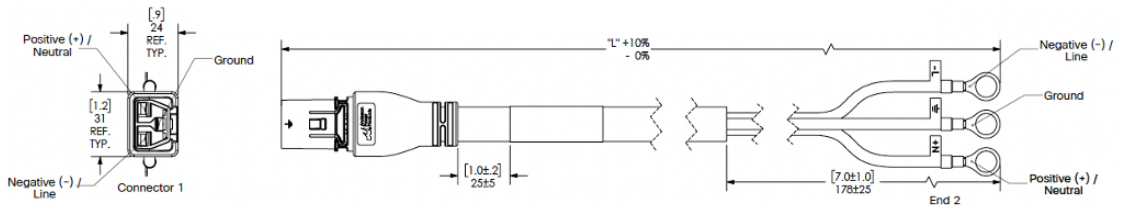




Figure 67: CAB-AC-30A-US3 Power Cord and Plugs for Standard AC Power Supply

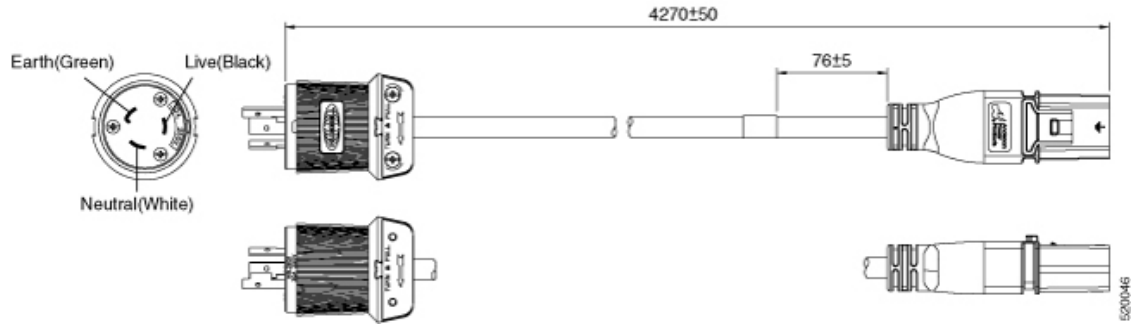


Figure 68: CAB-AC-30A-US4 Power Cord and Plugs for Standard AC Power Supply

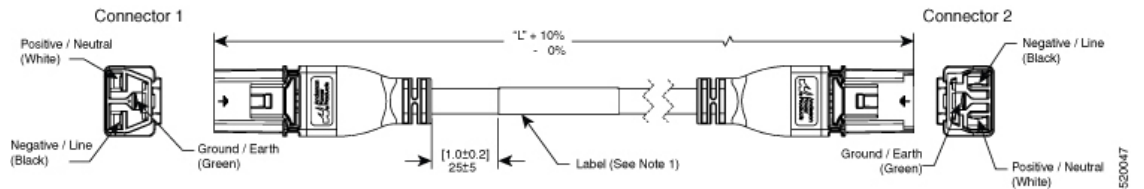


Figure 69: CAB-AC-32A-EU Power Cord and Plugs for Standard AC Power Supply

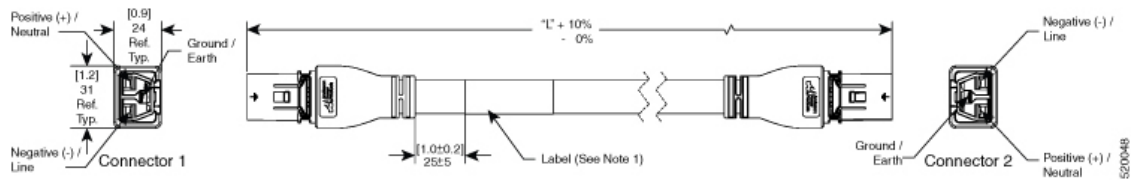


Figure 70: CAB-DC-32A-EU1 Power Cord and Plugs for HVDC Power Supply

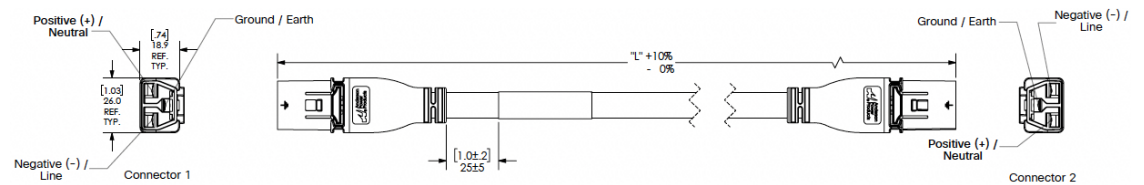


Figure 71: CAB-DC-32A-EU2 Power Cord and Plugs for HVDC Power Supply

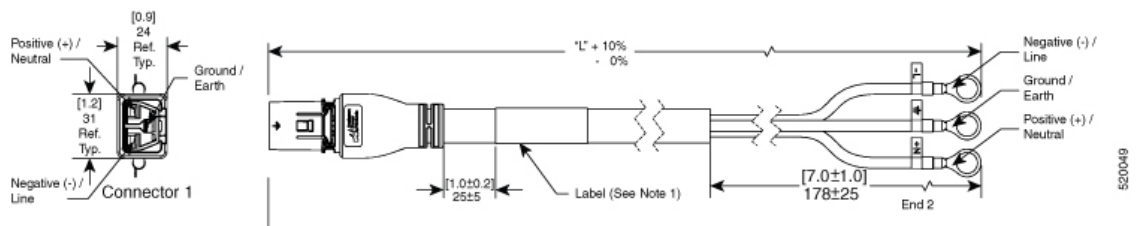


Figure 72: CAB-AC-32A-CHN Power Cord and Plugs for Standard AC Power Supply

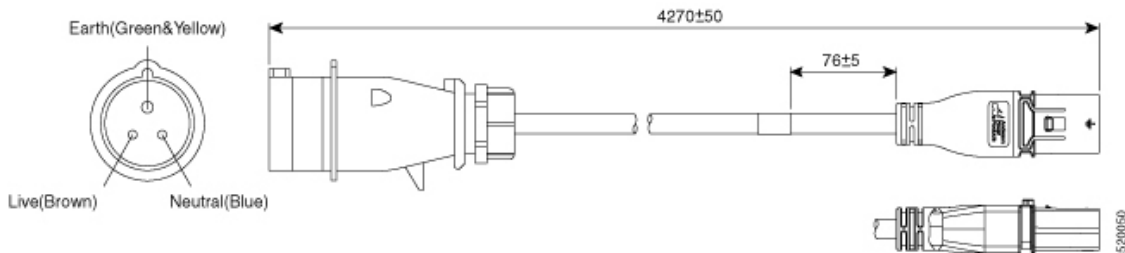


Figure 73: CAB-AC-32A-KOR Power Cord and Plugs for Standard AC Power Supply

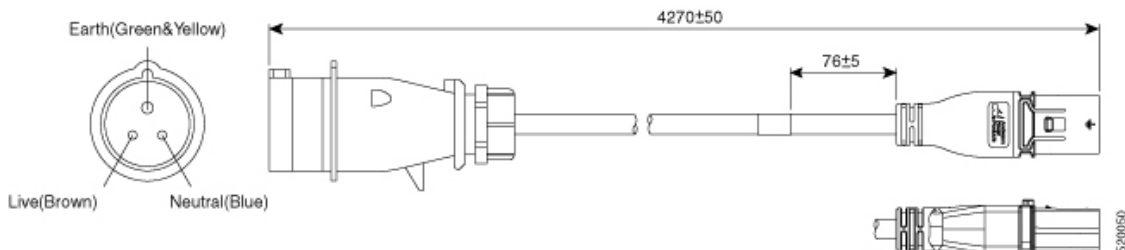


Table 20: 20A HVAC/HVDC Cables for PSU6.3KW-20A-HV

Locale	Part Number	Cisco Part Number (CPN)	Length	Power Cord Rating	Connectors	Power Cord Illustration
Argentina	CAB-AC-16A-SG-AR	37-1649-01	14 ft (4.26 m)	16A, 250 VAC	–	Refer the figure in <a href="#">20A HVAC/HVDC Cables for PSU6.3KW-20A-HV</a>
Australia	CAB-AC-16A-SG-AZ	37-1661-01	14 ft (4.26 m)	16A, 250 VAC	–	Refer the figure in <a href="#">20A HVAC/HVDC Cables for PSU6.3KW-20A-HV</a>
Brazil	CAB-AC-16A-SG-BR	37-1650-01	14 ft (4.26 m)	16A, 250 VAC	–	Refer the figure in <a href="#">20A HVAC/HVDC Cables for PSU6.3KW-20A-HV</a>
China	CAB-AC-16A-SG-CH	37-1655-01	14 ft (4.26 m)	16A, 250 VAC	–	Refer the figure in <a href="#">20A HVAC/HVDC Cables for PSU6.3KW-20A-HV</a>
China	CAB-AC-16A-CN	37-1655-01	14 ft (4.26 m)	16A, 250 VAC	–	Refer the figure in <a href="#">20A HVAC/HVDC Cables for PSU6.3KW-20A-HV</a>
Europe	CAB-AC-16A-SG-EU	37-1660-01	14 ft (4.26 m)	16A, 250 VAC	–	Refer the figure in <a href="#">20A HVAC/HVDC Cables for PSU6.3KW-20A-HV</a>

Locale	Part Number	Cisco Part Number (CPN)	Length	Power Cord Rating	Connectors	Power Cord Illustration
India	CAB-AC-16A-SG-IND	37-1863-01	14 ft (4.26 m)	16A, 250 VAC	–	Refer the figure in <a href="#">20A HVAC/HVDC Cables for PSU6.3KW-20A-HV</a>
International/UK	CAB-AC-16A-SG-IN	37-1659-01	14 ft (4.26 m)	16A, 250 VAC	–	Refer the figure in <a href="#">20A HVAC/HVDC Cables for PSU6.3KW-20A-HV</a>
Israel	CAB-AC-16A-SG-IS	37-1658-01	14 ft (4.26 m)	16A, 250 VAC	–	Refer the figure in <a href="#">20A HVAC/HVDC Cables for PSU6.3KW-20A-HV</a>
Italy	CAB-AC-16A-SG-IT	37-1651-01	14 ft (4.26 m)	16A, 250 VAC	–	Refer the figure in <a href="#">20A HVAC/HVDC Cables for PSU6.3KW-20A-HV</a>
Japan	CAB-AC-16A-SG-JPN	37-1656-01	14 ft (4.26 m)	16A, 250 VAC	–	Refer the figure in <a href="#">20A HVAC/HVDC Cables for PSU6.3KW-20A-HV</a>
South Africa	CAB-AC-16A-SG-SA	37-1647-01	14 ft (4.26 m)	16A, 250 VAC	–	Refer the figure in <a href="#">20A HVAC/HVDC Cables for PSU6.3KW-20A-HV</a>
Switzerland	CAB-AC-16A-SG-SW	37-1654-01	14 ft (4.26 m)	16A, 250 VAC	–	Refer the figure in <a href="#">20A HVAC/HVDC Cables for PSU6.3KW-20A-HV</a>
South Korea	CAB-AC-16A-SG-SK	37-1646-01	14 ft (4.26 m)	16A, 250 VAC	–	Refer the figure in <a href="#">20A HVAC/HVDC Cables for PSU6.3KW-20A-HV</a>
UK	CAB-AC-16A-SG-UK	37-1864-01	14 ft (4.26 m)	16A, 250 VAC	–	Refer the figure in <a href="#">20A HVAC/HVDC Cables for PSU6.3KW-20A-HV</a>
North America (locking) 200-240 VAC operation	CAB-AC-20A-SG-US3	37-1656-01	14 ft (4.26 m)	20A, 250 VAC	Saf-D-Grid to L6-20	Refer the figure in <a href="#">20A HVAC/HVDC Cables for PSU6.3KW-20A-HV</a>
North America 277 VAC operation	CAB-AC-20A-SG-US4	37-1645-01	14 ft (4.26 m)	20A, 277 VAC	Saf-D-Grid to L7-20	Refer the figure in <a href="#">20A HVAC/HVDC Cables for PSU6.3KW-20A-HV</a>
North America Cabinet Jumper Power Distribution unit (PDU)	CAB-AC-20A-SG-C20	37-1653-01	14 ft (4.26 m)	20A, 250 VAC	Saf-D-Grid to C20	Refer the figure in <a href="#">20A HVAC/HVDC Cables for PSU6.3KW-20A-HV</a>

Locale	Part Number	Cisco Part Number (CPN)	Length	Power Cord Rating	Connectors	Power Cord Illustration
North America, Ring Terminal source plug	CAB-HV-25A-SG-US2	37-1641-01	14 ft (4.26 m)	20A, 300 VAC/500 VDC	Saf-D-Grid to 3 ring terminal	Refer the figure in <a href="#">20A HVAC/HVDC Cables for PSU6.3KW-20A-HV</a>
International IEC/EU, Ring Terminal source plug	CAB-HV-25A-SG-IN2	37-1640-01	14 ft (4.26 m)	20A, 300 VAC/500 VDC	Saf-D-Grid to 3 ring terminal	Refer the figure in <a href="#">20A HVAC/HVDC Cables for PSU6.3KW-20A-HV</a>
US, IEC/EU, CANADA, MEXICO, BRAZIL, NETHERLANDS, IRELAND, FRANCE, UK, GERMANY, SWITZERLAND, NORWAY, SPAIN, ITALY, SINGAPORE, CHINA	CAB-AC-20A-NA	37-2126-01	6.6 ft (2m)	20A, 250VAC	Saf-D-Grid 3-5958P2 to IEC 60320 C20	Refer the figure in <a href="#">20A HVAC/HVDC Cables for PSU6.3KW-20A-HV</a>

## 20A HVAC/HVDC Cable Illustrations

Figure 74: CAB-AC-16A-SG-AR Power Cord

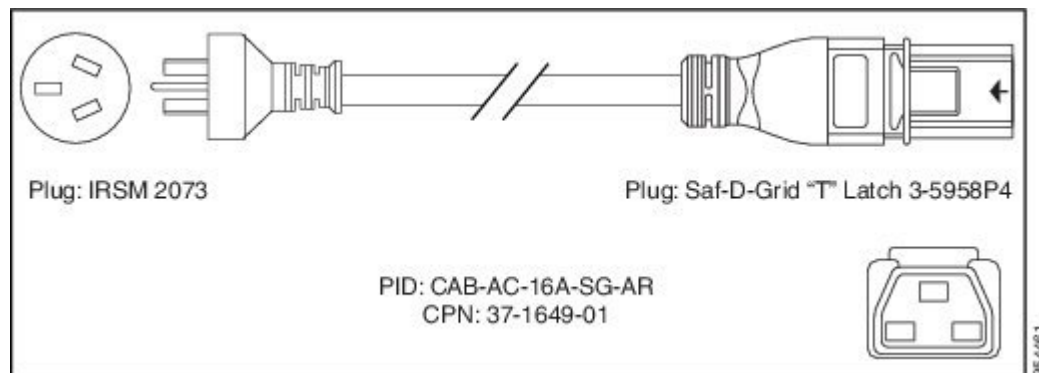


Figure 75: CAB-AC-16A-SG-AZ Power Cord

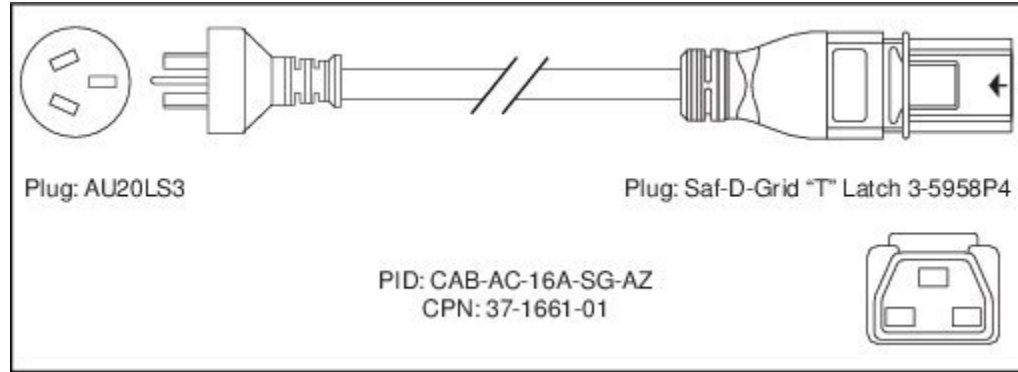


Figure 76: CAB-AC-16A-SG-BR Power Cord

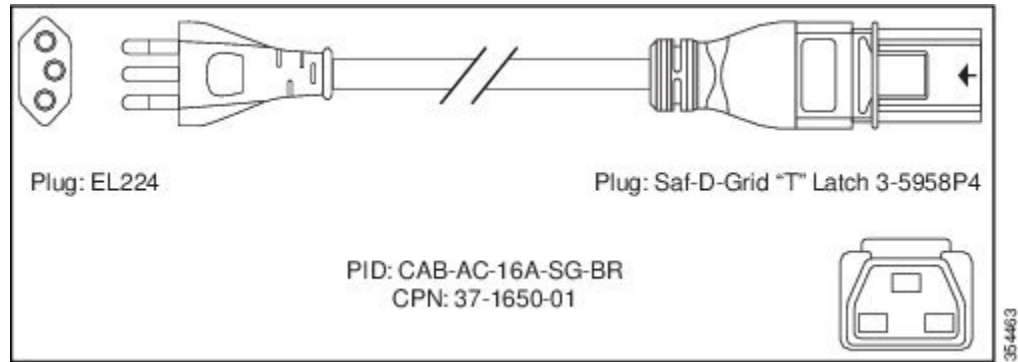


Figure 77: CAB-AC-16A-SG-CH Power Cord

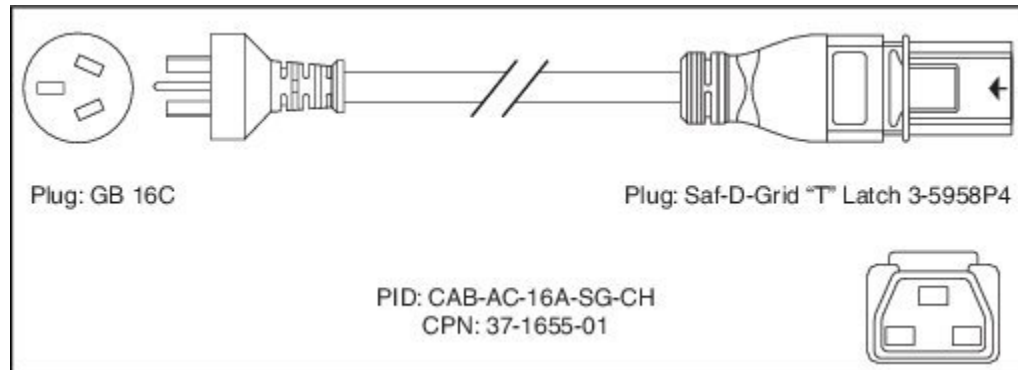


Figure 78: CAB-AC-16A-SG-EU Power Cord

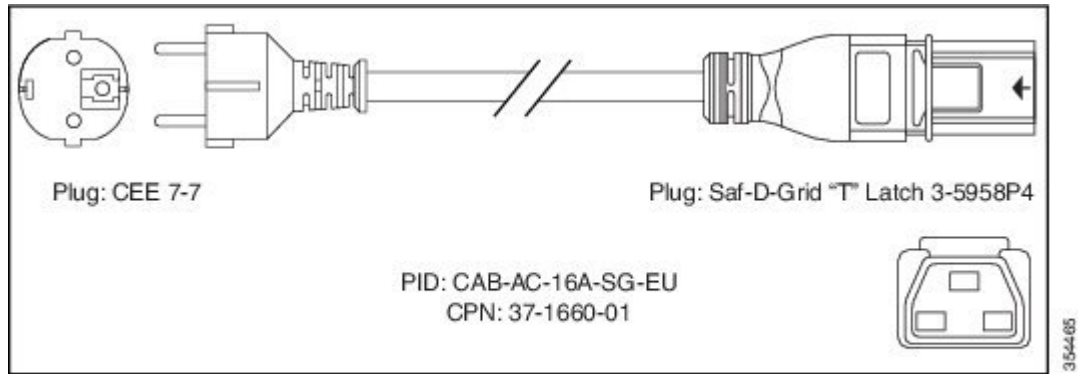


Figure 79: CAB-AC-16A-SG-IND Power Cord

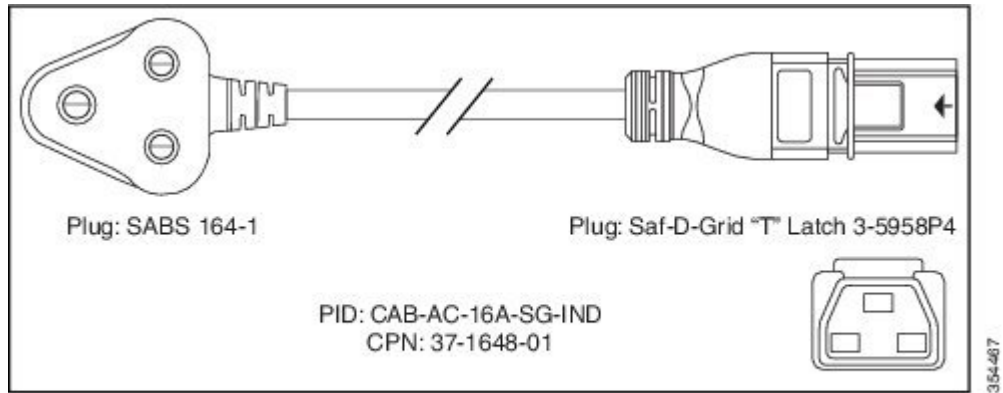


Figure 80: CAB-AC-16A-SG-IN Power Cord

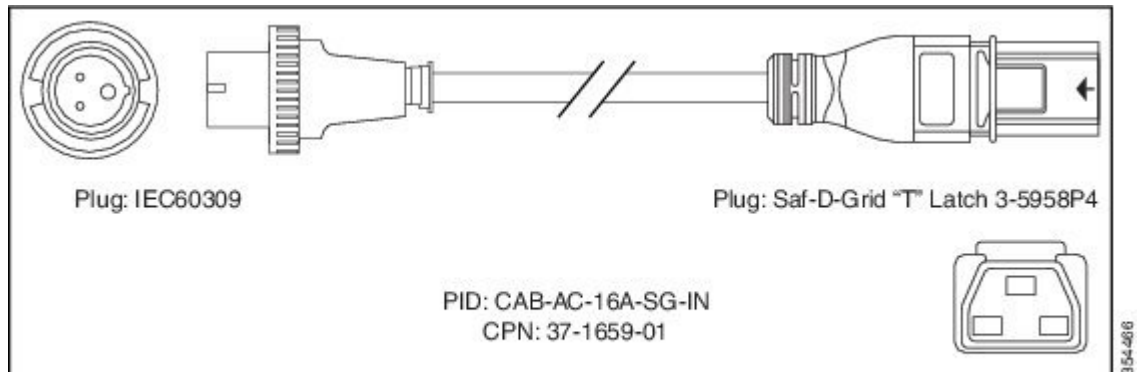


Figure 81: CAB-AC-16A-SG-IS Power Cord

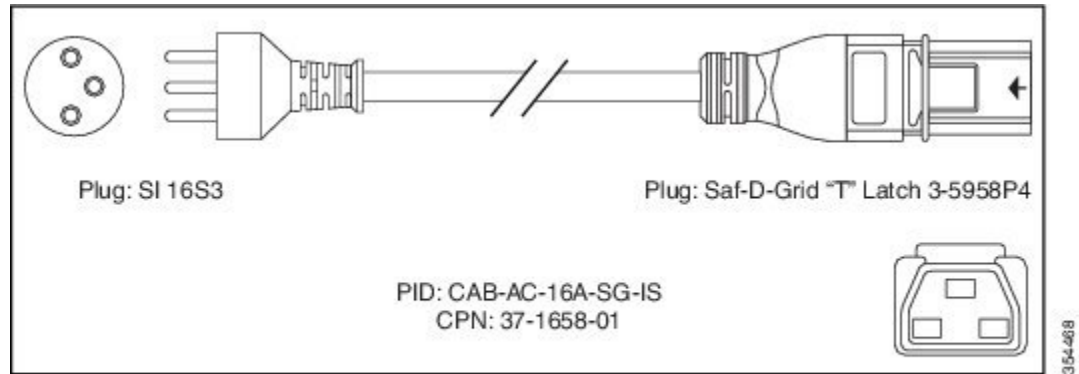


Figure 82: CAB-AC-16A-SG-IT Power Cord

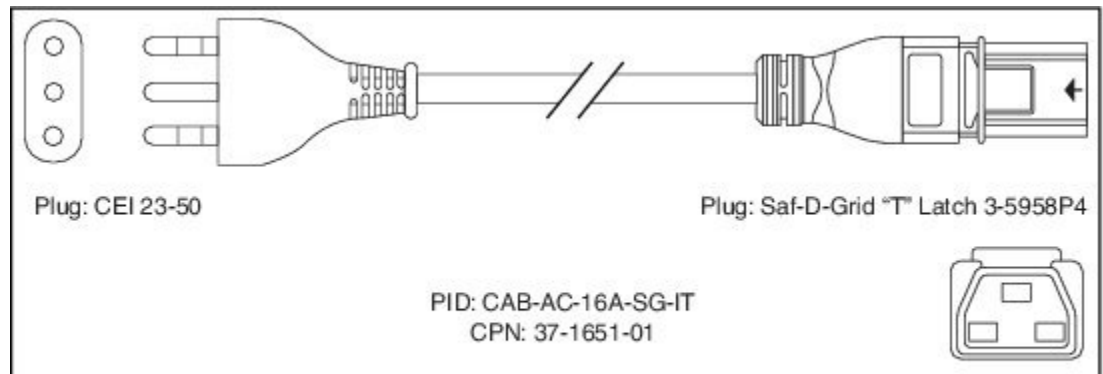


Figure 83: CAB-AC-16A-SG-JPN Power Cord

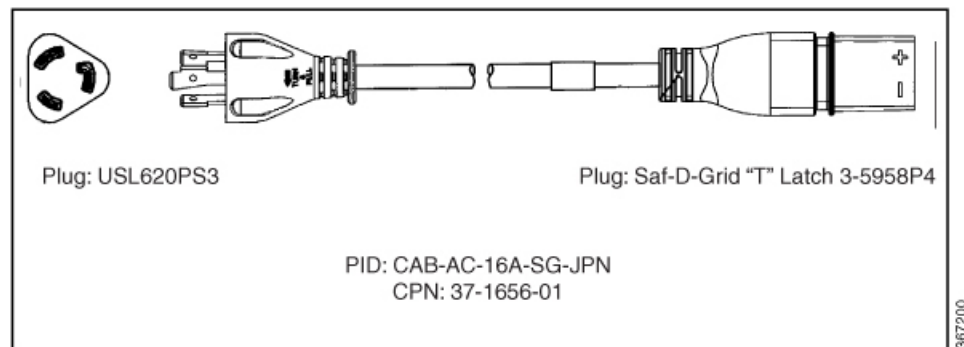


Figure 84: CAB-AC-16A-SG-SA Power Cord

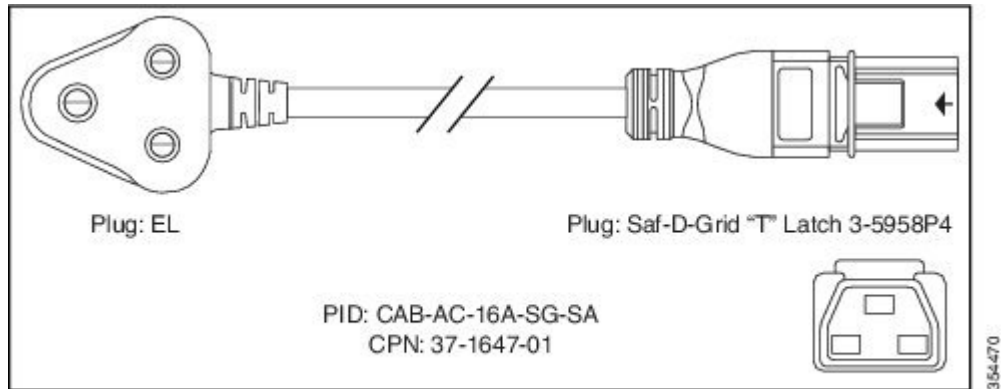


Figure 85: CAB-AC-16A-SG-SW Power Cord

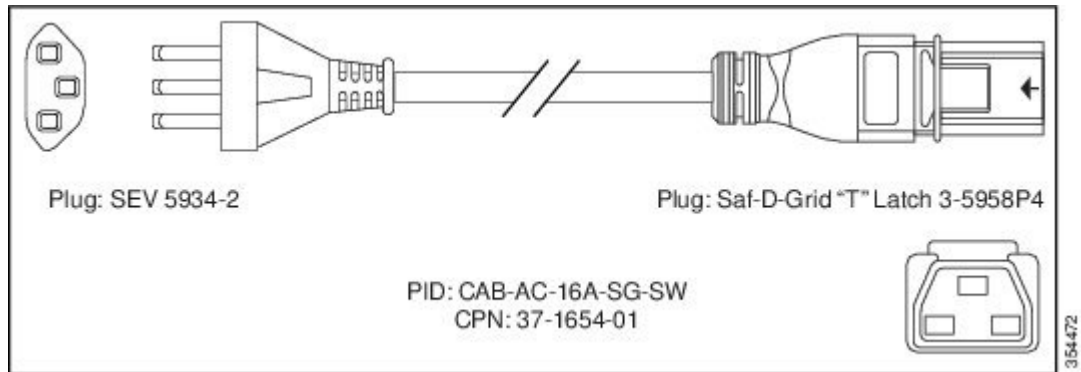


Figure 86: CAB-AC-16A-SG-UK Power Cord

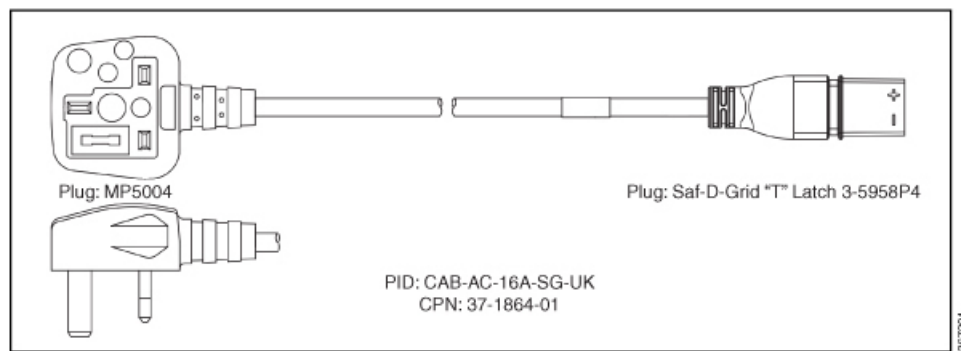




Figure 87: CAB-AC-20A-SG-US Power Cord

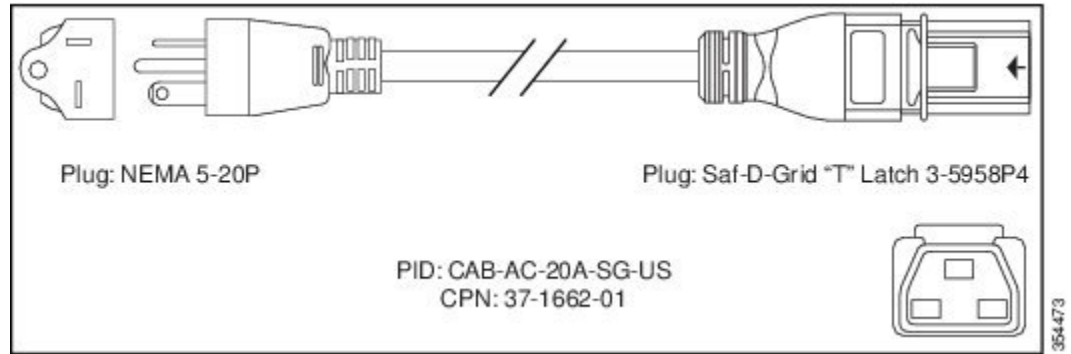


Figure 88: CAB-AC-20A-SG-US1 Power Cord

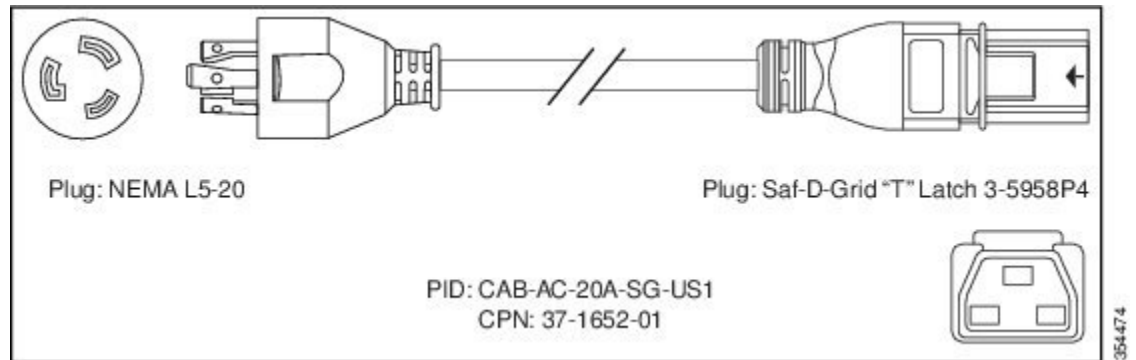


Figure 89: CAB-AC-20A-SG-US2 Power Cord

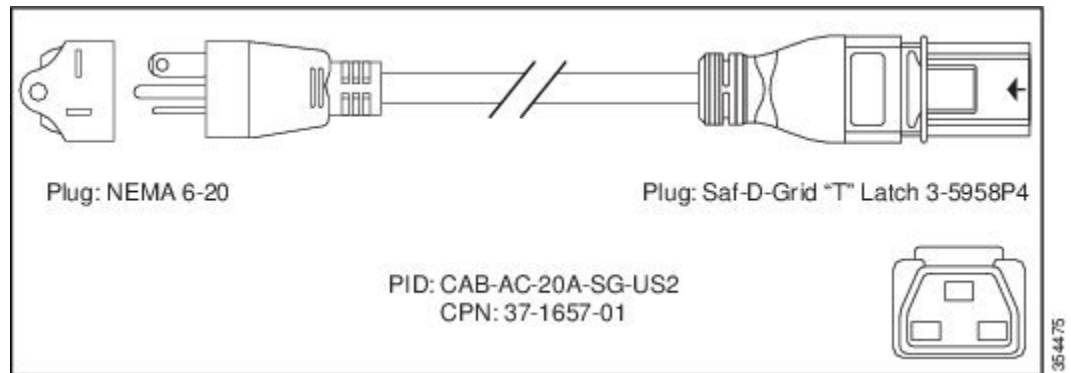


Figure 90: CAB-AC-20A-SG-US3 Power Cord

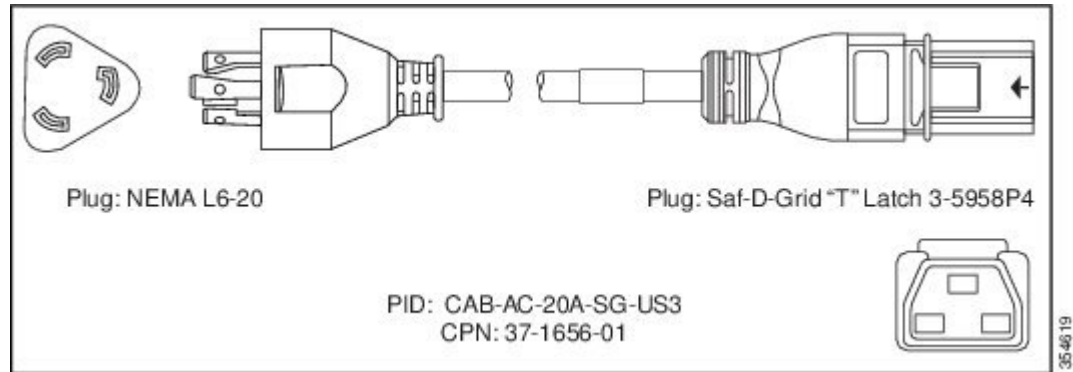


Figure 91: CAB-AC-20A-SG-US4 Power Cord

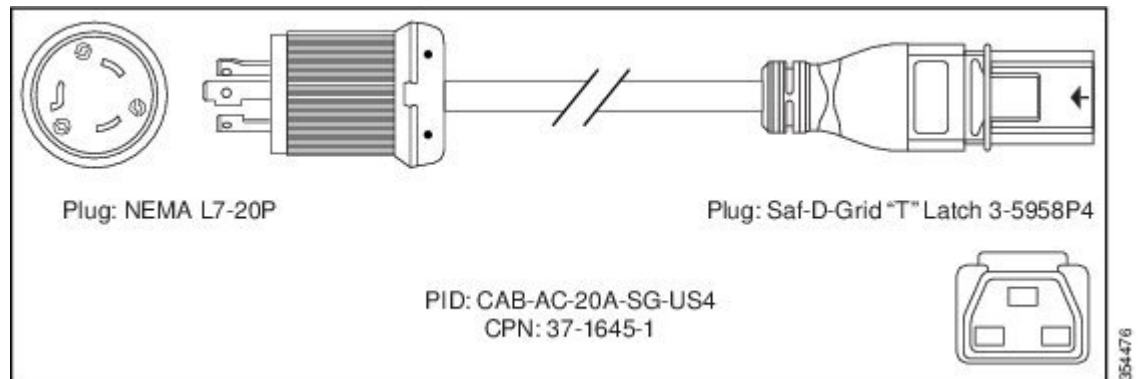


Figure 92: CAB-AC-20A-SG-C20 Power Cord

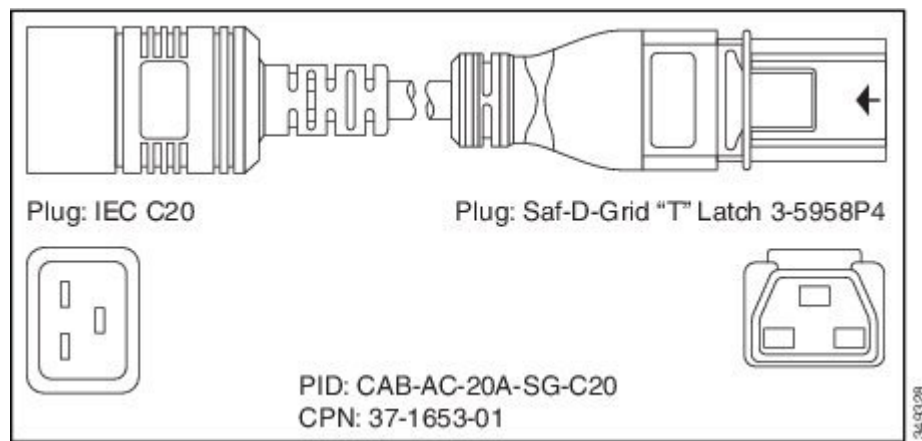


Figure 93: CAB-HV-25A-SG-US2 Power Cord

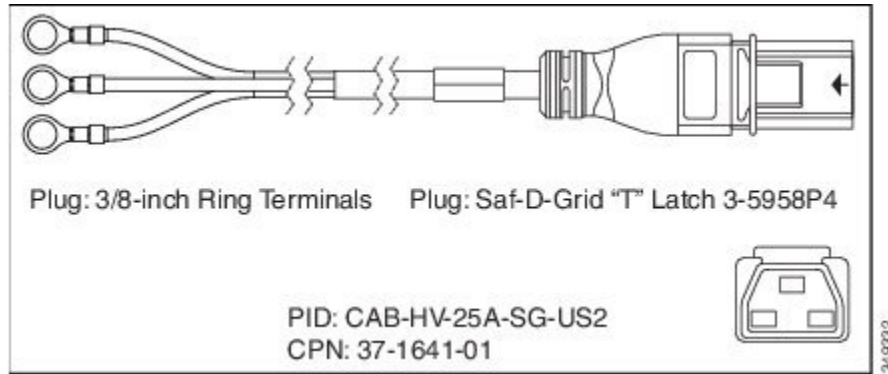


Figure 94: CAB-HV-25A-SG-IN2 Power Cord

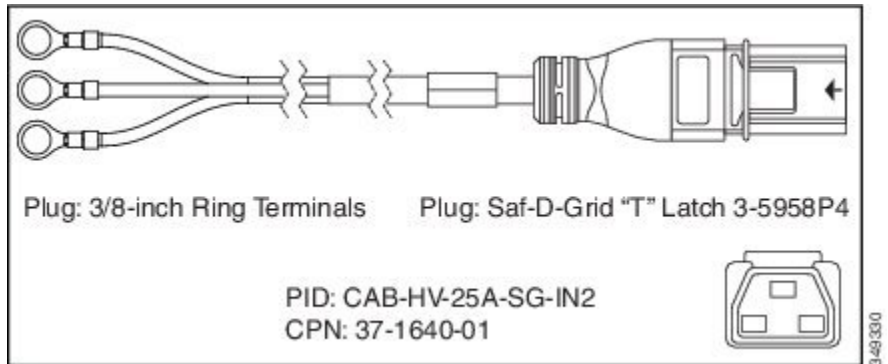


Figure 95: CAB-HV-25A-SG-IN3 Power Cord

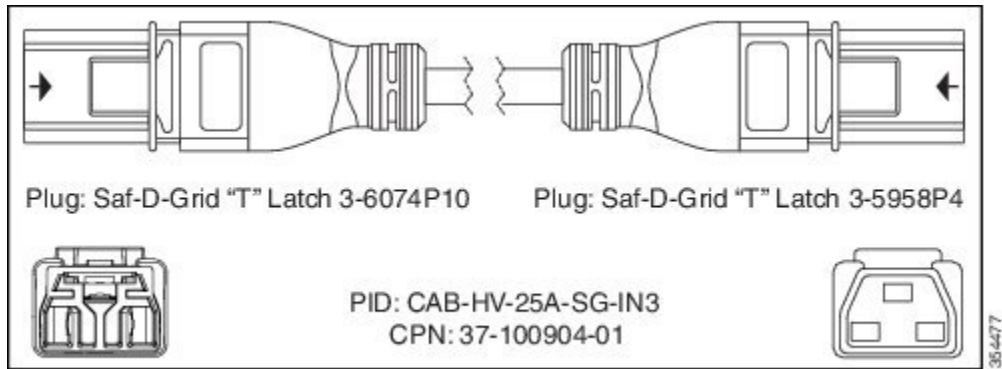
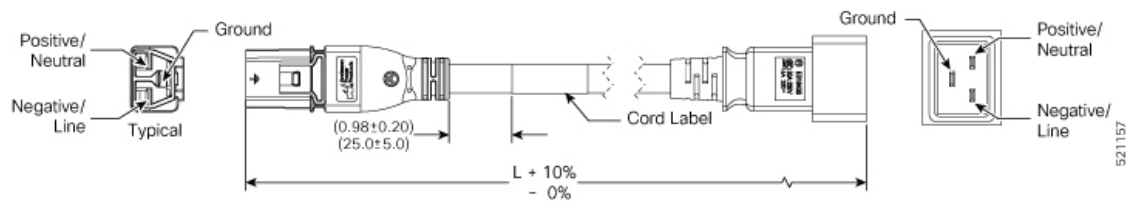


Figure 96: CAB-AC-20A-NA Power Cord







## CHAPTER 5

# Connect Router to the Network



**Note** The images in this chapter are only for representation purposes, unless specified otherwise. The chassis' actual appearance and size may vary.

- [Connecting a Console to the Router, on page 99](#)
- [Connect the Management Interface, on page 100](#)
- [Transceivers, Connectors, and Cables, on page 101](#)
- [Install and Remove SFP28 and SFP+ Modules, on page 102](#)
- [Install and Remove QSFP Transceiver Modules, on page 109](#)
- [Connect Interface Ports, on page 116](#)
- [Maintain Transceivers and Optical Cables, on page 116](#)
- [Create the Initial Router Configuration, on page 116](#)
- [Set Fabric Bandwidth Threshold, on page 125](#)

## Connecting a Console to the Router

Before you create a network management connection for the router or connect the router to the network, you must create a local management connection through a console terminal and configure an IP address for the router. The router can be accessed using remote management protocols, such as SSH and Telnet. By default, SSH is included in the software image. But telnet is not part of the software image. You must manually install the telnet optional package to use it.

You also can use the console to perform the following functions, each of which can be performed through the management interface after you make that connection:

- configure the router using the command-line interface (CLI)
- monitor network statistics and errors
- configure Simple Network Management Protocol (SNMP) agent parameters
- initiate software download updates via console

You make this local management connection between the asynchronous serial port on a Route Processor card and a console device capable of asynchronous transmission. Typically, you can use a computer terminal as the console device. On the Route Processor cards, you use the console serial port.



---

**Note** Before you can connect the console port to a computer terminal, make sure that the computer terminal supports VT100 terminal emulation. The terminal emulation software makes communication between the router and computer possible during setup and configuration.

---

### Before you begin

- The router must be fully installed in its rack. The router must be connected to a power source and grounded.
- The necessary cabling for the console, management, and network connections must be available.
  - An RJ45 rollover cable and a DB9F/RJ45 adapter.
  - Network cabling should already be routed to the location of the installed router.

### Procedure

---

**Step 1** Configure the console device to match the following default port characteristics:

- 115200 baud
- 8 data bits
- 1 stop bit
- No parity

**Step 2** Connect an RJ45 rollover cable to a terminal, PC terminal emulator, or terminal server.  
The RJ45 rollover cable is not part of the accessory kit.

**Step 3** Route the RJ45 rollover cable as appropriate and connect the cable to the console port on the chassis.  
If the console or modem cannot use an RJ45 connection, use the DB9F/RJ45F PC terminal adapter. Alternatively, you can use an RJ45/DSUB F/F or RJ45/DSUB R/P adapter, but you must provide those adapters.

---

### What to do next

You are ready to create the initial router configuration.

## Connect the Management Interface

The Route Processor management port (MGMT ETH) provides out-of-band management, which lets you to use the command-line interface (CLI) to manage the router by its IP address. This port uses a 10/100/1000 Ethernet connection with an RJ-45 interface.



**Note** In a dual Route Processor router, you can ensure that the active Route Processor card is always connected to the network by connecting the management interface on both Route Processor cards to the network. That is, you can perform this task for each Route Processor card. When the Route Processor card is active, the router automatically has a management interface that is running and accessible from the network.



**Caution** To prevent an IP address conflict, do not connect the MGMT 100/1000 Ethernet port until the initial configuration is complete.

### Before you begin

You must have completed the initial router configuration.

### Procedure

- Step 1** Connect a modular, RJ-45, UTP cable to the MGMT ETH port on the Route Processor card.
- Step 2** Route the cable through the central slot in the cable management system.
- Step 3** Connect the other end of the cable to a 100/1000 Ethernet port on a network device.

### What to do next

You are ready to connect the interface ports on each of the line cards to the network.

## Transceivers, Connectors, and Cables

### Transceiver and Cable Specifications

To determine which transceivers and cables are supported by this router, see [Cisco Transceiver Modules Compatibility Information](#).

To see the transceiver specifications and installation information, see [Cisco Transceiver Modules Install and Upgrade Guides](#).

### RJ-45 Connectors

The RJ-45 connector connects Category 3, Category 5, Category 5e, Category 6, or Category 6A foil twisted-pair or unshielded twisted-pair cable from the external network to the following module interface connectors:

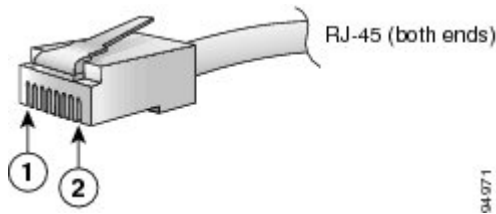
- Router chassis
  - CONSOLE port
  - MGMT ETH port



**Caution** To comply with GR-1089 intrabuilding, lightning immunity requirements, you must use a foil twisted-pair (FTP) cable that is properly grounded at both ends.

The following figure shows the RJ-45 connector.

**Figure 97: RJ-45 Connector**



1	Pin 1	2	Pin 8
---	-------	---	-------

## Install and Remove SFP28 and SFP+ Modules

Before you remove or install an SFP28 and SFP+ module, read the installation information in this section.

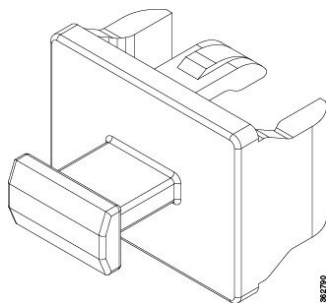


**Warning** **Statement 1051—Laser Radiation**  
Invisible laser radiation may be emitted from disconnected fibers or connectors. Do not stare into beams or view directly with optical instruments.



**Caution** Protect the line card by inserting a clean SFP28/SFP+ module cage cover, which is shown in the figure below, into the optical module cage when there is no SFP28/SFP+ module installed.

**Figure 98: SFP28/SFP+ Module Cage Cover**







**Caution** Protect the SFP28 or SFP+ modules by inserting clean dust covers into them after the cables are removed. Be sure to clean the optic surfaces of the fiber cables before you plug them back into the optical ports of another module. Avoid getting dust and other contaminants into the optical ports of your SFP or SFP+ modules, because the optics do not work correctly when obstructed by dust.



**Caution** We strongly recommended that you do not install or remove the SFP28 or SFP+ module with fiber-optic cables that are attached to it because of the potential of damaging the cable, the cable connector, or the optical interfaces in the module. Disconnect all cables before removing or installing an SFP28 or SFP+ module. Removing and inserting a module can shorten its useful life, so you should not remove and insert modules any more than is absolutely necessary.

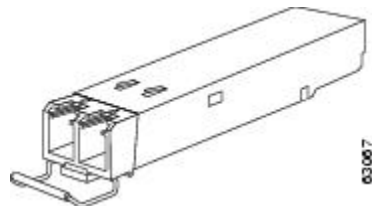


**Note** When installing an SFP28 or SFP+ module, you should hear a click as the triangular pin on the bottom of the module snaps into the hole in the receptacle. The click indicates that the module is correctly seated and secured in the receptacle. Verify that the modules are seated and secured in their assigned receptacles on the line card by firmly pushing on each SFP28 or SFP+ module.

## Bale Clasp SFP28 or SFP+ Module

The bale clasp SFP28 or SFP+ module has a clasp that you use to remove or install the module (see the figure below).

*Figure 99: Bale Clasp SFP28 or SFP+ Module*



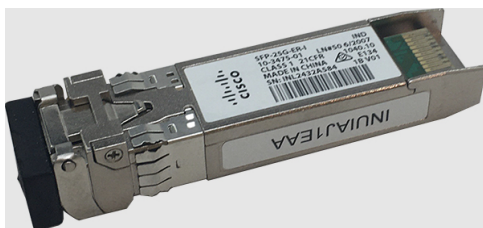
## Install a Bale Clasp SFP28 or SFP+ Module

To install this type of SFP28 or SFP+ module, follow these steps:

### Procedure

- Step 1** Attach an ESD-preventive wrist or ankle strap and follow its instructions for use.
- Step 2** Close the bale clasp before inserting the SFP28 or SFP+ module.

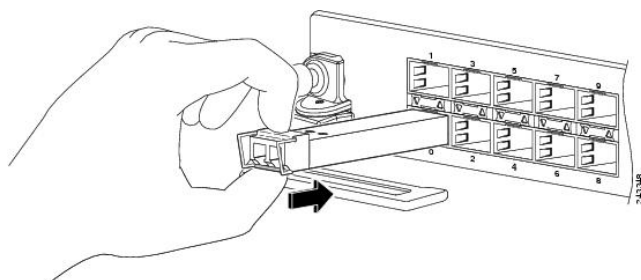
**Note** 88-LC1-52Y8H-EM: For the top and middle rows of SFP28 or SFP+ ports, you must install transceivers right-side up (Cisco transceiver label facing down). For the bottom row of SFP28 or SFP+ ports, you must install transceivers upside down (Cisco transceiver label facing up, see illustration below).



**Step 3** Line up the SFP28 or SFP+ module with the port and slide it into the port (see the figure below).

**Note** To minimize the chance of damaging transceivers when installing them, slide them gently into their port. Never force transceivers all the way into the port. If the transceiver stops part way into the slot, it might be in the wrong orientation. Remove the transceiver before turning it over and reinstalling it. If positioned correctly, the transceiver slides all the way into the port and clicks when fully installed.

*Figure 100: Installing a Bale Clasp SFP28 or SFP+ Module into a Port*



**Note** When installing an SFP28 or SFP+ module, you should hear a click as the triangular pin on the bottom of the SFP28 or SFP+ module snaps into the hole in the receptacle. This click indicates that the module is correctly seated and secured in the receptacle. Verify that the SFP28 or SFP+ modules are seated and secured in their assigned receptacles on the line card by firmly pushing on each SFP28 or SFP+ module.

## Remove a Bale Clasp SFP28 or SFP+ Module

To remove this type of SFP28 or SFP+ module, follow these steps:

### Procedure

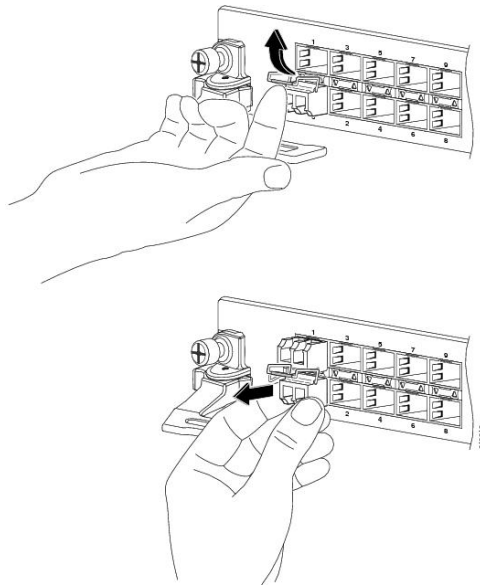
- Step 1** Attach an ESD-preventive wrist or ankle strap and follow its instructions for use.
- Step 2** Disconnect and remove all interface cables from the ports; note the current connections of the cables to the ports on the line card.
- Step 3** Open the bale clasp on the SFP28/SFP+ module with your index finger, as shown in the figure below.

**Note** If the bale clasp is obstructed and you cannot use your index finger to open it, use the Optical Transceiver Extraction Tool, a small flat-blade screwdriver, or other long, narrow instrument to open the bale clasp. See [Using the Optical Transceiver Extraction Tool, on page 105](#).

**Step 4** Grasp the SFP module between your thumb and index finger and carefully remove it from the port, as shown in the figure below.

**Note** This action must be performed during your first instance. After adjacent ports are populated, you may need to use the Optical Transceiver Extraction Tool.

**Figure 101: Removing a Bale Clasp SFP or SFP+ Module**



**Step 5** Place the removed SFP module on an antistatic mat, or immediately place it in a static shielding bag if you plan to return it to the factory.

**Step 6** Protect your line card by inserting a clean SFP module cage covers into the optical module cage when there is no SFP module installed.

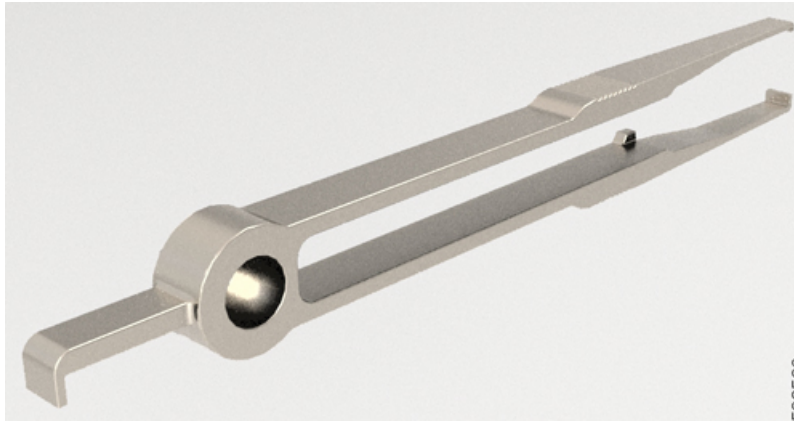
## Using the Optical Transceiver Extraction Tool

In a fully loaded 88-LC1-52Y8H-EM line card, the bale clasps of the SFP28 optics can be difficult to access. You can use the Optical Transceiver Extraction Tool to remove the network cable, open the bale clasp, and remove the transceiver.



**Note** SFP28 optics with pull tabs do not require the tool.

Figure 102: Optical Transceiver Extraction Tool



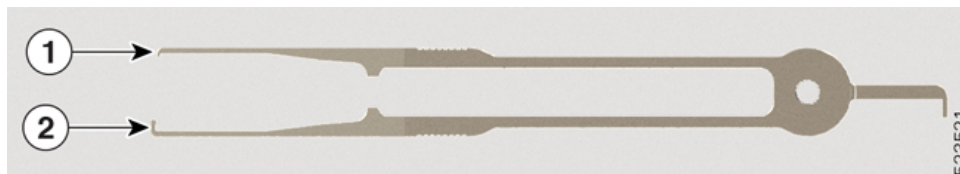
To use the Optical Transceiver Extraction Tool to remove an SFP28 or SFP+ module, follow these steps:

### Procedure

#### Step 1

Remove the optical cable from the transceiver:

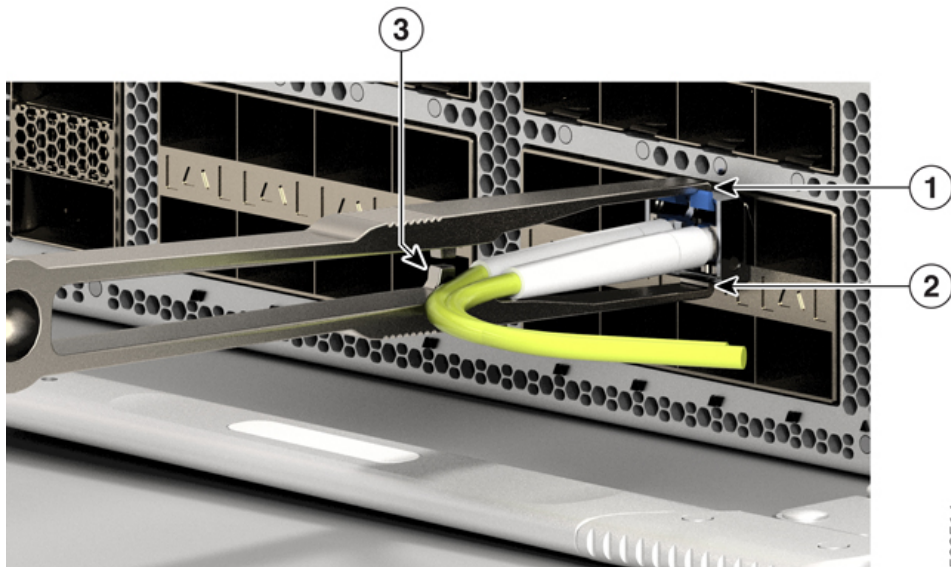
- a) Hold the tool with the small hook at the top, as shown in the illustration.



1	Small hook: <ul style="list-style-type: none"> <li>• Press down on cable connector</li> <li>• Grasp bale clasp</li> </ul>
2	Large hook: <ul style="list-style-type: none"> <li>• Grab the open bale clasp</li> <li>• Remove the transceiver from the port</li> </ul>

- b) Place the opening of the extraction tool over the optical cable connector.

**Note** The large hook should be in contact with the transceiver so that the small hook can squeeze the cable connector.



523514

1	Small hook
2	Large hook, in contact with transceiver
3	Do not pinch optical cable

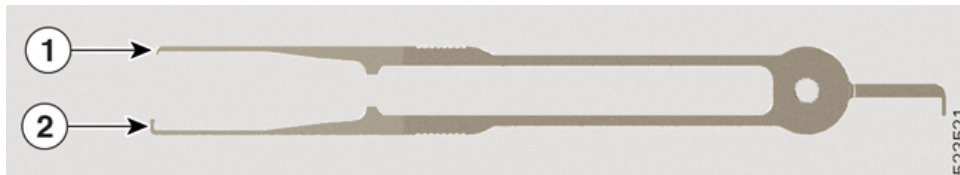
c) Squeeze the tool to press down on the optical cable connector latch.

**Note** Make sure that the tool does not pinch the optical cable.

d) Pull the cable from the transceiver.

**Step 2** Remove the transceiver from the port:

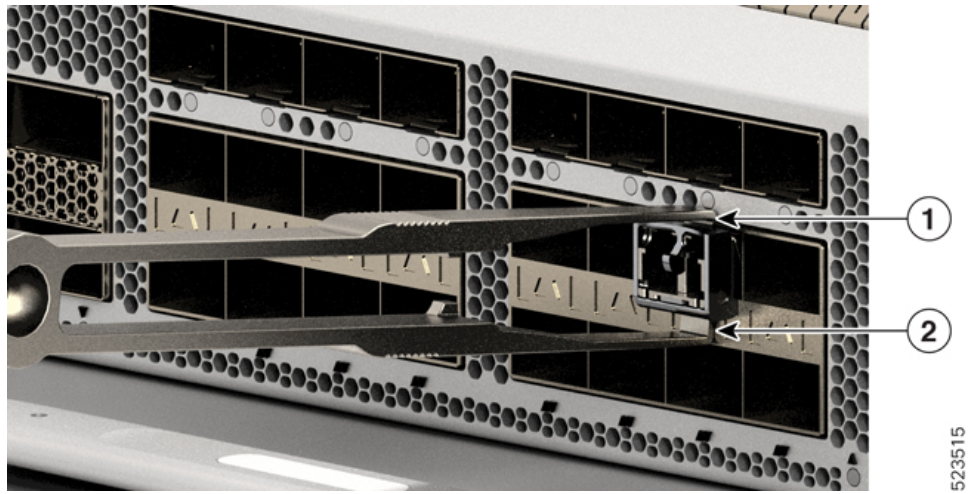
a) Hold the tool with the small hook at the top, as shown in the illustration.



523521

1	<p>Small hook:</p> <ul style="list-style-type: none"> <li>• Press down on cable connector</li> <li>• Grasp bale clasp</li> </ul>
2	<p>Large hook:</p> <ul style="list-style-type: none"> <li>• Grab the open bale clasp</li> <li>• Remove the transceiver from the port</li> </ul>

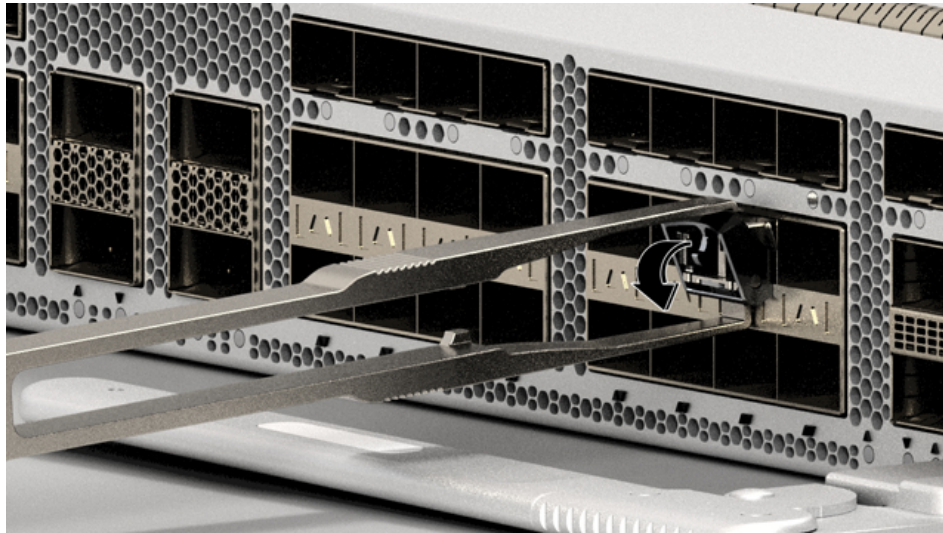
b) Use the small hook on the top to grasp the bale clasp.



523515

1	Small hook
2	Large hook

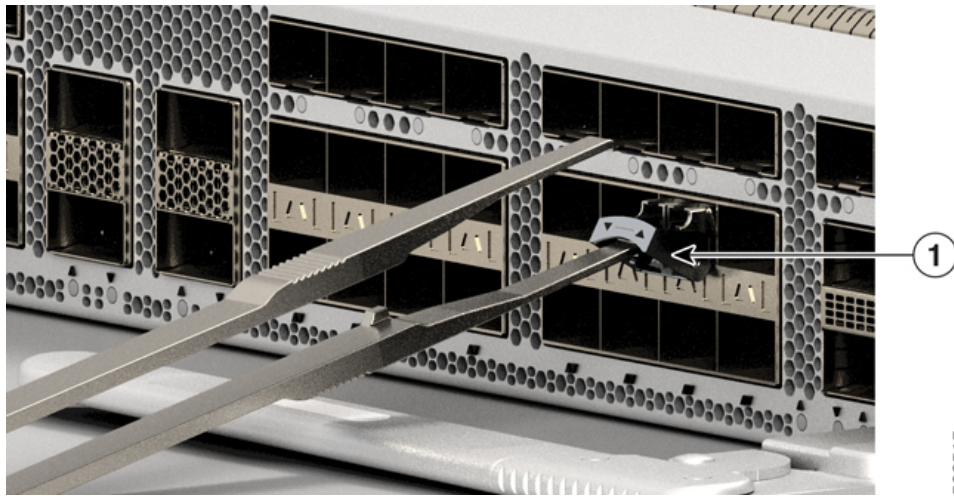
c) Open the bale clasp latch.



523516

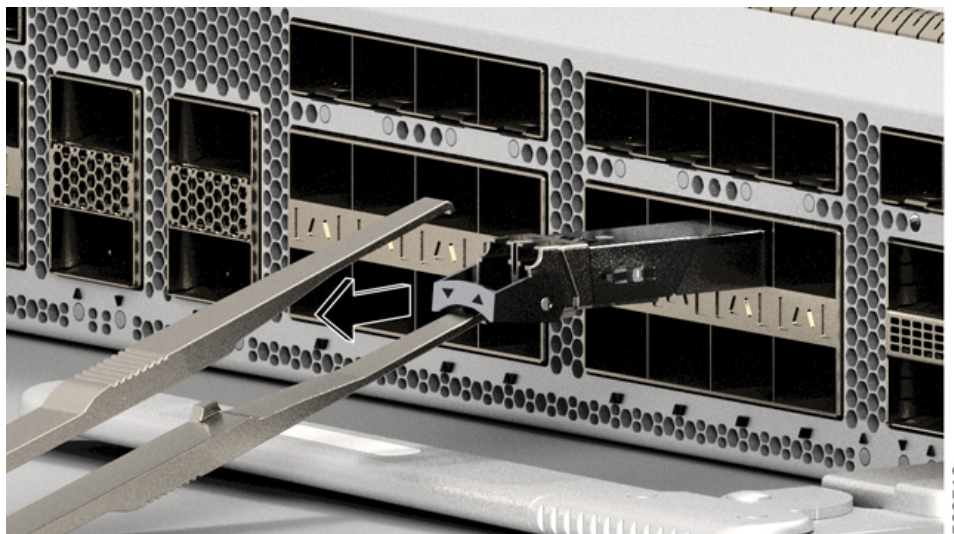
d) Use the larger hook on the bottom to grab the open bale clasp.





1	Large hook
---	------------

- e) Remove the transceiver from the port.



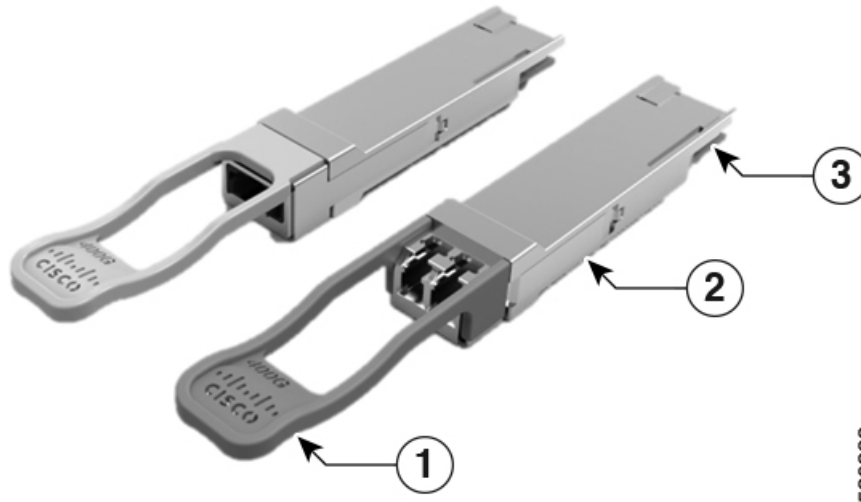
- f) Place the removed SFP28 module on an antistatic mat, or immediately place it in a static shielding bag if you plan to return it to the factory.
- g) Protect your line card by inserting a clean SFP28 module cage cover into the optical module cage when there is no SFP28 module installed.

## Install and Remove QSFP Transceiver Modules

This section provides the installation, cabling, and removal instructions for the Quad Small Form-Factor Pluggable transceiver modules. Refer to the [Cisco Optical Transceiver Handling Guide](#) for additional details on optical transceivers.

The following figure shows a 400-Gigabit QSFP-DD optical transceiver.

**Figure 103: 400-Gigabit QSFP-DD Transceiver Module**



520383

1	Pull-tab	2	QSFP-DD transceiver body
3	Electrical connection to the module circuitry		



**Warning Statement 1079—Hot Surface**

This icon is a hot surface warning. To avoid personal injury, do not touch without proper protection.



## Required Tools and Equipment

You need these tools to install the transceiver modules:

- Wrist strap or other personal grounding device to prevent ESD occurrences.
- Antistatic mat or antistatic foam to set the transceiver on.
- Fiber-optic end-face cleaning tools and inspection equipment.



## Installing the Transceiver Module



### Warning Statement 1079—Hot Surface

This icon is a hot surface warning. To avoid personal injury, do not touch without proper protection.



**Caution** The transceiver module is a static-sensitive device. Always use an ESD wrist strap or similar individual grounding device when handling transceiver modules or coming into contact with system modules.



**Caution** Protect the transceiver ports by inserting clean dust caps (8000-QSFP-DCAP) into any ports not in use and do not have optical modules plugged in. If optical modules are plugged in but not in use, the dust caps that were supplied with the optical modules, should be used to protect the TX and RX surfaces of the optical module.

Be sure to clean the optic surfaces of the fiber cables before you plug them back into the optical ports of another module.

The router ships with dust caps plugged in. We highly recommend you to keep the dust caps plugged in until you are ready to plug an optic.

The dust caps protect the ports from possible EMI interference and also avoid contamination due to dust collection. To meet the EMI interference requirements, you must use the metal dust caps when the ports are not in use by optical modules.

The following table provides the supported port details and operating temperature of the QDD-400G-ZR-S and QDD-400G-ZRP-S optical modules when port side exhaust or port side intake fans and power supplies are used.

**Table 21: Supported Ports and Operating Temperature of QDD-400G-ZR-S and QDD-400G-ZRP-S Optical Modules**

Line Cards	Port Side Intake Fans and Power Supplies	Port Side Exhaust Fans and Power Supplies	Port Side Intake Operating Temperature
8800-LC-36FH	<ul style="list-style-type: none"> <li>QDD-400G-ZR-S – supported on all 400G ports</li> <li>QDD-400G-ZRP-S – supported on even-numbered 400G ports</li> </ul>	NA	40° C at sea level or 35° C at 1500 meter

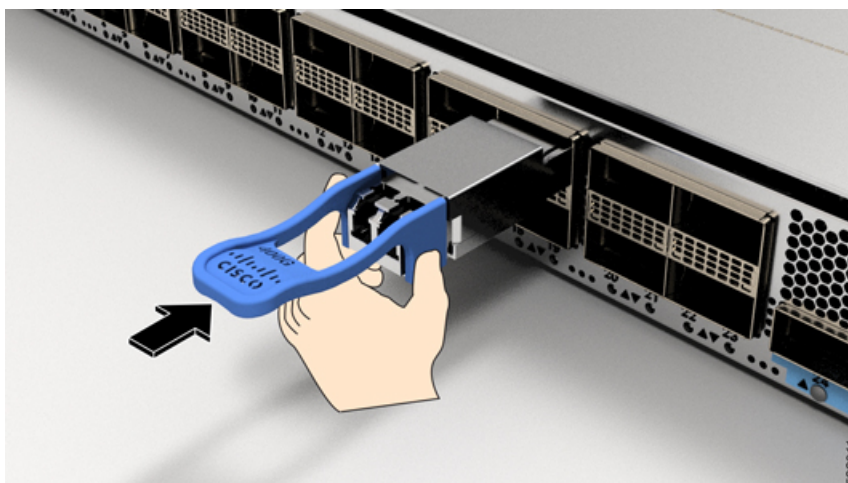
88-LC0-36FH-M	<ul style="list-style-type: none"> <li>• QDD-400G-ZR-S – supported on all 400G ports</li> <li>• QDD-400G-ZRP-S – supported on even-numbered 400G ports</li> </ul>	NA	40° C at sea level or 35° C at 1500 meter
88-LC0-36FH	<ul style="list-style-type: none"> <li>• QDD-400G-ZR-S – supported on all 400G ports</li> <li>• QDD-400G-ZRP-S – supported on even-numbered 400G ports</li> </ul>	NA	40° C at sea level or 35° C at 1500 meter

The QSFP transceiver module has a pull-tab latch. To install a transceiver module, follow these steps:

### Procedure

- 
- Step 1** Attach an ESD wrist strap to yourself and a properly grounded point on the chassis or the rack.
- Step 2** Remove the transceiver module from its protective packaging.
- Step 3** Check the label on the transceiver module body to verify that you have the correct model for your network. Do not remove the dust plug until you're ready to attach the network interface cable. Dust plug is not shown in the images.
- Step 4** Hold the transceiver by the pull-tab so that the identifier label is on the top.
- Step 5** Align the transceiver module in front of the module's transceiver socket opening and carefully slide the transceiver into the socket until the transceiver contact with the socket electrical connector.

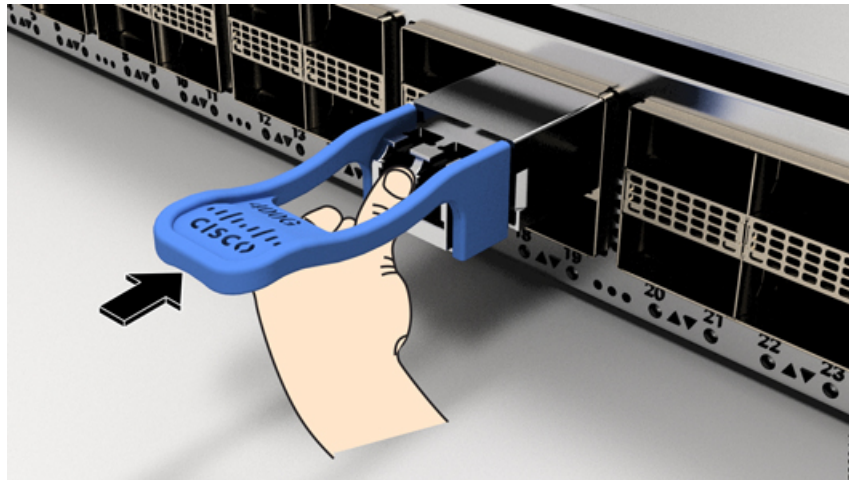
*Figure 104: Installing the QSFP Transceiver Module*



- Step 6** Press firmly on the front of the transceiver module with your thumb to fully seat the transceiver in the module's transceiver socket (see the below figure).

**Caution** If the latch isn't fully engaged, you might accidentally disconnect the transceiver module.

Figure 105: Seating the QSFP Transceiver Module



## Attach the Optical Network Cable

### Before you begin

Before you remove the dust plugs and make any optical connections, follow these guidelines:

- Keep the protective dust plugs installed in the unplugged fiber-optic cable connectors and in the transceiver optical bores until you are ready to make a connection.
- Inspect and clean the optical connector end faces just before you make any connections.
- Grasp the optical connector only by the housing to plug or unplug a fiber-optic cable.



**Note** The transceiver modules and fiber connectors are keyed to prevent incorrect insertion.



**Note** The multiple-fiber push-on (MPO) connectors on the optical transceivers support network interface cables with either physical contact (PC) or ultra-physical contact (UPC) flat polished face types. The MPO connectors on the optical transceivers do not support network interface cables with an angle-polished contact (APC) face type.



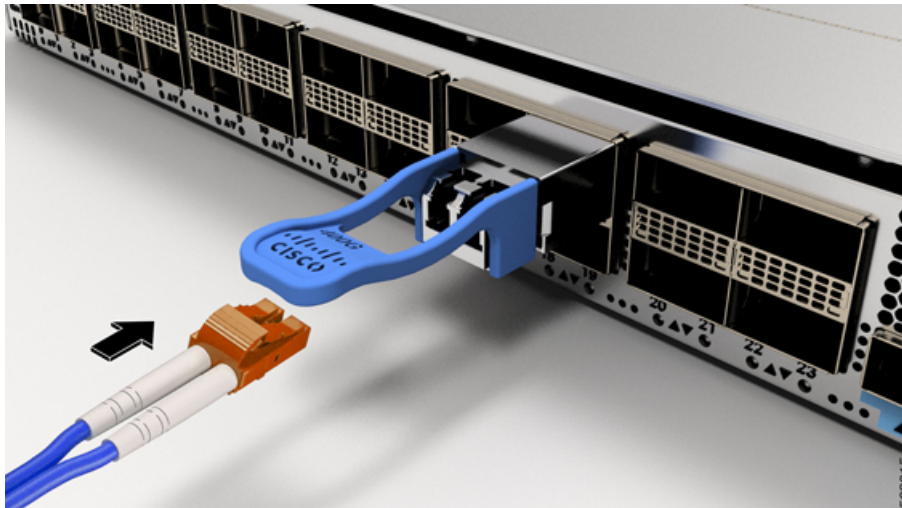
**Note** Inspect the MPO connector for the correct cable type, cleanliness, and any damage. For complete information on inspecting and cleaning fiber-optic connections, see the [Inspection and Cleaning Procedures for Fiber-Optic Connections](#) document.

### Procedure

---

- Step 1** Remove the dust plugs from the optical network interface cable MPO connectors and from the transceiver module optical bores. Save the dust plugs for future use.
- Step 2** Attach the network interface cable MPO connectors immediately to the transceiver module.

*Figure 106: Cabling a Transceiver Module*



## Removing the Transceiver Module



**Caution** The transceiver module is a static-sensitive device. Always use an ESD wrist strap or similar individual grounding device when handling transceiver modules or coming into contact with modules.

To remove a transceiver module, follow these steps:

### Procedure

---

- Step 1** Disconnect the network interface cable from the transceiver connector.
- Step 2** Install the dust plug immediately into the transceiver's optical bore.
- Step 3** Grasp the pull-tab and gently pull to release the transceiver from the socket.

Figure 107: Removing the QSFP Transceiver Module

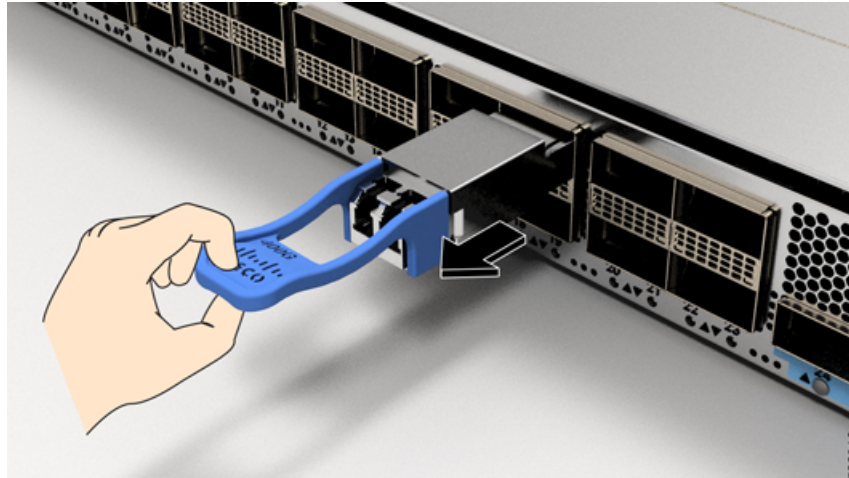
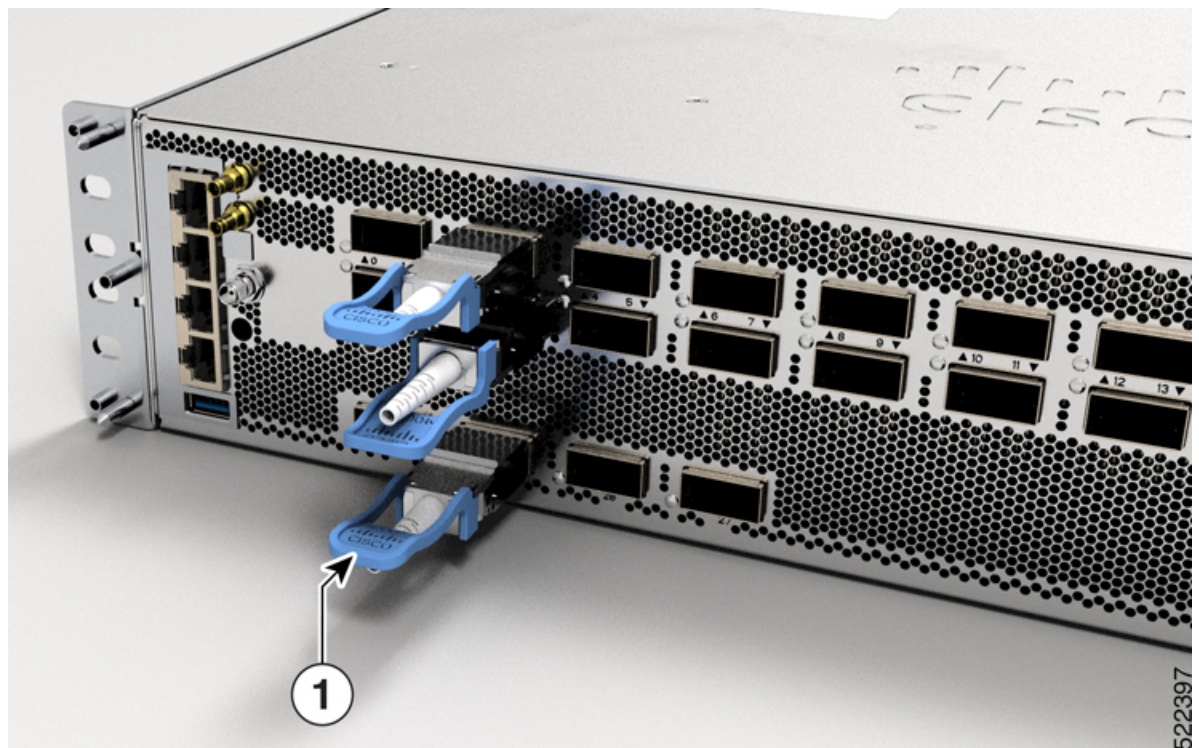


Figure 108: Removing the QSFP Transceiver Module from Cisco 8202-32FH-M Router



1	Grasp the pull-tab and gently pull to release the transceiver from the socket.
---	--

**Step 4** Slide the transceiver out of the socket.

**Step 5** Place the transceiver module into an antistatic bag.



## Connect Interface Ports

You can connect optical interface ports on line cards with other devices for network connectivity.

### Connect a Fiber-Optic Port to the Network

Depending on which line card model that you are using, you can use either QSFP+ or QSFP28 transceivers. Some transceivers work with fiber-optic cables that you attach to the transceivers and other transceivers work with pre-attached copper cables. You must install a transceiver in the port before installing the fiber-optic cable in the transceiver.



---

**Caution** Removing and installing a transceiver can shorten its useful life. Do not remove and insert transceivers any more than is absolutely necessary. We recommend that you disconnect cables before installing or removing transceivers to prevent damage to the cable or transceiver.

---

### Disconnect Optical Ports from the Network

When you need to remove fiber-optic transceivers, you must first remove the fiber-optic cables from the transceiver before you remove the transceiver from the port.

## Maintain Transceivers and Optical Cables

Refer to [Inspection and Cleaning Procedures for Fiber-Optic Connections](#) document for inspection and cleaning processes for fiber optic connections.

## Create the Initial Router Configuration

Assign an IP address to the router management interface to connect the router to the network.

When you initially power up the router, it boots up and displays a series of configuration-related questions. You can use the default choices for each configuration except for the IP address, which you must provide.



---

**Note** These routers are designed to boot up in less than 30 mins, provided the neighboring devices are in full-operational state.

---

When the system is powered on and the console port is connected to the terminal, the RP CPU messages are seen. You can toggle between BMC CPU messages and RP CPU messages by pressing the hot-key sequence Ctrl-O.

To configure IP address for Ethernet port on BMC and other additional information that is related to BMC, please see the *System Setup Guide for Cisco 8000 Series Routers*.

**Before you begin**

- A console device must be connected with the router.
- The router must be connected to a power source.
- Determine the IP address and netmask that is needed for the Management interfaces: `MgmtEth0/RP0/CPU0/0` and `MgmtEth0/RP1/CPU0/0`:

**Procedure**

**Step 1** Power up the router.

The LEDs on each power supply light up (green) when the power supply units are sending power to the router, and the software asks you to specify a password to use with the router.

**Step 2** When the system boots up for the first time, the system prompts you to create a new username and password. The following prompt appears:

```
!!!!!!!!!!!!!!!!!!!!!! NO root-system username is configured. Need to configure root-system
username. !!!!!!!!!!!!!!!!!!!!!!!

--- Administrative User Dialog ---

Enter root-system username:
% Entry must not be null.

Enter root-system username: cisco
Enter secret:
Use the 'configure' command to modify this configuration.
User Access Verification

Username: cisco
Password:

RP/0/RP0/CPU0:ios#
```

**Step 3** Enter a new password to use for this router.

The software checks the security strength of your password and rejects your password if the system does not consider it as a strong password. To increase the security strength of your password, make sure that it adheres to the following guidelines:

- At least eight characters
- Minimizes or avoids the use of consecutive characters (such as "abcd")
- Minimizes or avoids repeating characters (such as "AAA")
- Does not contain recognizable words in the dictionary
- Does not contain proper names
- Contains both uppercase and lowercase characters
- Contains numbers and letters

**Note** Cleartext passwords cannot include the dollar sign (\$) special character.

**Tip** If a password is trivial (such as a short, easy-to-decipher password), the software rejects that password. Passwords are case-sensitive.

When you enter a strong password, the software asks you to confirm the password.

**Step 4** Reenter the password.

When you enter the same password, the software accepts the password.

**Step 5** Enter the configuration mode.

**Step 6** Enter the IP address for the management interface. If using dual RPs, enter the IP address on both management interfaces.

**Step 7** Enter a network mask for the management interface.

**Step 8** The software asks whether you want to edit the configuration. Enter **'no'** to decline.

## Verify Chassis Installation

After installing the chassis, use the following **show** commands to verify the installation and configuration in the EXEC mode. Any issue if detected, take corrective action before making further configurations.

Command	Description
show platform	Displays the state information of each card.
show redundancy	Displays the status of route processor redundancy.
show led	Displays LED information for the router, or for a specific LED location.
show hw-module fpd	Displays field-programmable device (FPD) compatibility for all modules or a specific module.
show alarms brief system active	Displays all existing alarms in the router.
show media	Displays the current state of the disk storage media.
show inventory	Displays information about the field replaceable units (FRUs), including product IDs, serial numbers, and version IDs.
show environment	Displays all the environment-related router information.



Command	Description
show environment temperature	<p>Displays temperature readings for card temperature sensors. Each Route Processor, line card, and fabric cards have temperature sensors with two thresholds:</p> <ul style="list-style-type: none"> <li>• Minor temperature threshold – When a minor threshold is exceeded, minor alarm occurs and the following actions occur for all four sensors: <ul style="list-style-type: none"> <li>• Displays system messages</li> <li>• Sends SNMP notifications (if configured)</li> <li>• Log environmental alarm event that can be reviewed by running the show alarm command.</li> </ul> </li> <li>• Major temperature threshold – When a major threshold is exceeded, a major alarm occurs and the following actions occur: <ul style="list-style-type: none"> <li>• For sensors 1, 3, and 4 (outlet and on board sensors), the following actions occur: <ul style="list-style-type: none"> <li>• Displays system messages.</li> <li>• Sends SNMP notifications (if configured).</li> <li>• Logs environmental alarm event that can be reviewed by running the show alarm command.</li> </ul> </li> <li>• For sensor 2 (intake sensor), the following actions occur: <ul style="list-style-type: none"> <li>• If the threshold is exceeded in a switching card, only that card is shut down.</li> <li>• If the threshold exceeds an active Route Processor card with HA-standby or standby present, only that Route Processor card is shut down and the standby Route Processor card takes over.</li> <li>• If you do not have a standby Route Processor card in your router, you have up to 2 minutes to decrease the temperature. During this interval, the software monitors the temperature every 5 seconds and continuously sends system messages as configured.</li> </ul> </li> </ul> </li> </ul> <p><b>Note</b></p> <ul style="list-style-type: none"> <li>• Cisco recommends that you install dual Route Processor cards.</li> <li>• For some card temperature sensors, the temperature thresholds for both minor and major might display 'NA'. This is an expected behaviour and indicates that there are no alarms for those corresponding thresholds.</li> </ul>
show environment power	Displays the power usage information for the entire router.
show environment voltage	Displays the voltage for the entire router.
show environment current	Displays the current environment status.

Command	Description
show environment fan	Displays the status of the fan trays.

The following example shows sample output from the **show environment** command:

Location	TEMPERATURE	Value	Crit	Major	Minor	Minor
Major	Crit	(deg C)	(Lo)	(Lo)	(Lo)	(Hi)
(Hi)	Sensor					
-----						
0/RP0/CPU0						
	Inlet_Temp	30	-10	-5	0	46
50	52					
	X86_CORE_5_T	72	-10	-5	0	NA
100	105					
	DIMM_TEMP1	44	-10	-5	0	NA
95	100					
	DIMM_TEMP2	43	-10	-5	0	NA
95	100					
	SSD_Temp	48	-10	-5	0	NA
80	83					
	T1_2PLUS1_TEMP	45	-10	-5	0	125
130	135					
	T1_1PLUS1_TEMP	44	-10	-5	0	125
130	135					
	Outlet_Temp	44	NA	NA	NA	NA
NA	140					
	Hot_Spot_Temp	44	NA	NA	NA	NA
NA	140					
	X86_PKG_TEMP	72	-10	-5	0	NA
100	105					
	X86_CORE_0_T	73	-10	-5	0	NA
100	105					
	X86_CORE_1_T	72	-10	-5	0	NA
100	105					
	X86_CORE_2_T	73	-10	-5	0	NA
100	105					
	X86_CORE_3_T	73	-10	-5	0	NA
100	105					
	X86_CORE_4_T	73	-10	-5	0	NA
100	105					
-----						
Location	VOLTAGE	Value	Crit	Minor	Minor	
Crit	Sensor	(mV)	(Lo)	(Lo)	(Hi)	
(Hi)						
-----						
0/RP0/CPU0						
	IBV	10288	8928	9312	11536	
11984						
	VP1P8_OCXO	1806	1638	1710	1890	
1962						
	P1_8V	1816	1638	1710	1890	
1962						
	P1_0V_ALDRIN_SD	1006	910	950	1050	
1090						
	P1_0V_ALDRIN_CRE	985	930	970	1030	

1070	P1V	1006	910	950	1050
1090	P0_9V	911	819	855	945
981					

Location	CURRENT Sensor	Value (mA)
0/RP0/CPU0	MB_VP54P0V_curr	1448

Location	FRU Type	Fan speed (rpm)					
		FAN_0	FAN_1	FAN_2	FAN_3	FAN_4	FAN_5
0/FT0	8812-FAN	8130	8100	8160	8160	8160	8100
0/FT1	8812-FAN	8190	8160	8250	8190	8160	8160
0/FT2	8812-FAN	8130	8160	8190	8190	8220	8190
0/FT3	8812-FAN	8460	8400	8460	8400	8400	8370
0/PT0-PM0	PSU6.3KW-HV	7010	7290				
0/PT0-PM1	PSU6.3KW-HV	7204	7677				
0/PT0-PM2	PSU6.3KW-HV	8559	8709				

CHASSIS LEVEL POWER INFO: 0

Total output power capacity (N + 1)	:	17400W +	0W
Total output power required	:	15280W	
Total power input	:	8571W	
Total power output	:	8185W	

Power Module	Supply Type	-----Input-----		-----Output---		Status
		Volts A/B	Amps A/B	Volts	Amps	
0/PT0-PM0	PSU6.3KW-HV	205.0/205.3	7.4/7.6	54.0	54.4	OK
0/PT0-PM1	PSU6.3KW-HV	205.0/205.0	7.5/7.9	54.3	56.0	OK
0/PT0-PM2	PSU6.3KW-HV	0.0 /205.0	0.0/11.4	53.7	41.1	OK

Total of Power Modules: 10307W/46.0A 9691W/176.0A

Location	Card Type	Power Allocated Watts	Power Used Watts	Status
0/RP0/CPU0	8800-RP	249	80	ON
0/RP1/CPU0	8800-RP	249	73	ON
0/0/CPU0	-	25	-	RESERVED
0/1/CPU0	8800-LC-48H	1365	499	ON
0/2/CPU0	8800-LC-48H	1365	499	ON
0/3/CPU0	8800-LC-48H	1365	509	ON
0/4/CPU0	8800-LC-48H	1365	503	ON
0/5/CPU0	8800-LC-48H	1365	511	ON
0/6/CPU0	8800-LC-48H	1365	664	ON
0/7/CPU0	8800-LC-48H	1365	501	ON
0/8/CPU0	8800-LC-48H	1365	499	ON

0/9/CPU0	8800-LC-48H	1365	501	ON
0/10/CPU0	8800-LC-48H	1365	495	ON
0/11/CPU0	8800-LC-48H	1365	506	ON
0/FC0	-	1040	-	RESERVED
0/FC1	8812-FC	1040	524	ON
0/FC2	8812-FC	1040	528	ON
0/FC3	8812-FC	1040	523	ON
0/FC4	8812-FC	1040	529	ON
0/FC5	8812-FC	1040	531	ON
0/FC6	-	1040	-	RESERVED
0/FC7	-	1040	-	RESERVED
0/FT0	8812-FAN	762	370	ON
0/FT1	8812-FAN	762	364	ON
0/FT2	8812-FAN	762	362	ON
0/FT3	8812-FAN	762	371	ON

The following example displays the temperature readings for each of the powered-up cards using the **show environment temperatures** command:

Location	TEMPERATURE	Value	Crit	Major	Minor	Minor
Major	Crit					
(Hi)	Sensor	(deg C)	(Lo)	(Lo)	(Lo)	(Hi)
(Hi)	(Hi)					
-----						
0/RP0/CPU0						
	Inlet_Temp	28	-10	-5	0	60
65	70					
	Pwr_Brick_Temp2	33	-10	-5	0	120
125	130					
	Mosfet_54v_Temp1	27	-10	-5	0	120
125	130					
	Mosfet_54v_Temp2	27	-10	-5	0	120
125	130					
	SSD_Temp	26	-10	-5	0	65
72	80					
	Outlet_Temp	29	-10	-5	0	80
85	90					
	Hot_Spot_1_Temp	31	-10	-5	0	80
85	90					
	Hot_Spot_2_Temp	31	-10	-5	0	80
85	90					
	TMP421_Temp	30	-10	-5	0	95
100	105					
	PEX8725_Temp	39	-10	-5	0	95
100	105					
	X86_PKG_TEMP	39	-10	-5	0	93
97	102					
	Pwr_Brick_Temp1	34	-10	-5	0	120
125	130					
	ALDRIN_TEMP_0	36	-5	0	5	95
100	110					
	Control_Sensor	28	-10	-5	0	60
65	70					
0/FT0						
	Hotswap_Temp	29	-10	-5	0	65
75	85					
	Low_vol_Temp	31	-10	-5	0	65
75	85					
0/FT1						
	Hotswap_Temp	30	-10	-5	0	65

75	85					
	Low_vol_Temp	32	-10	-5	0	65
75	85					
0/FT2						
	Hotswap_Temp	31	-10	-5	0	65
75	85					
	Low_vol_Temp	32	-10	-5	0	65
75	85					
0/FT3						
	Hotswap_Temp	31	-10	-5	0	65
75	85					
	Low_vol_Temp	32	-10	-5	0	65
75	85					
0/PT0-PM0						
	! PFC_B_Temp	10245	-10	-5	0	125
127	130					
	Inlet_Temp	28	-10	-5	0	65
67	70					
	HSNK_Temp	100	-10	-5	0	125
127	130					
	Outlet_Temp	87	-10	-5	0	105
108	110					
	! LLC_B_Temp	10245	-10	-5	0	125
127	130					
	! SR_B_Temp	10245	-10	-5	0	125
127	130					
	! ORING_B_Temp	10245	-10	-5	0	125
127	130					
	! PFC_A_Temp	10245	-10	-5	0	125
127	130					
	! LLC_A_Temp	10245	-10	-5	0	125
127	130					
	! SR_A_Temp	10245	-10	-5	0	125
127	130					
	! ORING_A_Temp	10245	-10	-5	0	125
127	130					
0/PT0-PM1						
	! PFC_B_Temp	10245	-10	-5	0	125
127	130					
	Inlet_Temp	28	-10	-5	0	65
67	70					
	HSNK_Temp	99	-10	-5	0	125
127	130					
	Outlet_Temp	87	-10	-5	0	105
108	110					
	! LLC_B_Temp	10245	-10	-5	0	125
127	130					
	! SR_B_Temp	10245	-10	-5	0	125
127	130					
	! ORING_B_Temp	10245	-10	-5	0	125
127	130					
	! PFC_A_Temp	10245	-10	-5	0	125
127	130					
	! LLC_A_Temp	10245	-10	-5	0	125
127	130					
	! SR_A_Temp	10245	-10	-5	0	125
127	130					
	! ORING_A_Temp	10245	-10	-5	0	125
127	130					
0/PT0-PM2						
	PFC_B_Temp	72	-10	-5	0	125
127	130					
	Inlet_Temp	25	-10	-5	0	65
67	70					

127	HSNK_Temp	72	-10	-5	0	125
127	130					
108	Outlet_Temp	61	-10	-5	0	105
127	110					
127	LLC_B_Temp	69	-10	-5	0	125
127	130					
127	SR_B_Temp	58	-10	-5	0	125
127	130					
127	ORING_B_Temp	64	-10	-5	0	125
127	130					
127	! PFC_A_Temp	0	-10	-5	0	125
127	130					
127	! LLC_A_Temp	0	-10	-5	0	125
127	130					
127	! SR_A_Temp	0	-10	-5	0	125
127	130					
127	! ORING_A_Temp	0	-10	-5	0	125
127	130					



**Caution** Please be careful while increasing the Altitude setting, as it leads to a rise in control sensor values and consequently the Chassis could shut down immediately if the control sensor crosses the critical threshold.

The following example shows sample output from the **show environment power** command:

```

=====
CHASSIS LEVEL POWER INFO: 0
=====
Total output power capacity (N + 1)      : 107100W + 6300W
Total output power required              : 25015W
Total power input                        : 6019W
Total power output                       : 4636W
=====

Power      Supply      -----Input-----  -----Output---  Status
Module     Type                Volts A/B  Amps A/B  Volts  Amps
=====
0/PT0-PM0  PSU6.3KW-HV         402.3/401.5 0.5/0.4   55.6    4.9    OK
0/PT0-PM1  PSU6.3KW-HV         400.6/400.9 0.5/0.5   55.6    6.0    OK
0/PT0-PM2  PSU6.3KW-HV         400.6/400.6 0.5/0.4   55.5    5.0    OK
0/PT1-PM0  PSU6.3KW-HV         400.0/400.0 0.5/0.3   55.4    4.4    OK
0/PT1-PM1  PSU6.3KW-HV         401.8/401.8 0.4/0.3   55.6    3.7    OK
0/PT1-PM2  PSU6.3KW-HV         400.0/400.0 0.4/0.3   55.4    3.6    OK
0/PT2-PM0  PSU6.3KW-HV         401.5/401.5 0.5/0.4   55.6    4.8    OK
0/PT2-PM1  PSU6.3KW-HV         400.0/400.0 0.4/0.4   55.4    4.4    OK
0/PT2-PM2  PSU6.3KW-HV         401.2/401.5 0.5/0.4   55.6    5.0    OK
0/PT3-PM0  PSU6.3KW-HV         300.6/300.9 0.6/0.5   55.5    4.4    OK
0/PT3-PM1  PSU6.3KW-HV         299.7/299.7 0.6/0.4   55.5    4.4    OK
0/PT3-PM2  PSU6.3KW-HV         300.6/300.9 0.5/0.6   55.3    4.4    OK
0/PT4-PM0  PSU6.3KW-HV         299.7/299.7 0.5/0.6   55.2    4.4    OK
0/PT4-PM1  PSU6.3KW-HV         300.6/300.9 0.6/0.5   55.4    4.7    OK
0/PT4-PM2  PSU6.3KW-HV         299.7/299.7 0.5/0.6   55.2    4.4    OK
0/PT5-PM0  PSU6.3KW-HV         300.6/300.9 0.7/0.6   55.6    6.0    OK
0/PT5-PM1  PSU6.3KW-HV         299.7/299.7 0.5/0.5   55.4    4.0    OK
0/PT5-PM2  PSU6.3KW-HV         300.6/300.9 0.5/0.6   55.4    5.1    OK

Total of Power Modules:                6019W/17.5A                4636W/83.6A
=====

Location      Card Type                Power      Power      Status
=====

```

		Allocated Watts	Used Watts	
0/RP0/CPU0	8800-RP	95	70	ON
0/RP1/CPU0	8800-RP	95	69	ON
0/0/CPU0	-	60	-	RESERVED
0/1/CPU0	-	60	-	RESERVED
0/2/CPU0	-	60	-	RESERVED
0/3/CPU0	-	60	-	RESERVED
0/4/CPU0	-	60	-	RESERVED
0/5/CPU0	8800-LC-48H	1065	489	ON
0/6/CPU0	-	60	-	RESERVED
0/7/CPU0	-	60	-	RESERVED
0/8/CPU0	-	60	-	RESERVED
0/9/CPU0	-	60	-	RESERVED
0/10/CPU0	-	60	-	RESERVED
0/11/CPU0	-	60	-	RESERVED
0/12/CPU0	-	60	-	RESERVED
0/13/CPU0	-	60	-	RESERVED
0/14/CPU0	-	60	-	RESERVED
0/15/CPU0	-	60	-	RESERVED
0/16/CPU0	-	60	-	RESERVED
0/17/CPU0	8800-LC-36FH	1896	679	ON
0/FC0	-	1713	-	RESERVED
0/FC1	-	1713	-	RESERVED
0/FC2	-	1713	-	RESERVED
0/FC3	-	1713	-	RESERVED
0/FC4	8818-FC	1713	429	ON
0/FC5	8818-FC	1713	435	ON
0/FC6	-	1713	-	RESERVED
0/FC7	-	1713	-	RESERVED
0/FT0	8818-FAN	1800	574	ON
0/FT1	8818-FAN	1800	587	ON
0/FT2	8818-FAN	1800	569	ON
0/FT3	8818-FAN	1800	578	ON

## Set Fabric Bandwidth Threshold

Fabric bandwidth refers to the bandwidth requirements for communication and traffic flow between the line card and fabric card. The following table provides explanation of terminologies that are associated with fabric bandwidth.

**Table 22: Fabric Bandwidth**

Fabric Bandwidth	Definition	Significance
Total fabric bandwidth	Maximum bandwidth that is supported between a line card NPU and all fabric cards.	It is a constant value that is defined by the hardware capacity.
Available bandwidth	Total fabric bandwidth available for traffic.	It is a variable denoting real-time bandwidth consumption.

Fabric Bandwidth	Definition	Significance
Bandwidth threshold	A percentage value denoting a limit for bandwidth consumption.  Being a system level setting, the threshold applies to all the line card NPUs in the chassis.	It is a user configurable limit; default value is 5%.
Total required bandwidth	Total Fabric Bandwidth x Bandwidth Threshold.	If is a calculated value as a function of user-defined threshold.  Network interfaces on line card are active only when “Available bandwidth” is more than “Total required bandwidth”.
Lower required bandwidth	Total fabric bandwidth x (Bandwidth Threshold - 10%)  This computation is applicable only for bandwidth threshold values 20% or higher.  For bandwidth threshold values of below 20%, the “Lower required bandwidth” is equal to “Total required bandwidth”.	If is also a calculated value as a function of user-defined threshold and denotes a lower cut-off for disabling network interfaces on line card.  Disabling happens when “Available bandwidth” falls below the “Lower required bandwidth”.

The Bandwidth Threshold acts a check point to ensure substantial bandwidth availability to carry traffic to the fabric cards. To configure the bandwidth threshold, use the following commands:

```
Router# configure
Router (config)# hw-module profile bw-threshold <value>
Router (config)# commit
```

User can set the threshold value starting with 10 and in increments of 10.

For example, consider that the bandwidth threshold is set to 20%. If the available bandwidth goes below 10%, then the network interfaces of the line card are shut. If the available bandwidth goes above 20%, then the network interfaces of the line card are unshut. The following table provides threshold references.

**Table 23: Threshold Reference**

Threshold	Percentage								
Bandwidth threshold	5	10	20	30	40	50	60	70	80
Total required bandwidth	5	10	20	30	40	50	60	70	80
Lower required bandwidth	5	10	10	20	30	40	50	60	70





## CHAPTER 6

# Replace Chassis Components

---



**Note** The images in this chapter are only for representation purposes, unless specified otherwise. The chassis' actual appearance and size may vary.

---



**Caution** Whenever you replace any card, you must always ensure to secure the ejector thumbscrews properly.

---

- [Replace Chassis Door Foam Air Filters, on page 127](#)
- [Provision of Grace Period Before Route Processor Shutdown from Ejector Lever, on page 129](#)
- [Replace a Route Processor Card, on page 130](#)
- [Replace a Line Card, on page 142](#)
- [Replace a Fan Tray, on page 156](#)
- [Replace Fabric Card, on page 159](#)
- [Replace Power Supply Components, on page 168](#)

## Replace Chassis Door Foam Air Filters



**Note** In general, we recommend that you inspect the air filter every 3 months and replace.

---

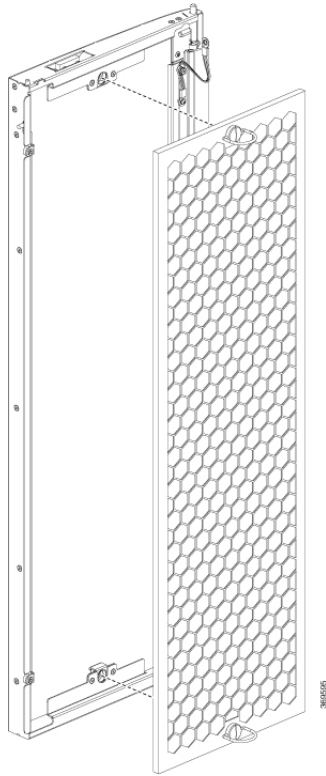
The front doors come with pre-installed air filters (8818-FILTER, 8812-FILTER, 8808-FILTER, or 8804-FILTER). If air filters need a replacement, follow this procedure.

### Procedure

---

**Step 1** Remove the two quarter turn fasteners from the front door as shown.

**Figure 109: Replace Air Filter**



**Step 2** Install the new door filters on both the front doors.

**Step 3** Tighten the two quarter turn fasteners back on the doors.

---

# Provision of Grace Period Before Route Processor Shutdown from Ejector Lever

Table 24: Feature History Table

Feature Name	Release Information	Feature Description
Provision of Grace Period Before Route Processor Shutdown from Ejector Lever	Release 7.3.1	<p>Unlatching the ejector lever of any card that is in operational state, triggers a graceful shutdown of that card.</p> <p>With this release, the active RP card is enabled with a grace period of 15 seconds before it shuts down. In the event the ejector lever is unlatched, or for any other reason, you have 15 seconds to relatch the ejector lever and return the active RP back to its operational state.</p> <p>The <b>hw-module ejector close wait</b> command is introduced for this feature.</p>

Earlier, unlatching the ejector lever from the latch lock immediately would trigger a graceful shutdown of the Route Processor if the card is in the operational state. However, after enabling this feature, the active RP card has a grace period of 15 seconds before shutdown.

If the ejector lever is latched back within this grace period, then the card returns to the operational state. This feature, therefore, provides the option of closing the ejector lever without triggering a shutdown. This feature is especially useful when an ejector lever is accidentally unlatched.

This feature is supported only on a route processor card.

If the ejector is unlatched when card is in a status other than operational state then the grace period feature will not be supported.



**Caution** When you enable this feature, *do not* remove the RP during the 15-second grace period. Remove the RP *only* in either of the following two ways:

- Allow the RP to shut down after the 15-second grace period, then remove the RP.
- Close the ejector lever within the 15-second grace period, then remove the RP gracefully (shutdown the RP first) or ungracefully.

## LED Status

The RP status LED blinks twice with one second gap until the grace period is over.

### Enabling Grace Period Before Shutting down a RP Card

This task explains how to enable grace period before shutting down a RP card:

```
Router(config)# hw-module ejector close wait
Router(config)# commit
Router(config)# end
```

The configuration is applied only on the active RP.

Use the **no** form of the command to remove the grace period configuration.

```
Router(config)# no hw-module ejector close wait
```

## Replace a Route Processor Card

The Cisco 8818, Cisco 8812, Cisco 8808, and Cisco 8804 Routers support OIR of RSP cards.

The router supports up to two redundant Route Processor cards (8800-RP). When two Route Processor cards are installed in the router, one acts as an active card and the other as the standby card. When the active Route Processor card is removed, the router automatically makes the standby Route Processor card active. If the router has only one Route Processor card that is installed, a new Route Processor can be installed in the empty Route Processor slot during operation.



### Warning Statement 1029—Blank Faceplates and Cover Panels

Blank faceplates and cover panels serve three important functions: they reduce the risk of electric shock and fire, they contain electromagnetic interference (EMI) that might disrupt other equipment, and they direct the flow of cooling air through the chassis. Do not operate the system unless all cards, faceplates, front covers, and rear covers are in place.



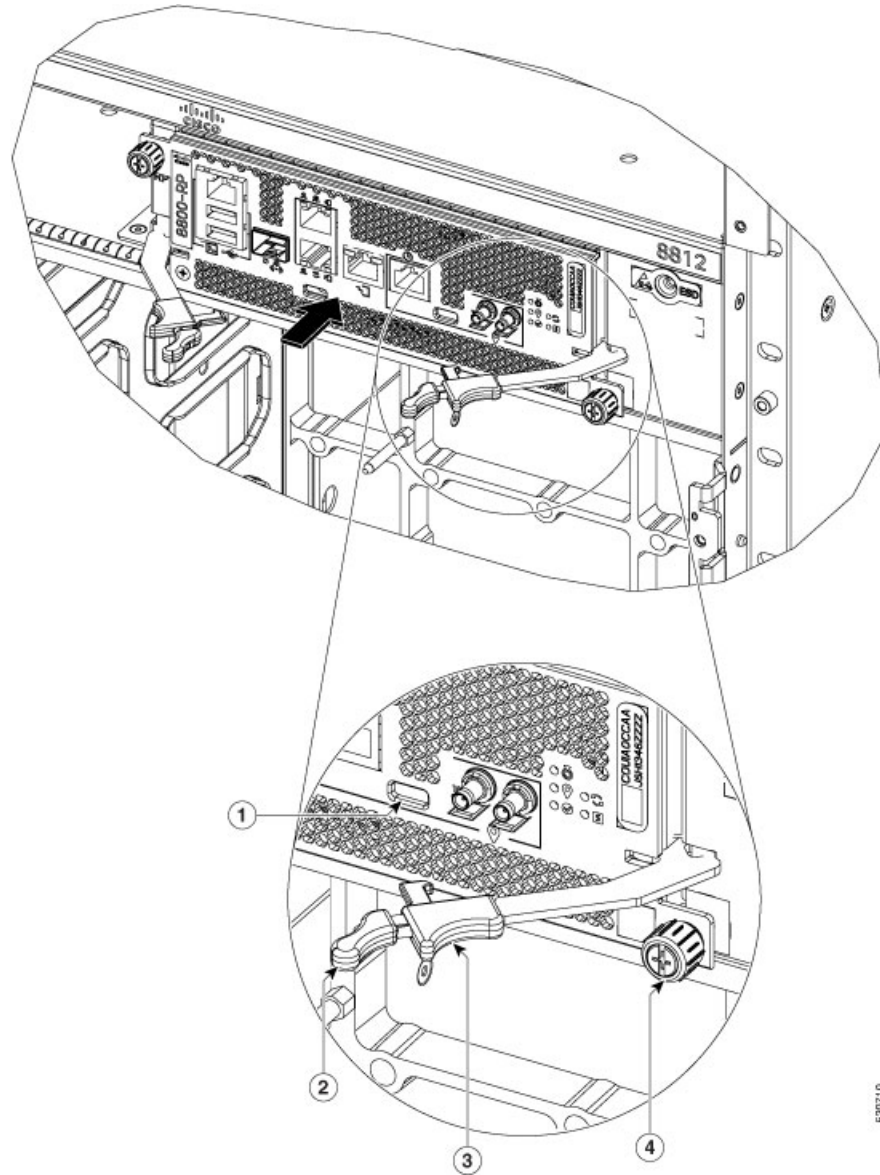
**Note** Opening the ejector levers of an installed RP card causes the RP card to shut down even when the captive screws are screwed in. To reboot the RP card, users must do one of the following:

- Remove and reinsert the RP card and close the ejector levers.
- Close the ejector levers and reload the card using the **reload location** `<rack>/<{RP0 | RP1}> force` command.

## Replace the 8800-RP Card

The following figure describes the components used in the Route Processor installation procedure.

Figure 110: Route Processor Card Components



1	Latch Lock	3	Latching Mechanism
2	Ejector Lever Handle	4	Captive Screw



**Caution** Unlatching the right ejector lever, so that it disengages from the latch lock (Callout 1 in the previous figure) triggers graceful shutdown of the Route Processor if the card is up. If the card shuts down, then wait for the Route Processor status LED to turn off before proceeding.

Moving the latch to the side doesn't disengage the latch from the lock. This is a safeguard mechanism if an operator-initiated shutdown of the route processor hasn't been performed before opening the levers. The ejector open will be logged.

1. Open the packaging for the new Route Processor card. Inspect the card for damage, and verify that the card is the same type as the other Route Processor card installed in the chassis. If the card is damaged, alert the Technical Assistance Center (TAC).



---

**Note** If the card is damaged, alert the Technical Assistance Center (TAC).

---

2. If you're installing the card in an empty slot, remove the blank card that is already in that slot by unscrewing its captive screw and pulling it out of the slot.
3. If you're replacing a card that is currently in the chassis, remove the existing card from the chassis by following these steps:
  - a. Run the **shutdown location 0/ {RP0 | RP1}** command in EXEC mode, which gracefully shuts down the Route Processor module to prevent any of the file systems from being corrupted.
  - b. Verify that the Route Processor Status LED for the slot that you specified turns to Amber. Also, you can use the **show platform** command to verify that the status of the card is SHUT DOWN.
  - c. Disconnect the cables from the card.
  - d. If there are any external drives attached to the card through its USB ports, detach those drives.
  - e. Loosen the two captive screws (one on each side of the RP) until the screws are no longer in contact with the chassis.
  - f. Slide the latch on each of the ejector levers outwards from the lever center (see Callout 1 in the following figure).

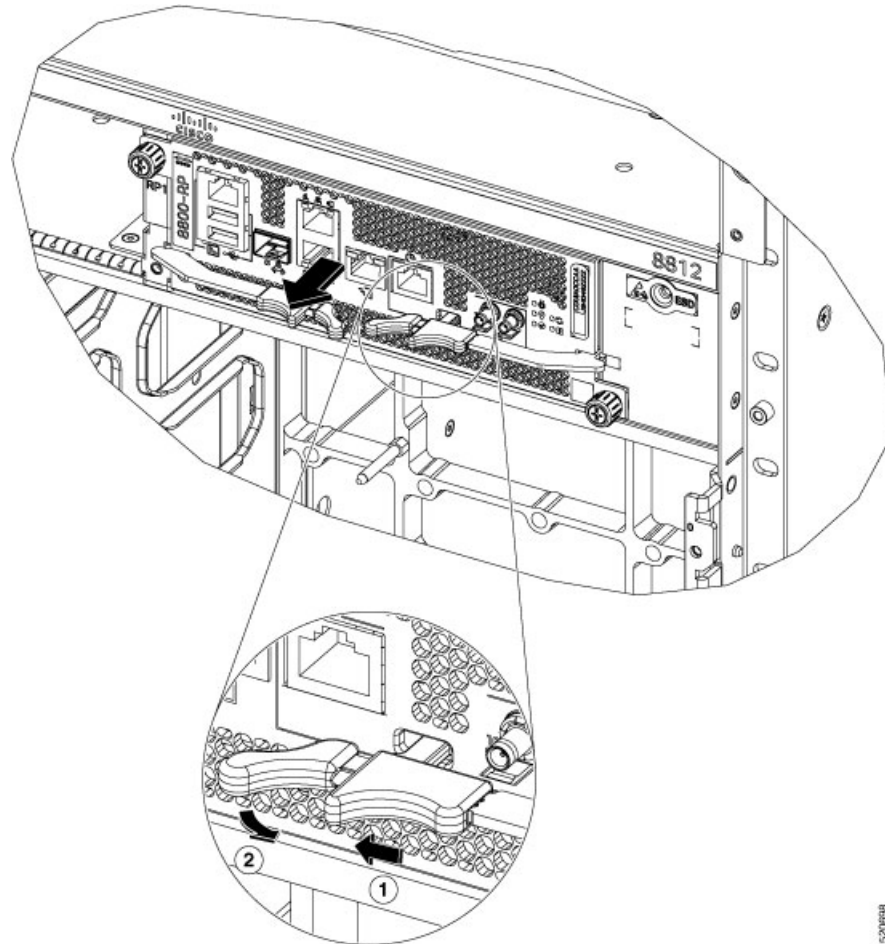


---

**Attention** This action disengages the ejector levers from the faceplate.

---

Figure 111: Remove Route Processor Card from Chassis



- g. Pull to rotate the levers away from the front of the card (see Callout 2 in the previous figure). The card unseats its connectors from the midplane and moves slightly out of the chassis.
- h. Use one hand to hold the front of the card. Place your other hand under the card to support its weight. Pull the card out of the chassis, and set it on an antistatic surface or inside an antistatic bag.



**Note** While performing OIR of the card, wait for 30 seconds before inserting the same or new card in the same slot. This allows the card to boot properly and reach an operational state.

## Install a New 8800-RP Card

To install a new card, follow these steps:

1. If any of the ejector levers are in closed position, slide the latch on the ejector lever outwards from the lever center. Then, pull to rotate the lever away from the front of the card.

This action opens the lever so that the card can be fully inserted into the slot.

2. Hold the front of the card with one hand and place your other hand under the card to support its weight.



---

**Note** Ensure that you hold the route processor card parallel to the chassis while inserting it. Inserting the route processor card at an angle may damage the card's PCB.

---

3. Align the back of the card to the guides in the open Route Processor slot and slide the card all the way into the slot.

The card stops when its front is about 0.25 inches (0.6 cm) outside the front of the chassis.

4. Rotate the levers firmly all the way to the front of the chassis. Then firmly push the tip of the lever towards the faceplate until the latch hook locks in place behind the faceplate. You may hear a click or see the latch engage. (See Callout 1 in the following figure.)

Ensure that the other end of both levers engages behind the latching slot on the faceplate so that the card fully seats onto the connectors on the midplane.



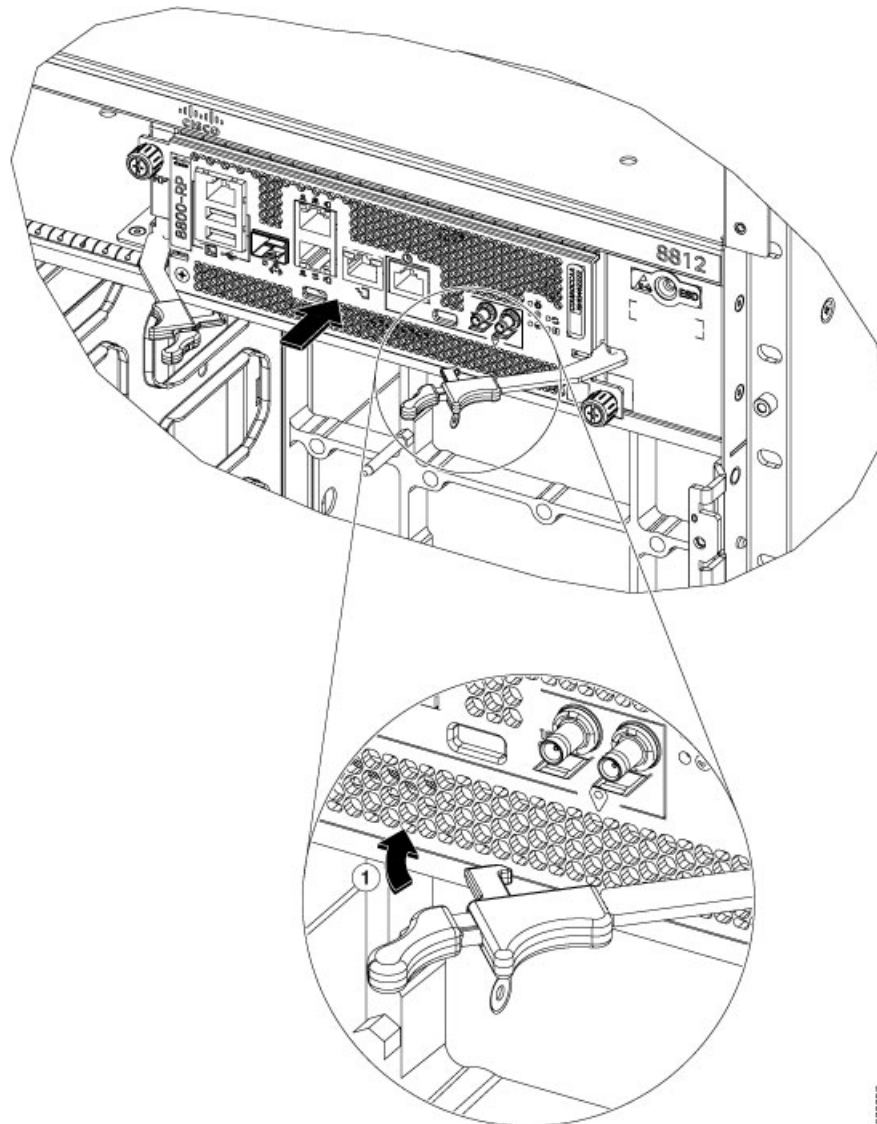
---

**Note** To confirm that the card is installed properly, pull the black tip of each ejector lever lightly, and ensure that the lever doesn't pop out.

---



Figure 112: Install Route Processor Card into Chassis



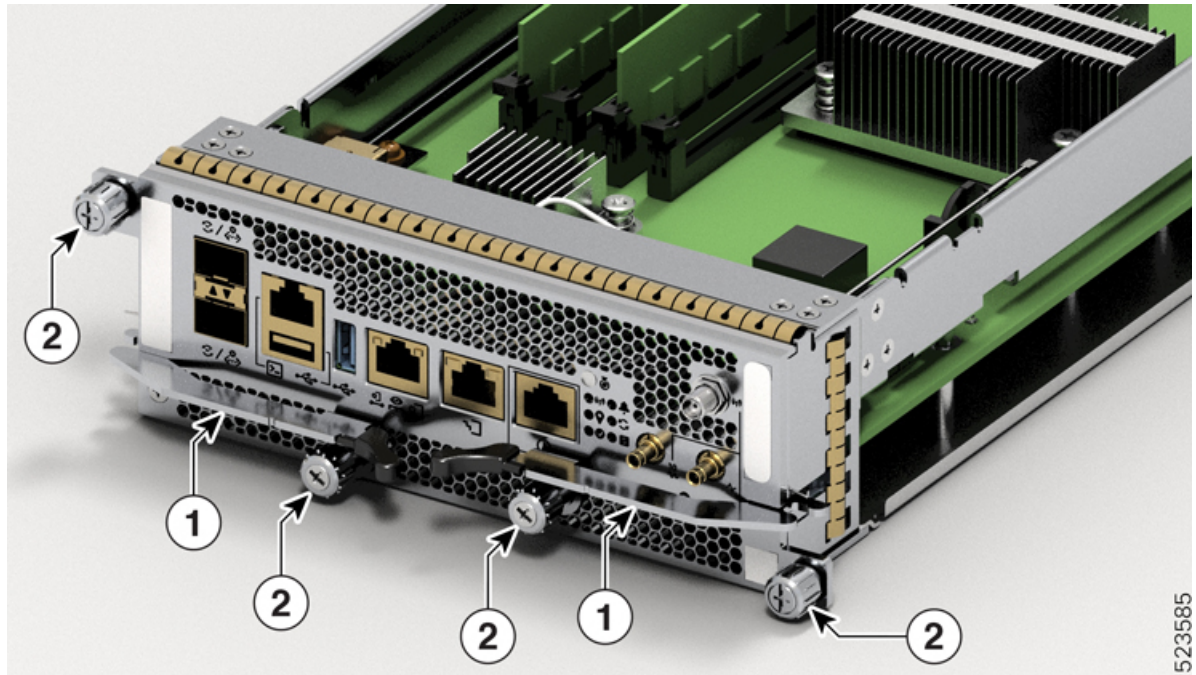
5200837

5. Screw in the two captive screws to secure the card to the chassis. Tighten the screws to 8 in-lb (0.9 N·m) of torque.
6. Attach the cables to the card.
7. Verify that the Route Processor card status LEDs turn on and appear green.

## Replace the 8800-RP2 Card

The following figure describes the components used in the Route Processor (8800-RP2) installation procedure.

Figure 113: Route Processor Card (8800-RP2) Components



1	Ejector Lever Handles
2	Captive Screws



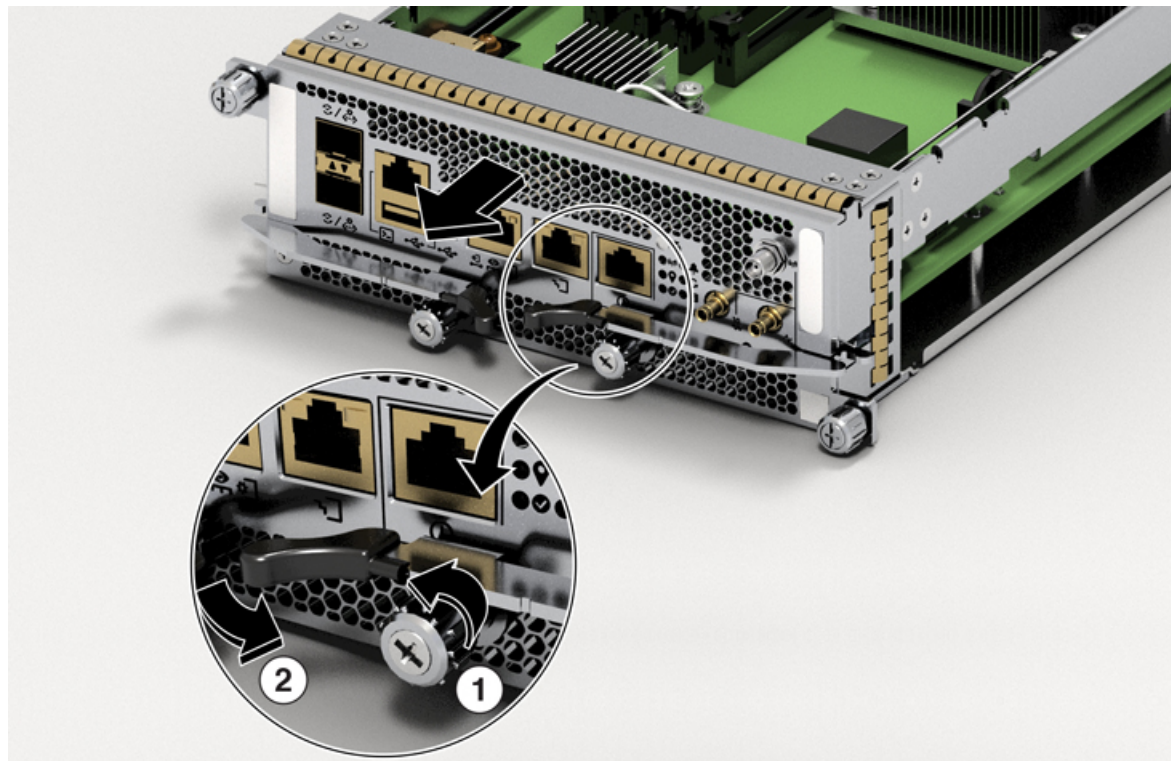
**Caution** Unlatching the right ejector lever handle, so that it disengages from the latch lock (Callout 1 in above figure) triggers graceful shutdown of the Route Processor if the card is up. If the card shuts down, then wait for the Route Processor status LED to turn off before proceeding.

Unscrewing the captive screw doesn't disengage the latch from the lock. This is a safeguard mechanism if an operator-initiated shutdown of the route processor hasn't been performed before opening the levers. The ejector open will be logged.

1. Open the packaging for the new Route Processor card, inspect the card for damage, and verify that the card is the same type as the other Route Processor card installed in the chassis.  
If the card is damaged, alert the Technical Assistance Center (TAC). For more information, see [More Hardware Components, on page 25](#).
2. If you're installing the card in an empty slot, remove the blank card that is already in that slot by unscrewing its captive screws and pulling it out of the slot.
3. If you're replacing a card that is currently in the chassis, remove the existing card from the chassis by following these steps:
  - a. Run the **shutdown location 0/ {RP0 | RP1}** command in EXEC mode, which gracefully shuts down the Route Processor module to prevent any of the file systems from being corrupted.

- b. Verify that the Route Processor Status LED for the slot that you specified turns to Amber. Also, you can use the **show platform** command to verify that the status of the card is SHUT DOWN.
- c. Disconnect the cables from the card.
- d. If there are any external drives attached to the card through its USB ports, detach those drives.
- e. Loosen the two captive screws (one on each side of the RP) until the screws are no longer in contact with the chassis.
- f. Unscrew the captive screws on each of the ejector levers (see Callout 1 in the following figure). This action disengages the ejector levers from the faceplate.

**Figure 114: Remove Route Processor Card (8800-RP2) from Chassis**



1	Rotate the captive screws
2	Pull to rotate the levers away from the card

- g. Pull to rotate the levers away from the front of the card (see Callout 2 in the previous figure). The card unseats its connectors from the midplane and moves slightly out of the chassis.
- h. Use one hand to hold the front of the card, place your other hand under the card to support its weight, pull the card out of the chassis, and set it on an antistatic surface or inside an antistatic bag.



**Note** While performing OIR of the card, wait for 30 seconds before inserting the same or new card in the same slot. This allows the card to boot properly and reach an operational state.

## Install an 8800-RP2 Card

To install a new card, follow these steps:

1. If any of the ejector levers are in closed position, slide the latch on the ejector lever outwards from the lever center and pull to rotate the lever away from the front of the card.

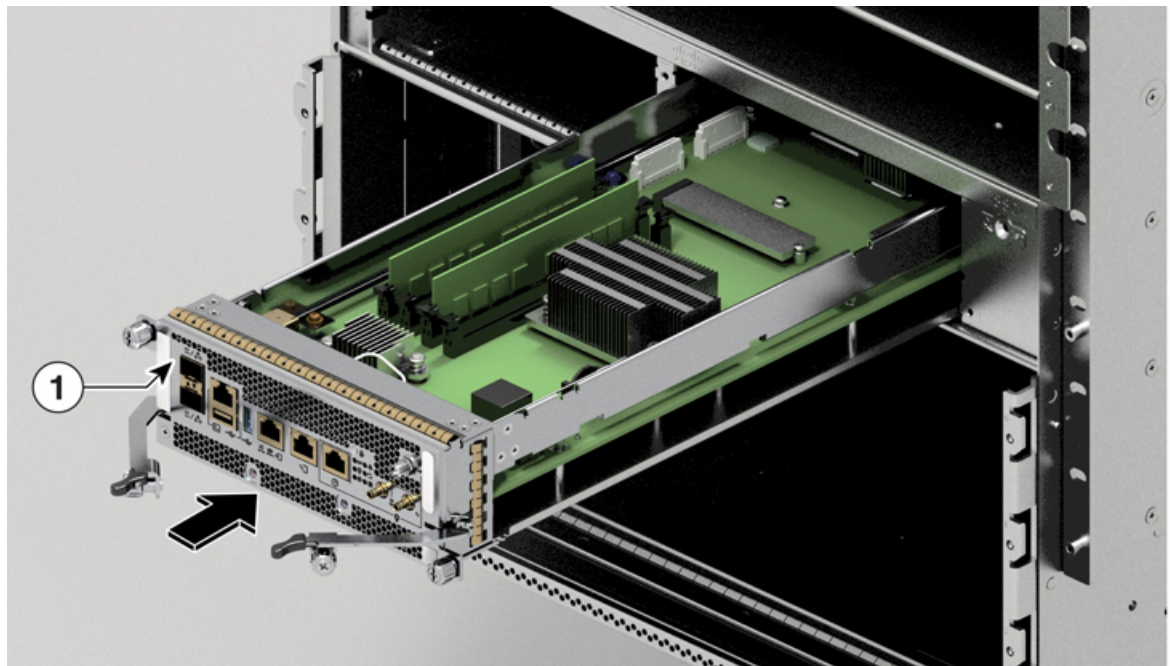
If the ejector levers are in closed position, unscrew the captive screw that's holding the ejector levers closed.

2. Hold the front of the card with one hand and place your other hand under the card to support its weight.



**Note** Ensure that you hold the route processor card parallel to the chassis while inserting it. Inserting the route processor card at an angle may damage the card's PCB.

*Figure 115: Hold RP Card Parallel to Chassis*



1	Route processor card (8800-RP2)
---	---------------------------------

3. Align the back of the card to the guide pin in the open Route Processor slot and slide the card all the way into the slot.



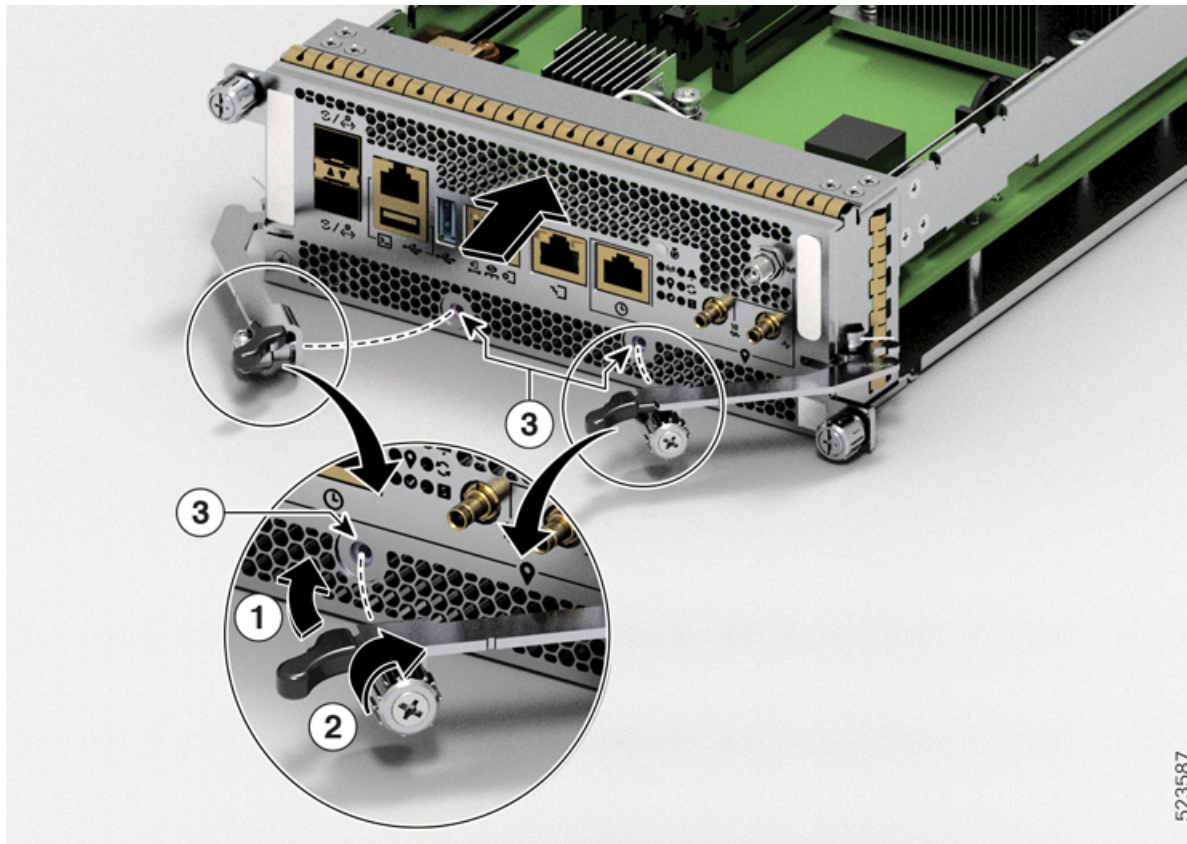
4. Rotate the levers firmly all the way to the front of the chassis. Then firmly push the tip of the lever towards the faceplate until the latch hook locks in place behind the faceplate. (See Callout 1 in the following figure.)

Ensure that the other end of both levers engages behind the latching slot on the faceplate. So that the card fully seats onto the connectors on the midplane of the chassis.



**Note** To confirm that the card is installed properly, pull the black tip of each ejector lever lightly, and ensure that the lever doesn't pop out.

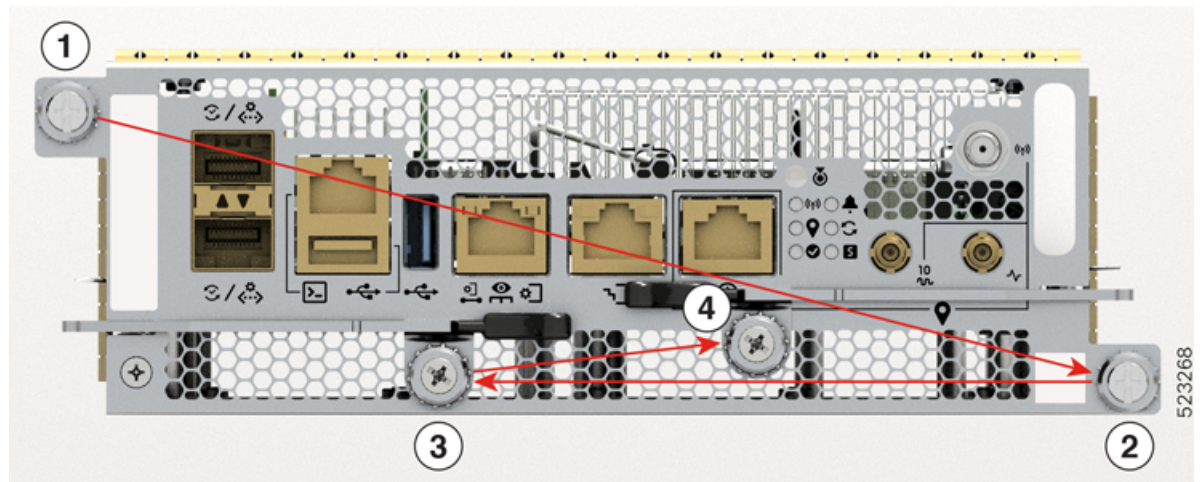
Figure 116: Install Route Processor Card (8800-RP2) into Chassis



1	Push the ejector lever towards the latch lock
2	After the ejector lever locks in place, rotate the captive screws
3	Latch lock

5. Screw in the two captive screws to secure the card to the chassis. Tighten the screws as shown in the following figure and apply the torque as mentioned in the [Torque recommendation](#) section:

Figure 117: Tighten the Screws in Order



Torque recommendation:

- Hand-tighten all the four captive screws.
- Torque all the four screws to 4 in-lbs (0.45 N·m) in the sequence as shown in the [figure](#).
- Torque another 4 in-lbs (0.45 N·m) to the captive screws such that the total torque applied becomes 8 in-lbs (0.9 N·m). Follow the same sequence as shown in the [figure](#).



**Important** The total torque must not be more than 8 in-lbs.

6. Attach the cables to the card.
7. Verify that the Route Processor card status LEDs turn on and appear green.

## Migrating from RP1 to RP2 Card

Before you begin:

- You must have console access to the router.
- The router must be running Cisco IOS XR software release 7.11.1 or later version.
- The router must have two RP1 cards (active and standby) up and running.

### Procedure

- Step 1** Use the **show platform** command to verify that all the router nodes are up and running.
- Step 2** Use the **show redundancy summary** command to verify that the active RP and standby RP are in the NSR-ready State.

**Example:**

```

Router# show redundancy summary
Wed Jun 17 11:18:51.391 PST
Active/Primary Standby/Backup
-----
0/RP0/CPU0(A) 0/RP1/CPU0(S) (Node Ready, NSR: Ready)
0/RP0/CPU0(P) 0/RP1/CPU0(B) (Proc Group Ready, NSR: Ready)

Router# show redundancy

Wed Jun 17 11:20:19.086 PST
Redundancy information for node 0/RP1/CPU0:
=====
Node 0/RP1/CPU0 is in ACTIVE role
Node Redundancy Partner (0/RP0/CPU0) is in STANDBY role
Standby node in 0/RP0/CPU0 is ready
Standby node in 0/RP0/CPU0 is NSR-ready
Node 0/RP1/CPU0 is in process group PRIMARY role
Process Redundancy Partner (0/RP0/CPU0) is in BACKUP role
Backup node in 0/RP0/CPU0 is ready
Backup node in 0/RP0/CPU0 is NSR-ready

Group           Primary      Backup      Status
-----
v6-routing      0/RP1/CPU0  0/RP0/CPU0  Ready
mcast-routing   0/RP1/CPU0  0/RP0/CPU0  Ready
netmgmt         0/RP1/CPU0  0/RP0/CPU0  Ready
v4-routing      0/RP1/CPU0  0/RP0/CPU0  Ready
central-services 0/RP1/CPU0  0/RP0/CPU0  Ready
dlrsc           0/RP1/CPU0  0/RP0/CPU0  Ready
dsc             0/RP1/CPU0  0/RP0/CPU0  Ready

Active node reload "Cause: Initiating switch-over."
Standby node reload "Cause: Initiating switch-over."

```

- Step 3** Remove the standby RP (8800-RP) card from slot1. Follow the procedure explained in the topic [Replace a Route Processor Card, on page 130](#).
- Step 4** Insert RP2 (8800-RP2) card in slot1. Follow the procedure explained in the topic [Install an 8800-RP2 Card](#).
- Step 5** Wait until the standby RP card reach NSR-ready state and status of ALL the groups is Ready state. Use **show redundancy** command to verify the same.
- Step 6** Reload the active RP by using the **reload location0/RP0/CPU0** command. Executing the command makes the 8800-RP2 card in slot1 the active card.
- Step 7** Verify that the active RP is 8800-RP2 and that it is in the NSR-ready state. Verify that RP2 has the running configuration from RP1.

**Example:**

```

Router# show redundancy summary
Router# show running config

```

- Step 8** Remove the standby RP(8800-RP) from slot0. Follow the procedure explained in [Step 3](#).
- Step 9** Insert the RP2 (8800-RP2) in slot1. Follow the procedure explained in [Step 4](#).
- Step 10** Verify that the active RP card reach NSR-ready state and status of ALL the groups is Ready state. Use **show redundancy** command to verify the same.

**Note** If you want to migrate to RP1 from RP2, follow the same steps as mentioned in this procedure, *Migrating from RP1 to RP2 Card*.

---

## Replace a Line Card

The Cisco 8800 series routers can operate with one or more line cards. If there is at least one line card that is installed and operating in the chassis, you can replace another line card or install a new line card in an empty line card slot.

The Cisco 8800 series routers support OIR of line cards.



---

**Note** You must install at least one route processor card when you power on the router.

---

Cisco 8800 series line cards use either buttons or latches to lock the ejector levers.

- [Replace or Install a Line Card - Ejector Levers with Buttons, on page 142](#)
- [Replace or Install a Line Card - Ejector Levers with Latches, on page 150](#)

Watch [Replace a Line Card \(Video\)](#).

## Replace or Install a Line Card - Ejector Levers with Buttons



---

**Warning** **Statement 1029**—Blank Faceplates and Cover Panels

Blank faceplates and cover panels serve three important functions: they reduce the risk of electric shock and fire, they contain electromagnetic interference (EMI) that might disrupt other equipment, and they direct the flow of cooling air through the chassis. Do not operate the system unless all cards, faceplates, front covers, and rear covers are in place.

---



---

**Warning** **Statement 1051**—Laser Radiation

Invisible laser radiation may be emitted from disconnected fibers or connectors. Do not stare into beams or view directly with optical instruments.

---



**Caution**

- Line cards have two ejector levers to release the card from the router. Use these levers to remove the line card and to seat the line card firmly in the router when you are installing the line card. The ejector levers align and seat the card connectors in the router. To avoid damaging card mechanical components, never carry a line card by the captive installation screws or ejector levers. Doing so can damage these components and cause card insertion problems.
- Ensure that all the line card screws are fully tightened. Failure to properly tighten the line card screws may result in fabric links not coming up.
- Rotate the ejector levers towards the faceplate past parallel until it stops. This ensure that the line card fully sits when you install the line card.

**Note**

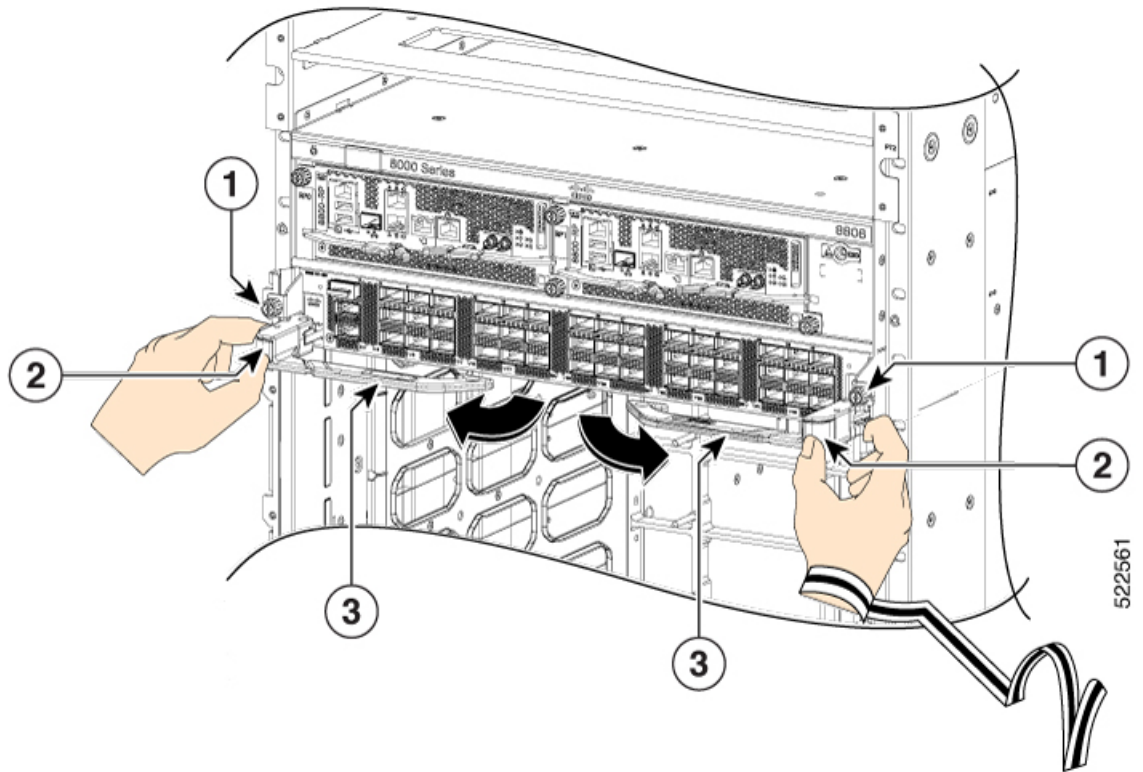
Opening the ejector levers of an installed line card causes the line card to shut down even when the captive screws are screwed in. To reboot the line card, you must do one of the following:

- Remove and reinsert the line card and close the ejector levers.
- Close the ejector levers and reload the card using the **reload location** `<rack>/<line-card-slot>` **force** command.

**Procedure**

- Step 1** Open the packaging for the new line card and inspect the line card for damage.  
If the line card is damaged, contact the Technical Assistance Center (TAC).
- Step 2** If you are replacing a line card that is currently in the chassis, remove the existing line card from the chassis by following these steps:
- a) Run the **shutdown location 0/ location/CPU0** command, which gracefully shuts down the line card.
  - b) Verify that the Line Card LED for the slot that you specified turns off. Also, you can use the **show platform** command to verify that the status of the card is SHUT DOWN.
  - c) Disconnect and label each of the interface cables from the line card.
  - d) Loosen the two captive screws.
  - e) Press the ejector buttons and the two ejector levers open in the direction as shown in the image below.

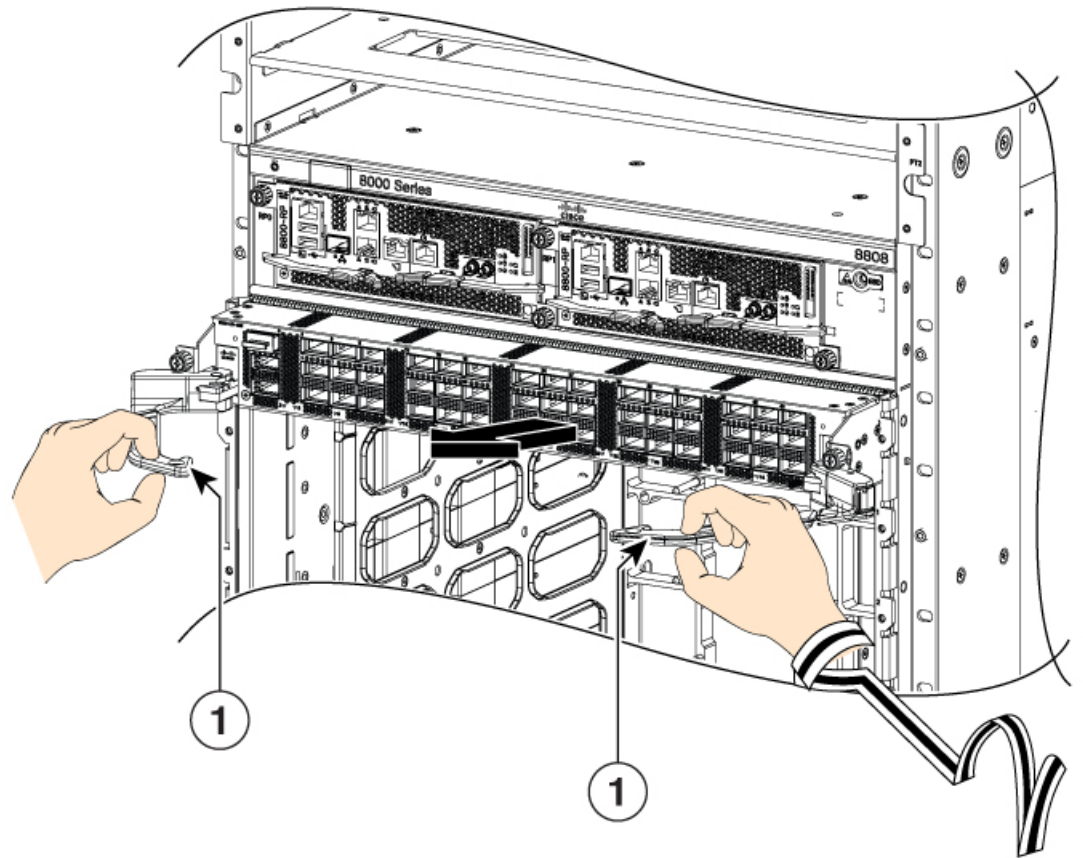
Figure 118: Press the Ejector Buttons



1	Captive screws	3	Ejector levers
2	Ejector buttons		

f) Use the ejector levers to pull the line card a couple of inches (about 5 cm) from the chassis.

Figure 119: Pull the Line Card from the Chassis

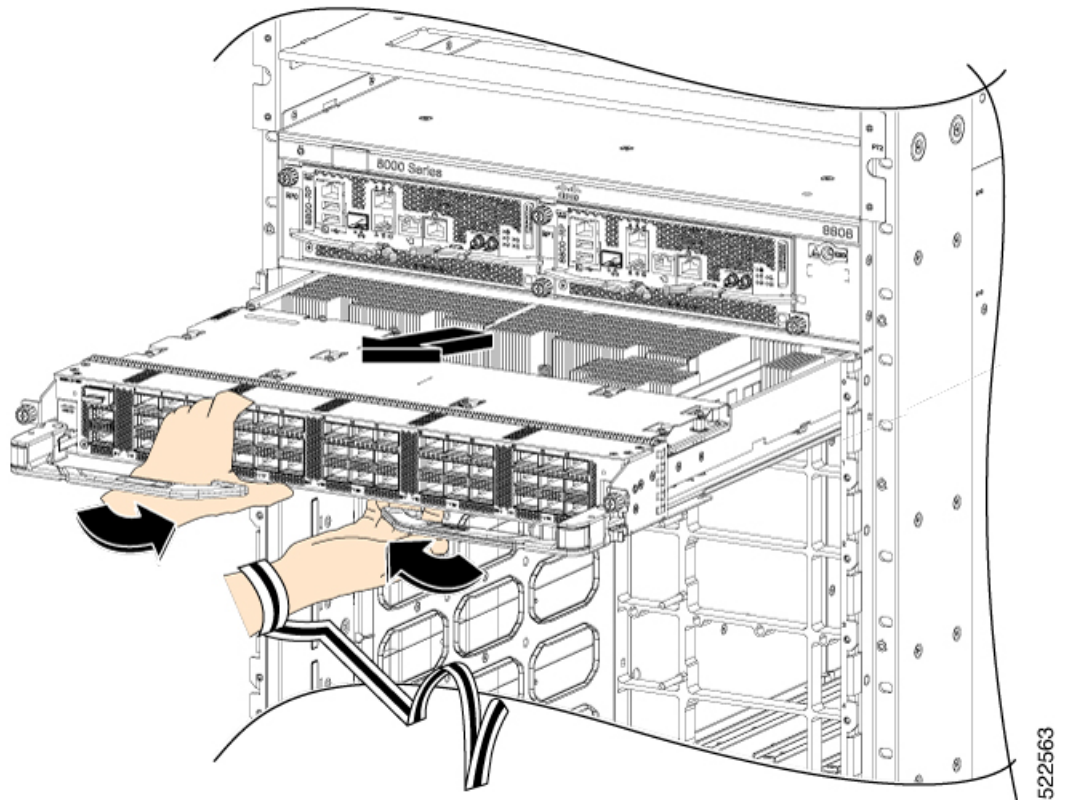


522562

1	Ejector levers
---	----------------

- g) Close the ejector levers in the direction as shown in the image below. Use one hand to hold the front of the line card, place your other hand under the line card to support its weight, pull it out of the chassis, and set it on an antistatic surface or inside an antistatic bag.

Figure 120: Remove the line card from the chassis

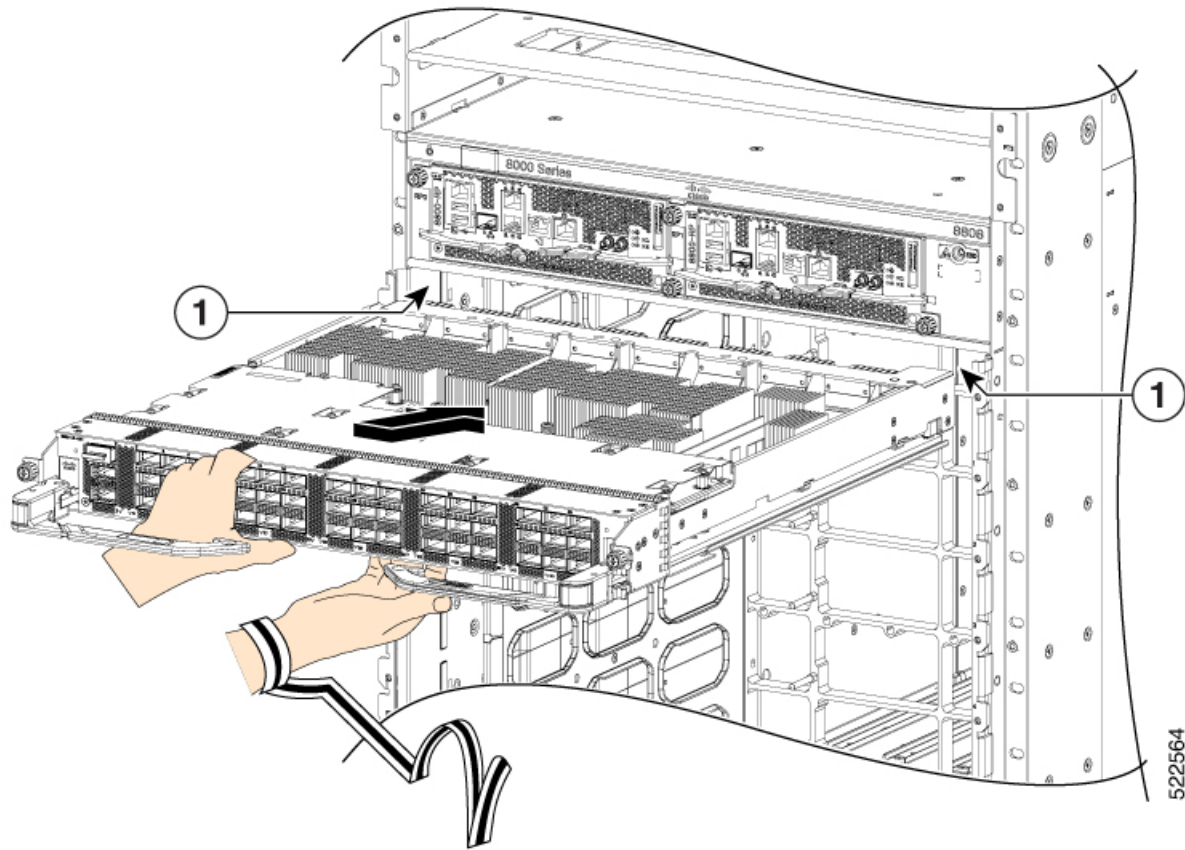


### Step 3

To install the line card, follow these steps:

- Hold the front of the line card with one hand and place your other hand under the line card to support its weight.
- Align the back of the line card to the guides in the open line card slot and slide the line card all the way into the slot (see the following figure).

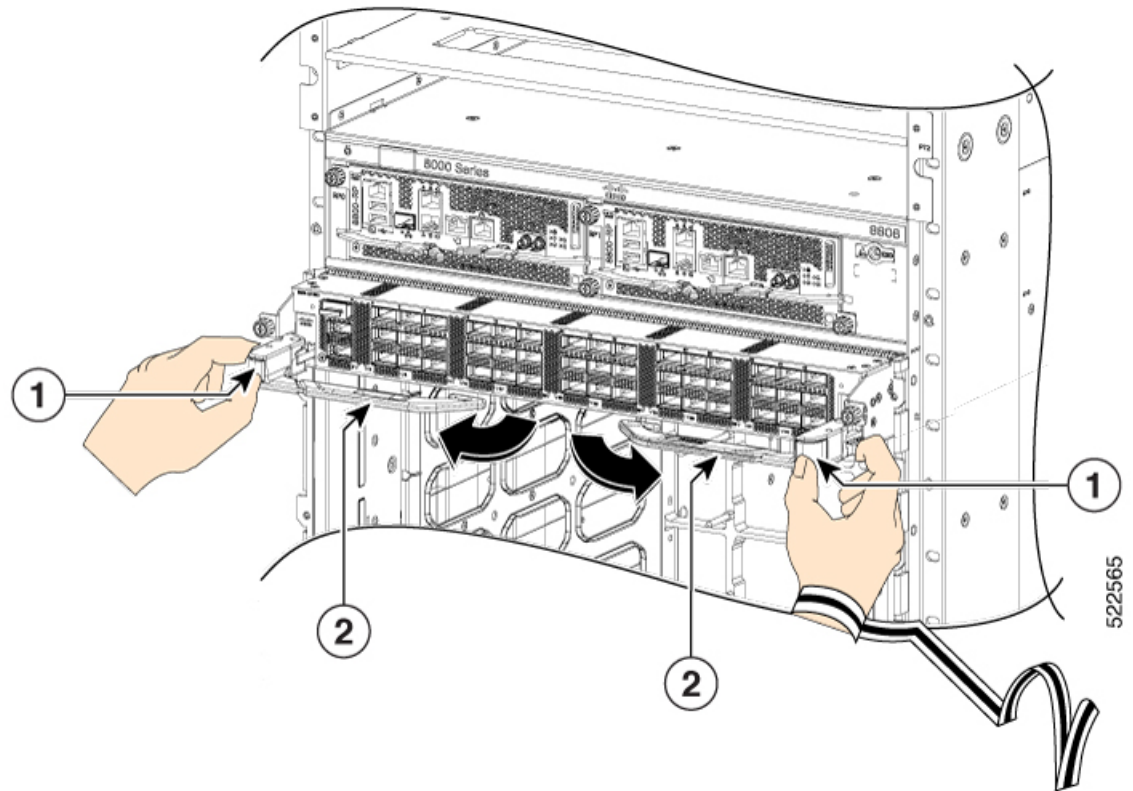
Figure 121: Insert a Line Card into the Chassis



1	Guides (line card slot)
---	-------------------------

The line card stops when its front is about 0.25 inches (0.6 cm) outside the front of the chassis. Press the ejector buttons, and the two levers move partway from the center of the line card in the direction as shown in the image.

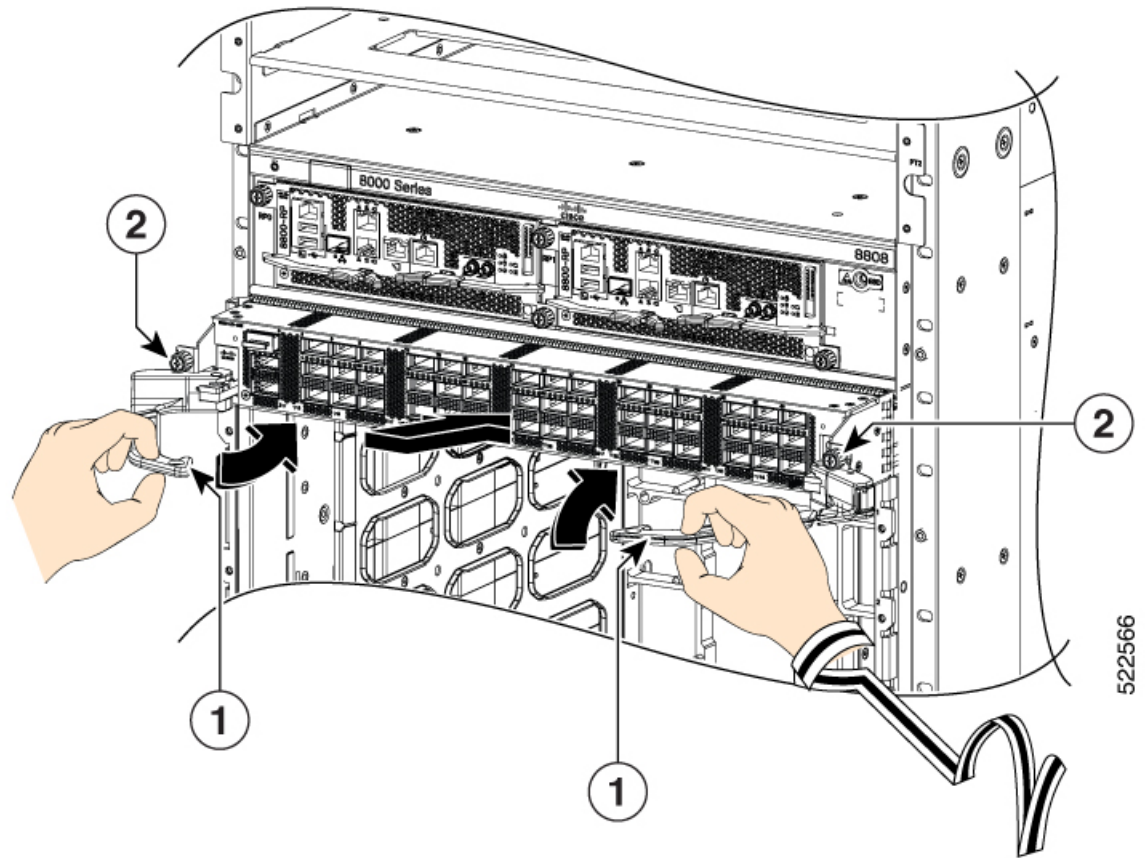
Figure 122: Press the Ejector Buttons



1	Ejector buttons	2	Ejector levers
---	-----------------	---	----------------

c) Close the ejectors by rotating the ends of the two levers toward the center of the chassis.

Figure 123: Close the Ejector Levers



1	Ejector levers	2	Captive screws
---	----------------	---	----------------

**Note** As you rotate the levers, the front of the line card moves all the way to the front of the chassis and the line card fully seats on the chassis.

d) Tighten the two captive screws to 8 in-lb (0.9 Nm) torque.

**Note** When installing a line card, fully tighten both captive installation screws to ensure that the card is correctly seated in the router. A card that is only partially seated in the router might not operate properly, even if it boots.

e) Attach each interface cable to the appropriate port on the line card. Use the label on each cable to determine which port each cable attaches to.

f) Verify that the line card LEDs turn on and appear green.



## Replace or Install a Line Card - Ejector Levers with Latches



### Warning Statement 1029—Blank Faceplates and Cover Panels

Blank faceplates and cover panels serve three important functions: they reduce the risk of electric shock and fire, they contain electromagnetic interference (EMI) that might disrupt other equipment, and they direct the flow of cooling air through the chassis. Do not operate the system unless all cards, faceplates, front covers, and rear covers are in place.



### Warning Statement 1051—Laser Radiation

Invisible laser radiation may be emitted from disconnected fibers or connectors. Do not stare into beams or view directly with optical instruments.



**Caution** Line cards have two ejector levers to release the card from the router. Use these levers to remove the line card and to seat the line card firmly in the router when you are installing the line card. The ejector levers align and seat the card connectors in the router. To avoid damaging card mechanical components, never carry a line card by the captive installation screws or ejector levers. Doing so can damage these components and cause card insertion problems.



**Note** Opening the ejector levers of an installed line card causes the line card to shut down even when the captive screws are screwed in. To reboot the line card, users must do one of the following:

- Remove and reinsert the line card and close the ejector levers.
- Close the ejector levers and reload the card using the **reload location rack line-card-slot i force** command.

### Procedure

**Step 1** Open the packaging for the new line card and inspect the line card for damage.

If the line card is damaged, contact the Technical Assistance Center (TAC).

**Step 2** If you are replacing a line card that is currently in the chassis, remove the existing line card from the chassis by following these steps:

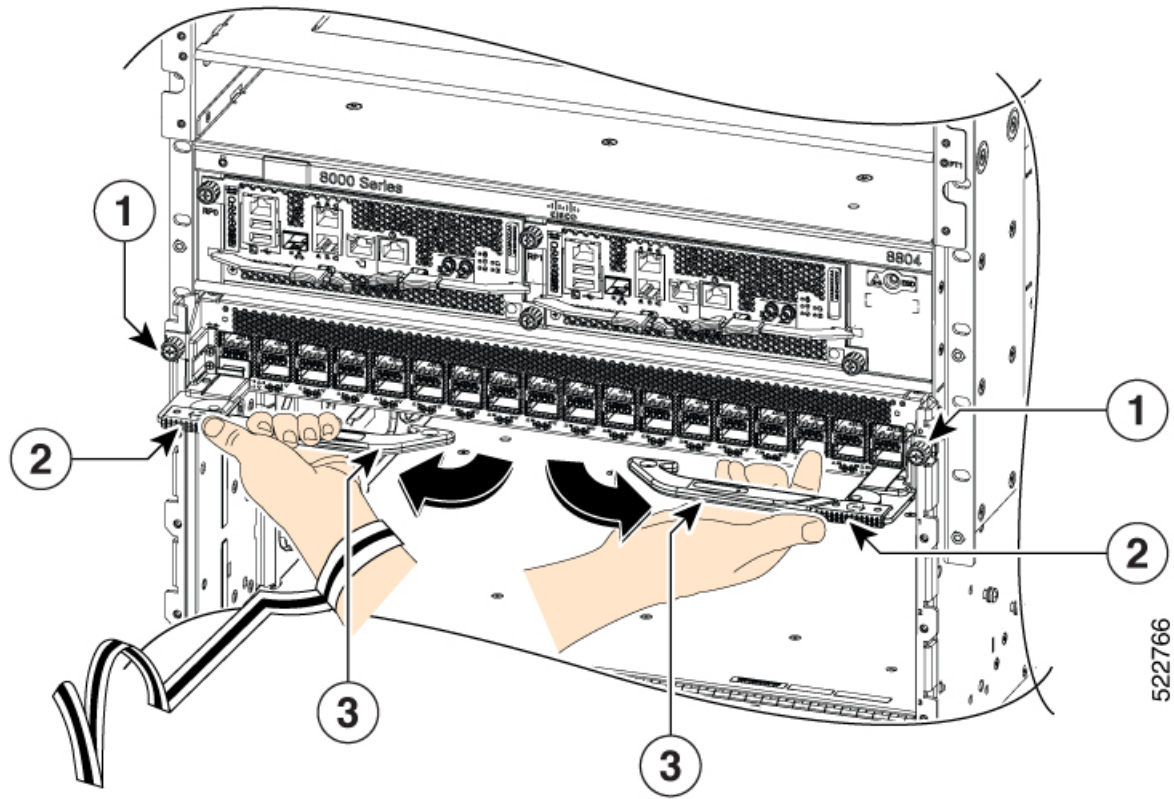
- a) Run the **shutdown location 0/ location/CPU0** command, which gracefully shuts down the line card.
- b) Verify that the Line Card LED for the slot that you specified turns off. Also, you can use the **show platform** command to verify that the status of the card is SHUT DOWN.
- c) Disconnect and label each of the interface cables from the line card.
- d) Loosen the two captive screws.

**Note** You must loosen the two captive screws completely before using the ejector levers to remove the line card. Failure to loosen the captive screws can cause damage to the ejector levers.



- e) Slide the ejector lever latches outward and pull the two ejector levers in the direction as shown in the image below.

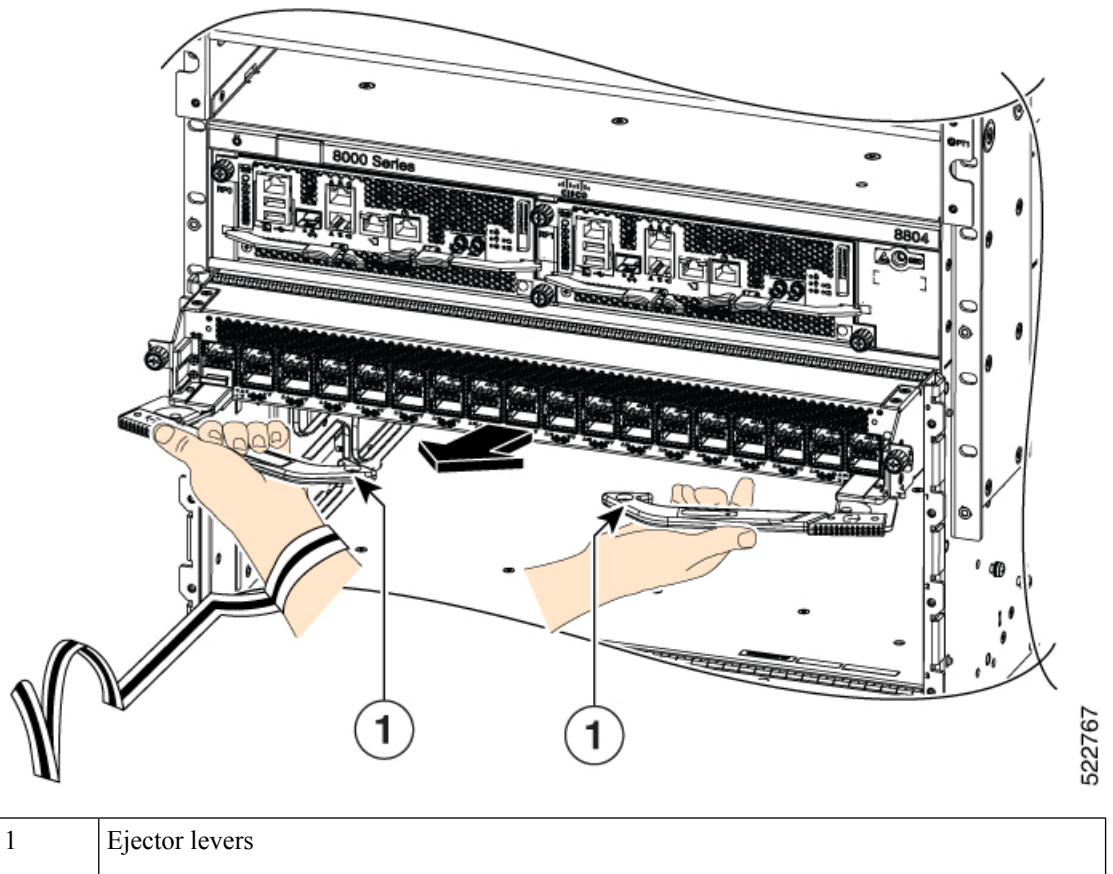
Figure 124: Slide the Ejector Lever Latches



1	Captive screws	3	Ejector levers
2	Ejector lever latches		

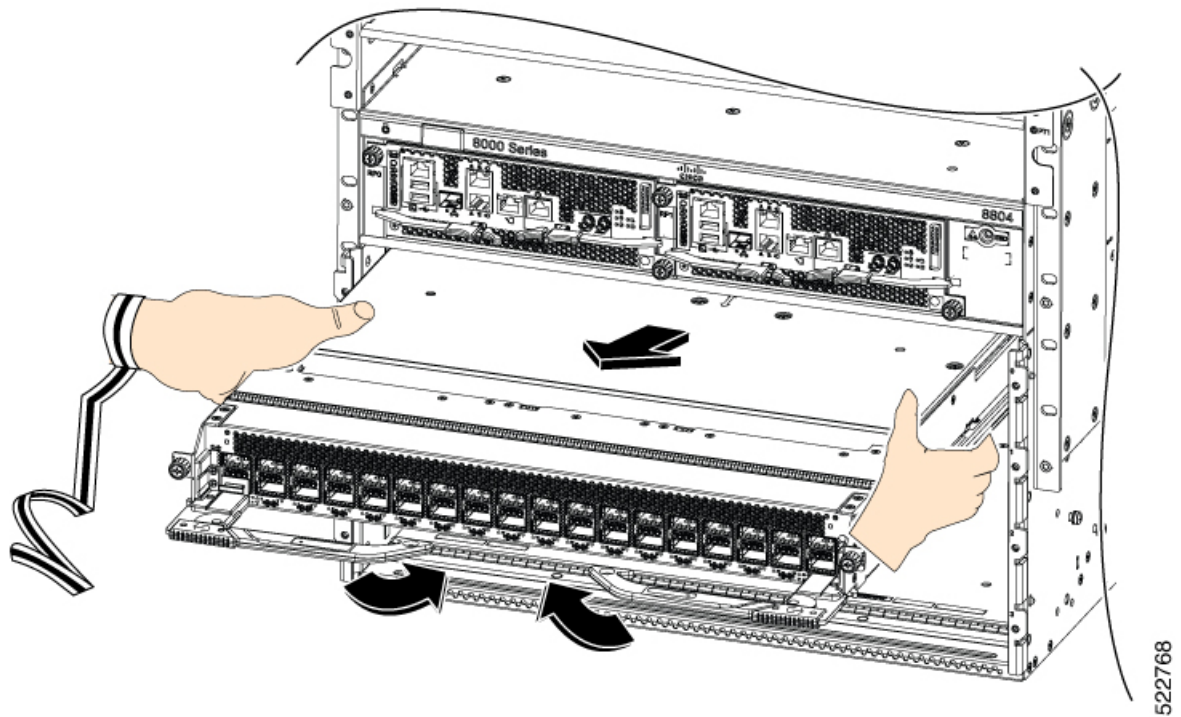
- f) Use the ejector levers to pull the line card a couple of inches (about 5 cm) from the chassis.

Figure 125: Pull the Line Card from the Chassis



- g) Close the ejector levers. The ejector lever latches will lock the ejector levers closed.
- h) Place your hands on the sides of the line card, pull it out of the chassis, and set it on an antistatic surface or inside an antistatic bag.

Figure 126: Remove the Line Card from the Chassis



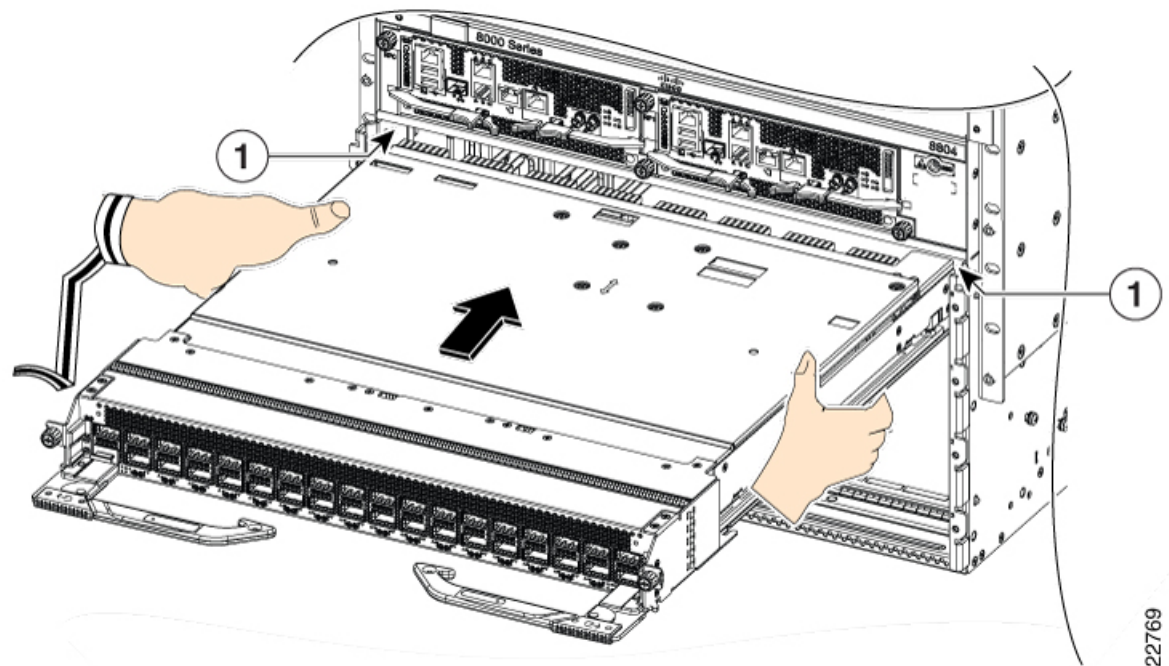
522768

**Step 3**

To install the line card, follow these steps:

- a) Hold the sides of the line card with both hands to support its weight.
- b) Align the back of the line card to the guides in the open line card slot and slide the line card all the way into the slot (see the following figure).

Figure 127: Insert a Line Card into the Chassis



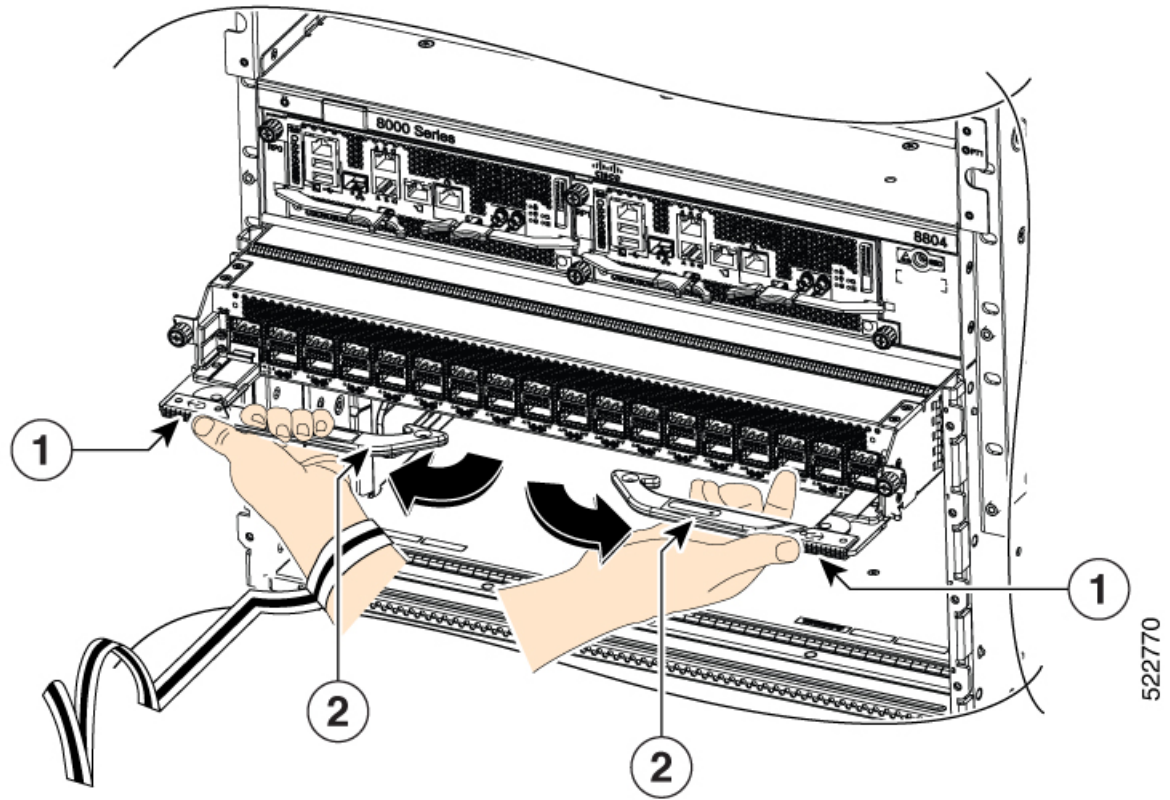
522769

1	Guides (line card slot)
---	-------------------------

The line card stops when its front is about 0.25 inches (0.6 cm) outside the front of the chassis.

- c) Slide the ejector lever latches to unlock the ejector levers and open the ejector levers outward as shown in the image.

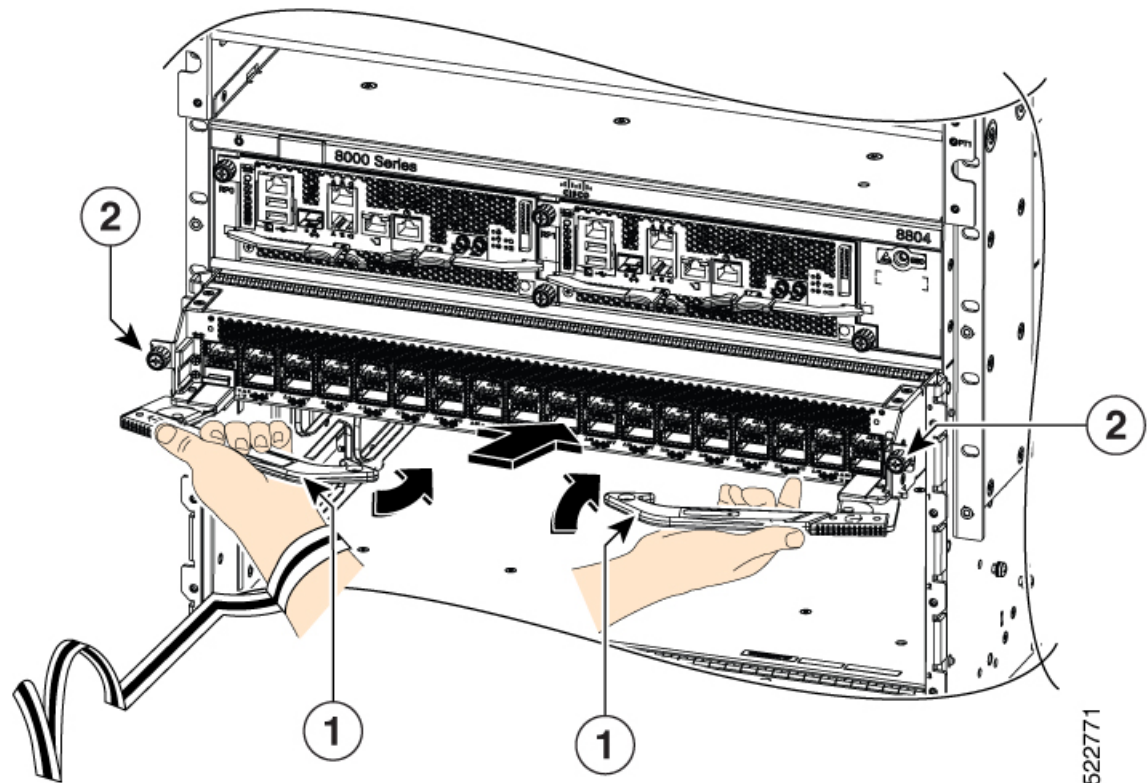
Figure 128: Unlock the Ejector Levers



- d) While holding the ejector levers in the open position, slide the line card further into the slot until the ejector levers engage with the sides of the line card slot.
- e) To fully seat the line card, close the ejectors by rotating the ends of the two levers toward the center of the chassis.



Figure 129: Close the Ejector Levers



1	Ejector levers	2	Captive screws
---	----------------	---	----------------

**Note** As you rotate the levers, the front of the line card moves all the way to the front of the chassis and the line card fully seats on the chassis.

- f) Tighten the two captive screws to 8 in-lb (0.9 Nm) torque.

**Note** When installing a line card, fully tighten both captive installation screws to ensure that the card is correctly seated in the router. A card that is only partially seated in the router might not operate properly, even if it boots.

- g) Attach each interface cable to the appropriate port on the line card. Use the label on each cable to determine which port each cable attaches to.
- h) Verify that the line card LEDs turn on and appear green.

## Replace a Fan Tray

You can remove a fan tray (8818-FAN, 8812-FAN, 8808-FAN, or 8804-FAN) to either replace it with another fan tray or to replace a fabric card located behind it.

The router uses four fan trays but it can operate with three fan trays while you replace one or remove one to replace one of the fabric cards behind the fan tray. When you remove one fan tray, the other fan trays speed up their fans to maintain the designed airflow.



---

**Note** To ensure adequate airflow and prevent overheating, do not operate the router with three fan trays for more than 10 minutes.

---



---

**Caution** Never remove two fan trays at a time during operation, the router allows up to two minutes of operations before shutting down unless you replace the missing fan tray within that time. If the router senses an over temperature condition when multiple fan trays are removed, the shutdown can occur in less than two minutes.

---

To replace a fan tray, you must perform the following functions:

1. Remove the fan tray.
2. Install a fan tray.

Watch [Replace a Fan Tray \(Video\)](#).

## Remove Fan Tray

Remove only one fan tray at a time during router operations. If you remove more than one fan tray at a time, the router shuts down within two minutes unless you replace the extra fan trays that you removed within that time.

### Procedure

- 
- |               |   |
|---------------|---|
| <b>Step 1</b> | Unscrew the four captive screws on the front of the fan tray until each screw is free of the chassis.         |
| <b>Step 2</b> | Hold both handles on the front of the fan tray with both of your hands and pull the fan tray out of the slot. |
| <b>Step 3</b> | Set the fan tray on antistatic material or inside an antistatic bag.  |
- 

## Install Fan Tray

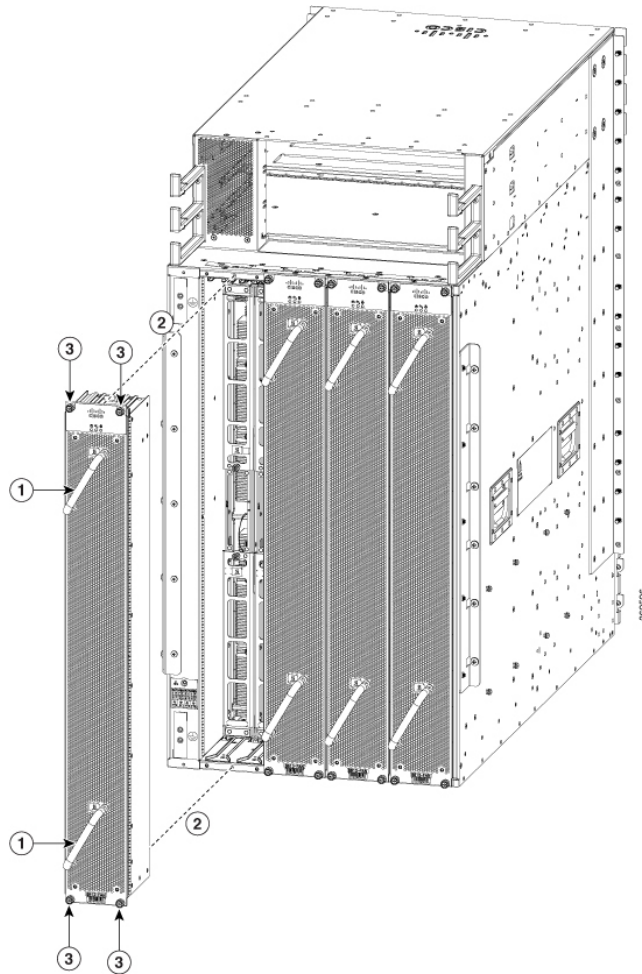
### Before you begin

- Fan tray slot is open in the chassis.
- If you are replacing a fabric card behind the open fan tray slot, ensure that the fabric card replacement operation is completed.

## Procedure

**Step 1** Use both of your hands to hold the two handles on the front of the fan tray that you are installing.

**Figure 130: Remove Fan Tray from the Chassis**



1	Handle	3	Captive screws
2	Align fan tray in position		

- Step 2** Position the fan tray with its rear (the side with the electrical connectors) at the opening for the fan tray slot in the chassis.
- Step 3** Align the two tracks on the top of the fan tray with the two sets of rails at the top of the open fan tray slot in the chassis.
- Step 4** Slide the fan tray all the way into the slot until the front of the fan tray touches the chassis. Make sure that the four captive screws on the front of the fan tray align with the four screw holes in the chassis.
- Step 5** Screw in the four captive screws to secure the fan tray to the chassis. Tighten the screws to 8 in-lb (0.9 N·m) of torque.



- Step 6** Verify that the fan tray STATUS LED turns on and becomes green, approximately within 20 seconds.
- 

## Replace Fabric Card

The router uses either a minimum of four or a maximum of eight fabric cards but you can replace a fabric card while others are operating. To replace a fabric card, you must do each of the following:

- Shut down the fabric card being replaced.
- Remove the fan tray covering the fabric card in the chassis.



---

**Note** To ensure adequate airflow and prevent overheating, do not operate the router with three fan trays for more than 10 minutes.

---

- Remove the fabric card.
- Install the new fabric card.



---

**Note** We recommend that you insert the fabric cards in the sequence starting with FC0, FC1, and so on (from left to right). Use the adjacent card as a guide to retain the cards in vertical position.

---

- Reinstall the fan tray over the fabric card.
- Activate the fabric card.

The Cisco 8800 series routers support OIR of fabric card.

To maintain the designed airflow while you remove the fan tray, the fans in the other fan trays increase their speed. During operations, it is required that you remove only one fan tray at a time and reinstall that fan tray within 10 minutes to avoid the possibility of having the router overheat and shut down. If you remove more than one fan tray at a time, the router shuts down if you do not reinstall the extra missing fan trays within two minutes (the shutdown can occur earlier if the router overheats).



---

**Note** If the router is using only five fabric cards (5fc mode), the fabric cards must be inserted in FC slots 1, 2, 3, 4, and 5.

---



**Note** Opening the ejector levers of an installed fabric card causes the fabric card to shut down even when the captive screws are screwed in. To reboot the fabric card, users must do one of the following:

- Remove and reinsert the fabric card and close the ejector levers.
- Close the ejector levers and reload the fabric card using the **reload location** `<rack>/<fabric card location>` **force** command.

Watch [Replace a Fabric Card \(Video\)](#).

## Remove a Fabric Card

### Before you begin

- You must wear an electrostatic discharge (ESD) wrist strap or other ESD protective device while handling modules.
- Prepare an antistatic surface or packing materials for each module that you remove from the chassis.

### Procedure

- 
- Step 1** If you are replacing a fabric card, open the packaging for the new module and inspect it for damage. If the module is damaged, alert the Technical Assistance Center (TAC) and stop this replacement process until you have an undamaged module to install.
- Step 2** To prevent loss of packets during operations, shut down the fabric card as follows:
- Shut the fabric control plane using the **controller fabric plane** `<plane-id>` **shutdown** command.  
There are eight planes and the value of the `<plane-id>` is between 0–7.  
When you are replacing the card, shut down the corresponding fabric plane of the card. For example, when you are replacing the card in slot 0 (0/FC0), shut down fabric plane 0.
  - Run the **shutdown location** `0/FC location` command.
  - Verify that the Fabric LED for the slot that you specified turns off. Also, you can use the **show platform** command to verify that the status of the card is SHUT DOWN.
- Step 3** Remove the fan tray covering the fabric card in the chassis.  
Refer the fan tray removal procedure: [Replace a Fan Tray, on page 156](#)
- Step 4** Remove the fabric card that you are replacing by following these steps:
- Unscrew the two captive screws on the center of each of the two handles on the fabric card (see Callout 1 in the following figure).
  - Rotate the handles outwards until they stop (see Callout 2 in the following figure).
  - With each of the two handles in your two hands, pull the module a couple of inches (about 5 cm) out of the slot (see the following figure).

Figure 131: Removing a Fabric Card from the Chassis

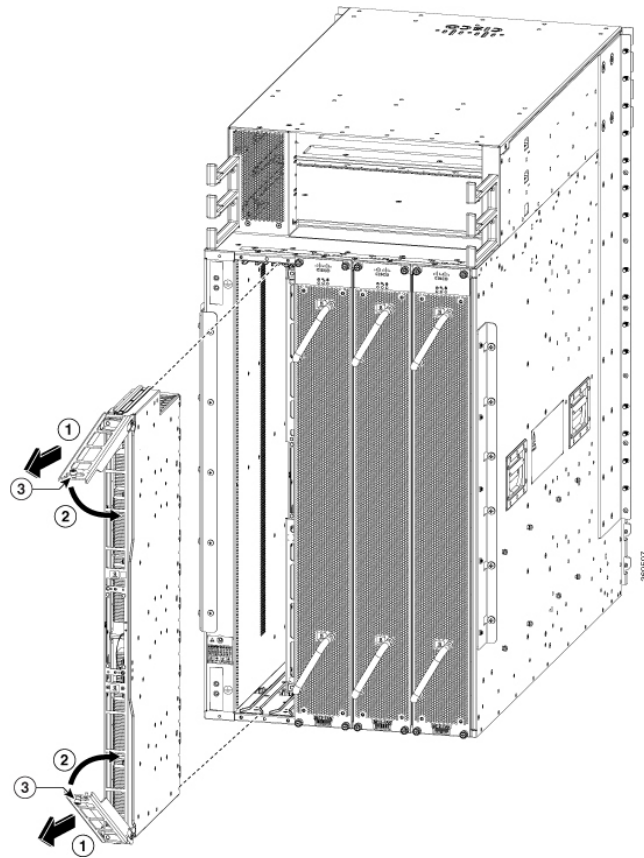
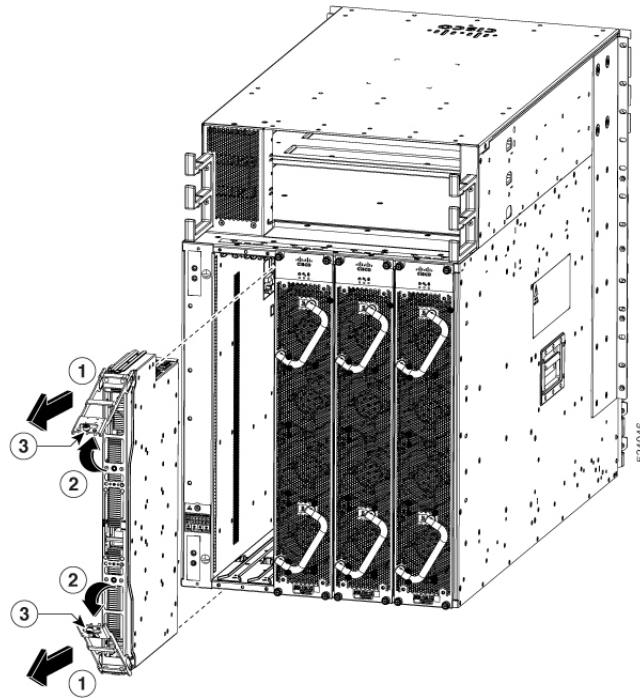


Figure 132: Removing a Fabric Card from the Chassis - 8808-FC1



1	Pull on both handles to partially remove the fabric card from the chassis	3	Two captive screws (one on each handle)
2	Rotate both ejector handles to the front of the module		

- d) Place one hand under the fabric card to support its weight, place your other hand on the front of the module, and slide the module out of the slot.
- e) Rotate both handles back to the front of the module until they are in place. Fasten each handle to the module using the captive screw on the back of the handle. Tighten the screw to 8 in-lb (0.9 N·m) of torque.
- f) Rotate the module 90 degrees and lay it flat on an antistatic surface or in an antistatic bag.

## Install a Fabric Card

### Procedure

- Step 1** Unscrew the two captive screws (one on each ejector handle) and rotate the ejector handles at least 30 degrees. Ensure that the locking posts on the top and bottom of the chassis rotate into the module so that the module can slide fully into the slot.
- Step 2** Place one hand on the front of the module and turn the module 90 degrees so that the electrical connectors are on the bottom.

**Step 3**

Align the guide bar on the bottom of the fabric card into the guide slot at the bottom of the fabric card slot, and make sure that the guide rails on the top of the fabric card align with the track on the top of the slot.

**Note** The lower guide rail extends to the back of the chassis. The upper guide rail does not connect until the card is halfway into the chassis.

*Figure 133: Install Fabric Card*

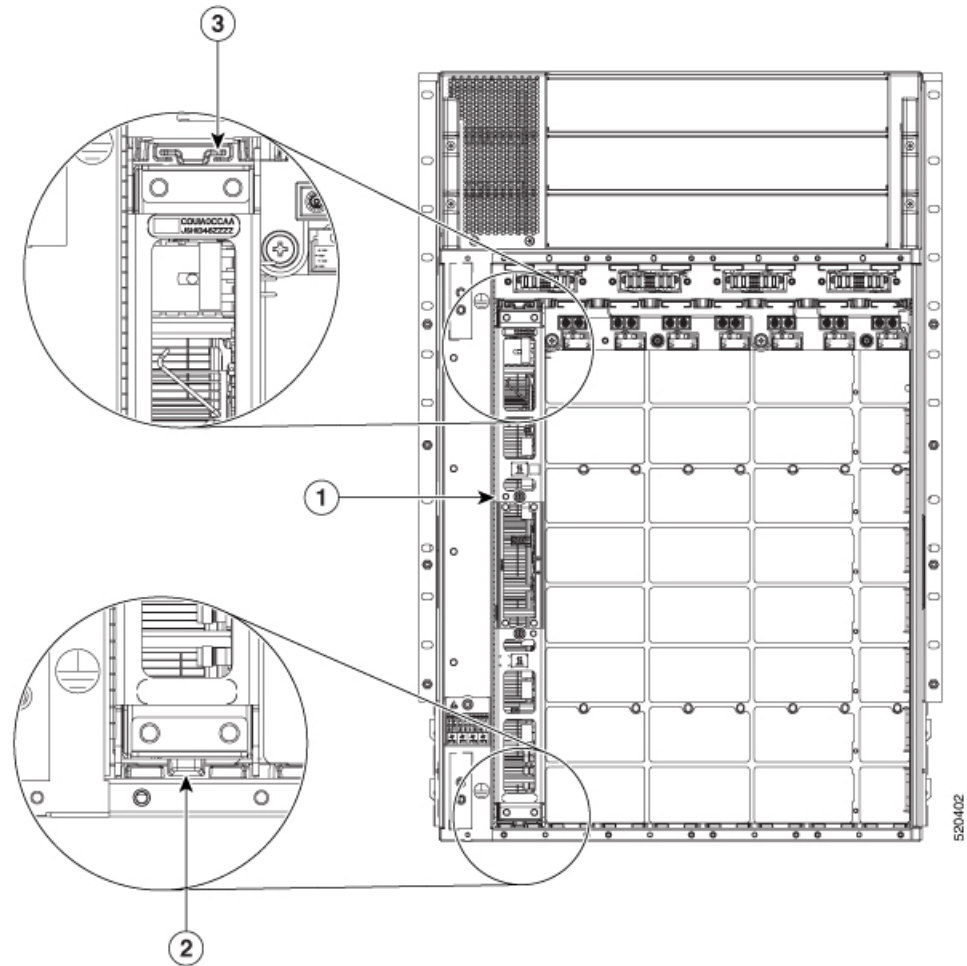
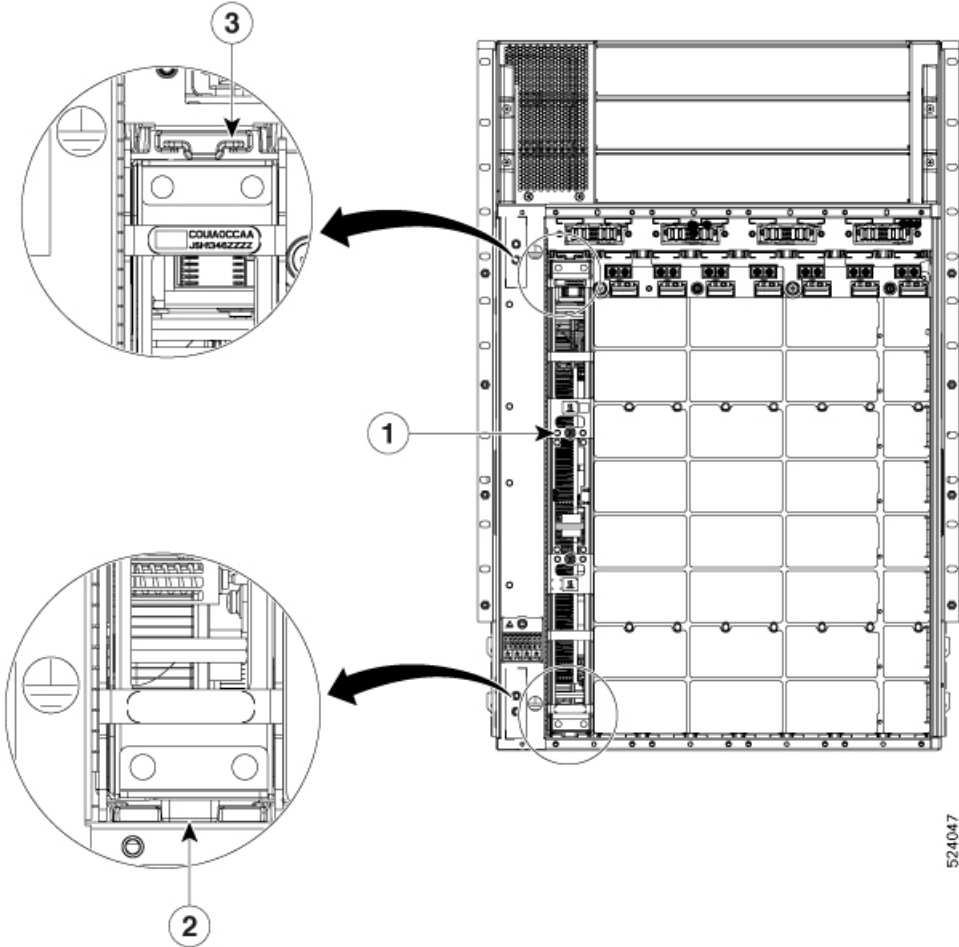


Figure 134: Install Fabric Card - 8808-FC1



524047

1	Always install the fabric card in a vertical position
2	Guide bar and guide slot
3	Guide rail and track

Figure 135: Installing a Fabric Card

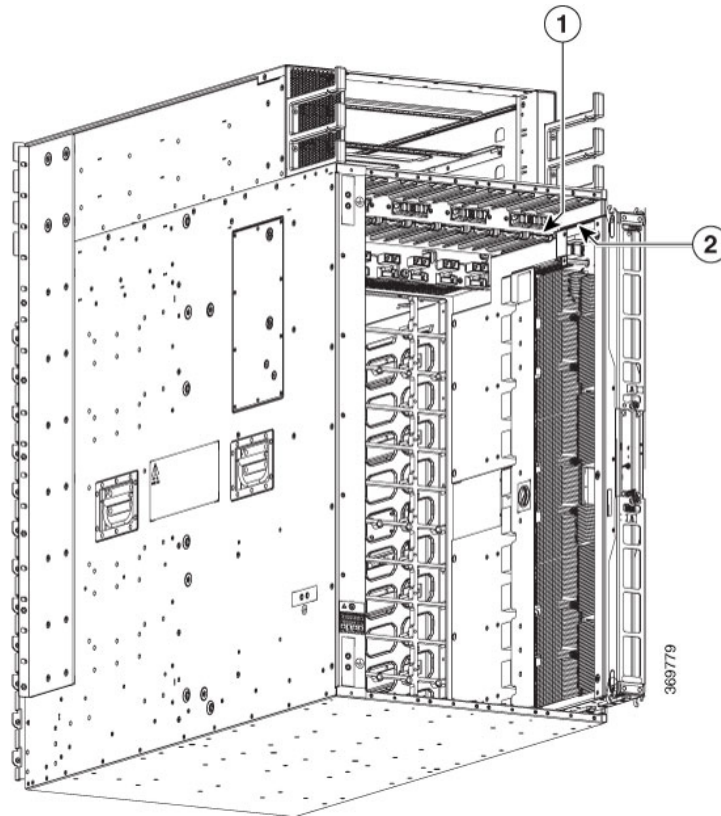
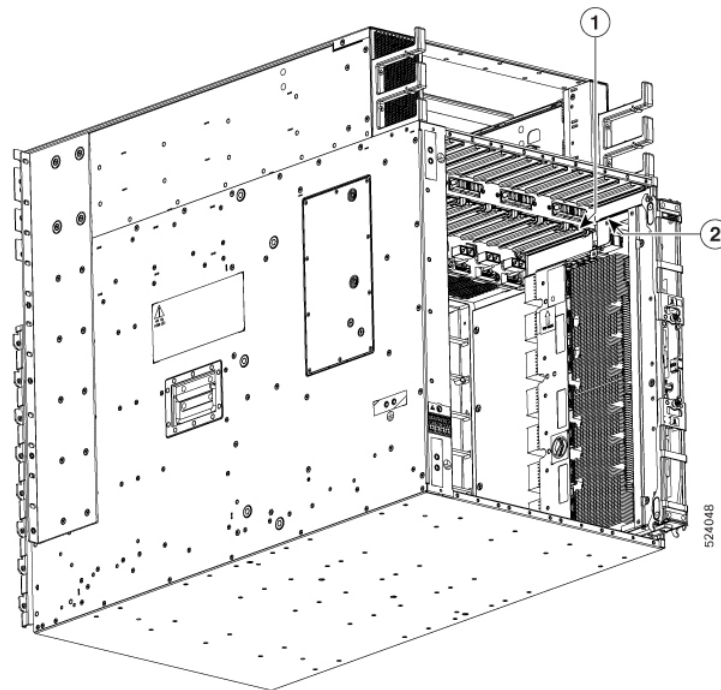


Figure 136: Installing a Fabric Card - 8808-FC1



1	Chassis top fabric card guide rail.	2	Insert fabric card top guide rail into chassis top guide rail.
---	-------------------------------------	---	--

*Figure 137: Fabric Card Installed in a Chassis*

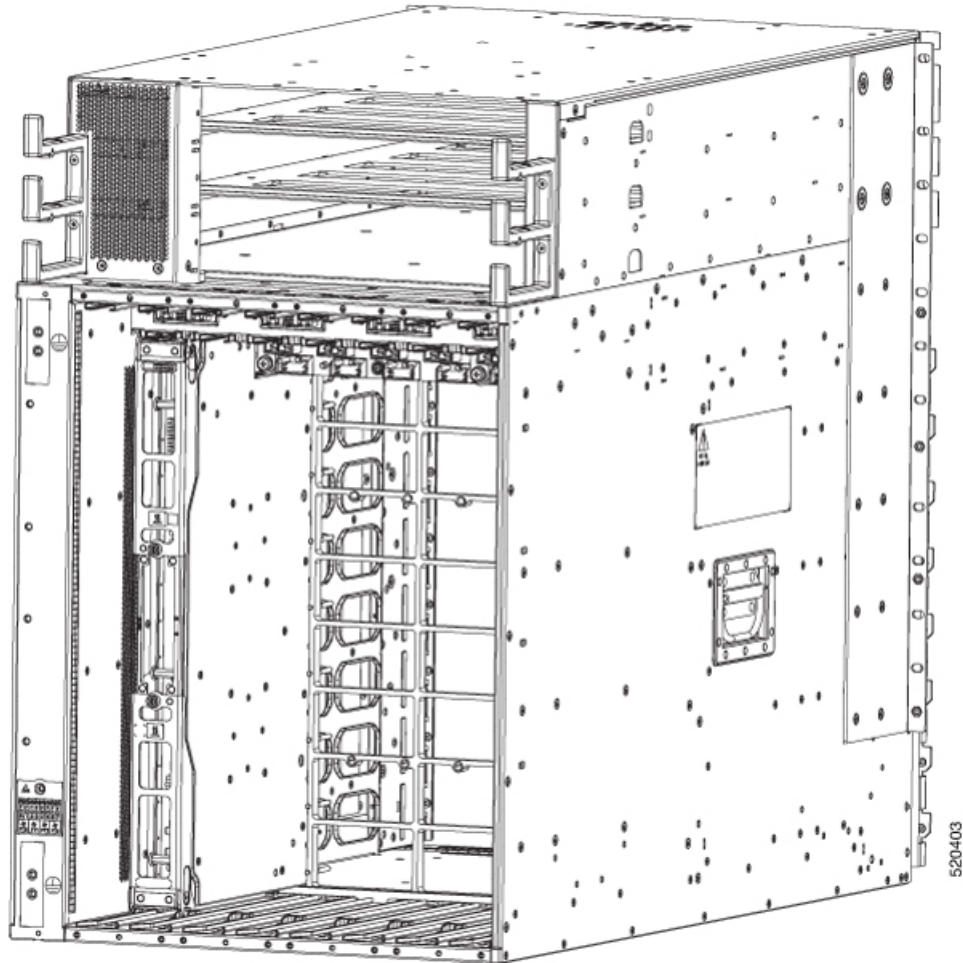
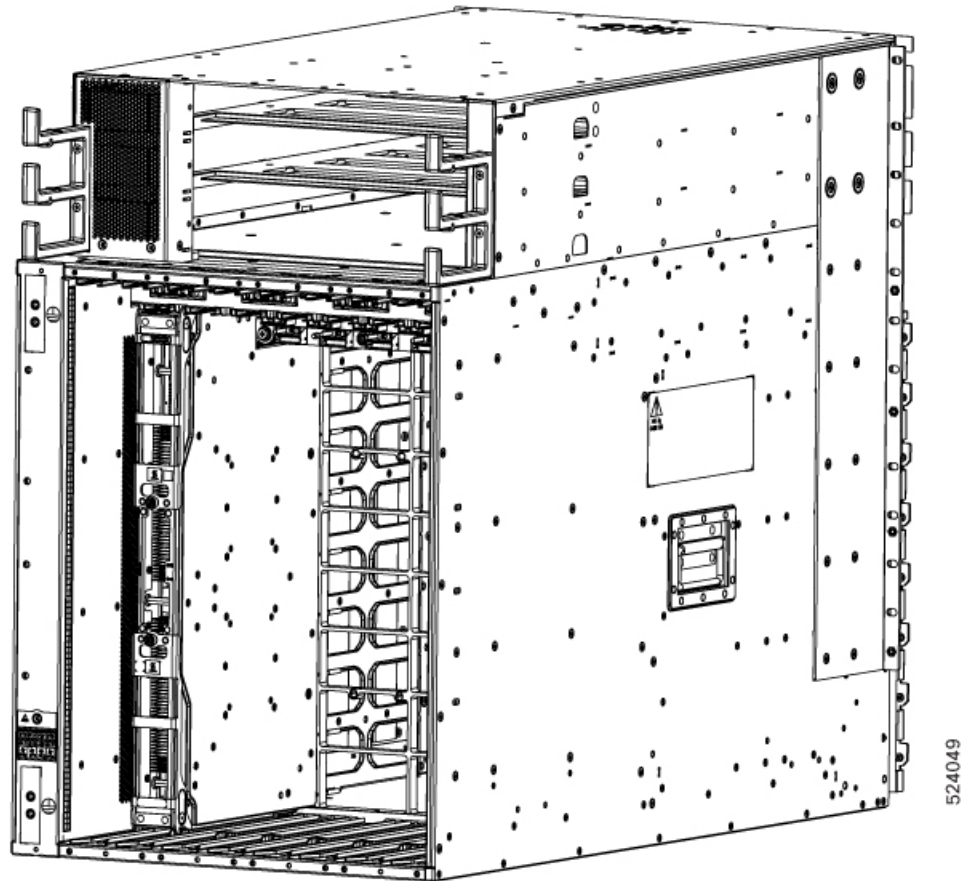




Figure 138: Fabric Card Installed in a Chassis - 8808-FC1



- Step 4** Slide the module all the way into the slot.
- Step 5** Rotate both ejector levers to 90 degrees to the front of the chassis and be sure that the module is locked to the top and bottom of the slot.
- Step 6** Tighten the captive screw on each of the two levers to 8 in-lb (0.9 N-m) of torque, so that each lever is locked in place on the module.
- Step 7** Verify the fabric card LEDs become green.
- Step 8** Reinstall the fan tray over the fabric card.  
Refer the installing the fan tray procedure: [Install Fan Tray, on page 157](#)
- Step 9** Run the **reload location 0/location/CPU0** command.
- Step 10** Wait for the fabric card to become operational. Use the **show platform | inc FC** command to verify the status.
- Note** The fabric card must be operational before resetting the fabric plane.
- Step 11** Reset the fabric control plane using the **no controller fabric plane <plane-id> shutdown** command
- Step 12** Verify that the Fabric LED for the slot that you specified turns on. Also, you can verify that the card is in power on state by running the **show platform** command to verify the status of the card to be POWERED\_ON.

Since the Fan trays are blocking the view, Fabric card LEDs might not be visible. Therefore, you can verify the Fabric card LEDs status using **show led location 0/FClocation** command.

## Migrate from 8808-FC1-G to 8808-FC1 Card

The Cisco 8800 Series Router supports the 8808-FC1 fabric card.

### Procedure

- Step 1** Remove the 8808-FC1-G card from slot FC0. Follow the procedure explained in the topic [Remove a Fabric Card, on page 160](#).
- Alarms are raised when fabric cards are removed and when the system has a combination of old and new generation fabric cards. These alarms clear when all the fabric cards are replaced.
- Step 2** Insert 8808-FC1 card in slot FC0. Follow the procedure explained in the topic [Install a Fabric Card, on page 162](#)
- Step 3** Wait for 8808-FC1 card to become operational. Verify the card state is OPERATIONAL by using the **show platform** command.
- Step 4** Repeat Step1 through Step 3 for migrating remaining FCs from slot FC1 to slot FC7.

### Example:

```
Router# show platform
Mon May 17 12:45:12.808 UTC
Node           Type                               State           Type           Config state
-----
0/RP0/CPU0     8800-RP (Active)                   IOS XR RUN
0/0/CPU0       8800-LC-48H                         DATA PATH POWERED ON
0/FC0          8812-FC                             OPERATIONAL
0/FC1          8812-FC                             OPERATIONAL
0/FT0          8812-FAN                            OPERATIONAL
0/FT1          8812-FAN                            OPERATIONAL
0/FT2          8812-FAN                            OPERATIONAL
0/FT3          8812-FAN                            OPERATIONAL
0/PT0          8800-HV-TRAY                       OPERATIONAL
0/PT1          8800-HV-TRAY                       OPERATIONAL
0/PT2          8800-HV-TRAY                       OPERATIONAL
```

Use the **admin show alarm** and **show pfm location all** commands to verify no additional alarms are raised after replacing all the FCs.

## Replace Power Supply Components

The Cisco 8800 series routers support OIR of power modules. If you are replacing a redundant power module, you can replace the power module while the system remains powered on without any electrical hazard or

damage to the system. This feature enables you to replace a power module while the system maintains all routing information and ensures session preservation.

However, to maintain operational redundancy and proper cooling, and to meet EMI compliance standards, you must have at least one working redundant power module that is installed. When you remove a failed power module with the router in operation, perform the replacement as quickly as possible. Make sure you have the replacement power module ready before beginning the removal and installation procedure.



---

**Note** For the RP to communicate properly to a power module in a power tray, input power to at least one of the power modules in the power tray should be present.

---

This section contains procedures on how to replace the power modules.



---

**Caution** Do not turn off the switch on the power tray to remove individual power modules. Power modules support OIR, so they can be removed and replaced with the power on and the system operating.

---

## Install Power Shelf Bezel

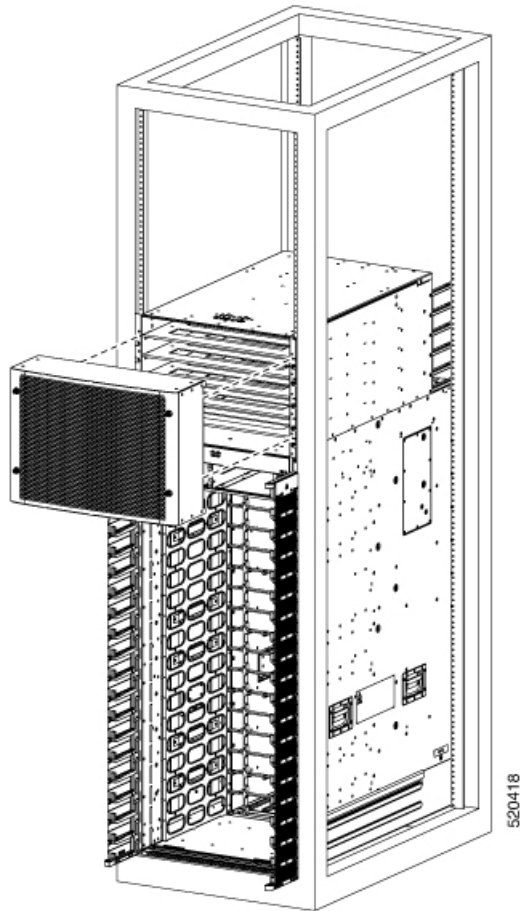
Follow these steps to install a power shelf bezel on a chassis:

### Procedure

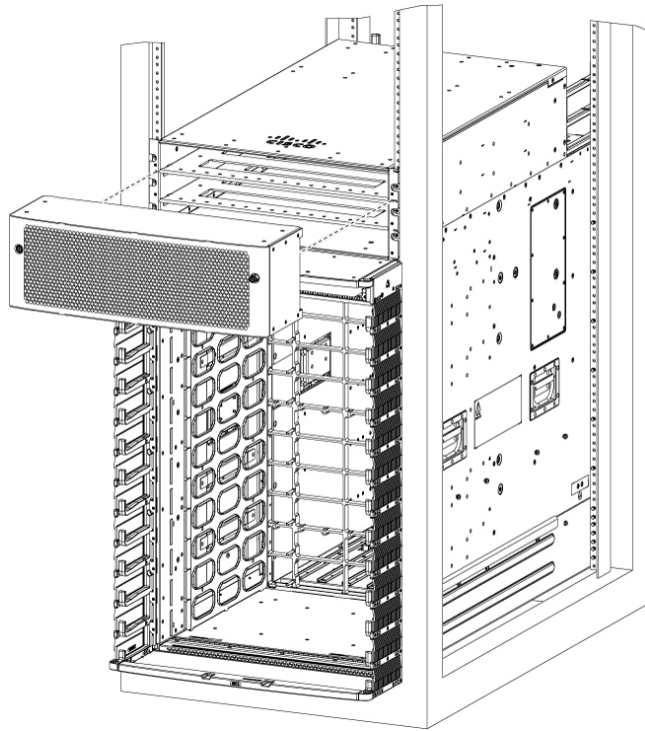
---

Place the power supply bezel as shown in the below figure and secure it with the provided jackscrews.

Figure 139: Power Supply Bezel for 8818 Chassis



**Figure 140: Power Supply Bezel for 8812 Chassis**



**Figure 141: Power Supply Bezel for 8808 Chassis**

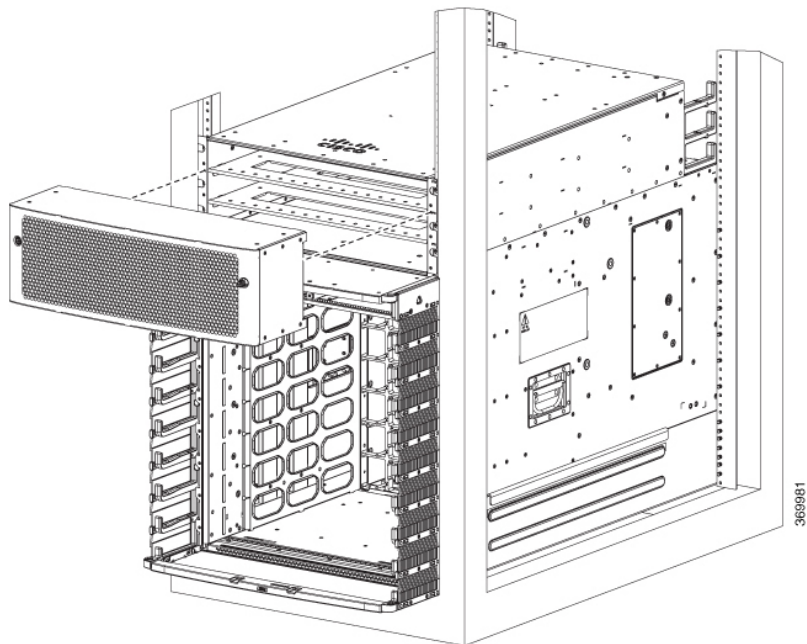
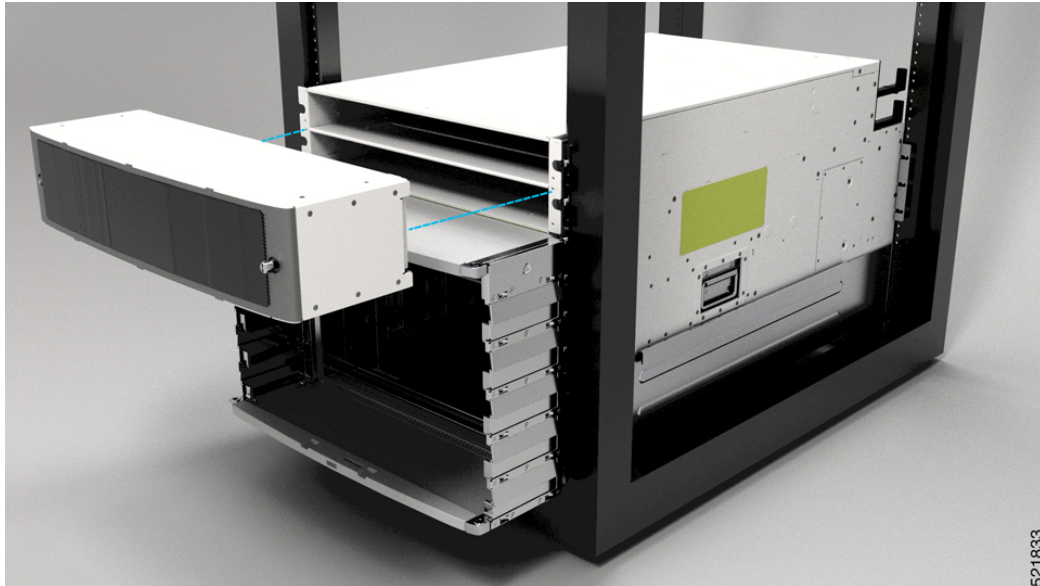


Figure 142: Power Supply Bezel for 8804 Chassis



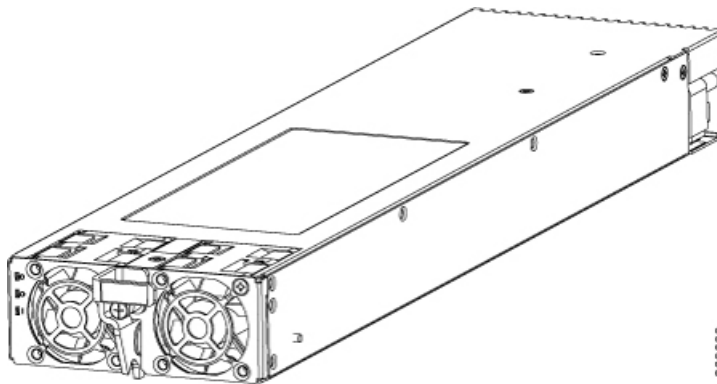
## Replace DC Power Module

Follow these steps to remove a DC power module from the chassis.

### Procedure

- Step 1** Pull the handle down.
- Step 2** Unscrew the screw that secures the power module using a Phillips screw driver.
- Step 3** Slide the power module out of its bay while supporting it with your other hand to remove it.

Figure 143: DC Power Module



- Step 4** Slide the new power module into the bay until it mates with its backplane connector.

- Step 5** Move the handle up.
- Step 6** Tighten the screw that secures the power module using a Phillips screw driver.
- Caution** To prevent damage to the power tray backplane connector, do not use excessive force when inserting the power module into the power tray.
- Step 7** Verify that the (green) Power Input indicator on the front of the power module goes on.
- 

## Disconnect DC Power

### Procedure

---

- Step 1** Power off the circuit breaker assigned to the DC power source you are disconnecting.
- Caution** To ensure that power remains off while you are performing this procedure, lock-out/tag-out the circuit breaker switch in the STANDBY (0) position until you are ready to turn it on.
- Step 2** Remove the clear plastic safety covers that fit over the DC power connection terminal studs.
- Caution** To prevent injury and damage to the equipment, always remove the source DC power cables and ground from the power tray terminals *in the following order* : (1) negative (-), (2) positive (+).
- Step 3** Disconnect the DC power cables from their terminals in the following order and note the color of each cable.
- Negative (PWR) cables first.
  - Positive (RTN) cables last.
- Step 4** Repeat Step 1 through Step 3 for the other power tray, if installed.
- Caution** It is not necessary to disconnect all power from the router to replace components, including power modules.
- 

## Reconnect DC Power

Follow these steps to reconnect DC power to a DC power tray:

### Procedure

---

- Step 1** Set the power switch to the OFF (0) position.
- Step 2** Check that the circuit breaker assigned to the DC power source you are reconnecting is powered OFF (0).
- Step 3** Reconnect the DC power cables in the following order.
- Positive (RTN) cables first.
  - Negative (PWR) cable last.
  - Repeat Step 1 through Step 3 for the other power trays.

**Caution** To prevent injury and damage to the equipment, always attach the ground and source DC power cable lugs to the power tray terminals in the following order: (1) positive (+) to positive (+), (2) negative (–) to negative (–).

**Caution** Do not overtighten the nuts that secure the DC power cables to the power tray terminals. The nuts should be tightened using the 7/16 hex socket and torque wrench to a torque of 45–50 in-lb.

**Step 4** Replace the clear plastic safety covers over the DC power connection terminal studs and tighten the screws.

**Step 5** Set the DC power source circuit breaker to ON (1).

**Step 6** Set the power tray switch to ON (1).

**Caution** Use this procedure only when reconnecting power to all power modules in a system that is powered down completely.

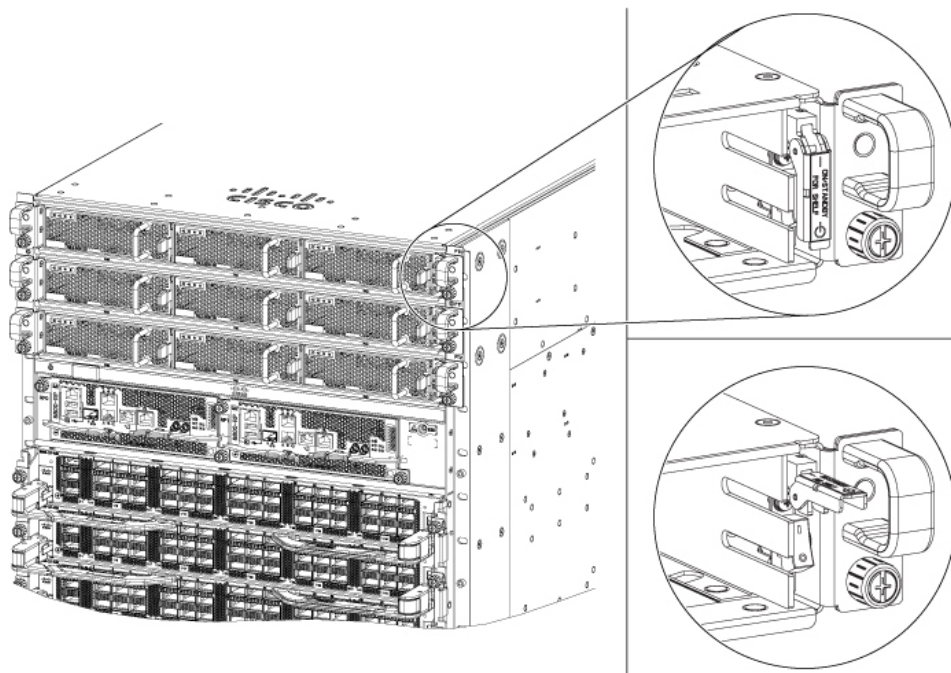
## Replace HVAC and HVDC Power Module

Follow these steps to remove HVAC and HVDC power modules from the chassis.

### Procedure

**Step 1** Do not Power OFF (0) the standby mode switch.

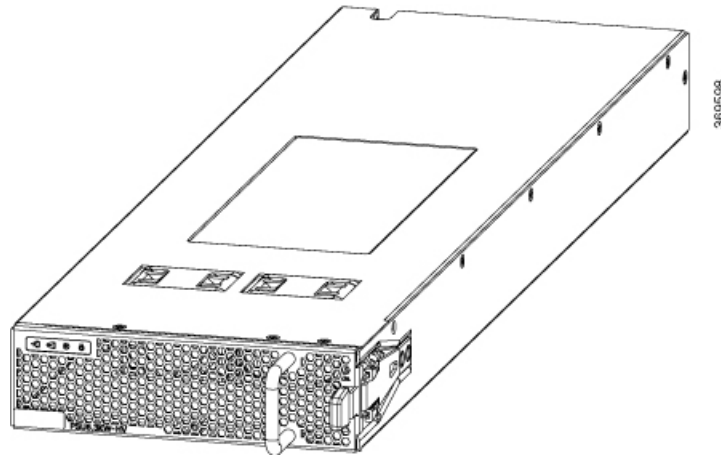
*Figure 144: HV Power Tray Standby Mode Switch*



**Step 2** Slide the power module out of its bay while supporting it with your other hand to remove it.



*Figure 145: HV Power Supply*



**Step 3** Slide the new power module into the bay until it mates with its connector.

*Figure 146: HV Power Supply on Tray*

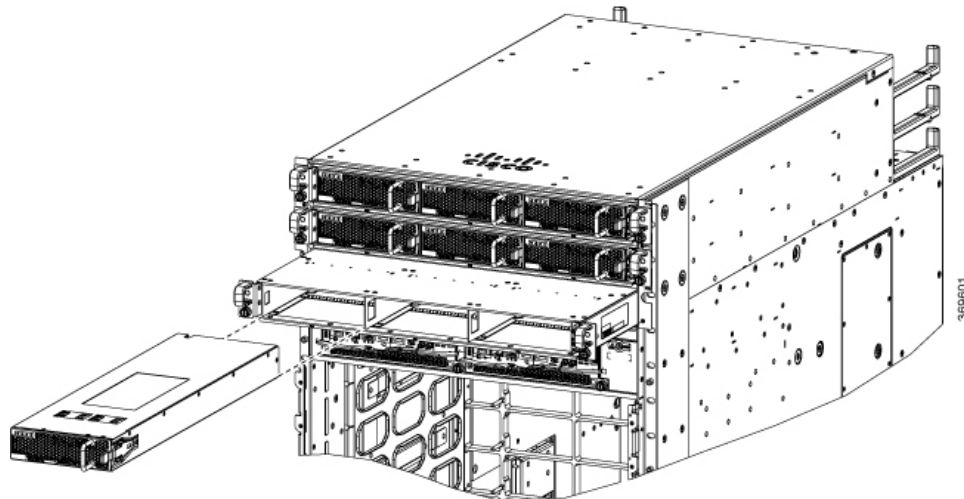
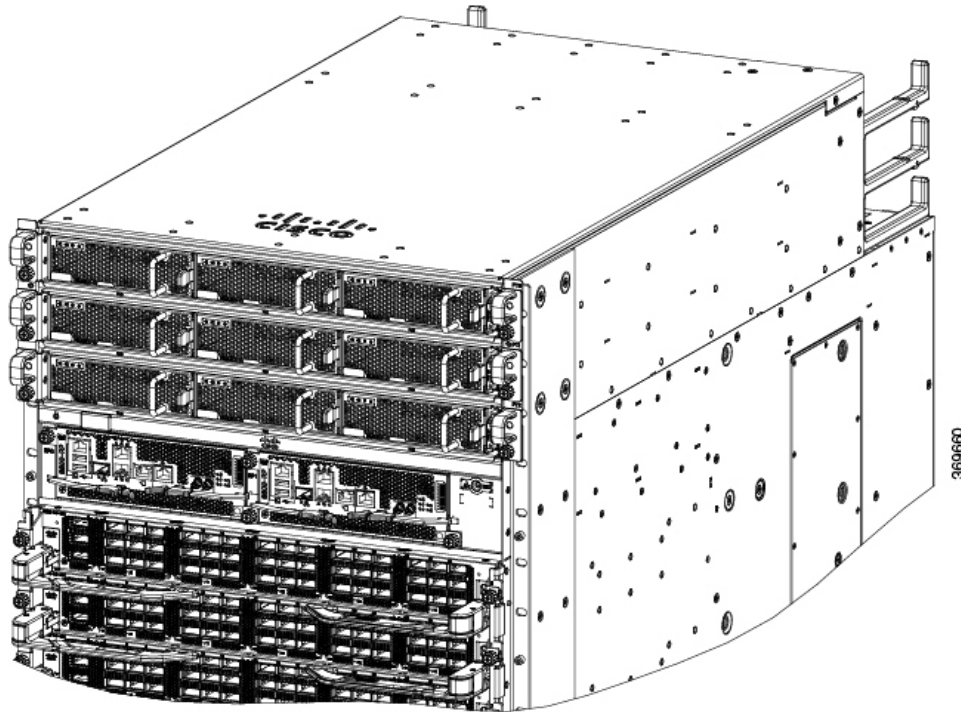


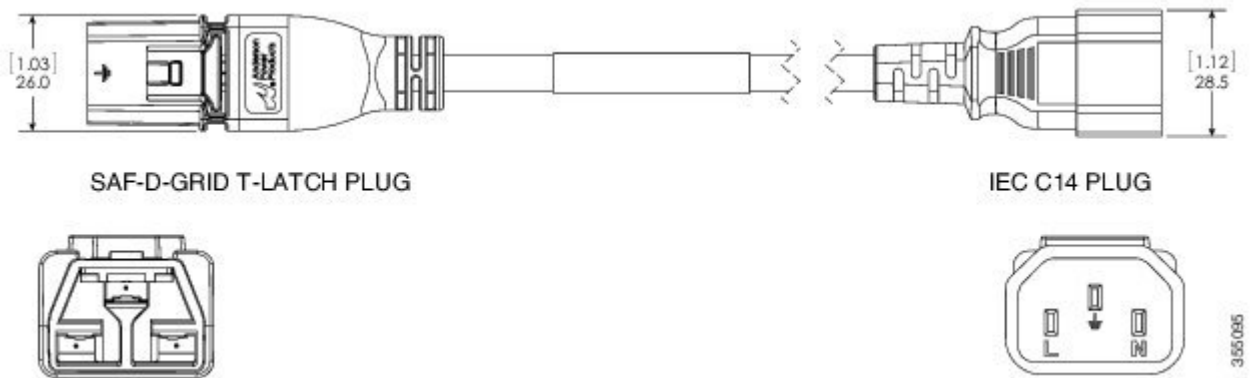
Figure 147: HV Power Supply Trays



**Step 4** Verify that the Saf-D-Grid plug is plugged in completely to secure the built-in retaining latch.

**Note** Saf-D-Grid plug has a retaining latch that must be depressed and gently pulled to release the plug from the receptacle.

Figure 148: SAF-D-Grid Plug



**Step 5** Verify that the (green) power indicator on the front of the power module goes on.



# CHAPTER 7

## LEDs


You can perform the following check on LEDs that assist you with the troubleshooting process:

- [Chassis LED, on page 177](#)
- [Port Status LEDs, on page 177](#)
- [Power Supply LEDs, on page 178](#)
- [Fan Tray LEDs, on page 179](#)
- [Route Processor Card LEDs, on page 181](#)
- [Fabric Card LEDs, on page 184](#)
- [Line Card LEDs, on page 185](#)

## Chassis LED

The LEDs indicate whether each type of module (Route Processor, line cards, fabric cards, fan trays, and power supplies) is fully functional or have a fault condition.

**Table 25: Chassis LED Descriptions**

LED	Color	Status
ATTN (Attention) 	Blue	The operator has activated this LED to identify this chassis.
	Off	The chassis is not functional.

## Port Status LEDs



**Note** The 8800-LC-48H does not have port LEDs.

Each port on the 8800-LC-36FH has an LED. The following table describes port status LEDs.

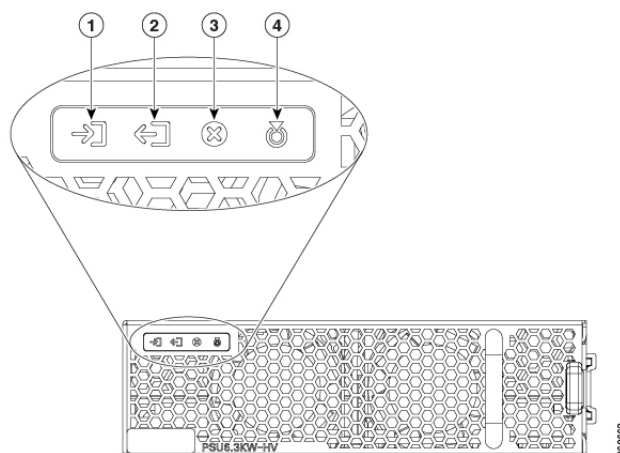
Table 26: Port Status LEDs (One Per Port)

LED Color	Description
Off	Port is administratively shut down.
Green	Port is administratively enabled and the link is up.
Amber	Port is administratively enabled and the link is down.
Flashing Amber	Port is faulty and disabled.

## Power Supply LEDs

The power supply LEDs are located on the front portion of the module.


Figure 149: Power Supply LEDs



1	Input OK	3	Fault
2	Output OK	4	ATTN (Attention)

Table 27: Power Supply LED Descriptions

LED	Color	Status
Input OK	Green	Both input voltages are present.
	Flashing Green	Only one input power is present.
	Off	No input power is present.

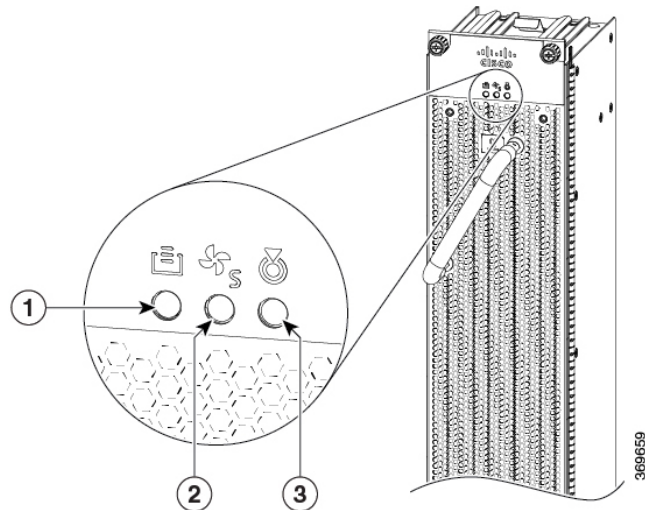
LED	Color	Status
Output OK	Green	Output power is enabled.
	Flashing Green	Output power in power limit, or in overcurrent condition, or is in the sleep-mode. <sup>1</sup>
	Off	Output disabled, or no inputs present, or firmware upgrade in-progress.
Fault	Red	Output voltage is out of the specified range, or a fan has failed, or internal fault.
	Flashing red	Firmware upgrade in-progress.
ATTN (Attention) 	Flashing blue	User configured action <i>config hw-module attention-led location 0/PTx/PMx</i> .
	Off	No user configuration is set.

<sup>1</sup> Sleep mode is not applicable for DC-60 power module.

## Fan Tray LEDs


The fan tray LEDs are located on the top portion of the module.

**Figure 150: Fan Tray LEDs**



1	FC STS (Status)	3	ATTN (Attention)
2	FT STS (Status)		

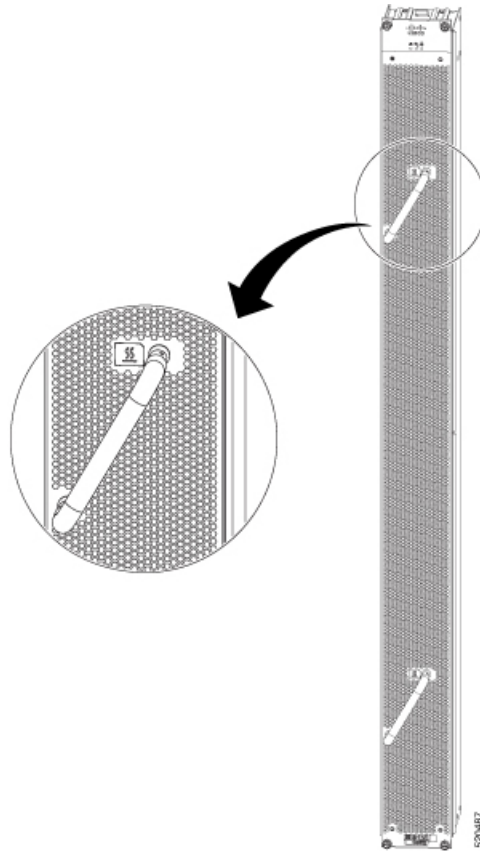
Table 28: Fan Tray LED Descriptions

LED	Color	Status
ATTN (Attention) 	Flashing Blue	The operator has activated this LED to identify the fan tray in the chassis.
	Off	The operator had not activated the LED to identify the fan tray in the chassis.
FT STS	Amber	The fan tray is powered on.
	Green	The fan tray is operational.
	Flashing amber	The module has minor alarm.
	Flashing red	The module has active major or critical alarms.
	Flashing green	FPD upgrade in-progress.
	Off	No power to the fan tray.
FC STS	Amber	The fabric cards are powered on and is in one of the following states: <ul style="list-style-type: none"> <li>• Either one or more fabric cards behind this fan tray is not operational.</li> <li>• Either one or more fabric cards behind this fan tray have minor, major or critical alarm.</li> </ul>
	Green	<ul style="list-style-type: none"> <li>• One of the fabric modules is operational and other one not present.</li> <li>• Both fabric cards behind this fan tray are operational.</li> </ul>
	Off	If both the fabric modules behind this fan tray are plugged out (or not present).

## Temperature Warning Label

Every fan tray has a temperature warning label beside its handle. The temperature warning label is temperature sensitive. At normal operating temperatures (less than 55°C), the warning label has a black background with black edges. At temperatures above 55°C, the background color changes to white and the edges' color changes to red.

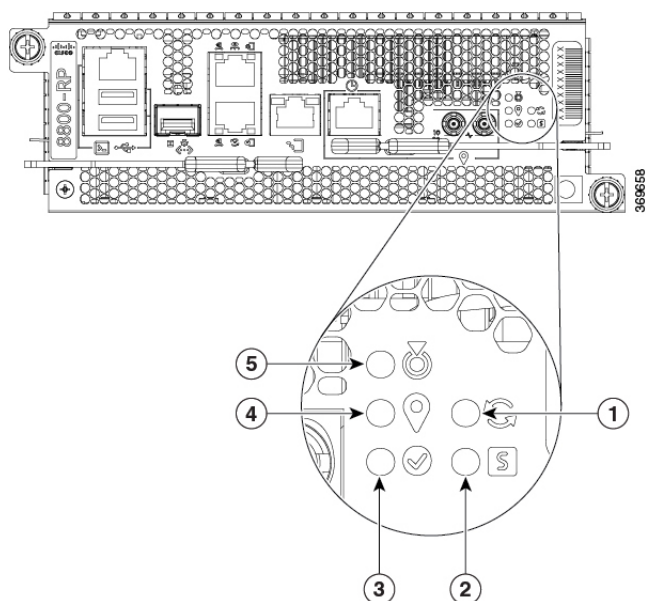
*Figure 151: Temperature Warning Label*



## Route Processor Card LEDs

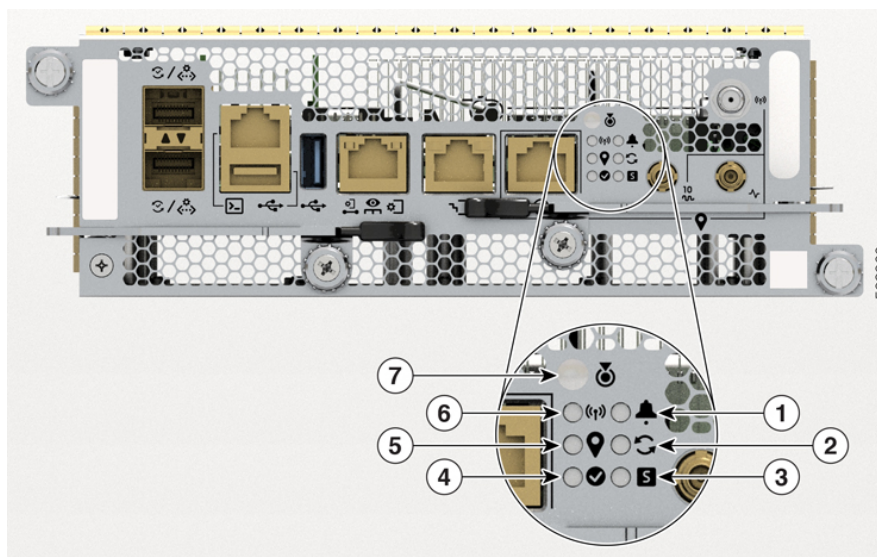
The Route Processor LEDs are located on the front of the module.

Figure 152: Route Processor LEDs - 8800-RP



1	Sync	4	GPS
2	Status	5	Attention
3	Active		

Figure 153: Route Processor LEDs - 8800-RP2









1	Alarm	5	GPS
2	Sync	6	GNSS



3	Status	7	Attention
4	Active		

Table 29: Route Processor Card LED Descriptions

LED	Color	Status
Attention 	Flashing blue	The operator has activated this LED to identify this module in the chassis.
	Off	This module is not being identified.
Status 	Green	This router processor is operational with no issues.
	Flashing green	The auto or manual FPD upgrade in-progress.
	Flashing amber	The module has minor alarm.
	Flashing red	The module has active major or critical alarms.
	Amber	The module is in one of the following states: <ul style="list-style-type: none"> <li>• Power cycle</li> <li>• Reload or reimage</li> <li>• Shutdown</li> </ul>
	Red	For 8800-RP: <ul style="list-style-type: none"> <li>• BIOS boot failure. Also, the Attention LED remains blue.</li> </ul> For 8800-RP2: <ul style="list-style-type: none"> <li>• BIOS boot failure.</li> <li>• Card power-up failure. Also, the Attention LED remains Off.</li> </ul> This allows you to distinguish the status between BIOS boot failure and card power-up failure.
Off	The module is not enabled.	
Active	Green	The RP/RSP is in the Active state.
	Off	The RP/RSP is in the Standby state.
GPS 	Green	The GPS interface is provisioned and frequency, time of day and phase inputs are all operating correctly.
	Off	The GPS interface is not provisioned, or the GPS inputs are not working correctly.

LED	Color	Status
	Green	The frequency, time, and phase are synchronized to an external interface. The external interface could be: <ul style="list-style-type: none"> <li>• BITS</li> <li>• GPS</li> <li>• Recovered RX Clock</li> </ul>
	Amber	The system is running in holdover or free-run mode and it is not synchronized to an external interface.
	Off	The centralized frequency or time and phase distribution is not enabled.
	Green	GNSS receiver interface is up.
	Off	GNSS receiver interface could be: <ul style="list-style-type: none"> <li>• not provisioned</li> <li>• shutdown</li> </ul>
	Flashing Red	Chassis-wide Critical Alarm (on active RP)
	Flashing Amber	Chassis-wide Major Alarm (on active RP)
	Solid Amber	Chassis-wide Minor Alarm (on active RP)
	Off	No Alarm (on active RP) Not applicable (on standby RP)



## Fabric Card LEDs

The fabric cards are located behind the fan trays.



**Note** The fabric cards are located behind the fan tray. Therefore, the fabric card LEDs are seen when the fan tray is removed.


Table 30: Fabric Card LED Descriptions


LED	Color	Status
ATTN (Attention) 	Flashing blue	The operator has activated this LED to identify this module in the chassis.
	Off	This module is not being identified.
STS 	Green	The fabric card is operational with no issues.
	Flashing green	Auto or manual FPD upgrade in-progress.
	Amber	The module is in one of the following states: <ul style="list-style-type: none"> <li>• Power cycle</li> <li>• Reload or reimage</li> <li>• Shutdown</li> </ul>
	Flashing red	The fabric card has major or critical alarms.
	Flashing amber	The module has minor alarm.
	Off	No power is going to the fabric card.

## Line Card LEDs

The line card has LEDs located on the right of the front panel.

Table 31: Line Card LED Descriptions

LED	Color	Status
ATTN (Attention) 	Flashing blue	The operator has activated this LED to identify this module in the chassis.
	Off	The line card is not enabled.

LED	Color	Status
STS (Status) 	Amber	The module is in one of the following states: <ul style="list-style-type: none"> <li>• Power cycle</li> <li>• Reload or reimage</li> <li>• Shutdown</li> </ul>
	Green	This module is operational with no issues.
	Flashing green	The auto or manual FPD upgrade in-progress.
	Flashing amber	The module has a minor alarm.
	Flashing red	The module has active major or critical alarms.
	Red	BIOS boot failure. Also, the ATTN LED remains blue.
	Off	The module is not enabled.