



Overview

This chapter provides an overview of the Cisco UCS S3260 storage server.

For information about the server nodes that are supported in this system, see the service note for your server node:

- [Cisco UCS C3X60 M3 Server Node For Cisco UCS S3260 System Service Note](#)
- [Cisco UCS C3X60 M4 Server Node For Cisco UCS S3260 System Service Note](#)
- [Cisco UCS S3260 M5 Server Node For Cisco UCS S3260 System Service Note](#)

For instructions on migrating from C3X60 M4 server nodes to S3260 M5 server nodes, see [Upgrading to Cisco UCS S3260 System With S3260 M5 Server Nodes](#), page E-1.

Front Panel Features

Figure 1-1 shows the front panel features of the system. The system is shown with the removable front bezel installed. See [Front-Panel LEDs](#), page 3-2 for definitions of LED states.

Figure 1-1 Front Panel Features

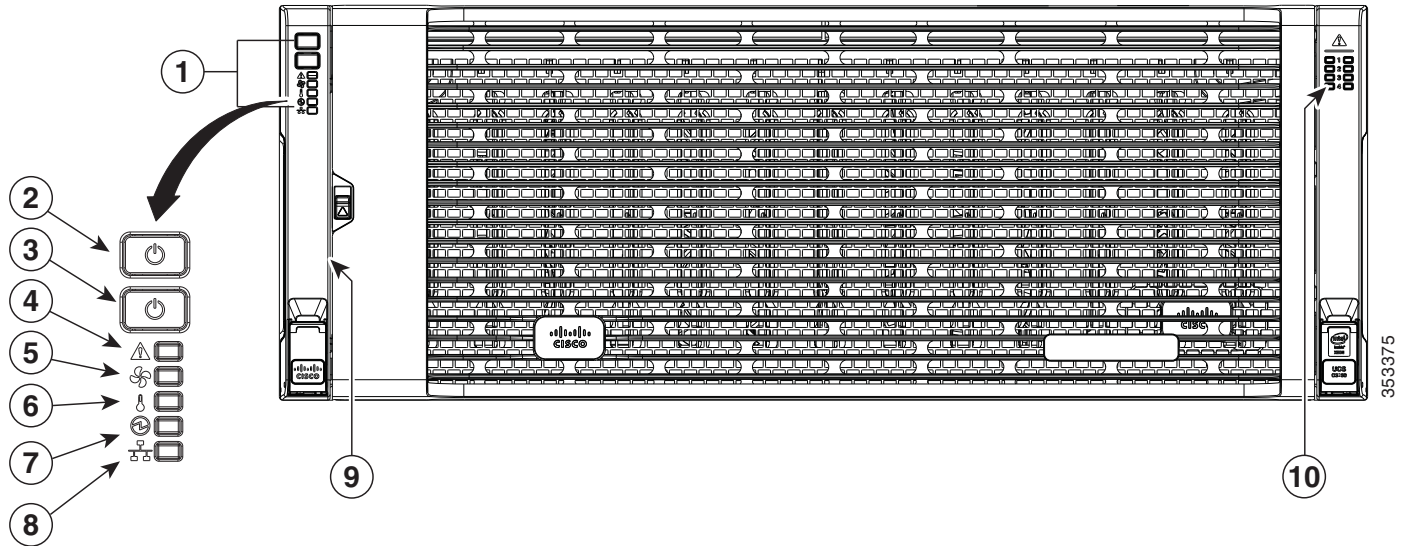

1	Operations panel	6	Temperature status LED
2	System Power button/LED	7	Power supply status LED
3	System unit identification button/LED	8	Network link activity LED
4	System status LED	9	Pull-out asset tag (not visible under front bezel)
5	Fan status LED	10	Internal-drive status LEDs

Rear Panel Features

Figure 1-2 Rear Panel Features (S3260 M5 Server Node With I/O Expander and Version 03 SIOC's Shown)

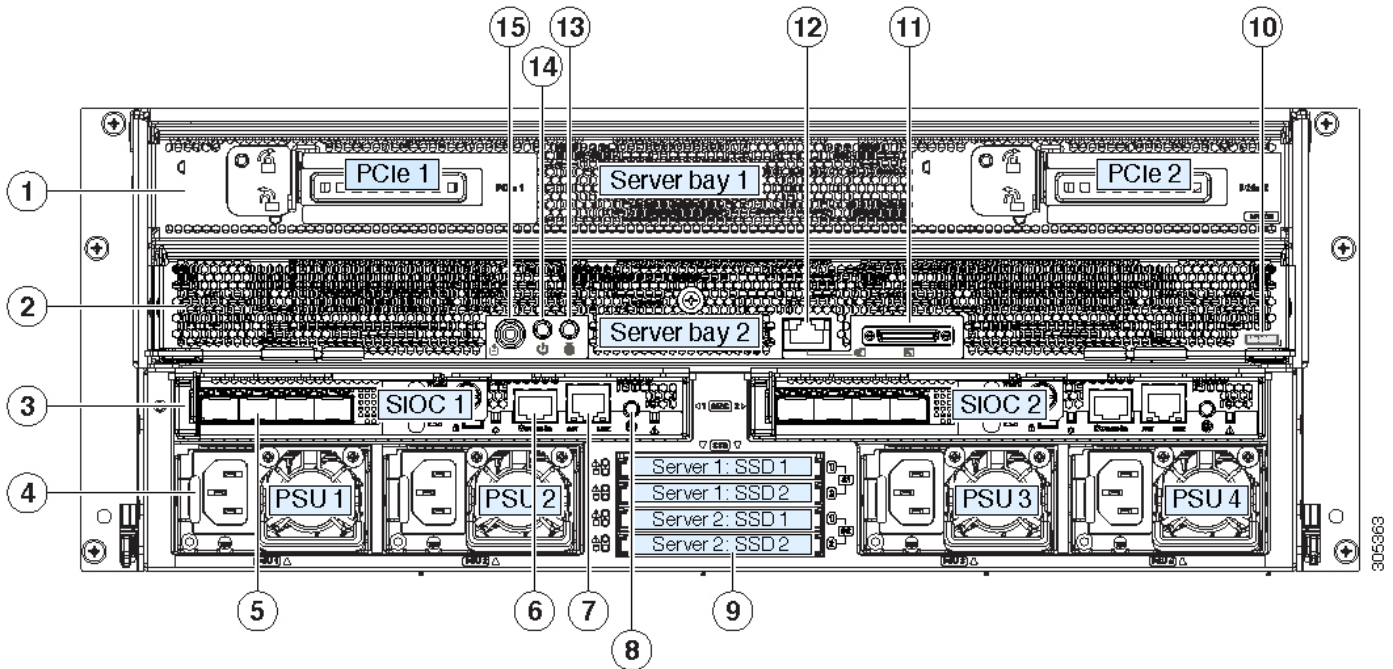

1	Server bay 1 <ul style="list-style-type: none"> (Optional) I/O expander, as shown (attaches to C3X60 M4 or S3260 M5 server node only) (Optional) server node 	9	Solid state drive bays (up to four 2.5-inch SAS SSDs) <ul style="list-style-type: none"> SSDs in Server 1 bays 1 and 2 require a server node in server bay 1 SSDs in Server 2 bays 1 and 2 require a server node in server bay 2
2	Server bay 2 <ul style="list-style-type: none"> (Optional) server node (S3260 M5 shown) (Optional) disk expansion tray 	10	S3260 M5 server node label (M5 SVRN) or C3X60 M4 server node label (M4 SVRN) Note: This label identifies an M4 or M5 server node. The C3X60 M3 server node does not have a label.
3	System I/O controller (SIOC) (Version 03 SIOC's shown) <ul style="list-style-type: none"> SIOC 1 is required if you have a server node in server bay 1 SIOC 2 is required if you have a server node in server bay 2 	11	KVM console connector (one each server node) Used with a KVM cable that provides two USB, one VGA, and one serial connector
4	Power supplies (four, redundant as 3+1)	12	1 Gb Ethernet LOM port (RJ-45)
5	QSFP ports (each SIOC) When using the Version 03 SIOC as shown, the ports vary depending on which adapter card is installed.	13	Server node unit identification button/LED
6	Chassis Management Controller (CMC) Debug Firmware Utility port (one each SIOC)	14	Server node power button
7	10/100/1000 dedicated management port, RJ-45 connector (one each SIOC)	15	Server node reset button (resets the chipset in the server node)
8	Not used at this time		

Replaceable Component Locations

This section contains the following topics:

- [Replaceable Components Inside the Main Chassis, page 1-4](#)
- [Components Inside the C3X60 Server Node, page 1-6](#)
- [Components Inside the I/O Expander, page 1-6](#)
- [Components Inside the System I/O Controller, page 1-7](#)

Replaceable Components Inside the Main Chassis

This section shows the locations of the replaceable components that are inside the main chassis. Some components are accessible from the rear panel and others are accessible by opening the top covers.

The top view of the system in [Figure 1-3](#) shows the top covers open.

**Note**

The internal drives and cooling fans in the system are hot-swappable and are accessed by opening the top covers. When you rack and cable the system, be sure to allow enough slack in the power cords and other cables so that the system can be pulled out on the slide rails far enough to allow clearance for opening the top covers.

Figure 1-3 Replaceable Components Inside the Main Chassis (Top View and Rear View)

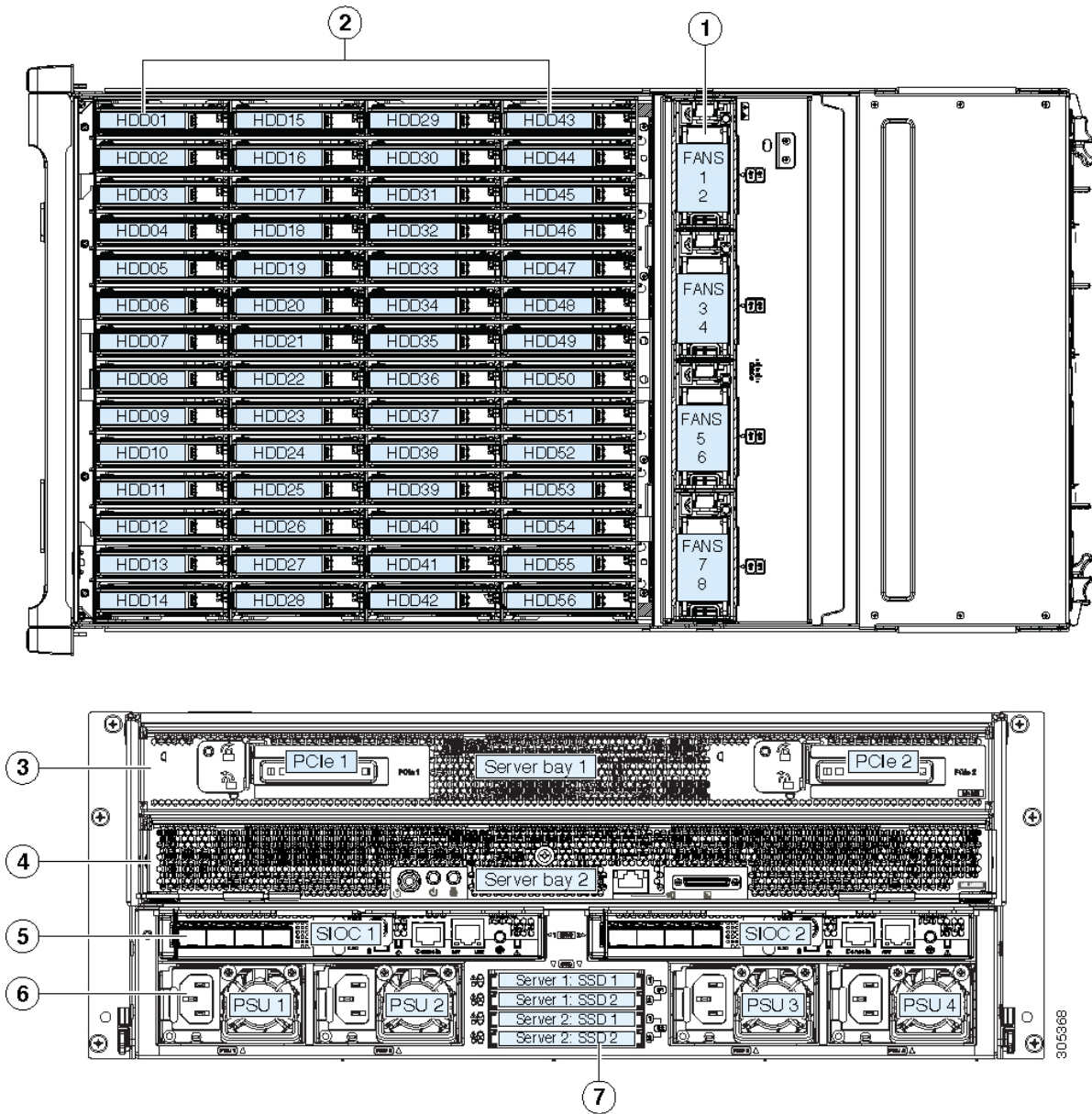

1	Fan modules (four, hot-swappable) Each fan module contains two fans.	5	System I/O controllers (SIOCs) (one or two)
2	Top-loading drive bays (up to 56 3.5-inch HDDs or SSDs, hot-swappable)	6	Power supplies (four, redundant as 3+1)
3	Server bay 1 <ul style="list-style-type: none"> • (Optional) I/O expander, as shown (with M4 or M5 server node only) • (Optional) server node 	7	2.5-inch SAS SSDs (up to four)
4	Server bay 2 <ul style="list-style-type: none"> • (Optional) server node (C3X60 M4 shown) • (Optional) disk expansion tray 		

Components Inside the C3X60 Server Node

For the locations of the replaceable components that are inside a server node, see the service note for your server node:

- [Cisco UCS C3X60 M3 Server Node For Cisco UCS S3260 System Service Note](#)
- [Cisco UCS C3X60 M4 Server Node For Cisco UCS S3260 System Service Note](#)
- [Cisco UCS S3260 M5 Server Node For Cisco UCS S3260 System Service Note](#)

Components Inside the I/O Expander

The C3X60 M4 or S3260 M5 server node might include an optional I/O expander that attaches to the top of the server node. For the locations of the replaceable components that are inside an I/O expander, see the service note for your server node:

- [Cisco UCS C3X60 M4 Server Node For Cisco UCS S3260 System Service Note](#)
- [Cisco UCS S3260 M5 Server Node For Cisco UCS S3260 System Service Note](#)

Components Inside the System I/O Controller

This section shows the locations of the replaceable components that are inside the system I/O controller (SIOC), which is accessible from the rear of the chassis.

- The Version 02 SIOC (UCSC-S3260-SIOC) uses an integrated Cisco UCS VIC 1300 Series chip on-board, so there is no removable adapter card. The only replaceable component is an RTC battery.
- The Version 03 SIOC (UCS-S3260-PCISIOC) uses a removable PCIe-style adapter card (half-height, half-length, Gen-3, x8 lane). It also supports up to two 2.5-inch NVMe SSDs and an RTC battery.



Note The Version 03 SIOC is supported only with S3260 M5 server node. It is not supported with earlier server nodes.

Figure 1-4 Replaceable Components Inside the Version 02 SIOC (UCSC-S3260-SIOC)

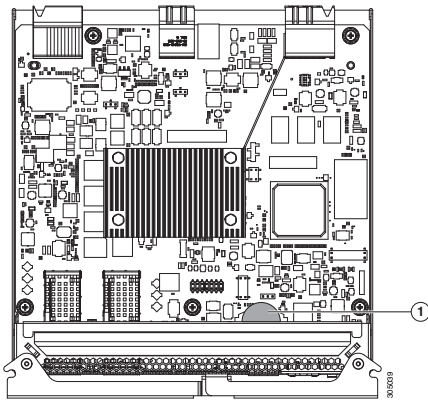

1	RTC battery CR1632
----------	--------------------

Figure 1-5 Replaceable Components Inside the Version 03 SIOC (UCS-S3260-PCISIOC)

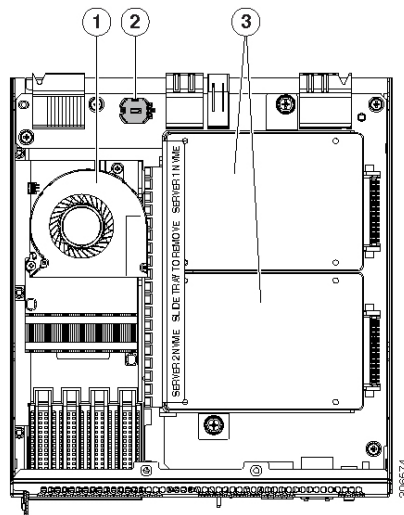

1	PCIe-style adapter card plugs into horizontal socket	3	Up to two 2.5-inch NVMe SSDs plug into two horizontal sockets (both SSDs are secured to a single drive sled).
2	RTC battery CR1632		

Overview of Cisco UCS S3260 Architecture

This section describes the high-level organization of the system’s management and data architecture, in relation to the hardware.

Management Architecture

The system uses a chassis management controller (CMC) to manage the server nodes. Each system I/O controller (SIOC) module contains an onboard CMC. If you have two SIOCs, the two CMCs act in an active/standby organization. The CMC in the SIOC that you log into with the Cisco IMC interface becomes the active CMC and it allows you to manage the board management controllers (BMCs) in *both* server nodes.

When you connect to the system to manage the server nodes’ BMCs via the Cisco IMC interface, you physically connect to the ports on a SIOC. When you log into the Cisco IMC interface, you use a system management IP address. Each CMC and each BMC also has an IP address for internal communication.

All user interfaces run only on the active CMC. Configuration changes are automatically synchronized between the active and standby CMCs.

The active CMC will fail over to the standby CMC when any of the following conditions occur:

- The active CMC is rebooted or fails.
- The SIOC with active CMC is removed.
- Network connectivity is lost on the active CMC.

Figure 1-6 shows an example of a system with two server nodes in which there is a physical connection to the QSFP ports on both SIOCs, but the SIOC 1 CMC is the active CMC that manages both server nodes.

Figure 1-6 Management Architecture

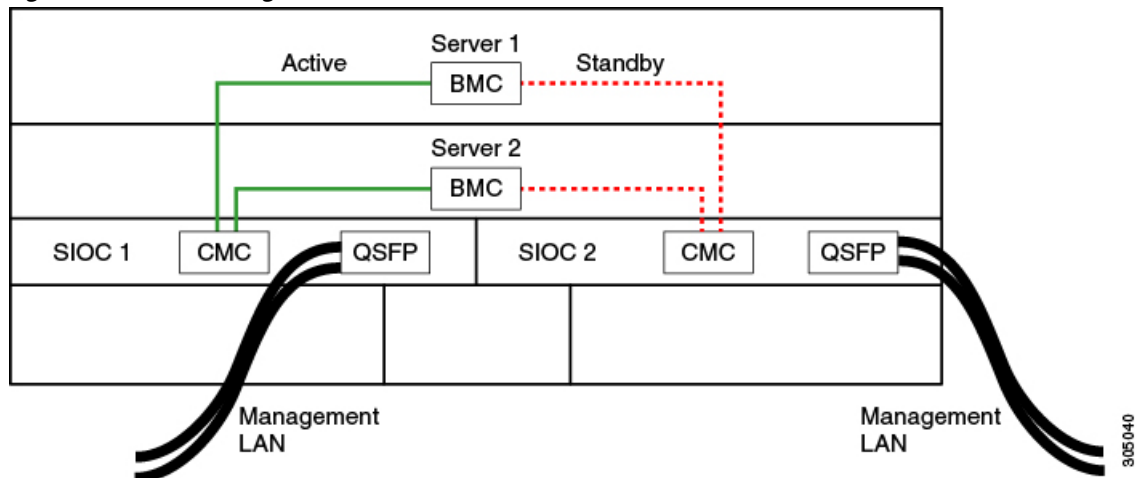
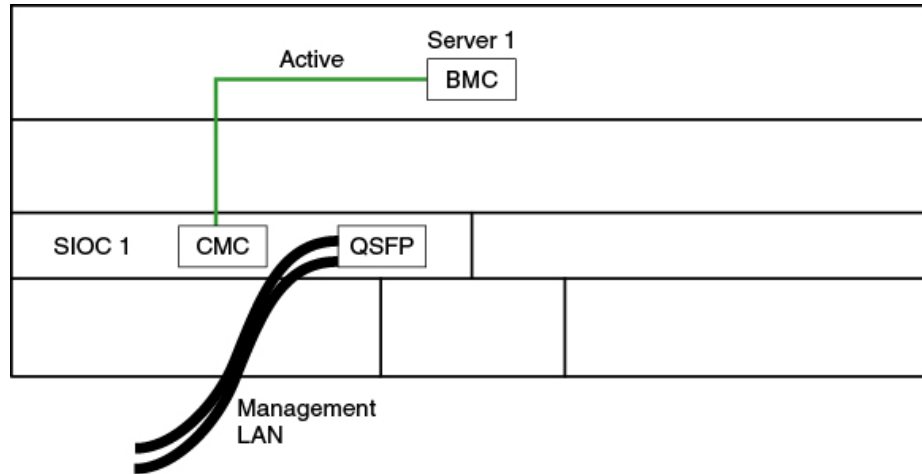

Figure 1-6 shows an example of a system with one server node and one SIOC. In this case, there is no standby or failover.

Figure 1-7 Management Architecture



305-407

Data Architecture

The data plane architecture has different associations between components than the management plane. The diagram shown in [Figure 1-8](#) illustrates the following associations for a dual-server system:

- The data bus in server node 1 connects through SIOC 1.
- The data bus in server node 2 connects through SIOC 2.
- Server 1 SSDs 1 and 2 can be controlled by a RAID controller card in server node 1.
- Server 2 SSDs 1 and 2 can be controlled by a RAID controller card in server node 2.

Figure 1-8 Data Architecture in a Dual-Server System

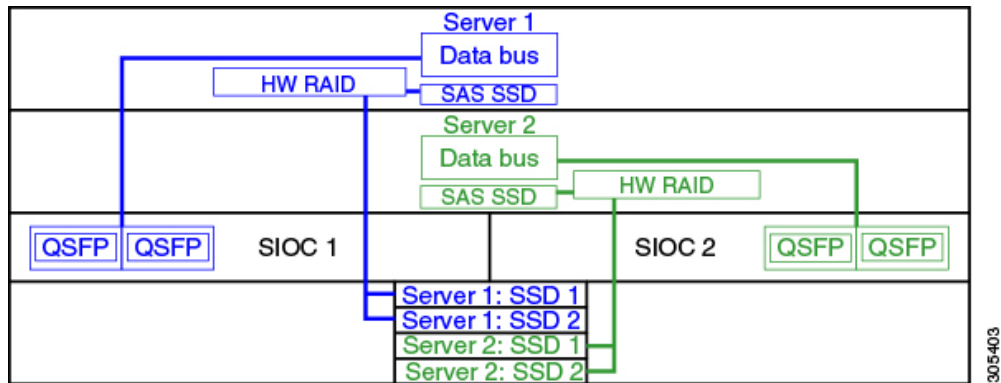

305403

The diagram shown in [Figure 1-9](#) illustrates the following associations for a single-server system:

- The data bus in server node 2 connects through SIOC 2.
- Server 2 SSDs 1 and 2 can be controlled by a RAID controller card in server node 2.

Figure 1-9 Data Architecture in a Single-Server System With I/O Expander

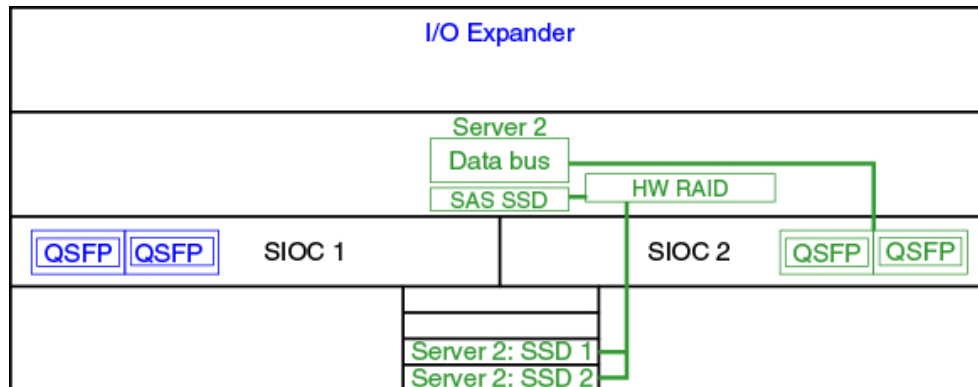

305244

System Features Overview

Table 1-1 lists the features of the system.

Table 1-1 Cisco UCS S3260 System Features

Chassis	Four rack-unit (4RU) chassis.
Processors	<ul style="list-style-type: none"> • C3X60 M3 server nodes: Two Intel Xeon E5-2600 v2 Series processors inside each server node. • C3X60 M4 server nodes: Two Intel Xeon E5-2600 v4 Series processors inside each server node. • S3260 M5 server nodes: Two CPUs from the Intel Xeon Processor Scalable Family. This includes CPUs from the following series: <ul style="list-style-type: none"> – Intel Xeon Silver 4XXX Processors – Intel Xeon Gold 5XXX and 6XXX Processors
Memory	Up to 14 DIMMs inside each server node.
Multi-bit error protection	This system supports multi-bit error protection.
Storage	<p>The system has the following storage options:</p> <ul style="list-style-type: none"> • Up to 56 top-loading 3.5-inch hard drives • Up to four 3.5-inch rear-loading hard drives in an optional disk expansion tray. • Up to four 2.5-inch, rear-loading SATA solid state drives (SSDs) • M4 server node: one 2.5-inch, NVMe SSD inside each server node; M5 server node: two 2.5-inch, NVMe SSDs inside each server node. • Version 03 SIOC only: two 2.5-inch NVMe SSDs inside each SIOC.
Disk Management	<p>The system supports up to two storage controllers:</p> <ul style="list-style-type: none"> • One dedicated mezzanine-style socket for a Cisco storage controller card inside each server node • One dedicated mezzanine-style socket for a Cisco 12G modular storage controller inside the optional I/O expander (when used with C3X60 M4 server nodes) <p> Note The storage controllers that are supported in the S3260 M5 server node are not supported in the I/O expander.</p>
RAID Backup	<p>The supercap battery backup mounts to the RAID controller card.</p> <p>The dual RAID controller used in M5 server nodes uses two supercap units.</p>
PCIe I/O	<ul style="list-style-type: none"> • The optional I/O expander provides two 8x Gen 3 PCIe expansion slots. • Version 03 SIOC only: one 8x Gen 3 PCIe expansion slot.

Table 1-1 Cisco UCS S3260 System Features (continued)

Network and management I/O	<p>The system can have one or two system I/O controllers (SIOCs). These provide rear-panel management and data connectivity.</p> <ul style="list-style-type: none"> • Two QSFP ports each SIOC. • One 10/100/1000 Ethernet dedicated management port on each SIOC. <p>The server nodes each have one rear-panel KVM connector that can be used with a KVM cable, which provides two USB, one VGA DB-15, and one serial DB-9 connector.</p>
Power	Four power supplies, hot-swappable and redundant as 3+1. All installed power supplies must be identical.
Cooling	Four internal fan modules that pull front-to-rear cooling, hot-swappable. Each fan module contains two fans.
Baseboard management	<p>Cisco Integrated Management Controller (Cisco IMC) firmware.</p> <p>Depending on your NIC mode settings, the Cisco IMC can be accessed through the SIOC dedicated management port or the SIOC QSFP ports.</p> <p>See also Management Architecture, page 1-8.</p>