



# User Guide

## **SUMMARY**

This guide provides technical specifications and information about monitor features, setting up the monitor, and using the monitor.

## Legal information

© Copyright 2021 HP Development Company, L.P.

DisplayPort™, the DisplayPort™ logo, and VESA® are trademarks or registered trademarks owned by the Video Electronics Standards Association (VESA) in the United States and other countries. HDMI, the HDMI Logo and High-Definition Multimedia Interface are trademarks or registered trademarks of HDMI Licensing LLC. Intel and Thunderbolt are trademarks of Intel Corporation or its subsidiaries in the U.S. and/or other countries. Linux® is the registered trademark of Linus Torvalds in the U.S. and other countries. macOS is a trademark of Apple Inc. NVIDIA, the NVIDIA logo, and G-SYNC are trademarks and/or registered trademarks of NVIDIA Corporation in the U.S. and other countries. Windows is either a registered trademark or trademark of Microsoft Corporation in the United States and/or other countries.

The information contained herein is subject to change without notice. The only warranties for HP products and services are set forth in the express warranty statements accompanying such products and services. Nothing herein should be construed as constituting an additional warranty. HP shall not be liable for technical or editorial errors or omissions contained herein.

### Product notice

This guide describes features that are common to most models. Some features may not be available on your product. To access the latest user guide, go to <http://www.hp.com/support>, and follow the instructions to find your product. Then select **Manuals**.





First Edition: October 2021

Document part number: M91022-001

---

# About this guide

This guide provides technical specifications and information about monitor features, setting up the monitor, and using the software. Depending on the model, your monitor may not have all the features included in this guide.

- 
-  **WARNING!** Indicates a hazardous situation that, if not avoided, **could** result in serious injury or death.
  -  **CAUTION:** Indicates a hazardous situation that, if not avoided, **could** result in minor or moderate injury.
  -  **IMPORTANT:** Indicates information considered important but not hazard-related (for example, messages related to property damage). Warns the user that failure to follow a procedure exactly as described could result in loss of data or in damage to hardware or software. Also contains essential information to explain a concept or to complete a task.
  -  **NOTE:** Contains additional information to emphasize or supplement important points of the main text.
  -  **TIP:** Provides helpful hints for completing a task.
- 



This product incorporates HDMI technology.

---

# Table of contents

<b>1 Getting started</b>	<b>1</b>
Important safety information	1
More HP resources	2
Preparing to call technical support	2
Getting to know your monitor	2
Features	2
Front components	4
Rear components	5
Locating the serial number and product number	5
Setting up the monitor	6
Attaching the monitor stand	6
Mounting the monitor head	7
Removing the monitor stand	7
Attaching the monitor head to a mounting device	8
Video connection combinations	9
Connecting the cables	11
HP Device Bridge	13
Connecting USB devices (select products only)	14
Adjusting the monitor (select products only)	14
Installing a security cable	15
Turning on the monitor	16
HP watermark and image retention policy	16
<b>2 Using the monitor</b>	<b>17</b>
Downloading software and utilities	17
The Information file	17
The Image Color Matching file	17
Using the OSD menu	18
Using the OSD function buttons	18
Reassigning the function buttons	20
Selecting the input source	20
Changing the Power Mode setting (select products only)	21
Using Auto-Sleep Mode (select products only)	21
Using the camera	21
Setting up Windows Hello facial recognition	22
Using the computer camera for Windows Hello	23
Using the monitor camera for Windows Hello	23
Using PbP	23

<b>3 Setting up HP Device Bridge .....</b>	<b>25</b>
Windows.....	25
macOS .....	25
Linux.....	26
Using HP Device Bridge.....	26
Transferring files and data .....	27
Windows and macOS.....	27
Linux.....	27
Stopping HP Device Bridge .....	28
Windows.....	28
macOS .....	28
Linux.....	28
<b>4 Support and troubleshooting .....</b>	<b>29</b>
Solving common issues .....	29
Button lockouts.....	30
<b>5 Maintaining the monitor .....</b>	<b>31</b>
Maintenance guidelines.....	31
Cleaning the monitor .....	31
Shipping the monitor .....	32
<b>Appendix A Technical specifications .....</b>	<b>33</b>
100.8 cm (39.7 in) model specifications .....	33
Preset display resolutions .....	34
100.8 cm (39.7 in) model.....	34
Energy saver feature .....	35
<b>Appendix B Accessibility .....</b>	<b>36</b>
HP and accessibility .....	36
Finding the technology tools you need .....	36
The HP commitment .....	36
International Association of Accessibility Professionals (IAAP) .....	37
Finding the best assistive technology .....	37
Assessing your needs .....	37
Accessibility for HP products .....	37
Standards and legislation.....	38
Standards.....	38
Mandate 376 – EN 301 549.....	38
Web Content Accessibility Guidelines (WCAG) .....	38
Legislation and regulations.....	39
Useful accessibility resources and links .....	39
Organizations.....	39
Educational institutions.....	39
Other disability resources.....	40
HP links .....	40

Contacting support .....	40
<b>Index .....</b>	<b>41</b>

---

# 1 Getting started

Read this chapter to learn about safety information and where to find additional HP resources.

## Important safety information

A power cord might be included with the monitor. If you use another cord, use only a power source and connection appropriate for this monitor. For information about the correct power cord set to use with the monitor, see the *Product Notices* provided in your documentation kit.

---

 **WARNING!** To reduce the risk of electric shock or damage to the equipment:

- Plug the power cord into an AC outlet that is easily accessible at all times.
- If the power cord has a three-pin attachment plug, plug the cord into a grounded (earthed) three-pin outlet.
- Disconnect power from the computer by unplugging the power cord from the AC outlet. When unplugging the power cord from the AC outlet, grasp the cord by the plug.

---

For your safety, do not place anything on power cords or cables. Take care to route all cords and cables connected to the monitor so that they cannot be stepped on, pulled, grabbed, or tripped over.

To reduce the risk of serious injury, read the *Safety & Comfort Guide* provided with your user guides. It describes proper workstation setup and proper posture, health, and work habits for computer users. The *Safety & Comfort Guide* also provides important electrical and mechanical safety information. The *Safety & Comfort Guide* is also available on the web at <http://www.hp.com/ergo>.

---

 **IMPORTANT:** For the protection of the monitor and the computer, connect all power cords for the computer and its peripheral devices (such as a monitor, printer, scanner) to a surge protection device such as a power strip or uninterruptible power supply (UPS). Not all power strips provide surge protection; the power strip must be specifically labeled as having this capability. Use a power strip whose manufacturer offers a damage replacement policy so that you can replace the equipment if surge protection fails.

---

Use the appropriate and correctly sized furniture designed to properly support your monitor.

---

 **WARNING!** Monitors that are inappropriately situated on dressers, bookcases, shelves, desks, speakers, chests, or carts could fall over and cause personal injury. This equipment is not suitable for use in locations where children are likely to be present.

 **WARNING! Stability hazard:** The device might fall, causing serious personal injury or death. To prevent injury, securely attach the monitor to the floor or wall in accordance with the installation instructions.

 **NOTE:** This product is suitable for entertainment purposes. Consider placing the monitor in a controlled luminous environment to avoid interference from surrounding light and bright surfaces that might cause disturbing reflections from the screen.

---

## More HP resources

Use this table to locate resources that provide product details, how-to information, and more.

**Table 1-1 Additional information**

Resource	Contents
Setup Instructions	Overview of monitor setup and features
HP support	<p>For HP support or to resolve a hardware or software problem, go to <a href="http://www.hp.com/support">http://www.hp.com/support</a>, and follow the instructions to find your product.</p> <p>– or –</p> <p>Select the <b>Search</b> icon in the taskbar, type <code>support</code> in the search box, and then select <b>HP Support Assistant</b>.</p> <p>– or –</p> <p>Select the question mark icon in the taskbar.</p>

**NOTE:** Contact customer support to replace the power cord, the AC adapter (select products only), or any other cables that shipped with your monitor.

## Preparing to call technical support

Use this information if you have to troubleshoot an issue.

If you cannot solve a problem using [Support and troubleshooting on page 29](#), a call to technical support can provide additional help. Have the following information available when you call.

- Monitor model number
- Monitor serial number
- Purchase date on invoice
- Conditions under which the problem occurred
- Error messages received
- Hardware configuration
- Name and version of the hardware and software that you are using

## Getting to know your monitor

Your monitor has top-rated features. This section provides details about your components, where they are located, and how they work.

### Features

Depending on the model, your monitor might include the following features:



## Display features

- Three-sided borderless 100.8 cm (39.7 in) curved diagonal viewable screen area with 5120 × 2160 @ 60 Hz resolution, plus full-screen support for lower resolutions; includes custom scaling for maximum image size while preserving original aspect ratio
- Liquid crystal display (LCD) with active matrix and in-plane switching (IPS)
- Wide color gamut to provide coverage of sRGB and P3(D65) color spaces
- Nonglare panel with an LED backlight
- Wide viewing angle to allow viewing from a sitting or standing position, or moving from side to side
- Tilt, swivel, and height adjustment capabilities
- Dual Picture beside Picture (PbP) functionality to enable the DisplayPort™, High-Definition Multimedia Interface™ (HDMI), and Thunderbolt™ inputs to be viewed in each half of the screen
- Integrated pop-up infrared (IR) and RGB camera with noise canceling microphones for conferencing and Microsoft Windows® Hello support
- Integrated HP Device Bridge technology that allows you to use a single keyboard and mouse across two connected computers to control software and transfer files and data from one computer to the other
- Five on-screen display (OSD) buttons, four that you can reconfigure to quickly allow selection of the most commonly used operations
- On-screen display (OSD) adjustments in several languages for easy setup and screen optimization
- Color space preset for P3(D65)
- Energy saver feature to meet requirements for reduced power consumption
- Security cable slot on the rear of the monitor for an optional security cable
- Cable management feature for placement of cables and cords

## Connectors

- DisplayPort video input (cable included in select regions)
- HDMI video input
- Two USB Type-C® Thunderbolt ports (cable included in select regions)
- RJ-45 (network) jack
- Four USB ports (downstream)
- Plug and Play capability, if supported by your operating system

## Monitor stand

- Removable stand for flexible monitor head mounting solutions
- HP Quick Release 2 device to quickly attach the monitor head to the stand with a click, and then remove it with the convenient sliding tab release
- VESA® mounting bracket for attaching the monitor head to a wall-mount device or swing arm

- VESA mounting capability (100 × 100 mm) for attaching the monitor to a swing arm mount
- Support for a mounting bracket to attach the monitor to a workstation

 **NOTE:** For safety and regulatory information, see the *Product Notices* provided in your documentation kit. To access the latest user guide, go to <http://www.hp.com/support>, and follow the instructions to find your product. Then select **Manuals**.

## Front components

To identify the components on the front of the monitor, use this illustration and table.

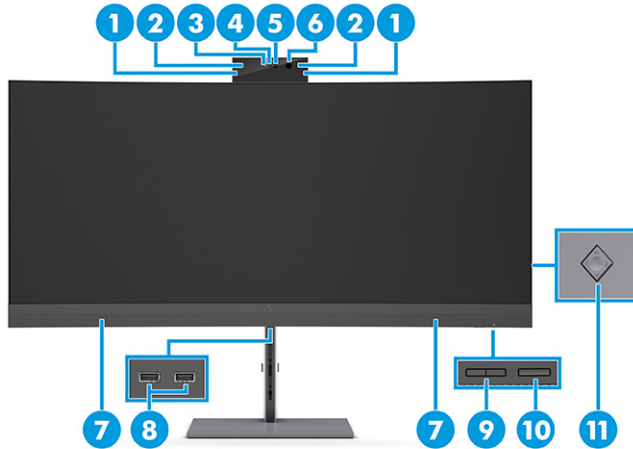
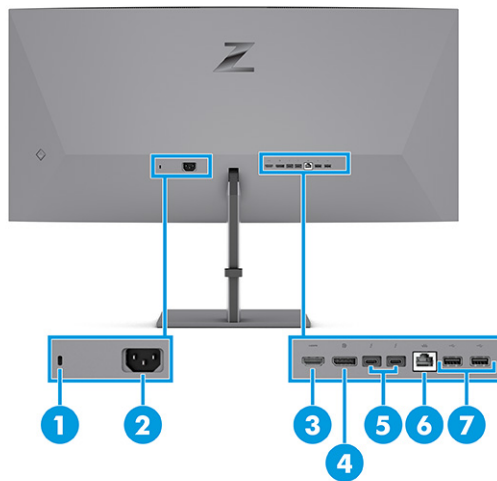

**Table 1-2 Front components and their descriptions**

Component	Description
(1) Tilt levers	Allow you to tilt the camera.
(2) Camera microphones	Allow you to participate in a video conference.
(3) Camera light	On: The camera is in use.
(4) Camera RGB lens	Transmits your image in a video conference.
(5) Camera IR lens	Transmits your image for Windows Hello facial recognition.
(6) Camera IR light	Additional IR light for facial recognition. <b>NOTE:</b> You might not be able to see the camera IR light when it is on.
(7) Speakers	Produce sound. You can control the audio volume from the OSD menu in the <b>Input</b> menu. <b>NOTE:</b> For the best audio experience, connect a USB cable from your monitor to your computer, and then select your monitor as the sound device.
(8) USB ports (downstream)	Connect a USB cable to a peripheral device, such as a keyboard, mouse, or USB hard drive, and supports battery charging.
(9) PbP or brightness buttons	The buttons function as left and right when PbP is on and brightness plus and minus when PbP is off.
(10) Power button	Turns the monitor on or off.
(11) OSD control	Activates the OSD buttons so that the button labels appear on the right side of the screen.

## Rear components

To identify the components on the rear of the monitor, use this illustration and table.



**Table 1-3** Rear components and their descriptions

Component	Description
(1) Security cable slot	Connects an optional security cable.
(2) Power connector	Connects your monitor to a power outlet.
(3) HDMI port	Connects the HDMI cable to a source device such as a computer or game console.
(4) DisplayPort connector	Connects the DisplayPort cable to a source device such as a computer or game console.
(5) USB Type-C Thunderbolt ports (2)	Connect the Thunderbolt or USB Type-C cable to a source device such as a computer or game console. The left hand side port is USB Type-C (1) and right hand side port is USB Type-C (2). <b>NOTE:</b> Use a standard USB Type-C charging cable or cable adapter (purchased separately) when charging a small external device.
(6) RJ-45 (network) jack	Connects a network cable.
(7) USB ports (downstream) (2)	Connect a USB cable to a peripheral device, such as a keyboard, mouse, or USB hard drive, and supports battery charging.

## Locating the serial number and product number

Depending on the product, the serial number and product number are located on a label on the rear of the monitor or on a label under the front bezel of the monitor head. You might need these numbers when contacting HP for support.



## Setting up the monitor

This section describes attaching the monitor stand or wall mount and the options for connecting your monitor to a PC, notebook, gaming console, or similar device.

- 
- ⚠ WARNING!** To reduce the risk of serious injury, read the *Safety & Comfort Guide*. It describes proper workstation setup and proper posture, health, and work habits for computer users. The *Safety & Comfort Guide* also provides important electrical and mechanical safety information. The *Safety & Comfort Guide* is available on the web at <http://www.hp.com/ergo>.
  - 📄 IMPORTANT:** To prevent damage to the monitor, do not touch the surface of the LCD panel. Pressure on the panel can cause nonuniformity of color or disorientation of the liquid crystals. If this occurs, the screen will not recover to its normal condition.
  - 📄 IMPORTANT:** To prevent the screen from getting scratched, defaced, or broken and to prevent damage to the control buttons, position the monitor facedown on a flat surface covered with protective sheet foam or a nonabrasive cloth.
- 

## Attaching the monitor stand

Correctly attaching your monitor stand is critical for safe use. This section describes how to safely attach a stand.

- 
- 💡 TIP:** Consider the placement of the monitor, because surrounding light and bright surfaces might cause interfering reflections.
  - 📄 NOTE:** The procedures for attaching a monitor stand might be different on other models.
- 

1. Position the monitor head facedown in the box, and then attach the stand to the connector on the back of the monitor. The latch on the stand clicks when the stand is locked in place.
2. Attach the base into the bottom of the monitor stand (1).

3. Rotate the captive screw clockwise to tighten the base (2).

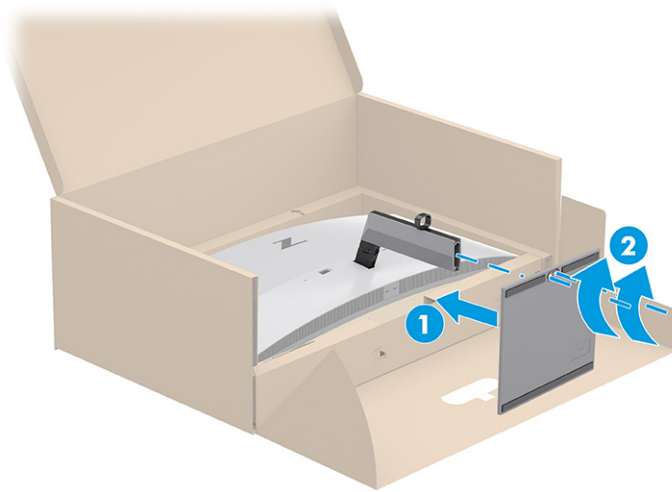
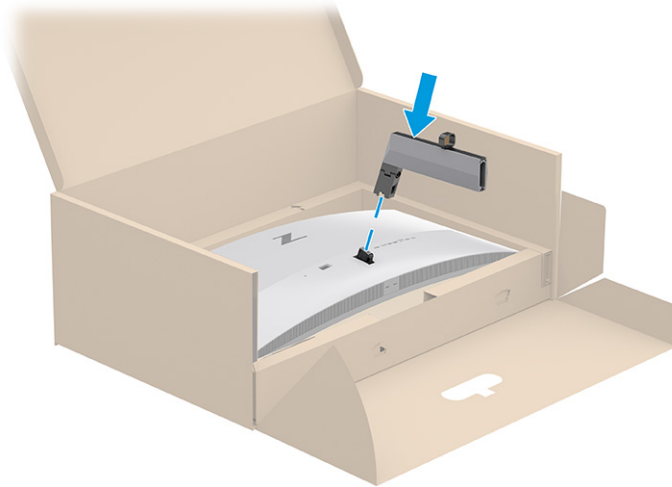

## Mounting the monitor head

To attach your monitor to a wall using a swing arm or other mounting fixture, follow the steps in this section to safely and securely connect your monitor.

 **IMPORTANT:** This monitor supports the VESA industry-standard 100 mm mounting holes. To attach a third-party mounting solution to the monitor head, use four 4 mm, 0.7 pitch, and 10 mm long screws. Longer screws might damage the monitor. Be sure that the manufacturer's mounting solution is compliant with the VESA standard and is rated to support the weight of the monitor head. For best performance, use the power and video cables provided with the monitor.

 **NOTE:** This apparatus is intended to be supported by a UL-listed or CSA-listed wall-mount bracket.

## Removing the monitor stand

If you decide to use a wall mount instead of the monitor stand that you attached, first remove the stand.

 **IMPORTANT:** Before you disassemble the monitor, be sure that the monitor is turned off and all cables are disconnected.

 **IMPORTANT:** To position and stabilize the monitor, HP recommends that two people perform these procedures.

---

1. Disconnect and remove all cables from the monitor.
2. Position the monitor upside-down on the top edge on a flat surface covered by a protective sheet made of foam or a clean, dry cloth.
3. Push up the latch near the bottom center of the stand's hinge (1).
4. Slide the stand out of the recess (2).

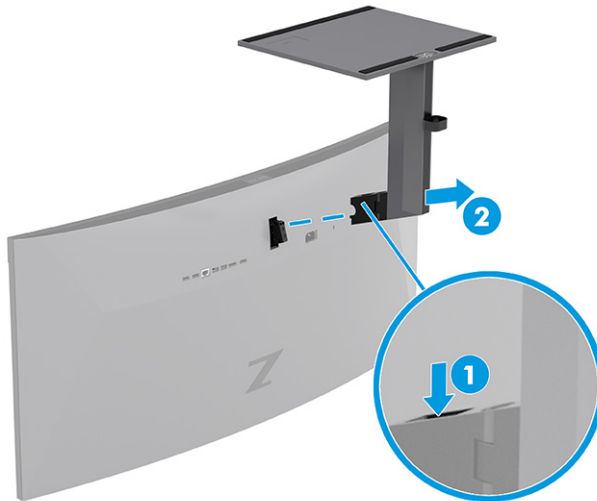

### Attaching the monitor head to a mounting device

You might need additional tools such as a screwdriver (purchased separately) when you attach a mounting device. To avoid damage to your monitor, follow these instructions.

1. Remove two screws (1) and plastic from the hinge (2), located on the rear of the monitor head.

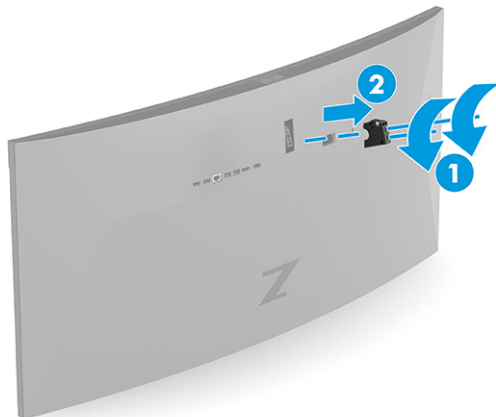

2. Install the VESA mounting bracket (1). Fit two screws into the VESA cover hole (2).

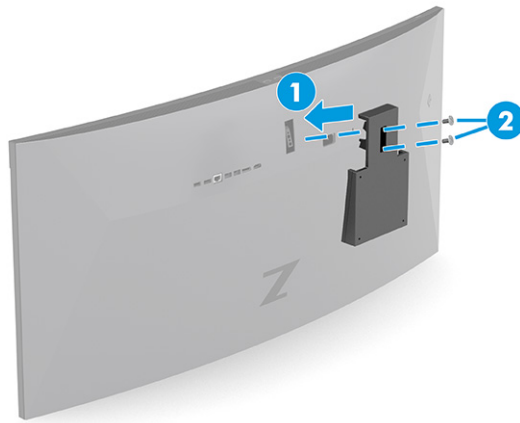

3. To attach the monitor head to a swing arm or other mounting device, insert four mounting screws through the holes on the mounting device and into the VESA screw holes on the back of the monitor head.

 **IMPORTANT:** If these instructions do not apply to your device, then follow the mounting device manufacturer's instructions when mounting the monitor to a wall or swing arm.

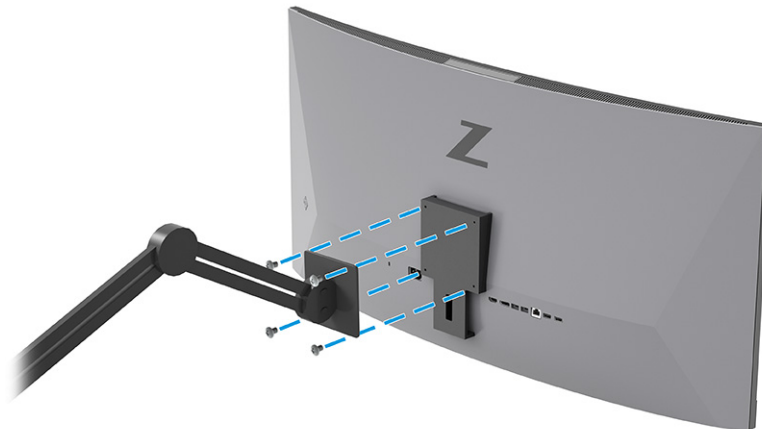

## Video connection combinations

The following table lists the active video connection, image display location, upstream connection, and power delivery connection for each combination of host computer video connections.

**Table 1-4 Video connection combinations**

First USB Type-C port	Second USB Type-C port	DisplayPort	HDMI	Left image	Right image	Manual swap <sup>1</sup>
USB Type-C Thunderbolt cable <sup>2</sup>	USB Type-C Thunderbolt cable	No video	No video	Second USB Type-C port	First USB Type-C port	OK

**Table 1-4 Video connection combinations (continued)**

First USB Type-C port	Second USB Type-C port	DisplayPort	HDMI	Left image	Right image	Manual swap <sup>1</sup>
(Video alternate mode & data)  PD Max. up to 100 W <sup>3</sup>  5	(Video alternate mode & data) <sup>4</sup>  PD Max. up to 100 W  6					
USB Type-C Thunderbolt cable  (Video alternate Mode + Data)  PD Max. up to 100 W	USB to USB Type-C cable  (Data for DP input)  No PD function	Video	No video	First USB Type-C port	DisplayPort	OK
USB Type-C Thunderbolt cable  (Video alternate mode & data)  PD Max. up to 100 W	USB to USB Type-C cable  (Data for HDMI input)  No PD function	No video	Video	First USB Type-C port	HDMI	OK
USB to USB Type-C cable  (Data for DP input)  No PD function	USB Type-C Thunderbolt cable  (Video alternate mode & data)  PD Max. 100 W	Video	No video	Second USB Type-C port	DisplayPort	OK
USB to USB Type-C cable  (Data for DP input)  No PD function	Thunderbolt cable  (Video alternate mode & data)  PD Max. 100 W	No video	Video	Second USB Type-C port	HDMI	OK
USB to USB Type-C cable  (Data for DP input)  No PD function	USB to USB Type-C cable  (Data for HDMI input)  No PD function	Video	Video	DisplayPort	HDMI	OK
USB to USB Type-C cable  (Data for HDMI input)	USB to USB Type-C cable  (Data for DP input)	Video	Video	DisplayPort	HDMI	OK



**Table 1-4 Video connection combinations (continued)**

First USB Type-C port	Second USB Type-C port	DisplayPort	HDMI	Left image	Right image	Manual swap <sup>1</sup>
No PD function	No PD function					

<sup>1</sup> Select **Assign PbP Inputs to Manual**, and select and swap two inputs when you use DP & HDMI; be sure **USB Host** is set properly to enable HP Device Bridge.

<sup>2</sup> The USB Type-C Thunderbolt cable is included in the box.

<sup>3</sup> This is the power delivery measurement.

<sup>4</sup> This is the DisplayPort alternate mode.

<sup>5</sup> **NOTE:** Be sure that the first USB Type-C port is plugged-in and receives power before you plug in a cable to the second USB Type-C port. It can charge up to 100 W. If the first USB Type-C port is connected to the computer and only needs 65 W to charge, then the second USB Type-C port supports up to 100 W charge.

<sup>6</sup> **NOTE:** Be sure that the second USB Type-C port is plugged-in and receives power before you plug in a cable into the first USB Type-C port. It can charge up to 100 W. If the second USB Type-C port is connected to the computer and only needs 65 W to charge, then the first USB Type-C port supports up to 100 W charge.

## Connecting the cables

In addition to details about how to connect a cable, this section contains information about how your monitor functions when you connect certain cables.

 **NOTE:** Depending on the model, the monitor might be capable of supporting HDMI, DisplayPort, or Thunderbolt inputs. The video mode is determined by the video cable used. The monitor automatically determines which inputs have valid video signals. You can select the inputs through the OSD menu. The monitor ships with select cables. Not all cables shown in this section are included with the monitor.

1. Place the monitor in a convenient, well-ventilated location near the computer.
2. Connect a video cable.
  - Connect one end of a DisplayPort cable to the DisplayPort connector on the rear of the monitor and the other end to the DisplayPort connector on the source device.

 **NOTE:** You must connect the USB Type-C to USB cable between the monitor and source device (computer) to enable HP Device Bridge and the USB ports on the monitor (the USB Type-C to USB cable is included in select regions).

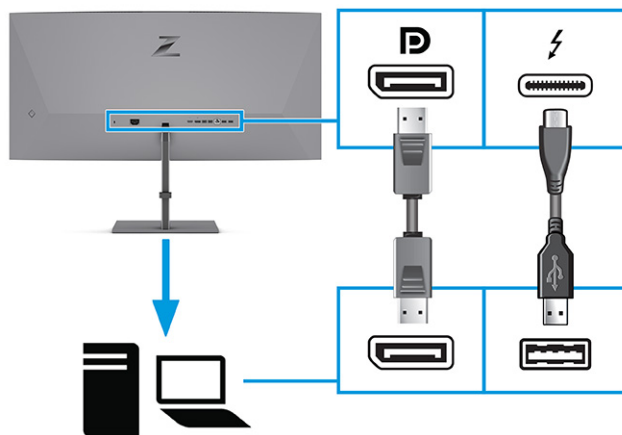

- Connect one end of an HDMI cable to the HDMI port on the rear of the monitor and the other end to the HDMI port on the source device.

 **NOTE:** You must connect the USB Type-C to USB cable between the monitor and source device (computer) to enable HP Device Bridge and the USB ports on the monitor (the USB Type-C to USB cable is included in select regions).

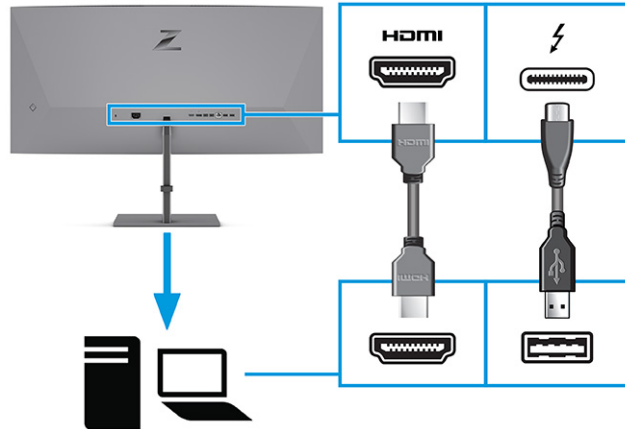

- Connect one end of a Thunderbolt cable to the Thunderbolt port on the rear of the monitor and the other end to the Thunderbolt port on the source device. (Use only the HP-approved Thunderbolt cable provided with the monitor.)

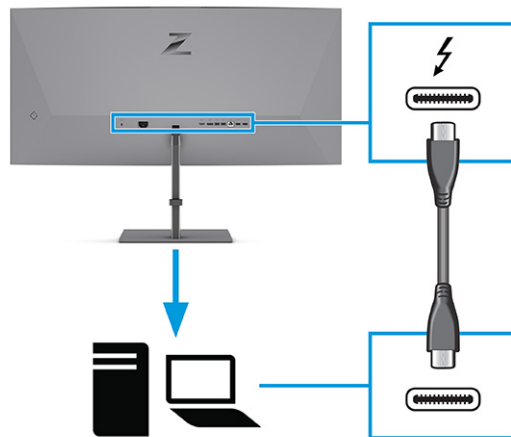

- Connect one end of a network cable to the network jack on the monitor and the other end to a network wall jack or router.

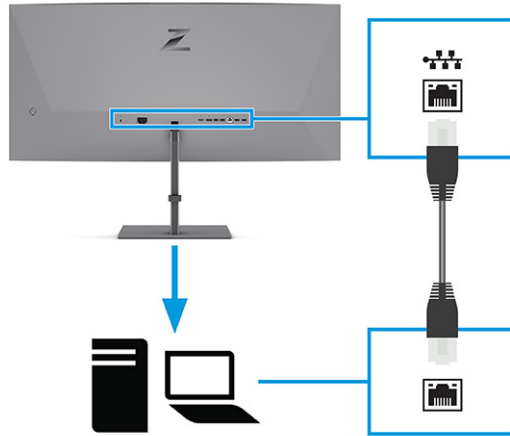

---

 **NOTE:** To enable the network function, be sure that the USB Type-C Thunderbolt port is connected.

---

3. Connect one end of the power cord to the monitor and the other end to a grounded AC outlet.
- 

 **WARNING!** To reduce the risk of electric shock or damage to the equipment:

Do not disable the power cord grounding plug. The grounding plug is an important safety feature.

Plug the power cord into a grounded (earthed) AC outlet that is easily accessible at all times.

Disconnect power from the equipment by unplugging the power cord from the AC outlet.

For your safety, do not place anything on power cords or cables. Arrange them so that no one can accidentally step on or trip over them. Do not pull on a cord or cable. When unplugging the power cord from the AC outlet, grasp the cord by the plug.

---

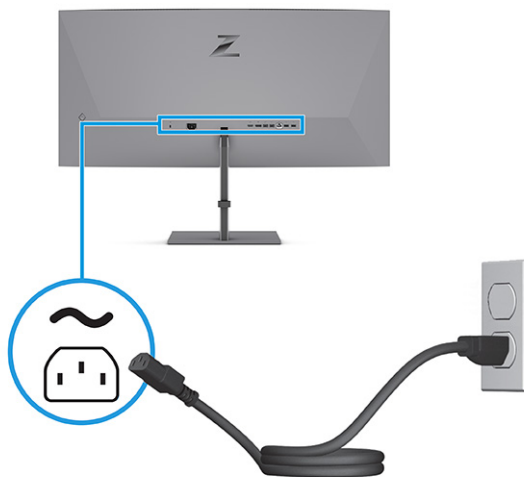

## HP Device Bridge

You need HP Device Bridge to enable the monitor to use a single keyboard and mouse across two connected host computers to control software and transfer files and data from one computer to the other. HP Device Bridge is available for Windows and macOS and Linux host computers.

## Connecting USB devices (select products only)

Use USB ports to connect devices such as a digital camera, USB keyboard, or USB mouse. There are four USB ports on the monitor to connect to a device (downstream): two USB ports on the rear, and two USB ports under the front bezel of the monitor.

See [Front components on page 4](#) and [Rear components on page 5](#) for the location of the USB ports.

 **NOTE:** You must connect the Thunderbolt cable from the source device (computer) to the rear of the monitor to enable the USB ports to serve as a USB hub for a mouse, keyboards, phones, external hard drives, and practically anything that is USB-connected and can accept 5 V.

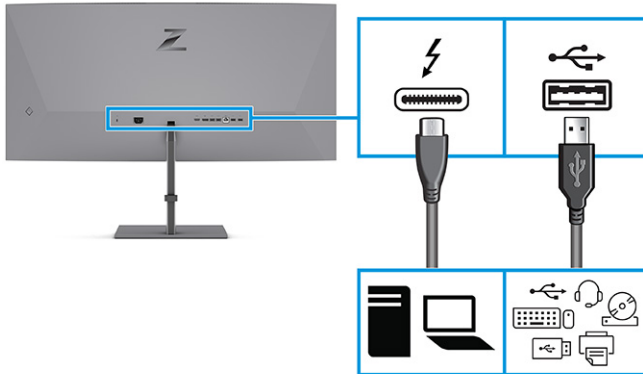

## Adjusting the monitor (select products only)

To support an ergonomic work space, your monitor offers the adjustment options outlined in this section.

 **WARNING!** To reduce the risk of serious injury, read the *Safety & Comfort Guide*. It describes proper workstation setup and proper posture, health, and work habits for computer users. The *Safety & Comfort Guide* also provides important electrical and mechanical safety information. The *Safety & Comfort Guide* is available on the web at <http://www.hp.com/ergo>.

1. Tilt the monitor head forward or backward to set it to a comfortable eye level.



2. Adjust the monitor's height to a comfortable position for your individual workstation. The monitor's top bezel edge should not exceed a height that is parallel to your eye height. A monitor that is positioned low and reclined might be more comfortable for users with corrective lenses. Reposition your monitor as you adjust your working posture throughout the work day.

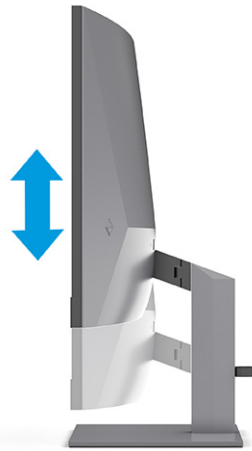

3. Swivel the monitor head to the left or right for the best viewing angle.

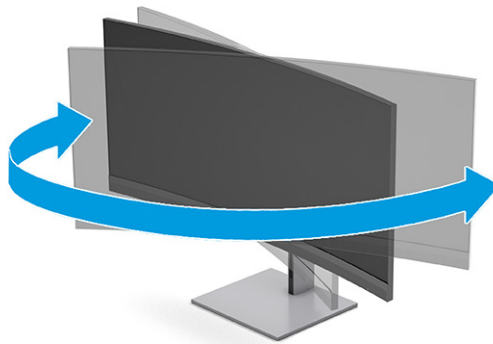

## Installing a security cable

As a security measure, you can secure the monitor to a fixed object with an optional security cable available from HP. Use the key that came with the optional security cable to attach and remove the lock.

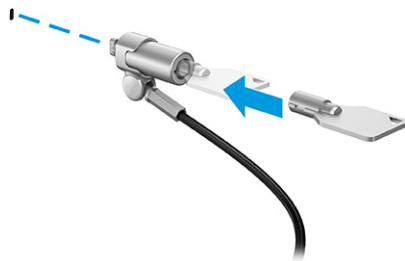

## Turning on the monitor

This section provides important information about preventing damage to your monitor, startup indicators, and troubleshooting information.

 **IMPORTANT:** Burn-in image damage might occur on monitors that display the same static image on the screen for 12 or more hours. To avoid burn-in image damage, you should always activate a screen saver application or turn off the monitor when it will not be in use for a prolonged period of time. Image retention is a condition that might occur on all LCD screens. Burn-in damage on the monitor is not covered under the HP warranty.

 **NOTE:** If pressing the power button has no effect, the Power Button Lockout feature might be enabled. To disable this feature, press and hold the monitor power button for 10 seconds.

 **NOTE:** On select HP monitors, you can disable the power light in the OSD menu. Press the **Menu** button to open the OSD, select **Power**, select **Power LED**, and then select **Off**.

- ▲ Press the power button on the monitor to turn it on.



When you first turn on your monitor, a monitor status message is displayed for 5 seconds. The message shows which input is the current active signal, the status of the auto-switch source setting (On or Off; default setting is On), the current preset display resolution, and the recommended preset display resolution.

The monitor automatically scans the signal inputs for an active input and uses that input for the display.

## HP watermark and image retention policy

Some monitors are designed with In-Plane Switching (IPS) display technology, which provides ultrawide viewing angles and advanced image quality. Though suitable for many applications, this panel technology is not suitable for static, stationary, or fixed images for long periods of time, unless you use screen savers.

Applications with static images can include camera surveillance, video games, marketing logos, and templates. Static images can cause image retention damage that could look like stains or watermarks on the monitor's screen.

Image retention damage on monitors that are in use 24 hours per day is not covered under the HP warranty. To avoid image retention damage, always turn off the monitor when it is not in use, or use the power management setting, if supported on your computer, to turn off the monitor when the computer is idle.

---

## 2 Using the monitor

This chapter describes how to use your monitor and its features, including software and utilities, the OSD menu, the function buttons, power modes, and Windows Hello.

### Downloading software and utilities

You can download and install these files from HP Support.

- HP Device Bridge for Windows
- HP Device Bridge for macOS
- HP Device Bridge for Linux
- INF (Information) file
- ICM (Image Color Matching) files

To download the files:

1. Go to <http://www.hp.com/support>.
2. Select **Software and Drivers**.
3. Select your product type.
4. Enter your HP monitor model in the search field and follow the on-screen instructions.

### The Information file

The INF file defines monitor resources used by Windows® operating systems to ensure monitor compatibility with the computer's graphics adapter.

This monitor is Plug and Play compatible, and the monitor will work correctly without installing the INF file. Monitor Plug and Play compatibility requires that the computer's graphics card is VESA DDC2 compliant and that the monitor connects directly to the graphics card. Plug and Play does not work through separate BNC-type connectors or through distribution buffers, boxes, or both.

### The Image Color Matching file

The ICM files are data files that are used in conjunction with graphics programs to provide consistent color matching from monitor screen to printer, or from scanner to monitor screen. These files are activated from within graphics programs that support this feature.



**NOTE:** The ICM color profile is written in accordance with the International Color Consortium (ICC) Profile Format specification.

---

## Using the OSD menu

You can adjust your HP monitor to suit your preferences. Use the OSD menu to customize the viewing features of your monitor.

To access and make adjustments in the OSD:

- Use the buttons at the bottom of the monitor's front bezel.
- or -
- Use the OSD controller on the monitor's rear panel.

To access the OSD menu and make adjustments:

1. If the monitor is not already on, press the power button to turn on the monitor.
2. Press the **Menu** button or, if you are using the OSD controller, press the center of the OSD controller.
3. Use the five function buttons to navigate, select, and adjust the menu choices. The on-screen button labels vary, depending on which menu or submenu is active.

-or-

Move the controller up, down, left, or right to navigate menu choices. Press the center of the controller to make a selection.

The following table lists possible menu selections in the OSD main menu. It includes descriptions for each setting and its impacts on your monitor's appearance or performance.

**Table 2-1 OSD menu options and descriptions for using a button or a controller (select products only)**

Main menu	Description
Brightness+	Adjusts the brightness, contrast levels, dynamic contrast, black stretch level, and video level.
Color	Selects and adjusts the screen color and provides a variety of color presets that configure the monitor for different viewing situations.
Image	Adjusts the screen image, including response time, sharpness, image scaling, and HDMI overscan settings.
Input	Selects the video input signal and adjusts related settings.
Picture beside Picture (PbP)	Adjusts PbP settings (turning on or off and assigning inputs) and enables or disables HP Device Bridge file transfer.
Power	Adjusts the power settings.
Menu	Adjusts the OSD controls including language, position, transparency, timeout, messages, and assignable buttons.
Management	Shows information, adjusts the DDC/CI and Audio settings, and returns all OSD menu settings to the factory default settings.
Exit	Exits the OSD menu screen.

## Using the OSD function buttons

The function buttons offer useful actions, and you can customize all but one of them to make them even more useful.





**NOTE:** The actions of the function buttons vary among monitor models.

For information about changing the function of the buttons, see [Reassigning the function buttons on page 20](#).

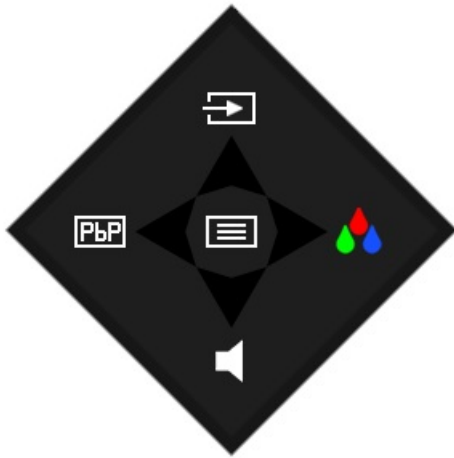

**Table 2-2 Button names and descriptions**



Button	Description
<b>Left</b> PbP On or Off button (function assignable)	Switches PbP on or off.
<b>Right</b> Color button (function assignable)	Opens the <b>Color</b> menu.
<b>Up</b> Next Active Input button (function assignable)	Switches to the next active video inputs.  If only one input is active or there are no active inputs detected, then pressing the <b>Next Input</b> button will show the <b>Input Control</b> menu.
<b>Down</b> Volume button (function assignable)	Opens the <b>Volume</b> adjust slider.
<b>Center</b> Menu button	Opens the OSD main menu, selects a menu item from the OSD, or closes the OSD menu.

When PbP mode is on with two host computers connected to the monitor, the icons above the buttons change as shown in the following table.

**Table 2-3 PbP or brightness buttons and descriptions**

PbP	Two-button menu	Description
Off		Opens the <b>Brightness</b> menu with the <b>Brightness</b> adjustment window/mode active.
On		Switches the left side to full screen and the right side to full screen.

**Table 2-3 PbP or brightness buttons and descriptions (continued)**

PbP	Two-button menu	Description
On		Turns split screen on and switches the right side to full screen.
On		Switches the left side to full screen and turns the right side to split screen.

## Reassigning the function buttons

Except for the center button, you can change the action associated with a function button from the default action so that you can quickly access your most commonly used menu items.

To reassign the function buttons:

1. Press the center button of the OSD controller to open the OSD menu.
2. Select **Assign Buttons**, and then select one of the available options for the button that you want to assign.

## Selecting the input source

The monitor has four video input connectors.

- Two USB Type-C Thunderbolt (DP alternate mode)
- DisplayPort
- HDMI

The monitor automatically scans all video input sources to search for an active video input signal. The scan sequence is USB Type-C (2), USB Type-C (1), DisplayPort, and HDMI.

If multiple host computers are connected to the monitor and PbP is off, then you can change the video input source by pressing the **Next Active Input** button on the OSD shortcut menu or by going to the OSD menu, selecting **Input**, and choosing your video input source. The following table lists menu options in the **Input** menu functions:

**Table 2-4 Input menu options and descriptions**

Option	Description
USB-C (1) Video	Selects USB Type-C (1) as the active video input source.
USB-C (2) Video	Selects USB Type-C (2) as the active video input source.
DisplayPort	Selects DisplayPort as the active video input source.
HDMI	Selects HDMI as the active video input source.
Auto-Switch Input	Sets Auto-Switch Input to On or Off.
DP Hot-Plug Detection	Selects Low Power or Always Active.

**Table 2-4 Input menu options and descriptions (continued)**

Option	Description
DisplayPort Mode	Selects DisplayPort 1.1 or DisplayPort 1.2 mode.

## Changing the Power Mode setting (select products only)

This section describes how to activate Performance mode. Certain features on your monitor might require Performance mode to be active.

When in sleep mode, to comply with international power standards, the monitor default setting is Power Saver mode.

If your monitor supports Performance mode, then to keep the USB ports enabled when the monitor is in Auto-Sleep Mode, change the Power Mode setting from **Power Saver** to **Performance**.

 **NOTE:** If you are connecting a computer that is not battery powered, the Power Mode setting must be changed to Performance mode.

To change the power mode setting:

1. Press the **Menu** button to open the OSD menu.
2. Select **Power**, select **Power Mode**, and then select **Performance**.
3. Select **Back** and close the OSD.

## Using Auto-Sleep Mode (select products only)

Your monitor has an energy-saving feature called Auto-Sleep Mode, a reduced power state. This section describes how to activate or adjust Auto-Sleep Mode on your monitor.

When Auto-Sleep Mode is enabled (enabled by default), the monitor enters a reduced power state when the computer signals low power mode (absence of either horizontal or vertical sync signal).

Upon entering this reduced power state (Auto-Sleep mode), the monitor screen is blanked, the backlight turns off, and the power light turns amber. The monitor draws less than 0.5 W of power when in this reduced power state. The monitor wakes from Auto-Sleep mode when the computer sends an active signal to the monitor (for example, when you activate the mouse or keyboard).

To disable Auto-Sleep Mode in the OSD:

1. Press the **Menu** button to open the OSD, or press the center of the OSD controller to open the OSD.
2. In the OSD, select **Power**.
3. Select **Auto-Sleep Mode**, and then select **Off**.

## Using the camera

To unlock the camera, gently press down until it clicks. The camera rises up to the uppermost position.

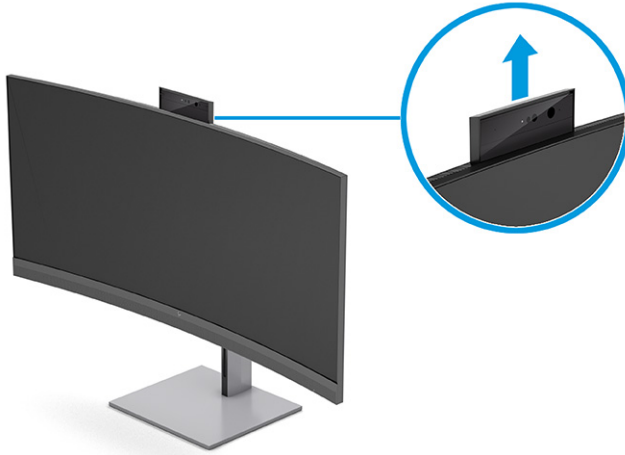

You can use the camera on the monitor when you sign in to Windows Hello facial recognition, maintain conversation security, and conduct video conferencing.

---

 **NOTE:** For video conferencing, connect the computer to the monitor. Select **HP Display Camera** from the video-conferencing interface.

---

When the camera is closed, the microphone is turned off.

When the camera is not in use, you can close the camera by pressing down on it until it clicks into the closed position.

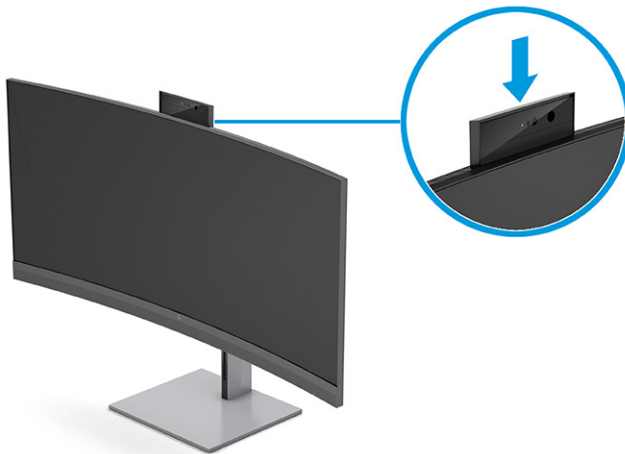

## Setting up Windows Hello facial recognition

In select products, you can use Windows Hello facial recognition to gain quick, secure access to your computer. You can establish facial recognition by using either the camera on your computer or the camera on your monitor.

Be sure that the camera is in the up position for setting up Windows Hello facial recognition.

---

 **NOTE:** Windows Hello is only supported on the Windows 10 operating system.

---

## Using the computer camera for Windows Hello

Follow these steps to set up Windows Hello facial recognition on a device with a Windows Hello camera.

1. Download the HP Windows Hello software driver from <http://support.hp.com/us-en/drivers/products>.
2. Connect the monitor to the computer and turn on the computer and monitor.
3. Right-click the Windows desktop and select **Display settings**.
4. Select the 100.8 cm (39.7 in) monitor and scroll down to the **Multiple displays** section.
5. From the drop-down menu, select **Extend desktop to this display**.
6. Select the **Make this my main display** check box.
7. Select the **Start** button, select **Settings**, select **Accounts**, and then select **Sign-in options**.
8. Under **Windows Hello**, select **Set up** under **Face Recognition**.
9. Under **Welcome to Windows Hello**, select **Get Started**, and then follow the on-screen instructions to enroll your facial ID and set up a personal identification number (PIN).

You can now use the infrared (IR) camera on the monitor to log in when using Windows Hello.

## Using the monitor camera for Windows Hello

Even if your computer does not have a Windows Hello camera, you can still set up Windows Hello facial recognition using the IR camera on your monitor.

1. Select the **Start** button, select **Settings**, select **Accounts**, and then select **Sign-in options**.
2. Under **Windows Hello**, select **Set up** under **Face Recognition**.
3. Under **Welcome to Windows Hello**, select **Get Started**, and then follow the on-screen instructions to enroll your facial ID and set up a PIN.

You can now use the IR camera on the monitor to log in when using Windows Hello.

## Using PbP

The monitor supports PbP, where one source is positioned adjacent to another. The monitor default setting for PbP is **On, Automatic**.

When PbP is in automatic mode:

- The host computer attached to the USB Type-C (1) port or HDMI video connector appears on the right side of the PbP image.
- The host computer attached to the USB Type-C (2) port or DisplayPort video connector appears on the left side of the PbP image.
- The default upstream connection is connected to the host computer that is connected to the USB Type-C (1) port. The default upstream connection cannot be changed.
- The priority in power negotiation goes to the host computer connected to the USB Type-C (1) port.

- The host computer connected to the USB Type-C (2) port is guaranteed a minimum of 65 W of power and maximum of 100 W of power, or any watts remaining after power is supplied to the USB Type-C (1) port (165 W minus the power currently being used by the USB Type-C (1) port, up to a maximum of 100 W). If the USB Type-C (1) port is using the maximum 65 W of power, then the maximum power remaining for USB Type-C (2) is 100 W.

For the priority in power negotiation and PBP using , see [Video connection combinations on page 9](#).



**NOTE:** When a host computer that does not have battery power is attached to the USB Type-C (1) port on the monitor, the Power Mode setting must be set to Performance mode. For detailed instructions, see [Changing the Power Mode setting \(select products only\) on page 21](#).

PbP can be set to **On, Manual** mode in the PbP OSD menu. In this mode, you can control which side of the screen each host computer appears on (left or right) and which video source is assigned to each host computer. To change PbP to manual mode:

1. With two source devices (host computers) connected to the monitor, press one of the OSD buttons on the rear to activate the buttons.
2. Press the **Menu** button to open the OSD.
3. In the OSD, select **PbP**, select **On**, and then select **Manual**.
4. Under **Set Left Side**, select the video input source to be displayed on the left side of the PbP image.
5. Under **Set Right Side**, select the video input source to be displayed on the right side of the PbP image.



**NOTE:** If PbP is set to **Off**, the monitor displays the image from the host computer that is selected as the active video input source in the **Input** OSD dialog. For more information about the OSD, see [Using the OSD menu on page 18](#).

If you decide to change PbP back to the default **On, Automatic** mode:

1. With two host computers connected to the monitor, press one of the OSD buttons on the rear of the monitor to activate the buttons. Then press the **Menu** button to open the OSD. For the location of the OSD buttons, see [Front components on page 4](#).
2. In the OSD, select **PbP**, and then select **Enable PbP**.

The monitor scans the secondary inputs for a valid video input source and uses that source for the PbP image.

---

## 3 Setting up HP Device Bridge

HP Device Bridge allows two host computers to connect to a single monitor and enables a single keyboard and mouse to control both host computers by switching from one computer to the other. The software also allows you to move files and data from one host computer to the other.

HP Device Bridge is available for the following platforms and must be installed and active on both host computers for the software to work properly:

- Windows
- macOS®
- Linux®

Keep these considerations in mind when using HP Device Bridge:

1. VM simulation systems are not supported.
2. HP Device Bridge works only on select USB host ports.
3. Only Ubuntu 18.04 is tested and supported.
4. If one computer has abnormal HP Device Bridge operation caused by entering sleep, suspend, or restart mode, unplug both upstream ports, restart the software on both computers, and re-plug both upstream ports to return to normal operation.

### Windows

Use this procedure to install HP Device Bridge for Windows.

1. Go to the HP Customer Support website: <http://www.hp.com/support>.
2. Select **Software and Drivers**, and select **Other**.
3. Enter your monitor model name in the product search box, and select **Submit**.
4. Select **Driver-Display / Monitor**.
5. Download and install the **HP Z40c G3 Device Bridge Software**.
6. Double-click `HPDeviceBridge_ForWin.exe` to start the installation.



---

**NOTE:** HP Device Bridge runs in the background. It must be active to enable HP Device Bridge functions.

---

### macOS

Use this procedure to install HP Device Bridge for macOS.

1. Go to the HP Customer Support website: <http://www.hp.com/support>.
2. Select **Software and Drivers**, and select **Other**.

3. Enter your monitor model name in the product search box, and select **Submit**.
4. Select **Choose a different OS**, select **macOS**, and then specify the version.



---

**NOTE:** HP Device Bridge supports:

- 10.15 Catalina
  - 10.14 Mojave
  - 10.13 High Sierra
- 

5. Select **Driver-Display / Monitor**.
6. Download and install the **HP Z40c G3 Device Bridge Software**.

HP Device Bridge runs in the background. It must be active to enable HP Device Bridge functions.

## Linux

Use this procedure to install HP Device Bridge for Linux.

1. Go to the HP Customer Support website: <http://www.hp.com/support>.
2. Select **Software and Drivers**, and select **Other**.
3. Enter your monitor model name in the product search box, and select **Submit**.
4. Select **Choose a different OS**, select **Linux**, and then specify the version.



---

**NOTE:** Only Ubuntu 18.04 is tested and supported.

---

5. Select **Driver-Display / Monitor**.
6. Download and install the **HP Z40c G3 Device Bridge Software**.
7. Be sure that you are connected to the internet.
8. Run `./install_script.sh`.
9. Restart the system.
10. Select the **Show Applications** icon.
11. Select **HP Device Bridge**.



---

**NOTE:** HP Device Bridge runs in the background. It must be active to enable HP Device Bridge functions.

---

## Using HP Device Bridge

HP Device Bridge allows two host computers to connect to a single monitor and transfer files and data between computers using one common keyboard and mouse. HP Device Bridge must be installed on both host computers for the software to function properly.

If either of the host computers is disconnected from the monitor:

- The remaining connected host computer automatically shows on the monitor in full-screen mode.



- The USB upstream connection switches to the remaining connected host computer to enable the USB hub and USB devices.
- The remaining connected host computer can receive up to 100 W of power.

When the disconnected host computer is reconnected:

- HP Device Bridge automatically changes the monitor screen to PbP mode.
- The USB upstream connection switches to the host computer that is connected to the first USB Type-C video port to enable the USB hub and USB devices.
- Power delivery to each of the two host computers returns to the original shared levels.

## Transferring files and data

After HP Device Bridge is installed and active on both host computers, you can move files and data back and forth between host computers. The software enables a single keyboard and mouse to control both host computers by switching from one computer to the other.

### Windows and macOS

If your host computers are running Windows operating system, macOS, or a combination of both, you can transfer files between host computers using the drag-and-drop method, copy-and-paste method, or cut-and-paste method. You can transfer data using the copy-and-paste or cut-and-paste methods; however, you cannot transfer data using the drag-and-drop method.

Follow this procedure to use the drag-and-drop method:

1. Select the file that you want to transfer.
2. Drag the file from one host computer to the other and drop it in the selected location.

Follow this procedure to use the copy-and-paste or cut-and-paste method:

1. Right-click the file to be transferred, and then select **Copy** or **Cut**, or highlight the data to be copied.
2. Right-click the paste location, and then select **Paste**.

### Linux

Follow this procedure to transfer files and data with HP Device Bridge with Linux.

1. You cannot use the desktop software Gnome to paste files. You must use the Paste Files option on HP Device Bridge. Right-click the icon of HP Device Bridge, and select **Paste Files** to paste the files.
2. When the name of file or folder to be copied is the same as the destination, the file or the folder is renamed as xxx (0001).



**NOTE:** Drag-and-Drop is not supported on Linux.

The received files are placed in the `/tmp` directory.



**NOTE:** HP Device Bridge cannot be closed while transferring files.

# Stopping HP Device Bridge

Use the procedures in this section to stop HP Device Bridge.

## Windows

Use this procedure to stop using HP Device Bridge with Windows.

1. Right-click the Windows desktop, and then select **HP Device Bridge**.
2. Select **Exit**.

## macOS

Use this procedure to stop using HP Device Bridge with macOS.

1. Select the HP Device Bridge icon at the top right corner of your screen.
2. Select **Exit**.

## Linux

Use this procedure to stop using HP Device Bridge with Linux.

1. Select the HP Device Bridge icon at the top right corner of the Ubuntu desktop.
2. Select **Exit**.

## 4 Support and troubleshooting

If your monitor is not working as expected, you might be able to resolve the issue by following the instructions in this section.

### Solving common issues

The following table lists possible issues, the possible cause of each issue, and the recommended solutions.

**Table 4-1 Common issues and solutions**

Issues	Possible cause	Solution
Screen is blank or video is blinking.	Power cord is disconnected.	Connect the power cord.
	Monitor is off.	Press the monitor power button.  <b>NOTE:</b> If pressing the power button has no effect, press and hold the power button for 10 seconds to disable the Power Button Lockout feature.
	Video cable is improperly connected.	Connect the video cable properly. For more information, see <a href="#">Connecting the cables on page 11</a> .
	System is in Auto-Sleep Mode.	Press any key on the keyboard or move the mouse to inactivate the screen blanking utility.
	Video card is incompatible.	Open the OSD menu and select the <b>Input</b> menu. Set <b>Auto-Switch Input</b> to <b>Off</b> and manually select the input.  or  Replace the video card or connect the video cable to one of the computer's on-board video sources.
Image appears blurred, indistinct, or too dark.	Brightness setting is too low.	Open the OSD menu, and select <b>Brightness</b> to adjust the brightness scale as needed.
"Check Video Cable" is displayed on the screen.	Monitor video cable is disconnected.	Connect the appropriate video signal cable between the computer and monitor. Be sure that the computer power is off while connecting the video cable.
"Input Signal Out of Range" is displayed on screen.	Video resolution and/or refresh rate are set higher than the monitor supports.	Change the settings to a supported setting (see <a href="#">100.8 cm (39.7 in) model on page 34</a> ).
The monitor does not enter into a low-power sleep state.	The monitor's power saving control is disabled.	Open the OSD menu and select <b>Power</b> , select <b>Auto-Sleep Mode</b> , and then set auto-sleep to <b>On</b> .
"OSD Lockout" is displayed.	The monitor's OSD Lockout function is enabled.	Press and hold the <b>Menu</b> button for 10 seconds to disable the OSD Lockout function.
"Power Button Lockout" is displayed.	The monitor's Power Button Lockout feature is enabled.	Press and hold the <b>Power</b> button for 10 seconds to unlock the power button function.
The camera and USB ports do not work, but the monitor is turned on.	There is no upstream USB connection.	Be sure that the host computer is connected to the monitor with a USB Type-C to USB Type-C cable or a USB Type-C to USB cable.

**Table 4-1 Common issues and solutions (continued)**

Issues	Possible cause	Solution
No power from the USB Type-C or USB ports when the monitor is in sleep mode.	The monitor is in Power Saver mode	Open the OSD menu, select <b>Power</b> , and then change the power mode to <b>Performance</b> .
In PbP mode, the cursor does not move across the two host computer boundaries on the monitor screen.	The two host computers do not have HP Device Bridge installed, HP Device Bridge is not running on both host computers, or a non-TBT host is connected.	Right-click the Windows desktop, and check to see if HP Device Bridge is listed. If HP Device Bridge is not listed, start HP Device Bridge by double-clicking the HP Device Bridge icon on your desktop.  -or-  Change USB-C configuration to 5120 × 2160 @ 30 Hz + USB 3.0 from the default 5120 × 2160 @ 60 Hz + USB 2.0.  Install HP Device Bridge. For more information, see <a href="#">Setting up HP Device Bridge on page 25</a> .
The computer turns off when the monitor enters sleep mode.	The monitor is in Power Saver mode.	Open the OSD menu, select <b>Power</b> , and then change the power mode to <b>Performance</b> .
In PbP mode, the image on the left or right side of the screen is letter boxed.	The monitor is in mirror mode.	Right-click the Windows desktop, and select <b>Display settings</b> . Under <b>Multiple displays</b> , select <b>Extend desktop to this display</b> .
OCI package update fail	The Windows 10 software is not updated.	<ol style="list-style-type: none"> <li>1. Press the <b>Win</b> button.</li> <li>2. Search <b>Core Isolation</b> and select it.</li> <li>3. Turn off the <b>Memory Integrity</b> option.</li> <li>4. Save all tasks and restart the computer.</li> <li>5. Run the Z40C G3 FW update installer again.</li> </ol>

## Button lockouts

The button lockout function is available only when the monitor is on, an active signal is displayed, and the OSD menu is closed. Holding down the power button or **Menu** button for 10 seconds disables that button. You can re-enable the button by holding it down again for 10 seconds.

---

# 5 Maintaining the monitor

Properly maintained, your monitor can run for many years. These instructions provide steps you can perform to keep your monitor in the best condition.

## Maintenance guidelines

Follow these instructions to enhance the performance and extend the life of the monitor.

- Do not open the monitor cabinet or attempt to service this product yourself. Adjust only those controls that are covered in the operating instructions. If the monitor is not operating properly or has been dropped or damaged, contact an authorized HP dealer, reseller, or service provider.
- Use only a power source and connection appropriate for this monitor, as indicated on the label or back plate of the monitor.
- Be sure that the total ampere rating of the products connected to the outlet does not exceed the current rating of the AC outlet and that the total ampere rating of the products connected to the cord does not exceed the rating of the cord. Look on the power label to determine the ampere rating (AMPS or A) for each device.
- Install the monitor near an outlet that you can easily reach. Disconnect the monitor by grasping the plug firmly and pulling it from the outlet. Never disconnect the monitor by pulling the cord.
- Turn the monitor off when it is not in use, and use a screen saver program. Doing this can substantially increase the life expectancy of the monitor.



**NOTE:** A burned-in image on the monitor is not covered under the HP warranty.

---

- Never block the slots and openings of the cabinet or push objects into them. These openings provide ventilation.
- Do not drop the monitor or place it on an unstable surface.
- Do not allow anything to rest on the power cord. Do not walk on the cord.
- Keep the monitor in a well-ventilated area, away from excessive light, heat, or moisture.

## Cleaning the monitor

Use these instructions to clean your monitor when necessary.

1. Turn off the monitor and unplug the power cord from the AC outlet.
2. Disconnect any external devices.
3. Dust the monitor by wiping the screen and the cabinet with a soft, clean antistatic cloth.

4. For more difficult cleaning situations, use a 50/50 mix of water and isopropyl alcohol.

---

 **IMPORTANT:** Do not use cleaners that contain petroleum-based materials such as benzene, thinner, or any volatile substance to clean the monitor screen or cabinet. These chemicals might damage the monitor.

 **IMPORTANT:** Spray the cleaner onto a cloth and use the damp cloth to gently wipe the screen surface. Never spray the cleaner directly on the screen surface. It can run behind the bezel and damage the electronics. The cloth should be moist, but not wet. Water dripping into the ventilation openings or other points of entry can cause damage to the monitor. Allow the monitor to air-dry before use.

---

5. After you remove the dirt and debris, you can also clean the surfaces with a disinfectant. The World Health Organization (WHO) recommends cleaning surfaces, followed by disinfection, as a best practice for preventing the spread of viral respiratory illnesses and harmful bacteria. A disinfectant that is within HP's cleaning guidelines is an alcohol solution consisting of 70% isopropyl alcohol and 30% water. This solution is also known as rubbing alcohol and is sold in most stores.

## Shipping the monitor

Keep the original packing box in a storage area. You might need it later if you ship the monitor or move.

# A Technical specifications

This section contains technical specifications for the physical aspects of your monitor, such as the weight and viewing dimensions, as well as required environmental operating conditions and power source ranges.

All specifications represent the typical specifications provided by HP component manufacturers; actual performance can vary either higher or lower.

 **NOTE:** For the latest specifications or additional specifications for this product, go to <http://www.hp.com/go/quickspecs/> and search for your specific monitor model to find the model-specific QuickSpecs.

## 100.8 cm (39.7 in) model specifications

This section provides specifications for your monitor.

**Table A-1** Technical specifications

Specification	Measurement	
<b>Display, wide-screen</b>	<b>100.80 cm</b>	39.70 in
Type	IPS	
<b>Viewable image size</b>	<b>100.80 cm diagonal</b>	39.70 in diagonal
<b>Maximum weight (unpacked)</b>	<b>14.30 kg</b>	31.53 lbs
<b>Dimensions (include base)</b>		
Height (highest position)	<b>64.48 cm</b>	25.38 in
Height (lowest position)	<b>49.48 cm</b>	19.48 in
Depth	<b>29.25 cm</b>	11.52 in
Width	<b>94.74 cm</b>	37.30 in
<b>Tilt</b>	<b>-5° to 20°</b>	
<b>Swivel</b>	<b>±30°</b>	
<b>Environmental requirements temperature</b>		
Operating temperature	<b>5°C to 35°C</b>	41°F to 95°F
Storage temperature	<b>-20°C to 60°C</b>	-4°F to 140°F
Storage humidity	5% to 95% (noncondensing)	
<b>Power source</b>	100 V ac to 240 V ac 50/60 Hz	
<b>Input terminal</b>	One HDMI port, one DisplayPort connector, and two Thunderbolt connectors	

# Preset display resolutions

The following display resolutions are the most commonly used modes and are set as factory defaults. The monitor automatically recognizes these preset modes, and they will appear properly sized and centered on the screen.

## 100.8 cm (39.7 in) model

This section provides preset display resolutions and preset timing resolutions.

**Table A-2** Preset display resolutions

Preset	Pixel format	Horz freq (kHz)	Vert freq (Hz)	USB Type-C/ DisplayPort	HDMI	PbP
1	640 × 480	31.469	59.940	✓	✓	✓
2	720 × 400	31.469	70.087	✓	✓	✓
3	800 × 600	37.879	60.317	✓	✓	✓
4	1024 × 768	48.363	60.004	✓	✓	✓
5	1280 × 800	49.702	59.810	✓	✓	✓
6	1280 × 1024	63.981	60.020	✓	✓	✓
7	1440 × 900	55.935	59.887	✓	✓	✓
8	1600 × 900	60.000	60.000	✓	✓	✓
9	1600 × 1200	75.000	60.000	✓	✓	✓
10	1680 × 1050	65.290	59.954	✓	✓	✓
11	1920 × 1080	67.500	60.000	✓	✓	✓
12	1920 × 1200	74.556	59.885	✓	✓	✓
13	2560 × 1440	88.787	59.951	✓	✓	✓
14	3840 × 1600*	98.750	59.994	✓	✓	
15	2560 × 2160	133.272	59.978		✓	✓
16	3840 × 2160	65.688	29.981	✓	✓	
17	3840 × 2160	133.313	59.997	✓	✓	
18	4096 × 2160	65.672	29.974	✓	✓	
19	4096 × 2160	133.282	59.983	✓	✓	
20	5120 × 2160	65.720	29.995	✓	✓	
21	5120 × 2160	133.286	59.985	✓		

\* Firmware update required if you are not able to see it.

**Table A-3** Preset timing resolutions

Preset	Timing name	Pixel format	Horz freq (kHz)	Vert freq (Hz)	USB Type-C/ DisplayPort	HDMI
1	480i	720 × 480	15.734	59.940		✓



**Table A-3** Preset timing resolutions (continued)

Preset	Timing name	Pixel format	Horz freq (kHz)	Vert freq (Hz)	USB Type-C/ DisplayPort	HDMI
2	480p	720 × 480	31.469	59.940	✓	✓
3	576i	720 × 576	15.625	50.000		✓
4	576p	720 × 576	31.250	50.000	✓	✓
5	720p50	1280 × 720	37.500	50.000	✓	✓
6	720p60	1280 × 720	45.000	60.000	✓	✓
7	1080i50	1920 × 1080	28.125	50.000		✓
8	1080i60	1920 × 1080	33.750	60.000		✓
9	1080p50	1920 × 1080	56.250	50.000	✓	✓
10	1080p60	1920 × 1080	67.500	60.000	✓	✓

## Energy saver feature

This monitor supports a reduced power state.

The reduced power state is initiated if the monitor detects the absence of either the horizontal sync signal or the vertical sync signal. Upon detecting the absence of these signals, the monitor screen is blank, the backlight is turned off, and the power light turns amber. In the reduced power state, the monitor uses < 0.5 W of power. There is a brief warm-up period before the monitor returns to its normal operating state.

See the computer manual for instructions on setting the energy saver mode (sometimes called “power management feature”).



**NOTE:** This power saver feature works only when the monitor is connected to a computer that has energy-saver features.

By selecting the settings in the monitor Sleep Timer utility, you can also program the monitor to initiate the reduced power state at a predetermined time. When the monitor Sleep Timer utility initiates the reduced power state, the power light blinks amber.

---

## B Accessibility

HP's goal is to design, produce, and market products, services, and information that everyone everywhere can use, either on a stand-alone basis or with appropriate third-party assistive technology (AT) devices or applications.

### HP and accessibility

Because HP works to weave diversity, inclusion, and work/life into the fabric of the company, it is reflected in everything HP does. HP strives to create an inclusive environment focused on connecting people to the power of technology throughout the world.

### Finding the technology tools you need

Technology can unleash your human potential. Assistive technology removes barriers and helps you create independence at home, at work, and in the community. Assistive technology helps increase, maintain, and improve the functional capabilities of electronic and information technology.

For more information, see [Finding the best assistive technology on page 37](#).

### The HP commitment

HP is committed to providing products and services that are accessible for people with disabilities. This commitment supports the company's diversity objectives and helps ensure that the benefits of technology are available to all.

The HP accessibility goal is to design, produce, and market products and services that can be effectively used by everyone, including people with disabilities, either on a stand-alone basis or with appropriate assistive devices.

To achieve that goal, this Accessibility Policy establishes seven key objectives to guide HP actions. All HP managers and employees are expected to support these objectives and their implementation in accordance with their roles and responsibilities:

- Raise the level of awareness of accessibility issues within HP, and provide employees with the training they need to design, produce, market, and deliver accessible products and services.
- Develop accessibility guidelines for products and services, and hold product development groups accountable for implementing these guidelines where competitively, technically, and economically feasible.
- Involve people with disabilities in the development of accessibility guidelines and in the design and testing of products and services.
- Document accessibility features, and make information about HP products and services publicly available in an accessible form.
- Establish relationships with leading assistive technology and solution providers.
- Support internal and external research and development that improves assistive technology relevant to HP products and services.

- Support and contribute to industry standards and guidelines for accessibility.

## International Association of Accessibility Professionals (IAAP)

IAAP is a not-for-profit association focused on advancing the accessibility profession through networking, education, and certification. The objective is to help accessibility professionals develop and advance their careers and to better enable organizations to integrate accessibility into their products and infrastructure.

As a founding member, HP joined to participate with other organizations to advance the field of accessibility. This commitment supports HP's accessibility goal of designing, producing, and marketing products and services that people with disabilities can effectively use.

IAAP will make the profession strong by globally connecting individuals, students, and organizations to learn from one another. If you are interested in learning more, go to <http://www.accessibilityassociation.org> to join the online community, sign up for newsletters, and learn about membership options.

## Finding the best assistive technology

Everyone, including people with disabilities or age-related limitations, should be able to communicate, express themselves, and connect with the world using technology. HP is committed to increasing accessibility awareness within HP and with our customers and partners.

Whether it's large fonts that are easy on the eyes, voice recognition that lets you give your hands a rest, or any other assistive technology to help with your specific situation—a variety of assistive technologies make HP products easier to use. How do you choose?

## Assessing your needs

Technology can unleash your potential. Assistive technology removes barriers and helps you create independence at home, at work, and in the community. Assistive technology (AT) helps increase, maintain, and improve the functional capabilities of electronic and information technology.

You can choose from many AT products. Your AT assessment should allow you to evaluate several products, answer your questions, and facilitate your selection of the best solution for your situation. You will find that professionals qualified to do AT assessments come from many fields, including those licensed or certified in physical therapy, occupational therapy, speech/language pathology, and other areas of expertise. Others, while not certified or licensed, can also provide evaluation information. You will want to ask about the individual's experience, expertise, and fees to determine if they are appropriate for your needs.

## Accessibility for HP products

These links provide information about accessibility features and assistive technology, if applicable and available in your country or region, that are included in various HP products. These resources will help you select the specific assistive technology features and products most appropriate for your situation.

- **HP Aging & Accessibility:** Go to <http://www.hp.com>, type `Accessibility` in the search box. Select **Office of Aging and Accessibility**.
- **HP computers:** For Windows 7, Windows 8, and Windows 10, go to <http://www.hp.com/support>, type `Windows Accessibility Options` in the **Search our knowledge** search box. Select the appropriate operating system in the results.
- **HP Shopping, peripherals for HP products:** Go to <http://store.hp.com>, select **Shop**, and then select **Monitors or Accessories**.

If you need additional support with the accessibility features on your HP product, see [Contacting support on page 40](#).

Additional links to external partners and suppliers that may provide additional assistance:

- [Microsoft Accessibility information \(Windows 7, Windows 8, Windows 10, Microsoft Office\)](#)
- [Google Products accessibility information \(Android, Chrome, Google Apps\)](#)

## Standards and legislation

Countries worldwide are enacting regulations to improve access to products and services for persons with disabilities. These regulations are historically applicable to telecommunications products and services, PCs and printers with certain communications and video playback features, their associated user documentation, and their customer support.

### Standards

The US Access Board created Section 508 of the Federal Acquisition Regulation (FAR) standards to address access to information and communication technology (ICT) for people with physical, sensory, or cognitive disabilities.

The standards contain technical criteria specific to various types of technologies, as well as performance-based requirements which focus on functional capabilities of covered products. Specific criteria cover software applications and operating systems, web-based information and applications, computers, telecommunications products, video and multimedia, and self-contained closed products.

### Mandate 376 – EN 301 549

The European Union created the EN 301 549 standard within Mandate 376 as an online toolkit for public procurement of ICT products. The standard specifies the accessibility requirements applicable to ICT products and services, with a description of the test procedures and evaluation methodology for each requirement.

### Web Content Accessibility Guidelines (WCAG)

Web Content Accessibility Guidelines (WCAG) from the W3C's Web Accessibility Initiative (WAI) helps web designers and developers create sites that better meet the needs of people with disabilities or age-related limitations.

WCAG advances accessibility across the full range of web content (text, images, audio, and video) and web applications. WCAG can be precisely tested, is easy to understand and use, and allows web developers flexibility for innovation. WCAG 2.0 has also been approved as [ISO/IEC 40500:2012](#).

WCAG specifically addresses barriers to accessing the web experienced by people with visual, auditory, physical, cognitive, and neurological disabilities, and by older web users with accessibility needs. WCAG 2.0 provides characteristics of accessible content:

- **Perceivable** (for instance, by addressing text alternatives for images, captions for audio, adaptability of presentation, and color contrast)
- **Operable** (by addressing keyboard access, color contrast, timing of input, seizure avoidance, and navigability)
- **Understandable** (by addressing readability, predictability, and input assistance)
- **Robust** (for instance, by addressing compatibility with assistive technologies)

## Legislation and regulations

Accessibility of IT and information has become an area of increasing legislative importance. These links provide information about key legislation, regulations, and standards.

- [United States](#)
- [Canada](#)
- [Europe](#)
- [Australia](#)

## Useful accessibility resources and links

These organizations, institutions, and resources might be good sources of information about disabilities and age-related limitations.

---

 **NOTE:** This is not an exhaustive list. These organizations are provided for informational purposes only. HP assumes no responsibility for information or contacts you encounter on the internet. Listing on this page does not imply endorsement by HP.

---

## Organizations

These organizations are a few of the many that provide information about disabilities and age-related limitations.

- American Association of People with Disabilities (AAPD)
- The Association of Assistive Technology Act Programs (ATAP)
- Hearing Loss Association of America (HLAA)
- Information Technology Technical Assistance and Training Center (ITTATC)
- Lighthouse International
- National Association of the Deaf
- National Federation of the Blind
- Rehabilitation Engineering & Assistive Technology Society of North America (RESNA)
- Telecommunications for the Deaf and Hard of Hearing, Inc. (TDI)
- W3C Web Accessibility Initiative (WAI)

## Educational institutions

Many educational institutions, including these examples, provide information about disabilities and age-related limitations.

- California State University, Northridge, Center on Disabilities (CSUN)
- University of Wisconsin - Madison, Trace Center
- University of Minnesota computer accommodations program

## Other disability resources

Many resources, including these examples, provide information about disabilities and age-related limitations.

- ADA (Americans with Disabilities Act) Technical Assistance Program
- ILO Global Business and Disability network
- EnableMart
- European Disability Forum
- Job Accommodation Network
- Microsoft Enable

## HP links

These HP-specific links provide information that relates to disabilities and age-related limitations.

[HP comfort and safety guide](#)

[HP public sector sales](#)

## Contacting support

HP offers technical support and assistance with accessibility options for customers with disabilities.



---

**NOTE:** Support is in English only.

---

- Customers who are deaf or hard of hearing who have questions about technical support or accessibility of HP products:
  - Use TRS/VRS/WebCapTel to call (877) 656-7058 Monday through Friday, 6 a.m. to 9 p.m. Mountain Time.
- Customers with other disabilities or age-related limitations who have questions about technical support or accessibility of HP products:
  - Call (888) 259-5707 Monday through Friday, 6 a.m. to 9 p.m. Mountain Time.

---

# Index

## A

- accessibility 36, 37, 39, 40
- accessibility needs assessment 37
- assistive technology (AT)
  - finding 37
  - purpose 36
- AT (assistive technology)
  - finding 37
  - purpose 36
- auto-adjustment (analog input) 29

## C

- calling technical support 2
- components
  - front 4
  - rear 5
- connectors
  - DisplayPort 5
  - power 5
- customer support, accessibility 40

## D

- DisplayPort connector 5

## F

- front components 4

## G

- getting started 1
- getting to know your monitor 2

## H

- HDMI port 5
- HP Assistive Policy 36
- HP Device Bridge 13, 25, 26, 28
- HP resources 2
- HP support 2

## I

- International Association of Accessibility Professionals 37

## L

- label 5

## M

- menu button 4

## O

- optimizing image performance (analog input) 29
- OSD button 4

## P

- ports
  - HDMI 5
  - USB Type-C 5
- power connector 5
- product label 5
- product number 5

## R

- rear components 5
- resources, accessibility 39

## S

- safety information 1
- Section 508 accessibility standards 38
- Selecting the input source 20
- serial number 5
- standards and legislation, accessibility 38
- support 2

## T

- technical support 2

## U

- USB Type-C port 5

## V

- Video connection combinations 9

## W

- warnings 1