

Aruba 570EX Series Hazardous Location Access Points

Installation Guide

The Aruba 570EX Series outdoor wireless access points (AP-575EX and AP-577EX) are high-performance, multi-radio wireless devices that can be deployed in either controller-based (ArubaOS) or controllerless (Aruba Instant) network environment.

The Aruba 570EX Series access points support IEEE 802.11ax standard, delivering high performance with the MU-MIMO (Multi-User Multiple-Input, Multiple-Output) technology, while also supporting 802.11a/b/g/n/ac wireless services.

Package Contents

- 570EX Series access point
- Cable gland x 2
- USB Type-C console cable x 1
- Grounding lug and M4x6 screw x 1

Tools Required

- Phillips screwdriver (#2 for M4x6 screw)
- Flat blade screwdriver (Ethernet cable gland covers)
- 8mm allen or hex key (USB console cover)



The weatherproof caps for Ethernet and Console interfaces are connected to the access point, not loose in the package.



Mounting kits for use with the 570EX Series access points are sold separately. Contact your Aruba sales representative for details.



Inform your supplier if there are any incorrect, missing, or damaged parts. If possible, retain the carton, including the original packing materials. Use these materials to repack and return the unit to the supplier if needed.

Hardware Overview

Figure 1 AP-575EX Front View

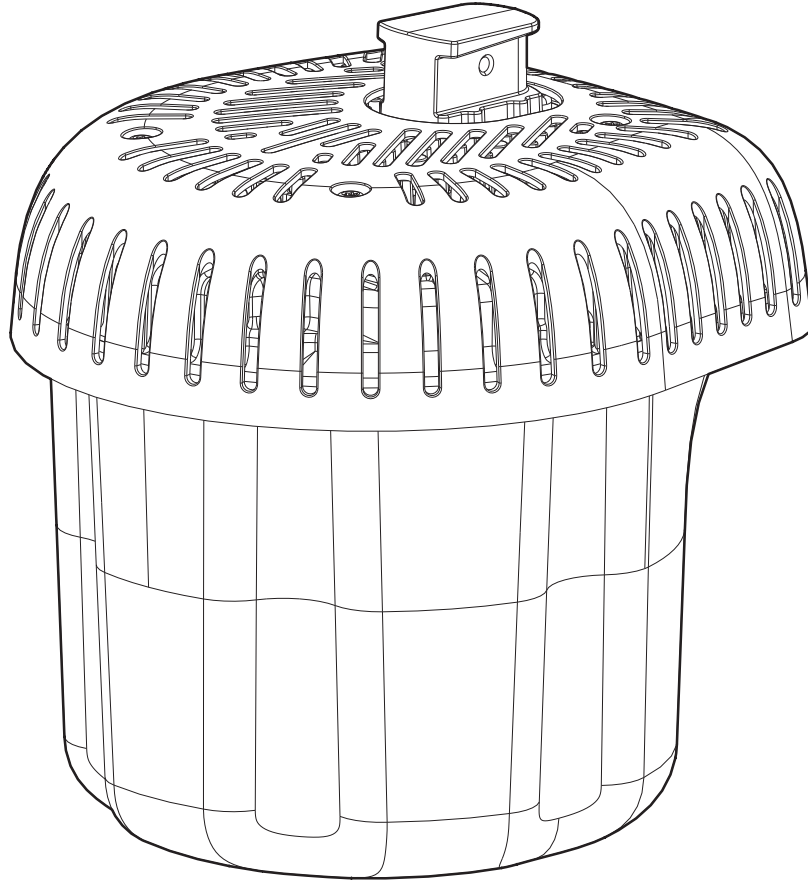

Figure 2 AP-575EX Rear View

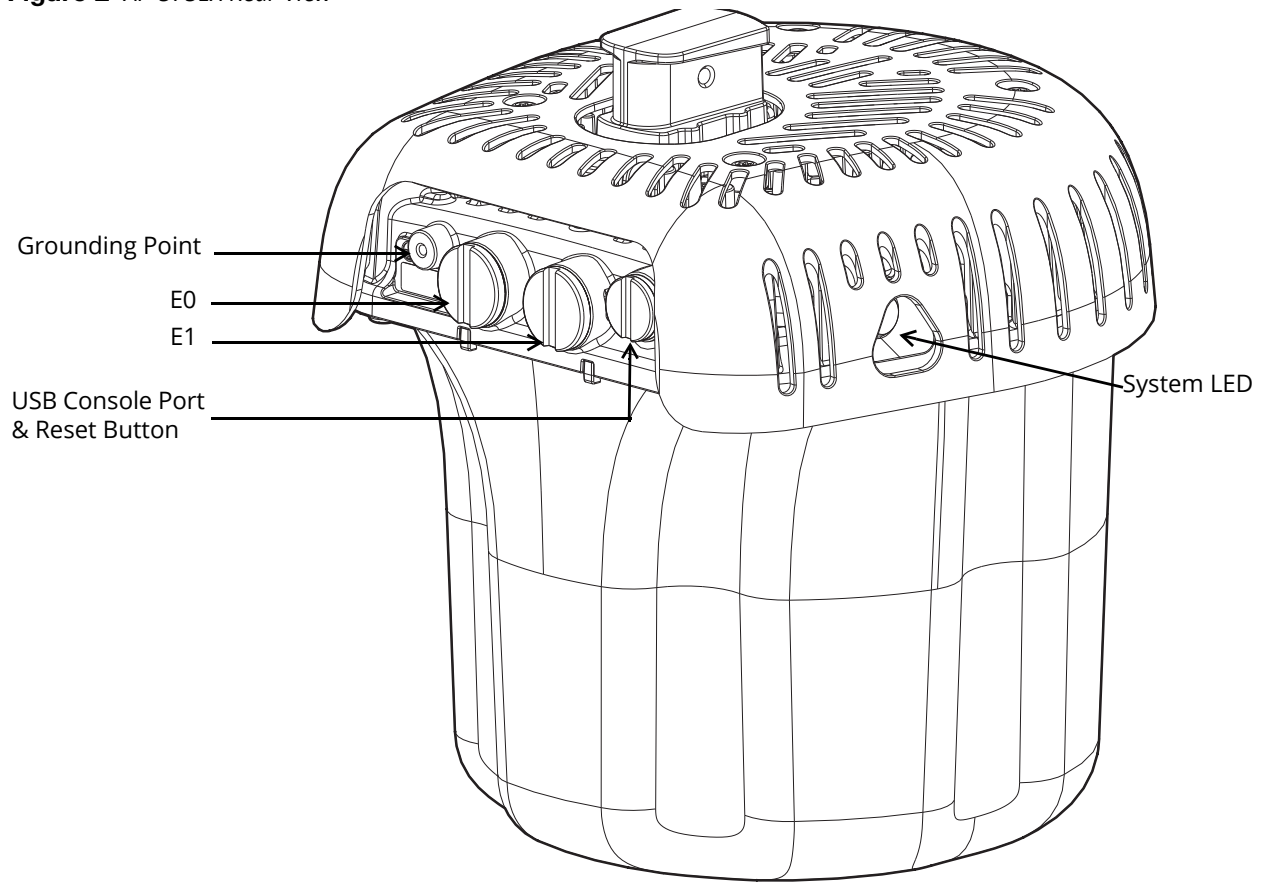

Figure 3 AP-577EX Front View

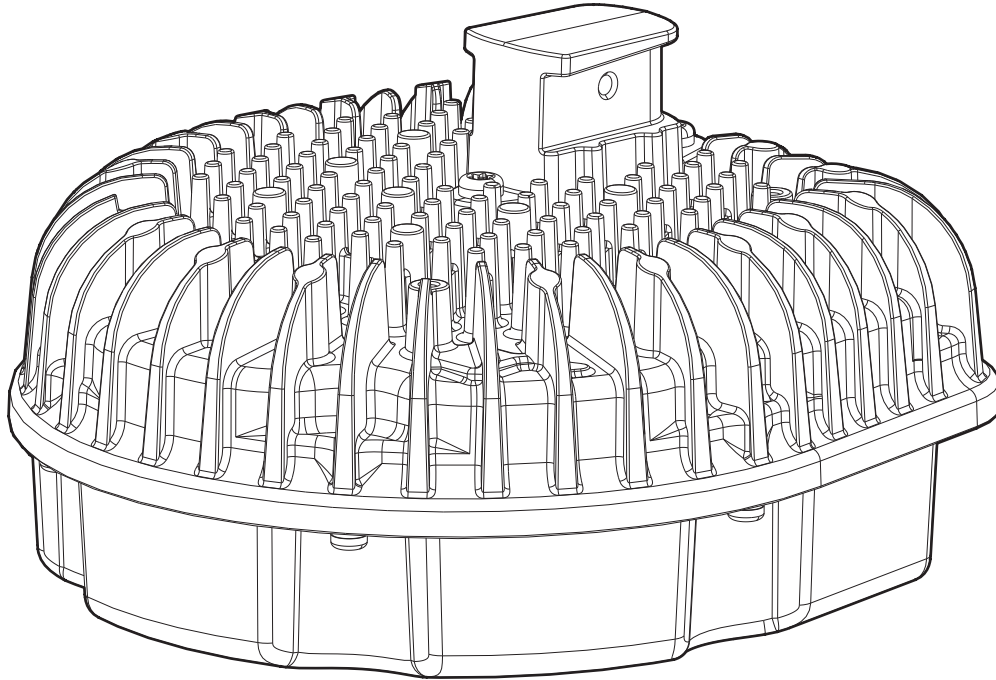
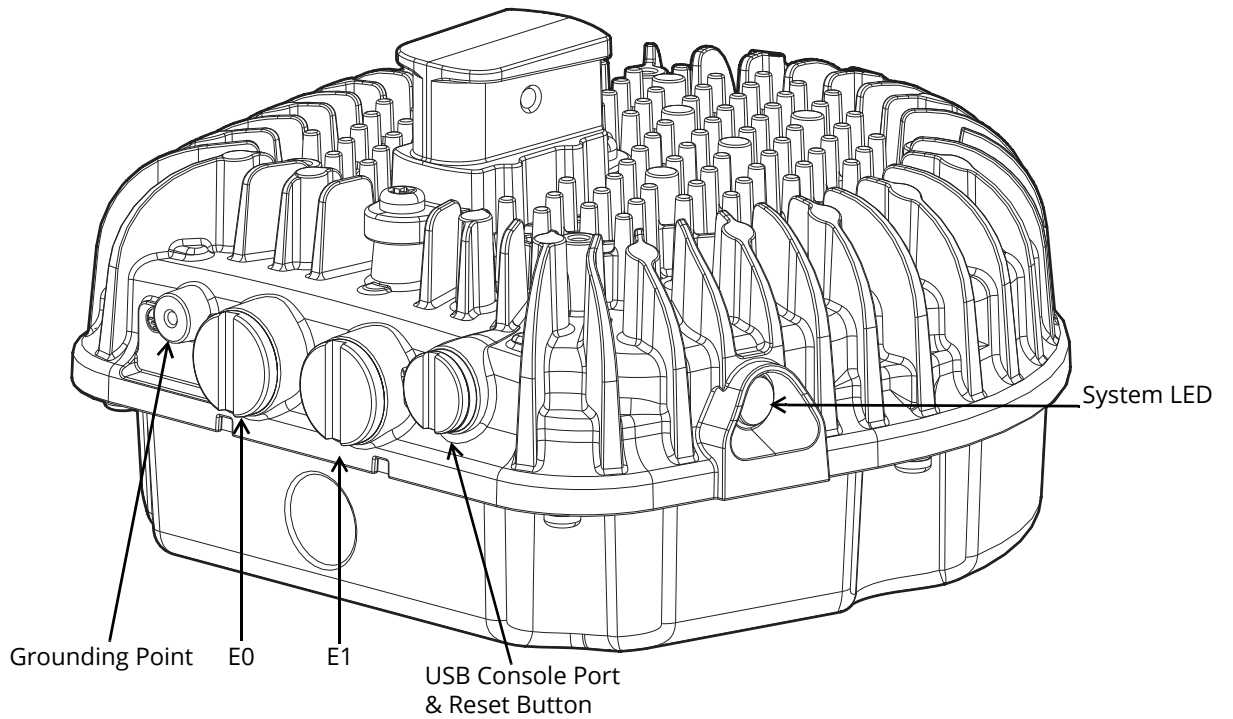

Figure 4 AP-577EX Rear View



LED

The 570EX Series access point is equipped with one LED that indicates the system status of the access point.

Table 1 570EX Series LED Meanings during Boot Up

LED	Color/State	Meaning
System LED	Off	No power to AP
	Red	Initial power-up
	Green - Flashing	AP booting, not ready
	Green - Steady	AP ready and Gigabit Ethernet connected. The LED turns off after 1200 seconds
	Green - Yellow, 6 seconds period	AP ready and 10/100Mbps Ethernet link established. The LED turns off after 1200 seconds

Table 2 570EX Series LED Meanings during Operation

LED	Color/State	Meaning
System LED	Solid Red	General fault - Immediate attention required
	One blink off every 3 seconds	Radio 0 fault (5GHz)
	Two quick blink off 0.5 seconds apart cycled every 3 seconds	Radio 1 fault (2.4GHz)

Ethernet Ports

The Aruba 570EX Series access points are equipped with two Ethernet ports (E0 and E1):

- E0 port: 100/1000/2500Base-T auto-sensing MDI/MDX wired RJ45 network connectivity port
- E1 port: 100/1000Base-T auto-sensing MDI/MDX wired RJ45 network connectivity port

Power

Both E0 and E1 ports support PoE-in, allowing the AP to draw power from an 802.3at/802.3bt PoE power source. When the AP is powered by both E0 and E1 ports simultaneously, the AP can be configured by management software to source PoE power from either port, or to combine power from both ports.

The 570EX Series access points support the Intelligent Power Monitoring (IPM) feature, to report AP power consumption and enable intelligent management of power-save capabilities.

Table 3 lists operational restrictions when the AP is powered by different power options.

Table 3 Power Options and Operational Restrictions

Power Source	IPM	Restrictions
1 x 802.3bt PoE	n/a	No restrictions, all capabilities available.
2 x 802.3at PoE	n/a	No restrictions, all capabilities available.
1 x 802.3at PoE	enabled	AP starts up in unrestricted mode, but may dynamically apply restrictions depending on the PoE budget and actual power.
1 x 802.3at PoE	disabled	Second (other) Ethernet port disabled.
1 x 802.3af PoE	n/a	AP does not start up, red system LED.

Grounding Point

Always remember to protect the access point by installing grounding lines. The ground connection must be complete before connecting power to the access point enclosure.

USB Type-C Console Port

Use the included USB Type-C console cable to connect the access point to a laptop or a serial terminal for direct management.



You need a proper 8mm allen or hex key to open the cover of the USB Console port.

Reset Button

The reset button can be used to reset the access point to factory default settings or turn off/on the LED display.

There are two ways to reset the access point to factory default settings:

Reset the AP during normal operation

Press and hold down the reset button using a small, narrow object such as a paper clip for more than 10 seconds during normal operation.

Reset the AP while powering up

1. Press and hold down the reset button using a small, narrow object such as a paper clip while the access point is not powered on via PoE.
2. Connect the power supply (PoE) to the access point while the reset button is being held down.
3. Release the reset button on the access point after 15 seconds.

To turn off/on the LED display, press and release the reset button using a small, narrow object, such as a paperclip for less than 10 seconds during normal operation of the access point.

Before You Begin

Refer to the sections below before beginning the installation process.



FCC Statement: Improper termination of access points installed in the United States configured to non-US model controllers will be in violation of the FCC grant of equipment authorization. Any such willful or intentional violation may result in a requirement by the FCC for immediate termination of operation and may be subject to forfeiture (47 CFR 1.80).

Pre-Installation Checklist

Before installing your 570EX Series access point, be sure that you have the following:

- Cat5E or better UTP cable with network access
- A compatible PoE injector with power cord

One of the following network services:

- Aruba Discovery Protocol (ADP)
- DNS server with an "A" record
- DHCP Server with vendor specific options



Aruba, in compliance with governmental requirements, has designed the 570EX Series access points so that only authorized network administrators can change configuration settings. For more information about AP configuration, refer to the *AP Software Quick Start Guide*.



Access points are radio transmission devices and as such are subject to governmental regulation. Network administrators responsible for the configuration and operation of access points must comply with local broadcast regulations. Specifically, access points must use channel assignments appropriate to the location in which the access point will be used.

Outdoor Planning and Deployment Considerations

Prior to deploying an outdoor wireless network, the environment must be evaluated to plan for a successful WLAN deployment. Successfully evaluating the environment enables the proper selection of routers and antennas and assists in the determination of their placement for optimal RF coverage. This process is considered WLAN or RF planning and Aruba's system engineers can assist in the outdoor planning process.



The rules for the 5600-5650 MHz band vary by region.

Identifying Specific Installation Locations

Use the access point placement map generated by Aruba RF Plan software application to determine the proper installation location(s). Each location should be as close as possible to the center of the intended coverage area and should be free from obstructions or obvious sources of interference. These RF absorbers/reflectors/interference sources will impact RF propagation and should be accounted for during the planning phase and adjusted for in RF plan.



Use of this equipment adjacent to or stacked with other equipment should be avoided because it could result in improper operation. If such use is necessary, this equipment and the other equipment should be observed to verify that they are operating normally.

Identifying Known RF Absorbers/Reflectors/Interference Sources

Identifying known RF absorbers, reflectors, and interference sources while in the field during the installation phase is critical. Make sure that these sources are taken into consideration when you attach an access point to its fixed location.

RF absorbers include:

- Cement/concrete—Old concrete has high levels of water dissipation, which dries out the concrete, allowing for potential RF propagation. New concrete has high levels of water concentration in the concrete, blocking RF signals.
- Natural Items—Fish tanks, water fountains, ponds, and trees
- Brick

RF reflectors include:

- Metal Objects—Metal pans between floors, rebar, fire doors, air conditioning/heating ducts, mesh windows, blinds, chain link fences (depending on aperture size), refrigerators, racks, shelves, and filing cabinets.
- Do not place an access point between two air conditioning/heating ducts. Make sure that access points are placed below ducts to avoid RF disturbances.

RF interference sources include:

- Microwave ovens and other 2.4 or 5 GHz objects (such as cordless phones)
- Cordless headset such as those used in call centers or lunch rooms

Access Point Installation



Service to all Aruba products should be performed by trained service personnel only.

Using Mount Kits

The 570EX Series access point can be installed on a wall or attached to a pole by using mount kits:

Table 4 *Applicable Mount Kits for 570EX Series Access Point*

Part Number	Description
JW052A	AP-270-MNT-V1 long mount kit for wall and vertical pole mounting, 300 mm from vertical mounting asset.
JW053A	AP-270-MNT-V2 short mount kit for wall and vertical pole mounting, 75 mm from vertical mounting asset.
JW054A	AP-270-MNT-H1 mount kit for hanging from inclined or horizontal structure.
JW055A	AP-270-MNT-H2 flush mount kit for wall and ceiling mounting.



The 570EX Series access point does not ship with any mount kits. These mount kits are available as accessories and must be ordered separately.



For installation instructions on AP-270-MNT-V1, AP-270-MNT-V2, AP-270-MNT-H1 and AP-270-MNT-H2 mount kit, please refer to the *AP-270-MNT-V1 Installation Guide*, *AP-270-MNT-V2 Installation Guide*, *AP-270-MNT-H1 Installation Guide* and *AP-270-MNT-H2 Installation Guide* respectively.



This 570EX Series access point is intended for installation in a RESTRICTED ACCESS LOCATION attached to a pole or installed on a wall. Installers should disconnect power before working with or near the access point.

Grounding the Access Point

The grounding must be completed before powering up the access point. The grounding wire should be #8 AWG.

1. Peel the cover of one end of the grounding wire and place the bare grounding wire into the grounding lug (included in the package), and press firmly with the crimping pliers.
2. Fasten the grounding lug to the grounding hole on the access point with the M4x6 screw (included in the package). We recommend to torque the M4x6 screw to 1.5 N.m.

Connecting the Ethernet Cable

To connect the Ethernet cable to the access point, perform the following steps.



Failure to use the included Ethernet cable glands can lead to connectivity and POE issues.



The cable is not included and must be purchased separately. Purchase a suitable UV-resistant, outdoor rated, CAT 5E or better RJ45 cable for use with the access point.

Figure 5 Cable Gland

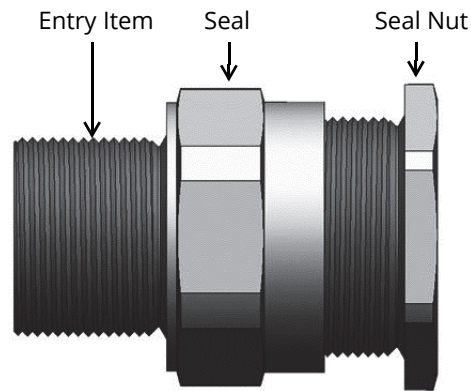

1. Remove the dust cap from the Ethernet port.
2. It is not necessary to dismantle the cable gland any further than illustrated in [Figure 5](#).
3. Fit the cable gland into the Ethernet port with the shroud and fully tighten the entry item.
4. Determine the conductor length required to suit the installation and prepare the cable accordingly, removing part of the outer sheath where required to reveal the insulated conductors.
5. Slacken the seal nut to relax the seal.
6. Pass the cable through the cable gland (See [Figure 6](#)), then attach the connector to the end of the cable.
7. Insert the cable connector to the Ethernet port, then tighten the seal nut by hand until resistance is felt (when the seal contacts the cable). Tighten with a spanner one further turn.

Figure 6 Passing a Cable through the Cable Gland

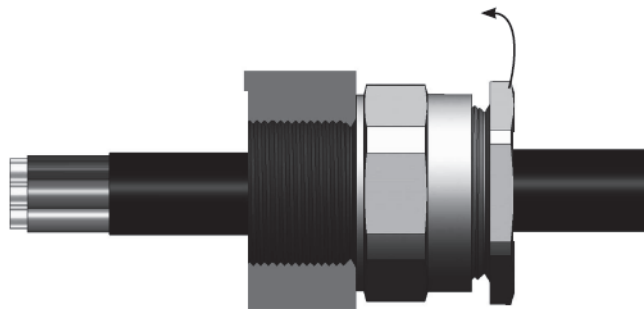

Software

For instructions on choosing operating modes and initial software configuration, refer to the AP Software Quick Start Guide.



Aruba access points are classified as radio transmission devices, and are subject to government regulations of the host country. The network administrator(s) is/are responsible for ensuring that configuration and operation of this equipment is in compliance with their country's regulations. For a complete list of approved channels in your country, refer to the *Aruba Downloadable Regulatory Table* at <https://www.arubanetworks.com/techdocs/DRT/Default.htm>.

Verifying Post-Installation Connectivity

The integrated LEDs on the access point can be used to verify that the access point is receiving power and initializing successfully (see [Table 1](#) and [Table 2](#)). Refer to the **AP Software Quick Start Guide** for further details on verifying post-installation network connectivity.

Electrical and Environmental Specifications

Electrical

- Ethernet
 - E0: 100/1000/2500Base-T auto-sensing Ethernet RJ-45 Interfaces
 - E1: 100/1000Base-T auto-sensing Ethernet RJ-45 Interfaces
 - Power over Ethernet (IEEE 802.3at and 802.3bt compliant): 57Vdc, 750mA

Environmental

- Operating
 - Temperature: -40°C to 65°C (-40°F to 149°F)
- Storage
 - Temperature: -40°C to 70°C (-40°F to 158°F)
 - Humidity: 5% to 93% non-condensing

For additional specifications on this product, please refer to the data sheet at www.arubanetworks.com.

Regulatory Model Number

For the purpose of regulatory compliance certifications and identification, this product has been assigned a unique regulatory model number (RMN). The regulatory model number can be found on the product nameplate label, along with all required approval markings and information. When requesting compliance information for this product, always refer to this regulatory model number. The regulatory model number RMN is not the marketing name or model number of the product.

The following regulatory model numbers apply to the 570EX Series:

- AP-575EX RMN: APEX0575
- AP-577EX RMN: APEX0577

Safety and Regulatory Compliance



CAUTION

RF Radiation Exposure Statement: This equipment complies with RF radiation exposure limits. This equipment should be installed and operated with a minimum distance of 13.78 inches (35cm) between the radiator and your body for 2.4 GHz and 5 GHz operations. This transmitter must not be co-located or operating in conjunction with any other antenna or transmitter.



CAUTION

Déclaration de la concernant l'exposition aux rayonnements à fréquence radioélectrique (FR): Cet appareil est conforme aux limites d'exposition aux rayonnements FR établies par la FCC. Il doit être installé et utilisé à une distance minimale de 35 cm (13,78 pouces) entre le radiateur et votre corps, qu'il opère sur la bande 2,4 GHz ou 5 GHz. Cet émetteur ne doit pas être installé ou utilisé à proximité immédiate d'une autre antenne ni d'un autre transmetteur.



CAUTION

The device could automatically discontinue transmission in case of absence of information to transmit, or operational failure. Note that this is not intended to prohibit transmission of control or signaling information or the use of repetitive codes where required by the technology.



CAUTION

Changes or modifications to this unit not expressly approved by the party responsible for compliance could void the user's authority to operate this equipment.



CAUTION

Toute modification effectuée sur cet équipement sans l'autorisation expresse de la partie responsable de la conformité est susceptible d'annuler son droit d'utilisation.

United States

This equipment has been tested and found to comply with the limits for a Class B digital device, pursuant to Part 15 of the FCC Rules. These limits are designed to provide reasonable protection against harmful interference in a residential installation. This equipment generates, uses and can radiate radio frequency energy and, if not installed and used in accordance with the manufacturer's instructions, may cause harmful interference to radio communications. However, there is no guarantee that interference will not occur in a particular installation. If this equipment does cause harmful interference to radio or television reception, which can be determined by turning the equipment off and on, the user is encouraged to try to correct the interference by one or more of the following measures:

- Reorient or relocate the receiving antenna.
- Increase the separation between the equipment and receiver.
- Connect the equipment to an outlet on a circuit different from that to which the receiver is connected.
- Consult the dealer or an experienced radio or TV technician for help.

Improper termination of access points installed in the United States configured to a non-US model controller is a violation of the FCC grant of equipment authorization. Any such willful or intentional violation may result in a requirement by the FCC for immediate termination of operation and may be subject to forfeiture (47 CFR 1.80).

Industry Canada

This Class B digital apparatus meets all of the requirements of the Canadian Interference-Causing Equipment Regulations.

In accordance with Industry Canada regulations, this radio transmitter and receiver may only be used with an antenna, the maximum type and gain of which must be approved by Industry Canada. To reduce potential radio interference, the type of antenna and its gain shall be chosen so that the equivalent isotropic radiated power (EIRP) does not exceed the values necessary for effective communication.

This device complies with Industry Canada's license-exempt RSS regulations. Operation of this device is subject to the following two conditions: (1) this device may not cause interference, and (2) this device must accept any interference, including interference that may cause undesired operation.

When operated in 5.15 to 5.25 GHz frequency range, this device is restricted to indoor use to reduce the potential for harmful interference with co-channel Mobile Satellite Systems.

Déclaration d'Industrie Canada

Ce périphérique est conforme aux règlements RSS exempts de licence d'Industrie Canada. L'utilisation de ce périphérique est soumise aux deux conditions suivantes : (1) ce périphérique ne doit pas provoquer d'interférences, et (2) ce périphérique doit accepter toute interférence, y compris les interférences susceptibles de provoquer un dysfonctionnement.

En cas d'utilisation dans la plage de fréquences de 5,15 à 5,25 GHz, cet appareil doit uniquement être utilisé en intérieur afin de réduire les risques d'interférence avec les systèmes satellites mobiles partageant le même canal.

European Union Regulatory Conformance

The Declaration of Conformity made under Radio Equipment Directive 2014/53/EU is available for viewing at: www.hpe.com/eu/certificates. Select the document that corresponds to your device's model number as it is indicated on the product label.

Wireless Channel Restrictions

5150-5350MHz band is limited to indoor only in the following countries; Austria (AT), Belgium (BE), Bulgaria (BG), Croatia (HR), Cyprus (CY), Czech Republic (CZ), Denmark (DK), Estonia (EE), Finland (FI), France (FR), Germany (DE), Greece (GR), Hungary (HU), Iceland (IS), Ireland (IE), Italy (IT), Latvia (LV), Liechtenstein (LI), Lithuania (LT), Luxembourg (LU), Malta (MT), Netherlands (NL), Norway (NO), Poland (PL), Portugal (PT), Romania (RO), Slovakia (SK), Slovenia (SL), Spain (ES), Sweden (SE), Switzerland (CH), Turkey (TR), United Kingdom (UK).

Radio	Frequency Range MHz	Max EIRP
BLE/Zigbee	2402-2480	9 dBm

Radio	Frequency Range MHz	Max EIRP
Wi-Fi	2412-2472	20 dBm
	5150-5250	23 dBm
	5250-5350	23 dBm
	5470-5725	30 dBm
	5725-5850	14 dBm



Lower power radio LAN product operating in 2.4 GHz and 5 GHz bands. Please refer to the ArubaOS User Guide/ Instant User Guide for details on restrictions.

Medical

1. Equipment not suitable for use in the presence of flammable mixtures.
2. Connect to only IEC 60950-1 or IEC 60601-1 certified products and power sources. The end user is responsible for the resulting medical system complies with the requirements of IEC 60601-1.
3. Wipe with a dry cloth, no additional maintenance required.
4. No serviceable parts, the unit must be sent back to the manufacturer for repair.
5. No modifications are allowed without Aruba approval.

Taiwan

第十二條

經型式認證合格之低功率射頻電機，非經許可，公司，商號或使用者均不得擅自變更頻率、加大功率或變更原設計之特性及功能。

第十四條

低功率射頻電機之使用不得影響飛航安全及干擾合法通信；經發現有干擾現象時，應立即停用，並改善至無干擾時方得繼續使用。前項合法通信，指依電信法規定作業之無線電通信。低功率射頻電機須忍受合法通信或工業、科學及醫療用電波輻射性電機設備之干擾。

1. 應避免影響附近雷達系統之操作。
2. 高增益指向性天線只得應用於固定式點對點系統
3. 電磁波暴露量 MPE 標準值 1 mW/cm²，送測產品實測值為：0.97mW/cm²

Brazil

Este equipamento não tem direito à proteção contra interferência prejudicial e não pode causar interferência em sistemas devidamente autorizados.

Japan

ご使用になっている装置に VCCI マークが付いていましたら、次の説明文をお読み下さい。

この装置は、クラス B 情報技術装置です。この装置は、家庭環境で使用することを目的としていますが、この装置がラジオやテレビジョン受信機に近接して使用されると、受信障害を引き起こすことがあります。取扱説明書に従って正しい取り扱いをして下さい。

VCCI-B

México

La operación de este equipo está sujeta a las siguientes dos condiciones: (1) es posible que este equipo o dispositivo no cause interferencia perjudicial y (2) este equipo o dispositivo debe aceptar cualquier interferencia, incluyendo la que pueda causar su operación no deseada.

Нормативные требования Евразийского Экономического Союза



HPE Russia: ООО "Хьюлетт Паккард Энтерпрайз" Российская Федерация, 125171, г. Москва, Ленинградское шоссе, 16А, стр.3, Телефон: +7 499 403 4248 Факс: +7 499 403 4677

'HPE Kazakhstan': ТОО «Хьюлетт-Паккард (К)», Республика Казахстан, 050040, г. Алматы, Бостандыкский район, проспект Аль-Фараби, 77/7, Телефон/факс: + 7 727 355 35 50

Kazakhstan

ЖШС "Хьюлетт Паккард Энтерпрайз" Ресей Федерациясы, 125171, Мәскеу, Ленинград тас жолы, 16А блок 3, Телефон: +7 499 403 4248 Факс: +7 499 403 4677

ЖШС «Хьюлетт-Паккард (К)», Қазақстан Республикасы, 050040, Алматы к., Бостандық ауданы, Әл-Фараби даңғылы, 77/7, Телефон/факс: +7 (727) 355 35 50

Ukraine

Hereby, Hewlett Packard Enterprise Company declares that the radio equipment type [The Regulatory Model Number [RMN] for this device can be found in the [Regulatory Model Number](#) section of this document] is in compliance with Ukrainian Technical Regulation on Radio Equipment, approved by resolution of the CABINET OF MINISTERS OF UKRAINE dated May 24, 2017, No. 355. The full text of the UA declaration of conformity is available at the following internet address: <https://certificates.ext.hpe.com/public/certificates.html>

ХЬЮЛЕТТ ПАКАРД ЭНТЕРПРАЙЗ, 6280 АМЕРИКА ЦЕНТР Д-Р, САН-ХОСЕ, КАЛИФОРНИЯ 95002, США

Special Conditions for Safe Use

- WARNING – DO NOT OPEN WHEN AN EXPLOSIVE ATMOSPHERE IS PRESENT
- The connections on this equipment are not intended to be connected or disconnected when an explosive atmosphere is present.
- Only qualified Ex person are allowed for on-site installation and electrical connections of equipment.
- Manual switch TS4V-2PL-R are protected by minimum IP66 enclosure, it is not allowed to operate the switch in hazardous area.
- Required protection shall be applied to avoid the mechanical damage of high risk occurred by the final installation.
- The equipment must be installed and used in an area of at least pollution degree 2, as defined in IEC 60664-1.
- Only ATEX/IECEx cable glands as specified in the instruction to be installed and used on the enclosure, and IEC/EN 60079-14 shall be observed when installing. Suitable type of protection Cable gland to be selected with spec: M20x1.5 with minimum IP66 rating.
- Type-C USB port is not used in hazardous area.
- Damaged Protective Vents have to be replaced immediately.
- Earthing system shall be finished in accordance with user manual before use.
- Use cable gland, stopping plug, conduit fitting or similar device with ingress of protection of IP66, and the installation shall meet the requirements of CEC (for Canada) and NEC (for USA) for wiring method in Division 2 and is subjected to acceptance of local authorities having jurisdiction.
- Wipe with a wet cloth and use PPE for routine maintenance.

Standard Compliance

- EN 60079-0:2018
- EN 60079-7:2015/A1:2018
- IEC 60079-0:2017 Edition 7.0
- IEC 60079-7:2015+A1:2017 Edition 5.1
- CSA C22.2 No.213-17
- UL 121201 ninth edition

ATEX Certificate Number and Marking

TÜV 20 ATEX 8562 X



II 3 G Ex ec IIC T4 Gc

IECEX Certificate Number and Marking

IECEX TUR 20.0044X

Ex ec IIC T4 Gc

cCSAus Ex Marking

Class I, Division 2, Groups A, B, C and D T4



NOTE

The equipment is intended to use in outdoor and environmentally challenging locations such as oil rigs, mining facilities, and industrial plants, networks need to be protected from extreme temperatures, flammable gases or vapors, and dust concentrations.



NOTE

The equipment to be used in Zone 2 or CID2 hazardous area only with gas group IIC or Groups A, B,C and D.

Contact Aruba

Main Site	https://www.arubanetworks.com
Support Site	https://asp.arubanetworks.com
Airheads Social Forums and Knowledge Base	https://community.arubanetworks.com/
North America Telephone	1-800-943-4526 1-408-754-1200
International Telephone	https://www.arubanetworks.com/support-services/contact-support/
Software Licensing Site	https://www.hpe.com/networking/support
End-of-Life Information	https://www.arubanetworks.com/support-services/end-of-life/
Security Incident Response Team (SIRT)	https://www.arubanetworks.com/support-service/security-bulletins/ Email: aruba-sirt@hpe.com

Copyright

© Copyright 2020 Hewlett Packard Enterprise Development LP

Open Source Code

This product includes code licensed under the GNU General Public License, the GNU Lesser General Public License, and/or certain other open source licenses.

A complete machine-readable copy of the source code corresponding to such code is available upon request. This offer is valid to anyone in receipt of this information and shall expire three years following the date of the final distribution of this product version by Hewlett Packard Enterprise Company.

To obtain such source code, send a check or money order in the amount of US \$10.00 to:

Hewlett Packard Enterprise Company

Attn: General Counsel

6280 America Center Drive

San Jose, CA 94089

USA

Warranty

This hardware product is protected by an Aruba warranty. For more details, visit www.hpe.com/us/en/support.html