

Eaton® 93PM Integrated Accessory Cabinet-Bypass

400 kW (480V) IAC-B
Installation and Operation Manual



p/n: P-164000615
Revision 03

IMPORTANT SAFETY INSTRUCTIONS - SAVE THESE INSTRUCTIONS

This manual contains important instructions that you should follow during installation and maintenance of the UPS and batteries. Please read all instructions before operating the equipment and save this manual for future reference.

CONSIGNES DE SÉCURITÉ IMPORTANTES – CONSERVER CES INSTRUCTIONS

Ce manuel comporte des instructions importantes que vous êtes invité à suivre lors de toute procédure d'installation et de maintenance des batteries et de l'onduleur. Veuillez consulter entièrement ces instructions avant de faire fonctionner l'équipement et conserver ce manuel afin de pouvoir vous y reporter ultérieurement.



IMPORTANT

To ensure you have the most up-to-date content and information for this product, please review the latest manual revision on our website, www.eaton.com/93PM.

Eaton reserves the right to change specifications without prior notice. Modbus is a registered trademark of Schneider Automation, Inc. MOXA is a registered trademark and MGate is a trademark of MOXA, Inc. Spiralock is a registered trademark of Spiralock Corporation. KIRK is a registered trademark of Kirk Key Interlock company, LLC, a subsidiary of Halma plc. National Electrical Code and NEC are registered trademarks of National Fire Protection Association, Inc. ERIFLEX and FLEXIBAR are registered trademark of Erico International Corporation. All other trademarks are property of their respective companies.

©Copyright 2016-2022 Eaton, Raleigh, NC, USA. All rights reserved. No part of this document may be reproduced in any way without the express written approval of Eaton.

Table of Contents

1 Introduction	1
1.1 Features	2
1.2 Installation Features	2
1.3 Model Configurations	2
1.4 Using This Manual	2
1.5 Conventions Used in This Manual	4
1.6 Symbols, Controls, and Indicators	5
1.7 For More Information	5
1.8 Getting Help	6
1.9 Equipment Registration	6
2 Safety Warnings	7
3 Installation Plan and Unpacking	9
3.1 Creating an Installation Plan	9
3.2 Preparing the Site	9
3.2.1 Environmental and Installation Considerations	9
3.2.2 IAC-B Power Wiring Preparation	16
3.2.3 IAC-B Interface Wiring Preparation	20
3.3 Inspecting and Unpacking the IAC-B	21
4 Installation	23
4.1 Preliminary Installation Information	23
4.2 Unloading the IAC-B from the Pallet	23
4.3 Two-Hole Barrel Lug Terminations to Bus Bar Installation	26
4.4 Installing IAC-B External Power Wiring	27
4.4.1 IAC-B with a Maintenance Bypass Breaker and Maintenance Isolation Switch	27
4.4.2 IAC-B with a Maintenance Bypass Breaker, Maintenance Isolation Switch, and Bypass Input Breaker	33
4.5 Installing IAC-B Interface Connections	36
4.5.1 MBP Auxiliary Contact Interface Connections	36
4.5.2 SKRU Interface Connections (if installed)	42
4.6 Initial Startup	45
4.7 Completing the Installation Checklist	46
4.8 Installation Checklist	46
5 Onelines and Schematics	49
5.1 Onelines	49
5.2 System Onelines	50
5.3 Schematics	53
6 Integrated Accessory Cabinet-Bypass Operating Instructions	57
6.1 IAC-B Breakers	57

Table of Contents

6.2 Using the UPS when an IAC-B is Installed	57
6.3 IAC-B Operation – Bypass Interlock Plate	60
6.3.1 Transferring the UPS to Maintenance Bypass	60
6.3.2 Transferring the UPS from Maintenance	61
6.4 IAC-B Operation – Trapped Key Interlock	62
6.4.1 Transferring the UPS to Maintenance Bypass	62
6.4.2 Transferring the UPS from Maintenance Bypass.....	63
7 Maintenance.....	65
7.1 Important Safety Instructions	65
7.2 Performing Preventive Maintenance	65
7.2.1 DAILY Maintenance	65
7.2.2 PERIODIC Maintenance	65
7.2.3 ANNUAL Maintenance.....	65
7.3 Maintenance Training	66
8 Product Specifications	67
8.1 Model Numbers	67
8.2 Specifications	67
8.2.1 Input	67
8.2.2 Output.....	67
8.2.3 Environmental and Safety Specifications.....	67
9 Warranty	69

List of Figures

Figure 1.	Eaton 93PM 400 kW IAC-B	1
Figure 2.	Eaton 93PM 400 kW UPS with Left Positioned Eaton 93PM 400 kW IAC-B	3
Figure 3.	Eaton 93PM 400 kW UPS with Right Positioned Eaton 93PM 400 kW IAC-B.....	4
Figure 4.	93PM IAC-B Dimensions (Front, Right Side, and Rear Views)	11
Figure 5.	93PM IAC-B Dimensions (Top and Bottom Views).....	12
Figure 6.	93PM IAC-B Center of Gravity.....	13
Figure 7.	Cabinet Ventilation – Top Venting	14
Figure 8.	Cabinet Ventilation – Rear Venting	15
Figure 9.	Eaton 93PM IAC-B as Shipped on Pallet.....	22
Figure 10.	Removing the Pallet Skids and Supports – Eaton 93PM 400 kW IAC-B.....	24
Figure 11.	Line-Up-and-Match Wiring Access Locations.....	26
Figure 12.	Typical Bus Bar Barrel Lug Mounting – Hardware Assembly Sequence	27
Figure 13.	Top and Bottom Conduit Landing Wire Entry Locations	28
Figure 14.	93PM IAC-B Power Terminal Locations – with MBP, MIS, and BIB	30
Figure 15.	93PM IAC-B Maintenance Bypass and Output Terminal Detail	32
Figure 16.	93PM IAC-B MIS Input and BIB Output Terminal Detail	33
Figure 17.	93PM IAC-B Interface Terminal Location	38
Figure 18.	Bottom Entry Interface Wiring Location	39
Figure 19.	Wire Tie Anchors	40
Figure 20.	IAC-B MBP Interface Terminal Detail.....	41
Figure 21.	IAC-B SKRU Interface Terminal Detail.....	44
Figure 22.	Eaton 93PM 400 kW IAC-B Internal Oneline – Two-Breaker Maintenance Bypass	49
Figure 23.	Eaton 93PM 400 kW IAC-B Internal Oneline – Three-Breaker Maintenance Bypass	50
Figure 24.	Eaton 93PM 100-400 kW UPS with Two-Breaker 93PM 400 kW IAC-B System Online.....	51
Figure 25.	Eaton 93PM 100-400 kW UPS with Three-Breaker 93PM 400 kW IAC-B System Online.....	52
Figure 26.	Eaton 93PM 400 kW IAC-B Schematic – Two Breaker Maintenance Bypass	53
Figure 27.	Eaton 93PM 400 kW IAC-B Schematic – Three Breaker Maintenance Bypass	54
Figure 28.	Eaton 93PM 400 kW IAC-B Breaker Auxiliary Contact Schematic.....	55
Figure 29.	Eaton 93PM 400 kW IAC-B Trapped Key and Solenoid Key Release Unit (SKRU) Schematic.....	56
Figure 30.	93PM IAC-B Breakers – Bypass Interlock Plate	58
Figure 31.	93PM IAC-B Breakers – Trapped Key Interlock	59
Figure 32.	93PM IAC-B – Trapped Key Interlock Detail.....	60

List of Figures

List of Tables

Table 1.	IAC-B Weights	10
Table 2.	IAC-B Cabinet Clearances.....	10
Table 3.	External Power Wiring Recommendations for the Eaton 93PM IAC-B – Two Breaker Maintenance Bypass	17
Table 4.	External Power Wiring Recommendations for the Eaton 93PM IAC-B – Three Breaker Maintenance Bypass	18
Table 5.	External Input and Output Power Cable Terminations for the Eaton 93PM IAC-B.....	19
Table 6.	Supplied External Wiring Terminal Hardware Kit.....	20
Table 7.	Recommended Installation Parts and Tools (Not Supplied by Eaton)	20
Table 8.	IAC-B MBP Interface Wiring Terminal Block Terminations	41
Table 9.	IAC-B MBP Interface Terminals	41
Table 10.	IAC-B SKRU Interface Wiring Terminal Block Terminations	44
Table 11.	IAC-B SKRU Interface Terminals	45

List of Tables

Chapter 1 Introduction

The Eaton® 93PM Integrated Accessory Cabinet-Bypass (IAC-B) is designed for use with the Eaton 93PM 400 kW Series Uninterruptible Power Supplies (UPSs). The IAC-B provides maintenance bypass functions with configurable features, enabling adaptation and expansion without costly electrical rework. One 480V model is available, the 93PM 400 kW IAC-B.

The IAC-B is housed in single free-standing cabinet with safety shields behind the doors for hazardous voltage protection. The cabinet matches the UPS cabinet in style and color.

[Figure 1](#) shows the Eaton 93PM 400 kW IAC-B.

NOTE Startup and operational checks must be performed by an authorized Eaton Customer Service Engineer, or the warranty terms specified in [Warranty](#) become void. This service is offered as part of the sales contract for the UPS. Contact an Eaton service representative in advance (a minimum two-week notice is required) to reserve a preferred startup date.



Figure 1. Eaton 93PM 400 kW IAC-B

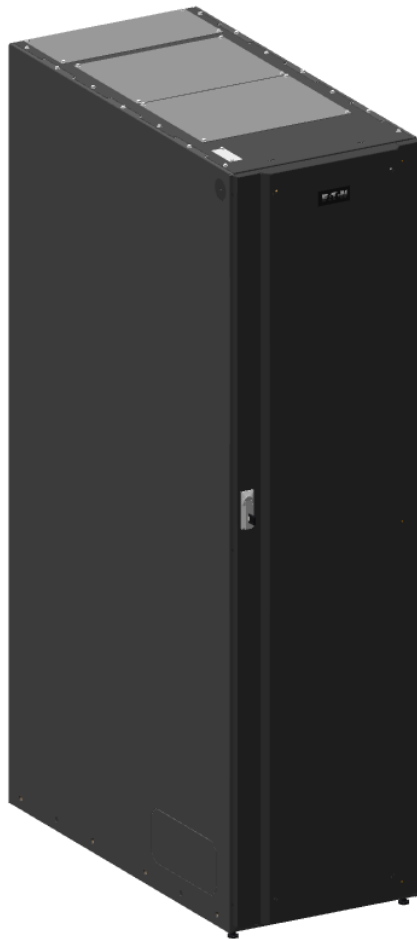

1.1 Features

The following descriptions provide a brief overview of the IAC-B functions:

- Maintenance Bypass Functions
 - Two breaker bypass configuration: The bypass contains a Maintenance Bypass (MBP) and Maintenance Isolation (MIS) breaker. This allows Maintenance bypass for system repair or maintenance. The critical load is NOT protected in the Maintenance bypass mode.
 - Optional three breaker bypass configuration: Maintenance Bypass (MBP) and Maintenance Isolation (MIS) breakers, and a Bypass Input Breaker (BIB) enable power to completely bypass the UPS. The UPS can then be safely serviced or replaced without interrupting power to critical systems.
 - Mechanical bypass interlock standard.
 - Optional Trapped Key interlock with Solenoid Key Release Unit (SKRU).

1.2 Installation Features

- The IAC-B is designed to be installed in line-up-and-match or standalone configurations:
 - In line-up-and-match configurations input power wiring is routed through the side panels between the UPS and the IAC-B.
 - In standalone configurations input power wiring is routed using external conduit through top or bottom entry conduit plates.
 - Output wiring is routed using external conduit through top or bottom entry conduit plates.
- To reduce installation time, connections to the bypass input, MIS, and output are made to easily accessible mechanical lug terminals located at the bottom front of the cabinet.
- Top exhaust or rear exhaust is available
- The cabinet can be leveled and secured in place using leveling feet

A line-up-and-match IAC-B is installed adjacent to the UPS. The IAC-B may be installed on the right side or the left side of the UPS cabinet as viewed from the front of the cabinets. See [Figure 2](#) or [Figure 3](#) for line-up-and-match configuration views.

1.3 Model Configurations

The following 93PM IAC-B model configurations are available for use with the 93PM 400 kW UPS Series:

- Two breaker configurations containing a MBP with auxiliary contacts and MIS.
 - Optional Trapped Key interlock with SKRU.
- Three breaker configurations containing a MBP with auxiliary contacts, a MIS, and a BIB
 - Optional Trapped Key interlock with SKRU.

1.4 Using This Manual

This manual describes how to install the IAC-B and is divided into chapters. Read and understand the procedures described to ensure trouble-free installation and operation.

Read through each procedure before beginning the procedure. Perform only those procedures that apply to the UPS system being installed or operated.

Figure 2. Eaton 93PM 400 kW UPS with Left Positioned Eaton 93PM 400 kW IAC-B

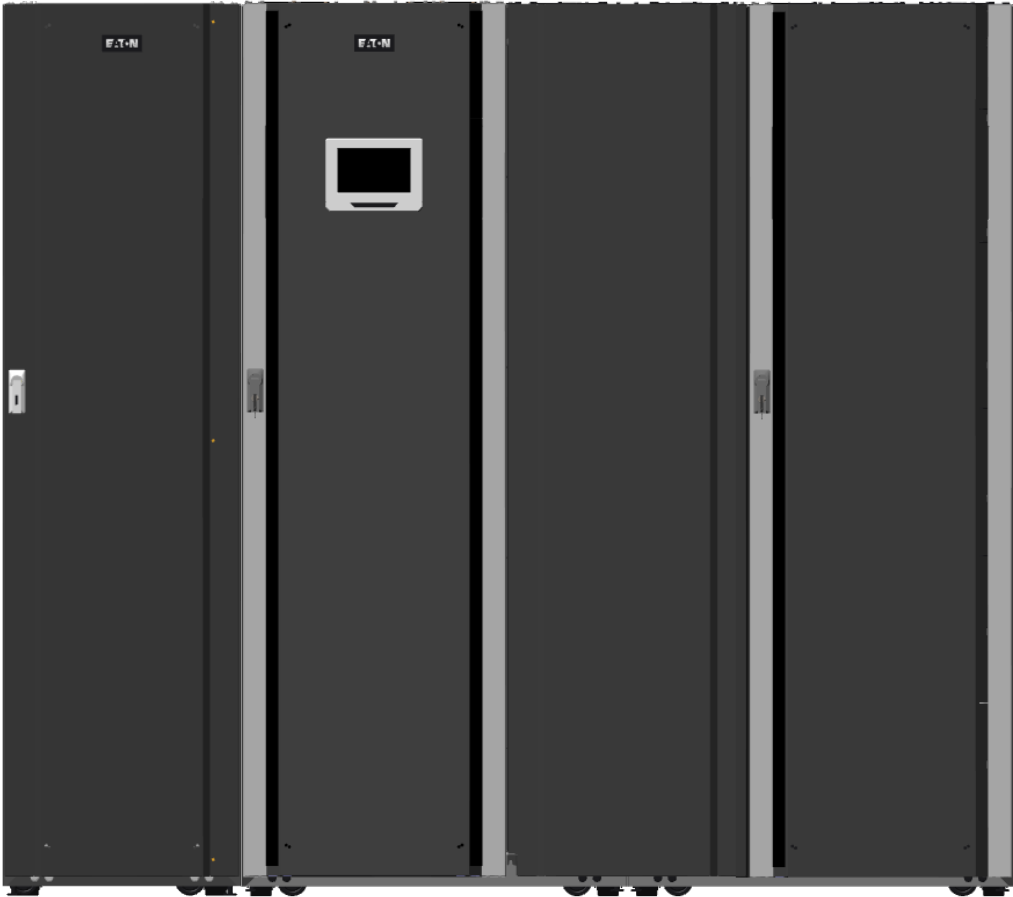

93PM 400 kW IAC-B

93PM 400 kW UPS

Figure 3. Eaton 93PM 400 kW UPS with Right Positioned Eaton 93PM 400 kW IAC-B

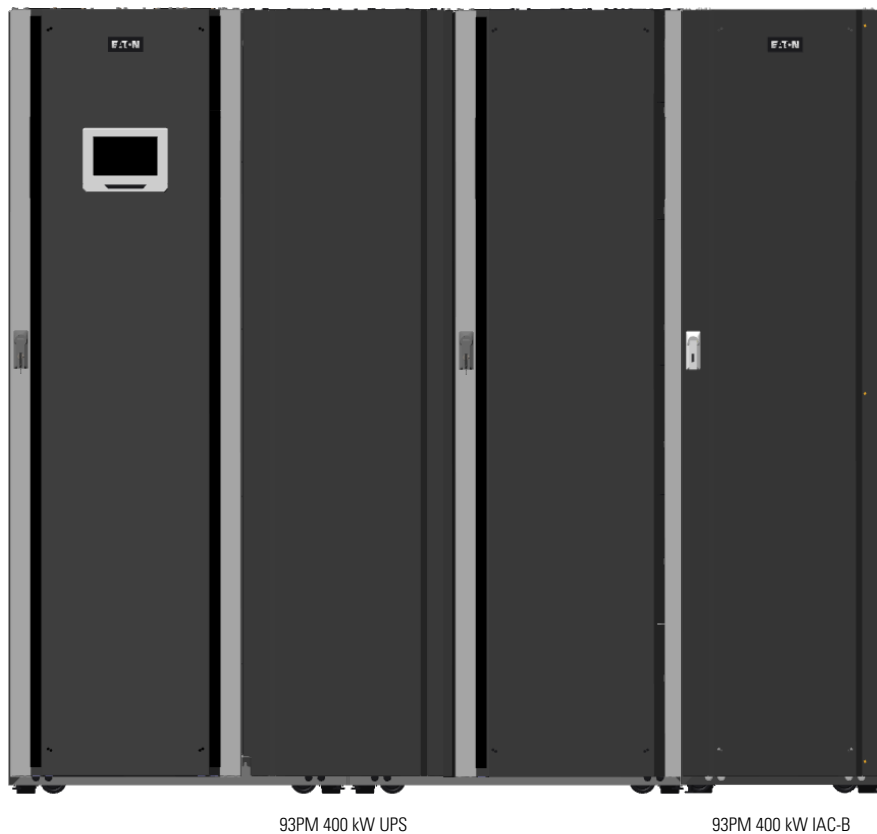

1.5 Conventions Used in This Manual

This manual uses these type conventions:

- **Bold type** highlights important concepts in discussions, key terms in procedures, and menu options, or represents a command or option that you type or enter at a prompt.
- *Italic type* highlights notes and new terms where they are defined.
- `Screen` type represents information that appears on the screen or LCD.

Icon	Description
Note	Information notes call attention to important features or instructions.
[Keys]	Brackets are used when referring to a specific key, such as [Enter] or [Ctrl].

In this manual, the term UPS refers only to the UPS cabinet and its internal elements. The term UPS system refers to the entire power protection system – the UPS cabinet, an external battery system, and options or accessories installed.

The term line-up-and-match refers to accessory cabinets that are physically located adjacent to the UPS. The term standalone refers to accessory cabinets that are located separate from the UPS.

1.6 Symbols, Controls, and Indicators

The following are examples of symbols used on the UPS or accessories to alert you to important information:



RISK OF ELECTRIC SHOCK - Observe the warning associated with the risk of electric shock symbol.



CAUTION: REFER TO OPERATOR'S MANUAL - Refer to your operator's manual for additional information, such as important operating and maintenance instructions.



This symbol indicates that you should not discard the UPS or the UPS batteries in the trash. This product contains sealed, lead-acid batteries and must be disposed of properly. For more information, contact your local recycling/reuse or hazardous waste center.



This symbol indicates that you should not discard waste electrical or electronic equipment (WEEE) in the trash. For proper disposal, contact your local recycling/reuse or hazardous waste center.

1.7 For More Information

Refer to the *Eaton 93PM UPS (100–400 kVA, 480V 400 kW Frame) Installation and Operation Manual* for the following additional information:

- UPS, optional components, and accessory installation instructions, including site preparation, planning for installation, and wiring and safety information. Detailed illustrations of cabinets and optional accessories with dimensional and connection point drawings are provided.
- UPS operation, including UPS controls, functions of the UPS, standard features and optional accessories, procedures for starting and stopping the UPS, and information about maintenance and responding to system events.
- Communication capabilities of the UPS system.

Visit www.eaton.com/powerquality or contact an Eaton service representative for information on how to obtain copies of these manuals.

1.8 Getting Help

If help is needed with any of the following:

Scheduling initial startup

Regional locations and telephone numbers

A question about any of the information in this manual

A question this manual does not answer

Please call the Help Desk at:

United States:

1-800-843-9433

Canada:

1-800-461-9166 ext 260

All other countries:

Call your local service representative

Please use the following e-mail address for manual comments, suggestions, or to report an error in this manual:

E-ESSDocumentation@eaton.com

1.9 Equipment Registration

Please visit www.eaton.com/pg/register to register your new Eaton UPS / Eaton UPS Accessory.

Model Number:

Serial Number:

Chapter 2 Safety Warnings

IMPORTANT SAFETY INSTRUCTIONS - SAVE THESE INSTRUCTIONS

This manual contains important instructions that should be followed during installation and maintenance of the UPS system and batteries. Read all instructions before operating the equipment and save this manual for future reference.

The UPS system is designed for industrial or computer room applications, and contains safety shields behind the door and front panels. However, the UPS system is a sophisticated power system and should be handled with appropriate care.

DANGER

This UPS system contains LETHAL VOLTAGES. All repairs and service should be performed by AUTHORIZED SERVICE PERSONNEL ONLY. There are NO USER SERVICEABLE PARTS inside the UPS.

WARNING

- The UPS system is powered by its own energy source (batteries). The output terminals may carry live voltage even when the UPS is disconnected from an AC source.
- To reduce the risk of fire or electric shock, install this UPS system in a temperature and humidity controlled, indoor environment, free of conductive contaminants. Ambient temperature must not exceed 40°C (104°F). Do not operate near water or excessive humidity (95% maximum). The system is not intended for outdoor use.
- As a result of the connected loads high leakage current is possible. Connection to earth ground is required for safety and proper product operation. Do not check UPS system operation by any action that includes removal of the earth (ground) connection with loads attached.
- Ensure all power is disconnected before performing installation or service.
- ELECTRIC ENERGY HAZARD. Do not attempt to alter any UPS system or battery wiring or connectors. Attempting to alter wiring can cause injury.

CAUTION

- Installation or servicing should be performed by qualified service personnel knowledgeable of UPS and battery systems, and required precautions. Keep unauthorized personnel away from equipment. Consider all warnings, cautions, and notes before installing or servicing equipment.
 - Keep the Accessory cabinet doors closed and front panels installed to ensure proper cooling airflow and to protect personnel from dangerous voltages inside the unit.
 - Do not install or operate the UPS system close to gas or electric heat sources.
 - The operating environment should be maintained within the parameters stated in this manual.
 - Keep surroundings uncluttered, clean, and free from excess moisture.
 - Observe all DANGER, CAUTION, and WARNING notices affixed to the inside and outside of the equipment.
-

Safety Warnings

Chapter 3 Installation Plan and Unpacking

This chapter includes planning and unpacking for the Eaton 93PM Integrated Accessory Cabinet-Bypass (IAC-B). Use the following basic sequence of steps to install the IAC-B:

1. Create an installation plan for the IAC-B (Chapter 3).
2. Prepare your site for the IAC-B (Chapter 3).
3. Inspect and unpack the IAC-B (Chapter 3).
4. Unload and install the IAC-B, and wire the system (Chapter 4).
5. Complete the Installation Checklist (Chapter 4).
6. Have authorized service personnel perform preliminary operational checks and start up the system.



NOTE

Startup and operational checks must be performed by an authorized Eaton Customer Service Engineer, or the warranty terms specified in [Chapter 9 Warranty](#) become void. This service is offered as part of the sales contract for the UPS. Contact an Eaton service representative in advance (usually a two-week notice is required) to reserve a preferred startup date.

3.1 Creating an Installation Plan

Before installing the IAC-B, read and understand how this manual applies to the system being installed. Use the procedures and illustrations in this section to create a logical plan for installing the IAC-B. This section contains the following information:

- Physical features and requirements, including dimensions
- Power wiring installation notes

3.2 Preparing the Site

For the UPS system to operate at peak efficiency, the installation site should meet the environmental parameters outlined in this manual. The operating environment must meet the weight, clearance, and environmental requirements specified for the applicable accessory cabinet. Specifications subject to change.

3.2.1 Environmental and Installation Considerations

The UPS system installation, including the IAC-B, must meet the following guidelines:

- The system must be installed on a level floor suitable for computer or electronic equipment.
- The system must be operated at an altitude no higher than 1500m (5000 ft.) without derating. For additional assistance with high altitude operation, contact an Eaton service representative (see paragraph [1.8 Getting Help](#)).
- The system must be installed in a temperature and humidity controlled indoor area free of conductive contaminants.

Failure to follow guidelines may void your warranty.

The basic environmental requirements for operation of the IAC-B are:

- Recommended Operating Range: 5–40°C (41–104°F)
- Maximum Relative Humidity: 5–95%, noncondensing

The IAC-B operating environment must meet the weight requirements shown in [Table 1](#) and the size requirements shown in [Figure 4](#) through [Figure 6](#). Dimensions are in millimeters (inches).

Table 1. IAC-B Weights

Model	Weight kg (lb)		
	Shipping	Installed	Point Loading
Eaton 93PM 400 kW IAC-B with MBP, MIS, BIB	292 (643)	265 (584)	4 at 66 (146)

The IAC-B uses convection cooling to regulate internal component temperature. Air inlets are in the front of the cabinet and outlets are on top of the cabinet for top exhaust (see [Figure 7](#)) or in the back of the cabinet for rear exhaust (see [Figure 8](#)). Allow clearance in front of and on top or in back of the cabinet depending on type of exhaust for proper air circulation. The clearances required around the IAC-B are shown in [Table 2](#).

Table 2. IAC-B Cabinet Clearances

Viewing the IAC-B	Clearance
From Front of Cabinet	914.4 mm (36") working space
From Top of Cabinet with Top Venting	203 mm (8") minimum clearance for ventilation *
From Top of Cabinet with Rear Venting	203 mm (8") *
From Back of Cabinet with Rear Venting	203 mm (8") minimum clearance for ventilation
From Back of Cabinet with Top Venting	None Required
From Back of Cabinet – Seismic Installation	914.4 mm (36") working space
From Right Side of Cabinet	None Required
From Left Side of Cabinet	None Required

NOTE *Additional Top of Cabinet clearance may be required for conduit in top entry applications.

Figure 4. 93PM IAC-B Dimensions (Front, Right Side, and Rear Views)

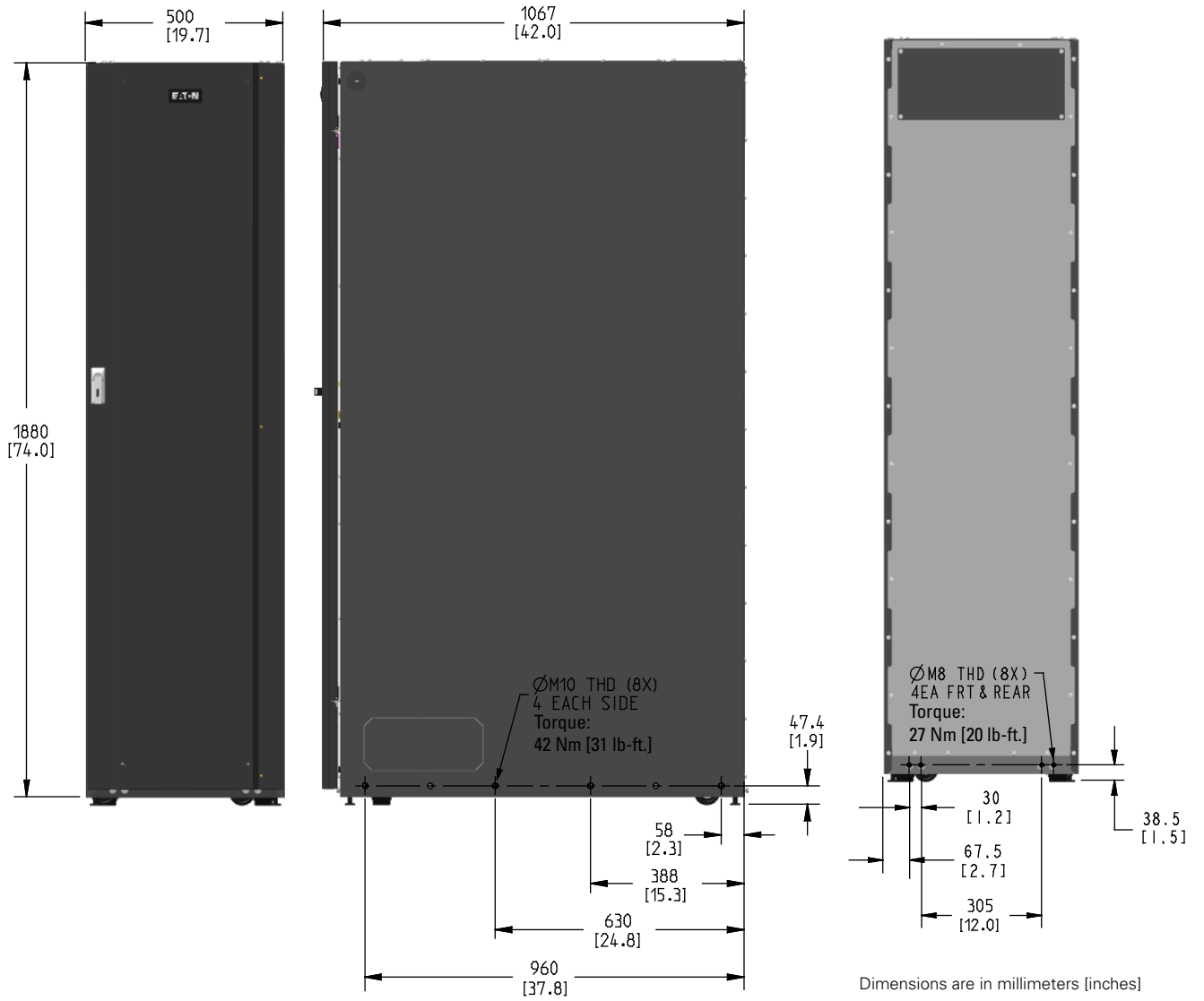

Figure 5. 93PM IAC-B Dimensions (Top and Bottom Views)

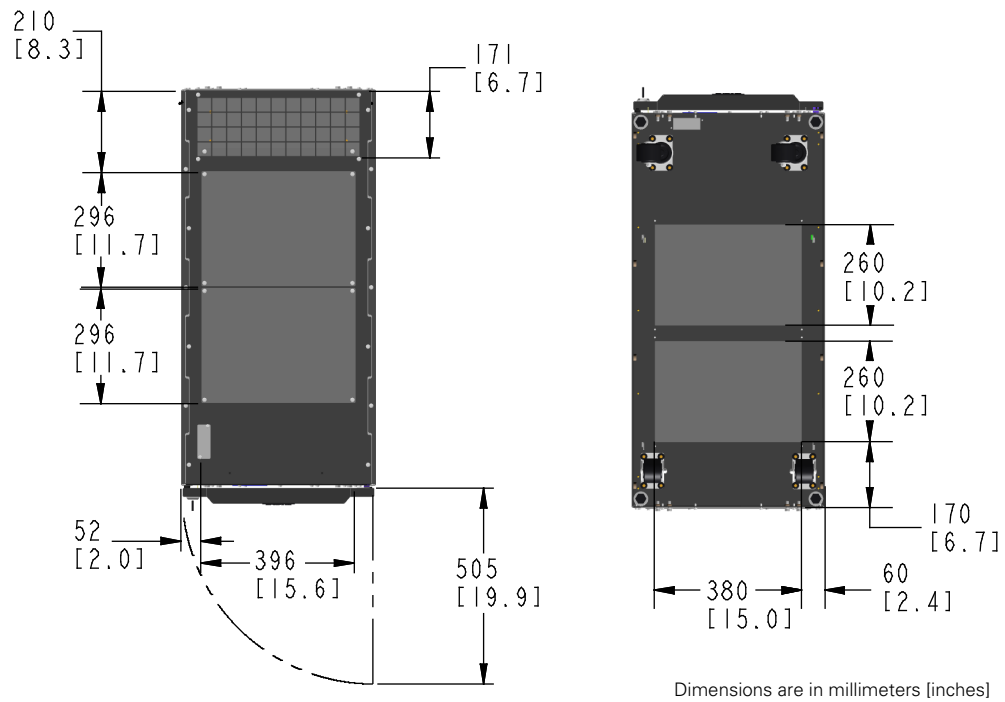
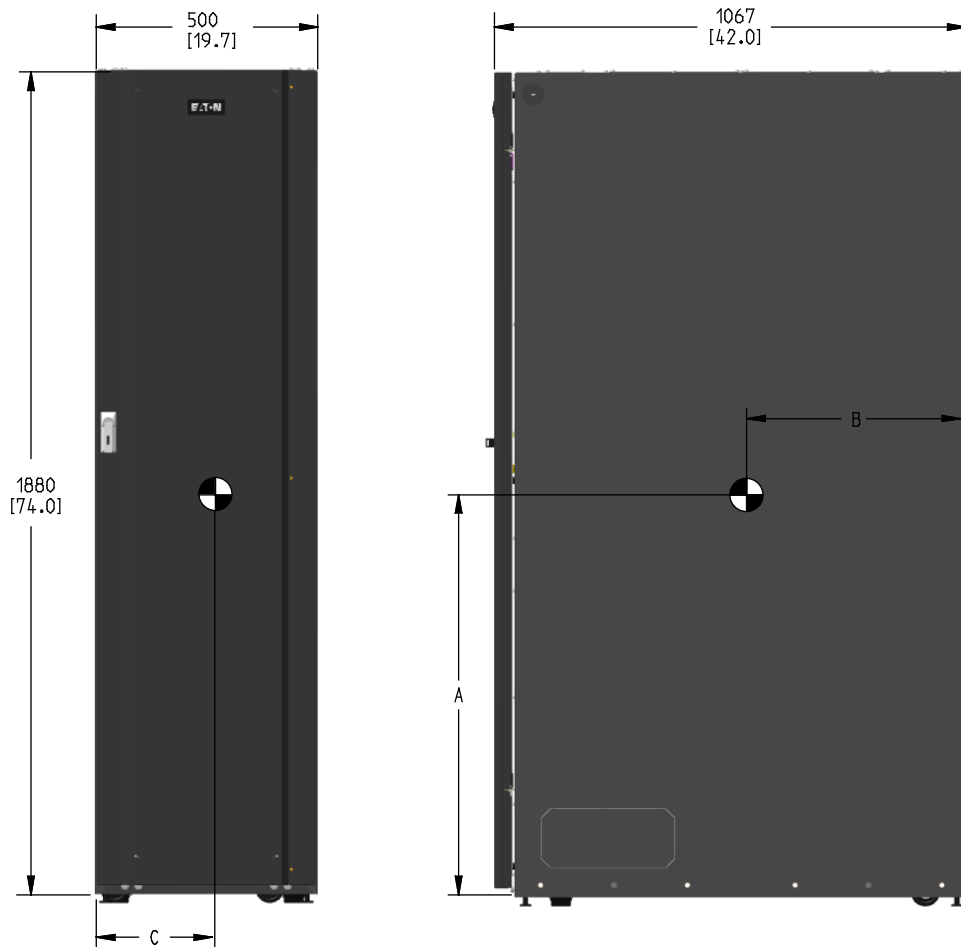

Figure 6. 93PM IAC-B Center of Gravity



Dimensions are in millimeters [inches]

Weight and Center of Gravity: Eaton 93PM-400 kW IAC-B with 3 Breakers (See Figure 6)			
A mm [in]	B mm [in]	C mm [in]	Weight kg [lb]
954 [37.6]	627 [24.7]	251 [9.9]	265 [584.0]

Figure 7. Cabinet Ventilation – Top Venting

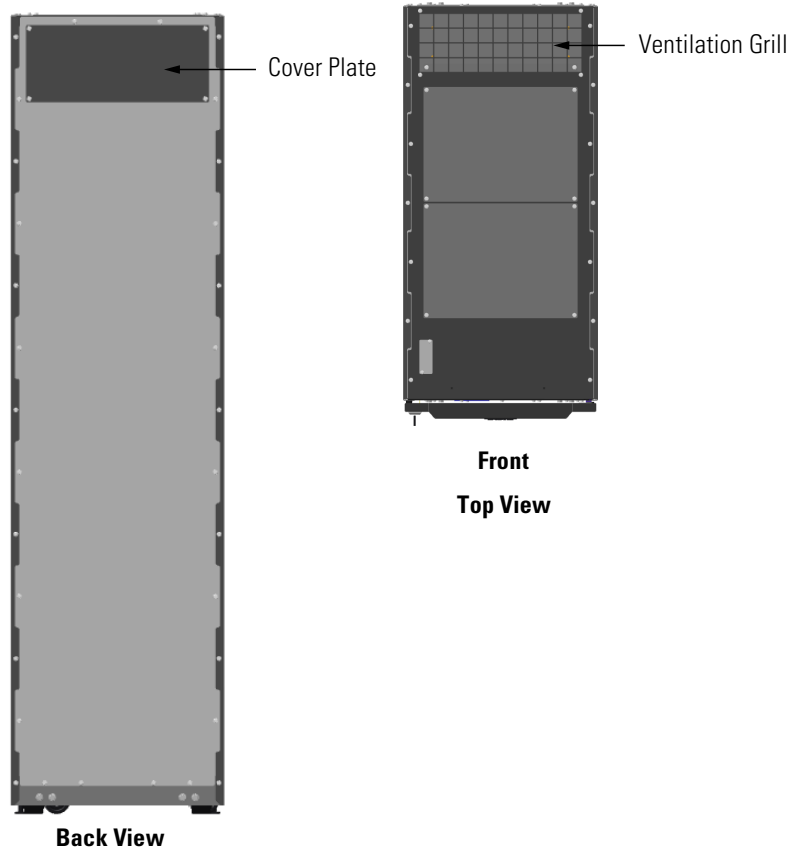
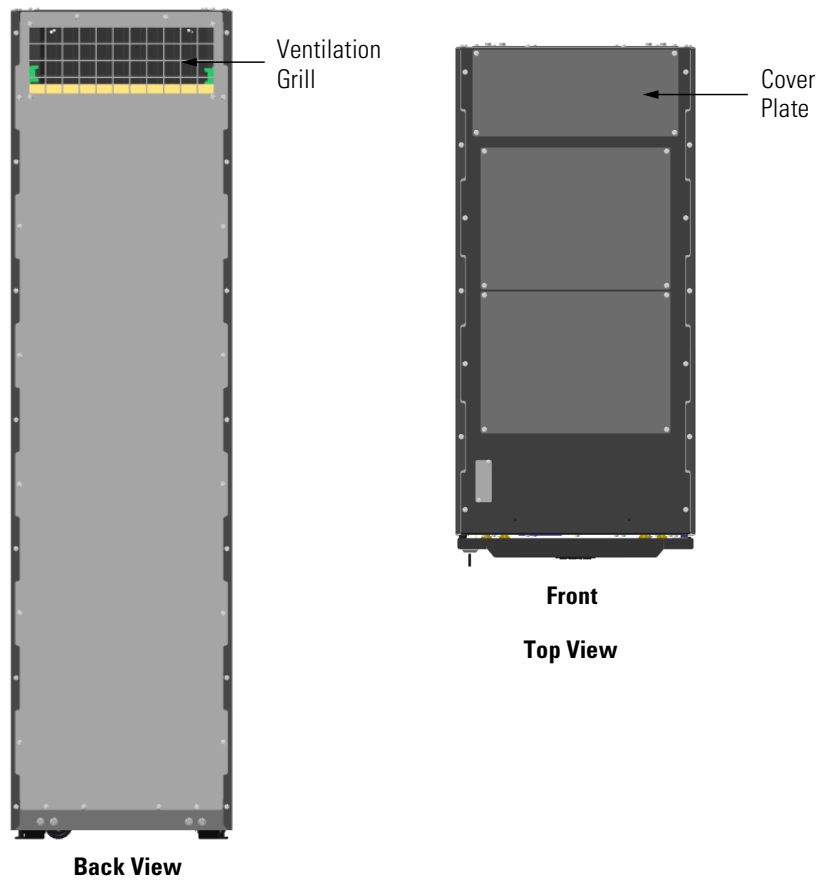

Figure 8. Cabinet Ventilation – Rear Venting



3.2.2 IAC-B Power Wiring Preparation

Read and understand the following notes while planning and performing the installation:

WARNING

As a result of the connected loads high leakage current is possible. Connection to earth ground is required for safety and proper product operation. Do not check IAC-B operation by any action that includes removal of the earth (ground) connection with loads attached.

- Refer to national and local electrical codes for acceptable external wiring practices.
- For external maintenance bypass input, MIS, and BIB wiring, use copper wire with 75°C rated insulation. Wire sizes listed in [Table 3](#) through [Table 4](#) are for copper wiring only. If wire is run in an ambient temperature greater than 40°C (104°F), higher temperature wire and/or larger size wire may be necessary. Wire sizes are based on using the specified breakers.
- Recommended wire sizes are based on NFPA National Electrical Code® (NEC®) 70 Table 310.15(B)(16) 75° C ampacity with 40°C ambient correction factors.
- Refer to NEC Article 250 and local codes for proper grounding practices.
- Per NEC Article 300-20(B), all three-phase conductors must be run in the same conduit. Ground must be run in the same conduit as the phase conductors.
- A neutral conductor is not used from the source or supplied to the load.
- Conduit is to be sized to accommodate three phase conductors and one ground conductor.
- Phase rotation must be clockwise starting with phase A (rotation A, B, C).
- Material and labor for external wiring recommendations are to be provided by the customer.
- When installing an external maintenance bypass, all feeds to the UPS must have a service disconnect independent of the maintenance bypass power path. Most maintenance bypass solutions provide UPS input feeds derived from but isolated from the maintenance bypass power path. The source disconnect devices for maintenance bypass and the UPS input must be isolated but derived from the same voltage source. If the maintenance bypass solution being installed does not provide such functionality, DO NOT use a single feeder breaker to supply both the UPS and the maintenance bypass.
- Refer to the appropriate Eaton 93PM UPS installation and operation manual listed in paragraph [1.7 For More Information](#) for UPS cabinet conduit and terminal specifications and locations.
- The term *line-up-and-match* refers to accessory cabinets that are physically located adjacent to the UPS. The term *standalone* refers to accessory cabinets that are located separate from the UPS.

For external power wiring recommendations, including the minimum AWG size of external wiring, see [Table 3](#) or [Table 4](#). Wire sizes listed are for copper wiring only.

Table 3. External Power Wiring Recommendations for the Eaton 93PM IAC-B – Two Breaker Maintenance Bypass

	Units		Rating 60 Hz	
	kW		400	
Basic Unit Rating				
Input/Output Voltage	Volts		480/480	
AC Input to Maintenance Bypass (3) Phases, (1) Ground Minimum Conductor Size (Phase A, B, and C) Number per Phase Minimum Conductor Size (Ground) Number per Phase	A	Maximum Amps	582	
		AWG or kcmil (each)	300 (3)	
	—	AWG or kcmil (each)	1/0 (1)	
AC Input to MIS from UPS Output (3) Phases, (1) Ground Minimum Conductor Size (Phase A, B, and C) Number per Phase Minimum Conductor Size (Ground) Number per Phase	C	Maximum Amps	480	
		AWG or kcmil (each)	4/0 (3)	or
	—	AWG or kcmil (each)	1 (1)	
AC Output to the Critical Load Full Load Current (3) Phases, (1) Ground Minimum Conductor Size (Phase A, B, and C) Number per Phase Minimum Conductor Size (Ground) Number per Phase	D	Maximum Amps	480	
		AWG or kcmil (each)	4/0 (3)	or
	—	AWG or kcmil (each)	1 (1)	
AC Output to Load Bank (3) Phases, (1) Ground Minimum Conductor Size (Phase A, B, and C) Number per Phase Minimum Conductor Size (Ground) Number per Phase	E	Maximum Amps	480	
		AWG or kcmil (each)	500 (2)	
	—	AWG or kcmil (each)	1 (1)	
Building and Inter-Cabinet Ground Minimum Conductor Size (Ground) Number per Phase	—	AWG or kcmil (each)	1/0 (1)	

NOTE Callout letters **A**, **C**, **D**, and **E** map to [Figure 22](#) and [Figure 24](#).

Table 4. External Power Wiring Recommendations for the Eaton 93PM IAC-B – Three Breaker Maintenance Bypass

Basic Unit Rating	Units		Rating 60 Hz		
	kW		400		
Input/Output Voltage	Volts		480/480		
AC Input to Maintenance Bypass (3) Phases, (1) Ground	Maximum Amps		582		
Minimum Conductor Size (Phase A, B, and C) Number per Phase	A	AWG or kcmil (each)	300 (3)		
Minimum Conductor Size (Ground) Number per Phase		—	AWG or kcmil (each)	1/0 (1)	
AC Output from BIB to UPS Bypass (3) Phases, (1) Ground	Maximum Amps		582		
Minimum Conductor Size (Phase A, B, and C) Number per Phase	B	AWG or kcmil (each)	300 (3)		
Minimum Conductor Size (Ground) Number per Phase		—	AWG or kcmil (each)	1/0 (1)	
AC Input to MIS from UPS Output (3) Phases, (1) Ground	Maximum Amps		480		
Minimum Conductor Size (Phase A, B, and C) Number per Phase	C	AWG or kcmil (each)	4/0 (3)	or	500 (2)
Minimum Conductor Size (Ground) Number per Phase		—	AWG or kcmil (each)	1 (1)	
AC Output to Critical Load Full Load Current (3) Phases, (1) Ground	Maximum Amps		480		
Minimum Conductor Size (Phase A, B, and C) Number per Phase	D	AWG or kcmil (each)	4/0 (3)	or	500 (2)
Minimum Conductor Size (Ground) Number per Phase		—	AWG or kcmil (each)	1 (1)	
AC Output to Load Bank (3) Phases, (1) Ground	Maximum Amps		480		
Minimum Conductor Size (Phase A, B, and C) Number per Phase	E	AWG or kcmil (each)	500 (2)		
Minimum Conductor Size (Ground) Number per Phase		—	AWG or kcmil (each)	1 (1)	
Building and Inter-Cabinet Ground Minimum Conductor Size (Ground) Number per Phase	—	AWG or kcmil (each)	1/0 (1)		

NOTE Callout letters **A, B, C, D** and **E** map to [Figure 23](#) and [Figure 25](#).

The power wiring terminals are 2-hole bus bar mountings for standard NEMA 2-hole barrel lugs. See [Table 5](#) for external power cable terminations. See [Table 6](#) for supplied external wiring terminal hardware and [Table 7](#) for recommended installation parts and tools not supplied by Eaton.

[Figure 14](#) through [Figure 16](#) show the IAC-B power terminal locations and detail.

Table 5. External Input and Output Power Cable Terminations for the Eaton 93PM IAC-B

Terminal Function	Terminal	Function	Number and Size of Pressure Termination (AWG or kcmil)	Tightening Torque Nm (lb ft.)	Size Screw and Type
AC Input to Maintenance Bypass	E6	Phase A	2 – 2 bolt mounting	35 (26)	M12 Hex (19 mm Hex Head)
	E7	Phase B			
	E8	Phase C			
AC Output from BIB to UPS Bypass (3-breaker version only)	E6	Phase A			
	E7	Phase B			
	E8	Phase C			
AC Input to MIS from UPS Output and AC Output to Load Bank	E9	Phase A			
	E10	Phase B			
	E11	Phase C			
AC Output to Critical Load	E9	Phase A			
	E10	Phase B			
	E11	Phase C			
Building, Inter-Cabinet, and Load Ground	TBG	Ground	4 – #14–1/0	5.6 Nm (50 lb in)	Slotted

Table 6. Supplied External Wiring Terminal Hardware Kit

Part	Size	Quantity	Terminal Used On
Bolt, Hex Head, Grade 5	M12 x 40mm	72	Bypass and MIS Input, BIB Output, and Output to Critical Load
Washer, Flat	M12	144	
Washer, Conical Spring	M12	72	

NOTE For additional information (including part numbers and manufacturer information) and/or assistance contact an Eaton service representative (see paragraph [1.8 Getting Help](#)).

Table 7. Recommended Installation Parts and Tools (Not Supplied by Eaton)

Part	Size	Quantity	Notes
Long Barrel 2-Hole Lug	2/0 AWG	As Required	Copper wire only
	3/0 AWG		
	4/0 AWG		
	250 MCM		
	300 MCM		
	350 MCM		
	400 MCM		
	500 MCM		
Manual Hydraulic Crimp Tool	14 Ton	1	
Die Set	N/A	1	

NOTE For additional information (including part numbers and manufacturer information) and/or assistance contact an Eaton service representative (see paragraph [1.8 Getting Help](#)).

3.2.3 IAC-B Interface Wiring Preparation

Control wiring for features and options should be connected at the customer interface terminal blocks located inside the IAC-B.



Do not directly connect relay contacts to the mains related circuits. Reinforced insulation to the mains is required.

Read and understand the following notes while planning and performing the installation:

- Use Class 1 wiring methods (as defined by NEC Article 725) for interface wiring from 30V to 600V. The wire should be rated for 600V, 1A minimum. 12 AWG maximum wire size.
- Use Class 2 wiring methods (as defined by NEC Article 725) for interface wiring up to 30V. The wire should be rated for 24V, 1A minimum.
- Use twisted-pair wires for each input and return or common.
- All interface wiring and conduit is to be supplied by the customer.

- Interface wiring can be installed using the inter-cabinet wiring access pass-through or by routing wiring through conduit between cabinets.
- Install the interface wiring in separate conduit from the power wiring.

3.3 Inspecting and Unpacking the IAC-B

The cabinet is shipped bolted to a wooden pallet and covered with outer protective packaging material (see [Figure 9](#)).

NOTE  Startup and operational checks must be performed by an authorized Eaton Customer Service Engineer, or the warranty terms specified in [Chapter 9 Warranty](#) become void. This service is offered as part of the sales contract for the UPS. Contact an Eaton service representative in advance (a minimum two-week notice is required) to reserve a preferred startup date.

WARNING

The IAC-B is heavy (see [Table 1](#)). If unpacking and unloading instructions are not closely followed, the cabinet may tip and cause serious injury.

1. Carefully inspect the outer packaging for evidence of damage during transit.

CAUTION

Do not install a damaged cabinet. Report any damage to the carrier and contact an Eaton service representative immediately.

NOTE  For the following step, verify that the forklift or pallet jack is rated to handle the weight of the cabinet (see [Table 3-1](#) for cabinet weight).

2. Use a forklift or pallet jack to move the packaged cabinet to the installation site, or as close as possible, before unpacking. If possible, move the cabinet using the pallet. Insert the forklift or pallet jack forks between the supports on the bottom of the pallet. See [Figure 6](#) for the IAC-B center of gravity measurements.

CAUTION

Do not tilt the IAC-B more than 10° from vertical or the cabinet may tip over.

3. Set the pallet on a firm, level surface, allowing a minimum clearance of 3m (10 ft.) on each side for removing the cabinet from the pallet.
4. Remove the protective packaging material from the cabinet and recycle in a responsible manner. Retain the parts kit box packed at the top of the cabinet.
5. Inspect the contents for any evidence of physical damage, and compare each item with the Bill of Lading. If damage has occurred or shortages are evident, contact an Eaton service representative immediately to determine the extent of the damage and its impact on further installation.

NOTE  While waiting for installation, protect the unpacked cabinet from moisture, dust, and other harmful contaminants. Failure to store and protect the IAC-B properly may void your warranty.

Figure 9. Eaton 93PM IAC-B as Shipped on Pallet



Chapter 4 Installation

This chapter contains installation instructions, including unloading, power wiring, and interface wiring, for the Integrated Accessory Cabinet-Bypass (IAC-B).

4.1 Preliminary Installation Information

WARNING

Installation should be performed only by qualified personnel knowledgeable of batteries and the required precautions.

- Refer to [Chapter 3 Installation Plan and Unpacking](#) for cabinet dimensions, equipment weight, wiring and terminal data, and installation notes.
- Remove conduit landing plates to add conduit landing holes as required.

4.2 Unloading the IAC-B from the Pallet

WARNING

- RISK OF INSTABILITY. Do not remove any internal panels until the cabinet is removed from and lowered from the pallet.
- The IAC-B is heavy (see [Table 1](#)).
- Do not tilt cabinet more than 10° from vertical.
- Lift the cabinet only with a forklift or pallet jack or damage may occur.
- Ensure forklift is rated to handle the weight of the cabinet.

Failure to follow these instructions may result in severe injury or death.

**NOTE**

For the following steps, verify that the forklift or pallet jack is rated to handle the weight of the cabinet (see [Table 1](#) for cabinet weights).

The IAC-B is bolted to a pallet consisting of four metal angle supports secured to two wood supports. To remove the pallet:

1. If not already accomplished, use a forklift or pallet jack to move the IAC-B to the installation area, or as close as possible, before unloading from the pallet. Insert the forklift or pallet jack forks between the supports on the bottom of the pallet (see [Figure 6](#) for the UPS cabinet center of gravity measurements).
2. Open the front door by lifting the latch from the bottom and turning to the right (counterclockwise) and swing the door open.
3. Locate the four 1/2" jacking bolts from the parts kit and install them in the threaded holes in the front and rear supports as shown in [Figure 10](#). Place a floor protector from the parts kit underneath each jacking bolt, and screw the bolts down against them.

The floor protectors protect the floor from being marred by the jacking bolts.

Figure 10. Removing the Pallet Skids and Supports – Eaton 93PM 400 kW IAC-B

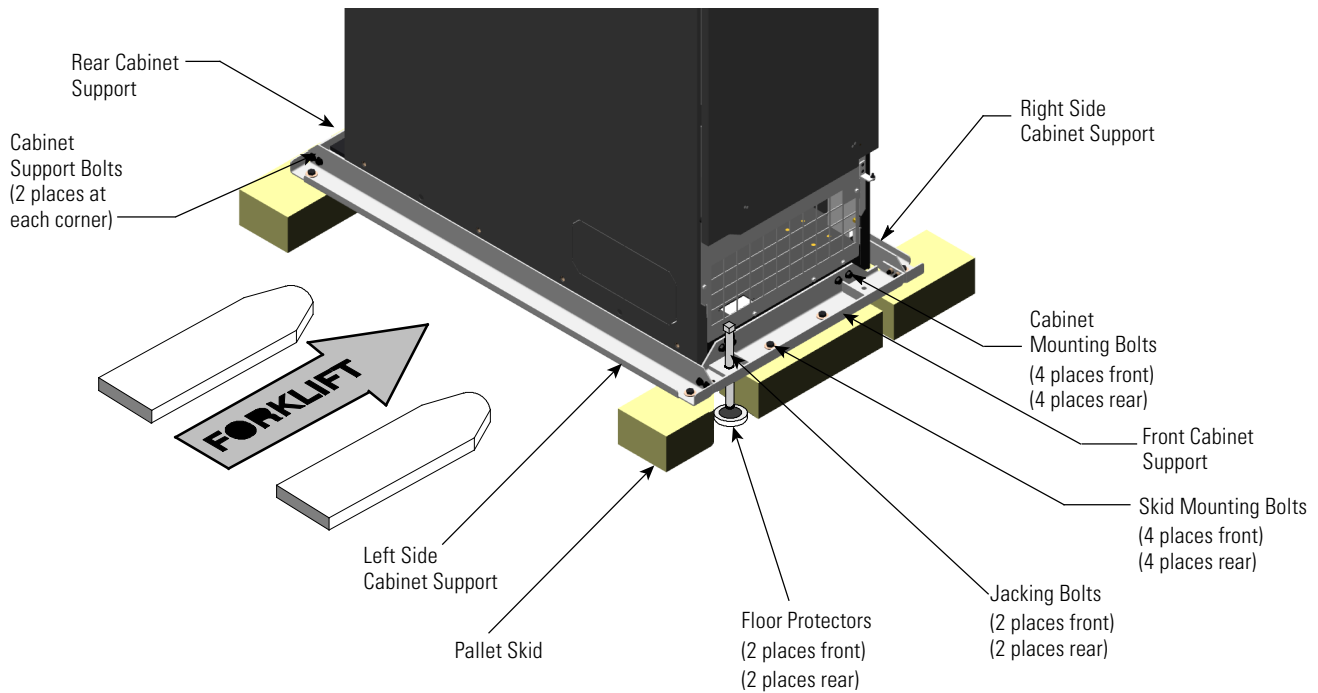

⚠ WARNING

Do not remove or loosen the cabinet mounting or cabinet support bolts until instructed.

4. Loosen, but do not remove, the skid mounting bolts holding the pallet skids to the front and rear supports, and to the left and right side supports (see [Figure 10](#)).

⚠ WARNING

RISK OF INSTABILITY. Turning the jacking bolts unevenly may cause the cabinet to become unbalanced. To prevent tipping the cabinet, raise and lower the jacking bolts evenly.

⚠ CAUTION

CABINET MAY TIP. Raise the IAC-B no more than 3 mm (1/8") above the floor (just enough to allow the removal of the pallet skids).

5. Turn each jacking bolt consecutively, two full turns, until the pallet skids clear the floor by approximately 3 mm (1/8").
6. Remove the hardware loosened in [Step 4](#).
7. Pull the pallet skids out from under the metal angle supports without disturbing the jacking bolts. Recycle the pallet skids and hardware in a responsible manner.

CAUTION

CABINET MAY FALL. Do not loosen the hardware attaching the front supports to the cabinet base. The cabinet must be lowered by the jacking bolts before the supports can be removed.

8. Carefully and evenly **lower the cabinet by turning each jacking bolt consecutively two full turns (maximum)** until the casters contact the floor and the cabinet is no longer supported by the jacking bolts.
9. After the IAC-B is resting on the floor, remove the jacking bolts and floor protectors. Recycle them in a responsible manner.
10. Remove the cabinet support bolts fastening the front, rear, and side cabinet supports together and remove the side supports (see [Figure 10](#)).
11. Remove the cabinet mounting bolts holding the front and rear supports to the cabinet base (see [Figure 10](#)).
12. Recycle the bolts along with the support brackets in a responsible manner.
13. Close the door and secure the latch.
14. If the leveling feet are not retracted, turn all four leveling feet until they are retracted as far into the cabinet as possible.

**NOTE**

The IAC-B may be located to either the right or left of the UPS cabinet.

15. If line-up-and-match installation, remove the rectangular knockout on the bottom front side of the UPS and the IAC-B (see [Figure 11](#)).
16. The IAC-B is shipped set up for top ventilation with a cover plate installed over the ventilation grill on the back of the cabinet (see [Figure 7](#)). If rear ventilation is required, remove the screws securing the plate at the back of the cabinet and install the plate over the top ventilation grill (see [Figure 8](#)). T

**NOTE**

In line-up-and-match installations, the IAC-B and UPS cabinets should be located as shown in [Figure 2](#) or [Figure 3](#).

CAUTION

To prevent tipping when rolling the cabinet and damage to the front door, push the cabinet from the rear whenever possible. Do not push the cabinet from the sides.

17. Roll the cabinet to the final installation location.

**NOTE**

Use the leveling feet to level and lock the cabinet in place.

18. Secure the IAC-B in position by lowering the leveling feet until the cabinet is level and locked in place.
19. Locate the top splice bracket shipped with the IAC-B.
20. Remove the screws along each adjacent cabinet top panel securing the top panels. Retain the hardware for later use.
21. Install the top splice bracket between the adjacent cabinet and secure the tie strap with retained hardware.

**NOTE**

Optional front and back floor mounting brackets are available to order for permanently mounting the IAC-B.

22. If permanently mounting the IAC-B, proceed to [Step 23](#); otherwise, proceed to [Step 26](#).

23. Locate the front and back floor mounting brackets from the optional floor mounting kit.
24. Using the cabinet mounting bolts from the kit, install the floor mounting brackets to the front and rear of the IAC-B with the angle facing outward.
25. Secure the cabinet to the floor with customer-supplied hardware.
26. Proceed to paragraph [4.3 Two-Hole Barrel Lug Terminations to Bus Bar Installation](#)

Figure 11. Line-Up-and-Match Wiring Access Locations

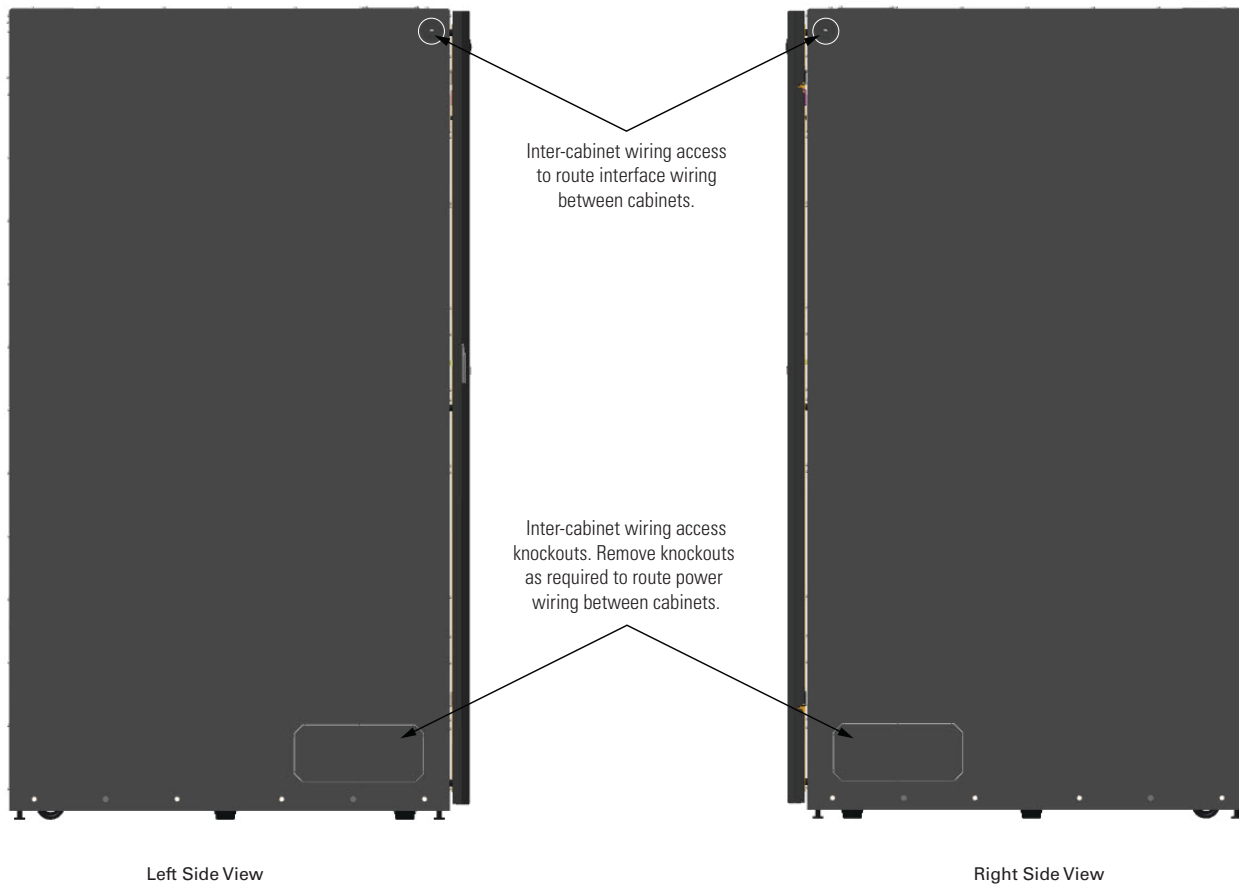

4.3 Two-Hole Barrel Lug Terminations to Bus Bar Installation

Paragraphs [4.4.1 IAC-B with a Maintenance Bypass Breaker and Maintenance Isolation Switch](#) and [4.4.2 IAC-B with a Maintenance Bypass Breaker, Maintenance Isolation Switch, and Bypass Input Breaker](#) may require connecting input and output power wiring using 2-hole barrel lugs. See [Figure 12](#) for the hardware sequence when installing the lugs to the bus bars. Tighten the bolt to the torque value listed in [Table 5](#).

Proceed to paragraph [4.4 Installing IAC-B External Power Wiring](#).



NOTE

Conical washers are special purpose washers that look similar to flat washers, except for a slight conical shape. When installing conical washers, the top of the dome should be next to the bolt head and the base of the washer should be against a flat surface such as a bus bar, flat washer, or large terminal.

Figure 12. Typical Bus Bar Barrel Lug Mounting – Hardware Assembly Sequence

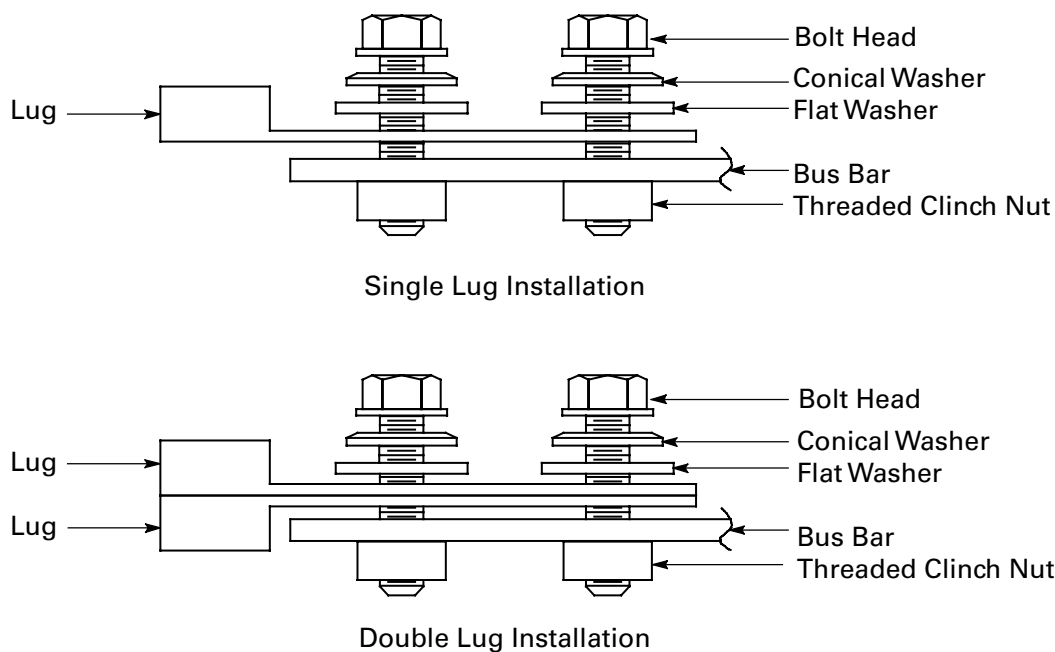

4.4 Installing IAC-B External Power Wiring

- NOTE 1** Power wiring from the UPS is routed through the inside bottom of the IAC-B and UPS for line-up-and-match configurations using the pass-through wiring procedures or wiring can be installed using conduit between the cabinets for standalone installations using the top or bottom entry wiring procedures. Input and output power wiring is routed through the top or bottom of the cabinet using conduit.
- NOTE 2** Line-up-and-match UPS phase power wiring is factory supplied coiled inside the bottom of the IAC-B.
- NOTE 3** Two-hole barrel lugs are installed on the ends of the factory supplied cable harnesses. Do not shorten or cut factory supplied wiring.
- NOTE 4** Remove the IAC-B conduit landing plates to drill or punch conduit holes in the conduit plates (see [Figure 4-4](#)).
- NOTE 5** Refer to the applicable Eaton 93PM UPS Installation and Operation manual, listed in paragraph [1.7 For More Information](#), for UPS installation procedures.

4.4.1 IAC-B with a Maintenance Bypass Breaker and Maintenance Isolation Switch

To install wiring to terminal connections:

1. Verify the UPS system is turned off and all power sources are removed. Refer to the applicable Eaton 93PM UPS Installation and Operation manual, listed in paragraph [1.7 For More Information](#), for UPS operating procedures.

2. Open the front door by lifting the latch from the bottom and turning to the right (counterclockwise) and swing the door open.
3. Remove the screws securing the top and bottom internal safety shield panels and remove the panels to gain access to the maintenance bypass input terminals, the Maintenance Isolation Switch (MIS) input and load bank terminals, and the output terminals. Retain the hardware for later use.
4. If wiring the IAC-B power terminals using the inter-cabinet wiring access pass-through (line-up-and-match configurations), proceed to [Step 5](#); if wiring the IAC-B power terminals using the bottom entry access, proceed to [Step 11](#); if wiring the IAC-B power terminals using the top entry access, proceed to [Step 16](#).
5. **Pass-through Wiring.** Locate and remove the phase power cable harness labeled UPS OUTPUT (MIS input cables) packed inside the IAC-B.



NOTE

UPS OUTPUT power cables (MIS input cables) have two-hole barrel lugs installed on the ends. Route the cable ends marked E9, E10, E11 to the UPS output terminals.

6. Route the IAC-B UPS OUTPUT (MIS input) cables (phase A, B, and C) and Ground wire from the UPS cabinets through the bottom UPS and IAC-B inter-cabinet wiring access pass-through to the IAC-B MIS input terminals. See [Figure 11](#) for IAC-B wiring access information and [Figure 14](#) for IAC-B terminal locations. See paragraph [3.2.2 IAC-B Power Wiring Preparation](#), [Table 3](#), and [Table 5](#) for IAC-B wiring and termination requirements.
7. Remove the top or bottom conduit plate (see [Figure 13](#)) from the IAC-B. Identify all input and output conduit requirements and mark their location. Drill and punch all conduit holes in the conduit plate prior to mounting on the IAC-B. Reinstall the conduit plate. Install conduit between the IAC-B and the maintenance bypass input source, and between the IAC-B and the critical load. Pull the wiring through conduit into the wiring area.

Figure 13. Top and Bottom Conduit Landing Wire Entry Locations

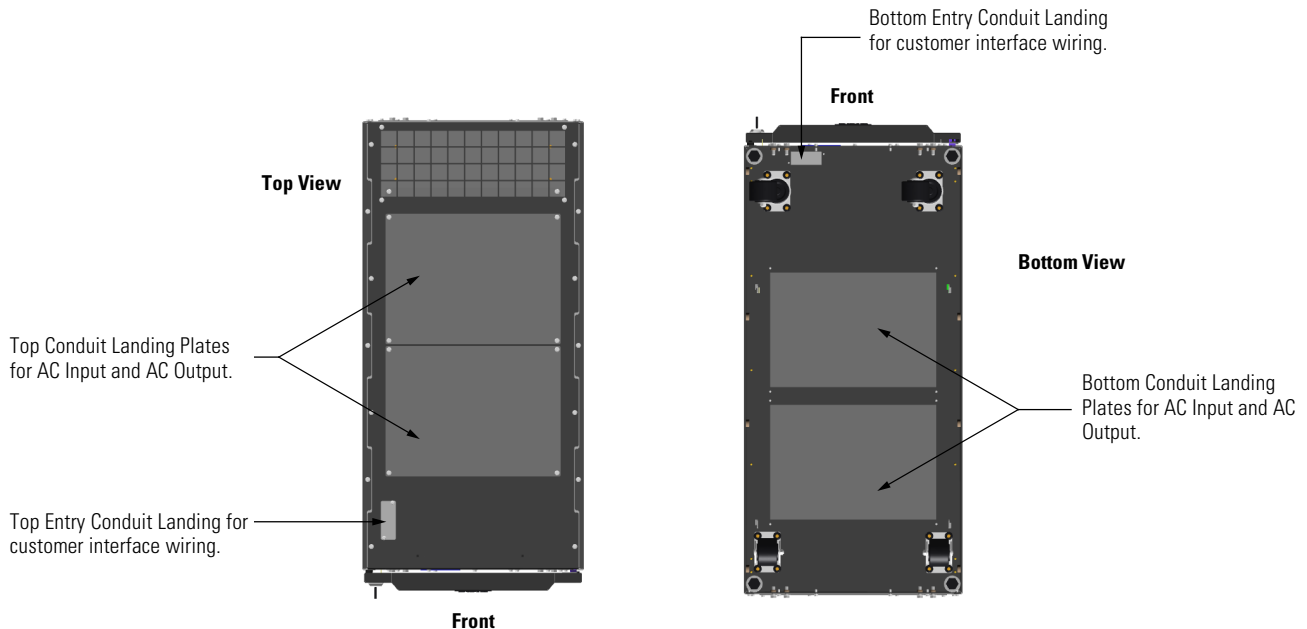

NOTE: Remove panels to drill or punch conduit holes.

8. Route the maintenance bypass input cables (phase A, B, and C) and Ground wire through the top or bottom of the IAC-B to the maintenance bypass input terminals. See [Figure 14](#) for IAC-B terminal locations.
9. Route the output cables (phase A, B, and C) and Ground wire from the IAC-B output terminals through the top or bottom of the cabinet to the critical load. See [Figure 14](#) for IAC-B terminal locations.
10. Proceed to [Step 20](#).
11. **Bottom Entry Wiring.** Remove the bottom conduit plate (see [Figure 13](#)) from the IAC-B. Identify all input and output conduit requirements and mark their location. Drill and punch all conduit holes in the conduit plate prior to mounting on the IAC-B. Reinstall the conduit plate. Install conduit between the IAC-B and the maintenance bypass input source, between the IAC-B and the UPS output, and between the IAC-B and the critical load. Pull the wiring through conduit into the wiring area.
12. Route the IAC-B MIS input cables (phase A, B, and C) and Ground wire from the UPS cabinets through the bottom of the IAC-B to the IAC-B MIS input terminals. See [Figure 13](#) for IAC-B wiring access information and [Figure 14](#) for IAC-B terminal locations.
13. Route the maintenance bypass input cables (phase A, B, and C) and Ground wire through the bottom of the IAC-B to the maintenance bypass input terminals.
14. Route the output cables (phase A, B, and C) and Ground wire from the IAC-B output terminals through the bottom of the cabinet to the critical load.
15. Proceed to [Step 20](#).

Figure 14. 93PM IAC-B Power Terminal Locations – with MBP, MIS, and BIB

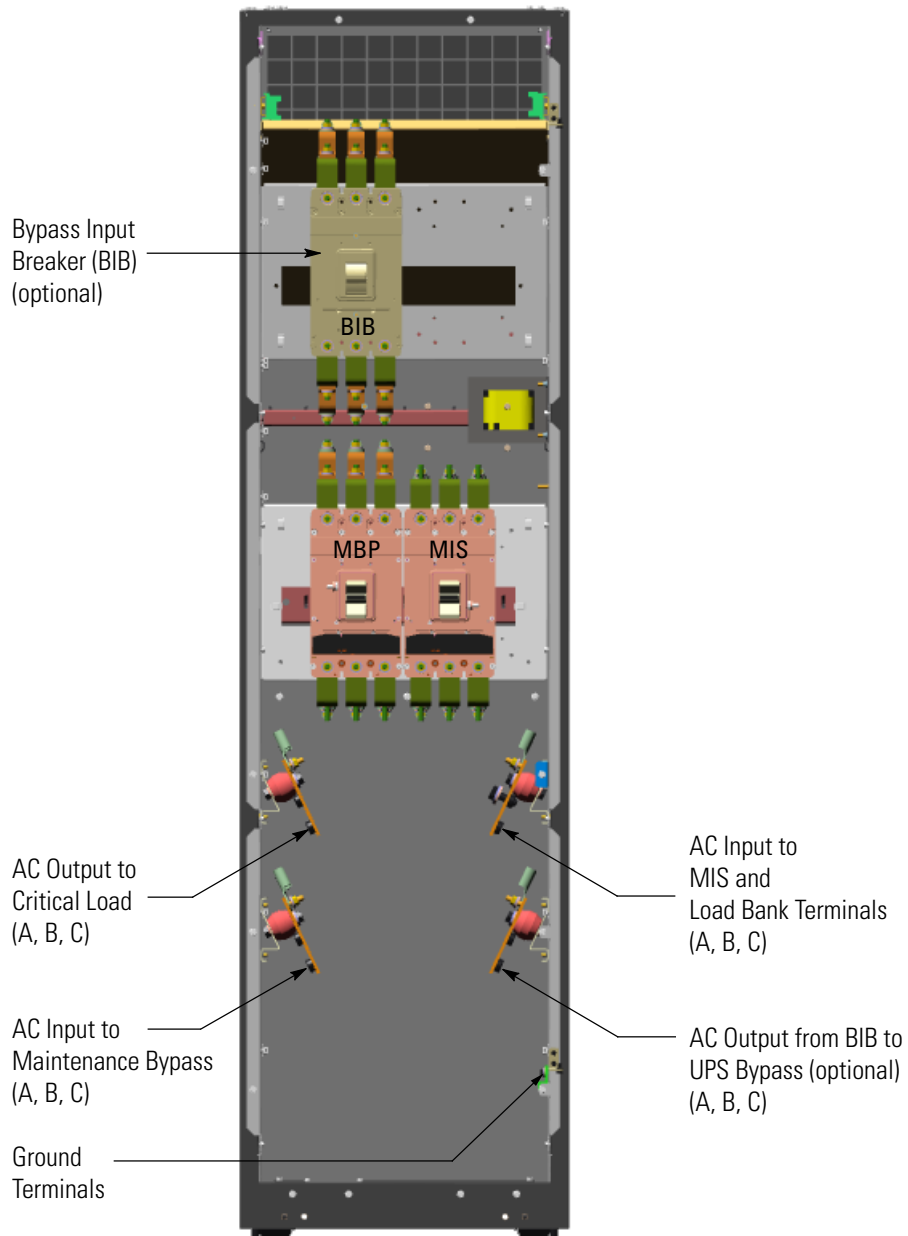

16. **Top Entry Wiring.** Remove the top conduit plate (see [Figure 13](#)) from the IAC-B. Identify all input and output conduit requirements and mark their location. Drill and punch all conduit holes in the conduit plate prior to mounting on the IAC-B. Reinstall the conduit plate. Install conduit between the IAC-B and the maintenance bypass input source, between the IAC-B and the UPS output, and between the IAC-B and the critical load. Pull the wiring through the conduit into the wiring area.
17. Route the IAC-B MIS input cables (phase A, B, and C) and Ground wire from the UPS cabinets through the top of the IAC-B to the IAC-B MIS input terminals. See [Figure 13](#) for IAC-B wiring access information and [Figure 14](#) for IAC-B terminal locations. See paragraph [3.2.2 IAC-B Power Wiring Preparation, Table 3](#), and

[Table 5](#) for IAC-B wiring and termination requirements. Refer to the applicable Eaton 93PM UPS Installation and Operation manual, listed in paragraph [1.7 For More Information](#), for the UPS terminal locations and termination requirements.

18. Route the maintenance bypass input cables (phase A, B, and C) and Ground wire through the top of the IAC-B to the maintenance bypass input terminals. See [Figure 14](#) for IAC-B terminal locations.
19. Route the output cables (phase A, B, and C) and Ground wire from the IAC-B output terminals through the top of the cabinet to the critical load.
20. Locate the external wiring terminal hardware kit (see [Table 6](#)) packed at the bottom of the IAC-B.
21. Using hardware from the external wiring terminal hardware kit, connect the Ground, MIS phase A, B, and C power wiring to the corresponding MIS input terminals on the IAC-B.

For a detailed view of the IAC-B MIS input terminals, see [Figure 16](#).

22. Connect the Ground, MIS A, B, and C power wiring from the IAC-B to the corresponding UPS output power terminals.

For termination requirements and a detailed view of the UPS output terminals, refer to the applicable Eaton 93PM UPS Installation and Operation manual, listed in paragraph [1.7 For More Information](#).

23. Using hardware from the external wiring terminal hardware kit, connect the Ground, phase A, B, and C maintenance bypass input power wiring from the utility source to the IAC-B maintenance bypass input terminals.

For a detailed view of the IAC-B maintenance bypass input terminals, see [Figure 15](#).

24. Using hardware from the external wiring terminal hardware kit, connect the Ground, phase A, B, and C output power wiring from the IAC-B output terminals to the critical load.

For a detailed view of the IAC-B output terminals, see [Figure 15](#).

25. If wiring interface connections, proceed to paragraph [4.5 Installing IAC-B Interface Connections](#); otherwise, proceed to [Step 26](#).
26. Reinstall the internal safety shield panel removed in [Step 3](#).
27. Close the outside door and secure the latch.
28. After the IAC-B is installed and wired, return to the applicable Eaton 93PM UPS Installation and Operation manual, listed in paragraph [1.7 For More Information](#), to complete the UPS wiring.

Figure 15. 93PM IAC-B Maintenance Bypass and Output Terminal Detail

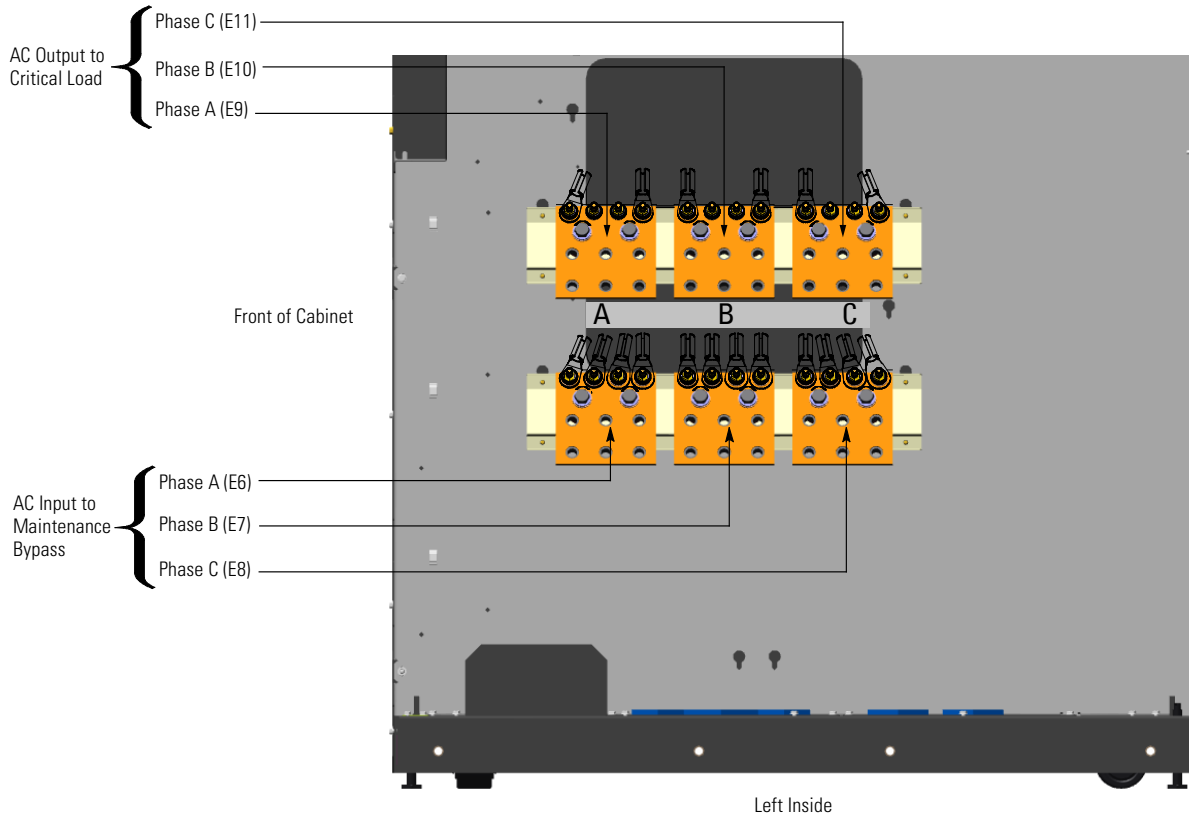
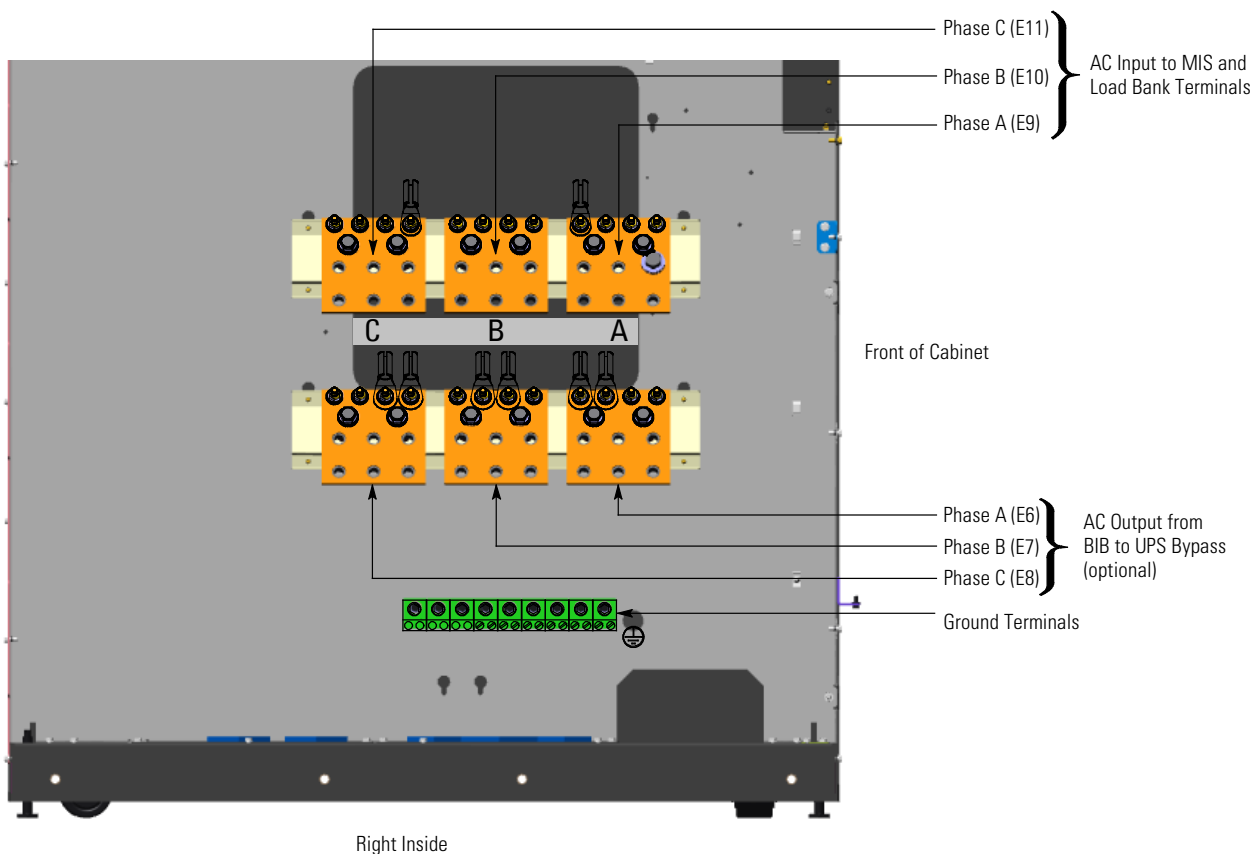

Figure 16. 93PM IAC-B MIS Input and BIB Output Terminal Detail



Breaker

4.4.2 IAC-B with a Maintenance Bypass Breaker, Maintenance Isolation Switch, and Bypass Input

To install wiring to terminal connections:

1. Verify the UPS system is turned off and all power sources are removed. Refer to the applicable Eaton 93PM UPS Installation and Operation manual, listed in paragraph [1.7 For More Information](#), for UPS operating procedures.
2. Open the front door by lifting the latch from the bottom and turning to the right (counterclockwise) and swing the door open.
3. Remove the screws securing the bottom internal safety shield panels and remove the panels to gain access to the maintenance bypass input terminals, the Maintenance Isolation Switch (MIS) input and load bank terminals, the Bypass Input Breaker (BIB) terminals, and the output terminals. Retain the hardware for later use.
4. If wiring the IAC-B power terminals using the inter-cabinet wiring access pass-through (line-up-and-match configurations), proceed to [Step 5](#); if wiring the IAC-B power terminals using the bottom entry access, proceed to [Step 11](#); if wiring the IAC-B power terminals using the top entry access, proceed to [Step 17](#).
5. **Pass-through Wiring.** Locate and remove the phase power cables harnesses labeled UPS OUTPUT (MIS input cables) and BIB packed inside the IAC-B.

	NOTE 1	UPS OUTPUT power cables (MIS input cables) have two-hole barrel lugs installed on the ends. Route the cable ends marked E9, E10, E11 to the UPS output terminals.
	NOTE 2	BIB power cables have two-hole barrel lugs installed on the ends. Route the cable ends marked E6, E7, E8 to the UPS bypass input terminals.

6. Route the IAC-B UPS OUTPUT (MIS input) cables and BIB output cables (phase A, B, and C) and Ground wires from the UPS cabinets through the bottom UPS and IAC-B inter-cabinet wiring access pass-through to the IAC-B MIS input terminals and BIB output terminals. See [Figure 11](#) for IAC-B wiring access information and [Figure 14](#) for IAC-B terminal locations. See paragraph [3.2.2 IAC-B Power Wiring Preparation, Table 4](#), and [Table 5](#) for IAC-B wiring and termination requirements. Refer to the applicable Eaton 93PM UPS Installation and Operation manual, listed in paragraph [1.7 For More Information](#), for the UPS terminal locations and termination requirements.
7. Remove the top or bottom conduit plate (see [Figure 13](#)) from the IAC-B. Identify all input and output conduit requirements and mark their location. Drill and punch all conduit holes in the conduit plate prior to mounting on the IAC-B. Reinstall the conduit plate. Install conduit between the IAC-B and the maintenance bypass input source, and between the IAC-B and the critical load. Pull the wiring through conduit into the wiring area.
8. Route the maintenance bypass input cables (phase A, B, and C) and Ground wire through the top or bottom of the IAC-B to the maintenance bypass input terminals. See [Figure 14](#) for IAC-B terminal locations.
9. Route the output cables (phase A, B, and C) and Ground wire from the IAC-B output terminals through the top or bottom of the cabinet to the critical load. See [Figure 14](#) for IAC-B terminal locations.
10. Proceed to [Step 22](#).
11. **Bottom Entry Wiring.** Remove the bottom conduit plate (see [Figure 13](#)) from the IAC-B. Identify all input and output conduit requirements and mark their location. Drill and punch all conduit holes in the conduit plate prior to mounting on the IAC-B. Reinstall the conduit plate. Install conduit between the IAC-B and the maintenance bypass input source, between the IAC-B and the UPS bypass input, between the IAC-B and the UPS output, and between the IAC-B and the critical load. Pull the wiring through the conduit into the wiring area.
12. Route the IAC-B MIS input cables (phase A, B, and C) and Ground wire from the UPS cabinets through the bottom of the IAC-B to the IAC-B MIS input terminals. See [Figure 13](#) for IAC-B wiring access information and [Figure 14](#) for IAC-B terminal locations.
13. Route the IAC-B BIB output cables (phase A, B, and C) and Ground wire from the UPS cabinets through the bottom of the IAC-B to the IAC-B BIB output terminals.
14. Route the maintenance bypass input cables (phase A, B, and C) and Ground wire through the bottom of the IAC-B to the maintenance bypass input terminals.
15. Route the output cables (phase A, B, and C) and Ground wire from the IAC-B output terminals through the bottom of the cabinet to the critical load.
16. Proceed to [Step 22](#).
17. **Top Entry Wiring.** Remove the top conduit plate (see [Figure 13](#)) from the IAC-B. Identify all input and output conduit requirements and mark their location. Drill and punch all conduit holes in the conduit plate prior to mounting on the IAC-B. Reinstall the conduit plate. Install conduit between the IAC-B and the maintenance bypass input source, between the IAC-B and the UPS bypass input, between the IAC-B and the UPS output, and between the IAC-B and the critical load. Pull the wiring through conduit into the wiring area.
18. Route the IAC-B MIS input cables (phase A, B, and C) and Ground wire from the UPS cabinets through the top of the IAC-B to the IAC-B MIS input terminals. See [Figure 13](#) for IAC-B wiring access information and [Figure 14](#) for IAC-B terminal locations. See paragraph [3.2.2 IAC-B Power Wiring Preparation, Table 4](#), and

[Table 5](#) for IAC-B wiring and termination requirements. Refer to the applicable Eaton 93PM UPS Installation and Operation manual, listed in paragraph [1.7 For More Information](#), for the UPS terminal locations and termination requirements.

19. Route the IAC-B BIB output cables (phase A, B, and C) and Ground wire from the UPS cabinets through the top of the IAC-B to the IAC-B BIB output terminals. See [Figure 13](#) for IAC-B wiring access information and [Figure 14](#) for IAC-B terminal locations.
20. Route the maintenance bypass input cables (phase A, B, and C) and Ground wire through the top of the IAC-B to the maintenance bypass input terminals.
21. Route the output cables (phase A, B, and C) and Ground wire from the IAC-B output terminals through the top of the cabinet to the critical load.
22. Locate the external wiring terminal hardware kit (see [Table 6](#)) packed at the bottom of the IAC-B.
23. Using hardware from the external wiring terminal hardware kit, connect the Ground, MIS phase A, B, and C power wiring to the corresponding MIS input terminals on the IAC-B.
For a detailed view of the IAC-B MIS input terminals, see [Figure 16](#).
24. Connect the Ground, MIS A, B, and C power wiring from the IAC-B to the corresponding UPS output power terminals.
For termination requirements and a detailed view of the UPS output terminals, refer to the applicable Eaton 93PM UPS Installation and Operation manual, listed in paragraph [1.7 For More Information](#).
25. Using hardware from the external wiring terminal hardware kit, connect the Ground, BIB phase A, B, and C power wiring to the corresponding BIB output terminals on the IAC-B.
For a detailed view of the IAC-B BIB output terminals, see [Figure 16](#).
26. Connect the Ground, BIB A, B, and C power wiring from the IAC-B to the corresponding UPS bypass input power terminals.
27. Using hardware from the external wiring terminal hardware kit, connect the Ground, phase A, B, and C maintenance bypass input power wiring from the utility source to the IAC-B maintenance bypass input terminals.
For a detailed view of the IAC-B maintenance bypass input terminals, see [Figure 15](#).
28. Using hardware from the external wiring terminal hardware kit, connect the Ground, phase A, B, and C output power wiring from the IAC-B output terminals to the critical load.
For a detailed view of the IAC-B output terminals, see [Figure 15](#).
29. If wiring interface connections, proceed to paragraph [4.5 Installing IAC-B Interface Connections](#); otherwise, proceed to [Step 30](#).
30. Reinstall the internal safety shield panel removed in [Step 3](#).
31. Close the outside door and secure the latch.
32. After the IAC-B is installed and wired, return to the applicable Eaton 93PM UPS Installation and Operation manual, listed in paragraph [1.7 For More Information](#), to complete the UPS wiring.

4.5 Installing IAC-B Interface Connections

Use the procedures in the following paragraphs to connect the MBP and Solenoid Key Release Unit (SKRU) interface connections.

4.5.1 MBP Auxiliary Contact Interface Connections

-
- NOTE 1** MBP auxiliary contact control interface wiring can be installed using the inter-cabinet wiring access pass through (line-up-and-match configurations) or conduit between cabinets (standalone configurations).
- NOTE 2** If using conduit, install the control wiring in separate conduit from the power wiring.
-  **NOTE 3** Remove the IAC-B interface conduit landing plates to drill or punch conduit holes in the conduit plate (see [Figure 4-4](#)).
- NOTE 4** Disconnect terminal block plug from terminal block to wire plug.
- NOTE 5** Keep Class 2 interface wiring separate from power wiring.
-

To install wiring:

1. Verify the UPS system is turned off and all power sources are removed. Refer to the applicable Eaton 93PM UPS Installation and Operation manual, listed in paragraph [1.7 For More Information](#), for UPS operating procedures.
2. If not already opened, open the front door by lifting the latch from the bottom and turning to the right (counterclockwise) and swing the door open.
3. If not already removed, remove the screws securing the top and bottom internal safety shield panels and remove the panels to gain access to the interface terminals and conduit landing plates. Retain the hardware for later use.
4. If wiring the IAC-B interface terminals using the inter-cabinet wiring access pass-through (line-up-and-match configurations), proceed to [Step 5](#); if wiring the IAC-B interface terminals using the bottom entry access, proceed to [Step 7](#); if wiring the IAC-B interface terminals using the top entry access, proceed to [Step 10](#).
5. **Pass-through Wiring.** Route MBP control wiring between the IAC-B interface terminals and the UPS interface terminals using the inter-cabinet wiring access pass-through. See [Figure 11](#) for wiring access information, and [Figure 17](#) for IAC-B interface terminal locations. Refer to the applicable Eaton 93PM UPS Installation and Operation manual, listed in paragraph [1.7 For More Information](#), for the UPS wiring access information, terminal locations, and termination requirements.
6. Proceed to [Step 12](#).
7. **Bottom Entry Wiring.** Remove the bottom interface conduit plate (see [Figure 13](#)) from the inside bottom of the IAC-B. Identify all conduit requirements and mark their location. Drill and punch all conduit holes in the bottom interface conduit plate prior to mounting on the IAC-B. Install the conduit plate and install all conduit runs into the plate. Pull the wiring through the conduit into the wiring areas.
8. Route the MBP control wiring between the IAC-B interface terminals and the UPS interface terminals using the bottom entry interface conduit landing plates on the IAC-B (see [Figure 18](#)) and the UPS. Route the wiring along the left side of the cabinet (see [Figure 18](#)) to the terminals. Secure the wiring to the wire tie anchors provided (see [Figure 19](#)) using Zip ties. See [Figure 17](#) for IAC-B interface terminal locations.
9. Proceed to [Step 12](#).
10. **Top Entry Wiring.** Remove the top interface conduit plate (see [Figure 13](#)) from the top of the IAC-B. Identify all conduit requirements and mark their location. Drill and punch all conduit holes in the top interface conduit plate prior to mounting on the IAC-B. Install the conduit plate and install all conduit runs into the plate. Pull the wiring through the conduit into the wiring area.

11. Route the MBP control wiring between the IAC-B interface terminals and the UPS interface terminals using the top entry interface conduit landing plate on the IAC-B and the UPS. See [Figure 13](#) for wiring access information, and [Figure 17](#) for IAC-B interface terminal locations.
12. Connect the MBP control wiring to the IAC-B and UPS terminals. See paragraph [3.2.3 IAC-B Interface Wiring Preparation](#) and [Table 8](#) for terminal block wiring and termination requirements. See [Table 9](#) for IAC-B wiring information and terminal assignments. Refer to the applicable Eaton 93PM UPS Installation and Operation manual, listed in paragraph [1.7 For More Information](#), for the UPS building alarm terminal assignments.

For a detailed view of the IAC-B terminals, see [Figure 20](#).
13. If wiring SKRU interface connections, proceed to paragraph [4.5.2 SKRU Interface Connections \(if installed\)](#); otherwise, proceed to [Step 14](#).
14. Reinstall the internal safety shield panels removed in [Step 3](#).
15. Close the outside door and secure the latch.
16. After the IAC-B is installed and wired, return to the applicable Eaton 93PM UPS Installation and Operation manual, listed in paragraph [1.7 For More Information](#), to complete the UPS wiring.

Figure 17. 93PM IAC-B Interface Terminal Location

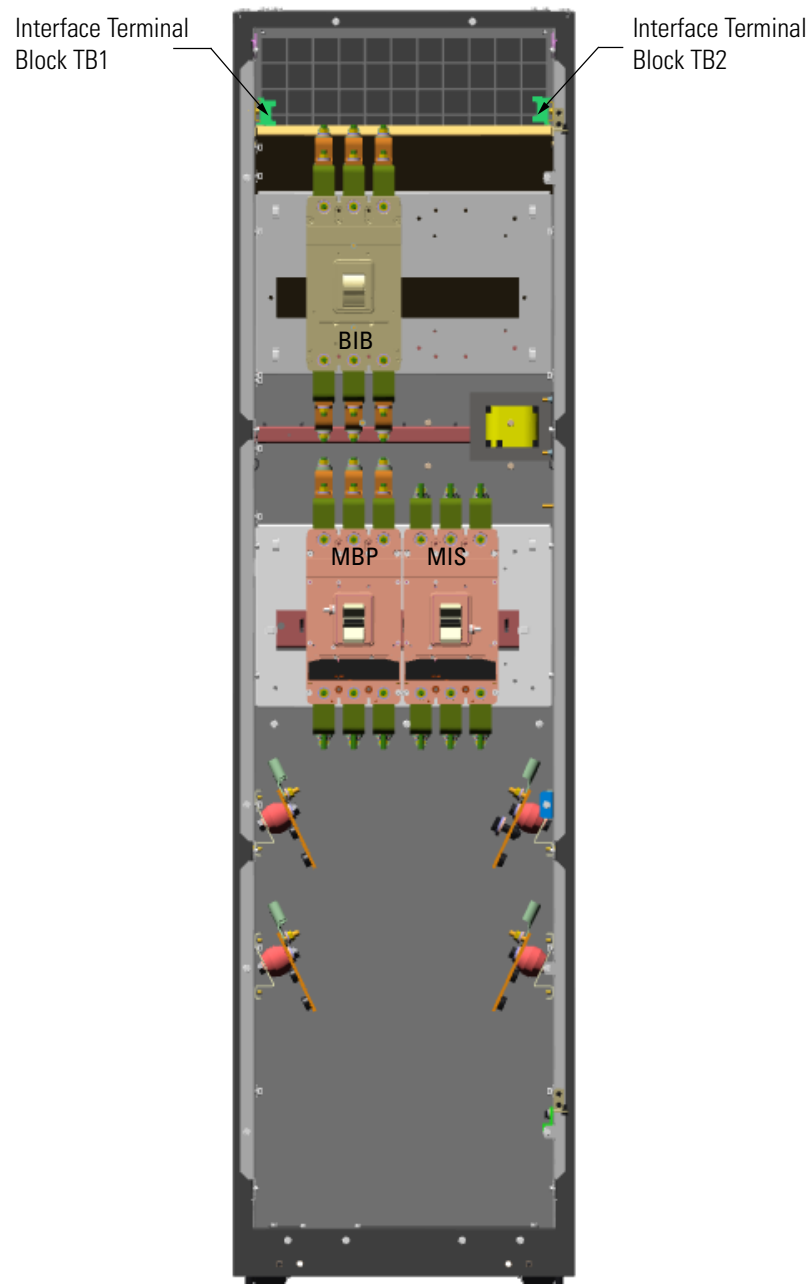

Figure 18. Bottom Entry Interface Wiring Location

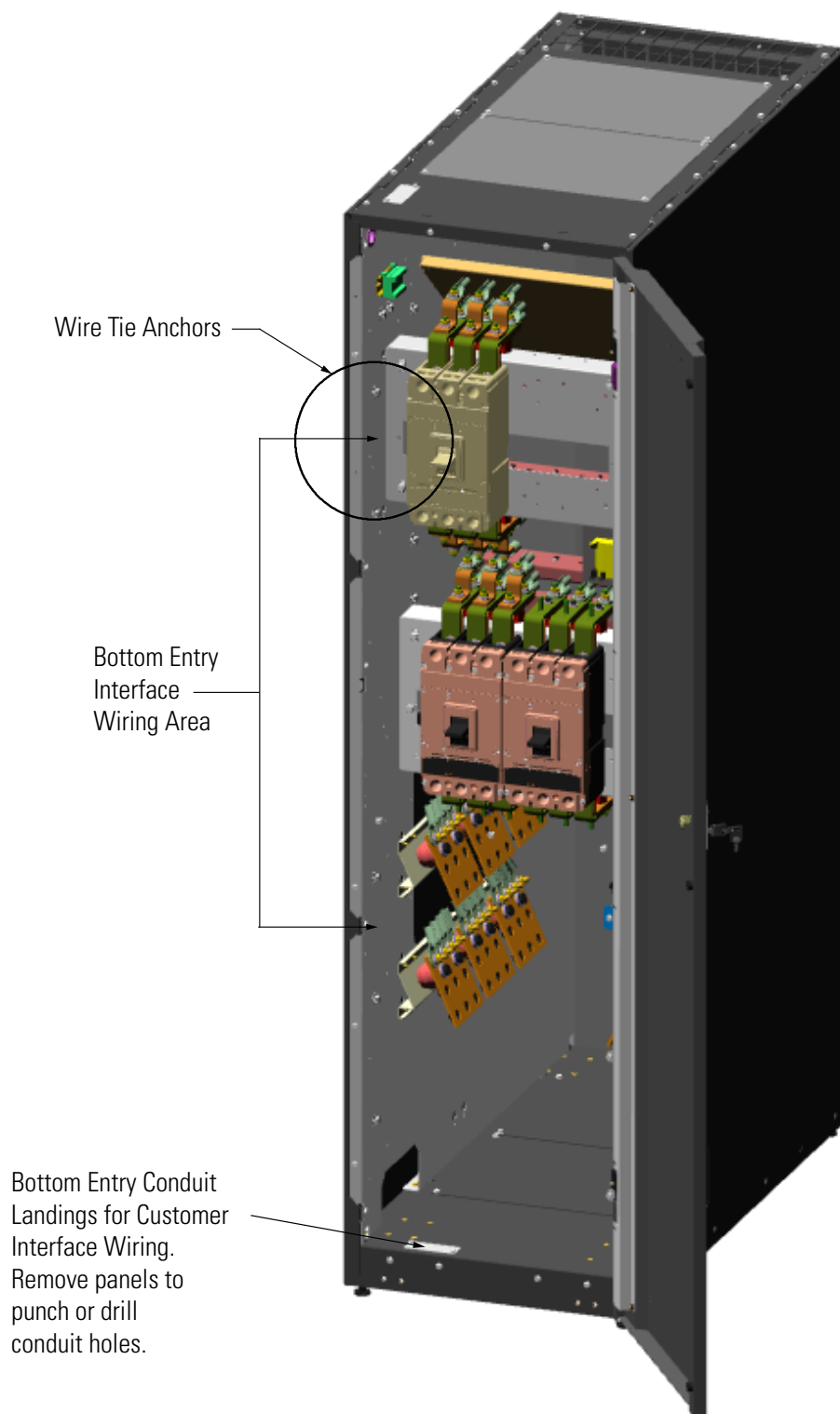

Figure 19. Wire Tie Anchors

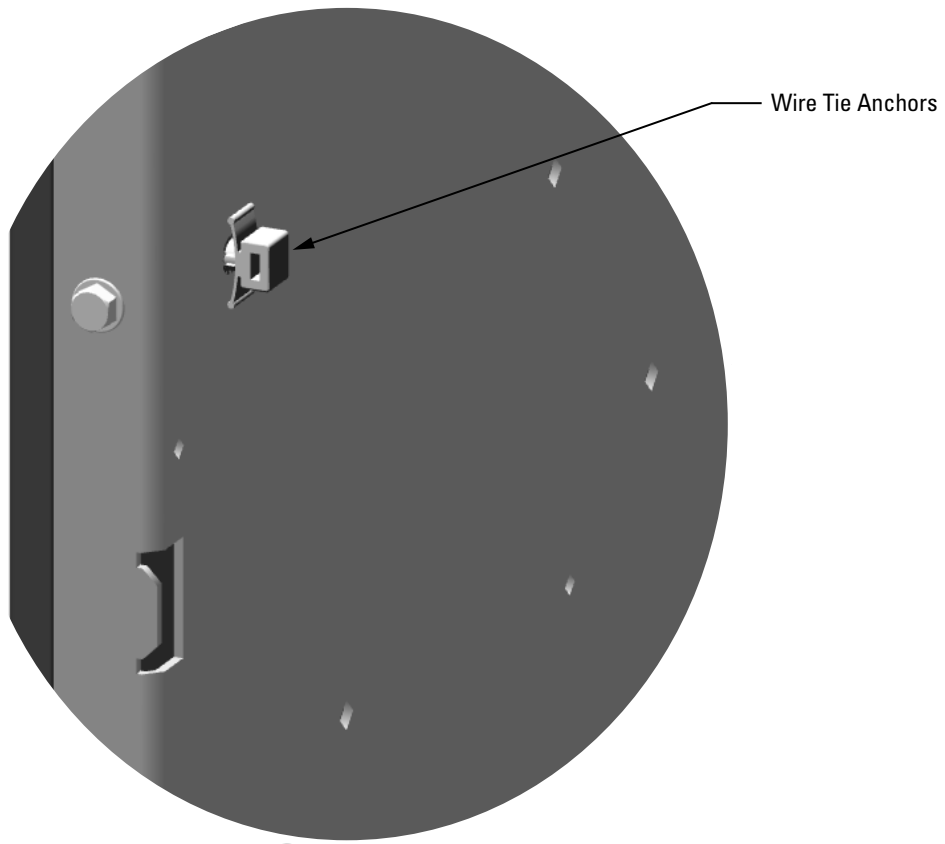
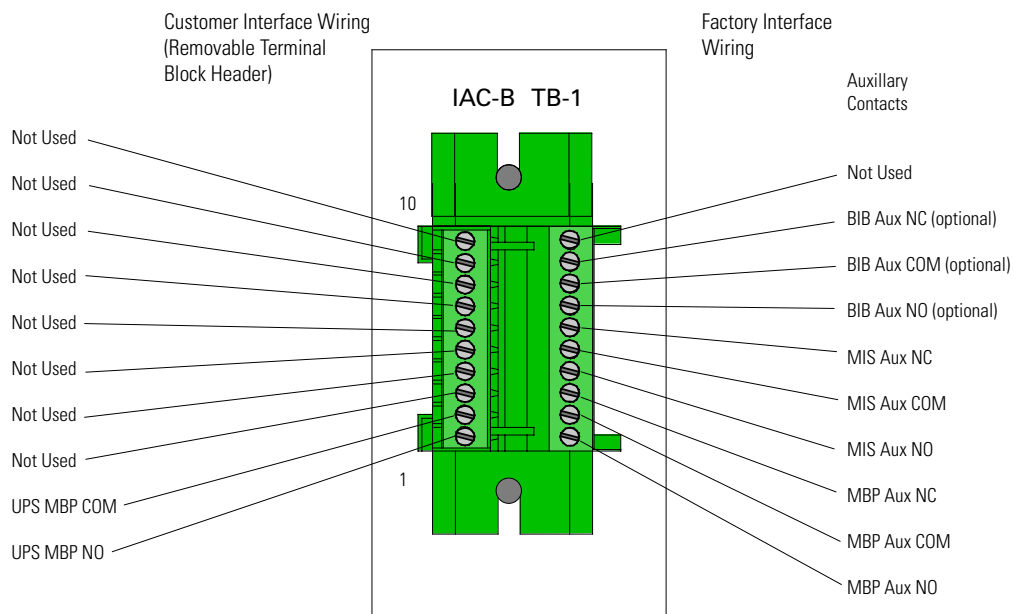

Figure 20. IAC-B MBP Interface Terminal Detail



NOTE 1: The removable terminal block header faces up when installed. Terminal block is shown rotated 90 degrees counterclockwise for clarity.

NOTE 2: UPS building alarm signals are customer programmable. Customer interface wiring for the IAC-B MBP assumes that the UPS Building Alarm is programmed to monitor Normally Open (NO) contacts.

Table 8. IAC-B MBP Interface Wiring Terminal Block Terminations

Terminal Function	Size of Pressure Termination	Tightening Torque Nm (lb in)	Type Screw	Comments
Auxiliary Contacts	#26-#16	0.4 (3.5) - 0.8 (7.1)	Slotted	Use twisted-pair wires for each input and return or common. Strip wire insulation back 10 millimeters to wire terminal blocks.

Table 9. IAC-B MBP Interface Terminals

IAC-B Terminal	Name	UPS Terminal	Description
TB1-1	MBP Aux NO	UPS Building Alarm 1	Output: Normally Open (NO) contact used to indicate whether the MBP is closed and the UPS system is on maintenance bypass. Contacts are closed when the MBP is closed.
TB1-2	MBP Aux COM	UPS Building Alarm 1 Return	
TB1-3	MBP Aux NC	—	Contacts available as a convenience for the customer to monitor MIS status using customer installed monitoring equipment. These interface connections are not wired to the UPS.
TB1-4	MIS Aux NO	—	
TB1-5	MIS Aux COM	—	

Table 9. IAC-B MBP Interface Terminals (Continued)

IAC-B Terminal	Name	UPS Terminal	Description
TB1-6	MIS Aux NC	—	
TB1-7	BIB Aux NO (optional)	—	
TB1-8	BIB Aux COM (optional)	—	When a BIB is installed, contacts available as a convenience for the customer to monitor BIB status using customer installed monitoring equipment. These interface connections are not wired to the UPS.
TB1-9	BIB Aux NC (optional)	—	
TB1-10	Not Used	—	

NOTE UPS building alarm signals are customer programmable. Customer interface wiring for the IAC-B MBP assumes that the UPS Building Alarm is programmed to monitor Normally Open (NO) contacts.
 “Return” indicates connection to electronics circuit ground. “Common” indicates connection to common side of isolated relay contact

4.5.2 SKRU Interface Connections (if installed)

- NOTE 1** Trapped Key and SKRU interlock system are optional equipment.
- NOTE 2** SKRU control wiring can be installed using the inter-cabinet wiring access pass through (line-up-and-match configurations) or conduit between cabinets (standalone configurations).
- NOTE 3** If using conduit, install the control wiring in separate conduit from the power wiring.
-  **NOTE 4** Remove the IAC-B interface conduit landing plates to drill or punch conduit holes in the conduit plate (see [Figure 4-4](#)).
- NOTE 5** Disconnect terminal block plug from terminal block to wire plug.
- NOTE 6** Use wire rated for 600V and Class 1 wiring methods.
- NOTE 7** Keep SKRU control wiring separate from Class 2 interface wiring.

To install wiring:

1. Verify the UPS system is turned off and all power sources are removed. Refer to the applicable Eaton 93PM UPS Installation and Operation manual, listed in paragraph [1.7 For More Information](#), for UPS operating procedures.
2. If not already installed, install the Eaton Industrial Relay Card (IRC). Refer to the user instructions supplied with the IRC or contact an Eaton service representative (see paragraph [1.8 Getting Help](#)) for IRC installation and setup.
3. If not already opened, open the front door by lifting the latch from the bottom and turning to the right (counterclockwise) and swing the door open.
4. If not already removed, remove the screws securing the top and bottom internal safety shield panels and remove the panels to gain access to the interface terminals and conduit landing plates. Retain the hardware for later use.
5. If wiring the IAC-B interface terminals using the inter-cabinet wiring access pass-through (line-up-and-match configurations), proceed to [Step 6](#); if wiring the IAC-B interface terminals using the bottom entry

access, proceed to [Step 8](#); if wiring the IAC-B interface terminals using the top entry access, proceed to [Step 11](#).

6. **Pass-through Wiring.** Route SKRU control wiring between the IAC-B interface terminals and the UPS IRC terminals using the inter-cabinet wiring access pass-through. See [Figure 11](#) for wiring access information, and [Figure 17](#) for IAC-B interface terminal locations. Refer to the applicable Eaton 93PM UPS Installation and Operation manual, listed in paragraph [1.7 For More Information](#), for the UPS wiring access information. Refer to the user instructions supplied with the IRC for terminal locations and termination requirements.
7. Proceed to [Step 13](#).
8. **Bottom Entry Wiring.** Remove the bottom interface conduit plate (see [Figure 13](#)) from the inside bottom of the IAC-B. Identify all conduit requirements and mark their location. Drill and punch all conduit holes in the bottom interface conduit plate prior to mounting on the IAC-B. Install the conduit plate and install all conduit runs into the plate. Pull the wiring through the conduit into the wiring areas.
9. Route the SKRU control wiring between the IAC-B interface terminals and the UPS IRC terminals using the bottom entry interface conduit landing plates on the IAC-B and the UPS. Secure wiring to wire tie anchors along the right inside of IAC-B. See [Figure 13](#) for wiring access information, and [Figure 17](#) for IAC-B interface terminal locations.
10. Proceed to [Step 13](#).
11. **Top Entry Wiring.** Remove the top interface conduit plate (see [Figure 13](#)) from the top of the IAC-B. Identify all conduit requirements and mark their location. Drill and punch all conduit holes in the top interface conduit plate prior to mounting on the IAC-B. Install the conduit plate and install all conduit runs into the plate. Pull the wiring through the conduit into the wiring area.
12. Route the SKRU control wiring between the IAC-B interface terminals and the UPS IRC terminals using the top entry conduit landing plates on the IAC-B and the UPS. See [Figure 13](#) for wiring access information, and [Figure 17](#) for IAC-B interface terminal locations. Refer to the applicable Eaton 93PM UPS Installation and Operation manual, listed in paragraph [1.7 For More Information](#), for the UPS wiring access information. Refer to the user instructions supplied with the IRC for terminal locations and termination requirements.
13. Connect the SKRU control wiring to the IAC-B and UPS IRC terminals. See paragraph [3.2.3 IAC-B Interface Wiring Preparation](#) and [Table 10](#) for terminal block wiring and termination requirements. See [Table 11](#) for IAC-B wiring information and terminal assignments. Refer to the user instructions supplied with the IRC for IRC terminal assignments.

For a detailed view of the IAC-B terminals, see [Figure 21](#).
14. Reinstall the internal safety shield panels removed in [Step 4](#).
15. Close the outside door and secure the latch.
16. After the IAC-B is installed and wired, return to the applicable Eaton 93PM UPS Installation and Operation manual, listed in paragraph [1.7 For More Information](#), to complete the UPS wiring.

Figure 21. IAC-B SKRU Interface Terminal Detail

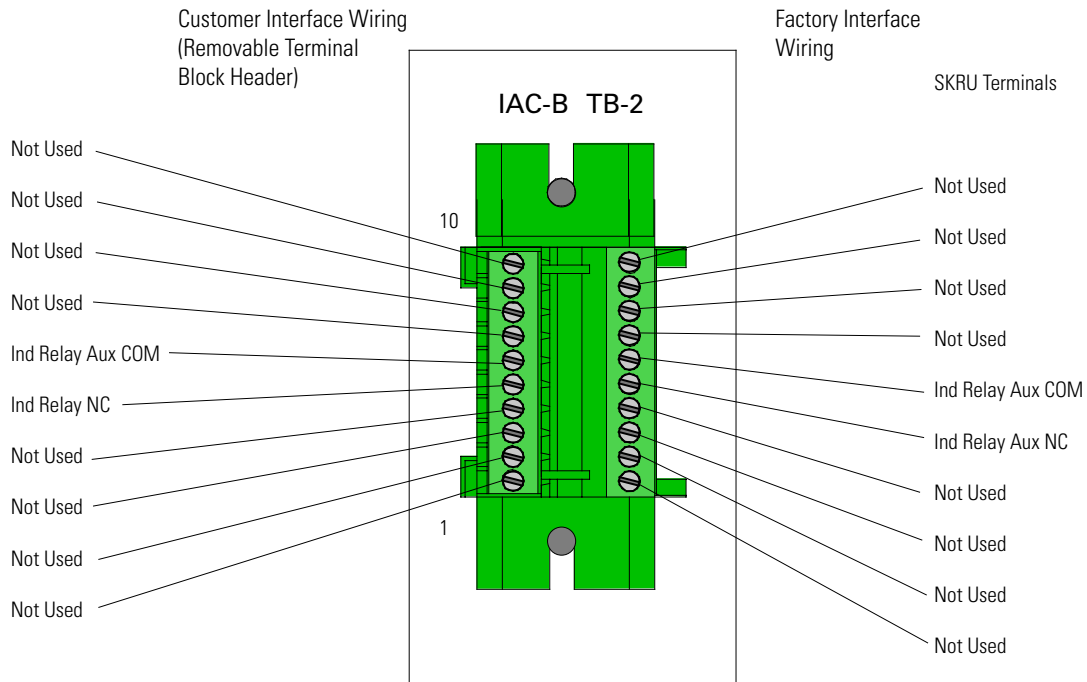

NOTE 1: The removable terminal block header faces up when installed. Terminal block is shown rotated 90 degrees counterclockwise for clarity.

Table 10. IAC-B SKRU Interface Wiring Terminal Block Terminations

Terminal Function	Size of Pressure Termination	Tightening Torque Nm (lb in)	Type Screw	Comments
SKRU	#26-#16	0.4 (3.5) - 0.8 (7.1)	Slotted	Use twisted-pair wires for each input and return or common. Strip wire insulation back 10 millimeters to wire terminal blocks. Use wire rated for 600V and Class 1 wiring methods.

Table 11. IAC-B SKRU Interface Terminals

IAC-B Terminal	Name	UPS IRC Terminal	Description
TB2-1	Not Used	—	
TB2-2	Not Used	—	
TB2-3	Not Used	—	
TB2-4	Not Used	—	
TB2-5	Ind Relay Aux NC	IRC Relay K4 NC	Used to provide control power to the SKRU when the UPS is on bypass allowing maintenance bypass transfer. IRC relay K4 contacts are closed when the UPS is on bypass.
TB2-6	Ind Relay Aux COM	IRC Relay K4 COM	
TB2-7	Not Used	—	
TB2-8	Not Used	—	
TB2-9	Not Used	—	
TB2-10	Not Used	—	

NOTE “Return” indicates connection to electronics circuit ground. “Common” indicates connection to common side of isolated relay contact

4.6 Initial Startup

Startup and operational checks must be performed by an authorized Eaton Customer Service Engineer, or the warranty terms specified in [Chapter 9 Warranty](#) become void. This service is offered as part of the sales contract for the UPS. Contact an Eaton service representative in advance (usually a two-week notice is required) to reserve a preferred startup date.

4.7 Completing the Installation Checklist

The final step in installing the IAC-B is completing the following Installation Checklist. This checklist ensures that you have completely installed all hardware, cables, and other equipment. Complete all items listed on the checklist to ensure a smooth installation. Make a copy of the Installation Checklist before filling it out, and retain the original.

After the installation is complete, an Eaton Customer Service Engineer must verify the operation of the UPS system and commission it to support the critical load. The service representative cannot perform any installation tasks other than verifying software and operating setup parameters. Service personnel may request a copy of the completed Installation Checklist to verify all applicable equipment installations have been completed.

**NOTE**

The Installation Checklist **MUST** be completed prior to starting the UPS system for the first time.

4.8 Installation Checklist

- All packing materials and restraints have been removed from each cabinet.
- The IAC-B is installed on a level floor suitable for computer or electronic equipment.
- The IAC-B is placed in its installed location.
- The IAC-B is secured to the building floor, if required.
- All conduits and cables are properly routed between the IAC-B and the UPS.
- All power cables are properly sized and terminated.
- Output is wired to the critical load.
- A ground conductor is properly installed.
- Interface wiring between the IAC-B and UPS cabinets is properly installed.
- All terminal cover plates are installed.
- Air conditioning equipment is installed and operating correctly.
- The area around the UPS system is clean and dust-free.
- Adequate workspace exists around the IAC-B and other cabinets.
- Adequate lighting is provided around all IAC-B and UPS equipment.
- A 120 Vac service outlet is located within 7.5m (25 ft) of the IAC-B and UPS equipment.
- Startup and operational checks are performed by an authorized Eaton Customer Service Engineer.
- Visit www.eaton.com/pg/register to register your new Eaton UPS / Eaton UPS Accessory.

Notes:

Chapter 5 Onelines and Schematics

5.1 Onelines

Figure 22 and Figure 23 show the simplified internal structure of the Integrated Accessory Cabinet-Bypass (IAC-B) for the following configurations:

- Two-breaker Maintenance Bypass with a Maintenance Isolation Breaker (MIS) and a Maintenance Bypass Breaker (MBP)
- Three-breaker Maintenance Bypass with a MIS, a MBP, and a Bypass Input Breaker (BIB)

Figure 22. Eaton 93PM 400 kW IAC-B Internal Oneline – Two-Breaker Maintenance Bypass

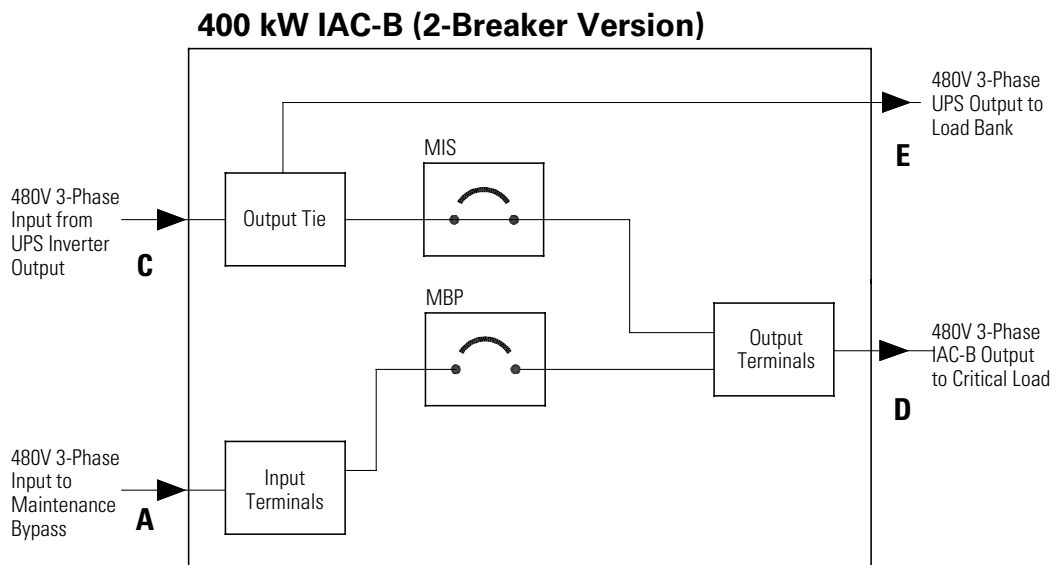
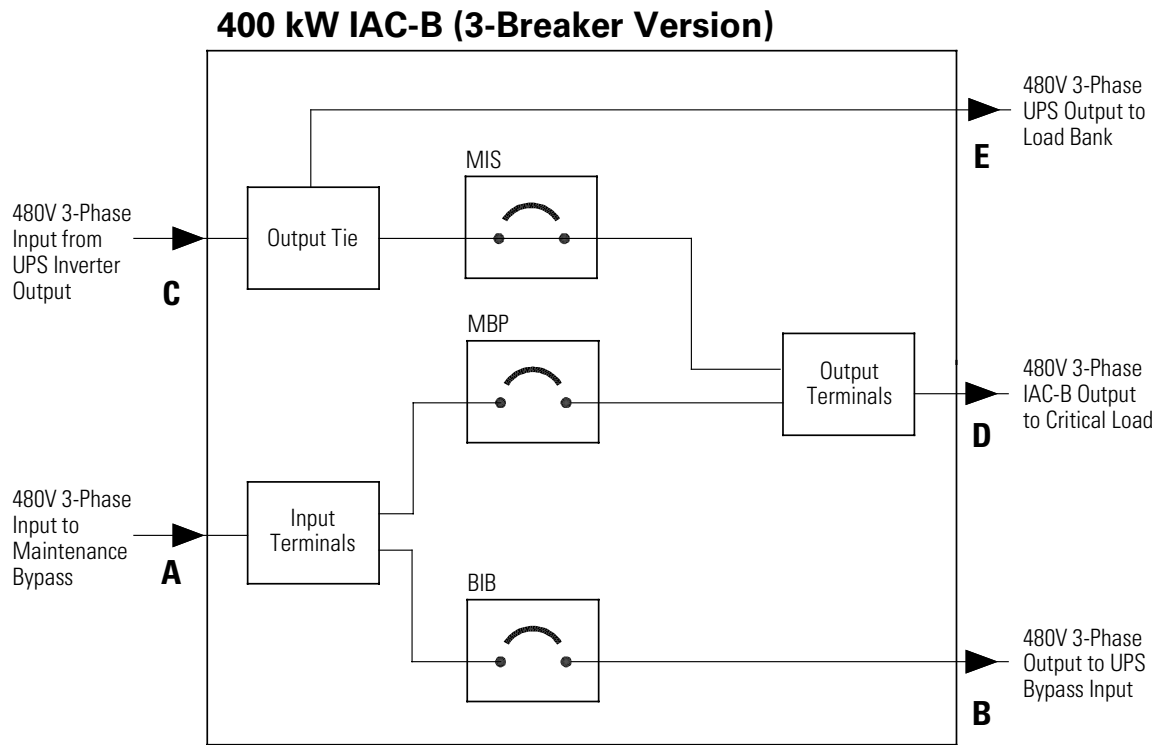

Figure 23. Eaton 93PM 400 kW IAC-B Internal Online – Three-Breaker Maintenance Bypass



5.2 System Onelines

The system oneline drawings in this section show the simplified internal structure of the UPS, battery supply, and IAC-B.

Oneline Drawing	UPS Model	Voltage		System Type
		Input	Output	
See Figure 24	93PM 100-400 kW 3-Wire	480	480	Single reverse transfer three-wire UPS with external battery and two-breaker three-wire 400 kW IAC-B
See Figure 25	93PM 100-400 kW 3-Wire	480	480	Single reverse transfer three-wire UPS with external battery and three-breaker three-wire 400 kW IAC-B

Figure 24. Eaton 93PM 100-400 kW UPS with Two-Breaker 93PM 400 kW IAC-B System Online

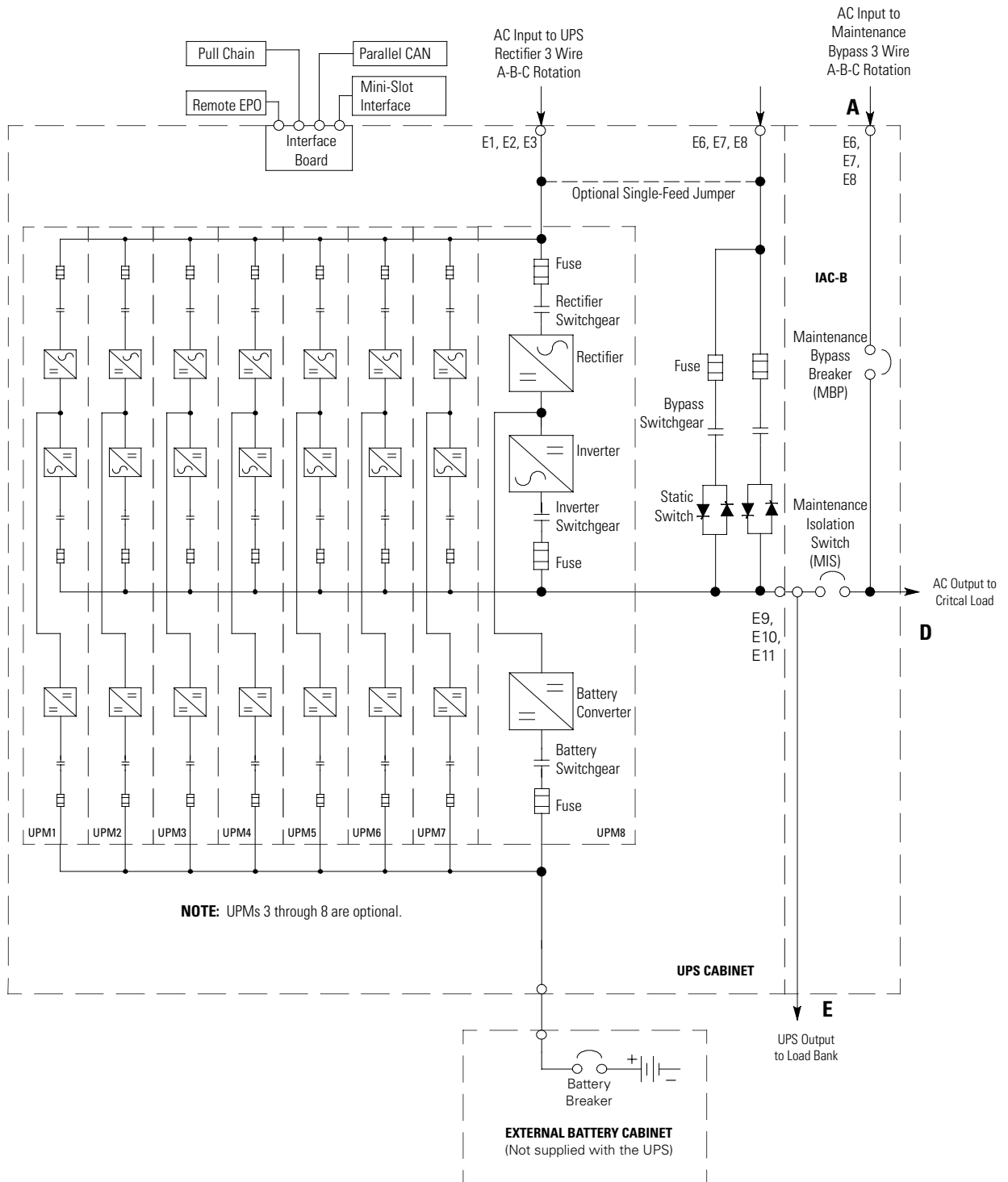
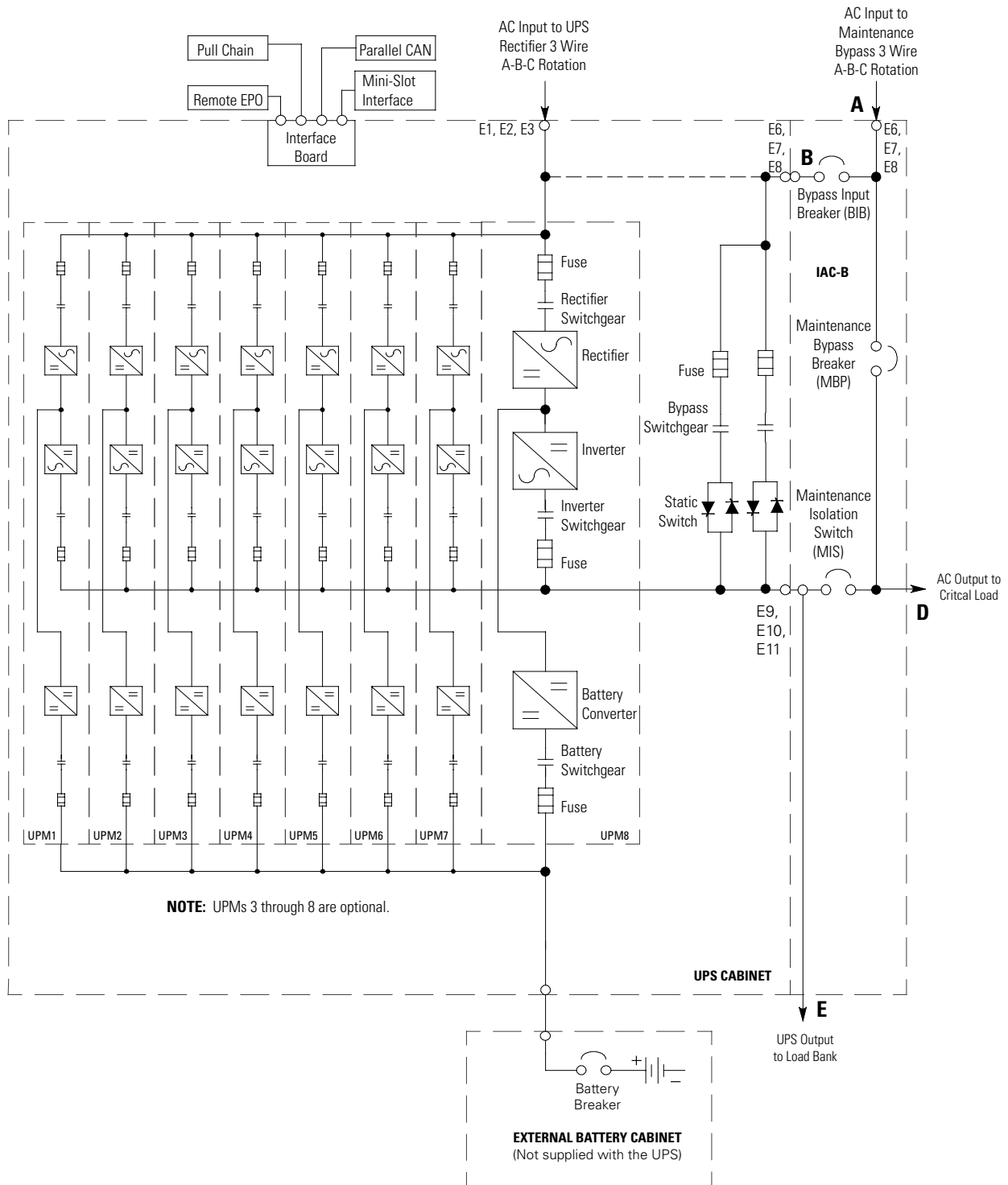

Figure 25. Eaton 93PM 100-400 kW UPS with Three-Breaker 93PM 400 kW IAC-B System Online



5.3 Schematics

Figure 26 through Figure 29 show the IAC-B schematics.

Figure 26. Eaton 93PM 400 kW IAC-B Schematic – Two Breaker Maintenance Bypass

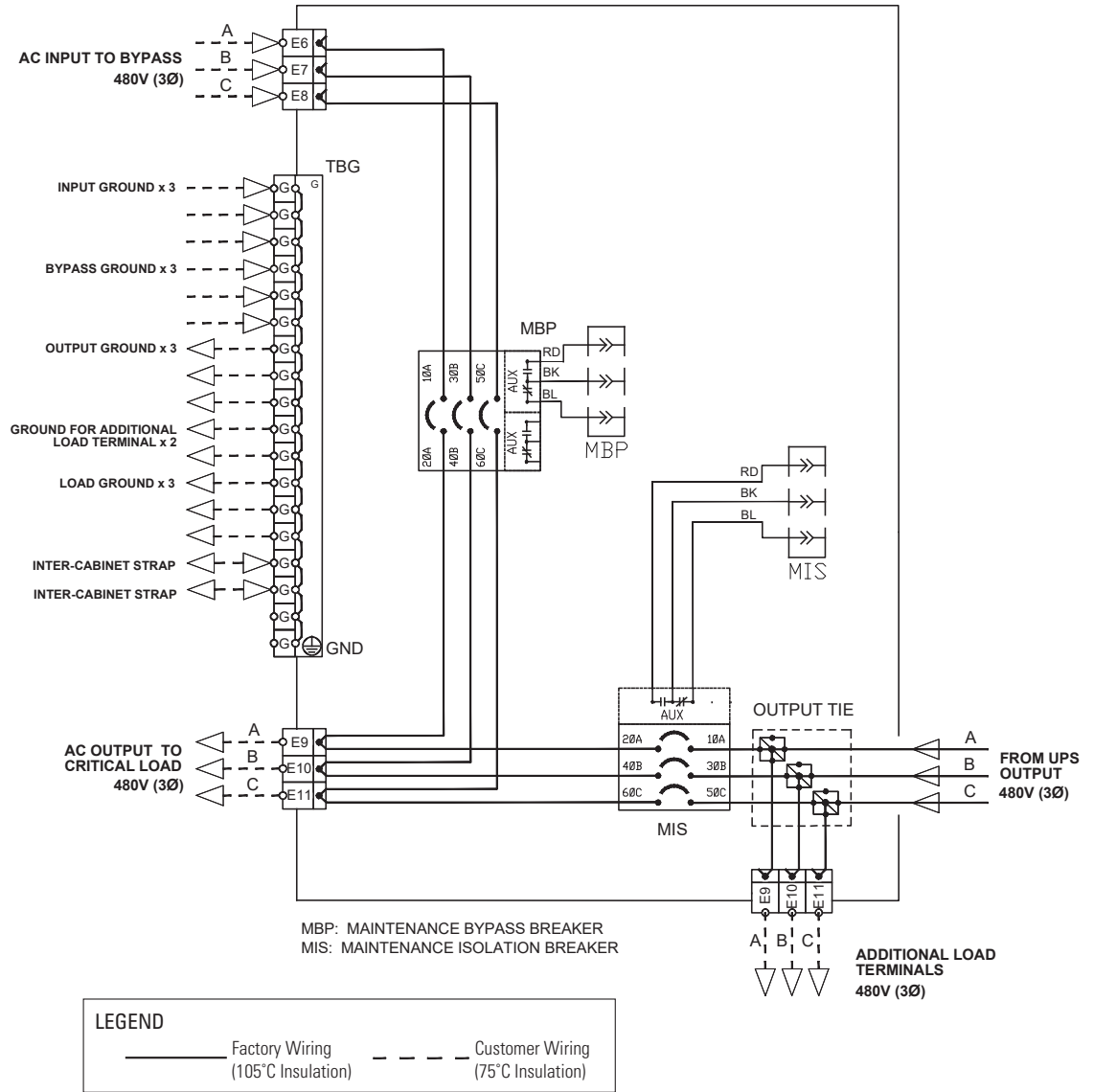

Figure 27. Eaton 93PM 400 kW IAC-B Schematic – Three Breaker Maintenance Bypass

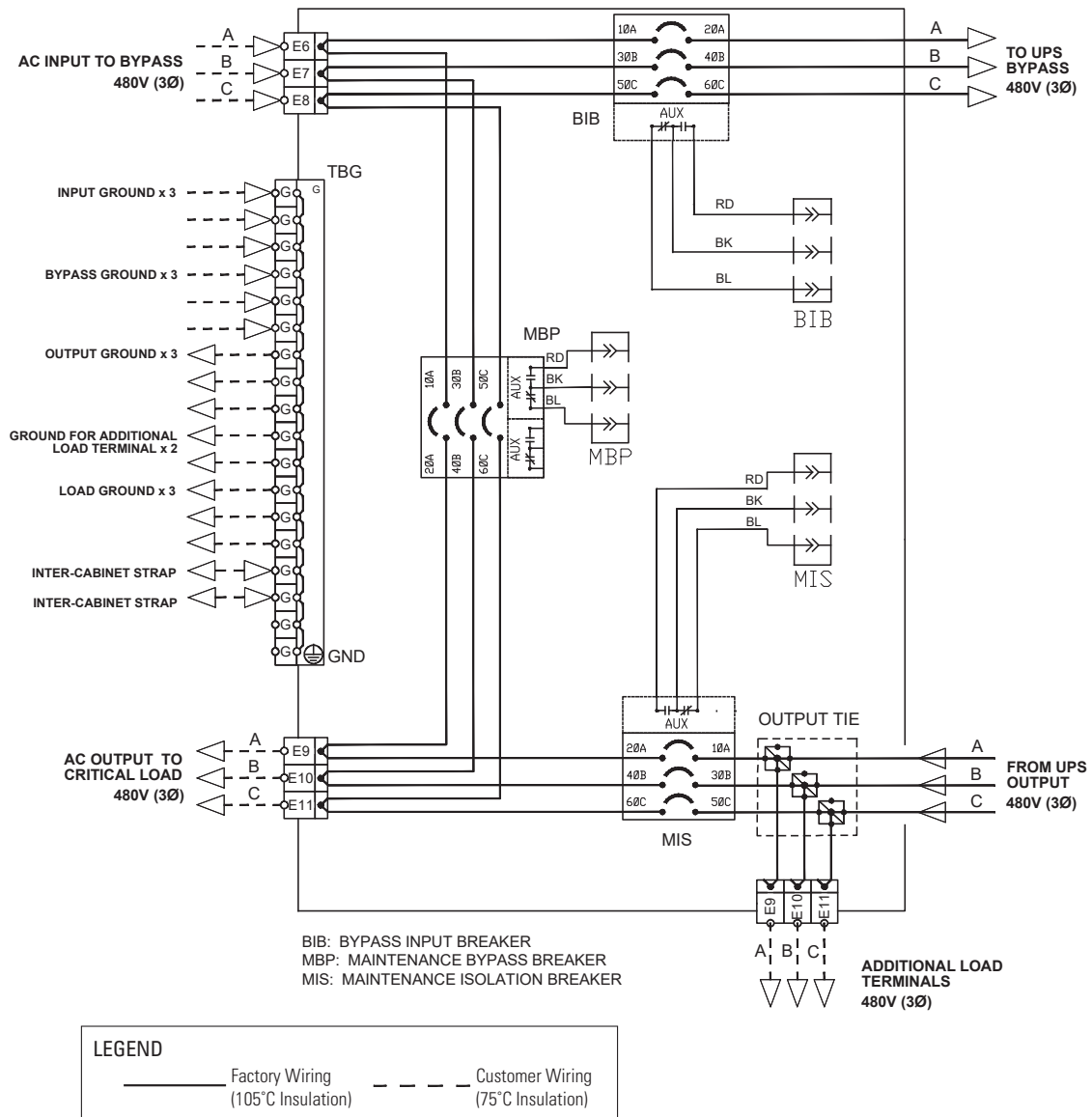

Figure 28. Eaton 93PM 400 kW IAC-B Breaker Auxiliary Contact Schematic

TB1 Designation

- 1 = MBP AUX NO
- 2 = MBP AUX COMMON
- 3 = MBP AUX NC
- 4 = MIS AUX NO
- 5 = MIS AUX COMMON
- 6 = MIS AUX NC
- 7 = BIB AUX NO
- 8 = BIB AUX COMMON
- 9 = BIB AUX NC
- 10 = Not Used

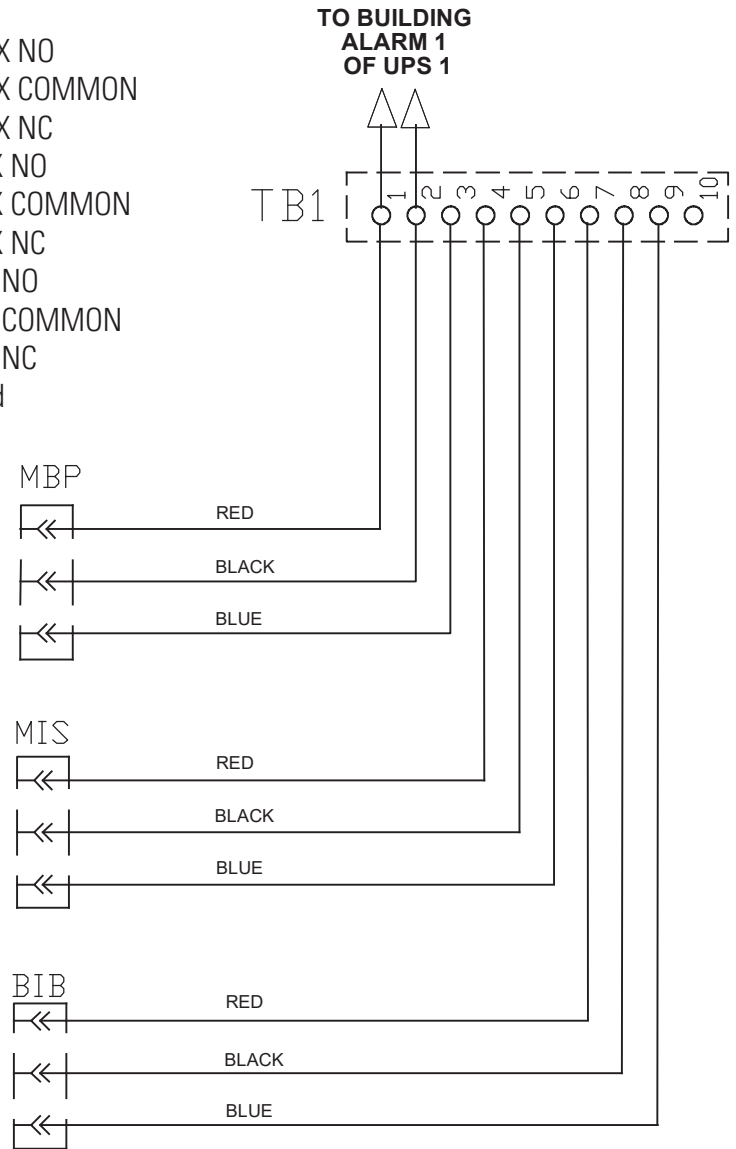
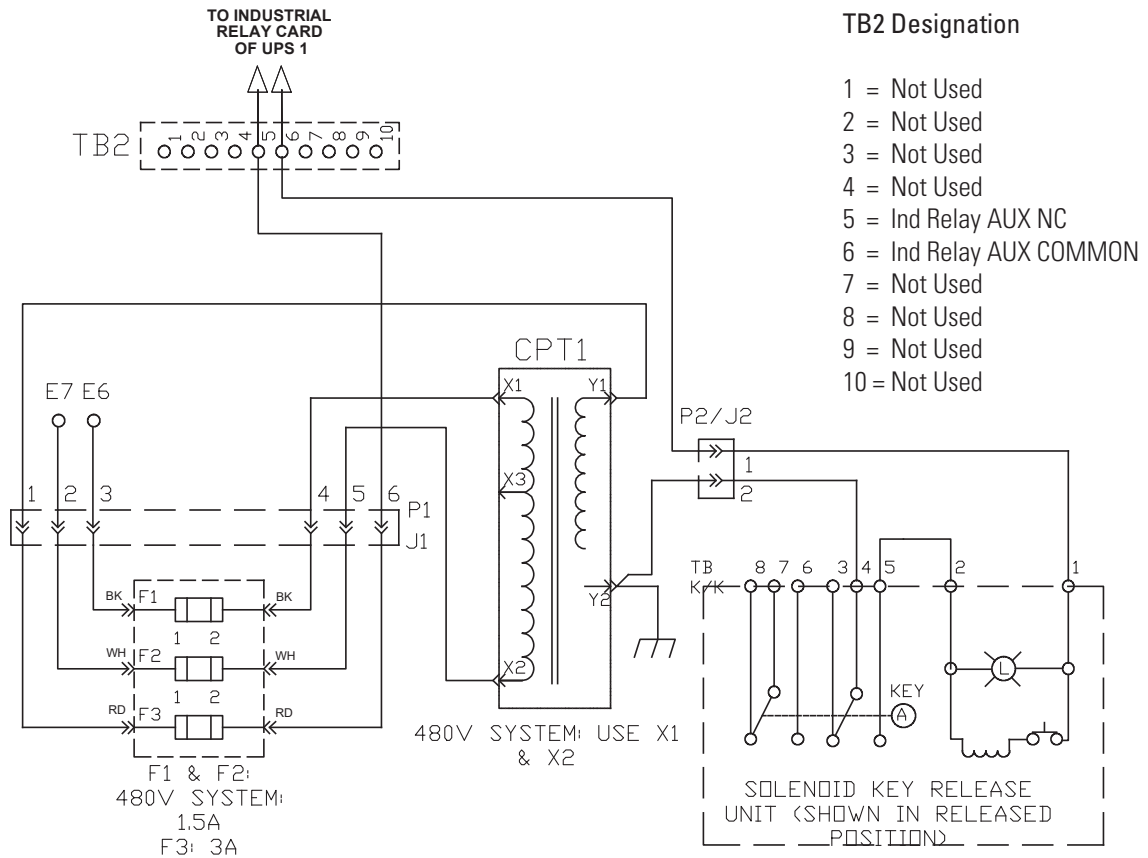

Figure 29. Eaton 93PM 400 kW IAC-B Trapped Key and Solenoid Key Release Unit (SKRU) Schematic



Chapter 6 Integrated Accessory Cabinet-Bypass Operating Instructions

This section describes how to operate the Integrated Accessory Cabinet-Bypass (IAC-B).



NOTE 1 Before using the IAC-B, ensure all installation tasks are complete and a preliminary startup has been performed by authorized service personnel. The preliminary startup verifies all electrical interconnections to ensure the installation was successful and the system operates properly.

NOTE 2 Read this section of the manual and have thorough knowledge of UPS and IAC-B operation before attempting to operate any of the controls.

6.1 IAC-B Breakers

The descriptions provide a brief overview of the IAC-B breaker use. [Figure 30](#) and [Figure 31](#) identify and show the location of the breakers on the IAC-B.

- **Maintenance Bypass Breaker** – The Maintenance Bypass Breaker (MBP) transfers the load from the UPS output to the bypass input feeder.
- **Maintenance Isolation Breaker** – The Maintenance Isolation Breaker (MIS) isolates the UPS from the bypass feed and the load.
- **Bypass Input Breaker** – (Optional – only three breaker configurations) The Bypass Input Breaker (BIB) provides a single point of input power control to the UPS on single-feed systems or bypass input power control to the UPS on dual-feed systems. Using the BIB easily removes power from the UPS for servicing.

6.2 Using the UPS when an IAC-B is Installed

To operate the IAC-B:

1. Open the front door by lifting the latch from the bottom and turning to the right (counterclockwise) and swing the door open.
2. Close the IAC-B maintenance bypass input feeder circuit breaker.
3. Verify that the IAC-B circuit breakers are set as follows (see [Figure 30](#) or [Figure 31](#) for breaker locations):

MBP	OPEN
MIS	CLOSED
BIB (if installed)	CLOSED

4. Start the UPS. Refer to the applicable Eaton 93PM UPS Installation and Operation manual, listed in paragraph [1.7 For More Information](#), for UPS operating procedures.
5. Close the door and secure the latch.

Figure 30. 93PM IAC-B Breakers – Bypass Interlock Plate

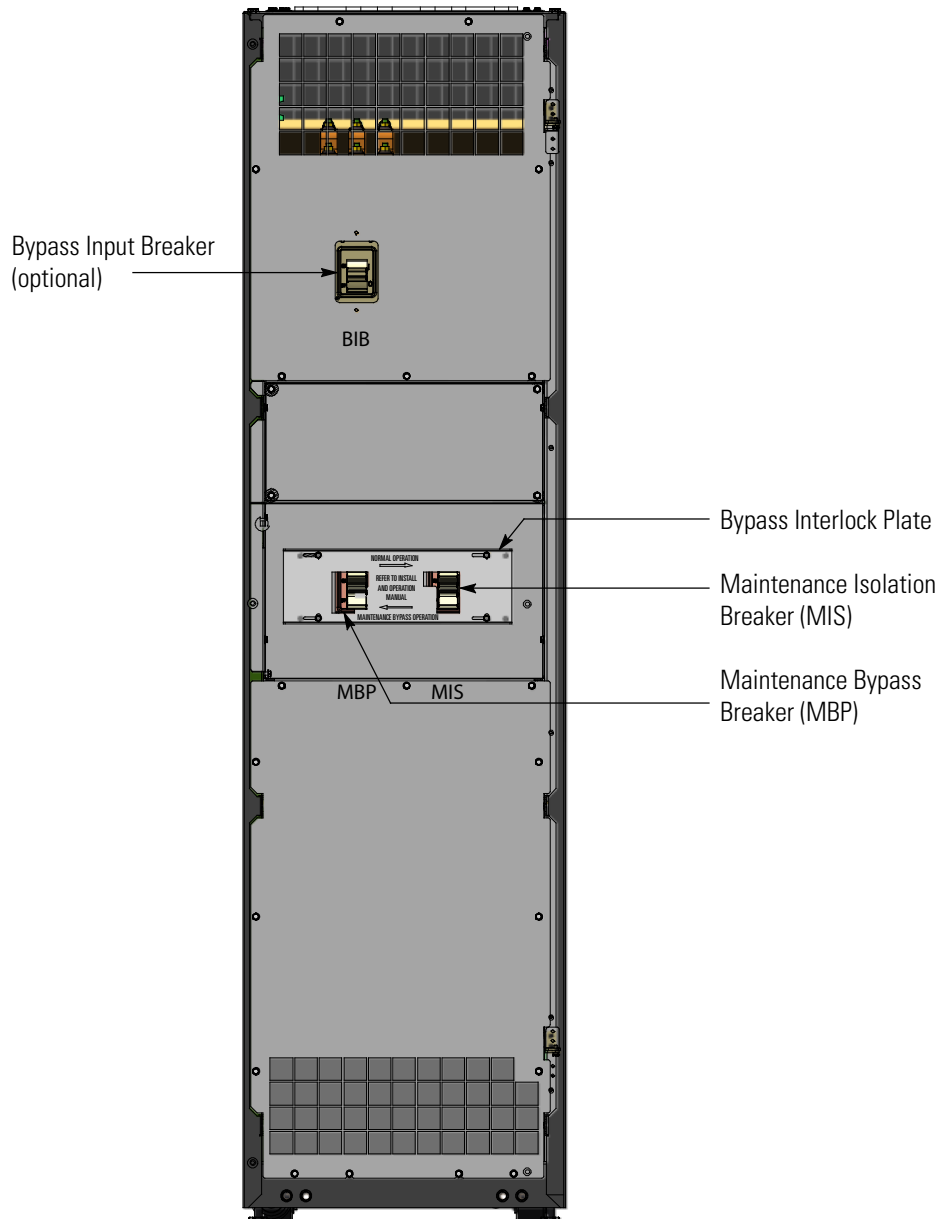

Figure 31. 93PM IAC-B Breakers – Trapped Key Interlock

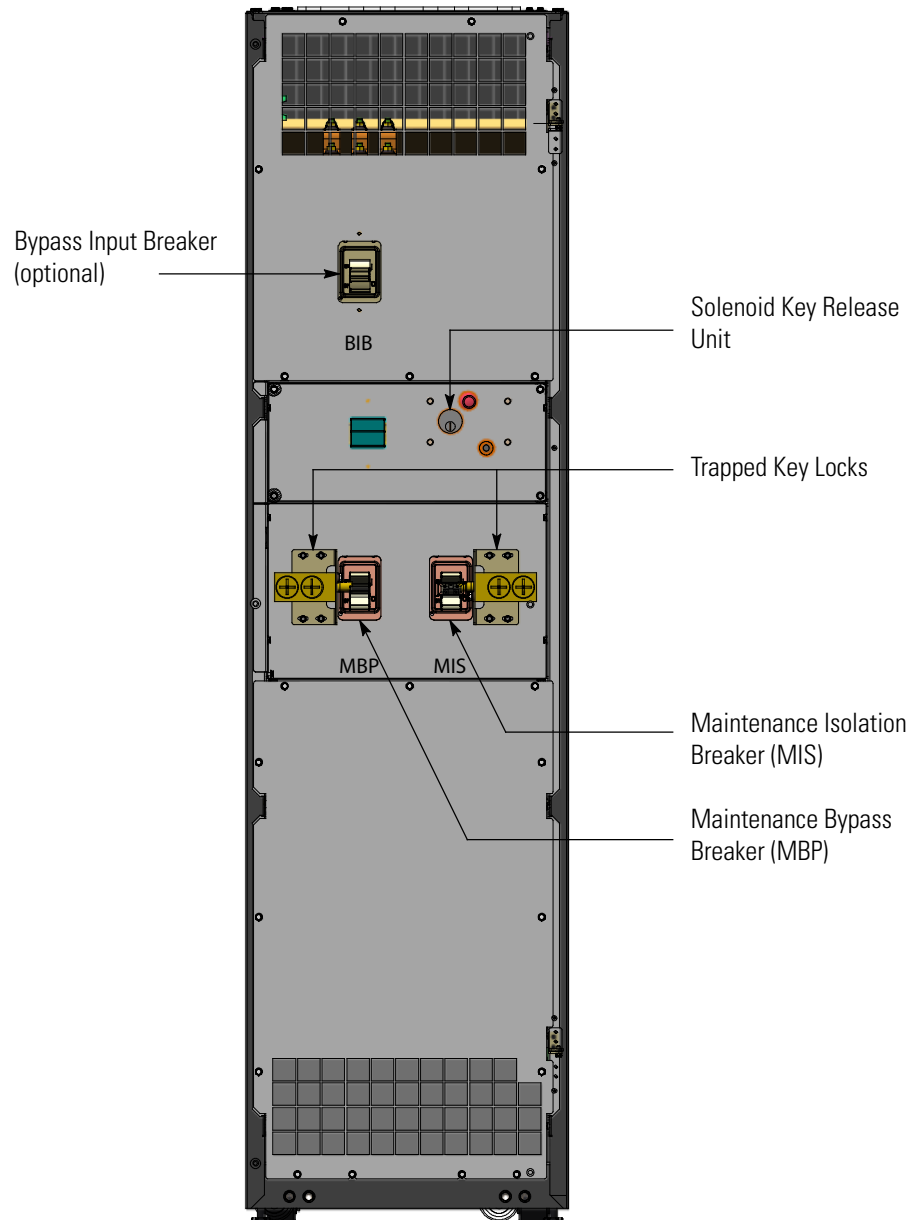
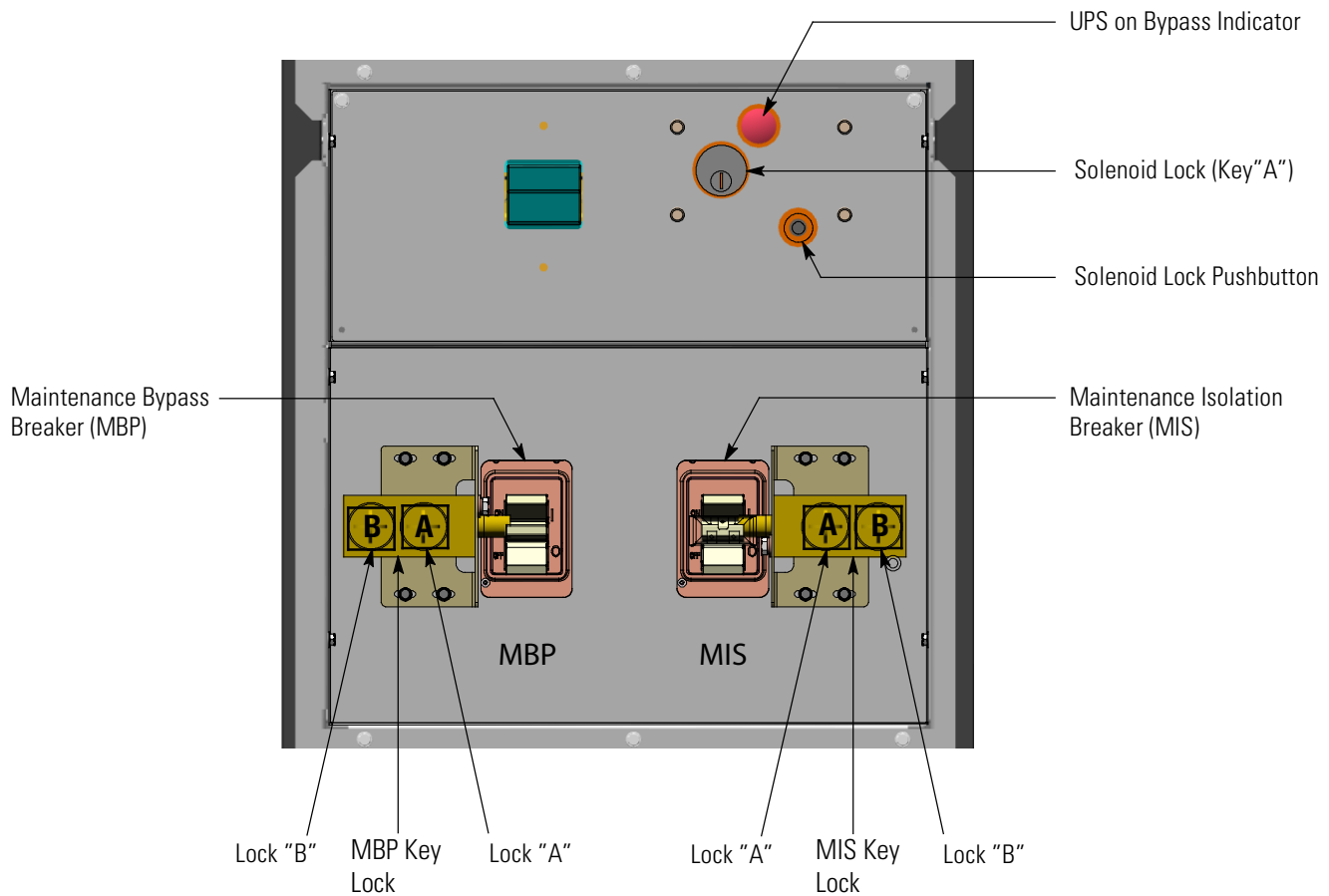

Figure 32. 93PM IAC-B – Trapped Key Interlock Detail



6.3 IAC-B Operation – Bypass Interlock Plate

6.3.1 Transferring the UPS to Maintenance Bypass

CAUTION

Only trained personnel familiar with the operation of this equipment should transfer loads. Failure to follow this transfer sequence may cause loss of power to loads.

CAUTION

In Bypass mode, the critical load is not protected from commercial power interruptions and abnormalities.

To transfer the load to maintenance bypass:

1. Open the front door by lifting the latch from the bottom and turning to the right (counterclockwise) and swing the door open.
2. Verify the BIB (if installed) is closed.

3. Transfer the UPS from normal mode to bypass mode. Refer to the applicable Eaton 93PM UPS Installation and Operation manual, listed in paragraph [1.7 For More Information](#), for UPS operating procedures.

⚠ WARNING

Power is present inside the cabinets.

⚠ CAUTION

Failure to close the MBP before opening the MIS will result in the loss of power to the critical load.

4. Close the MBP.
5. Slide the bypass interlock plate to the left (see [Figure 30](#)).
6. Open the MIS.
The critical load is supplied by the maintenance bypass source.
7. Shut down the UPS. Refer to the applicable Eaton 93PM UPS Installation and Operation manual, listed in paragraph [1.7 For More Information](#), for UPS operating procedures.

⚠ WARNING

The BIB (if installed) or the bypass feeder breaker must be opened to electrically isolate the UPS.

8. If installed, open the BIB.
9. Close the door and secure the latch.

6.3.2 Transferring the UPS from Maintenance

⚠ CAUTION

Only trained personnel familiar with the operation of this equipment should transfer loads. Failure to follow this transfer sequence may cause loss of power to loads.

To transfer the load from maintenance:

1. Open the front door by lifting the latch from the bottom and turning to the right (counterclockwise) and swing the door open.
2. If installed, close the BIB.
3. Start the UPS in bypass mode. Refer to the applicable Eaton 93PM UPS Installation and Operation manual, listed in paragraph [1.7 For More Information](#), for UPS operating procedures.

⚠ CAUTION

Failure to close the MIS before opening the MBP will result in the loss of power to the critical load.

4. Close the MIS.
5. Slide the bypass interlock plate to the right (see [Figure 30](#)).
6. Open the MBP.
7. Close the door and secure the latch.

8. Transfer the UPS to Normal mode. Refer to the applicable Eaton 93PM UPS Installation and Operation manual, listed in paragraph [1.7 For More Information](#), for UPS operating procedures.

6.4 IAC-B Operation – Trapped Key Interlock

6.4.1 Transferring the UPS to Maintenance Bypass

CAUTION

Only trained personnel familiar with the operation of this equipment should transfer loads. Failure to follow this transfer sequence may cause loss of power to loads.

CAUTION

In Bypass mode, the critical load is not protected from commercial power interruptions and abnormalities.

1. Open the front door by lifting the latch from the bottom and turning to the right (counterclockwise) and swing the door open.
 2. Verify the BIB (if installed) is closed.
 3. Transfer the UPS from normal mode to bypass mode. Refer to the applicable Eaton 93PM UPS Installation and Operation manual, listed in paragraph [1.7 For More Information](#), for UPS operating procedures.
-

WARNING

Power is present inside the cabinets.

4. Verify the UPS on Bypass indicator on the IAC-B is illuminated (see [Figure 32](#)).
-

**NOTE**

Key "A" can be removed from the solenoid lock only when the UPS on Bypass indicator is illuminated indicating the UPS is on bypass.

5. Press and hold the solenoid lock pushbutton. Unlock and remove key "A" from the solenoid lock (see [Figure 32](#)).
-

CAUTION

Failure to close the MBP before opening the MIS will result in the loss of power to the critical load.

6. Insert key "A" into lock "A" on the MBP Trapped key lock. Unlock and close the MBP.
7. Remove key "B" from the MBP Trapped key lock "B".
8. Insert key "B" into lock "B" on the MIS Trapped key lock. Open the MIS.
9. Lock the MIS and remove key "A" from the MIS Trapped key lock "A".
10. Insert key "A" into the solenoid lock and lock.

The critical load is supplied by the maintenance bypass source.

11. Shut down the UPS. Refer to the applicable Eaton 93PM UPS Installation and Operation manual, listed in paragraph [1.7 For More Information](#), for UPS operating procedures.

⚠ WARNING

The BIB (if installed) or the bypass feeder breaker must be opened to electrically isolate the UPS.

12. If installed, open the BIB.
13. Close the door and secure the latch.

6.4.2 Transferring the UPS from Maintenance Bypass

⚠ CAUTION

Only trained personnel familiar with the operation of this equipment should transfer loads. Failure to follow this transfer sequence may cause loss of power to loads.

To transfer the load from maintenance:

1. Open the front door by lifting the latch from the bottom and turning to the right (counterclockwise) and swing the door open.
 2. If installed, close the BIB.
 3. Start the UPS in bypass mode. Refer to the applicable Eaton 93PM UPS Installation and Operation manual, listed in paragraph [1.7 For More Information](#), for UPS operating procedures.
 4. Press and hold the solenoid lock pushbutton. Unlock and remove key "A" from the solenoid lock (see [Figure 32](#)).
-

⚠ CAUTION

Failure to close the MIS before opening the MBP will result in the loss of power to the critical load.

5. Insert key "A" into lock "A" on the MIS Trapped key lock. Unlock and close the MIS.
6. Remove key "B" from the MIS Trapped key lock "B".
7. Insert key "B" into lock "B" on the MBP Trapped key lock. Open the MBP.
8. Lock the MBP and remove key "A" from the MBP Trapped key lock "A".
9. Insert key "A" into the solenoid lock and lock.
10. Close the front door and secure the latch.
11. Transfer the UPS to Normal mode. Refer to the applicable Eaton 93PM UPS Installation and Operation manual, listed in paragraph [1.7 For More Information](#), for UPS operating procedures.

Chapter 7 Maintenance

The components inside the Integrated Accessory Cabinet-Bypass (IAC-B) are secured to a sturdy metal frame. All repairable parts and assemblies are located for easy removal, with very little disassembly. This design allows authorized service personnel to perform routine maintenance and servicing quickly.

You must schedule periodic performance checks of the UPS system to keep it running properly. Regular routine checks of operation and system parameters enable your system to function efficiently for many trouble-free years.

7.1 Important Safety Instructions

Remember that your UPS system is designed to supply power **EVEN WHEN DISCONNECTED FROM THE UTILITY POWER.**



- No user serviceable components.
 - Servicing and maintenance should be performed by qualified service personnel only.
 - LETHAL VOLTAGE PRESENT. This unit should not be operated with the cabinet doors open or protective panels removed. Do not make any assumptions about the electrical state of any cabinet in the UPS system.
-

7.2 Performing Preventive Maintenance

The UPS system requires very little preventive maintenance. However, the system should be inspected periodically to verify that the units are operating normally. Record maintenance results and any corrective actions in a suitable log.

7.2.1 DAILY Maintenance

Perform the following steps daily:

1. Check the area surrounding the UPS system. Ensure the area is not cluttered, allowing free access to the unit.
2. Ensure the air intakes on the Accessory cabinets are not blocked.
3. Ensure the operating environment is within the parameters specified in paragraph [3.2.1 Environmental and Installation Considerations](#) and in [Chapter 8 Product Specifications](#).

7.2.2 PERIODIC Maintenance

Periodic inspections of the IAC-B should be made to determine if components, wiring, and connections exhibit evidence of overheating. Particular attention should be given to the compression lug connections. Maintenance procedures should specify that the compression lug connections be retorqued to values listed in this manual.

7.2.3 ANNUAL Maintenance

Annual preventive maintenance should be performed only by authorized service personnel familiar with maintenance and servicing of the UPS system. Contact an Eaton service representative for more information about service offerings.

7.3 Maintenance Training

A basic training course, available from Eaton, gives you a competent working knowledge of the UPS system operation and teaches you how to perform first level corrective maintenance. For more information about training and other services, contact the Customer Reliability Center (see paragraph [1.8 Getting Help](#)).

Chapter 8 Product Specifications

This section provides the following specifications:

- Model Number
- Input specifications
- Output specifications
- Environmental and safety specifications

8.1 Model Numbers

The Integrated Accessory Cabinet-Bypass (IAC-B) is available in one model to meet the needs of the Eaton 93PM 400 kW UPS product line.

Integrated Accessory Cabinet-Bypass (IAC-B) Model	Description
Eaton 93PM IAC-B	IAC-B for the Eaton 93PM 400 kW UPS Frame

8.2 Specifications

The following sections detail the input, output, and environmental and safety specifications for the IAC-B.

8.2.1 Input

Operating Input Voltage Range	480 Vac, 60 Hz
Input Wiring	3 wire + ground – No neutral
Operating Frequency Range	60 Hz \pm 5 Hz
Operating Input Current	See Table 3 or Table 4 .

8.2.2 Output

Operating Output Voltage	480 Vac, 60 Hz
Output Wiring:	3 wire + ground – No neutral
Operating Output Frequency Range	60 Hz \pm 5 Hz
Output Current	See Table 3 or Table 4 .

8.2.3 Environmental and Safety Specifications

Operating Temperature	5 to 40°C (41 to 104°F). The recommended operating temperature is 25°C (77°F)
Storage Temperature	-25 to +55°C (-13 to +131°F)
Operating Altitude	Maximum 1500m (5000 ft) at 40°C without derating
Ventilation	Natural convection air cooling for top or rear exhaust

Product Specifications

Relative Humidity (operating and storage)	95%, noncondensing
Acoustical Noise	Not applicable
Safety Conformance	UL1778 4 th edition
Agency Markings	cULus

Chapter 9 Warranty

To view the UPS warranty please click on the link or copy the address to download from the Eaton website:
[UPS Product Warranty](#)

<https://www.eaton.com/content/dam/eaton/products/backup-power-ups-surge-it-power-distribution/backup-power-ups/portfolio/eaton-three-phase-ups-warranty.pdf>

EQUIPMENT REGISTRATION

Please visit www.eaton.com/pg/register to register your new Eaton UPS / Eaton UPS Accessory.

Model Number:

Serial Number:



P-164000615 03