



# ADD-LTSAM

## AMPS Mounting Base w/ VESA Plate

### INSTRUCTION MANUAL

Thank you for choosing CTA Digital's product. We hope that you will enjoy using it. Please follow the guidelines and instructions as laid out in this instruction manual.

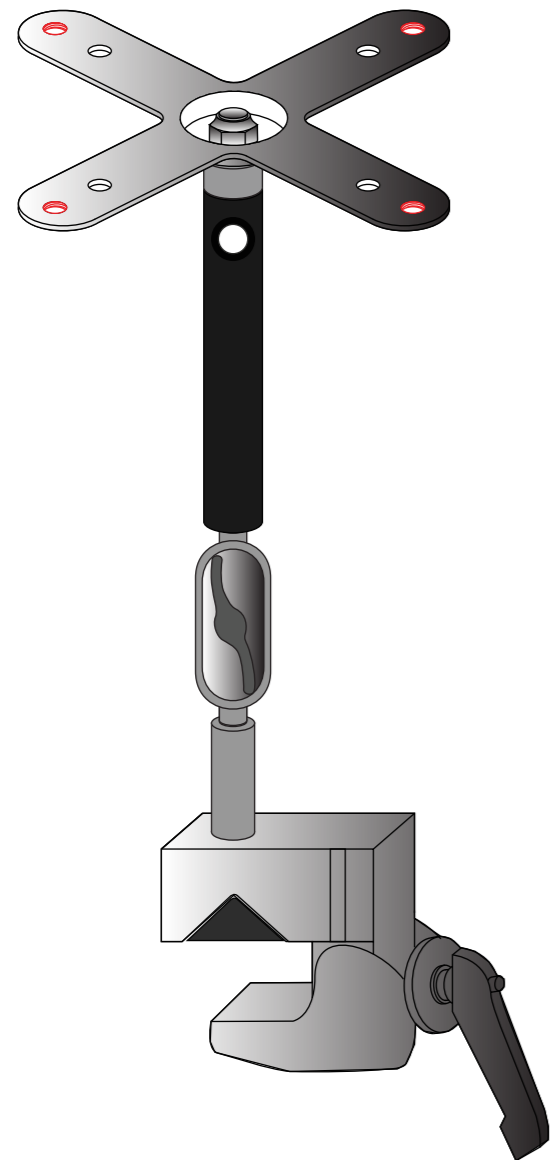

#### Package Contents:

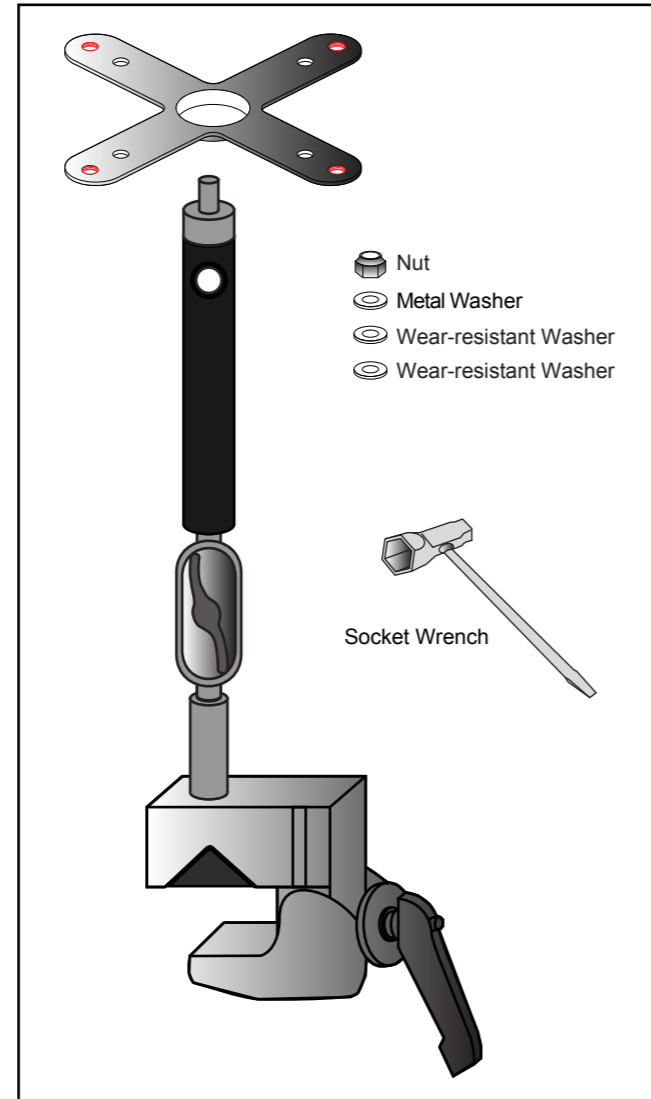

#### Instructions:

##### 1. Installing the Clamp

###### On a Flat Surface:

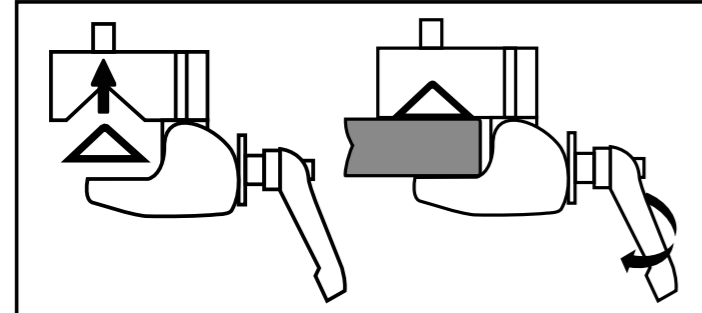

1. Place rubber grip flat insert into the clamp groove. Rotate tightening handle counter-clockwise to widen around surface ledge. Rotate clockwise to tighten until secure.

###### On a Pole:

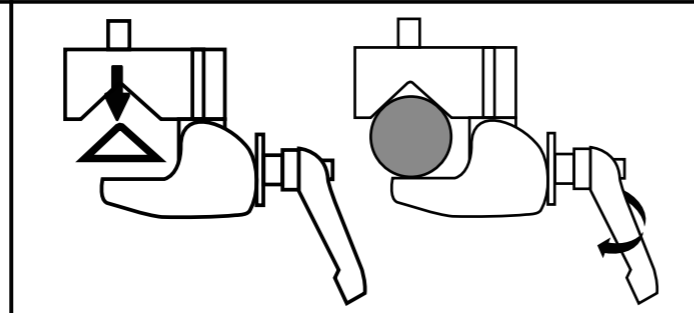

2. Remove rubber grip flat insert from clamp groove. Rotate tightening handle counter-clockwise to widen around surface ledge. Rotate clockwise to tighten until secure.

#### 2. Connecting VESA Plate to the Pole Body

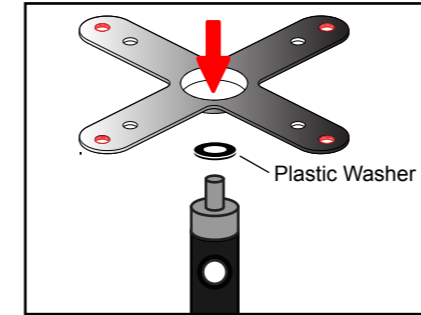

1. Put a plastic washer on the top of the Pole and then insert it into the VESA Plate.

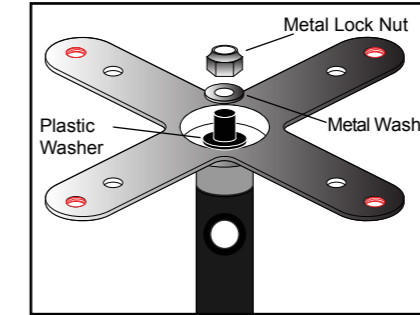

2. Place a plastic washer then a metal washer over the Pole tip, screw nut over to lock in place.

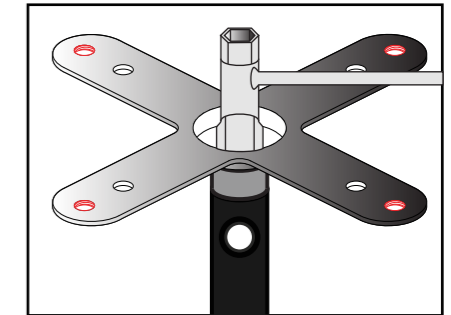

3. Use the Socket Wrench to tighten it securely.

#### 3. Adjusting Joints

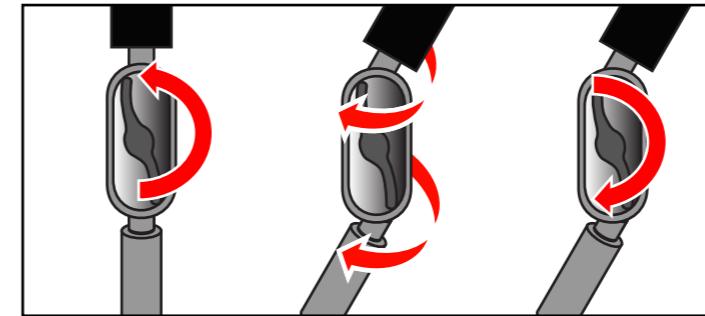

1. Loosen the Handle Rod of the Pole, Adjust the Pole to desired position then tighten the Handle Rod.

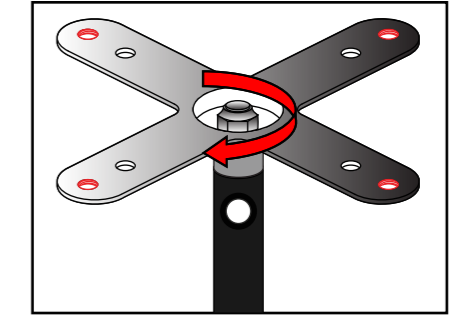

2. Rotate the VESA Plate to adjust it in horizontal.