

Aruba 9012 Gateway



Installation Guide

Copyright

Copyright Information© Copyright 2019 Hewlett Packard Enterprise Development LP.

Open Source Code

This product includes code licensed under the GNU General Public License, the GNU Lesser General Public License, and/or certain other open source licenses. A complete machine-readable copy of the source code corresponding to such code is available upon request. This offer is valid to anyone in receipt of this information and shall expire three years following the date of the final distribution of this product version by Hewlett Packard Enterprise Company. To obtain such source code, send a check or money order in the amount of US \$10.00 to:

Hewlett Packard Enterprise Company
Attn: General Counsel
6280 America Center Drive
San Jose, CA 94089



www.arubanetworks.com

Hewlett Packard Enterprise Company
Attn: General Counsel
6280 America Center Drive
San Jose, CA 94089

Phone: 408.227.4500
Fax 408.227.4550

| | |
|--|----|
| Guide Overview..... | 5 |
| Related Documentation..... | 5 |
| Contacting Support | 5 |
| Package Checklist | 7 |
| Aruba 9012 Gateway Components | 8 |
| Front Panel LEDs..... | 8 |
| Kensington Lock Slot | 9 |
| Power Supply..... | 9 |
| Reset Switch | 10 |
| Ethernet Ports | 10 |
| Micro-USB Console Port..... | 11 |
| RJ-45 Console Port | 11 |
| USB Port..... | 12 |
| Installation Recommendations..... | 15 |
| Precautions..... | 15 |
| Rack Mounting- Front and Rear | 16 |
| Required Tools and Equipment | 16 |
| Installation Steps | 16 |
| Table or Shelf Installation..... | 17 |
| Required Tools and Equipment | 17 |
| Installation Steps | 17 |
| Wall Mounting..... | 18 |
| Required Tools and Equipment | 18 |
| Installation Steps | 18 |
| Aruba 9012 Gateway Specifications | 21 |
| Physical | 21 |
| Electrical..... | 21 |
| Environmental..... | 21 |
| Safety and Regulatory Compliance | 21 |
| FCC..... | 22 |
| EU Regulatory Conformance | 22 |
| Wireless Channel Restrictions..... | 23 |
| Japan VCCI | 24 |
| Thailand | 24 |
| Regulatory Model Name | 24 |
| Proper Disposal of Aruba Equipment..... | 24 |
| Waste of Electrical and Electronic Equipment..... | 24 |
| European Union RoHS..... | 24 |
| India RoHS | 24 |
| China RoHS | 25 |
| Korean..... | 25 |
| Taiwan..... | 25 |
| Нормативные требования Евразийского Экономического Союза | 26 |
| Mexico | 26 |

This document describes the hardware features of the Aruba 9012 gateway. It provides a detailed overview of the physical and performance characteristics of the gateway and explains how to install the gateway and its accessories.

Guide Overview

- [Chapter 1, “9012 Gateway” on page 7](#) provides a detailed hardware overview of the Aruba 9012 gateway and each of its components.
- [Chapter 2, “Installation” on page 15](#) describes how to install the Aruba 9012 gateway.
- [Chapter 3, “Specifications, Safety, and Compliance” on page 21](#) lists the Aruba 9012 gateway’s technical specifications and safety and regulatory compliance information.

Related Documentation

The latest ArubaOS User Guide and ArubaOS CLI Reference Guide are required for the complete management of an Aruba gateway. The latest documentation and the translation of this document into other languages can be found at www.arubanetworks.com/documentation.

Contacting Support

Table 1 *Contact Information*

| | |
|---|--|
| Main Site | www.arubanetworks.com |
| Support Site | http://support.arubanetworks.com |
| Airheads Social Forums and Knowledge Base | www.community.arubanetworks.com |
| North American Telephone | 1-800-943-4526 (Toll Free) 1-408-754-1200 |
| International Telephones | https://www.arubanetworks.com/support-services/contact-support/ |
| Software Licensing Site | lms.arubanetworks.com |
| End of Support information | www.arubanetworks.com/support-services/end-of-life/end-of-life-policy/ |
| Security Incident Response Team (SIRT) | Site: https://www.arubanetworks.com/support-services/security-bulletins/ Email: aruba-sirt@hpe.com |

The Aruba 9012 gateway is a dual purpose gateway that supports both SD-WAN and wireless LAN capabilities. The wireless LAN connects, controls, and intelligently integrates wireless Access Points (APs), Managed Devices, and Air Monitors (AMs). The gateway has the ability to directly connect a branch to cloud, provide resilient connectivity from the cloud, and centralized control for policy management across all branches.

The Aruba 9012 gateway has the following port configuration:

Table 2 Aruba 9012 Gateway Port Configuration

| Model | Ports | Number of APs Supported | Number of Users Supported |
|-------|--|-------------------------|---------------------------|
| 9012 | <ul style="list-style-type: none"> ● 12 x 10/100/1000BASE-T ports ■ 6 x PoE+ ports | 32 | 2048 |



The Aruba 9012 gateway requires ArubaOS 8.7.0.0 or SD-Wan 2.0 and later versions.

Package Checklist

Inform your supplier if there are any incorrect, missing, or damaged parts. To return this product, repack this unit and other materials included into the original packaging, before returning it to the supplier.

Table 3 Package Contents

| Item | Quantity |
|--|----------|
| Aruba 9012 gateway | 1 |
| Power cable | 1 |
| Micro USB console cable | 1 |
| Rack mount brackets | 2 |
| M3 x 8 mm flat head screws | 8 |
| M6 x 15 mm Phillips pan head screws | 4 |
| M6 x 7 mm grounding screws | 2 |
| Rubber feet | 4 |
| Aruba 9012 Start-up Guide (Printed) | 1 |
| Safety, Compliance, and Warranty Information (Printed) | 1 |



The rack mounting kit is available for use with the Aruba 9012 gateway and is sold separately. Contact your Aruba sales representative for details and assistance.

Aruba 9012 Gateway Components

This section introduces the different component and its location in the Aruba 9012 gateway.

Figure 1 shows the front panel of the Aruba 9012 gateway and Figure 2 shows the back panel of the Aruba 9012 gateway.

Figure 1 Front Panel of the Aruba 9012 gateway

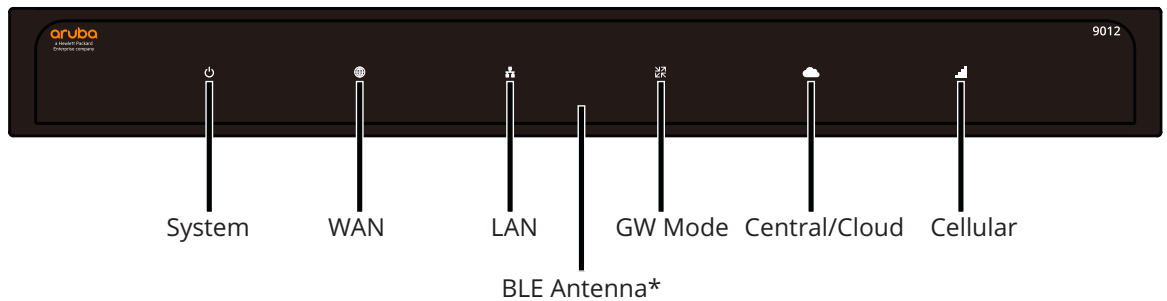

* The antenna is integrated within the hardware and is not displayed on the front panel.

Figure 2 Back Panel of the Aruba 9012 gateway

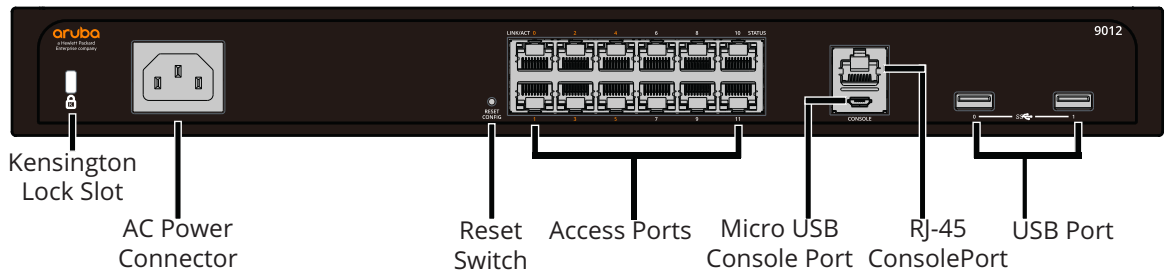

Front Panel LEDs

The front panel LEDs show the System, WAN, and LAN status including various other features. These front panel LEDs provide basic monitoring information of the overall status of the Aruba 9012 gateway. The following table describes the LED indicators and their corresponding status:

Table 4 LED Status

| LED | Function | Indicator | Status |
|--------|---------------|------------------|-------------------------|
| System | System status | Green (Solid) | Powered and Operational |
| | | Green (Blinking) | Loading Software |
| | | Amber (Solid) | Critical Alarm |
| | | Amber (Blinking) | Major Alarm |
| | | Off | Power Off |

Table 4 LED Status

| LED | Function | Indicator | Status |
|---------------|--|---|---|
| WAN | WAN Connectivity Status | | |
| LAN | Link Status | Green (Solid) | All LAN Ports Established |
| | | Amber (Solid) | No LAN Ports Established |
| GW Mode | WLAN Gateway mode / SDWAN Gateway mode | Green (Solid) | The WLAN Gateway is Up and Functioning. |
| | | Green (Blinking) | WLAN Gateway Booting |
| Central/Cloud | Central Connectivity Status | Blue (Solid) | Connected to Central |
| | | Blue (Blinking) | Connecting to Central |
| Cellular | Link Status | Green (Solid) | Modem Initialized and Connected to the Network. Good Signal Strength. Signal Strength Threshold: > -65 dBm |
| | | Green (Blinking) | Modem Initializing |
| | | Green + Amber (Greenish Yellow) (Solid) | Modem Initialized and Connected to the Network. Average Signal Strength. Signal Strength Threshold: < -65 dBm > -80 dBm |
| | | Amber (Solid) | Modem Initialized and Connected to the Network. Poor Signal Strength. Signal Strength Threshold: < -80 dBm |
| | | Amber (Blinking) | Network Connection Failure. SIM Removal. Modem not Responding to Web Commands. |
| | | Red (Solid) | Modem Lost IP Address or Disconnected from the Network. Acting as a Backup Uplink. |
| | | Red (Blinking) | Hardware Failure. USB Failure. Unsupported USB Device Attached. |

Kensington Lock Slot

The Aruba 9012 gateway is equipped with a Kensington security slot for additional security.

Power Supply

The Aruba 9012 Gateway is equipped with an integrated AC power supply of 185 W. The integrated power supply supports an input voltage of 100 V AC to 240 V AC.

PoE

The Aruba 9012 gateway supports PoE (802.3af) and PoE+ (802.3at) to provide power to connected devices. PoE/PoE+ is enabled by default to provide plug and play capability for PoE capable devices.

The gateway supports a total available power of 120 W in PoE mode. Each port can support both PoE+ (802.3at) and PoE (802.3af).

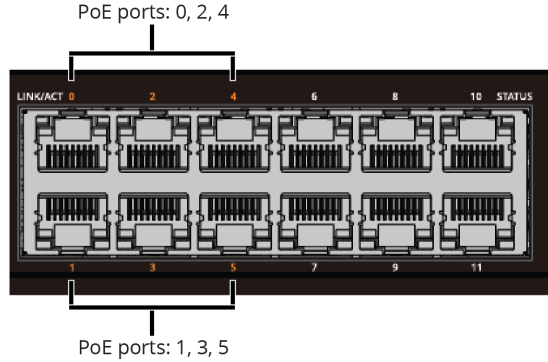

The Aruba 9012 gateway supports up to four PoE+ Class 4 ports simultaneously, with a power supply of up to 30 W only. All the 6 PoE ports can support power up to 15.4 W simultaneously.

Reset Switch

The Aruba 9012 gateway includes a recessed button for resetting the gateway configurations. Insert a pin into the Reset Switch hole until you feel the pin touch a surface. Push and hold the pin for two seconds to reset the gateway configuration.

Ethernet Ports

The Aruba 9012 gateway is equipped with twelve 10/100/1000BASE-T Gigabit Ethernet ports (0 to 11). Gigabit Ethernet uses all eight wires and each pair is bidirectional, which means, the same pair is used for both data transmission and reception. Figure 3 illustrates the Gigabit Ethernet port pin-out for an RJ-45 connector. The pins paired on a 10/100/1000Base-T Gigabit Ethernet port are: 1/2, 3/6, 4/5, and 7/8.

Figure 3 Figure 3 Gigabit Ethernet Port Pin-Out

1000Base-T Gigabit Ethernet Port

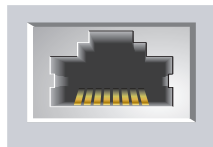

RJ-45 Female Pin-Out

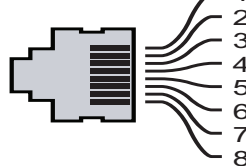

| Signal Name | Function |
|-------------|----------|
| 1 | BI_DA+ |
| 2 | BI_DA- |
| 3 | BI_DB+ |
| 4 | BI_DC+ |
| 5 | BI_DC- |
| 6 | BI_DB- |
| 7 | BI_DD+ |
| 8 | BI_DD- |

Ethernet Port LEDs

Each 10/100/1000BASE-T Ethernet port is equipped with two LEDs that allow basic monitoring of link/act and status activities.

- **LINK/ACT:** Placed on the left side of the port, and displays the link status and activity of the port.

- **STATUS:** Placed on the right side of the port, and displays the status of the port based on the CLI.

The following table describes the LED behavior for each mode:

Table 5 10/100/1000BASE-T Ethernet Port LEDs

| LED | Function | Mode | Indicator | Status |
|----------|-------------|-------|------------------|--|
| LINK/ACT | Link status | NA | Green (Solid) | Link established |
| | | | Green (Blinking) | Port is transmitting or receiving data |
| | | | Off | No link |
| STATUS | Port status | Speed | Green (Solid) | Link at 1000 Mbps |
| | | | Off | Link at 10/100 Mbps |

Micro-USB Console Port

The Aruba 9012 gateway is equipped with a Micro-USB (type B) connector that provides direct local console access. If both Micro-USB and RJ-45 console ports are connected, the Micro-USB connection takes precedence over the RJ-45 console connection.

Micro-USB Driver

To use the Micro-USB console port, you must install the Aruba Micro-USB driver on the computer that will manage your gateway. To download the driver, perform the following steps:

1. Go to <https://support.arubanetworks.com>.
2. Click on the **Tools & Resources** tab.
3. Open the **USB Console Driver** folder.
4. Open the **Mobility Gateway and Mobility Access Switch** folder.

Select the appropriate file for your application. The corresponding operating system is in the file name.

RJ-45 Console Port

The serial console port allows connecting a gateway to a serial terminal or a laptop for direct local management. This port is a RJ-45 female connector with the pin-outs described in [Figure 4](#). Connect it directly to a terminal or terminal server using an Ethernet cable.

Figure 4 Serial Console Port Pin-Out

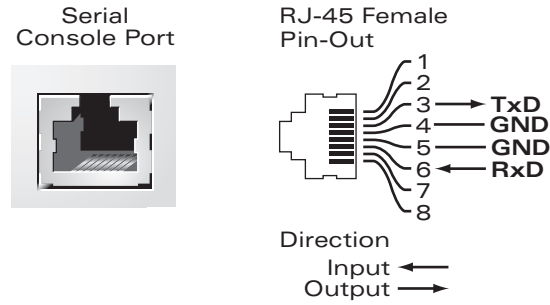

The communication settings for the RJ-45 console port is shown in the following table:

Table 6 RJ-45 Console Terminal Settings

| Baud Rate | Data Bits | Parity | Stop Bits | Flow Control |
|-----------|-----------|--------|-----------|--------------|
| 9600 | 8 | None | 1 | None |



The RJ-45 CONSOLE port is compatible only with RS-232 devices. Non-RS-232 devices, such as APs, are not supported.



Do not connect the RJ-45 Console port to an Ethernet switch or a PoE power source. This may damage the gateway.

Serial Console Port Adapter

A modular adapter can be used to convert the female RJ-45 connector to a male DB9 connector. See [Figure 5](#) for complete details.

Figure 5 RJ-45 (Female) to DB9 (Male) Modular Adapter Conversion

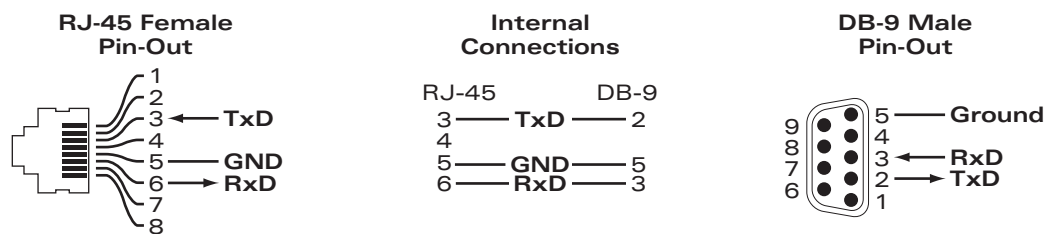

USB Port

The Aruba 9012 gateway is equipped with two USB 3.0 interfaces. A USB storage device can be used to save and upload configurations to the gateway.

The Aruba 9012 gateway also provides support for USB LTE Modems. These modems can be connected to either USB Port 0 and Port 1. When two modems are connected simultaneously, the modem that gets registered with the device first, will be in use. To use the second modem,

disconnect the first one and reboot the device. After initiation, the second modem gets registered, and can be used.



The 9012 gateway provides support for two USB LTE Modems. You can use only one USB LTE Modem at a time. To use both modems simultaneously, it is recommended to use a USB extension cable.



Installation of the device should be performed by a trained installation professional.

This chapter describes how to install an Aruba 9012 Gateway using the many mounting options available. The 9012 gateway ships with an accessory kit that includes the equipment needed to install the gateway in a standard, 19-inch telco rack or on a wall.

Installation Recommendations

- For proper air circulation, leave at least 10 cm (4 inches) clearance on the left, right, front, and rear side of the gateway.
- Leave additional space in front and rear side of the gateway to access power cords, network cables, and indicator LEDs.
- Avoid placing anything on top of the gateway as it can lead to overheating of the gateway.
- Avoid placing this gateway on any other device as the heat dissipated from the other device can over heat the gateway.
- Ensure that the rack is correctly and securely installed to prevent it from falling or becoming unstable.

Precautions

- Ensure that the rack is correctly and securely installed to prevent it from falling or becoming unstable.
- Dangerous voltage above 240 V AC is always present while the Aruba Power Supply Module is plugged into an electrical outlet. Remove all rings, jewelry, and other potentially conductive material before working with this device.
- Never insert foreign objects into the chassis, power supply, or any other component, even when the power supply is turned off, unplugged, or removed.
- Ensure that the main power is fully disconnected from the gateway by unplugging all power cords from their outlets. For safety, verify that the power outlets and plugs are easily reachable by the operator.
- Do not handle electrical cables which are not insulated. This also includes network cables.
- Keep water and other fluids away from the gateway to minimize electrical hazards.
- Comply with electrical grounding standards during all phases of installation and operation of the product. Do not allow the gateway's chassis, network ports, power supply, or mounting brackets to contact any device, cable, object, or person attached to a different electrical ground. Also, never connect the device to external storm grounding sources.
- Perform installation or removal of the chassis or any module in a static-free environment. Proper use of anti-static body straps and mats is strongly recommended.
- Modules must be kept in anti-static packaging when not installed in the chassis.

- Do not ship or store this product near strong electromagnetic, electrostatic, magnetic, or radioactive fields.
- This product, power cords, and all interconnected cables are for indoor use only.

Rack Mounting- Front and Rear

This mounting option allows mounting the 9012 gateway in a two-post 19-inch Telco rack.



Each 9012 gateway should have its own mounting equipment. Do not place other networking equipment directly on top of a mounted gateway. Failure to do so can damage the device.

Required Tools and Equipment

The following tools and equipment are required for installing a 9012 gateway:

- Mounting Bracket (x2) (included in the kit)
- Screws for mounting bracket (x8): M3 x 8 mm Phillips Flat Head Screws (included in the kit)
- Screws for system rack mount (x4): M6 x 15 mm Phillips Pan Head Screws (included in the kit)
- Suitable Screwdrivers for all screw types provided in the box (not included in the kit)



Some racks require screws that differ from those included with the 9012 gateway. Ensure that you have the correct screws before installing the device.

Installation Steps

To install a 9012 gateway into a two-post 19-inch Telco rack:

1. Place the mounting bracket over the mounting holes of the gateway. See [Figure 6](#).

Figure 6 Rack Mount Bracket

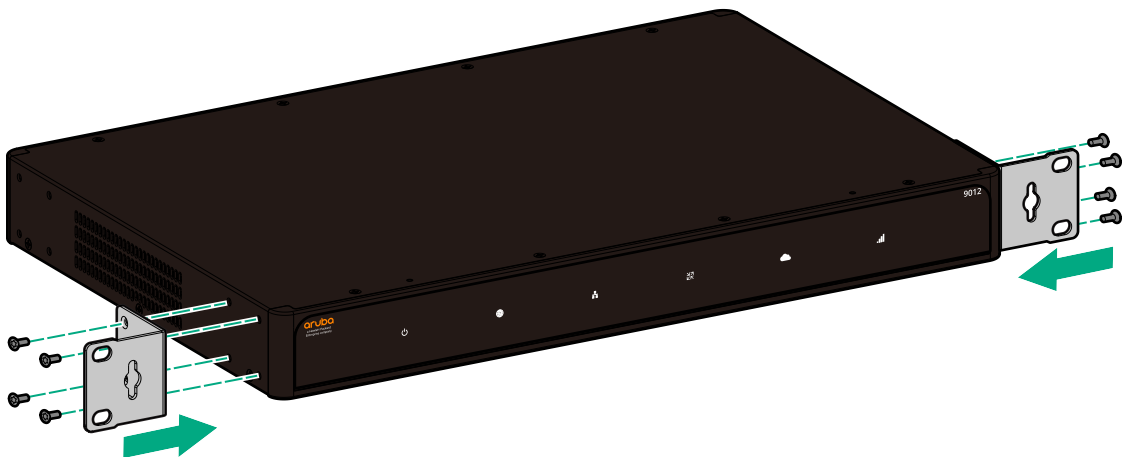

2. Secure the bracket to the gateway using the eight screws for the mount bracket (four per bracket) and a suitable screwdriver.
3. Mount the gateway within your organization's rack system using the four screws for the system rack mount (two per bracket) and a suitable screwdriver. See [Figure 7](#).

Figure 7 Rack Mount Installation



Leave a minimum of 10 cm (4 inches) of space on the left and right side of the device for proper air flow and ventilation.

Leave additional space in the front and the back of the device to access network cables, LED status indicators, and power cord.

Table or Shelf Installation

Required Tools and Equipment

- Rubber feet (included in the kit)

Installation Steps

1. Attach the rubber feet to the bottom of the gateway. See [Figure 8](#).

Figure 8 Attaching Rubber Feet

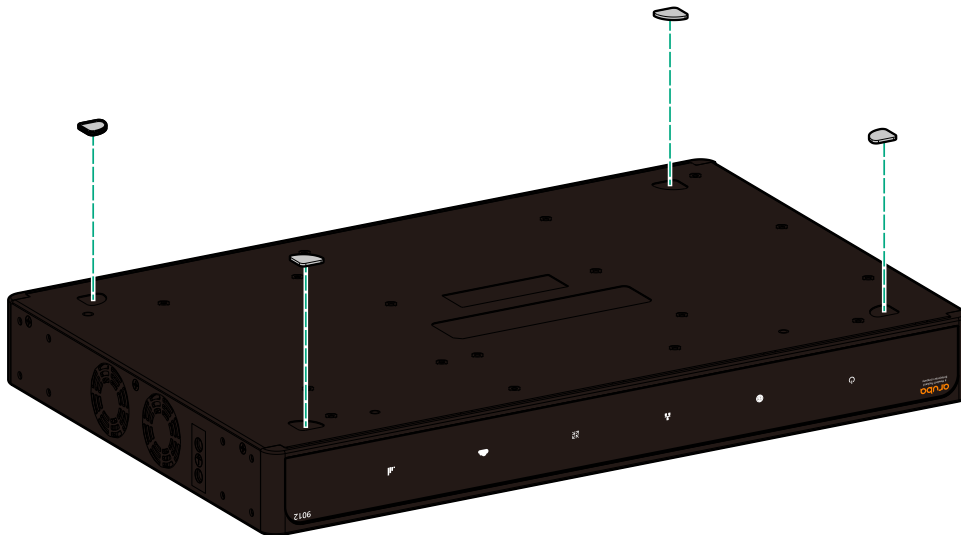

2. Place the gateway in the location you have chosen.

Wall Mounting

The mounting brackets can also be used for wall mounting the 9012 gateway.

Required Tools and Equipment

The following tools and equipment are required for installing the 9012 gateway:

- Mounting Brackets (x2) (included in the kit)
- Screws for mounting bracket (x8): M3 x 8 mm Phillips Flat Head Screws (included in the kit)
- Wall Anchors: Optional accessory (not included in the kit)
- Wall Mounting Screws: The type of screw depends on the installation surface (not included in the kit)
- Suitable Screwdrivers for all screw types (not included in the kit)
- Screws and Anchors recommendation:
 - Use 1 inch long #6 screws with #4-6 x 7/8 inch anchors
 - Minimum weight rating: 20 lbs / 9 kg
 - Required quantity: 2 screws and 2 anchors per unit

Installation Steps

To install a 9012 gateway on a wall:



Ensure that the Ethernet ports are facing down when installing the 9012 gateway on a wall.

1. Fasten the mounting brackets over the mounting holes on the sides of the gateway using the eight screws for mounting brackets (four per bracket) and a suitable screwdriver. See [Figure 9](#).

Figure 9 Attaching the Wall Mount Brackets



2. After you have chosen a mounting location, mark the locations on a wall where you intend to make the mounting holes.
3. Create the holes and insert wall anchors if your installation requires them. Refer the installation instructions provided with the anchors being used, for details.
4. Align the mounting bracket holes with the holes you created on the wall. See [Figure 10](#).
5. Use appropriate screws to secure the 9012 gateway.

Figure 10 *Wall Mounting*

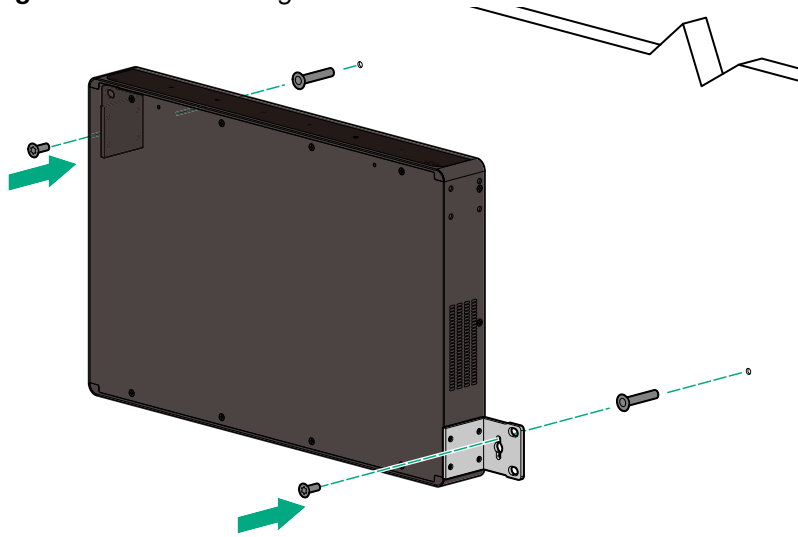

Aruba 9012 Gateway Specifications

Physical

- Device Dimensions (without mounting brackets) (HxWxD): 3.95 cm x 26.00 cm x 4.37 cm
- Device Weight: 7.54 lbs (3.42 kg)

Electrical

- Ethernet
 - 12 x 10/100/1000BASE-T auto-sensing Ethernet RJ-45 ports
 - 6 x PoE+ ports
 - MDI/MDX
 - 2 x USB A 3.0 ports
 - 1 x Micro USB console port
 - 1 x RJ-45 console port
 - Bluetooth
- 185 W AC Power Supply
 - AC Input Voltage: 100 V AC to 240 V AC
 - AC Input Current: 3 A at 100 Vrms
 - AC Input Frequency: 50 Hz to 60 Hz

Environmental

- Operating
 - Temperature Range: 0 °C to 40 °C (32 °F to 104 °F)
 - Humidity Range: 10% to 90% (RH), non-condensing
- Storage and Transportation
 - Temperature Range: -40 °C to 70 °C (-40 °F to 158 °F)
 - Humidity Range: 10% to 95% (RH), non-condensing

For additional specifications on this product, please refer to the data sheet. The data sheet can be found at www.arubanetworks.com

Safety and Regulatory Compliance

Aruba, a Hewlett Packard Enterprise company provides a multi-language document that contains country-specific restrictions and additional safety and regulatory information for all Aruba products.

This document can be viewed or downloaded from the following location: www.arubanetworks.com/safety_addendum



Aruba gateways must be installed by a professional installer. The professional installer is responsible for ensuring that grounding is available and it meets applicable local and national electrical codes.



RF Radiation Exposure Statement: This equipment complies with RF radiation exposure limits. This equipment should be installed and operated with a minimum distance of 7.874 inches (20cm) between the radiator and your body for 2.4 GHz operations. This transmitter must not be co-located or operating in conjunction with any other antenna or transmitter.



Déclaration sur les limites d'exposition aux radiofréquences : cet équipement est conforme aux limites d'exposition aux rayonnements radioélectriques spécifiées. Il doit être installé et utilisé à une distance minimale de 20 cm par rapport à votre corps pour les fréquences de 2,4 GHz. Cet émetteur-récepteur ne doit pas être utilisé ou situé à proximité d'autres antennes ou émetteurs-récepteurs.

FCC

This device complies with Part 15 of the FCC Rules. Operation is subject to the following two conditions: (1) this device may not cause harmful interference, and (2) this device must accept any interference received, including interference that may cause undesired operation.

Canada

This device contains license-exempt transmitter(s)/receiver(s) that comply with Innovation, Science and Economic Development Canada's license-exempt RSS(s). Operation is subject to the following two conditions:

1. This device may not cause interference.
2. This device must accept any interference, including interference that may cause undesired operation of the device.

Cet appareil contient des émetteurs / récepteurs exempts de licence qui sont conformes au (x) RSS (s) exemptés de licence d'Innovation, Sciences et Développement économique Canada. L'opération est soumise aux deux conditions suivantes:

1. Cet appareil ne doit pas causer d'interférences
2. Cet appareil doit accepter toute interférence, y compris les interférences pouvant provoquer un fonctionnement indésirable de l'appareil.

EU Regulatory Conformance



The Declaration of Conformity made under RED Directive 2014/53/EU is available for viewing at <http://www.hpe.com/eu/certificates>. Select the document that corresponds to your device's model number as it is indicated on the product label.



Use of controls or adjustments of performance or procedures other than those specified in this manual may result in hazardous radiation exposure.



Although this gateway has been tested up to 1 kV per CE immunity requirements, it requires surge protection to be provided as part of the building installation to protect against unidirectional surges resulting from electrical switching and lightning strikes.

For protection against these surges in an outdoor installation, any exposed wiring must be shielded, and the shield for the wiring must be grounded at both ends.

Wireless Channel Restrictions

Table 7 *Frequency Range Table*

| Frequency Range MHz | Max EIRP |
|---------------------|----------|
| 2402-2480 | 5 dBm |

Battery Statements



Il y a danger d'explosion s'il y a remplacement incorrect de la batterie.

Remplacer uniquement avec une batterie due même type ou d'un équivalent recommandé par le constructeur.

Mettre au rebut les batteries usagées conformément aux unstruction du fabricant.



The battery supplied with this product may contain perchlorate material. Special handling may apply in California and certain other states. See www.dtsc.ca.gov/hazardouswaste/perchlorate for more information.



There is a risk of explosion if battery is replaced by an incorrect type, so dispose used batteries according to the instructions.

Japan VCCI

この装置は、クラス A 情報技術装置です。この装置を家庭環境で使用する
と電波妨害を引き起こすことがあります。この場合には使用者が適切な対策
を講ずるよう要求されることがあります。 VCCI-A

Thailand



Regulatory Model Name

The regulatory model name for the Aruba 9012 Gateway is ARCN9012.

Proper Disposal of Aruba Equipment

Waste of Electrical and Electronic Equipment

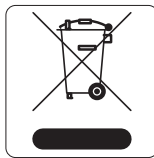

Aruba, a Hewlett Packard Enterprise company products at end of life are subject to separate collection and treatment in the EU Member States, Norway, and Switzerland and therefore are marked with the symbol shown at the left (crossed-out wheelie bin). The treatment applied at end of life of these products in these countries shall comply with the applicable national laws of countries implementing Directive 2012/19/EU on Waste of Electrical and Electronic Equipment (WEEE).

European Union RoHS



Aruba, a Hewlett Packard Enterprise company products also comply with the EU Restriction of Hazardous Substances Directive 2011/65/EU (RoHS). EU RoHS restricts the use of specific hazardous materials in the manufacture of electrical and electronic equipment. Specifically, restricted materials under the RoHS Directive are Lead (including Solder used in printed circuit assemblies), Cadmium, Mercury, Hexavalent Chromium, and Bromine. Some Aruba products are subject to the exemptions listed in RoHS Directive Annex 7 (Lead in solder used in printed circuit assemblies). Products and packaging will be marked with the "RoHS" label shown at the left indicating conformance to this Directive.

India RoHS

This product complies with RoHS requirements as prescribed by E-Waste (Management & Handling) Rules, governed by the Ministry of Environment & Forests, Government of India.

China RoHS



Aruba, a Hewlett Packard Enterprise company products also comply with China environmental declaration requirements and are labeled with the "EFUP 50" label shown at the left.

有毒有害物质声明 Hazardous Materials Declaration

| 部件名称 (Parts) | 有毒有害物质或元素 (Hazardous Substances) | | | | | |
|--|----------------------------------|----------------------|----------------------|--|--|---|
| | 铅 Lead (Pb) | 汞 Mercury (Hg) | 镉 Cadmium (Cd) | 六价铬 Chromium VI Compounds (Cr ⁶⁺) | 多溴联苯 Polybrominated Biphenyls (PBB) | 多溴二苯醚 Polybrominated Diphenyl Ether (PBDE) |
| 电路板 PCA Board | X | ○ | ○ | ○ | ○ | ○ |
| 机械组件 Mechanical Subassembly | X | ○ | ○ | ○ | ○ | ○ |
| 电源适配器 Power Adaptor | X | ○ | ○ | ○ | ○ | ○ |
| O: 表示该有毒有害物质在该部件所有均质材料中的含量均在SJ/T11363-2006标准规定的限量要求以下。 This component does not contain this hazardous substance above the maximum concentration values in homogeneous materials specified in the SJ/T11363-2006 Industry Standard. | | | | | | |
| X: 表示该有毒有害物质至少在该部件的某一均质材料中的含量超出SJ/T11363-2006标准规定的限量要求。 This component does contain this hazardous substance above the maximum concentration values in homogeneous materials specified in the SJ/T11363-2006 Industry Standard. | | | | | | |
| 对销售之目的所售产品, 本表显示, 供应链的电子产品信息可能包含这些物质。 This table shows where these substances may be found in the supply chain of electronic information products, as of the date of sale of the enclosed product. | | | | | | |
| 此标志为针对所涉及产品的环保使用期标志。 某些零部件会有一个不同的环保使用期(例如, 电池单元模块)贴在其产品上。 此环保使用期限只适用于产品是在产品手册中所规定的条件下工作。 The Environment- Friendly Use Period (EFUP) for all enclosed products and their parts are per the symbol shown here. The Environment- Friendly Use Period is valid only when the product is operated under the conditions defined in the product manual. | | | | | | |



Korean

| 사용자안내문 |
|---|
| 이 기기는 업무용 환경에서 사용할 목적으로 적합성평가를 받은 기기로서 가정용 환경에서 사용하는 경우 전파간섭의 우려가 있습니다. |

이 기기는 업무용 환경에서 사용할 목적으로 적합성평가를 받은 기기로서 가정용 환경에서 사용하는 경우 전파간섭의 우려가 있습니다.

Taiwan

警告使用者：

這是甲類的資訊產品，在居住的環境中使用時，可能會造成射頻干擾，在這種情況下，使用者會被要求採取某些適當的對策。

1. 應避免影響附近雷達系統之操作。
2. 高增益指向性天線只得應用於固定式點對點系統
3. 電磁波暴露量 MPE 標準值 1 mW/cm², 送測產品實測值為：0.001mW/cm²

所有技術文件皆必須秀出廠牌 / 型號，而使用手冊必須再補上警語，其警語內容如下：依據低功率電波射性電機管辦法第十二條

經型式認證合格之低功率射頻電機，非經許可，公司，商號或使用者均不得擅自變更頻率、加大功率或變更原設計之特性及功能。

第十四條

低功率射頻電機之使用不得影響飛航安全及干擾合法通信；經發現有干擾現象時，應立即停用，並改善至無干擾時方得繼續使用。

前項合法通信，指依電信法規定作業之無線電通信。低功率射頻電機須忍受合法通信或工業、科學及醫療用電波輻射性電機設備之干擾。

Нормативные требования Евразийского Экономического Союза

Russia



HPE Russia: ООО "Хьюлетт Паккард Энтерпрайз" Российская Федерация, 125171, г. Москва, Ленинградское шоссе, 16А, стр.3, Телефон: +7 499 403 4248 Факс: +7 499 403 4677

'HPE Belarus': ИООО «Хьюлетт-Паккард Бел», Республика Беларусь, 220030, г. Минск, ул. Интернациональная, 36-1, Телефон/факс: +375 17 392 28 20

'HPE Kazakhstan': ТОО «Хьюлетт-Паккард (К)», Республика Казахстан, 050040, г. Алматы, Бостандыкский район, проспект Аль-Фараби, 77/7, Телефон/факс: + 7 727 355 35 50

Kazakhstan

ЖШС "Хьюлетт Паккард Энтерпрайз" Ресей Федерациясы, 125171, Мәскеу, Ленинград тас жолы, 16А блок 3, Телефон: +7 499 403 4248 Факс: +7 499 403 4677

«HEWLETT-PACKARD Bel» ЖШС, Беларусь Республикасы, 220030, Минск қ., Интернациональная көшесі, 36/1, Телефон/факс: +375 17 392 28 20

ЖШС «Хьюлетт-Паккард (К)», Қазақстан Республикасы, 050040, Алматы қ., Бостандық ауданы, Әл-Фараби даңғылы, 77/7, Телефон/факс: +7 (727) 355 35 50

Mexico

La operación de este equipo está sujeta a las siguientes dos condiciones: (1) es posible que este equipo o dispositivo no cause interferencia perjudicial y (2) este equipo o dispositivo debe aceptar cualquier interferencia, incluyendo la que pueda causar su operación no deseada.