

---

INSTRUCTION MANUAL  
Fast-Fold Deluxe  
Screen Frames  
with Standard or HD Legs

---

**DA-LITE**<sup>®</sup>

# Set-up

1. Remove screen surface from case, and set aside.
2. Fast-Fold® Deluxe frames are made of 1 1/4" square hard aluminum tubing with an anodized finish. With proper care, will provide many years of use. Remove the frame from case and wrapping. Position as shown (front view).



# Set-up

3. Unfold the frame so that it is lying flat on the floor. Ensure wheels are positioned down, facing the floor.

4. While holding the bottom of the frame in place, extend the top of the frame to unfold the sides. Snap-latches will automatically lock.

5. Lock down all four corner braces.

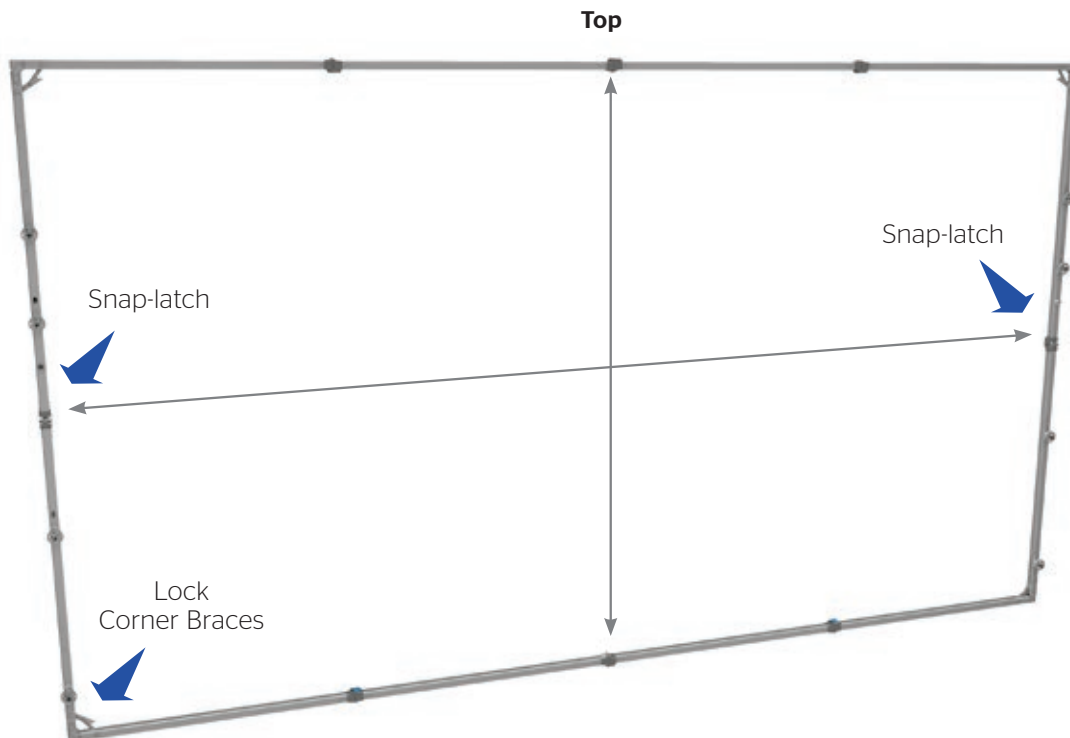

# Set-up

6. Remove legs from the case. Unfold, ensuring keyways are facing up. Start at wheel closest to bottom of frame, and align stud/wheel with corresponding keyway. Attach furthestmost wheel from bottom of frame (that falls within height of leg) and align stud/wheel with keyway. Move to the center of frame and with a firm grip, slide the leg down toward the feet of leg to lock studs into the keyways. Ensure the wheel is completely seated into the keyway safety channel. Turn wheels clockwise until secure.

7. Match top of screen surface (labeled TOP) with top of frame.

8. Snap all four corners.

9. Starting at the bottom section, snap the center button. Continue snapping the remaining buttons.

10. Snap the top and sides in the same manner.

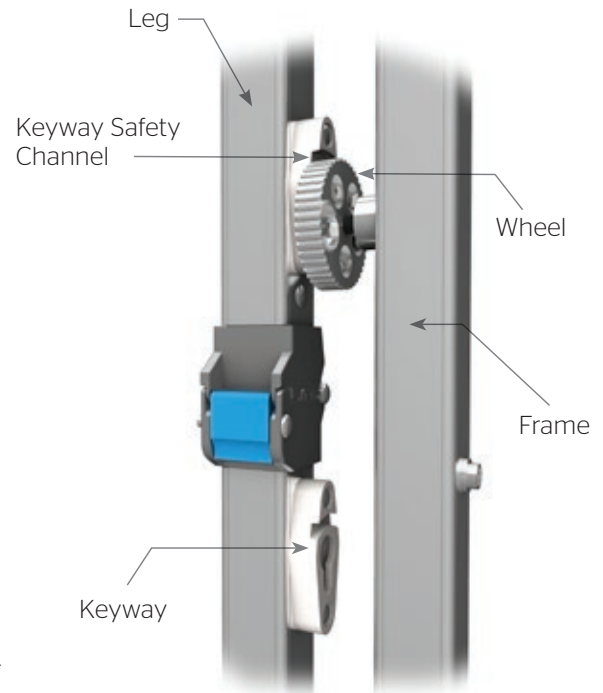

# 11.

## Standard T-Legs

- A. Open and latch front foot braces.
- B. Walk frame until upright.
- C. Open and latch back foot braces. Tighten leg brace knobs to secure.



**HD Legs** (Accessory, recommended for screens 10' wide and greater or those screens where drapery kits are used)

- A. Open and latch front foot braces.
- B. Walk frame until upright.
- C. Open back foot braces. DO NOT latch braces at this time.
- D. Raise A-braces to engage wheel on A-braces into keyway on legs.  
Slide A-braces down until fully seated into keyways.  
Turn wheels counter clockwise until secure.
- E. Latch back foot braces.

# 12.

Fast-Fold Deluxe screen height is adjustable in 6" increments either up or down. Normal screen height is 44" from bottom of frame to floor and is the standard height for use with presentation drapery accessories.

**NOTE:** Do not extend frame so that more than half of the frame height is above the top of the legs.

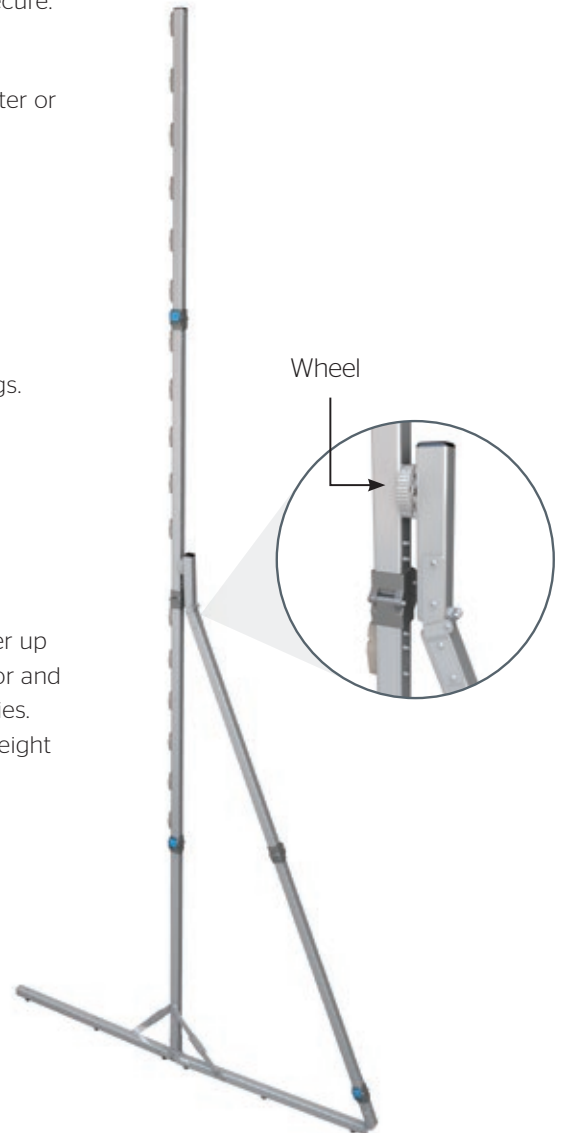

# Tear-down

1. For tear-down, follow set-up procedures in reverse order.
2. To fold frame, unlock all four corner braces.  
Push the blue snap-latch buttons and fold the frame.

**NOTE:** For some frames, fold the top and bottom first.

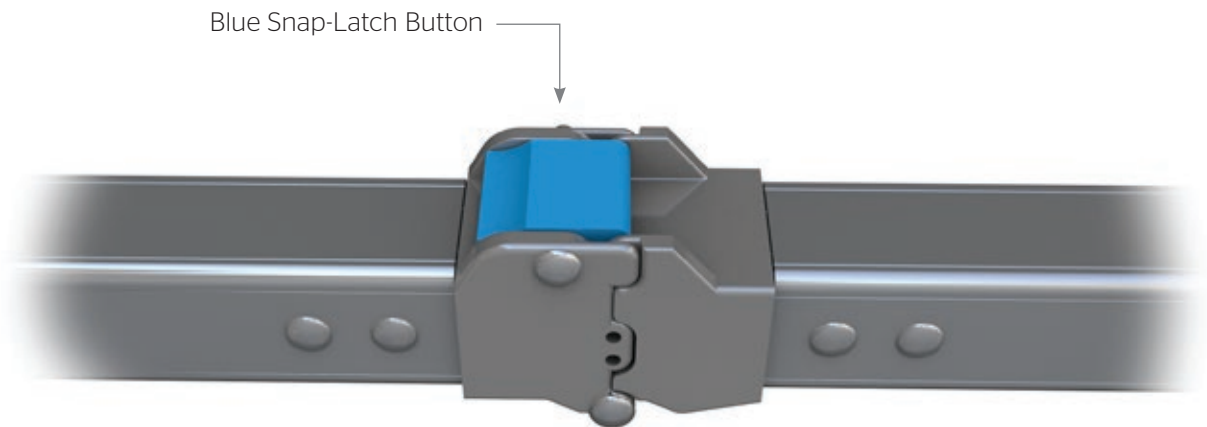

---

# Folding the Screen Surface for Packing

**When folding the screen material for packing, observe the following precautions before proceeding:**

- The surface should not be allowed to contact painted, varnished or plastic finished objects for a prolonged period of time.
- Make certain the viewing surface is on a clean, flat surface.

**NOTE:** Keep the screen surface in the envelope provided when it is not in use. Failure to observe these normal precautions may cause discoloration of the surface.

---

## Then proceed in the following manner:

Place clean white tissue paper - with no printing - on top of the viewing surface. If tissue is not available, a soft **white** cloth or something similar will serve the same purpose. Under no circumstances should newspaper or anything similar be used since these may damage the screen material.

1. With the viewing side facing up, fold the surface in half from top to bottom. Make certain when folding, the surface does not come in contact with either the black binding, grommets or snap buttons.
2. If the material on the first fold is more than 3 feet high, then fold once again, but always place clean tissue paper between the folds.
3. For large size screens, fold in half again if necessary. Make certain when folding, the surface does not come in contact with either the black binding, grommets or snap buttons.
4. After the top to bottom folding procedure is completed, then fold from left to right and continue folding until the fabric is of sufficient size to fit into the leatherette case.

## Cleaning

**Da-Tex®**, **Dual Vision** and **HD Rental** surfaces can be cleaned as follows: Using a white clean cloth (100% cotton preferred) that is dampened with clear water, gently wipe the area in one direction. Do not use a circular motion. Using a dry 100% cotton cloth, wipe dry after each cleaning session. To clean a stubborn stain or a sticky surface, use denatured alcohol (methanol or methyl alcohol) following the same procedure as for water. For extremely stubborn stains, use VM&P Naphtha or Super Naphtha and follow the same procedure as for water.

**NOTE:** Fast-Fold® screens are shipped with tissue paper packed between the folds. This keeps the material from sticking to itself and makes it easier to unfold.

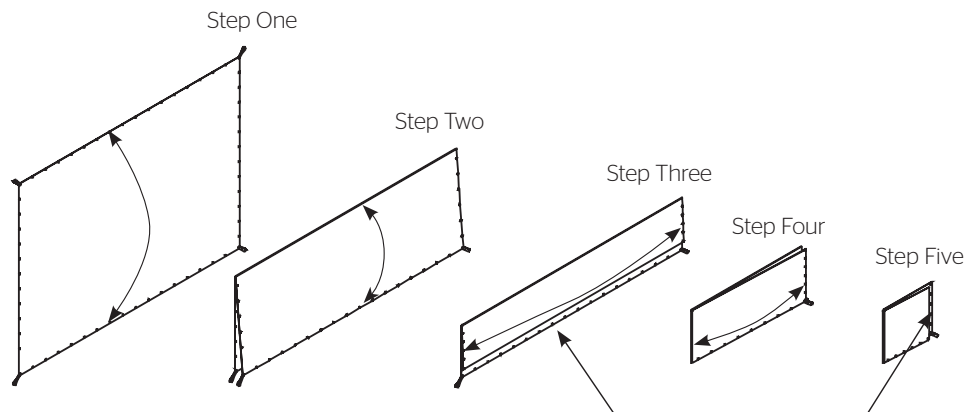

**Do not fold fabric onto black binding, grommets or snap buttons**

# Conditions for Transportation and Storage

- Temperature: Between 40 - 100°F (5 - 40°C)
- Relative humidity: 30% to 70%, non-condensing
- Always keep the projection screen horizontal during transport and storage
- Make sure the entire package is supported when stored
- Do not stack more than six projection screens on top of each other
- Make sure the heaviest package is placed at the bottom of the stack

**Screen surface should be allowed to air out once every two months, or otherwise used on a regular basis, if the temperature is above 72°F (22°C) and at least once every month if the temperature goes above 85°F (30°C).**

## LIMITED FIVE YEAR WARRANTY ON DA-LITE PRESENTATION PRODUCTS

Legrand AV Inc. warrants certain Da-Lite branded products to the original purchaser only, to be free from defects in materials and workmanship for a period of five (5) years from the date of purchase by the original purchaser; provided they are properly operated according to Da-Lite's instructions and are not damaged due to improper handling or treatment after shipment from the factory.

This warranty does not apply to equipment showing evidence of misuse, abuse or accidental damage, or which has been tampered with or repaired by a person other than authorized Da-Lite personnel.

Da-Lite's sole obligation under this warranty shall be to repair or to replace (at Da-Lite's option) the defective part of the merchandise. Returns for service should be made to your Da-Lite dealer. If it is necessary for the dealer to return the screen or part to Da-Lite, transportation expenses to and from Da-Lite are payable by the purchaser and Da-Lite is not responsible for damage in shipment. To protect yourself against damage or loss in transit, insure the product and prepay all transportation expenses.

**TO THE MAXIMUM EXTENT PERMITTED BY APPLICABLE LAW, THIS WARRANTY IS IN LIEU OF ALL OTHER WARRANTIES, EXPRESS OR IMPLIED, INCLUDING WARRANTIES AS TO FITNESS FOR USE AND MERCHANTABILITY.** Any implied warranties of fitness for use, or merchantability, that may be mandated by statute or rule of law are limited to the five (5) year warranty period. This warranty gives you specific legal rights, and you may also have other rights, which vary from state-to-state. **TO THE MAXIMUM EXTENT PERMITTED BY APPLICABLE LAW, NO LIABILITY IS ASSUMED FOR EXPENSES OR DAMAGES RESULTING FROM INTERRUPTION IN OPERATION OF EQUIPMENT, OR FOR INCIDENTAL, DIRECT, OR CONSEQUENTIAL DAMAGES OF ANY NATURE.**

In the event that there is a defect in materials or workmanship of a Da-Lite product, you may contact Customer Care at 3100 North Detroit Street, Warsaw, IN 46582, (866) 977-3901.

**IMPORTANT: THIS WARRANTY SHALL NOT BE VALID AND DA-LITE BRANDED PRODUCTS SHALL NOT BE BOUND BY THIS WARRANTY IF THE PRODUCT IS NOT OPERATED IN ACCORDANCE WITH THE DA-LITE WRITTEN INSTRUCTIONS.**

Keep your sales receipt to prove the date of purchase and your original ownership.



FOR YOUR IMAGE | [legrandav.com](http://legrandav.com)

**USA** P 866.977.3901 E [av.da-lite.support@legrand.com](mailto:av.da-lite.support@legrand.com)  
**CANADA** P 877.345.4329 E [av.da-lite.support@legrand.com](mailto:av.da-lite.support@legrand.com)  
**EMEA** P +31 495 580 840 E [av.emea.sales@legrand.com](mailto:av.emea.sales@legrand.com)  
**APAC** P +852 2145 4099 E [av.asia.sales@legrand.com](mailto:av.asia.sales@legrand.com)

© 2019 Legrand AV Inc. DL-0284 (Rev.2) 9/19 Da-Lite is a registered trademark of Legrand AV Inc. All other brand names or marks are used for identification purposes and are trademarks of their respective owners. All patents are protected under existing designations. Other patents pending.



**COMMERCIAL BRANDS**

Chief | Da-Lite | Middle Atlantic | Projecta | Vaddio