

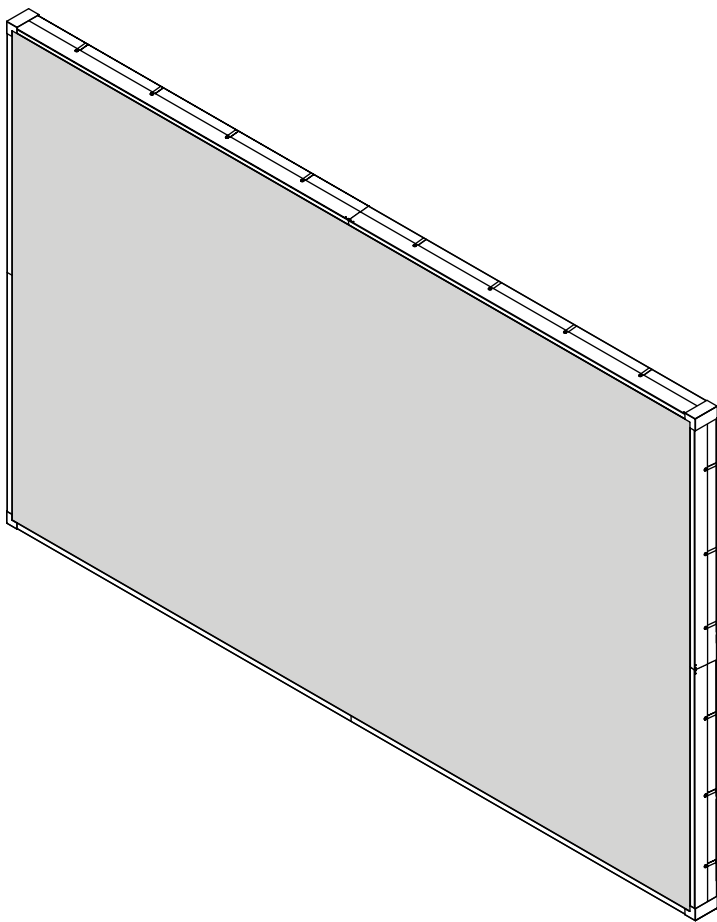

DS-LEDTK Series

*Actual configuration may vary



⚠ WARNING

ENG - This product is designed to be installed on plywood walls. Hardware is included for plywood installation. This product is designed to be installed on flat, unobstructed, vertical walls. Do not install on curved or angled walls. Before installing make sure the supporting surface will support the combined load of the equipment and hardware. Screws must be tightly secured. Do not overtighten screws or damage can occur and product may fail. Never exceed the Maximum Load Capacity. Always use an assistant or mechanical lifting equipment to safely lift and position equipment. This product is intended for indoor use only. Use of this product outdoors could lead to product failure or personal injury. Be careful not to pinch fingers when operating the mount. For support please call customer care at 1-800-865-2112.

ENG Symbols



ENG WARNING



ENG Skip to step.

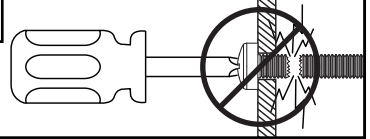

ENG Do not overtighten screws.

ENG Tools Needed for Assembly.

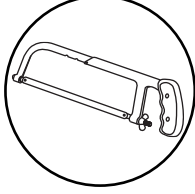
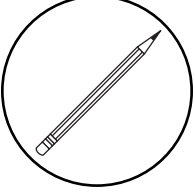
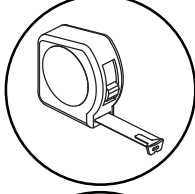
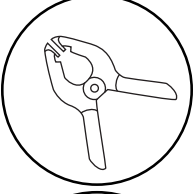
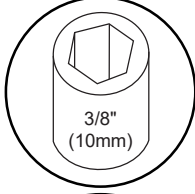
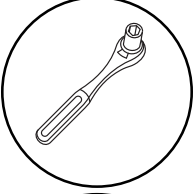
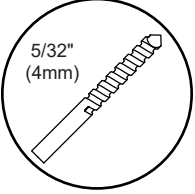
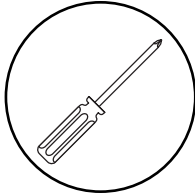
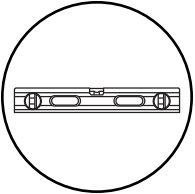

ENG To properly tighten screws: Tighten until screw head makes contact, then tighten another 1/2 turn. Do not overtighten screws.

1

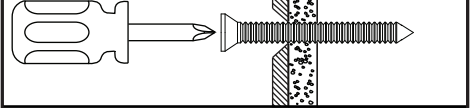

2

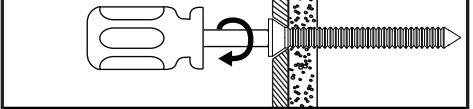

3

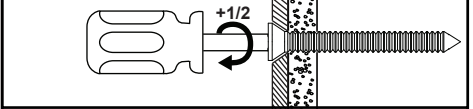

4



ENG Parts (Before beginning, make sure you have all parts shown below).

Parts List	
Description	Part #
A solid cover	-
B perforated cover	-
C right solid wall bracket	-
D perforated wall bracket	-
E corner cover	10016409-BLKM2
F nut bar	147-T1881
G 1/4-20 x 0.375" socket screw	10007616
H solid wall bracket spacer	147-T1880
I left solid wall bracket	-
J 4mm allen wrench	560-9646
K wall plate shim	147-1891
L 1/4-20 x 25mm screw	521-0710
M #14-10 x 1.75" wood screw	521-1688
N M3 x 8mm phillips	521-0711
O 1/4-20 hex nut	10010403
P vinyl sticker	580-0535

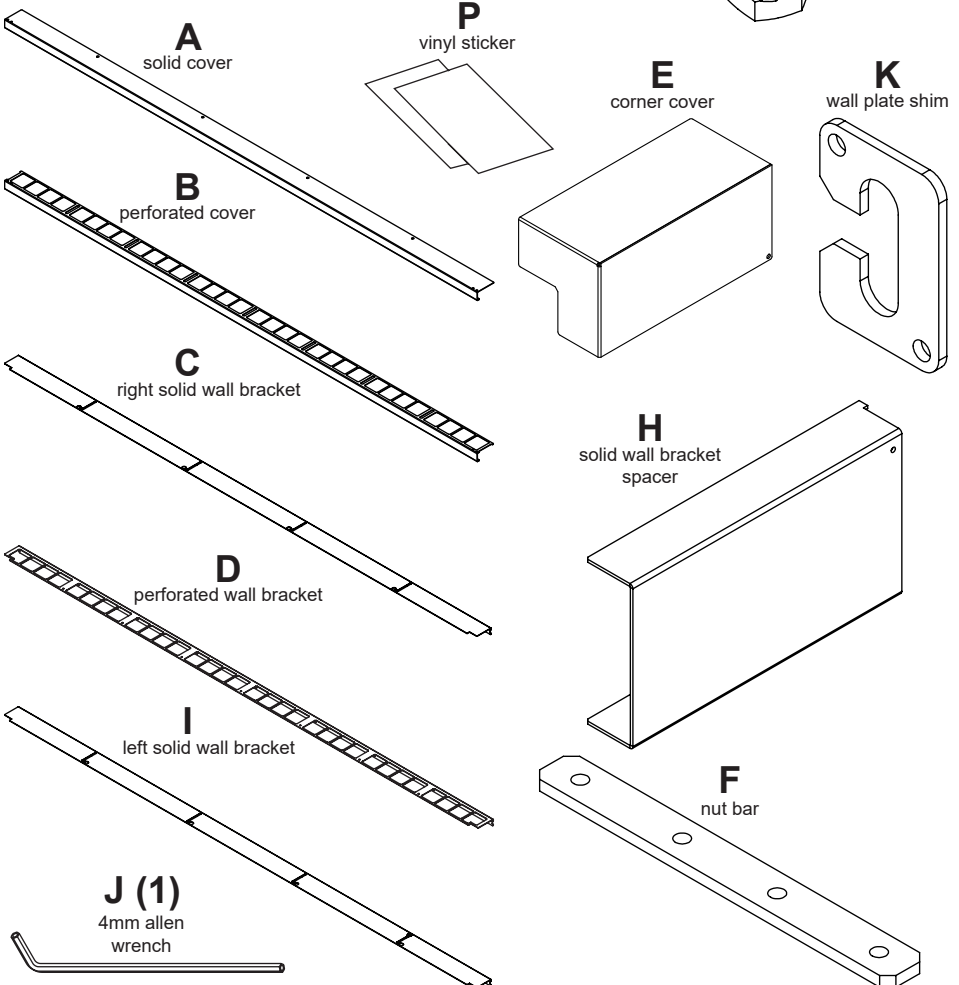
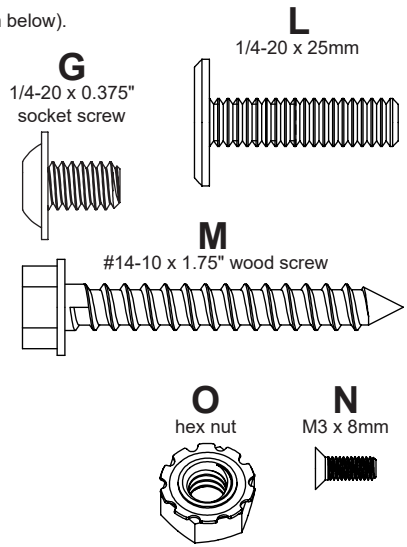

1

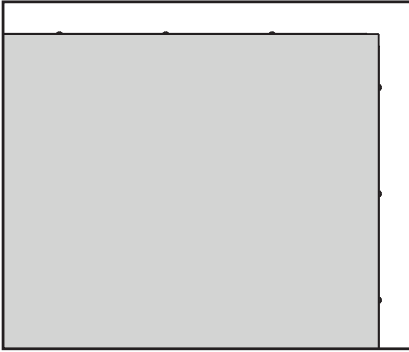

ENG Standard steps for solid or perforated trim kits.

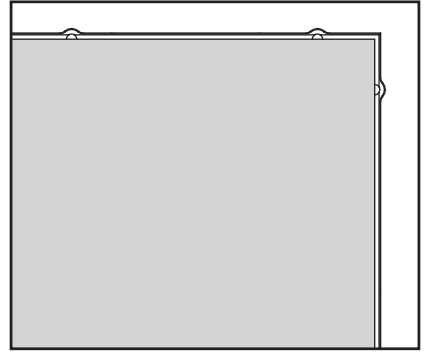

ENG Steps for Unilumin UpanelS sides with bump-outs.



1a-1

ENG Measure video wall dimensions.

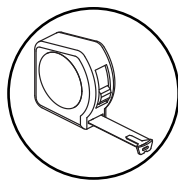
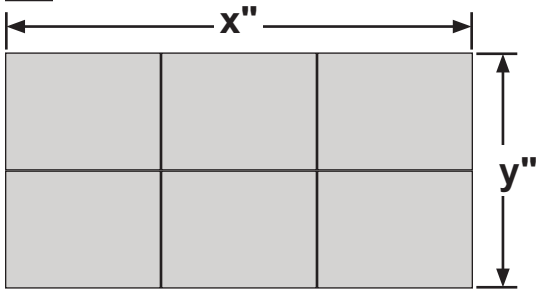

1a-2

ENG Mark cutting line on covers and wall brackets.

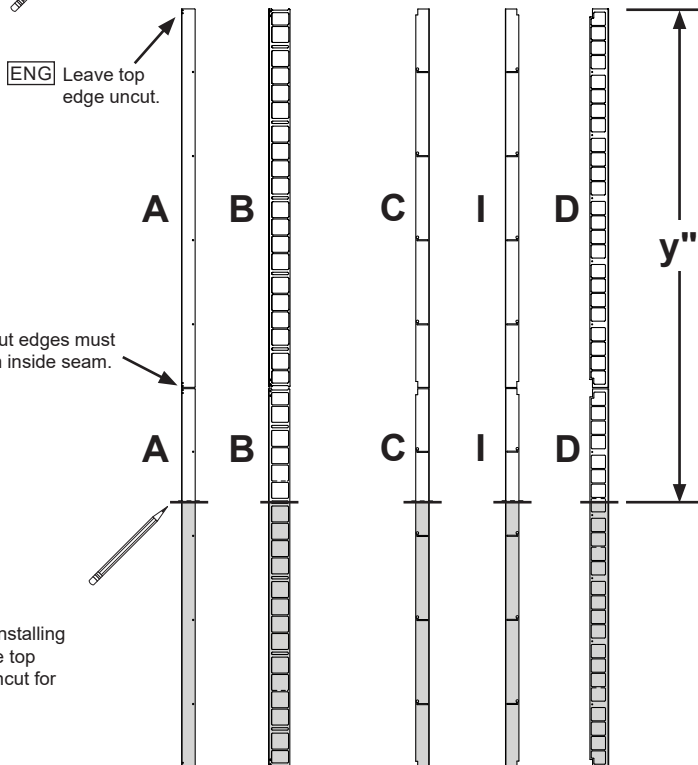
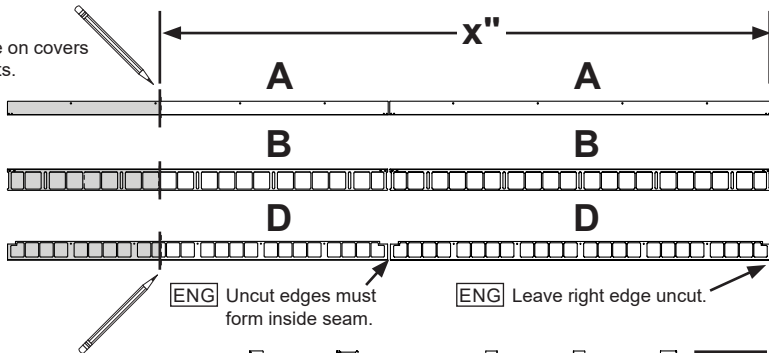
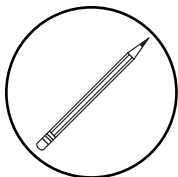

1a-3

ENG Do not join covers until installing covers to the wall. Leave top and right cover edges uncut for proper alignment.

2a-1

ENG Optional: Clamp cutting guide to side of wall bracket or cover being discarded.

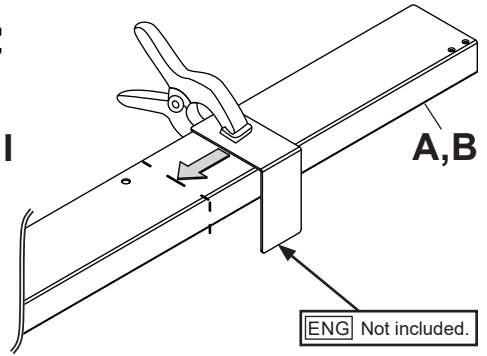
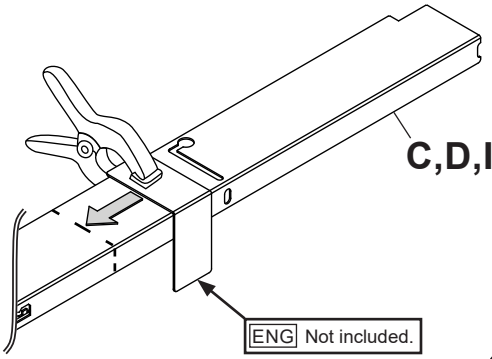
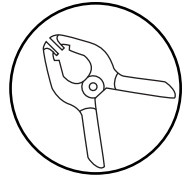

2a-2

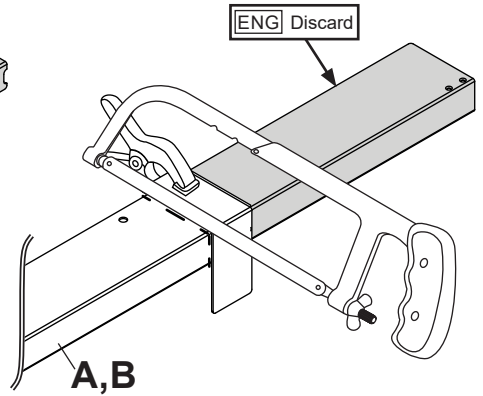
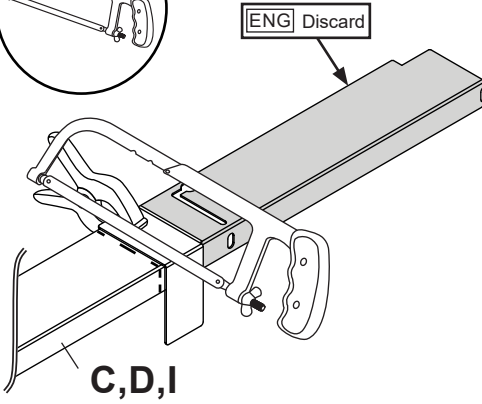
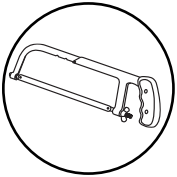

3a

⚠ WARNING

ENG - When installing Peerless wall mounts on a wood stud wall covered with plywood, verify that the wood studs are a minimum of 2" x 4" nominal size and plywood is a minimum Grade BC, 1/2" (13mm) thick. Plywood may be covered by gypsum board (drywall) up to 5/8" thick.

3a-1

ENG Align wall bracket with edge of video wall. Use spacer to set final position. Mark mounting holes.

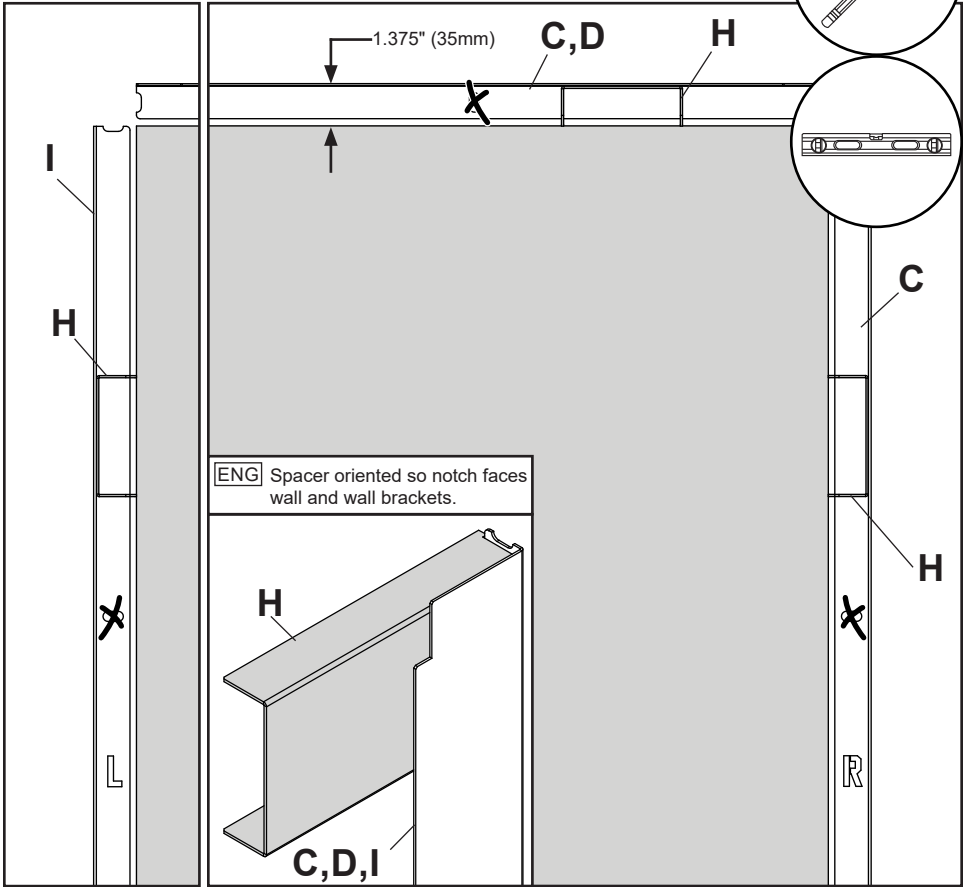

3a-2

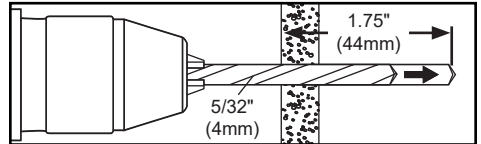

ENG Drill mounting holes into supporting surface (1.75" (44mm) minimum depth required).

3a-3

ENG Install using wood screws provided. Use spacer to set final position of wall bracket.

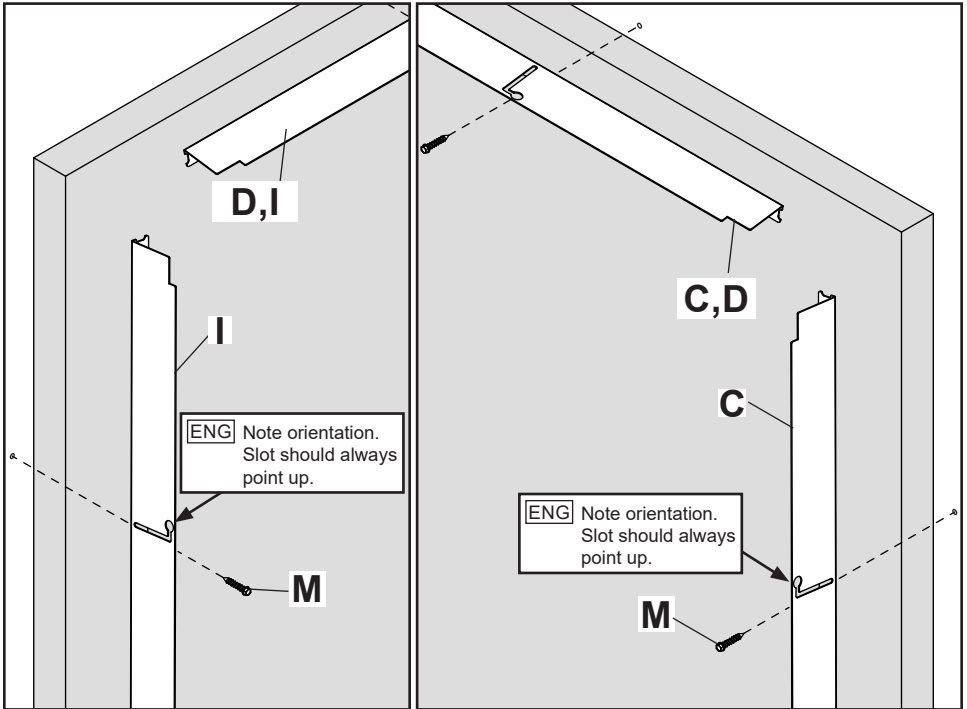

ENG Spacer oriented so notch faces wall and wall brackets.

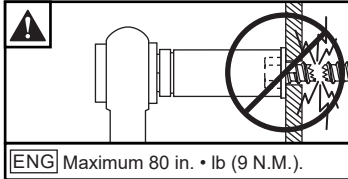
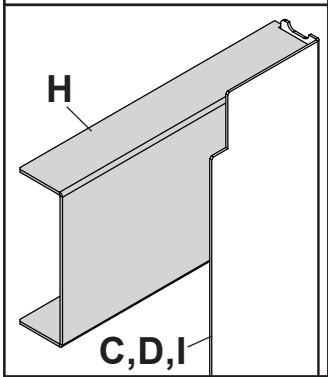

ENG Optional shim for leveling.

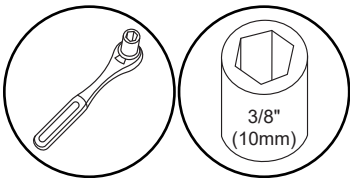
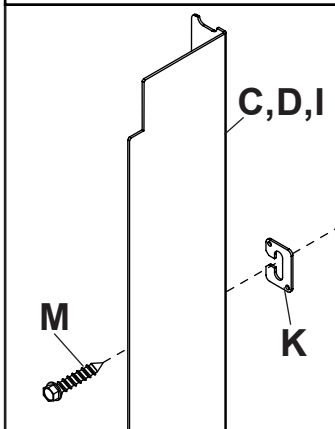

Alternate steps for Unilumin Upanels sides with bump-outs

1b-1

ENG To begin installing solid trim on Unilumin Upanels edges with bump-outs, create guiding line for the top and right side of the unit using spacer provided.

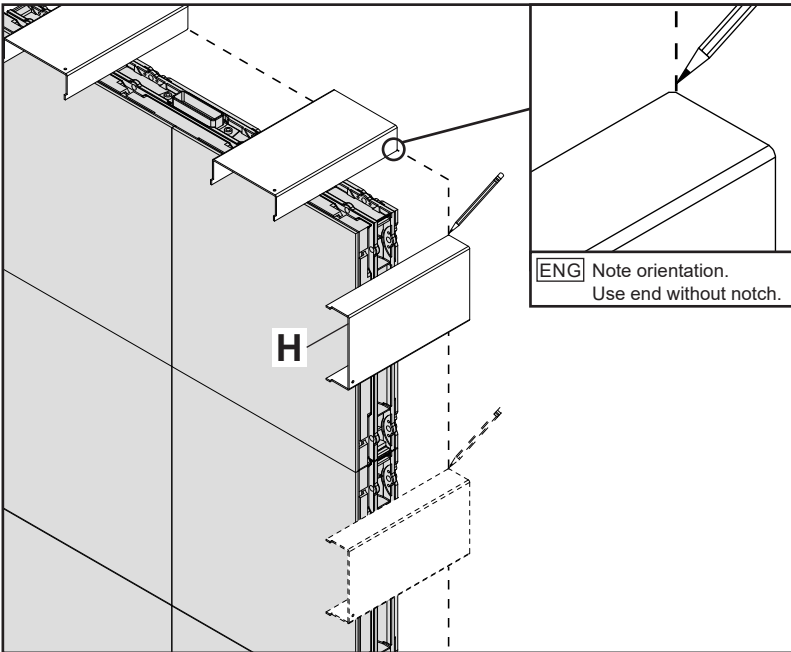
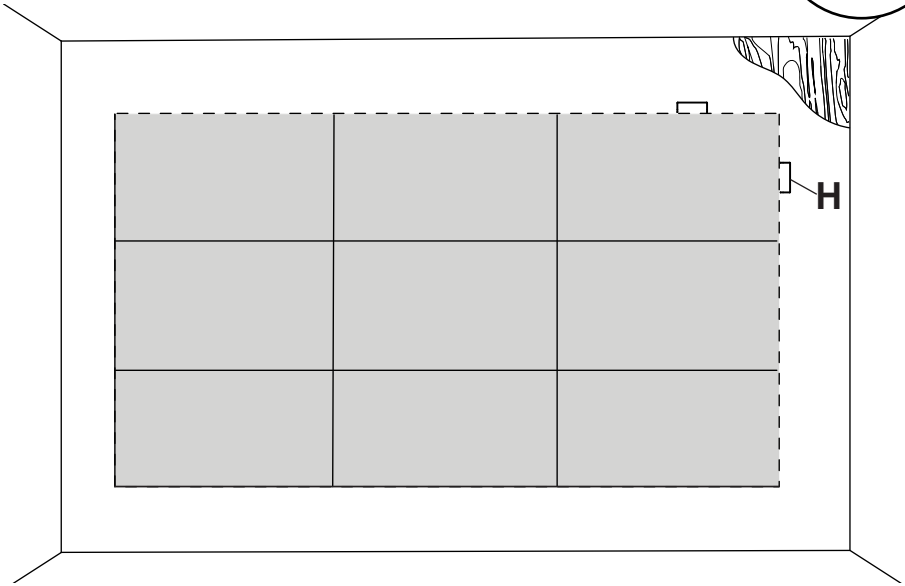
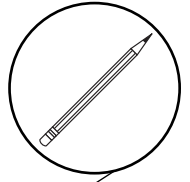

1b-2

ENG Measure video wall dimensions.

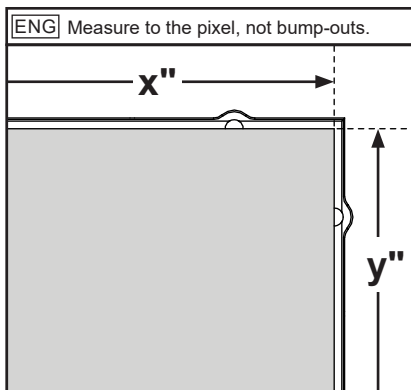
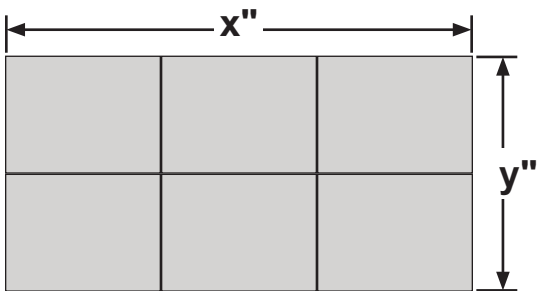

1b-3

ENG Mark cutting line on covers and wall brackets.

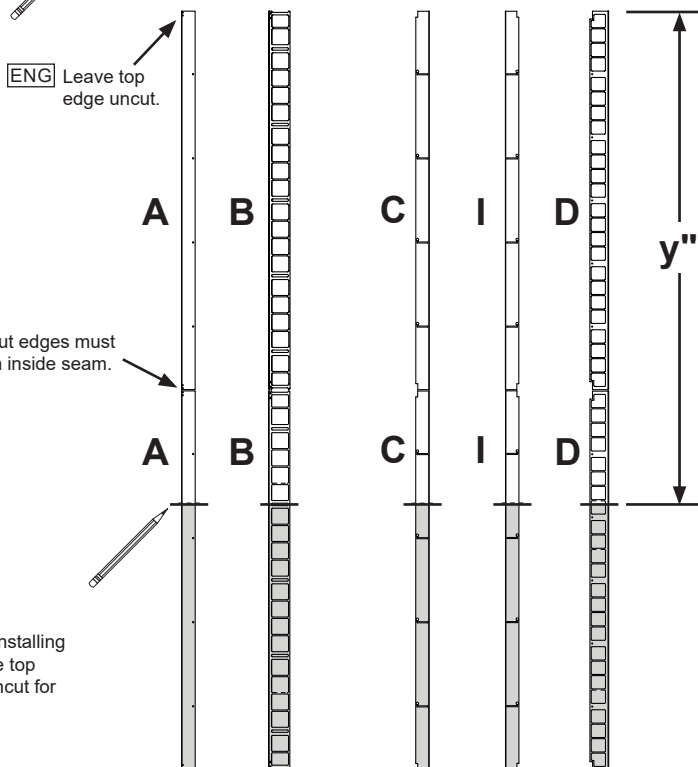
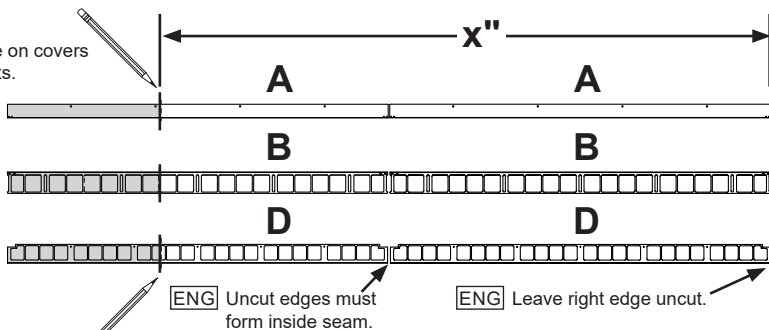
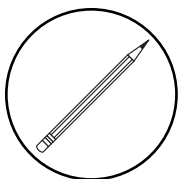

1b-4

ENG Do not join covers until installing covers to the wall. Leave top and right cover edges uncut for proper alignment.

2b-1

ENG Optional: Clamp cutting guide to side of wall bracket or cover being discarded.

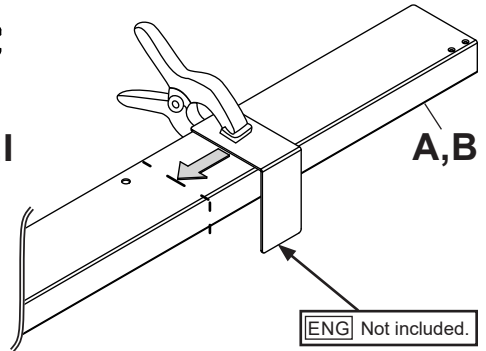
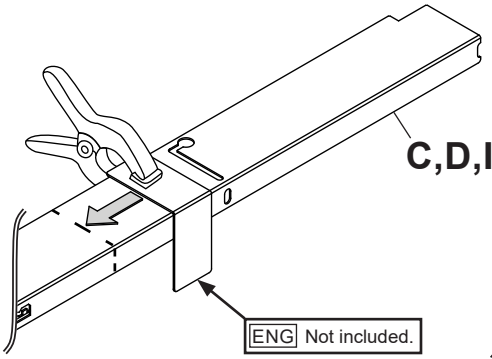

2b-2

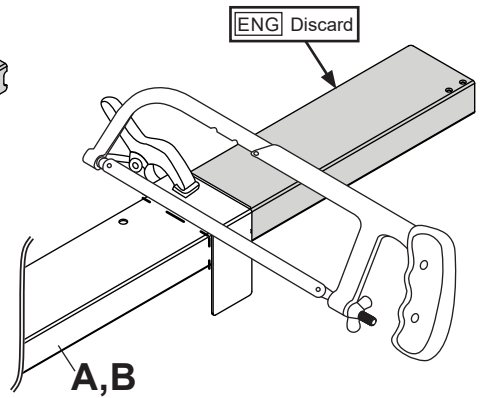
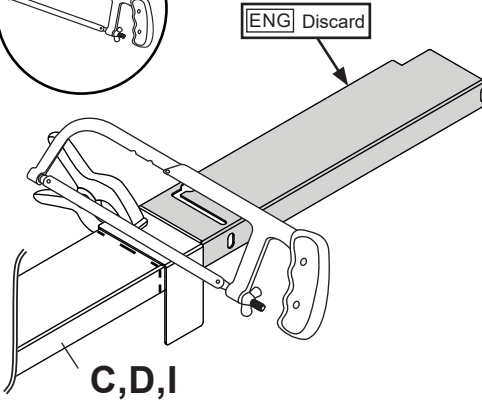
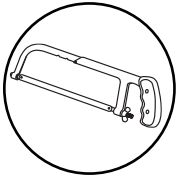

3b

▲ WARNING

ENG - When installing Peerless wall mounts on a wood stud wall covered with plywood, verify that the wood studs are a minimum of 2" x 4" nominal size and plywood is a minimum Grade BC, 1/2" (13mm) thick. Plywood may be covered by gypsum board (drywall) up to 5/8" thick.

3b-1

ENG Align top and right wall brackets with display guiding lines. Mark mounting holes. For left and bottom wall brackets, align wall bracket with edge of video wall. Use spacer to set final position. Mark mounting holes.

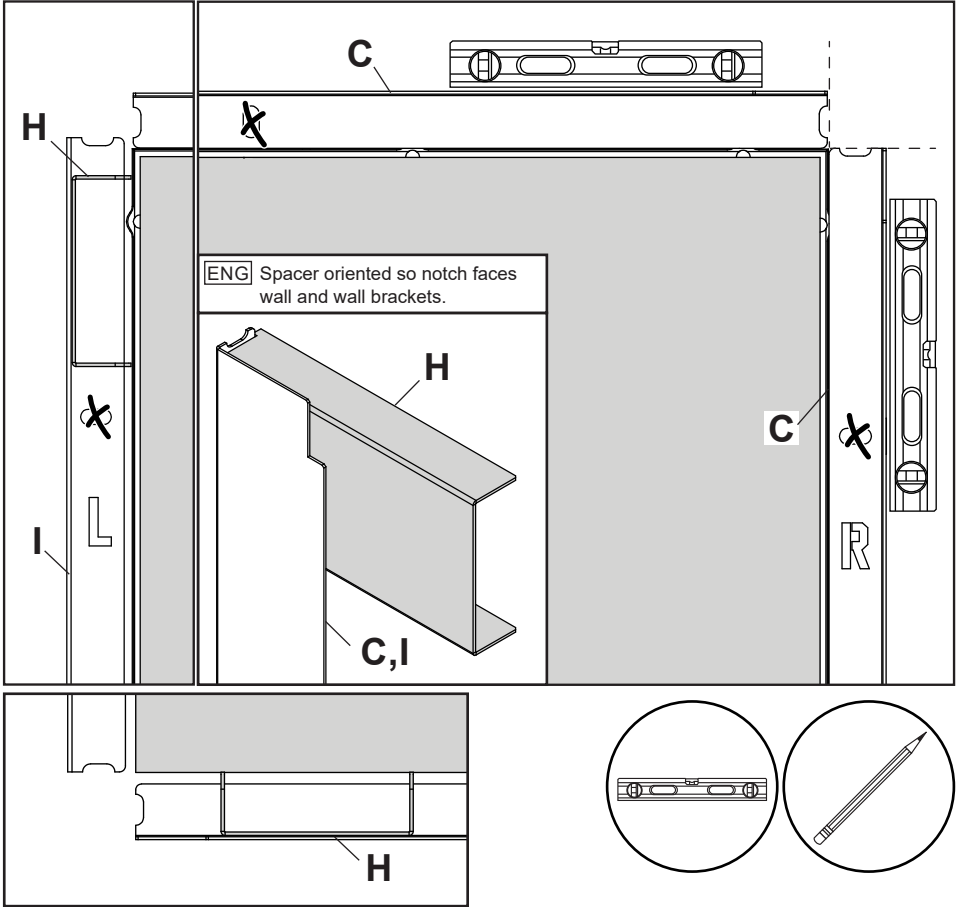

3b-2

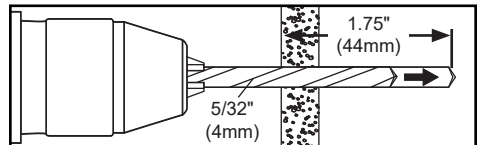
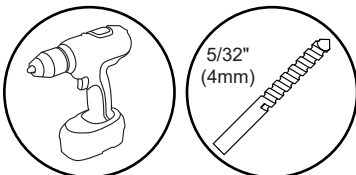

ENG Drill mounting holes into supporting surface (1.75" (44mm) minimum depth required).

3b-3

ENG Install using wood screws provided. Do not fully tighten.

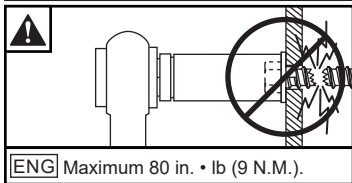
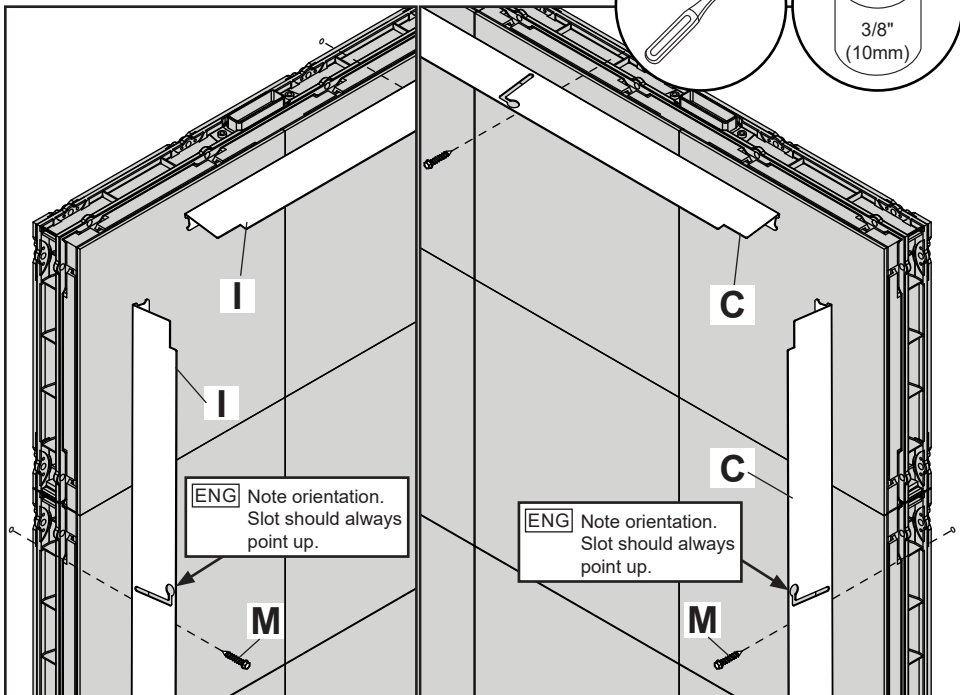
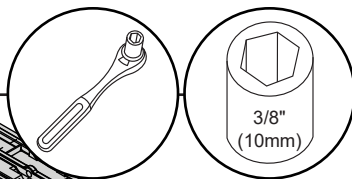

ENG Maximum 80 in. • lb (9 N.M.).

ENG Slide wall brackets in slot until they sit 1.25" from display guiding lines. Level and tighten wood screws. Repeat for left side.

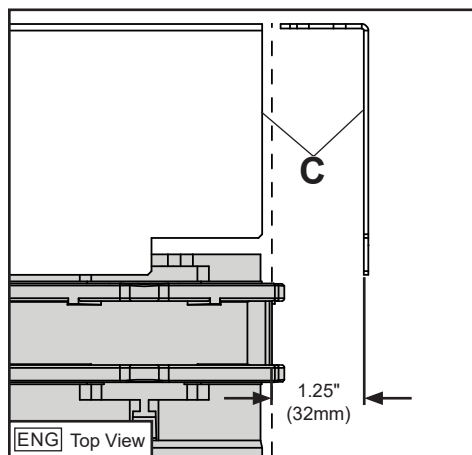
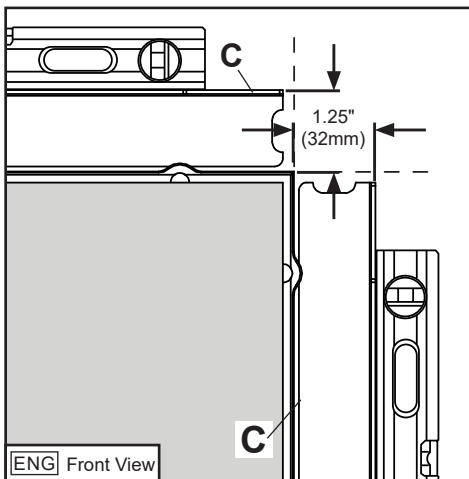

4

ENG Follow steps for solid or perforated trim kits.

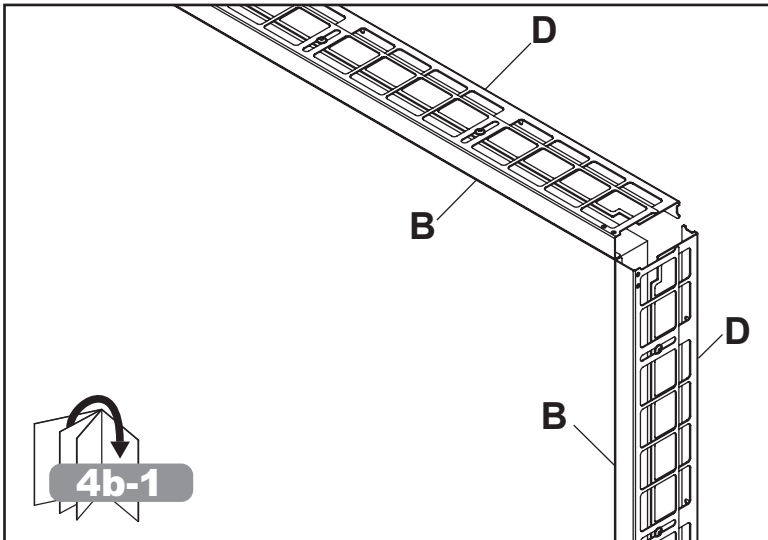
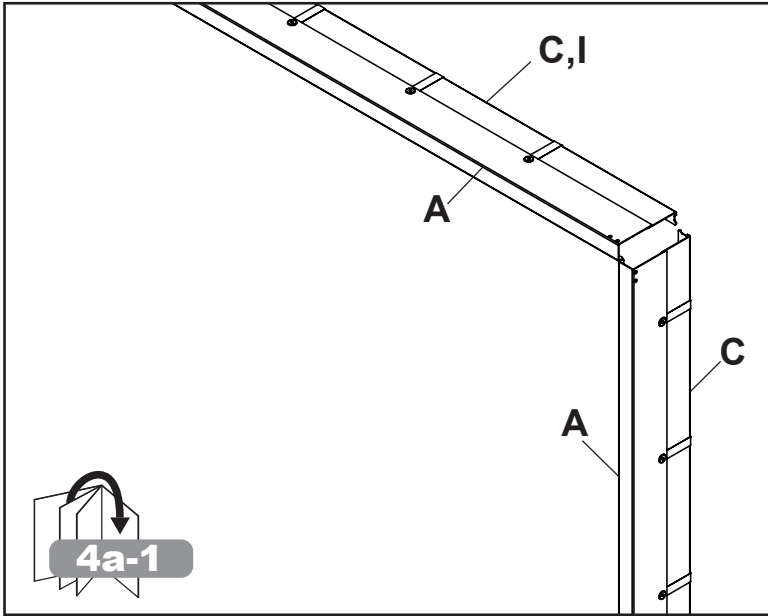

4a-1

ENG Do not tighten hardware to solid cover.

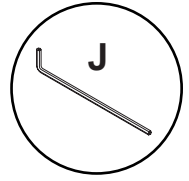
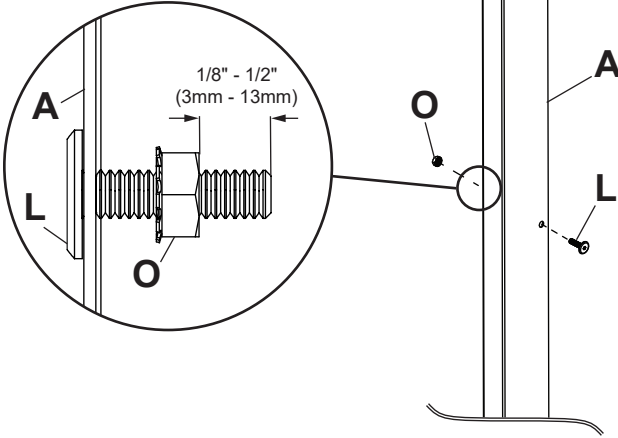

4a-2

ENG Place wall plate cover over wall bracket. Slide back until flush with front of video wall.

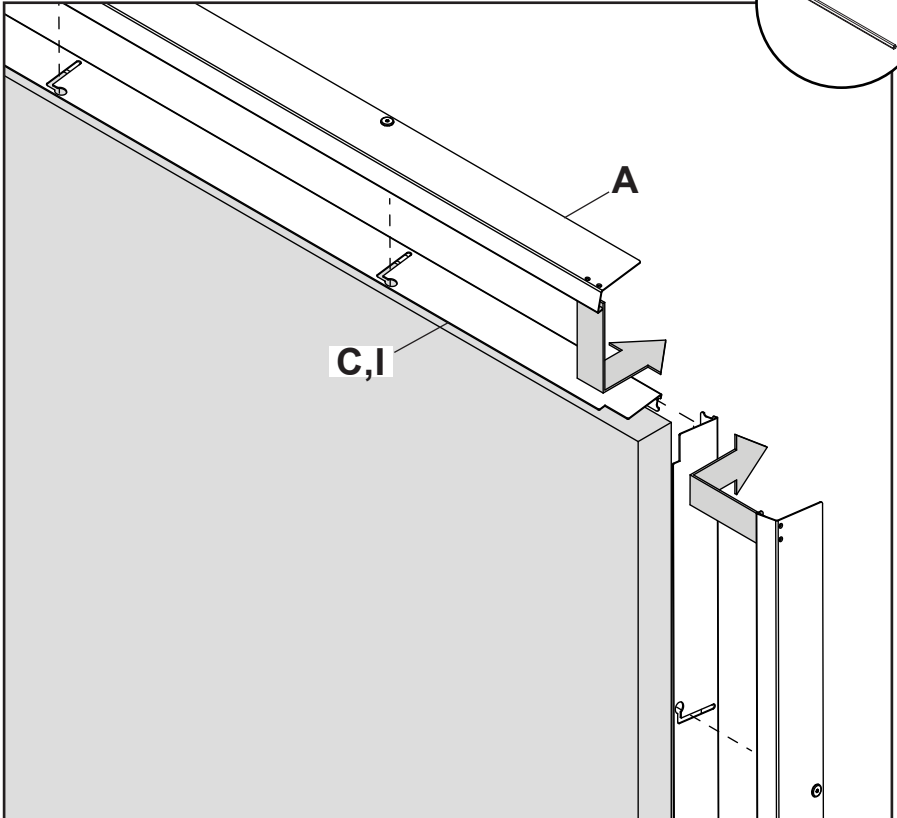
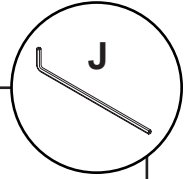

4a-3

ENG Attach covers with nut bar inside cover. Displays not shown for clarity.

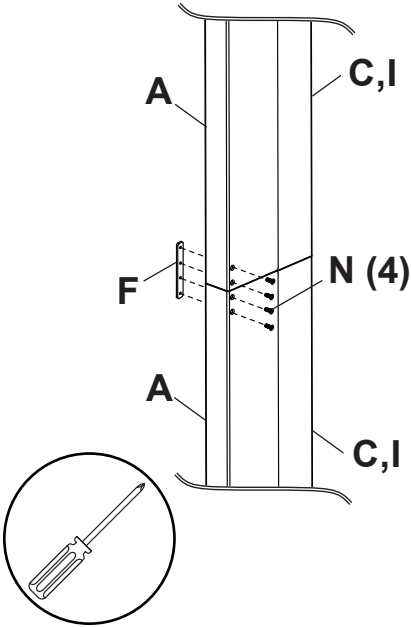

4a-4

ENG Slide cover back flush with video wall. Tighten screws.

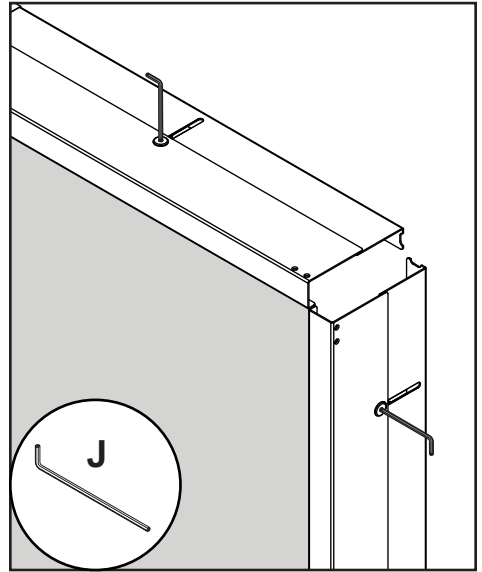

4a-5

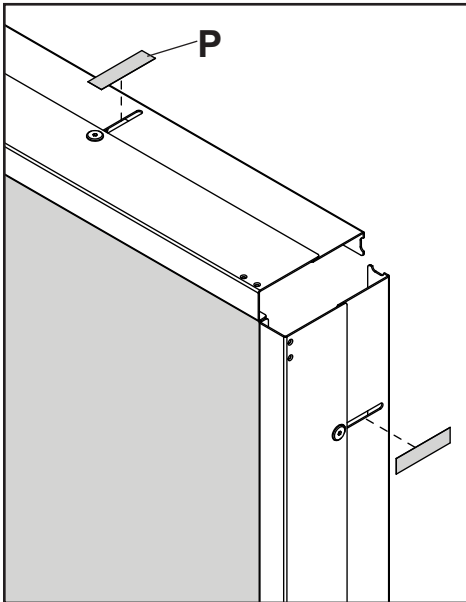

4b-1

ENG Place cover over wall bracket. Slide back until flush with front of video wall.

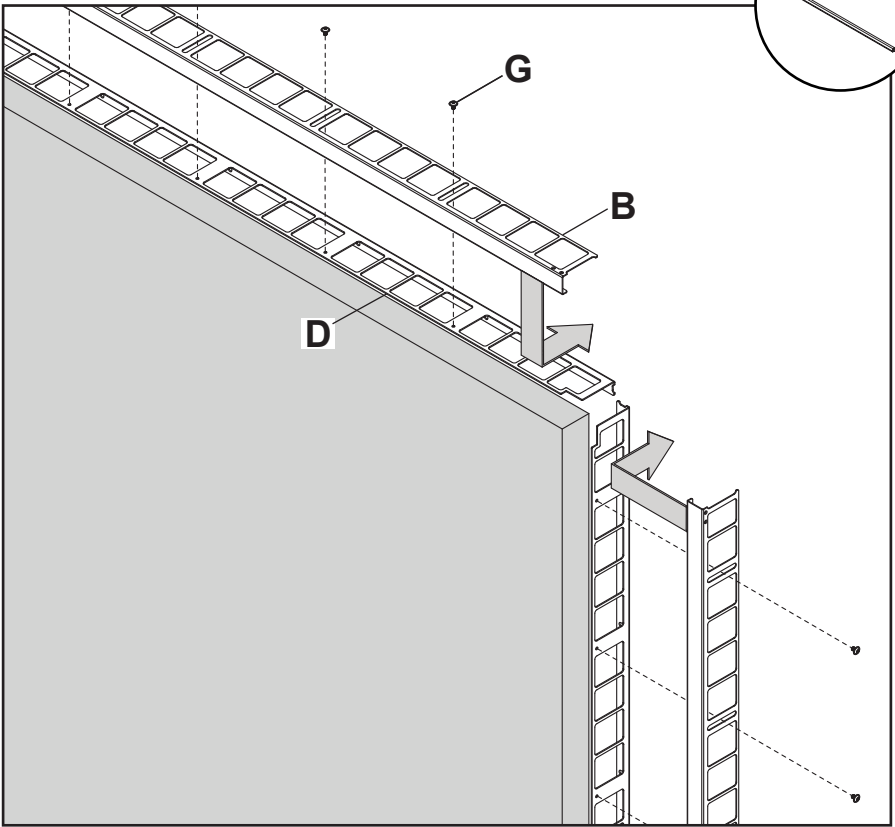

4b-2

ENG Attach covers with nut bar inside cover.
Displays not shown for clarity.

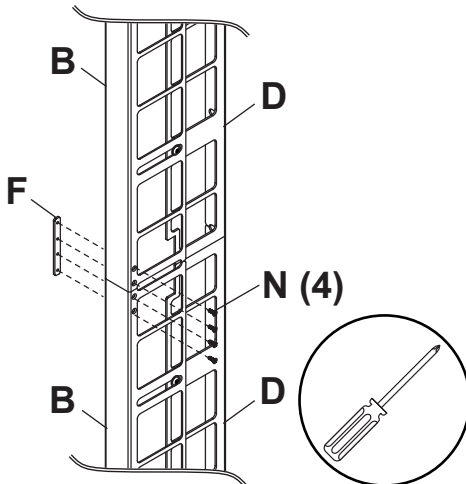

4b-3

ENG Tighten screws.

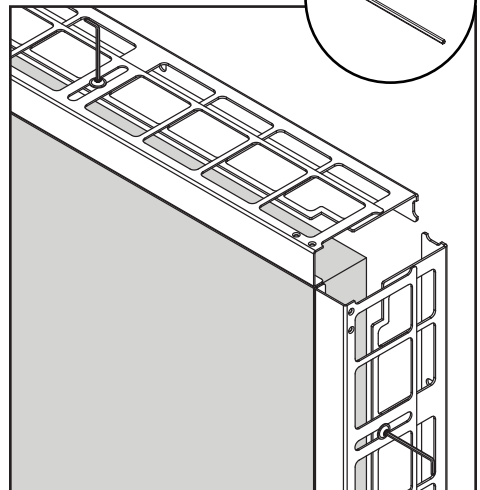

4b-4

ENG Place corner cover against wall and mark cutting line.

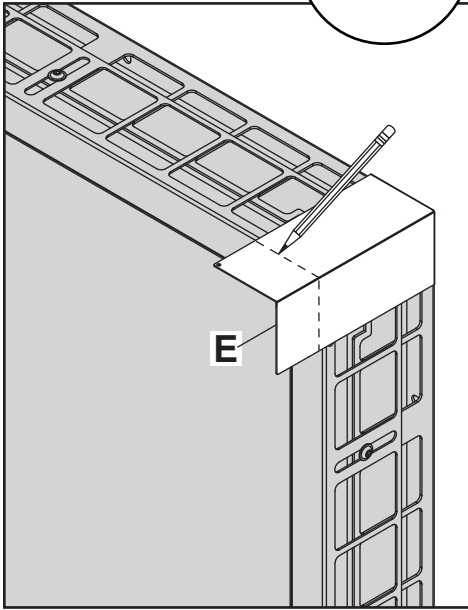
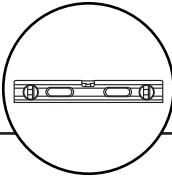

4b-5

ENG Optional: Slide corner cutting guide into place and clamp onto side of cover being discarded.

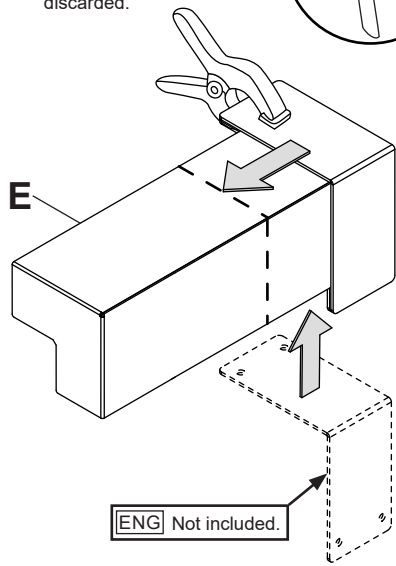
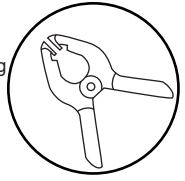

4b-6

ENG Cut excess corner cover off.

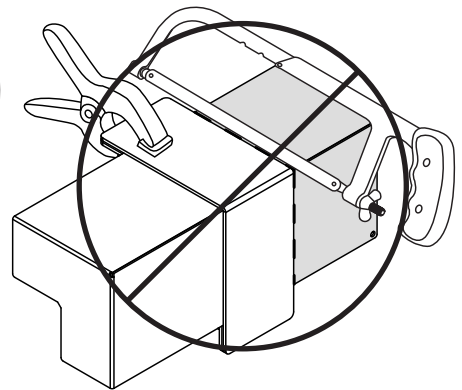
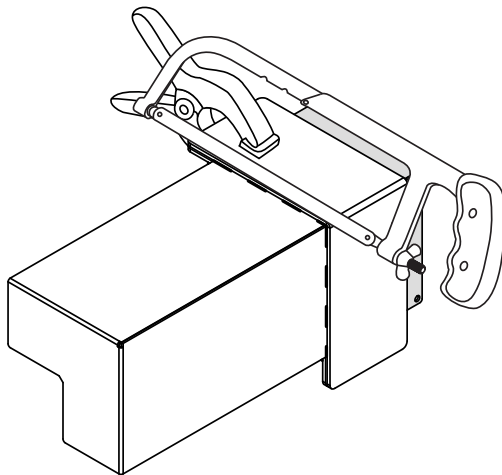
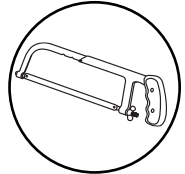

ENG Do not clamp fixture on wrong side of cutting line.

4b-7

ENG File sharp edges of corner cover.
Remove adhesive backing.

x4

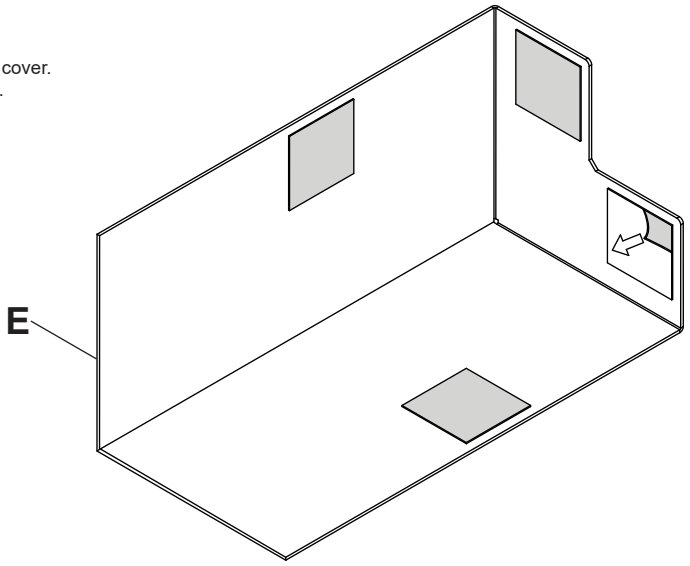

4b-8

ENG Clean surfaces before applying VHB.

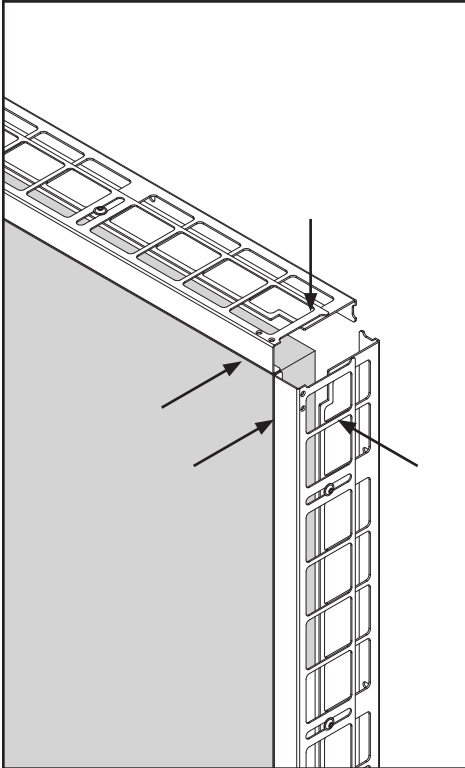

4b-9

ENG Attach four corner covers with VHB.

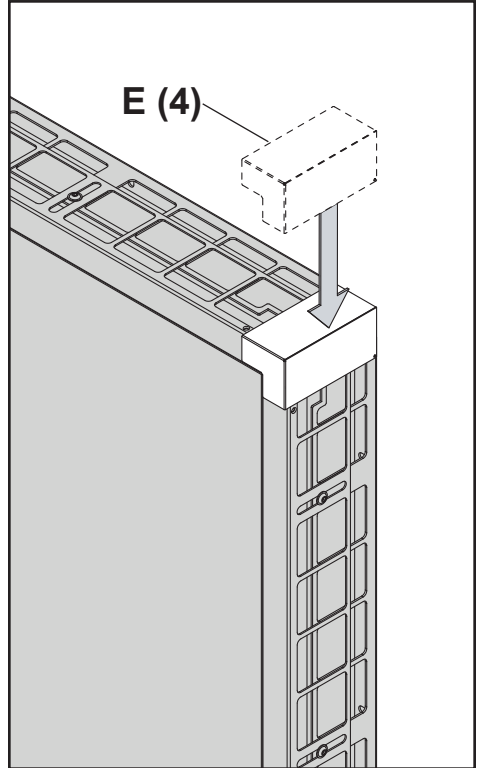

ENG Warranty	ESP Garantía	FRN Garantie	DEU Garantie	NEL Garantie
ITL Garanzia	ČES Záruka	SLK Záruka	POR Garantia	TÜR Garanti

www.peerless-av.com/warranty • www.peerless-av.com • www.peerless-av.com/patents

peerless-AV®

Peerless-AV
2300 White Oak Circle
Aurora, IL 60502, USA
info@peerless-av.com

(800) 865-2112
(630) 375-5100

Peerless-AV EMEA
Unit 2, Curo Park
Frogmore, St. Albans,
Hertfordshire, AL2 2DD
United Kingdom

+44 (0) 1923 200 100

Peerless-AV B.V.
Papendorpseweg 75
3528 BJ Utrecht
The Netherlands

+31 (0) 70 770 8037

Peerless-AV Latin America
Av. de las Industrias 413
Parque Industrial Escobedo
General Escobedo N.L.,
México 66062

+52 (81) 8384-8300