

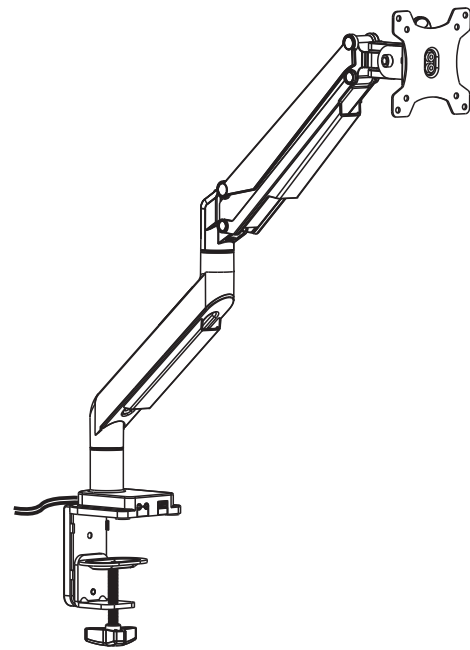

# VESA Clamp Mount & Full Cable Management PAD-LTMUH2 INSTRUCTION MANUAL

Thank you for choosing CTA Digital's product. We hope that you will enjoy using it. Please follow the guidelines and instructions as laid out in this instruction manual.



**Package Contents:**

- A (x1)
- B (x1)
- C (x1)
- D (x1)
- E (x1)
- F (x1)
- G (x1)
- H (x1)
- I (x1)
- J (x1)
- K (x4)
- L (4mm (x1))
- M (6mm (x1))
- N (x1)
- O (D5 (x4), M C)
- P (M6x10 (x2), M6x12 (x3))
- M-A (M4x12 (x4))
- M-B (M5x12 (x4))

## Instructions:

**1**

STEP 1: Setup mounting base as illustrated.

**2**

STEP 2: Attach clamp with bolts and tools as illustrated. Left and right images illustrate (2) options. Select option pending table depth options. Measure table depth and select accordingly.

**3**

STEP 3: Attach component and clamp down on table as illustrated.

**4**

STEP 4: Attach VESA plate to VESA compatible device. Attach VESA plate along with device to clamp mount arm as shown. *(VESA compatible device not included and just for example)*

**\*HOW TO LOCK CLAMP ARM IN PLACE**

Use allen key as illustrated to lock arm in a static position

**\*CLAMP ARM ADJUSTABLE JOINTS**

**\*ATTACHING CABLE MANAGEMENT TRAY & CABLE ROUTING**

**\*REMOVING CABLE MANAGEMENT TRAY**

**Caution**  
Please be sure to fasten all the screws securely before using. Failure to do so may compromise integrity.

SUPPORT@CTADIGITAL.COM