



ThinkSystem SR665 Maintenance Manual



Machine Types: 7D2V and 7D2W

Note

Before using this information and the product it supports, be sure to read and understand the safety information and the safety instructions, which are available at:

http://thinksystem.lenovofiles.com/help/topic/safety_documentation/pdf_files.html

In addition, ensure that you are familiar with the terms and conditions of the Lenovo warranty for your server, which can be found at:

<http://datacentersupport.lenovo.com/warrantylookup>

First Edition (June 2020)

© Copyright Lenovo 2019.

LIMITED AND RESTRICTED RIGHTS NOTICE: If data or software is delivered pursuant to a General Services Administration (GSA) contract, use, reproduction, or disclosure is subject to restrictions set forth in Contract No. GS-35F-05925.

Contents

Safety	v	24 x 2.5-inch front drive bays (16SAS/SATA +8AnyBay)	92
Safety inspection checklist	vi	24 x 2.5-inch front drive bays (16SAS/SATA +8NVMe)	99
Chapter 1. Introduction	1	24 x 2.5-inch front drive bays (SAS/SATA).	103
Specifications	3	24 x 2.5-inch front drive bays (NVMe)	111
Firmware updates	7	8 x 3.5-inch front drive bays (SAS/SATA)	115
Tech Tips	9	12 x 3.5-inch front drive bays (SAS/SATA).	117
Security advisories	10	12 x 3.5-inch front drive bays (AnyBay)	124
Turn on the server	10		
Turn off the server	10		
Chapter 2. Server components	11	Chapter 4. Hardware replacement procedures.	129
Front view	11	Installation Guidelines	129
Diagnostics panel	23	System reliability guidelines	130
LCD diagnostics panel/handset	26	Working inside the server with the power on	130
Rear view	33	Handling static-sensitive devices	131
Rear view LEDs	41	Technical rules	132
System board components	43	Technical rules for processor and heat sink.	135
System board LEDs	45	Technical rules for memory modules	135
Switch block and jumper	48	Drive bay configurations and requirements	139
Parts list.	50	Technical rules for PCIe slots.	144
Power cords	55	Technical rules for GPU	147
		Technical rules for system fans	148
Chapter 3. Internal cable routing	57	Air baffle replacement	149
Front I/O assembly	58	Remove the air baffle	149
GPUs.	59	Install the air baffle	152
Riser cards	59	Cable wall brackets replacement (full-height/half-height)	155
RAID super capacitor modules	62	Remove the cable wall brackets	155
Internal CFF RAID/HBA/Expander adapters (power)	63	Install the cable wall brackets	158
7mm drives	64	CMOS battery replacement	160
M.2 drives	65	Remove the CMOS battery	160
2.5-inch/3.5-inch drive backplane (power)	66	Install the CMOS battery	162
2.5-inch/3.5-inch drive backplane (signal).	71	Front I/O assembly replacement	164
8 x 2.5-inch front drive bays (SAS/SATA)	71	Remove the front I/O assembly	165
8 x 2.5-inch front drive bays (AnyBay)	73	Install the front I/O assembly	167
8 x 2.5-inch front drive bays (NVMe)	75	GPU replacement	169
16 x 2.5-inch front drive bays (SAS/SATA).	77	Remove a GPU adapter	169
16 x 2.5-inch front drive bays (NVMe)	79	Install a GPU adapter	172
16 x 2.5-inch front drive bays (8SAS +8AnyBay)	81	Hot-swap drive replacement	175
16 x 2.5-inch front drive bays (8SAS/SATA +8NVMe)	83	Remove a hot-swap drive	176
16 x 2.5-inch front drive bays (8AnyBay +8NVMe)	86	Install a hot-swap drive	178
24 x 2.5-inch front drive bays (8SAS/SATA +16NVMe)	89	Hot-swap drive backplane replacement	181
		Remove the front 2.5-inch-drive backplane	182
		Install the front 2.5-inch-drive backplane	185

Remove the middle or rear 2.5-inch-drive backplane	188	Install a super capacitor module on the air baffle	293
Install the middle or rear 2.5-inch-drive backplane	191	Remove a super capacitor module from the middle 2.5-inch drive cage.	295
Remove the front 3.5-inch-drive backplane	194	Install a super capacitor module on the middle 2.5-inch drive cage.	297
Install the front 3.5-inch-drive backplane	196	Remove a super capacitor from the chassis	300
Remove the middle or rear 3.5-inch-drive backplane	198	Install a super capacitor on the chassis	303
Install the middle or rear 3.5-inch-drive backplane	201	Rearwall bracket replacement	306
Remove the 7mm drive backplane.	203	Remove an A1 rearwall bracket (left)	308
Install the 7mm drive backplanes	205	Install an A1 rearwall bracket (left)	310
Hot-swap power supply unit replacement	208	Remove a B1/B2 rearwall bracket (middle)	312
Remove a hot-swap power supply unit	209	Install a B1/B2 rearwall bracket (middle)	314
Install a hot-swap power supply	216	Remove a C1/C2 rearwall bracket (right)	316
Internal CFF adapter replacement.	224	Install a C1/C2 rearwall bracket (right)	318
Remove the internal CFF RAID/HBA/RAID expander adapter	224	Rear drive cage replacement.	320
Install the internal CFF RAID/HBA/RAID expander adapter	226	Remove the 2 x 3.5-inch rear drive cage	321
Intrusion switch replacement	228	Install the 2 x 3.5-inch rear drive cage	323
Remove the intrusion switch	228	Remove the 4 x 3.5-inch rear drive cage	325
Install the intrusion switch	230	Install the 4 x 3.5-inch rear drive cage	327
M.2 adapter and M.2 drive replacement	233	Remove the 4 x 2.5-inch rear drive cage	330
Remove the M.2 adapter and M.2 drive.	234	Install the 4 x 2.5-inch rear drive cage	332
Adjust the retainer on the M.2 adapter	237	Remove the 8 x 2.5-inch rear drive cage	334
Install the M.2 adapter and M.2 drive.	239	Install the 8 x 2.5-inch rear drive cage	336
Middle drive cage replacement	242	Remove the 7mm drive cage	338
Remove the middle 2.5-inch drive cage.	242	Install the 7mm drive cage	341
Install the middle 2.5-inch drive cage.	244	PCIe adapter and riser assembly replacement	345
Remove the middle 3.5-inch drive cage.	246	Remove a PCIe adapter and riser 1/2 assembly	346
Install the middle 3.5-inch drive cage.	249	Install a PCIe adapter and riser 1/2 assembly	350
Memory module replacement	251	Remove a PCIe adapter and riser 3 assembly	355
Remove a memory module	252	Install a PCIe adapter and riser 3 assembly	359
Memory module installation rules	254	Security bezel replacement	361
Install a memory module	255	Remove the security bezel.	362
OCP 3.0 Ethernet adapter replacement	259	Install the security bezel.	365
Remove the OCP 3.0 Ethernet adapter	260	System board replacement	368
Install the OCP 3.0 Ethernet adapter	262	Remove the system board	369
Processor and heat sink replacement	265	Install the system board.	372
Remove a heat sink	266	Update the Universal Unique Identifier (UUID).	375
Remove a processor	269	Update the DMI/SMBIOS data	376
Install a processor	271	Enable TPM	376
Install a heat sink	273	Enable UEFI Secure Boot	378
Rack latches replacement.	277	System fan replacement	380
Remove the rack latches	278	Remove a system fan.	381
Install the rack latches	282	Install a system fan.	384
RAID super capacitor module replacement	287	System fan cage replacement	386
Remove a super capacitor module from the air baffle	291	Remove the system fan cage.	387
		Install the system fan cage.	389

Top cover replacement	391
Remove the top cover	392
Install the top cover	394
Complete the parts replacement	397

Chapter 5. Problem determination399

Event logs	400
Light path diagnostics	401
General problem determination procedures	402
Resolving suspected power problems	403
Resolving suspected Ethernet controller problems	404
Troubleshooting by symptom	405
Power on and power off problems	406
Memory problems	409
Hard disk drive problems	410
Monitor and video problems	413
Keyboard, mouse, KVM switch or USB-device problems	417
Optional-device problems	419
Serial-device problems	422
Intermittent problems	424
Power problems	427
Network problems	428

Observable problems	429
Software problems	433

Appendix A. Hardware disassembling for recycle436

Disassembling the system board for recycle	436
--	-----

Appendix B. Getting help and technical assistance440

Before you call	440
Collecting service data	441
Contacting Support	441

Appendix C. Notices.443

Trademarks	444
Important notes	444
Particulate contamination	445
ASHRAE class compliance information	446
Telecommunication regulatory statement	447
Electronic emission notices	447
Taiwan BSMI RoHS declaration	448
Taiwan import and export contact information	448

Index449

Safety

Before installing this product, read the Safety Information.

قبل تركيب هذا المنتج، يجب قراءة الملاحظات الأمنية

Antes de instalar este produto, leia as Informações de Segurança.

在安装本产品之前，请仔细阅读 Safety Information（安全信息）。

安裝本產品之前，請先閱讀「安全資訊」。

Prije instalacije ovog produkta obavezno pročitajte Sigurnosne Upute.

Před instalací tohoto produktu si přečtěte příručku bezpečnostních instrukcí.

Læs sikkerhedsforskrifterne, før du installerer dette produkt.

Lees voordat u dit product installeert eerst de veiligheidsvoorschriften.

Ennen kuin asennat tämän tuotteen, lue turvaohjeet kohdasta Safety Information.

Avant d'installer ce produit, lisez les consignes de sécurité.

Vor der Installation dieses Produkts die Sicherheitshinweise lesen.

Πριν εγκαταστήσετε το προϊόν αυτό, διαβάστε τις πληροφορίες ασφάλειας (safety information).

לפני שתתקינו מוצר זה, קראו את הוראות הבטיחות.

A termék telepítése előtt olvassa el a Biztonsági előírásokat!

Prima di installare questo prodotto, leggere le Informazioni sulla Sicurezza.

製品の設置の前に、安全情報をお読みください。

본 제품을 설치하기 전에 안전 정보를 읽으십시오.

Пред да се инсталира овој продукт, прочитајте информацијата за безбедност.

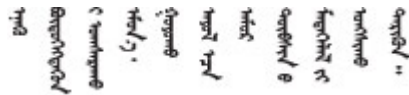

Les sikkerhetsinformasjonen (Safety Information) før du installerer dette produktet.

Przed zainstalowaniem tego produktu, należy zapoznać się z książką "Informacje dotyczące bezpieczeństwa" (Safety Information).

Antes de instalar este produto, leia as Informações sobre Segurança.

Перед установкой продукта прочтите инструкции по технике безопасности.

Pred inštaláciou tohto zariadenia si pečítajte Bezpečnostné predpisy.

Pred namestitvijo tega proizvoda preberite Varnostne informacije.

Antes de instalar este producto, lea la información de seguridad.

Läs säkerhetsinformationen innan du installerar den här produkten.

ཐོན་ཇུས་འདི་བདེ་སྤྱོད་མ་བྱས་གོང་། སྐྱོར་གྱི་ཡིད་གཟབ་
བྱ་འདྲ་མིན་ཡོད་པའི་འོད་སྤེར་བལྟ་དགོས།

Bu ürünü kurmadan önce güvenlik bilgilerini okuyun.

مەزكۇر مەھسۇلاتنى ئورنىتىشتىن بۇرۇن بىخەتەرلىك ئۇچۇرلىرىنى ئوقۇپ چىقىڭ.

Youq mwngz yungh canjbinj neix gaxgonq, itdingh aeu doeg aen
canjbinj soengq cungj vahgangj ancien siusik.

Safety inspection checklist

Use the information in this section to identify potentially unsafe conditions with your server. As each machine was designed and built, required safety items were installed to protect users and service technicians from injury.

CAUTION:

This equipment must be installed or serviced by trained personnel, as defined by the NEC, IEC 62368-1 & IEC 60950-1, the standard for Safety of Electronic Equipment within the Field of Audio/Video, Information Technology and Communication Technology. Lenovo assumes you are qualified in the servicing of equipment and trained in recognizing hazards energy levels in products. Access to the equipment is by the use of a tool, lock and key, or other means of security, and is controlled by the authority responsible for the location.

Important: Electrical grounding of the server is required for operator safety and correct system function. Proper grounding of the electrical outlet can be verified by a certified electrician.

Use the following checklist to verify that there are no potentially unsafe conditions:

1. Make sure that the power is off and the power cord is disconnected.
2. Check the power cord.
 - Make sure that the third-wire ground connector is in good condition. Use a meter to measure third-wire ground continuity for 0.1 ohm or less between the external ground pin and the frame ground.
 - Make sure that the power cord is the correct type.

To view the power cords that are available for the server:

a. Go to:

<http://dcsc.lenovo.com/#/>

b. In the Customize a Model pane:

- 1) Click **Select Options/Parts for a Model**.
- 2) Enter the machine type and model for your server.

- c. Click the Power tab to see all line cords.
 - Make sure that the insulation is not frayed or worn.
3. Check for any obvious non-Lenovo alterations. Use good judgment as to the safety of any non-Lenovo alterations.
4. Check inside the server for any obvious unsafe conditions, such as metal filings, contamination, water or other liquid, or signs of fire or smoke damage.
5. Check for worn, frayed, or pinched cables.
6. Make sure that the power-supply cover fasteners (screws or rivets) have not been removed or tampered with.

Chapter 1. Introduction

The ThinkSystem™ SR665 server is a 2-socket 2U server that features the new AMD® EPYC™ family of processors. The server offers a broad selection of drive and slot configurations and offers high performance and expansion for various IT workloads. Combining performance and flexibility, the server is a great choice for enterprises of all sizes.

Performance, ease of use, reliability, and expansion capabilities were key considerations in the design of the server. These design features make it possible for you to customize the system hardware to meet your needs today and provide flexible expansion capabilities for the future.

The server comes with a limited warranty. For details about the warranty, see:

<https://support.lenovo.com/us/en/solutions/ht503310>

For details about your specific warranty, see:

<http://datacentersupport.lenovo.com/warrantylookup>

Identifying your server

When you contact Lenovo for help, the machine type and serial number information helps support technicians to identify your server and provide faster service.

The machine type and serial number are on the ID label on the right rack latch in the front of the server.

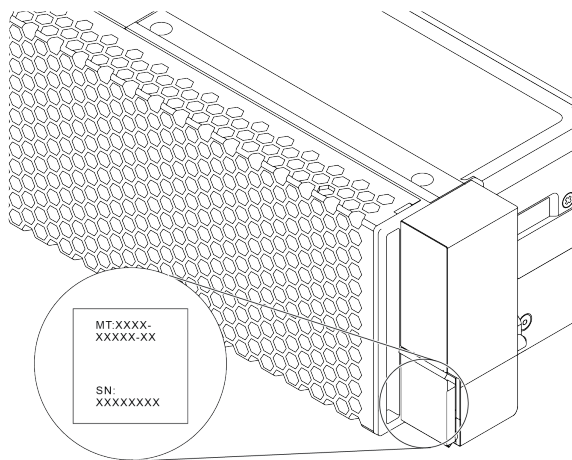

Figure 1. Location of the ID label

XCC network access label

The network access label for the XClarity Controller (XCC) is attached on the top side of the pull-out information tab as shown. After you get the server, peel the network access label away and store it in a safe place.

Note: The pull-out information tab is located on the right bottom of the front side of your server. For detailed information, see “Front view” on page 11

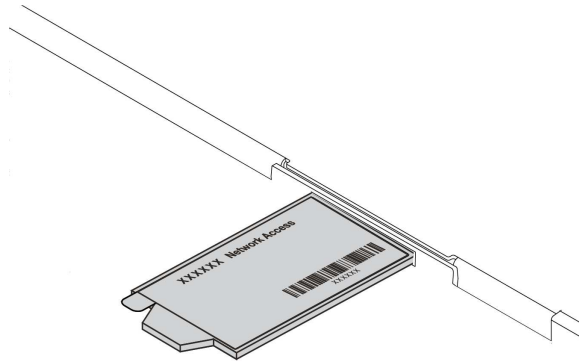

Figure 2. Location of the XCC network access label

Quick response code

The system service label, which is on the top cover, provides a quick response (QR) code for mobile access to service information. Scan the QR code with a mobile device and a QR code reader application to get quick access to the Lenovo Service Web site for this server. The Lenovo Service Information Web site provides additional information for parts installation and replacement videos, and error codes for server support.

The following illustration shows the QR code: <https://datacentersupport.lenovo.com/products/servers/thinksystem/sr665/7d2w>



Figure 3. QR code

Specifications

The following information is a summary of the features and specifications of the server. Depending on the model, some features might not be available, or some specifications might not apply.

Table 1. Server specifications

Specification	Description
Dimension	<ul style="list-style-type: none"> • 2U • Height: 86.5 mm (3.4 inches) • Width: <ul style="list-style-type: none"> – With rack latches: 482.1 mm (19.0 inches) – Without rack latches: 445.0 mm (17.5 inches) • Depth: 763.7 mm (30.1 inches) <p>Note: The depth is measured with rack latches installed, but without the security bezel installed.</p>
Weight	Up to 38.8 kg (85.5 lb), depending on the server configuration
Processor (depending on the model)	<ul style="list-style-type: none"> • Up to two AMD® EPYC™ processors • Designed for Land Grid Array (LGA) 4094 (SP3) socket • Scalable up to 128 cores • Thermal Design Power (TDP): up to 280 watts <p>For technical rules about processors, see “Technical rules for processor and heat sink” on page 135.</p> <p>For a list of supported processors, see: https://static.lenovo.com/us/en/serverproven/index.shtml</p>
Memory	<ul style="list-style-type: none"> • Slots: 32 memory module slots • Supported memory module type: <ul style="list-style-type: none"> – TruDDR4 3200, dual-rank, 16 GB/32 GB/64 GB RDIMM – TruDDR4 3200, dual-rank, 128 GB 3DS RDIMM • Minimum memory: <ul style="list-style-type: none"> – 16 GB using RDIMMs – 128 GB using 3DS RDIMMs • Maximum memory: <ul style="list-style-type: none"> – 2 TB using RDIMMs – 4 TB using 3DS RDIMMs <p>Note: The operating speed and total memory capacity depend on the processor model and UEFI settings.</p> <p>For a list of supported memory, see the Lenovo ServerProven Web site: https://static.lenovo.com/us/en/serverproven/index.shtml.</p> <p>For technical rules for memory modules, see “Technical rules for memory modules” on page 135.</p>

Table 1. Server specifications (continued)

Specification	Description
Internal drives	<p>Front:</p> <ul style="list-style-type: none"> • Up to twenty-four 2.5-inch hot-swap SAS/SATA/NVMe drives • Up to twelve 3.5-inch hot-swap SAS/SATA/NVMe drives <p>Middle/Inside:</p> <ul style="list-style-type: none"> • Up to eight 2.5-inch hot-swap SAS/SATA/NVMe drives • Up to four 3.5-inch hot-swap SAS/SATA drives • Up to two internal SATA/NVMe M.2 drives (On Air baffle or middle drive bays) <p>Rear:</p> <ul style="list-style-type: none"> • Up to eight 2.5-inch hot-swap SAS/SATA drives • Up to four 3.5-inch hot-swap SAS/SATA drives • Up to two 7mm hot-swap SATA/NVMe drives <p>For technical rules for drives, see “Drive bay configurations and requirements” on page 139.</p>
Expansion slots	<ul style="list-style-type: none"> • Your server supports up to eight PCIe slots in the rear: <ul style="list-style-type: none"> – PCIe x16/x8/x8, full-height – PCIe x16/x16/E*, full-height – PCIe E*/x16/x16, full-height – PCIe x16/x16, full-height – PCIe x8/x8, full-height – PCIe x16, full-height <p>Note: “E” is short for “empty”. It means the slot in the three-slot riser card is unavailable.</p> <ul style="list-style-type: none"> • Your server supports up to one slot for OCP 3.0 Ethernet adapter <p>For technical rules for PCIe slots, see “Rear view” on page 33 and “Technical rules for PCIe slots” on page 144.</p>
Graphics processing unit (GPU)	<p>Your server supports the following GPUs:</p> <ul style="list-style-type: none"> • Low-profile, half-length, double-wide: NVIDIA® Tesla® V100, V100S • Full-height, full-length, single-wide: NVIDIA Quadro® P620, NVIDIA Tesla T4 <p>For technical rules for GPU, see “Technical rules for GPU” on page 147.</p>
Input/Output (I/O) features	<ul style="list-style-type: none"> • Front : <ul style="list-style-type: none"> – One VGA connector (optional) – One USB 3.1 Gen 1 connector and one USB 2.0 connector with XClarity Controller management – One external diagnostics connector – One diagnostics panel or LCD diagnostics panel (optional) • Rear: <ul style="list-style-type: none"> – One VGA connector – Three USB 3.1 Gen 1 connectors – One XClarity Controller network connector – Two or four Ethernet connectors on the OCP 3.0 Ethernet adapter (optional)

Table 1. Server specifications (continued)

Specification	Description
Storage controllers	<p>Support for JBOD mode and RAID level 0, 1, 10:</p> <ul style="list-style-type: none"> • 530-16i PCIe 12Gb SFF RAID adapter (Gen3) <p>Support for JBOD mode and RAID level 0, 1, 5, 10, 50:</p> <ul style="list-style-type: none"> • 530-8i PCIe 12Gb SFF RAID adapter (Gen3) <p>Support for JBOD mode and RAID level 0, 1, 5, 6, 10, 50, 60:</p> <ul style="list-style-type: none"> • 930-8i 2 GB Flash 12Gb SFF RAID adapter (Gen3) • 930-16i 4 GB Flash 12Gb SFF RAID adapter (Gen 3) • 940-8i 4 GB Flash 12Gb SFF RAID adapter (Gen4) • 940-8i 8 GB Flash 12Gb SFF RAID adapter (Gen4) • 940-16i 8 GB Flash 12Gb SFF RAID adapter (Gen4) • 930-8e 4 GB Flash 12Gb SFF RAID adapter (Gen3) • 940-16i 8 GB Flash 12Gb Internal CFF RAID adapter (Gen4) • 940-32i 8GB Flash 12Gb SFF RAID adapter (Gen4) <p>Support the following HBA adapter:</p> <ul style="list-style-type: none"> • 430-8i SAS/SATA 12Gb SFF HBA adapter (Gen3) • 430-16i SAS/SATA 12Gb SFF HBA adapter (Gen3) • 430-8e SAS/SATA 12Gb SFF HBA adapter (Gen3) • 430-16e SAS/SATA 12Gb SFF HBA adapter (Gen3) • 440-16e SAS/SATA 12Gb SFF HBA adapter (Gen4) • 440-16i SAS/SATA 12Gb Internal CFF HBA adapter (Gen4) <p>Support the following RAID expander adapter:</p> <ul style="list-style-type: none"> • 36i 12Gb Internal CFF RAID Expander <p>Notes:</p> <ul style="list-style-type: none"> • SFF: Standard Form Factor. This type of RAID/HBA adapter is installed in the PCIe slots on the rear of the server. • CFF: Custom Form Factor. This type of RAID/HBA adapter is installed on the chassis between fans and front backplane. • CFF RAID/HBA Expander: Custom Form Factor. This type of Expander receives signals from CFF/SFF RAID/HBA adapters and used for SAS/SATA configurations only. It is installed next to the CFF RAID/HBA adapter on the chassis between fans and front backplane. <p>For technical rules for storage controllers, see “” on page .</p>
System fans	<ul style="list-style-type: none"> • Up to six hot-swap system fans (N+1 redundancy, one redundant fan) • Supported fan types: <ul style="list-style-type: none"> – Standard fan 6038 (single-rotor 17000 RPM) – Performance fan 6056 (rual-rotor 18000 RPM) <p>For technical rules for system fans, see “Technical rules for system fans” on page 148.</p>

Table 1. Server specifications (continued)

Specification	Description																																			
Electrical input	<p>The server supports up to two power supplies for redundancy.</p> <p><i>Table 2. Electrical input for power supplies</i></p> <table border="1" data-bbox="451 378 1421 886"> <thead> <tr> <th data-bbox="451 378 727 447">Power supply</th> <th data-bbox="727 378 889 447">100–127 V ac</th> <th data-bbox="889 378 1065 447">200–240 V ac</th> <th data-bbox="1065 378 1291 447">240 V dc</th> <th data-bbox="1291 378 1421 447">-48 V dc</th> </tr> </thead> <tbody> <tr> <td data-bbox="451 447 727 520">500-watt 80 PLUS Platinum</td> <td data-bbox="727 447 889 520">√</td> <td data-bbox="889 447 1065 520">√</td> <td data-bbox="1065 447 1291 520">√</td> <td data-bbox="1291 447 1421 520"></td> </tr> <tr> <td data-bbox="451 520 727 594">750-watt 80 PLUS Platinum</td> <td data-bbox="727 520 889 594">√</td> <td data-bbox="889 520 1065 594">√</td> <td data-bbox="1065 520 1291 594">√</td> <td data-bbox="1291 520 1421 594"></td> </tr> <tr> <td data-bbox="451 594 727 667">750-watt 80 PLUS Titanium</td> <td data-bbox="727 594 889 667"></td> <td data-bbox="889 594 1065 667">√</td> <td data-bbox="1065 594 1291 667">√</td> <td data-bbox="1291 594 1421 667"></td> </tr> <tr> <td data-bbox="451 667 727 741">1100-watt 80 PLUS Platinum</td> <td data-bbox="727 667 889 741">√</td> <td data-bbox="889 667 1065 741">√</td> <td data-bbox="1065 667 1291 741">√</td> <td data-bbox="1291 667 1421 741"></td> </tr> <tr> <td data-bbox="451 741 727 814">1100-watt 80 PLUS Platinum</td> <td data-bbox="727 741 889 814"></td> <td data-bbox="889 741 1065 814"></td> <td data-bbox="1065 741 1291 814"></td> <td data-bbox="1291 741 1421 814">√</td> </tr> <tr> <td data-bbox="451 814 727 886">1800-watt 80 PLUS Platinum</td> <td data-bbox="727 814 889 886"></td> <td data-bbox="889 814 1065 886">√</td> <td data-bbox="1065 814 1291 886">√</td> <td data-bbox="1291 814 1421 886"></td> </tr> </tbody> </table> <p>CAUTION:</p> <ul data-bbox="451 961 1421 1113" style="list-style-type: none"> • 240 V dc input (input range: 180-300 V dc) is supported in Chinese Mainland ONLY. • Power supply with 240 V dc input cannot support hot plugging power cord function. Before removing the power supply with dc input, please turn off server or disconnect dc power sources at the breaker panel or by turning off the power source. Then, remove the power cord. 	Power supply	100–127 V ac	200–240 V ac	240 V dc	-48 V dc	500-watt 80 PLUS Platinum	√	√	√		750-watt 80 PLUS Platinum	√	√	√		750-watt 80 PLUS Titanium		√	√		1100-watt 80 PLUS Platinum	√	√	√		1100-watt 80 PLUS Platinum				√	1800-watt 80 PLUS Platinum		√	√	
Power supply	100–127 V ac	200–240 V ac	240 V dc	-48 V dc																																
500-watt 80 PLUS Platinum	√	√	√																																	
750-watt 80 PLUS Platinum	√	√	√																																	
750-watt 80 PLUS Titanium		√	√																																	
1100-watt 80 PLUS Platinum	√	√	√																																	
1100-watt 80 PLUS Platinum				√																																
1800-watt 80 PLUS Platinum		√	√																																	
Minimal configuration for debugging	<ul data-bbox="451 1150 1388 1375" style="list-style-type: none"> • One processor • One DIMM in slot 14 • One power supply • One heatsink • One HDD/SSD drive, one M.2 drive, or one 7mm drive (if OS is needed for debugging) • Five system fans 																																			

Table 1. Server specifications (continued)

Specification	Description
Acoustical noise emissions	<ul style="list-style-type: none"> • Sound power levels, idle <ul style="list-style-type: none"> – 6.3 bels, typical – 6.5 bels, maximum • Sound power levels, operating <ul style="list-style-type: none"> – 6.7 bels, typical – 6.9 bels, maximum <p>Notes:</p> <ul style="list-style-type: none"> • These sound power levels are measured in controlled acoustical environments according to procedures specified by ISO 7779 and are reported in accordance with ISO 9296. • The declared acoustic noise levels are based on specified configurations, which may change slightly depending on configuration and conditions.
Environment	Your server complies with ASHRAE class A2 specifications. Depending on the hardware configuration, some server models comply with ASHRAE class A3 and class A4 specifications, see “ASHRAE class compliance information” on page 446.

Firmware updates

Several options are available to update the firmware for the server.

You can use the tools listed here to update the most current firmware for your server and the devices that are installed in the server.

Note: Lenovo typically releases firmware in bundles called UpdateXpress System Packs (UXSPs). To ensure that all of the firmware updates are compatible, you should update all firmware at the same time. If you are updating firmware for both the Lenovo XClarity Controller and UEFI, update the firmware for Lenovo XClarity Controller first.

Best practices related to updating firmware are available at the following location:

<http://lenovopress.com/LP0656>

Important terminology

- **In-band update.** The installation or update is performed using a tool or application within an operating system that is executing on the server’s core processor.
- **Out-of-band update.** The installation or update is performed by the Lenovo XClarity Controller collecting the update and then directing the update to the target subsystem or device. Out-of-band updates have no dependency on an operating system executing on the core processor. However, most out-of-band operations do require the server to be in the S0 (Working) power state.
- **On-Target update.** The installation or update is initiated from an operating system running on the server.
- **Off-Target update.** The installation or update is initiated from a computing device interacting directly with the server’s Lenovo XClarity Controller.
- **UpdateXpress System Packs (UXSPs).** UXSPs are bundled updates designed and tested to provide the interdependent level of functionality, performance, and compatibility. UXSPs are server machine-type specific and are built (with firmware and device driver updates) to support specific Windows Server, Red Hat Enterprise Linux (RHEL) and SUSE Linux Enterprise Server (SLES) operating system distributions. Machine-type-specific firmware-only UXSPs are also available.

See the following table to determine the best Lenovo tool to use for installing and setting up the firmware:

Note: The server UEFI settings for option ROM must be set to **Auto** or **UEFI** to update firmware using Lenovo XClarity Essentials. For more information, see the following Tech Tip:

<https://datacentersupport.lenovo.com/us/en/solutions/ht506118>

Tool	In-band update	Out-of-band update	On-target update	Off-target update	Graphical user interface	Command-line interface	Supports UXSPs
Lenovo XClarity Provisioning Manager V3 Limited to core system firmware only.	✓			✓	✓		✓
Lenovo XClarity Essentials OneCLI Supports all core system firmware, I/O firmware, and installed operating system driver updates.	✓	✓	✓	✓		✓	✓
Lenovo XClarity Essentials UpdateXpress Supports all core system firmware, I/O firmware, and installed operating system driver updates.	✓	✓	✓	✓	✓		✓
Lenovo XClarity Essentials Bootable Media Creator Supports core system firmware and I/O firmware updates. You can update the Microsoft® Windows® operating system, but device drivers are not included on the bootable image.	✓			✓	✓	✓	✓

The latest firmware can be found at the following site:

<https://datacentersupport.lenovo.com/products/servers/thinksystem/sr665/7d2w/parts/downloads>

- **Lenovo XClarity Provisioning Manager V3**

From Lenovo XClarity Provisioning Manager V3, you can update the Lenovo XClarity Controller firmware, the UEFI firmware, and the Lenovo XClarity Provisioning Manager V3 software.

Note: By default, the Lenovo XClarity Provisioning Manager V3 Graphical User Interface (GUI) is displayed when you press F1. If you have changed that default to be the text-based system setup, you can bring up the GUI from the text-based system setup interface.

Additional information about using Lenovo XClarity Provisioning Manager V3 to update firmware is available at:

http://sysmgt.lenovofiles.com/help/topic/LXPMv3/LXPMv3_platform_update.html

- **Lenovo XClarity Controller**

If you need to install a specific update, you can use the Lenovo XClarity Controller interface for a specific server.

Notes:

- To perform an in-band update through Windows or Linux, the operating system driver must be installed and the Ethernet-over-USB (sometimes called LAN over USB) interface must be enabled.

Additional information about configuring Ethernet over USB is available at:

http://sysmgt.lenovofiles.com/help/topic/com.lenovo.systems.management.xcc.doc/NN1ia_c_configuringUSB.html

- If you update firmware through the Lenovo XClarity Controller, make sure that you have downloaded and installed the latest device drivers for the operating system that is running on the server.
- Specific details about updating firmware using Lenovo XClarity Controller are available at:

http://sysmgt.lenovofiles.com/help/topic/com.lenovo.systems.management.xcc.doc/NN1ia_c_manageserverfirmware.html

- **Lenovo XClarity Essentials OneCLI**

Lenovo XClarity Essentials OneCLI is a collection of command line applications that can be used to manage Lenovo servers. Its update application can be used to update firmware and device drivers for your servers. The update can be performed within the host operating system of the server (in-band) or remotely through the BMC of the server (out-of-band).

Specific details about updating firmware using Lenovo XClarity Essentials OneCLI is available at:

http://sysmgt.lenovofiles.com/help/topic/toolstr_cli_lenovo/onecli_c_update.html

- **Lenovo XClarity Essentials UpdateXpress**

Lenovo XClarity Essentials UpdateXpress provides most of OneCLI update functions through a graphical user interface (GUI). It can be used to acquire and deploy UXSP update packages and individual updates. UXSP contains firmware and device driver updates for Microsoft Windows and for Linux.

You can obtain UXSP from the following location:

<https://datacentersupport.lenovo.com/solutions/Invo-xpress>

- **Lenovo XClarity Essentials Bootable Media Creator**

You can use Lenovo XClarity Essentials Bootable Media Creator (BoMC) to create bootable media that is suitable for firmware updates, VPD updates, inventory and FFDC collection, advanced system configuration, FoD Keys management, secure erase, RAID configuration, and diagnostics on supported servers.

You can obtain BoMC from the following location:

<https://datacentersupport.lenovo.com/solutions/Invo-bomc>

Tech Tips

Lenovo continually updates the support website with the latest tips and techniques that you can use to solve issues that your server might encounter. These Tech Tips (also called retain tips or service bulletins) provide procedures to work around issues or solve problems related to the operation of your server.

To find the Tech Tips available for your server:

1. Go to <http://datacentersupport.lenovo.com> and navigate to the support page for your server.
2. Click **Documentation** from the navigation pane.

Follow the on-screen instructions to choose the category for the problem that you are having.

Security advisories

Lenovo is committed to developing products and services that adhere to the highest security standards in order to protect our customers and their data. When potential vulnerabilities are reported, it is the responsibility of the Lenovo Product Security Incident Response Team (PSIRT) to investigate and provide information to our customers so they may put mitigation plans in place as we work toward providing solutions.

The list of current advisories is available at the following location:

https://datacentersupport.lenovo.com/product_security/home

Turn on the server

After the server performs a short self-test (power status LED flashes quickly) when connected to input power, it enters a standby state (power status LED flashes once per second).

The server can be turned on (power LED on) in any of the following ways:

- You can press the power button.
- The server can restart automatically after a power interruption.
- The server can respond to remote power-on requests sent to the Lenovo XClarity Controller.

For information about powering off the server, see “Turn off the server” on page 10.

Turn off the server

The server remains in a standby state when it is connected to a power source, allowing the Lenovo XClarity Controller to respond to remote power-on requests. To remove all power from the server (power status LED off), you must disconnect all power cables.

To place the server in a standby state (power status LED flashes once per second):

Note: The Lenovo XClarity Controller can place the server in a standby state as an automatic response to a critical system failure.

- Start an orderly shutdown using the operating system (if supported by your operating system).
- Press the power button to start an orderly shutdown (if supported by your operating system).
- Press and hold the power button for more than 4 seconds to force a shutdown.

When in a standby state, the server can respond to remote power-on requests sent to the Lenovo XClarity Controller. For information about powering on the server, see “Turn on the server” on page 10.

Chapter 2. Server components

This section provides information to help you locate your server components.

Front view

The front view of the server varies by model. Depending on the model, your server might look slightly different from the illustrations in this topic.

Refer to the following front view for different server models:

- Server models with 2.5-inch front drive bays
 - [“Eight 2.5-inch front drive bays” on page 12](#)
 - [“Eight 2.5-inch front drive bays \(with LCD diagnostics panel\)” on page 13](#)
 - [“Sixteen 2.5-inch front drive bays” on page 14](#)
 - [“Sixteen 2.5-inch front drive bays \(with LCD diagnostics panel\)” on page 15](#)
 - [“Twenty-four 2.5-inch front drive bays” on page 16](#)
 - [“Backplane-less” on page 17](#)
- Server models with 3.5-inch front drive bays
 - [“Eight 3.5-inch front drive bays” on page 18](#)
 - [“Twelve 3.5-inch front drive bays” on page 19](#)
 - [“Backplane-less” on page 20](#)

Server models with eight 2.5-inch front drive bays

The following illustration shows the front view of server models with eight 2.5-inch drive bays.

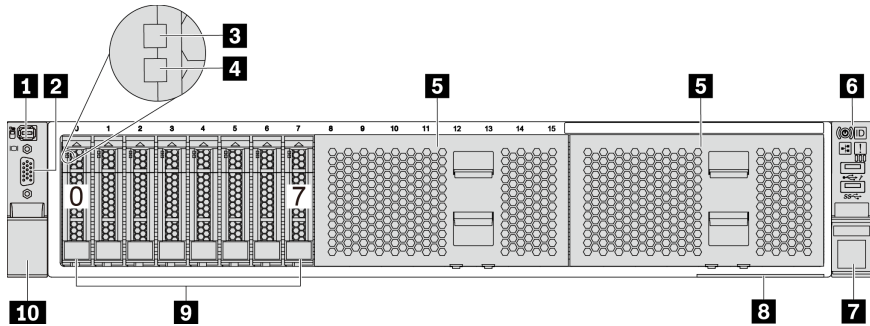

Figure 4. Server model with eight 2.5-inch front drive bays

Table 3. Components on the front of the server

Callout	Callout
1 External diagnostics connector	2 VGA connector (optional)
3 Drive activity LED	4 Drive status LED
5 Drive bay fillers (2)	6 Front I/O assembly with diagnostics panel
7 Rack latch (right)	8 Pull-out information tab
9 Drive bays (8)	10 Rack latch (left)

Note: For more information about each component, see [“Front components overview” on page 21](#).

Server models with eight 2.5-inch front drive bays (with LCD diagnostics panel)

The following illustration shows the front view of server models with eight 2.5-inch drive bays.

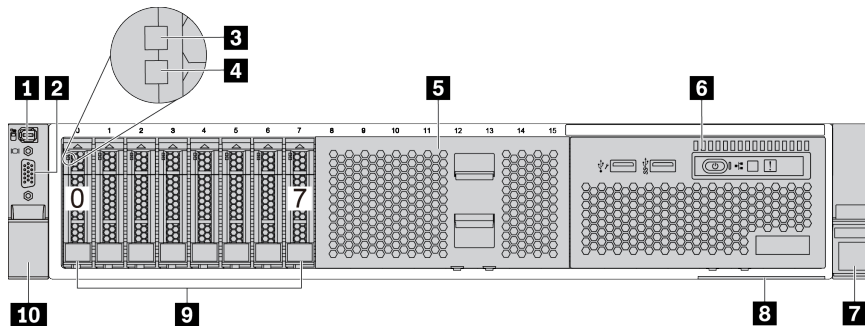

Table 4. Components on the front of the server

Callout	Callout
1 External diagnostics connector	2 VGA connector (optional)
3 Drive activity LED	4 Drive status LED
5 Drive bay filler	6 Front I/O assembly with LCD diagnostics panel
7 Rack latch (right)	8 Pull-out information tab
9 Drive bays (8)	10 Rack latch (left)

Note: For more information about each component, see [“Front components overview” on page 21](#).

Server models with sixteen 2.5-inch drive bays

The following illustration shows the front view of server models with sixteen 2.5-inch drive bays.

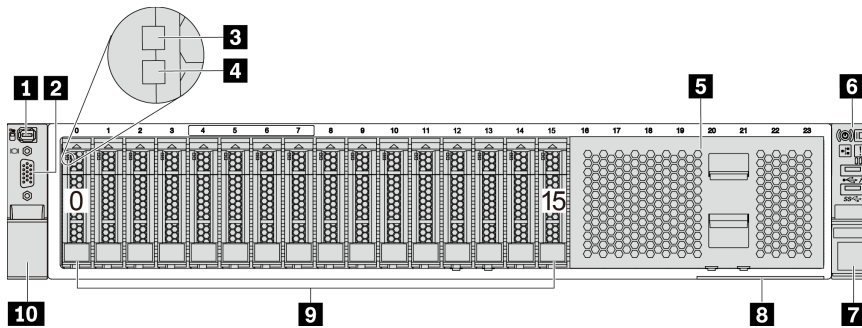

Table 5. Components on the front of server models

Callout	Callout
1 External diagnostics connector	2 VGA connector (optional)
3 Drive activity LED	4 Drive status LED
5 Drive bay filler	6 Front I/O assembly with diagnostics panel
7 Rack latch (right)	8 Pull-out information tab
9 Drive bays (16)	10 Rack latch (left)

Note: For more information about each component, see [“Front components overview” on page 21](#).

Server models with sixteen 2.5-inch drive bays (with LCD diagnostics panel)

The following illustration shows the front view of server models with sixteen 2.5-inch drive bays.

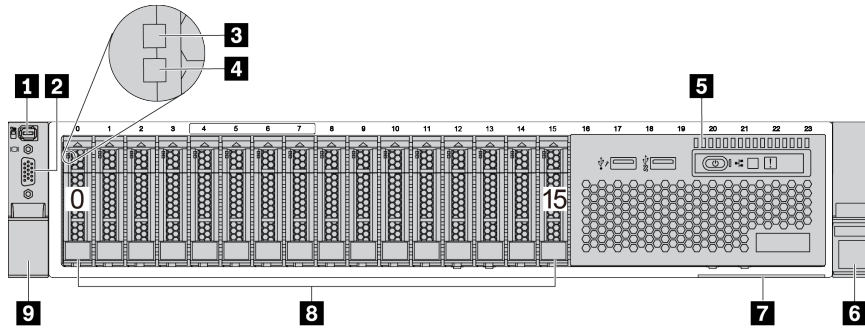

Table 6. Components on the front of the server

Callout	Callout
1 External diagnostics connector	2 VGA connector (optional)
3 Drive activity LED	4 Drive status LED
5 Front I/O assembly with LCD diagnostics panel	6 Rack latch (right)
7 Pull-out information tab	8 Drive bays (16)
9 Rack latch (left)	

Note: For more information about each component, see [“Front components overview” on page 21](#).

Server models with twenty-four 2.5-inch front drive bays

The following illustration shows the front view of server models with twenty-four 2.5-inch front drive bays.

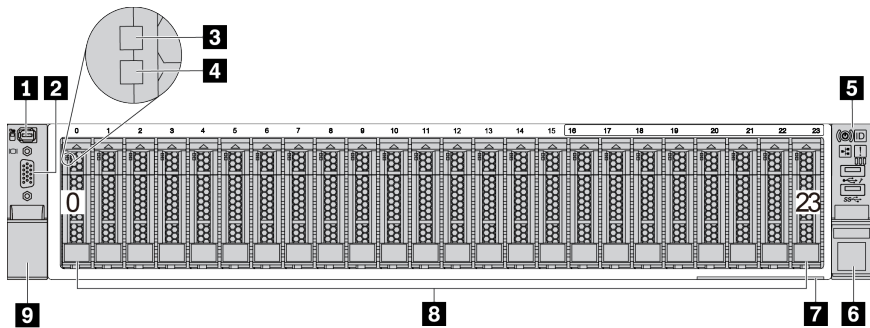

Table 7. Components on the front of server models

Callout	Callout
1 External diagnostics connector	2 VGA connector (optional)
3 Drive activity LED	4 Drive status LED
5 Front I/O assembly with diagnostics panel	6 Rack latch (right)
7 Pull-out information tab	8 Drive bays (24)
9 Rack latch (left)	

Note: For more information about each component, see [“Front components overview” on page 21](#).

Server models with 2.5-inch front drive bays (backplane-less)

The following illustration shows the front view of server models with 2.5-inch front drive bays (backplane-less).

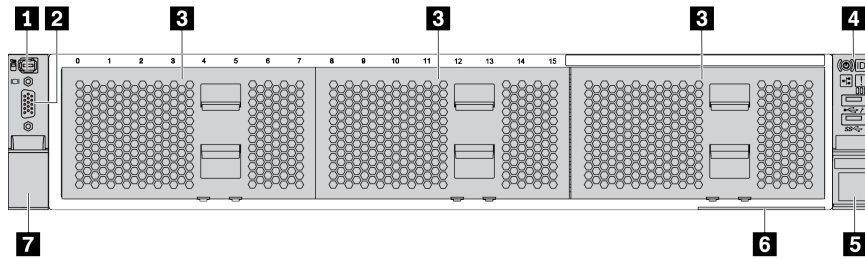

Table 8. Components on the front of server models

Callout	Callout
1 External diagnostics connector	2 VGA connector (optional)
3 Drive bay fillers(3)	4 Front I/O assembly with diagnostics panel
5 Rack latch (right)	6 Pull-out information tab
7 Rack latch (left)	

Note: For more information about each component, see [“Front components overview” on page 21](#).

Server models with eight 3.5-inch front drive bays

The following illustration shows the front view of server models with eight 3.5-inch front drive bays.

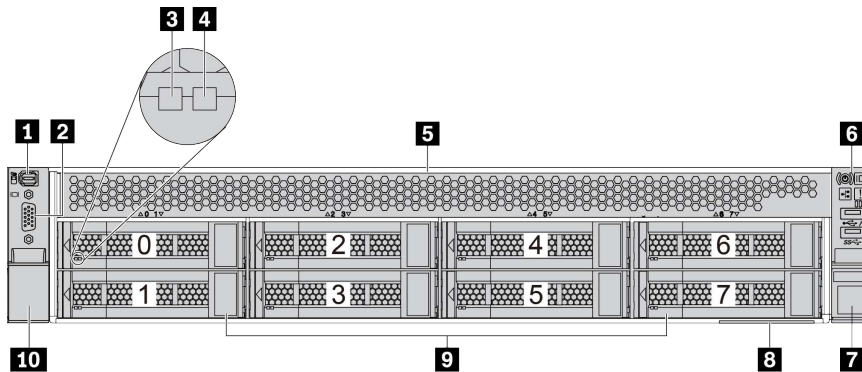

Table 9. Components on the front of server models

Callout	Callout
1 External diagnostics connector	2 VGA connector (optional)
3 Drive activity LED	4 Drive status LED
5 Drive bay filler	6 Front I/O assembly with diagnostics panel
7 Rack latch (right)	8 Pull-out information tab
9 Drive bays (8)	10 Rack latch (left)

Note: For more information about each component, see [“Front components overview” on page 21](#).

Server models with twelve 3.5-inch front drive bays

The following illustration shows the front view of server models with twelve 2.5-inch drive bays.

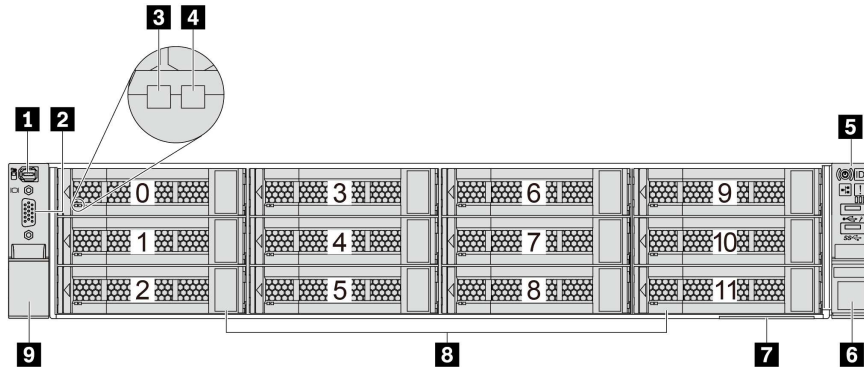

Table 10. Components on the front of server models

Callout	Callout
1 External diagnostics connector	2 VGA connector (optional)
3 Drive activity LED	4 Drive status LED
5 Front I/O assembly with diagnostics panel	6 Rack latch (right)
7 Pull-out information tab	8 Drive bays (12)
9 Rack latch (left)	

Note: For more information about each component, see [“Front components overview” on page 21](#).

Front view of server models with 3.5-inch front drive bays (backplane-less)

The following illustration shows the front view of server models with 3.5-inch drive bays (backplane-less).

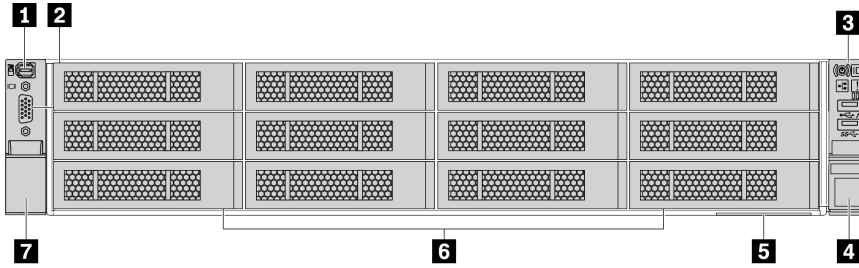

Table 11. Components on the front of server models

Callout	Callout
1 External diagnostics connector	2 VGA connector (optional)
3 Front I/O assembly with diagnostics panel	4 Rack latch (right)
5 Pull-out information tab	6 Drive bay fillers (12)
7 Rack latch (left)	

Note: For more information about each component, see [“Front components overview” on page 21](#).

Front components overview

Diagnostics panel

The diagnostics panel is integrated in front I/O assembly on some models. For information about the controls and status LEDs on the diagnostics panel, see “Diagnostics panel” on page 23.

Drive LEDs

Each hot-swap drive comes with an activity LED and status LED and the signals are controlled by the backplanes. Different colors and speeds indicate different activities or status of the drive. The following illustration shows the LEDs on a hard disk drive or solid-state drive.

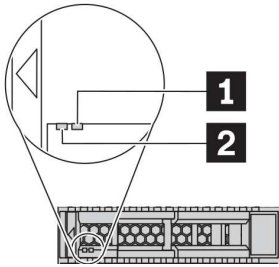

Figure 5. Drive LEDs

Drive LED	Status	Description
1 Drive status LED (right)	Solid yellow	The drive has an error.
	Blinking yellow (blinking slowly, about one flash per second)	The drive is being rebuilt.
	Blinking yellow (blinking rapidly, about four flashes per second)	The RAID adapter is locating the drive.
2 Drive activity LED (left)	Solid green	The drive is powered but not active.
	Blinking green	The drive is active.

External diagnostics connector

The connector is for connecting an external diagnostics handset. For more about its functions, see “LCD diagnostics panel/handset” on page 26.

Front I/O assembly with LCD diagnostics panel

The assembly comes with an integrated LCD diagnostics panel that can be used to quickly obtain system status, firmware levels, network information, and health information about the system. For more about the panel functions, see “LCD diagnostics panel/handset” on page 26.

Hot-swap drives and drive bays

The drive bays on the front and rear of your server are designed for hot-swap drives. The number of the installed drives in your server varies by model. When you install drives, follow the order of the drive bay numbers.

The EMI integrity and cooling of the server are protected by having all drive bays occupied. Vacant drive bays must be occupied by drive fillers.

Pull-out information tab

The Lenovo XClarity Controller network access label is attached on the pull-out information tab. The default Lenovo XClarity Controller hostname and the IPv6 Link Local Address (LLA) are provided on the tab.

Rack latches

If your server is installed in a rack, you can use the rack latches to help you slide the server out of the rack. You also can use the rack latches and screws to secure the server in the rack so that the server cannot slide out, especially in vibration-prone areas. For more information, refer to the *Rack Installation Guide* that comes with your rail kit.

USB 3.1 Gen 1 connectors

The USB 3.1 Gen 1 connectors can be used to attach a USB-compatible device, such as a USB keyboard, USB mouse, or USB storage device.

VGA connector

The VGA connectors on the front and rear of the server can be used to attach a high-performance monitor, a direct-drive monitor, or other devices that use a VGA connector.

XClarity Controller USB connector

The XClarity Controller USB connector can be used to attach an Ethernet cable to manage the system using XClarity Controller. The USB can also be used as a regular USB connector to the host OS.

Diagnostics panel

The diagnostics panel provides controls, connectors, and LEDs.

Note: Diagnostics panel with an LCD display is available for some models. For details, see “LCD diagnostics panel/handset” on page 26.

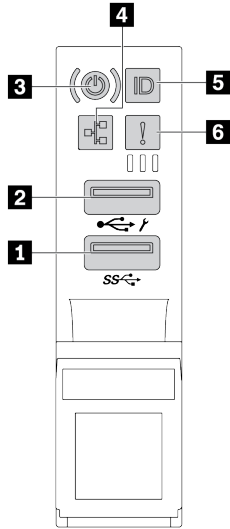

Figure 6. Front I/O assembly for server models

Table 12. Components on the front I/O assembly

Callout	Callout
1 USB 3.1 Gen 1 connector	2 USB 2.0 connector with XClarity Controller management
3 Power button with power status LED	4 Network activity LED (for OCP 3.0 Ethernet adapter)
5 System ID button with system ID LED	6 System error LED

1 USB 2.0 connector with XClarity Controller management

Depending on the setting, this connector supports USB 2.0 function, XClarity Controller management function, or both.

- If the connector is set for USB 2.0 function, you can attach a device that requires a USB 2.0 connection, such as a keyboard, a mouse, or a USB storage device.
- If the connector is set for XClarity Controller management function, you can attach a mobile device installed with the application to run XClarity Controller event logs.
- If the connector is set to have both functions, you can press the system ID button for three seconds to switch between the two functions.

2 USB 3.1 Gen 1 connector

Used to attach a device that requires a USB 2.0 or 3.1 connection, such as a keyboard, a mouse, or a USB storage device.

3 Power button with power status LED

You can press the power button to turn on the server when you finish setting up the server. You also can hold the power button for several seconds to turn off the server if you cannot turn off the server from the operating system. The power status LED helps you to determine the current power status.

Status	Color	Description
Solid on	Green	The server is on and running.
Slow blinking (about one flash per second)	Green	The server is off and is ready to be powered on (standby state).
Fast blinking (about four flashes per second)	Green	The server is off, but the XClarity Controller is initializing, and the server is not ready to be powered on.
Off	None	There is no ac power applied to the server.

4 Network activity LED

When an OCP 3.0 Ethernet adapter is installed, the network activity LED on the front I/O assembly helps you identify the network connectivity and activity.

Status	Color	Description
On	Green	The server is connected to a network.
Blinking	Green	The network is connected and active.
Off	None	The server is disconnected from the network.

Note: If no OCP 3.0 Ethernet adapter is installed, this LED is off.

System ID button with system ID LED

Use this system ID button and the blue system ID LED to visually locate the server. A system ID LED is also located on the rear of the server. Each time you press the system ID button, the state of both the system ID LEDs changes. The LEDs can be changed to on, blinking, or off.

If the XClarity Controller USB connector is set to have both the USB 2.0 function and XClarity Controller management function, you can press the system ID button for three seconds to switch between the two functions.

System error LED

The system error LED provides basic diagnostic functions for your server. If the system error LED is lit, one or more LEDs elsewhere in the server might also be lit to direct you to the source of the error.

Status	Color	Description	Action
On	Yellow	An error has been detected on the server. Causes might include but not limited to the following errors: <ul style="list-style-type: none">• A fan failure• A memory error• A storage failure• A PCIe device failure• A power supply failure• A CPU error• A system board error	Check the event log to determine the exact cause of the error. Alternatively, follow the light path diagnostics to determine if additional LEDs are lit that will direct you to identify the cause of the error. For information about light path diagnostics, see “Light path diagnostics” on page 401.
Off	None	The server is off or the server is on and is working correctly.	None.

LCD diagnostics panel/handset

The LCD diagnostics panel is a component attached to the front of the server. The external LCD diagnostics handset is an external device that can be connected to the server with a cable. Functions of the integrated component and the external device are the same, both of them can be used to quickly access system information such as active errors, system status, firmware information, network information, and health information.

Where to find the LCD diagnostics panel

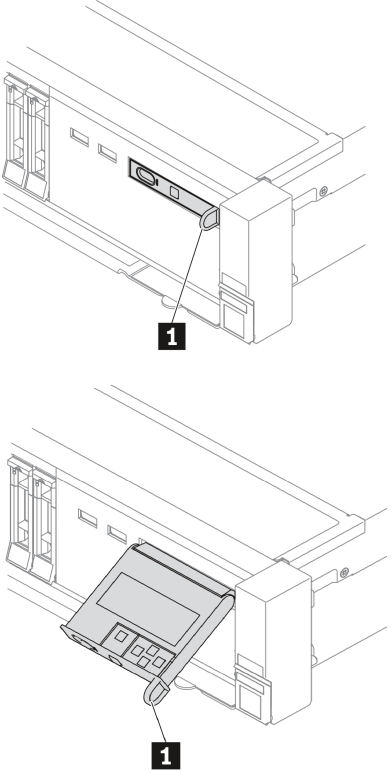
Location	Callout
<p>The LCD diagnostics panel is attached to the front of the server.</p>  <p>The top diagram shows a server rack with the LCD diagnostics panel in its closed position. A callout '1' points to the handle on the right side of the panel. The bottom diagram shows the same server rack with the LCD diagnostics panel pulled out. A callout '1' points to the handle on the right side of the panel.</p>	<p>1 The handle with which the panel can be pulled out and inserted into the rack.</p> <p>Notes:</p> <ul style="list-style-type: none">• The panel can be inserted or pulled out regardless of the system status.• When pulling out the panel, carefully hold it by the handle and avoid any hard pulling.

Where to find the external LCD diagnostics handset

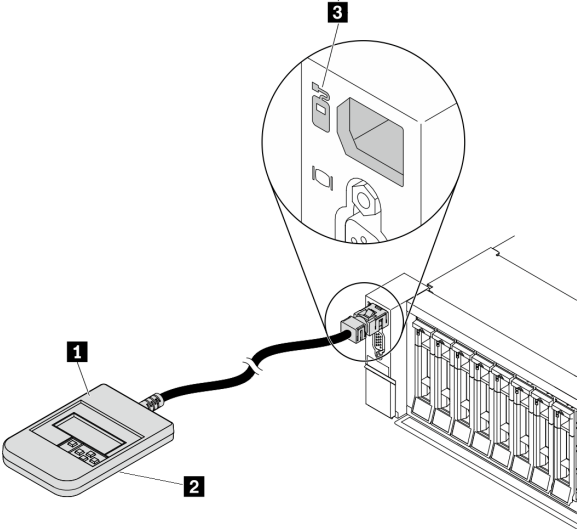
Location	Callout
<p>The external LCD diagnostics handset is connected to the server with an external cable.</p>  <p>The diagram shows a server rack with a cable connected to an external LCD diagnostics handset. Callout 1 points to the handset, callout 2 points to the magnetic bottom, and callout 3 points to the external diagnostics connector on the server.</p>	<p>1 The LCD diagnostics handset that can be connected to the server with an external cable.</p> <p>2 The magnetic bottom with which the device can be attached to the top or side of the rack. This is helpful and can free up both hands for certain service tasks.</p> <p>3 The external diagnostics connector on the front of the server that can be used to connect an external LCD diagnostics handset.</p>

Note: Pay attention to the following steps when unplugging the external handset:

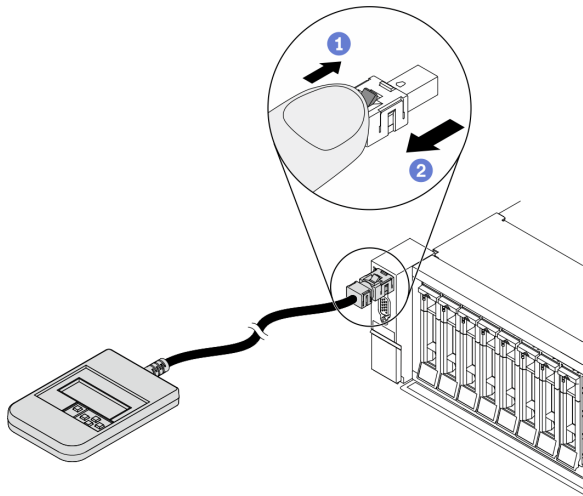

Step 1. Press the plastic clip on the plug in the shown direction.

Step 2. Gently pull out the cable from the connector while keeping the clip pressed down.

LCD diagnostics panel overview

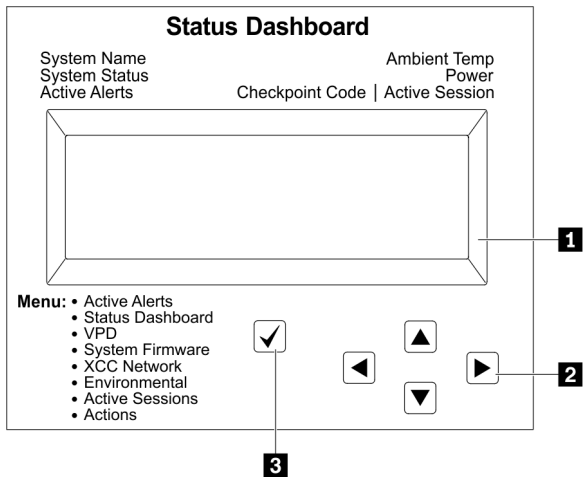

1 LCD display

2 Scroll buttons (up/down/left/right).

Press the scroll buttons to locate and select system information.

3 Select button.

Press the select button to select from the menu options.

Options flow diagram

The LCD diagnostics panel/handset shows various system information. Navigate through the options with the scroll keys.

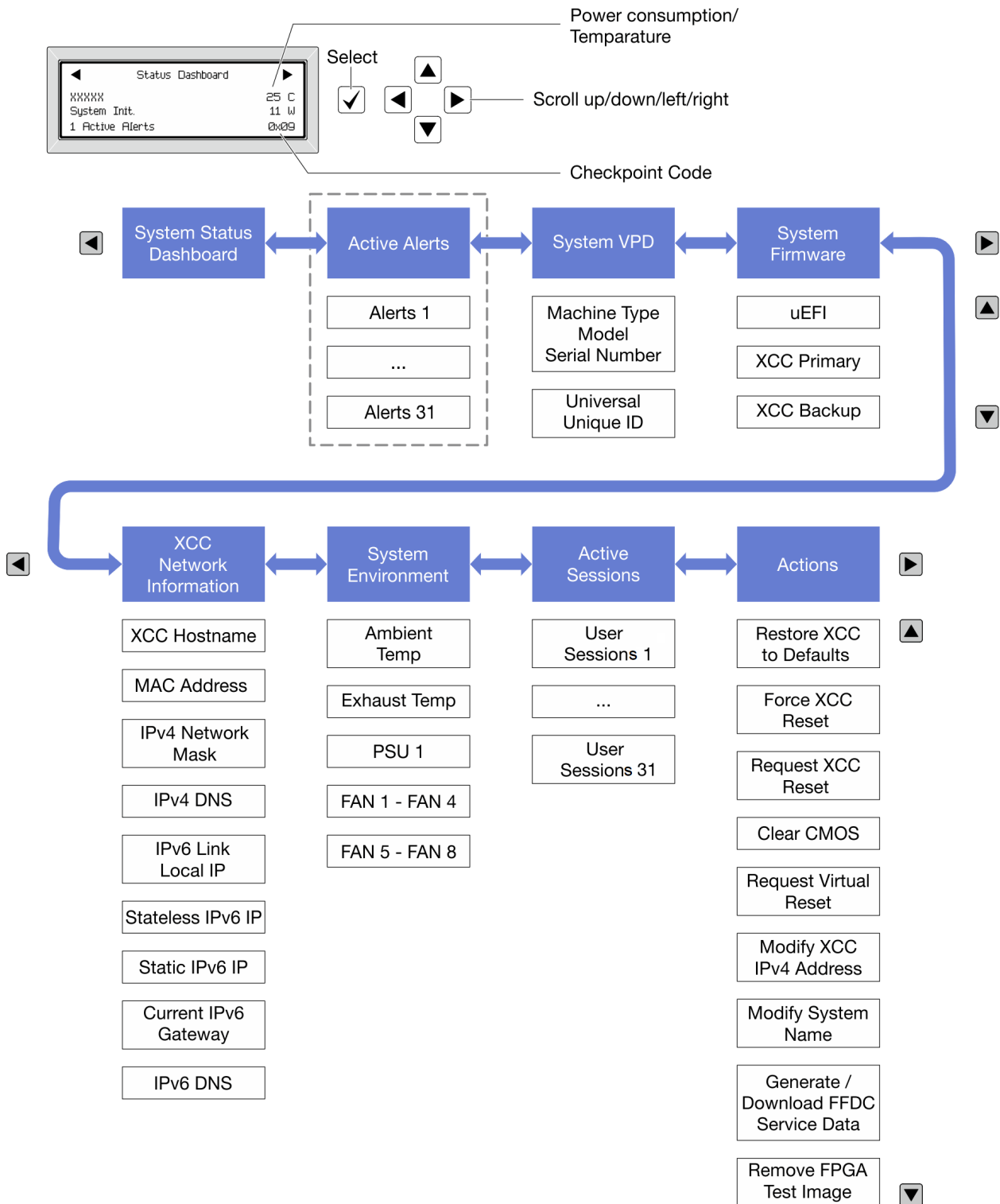

Full menu list

Following is the list of options available on the LCD diagnostics panel/handset. Switch between an option and the subordinate information entries with the select button, and switch among options or information entries with the scroll buttons.

Home Menu (System Status Dashboard)

Home Menu	Example
<ul style="list-style-type: none"> 1 System name 2 System status 3 Active alert quantity 4 Temperature 5 Power consumption 6 Checkpoint code 	<p>The screenshot shows a 'Status Dashboard' screen with the following items: 'xxxxxx' (1), 'System Init.' (2), '1 Active Alerts' (3), '25 C' (4), '11 W' (5), and '0x09' (6). Navigation arrows are visible at the top.</p>

Active Alerts

Sub Menu	Example
Home screen: Active error quantity Note: The "Active Alerts" menu displays only the quantity of active errors. If no errors occur, the "Active Alerts" menu will not be available during navigation.	1 Active Alerts
Details screen: <ul style="list-style-type: none"> • Error message ID (Type: Error/Warning/Information) • Occurrence time • Possible sources of the error 	Active Alerts: 1 Press ▼ to view alert details FQXSPPU009N(Error) 04/07/2020 02:37:39 PM CPU 1 Status: Configuration Error

System VPD Information

Sub Menu	Example
<ul style="list-style-type: none"> • Machine type and serial number • Universal Unique ID (UUID) 	Machine Type: xxxx Serial Num: xxxxxx Universal Unique ID: xxxxxxxxxxxxxxxxxxxxxxxxxxxxxxxxxxxx

System Firmware

Sub Menu	Example
UEFI <ul style="list-style-type: none"> Firmware level (status) Build ID Version number Release date 	UEFI (Inactive) Build: D0E101P Version: 1.00 Date: 2019-12-26
XCC Primary <ul style="list-style-type: none"> Firmware level (status) Build ID Version number Release date 	XCC Primary (Active) Build: DVI399T Version: 4.07 Date: 2020-04-07
XCC Backup <ul style="list-style-type: none"> Firmware level (status) Build ID Version number Release date 	XCC Backup (Active) Build: D8BT05I Version: 1.00 Date: 2019-12-30

XCC Network Information

Sub Menu	Example
<ul style="list-style-type: none"> XCC hostname MAC address IPv4 Network Mask IPv4 DNS IPv6 Link Local IP Stateless IPv6 IP Static IPv6 IP Current IPv6 Gateway IPv6 DNS <p>Note: Only the MAC address that is currently in use is displayed (extension or shared).</p>	XCC Network Information XCC Hostname: XCC-xxxx-SN MAC Address: xx:xx:xx:xx:xx:xx IPv4 IP: xx.xx.xx.xx IPv4 Network Mask :x.x.x.x IPv4 Default Gateway : x.x.x.x

System Environmental Information

Sub Menu	Example
<ul style="list-style-type: none"> • Ambient temperature • Exhaust temperature • PSU status • Spinning speed of fans by RPM 	<pre>Ambient Temp: 24 C Exhaust Temp: 0 C PSU1: Vin= 213 w Inlet= 26 C FAN1 Front: 21000 RPM FAN2 Front: 21000 RPM FAN3 Front: 21000 RPM FAN4 Front: 21000 RPM</pre>

Active Sessions

Sub Menu	Example
Quantity of active sessions	Active User Sessions: 1

Actions

Sub Menu	Example
<p>Several quick actions supported for users</p> <ul style="list-style-type: none"> • Restore XCC to Defaults • Force XCC Reset • Request XCC Reset • Clear CMOS • Request Virtual Reseat • Modify XCC Static IPv4 Address/Net mask/ Gateway • Modify System Name • Generate/Download FFDC Service Data • Remove FPGA Test Image 	<pre>Request XCC Reset? This will request the BMC to reboot itself. Hold √ for 3 seconds</pre>

Rear view

The rear of the server provides access to several connectors and components.

Refer to the following rear view for different server models:

- “Server model with eight PCIe slots” on page 34
- “Server model with four 2.5-inch rear drive bays and six PCIe slots” on page 35
- “Server model with eight 2.5-inch rear drive bays and four PCIe slots” on page 36
- “Server model with two 3.5-inch rear drive bays and four PCIe slots” on page 37
- “Server model with four 3.5-inch rear drive bays and two PCIe slots” on page 38

Server models with eight PCIe slots

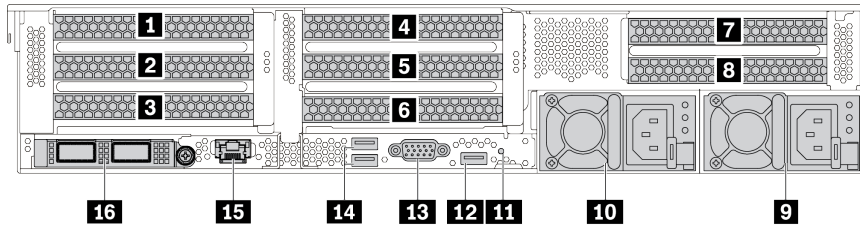

Table 13. Components on the rear of the server

Callout	Callout
1 PCIe slot 1 (on riser 1 assembly)	2 PCIe slot 2 (on riser 1 assembly)
3 PCIe slot 3 (on riser 1 assembly)	4 PCIe slot 4 (on riser 2 assembly)
5 PCIe slot 5 (on riser 2 assembly)	6 PCIe slot 6 (on riser 2 assembly)
7 PCIe slot 7 (on riser 3 assembly)	8 PCIe slot 8 (on riser 3 assembly)
9 Power supply 1	10 Power supply 2 (optional)
11 NMI button	12 USB 3.1 Gen 1 connector
13 VGA connector	14 USB 3.1 Gen 1 connectors (2)
15 XClarity Controller Network connector	16 Ethernet connectors on OCP 3.0 Ethernet adapter (optional, two or four connectors may be available)

Note: For more information about each component, see “Rear components overview” on page 39.

Server models with four 2.5-inch rear drive bays and six PCIe slots

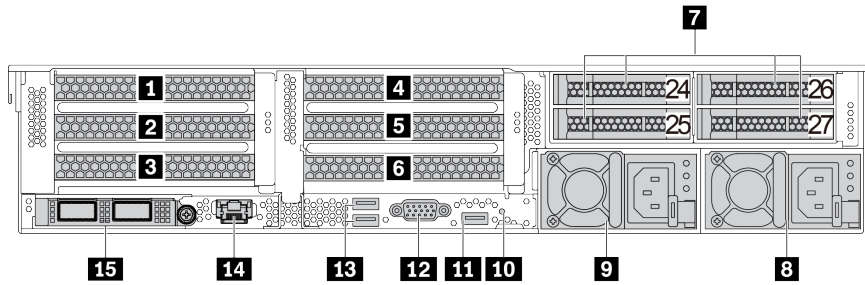

Table 14. Components on the rear of the server

Callout	Callout
1 PCIe slot 1 (on riser 1 assembly)	2 PCIe slot 2 (on riser 1 assembly)
3 PCIe slot 3 (on riser 1 assembly)	4 PCIe slot 4 (on riser 2 assembly)
5 PCIe slot 5 (on riser 2 assembly)	6 PCIe slot 6 (on riser 2 assembly)
7 2.5-inch rear drive bays (4)	8 Power supply 1
9 Power supply 2 (optional)	10 NMI button
11 USB 3.1 Gen 1 connector	12 VGA connector
13 USB 3.1 Gen 1 connectors (2)	14 XClarity Controller Network connector
15 Ethernet connectors on OCP 3.0 Ethernet adapter (optional, two or four connectors may be available)	

Note: For more information about each component, see “Rear components overview” on page 39.

Server models with eight 2.5-inch rear drive bays and four PCIe slots

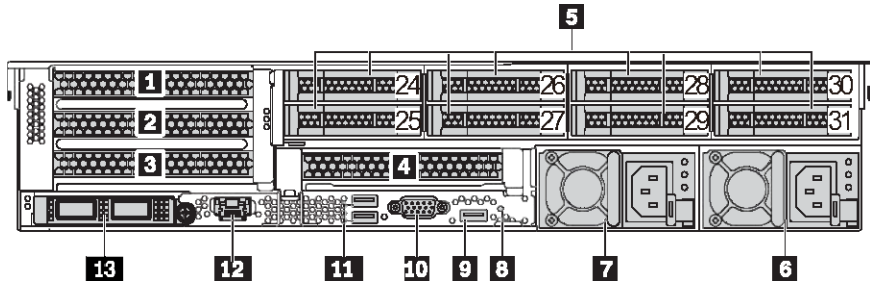

Table 15. Components on the rear of the server

Callout	Callout
1 PCIe slot 1 (on riser 1 assembly)	2 PCIe slot 2 (on riser 1 assembly)
3 PCIe slot 3 (on riser 1 assembly)	4 PCIe slot 6 (on riser 2 assembly)
5 2.5-inch rear drive bays (8)	6 Power supply 1
7 Power supply 2 (optional)	8 NMI button
9 USB 3.1 Gen 1 connector	10 VGA connector
11 USB 3.1 Gen 1 connectors (2)	12 XClarity Controller Network connector
13 Ethernet connectors on OCP 3.0 Ethernet adapter (optional, two or four connectors may be available)	

Note: For more information about each component, see “Rear components overview” on page 39.

Server models with two 3.5-inch rear drive bays and four PCIe slots

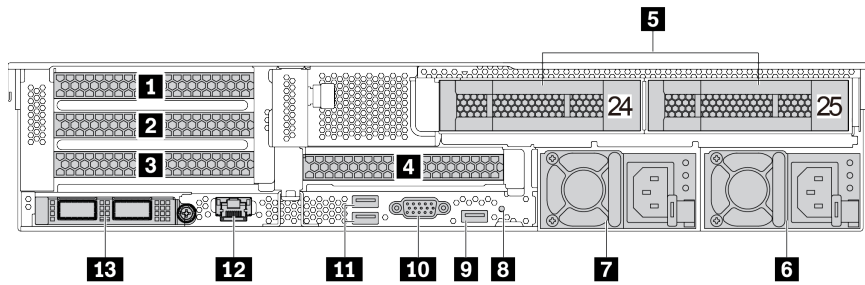

Table 16. Components on the rear of the server

Callout	Callout
1 PCIe slot 1 (on riser 1 assembly)	2 PCIe slot 2 (on riser 1 assembly)
3 PCIe slot 3 (on riser 1 assembly)	4 PCIe slot 6 (on riser 2 assembly)
5 3.5-inch rear drive bays (2)	6 Power supply 1
7 Power supply 2 (optional)	8 NMI button
9 USB 3.1 Gen 1 connector	10 VGA connector
11 USB 3.1 Gen 1 connectors (2)	12 XClarity Controller Network connector
13 Ethernet connectors on OCP 3.0 Ethernet adapter (optional, two or four connectors may be available)	

Note: For more information about each component, see “Rear components overview” on page 39.

Server models with four 3.5-inch rear drive bays and two PCIe slots

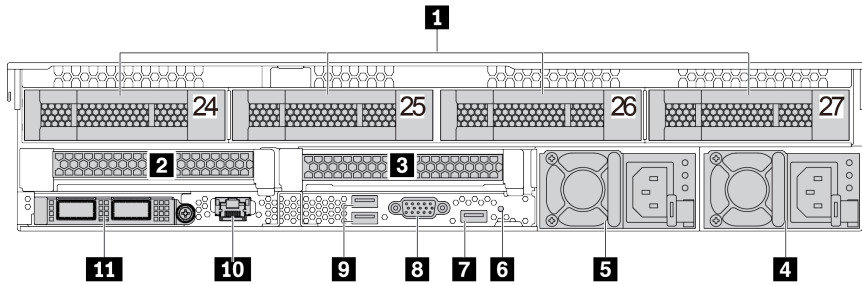

Table 17. Components on the rear of the server

Callout	Callout
1 3.5-inch rear drive bays (4)	2 PCIe slot 3 (on riser 1 assembly)
3 PCIe slot 6 (on riser 2 assembly)	4 Power supply 1
5 Power supply 2 (optional)	6 NMI button
7 USB 3.1 Gen 1 connector	8 VGA connector
9 USB 3.1 Gen 1 connectors (2)	10 XClarity Controller Network connector
11 Ethernet connectors on OCP 3.0 Ethernet adapter (optional, two or four connectors may be available)	

Note: For more information about each component, see “Rear components overview” on page 39.

Rear components overview

Drive LEDs

Each hot-swap drive comes with an activity LED and status LED and the signals are controlled by the backplanes. Different colors and speeds indicate different activities or status of the drive. The following illustration shows the LEDs on a Hard disk drive or solid-state drive.

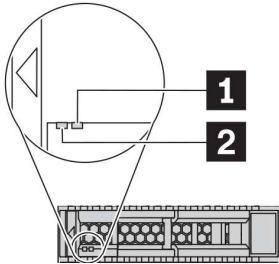

Figure 7. Drive LEDs

Drive LED	Status	Description
1 Drive status LED (right)	Solid yellow	The drive has an error.
	Blinking yellow (blinking slowly, about one flash per second)	The drive is being rebuilt.
	Blinking yellow (blinking rapidly, about four flashes per second)	The RAID adapter is locating the drive.
2 Drive activity LED (left)	Solid green	The drive is powered but not active.
	Blinking green	The drive is active.

Ethernet connectors

The OCP 3.0 Ethernet adapter provides two or four extra Ethernet connectors for network connections.

One of the Ethernet connectors on the OCP 3.0 Ethernet adapter can also function as a management connector using the shared management capacity. If the shared management connector fails, traffic can automatically switch over to another connector on the adapter.

Hot-swap drives and drive bays

The drive bays on the front and rear of your server are designed for hot-swap drives. The number of the installed drives in your server varies by model. When you install drives, follow the order of the drive bay numbers.

The EMI integrity and cooling of the server are protected by having all drive bays occupied. Vacant drive bays must be occupied by drive fillers.

NMI button

Press this button to force a nonmaskable interrupt (NMI) to the processor. By this way, you can make the operating system halt (such as Windows Blue Screen of Death) and take a memory dump. You might have to use a pen or the end of a straightened paper clip to press the button.

PCIe slots

The PCIe slots are on the rear of the server and your server supports up to eight PCIe slots on riser 1, 2, and 3 assemblies. Below lists all supported parts in the slots:

- RAID/HBA adapters
- COM cable
- GPU adapters
- PCIe SSDs
- PCIe switch
- 7mm SSDs (slot 6 only)

Power supplies

The hot-swap redundant power supply helps you avoid significant interruption to the operation of the system when a power supply fails. You can purchase a power supply option from Lenovo and install the power supply to provide power redundancy without turning off the server.

On each power supply, there are three status LEDs near the power cord connector. For information about the LEDs, see “Rear view LEDs” on page 41.

USB 3.1 Gen 1 connectors

The USB 3.1 Gen 1 connectors can be used to attach a USB-compatible device, such as a USB keyboard, USB mouse, or USB storage device.

VGA connector

The VGA connectors on the front and rear of the server can be used to attach a high-performance monitor, a direct-drive monitor, or other devices that use a VGA connector.

XClarity Controller network connector

The XClarity Controller network connector can be used to attach an Ethernet cable to manage the baseboard management controller (BMC).

Rear view LEDs

The illustration in this section shows the LEDs on the rear of the server.

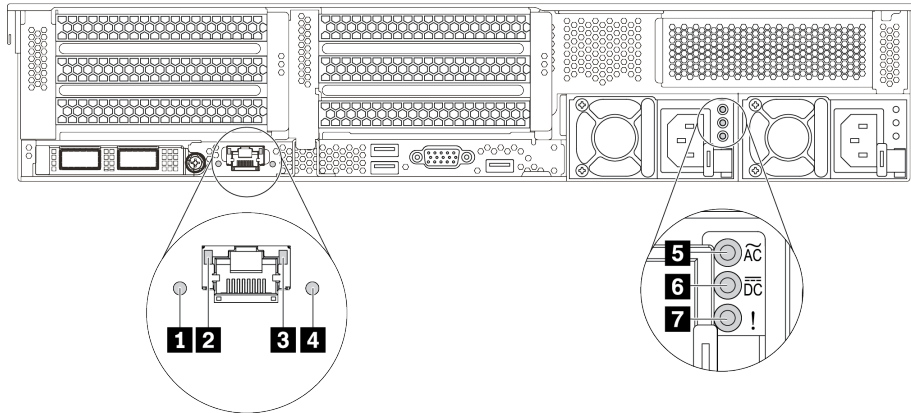

Figure 8. Rear view LEDs of the server

Table 18. LEDs on the rear of the server

Callout	Callout
1 System ID LED	2 Ethernet link LED
3 Ethernet activity LED	4 System error LED
5 Power input LED	6 Power output LED
7 Power supply error LED	

1 System error LED

The system error LED provides basic diagnostic functions for your server. If the system error LED is lit, one or more LEDs elsewhere in the server might also be lit to direct you to the source of the error. For more information, see “Diagnostics panel” on page 23.

2 3 Ethernet status LEDs

The BMC management connector has two status LEDs.

Ethernet status LED	Color	Status	Description
2 Ethernet link LED	Green	On	Network link is established.
	None	Off	Network link is disconnected.
3 Ethernet activity LED	Green	Blinking	Network link is connected and active.
	None	Off	The server is disconnected from a LAN.

4 System ID LED

The blue system ID LED helps you to visually locate the server. A system ID LED is also located on the front of the server. Each time you press the system ID button, the state of both the system ID LEDs changes. The LEDs can be changed to on, blinking, or off.

5 Power input LED

6 Power output LED

7 Power supply error LED

Each hot-swap power supply has three status LEDs.

LED	Description
5 Power input LED	<ul style="list-style-type: none">Green: The power supply is connected to the ac power source.Off: The power supply is disconnected from the ac power source or a power problem occurs.
6 Power output LED	<ul style="list-style-type: none">Green: The server is on and the power supply is working normally.Blinking green: The power supply is in zero-output mode (standby). When the server power load is low, one of the installed power supplies enters into the standby state while the other one delivers entire load. When the power load increases, the standby power supply will switch to active state to provide sufficient power to the server. To disable zero-output mode, start the Setup utility, go to Advanced → Power → Zero Output and select Disable. If you disable zero-output mode, both power supplies will be in the active state.Off: The server is powered off, or the power supply is not working properly. If the server is powered on but the power output LED is off, replace the power supply.
7 Power supply error LED	<ul style="list-style-type: none">Yellow: The power supply has failed. To resolve the issue, replace the power supply.Off: The power supply is working normally.

System board components

The illustration in this section shows the component locations on the system board.

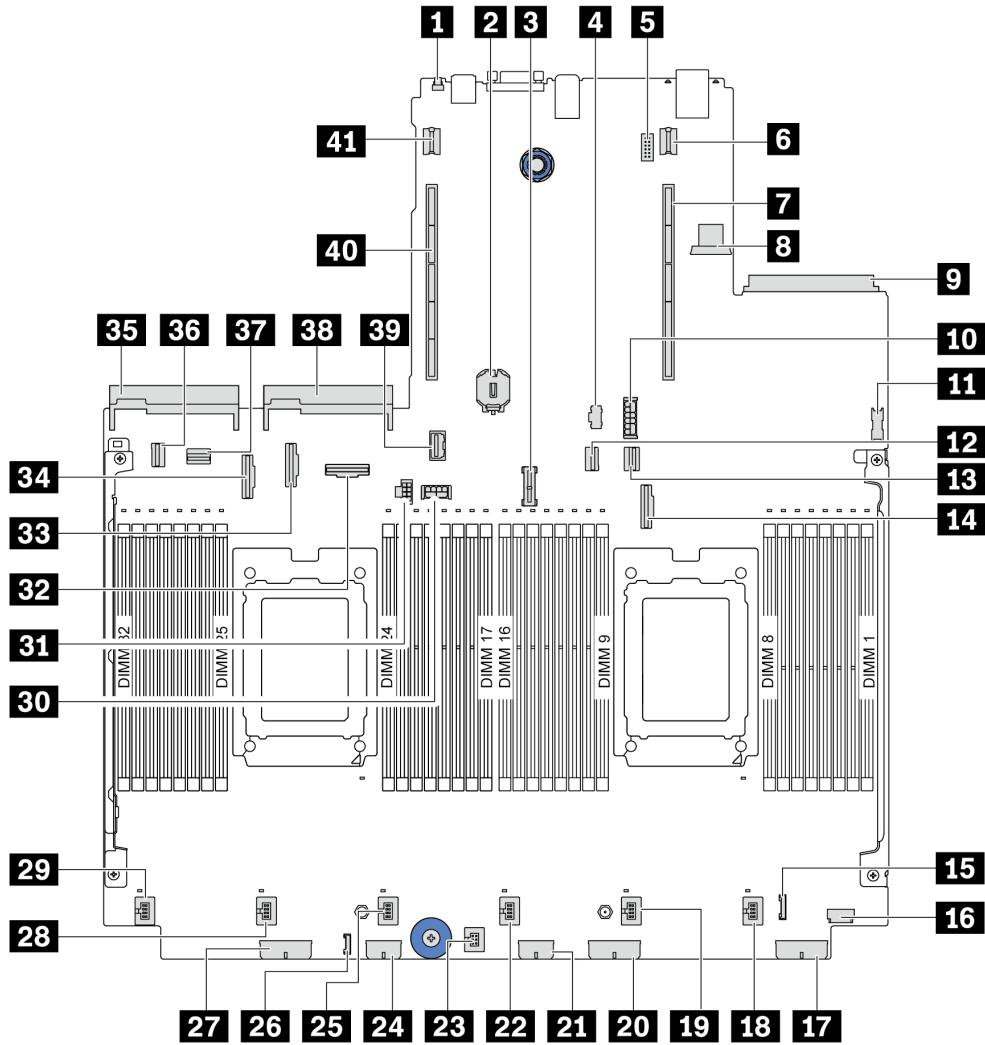

Figure 9. System board components

1 NMI button	2 CMOS battery (CR2032)
3 TPM module connector	4 M.2 power connector
5 Serial port module connector	6 Riser 1 power connector
7 Riser 1 slot	8 Internal USB connector
9 OCP 3.0 Ethernet adapter connector	10 7 mm SSD power connector
11 Front USB connector	12 PCIe connector 1
13 PCIe connector 2	14 PCIe connector 3
15 Front I/O connector	16 Front VGA connector

17 Backplane power connector 3	18 Fan 1 connector
19 Fan 2 connector	20 Backplane power connector 2
21 Internal expander power connector	22 Fan 3 connector
23 Intrusion switch connector	24 Internal RAID power connector
25 Fan 4 connector	26 External LCD connector
27 Backplane power connector 1	28 Fan 5 connector
29 Fan 6 connector	30 Riser 3 GPU power connector
31 Riser 3 power connector	32 PCIe connector 6
33 PCIe connector 8	34 PCIe connector 7
35 Power supply 1 connector	36 PCIe connector 4
37 PCIe connector 5	38 Power supply 2 connector
39 Riser 3 sideband connector	40 Riser 2 slot
41 Riser 2 power connector	

System board LEDs

The illustration in this section shows the LEDs on the system board.

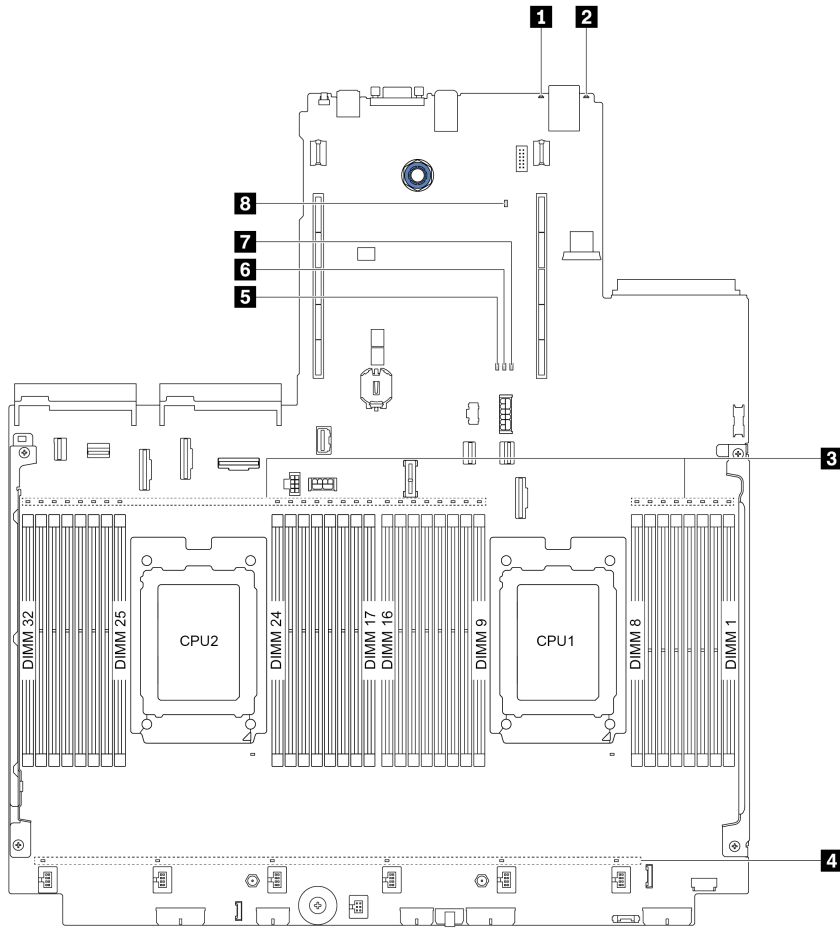

Figure 10. System board LEDs

Table 19. LEDs on the system board

Callout	Callout
1 System error LED	2 System ID LED
3 DIMM error LEDs (32)	4 Fan error LEDs (6)
5 FPGA error LED	6 FPGA heartbeat LED
7 FPGA power LED	8 BMC heart beat LED

1 System error LED

When this yellow LED is lit, one or more LEDs elsewhere in the server might also be lit to direct you to the source of the error. For more information, see “Diagnostics panel” on page 23.

2 System ID LED

The blue system ID LED helps you to visually locate the server. A system ID LED is also located on the front of the server. Each time you press the system ID button, the state of both the system ID LEDs changes. The LEDs can be changed to on, blinking, or off.

3 DIMM error LEDs

When a DIMM error LED is lit, it indicates that the corresponding memory module has failed.

4 Fan error LEDs

When a fan error LED is lit, it indicates that the corresponding system fan is operating slowly or has failed.

5 FPGA error LED

The FPGA error LED helps you identify different FPGA errors.

Status	Color	Description
On	Green	FPGA running image is test build image.
Blinking	Green	<ul style="list-style-type: none">Blinking (blinking slowly, about one flash per second): Power Fault happened.Blinking (blinking rapidly, about four flashes per second): FPGA does not assert RSMRST_N.
Off	None	No Power Fault.

6 FPGA heart beat LED

The FPGA heart beat LED helps you identify different FPGA errors.

Status	Color	Description
On or Off	Green	FPGA does not work.
Blinking	Green	FPGA works normally.

7 FPGA power LED

The FPGA power LED helps you identify different FPGA errors.

Status	Color	Description
On	Green	The FPGA power is on.
Blinking	Green	<ul style="list-style-type: none">Blinking (blinking slowly, about one flash per second): The FPGA power is off.Blinking (blinking rapidly, about four flashes per second): The FPGA permission is delayed.

8 XCC heart beat LED

The XCC heart beat LED helps you identify the XCC status.

Status	Color	Description
On	Green	The XCC is not alive.
Blinking	Green	The XCC is alive.
Off	None	The XCC is not alive.

Switch block and jumper

The following illustrates locations and functions of the switch block and jumper on the system board.

Important:

- Before you move any jumpers, turn off the server; then, disconnect all power cords and external cables.
Do not open your server or attempt any repair before reading and understanding the following information:
 - http://thinksystem.lenovofiles.com/help/topic/safety_documentation/pdf_files.html
 - “Handling static-sensitive devices” on page 131
- If there is a clear protective sticker on the top of the switch blocks, you must remove and discard it to access the switches.
- Any system-board switch or jumper block that is not shown in the illustrations in this document is reserved.

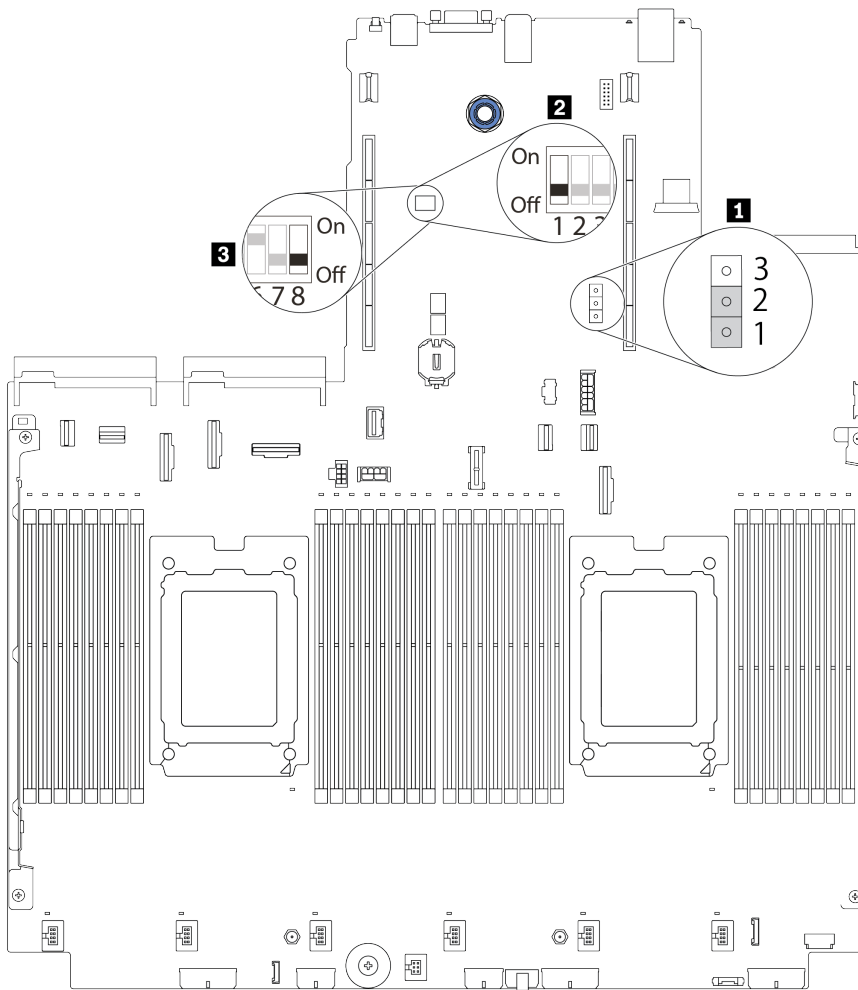

Figure 11. Switch block and jumper locations on system board

Table 20. Switch block and jumper description

Switch/jumper name	Switch/jumper number	Description
1 Clear CMOS jumper	J1	<ul style="list-style-type: none"> • Pins 1 and 2: The jumper is in default setting. • Pins 2 and 3: Clear the real-time clock (RTC) registry.
2, 3 Switch 1 block	SW1	<ul style="list-style-type: none"> • Switch 1: One-time power-on password bypass <ul style="list-style-type: none"> – Toggle to ON or OFF to bypass the power-on password for one time. After bypassing the password, you can boot the server and set a new one in UEFI Setup interface. <p>Note: The switch cannot skip the privilege administrator password.</p> • Switch 3: TPM physical presence status (Default setting: OFF) <ul style="list-style-type: none"> – Toggle to ON to assert host TPM physical presence, which is required for some security settings. • Switch 4: XCC force update (Default setting: OFF) <ul style="list-style-type: none"> – Toggle to ON to force XClarity Controller firmware to enter the booting mode (For development purpose only). • Switch 5: XCC SPI0 half ROM (Default setting: OFF) <ul style="list-style-type: none"> – Toggle to ON to force XClarity Controller to boot from a backup image. • Switch 6: Low security (Default setting: OFF) <ul style="list-style-type: none"> – Toggle to ON to enable low security mode for XClarity Controller firmware (For development purpose only). • Switch 2, 7, 8: Reserved

Parts list

Use the parts list to identify each of the components that are available for your server.

For more information about ordering the parts shown in Figure 12 “Server components” on page 51:

<https://datacentersupport.lenovo.com/us/en/products/servers/thinksystem/sr665/7d2w/parts>

Note: Depending on the model, your server might look slightly different from the illustration. Some parts are available only on some models.

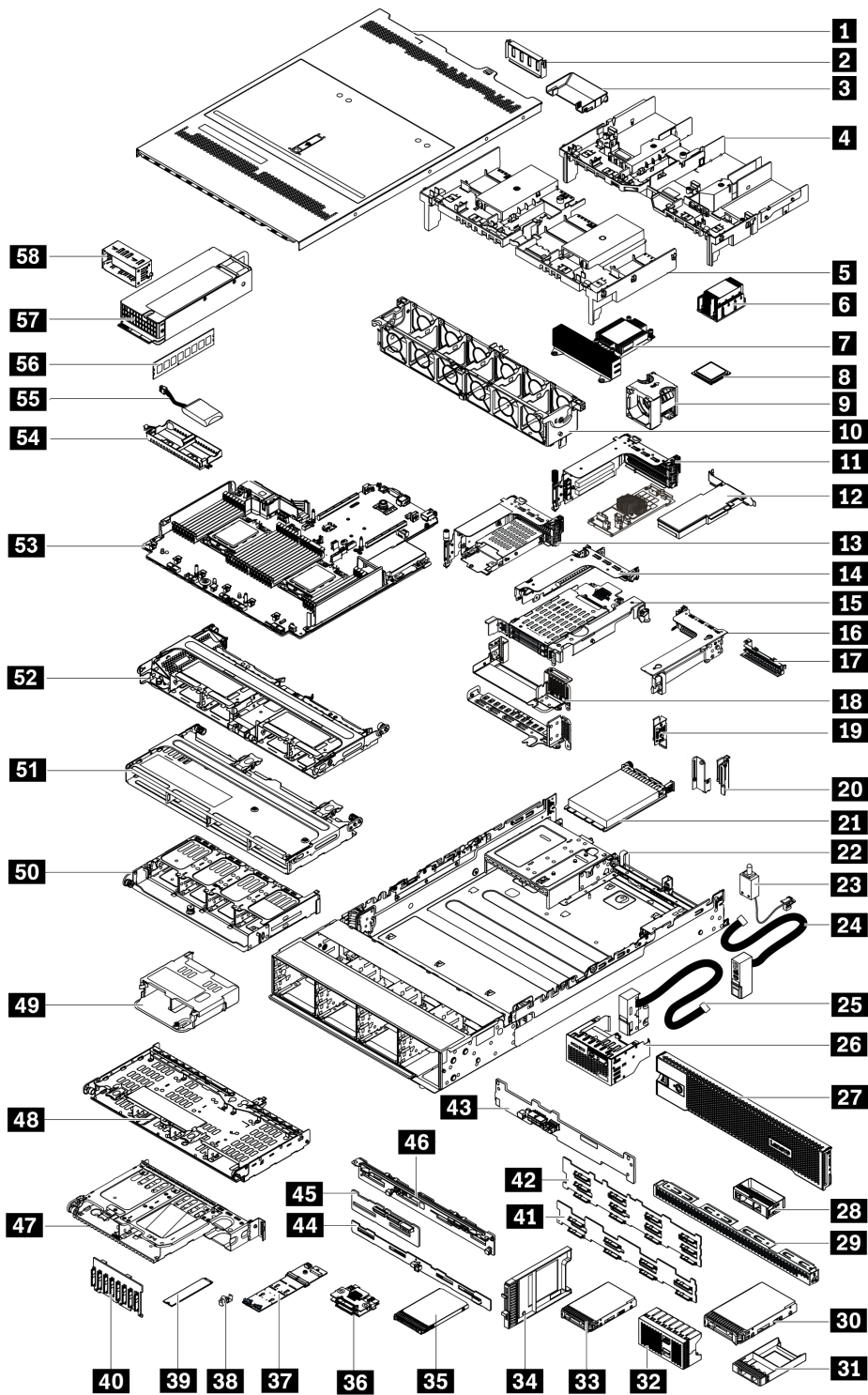

Figure 12. Server components

The parts listed in the following table are identified as one of the following:

- **Tier 1 customer replaceable unit (CRU):** Replacement of Tier 1 CRUs is your responsibility. If Lenovo installs a Tier 1 CRU at your request with no service agreement, you will be charged for the installation.

- **Tier 2 customer replaceable unit:** You may install a Tier 2 CRU yourself or request Lenovo to install it, at no additional charge, under the type of warranty service that is designated for your server.
- **Field replaceable unit (FRU):** FRUs must be installed only by trained service technicians.
- **Consumable and Structural parts:** Purchase and replacement of consumable and structural parts is your responsibility. If Lenovo acquires or installs a structural component at your request, you will be charged for the service.

Table 21. Parts listing

Index	Description	Tier 1 CRU	Tier 2 CRU	FRU	Consumable and Structural parts
For more information about ordering the parts shown in Figure 12 “Server components” on page 51: https://datacentersupport.lenovo.com/us/en/products/servers/thinksystem/sr665/7d2w/parts					
1	Top cover	√			
2	GPU air baffle filler				√
3	Add-on GPU air baffle	√			
4	GPU air baffle	√			
5	Standard air baffle	√			
6	Standard heat sink			√	
7	Performance heat sink (T-shape)			√	
8	Processor			√	
9	Fan module	√			
10	Fan cage	√			
11	Riser 1/2 assembly, 3 FH	√			
12	Internal SFF RAID/HBA/PCIe switch adapter or internal CFF RAID/HBA/Expander adapter	√			
13	Riser 1 assembly, 7mm drive cage+2 FH slots	√			
14	Riser 2 assembly, 1 full-height slot	√			
15	Riser 2 7mm drive assembly	√			
16	Riser 3 assembly, 2FH	√			
17	Riser 2 filler, 1FH				√
18	Rearwall bracket (right, C1 or C2)	√			
19	Rearwall bracket (left, A1)	√			
20	Rearwall brackets (middle, B1 or B2)	√			
21	OCP 3.0 Ethernet adapter	√			
22	Chassis			√	
23	Intrusion switch cable	√			

Table 21. Parts listing (continued)

Index	Description	Tier 1 CRU	Tier 2 CRU	FRU	Consumable and Structural parts
24	Rack latch (integrated with front I/O)	√			
25	Standard rack latch	√			
26	Front I/O assembly with LCD diagnostics panel	√			
27	Security bezel	√			
28	1 x 3.5-inch drive bay filler				√
29	4 x 3.5-inch drive bay filler				√
30	3.5-inch drive	√			
31	1 x 2.5-inch drive bay filler				√
32	4 x 2.5-inch drive bay filler				√
33	2.5-inch drive	√			
34	7mm drive filler				√
35	7mm drive	√			
36	7mm drive backplanes (top+bottom)		√		
37	M.2 adapter			√	
38	M.2 retainer clip		√		
39	M.2 drive			√	
40	8 x 2.5-inch front drive backplane	√			
41	8 x 3.5-inch front drive backplane	√			
42	12 x 3.5-inch front drive backplane	√			
43	2 x 3.5-inch rear drive backplane	√			
44	8 x 2.5-inch rear drive backplane	√			
45	4 x 2.5-inch rear/middle drive backplane	√			
46	4 x 3.5-inch rear/middle drive backplane	√			
47	2 x 3.5-inch rear drive cage (BP4)	√			
48	4 x 3.5-inch rear drive cage (BP4)	√			
49	4 x 2.5-inch rear drive cage (BP4)	√			
50	8 x 2.5-inch rear drive cage (BP4)	√			
51	4 x 3.5-inch middle drive cage (BP5)	√			
52	8 x 2.5-inch middle drive cage (BP5, BP6)	√			
53	System board			√	
54	RAID super capacitor holder				√

Table 21. Parts listing (continued)

Index	Description	Tier 1 CRU	Tier 2 CRU	FRU	Consumable and Structural parts
55	RAID super capacitor module	√			
56	Memory module	√			
57	Power supply unit	√			
58	Power supply unit filler				√
59					

Power cords

Several power cords are available, depending on the country and region where the server is installed.

To view the power cords that are available for the server:

1. Go to: <http://dcsc.lenovo.com/#/>
2. Click **Preconfigured Model** or **Configure to order**.
3. Enter the machine type and model for your server to display the configurator page.
4. Click **Power** → **Power Cables** to see all line cords.

Notes:

- For your safety, a power cord with a grounded attachment plug is provided to use with this product. To avoid electrical shock, always use the power cord and plug with a properly grounded outlet.
- Power cords for this product that are used in the United States and Canada are listed by Underwriter's Laboratories (UL) and certified by the Canadian Standards Association (CSA).
- For units intended to be operated at 115 volts: Use a UL-listed and CSA-certified cord set consisting of a minimum of 18 AWG, Type SVT or SJT, three-conductor cord, a maximum of 15 feet in length and a parallel blade, grounding-type attachment plug rated 15 amperes, 125 volts.
- For units intended to be operated at 230 volts (U.S. use): Use a UL-listed and CSA-certified cord set consisting of a minimum of 18 AWG, Type SVT or SJT, three-conductor cord, a maximum of 15 feet in length and a tandem blade, grounding-type attachment plug rated 15 amperes, 250 volts.
- For units intended to be operated at 230 volts (outside the U.S.): Use a cord set with a grounding-type attachment plug. The cord set should have the appropriate safety approvals for the country in which the equipment will be installed.
- Power cords for a specific country or region are usually available only in that country or region.

Chapter 3. Internal cable routing

Some of the components in the server have internal cables and cable connectors.

To connect cables, observe the following guidelines:

- Turn off the server before you connect or disconnect any internal cables.
- See the documentation that comes with any external devices for additional cabling instructions. It might be easier for you to route cables before you connect the devices to the server.
- Cable identifiers of some cables are printed on the cables that come with the server and optional devices. Use these identifiers to connect the cables to the correct connectors.
- Ensure that the cable is not pinched and does not cover any connectors or obstruct any components on the system board.
- Ensure that the relevant cables pass through the cable clips.

Note: Disengage all latches, release tabs, or locks on cable connectors when you disconnect cables from the system board. Failing to release them before removing the cables will damage the cable sockets on the system board, which are fragile. Any damage to the cable sockets might require replacing the system board.

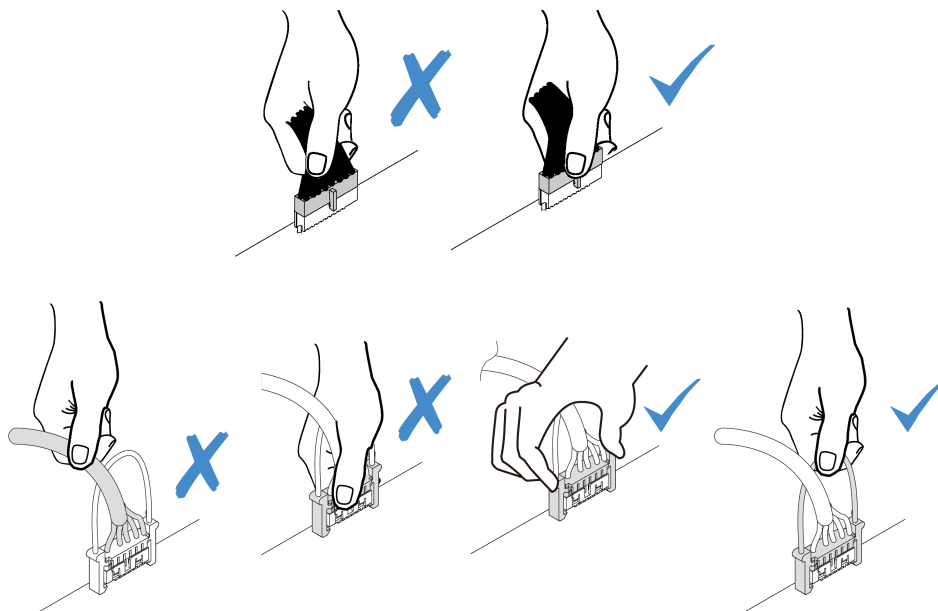

Front I/O assembly

Use the section to understand the cable routing for front I/O assemblies.

Notes:

- The illustration shows the cabling scenario for server models with twelve 3.5-inch front drive bays. Location of each connector on the front of the server varies by models. For detailed location of front I/O components for different models, see [“Front view” on page 11](#).
- When routing the callout **3** cable, ensure that it is fixed on the upper frame of the cable retainer. For details, refer to [“Install the rack latches” on page 282](#).

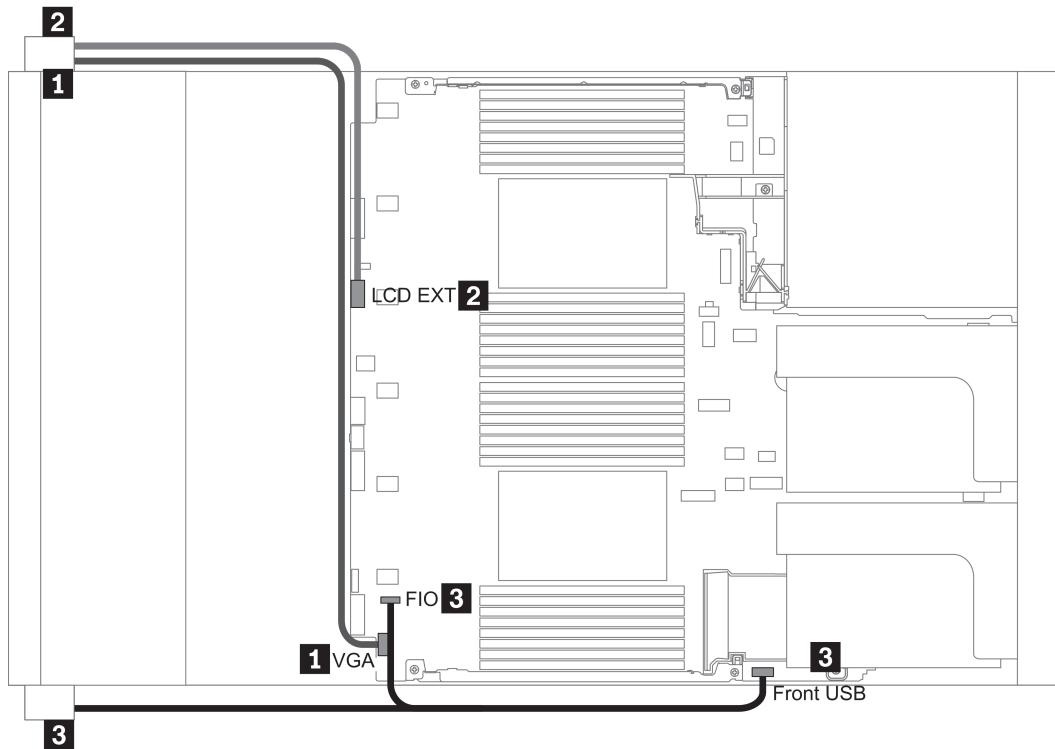

Figure 13. VGA connector and front I/O assembly cable routing

From	To
1 VGA cable on the left rack latch	VGA connector on the system board
2 External diagnostics cable on the left rack latch	External LCD connector on the system board
3 Front USB and panel cable on the right rack latch	Front I/O and front USB connectors on the system board

GPUs

Use this section to understand the routing for GPUs.

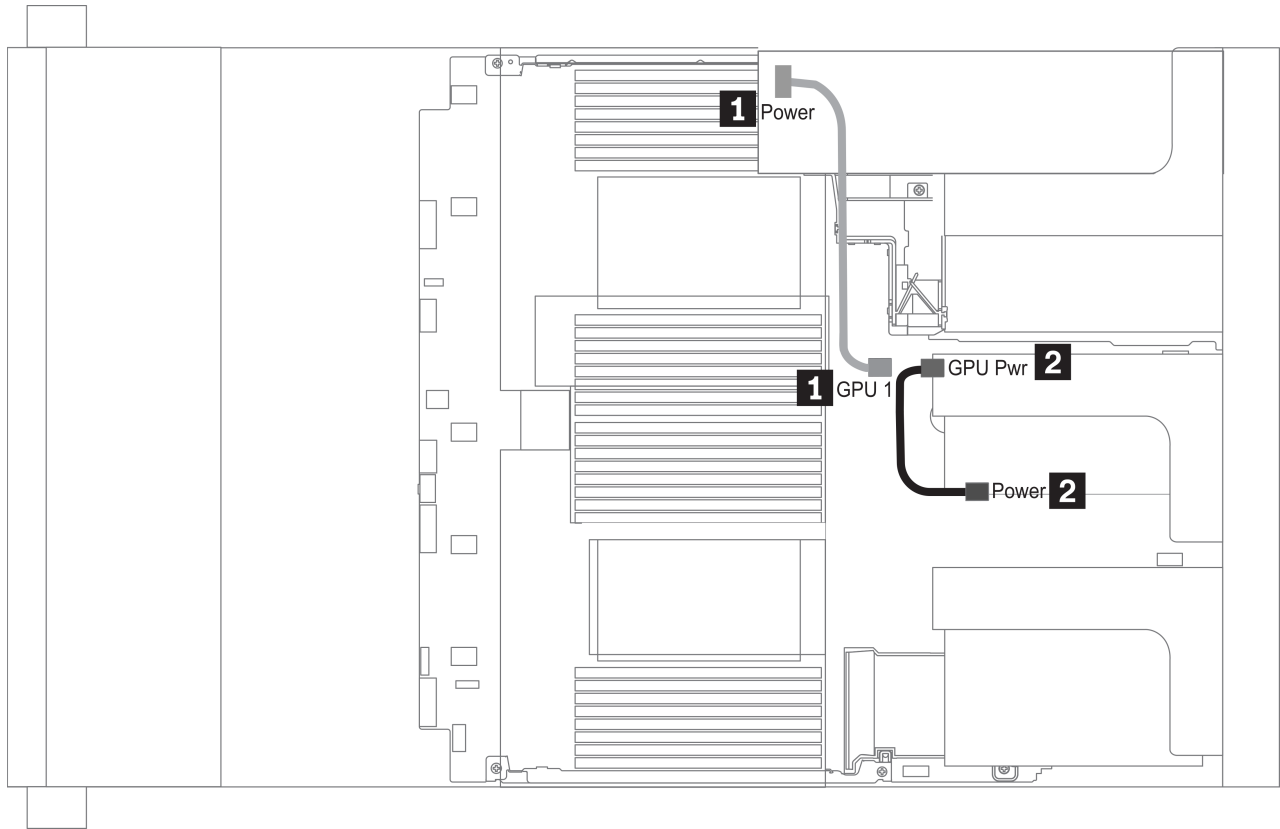

Figure 14. Cable routing for single-wide and double-wide GPU

From	To
1 Power connector on a single-wide GPU (on riser 3 assembly)	GPU 1 connector on the system board
2 Power connector on a double-wide GPU (on riser 1 or 2 assembly)	GPU Pwr connector on the riser card (on riser 1 or 2 assembly)

Riser cards

Use this section to understand the cable routing for riser cards.

The server supports up to three riser cards: riser card 1, riser card 2, and riser card 3. Among which, only riser card 3 needs cable connections:

- [“Riser card 3 power and sideband connection” on page 60](#)
- [“Riser card 3 \(x8/x8 or x16/x16 PCIe\) cable connection” on page 61](#)

The riser card types vary by server model. For detailed information, see “Rear view” on page 33.

Riser card 3 power and sideband connection

Note: The power and sideband connections for x8/x8 PCIe riser card 3 and x16/x16 PCIe riser card 3 are the same.

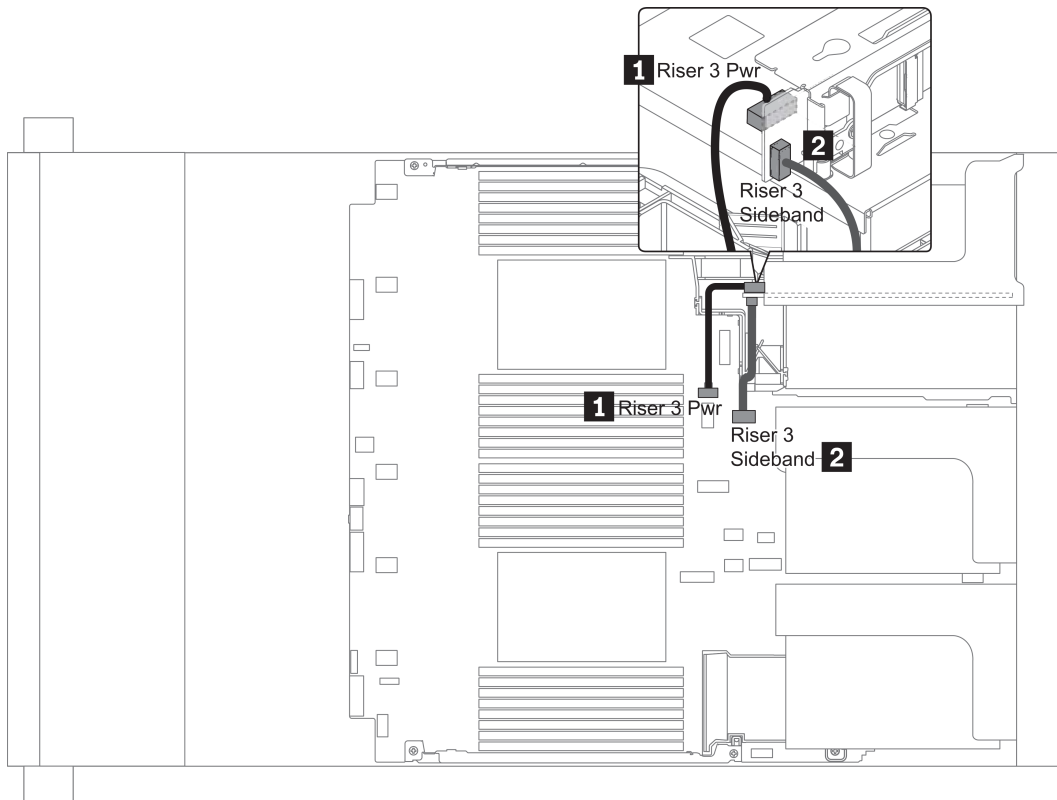

Figure 15. Riser card 3 power and sideband connection

From	To
1 Power connector on the riser card	Riser 3 power connector on the system board
2 Sideband connector on the riser card	Riser 3 sideband on the system board

Riser card 3 (x8/x8 or x16/x16 PCIe) cable connection

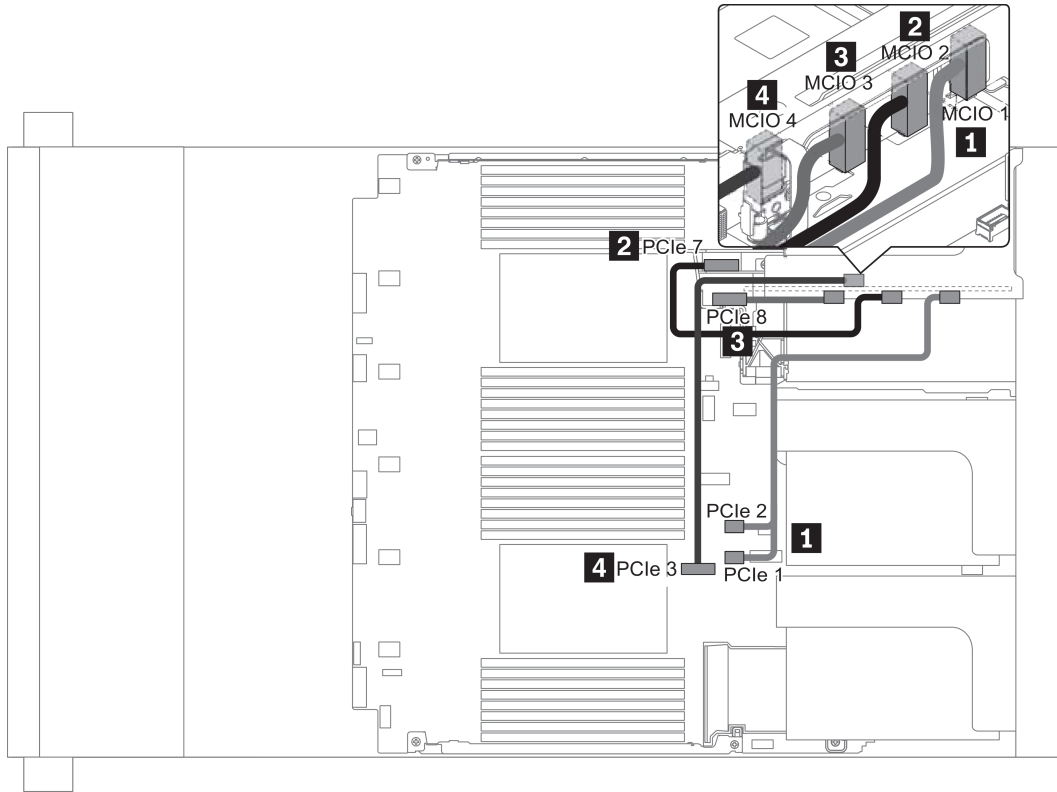

Figure 16. Cable routing for riser card 3 (x8/x8 or x16/x16 PCIe)

From	To
1 PCIe connector 1-2 on the riser card	PCIe connector 1-2 on the system board
2 PCIe connectors 7 on the riser card	PCIe connectors 7 on the system board
3 PCIe connector 8 on the riser card	PCIe connector 8 on the system board
4 PCIe connector 3 on the riser card	PCIe connector 3 on the system board

Note: **3** and **4** are for x16/x16 PCIe riser card 3 only.

RAID super capacitor modules

Use this section to understand the cable routing for RAID super capacitor modules.

RAID super capacitor modules can be installed on the air baffle (scenario 1), the middle drive cage (scenario 2), or the front chassis (scenario 3). The following illustration shows the cable connection for scenario 1. The cable connections for other scenarios are the similar.



Note: An extension cable is provided for each RAID super capacitor module for connection. Connect the super capacitor cable to the super capacitor connector on the corresponding RAID adapter as shown.

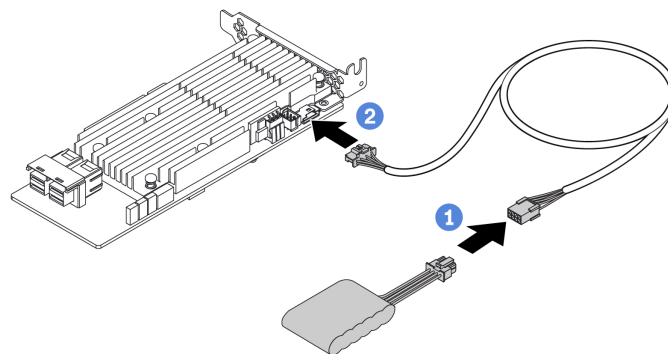

Figure 17. Connecting the RAID super capacitor module to the RAID adapter

From	To
RAID super capacitor module	Supercap connector on the RAID adapter

Internal CFF RAID/HBA/Expander adapters (power)

Use the section to understand the power cable routing for internal CFF RAID/HBA/Expander adapter.

Power cable routing for internal CFF RAID/HBA/Expander adapters

Note: The illustration only involves power cable routing. For signal cable routing, see “2.5-inch/3.5-inch drive backplane (signal)” on page 71

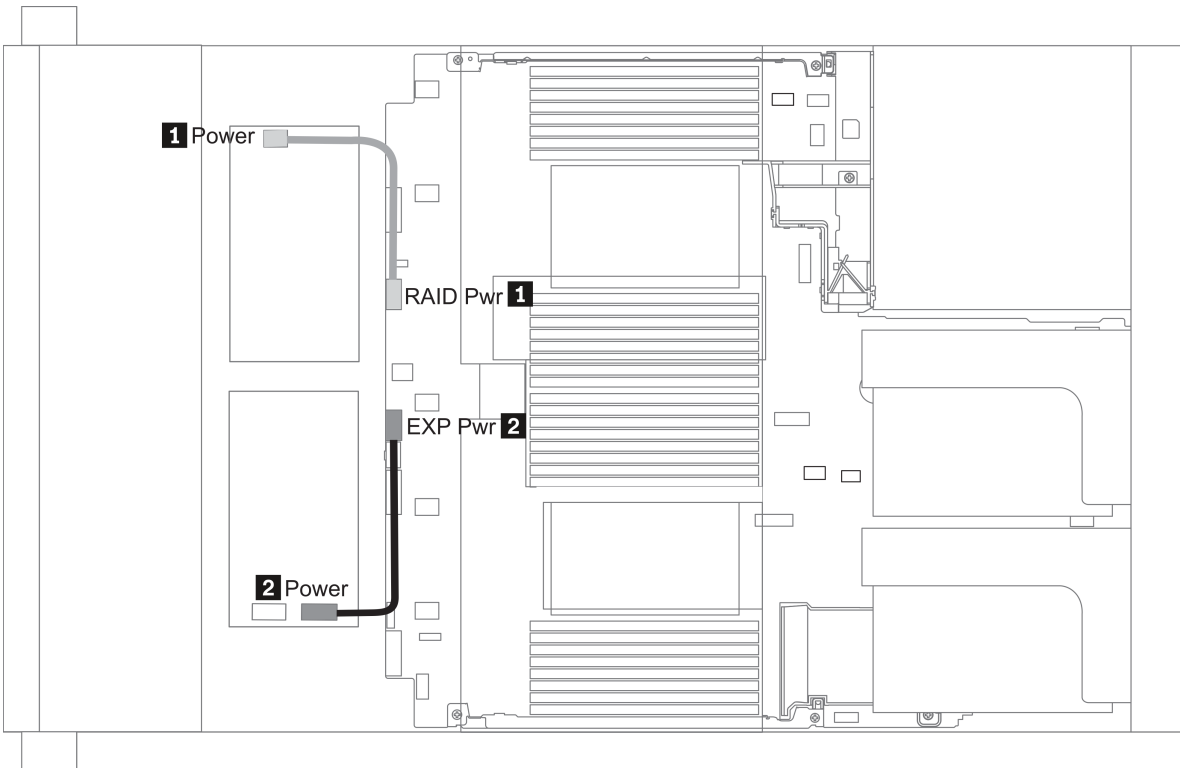

From	To
1 Power connector on the CFF RAID/HBA adapter	RAID Pwr connector on the system board
1 Power connector on the CFF RAID Expander adapter	EXP Pwr connector on the system board

7mm drives

This section provides cable routing information for the 7mm drives.

Note: 7mm drives can only be installed in slot 6.

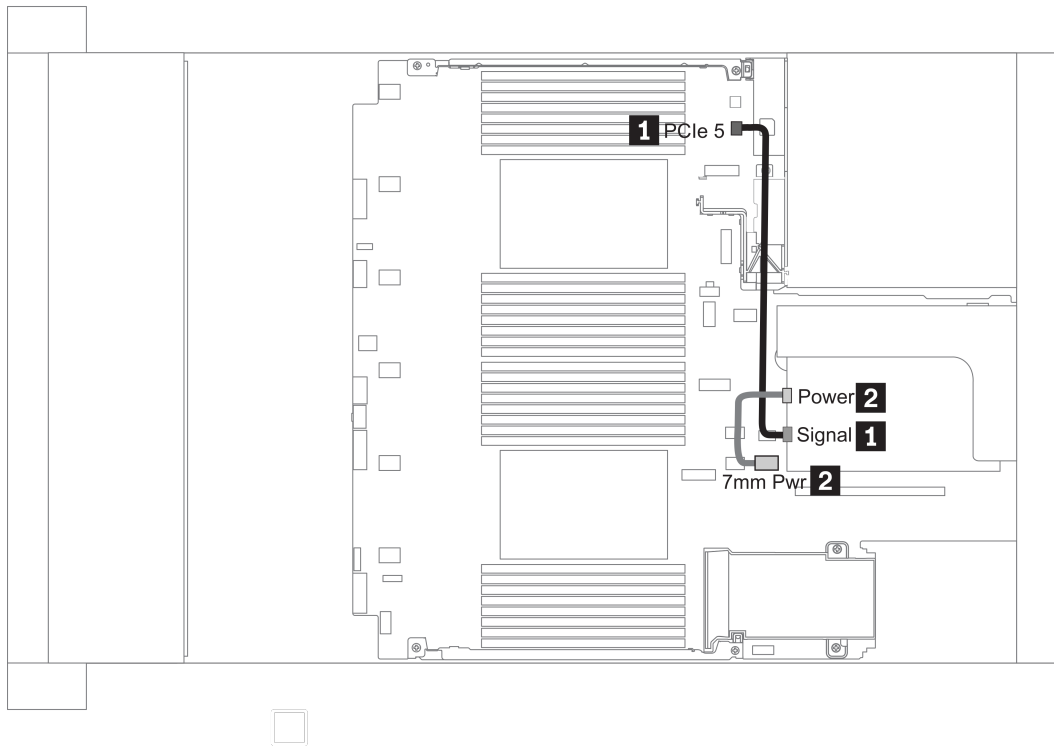

Figure 18. Cable routing for 7mm drives

From	To
1 7mm signal cable	PCIe connector 5 on the system board
2 Power cable	7mm power connector on the system board

M.2 drives

This section provides cable routing information for the M.2 drives.

M.2 drives can be installed on the standard air baffle (scenario 1), GPU air baffle (scenario 2), 2.5-inch middle drive cage (scenario 3), or 3.5-inch middle drive cage (scenario 4). The following illustration shows the cable connection for scenario 1. The cable connections for other scenarios are the same.

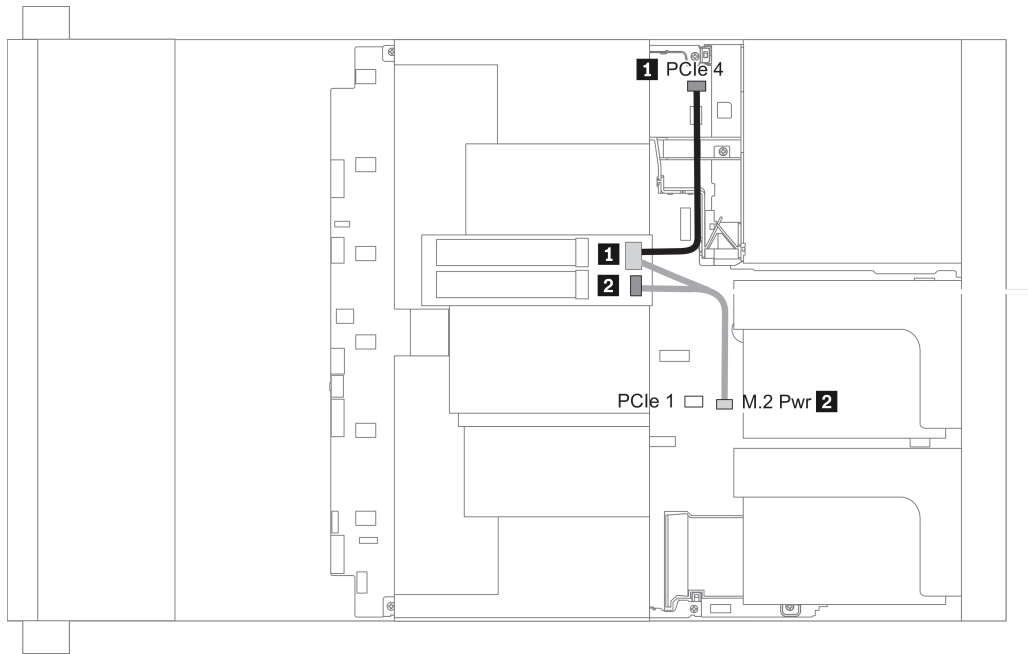

Figure 19. Cable routing for M.2 drives

From	To
1 M.2 signal cable	<ul style="list-style-type: none">• PCIe connector 4 on the system board (two processors installed)• PCIe connector 1 on the system board (one processor installed)
2 Power cable	M.2 power connector on the system board

2.5-inch/3.5-inch drive backplane (power)

This section provides information for backplane power connections.

- “Front drive backplanes” on page 66
- “Middle drive backplanes” on page 68
- “Rear drive backplanes” on page 70

Front drive backplanes

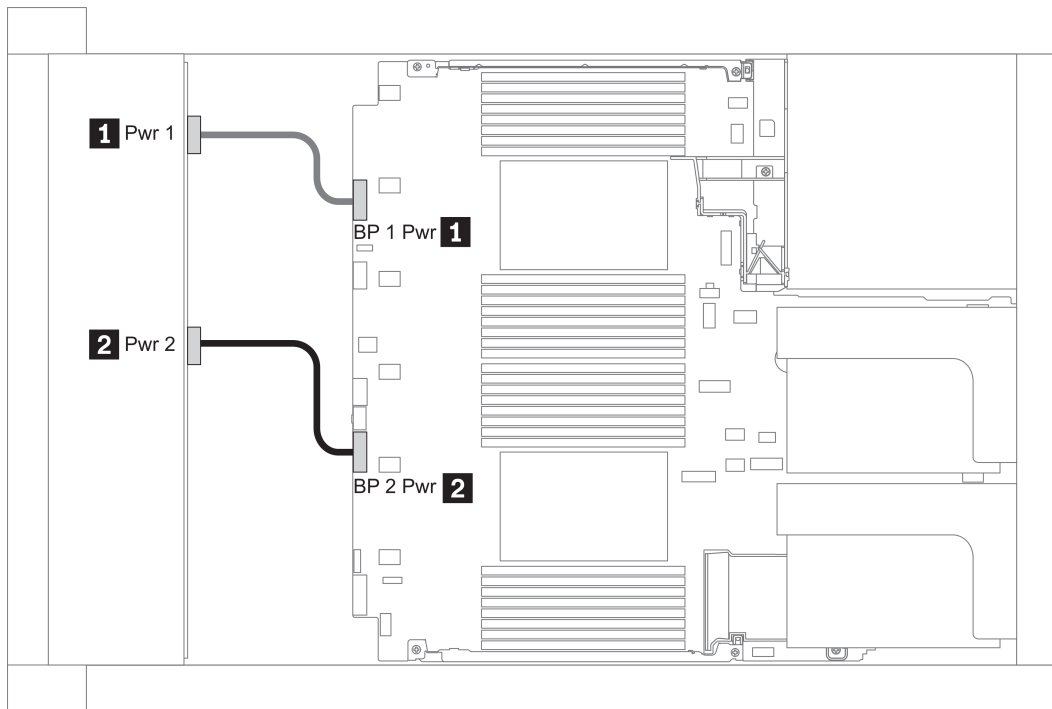

Figure 20. Power cabling for 3.5-inch chassis

From	To
1 Power 1 connector on backplane	Front backplane 1 power connector on the system board
2 Power 2 connector on backplane	Front backplane 2 power connector on the system board

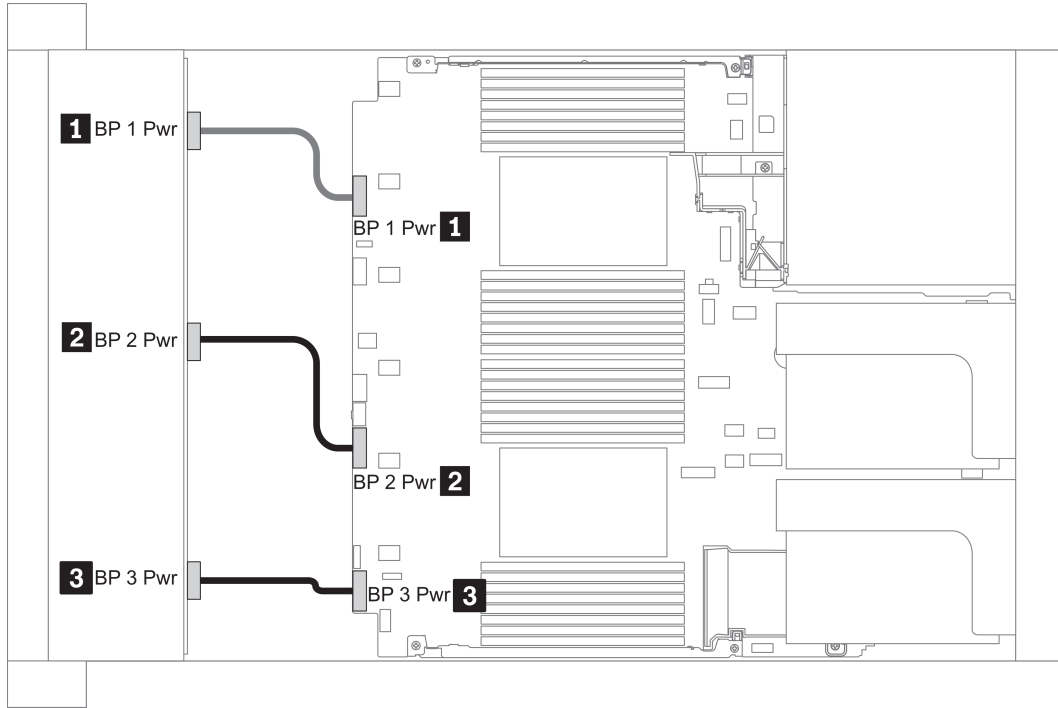

Figure 21. Power cabling for 2.5-inch chassis

From	To
1 Power connector on backplane 1	Front backplane 1 power connector on the system board
2 Power connector on backplane 2	Front backplane 2 power connector on the system board
3 Power connector on backplane 3	Front backplane 3 power connector on the system board

Middle drive backplanes

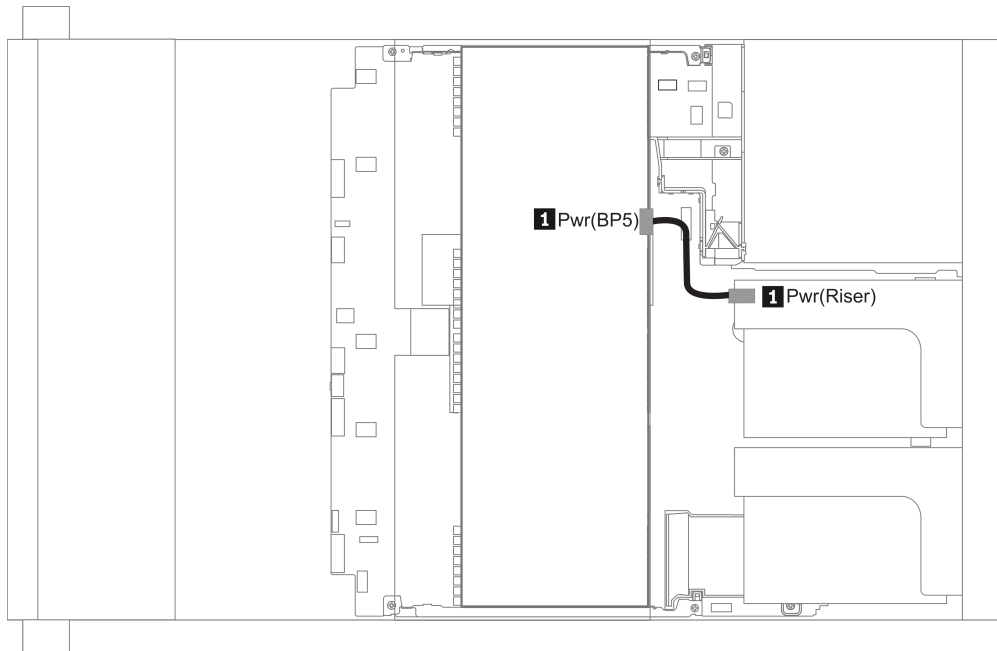

Figure 22. Power cabling for 3.5-inch chassis

From	To
1 Power connector on backplane 5	Power connector on riser 1 or 2 assembly

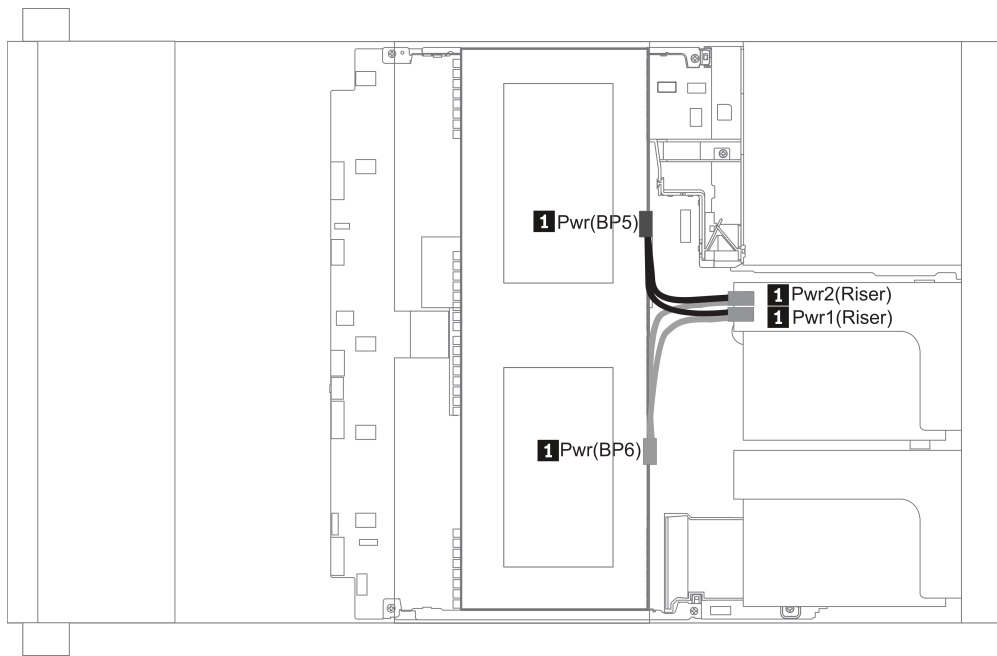

Figure 23. Power cabling for 2.5-inch chassis

From	To
1 Power connector on backplane 5 and backplane 6	Power connector 1 and power connector 2 on riser 1 or 2 assembly

Rear drive backplanes

Note: The illustration shows the cable routing for the 4 x 2.5-inch rear drive backplane, routing for the other rear drive backplanes are similar.

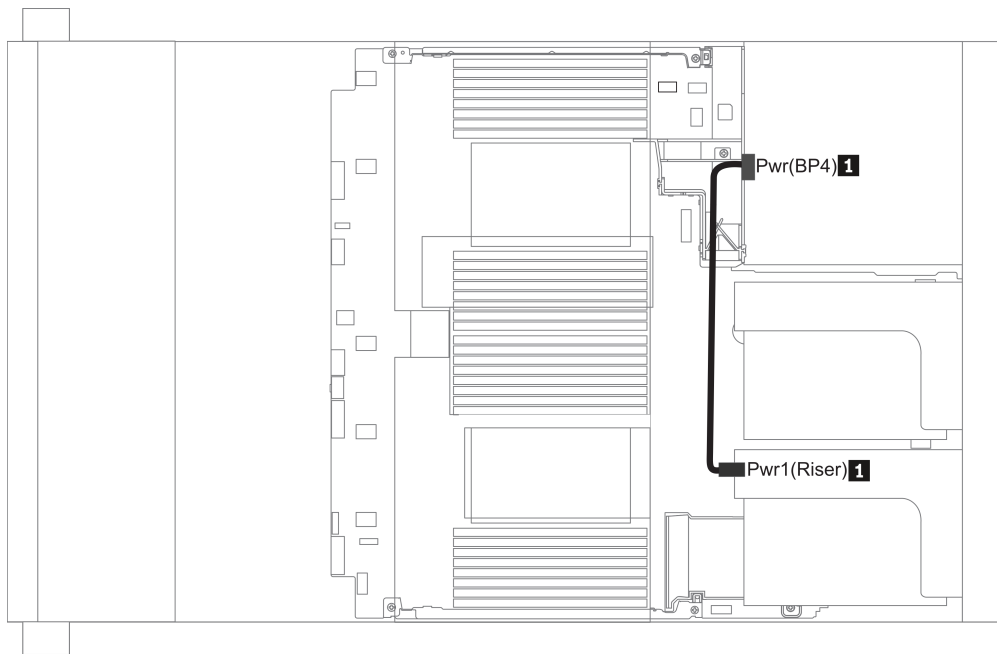

Figure 24. Power cabling for 3.5-inch chassis or 2.5-inch chassis

From	To
1 Power connector on backplane 4	Power connector on riser 1 or 2 assembly

2.5-inch/3.5-inch drive backplane (signal)

Use the section to understand the cable routing for signal cable connections for 2.5-inch/3.5-inch drive backplanes.

8 x 2.5-inch front drive bays (SAS/SATA)

This section provides cable routing information for the server model with 8 x 2.5-inch SAS/SATA front drive bays.

The server model is configured with one 8 x 2.5-inch SAS/SATA front drive backplane (BP 1). Below lists all supported configurations with this front drive backplane.

Configuration	Storage controller	
	Qty.	Type
Config. 1		
Config. 2	1	SFF 8i RAID/HBA
Config. 3	1	SFF 16i RAID/HBA
Config. 4	1	CFF 16i RAID/HBA

The following table shows the cable connections for all configurations:

Configuration 1, 2, and 3 4:

Front: one 8 x 2.5-inch SAS/SATA backplane

Con-fig.	Front BP	System board	Storage controller		
			SFF 8i RAID/HBA	SFF 16i RAID/HBA	CFF 16i RAID/HBA
1	BP 1: SAS	PCIe 1, PCIe 2			
2	BP 1: SAS		Gen 4: C 0 Gen3: C 0, C 1		
3	BP 1: SAS			Gen 4: C 0 Gen3: C 0, C 1	
4	SAS				C 0, C1
		PCIe 6			MB

The following illustration shows the cable routing for the configuration 4, the routing for configurations 1 to 3 is similar. Connections between connectors: **1** ↔ **1**, **2** ↔ **2**, **3** ↔ **3**, ... **n** ↔ **n**

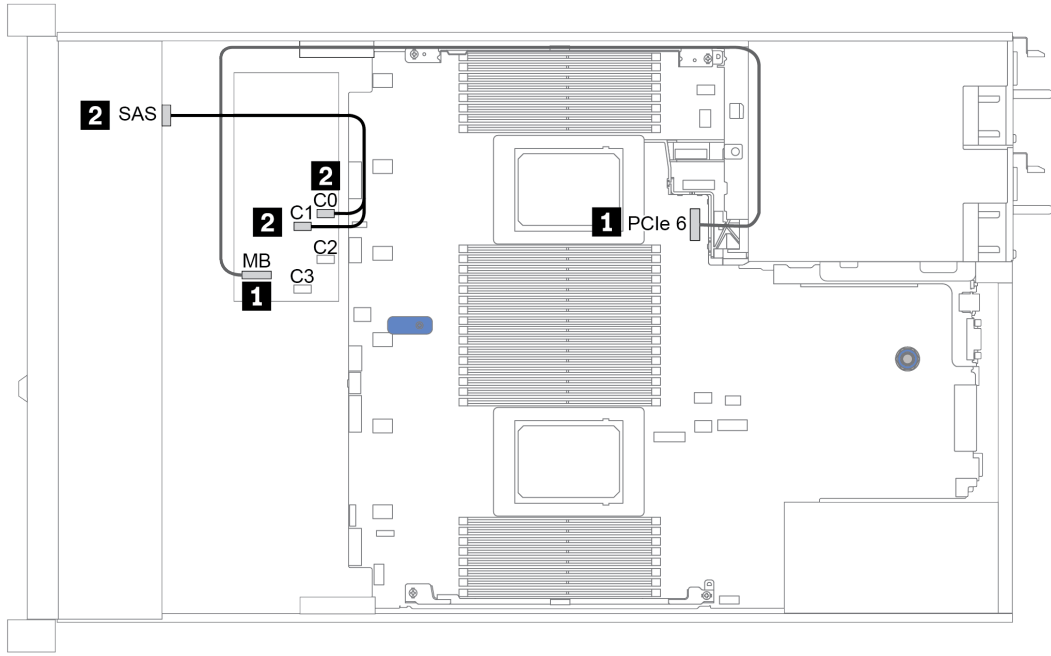

Figure 25. Cable routing for configuration 4

8 x 2.5-inch front drive bays (AnyBay)

This section provides cable routing information for the server model with eight 2.5-inch front drive bays.

The server model is configured with one 8 x 2.5-inch Anybay front drive backplane. Below lists all supported configurations with this front drive backplane.

Configuration	Storage controllers	
	Qty.	Type
Config. 1	1	SFF 8i RAID/HBA
Config. 2	1	SFF 16i RAID/HBA
Config. 3	1	CFF 16i RAID/HBA

Configuration 1, 2, and 3:

Front: one 8 x 2.5-inch AnyBay backplane

Config.	Front BP	System board	Storage controller		
			SFF 8i RAID/HBA	SFF 16i RAID/HBA	CFF 16i RAID/HBA
1	BP1:NVMe 0-1	PCle 1, PCle 2			
	BP1: NVMe 2-3	PCle 3			
	BP1: NVMe 4-5	PCle 7			
	BP1: NVMe 6-7	PCle 8			
	BP1: SAS		Gen 4: C 0 Gen3: C 0, C 1		
2	BP1:NVMe 0-1	PCle 1, PCle 2			
	BP1: NVMe 2-3	PCle 3			
	BP1: NVMe 4-5	PCle 7			
	BP1: NVMe 6-7	PCle 8			
	BP1: SAS			Gen 4: C 0 Gen3: C 0, C 1	
3	BP1:NVMe 0-1	PCle 1, PCle 2			
	BP1: NVMe 2-3	PCle 3			
	BP1: NVMe 4-5	PCle 7			
	BP1: NVMe 6-7	PCle 8			
	BP1: SAS				C 0, C 1
		PCle 6			MB

The following illustration shows the cable routing for the configuration 2, the routing for configuration 1 and 3 is similar. Connections between connectors: **1** ↔ **1**, **2** ↔ **2**, **3** ↔ **3**, ... **n** ↔ **n**

Note: For models that support Gen 3 and Gen4 adapters at the same slot, the illustration shows only the cable routing information for Gen 4 adapters, the routing and connector information is similar for Gen 3 adapters.

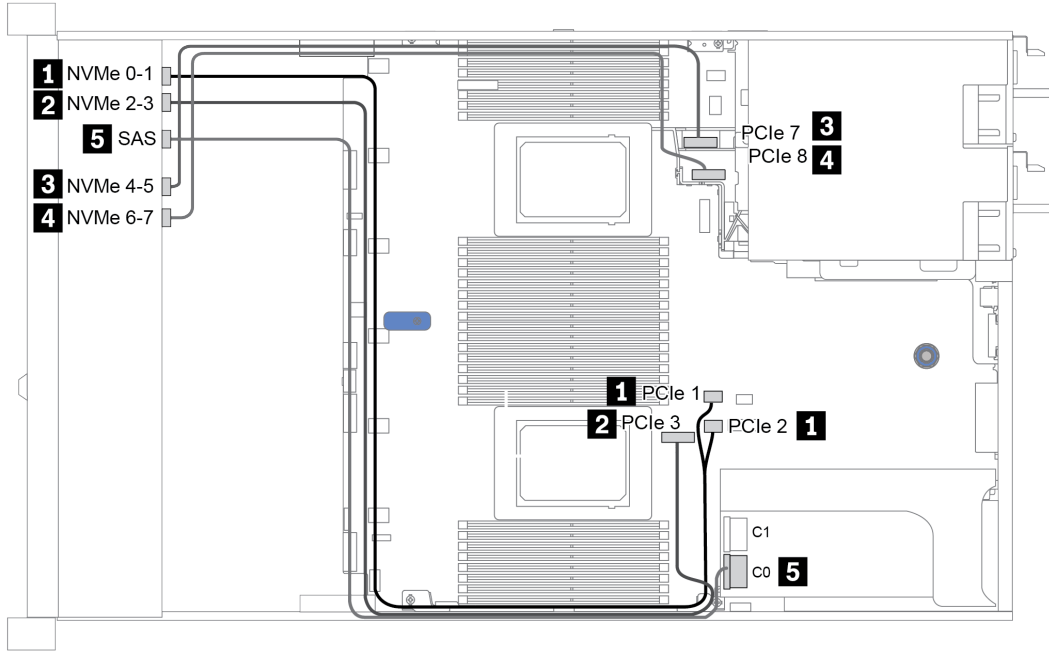

Figure 26. Cable routing for configuration 2

8 x 2.5-inch front drive bays (NVMe)

This section provides cable routing information for the server model with eight 2.5-inch front drive bays.

The server model is configured with one 8 x 2.5-inch AnyBay front drive backplane (BP 1). Only onboard configuration is supported.

Note: The AnyBay backplane (BP 1) is used as a pure NVMe backplane.

Configuration 1: (front drive bays only)

Config.	Front BP	System board
1	BP1:NVMe 0-1	PCIe 1, PCIe 2
	BP1: NVMe 2-3	PCIe 3
	BP1: NVMe 4-5	PCIe 7
	BP1: NVMe 6-7	PCIe 8

The following illustration shows the cable routing for the configuration 1. Connections between connectors:
1 ↔ **1**, **2** ↔ **2**, **3** ↔ **3**, ... **n** ↔ **n**

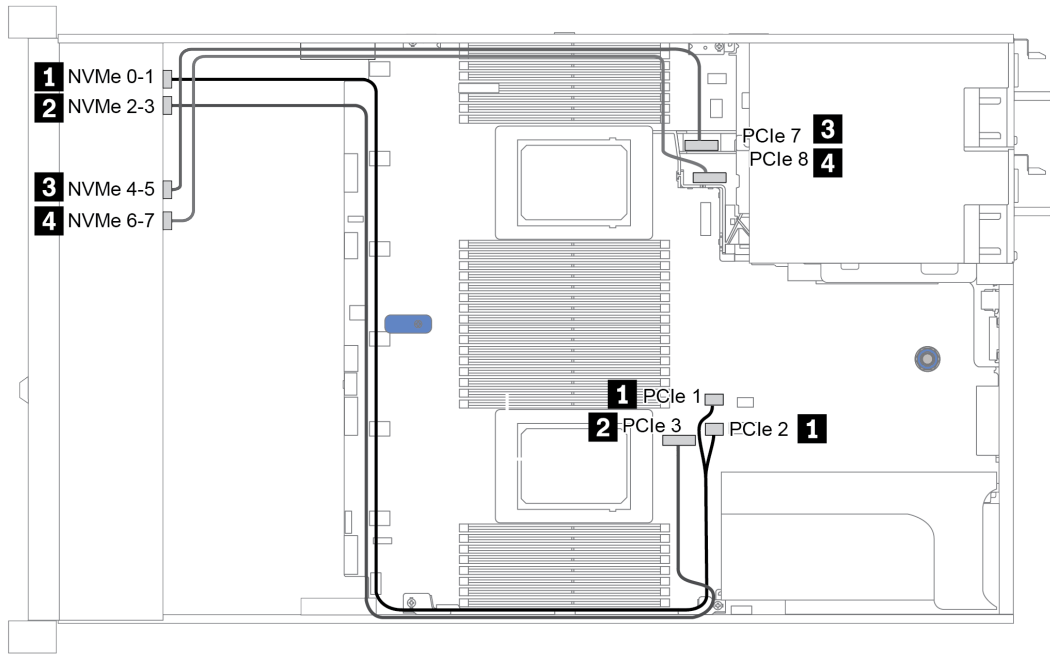

Figure 27. Cable routing for configuration 1

16 x 2.5-inch front drive bays (SAS/SATA)

This section provides cable routing information for the server model with 16 x 2.5-inch SAS/SATA front drive bays.

The server model is configured with two 8 x 2.5-inch SAS/SATA backplanes (BP 1 and BP 2). Below lists all supported configurations with these two front drive backplanes.

Configuration	Storage controller	
	Qty.	Type
Config. 1		
Config. 2	2	SFF 8i RAID/HBA
Config. 3	1	SFF 16i RAID/HBA
Config. 4	1	CFF 16i RAID/HBA

The following table shows the cable connections for all configurations:

Configuration 1, 2, 3, and 4: (front drive bays only)

Front: two 8 x 2.5-inch SAS/SATA backplanes (BP 1 and BP 2)

Con-fig.	Front BP	System board	Storage controller		
			SFF 8i RAID/HBA	SFF 16i RAID/HBA	CFF 16i RAID/HBA
1	BP 1: SAS	PCIe 1, PCIe 2			
	BP 2: SAS	PCIe 4, PCIe 5			
2	BP 1: SAS,		Gen 4: C 0 Gen3: C 0, C 1		
	BP 2: SAS		Gen 4: C 0 Gen3: C 0, C 1		
3	BP 1: SAS,			Gen 4: C 0 Gen3: C 0, C 1	
	BP 2: SAS			Gen 4: C 1 Gen3: C 2, C 3	
4	BP 1: SAS				C 0, C1
	BP 2: SAS				C 2, C3
		PCIe 6			MB

The following illustration shows the cable routing for the configuration 4, the routing for configurations 1 to 3 is similar. Connections between connectors: **1** ↔ **1**, **2** ↔ **2**, **3** ↔ **3**, ... **n** ↔ **n**

Note: For models that support Gen 3 and Gen4 adapters at the same slot, the illustration shows only the cable routing information for Gen 4 adapters, the routing and connector information is similar for Gen 3 adapters.

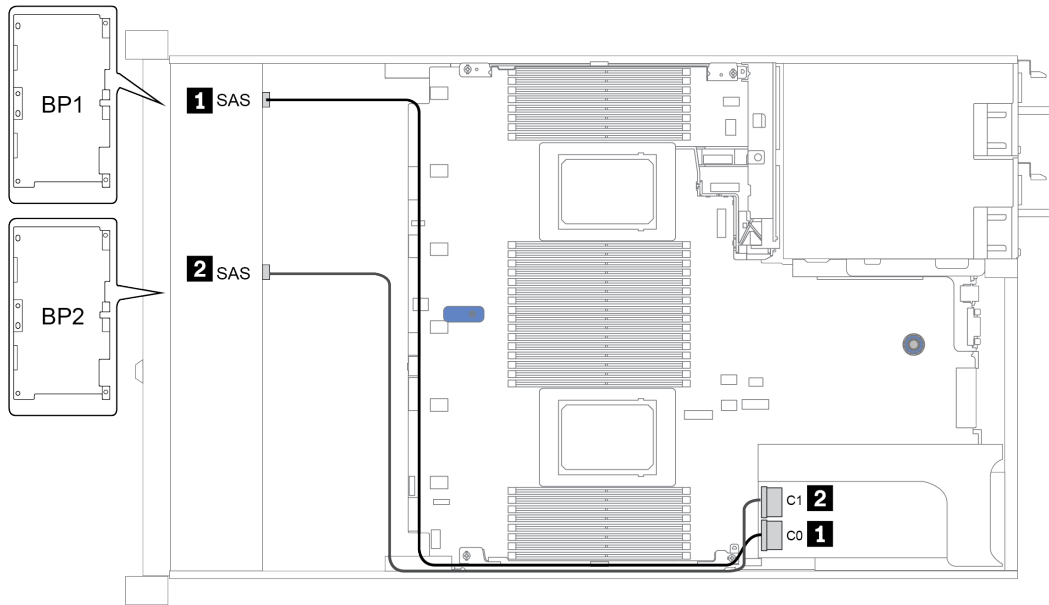

Figure 28. Cable routing for configuration 3

16 x 2.5-inch front drive bays (NVMe)

This section provides cable routing information for the server model with 16 x 2.5-inch NVMe front drive bays.

The server model is configured with two 8 x 2.5-inch AnyBay backplanes (BP 1 and BP 2). Below lists the supported configuration with these two front drive backplanes.

Note: The two AnyBay backplanes are used as two pure NVMe backplanes.

Configuration	Storage controller	
	Qty.	Type
Config. 1	1	PCIe switch

The following table shows the cable connections for all configurations:

Configuration 1: (front drive bays only)

Config.	Front BP	System board	Storage controller
			PCIe switch
1	BP 1: NVMe 0-1	PCIe 1, PCIe 2	
	BP 1: NVMe 2-3	PCIe 3	
	BP 1: NVMe 4-5, NVMe 6-7		C 0, C1
	BP 2: NVMe 0-1	PCIe 4, PCIe 5	
	BP 2: NVMe 2-3	PCIe 6	
	BP 2: NVMe 4-5	PCIe 7	
	BP 2: NVMe 6-7	PCIe 8	

The following illustration shows the cable routing for the configuration 1. Connections between connectors:
1 ↔ **1**, **2** ↔ **2**, **3** ↔ **3**, ... **n** ↔ **n**

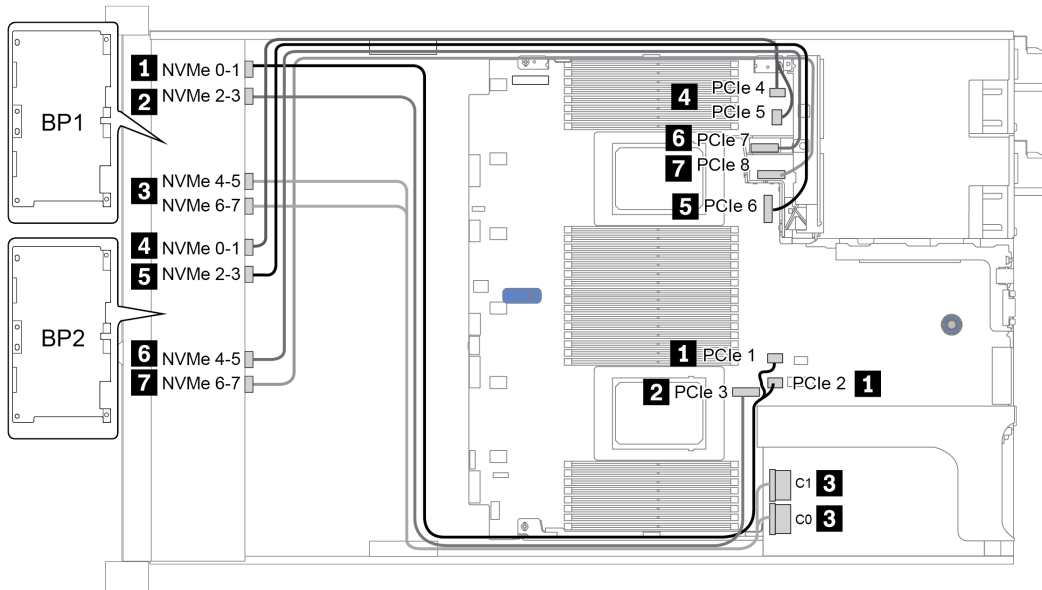

Figure 29. Cable routing for configuration 1

16 x 2.5-inch front drive bays (8SAS+8AnyBay)

This section provides cable routing information for the server model with 16 x 2.5-inch front drive bays (8SAS +8AnyBay).

The following table lists the configurations for the server model with 16 x 2.5-inch front drive bays(8SAS +8AnyBay).

Configuration	Storage controller	
	Qty.	Type
Config. 1	2	SFF 8i RAID/HBA
Config. 2	1	SFF 16i RAID/HBA
Config. 3	1	CFF 16i RAID/HBA
Config. 4	1	SFF 32i RAID

The following table shows the cable connections for all configurations:

Configuration 1, 2, 3, and 4: (front drive bays only)

Front: one 8 x 2.5-inch SAS/SATA backplane and one 8 x 2.5-inch AnyBay backplane

- SFF 8i RAID/HBA
- SFF 16i RAID/HBA

Config.	Front BP	System board	Storage controller	
			SFF 8i RAID/HBA	SFF 16i RAID/HBA
1	BP 1: SAS		Gen 4: C 0 Gen3: C 0, C 1	
	BP 2: SAS		Gen 4: C 0 Gen3: C 0, C 1	
	BP 2: NVMe 0-1	PCle 1, PCle 2		
	BP 2: NVMe 2-3	PCle 3		
	BP 2: NVMe 4-5	PCle 7		
	BP 2: NVMe 6-7	PCle 8		
2	BP 1: SAS			Gen 4: C 0 Gen3: C 0, C 1
	BP 2: SAS			Gen 4: C 1 Gen3: C 2, C 3
	BP 2: NVMe 0-1	PCle 1, PCle 2		
	BP 2: NVMe 2-3	PCle 3		
	BP 2: NVMe 4-5	PCle 7		
	BP 2: NVMe 6-7	PCle 8		

Front: one 8 x 2.5-inch SAS/SATA backplane and one 8 x 2.5-inch AnyBay backplane

- CFF 16i RAID/HBA
- SFF 32i RAID/HBA

Con-fig.	Front BP	System board	Storage controller	
			CFF 16i RAID/HBA	SFF 32i RAID/HBA
3	BP 1: SAS		C 0, C 1	
	BP 2: SAS		C 2, C 3	
	BP 2: NVMe 0–1	PCIe 1, PCIe 2		
	BP 2: NVMe 2–3	PCIe 3		
	BP 2: NVMe 4–5	PCIe 7		
	BP 2: NVMe 6–7	PCIe 8		
4	BP 1: SAS			C 0
	BP 2: SAS			C 1
	BP 2: NVMe 0–1	PCIe 1, PCIe 2		
	BP 2: NVMe 2–3	PCIe 3		
	BP 2: NVMe 4–5	PCIe 7		
	BP 2: NVMe 6–7	PCIe 8		

The following illustration shows the cable routing for the configuration 1, the routing for the other configurations is similar. Connections between connectors: **1** ↔ **1**, **2** ↔ **2**, **3** ↔ **3**, ... **n** ↔ **n**

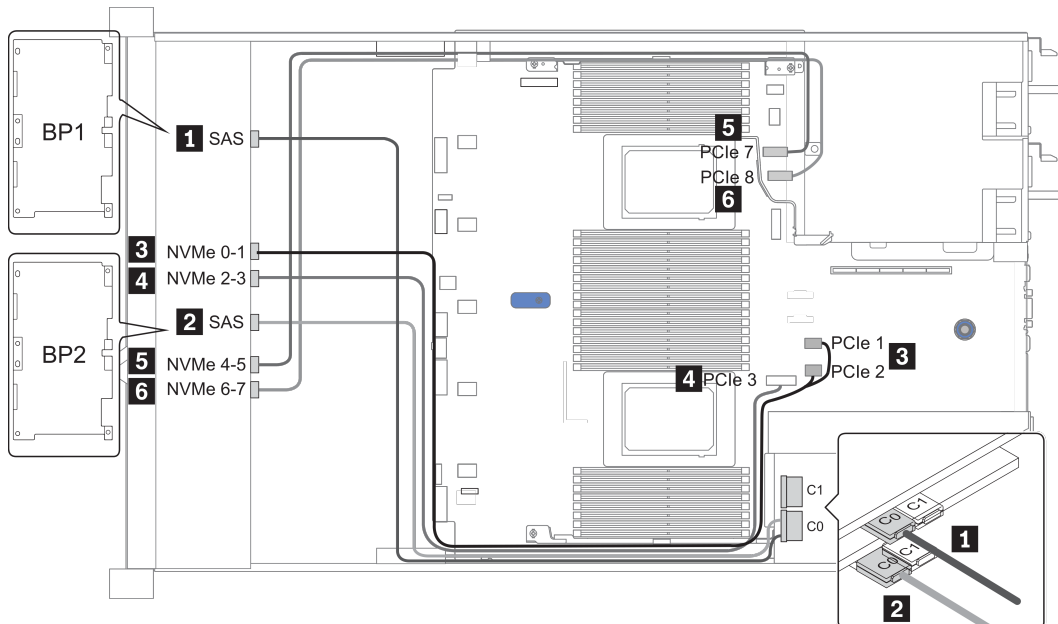

Figure 30. Cable routing for configuration 1

16 x 2.5-inch front drive bays (8SAS/SATA+8NVMe)

This section provides cable routing information for the server model with 16 x 2.5-inch front drive bays (8SAS/SATA+8NVMe).

The server model is configured with one 8 x 2.5-inch SAS/SATA backplane (BP 1) and one 8 x 2.5-inch AnyBay backplane (BP 2). Below lists all supported configurations with these two front drive backplanes.

Note: The AnyBay backplane (BP 2) is used as pure NVMe backplane.

Configuration	Storage controller	
	Qty.	Type
Config. 1		
Config. 2	2	SFF 8i RAID/HBA
Config. 3	1	SFF 16i RAID/HBA
Config. 4	1	CFF 16i RAID/HBA

The following table shows the cable connections for all configurations:

Configuration 1, 2, 3, and 4: (front drive bays only)

Front: one 8 x 2.5-inch SAS/SATA backplane and one 8 x 2.5-inch NVMe backplane

Con-fig.	Front BP	System board	Storage controller		
			SFF 8i RAID/HBA	SFF 16i RAID/HBA	CFF 16i RAID/HBA
1	BP 1: SAS	PCle 4, PCle 5			
	BP 2: NVMe 0-1	PCle 1, PCle 2			
	BP 2: NVMe 2-3	PCle 3			
	BP 2: NVMe 4-5	PCle 7			
	BP 2: NVMe 6-7	PCle 8			
2	BP 1: SAS		Gen 4: C 0 Gen3: C 0, C 1		
	BP 2: NVMe 0-1	PCle 1, PCle 2			
	BP 2: NVMe 2-3	PCle 3			
	BP 2: NVMe 4-5	PCle 7			
	BP 2: NVMe 6-7	PCle 8			
3	BP 1: SAS			Gen 4: C 0 Gen3: C 0, C 1	
	BP 2: NVMe 0-1	PCle 1, PCle 2			
	BP 2: NVMe 2-3	PCle 3			
	BP 2: NVMe 4-5	PCle 7			
	BP 2: NVMe 6-7	PCle 8			

Con-fig.	Front BP	System board	Storage controller		
			SFF 8i RAID/HBA	SFF 16i RAID/HBA	CFF 16i RAID/HBA
4	BP 1: SAS				C 0, C 1
		PCle 6			MB
	BP 2: NVMe 0-1	PCle 1, PCle 2			
	BP 2: NVMe 2-3	PCle 3			
	BP 2: NVMe 4-5	PCle 7			
	BP 2: NVMe 6-7	PCle 8			

The following illustration shows the cable routing for the configuration 3, the routing for the other configurations is similar. . Connections between connectors: **1** ↔ **1**, **2** ↔ **2**, **3** ↔ **3**, ... **n** ↔ **n**

Note: For models that support Gen 3 and Gen4 adapters at the same slot, the illustration shows only the cable routing information for Gen 4 adapters, the routing and connector information is similar for Gen 3 adapters.

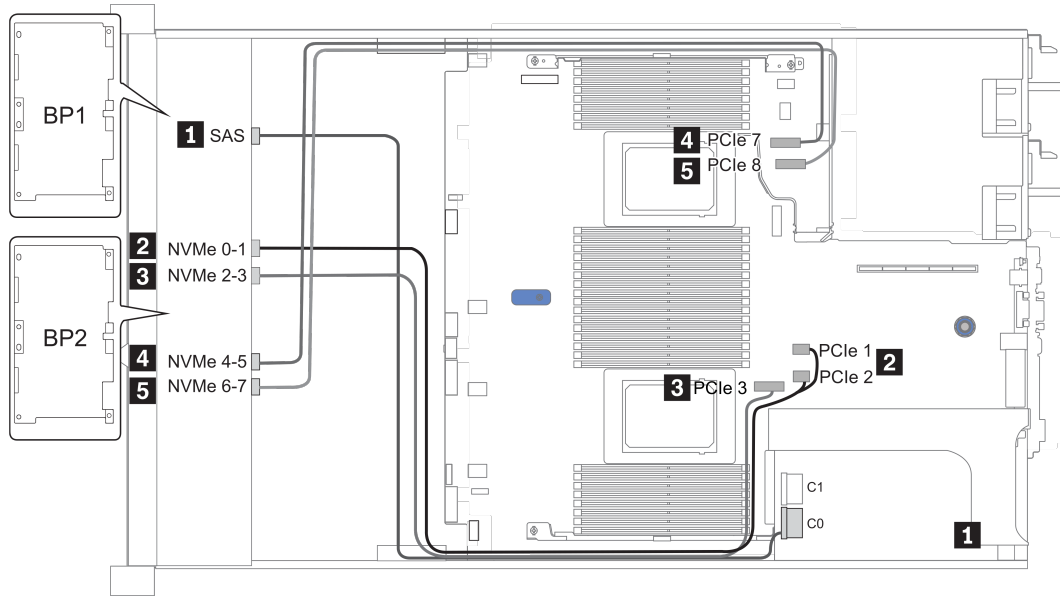

Figure 31. Cable routing for configuration 3

16 x 2.5-inch front drive bays (8AnyBay+8NVMe)

This section provides cable routing information for the server model with 16 x 2.5-inch front drive bays (8AnyBay+8NVMe).

The server model is configured with two 8 x 2.5-inch AnyBay backplanes (BP 1 and BP 2). Below lists all supported configurations with these two front drive backplanes.

Note: The AnyBay backplane (BP 2) is used as pure NVMe backplane.

Configuration	Storage controller	
	Qty.	Type
Config. 1	2	PCIe switch +SFF 8i RAID/HBA
Config. 2	2	PCIe switch +SFF 16i RAID/HBA

The following table shows the cable connections for all configurations:

Configuration 1 and 2: (front drive bays only)

Front: one 8 x 2.5-inch AnyBay backplane and one 8 x 2.5-inch pure NVMe backplane

Con-fig.	Front BP	System board	Storage controller		
			PCIe switch	SFF 8i RAID/HBA	SFF 16i RAID/HBA
1	BP 1: NVMe 0-1	PCIe 1, PCIe 2			
	BP 1: NVMe 2-3	PCIe 3			
	BP 1: NVMe 4-5, NVMe 6-7		C 0, C 1		
	BP 1: SAS			Gen 4: C 0 Gen3: C 0, C 1	
	BP 2: NVMe 0-1	PCIe 4, PCIe 5			
	BP 2: NVMe 2-3	PCIe 6			
	BP 2: NVMe 4-5	PCIe 7			
	BP 2: NVMe 6-7	PCIe 8			
2	BP 1: NVMe 0-1	PCIe 1, PCIe 2			
	BP 1: NVMe 2-3	PCIe 3			
	BP 1: NVMe 4-5, NVMe 6-7		C 0, C 1		
	BP 1: SAS			Gen 4: C 0 Gen3: C 0, C 1	
	BP 2: NVMe 0-1	PCIe 4, PCIe 5			
	BP 2: NVMe 2-3	PCIe 6			
	BP 2: NVMe 4-5	PCIe 7			
	BP 2: NVMe 6-7	PCIe 8			

Con- fig.	Front BP	System board	Storage controller		
			PCIe switch	SFF 8i RAID/HBA	SFF 16i RAID/ HBA
	BP 2: NVMe 6-7	PCIe 8			

The following illustration shows the cable routing for the configuration 2, the routing for configuration 1 is similar. . Connections between connectors: **1** ↔ **1**, **2** ↔ **2**, **3** ↔ **3**, ... **n** ↔ **n**

Note: For models that support Gen 3 and Gen4 adapters at the same slot, the illustration shows only the cable routing information for Gen 4 adapters, the routing and connector information is similar for Gen 3 adapters.

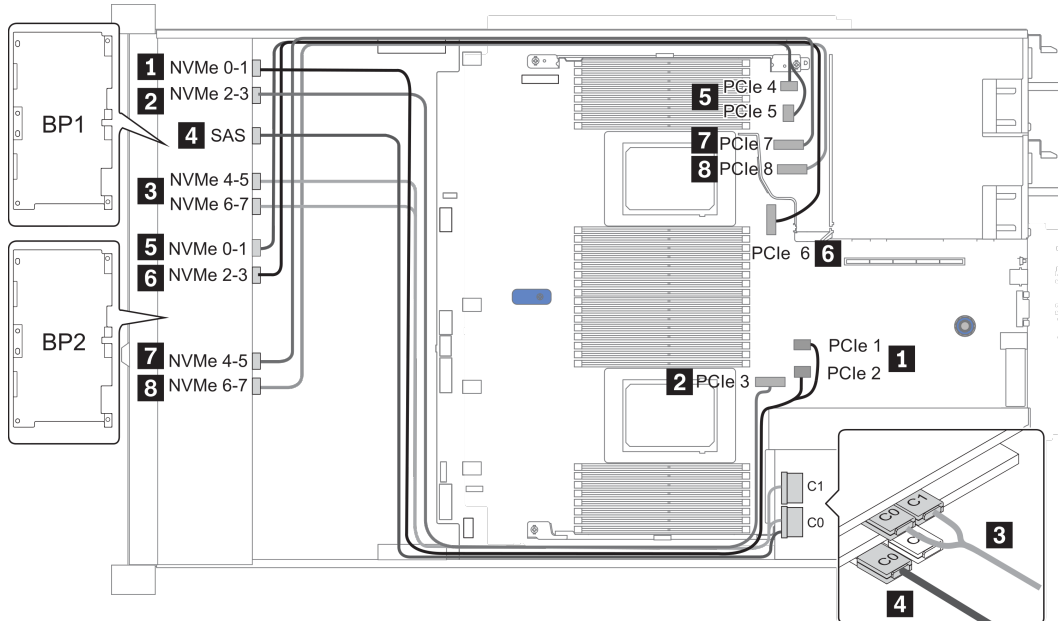

Figure 32. Cable routing for configuration 2

24 x 2.5-inch front drive bays (8SAS/SATA+16NVMe)

This section provides cable routing information for the server model with 24 x 2.5-inch front drive bays (8SAS/SATA+16NVMe).

The server model is configured with one 8 x 2.5-inch SAS/SATA backplane (BP 1) and two 8 x 2.5-inch AnyBay backplanes (BP 2 and BP 3). Below lists all supported configurations with these three front drive backplanes.

Note: The AnyBay backplanes (BP 2 and BP3) are used as pure NVMe backplanes.

Configuration	Storage controller	
	Qty.	Type
Config. 1	2	PCIe switch +SFF 8i RAID/HBA
Config. 2	2	PCIe switch +SFF 16i RAID/HBA

The following table shows the cable connections for all configurations:

Configuration 1 and 2: (front drive bays only)

Front: one 8 x 2.5-inch SAS/SATA backplane and two 8 x 2.5-inch pure NVMe backplanes

Co- nfig.	Front BP	System board	Storage controller		
			PCIe switch	SFF 8i RAID/HBA	SFF 16i RAID/ HBA
1	BP 1: SAS			Gen 4: C 0 Gen3: C 0, C 1	
	BP 2: NVMe 0-1	PCIe 1, PCIe 2			
	BP 2: NVMe 2-3	PCIe 3			
	BP 2: NVMe 4-5, NVMe 6-7		C 0, C 1		
	BP3: NVMe 0-1	PCIe 4, PCIe 5			
	BP3: NVMe 2-3	PCIe 6			
	BP3: NVMe 4-5	PCIe 7			
2	BP 1: SAS				Gen 4: C 0 Gen3: C 0, C 1
	BP 2: NVMe 0-1	PCIe 1, PCIe 2			
	BP 2: NVMe 2-3	PCIe 3			
	BP 2: NVMe 4-5, NVMe 6-7		C 0, C 1		
	BP3: NVMe 0-1	PCIe 4, PCIe 5			
	BP3: NVMe 2-3	PCIe 6			
	BP3: NVMe 4-5	PCIe 7			

Co- nfig.	Front BP	System board	Storage controller		
			PCIe switch	SFF 8i RAID/HBA	SFF 16i RAID/ HBA
	BP3: NVMe 6-7	PCIe 8			

The following illustration shows the cable routing for the configuration 2, the routing for the configuration 1 is similar. Connections between connectors: **1** ↔ **1**, **2** ↔ **2**, **3** ↔ **3**, ... **n** ↔ **n**

Note: For models that support Gen 3 and Gen4 adapters at the same slot, the illustration shows only the cable routing information for Gen 4 adapters, the routing and connector information is similar for Gen 3 adapters.

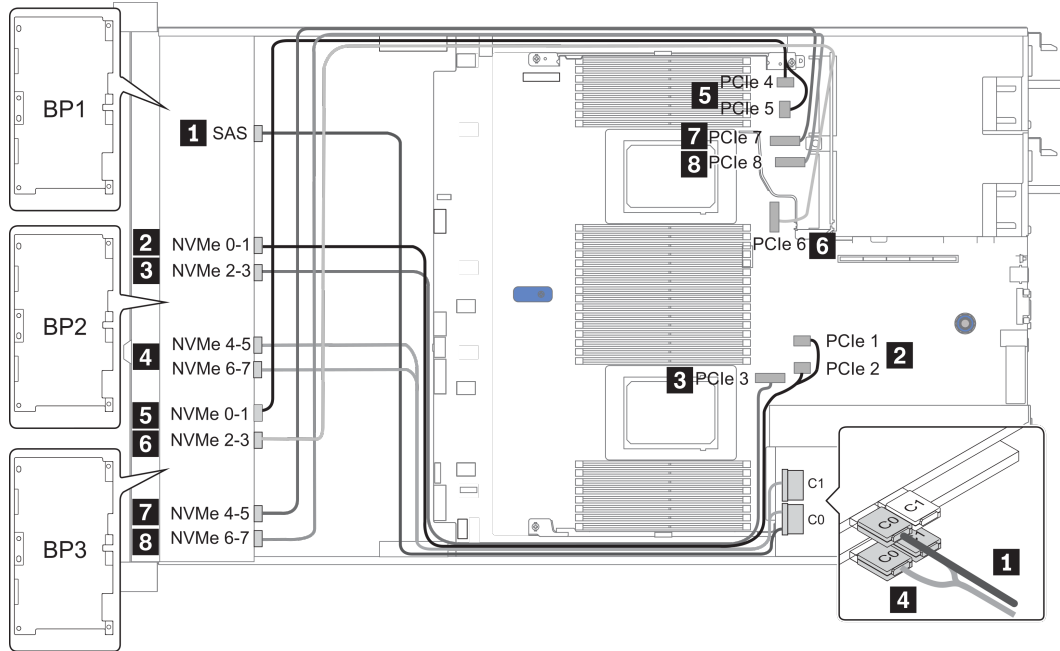

Figure 33. Cable routing for configuration 2

24 x 2.5-inch front drive bays (16SAS/SATA+8AnyBay)

This section provides cable routing information for the server model with 24 x 2.5-inch front drive bays (16SAS/SATA+8AnyBay).

The server model is configured with two 8 x 2.5-inch SAS/SATA backplane (BP 1 and BP 2) and one 8 x 2.5-inch AnyBay backplanes (BP 3). Below lists all supported configurations with these three front drive backplanes.

Configuration	Rear BP		Storage controller	
	Qty.	Type	Qty.	Type
Config. 1			2	CFF 16i RAID/HBA +CFF 36i RAID Expander
Config. 2			2	SFF 8i RAID/HBA +CFF 36i RAID Expander
Config. 3			3	SFF 8i RAID/HBA
Config. 4			1	SFF 32i RAID
Config. 5	1	Rear: 4 x 2.5" SAS/SATA	2	CFF 16i RAID/HBA +CFF 36i RAID Expander
Config. 6	1	Rear: 4 x 2.5" SAS/SATA	2	SFF 8i RAID/HBA +CFF 36i RAID Expander
Config. 7	1	Rear: 4 x 2.5" SAS/SATA	3	SFF 8i RAID/HBA
Config. 8	1	Rear: 4 x 2.5" SAS/SATA	1	SFF 32i RAID

Depending on your server configurations, refer to one of the following sections for cable routing information.

- [Configuration 1 to 4: front drive bays only](#)
- [Configuration 5 to 8: front drive bays and rear drive bays](#)

The following table shows the cable connections for all configurations:

Configuration 1 to 4: (front drive bays only)

Front: two 8 x 2.5-inch SAS/SATA backplanes and one 8 x 2.5-inch AnyBay backplane

Con-fig.	Front BP	System board	Storage controller		
			CFF 36i RAID Expander	CFF 16i RAID/HBA	SFF 8i RAID/HBA
1	BP 1: SAS		C 0		
	BP 2: SAS		C 1		
	BP 3: SAS		C 2		
			RAID/HBA	C 0, C 1	
		PCIe 6		MB	
	BP 3: NVMe 0–1	PCIe 1, PCIe 2			
	BP 3: NVMe 2–3	PCIe 3			
	BP 3: NVMe 4–5	PCIe 7			
	BP3: NVMe 6–7	PCIe 8			
2	BP 1: SAS		C 0		
	BP 2: SAS		C 1		
	BP 3: SAS		C 2		
			RAID/HBA		Gen 4: C 0 Gen3: C 0, C 1
	BP 3: NVMe 0–1	PCIe 1, PCIe 2			
	BP 3: NVMe 2–3	PCIe 3			
	BP 3: NVMe 4–5	PCIe 7			
	BP3: NVMe 6–7	PCIe 8			

Front: two 8 x 2.5-inch SAS/SATA backplanes and one 8 x 2.5-inch AnyBay backplane

Config.	Front BP	System board	Storage controller	
			SFF 8i RAID/HBA	SFF 32i RAID
3	BP 1: SAS		Gen 4: C 0 Gen3: C 0, C 1	
	BP 2: SAS		Gen 4: C 0 Gen3: C 0, C 1	
	BP 3: SAS		Gen 4: C 0 Gen3: C 0, C 1	
	BP 3: NVMe 0-1	PCIe 1, PCIe 2		
	BP 3: NVMe 2-3	PCIe 3		
	BP 3: NVMe 4-5	PCIe 7		
	BP3: NVMe 6-7	PCIe 8		
4	BP 1: SAS			C 0
	BP 2: SAS			C 1
	BP 3: SAS			C 2
	BP 3: NVMe 0-1	PCIe 1, PCIe 2		
	BP 3: NVMe 2-3	PCIe 3		
	BP 3: NVMe 4-5	PCIe 7		
	BP3: NVMe 6-7	PCIe 8		

The following illustration shows the cable routing for the configuration 2, the routing for configuration 1, 3, and 4 is similar. Connections between connectors: **1** ↔ **1**, **2** ↔ **2**, **3** ↔ **3**, ... **n** ↔ **n**

Note: For models that support Gen 3 and Gen4 adapters at the same slot, the illustration shows only the cable routing information for Gen 4 adapters, the routing and connector information is similar for Gen 3 adapters.

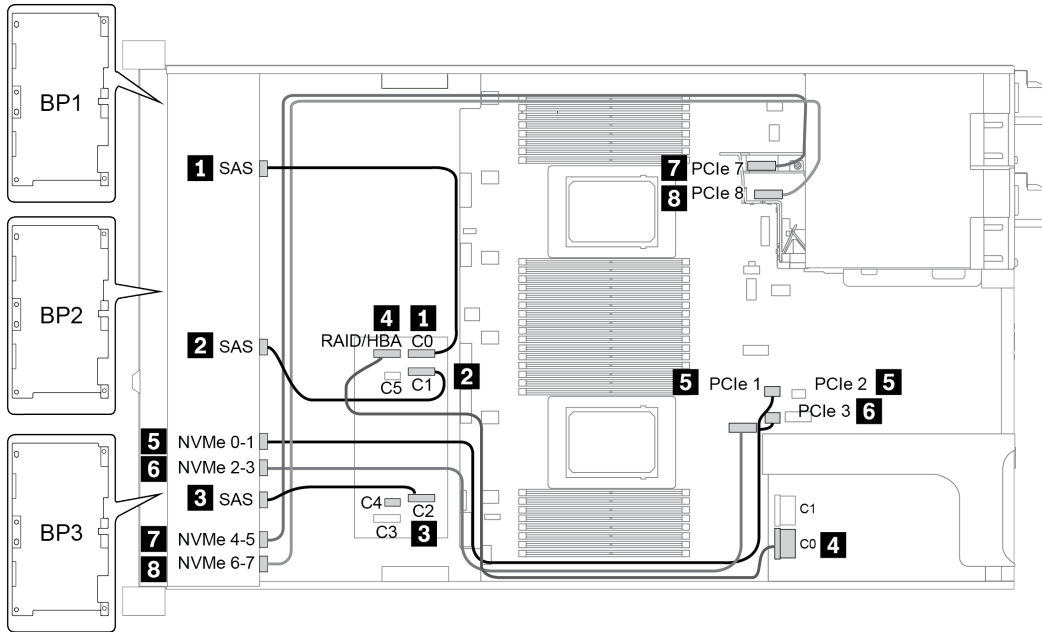

Figure 34. Cable routing for configuration 2

Configuration 5 and 6: (front drive bays and rear drive bays)

Front: two 8 x 2.5-inch SAS/SATA backplanes and one 8 x 2.5-inch AnyBay backplane

Rear: one 4 x 2.5-inch SAS/SATA backplanes

Co- nfi- g.	Front BP	Rear BP	System board	Storage controller		
				CFF 36i RAID Expander	CFF 16i RAID/HBA	SFF 8i RAID/HBA
5	BP 1: SAS			C 0		
	BP 2: SAS			C 1		
	BP 3: SAS			C 2		
				RAID/HBA	C 0/C 2, C 1/C 3	
			PCIe 6		MB	
		BP 4: SAS		C 3		
	BP 3: NVMe 0–1		PCIe 1, PCIe 2			
	BP 3: NVMe 2–3		PCIe 3			
	BP 3: NVMe 4–5		PCIe 7			
BP3: NVMe 6–7		PCIe 8				
6	BP 1: SAS			C 0		
	BP 2: SAS			C 1		
	BP 3: SAS			C 2		
		BP 4: SAS		C 3		
				RAID/HBA		Gen 4: C 0 Gen3: C 0, C 1
	BP 3: NVMe 0–1		PCIe 1, PCIe 2			
	BP 3: NVMe 2–3		PCIe 3			
	BP 3: NVMe 4–5		PCIe 7			
	BP3: NVMe 6–7		PCIe 8			

Front: two 8 x 2.5-inch SAS/SATA backplanes and one 8 x 2.5-inch AnyBay backplane

Rear: one 4 x 2.5-inch SAS/SATA backplanes

Co- nfi- g.	Front BP	Rear BP	System board	Storage controller	
				SFF 8i RAID/HBA	SFF 32i RAID
7	BP 1: SAS			Slot 2: Gen 4: C 0/C 1 Gen3: C 0	
	BP 2: SAS			Slot 3: Gen 4: C 0/C 1 Gen3: C 0	
	BP 3: SAS			Slot 4: Gen 4: C 0/C 2 Gen3: C 0/C 1	
		BP 4: SAS		Slot 5: C 0	
	BP 3: NVMe 0-1		PCIe 1, PCIe 2		
	BP 3: NVMe 2-3		PCIe 3		
	BP 3: NVMe 4-5		PCIe 7		
	BP3: NVMe 6-7		PCIe 8		
8	BP 1: SAS				C 0
	BP 2: SAS				C 1
	BP 3: SAS				C 2
		BP 4: SAS			C 3
	BP 3: NVMe 0-1		PCIe 1, PCIe 2		
	BP 3: NVMe 2-3		PCIe 3		
	BP 3: NVMe 4-5		PCIe 7		
	BP3: NVMe 6-7		PCIe 8		

The following illustration shows the cable routing for the configuration 2, the routing for the other configurations is similar. Connections between connectors: **1** ↔ **1**, **2** ↔ **2**, **3** ↔ **3**, ... **n** ↔ **n**

Note: For models that support Gen 3 and Gen4 adapters at the same slot, the illustration shows only the cable routing information for Gen 4 adapters, the routing and connector information is similar for Gen 3 adapters.

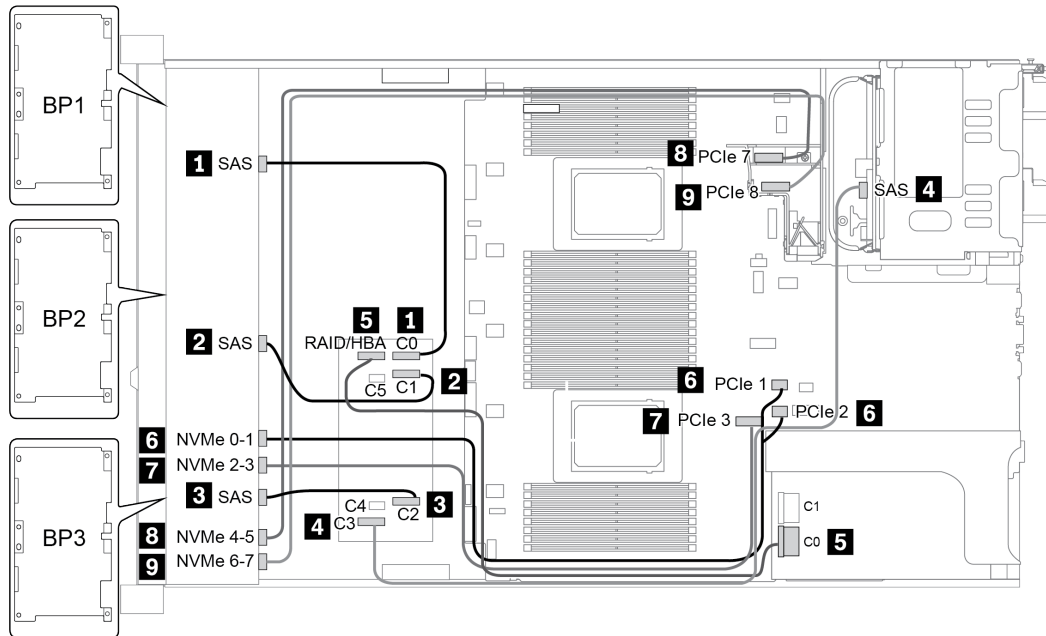

Figure 35. Cable routing for configuration 5

24 x 2.5-inch front drive bays (16SAS/SATA+8NVMe)

This section provides cable routing information for the server model with 24 x 2.5-inch front drive bays (16SAS/SATA+8NVMe).

The server model is configured with two 8 x 2.5-inch SAS/SATA backplane (BP 1 and BP 2) and one 8 x 2.5-inch AnyBay backplanes (BP 3). Below lists all supported configurations with these three front drive backplanes.

Note: The AnyBay backplane (BP3) is used as a pure NVMe backplane.

Configuration	Storage controller	
	Qty.	Type
Config. 1	2	SFF 8i RAID/HBA
Config. 2	1	SFF 16i RAID/HBA
Config. 3	1	CFF 16i RAID/HBA
Config. 4	1	SFF 32i RAID

The following table shows the cable connections for all configurations:

Configuration 1, 2, 3, and 4: (front drive bays only)

Front: two 8 x 2.5-inch SAS/SATA backplanes and one 8 x 2.5-inch pure NVMe backplane

- SFF 8i RAID/HBA
- SFF 16i RAID/HBA

Co-nfig.	Front BP	System board	Storage controller	
			SFF 8i RAID/HBA	SFF 16i RAID/HBA
1	BP 1: SAS		Gen 4: C 0 Gen 3: C 0, C 1	
	BP 2: SAS		Gen 4: C 0 Gen3: C 0, C 1	
	BP 3: NVMe 0-1	PCIe 1, PCIe 2		
	BP 3: NVMe 2-3	PCIe 3		
	BP 3: NVMe 4-5	PCIe 7		
	BP3: NVMe 6-7	PCIe 8		
2	BP 1: SAS			Gen 4: C 0 Gen3: C 0, C 1
	BP 2: SAS			Gen 4: C 1 Gen3: C 2, C 3
	BP 3: NVMe 0-1	PCIe 1, PCIe 2		
	BP 3: NVMe 2-3	PCIe 3		
	BP 3: NVMe 4-5	PCIe 7		
	BP3: NVMe 6-7	PCIe 8		

- CFF 16i RAID/HBA
- SFF 32i RAID/HBA

Co-nfig.	Front BP	System board	Storage controller	
			CFF 16i RAID/HBA	SFF 32i RAID/HBA
3	BP 1/BP 2: SAS		C 0/C 2, C 1/C 3	
		PCIe 6	MB	
	BP 3: NVMe 0-1	PCIe 1, PCIe 2		
	BP 3: NVMe 2-3	PCIe 3		
	BP 3: NVMe 4-5	PCIe 7		
	BP3: NVMe 6-7	PCIe 8		
4	BP 1: SAS			C 0
	BP 2: SAS			C 1
	BP 3: NVMe 0-1	PCIe 1, PCIe 2		

	BP 3: NVMe 2-3	PCIe 3		
	BP 3: NVMe 4-5	PCIe 7		
	BP3: NVMe 6-7	PCIe 8		

The following illustration shows the cable routing for the configuration 4, the routing for the other configurations is similar. Connections between connectors: **1** ↔ **1**, **2** ↔ **2**, **3** ↔ **3**, ... **n** ↔ **n**

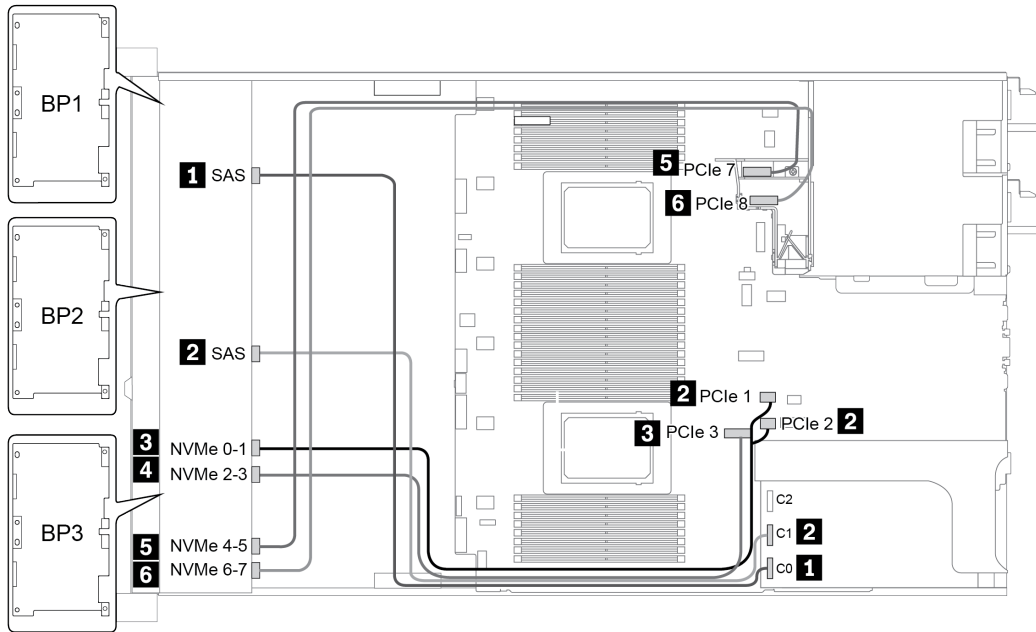

Figure 36. Cable routing for configuration 4

24 x 2.5-inch front drive bays (SAS/SATA)

This section provides cable routing information for the server model with 24 x 2.5-inch front drive bays (SAS/SATA).

The server model is configured with three 8 x 2.5-inch SAS/SATA backplane (BP 1, BP 2, and BP 3). Below lists all supported configurations with these three front drive backplanes.

Configuration	Mid or Rear BP		Storage controller	
	Qty.	Type	Qty.	Type
Config. 1			2	CFF 16i RAID/HBA CFF 36i RAID Expander
Config. 2			2	SFF 8i RAID/HBA CFF 36i RAID Expander
Config. 3			3	SFF 8i RAID/HBA
Config. 4			1	SFF 32i RAID
Config. 5	1	Rear: 4 x 2.5" SAS/SATA	2	CFF 16i RAID/HBA CFF 36i RAID Expander
Config. 6	1	Rear: 4 x 2.5" SAS/SATA	2	SFF 8i RAID/HBA CFF 36i RAID Expander
Config. 7	1	Rear: 4 x 2.5" SAS/SATA	4	SFF 8i RAID/HBA
Config. 8	1	Rear: 4 x 2.5" SAS/SATA	1	SFF 32i RAID
Config. 9	3	Mid: 4 x 2.5" SAS/SATA Mid: 4 x 2.5" SAS/SATA Rear: 8 x 2.5" SAS/SATA	2	CFF 16i RAID/HBA CFF 36i RAID Expander
Config. 10	3	Mid: 4 x 2.5" SAS/SATA Mid: 4 x 2.5" SAS/SATA Rear: 4 x 2.5" SAS/SATA	2	CFF 16i RAID/HBA CFF 36i RAID Expander
Config. 11	3	Mid: 4 x 2.5" SAS/SATA Mid: 4 x 2.5" SAS/SATA Rear: 4 x 2.5" SAS/SATA	2	SFF 8i RAID/HBA CFF 36i RAID Expander

Depending on your server configurations, refer to one of the following sections for cable routing information.

- [Configuration 1 to 4: front drive bays only](#)
- [Configuration 5 to 8: front drive bays and rear drive bays](#)
- [Configuration 9 to 11: front drive bays, mid drive bays, and rear drive bays](#)

The following table shows the cable connections for all configurations:

Configuration 1 and 2: (front drive bays only)

Front: three 8 x 2.5-inch SAS/SATA backplanes (BP 1, BP 2, and BP 3)

- CFF RAID expander + CFF 16i RAID/HBA
- CFF RAID expander + SFF 8i RAID/HBA

Co-nfig.	Front BP	System board	Storage controller			
			CFF 36i RAID Expander	CFF 16i RAID/HBA	SFF 8i RAID/HBA	SFF 32i RAID
1	BP 1: SAS		C 0			
	BP 2: SAS		C 1			
	BP 3: SAS		C 2			
			RAID/HBA	C 0, C 1		
		PCIe 6		MB		
2	BP 1: SAS		C 0			
	BP 2: SAS		C 1			
	BP 3: SAS		C 2			
			RAID/HBA		Gen 4: C 0 Gen 3: C 0/C 1	
3	BP 1: SAS				Gen 4: C 0 Gen 3: C 0/C 1	
	BP 2: SAS				Gen 4: C 0 Gen 3: C 0/C 1	
	BP 3: SAS				Gen 4: C 0/C 2 Gen 3: C 0/C 1	
4	BP 1: SAS					C 0
	BP 2: SAS					C 1
	BP 3: SAS					C 2

The following illustration shows the cable routing for the configuration 4, the routing for the other configurations is similar. Connections between connectors: **1** ↔ **1**, **2** ↔ **2**, **3** ↔ **3**, ... **n** ↔ **n**

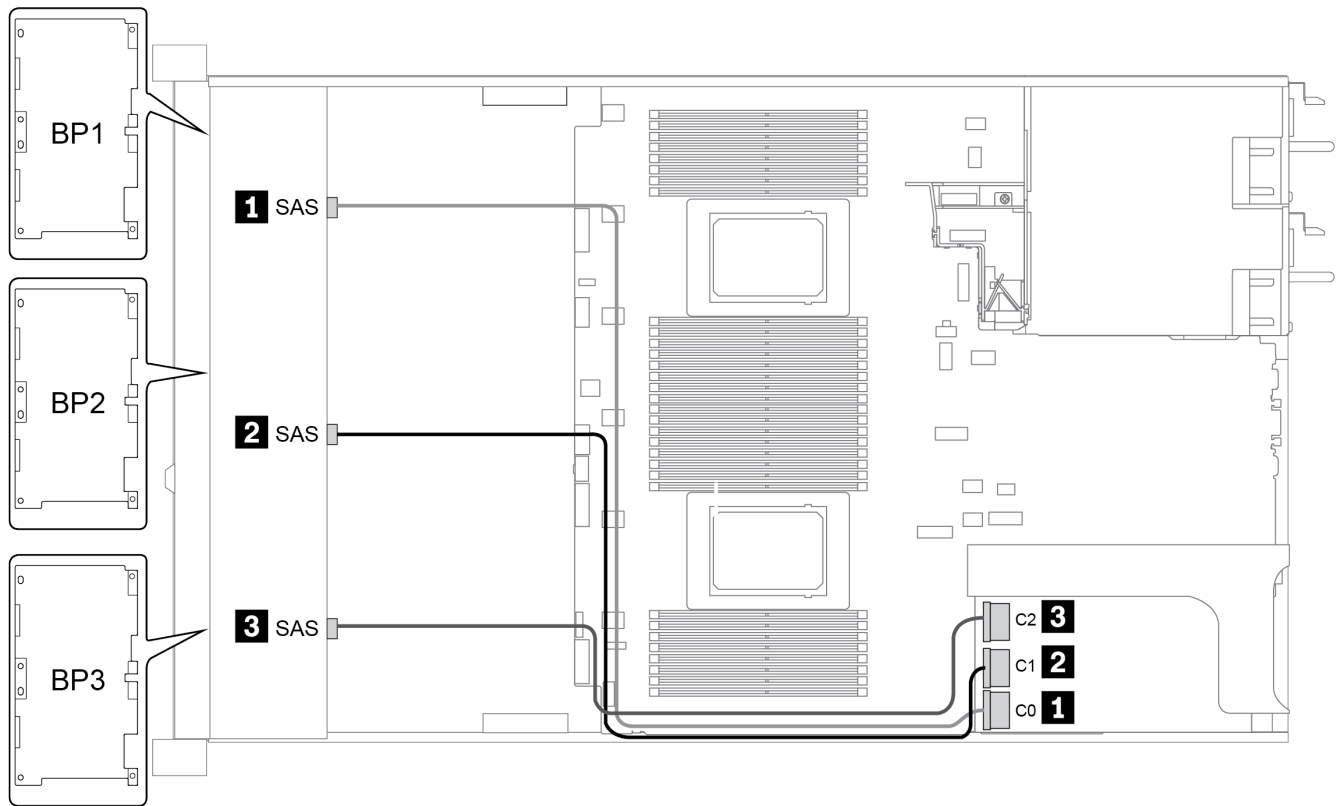

Figure 37. Cable routing for configuration 4

The following table shows the cable connections for all configurations:

Configuration 5 to 8: (front drive bays and rear drive bays)

Front: three 8 x 2.5-inch SAS/SATA backplanes (BP 1, BP 2, and BP 3)

Rear: one 4 x 2.5" SAS/SATA (BP 4)

Co- nfi- g.	Front BP	Rear BP	System board	Storage controller		
				CFF 36i RAID Expander	CFF 16i RAID/HBA	SFF 8i RAID/ HBA
5	BP 1: SAS			C 0		
	BP 2: SAS			C 1		
	BP 3: SAS			C 2		
		BP 4: SAS		C 3		
			PCIe 6		MB	
				RAID/HBA	C 0, C 1	
6	BP 1: SAS			C 0		
	BP 2: SAS			C 1		
	BP 3: SAS			C 2		
		BP 4: SAS		C 3		
				RAID/HBA		Gen 4: C 0 Gen 3: C 0/C 1

Front: three 8 x 2.5-inch SAS/SATA backplanes (BP 1, BP 2, and BP 3)

Rear: one 4 x 2.5" SAS/SATA (BP 4)

Configura- tion option	Front BP	Rear BP	Storage controller	
			SFF 8i RAID/HBA	SFF 32i RAID
7	BP 1: SAS		Slot 2: Gen 4: C 0 Gen 3: C 0/C 1	
	BP 2: SAS		Slot 3: Gen 4: C 0 Gen 3: C 0/C 1	
	BP 3: SAS		Slot 5: Gen 4: C 0/C 2 Gen 3: C 0/C 1	

Configura- tion option	Front BP	Rear BP	Storage controller	
			SFF 8i RAID/HBA	SFF 32i RAID
		BP 4: SAS	Slot 6: Gen 4: C 0 Gen 3: C 0/C 1	
8	BP 1: SAS			C 0
	BP 2: SAS			C 1
	BP 3: SAS			C 2
		BP 4: SAS		C 3

The following illustration shows the cable routing for the configuration 4, the routing for the other configurations is similar. Connections between connectors: **1** ↔ **1**, **2** ↔ **2**, **3** ↔ **3**, ... **n** ↔ **n**

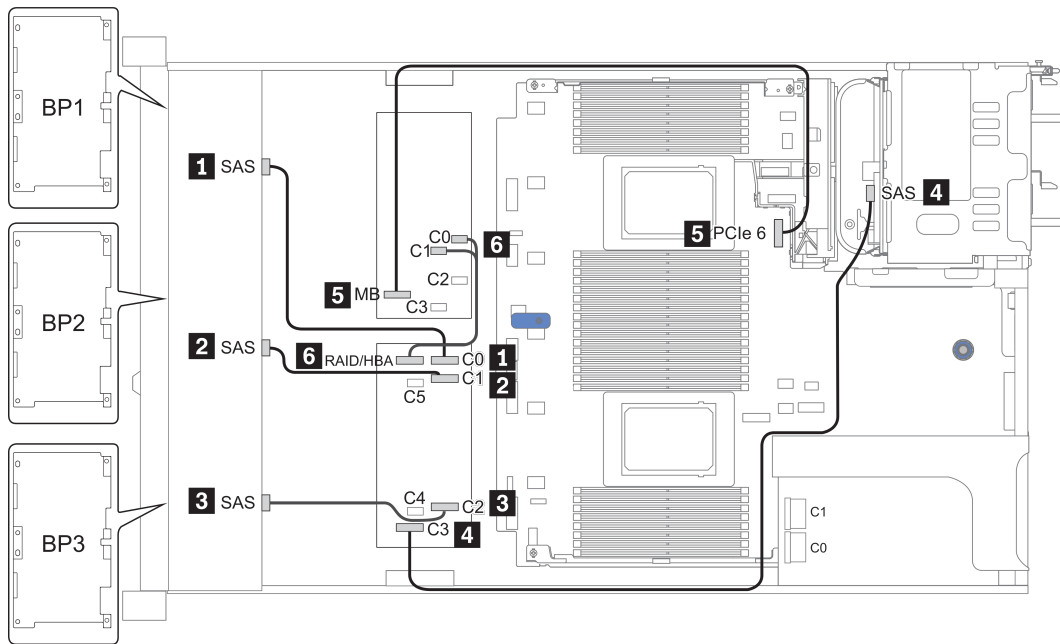

Figure 38. Cable routing for configuration 5

Configuration 9 to 11: (front drive bays, mid drive bays, and rear drive bays)

Front: three 8 x 2.5-inch SAS/SATA backplanes (BP 1, BP 2, and BP 3)

Mid: two 4 x 2.5-inch SAS/SATA backplanes (BP 5 and BP 6)

Rear: one 8 x 2.5-inch SAS/SATA backplane (BP 4)

Config.	Front BP	Mid/Rear BP	System board	Storage controller	
				CFF 36i RAID Expander	CFF 16i RAID/HBA
9	BP 1: SAS			C 0	
	BP 2: SAS			C 1	
	BP 3: SAS			C 2	
		BP 4: SAS 0			C 2
		BP 4: SAS 1			C 3
		BP5: SAS, SAS		C 3	
			PCIe 6		MB
				RAID/HBA	C 0, C 1

Front: three 8 x 2.5-inch SAS/SATA backplanes (BP 1, BP 2, and BP 3)

Mid: two 4 x 2.5-inch SAS/SATA backplanes (BP 5 and BP 6)

Rear: one 4 x 2.5-inch SAS/SATA backplane (BP 4)

Con-fig.	Front BP	Mid/Rear BP	Sys-tem board	Storage controller		
				CFF 36i RAID Expander	CFF 16i RAID/HBA	SFF 8i RAID/HBA
10	BP 1: SAS			C 0		
	BP 2: SAS			C 1		
	BP 3: SAS			C 2		
		BP 4: SAS, BP 5: SAS		C 3		
		BP 6: SAS		C 4		
				RAID/HBA	C 0, C 1	
				PCIe 6	MB	
11	BP 1: SAS			C 0		
	BP 2: SAS			C 1		
	BP 3: SAS			C 2		
		BP 4: SAS, BP 5: SAS		C 3		
		BP 6: SAS		C 4		
				RAID/HBA		Gen 4: C 0 Gen 3: C 0/C 1

The following illustration shows the cable routing for the configuration 10. the routing for the other configurations is similar. Connections between connectors: **1** ↔ **1**, **2** ↔ **2**, **3** ↔ **3**, ... **n** ↔ **n**

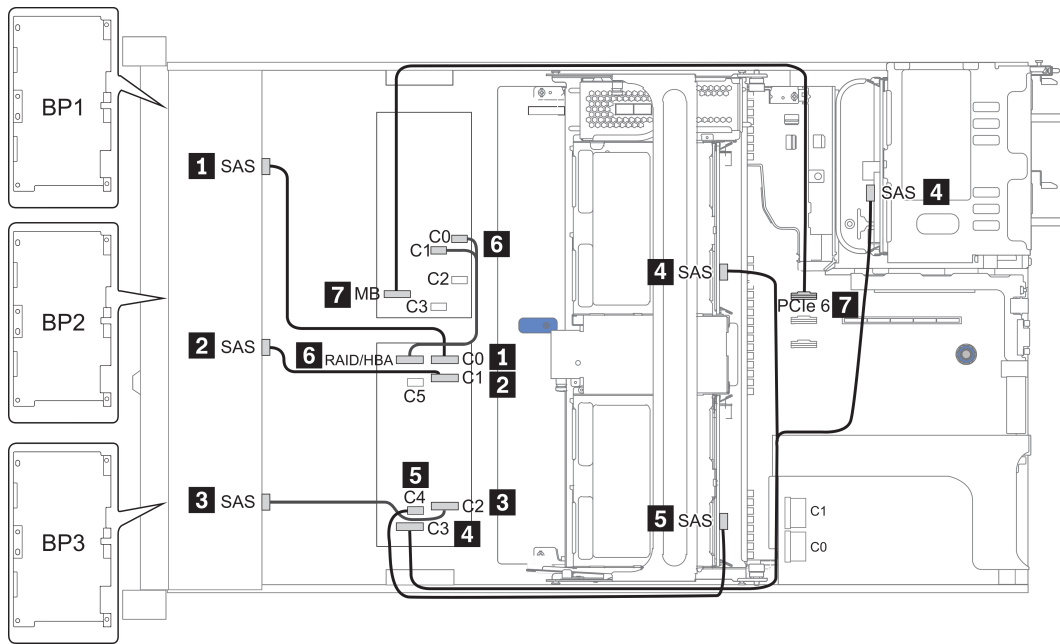

Figure 39. Cable routing for configuration 10

24 x 2.5-inch front drive bays (NVMe)

This section provides cable routing information for the server model with 24 x 2.5-inch front drive bays (NVMe).

The server model is configured with three 8 x 2.5-inch AnyBay backplanes (BP 1, BP 2, and BP 3). Below lists all supported configurations with these three front drive backplanes.

Note: The AnyBay backplanes are used as pure NVMe backplanes.

Configuration	Mid or Rear BP		Storage controller	
	Qty.	Type	Qty.	Type
Config. 1			3	PCIe switch
Config. 2	2	Mid: 4 x 2.5" NVMe	4	PCIe switch

Depending on your server configurations, refer to one of the following sections for cable routing information.

- [Configuration 1: front drive bays only](#)
- [Configuration 2: front drive bays and mid drive bays](#)

The following table shows the cable connections for all configurations:

Configuration 1: (front drive bays only)

Front: three 8 x 2.5-inch SAS/SATA backplanes (BP 1, BP 2, and BP 3)

Config.	Front BP	System board	Storage controller
			PCIe switch
1	BP1: NVMe 0-1	PCIe 1, PCIe 2	
	BP1: NVMe 2-3	PCIe 3	
	BP1: NVMe 4-5, NVMe 6-7		Slot 1 C 0, C 1
	BP2: NVMe 0-1, NVMe 2-3		Slot 2 C 0, C 1
	BP2: NVMe 4-5	PCIe 4, PCIe 5	
	BP2: NVMe 6-7	PCIe 6	
	BP3: NVMe 0-1	PCIe 7	
	BP3: NVMe 2-3	PCIe 8	
	BP3: NVMe 4-5, NVMe 6-7		Slot 4 C 0, C 1

The following illustration shows the cable routing for the configuration 4. Connections between connectors:

1 ↔ 1, 2 ↔ 2, 3 ↔ 3, ... n ↔ n

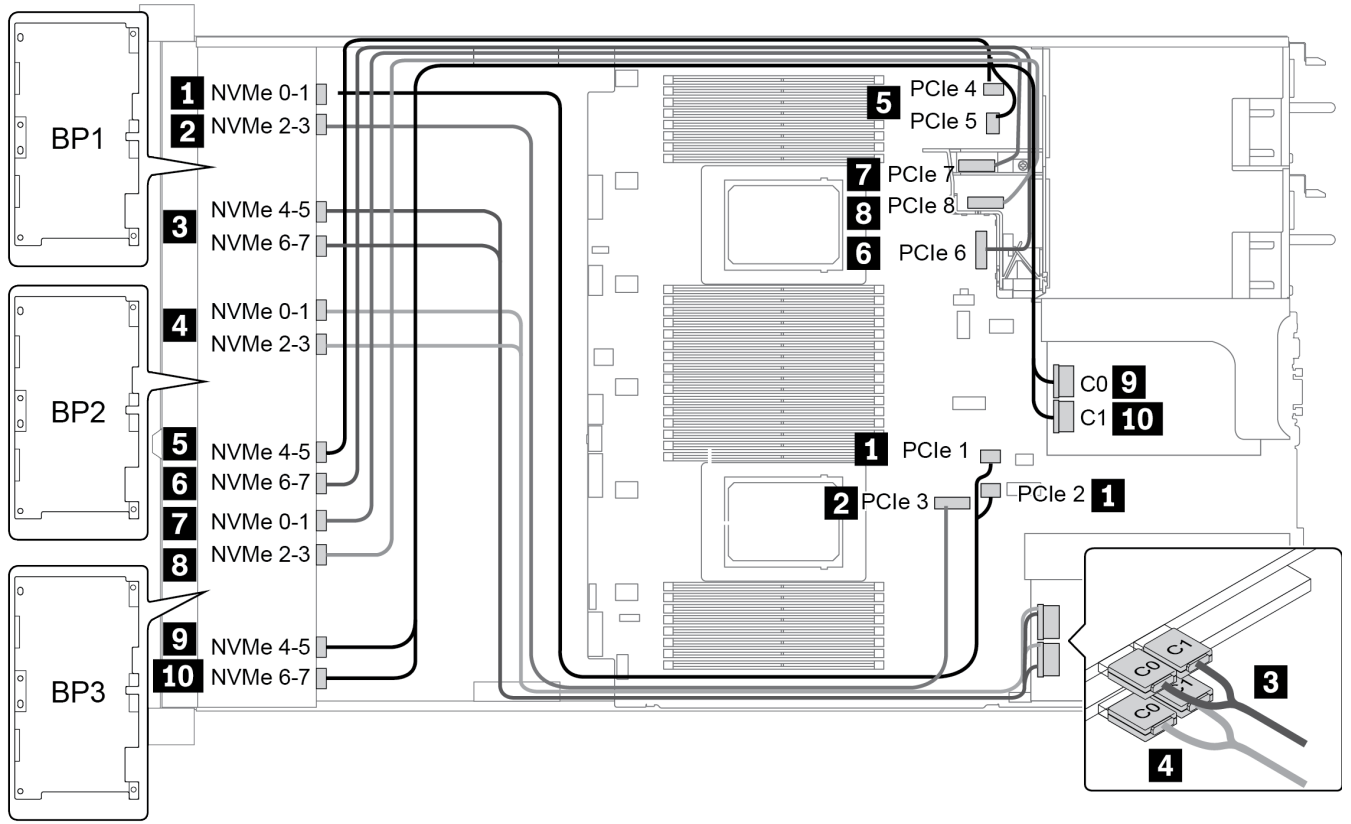

Figure 40. Cable routing for configuration 1

The following table shows the cable connections for all configurations:

Configuration 2: (front drive bays and mid drive bays)

Front: three 8 x 2.5-inch SAS/SATA backplanes (BP 1, BP 2, and BP 3)

Mid: two 4 x 2.5" NVMe backplanes (BP 5 and BP 6)

Co-nfig.	Front BP	Mid BP	Storage controller
			PCIe switch
2	BP 1: NVMe 0-1, NVMe 2-3 NVMe 4-5, NVMe 6-7		Slot 1 C 0, C 1, C 2, C 3
	BP 2: NVMe 0-1, NVMe 2-3 NVMe 4-5, NVMe 6-7		Slot 2 C 0, C 1, C 2, C 3
	BP 3: NVMe 0-1, NVMe 2-3 NVMe 4-5, NVMe 6-7		Slot 4 C 0, C 1, C 2, C 3
		BP 5: NVMe 0-1, NVMe 2-3 BP 6: NVMe 0-1, NVMe 2-3	Slot 5 C 0, C 1, C 2, C 3

The following illustration shows the cable routing for the configuration 2. Connections between connectors: **1 ↔ 1, 2 ↔ 2, 3 ↔ 3, ... n ↔ n**

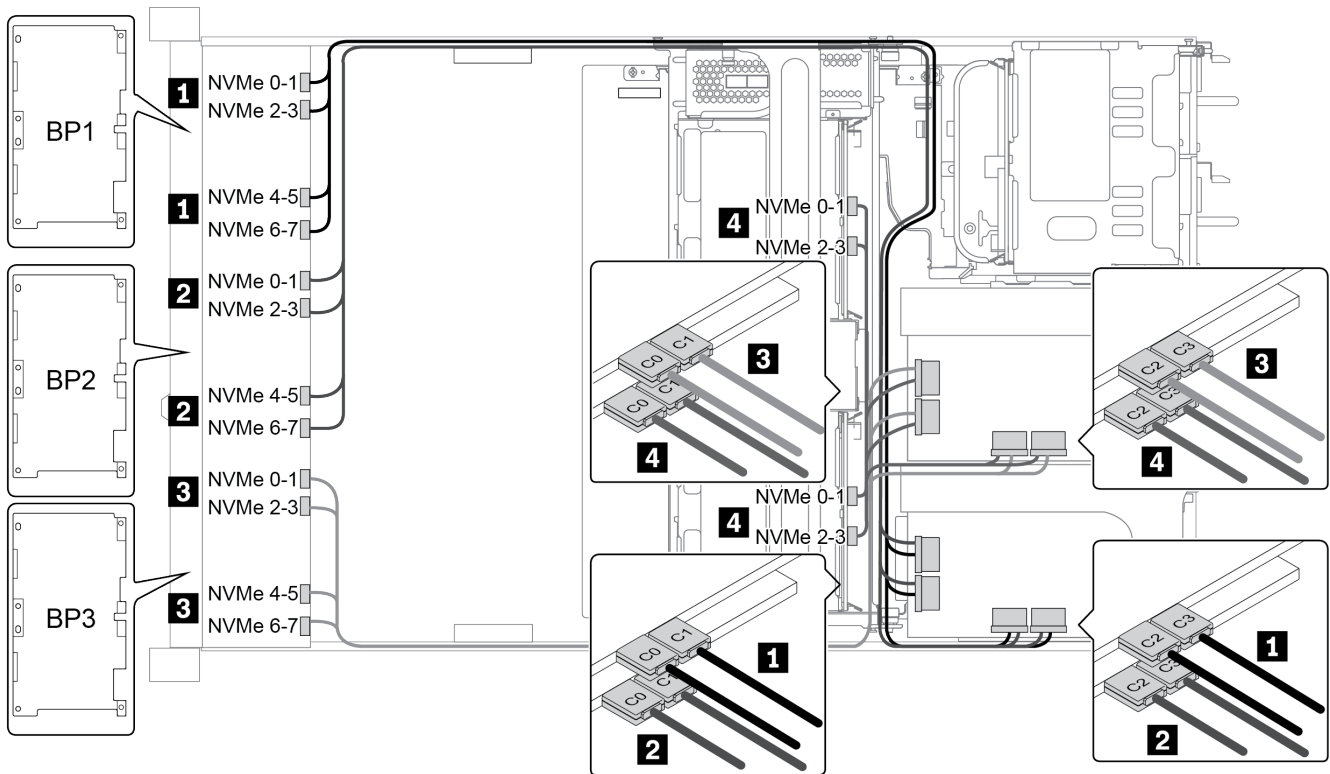

Figure 41. Cable routing for configuration 2

8 x 3.5-inch front drive bays (SAS/SATA)

This section provides cable routing information for the server model with 8 x 2.5-inch SAS/SATA front drive bays.

The server model is configured with one 8 x 3.5-inch SAS/SATA front drive backplane. Below lists all supported configurations with this front drive backplane.

Configuration	Storage controller	
	Qty.	Type
Config. 1		
Config. 2	1	SFF 8i RAID/HBA

The following table shows the cable connections for all configurations:

Configuration 1 and 2: (front drive bays only)

Front: one 8 x 3.5-inch SAS/SATA backplanes

Con-fig.	Front BP	System board	Storage controller
			SFF 16i RAID/HBA
1	SAS 0	PCIe 1	
	SAS 1	PCIe 2	
2	SAS 0, SAS 1		Gen 4: C 0 Gen3: C 0, C 1

The following illustration shows the cable routing for the configuration 2, the routing for configurations 1 is similar. Connections between connectors: **1 ↔ 1, 2 ↔ 2, 3 ↔ 3, ... n ↔ n**

Note: For models that support Gen 3 and Gen4 adapters at the same slot, the illustration shows only the cable routing information for Gen 4 adapters, the routing and connector information is similar for Gen 3 adapters.

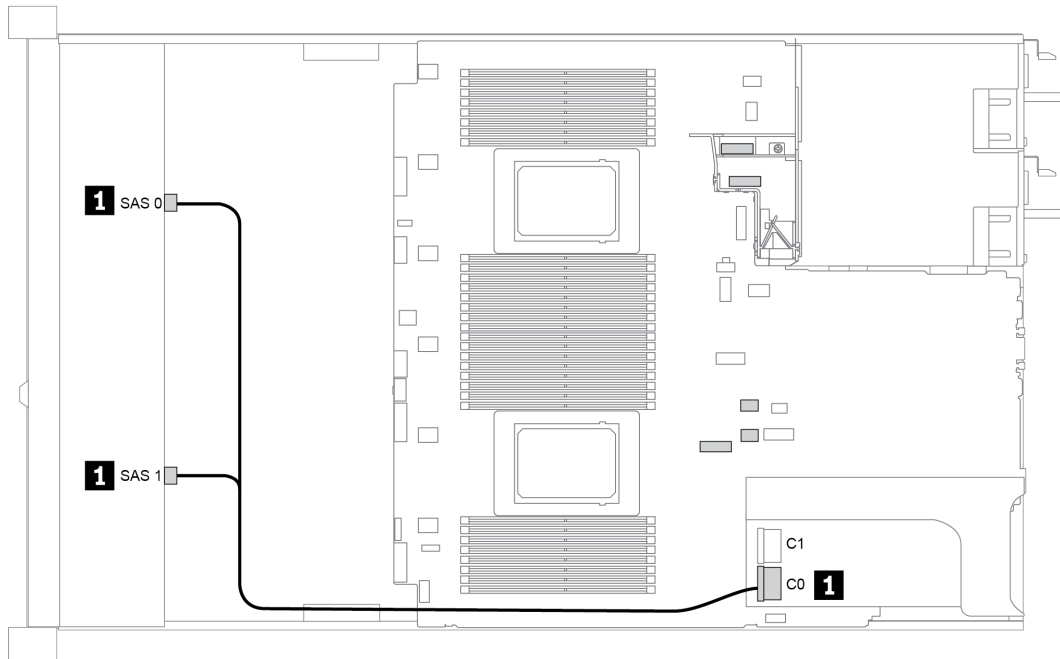

Figure 42. Cable routing for configuration 2

12 x 3.5-inch front drive bays (SAS/SATA)

This section provides cable routing information for the server model with 12 x 3.5-inch SAS/SATA front drive bays.

The server model is configured with one 12 x 3.5-inch SAS/SATA front drive backplane. Below lists all supported configurations with this front drive backplane.

Configuration	Mid/Rear BP		Storage controller	
	Qty.	Type	Qty.	Type
Config. 1				
Config. 2			1	SFF 16i RAID/HBA
Config. 3	2	Mid: 4 x 2.5" NVMe	1	SFF 16i RAID/HBA
Config. 4	1	Rear: 2 x 3.5" SAS/SATA	1	SFF 16i RAID/HBA
Config. 5	1	Rear: 2 x 3.5" SAS/SATA	2	SFF 8i HBA + SFF 16i RAID/HBA
Config. 6	1	Rear: 4 x 3.5" SAS/SATA	1	SFF 16i RAID/HBA
Config. 7	1	Rear: 4 x 3.5" SAS/SATA	2	SFF 8i HBA + SFF 16i RAID/HBA
Config. 8	1	Rear: 4 x 2.5" SAS/SATA	1	SFF 16i RAID/HBA
Config. 9	1	Rear: 4 x 2.5" SAS/SATA	2	SFF 8i HBA + SFF 16i RAID/HBA
Config. 10	2	Mid: 4 x 3.5" SAS/SATA Rear: 4 x 3.5" SAS/SATA	1	SFF 8i HBA
Config. 11	2	Mid: 4 x 3.5" SAS/SATA Rear: 4 x 3.5" SAS/SATA	1	SFF 32i RAID
Config. 12	2	Mid: 4 x 3.5" SAS/SATA Rear: 4 x 2.5" SAS/SATA	1	SFF 8i HBA
Config. 13	2	Mid: 4 x 3.5" SAS/SATA Rear: 4 x 2.5" SAS/SATA	1	SFF 32i RAID

Depending on your server configurations, refer to one of the following sections for cable routing information.

- [“Configuration 1 and 2: front drive bays only” on page 118](#)
- [“Configuration 3: front drive bays and mid drive bays” on page 119](#)
- [“Configuration 4 to 9: front drive bays and rear drive bays” on page 120](#)
- [“Configuration 10 to 13: front drive bays, mid drive bays, and rear drive bays” on page 122](#)

The following table shows the cable connections for all configurations:

Configuration 1 and 2: (front drive bays only)

Front: one 12 x 3.5-inch SAS/SATA backplane

Config.	Front BP	System board	Storage controller
			SFF 16i RAID/HBA
1	SAS 0	PCIe 1	
	SAS 1	PCIe 2	
2	SAS 0, SAS 1		Gen 4: C 0 Gen3: C 0/ C 1

The following illustration shows the cable routing for the configuration 2, the routing for configurations 1 is similar. Connections between connectors: **1** ↔ **1**, **2** ↔ **2**, **3** ↔ **3**, ... **n** ↔ **n**

Note: For models that support Gen 3 and Gen4 adapters at the same slot, the illustration shows only the cable routing information for Gen 4 adapters, the routing and connector information is similar for Gen 3 adapters.

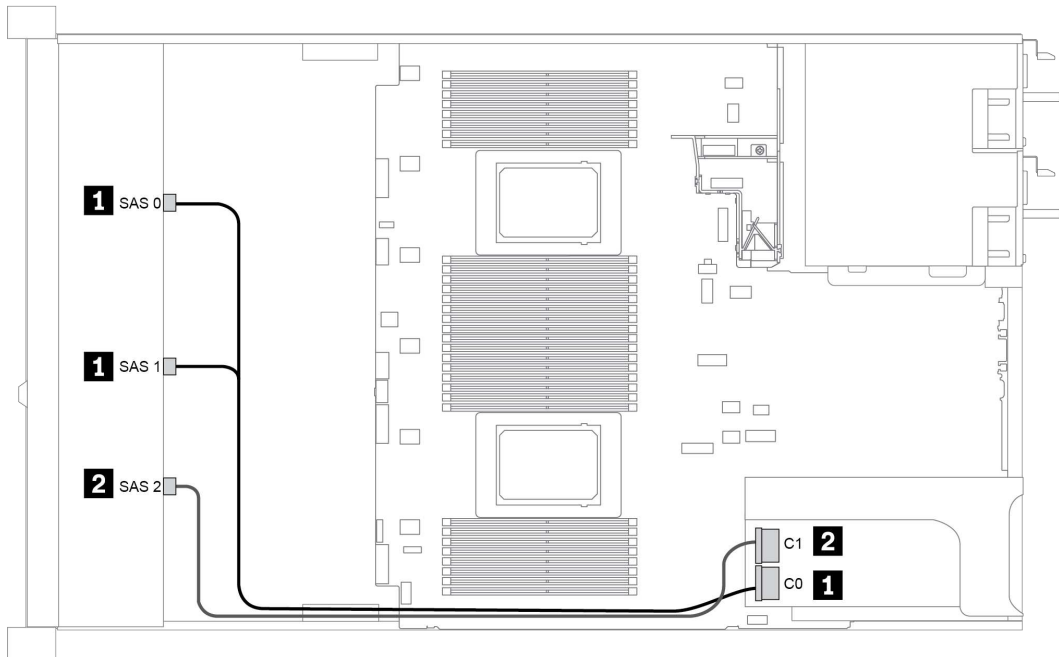

Figure 43. Cable routing for configuration 2

The following table shows the cable connections for all configurations:

Configuration 3: (front drive bays and mid drive bays)

Front: one 12 x 3.5-inch SAS/SATA backplane

Mid: two 4 x 2.5-inch NVMe backplanes

Con-fig.	Front BP	Mid BP	System board	Storage controller
				SFF 16i RAID/HBA
3	SAS 0, SAS 1			Gen 4: C 0 Gen3: C 0/ C 1
	SAS 2			C 1
		BP 5: NVMe 0-1	PCIe 1, PCIe 2	
		BP 5: NVMe 2-3	PCIe 3	
		BP 6: NVMe 0-1	PCIe 7	
		BP 6: NVMe 2-3	PCIe 8	

The following illustration shows the cable routing for the configuration 3. Connections between connectors: **1 ↔ 1, 2 ↔ 2, 3 ↔ 3, ... n ↔ n**

Note: For models that support Gen 3 and Gen4 adapters at the same slot, the illustration shows only the cable routing information for Gen 4 adapters, the routing and connector information is similar for Gen 3 adapters.

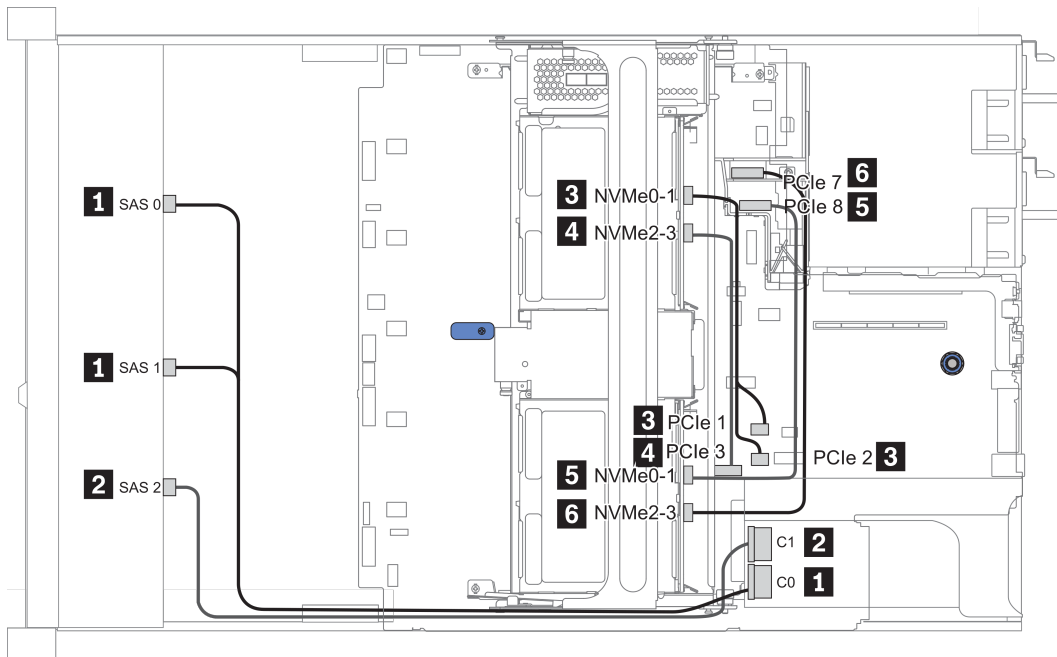

Figure 44. Cable routing for configuration 3

Configuration 4 to 9: (front drive bays and rear drive bays)

Front: one 12 x 3.5-inch SAS/SATA backplane

Rear: one 2 x 3.5-inch SAS/SATA backplane/4 x 3.5-inch SAS/SATA backplane/4 x 2.5-inch SAS/SATA backplane

Configuration option	Front BP	Rear BP	Storage controller	
			SFF 16i RAID/HBA	SFF 8i RAID
4/6/8	SAS 0, SAS 1		Gen 4: C 0 Gen3: C 0/C 1	
	SAS 2	BP 4: SAS	Gen 4: C 1 Gen3: C 2/C 3	
5/7/9	SAS 0, SAS 1		Gen 4: C 0 Gen3: C 0/C 1	
	SAS 2		Gen 4: C 1 Gen3: C 2	
		BP 4: SAS		Gen 4: C 0 Gen3: C 0

The following illustration shows the cable routing for the configuration 6, the routing for the other configurations is similar. Connections between connectors: **1** ↔ **1**, **2** ↔ **2**, **3** ↔ **3**, ... **n** ↔ **n**

Note: For models that support Gen 3 and Gen4 adapters at the same slot, the illustration shows only the cable routing information for Gen 4 adapters, the routing and connector information is similar for Gen 3 adapters.

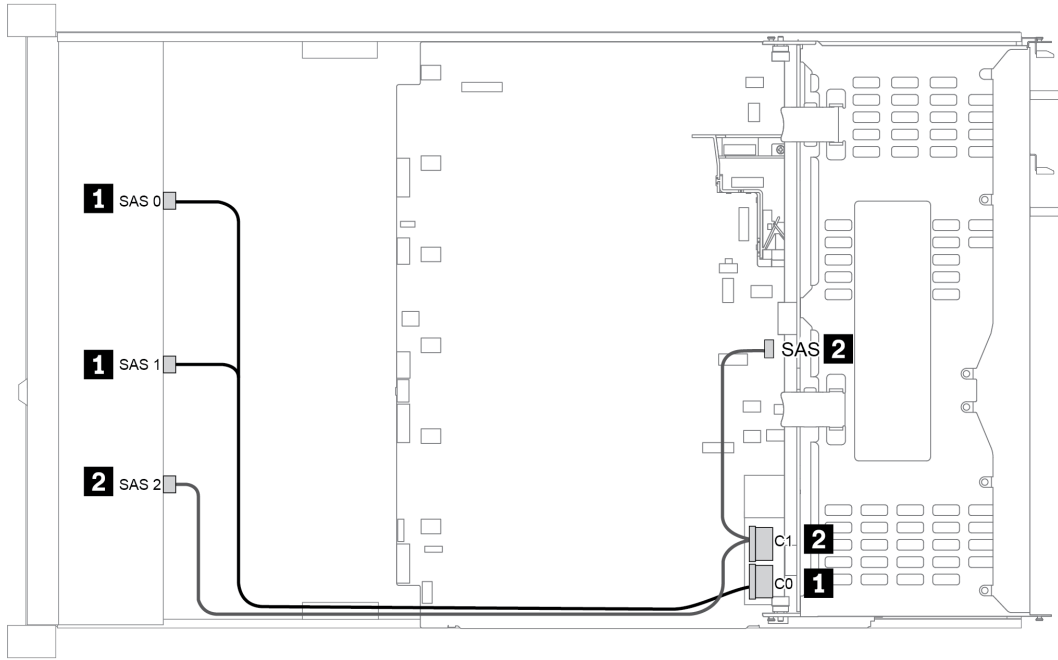

Figure 45. Cable routing for configuration 6

Configuration 10 to 13: (front drive bays, mid drive bays, and rear drive bays)

Front: one 12 x 3.5-inch SAS/SATA backplanes

Mid: one 4 x 3.5-inch SAS/SATA backplane (BP 5)

Rear: one 4 x 3.5-inch SAS/SATA backplane/4 x 2.5-inch SAS/SATA backplane

Co- nfig.	Front BP	Mid/Rear BP	System board	Storage controller	
				SFF 8i HBA	SFF 32i RAID
10/ 12	SAS 0		PCle 1		
	SAS 1		PCle 2		
	SAS 2		PCle 4, PCle 5		
		BP 4: SAS BP 5: SAS		Gen 4: C 0 Gen3: C 0/C 1	
11/ 13	SAS 0, SAS 1				C 0
	SAS 2	BP 4: SAS			C 1
		BP 5: SAS			C 2

The following illustration shows the cable routing for the configuration 10, the routing for the other configurations is similar. Connections between connectors: **1** ↔ **1**, **2** ↔ **2**, **3** ↔ **3**, ... **n** ↔ **n**

Note: For models that support Gen 3 and Gen4 adapters at the same slot, the illustration shows only the cable routing information for Gen 4 adapters, the routing and connector information is similar for Gen 3 adapters.

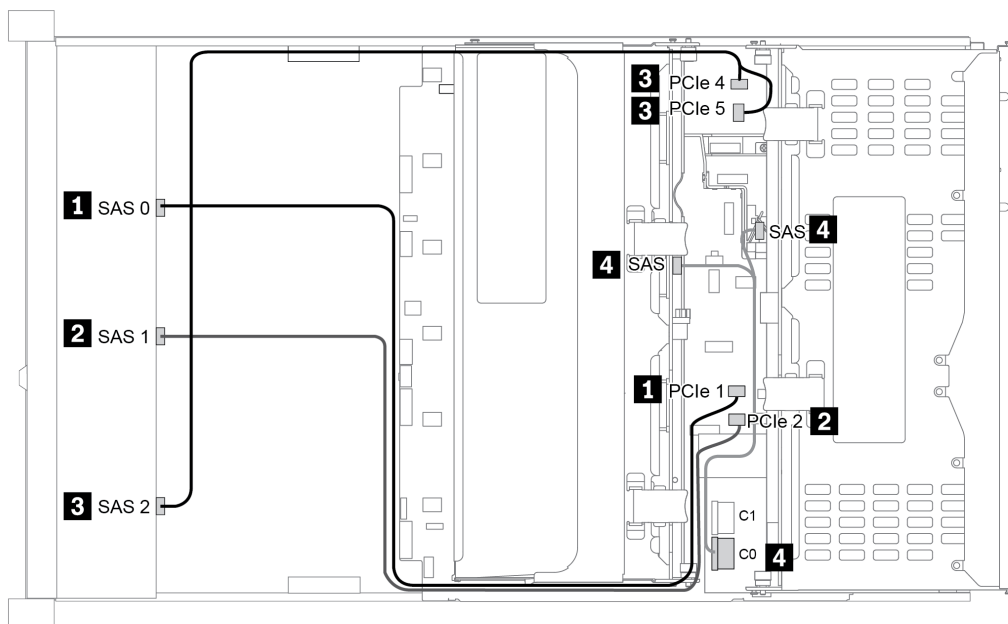

Figure 46. Cable routing for configuration 10

12 x 3.5-inch front drive bays (AnyBay)

This section provides cable routing information for the server model with 12 x 3.5-inch AnyBay front drive bays.

The server model is configured with one 12 x 3.5-inch AnyBay front drive backplane. Below lists all supported configurations with this front drive backplane.

Configuration	Mid/Rear BP		Storage controller	
	Qty.	Type	Qty.	Type
Config. 1			1	SFF 16i RAID/HBA
Config. 2	1	Rear: 4 x 3.5" SAS/SATA	1	SFF 16i RAID/HBA
Config. 3	1	Rear: 4 x 3.5" SAS/SATA	2	SFF 8i HBA + SFF 16i RAID/HBA
Config. 4	2	Mid: 4 x 3.5" SAS/SATA Rear: 4 x 3.5" SAS/SATA	1	SFF 32i RAID

Depending on your server configurations, refer to one of the following sections for cable routing information.

- [“Configuration 1: front drive bays only” on page 125](#)
- [Configuration 2 and 3: front drive bays and rear drive bays](#)
- [Configuration 4: front drive bays, mid drive bays, and rear drive bays](#)

The following table shows the cable connections for all configurations:

Configuration 1: (front drive bays only)

Front: one 12 x 3.5-inch AnyBay backplane

Con-fig.	Front BP	System board	Storage controller
			SFF 16i RAID/HBA
1	NVMe 0-1	PCIe 1, PCIe 2	
	NVMe 2-3	PCIe 3	
	NVMe 4-5	PCIe 4, PCIe 5	
	NVMe 6-7	PCIe 6	
	NVMe 8-9	PCIe 7	
	NVMe 10-11	PCIe 8	
	SAS 0, SAS 1		Gen 4: C 0 Gen3: C 0/ C 1
	SAS 2		C 1

Configuration 2 and 3: (front drive bays and rear drive bays)

Front: one 12 x 3.5-inch AnyBay backplane

Rear: one 4 x 3.5-inch AnyBay backplane

Co- nfig.	Front BP	Rear BP	System board	Storage controller	
				SFF 16i RAID/HBA	SFF 8i RAID
2	NVMe 0-1		PCIe 1, PCIe 2		
	NVMe 2-3		PCIe 3		
	NVMe 4-5		PCIe 4, PCIe 5		
	NVMe 6-7		PCIe 6		
	NVMe 8-9		PCIe 7		
	NVMe 10-11		PCIe 8		
	SAS 0, SAS 1			Gen 4: C 0 Gen3: C 0/ C 1	
	SAS 2	BP 4: SAS		Gen 4: C 1 Gen3: C 2/C 3	
3	NVMe 0-1		PCIe 1, PCIe 2		
	NVMe 2-3		PCIe 3		
	NVMe 4-5		PCIe 4, PCIe 5		
	NVMe 6-7		PCIe 6		
	NVMe 8-9		PCIe 7		
	NVMe 10-11		PCIe 8		
	SAS 0, SAS 1			Gen 4: C 0 Gen3: C 1	
	SAS 2			Gen 4: C 1 Gen3: C 0	
		BP 4: SAS			Gen 4: C 0 Gen3: C 0

Configuration 4: (front drive bays, mid drive bays, and rear drive bays)

Front: one 12 x 3.5-inch AnyBay backplane

Mid: one 4 x 3.5-inch AnyBay backplane

Rear: one 4 x 3.5-inch AnyBay backplane

Con-fig.	Front BP	Rear BP	System board	Storage controller
				SFF 32i RAID
4	NVMe 0–1		PCIe 1, PCIe 2	
	NVMe 2–3		PCIe 3	
	NVMe 4–5		PCIe 4, PCIe 5	
	NVMe 6–7		PCIe 6	
	NVMe 8–9		PCIe 7	
	NVMe 10–11		PCIe 8	
	SAS 0, SAS 1			C 0
	SAS 2	BP 4: SAS		C 1
		BP 5: SAS		C 2

The following illustration shows the cable routing for the configuration 4, the routing for the other configurations is similar. Connections between connectors: **1** ↔ **1**, **2** ↔ **2**, **3** ↔ **3**, ... **n** ↔ **n**

Note: For models that support Gen 3 and Gen4 adapters at the same slot, the illustration shows only the cable routing information for Gen 4 adapters, the routing and connector information is similar for Gen 3 adapters.

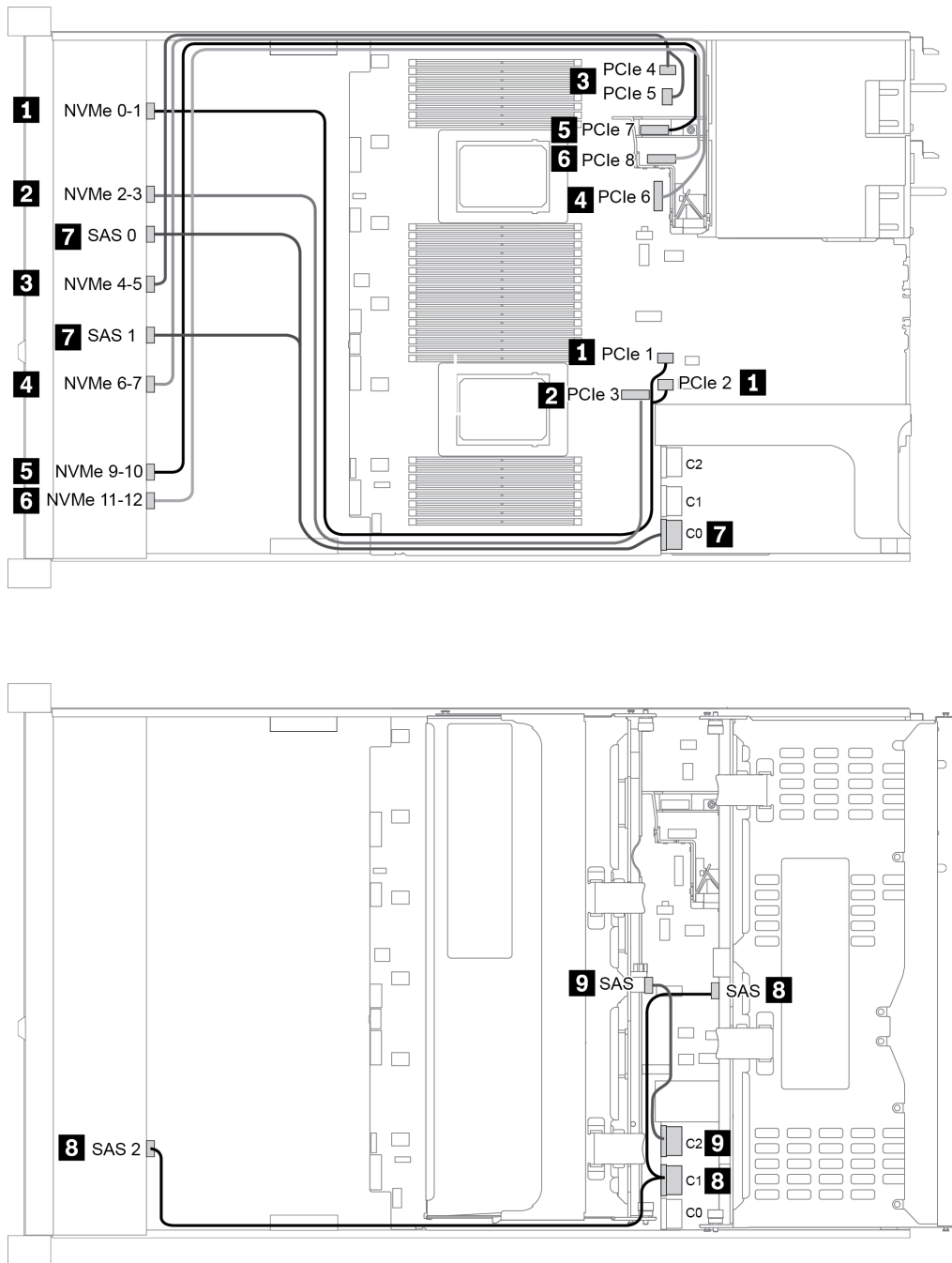

Figure 47. Cable routing for configuration 4

Chapter 4. Hardware replacement procedures

This section provides installation and removal procedures for all serviceable system components. Each component replacement procedure references any tasks that need to be performed to gain access to the component being replaced.

For more information about ordering parts:

<https://datacentersupport.lenovo.com/us/en/products/servers/thinksystem/sr665/7d2w/parts>

Note: If you replace a part, such as an adapter, that contains firmware, you might also need to update the firmware for that part. For more information about updating firmware, see “Firmware updates” on page 7.

Installation Guidelines

Before installing components in your server, read the installation guidelines.

Before installing optional devices, read the following notices carefully:

Attention: Prevent exposure to static electricity, which might lead to system halt and loss of data, by keeping static-sensitive components in their static-protective packages until installation, and handling these devices with an electrostatic-discharge wrist strap or other grounding system.

- Read the safety information and guidelines to ensure to ensure your safety at work: http://thinksystem.lenovofiles.com/help/topic/safety_documentation/pdf_files.html
- Make sure the components you are installing are supported by your server. For a list of supported optional components for the server, see <https://static.lenovo.com/us/en/serverproven/index.shtml>.
- When you install a new server, download and apply the latest firmware. This will help ensure that any known issues are addressed, and that your server is ready to work with optimal performance. Go to [ThinkSystem SR665 Drivers and Software](#) to download firmware updates for your server.

Important: Some cluster solutions require specific code levels or coordinated code updates. If the component is part of a cluster solution, verify that the latest level of code is supported for the cluster solution before you update the code.

- It is good practice to make sure that the server is working correctly before you install an optional component.
- Keep the working area clean, and place removed components on a flat and smooth surface that does not shake or tilt.
- Do not attempt to lift an object that might be too heavy for you. If you have to lift a heavy object, read the following precautions carefully:
 - Make sure that you can stand steadily without slipping.
 - Distribute the weight of the object equally between your feet.
 - Use a slow lifting force. Never move suddenly or twist when you lift a heavy object.
 - To avoid straining the muscles in your back, lift by standing or by pushing up with your leg muscles.
- Back up all important data before you make changes related to the disk drives.
- Have a small flat-blade screwdriver, a small Phillips screwdriver, and a T8 torx screwdriver available.
- To view the error LEDs on the system board and internal components, leave the power on.
- You do not have to turn off the server to remove or install hot-swap power supplies, hot-swap fans, or hot-plug USB devices. However, you must turn off the server before you perform any steps that involve

removing or installing adapter cables, and you must disconnect the power source from the server before you perform any steps that involve removing or installing a riser card.

- Blue on a component indicates touch points, where you can grip to remove a component from or install it in the server, open or close a latch, and so on.
- The Red strip on the drives, adjacent to the release latch, indicates that the drive can be hot-swapped if the server and operating system support hot-swap capability. This means that you can remove or install the drive while the server is still running.

Note: See the system specific instructions for removing or installing a hot-swap drive for any additional procedures that you might need to perform before you remove or install the drive.

- After finishing working on the server, make sure you reinstall all safety shields, guards, labels, and ground wires.

System reliability guidelines

Review the system reliability guidelines to ensure proper system cooling and reliability.

Make sure the following requirements are met:

- When the server comes with redundant power, a power supply must be installed in each power-supply bay.
- Adequate space around the server must be spared to allow server cooling system to work properly. Leave approximately 50 mm (2.0 in.) of open space around the front and rear of the server. Do not place any object in front of the fans.
- For proper cooling and airflow, refit the server cover before you turn the power on. Do not operate the server for more than 30 minutes with the server cover removed, for it might damage server components.
- Cabling instructions that come with optional components must be followed.
- A failed fan must be replaced within 48 hours after malfunction.
- A removed hot-swap fan must be replaced within 30 seconds after removal.
- A removed hot-swap drive must be replaced within two minutes after removal.
- A removed hot-swap power supply must be replaced within two minutes after removal.
- Every air baffle that comes with the server must be installed when the server starts (some servers might come with more than one air baffle). Operating the server with a missing air baffle might damage the processor.
- All processor sockets must contain either a socket cover or a processor with heat sink.
- When more than one processor is installed, fan population rules for each server must be strictly followed.

Working inside the server with the power on

You might need to keep the power on with the server cover removed to look at system information on the display panel or to replace hot-swap components. Review these guidelines before doing so.

Attention: The server might stop and data loss might occur when internal server components are exposed to static electricity. To avoid this potential problem, always use an electrostatic-discharge wrist strap or other grounding systems when working inside the server with the power on.

- Avoid loose-fitting clothing, particularly around your forearms. Button or roll up long sleeves before working inside the server.
- Prevent your necktie, scarf, badge rope, or hair from dangling into the server.
- Remove jewelry, such as bracelets, necklaces, rings, cuff links, and wrist watches.

- Remove items from your shirt pocket, such as pens and pencils, in case they fall into the server as you lean over it.
- Avoid dropping any metallic objects, such as paper clips, hairpins, and screws, into the server.

Handling static-sensitive devices

Review these guidelines before you handle static-sensitive devices to reduce the possibility of damage from electrostatic discharge.

Attention: Prevent exposure to static electricity, which might lead to system halt and loss of data, by keeping static-sensitive components in their static-protective packages until installation, and handling these devices with an electrostatic-discharge wrist strap or other grounding system.

- Limit your movement to prevent building up static electricity around you.
- Take additional care when handling devices during cold weather, for heating would reduce indoor humidity and increase static electricity.
- Always use an electrostatic-discharge wrist strap or other grounding system, particularly when working inside the server with the power on.
- While the device is still in its static-protective package, touch it to an unpainted metal surface on the outside of the server for at least two seconds. This drains static electricity from the package and from your body.
- Remove the device from the package and install it directly into the server without putting it down. If it is necessary to put the device down, put it back into the static-protective package. Never place the device on the server or on any metal surface.
- When handling a device, carefully hold it by the edges or the frame.
- Do not touch solder joints, pins, or exposed circuitry.
- Keep the device from others' reach to prevent possible damages.

Technical rules

This topic provides technical rules for the server.

- “Drive bay configurations and requirements” on page 139
- “Technical rules for GPU” on page 147
- “” on page
- “Technical rules for memory modules” on page 135
- “Technical rules for processor and heat sink” on page 135
- “Technical rules for system fans” on page 148

Technical rules for heat sink

The following lists the required heat sinks and fans when different processors are installed.

Processor TDP		With Mid bays/Full-length GPUs		Without Mid bays/Full-length GPUs	
		Heat sink			
		1U STD	2U Perf.	2U STD	2U Perf.
Group C	120W	√		√	
Group B	155W	√		√	
Group A	180/200W	√			√
Group D	225/240W		√		√
Group Z	280W		√		√

Technical rules for system fans

The following lists the required fans when different processors are installed.

Server model	Fan type	
	With GPUs/CX6 adapters	Without GPUs/CX6 adapter
8 x 2.5", 8 x 3.5", 16 x 2.5"	Performance	Standard
12 x 3.5", 24 x 2.5"	Performance	Performance
backplane-less	Performance	Performance

Technical rules for DIMMs

The following figure and table help you locate the memory slots and channels on the system board.

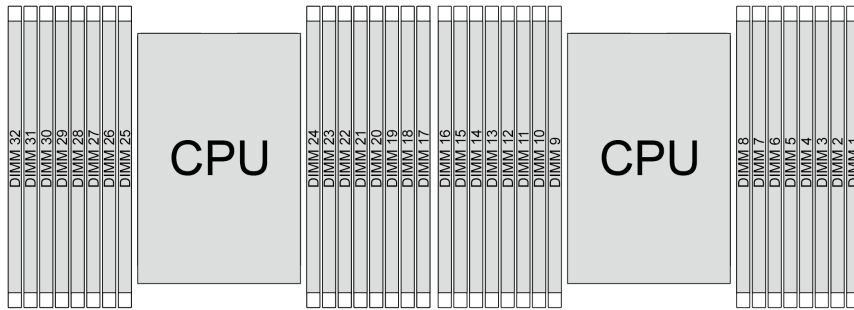

Figure 48. Memory module locations

Table 22. Memory slot and channel identification

Channel	D1	D0	C1	C0	B1	B0	A1	A0	E0	E1	F0	F1	G0	G1	H0	H1
Slot number	16	15	14	13	12	11	10	9	8	7	6	5	4	3	2	1
	32	31	30	29	28	27	26	25	24	23	22	21	20	19	18	17

Rules you need to follow when installing or replacing a DIMM.

- **Slot:**
 - When a **data bus daisy chain topology** is used: populate DIMMs **from farthest slot (slot 1) to closest slot (slot 0) to the processor** on a per-channel basis.
 - When a **data bus balanced tee route topology** is used: populate DIMMs **in either slot** on a per-channel basis.

Table 23. DIMM installation sequence

Number of processor	Slot sequence
With one processor	14, 16, 3, 1, 10, 12, 7, 5, 13, 15, 4, 2, 9, 11, 8, 6
With two processors	14, 30, 16, 32, 3, 19, 1, 17, 10, 26, 12, 28, 7, 23, 5, 21, 13, 29, 15, 31, 4, 20, 2, 18, 9, 25, 11, 27, 8, 24, 6, 22

- **Capacity:**
DIMMs with different capacities (only two different capacities) **can be mixed**, install the one with **the highest capacity first**.
- **Rank:**
DIMMs with different ranks **can be mixed**, install the one with **the highest rank first**.
- **Frequency:**
DIMMs with different frequencies **can be mixed** in the same channel.
- **Voltage:**
DIMMs with different operating voltage **cannot be mixed**. (The only supported DIMM voltage is 1.2V.)
- **ECC/Non-ECC:**
ECC and non-ECC DIMM **cannot be mixed**. (Non-ECC DIMM is not supported for the server.)
- **DRAM:**
x4 and x8 DRAM based DIMMs **can be mixed**, but **not in the same channel**.
- **Type:**
DIMMs of different base module types **can be mixed**, but **not in the same channel**.
- **Vendor:**
DIMMs from different vendors **can be mixed** in the same channel.

Technical rules for processor and heat sink

Understanding the technical rules helps you choose the correct heat sinks, fans, and other components based on what processors are configured for your server.

Supported heat sinks for processors

The following lists the required heat sinks and fans when different processors are installed.

Processor TDP		With Mid bays/Full-length GPUs		Without Mid bays/Full-length GPUs	
		Heat sink			
		1U STD	2U Perf.	2U STD	2U Perf.
Group C	120W	✓		✓	
Group B	155W	✓		✓	
Group A	180/200W	✓			✓
Group D	225/240W		✓		✓
Group Z	280W		✓		✓

Supported fans for processors

The following lists the required fans when different processors are installed.

Server model	Fan type	
	With GPUs/CX6 adapters	Without GPUs/CX6 adapter
8 x 2.5", 8 x 3.5", 16 x 2.5"	Performance	Standard
12 x 3.5", 24 x 2.5"	Performance	Performance
backplane-less	Performance	Performance

Notes for one-processor configurations

- Internal CFF RAID expander is supported while internal RAID/HBA adapters are not supported
- Up to four onboard NVMe signals are supported.
- 7mm drives and M.2 drives are not supported when eight onboard SATA signals are configured.
- M.2 or SATA drives can be connected to slimline x 4 connectors.

Notes for two-processor configurations

- Internal CFF RAID expander is supported while Internal RAID/HBA adapters are not supported.
- Up to four onboard NVMe signals are supported.
- 7mm drives and M.2 drives are not supported when eight onboard SATA signals are configured.

Technical rules for memory modules

Memory modules must be installed in a specific sequence based on the memory configuration that you implement on your server. Understanding the technical rules for DIMMs helps you install the correct DIMMs in the correct sequence.

Your server has 8 channels, 32 memory slots, and supports:

- Minimum capacity:
 - 16 GB using RDIMMs
 - 128 GB using 3DS RDIMMs
- Maximum capacity:
 - 2 TB using RDIMMs
 - 4 TB using 3DS RDIMMs
- Type (depending on the model): TruDDR4 3200, dual-rank, 16 GB/32 GB/64 GB RDIMM
 For a list of supported memory options, see: <https://static.lenovo.com/us/en/serverproven/index.shtml>

Note: The operating speed and total memory capacity depend on the processor model and UEFI settings.

The following figure and table help you locate the memory slots and channels on the system board.

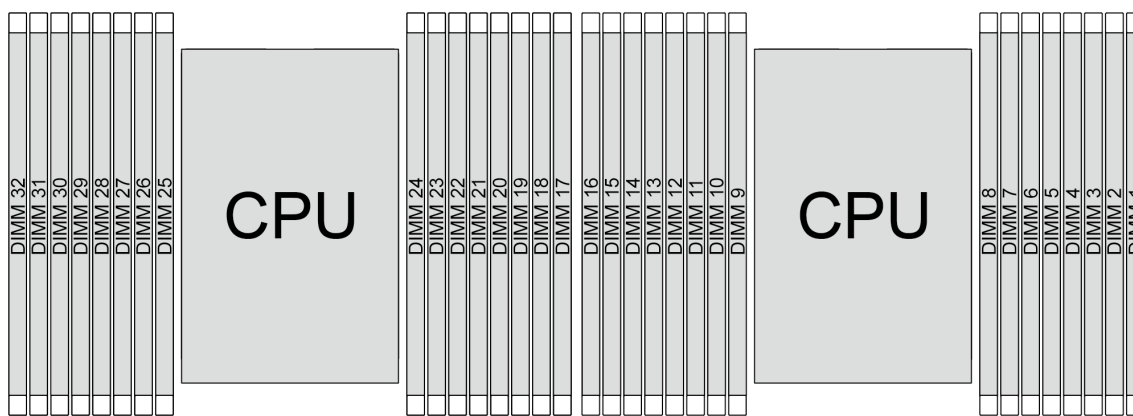

Figure 49. Memory module locations

Table 24. Memory slot and channel identification

Channel	D1	D0	C1	C0	B1	B0	A1	A0	E0	E1	F0	F1	G0	G1	H0	H1
Slot number	16	15	14	13	12	11	10	9	8	7	6	5	4	3	2	1
	32	31	30	29	28	27	26	25	24	23	22	21	20	19	18	17

Rules you need to follow when installing or replacing a DIMM.

- **Slot:**
 - When a **data bus daisy chain topology** is used: populate DIMMs **from farthest slot (slot 1) to closest slot (slot 0) to the processor** on a per-channel basis.
 - When a **data bus balanced tee route topology** is used: populate DIMMs **in either slot** on a per-channel basis.

Table 25. DIMM installation sequence

Number of processor	Slot sequence
With one processor	14, 16, 3, 1, 10, 12, 7, 5, 13, 15, 4, 2, 9, 11, 8, 6
With two processors	14, 30, 16, 32, 3, 19, 1, 17, 10, 26, 12, 28, 7, 23, 5, 21, 13, 29, 15, 31, 4, 20, 2, 18, 9, 25, 11, 27, 8, 24, 6, 22

- **Capacity:**
DIMMs with different capacities (only two different capacities) **can be mixed**, install the one with **the highest capacity first**.
- **Rank:**
DIMMs with different ranks **can be mixed**, install the one with **the highest rank first**.
- **Frequency:**
DIMMs with different frequencies **can be mixed** in the same channel.
- **Voltage:**
DIMMs with different operating voltage **cannot be mixed**. (The only supported DIMM voltage is 1.2V.)
- **ECC/Non-ECC:**
ECC and non-ECC DIMM **cannot be mixed**. (Non-ECC DIMM is not supported for the server.)
- **DRAM:**
x4 and x8 DRAM based DIMMs **can be mixed**, but **not in the same channel**.
- **Type:**
DIMMs of different base module types **can be mixed**, but **not in the same channel**.
- **Vendor:**
DIMMs from different vendors **can be mixed** in the same channel.

Drive bay configurations and requirements

This topic describes the drive bay configurations supported by the server and the requirements for hardware configurations.

Depending on models, the server supports:

- Up to twenty-four 2.5-inch or twelve 3.5-inch SAS/SATA/NVMe front drives
- Up to eight 2.5-inch SAS/SATA/NVMe or four 3.5-inch SAS/SATA/NVMe middle drives
- Up to eight 2.5-inch SAS/SATA or two 7mm SAS/SATA rear drives
- Up to two M.2 SATA/NVMe drives

For a list of supported drives, see:

<https://static.lenovo.com/us/en/serverproven/index.shtml>

Drive bay combinations

The following table shows the supported drive bay combinations for the chassis with 3.5-inch/2.5-inch front drive bays.

- “Supported drive bay combinations (Two processors installed)” on page 140
- “Supported drive bay combinations (One processor installed)” on page 142

Supported drive bay combinations (Two processors installed)

The following table shows the supported drive bay combinations when two processors are installed.

Table 26. 3.5-inch drive bay combinations matrix

No.	Total drives	Front bays		Middle bays		Rear bays	
		3.5" SAS/SATA	3.5" Any-Bay	3.5" SAS/SATA	2.5" NVMe	2.5" SAS/SATA	3.5" SAS/SATA
1	8	8					
2a	12	12					
2b	14	12					2
2c	16	12					4
2d	16	12		4			4
2e	16	12				4	
2f	20	12		4		4	
2g	20	12			4+4		
3a	12		12				
3b	16		12			4	
3c	20		12	4		4	

Table 27. 2.5-inch drive bay configuration matrix

No.	Total drives	Front bays			Middle bays		Rear bays
		2.5"SAS/SATA	2.5"N-VMe	2.5"Any-Bay	2.5"SAS/SATA	2.5"NVMe	2.5"SAS/SATA
1	8	8					
2	8		8				
3	8			8			
4	16	8+8					
5	16		8+8				
6	16	8	8				
7	16	8		8			
8	16		8	8			
9	24	8	8+8				
10	24	8+8	8				
11a	24	8+8		8			
11b	28	8+8		8			4
12a	24	8+8+8					
12b	28	8+8+8					4
12c	36	8+8+8			4+4		4
12d	40	8+8+8			4+4		8
13a	24		8+8+8				
13b	32		8+8+8			4+4	

Supported drive bay combinations (One processor installed)

The following table shows the supported drive bay combinations when two processors are installed.

Table 28. 3.5-inch drive bay combinations matrix

No.	Total drives	Front bays	Middle bays	Rear bays	
		3.5" SAS/SATA	3.5" SAS/SATA	2.5" SAS/SATA	3.5" SAS/SATA
1	8	8			
2a	12	12			
2b	14	12			2
2c	16	12			4
2d	16	12	4		4
2e	16	12		4	
2f	20	12	4	4	

Table 29. 2.5-inch drive bay configuration matrix

No.	Total drives	Front bays		Middle bays	Rear bays
		2.5"SAS/SATA	2.5"NVMe	2.5"SAS/SATA	2.5"SAS/SATA
1	8	8			
2	8		8		
3	16	8+8			
4a	24	8+8+8			
4b	28	8+8+8			4
4c	36	8+8+8		4+4	4
4d	40	8+8+8		4+4	8

Note: For models without any backplanes or drives, field upgrades to other models are available. For details, check the option part numbers you will need when ordering for different configurations: [Field upgrades](#)

Drive installation requirements

The following notes describe information that you must consider when you install a drive.

- NVMe drives are only supported in the front drive bays (bays 8–11), using the AnyBay backplane (which offers 4 x NVMe capable drive bays).
- With the 3.5-inch chassis, the middle drive bays are 3.5-inch bays. However, the rear drive bays can be either 2.5-inch SAS/SATA or 3.5-inch SAS/SATA bays.
- With the 2.5-inch chassis, all drive bays are 2.5-inch bays. No 3.5-inch drives are supported.
- When the front SAS/SATA backplane is connected to PCIe connectors on the system board, only SATA drives are supported. No SAS drives are supported.
- For the middle/rear drive cage with an NVMe backplane, only 7 mm NVMe drives (installed in the 15 mm-height drive trays) are supported. The 15 mm drives are not supported.
- To support a middle drive cage:
 - Performance fans (speed of 18000 RPM) must be installed.
 - The processor TDP must be lower than or equal to 155 watts.
 - The ambient temperature must be lower than or equal to 35°C (95°F).

- To support a rear drive cage:
 - Performance fans (speed of 18000 RPM) must be installed.
 - The processor TDP must be lower than or equal to 225 watts.
 - The ambient temperature must be lower than or equal to 35°C (95°F).

Technical rules for PCIe slots

Your server supports four types of riser cards for riser 1 assembly: Your server supports the following rear configurations:

FH = full height, FL = full length, HL = half length

Server model	Riser slot configuration
Server model with 8 PCIe slots	<p>The server has 8 PCIe slots:</p> <ul style="list-style-type: none"> (slot 1-3): riser 1 bracket, 2FHFL+1FHHL (slot 4-6): riser 2 bracket, 2FHFL+1FHHL/7 mm drives (slot 7-8): riser 3 bracket, 2FHFL
Server model with 4 x 2.5-inch rear drives	<p>The server has 6 PCIe slots:</p> <ul style="list-style-type: none"> (slot 1-3): riser 1 bracket, 2FHFL+1FHHL (slot 4-6): riser 2 bracket, 2FHFL+1FHHL/7 mm drives
Server model with 8 x 2.5-inch rear drives	<p>The server has 4 PCIe slots:</p> <ul style="list-style-type: none"> (slot 1-3): riser 1 bracket, 2FHFL+1FHHL (slot 6): riser 2 bracket, 1FHHL/7 mm drives
Server model with 2 x 3.5-inch rear drives	<p>The server has 4 PCIe slots:</p> <ul style="list-style-type: none"> (slot 1-3): riser 1 bracket, 2FHFL+1FHHL (slot 6): riser 2 bracket, 1FHHL/7 mm drives
Server model with 4x 3.5-inch rear drives	<p>The server has 2 PCIe slots:</p> <ul style="list-style-type: none"> (slot 3): riser 1 bracket, 1FHHL (slot 6): riser 2 bracket, 1FHHL/7 mm drives

Compatibility of Riser cards and PCIe adapters

- Gen 3 riser cards can **only** support Gen 3 RAID adapters.
- Gen 4 riser adapters can support **both** Gen 3 and Gen 4 RAID adapters.
- Gen 3 and Gen 4 RAID adapters of the same group can be installed to the same riser card.
- Gen 3 and Gen 4 RAID adapters of the different groups **cannot** be installed to the same riser card.
- RAID adapters and HBA adapters can be installed to the same riser card.
- RAID arrays are not support for AIC(all-in-card) SSD drives.
- RAID arrays are not support for SED or FIPS HDD/SSD drives.

Note: FIPS (Federal Information Processing Standard) 140-2 is a U.S. government standard that describes the encryption and related security requirements for sensitive but unclassified (SBU) information technology (IT) products. FIPS 140-2 defines four levels of security, SEDs(Self-Encrypting Drives) are FIPS 140-2 Level 2 validated drives.

- When one or more SED drives are installed, the following internal SAS HBA adapters are not supported:
 - 430-8i
 - 430-16i
 - 440-16i
- One super capacitor module is required for each 930/940 series internal RAID or 940-8e RAID/HBA adapter.

- Gen 3 and Gen 4 SFF RAID adapters are **not** supported when 7mm drives or M.2 drives are installed.
- Gen 3 and Gen 4 SFF RAID adapters are available on the following server models when **one** processor is installed.
 - Server models with 8 x 2.5-inch front drive bays (SAS/SATA)
 - Server models with 4 x 2.5-inch front drive bays (SAS/SATA)
 - Server models with 4 x 3.5-inch front drive bays (SAS/SATA)
- Gen 3 and Gen 4 internal SFF RAID adapters are available on the following server models when **two** processors are installed.
 - Server models with 10 x 2.5-inch front drive bays (6 SAS/SATA +4 AnyBay, 10 AnyBay, or 10 NVMe)
 - Server models with 4 x 3.5-inch front drive bays (AnyBay)
 - Server models with 2 x 2.5-inch rear drive bays (SAS/SATA)
- Gen 4 internal CFF RAID/HBA adapters are available on the following server models and when **two** processors are installed.
 - Server models with 8 x 2.5-inch front drive bays (SAS/SATA)
 - Server models with 10 x 2.5-inch front drive bays (6 SAS/SATA +4 AnyBay, 10 AnyBay, or 10 NVMe)
 - Server models with 4 x 3.5-inch front drive bays (AnyBay)
 - Server models with 2 x 2.5-inch rear drive bays (SAS/SATA)

Supported slots for different PCIe adapters

- Slot priority for most PCIe adapters:
 - One processor installed: Slot 2, slot 3, slot 1
 - Two processors installed:

If...	Slot priorities
Riser 3B is installed	2, 3, 5, 6, 7, 8, 1, 4
Riser 3C is installed	2, 3, 5, 6, 1, 4, 7, 8

- Slot priority exceptions:
 - Internal CFF RAID/HBA/RAID expander adapters are always installed on the chassis between the front backplanes and fans.
 - Slot priorities for GPU adapters:

GPU adapters	One processor installed	Two processors installed
Tesla V100S/ V100	2	<ul style="list-style-type: none"> – If riser 3B is installed: 2, 5 – If riser 3C is installed: 2, 5, 7
Tesla T4/Quadro P620	1, 2, 3	<ul style="list-style-type: none"> – If riser 3B is installed: 1, 4, 5, 6, 7, 8, 2, 3 – If riser 3C is installed: 1, 4, 7, 8, 5, 6, 2, 3

- Slot priorities for the 1610-8P NVMe Switch (or PCIe switch) Adapter:

If...	Slot priorities
Used in 32 NVMe configuration when 2 processors are installed	1, 2, 4, 5
Used in 24 NVMe configuration when 2 processors are installed	1, 2, 4
Used in 16 NVMe configuration when 1 processor is installed	1, 2, 3
Used in 16 NVMe configuration when 2 processors are installed	1, 2, 4, 5, 3, 6, 7, 8

- Slot priorities for most Mellanox NIC adapters:

If...	Slot priorities
One processor is installed	1,2,3
Two processors are installed	1,4,2,5,3,6,7,8

Notes: The following two Mellanox ConnectX-6 adapters are always installed on slot 1:

- Mellanox ConnectX-6 HDR IB/200GbE Single Port x16 PCIe Adapter
- Mellanox HDR Auxiliary x16 PCIe 3.0 Connection Card

Technical rules for GPU

Understanding the technical rules helps you choose the correct GPUs and install them in the supported slots based on what is configured for your server.

GPU	Type	Maximum supported
Tesla V100S/V100	full-height, full-length, double-wide	2
Tesla T4/Quadro P620	low-profile, half-length, single-wide	8

Notes:

- Use E/16/16 riser assembly (riser 1/2) or riser 3C assembly for installing a double-wide GPU.

Technical rules for system fans

Your server supports two types of fans:

- Standard fan (27000 RPM)
- Performance fan (29000 RPM)

Server model	Fan type	
	With GPUs/CX6 adapters	Without GPUs/CX6 adapter
8 x 2.5", 8 x 3.5", 16 x 2.5"	Performance	Standard
12 x 3.5", 24 x 2.5"	Performance	Performance
backplane-less	Performance	Performance

Notes:

- If your server is configured with one processor, five system fans (fan 1 to fan 5) are adequate to provide proper cooling. However, you must keep the location for fan 6 occupied by a fan filler to ensure proper airflow. Install fan 6 when there are two processors onboard.
- If there is an OCP 3.0 Ethernet adapter installed, when the system is powered off but still plugged in to AC power, fan 1 and fan 2 will continue to spin at a much lower speed. This is the system design to provide proper cooling for the OCP 3.0 Ethernet adapter.

Air baffle replacement

Use this information to remove and install the air baffle.

- “Remove the air baffle” on page 149
- “Install the air baffle” on page 152

Remove the air baffle

Use this information to remove the air baffle.

About this task

Attention: For proper cooling and airflow, install the air baffle before you turn on the server. Operating the server without the air baffle might damage server components.

S033



CAUTION:

Hazardous energy present. Voltages with hazardous energy might cause heating when shorted with metal, which might result in spattered metal, burns, or both.

S017



CAUTION:

Hazardous moving fan blades nearby.

Attention:

- Read “Installation Guidelines” on page 129 to ensure that you work safely.
- Power off the server and disconnect all power cords for this task.
- Prevent exposure to static electricity, which might lead to system halt and loss of data, by keeping static-sensitive components in their static-protective packages until installation, and handling these devices with an electrostatic-discharge wrist strap or other grounding system.

A video for this task is available at:

- Youtube: https://www.youtube.com/playlist?list=PLYV5R7hVcs-Bz2XleLEfGcrLGm9TSY_yt
- Youku: http://list.youku.com/albumlist/show/id_52339612.html

Procedure

Step 1. Prepare your server.

1. Remove the top cover. See “Remove the top cover” on page 392.
2. If there is a RAID super capacitor module installed on the air baffle, disconnect the RAID super capacitor module cable first.
3. If there is a GPU installed on the air baffle, remove the GPU first. See “Remove a GPU adapter” on page 169.

Step 2. Grasp the air baffle and carefully lift it out of the server.

Note: The illustrated air baffle is a standard air baffle. The removal procedure is the same for GPU air baffle.

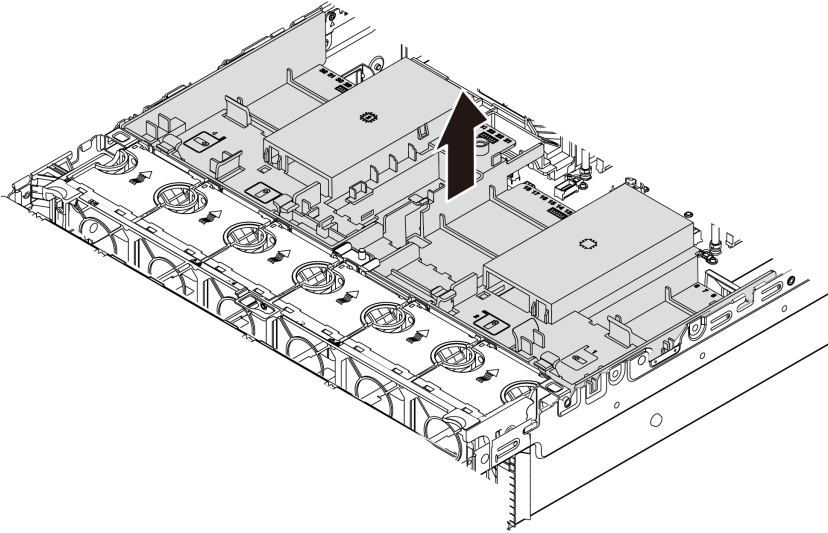

Figure 50. Removal of the standard air baffle

Install the air baffle

Use this information to install the air baffle.

About this task

S033



CAUTION:

Hazardous energy present. Voltages with hazardous energy might cause heating when shorted with metal, which might result in spattered metal, burns, or both.

S017



CAUTION:

Hazardous moving fan blades nearby.

Attention:

- Read “Installation Guidelines” on page 129 to ensure that you work safely.
- Prevent exposure to static electricity, which might lead to system halt and loss of data, by keeping static-sensitive components in their static-protective packages until installation, and handling these devices with an electrostatic-discharge wrist strap or other grounding system.

A video for this task is available at:

- Youtube: https://www.youtube.com/playlist?list=PLYV5R7hVcs-Bz2XleLEfGcrLGm9TSY_yt
- Youku: http://list.youku.com/albumlist/show/id_52339612.html

About this task

Step 1. Check your server and ensure that:

- No tools or loose screws are left inside your server.
- All components have been reassembled correctly.
- All cables inside the server have been properly routed and they will not interfere with installing the air baffle.

Step 2. Select the appropriate air baffle for your server.

Step 3. Note the orientation of the air baffle.

Step 4. Align the tabs on both sides of the air baffle with the corresponding slots on both sides of the chassis. Then, lower the air baffle into the chassis and press the air baffle down until it is securely seated.

Note: The illustrated air baffle is a standard air baffle. The installation procedure is the same for GPU air baffle.

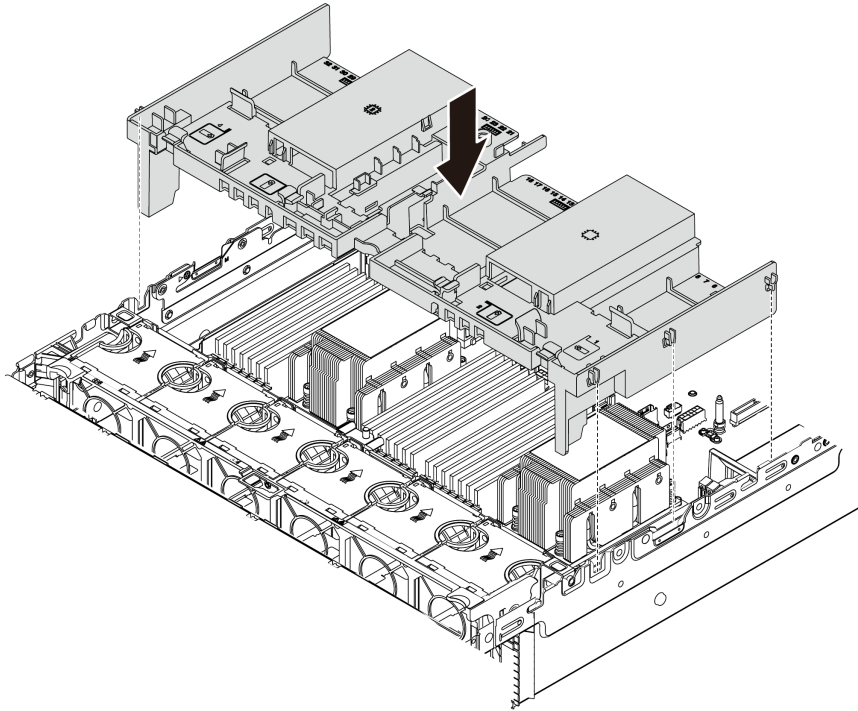

Figure 51. Installation of the standard air baffle

After you finish

1. If you have removed a RAID super capacitor module, reinstall it and connect it to the RAID adapter with the extension cable. See “Install a super capacitor module on the air baffle” on page 293.
2. If you have removed a GPU, reinstall it. See “Install a GPU adapter” on page 172.
3. Complete the parts replacement. See “Complete the parts replacement” on page 397.

Cable wall brackets replacement (full-height/half-height)

Use this information to remove and install the full-height or half-height cable wall brackets.

Your server supports two full-height or half-height cable wall brackets on the left and right side of the system board:

- **Half-height:** designed for most models;
- **Full-height:** specially designed for models with 32 NVMe drives.
- “Remove the cable wall brackets” on page 155
- “Install the cable wall brackets” on page 158

Remove the cable wall brackets

Use this information to remove full-height or half-height cable wall brackets.

About this task

Your server is shipped two half-height or full-height cable wall brackets on the left and right side of the system board. The illustration shows the removal of the full-height cable wall brackets, the removal method of the half-height cable wall brackets is the same.

Attention:

- Read “Installation Guidelines” on page 129 to ensure that you work safely.
- Prevent exposure to static electricity, which might lead to system halt and loss of data, by keeping static-sensitive components in their static-protective packages until installation, and handling these devices with an electrostatic-discharge wrist strap or other grounding system.

A video for this task is available at:

- Youtube: https://www.youtube.com/playlist?list=PLYV5R7hVcs-Bz2XleLEfGcrLGm9TSY_yt
- Youku: http://list.youku.com/albumlist/show/id_52339612.html

Procedure

Step 1. Touch the static-protective package that contains the new riser card to any unpainted surface on the outside of the server. Then, take the new riser card out of the package and place it on a static-protective surface.

Step 2. Prepare your server.

1. Power off the server.
2. Remove the top cover. See “Remove the top cover” on page 392.
3. If your server comes with an air baffle, remove it first. See “Remove the air baffle” on page 149.
4. Record all the cables that are passing through the cable wall brackets and disconnect them . Then, remove any of the following components that are installed on the system board and put them in a safe, static-protective place.
 - “M.2 module” on page 234
 - “RAID super capacitor modules” on page 291
 - “Middle drive cage” on page 242
 - “Rear drive cage” on page 320
 - “Backplanes” on page 181

Step 3. Remove the cable wall brackets.

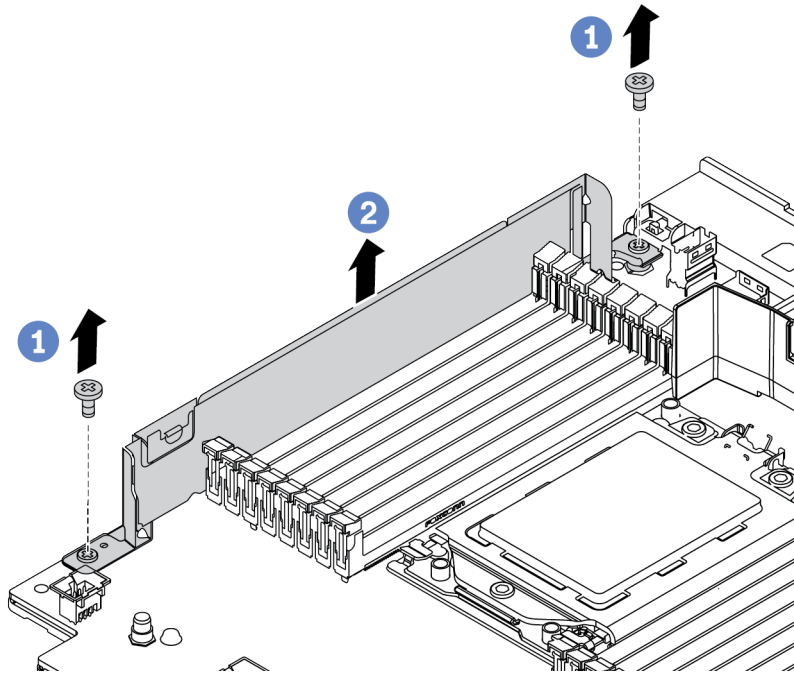

Figure 52. Cable wall brackets removal

- a. Remove the two screws.
- b. Lift up the brackets from the system board as shown.

After you finish

1. Connect any cables. See Chapter 3 “Internal cable routing” on page 57.
2. Complete the parts replacement. See “Complete the parts replacement” on page 397.

Install the cable wall brackets

Use this information to install the full-height or half-height cable wall brackets.

About this task

Your server supports two full-height or half-height cable wall brackets on the left and right side of the system board. The illustration shows the installation of the full-height cable wall brackets, the installation method of the half-height cable wall brackets is the same.

Attention:

- Read “Installation Guidelines” on page 129 to ensure that you work safely.
- Prevent exposure to static electricity, which might lead to system halt and loss of data, by keeping static-sensitive components in their static-protective packages until installation, and handling these devices with an electrostatic-discharge wrist strap or other grounding system.

A video for this task is available at:

- Youtube: https://www.youtube.com/playlist?list=PLYV5R7hVcs-Bz2XleLEfGcrLGm9TSY_yt
- Youku: http://list.youku.com/albumlist/show/id_52339612.html

Procedure

- Step 1. Touch the static-protective package that contains the new cable holder to any unpainted surface on the outside of the server. Then, take the new cable holder out of the package and place it on a static-protective surface.
- Step 2. Install the cable wall brackets.

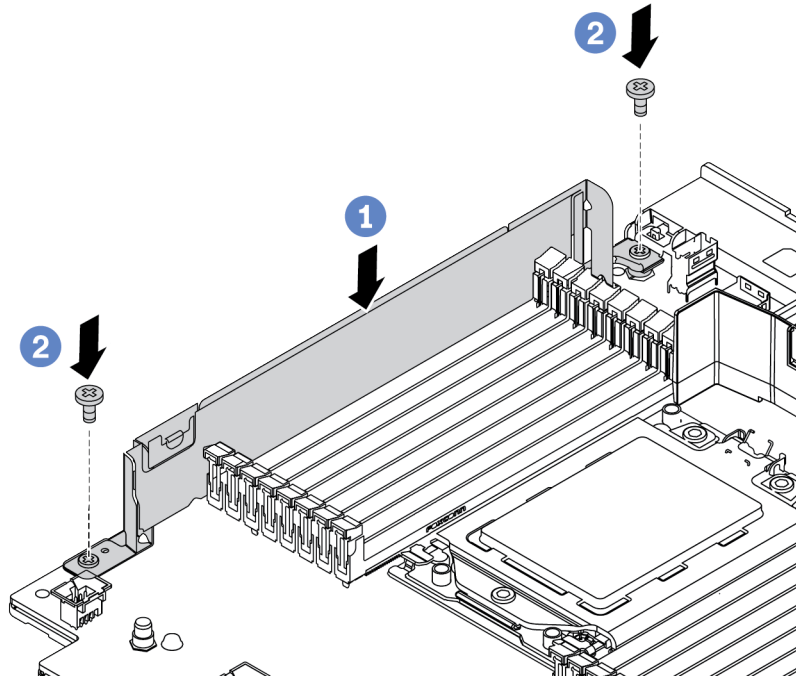

Figure 53. Cable wall brackets installation

C

- a. Align the two holes on the system board. Install the brackets to the system board as shown.
- b. Install the two screws to secure the brackets.

After you finish

1. Connect any cables. See Chapter 3 “Internal cable routing” on page 57.
2. Complete the parts replacement. See “Complete the parts replacement” on page 397.

CMOS battery replacement

Use this information to remove and install the CMOS battery.

- “Remove the CMOS battery” on page 160
- “Install the CMOS battery” on page 162

Remove the CMOS battery

Use this information to remove the CMOS battery.

About this task

Attention:

- Lenovo has designed this product with your safety in mind. The lithium CMOS battery must be handled correctly to avoid possible danger. If you replace the CMOS battery, you must adhere to local ordinances or regulations.
- If you replace the original lithium battery with a heavy-metal battery or a battery with heavy-metal components, be aware of the following environmental consideration. Batteries and accumulators that contain heavy metals must not be disposed of with normal domestic waste. They will be taken back free of charge by the manufacturer, distributor, or representative, to be recycled or disposed of in a proper manner.
- Power off the server and disconnect all power cords for this task.

S002



CAUTION:

The power-control button on the device and the power switch on the power supply do not turn off the electrical current supplied to the device. The device also might have more than one power cord. To remove all electrical current from the device, ensure that all power cords are disconnected from the power source.

- Prevent exposure to static electricity, which might lead to system halt and loss of data, by keeping static-sensitive components in their static-protective packages until installation, and handling these devices with an electrostatic-discharge wrist strap or other grounding system.

A video for this task is available at:

- Youtube: https://www.youtube.com/playlist?list=PLYV5R7hVcs-Bz2XleLEfGcrLGm9TSY_yt
- Youku: http://list.youku.com/albumlist/show/id_52339612.html

Procedure

- Step 1. Remove the top cover. See “Remove the top cover” on page 392.
- Step 2. Remove any parts and disconnect any cables that might impede your access to the CMOS battery.
- Step 3. Locate the CMOS battery. See “System board components” on page 43.
- Step 4. Press the battery clip as shown and carefully lift CMOS battery out of the socket.

Attention:

- Failing to remove the CMOS battery properly might damage the socket on the system board. Any damage to the socket might require replacing the system board.
- Do not tilt or push the CMOS battery by using excessive force.

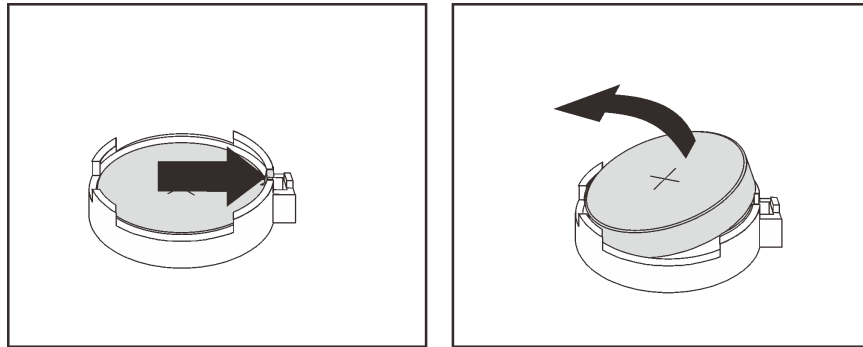

Figure 54. CMOS battery removal

After you finish

Note: After you replace the CMOS battery, you must reconfigure the server and reset the system date and time.

1. Install a new one. See “Install the CMOS battery” on page 162.
2. Dispose of the CMOS battery as required by local ordinances or regulations.

S004



CAUTION:

When replacing the lithium battery, use only Lenovo specified part number or an equivalent type battery recommended by the manufacturer. If your system has a module containing a lithium battery, replace it only with the same module type made by the same manufacturer. The battery contains lithium and can explode if not properly used, handled, or disposed of. *Do not:*

- Throw or immerse into water
- Heat to more than 100°C (212°F)
- Repair or disassemble

Dispose of the battery as required by local ordinances or regulations.

Install the CMOS battery

Use this information to install the CMOS battery.

About this task

The following tips describe information that you must consider when installing the CMOS battery.

- Lenovo has designed this product with your safety in mind. The lithium battery must be handled correctly to avoid possible danger. If you install the CMOS battery, you must adhere to the following instructions.
- If you replace the original lithium battery with a heavy-metal battery or a battery with heavy-metal components, be aware of the following environmental consideration. Batteries and accumulators that contain heavy metals must not be disposed of with normal domestic waste. They will be taken back free of charge by the manufacturer, distributor, or representative, to be recycled or disposed of in a proper manner.

Attention:

- Read “Installation Guidelines” on page 129 to ensure that you work safely.
- Power off the server and disconnect all power cords for this task.

S002



CAUTION:

The power-control button on the device and the power switch on the power supply do not turn off the electrical current supplied to the device. The device also might have more than one power cord. To remove all electrical current from the device, ensure that all power cords are disconnected from the power source.

- Prevent exposure to static electricity, which might lead to system halt and loss of data, by keeping static-sensitive components in their static-protective packages until installation, and handling these devices with an electrostatic-discharge wrist strap or other grounding system.

A video for this task is available at:

- Youtube: https://www.youtube.com/playlist?list=PLYV5R7hVcs-Bz2XleLEfGcrLGm9TSY_yt
- Youku: http://list.youku.com/albumlist/show/id_52339612.html

Procedure

- Step 1. Touch the static-protective package that contains the CMOS battery to any unpainted surface on the outside of the server. Then, take the CMOS battery out of the package.
- Step 2. Install the CMOS battery. Ensure that the CMOS battery is seated in place.

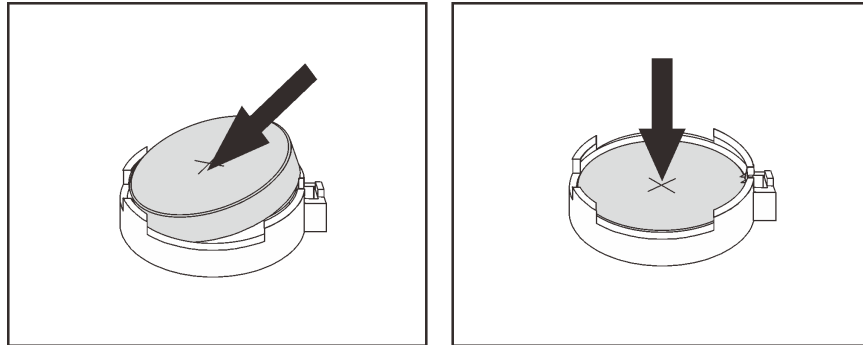

Figure 55. CMOS battery installation

After you finish

1. Complete the parts replacement. See “Complete the parts replacement” on page 397.
2. Use the Setup utility to set the date, time, and any passwords.

Note: After you install the CMOS battery, you must reconfigure the server and reset the system date and time.

Front I/O assembly replacement

Use this information to remove and install the media bay.

Notes: The front I/O connectors for most models are integrated on rack latches. The front I/O assembly illustrated in this topic comes with an LCD diagnostics panel and is supported only in the following server models:

- Server models with eight 2.5-inch front drive bays
- Server models with sixteen 2.5-inch front drive bays
- “Remove the front I/O assembly” on page 165
- “Install the front I/O assembly” on page 167

Remove the front I/O assembly

Use this information to remove the front I/O assembly.

About this task

Attention:

- Read “Installation Guidelines” on page 129 to ensure that you work safely.
- Power off the server and disconnect all power cords for this task.
- Prevent exposure to static electricity, which might lead to system halt and loss of data, by keeping static-sensitive components in their static-protective packages until installation, and handling these devices with an electrostatic-discharge wrist strap or other grounding system.

A video for this task is available at:

- Youtube: https://www.youtube.com/playlist?list=PLYV5R7hVcs-Bz2XIeLEfGcrLGm9TSY_yt
- Youku: http://list.youku.com/albumlist/show/id_52339612.html

Procedure

- Step 1. Remove the top cover. See “Remove the top cover” on page 392.
- Step 2. If the security bezel is installed, remove it. See “Remove the security bezel” on page 362.
- Step 3. Disconnect the cables of the front I/O assembly from the system board. See “Front I/O assembly” on page 58.
- Step 4. Remove the front I/O assembly from the front chassis.

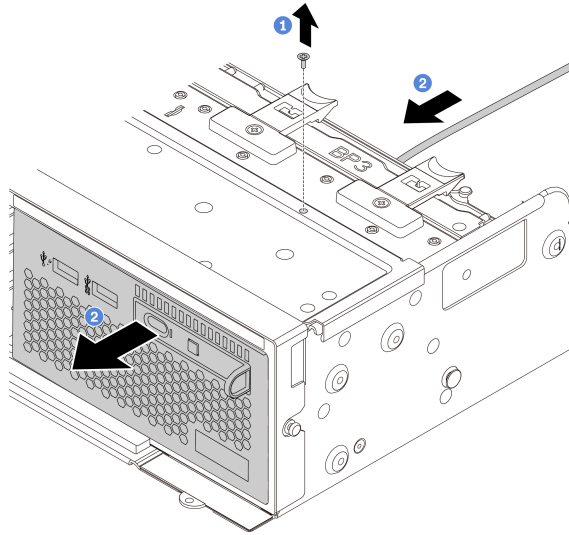

Figure 56. Front I/O assembly removal

1. Remove the screws that secure the front I/O assembly.
2. Slide the media bay out of the front chassis.

After you finish

If you are instructed to return the old front I/O assembly, follow all packaging instructions and use any packaging materials that are provided.

Install the front I/O assembly

Use this information to install the front I/O assembly.

About this task

Attention:

- Read “Installation Guidelines” on page 129 to ensure that you work safely.
- Prevent exposure to static electricity, which might lead to system halt and loss of data, by keeping static-sensitive components in their static-protective packages until installation, and handling these devices with an electrostatic-discharge wrist strap or other grounding system.

A video for this task is available at:

- Youtube: https://www.youtube.com/playlist?list=PLYV5R7hVcs-Bz2XleLEfGcrLGm9TSY_yt
- Youku: http://list.youku.com/albumlist/show/id_52339612.html

Procedure

- Step 1. Touch the static-protective package that contains the front I/O assembly to any unpainted surface on the outside of the server. Then, take the front I/O assembly out of the package and place it on a static-protective surface.
- Step 2. Install the front I/O assembly.

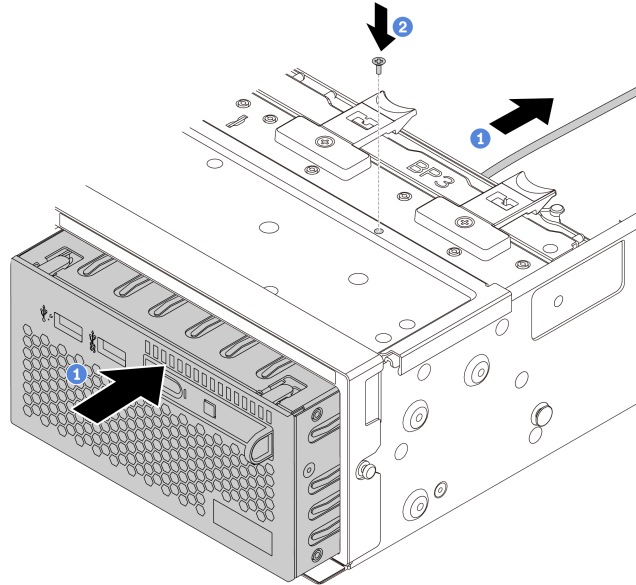

Figure 57. Front I/O assembly installation

1. Insert the front I/O assembly into the front chassis.
2. Install the screws to secure the front I/O assembly in place.

After you finish

1. Connect the cables of the front I/O assembly to the system board. See “Front I/O assembly” on page 58.
2. Complete the parts replacement. See “Complete the parts replacement” on page 397.

GPU replacement

Use this information to remove and install a GPU adapter.

- “Remove a GPU adapter” on page 169
- “Install a GPU adapter” on page 172

Remove a GPU adapter

Use this information to remove a GPU adapter.

About this task

Attention:

- Read “Installation Guidelines” on page 129 to ensure that you work safely.
- Power off the server and disconnect all power cords for this task.
- Prevent exposure to static electricity, which might lead to system halt and loss of data, by keeping static-sensitive components in their static-protective packages until installation, and handling these devices with an electrostatic-discharge wrist strap or other grounding system.
- Depending on the specific type, your GPU adapter might look different from the illustration in this topic.
- Use any documentation that comes with the GPU adapter and follow those instructions in addition to the instructions in this topic.

A video for this task is available at:

- Youtube: https://www.youtube.com/playlist?list=PLYV5R7hVcs-Bz2XleLEfGcrLGm9TSY_yt
- Youku: http://list.youku.com/albumlist/show/id_52339612.html

Procedure

- Step 1. Remove the top cover. See “Remove the top cover” on page 392.
- Step 2. Remove the riser bracket that has the GPU adapter installed. For instructions on how to remove the riser bracket, see “PCIe adapter and riser assembly replacement” on page 345.
- Step 3. Depending on the GPU type, remove the GPU air baffle filler or extender for the GPU adapter.
 - For a single wide GPU adapter (for example, NVIDIA V100 GPU):

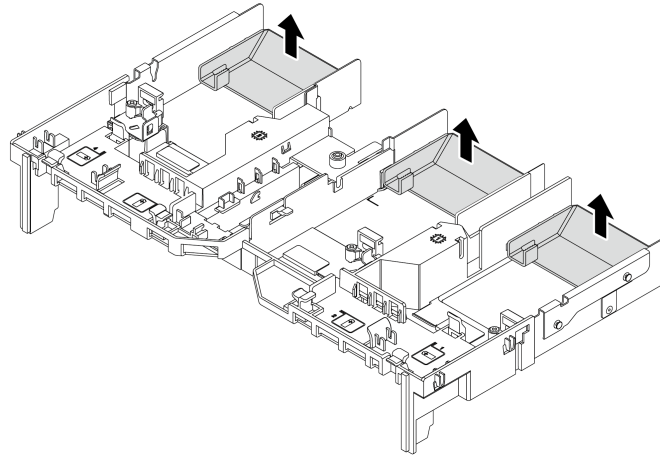

Figure 58. Removing the add-on air baffle for a single-wide GPU adapter

- For a double wide GPU adapter (for example, NVIDIA T4 GPU):

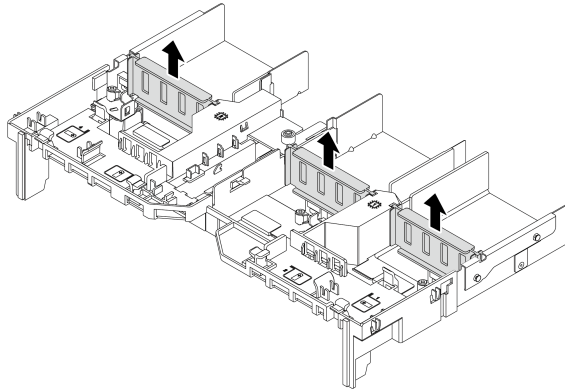

Figure 59. Removing the GPU air baffle filler for a double wide GPU adapter

- Step 4. Disconnect the power cable from the GPU adapter.
- Step 5. Remove the GPU adapter from the riser bracket. See “Remove a PCIe adapter and riser 1/2 assembly” on page 346 and “Remove a PCIe adapter and riser 3 assembly” on page 355.

After you finish

If you are instructed to return the old GPU adapter, follow all packaging instructions and use any packaging materials that are provided.

Install a GPU adapter

Use this information to install a GPU adapter.

About this task

Attention:

- Read “Installation Guidelines” on page 129 to ensure that you work safely.
- Prevent exposure to static electricity, which might lead to system halt and loss of data, by keeping static-sensitive components in their static-protective packages until installation, and handling these devices with an electrostatic-discharge wrist strap or other grounding system.
- GPU adapters are supported on some server models with requirements. See “Technical rules for GPU” on page 147.
- Depending on the specific type, your GPU adapter might look different from the illustration in this topic.
- Use any documentation that comes with the GPU adapter and follow those instructions in addition to the instructions in this topic.

A video for this task is available at:

- Youtube: https://www.youtube.com/playlist?list=PLYV5R7hVcs-Bz2XleLEfGcrLGm9TSY_yt
- Youku: http://list.youku.com/albumlist/show/id_52339612.html

Procedure

Step 1. Depending on the GPU type, install the GPU air baffle filler or extender for the GPU adapter.

- For a double-wide GPU adapter (for example, NVIDIA V100 GPU):

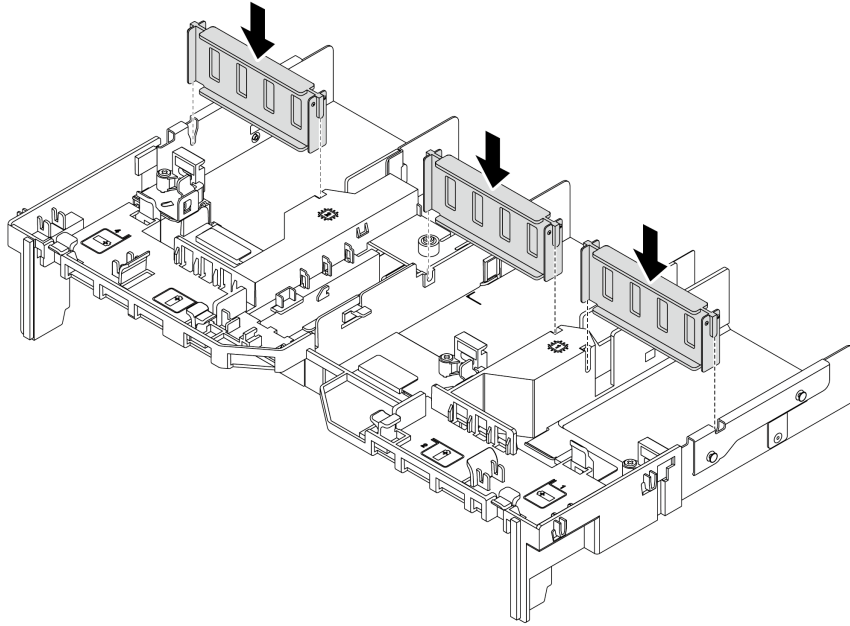

Figure 60. Installing the GPU air baffle filler for a double-wide GPU adapter

- For a single-wide GPU adapter (for example, NVIDIA T4 GPU), install the add-on air baffle onto the GPU air baffle.

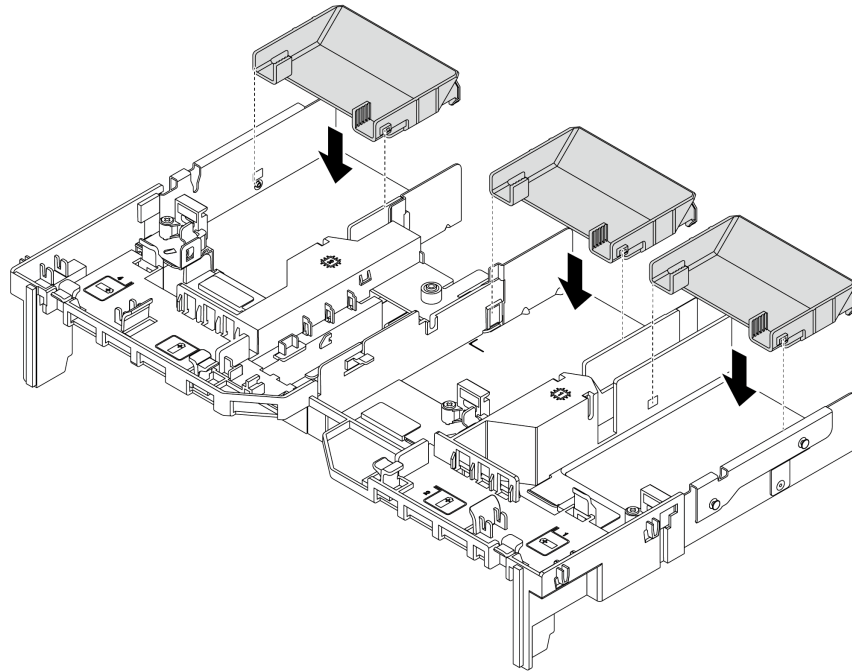

Figure 61. Installing the add-on air baffle for a single-wide GPU adapter

- Step 2. Locate the appropriate PCIe slot for the GPU adapter.
- Step 3. Align the GPU adapter with the PCIe slot on the riser card. Then, carefully press the GPU adapter straight into the slot until it is securely seated.
- Step 4. Connect the power cable to the power connector on the GPU.
- Step 5. Install the riser assembly. See “Install a PCIe adapter and riser 1/2 assembly” on page 350 and “Install a PCIe adapter and riser 3 assembly” on page 359.

After you finish

Complete the parts replacement. See “Complete the parts replacement” on page 397.

Hot-swap drive replacement

Use this information to remove and install a hot-swap drive. You can remove or install a hot-swap drive without turning off the server, which helps you avoid significant interruption to the operation of the system.

Notes:

- The term “hot-swap drive” refers to all the supported types of hot-swap hard disk drives, hot-swap solid-state drives, and hot-swap NVMe drives.
- Use any documentation that comes with the drive and follow those instructions in addition to the instructions in this topic. Ensure that you have all the cables and other equipment that are specified in the documentation that comes with the drive.
- The electromagnetic interference (EMI) integrity and cooling of the server are protected by having all drive bays covered or occupied. The vacant bays are either covered by an EMI-protective panel or occupied by drive fillers. When installing a drive, save the removed drive filler in case that you later remove the drive and need the drive filler to cover the place.
- To avoid damage to the drive connectors, ensure that the top cover is in place and fully closed whenever you install or remove a drive.

- “Remove a hot-swap drive” on page 176
- “Install a hot-swap drive” on page 178

Remove a hot-swap drive

Use this information to remove a hot-swap drive.

About this task

Attention:

- Read “Installation Guidelines” on page 129 to ensure that you work safely.
- Prevent exposure to static electricity, which might lead to system halt and loss of data, by keeping static-sensitive components in their static-protective packages until installation, and handling these devices with an electrostatic-discharge wrist strap or other grounding system.
- To ensure that there is adequate system cooling, do not operate the server for more than two minutes without either a drive or a drive filler installed in each bay.

The following describes the information that you must consider for this task:

- Ensure that you have backed up data on your drive, especially if it is part of a RAID array.
 - Before you make changes to drives, RAID adapters, drive backplanes, or drive cables, back up all important data that is stored on the drives.
 - Before you remove any component of a RAID array, back up all RAID configuration information.
- If one or more NVMe drives are to be removed, it is recommended to disable them first in Safely Remove Hardware and Eject Media (Windows) or filesystem (Linux). See the indications above the drive bays to determine the type of the drive to remove. If the drive bay numbers come with the term “NVMe”, it indicates the installed drives are NVMe drives.

A video for this task is available at:

- Youtube: https://www.youtube.com/playlist?list=PLYV5R7hVcs-Bz2XleLEfGcrLGm9TSY_yt
- Youku: http://list.youku.com/albumlist/show/id_52339612.html

Procedure

- Step 1. If the security bezel is installed, remove it first. See “Remove the security bezel” on page 362.
- Step 2. Slide the release latch to the left to open the drive tray handle.

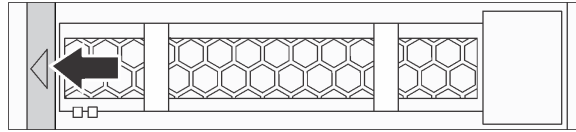

Figure 62. Opening the drive tray handle

- Step 3. Grasp the handle and slide the drive out of the drive bay.

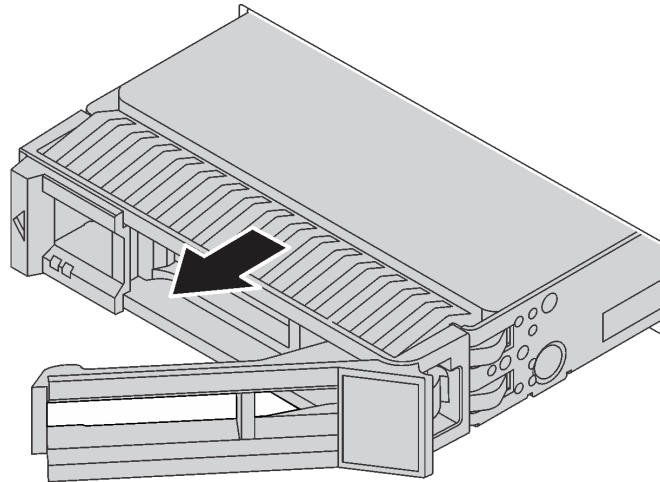

Figure 63. Hot-swap drive removal

After you finish

1. Install the drive filler or a new drive to cover the drive bay. See “Install a hot-swap drive” on page 178.
2. If you are instructed to return the old hot-swap drive, follow all packaging instructions and use any packaging materials that are provided.

Install a hot-swap drive

Use this information to install a hot-swap drive.

About this task

Attention:

- Read “Installation Guidelines” on page 129 to ensure that you work safely.
- Prevent exposure to static electricity, which might lead to system halt and loss of data, by keeping static-sensitive components in their static-protective packages until installation, and handling these devices with an electrostatic-discharge wrist strap or other grounding system.

A video for this task is available at:

- Youtube: https://www.youtube.com/playlist?list=PLYV5R7hVcs-Bz2XleLEfGcrLGm9TSY_yt
- Youku: http://list.youku.com/albumlist/show/id_52339612.html

Procedure

Step 1. Touch the static-protective package that contains the drive to any unpainted surface on the outside of the server. Then, take the drive out of the package and place it on a static-protective surface.

Note: Ensure that drive installation meets “Drive bay configurations and requirements” on page 139.

Step 2. Remove the drive filler from the drive bay and keep the drive filler in a safe place.

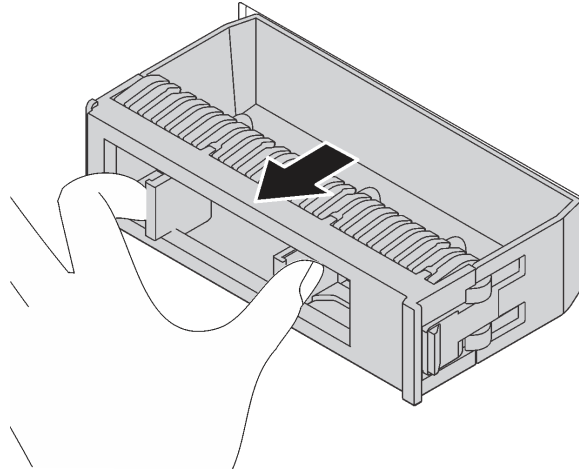

Figure 64. Drive filler removal

Step 3. Install the drive in the drive bay.

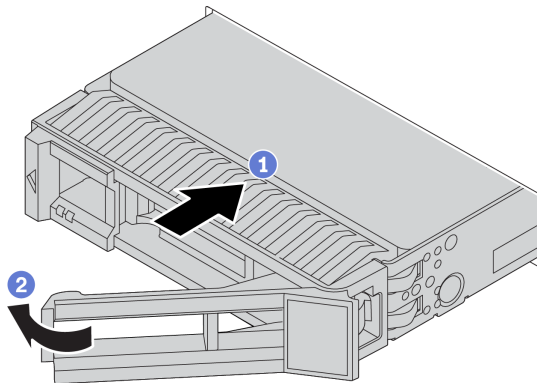

Figure 65. Hot-swap drive installation

- Ensure that the drive tray handle is in the open position. Slide the drive into the drive bay until it snaps into position.
- Close the drive tray handle to lock the drive in place.

Step 4. Check the drive status LED to verify that the drive is operating correctly.

- If the yellow drive status LED is lit continuously, that drive is faulty and must be replaced.
- If the green drive activity LED is flashing, the drive is being accessed.

Step 5. Continue to install additional hot-swap drives if necessary.

After you finish

1. Reinstall the security bezel if you have removed it. See “Install the security bezel” on page 365.
2. Use the Lenovo XClarity Provisioning Manager Lite to configure the RAID if necessary. For more information, see:
https://sysmgmt.lenovofiles.com/help/topic/LXPMv3/LXPMv3_introduction.html

Hot-swap drive backplane replacement

Use this information to remove and install a hot-swap-drive backplane.

Front drive backplane replacement:

- “Remove the front 2.5-inch-drive backplane” on page 182
- “Install the front 2.5-inch-drive backplane” on page 185
- “Remove the front 3.5-inch-drive backplane” on page 194
- “Install the front 3.5-inch-drive backplane” on page 196

Middle and rear drive backplane replacement:

- “Remove the middle or rear 2.5-inch-drive backplane” on page 188
- “Install the middle or rear 2.5-inch-drive backplane” on page 191
- “Remove the middle or rear 3.5-inch-drive backplane” on page 198
- “Install the middle or rear 3.5-inch-drive backplane” on page 201

Remove the front 2.5-inch-drive backplane

Use this information to remove the front 2.5-inch-drive backplane.

About this task

Attention:

- Read “Installation Guidelines” on page 129 to ensure that you work safely.
- Power off the server and disconnect all power cords for this task.
- Prevent exposure to static electricity, which might lead to system halt and loss of data, by keeping static-sensitive components in their static-protective packages until installation, and handling these devices with an electrostatic-discharge wrist strap or other grounding system.

A video for this task is available at:

- Youtube: https://www.youtube.com/playlist?list=PLYV5R7hVcs-Bz2XleLEfGcrLGm9TSY_yt
- Youku: http://list.youku.com/albumlist/show/id_52339612.html

Procedure

Note: Depending on the specific type, your backplane might look different from the illustration in this topic.

Step 1. Prepare your server.

- a. Remove the top cover. See “Remove the top cover” on page 392.
- b. Remove the system fan cage for easier operation. See “Remove a system fan” on page 381.
- c. Remove all the installed drives and fillers (if any) from the drive bays. See “Remove a hot-swap drive” on page 176.

Step 2. Remove the 2.5-inch-drive backplane.

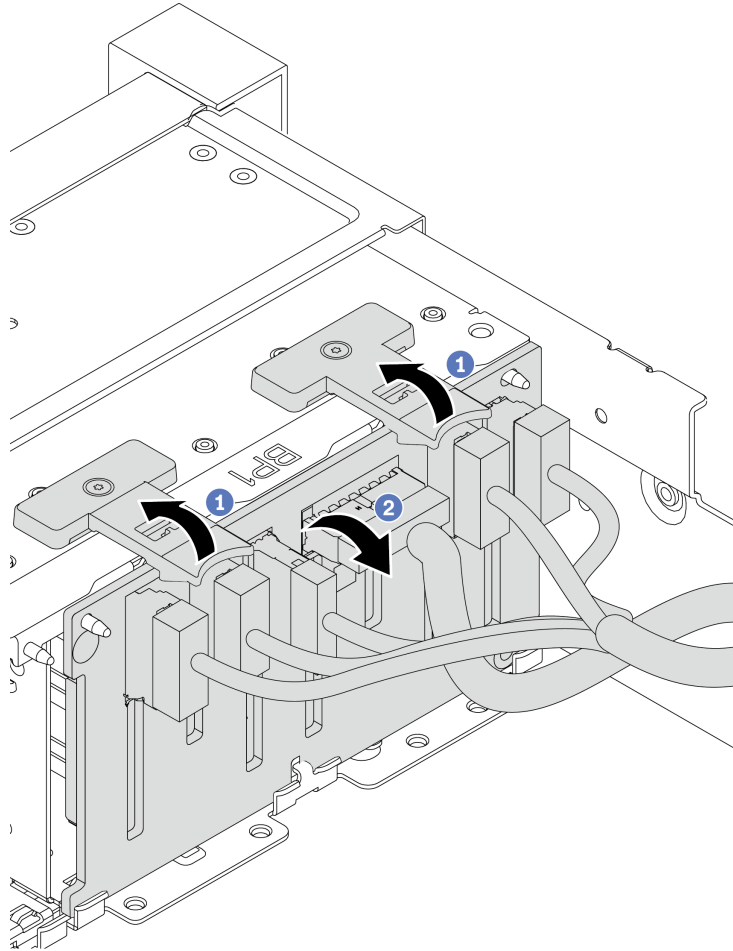

Figure 66. 2.5-inch-drive backplane removal

- a. Lift the release tabs.
- b. Rotate the backplane backward slightly to release it from the two pins on the chassis.

Step 3. Record the cable connections on the backplane and then disconnect all cables from the backplane. See “2.5-inch/3.5-inch drive backplane (power)” on page 66 and “2.5-inch/3.5-inch drive backplane (signal)” on page 71.

After you finish

If you are instructed to return the old backplane, follow all packaging instructions and use any packaging materials that are provided.

Install the front 2.5-inch-drive backplane

Use this information to install the front 2.5-inch-drive backplane.

About this task

Your server supports two SATA/SAS 8-bay backplanes and one Anybay 8-bay backplane. The two SATA/SAS 8-bay backplanes should be installed to drive bays 0–7 and drive bays 8–15, and the Anybay 8-bay backplane should be installed to drive bays 16–23.

Attention:

- Read “Installation Guidelines” on page 129 to ensure that you work safely.
- Power off the server and disconnect all power cords for this task.
- Prevent exposure to static electricity, which might lead to system halt and loss of data, by keeping static-sensitive components in their static-protective packages until installation, and handling these devices with an electrostatic-discharge wrist strap or other grounding system.

A video for this task is available at:

- Youtube: https://www.youtube.com/playlist?list=PLYV5R7hVcs-Bz2XIeLEfGcrLGm9TSY_yt
- Youku: http://list.youku.com/albumlist/show/id_52339612.html

Procedure

- Step 1. Touch the static-protective package that contains the new backplane to any unpainted surface on the outside of the server. Then, take the new backplane out of the package and place it on a static-protective surface.
- Step 2. Connect the cables to the backplane. See “2.5-inch/3.5-inch drive backplane (power)” on page 66 and “2.5-inch/3.5-inch drive backplane (signal)” on page 71.

Step 3. Install the 2.5-inch-drive front backplane.

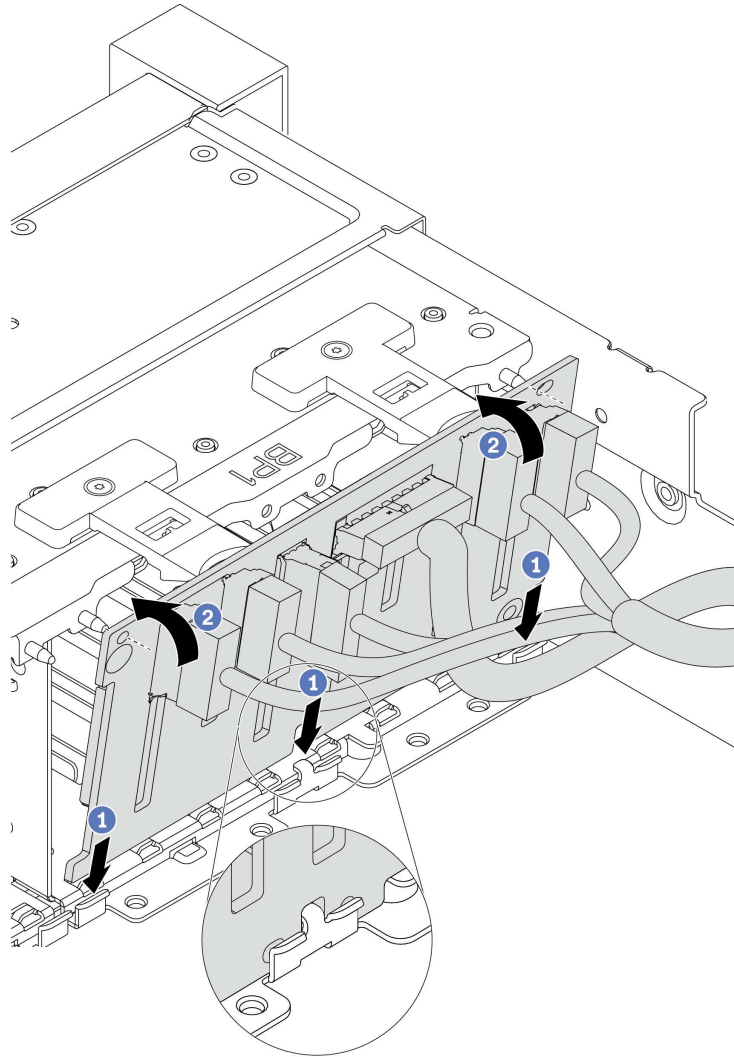

Figure 67. 2.5-inch-drive backplane installation

- a. Align the bottom of the backplane in the slots on the bottom of the chassis.
- b. Rotate the backplane to the vertical position and align the holes in the backplane with the pins on the chassis and press the backplane into position. The release tabs will secure the backplane in place.

Step 4. Connect the cables to the system board. See “2.5-inch/3.5-inch drive backplane (power)” on page 66 and “2.5-inch/3.5-inch drive backplane (signal)” on page 71.

After you finish

1. Reinstall all the drives and fillers (if any) into the drive bays. See “Install a hot-swap drive” on page 178.
2. Complete the parts replacement. See “Complete the parts replacement” on page 397.

Remove the middle or rear 2.5-inch-drive backplane

Use this information to remove the middle or rear 2.5-inch-drive backplane.

About this task

Attention:

- Read “Installation Guidelines” on page 129 to ensure that you work safely.
- Power off the server and disconnect all power cords for this task.
- Prevent exposure to static electricity, which might lead to system halt and loss of data, by keeping static-sensitive components in their static-protective packages until installation, and handling these devices with an electrostatic-discharge wrist strap or other grounding system.
- Depending on the specific type, your backplane might look different from the illustration in this topic.

A video for this task is available at:

- Youtube: https://www.youtube.com/playlist?list=PLYV5R7hVcs-Bz2XleLEfGcrLGm9TSY_yt
- Youku: http://list.youku.com/albumlist/show/id_52339612.html

Procedure

Note: The illustration shows removing the backplane from the rear drive cage. The procedure is the same for removing the backplane from the middle drive cage.

Step 1. Prepare your server.

1. Remove the top cover. See “Remove the top cover” on page 392.
2. If you are removing the middle backplane, remove the system fan cage for easier operation. See “Remove the system fan cage” on page 387.
3. Remove all the installed drives and fillers (if any) from the drive bays. See “Remove a hot-swap drive” on page 176.

Step 2. Remove the 2.5-inch-drive backplane.

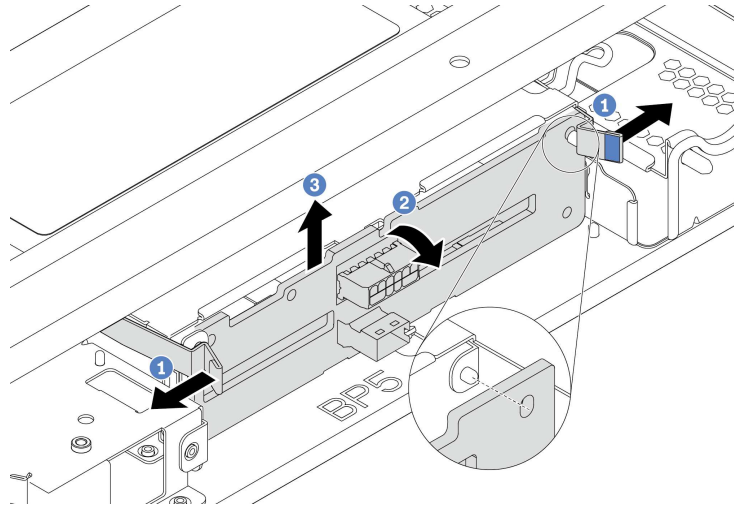

Figure 68. Removing the 4 x 2.5-inch-drive backplane

1. Slightly pivot the release latches outwards in the direction as shown.
2. Pivot the backplane to release it from the two pins on the drive cage.
3. Carefully lift the backplane out of the drive cage.

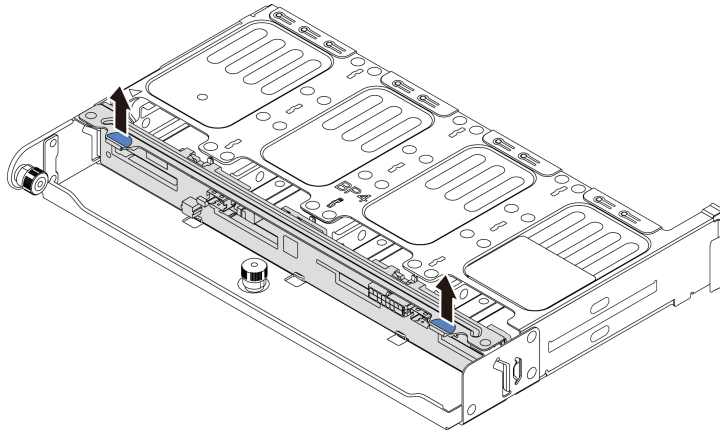

Figure 69. Removing the 8 x 2.5-inch-drive backplane

Carefully lift the backplane out of the drive cage.

- Step 3. Record the cable connections on the backplane and then disconnect all cables from the backplane. See “2.5-inch/3.5-inch drive backplane (power)” on page 66 and “2.5-inch/3.5-inch drive backplane (signal)” on page 71.

Install the middle or rear 2.5-inch-drive backplane

Use this information to install the middle or rear 2.5-inch-drive backplane.

About this task

Your server supports:

- Two types of middle 2.5-inch-drive backplane
 - 4 x 2.5-inch SAS/SATA backplane
 - 4 x 2.5-inch NVMe backplane
- Three types of rear 2.5-inch-drive backplane
 - 4 x 2.5-inch SAS/SATA backplane
 - 4 x 2.5-inch NVMe backplane
 - 8 x 2.5-inch SAS/SATA backplane

Notes:

- The procedure shows the installation of the backplane on the rear drive cage. The procedure is the same for installing the backplane on the middle drive cage.

Attention:

- Read “Installation Guidelines” on page 129 to ensure that you work safely.
- Prevent exposure to static electricity, which might lead to system halt and loss of data, by keeping static-sensitive components in their static-protective packages until installation, and handling these devices with an electrostatic-discharge wrist strap or other grounding system.

A video for this task is available at:

- Youtube: https://www.youtube.com/playlist?list=PLYV5R7hVcs-Bz2XIeLEfGcrLGm9TSY_yt
- Youku: http://list.youku.com/albumlist/show/id_52339612.html

Procedure

- Step 1. Touch the static-protective package that contains the new backplane to any unpainted surface on the outside of the server. Then, take the new backplane out of the package and place it on a static-protective surface.
- Step 2. Connect the cables to the backplane. See “2.5-inch/3.5-inch drive backplane (power)” on page 66 and “2.5-inch/3.5-inch drive backplane (signal)” on page 71.
- Step 3. Align the bottom of the backplane with the studs at the bottom of the drive cage. Rotate the backplane to vertical position so that the holes in the backplane pass through the pins on the drive cage, and press the backplane into position. The release latches will secure the backplane in place.

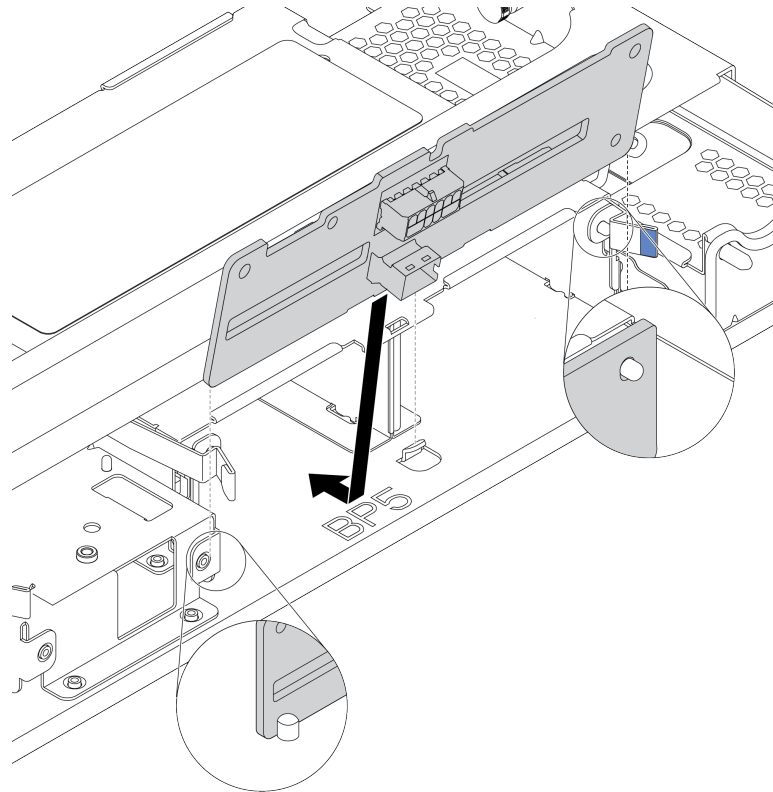

Figure 70. Installing the 4 x 2.5-inch-drive backplane

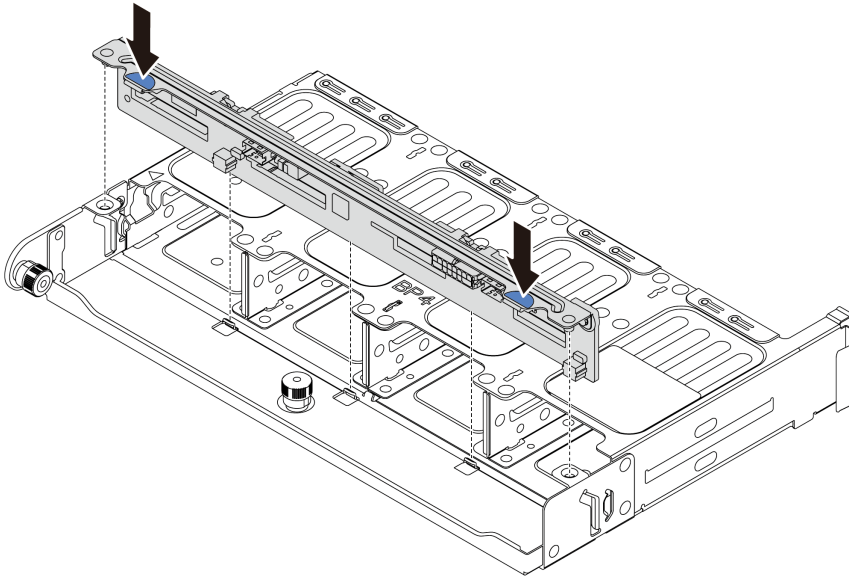

Figure 71. Installing the 8 x 2.5-inch-drive backplane

After you finish

1. Reinstall all the drives and fillers (if any) into the drive bays. See “Install a hot-swap drive” on page 178.
2. Complete the parts replacement. See “Complete the parts replacement” on page 397.

Remove the front 3.5-inch-drive backplane

Use this information to remove the front 3.5-inch-drive backplane.

About this task

Attention:

- Read “Installation Guidelines” on page 129 to ensure that you work safely.
- Power off the server and disconnect all power cords for this task.
- Prevent exposure to static electricity, which might lead to system halt and loss of data, by keeping static-sensitive components in their static-protective packages until installation, and handling these devices with an electrostatic-discharge wrist strap or other grounding system.

A video for this task is available at:

- Youtube: https://www.youtube.com/playlist?list=PLYV5R7hVcs-Bz2XleLEfGcrLGm9TSY_yt
- Youku: http://list.youku.com/albumlist/show/id_52339612.html

Procedure

Note: Depending on the specific type, your backplane might look different from the illustration in this topic.

Step 1. Prepare your server.

- a. Remove the top cover. See “Remove the top cover” on page 392.
- b. Remove the system fan cage for easier operation. See “Remove a system fan” on page 381.
- c. Remove all the installed drives and fillers (if any) from the drive bays. See “Remove a hot-swap drive” on page 176.

Step 2. Lift the release tabs and rotate the backplane backward slightly to release it from the two pins on the chassis.

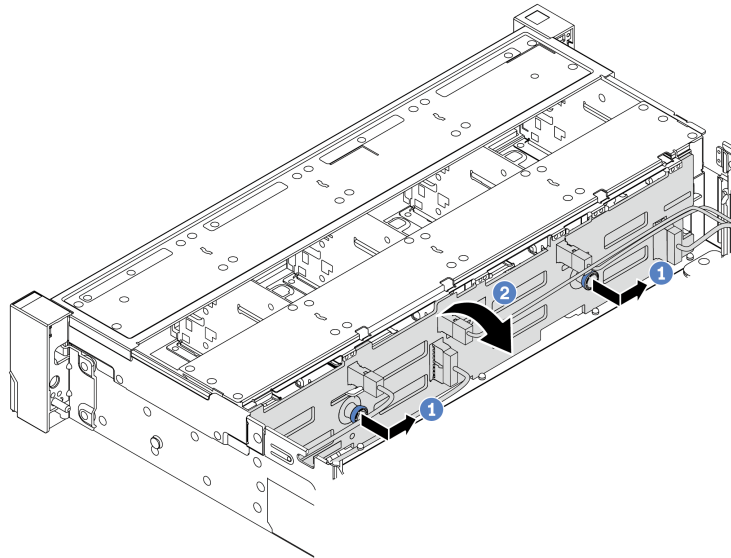

Figure 72. 3.5-inch-drive backplane removal

- a. Pull out the plungers and slightly slide the backplane to the side as shown.
- b. Rotate the backplane down to release it from the four hooks on the chassis. Then, carefully lift the backplane out of the chassis.

Step 3. Record the cable connections on the backplane and then disconnect all cables from the backplane. See “2.5-inch/3.5-inch drive backplane (power)” on page 66 and “2.5-inch/3.5-inch drive backplane (signal)” on page 71.

After you finish

If you are instructed to return the old backplane, follow all packaging instructions and use any packaging materials that are provided.

Install the front 3.5-inch-drive backplane

Use this information to install the front 3.5-inch-drive backplane.

About this task

Your server supports one SAS/SATA 12-bay backplane.

Attention:

- Read “Installation Guidelines” on page 129 to ensure that you work safely.
- Power off the server and disconnect all power cords for this task.
- Prevent exposure to static electricity, which might lead to system halt and loss of data, by keeping static-sensitive components in their static-protective packages until installation, and handling these devices with an electrostatic-discharge wrist strap or other grounding system.

A video for this task is available at:

- Youtube: https://www.youtube.com/playlist?list=PLYV5R7hVcs-Bz2XleLEfGcrLGm9TSY_yt
- Youku: http://list.youku.com/albumlist/show/id_52339612.html

Procedure

- Step 1. Touch the static-protective package that contains the new backplane to any unpainted surface on the outside of the server. Then, take the new backplane out of the package and place it on a static-protective surface.
- Step 2. Connect the cables to the backplane. See “2.5-inch/3.5-inch drive backplane (power)” on page 66 and “2.5-inch/3.5-inch drive backplane (signal)” on page 71.
- Step 3. Install the 3.5-inch-drive backplane.

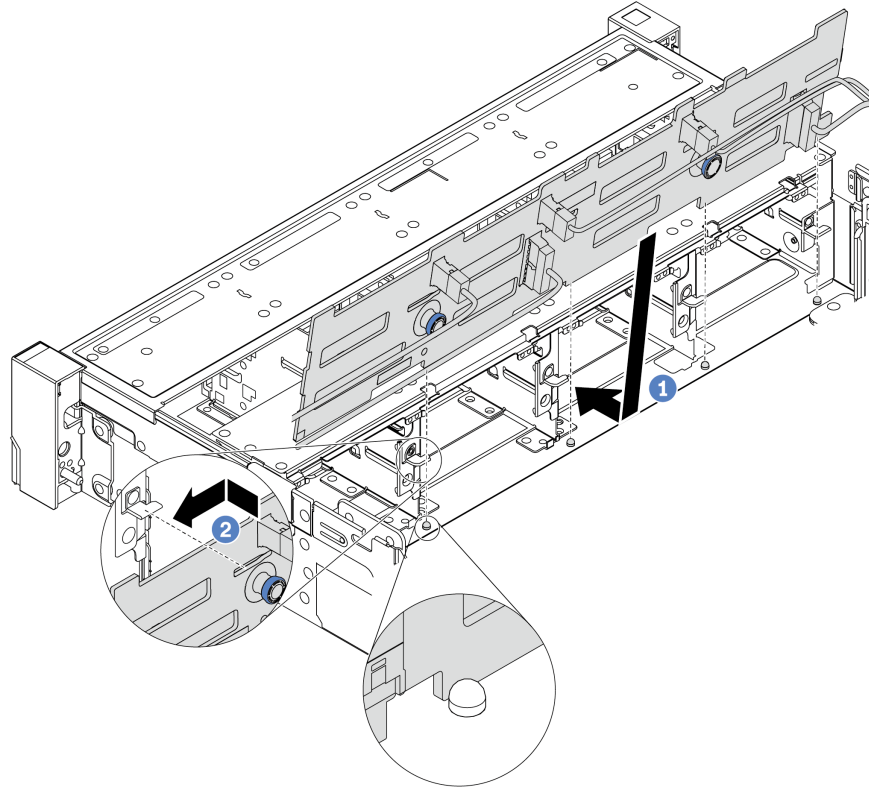

Figure 73. 3.5-inch-drive backplane installation

- a. Align the backplane with the chassis and lower it into the chassis. Then, put the backplane into place with it leaning backward slightly.
 - b. Rotate the backplane to vertical position to ensure that the four hooks on the chassis pass through the corresponding holes in the backplane. Then, slide the new backplane as shown until it is secured into place.
- Step 4. Connect the cables to the system board. See “2.5-inch/3.5-inch drive backplane (power)” on page 66 and “2.5-inch/3.5-inch drive backplane (signal)” on page 71.

After you finish

1. Reinstall all the drives and fillers (if any) into the drive bays. See “Install a hot-swap drive” on page 178.
2. Complete the parts replacement. See “Complete the parts replacement” on page 397.

Remove the middle or rear 3.5-inch-drive backplane

Use this information to remove the middle or rear 3.5-inch-drive backplane.

About this task

Attention:

- Read “Installation Guidelines” on page 129 to ensure that you work safely.
- Power off the server and disconnect all power cords for this task.
- Prevent exposure to static electricity, which might lead to system halt and loss of data, by keeping static-sensitive components in their static-protective packages until installation, and handling these devices with an electrostatic-discharge wrist strap or other grounding system.

A video for this task is available at:

- Youtube: https://www.youtube.com/playlist?list=PLYV5R7hVcs-Bz2XleLEfGcrLGm9TSY_yt
- Youku: http://list.youku.com/albumlist/show/id_52339612.html

Procedure

Note: The illustration shows removing the backplane from the rear drive cage. The procedure is the same for removing the backplane from the middle drive cage.

Step 1. Prepare your server.

1. Remove the top cover. See “Remove the top cover” on page 392.
2. If you are removing the middle backplane, remove the system fan cage for easier operation. See “Remove the system fan cage” on page 387.
3. Remove all the installed drives and fillers (if any) from the drive bays. See “Remove a hot-swap drive” on page 176.

Step 2. Remove the 3.5-inch-drive backplane.

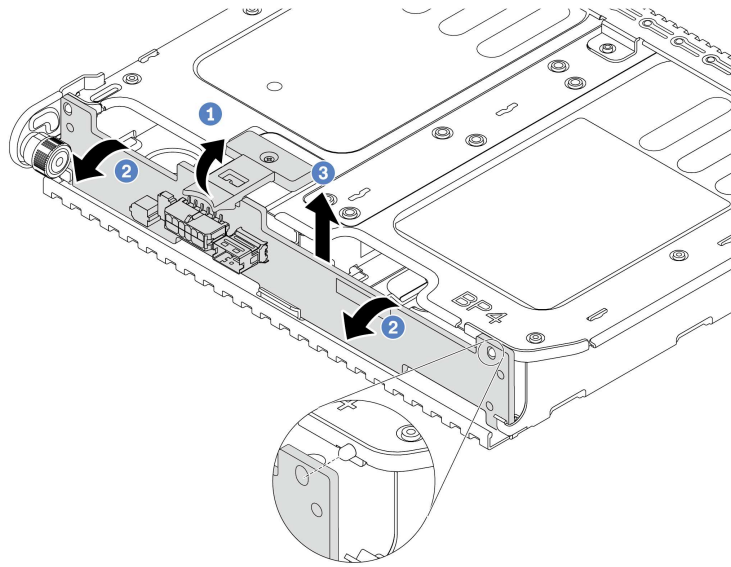

Figure 74. Removing the 2 x 3.5-inch-drive backplane

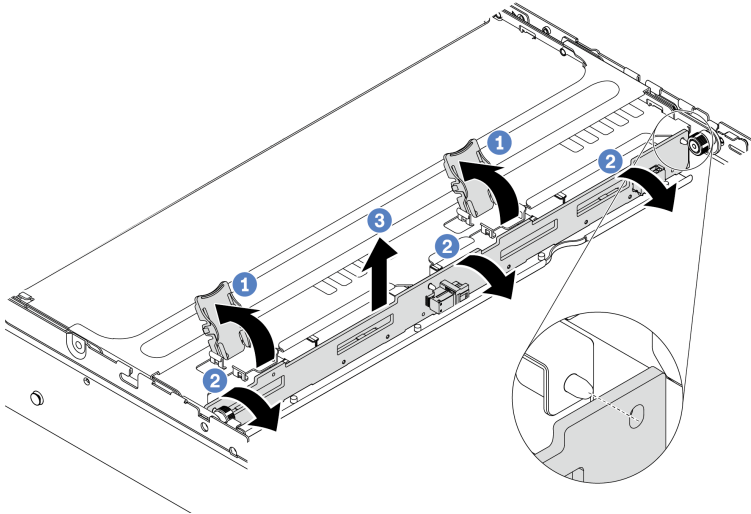

Figure 75. Removing the 4 x 3.5-inch-drive backplane

1. Slightly pivot the release latches outwards in the direction as shown.
 2. Pivot the backplane to release it from the two pins on the drive cage.
 3. Carefully lift the backplane out of the drive cage.
- Step 3. Record the cable connections on the backplane and then disconnect all cables from the backplane. See “2.5-inch/3.5-inch drive backplane (power)” on page 66 and “2.5-inch/3.5-inch drive backplane (signal)” on page 71.

Install the middle or rear 3.5-inch-drive backplane

Use this information to install the middle or rear 3.5-inch-drive backplane.

About this task

Your server supports:

- One type of middle 3.5-inch-drive backplane
 - 4 x 3.5-inch SAS/SATA backplane
- Two types of rear 3.5-inch-drive backplane
 - 2 x 3.5-inch SAS/SATA backplane
 - 4 x 3.5-inch SAS/SATA backplane

Notes:

- The procedure shows the installation of the backplane on the rear drive cage. The procedure is the same for installing the backplane on the middle drive cage.

Attention:

- Read “Installation Guidelines” on page 129 to ensure that you work safely.
- Prevent exposure to static electricity, which might lead to system halt and loss of data, by keeping static-sensitive components in their static-protective packages until installation, and handling these devices with an electrostatic-discharge wrist strap or other grounding system.

A video for this task is available at:

- Youtube: https://www.youtube.com/playlist?list=PLYV5R7hVcs-Bz2XIeLEfGcrLGm9TSY_yt
- Youku: http://list.youku.com/albumlist/show/id_52339612.html

Procedure

- Step 1. Touch the static-protective package that contains the new backplane to any unpainted surface on the outside of the server. Then, take the new backplane out of the package and place it on a static-protective surface.
- Step 2. Connect the cables to the backplane. See “2.5-inch/3.5-inch drive backplane (power)” on page 66 and “2.5-inch/3.5-inch drive backplane (signal)” on page 71.
- Step 3. Align the bottom of the backplane with the studs at the bottom of the drive cage. Rotate the backplane to vertical position so that the holes in the backplane pass through the pins on the drive cage, and press the backplane into position. The release latches will secure the backplane in place.

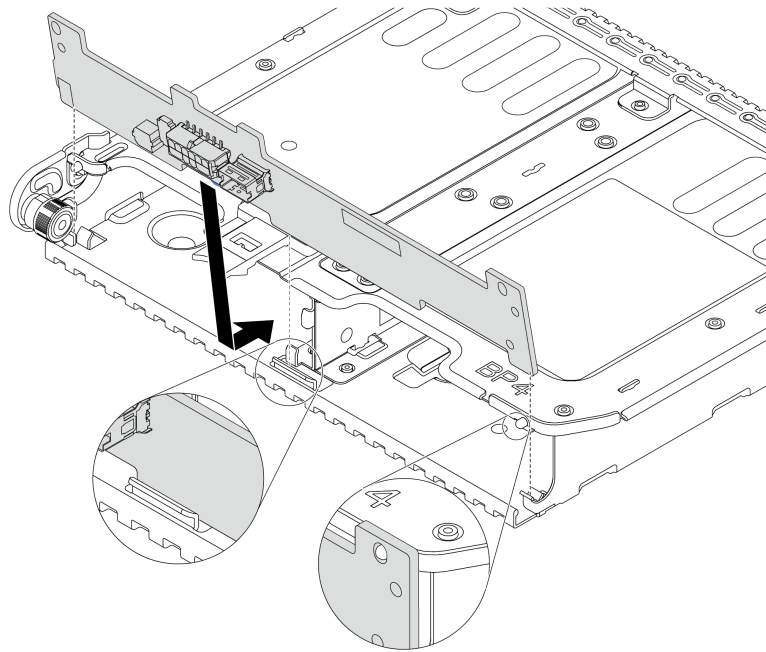

Figure 76. Installing the 2 x 3.5-inch-drive backplane

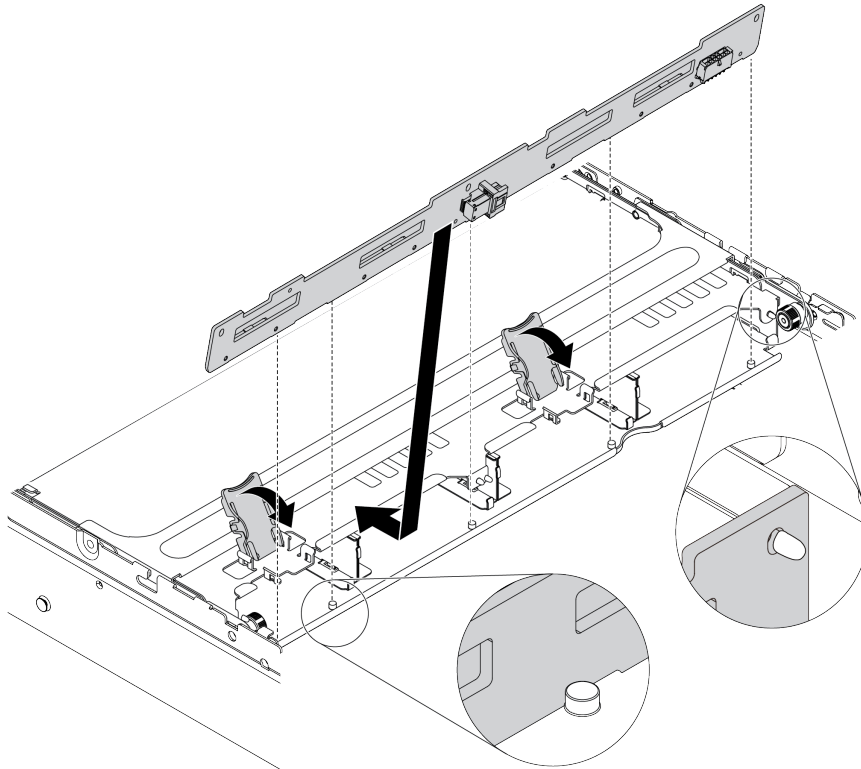

Figure 77. Installing the 4 x 3.5-inch-drive backplane

After you finish

1. Reinstall all the drives and fillers (if any) into the drive bays. See “Install a hot-swap drive” on page 178.
2. Complete the parts replacement. See “Complete the parts replacement” on page 397.

Remove the 7mm drive backplane

Use this information to remove the 7mm drive backplane.

About this task

Attention:

- Read “Installation Guidelines” on page 129 to ensure that you work safely.
- Power off the server and disconnect all power cords for this task.
- Prevent exposure to static electricity, which might lead to system halt and loss of data, by keeping static-sensitive components in their static-protective packages until installation, and handling these devices with an electrostatic-discharge wrist strap or other grounding system.

A video for this task is available at:

- Youtube: https://www.youtube.com/playlist?list=PLYV5R7hVcs-Bz2XIeLEfGcrLGm9TSY_yt
- Youku: http://list.youku.com/albumlist/show/id_52339612.html

Procedure

Note: Depending on the specific type, your backplane might look different from the illustration in this topic.

Step 1. Prepare your server.

- a. Remove the top cover. See “Remove the top cover” on page 392.
- b. Remove all the installed drives and fillers (if any) from the drive bays. See “Remove a hot-swap drive” on page 176.
- c. Record the cable connections for 7mm drives and then disconnect all cables from the backplanes. For information about the backplane cable routing, see “7mm drives” on page 64.
- d. Remove the 7mm drive assembly (if any) from the rear chassis. See “Remove the 7mm drive cage” on page 338.

Step 2. Remove the 7mm drive backplane on the top.

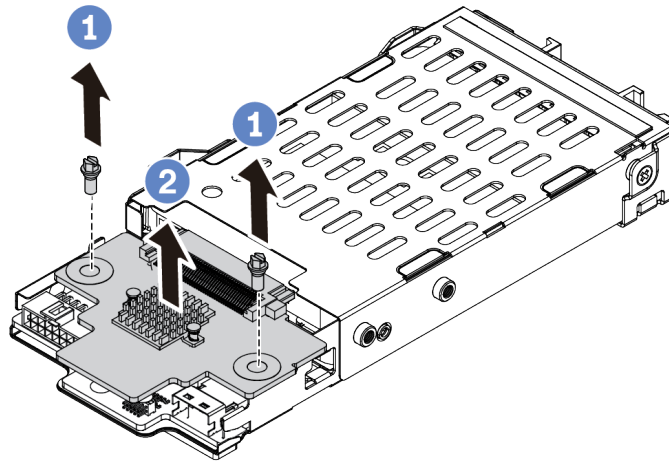

Figure 78. 7mm drive backplane removal (top)

- a. Remove the two screws as shown.
- b. Vertically lift the backplane up and put it aside.

Step 3. Remove the 7mm drive backplane at the bottom.

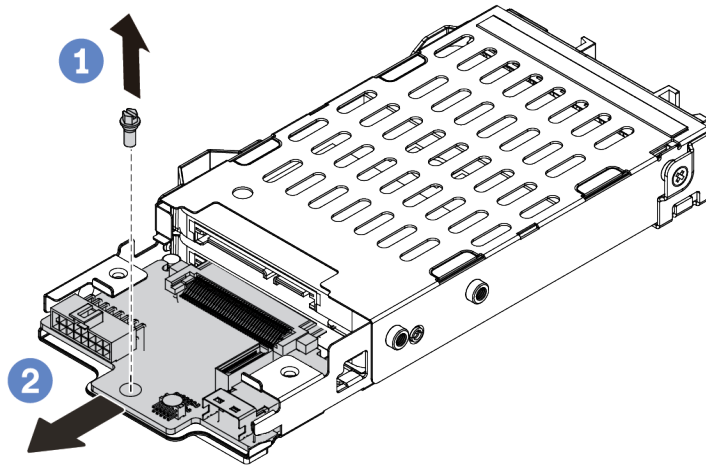

Figure 79. 7mm drive backplane removal (bottom)

- a. Remove the screw as shown.
- b. Remove the backplane horizontally from the cage as shown.

After you finish

If you are instructed to return the old backplanes, follow all packaging instructions and use any packaging materials that are provided.

Install the 7mm drive backplanes

Use this information to install the 7mm drive backplanes.

About this task

Attention:

- Read “Installation Guidelines” on page 129 to ensure that you work safely.
- Power off the server and disconnect all power cords for this task.
- Prevent exposure to static electricity, which might lead to system halt and loss of data, by keeping static-sensitive components in their static-protective packages until installation, and handling these devices with an electrostatic-discharge wrist strap or other grounding system.

A video for this task is available at:

- Youtube: https://www.youtube.com/playlist?list=PLYV5R7hVcs-Bz2XleLEfGcrLGm9TSY_yt
- Youku: http://list.youku.com/albumlist/show/id_52339612.html

Procedure

Step 1. Touch the static-protective package that contains the new backplane to any unpainted surface on the outside of the server. Then, take the new backplane out of the package and place it on a static-protective surface.

Step 2. Connect the cables to the backplanes. See “7mm drives” on page 64.

Step 3. Install the 7mm drive backplane at the bottom.

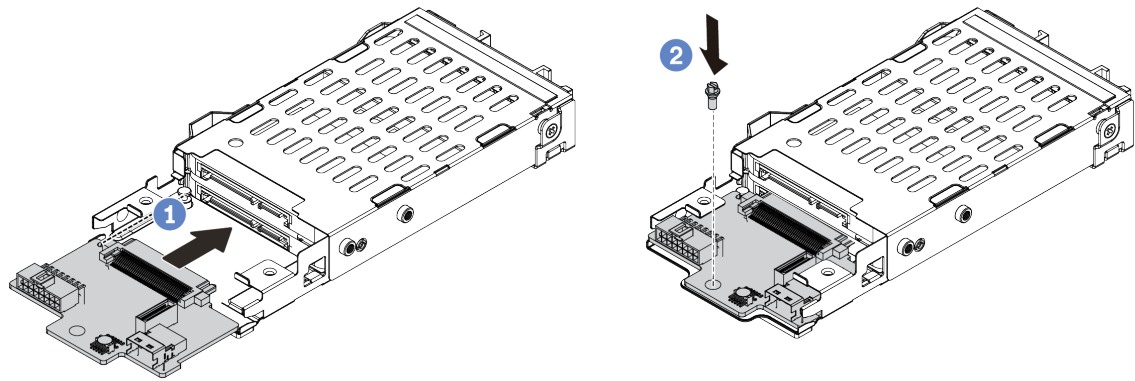

Figure 80. 7mm drive backplane installation (bottom)

- a. Align the pin on the cage and slightly slide the backplane into the cage until it is fully seated.
- b. Install the screw as shown.

Step 4. Install the 7mm drive backplane on the top.

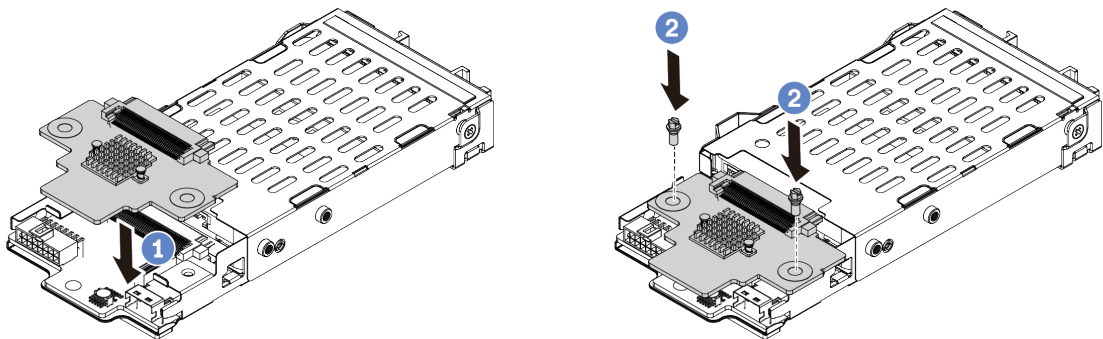

Figure 81. 7mm drive backplane installation (top)

- a. Put the backplane down on the cage as shown.
- b. Install the two screws to secure the backplane in place

Step 5. Connect the cables to the system board. See “7mm drives” on page 64.

After you finish

1. Reinstall all the drives and fillers (if any) into the drive bays. See “Install a hot-swap drive” on page 178.
2. Complete the parts replacement. See “Complete the parts replacement” on page 397.

Hot-swap power supply unit replacement

Use this information to remove and install a power supply unit.

- “Remove a hot-swap power supply unit” on page 209
- “Install a hot-swap power supply” on page 216

Remove a hot-swap power supply unit

Use this information to remove a power supply unit.

About this task

The following describes the information that you must consider when removing a power supply:

Note: If the power supply unit to be removed is the only one installed, the power supply is non-hot-swap and before removing it, you must turn off the server first. To support redundancy mode or hot-swap, install an additional hot-swap power supply.

Safety information for AC power supplies

S035



CAUTION:

Never remove the cover on a power supply or any part that has this label attached. Hazardous voltage, current, and energy levels are present inside any component that has this label attached. There are no serviceable parts inside these components. If you suspect a problem with one of these parts, contact a service technician.

S002



CAUTION:

The power-control button on the device and the power switch on the power supply do not turn off the electrical current supplied to the device. The device also might have more than one power cord. To remove all electrical current from the device, ensure that all power cords are disconnected from the power source.

S001



 DANGER

**Electrical current from power, telephone, and communication cables is hazardous.
To avoid a shock hazard:**

- **Do not connect or disconnect any cables or perform installation, maintenance, or reconfiguration of this product during an electrical storm.**
- **Connect all power cords to a properly wired and grounded electrical outlet.**
- **Connect any equipment that will be attached to this product to properly wired outlets .**
- **When possible, use one hand only to connect or disconnect signal cables.**
- **Never turn on any equipment when there is evidence of fire, water, or structural damage.**
- **Disconnect the attached power cords, telecommunications systems, networks, and modems before you open the device covers, unless instructed otherwise in the installation and configuration procedures.**
- **Connect and disconnect cables as described in the following table when installing, moving, or opening covers on this product or attached devices.**

To Connect:

1. Turn everything OFF.
2. Attach all cables to devices.
3. Attach signal cables to connectors.
4. Attach power cords to outlet.
5. Turn device ON.

To Disconnect:

1. Turn everything OFF.
2. Remove power cords from outlet.
3. Remove signal cables from connectors.
4. Remove all cables from devices.

Safety information for DC power supplies

CAUTION:

240 V dc input (input range: 180-300 V dc) is supported in Chinese Mainland ONLY. Power supply with 240 V dc input cannot support hot plugging power cord function. Before removing the power supply with dc input, please turn off server or disconnect dc power sources at the breaker panel or by turning off the power source. Then, remove the power cord.



在直流输入状态下，若电源供应器插座不支持热插拔功能，请务必不要对设备电源线进行热插拔，此操作可能导致设备损坏及数据丢失。因错误执行热插拔导致的设备故障或损坏，不属于保修范围。

NEVER CONNECT AND DISCONNECT THE POWER SUPPLY CABLE AND EQUIPMENT WHILE YOUR EQUIPMENT IS POWERED ON WITH DC SUPPLY (hot-plugging). Otherwise you may damage the equipment and result in data loss, the damages and losses result from incorrect operation of the equipment will not be covered by the manufacturers' warranty.

S035



CAUTION:

Never remove the cover on a power supply or any part that has this label attached. Hazardous voltage, current, and energy levels are present inside any component that has this label attached. There are no serviceable parts inside these components. If you suspect a problem with one of these parts, contact a service technician.

S019



CAUTION:

The power-control button on the device does not turn off the electrical current supplied to the device. The device also might have more than one connection to dc power. To remove all electrical current from the device, ensure that all connections to dc power are disconnected at the dc power input terminals.

S029



 **DANGER**

**Electrical current from power, telephone, and communication cables is hazardous.
To avoid a shock hazard:**

- **Do not connect or disconnect any cables or perform installation, maintenance, or reconfiguration of this product during an electrical storm.**
- **Connect all power cords to a properly wired and grounded power source.**
- **Connect to properly wired power sources any equipment that will be attached to this product.**
- **When possible, use one hand only to connect or disconnect signal cables.**
- **Never turn on any equipment when there is evidence of fire, water, or structural damage.**
- **Disconnect the attached ac power cords, dc power sources, network connections, telecommunications systems, and serial cables before you open the device covers, unless you are instructed otherwise in the installation and configuration procedures.**
- **Connect and disconnect cables as described in the following table when installing, moving, or opening covers on this product or attached devices.**

To Connect:

1. Turn OFF all power sources and equipment that is to be attached to this product.
2. Attach signal cables to the product.
3. Attach power cords to the product.
 - For ac systems, use appliance inlets.
 - For dc systems, ensure correct polarity of -48 V dc connections: RTN is + and -48 V dc is -. Earth ground should use a two-hole lug for safety.
4. Attach signal cables to other devices.
5. Connect power cords to their sources.
6. Turn ON all the power sources.

To Disconnect:

1. Turn OFF all power sources and equipment that is to be attached to this product.
 - For ac systems, remove all power cords from the chassis power receptacles or interrupt power at the ac power distribution unit.
 - For dc systems, disconnect dc power sources at the breaker panel or by turning off the power source. Then, remove the dc cables.
2. Remove the signal cables from the connectors.
3. Remove all cables from the devices.

Attention:

- Read “Installation Guidelines” on page 129 to ensure that you work safely.
- Prevent exposure to static electricity, which might lead to system halt and loss of data, by keeping static-sensitive components in their static-protective packages until installation, and handling these devices with an electrostatic-discharge wrist strap or other grounding system.

A video for this task is available at:

- Youtube: https://www.youtube.com/playlist?list=PLYV5R7hVcs-Bz2XleLEfGcrLGm9TSY_yt
- Youku: http://list.youku.com/albumlist/show/id_52339612.html

Procedure

Step 1. If the server is in a rack, adjust the cable management arm (CMA) to gain access to the power supply bay.

If you have installed the 2U CMA Upgrade Kit for Toolless Slide Rail or Toolless Slide Rail Kit with 2U CMA, do the following:

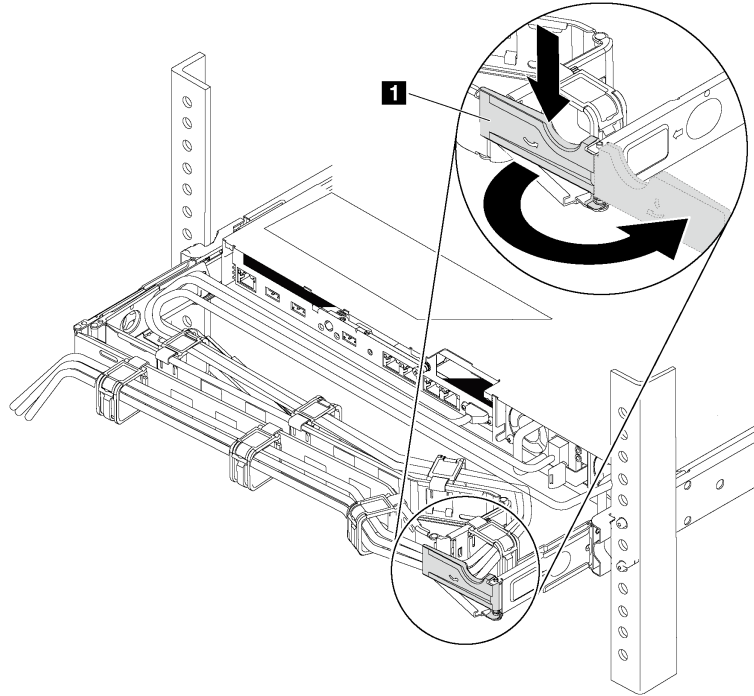

Figure 82. CMA adjustment

1. Press down the stop bracket **1** and rotate it to the open position.
2. Rotate the CMA out of the way to gain access to the power supply.

Step 2. Disconnect the power cord from the hot-swap power supply.

Note: If you are replacing two power supplies, replace them one by one to ensure that the power supply to the server is not interrupted. Do not disconnect the power cord from the secondly replaced power supply until the power output LED for the firstly replaced power supply is lit. For the location of the power output LED, refer to “Rear view LEDs” on page 41.

Step 3. Press the release tab toward the handle and carefully pull the handle at the same time to slide the hot-swap power supply out of the chassis.

Note:

Slightly pull the power supply upwards when sliding the power supply out of the chassis, if you have installed one of the following CMA kits:

- 2U CMA Upgrade Kit for Toolless Slide Rail
- Toolless Slide Rail Kit with 2U CMA

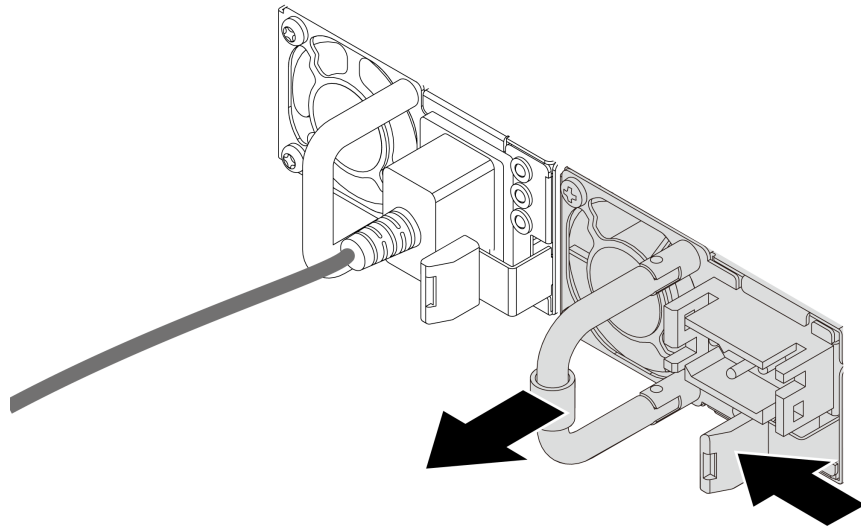

Figure 83. Hot-swap power supply removal

After you finish

1. Install a new power supply or install the power-supply filler to cover the power supply bay. See “Install a hot-swap power supply” on page 216.

Important: To ensure proper cooling during normal server operation, both of the power supply bays must be occupied. This means that each bay must have a power supply installed; or one has a power supply installed and the other has a power supply filler installed.

2. If you are instructed to return the old hot-swap power supply, follow all packaging instructions and use any packaging materials that are provided.

Install a hot-swap power supply

Use this information to install a hot-swap power supply.

About this task

The following describes the information that you must consider when installing a power supply:

- The server is shipped with only one power supply by default. In this case, the power supply is non-hot-swap and before removing it, you must turn off the server first. To support redundancy mode or hot-swap, install an additional hot-swap power supply.
- If you are replacing the existing power supply with a new power supply:
 - Use Lenovo Capacity Planner to calculate the required power capacity for what is configured for your server. More information about Lenovo Capacity Planner is available at:
<https://datacentersupport.lenovo.com/solutions/lnvo-lcp>
 - Ensure that the devices that you are installing are supported. For a list of supported optional devices for the server, go to:
<https://static.lenovo.com/us/en/serverproven/index.shtml>
 - Attach the power information label that comes with this option onto the existing label near the power supply.



Figure 84. Example power supply unit label on the top cover

Safety information for AC power supplies

S035

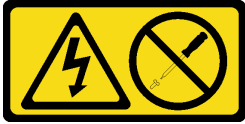

CAUTION:

Never remove the cover on a power supply or any part that has this label attached. Hazardous voltage, current, and energy levels are present inside any component that has this label attached. There are no serviceable parts inside these components. If you suspect a problem with one of these parts, contact a service technician.

S002



CAUTION:

The power-control button on the device and the power switch on the power supply do not turn off the electrical current supplied to the device. The device also might have more than one power cord. To remove all electrical current from the device, ensure that all power cords are disconnected from the power source.

S001



Electrical current from power, telephone, and communication cables is hazardous.

To avoid a shock hazard:

- Do not connect or disconnect any cables or perform installation, maintenance, or reconfiguration of this product during an electrical storm.
- Connect all power cords to a properly wired and grounded electrical outlet.
- Connect any equipment that will be attached to this product to properly wired outlets .
- When possible, use one hand only to connect or disconnect signal cables.
- Never turn on any equipment when there is evidence of fire, water, or structural damage.
- Disconnect the attached power cords, telecommunications systems, networks, and modems before you open the device covers, unless instructed otherwise in the installation and configuration procedures.
- Connect and disconnect cables as described in the following table when installing, moving, or opening covers on this product or attached devices.

To Connect:

1. Turn everything OFF.
2. Attach all cables to devices.
3. Attach signal cables to connectors.
4. Attach power cords to outlet.
5. Turn device ON.

To Disconnect:

1. Turn everything OFF.
2. Remove power cords from outlet.
3. Remove signal cables from connectors.
4. Remove all cables from devices.

Safety information for DC power supplies

CAUTION:

240 V dc input (input range: 180-300 V dc) is supported in Chinese Mainland ONLY. Power supply with 240 V dc input cannot support hot plugging power cord function. Before removing the power supply with dc input, please turn off server or disconnect dc power sources at the breaker panel or by turning off the power source. Then, remove the power cord.



在直流输入状态下，若电源供应器插座不支持热插拔功能，请务必不要对设备电源线进行热插拔，此操作可能导致设备损坏及数据丢失。因错误执行热插拔导致的设备故障或损坏，不属于保修范围。

NEVER CONNECT AND DISCONNECT THE POWER SUPPLY CABLE AND EQUIPMENT WHILE YOUR EQUIPMENT IS POWERED ON WITH DC SUPPLY (hot-plugging). Otherwise you may damage the equipment and result in data loss, the damages and losses result from incorrect operation of the equipment will not be covered by the manufacturers' warranty.

S035



CAUTION:

Never remove the cover on a power supply or any part that has this label attached. Hazardous voltage, current, and energy levels are present inside any component that has this label attached. There are no serviceable parts inside these components. If you suspect a problem with one of these parts, contact a service technician.

S019



CAUTION:

The power-control button on the device does not turn off the electrical current supplied to the device. The device also might have more than one connection to dc power. To remove all electrical current from the device, ensure that all connections to dc power are disconnected at the dc power input terminals.



 **DANGER**

**Electrical current from power, telephone, and communication cables is hazardous.
To avoid a shock hazard:**

- **Do not connect or disconnect any cables or perform installation, maintenance, or reconfiguration of this product during an electrical storm.**
- **Connect all power cords to a properly wired and grounded power source.**
- **Connect to properly wired power sources any equipment that will be attached to this product.**
- **When possible, use one hand only to connect or disconnect signal cables.**
- **Never turn on any equipment when there is evidence of fire, water, or structural damage.**
- **Disconnect the attached ac power cords, dc power sources, network connections, telecommunications systems, and serial cables before you open the device covers, unless you are instructed otherwise in the installation and configuration procedures.**
- **Connect and disconnect cables as described in the following table when installing, moving, or opening covers on this product or attached devices.**

To Connect:

1. Turn OFF all power sources and equipment that is to be attached to this product.
2. Attach signal cables to the product.
3. Attach power cords to the product.
 - For ac systems, use appliance inlets.
 - For dc systems, ensure correct polarity of -48 V dc connections: RTN is + and -48 V dc is -. Earth ground should use a two-hole lug for safety.
4. Attach signal cables to other devices.
5. Connect power cords to their sources.
6. Turn ON all the power sources.

To Disconnect:

1. Turn OFF all power sources and equipment that is to be attached to this product.
 - For ac systems, remove all power cords from the chassis power receptacles or interrupt power at the ac power distribution unit.
 - For dc systems, disconnect dc power sources at the breaker panel or by turning off the power source. Then, remove the dc cables.
2. Remove the signal cables from the connectors.
3. Remove all cables from the devices.

Attention:

- Read “Installation Guidelines” on page 129 to ensure that you work safely.
- Prevent exposure to static electricity, which might lead to system halt and loss of data, by keeping static-sensitive components in their static-protective packages until installation, and handling these devices with an electrostatic-discharge wrist strap or other grounding system.

A video for this task is available at:

- Youtube: https://www.youtube.com/playlist?list=PLYV5R7hVcs-Bz2XleLEfGcrLGm9TSY_yt
- Youku: http://list.youku.com/albumlist/show/id_52339612.html

Procedure

- Step 1. Touch the static-protective package that contains the hot-swap power supply to any unpainted surface on the outside of the server. Then, take the hot-swap power supply out of the package and place it on a static-protective surface.
- Step 2. If there is a power-supply filler installed, remove it.

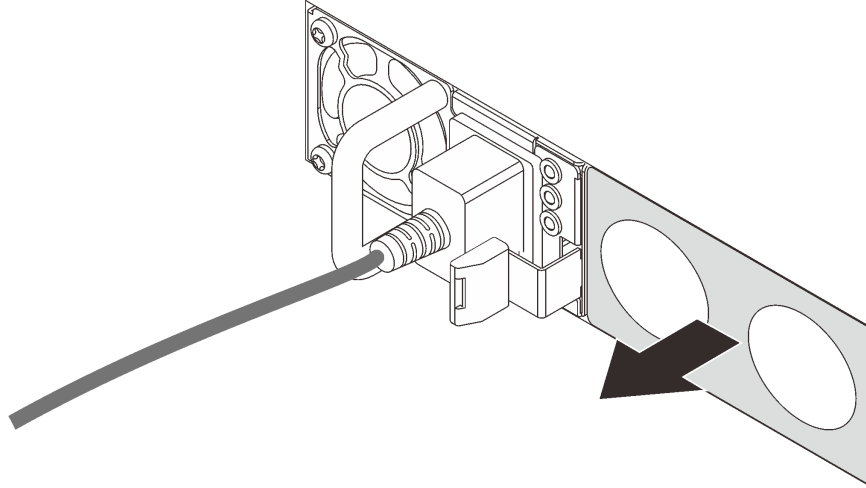

Figure 85. Hot-swap power supply filler removal

- Step 3. Slide the new hot-swap power supply into the bay until it snaps into position.

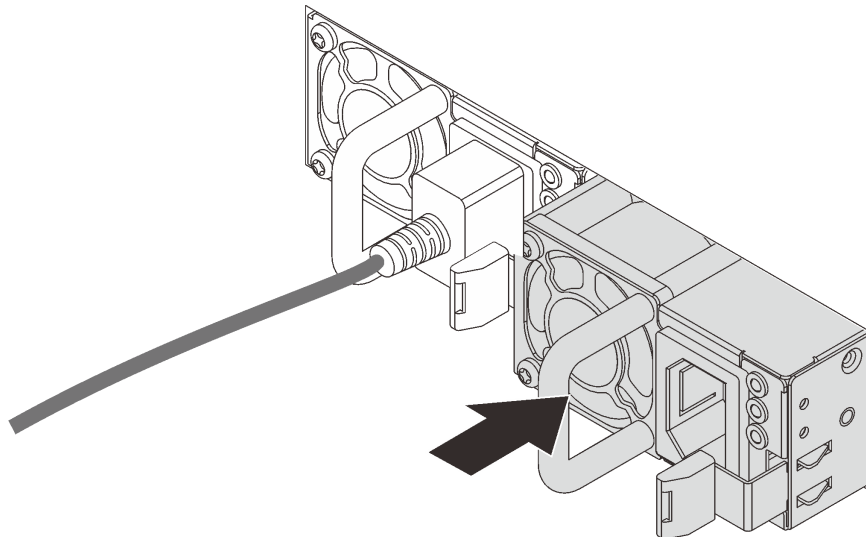

Figure 86. Hot-swap power supply installation

After you finish

1. Connect one end of the power cord to the new power supply connector; then, connect the other end of the power cord into a properly grounded electrical outlet.
2. If you have adjusted the CMA to gain access to the power supply bay, properly readjust the CMA back in place.

3. If the server is turned off, turn on the server. Ensure that both the power input LED and the power output LED on the power supply are lit, indicating that the power supply is operating properly.

Internal CFF adapter replacement

Use this information to remove and install the internal CFF RAID adapter, internal CFF HBA adapter, or internal CFF RAID expander adapter.

Remove the internal CFF RAID/HBA/RAID expander adapter

Use this information to remove internal CFF RAID adapter, internal CFF HBA adapter, or internal CFF RAID expander adapter.

About this task

Attention:

- Read “Installation Guidelines” on page 129 to ensure that you work safely.
- Power off the server and disconnect all power cords for this task.
- Prevent exposure to static electricity, which might lead to system halt and loss of data, by keeping static-sensitive components in their static-protective packages until installation, and handling these devices with an electrostatic-discharge wrist strap or other grounding system.

A video for this task is available at:

- Youtube: https://www.youtube.com/playlist?list=PLYV5R7hVcs-Bz2XleLfGcrLGm9TSY_yt
- Youku: http://list.youku.com/albumlist/show/id_52339612.html

Procedure

Step 1. Prepare your server.

1. Power off the server.
2. Remove the top cover. See “Remove the top cover” on page 392.
3. Record the cabling for cables that are crossing over the adapter; then, disconnect all the cables. See Chapter 3 “Internal cable routing” on page 57.

Step 2. Disconnect all cables from the adapter. See Chapter 3 “Internal cable routing” on page 57.

Step 3. Lift the release pin, slightly slide the adapter as shown, and carefully lift it out of the chassis.

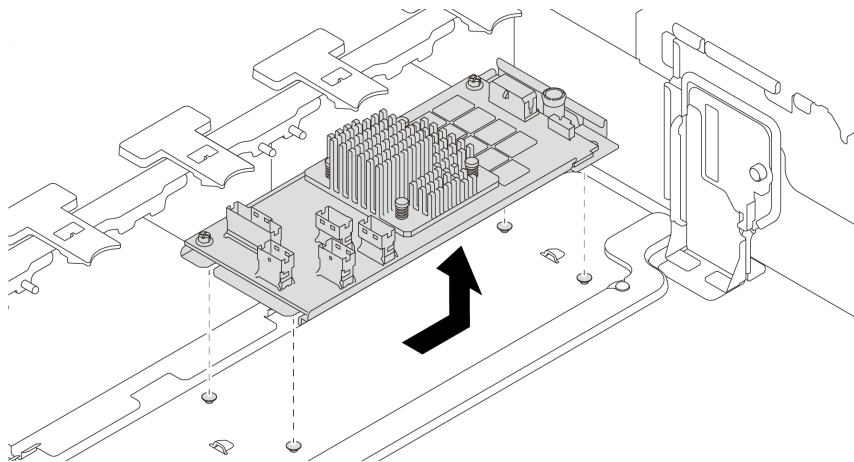

Figure 87. Internal CFF RAID/HBA/RAID expander adapter removal

After you finish

If you are instructed to return the old adapter, follow all packaging instructions and use any packaging materials that are provided.

Install the internal CFF RAID/HBA/RAID expander adapter

Use this information to install the internal CFF RAID/HBA/RAID expander adapter.

About this task

Attention:

- Read “Installation Guidelines” on page 129 to ensure that you work safely.
- Power off the server and disconnect all power cords for this task.
- Prevent exposure to static electricity, which might lead to system halt and loss of data, by keeping static-sensitive components in their static-protective packages until installation, and handling these devices with an electrostatic-discharge wrist strap or other grounding system.

A video for this task is available at:

- Youtube: https://www.youtube.com/playlist?list=PLYV5R7hVcs-Bz2XleLEfGcrLGm9TSY_yt
- Youku: http://list.youku.com/albumlist/show/id_52339612.html

Procedure

- Step 1. Remove the top cover. See “Remove the top cover” on page 392.
- Step 2. Touch the static-protective package that contains the adapter to any unpainted surface on the outside of the server. Then, take the adapter out of the package and place it on a static-protective surface.

Note: The adapter is shipped with and preinstalled on a mounting bracket, check and ensure that the adapter is fixed in place. If there are any loosen screws, tighten the screws using a No.1 Phillips torque screwdriver. The maximum torque value is 4.8 ± 0.5 inch-pounds.

- Step 3. Align the notches on the mounting bracket with the pins on the chassis, place down the adapter, and slightly slide it as shown to secure it on the chassis.

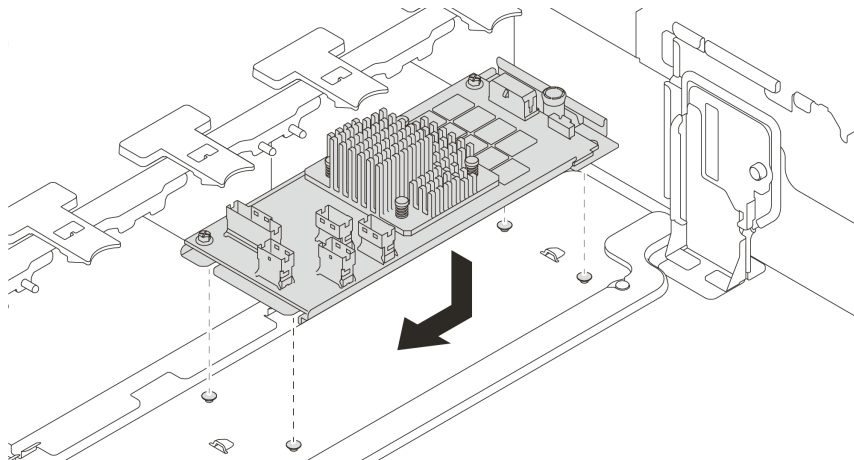

Figure 88. Internal CFF RAID/HBA adapter installation

- Step 4. Connect cables to the adapter.

After you finish

Complete the parts replacement. See “Complete the parts replacement” on page 397.

Intrusion switch replacement

Use this information to remove and install the intrusion switch. The intrusion switch informs you that the server cover is not properly installed or closed by creating an event in the system event log (SEL).

- “Remove the intrusion switch” on page 228
- “Install the intrusion switch” on page 230

Remove the intrusion switch

Use this information to remove the intrusion switch.

About this task

- Read “Installation Guidelines” on page 129 to ensure that you work safely.
- Power off the server and disconnect all power cords for this task.
- Prevent exposure to static electricity, which might lead to system halt and loss of data, by keeping static-sensitive components in their static-protective packages until installation, and handling these devices with an electrostatic-discharge wrist strap or other grounding system.

A video for this task is available at:

- Youtube: https://www.youtube.com/playlist?list=PLYV5R7hVcs-Bz2XleLEfGcrLGm9TSY_yt
- Youku: http://list.youku.com/albumlist/show/id_52339612.html

Procedure

- Step 1. If the server is installed in a rack, extend the server from the rack.
- Step 2. Remove the top cover. See “Remove the top cover” on page 392.
- Step 3. Remove the intrusion switch assembly from the fan cage as shown.

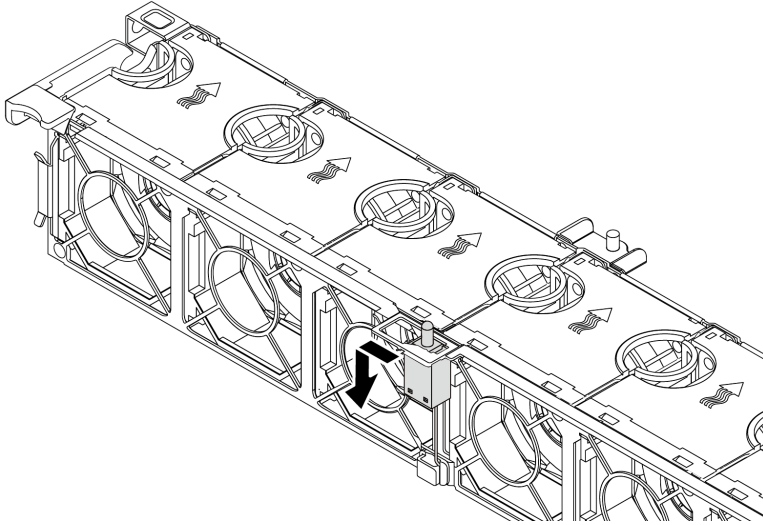

Figure 89. Intrusion switch removal

- Step 4. Remove the fan cage from the system board. See “Remove the system fan cage” on page 387.
- Step 5. Disconnect the cable of the intrusion switch from the system board.

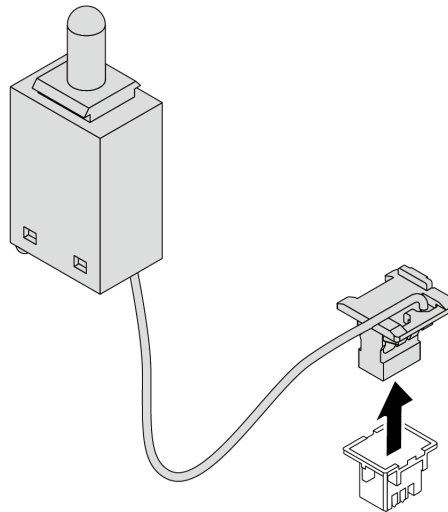

Figure 90. Intrusion switch cable disconnection

After you finish

If you are instructed to return the old intrusion switch, follow all of the packaging instructions and use any packaging materials that are provided.

Install the intrusion switch

Use this information to install the intrusion switch.

About this task

- Read “Installation Guidelines” on page 129 to ensure that you work safely.
- Power off the server and disconnect all power cords for this task.
- Prevent exposure to static electricity, which might lead to system halt and loss of data, by keeping static-sensitive components in their static-protective packages until installation, and handling these devices with an electrostatic-discharge wrist strap or other grounding system.

A video for this task is available at:

- Youtube: https://www.youtube.com/playlist?list=PLYV5R7hVcs-Bz2XleLEfGcrLGm9TSY_yt
- Youku: http://list.youku.com/albumlist/show/id_52339612.html

Procedure

- Step 1. Touch the static-protective package that contains the new intrusion switch to any unpainted surface on the outside of the server. Then, take the new intrusion switch out of the package and place them on a static-protective surface.
- Step 2. Connect the intrusion switch cable to the system board. See “System board components” on page 43.

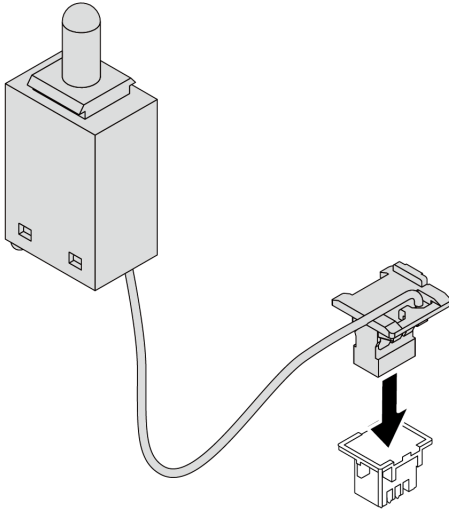

Figure 91. Intrusion switch connection

- Step 3. Insert the intrusion switch into the intrusion switch bracket on the fan cage and push it in the direction as shown until it is fully seated.

Note: Ensure that the intrusion switch cable is routed through the cable clip on the fan cage.

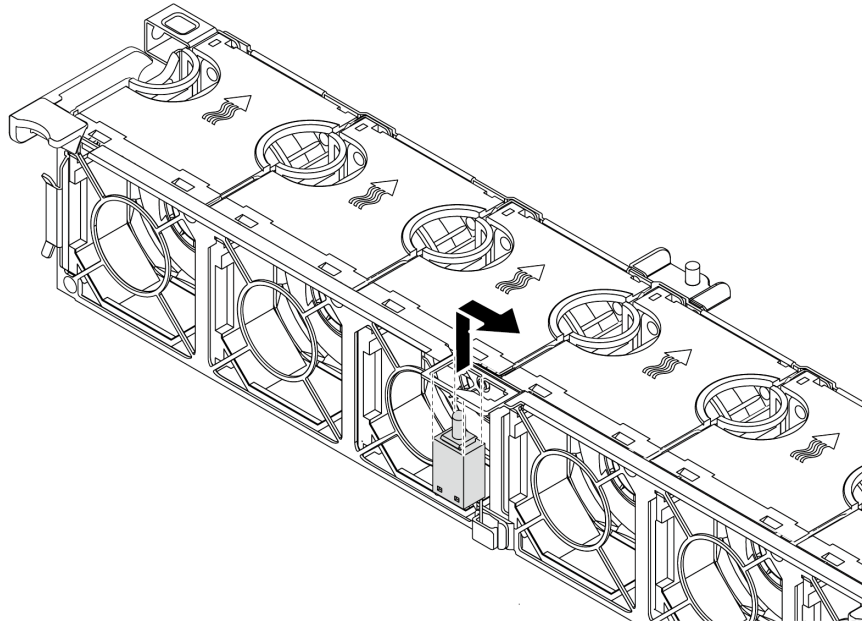

Figure 92. Intrusion switch installation

After you finish

Complete the parts replacement. See “Complete the parts replacement” on page 397.

M.2 adapter and M.2 drive replacement

Use this information to remove and install the M.2 adapter and M.2 drive.

- “Remove the M.2 adapter and M.2 drive” on page 234
- “Adjust the retainer on the M.2 adapter” on page 237
- “Install the M.2 adapter and M.2 drive” on page 239

Remove the M.2 adapter and M.2 drive

Use this information to remove the M.2 adapter and M.2 drive.

About this task

Attention:

- Read “Installation Guidelines” on page 129 to ensure that you work safely.
- Power off the server and disconnect all power cords for this task.
- Prevent exposure to static electricity, which might lead to system halt and loss of data, by keeping static-sensitive components in their static-protective packages until installation, and handling these devices with an electrostatic-discharge wrist strap or other grounding system.

A video for this task is available at:

- Youtube: https://www.youtube.com/playlist?list=PLYV5R7hVcs-Bz2XleLEfGcrLGm9TSY_yt
- Youku: http://list.youku.com/albumlist/show/id_52339612.html

Procedure

Note: The M.2 adapter you want to remove might be different from the following illustrations, but the removal method is the same.

- Step 1. Remove the top cover. See “Remove the top cover” on page 392.
- Step 2. Disconnect the cables from the system board.
- Step 3. Remove the M.2 drive from the M.2 adapter.

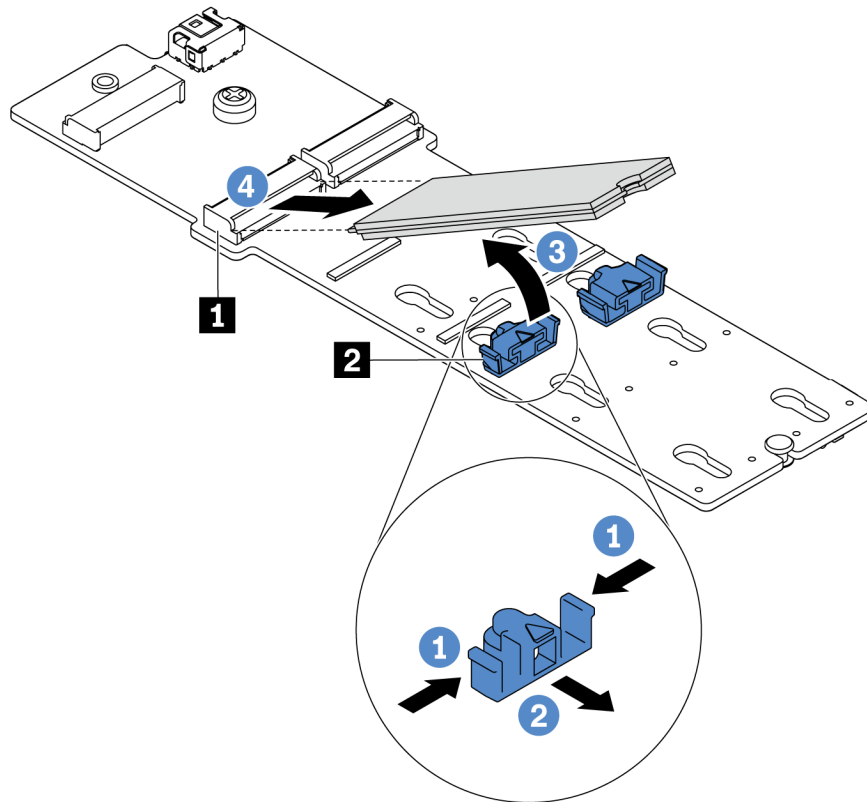

Figure 93. M.2 drive removal

- a. Press both sides of the retainer **2**.
- b. Slide the retainer backward to loosen the M.2 drive from the M.2 adapter.
- c. Rotate the M.2 drive away from the M.2 adapter.
- d. Pull the M.2 drive away from the connector **1** at an angle of approximately 30 degrees.

Step 4. Remove the M.2 adapter.

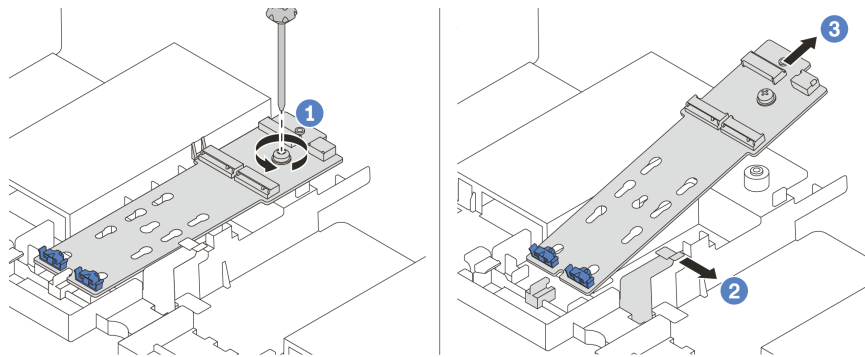

Figure 94. M.2 adapter removal

- a. Loosen the screw and remove the M.2 adapter from the bracket.
- b. Open the retainer clip on the air baffle.
- c. Remove the M.2 adapter from the air baffle.

Adjust the retainer on the M.2 adapter

Use this information to adjust the retainer on the M.2 adapter.

Attention:

- Read “Installation Guidelines” on page 129 to ensure that you work safely.
- Power off the server and disconnect all power cords for this task.
- Prevent exposure to static electricity, which might lead to system halt and loss of data, by keeping static-sensitive components in their static-protective packages until installation, and handling these devices with an electrostatic-discharge wrist strap or other grounding system.

A video for this task is available at:

- Youtube: https://www.youtube.com/playlist?list=PLYV5R7hVcs-Bz2XIeLEfGcrLGm9TSY_yt
- Youku: http://list.youku.com/albumlist/show/id_52339612.html

Procedure

- Step 1. Locate the correct keyhole that the retainer should be installed into to accommodate the particular size of the M.2 drive you wish to install.
- Step 2. Adjust the M.2 retainer.

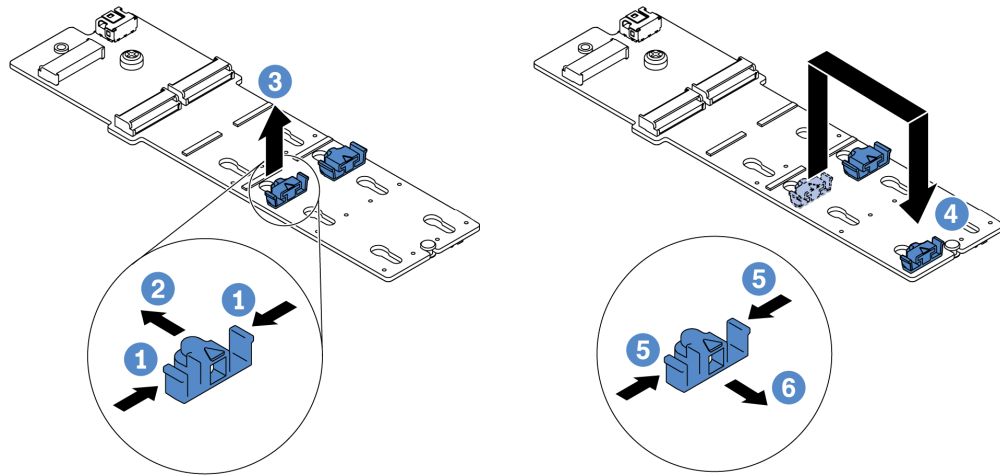

Figure 95. M.2 retainer adjustment

- a. Press both sides of the retainer.
- b. Move the retainer forward until it is in the large opening of the keyhole.
- c. Take the retainer out of the keyhole.
- d. Insert the retainer into the correct keyhole.
- e. Press both sides of the retainer.
- f. Slide the retainer backwards (toward the small opening of the keyhole) until it is seated in place.

Install the M.2 adapter and M.2 drive

Use this information to install the M.2 adapter and M.2 drive.

Attention:

- Read “Installation Guidelines” on page 129 to ensure that you work safely.
- Power off the server and disconnect all power cords for this task.
- Prevent exposure to static electricity, which might lead to system halt and loss of data, by keeping static-sensitive components in their static-protective packages until installation, and handling these devices with an electrostatic-discharge wrist strap or other grounding system.

A video for this task is available at:

- Youtube: https://www.youtube.com/playlist?list=PLYV5R7hVcs-Bz2XleLEfGcrLGm9TSY_yt
- Youku: http://list.youku.com/albumlist/show/id_52339612.html

Procedure

Step 1. Touch the static-protective package that contains the new M.2 adapter and M.2 drive to any unpainted surface on the outside of the server. Then, take the new M.2 adapter and M.2 drive out of the package and place them on a static-protective surface.

Notes:

- The M.2 adapter is shipped with a loose screw, but the screw is not necessarily used for the installation.
- The M.2 adapter you want to install might be different from the following illustrations, but the installation method is the same.

Step 2. Adjust the retainer on the M.2 adapter to accommodate the particular size of the M.2 drive you wish to install. See “Adjust the retainer on the M.2 adapter” on page 237.

Step 3. Locate the connector on the M.2 adapter.

Note: Some M.2 adapters support two identical M.2 drives. Install the M.2 drive in slot 0 first.

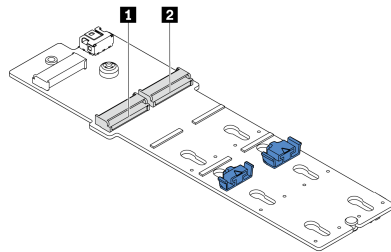

- 1** Slot 0
- 2** Slot 1

Figure 96. M.2 drive slot

Step 4. Install the M.2 adapter into the M.2 tray.

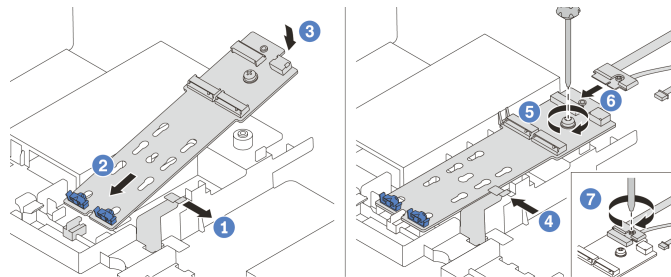

Figure 97. M.2 adapter installation

- a. Open the retention clip on the air baffle.
- b. Insert the M.2 adapter at an angle of approximately 30 degrees into the tray as shown.
- c. Rotate the M.2 adapter downward until it snaps into place.

Step 5. Install the M.2 drive on the M.2 adapter.

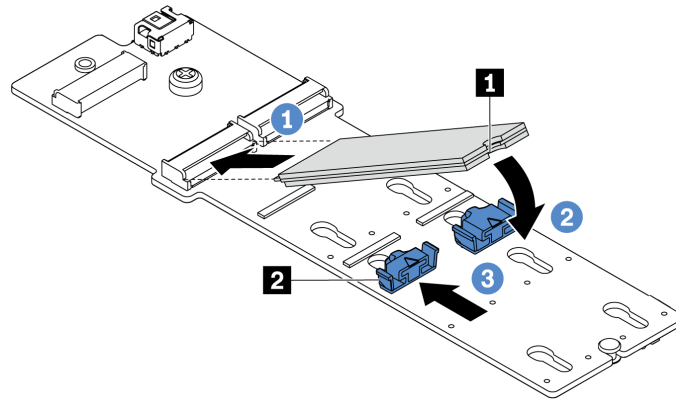

Figure 98. M.2 drive installation

- Insert the M.2 drive at an angle of approximately 30 degrees into the connector.
- Rotate the M.2 drive down until the notch **1** catches on the lip of the retainer **2**.
- Slide the retainer forward (toward the connector) to secure the M.2 drive into place.

Step 6. Connect the cables to the system board. See “M.2 drives” on page 65.

After you finish

Use the Lenovo XClarity Provisioning Manager to configure the RAID. For more information, see: https://sysmgmt.lenovofiles.com/help/topic/LXPMv3/LXPMv3_introduction.html.

Middle drive cage replacement

Use this information to remove and install the middle 2.5-inch or 3.5-inch drive cage.

- “Remove the middle 2.5-inch drive cage” on page 242
- “Install the middle 2.5-inch drive cage” on page 244
- “Remove the middle 3.5-inch drive cage” on page 246
- “Install the middle 3.5-inch drive cage” on page 249

Remove the middle 2.5-inch drive cage

Use this information to remove the middle 2.5-inch drive cage.

About this task

Attention:

- Read “Installation Guidelines” on page 129 to ensure that you work safely.
- Power off the server and disconnect all power cords for this task.
- Prevent exposure to static electricity, which might lead to system halt and loss of data, by keeping static-sensitive components in their static-protective packages until installation, and handling these devices with an electrostatic-discharge wrist strap or other grounding system.

A video for this task is available at:

- Youtube: https://www.youtube.com/playlist?list=PLYV5R7hVcs-Bz2XIeLEfGcrLGm9TSY_yt
- Youku: http://list.youku.com/albumlist/show/id_52339612.html

Procedure

Step 1. Prepare your server.

- Remove the top cover. See “Remove the top cover” on page 392.
- Remove the system fan cage for easier operation. See “Remove the system fan cage” on page 387.
- Disconnect cables from the middle drive cage.
- Remove all the installed drives and fillers (if any) from the drive bays. See “Remove a hot-swap drive” on page 176.

Step 2. Rotate the handle to open it. Then remove the drives from the drive cage.

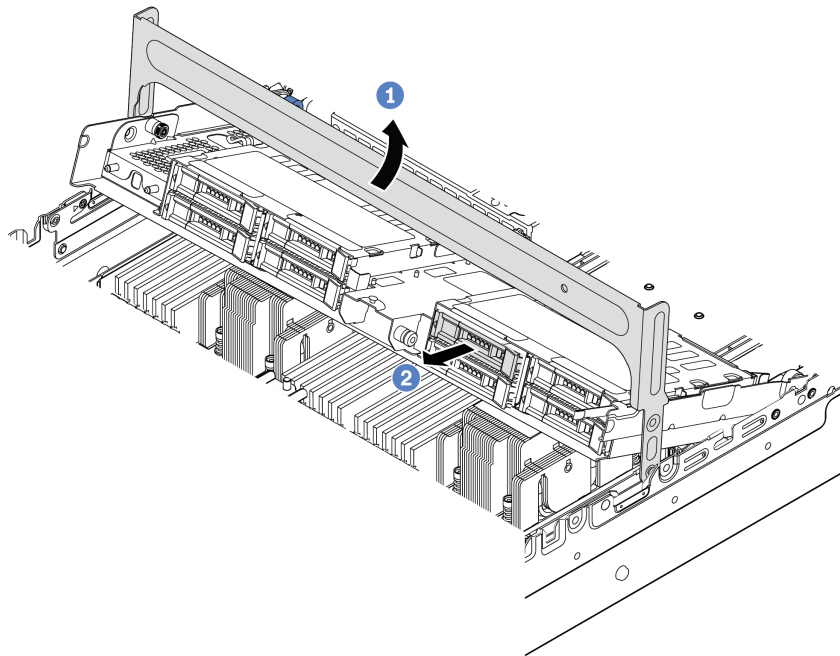

Figure 99. Opening the drive cage handle and removing the drives

Step 3. Pull and twist plunger pins and carefully lift the middle rear cage upward to release it from the chassis.

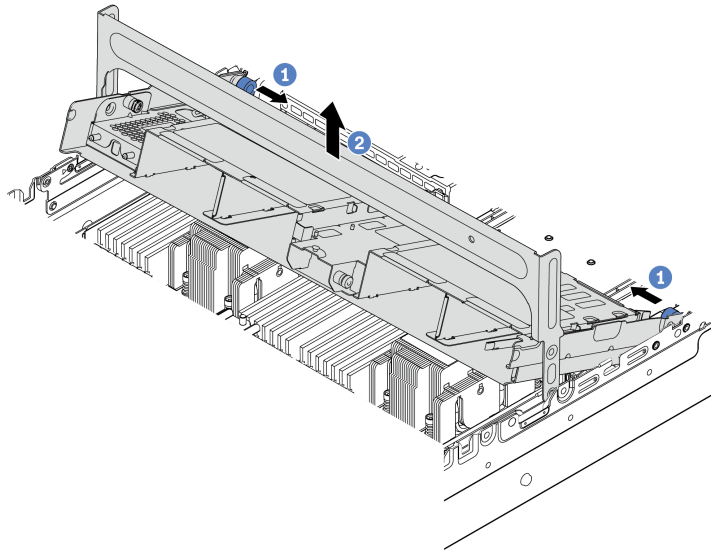

Figure 100. Removing the middle 2.5-inch drive cage

Step 4. Press the latch as shown and close the handle.

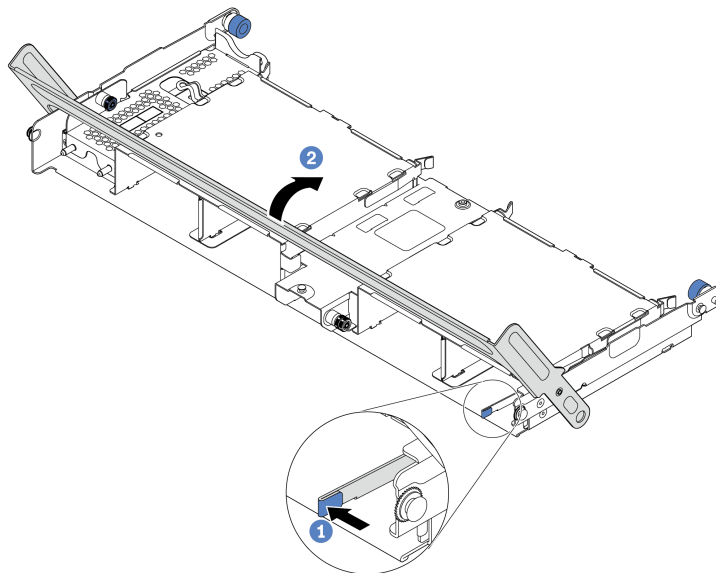

Figure 101. Closing the handle for the middle 2.5-inch drive cage

After you finish

If you are instructed to return the old drive cage, follow all packaging instructions and use any packaging materials that are provided.

Install the middle 2.5-inch drive cage

Use this information to install the middle 2.5-inch drive cage.

About this task

The middle drive cage is supported on some server models at certain conditions. For detailed information, see “Drive bay configurations and requirements” on page 139.

Attention:

- Read “Installation Guidelines” on page 129 to ensure that you work safely.
- Prevent exposure to static electricity, which might lead to system halt and loss of data, by keeping static-sensitive components in their static-protective packages until installation, and handling these devices with an electrostatic-discharge wrist strap or other grounding system.

A video for this task is available at:

- Youtube: https://www.youtube.com/playlist?list=PLYV5R7hVcs-Bz2XIeLEfGcrLGm9TSY_yt
- Youku: http://list.youku.com/albumlist/show/id_52339612.html

Procedure

Step 1. Connect cables to the backplane.

Step 2. Align the bottom of the backplane with the studs at the bottom of the drive cage. Rotate the backplane to vertical position so that the holes in the backplane pass through the pins on the drive cage, and press the backplane into position. The release latches will secure the backplane in place.

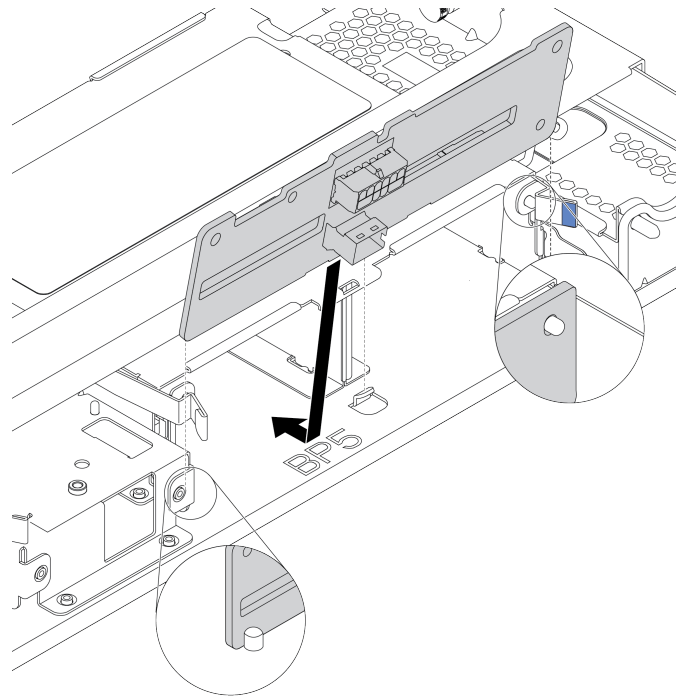

Figure 102. Installing the backplane

Step 3. Install the middle drive cage onto chassis and drives into drive bays. Then close the handle.

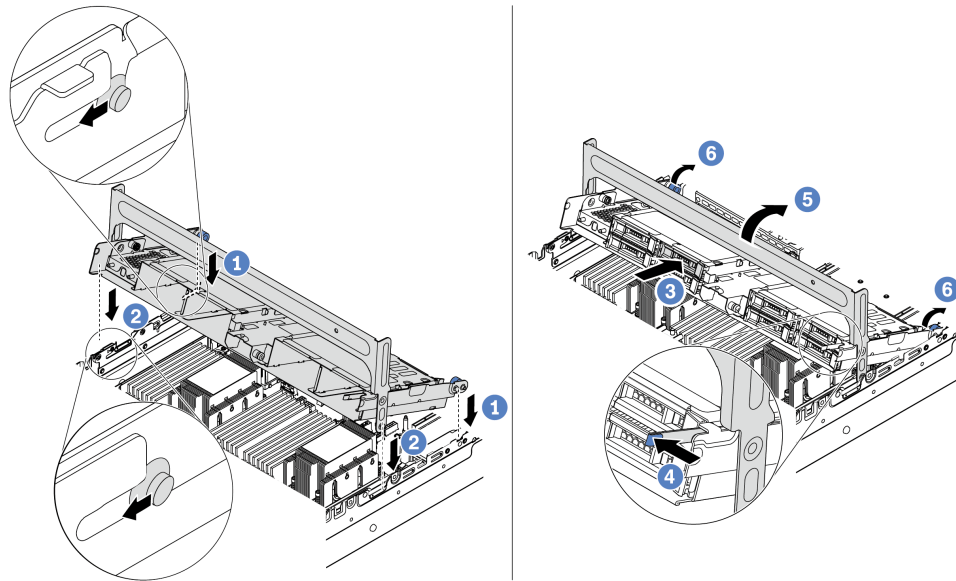

Figure 103. Installing the middle 2.5-inch drive cage and drives

1. Put the rear pins into the chassis slots.
2. Rotate the front of the drive cage down into place.
3. Install drives into the middle drive cage. See “” on page .
4. Press the latch as shown.
5. Rotate the handle to close it.

Step 4. Connect cables from the backplanes to a RAID/HBA adapter. See Chapter 3 “Internal cable routing” on page 57.

After you finish

1. Connect cables from the backplanes to a RAID/HBA adapter. See Chapter 3 “Internal cable routing” on page 57.
2. Complete the parts replacement. See “Complete the parts replacement” on page 397.

Remove the middle 3.5-inch drive cage

Use this information to remove the middle 3.5-inch drive cage.

About this task

Attention:

- Read “Installation Guidelines” on page 129 to ensure that you work safely.
- Power off the server and disconnect all power cords for this task.
- Prevent exposure to static electricity, which might lead to system halt and loss of data, by keeping static-sensitive components in their static-protective packages until installation, and handling these devices with an electrostatic-discharge wrist strap or other grounding system.

A video for this task is available at:

- Youtube: https://www.youtube.com/playlist?list=PLYV5R7hVcs-Bz2XleLEfGcrLGm9TSY_yt
- Youku: http://list.youku.com/albumlist/show/id_52339612.html

Procedure

Step 1. Prepare your server.

- Remove the top cover. See “Remove the top cover” on page 392.
- Remove the system fan cage for easier operation. See “Remove the system fan cage” on page 387.
- Disconnect cables from the middle drive cage.
- Remove all the installed drives and fillers (if any) from the drive bays. See “Remove a hot-swap drive” on page 176.

Step 2. Rotate the handle to open it. Then removing the drives from the drive cage.

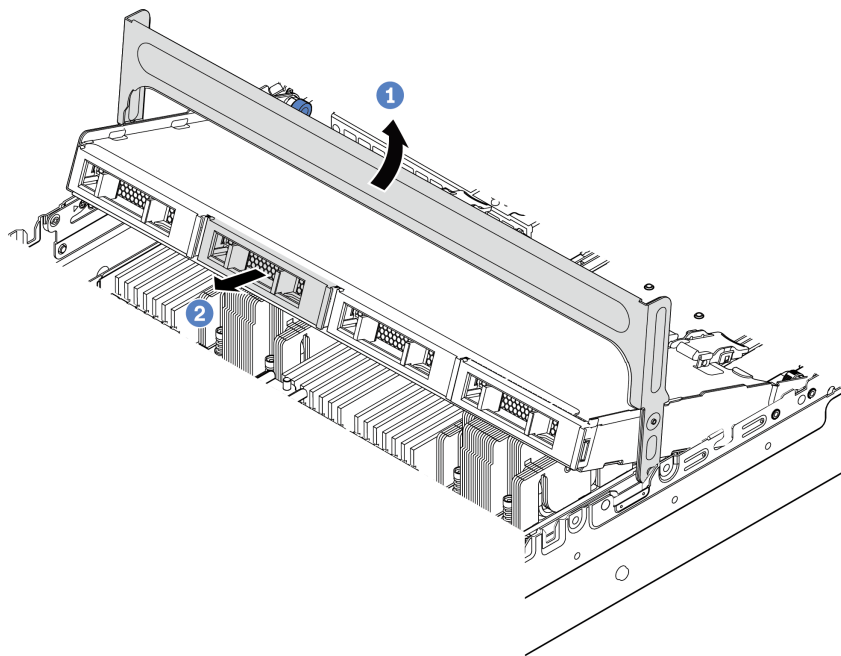

Figure 104. Opening the drive cage handle and removing the drives

Step 3. Pull and twist plunger pins and carefully lift the middle rear cage upward to release it from the chassis.

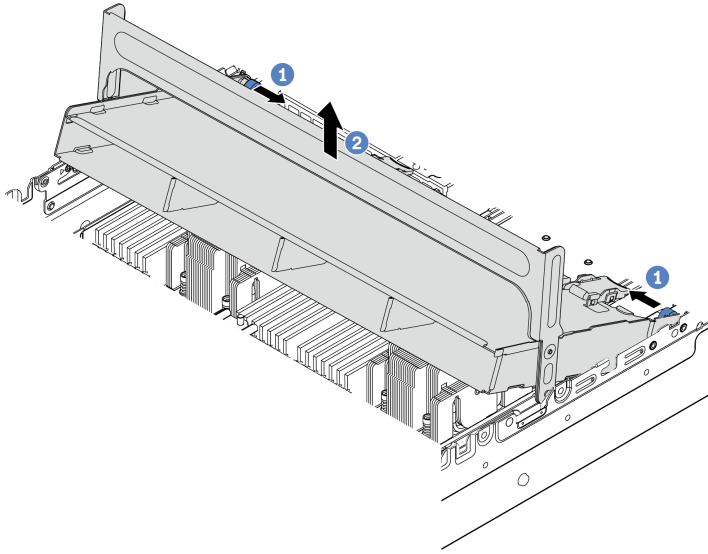

Figure 105. Removing the middle 3.5-inch drive cage

Step 4. Press the latch as shown and close the handle.

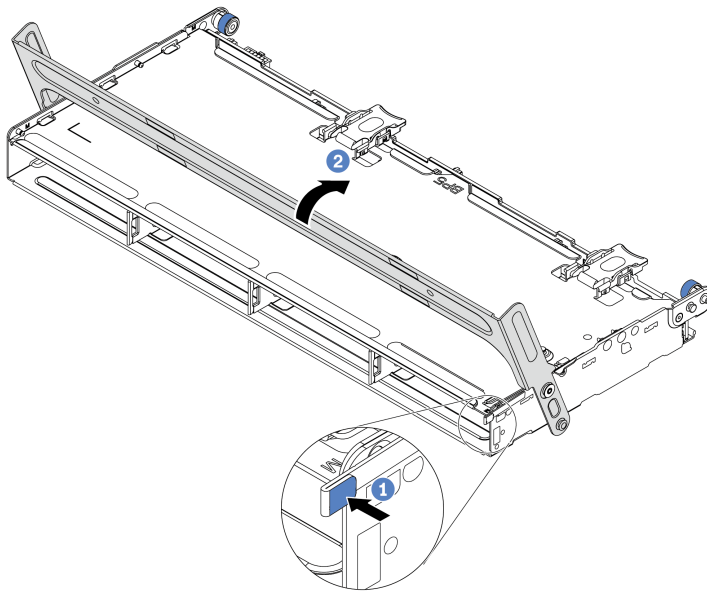

Figure 106. Closing the handle for the middle 3.5-inch drive cage

After you finish

If you are instructed to return the old drive cage, follow all packaging instructions and use any packaging materials that are provided.

Install the middle 3.5-inch drive cage

Use this information to install the middle 3.5-inch drive cage.

About this task

The middle drive cage is supported on some server models at certain conditions. For detailed information, see “Drive bay configurations and requirements” on page 139.

Attention:

- Read “Installation Guidelines” on page 129 to ensure that you work safely.
- Prevent exposure to static electricity, which might lead to system halt and loss of data, by keeping static-sensitive components in their static-protective packages until installation, and handling these devices with an electrostatic-discharge wrist strap or other grounding system.

A video for this task is available at:

- Youtube: https://www.youtube.com/playlist?list=PLYV5R7hVcs-Bz2XIeLEfGcrLGm9TSY_yt
- Youku: http://list.youku.com/albumlist/show/id_52339612.html

Procedure

Step 1. Connect cables to the backplane.

Step 2. Align the bottom of the backplane with the studs at the bottom of the drive cage. Rotate the backplane to vertical position so that the holes in the backplane pass through the pins on the drive cage, and press the backplane into position. The release latches will secure the backplane in place.

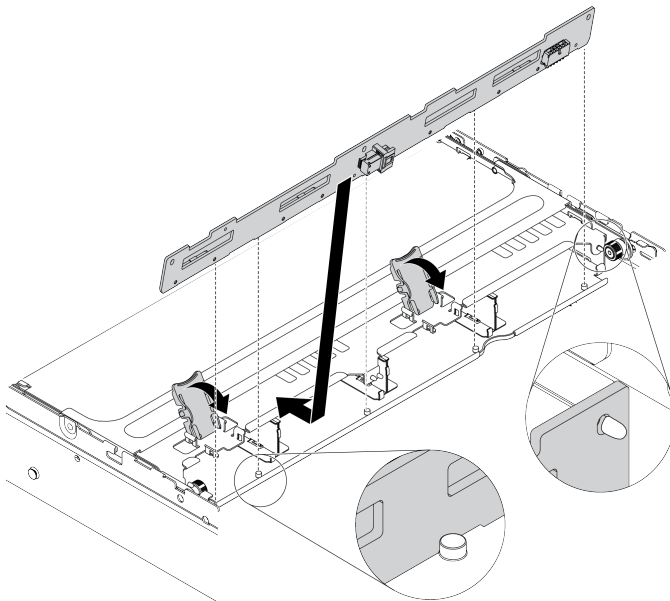

Figure 107. Installing the backplane

Step 3. Install the middle drive cage onto chassis and drives into the drive bays. Then close the handle.

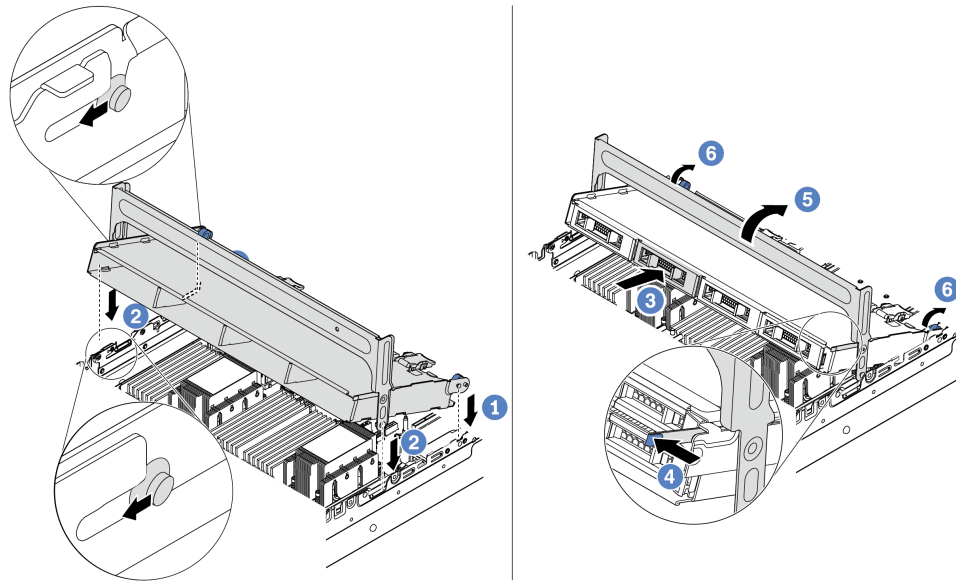

Figure 108. Installing the middle 3.5-inch drive cage and drives

1. Put the rear pins into the chassis slots.
2. Rotate the front of the drive cage down into place.
3. Install drives into the middle drive cage. See “” on page .
4. Press the latch as shown.
5. Rotate the handle to close it.

After you finish

1. Connect cables from the backplanes to a RAID/HBA adapter. See Chapter 3 “Internal cable routing” on page 57.
2. Complete the parts replacement. See “Complete the parts replacement” on page 397.

Memory module replacement

Use this information to remove and install a memory module.

- “Remove a memory module” on page 252
- “Memory module installation rules” on page 254
- “Install a memory module” on page 255

Remove a memory module

Use this information to remove a memory module.

About this task

Attention:

- Read “Installation Guidelines” on page 129 to ensure that you work safely.
- Power off the server and disconnect all power cords for this task.
- Memory modules are sensitive to static discharge and require special handling. Refer to the standard guidelines for “Handling static-sensitive devices” on page 131.
 - Always wear an electrostatic-discharge strap when removing or installing memory modules. Electrostatic-discharge gloves can also be used.
 - Never hold two or more memory modules together so that they touch. Do not stack memory modules directly on top of each other during storage.
 - Never touch the gold memory module connector contacts or allow these contacts to touch the outside of the memory module connector housing.
 - Handle memory modules with care: never bend, twist, or drop a memory module.
 - Do not use any metal tools (such as jigs or clamps) to handle the memory modules, because the rigid metals may damage the memory modules.
 - Do not insert memory modules while holding packages or passive components, which can cause package cracks or detachment of passive components by the high insertion force.

A video for this task is available at:

- Youtube: https://www.youtube.com/playlist?list=PLYV5R7hVcs-Bz2XleLEfGcrLGm9TSY_yt
- Youku: http://list.youku.com/albumlist/show/id_52339612.html

Procedure

- Step 1. Remove the top cover. See “Remove the top cover” on page 392.
- Step 2. If your server comes with an air baffle, remove it. See “Remove the air baffle” on page 149.
- Step 3. Remove the memory module from the slot.

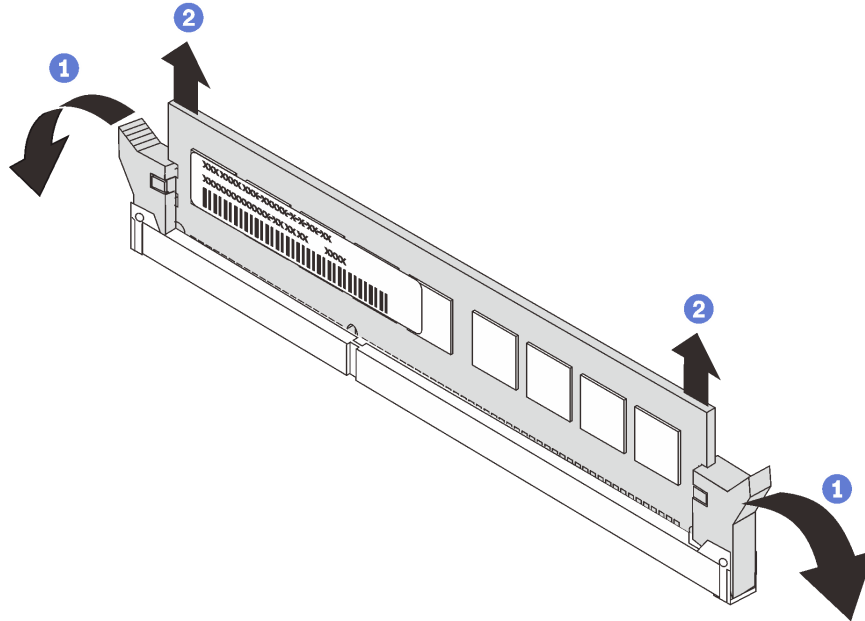

Figure 109. Memory module removal

- a. Open the retaining clip on each end of the memory module slot.

Attention: To avoid breaking the retaining clips or damaging the memory module slots, handle the clips gently.

- b. Grasp the memory module at both ends and carefully lift it out of the slot.

After you finish

1. Install a memory module filler or a new memory module to cover the slot. See “Install a memory module” on page 255.
2. If you are instructed to return the old memory module, follow all packaging instructions and use any packaging materials that are provided.

Memory module installation rules

Memory modules must be installed in a specific sequence based on the memory configuration that you implement on your server. Understanding the technical rules for DIMMs helps you install the correct DIMMs in the correct sequence.

Your server has 8 channels, 32 memory slots, and supports:

- Minimum capacity:
 - 16 GB using RDIMMs
 - 128 GB using 3DS RDIMMs
- Maximum capacity:
 - 2 TB using RDIMMs
 - 4 TB using 3DS RDIMMs
- Type (depending on the model): TruDDR4 3200, dual-rank, 16 GB/32 GB/64 GB RDIMM
For a list of supported memory options, see: <https://static.lenovo.com/us/en/serverproven/index.shtml>

Note: The operating speed and total memory capacity depend on the processor model and UEFI settings.

The following figure and table help you locate the memory slots and channels on the system board.

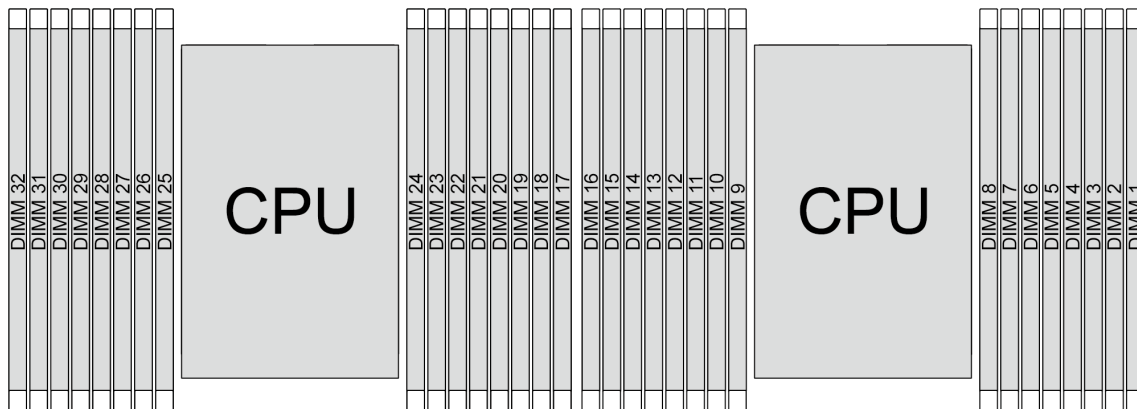

Figure 110. Memory module locations

Table 30. Memory slot and channel identification

Channel	D1	D0	C1	C0	B1	B0	A1	A0	E0	E1	F0	F1	G0	G1	H0	H1
Slot number	16	15	14	13	12	11	10	9	8	7	6	5	4	3	2	1
	32	31	30	29	28	27	26	25	24	23	22	21	20	19	18	17

Rules you need to follow when installing or replacing a DIMM.

- **Slot:**
 - When a **data bus daisy chain topology** is used: populate DIMMs **from farthest slot (slot 1) to closest slot (slot 0) to the processor** on a per-channel basis.
 - When a **data bus balanced tee route topology** is used: populate DIMMs **in either slot** on a per-channel basis.

Table 31. DIMM installation sequence

Number of processor	Slot sequence
With one processor	14, 16, 3, 1, 10, 12, 7, 5, 13, 15, 4, 2, 9, 11, 8, 6
With two processors	14, 30, 16, 32, 3, 19, 1, 17, 10, 26, 12, 28, 7, 23, 5, 21, 13, 29, 15, 31, 4, 20, 2, 18, 9, 25, 11, 27, 8, 24, 6, 22

- **Capacity:**
DIMMs with different capacities (only two different capacities) **can be mixed**, install the one with **the highest capacity first**.
- **Rank:**
DIMMs with different ranks **can be mixed**, install the one with **the highest rank first**.
- **Frequency:**
DIMMs with different frequencies **can be mixed** in the same channel.
- **Voltage:**
DIMMs with different operating voltage **cannot be mixed**. (The only supported DIMM voltage is 1.2V.)
- **ECC/Non-ECC:**
ECC and non-ECC DIMM **cannot be mixed**. (Non-ECC DIMM is not supported for the server.)
- **DRAM:**
x4 and x8 DRAM based DIMMs **can be mixed**, but **not in the same channel**.
- **Type:**
DIMMs of different base module types **can be mixed**, but **not in the same channel**.
- **Vendor:**
DIMMs from different vendors **can be mixed** in the same channel.

Install a memory module

Use this information to install a memory module.

About this task

Attention:

- Read “Installation Guidelines” on page 129 to ensure that you work safely.
- Power off the server and disconnect all power cords for this task.
- Memory modules are sensitive to static discharge and require special handling. Refer to the standard guidelines for “Handling static-sensitive devices” on page 131:
 - Always wear an electrostatic-discharge strap when removing or installing memory modules. Electrostatic-discharge gloves can also be used.
 - Never hold two or more memory modules together so that they do not touch each other. Do not stack memory modules directly on top of each other during storage.
 - Never touch the gold memory module connector contacts or allow these contacts to touch the outside of the memory module connector housing.
 - Handle memory modules with care: never bend, twist, or drop a memory module.
 - Do not use any metal tools (such as jigs or clamps) to handle the memory modules, because the rigid metals may damage the memory modules.
 - Do not insert memory modules while holding packages or passive components, which can cause package cracks or detachment of passive components by the high insertion force.

A video for this task is available at:

- Youtube: https://www.youtube.com/playlist?list=PLYV5R7hVcs-Bz2XleLEfGcrLGm9TSY_yt
- Youku: http://list.youku.com/albumlist/show/id_52339612.html

Procedure

Step 1. Touch the static-protective package that contains the memory module to any unpainted surface on the outside of the server. Then, take the memory module out of the package and place it on a static-protective surface.

Step 2. Locate the required memory module slot on the system board.

Note: Ensure that you observe the installation rules and sequence in “Memory module installation rules” on page 254.

Step 3. Install the memory module into the slot.

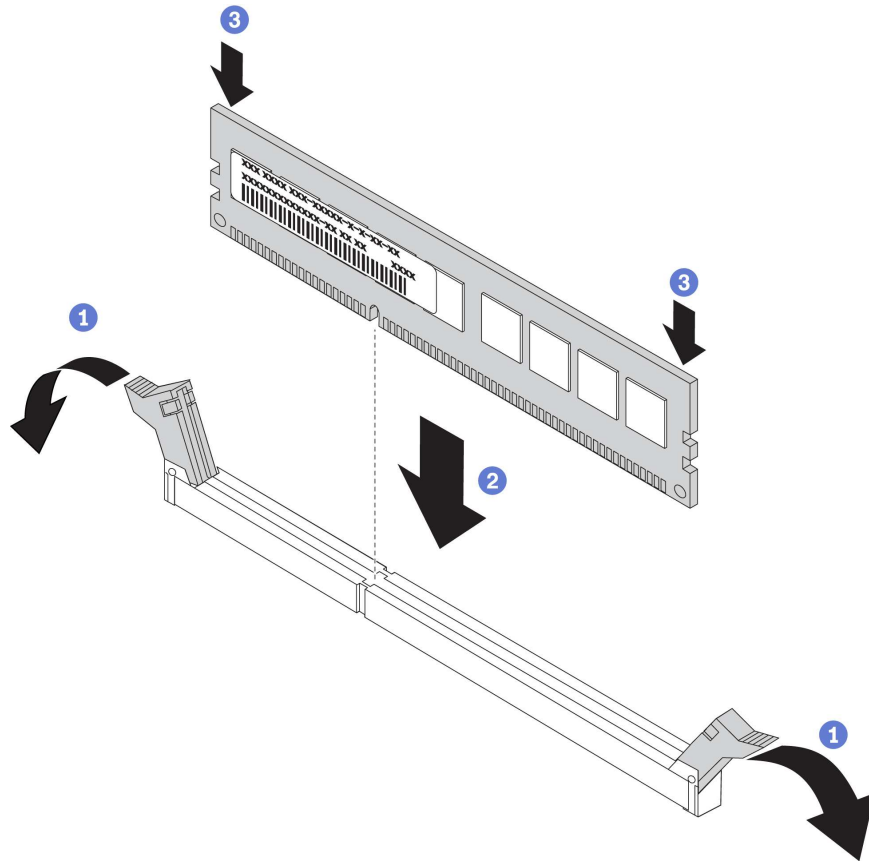

Figure 111. Memory module installation

a. Open the retaining clip on each end of the memory module slot.

Attention: To avoid breaking the retaining clips or damaging the memory module slots, open and close the clips gently.

b. Align the memory module with the slot, and gently place the memory module on the slot with both hands.

c. Firmly press both ends of the memory module straight down into the slot until the retaining clips snap into the locked position.

Note: If there is a gap between the memory module and the retaining clips, the memory module has not been correctly inserted. In this case, open the retaining clips, remove the memory module, and then reinsert it.

After you finish

Complete the parts replacement. See “Complete the parts replacement” on page 397.

OCP 3.0 Ethernet adapter replacement

Use this information to remove and install the OCP 3.0 Ethernet adapter.

- “Remove the OCP 3.0 Ethernet adapter” on page 260
- “Install the OCP 3.0 Ethernet adapter” on page 262

Remove the OCP 3.0 Ethernet adapter

Use this information to remove the OCP 3.0 Ethernet adapter.

About this task

CAUTION:

Make sure that all server power cords are disconnected from their power sources before performing this procedure.

Attention:

- Read “Installation Guidelines” on page 129 to ensure that you work safely.
- Power off the server and disconnect all power cords for this task.
- Prevent exposure to static electricity, which might lead to system halt and loss of data, by keeping static-sensitive components in their static-protective packages until installation, and handling these devices with an electrostatic-discharge wrist strap or other grounding system.

A video for this task is available at:

- Youtube: https://www.youtube.com/playlist?list=PLYV5R7hVcs-Bz2XleLEfGcrLGm9TSY_yt
- Youku: http://list.youku.com/albumlist/show/id_52339612.html

Procedure

Step 1. Remove the OCP 3.0 Ethernet adapter.

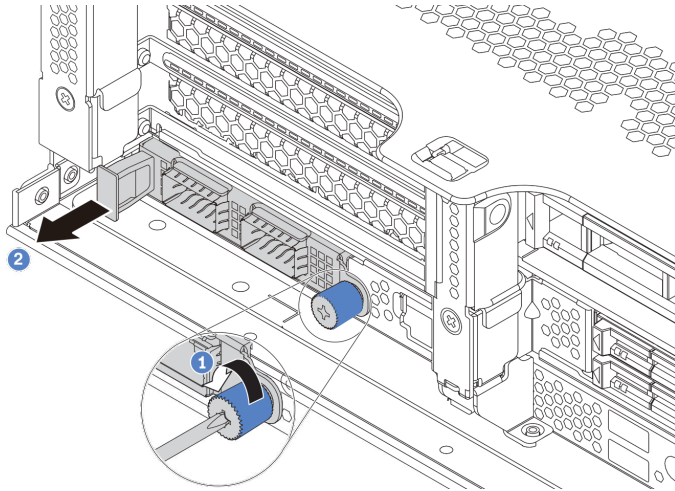

Figure 112. OCP 3.0 Ethernet adapter removal

1. Loosen the thumbscrew that secures the card.
2. Pull out the OCP 3.0 Ethernet adapter.

Step 2. Remove the OCP label.

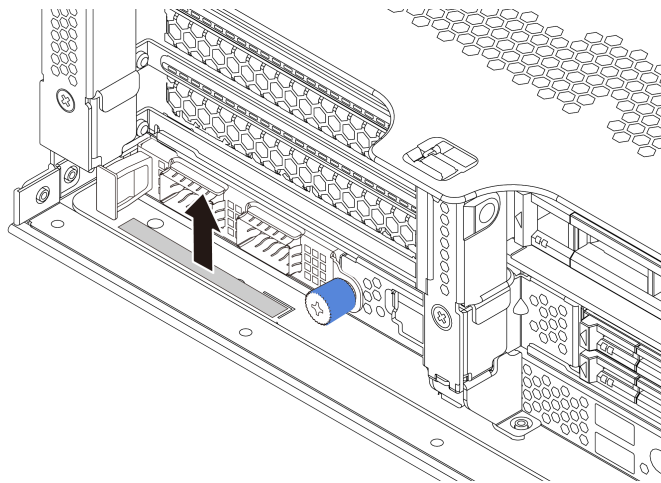

Figure 113. OCP label removal

After you finish

Reinstall a new OCP 3.0 Ethernet adapter or a card filler.

Install the OCP 3.0 Ethernet adapter

Use this information to install the OCP 3.0 Ethernet adapter.

About this task

CAUTION:

Make sure that all server power cords are disconnected from their power sources before performing this procedure.

Attention:

- Read “Installation Guidelines” on page 129 to ensure that you work safely.
- Power off the server and disconnect all power cords for this task.
- Prevent exposure to static electricity, which might lead to system halt and loss of data, by keeping static-sensitive components in their static-protective packages until installation, and handling these devices with an electrostatic-discharge wrist strap or other grounding system.

A video for this task is available at:

- Youtube: https://www.youtube.com/playlist?list=PLYV5R7hVcs-Bz2XleLEfGcrLGm9TSY_yt
- Youku: http://list.youku.com/albumlist/show/id_52339612.html

Procedure

- Step 1. Touch the static-protective package that contains the new OCP 3.0 Ethernet adapter to any unpainted surface on the outside of the server. Then, take the new OCP 3.0 Ethernet adapter out of the package and place it on a static-protective surface.
- Step 2. Remove the OCP 3.0 Ethernet adapter filler if there is.
- Step 3. Install the OCP 3.0 Ethernet adapter.

Notes:

- Ensure that the Ethernet adapter is fully seated and the thumbscrew is securely tightened. Otherwise, the OCP 3.0 Ethernet adapter will not get full connection and may not function.
- If there is an OCP 3.0 Ethernet adapter installed, when the system is powered off but still plugged in to AC power, system fans will continue to spin at a much lower speed. This is the system design to provide proper cooling for the OCP 3.0 Ethernet adapter.

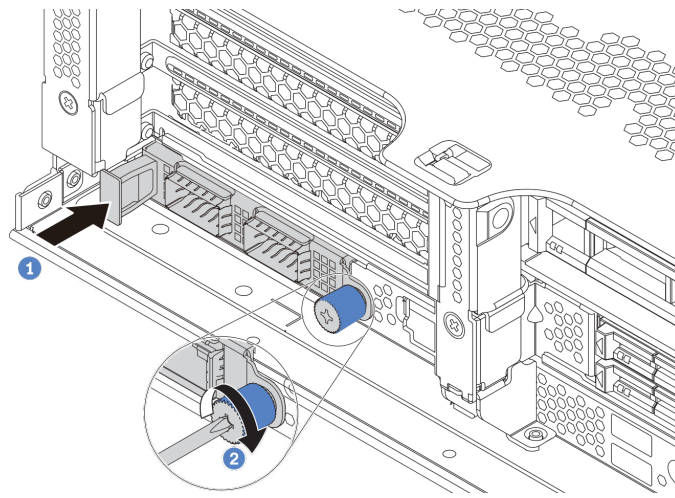

Figure 114. OCP 3.0 Ethernet adapter installation

- a. Push the OCP 3.0 Ethernet adapter as shown to insert it into the connector on the system board.
 - b. Tighten the thumbscrew to secure the card.
- Step 4. Attach the OCP label to the rear of the server.

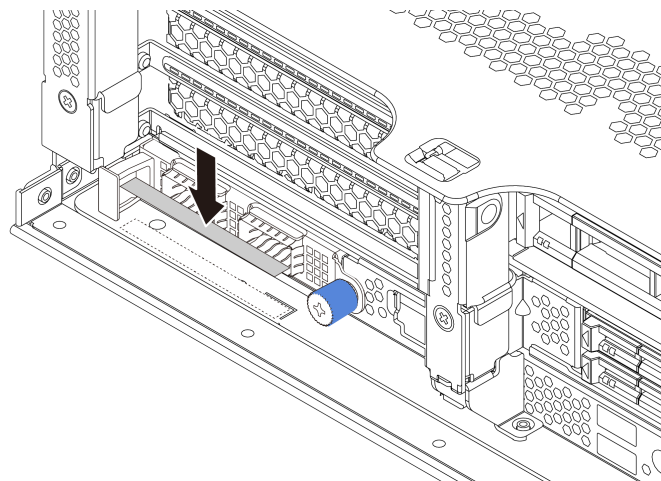

Figure 115. Attaching the OCP label

Step 5. Connect the cables to the OCP 3.0 Ethernet adapter.

After you finish

Complete the parts replacement. See “Complete the parts replacement” on page 397.

Processor and heat sink replacement

Use this information to remove and install a processor and heat sink.

The server supports the second-generation AMD® EPYC™ family of processors.

The server supports three types of heat sinks. Depending on the specific type, the heat sink on your server might be different from that shown in the illustrations. For detailed information on heat sink selection, see “Technical rules for processor and heat sink” on page 135.

CAUTION:

Make sure that all server power cords are disconnected from their power sources before performing this procedure.

Attention:

- Each processor socket must always contain a cover or a processor and heat sink. When removing or installing a processor and heat sink, protect empty processor sockets with a cover.
- Do not touch the processor socket or processor contacts. Processor-socket contacts are very fragile and easily damaged. Contaminants on the processor contacts, such as oil from your skin, can cause connection failures.
- Do not allow the thermal grease on the processor or heat sink to come in contact with anything. Contact with any surface can compromise the thermal grease, rendering it ineffective. Thermal grease can damage components, such as electrical connectors in the processor socket. Do not remove the grease cover from a heat sink until you are instructed to do so.
- “Remove a heat sink” on page 266
- “Remove a processor” on page 269
- “Install a processor” on page 271
- “Install a heat sink” on page 273

Remove a heat sink

Use this information to remove a heat sink.

About this task

Attention:

- Read “Installation Guidelines” on page 129 to ensure that you work safely.
- Power off the server and disconnect all power cords for this task.
- Prevent exposure to static electricity, which might lead to system halt and loss of data, by keeping static-sensitive components in their static-protective packages until installation, and handling these devices with an electrostatic-discharge wrist strap or other grounding system.

A video for this task is available at:

- Youtube: https://www.youtube.com/playlist?list=PLYV5R7hVcs-Bz2XleLEfGcrLGm9TSY_yt
- Youku: http://list.youku.com/albumlist/show/id_52339612.html

Procedure

Notes:

- It may take some time for the heat sink to cool down after the system has been powered down.
- The heat sink is necessary to maintain proper thermal conditions for the processor. Do not power on the server with the heat sink removed.

Step 1. Prepare your server.

1. Remove the top cover. See “Remove the top cover” on page 392.
2. Remove the air baffle. See “Remove the air baffle” on page 149.
3. Remove the fan cage (only for removing the performance heat sink). See “Remove the system fan cage” on page 387.
4. Remove any parts and disconnect any cables that might impede your access to the heat sink and processor.

Step 2. Use a Torx #T20 screwdriver to loosen all the captive screws in the *removal sequence* shown on the heat-sink label. After loosening each captive screw, wait for several seconds for the heat sink to loosen from the processor. Then, slightly lift the heat sink away from the system.

Note: The suggested tightening torque value is 14.0 ± 0.5 inch-pounds (1.525 – 1.638 newton meters).

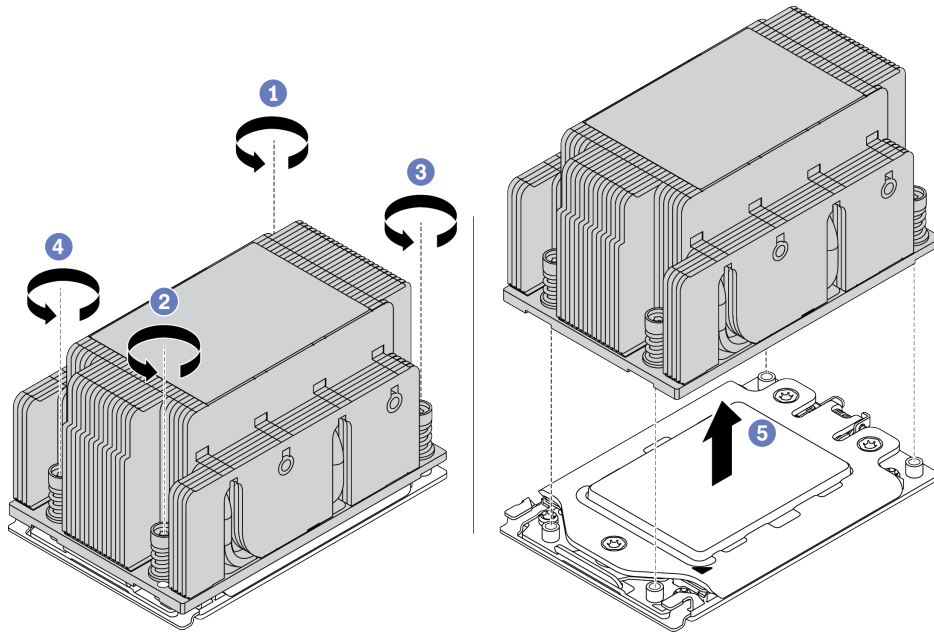

Figure 116. Removing a standard heat sink

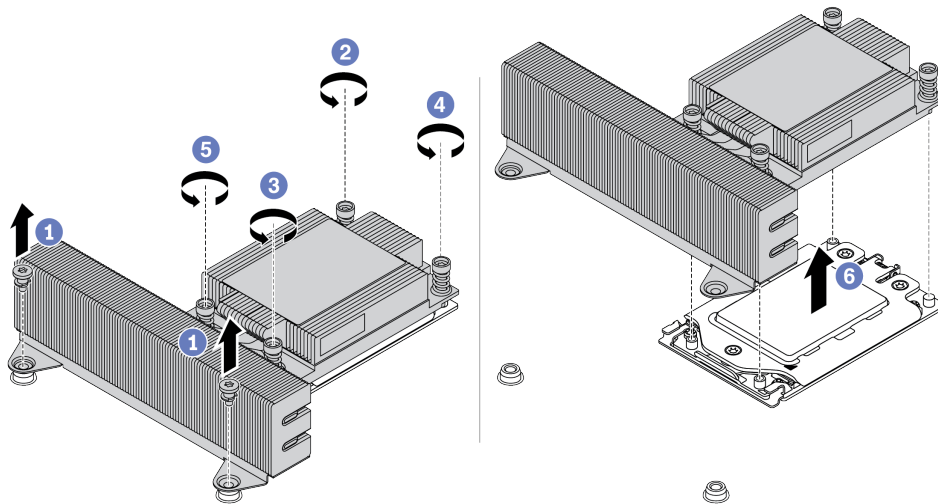

Figure 117. Removing a performance heat sink

After you finish

- If you are replacing a heat sink, install a new heat sink. See “Install a heat sink” on page 273.
- If you are replacing a processor, remove the processor. See “Remove a processor” on page 269.

Remove a processor

Use this information to remove a processor.

About this task

Attention:

- Read “Installation Guidelines” on page 129 to ensure that you work safely.
- Power off the server and disconnect all power cords for this task.
- Prevent exposure to static electricity, which might lead to system halt and loss of data, by keeping static-sensitive components in their static-protective packages until installation, and handling these devices with an electrostatic-discharge wrist strap or other grounding system.

A video for this task is available at:

- Youtube: https://www.youtube.com/playlist?list=PLYV5R7hVcs-Bz2XIeLEfGcrLGm9TSY_yt
- Youku: http://list.youku.com/albumlist/show/id_52339612.html

Procedure

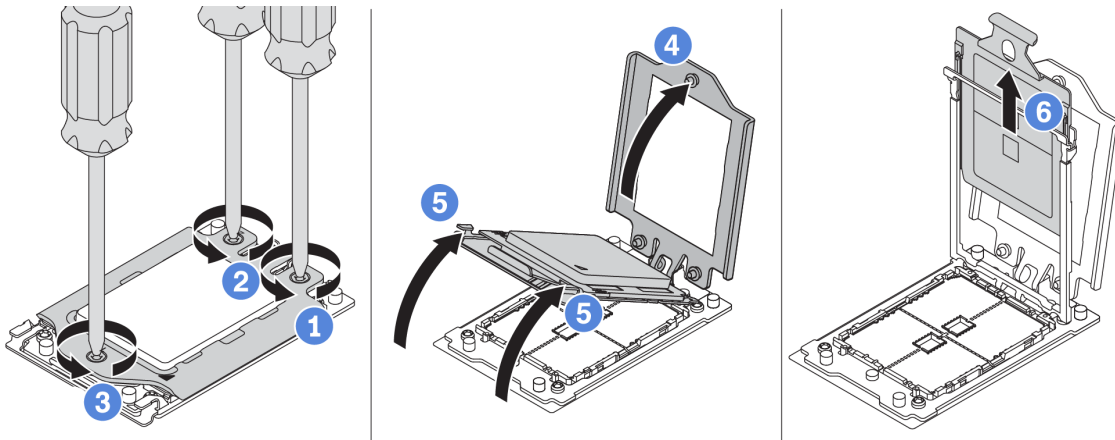

Figure 118. Processor removal

Step 1. Use a Torx #T20 screwdriver to loosen the captive screws in the *removal sequence* shown on the force frame.

Note: Use an ESD safe screwdriver and set the maximum torque value to 14.0 ± 0.5 inch-pounds.

Step 2. Slightly lift up the force frame and the rail frame in the direction shown. The processor in the rail frame is spring-loaded.

Step 3. Hold the blue tab of the processor carrier and slide the processor carrier out of the rail frame.

After you finish

Install a new processor. See “Install a processor” on page 271.

Install a processor

Use this information to install a processor.

About this task

Attention:

- Read “Installation Guidelines” on page 129 to ensure that you work safely.
- Power off the server and disconnect all power cords for this task.
- Prevent exposure to static electricity, which might lead to system halt and loss of data, by keeping static-sensitive components in their static-protective packages until installation, and handling these devices with an electrostatic-discharge wrist strap or other grounding system.

A video for this task is available at:

- Youtube: https://www.youtube.com/playlist?list=PLYV5R7hVcs-Bz2XIeLEfGcrLGm9TSY_yt
- Youku: http://list.youku.com/albumlist/show/id_52339612.html

Notes:

- See <https://static.lenovo.com/us/en/serverproven/index.shtml> for a list of processors supported for your server. All processors on the system board must have the same speed, number of cores, and frequency.
- Before you install a new processor, update your system firmware to the latest level. See “Firmware updates” on page 7.
- Optional devices available for your system might have specific processor requirements. See “Technical rules for processor and heat sink” on page 135.

Procedure

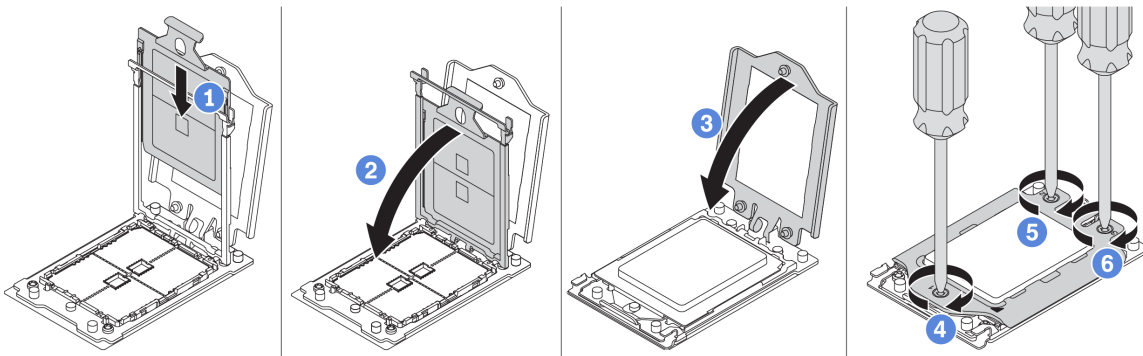

Figure 119. Processor installation

- Step 1. Slide the processor and carrier into the rail frame.
- Step 2. Push the rail frame down until the blue latches lock into place.
- Step 3. Close the force frame.
- Step 4. Tighten the screws in the *installation sequence* shown on the force frame.

Note: Use an ESD safe screwdriver and set the maximum torque value to 14.0 ± 0.5 inch-pounds.

After you finish

Install the heat sink. See “Install a heat sink” on page 273.

Install a heat sink

This task has instructions for installing a heat sink.

About this task

Attention:

- Read “Installation Guidelines” on page 129 to ensure that you work safely.
- Power off the server and disconnect all power cords for this task.
- Prevent exposure to static electricity, which might lead to system halt and loss of data, by keeping static-sensitive components in their static-protective packages until installation, and handling these devices with an electrostatic-discharge wrist strap or other grounding system.

Procedure

Step 1. If you use the existing heat sink:

1. Remove the thermal grease on the heat sink by using an alcohol cleaning pad.
2. Apply new thermal grease (TaiSol TC5288) in a quadrilateral design on the top of the processor.

Note: Do not apply too much thermal grease. Too much thermal grease can result in excess grease coming in contact with and contaminating the processor socket.

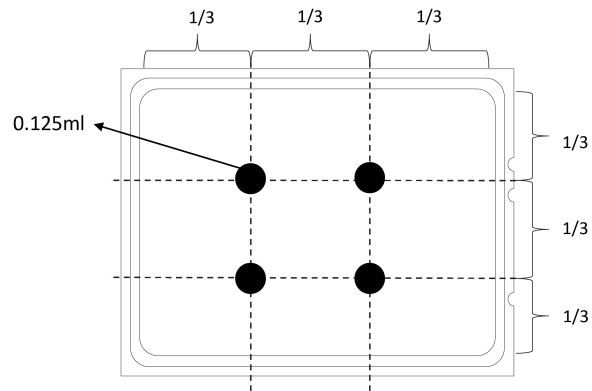

Figure 120. Applying thermal grease

Step 2. If you use a new heat sink, the thermal grease is pre-applied to the heat sink. Remove the protective cover and install the heat sink.

Step 3. Orient the heat sink with the screw holes on the processor plate. The captive screws on the heat sink should align with the screw holes on the processor plate. Tighten all the captive screws in the *installation sequence* shown on the heat-sink label.

Note: The suggested tightening torque value is 14.0 ± 0.5 inch-pounds (1.525 – 1.638 newton meters).

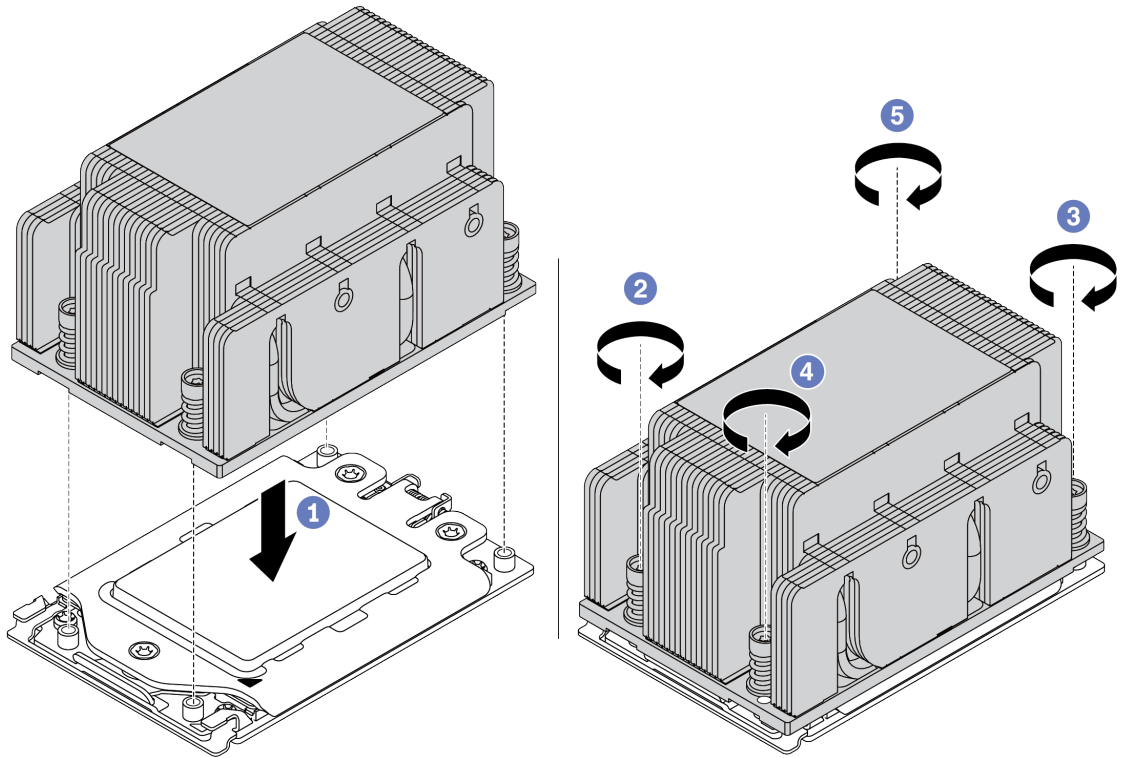

Figure 121. Installing a standard heat sink

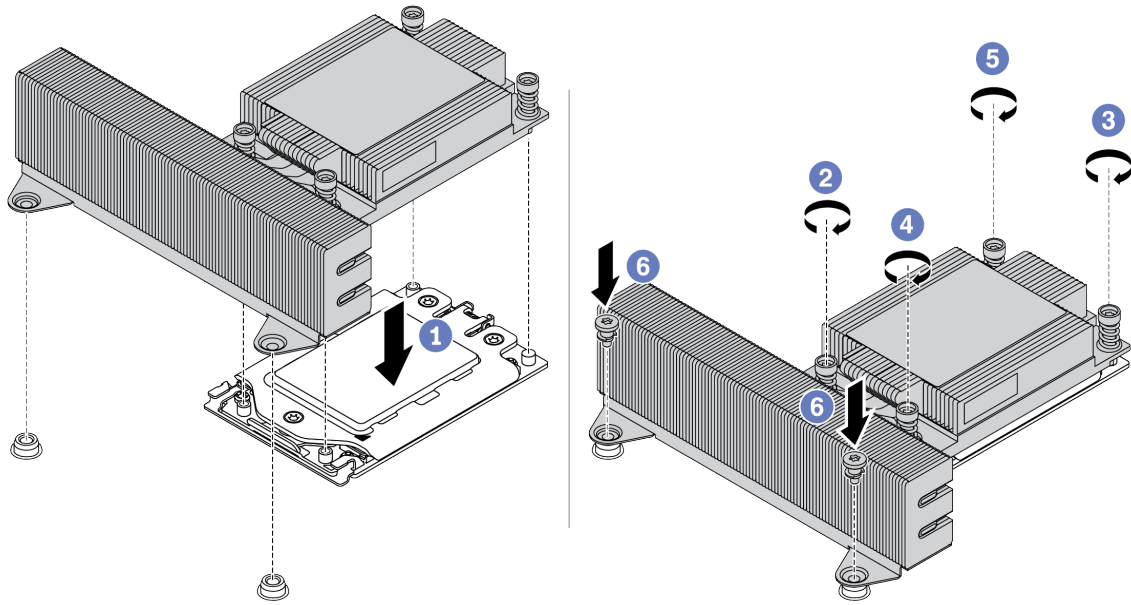

Figure 122. Installing a performance heat sink

After you finish

1. Install the air baffle. See “Install the air baffle” on page 152.
2. Install any parts that you have removed.
3. Complete the parts replacement. See “Complete the parts replacement” on page 397.

Rack latches replacement

Use this information to remove and install the rack latches.

Note: Depending on the model, the left rack latch might be assembled with a VGA connector and the right rack latch might be assembled with the front I/O assembly.

- “Remove the rack latches” on page 278
- “Install the rack latches” on page 282

Remove the rack latches

Use this information to remove the rack latches.

About this task

Attention:

- Read “Installation Guidelines” on page 129 to ensure that you work safely.
- Power off the server and disconnect all power cords for this task.

Note: If the rack latches are not assembled with a VGA connector or the front I/O assembly, you can remove the rack latches without powering off the server.

- Prevent exposure to static electricity, which might lead to system halt and loss of data, by keeping static-sensitive components in their static-protective packages until installation, and handling these devices with an electrostatic-discharge wrist strap or other grounding system.

A video for this task is available at:

- Youtube: https://www.youtube.com/playlist?list=PLYV5R7hVcs-Bz2XleEfGcrLGm9TSY_yt
- Youku: http://list.youku.com/albumlist/show/id_52339612.html

Procedure

- Step 1. If the server is installed with the security bezel, remove it first. See “Remove the security bezel” on page 362.
- Step 2. Use a flat-blade screwdriver to remove the ID label plate on the right rack latch and place it in a safe place.

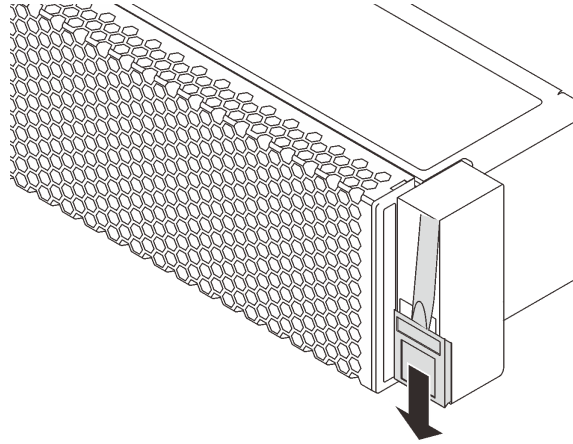

Figure 123. ID label plate removal

- Step 3. Disconnect the VGA cable , the front-I/O-assembly cable, or both cables from the system board.
- Step 4. Remove the screws that secure the cable retainer on the side of the server. Then, remove the cable retainer from the chassis.

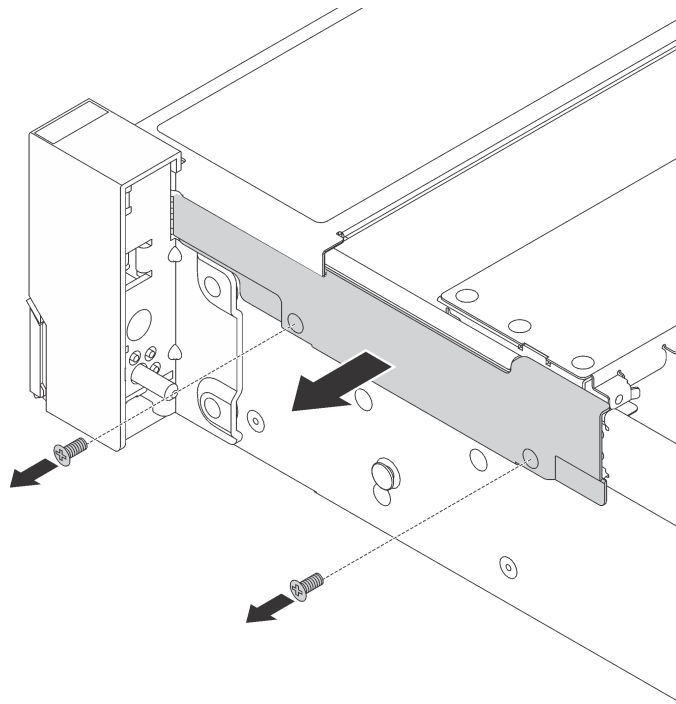

Figure 124. Cable retainer removal

Step 5. On each side of the server, remove the screws that secure the rack latch.

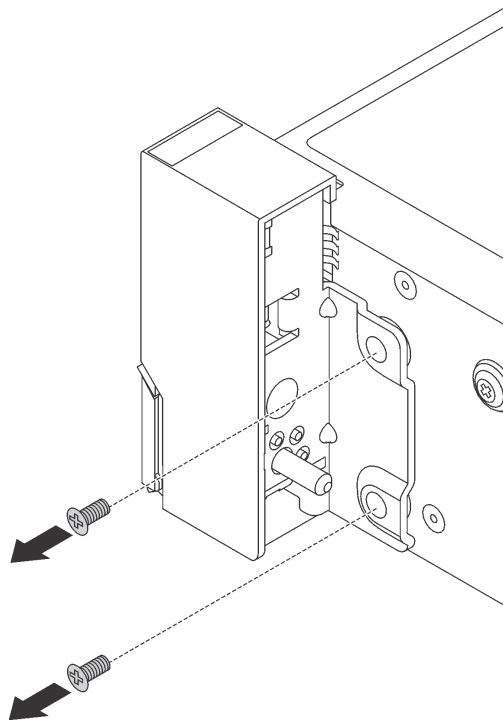

Figure 125. Screws removal

Step 6. On each side of the server, slide the rack latch forward slightly and then remove the rack latch from the chassis.

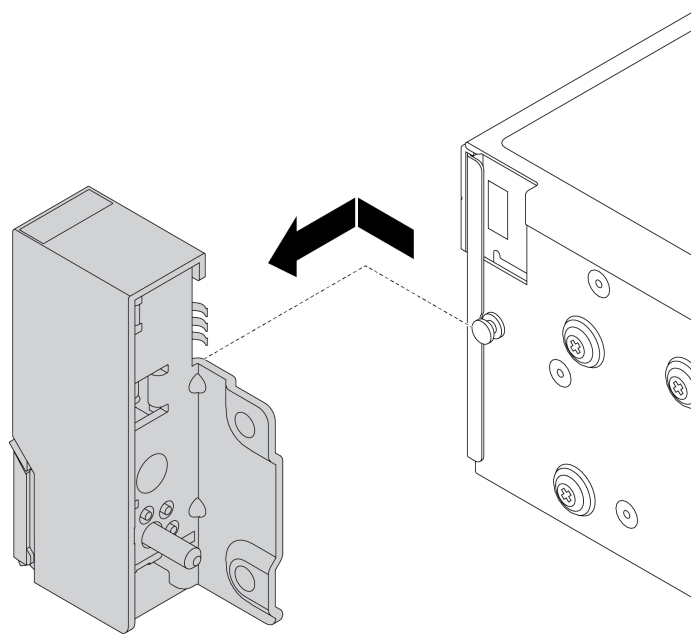

Figure 126. Rack latch removal

After you finish

If you are instructed to return the old rack latches, follow all packaging instructions and use any packaging materials that are provided.

Install the rack latches

Use this information to install the rack latches.

About this task

Attention:

- Read “Installation Guidelines” on page 129 to ensure that you work safely.
- Power off the server and disconnect all power cords for this task.

Note: If the rack latches are not assembled with a VGA connector or the front I/O assembly, you can install the rack latches without powering off the server.

- Prevent exposure to static electricity, which might lead to system halt and loss of data, by keeping static-sensitive components in their static-protective packages until installation, and handling these devices with an electrostatic-discharge wrist strap or other grounding system.

A video for this task is available at:

- Youtube: https://www.youtube.com/playlist?list=PLYV5R7hVcs-Bz2XleEfGcrLGm9TSY_yt
- Youku: http://list.youku.com/albumlist/show/id_52339612.html

Procedure

- Step 1. Touch the static-protective package that contains the new rack latches to any unpainted surface on the outside of the server. Then, take the new rack latches out of the package and place them on a static-protective surface.
- Step 2. On each side of the server, align the rack latch with the pin on the chassis. Then, press the rack latch onto the chassis and slightly slide it backward.

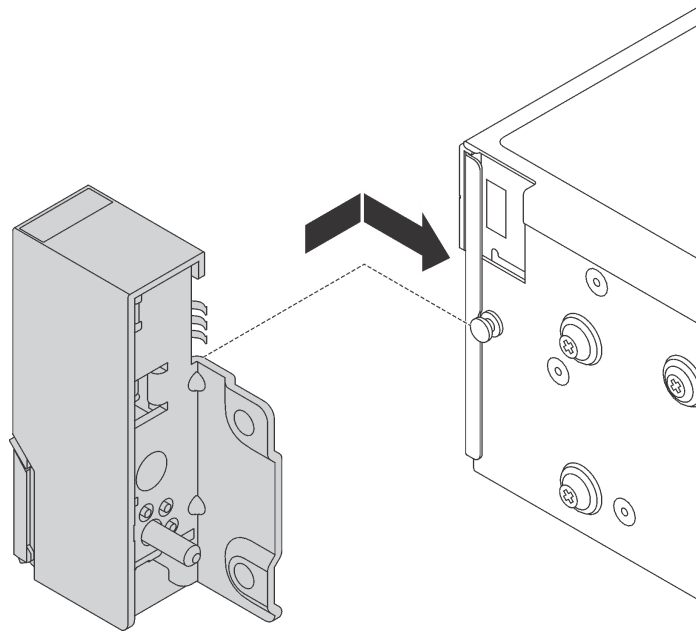

Figure 127. Rack latch installation

Step 3. Install the screws to secure the rack latch on each side of the server.

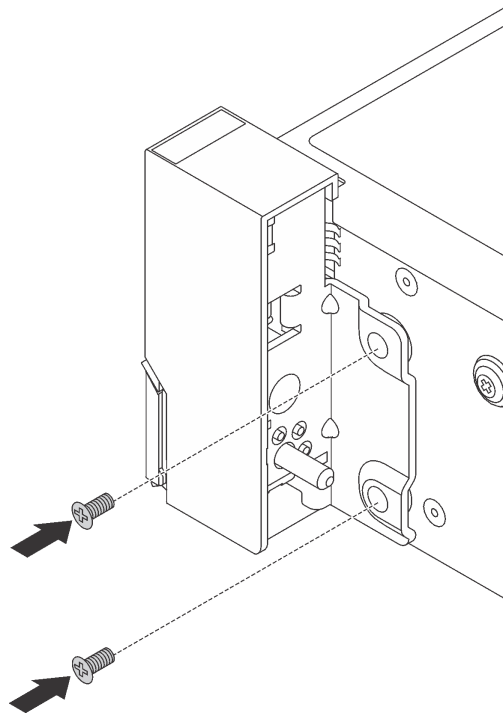

Figure 128. Screws installation

Step 4. Route the bundle cable for I/O connectors on the right or left latches as shown. Then, install the screws to secure the cable retainer.

Note: To avoid unnecessary damage to the bundle cable, ensure that it is routed and fixed on the upper frame of the cable retainer.

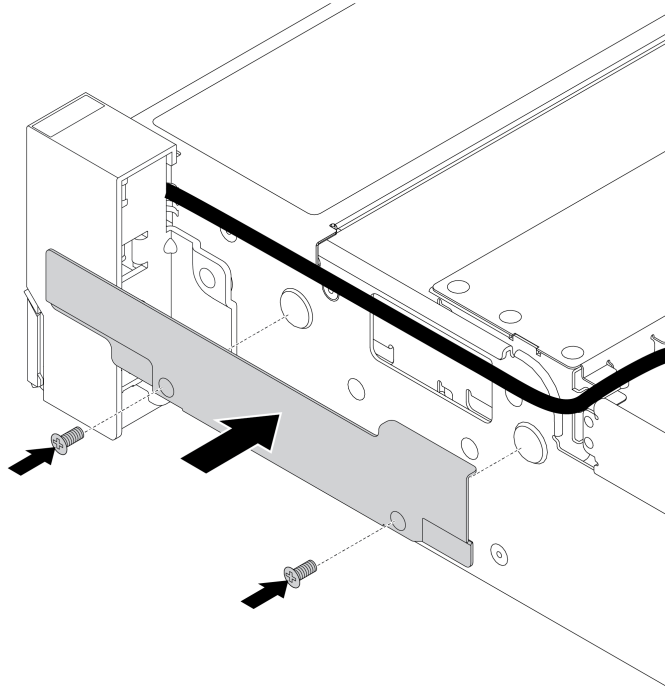

Figure 129. Cable retainer installation

Step 5. Connect the cables to the system board. See Chapter 3 “Internal cable routing” on page 57.

After you finish

1. Install the ID label plate to the right rack latch as shown.

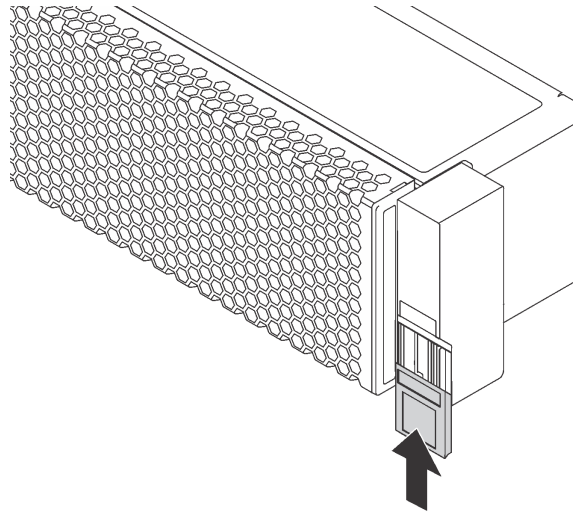

Figure 130. ID label plate installation

2. Complete the parts replacement. See “Complete the parts replacement” on page 397.

RAID super capacitor module replacement

The RAID super capacitor module protects the cache memory on the installed RAID adapter. Use this information to remove and install a RAID super capacitor module.

- “Remove a super capacitor module from the air baffle” on page 291
- “Install a super capacitor module on the air baffle” on page 293
- “Remove a super capacitor module from the middle 2.5-inch drive cage” on page 295
- “Install a super capacitor module on the middle 2.5-inch drive cage” on page 297
- “Remove a super capacitor from the chassis” on page 300
- “Install a super capacitor on the chassis” on page 303

Super capacitor locations in the system

On the chassis

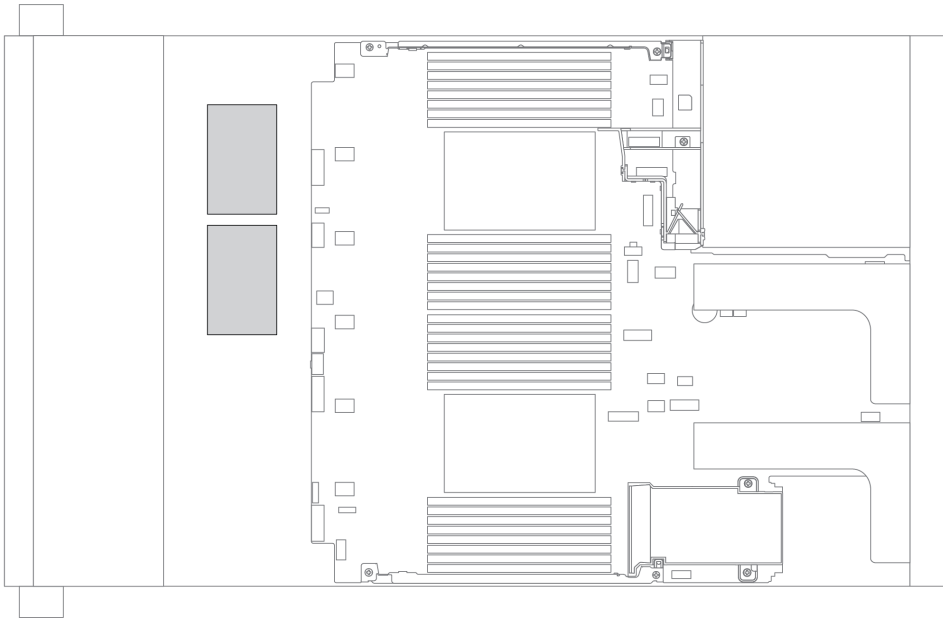

On standard air baffle



On GPU air baffle

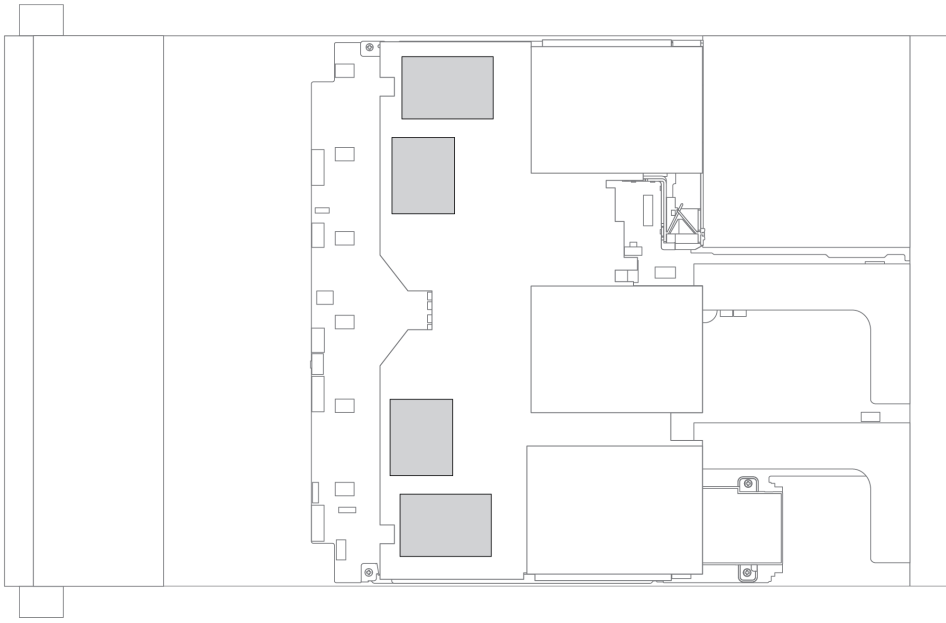

On the 2.5-inch middle drive cage

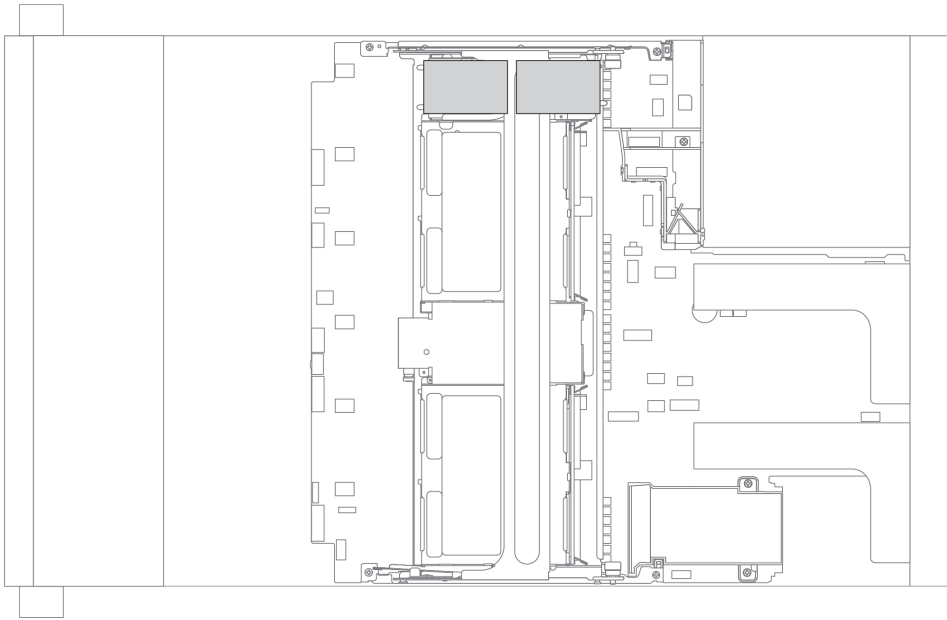

Remove a super capacitor module from the air baffle

Use this information to remove a super capacitor module from the air baffle.

About this task

Attention:

- Read “Installation Guidelines” on page 129 to ensure that you work safely.
- Power off the server and disconnect all power cords for this task.
- Prevent exposure to static electricity, which might lead to system halt and loss of data, by keeping static-sensitive components in their static-protective packages until installation, and handling these devices with an electrostatic-discharge wrist strap or other grounding system.

A video for this task is available at:

- Youtube: https://www.youtube.com/playlist?list=PLYV5R7hVcs-Bz2XleLEfGcrLGm9TSY_yt
- Youku: http://list.youku.com/albumlist/show/id_52339612.html

Procedure

- Step 1. Remove the top cover. See “Remove the top cover” on page 392.
- Step 2. Disconnect the cable of the RAID super capacitor module.
- Step 3. Remove the super capacitor module from the air baffle.

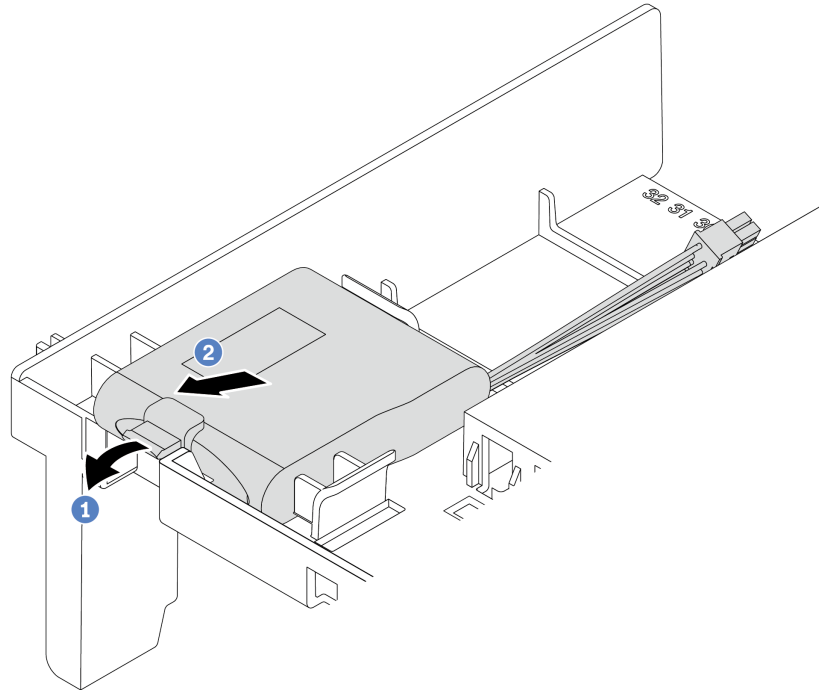

Figure 131. Super capacitor module removal

- a. Open the retention clip on the holder of the super capacitor module.
- b. Take the super capacitor module out of the holder.

After you finish

If you are instructed to return the old RAID super capacitor module, follow all packaging instructions and use any packaging materials that are provided.

Install a super capacitor module on the air baffle

Use this information to install a super capacitor module on the air baffle.

About this task

Attention:

- Read “Installation Guidelines” on page 129 to ensure that you work safely.
- Prevent exposure to static electricity, which might lead to system halt and loss of data, by keeping static-sensitive components in their static-protective packages until installation, and handling these devices with an electrostatic-discharge wrist strap or other grounding system.

A video for this task is available at:

- Youtube: https://www.youtube.com/playlist?list=PLYV5R7hVcs-Bz2XleLEfGcrLGm9TSY_yt
- Youku: http://list.youku.com/albumlist/show/id_52339612.html

Procedure

- Step 1. Touch the static-protective package that contains the new RAID super capacitor module to any unpainted surface on the outside of the server. Then, take the new RAID super capacitor module out of the package and place it on a static-protective surface.
- Step 2. Install the super capacitor module.

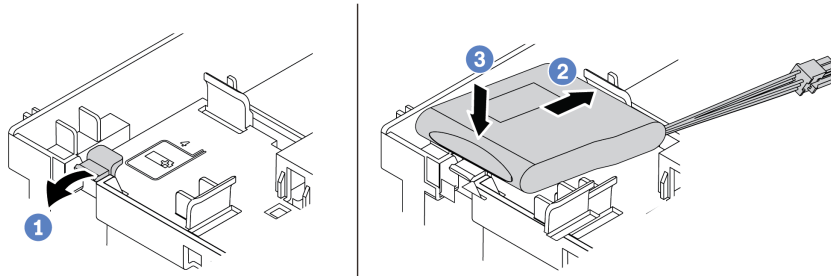

Figure 132. Super capacitor installation on the air baffle

1. Open the retention clip on a holder.
 2. Put a super capacitor module into the holder.
 3. Press it down to secure it into the holder.
- Step 3. Connect the super capacitor module to an adapter with the extension cable that comes with the super capacitor module. See “RAID super capacitor modules” on page 62.

After you finish

Complete the parts replacement. See “Complete the parts replacement” on page 397.

Remove a super capacitor module from the middle 2.5-inch drive cage

Use this information to remove a super capacitor module from the middle 2.5-inch drive cage.

About this task

Attention:

- Read “Installation Guidelines” on page 129 to ensure that you work safely.
- Power off the server and disconnect all power cords for this task.
- Prevent exposure to static electricity, which might lead to system halt and loss of data, by keeping static-sensitive components in their static-protective packages until installation, and handling these devices with an electrostatic-discharge wrist strap or other grounding system.

A video for this task is available at:

- Youtube: https://www.youtube.com/playlist?list=PLYV5R7hVcs-Bz2XIeLEfGcrLGm9TSY_yt
- Youku: http://list.youku.com/albumlist/show/id_52339612.html

Procedure

- Step 1. Remove the top cover. See “Remove the top cover” on page 392.
- Step 2. Disconnect the cable of the RAID super capacitor module.
- Step 3. Open the drive cage handle.

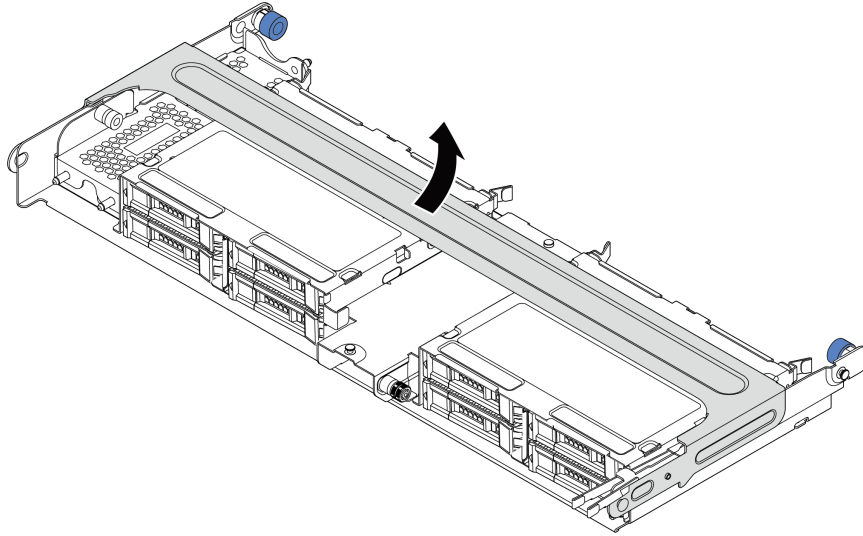

Figure 133. Opening the handle of the middle drive cage

- Step 4. Remove the super capacitor module.

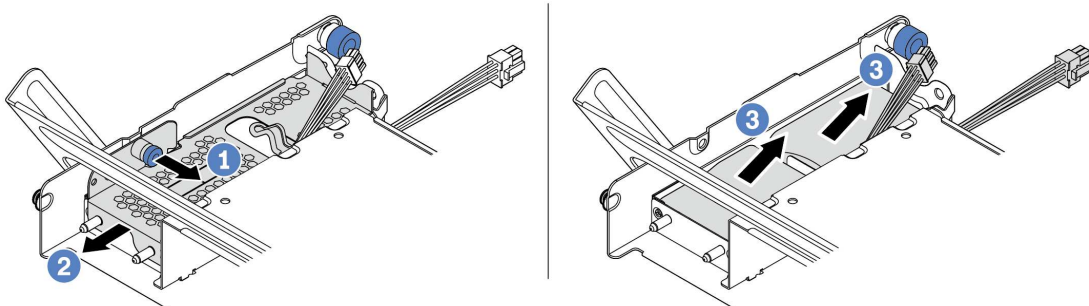

Figure 134. Removing the super capacitor module

1. Pull out the blue latch on the super capacitor cover.
2. Slide the cover out of the holder.
3. Take the super capacitor module out of the holder.

After you finish

If you are instructed to return the old RAID super capacitor module, follow all packaging instructions and use any packaging materials that are provided.

Install a super capacitor module on the middle 2.5-inch drive cage

Use this information to install a super capacitor module the middle 2.5-inch drive cage.

About this task

Attention:

- Read “Installation Guidelines” on page 129 to ensure that you work safely.
- Prevent exposure to static electricity, which might lead to system halt and loss of data, by keeping static-sensitive components in their static-protective packages until installation, and handling these devices with an electrostatic-discharge wrist strap or other grounding system.

A video for this task is available at:

- Youtube: https://www.youtube.com/playlist?list=PLYV5R7hVcs-Bz2XleLEfGcrLGm9TSY_yt
- Youku: http://list.youku.com/albumlist/show/id_52339612.html

Procedure

- Step 1. Touch the static-protective package that contains the new RAID super capacitor module to any unpainted surface on the outside of the server. Then, take the new RAID super capacitor module out of the package and place it on a static-protective surface.
- Step 2. Open the drive cage handle.

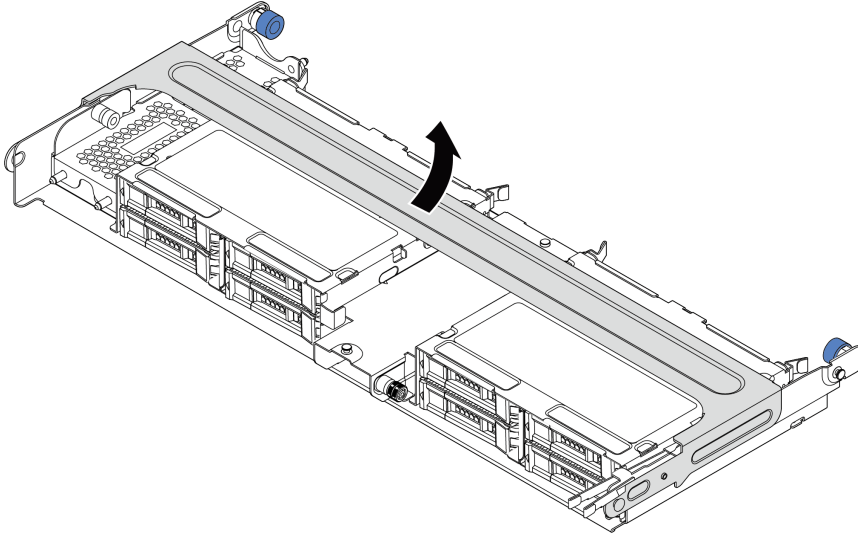

Figure 135. Opening the handle of the middle drive cage

1. Pull out the blue plunger.
 2. Slide the metal cover out of the drive cage.
- Step 3. Remove the metal cover.

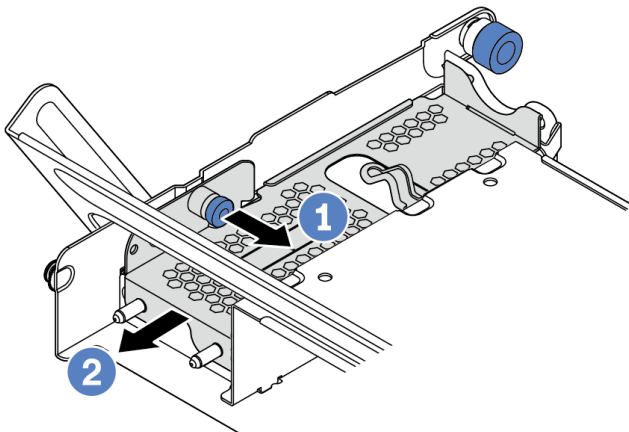

Figure 136. Removing the metal cover

1. Pull out the blue plunger.
2. Slide the metal cover out of the drive cage.

Step 4. Install the super capacitor module.

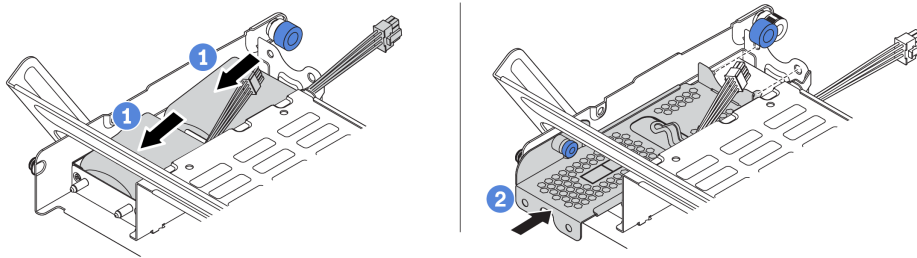

Figure 137. Installing the super capacitor module

1. Put a super capacitor module into the holder, and press it down to secure it into the holder.
2. Align the pins on the metal cover with the holes in the super capacitor holder, pull out the blue latch on the cover, and slide the cover into the holder until the pins pass through the holes. Then, release the blue latch to lock the cover into place.

Step 5. Connect the super capacitor module to an adapter with the extension cable that comes with the super capacitor module. See “RAID super capacitor modules” on page 62.

After you finish

Complete the parts replacement. See “Complete the parts replacement” on page 397

Remove a super capacitor from the chassis

Use this information to remove a super capacitor module from the chassis.

About this task

Attention:

- Read “Installation Guidelines” on page 129 to ensure that you work safely.
- Power off the server and disconnect all power cords for this task.
- Prevent exposure to static electricity, which might lead to system halt and loss of data, by keeping static-sensitive components in their static-protective packages until installation, and handling these devices with an electrostatic-discharge wrist strap or other grounding system.

A video for this task is available at:

- Youtube: https://www.youtube.com/playlist?list=PLYV5R7hVcs-Bz2XleLEfGcrLGm9TSY_yt
- Youku: http://list.youku.com/albumlist/show/id_52339612.html

Procedure

- Step 1. Remove the top cover. See “Remove the top cover” on page 392.
- Step 2. Disconnect the cable of the super capacitor module.
- Step 3. Remove the super capacitor module.

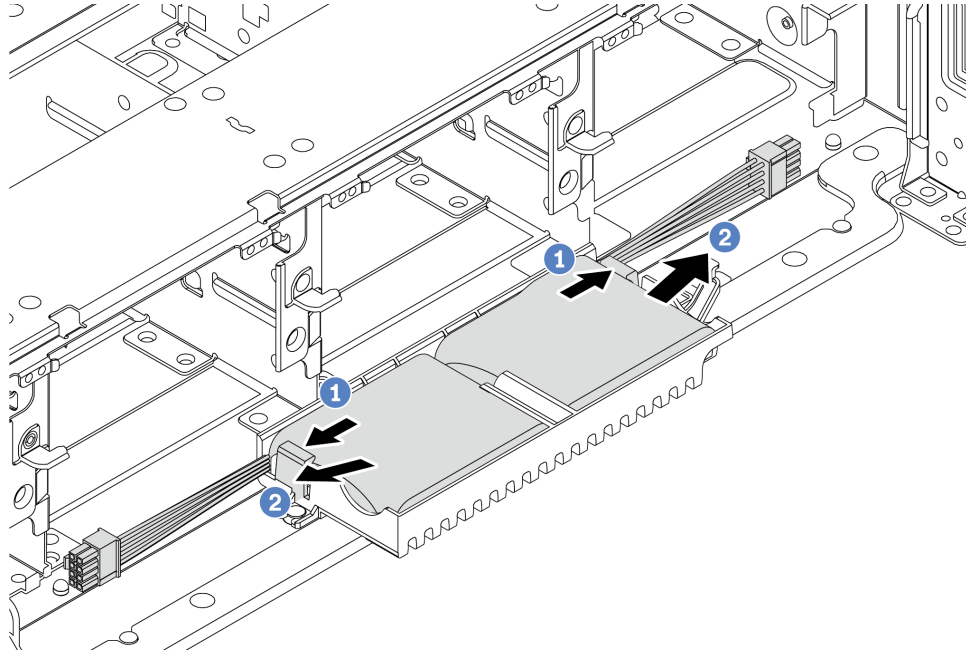

Figure 138. Super capacitor module removal

1. Open the retention clip on the super capacitor holder.
 2. Take the super capacitor module out of the holder.
- Step 4. Remove the super capacitor holder as shown if necessary.

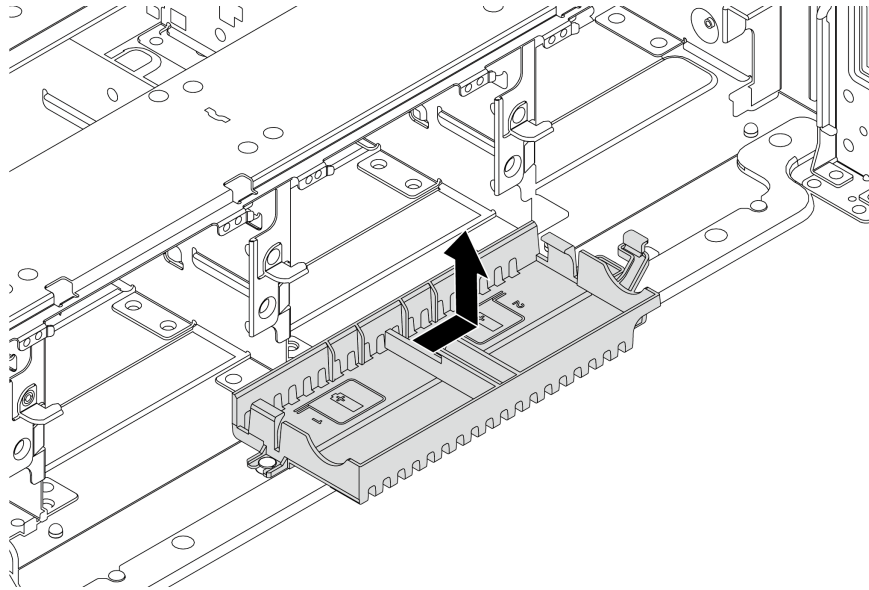

Figure 139. Super capacitor holder removal

After you finish

If you are instructed to return the old RAID super capacitor module, follow all packaging instructions and use any packaging materials that are provided.

Install a super capacitor on the chassis

Use this information to install a super capacitor module on the chassis.

About this task

Attention:

- Read “Installation Guidelines” on page 129 to ensure that you work safely.
- Prevent exposure to static electricity, which might lead to system halt and loss of data, by keeping static-sensitive components in their static-protective packages until installation, and handling these devices with an electrostatic-discharge wrist strap or other grounding system.

A video for this task is available at:

- Youtube: https://www.youtube.com/playlist?list=PLYV5R7hVcs-Bz2XleLEfGcrLGm9TSY_yt
- Youku: http://list.youku.com/albumlist/show/id_52339612.html

Procedure

- Step 1. Touch the static-protective package that contains the new RAID super capacitor module to any unpainted surface on the outside of the server. Then, take the new RAID super capacitor module out of the package and place it on a static-protective surface.
- Step 2. Install the super capacitor holder.

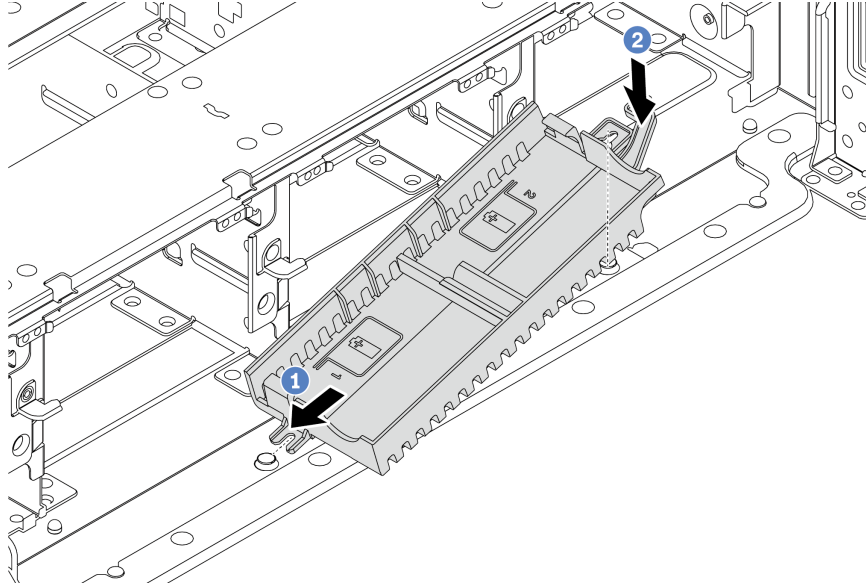

Figure 140. Super capacitor box installation

1. Align the notch on the super capacitor holder with the pin on the chassis as shown.
2. Pivot the super capacitor holder inward until the other side clicks into place.

Step 3. Install the super capacitor module.

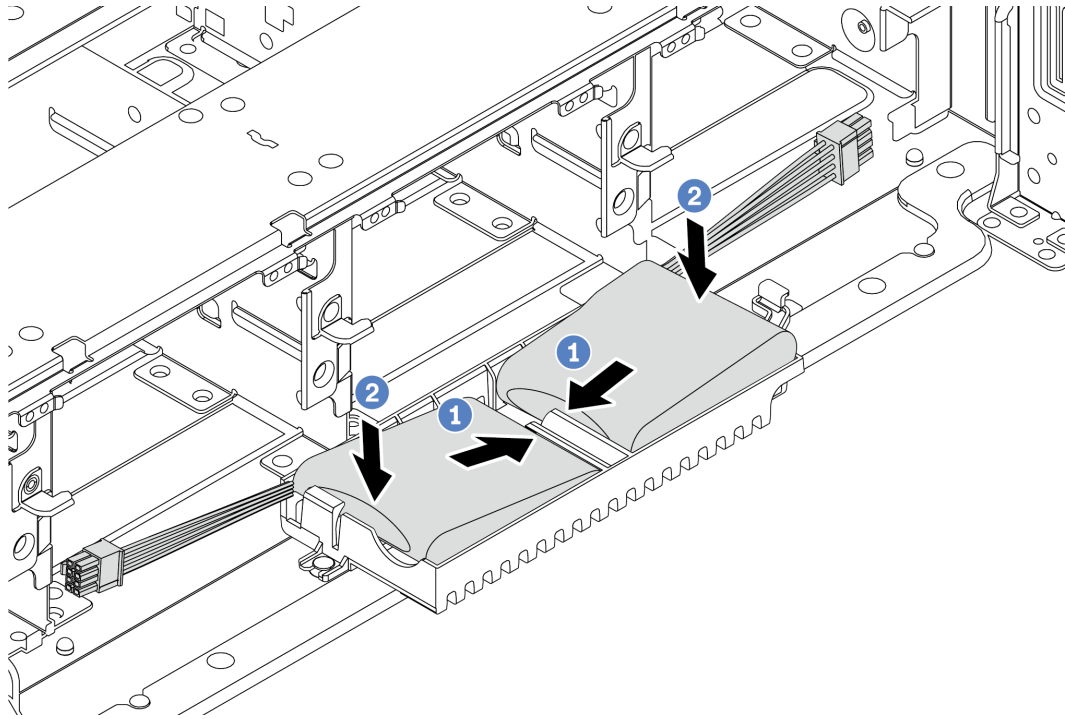

Figure 141. Super capacitor module installation

1. Insert the RAID super capacitor module into the retaining clip at one side as shown.
2. Press the RAID super capacitor module down on the other side until it snaps into place.

Step 4. Connect the super capacitor module to an adapter with the extension cable that comes with the super capacitor module. See “RAID super capacitor modules” on page 62.

After you finish

Complete the parts replacement. See “Complete the parts replacement” on page 397

Rearwall bracket replacement

Use this information to remove and install a rearwall bracket.

- “Remove an A1 rearwall bracket (left)” on page 308
- “Install an A1 rearwall bracket (left)” on page 310
- “Remove a B1/B2 rearwall bracket (middle)” on page 312
- “Install a B1/B2 rearwall bracket (middle)” on page 314
- “Remove a C1/C2 rearwall bracket (right)” on page 316
- “Install a C1/C2 rearwall bracket (right)” on page 318

Rearwall bracket matrix

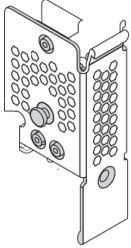
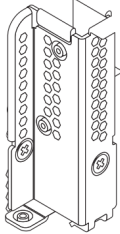
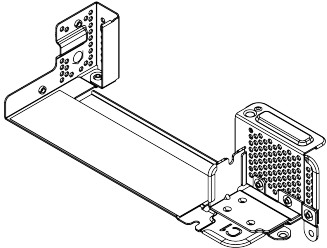
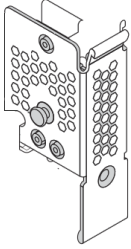
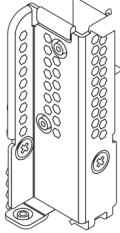
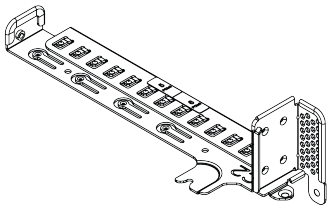
Server model	Required rearwall brackets
Server model with 8 PCIe slots	<p>The server requires 3 rearwall brackets:</p> <div style="display: flex; justify-content: space-around;"> <div style="text-align: center;"> <p>A1 rearwall bracket on the left</p>  </div> <div style="text-align: center;"> <p>B1 rearwall bracket on the middle</p>  </div> <div style="text-align: center;"> <p>C1 rearwall bracket on the right</p>  </div> </div>
Server model with 4 x 2.5-inch rear drives	<p>The server requires 3 rearwall brackets:</p> <div style="display: flex; justify-content: space-around;"> <div style="text-align: center;"> <p>A1 rearwall bracket on the left</p>  </div> <div style="text-align: center;"> <p>B1 rearwall bracket on the middle</p>  </div> <div style="text-align: center;"> <p>C2 rearwall bracket on the right</p>  </div> </div>
Server model with 2 x 3.5-inch rear drives	<p>The server requires 2 rearwall brackets:</p>

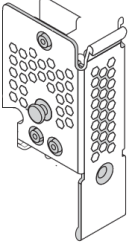
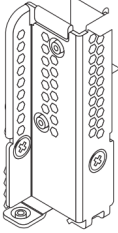
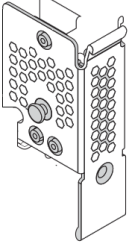
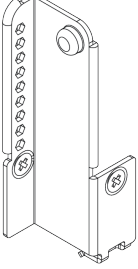
Server model	Required rearwall brackets
	<p data-bbox="397 233 716 258">A1 rearwall bracket on the left</p> <p data-bbox="760 233 1036 285">B1 rearwall bracket on the middle</p>  
<p data-bbox="199 758 367 842">Server model with 8 x 2.5-inch rear drives</p>	<p data-bbox="397 583 802 609">The server requires 1 rearwall bracket:</p> <p data-bbox="397 674 716 699">A1 rearwall bracket on the left</p> <p data-bbox="760 632 1036 684">B2 rearwall bracket on the middle</p>  
<p data-bbox="199 1039 367 1123">Server model with 4 x 3.5-inch rear drives</p>	<p data-bbox="397 1066 821 1092">The server requires no rearwall brackets</p>

Remove an A1 rearwall bracket (left)

Use this information to remove an A1 rearwall on the left of the rear chassis.

About this task

Attention:

- Read “Installation Guidelines” on page 129 to ensure that you work safely.
- Prevent exposure to static electricity, which might lead to system halt and loss of data, by keeping static-sensitive components in their static-protective packages until installation, and handling these devices with an electrostatic-discharge wrist strap or other grounding system.

A video for this task is available at:

- Youtube: https://www.youtube.com/playlist?list=PLYV5R7hVcs-Bz2XleLEfGcrLGm9TSY_yt
- Youku: http://list.youku.com/albumlist/show/id_52339612.html

Procedure

- Step 1. Touch the static-protective package that contains the new riser card to any unpainted surface on the outside of the server. Then, take the new riser card out of the package and place it on a static-protective surface.
- Step 2. Remove an A1 rearwall bracket.

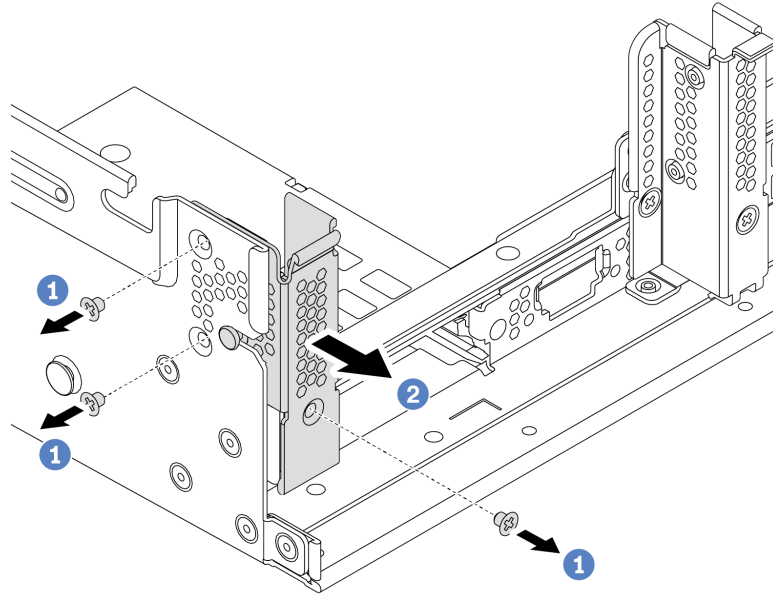

Figure 142. A1 rearwall bracket installation

- a. Remove the three screws as shown.
- b. Remove the bracket from the chassis as shown.

After you finish

1. Remove or install a rear drive cage or riser assemblies. See
 - “PCIe adapter and riser assembly replacement” on page 345
 - “Rear drive cage replacement” on page 320
2. Complete the parts replacement. See “Complete the parts replacement” on page 397.

Install an A1 rearwall bracket (left)

Use this information to install an A1 rearwall on the left of the rear chassis.

About this task

Attention:

- Read “Installation Guidelines” on page 129 to ensure that you work safely.
- Prevent exposure to static electricity, which might lead to system halt and loss of data, by keeping static-sensitive components in their static-protective packages until installation, and handling these devices with an electrostatic-discharge wrist strap or other grounding system.

A video for this task is available at:

- Youtube: https://www.youtube.com/playlist?list=PLYV5R7hVcs-Bz2XleLEfGcrLGm9TSY_yt
- Youku: http://list.youku.com/albumlist/show/id_52339612.html

Procedure

- Step 1. Touch the static-protective package that contains the new riser card to any unpainted surface on the outside of the server. Then, take the new riser card out of the package and place it on a static-protective surface.
- Step 2. Install an A1 rearwall bracket.

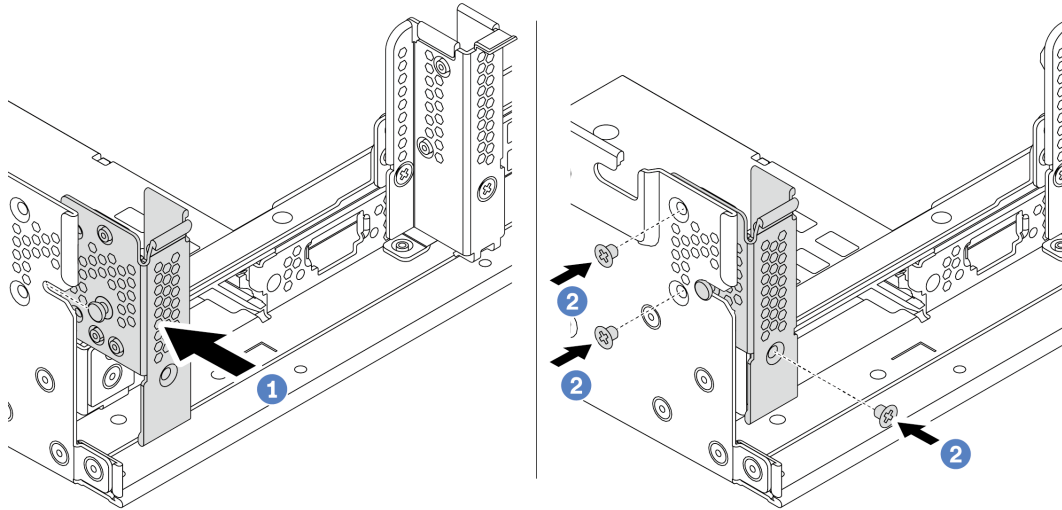

Figure 143. A1 rearwall bracket installation

- a. Align the pin on the rearwall bracket and the pin slot on the left side of the rear chassis. Install the bracket to the chassis as shown.
- b. Install the three screws to secure the rearwall bracket.

After you finish

1. Install a rear drive cage or riser assemblies. See
 - “Install the 4 x 2.5-inch rear drive cage” on page 332
 - “Install the 8 x 2.5-inch rear drive cage” on page 336
 - “Install the 2 x 3.5-inch rear drive cage” on page 323
 - “Install the 4 x 3.5-inch rear drive cage” on page 327
 - “Install a PCIe adapter and riser 1/2 assembly” on page 350
2. Complete the parts replacement. See “Complete the parts replacement” on page 397.

Remove a B1/B2 rearwall bracket (middle)

Use this information to remove a B1 or B2 rearwall on the middle of the rear chassis.

About this task

Attention:

- Read “Installation Guidelines” on page 129 to ensure that you work safely.
- Prevent exposure to static electricity, which might lead to system halt and loss of data, by keeping static-sensitive components in their static-protective packages until installation, and handling these devices with an electrostatic-discharge wrist strap or other grounding system.

A video for this task is available at:

- Youtube: https://www.youtube.com/playlist?list=PLYV5R7hVcs-Bz2XleLEfGcrLGm9TSY_yt
- Youku: http://list.youku.com/albumlist/show/id_52339612.html

Procedure

Step 1. Touch the static-protective package that contains the new riser card to any unpainted surface on the outside of the server. Then, take the new riser card out of the package and place it on a static-protective surface.

Step 2. Remove a B1 or B2 rearwall bracket.

Note: The illustration shows only the removal of B1 rearwall bracket, the B2 rearwall bracket can be removed in the same way.

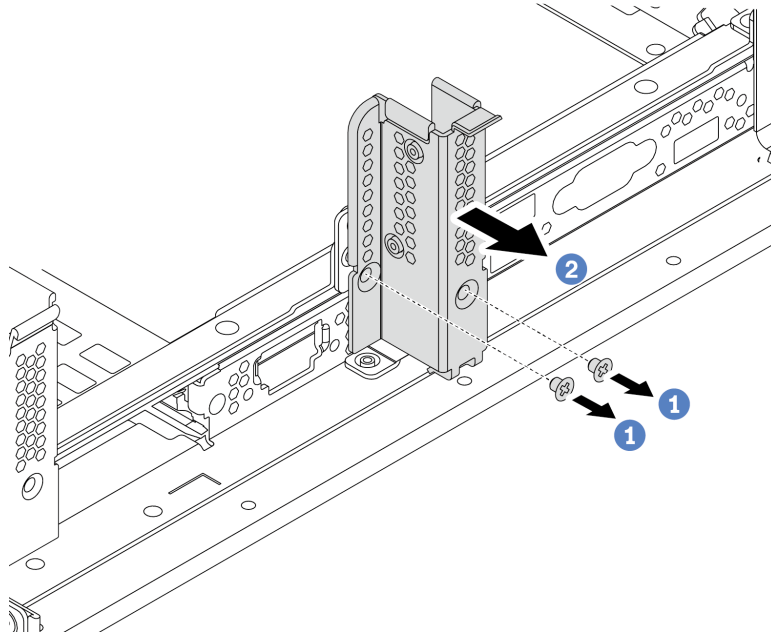

Figure 144. B1 rearwall bracket removal

- a. Remove the two screws.
- b. Remove the bracket from the chassis in the direction as shown.

After you finish

1. Remove or install a rear drive cage or riser assemblies. See
 - “PCIe adapter and riser assembly replacement” on page 345
 - “Rear drive cage replacement” on page 320
2. Complete the parts replacement. See “Complete the parts replacement” on page 397.

Install a B1/B2 rearwall bracket (middle)

Use this information to install a B1 or B2 rearwall on the middle of the rear chassis.

About this task

Attention:

- Read “Installation Guidelines” on page 129 to ensure that you work safely.
- Prevent exposure to static electricity, which might lead to system halt and loss of data, by keeping static-sensitive components in their static-protective packages until installation, and handling these devices with an electrostatic-discharge wrist strap or other grounding system.

A video for this task is available at:

- Youtube: https://www.youtube.com/playlist?list=PLYV5R7hVcs-Bz2XleLEfGcrLGm9TSY_yt
- Youku: http://list.youku.com/albumlist/show/id_52339612.html

Procedure

- Step 1. Touch the static-protective package that contains the new riser card to any unpainted surface on the outside of the server. Then, take the new riser card out of the package and place it on a static-protective surface.
- Step 2. Install a B1 or B2 rearwall bracket.

Note: The illustration shows only the installation of B1 rearwall bracket, the B2 rearwall bracket can be installed in the same way.

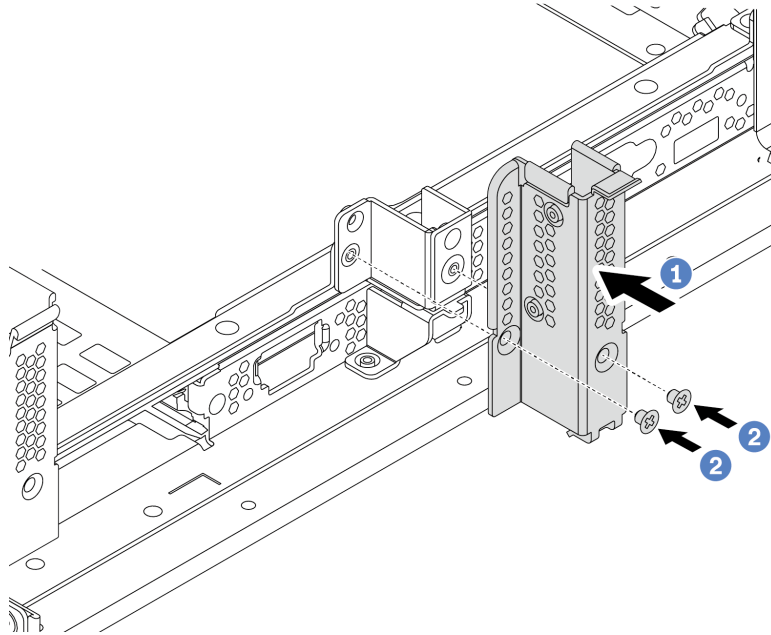

Figure 145. B1 rearwall bracket installation

- a. Align the holes on the rearwall bracket and the chassis. Install the bracket to the chassis as shown.
- b. Install the two screws to secure the rearwall bracket.

After you finish

1. Install a rear drive cage or riser assemblies. See
 - “Install the 4 x 2.5-inch rear drive cage” on page 332
 - “Install the 2 x 3.5-inch rear drive cage” on page 323
 - “Install a PCIe adapter and riser 1/2 assembly” on page 350
2. Complete the parts replacement. See “Complete the parts replacement” on page 397.

Remove a C1/C2 rearwall bracket (right)

Use this information to remove a C1/C2 rearwall on the right of the rear chassis.

About this task

Attention:

- Read “Installation Guidelines” on page 129 to ensure that you work safely.
- Prevent exposure to static electricity, which might lead to system halt and loss of data, by keeping static-sensitive components in their static-protective packages until installation, and handling these devices with an electrostatic-discharge wrist strap or other grounding system.

A video for this task is available at:

- Youtube: https://www.youtube.com/playlist?list=PLYV5R7hVcs-Bz2XleLEfGcrLGm9TSY_yt
- Youku: http://list.youku.com/albumlist/show/id_52339612.html

Procedure

Step 1. Touch the static-protective package that contains the new riser card to any unpainted surface on the outside of the server. Then, take the new riser card out of the package and place it on a static-protective surface.

Step 2. Remove a C1 rearwall bracket.

Note: The illustration shows removing a C1 rearwall bracket. The procedure is the same for removing the C2 rearwall bracket.

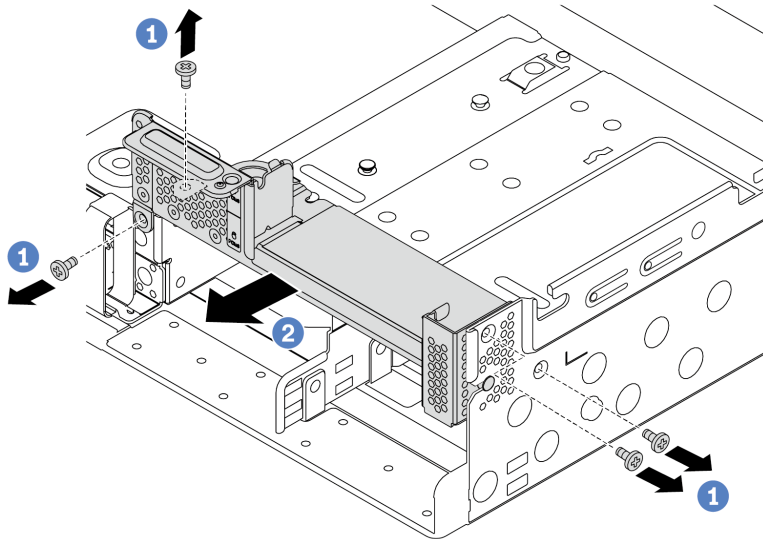

Figure 146. C1 rearwall bracket removal

- a. Remove the four screws.
- b. Remove the bracket from the chassis in the direction as shown.

After you finish

1. Remove or install a rear drive cage or riser assemblies. See
 - “PCIe adapter and riser assembly replacement” on page 345
 - “Rear drive cage replacement” on page 320
2. Complete the parts replacement. See “Complete the parts replacement” on page 397.

Install a C1/C2 rearwall bracket (right)

Use this information to install a C1 rearwall on the right of the rear chassis.

About this task

Attention:

- Read “Installation Guidelines” on page 129 to ensure that you work safely.
- Prevent exposure to static electricity, which might lead to system halt and loss of data, by keeping static-sensitive components in their static-protective packages until installation, and handling these devices with an electrostatic-discharge wrist strap or other grounding system.

A video for this task is available at:

- Youtube: https://www.youtube.com/playlist?list=PLYV5R7hVcs-Bz2XleLEfGcrLGm9TSY_yt
- Youku: http://list.youku.com/albumlist/show/id_52339612.html

Procedure

Step 1. Touch the static-protective package that contains the new riser card to any unpainted surface on the outside of the server. Then, take the new riser card out of the package and place it on a static-protective surface.

Step 2. Install a C1 rearwall bracket.

Note: The illustration shows removing a C1 rearwall bracket. The procedure is the same for removing the C2 rearwall bracket.

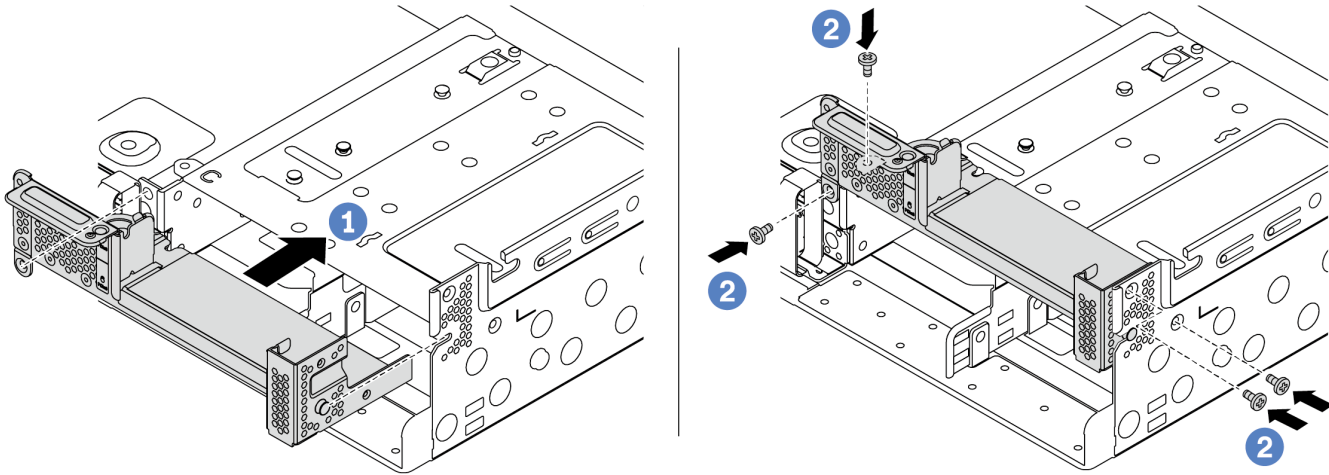

Figure 147. C1 rearwall bracket installation

- a. Align the pin on the rearwall bracket and the pin slot on the right side of the rear chassis. Install the bracket to the chassis as shown.
- b. Install the four screws to secure the rearwall bracket.

After you finish

1. Install a rear drive cage or riser assemblies. See
 - “Install the 4 x 2.5-inch rear drive cage” on page 332
 - “Install a PCIe adapter and riser 1/2 assembly” on page 350
2. Complete the parts replacement. See “Complete the parts replacement” on page 397.

Rear drive cage replacement

Use this information to remove and install the 2.5-inch or 3.5-inch rear drive cage.

- “Remove the 2 x 3.5-inch rear drive cage” on page 321
- “Install the 2 x 3.5-inch rear drive cage” on page 323
- “Remove the 4 x 3.5-inch rear drive cage” on page 325
- “Install the 4 x 3.5-inch rear drive cage” on page 327
- “Remove the 4 x 2.5-inch rear drive cage” on page 330
- “Install the 4 x 2.5-inch rear drive cage” on page 332
- “Remove the 8 x 2.5-inch rear drive cage” on page 334
- “Install the 8 x 2.5-inch rear drive cage” on page 336
- “Remove the 7mm drive cage” on page 338
- “Install the 7mm drive cage” on page 341

Remove the 2 x 3.5-inch rear drive cage

Use this information to remove the 2 x 3.5-inch rear drive cage.

About this task

Attention:

1. Read “Installation Guidelines” on page 129 to ensure that you work safely.
2. Power off the server and disconnect all power cords for this task.
3. Prevent exposure to static electricity, which might lead to system halt and loss of data, by keeping static-sensitive components in their static-protective packages until installation, and handling these devices with an electrostatic-discharge wrist strap or other grounding system.

A video for this task is available at:

- Youtube: https://www.youtube.com/playlist?list=PLYV5R7hVcs-Bz2XleLEfGcrLGm9TSY_yt
- Youku: http://list.youku.com/albumlist/show/id_52339612.html

Procedure

Step 1. Prepare your server.

1. Remove the top cover. See “Remove the top cover” on page 392.
2. Disconnect the cables from the rear drive backplane. See Chapter 3 “Internal cable routing” on page 57.
3. Remove all the installed drives and fillers (if any) from the drive bays. See “Remove a hot-swap drive” on page 176.

Step 2. Remove the 2 x 3.5-inch rear drive cage.

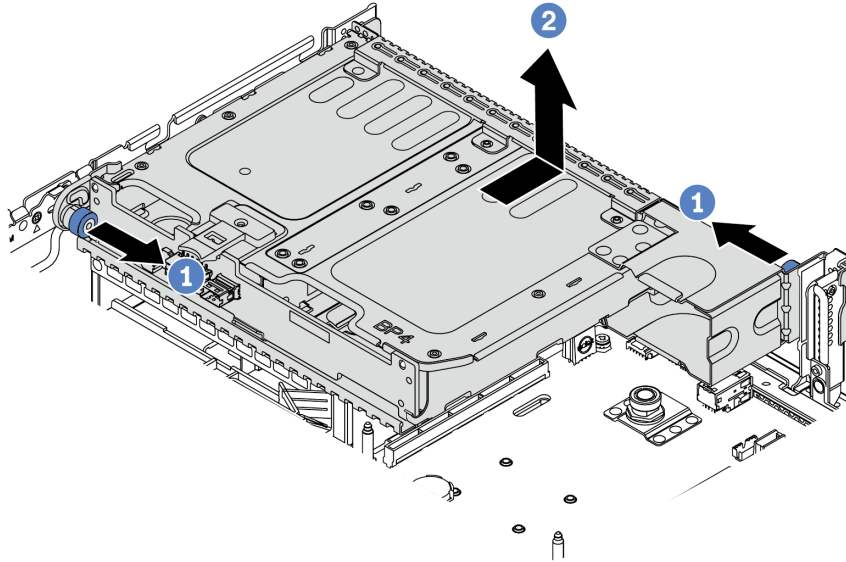

Figure 148. Removing the 2 x 3.5-inch rear drive cage

1. Twist and pull out the blue plungers.
2. Slide the drive cage towards the rear of the chassis to release it.

Step 3. If needed, remove the backplane from the drive cage. See “Remove the middle or rear 3.5-inch-drive backplane” on page 198.

After you finish

If you are instructed to return the old drive cage, follow all packaging instructions and use any packaging materials that are provided.

Install the 2 x 3.5-inch rear drive cage

Use this information to install the 2 x 3.5-inch rear drive cage.

About this task

The rear drive cage is supported on some server models at certain conditions. For detailed information, see “Drive bay configurations and requirements” on page 139.

Attention:

- Read “Installation Guidelines” on page 129 to ensure that you work safely.
- Prevent exposure to static electricity, which might lead to system halt and loss of data, by keeping static-sensitive components in their static-protective packages until installation, and handling these devices with an electrostatic-discharge wrist strap or other grounding system.

A video for this task is available at:

- Youtube: https://www.youtube.com/playlist?list=PLYV5R7hVcs-Bz2XleLEfGcrLGm9TSY_yt
- Youku: http://list.youku.com/albumlist/show/id_52339612.html

Procedure

Step 1. Prepare your server.

1. Install the required performance system fans. See “System fan replacement” on page 380.
2. Install the required riser brackets. See “PCIe adapter and riser assembly replacement” on page 345.
3. Install the backplane to the drive cage. See “Install the middle or rear 2.5-inch-drive backplane” on page 191.
4. Remove irrelevant rearwall brackets and install the rearwall brackets required for installing the 2 x 3.5-inch rear drive cage. See “Rearwall bracket replacement” on page 306

Step 2. Install the 2 x 3.5-inch rear drive cage.

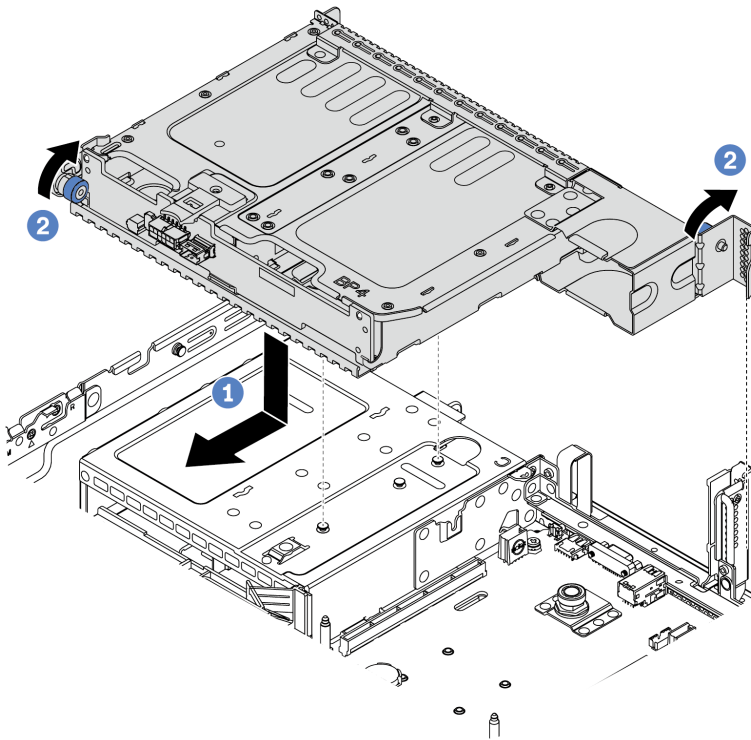

Figure 149. Installing the 2 x 3.5-inch rear drive cage

1. Align the rear drive cage with the chassis, and lower the drive cage into the chassis. Move the rear drive cage forward until it clicks into position.
2. Twist and release the blue plunger to secure the drive cage

Step 3. Check and ensure that the blue plungers are latched into place to secure the rear drive cage.

After you finish

1. Reinstall the drives or drive fillers into the rear drive cage. See “Install a hot-swap drive” on page 178.
2. Connect cables to the rear drive backplane. See Chapter 3 “Internal cable routing” on page 57.
3. Complete the parts replacement. See “Complete the parts replacement” on page 397.

Remove the 4 x 3.5-inch rear drive cage

Use this information to remove the 4 x 3.5-inch rear drive cage.

About this task

Attention:

1. Read “Installation Guidelines” on page 129 to ensure that you work safely.
2. Power off the server and disconnect all power cords for this task.
3. Prevent exposure to static electricity, which might lead to system halt and loss of data, by keeping static-sensitive components in their static-protective packages until installation, and handling these devices with an electrostatic-discharge wrist strap or other grounding system.

A video for this task is available at:

- Youtube: https://www.youtube.com/playlist?list=PLYV5R7hVcs-Bz2XleLEfGcrLGm9TSY_yt
- Youku: http://list.youku.com/albumlist/show/id_52339612.html

Procedure

Step 1. Prepare your server.

1. Remove the top cover. See “Remove the top cover” on page 392.
2. Disconnect the cables from the rear drive backplane. See Chapter 3 “Internal cable routing” on page 57.
3. Remove all the installed drives and fillers (if any) from the drive bays. See “Remove a hot-swap drive” on page 176.

Step 2. Remove the 4 x 3.5-inch rear drive cage.

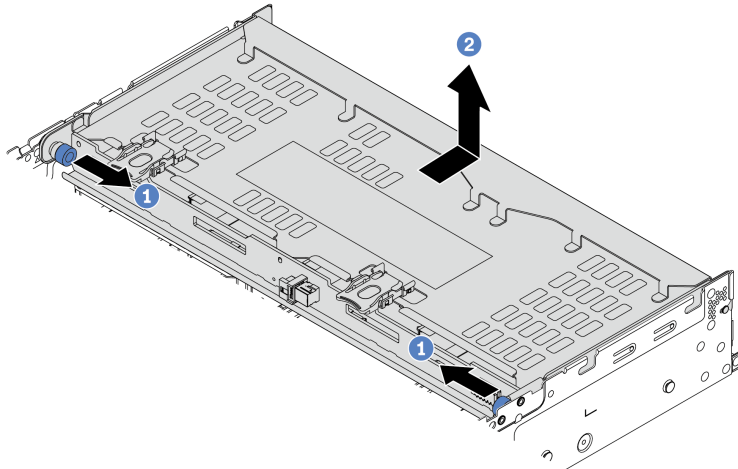

Figure 150. Removing the 4 x 3.5-inch rear drive cage

1. Twist and pull out the blue plungers.
2. Slide the drive cage towards the rear of the chassis to release it.

Step 3. If needed, remove the backplane from the drive cage. See “Remove the middle or rear 3.5-inch-drive backplane” on page 198.

After you finish

If you are instructed to return the old drive cage, follow all packaging instructions and use any packaging materials that are provided.

Install the 4 x 3.5-inch rear drive cage

Use this information to install the 4 x 3.5-inch rear drive cage.

About this task

The rear drive cage is supported on some server models at certain conditions. For detailed information, see “Drive bay configurations and requirements” on page 139.

Attention:

- Read “Installation Guidelines” on page 129 to ensure that you work safely.
- Prevent exposure to static electricity, which might lead to system halt and loss of data, by keeping static-sensitive components in their static-protective packages until installation, and handling these devices with an electrostatic-discharge wrist strap or other grounding system.

A video for this task is available at:

- Youtube: https://www.youtube.com/playlist?list=PLYV5R7hVcs-Bz2XleLEfGcrLGm9TSY_yt
- Youku: http://list.youku.com/albumlist/show/id_52339612.html

Procedure

Step 1. Prepare your server.

1. Install the required performance system fans. See “System fan replacement” on page 380.
2. Install the required riser brackets. See “PCIe adapter and riser assembly replacement” on page 345.
3. Install the backplane to the drive cage. See “Install the middle or rear 3.5-inch-drive backplane” on page 201.
4. Remove all rearwall brackets (if any). See “Rearwall bracket replacement” on page 306

Step 2. Align the rear drive cage with the chassis, and lower the drive cage into the chassis. Move the rear drive cage forward until it clicks into position.

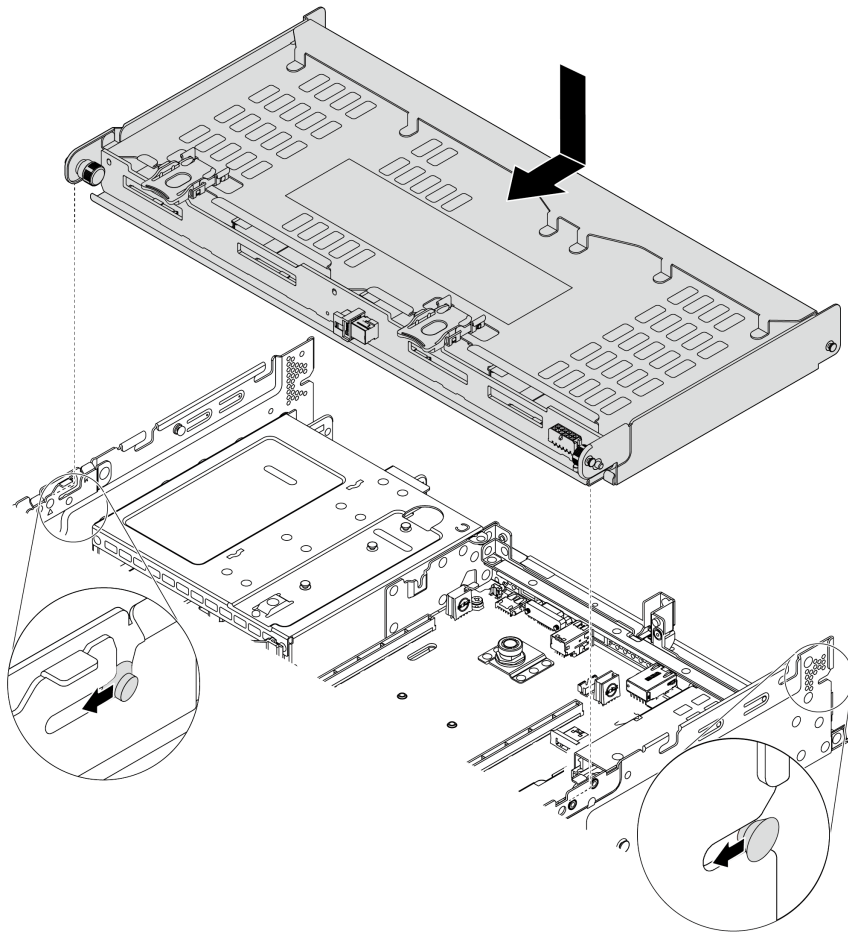

Figure 151.

Step 3. Check and ensure that the blue plungers are latched into place to secure the rear drive cage.

After you finish

1. Reinstall the drives or drive fillers into the rear drive cage. See “Install a hot-swap drive” on page 178.
2. Connect cables to the rear drive cage. See Chapter 3 “Internal cable routing” on page 57.
3. Complete the parts replacement. See “Complete the parts replacement” on page 397.

Remove the 4 x 2.5-inch rear drive cage

Use this information to remove the 4 x 2.5-inch rear drive cage.

About this task

Attention:

1. Read “Installation Guidelines” on page 129 to ensure that you work safely.
2. Power off the server and disconnect all power cords for this task.
3. Prevent exposure to static electricity, which might lead to system halt and loss of data, by keeping static-sensitive components in their static-protective packages until installation, and handling these devices with an electrostatic-discharge wrist strap or other grounding system.

A video for this task is available at:

- Youtube: https://www.youtube.com/playlist?list=PLYV5R7hVcs-Bz2XleLEfGcrLGm9TSY_yt
- Youku: http://list.youku.com/albumlist/show/id_52339612.html

Procedure

Step 1. Prepare your server.

1. Remove the top cover. See “Remove the top cover” on page 392.
2. Disconnect the cables from the rear drive cage.
3. Remove all the installed drives and fillers (if any) from the drive bays. See “Remove a hot-swap drive” on page 176.

Step 2. Remove the 4 x 2.5-inch drive cage.

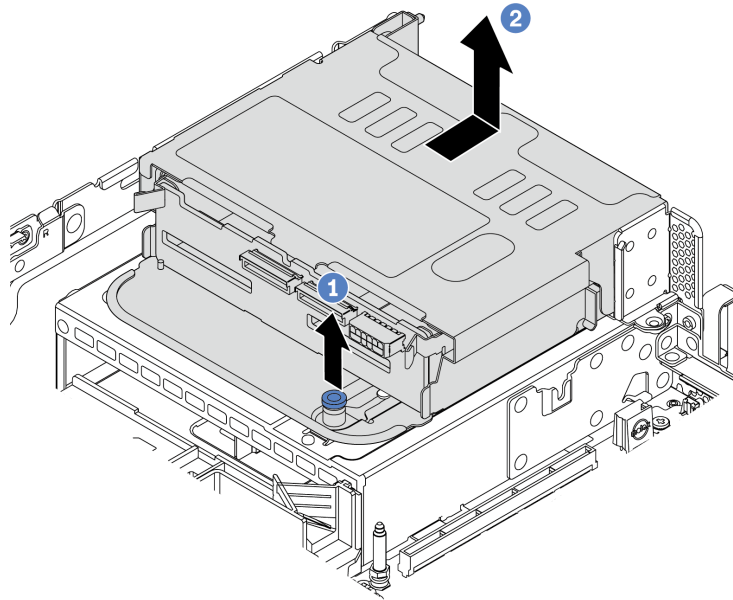

Figure 152. Removing the rear 4 x 2.5-inch drive cage

1. Twist and pull out the blue plunger.
2. Slide the drive cage towards the rear of the chassis to release it.

Step 3. If needed, remove the backplane from the drive cage. See “Remove the middle or rear 2.5-inch-drive backplane” on page 188.

After you finish

If you are instructed to return the old drive cage, follow all packaging instructions and use any packaging materials that are provided.

Install the 4 x 2.5-inch rear drive cage

Use this information to install the 4 x 2.5-inch rear drive cage.

About this task

The rear drive cage is supported on some server models at certain conditions. For detailed information, see “Drive bay configurations and requirements” on page 139.

Attention:

- Read “Installation Guidelines” on page 129 to ensure that you work safely.
- Prevent exposure to static electricity, which might lead to system halt and loss of data, by keeping static-sensitive components in their static-protective packages until installation, and handling these devices with an electrostatic-discharge wrist strap or other grounding system.

A video for this task is available at:

- Youtube: https://www.youtube.com/playlist?list=PLYV5R7hVcs-Bz2XleLEfGcrLGm9TSY_yt
- Youku: http://list.youku.com/albumlist/show/id_52339612.html

Procedure

Step 1. Prepare your server.

1. Install the required performance system fans. See “System fan replacement” on page 380.
2. Install the required riser brackets. See “PCIe adapter and riser assembly replacement” on page 345.
3. Install the backplane to the drive cage. See “Install the middle or rear 2.5-inch-drive backplane” on page 191.
4. Remove irrelevant rearwall brackets and install the rearwall brackets required for installing the 4 x 2.5-inch rear drive cage. See “Rearwall bracket replacement” on page 306

Step 2. Install the 4 x 2.5-inch rear drive cage.

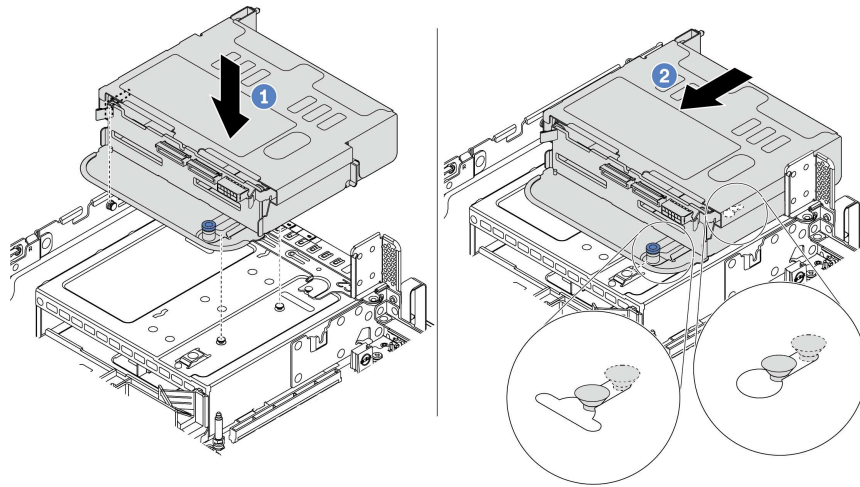

Figure 153. Installing the 4 x 2.5-inch rear drive cage

1. Align the rear drive cage with the chassis, and lower the drive cage into the chassis.
2. Move the rear drive cage forward until it clicks into position.

After you finish

1. Reinstall the drives or drive fillers into the rear drive cage. See “Install a hot-swap drive” on page 178.
2. Connect cables to the rear drive backplane. See Chapter 3 “Internal cable routing” on page 57.
3. Complete the parts replacement. See “Complete the parts replacement” on page 397.

Remove the 8 x 2.5-inch rear drive cage

Use this information to remove the 8 x 2.5-inch rear drive cage.

About this task

Attention:

1. Read “Installation Guidelines” on page 129 to ensure that you work safely.
2. Power off the server and disconnect all power cords for this task.
3. Prevent exposure to static electricity, which might lead to system halt and loss of data, by keeping static-sensitive components in their static-protective packages until installation, and handling these devices with an electrostatic-discharge wrist strap or other grounding system.

A video for this task is available at:

- Youtube: https://www.youtube.com/playlist?list=PLYV5R7hVcs-Bz2XleLEfGcrLGm9TSY_yt
- Youku: http://list.youku.com/albumlist/show/id_52339612.html

Procedure

Step 1. Prepare your server.

1. Remove the top cover. See “Remove the top cover” on page 392.
2. Disconnect the cables from the rear drive cage.
3. Remove all the installed drives and fillers (if any) from the drive bays. See “Remove a hot-swap drive” on page 176.

Step 2. Remove the 8 x 2.5-inch rear drive cage.

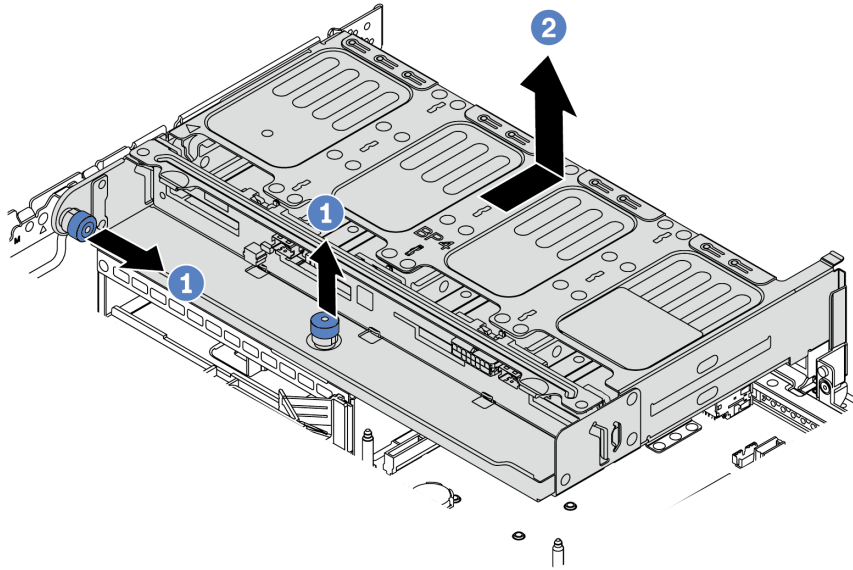

Figure 154. Removing the 8 x 2.5-inch rear drive cage

1. Twist and pull out the blue plunger.
 2. Slide the drive cage towards the rear of the chassis to release it.
- Step 3. If needed, remove the backplane from the drive cage. See “Remove the middle or rear 2.5-inch-drive backplane” on page 188.

After you finish

If you are instructed to return the old drive cage, follow all packaging instructions and use any packaging materials that are provided.

Install the 8 x 2.5-inch rear drive cage

Use this information to install the 8 x 2.5-inch rear drive cage.

About this task

The rear drive cage is supported on some server models at certain conditions. For detailed information, see “Drive bay configurations and requirements” on page 139.

Attention:

- Read “Installation Guidelines” on page 129 to ensure that you work safely.
- Prevent exposure to static electricity, which might lead to system halt and loss of data, by keeping static-sensitive components in their static-protective packages until installation, and handling these devices with an electrostatic-discharge wrist strap or other grounding system.

A video for this task is available at:

- Youtube: https://www.youtube.com/playlist?list=PLYV5R7hVcs-Bz2XleLEfGcrLGm9TSY_yt
- Youku: http://list.youku.com/albumlist/show/id_52339612.html

Procedure

Step 1. Prepare your server.

1. Install the required performance system fans. See “System fan replacement” on page 380.
2. Install the required riser brackets. See “PCIe adapter and riser assembly replacement” on page 345.
3. Install the backplane to the drive cage. See “Install the middle or rear 2.5-inch-drive backplane” on page 191.
4. Remove irrelevant rearwall brackets and install the rearwall brackets required for installing the 8 x 2.5-inch rear drive cage. See “Rearwall bracket replacement” on page 306

Step 2. Install the 8 x 2.5-inch rear drive cage.

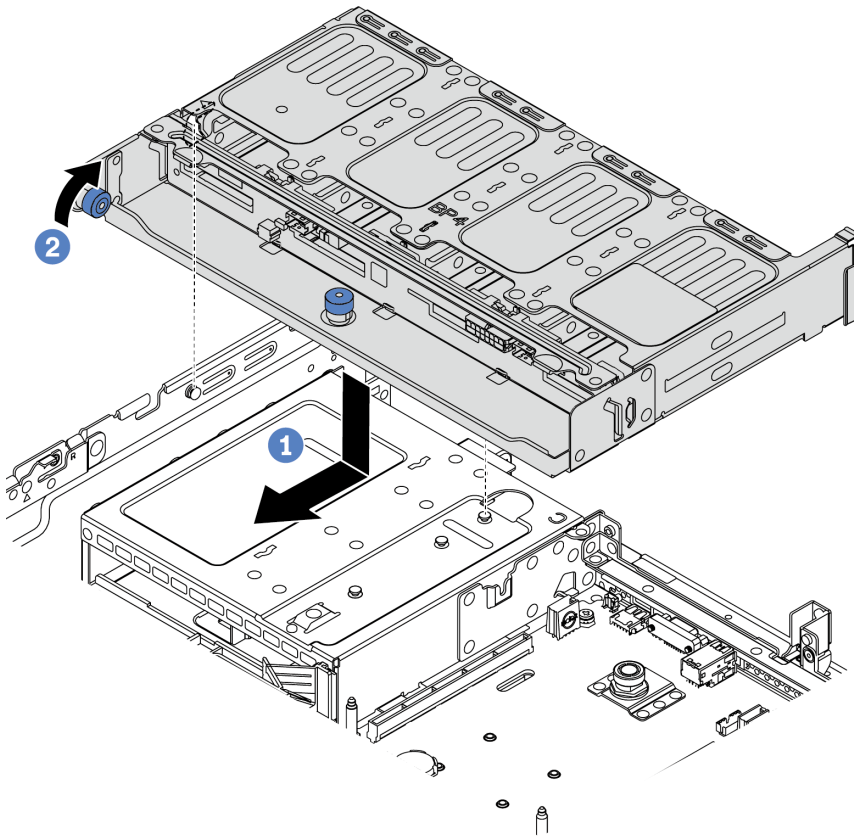

Figure 155. Installing the 8 x 2.5-inch rear drive cage

1. Align the rear drive cage with the chassis, and lower the drive cage into the chassis. Move the rear drive cage forward until it clicks into position.
2. Twist and put down the blue plunger.

After you finish

1. Reinstall the drives or drive fillers into the rear drive cage. See “Install a hot-swap drive” on page 178.
2. Connect cables to the rear drive cage. See Chapter 3 “Internal cable routing” on page 57.
3. Complete the parts replacement. See “Complete the parts replacement” on page 397.

Remove the 7mm drive cage

Use this information to remove the 7mm drive backplane.

About this task

The following illustrates how to remove the 7mm rear drive assembly from a riser cage assembly (two full-height slots + one 7mm cage). The single-slot 7mm rear drive assembly is directly installed on the chassis and can be removed the same way as that for riser 1/2 assembly.

Attention:

- Read “Installation Guidelines” on page 129 to ensure that you work safely.
- Power off the server and disconnect all power cords for this task.
- Prevent exposure to static electricity, which might lead to system halt and loss of data, by keeping static-sensitive components in their static-protective packages until installation, and handling these devices with an electrostatic-discharge wrist strap or other grounding system.

A video for this task is available at:

- Youtube: https://www.youtube.com/playlist?list=PLYV5R7hVcs-Bz2XleLEfGcrLGm9TSY_yt
- Youku: http://list.youku.com/albumlist/show/id_52339612.html

Procedure

Note: Depending on the specific type, your backplane might look different from the illustration in this topic.

Step 1. Prepare your server.

1. Remove the top cover. See “Remove the top cover” on page 392.
2. Remove all the installed drives and fillers (if any) from the drive bays. See “Remove a hot-swap drive” on page 176.
3. Record the cable connections for 7mm drives and then disconnect all cables from the backplanes. See “7mm drives” on page 64.
4. Remove the 7mm drive assembly (if any) from the rear chassis. See “Rear drive cage replacement” on page 320.

Step 2. Remove the 7mm drive cage from the riser 2 cage.

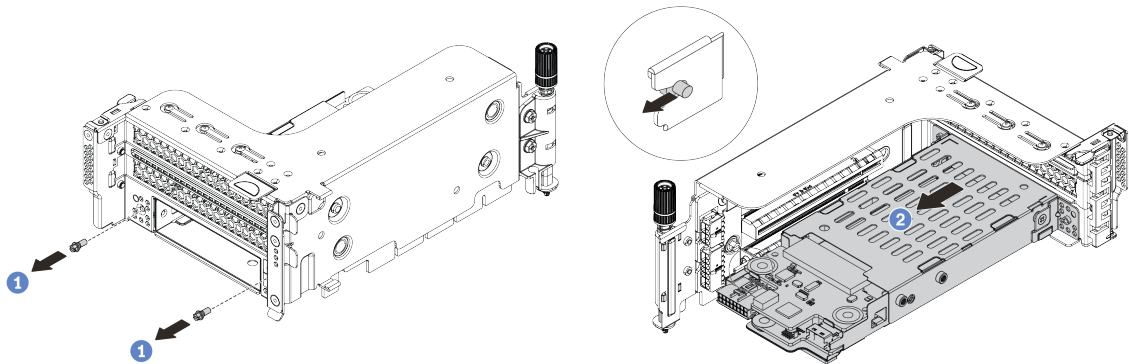

Figure 156. 7mm drive cage removal

1. Remove the two screws as shown.
2. Slightly and horizontally slide the cage out of the riser 2 cage.

- Step 3. Remove the two 7mm backplanes from the 7mm drive cage. See “Remove the 7mm drive backplane” on page 203.
- Step 4. Remove the 7mm drive cage securing clip as shown.

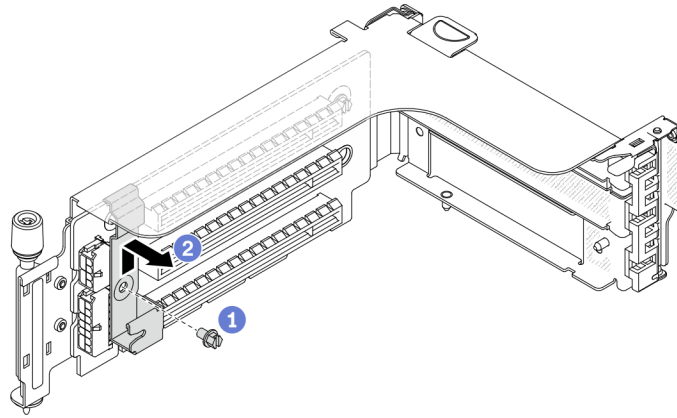

Figure 157. 7mm drive cage securing clip removal

- Step 5. (Optional) Remove the riser 2 assembly from the riser 2 slot on the system board. See “Remove a PCIe adapter and riser 1/2 assembly” on page 346.

After you finish

If you are instructed to return the old cage, follow all packaging instructions and use any packaging materials that are provided.

Install the 7mm drive cage

Use this information to install the 7mm drive backplanes.

About this task

The following illustrates how to install the 7mm rear drive assembly to a riser cage assembly (two full-height slots + one 7mm cage). The single-slot 7mm rear drive assembly is directly installed on the chassis and the installation method is the same as that for 2.5-inch rear drive assembly.

Attention:

- Read “Installation Guidelines” on page 129 to ensure that you work safely.
- Power off the server and disconnect all power cords for this task.
- Prevent exposure to static electricity, which might lead to system halt and loss of data, by keeping static-sensitive components in their static-protective packages until installation, and handling these devices with an electrostatic-discharge wrist strap or other grounding system.

A video for this task is available at:

- Youtube: https://www.youtube.com/playlist?list=PLYV5R7hVcs-Bz2XIeLEfGcrLGm9TSY_yt
- Youku: http://list.youku.com/albumlist/show/id_52339612.html

Procedure

- Step 1. Touch the static-protective package that contains the new backplane to any unpainted surface on the outside of the server. Then, take the new backplane out of the package and place it on a static-protective surface.
- Step 2. Install the two 7mm backplanes to the 7mm drive cage. See “Install the 7mm drive backplanes” on page 205.
- Step 3. Connect the cables any cables from the 7mm drive backplanes. See “7mm drives” on page 64.

Step 4. Hook the securing clip over the riser adapter on the riser cage.

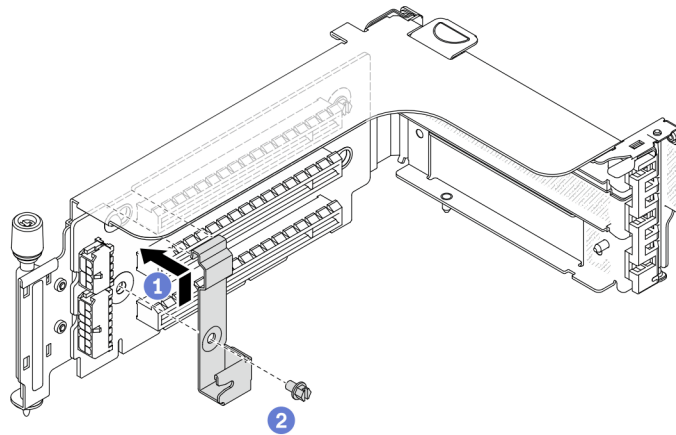

Figure 158. 7mm drive cage securing clip installation

Step 5. Install the 7mm drive cage to the riser cage.

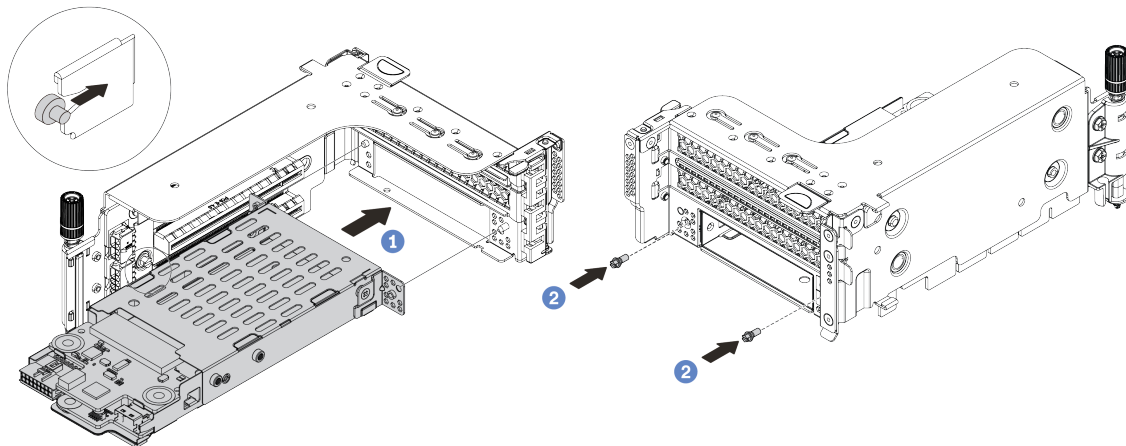

Figure 159. 7mm drive cage installation

- a. Align the left-side pin on the 7mm drive cage with the positioning slot on the securing clip, the two holes on the side brackets of the 7mm drive cage with the two holes on the front of the riser cage.
- b. Install the two screws to secure the 7mm drive cage in place

Step 6. Install the riser 2 assembly to the riser 2 slot on the system board. See “Install a PCIe adapter and riser 1/2 assembly” on page 350.

After you finish

1. Reinstall all the drives and fillers (if any) into the drive bays. See “Install a hot-swap drive” on page 178.
2. Complete the parts replacement. See “Complete the parts replacement” on page 397.

PCIe adapter and riser assembly replacement

Use this information to remove and install a riser card.

Depending on your configuration, refer to the specific topics to remove or install a riser assembly:

- “Remove a PCIe adapter and riser 1/2 assembly” on page 346
- “Remove a PCIe adapter and riser 3 assembly” on page 355
- “Install a PCIe adapter and riser 1/2 assembly” on page 350
- “Install a PCIe adapter and riser 3 assembly” on page 359

Your server supports the following rear configurations:

FH = full height, FL = full length, HL = half length

Server model	Riser slot configuration
Server model with 8 PCIe slots	The server has 8 PCIe slots: <ul style="list-style-type: none">• Riser 1(slot 1-3): 2FHFL+1FHHL• Riser 2(slot 4-6): 2FHFL+1FHHL/7 mm drives• Riser 3(slot 7-8): 2FHFL
Server model with 4 x 2.5-inch rear drives	The server has 6 PCIe slots: <ul style="list-style-type: none">• Riser 1(slot 1-3): 2FHFL+1FHHL• Riser 2(slot 4-6): 2FHFL+1FHHL/7 mm drives
Server model with 8 x 2.5-inch rear drives	The server has 4 PCIe slots: <ul style="list-style-type: none">• Riser 1(slot 1-3): 2FHFL+1FHHL• Riser 2(slot 6): 1FHHL/7 mm drives
Server model with 2 x 3.5-inch rear drives	The server has 4 PCIe slots: <ul style="list-style-type: none">• Riser 1(slot 1-3): 2FHFL+1FHHL• Riser 2(slot 6): 1FHHL/7 mm drives
Server model with 4x 3.5-inch rear drives	The server has 2 PCIe slots: <ul style="list-style-type: none">• Riser 1(slot 3): 1FHHL• Riser 2(slot 6): 1FHHL/7 mm drives

Remove a PCIe adapter and riser 1/2 assembly

Use this information to remove a PCIe adapter and riser 1/2 assembly.

About this task

Attention:

- Read “Installation Guidelines” on page 129 to ensure that you work safely.
- Prevent exposure to static electricity, which might lead to system halt and loss of data, by keeping static-sensitive components in their static-protective packages until installation, and handling these devices with an electrostatic-discharge wrist strap or other grounding system.

A video for this task is available at:

- Youtube: https://www.youtube.com/playlist?list=PLYV5R7hVcs-Bz2XleLEfGcrLGm9TSY_yt
- Youku: http://list.youku.com/albumlist/show/id_52339612.html

Procedure

- Step 1. Touch the static-protective package that contains the new riser card to any unpainted surface on the outside of the server. Then, take the new riser card out of the package and place it on a static-protective surface.
- Step 2. Remove the top cover. See “Remove the top cover” on page 392.
- Step 3. If there is any PCIe adapter installed on the riser card, record the cable connections first. Then, disconnect all cables from the PCIe adapter.
- Step 4. Remove a riser 1 assembly or riser 2 assembly. The illustration shows removing the riser 1 assemblies. The procedure is the same for removing riser 2 assemblies.

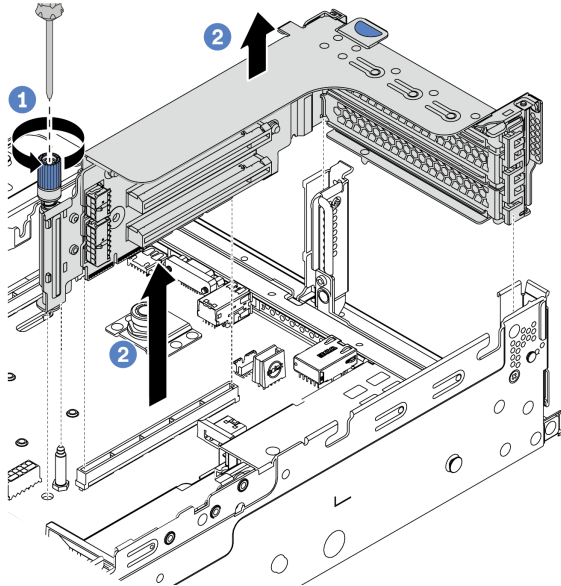

Figure 160. Riser 1/2 assembly removal (three-slot bracket)

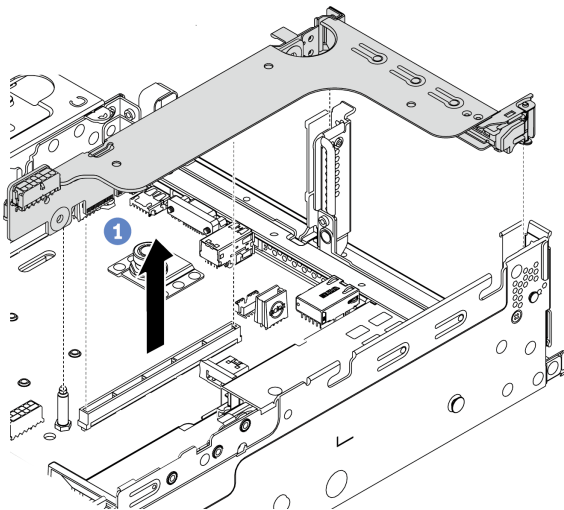

Figure 161. Riser 1/2 assembly removal (one-slot riser bracket)

1. (Optional) Loosen the screw that secures the riser assembly.
2. Grasp the riser assembly by its edges and carefully lift it straight up and off the chassis.

Step 5. Remove any PCIe adapters from the riser assembly. The illustration shows how to remove a PCIe adapter from a riser 1/2 assembly, the method is the same for removing other PCIe adapters.

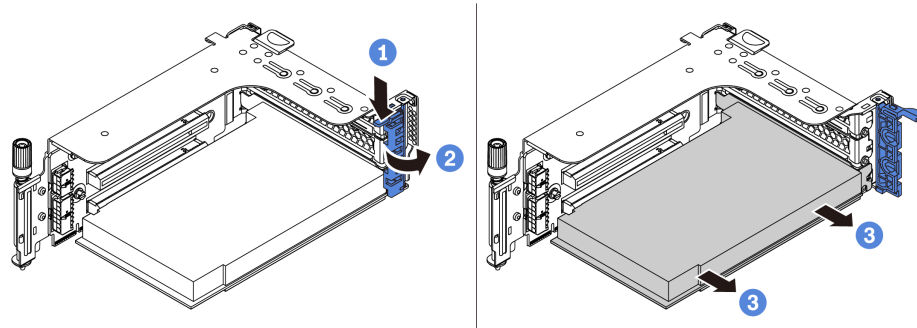

Figure 162. PCIe adapter removal

1. Press the retainer clip downward.
2. Rotate the PCIe adapter retention latch to the open position.
3. Grasp the PCIe adapter by its edges and carefully pull it out of the PCIe slot.

Note: The PCIe adapter might fit tightly into the PCIe slot. If necessary, alternatively move each side of the PCIe adapter a small and equal amount until it is removed from the slot.

Step 6. Remove a riser card in a riser cage.

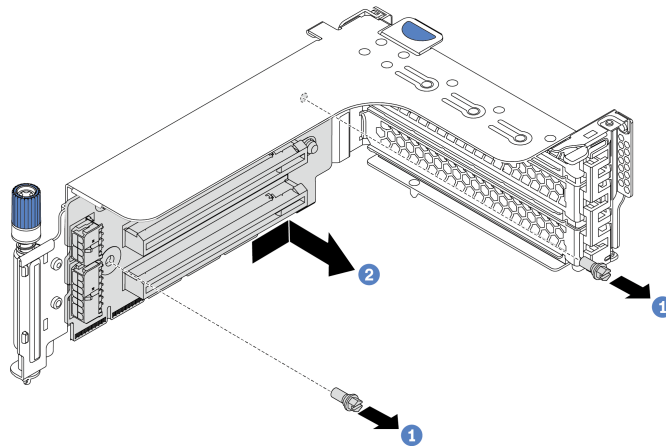

Figure 163. Riser card removal (three-slot riser bracket)

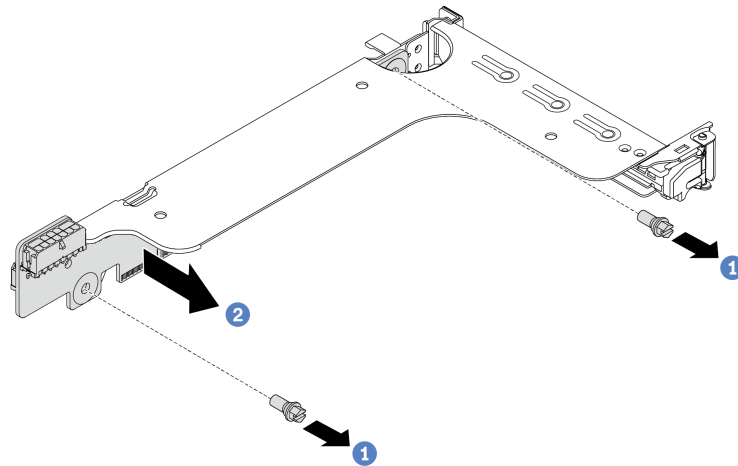

Figure 164. Riser card removal (one-slot or two-slot riser bracket)

1. Remove the two screws.
2. Remove the riser card from the bracket in the direction as shown.

After you finish

1. Refer to Chapter 3 “Internal cable routing” on page 57 if you need reconnect any cables to the removed PCIe adapters or riser cards.
2. Reinstall the PCIe adapters and riser assembly. See “Install a PCIe adapter and riser 1/2 assembly” on page 350.
3. Complete the parts replacement. See “Complete the parts replacement” on page 397.

Install a PCIe adapter and riser 1/2 assembly

Use this information to install a PCIe adapter and riser 1/2 assembly.

About this task

Attention:

- Read “Installation Guidelines” on page 129 to ensure that you work safely.
- Prevent exposure to static electricity, which might lead to system halt and loss of data, by keeping static-sensitive components in their static-protective packages until installation, and handling these devices with an electrostatic-discharge wrist strap or other grounding system.

A video for this task is available at:

- Youtube: https://www.youtube.com/playlist?list=PLYV5R7hVcs-Bz2XleLEfGcrLGm9TSY_yt
- Youku: http://list.youku.com/albumlist/show/id_52339612.html

Procedure

- Step 1. Touch the static-protective package that contains the new riser card to any unpainted surface on the outside of the server. Then, take the new riser card out of the package and place it on a static-protective surface.
- Step 2. Install a riser card in a riser cage.

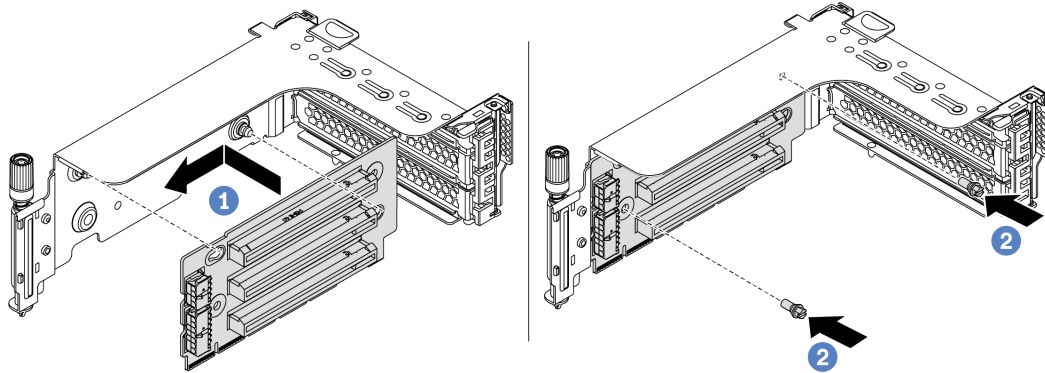

Figure 165. Riser card installation (three-slot riser bracket)

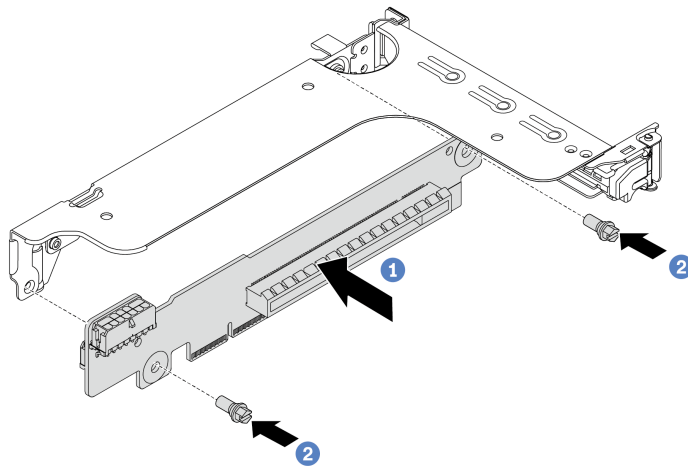

Figure 166. Riser card installation (one-slot or two-slot riser bracket)

1. Align the holes in the riser card with the mounting studs on the bracket. Install the riser card to the bracket in the direction as shown.
2. Install the two screws to secure the riser card to the bracket.

Step 3. Install PCIe adapters.

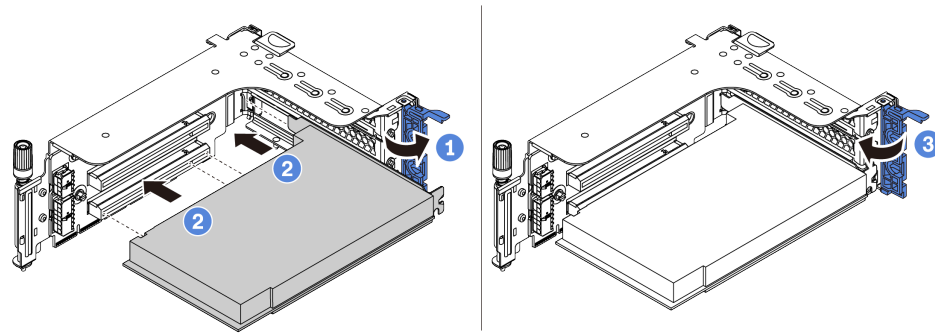

Figure 167. PCIe adapter installation

Note: Carefully handle the PCIe adapter by its edges.

1. Align the PCIe adapter with the PCIe slot on the riser card. Carefully press the PCIe adapter straight into the slot until it is securely seated and its bracket also is secured.
2. Rotate the PCIe adapter retention latch to the closed position.

- Step 4. Check the rearwall matrix and decide which rearwall brackets need to be installed or removed for installing your riser assemblies. See “Rearwall bracket replacement” on page 306
- Step 5. Install a riser 1 assembly or riser 2 assembly. The illustration shows installing the riser 1 assemblies. The procedure is the same for installing riser 2 assemblies.

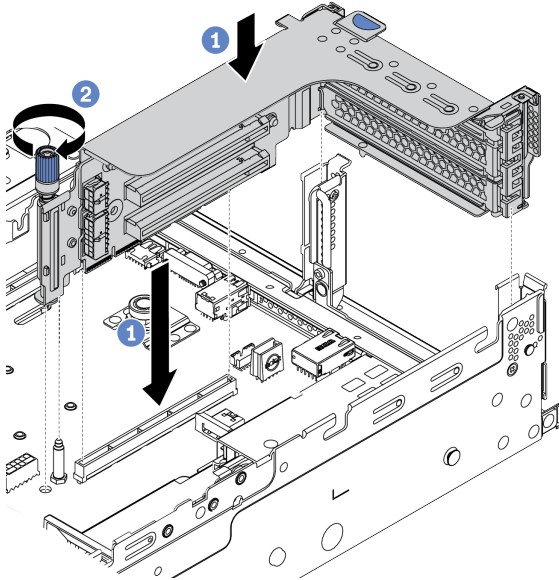

Figure 168. Riser 1/2 assembly installation (three-slot riser bracket)

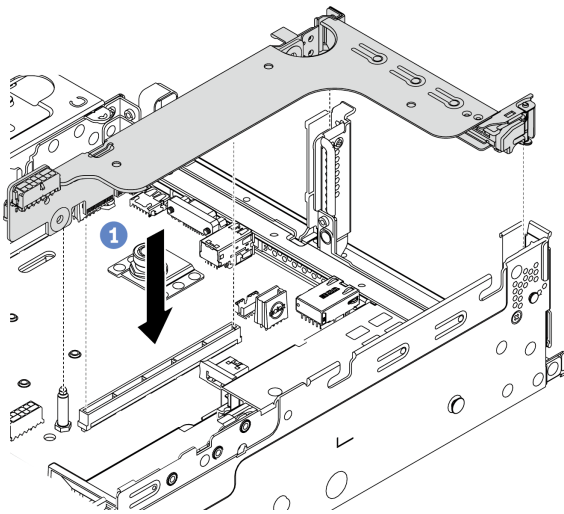

Figure 169. Riser 1/2 assembly installation (one-slot riser bracket)

1. Align the riser adapter in the riser cage with the PCIe riser slot on the system board. Carefully press the PCIe adapter straight into the slot until it is securely seated and its bracket also is secured.
2. (Optional) If there is one screw on the riser cage, tighten the screw.

After you finish

1. Refer to Chapter 3 “Internal cable routing” on page 57 to connect any cables to the PCIe adapters.
2. Complete the parts replacement. See “Complete the parts replacement” on page 397.

Remove a PCIe adapter and riser 3 assembly

Use this information to remove a PCIe adapter and riser 3 assembly.

About this task

Attention:

- Read “Installation Guidelines” on page 129 to ensure that you work safely.
- Prevent exposure to static electricity, which might lead to system halt and loss of data, by keeping static-sensitive components in their static-protective packages until installation, and handling these devices with an electrostatic-discharge wrist strap or other grounding system.

A video for this task is available at:

- Youtube: https://www.youtube.com/playlist?list=PLYV5R7hVcs-Bz2XleLEfGcrLGm9TSY_yt
- Youku: http://list.youku.com/albumlist/show/id_52339612.html

Procedure

- Step 1. Touch the static-protective package that contains the new riser card to any unpainted surface on the outside of the server. Then, take the new riser card out of the package and place it on a static-protective surface.
- Step 2. Remove the top cover. See “Remove the top cover” on page 392.
- Step 3. If there is any PCIe adapter installed on the riser card, record the cable connections first. Then, disconnect all cables from the PCIe adapter.
- Step 4. Remove the riser 3 assembly in the direction as shown.

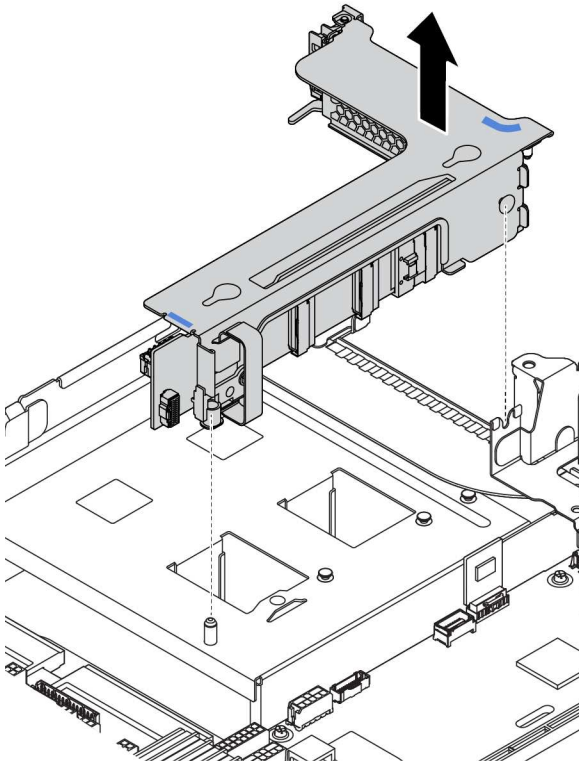

Figure 170. Riser 3 assembly removal (two-slot riser bracket)

Step 5. Remove any PCIe adapters from the riser assembly. The illustration shows how to remove a PCIe adapter from a riser 1/2 assembly, the method is the same for removing other PCIe adapters.

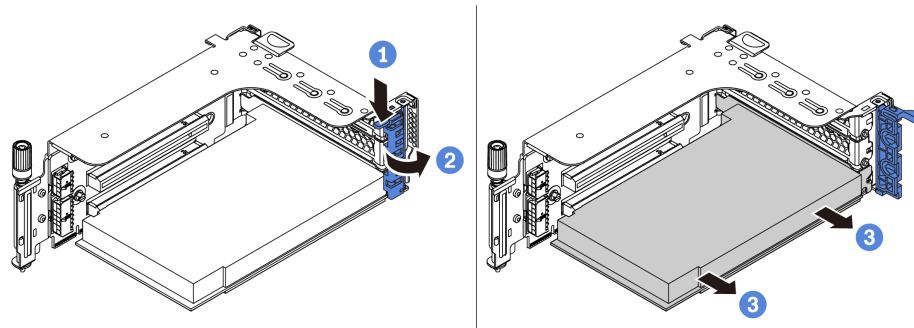

Figure 171. PCIe adapter removal

1. Press the retainer clip downward.
2. Rotate the PCIe adapter retention latch to the open position.
3. Grasp the PCIe adapter by its edges and carefully pull it out of the PCIe slot.

Note: The PCIe adapter might fit tightly into the PCIe slot. If necessary, alternatively move each side of the PCIe adapter a small and equal amount until it is removed from the slot.

Step 6. Remove a riser card in a riser cage.

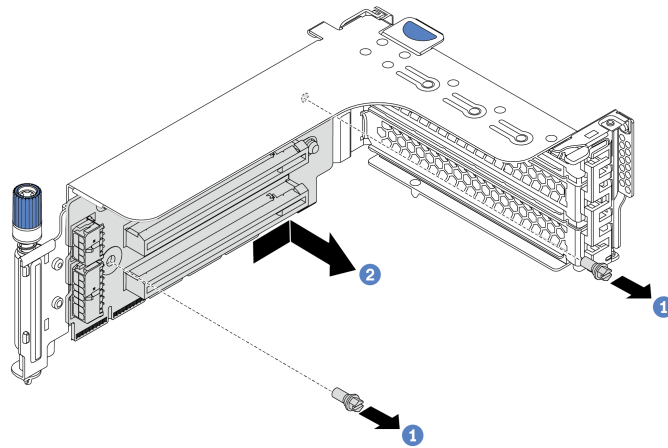

Figure 172. Riser card removal (three-slot riser bracket)

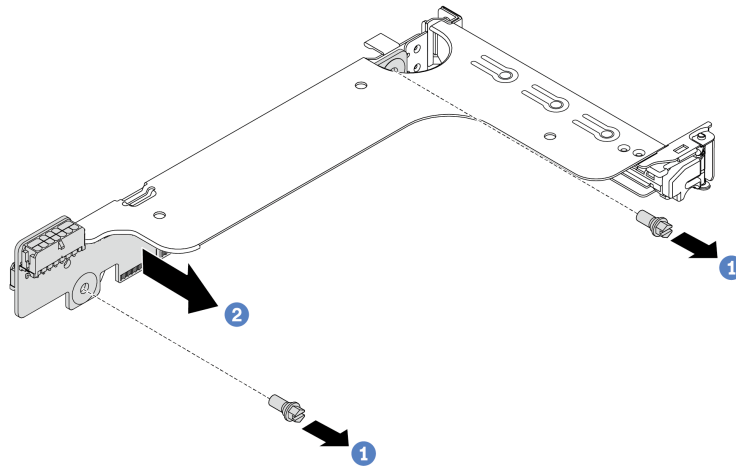

Figure 173. Riser card removal (one-slot or two-slot riser bracket)

1. Remove the two screws.
2. Remove the riser card from the bracket in the direction as shown.

After you finish

1. Refer to Chapter 3 “Internal cable routing” on page 57 if you need reconnect any cables to the removed PCIe adapters or riser cards.
2. Reinstall the PCIe adapters and riser assembly. See “Install a PCIe adapter and riser 3 assembly” on page 359
3. Complete the parts replacement. See “Complete the parts replacement” on page 397.

Install a PCIe adapter and riser 3 assembly

Use this information to install a PCIe adapter and riser 3 assembly.

About this task

Attention:

- Read “Installation Guidelines” on page 129 to ensure that you work safely.
- Prevent exposure to static electricity, which might lead to system halt and loss of data, by keeping static-sensitive components in their static-protective packages until installation, and handling these devices with an electrostatic-discharge wrist strap or other grounding system.

A video for this task is available at:

- Youtube: https://www.youtube.com/playlist?list=PLYV5R7hVcs-Bz2XleLEfGcrLGm9TSY_yt
- Youku: http://list.youku.com/albumlist/show/id_52339612.html

Procedure

- Step 1. Touch the static-protective package that contains the new riser card to any unpainted surface on the outside of the server. Then, take the new riser card out of the package and place it on a static-protective surface.
- Step 2. Install the riser card to the riser bracket. See Step 2 Install a riser card on page 351.
- Step 3. Install PCIe adapters. See Step 3 Install a PCIe adapter on page 352.
- Step 4. Check the rearwall matrix and decide which rearwall brackets need to be installed or removed for installing your riser assemblies. See “Rearwall bracket replacement” on page 306
- Step 5. Install a riser 3 assembly. Align the securing clip at the end of the riser cage with the pin on the rear chassis, the pin on the right side of the riser cage with the pin slot on the C1 rearwall bracket. Carefully put down the riser 3 assembly until it is securely seated.

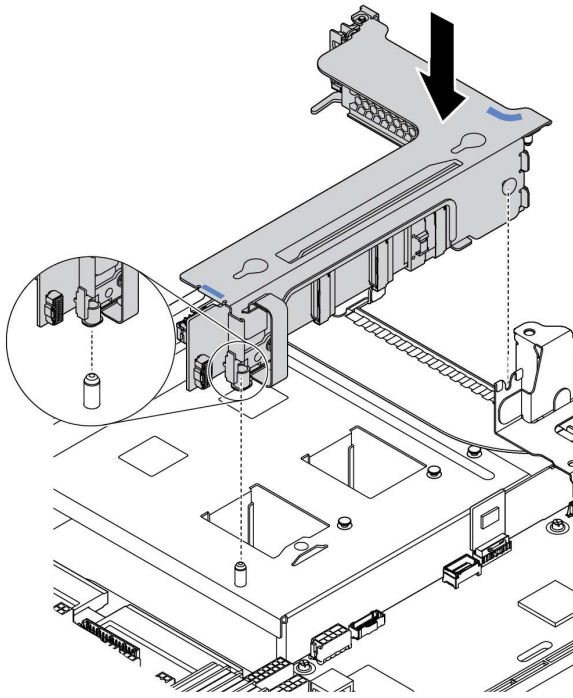

Figure 174. Riser 3 assembly installation

After you finish

1. Refer to Chapter 3 “Internal cable routing” on page 57 to connect any cables to the PCIe adapters.
2. Complete the parts replacement. See “Complete the parts replacement” on page 397.

Security bezel replacement

Use this information to remove and install the security bezel.

Note: The security bezel is available on some models.

- “Remove the security bezel” on page 362
- “Install the security bezel” on page 365

Remove the security bezel

Use this information to remove the security bezel.

About this task

Attention:

- Read “Installation Guidelines” on page 129 to ensure that you work safely.
- Before you ship the rack with the server installed, reinstall and lock the security bezel into place.

A video for this task is available at:

- Youtube: https://www.youtube.com/playlist?list=PLYV5R7hVcs-Bz2XleLEfGcrLGm9TSY_yt
- Youku: http://list.youku.com/albumlist/show/id_52339612.html

Procedure

Step 1. Use the key to unlock the security bezel.

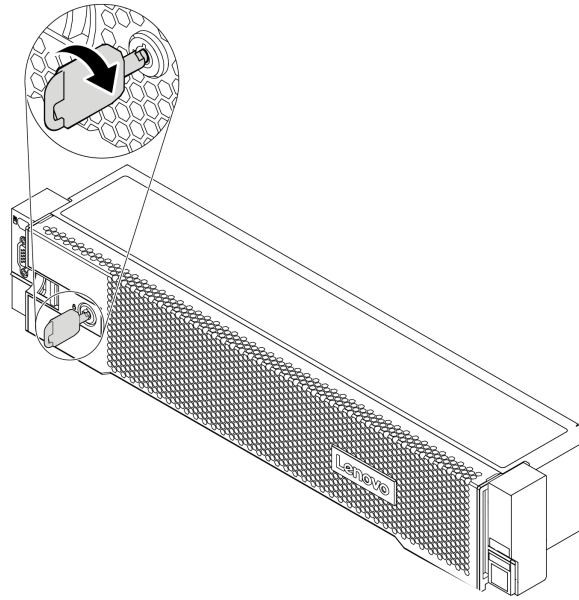

Figure 175. Unlocking the security bezel

Step 2. Press the release latch **1** and rotate the security bezel outward to remove it from the chassis.

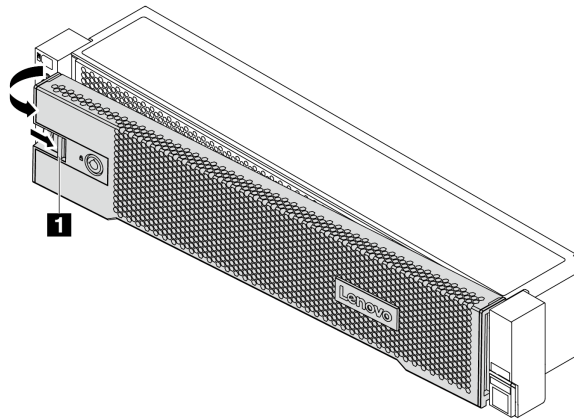

Figure 176. Security bezel removal

After you finish

Complete the parts replacement. See “Complete the parts replacement” on page 397.

Install the security bezel

Use this information to install the security bezel.

About this task

Before you ship the rack with the server installed, reinstall and lock the security bezel into place.

Attention: Read “Installation Guidelines” on page 129 to ensure that you work safely.

A video for this task is available at:

- Youtube: https://www.youtube.com/playlist?list=PLYV5R7hVcs-Bz2XIeLEfGcrLGm9TSY_yt
- Youku: http://list.youku.com/albumlist/show/id_52339612.html

Procedure

- Step 1. If you have removed the rack latches, reinstall them. See “Install the rack latches” on page 282.
- Step 2. If the key is held inside the security bezel, remove it out of the security bezel.

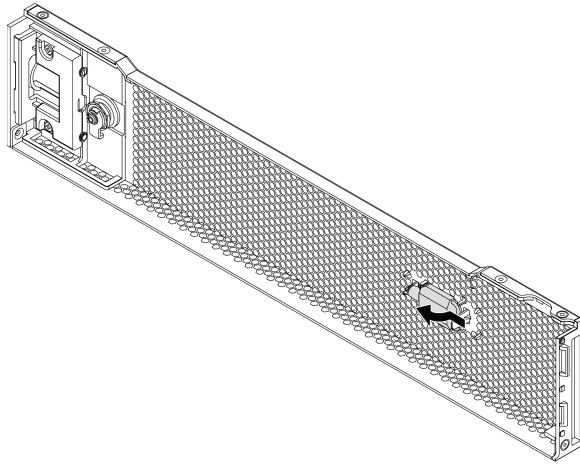

Figure 177. Key removal

Step 3. Carefully insert the tabs on the security bezel into the slots on the right rack latch. Then, press and hold the release latch **1** and rotate the security bezel inward until the other side clicks into place.

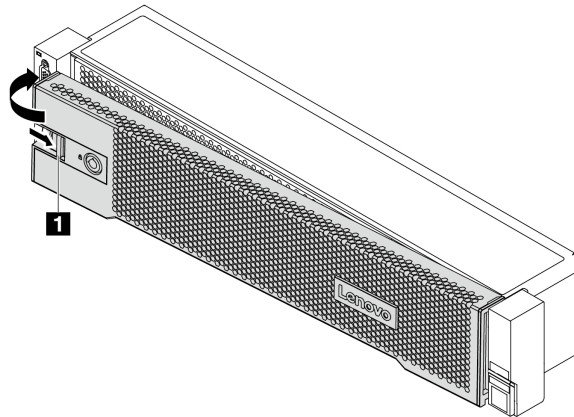

Figure 178. Security bezel installation

Step 4. Use the key to lock the security bezel to the closed position.

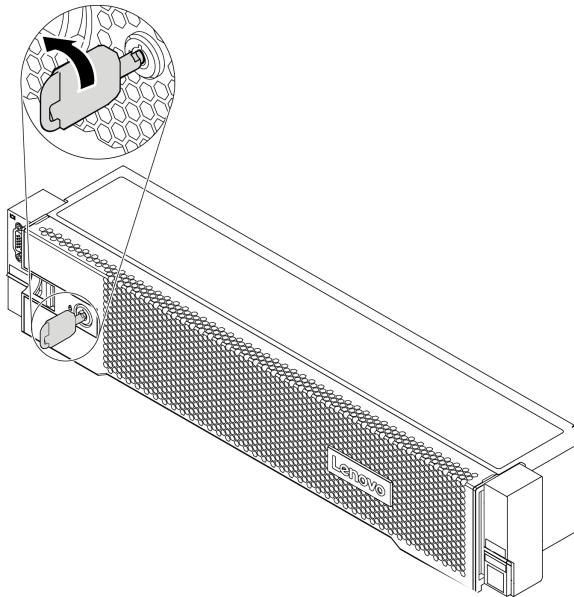

Figure 179. Locking the security bezel

System board replacement

Use this information to remove and install the system board.

- “Remove the system board” on page 369
- “Install the system board” on page 372
- “Update the Universal Unique Identifier (UUID)” on page 375
- “Update the DMI/SMBIOS data” on page 376
- “Enable TPM” on page 376
 - “Set the TPM policy” on page 376
 - “(Optional) assert physical presence” on page 376
- “Enable UEFI Secure Boot” on page 378

S017



CAUTION:
Hazardous moving fan blades nearby.

S012



CAUTION:
Hot surface nearby.

Remove the system board

Use this information to remove the system board.

About this task

A system board, also known as the motherboard, provides different connectors or slots to connect different components or peripherals of the system for communication. If the system board fails, it must be replaced.

Attention:

- Read “Installation Guidelines” on page 129 to ensure that you work safely.
- Power off the server and disconnect all power cords for this task.
- Prevent exposure to static electricity, which might lead to system halt and loss of data, by keeping static-sensitive components in their static-protective packages until installation, and handling these devices with an electrostatic-discharge wrist strap or other grounding system.

A video for this task is available at:

- Youtube: https://www.youtube.com/playlist?list=PLYV5R7hVcs-Bz2XIeLEfGcrLGm9TSY_yt
- Youku: http://list.youku.com/albumlist/show/id_52339612.html

Procedure

Step 1. Prepare your server.

1. Remove the top cover. See “Remove the top cover” on page 392.
2. If your server comes with an air baffle, remove it first. See “Remove the air baffle” on page 149.
3. Record where the cables are connected to the system board; then, disconnect all the cables.
4. Remove any of the following components that are installed on the system board and put them in a safe, static-protective place.
 - “Heat sink” on page 266 and “Processor” on page 269
 - “Memory modules” on page 252
 - “System fans” on page 381 and “System fan cage” on page 387
 - “M.2 module” on page 234
 - “RAID super capacitor modules” on page 291
 - “Middle drive cage” on page 242
 - “Rear drive cage” on page 320
 - “Riser 1/2 assembly” on page 346 and “Riser 3 assembly” on page 355
 - “Backplanes” on page 181
 - “CFF RAID/HBA/RAID expander adapters” on page 226
 - “CMOS battery” on page 160
 - “OCP 3.0 Ethernet adapter” on page 260
5. Pull out the power supplies slightly. Ensure that they are disconnected from the system board.

Step 2. Lift the release pin **1** and hold the lift handle **2** at the same time and slide the system board toward the front of the server.

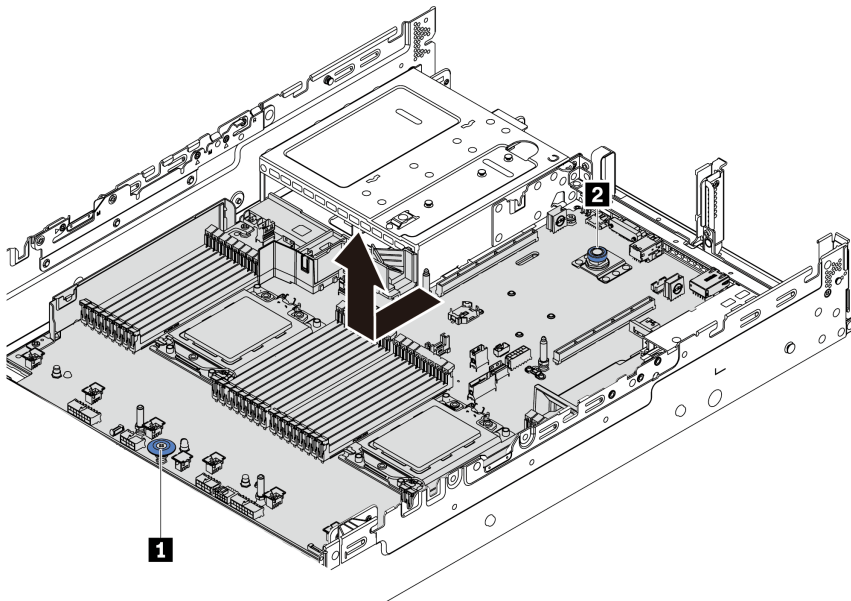

Figure 180. System board removal

Step 3. Tilt and lift the system board out of the chassis.

After you finish

If you are instructed to return the old system board, follow all packaging instructions and use any packaging materials that are provided.

Important: Before you return the system board, make sure that the CPU socket is covered. There is a CPU external cap covering the CPU socket on the new system board. Slide the CPU external cap out from the CPU socket on the new system board, and install the external cap on the CPU socket on the removed system board.

If you are planning to recycle the system board, follow the instructions in “Disassembling the system board for recycle” on page 436 for compliance with local regulations.

Install the system board

Use this information to install the system board.

About this task

Attention:

- Read “Installation Guidelines” on page 129 to ensure that you work safely.
- Power off the server and disconnect all power cords for this task.
- Prevent exposure to static electricity, which might lead to system halt and loss of data, by keeping static-sensitive components in their static-protective packages until installation, and handling these devices with an electrostatic-discharge wrist strap or other grounding system.

A video for this task is available at:

- Youtube: https://www.youtube.com/playlist?list=PLYV5R7hVcs-Bz2XleLEfGcrLGm9TSY_yt
- Youku: http://list.youku.com/albumlist/show/id_52339612.html

Procedure

- Step 1. Touch the static-protective package that contains the new system board to any unpainted surface on the outside of the server. Then, take the new system board out of the package and place it on a static-protective surface.
- Step 2. Install the new system board to the server.

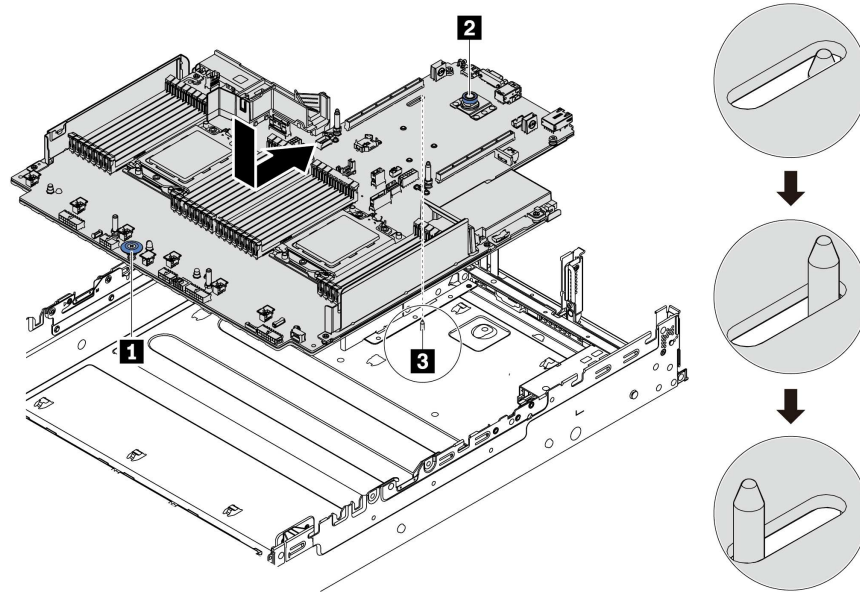

Figure 181. System board installation

1. Hold the release pin **1** and the lift handle **2** at the same time to lower the system board into the chassis.
2. Slide the system board to the rear of the server until the system board snaps into position. Ensure that:
 - The new system board is engaged by the mounting stud **3** on the chassis.
 - The rear connectors on the new system board are inserted into the corresponding holes in the rear panel.
 - The release pin **1** secures the system board in place.
- Step 3. A new system board comes with half-height cable holders by default. If the old system board is installed with full-height cable holders, remove them from the old system board and install them to the new system board. See “Cable wall brackets replacement (full-height/half-height)” on page 155.

After you finish

1. Install any components that you have removed from the failing system board.
 - “Processor ” on page 271 and “Heat sink” on page 273
 - “Memory modules” on page 255
 - “System fans” on page 384 and “System fan cage” on page 389
 - “M.2 module” on page 239
 - “RAID super capacitor modules” on page 293
 - “Riser 1/2 assembly” on page 350 and “Riser 3 assembly” on page 359
 - “CMOS battery” on page 162
 - “OCP 3.0 Ethernet adapter” on page 262
2. Properly route and secure the cables in the server. Refer to the cable connecting and routing information for each component.
3. Install the air baffle if you have removed it. See “Install the air baffle” on page 152.
4. Install the top cover. See “Install the top cover” on page 394.
5. Push the power supplies into the bays until they click into place.
6. Connect power cords to the server and turn on the server.
7. Update the Universally Unique Identifier (UUID) and DMI/SMBIOS data with new vital product data (VPD). Use the Lenovo XClarity Provisioning Manager Liteto update the UUID and DMI/SMBIOS data. See “Update the Universal Unique Identifier (UUID)” on page 375 and “Update the DMI/SMBIOS data” on page 376.
8. Enable TPM. See “Enable TPM” on page 376.
9. Optionally, enable Secure Boot.

Update the Universal Unique Identifier (UUID)

The Universal Unique Identifier (UUID) must be updated when the system board is replaced. Use the Lenovo XClarity Provisioning Manager V3 to update the UUID in the UEFI-based server.

1. Start the server and press F11 to display the Lenovo XClarity Provisioning Manager V3 interface.
2. From the System Summary page, click **Update VPD**.
3. Update the UUID.

Update the DMI/SMBIOS data

The Desktop Management Interface (DMI) must be updated when the system board is replaced. Use the Lenovo XClarity Provisioning Manager V3 to update the DMI in the UEFI-based server.

1. Start the server and press F11 to display the Lenovo XClarity Provisioning Manager V3 interface.
2. From the System Summary page, click **Update VPD**.
3. Update the asset tag information.

Enable TPM

The server supports Trusted Platform Module (TPM) of version 2.0 or 1.2.

Note: For customers in the Chinese Mainland, integrated TPM is not supported. However, customers in the Chinese Mainland can install a TPM adapter (sometimes called a daughter card), only version 2.0 is available.

When a system board is replaced, you must make sure that the TPM policy is set correctly.

CAUTION:

Take special care when setting the TPM policy. If it is not set correctly, the system board can become unusable.

Set the TPM policy

By default, a replacement system board is shipped with the TPM policy set to **undefined**. You must modify this setting to match the setting that was in place for the system board that is being replaced.

You can set the TPM policy from Lenovo XClarity Provisioning Manager V3.

Complete the following steps to set the TPM policy.

- Step 1. Start the server and when prompted, press F1 to display Lenovo XClarity Provisioning Manager V3.
- Step 2. If the power-on Administrator password is required, enter the password.
- Step 3. From the System Summary page, click **Update VPD**.
- Step 4. Set the policy to one of the following settings.
 - **NationZ TPM 2.0 enabled - China only.** Customers in the Chinese Mainland should choose this setting if a NationZ TPM 2.0 adapter is installed.
 - **TPM enabled - ROW.** Customers outside of the Chinese Mainland should choose this setting.
 - **Permanently disabled.** Customers in the Chinese Mainland should use this setting if no TPM adapter is installed.

Although the setting **undefined** is available as a policy setting, it should not be used.

(Optional) assert physical presence

Before you can assert Physical Presence, the Physical Presence Policy must be enabled. By default, the Physical Presence Policy is enabled with a timeout of 30 minutes.

If the Physical Presence Policy is enabled, you can assert Physical Presence through hardware jumpers on the system board

Notes: If the Physical Presence Policy has been disabled:

1. Set the hardware Physical Presence jumper on the system board to assert Physical Presence.
2. Enable the Physical Presence Policy using F1 (UEFI Settings).

Assert Physical Presence through the hardware

You can also assert hardware Physical Presence through the use of a jumper on the system board. For more information about asserting hardware Physical Presence through the use of a jumper, see: “Switch block and jumper” on page 48.

Enable UEFI Secure Boot

Optionally, you can enable UEFI Secure Boot.

Physical Presence must be asserted if you are going to enable UEFI Secure Boot. See “(Optional) assert physical presence” on page 376.

For information about accessing the Lenovo XClarity Controller interface, see:

http://sysmgt.lenovofiles.com/help/topic/com.lenovo.systems.management.xcc.doc/dw1lm_c_chapter2_openingandusing.html

There are two methods available to enable UEFI Secure Boot:

- From Lenovo XClarity Provisioning Manager V3

To enable UEFI Secure Boot from Lenovo XClarity Provisioning Manager V3:

1. Start the server and when prompted, press F1 to display Lenovo XClarity Provisioning Manager V3.
2. If the power-on Administrator password is required, enter the password.
3. From the UEFI Setup page, click **System Settings** → **Security** → **Secure Boot**.
4. Enable Secure Boot and save the settings.

- From Lenovo XClarity Essentials OneCLI

To enable UEFI Secure Boot from Lenovo XClarity Essentials OneCLI:

1. Download and install Lenovo XClarity Essentials OneCLI.
 - a. Go to <http://datacentersupport.lenovo.com> and navigate to the support page for your server.
 - b. Click **Drivers & Software**.
 - c. Navigate to the version of Lenovo XClarity Essentials OneCLI for your operating system and download the package.
2. Run the following command to enable Secure Boot:

```
OneCli.exe config set SecureBootConfiguration.SecureBootSetting Enabled --override  
--imm <userid>:<password>@<ip_address>
```

where:

- *<userid>:<password>* are the credentials used to access the BMC (Lenovo XClarity Controller interface) of your server. The default user ID is USERID, and the default password is PASSWORD (zero, not an uppercase o).
- *<ip_address>* is the IP address of the BMC.

For more information about the Lenovo XClarity Essentials OneCLI **set** command, see:

http://sysmgt.lenovofiles.com/help/topic/toolstr_cli_lenovo/onecli_r_set_command.html

3. Alternatively, you can use the following Advanced Settings Utility (ASU) commands:

To enable secure boot:

```
asu64.exe set SecureBootConfiguration.SecureBootis Enabled -v --override --host <ip_address>  
--user <userid> --password <password>
```

To disable secure boot:

```
asu64.exe set SecureBootConfiguration.SecureBootis Disabled -v --override --host <ip_address>  
--user <userid> --password <password>
```

To read the secure boot setting:

```
asu64.exe show SecureBootConfiguration.SecureBootis -v --override --host <ip_address>  
--user <userid> --password <password>
```

where:

- *<userid>* and *<password>* are the credentials used to the BMC (Lenovo XClarity Controller interface) of your server. The default user ID is USERID, and the default password is PASSWORD (zero, not an uppercase o).
- *<ip_address>* is the IP address of the BMC.

System fan replacement

Use this information to remove and install a system fan.

- “Remove a system fan” on page 381
- “Install a system fan” on page 384

Remove a system fan

Use this information to remove a system fan.

About this task

S033



CAUTION:

Hazardous energy present. Voltages with hazardous energy might cause heating when shorted with metal, which might result in spattered metal, burns, or both.

S017



CAUTION:

Hazardous moving fan blades nearby.

Attention:

- Read “Installation Guidelines” on page 129 to ensure that you work safely.
- Prevent exposure to static electricity, which might lead to system halt and loss of data, by keeping static-sensitive components in their static-protective packages until installation, and handling these devices with an electrostatic-discharge wrist strap or other grounding system.
- You can remove a hot-swap fan without powering off the server, which helps you avoid significant interruption to the operation of the system.

Note: When removing a system fan without powering off the server, do not touch the system fan cage.

A video for this task is available at:

- Youtube: https://www.youtube.com/playlist?list=PLYV5R7hVcs-Bz2XIeLEfGcrLGm9TSY_yt
- Youku: http://list.youku.com/albumlist/show/id_52339612.html

Procedure

Step 1. Remove the top cover. See “Remove the top cover” on page 392.

Step 2. View the fan error LEDs **1** to locate the failing system fan.

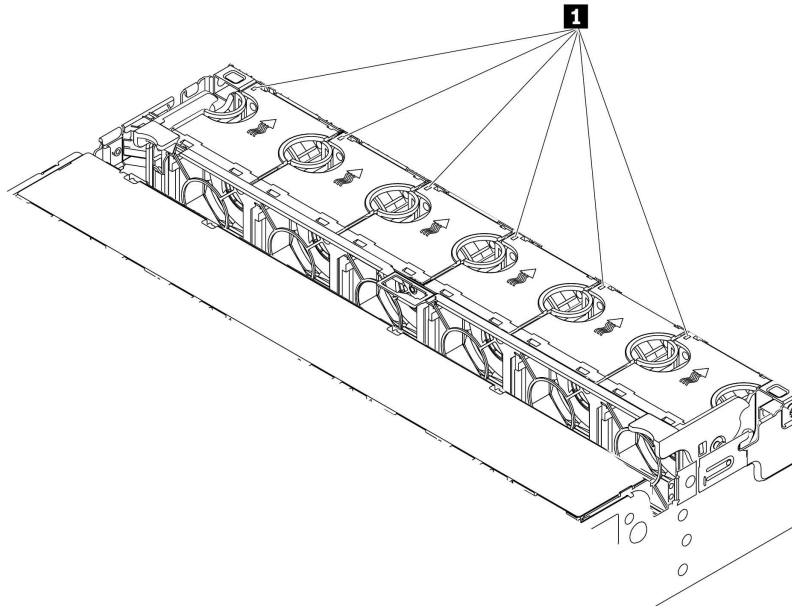

Figure 182. Viewing the fan error LEDs from the top of the system fans

Step 3. Remove the system fan.

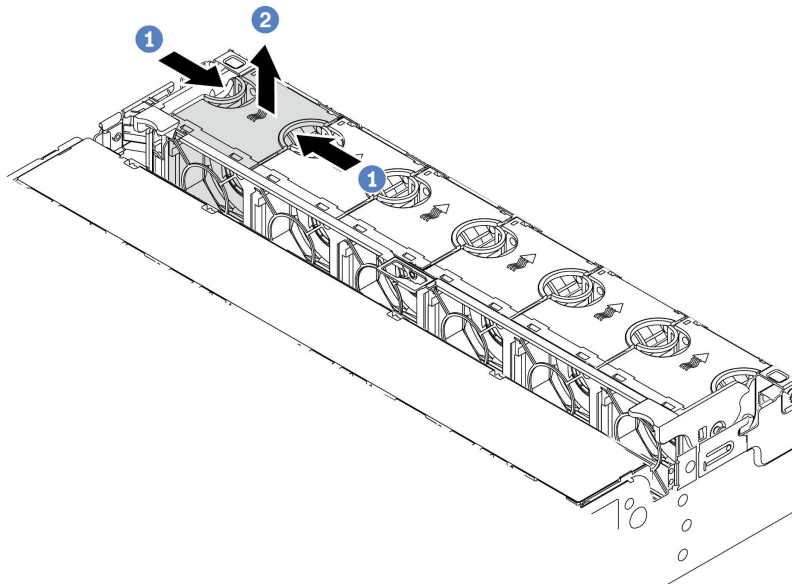

Figure 183. System fan removal

- a. Grasp the top of the system fan with your fingers.
- b. Lift the system fan out of the server.

After you finish

1. Install a new system fan or install a fan filler to cover the place. See “Install a system fan” on page 384.
2. If you are instructed to return the old system fan, follow all packaging instructions and use any packaging materials that are provided.

Install a system fan

Use this information to install a system fan.

About this task

Attention:

- Read “Installation Guidelines” on page 129 to ensure that you work safely.
- Power off the server and disconnect all power cords for this task.
- Prevent exposure to static electricity, which might lead to system halt and loss of data, by keeping static-sensitive components in their static-protective packages until installation, and handling these devices with an electrostatic-discharge wrist strap or other grounding system.

S033



CAUTION:

Hazardous energy present. Voltages with hazardous energy might cause heating when shorted with metal, which might result in spattered metal, burns, or both.

S017



CAUTION:

Hazardous moving fan blades nearby.

A video for this task is available at:

- Youtube: https://www.youtube.com/playlist?list=PLYV5R7hVcs-Bz2XleLEfGcrLGm9TSY_yt
- Youku: http://list.youku.com/albumlist/show/id_52339612.html

Procedure

- Step 1. Touch the static-protective package that contains the new system fan to any unpainted surface on the outside of the server. Then, take the new system fan out of the package and place it on a static-protective surface.
- Step 2. Position the system fan above the system fan cage. The system fan connector on the bottom of the system fan should face the rear of the chassis. Press the system fan straight down until it is seated into place.

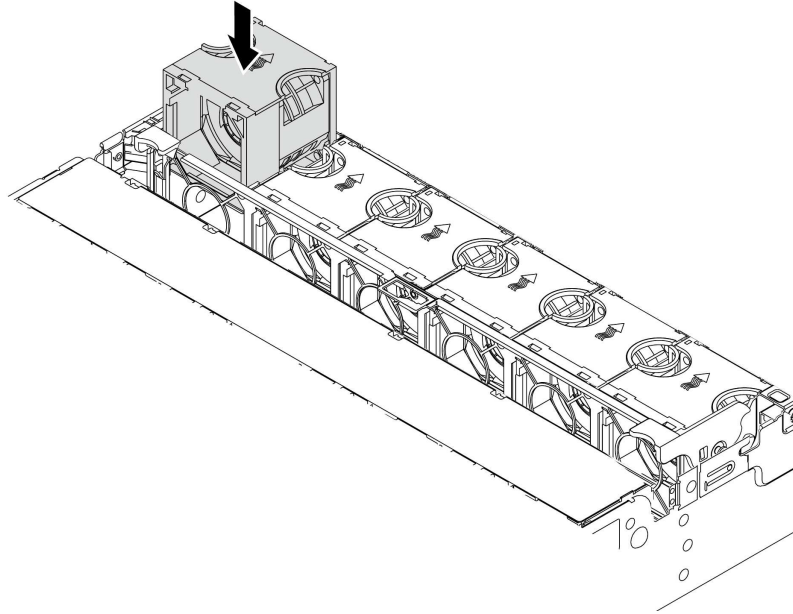

Figure 184. System fan installation

After you finish

Complete the parts replacement. See “Complete the parts replacement” on page 397.

System fan cage replacement

Use this information to remove and install the system fan cage.

- “Remove the system fan cage” on page 387
- “Install the system fan cage” on page 389

Remove the system fan cage

Use this information to remove the system fan cage.

About this task

Attention:

- Read “Installation Guidelines” on page 129 to ensure that you work safely.
- Power off the server and disconnect all power cords for this task.
- Prevent exposure to static electricity, which might lead to system halt and loss of data, by keeping static-sensitive components in their static-protective packages until installation, and handling these devices with an electrostatic-discharge wrist strap or other grounding system.

A video for this task is available at:

- Youtube: https://www.youtube.com/playlist?list=PLYV5R7hVcs-Bz2XIeLEfGcrLGm9TSY_yt
- Youku: http://list.youku.com/albumlist/show/id_52339612.html

Procedure

Step 1. Prepare your server.

- a. Remove the top cover. See “Remove the top cover” on page 392.
- b. If you are replacing the system fan cage, remove all system fans first. See “Remove a system fan” on page 381.
- c. If you are removing the system fan cage to access other components, you can remove it with the system fans installed.

Step 2. Remove the system fan cage.

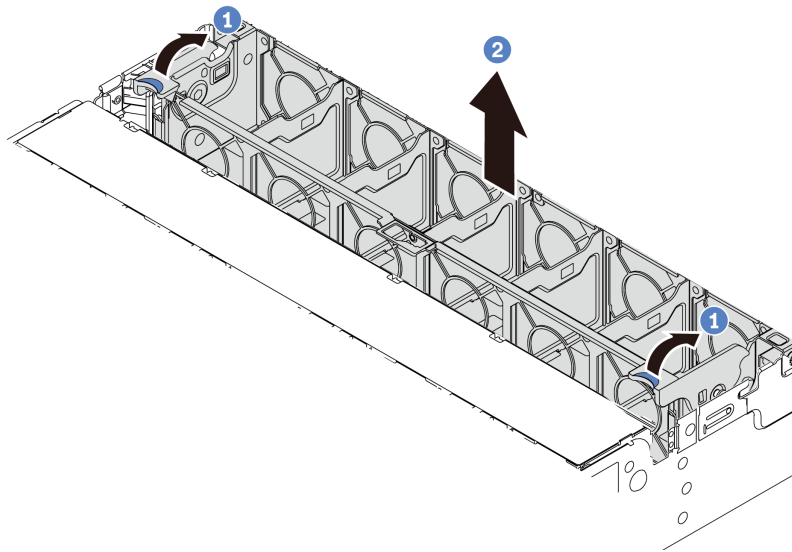

Figure 185. System fan cage removal

- a. Rotate the levers of the system fan cage to the rear of the server.
- b. Lift the system fan cage straight up and out of the chassis.

Install the system fan cage

Use this information to install the system fan cage.

About this task

Attention:

- Read “Installation Guidelines” on page 129 to ensure that you work safely.
- Power off the server and disconnect all power cords for this task.
- Prevent exposure to static electricity, which might lead to system halt and loss of data, by keeping static-sensitive components in their static-protective packages until installation, and handling these devices with an electrostatic-discharge wrist strap or other grounding system.

A video for this task is available at:

- Youtube: https://www.youtube.com/playlist?list=PLYV5R7hVcs-Bz2XleLEfGcrLGm9TSY_yt
- Youku: http://list.youku.com/albumlist/show/id_52339612.html

Procedure

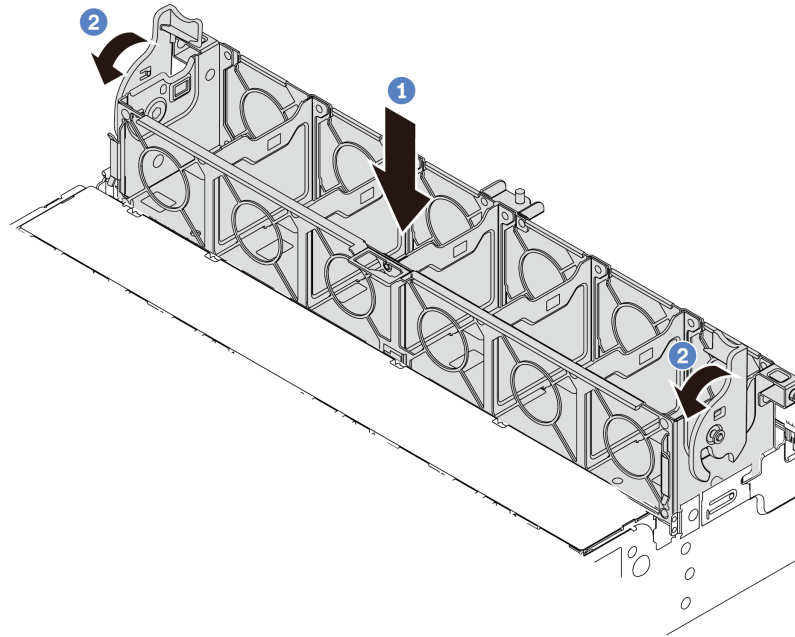

Figure 186. System fan cage installation

Step 1. Align both sides of the system fan cage with the corresponding mounting posts in the chassis. Then, press the system fan cage straight down into the chassis.

Note: If there are system fans installed in the system fan cage, ensure that the system fans are correctly connected to the system fan connectors on the system board.

Step 2. Rotate the levers of the system fan cage to the front of the server to secure the system fan cage.

After you finish

1. If you have removed the system fans, reinstall them. See “Install a system fan” on page 384.
2. Complete the parts replacement. See “Complete the parts replacement” on page 397.

Top cover replacement

Use this information to remove and install the top cover.

- “Remove the top cover” on page 392
- “Install the top cover” on page 394

S033



CAUTION:

Hazardous energy present. Voltages with hazardous energy might cause heating when shorted with metal, which might result in spattered metal, burns, or both.

S014



CAUTION:

Hazardous voltage, current, and energy levels might be present. Only a qualified service technician is authorized to remove the covers where the label is attached.

Remove the top cover

Use this information to remove the top cover.

About this task

Attention:

- Read “Installation Guidelines” on page 129 to ensure that you work safely.
- Power off the server and disconnect all power cords for this task.

A video for this task is available at:

- Youtube: https://www.youtube.com/playlist?list=PLYV5R7hVcs-Bz2XleLEfGcrLGm9TSY_yt
- Youku: http://list.youku.com/albumlist/show/id_52339612.html

Procedure

- Step 1. If the server is installed in a rack, remove the server from the rack. See the Rack Installation Guide that comes with the rail kit for your server.
- Step 2. Remove the top cover.

Attention: Handle the top cover carefully. Dropping the top cover with the cover latch open might damage the cover latch.

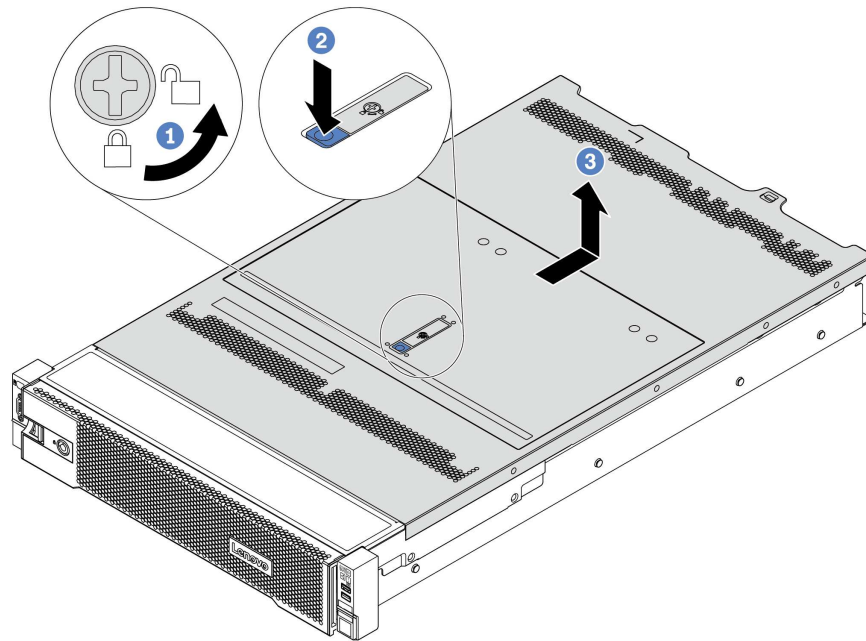

Figure 187. Top cover removal

- a. Use a screwdriver to turn the cover lock to the unlocked position as shown.
- b. Press the release button on the cover latch and then fully open the cover latch.
- c. Slide the top cover to the rear until it is disengaged from the chassis. Then, lift the top cover off the chassis and place the top cover on a flat clean surface.

Install the top cover

Use this information to install the top cover.

About this task

Operating the server with the top cover removed might damage server components. For proper cooling and airflow, install the top cover before you turn on the server.

Note: A new top cover comes without a service label attached. If you need a service label, order it together with the new top cover and attach the service label to the new top cover first.

A video for this task is available at:

- Youtube: https://www.youtube.com/playlist?list=PLYV5R7hVcs-Bz2XleLEfGcrLGm9TSY_yt
- Youku: http://list.youku.com/albumlist/show/id_52339612.html

Procedure

Step 1. Check your server and ensure that:

- All cables, adapters, and other components are installed and seated correctly and that you have not left loose tools or parts inside the server.
- All internal cables are connected and routed correctly. See Chapter 3 “Internal cable routing” on page 57.

Step 2. A new top cover comes without sponges by default. If the old top cover is installed with sponges, remove the sponges from the old top cover and attach them to the new top cover.

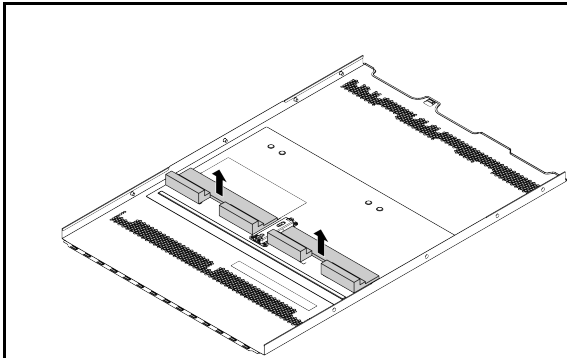

Figure 188. Remove the sponges from the old top cover

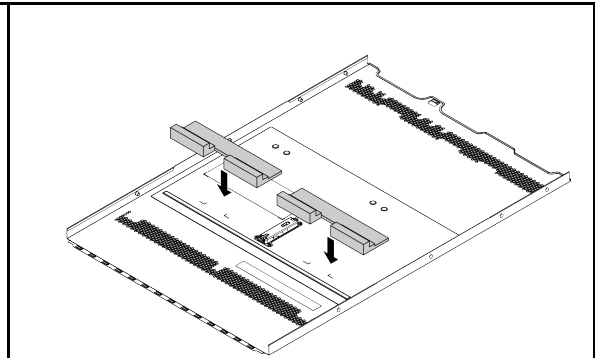

Figure 189. Attach the sponges to the new top cover

Step 3. Install the top cover to your server.

Attention: Handle the top cover carefully. Dropping the top cover with the cover latch open might damage the cover latch.

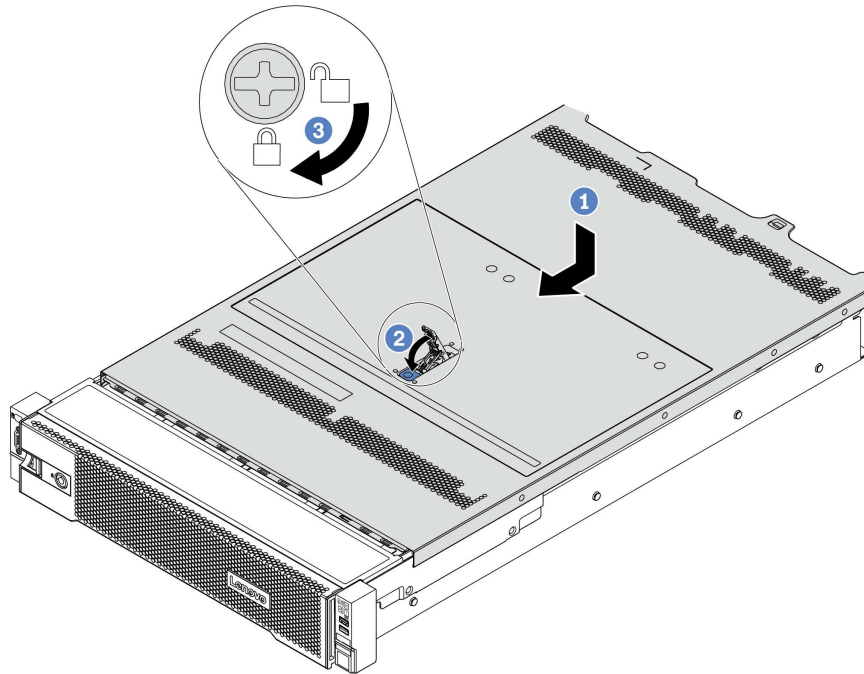

Figure 190. Top cover installation

1. Ensure that the cover latch is in the open position. Lower the top cover onto the chassis until both sides of the top cover engage the guides on both sides of the chassis. Then, slide the top cover to the front of the chassis.

Note: Before you slide the top cover forward, ensure that all the tabs on the top cover engage the chassis correctly.

2. Rotate the cover latch until the top cover snaps into position. Ensure that the cover latch is completely closed.
3. Use a screwdriver to turn the cover lock to the locked position.

After you finish

Complete the parts replacement. See “Complete the parts replacement” on page 397.

Complete the parts replacement

Use this information to complete the parts replacement.

To complete the parts replacement, do the following:

1. Ensure that all components have been reassembled correctly and that no tools or loose screws are left inside your server.
2. Properly route and secure the cables in the server. Refer to the cable connecting and routing information for each component.
3. If you have removed the top cover, reinstall it. See “Install the top cover” on page 394.
4. Reconnect external cables and power cords to the server.

Attention: To avoid component damage, connect the power cords last.

5. Update the server configuration if necessary.
 - Download and install the latest device drivers: <http://datacentersupport.lenovo.com>
 - Update the system firmware. See “Firmware updates” on page 7.
 - Use the Lenovo XClarity Provisioning Manager Lite to configure the RAID if you have installed or removed a hot-swap drive, a RAID adapter, or the M.2 backplane and M.2 drive. For more information, see: https://sysmgmt.lenovofiles.com/help/topic/LXPMv3/LXPMv3_introduction.html

Chapter 5. Problem determination

Use the information in this section to isolate and resolve issues that you might encounter while using your server.

Lenovo servers can be configured to automatically notify Lenovo Support if certain events are generated. You can configure automatic notification, also known as Call Home, from management applications, such as the Lenovo XClarity Administrator. If you configure automatic problem notification, Lenovo Support is automatically alerted whenever a server encounters a potentially significant event.

To isolate a problem, you should typically begin with the event log of the application that is managing the server:

- If you are managing the server from the Lenovo XClarity Administrator, begin with the Lenovo XClarity Administrator event log.
- If you are using some other management application, begin with the Lenovo XClarity Controller event log.

Event logs

An *alert* is a message or other indication that signals an event or an impending event. Alerts are generated by the Lenovo XClarity Controller or by UEFI in the servers. These alerts are stored in the Lenovo XClarity Controller Event Log.

Note: For a listing of events, including user actions that might need to be performed to recover from an event, see the *Messages and Codes Reference*, which is available at: http://thinksystem.lenovofiles.com/help/topic/7d2w/pdf_files.html

Lenovo XClarity Controller event log

The Lenovo XClarity Controller monitors the physical state of the server and its components using sensors that measure internal physical variables such as temperature, power-supply voltages, fan speeds, and component status. The Lenovo XClarity Controller provides various interfaces to system management software and to system administrators and users to enable remote management and control of a server.

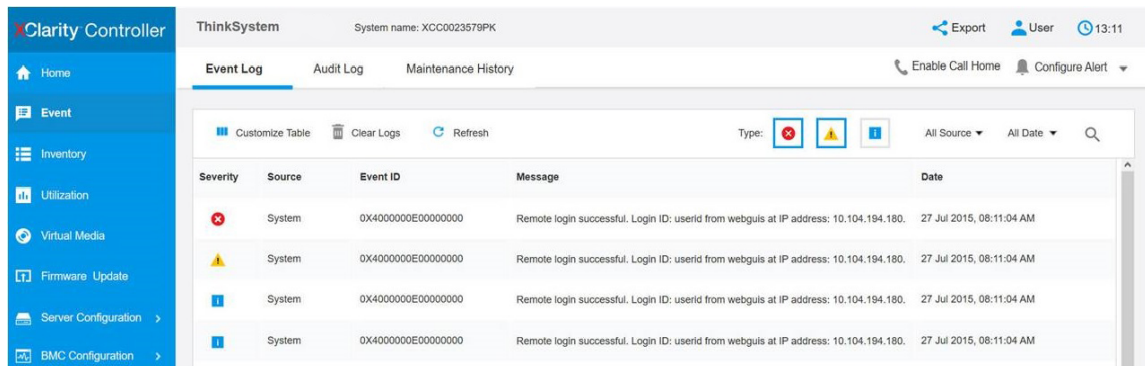

Severity	Source	Event ID	Message	Date
✖	System	0X4000000E00000000	Remote login successful. Login ID: userid from webgui at IP address: 10.104.194.180.	27 Jul 2015, 08:11:04 AM
⚠	System	0X4000000E00000000	Remote login successful. Login ID: userid from webgui at IP address: 10.104.194.180.	27 Jul 2015, 08:11:04 AM
ℹ	System	0X4000000E00000000	Remote login successful. Login ID: userid from webgui at IP address: 10.104.194.180.	27 Jul 2015, 08:11:04 AM
ℹ	System	0X4000000E00000000	Remote login successful. Login ID: userid from webgui at IP address: 10.104.194.180.	27 Jul 2015, 08:11:04 AM

Figure 191. Lenovo XClarity Controller event log

For more information about accessing the Lenovo XClarity Controller event log, see:

http://sysmgt.lenovofiles.com/help/topic/com.lenovo.systems.management.xcc.doc/product_page.html

Light path diagnostics

Light path diagnostics is a system of LEDs on various external and internal components of the server that leads you to the failed component. When an error occurs, LEDs are lit on the front I/O assembly, the rear panel, the system board, and the failed component. By viewing the following LEDs, you can often identify the system and device status and diagnose problems.

- “Front view” on page 11
- “Diagnostics panel” on page 23
- “LCD diagnostics panel/handset” on page 26
- “Rear view LEDs” on page 41
- “System board LEDs” on page 45

General problem determination procedures

Use the information in this section to resolve problems if the event log does not contain specific errors or the server is inoperative.

If you are not sure about the cause of a problem and the power supplies are working correctly, complete the following steps to attempt to resolve the problem:

1. Power off the server.
2. Make sure that the server is cabled correctly.
3. Remove or disconnect the following devices, one at a time, until you find the failure. Power on and configure the server each time you remove or disconnect a device.
 - Any external devices.
 - Surge-suppressor device (on the server).
 - Printer, mouse, and non-Lenovo devices.
 - Each adapter.
 - Hard disk drives.
 - Memory modules until you reach the minimum configuration that is supported for the server.

Note: The minimum configuration required for the server to start is one processor and one 2 GB DIMM.

4. Power on the server.

If the problem is solved when you remove an adapter from the server, but the problem recurs when you install the same adapter again, suspect the adapter. If the problem recurs when you replace the adapter with a different one, try a different PCIe slot.

If the problem appears to be a networking problem and the server passes all system tests, suspect a network cabling problem that is external to the server.

Resolving suspected power problems

Power problems can be difficult to solve. For example, a short circuit can exist anywhere on any of the power distribution buses. Usually, a short circuit will cause the power subsystem to shut down because of an overcurrent condition.

Complete the following steps to diagnose and resolve a suspected power problem.

Step 1. Check the event log and resolve any errors related to the power.

Note: Start with the event log of the application that is managing the server.

Step 2. Check for short circuits, for example, if a loose screw is causing a short circuit on a circuit board.

Step 3. Remove the adapters and disconnect the cables and power cords to all internal and external devices until the server is at the minimum configuration that is required for the server to start. See “Specifications” on page 3 to determine the minimum configuration for your server.

Step 4. Reconnect all ac power cords and turn on the server. If the server starts successfully, reseal the adapters and devices one at a time until the problem is isolated.

If the server does not start from the minimum configuration, replace the components in the minimum configuration one at a time until the problem is isolated.

Resolving suspected Ethernet controller problems

The method that you use to test the Ethernet controller depends on which operating system you are using. See the operating-system documentation for information about Ethernet controllers, and see the Ethernet controller device-driver readme file.

Complete the following steps to attempt to resolve suspected problems with the Ethernet controller.

- Step 1. Make sure that the correct device drivers, which come with the server are installed and that they are at the latest level.
- Step 2. Make sure that the Ethernet cable is installed correctly.
 - The cable must be securely attached at all connections. If the cable is attached but the problem remains, try a different cable.
 - If you set the Ethernet controller to operate at 100 Mbps or 1000 Mbps, you must use Category 5 cabling.
- Step 3. Determine whether the hub supports auto-negotiation. If it does not, try configuring the integrated Ethernet controller manually to match the speed and duplex mode of the hub.
- Step 4. Check the Ethernet controller LEDs on the rear panel of the server. These LEDs indicate whether there is a problem with the connector, cable, or hub.
 - The Ethernet link status LED is lit when the Ethernet controller receives a link pulse from the hub. If the LED is off, there might be a defective connector or cable or a problem with the hub.
 - The Ethernet transmit/receive activity LED is lit when the Ethernet controller sends or receives data over the Ethernet network. If the Ethernet transmit/receive activity is off, make sure that the hub and network are operating and that the correct device drivers are installed.
- Step 5. Check the LAN activity LED on the rear of the server. The LAN activity LED is lit when data is active on the Ethernet network. If the LAN activity LED is off, make sure that the hub and network are operating and that the correct device drivers are installed.
- Step 6. Check for operating-system-specific causes of the problem, and also make sure that the operating system drivers are installed correctly.
- Step 7. Make sure that the device drivers on the client and server are using the same protocol.

If the Ethernet controller still cannot connect to the network but the hardware appears to be working, the network administrator must investigate other possible causes of the error.

Troubleshooting by symptom

Use this information to find solutions to problems that have identifiable symptoms.

To use the symptom-based troubleshooting information in this section, complete the following steps:

1. Check the event log of Lenovo XClarity Controller and follow the suggested actions to resolve any event codes.

For more information about event logs, see “Event logs” on page 400)

2. Review this section to find the symptoms that you are experiencing and follow the suggested actions to resolve the issue.
3. If the problem persists, contact support (see “Contacting Support” on page 441).

Power on and power off problems

Use this information to resolve issues when powering on or powering off the server.

- “Embedded hypervisor is not in the boot list” on page 406
- “The power button does not work (server does not start)” on page 407
- “Server does not power on” on page 408

Embedded hypervisor is not in the boot list

Complete the following steps until the problem is solved.

1. If the server has been installed, moved, or serviced recently, or if this is the first time the embedded hypervisor is being used, make sure that the device is connected properly and that there is no physical damage to the connectors.
2. See the documentation that comes with the optional embedded hypervisor flash device for setup and configuration information.
3. Check <https://static.lenovo.com/us/en/serverproven/index.shtml> to validate that the embedded hypervisor device is supported for the server.
4. Make sure that the embedded hypervisor device is listed in the list of available boot options. From the management controller user interface, click **Server Configuration** → **Boot Options**.

For information about accessing the management controller user interface, see the XClarity Controller product documentation:

http://sysmgt.lenovofiles.com/help/topic/com.lenovo.systems.management.xcc.doc/dw1lm_c_chapter2_openingandusing.html

5. Check <http://datacentersupport.lenovo.com> for any tech tips (service bulletins) related to the embedded hypervisor and the server.
6. Make sure that other software works on the server to ensure that it is working properly.

The power button does not work (server does not start)

Note: The power button will not function until approximately 1 to 3 minutes after the server has been connected to ac power to allow time for BMC to initialize.

Complete the following steps until the problem is resolved:

1. Make sure that the power button on the server is working correctly:
 - a. Disconnect the server power cords.
 - b. Reconnect the server power cords.
 - c. Reseat the operator information panel cable, and then repeat steps 3a and 3b.
 - If the server starts, reseat the operator information panel.
 - If the problem remains, replace the operator information panel.
2. Make sure that:
 - The power cords are correctly connected to the server and to a working electrical outlet.
 - The LEDs on the power supply do not indicate a problem.
 - The Power button LED is lit on and flash slowly.
 - The push force is enough and with button force response.
3. If the power button LED didn't lit on or flash correctly, Please reseat all the power supplies and make sure AC LED on PSU rear side are lit on.
4. If you have just installed an optional device, remove it, and restart the server.
5. If the issue is still observed or without power button LED lit on, implement the minimum configuration to check whether any specific components lock the power permission. Replace the each power supply and check the power button function after installing the each one.
6. If everything is still done and the issue cannot be resolved, please collect the failure information with system logs captured to Lenovo support.

Server does not power on

Complete the following steps until the problem is resolved:

1. Check the event log for any events related to the server not powering on.
2. Check for any LEDs that are flashing amber.
3. Check the power LED on the system board.
4. Check if AC power LED is lit on or the amber LED is lit on at the PSU rear side.
5. AC cycle the system.
6. Remove the CMOS battery for at least ten seconds, then, reinstall the CMOS battery.
7. Try to power on the system by IPMI command through XCC or by the power button.
8. Implement the minimum configuration (one processor, one DIMM and one PSU without any adapter and any drive installed).
9. Reseat all power supplies and make sure that AC LEDs on the PSU rear side are lit.
10. Replace the each power supply and check the power button function after installing the each one.
11. If the issue cannot be resolved by above actions, please call service to review the issue symptom and see whether the system board replacement is necessary.

Memory problems

Use this information to resolve issues related to memory.

- “Displayed system memory is less than installed physical memory” on page 409
- “Multiple rows of DIMMs in a branch identified as failing” on page 410
- “DIMM PFA issue” on page 410

Displayed system memory is less than installed physical memory

Complete the following steps until the problem is resolved.

Note: Each time you install or remove a DIMM, you must disconnect the server from the power source; then, wait 10 seconds before restarting the server.

1. Make sure that:

- Memory modules from different vendors are not in the same channel.
- No error LEDs are lit on the operator information panel.
- No DIMM error LEDs are lit on the system board.
- Memory mirrored channel does not account for the discrepancy.
- The memory modules are seated correctly.
- You have installed the correct type of memory.
- If you changed the memory, you updated the memory configuration in the Setup utility.
- All banks of memory are enabled. The server might have automatically disabled a memory bank when it detected a problem, or a memory bank might have been manually disabled.
- There is no memory mismatch when the server is at the minimum memory configuration.

2. Reseat the DIMMs and then restart the server.

3. Run the memory module diagnostics. When you start a server and press F1, the Lenovo XClarity Provisioning Manager V3 interface is displayed by default. You can perform memory diagnostics from this interface. From the Diagnostic page, click **Run Diagnostic → Memory test**.

4. Check the POST error log:

- If a DIMM was disabled by a systems-management interrupt (SMI), replace the DIMM.
- If a DIMM was disabled by the user or by POST, reseat the DIMM; then, run the Setup utility and enable the DIMM.

5. Reseat the DIMM.

6. Restart the server.

Multiple rows of DIMMs in a branch identified as failing

1. Reseat the DIMMs; then, restart the server.
2. Remove the lowest-numbered DIMM pair of those that are identified and replace it with an identical known good DIMM; then, restart the server. Repeat as necessary. If the failures continue after all identified DIMMs are replaced, go to step 4.
3. Return the removed DIMMs, one at a time, to their original connectors, restarting the server after each DIMM, until a DIMM fails. Replace each failing DIMM with an identical known good DIMM, restarting the server after each DIMM replacement. Repeat step 3 until you have tested all removed DIMMs.
4. Replace the lowest-numbered DIMM of those identified; then, restart the server. Repeat as necessary.
5. Reverse the DIMMs between the channels (of the same processor), and then restart the server. If the problem is related to a DIMM, replace the failing DIMM.
6. Swap processors to see if the memory issue followed by the processors or DIMMs. If it follows the failing components, then replace the failing components.
7. (Trained technician only) Replace the system board.

DIMM PFA issue

1. Update the UEFI and XCC firmware to the latest version.
2. Reseat the failing DIMMs.
3. Swap processors and make sure that there are no damages to processor socket pins.
4. (Train service only) Ensure there is no abnormal material in any DIMM slot.
5. Run the memory module diagnostics. When you start a server and press F1, the Lenovo XClarity Provisioning Manager V3 interface is displayed by default. You can perform memory diagnostics from this interface. From the Diagnostic page, click **Run Diagnostic → Memory test**.
6. Replace the failing DIMMs that fails Memory Test.

Hard disk drive problems

Use this information to resolve issues related to the hard disk drives.

- “Server cannot recognize a hard drive” on page 410
- “Multiple hard drives fail” on page 411
- “Multiple hard drives are offline” on page 411
- “A replacement hard disk drive does not rebuild” on page 412
- “Green hard disk drive activity LED does not represent actual state of associated drive” on page 412

Server cannot recognize a hard drive

Complete the following steps until the problem is solved.

1. Observe the associated yellow hard disk drive status LED. If the LED is lit, it indicates a drive fault.
2. If the status LED is lit, remove the drive from the bay, wait 45 seconds, and reinsert the drive, making sure that the drive assembly connects to the hard disk drive backplane.
3. Observe the associated green hard disk drive activity LED and the yellow status LED and perform corresponding operations in different situations:
 - If the green activity LED is flashing and the yellow status LED is not lit, the drive is recognized by the controller and is working correctly. Run the diagnostics tests for the hard disk drives. When you start a server and press F1, the Lenovo XClarity Provisioning Manager V3 interface is displayed by default. You can perform hard drive diagnostics from this interface. From the Diagnostic page, click **Run Diagnostic → HDD test**.

- If the green activity LED is flashing and the yellow status LED is flashing slowly, the drive is recognized by the controller and is rebuilding.
 - If neither LED is lit or flashing, check whether the hard disk drive backplane is correctly seated. For details, go to step 4.
 - If the green activity LED is flashing and the yellow status LED is lit, replace the drive. If the activity of the LEDs remains the same, go to step Hard disk drive problems. If the activity of the LEDs changes, return to step 1.
4. Make sure that the hard disk drive backplane is correctly seated. When it is correctly seated, the drive assemblies correctly connect to the backplane without bowing or causing movement of the backplane.
 5. Reseat the backplane power cable and repeat steps 1 through 3.
 6. Reseat the backplane signal cable and repeat steps 1 through 3.
 7. Suspect the backplane signal cable or the backplane:
 - Replace the affected backplane signal cable.
 - Replace the affected backplane.
 8. Run the diagnostics tests for the hard disk drives. When you start a server and press F1, the Lenovo XClarity Provisioning Manager V3 interface is displayed by default. You can perform hard drive diagnostics from this interface. From the Diagnostic page, click **Run Diagnostic → HDD test**.

Based on those tests:

- If the backplane passes the test but the drives are not recognized, replace the backplane signal cable and run the tests again.
- Replace the backplane.
- If the adapter fails the test, disconnect the backplane signal cable from the adapter and run the tests again.
- If the adapter fails the test, replace the adapter.

Multiple hard drives fail

Complete the following steps until the problem is solved:

- View the Lenovo XClarity Controller event log for events related to power supplies or vibration issues and resolve those events.
- Make sure that the device drivers and firmware for the hard disk drive and server are at the latest level

Important: Some cluster solutions require specific code levels or coordinated code updates. If the device is part of a cluster solution, verify that the latest level of code is supported for the cluster solution before you update the code.

Multiple hard drives are offline

Complete the following steps until the problem is solved:

- View the Lenovo XClarity Controller event log for events related to power supplies or vibration issues and resolve those events.
- View the storage subsystem log for events related to the storage subsystem and resolve those events.

One or two 7mm drives identified as failing

Complete the following steps until the problem is solved:

1. Remove and reinstall the reported drive(s) in the same drive bay or another drive bay.
2. If the problem persists, consider replacing the current drives with new ones.
3. If the problem is persists, consider replacing the bottom backplane.

4. If the problem is persists, consider replacing the top backplane.

A replacement hard disk drive does not rebuild

Complete the following steps until the problem is solved:

1. Make sure that the hard disk drive is recognized by the adapter (the green hard disk drive activity LED is flashing).
2. Review the SAS/SATA RAID adapter documentation to determine the correct configuration parameters and settings.

Green hard disk drive activity LED does not represent actual state of associated drive

Complete the following steps until the problem is solved:

1. If the green hard disk drive activity LED does not flash when the drive is in use, run the diagnostics tests for the hard disk drives. When you start a server and press F1, the Lenovo XClarity Provisioning Manager V3 interface is displayed by default. You can perform hard drive diagnostics from this interface. From the Diagnostic page, click **Run Diagnostic → HDD test**
2. If the drive passes the test, replace the backplane.
3. If the drive fails the test, replace the drive.

Monitor and video problems

Use this information to solve problems related to a monitor or video.

- “Incorrect characters are displayed” on page 414
- “Screen is blank” on page 415
- “Screen goes blank when you start some application programs” on page 416
- “The monitor has screen jitter, or the screen image is wavy, unreadable, rolling, or distorted” on page 416
- “The wrong characters appear on the screen” on page 416

Incorrect characters are displayed

Complete the following steps:

1. Verify that the language and locality settings are correct for the keyboard and operating system.
2. If the wrong language is displayed, update the server firmware to the latest level. See “Firmware updates” on page 7.

Screen is blank

Note: Make sure that the expected boot mode has not been changed from the UEFI to Legacy or vice versa.

1. If the server is attached to a KVM switch, bypass the KVM switch to eliminate it as a possible cause of the problem: connect the monitor cable directly to the correct connector on the rear of the server.
2. The management controller remote presence function is disabled if you install an optional video adapter. To use the management controller remote presence function, remove the optional video adapter.
3. If the server is installed with the graphical adapters while turning on the server, the Lenovo logo is displayed on the screen after approximately 3 minutes. This is normal operation while the system loads.
4. Make sure that:
 - The server is turned on and there is power supplied to the server.
 - The monitor cables are connected correctly.
 - The monitor is turned on and the brightness and contrast controls are adjusted correctly.
5. Make sure that the correct server is controlling the monitor, if applicable.
6. Make sure that the video output is not affected by corrupted server firmware; see “Firmware updates” on page 7.
7. If the problem remains, contact Lenovo Support.

Screen goes blank when you start some application programs

1. Make sure that:
 - The application program is not setting a display mode that is higher than the capability of the monitor.
 - You installed the necessary device drivers for the application.

The monitor has screen jitter, or the screen image is wavy, unreadable, rolling, or distorted

1. If the monitor self-tests show that the monitor is working correctly, consider the location of the monitor. Magnetic fields around other devices (such as transformers, appliances, fluorescents, and other monitors) can cause screen jitter or wavy, unreadable, rolling, or distorted screen images. If this happens, turn off the monitor.

Attention: Moving a color monitor while it is turned on might cause screen discoloration.

Move the device and the monitor at least 305 mm (12 in.) apart, and turn on the monitor.

Notes:

- a. To prevent diskette drive read/write errors, make sure that the distance between the monitor and any external diskette drive is at least 76 mm (3 in.).
 - b. Non-Lenovo monitor cables might cause unpredictable problems.
2. Reseat the monitor cable.
 3. Replace the components listed in step 2 one at a time, in the order shown, restarting the server each time:
 - a. Monitor cable
 - b. Video adapter (if one is installed)
 - c. Monitor
 - d. (Trained technician only) System board.

The wrong characters appear on the screen

Complete the following steps until the problem is solved:

1. Verify that the language and locality settings are correct for the keyboard and operating system.
2. If the wrong language is displayed, update the server firmware to the latest level. See “Firmware updates” on page 7.

Keyboard, mouse, KVM switch or USB-device problems

Use this information to solve problems related to a keyboard, mouse, KVM switch or USB-device problems.

- “All or some keys on the keyboard do not work” on page 418
- “Mouse does not work” on page 418
- “KVM switch problems” on page 419
- “USB-device does not work” on page 419

All or some keys on the keyboard do not work

1. Make sure that:
 - The keyboard cable is securely connected.
 - The server and the monitor are turned on.
2. If you are using a USB keyboard, run the Setup utility and enable keyboardless operation.
3. If you are using a USB keyboard and it is connected to a USB hub, disconnect the keyboard from the hub and connect it directly to the server.
4. Replace the keyboard.

Mouse does not work

1. Make sure that:
 - The mouse cable is securely connected to the server.
 - The mouse device drivers are installed correctly.
 - The server and the monitor are turned on.
 - The mouse option is enabled in the Setup utility.
2. If you are using a USB mouse and it is connected to a USB hub, disconnect the mouse from the hub and connect it directly to the server.
3. Replace the mouse.

KVM switch problems

1. Make sure that the KVM switch is supported by your server.
2. Make sure that the KVM switch is powered on correctly.
3. If the keyboard, mouse or monitor can be operated normally with direct connection to the server, then replace the KVM switch.

USB-device does not work

1. Make sure that:
 - The correct USB device driver is installed.
 - The operating system supports USB devices.
2. Make sure that the USB configuration options are set correctly in system setup.

Restart the server and press F1 to display the Lenovo XClarity Provisioning Manager V3 system setup interface. Then, click **System Settings → Devices and I/O Ports → USB Configuration**.

3. If you are using a USB hub, disconnect the USB device from the hub and connect it directly to the server.

Optional-device problems

Use this information to solve problems related to optional devices.

- “External USB device is not recognized” on page 419
- “PCIe adapter is not recognized or is not functioning” on page 419
- “A Lenovo optional device that worked previously does not work now” on page 420
- “A Lenovo optional device that was just installed does not work.” on page 420
- “A Lenovo optional device that worked previously does not work now” on page 420

External USB device is not recognized

Complete the following steps until the problem is resolved:

1. Update the UEFI firmware to the latest version.
2. Make sure that the proper drivers are installed on the compute node. See the product documentation for the USB device for information about device drivers.
3. Use the Setup utility to make sure that the device is configured correctly.
4. If the USB device is plugged into a hub or the console breakout cable, unplug the device and plug it directly into the USB port on the front of the compute node.

PCIe adapter is not recognized or is not functioning

Complete the following steps until the problem is resolved:

1. Update the UEFI firmware to the latest version.
2. Check the event log and resolve any issues related to the device.
3. Validate that the device is supported for the server (see <https://static.lenovo.com/us/en/serverproven/index.shtml>). Make sure that the firmware level on the device is at the latest supported level and update the firmware if applicable.
4. Make sure that the adapter is installed in a correct slot.
5. Make sure that the proper device drivers are installed for the device.
6. Resolve any resource conflicts if running legacy mode (UEFI). Check legacy ROM boot orders and modify the UEFI setting for MM config base.

Note: Ensure that you modify the ROM boot order associated with the PCIe adapter to the first execution order.

7. Check <http://datacentersupport.lenovo.com> for any tech tips (also known as retain tips or service bulletins) that might be related to the adapter.
8. Ensure any adapter external connections are correct and that the connectors are not physically damaged.
9. Make sure that the PCIe adapter is installed with the supported operating system.

Insufficient PCIe resources are detected.

If you see an error message stating “Insufficient PCI Resources Detected,” complete the following steps until the problem is resolved:

1. Press Enter to access System Setup Utility.
2. Select **System Settings → Devices and I/O Ports → MM Config Base**; then, modify the setting to increase the device resources. For example, modify 3 GB to 2 GB or modify 2 GB to 1 GB.
3. Save the settings and restart the system.
4. If the error recurs with the highest device resource setting (1GB), shutdown the system and remove some PCIe devices; then, power on the system.
5. If the reboot failed, repeat step 1 to step 4.
6. If the error recurs, press Enter to access System Setup Utility.
7. Select **System Settings → Devices and I/O Ports → PCI 64–Bit Resource Allocation**, then; modify the setting from **Auto** to **Enable**.
8. If the Boot Device does not support MMIO above 4GB for Legacy Boot, use UEFI Boot Mode or remove/disable some PCIe devices.
9. DC cycle the system and ensure the system is enter UEFI boot menu or the operating system; then, capture the FFDC log.
10. Contact Lenovo technical support.

A Lenovo optional device that was just installed does not work.

1. Make sure that:
 - The device is supported for the server (see <https://static.lenovo.com/us/en/serverproven/index.shtml>).
 - You followed the installation instructions that came with the device and the device is installed correctly.
 - You have not loosened any other installed devices or cables.
 - You updated the configuration information in system setup. When you start a server and press F1 to display the Setup Utility. Whenever memory or any other device is changed, you must update the configuration.
2. Reseat the device that you have just installed.
3. Replace the device that you have just installed.
4. Reseat the cable connection and check there is no physical damage to the cable.
5. If there is any cable damages, then replace the cable.

A Lenovo optional device that worked previously does not work now

1. Make sure that all of the cable connections for the device are secure.
2. If the device comes with test instructions, use those instructions to test the device.
3. Reseat the cable connection and check if any physical parts have been damaged, .
4. Replace the cable.

5. Reseat the failing device.
6. Replace the failing device.

Serial-device problems

Use this information to solve problems with serial ports or devices.

- “Number of displayed serial ports is less than the number of installed serial ports” on page 422
- “Serial device does not work” on page 423

Number of displayed serial ports is less than the number of installed serial ports

Complete the following steps until the problem is solved.

1. Make sure that:
 - Each port is assigned a unique address in the Setup utility and none of the serial ports is disabled.
 - The serial-port adapter (if one is present) is seated correctly.
2. Reseat the serial port adapter.
3. Replace the serial port adapter.

Serial device does not work

1. Make sure that:
 - The device is compatible with the server.
 - The serial port is enabled and is assigned a unique address.
 - The device is connected to the correct connector.
2. Reseat the following components:
 - a. Failing serial device.
 - b. Serial cable.
3. Replace the following components:
 - a. Failing serial device.
 - b. Serial cable.
4. (Trained technician only) Replace the system board.

Intermittent problems

Use this information to solve intermittent problems.

- “Intermittent external device problems” on page 425
- “Intermittent KVM problems” on page 425
- “Intermittent unexpected reboots” on page 426

Intermittent external device problems

Complete the following steps until the problem is solved.

1. Update the UEFI and XCC firmware to the latest versions.
2. Make sure that the correct device drivers are installed. See the manufacturer's website for documentation.
3. For a USB device:
 - a. Make sure that the device is configured correctly.

Restart the server and press F1 to display the Lenovo XClarity Provisioning Manager V3 system setup interface. Then, click **System Settings → Devices and I/O Ports → USB Configuration**.

- b. Connect the device to another port. If using a USB hub, remove the hub and connect the device directly to the compute node. Make sure that the device is configured correctly for the port.

Intermittent KVM problems

Complete the following steps until the problem is solved.

Video problems:

1. Make sure that all cables and the console breakout cable are properly connected and secure.
2. Make sure that the monitor is working properly by testing it on another compute node.
3. Test the console breakout cable on a working compute node to ensure that it is operating properly. Replace the console breakout cable if it is defective.

Keyboard problems:

Make sure that all cables and the console breakout cable are properly connected and secure.

Mouse problems:

Make sure that all cables and the console breakout cable are properly connected and secure.

Intermittent unexpected reboots

Note: Some correctable errors require that the server reboot so that it can disable a device, such as a memory DIMM or a processor to allow the machine to boot up properly.

1. If the reset occurs during POST and the POST watchdog timer is enabled, make sure that sufficient time is allowed in the watchdog timeout value (POST Watchdog Timer).

To check the POST watchdog time, restart the server and press F1 to display the Lenovo XClarity Provisioning Manager V3 system setup interface. Then, click **BMC Settings → POST Watchdog Timer**.

2. If the reset occurs after the operating system starts, enter the operating system when the system operates normally and set up operating system kernel dump process (Windows and Linux base operating systems will be using different method). Enter the UEFI setup menus and disable the feature, or disable it with the following OneCli command.

```
OneCli.exe config set SystemRecovery.RebootSystemOnNMI Disable --bmcxcc_userid PASSWORD@xcc_ipaddress
```

3. See the management controller event log to check for an event code that indicates a reboot. See “Event logs” on page 400 for information about viewing the event log. If you are using Linux base operating system, then capture all logs back to Lenovo support for further investigation.

Power problems

Use this information to resolve issues related to power.

System error LED is on and event log "Power supply has lost input" is displayed

To resolve the problem, ensure that:

1. The power supply is properly connected to a power cord.
2. The power cord is connected to a properly grounded electrical outlet for the server.
3. Make sure that the power supply AC source is stable within the supported range.
4. Swap the power supply to see if the issue follows the power supply, if it follows the power supply, then replace the failing one.
5. Review the event log and see how the problem it is to follow the event log actions to resolved the problems.

Network problems

Use this information to resolve issues related to networking.

- “Cannot wake server using Wake on LAN” on page 428
- “Could not log in using LDAP account with SSL enabled” on page 428

Cannot wake server using Wake on LAN

Complete the following steps until the problem is resolved:

1. If you are using the dual-port network adapter and the server is connected to the network using Ethernet 5 connector, check the system-error log or TSM system event log, make sure:
 - a. Fan 3 is running in standby mode, if Emulex dual port 10GBase-T embedded adapter is installed.
 - b. The room temperature is not too high (see “Specifications” on page 3).
 - c. The air vents are not blocked.
 - d. The air baffle is installed securely.
2. Reseat the dual-port network adapter.
3. Turn off the server and disconnect it from the power source; then, wait 10 seconds before restarting the server.
4. If the problem still remains, replace the dual-port network adapter.

Could not log in using LDAP account with SSL enabled

Complete the following steps until the problem is resolved:

1. Make sure that the license key is valid.
2. Generate a new license key and log in again.

Observable problems

Use this information to solve observable problems.

- “Server hangs during the UEFI boot process” on page 430
- “The server immediately displays the POST Event Viewer when it is turned on” on page 430
- “Server is unresponsive (POST is complete and operating system is running)” on page 431
- “Server is unresponsive (cannot press F1 to start System Setup)” on page 431
- “Voltage planar fault is displayed in the event log” on page 432
- “Unusual smell” on page 432
- “Server seems to be running hot” on page 432
- “Cracked parts or cracked chassis” on page 432

Server hangs during the UEFI boot process

If the system hangs during the UEFI boot process with the message UEFI: DXE INIT on the display, make sure that Option ROMs were not configured with a setting of **Legacy**. You can remotely view the current settings for Option ROMs by running the following command using the Lenovo XClarity Essentials OneCLI:

```
onecli config show EnableDisableAdapterOptionROMSupport --bmc xcc_userid:xcc_password@xcc_ipaddress
```

To recover a system that hangs during the boot process with Legacy Option ROM settings, see the following Tech Tip:

<https://datacentersupport.lenovo.com/us/en/solutions/ht506118>

If legacy Option ROMs must be used, do not set slot Option ROMs to **Legacy** on the Devices and I/O Ports menu. Instead, set slot Option ROMs to **Auto** (the default setting), and set the System Boot Mode to **Legacy Mode**. Legacy option ROMs will be invoked shortly before the system boots.

The server immediately displays the POST Event Viewer when it is turned on

Complete the following steps until the problem is solved.

1. Correct any errors that are indicated by the light path diagnostics LEDs.
2. Make sure that the server supports all the processors and that the processors match in speed and cache size.

You can view processor details from system setup.

To determine if the processor is supported for the server, see <https://static.lenovo.com/us/en/serverproven/index.shtml>.

3. (Trained technician only) Make sure that processor 1 is seated correctly
4. (Trained technician only) Remove processor 2 and restart the server.
5. Replace the following components one at a time, in the order shown, restarting the server each time:
 - a. (Trained technician only) Processor
 - b. (Trained technician only) System board

Server is unresponsive (POST is complete and operating system is running)

Complete the following steps until the problem is solved.

- If you are in the same location as the compute node, complete the following steps:
 1. If you are using a KVM connection, make sure that the connection is operating correctly. Otherwise, make sure that the keyboard and mouse are operating correctly.
 2. If possible, log in to the compute node and verify that all applications are running (no applications are hung).
 3. Restart the compute node.
 4. If the problem remains, make sure that any new software has been installed and configured correctly.
 5. Contact your place of purchase of the software or your software provider.
- If you are accessing the compute node from a remote location, complete the following steps:
 1. Make sure that all applications are running (no applications are hung).
 2. Attempt to log out of the system and log back in.
 3. Validate the network access by pinging or running a trace route to the compute node from a command line.
 - a. If you are unable to get a response during a ping test, attempt to ping another compute node in the enclosure to determine whether it is a connection problem or compute node problem.
 - b. Run a trace route to determine where the connection breaks down. Attempt to resolve a connection issue with either the VPN or the point at which the connection breaks down.
 4. Restart the compute node remotely through the management interface.
 5. If the problem remains, verify that any new software has been installed and configured correctly.
 6. Contact your place of purchase of the software or your software provider.

Server is unresponsive (cannot press F1 to start System Setup)

Configuration changes, such as added devices or adapter firmware updates, and firmware or application code problems can cause the server to fail POST (the power-on self-test).

If this occurs, the server responds in either of the following ways:

- The server restarts automatically and attempts POST again.
- The server hangs, and you must manually restart the server for the server to attempt POST again.

After a specified number of consecutive attempts (automatic or manual), the server reverts to the default UEFI configuration and starts System Setup so that you can make the necessary corrections to the configuration and restart the server. If the server is unable to successfully complete POST with the default configuration, there might be a problem with the system board.

You can specify the number of consecutive restart attempts in System Setup. Restart the server and press F1 to display the Lenovo XClarity Provisioning Manager V3 system setup interface. Then, click **System Settings** → **Recovery and RAS** → **POST Attempts** → **POST Attempts Limit**. Available options are 3, 6, 9, and disable.

Voltage planar fault is displayed in the event log

Complete the following steps until the problem is solved.

1. Revert the system to the minimum configuration. See “Specifications” on page 3 for the minimally required number of processors and DIMMs.
2. Restart the system.
 - If the system restarts, add each of the removed items one at a time and restart the system each time until the error occurs. Replace the item for which the error occurs.
 - If the system does not restart, suspect the system board.

Unusual smell

Complete the following steps until the problem is solved.

1. An unusual smell might be coming from newly installed equipment.
2. If the problem remains, contact Lenovo Support.

Server seems to be running hot

Complete the following steps until the problem is solved.

Multiple compute nodes or chassis:

1. Make sure that the room temperature is within the specified range (see “Specifications” on page 3).
2. Make sure that the fans are installed correctly.
3. Update the UEFI and XCC to the latest versions.
4. Make sure that the fillers in the server are installed correctly (see *Maintenance Manual* for detailed installation procedures).
5. Use the IPMI command to ramp up the fan speed to the full fan speed to see whether the issue can be resolved.

Note: The IPMI raw command should only be used by trained technician and the each system has its own specific PMI raw command.

6. Check the management processor event log for rising temperature events. If there are no events, the compute node is running within normal operating temperatures. Note that you can expect some variation in temperature.

Cracked parts or cracked chassis

Contact Lenovo Support.

Software problems

Use this information to solve software problems.

1. To determine whether the problem is caused by the software, make sure that:
 - The server has the minimum memory that is needed to use the software. For memory requirements, see the information that comes with the software.

Note: If you have just installed an adapter or memory, the server might have a memory-address conflict.

 - The software is designed to operate on the server.
 - Other software works on the server.
 - The software works on another server.
2. If you receive any error messages while you use the software, see the information that comes with the software for a description of the messages and suggested solutions to the problem.
3. Contact your place of purchase of the software.



Appendix A. Hardware disassembling for recycle

Follow the instructions in this section to recycle components with compliance with local laws or regulations.

Disassembling the system board for recycle

Follow the instructions in this section to disassemble the system board before recycling.

About this task

Refer to local environmental, waste or disposal regulations to ensure compliance.

Procedure

Step 1. Remove the system board from the server (see “Remove the system board” on page 369).

Step 2. Disassemble the system board.

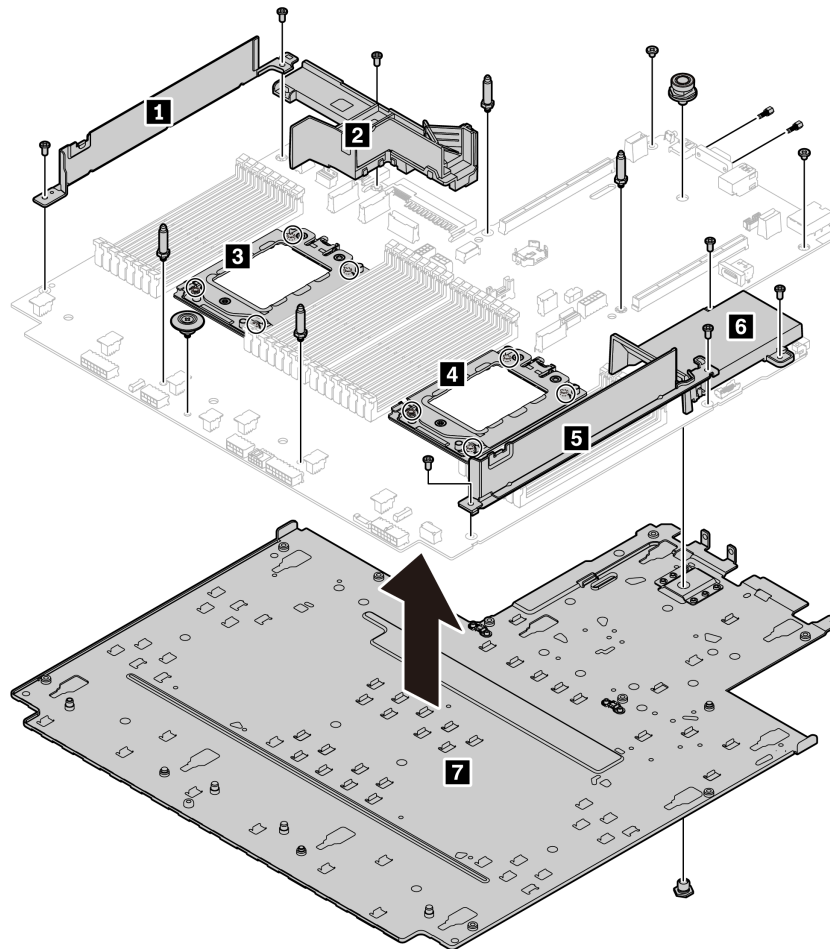

Figure 192. Disassembling the system board

1. Remove the following screws as illustrated:
 - Nine slotted screws (with PH2 screwdriver)
 - Four guiding pin standoffs (with 6 mm wrench)
 - One plunger (with 11 mm and 16 mm wrench)
 - Eight T20 screws on the CPU sockets (with T20 screwdriver)
 - Two hexagon bolts on VGA and COM (RS232) connectors (with 5 mm wrench)
2. Separate the components **1 2 3 4 5 6 7** from the system board.

After you finish

After disassembling the system board, comply with local regulations when recycling.



Appendix B. Getting help and technical assistance

If you need help, service, or technical assistance or just want more information about Lenovo products, you will find a wide variety of sources available from Lenovo to assist you.

On the World Wide Web, up-to-date information about Lenovo systems, optional devices, services, and support are available at:

<http://datacentersupport.lenovo.com>

Note: This section includes references to IBM Web sites and information about obtaining service. IBM is Lenovo's preferred service provider for ThinkSystem.

Before you call

Before you call, there are several steps that you can take to try and solve the problem yourself. If you decide that you do need to call for assistance, gather the information that will be needed by the service technician to more quickly resolve your problem.

Attempt to resolve the problem yourself

You can solve many problems without outside assistance by following the troubleshooting procedures that Lenovo provides in the online help or in the Lenovo product documentation. The Lenovo product documentation also describes the diagnostic tests that you can perform. The documentation for most systems, operating systems, and programs contains troubleshooting procedures and explanations of error messages and error codes. If you suspect a software problem, see the documentation for the operating system or program.

You can find the product documentation for your ThinkSystem products at the following location:

<http://thinksystem.lenovofiles.com/help/index.jsp>

You can take these steps to try to solve the problem yourself:

- Check all cables to make sure that they are connected.
- Check the power switches to make sure that the system and any optional devices are turned on.
- Check for updated software, firmware, and operating-system device drivers for your Lenovo product. The Lenovo Warranty terms and conditions state that you, the owner of the Lenovo product, are responsible for maintaining and updating all software and firmware for the product (unless it is covered by an additional maintenance contract). Your service technician will request that you upgrade your software and firmware if the problem has a documented solution within a software upgrade.
- If you have installed new hardware or software in your environment, check <https://static.lenovo.com/us/en/serverproven/index.shtml> to make sure that the hardware and software are supported by your product.
- Go to <http://datacentersupport.lenovo.com> and check for information to help you solve the problem.
 - Check the Lenovo forums at https://forums.lenovo.com/t5/Datacenter-Systems/ct-p/sv_eg to see if someone else has encountered a similar problem.

You can solve many problems without outside assistance by following the troubleshooting procedures that Lenovo provides in the online help or in the Lenovo product documentation. The Lenovo product documentation also describes the diagnostic tests that you can perform. The documentation for most systems, operating systems, and programs contains troubleshooting procedures and explanations of error

messages and error codes. If you suspect a software problem, see the documentation for the operating system or program.

Gathering information needed to call Support

If you require warranty service for your Lenovo product, the service technicians will be able to assist you more efficiently if you prepare the appropriate information before you call. You can also go to <http://datacentersupport.lenovo.com/warrantylookup> for more information about your product warranty.

Gather the following information to provide to the service technician. This data will help the service technician quickly provide a solution to your problem and ensure that you receive the level of service for which you might have contracted.

- Hardware and Software Maintenance agreement contract numbers, if applicable
- Machine type number (Lenovo 4-digit machine identifier)
- Model number
- Serial number
- Current system UEFI and firmware levels
- Other pertinent information such as error messages and logs

As an alternative to calling Lenovo Support, you can go to <https://support.lenovo.com/servicerequest> to submit an Electronic Service Request. Submitting an Electronic Service Request will start the process of determining a solution to your problem by making the pertinent information available to the service technicians. The Lenovo service technicians can start working on your solution as soon as you have completed and submitted an Electronic Service Request.

Collecting service data

To clearly identify the root cause of a server issue or at the request of Lenovo Support, you might need collect service data that can be used for further analysis. Service data includes information such as event logs and hardware inventory.

Service data can be collected through the following tools:

- **Lenovo XClarity Provisioning Manager V3**

Use the Collect Service Data function of Lenovo XClarity Provisioning Manager V3 to collect system service data. You can collect existing system log data or run a new diagnostic to collect new data.

- **BMC**

You can use the BMC Web user interface or the CLI to collect service data for the server. The file can be saved and sent to Lenovo Support.

- For more information about using the web interface to collect service data, see .

Contacting Support

You can contact Support to obtain help for your issue.

You can receive hardware service through a Lenovo Authorized Service Provider. To locate a service provider authorized by Lenovo to provide warranty service, go to <https://datacentersupport.lenovo.com/serviceprovider> and use filter searching for different countries. For Lenovo support telephone numbers, see <https://datacentersupport.lenovo.com/supportphonenumberlist> for your region support details.

Appendix C. Notices

Lenovo may not offer the products, services, or features discussed in this document in all countries. Consult your local Lenovo representative for information on the products and services currently available in your area.

Any reference to a Lenovo product, program, or service is not intended to state or imply that only that Lenovo product, program, or service may be used. Any functionally equivalent product, program, or service that does not infringe any Lenovo intellectual property right may be used instead. However, it is the user's responsibility to evaluate and verify the operation of any other product, program, or service.

Lenovo may have patents or pending patent applications covering subject matter described in this document. The furnishing of this document is not an offer and does not provide a license under any patents or patent applications. You can send inquiries in writing to the following:

*Lenovo (United States), Inc.
8001 Development Drive
Morrisville, NC 27560
U.S.A.
Attention: Lenovo Director of Licensing*

LENOVO PROVIDES THIS PUBLICATION "AS IS" WITHOUT WARRANTY OF ANY KIND, EITHER EXPRESS OR IMPLIED, INCLUDING, BUT NOT LIMITED TO, THE IMPLIED WARRANTIES OF NON-INFRINGEMENT, MERCHANTABILITY OR FITNESS FOR A PARTICULAR PURPOSE. Some jurisdictions do not allow disclaimer of express or implied warranties in certain transactions, therefore, this statement may not apply to you.

This information could include technical inaccuracies or typographical errors. Changes are periodically made to the information herein; these changes will be incorporated in new editions of the publication. Lenovo may make improvements and/or changes in the product(s) and/or the program(s) described in this publication at any time without notice.

The products described in this document are not intended for use in implantation or other life support applications where malfunction may result in injury or death to persons. The information contained in this document does not affect or change Lenovo product specifications or warranties. Nothing in this document shall operate as an express or implied license or indemnity under the intellectual property rights of Lenovo or third parties. All information contained in this document was obtained in specific environments and is presented as an illustration. The result obtained in other operating environments may vary.

Lenovo may use or distribute any of the information you supply in any way it believes appropriate without incurring any obligation to you.

Any references in this publication to non-Lenovo Web sites are provided for convenience only and do not in any manner serve as an endorsement of those Web sites. The materials at those Web sites are not part of the materials for this Lenovo product, and use of those Web sites is at your own risk.

Any performance data contained herein was determined in a controlled environment. Therefore, the result obtained in other operating environments may vary significantly. Some measurements may have been made on development-level systems and there is no guarantee that these measurements will be the same on generally available systems. Furthermore, some measurements may have been estimated through extrapolation. Actual results may vary. Users of this document should verify the applicable data for their specific environment.

Trademarks

LENOVO, THINKSYSTEM, and XCLARITY are trademarks of Lenovo.

AMD and EPYC are trademarks of AMD Corporation in United States. Microsoft and Windows are trademarks of the Microsoft group of companies. Linux is a registered trademark of Linus Torvalds. All other trademarks are the property of their respective owners. © 2020 Lenovo.

Important notes

Processor speed indicates the internal clock speed of the microprocessor; other factors also affect application performance.

CD or DVD drive speed is the variable read rate. Actual speeds vary and are often less than the possible maximum.

When referring to processor storage, real and virtual storage, or channel volume, KB stands for 1 024 bytes, MB stands for 1 048 576 bytes, and GB stands for 1 073 741 824 bytes.

When referring to hard disk drive capacity or communications volume, MB stands for 1 000 000 bytes, and GB stands for 1 000 000 000 bytes. Total user-accessible capacity can vary depending on operating environments.

Maximum internal hard disk drive capacities assume the replacement of any standard hard disk drives and population of all hard-disk-drive bays with the largest currently supported drives that are available from Lenovo.

Maximum memory might require replacement of the standard memory with an optional memory module.

Each solid-state memory cell has an intrinsic, finite number of write cycles that the cell can incur. Therefore, a solid-state device has a maximum number of write cycles that it can be subjected to, expressed as total bytes written (TBW). A device that has exceeded this limit might fail to respond to system-generated commands or might be incapable of being written to. Lenovo is not responsible for replacement of a device that has exceeded its maximum guaranteed number of program/erase cycles, as documented in the Official Published Specifications for the device.

Lenovo makes no representations or warranties with respect to non-Lenovo products. Support (if any) for the non-Lenovo products is provided by the third party, not Lenovo.

Some software might differ from its retail version (if available) and might not include user manuals or all program functionality.

Particulate contamination

Attention: Airborne particulates (including metal flakes or particles) and reactive gases acting alone or in combination with other environmental factors such as humidity or temperature might pose a risk to the device that is described in this document.

Risks that are posed by the presence of excessive particulate levels or concentrations of harmful gases include damage that might cause the device to malfunction or cease functioning altogether. This specification sets forth limits for particulates and gases that are intended to avoid such damage. The limits must not be viewed or used as definitive limits, because numerous other factors, such as temperature or moisture content of the air, can influence the impact of particulates or environmental corrosives and gaseous contaminant transfer. In the absence of specific limits that are set forth in this document, you must implement practices that maintain particulate and gas levels that are consistent with the protection of human health and safety. If Lenovo determines that the levels of particulates or gases in your environment have caused damage to the device, Lenovo may condition provision of repair or replacement of devices or parts on implementation of appropriate remedial measures to mitigate such environmental contamination. Implementation of such remedial measures is a customer responsibility.

Table 32. Limits for particulates and gases

Contaminant	Limits
Particulate	<ul style="list-style-type: none"> The room air must be continuously filtered with 40% atmospheric dust spot efficiency (MERV 9) according to ASHRAE Standard 52.2¹. Air that enters a data center must be filtered to 99.97% efficiency or greater, using high-efficiency particulate air (HEPA) filters that meet MIL-STD-282. The deliquescent relative humidity of the particulate contamination must be more than 60%². The room must be free of conductive contamination such as zinc whiskers.
Gaseous	<ul style="list-style-type: none"> Copper: Class G1 as per ANSI/ISA 71.04-1985³ Silver: Corrosion rate of less than 300 Å in 30 days
<p>¹ ASHRAE 52.2-2008 - <i>Method of Testing General Ventilation Air-Cleaning Devices for Removal Efficiency by Particle Size</i>. Atlanta: American Society of Heating, Refrigerating and Air-Conditioning Engineers, Inc.</p> <p>² The deliquescent relative humidity of particulate contamination is the relative humidity at which the dust absorbs enough water to become wet and promote ionic conduction.</p> <p>³ ANSI/ISA-71.04-1985. <i>Environmental conditions for process measurement and control systems: Airborne contaminants</i>. Instrument Society of America, Research Triangle Park, North Carolina, U.S.A.</p>	

ASHRAE class compliance information

Your server complies with ASHRAE class A2, A3 and A4 specifications. System performance may be impacted when operating temperature is outside ASHRAE A2, A3 or A4 specifications. The restrictions to ASHRAE A2 (10-35°C) support are as follows:

Server status	Environment requirements
Operating	<p>Ambient temperature:</p> <ul style="list-style-type: none"> ASHRAE class A2: 10–35°C (50–95°F); when the altitude exceeds 900 m (2953 ft), the maximum ambient temperature value decreases by 1°C (1.8°F) with every 300 m (984 ft) of altitude increase. ASHRAE class A3: 5–40°C (41–104°F); when the altitude exceeds 900 m (2953 ft), the maximum ambient temperature value decreases by 1°C (1.8°F) with every 175 m (574 ft) of altitude increase. ASHRAE class A4: 5–45°C (41–113°F); when the altitude exceeds 900 m (2953 ft), the maximum ambient temperature value decreases by 1°C (1.8°F) with every 125 m (410 ft) of altitude increase. <p>Maximum altitude: 3050 m (10 000 ft)</p> <p>Relative humidity (non-condensing):</p> <ul style="list-style-type: none"> ASHRAE class A2: 8%–80%; maximum dew point: 21°C (70°F) ASHRAE class A3: 8%–85%; maximum dew point: 24°C (75°F) ASHRAE class A4: 8%–90%; maximum dew point: 24°C (75°F)
Server off	<p>Ambient temperature:</p> <p>5–45°C (41–113°F)</p>
Shipping or storage	<p>Ambient temperature:</p> <p>-40–60°C (-40–140°F)</p> <p>Maximum altitude: 3050 m (10 000 ft)</p> <p>Relative humidity (non-condensing): 8%–90%</p>

Attention: Airborne particulates and reactive gases acting alone or in combination with other environmental factors such as humidity or temperature might pose a risk to the server. For information about the limits for particulates and gases, see “Particulate contamination” on page 445.

Notes: The restrictions to ASHRAE A2 (10-35°C) support are as follows:

- Mellanox ConnectX-6 adapters with Active Optical Cables (AOCs), ambient temperature cannot exceed 30°C
- With 8x 3.5-inch or 8x 2.5-inch or 16x 2.5-inch front drive bays + double-wide GPUs, ambient temperature cannot exceed 30°C
- With 8x 3.5-inch or 16x 2.5-inch front drive bays + NVIDIA T4 GPU, ambient temperature cannot exceed 30°C

To comply with ASHRAE A3 (5-40°C) and A4 (5-45°C) specifications, the server models must meet the following hardware configuration requirements:

- No Mellanox ConnectX-6 adapters
- No Broadcom 57454 10GBASE-T 4-port OCP Ethernet Adapter, 4XC7A08240
- No GPUs

- No $\geq 170\text{W}$ TDP CPUs
- No NVMe PCIe AIC
- No $\geq 128\text{G}$ 3DS RDIMM
- Mid and rear drive support is per the tables below.

Telecommunication regulatory statement

This product may not be certified in your country for connection by any means whatsoever to interfaces of public telecommunications networks. Further certification may be required by law prior to making any such connection. Contact a Lenovo representative or reseller for any questions.

Electronic emission notices

When you attach a monitor to the equipment, you must use the designated monitor cable and any interference suppression devices that are supplied with the monitor.

Additional electronic emissions notices are available at:

<http://thinksystem.lenovofiles.com/help/index.jsp>

Taiwan BSMI RoHS declaration

單元 Unit	限用物質及其化學符號 Restricted substances and its chemical symbols					
	鉛Lead (PB)	汞Mercury (Hg)	鎘Cadmium (Cd)	六價鉻 Hexavalent chromium (Cr ⁺⁶)	多溴聯苯 Polybrominated biphenyls (PBB)	多溴二苯醚 Polybrominated diphenyl ethers (PBDE)
機架	○	○	○	○	○	○
外部蓋板	○	○	○	○	○	○
機械組零件	-	○	○	○	○	○
空氣傳動設備	-	○	○	○	○	○
冷卻組零件	-	○	○	○	○	○
內存模組	-	○	○	○	○	○
處理器模組	-	○	○	○	○	○
電纜組零件	-	○	○	○	○	○
電源供應器	-	○	○	○	○	○
儲備設備	-	○	○	○	○	○
電路卡	-	○	○	○	○	○
光碟機	-	○	○	○	○	○

備考1. “超出0.1 wt %”及“超出0.01 wt %”係指限用物質之百分比含量超出百分比含量基準值。
 Note1: “exceeding 0.1 wt%” and “exceeding 0.01 wt%” indicate that the percentage content of the restricted substance exceeds the reference percentage value of presence condition.

備考2. “○”係指該項限用物質之百分比含量未超出百分比含量基準值。
 Note2: “○” indicates that the percentage content of the restricted substance does not exceed the percentage of reference value of presence.

備考3. “-”係指該項限用物質為排除項目。
 Note3: The “-” indicates that the restricted substance corresponds to the exemption.

Taiwan import and export contact information

Contacts are available for Taiwan import and export information.

委製商/進口商名稱: 台灣聯想環球科技股份有限公司
 進口商地址: 台北市南港區三重路 66 號 8 樓
 進口商電話: 0800-000-702

Index

- 2 x 3.5-inch rear drive cage
 - installing 323
 - removing 321
- 2.5-inch middle drive cage
 - installing 244
 - removing 242
- 2.5-inch or 3.5-inch middle drive cage
 - removing 242
- 2.5-inch or 3.5-inch rear drive cage
 - removing 320
- 2.5-inch rear drive cage
 - installing 332
- 3.5-inch middle drive cage
 - installing 249
 - removing 246
- 4 x 2.5-inch rear drive cage
 - removing 330
- 4 x 3.5-inch rear drive cage
 - installing 327
 - removing 325
- 7mm drive backplane
 - installing 205, 341
 - removing 203, 338
- 8 x 2.5-inch rear drive cage
 - installing 336
 - removing 334

A

- A1 rearwall (left)
 - installing 308, 310
- air baffle
 - installing 152
 - removing 149
 - replacing 149
- ASHRAE class compliance information 446
- assert
 - physical presence 376

B

- B1 or B2 rearwall (middle)
 - installing 314
 - removing 312
- backplane
 - installing 185, 196, 205, 341
 - removing 182, 194, 203, 338
 - replacing 181
- bezel
 - installing 365
 - removing 362
 - replacing 361

C

- C1/C2 rearwall (right)
 - installing 318
 - removing 316
- cable routing
 - front I/O assembly 58
 - VGA connector 58
- Cable routing for riser cards. 59, 62
- Cable routing for server model with 12 x 3.5-inch AnyBay front drive bays. 124

- Cable routing for server model with 12 x 3.5-inch SAS/SATA front drive bays. 117
- Cable routing for server model with 16 x 2.5-inch front drive bays(8AnyBay+8NVMe). 86
- Cable routing for server model with 16 x 2.5-inch front drive bays(8SAS/SATA+8NVMe). 83
- Cable routing for server model with 16 x 2.5-inch front drive bays(8SAS+8AnyBay). 81
- Cable routing for server model with 16 x 2.5-inch NVMe front drive bays. 79
- Cable routing for server model with 16 x 2.5-inch SAS/SATA front drive bays. 77
- Cable routing for server model with 24 x 2.5-inch front drive bays (SAS/SATA). 111
- Cable routing for server model with 24 x 2.5-inch front drive bays(16SAS/SATA+8AnyBay). 92
- Cable routing for server model with 24 x 2.5-inch front drive bays(16SAS/SATA+8NVMe). 99
- Cable routing for server model with 24 x 2.5-inch front drive bays(8SAS/SATA+16NVMe). 89
- Cable routing for server model with 24 x 2.5-inch front drive bays(SAS/SATA). 103
- Cable routing for server model with 8 x 2.5-inch SAS/SATA front drive bays. 71, 115
- Cable routing for server model with eight 2.5-inch front drive bays. 73
- Cable routing for server model with eight 2.5-inch NVMe front drive bays. 75
- Cable routing for the 7mm drives. 64
- Cable routing for the GPUs. 59
- Cable routing for the M.2 drives. 65
- CMOS battery
 - install 162
 - remove 160
 - replacing 160
- collecting service data 441
- completing
 - parts replacement 397
- contamination, particulate and gaseous 445
- cover
 - installing 394
 - removing 392
 - replacing 391
- CPU
 - installing 271
 - replacing 265
- creating a personalized support web page 440
- custom support web page 440

D

- devices, static-sensitive
 - handling 131
- diagnostics panel
 - LCD 26
- DIMM
 - replacing 251
- disassembling 436
- drive activity LED 11
- drive status LED 11

E

- enable
 - TPM 376
- Ethernet

- controller
 - troubleshooting 404
- Ethernet controller problems solving 404
- External
 - LCD diagnostics handset 26
 - external LCD connector 11

F

- fan
 - installing 384
 - removing 381
 - replacing 380
- fan error LED 45
- firmware updates 7
- front 2.5-inch-drive backplane
 - installing 185
 - removing 182
- front 3.5-inch-drive backplane
 - installing 196
 - removing 194
- front I/O assembly 11
 - installing 167
 - removing 165
- front view 11
- full-height or half-height cable wall brackets
 - installing 155, 158
 - removing 155

G

- gaseous contamination 445
- Getting help 440
- GPU
 - installing 172
 - removing 169
 - replacing 169
- graphic processing unit
 - installing 172
 - removing 169
- guidelines
 - options installation 129
 - system reliability 130

H

- handling static-sensitive devices 131
- hard disk drive
 - installing 178
 - replacing 175
- hard disk drive problems 410
- hard disk drives
 - removing 176
- hardware service and support telephone numbers 441
- heat sink
 - installing 273
 - removing 266
 - replacing 265
- Heat sink and processor
 - replacing 265
- help 440
- hot-swap drive
 - installing 178
 - replacing 175
- hot-swap drives
 - removing 176
- hot-swap power supply
 - installing 216

I

- ID label 1
- important notices 444
- install
 - CMOS battery 162
- installation
 - guidelines 129
- installation guidelines 129
- installing
 - 2 x 3.5-inch rear drive cage 323
 - 2.5-inch middle bay drive cage 244
 - 3.5-inch middle drive cage 249
 - 4 x 2.5-inch rear drive cage 332
 - 4 x 3.5-inch rear drive cage 327
 - 8 x 2.5-inch rear drive cage 336
 - a riser 3 assembly 359
 - air baffle 152
 - backplane 185, 196, 205, 341
 - CPU 271
 - front I/O assembly 167
 - full-height or half-height cable wall brackets 155, 158
 - GPU 172
 - graphic processing unit 172
 - hard disk drive 178
 - heat sink 273
 - hot-swap drive 178
 - hot-swap power supply 216
 - install a B1 or B2 rearwall 314
 - install a C1/C2 rearwall 318
 - install an A1 rearwall 308, 310
 - install_a_riser_assembly 350
 - internal CFF RAID/HBA/RAID expander adapter 226
 - intrusion switch 230
 - memory module 255
 - microprocessor 271
 - middle drive cage 244, 249
 - middle or rear 2.5-inch-drive backplane 191
 - middle or rear 3.5-inch-drive backplane 201
 - OCP 3.0 Ethernet adapter 262
 - processor 271, 273
 - rack latches 282
 - rear drive cage 332
 - rearwall bracket 306
 - security bezel 365
 - super capacitor module on the air baffle 293
 - super capacitor module on the chassis 303
 - super capacitor module the middle 2.5-inch drive cage 297
 - system board 372
 - system fan 384
 - system fan cage 389
 - top cover 394
- insufficient PCIe resource
 - solving 419
- intermittent problems 424
- internal cable routing 57
- internal CFF RAID/HBA/Expander adapter
 - power cable routing 63
 - replacing 224
- internal CFF RAID/HBA/RAID expander adapter
 - installing 226
 - removing 224
- introduction 1
- intrusion switch
 - installing 230
 - removing 228
 - replacing 228

J

- jumper 48

K

keyboard problems 417

L

LCD
 diagnostics panel 26
LCD diagnostics handset
 External 26
light path diagnostics 401

M

M.2 adapter and M.2 drive
 installing 239
 replacing 233
media bay
 replacing 164
memory
 problems 409
memory module
 removing 252
memory module error LED 45
memory module, install 255
memory modules
 removal 252
memory modules installation rules 135, 254
microprocessor
 installing 271
middle drive cage
 installing 244, 249
 removing 242, 246
middle or rear 2.5-inch-drive backplane
 installing 191
 removing 188
middle or rear 3.5-inch-drive backplane
 removing 198
monitor problems 413
mouse problems 417

N

network
 problems 428
network access label 1
notes, important 444
notices 443

O

observable problems 429
OCP 3.0 Ethernet adapter
 replacing 259
optional-device problems 419

P

particulate contamination 445
parts list 50
parts replacement, completing 397
PCIe
 troubleshooting 419
physical presence 376
power
 problems 427
power cable routing
 internal CFF RAID/HBA/Expander adapter 63

Power connections for backplane power connections 66
power cords 55
power problems 403
power supply unit
 removing 209
 replacing 208
problems
 Ethernet controller 404
 hard disk drive 410
 intermittent 424
 keyboard 417
 memory 409
 monitor 413
 mouse 417
 network 428
 observable 429
 optional devices 419
 PCIe 419
 power 403, 427
 power on and power off 406
 serial-device 422
 software 433
 USB device 417
 video 413
processor
 installing 266, 269, 271, 273
 removing 269
 replacing 265
processor-heat-sink module
 installing 271
pull-out information tab 11

Q

QR code 1

R

rack latch 11
rack latches
 installing 282
 removing 278
 replacing 277
RAID super capacitor module
 replacing 287
rear drive cage
 installing 332
 removing 320
rear view 33
rear view LED 41
rearwall bracket
 installing 306
 removing 306
recycle 436
recycling 436
remove
 CMOS battery 160
 M.2 adapter and M.2 drive 234
 OCP 3.0 Ethernet adapter 260
removing
 2 x 3.5-inch rear drive cage 321
 2.5-inch or 3.5-inch middle drive cage 242
 2.5-inch or 3.5-inch rear drive cage 320
 4 x 2.5-inch rear drive cage 330
 4 x 3.5-inch rear drive cage 325
 7mm drive backplane 203, 338
 8 x 2.5-inch rear drive cage 334
 air baffle 149
 backplane 182, 194, 203, 338
 front I/O assembly 165
 full-height or half-height cable wall brackets 155
 GPU 169

- graphic processing unit 169
- hard disk drive 176
- heat sink 266
- hot-swap drive 176
- internal CFF RAID/HBA/RAID expander adapter 224
- intrusion switch 228
- memory modules 252
- middle 2.5-inch drive cage 242
- middle 3.5-inch drive cage 246
- middle drive cage 242, 246
- middle or rear 2.5-inch-drive backplane 188
- middle or rear 3.5-inch-drive backplane 198
- power supply unit 209
- processor 266, 269
- rack latches 278
- rear bay 320
- rearwall bracket 306
- remove a B1 or B2 rearwall 312
- remove a C1/C2 rearwall 316
- riser 1 assembly or riser 2 assembly 346
- riser 3 assembly 355
- security bezel 362
- super capacitor module from the air baffle 291
- super capacitor module from the chassis 300
- super capacitor module from the middle 2.5-inch drive cage 295
- system board 369
- system fan 381
- system fan cage 387
- top cover 392
- removing, memory module 252
- replacing
 - air baffle 149
 - backplane 181
 - CMOS battery 160
 - CPU 265
 - DIMM 251
 - GPU 169
 - graphics processing unit 169
 - hard disk drive 175
 - heat sink 265
 - Heat sink and processor 265
 - hot-swap drive 175
 - internal CFF RAID/HBA/Expander adapter 224
 - intrusion switch 228
 - M.2 adapter and M.2 drive 233
 - media bay 164
 - OCP 3.0 Ethernet adapter 259
 - power supply unit 208
 - processor 265
 - rack latches 277
 - RAID super capacitor module 287
 - riser card 345
 - security bezel 361
 - system board 368
 - system fan 380
 - system fan cage 386
 - top cover 391
- retainer on M.2 adapter
 - adjusting 237
- riser 1 assembly or riser 2 assembly
 - removing 346
- riser 3 assembly
 - installing 359
 - removing 355
- riser assembly
 - installing 350
- riser card
 - replacing 345

S

- safety v

- safety inspection checklist vi
- Secure Boot 378
- security advisories 10
- security bezel
 - installing 365
 - removing 362
 - replacing 361
- serial-device problems 422
- server components 11
- server power on or power off problems 406
- service and support
 - before you call 440
 - hardware 441
 - software 441
- service data 441
- signal cable routing
 - 2.5-inch/3.5-inch drive backplanes 71
- software problems 433
- software service and support telephone numbers 441
- solving
 - Ethernet controller problems 404
 - insufficient PCIe resource 419
- solving power problems 403
- static-sensitive devices
 - handling 131
- super capacitor module from the air baffle
 - removing 291
- super capacitor module from the chassis
 - removing 300
- super capacitor module from the middle 2.5-inch drive cage
 - removing 295
- super capacitor module on the air baffle
 - installing 293
- super capacitor module on the chassis
 - installing 303
- super capacitor module the middle 2.5-inch drive cage
 - installing 297
- support web page, custom 440
- supported drive bay combinations 139
- system board 436
 - installing 372
 - removing 369
 - replacing 368
- system board components 43
- system board LED 45
- system error LED 45
- system fan
 - installing 384
 - removing 381
 - replacing 380
- system fan cage
 - installing 389
 - removing 387
 - replacing 386
- system ID LED 45
- system power LED 45
- system reliability guidelines 130

T

- Taiwan BSMI RoHS declaration 448
- Taiwan import and export contact information 448
- tech tips 9
- technical rules 132
- Technical rules for GPU 147
- Technical rules for HBA/RAID adapters 144
- Technical rules for processorsf 135
- technical rules for system fans 148
- telecommunication regulatory statement 447
- telephone numbers 441
- top cover
 - installing 394
 - removing 392

- replacing 391
- TPM 376
- TPM policy 376
- trademarks 444
- troubleshooting 413, 419, 433
 - by symptom 405
 - hard disk drive problems 410
 - intermittent problems 424
 - keyboard problems 417
 - memory problems 409
 - mouse problems 417
 - network problems 428
 - observable problems 429
 - power on and power off problems 406
 - power problems 427
 - serial-device problems 422
 - symptoms-based troubleshooting 405
 - USB-device problems 417
 - video 413
- Trusted Platform Module 376
- turn off the server 10
- turn on the server 10

U

- UEFI Secure Boot 378
- update firmware 7
- updating
 - DMI/SMBIOS 376
 - Universal Unique Identifier (UUID) 375
- USB-device problems 417

V

- VGA connector 11
- video problems 413

W

- warranty 1
- working inside the server
 - power on 130

Lenovo