

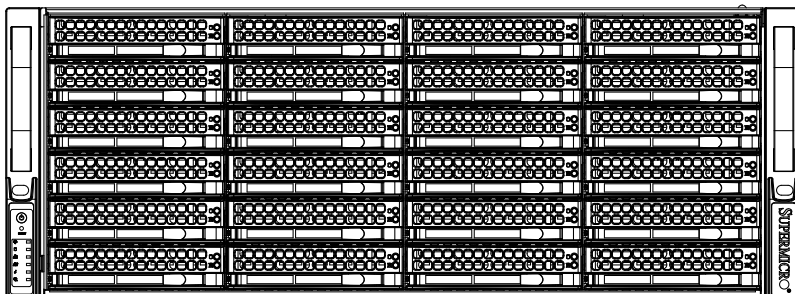

SC847BE1C/2C and SC847BA

CHASSIS SERIES



SC847BE1C-R1K28LPB

SC847BE2C-R1K28LPB

SC847BE1C-R1K28WB

SC847BE2C-R1K28WB

SC847BA-R1K28LPB

USER'S MANUAL

1.0b

The information in this User's Manual has been carefully reviewed and is believed to be accurate. The vendor assumes no responsibility for any inaccuracies that may be contained in this document, makes no commitment to update or to keep current the information in this manual, or to notify any person or organization of the updates. **Please Note: For the most up-to-date version of this manual, please see our web site at www.supermicro.com.**

Super Micro Computer, Inc. ("Supermicro") reserves the right to make changes to the product described in this manual at any time and without notice. This product, including software and documentation, is the property of Supermicro and/or its licensors, and is supplied only under a license. Any use or reproduction of this product is not allowed, except as expressly permitted by the terms of said license.

IN NO EVENT WILL SUPERMICRO BE LIABLE FOR DIRECT, INDIRECT, SPECIAL, INCIDENTAL, SPECULATIVE OR CONSEQUENTIAL DAMAGES ARISING FROM THE USE OR INABILITY TO USE THIS PRODUCT OR DOCUMENTATION, EVEN IF ADVISED OF THE POSSIBILITY OF SUCH DAMAGES. IN PARTICULAR, SUPERMICRO SHALL NOT HAVE LIABILITY FOR ANY HARDWARE, SOFTWARE, OR DATA STORED OR USED WITH THE PRODUCT, INCLUDING THE COSTS OF REPAIRING, REPLACING, INTEGRATING, INSTALLING OR RECOVERING SUCH HARDWARE, SOFTWARE, OR DATA.

Any disputes arising between manufacturer and customer shall be governed by the laws of Santa Clara County in the State of California, USA. The State of California, County of Santa Clara shall be the exclusive venue for the resolution of any such disputes. Super Micro's total liability for all claims will not exceed the price paid for the hardware product.

California Best Management Practices Regulations for Perchlorate Materials: This Perchlorate warning applies only to products containing CR (Manganese Dioxide) Lithium coin cells. "Perchlorate Material-special handling may apply. See www.dtsc.ca.gov/hazardouswaste/perchlorate"

WARNING: Handling of lead solder materials used in this product may expose you to lead, a chemical known to the State of California to cause birth defects and other reproductive harm.

Manual Revision 1.0b
Release Date: December 4, 2015

Unless you request and receive written permission from Super Micro Computer, Inc., you may not copy any part of this document.

Information in this document is subject to change without notice. Other products and companies referred to herein are trademarks or registered trademarks of their respective companies or mark holders.

Copyright © 2015 by Super Micro Computer, Inc.
All rights reserved.
Printed in the United States of America

Preface

About This Manual

This manual is written for professional system integrators and PC technicians. It provides information for the installation and use of the SC847BEC1/C2 and SC847BA chassis. Installation and maintenance should be performed by experienced technicians only.

This manual lists compatible parts available when this document was published. Always refer to the our website for updates on supported parts and configurations.

Manual Organization

Chapter 1: Introduction

The first chapter provides a checklist of the main components included with this chassis and describes the main features of the SC847BEC1/C2 and SC847BA chassis. This chapter also includes contact information.

Chapter 2: Standardized Warning Statements for AC/DC Systems

This chapter lists warnings, precautions, and system safety. It is recommended that you thoroughly familiarize yourself with installing and servicing the chassis and all safety precautions.

Chapter 3: System Interface

Refer to this chapter for details on the system interface, which includes the functions and information provided by the chassis control panel, as well as other LEDs located throughout the system.

Chapter 4: Chassis Setup and Maintenance

Follow the procedures given in this chapter when installing, removing, or reconfiguring components in your chassis.

Chapter 5: Rack Installation

Refer to this chapter for detailed information on chassis rack installation. You should follow the procedures given in this chapter when installing, removing or reconfiguring your chassis into a rack environment.

This section lists compatible cables, power supply specifications, and compatible backplanes. Not all compatible backplanes are listed. Refer to our website for the latest compatible backplane information.

Appendix A: Cables and Hardware

This section provides information on cabling, and other hardware which is compatible with your chassis.

Appendix B: Power Supply Specifications

This chapter lists the specifications of the power supply provided with your chassis.

Appendix C: BPN-SAS3-846EL Backplane Specifications

This chapter contains information on the BPN-SAS3-846EL1 and BPN-SAS3-846EL2 backplanes.

Appendix D: BPN-SAS3-826EL Backplane Specifications

This section covers the BPN-SAS3-826EL1 and BPN-SAS3-826EL2 backplane specifications.

Appendix E: Front to Rear Backplane Cascading- SC847BE1C/2C

This appendix provides information on cascading from the front backplane to the rear backplane on SC847BE1C/2C chassis models only.

Appendix F: BPN-SAS-826A Backplane Specifications

This appendix covers the BPN-SAS-826A backplane specifications.

Appendix G: BPN-SAS-846A Backplane Specifications

This appendix covers the BPN-SAS-846A backplane specifications.

For additional information on all the appendices listed above, visit the Supermicro website at www.supermicro.com.

Table of Contents

Contacting Supermicro.....	iii
Chapter 1 Introduction	
1-1 Overview	1-1
1-2 Shipping List.....	1-1
1-3 Where to get Replacement Components.....	1-2
1-4 Returning Merchandise for Service.....	1-3
Chapter 2 Standardized Warning Statements for AC/DC Systems	
2-1 About Standardized Warning Statements.....	2-1
Warning Definition	2-1
Installation Instructions.....	2-4
Circuit Breaker	2-5
Power Disconnection Warning.....	2-6
Equipment Installation.....	2-8
Restricted Area.....	2-9
Battery Handling.....	2-10
Redundant Power Supplies	2-12
Backplane Voltage	2-13
Comply with Local and National Electrical Codes.....	2-14
Product Disposal	2-15
Hot Swap Fan Warning.....	2-16
DC Power Supply	2-18
DC Power Disconnection	2-20
Hazardous Voltage or Energy Present on DC Power Terminals.....	2-21
Chapter 3 System Interface	
3-1 Overview	3-1
3-2 Control Panel Buttons.....	3-2
3-3 Control Panel LEDs	3-2
3-4 Drive Carrier LEDs.....	3-4
SAS/SATA Drives	3-4
SCSI Drives.....	3-4
Chapter 4 Chassis Setup and Maintenance	
4-1 Overview	4-1
4-2 Removing the Chassis Cover.....	4-2
4-3 3.5" Hard Drives.....	4-3
4-4 2.5" Hard Drives and the Rear Hard Drive Cage.....	4-6
4-5 Installing the Motherboard	4-8

Permanent and Optional Standoffs.....	4-8
4-6 Expansion Card Setup.....	4-10
Installing Expansion Cards	4-10
4-7 Removing and Installing the Backplanes.....	4-11
4-8 Air Shroud Modification and Installation	4-15
Air Shroud Installation.....	4-15
4-9 System Fans	4-18
4-10 Power Supply	4-20
Chapter 5 Rack Installation	
5-1 Overview	5-1
5-2 Unpacking the System.....	5-1
5-3 Preparing for Setup.....	5-1
Choosing a Setup Location.....	5-1
5-4 Warnings and Precautions	5-2
Rack Precautions	5-2
General Server Precautions.....	5-2
Rack Mounting Considerations	5-3
Ambient Operating Temperature	5-3
Reduced Airflow	5-3
Mechanical Loading	5-3
Circuit Overloading.....	5-3
Reliable Ground	5-3
5-5 Rack Mounting Instructions.....	5-4
Identifying the Sections of the Rack Rails.....	5-4
Locking Tabs	5-5
Releasing the Inner Rail	5-5
Installing The Inner Rails on the Chassis.....	5-6
Installing the Outer Rails on the Rack.....	5-7
Standard Chassis Installation	5-8
Optional Quick Installation Method.....	5-9
Appendix A SC847BE1C/2C Cables and Hardware	
Appendix B SC847BE1C/2C Power Supply Specifications	
Appendix C BPN-SAS-846EL Front Backplane Specifications	
Appendix D BPN-SAS-826EL Backplane Specifications	
Appendix E Front and Rear Backplane Cascading	
Appendix F BPN-SAS3-826A Backplane Specifications	
Appendix G BPN-SAS3-846A Backplane Specifications	

Chapter 1

Introduction

1-1 Overview

Optimized for enterprise-level heavy-capacity storage applications, Supermicro's SC847BE1C/2C and SC847BA chassis features up to 36x (24 front + 12 rear) 3.5" hot-swap HDD bays SAS/SATA drive bays supporting SAS3/2 or SATA3 HDDs with 12 Gbps throughput.

The SC847BE1C/2C and SC847BA designs provide high-density storage in a 4U form factor, with high power efficiency, optimized HDD signal trace routing and improved HDD carrier design to dampen vibration and maximize performance. Equipped with a 1280W (Platinum Level) high-efficiency redundant power supply and seven hot-plug redundant cooling fans, the SC847BE1C/2C and SC847BA are reliable, high-quality storage workhorse systems.

1-2 Shipping List

Please visit the Supermicro website for the latest shipping lists and part numbers for your particular chassis model at www.supermicro.com.

SC847BE1C/2C Chassis			
Model	HDD	I/O Slots	Power Supply
SC847BA-R1K28LPB	36x (24 front + 12 rear) 3.5" hot-swap HDD bays	7x LP	1280W redundant (Platinum Level)
SC847BE1C-R1K28LPB	36x (24 front + 12 rear) 3.5" hot-swap SAS3	7x LP	1280W redundant (Platinum Level)
SC847BE2C-R1K28LPB	36x (24 front + 12 rear) 3.5" hot-swap SAS3	7x LP	1280W redundant (Platinum Level)
SC847BE1C-R1K28WB	36x (24 front + 12 rear) 3.5" hot-swap SAS3	4x FH 3x LP (WIO)	1280W redundant (Platinum Level)
SC847BE2C-R1K28WB	36x (24 front + 12 rear) 3.5" hot-swap SAS3	4x FH 3x LP (WIO)	1280W redundant (Platinum Level)

1-3 Where to get Replacement Components

Though not frequently, you may need replacement parts for your system. To ensure the highest level of professional service and technical support, we strongly recommend purchasing exclusively from our Supermicro Authorized Distributors/System Integrators/Resellers. A list of Supermicro Authorized Distributors/System Integrators/Resellers can be found at: <http://www.supermicro.com>. Click the Where to Buy link.

Contacting Supermicro

Headquarters

Address: Super Micro Computer, Inc.
980 Rock Ave.
San Jose, CA 95131 U.S.A.

Tel: +1 (408) 503-8000

Fax: +1 (408) 503-8008

Email: marketing@supermicro.com (General Information)
support@supermicro.com (Technical Support)

Website: www.supermicro.com

Europe

Address: Super Micro Computer B.V.
Het Sterrenbeeld 28, 5215 ML
's-Hertogenbosch, The Netherlands

Tel: +31 (0) 73-6400390

Fax: +31 (0) 73-6416525

Email: sales@supermicro.nl (General Information)
support@supermicro.nl (Technical Support)
rma@supermicro.nl (Customer Support)

Website: www.supermicro.nl

Asia-Pacific

Address: Super Micro Computer, Inc.
3F, No. 150, Jian 1st Rd.
Zhonghe Dist., New Taipei City 235
Taiwan (R.O.C)

Tel: +886-(2) 8226-3990

Fax: +886-(2) 8226-3992

Email: support@supermicro.com.tw

Website: www.supermicro.com.tw

1-4 Returning Merchandise for Service

A receipt or copy of your invoice marked with the date of purchase is required before any warranty service will be rendered. You can obtain service by calling your vendor for a Returned Merchandise Authorization (RMA) number. When returning to the manufacturer, the RMA number should be prominently displayed on the outside of the shipping carton, and mailed prepaid or hand-carried. Shipping and handling charges will be applied for all orders that must be mailed when service is complete.

For faster service, RMA authorizations may be requested online (<http://www.supermicro.com/support/rma/>).

Whenever possible, repack the chassis in the original Supermicro carton, using the original packaging material. If these are no longer available, be sure to pack the chassis securely, using packaging material to surround the chassis so that it does not shift within the carton and become damaged during shipping.

This warranty only covers normal consumer use and does not cover damages incurred in shipping or from failure due to the alteration, misuse, abuse or improper maintenance of products.

During the warranty period, contact your distributor first for any product problems.

Notes

Chapter 2

Standardized Warning Statements for AC/DC Systems

2-1 About Standardized Warning Statements

The following statements are industry standard warnings, provided to warn the user of situations which have the potential for bodily injury. Should you have questions or experience difficulty, contact Supermicro's Technical Support department for assistance. Only certified technicians should attempt to install or configure components.

Read this appendix in its entirety before installing or configuring components in the Supermicro chassis.

These warnings may also be found on our web site at http://www.supermicro.com/about/policies/safety_information.cfm.

Warning Definition



Warning!

This warning symbol means danger. You are in a situation that could cause bodily injury. Before you work on any equipment, be aware of the hazards involved with electrical circuitry and be familiar with standard practices for preventing accidents.

警告の定義

この警告サインは危険を意味します。

人身事故につながる可能性がありますので、いずれの機器でも動作させる前に、電気回路に含まれる危険性に注意して、標準的な事故防止策に精通して下さい。

此警告符号代表危險。

您正处于可能受到严重伤害的工作环境中。在您使用设备开始工作之前，必须充分意识到触电的危险，并熟练掌握防止事故发生的标准工作程序。请根据每项警告结尾的声明号码找到此设备的安全性警告说明的翻译文本。

此警告符號代表危險。

您正處於可能身體可能會受損傷的工作環境中。在您使用任何設備之前，請注意觸電的危險，並且要熟悉預防事故發生的標準工作程序。請依照每一注意事項後的號碼找到相關的翻譯說明內容。

Warnung

WICHTIGE SICHERHEITSHINWEISE

Dieses Warnsymbol bedeutet Gefahr. Sie befinden sich in einer Situation, die zu Verletzungen führen kann. Machen Sie sich vor der Arbeit mit Geräten mit den Gefahren elektrischer Schaltungen und den üblichen Verfahren zur Vorbeugung vor Unfällen vertraut. Suchen Sie mit der am Ende jeder Warnung angegebenen Anweisungsnummer nach der jeweiligen Übersetzung in den übersetzten Sicherheitshinweisen, die zusammen mit diesem Gerät ausgeliefert wurden.

BEWAHREN SIE DIESE HINWEISE GUT AUF.

INSTRUCCIONES IMPORTANTES DE SEGURIDAD

Este símbolo de aviso indica peligro. Existe riesgo para su integridad física. Antes de manipular cualquier equipo, considere los riesgos de la corriente eléctrica y familiarícese con los procedimientos estándar de prevención de accidentes. Al final de cada advertencia encontrará el número que le ayudará a encontrar el texto traducido en el apartado de traducciones que acompaña a este dispositivo.

GUARDE ESTAS INSTRUCCIONES.

IMPORTANTES INFORMATIONS DE SÉCURITÉ

Ce symbole d'avertissement indique un danger. Vous vous trouvez dans une situation pouvant entraîner des blessures ou des dommages corporels. Avant de travailler sur un équipement, soyez conscient des dangers liés aux circuits électriques et familiarisez-vous avec les procédures couramment utilisées pour éviter les accidents. Pour prendre connaissance des traductions des avertissements figurant dans les consignes de sécurité traduites qui accompagnent cet appareil, référez-vous au numéro de l'instruction situé à la fin de chaque avertissement.

CONSERVEZ CES INFORMATIONS.

תקנון הצהרות אזהרה

הצהרות הבאות הן אזהרות על פי תקני התעשייה, על מנת להזהיר את המשתמש מפני חבלה פיזית אפשרית. במידה ויש שאלות או היתקלות בבעיה כלשהי, יש ליצור קשר עם מחלקת תמיכה טכנית של סופרמיקרו. טכנאים מוסמכים בלבד רשאים להתקין או להגדיר את הרכיבים.

יש לקרוא את הנספח במלואו לפני התקנת או הגדרת הרכיבים במארוזי סופרמיקרו.

تحذير! هذا الرمز يعني خطر انك في حالة يمكن أن تتسبب في اصابة جسدية . قبل أن تعمل على أي معدات،كن على علم بالمخاطر الناجمة عن الدوائر الكهربائية
وكن على دراية بالممارسات الوقائية لمنع وقوع أي حوادث
استخدم رقم البيان المنصوص في نهاية كل تحذير للعثور ترجمتها

안전을 위한 주의사항

경고!

이 경고 기호는 위험이 있음을 알려 줍니다. 작업자의 신체에 부상을 야기 할 수 있는 상태에 있게 됩니다. 모든 장비에 대한 작업을 수행하기 전에 전기회로와 관련된 위험요소들을 확인하시고 사전에 사고를 방지할 수 있도록 표준 작업절차를 준수해 주시기 바랍니다.

해당 번역문을 찾기 위해 각 경고의 마지막 부분에 제공된 경고문 번호를 참조하십시오

BELANGRIJKE VEILIGHEIDSINSTRUCTIES

Dit waarschuwings symbool betekent gevaar. U verkeert in een situatie die lichamelijk letsel kan veroorzaken. Voordat u aan enige apparatuur gaat werken, dient u zich bewust te zijn van de bij een elektrische installatie betrokken risico's en dient u op de hoogte te zijn van de standaard procedures om ongelukken te voorkomen. Gebruik de nummers aan het eind van elke waarschuwing om deze te herleiden naar de desbetreffende locatie.

BEWAAR DEZE INSTRUCTIES

Installation Instructions



Warning!

Read the installation instructions before connecting the system to the power source.

設置手順書

システムを電源に接続する前に、設置手順書をお読み下さい。

警告

将此系统连接电源前, 请先阅读安装说明。

警告

將系統與電源連接前, 請先閱讀安裝說明。

Warnung

Vor dem Anschließen des Systems an die Stromquelle die Installationsanweisungen lesen.

¡Advertencia!

Lea las instrucciones de instalación antes de conectar el sistema a la red de alimentación.

Attention

Avant de brancher le système sur la source d'alimentation, consulter les directives d'installation.

יש לקרוא את הוראות התקנה לפני חיבור המערכת למקור מתח.

اقرأ إرشادات التركيب قبل توصيل النظام إلى مصدر للطاقة

주의!

시스템을 전원에 연결하기 전에 설치 안내를 읽어주십시오.

Waarschuwing

Raadpleeg de installatie-instructies voordat u het systeem op de voedingsbron aansluit.

Circuit Breaker



Warning!

This product relies on the building's installation for short-circuit (overcurrent) protection. Ensure that the protective device is rated not greater than: 60VDC, 20 A.

サーキット・ブレーカー

この製品は、短絡(過電流)保護装置がある建物での設置を前提としています。

保護装置の定格が60VDC、20Aを超えないことを確認下さい。

警告

此产品的短路(过载电流)保护由建筑物的供电系统提供, 确保短路保护设备的额定电流不大于60VDC, 20A。

警告

此產品的短路(過載電流)保護由建築物的供電系統提供, 確保短路保護設備的額定電流不大於60VDC, 20A。

Warnung

Dieses Produkt ist darauf angewiesen, dass im Gebäude ein Kurzschluss- bzw. Überstromschutz installiert ist. Stellen Sie sicher, dass der Nennwert der Schutzvorrichtung nicht mehr als: 60VDC, 20A beträgt.

¡Advertencia!

Este equipo utiliza el sistema de protección contra cortocircuitos (o sobrecorrientes) del edificio. Asegúrese de que el dispositivo de protección no sea superior a: 60VDC, 20A.

Attention

Pour ce qui est de la protection contre les courts-circuits (surtension), ce produit dépend de l'installation électrique du local. Vérifiez que le courant nominal du dispositif de protection n'est pas supérieur à : 60VDC, 20A.

מוצר זה מסתמך על הגנה המותקנת במבנים למניעת קצר חשמלי. יש לוודא כי המכשיר המגן מפני הקצר החשמלי הוא לא יותר מ-250 V, 20 A

هذا المنتج يعتمد على معدات الحماية من الدوائر القصيرة التي تم تثبيتها في المبنى

경고!

이 제품은 전원의 단락(과전류)방지에 대해서 전적으로 건물의 관련 설비에 의존합니다. 보호장치의 정격이 반드시 60V(볼트), 20A(암페어)를 초과하지 않도록 해야 합니다.

Waarschuwing

Dit product is afhankelijk van de kortsluitbeveiliging (overspanning) van uw elektrische installatie. Controleer of het beveiligde apparaat niet groter gedimensioneerd is dan 60V, 20A.

Power Disconnection Warning



Warning!

The system must be disconnected from all sources of power and the power cord removed from the power supply module(s) before accessing the chassis interior to install or remove system components.

電源切斷の警告

システムコンポーネントの取り付けまたは取り外しのために、シャーシー内部にアクセスするには、

システムの電源はすべてのソースから切斷され、電源コードは電源モジュールから取り外す必要があります。

警告

在你打开机箱并安装或移除内部器件前，必须将系统完全断电，并移除电源线。

警告

在您打開機殼安裝或移除內部元件前，必須將系統完全斷電，並移除電源線。

Warnung

Das System muss von allen Quellen der Energie und vom Netzanschlusskabel getrennt sein, das von den Spg.Versorgungsteilmodulen entfernt wird, bevor es auf den Chassisinnenraum zurückgreift, um Systemsbestandteile anzubringen oder zu entfernen.

¡Advertencia!

El sistema debe ser disconnected de todas las fuentes de energía y del cable eléctrico quitado de los módulos de fuente de alimentación antes de tener acceso el interior del chasis para instalar o para quitar componentes de sistema.

Attention

Le système doit être débranché de toutes les sources de puissance ainsi que de son cordon d'alimentation secteur avant d'accéder à l'intérieur du châssis pour installer ou enlever des composants de système.

אזהרה!

יש לנתק את המערכת מכל מקורות החשמל ויש להסיר את כבל החשמלי מהספק לפני גישה לחלק הפנימי של המארז לצורך התקנת או הסרת רכיבים.

يجب فصل النظام من جميع مصادر الطاقة وإزالة سلك الكهرباء من وحدة امداد الطاقة قبل

الوصول إلى المناطق الداخلية للهيكल لتنشيت أو إزالة مكونات الجهاز

경고!

시스템에 부품들을 장착하거나 제거하기 위해서는 새시 내부에 접근하기 전에 반드시 전원 공급장치로부터 연결되어있는 모든 전원과 전기코드를 분리해주어야 합니다.

Waarschuwing

Voordat u toegang neemt tot het binnenwerk van de behuizing voor het installeren of verwijderen van systeem onderdelen, dient u alle spanningsbronnen en alle stroomkabels aangesloten op de voeding(en) van de behuizing te verwijderen

Equipment Installation



Warning!

Only trained and qualified personnel should be allowed to install, replace, or service this equipment.

機器の設置

トレーニングを受け認定された人だけがこの装置の設置、交換、またはサービスを許可されています。

警告

只有经过培训且具有资格的人员才能进行此设备的安装、更换和维修。

警告

只有經過受訓且具資格人員才可安裝、更換與維修此設備。

Warnung

Das Installieren, Ersetzen oder Bedienen dieser Ausrüstung sollte nur geschultem, qualifiziertem Personal gestattet werden.

¡Advertencia!

Solamente el personal calificado debe instalar, reemplazar o utilizar este equipo.

Attention

Il est vivement recommandé de confier l'installation, le remplacement et la maintenance de ces équipements à des personnels qualifiés et expérimentés.

אזהרה!

צוות מוסמך בלבד רשאי להתקין, להחליף את הציוד או לתת שירות עבור הציוד.

يجب أن يسمح فقط للموظفين المؤهلين والمدربين لتكيب واستبدال أو خدمة هذا الجهاز

경고!

훈련을 받고 공인된 기술자만이 이 장비의 설치, 교체 또는 서비스를 수행할 수 있습니다.

Waarschuwing

Deze apparatuur mag alleen worden geïnstalleerd, vervangen of hersteld door geschoold en gekwalificeerd personeel.

Restricted Area



Warning!

This unit is intended for installation in restricted access areas. A restricted access area can be accessed only through the use of a special tool, lock and key, or other means of security. (This warning does not apply to workstations).

アクセス制限区域

このユニットは、アクセス制限区域に設置されることを想定しています。

アクセス制限区域は、特別なツール、鍵と錠前、その他のセキュリティの手段を用いてのみ出入りが可能です。

警告

此部件应安装在限制进出的场所，限制进出的场所指只能通过使用特殊工具、锁和钥匙或其它安全手段进出的场所。

警告

此裝置僅限安裝於進出管制區域，進出管制區域係指僅能以特殊工具、鎖頭及鑰匙或其他安全方式才能進入的區域。

Warnung

Diese Einheit ist zur Installation in Bereichen mit beschränktem Zutritt vorgesehen. Der Zutritt zu derartigen Bereichen ist nur mit einem Spezialwerkzeug, Schloss und Schlüssel oder einer sonstigen Sicherheitsvorkehrung möglich.

¡Advertencia!

Esta unidad ha sido diseñada para instalación en áreas de acceso restringido. Sólo puede obtenerse acceso a una de estas áreas mediante la utilización de una herramienta especial, cerradura con llave u otro medio de seguridad.

Attention

Cet appareil doit être installé dans des zones d'accès réservés. L'accès à une zone d'accès réservé n'est possible qu'en utilisant un outil spécial, un mécanisme de verrouillage et une clé, ou tout autre moyen de sécurité.

אזור עם גישה מוגבלת**אזהרה!**

יש להתקין את היחידה באזורים שיש בהם הגבלת גישה. הגישה ניתנת בעזרת כלי אבטחה בלבד (מפתח, מנעול וכד').

تم تخصيص هذه الوحدة لتركيبها في مناطق محظورة . يمكن الوصول إلى منطقة محظورة فقط من خلال استخدام أداة خاصة، قفل ومفتاح أو أي وسيلة أخرى للأمان

경고!

이 장치는 접근이 제한된 구역에 설치하도록 되어 있습니다. 특수도구, 잠금 장치 및 키, 또는 기타 보안 수단을 통해서만 접근 제한 구역에 들어갈 수 있습니다.

Waarschuwing

Dit apparaat is bedoeld voor installatie in gebieden met een beperkte toegang. Toegang tot dergelijke gebieden kunnen alleen verkregen worden door gebruik te maken van speciaal gereedschap, slot en sleutel of andere veiligheidsmaatregelen.

Battery Handling**Warning!**

There is the danger of explosion if the battery is replaced incorrectly. Replace the battery only with the same or equivalent type recommended by the manufacturer. Dispose of used batteries according to the manufacturer's instructions

電池の取り扱い

電池交換が正しく行われなかった場合、破裂の危険性があります。交換する電池はメーカーが推奨する型、または同等のものを使用下さい。使用済電池は製造元の指示に従って処分して下さい。

警告

電池更換不當會有爆炸危險。請只使用同類電池或制造商推薦的功能相當的電池更換原有電池。請按製造商的說明處理廢舊電池。

警告

電池更換不當會有爆炸危險。請使用製造商建議之相同或功能相當的電池更換原有電池。請按照製造商的說明指示處理廢棄舊電池。

Warnung

Bei Einsetzen einer falschen Batterie besteht Explosionsgefahr. Ersetzen Sie die Batterie nur durch den gleichen oder vom Hersteller empfohlenen Batterietyp. Entsorgen Sie die benutzten Batterien nach den Anweisungen des Herstellers.

Attention

Danger d'explosion si la pile n'est pas remplacée correctement. Ne la remplacer que par une pile de type semblable ou équivalent, recommandée par le fabricant. Jeter les piles usagées conformément aux instructions du fabricant.

¡Advertencia!

Existe peligro de explosión si la batería se reemplaza de manera incorrecta. Reemplazar la batería exclusivamente con el mismo tipo o el equivalente recomendado por el fabricante. Desechar las baterías gastadas según las instrucciones del fabricante.

אזהרה!

קיימת סכנת פיצוץ של הסוללה במידה והוחלפה בדרך לא תקינה. יש להחליף את הסוללה בסוג התואם מחברת יצרן מומלצת.

סילוק הסוללות המשומשות יש לבצע לפי הוראות היצרן.

هناك خطر من انفجار في حالة استبدال البطارية بطريقة غير صحيحة فعليك استبدال البطارية فقط بنفس النوع أو ما يعادلها كما أوصت به الشركة المصنعة تخلص من البطاريات المستعملة وفقا لتعليمات الشركة الصانعة

경고!

배터리가 올바르게 교체되지 않으면 폭발의 위험이 있습니다. 기존 배터리와 동일하거나 제조사에서 권장하는 동등한 종류의 배터리로만 교체해야 합니다. 제조사의 안내에 따라 사용된 배터리를 처리하여 주십시오.

Waarschuwing

Er is ontploffingsgevaar indien de batterij verkeerd vervangen wordt. Vervang de batterij slechts met hetzelfde of een equivalent type die door de fabrikant aanbevolen wordt. Gebruikte batterijen dienen overeenkomstig fabrieksvoorschriften afgevoerd te worden.

Redundant Power Supplies



Warning!

This unit might have more than one power supply connection. All connections must be removed to de-energize the unit.

冗長電源装置

このユニットは複数の電源装置が接続されている場合があります。
ユニットの電源を切るためには、すべての接続を取り外さなければなりません。

警告

此部件连接的电源可能不止一个，必须将所有电源断开才能停止给该部件供电。

警告

此裝置連接的電源可能不只一個，必須切斷所有電源才能停止對該裝置的供電。

Warnung

Dieses Gerät kann mehr als eine Stromzufuhr haben. Um sicherzustellen, dass der Einheit kein Strom zugeführt wird, müssen alle Verbindungen entfernt werden.

¡Advertencia!

Puede que esta unidad tenga más de una conexión para fuentes de alimentación. Para cortar por completo el suministro de energía, deben desconectarse todas las conexiones.

Attention

Cette unité peut avoir plus d'une connexion d'alimentation. Pour supprimer toute tension et tout courant électrique de l'unité, toutes les connexions d'alimentation doivent être débranchées.

אם קיים יותר מספק אחד

אזהרה!

ליחידה יש יותר מחיבור אחד של ספק. יש להסיר את כל החיבורים על מנת לרוקן את היחידה.

قد يكون لهذا الجهاز عدة اتصالات بوحدة امداد الطاقة.
يجب إزالة كافة الاتصالات لعزل الوحدة عن الكهرباء

경고!

이 장치에는 한 개 이상의 전원 공급 단자가 연결되어 있을 수 있습니다. 이 장치에 전원을 차단하기 위해서는 모든 연결 단자를 제거해야만 합니다.

Waarschuwing

Deze eenheid kan meer dan één stroomtoevoeraansluiting bevatten. Alle aansluitingen dienen verwijderd te worden om het apparaat stroomloos te maken.

Backplane Voltage



Warning!

Hazardous voltage or energy is present on the backplane when the system is operating. Use caution when servicing.

バックプレーンの電圧

システムの稼働中は危険な電圧または電力が、バックプレーン上にかかっています。

修理する際にはご注意ください。

警告

当系统正在进行时，背板上有很危险的电压或能量，进行维修时务必小心。

警告

當系統正在進行時，背板上有危險的電壓或能量，進行維修時務必小心。

Warnung

Wenn das System in Betrieb ist, treten auf der Rückwandplatine gefährliche Spannungen oder Energien auf. Vorsicht bei der Wartung.

¡Advertencia!

Quando el sistema está en funcionamiento, el voltaje del plano trasero es peligroso. Tenga cuidado cuando lo revise.

Attention

Lorsque le système est en fonctionnement, des tensions électriques circulent sur le fond de panier. Prendre des précautions lors de la maintenance.

מתח בפנל האחורי**אזהרה!**

קיימת סכנת מתח בפנל האחורי בזמן תפעול המערכת. יש להיזהר במהלך העבודה.

هناك خطر من التيار الكهربائي أو الطاقة الموجودة على اللوحة عندما يكون النظام يعمل كن حذرا عند خدمة هذا الجهاز

경고!

시스템이 동작 중일 때 후면판 (Backplane)에는 위험한 전압이나 에너지가 발생 합니다. 서비스 작업 시 주의하십시오.

Waarschuwing

Een gevaarlijke spanning of energie is aanwezig op de backplane wanneer het systeem in gebruik is. Voorzichtigheid is geboden tijdens het onderhoud.

Comply with Local and National Electrical Codes**Warning!**

Installation of the equipment must comply with local and national electrical codes.

地方および国の電気規格に準拠

機器の取り付けはその地方および国の電気規格に準拠する必要があります。

警告

设备安装必须符合本地与本国电气法规。

警告

設備安裝必須符合本地與本國電氣法規。

Warnung

Die Installation der Geräte muss den Sicherheitsstandards entsprechen.

¡Advertencia!

La instalación del equipo debe cumplir con las normas de electricidad locales y nacionales.

Attention

L'équipement doit être installé conformément aux normes électriques nationales et locales.

תיאום חוקי החשמל הארצי**אזהרה!**

התקנת הציוד חייבת להיות תואמת לחוקי החשמל המקומיים והארציים.

تركيب المعدات الكهربائية يجب أن يمتثل للقوانين المحلية والوطنية المتعلقة بالكهرباء

경고!

현 지역 및 국가의 전기 규정에 따라 장비를 설치해야 합니다.

Waarschuwing

Bij installatie van de apparatuur moet worden voldaan aan de lokale en nationale elektriciteitsvoorschriften.

Product Disposal**Warning!**

Ultimate disposal of this product should be handled according to all national laws and regulations.

製品の廃棄

この製品を廃棄処分する場合、国の関係する全ての法律・条例に従い処理する必要があります。

警告

本产品的废弃处理应根据所有国家的法律和规章进行。

警告

本產品的廢棄處理應根據所有國家的法律和規章進行。

Warnung

Die Entsorgung dieses Produkts sollte gemäß allen Bestimmungen und Gesetzen des Landes erfolgen.

¡Advertencia!

Al deshacerse por completo de este producto debe seguir todas las leyes y reglamentos nacionales.

Attention

La mise au rebut ou le recyclage de ce produit sont généralement soumis à des lois et/ou directives de respect de l'environnement. Renseignez-vous auprès de l'organisme compétent.

סילוק המוצר

! אזהרה

סילוק סופי של מוצר זה חייב להיות בהתאם להנחיות וחוקי המדינה.

عند التخلص النهائي من هذا المنتج ينبغي التعامل معه وفقا لجميع القوانين واللوائح الوطنية

경고!

이 제품은 해당 국가의 관련 법규 및 규정에 따라 폐기되어야 합니다.

Waarschuwing

De uiteindelijke verwijdering van dit product dient te geschieden in overeenstemming met alle nationale wetten en reglementen.

Hot Swap Fan Warning



Warning!

The fans might still be turning when you remove the fan assembly from the chassis. Keep fingers, screwdrivers, and other objects away from the openings in the fan assembly's housing.

ファン・ホットスワップの警告

シャーシから冷却ファン装置を取り外した際、ファンがまだ回転している可能性があります。ファンの開口部に、指、ドライバー、およびその他のものを近づけないで下さい。

警告

当您从机架移除风扇装置，风扇可能仍在转动。小心不要将手指、螺丝起子和其他物品太靠近风扇。

警告

當您從機架移除風扇裝置，風扇可能仍在轉動。小心不要將手指、螺絲起子和其他物品太靠近風扇。

Warnung

Die Lüfter drehen sich u. U. noch, wenn die Lüfterbaugruppe aus dem Chassis genommen wird. Halten Sie Finger, Schraubendreher und andere Gegenstände von den Öffnungen des Lüftergehäuses entfernt.

¡Advertencia!

Los ventiladores podran dar vuelta cuando usted quite el montaje del ventilador del chasis. Mantenga los dedos, los destornilladores y todos los objetos lejos de las aberturas del ventilador

Attention

Il est possible que les ventilateurs soient toujours en rotation lorsque vous retirez le bloc ventilateur du châssis. Prenez garde à ce que doigts, tournevis et autres objets soient éloignés du logement du bloc ventilateur.

! אזהרה

כאשר מסירים את חלקי המאוורר מהמארז, יתכן והמאווררים עדיין עובדים. יש להרחיק למרחק בטוח את האצבעות וכלי עבודה שונים מהפתחים בתוך המאוורר

من الممكن أن المراوح لا تزال تدور عند إزالة كتلة المروحة من الهيكل يجب إبقاء الأصابع ومفكات البراغي وغيرها من الأشياء بعيدا عن الفتحات في كتلة المروحة.

경고!

새시로부터 팬 조립품을 제거할 때 팬은 여전히 회전하고 있을 수 있습니다. 팬 조립품 외곽의 열려있는 부분들로부터 손가락 및 스크류드라이버, 다른 물체들이 가까이 하지 않도록 배치해 주십시오.

Waarschuwing

Het is mogelijk dat de ventilator nog draait tijdens het verwijderen van het ventilatorsamenstel uit het chassis. Houd uw vingers, schroevendraaiers en eventuele andere voorwerpen uit de buurt van de openingen in de ventilatorbehuizing.

DC Power Supply



Warning!

When stranded wiring is required, use approved wiring terminations, such as closedloop or spade-type with upturned lugs. These terminations should be the appropriate size for the wires and should clamp both the insulation and conductor.

警告

より線が必要な場合、承認済みのケーブル終端(上向きの端子を備えたクローズループ型またはU字型の終端など)を使用してください。使用するワイヤーに適したサイズで、絶縁体および導体が両方ともクランプされている終端でなければなりません。

警告

需要多股佈線時，請使用經核准的佈線終端，例如閉環或鑷型接線片。這些終端的大小應適合線路，並且可以同時夾住絕緣體和導體。

警告

需要使用绞线连接时，请使用经认可的连接端子，如闭环端子或具有接线柱的铲形端子。这些端子的大小应与线缆相吻合，并且可以将绝缘部分和导体夹紧固定。

Warnung

Wenn Litzenverdrahtung erforderlich ist, sind zugelassene Verdrahtungsabschlüsse, z.B. für einen geschlossenen Regelkreis oder gabelförmig, mit nach oben gerichteten Kabelschuhen zu verwenden. Diese Abschlüsse sollten die angemessene Größe für die Drähte haben und sowohl die Isolierung als auch den Leiter festklemmen.

¡Advertencia!

Quando se necesite hilo trenzado, utilizar terminales para cables homologados, tales como las de tipo "bucle cerrado" o "espada", con las lengüetas de conexión vueltas hacia arriba. Estos terminales deberán ser del tamaño apropiado para los cables que se utilicen, y tendrán que sujetar tanto el aislante como el conductor.

Attention

Quand des fils torsadés sont nécessaires, utiliser des douilles terminales homologuées telles que celles à circuit fermé ou du type à plage ouverte avec cosses rebroussées. Ces douilles terminales doivent être de la taille qui convient aux fils et doivent être refermées sur la gaine isolante et sur le conducteur.

תקנון הצהרות אזהרה

הצהרות הבאות הן אזהרות על פי תקני התעשייה, על מנת להזהיר את המשתמש מפני חבלה פיזית אפשרית. במידה ויש שאלות או היתקלות בבעיה כלשהי, יש ליצור קשר עם בחלקת תמיכה טכנית של סופרמיקרו. טכנאים מוסמכים בלבד רשאים להתקין או להגדיר את הרכיבים.

יש לקרוא את הנספח במלואו לפני התקנת או הגדרת הרכיבים במארז סופרמיקרו.

تحذير

كالتسأل امدختسو، لبسلا مهب تعطقت ني ذل كالتسأل ابولطم نوكي امدن عونلا ةيقي قرحل اهئامس أب ايشأل أو ققلغم ققلح لشم، اهيلع ةقفاوملا اءان! كالتسأل بسانملا مچحلا نوكي تاءاهنإل اذهل يغبنني و. ةبولقم تاورعلا عم لصومو لزعلال نم لك حبك بجوي.

주의!

꼬인 배선이 요구 될 때에는 폐회로나 돌출부가 위로 튀어 나온 Spade 형태의 승인된 배선 터미네이션들을 사용하세요.

이 터미네이션들은 배선들을 위해 적절한 크기여야 하고, 절연체와 도체 모두를 고정시킬 수 있어야 합니다.

Waarschuwing

Wanneer geslagen bedrading vereist is, dient u bedrading te gebruiken die voorzien is van goedgekeurde aansluitingspunten, zoals het gesloten-lus type of het grijperschop type waarbij de aansluitpunten omhoog wijzen. Deze aansluitpunten dienen de juiste maat voor de draden te hebben en dienen zowel de isolatie als de geleider vast te klemmen.

¡Advertencia!

Puede haber energía o voltaje peligrosos en los terminales eléctricos de CC. Reemplace siempre la cubierta cuando no estén utilizándose los terminales. Asegúrese de que no haya acceso a conductores descubiertos cuando la cubierta esté colocada.

Attention

Le voltage ou l'énergie électrique des terminaux à courant continu peuvent être dangereux. Veuillez à toujours replacer le couvercle lors les terminaux ne sont pas en service. Assurez-vous que les conducteurs non isolés ne sont pas accessibles lorsque le couvercle est en place.

אזהרה!

בוקר מתח מסוכן עלול להיות נוכח על הקטבים של זרם ה-DC. החליף תמיד את המכסה כאשר הקטבים לא בשימוש. ודא כי המוליכים הלא מבודדים אינם נגישים כאשר המכסה נמצא במקומו.

تعليم

لادبتسا ؁ ؤمصاعلا ؤق اظلا تااطحم ىل ع ؤدوجوم نوكت ؤق اظلا و ا ؤرطخل ا دهجال دق ريغ تالصولا هيف لكش ال امم. ؤمدخل ا يف تسيل تااطحمل امدن ع امئاد اعاطغ هنالكم يف اعاطغلا امدن ع اهيل لوصولا نكمي ال لوزعم

주의!

DC전원 단자들에 위험한 전압이나 에너지가 발생할 수 있습니다.

단말기들을 운영하지 않을 때에는 덮개로 다시 덮어 놓아 주십시오. 덮개가 제자리에 있어야만 절연되지 않은 도체들의 접근을 막을 수 있습니다.

Waarschuwing

Op DC-aansluitingspunten kunnen zich gevaarlijke voltages of energieën voordoen. Plaats altijd de afsluiting wanneer de aansluitingspunten niet worden gebruikt. Zorg ervoor dat blootliggende contactpunten niet toegankelijk zijn wanneer de afsluiting is geplaatst.

Chapter 3

System Interface

3-1 Overview

There are several LEDs on the control panel as well as others on the drive carriers to keep you constantly informed of the overall status of the system as well as the activity and health of specific components. SC847BE1C/2C and SC847BA models have two buttons on the chassis control panel: A reset button and a power on/off switch. This chapter explains the meanings of all LED indicators and the appropriate responses you may need to take.

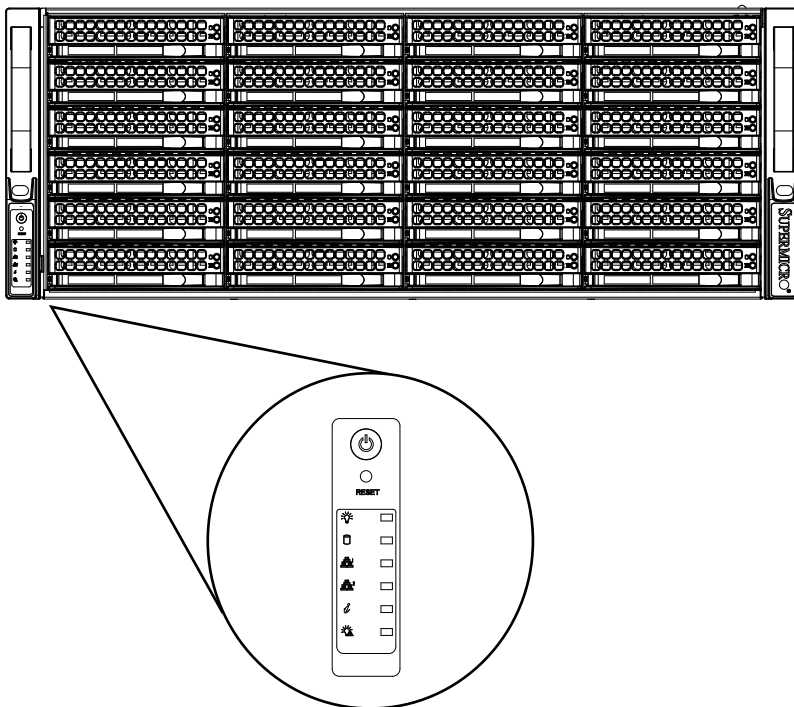

Figure 3-1. Control Panel

3-2 Control Panel Buttons

There are two push-buttons located on the left handle of the chassis. These are (in order from top to bottom) a power on/off button and a reset button.



Power: The main power button is used to apply or remove power from the power supply to the server system. Turning off system power with this button removes the main power but keeps standby power supplied to the system. Therefore, you must unplug system before servicing.



Reset: The reset button is used to reboot the system.

3-3 Control Panel LEDs

The control panel located on the left handle of the SC847BEC1/C2 and SC847BA chassis has five LEDs. These LEDs provide you with critical information related to different parts of the system. This section explains what each LED indicates when illuminated and any corrective action you may need to take.



Power: Indicates power is being supplied to the system's power supply units. This LED should normally be illuminated when the system is operating.



HDD: Indicates IDE channel activity. SAS/SATA drive, and/or DVD-ROM drive activity when flashing.



NIC1: Indicates network activity on GLAN1 when flashing.



NIC2: Indicates network activity on GLAN2 when flashing.



Informational LED	
Status	Description
Solid red	An overheat condition has occurred. (This may be caused by cable congestion).
Blinking red (1Hz)	Fan failure, check for an inoperative fan.
Blinking red (0.25Hz)	Power failure, check for a non-operational power supply.
Solid blue	Local UID has been activated. Use this function to locate the server in a rack mount environment.
Blinking blue (300 msec)	Remote UID is on. Use this function to identify the server from a remote location.



Power Failure: When this LED flashes, it indicates a failure in the redundant power supply.

3-4 Drive Carrier LEDs

The SC847E1C/2C and SC847BA chassis use SAS or SATA drives.

SAS/SATA Drives

Each SAS/SATA drive carrier has one set of LEDs, with one blue and red LED indicator for each drive. The LEDs function as follows:

Blue Drive Carrier LED Indicator	
Status	Description
Steady on	Indicates a SAS drive
Off	Indicates a SATA drive
Blinking	Drive is actively being accessed

Each drive carrier has a blue LED. When illuminated in a steady on state, this blue LED (on the front of the SAS/SATA drive carrier) indicates a SAS drive. A connection to the SAS/SATA backplane enables this LED to blink on and off when that particular drive is being accessed.

Red Drive Carrier LED Indicator	
Status	Description
Steady on	Drive failure
Blinking	RAID activity

When the red LED is blinking, it indicates that the system is either building, initializing or rebuilding RAID.

SCSI Drives

This chassis does not support SCSI drives at this time.

Chapter 4

Chassis Setup and Maintenance

4-1 Overview

This chapter covers the steps required to install components and perform maintenance on the chassis. The only tool you will need to install components and perform maintenance is a Phillips screwdriver. Print this chapter to use as a reference while setting up your chassis.

Review the warnings and precautions listed in the manual before setting up or servicing this chassis. These include information in Chapter 2: System Safety and the warnings/precautions listed in the setup instructions.

Safety Warning: Before performing any chassis setup or maintenance, it is recommended that the chassis be removed from the rack and placed on a stable bench or table. For instructions on how to uninstall the chassis from the rack, refer to Chapter 5 Rack Installation in this manual.

4-2 Removing the Chassis Cover

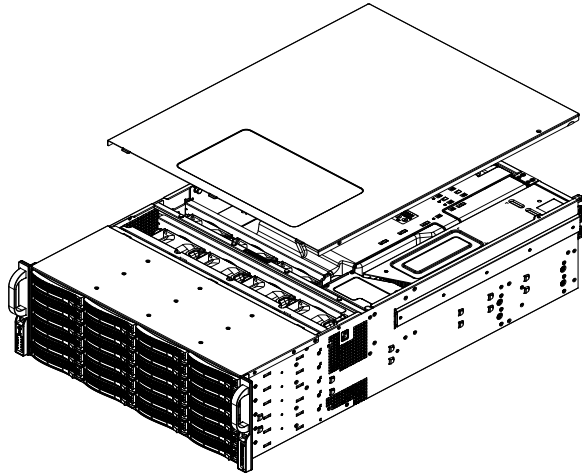

Figure 4-1. Removing the Chassis Cover

Removing the Chassis Cover

1. Power down the system and remove the power cords from the rear of the power supplies.
2. Remove the screws securing the cover to the chassis.
3. Lift the cover up and off the chassis.

Warning: Except for short periods of time, do NOT operate the server without the cover in place. The chassis cover must be in place to allow proper airflow and prevent overheating.

4-3 3.5" Hard Drives

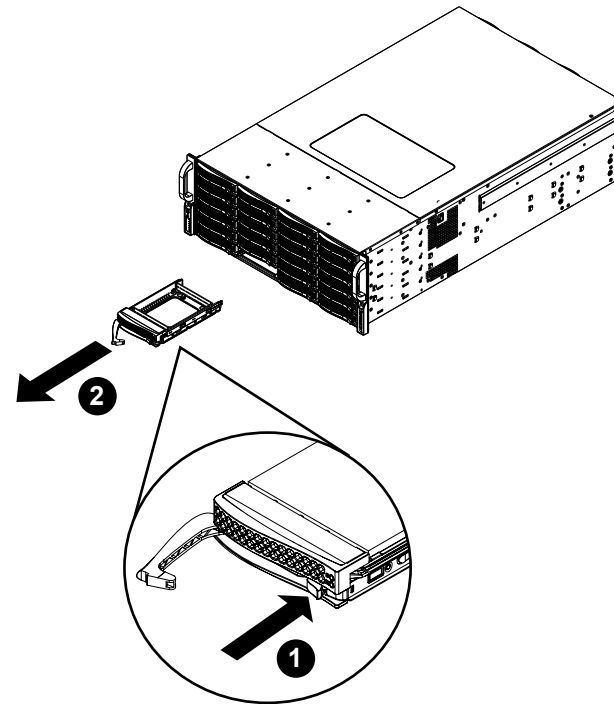

Figure 4-2. Removing a Hard Drive Carrier

The SC847BE1C/2C and SC847BA chassis have hot-swappable 3.5" hard drives which may be removed from the chassis without powering down the system.

Removing Hard Drive Carriers from the Chassis

1. Press the release button on the drive carrier. This extends the drive carrier handle.
2. Use the handle to pull the drive carrier out of the chassis.

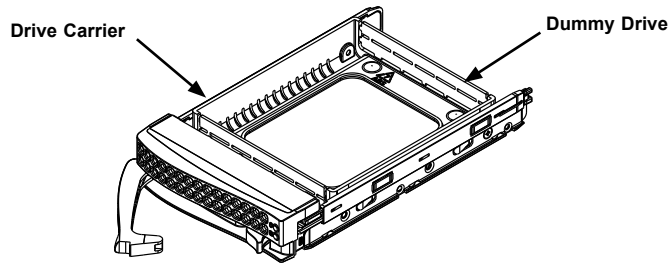

Figure 4-3. Chassis Drive Carrier

The drives are mounted in drive carriers to simplify their installation and removal from the chassis. These carriers also help to promote proper airflow for the drive bays.

Warning: Except for short periods of time (while swapping hard drives), do not operate the server with the drives removed from the chassis drive bays.

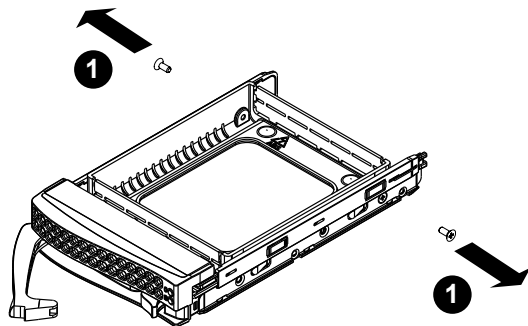

Figure 4-4. Removing the Dummy Drive from the Carrier

Warning! Enterprise level hard disk drives are recommended for use in Supermicro chassis and servers. For information on recommended HDDs, visit the Supermicro website at <http://www.supermicro.com/products/nfo/storage.cfm>

Installing a Hard Drive to the Hard Drive Carrier

1. Remove the two screws securing the dummy drive to the drive carrier and remove the dummy drive. Place the hard drive carrier on a flat surface such as a desk, table or work bench.

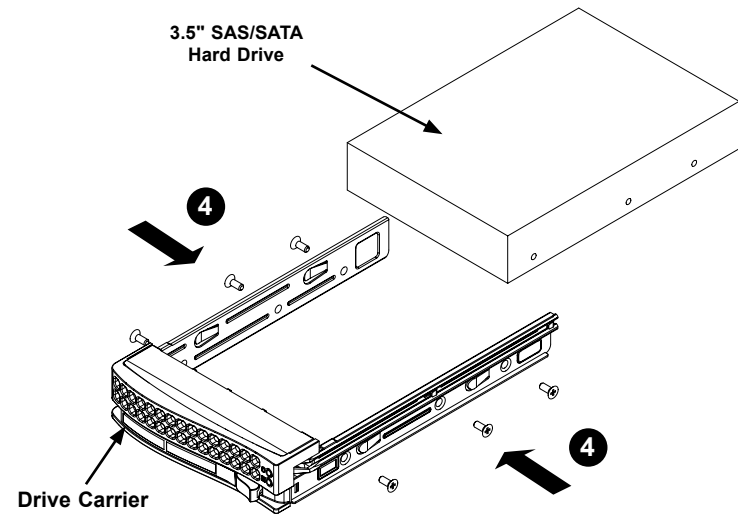

Figure 4-5. Installing the Hard Drive into the Carrier

2. Slide the hard drive into the carrier with the printed circuit board side facing down.
3. Carefully align the mounting holes in both the drive carrier and the hard drive.
4. Secure the hard drive to the carrier using six screws.
5. Replace the drive tray into the chassis. Make sure to close the drive carrier handle to lock the drive carrier into place.

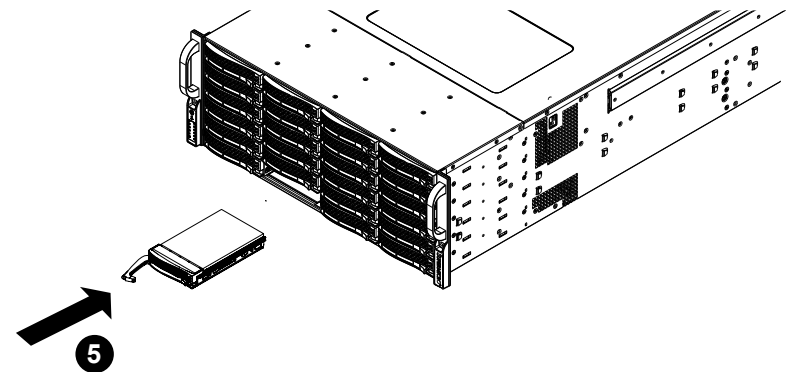
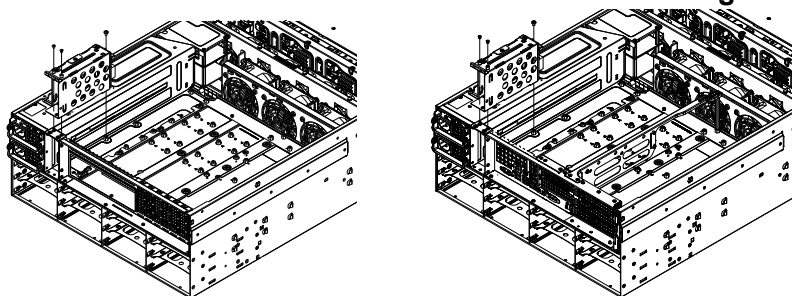

Figure 4-6. Installing the 3.5" Hard Drive

4-4 2.5" Hard Drives and the Rear Hard Drive Cage



LPB Model Chassis

WB Model Chassis

Figure 4-7. Installing the 2.5" Hard Drive Cage

The SC847BE1C/2C chassis comes with a rear hard drive cage which supports two 2.5" hard drives. The 2.5" hard drives are hot-swappable and may be removed from the chassis without powering down the system. When using the hard drive cage it is necessary to modify the air shroud to fit. See page 4-15 of this manual and remove part A-1 from the air shroud.

Installing the 2.5" Hard Drive Cage Into the Chassis

1. Power down the system and remove the power cords from the rear of the power supplies. Remove the chassis cover as described in section 4-2.
2. Place the hard drive cage into the chassis and secure with three screws as illustrated above.
3. Replace the chassis cover, plug the power cords into the rear of the power supplies and power up the system.

Removing 2.5" Hard Drives

1. Press the release button on the hard drive carrier. This extends the drive carrier handle.
2. Use the handle to pull the drive carrier out of the chassis.

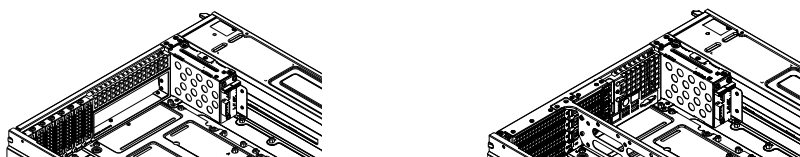

LPB Model Chassis

WB Model Chassis

Figure 4-8. 2.5" Hard Drive Cage Installed in the Chassis

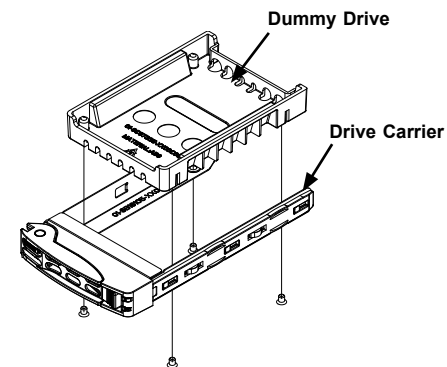

Figure 4-9. Removing a Dummy Drive From a Carrier

Installing 2.5" Hard Drives into Carriers

1. Remove the four screws securing the dummy drive from the drive carrier.
2. Lift the dummy drive out of the carrier.
3. Place a hard drive into the carrier with the printed circuit board facing downward.
4. Secure the hard drive to the carrier using the four M3 screws provided in the installation kit.

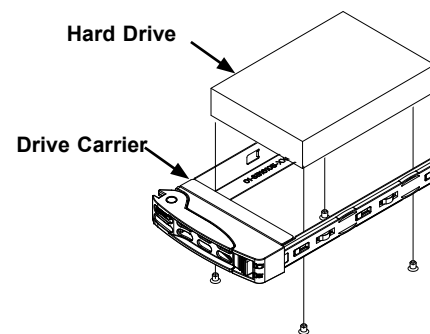

Figure 4-10. Installing a 2.5" Hard Drive Into a Carrier

4-5 Installing the Motherboard

Permanent and Optional Standoffs

Standoffs prevent short circuits by securing space between the motherboard and the chassis surface. The SC847 chassis includes permanent standoffs in locations used by most motherboards. These standoffs accept the rounded Phillips head screws included in the SC847 accessories packaging.

Some motherboards require additional screws for heatsinks, general components or non-standard security. Optional standoffs are included to these motherboards. To use an optional standoff, you must place the hexagonal screw through the bottom the chassis and secure the screw with the hexagon nut (rounded side up).



M/B standoff
6-32 to 6-32

Figure 4-11. Chassis Standoffs

Installing the Motherboard

1. Review your motherboard documentation. Become familiar with component placement, requirements, precautions, and cable connections.
2. Power down the system, remove the power cords from the rear of the power supply and remove the chassis cover as described in Section 4-2.
3. As required by your motherboard, install standoffs in any areas that do not have a permanent standoff. To do this:
 - 3a. Place a hexagonal standoff screw through the bottom the motherboard tray.
 - 3b. Secure the screw with the hexagon nut (rounded side up).

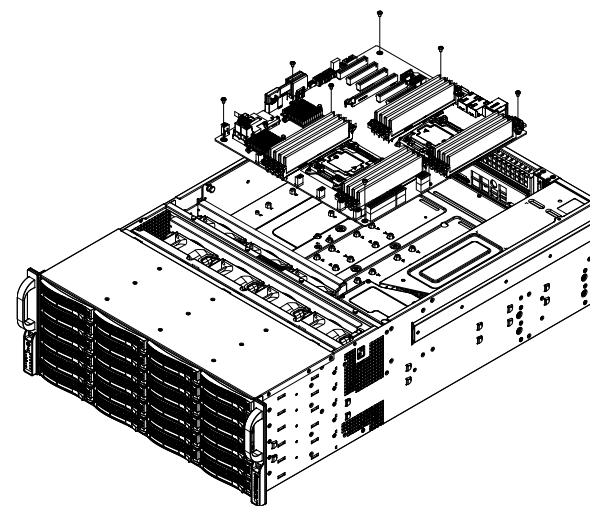

Figure 4-12. Installing the Motherboard

4. Lay the motherboard on the tray aligning the permanent and optional standoffs.
5. Secure the motherboard to the tray using the rounded, Phillips head screws. Do not exceed eight inch-pounds of torque.
6. Secure the CPUs, heatsinks, and other components to the motherboard as described in the motherboard documentation.
7. Connect the cables between the motherboard, backplane, chassis, front panel, and power supply, as needed. The fans may be temporarily removed to allow access to the backplane ports.

4-6 Expansion Card Setup

The chassis includes PCI slots for expansion cards. The SC847BE1C/2C and SC847BA feature seven low-profile PCI slots.

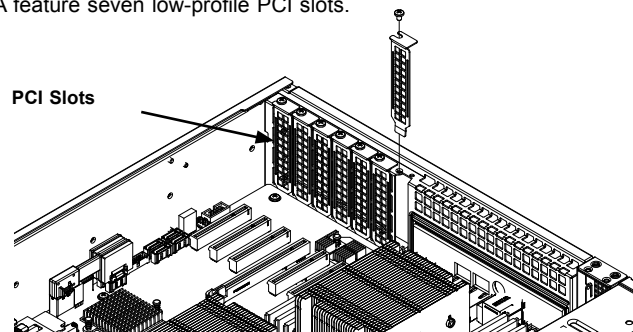

Figure 4-13. Removing the PCI Slot Cover

Installing Expansion Cards

Installing Expansion Cards into the Chassis

1. Power down the system as described in Section 4-2, lay the chassis on a flat surface, and open the chassis cover.
2. Remove the screw holding the PCI slot cover in place in each low-profile PCI slot you want to use. Keep this screw for later use.

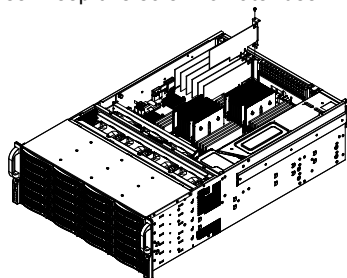

Figure 4-14. Installing Expansion Cards

3. Simultaneously slide each expansion card's bracket into an open PCI slot, while plugging the expansion card into the motherboard.
4. Secure each card to the chassis using the screw previously set aside.
5. Plug the power cords into the rear of the power supplies and power up the system.

4-7 Removing and Installing the Backplanes

The chassis comes equipped with a BPN-SAS3-846EL1/EL2 front backplane and a BPN-SAS3-826EL1/EL2 rear backplane. For detailed information and instructions on how to change the backplane settings, see Appendices C, D and E of this manual.

Removing the Front Backplane

1. Power down the system and remove the power cords from the rear of the power supplies. Remove the chassis cover as described in Section 4-2.
2. Remove the two side screws securing the front backplane to the chassis.
3. Remove the four horizontal screws along the top of the front backplane.
4. Remove the five horizontal screws that go through the bottom of the backplane.

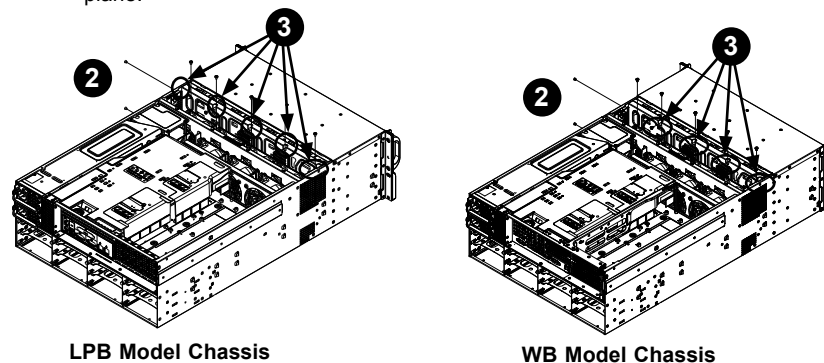

LPB Model Chassis

WB Model Chassis

Figure 4-15. Removing the Screws Securing the Backplane

5. Lift the front backplane up and out of the chassis.

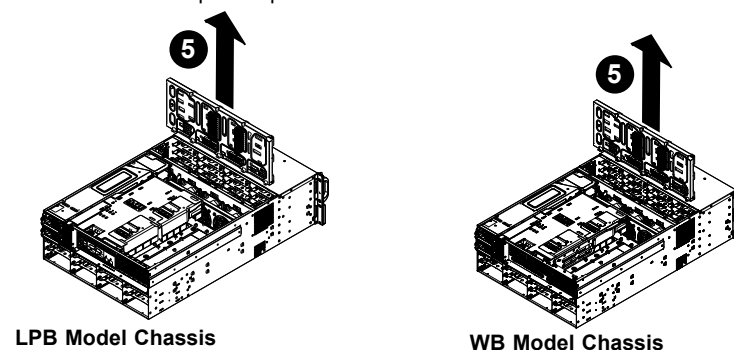

LPB Model Chassis

WB Model Chassis

Figure 4-16. Removing the Screws Securing the Backplane

Removing the Rear Backplane

1. Power down the system and remove the power cords from the rear of the power supplies. Remove the chassis cover as described in Section 4-2.
2. Remove the two side screws (one on each side of the chassis) which secure the rear tray to the chassis.
3. Pull out the blue release tab on the rear of the chassis.

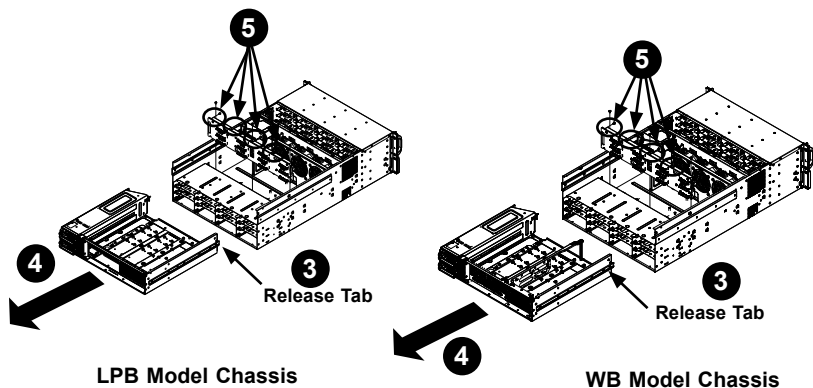
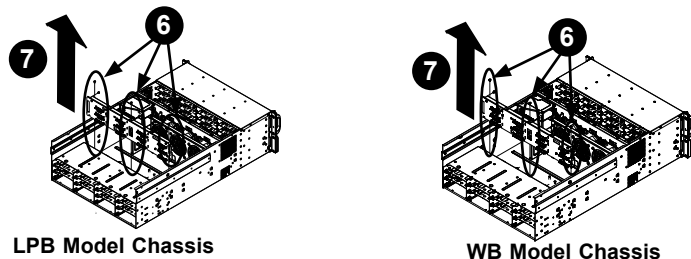

Figure 4-13. Removing the Two Horizontal Screws Securing the Backplane

4. Pull the rear tray out of the back of the chassis as illustrated.
5. Remove the five horizontal screws going through the bottom of the rear backplane
6. Remove the three vertical screws securing the backplane to the chassis floor.
7. Lift the backplane up and out of the chassis.



LPB Model Chassis WB Model Chassis
Figure 4-14. Removing the Three Screws Securing the Backplane

Installing the Front Backplane

1. Confirm that the power cords are still disconnected from the power supplies.
2. Place the front backplane in the chassis.

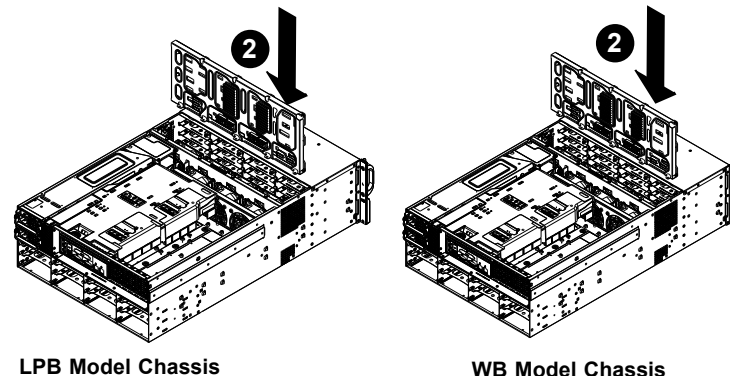

Figure 4-15. Installing the Front Backplane

3. Install the two side screws to secure the front backplane to the chassis.
4. Install the four horizontal screws along the top of the front backplane.
5. Install the five vertical screws along the bottom of the front backplane.

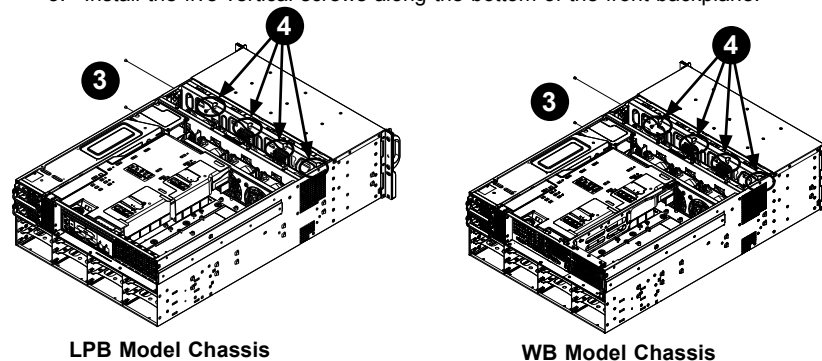

Figure 4-16. Installing the Screws Securing the Front Backplane

6. Plug the power cords into the rear of the power supply, replace the chassis cover and power up the system.

Installing the Rear Backplane

1. Confirm that the power cords are still disconnected from the power supplies.
2. Slide the rear tray out of the back of the chassis.

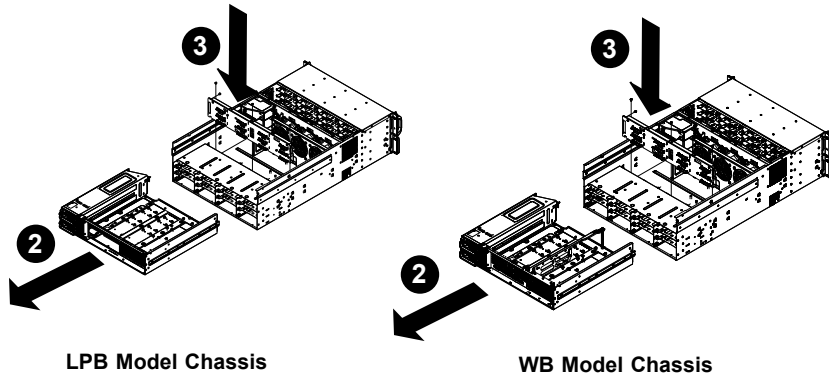

Figure 4-17. Installing the Rear Backplane

3. Place the rear backplane in the chassis and secure it with the three vertical screws along the top of the backplane.
4. Secure the backplane with four horizontal screws through the top of the backplane.
5. Install five horizontal screws through the bottom of the backplane.

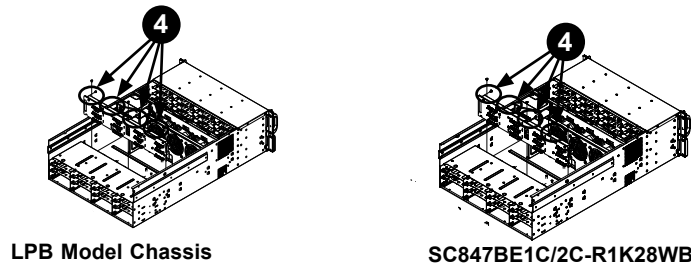

Figure 4-18. Installing the Screws Securing the Backplane

6. Plug the power cords into the rear of the power supply, replace the chassis cover and power up the system.

4-8 Air Shroud Modification and Installation

Air Shroud Installation

The SC847BE1C/2C and SC847BA chassis come with an air shroud which may be modified to fit over the top of a number of different motherboards. Use the chart and illustration below to set up the air shroud for your particular motherboard.

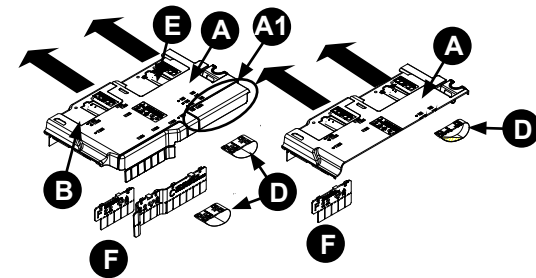

Figure 4-19. Identifying Air Shroud Components

MCP-310-49004-0N Air Shroud		
Item	Part Number	Description
	MCP-310-49004-0N	SC847B/SC417B DP X9 universal PC air shroud 1368x13/12x13MB.
A	MCP-310-84707-0N	SC847B/417B DP X9 universal PC air shroud main body. Remove part A1 when installing the optional rear HDD cage.
B	MCP-310-290041N	X9 SC825/826/216/213 universal air shroud component. Carefully pull this component from the main body of the air shroud in the direction shown by the arrows above.
C	MCP-310-49007-1N	X9 SC847/417 universal air shroud component partition. Remove this part only for 12"x13" motherboards.
D	MCP-310-29005-1N	X9 SC825/826/216/213 universal air shroud component. Remove both loops from the underside of the air shroud when using X9 motherboards.
E	MCP-310-29006-1N	X9 SC825/826/216/213 universal air shroud component. Carefully pull this component from the main body of the air shroud in the direction shown by the arrows above.
F	MCP-310-49008-1N	X9 SC847/417 universal air shroud component partition. Remove this part only when using an X8 motherboard.

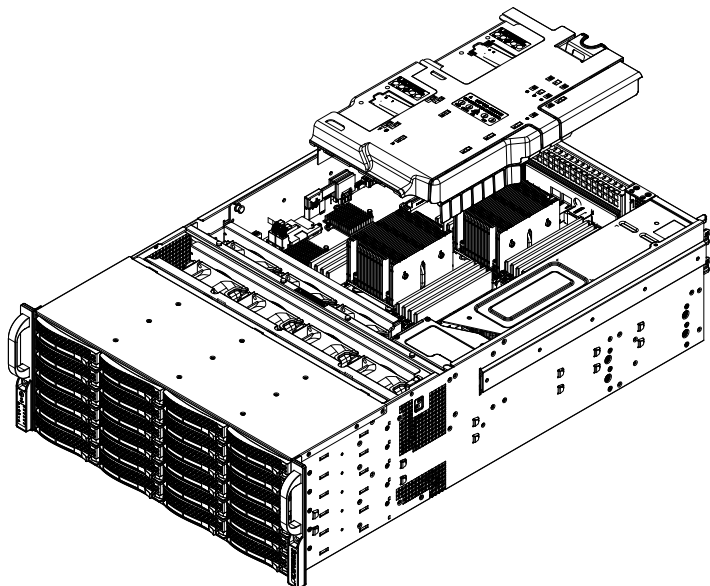

Figure 4-20. Installing the Air Shroud

Air shrouds concentrate airflow to maximize fan effectiveness. The SC847BE1C/2C and SC847BA chassis air shrouds does not require screws for its installation. The air shroud is designed with removeable break-away tabs that allow the air shroud to be adjusted to fit a variety of motherboards.

Installing the Air Shroud

1. Power down the system as described in Section 5-2 and remove the cover.
2. Place the air shroud in the chassis. The air shroud fits behind the fans and beside to the power supply.
3. After checking the fit of the air shroud, remove any break-away tabs necessary to ensure a proper fit with the motherboard.

Checking the Airflow

- Make sure there are no objects to obstruct airflow in and out of the server. In addition, if you are using a front bezel, make sure the bezel's filter is replaced periodically.
- Do not operate the server without drives or drive trays in the drive bays. Use only recommended server parts.
- Make sure no wires or foreign objects obstruct air flow through the chassis. Pull all excess cabling out of the airflow path or use shorter cables.

The control panel LEDs inform you of the system's status. See "Chapter 3 System Interface" for details on the LEDs and the control panel buttons.

In most cases, the chassis power supply and fans are pre-installed. If you need to install fans continue to the Systems Fans section of this chapter. If the chassis will be installed into a rack, continue to the next chapter for rack installation instructions

4-9 System Fans

Seven hot-swappable, heavy-duty fans provide cooling for the chassis. These fans circulate air through the chassis thereby lowering the chassis internal temperature.

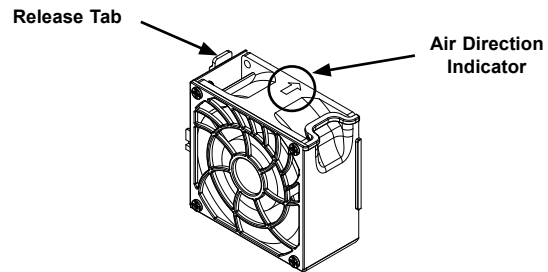

Figure 4-21. System Fan

Replacing a System Fan

1. Open the chassis while the power is running to determine which fan has failed. (Never run the server for an extended period of time with the chassis cover open.)
2. Press the fan release tab to lift the failed fan from the chassis and pull it completely out of the chassis.
3. Place the new fan into the vacant space in the housing while making sure the arrows on the top of the fan (indicating air direction) point in the same direction as the arrows on the other fans.
4. Check that the fan is working properly before replacing the chassis cover.

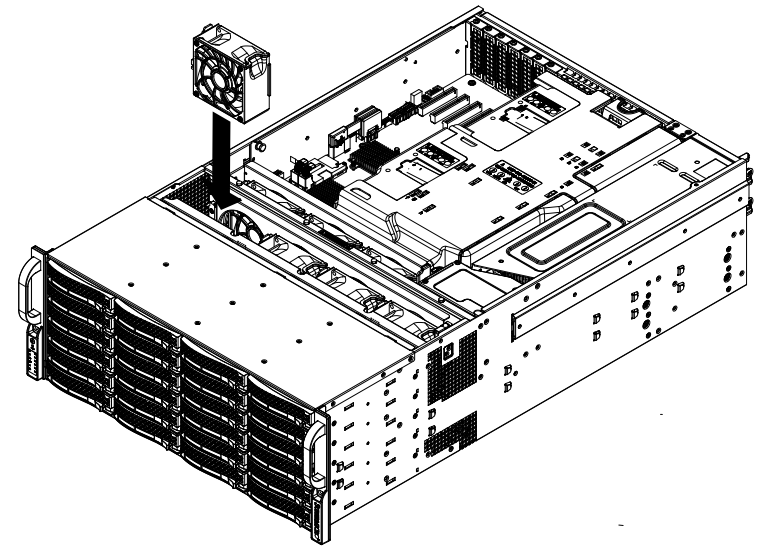

Figure 4-22. Placing the System Fan

4-10 Power Supply

The SC847BE1C/2C and SC847BA chassis have a 1280 Watt high-efficiency redundant power supply. This power supply is auto-switching capable. This enables it to automatically sense and operate at a 100v to 240v input voltage. An amber light will be illuminated on the power supply when the power is off. An illuminated green light indicates that the power supply is operating.

Redundant power supplies are hot-swappable, and can be changed without powering down the system. New units can be ordered directly from Supermicro (see contact information in the Preface).

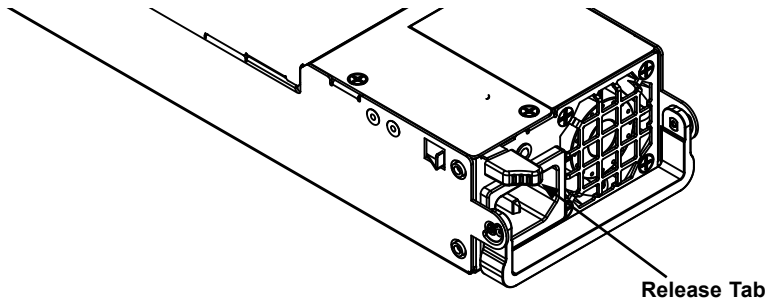

Figure 4-23. Power Supply Release Tab

Changing the Power Supply:

1. If your chassis includes a redundant power supply (at least two power modules), you can leave the server running and remove only one power supply. If your server has only one power supply, you must power down the server and unplug the power cord.
2. Push the release tab (on the back of the power supply) as illustrated.
3. Pull the power supply out using the handle provided.

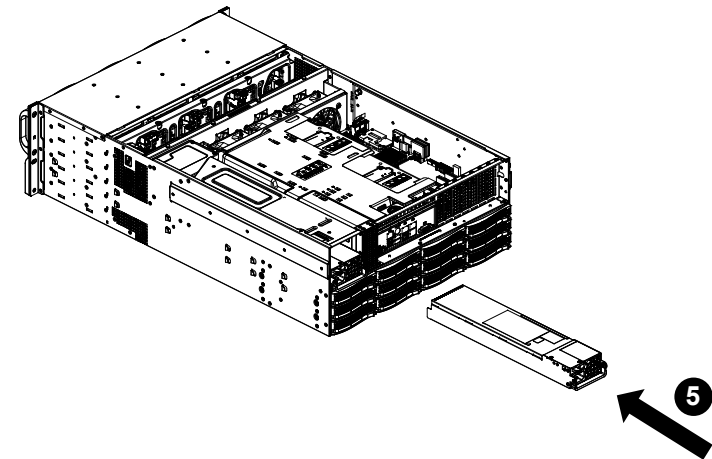

Figure 4-24. Power Supply Release Tab

4. Replace the failed power module with the same model.
5. Push the new power supply module into the power bay until you hear a click.
6. If using only one power supply, plug the AC power cord back into the module and power up the server.

Notes

Chapter 5

Rack Installation

5-1 Overview

This chapter provides a quick setup checklist to get your chassis up and running. Following these steps in the order given should enable you to have the system operational within a minimal amount of time.

5-2 Unpacking the System

You should inspect the box which the chassis was shipped in and note if it was damaged in any way. If the chassis itself shows damage, you should file a damage claim with the carrier who delivered it.

Decide on a suitable location for the rack unit that will hold your chassis. It should be situated in a clean, dust-free area that is well ventilated. Avoid areas where heat, electrical noise and electromagnetic fields are generated. The system needs to be placed near a grounded power outlet. Be sure to read the Rack and Server Precautions in the next section.

5-3 Preparing for Setup

The box your chassis was shipped in should include two sets of rail assemblies and the mounting screws needed for installing the system into the rack. Also included is an optional square hole to round hole converter bracket, for use in racks with round mounting holes. *Please read this section in its entirety before you begin the installation procedure outlined in the sections that follow.*

Choosing a Setup Location

- Leave enough clearance in front of the rack to enable you to open the front door completely (~25 inches).
- Leave approximately 30 inches of clearance in the back of the rack to allow for sufficient airflow and ease in servicing.
- This product is for installation only in a Restricted Access Location (dedicated equipment rooms, service closets and the like).

5-4 Warnings and Precautions

Rack Precautions

- Ensure that the leveling jacks on the bottom of the rack are fully extended to the floor with the full weight of the rack resting on them.
- In single rack installations, stabilizers should be attached to the rack.
- In multiple rack installations, the racks should be coupled together.
- Always make sure that the rack is stable before extending a component from the rack.
- You should extend only one component at a time - extending two or more simultaneously may cause the rack to become unstable.

General Server Precautions

- Review the electrical and general safety precautions that came with the components you are adding to your chassis.
- Determine the placement of each component in the rack *before* you install the rails.
- Install the heaviest server components on the bottom of the rack first, and then work upwards.
- Use a regulating uninterruptible power supply (UPS) to protect the server from power surges, voltage spikes and to keep your system operating in case of a power failure.
- Allow the hot plug hard drives and power supply modules to cool before touching them.
- Always keep the rack's front door and all panels and components on the servers closed when not servicing to maintain proper cooling.

Rack Mounting Considerations

Ambient Operating Temperature

If installed in a closed or multi-unit rack assembly, the ambient operating temperature of the rack environment may be greater than the ambient temperature of the room. Therefore, consideration should be given to installing the equipment in an environment compatible with the manufacturer's maximum rated ambient temperature (TMRA).

Reduced Airflow

Equipment should be mounted into a rack so that the amount of airflow required for safe operation is not compromised.

Mechanical Loading

Equipment should be mounted into a rack so that a hazardous condition does not arise due to uneven mechanical loading.

Circuit Overloading

Consideration should be given to the connection of the equipment to the power supply circuitry and the effect that any possible overloading of circuits might have on overcurrent protection and power supply wiring. Appropriate consideration of equipment nameplate ratings should be used when addressing this concern.

Reliable Ground

A reliable ground must be maintained at all times. To ensure this, the rack itself should be grounded. Particular attention should be given to power supply connections other than the direct connections to the branch circuit (i.e. the use of power strips, etc.).



To prevent bodily injury when mounting or servicing this unit in a rack, you must take special precautions to ensure that the system remains stable. The following guidelines are provided to ensure your safety:

- This unit should be mounted at the bottom of the rack if it is the only unit in the rack.
- When mounting this unit in a partially filled rack, load the rack from the bottom to the top with the heaviest component at the bottom of the rack.
- If the rack is provided with stabilizing devices, install the stabilizers before mounting or servicing the unit in the rack.

5-5 Rack Mounting Instructions

This section provides information on installing the chassis into a rack unit with the rails provided. There are a variety of rack units on the market, which may mean that the assembly procedure will differ slightly from the instructions provided. You should also refer to the installation instructions that came with the rack unit you are using. NOTE: This rail will fit a rack between 26.5" and 36.4" deep.

Identifying the Sections of the Rack Rails

The chassis package includes two rail assemblies in the rack mounting kit. Each assembly consists of three sections: An inner chassis rail which secures directly to the chassis, an outer rail that secures to the rack, and a middle rail which extends from the outer rail. These assemblies are specifically designed for the left and right side of the chassis.

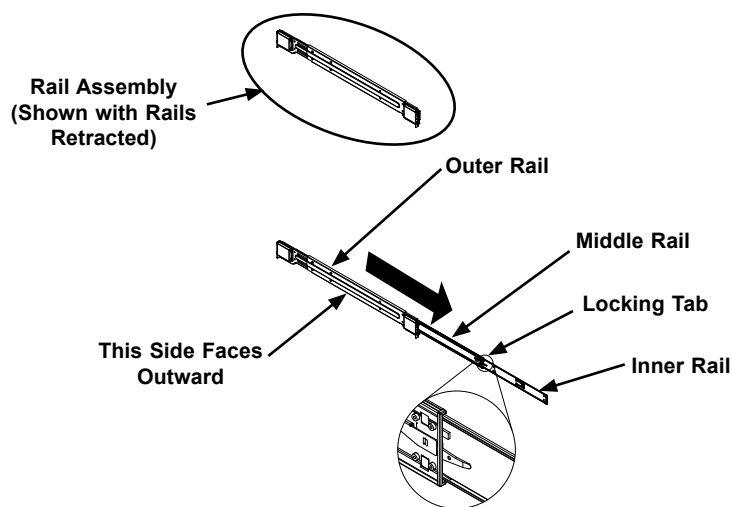

Figure 5-1. Identifying the Outer Rail, Middle Rail and Inner Rails (Left Rail Assembly Shown)

Locking Tabs

Each inner rail has a locking tab. This tab locks the chassis into place when installed and pushed fully into the rack. These tabs also lock the chassis in place when fully extended from the rack. This prevents the server from coming completely out of the rack when the chassis is pulled out for servicing.

Releasing the Inner Rail

Releasing Inner Rail from the Outer Rails

1. Identify the left and right outer rail assemblies as described on page 5-4.
2. Pull the inner rail out of the outer rail until it is fully extended as illustrated below.
3. Press the locking tab down to release the inner rail.
4. Pull the inner rail all the way out.
5. Repeat steps 1-4 for the second outer rail.

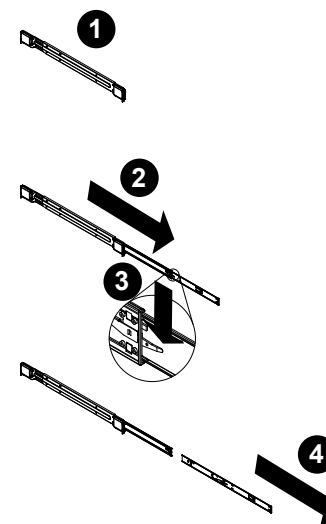

Figure 5-2. Extending and Releasing the Inner Rail

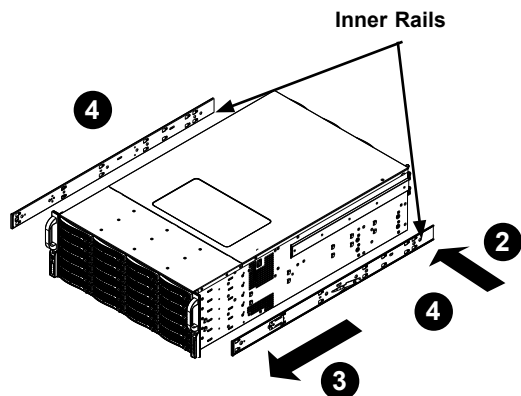

Figure 5-3. Installing the Inner Rails

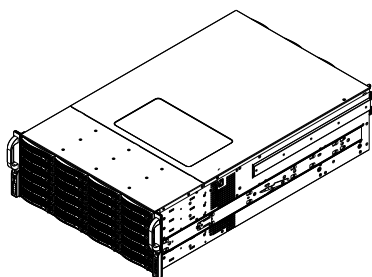

Figure 5-4. Inner Rails Installed on the Chassis

Installing The Inner Rails on the Chassis

Installing the Inner Rails

1. Confirm that the left and right inner rails have been correctly identified.
2. Place the inner rail firmly against the side of the chassis, aligning the hooks on the side of the chassis with the holes in the inner rail.
3. Slide the inner rail forward toward the front of the chassis until the rail clicks into the locked position, which secures the inner rail to the chassis.
4. Secure the inner rail to the chassis with the screws provided.
5. Repeat steps 1 through 4 above for the other inner rail.



Warning: do not pick up the server by the front handles. They are designed to pull the system from a rack only.

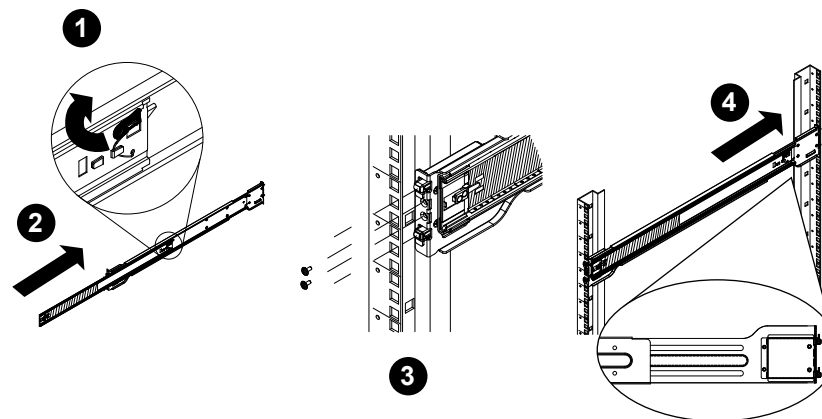

Figure 5-5. Extending and Releasing the Outer Rails

Installing the Outer Rails on the Rack

Installing the Outer Rails

1. Press upward on the locking tab at the rear end of the middle rail.
2. Push the middle rail back into the outer rail.
3. Hang the hooks of the front of the outer rail onto the slots on the front of the rack. If necessary, use screws to secure the outer rails to the rack, as illustrated above.
4. Pull out the rear of the outer rail, adjusting the length until it fits within the posts of the rack.
5. Hang the hooks of the rear portion of the outer rail onto the slots on the rear of the rack. If necessary, use screws to secure the rear of the outer rail to the rear of the rack.
6. Repeat steps 1-5 for the remaining outer rail.

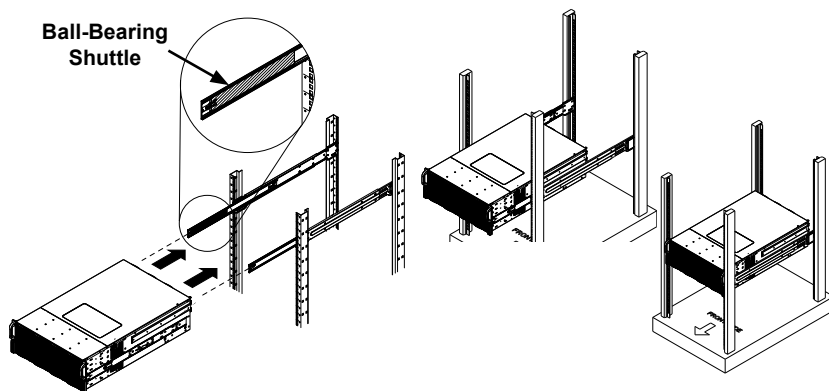

Figure 5-6. Installing into a Rack

Note: figures are for illustrative purposes only. Always install servers into racks from the bottom up.

Standard Chassis Installation

Installing the Chassis into a Rack

1. Confirm that the inner rails are properly installed on the chassis.
2. Confirm that the outer rails are correctly installed on the rack.
3. Pull the middle rail out from the front of the outer rail and make sure that the ball-bearing shuttle is at the front locking position of the middle rail.
4. Align the chassis inner rails with the front of the middle rails.
5. Slide the inner rails on the chassis into the middle rails, keeping the pressure even on both sides, until the locking tab of the inner rail clicks into the front of the middle rail, locking the chassis into the fully extended position.
6. Depress the locking tabs of both sides at the same time and push the chassis all the way into the rear of the rack.
7. If necessary for security purposes, use screws to secure the chassis handles to the front of the rack.



Stability hazard. The rack stabilizing mechanism must be in place, or the rack must be bolted to the floor before you slide the unit out for servicing. Failure to stabilize the rack can cause the rack to tip over.



Warning: When initially installing the server into a rack, test that the rail locking tabs engage to prevent the server from being overextended. Have a rack lift in place as a precaution in case the test fails.

Optional Quick Installation Method

The following quick installation method may be used to install the chassis onto a rack.

Installing the Chassis into a Rack

1. Install the whole rail assembly onto the rack as described on page X-7.
2. Release the inner rail without retracting the middle rail.
3. Install the inner rails on the chassis as previously described on page X-6.
4. Install the chassis onto the middle rail as described in the previous section.

Notes

Appendix A

Cables and Hardware

A-1 Overview

This appendix lists supported cables for your chassis system. It only includes the most commonly used components and configurations. For more compatible cables, refer to the manufacturer of the motherboard you are using and our Web site at: www.supermicro.com.

A-2 Cables Included

SC847BE1C/2C-R1K28LPB, SC847BE1C/2C-R1K28WB and SC847BA				
Part #	Type	Qty	Length	Description
CBL-0217L	Cable	1	---	16-pin control panel converter cable for SC826,846, 22 cm, PBF
CBL-0160L	Cable	2	6'	NEMA5-15P to C13 US power cord 16 AWG PBF (default for high Watt)
CBL-0071L	Cable	1	---	Round 16-pin to 16-pin ribbon FP cable 30

A-3 Compatible Cables

These cables are compatible with the SC847BE1C/2C and SC847BA chassis.

Alternate SAS/SATA Cables

Some compatible motherboards have different connectors. If your motherboard has only one SAS connector that the SAS/SATA cables must share, use one of the following cables. These cables must be purchased separately.

Cable Name: SAS Cable **Quantity:** 1

Part #: CBL-0175L

Alt. Name: "Big Four"

Description: This cable has one SFF-8484 (32-pin) connector on one end and four SAS connectors (seven pins each) at the other. This cable connects from the host (motherboard or other controller) to the backplane SAS hard drive port.

Cable Name: SAS Cable **Quantity:** 1

Part #: CBL-0116

Alt. Name: iPass or "Small Four"

Description: This cable has one iPass (SFF-8087/Mini-SAS) connector (36-pin) at one end and four SAS connectors on one end. This cable connects from the host (motherboard or other controller) to the backplane SAS hard drive port.

Extending Power Cables

Although Supermicro chassis are designed with to be efficient and cost-effective, some compatible motherboards have power connectors located in different areas.

To use these motherboards you may have to extend the power cables to the motherboards. To do this, use the following chart as a guide.

Power Cable Extenders		
Number of Pins	Cable Part #	Length
24-pin	CBL-0042	7.9" (20 cm)
20-pin	CBL-0059	7.9" (20 cm)
8-pin	CBL-0062	7.9" (20 cm)
4-pin	CBL-0060	7.9" (20 cm)

Front Panel to the Motherboard

The SC847BE1C/2C and SC847BA chassis includes a cable to connect the chassis front panel to the motherboard. If your motherboard uses a different connector, use the following list to find a compatible cable.

Front Panel to Motherboard Cable (Ribbon Cable)		
Number of Pins (Front Panel)	Number of Pins (Motherboard)	Cable Part #
16-pin	16-pin	CBL-0049
16-pin	20-pin	CBL-0048
20-pin	20-pin	CBL-0047
16-pin	various*	CBL-0068
20-pin	various*	CBL-0067

* Split cables: Use these cable if your motherboard requires several different connections from the front panel.

A-4 Chassis Screws

The accessory box includes all the screws needed to set up your chassis. This section lists and describes the most common screws used. Your chassis may not require all the parts listed.

M/B



Pan head
6-32 x 5 mm
[0.197]

HARD DRIVE



Flat head
6-32 x 5 mm
[0.197]

DVD-ROM, CD-ROM, and FLOPPY DRIVE



Pan head
6-32 x 5 mm
[0.197]



Flat head
6-32 x 5 mm
[0.197]



Round head
M3 x 5 mm
[0.197]



Round head
M2.6 x 5 mm
[0.197]

RAIL



Flat head
M4 x 4 mm
[0.157]



Round head
M4 x 4 mm
[0.157]



Flat head
M5 x 12 mm [0.472]
Washer for M5



M/B STANDOFFS



M/B standoff
6-32 to 6-32



M/B (CPU)
standoff
M5 to 6-32



Thumb screw
6-32 x 5 mm
[0.197]



1/U M/B standoff
6-32 x 5 mm
[0.197]

Appendix B

SC847BE1C/2C and SC847BA Power Supply Specifications

This appendix lists power supply specifications for your chassis system.

SC847BE1C/2C-R1K28LPB, SC847BE1C/2C-R1K28WB, SC847BA	
MFR Part #	PWS-1K28P-SQ
AC Input	1000W Output @ 100-140V, 12-8A, 50-60Hz 1280W Output @ 180-240V, 8-6A, 50-60Hz
DC Output	1000W: +12V/83A; +5Vsb/4A 1280W: +12V/106.7A, +5Vsb/4A

Notes

Appendix C

BPN-SAS3-846EL Front Backplane Specifications

To avoid personal injury and property damage, carefully follow all the safety steps listed below when accessing your system or handling the components.

C-1 ESD Safety Guidelines

Electrostatic Discharge (ESD) can damage electronic components. To prevent damage to your system, it is important to handle it very carefully. The following measures are generally sufficient to protect your equipment from ESD.

- Use a grounded wrist strap designed to prevent static discharge.
- Touch a grounded metal object before removing a component from the antistatic bag.
- Handle the backplane by its edges only; do not touch its components, peripheral chips, memory modules or gold contacts.
- When handling chips or modules, avoid touching their pins.
- Put the card and peripherals back into their antistatic bags when not in use.

C-2 General Safety Guidelines

- Always disconnect power cables before installing or removing any components from the computer, including the BPN-SAS3-846EL series backplane.
- Make sure that the backplane is properly and securely on the motherboard to prevent damage to the system due to power outages.

C-3 An Important Note to Users

All images and layouts shown in this user's guide are based upon the latest backplane revision available at the time of publishing. The card you have received may or may not look exactly the same as the graphics shown in this manual.

C-4 Introduction to the BPN-SAS3-846EL Backplane

The BPN-SAS3-846EL backplane has been designed to utilize the most up-to-date technology available, providing your system with reliable, high-quality performance.

This manual reflects BPN-SAS3-846EL Revision 1.01, the most current release available at the time of publication. Always refer to the Supermicro website at www.supermicro.com for the latest updates, compatible parts and supported configurations.

C-5 Overview of the BPN-SAS3-846EL1/EL2 Backplanes

The BPN-SAS3-846EL1 and BPN-SAS3-846EL2 model backplanes are identical, except that the BPN-SAS3-846EL2 backplane has duplicate secondary components which are not found on the BPN-SAS3-846EL1. The BPN-SAS3-846EL2 is divided into a two sections, with the primary components on the right side of the board and the secondary components on the left. SAS3 backplanes are not compatible with legacy SAS (3 Gbps), SATA (1.5 Gbps) backplanes or lower.

C-6 Front Connectors

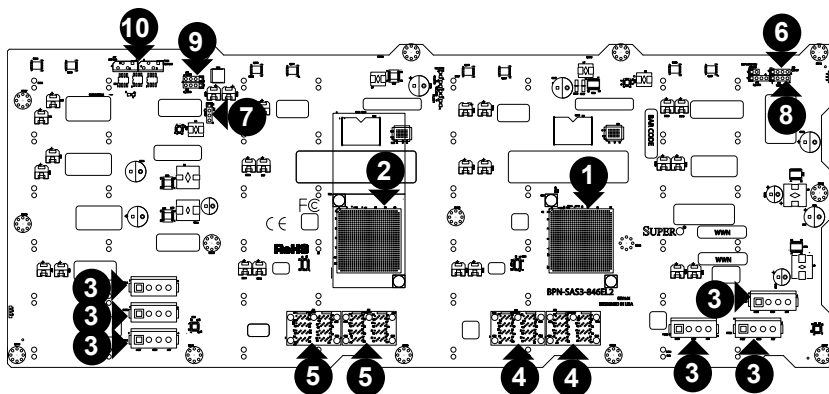

Figure C-1. BPN-SAS3-846EL1/EL2 Connectors and Components

- | | |
|---|---|
| <p>1. Primary Expander Chip.</p> <p>2. Secondary Expander Chip (not present on EL1 single port backplanes).</p> <p>3. Backplane Power Connectors: PWR1 through PWR6.</p> <p>4. Primary SAS Ports: J49, J50.</p> <p>5. Secondary SAS Ports: J51, J52. (not present on EL1 single port backplanes).</p> <p>6. Primary UART Connector: PRI-UART (J30) for manufacturer's use only.</p> | <p>7. Secondary UART Connector: SEC-UART(J24) for manufacturer's use only, not present on EL1 backplanes.</p> <p>8. Primary SDB Connector: PRI-SDB (J31), for manufacturer's use only.</p> <p>9. Secondary SDB Connector: SEC-SDB (J29), for manufacturer's use only, not present on EL1 backplanes.</p> <p>10. I²C Connector, EXP I2C0 (J48).</p> |
|---|---|

C-7 Front Connector and Pin Definitions

1. -2. Primary and Secondary Expander Chips

The primary and secondary expander chips allow the backplane to support dual port, cascading, and failover configurations.

3. Backplane Power Connectors

The 4-pin connectors, designated PWR1 - PWR6 provide power to the backplane. See the table on the right for pin definitions.

Backplane Main Power 4-Pin Connector	
Pin#	Definition
1	+12V
2 and 3	Ground
4	+5V

4. - 5. Primary and Secondary SAS Ports

The primary SAS connectors are designated J49 and J50. The secondary SAS Ports are designated J51 through J52 and are not present on EL1 single port backplanes.

6. - 7. Primary and Secondary UART Connectors

The primary UART connector is designated PRI-UART and J30. The secondary UART connector is designated SEC-UART and J24 and is not present on BPN-SAS3-846EL1. UART connectors are used for manufacturer's diagnostic purposes only.

8. - 9. SDB Connectors

The Primary SDB connector is designated PRI-SDB and J31. The secondary SDB connector is designated SEC-SDB and J29. (Not present on BPN-SAS3-846EL1 backplanes) These are debug connectors used for the manufacturer's diagnostic purposes only.

10. I²C Connectors

The I²C connector. is designated EXP I2C0 and J48.

C-8 Front Jumper Locations and Settings

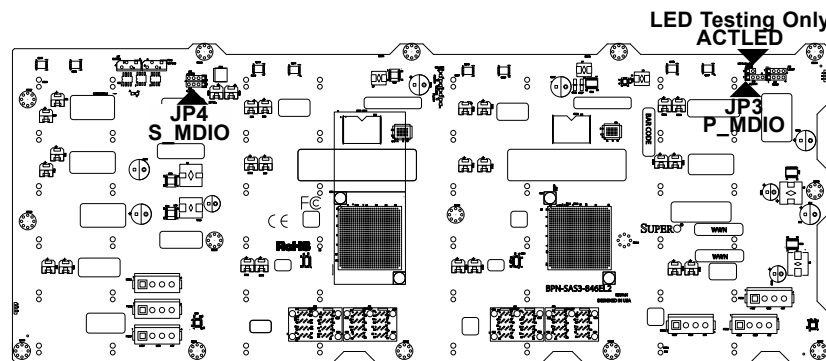
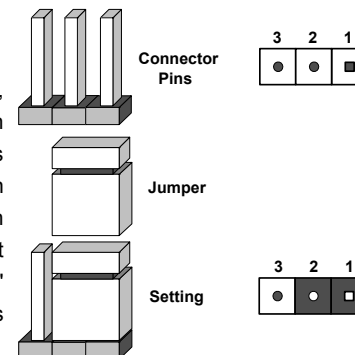

Figure C-2. Front Jumpers

Explanation of Jumpers

To modify the operation of the backplane, jumpers can be used to choose between optional settings. Jumpers create shorts between two pins to change the function of the connector. Pin 1 is identified with a square solder pad on the printed circuit board. Note: On two pin jumpers, "Closed" means the jumper is on and "Open" means the jumper is off the pins.



General Jumper Settings		
Jumper	Jumper Settings	Note
LED Testing Only ACTLED	Open: Disabled (Default) Closed: Enabled	Activity LED test.
JP3 P_MDIO	Open: Disabled (Default) Closed: Enabled	Primary management data in/out. For manufacturer's use only.
JP4 S_MDIO	Open: Disabled (Default) Closed: Enabled	Secondary management data in/out. For manufacturer's use only.

C-9 Front LED Indicators

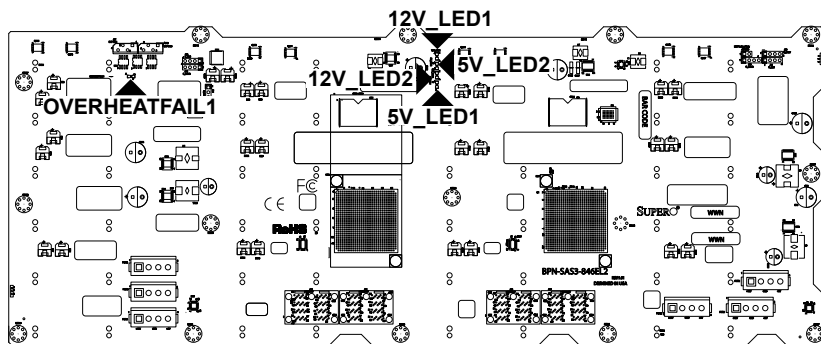

Figure C-3. Front LEDs

Front LEDs			
LED	Normal State	Abnormal State	Specification
12V_LED1	On	Off	12V power status.
12V_LED2	Blinking	Steady on, or off	Primary expander heartbeat indicator.
5V_LED1	On	Off	5V power status.
5V_LED2	Blinking	Steady on, or off	Secondary expander heartbeat indicator (not present on BPN-SAS3-846EL1 backplanes).
OVERHEATFAIL1	Off	On	System overheat/failure LED.

C-10 Rear Connectors and LED Indicators

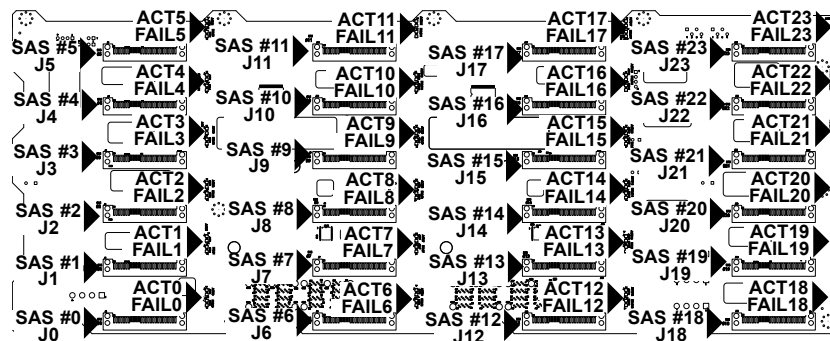

Figure C-4. Rear Connectors and LEDs

Rear SAS Connectors			
Rear Connector	SAS Drive Number	Rear Connector	SAS Drive Number
SAS #0	SAS HDD #0	SAS #12	SAS HDD #12
SAS #1	SAS HDD #1	SAS #13	SAS HDD #13
SAS #2	SAS HDD #2	SAS #14	SAS HDD #14
SAS #3	SAS HDD #3	SAS #15	SAS HDD #15
SAS #4	SAS HDD #4	SAS #16	SAS HDD #16
SAS #5	SAS HDD #5	SAS #17	SAS HDD #17
SAS #6	SAS HDD #6	SAS #18	SAS HDD #18
SAS #7	SAS HDD #7	SAS #19	SAS HDD #19
SAS #8	SAS HDD #8	SAS #20	SAS HDD #20
SAS #9	SAS HDD #9	SAS #21	SAS HDD #21
SAS #10	SAS HDD #10	SAS #22	SAS HDD #22
SAS #11	SAS HDD #11	SAS #23	SAS HDD #23

Rear LED Indicators		
Rear LED	Hard Drive Activity	Failure LED
SAS #0	ACT0	FAIL0
SAS #1	ACT1	FAIL1
SAS #2	ACT 2	FAIL2
SAS #3	ACT3	FAIL3
SAS #4	ACT4	FAIL4
SAS #5	ACT5	FAIL5
SAS #6	ACT6	FAIL6
SAS #7	ACT7	FAIL7
SAS #8	ACT8	FAIL8
SAS #9	ACT 9	FAIL9
SAS #10	ACT10	FAIL10
SAS #11	ACT11	FAIL11
SAS #12	ACT12	FAIL12
SAS #13	ACT13	FAIL13
SAS #14	ACT14	FAIL14
SAS #15	ACT15	FAIL15
SAS #16	ACT16	FAIL16
SAS #17	ACT17	FAIL17
SAS #18	ACT18	FAIL18
SAS #19	ACT19	FAIL19
SAS #20	ACT20	FAIL20
SAS #21	ACT21	FAIL21
SAS #22	ACT22	FAIL22
SAS #23	ACT23	FAIL23

C-11 Single and Dual Port Expanders

SAS primary connectors J49 to J50 and secondary connectors J51 to J52 are bidirectional and can be treated as input or output.

Single Ports

BPN-SAS3-846EL1 backplanes have a single port expander that accesses all of the drives and supports cascading.

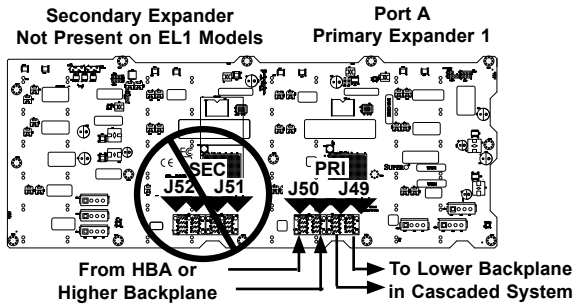

Figure C-5. BPN-SAS3-846EL1 Single Port Configuration

Dual Ports

BPN-SAS3-846EL2 model backplanes have dual-port expanders that access all of the hard drives. These dual-port expanders support cascading, failover, and recovery.

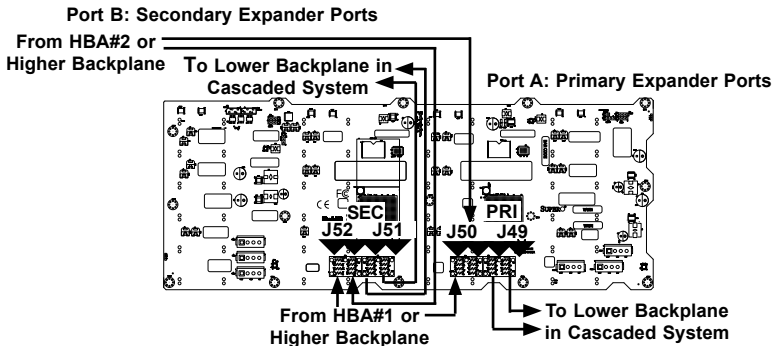

Figure C-6. BPN-SAS3-846EL2 Dual Port Configuration

C-12 Failover

The BPN-SAS3-846EL2 model backplane has two expanders which enable effective failover and recovery.

Single Host Bus Adapter

In a single host bus configuration, the backplane connects to one host bus adapter.

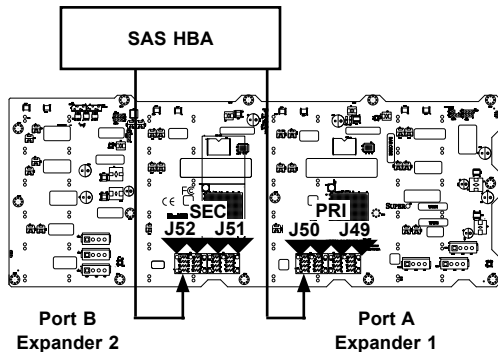

Figure C-7. Single HBA

Single Host Bus Adapter Failover

If the expander or data path in Port A fails, the system automatically switches to Port B with application software or failover support.

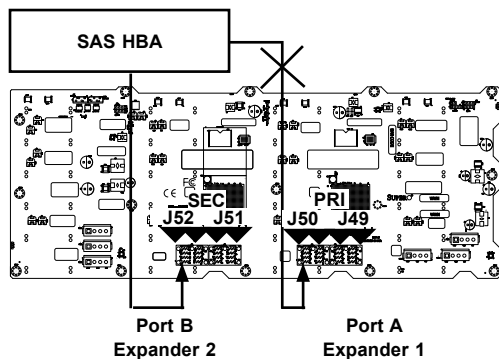

Figure C-8. Single HBA Failover

C-13 Failover with RAID Cards and Multiple HBAs

The BPN-SAS3-846EL backplane may be configured for failover with multiple HBAs using either RAID controllers or HBAs to achieve failover protection.

RAID Controllers: If RAID controllers are used, then the failover is accomplished through port failover on the same RAID card.

HBAs: If multiple HBAs are used to achieve failover protection and load balancing, Linux MPIO software must be installed and correctly configured to perform the load balancing and failover tasks.

Dual Host Bus Adapter

In a dual host bus configuration, the backplane connects to two HBA's.

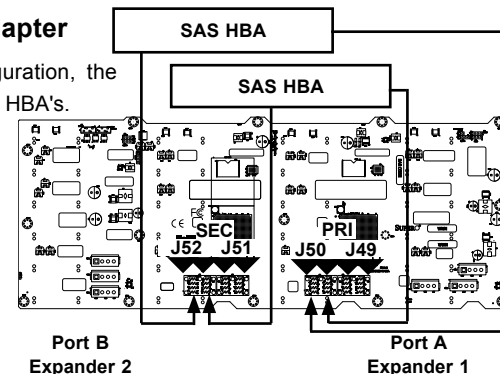

Figure C-9. Dual HBA

Dual Host Bus Adapter Failover

If the expander or data path in Port A fails, the system automatically switches to Port B. This maintains a full connection to all drives.

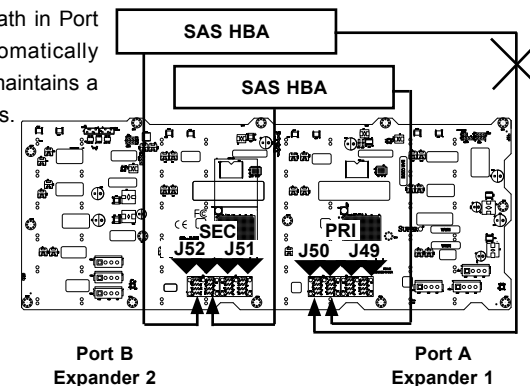

Figure C-10. Dual HBA Failover

IMPORTANT: For RAID controllers, redundancy is achieved through port failover. For multiple HBAs MPIO software is required to achieve failover protection.

C-14 Connecting HBAs to the Backplane

Connecting an Internal HBA to the Backplane

The following section lists the most common cables used to connect the HBA to the backplane.

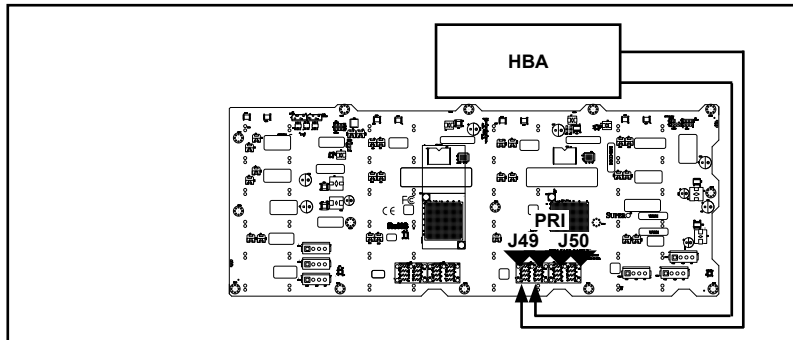

Figure C-11. Single Internal Host Bus Adapter

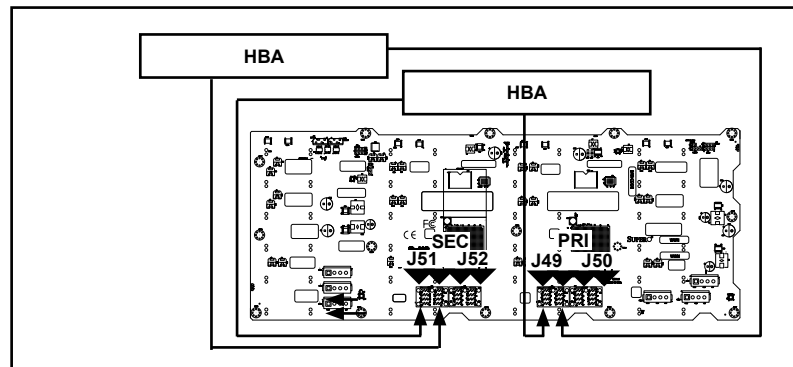

Figure C-12. Dual Internal Host Bus Adapter

Supported Internal HBA Cables

Use the following cables to create connections between the internal HBA and BPN-SAS3-846EL model backplane. The cables required depend upon the HBA connector.

IMPORTANT: See Section C-13 of this manual, *Failover with RAID Cards and Multiple HBAs* for important information on supported configurations.

Cable Name: Internal iPass (Mini-SAS) to HD (Mini-SAS)

Part #: CBL-SAST-0508-01

Length: 50 cm (19 inches)

Part #: CBL-SAST-0507-01

Length: 80 cm (31 inches)

Description: This cable has an iPass (SFF-8087/Mini-SAS) connector (36-pin) at one end and a Mini-SAS HD (SFF-8643) connector at the other end. It connects from the SAS2 HBA to the BPN-SAS3-846EL model backplane.

Cable name: Internal HD (Mini-SAS) to HD (Mini-SAS)

Part #: CBL-SAST-0568

Length: 35 cm (13 inches)

Part #: CBL-SAST-0593

Length: 60 cm (23 inches)

Part #: CBL-SAST-0531

Length: 80 cm (31 inches)

Description: This cable has a Mini-SAS HD (SFF-8643) connector at both ends. It connects from the SAS3 HBA to the BPN-SAS3-846EL model backplane.

Connecting an External HBA to the Backplane

This backplane supports external host bus adapters. In this configuration, the HBA and the backplane are in different physical chassis. This allows a JBOD (Just a Bunch Of Drives) configuration from an existing system.

Single External Host Bus Adapter

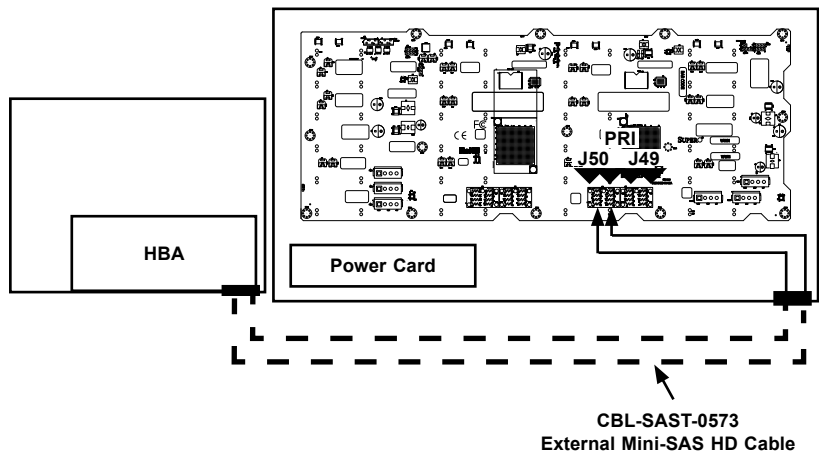

Figure C-13. Single External Host Adapter

Dual External Host Bus Adapter

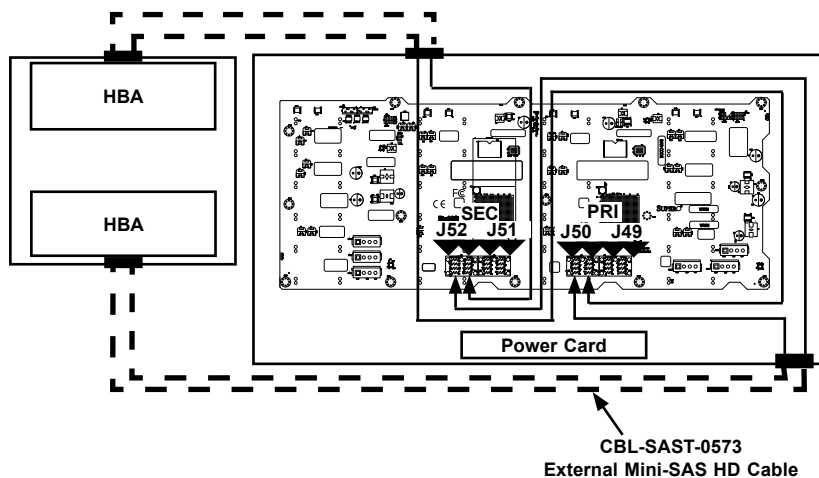

Figure C-14. Dual External Host Bus Adapter

IMPORTANT: See Section C-13 of this manual, *Failover with RAID Cards and Multiple HBAs* for important information on supported configurations.

Connecting Multiple Backplanes in a Single Channel Environment

This section describes the cables used when cascading from a single HBA. These connections use CBL-SAST-0531 internal cables and CBL-SAST-0573 external cables.

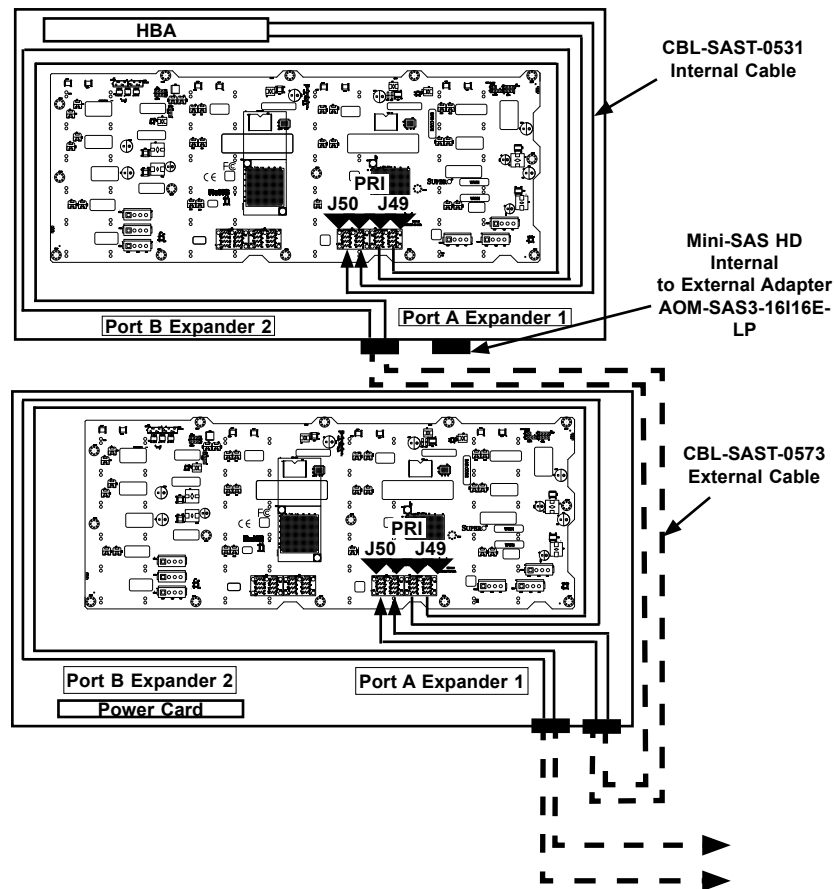

Figure C-15. Single HBA Configuration

Single HBA Configuration Cables



Figure C-16. External Mini-SAS HD to External Mini-SAS HD Cable

Cable Name: 1 Meter External Mini-SAS HD to External Mini-SAS HD Cable
Part #: CBL-SAST-0573
Ports: Single
Placement: External Cable
Description: External cascading cable, connects ports between servers and JBODs.



Figure C-17. Mini-SAS HD Internal to External Adapter

Cable Name: 16-port Mini-SAS HD Internal to External Cable Adapter with LP Bracket
Part #: AOM-SAS3-16I16E-LP
Ports: Four wide ports (sixteen ports total)
Placement: Internal cable with adapter
Description: Internal cable, connects the SAS3 backplane to external ports.

Connecting Multiple Backplanes in a Dual Channel Environment

This section describes the cables used when cascading from dual HBAs. These connections use CBL-SAST-0531 internal cables and CBL-SAST-0573 external cables.

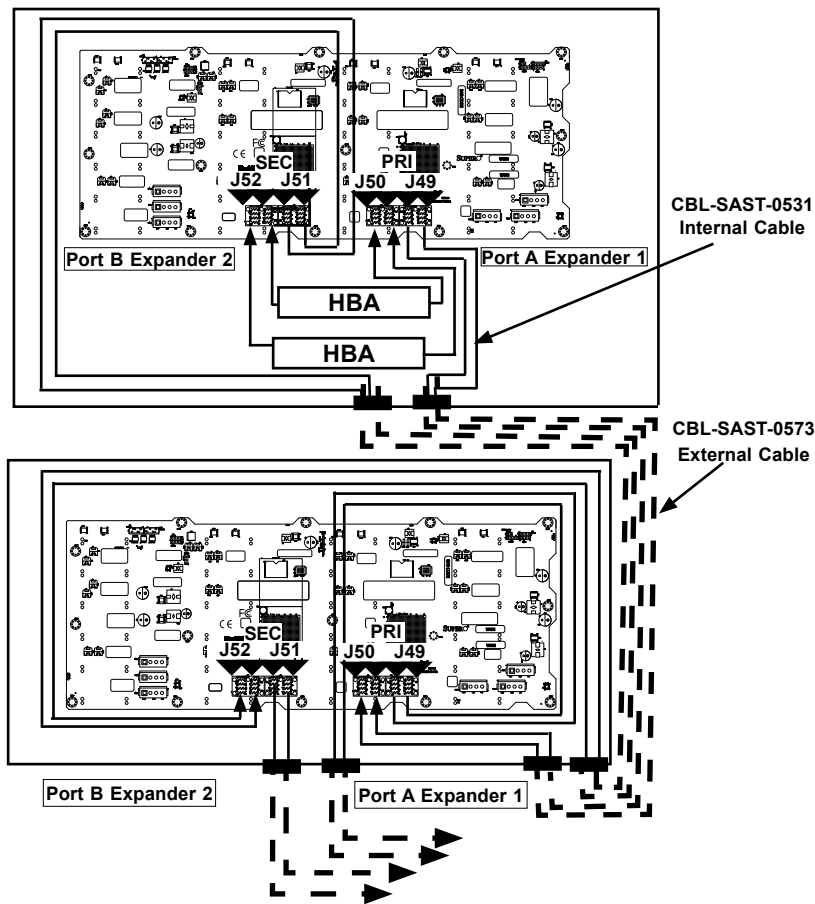

Figure C-18. Dual HBA Configuration

IMPORTANT: See Section C-13 of this manual, *Failover with RAID Cards and Multiple HBAs* for important information on supported configurations.

Notes

Appendix D

BPN-SAS3-826EL Backplane Specifications

To avoid personal injury and property damage, carefully follow all the safety steps listed below when accessing your system or handling the components.

D-1 ESD Safety Guidelines

Electrostatic Discharge (ESD) can damage electronic components. To prevent damage to your system, it is important to handle it very carefully. The following measures are generally sufficient to protect your equipment from ESD.

- Use a grounded wrist strap designed to prevent static discharge.
- Touch a grounded metal object before removing a component from the antistatic bag.
- Handle the backplane by its edges only; do not touch its components, peripheral chips, memory modules or gold contacts.
- When handling chips or modules, avoid touching their pins.
- Put the card and peripherals back into their antistatic bags when not in use.

D-2 General Safety Guidelines

- Always disconnect power cables before installing or removing any components from the computer, including the BPN-SAS3-826EL series backplane.
- Make sure that the backplane is properly and securely on the motherboard to prevent damage to the system due to power outages.

D-3 An Important Note to Users

All images and layouts shown in this user's guide are based upon the latest backplane revision available at the time of publishing. The card you have received may or may not look exactly the same as the graphics shown in this manual.

D-4 Introduction to the BPN-SAS3-826EL Backplane

The BPN-SAS3-826EL backplane has been designed to utilize the most up-to-date technology available, providing your system with reliable, high-quality performance.

This manual reflects BPN-SAS3-826EL Revision 1.00, the most current release available at the time of publication. Always refer to the Supermicro Web site at www.supermicro.com for the latest updates, compatible parts and supported configurations.

D-5 Overview of the BPN-SAS3-826EL1/EL2 Backplanes

The BPN-SAS3-826EL1 and BPN-SAS3-826EL2 model backplanes are identical, except that the BPN-SAS3-826EL2 backplane has duplicate secondary components which are not found on the BPN-SAS3-826EL1. The BPN-SAS3-826EL2 is divided into a two sections, with the primary components on the right side of the board and the secondary components on the left. SAS3 backplanes are not compatible with legacy SAS (3 Gbps) or SATA (1.5 Gbps) backplanes or lower.

D-6 Front Connectors

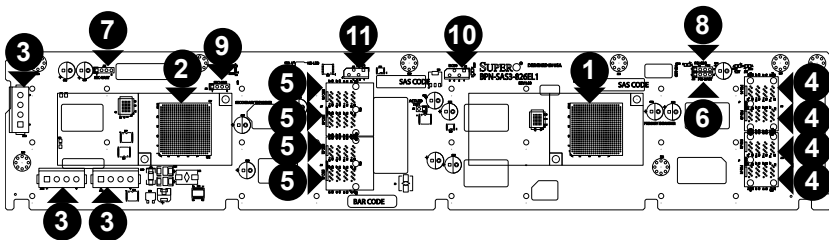

Figure D-1. BPN-SAS3-826EL1/EL2 Connectors and Components

- | | |
|--|---|
| <p>1. Primary expander chip.</p> <p>2. Secondary expander chip (not present on EL1 single port backplanes).</p> <p>3. Power connectors: JPW1, JPW2, and JPW3.</p> <p>4. Primary SAS ports: PRI-J1 through PRI-J4.</p> <p>5. Secondary SAS ports: SED-J1 through SED-J4 (not present on EL1 single port backplanes).</p> <p>6. Primary UART connector: PRI-UART (J22) for manufacturer's use only.</p> <p>7. Secondary UART connector: SED-UART(J23) for manufac-</p> | <p>urer's use only, not present on EL1 backplanes.</p> <p>8. Primary SDB connector: PRI-SDB (J18), for manufacturer's use only.</p> <p>9. Secondary SDB connector: SED-SDB (J19), for manufacturer's use only, not present on EL1 backplanes.</p> <p>10. Primary I²C connector. I2C#0 (J20).</p> <p>11. Secondary I²C connector, I2C#4 (J21).</p> |
|--|---|

D-7 Front Connector and Pin Definitions

1. - 2. Primary and Secondary Expander Chips

The primary and secondary expander chips allow the backplane to support dual port, cascading, and failover configurations.

3. Backplane Main Power Connectors

The 4-pin connectors, designated JPW1, JPW2, and JPW3, provide power to the backplane. See the table on the right for pin definitions.

Backplane Main Power 4-Pin Connector	
Pin#	Definition
1	+12V
2 and 3	Ground
4	+5V

4. - 5. Primary and Secondary SAS Connectors

The primary SAS connectors are designated PRI-J1 through PRI-J4. The secondary SAS Ports are designated SED-J1 through SED-J4 and are not present on EL1 single port backplanes.

6. - 7. Primary and Secondary UART Connectors

The primary UART connector is designated PRI-UART and J22. The secondary UART connector is designated SED-UART and J23 and is not present on BPN-SAS3-826EL1. UART connectors are used for manufacturer's diagnostic purposes only.

8. - 9. SDB Connectors

The Primary SDB connector is designated PRI-SDB and J18. The secondary SDB connector is designated SED-SDB and J19. (Not present on BPN-SAS3-826EL1 backplanes) These are debug connectors used for the manufacturer's diagnostic purposes only.

10. - 11. I²C Connectors

The primary I2C connector. is designated I2C#0 and J20. The secondary I2C connector is designated I2C#4 and J21.

D-8 Front Jumper Location and Settings

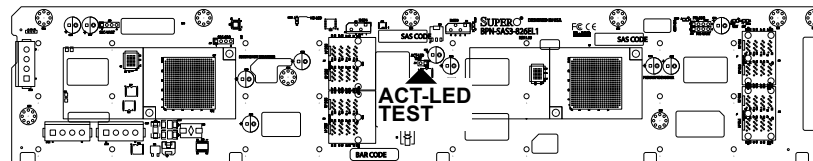
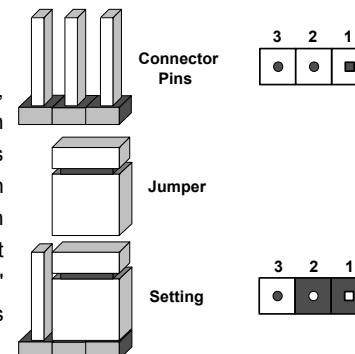

Figure D-2. Front Jumpers

Explanation of Jumpers

To modify the operation of the backplane, jumpers can be used to choose between optional settings. Jumpers create shorts between two pins to change the function of the connector. Pin 1 is identified with a square solder pad on the printed circuit board. Note: On two pin jumpers, "Closed" means the jumper is on and "Open" means the jumper is off the pins.



General Jumper Settings		
Jumper	Jumper Settings	Note
ACT-LED TEST	Open: Disabled (Default) Closed: Enabled	Activity LED test.

D-9 Front LED Indicators

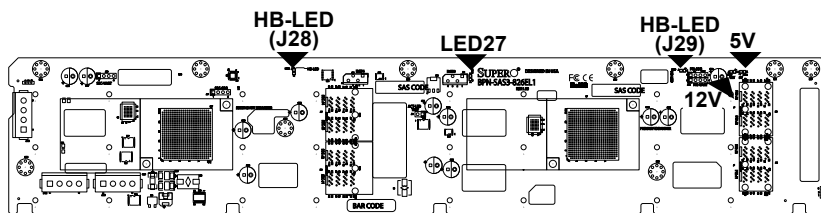

Figure D-3. Front LEDs

Backplane LEDs			
LED	Normal State	Abnormal State	Specification
HB-LED (J29)	Blinking	On/Off	Heartbeat LED, primary expander
HB-LED (J28)	Blinking	On/Off	Heartbeat LED, secondary expander
LED27	Off	On	System overheat LED
5V	On	Off	5V power status
12V	On	Off	12V power status

D-10 Rear Connectors and LED Indicators

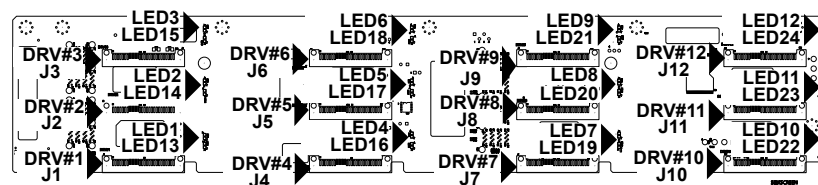

Figure D-4. Rear Connectors and LEDs

Rear SAS Connectors			
Rear Connector	SAS Drive Number	Rear Connector	SAS Drive Number
DRV#1	SAS HDD #1	DRV#7	SAS HDD #7
DRV#2	SAS HDD #2	DRV#8	SAS HDD #8
DRV#3	SAS HDD #3	DRV#9	SAS HDD #9
DRV#4	SAS HDD #4	DRV#10	SAS HDD #10
DRV#5	SAS HDD #5	DRV#11	SAS HDD #11
DRV#6	SAS HDD #6	DRV#12	SAS HDD #12

Rear LED Indicators		
Rear LED	Hard Drive Activity	Failure LED
SAS #1	LED1	LED13
SAS #2	LED2	LED14
SAS #3	LED3	LED15
SAS #4	LED4	LED16
SAS #5	LED5	LED17
SAS #6	LED6	LED18
SAS #7	LED7	LED19
SAS #8	LED8	LED20
SAS #9	LED9	LED21
SAS #10	LED10	LED22
SAS #11	LED11	LED23
SAS #12	LED12	LED24

D-11 Single and Dual Port Expanders

SAS connectors PRI-J1 to J4 and SED-J1 to J4 are bidirectional and can be treated as input or output.

Single Ports

BPN-SAS3-826EL1 backplanes have a single port expander that accesses all of the drives and supports cascading.

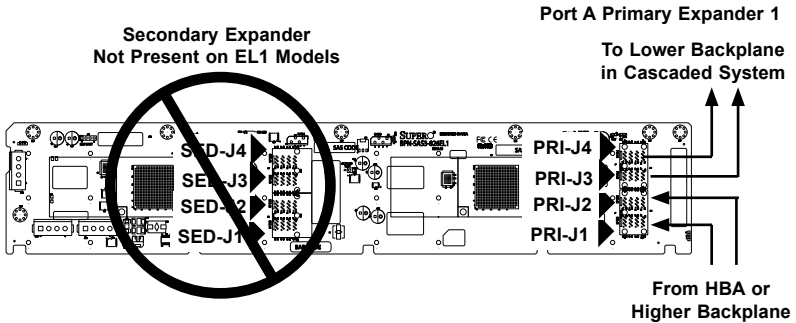

Figure D-5. BPN-SAS3-826EL1 Single Port Configuration

Dual Ports

BPN-SAS3-826EL2 model backplanes have dual-port expanders that access all of the hard drives. These dual-port expanders support cascading, failover, and recovery.

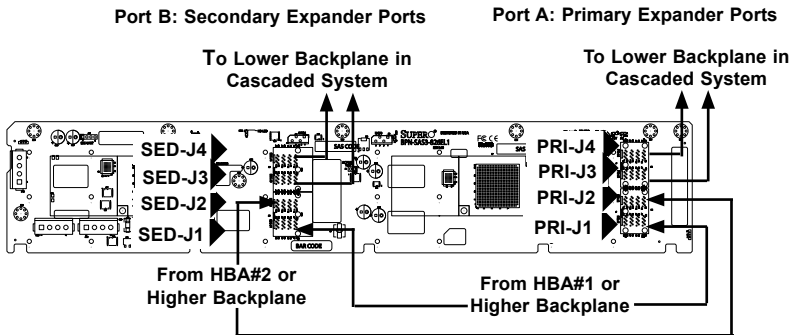

Figure D-6. BPN-SAS3-826EL2 Dual Port Configuration

D-12 Failover

The BPN-SAS3-826EL2 model backplane has two expanders which enable effective failover and recovery.

Single Host Bus Adapter

In a single host bus configuration, the backplane connects to one host bus adapter.

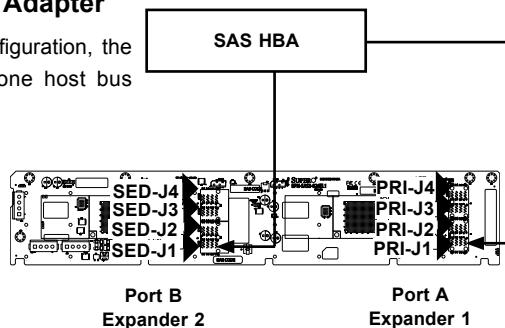

Figure D-7. Single HBA

Single Host Bus Adapter Failover

If the expander or data path in Port A fails, the system automatically switches to Port B with application software or failover support.

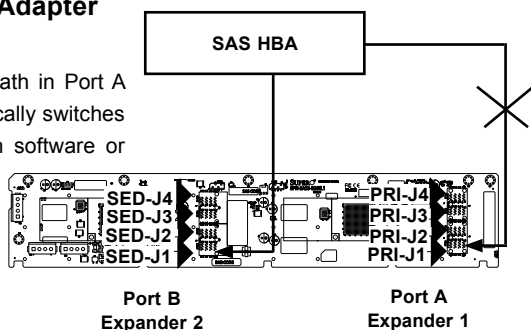

Figure D-8. Single HBA Failover

D-13 Failover with RAID Cards and Multiple HBAs

The BPN-SAS3-826EL backplane may be configured for failover with multiple HBAs using either RAID controllers or HBAs to achieve failover protection.

RAID Controllers: If RAID controllers are used, then the failover is accomplished through port failover on the same RAID card.

HBAs: If multiple HBAs are used to achieve failover protection and load balancing, **Linux MPIO software must be installed and correctly configured to perform the load balancing and failover tasks.**

Dual Host Bus Adapter

In a dual host bus configuration, the backplane connects to two HBA's.

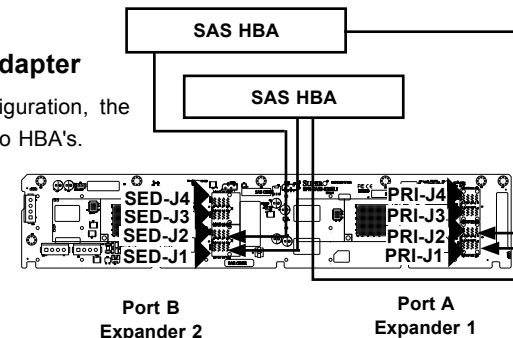

Figure D-9. Dual HBA

Dual Host Bus Adapter Failover

If the expander or data path in Port A fails, the system automatically switches to Port B. This maintains a full connection to all drives.

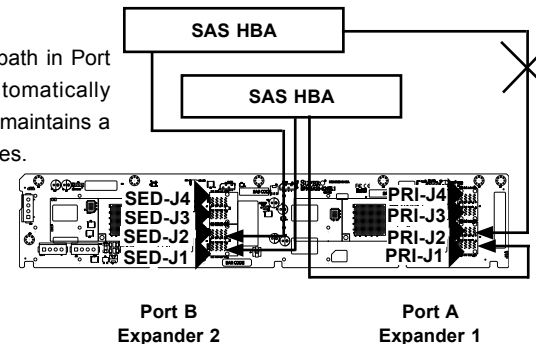

Figure D-10. Dual HBA Failover

IMPORTANT: For RAID controllers, redundancy is achieved through port failover. For multiple HBAs MPIO software is required to achieve failover protection.

D-14 Connecting HBAs to the Backplane

Connecting an Internal HBA to the Backplane

The following section lists the most common cables used to connect the HBA to the backplane.

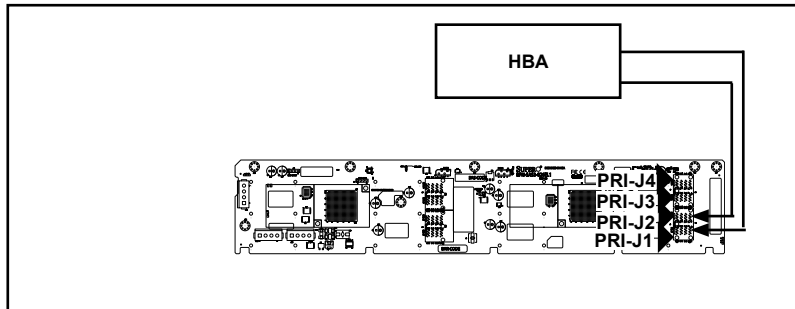

Figure D-11. Single Internal Host Bus Adapter

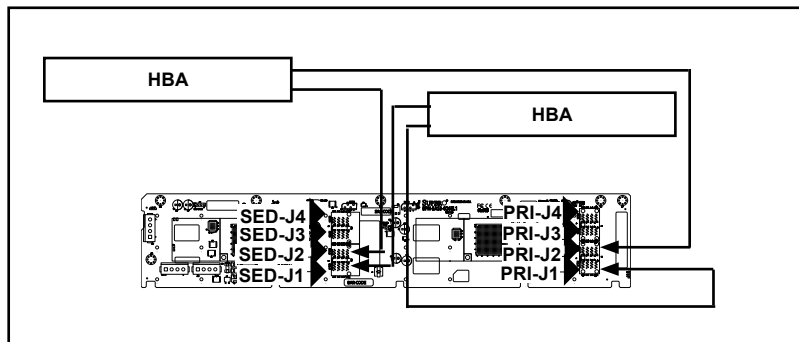

Figure D-12. Dual Internal Host Bus Adapter

Supported Internal HBA Cables

Use the following cables to create connections between the internal HBA and BPN-SAS3-826EL model backplane. The cables required depend upon the HBA connector.

IMPORTANT: See Section D-13 of this manual, *Failover with RAID Cards and Multiple HBAs* for important information on supported configurations.

Cable Name: Internal iPass (Mini-SAS) to HD (Mini-SAS)

Part #: CBL-SAST-0508-01 **Length:** 50 cm (19 inches)

Part #: CBL-SAST-0507-01 **Length:** 80 cm (31 inches)

Description: This cable has an iPass (SFF-8087/Mini-SAS) connector (36-pin) at one end and a Mini-SAS HD (SFF-8643) connector at the other end. It connects from the SAS2 HBA to the BPN-SAS3-826EL model backplane.

Cable name: Internal HD (Mini-SAS) to HD (Mini-SAS)

Part #: CBL-SAST-0568 **Length:** 35 cm (13 inches)

Part #: CBL-SAST-0593 **Length:** 60 cm (23 inches)

Part #: CBL-SAST-0531 **Length:** 80 cm (31 inches)

Description: This cable has a Mini-SAS HD (SFF-8643) connector at both ends. It connects from the SAS3 HBA to the BPN-SAS3-826EL model backplane.

Connecting an External HBA to the Backplane

This backplane supports external host bus adapters. In this configuration, the HBA and the backplane are in different physical chassis. This allows a JBOD (Just a Bunch Of Drives) configuration from an existing system.

Single External Host Bus Adapter

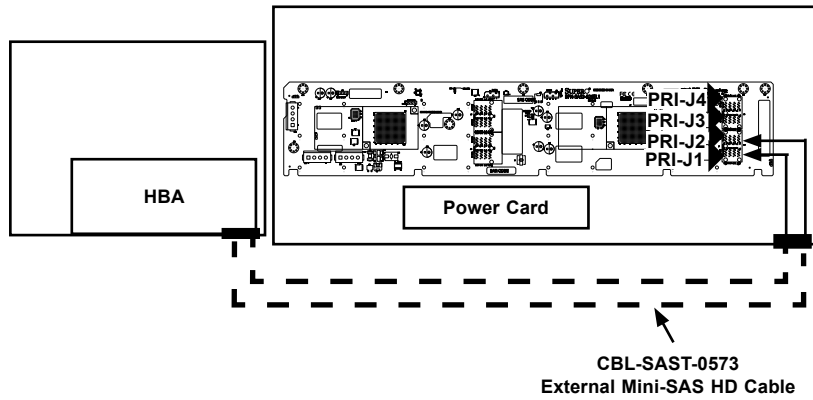

Figure D-13. Single External Host Adapter

Dual External Host Bus Adapter

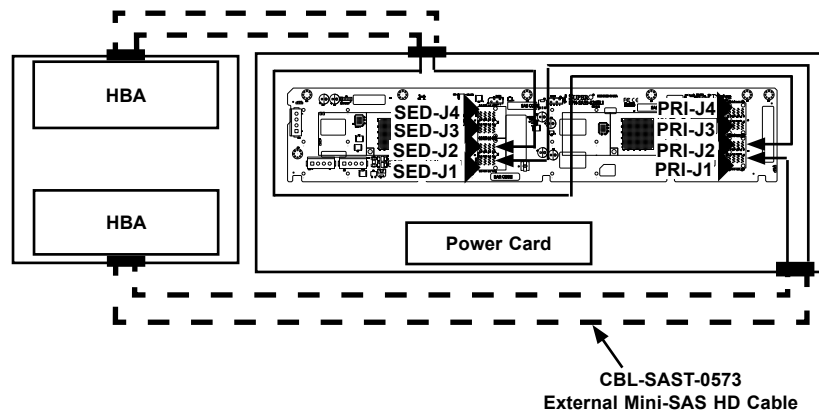

Figure D-14. Dual External Host Bus Adapter

IMPORTANT: See Section D-13 of this manual, *Failover with RAID Cards and Multiple HBAs* for important information on supported configurations.

Connecting Multiple Backplanes in a Single Channel Environment

This section describes the cables used when cascading from a single HBA. These connections use CBL-SAST-0531 internal cables and CBL-SAST-0573 external cables.

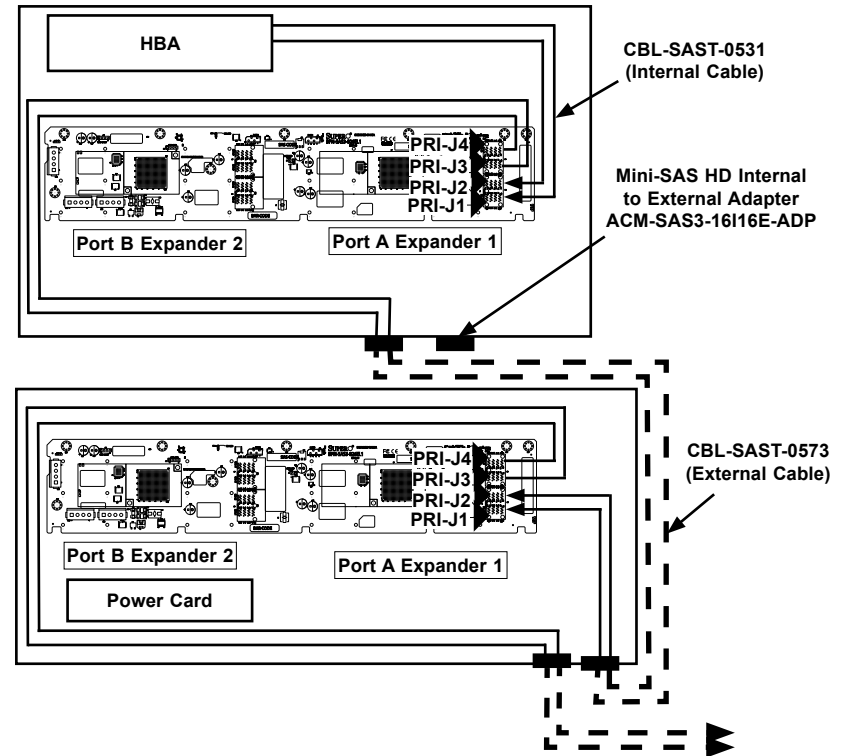

Figure D-15. Single HBA Configuration

Single HBA Configuration Cables



Figure D-16. External Mini-SAS HD to External Mini-SAS HD Cable

Cable Name: 1 Meter External Mini-SAS HD to External Mini-SAS HD Cable
Part #: CBL-SAST-0573
Ports: Single
Placement: External Cable
Description: External cascading cable, connects ports between servers and JBODs.



Figure D-17. Mini-SAS HD Internal to External Adapter

Cable Name: 16-port Mini-SAS HD Internal to External Cable Adapter with LP Bracket
Part #: AOM-SAS3-16I16E-LP
Ports: Four wide-ports (sixteen ports total)
Placement: Internal cable with adapter
Description: Internal cable, connects the SAS3 backplane to external ports.

Connecting Multiple Backplanes in a Dual Channel Environment

This section describes the cables used when cascading from dual HBAs. These connections use CBL-SAST-0531 internal cables and CBL-SAST-0573 external cables.

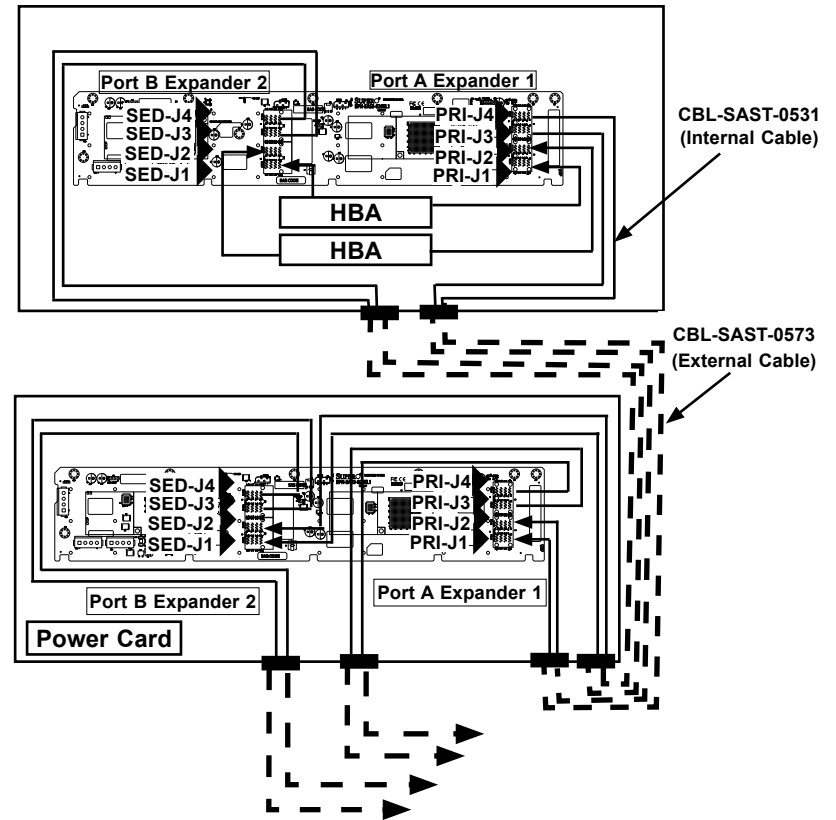

Figure D-18. Dual HBA Configuration

IMPORTANT: See Section D-13 of this manual, *Failover with RAID Cards and Multiple HBAs* for important information on supported configurations.

Notes

Appendix E

Front and Rear Backplane Cascading

To avoid personal injury and property damage, carefully follow all the safety steps listed below when accessing your system or handling the components.

E-1 ESD Safety Guidelines

Electrostatic Discharge (ESD) can damage electronic components. To prevent damage to your system, it is important to handle it very carefully. The following measures are generally sufficient to protect your equipment from ESD.

- Use a grounded wrist strap designed to prevent static discharge.
- Touch a grounded metal object before removing a component from the antistatic bag.
- Handle the backplane by its edges only; do not touch its components, peripheral chips, memory modules or gold contacts.
- When handling chips or modules, avoid touching their pins.
- Put the card and peripherals back into their antistatic bags when not in use.

E-2 General Safety Guidelines

- Always disconnect power cables before installing or removing any components from the computer, including the BPN-SAS3-826EL series backplane.
- Make sure that the backplane is properly and securely on the motherboard to prevent damage to the system due to power outages.

E-3 An Important Note to Users

All images and layouts shown in this user's guide are based upon the latest backplane revision available at the time of publishing. The card you have received may or may not look exactly the same as the graphics shown in this manual.

E-4 The BPN-SAS3-846EL Front Backplane

The BPN-SAS3-846EL backplane has been designed to utilize the most up-to-date technology available, providing your system with reliable, high-quality performance.

This manual reflects BPN-SAS3-846EL Revision 1.01, the most current release available at the time of publication. Always refer to the Supermicro website at www.supermicro.com for the latest updates, compatible parts and supported configurations.

The BPN-SAS3-846EL1 and BPN-SAS3-846EL2 model backplanes are identical, except that the BPN-SAS3-846EL2 backplane has duplicate secondary components which are not found on the BPN-SAS3-846EL1. The BPN-SAS3-846EL2 is divided into a two sections, with the primary components on the right side of the board and the secondary components on the left. SAS3 backplanes are not compatible with legacy SAS (3 Gbps), SATA (1.5 Gbps) backplanes or lower.

E-5 The BPN-SAS3-826EL Rear Backplane

The BPN-SAS3-826EL backplane has been designed to utilize the most up-to-date technology available, providing your system with reliable, high-quality performance.

This manual reflects BPN-SAS3-826EL Revision 1.00, the most current release available at the time of publication. Always refer to the Supermicro Web site at www.supermicro.com for the latest updates, compatible parts and supported configurations.

The BPN-SAS3-826EL1 and BPN-SAS3-826EL2 model backplanes are identical, except that the BPN-SAS3-826EL2 backplane has duplicate secondary components which are not found on the BPN-SAS3-826EL1. The BPN-SAS3-826EL2 is divided into a two sections, with the primary components on the right side of the board and the secondary components on the left. SAS3 backplanes are not compatible with legacy SAS (3 Gbps) or SATA (1.5 Gbps) backplanes or lower.

Connecting the Front and Rear Backplanes

This section describes the cables used when cascading from the front backplane to the rear backplane from multiple HBAs. These connections use CBL-SAST-0531 internal cables and CBL-SAST-0573 external cables.

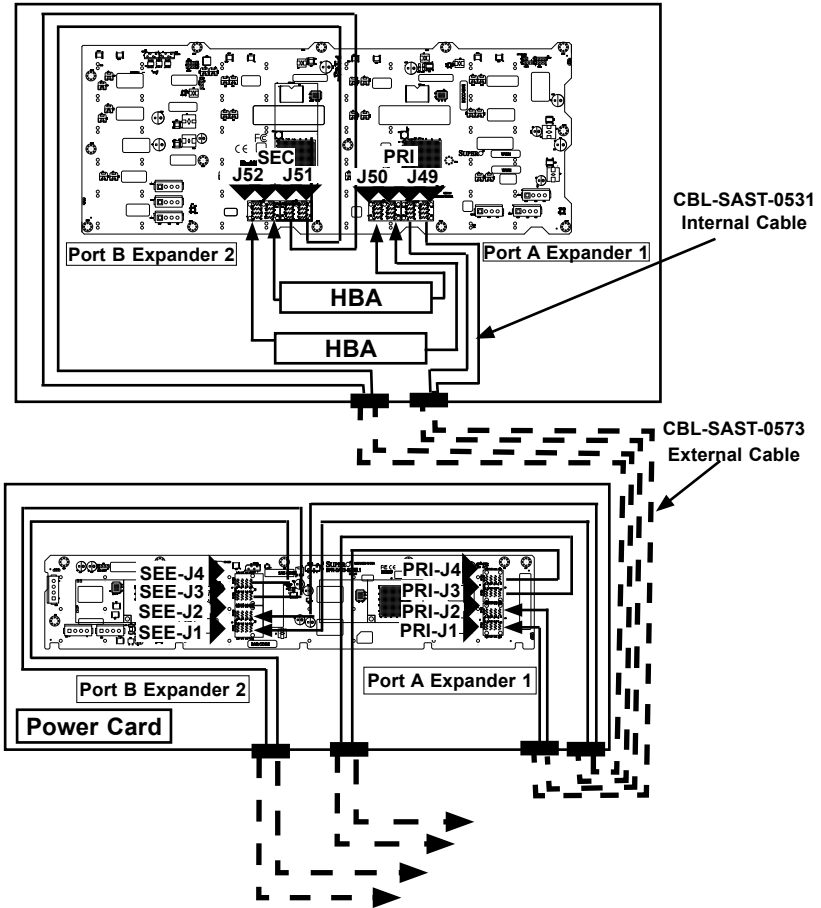

Figure E-1: Dual HBA Configuration

IMPORTANT: See Section D-13 of this manual, *Failover with RAID Cards and Multiple HBAs* for important information on supported configurations.

Notes

Appendix F

BPN-SAS-826A Backplane Specifications

To avoid personal injury and property damage, carefully follow all the safety steps listed below when accessing your system or handling the components.

F-1 ESD Safety Guidelines

Electrostatic Discharge (ESD) can damage electronic components. To prevent damage to your system, it is important to handle it very carefully. The following measures are generally sufficient to protect your equipment from ESD.

Use a grounded wrist strap designed to prevent static discharge.

Touch a grounded metal object before removing a component from the antistatic bag.

Handle the backplane by its edges only; do not touch its components, peripheral chips, memory modules or gold contacts.

When handling chips or modules, avoid touching their pins.

Put the card and peripherals back into their antistatic bags when not in use.

F-2 General Safety Guidelines

Always disconnect power cables before installing or removing any components from the computer, including the BPN-SAS-826A backplane.

Disconnect the power cord before installing or removing any cables from the BPN-SAS-826A backplane.

Make sure that the BPN-SAS-826A backplane is securely and properly installed on the motherboard to prevent damage to the system due to power shortage.

F-3 An Important Note to Users

All images and layouts shown in this user's guide are based upon the latest PCB Revision available at the time of publishing. The card you have received may or may not look exactly the same as the graphics shown in this manual.

F-4 Introduction to the BPN-SAS-846A Backplane

The BPN-SAS-826A backplane has been designed to utilize the most up-to-date technology available, providing your system with reliable, high-quality performance.

This manual reflects BPN-SAS-826A Revision 1.00, the most current release available at the time of publication. Always refer to the Supermicro Web site at www.supermicro.com for the latest updates, compatible parts and supported configurations.

F-4 Front Connectors and Jumpers

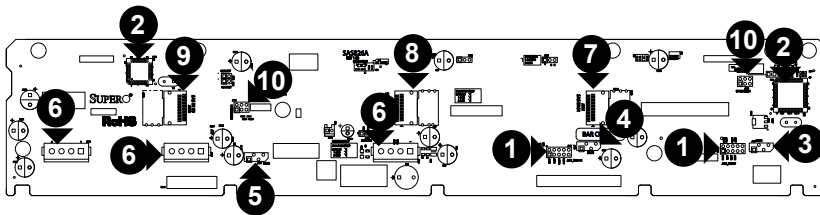

Figure F-1: Front Connectors

Front Connectors

- | | |
|---|---------------------------------------|
| 1. ACT_IN: JP26 and JP47 | 7. SAS IN #1: JSM1 |
| 2. Chips: MG9071 and MG9072 | 8. SAS IN #2: JSM2 |
| 3. I ² C Connector #1: JP37 | 9. SAS IN #3: JSM3 |
| 4. I ² C Connector #2: JP95 | 10. Upgrade Connectors, JP69 and JP78 |
| 5. I ² C Connector #3: JP52 | |
| 6. Power Connectors (4-pin): JP10, JP13, and JP46 | |

F-5 Front Connector and Pin Definitions

#1. Activity LED Headers

The activity LED headers, designated JP26 and JP47, are used to indicate the activity status of each SAS drive. The activity LED headers are located on the front panel. For the activity lead headers to work properly, connect to them using a 10-pin LED cable. This is only used when the activity LED is not supported by the hard drive.

SAS Activity LED Header Pin Definitions			
Pin #	Definition	Pin #	Definition
1	ACT IN#0	6	ACT IN#4
2	ACT IN#1	7	ACT IN#5
3	ACT IN#2	8	ACT IN#6
4	ACT IN#3	9	ACT IN#7
5	Ground	10	Empty

SAS Activity LED Header Pin Definitions			
Pin #	Definition	Pin #	Definition
1	ACT IN#8	6	ACT IN#12
2	ACT IN#9	7	ACT IN#13
3	ACT IN#10	8	ACT IN#14
4	ACT IN#11	9	ACT IN#15
5	Ground	10	Empty

#2. MG9071 and MG9072 Chips

The MG9071 and MG9072 are enclosure management chips that support the SES-2 controller and SES-2 protocols.

#3., #4., #5. I²C Connectors

The I²C Connectors, designated JP37, JP52, and JP95, are used to monitor HDD activity and status. See the table on the right for pin definitions.

I ² C Connector Pin Definitions	
Pin#	Definition
1	Data
2	Ground
3	Clock
4	No Connection

#6. Backplane Main Power Connectors

The 4-pin connectors, designated JP10, JP13, and JP46 provide power to the backplane. See the table on the right for pin definitions.

Backplane Main Power 4-Pin Connector	
Pin#	Definition
1	+12V
2 and 3	Ground
4	+5V

#7., #8., #9. SAS Ports

The SAS ports are used to connect the SAS drive cables. The three connectors are designated SAS IN #1 - SAS IN #3. Each of the three connectors has four ports for a total of twelve ports. These twelve ports are designated #0 - #11 and they are also compatible with SATA drives.

10. Upgrade Connectors

The upgrade connectors, designated JP69 and JP78, are used for manufacturer's diagnostic purposes only.

F-6 Front Jumper Locations and Pin Definitions

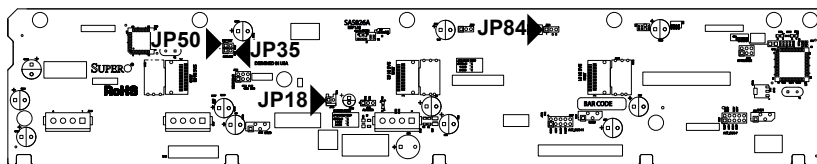
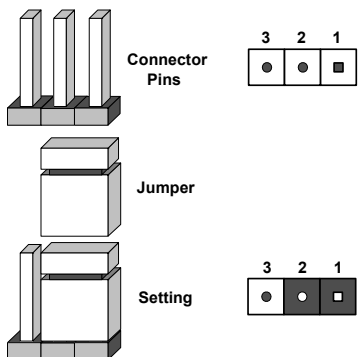

Figure F-2: Front Jumpers

Explanation of Jumpers

To modify the operation of the backplane, jumpers can be used to choose between optional settings. Jumpers create shorts between two pins to change the function of the connector. Pin 1 is identified with a square solder pad on the printed circuit board. **Note:** On two pin jumpers, "Closed" means the jumper is on and "Open" means the jumper is off the pins.



Jumper Settings		
Jumper	Jumper Settings	Note
JP35	Open: Default Closed: Reset	MG9072 Chip Reset #1
JP50	Open: Default Closed: Reset	MG9071 Chip Reset #2
JP18	Open: Default Closed: Reset	Buzzer Reset*

*The buzzer sound indicates that an overheat condition, a fan failure or a drive failure has occurred.

I²C and SGPIO Modes and Jumper Settings

This backplane can utilize I²C or SGPIO. SGPIO is the default mode and can be used without making changes to your jumpers. The following information details which jumper must be configured to use SGPIO mode or restore your backplane to I²C mode.

Jumper Settings: SGPIO (Default) and I ² C		
Jumper	SGPIO (Default) Setting	I ² C Setting
JP84	1-2: SGPIO mode enable	2-3: I ² C mode enable

Front LED Indicators

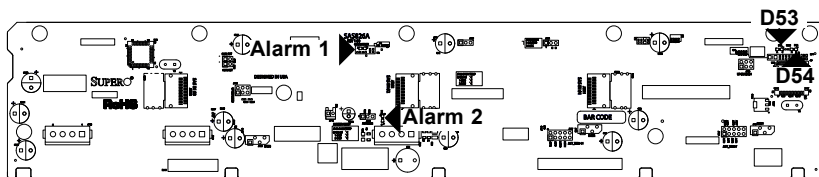

Figure F-3: Front LEDs

Front Panel LEDs		
LED	State	Specification
Alarm #1 (D3)	On	Overheat/drive failure in Channel 1 will activate the buzzer.
Alarm #2 (D36)	On	Overheat/drive failure in Channel 2 will activate the buzzer.
D53	On	Indicates +5V power. Light is on during normal operation.
D54	On	Indicates +12V power. Light is on during normal operation.

F-7 Rear Connectors and LED Indicators

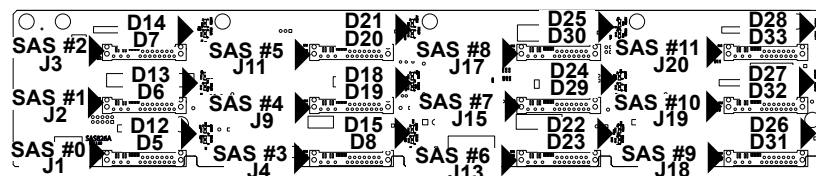

Figure F-4: Rear Connectors and LEDs

Rear SAS/SATA Connectors			
Rear Connector	SAS Drive Number	Rear Connector	SAS Drive Number
SAS #0	SAS/SATA HDD #0	SAS #6	SAS/SATA HDD #6
SAS #1	SAS/SATA HDD #1	SAS #7	SAS/SATA HDD #7
SAS #2	SAS/SATA HDD #2	SAS #8	SAS/SATA HDD #8
SAS #3	SAS/SATA HDD #3	SAS #9	SAS/SATA HDD #9
SAS #4	SAS/SATA HDD #4	SAS #10	SAS/SATA HDD #10
SAS #5	SAS/SATA HDD #5	SAS #11	SAS/SATA HDD #11

Rear LED Indicators		
Rear LED	Hard Drive Activity	Failure LED
SAS #0	D12	D5
SAS #1	D13	D6
SAS #2	D14	D7
SAS #3	D15	D8
SAS #4	D18	D19
SAS #5	D21	D20
SAS #6	D22	D23
SAS #7	D24	D29
SAS #8	D25	D30
SAS #9	D26	D31
SAS #10	D27	D32
SAS #11	D28	D33

Notes

Appendix G

BPN-SAS-846A Backplane Specifications

To avoid personal injury and property damage, carefully follow all the safety steps listed below when accessing your system or handling the components.

G-1 ESD Safety Guidelines

Electrostatic Discharge (ESD) can damage electronic components. To prevent damage to your system, it is important to handle it very carefully. The following measures are generally sufficient to protect your equipment from ESD.

Use a grounded wrist strap designed to prevent static discharge.

Touch a grounded metal object before removing a component from the antistatic bag.

Handle the RAID card by its edges only; do not touch its components, peripheral chips, memory modules or gold contacts.

When handling chips or modules, avoid touching their pins.

Put the card and peripherals back into their antistatic bags when not in use.

G-2 General Safety Guidelines

Always disconnect power cables before installing or removing any components from the computer, including the backplane.

Disconnect the power cable before installing or removing any cables from the backplane.

Make sure that the backplane is securely and properly installed on the motherboard to prevent damage to the system due to power shortage.

G-3 A Note to Users

All images and layouts shown in this user's guide are based upon the latest PCB Revision available at the time of publishing. The card you have received may or may not look exactly the same as the graphics shown in this manual.

G-4 Introduction to the BPN-SAS-846A Backplane

The BPN-SAS-846A backplane has been designed to utilize the most up-to-date technology available, providing your system with reliable, high-quality performance.

This manual reflects BPN-SAS-846A Revision 1.00, the most current release available at the time of publication. Always refer to the Supermicro Web site at www.supermicro.com for the latest updates, compatible parts and supported configurations.

G-5 Front Connectors and Jumpers

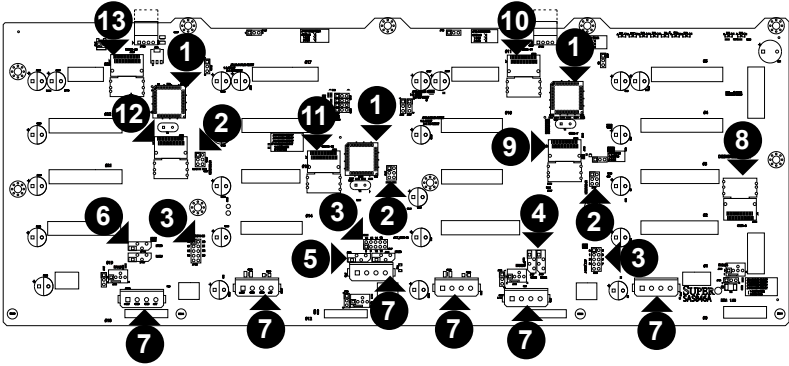

Figure G-1: Front Components

Front Connectors and Components

1. Chip: MG9072
2. Upgrade Connectors: JP69, JP78 and JP115
3. ACT_IN: JP26, JP47, and JP108
4. I²C Connector #1 (JP37) and #2 (JP95)
5. I²C Connector #3 (JP52) and #4 (JP96)
6. I²C Connector #5 (JP116) and #6 (JP117)
7. Power Connectors (4-pin): JP10, JP13, JP46, JP48, JP109, and JP110
8. IPASS Connector CH# 0-3, JSM1
9. IPASS Connector CH# 4-7, JSM2
10. IPASS Connector CH# 8-11, JSM3
11. IPASS Connector CH# 12-15, JSM4
12. IPASS Connector CH# 16-19, JSM5
13. IPASS Connector CH# 20-23, JSM6

G-6 Front Connector and Pin Definitions

1. MG9072 Chip

The MG9072 is an enclosure management chip that supports the SES-2 controller and SES-2 protocols.

2. Upgrade Connectors

The upgrade connectors are designated JP69, JP78, and JP115 and are used for manufacturer's diagnostic purposes only.

3. Activity LED Header

The activity LED header, designated JP26, JP47 and JP108, is used to indicate the activity status of each SAS drive. The Activity LED Header is located on the front panel. For the Activity LED Header to work properly, connect using a 10-pin LED cable.

4., 5., 6. I²C Connectors

The I²C Connectors, designated JP37, JP95, JP52, JP96, JP52, JP96, JP116, and JP117, are used to monitor HDD activity and status. See the table on the right for pin definitions.

I ² C Connector Pin Definitions (JP37, JP95, JP52, JP96, JP116, and JP117)	
Pin#	Definition
1	Data
2	Ground
3	Clock
4	No Connection

7. Backplane Main Power Connectors

The 4-pin connectors, designated JP10, JP13, JP46, JP48, JP109, and JP110, provide power to the backplane. See the table on the right for pin definitions.

Backplane Main Power 4-Pin Connector (JP10, JP13, JP46, JP48, 109 and 110)	
Pin#	Definition
1	+12V
2 and 3	Ground
4	+5V

G-7 Front Jumper Locations and Pin Definitions

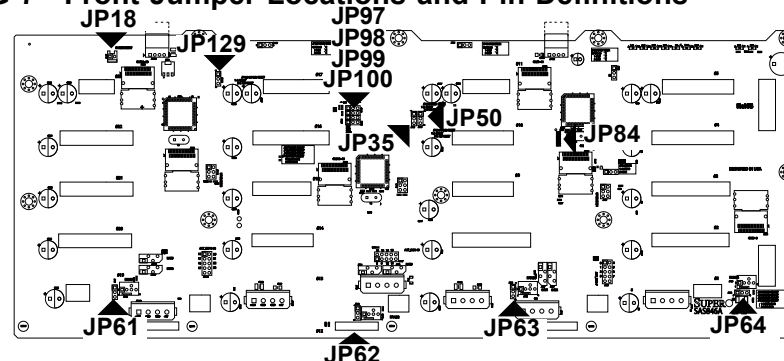
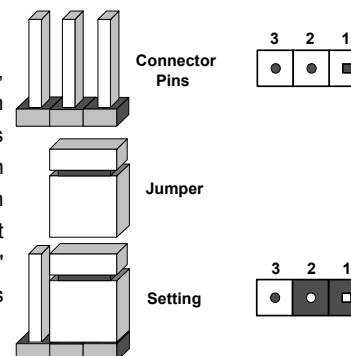

Figure G-2: Front Jumpers

Explanation of Jumpers

To modify the operation of the backplane, jumpers can be used to choose between optional settings. Jumpers create shorts between two pins to change the function of the connector. Pin 1 is identified with a square solder pad on the printed circuit board. Note: On two pin jumpers, "Closed" means the jumper is on and "Open" means the jumper is off the pins.



Jumper Settings		
Jumper	Jumper Setting	Notes
JP35	1-2: Reset 2-3: Default	MG9072 Chip Reset #1
JP50	1-2: Reset 2-3: Default	MG9072 Chip Reset #2
JP129	1-2: Reset 2-3: Default	MG9072 Chip Reset #3
JP18	1-2: Reset 2-3: Not reset (Default)	Buzzer disabled* Buzzer enabled*

*The buzzer sound indicates that a condition requiring immediate attention has occurred.

The buzzer alarm is triggered by the following conditions:

1. Hard drive failure
2. Fan failure
3. System temperature over 45° celcius.

Fan Jumper Settings

This backplane can use up to four fans. To utilize each fan, you must configure **both jumpers** as indicated below.

Fan Jumper Settings		
Jumper	Jumper Settings	Note
JP61	1-2:With Fan (Default) 2-3:No Fan	FAN#1
JP97	1-2:With Fan (Default) 2-3:No Fan	FAN#1
JP62	1-2:With Fan (Default) 2-3:No Fan	FAN#2
JP98	1-2:With Fan (Default) 2-3:No Fan	FAN#2
JP63	1-2:With Fan (Default) 2-3:No Fan	FAN#3
JP99	1-2:With Fan (Default) 2-3:No Fan	FAN#3
JP64	1-2:With Fan (Default) 2-3:No Fan	FAN#4
JP100	1-2:With Fan (Default) 2-3:No Fan	FAN#4

I²C and SGPIO Modes and Jumper Settings

This backplane can utilize I²C or SGPIO. SGPIO is the default mode and can be used without making changes to your jumper. The following information details which jumper must be configured to use SGPIO mode or restore your backplane to I²C mode.

SGPIO Setting (Default)		
Jumper	SGPIO Jumper Setting (Default)	I ² C Jumper Setting
JP84	1-2	2-3

Front LED Indicators

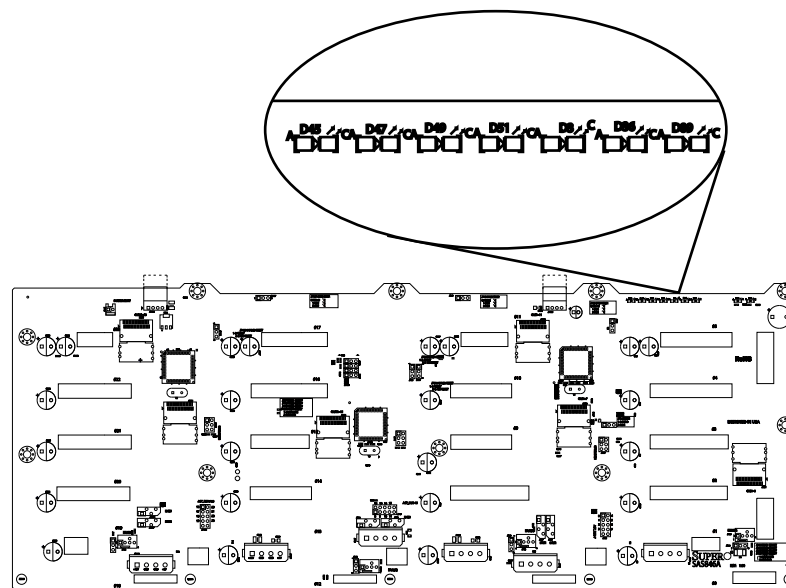

Figure G-3: Front LEDs

Front Panel LEDs		
LED	State	Specification
D45	On	Failure in Fan #1
D47	On	Failure in Fan #2
D49	On	Failure in Fan #3
D51	On	Failure in Fan #4
D3	On	Alarm #1: Overheat/Drive Failure in Channel 1
D36	On	Alarm #2: Overheat/Drive Failure in Channel 2
D89	On	Alarm #3: Overheat/Drive Failure in Channel 3
D53	Off	+5V : Backplane power failure. Light is on during normal operation.
D54	Off	+12V : Backplane power failure. Light is on during normal operation.

G-8 Rear Connectors and LED Indicators

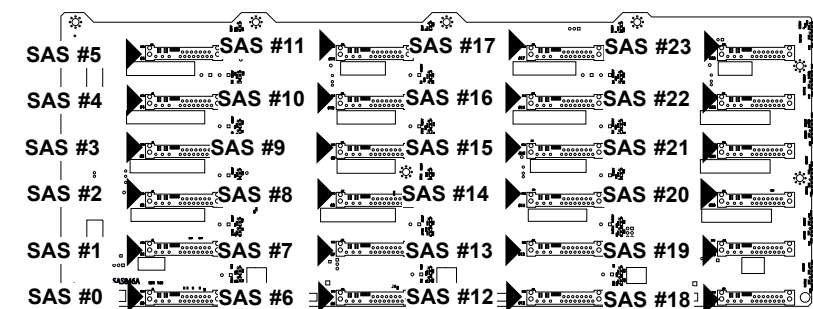
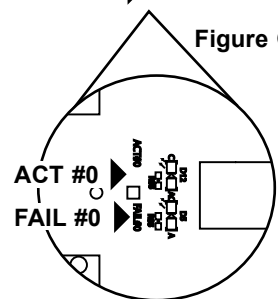

Figure G-4: Rear Connectors and LEDs



Rear SAS/SATA Connectors			
Rear Connector	SAS Drive Number	Rear Connector	SAS Drive Number
SAS #0	SAS/SATA HDD #1	SAS #12	SAS/SATA HDD #13
SAS #1	SAS/SATA HDD #2	SAS #13	SAS/SATA HDD #14
SAS #2	SAS/SATA HDD #3	SAS #14	SAS/SATA HDD #15
SAS #3	SAS/SATA HDD #4	SAS #15	SAS/SATA HDD #16
SAS #4	SAS/SATA HDD #5	SAS #16	SAS/SATA HDD #17
SAS #5	SAS/SATA HDD #6	SAS #17	SAS/SATA HDD #18
SAS #6	SAS/SATA HDD #7	SAS #18	SAS/SATA HDD #19
SAS #7	SAS/SATA HDD #8	SAS #19	SAS/SATA HDD #20
SAS #8	SAS/SATA HDD #9	SAS #20	SAS/SATA HDD #21
SAS #9	SAS/SATA HDD #10	SAS #21	SAS/SATA HDD #22
SAS #10	SAS/SATA HDD #11	SAS #22	SAS/SATA HDD #23
SAS #11	SAS/SATA HDD #12	SAS #23	SAS/SATA HDD #24

Rear LED Indicators		
Rear LED	Hard Drive Activity	Failure LED
SAS #0	D12	D5
SAS #1	D13	D6
SAS #2	D14	D7
SAS #3	D15	D8
SAS #4	D18	D19
SAS #5	D21	D20
SAS #6	D22	D23
SAS #7	D24	D29
SAS #8	D25	D30
SAS #9	D26	D31
SAS #10	D27	D32
SAS #11	D28	D33
SAS #12	D40	D37
SAS #13	D41	D38
SAS #14	D42	D39
SAS #15	D87	D88
SAS #16	D100	D103
SAS #17	D101	D105
SAS #18	D102	D107
SAS #19	D104	D108
SAS #20	D106	D109
SAS #21	D111	D110
SAS #22	D118	D119
SAS #23	D120	D121

Disclaimer (cont.)

The products sold by Supermicro are not intended for and will not be used in life support systems, medical equipment, nuclear facilities or systems, aircraft, aircraft devices, aircraft/emergency communication devices or other critical systems whose failure to perform be reasonably expected to result in significant injury or loss of life or catastrophic property damage. Accordingly, Supermicro disclaims any and all liability, and should buyer use or sell such products for use in such ultra-hazardous applications, it does so entirely at its own risk. Furthermore, buyer agrees to fully indemnify, defend and hold Supermicro harmless for and against any and all claims, demands, actions, litigation, and proceedings of any kind arising out of or related to such ultra-hazardous use or sale.