

Value IP Series Network Camera

2MP/5MP/8MP, H265, IR & WDR

User's Manual



EHN Series

EZN Series



Copyright © EverFocus Electronics Corp.
Release Date: May, 2019



Copyright © 1995-2019 EverFocus Electronics Corp.

Disclaimer

All the images including product pictures or screen shots in this document are for example only. The images may vary depending on the product and software version. Information contained in this document is subject to change without notice.

Copyright

All rights reserved. No part of the contents of this manual may be reproduced or transmitted in any form or by any means without written permission of the EverFocus Electronics Corporation.

EverFocus

2F., No.12, Ln. 270, Sec. 3, Beishen Rd., Shenkeng Dist.,

New Taipei City 222, Taiwan

TEL: +886 2 2662 2338

FAX: +886 2 2662 3632

www.everfocus.com.tw

About this document

All the safety and operating instructions should be read and followed before the unit is operated. This manual should be retained for future reference. The information in this manual was current when published. The manufacturer reserves the right to revise and improve its products. All specifications are therefore subject to change without notice.

Regulatory Notices

FCC Notice "Declaration of Conformity Information"

This equipment has been tested and found to comply with the limits for a Class A digital device, pursuant to part 15 of the FCC Rules. These limits are designed to provide reasonable protection against harmful interference in a residential installation. This equipment generates, uses and can radiate radio frequency energy and, if not installed and used in accordance with the instructions, may cause harmful interference to radio communications. However, there is no guarantee that interference will not occur in a particular installation. If this equipment does cause harmful interference to radio or television reception, which can be determined by turning the equipment off and on, the user is encouraged to try to correct the interference by one or more of the following measures:

- Reorient or relocate the receiving antenna.
- Increase the separation between the equipment and receiver.
- Connect the equipment into an outlet on a circuit different from that to which the receiver is connected.
- Consult the dealer or an experienced radio/TV technician for help.

Warning: Changes or modifications made to this equipment, not expressly approved by EverFocus or parties authorized by EverFocus could void the user's authority to operate the equipment.

This device complies with part 15 of the FCC Rules. Operation is subject to the following two conditions:

- (1) This device may not cause harmful interference, and
- (2) This device must accept any interference received, including interference that may cause undesired operation.

Value IP Series camera complies with CE and FCC.

Precautions

Do not install the camera near electric or magnetic fields.

Install the camera away from TV/radio transmitters, magnets, electric motors, transformers and audio speakers since the electromagnetic fields generated from these devices may distort the video image or otherwise interfere with camera operation.

Never disassemble the camera beyond the recommendations in this manual nor introduce materials other than those recommended herein.

Improper disassembly or introduction of corrosive materials may result in equipment failure or other damage.

Try to avoid facing the camera toward the sun.

In some circumstances, direct sunlight may cause permanent damage to the sensor and/or internal circuits, as well as creating unbalanced illumination beyond the capability of the camera to compensate.

1. Keep the power cord away from water and other liquids and never touch the power cord with wet hands.

Touching a wet power cord with your hands or touching the power cord with wet hands may result in electric shock.

2. Never install the camera in areas exposed to oil, gas or solvents.

Oil, gas or solvents may result in equipment failure, electric shock or, in extreme cases, fire.

3. Cleaning

For cameras with interchangeable lenses, do not touch the surface of the sensor directly with the hands. Use lens tissue or a cotton tipped applicator and ethanol to clean the sensor and the camera lens. Use a damp soft cloth to remove any dirt from the camera body. Please do not use complex solvents, corrosive or abrasive agents for cleaning of any part of the camera.

4. Do not operate the camera beyond the specified temperature, humidity or power source ratings.

Use the camera at temperatures within $-30^{\circ}\text{C} \sim 55^{\circ}\text{C}$ / $-22^{\circ}\text{F} \sim 131^{\circ}\text{F}$, and humidity $\leq 95\%$; this device is not rated as submersible. The input power source is 12VDC / PoE. Be sure to connect the proper + / - polarity and voltage, as incorrect polarity or too high a voltage will likely cause the camera to fail, and such damage is not covered by the warranty. The use of properly fused or Class 3 power limited type supplies is highly recommended.

5. Mounting

Use care in selecting a solid mounting surface which will support the weight of the camera plus any wind, snow, ice or other loading, and securely attach the camera to the mounting surface using screws and anchors which will properly support the camera. If necessary (e.g. when mounting to drop ceilings) use a safety wire to provide additional support for the camera.

CONTENTS_Toc3288504

1. Introduction	1
1.1 System Requirement.....	2
1.2 Features	2
1.3 Packing List.....	3
2 Physical Description	4
2.1 Dimensions	5
2.2 Cables.....	5
3 Installation	7
3.1 EHN Series.....	7
3.2 EZN Series	9
4 Accessing the Camera	10
4.1 Checking the Dynamic IP Address	10
4.2 Settings for Microsoft Internet Explorer.....	12
4.3 Connecting the Camera to the Network.....	13
5 Live View Window	15
5.1 Playback.....	16
5.1.1 Playback Panel	17
5.1.2 Download.....	18
5.2 Display Setting	19
5.2.1 Live.....	19
5.2.2 Image	20
5.2.2.1 Hallway Display.....	22
5.2.3 Privacy Mask.....	23
5.2.4 Audio.....	24
5.2.5 ROI	25
5.3 Record.....	26
5.3.1 Record Setting.....	26
5.3.2 Record Schedule	27
5.4 Alarm Setting	28
5.4.1 Motion	28
5.4.2 I/O.....	29
5.4.3 Tamper Alarm	30
5.4.4 Sound Detection	31
5.5 Network Setting.....	32

5.5.1	Network	32
5.5.2	Video Streaming	34
5.5.3	Email	35
5.5.4	DDNS.....	36
5.5.5	IP Filter.....	37
5.5.6	RTSP	38
5.5.7	FTP	39
5.5.8	SNMP	40
5.5.9	HTTPS.....	40
5.6	Storage Setting.....	41
5.6.1	Storage.....	41
5.6.2	Cloud Storage.....	42
5.7	System Setting	44
5.7.1	General	44
5.7.2	User Account	46
5.7.3	Firmware Upgrade	48
5.7.4	Load Default.....	48
5.7.5	System Reboot.....	49
5.7.6	Import and Export	49
5.7.7	Local Settings.....	50
5.7.8	Log	51
5.7.9	Info.....	52
	5.7.9.1 Performing the P2P Function	52
5.8	Intelligent Setting.....	55
5.8.1	Record Schedule	55
5.8.2	Detection	56
	5.8.2.1 Perimeter Intrusion Detection.....	56
	5.8.2.2 Line-Crossing Detection.....	58
	5.8.2.3 Object Detection	60
	5.8.2.4 Pedestrian Detection	62
	5.8.2.5 Face Detection	64
	5.8.2.6 Cross-Counting Detection.....	66
5.8.3	Analysis	68
5.9	Color Setting	69
5.10	Lens Control	70
5.11	Live View Function Icons.....	71

1. Introduction

The Value IP series H.265 Outdoor IP camera provides 30fps at 2MP / 5MP / 8MP (4K) viewing resolution. The series supports triple streams from H.265 or H.264 video compression formats. In same resolution, the H.265 provides higher compression efficiency and lower bitrate comparing with H.264 codec, allowing more efficient bandwidth and data storage usage. The Wide Dynamic Range function on the other hand enables the IP camera to provide clear images even under back light circumstances where intensity of illumination can vary excessively.

The motorized zoom lens models can provide the desired field of view with superior video quality in precise focus. Equipped with an IP66 weather-proof housing, the Value IP series meets a wide variety of needs for outdoor surveillance. Except 12VDC power supply, the series also supports Power over Ethernet (IEEE 802.3af), which eliminates the need for power cables and thus reduce the installation costs.

The Value IP series conforms to ONVIF for compatibility with other network video devices. You can also use EverFocus Mobile applications to remotely view the live views of the cameras through your iOS or android handheld devices; or use EverFocus CMS to remotely manage multiple IP devices connected on the network.

Series	2MP	5MP	8MP
EHN Series	EHN1250	EHN2550	EHN2850 / EHN2850-15
EZN Series	EZN1250 / EZN1240	EZN2550 / EZN2540	EZN2850 / EZN2850-15 / EZN2840 / EZN2840-15

Lens Type	Models
2.8~12mm motorized lens	EHN1250 / EHN2550 EZN1250 / EZN2550
3.3~12mm motorized lens	EHN2850 / EHN2850-15 EZN2850 / EZN2850-15
3.6mm fixed lens	EZN1240 / EZN2540 / EZN2840 / EZN2840-15

For more information on the product specifications, please refer to the datasheet of each product. To download datasheet, please click **Download** on each Product page on EverFocus Website

www.everfocus.com.tw

1.1 System Requirement

Before installing, please check that your computer meets the following system requirements.

- Operating System:
 - 32/64-bit: Windows 7, Windows 8, Windows 2008
 - 32-bit: Windows 2003, Window XP, Windows 2000
- CPU: Intel Core Duo II dual-core processor or higher
- Memory: 1G or more Video memory: 256M or more
- Display: 1024 × 768 or higher resolution
- IE: IE 6.0 or higher version

Note: For using the Internet Explorer, some settings are required. Please refer to *4.2 Settings for Microsoft Internet Explorer*.

1.2 Features

- Progressive Scan CMOS sensor
- Equipped with 2.8~12mm motorized lens or 3.6mm fixed lens (depends on model)
- Triple-streaming from H.265 / H.264
- Supports Wide Dynamic Range
- Provides True Day/Night functionality with automatic IR filter operation
- Equipped with IR LEDs
- Supports video analytics
- Supports ONVIF (V17.06, Profile S, Profile G)
- Weather-proof IP66 rated
- Supports micro SD card slot
- Supports live monitoring via mobile Apps (iOS & Android)
- Supports PoE and 12VDC

1.3 Packing List

Please check that there is no missing item in the package before installing.

EHN Series	EZN Series
1. Camera x 1	1. Camera x 1
2. MAC Address Sticker x 2	2. MAC Address Sticker x 2
3. Cable Gland Kit x 1	3. Cable Gland Kit x 1
4. Screw x 4	4. Screw x 3
5. Screw Anchor x 4	5. Screw Anchor x 3
6. Desiccant Bag x 1	6. Hexagon Wrench x 1
7. Torx Wrench x 1	7. Quick Installation Guide x 1
8. Mounting Sticker x 1	8. Software CD x 1
9. Quick Installation Guide x 1	
10. Software CD x 1	

Note:

1. Equipment configurations and supplied accessories vary by country. Please consult your local EverFocus office or agents for more information. Please also keep the shipping carton for possible future use.
2. Contact the shipper if any items appear to have been damaged in the shipping process.

Optional Accessory

You can go to the product page on EverFocus' website to check the related optional accessories. Please click **Accessories** on each Product page on EverFocus Website www.everfocus.com.tw

2 Physical Description

EHN Series

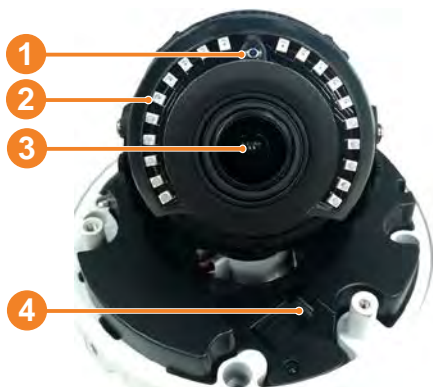

SD Card Slot on
EHN 2MP/5MP Series

EZN Series



No.	Item Name	Descriptions
1	Light Sensor	Detects lights.
2	IR LEDs	IR LEDs for infrared illumination in night vision applications.
3	Lens	Camera Lens.
4	Micro SD Card Slot (for 8MP models)	Insert a micro SD card. Please go to the product page on EverFocus website to see the latest Storage Compatibility List. http://www.everfocus.com.tw
5	Micro SD Card Slot (for 2MP/5MP models)	Insert a micro SD card. Please go to the product page on EverFocus website to see the latest Storage Compatibility List. http://www.everfocus.com.tw
6	Micro SD Card Slot	Insert a micro SD card. Please go to the product page on EverFocus website to see the latest Storage Compatibility List. http://www.everfocus.com.tw
7	Sunshield	Protect the camera from the direct sun rays.
8	Rotate Screw	Loosen the Rotate Screws (on both sides) to adjust the rotating angle.
9	Tilt Screw	Loosen the Tilt Screw to adjust the tilting angle.
10	Pan Screw	Loosen the Pan Screw to adjust the angle.

2.1 Dimensions

EHN Series

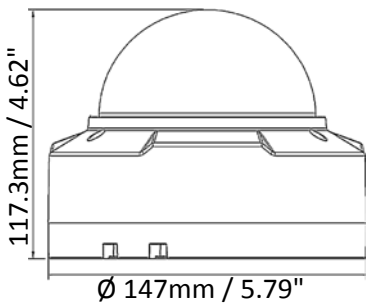

EZN Series

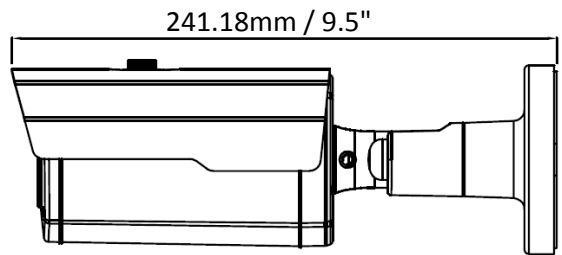
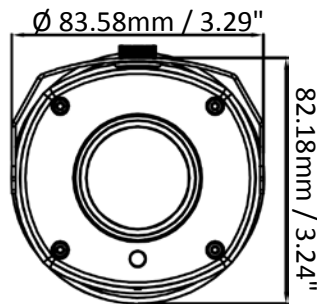

2.2 Cables

The cables provide connections for network, BNC video output, power, audio input / output and alarm input / output. A Reset Button Cable is also provided. Please be noted that microphones / speakers with a (built-in) amplifier and external power supply are required.

EHN Series

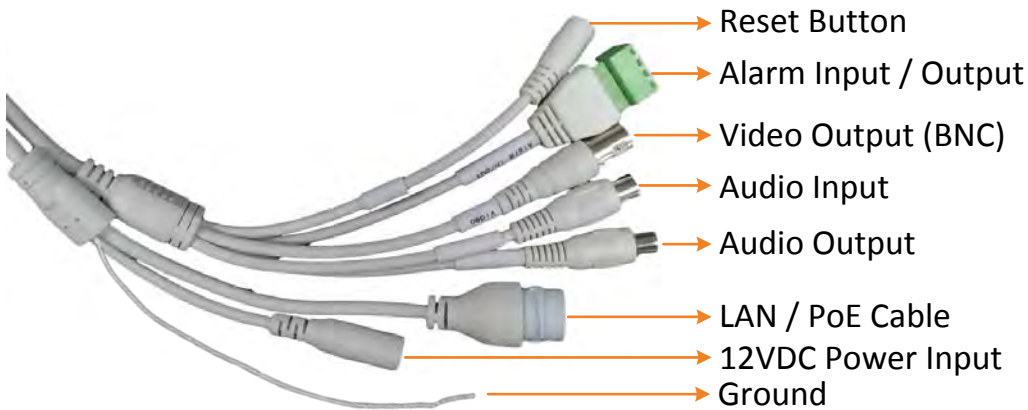

EZN Series

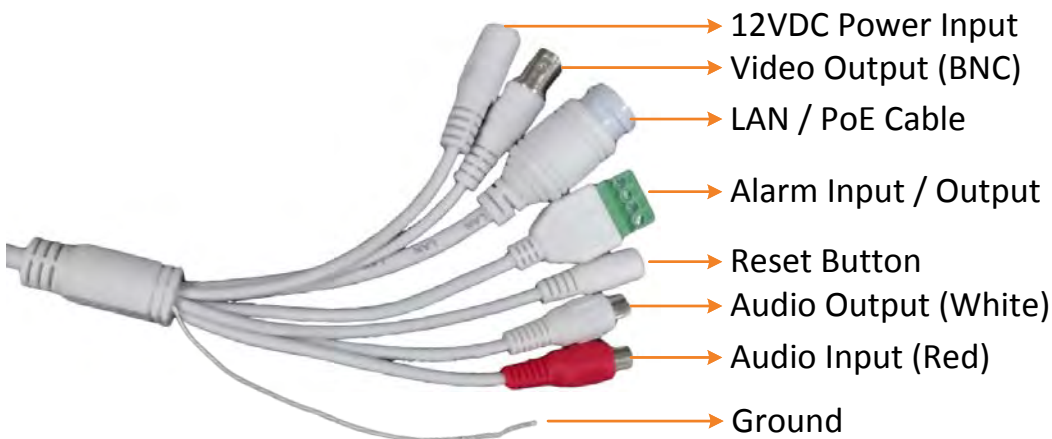

Note: To activate Audio function, the **Audio** function must be enabled please refer to 5.5.2 *Video Streaming*.

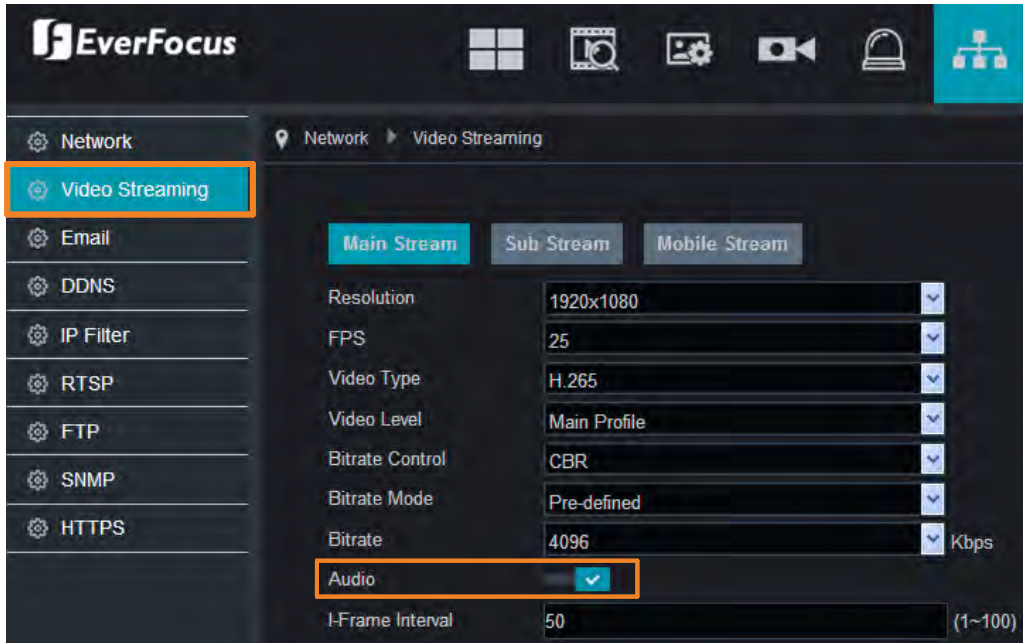

Alarm IO PIN Assignment



- 1 Alarm In
- 2 GND
- 3 COM
- 4 Alarm Out

Reset Button

The **Reset Button** can be used to restore the camera to factory default. When the camera is powered up, press the **Reset Button** about 8 seconds to reboot the camera.

3 Installation

3.1 EHN Series

1. Stick the supplied **Mounting Sticker** on the surface to mark the 4 screw positions. Drill the 4 screw-depth holes on the surface and then push the supplied 4 **Screw Anchors** into the screw holes. Optionally drill the bottom 2 Cable Holes if you want to run the cables through the surface.

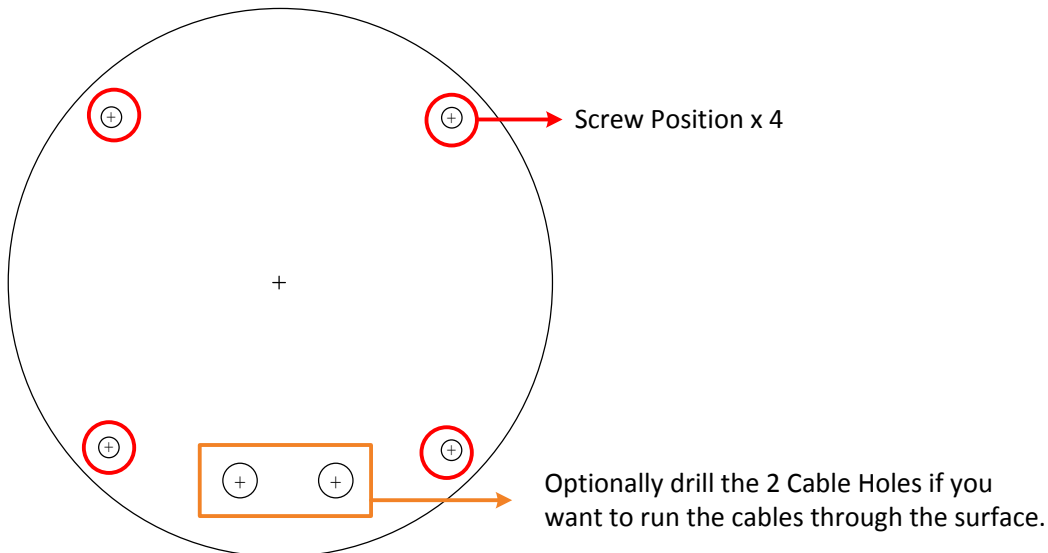

2. Remove the camera cover by unscrewing the 3 cover screws using the supplied **Torx Wrench** (Left Image). Screw the camera base to the surface using the supplied 4 **Screws** (Right Image).



3. Optionally insert a micro SD card into the card slot (please refer to 2. *Physical Description*).
4. Adjust the pan / tilt / rotate angles of the camera.
5. Connect the camera to power. You can either connect the camera to a 12VDC power source or to a PoE switch using the PoE cable.

6. Connect the camera to the network using the supplied **Cable Gland Kit**.

- a. Insert a RJ-45 network cable (without the RJ-45 connector on the one end) through the supplied **Waterproof Ring, Cable Gland, Stopper** and **Screw Cap** accordingly.

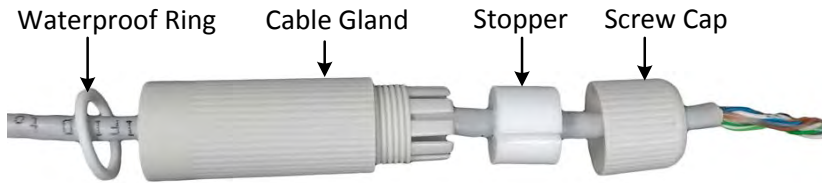

- b. Connect the RJ-45 cable to the **LAN/PoE Cable** of the camera.

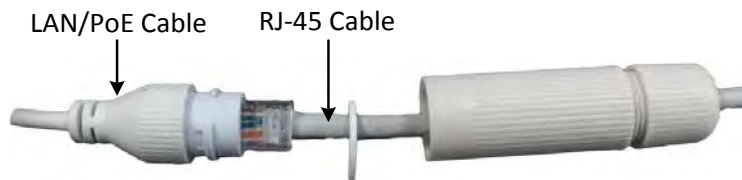

- c. Tightly screw the **Cable Gland** and **Screw Cap** to the Rugged RJ-45 Connector Cable.

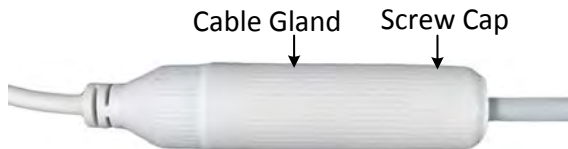

- d. Crimp the RJ-45 connector onto the RJ-45 network cable. Note that the wires should be placed into the RJ-45 connector based on the following order (from left to right).

- Orange with white stripe
- Orange
- Green with white stripe
- Blue
- Blue with white stripe
- Green
- Brown with white stripe
- Brown



7. Before screwing back the camera cover, remove the 3 old desiccant bags from the inside of Camera Cover and replace them with the supplied Desiccant Bag. Screw the camera cover back to the camera.

Remove the 3 desiccant bags



Stick the supplied desiccant bag



Note: Please screw back the Camera Cover immediately in case of reducing the absorption capacity of the desiccant bag inside the camera body.

8. Now you can access the camera live view. See 4. *Accessing the Camera*.

3.2 EZN Series

- 1 Optionally insert a micro SD card into the card slot on the rear panel of the camera. To do this, unscrew the 2 screw, remove the SD card slot cover and then insert the micro SD card.



- 2 Drill three holes on the surface according to the screw positions on the Camera Base. Push the supplied 3 **Screw Anchors** into the holes. Drill another hole in the middle within the 3 screw holes if you wish to run the wires into the surface. Screw the camera to surface using the supplied 3 **Screws**.

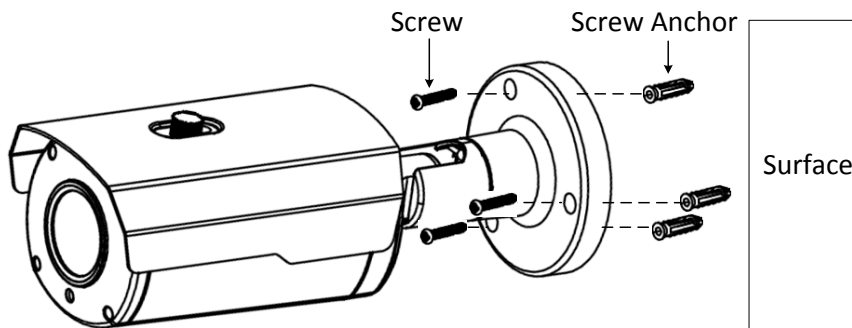

- 3 Adjust the pan/tilt/rotate angles of the camera by loosen the Pan/Tilt/Rotate screws using the supplied **Hexagon Wrench**.

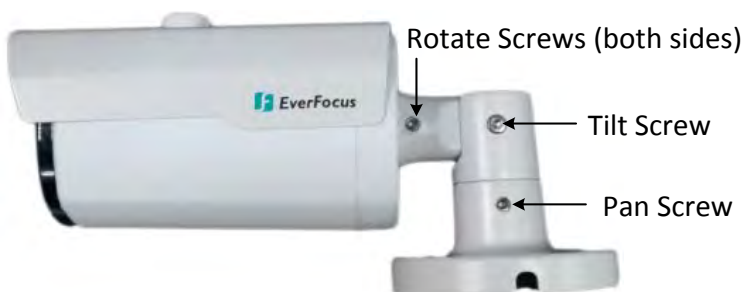

- 4 Connect the camera to power. You can either connect the camera to a 12VDC power source or to a PoE switch using the PoE cable.
- 5 Connect the camera to the network using the supplied **Cable Gland Kit**. Please refer to **Step 6** in 3.1 *EHN Series*.
- 6 Now you can access the camera live view. See 4. *Accessing the Camera*.

4 Accessing the Camera

This section explains how to access the Web interface of the camera for configuration.

4.1 Checking the Dynamic IP Address

You can look up the IP address of the IP camera using the **IP Utility (IPU)** program, which is included in the Software CD. The IP Utility can also be downloaded from EverFocus' Website (Support > Download > Keyword Search: IP Utility): <http://www.everfocus.com.tw/download/>

Please connect the IP camera on the same LAN of your computer.

1. Save **IP Utility Setup .exe**  in your computer. Double click the .exe file and follow the on-screen instructions to install the IP Utility.



2. Click the **Finish** button, the IP Utility will be automatically launched to search the IP devices connected on the same LAN.

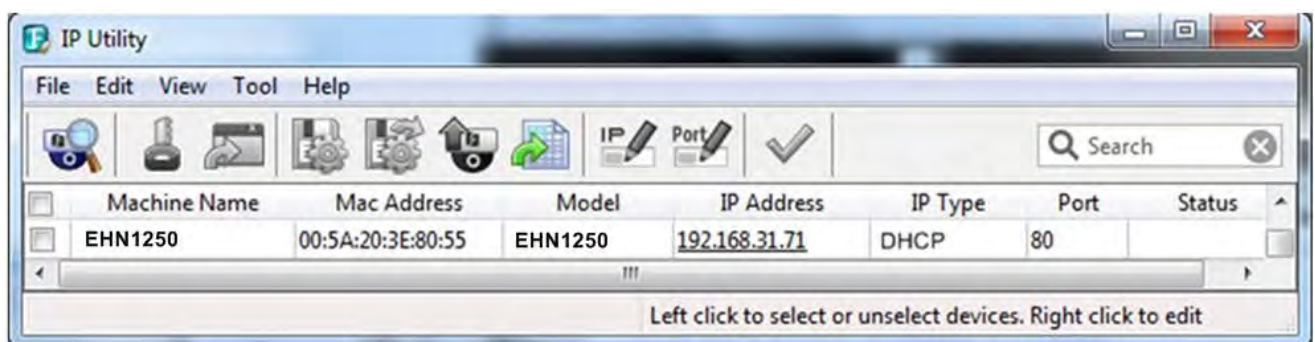

Note: The default IP mode of the IP camera is DHCP. However, if there is no dynamic IP address assigned to the device, its IP will switch to **192.168.0.10**

- To access the Live View window, double click the IP address in the **IP Address** column, the Password window pops up. By default, the ID is **admin** and there is no password. Please input a password for the first-time login. Click the **OK** button, the Login window appears. Input the password and then click **Login**, the Live View window appears.

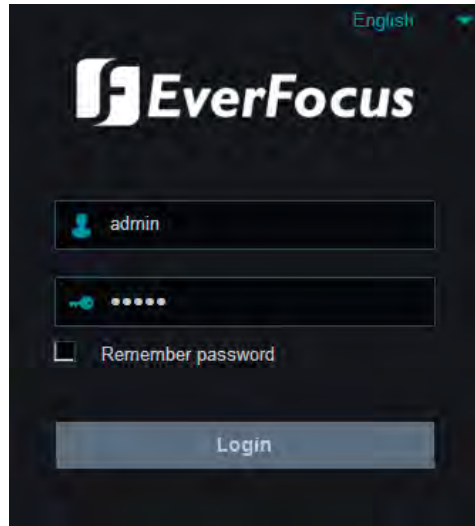
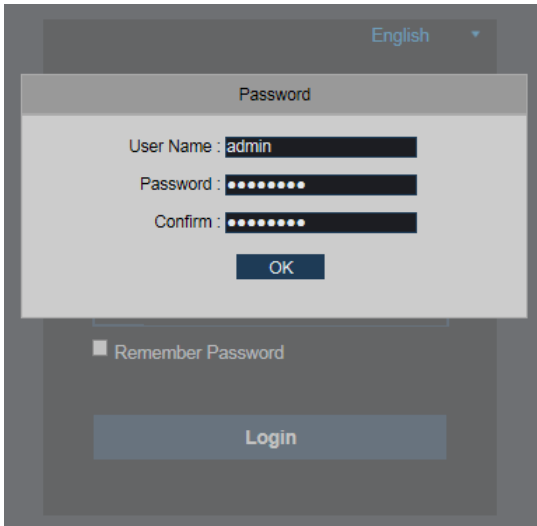

Note for the first time login:

- ◆ When the Plug-in block appears on the browser, click **download** to install the plug-in. Reload the webpage and you should see the live view page now.

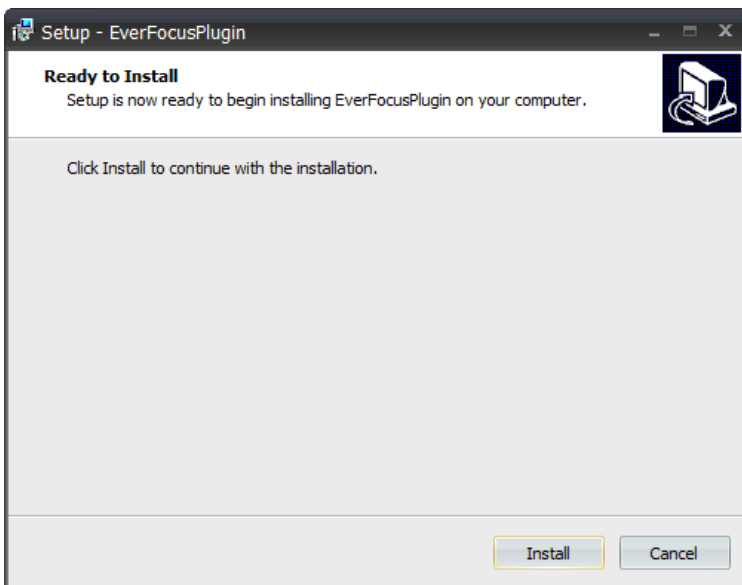

4.2 Settings for Microsoft Internet Explorer

If you have difficulties viewing live view or upgrading firmware, it is suggested to complete the following settings of your computer.

1. If your PC or laptop is running with Windows, it's required to run the browser as administrator when first entering the camera live view. Go to **C:\Program Files (x86)\Internet Explorer**, right-click the browser and then click **Run as administrator**.

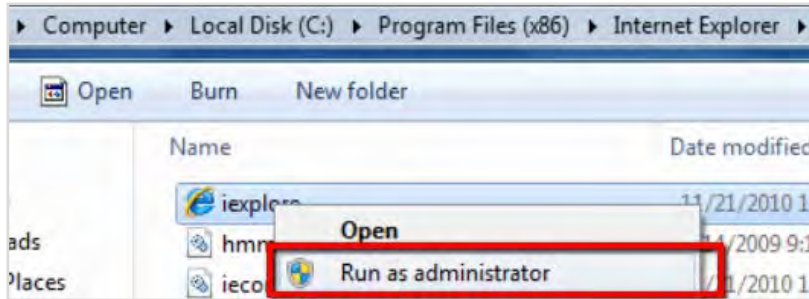

2. You may need to turn off the firewall and turn **User Account Control** off if you still can't see the camera Live View.

To turn **User Account Control** off, on the computer, click **Start > Control Panel > System and Security > Action Center** (click Change User Account Control Settings), the **User Account Control Settings** window appears. Adjust the slide bar to **Never Notify** and then click **OK**. Restart your computer if requested.

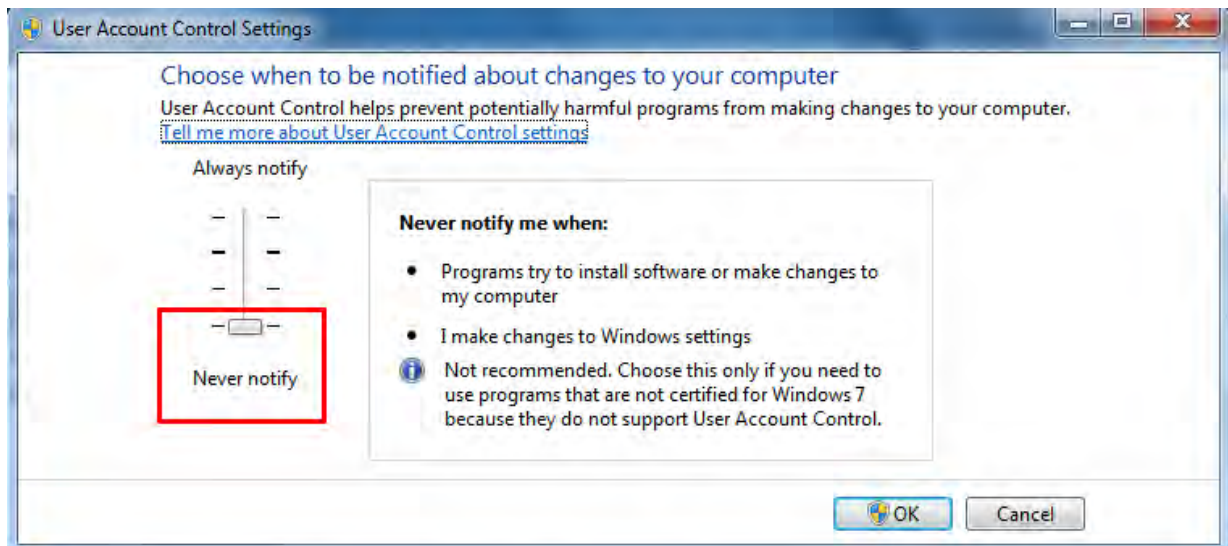

4.3 Connecting the Camera to the Network

There are three methods to connect the IP camera to the network: **Router or LAN Connection**, **One-to-One Connection** and **Direct High-Speed Connection**.

Router or LAN connection

This is the most common connection in which the IP camera is connected to a router and allows multiple users on and off site to see the IP camera on a LAN / WAN (Internet). The camera must be assigned an IP address that is compatible with its LAN. By setting up port forwarding on the router, you can remotely access the cameras from outside of the LAN via the Internet.

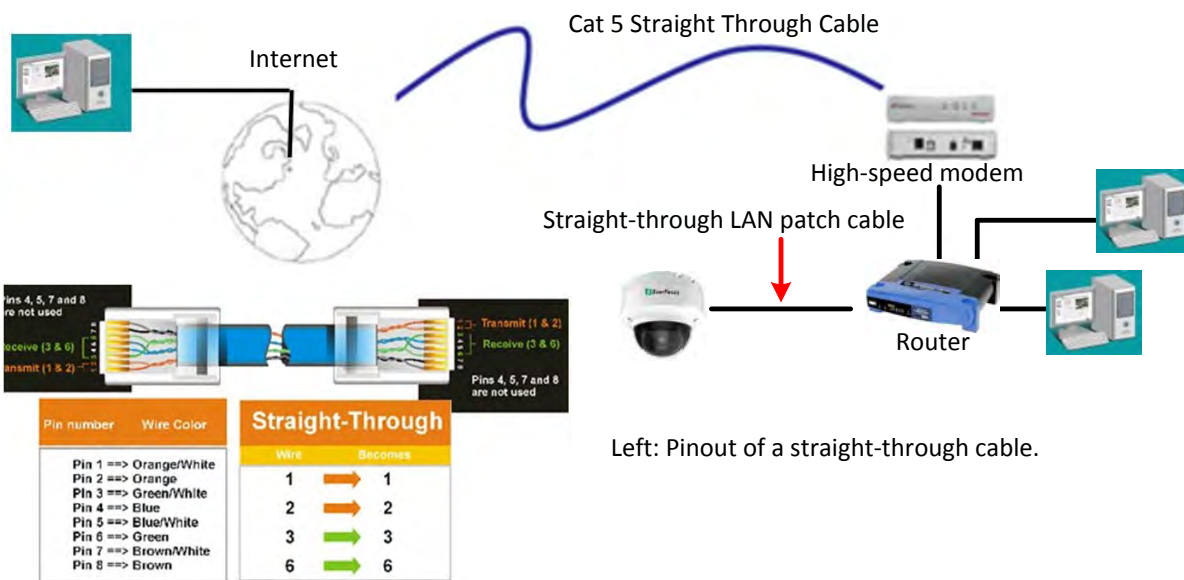

One-to-One Connection (Directly from PC to IP Camera)

You can connect directly without using a switch, router or modem. However, only the PC connected to the camera will be able to view the IP camera. You will also have to manually assign a compatible IP address to both the computer and the IP camera. Unless the PC has another network connection, the IP camera will be the only network device visible to the PC. See the diagram below:

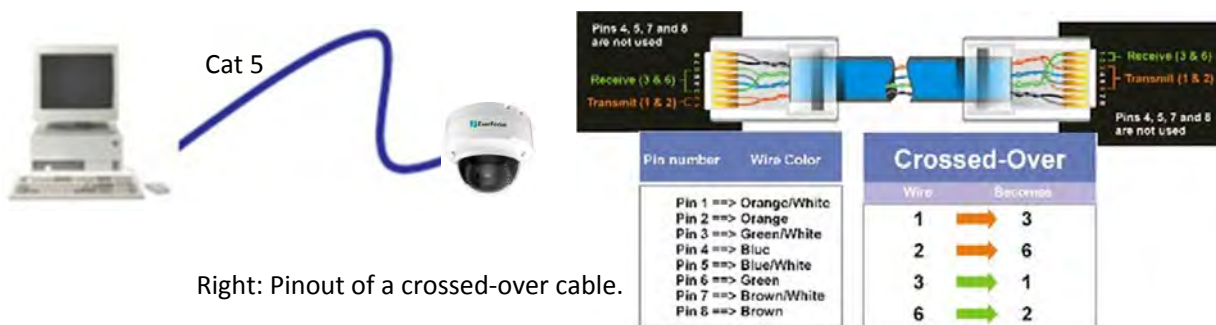

Direct High-Speed Connection

In a Direct High-Speed Connection, the camera connects directly to a modem without the need for a router. You need to set the static or dynamic WAN IP address assigned by your ISP (Internet Service Provider) in the camera's configuration web pages. To access the camera, just type "http://xxx.xxx.xxx.xxx", where xxx.xxx.xxx.xxx is the IP address given by your ISP. If you have a dynamic IP address, this connection may require that you use DDNS for a reliable connection.



5 Live View Window

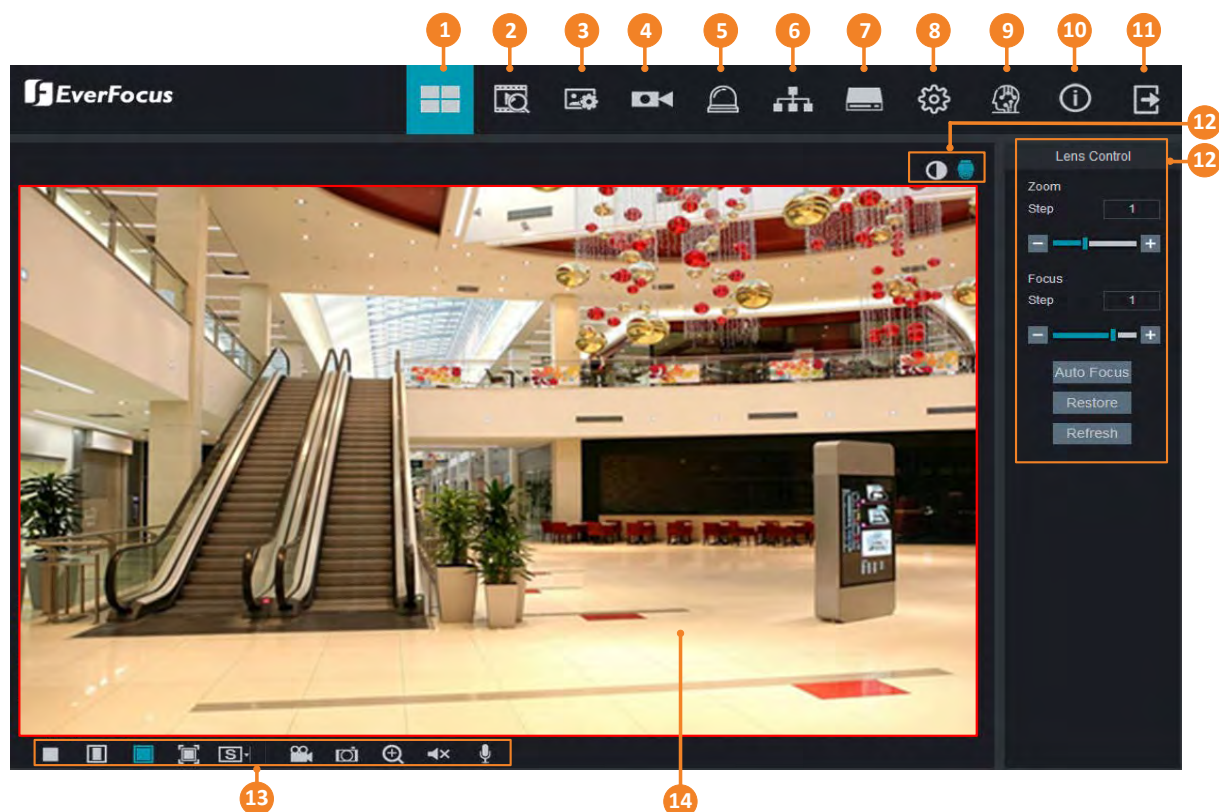

No.	Name	Description
1	Live	Click to display the Live View window.
2	Playback	Click to enter the Playback page. Please refer to 5.1 Playback.
3	Display	Click to enter the Display setting page. Please refer to 5.2 Display Setting.
4	Record	Click to enter the Record setting page. Please refer to 5.3 Record.
5	Alarm	Click to enter the Alarm setting page. Please refer to 5.4 Alarm Setting.
6	Network	Click to enter the Network setting page. Please refer to 5.5 Network Setting.
7	Storage	Click to enter the Storage Device setting page. Please refer to 5.6 Storage Setting.
8	System	Click to enter the System setting page. Please refer to 5.7 System Setting.
9	Intelligent	Click to enter the Intelligent setting page. Please refer to 5.8 Intelligent Setting.
10	Login Info	Move the mouse cursor over this icon to display the Login information.
11	Logout	Click to logout the IP camera.
12	Color Setting / Lens Control	Click the buttons to display the setup panel. Please refer to 5.9 Color Setting and 5.10 Lens Control.
13	Live View Function Icons	You can perform some functions on the Live View using these icons. Please refer to 5.11 Live View Function Icons.
14	Live View Window	Displays the IP camera live view. You can double click on the Live View window to full screen. Double click on the Live View can exit full screen.

5.1 Playback

Click the **Playback** button on the top navigation bar. The Playback window displays. You can play back the recordings stored in the on-camera micro SD card.

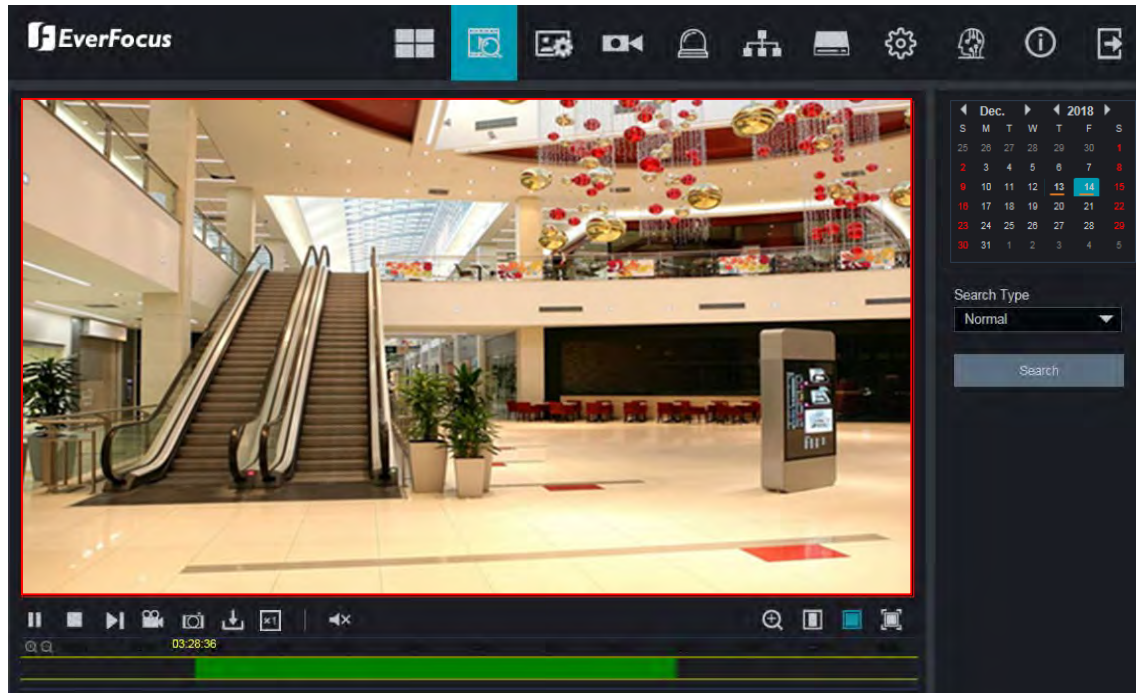



To start playing back:

1. Select the date on the calendar (the date with an orange bar on the bottom indicates there are recordings on the date).
2. Select the desired recording type(s) from the **Search Type** drop-down list.
3. Click the **Search** button, the recordings will be displayed on the time bar in different colors.
Green: Normal recordings; Yellow: Motion recordings; Blue: Intelligent recordings; Red: IO; Purple: Sound Detection recordings.
4. Click the **Play** button to start playing back.

5.1.1 Playback Panel

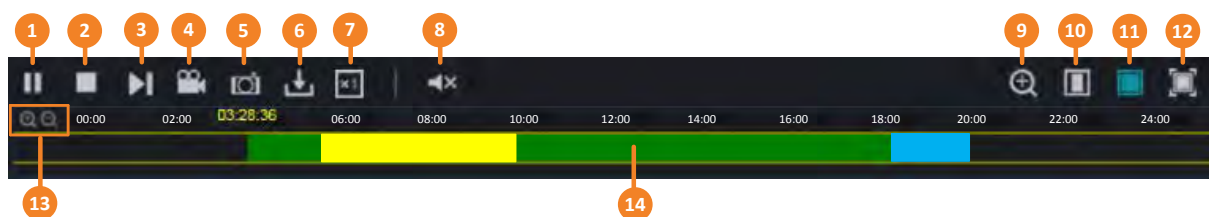
You can use the **Playback Panel** to operate the below functions:

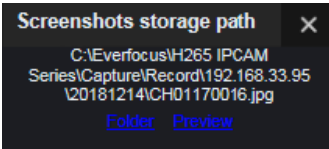

No.	Name	Description
1	Play/Pause	Click to Play or Pause playing back.
2	Stop	Click to Stop playing back.
3	Step Forward	Click the button to play the recording frame by frame.
4	Video Clips	<p>During the playback process, you can click the Video Clips button to start recording from the clicked time, click the button again to stop recording, a message window appears on the bottom-left corner of the screen. Click Folder to open the folder to find the recording file. To change the manual record storage path or the file format, please refer to <i>5.7.7 Local Settings</i>. You can use EverFocus Player or any player supporting the video format to play back the recordings. EverFocus Player is included in the Software CD.</p> 
5	Snapshot	<p>Click to take a snapshot, a message window appears on the bottom-left corner of the screen. Click Folder to open the folder to find the snapshot image. Or click Preview to preview the snapshot image. To change the storage path or image format, please refer to <i>5.7.7 Local Settings</i>.</p> 
6	Download	Click to download recordings. To perform the Download function, please refer to <i>5.1.2 Download</i> .
7	Speed	Click to select a playback speed.
8	Audio	Click to switch on/off the speaker. You can also adjust the volume.
9	Digital Zoom	<p>Click to enable the Digital Zoom mode. To exit the Digital Zoom mode, click the button again. To perform the Digital Zoom function:</p> <ol style="list-style-type: none"> Click the Digital Zoom button to enable the function. Use your mouse to draw an area where you want to have a close-up view on the stream. The area will be zoom-in. Right-click to exit the Digital Zoom mode.

10	Original Aspect Ratio	Click to play back all the streams with original aspect ratio.
11	Stretch	Click to stretch all the streams on the Playback window.
12	Full Screen	Click to display the Playback window in full screen mode. To exit full screen mode, press the ESC button on the keyboard or double-click on the screen.
13	Time Span Buttons	You can adjust the time span on the Time Bar by clicking the buttons.
14	Time Bar	Single-click on the time bar at a certain time will start playing back from the clicked time. The colors on the time bar represent different recording types. <u>Green</u> : Normal recordings; <u>Yellow</u> : Motion recordings; <u>Blue</u> : Intelligent recordings; <u>Red</u> : IO; <u>Purple</u> : Sound Detection recordings.

5.1.2 Download

You can download the recordings on the Playback window.

1. Click the **Download** button, the corresponding recordings will be displayed.

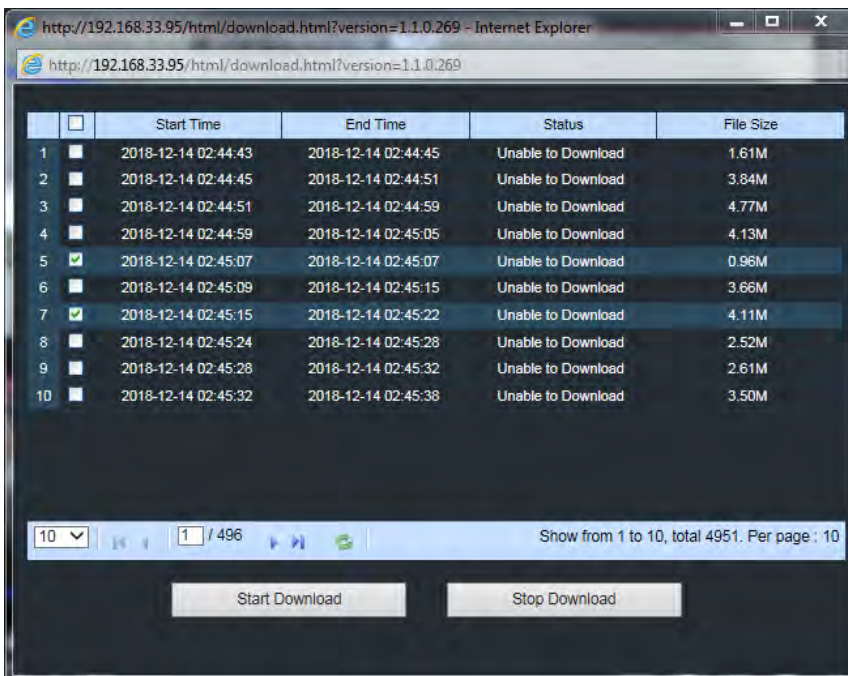

2. Select the desired recordings you want to download, and then click **Start Download**. To change the storage path or the file format, please refer to *5.7.7 Local Settings*.

5.2 Display Setting

Click the **Display** button on the top navigation bar to enter the Display Setting page.

5.2.1 Live

You can configure the live display settings on this page.

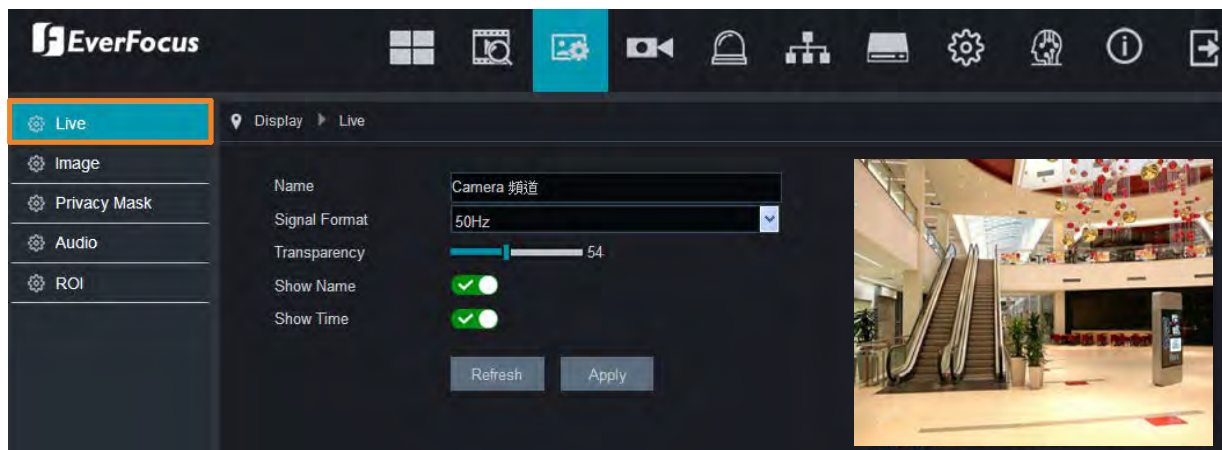

Name: Input a camera name. Alphabetic, numeric and Chinese characters are supported.

Signal Format: Select a signal format from 60Hz or 50Hz.

Transparency: Adjust the transparency of the text (time or camera name) overlay displayed on the stream.

Show Name: Switch the button to the right to enable displaying camera name on the stream.

Show Time: Switch the button to the right to enable displaying system time on the stream.

Click **Refresh** to refresh the page; click **Apply** to save the settings.

5.2.2 Image

You can configure the image settings on this page.

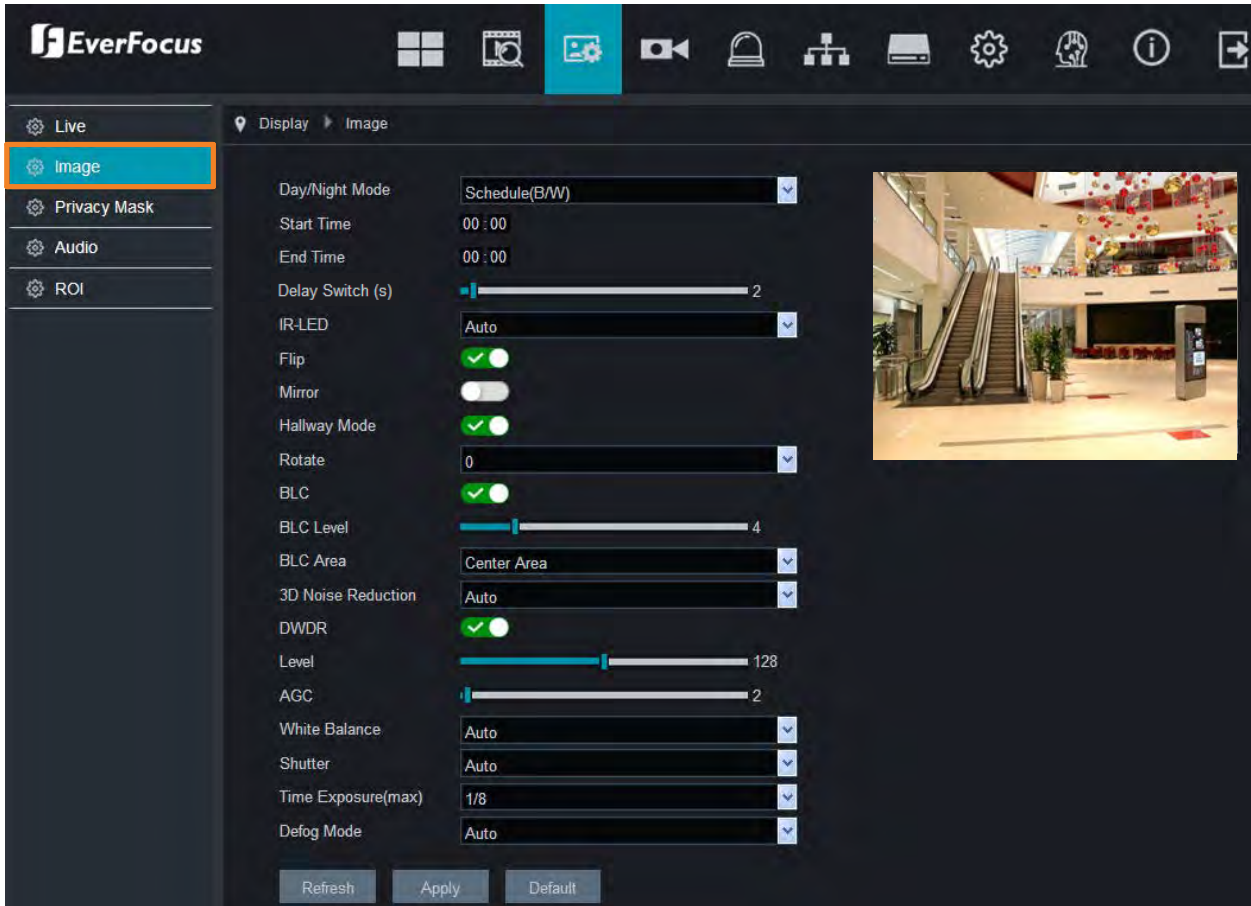

Day/Night Mode: Select a Day/Night mode for the camera to display the color or B/W images.

- **Auto:** Select Auto for the camera to automatically switch to day or night mode. You can further set up a **Delay Switch** time (second) in the below field.
- **Color Mode:** Select Color Mode for the camera to display color images.
- **Black White Mode:** Select Black White Mode for the camera to display B/W images.
- **Schedule (B/W):** Select Schedule (B/W) for the camera to display B/W images during the setup time range. Please select the **Start Time** and **End Time** in the below field.

Delay Switch (s): This function can only be activated if you select **Auto** for the **Day/Night Mode**. Set up a delay switch time (seconds) for the camera to auto switch between day and night modes.

IR-LED: Select **On** to turn on IR LEDs; select **Off** to turn off IR-LED; select **Auto** for the camera to automatically turn on / off the IR-LED based on the light sensor on the IP camera.

Flip: Switch the button to the right to enable the Flip function. The image will be rotated vertically around a horizontal axis.

Mirror: Switch the button to the right to enable the Mirror function. The image will be rotated horizontally around a vertical axis.

Hallway Mode: Switch the button to the right to enable the Hallway Mode function. This function allows users to monitor vertically-oriented areas such as hallway, corridors and aisles. Please refer to *5.2.2.1 Hallway Display* for more details.

Rotate: Select 0 to rotate the camera view by 0 degree; select 180 to rotate the camera view by 180 degree.

BLC: Switch the button to the right to enable the BLC (Backlight Compensation) function.

BLC Level: Adjust the level for the BLC function.

BLC Area: Select an area to apply the BLC function.

3D Noise Reduction: Select Auto to

- **Auto:** Select Auto for the camera to automatically turn on the 3DNR function.
- **Manual:** Select to turn on the 3DNR function based on the setup **Level**.
- **Disable:** Select to disable the 3DNR function.

DWDR: Switch the button to the right to enable the DWDR function and then you will have to adjust a **Level** for the DWDR function.

AGC: If you select **Manual** in the Shutter field, set up the AGC for the camera. The lower the AGC level, the lower the video signal and the noise.

White Balance:

- **Auto:** Select for the camera to automatically adjust the white balance.
- **Manual:** Select to adjust the Red, Green, Blue values yourself.
- **Indoor:** Select Indoor if your camera is installed in an indoor environment.

Shutter:

- **Auto:** Select for the camera to automatically adjust the Shutter.
- **Manual:** Select to manually adjust the shutter speed. Select a speed in the **Time Exposure** field. Also set up the **AGC** in the AGC field above.

Time Exposure: If you select **Auto** in the Shutter field, the camera will automatically apply a max. shutter speed. If you select **Manual** in the Shutter field, select a shutter speed from the drop-down list.

Defog Mode:

- **Auto:** Select Auto for the camera to automatically turn on the Defog function.
- **Manual:** Select to turn on the Defog function based on the setup Level.
- **Disable:** Select to disable the Defog function.

Click **Refresh** to refresh the page; click **Apply** to save the settings; click **Default** to restore to the default settings.

5.2.2.1 Hallway Display

Hallway Display (9:16) allows users to monitor vertically-oriented areas such as hallway, corridors and aisles. To achieve the best 9:16 display effect, it is recommended to:

1. Rotate the camera sideways by 90°:

For EHN Series:

Rotate the camera to the left or right by 90°.



For EZN Series:

Loosen the Rotate Screws on both sides and rotate the camera to the left or right by 90°.



2. Go to Display > Image and enable the **Hallway Mode**.

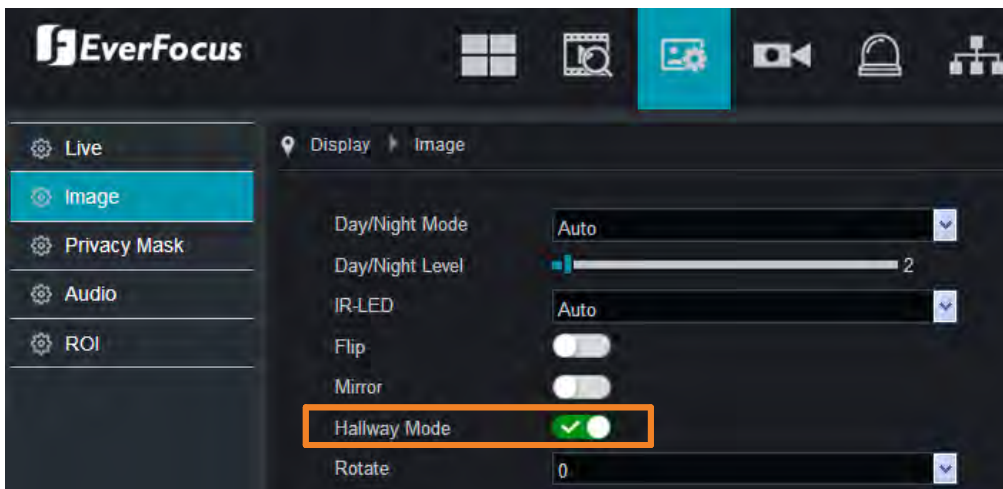

3. On the Live View, click the **Original Ratio / Hallway** button to display the streams in Hallway mode (9:16).

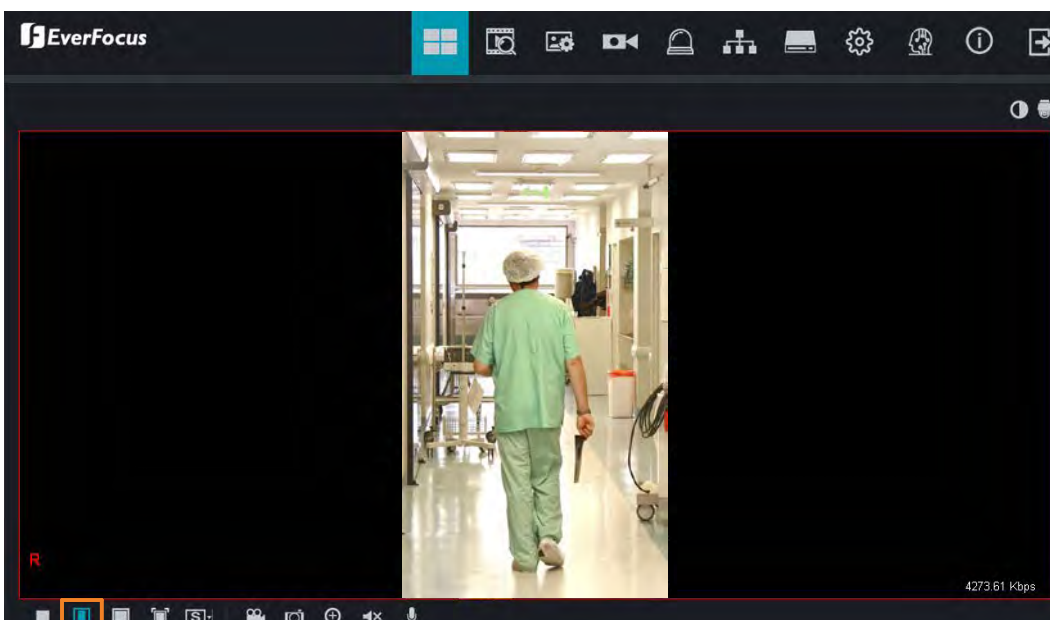

5.2.3 Privacy Mask

You can configure the Privacy Mask settings on this page. The Privacy Mask can block out sensitive areas from view, covering the areas in both Live View and Recordings. This feature is useful when users don't want the sensitive information visible. Up to four Privacy Masks can be configured.

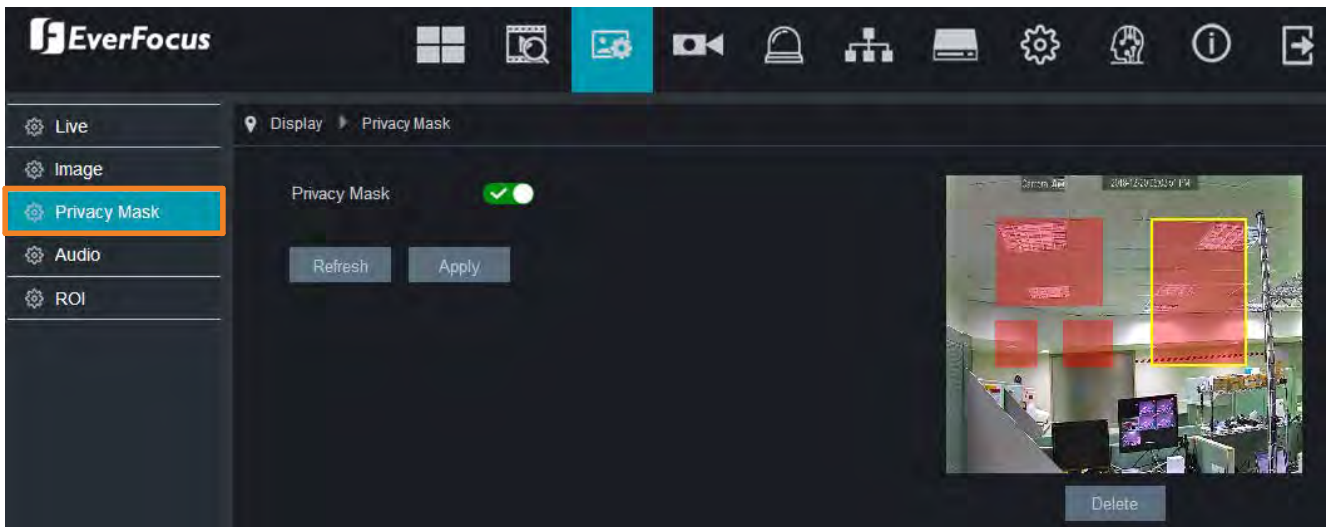

To set up Privacy Mask:

1. Switch the **Privacy Mask** button to the right to enable the function.
2. On the preview window, draw a rectangle area (red color) to apply with the privacy mask. Up to four areas can be configured.
3. To delete an area, click on an area, the selected area will be highlighted with a yellow frame. Click the **Delete** button to delete the selected area.
4. After configuring the privacy mask areas, click the **Apply** button to apply the settings.

Click **Refresh** to refresh the page; click **Apply** to save the settings.

5.2.4 Audio

You can configure the audio settings on this page.

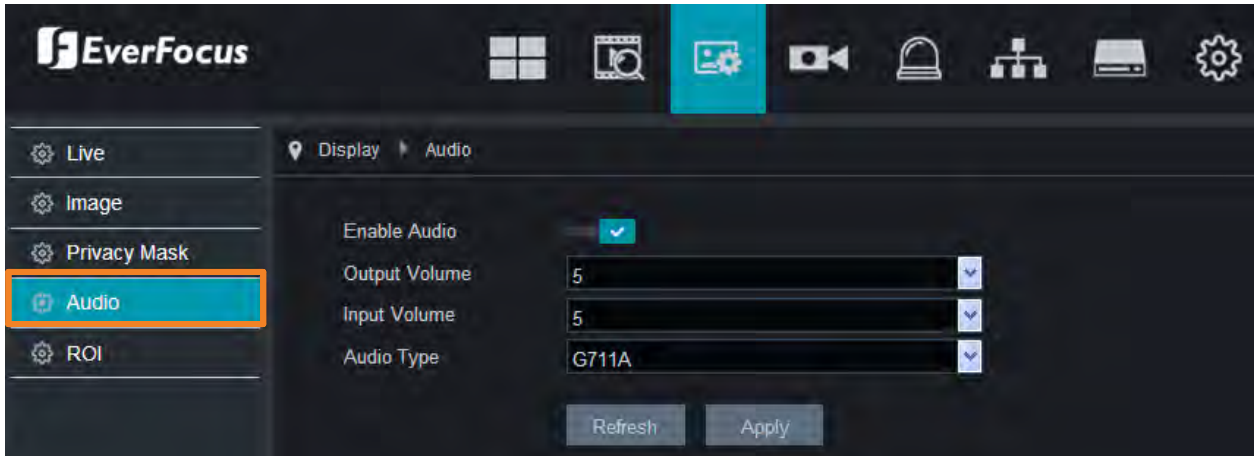

Enable Audio: Switch the button to the right to enable audio configuration.

Note: If you want to enable the Audio function, after configuring the Audio configuration on this page, please turn on the **Audio** function on the Video Streaming page (please refer to 5.5.2 Video Streaming).

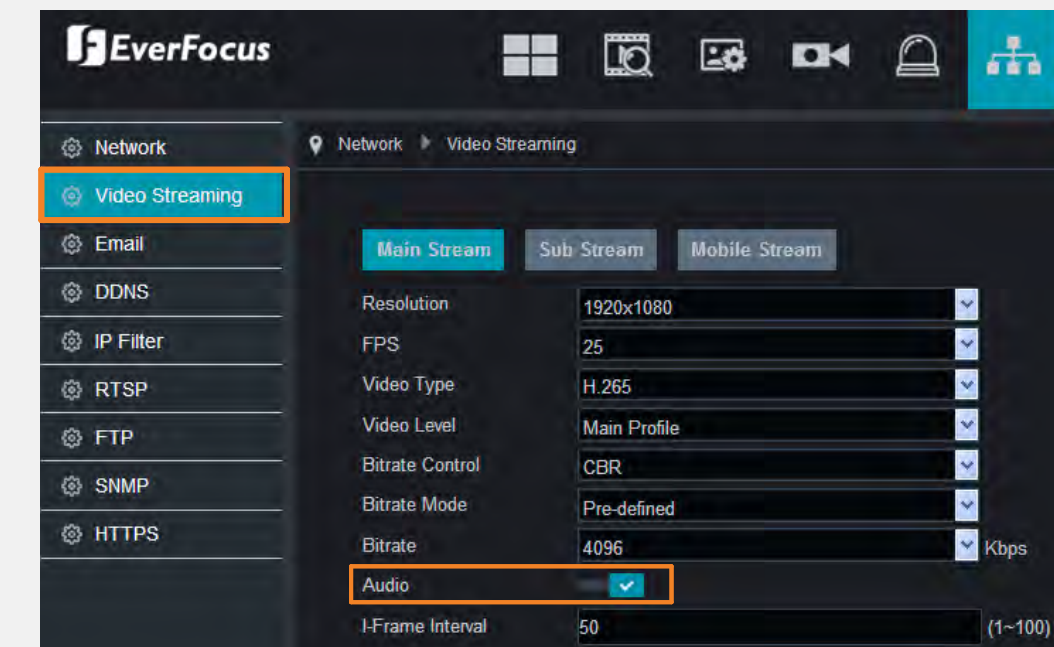

Output Volume: Select an audio output volume (0~10).

Input Volume: Select an audio input volume (0~10).

Audio Type: Select an audio codec.

Click **Refresh** to refresh the page; click **Apply** to save the settings.

5.2.5 ROI

You can configure the ROI settings on this page.

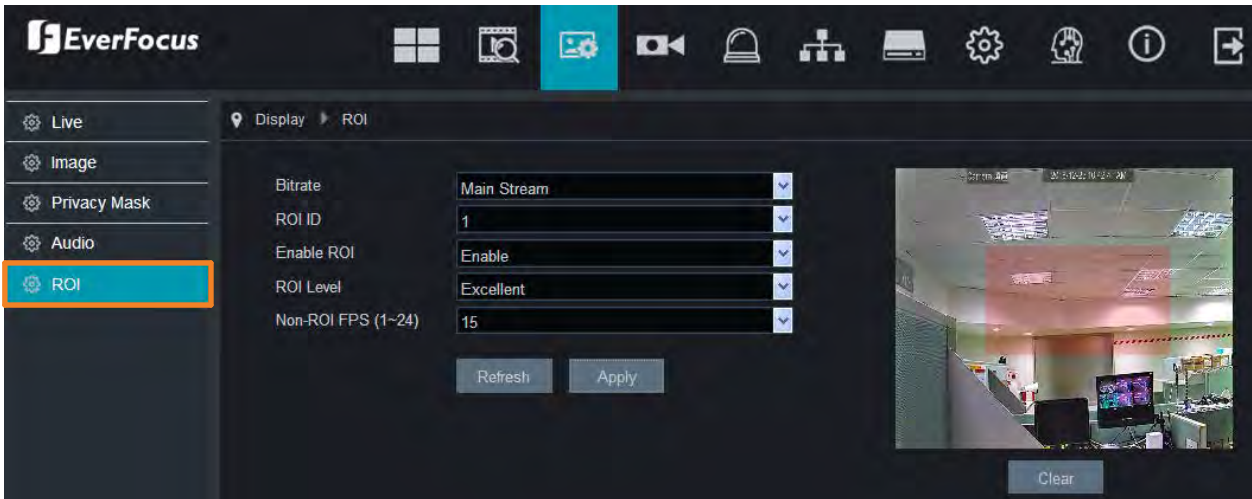

Bitrate: Select a stream type to be applied with the ROI bitrate.

ROI ID: Up to 8 ROI areas can be configured for each stream type.

Enable ROI: Select **Enable** to enable the configured ROI area(s).

ROI Level: Select an ROI level for each area. The higher the level, the better the image quality in ROI area.

Non-ROI FPS (1-24): Select a FPS to be applied to the non-ROI areas. Lower FPS can not only reduce the bandwidth, but also increase the recording time to the on-camera SD card.

Click **Refresh** to refresh the page; click **Apply** to save the settings.

To set up ROI:

1. Set up the configurations including Bitrate, ROI ID, Enable ROI, ROI Level and FPS for the Non-ROI FPS.
2. On the preview window, draw a rectangle area (red color) to apply with the ROI. You can only configure 1 ROI area for each ROI ID. Up to 8 ROI ID can be configured.
3. To delete the ROI area, click the **Clear** button.
4. Click the **Apply** button to apply the settings.

5.3 Record

5.3.1 Record Setting

You can configure the record settings on this page. Please note that to enable the record function, a micro SD card has to be inserted to the IP camera in advance. Please also format the micro SD card for the first-time use (refer to 5.6.1 Storage).

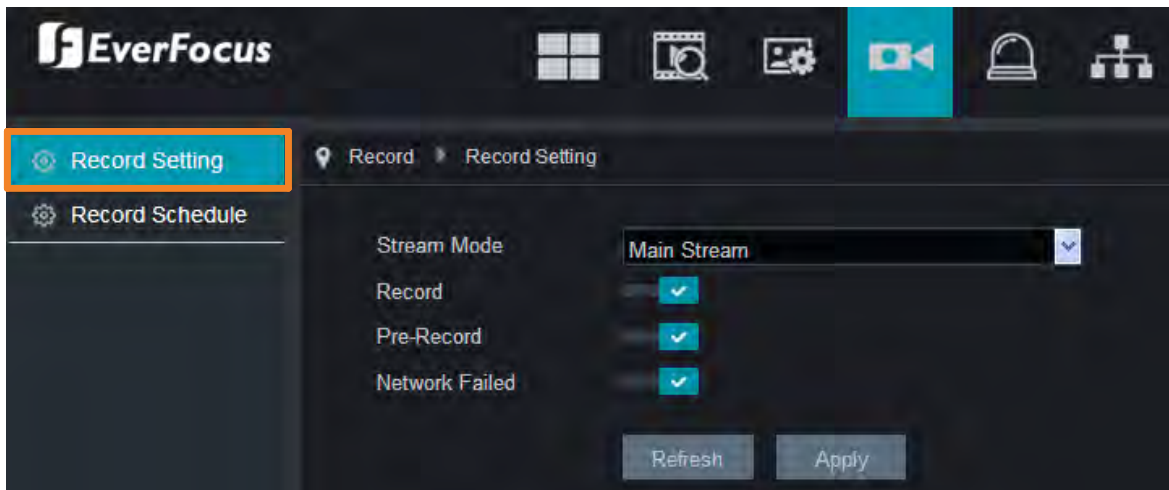

Stream Mode: Select a recording stream mode.

Record: Switch the button to the right to enable the record function. Please note that to enable the record function, a micro SD card has to be inserted to the IP camera in advance. Please also format the micro SD card for the first-time use (refer to 5.6.1 Storage).

Pre-Record: Switch the button to the right to enable the pre-record function for all the alarm recordings. The camera will start recording 10 seconds before the alarms occur.

Network Failed: Switch the button to the right to enable the network failed function. When the network is disconnecting, the IP camera will start recording until the network connection is back to normal.

Click **Refresh** to refresh the page; click **Apply** to save the settings.

Note:

1. To configure the recording storage path, please refer to 5.7.7 Local Settings.
2. After setting up the Record settings, you can optionally set up the Record Schedule, please refer to 5.3.2 Record Schedule.

5.3.2 Record Schedule

After setting up the Record settings, you can configure the record schedule on this page.

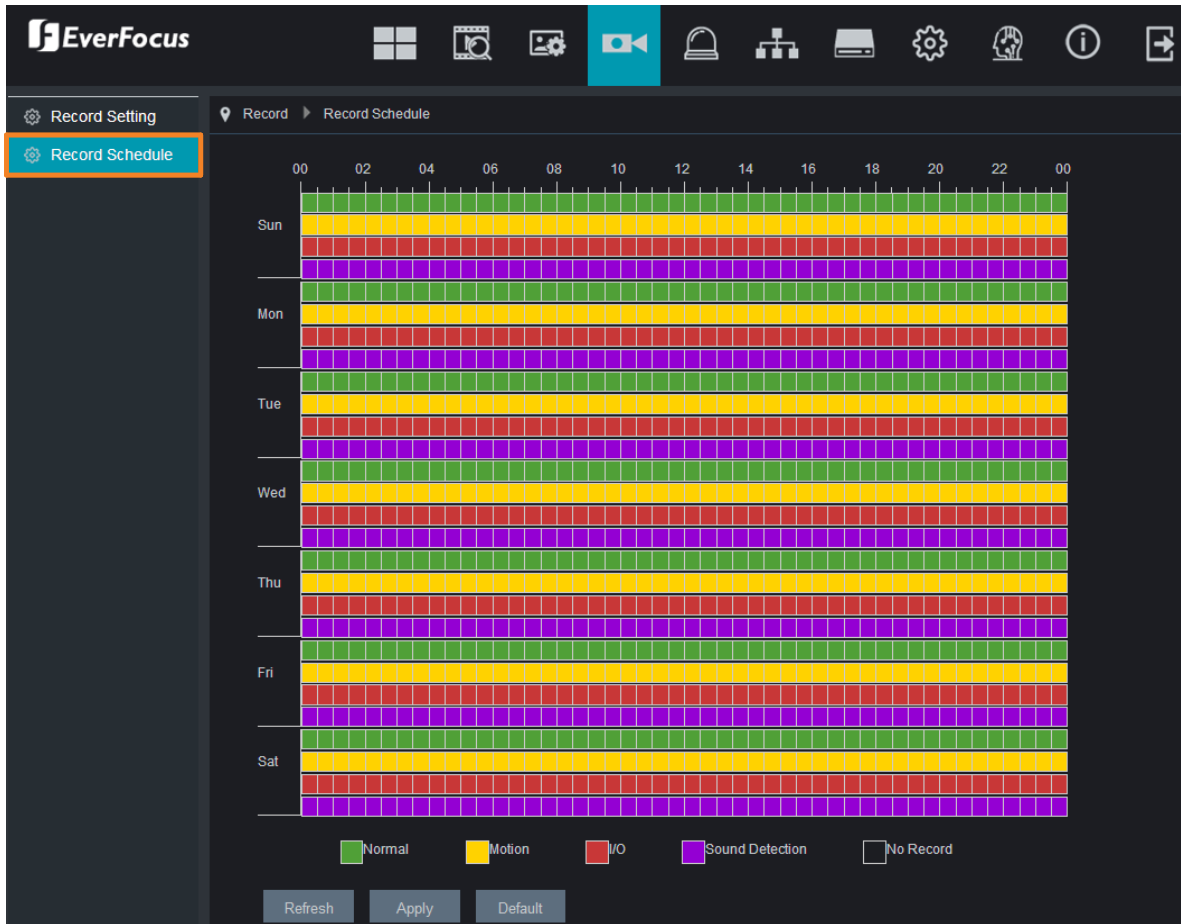

Normal: Move your mouse cursor over the schedule time blocks. The first line of the time block on each day is the Normal time blocks. Click and drag on the schedule time blocks to draw the blocks with green color, which will be applied with normal recording function.

Motion: Move your mouse cursor over the schedule time blocks. The second line of the time block on each day is the Motion time blocks. Click and drag on the schedule time blocks to draw the blocks with yellow color, which will be applied with motion recording function. Note that for this function to work, you will have to configure the motion settings in advance (please refer to 5.4.1 Motion).

IO: Move your mouse cursor over the schedule time blocks. The third line of the time block on each day is the IO time blocks. Click and drag on the schedule time blocks to draw the blocks with red color, which will be applied with IO recording function. Note that for this function to work, you will have to configure the IO settings in advance (please refer to 5.4.2 I/O).

Sound Detection: Move your mouse cursor over the schedule time blocks. The fourth line of the time block on each day is the Sound Detection time blocks. Click and drag on the schedule time blocks to draw the blocks with purple color, which will be applied with Sound Detection recording function. Note that for this function to work, you will have to configure the Sound Detection settings in advance (please refer to 5.4.4 Sound Detection).

Click **Refresh** to refresh the page; click **Apply** to save the settings; click **Default** to restore to the default settings.

5.4 Alarm Setting

5.4.1 Motion

You can configure the motion settings on this page.

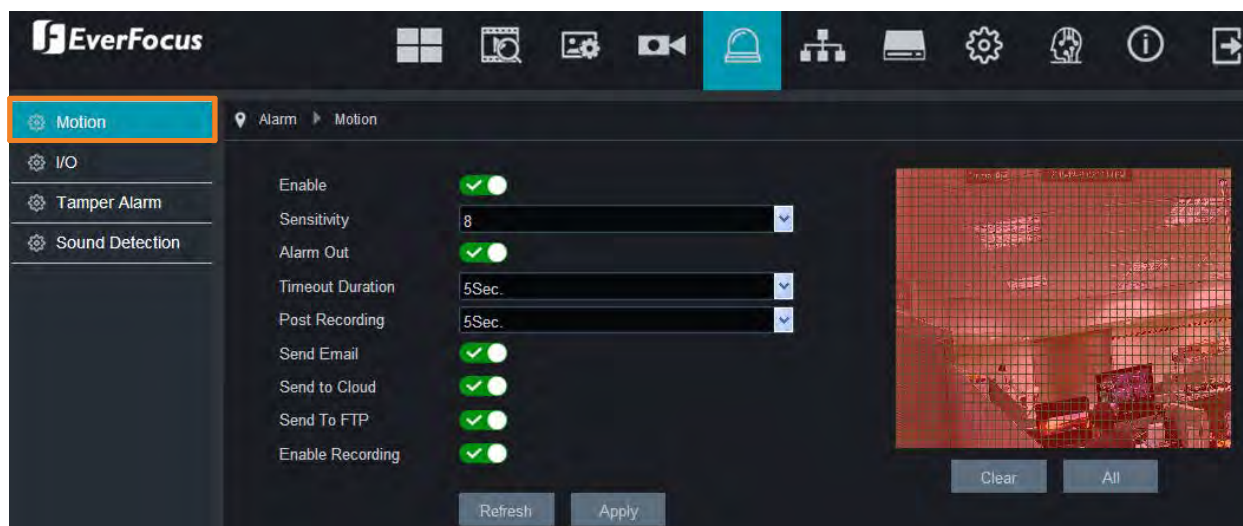

Enable: Switch the button to the right to enable the Motion function.

Sensitivity: Select a sensitivity for the motion detection. The larger the value, the higher the sensitivity.

Alarm Out: Switch the button to the right to enable the alarm output, and then further configure the **Timeout Duration** below.

Timeout Duration: After enabling the Alarm Out, select a timeout duration for the alarm output.

Post Recording: Select a post recording time when a motion event is triggered.

Send Email: Switch the button to the right to enable the Email alert function. When a motion event is triggered, the camera will send an email alert with a snapshot image to the pre-configured Email receiver. Note that for this function to work, you have to set up the Email function in advance (refer to 5.5.3 Email).

Send to Cloud: Switch the button to the right to enable the camera to automatically send the Motion alarm snapshot images to the associated Dropbox. Note that for this function to work, you have to set up the Cloud Storage function in advance (refer to 5.6.2 Cloud Storage).

Send to FTP: Switch the button to the right to enable the FTP function. When a motion event is triggered, the camera will upload alarm images to FTP server. Note that for this function to work, you have to set up FTP in advance, please refer to 5.5.7 FTP.

Enable Recording: Switch the button to the right to enable the motion recording function. Note that for Motion recording function to work, the Record Schedule function has to be configured (please refer to 5.3.2 Record Schedule).

Click **Refresh** to refresh the page; click **Apply** to save the settings.

5.4.2 I/O

After connecting the external I/O devices to the camera, you can configure the I/O settings on this page.

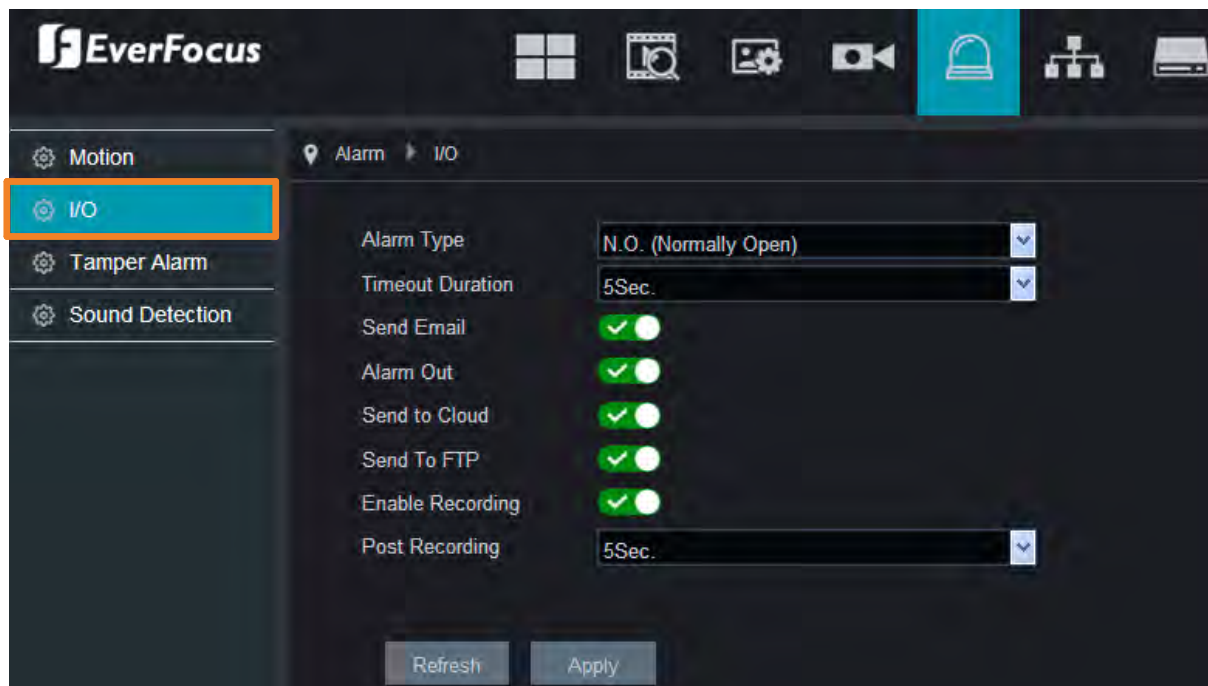

Alarm Type: Select an alarm type for the alarm input. Options include Normally-Open, Normally-Close and Off.

Timeout Duration: After enabling the Alarm Out, select a timeout duration for the alarm output.

Send Email: Switch the button to the right to enable the Email alert function. When an I/O alarm is triggered, the camera will send an email alert with a snapshot image to the pre-configured Email receiver. Note that for this function to work, you have to set up the Email function in advance (refer to 5.5.3 Email).

Alarm Out: Switch the button to the right to enable the alarm output, and then further configure the **Timeout Duration** above.

Send to Cloud: Switch the button to the right to enable the camera to automatically send the I/O alarm snapshot images to the associated Dropbox. Note that for this function to work, you have to set up the Cloud Storage function in advance (refer to 5.6.2 Cloud Storage).

Send to FTP: Switch the button to the right to enable the FTP function. When an I/O alarm is triggered, the camera will upload alarm images to FTP server. Note that for this function to work, you have to set up FTP in advance, please refer to 5.5.7 FTP.

Enable Recording: Switch the button to the right to enable the I/O alarm recording function. Note that for /O alarm recording to work, the Record Schedule function has to be configured (please refer to 5.3.2 Record Schedule).

Post Recording: Select a post recording time when an I/O alarm is triggered.

Click **Refresh** to refresh the page; click **Apply** to save the settings.

5.4.3 Tamper Alarm

You can configure the tamper alarm settings on this page.

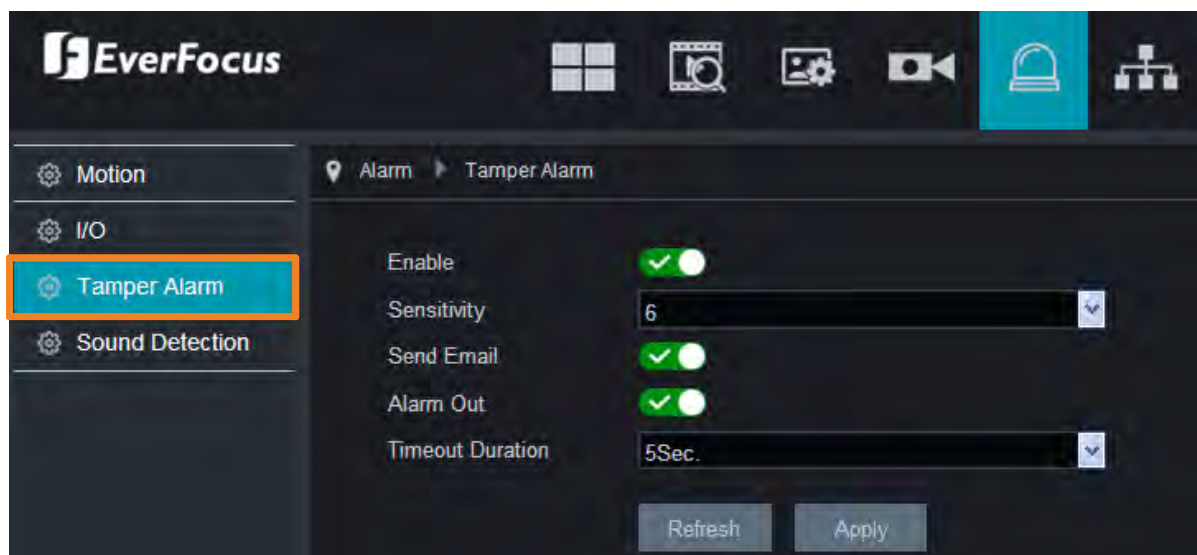

Enable: Switch the button to the right to enable the Tamper Alarm function.

Sensitivity: Select a sensitivity for the tamper detection. The larger the value, the higher the sensitivity.

Send Email: Switch the button to the right to enable the Email alert function. When a tamper alarm is triggered, the camera will send an email alert with a snapshot image to the pre-configured Email receiver. Note that for this function to work, you have to set up the Email function in advance (refer to 5.5.3 Email).

Alarm Out: Switch the button to the right to enable the alarm output, and then further configure the **Timeout Duration** below.

Timeout Duration: After enabling the Alarm Out, select a timeout duration for the alarm output.

Click **Refresh** to refresh the page; click **Apply** to save the settings.

5.4.4 Sound Detection

You can configure the sound detection settings on this page. This function is only available for the supported IP cameras. Please contact EverFocus for more details. ts@everfocus.com.tw

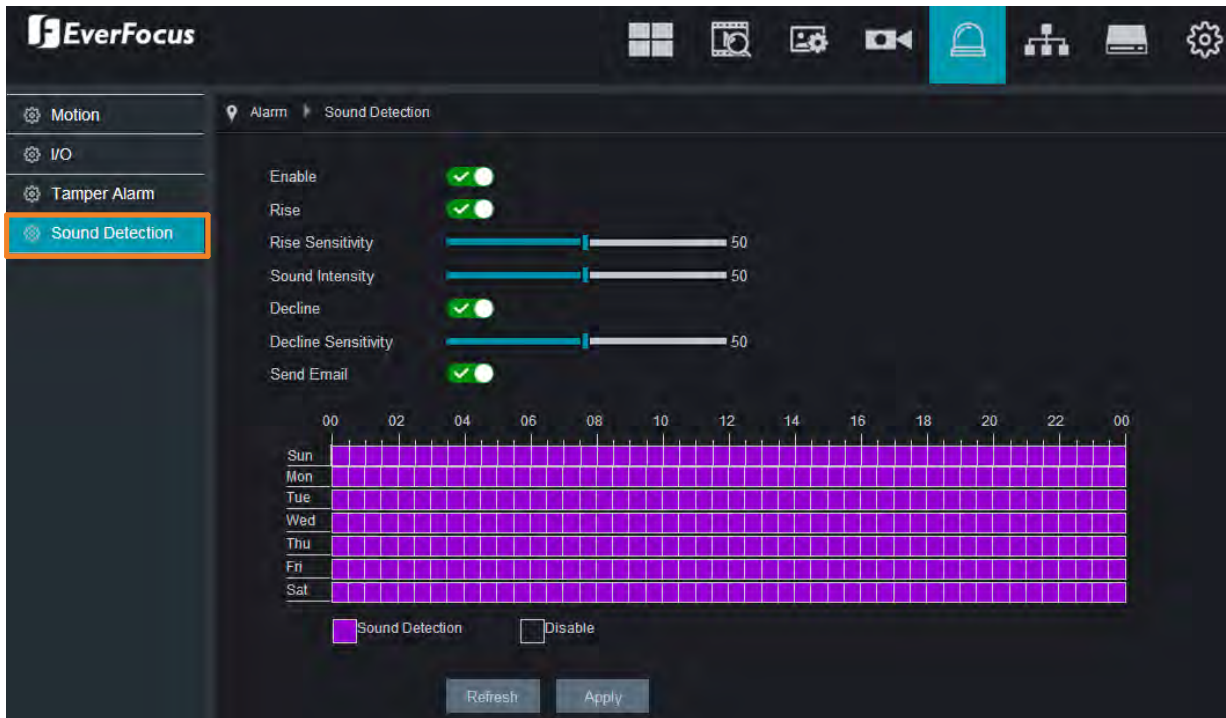

Enable: Switch the button to the right to enable the Sound Detection function. And then configure the Sound Detection Schedule on the below schedule grids.

Rise: Switch the button to the right to enable the Sound Rise function.

Rise Sensitivity: Adjust the sensitivity for the sound rise detection.

Sound Intensity: Adjust the intensity for the sound rise detection.

Decline: Switch the button to the right to enable the Sound Decline function.

Decline Sensitivity: Adjust the sensitivity for the sound decline detection.

Send Email: Switch the button to the right to enable the Email alert function. When a sound detection event is triggered, the camera will send an email alert with a snapshot image to the pre-configured Email receiver. Note that for this function to work, you have to set up the Email function in advance (refer to 5.5.3 Email).

Sound Detection Schedule:

Move your mouse cursor over the schedule time blocks. Click and drag on the schedule time blocks to draw the blocks with purple color, which will be applied with Sound Detection function.

Sound Detection Record Schedule:

If you want the camera to record the Sound Detection alarm, you will have to configure the record schedule for the sound detection function (please refer to 5.3.2 Record Schedule).

Click **Refresh** to refresh the page; click **Apply** to save the settings.

5.5 Network Setting

5.5.1 Network

You can configure the network settings on this page.



Type	DHCP	
Client Port	9988	
HTTP Port	80	
IP Address	192.168.33.95	
Subnet Mask	255.255.255.0	
Gateway	255.255.255.127	
DNS 1	192.168.10.188	
DNS 2	8.8.8.8	
IPv6-IP Address	fe80::223:63ff:fe0a:901b	64
IPv6-Gateway		
UPnP	<input checked="" type="checkbox"/>	
P2P Switch	<input checked="" type="checkbox"/>	
Port Range: 1024~65535 (Client Port , HTTP Port)		

Type: Select a network type.

- **DHCP:** This setting lets the system use an automatically assigned (dynamic) IP address. This address can change under certain circumstances. For instance, when the camera's network switch/hub has to be rebooted. Do not assign to the DHCP server the same IP addresses used for the other network cameras and PCs with unique IP addresses.
- **PPPoE:** This is a DSL-connection application. The ISP will ask the user to input a username and password. Contact your ISP for these details.
- **Static IP:** The user can manually set the Static IP address. This type of address is stable and cannot change, but the user has to make sure there are no address conflicts with other network-connected devices.

Client Port: The Client port can be used to send information through (e.g. using the mobile app). If the default port 9988 is already taken by other applications, please change it.

IP Address: The IP address of the IP Camera. The IP address consists of four groups of numbers, separated by periods. For example, "192.168.001.100".

Subnet Mask: Subnet mask is a network parameter which defines a range of IP addresses that can be used on a network. The subnet address also consists of four groups of numbers, separated by periods. For example, "255.255.000.000".

Gateway: This address allows the IP Camera to access the Internet. The format of the Gateway address is the same as the IP Address. For example, “192.168.001.001”.

DNS: DNS1 is the primary DNS server and DNS2 is a backup DNS server. Usually, it’s enough to just enter the DNS1 server address.

IPV6-IP Address: The IPV6 address of the IP Camera.

IPV6-Gateway: This address allows the IP Camera to access the Internet.

UPnP: If you want to remotely login the IP Camera using Web Client, you need to enable the UPnP function and also enable the Port Forwarding function on your router.

Note:

1. For the UPnP function to work, an UPnP-enabled router is required.
2. If your router does not support UPnP, ensure the **Port Forwarding** function is manually enabled on your router.
3. To enable UPnP, the Client port and HTTP port should be within 1024~65535.

P2P Switch: Check the box to enable the P2P function. If **P2P** function is enabled, a QR code will be displayed on the System Info page (System > Info). You can scan the QR code with **EverFocus eFVMS** App installed on your mobile device to add and remote access the IP Camera. Please refer to *5.7.9.1 Performing the P2P Function*.

Click **Refresh** to refresh the page; click **Apply** to save the settings.

5.5.2 Video Streaming

You can configure the video streaming settings on this page.



You can configure the below configurations to **Main Stream**, **Sub Stream** and **Mobile Stream**.

Resolution: Select a resolution.

FPS: Select a frame rate per second for the selected stream type.

Video Type: Select a video codec.

Video Level: Select Main Profile for the video codec.

Bitrate Control: Select **CBR** (constant bitrate) if the scene is simple and less changing, such as a gray wall. Select **VBR** (variable bitrate) if the scene is complex, such as a department store. If VBR is selected, select a video quality from the drop-down list.

Bitrate Mode: Select **User-defined** to set up bitrate manually; or **Pre-defined** to auto-select bitrate.

Bitrate: The Bitrate corresponds to the speed of data transfer that the IP Camera will use to record video. Recordings that are encoded at higher bitrates, will be of better quality.

Audio: Switch the button to the right to enable the audio function.

I-Frame Interval: Set up an I-Frame interval.

Click **Refresh** to refresh the page; click **Apply** to save the settings.

5.5.3 Email

You can configure the email settings on this page.

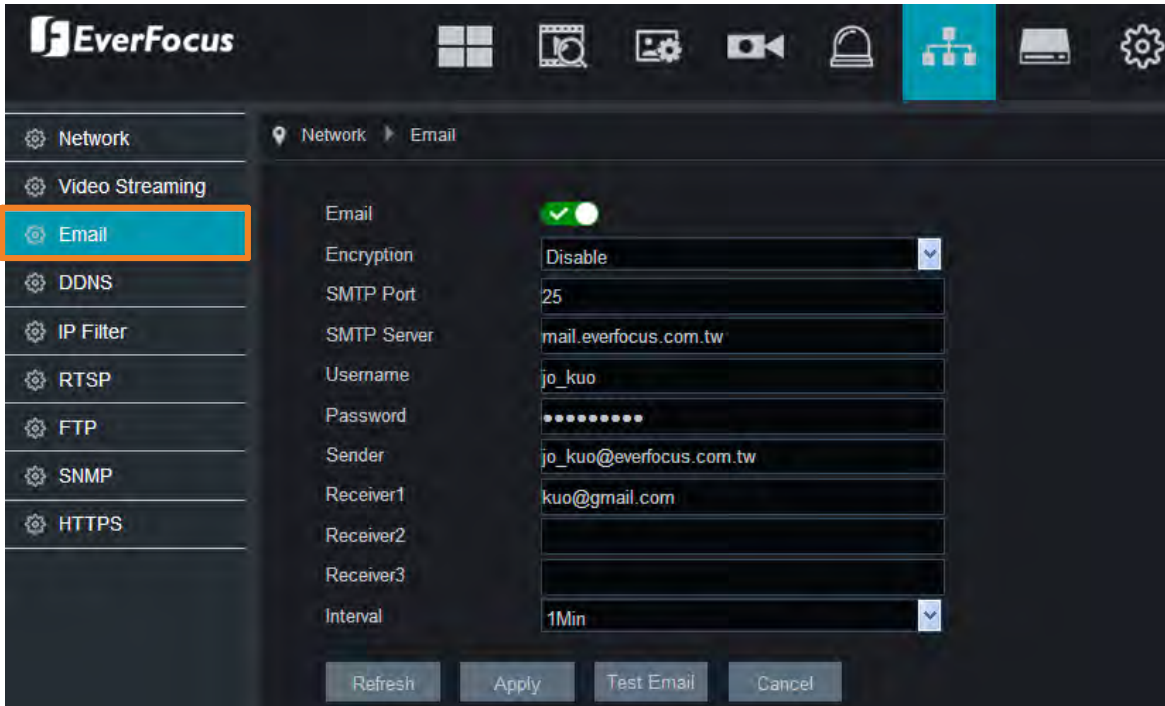

Email: Switch the button to the right to enable the Email function.

Encryption: Select an encryption if your Email server requires the **SSL** or **TLS** verification. Select **Auto** if you are not sure. Select **Disable** to disable this function.

SMTP Port: Enter the port number used by the SMTP server.

SMTP Server: Enter the SMTP server address of your Email.

User Name: Input the user name of your Email account.

Password: Input the password of the sender.

Sender: Input the Email address of the sender.

Receiver1-3: Input the Email address of the receiver. You can input 3 receiver email addresses.

Interval: Configure an interval to send Emails when events occur.

Click **Refresh** to refresh the page; click **Apply** to save the settings; click **Test Email** to test the Email function; click **Cancel** to cancel the settings.

5.5.4 DDNS

You can configure the DDNS setting on this page. DDNS (Dynamic Domain Name System) is a service used to map a domain name to the dynamic IP address of a network device. You can set up the DDNS service for remote access to the IP Camera.

DDNS assigns a domain name (URL) to the IP Camera, so that the user does not need to go through the trouble of checking if the IP address assigned by DHCP Server has changed. Once the IP is changed, the IP Camera will automatically update the information to the DDNS to ensure it is always available for remote access.

Note that before enabling the following DDNS function, user should have applied for a host name from the DDS service provider's website.

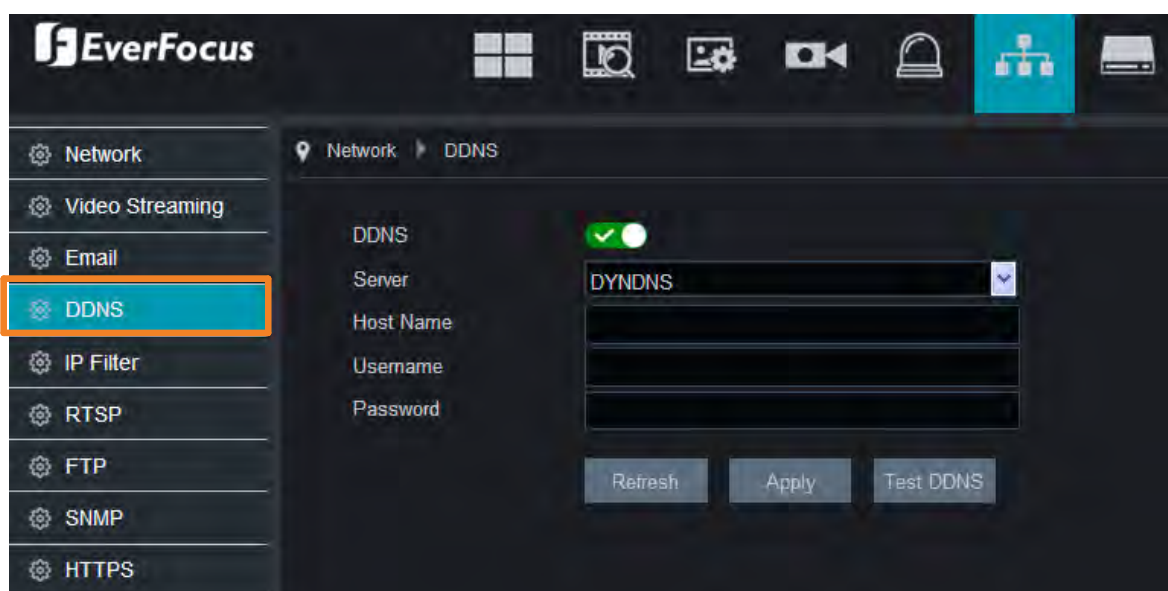

DDNS: Switch the button to the right to enable the DDNS function

Server: Select a DDNS service provider from the drop-down list. Note that before enabling the following DDNS function, user should have applied for a host name from the DDS service provider's website.

Hostname: Input the domain name obtained from the DDNS service provider.

Username: Input the user name of the DDNS account.

Password: Input the password of the DDNS account.

Click **Refresh** to refresh the page; click **Apply** to save the settings; click the **Test DDNS** button to test whether the DDNS function is working normally.

5.5.5 IP Filter

You can configure the IP Filter settings on this page. This function allows you to allow or deny some specific IP address to access the IP Camera. By default, all IP addresses are allowed to access the camera.

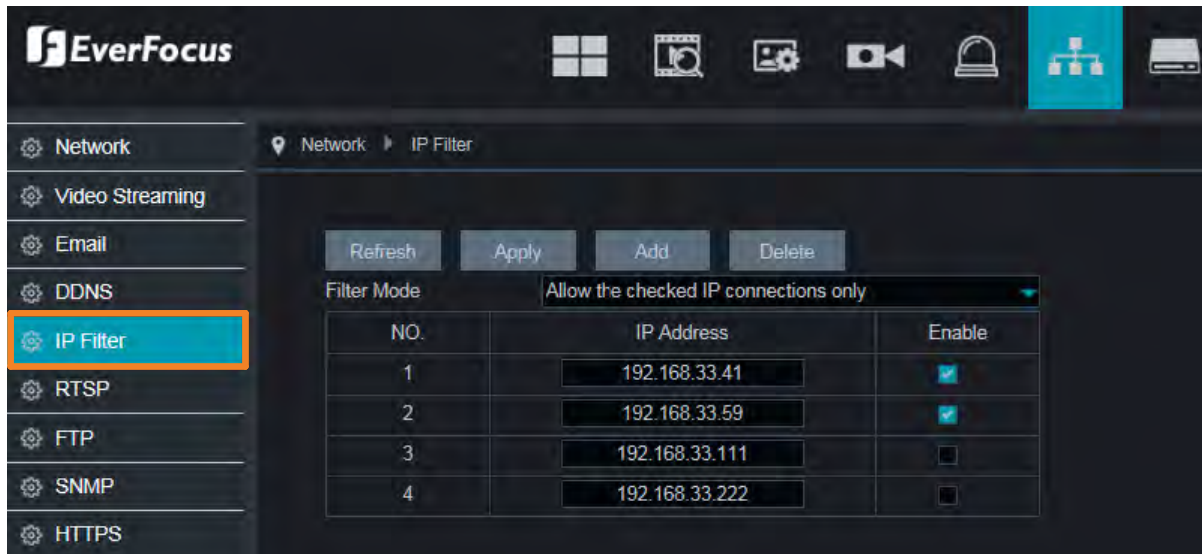

To set up IP filtering:

- From the **Filter Mode** drop-down list, select a filter mode. You can only activate one mode for the IP camera:
 - Allow all IP connections:** Select this mode to allow all IP addresses to access the IP camera. Click the **Apply** button to save the settings.
 - Allow the checked IP connections only:** Select this mode to allow only some specific IP addresses to access the IP camera. Click the **Add** button to add the IP addresses and then check the **Enable** box. Click the **Apply** button to save the settings.
 - Deny the checked IP connections only:** Select this mode to deny only some specific IP addresses to access the IP camera. Click the **Add** button to add the IP addresses and then check the **Enable** box. Click the **Apply** button to save the settings.
- If you want to delete the IP addresses from the list, click on the column of the IP address, the column will be highlighted with a blue background, and then click the **Delete** button.

5.5.6 RTSP

You can enable the RTSP function on this page.

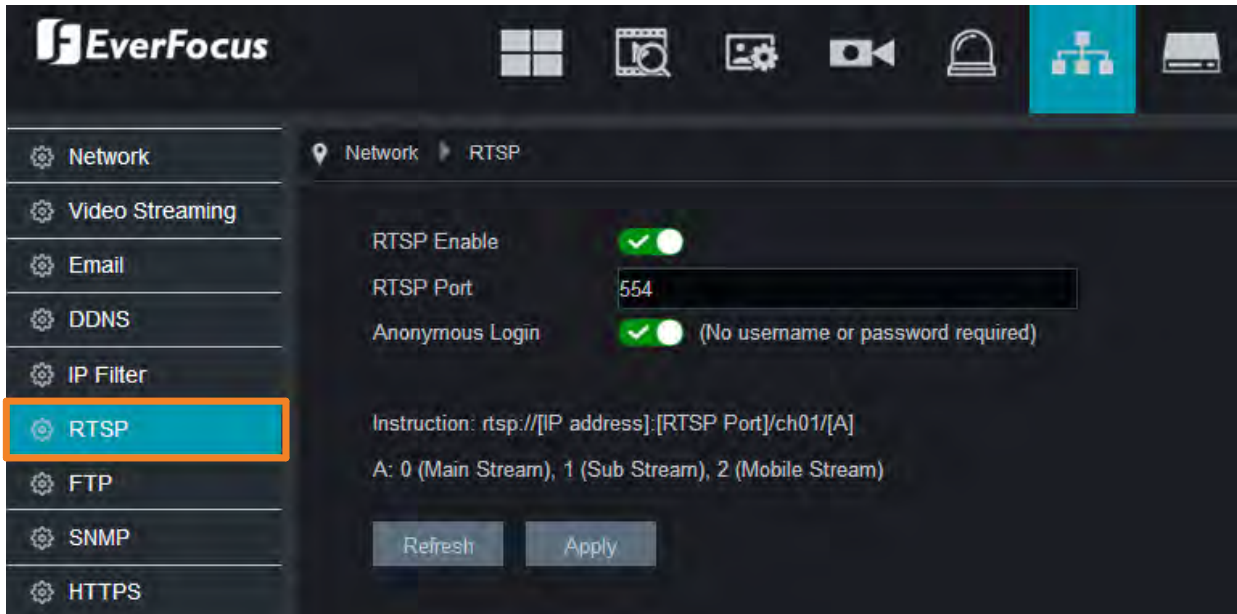

RTSP Enable: Switch the button to the right to enable the RTSP function.

RTSP Port: The RTSP port allows the IP Camera to transmit real-time streaming to other devices (e.g. using a streaming media player).

Anonymous Login: Switch the button to the right to enable this function.

RTSP Syntax:

`rtsp://[IP Address]:[RTSP Port]/ch01/[A]`

- * IP Address: IP address of the IP Camera
- * RTSP Port: The default RTSP port is 554, which can be changed between 1024 and 65535. Changing the RTSP port will restart the IP camera.
- * A: Stream Type: 0 (main stream), 1 (sub stream), 2 (mobile stream)

Example:

`rtsp://192.168.31.33:554/ch01/0`

Click **Refresh** to refresh the page; click **Apply** to save the settings.

5.5.7 FTP

You can configure the FTP settings on this page. When an alarm is triggered, the IP Camera will send an instant snapshot image to the FTP.

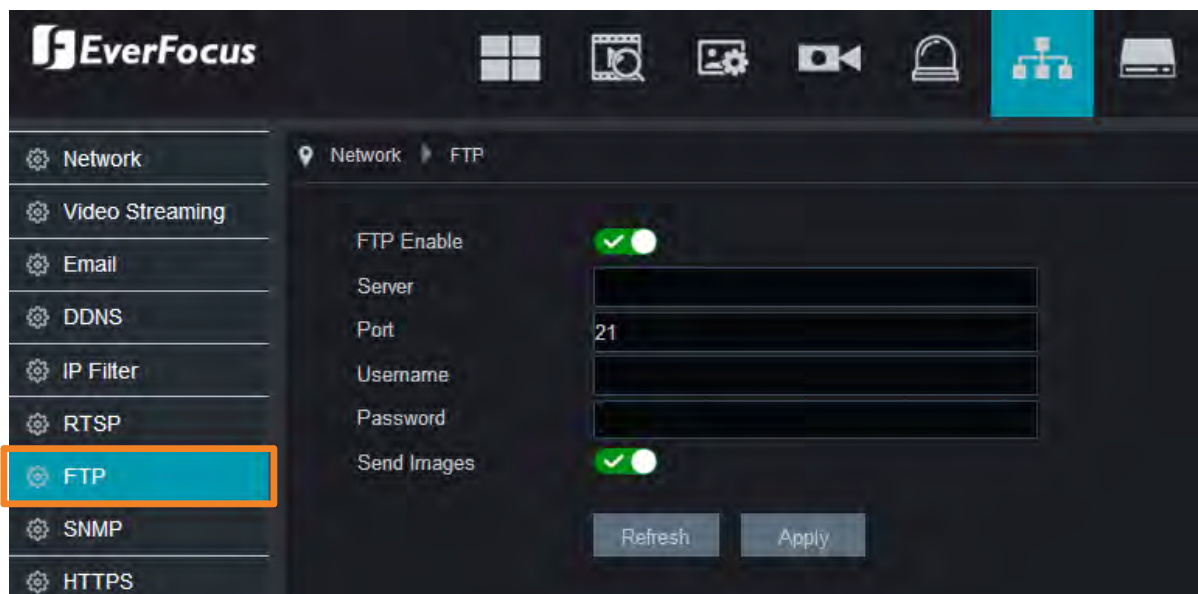

FTP Enable: Switch the button to the right to enable the function.

Server: Input the FTP server IP.

Port: Keep the port 21.

Username: Input the user name of the FTP server.

Password: Input the password of the FTP server.

Send Images: Switch the button to the right to enable the function.

Click **Refresh** to refresh the page; click **Apply** to save the settings.

Note: For the FTP function to work, after configuring the FTP settings, you will have to enable the **Send to FTP** function on the Motion (see 5.4.1 Motion) and I/O (see 5.4.2 I/O) alarm setup page.

5.5.8 SNMP

You can configure the SNMP settings on this page. Select a SNMP version and input the configurations. Click the **Apply** button to apply the settings.



5.5.9 HTTPS

You can configure the HTTPS settings on this page. Switch the **HTTPS** button to the right to enable the function. Select an **HTTPS Type** and then click the **Apply** button.

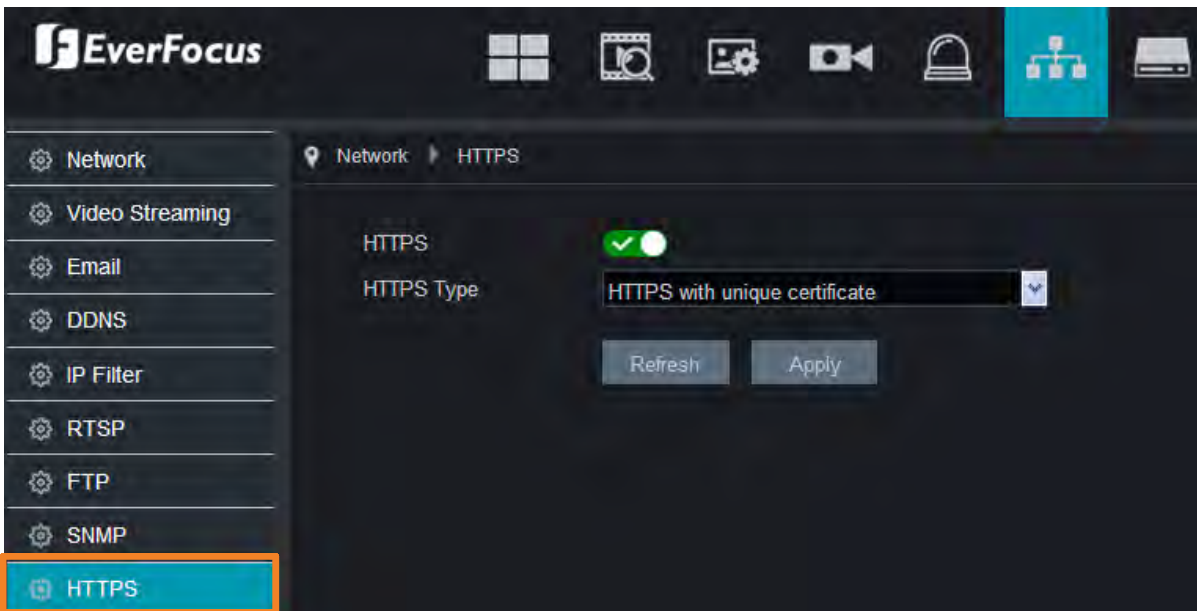

5.6 Storage Setting

5.6.1 Storage

You can configure the SD card storage on this page. After inserting an micro SD card to the card slot, the IP camera will automatically detect the capacity of the on-camera SD card.

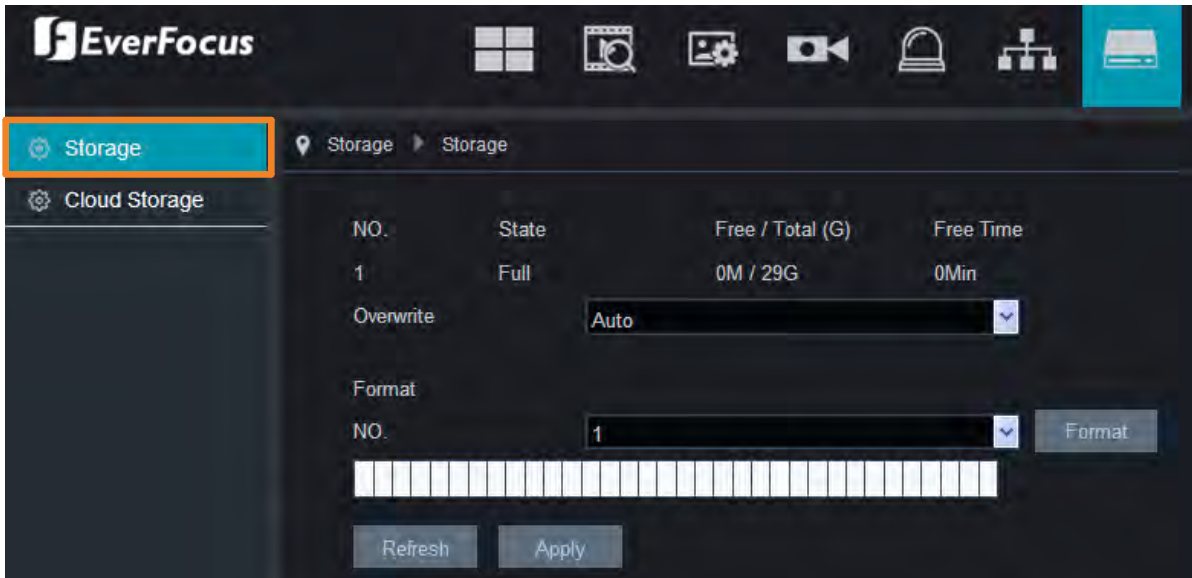

Overwrite: Select **Auto** to enable the overwrite function. If **Auto** is selected, the IP camera will overwrite the oldest files on the SD card when SD card is full.

Format: Click to format the on-camera SD card. For the first time use SD card or a new SD card, users have to format the SD card before use.

Click **Refresh** to refresh the page; click **Apply** to save the settings.

5.6.2 Cloud Storage

You can configure the cloud storage (Dropbox) settings on this page. After configuring the settings, the IP camera will automatically send the alarm snapshot images to the associated Dropbox when alarm events occur.

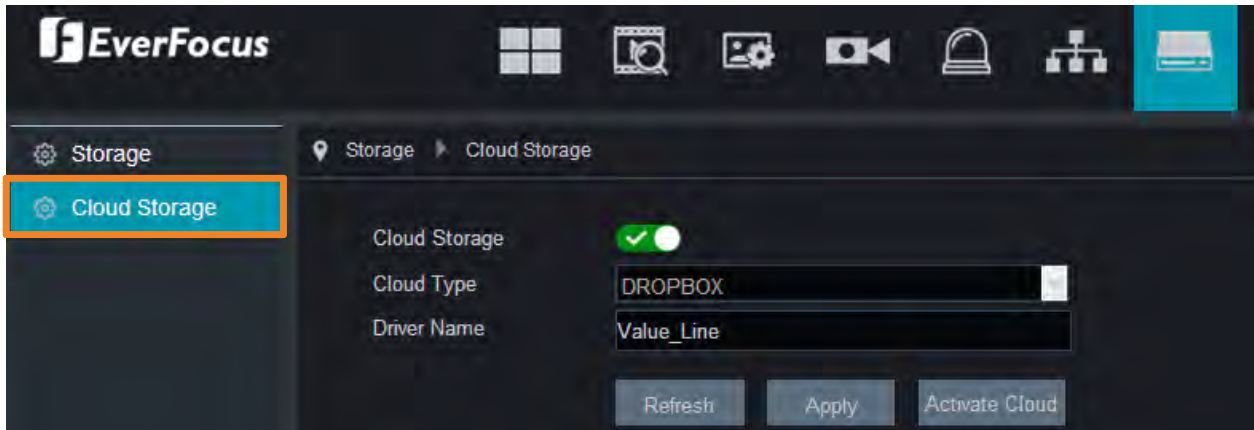

To perform the Cloud function:

1. Register an account on Dropbox website. It's recommended to create the account with the same Email address and password used for your IP camera.
2. Ensure the IP camera network is working properly.
3. Configure the Email function (refer to 5.5.3 *Email*) of the IP camera.
4. Configure the Cloud settings on this page:
 - a. Switch the **Cloud Storage** button to the right to enable the Cloud function.
 - b. Input a name in the **Driver Name** field, which will be created on the Dropbox as a directory for restoring the snapshot images from IP camera.
 - c. Click the **Apply** button.
5. Click the **Activate Cloud** button to activate the Cloud function.
 - a. After clicking the **Activate Cloud** button, the sign in page of Dropbox appears. Sign in the Dropbox, the below page appears. Input the IP address of the IP camera and then click the **Authorize** button.

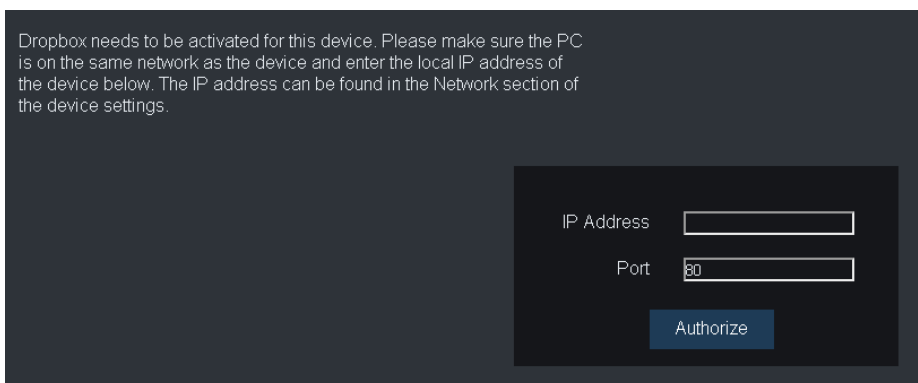

- b. Input the username and password of the IP camera.

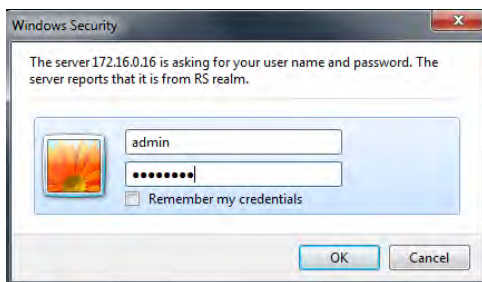

- c. When this message appears, you are able to use the Cloud function.

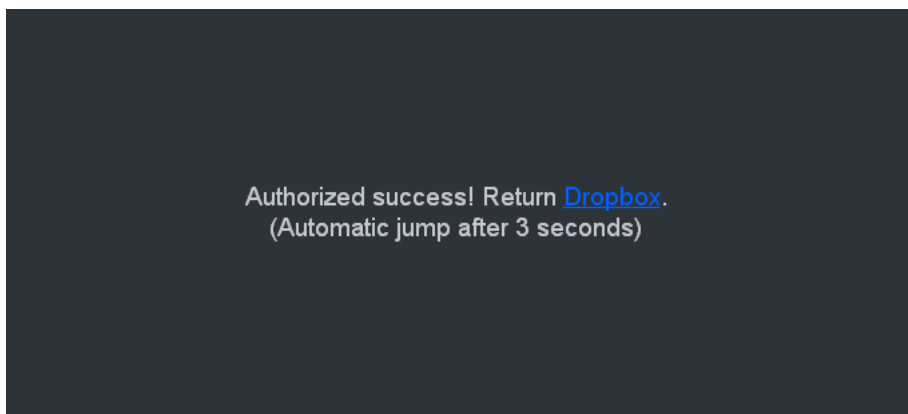

Note: For the Cloud Storage function to work, after configuring the Cloud Storage settings, you will have to enable the **Send to Cloud** function on the Motion (see 5.4.1 Motion) and I/O (see 5.4.2 I/O) alarm setup page.

5.7 System Setting

5.7.1 General

You can configure the system general settings on this page.

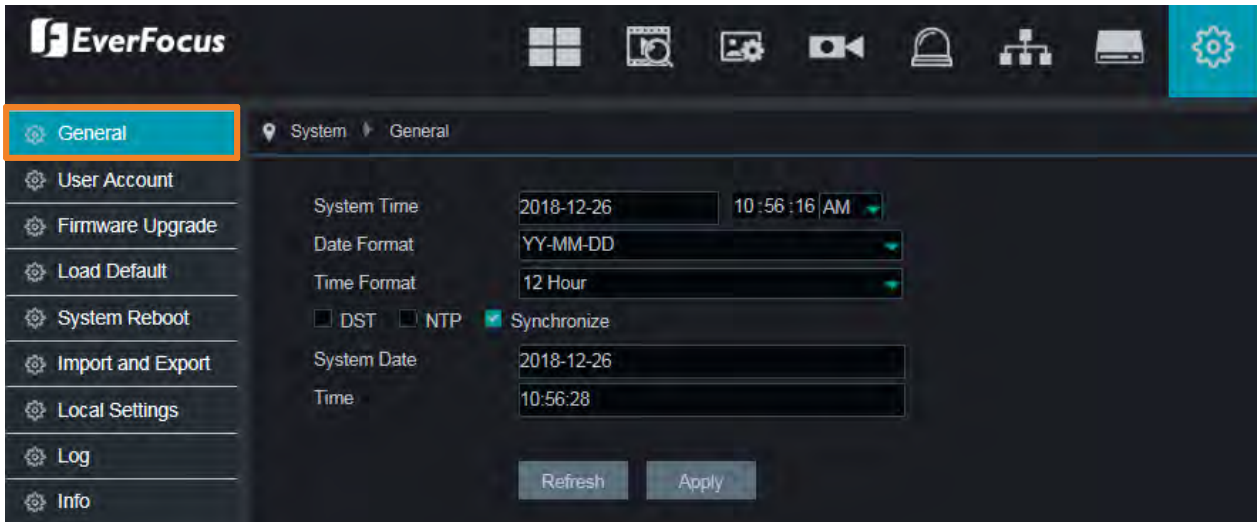

System Time: Set up a system date and time.

Date Format: Select a format for the date.

Time Format: Select a format for the time.

[DST Setting] Select DST and then configure the below settings. The DST (Daylight Saving Time) function allows you to select the amount of time that Daylight Saving has increased by in your particular time zone or region.

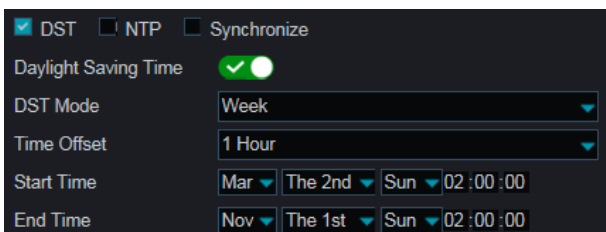

Daylight Saving Time: Switch the button to the right to enable the DST function.

DST Mode: Select **Week** or **Date** to configure the start/end time below.

Week: Select a month, a particular day and time when Daylight Saving starts and ends. For example, 2am on the first Sunday of a particular month.

Date: Select the start date (click the calendar icon), end date and time when Daylight Saving starts and ends.

Time Offset: Select the amount of time that Daylight Saving has increased by in your time zone. This refers to the difference in minutes, between Coordinated Universal Time (UTC) and the local time.

Start Time: Select a start time for the DST to start.

End Time: Select an end time for the DST to stop.

【NTP Settings】 Select NTP and then configure the below settings. The NTP (Network Time Protocol) function allows your IP camera to automatically sync its clock with a time server. This gives it the ability to constantly have an accurate time setting (your IP camera will periodically sync automatically).

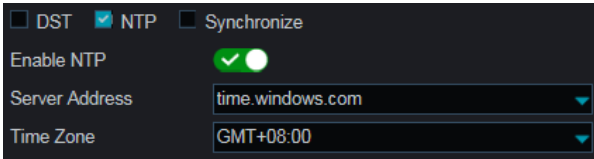

The screenshot shows a settings panel with a dark background. At the top, there are three checkboxes: 'DST' (unchecked), 'NTP' (checked with a blue checkmark), and 'Synchronize' (unchecked). Below these are three rows of settings: 'Enable NTP' with a green toggle switch and a checkmark; 'Server Address' with a dropdown menu showing 'time.windows.com'; and 'Time Zone' with a dropdown menu showing 'GMT+08:00'.

Enable NTP: Switch the button to the right to enable the NTP function. When NTP function is enabled, the system will calibrate the system time at 00:07:50 daily and every time when the system is started up.

Server Address: Select a NTP server.

Time Zone: Select a time zone of your region.

【Synchronize】 Select Synchronize to synchronize the time with your PC.

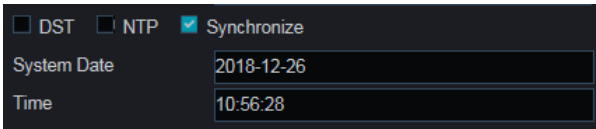

The screenshot shows a settings panel with a dark background. At the top, there are three checkboxes: 'DST' (unchecked), 'NTP' (unchecked), and 'Synchronize' (checked with a blue checkmark). Below these are two rows of settings: 'System Date' with a text field showing '2018-12-26'; and 'Time' with a text field showing '10:56:28'.

Click **Refresh** to refresh the page; click **Apply** to save the settings.

5.7.2 User Account

You can configure the user account settings on this page. Up to 7 user accounts (1 administrator and 6 users) can be configured.

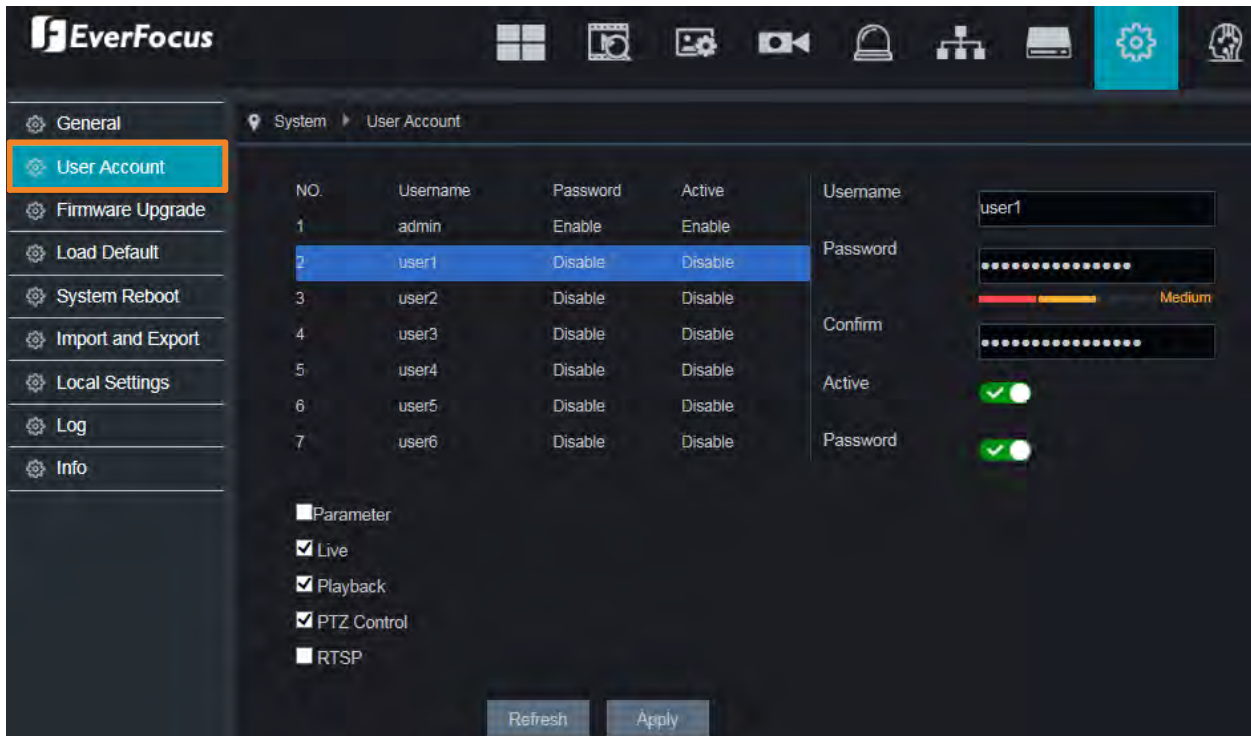

To edit the user privileges:

1. Select a user from the list by clicking on it, the below privilege options appears.

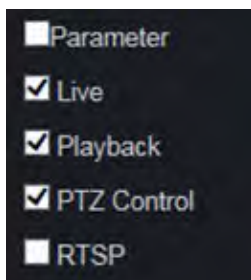

2. Check the boxes to grant functions for the selected user account. After the configuration, click **Apply** to save the settings.

Parameter: Allow users to set all the parameter settings.

Live: Allow users to access the Live View.

Playback: Allow users to access and operate the Playback function.

PTZ Control: Allow users to operate the PTZ control function.

RTSP: Allow users to operate the RTSP function.

3. You can configure the user name/password in the right-side field. In the **Active** field, switch to the right to enable the user account. At the bottom **Password** field, switch to enable the password (if Disable is selected, the user can login without password).

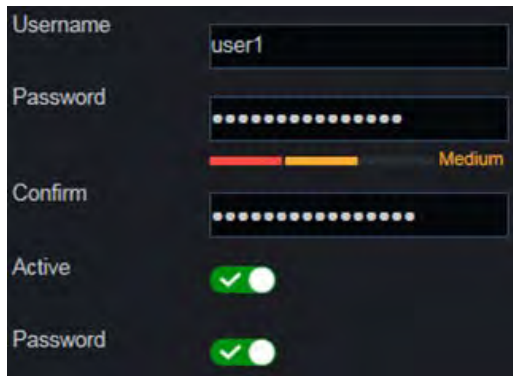

The screenshot displays a user configuration form with the following elements:

- Username:** A text input field containing the text "user1".
- Password:** A password input field with masked characters (dots). Below it is a strength indicator bar with a red section on the left, a yellow section in the middle, and the word "Medium" in orange text on the right.
- Confirm:** A second password input field with masked characters (dots).
- Active:** A toggle switch that is currently turned on, indicated by a green checkmark and a white circle on the right.
- Password:** A second toggle switch that is currently turned on, indicated by a green checkmark and a white circle on the right.

4. Click **Apply** to save the settings.

Note: The Administrator account has full privileges so the functions cannot be configured.

5.7.3 Firmware Upgrade

You can upgrade IP camera firmware on this page. Click the **Browse** button to select the firmware file from the computer. Click the **Start** button to start upgrading IP camera.

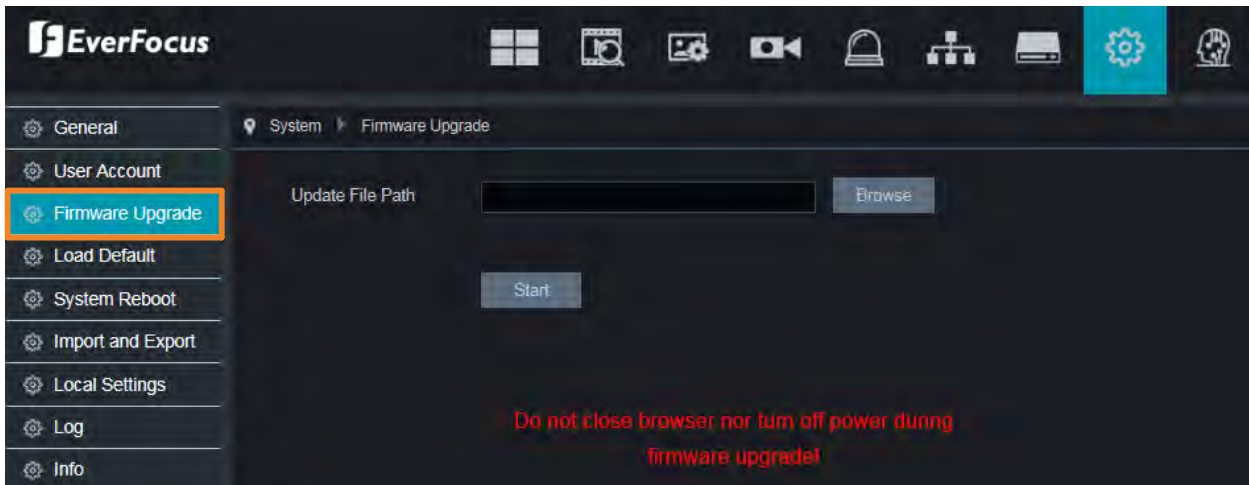

5.7.4 Load Default

You can load system default settings on this page. Select the desired items to be restored to factory default and then click **Apply**. Restoring default settings will not delete recordings and snapshots saved to the on-camera SD card.

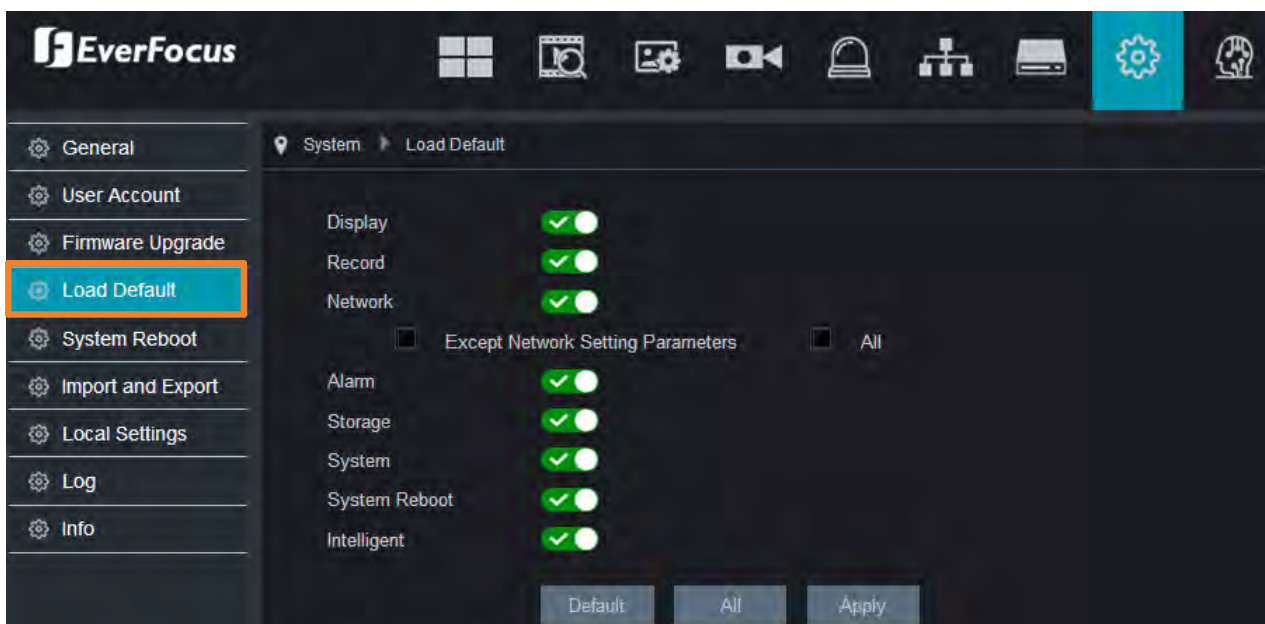

5.7.5 System Reboot

This menu allows the IP camera to auto reboot regularly. It is recommended to leave this function enabled, as it maintains the operational integrity of your IP camera.

Switch the **Reboot Schedule** button to the right to enable the function. Set up the reboot time for the IP camera to regularly reboot at the setup time. Click the **Apply** button to save the settings.

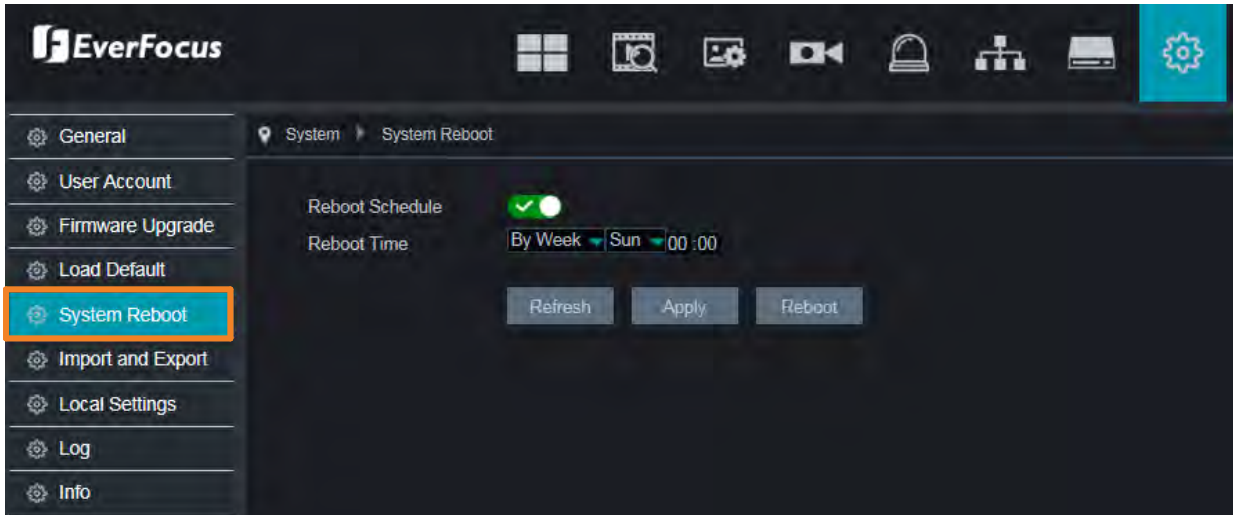

Click **Refresh** to refresh the page; click **Apply** to save the settings; click **Reboot** to reboot the IP camera.

5.7.6 Import and Export

You can import or export system configurations on this page.

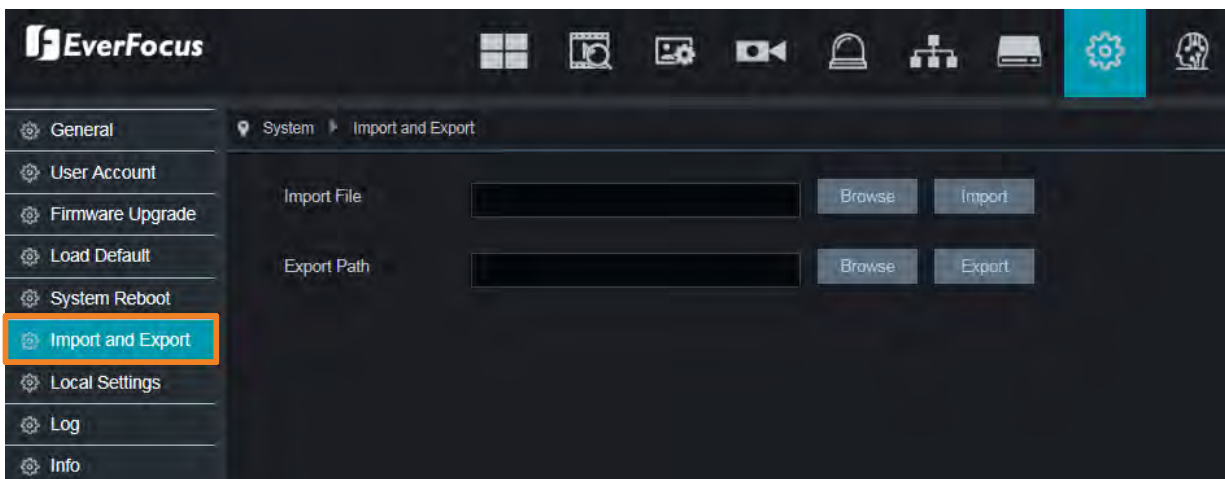

Import File: Click the **Browse** button to browse the file and then click the **Import** button.

Export Path: Click the **Browse** button to select a directory of your computer and then click the **Export** button.

5.7.7 Local Settings

You can configure the local storage path on this page.

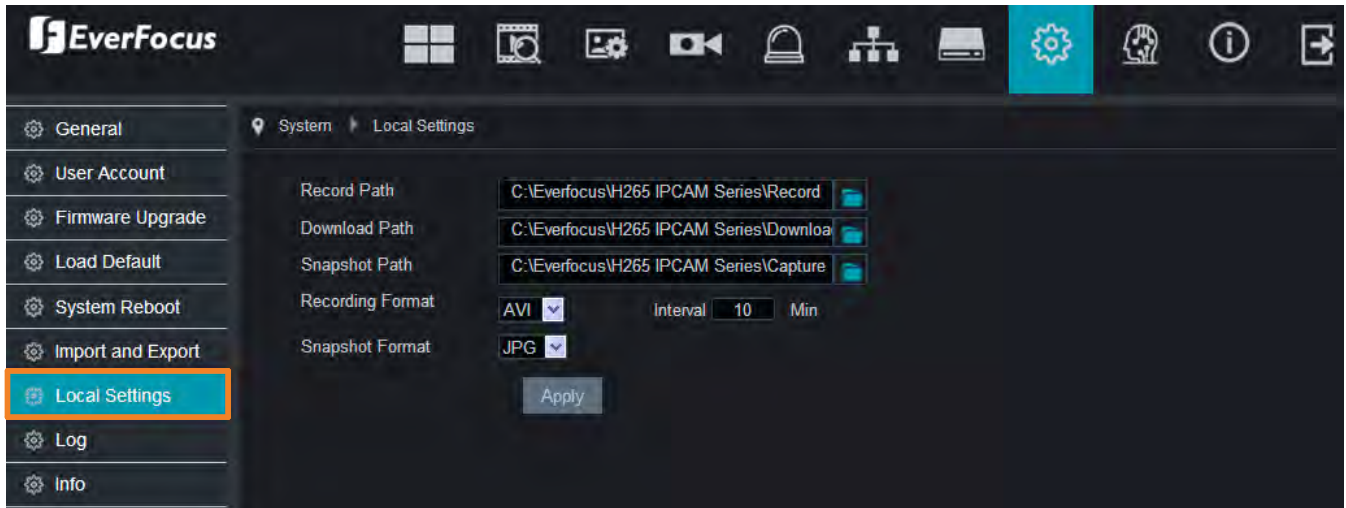

Record Path: Select a storage path for recordings.

Download Path: Select a storage path for download recordings.

Snapshot Path: Select a storage path for snapshot images.

Recording Format: Select a recording file format.

Interval: Set up an interval (recording length) for general recordings.

Snapshot Format: Select a snapshot image format.

Click **Apply** to save the settings.

5.7.8 Log

You can view log information on this page. Select the log types, start time, end time, and then click the **Search** button, the searched logs will be displayed on the list below.

The screenshot displays the EverFocus web interface for the 'Log' section. The sidebar on the left contains various system settings, with 'Log' highlighted. The main content area shows search filters for Log Type (Alarm Log), Minor Type (Motion Start), Start Time (2018-12-24 00:00:00), and End Time (2018-12-26 23:59:59). A 'Search' button is present. Below the filters is a table of log entries:

No.	Time	Operation	Log Info
1	2018-12-25 14:42:25	Motion Start	(i)
2	2018-12-25 14:41:56	Motion Start	(i)
3	2018-12-25 14:41:36	Motion Start	(i)
4	2018-12-25 14:40:52	Motion Start	(i)
5	2018-12-25 14:40:41	Motion Start	(i)
6	2018-12-25 14:39:07	Motion Start	(i)
7	2018-12-25 14:37:51	Motion Start	(i)
8	2018-12-25 14:37:18	Motion Start	(i)
9	2018-12-25 14:36:19	Motion Start	(i)
10	2018-12-25 14:36:00	Motion Start	(i)

At the bottom of the interface, there are pagination controls: 'First Page', 'Previous Page', '1', '2', '3', '4', '5', '6', '7', '8', '9', '10', 'Next', 'Last Page'. Below this, it says 'Total 61 Page(s), Go to page' followed by an input field and an 'OK' button.

5.7.9 Info

You can view system info on this page.

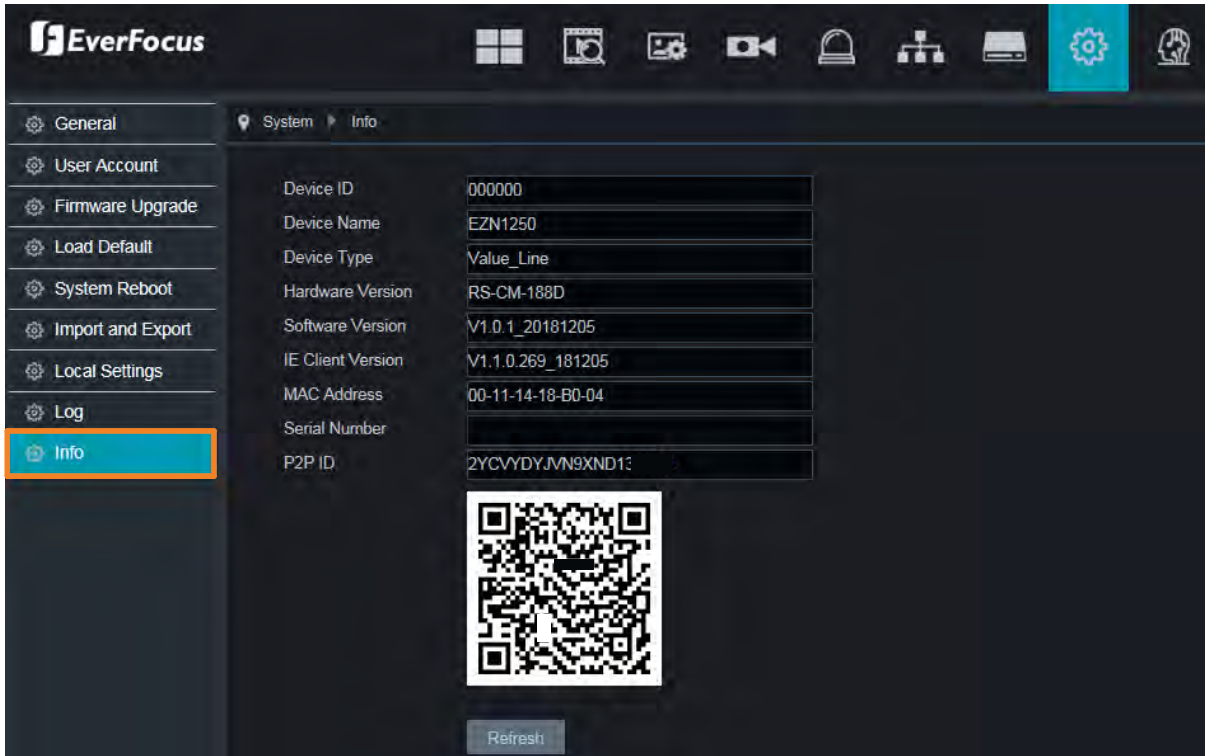

If **P2P** function has been enabled, a QR code will be displayed on the Info page. You can scan the QR code with **EverFocus eFVMS** App installed on your mobile device to add and remote access the IP camera. To enable the P2P function, please refer to **P2P Switch** in *5.5.1 Network*.

5.7.9.1 Performing the P2P Function

1. Install **EverFocus eFVMS** App. For Android users, go to Google Play Store. For iOS users, go to Apple Store. After the installation process is complete, start **eFVMS** App.

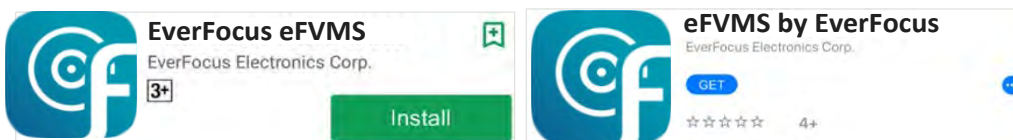

- To add an IP camera through P2P, tap **Menu > Device List**, and then tap the “+” button on the upper-right corner.

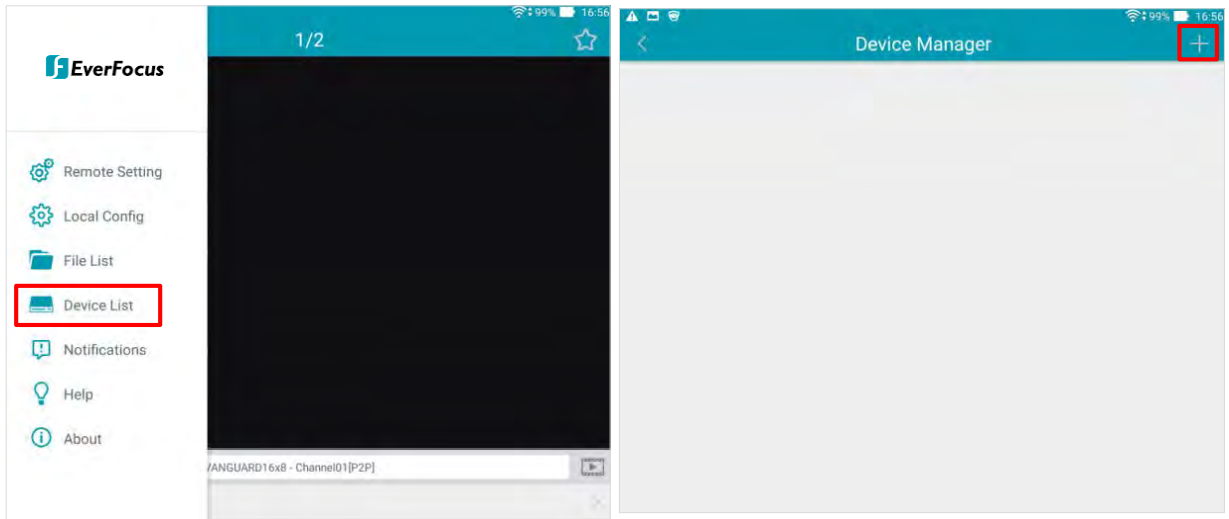

- Scan the IP camera’s **QR code** on the info page of the IP Camera Web interface. Input the IP camera password and Media Port 9988. Tap the **Save** button.

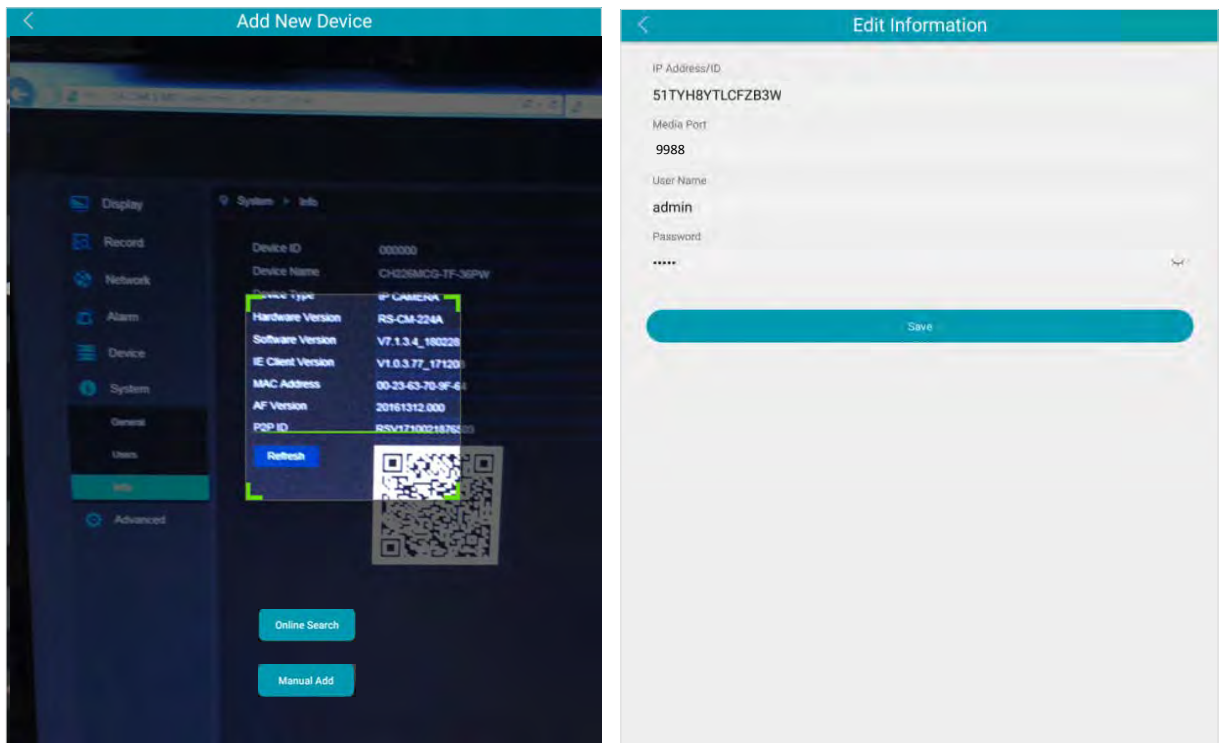

4. The IP camera is now added and connected to the App. You can start accessing the IP camera.

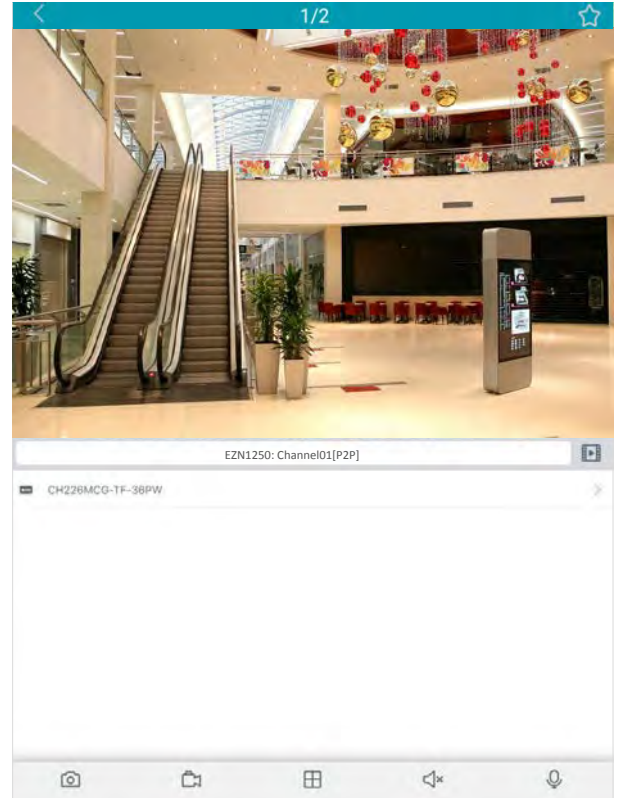

5.8 Intelligent Setting

5.8.1 Record Schedule

You can configure record schedule for intelligent detection on this page. In order to activate the intelligent recording function, you need to configure the schedule recording for intelligent detection events. The schedule will be activated 24 hours a day, 7 days a week.

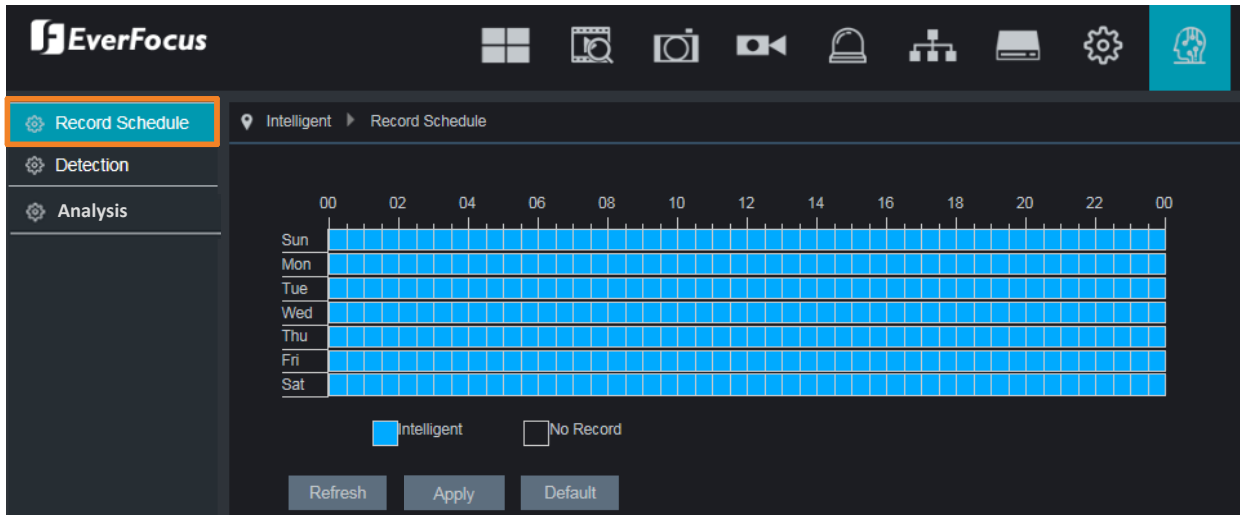

1. Move your mouse cursor over the schedule time blocks.
2. Click and drag on the schedule time blocks to draw the blocks with blue color, which will be applied with intelligent event recording function. To deselect the blocks, click and drag on the blue blocks to select again.
3. Click **Apply** to save the settings.

5.8.2 Detection

You can configure intelligent detection on this page. The intelligent detection functions include Perimeter Intrusion Detection, Line Crossing Detection, Object Detection, Pedestrian Detection, Face Detection and Cross Counting.

For 5MP and 8MP models, all intelligent detection functions are available. For 2MP models, only Perimeter Intrusion Detection, Line Crossing Detection and Object Detection functions are supported.

5.8.2.1 Perimeter Intrusion Detection

When objects (people, vehicle or other objects) enter in or out of a pre-defined region, the Perimeter Intrusion Detection event will be triggered. You can configure some event actions like event recording, alarm output or Email alert when an event is triggered.

Switch: Switch the button to the right to enable the function.

Timeout Duration: After enabling the Alarm Out, select a timeout duration for the alarm output.

Post Recording: Select a post recording time when a Perimeter Intrusion event is triggered.

Sensitivity: Select a sensitivity for the Perimeter Intrusion Detection. The larger the value, the higher the sensitivity.

Scene: Select **Indoor** or **Outdoor** based on the location where your IP camera is installed.

Alarm Out: Switch the button to the right to enable the alarm output, and then further configure the **Timeout Duration** above.

Send Email: Switch the button to the right to enable the Email alert function. When a Perimeter Intrusion event is triggered, the camera will send an email alert with a snapshot image to the pre-configured Email receiver. Note that for this function to work, you have to set up the Email function in advance (refer to 5.5.3 Email).

Rule Number: Select a number to configure the areas. Up to 4 areas can be configured.

Rule Switch: Switch the button to the right to enable the Rule Type setup below.

Rule Type: Select a rule type.

Enable Recording: Switch the button to the right to enable the Perimeter Intrusion Detection recording function. Note that for Perimeter Intrusion Detection recording function to work, the Record Schedule function has to be configured (please refer to 5.8.1 Record Schedule).

Click **Refresh** to refresh the page; click **Apply** to save the settings.

To configure the Perimeter Intrusion Detection function:

1. Select **1** from the **Rule Number** drop-down list to configure the first area. Up to 4 areas can be configured.
2. Enable the **Rule Switch** and then define a **Rule Type**:
 - A→B: Detects movement from A to B.
 - B→A: Detects movement from B to A.
 - A↔B: Detects both movements from A to B and from B to A.
3. To draw an area:
 - a. Use your mouse to click 4 points to draw a rectangle shape. The shape should be convex. Concave shape is not allowed.
 - b. If you want to move the area to other position or re-size the area, select the area by checking the red box on the upper-left corner of the area, the borders of the area will change to red color. Drag and drop the area to a desired position. Drag the red dots at the edge of the area can re-size the area.

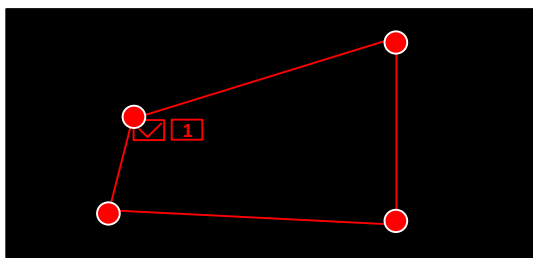

- c. Click the **Apply** button to save the settings.
- d. You can follow the steps above to configure more areas. Up to 4 areas can be configured.
- e. You can click the **Clean All** button to remove all the areas. To remove a certain area, select the area by checking the red box on the upper-left corner of the area, and then click the **Clear** button.

Note: The configured areas should not be too narrow or small in order to enhance the detection rate.

5.8.2.2 Line-Crossing Detection

When objects (people, vehicle or other objects) cross a pre-defined line, the Line-Crossing Detection event will be triggered. You can configure some event actions like event recording, alarm output or Email alert when an event is triggered.

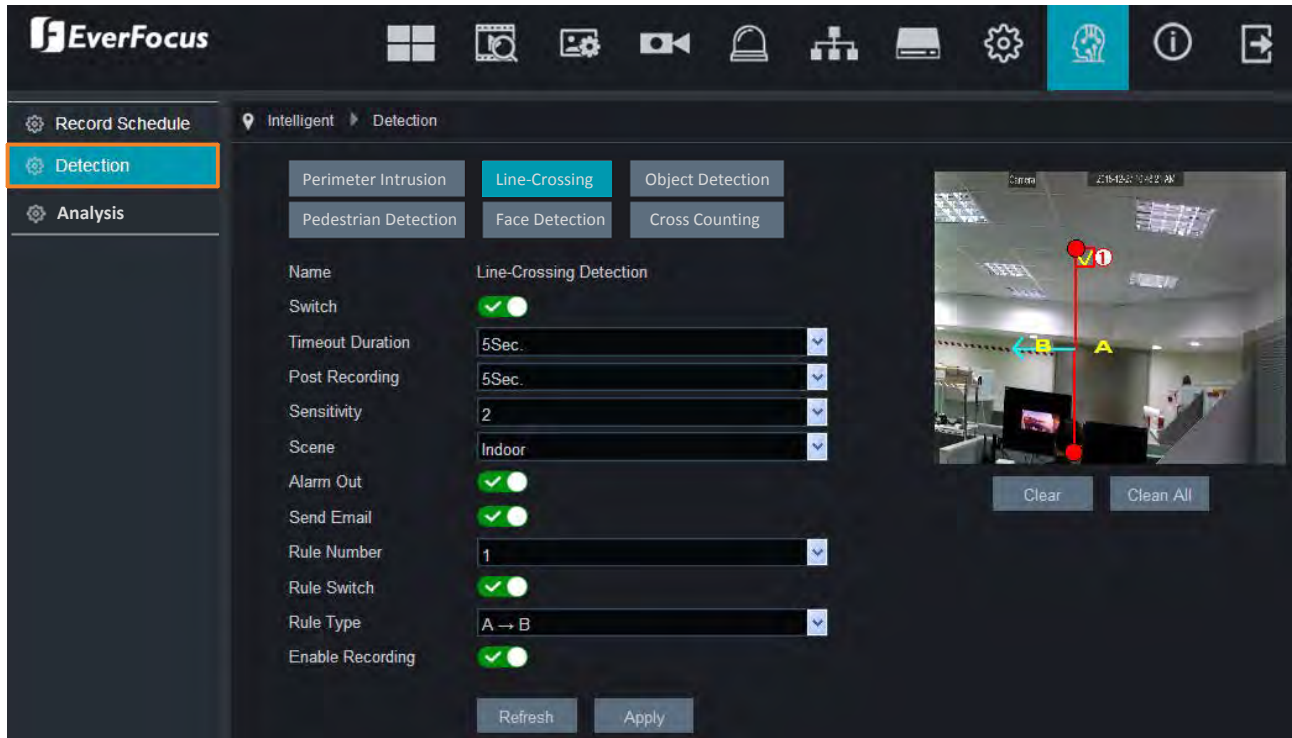

Switch: Switch the button to the right to enable the function.

Timeout Duration: After enabling the Alarm Out, select a timeout duration for the alarm output.

Post Recording: Select a post recording time when a Line-Crossing event is triggered.

Sensitivity: Select a sensitivity for the Line-Crossing Detection. The larger the value, the higher the sensitivity.

Scene: Select **Indoor** or **Outdoor** based on the location where your IP camera is installed.

Alarm Out: Switch the button to the right to enable the alarm output, and then further configure the **Timeout Duration** above.

Send Email: Switch the button to the right to enable the Email alert function. When a Line-Crossing event is triggered, the camera will send an email alert with a snapshot image to the pre-configured Email receiver. Note that for this function to work, you have to set up the Email function in advance (refer to 5.5.3 Email).

Rule Number: Select a number to configure the areas. Up to 4 areas can be configured.

Rule Switch: Switch the button to the right to enable the Rule Type setup below.

Rule Type: Select a rule type.

Enable Recording: Switch the button to the right to enable the Line-Crossing Detection recording function. Note that for Line-Crossing Detection recording function to work, the Record Schedule function has to be configured (please refer to 5.8.1 Record Schedule).

Click **Refresh** to refresh the page; click **Apply** to save the settings.

To configure the Line-Crossing Detection function:

1. Select **1** from the **Rule Number** drop-down list to configure the first line. Up to 4 lines can be configured.
2. Enable the **Rule Switch** and then define a **Rule Type**:

A→B: Detects movement from A to B.

B→A: Detects movement from B to A.

A↔B: Detects both movements from A to B and from B to A.

3. To draw a line:
 - a. Use your mouse to click 2 points to draw a line.
 - b. If you want to move the line to other position or re-draw the line, select the line by checking the red box on the upper-side of the line, the line will change to red color. Drag and drop the line to a desired position. Drag the red dots of the line can re-size the line.

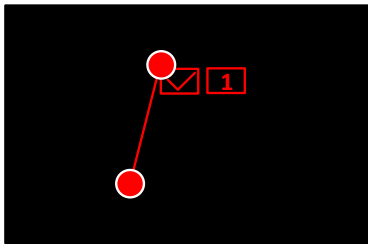

- c. Click the **Apply** button to save the settings.
- d. You can follow the steps above to configure more lines. Up to 4 lines can be configured.
- e. You can click the **Clean All** button to remove all the lines. To remove a certain line, select the line by checking the red box on the upper-left corner of the line, and then click the **Clear** button.

Note: The configured lines should not be too short in order to enhance the detection rate.

5.8.2.3 Object Detection

When IP Camera detects missing objects and foreign objects in a pre-defined area, the Foreign/Missing Object Detection event will be triggered. You can configure some event actions like event recording, alarm output or Email alert when an event is triggered.

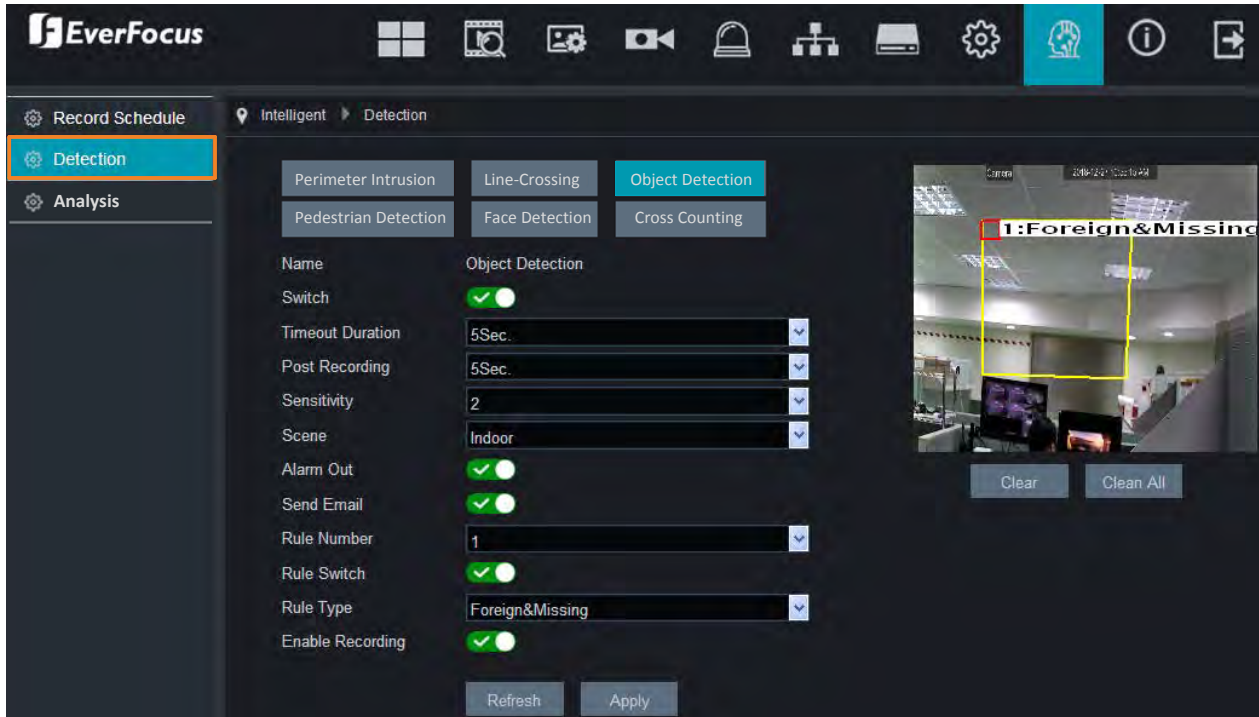

Switch: Switch the button to the right to enable the function.

Timeout Duration: After enabling the Alarm Out, select a timeout duration for the alarm output.

Post Recording: Select a post recording time when a Foreign/Missing Object event is triggered.

Sensitivity: Select a sensitivity for the Foreign/Missing Object Detection. The larger the value, the higher the sensitivity.

Scene: Select **Indoor** or **Outdoor** based on the location where your IP camera is installed.

Alarm Out: Switch the button to the right to enable the alarm output, and then further configure the **Timeout Duration** above.

Send Email: Switch the button to the right to enable the Email alert function. When a Foreign/Missing Object event is triggered, the camera will send an email alert with a snapshot image to the pre-configured Email receiver. Note that for this function to work, you have to set up the Email function in advance (refer to 5.5.3 *Email*).

Rule Number: Select a number to configure the areas. Up to 4 areas can be configured.

Rule Switch: Switch the button to the right to enable the Rule Type setup below.

Rule Type: Select a rule type.

Enable Recording: Switch the button to the right to enable the Foreign/Missing Object Detection recording function. Note that for Foreign/Missing Object Detection recording function to work, the Record Schedule function has to be configured (please refer to 5.8.1 *Record Schedule*).

Click **Refresh** to refresh the page; click **Apply** to save the settings.

To configure the Foreign/Missing Object Detection function:

1. Select **1** from the **Rule Number** drop-down list to configure the first area. Up to 4 areas can be configured.
2. Enable the **Rule Switch** and then define a **Rule Type**:

Foreign: Detects Foreign objects only.

Missing: Detects Missing objects only.

Foreign & Missing: Detects both Foreign and Missing objects.

3. To draw an area:
 - a. Use your mouse to click 4 points to draw a rectangle shape. The shape should be convex. Concave shape is not allowed.
 - b. If you want to move the area to other position or re-size the area, select the area by checking the red box on the upper-left corner of the area, the borders of the area will change to red color. Drag and drop the area to a desired position. Drag the red dots at the edge of the area can re-size the area.

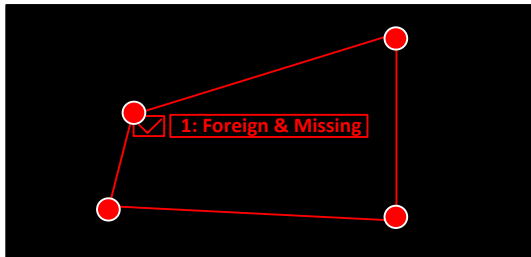

- c. Click the **Apply** button to save the settings.
- d. You can follow the steps above to configure more areas. Up to 4 areas can be configured.
- e. You can click the **Clean All** button to remove all the areas. To remove a certain area, select the area by checking the red box on the upper-left corner of the area, and then click the **Clear** button.

Note: The configured areas should not be too narrow or small in order to enhance the detection rate.

5.8.2.4 Pedestrian Detection

Only 5MP and 8MP models support this function. When IP Camera detects pedestrian in a pre-defined area, the Pedestrian Detection event will be triggered. You can configure some event actions like event recording, alarm output or Email alert when an event is triggered.

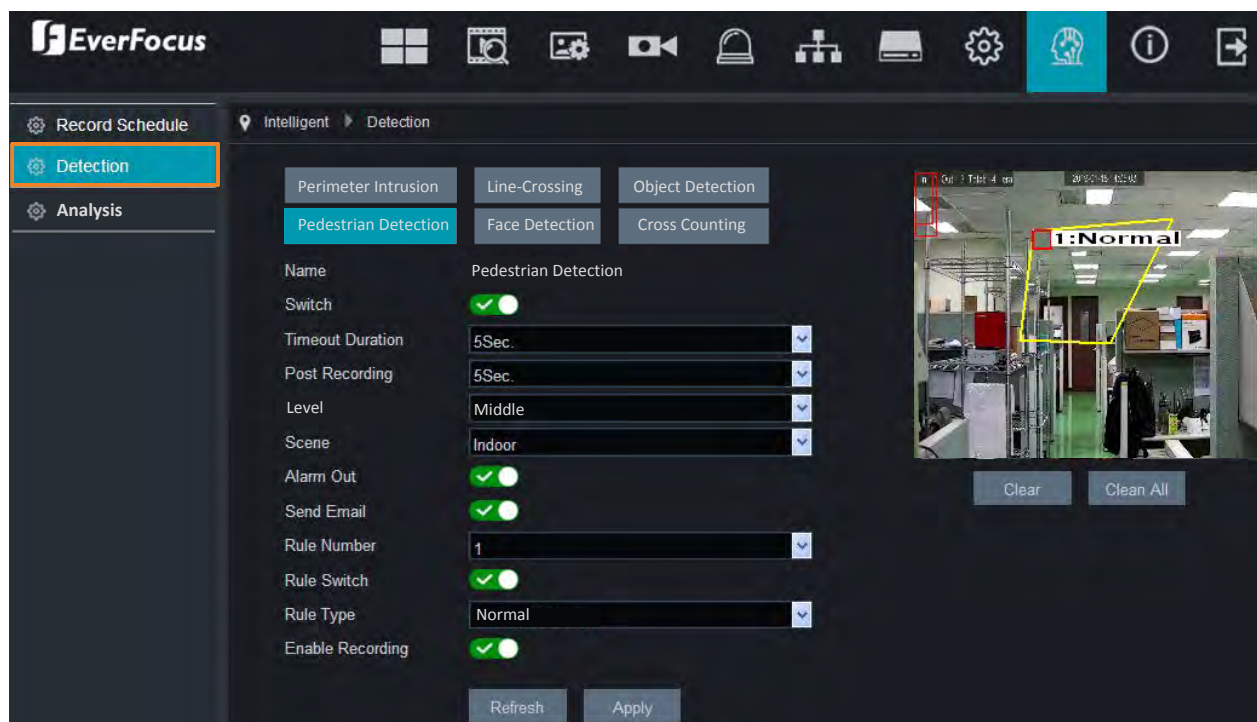

Switch: Switch the button to the right to enable the function.

Timeout Duration: After enabling the Alarm Out, select a timeout duration for the alarm output.

Post Recording: Select a post recording time when a Pedestrian Detection event is triggered.

Level: Select a detection level for the Pedestrian Detection. The value stands for the distance of the objects. Smaller value is suitable to detect objects that are far away from the camera. Larger value is suitable to detect objects near the camera. The red squares on the top left corner represent the max. and min. object size of the selected Level.

Scene: Select **Indoor** or **Outdoor** based on the location where your IP camera is installed.

Alarm Out: Switch the button to the right to enable the alarm output, and then further configure the **Timeout Duration** above.

Send Email: Switch the button to the right to enable the Email alert function. When a Pedestrian Detection event is triggered, the camera will send an email alert with a snapshot image to the pre-configured Email receiver. Note that for this function to work, you have to set up the Email function in advance (refer to 5.5.3 Email).

Rule Number: Select a number to configure the areas.

Rule Switch: Switch the button to the right to enable the Rule Type setup below.

Rule Type: Select a rule type.

Enable Recording: Switch the button to the right to enable the Pedestrian Detection recording function. Note that for Pedestrian Detection recording function to work, the Record Schedule function has to be configured (please refer to 5.8.1 Record Schedule).

Click **Refresh** to refresh the page; click **Apply** to save the settings.

To configure the Pedestrian Detection function:

1. Select **1** from the **Rule Number** drop-down list to configure the first area.
2. Enable the **Rule Switch** and then define a **Rule Type**.
3. To draw an area:
 - a. Use your mouse to click 4 points to draw a rectangle shape. The shape should be convex. Concave shape is not allowed.
 - b. If you want to move the area to other position or re-size the area, select the area by checking the red box on the upper-left corner of the area, the borders of the area will change to red color. Drag and drop the area to a desired position. Drag the red dots at the edge of the area can re-size the area.

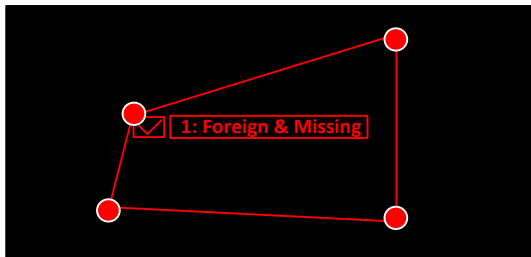

- c. Click the **Apply** button to save the settings.
- d. You can click the **Clean All** button to remove the area.

Note: The configured areas should not be too narrow or small in order to enhance the detection rate.

5.8.2.5 Face Detection

Only 5MP and 8MP models support this function. When IP Camera detects faces in a pre-defined area, the Face Detection event will be triggered. You can configure some event actions like event recording, alarm output or Email alert when an event is triggered.

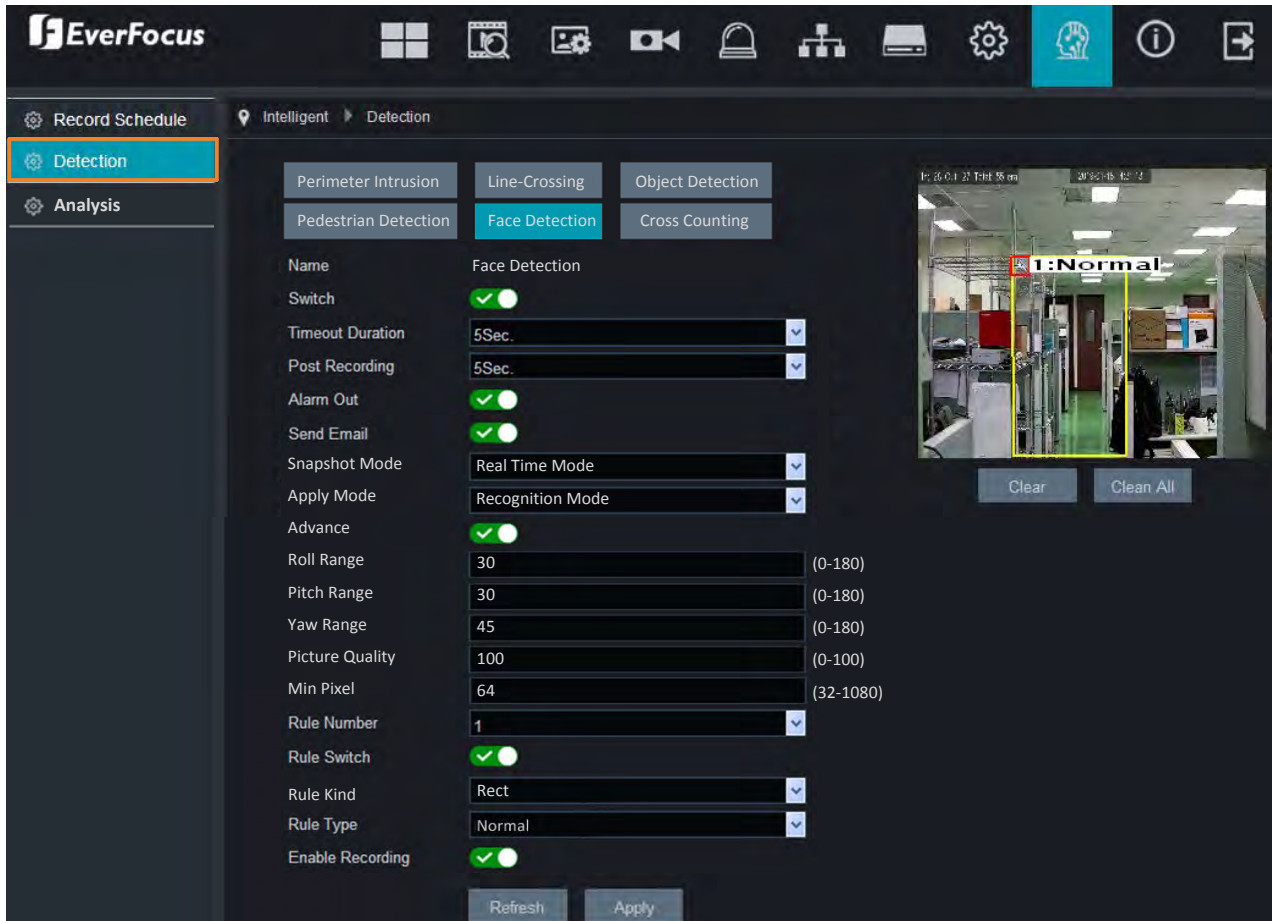

Switch: Switch the button to the right to enable the function.

Timeout Duration: After enabling the Alarm Out, select a timeout duration for the alarm output.

Post Recording: Select a post recording time when a Face Detection event is triggered.

Alarm Out: Switch the button to the right to enable the alarm output, and then further configure the **Timeout Duration** above.

Send Email: Switch the button to the right to enable the Email alert function. When a Face Detection event is triggered, the camera will send an email alert with a snapshot image to the pre-configured Email receiver. Note that for this function to work, you have to set up the Email function in advance (refer to 5.5.3 Email).

Snapshot Mode: Select a snapshot mode.

Apply Mode: Select a apply mode.

Advance: Switch the button to the right to enable the advanced functions including Roll Range, Pitch Range, Yaw Range, Picture Quality and Min Pixel.

Rule Number: Select a number to configure the areas.

Rule Switch: Switch the button to the right to enable the Rule Type setup below.

Rule Kind: Select a rule kind. Options include Area and Line.

Rule Type: Select a rule type.

Enable Recording: Switch the button to the right to enable the Face Detection recording function. Note that for Face Detection recording function to work, the Record Schedule function has to be configured (please refer to 5.8.1 Record Schedule).

Click **Refresh** to refresh the page; click **Apply** to save the settings.

To configure the Face Detection function:

1. Select **1** from the **Rule Number** drop-down list to configure the first area.
2. Enable the **Rule Switch** and then define a **Rule Kind** and **Rule Type**.
3. To draw an area:
 - a. To draw an area, use your mouse to click 4 points to draw a rectangle shape. The shape should be convex. Concave shape is not allowed. To draw a line, use your mouse to click 2 points to draw a line.
 - b. If you want to move the area (or line) to other position or re-size the area, select the area by checking the red box on the upper-left corner of the area, the borders of the area will change to red color. Drag and drop the area to a desired position. Drag the red dots at the edge of the area can re-size the area.

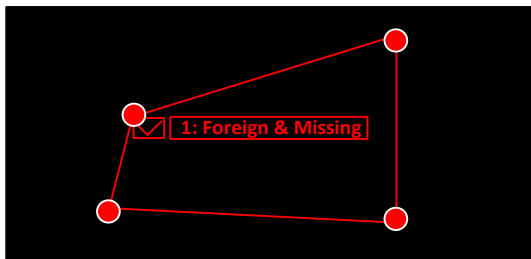

- c. Click the **Apply** button to save the settings.
- d. You can click the **Clean All** button to remove the area.

Note: The configured areas should not be too narrow or small in order to enhance the detection rate.

5.8.2.6 Cross-Counting Detection

Only 5MP and 8MP models support this function. The camera will count the times when objects (people, vehicle or other objects) cross a pre-defined line, and the Cross-Counting Detection event will be triggered. You can configure some event actions like event recording, alarm output or Email alert when an event is triggered. To search and view the statistical result of cross-counting, go to Intelligent > Analysis (please refer to 5.8.3 Analysis).

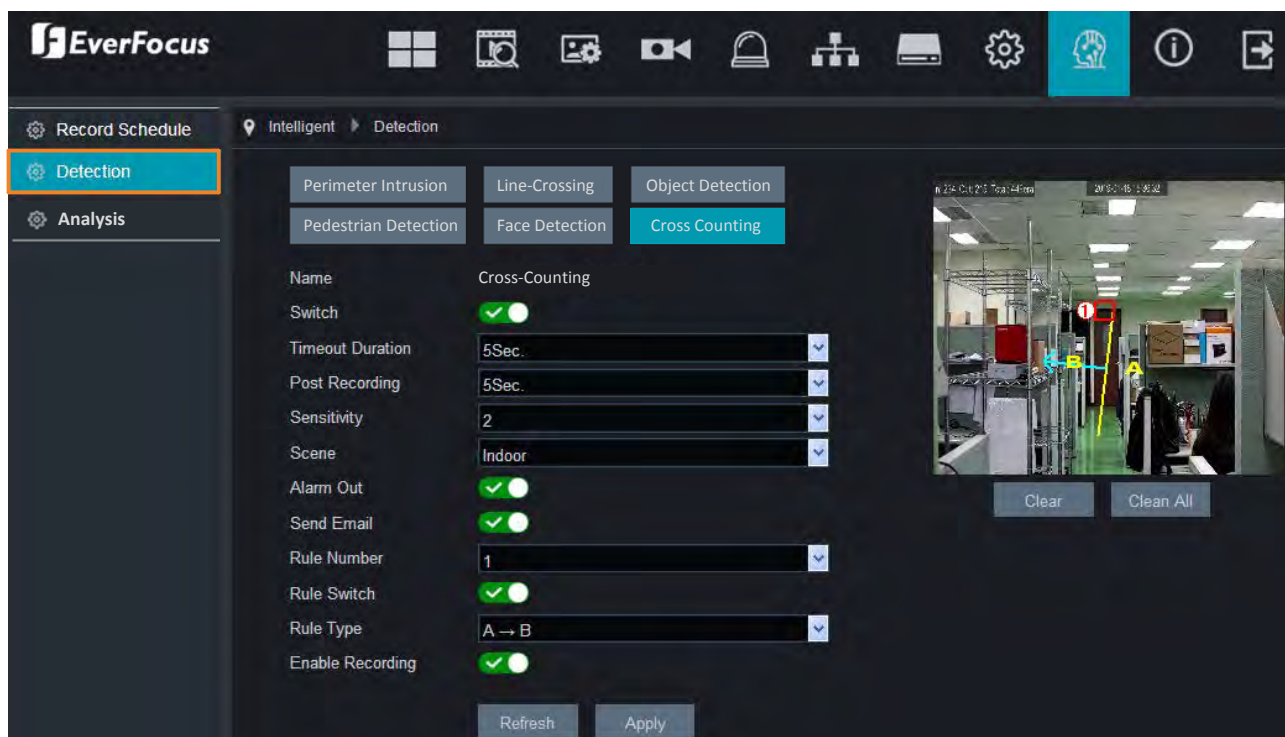

Switch: Switch the button to the right to enable the function.

Timeout Duration: After enabling the Alarm Out, select a timeout duration for the alarm output.

Post Recording: Select a post recording time when a Cross-Counting Detection event is triggered.

Sensitivity: Select a sensitivity for the Cross-Counting Detection. The larger the value, the higher the sensitivity.

Scene: Select **Indoor** or **Outdoor** based on the location where your IP camera is installed.

Alarm Out: Switch the button to the right to enable the alarm output, and then further configure the **Timeout Duration** above.

Send Email: Switch the button to the right to enable the Email alert function. When a Cross-Counting Detection event is triggered, the camera will send an email alert with a snapshot image to the pre-configured Email receiver. Note that for this function to work, you have to set up the Email function in advance (refer to 5.5.3 Email).

Rule Number: Select a number to configure the areas.

Rule Switch: Switch the button to the right to enable the Rule Type setup below.

Rule Type: Select a rule type.

Enable Recording: Switch the button to the right to enable the Cross-Counting Detection recording function. Note that for Cross-Counting Detection recording function to work, the Record Schedule function has to be configured (please refer to 5.8.1 Record Schedule).

Click **Refresh** to refresh the page; click **Apply** to save the settings.

To configure the Line-Crossing Detection function:

1. Select **1** from the **Rule Number** drop-down list to configure the line.
2. Enable the **Rule Switch** and then define a **Rule Type**:
 - A→B: Detects movement from A to B.
 - B→A: Detects movement from B to A.
 - A↔B: Detects both movements from A to B and from B to A.
3. To draw a line:
 - a. Use your mouse to click 2 points to draw a line.
 - b. If you want to move the line to other position or re-draw the line, select the line by checking the red box on the upper-side of the line, the line will change to red color. Drag and drop the line to a desired position. Drag the red dots of the line can re-size the line.

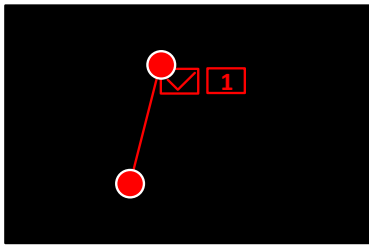

- c. Click the **Apply** button to save the settings.
- d. You can click the **Clean All** button to remove the line.

Note: The configured line should not be too short in order to enhance the detection rate.

5.8.3 Analysis

You can search and view the statistical result of the intelligent analysis with list, histogram or line chart format. You can also export the analysis report to your computer.

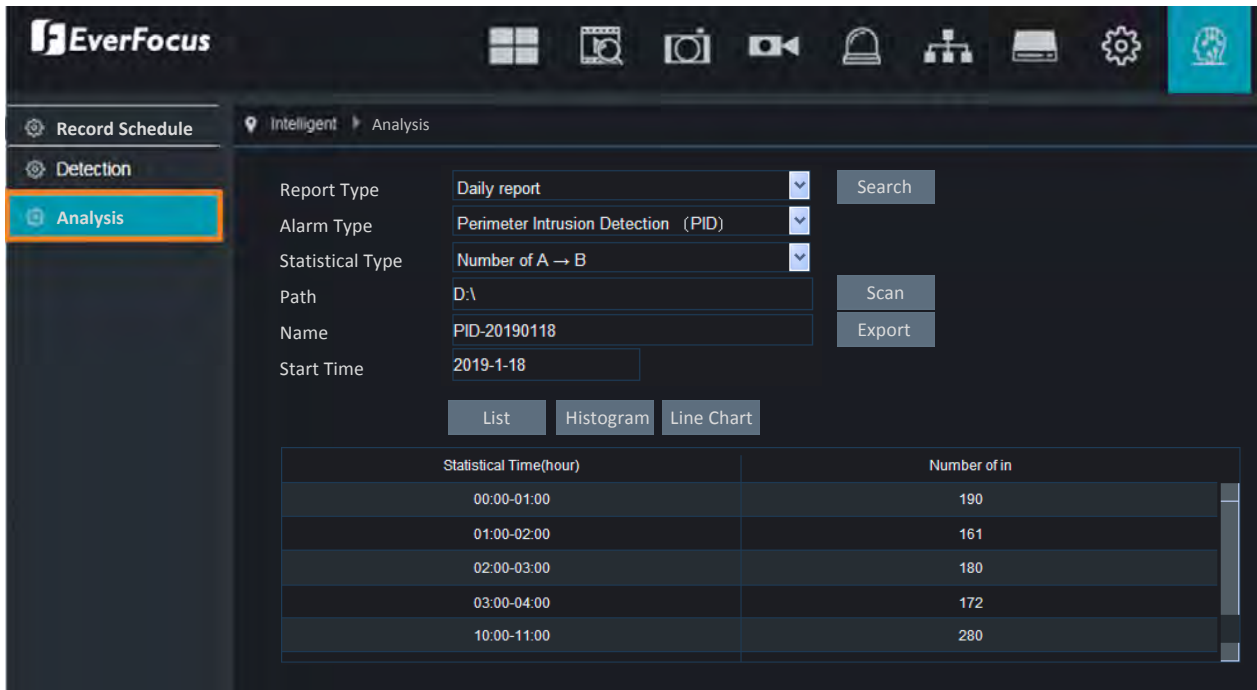

Report Type: Select a report type.

Alarm Type: Select an Intelligent alarm type.

Statistical Type: Select a statistical type of the selected intelligent alarm.

Path: If you want to export the statistic report, click the **Scan** button to select a storage path for the report, input a file name in the **Name** field and then click the **Export** button.

Name: If you want to export the statistic report, input a file name for the statistic report.

Start Time: Select a start time to search for the results.

List: After clicking the **Search** button, the statistic report will be displayed with list format.

Histogram: After clicking the **Search** button, the statistic report will be displayed with histogram.



Line Chart: After clicking the **Search** button, the statistic report will be displayed with line chart.



5.9 Color Setting

You can adjust Hue, Brightness, Contrast, Saturation and Sharpness value using the Color Panel. Click the **Default** button to restore all the value to factory default. On the Live View window, click the **Color** button to display the Color Panel. You can click the **Color** button again to hide the Color Panel.

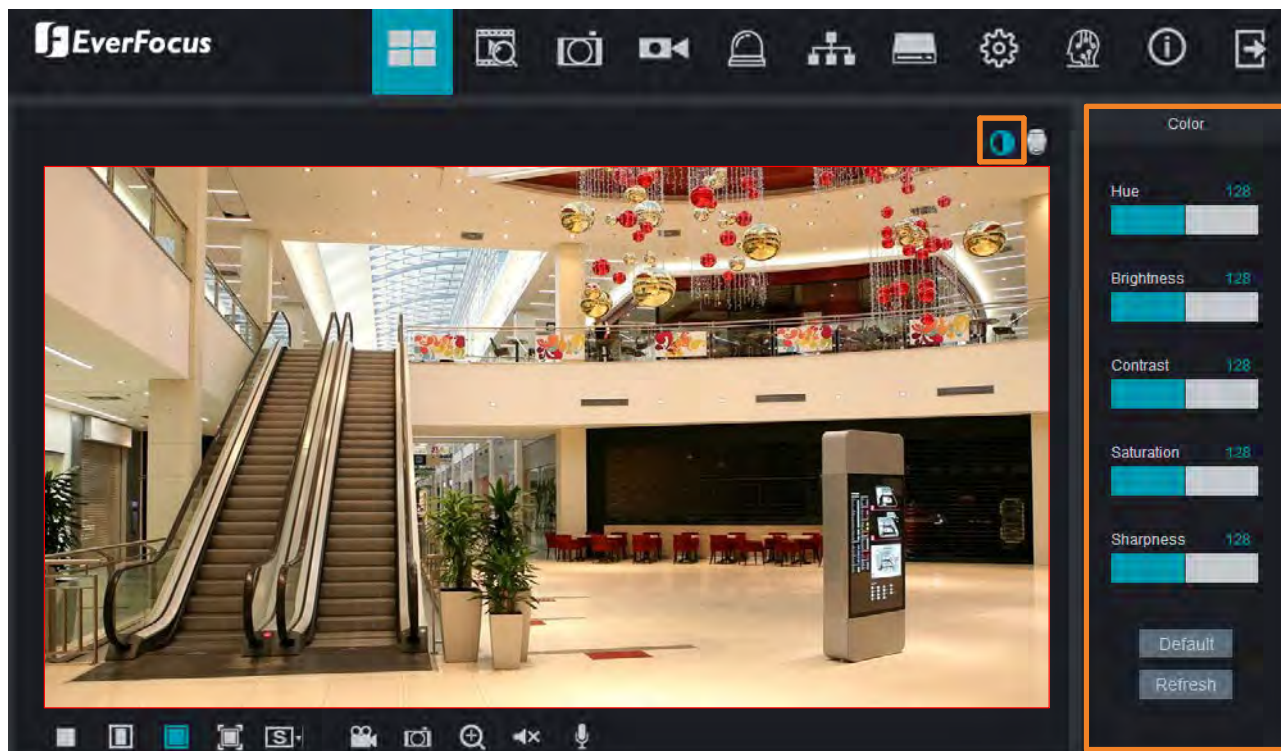

5.10 Lens Control

For motorized lens models, you can control the lens operation using the Lens Control panel. On the Live View window, click the **Lens Control** button to display the Lens Control Panel. You can click the **Lens Control** button again to hide the Lens Control Panel.

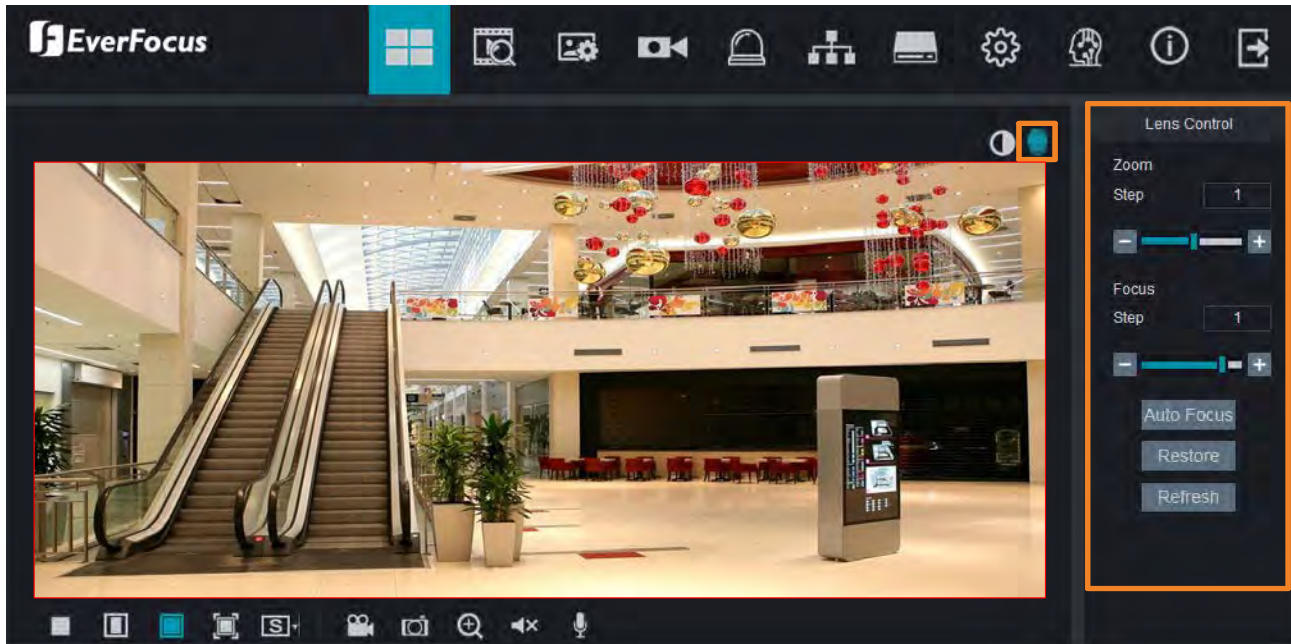

Important note for motorized lens models

For motorized lens models, if you find the live image out of focus, please try the instructions below:

1. On the **Lens Control** panel, click the **Restore** button for the lens to restore to the default position, and then click the **Auto Focus** button.
2. If the image is still out of focus, adjust the focus by clicking the Focus “+” or “-” buttons.

5.11 Live View Function Icons

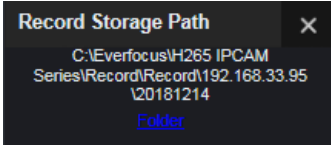
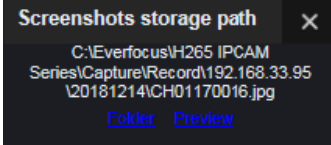

No	Name	Description
1	Stop / Play	Click to stop / play the video streaming on the Live View window.
2	Original Ratio / Hallway	Click to display the live streams with the original aspect ratio. If you enable the Hallway mode, you can also click this button to display live streams in 9:16. To enable Hallway mode, please refer to <i>5.2.2.1 Hallway Display</i> .
3	Stretch	Click to stretch live streams on the Live View window.
4	Full Screen	Click to display the Live View window in full screen mode. To exit full screen mode, double-click the live view or press the ESC button on the keyboard.
5	Stream Switch	Select a stream type to be displayed on the live view window. For this function to work, the stream types have to be pre-configured, please refer to <i>5.5.2 Video Streaming</i> .
6	Video Clips	<p>Click the Video Clips button to start recording the live streams, click the button again to stop recording, a message window appears on the bottom-left corner of the screen. Click Folder to open the folder to find the recording file. To change the storage path or the file format, please refer to <i>5.7.7 Local Settings</i>. You can use EverFocus Player or any player supporting the video format to play back the recordings. EverFocus Player is included in the Software CD.</p> 
7	Snapshot	<p>Click to take a snapshot, a message window appears on the bottom-left corner of the screen. Click Folder to open the folder to find the snapshot image. Or click Preview to preview the snapshot image. To change the storage path or image format, please refer to <i>5.7.7 Local Settings</i>.</p> 
8	Digital Zoom	<p>Click to enable the Digital Zoom mode. To exit the Digital Zoom mode, click the button again. To perform the Digital Zoom function:</p> <ol style="list-style-type: none"> Click the Digital Zoom button. Use your mouse to draw an area where you want to have a close-up view. The area will be zoom-in. Right-click to exit the Digital Zoom mode.
9	Audio	Click to switch on/off the speaker. You can also adjust the volume.
10	Voice Intercom	Click to enable the microphone. Click the button again to disable microphone.

EverFocus Electronics Corp.

EverFocus Taiwan:

2F., No.12, Ln. 270, Sec. 3, Beishen Rd., Shenkeng
Dist., New Taipei City 222, Taiwan
TEL: +886 2 2662 2338
FAX: +886 2 2662 3632
www.everfocus.com.tw
marketing@everfocus.com.tw

EverFocus USA - California:

1801 Highland Avenue, Unit A, Duarte,
CA 91010, USA
TEL: +1 626 844 8888
FAX: +1 626 844 8838
www.everfocus.com
sales@everfocus.com

EverFocus China - Shenzhen:

3F, Building 7, Longcheng Industrial
Park, No.440, Longguan Road, Dalang Street,
Longhua, Shenzhen, Guangdong, China
TEL: +86 755 2765 1313
FAX: +86 755 2765 0337
www.everfocus.com.cn
marketing@everfocus.com.cn

EverFocus Japan:

3F, Kuramochi, Building II
2-2-3 Koto-Bashi, Sumida-Ku,
Tokyo, 130-0022, Japan
TEL: +81 3 5625 8188
FAX: +81 3 5625 8189
www.everfocus.co.jp
info@everfocus.co.jp



Your EverFocus product is designed and manufactured with high quality materials and components which can be recycled and reused.

This symbol means that electrical and electronic equipment, at their end-of-life, should be disposed of separately from your household waste.

Please, dispose of this equipment at your local community waste collection/recycling centre.

In the European Union there are separate collection systems for used electrical and electronic product.

Please, help us to conserve the environment we live in!

Ihr EverFocus Produkt wurde entwickelt und hergestellt mit qualitativ hochwertigen Materialien und Komponenten, die recycelt und wieder verwendet werden können.

Dieses Symbol bedeutet, dass elektrische und elektronische Geräte am Ende ihrer Nutzungsdauer vom Hausmüll getrennt entsorgt werden sollen.

Bitte entsorgen Sie dieses Gerät bei Ihrer örtlichen kommunalen Sammelstelle oder im Recycling Centre.

Helfen Sie uns bitte, die Umwelt zu erhalten, in der wir leben!



EverFocus