



User Manual

IDK-2117 Series

**17" SXGA High Brightness
Display Kit with LED Backlight**

ADVANTECH

Enabling an Intelligent Planet

Copyright

The documentation and the software included with this product are copyrighted 2017 by Advantech Co., Ltd. All rights are reserved. Advantech Co., Ltd. reserves the right to make improvements in the products described in this manual at any time without notice. No part of this manual may be reproduced, copied, translated or transmitted in any form or by any means without the prior written permission of Advantech Co., Ltd. Information provided in this manual is intended to be accurate and reliable. However, Advantech Co., Ltd. assumes no responsibility for its use, nor for any infringements of the rights of third parties, which may result from its use.

Acknowledgements

AMI is a trademark of American Megatrends Inc.

IBM and PC are trademarks of International Business Machines Corporation.

Intel® Core 2 Quad, Pentium Dual Core and Celeron are trademarks of Intel Corporation.

WinBond is a trademark of Winbond Corporation.

All other product names or trademarks are properties of their respective owners.

A Message to the Customer

Advantech Customer Services

Each and every Advantech product is built to the most exacting specifications to ensure reliable performance in the harsh and demanding conditions typical of industrial environments. Whether your new Advantech equipment is destined for the laboratory or the factory floor, you can be assured that your product will provide the reliability and ease of operation for which the name Advantech has come to be known.

Your satisfaction is our primary concern. Here is a guide to Advantech's customer services. To ensure you get the full benefit of our services, please follow the instructions below carefully.

Technical Support

We want you to get the maximum performance from your products. So if you run into technical difficulties, we are here to help. For the most frequently asked questions, you can easily find answers in your product documentation. These answers are normally a lot more detailed than the ones we can give over the phone.

So please consult this manual first. If you still cannot find the answer, gather all the information or questions that apply to your problem, and with the product close at hand, call your dealer. Our dealers are well trained and ready to give you the support you need to get the most from your Advantech products. In fact, most problems reported are minor and are able to be easily solved over the phone.

In addition, free technical support is available from Advantech engineers every business day. We are always ready to give advice on application requirements or specific information on the installation and operation of any of our products.

Product Warranty (2 years)

Advantech warrants to you, the original purchaser, that each of its products will be free from defects in materials and workmanship for two years from the date of purchase.

This warranty does not apply to any products which have been repaired or altered by persons other than repair personnel authorized by Advantech, or which have been subject to misuse, abuse, accident or improper installation. Advantech assumes no liability under the terms of this warranty as a consequence of such events.

Because of Advantech's high quality-control standards and rigorous testing, most of our customers never need to use our repair service. If an Advantech product is defective, it will be repaired or replaced at no charge during the warranty period. For out-of-warranty repairs, you will be billed according to the cost of replacement materials, service time and freight. Please consult your dealer for more details.

If you think you have a defective product, follow these steps:

1. Collect all the information about the problem encountered. (For example, CPU speed, Advantech products used, other hardware and software used, etc.) Note anything abnormal and list any onscreen messages you get when the problem occurs.
2. Call your dealer and describe the problem. Please have your manual, product, and any helpful information readily available.
3. If your product is diagnosed as defective, obtain an RMA (return merchandise authorization) number from your dealer. This allows us to process your return more quickly.
4. Carefully pack the defective product, a fully-completed Repair and Replacement Order Card and a photocopy proof of purchase date (such as your sales receipt) in a shippable container. A product returned without proof of the purchase date is not eligible for warranty service.
5. Write the RMA number visibly on the outside of the package and ship it prepaid to your dealer.

Contents

Chapter 1	Overview.....	1
1.1	General Description	2
1.2	Specifications	2
1.2.1	LCD Panel.....	2
1.2.2	LED Driver Board.....	2
1.2.3	Touch Screen (R series).....	2
1.2.4	Environment.....	2
1.3	Functional Block Diagram	3
	Figure 1.1 Function block diagram	3
1.4	Mechanical Characteristics	3
1.4.1	IDK-2117N Series LCD Module.....	3
1.4.2	IDK-2117R Series LCD Module with Touch Screen	4
1.4.3	LED Driver Board.....	5
1.4.4	Touch Controller	5
1.5	Touch Screen driver.....	5
1.6	Absolute Maximum Ratings	6
1.6.1	TFT LCD Module	6
1.6.2	Absolute Environment Ratings.....	6
Chapter 2	Electrical Characteristics.....	7
2.1	TFT LCD Module.....	8
2.1.1	Power Specification	8
	Table 2.1: Power specification.....	8
2.1.2	Signal Electrical Characteristics.....	8
	Table 2.2: Signal electrical characteristics	8
2.2	Backlight Unit (LED Driver Board).....	9
	Table 2.3: Backlight driving conditions	9
Chapter 3	Signal Characteristics.....	11
3.1	Pixel Format Image	12
3.2	The Input Data Format	12
3.3	Pin Description	13
	Table 3.1: Pin Description	13
3.4	Interface Timing	14
3.4.1	Timing Characteristics	14
	Table 3.2: Timing Characteristics	14
3.4.2	Timing Diagram.....	14
3.5	Power ON/OFF Sequence	15
Chapter 4	Connector & Pin Assignment.....	17
4.1	TFT LCD Module.....	18
4.1.1	Connector	18
	Table 4.1: Connector.....	18
4.1.2	Pin Assignment.....	18
	Table 4.2: Pin Assignment.....	18
4.2	Backlight Unit (LED Driver Board).....	18
4.2.1	Pin Assignment.....	19

Chapter	5	Touchscreen & Touch Controller	21
5.1		Touchscreen (for IDK-2117R Only)	22
5.1.1		Touch Characteristics	22
5.1.2		Optical Characteristics	22
5.1.3		Mechanical Characteristics	22
5.2		Touch Controller (for IDK-2117R Only).....	22
5.2.1		Touch Controller Characteristics	22
5.2.2		Pin Assignment and Description	23
		Figure 5.1 Board mounted header	23
Appendix A		Optical Characteristics	25
A.1		LCD Module Optical Characteristics	26
		Table A.1: Optical Characteristics	26
Appendix B		Handling Precautions	29
B.1		Optical Characteristics	30

Chapter 1

Overview

1.1 General Description

The Advantech IDK- 2117 series comes with a 17" 1200 cd/m² industrial grade LCD display, and an LED driving board. The series is also available with flexible options for touchscreens and enhanced treatments such as an AR surface treatment and an optical bonding solution. IDK- 2117 series provides superior sunlight readability and is perfect for applications whether in semi-outdoor or out-door environments.

1.2 Specifications

1.2.1 LCD Panel

- **Display Size:** 17" LED backlight panel
- **Resolution:** 1280 x 1024
- **Viewing Angle (Horizontal / Vertical):** 170°/160°
- **Brightness:** 1200 cd/m²
- **Contrast Ratio:** 1000:1
- **Response Time (ms):** 5
- **Colors:** 16.2 M
- **Nominal Input Voltage:** 5V
- **Power Consumption:** 17 W
- **Signal Interface:** 2 channel LVDS
- **Weight:** N series:1300g; R series:1760g
- **Dimensions(W x H x D):** N series: 358.5 x 296.5 x 18.0 Max. mm
R series: 358.5 x 296.5 x 20.9 Max. mm

1.2.2 LED Driver Board

- **Brightness Adjustment:** PWM / Auto dimming (Optional) / VR (Optional)
- **Efficiency:** 90% (Constant Current output)
- **Output Current / Voltage:** 1.3A / 12V
- **Dimensions (W x H x D):** 80 x 54.2 x 10 mm

1.2.3 Touch Screen (R series)

- **Touch Screen:** 5-Wire Resistive
- **Light Transmission:** 80 ± 3%
- **Durability:** 10 million times

1.2.4 Environment

- **Operating Temperature:** 0~50 °C
- **Storage Temperature:** -20 ~ 60°C
- **Humidity:** 5~ 95% @ 40°C, non-condensing

1.3 Functional Block Diagram

The following diagram shows the functional block of the 17 inches Color TFT-LCD Module:

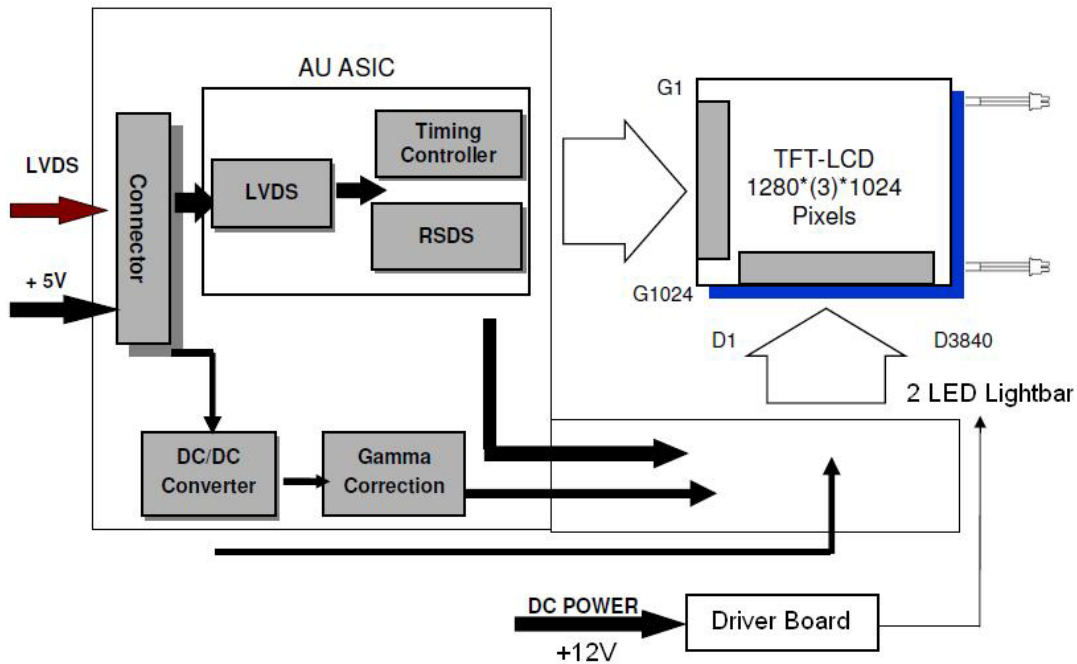
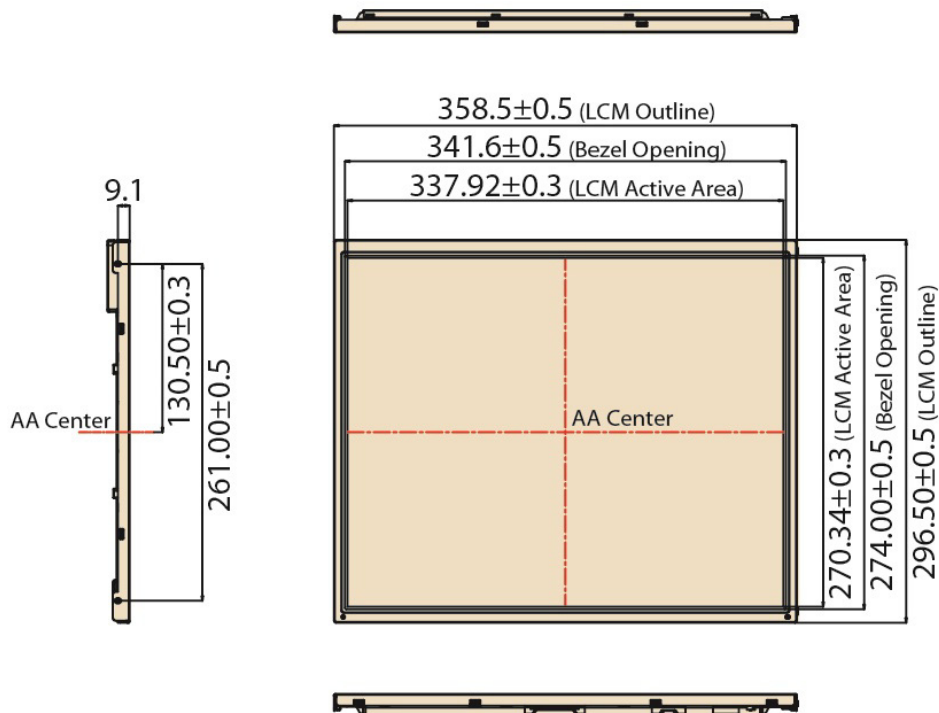

Figure 1.1 Function block diagram

1.4 Mechanical Characteristics

1.4.1 IDK-2117N Series LCD Module

Front View



Rear View

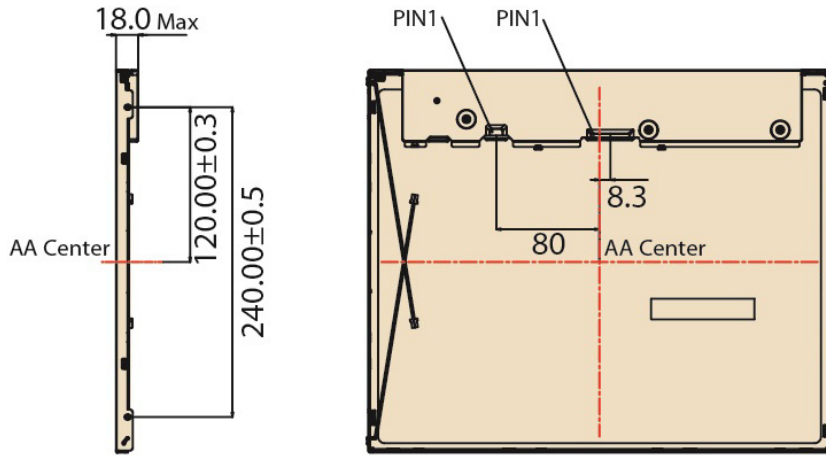

1.4.2 IDK-2117R Series LCD Module with Touch Screen

Front View

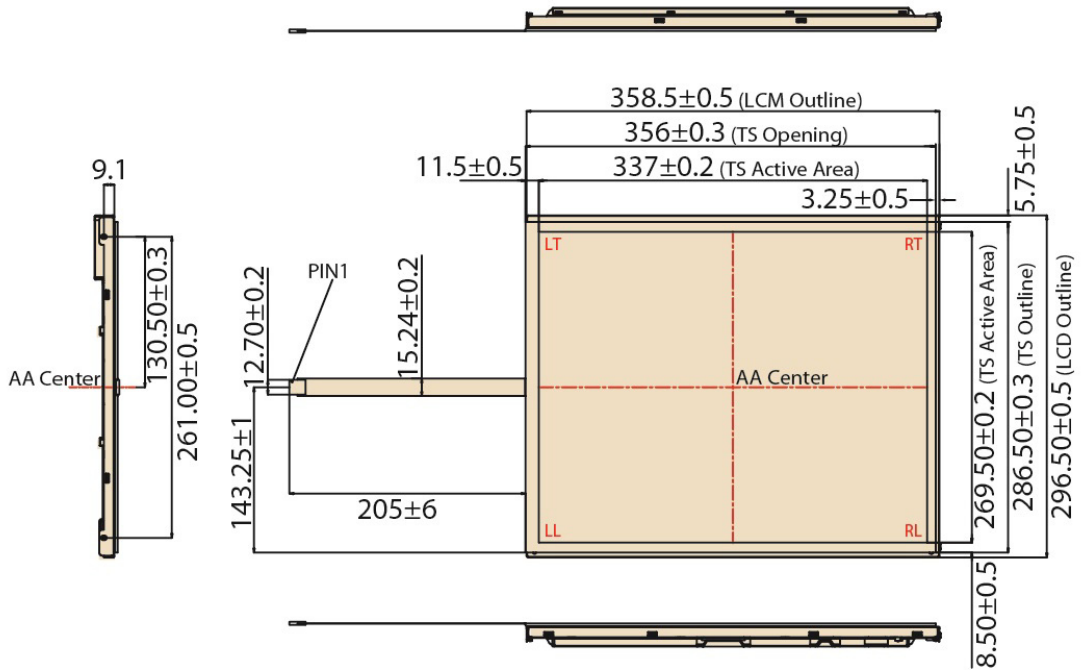

Rear View

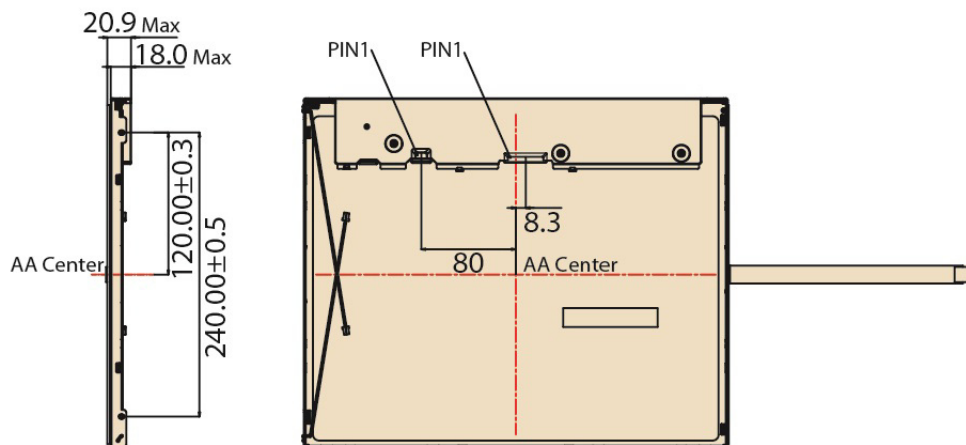

1.4.3 LED Driver Board

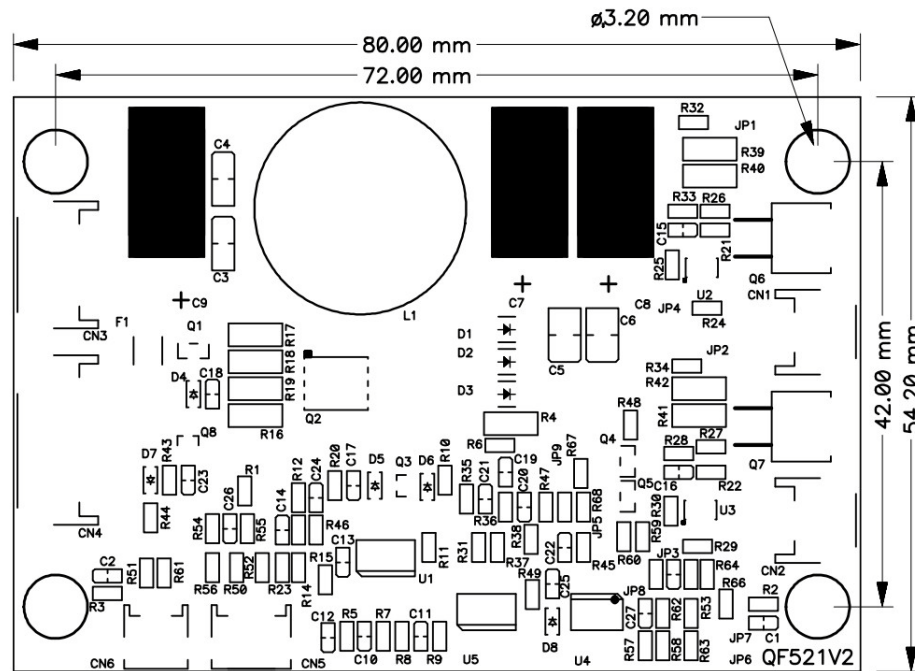

Dimension: 80±0.2mm x 54.2±0.2mm x 10±0.5mm

1.4.4 Touch Controller

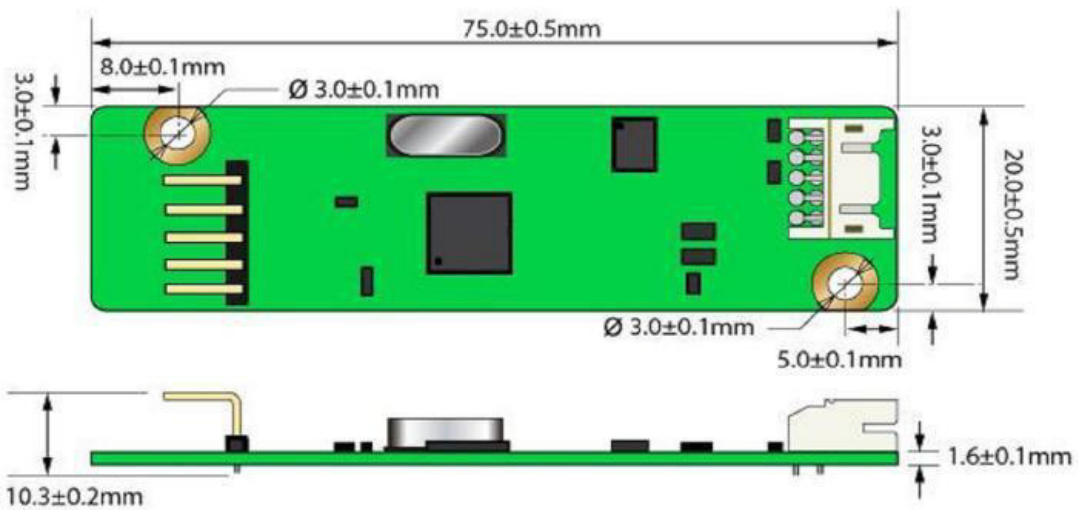

1.5 Touch Screen driver

Please download the touchscreen driver from Advantech website.

1.6 Absolute Maximum Ratings

1.6.1 TFT LCD Module

Item	Symbol	Min.	Max.	Unit	Conditions
Logic/LCD Drive Voltage	Vin	-0.3	6	[Volt]	Note 1, 2

1.6.2 Absolute Environment Ratings

Item	Symbol	Min.	Max.	Unit	Conditions
Operating Temperature	TOP	0	+50	[°C]	
Operation Humidity	HOP	5	90	[%RH]	
Storage Temperature	TST	-20	+60	[°C]	
Storage Humidity	HST	5	90	[%RH]	

Note1: With in Ta= 25°C

Note2: Permanent damage to the device may occur if exceed maximum values

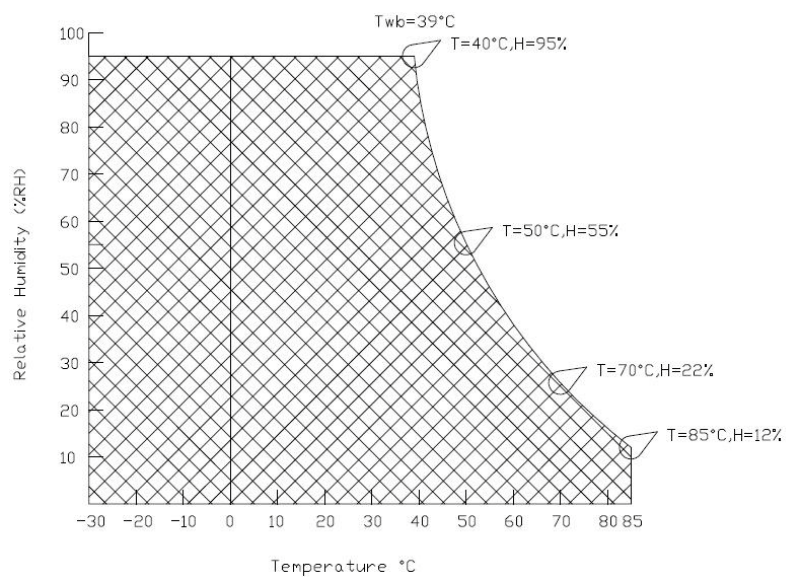

Chapter 2

Electrical
Characteristics

2.1 TFT LCD Module

2.1.1 Power Specification

Input power specifications are as follows:

Table 2.1: Power specification

Parameter	Symbol	Value			Unit	Condition
		Min.	Typ.	Max.		
Logic/LCD Drive Voltage	VCC	4.5	5	5.5	[Volt]	±10%
Input Current	ICC	-	0.59	0.71	[A]	All black pattern (VCC=5V, at 75Hz)
VCC Power	PCC	-	2.95	3.54	[Watt]	All black pattern (VCC=5V, at 75Hz)
Allowable Logic/LCD Drive Ripple Voltage	VCC _{rp}	-	-	500	[mV] p-p	With panel loading

2.1.2 Signal Electrical Characteristics

Input signals shall be low or Hi-Z state when Vin is off.

Each signal characteristics are as follows:

Table 2.2: Signal electrical characteristics

Symbol	Parameter	Min.	Typ.	Max.	Unit	Condition
VTH	Differential Input High Threshold	-	-	+100	[mV]	VICM=1.2V
VTL	Differential Input Low Threshold	-100	-	-	[mV]	VICM=1.2V
VID	Input Differential Voltage	100	400	600	[mV]	
VICM	Differential Input Common Mode Voltage	+1.0	+1.2	+1.5	[V]	VTH / VTL = ±100mV

Note: LVDS Signal Waveform.

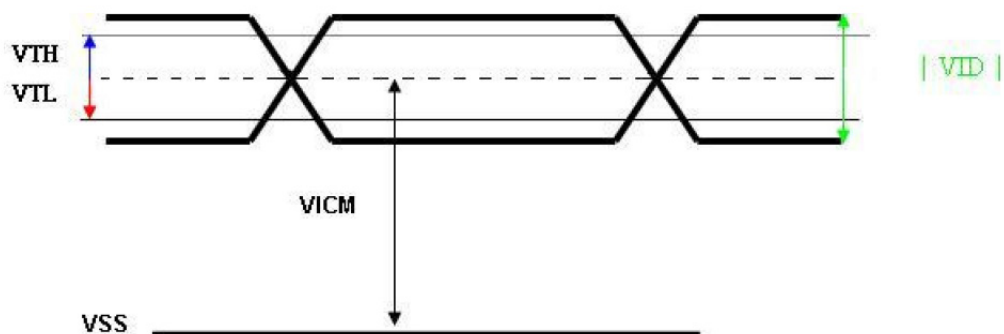

2.2 Backlight Unit (LED Driver Board)

Following characteristics are measured under stable condition at 25°C:

Table 2.3: Backlight driving conditions

Item	Symbol	Values			Unit	Condition
		Min.	Typ.	Max.		
Input Voltage	V_{LED}	10.8	12	13.2	[Volt]	
Input Current	I_{LED}	1.05	1.3	1.6	[A]	
Power Consumption	P_{LED}	11.34	15.6	21.12	[Watt]	
PWM Dimming Frequency	F_{PWM}	500	-	40K	[Hz]	Note 1,2
Dimming Duty Cycle	D_{PWM}	5%	-	100	[%]	
LED Forward Current	I_F	-	400	420	[mA]	One light bar
On Control Voltage	$V_{LED\ ON/OFF}$	1.5	5	-	[Volt]	Note 3,4
Off Control Voltage		-	0	0.8	[Volt]	
LED Life Time	-	50,000			[Hrs]	Note 5,6

Note 1: PWM dimming function can be operated by PWM signal. PWM duty cycle can adjust white Luminance. (PWM High: ON and PWM Low: OFF)

Note 2: PWM signal cannot be floating and pull-down to ground when waiting.

Note 3: Enable ($V_{LED\ ON/OFF}$) must be turned on late than V_{LED} and PWM Signal.

Note 4: Enable ($V_{LED\ ON/OFF}$) must be turned off early than V_{LED} and PWM Signal.

Note 5: If this module is driven by high current or at high ambient temperature & humidity condition. The operating life will be reduced.

Note 6: Operating life means brightness goes down to 50% initial brightness. Minimum operating life time is estimated data.

Chapter 3

Signal Characteristics

3.1 Pixel Format Image

Following figure shows the relationship between input signal and LCD pixel format.

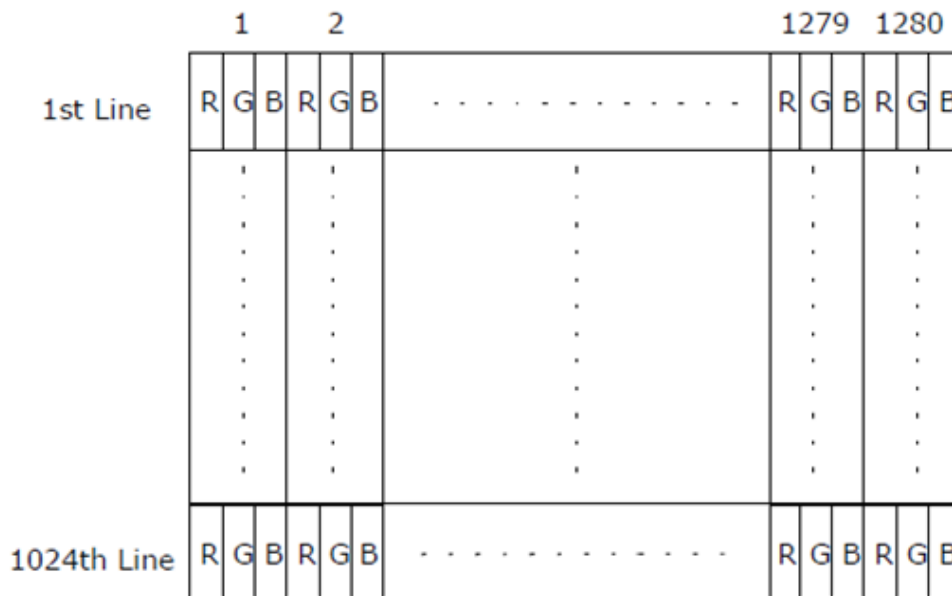

3.2 The Input Data Format

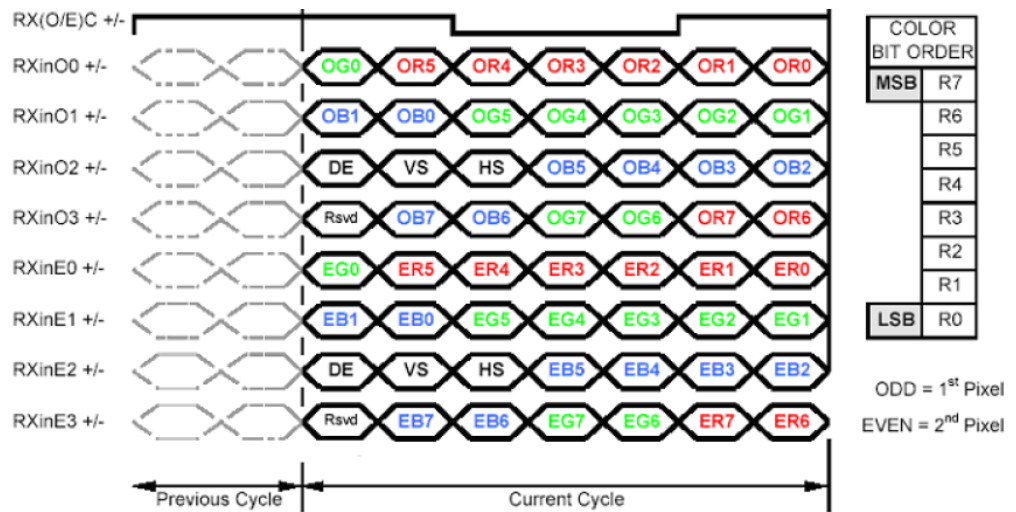

Note1: Normally, DE, VS, HS on EVEN channel are not used

Note2: 8-bit in

3.3 Pin Description

The module uses a pair of LVDS receivers- SN75LVDS82(Texas Instruments or similar). LVDS is a differential signal technology for LCD interface and high speed data transfer device. The transmitter is a SN75LVDS83 (negative edge sampling) or compatible. The first LVDS port (RxOxxx) transmits odd pixels while the second LVDS port (RxExxx) transmits even pixels.

Table 3.1: Pin Description

Pin No.	Symbol	Description
1	RxO0-	Negative LVDS differential data input (Odd data)
2	RxO0+	Positive LVDS differential data input (Odd data)
3	RxO1-	Negative LVDS differential data input (Odd data)
4	RxO1+	Positive LVDS differential data input (Odd data)
5	RxO2-	Negative LVDS differential data input (Odd data, H-Sync,V-Sync,DSPTMG)
6	RxO2+	Positive LVDS differential data input (Odd data, H-Sync,V-Sync,DSPTMG)
7	GND	Power Ground
8	RxOC-	Negative LVDS differential clock input (Odd clock)
9	RxOC+	Positive LVDS differential clock input (Odd clock)
10	RxO3-	Negative LVDS differential data input (Odd data)
11	RxO3+	Positive LVDS differential data input (Odd data)
12	RxE0-	Negative LVDS differential data input (Even data)
13	RxE0+	Positive LVDS differential data input (Even data)
14	GND	Power Ground
15	RxE1-	Negative LVDS differential data input (Even data)
16	RxE1+	Positive LVDS differential data input (Even data)
17	GND	Power Ground
18	RxE2-	Negative LVDS differential data input (Even data)
19	RxE2+	Positive LVDS differential data input (Even data)
20	RxEC-	Negative LVDS differential clock input (Even clock)
21	RxEC+	Positive LVDS differential clock input (Even clock)
22	RxE3-	Negative LVDS differential data input (Even data)
23	RxE3+	Positive LVDS differential data input (Even data)
24	GND	Power Ground
25	GND	Power Ground
26	NC	No contact
27	GND	Power Ground
28	VCC	+5.0V Power Supply
29	VCC	+5.0V Power Supply
30	VCC	+5.0V Power Supply

Note: Input signals of odd and even clock shall be the same timing.

3.4 Interface Timing

3.4.1 Timing Characteristics

Interface timings described here are not actual input timings of the LCD module but output timings of SN75LVDS82DGG (Texas Instruments or equivalent).

Table 3.2: Timing Characteristics

Signal	Item	Symbol	Min.	Typ.	Max.	Unit
Vertical Section	Period	T_v	1032	1066	1150	[Th]
	Active	$T_{disp(v)}$	1024	1024	1024	[Th]
	Blanking	$T_{bp(v)}+T_{fp(v)}+PW_{vs}$	8	42	126	[Th]
Horizontal Section	Period	T_h	780	844	2048	[Tclk]
	Active	$T_{disp(h)}$	640	640	640	[Tclk]
	Blanking	$T_{bp(h)}+T_{fp(h)}+PW_{hs}$	140	204	1408	[Tclk]
Clock	Period	T_{clk}	14.81	18.52	25	[ns]
	Frequency	Freq	40	54	67.5	[MHz]
Frame rate	Frame rate	F	50	60	75	[Hz]

Note DE mode only

3.4.2 Timing Diagram

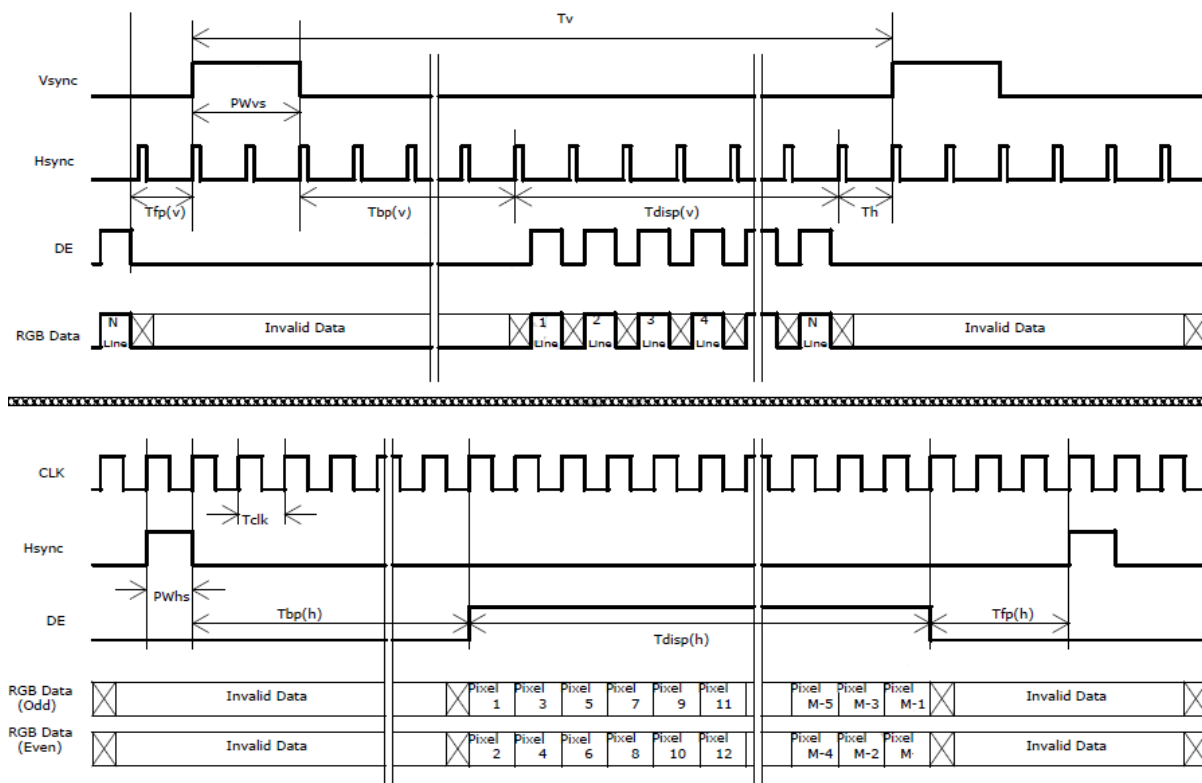

3.5 Power ON/OFF Sequence

VDD power and lamp on/off sequence is as follows. Interface signals are also shown in the chart. Signals from any system should be Hi-Z state or low level when VDD is off.

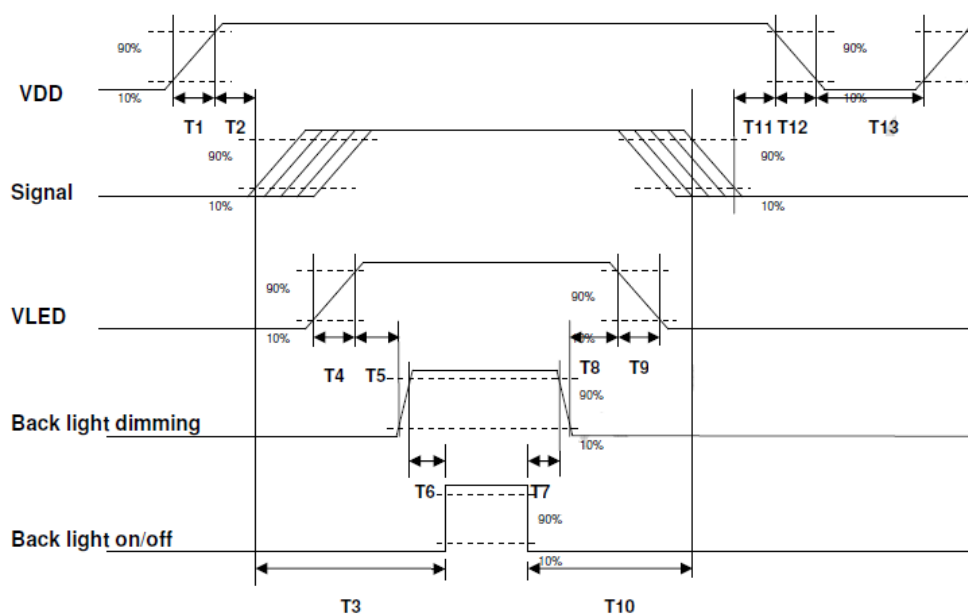

Power Sequence Timing

Parameter	Value			Unit
	Min.	Typ.	Max.	
T1	0.5	-	10	[ms]
T2	30	40	50	[ms]
T3	200	-	-	[ms]
T4	0.5	-	10	[ms]
T5	10	-	-	[ms]
T6	10	-	-	[ms]
T7	0	-	-	[ms]
T8	10	-	-	[ms]
T9	-	-	10	[ms]
T10	110	-	-	[ms]
T11	0	16	50	[ms]
T12	-	-	10	[ms]
T13	1000	-	-	[ms]

Chapter 4

Connector & Pin
Assignment

4.1 TFT LCD Module

The physical interface is described for the connector on module. These connectors are capable of accommodating the following signals and components.

4.1.1 Connector

Table 4.1: Connector

Connector Name	Manufacturer	Part Number	Mating Housing Part Number
Interface Connector	JAE or Compatible	FI-XB30SSL-HF15 or Compatible	JAE FI-X30HL or Compatible

4.1.2 Pin Assignment

Table 4.2: Pin Assignment

Pin No.	Symbol	Pin No.	Symbol
1	RxO0-	16	RxE1+
2	RxO0+	17	GND
3	RxO1-	18	RxE2-
4	RxO1+	19	RxE2+
5	RxO2-	20	RxEC-
6	RxO2+	21	RxEC+
7	GND	22	RxE3-
8	RxOC-	23	RxE3+
9	RxOC+	24	GND
10	RxO3-	25	GND
11	RxO3+	26	NC
12	RxE0-	27	GND
13	RxE0+	28	VCC +
14	GND	29	VCC +
15	RxE1-	30	VCC +

4.2 Backlight Unit (LED Driver Board)

These connectors are capable of accommodating the following signals and consist of the following components.

No.	Connector Name	Manufacturer	Part Number
CN1	Output Connector	JST or compatible	S2B-PH-SM4
CN2	Output Connector	JST or compatible	S2B-PH-SM4
CN3	Input Connector	JST or compatible	S4B-PH-SM4
CN4	Input Connector(Optional)	JST or compatible	S6B-PH-SM4
CN5	Input Connector (Optional)	JST or compatible	S3B-ZR-SM4
CN6	Input Connector (Optional)	JST or compatible	S2B-ZR-SM4

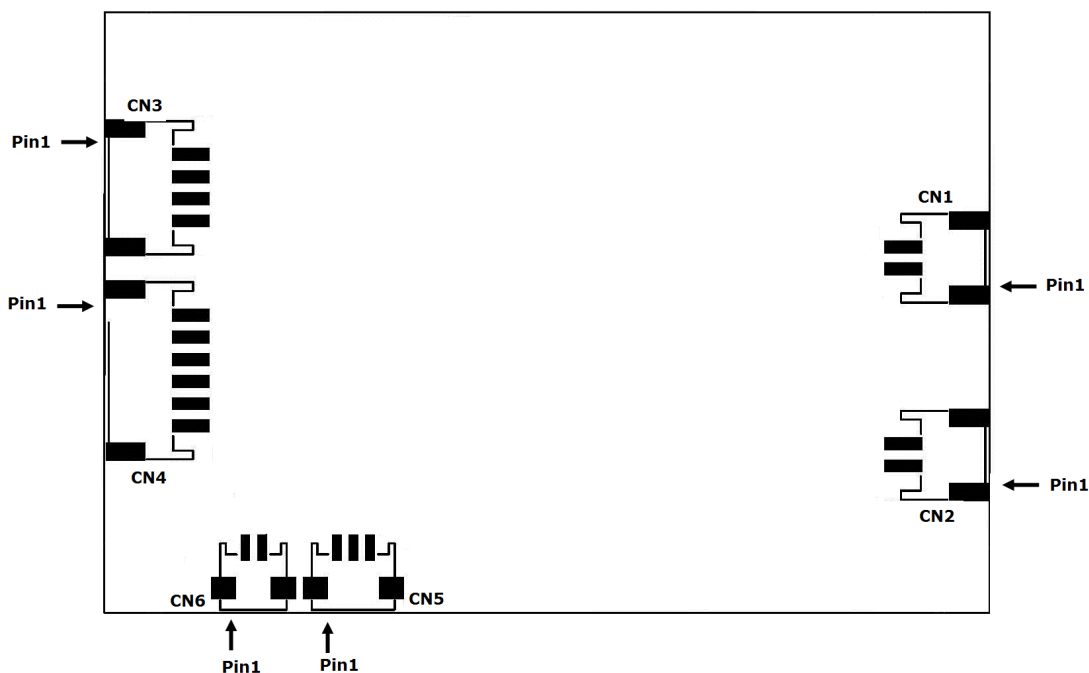

4.2.1 Pin Assignment

4.2.1.1 CN1&CN2 Output Connector (Connect to LCD Back light Cables)

Pin No.	Symbol	Description
1	Output	High Voltage
2	Output	Low Voltage

4.2.1.2 CN3 Input Connector

Pin No.	Symbol	Description
1	Vin	Input Voltage 12V
2	Vin	Input Voltage 12V
3	GND	Ground
4	GND	Ground

4.2.1.3 CN4 Input Connector (Optional for other model over 40W)

Pin No.	Symbol	Description
1	Vin	Input Voltage 12V
2	Vin	Input Voltage 12V
3	GND	Ground
4	GND	Ground
5	Control	ON/OFF control (ON=+1.5~5V OFF=0~0.8V)
6	PWM	Brightness control (0V Min ~ 5V Max)

4.2.1.4 CN5 Input Connector (Optional for VR adjustment Brightness)

Pin No.	Symbol	Description
1	Variable Resistor	VR High Voltage
2	Variable Resistor	VR
3	Variable Resistor	VR Low Voltage

4.2.1.5 CN6 Input Connector (Optional for light sensor auto dimming)

Pin No.	Symbol	Description
1	Light sensor	Sensor High Voltage
2	Light sensor	Sensor Low Voltage

Chapter 5

Touchscreen & Touch
Controller

5.1 Touchscreen (for IDK-2117R Only)

5.1.1 Touch Characteristics

The touch panel is a resistance type for use with flat displays like an LCD. Once the operator touches it with a stylus or a finger, the circuit for the touch panel sends coordinate points to a PC from the voltages at the contact points.

5.1.2 Optical Characteristics

Item	Specifications	Remarks
Transparency	80% 3%	BYK-Gardner
Haze	8.0% 3%	BYK-Gardner

5.1.3 Mechanical Characteristics

Item	Specifications	Remarks
Operation force	≤ 50g	Stylus = R0.8
Impact	25.0 φDIA. Steel Ball/67g Height=50cm	1 time, no damage [Impact at center area]
Static Load	5000g within 10cm area for 30sec	
Hardness of surface	Pencil hardness 3H.	750g, 45°
FPC peeling strength	800g by vertical 90°	
FPC bending	90° 10 times up & down	

5.2 Touch Controller (for IDK-2117R Only)

Advantech's ETM-RES04C Touch Control Board is the ultimate combo board. This touch panel controller provides optimal performance for 5-wire analog resistive touch panels. It communicates with a PC system directly through USB and RS-232 connectors. The superior design is sensitive, accurate and is friendly to operate. The touch panel driver emulates mouse left and right button functions.

5.2.1 Touch Controller Characteristics

Item	Specifications
Circuit Board Dimension	20mm x 75mm (0.79inches x 2.95inches)
Power Requirements	D.C. +5V (100mA typical, 50mV peak to peak maximum ripple and noise)
Interface	Bi-directional RS-232 serial communication USB: 1.1 Full Speed
Protocol	No parity, 8 data bits, 1 stop bit, 9600 baud (N, 8, 1, 9600)
Resolution	2048 x 2048 resolution
Report rate	RS232: Max. 180 points/sec USB: Max. 200 points/sec
Response time	Max. 20 ms
Attached Cable	RS232: 180cm shielded cable with 9-pin D-sub connector USB: 180cm shielded cable with USB-A connector

Panel resistance	5 wire resistive model: 50 ~ 200 ohm (Pin to pin on same layer, Touch Resistance under 3k ohm)
------------------	---

5.2.2 Pin Assignment and Description

5.2.2.1 Connector and LED Location

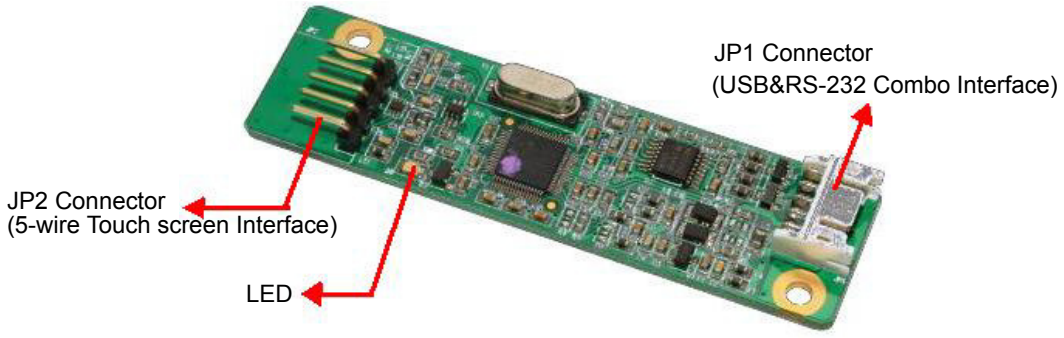

5.2.2.2 Combo Interface Connector, JP1, Pins and Signal Descriptions

The combo interface connector for USB and RS-232 is a 2.0mm, 10-pin, 90 degree box; male type with lock connector. It is intended to be used with single wired pins in 5+5 pins header. The pins are numbered as shown in the table below.

Pin No.	Signal Name	Signal Function
1	G	Ground
2	V	USB Power
3	G	Ground
4	D+	USB D+
5	D-	USB D-

Pin No.	Signal Name	Signal Function
1	G	Ground
2	V	Power
3	G	Ground
4	Tx	Serial Port
5	Rx	Serial Port

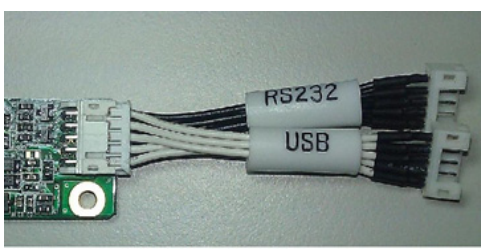
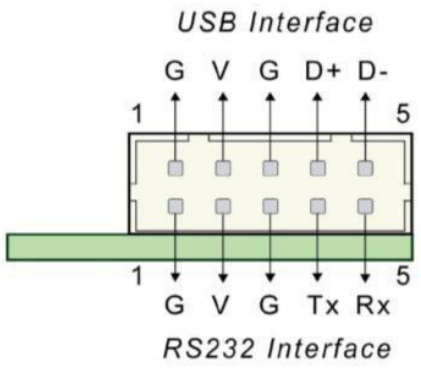
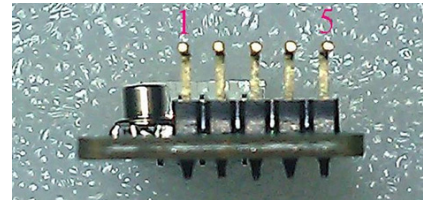
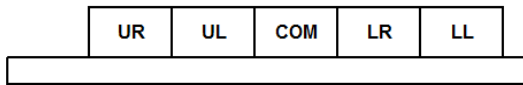

Figure 5.1 Board mounted header

5.2.2.3 Touch Screen Connector, JP2, Pins and Signal Descriptions

The touchscreen connector, JP2, is a single row, 2.54mm, 5-pins, 90 degrees; male type connector. The pins are numbered as shown in the table below.

Pin No.	Signal Name	Signal Description
1	UR	Drive signal attached to the touchscreen substrate upper right corner when viewed from a user's perspective.
2	UL	Drive signal attached to the substrate upper left corner.
3	COM	-
4	LR	Drive signal attached to the substrate lower right corner.
5	LL	Drive signal attached to the substrate lower left corner.



Appendix **A**

Optical Characteristics

A.1 LCD Module Optical Characteristics

The optical characteristics are measured under stable conditions at 25°C (Room Temperature):

Table A.1: Optical Characteristics

Item	Conditions	Min.	Typ.	Max.	Unit	Note
Viewing Angle	Horizontal CR = 10	140	170	-	[degree]	1
	Vertical CR = 10	140	160	-		
Luminance Uniformity	9 Points	75	80	-	[%]	2, 3
Color coordinates (CIE 1931)	White x	0.283	0.313	0.343	-	4
	White y	0.299	0.329	0.359		
Response Time	Rising	-	3.5	6	[ms]	4,5
	Falling	-	1.5	3		
Color Temperature		-	6500		[K]	
White Luminance		1100	1200	-	[cd/m ²]	4
Contrast Ratio		600	1000	-		4

Note1 Definition of viewing angle

Viewing angle is the measurement of contrast ratio ≥ 10 , at the screen center, over a 180° horizontal and 180° vertical range (off-normal viewing angles). The 180° viewing angle range is broken down as: 90°(θ) horizontal left and right, and 90°(ϕ) vertical high (up) and low (down). The measurement direction is typically perpendicular to the display surface with the screen rotated to its center to develop the desired measurement viewing angle.

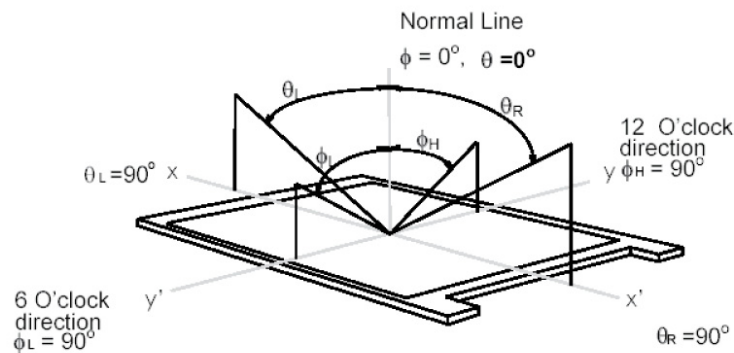

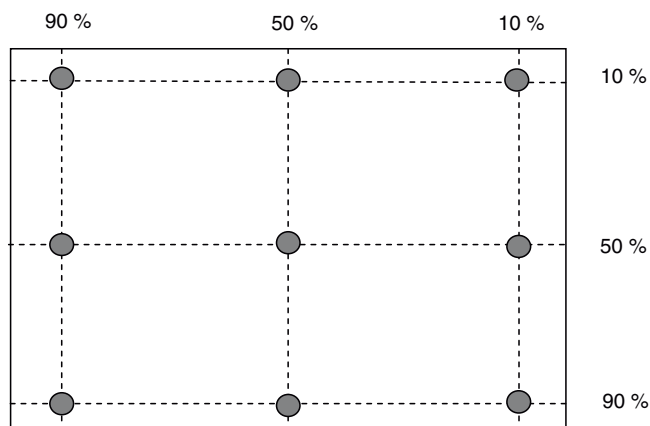
Note2 9 points position

Note3 9-point luminance uniformity is defined by dividing the maximum luminance values by the minimum test point luminance

$$\delta_{w9} = \frac{\text{Minimum Brightness of nine points}}{\text{Maximum Brightness of nine points}}$$

Note4 Measurement method

The LCD module should be stabilized at given temperature for 30 minutes to avoid abrupt temperature change during measuring. In order to stabilize the luminance, the measurement should be executed after lighting Backlight for 30 minutes in a stable, windless and dark room. Optical Equipment: DT-101, or equivalent

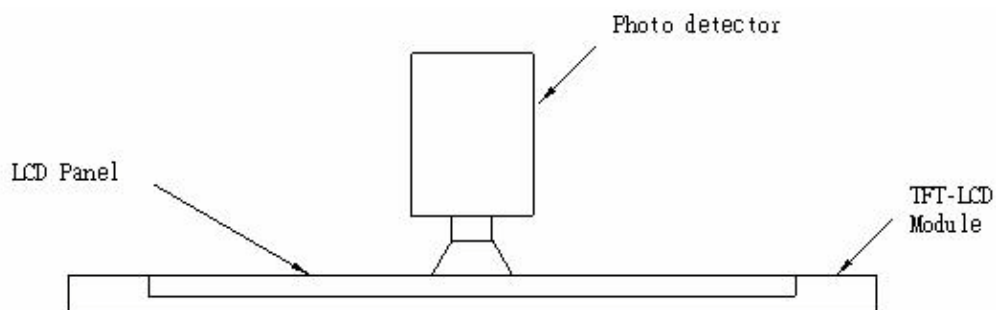

Note5 Definition of response time

The output signals of the photo detector are measured when the input signals are changed from "Full Black" to "Full White" (rising time), and from "Full White" to "Full Black" (falling time), respectively. The response time is an interval between 10% and 90% of amplitudes. Please refer to the figure below.

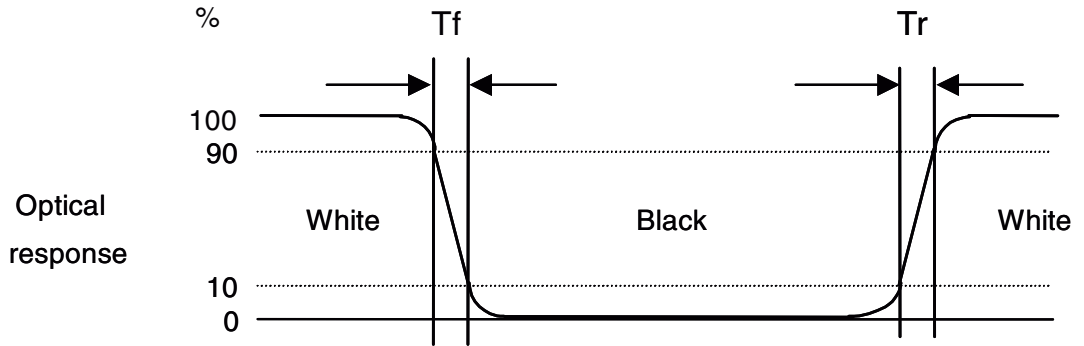

Appendix **B**

Handling Precautions

B.1 Optical Characteristics

The optical characteristics are measured under stable conditions at 25°C (Room Temperature)

1. Since the front polarizer is easily damaged, be very careful not to scratch it.
2. Be sure to turn off the power supply when inserting or disconnecting from the input connector.
3. Wipe off water drops immediately. Long contact with water may cause discoloration or spots.
4. When the panel surface is soiled, wipe it with absorbent cotton or another soft cloth.
5. Since the panel is made of glass, it may break or crack if dropped or bumped on a hard surface.
6. Since the CMOS LSI is used in this module, be careful of static electricity and ensure you ground yourself first before handling.
7. Do not open or modify the Module Assembly.
8. Do not press the reflector sheet at the back of the module in any direction.
9. In case a Module has to be put back into the packing container slot after it has been taken, please touch the far ends of the LED light bar reflector edge softly, otherwise the TFT Module may get damaged.
10. At the insertion or removal of the signal interface connector, be sure not to rotate nor tilt the Interface Connector on the TFT Module.
11. After installation of the TFT Module into an enclosure, do not twist nor bend the TFT Module even momentarily. During integration of the enclosure, it should be taken into consideration that no bending/twisting forces are applied to the TFT Module from outside. Otherwise the TFT Module may get damaged.
12. A small amount of materials having no flammability grade are used in the LCD module. The LCD module should be supplied by power compliant with the requirements of Limited Power Source (IEC60950 or UL1950), or be applied exempt thereof.

ADVANTECH

Enabling an Intelligent Planet

www.advantech.com

Please verify specifications before quoting. This guide is intended for reference purposes only.

All product specifications are subject to change without notice.

No part of this publication may be reproduced in any form or by any means, electronic, photocopying, recording or otherwise, without prior written permission of the publisher.

All brand and product names are trademarks or registered trademarks of their respective companies.

© Advantech Co., Ltd. 2017