

USER MANUAL

REVISION 1.0

DATE 2018/08/17

FWA-1012VC

TABLETOP NETWORK PLATFORM

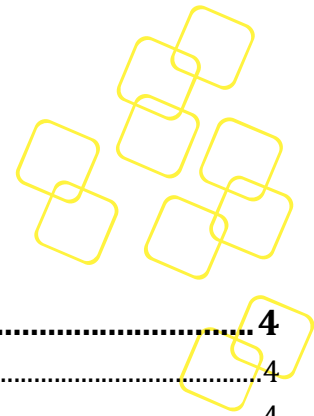

Content

PREFACE	4
<i>REVISION HISTORY</i>	4
<i>COPYRIGHT</i>	4
<i>WARNINGS, CAUTIONS AND NOTES</i>	5
<i>SAFETY INSTRUCTIONS</i>	6
<i>DECLARATION OF CONFORMITY</i>	8
FCC Class B	8
BSMI	8
CCC	9
CE Mark	10
<i>TECHNICAL SUPPORT AND ASSISTANCE</i>	10
<i>WARRANTY AND RMA</i>	11
1. INTRODUCTION	12
1.1 OVERVIEW	12
1.2 SYSTEM OUTLOOK	13
1.2.1 Front View.....	13
1.2.2 Rear View	13
1.3 SYSTEM LAYOUT	14
1.4 BLOCK DIAGRAM.....	15
1.5 COMPONENT INSTALLATION.....	15
1.5.1 Memory/2.5" SSD_HDD/ POE Module/ M.2 SSD/ LTE Module/WiFi Module	15
1.5.2 Rack mount Kits	16
1.5.3 Antenna installation	17
1.6 OPTIMUM MOUNTING ENVIRONMENT	18
1.6.1 Space Requirement	18
1.6.2 Temperature Requirement.....	18
2. OPERATION	19
2.1 POWERING UP/DOWN THE PLATFORM	19
2.2 BOOTING FROM NETWORK VIA PXE	20
2.3 LED BEHAVIOUR	24
2.4 MAIN BOARD CONNECTOR PLACEMENT.....	25
3. BIOS	28
3.1 BIOS DEFAULTS	28
3.2 BIOS SETUP MENU	28
3.2.1 Main Setup Menu	29
3.2.2 Platform Setup Menu	32
3.2.3 Hardware setup menu.....	40
3.2.4 Setup POST & Boot Menu	47
3.2.5 Security Setup.....	51
3.2.6 Save & Exit Menu	52
4. ADVANCED LAN BY PASS, BMC FIRMWARE AND BIOS UPGRADE	54

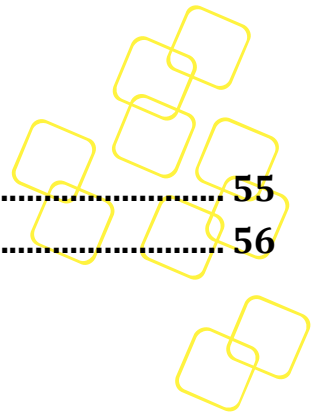

APPENDIX A: ACKNOWLEDGEMENTS 55

APPENDIX B: GLOSSARY 56

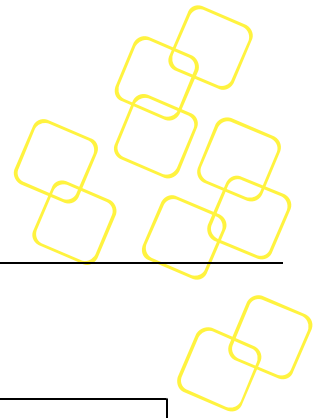

PREFACE

Revision History

Date	Revision	Modifications
6/August/2018	0.1	Initial version
16/August/2018	0.2	Update Operation and BIOS section
17/August/2018	1.0	Official release

Copyright

The documentation and the software included with this product are copyrighted by Advantech Co., Ltd.

Advantech Co., Ltd. reserves the right to make improvements in the products described in this manual at any time without notice.

No part of this manual may be reproduced, copied, translated or transmitted in any form or by any means without the prior written permission of Advantech Co., Ltd. Information provided in this manual is intended to be accurate and reliable.

For more information about this and other Advantech products, please visit our website at:

<http://www.advantech.com/>

<http://www.advantech.com/ePlatform/>

For technical support and service, please visit our support website at:

<http://support.advantech.com.tw/support/>

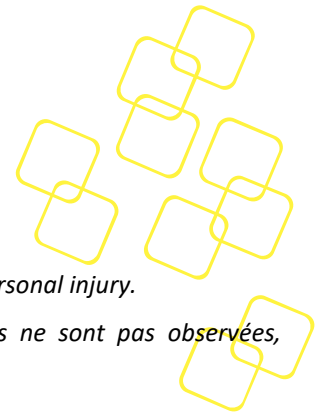

Warnings, Cautions and Notes



Warning! Warnings indicate conditions, which, if not observed, can cause personal injury.

AVERTISSEMENT! Les avertissements indiquent des conditions qui, si elles ne sont pas observées, peuvent provoquer des blessures.



Caution! Cautions are included to help you avoid damaging hardware or losing data.

ATTENTION! Des précautions sont incluses pour vous aider à éviter d'endommager le matériel ou de perdre des données.



Note! Notes provide additional information.

Remarque! Les notes fournissent des informations supplémentaires.

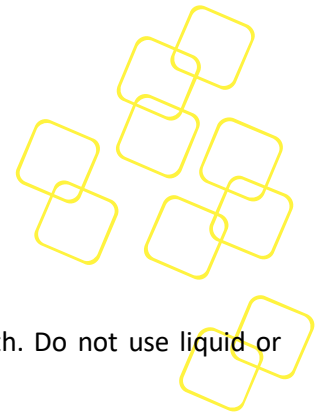

Safety Instructions

1. Read these safety instructions carefully.
2. Keep this User Manual for later reference.
3. Disconnect this equipment from any AC outlet before cleaning. Use a damp cloth. Do not use liquid or spray detergents for cleaning.
4. For plug-in equipment, the power outlet socket must be located near the equipment and must be easily accessible.
5. Keep this equipment away from humidity.
6. Put this equipment on a reliable surface during installation. Dropping it or letting it fall may cause damage.
7. The openings on the enclosure are for air convection. Protect the equipment from overheating. **DO NOT COVER THE OPENINGS.**
8. Make sure the voltage of the power source is correct before connecting the equipment to the power outlet.
9. Position the power cord so that people cannot step on it. Do not place anything over the power cord.
10. All cautions and warnings on the equipment should be noted.
11. If the equipment is not used for a long time, disconnect it from the power source to avoid damage by transient overvoltage.
12. Never pour any liquid into an opening. This may cause fire or electrical shock.
13. Never open the equipment. For safety reasons, the equipment should be opened only by qualified service personnel.
14. If one of the following situations arises, get the equipment checked by service personnel:
 - The power cord or plug is damaged.
 - Liquid has penetrated into the equipment.
 - The equipment has been exposed to moisture.
 - The equipment does not work well, or you cannot get it to work according to the user's manual.
 - The equipment has been dropped and damaged.
 - The equipment has obvious signs of breakage.
15. Do not leave this equipment in an environment where the storage temperature may go below -40° C (-40° F) or above 85° C (185° F). This could damage the equipment. The equipment should be in a controlled environment.
16. Caution: Danger of explosion if battery is incorrectly replaced. Replace only with the same or equivalent type recommended by the manufacturer, discard used batteries according to the manufacturer's instructions.
17. The sound pressure level at the operator's position according to IEC 704-1:1982 is no more than 70 dB (A).
18. **RESTRICTED ACCESS AREA:** The equipment should only be installed in a Restricted Access Area.
19. **DISCLAIMER:** This set of instructions is given according to IEC 704-1. Advantech disclaims all responsibility for the accuracy of any statements contained herein.

French:

1. Lisez ces instructions de sécurité attentivement.
2. Conservez ce manuel d'utilisation pour référence ultérieure.

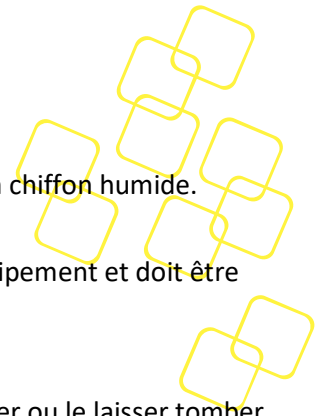

3. Débranchez cet équipement de toute prise secteur avant de le nettoyer. Utilisez un chiffon humide. N'utilisez pas de détergent liquide ou pulvérisé pour le nettoyage.
4. Pour les équipements enfichables, la prise de courant doit être située près de l'équipement et doit être facilement accessible.
5. Gardez cet équipement à l'abri de l'humidité.
6. Placez cet équipement sur une surface fiable pendant l'installation. Le laisser tomber ou le laisser tomber peut causer des dommages.
7. Les ouvertures sur l'enceinte servent à la convection de l'air. Protégez l'équipement contre la surchauffe. **NE COUVREZ PAS LES OUVERTURES.**
8. Assurez-vous que la tension de la source d'alimentation est correcte avant de connecter l'équipement à la prise de courant.
9. Placez le cordon d'alimentation de manière à ce que personne ne puisse marcher dessus. Ne placez rien sur le cordon d'alimentation.
10. Toutes les mises en garde et les avertissements sur l'équipement doivent être notés.
11. Si l'équipement n'est pas utilisé pendant une longue période, débranchez-le de la source d'alimentation pour éviter tout dommage dû à une surtension transitoire.
12. Ne versez jamais de liquide dans une ouverture. Cela pourrait provoquer un incendie ou un choc électrique.
13. N'ouvrez jamais l'équipement. Pour des raisons de sécurité, l'équipement doit être ouvert uniquement par du personnel qualifié.
14. Si l'une des situations suivantes se présente, faites vérifier l'équipement par le personnel de service:
 - Le cordon d'alimentation ou la prise est endommagé.
 - Le liquide a pénétré dans l'équipement.
 - L'équipement a été exposé à l'humidité.
 - L'équipement ne fonctionne pas bien, ou vous ne pouvez pas le faire fonctionner selon le manuel de l'utilisateur.
 - L'équipement a été échappé et endommagé.
 - L'équipement présente des signes évidents de rupture.
15. Ne laissez pas cet appareil dans un environnement où la température de stockage peut être inférieure à -40 ° C ou supérieure à 85 ° C. Cela pourrait endommager l'équipement. L'équipement devrait être dans un environnement contrôlé.
16. Attention: Danger d'explosion si la batterie est incorrectement remplacée. Remplacez uniquement par le même type ou un type équivalent recommandé par le fabricant, jetez les piles usagées conformément aux instructions du fabricant.
17. Le niveau de pression acoustique à la position de l'opérateur, conformément à la norme CEI 704-1: 1982, ne dépasse pas 70 dB (A).
18. ZONE D'ACCES RESTREINTE: L'équipement ne doit être installé que dans une zone d'accès restreint.
19. AVERTISSEMENT: Cet ensemble d'instructions est donné conformément à la CEI 704-1. Advantech décline toute responsabilité quant à l'exactitude des déclarations contenues dans ce document.

Declaration of Conformity

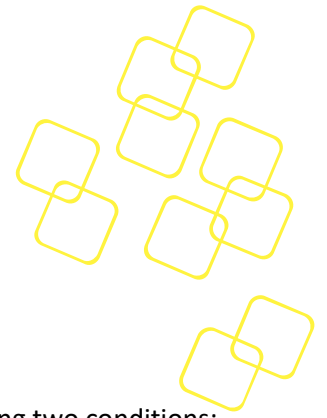

FCC CLASS B

Federal Communications Commission (FCC) Statement

This device complies with Part 15 of the FCC Rules. Operation is subject to the following two conditions:

- 1) this device may not cause harmful interference and
- 2) this device must accept any interference received, including interference that may cause undesired operation of the device

15.105(b)

This equipment has been tested and found to comply with the limits for a Class B digital device, pursuant to part 15 of the FCC rules. These limits are designed to provide reasonable protection against harmful interference in a residential installation.

This equipment generates uses and can radiate radio frequency energy and, if not installed and used in accordance with the instructions, may cause harmful interference to radio communications. However, there is no guarantee that interference will not occur in a particular installation. If this equipment does cause harmful interference to radio or television reception, which can be determined by turning the equipment off and on, the user is encouraged to try to correct the interference by one or more of the following measures:

- Reorient or relocate the receiving antenna.
- Increase the separation between the equipment and receiver.
- Connect the equipment into an outlet on a circuit different from that to which the receiver is connected.
- Consult the dealer or an experienced radio/TV technician for help.

FCC RF Radiation Exposure Statement:

1. This Transmitter must not be co-located or operating in conjunction with any other antenna or transmitter.
2. This equipment complies with FCC RF radiation exposure limits set forth for an uncontrolled environment. This equipment should be installed and operated with a minimum distance of 20 centimeters between the radiator and your body.

BSMI

警告使用者：這是甲類資訊產品，在居住的環境中使用時，可能會造成射頻干擾，在這種情況下，使用者會被要求採取某些適當對策。

安全指示

1. 請仔細閱讀此安全操作說明。
2. 請妥善保存此用戶手冊供日後參考。
3. 用濕抹布清洗設備前，請確認拔除電源線。請勿使用液體或去污噴霧劑清洗設備。
4. 對於使用電源線的設備，設備周圍必須有容易接觸到的電源插座。
5. 請勿在潮濕環境中試用設備。

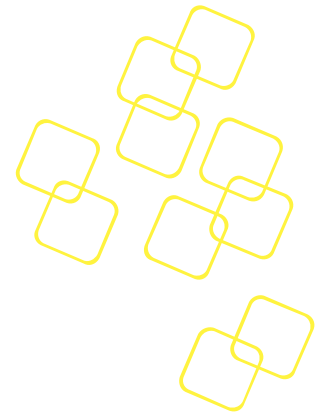

6. 請在安裝前確保設備放置在可靠的平面上，意外摔落可能會導致設備損壞。
7. 設備機殼的開孔適用於空氣對，從而防止設備過熱。請勿覆蓋開孔。
8. 當您連接設備到電源插座前，請確認電源插座的電壓符合要求。
9. 請將電源線佈置在人們不易絆倒的位置，請勿在電源線上覆蓋任何雜物。
10. 請注意設備上所有的警告標示。
11. 如果長時間不使用設備，請拔除與電源插座的連結，避免設備被超標的電壓波動損壞。
12. 請勿讓任何液體流入通風口，以免引起火災或短路。
13. 請勿自行打開設備。為了確保您的安全，請透過經認證的工程師來打開設備。
14. 如遇下列情况，請由專業人員維修：
 - 電源線或插頭損壞；
 - 設備內部有液體流入；
 - 設備曾暴露在過度潮濕環境中使用；
 - 設備無法正常工作，或您無法透過用戶手冊來正常工作；
 - 設備摔落或損壞；
 - 設備有明顯外觀損；
15. 請勿將設備放置在超出建議溫度範圍的環境，即不要低於0°C(-20°C;-4°F)或高於40°C(60°C;140°F)，否則可能會造成設備損壞。
16. 注意：若電池更換不正確，將有爆炸危險。因此，只可以使用製造商推薦的同一種或者同等型號的電池進行替換。請按照製造商的指示處理舊電池。
17. 根據IEC 704-1:1982 規定，設備產生的音量不高於70 分貝。
18. 免責聲明：請安全訓示符合IEC 704-1 要求。研華公司對其內容之準確性不承擔任何法律責任。

CCC

警告使用者：这是甲类资讯产品，在居住的环境中使用，可能会造成射频干扰，在这种情况下，使用者会被要求采取某些适当的对抗。

声明：此为A级产品，在生活环境中，可能会造成无线干扰，在这种情况下，可能需要用户对其干扰采取切实可行的措施。

安全指令

1. 请仔细阅读此安全操作说明。
2. 请妥善保存此用户手册供日后参考。
3. 用湿抹布清洗设备前，请从插座拔下电源线。请不要使用液体或去污喷雾剂清洗设备。
4. 对于使用电源线的设备，设备周围必须有容易连接到的电源插座。
5. 请让设备远离潮湿环境。
6. 请在安装前确保设备放置在可靠的平面上，意外跌落可能会导致设备损坏。
7. 设备外壳的开口是用于空气对流，从而防止设备过热。请不要覆盖这些开口。
8. 当您连接设备到电源插座上前，请确认电源插座的电压是否符合要求。
9. 请将电源线安置在人们不易绊到的位置，并不要在电源线覆盖任何杂物。



10. 请注意设备上的所有警告和注意标语。
11. 如果长时间不使用设备，请将设备与电源插座间的电线断开，避免设备被超目标电压波动损坏。
12. 请不要让任何液体流入通风口，以免引起火灾或者电路短路。
13. 请不要自行打开设备。为了确保您的安全，请由经过认证的工程师来打开设备。
14. 如遇下列情况，请由专业人员来维修：
 - 电源线或者插头损坏；
 - 设备内部有液体流入；
 - 设备曾暴露在于潮湿的环境中；
 - 设备无法正常工作，或您无法通过用户手册来使其正常工作；
 - 设备跌落或者损坏；
 - 设备有明显的外观破损。
15. 请不要把设备放置在超出我们建议的温度范围的环境，即不要低于0°C(-20°F) 或高于40°C(104°F)，否则可能会损坏设备。
16. 注意：如果电池放置不正确，将有爆炸的危险，因此，只可以使用制造商推荐的同一种或者同等型号的电池进行替换。请按照制造商的指示处理已使用过的电池。
17. 根据IEC 704-1:1982 规定，设备产生的音量不高于70 分贝。
18. 免责声明：请安全训示符合IEC 704-1 要求。研华公司对其内容之准确性不承担任何法律责任。

CE MARK

The CE marking on this product indicates that it is in compliance with the European Union EMC Directive 2014/30/EU, Safety Directive 2014/35/EU.

Le marquage CE sur ce produit indique qu'il est conforme à la Directive européenne sur la compatibilité électromagnétique 2014/30 / UE, Directive sur la sécurité 2014/35 / UE.



Note! *The equipment is operated and maintained only by professionals*

Remarque! *L'équipement est exploité et entretenu uniquement par des professionnels*

Technical Support and Assistance

1. Visit the Advantech web site at www.advantech.com/support where you can find the latest information about the product.
2. Contact your distributor, sales representative, or Advantech's customer service centre for technical support if you need additional assistance. Worldwide contact information can be found on www.advantech.com. Please have the following information ready before you call:
 - Product name and serial number
 - Description of your peripheral attachments
 - Description of firmware and software versions installed on the product
 - A complete description of the problem
 - The exact wording of any error messages
3. For more information please contact ncg@advantech.com or visit www.advantech.com/nc.



Warranty and RMA

Product Warranty (2 years)

Advantech warrants to you, the original purchaser, that each of its products will be free from defects in materials and workmanship for two years from the date of purchase.

This warranty does not apply to any products which have been repaired or altered by persons other than repair personnel authorized by Advantech, or which have been subject to misuse, abuse, accident or improper installation. Advantech assumes no liability under the terms of this warranty as a consequence of such events.

Because of Advantech's high quality-control standards and rigorous testing, most of our customers never need to use our repair service. If an Advantech product is defective, it will be repaired or replaced at no charge during the warranty period. For out-of-warranty repairs, you will be billed according to the cost of replacement materials, service time and freight. Please consult your dealer for more details.

If you think you have a defective product, follow these steps:

1. Collect all the information about the problem encountered. (For example, CPU speed, Advantech products used, other hardware and software used, etc.) Note anything abnormal and list any onscreen messages you get when the problem occurs.
2. Call your dealer and describe the problem. Please have your manual, product, and any helpful information readily available.
3. If your product is diagnosed as defective, obtain an RMA (return merchandise authorization) number from your dealer. This allows us to process your return more quickly.
4. Carefully pack the defective product, a fully-completed Repair and Replacement Order Card and a photocopy proof of purchase date (such as your sales receipt) in a shippable container. A product returned without proof of the purchase date is not eligible for warranty service.
5. Write the RMA number visibly on the outside of the package and ship it prepaid to your dealer.

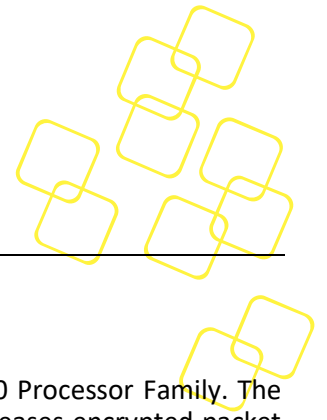

1. INTRODUCTION

1.1 Overview

FWA-1012VC is desktop network platform which is powered by Intel® Atom® C3000 Processor Family. The Intel® Atom® C3000 Processor is integrated with Intel QuickAssist Technology to increase encrypted packet throughput.

FWA-1012VC platform also integrates two 1 GbE FPS ports and six 1GbE RJ45 ports. Two of six RJ45 ports are supported IEEE® 802.3af POE which can power up to two 25.5W PD device. Storage options include one M.2 2280 and one 2.5" SATA device.

FWA-1012VC total can support 1x 2.4G/5G wireless module and 1x 2G/4G LTE module with dual SIM slots. Moreover, FWA-1012VC reserves design for 2nd 2.4G/5G wireless module and 1x 2G/4G LTE module.

For more information related to FWA-1012VC, please check below link:

http://www.advantech.com/products/6e5d3cbf-5420-4e95-9a4a-9a51d929623b/fwa-1012vc/mod_f0dba999-ef8c-45d4-be05-fe29cd7662a2

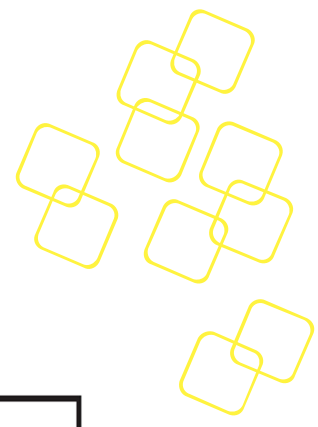

1.2 System Outlook

1.2.1 FRONT VIEW

There are 8 LED indicators and 4 antenna holds in front of the system:

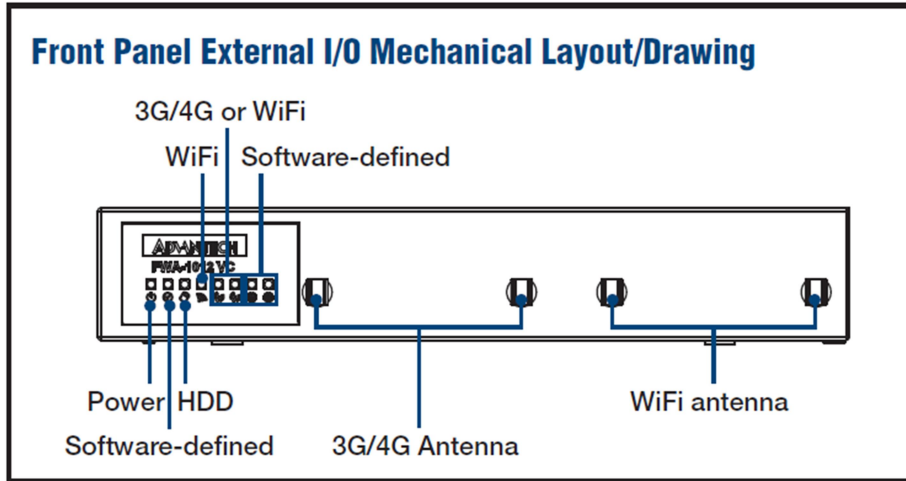

Figure 1: System Front View

1.2.2 REAR VIEW

There are power switch locates on back of chassis, lockable DC-In jack, one console port, two USB 3.0 ports, two 1GbE SFP ports, six RJ45 ports, two SIM slots, POE connector and SW defile LED /button the rear side.

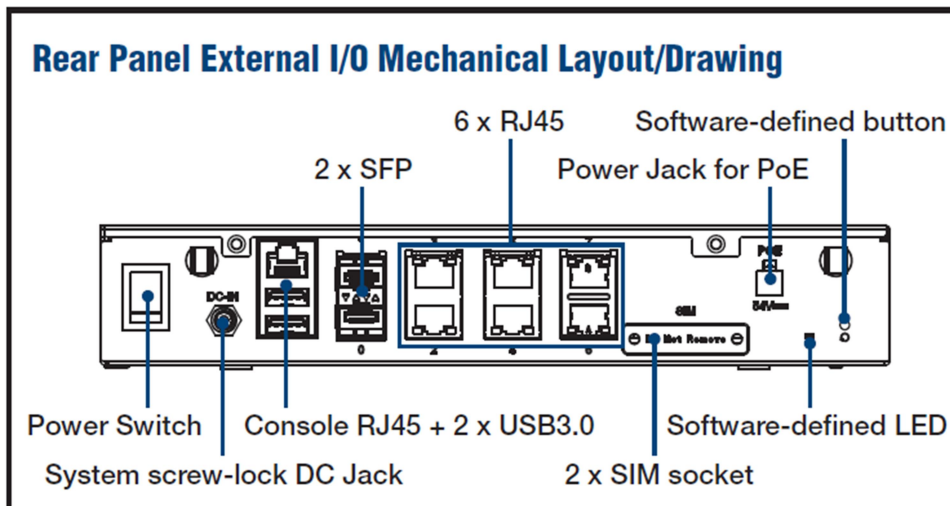

Figure 2: System Rear View

1.3 System layout

System layout as below picture:

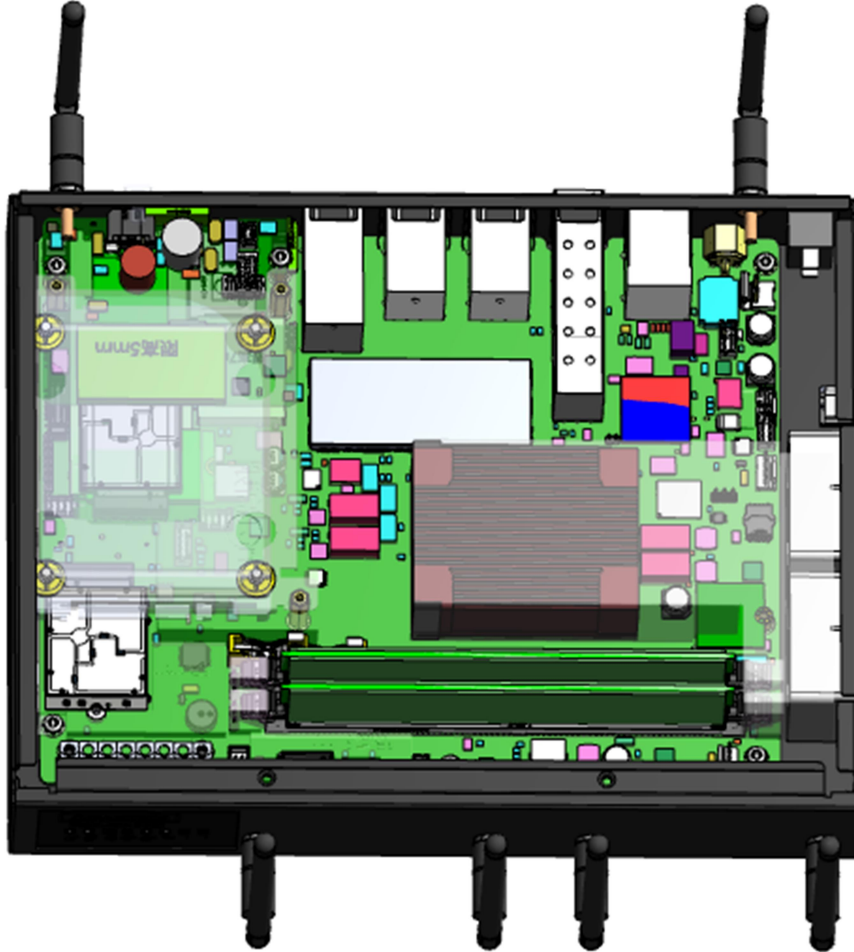

Figure 3: System Architecture

1.4 Block Diagram

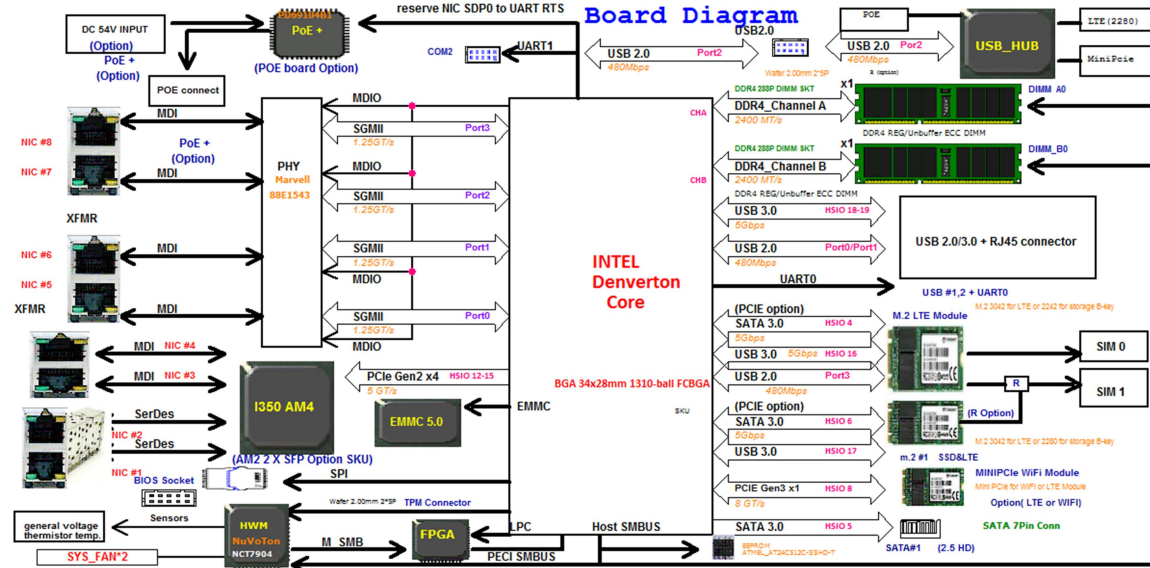

Figure 4: System Block diagram

1.5 Component Installation

1.5.1 MEMORY/2.5" SSD_HDD/ POE MODULE/ M.2 SSD/ LTE MODULE/WiFi MODULE

This is the drawing of memory location and the stacking of M.2 POE module, HDD bracket and SSD/HDD into FWA-1012VC unit.

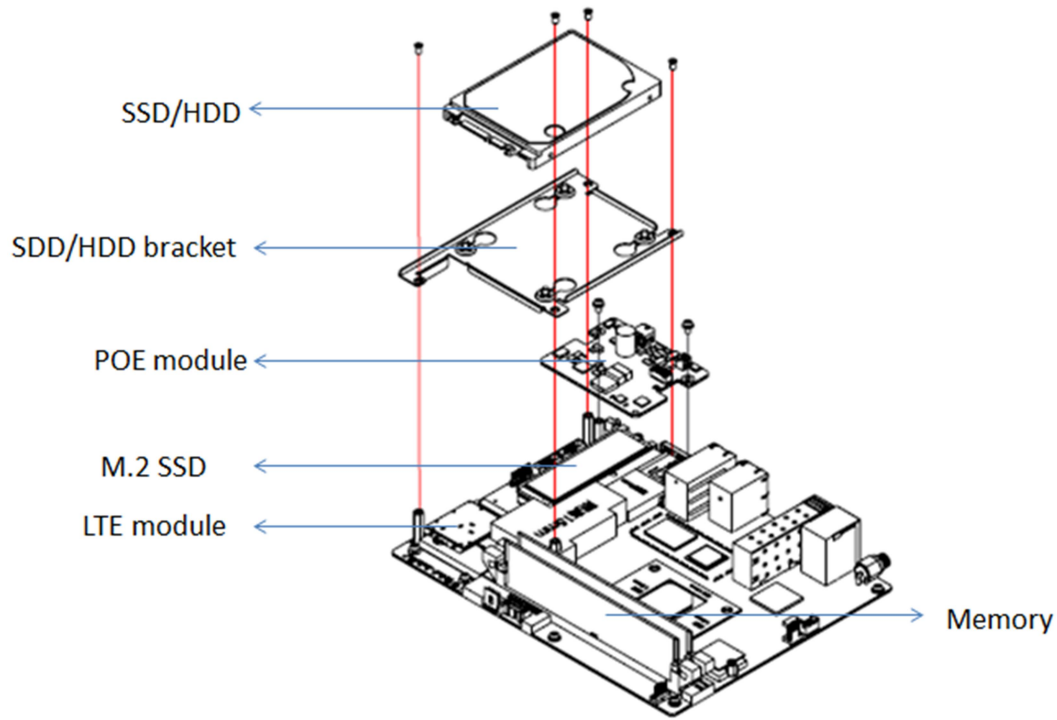
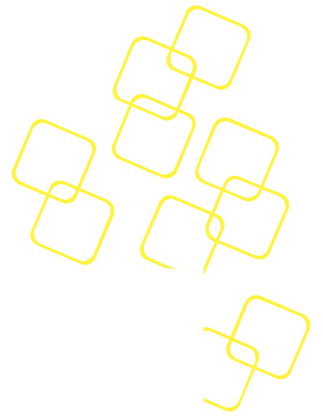

Figure 5: main components on the top side



Tighten screw by the instruction on Wifi module in bottom side as below:

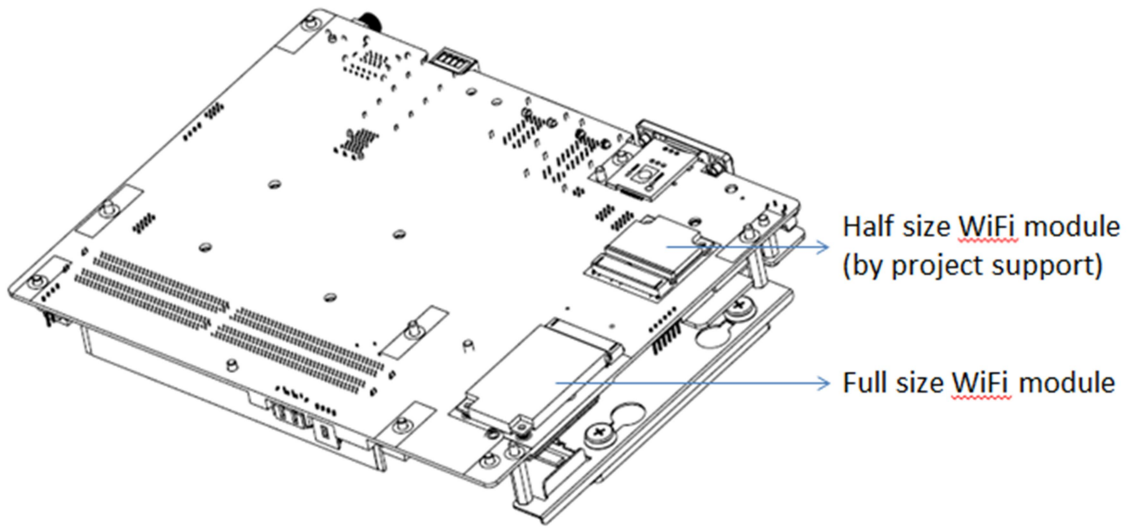

Figure 6: wifi module location on the bottom side

1.5.2 RACK MOUNT KITS

Rack mount kit assembly instruction:

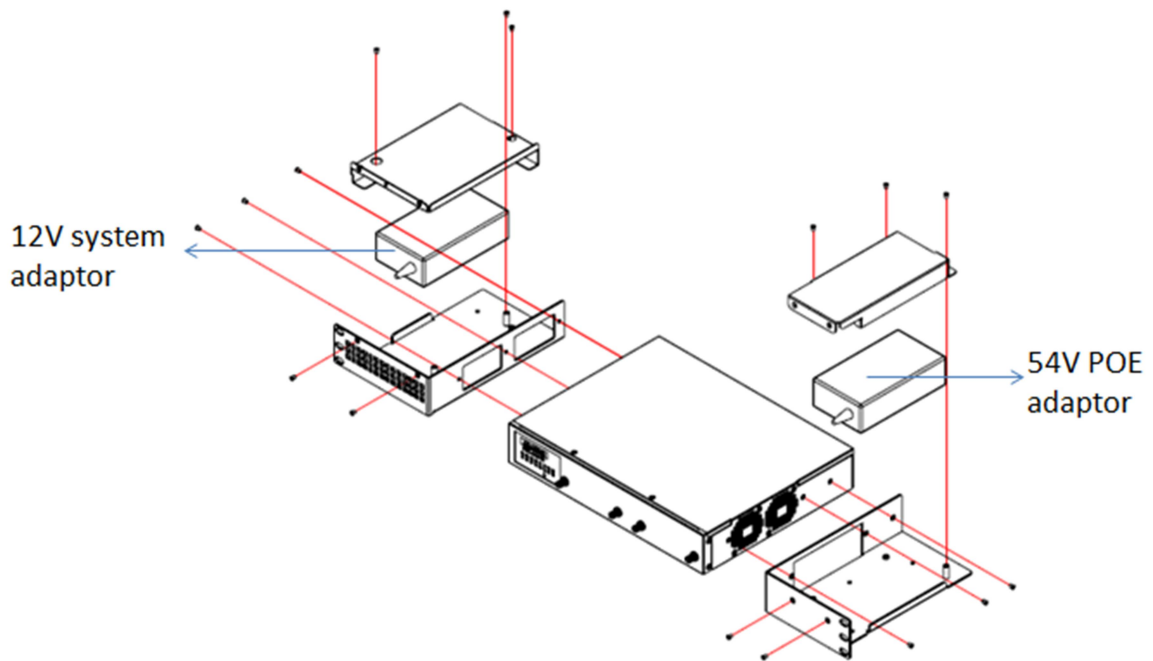
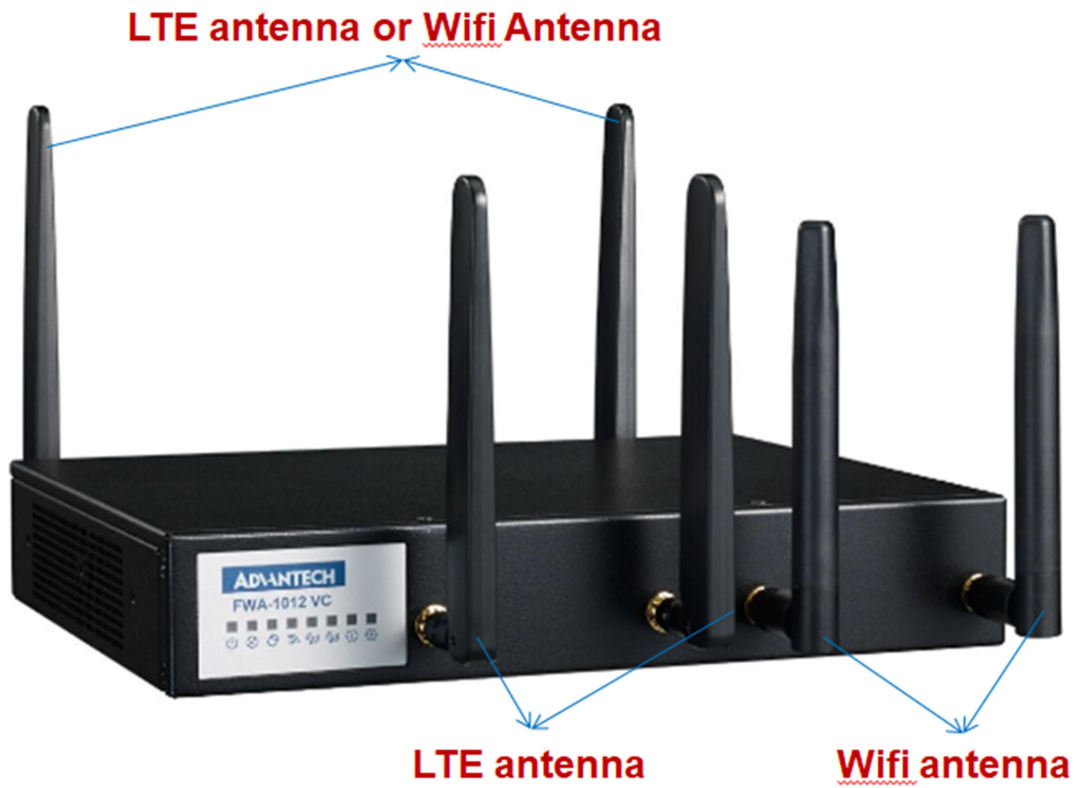
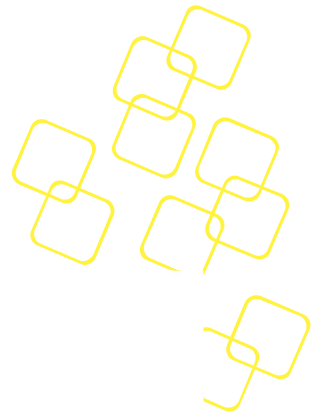

Figure 7: rack mount kit assembly instruction

1.5.3 ANTENNA INSTALLATION





1.6 Optimum Mounting Environment

1.6.1 SPACE REQUIREMENT

Please always keep 20cm space around platform for better thermal dissipation if not running FWA-1012VC on rack.

1.6.2 TEMPERATURE REQUIREMENT

Please make sure environment condition before power on this system:

- Operating temperature 0 ~ 35 °C (32 ~ 104 °F) with air flow speed 0.7 m/sec
- Non-operating Temperature -20 ~ 80° C (-4 ~ 167° F)
- Relative humidity 95% @ 40° C (non-condensing)
- Storage temperature -40 ~ 85° C (-40 ~ 185° F)

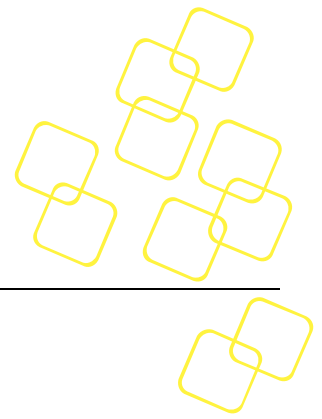

2. OPERATION

2.1 Powering up/down the platform

To power up the FWA-1012VC, please press the power switch button.

Before powering down the FWA-1012VC for any upgrade or maintenance procedures, perform a backup of critical data and programs.

Press the Power Switch

1. FWA-1012 is using Power Switch to power ON/OFF system, when user press power switch as ON (|), system will auto power up, , when user press power switch as OFF (O), system will force power OFF.
2. Please don't direct plug or unplug DC Jack when Power Switch sets as ON

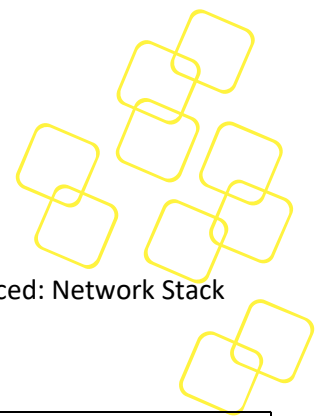

2.2 Booting from network via PXE

To boot an OS via network, please make sure the following BIOS options In the Advanced: Network Stack Configuration Menu is configured properly:

BIOS item CSM Parameters -> Network	BIOS item Network Stack	PXE setting
Do not launch	Disabled	Disabled PXE
	Enabled	Disabled PXE
UEFI	Disabled	Disabled PXE
	Enabled	Enabled UEFI IPV4 PXE
Legacy	Disabled	Enabled legacy IPV4 PXE
	Enabled	Enabled legacy IPV4 PXE

Table 1: PXE BIOS Options

Below are the steps to enable PXE boot.

1. When user sets “ BIOS/ Advanced-> CSM Parameters -> Network” as Legacy to enable PXE ROM function, set it as “Legacy” (IPV4 PXE) function .

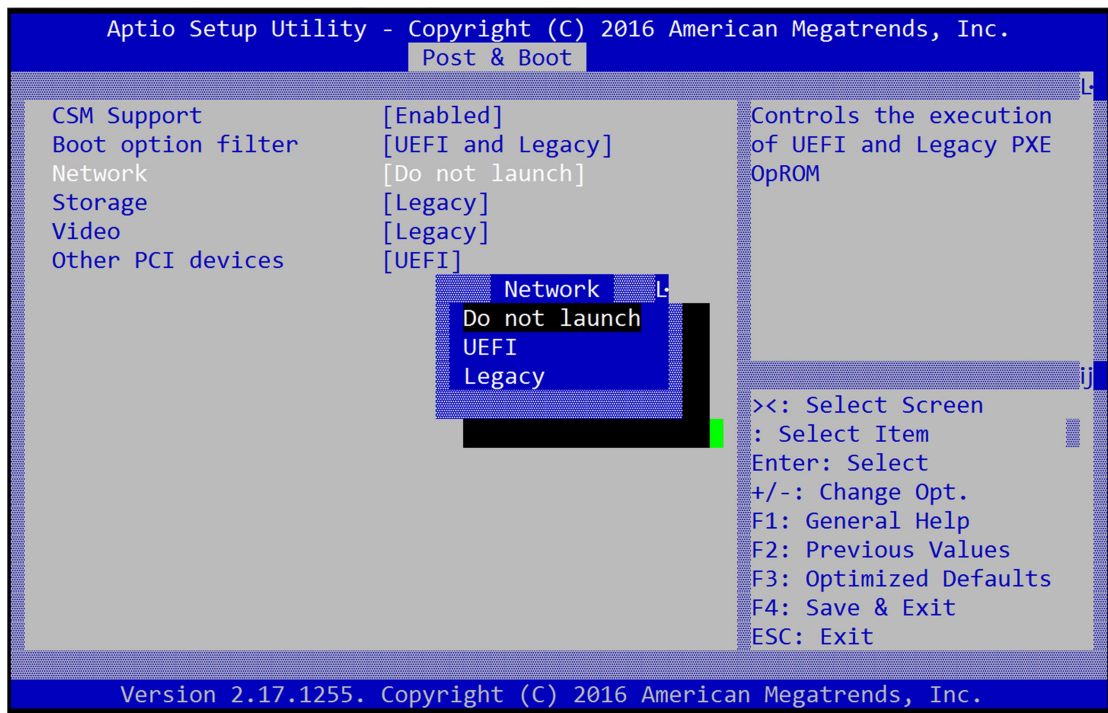

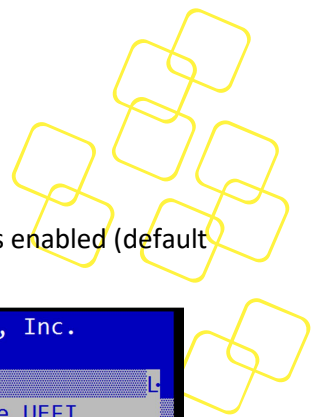

2. When user sets BIOS/ Advanced-> Network Stack Configuration-> Network Stack as enabled (default setting is disabled) , It will open UEFI IPV4 PXE support function.

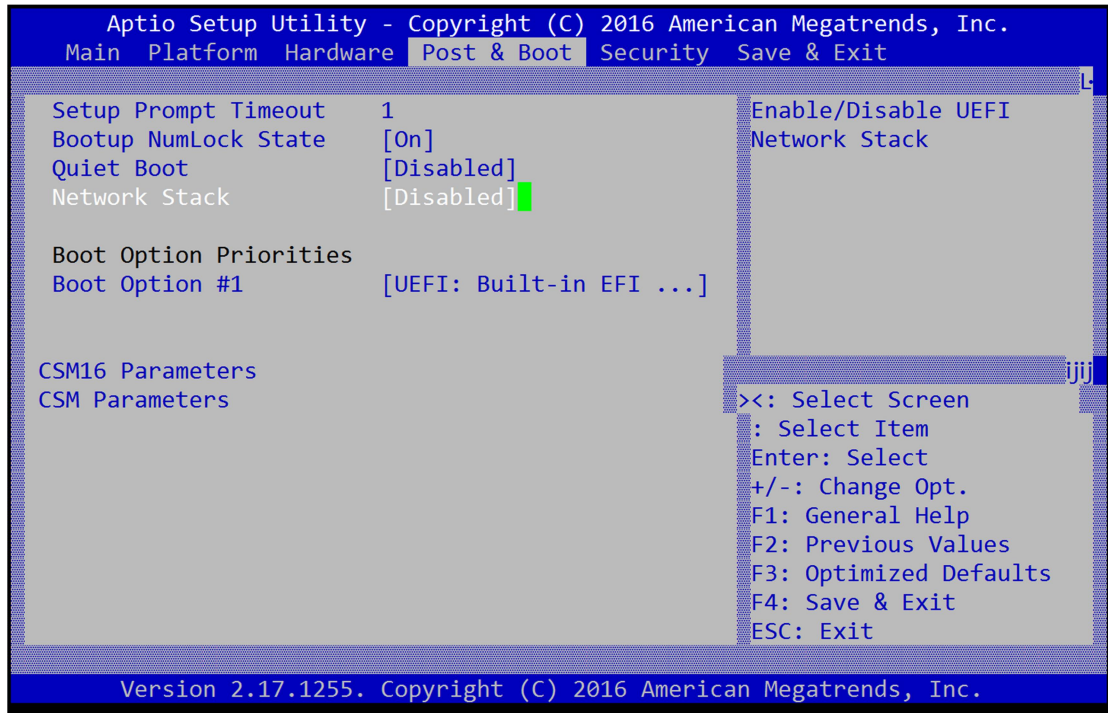

3. Save BIOS and reboot system. The BIOS will show “Checking Media Presence.....”, if system is not connected PXE server, it will show “No Media Present.....”

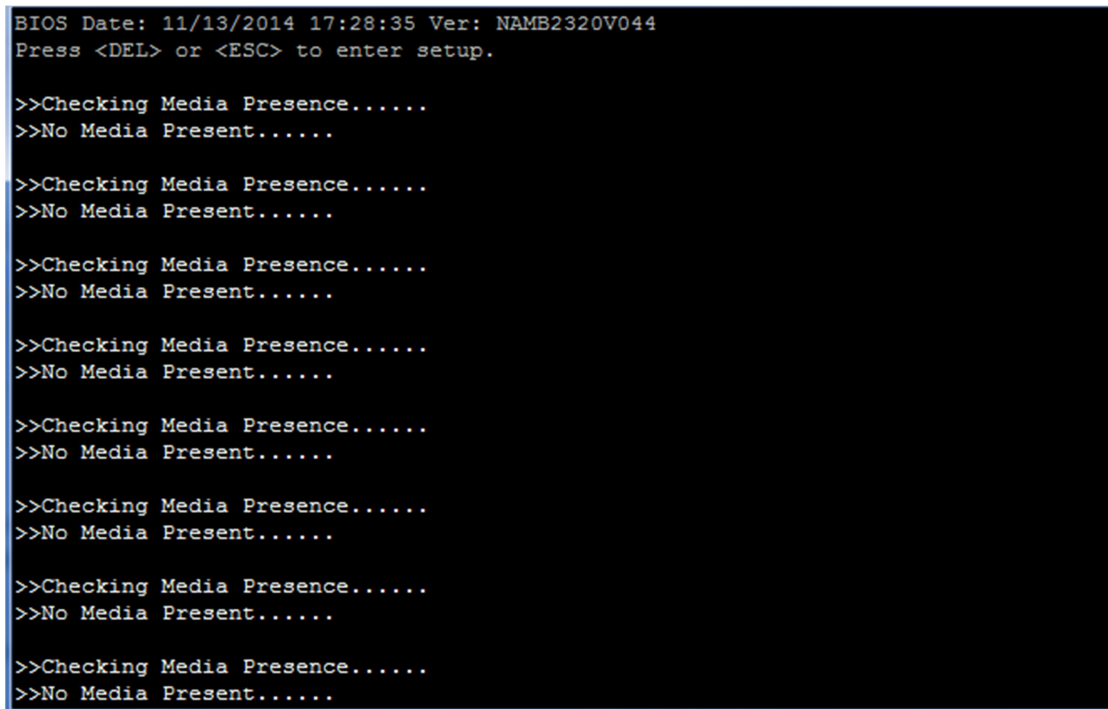



4. User may re-login in BIOS, choose BIOS/ boot item, it will has “Network Device BBS Priorities” item and set Legacy IPV4 PXE LAN boot sequence priority.

```

Aptio Setup Utility - Copyright (C) 2018 American Megatrends, Inc.
Main Platform Hardware Post & Boot Security Save & Exit
-----
| Setup Prompt Timeout      1          | Sets the system boot |
| Bootup NumLock State     [On]          | order                |
| Quiet Boot               [Disabled]   |                      |
| Network Stack            [Disabled]   |                      |
|
| Boot Option Priorities
| Boot Option #1           [P2: LITEON CV1-SB64]
| Boot Option #2           [IBA GE Slot 0400 v1570]
| Boot Option #3           [UEFI: Built-in EFI ...]
|
| Hard Drive BBS Priorities
| Network Device BBS Priorities
|
|> CSM16 Parameters
|> CSM Parameters
|
|-----|
|><: Select Screen
|^v: Select Item
|Enter: Select
|+/-: Change Opt.
|F1: General Help
|F2: Previous Values
|F3: Optimized Defaults
|F4: Save & Exit
|ESC: Exit
|
-----
Version 2.19.1266. Copyright (C) 2018 American Megatrends, Inc.
    
```

And please choose PXE Boot priority as “IBA GE Slot 0A00 v1570” it is on board Mgmt GbE port.

```

Aptio Setup Utility - Copyright (C) 2018 American Megatrends, Inc.
Post & Boot
-----
| Boot Option #1           [IBA GE Slot 0400 v1570] | Sets the system boot |
| Boot Option #2           [IBA GE Slot 0401 v1570] | order                |
|
|
|
|
|
|
|
|-----|
|><: Select Screen
|^v: Select Item
|Enter: Select
|+/-: Change Opt.
|F1: General Help
|F2: Previous Values
|F3: Optimized Defaults
|F4: Save & Exit
|ESC: Exit
|
-----
Version 2.19.1266. Copyright (C) 2018 American Megatrends, Inc.
    
```

When User sets “CSM Parameters -> Network” as UEFI and “Network Stack” as Enabled, the PXE choosing item is list in “Boot Option Priorities”, please choose Boot Option to set sequence priority of UEFI IPV4 PXE LAN port

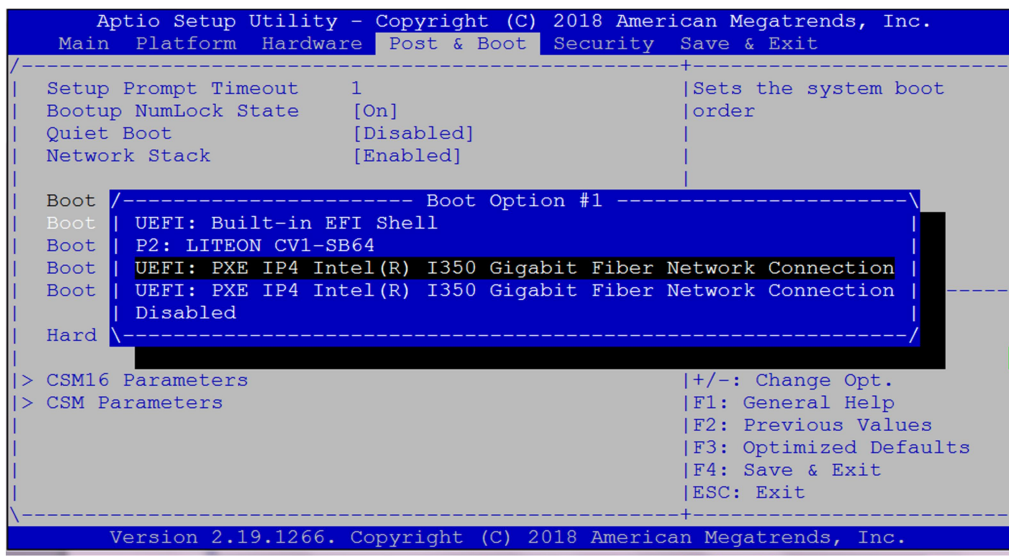

When UEFI IPV4 PXE doesn't detect UEFI PXE server, it will return to BIOS manual.

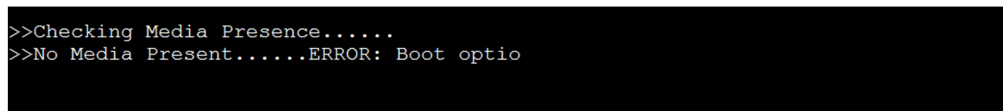

PXE boot usually does not allow for OS installation over network as the PXE client will only load a single file from the boot server. Similarly, booting Linux over network is usually a two stage process. In the first step, a boot loader such a grub or mini OS such as SysLinux are loaded via PXE from the boot server. The boot loader or miniOS then load the actual target OS which usually consists of multiple files which decompressed and installed into a RAM disk. The detailed process and required configuration of such network install will heavily depend on the target OS and boot loader / miniOS used. Please refer to the related documentation available.

PXE boot requires a DHCP server and a TFTP server in the network to complete. DHCP Server and TFTP server are commonly run on the same machine and collectively referred to as “boot server”. Setting up such a boot server implies a couple of steps. How-to guides for setting up Linux as PXE boot server are available on the internet, e.g.

[https://www.debianadministration.org/article/478/Setting up a server for PXE network booting.](https://www.debianadministration.org/article/478/Setting_up_a_server_for_PXE_network_booting.)

Please note that it is recommended to setup a separate network / subnet for network booting as the DHCP required for PXE booting may conflict with existing DHCP servers in your network.



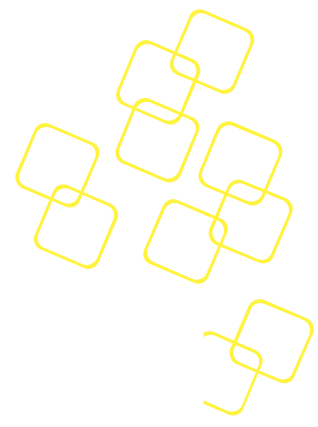

2.3 LED Behaviour

For the description of Lan port LEDs please refer to below table for ref.

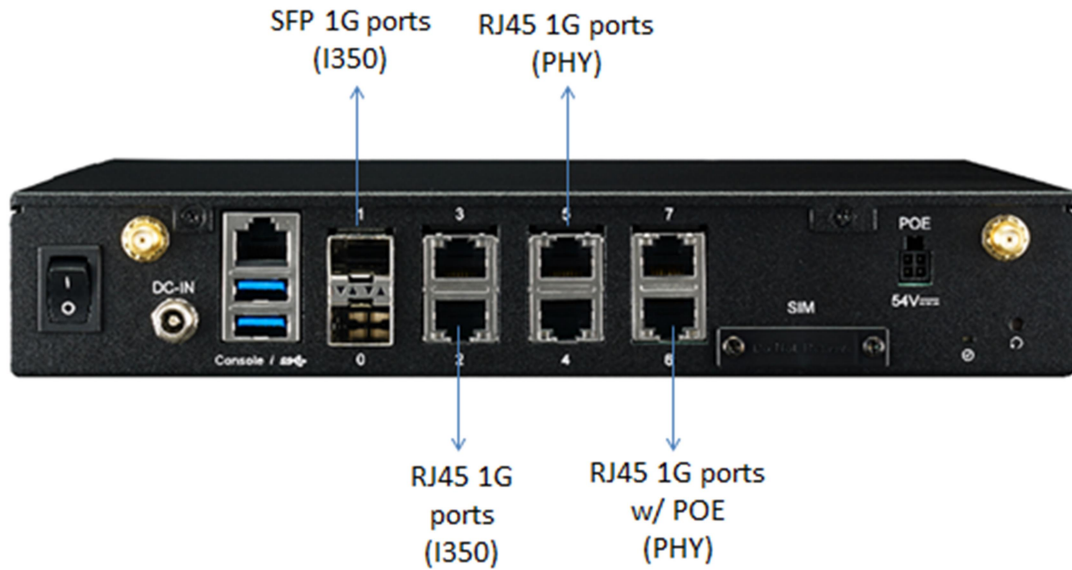

SFP LED indicator function in front:

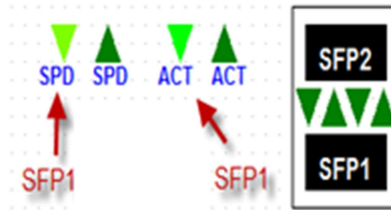

Figure :SFP connector drawing

SFP LED	LEFT	RIGHT
SFP1	SPEED: 1G Green	LINK/ACK LINK: Green ACK: Green Blinking
SFP2	SPEED: 1G Green	LINK/ACK LINK: Green ACK: Green Blinking

Table 2: SFP connector LED indication

RJ45 LED indicator function in front:

RJ45 LED	LEFT	RIGHT
1	SPEED:10M LED OFF 100M Amber,1G Green	LINK/ACK LINK: Green ACK: Green Blinking
2	SPEED: 10M LED OFF 100M Amber,1G Green	LINK/ACK LINK: Green ACK: Green Blinking

Table 3: RJ45 connector LED indication (Marvell PHY)

RJ45 LED indicator function w/ POE in front:

RJ45 LED	LEFT	RIGHT
1	SPEED:10M LED OFF 100M Amber,1G Green	LINK/ACK/SPEED LINK: 1G/Green,100M/Amber ACK: Blinking
2	SPEED: 10M LED OFF 100M Amber,1G Green	LINK/ACK LINK: Green ACK: Green Blinking

Table 3 RJ45 connector LED indication (Marvell PHY) without POE

RJ45 LED	LEFT	RIGHT
1	POE LED ON: GREEN	LINK/ACK/SPEED LINK: 1G/Green,100M/Amber ACK: Blinking
2	POE LED ON: GREEN	LINK/ACK/SPEED LINK: 1G/Green,100M/Amber ACK: Blinking

Table 4: RJ45 connector LED indication (Marvell PHY) with POE

2.4 Main Board Connector placement

Top side:

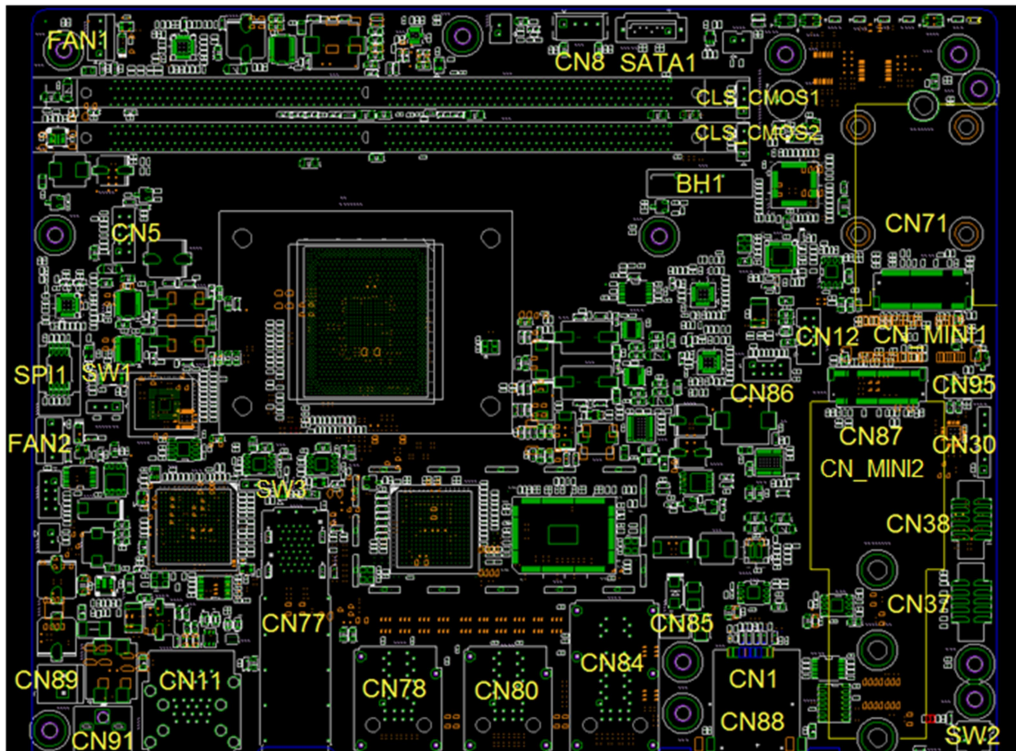

Figure 1: NAMB-1012VCMB Connector placement (Top side)

Bottom Side:

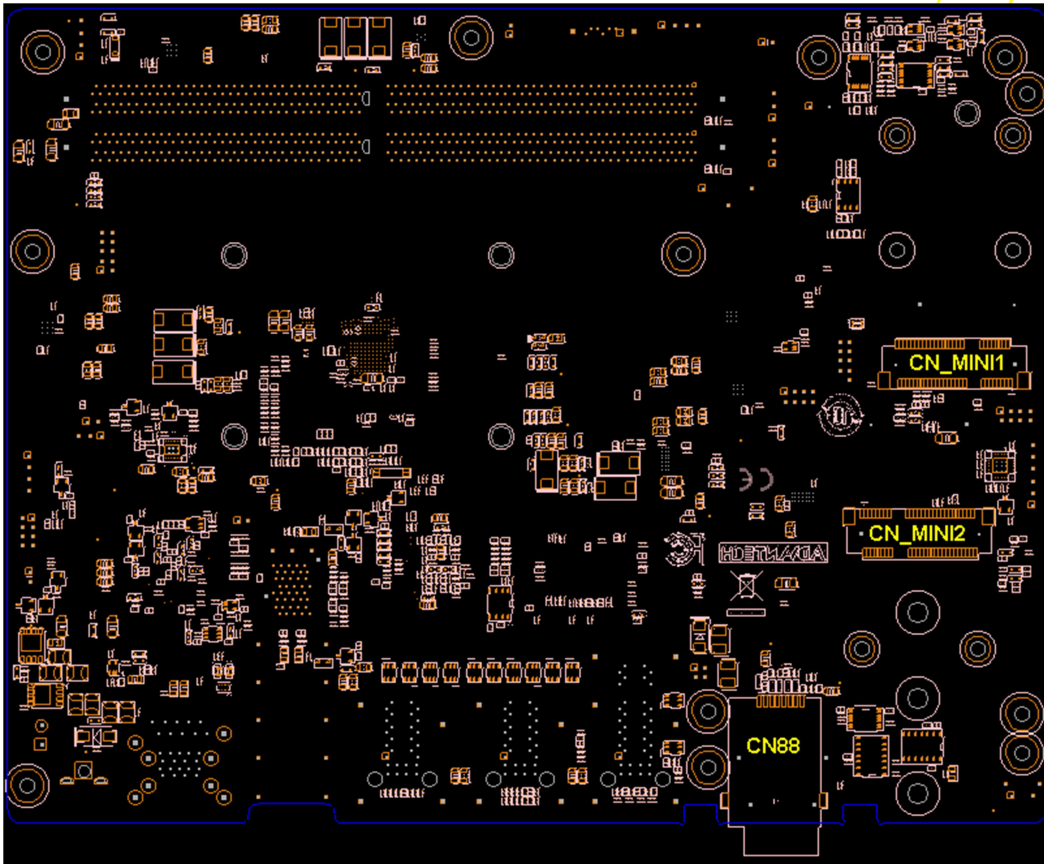
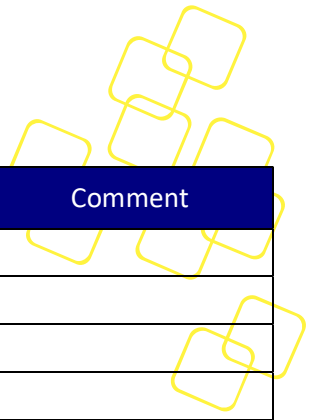

Figure 2: NAMB-1012VCMB Connector placement (Bottom side)

FWA-1012VC MB Jumper Setting and Connector List

Location	Description	Comment
CN89	12V SWITCH CONN	
CN91	12V Power Connector	
BH1	Battery holder for coin battery	
CLS_CMOS1	Clear CMOS pin header	
CLS_CMOS2	Clear RTC pin header	
CN5	LPC Connector	
CN8	4-PIN SATA POWER Connector	
CN11	RJ45+USBx2 Connector	
CN12	USB HEADER. 10-Pin wafer connector for USB 2.0	
CN95	COM2 UART CONN	
CN30	6-Pin pin header for FPGA JTAG	
CN13	UART COM2 Connector. 10-Pin wafer connector for COM2	



Location	Description	Comment
FAN1,FAN2	4-Pin fan connector	
SATA1	SATA IO connectors from Denverton	
SPI1	SPI socket for SPI flash (BIOS)	
SW2	SW Button	
CN77	SFP CONN	
CN78,CN80	RJ45 CONN	
CN84	RJ45(POE)CONN	
CN85	POE POWER CONN	
CN1 CN88	SIM CARD CONN	
CN37 CN38	BSCN CONN	
CN86	POE CONN	
CN_MINI1 CN_MINI2	MINIPICE CONN	
CN87	M.2 CONN (B+M KEY 3042 &2280)	
CN71	M.2 CONN (B+M KEY 3042 &2242)	
SW3	FPGA switch	
SW1	BSCN switch	
CN96	BSCN jumper	

Table 5: FWA-1012VC MB Jumper Setting and Connector List

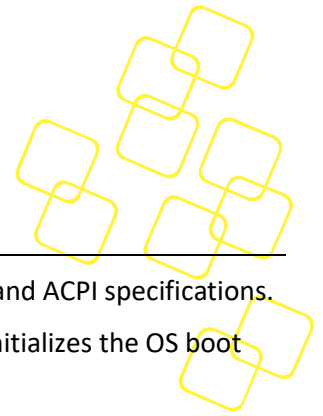

3. BIOS

FWA-1012VC BIOS is based on AMI's APTIO BIOS and compliant to the UEFI, SMBIOS and ACPI specifications.

The BIOS performs probing, initialization and configuration of the FWA-1012VC and initializes the OS boot process at the end of POST (Power-On-Self-Test).

Regular BIOS output as well as the setup menu are displayed via console port and please note that the FWA-1012VC does not have any on-board POST Code LEDs. A special POST code adapter is required to retrieve BIOS error codes.

All BIOS configuration parameters are stored in NVRAM, a dedicated section of the BIOS flash chip. Parameters are no longer stored in legacy CMOS RAM by the platform BIOS. I.e. BIOS configuration parameters will not be lost due to an empty battery.

3.1 BIOS Defaults

The BIOS comes with a set of configuration parameters when shipped by Advantech referred to as "Optimized Defaults" or "factory defaults". The user can change BIOS settings via the setup menu either temporarily or permanently by saving the changes as "User defaults".

The BIOS loads Optimized Defaults by the option "Restore Defaults; and loads User defaults by the option "Restore User Defaults". If no User defaults have been defined, the BIOS will do nothing.

3.2 BIOS Setup Menu

This section describes the FWA-1012VC's UEFI BIOS based on AMI's APTIO BIOS.

Users can modify BIOS settings and control the special features of the FWA-1012VC using the BIOS setup menu.

Please note that Advantech supports shipping the FWA-1012VC with custom BIOS defaults to simplify the deployment and integration for our customers. Please contact your Advantech representative if you want to receive more information regarding this service.

The BIOS Setup Menu can be entered via the BIOS POST screen displayed on the console interface:

```
Version 2.19.1266. Copyright (C) 2018 American Megatrends, Inc.  
**** FWA-1012VC BIOS V1.00 (07/13/2018) ****  
Press <DEL> or <F2> to enter setup.
```

Figure 10: BIOS POST screen (example)

BIOS Setup can be entered by hitting or <F2> keys during POST.

The BIOS setup menu screens have a few main elements as shown below. The menu bar displays the selectable menu pages as tabs. The parameter window displays and allows configuration of the settings available in a given menu page or a submenu thereof. Auxiliary text providing information about the selected setup item is displayed in the top right corner.

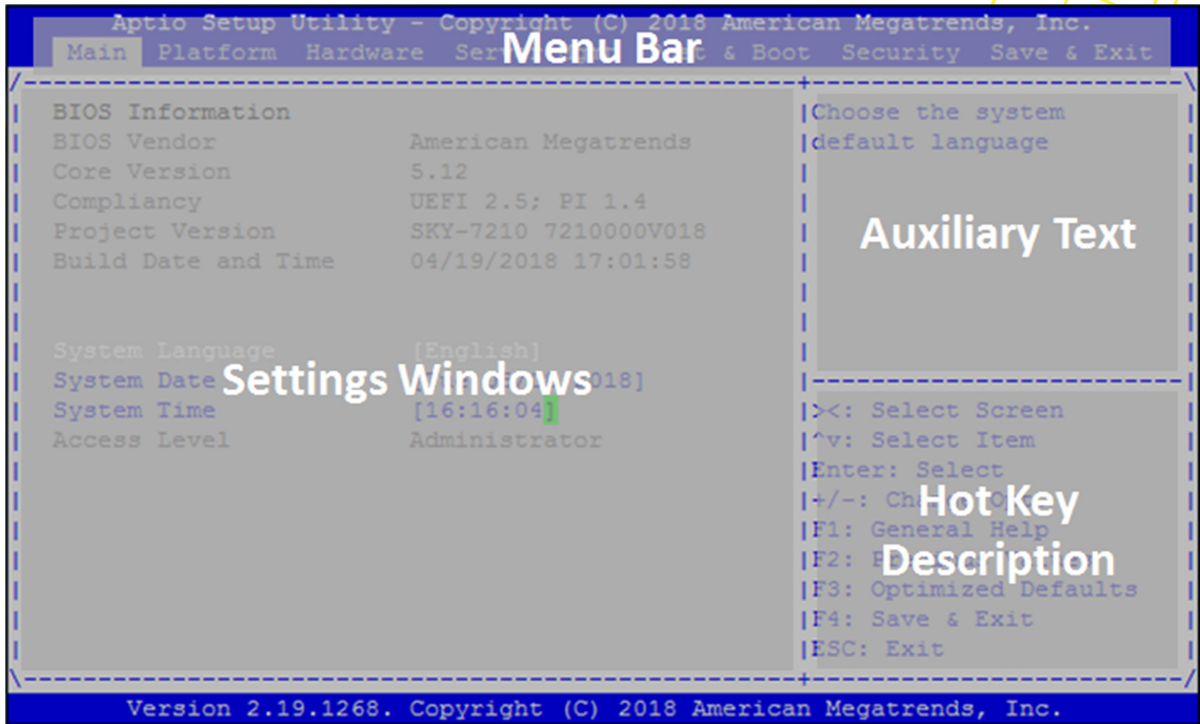

Figure 11: BIOS Setup Screen Organization

3.2.1 MAIN SETUP MENU

If security protection has been enabled previously (see chapter 錯誤! 找不到參照來源。), you will be prompted for the BIOS password upon entering the BIOS Setup. After a successful check or if password protection has not been enabled, users will see the Main Setup screen shown below. Users can always return to the Main setup screen by selecting the Main tab.

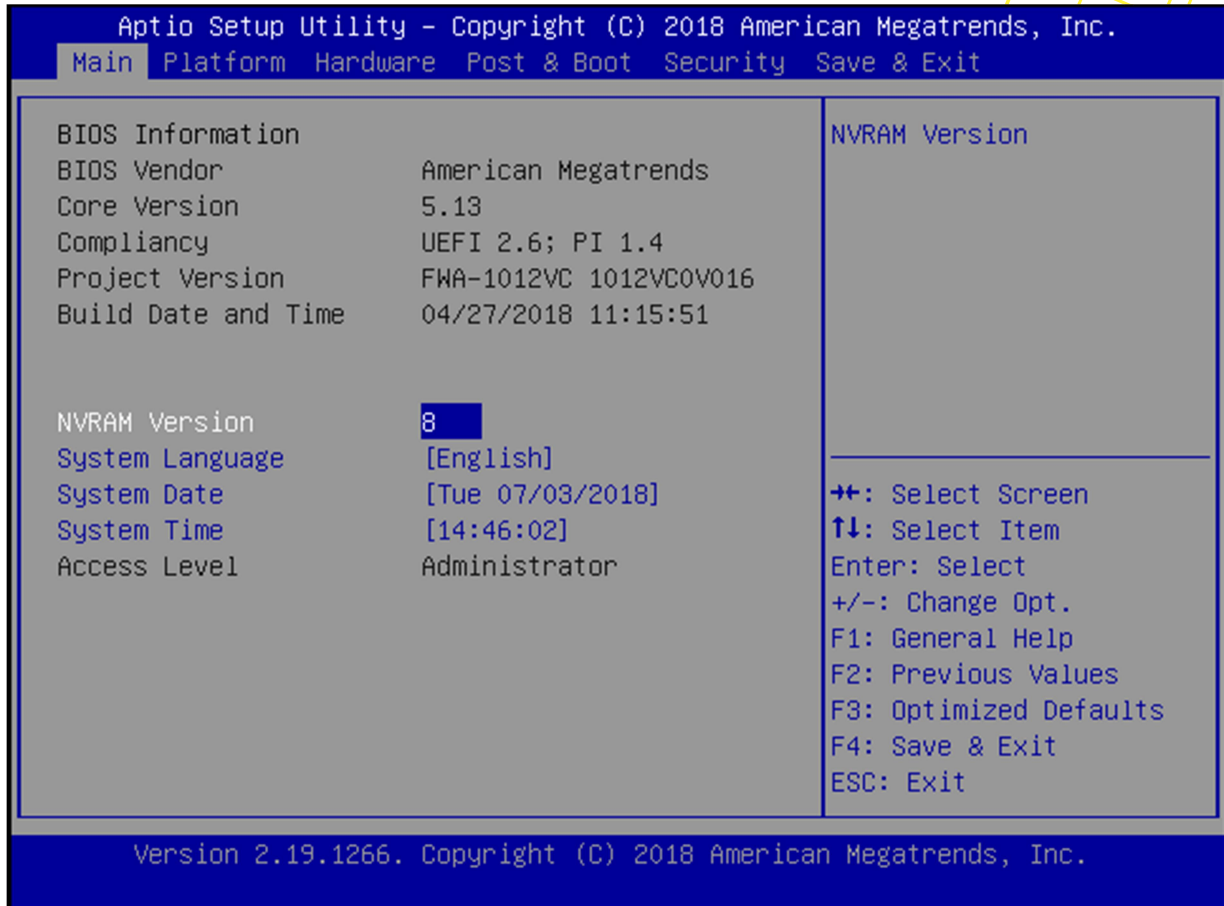
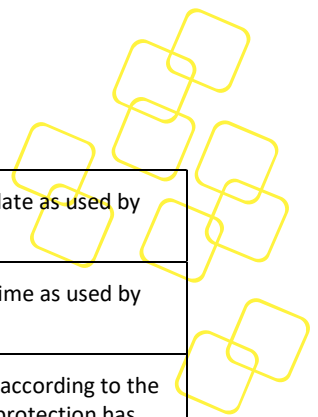

Figure16: BIOS Setup Main screen

The main setup page displays system a summary of system and BIOS configuration and status information. The fields on this page are read-only except for the System Date and Time setting.

Group	Setup item	Access / Options	Description
BIOS Information	BIOS Vendor	Display only	American Megatrends
	Core Version	Display only	Current AMI BIOS core version in use
	Compliancy	Display only	UEFI Spec revision that the BIOS complies to
	Project Version	Display only	Advantech BIOS Version info EX: mmmm Vx.yz mmmm : model name X : major version Yz: minor version
	Build Date & Time	Display only	Shows BIOS build date and time
System Language		Display only	Selects the Setup Menu Language. Only English is supported on the FWA-1012VC.



System Date		MM/DD/YY	Displays and sets the system date as used by the BIOS
System Time		HH:MM:SS	Displays and sets the system time as used by the BIOS
Access Level		Display only	Shows the user privilege level according to the security settings. If password protection has not been enabled, this will default to "Administrator"

Table 6: BIOS Setup: Main Menu

3.2.1.1 Setting System Time and Date

Use this option to change the system time and date. Highlight System Time or System Date using the <Arrow> keys. Enter new values through the keyboard. Press the <Tab> key or the <Arrow> keys to move between fields. The date must be entered in MM/DD/YY format. The time is entered in HH:MM:SS format.

Please note that system time and date are set during manufacturing process according to factory's local time zone. You may need to update system time to reflect the desired time zone when you receive the unit.

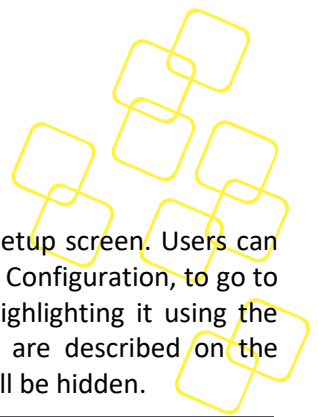

3.2.2 PLATFORM SETUP MENU

Select the Platform tab from the FWA-1012VC setup screen to enter the Platform Setup screen. Users can select any of the items in the left frame of the screen, such as the Trusted Computing Configuration, to go to the sub menu for that item. Users can display a Platform BIOS Setup option by highlighting it using the <Arrow> keys. The Platform BIOS Setup screen is shown below. The sub menus are described on the following pages. Note: If BMC is Present in the system and Hardware Monitor page will be hidden.

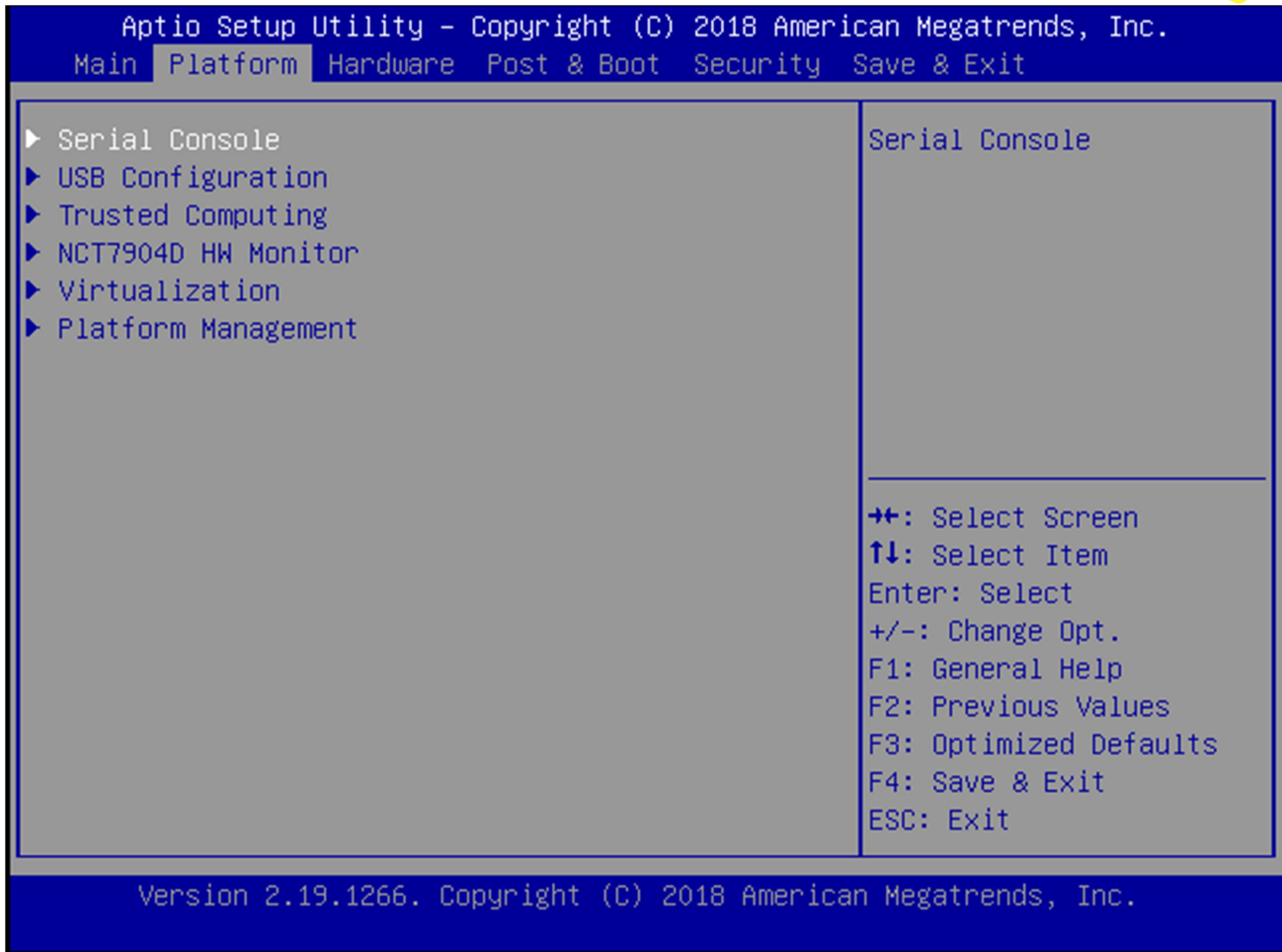

Figure 13: Platform Setup Main screen

3.2.2.1 Serial Console

This sub menu allows you to change the settings used for the serial console.

Note that the serial console is always using COM1 which is connected to the front panel.

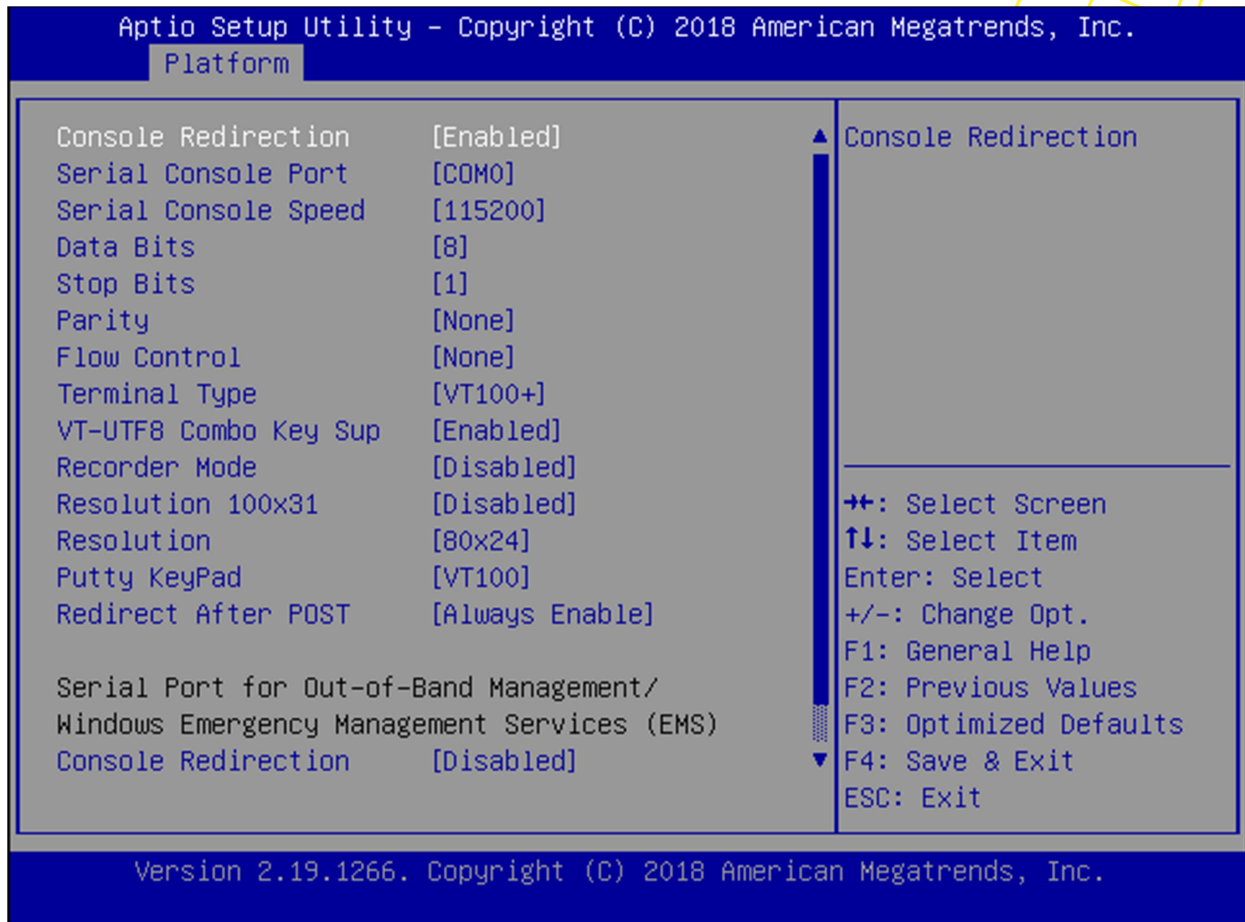
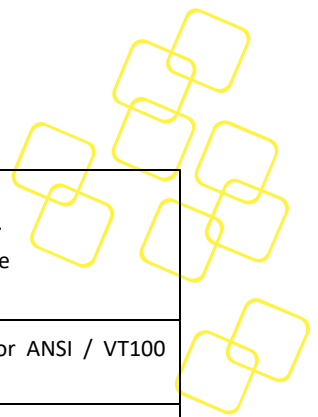

Figure148: Platform Setup: Console Redirection Menu

The settings for COM0 console can be accessed in this menu.

This sub menu allows you to change the settings used for the serial console. For example, users can define the terminal type, bits per second, data bits, parity, stop bits and others.

Setup item	Access / Options	Description
Console Redirection	Disabled / Enabled	Disabled / Enabled Console Redirection
Serial Console Port	COM0	Serial Console Port
Serial Console Speed	9600 / 19200 / 38400 / 57600 / 115200	Defines the baud rate.
Data Bits	7 / 8	Defines number of data bits in a character.
Stop Bits	1 / 2	Defines number of stop bits in a character.
Parity	None / Even / Odd / Mark / Space	Defines the parity scheme used.
Flow Control	None / Xon/Xoff	Defines the flow control scheme.
Terminal Type	ANSI / VT100 / VT100+ /	Select the target terminal emulation type:- ANSI to use the Extended ASCII Character Set.



	VT-UTF8	- VT100 to use the ASCII Character set. - VT100+ to add color and function key support. - VT-UTF8 to use UTF8 encoding to map Unicode characters into one or more bytes.
VT-UTF8 Combo Key	Disabled / Enabled	Enables VT-UTF8 Combination Key Support for ANSI / VT100 terminals
Recorder Mode	Disabled / Enabled	When Enabled the data displayed on a terminal will be captured and sent as text messages to a remote server.
Resolution 100x31	Disabled / Enabled	Enables or disables extended terminal resolution
Resolution	80x24 / 80x 25	When using Legacy OS, this item specifies the Number of Rows and Columns supported
PuTTY Keypad	VT100 / . LINUX / XTERMR6 / SCO / ESCN / VT400	Select Function Key and Key Pad Emulation on PuTTY.
Redirection after POST	Always Enable / BootLoader	This defines how long console redirection will be active: "BootLoader" means that legacy console redirection is disabled before booting into a Legacy OS. "Always Enable" means Legacy console Redirection is enabled permanently.
Emergency Management Services (EMS) Console Redirection	Disabled / Enabled	Disabled / Enabled serial console interface to the bootloader menu on modern versions of Microsoft Windows

Table 7: Platform Setup: COM0 Console Redirection Menu Items

3.2.2.2 USB Configuration

This sub menu allows you to change the settings used for USB and to get an overview of the USB devices detected by the BIOS.

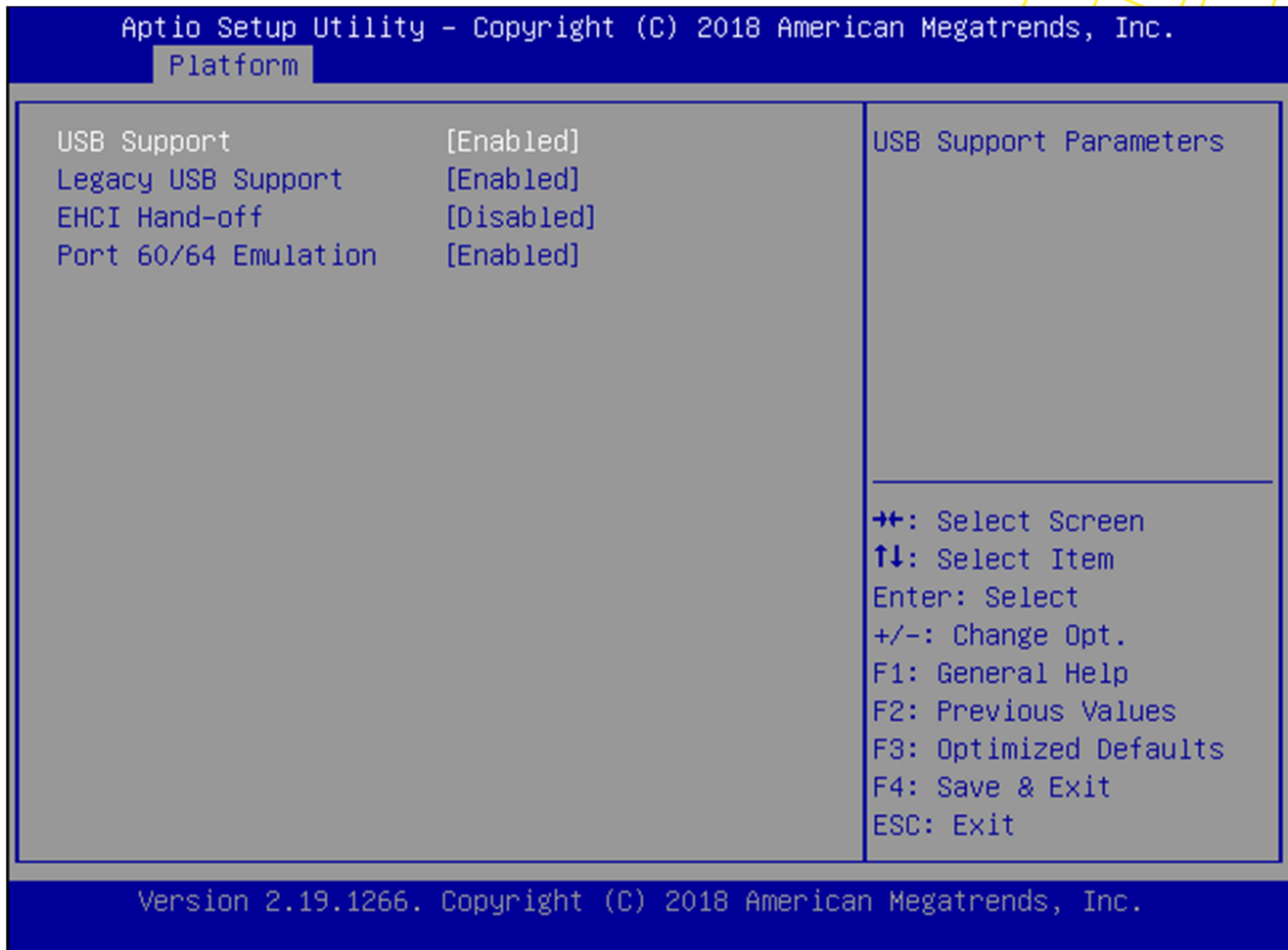

Figure 15: Platform Setup: USB Configuration Menu

Setup item	Access / Options	Description
USB Support	Enabled Disabled	Enables or disables the support for USB. If disabled, the USB EHCI controller will not be initialized by the BIOS.
Legacy USB Support	Auto Enabled Disabled	Enables legacy support over USB to support Keyboard and Mouse
EHCI Hand-Off	Enabled Disabled	Controls the hand off of XHCI ownership from BIOS to OS at boot time.
Port 60/64 Emulation	Enabled Disabled	Enables I/O port 60h/64h emulation support

Table 8 USB Configuration Menu

3.2.2.3 Trusted Computing

Please note that Trusted Computing support is disabled by default in the factory defaults to save system boot time. If disabled, the Trusted Computing Menu will not display any status information.

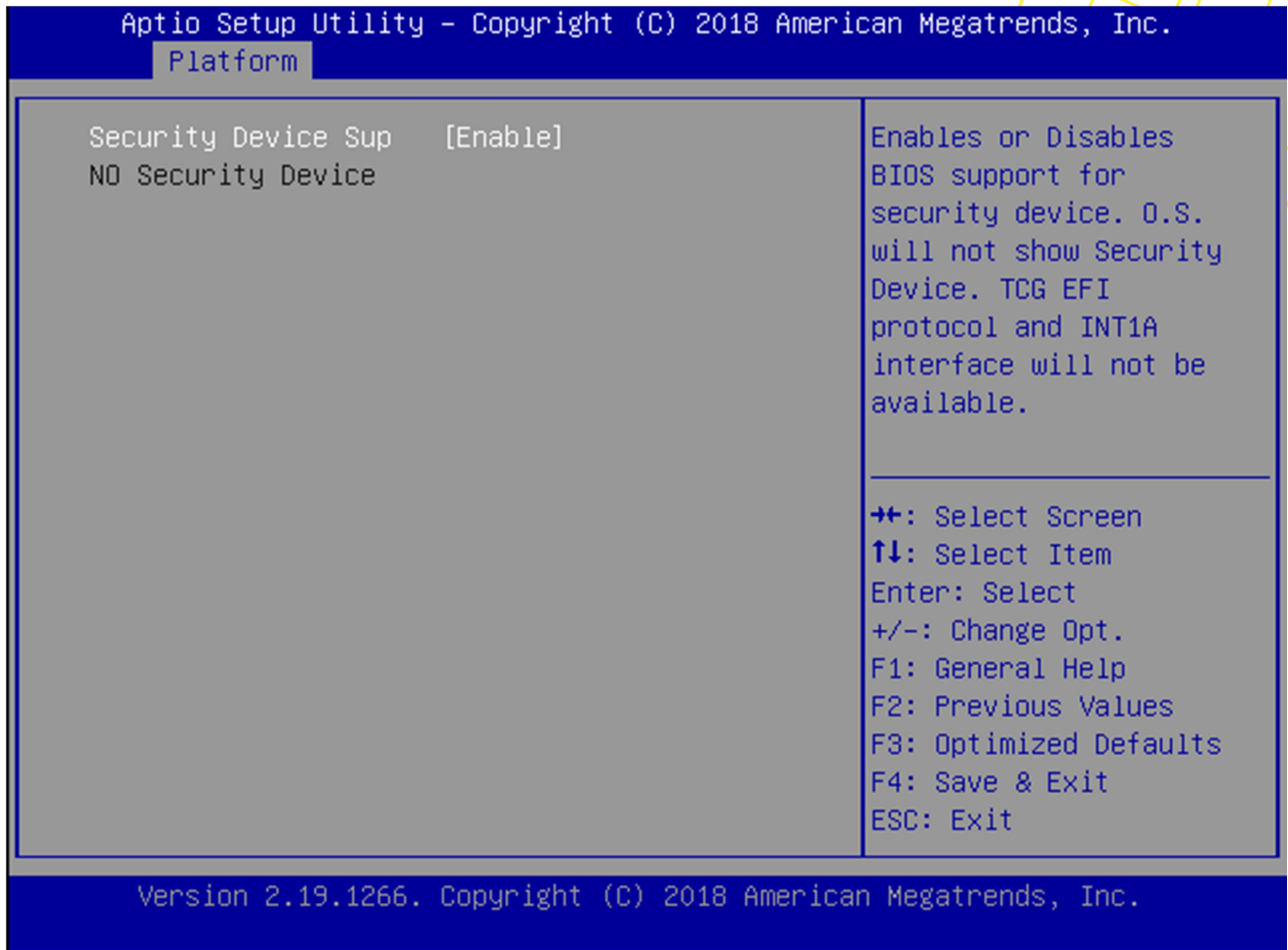

Figure 16: Platform Setup: Trusted Computing

Group	Setup item	Access / Options	Description
Configuration	Security Device Sup	Enable Disable	Enables or Disables BIOS support for security device. O.S. will not show Security Device. TCG EFI protocol and INT1A interface will not be available.

Table 9 Trusted Computing Menu



3.2.2.4 NCT7904D HW Monitor

The system with NCT7904D HW Monitor , and the BIOS will detect voltages and temperatures and the related information will be shown in the BIOS setup menu as below.

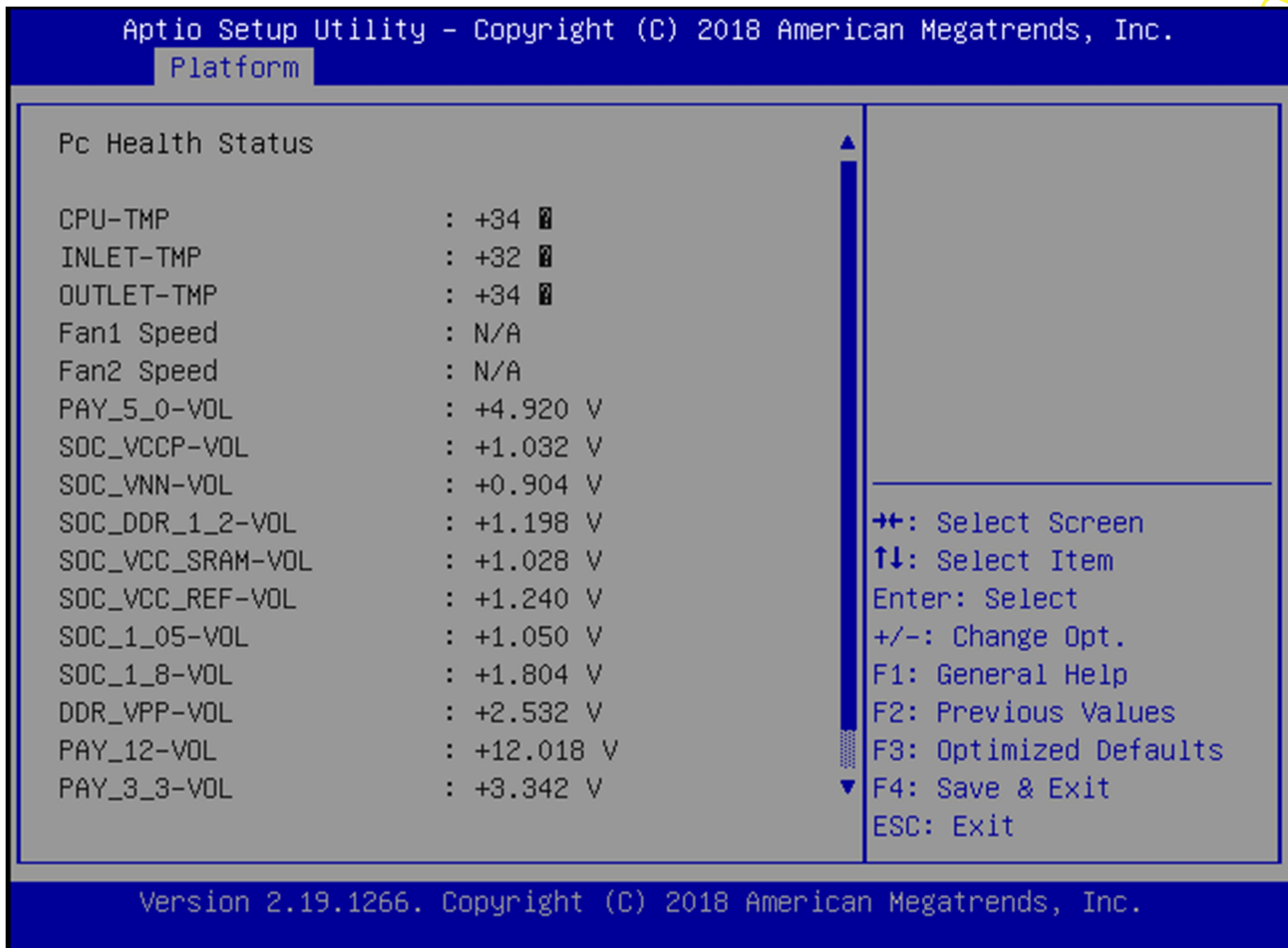

Figure 17: Platform Setup: Trusted Computing with TPM2.0

3.2.2.5 Virtualization

This sub menu allows you to change the settings used for Virtualization function.

Intel® Virtualization Technology for Directed I/O (VT-d). Thus, BIOS handle virtual functions exposed by PCIe devices in case SR-IOV is supported, otherwise PCIe devices will be assigned to virtual machines in pass-through mode. This applies for all PCIe devices.

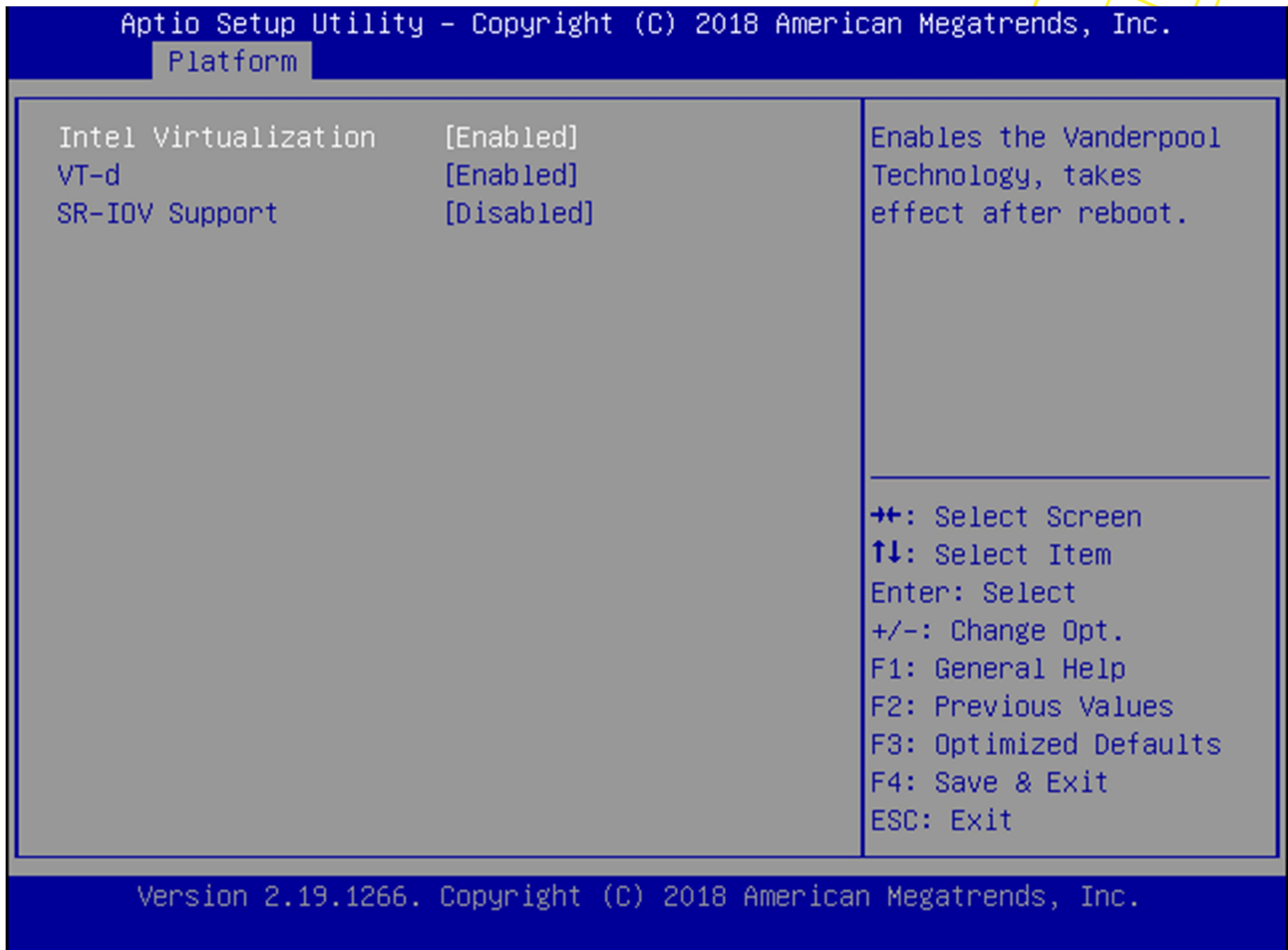

Figure 18: Platform Setup: Virtualization

Setup item	Access / Options	Description
Intel Virtualization	Enable Disable	Enable/Disable Intel Virtualization Technology , take effect after reboot
VT-d	Enable Disable	Enable/disable Intel Virtualization Technology for Directed I/O (VT-d) by reporting the I/O device
SR-IOV Support	Enable Disable	If system has SR-IOV capable PCIe Devices, this option Enables or Disables Single Root IO <u>Virtualization</u> Support

Table 10: Virtualization Menu

3.2.2.6 Platform Management

This sub menu allows you to change the settings used for related CPU utilization setting.

The default configuration for CPU was optimized setting for getting better performance for networking, so it is not recommend to change it.

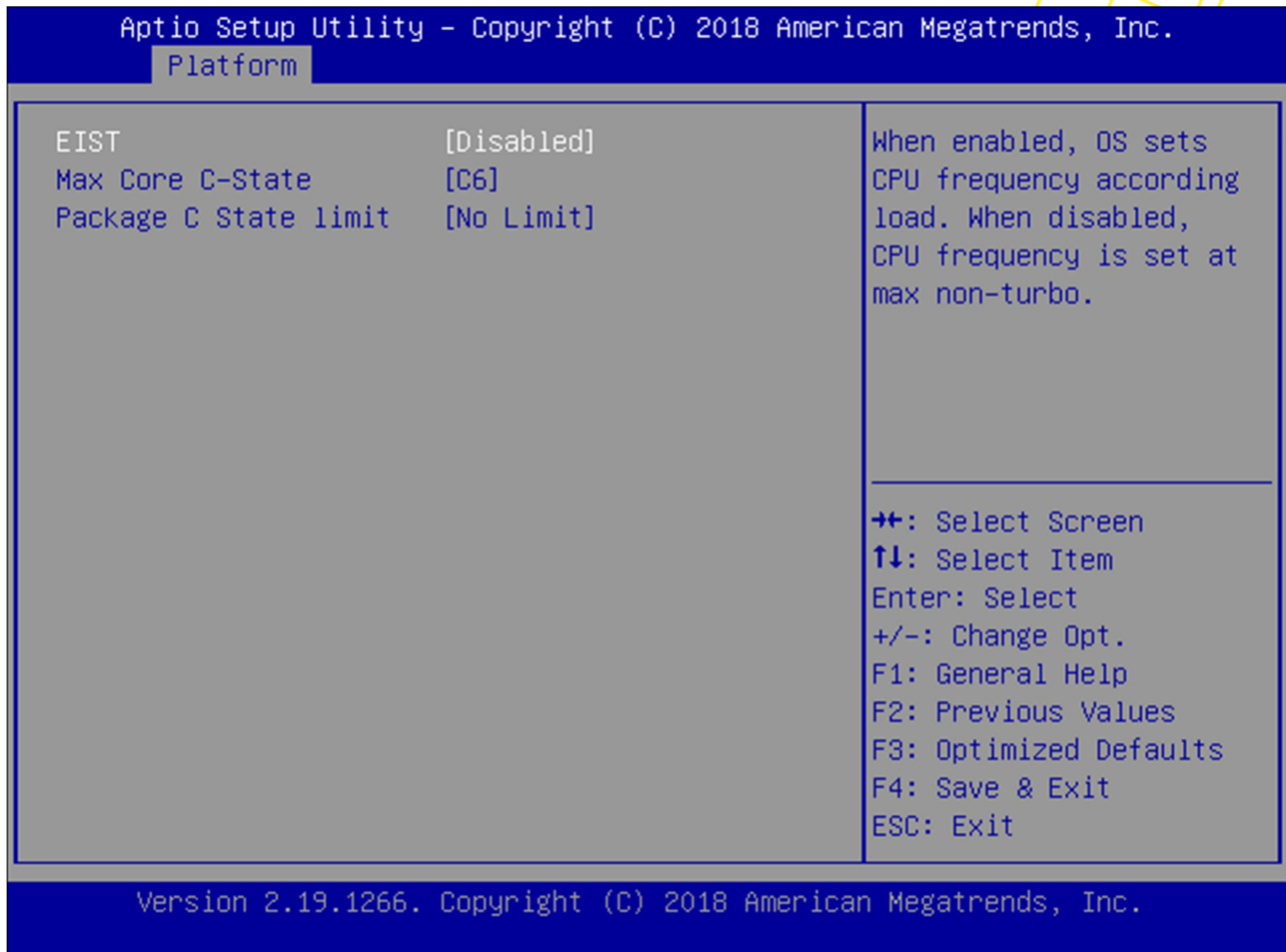

Figure 19: Platform Setup: Platform Management

Setup item	Access / Options	Description
EIST	Enable Disable	Enable or disable BIOS support for Enhanced Intel SpeedStep Technology, When enabled, OS sets CPU frequency according load. When disabled, CPU frequency is set at max non-turbo.
Max Core C-State	C1, C6	Enable/Disable CPU C6(ACPI C2) report to OS Recommended to be enabled.
Package C State limit	No Pkg C-State, No S0ix, No limit	Package C State limit. The "waking-up time" will be longer if Package C state limit setting is deep C state support.

Table 11: Platform Management Menu



3.2.3 HARDWARE SETUP MENU

This sub menu allows you to change the settings of the Intel chipset. Please note that “chipset” is a legacy term and the related functionality is split over the CPU and PCH portions of the SoC. Similarly, the terms “South Bridge” and “North Bridge” are legacy terms and do not represent the silicon implementation any more. However, those terms are kept consistent with previous products to allow users to navigate more easily.

The sub menus are described on the following pages.



Figure 20: Hardware Configuration Menu

3.2.3.1 Hardware Setup: CPU Configuration

This menu use example of Xeon D CPU configuration.

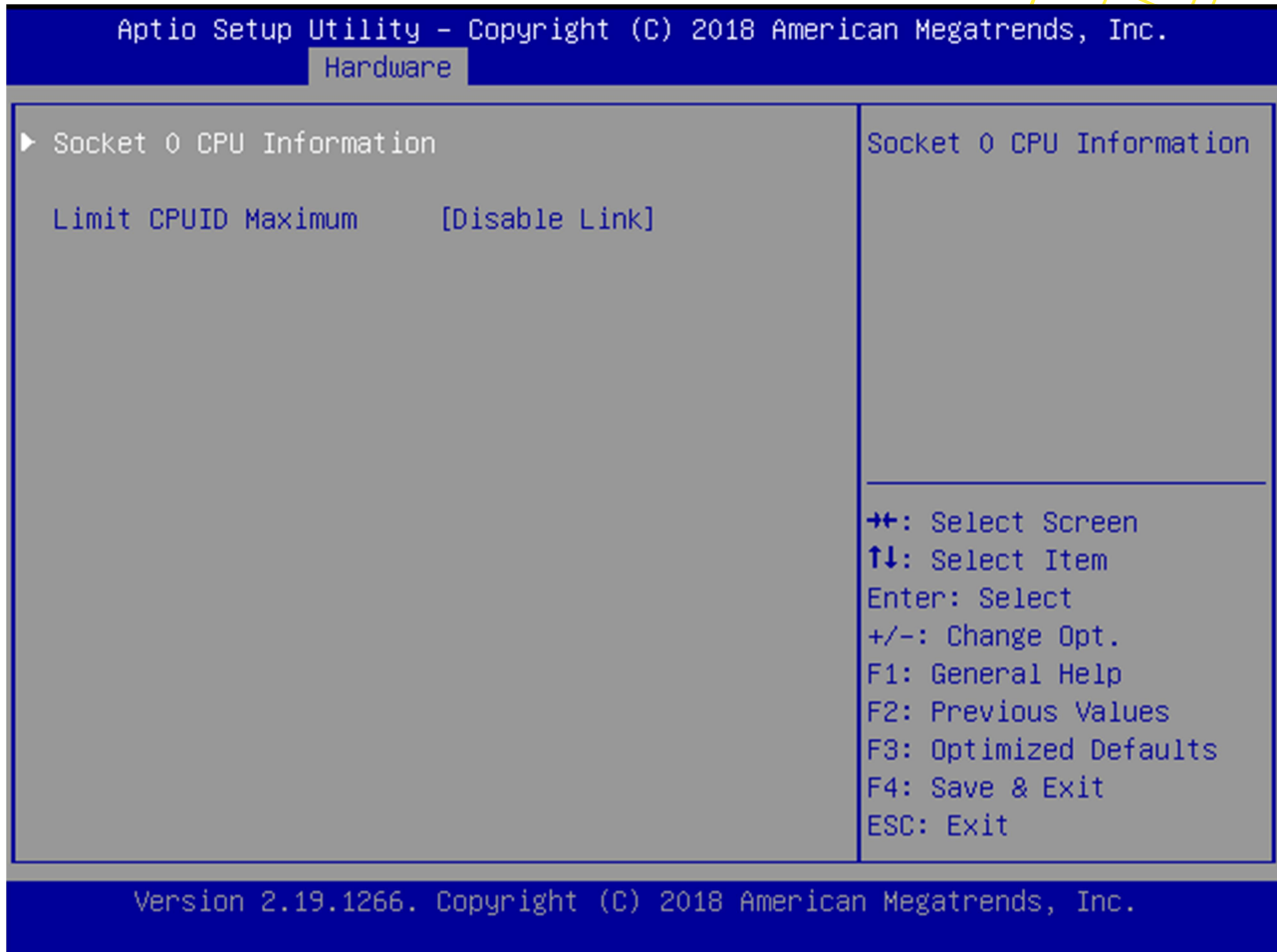

Figure 21: Chipset: Processor Configuration Menu

Group	Setup item	Access / Options	Description
Socket0 CPU information	CPU signature	Display only	Displays information on the processor installed
	Microcode Patch		
	CPU Frequency		
	Processor Cores		
	Intel VT-x Technology		
	L1 code Cache		
	L2 Cache		
None	Limit CPUID Maximum	Enabled, Disabled Link	Some legacy operating systems are unable to properly deal with the CPUID x86 opcode when called using operands greater than 3, Set this to Enabled if you experience just such a problem, otherwise leave this Disabled.

Table 12: Processor Configuration Menu



3.2.3.2 Hardware Setup: North Bridge Configuration

This menu allows the configuration of the memory controller and related features of the SoC.

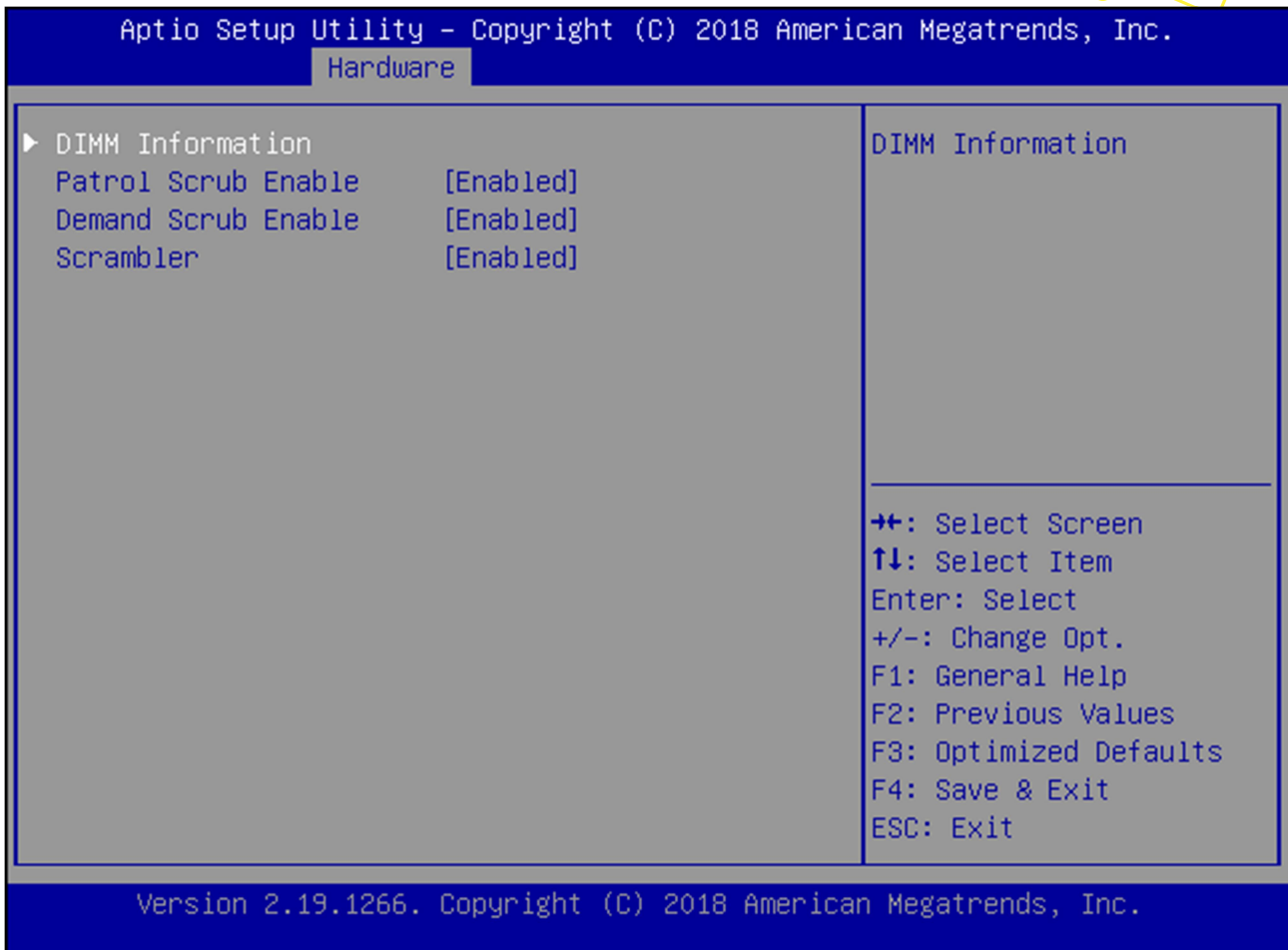

Figure 22: NorthBridge Configuration Menu

Group	Setup item	Access / Options	Description
DIMM Information	Node 0 Ch 0 Dimm 0	Display only	Displays information on the DIMM installed
	Node 0 Ch 1 Dimm 0		
	Patrol Scrub Enable	Enable Disable	Select to enable / disable Patrol Scrub Support
	Demand Scrub Enable	Enable Disable	Select to enable / disable Demand Scrub Support
	Scrambling	Enable Disable	Select to enable / disable the Scrambler

Table 11: Northbridge Configuration Menu



3.2.3.3 Hardware Setup: South Bridge Configuration

This menu contains settings for the South Bridge for related SATA and USB and ACPI setting etc.

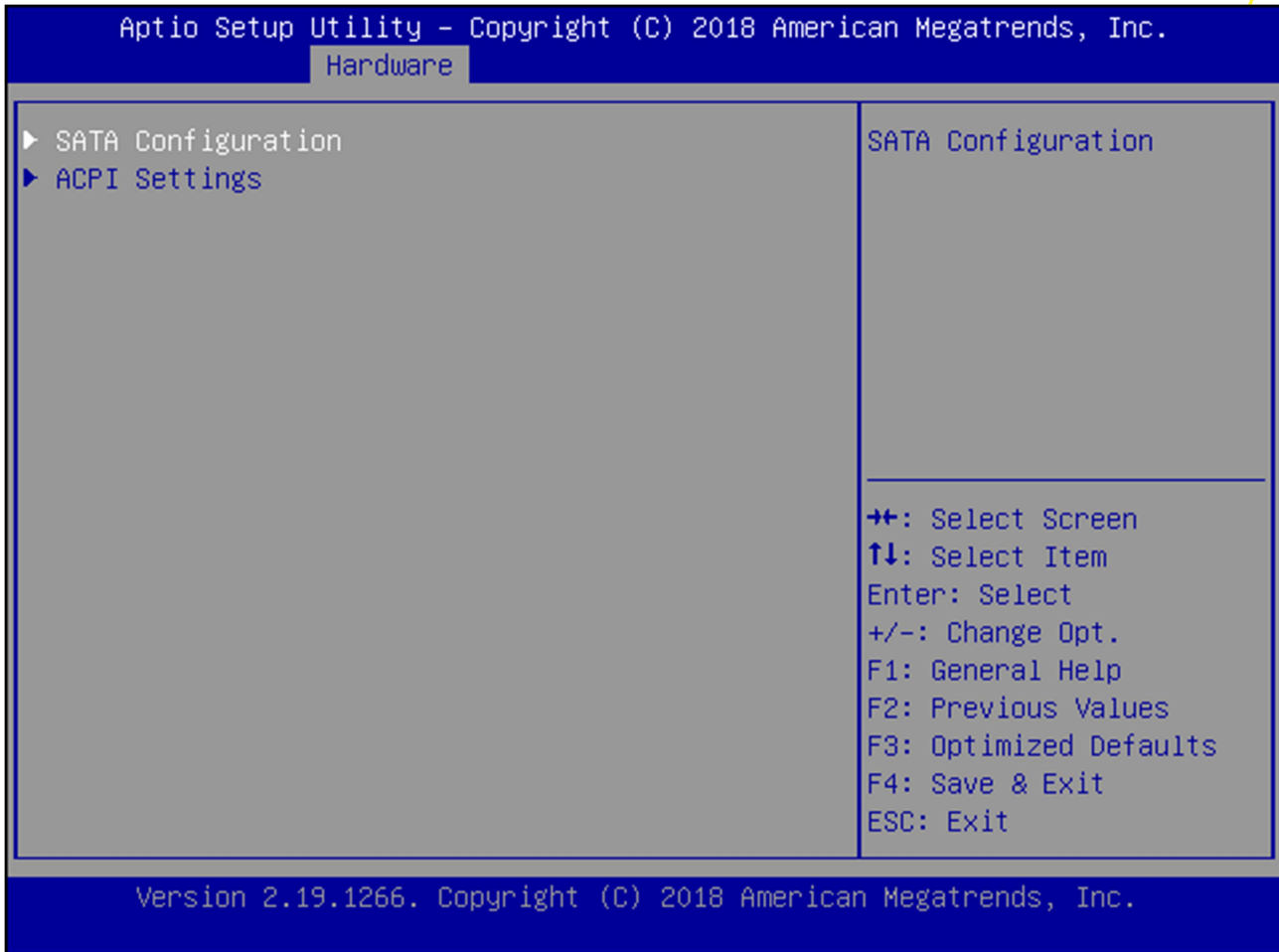

Figure 23: Hardware Setup: South Bridge configuration

Setup item	Access / Options	Description
SATA Configuration	N/A	Select sub-menu.
ACPI Settings	N/A	Select sub-menu.

Table 12: Hardware Setup: South Bridge configuration Menu Items

3.2.3.3.1 South Bridge Configuration: SATA Configuration

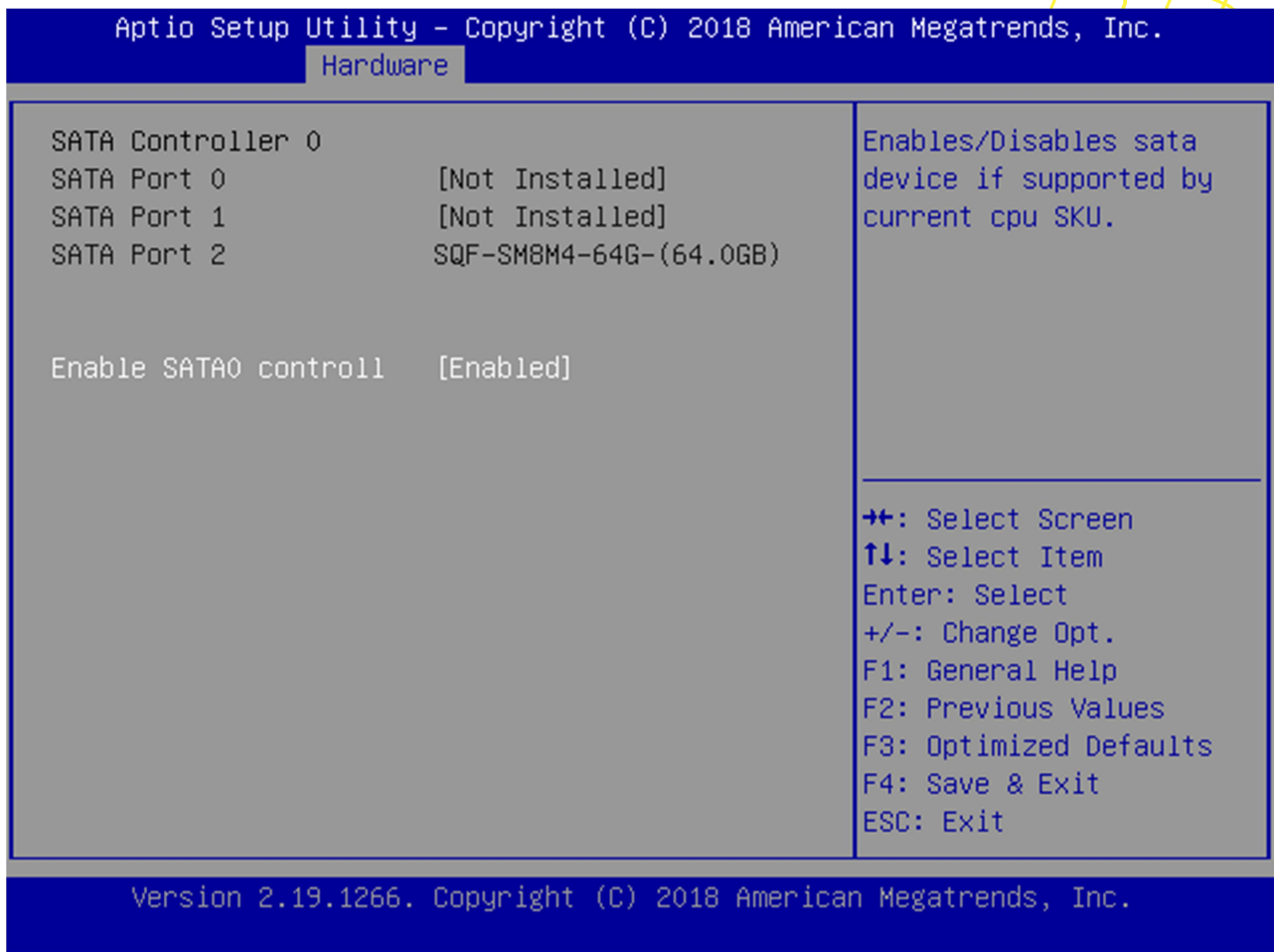

Figure 24: Hardware Setup: SATA configuration

Setup item	Access / Options	Description
SATA Port 0	Display only	Show current SATA devices in use on the FWA-1012VC
SATA Port 1	Display only	
SATA Port 2	Display only	
SATA Controller	Enabled Disabled	To enable the SATA controller

Table 13 Hardware Setup: SATA configuration Menu Items



3.2.3.4 ACPI Setting

This menu contains settings for the ACPI configuration.

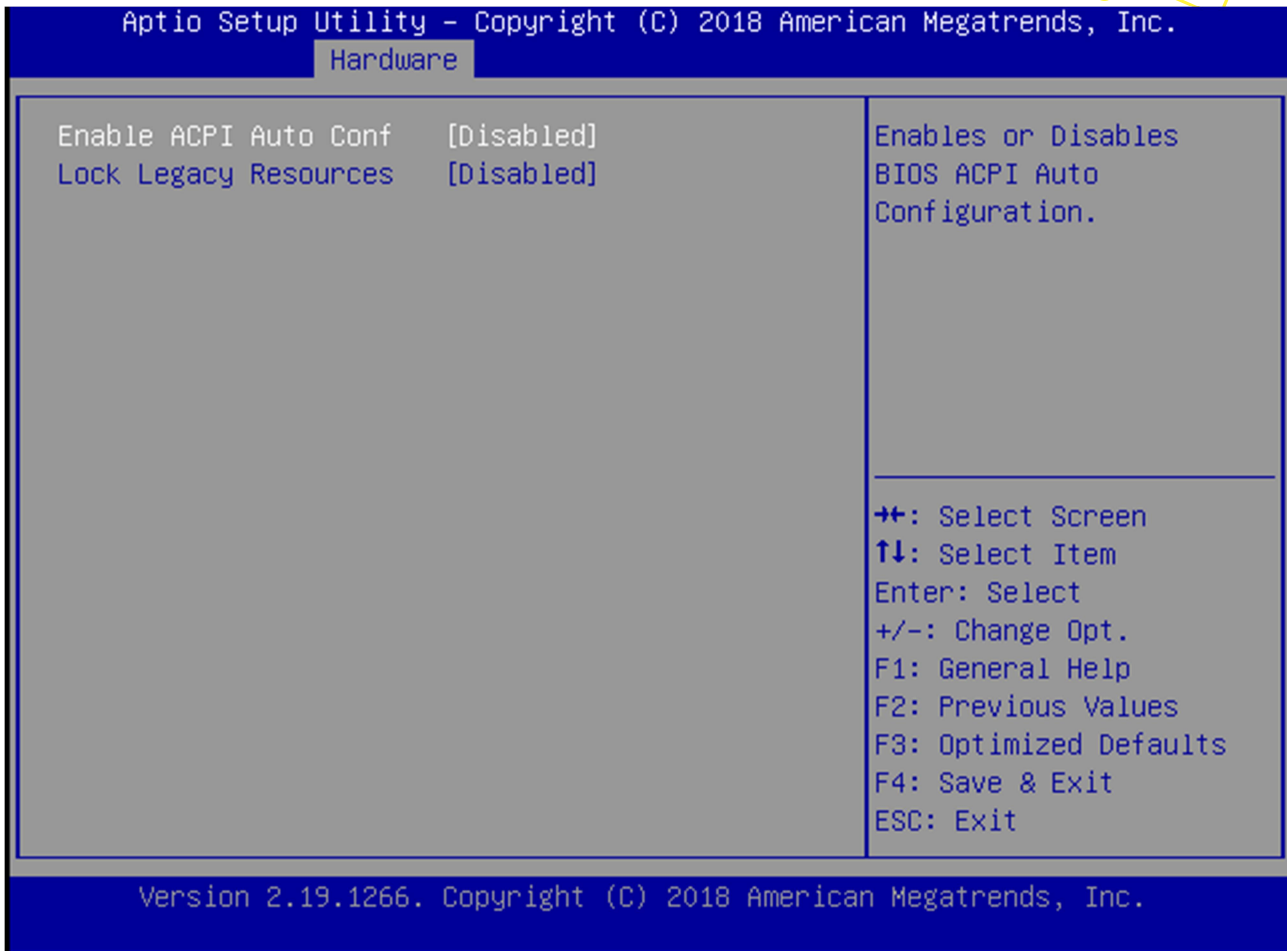

Figure 25: Hardware Setup: ACPI configuration

Setup item	Access / Options	Description
Enable ACPI Auto Configuration	Enabled Disabled	Enable or disable BIOS ACPI auto configuration
Lock Legacy Resources	Enabled Disabled	Enable lock of legacy resources

Table 14: Hardware Setup: ACPI configuration Menu Items

3.2.4 SETUP POST & BOOT MENU

Users can configure the system boot priority settings via the boot page. The default setting of boot priority of boot option #1 is “UEFI: Built-in EFI Shell”; Users can define the boot priorities based on the application.

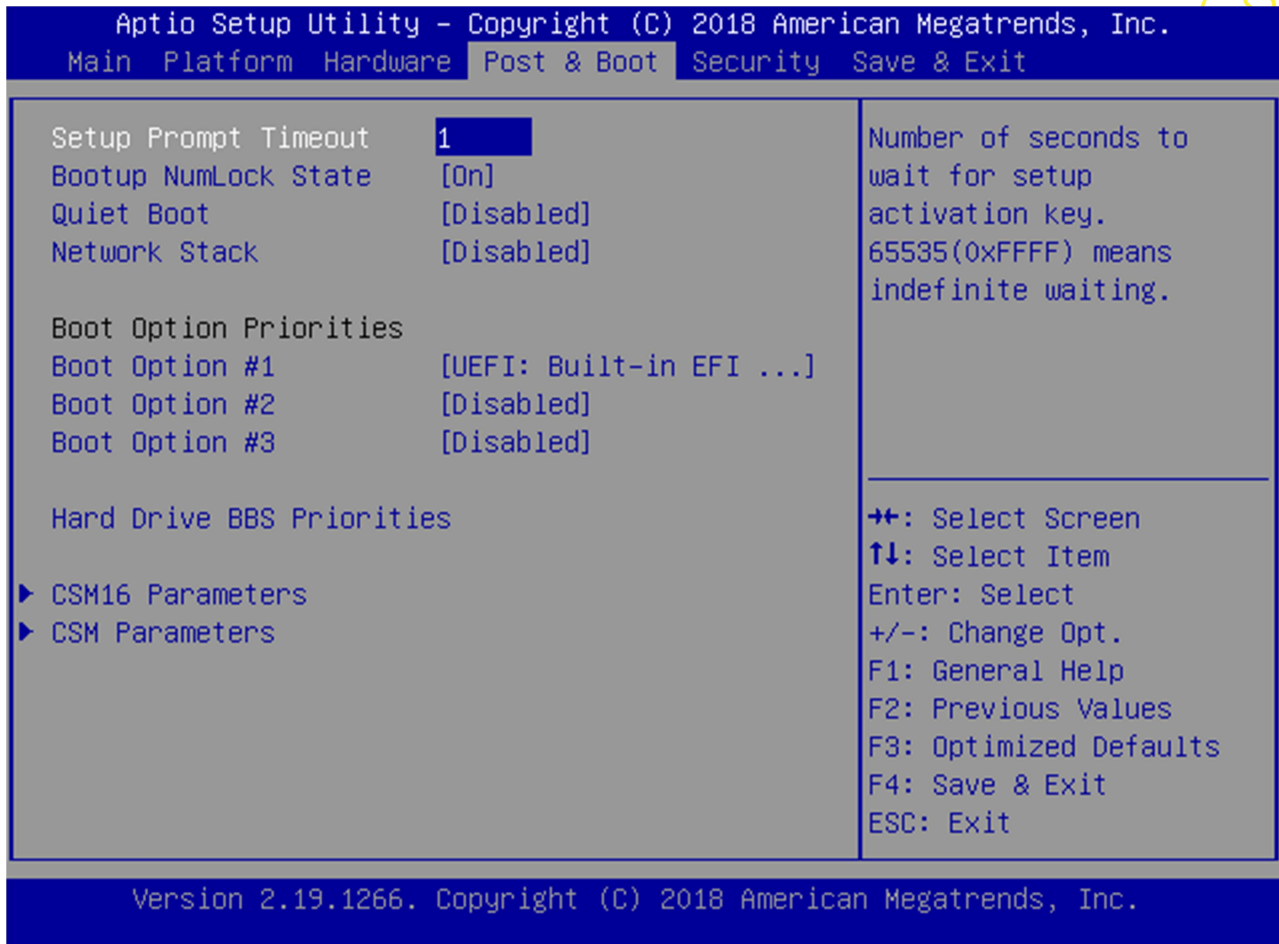
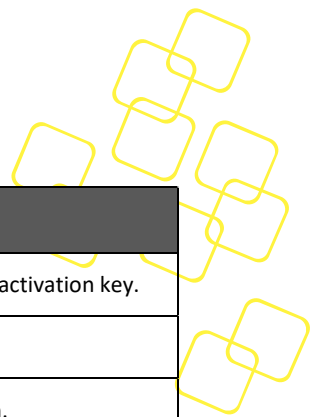

Figure 26: Boot Configuration



Feature	Default	Description
Setup Prompt Timeout	1	Number of seconds to wait for setup activation key.
Bootup NumLock State	On	Select the keyboard NumLock state.
Quiet Boot	Disabled	Enables or disables Quiet Boot option.
Network Stack	Disabled	Enables or disables boot via Network (PXE)
Boot Option Priority	User Defined	Sets the system boot order.
CSM16 Parameters	N/A	Select sub-menu.
CSM Parameters	N/A	Select sub-menu.

Table 15: Boot Configuration

3.2.4.1 Compatibility Support Module (CSM) Configuration

This submenu allows users to configure the support for legacy BIOS mechanisms and option ROMs.

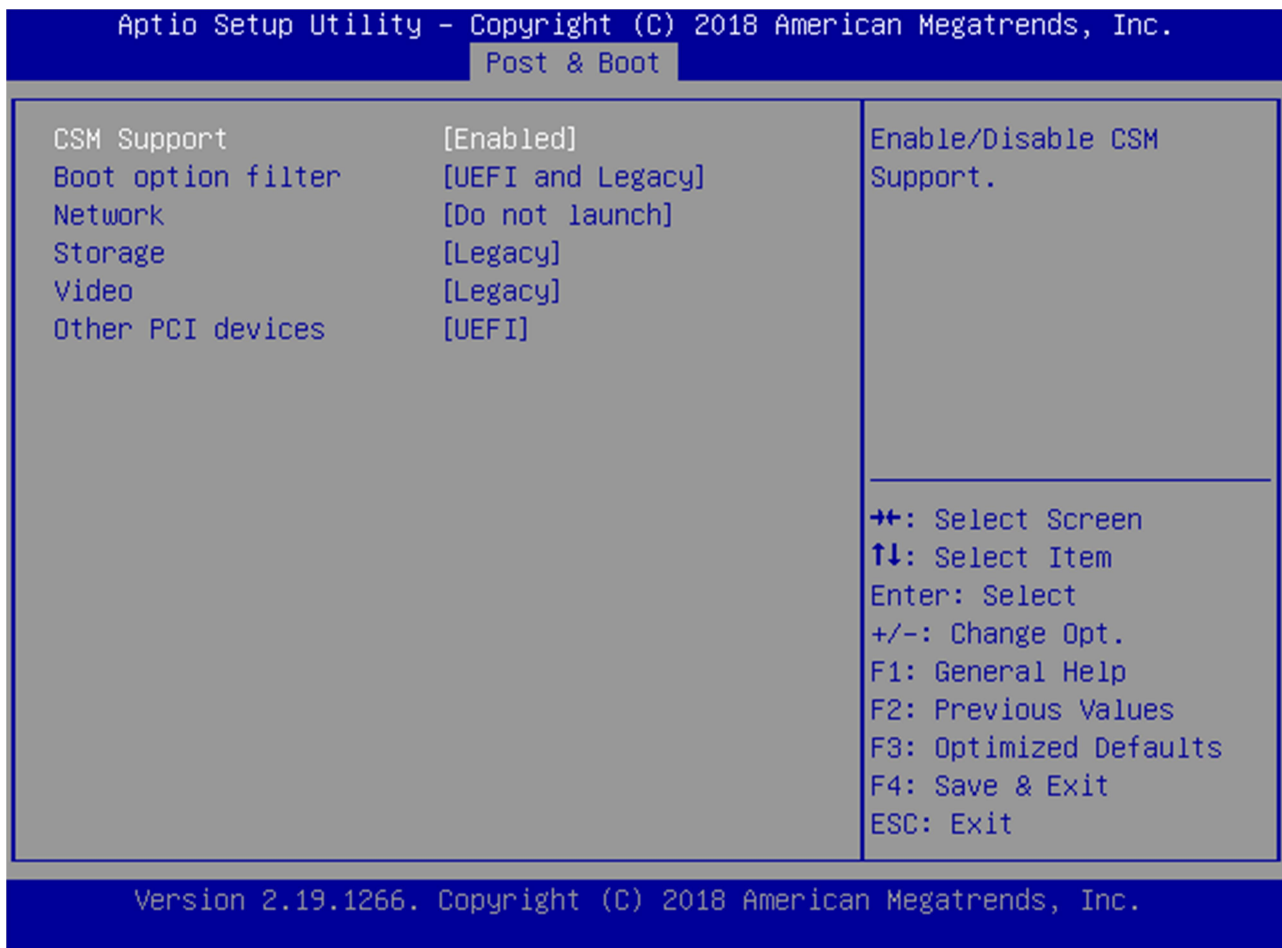
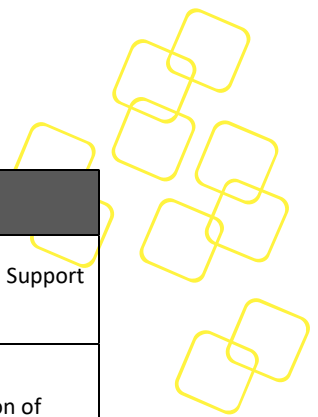

Figure 27: Post & Boot Setup: CSM Configuration Menu



Setup item	Access / Options	Description
CSM Support	Enabled Disabled	Enables or disables the Compatibility Support Module.
Boot option filter	UEFI and Legacy Legacy Only UEFI Only	This item allows to control the execution of legacy and UEFI compliant Option ROMs
Network	Do not launch UEFI Legacy	This item allows a more granular control of OptionROM execution depending of the type of extension device.
Storage		
Video		
Other PCI device ROM		

Table 16: CSM Configuration Menu

3.2.4.2 CSM16 Configuration

This submenu allows users to configure the support for legacy BIOS CSM16

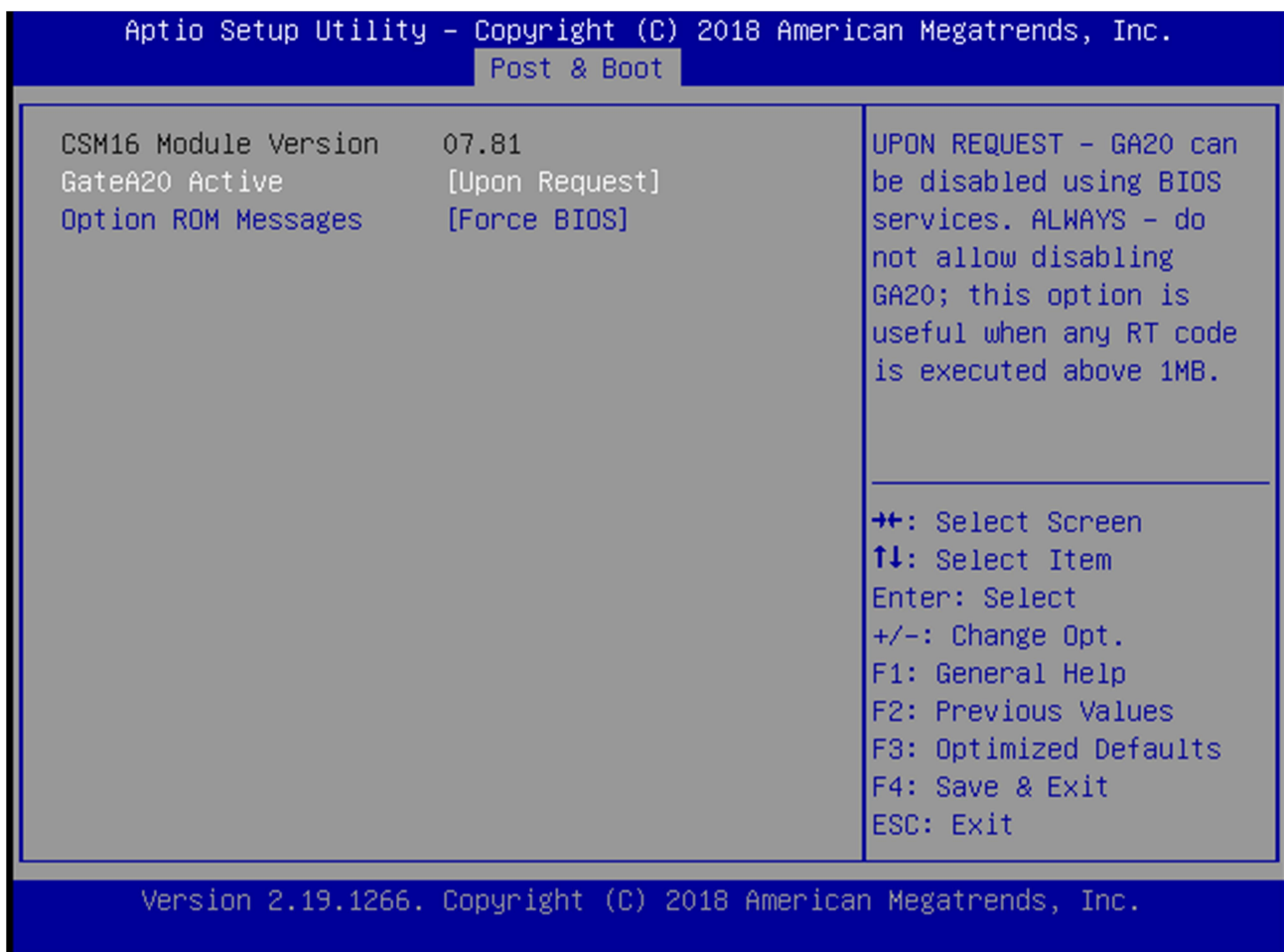
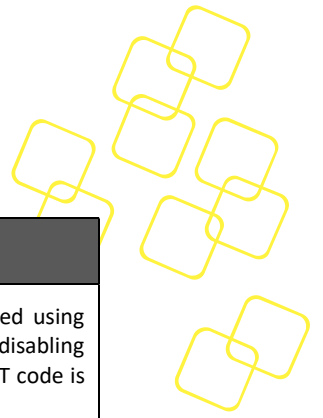

Figure 28: CSM16 Configuration



Setup item	Access / Options	Description
GateA20 Active	Upon Request Always	UPON REQUEST - GA20 can be disabled using BIOS services. ALWAYS - do not allow disabling GA20; this option is useful when any RT code is executed above 1MB
Option ROM Messages	Force BIOS Keep Current	Set display mode for Option ROM

Table 17: CSM16 Configuration Menu

3.2.5 SECURITY SETUP

“**Administrator Password**” allows users to configure the system so that a password after being installed is required each time the system boots, and/or an attempt is made to enter the Setup program.

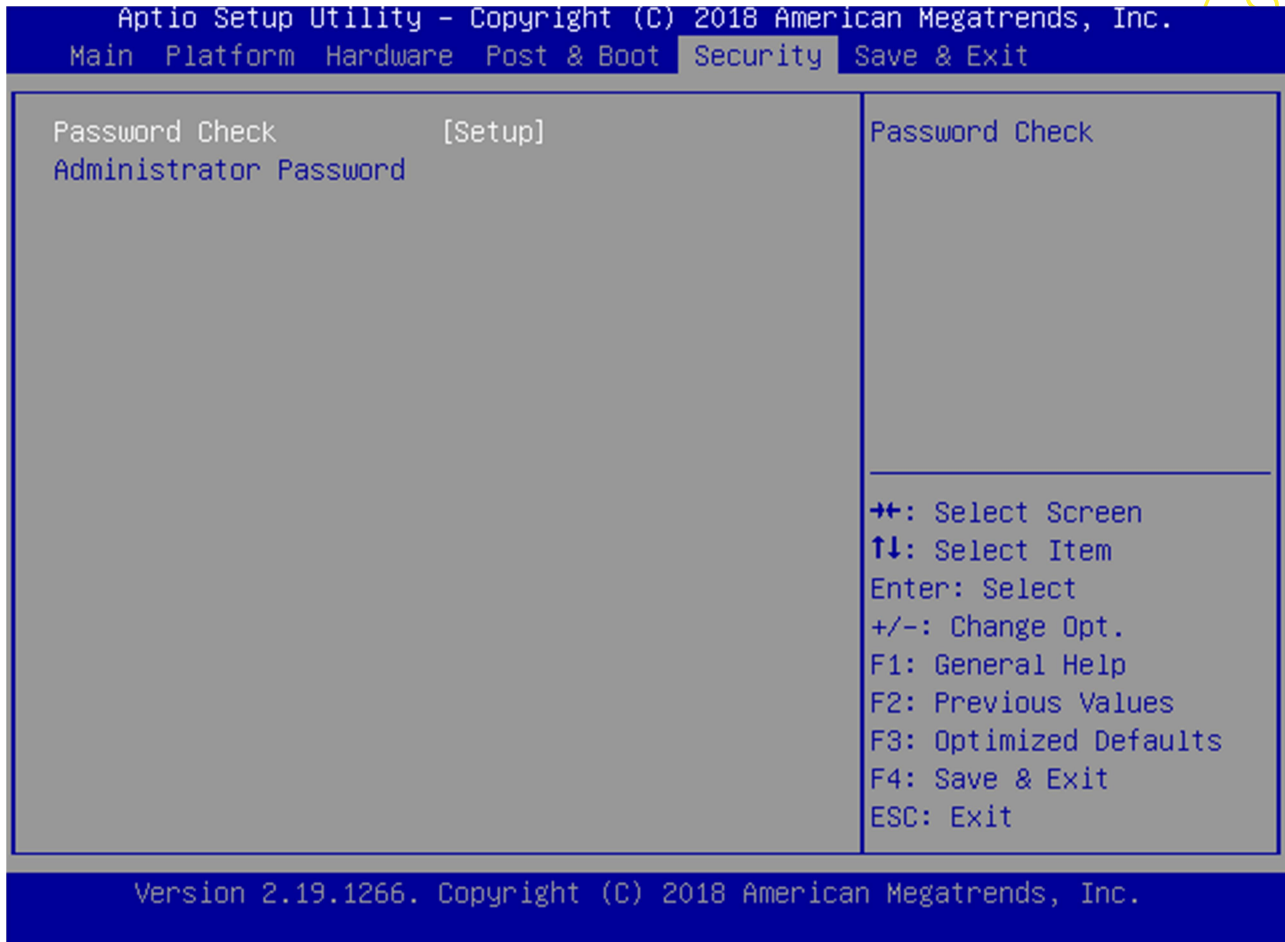
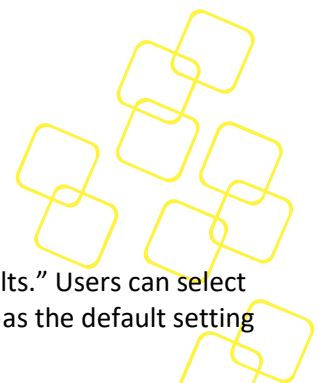

Figure 29: Administrator Setup

Note:

- ◆ If set the “Password Check” is [Setup], then this only limits access to Setup and is only asked for when entering Setup.
- ◆ If set the “Password Check” is [Always], then this is a power on password and must be entered to boot or enter Setup. In Setup the User will have Administrator rights.
- ◆ The password length must be in the following range:
 - Minimum length: 3
 - Maximum length: 20



3.2.6 SAVE & EXIT MENU

The FWA-1012VC BIOS allows users to store BIOS configuration results as “User Defaults.” Users can select “Save as User Defaults” to record all changes which had been made in previous pages as the default setting for further use.

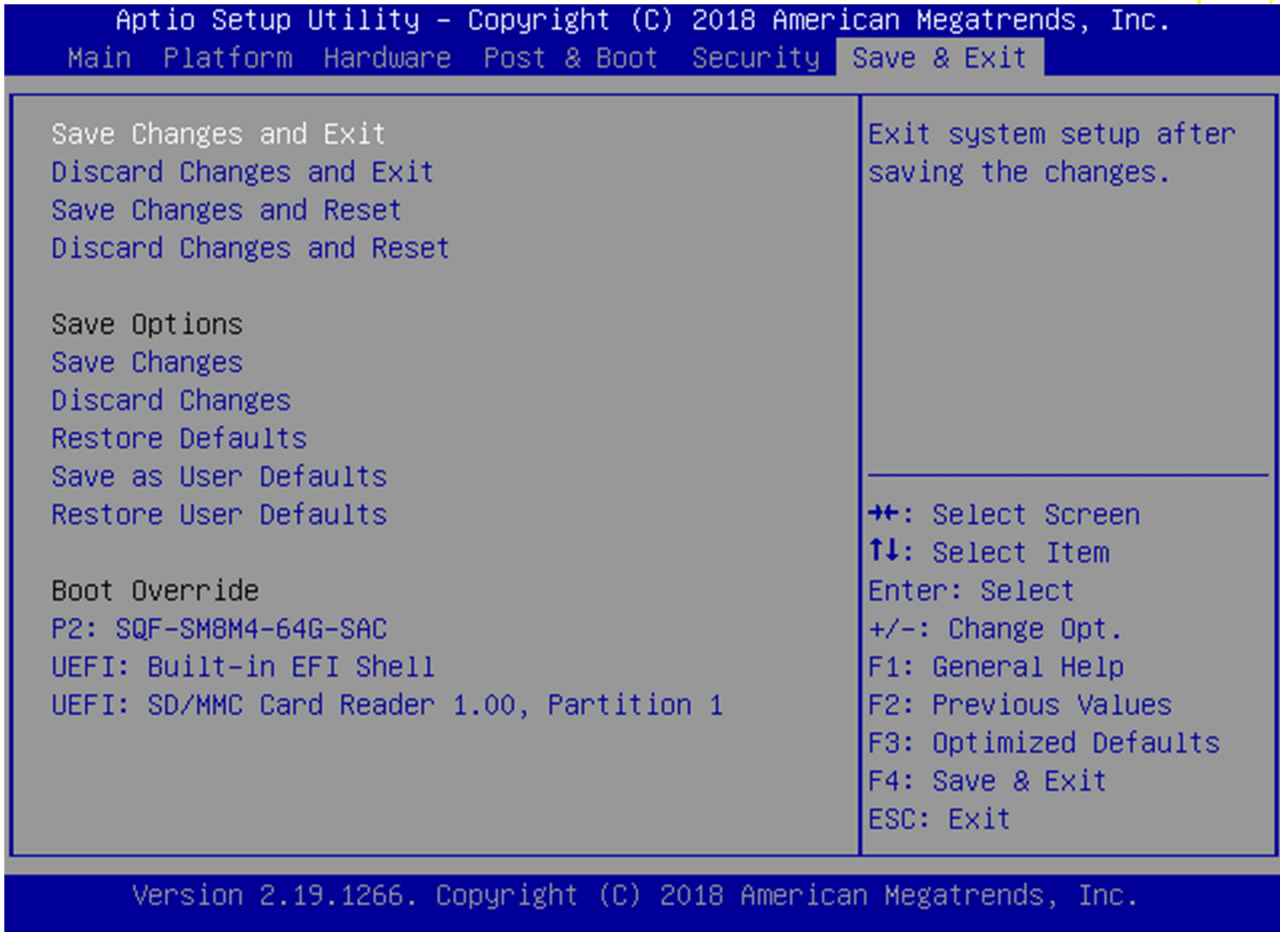
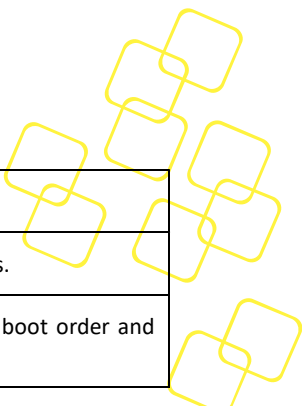

Figure 30: Save & Exit Menu

Group	Setup item	Description
None	Save Changes and Exit	Exit setup after saving the changes. Does not update User defaults.
	Discard Changes and Exit	Exit setup without saving any changes.
	Save Changes and Reset	Reset system after saving the changes. Does not update User Defaults.
	Discard Changes and Reset	Reset system without saving the changes.
Save Options	Save Changes	Save Changes made so far to any of the setup options.
	Discard Changes	Discard Changes made so far to any of the setup options.
	Restore Defaults	Restores the BIOS factory defaults to all the setup options.



	Save as User Defaults	Saves the Current BIOS Settings as User Defaults.
	Restore User Defaults	Restores the User defaults to all the setup options.
Boot Override	UEFI: < boot device>	This option allows you to override the specified boot order and use a different boot device for the next boot.

Table17: Save & Exit Menu Options

4. ADVANCED LAN BY PASS, BMC FIRMWARE AND BIOS UPGRADE

Please refer to [Advantech_QuickStart_Linux_Image_Getting_Started_Guide_FWA-1012VC](#)



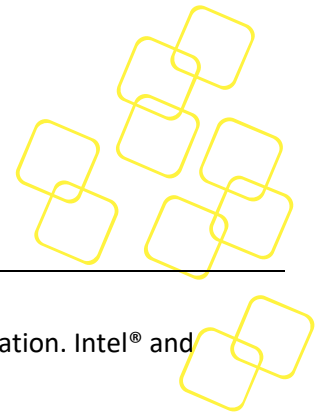

APPENDIX A: ACKNOWLEDGEMENTS

Award is a trademark of Award Software International, Inc.

IBM, PC/AT, PS/2 and VGA are trademarks of International Business Machines Corporation. Intel® and Pentium® are trademarks of Intel Corporation.

Microsoft Windows® is a registered trademark of Microsoft Corp.

All other product names or trademarks are properties of their respective owners.



APPENDIX B: GLOSSARY

Terminology	Description
ACPI	Advanced Configuration and Power Interface specification
AHCI	Advanced Host Controller Interface.
APIC	Advanced Programmable Interrupt Controller.
ASF	Alert Standard Format.
BGA	Ball Grid Array
BIST	Built-in self test
BMC	Base Board Management Controller
BSCAN	Boundary Scan Connector
BSP	Boot Strap Processor
DDR3	Third generation Double Data Rate SDRAM memory technology.
DMA	Direct Memory Access.
DMI	Direct Media Interface.
DMTF	The international organization responsible for managing and maintaining the ASF specification.
DTS	Digital Thermal Sensor
ECC	Error Correcting Code
EEPROM	Electrically Erasable Programmable Memory. A non-volatile memory located on the LAN controller that is directly accessible from the host
EHCI	Enhanced Host Controller Interface.
EMI	Electromagnetic Interface
ESD	Electrostatic Discharge
GB/s	Gigabytes per second(1000Mbytes per second)
Gb/s	Gigabits per second(1000Mbits per second)
GT/s	Giga-transfers per second
I2C	Inter-integrated circuit
IEEE	Institute of Electrical and Electronics Engineers.
IIO	Integrated I/O Controller.
ILM	Independent Loading Mechanism.
IMC	Integrated Memory Controller.
IOV	I/O virtualization.
IPMB	Intelligent Platform Management Bus
IPMI	Intelligent Platform Management Interface

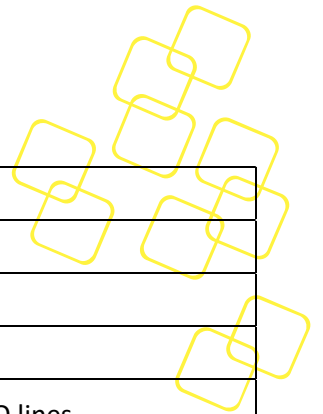

JTAG	Joint Test Action Group
LAN	Local Area Network
LPC	Low Pin Count
MAC	Media Access Control
MDIO	Management Data Input / Output Interface over MDC/MDIO lines
MTBF	Mean Time Between Failure
NC-SI	Network Controller Sideband Interface
NMC	Network Mezzanine Card
PCI	Peripheral Component Interconnect Local Bus
PCIe	PCI Express.
PCH	Platform Controller Hub
PECI	Platform Environment Control Interface.
PET	Platform Event Trap.
PHY	Physical Layer Device
PICMG	PCI Industrial Computer Manufacturers Group
QPI	Quick Path Interconnect. A cache-coherent, link-based interconnect specification for Intel Processors, chipsets, and I/O bridge.
RAID	Redundant Array of Inexpensive Disks or Redundant Array of Independent Disks
RANK	A unit of DRAM corresponds to four to eight devices in parallel, ignoring ECC. These devices are usually, but not always, mounted on a single side of a DDR3 DIMM.
RDIMM	Registered dual In-line Memory Module.
RGMII	Reduced gigabit media independent interface
RTC	Real Time Clock
Sandy Bridge-EP Processor	Intel's 32-nm processor design, follow-on to the 32-nm Sandy Bridge processor design.
SATA	Serial ATA.
SAS	Serial Attached SCSI
SCI	System Control Interrupt. Used in ACPI protocol.
SDRAM	Synchronous Dynamic Random Access Memory
SerDes	Serializer and De-Serializer Circuit
SGMII	Serialized Gigabit Media Independent Interface
SIU	Serial I/O Unit
SIW	Serial I/O and Watchdog Timer
SKU	Stock Keeping Unit

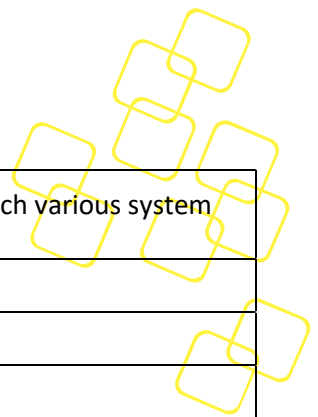

SMBus	System Management Bus. A two-wire interface through which various system components may communicate.
SPD	Serial Presence Detect
SPI	Serial Peripheral Interface.
TAC	Thermal Averaging Constant
TBD	To Be Defined.
TDP	Thermal Design Power
TPM	Trusted Platform Module
Turbo Boost Technology	Intel Turbo Boost Technology is a way to run the processor core faster than the marked frequency.
UART	Universal Asynchronous Receiver/Transmitter
UHCI	Universal Host Controller Interface
USB	Universal Serial Bus
USB DOM	USB disk-on-module
QAT	Intel® QuickAssist Technology