

HP ProLiant DL380 Gen9 Server User Guide

Abstract

This document is for the person who installs, administers, and troubleshoots servers and storage systems. HP assumes you are qualified in the servicing of computer equipment and trained in recognizing hazards in products with hazardous energy levels.



Part Number: 768830-003
March 2015
Edition: 3

© Copyright 2014, 2015 Hewlett-Packard Development Company, L.P.

The information contained herein is subject to change without notice. The only warranties for HP products and services are set forth in the express warranty statements accompanying such products and services. Nothing herein should be construed as constituting an additional warranty. HP shall not be liable for technical or editorial errors or omissions contained herein.

Microsoft® and Windows® are trademarks of the Microsoft group of companies.

Linux® is the registered trademark of Linus Torvalds in the U.S. and other countries.

Red Hat® is a registered trademark of Red Hat, Inc. in the United States and other countries.

Java is a registered trademark of Oracle and/or its affiliates.

SD and microSD are trademarks or registered trademarks of SD-3C in the United States, other countries or both.

VMware is a registered trademark or trademark of VMware, Inc. in the United States and/or other jurisdictions.

Contents

Component identification.....	7
Front panel components.....	7
Front panel LEDs and buttons.....	9
UID button functionality.....	11
Power fault LEDs.....	11
Access the optional HP Systems Insight Display.....	11
Systems Insight Display LEDs.....	12
Systems Insight Display LED combinations.....	12
Rear panel components.....	14
Rear panel LEDs.....	14
Flex slot battery backup module LEDs and buttons.....	15
Non-hot-plug PCI riser board slot definitions.....	16
System board components.....	17
System maintenance switch.....	18
NMI functionality.....	19
DIMM slot locations.....	19
SAS and SATA device numbers.....	20
Hot-plug drive LED definitions.....	22
Hot-plug fans.....	23
Operations.....	25
Power up the server.....	25
Power down the server.....	25
Extend the server from the rack.....	25
Remove the server from the rack.....	26
Remove the access panel.....	26
Install the access panel.....	27
Access the product rear panel.....	27
Opening the cable management arm.....	27
Remove the fan cage.....	28
Remove the hot-plug fan.....	29
Remove the PCI riser cage.....	30
Install the PCI riser cage.....	30
Secure the full-length expansion board retainer.....	31
Remove the air baffle.....	32
Setup.....	34
Optional services.....	34
Optimum environment.....	34
Space and airflow requirements.....	34
Temperature requirements.....	35
Power requirements.....	36
Electrical grounding requirements.....	36
Connecting a DC power cable to a DC power source.....	36
Rack warnings.....	37
Identifying the contents of the server shipping carton.....	38
Installing hardware options.....	38

Installing the server into the rack	38
Installing the operating system	40
Powering on and selecting boot options in UEFI Boot Mode	40
Registering the server.....	41
Hardware options installation.....	42
Server QuickSpecs	42
Introduction	42
Hot-plug drive guidelines	42
Installing a hot-plug SAS or SATA drive	42
Removing a hot-plug SAS or SATA drive.....	43
Redundant hot-plug power supply option	44
High performance fan option	45
Processor and fan option	47
Memory options	52
HP SmartMemory	53
Memory subsystem architecture	53
Single-, dual-, and quad-rank DIMMs	54
DIMM identification.....	54
Memory configurations	55
General DIMM slot population guidelines.....	56
Installing a DIMM.....	57
Universal media bay option	58
Expansion board options	61
Removing an expansion slot blank	61
Installing an expansion board	63
2-slot PCI riser cage option	64
3-slot PCI riser cage option	66
GPU enablement kit.....	68
Eight-bay SFF front drive cage option for bay 1	73
Eight-bay SFF front drive cage option for bay 2	78
Three-bay LFF rear drive cage option.....	82
Two-bay SFF front drive cage option	87
Two-bay SFF rear drive cage option.....	91
Systems Insight Display power switch module option.....	98
Location Discovery Services ear option	100
FlexibleLOM option	103
HP 12G SAS Expander Card	105
HP Flexible Smart Array Controller.....	112
HP Smart Storage Battery	113
Rear serial port option	115
M.2 SSD Enablement Board option.....	116
Installing an SSD module on the M.2 SSD Enablement Board	116
Installing an M.2 SSD enablement board.....	117
HP Dual 8Gb MicroSD Enterprise Midline USB device	119
HP 750 W Flex Slot Hot Plug Battery Backup Module	119
Flex slot battery backup module configuration load support	120
Installing the FSBBU.....	120
HP Trusted Platform Module option	121
Installing the Trusted Platform Module board	122
Retaining the recovery key/password.....	124
Enabling the Trusted Platform Module.....	124
Cabling.....	125

Two-bay SFF drive cage option cabling	125
Three-bay LFF rear drive cage cabling	129
Eight-bay SFF front drive cage cabling	131
Universal media bay cabling	137
150W PCIe power cable option	138
M.2 SSD Enablement Board option cabling	138
Software and configuration utilities	140
Server mode	140
Product QuickSpecs	140
HP iLO	140
Active Health System	141
HP RESTful API support for HP iLO	142
Integrated Management Log	142
HP Insight Remote Support	143
Intelligent Provisioning	144
HP Insight Diagnostics	144
Erase Utility	144
Scripting Toolkit for Windows and Linux	145
HP Service Pack for ProLiant	145
HP Smart Update Manager	145
HP UEFI System Utilities	146
Using HP UEFI System Utilities	146
Flexible boot control	147
Restoring and customizing configuration settings	147
Secure Boot configuration	147
Embedded UEFI shell	148
Embedded Diagnostics option	148
HP RESTful API support for UEFI	148
Re-entering the server serial number and product ID	148
Utilities and features	149
HP Smart Storage Administrator	149
Automatic Server Recovery	149
USB support	149
Redundant ROM support	150
Keeping the system current	151
Access to HP Support Materials	151
Updating firmware or System ROM	151
Drivers	153
Software and firmware	153
Operating System Version Support	153
Version control	153
HP operating systems and virtualization software support for ProLiant servers	154
HP Technology Service Portfolio	154
Change control and proactive notification	154
Troubleshooting	155
Troubleshooting resources	155
Battery replacement	156
Regulatory information	158
Safety and regulatory compliance	158
Belarus Kazakhstan Russia marking	158
Turkey RoHS material content declaration	159

Ukraine RoHS material content declaration	159
Warranty information	159
Electrostatic discharge	160
Preventing electrostatic discharge	160
Grounding methods to prevent electrostatic discharge.....	160
Specifications	161
Environmental specifications.....	161
Mechanical specifications	161
Power supply specifications.....	162
HP 500W Flex Slot Platinum Hot-plug Power Supply	163
HP 800W Flex Slot Platinum Hot-plug Power Supply.....	163
HP 800W Flex Slot Titanium Plus Hot-plug Power Supply	164
HP 800W Flex Slot Universal Hot-plug Power Supply.....	165
HP 800W Flex Slot -48VDC Hot-plug Power Supply	165
HP 1400W Flex Slot Platinum Plus Hot-plug Power Supply	166
Support and other resources	168
Before you contact HP	168
HP contact information.....	168
Customer Self Repair	168
Acronyms and abbreviations.....	176
Documentation feedback	180
Index.....	181

Component identification

Front panel components

- SFF model (8-drive)

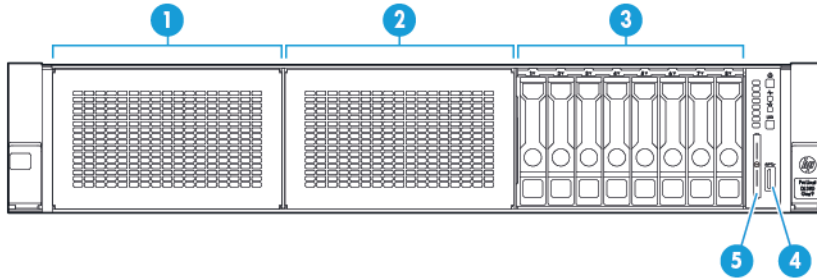

Item	Description
1	Bay 1 (optional drives or universal media bay)
2	Bay 2 (optional drives)
3	Fixed drive bays
4	Front USB 3.0 connector
5	Serial label pull tab

- SFF model (24-drive)

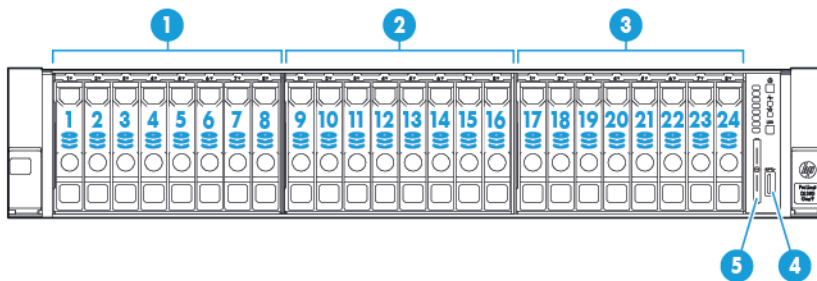

Item	Description
1	Bay 1
2	Bay 2
3	Bay 3, fixed drive bay
4	Front USB 3.0 connector
5	Serial label pull tab

- LFF model (12-drive)

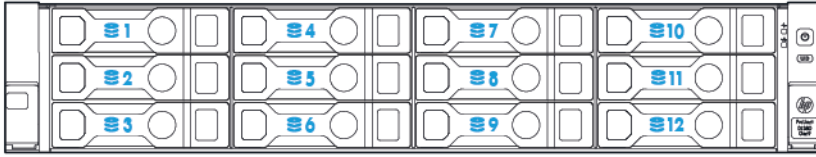

Item	Description
1-12	Drive bays

- LFF model (4-drive)

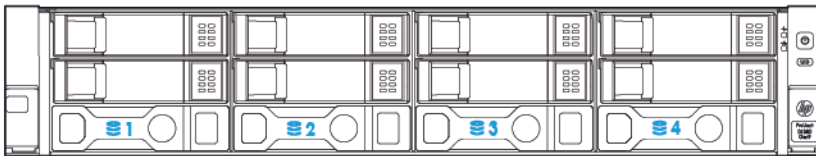

Item	Description
1-4	Drive bays

Front panel LEDs and buttons

- SFF front panel LEDs and button

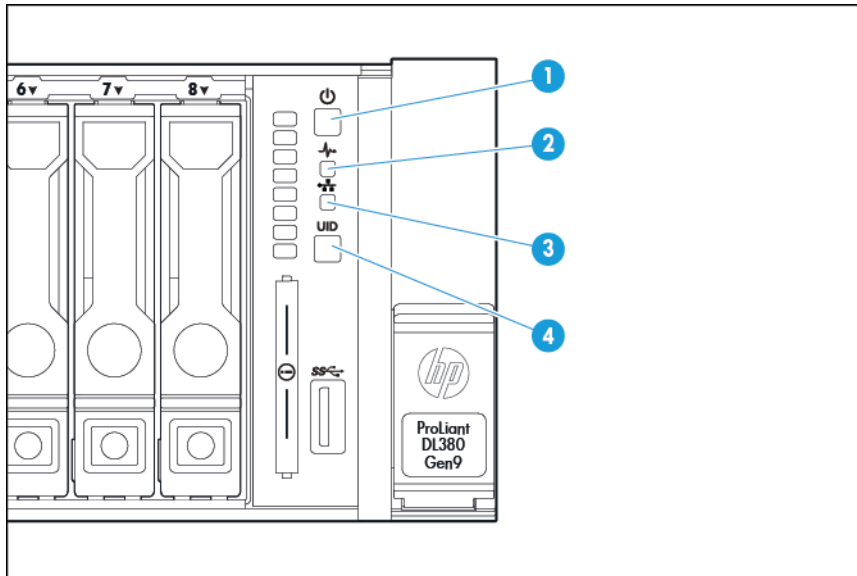

Item	Description	Status
1	Power On/Standby button and system power LED*	Solid green = System on Flashing green (1 Hz/cycle per sec) = Performing power on sequence Solid amber = System in standby Off = No power present**
2	Health LED*	Solid green = Normal Flashing green (1 Hz/cycle per sec) = iLO is rebooting Flashing amber = System degraded Flashing red (1 Hz/cycle per sec) = System critical†
3	NIC status LED*	Solid green = Link to network Flashing green (1 Hz/cycle per sec) = Network active Off = No network activity
4	UID button/LED*	Solid blue = Activated Flashing blue: <ul style="list-style-type: none"> • 1 Hz/cycle per sec = Remote management or firmware upgrade in progress • 4 Hz/cycle per sec = iLO manual reboot sequence initiated • 8 Hz/cycle per sec = iLO manual reboot sequence in progress Off = Deactivated

*When all four LEDs described in this table flash simultaneously, a power fault has occurred. For more information, see "Power fault LEDs (on page 11)."

**Facility power is not present, power cord is not attached, no power supplies are installed, power supply failure has occurred, or the power button cable is disconnected.

†If the health LED indicates a degraded or critical state, review the system IML or use iLO to review the system health status.

- LFF LEDs and button

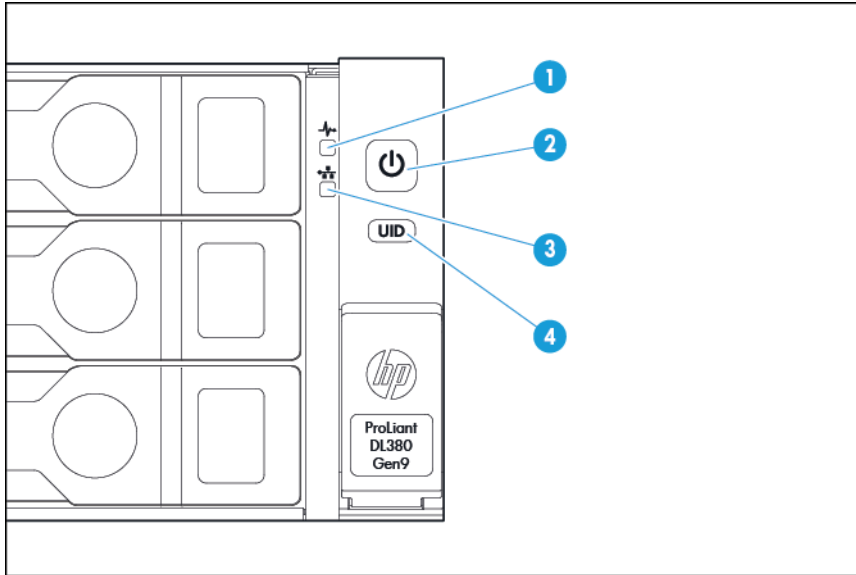

Item	Description	Status
1	Health LED*	Solid green = Normal Flashing green (1 Hz/cycle per sec) = iLO is rebooting Flashing amber = System degraded Flashing red (1 Hz/cycle per sec) = System critical**
2	Power On/Standby button and system power LED*	Solid green = System on Flashing green (1 Hz/cycle per sec) = Performing power on sequence Solid amber = System in standby Off = No power present†
3	NIC status LED*	Solid green = Link to network Flashing green (1 Hz/cycle per sec) = Network active Off = No network activity
4	UID button/LED*	Solid blue = Activated Flashing blue: <ul style="list-style-type: none"> 1 Hz/cycle per sec = Remote management or firmware upgrade in progress 4 Hz/cycle per sec = iLO manual reboot sequence initiated 8 Hz/cycle per sec = iLO manual reboot sequence in progress Off = Deactivated

*When all four LEDs described in this table flash simultaneously, a power fault has occurred. For more information, see "Power fault LEDs (on page 11)."

**If the health LED indicates a degraded or critical state, review the system IML or use iLO to review the system health status.

†Facility power is not present, power cord is not attached, no power supplies are installed, power supply failure has occurred, or the power button cable is disconnected.

UID button functionality

The UID button can be used to display the HP ProLiant Pre-boot Health Summary when the server will not power on. For more information, see the *HP iLO 4 User Guide* on the HP website (<http://www.hp.com/go/ilo/docs>).

Power fault LEDs

The following table provides a list of power fault LEDs, and the subsystems that are affected. Not all power faults are used by all servers.

Subsystem	LED behavior
System board	1 flash
Processor	2 flashes
Memory	3 flashes
Riser board PCIe slots	4 flashes
FlexibleLOM	5 flashes
Removable HP Flexible Smart Array controller/Smart SAS HBA controller	6 flashes
System board PCIe slots	7 flashes
Power backplane or storage backplane	8 flashes
Power supply	9 flashes

Access the optional HP Systems Insight Display

To access a pop-out HP Systems Insight Display on models with this option installed:

1. Press and release the panel.
2. After the display fully ejects, rotate the display to view the LEDs.

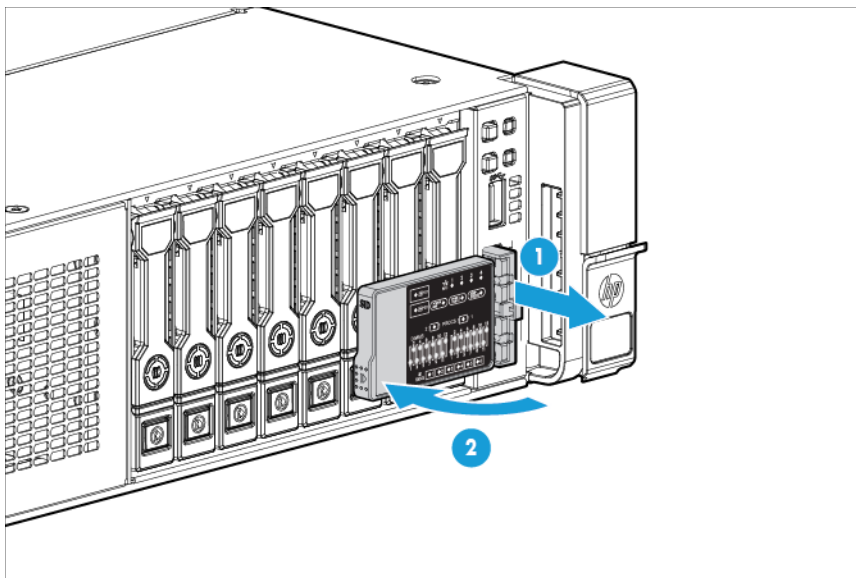

Systems Insight Display LEDs

The HP Systems Insight Display LEDs represent the system board layout. The display enables diagnosis with the access panel installed.

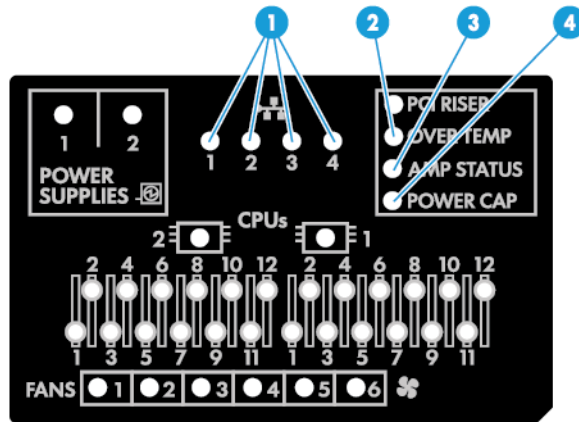

Item	Description	Status
1	NIC link/activity	Off = No link to network. If the power is off, view the rear panel RJ-45 LEDs for status (" Rear panel LEDs " on page 14). Flashing green = Network link and activity Solid green = Network link
2	Over temp	Off = Normal Solid amber = High system temperature detected
3	AMP status	Off = AMP modes disabled Solid green = AMP mode enabled Solid amber = Failover Flashing amber = Invalid configuration
4	Power cap	Off = System is in standby, or no cap is set. Solid green = Power cap applied
—	All other LEDs	Off = Normal Amber = Failure For more information on the activation of these LEDs, see " Systems Insight Display LED combinations " (on page 12)."

Systems Insight Display LED combinations

When the health LED on the front panel illuminates either amber or red, the server is experiencing a health event. Combinations of illuminated Systems Insight Display LEDs, the system power LED, and the health LED indicate system status.

Systems Insight Display LED and color	Health LED	System power LED	Status
Processor (amber)	Red	Amber	One or more of the following conditions may exist: <ul style="list-style-type: none"> • Processor in socket X has failed. • Processor X is not installed in the socket. • Processor X is unsupported. • ROM detects a failed processor during POST.
Processor (amber)	Amber	Green	Processor in socket X is in a pre-failure condition.
DIMM (amber)	Red	Green	One or more DIMMs have failed.
DIMM (amber)	Amber	Green	DIMM in slot X is in a pre-failure condition.
Over temp (amber)	Amber	Green	The Health Driver has detected a cautionary temperature level.
Over temp (amber)	Red	Amber	The server has detected a hardware critical temperature level.
PCI riser (amber)	Red	Green	The PCI riser cage is not seated properly.
Fan (amber)	Amber	Green	One fan has failed or has been removed.
Fan (amber)	Red	Green	Two or more fans have failed or been removed.
Power supply (amber)	Red	Amber	One or more of the following conditions may exist: <ul style="list-style-type: none"> • Only one power supply is installed and that power supply is in standby. • Power supply fault • System board fault
Power supply (amber)	Amber	Green	One or more of the following conditions may exist: <ul style="list-style-type: none"> • Redundant power supply is installed and only one power supply is functional. • AC power cord is not plugged into redundant power supply. • Redundant power supply fault • Power supply mismatch at POST or power supply mismatch through hot-plug addition
Power cap (off)	—	Amber	Standby
Power cap (green)	—	Flashing green	Waiting for power
Power cap (green)	—	Green	Power is available.
Power cap (flashing amber)	—	Amber	Power is not available.



IMPORTANT: If more than one DIMM slot LED is illuminated, further troubleshooting is required. Test each bank of DIMMs by removing all other DIMMs. Isolate the failed DIMM by replacing each DIMM in a bank with a known working DIMM.

Rear panel components

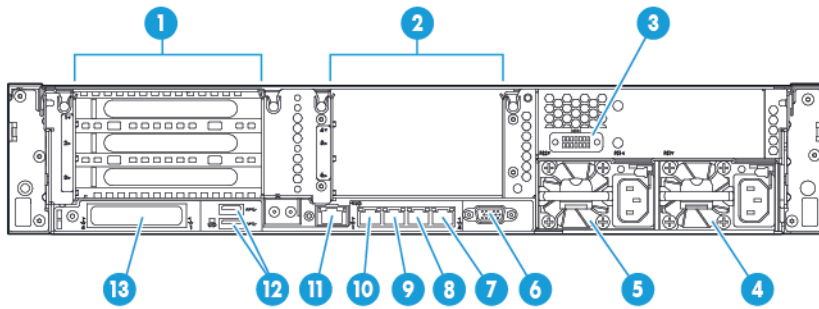

Item	Description
1	PCIe slots 1–3 (top to bottom)
2	Optional PCIe slots 4–6 (top to bottom)*
3	Optional serial port
4	Power supply 1 (PS1)
5	Power supply 2 (PS2)
6	Video connector
7	1Gb RJ-45 port 4
8	1Gb RJ-45 port 3
9	1Gb RJ-45 port 2
10	1Gb RJ-45 port 1
11	iLO connector
12	USB 3.0 connectors
13	FlexibleLOM option

*Requires second processor

Rear panel LEDs

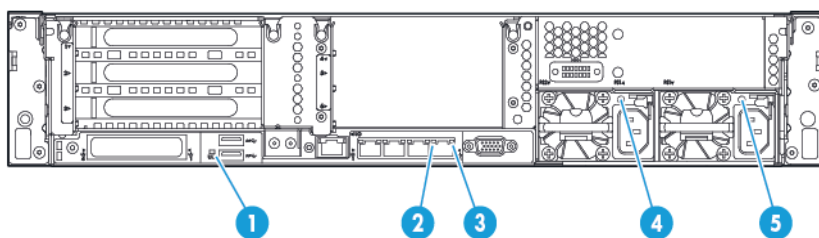

Item	Description	Status
1	UID LED	Off = Deactivated Solid blue = Activated

Item	Description	Status
		Flashing blue = System being managed remotely
2	NIC link LED	Off = No network link Green = Network link
3	NIC activity LED	Off = No network activity Solid green = Link to network Flashing green = Network activity
4	Power supply 2 LED	Off = System is off or power supply has failed. Solid green = Normal
5	Power supply 1 LED	Off = System is off or power supply has failed. Solid green = Normal

Flex slot battery backup module LEDs and buttons

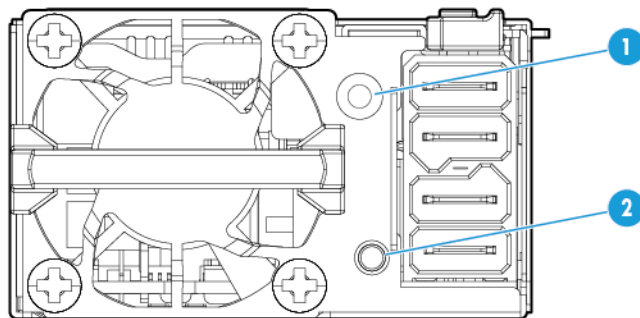

Item	Description
1	FSBBU module LED
2	Battery check button

When the battery check button is pressed, the LED indicates the state of the battery. The number of times that the LED flashes indicates the state of change.

# of LED flashes	% state of change
0	< 5%
1	<= 30%
2	31% – 69%
3	>= 70%

The state of the LED indicates the FSBBU operating mode.

LED	Mode/State
Off	<ul style="list-style-type: none"> • Ship/storage mode • Cycle power operating
Flashing amber	<ul style="list-style-type: none"> • Battery diagnostic • Active mode

LED	Mode/State
Solid amber	Online mode and charger is ON
Flashing green	Discharge mode <ul style="list-style-type: none"> • RSOC—70-100% frequency=0.5Hz; duty=0.5 • RSOC—31-69% frequency=1Hz; duty=0.5 • RSOC—0-30% frequency=1.5Hz; duty=0.5
Solid green	<ul style="list-style-type: none"> • Online mode and charger is OFF • Battery is fully charged
Flashing red	Auxiliary path A/B protection
Solid red	FSBBU fault or other protections

For more information about the FSBBU module, see "HP 750 W Flex Slot Hot Plug Battery Backup Module (on page 119)."

Non-hot-plug PCI riser board slot definitions

- Primary riser cage connector, connected to processor 1 or the Southbridge

	PCIe 3-slot riser cage*	Optional PCIe 2-slot x16 riser cage
1 - FL/FH	PCIe3 x16 (8,4,2,1)	—
2 - HL/FH	PCIe3 x16 (8,4,2,1)	PCIe3 x16 (16,8,4,2,1)
3 - HL/FH	PCIe3 x8 (8,4,2,1)	PCIe3 x8 (8,4,2,1)

- Secondary riser cage connector, connected to processor 2 (processor 2 must be installed)

	PCIe 3-slot riser cage*
4 - FL/FH	PCIe3 x16 (16,8,4,2,1)
5 - HL/FH	PCIe3 x16 (16,8,4,2,1)
6 - HL/FH	PCIe3 x8 (8,4,2,1)

*The server ships with one PCIe3 riser cage installed in the primary riser cage connector.

Notes:

- "Primary" denotes the riser cage is installed in the primary riser connector.
- "Secondary" denotes the riser cage is installed in the secondary riser connector.
- Installing the riser cages listed in the table above in either the primary or secondary riser connectors determines the form factor of the PCI expansion boards supported by those riser cages.

- FL/FH denotes full-length, full-height. HL/FH denotes half-length, full-height.

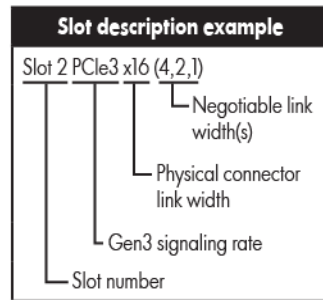

System board components

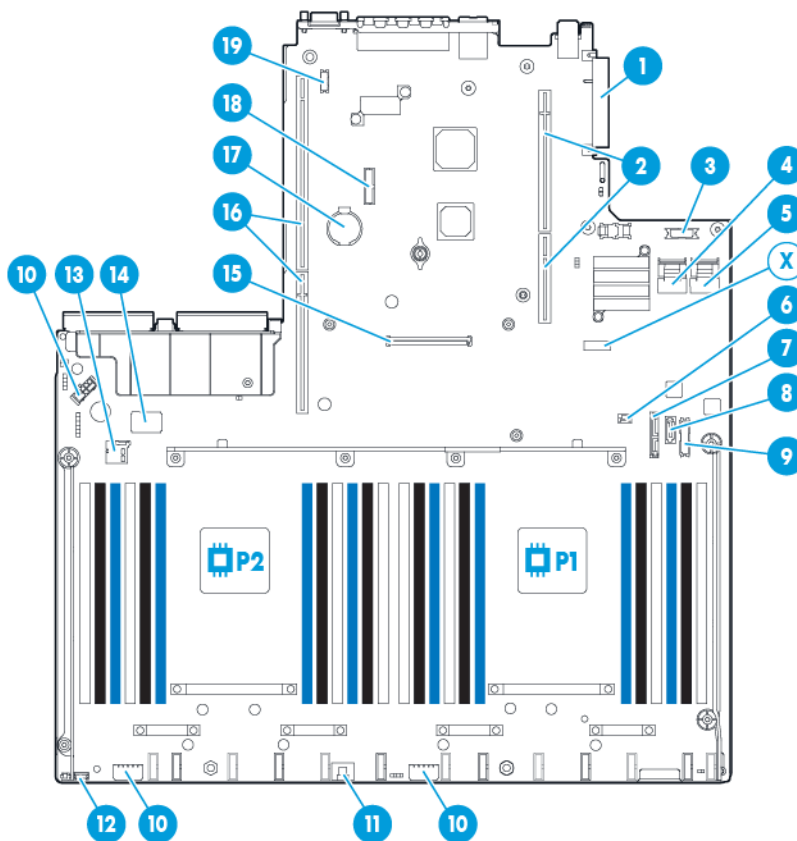

Item	Description
1	FlexibleLOM connector
2	Primary (processor 1) PCI riser connector
3	Optical front VGA/USB 2.0 connector
4	x4 SATA port 1
5	x4 SATA port 2
6	Backplane presence detect connector

Item	Description
7	Optical/SATA port 5
8	SATA port 4
9	Front power/USB 3.0 connector
10	Drive backplane power connector
11	HP Smart Storage Battery connector
12	Optional Location Discovery Services connector
13	Micro SD card slot
14	Dual internal USB 3.0 connector
15	Smart Array/HBA connector
16	Secondary processor (processor 2) PCI riser connector
17	System battery
18	TPM connector
19	Optional serial port connector
X	System maintenance switch

System maintenance switch

Position	Default	Function
S1	Off	Off = HP iLO security is enabled. On = HP iLO security is disabled.
S2	Off	Off = System configuration can be changed. On = System configuration is locked.
S3	Off	Reserved
S4	Off	Reserved
S5	Off	Off = Power-on password is enabled. On = Power-on password is disabled.
S6	Off	Off = No function On = ROM reads system configuration as invalid.
S7	Off	Off = Set default boot mode to UEFI. On = Set default boot mode to legacy.
S8	—	Reserved
S9	—	Reserved
S10	—	Reserved
S11	—	Reserved
S12	—	Reserved

To access the redundant ROM, set S1, S5, and S6 to on.

When the system maintenance switch position 6 is set to the On position, the system is prepared to erase all system configuration settings from both CMOS and NVRAM.



CAUTION: Clearing CMOS and/or NVRAM deletes configuration information. Be sure to properly configure the server or data loss could occur.



IMPORTANT: Before using the S7 switch to change to Legacy BIOS Boot Mode, be sure the HP Dynamic Smart Array B140i Controller is disabled. Do not use the B140i controller when the server is in Legacy BIOS Boot Mode.

NMI functionality

An NMI crash dump enables administrators to create crash dump files when a system is hung and not responding to traditional debug mechanisms.

Crash dump log analysis is an essential part of diagnosing reliability problems, such as hangs in operating systems, device drivers, and applications. Many crashes freeze a system, and the only available action for administrators is to cycle the system power. Resetting the system erases any information that could support problem analysis, but the NMI feature preserves that information by performing a memory dump before a hard reset.

To force the OS to invoke the NMI handler and generate a crash dump log, the administrator can use the iLO Virtual NMI feature.

For more information, see the HP website (<http://www.hp.com/support/NMI>).

DIMM slot locations

DIMM slots are numbered sequentially (1 through 12) for each processor. The supported AMP modes use the letter assignments for population guidelines.

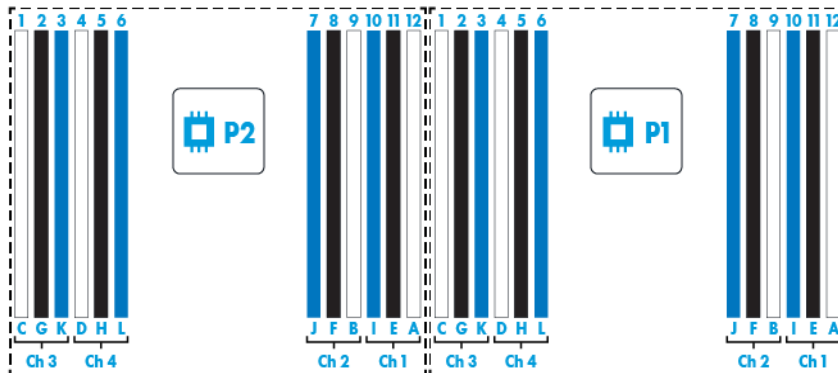

	1st slot of channel	2nd slot of channel	3rd slot of channel
	A B C D	E F G H	I J K L
Number of DIMMs to install	4		
	8		
	12		

SAS and SATA device numbers

- SFF 8-device bay numbering

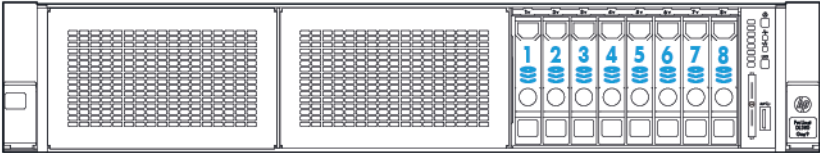

- SFF 8-device bay numbering with SAS expander solution used

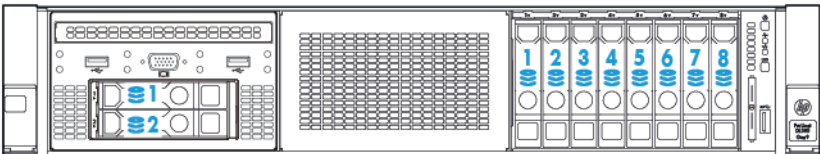

- Optional SFF 16-device bay numbering

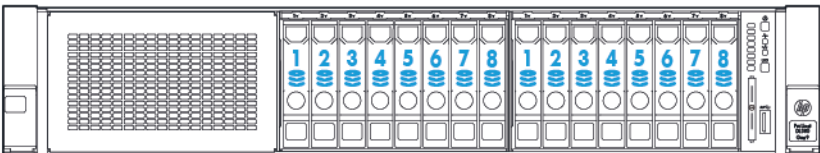

- Optional SFF 16-device bay numbering with SAS expander solution used

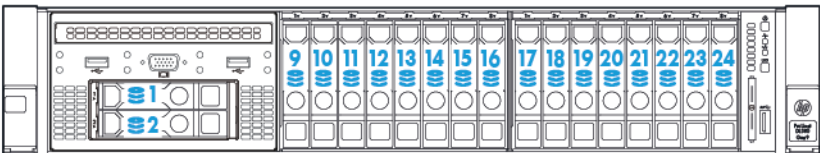

- Optional 24 SFF device bay numbering

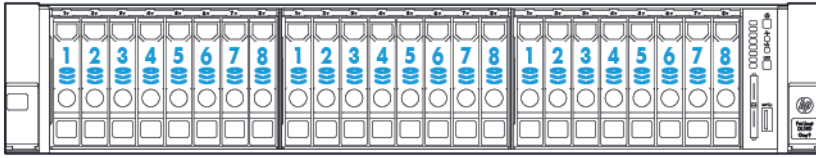

- Optional 24 SFF device bay numbering with SAS expander solution used

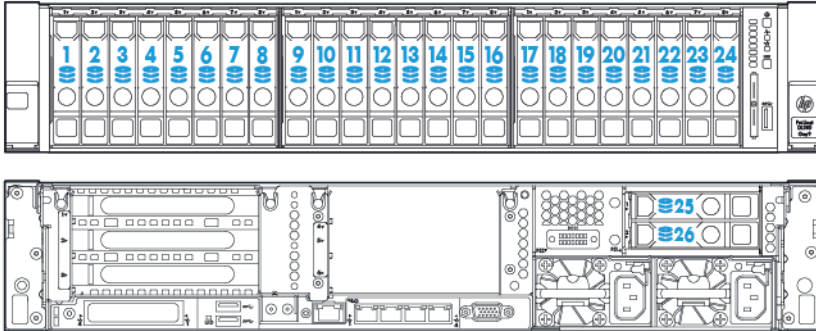

- LFF 12-device bay numbering

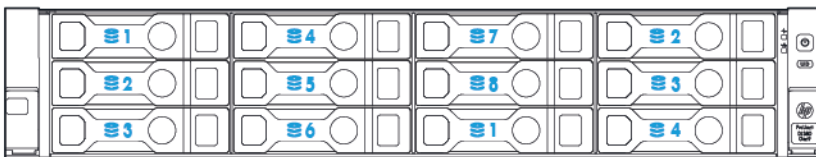

- LFF 12-device bay number with 2-bay rear SAS expander solution used

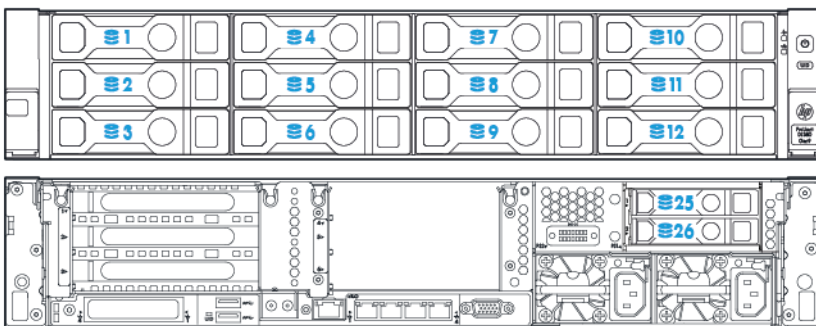

- LFF 12-device bay number with 3-bay rear SAS expander solution used

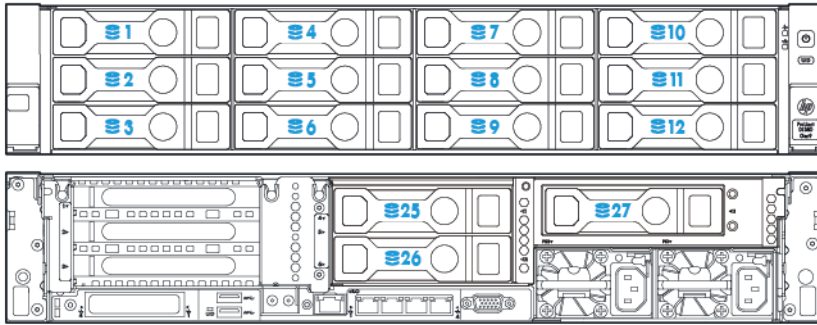

- LFF 4-device bay numbering

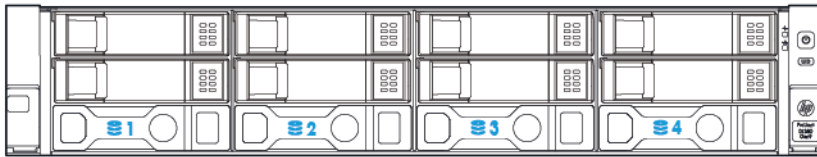

Hot-plug drive LED definitions

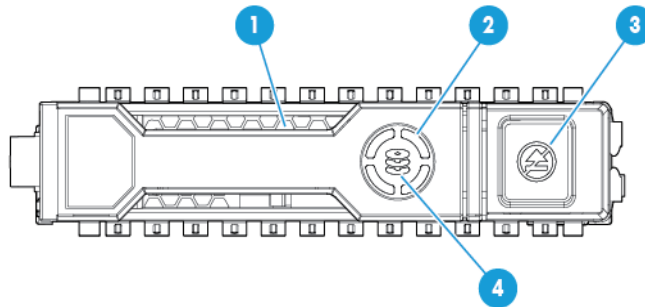

Item	LED	Status	Definition
1	Locate	Solid blue	The drive is being identified by a host application.
		Flashing blue	The drive carrier firmware is being updated or requires an update.
2	Activity ring	Rotating green	Drive activity
		Off	No drive activity
3	Do not remove	Solid white	Do not remove the drive. Removing the drive causes one or more of the logical drives to fail.
		Off	Removing the drive does not cause a logical drive to fail.

Item	LED	Status	Definition
4	Drive status	Solid green	The drive is a member of one or more logical drives.
		Flashing green	The drive is rebuilding or performing a RAID migration, strip size migration, capacity expansion, or logical drive extension, or is erasing.
		Flashing amber/green	The drive is a member of one or more logical drives and predicts the drive will fail.
		Flashing amber	The drive is not configured and predicts the drive will fail.
		Solid amber	The drive has failed.
		Off	The drive is not configured by a RAID controller.

Hot-plug fans



CAUTION: To avoid damage to server components, fan blanks must be installed in fan bays 1 and 2 in a single-processor configuration.



CAUTION: To avoid damage to the equipment, do not operate the server for extended periods of time if the server does not have the optimal number of fans installed. Although the server might boot, HP does not recommend operating the server without the required fans installed and operating.

Valid fan configurations are listed in the following table.

Configuration	Fan bay 1	Fan bay 2	Fan bay 3	Fan bay 4	Fan bay 5	Fan bay 6
1 processor	Fan blank	Fan blank	Fan	Fan	Fan	Fan
1 processor, 24 SFF or 12 LFF configuration with high performance fans	Fan	Fan	Fan	Fan	Fan	Fan
2 processors	Fan	Fan	Fan	Fan	Fan	Fan

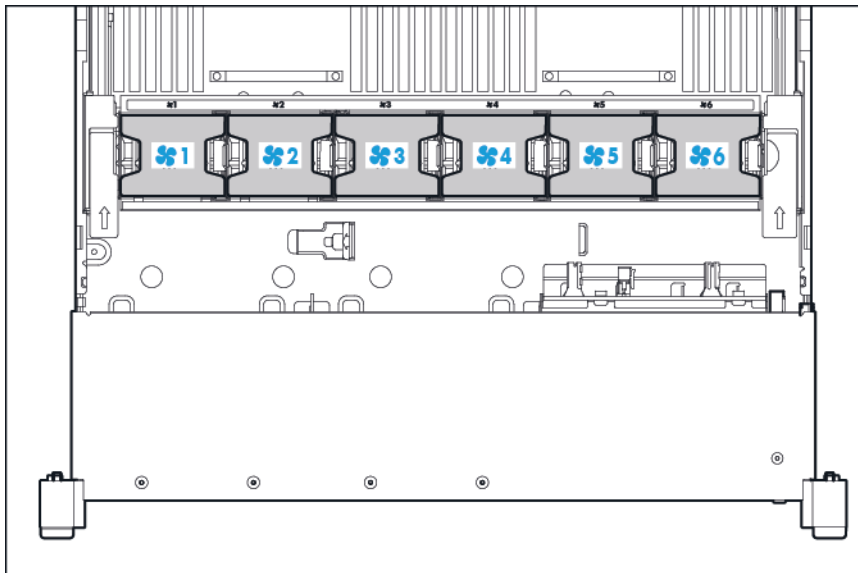

For a single-processor configuration, excluding 24-SFF and 12-LFF configurations, four fans and two blanks are required in specific fan bays for redundancy. A fan failure or missing fan causes a loss of redundancy. A second fan failure or missing fan causes an orderly shutdown of the server.

For a dual-processor configuration or single-processor 24-SFF or 12-LFF configurations, six fans are required for redundancy. A fan failure or missing fan causes a loss of redundancy. A second fan failure or missing fan causes an orderly shutdown of the server.

The high performance fans are used for 24-SFF and 12-LFF drive configurations and might be necessary for the following installations:

- Optional GPU riser installations
- ASHRAE compliant configurations

For more information, see the HP website (<http://www.hp.com/servers/ASHRAE>).

The server supports variable fan speeds. The fans operate at minimum speed until a temperature change requires a fan speed increase to cool the server. The server shuts down during the following temperature-related scenarios:

- At POST and in the OS, HP iLO performs an orderly shutdown if a cautionary temperature level is detected. If the server hardware detects a critical temperature level before an orderly shutdown occurs, the server performs an immediate shutdown.
- When the Thermal Shutdown feature is disabled in the BIOS/Platform Configuration (RBSU), HP iLO does not perform an orderly shutdown when a cautionary temperature level is detected. Disabling this feature does not disable the server hardware from performing an immediate shutdown when a critical temperature level is detected.



CAUTION: A thermal event can damage server components when the Thermal Shutdown feature is disabled in the BIOS/Platform Configuration (RBSU).

Operations

Power up the server

To power up the server, press the Power On/Standby button.

Power down the server

Before powering down the server for any upgrade or maintenance procedures, perform a backup of critical server data and programs.



IMPORTANT: When the server is in standby mode, auxiliary power is still being provided to the system.

To power down the server, use one of the following methods:

- Press and release the Power On/Standby button.
This method initiates a controlled shutdown of applications and the OS before the server enters standby mode.
- Press and hold the Power On/Standby button for more than 4 seconds to force the server to enter standby mode.
This method forces the server to enter standby mode without properly exiting applications and the OS. If an application stops responding, you can use this method to force a shutdown.
- Use a virtual power button selection through HP iLO.
This method initiates a controlled remote shutdown of applications and the OS before the server enters standby mode.

Before proceeding, verify the server is in standby mode by observing that the system power LED is amber.

Extend the server from the rack



WARNING: To reduce the risk of personal injury or equipment damage, be sure that the rack is adequately stabilized before extending a component from the rack.

1. Pull down the quick release levers on each side of the server.

2. Extend the server from the rack.

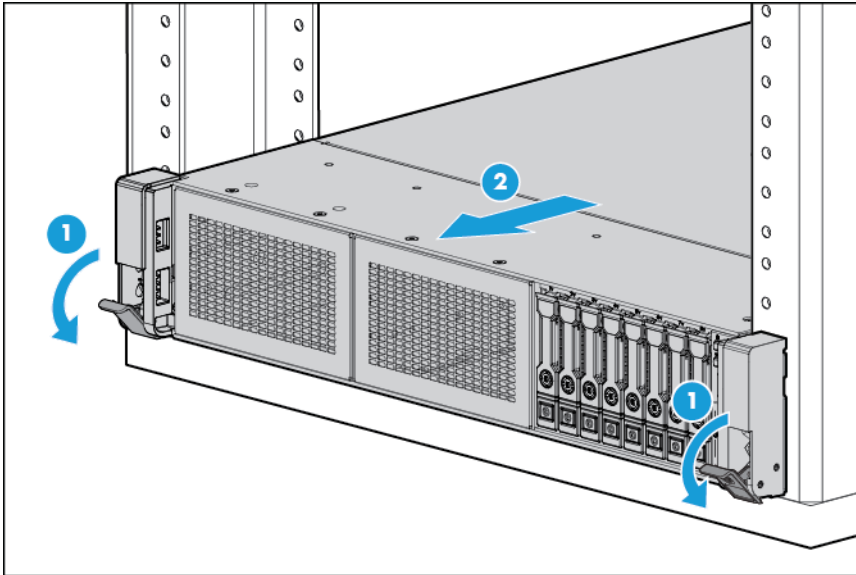

3. After performing the installation or maintenance procedure, slide the server back into the rack, and then press the server firmly into the rack to secure it in place.



WARNING: To reduce the risk of personal injury, be careful when pressing the server rail-release latches and sliding the server into the rack. The sliding rails could pinch your fingers.

Remove the server from the rack

To remove the server from an HP, Compaq branded, telco, or third-party rack:

1. Power down the server (on page 25).
2. Extend the server from the rack (on page 25).
3. Disconnect the cabling and remove the server from the rack. For more information, see the documentation that ships with the rack mounting option.
4. Place the server on a sturdy, level surface.

Remove the access panel



WARNING: To reduce the risk of personal injury from hot surfaces, allow the drives and the internal system components to cool before touching them.



CAUTION: Do not operate the server for long periods with the access panel open or removed. Operating the server in this manner results in improper airflow and improper cooling that can lead to thermal damage.

To remove the component:

1. Power down the server (on page 25).
2. Extend the server from the rack (on page 25).
3. Open or unlock the locking latch, slide the access panel to the rear of the chassis, and remove the access panel.

Install the access panel

1. Place the access panel on top of the server with the hood latch open. Allow the panel to extend past the rear of the server approximately 1.25 cm (0.5 in).
2. Push down on the hood latch. The access panel slides to a closed position.
3. Tighten the security screw on the hood latch.

Access the product rear panel

Opening the cable management arm

To access the server rear panel:

1. Release the cable management arm.

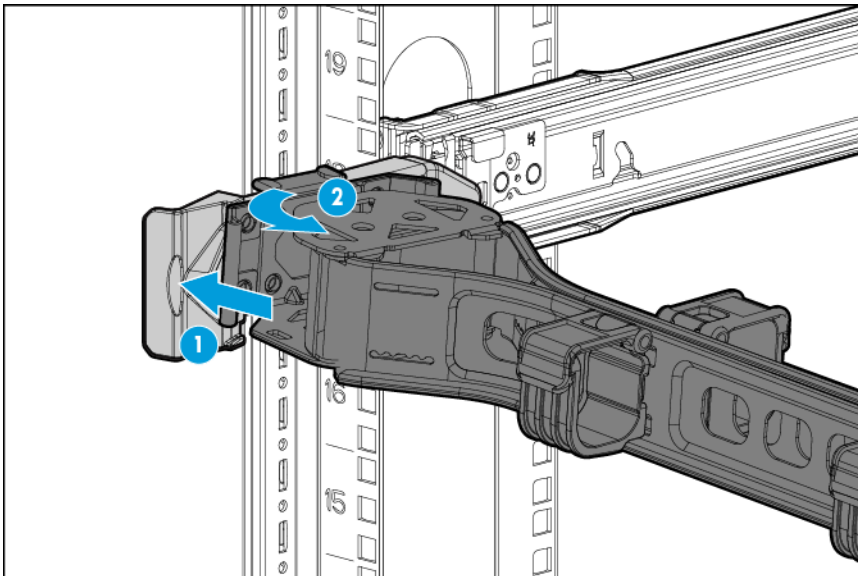

2. Open the cable management arm. The cable management arm can be right-mounted or left-mounted.

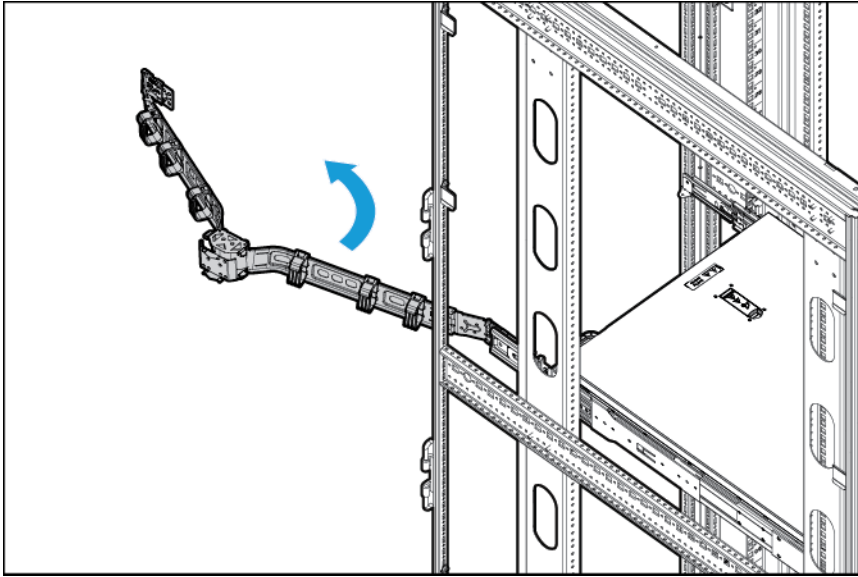

Remove the fan cage

To remove the component:

1. Power down the server (on page [25](#)).
2. Remove all power:
 - a. Disconnect each power cord from the power source.
 - b. Disconnect each power cord from the server.
3. Do one of the following:
 - o Extend the server from the rack (on page [25](#)).
 - o Remove the server from the rack (on page [26](#)).
4. Remove the access panel (on page [26](#)).

5. Remove the fan cage.

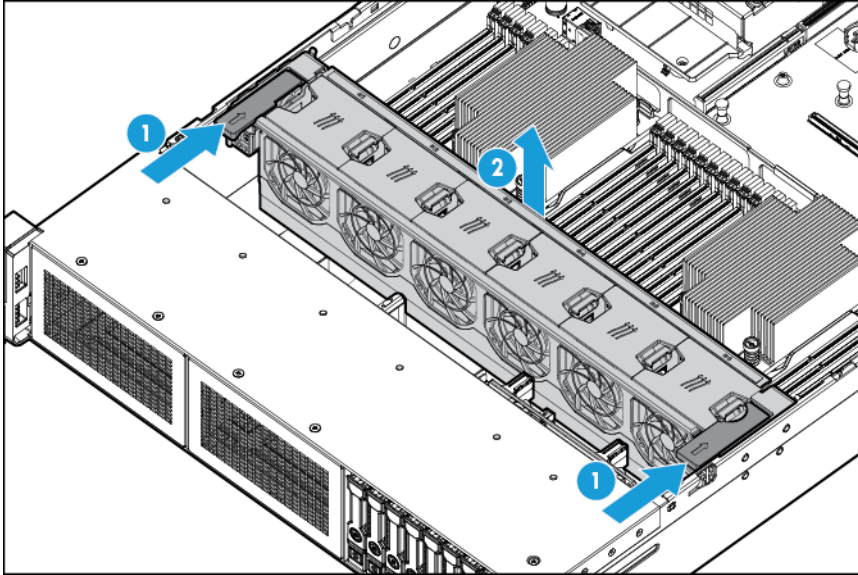

CAUTION: Do not operate the server for long periods with the access panel open or removed. Operating the server in this manner results in improper airflow and improper cooling that can lead to thermal damage.



IMPORTANT: For optimum cooling, install fans in all primary fan locations. For more information, refer to the fan locations table ("[Hot-plug fans](#)" on page 23).

Remove the hot-plug fan

To remove the component:

1. Extend the server from the rack (on page 25).
2. Remove the access panel (on page 26).
3. Remove the fan.

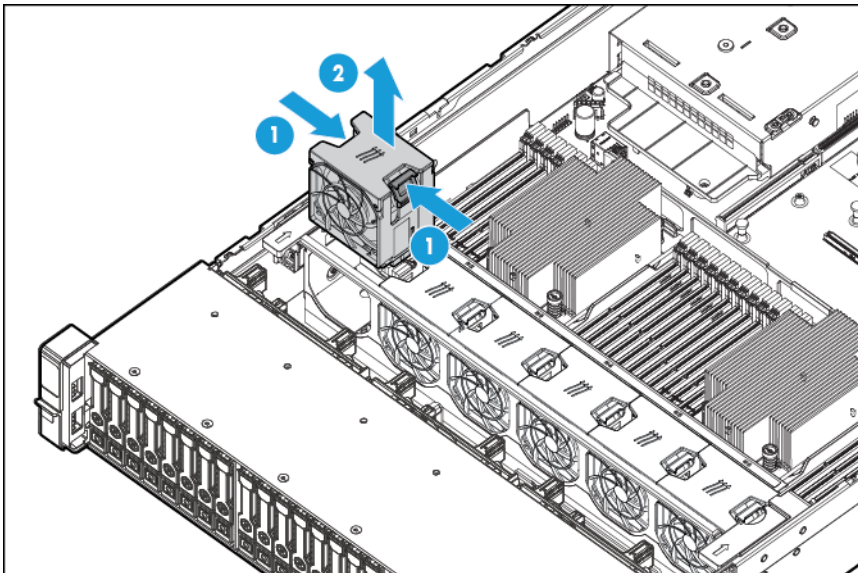



CAUTION: Do not operate the server for long periods with the access panel open or removed. Operating the server in this manner results in improper airflow and improper cooling that can lead to thermal damage.



IMPORTANT: For optimum cooling, install fans in all primary fan locations. For more information, refer to the fan locations table ("Hot-plug fans" on page 23).

Remove the PCI riser cage



CAUTION: To prevent damage to the server or expansion boards, power down the server and remove all AC power cords before removing or installing the PCI riser cage.

1. Power down the server (on page 25).
2. Remove all power:
 - a. Disconnect each power cord from the power source.
 - b. Disconnect each power cord from the server.
3. Do one of the following:
 - o Extend the server from the rack (on page 25).
 - o Remove the server from the rack (on page 26).
4. Remove the access panel (on page 26).
5. Remove the PCI riser cage.

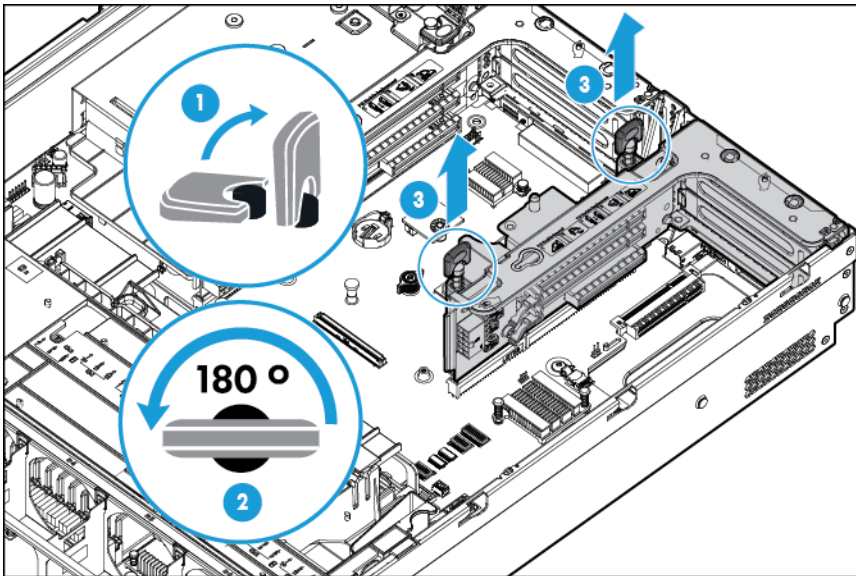

Install the PCI riser cage

1. Power down the server (on page 25).
2. Remove all power:
 - a. Disconnect each power cord from the power source.
 - b. Disconnect each power cord from the server.

3. Do one of the following:
 - o Extend the server from the rack (on page 25).
 - o Remove the server from the rack (on page 26).
4. Remove the access panel (on page 26).
5. Install the PCI riser cage.

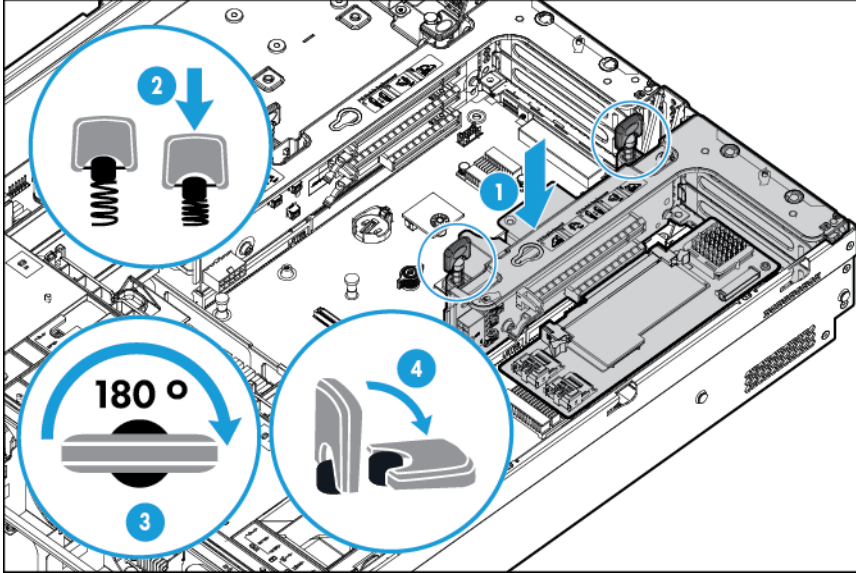

6. Install the access panel (on page 27).
7. Install the server into the rack ("Installing the server into the rack" on page 38).
8. Connect each power cord to the server.
9. Connect each power cord to the power source.
10. Power up the server (on page 25).

Secure the full-length expansion board retainer

1. Power down the server (on page 25).
2. Remove all power:
 - a. Disconnect each power cord from the power source.
 - b. Disconnect each power cord from the server.
3. Extend the server from the rack (on page 25).
4. Remove the access panel (on page 26).
5. Install a full-length expansion board ("Installing an expansion board" on page 63).
6. Install the PCI riser cage (on page 30).

7. Secure the full-length expansion board retainer.

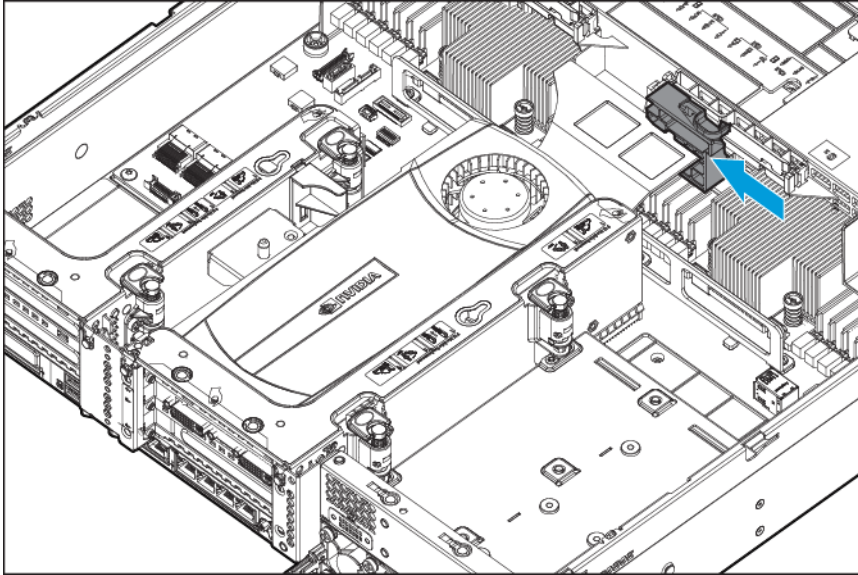

8. Install the access panel (on page 27).
9. Install the server into the rack ("Installing the server into the rack" on page 38).
10. Connect each power cord to the server.
11. Connect each power cord to the power source.
12. Power up the server (on page 25).

Remove the air baffle

CAUTION: For proper cooling, do not operate the server without the access panel, baffles, expansion slot covers, or blanks installed. If the server supports hot-plug components, minimize the amount of time the access panel is open.

To remove the component:

1. Power down the server (on page 25).
2. Remove all power:
 - a. Disconnect each power cord from the power source.
 - b. Disconnect each power cord from the server.
3. Extend the server from the rack (on page 25).
4. Remove the access panel (on page 26).

CAUTION: Do not detach the cable that connects the battery pack to the cache module. Detaching the cable causes any unsaved data in the cache module to be lost.

5. Remove the air baffle.

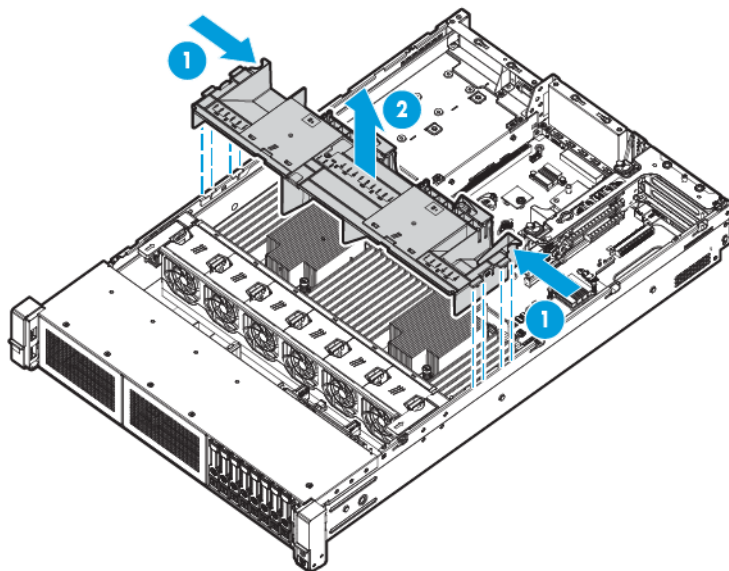

Setup

Optional services

Delivered by experienced, certified engineers, HP Care Pack services help you keep your servers up and running with support packages tailored specifically for HP ProLiant systems. HP Care Packs let you integrate both hardware and software support into a single package. A number of service level options are available to meet your needs.

HP Care Pack Services offer upgraded service levels to expand your standard product warranty with easy-to-buy, easy-to-use support packages that help you make the most of your server investments. Some of the Care Pack services are:

- Hardware support
 - 6-Hour Call-to-Repair
 - 4-Hour 24x7 Same Day
 - 4-Hour Same Business Day
- Software support
 - Microsoft®
 - Linux
 - HP ProLiant Essentials (HP SIM and RDP)
 - VMware
- Integrated hardware and software support
 - Critical Service
 - Proactive 24
 - Support Plus
 - Support Plus 24
- Startup and implementation services for both hardware and software

For more information on HP Care Pack Services, see the HP website (<http://www.hp.com/services/carepack>).

Optimum environment

When installing the server in a rack, select a location that meets the environmental standards described in this section.

Space and airflow requirements

To allow for servicing and adequate airflow, observe the following space and airflow requirements when deciding where to install a rack:

- Leave a minimum clearance of 63.5 cm (25 in) in front of the rack.
- Leave a minimum clearance of 76.2 cm (30 in) behind the rack.
- Leave a minimum clearance of 121.9 cm (48 in) from the back of the rack to the back of another rack or row of racks.

HP servers draw in cool air through the front door and expel warm air through the rear door. Therefore, the front and rear rack doors must be adequately ventilated to allow ambient room air to enter the cabinet, and the rear door must be adequately ventilated to allow the warm air to escape from the cabinet.

 **CAUTION:** To prevent improper cooling and damage to the equipment, do not block the ventilation openings.

When vertical space in the rack is not filled by a server or rack component, the gaps between the components cause changes in airflow through the rack and across the servers. Cover all gaps with blanking panels to maintain proper airflow.

 **CAUTION:** Always use blanking panels to fill empty vertical spaces in the rack. This arrangement ensures proper airflow. Using a rack without blanking panels results in improper cooling that can lead to thermal damage.

The 9000 and 10000 Series Racks provide proper server cooling from flow-through perforations in the front and rear doors that provide 64 percent open area for ventilation.

 **CAUTION:** When using a Compaq branded 7000 series rack, install the high airflow rack door insert (PN 327281-B21 for 42U rack, PN 157847-B21 for 22U rack) to provide proper front-to-back airflow and cooling.

 **CAUTION:** If a third-party rack is used, observe the following additional requirements to ensure adequate airflow and to prevent damage to the equipment:

- Front and rear doors—If the 42U rack includes closing front and rear doors, you must allow 5,350 sq cm (830 sq in) of holes evenly distributed from top to bottom to permit adequate airflow (equivalent to the required 64 percent open area for ventilation).
- Side—The clearance between the installed rack component and the side panels of the rack must be a minimum of 7 cm (2.75 in).

 **IMPORTANT:** The HP ProLiant DL380 Gen9 Server cable management arm is not supported on Compaq branded 7000 series racks.

Temperature requirements

To ensure continued safe and reliable equipment operation, install or position the system in a well-ventilated, climate-controlled environment.

The maximum recommended ambient operating temperature (TMRA) for most server products is 35°C (95°F). The temperature in the room where the rack is located must not exceed 35°C (95°F).

 **CAUTION:** To reduce the risk of damage to the equipment when installing third-party options:

- Do not permit optional equipment to impede airflow around the server or to increase the internal rack temperature beyond the maximum allowable limits.
- Do not exceed the manufacturer's TMRA.

Power requirements

Installation of this equipment must comply with local and regional electrical regulations governing the installation of information technology equipment by licensed electricians. This equipment is designed to operate in installations covered by NFPA 70, 1999 Edition (National Electric Code) and NFPA-75, 1992 (code for Protection of Electronic Computer/Data Processing Equipment). For electrical power ratings on options, refer to the product rating label or the user documentation supplied with that option.



WARNING: To reduce the risk of personal injury, fire, or damage to the equipment, do not overload the AC supply branch circuit that provides power to the rack. Consult the electrical authority having jurisdiction over wiring and installation requirements of your facility.



CAUTION: Protect the server from power fluctuations and temporary interruptions with a regulating uninterruptible power supply. This device protects the hardware from damage caused by power surges and voltage spikes and keeps the system in operation during a power failure.

When installing more than one server, you may need to use additional power distribution devices to safely provide power to all devices. Observe the following guidelines:

- Balance the server power load between available AC supply branch circuits.
- Do not allow the overall system AC current load to exceed 80% of the branch circuit AC current rating.
- Do not use common power outlet strips for this equipment.
- Provide a separate electrical circuit for the server.

Electrical grounding requirements

The server must be grounded properly for proper operation and safety. In the United States, you must install the equipment in accordance with NFPA 70, 1999 Edition (National Electric Code), Article 250, as well as any local and regional building codes. In Canada, you must install the equipment in accordance with Canadian Standards Association, CSA C22.1, Canadian Electrical Code. In all other countries, you must install the equipment in accordance with any regional or national electrical wiring codes, such as the International Electrotechnical Commission (IEC) Code 364, parts 1 through 7. Furthermore, you must be sure that all power distribution devices used in the installation, such as branch wiring and receptacles, are listed or certified grounding-type devices.

Because of the high ground-leakage currents associated with multiple servers connected to the same power source, HP recommends the use of a PDU that is either permanently wired to the building's branch circuit or includes a nondetachable cord that is wired to an industrial-style plug. NEMA locking-style plugs or those complying with IEC 60309 are considered suitable for this purpose. Using common power outlet strips for the server is not recommended.

Connecting a DC power cable to a DC power source



WARNING: To reduce the risk of electric shock or energy hazards:

- This equipment must be installed by trained service personnel, as defined by the NEC and IEC 60950-1, Second Edition, the standard for Safety of Information Technology Equipment.
- Connect the equipment to a reliably grounded Secondary circuit source. A Secondary

circuit has no direct connection to a Primary circuit and derives its power from a transformer, converter, or equivalent isolation device.

- The branch circuit overcurrent protection must be rated 27 A.
-



WARNING: When installing a DC power supply, the ground wire must be connected before the positive or negative leads.



WARNING: Remove power from the power supply before performing any installation steps or maintenance on the power supply.



CAUTION: The server equipment connects the earthed conductor of the DC supply circuit to the earthing conductor at the equipment. For more information, see the *HP 800W Common Slot - 40Vdc to -72Vdc or 380Vdc DC Input Hot-Plug Power Supply Kit Installation Instructions*.



CAUTION: If the DC connection exists between the earthed conductor of the DC supply circuit and the earthing conductor at the server equipment, the following conditions must be met:

- This equipment must be connected directly to the DC supply system earthing electrode conductor or to a bonding jumper from an earthing terminal bar or bus to which the DC supply system earthing electrode conductor is connected.
 - This equipment should be located in the same immediate area (such as adjacent cabinets) as any other equipment that has a connection between the earthed conductor of the same DC supply circuit and the earthing conductor, and also the point of earthing of the DC system. The DC system should be earthed elsewhere.
 - The DC supply source is to be located within the same premises as the equipment.
 - Switching or disconnecting devices should not be in the earthed circuit conductor between the DC source and the point of connection of the earthing electrode conductor.
-

To connect a DC power cable to a DC power source:

1. Cut the DC power cord ends no shorter than 150 cm (59.06 in).
2. If the power source requires ring tongues, use a crimping tool to install the ring tongues on the power cord wires.



IMPORTANT: The ring terminals must be UL approved and accommodate 10 gauge wires.



IMPORTANT: The minimum nominal thread diameter of a pillar or stud type terminal must be 3.5 mm (0.138 in); the diameter of a screw type terminal must be 4.0 mm (0.157 in).

3. Stack each same-colored pair of wires and then attach them to the same power source. The power cord consists of three wires (black, red, and green).

For more information, see the *HP 800W Common Slot -40Vdc to -72Vdc or 380Vdc DC Input Hot-Plug Power Supply Installation Instructions*.

Rack warnings



WARNING: To reduce the risk of personal injury or damage to the equipment, be sure that:

- The leveling jacks are extended to the floor.
 - The full weight of the rack rests on the leveling jacks.
 - The stabilizing feet are attached to the rack if it is a single-rack installation.
 - The racks are coupled together in multiple-rack installations.
 - Only one component is extended at a time. A rack may become unstable if more than one component is extended for any reason.
-



WARNING: To reduce the risk of personal injury or equipment damage when unloading a rack:

- At least two people are needed to safely unload the rack from the pallet. An empty 42U rack can weigh as much as 115 kg (253 lb), can stand more than 2.1 m (7 ft) tall, and might become unstable when being moved on its casters.
 - Never stand in front of the rack when it is rolling down the ramp from the pallet. Always handle the rack from both sides.
-

Identifying the contents of the server shipping carton

Unpack the server shipping carton and locate the materials and documentation necessary for installing the server. All the rack mounting hardware necessary for installing the server into the rack is included with the rack or the server.

The contents of the server shipping carton include:

- Server
- Power cord
- Hardware documentation and software products
- Rack-mounting hardware and documentation

In addition to the supplied items, you might need:

- Operating system or application software
- Hardware options
- Screwdriver

Installing hardware options

Install any hardware options before initializing the server. For options installation information, refer to the option documentation. For server-specific information, refer to "Hardware options installation (on page 42)."

Installing the server into the rack



CAUTION: Always plan the rack installation so that the heaviest item is on the bottom of the rack. Install the heaviest item first, and continue to populate the rack from the bottom to the top.

1. Install the server and cable management arm into the rack. For more information, see the installation instructions that ship with the 2U Quick Deploy Rail System.
2. Connect peripheral devices to the server. For information on identifying connectors, see "Rear panel components (on page 14)."



WARNING: To reduce the risk of electric shock, fire, or damage to the equipment, do not plug telephone or telecommunications connectors into RJ-45 connectors.

3. Connect the power cord to the rear of the server.
4. Install the power cord anchors.

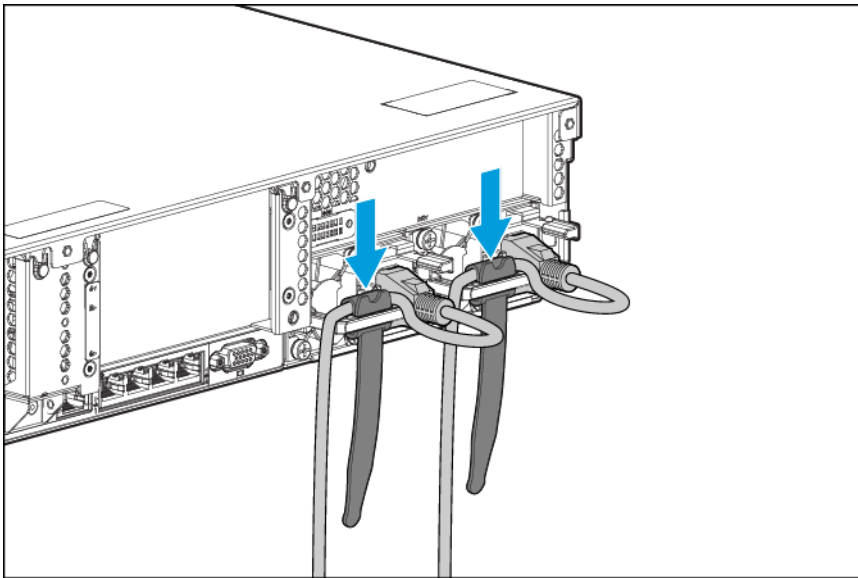

5. Secure the cables to the cable management arm.



IMPORTANT: When using cable management arm components, be sure to leave enough slack in each of the cables to prevent damage to the cables when the server is extended from the rack.

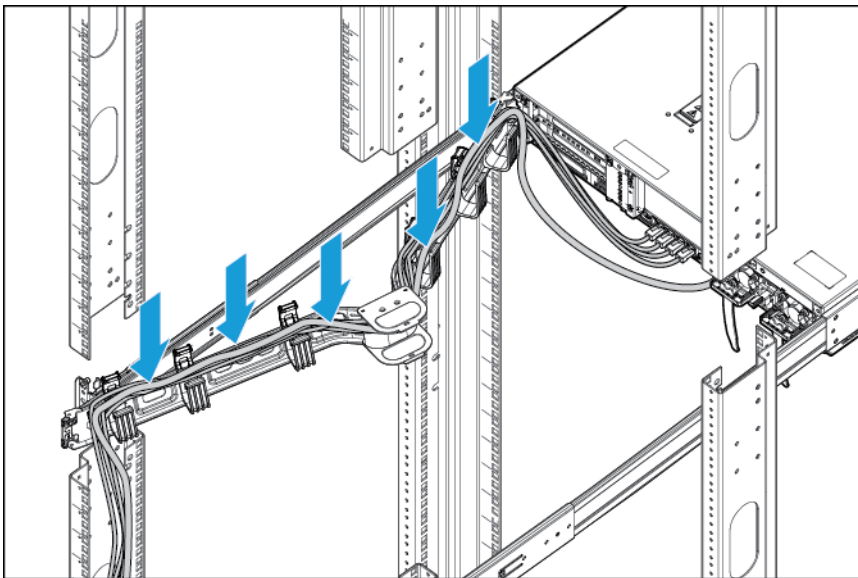

6. Connect the power cord to the AC power source.



WARNING: To reduce the risk of electric shock or damage to the equipment:

- Do not disable the power cord grounding plug. The grounding plug is an important safety feature.
 - Plug the power cord into a grounded (earthed) electrical outlet that is easily accessible at all times.
 - Unplug the power cord from the power supply to disconnect power to the equipment.
 - Do not route the power cord where it can be walked on or pinched by items placed against it. Pay particular attention to the plug, electrical outlet, and the point where the cord extends from the server.
-

Installing the operating system

This HP ProLiant server does not ship with provisioning media. Everything needed to manage and install the system software and firmware is preloaded on the server.

To operate properly, the server must have a supported operating system. For the latest information on operating system support, see the HP website (<http://www.hp.com/go/supportos>).

To install an operating system on the server, use one of the following methods:

- Intelligent Provisioning—iLO contains Intelligent Provisioning for embedded deployment, updating, and provisioning capabilities. Intelligent Provisioning can configure the server and install an operating system.

To install an operating system on the server with Intelligent Provisioning (local or remote):

- a. Connect the Ethernet cable between the network connector on the server and a network jack.
 - b. Press the Power On/Standby button.
 - c. During server POST, press **F10**.
 - d. Complete the initial Preferences and Registration portion of Intelligent Provisioning (on page 144).
 - e. At the 1 Start screen, click **Configure and Install**.
 - f. To finish the installation, follow the onscreen prompts. An Internet connection is required to update the firmware and systems software.
- Remote deployment installation—To deploy an operating system remotely, use Insight Control Server Provisioning for an automated solution.

For additional system software and firmware updates, download the HP Service Pack for ProLiant from the HP website (<http://www.hp.com/go/spp/download>). Software and firmware must be updated before using the server for the first time, unless any installed software or components require an older version. For more information, see the "Keeping the system current" section in the server user guide.

For more information on using these installation methods, see the HP website (<http://www.hp.com/go/ilo>).

Powering on and selecting boot options in UEFI Boot Mode

On servers operating in UEFI Boot Mode, the boot controller and boot order are set automatically.

1. Press the Power On/Standby button.
2. During the initial boot:
 - To modify the server configuration ROM default settings, press the **F9** key in the HP ProLiant POST screen to enter the UEFI System Utilities screen. By default, the System Utilities menus are in the English language.
 - If you do not need to modify the server configuration and are ready to install the system software, press the **F10** key to access Intelligent Provisioning.

For more information on automatic configuration, see the UEFI documentation on the HP website (<http://www.hp.com/go/ProLiantUEFI/docs>).

Registering the server

To experience quicker service and more efficient support, register the product at the HP Product Registration website (<http://register.hp.com>).

Hardware options installation

Server QuickSpecs

For more information about product features, specifications, options, configurations, and compatibility, see the product QuickSpecs on the HP website (<http://www.hp.com/servers/dl380gen9/qs>).

Introduction

If more than one option is being installed, read the installation instructions for all the hardware options and identify similar steps to streamline the installation process.

⚠ WARNING: To reduce the risk of personal injury from hot surfaces, allow the drives and the internal system components to cool before touching them.

⚠ CAUTION: To prevent damage to electrical components, properly ground the server before beginning any installation procedure. Improper grounding can cause electrostatic discharge.

Hot-plug drive guidelines

When adding drives to the server, observe the following general guidelines:

- The system automatically sets all device numbers.
- If only one drive is used, install it in the bay with the lowest device number.
- Drives should be the same capacity to provide the greatest storage space efficiency when drives are grouped together into the same drive array.

Installing a hot-plug SAS or SATA drive

To install the component:

1. Remove the drive blank.

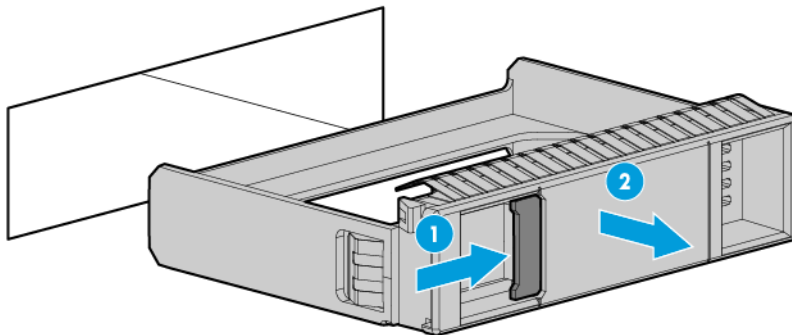

2. Prepare the drive.

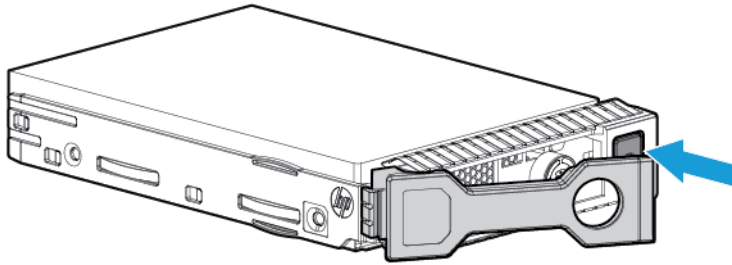

3. Install the drive.

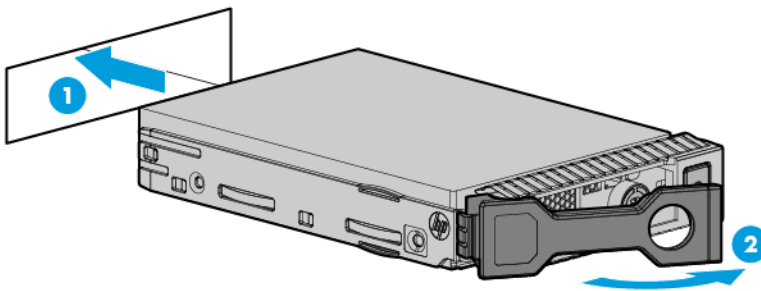

4. Determine the status of the drive from the drive LED definitions ("[Hot-plug drive LED definitions](#)" on page [22](#)).

Removing a hot-plug SAS or SATA drive

CAUTION: For proper cooling, do not operate the server without the access panel, baffles, expansion slot covers, or blanks installed. If the server supports hot-plug components, minimize the amount of time the access panel is open.

1. Determine the status of the drive from the hot-plug SAS drive LED combinations ("[Hot-plug drive LED definitions](#)" on page [22](#)).
2. Back up all server data on the drive.
3. Remove the drive.

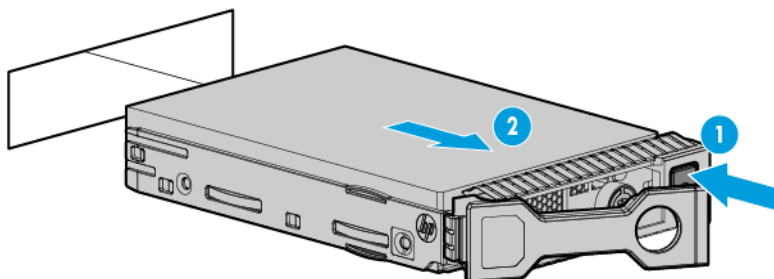

Redundant hot-plug power supply option

⚠ **CAUTION:** All power supplies installed in the server must have the same output power capacity. Verify that all power supplies have the same part number and label color. The system becomes unstable and may shut down when it detects mismatched power supplies.

⚠ **CAUTION:** To prevent improper cooling and thermal damage, do not operate the server unless all bays are populated with either a component or a blank.

To install the component:

1. Access the product rear panel (on page 27).
2. Remove the blank.

⚠ **WARNING:** To reduce the risk of personal injury from hot surfaces, allow the power supply or power supply blank to cool before touching it.

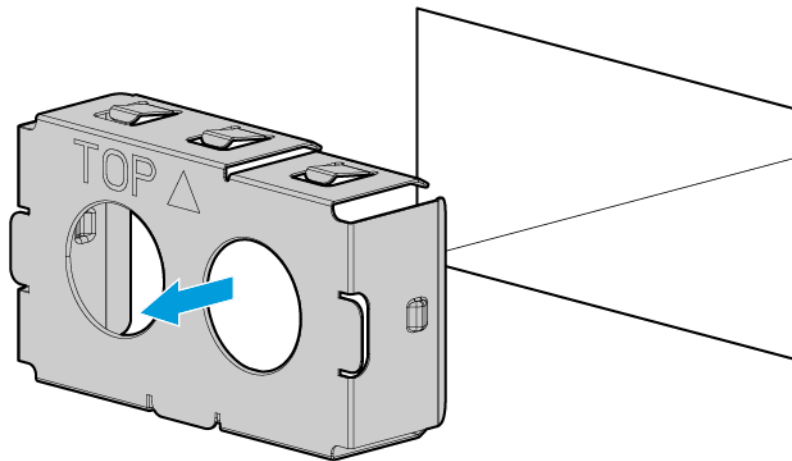

3. Insert the power supply into the power supply bay until it clicks into place.

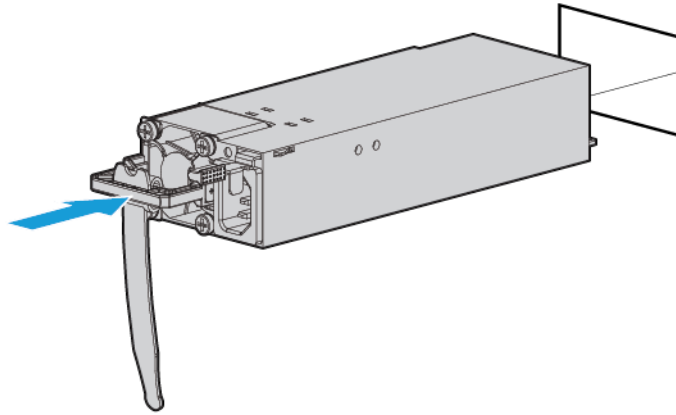

4. Connect the power cord to the power supply.
5. Route the power cord. Use best practices when routing power cords and other cables. A cable management arm is available to help with routing. To obtain a cable management arm, contact an HP authorized reseller.
6. Connect the power cord to the AC power source.
7. Be sure that the power supply LED is green ("[Rear panel LEDs](#)" on page [14](#)).

High performance fan option

To install the component:

1. Power down the server (on page [25](#)).
2. Remove all power:
 - a. Disconnect each power cord from the power source.
 - b. Disconnect each power cord from the server.
3. Do one of the following:
 - o Extend the server from the rack (on page [25](#)).
 - o Remove the server from the rack (on page [26](#)).
4. Remove the access panel (on page [26](#)).



IMPORTANT: Do not mix standard fans and high performance fans in the same server.

5. Remove fan blanks and standard fans from all locations:

- Fan blanks

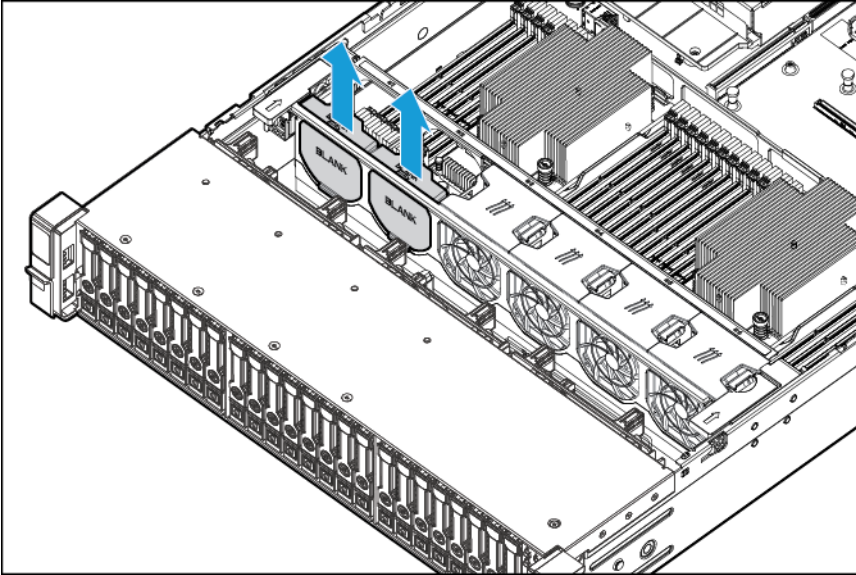

- Standard fans

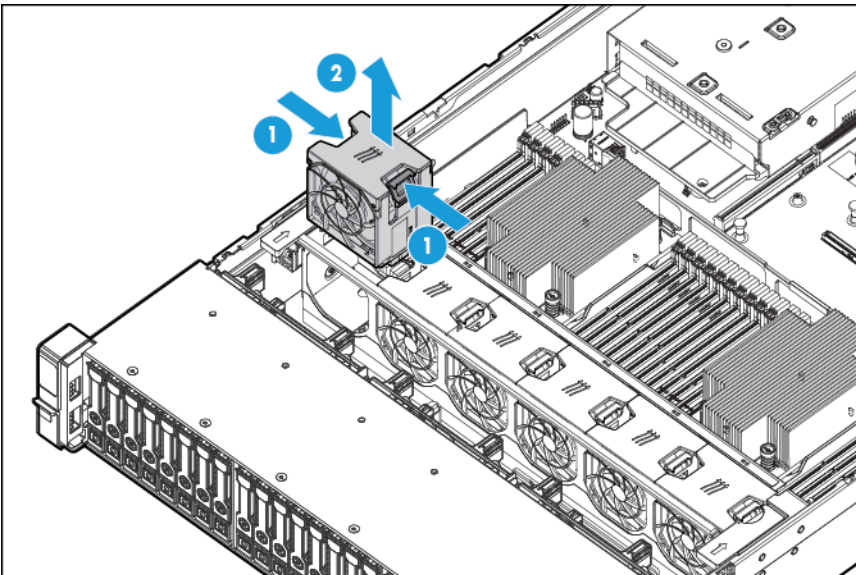

6. Install high performance fans in all locations.

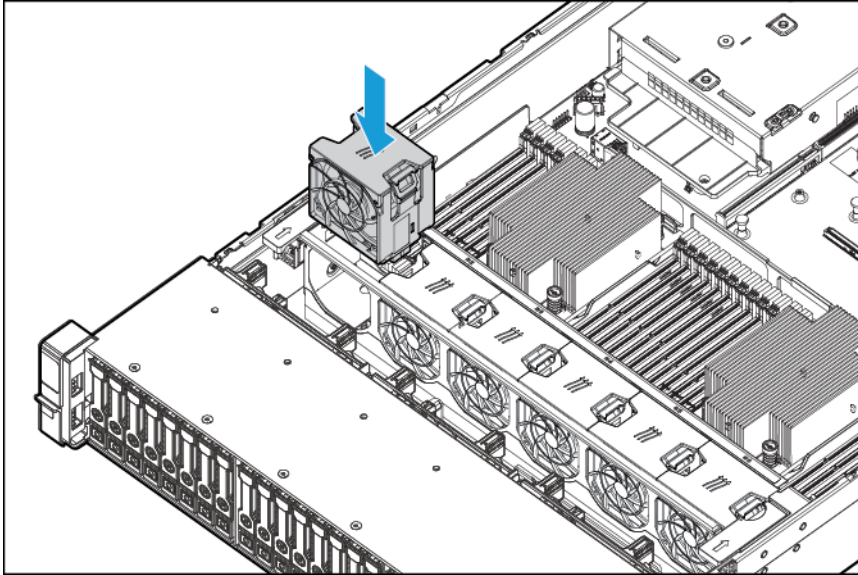

7. Install the access panel (on page 27).
8. Slide the server into the rack.
9. Connect each power cord to the server.
10. Connect each power cord to the power source.
11. Power up the server (on page 25).

Processor and fan option

The server supports single-processor and dual-processor operations.



CAUTION: To avoid damage to the processor and system board, only authorized personnel should attempt to replace or install the processor in this server.



CAUTION: To prevent possible server malfunction and damage to the equipment, multiprocessor configurations must contain processors with the same part number.



IMPORTANT: If installing a processor with a faster speed, update the system ROM before installing the processor.

To install a processor:

1. Power down the server (on page 25).
2. Remove all power:
 - a. Disconnect each power cord from the power source.
 - b. Disconnect each power cord from the server.
3. Do one of the following:
 - o Extend the server from the rack (on page 25).
 - o Remove the server from the rack (on page 26).
4. Remove the access panel (on page 26).

5. Remove the air baffle (on page 32).
6. Remove the processor blank.
7. Open each of the processor locking levers in the order indicated in the following illustration, and then open the processor retaining bracket.

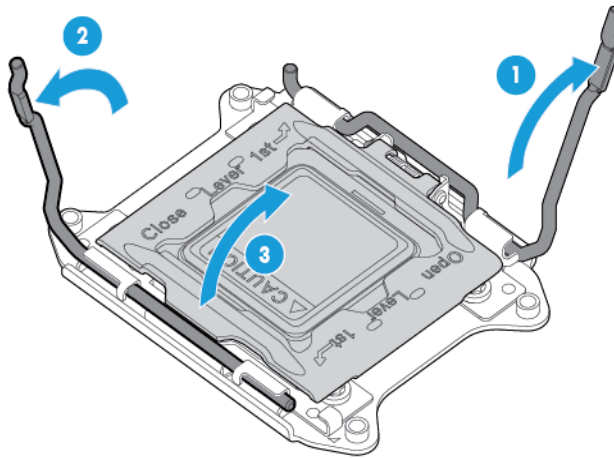

8. Remove the clear processor socket cover. Retain the processor socket cover for future use.

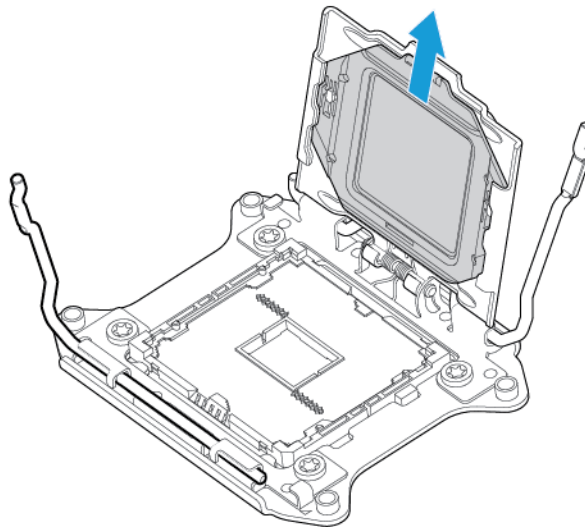

CAUTION: THE PINS ON THE SYSTEM BOARD ARE VERY FRAGILE AND EASILY DAMAGED. To avoid damage to the system board, do not touch the processor or the processor socket contacts.

9. Install the processor. Verify that the processor is fully seated in the processor retaining bracket by visually inspecting the processor installation guides on either side of the processor. **THE PINS ON THE SYSTEM BOARD ARE VERY FRAGILE AND EASILY DAMAGED.**

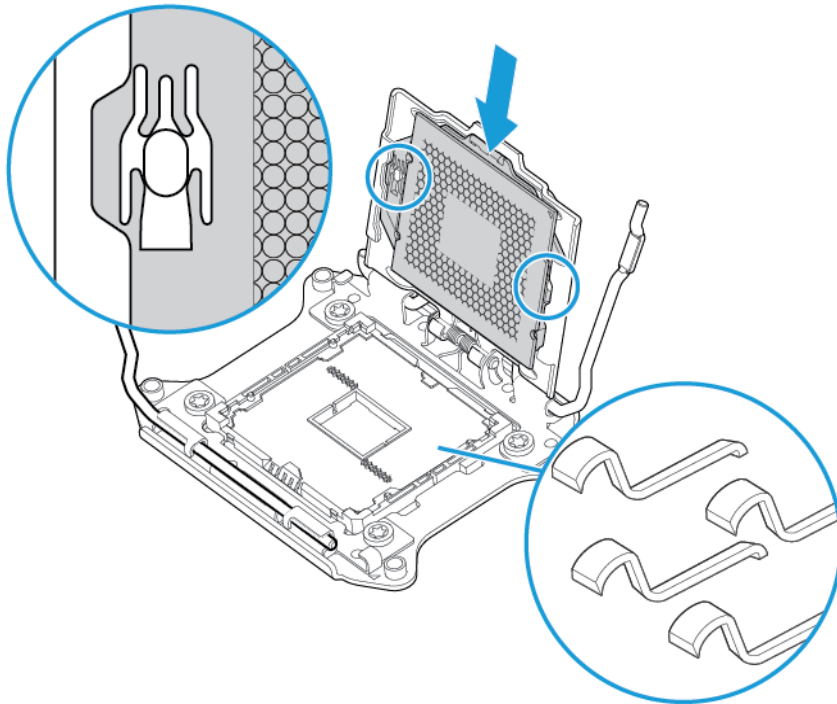

10. Close the processor retaining bracket. When the processor is installed properly inside the processor retaining bracket, the processor retaining bracket clears the flange on the front of the socket.

⚠ CAUTION: Do not press down on the processor. Pressing down on the processor may cause damage to the processor socket and the system board. Press only in the area indicated on the processor retaining bracket.

⚠ CAUTION: Close and hold down the processor cover socket while closing the processor locking levers. The levers should close without resistance. Forcing the levers closed can damage the processor and socket, requiring system board replacement.

11. Press and hold the processor retaining bracket in place, and then close each processor locking lever. Press only in the area indicated on the processor retaining bracket.

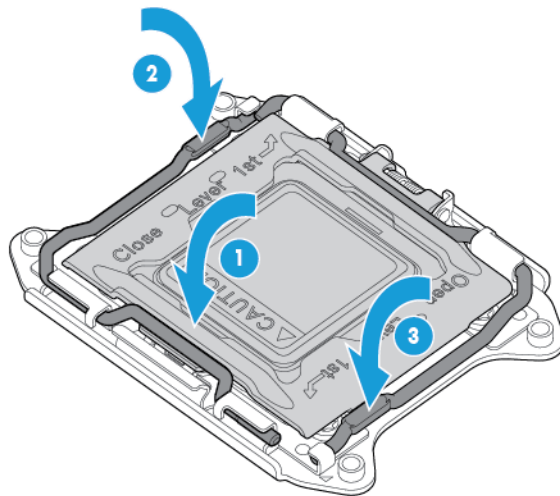

CAUTION: Close and hold down the processor cover socket while closing the processor locking levers. The levers should close without resistance. Forcing the levers closed can damage the processor and socket, requiring system board replacement.

12. Remove the heatsink cover.

CAUTION: After the cover is removed, do not touch the thermal interface media.

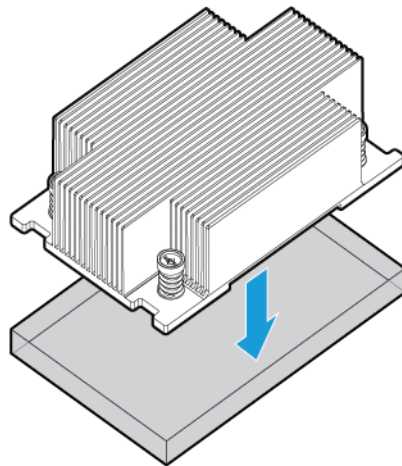

13. Install the heatsink:
 - a. Position the heatsink on the processor backplate.
 - b. Tighten one pair of diagonally opposite screws halfway, and then tighten the other pair of screws.

- c. Finish the installation by completely tightening the screws in the same sequence.

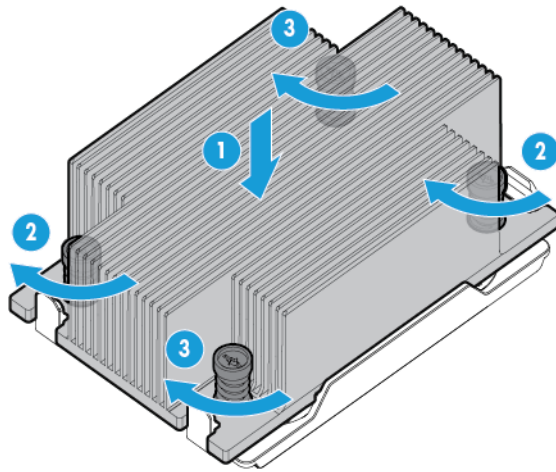

- 14. Remove the fan blanks from locations 1 and 2. For fan location and numbering information, see "Hot-plug fans (on page 23)" or the label attached to the chassis next to the fans.

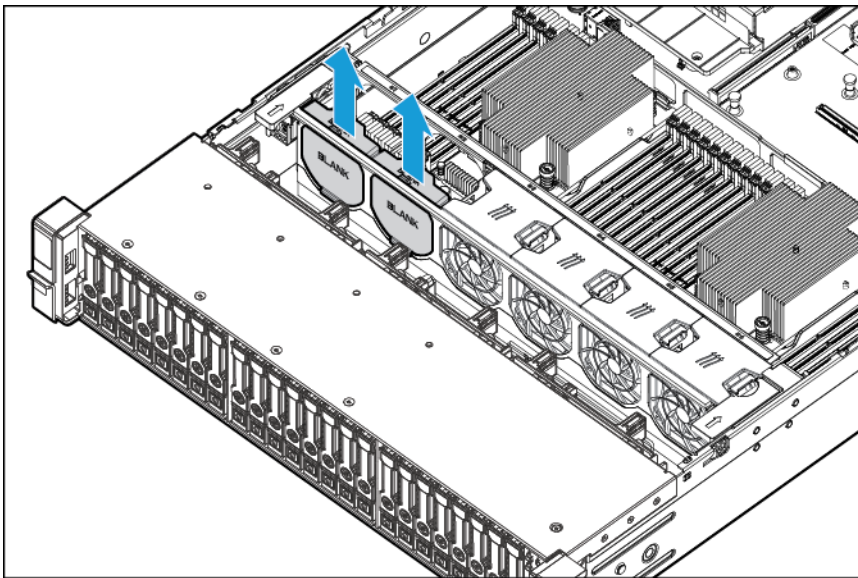

15. Install the fans into locations 1 and 2.

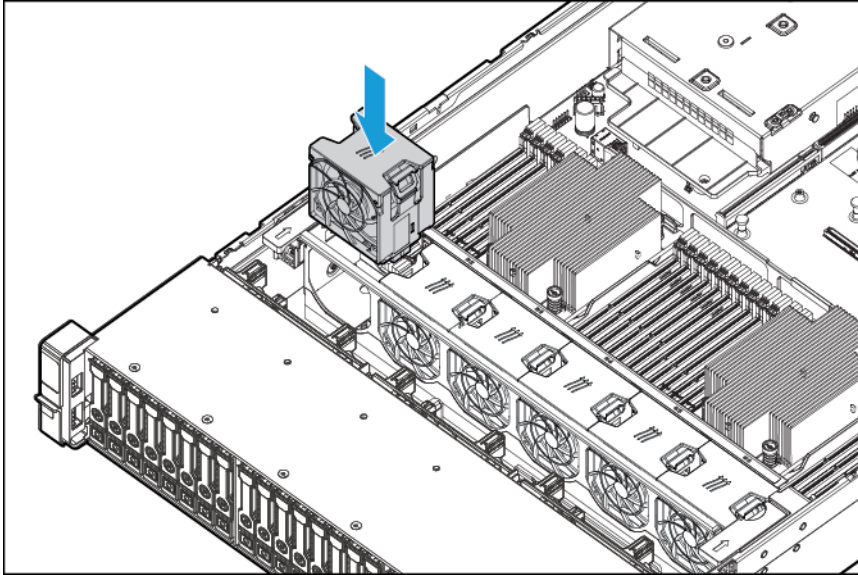

16. Install the air baffle.
17. Install the access panel (on page 27).
18. Install the server into the rack.
19. Connect each power cord to the server.
20. Connect each power cord to the power source.
21. Press the Power On/Standby button.

The server exits standby mode and applies full power to the system. The system power LED changes from amber to green.

Memory options



IMPORTANT: This server does not support mixing LRDIMMs or RDIMMs. Attempting to mix any combination of these DIMMs can cause the server to halt during BIOS initialization.

The memory subsystem in this server can support LRDIMMs and RDIMMs:

- RDIMMs offer address parity protection.
- LRDIMMs support higher densities than single- and dual-rank RDIMMs, and higher speeds than quad-rank RDIMMs. This support enables you to install more high capacity DIMMs, resulting in higher system capacities and higher bandwidth.

All types are referred to as DIMMs when the information applies to all types. When specified as LRDIMM or RDIMM, the information applies to that type only. All memory installed in the server must be the same type.

The server supports the following DIMM speeds:

- Single- and dual-rank PC4-2133 (DDR4-2133) RDIMMs operating at up to 2133 MT/s
- Quad-rank PC4L-2133 (DDR4-2133) LRDIMMs operating at up to 2133 MT/s

Speed and capacity

DIMM type	DIMM rank	DIMM capacity	Native speed (MT/s)
RDIMM	Single-rank	8 GB	2133
RDIMM	Dual-rank	16 GB	2133
LRDIMM	Quad-rank	32 GB	2133

Depending on the processor model, the number of DIMMs installed, and whether LRDIMMs or RDIMMs are installed, the memory clock speed can be reduced to 1600 MT/s.

Populated DIMM speed (MT/s)

DIMM type	DIMM rank	1 DIMM per channel	2 DIMMs per channel	3 DIMMs per channel
RDIMM	Single-rank (8 GB)	2133	2133	1600
RDIMM	Dual-rank (16 GB)	2133	2133	1600
LRDIMM	Quad-rank (32 GB)	2133	2133	1600

For more information about product features, specifications, options, configurations, and compatibility, see the product QuickSpecs on the HP website (<http://www.hp.com/go/qs>).

HP SmartMemory

HP SmartMemory authenticates and unlocks certain features available only on HP Qualified memory and verifies whether installed memory has passed HP qualification and test processes. Qualified memory is performance-tuned for HP ProLiant and BladeSystem servers and provides future enhanced support through HP Active Health and manageability software.

Memory subsystem architecture

The memory subsystem in this server is divided into channels. Each processor supports four channels, and each channel supports three DIMM slots, as shown in the following table.

Channel	Population order	Slot number
1	A E I	12 11 10
2	B F J	9 8 7
3	C G K	1 2 3
4	D H L	4 5 6

For the location of the slot numbers, see "DIMM slot locations (on page 19)."

This multi-channel architecture provides enhanced performance in Advanced ECC mode. This architecture also enables Online Spare Memory mode.

DIMM slots in this server are identified by number and by letter. Letters identify the population order. Slot numbers indicate the DIMM slot ID for spare replacement.

Single-, dual-, and quad-rank DIMMs

To understand and configure memory protection modes properly, an understanding of single-, dual-, and quad-rank DIMMs is helpful. Some DIMM configuration requirements are based on these classifications.

A single-rank DIMM has one set of memory chips that is accessed while writing to or reading from the memory. A dual-rank DIMM is similar to having two single-rank DIMMs on the same module, with only one rank accessible at a time. A quad-rank DIMM is, effectively, two dual-rank DIMMs on the same module. Only one rank is accessible at a time. The server memory control subsystem selects the proper rank within the DIMM when writing to or reading from the DIMM.

Dual- and quad-rank DIMMs provide the greatest capacity with the existing memory technology. For example, if current DRAM technology supports 8-GB single-rank DIMMs, a dual-rank DIMM would be 16 GB, and a quad-rank DIMM would be 32 GB.

LRDIMMs are labeled as quad-rank DIMMs. There are four ranks of DRAM on the DIMM, but the LRDIMM buffer creates an abstraction that allows the DIMM to appear as a dual-rank DIMM to the system. The LRDIMM buffer isolates the electrical loading of the DRAM from the system to allow for faster operation. This allows higher memory operating speed compared to quad-rank RDIMMs.

DIMM identification

To determine DIMM characteristics, use the label attached to the DIMM and the following illustration and table.

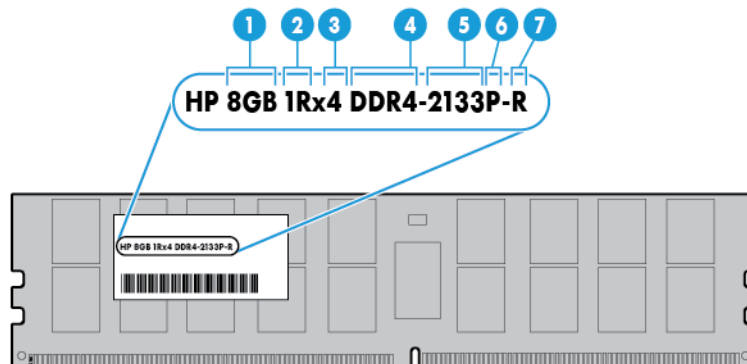

Item	Description	Definition
1	Capacity	8 GB 16 GB 32 GB
2	Rank	1R = Single-rank 2R = Dual-rank 4R = Quad-rank

Item	Description	Definition
3	Data width	x4 = 4-bit x8 = 8-bit
4	Memory generation	DDR4
5	Maximum memory speed	2133 MT/s
6	CAS latency	P=15
7	DIMM type	R = RDIMM (registered) L = LRDIMM (load reduced)

For more information about product features, specifications, options, configurations, and compatibility, see the product QuickSpecs on the HP website (<http://www.hp.com/go/qs>).

Memory configurations

To optimize server availability, the server supports the following AMP modes:

- **Advanced ECC**—Provides up to 4-bit error correction and enhanced performance over Lockstep mode. This mode is the default option for this server.
- **Online spare memory**—Provides protection against failing or degraded DIMMs. Certain memory is reserved as spare, and automatic failover to spare memory occurs when the system detects a DIMM that is degrading. This allows DIMMs that have a higher probability of receiving an uncorrectable memory error (which would result in system downtime) to be removed from operation.

Advanced Memory Protection options are configured in the BIOS/Platform Configuration (RBSU). If the requested AMP mode is not supported by the installed DIMM configuration, the server boots in Advanced ECC mode. For more information, see the *HP UEFI System Utilities User Guide for HP ProLiant Gen9 Servers* on the HP website (<http://www.hp.com/go/ProLiantUEFI/docs>).

Maximum capacity

DIMM type	DIMM rank	One processor	Two processors
RDIMM	Single-rank (8 GB)	96 GB	192 GB
RDIMM	Dual-rank (16 GB)	192 GB	384 GB
LRDIMM	Quad-rank (32 GB)	384 GB	768 GB

For the latest memory configuration information, see the QuickSpecs on the HP website (<http://www.hp.com>).

Advanced ECC memory configuration

Advanced ECC memory is the default memory protection mode for this server. Standard ECC can correct single-bit memory errors and detect multi-bit memory errors. When multi-bit errors are detected using Standard ECC, the error is signaled to the server and causes the server to halt.

Advanced ECC protects the server against some multi-bit memory errors. Advanced ECC can correct both single-bit memory errors and 4-bit memory errors if all failed bits are on the same DRAM device on the DIMM.

Advanced ECC provides additional protection over Standard ECC because it is possible to correct certain memory errors that would otherwise be uncorrected and result in a server failure. Using HP Advanced Memory Error Detection technology, the server provides notification when a DIMM is degrading and has a higher probability of uncorrectable memory error.

Online Spare memory configuration

Online spare memory provides protection against degraded DIMMs by reducing the likelihood of uncorrected memory errors. This protection is available without any operating system support.

Online spare memory protection dedicates one rank of each memory channel for use as spare memory. The remaining ranks are available for OS and application use. If correctable memory errors occur at a rate higher than a specific threshold on any of the non-spare ranks, the server automatically copies the memory contents of the degraded rank to the online spare rank. The server then deactivates the failing rank and automatically switches over to the online spare rank.

General DIMM slot population guidelines

Observe the following guidelines for all AMP modes:

- Install DIMMs only if the corresponding processor is installed.
- When two processors are installed, balance the DIMMs across the two processors.
- White DIMM slots denote the first slot of a channel (Ch 1-A, Ch 2-B, Ch 3-C, Ch 4-D)
- Do not mix RDIMMs and LRDIMMs.
- When one processor is installed, install DIMMs in sequential alphabetic order: A, B, C, D, E, F, and so forth.
- When two processors are installed, install the DIMMs in sequential alphabetic order balanced between the two processors: P1-A, P2-A, P1-B, P2-B, P1-C, P2-C, and so forth.
- When single-rank, dual-rank, and quad-rank DIMMs are populated for two DIMMs per channel or three DIMMs per channel, always populate the higher number rank DIMM first (starting from the farthest slot). For example, first quad-rank DIMM, then dual-rank DIMM, and then lastly single-rank DIMM.
- DIMMs should be populated starting farthest from the processor on each channel.
- For DIMM spare replacement, install the DIMMs per slot number as instructed by the system software.

For more information about server memory, see the HP website (<http://www.hp.com/go/memory>).

DIMM speeds are supported as indicated in the following table.

Populated slots (per channel)	Rank	Speeds supported (MT/s)
1	Single-, dual-, or quad-rank	2133
2	Single- or dual-rank	2133
2	Quad-rank	2133
3	Single-, dual-, or quad-rank	1600

Depending on the processor model, the number of DIMMs installed, and whether LRDIMMs or RDIMMs are installed, the memory clock speed can be reduced to 1600 MT/s.

Advanced ECC population guidelines

For Advanced ECC mode configurations, observe the following guidelines:

- Observe the general DIMM slot population guidelines (on page 56).
- DIMMs may be installed individually.

Online spare population guidelines

For Online Spare memory mode configurations, observe the following guidelines:

- Observe the general DIMM slot population guidelines (on page 56).
- Each channel must have a valid online spare configuration.
- Each channel can have a different valid online spare configuration.
- Each populated channel must have a spare rank. A single dual-rank DIMM is not a valid configuration.

Population order

For memory configurations with a single processor or multiple processors, DIMMs must be populated sequentially in alphabetical order (A through L).

After installing the DIMMs, use the BIOS/Platform Configuration (RBSU) in the UEFI System Utilities to configure supported AMP modes.

Installing a DIMM

The server supports up to 24 DIMMs. To install a DIMM:

1. Power down the server (on page 25).
2. Remove all power:
 - a. Disconnect each power cord from the power source.
 - b. Disconnect each power cord from the server.
3. Do one of the following:
 - Extend the server from the rack (on page 25).
 - Remove the server from the rack (on page 26).
4. Remove the access panel (on page 26).
5. Remove the air baffle (on page 32).
6. Open the DIMM slot latches.

7. Install the DIMM.

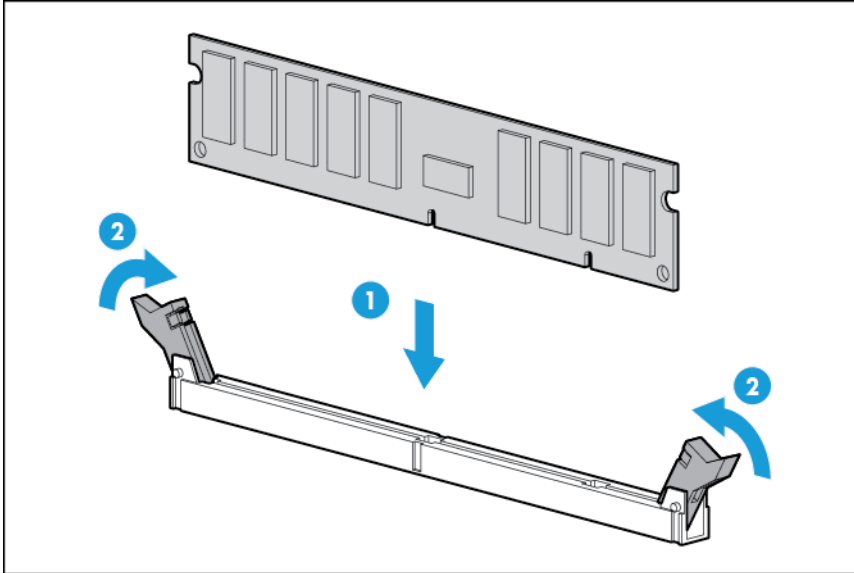

8. Install the air baffle.
9. Install the access panel (on page 27).
10. Install the server into the rack ("[Installing the server into the rack](#)" on page 38).
11. Connect each power cord to the server.
12. Connect each power cord to the power source.
13. Power up the server (on page 25).

Use the BIOS/Platform Configuration (RBSU) in the UEFI System Utilities to configure the memory mode.

For more information about LEDs and troubleshooting failed DIMMs, see "[Systems Insight Display LED combinations](#) (on page 12)."

Universal media bay option

The following procedure provides the steps to install the universal media bay option, route the VGA and USB cables, and install an optional optical disk drive. The universal media bay option also accommodates the two-bay SFF front drive cage option. For information on installing this option, see "[Two-bay SFF front drive cage option](#) (on page 87)."

1. Power down the server (on page 25).
2. Remove all power:
 - a. Disconnect each power cord from the power source.
 - b. Disconnect each power cord from the server.
3. Do one of the following:
 - o Extend the server from the rack (on page 25).
 - o Remove the server from the rack (on page 26).
4. Remove the access panel (on page 26).
5. Remove the air baffle (on page 32).
6. Remove the fan cage (on page 28).

7. Remove the bay blank.

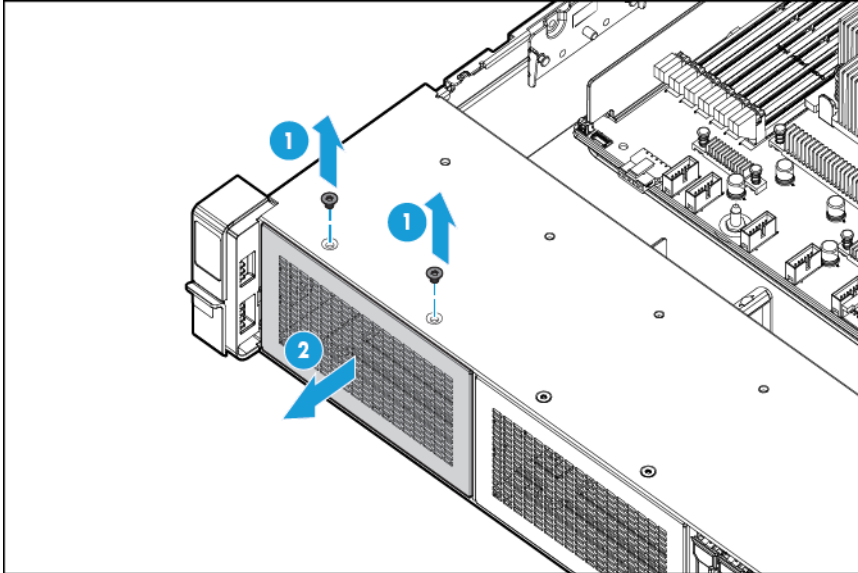

8. Route the USB/VGA cables through the opening, and then install the universal media bay.

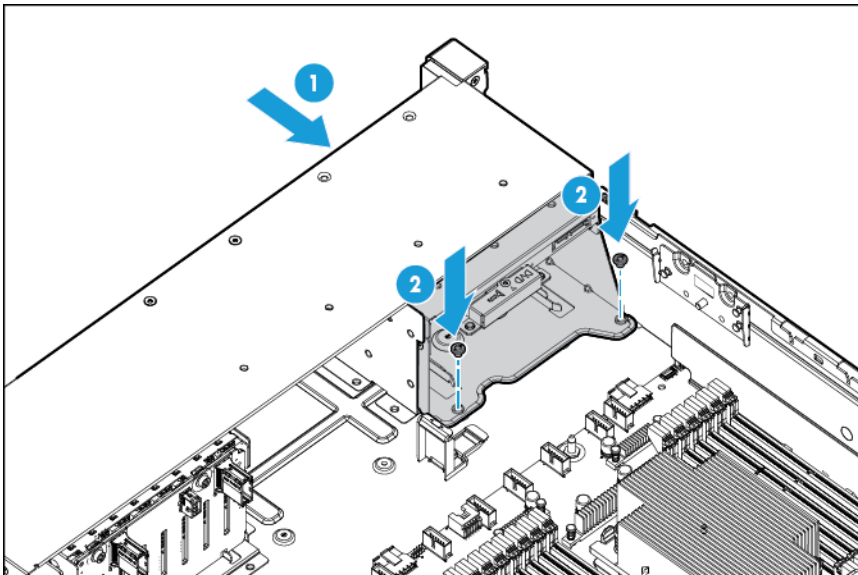

9. Install the optional optical disk drive (optional).

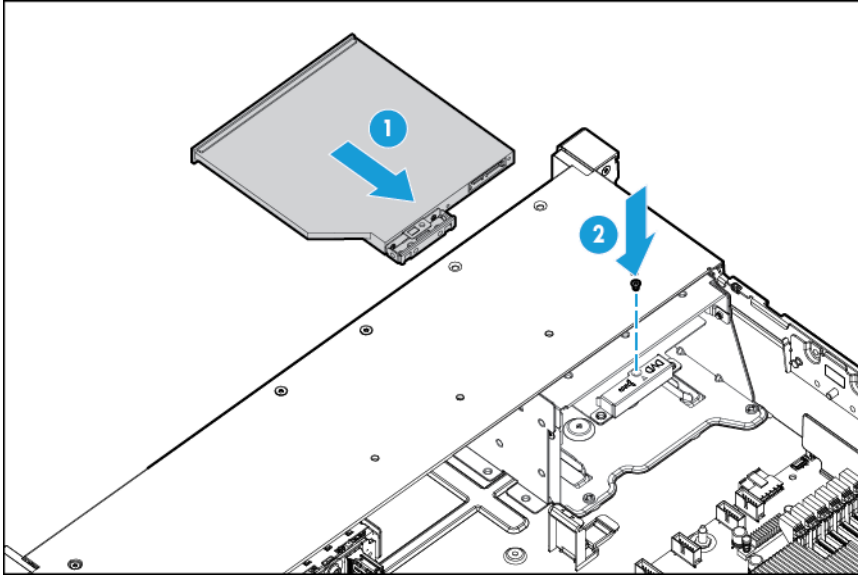

10. Connect the cables:

- Connect the VGA cable to the optional VGA connector. Connect the USB cable to the front dual internal USB 3.0 connector.

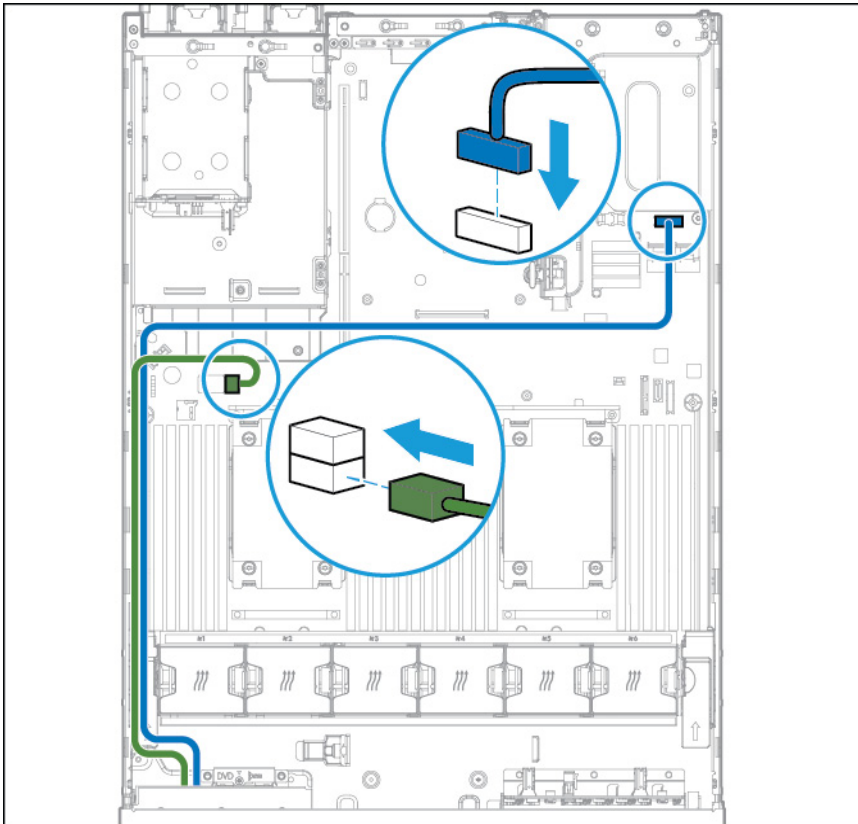

- Connect the SATA optical drive cable to the front optical disk drive connector (optional).

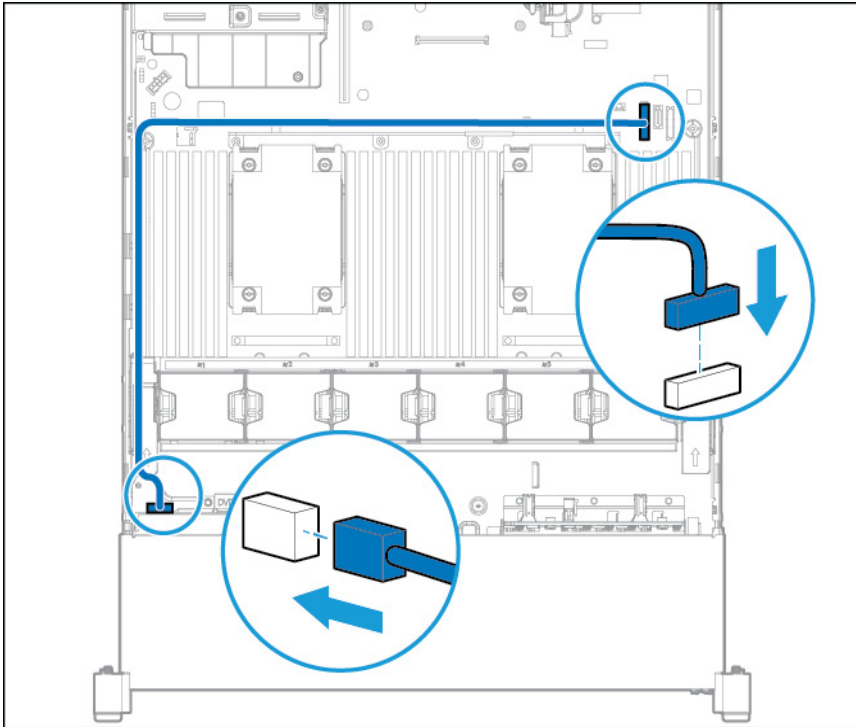

11. Install the fan cage.
12. Install the air baffle.
13. Install the access panel (on page 27).
14. Slide the server into the rack.
15. Connect each power cord to the server.
16. Connect each power cord to the power source.
17. Power up the server (on page 25).

Expansion board options

The server supports PCI Express expansion boards. The server ships with PCIe riser boards and expansion slots. PCIe expansion boards are supported with optional riser boards.

Removing an expansion slot blank



WARNING: To reduce the risk of personal injury, electric shock, or damage to the equipment, remove the power cord to remove power from the server. The front panel Power On/Standby button does not completely shut off system power. Portions of the power supply and some internal circuitry remain active until AC power is removed.



CAUTION: For proper cooling, do not operate the server without the access panel, baffles, expansion slot covers, or blanks installed. If the server supports hot-plug components, minimize the amount of time the access panel is open.

To remove the component:

1. Power down the server (on page 25).
2. Remove all power:
 - a. Disconnect each power cord from the power source.
 - b. Disconnect each power cord from the server.
3. Do one of the following:
 - o Extend the server from the rack (on page 25).
 - o Remove the server from the rack (on page 26).
4. Remove the access panel (on page 26).
5. Remove the PCIe riser cage:
 - o Primary PCIe riser cage ("Remove the PCI riser cage" on page 30)
 - o Secondary PCIe riser cage ("3-slot PCI riser cage option" on page 66)
6. Remove the expansion slot blank:
 - o Primary PCIe riser cage

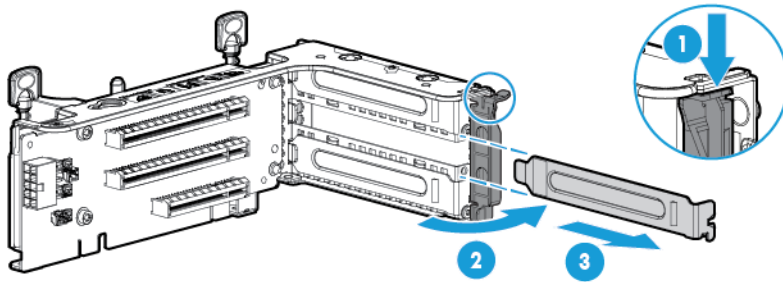

- o Optional primary PCIe riser cage

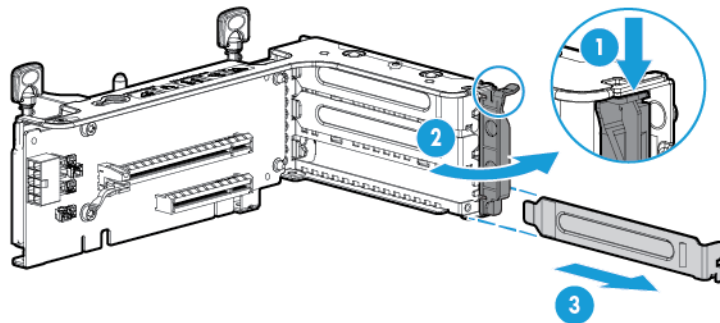

- Secondary PCIe riser cage

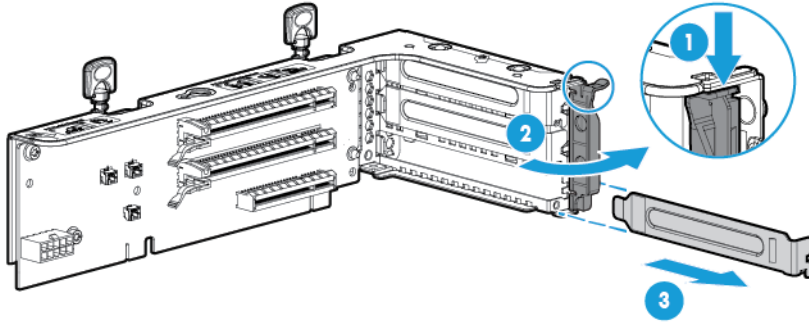

To replace the component, reverse the removal procedure.

Installing an expansion board

1. Power down the server (on page 25).
2. Remove all power:
 - a. Disconnect each power cord from the power source.
 - b. Disconnect each power cord from the server.
3. Do one of the following:
 - Extend the server from the rack (on page 25).
 - Remove the server from the rack (on page 26).
4. Remove the access panel (on page 26).
5. Remove the PCI riser cage (on page 30).
6. Remove the expansion slot blank ("Removing an expansion slot blank" on page 61).
7. Install the expansion board.

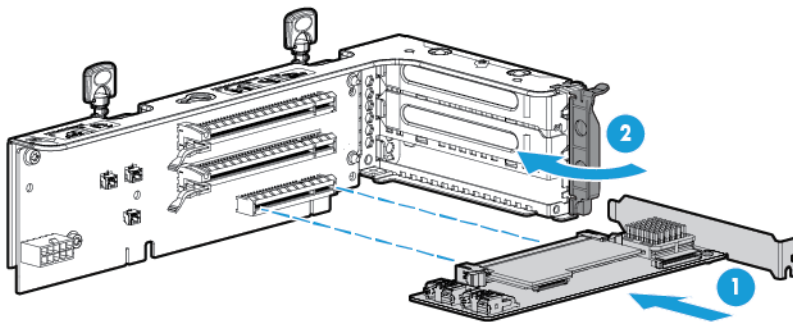

8. Connect any required internal or external cables to the expansion board. See the documentation that ships with the expansion board.
9. Install the PCI riser cage (on page 30).
10. Install the access panel (on page 27).
11. Install the server into the rack ("Installing the server into the rack" on page 38).
12. Connect each power cord to the server.

13. Connect each power cord to the power source.
14. Power up the server (on page 25).

2-slot PCI riser cage option



WARNING: To reduce the risk of personal injury, electric shock, or damage to the equipment, remove the power cord to remove power from the server. The front panel Power On/Standby button does not completely shut off system power. Portions of the power supply and some internal circuitry remain active until AC power is removed.



CAUTION: To prevent improper cooling and thermal damage, do not operate the server unless all PCI slots have either an expansion slot cover or an expansion board installed.

To install the component:

1. Power down the server (on page 25).
2. Remove all power:
 - a. Disconnect each power cord from the power source.
 - b. Disconnect each power cord from the server.
3. Do one of the following:
 - o Extend the server from the rack (on page 25).
 - o Remove the server from the rack (on page 26).
4. Remove the access panel (on page 26).
5. Remove the standard PCI riser from the primary slot.

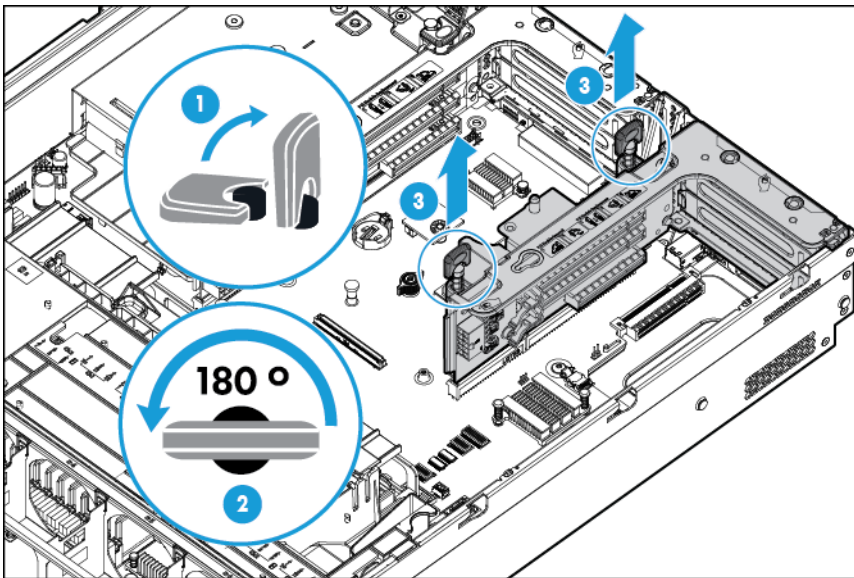

6. Remove the blank from the optional 2-slot PCI riser cage.

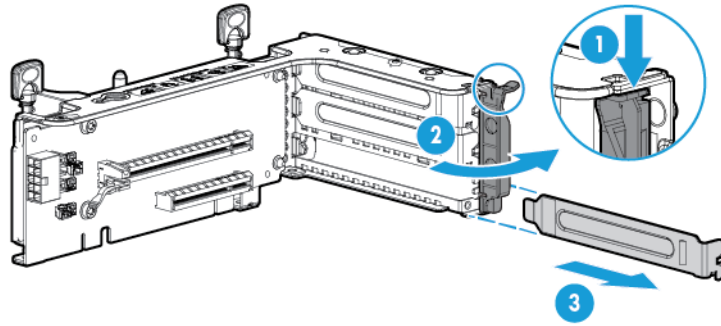

7. Install an optional expansion board into the PCI riser cage.

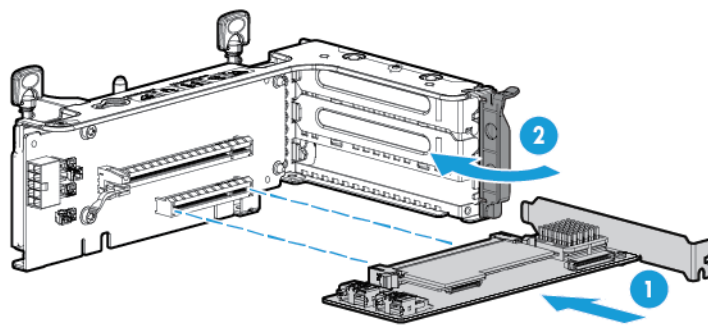

8. Install the optional 2-slot PCI riser cage.

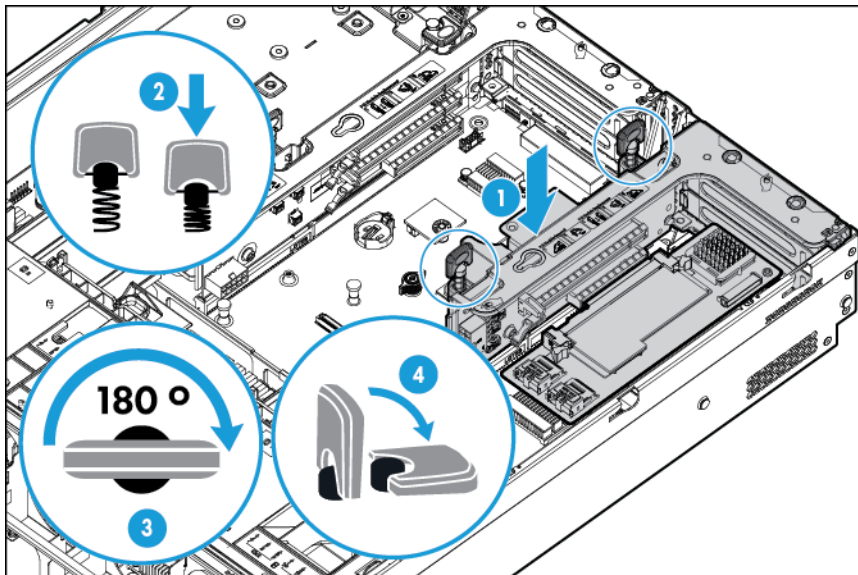

9. Connect any required internal or external cables to the expansion board. See the documentation that ships with the expansion board.
10. Install the access panel (on page 27).
11. Slide the server into the rack.
12. Connect each power cord to the server.
13. Connect each power cord to the power source.

14. Power up the server (on page 25).

3-slot PCI riser cage option



WARNING: To reduce the risk of personal injury, electric shock, or damage to the equipment, remove the power cord to remove power from the server. The front panel Power On/Standby button does not completely shut off system power. Portions of the power supply and some internal circuitry remain active until AC power is removed.



CAUTION: To prevent improper cooling and thermal damage, do not operate the server unless all PCI slots have either an expansion slot cover or an expansion board installed.

To install the component:

1. Power down the server (on page 25).
2. Remove all power:
 - a. Disconnect each power cord from the power source.
 - b. Disconnect each power cord from the server.
3. Do one of the following:
 - o Extend the server from the rack (on page 25).
 - o Remove the server from the rack (on page 26).
4. Remove the access panel (on page 26).
5. Remove the secondary PCI riser blank. Some models might require removing only two screws.

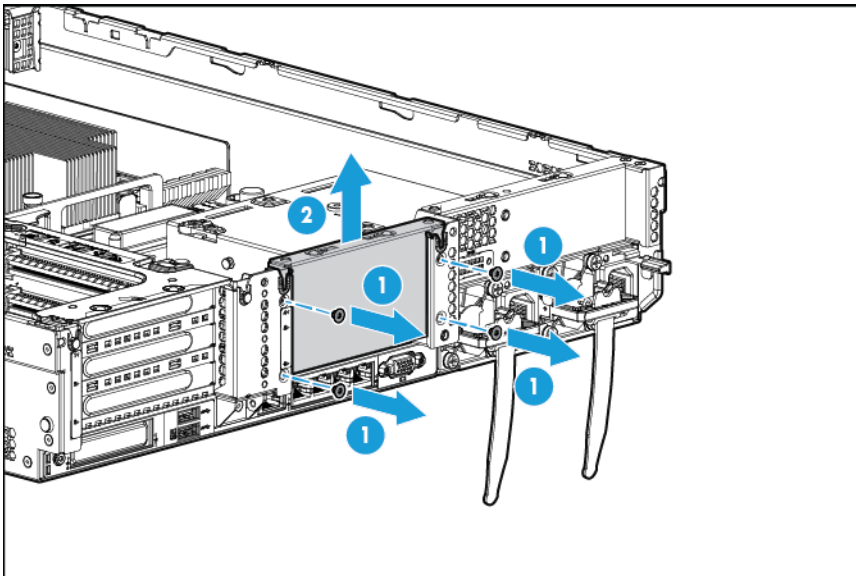

6. Remove the blank from the optional 3-slot PCI riser cage.

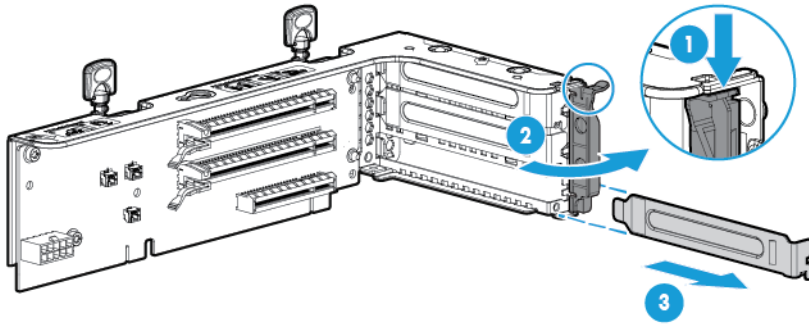

7. Install an expansion board into the PCI riser cage.

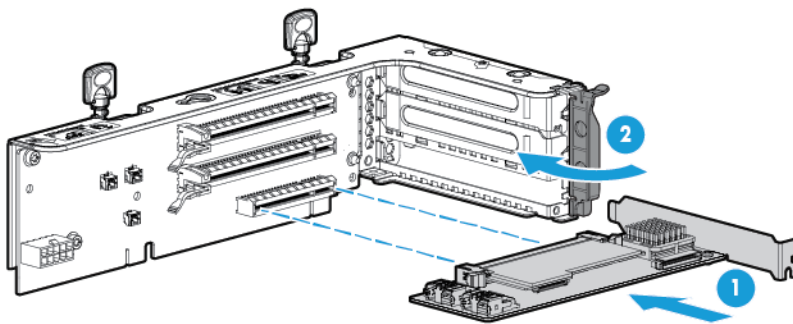

8. Install the optional 3-slot PCI riser cage.

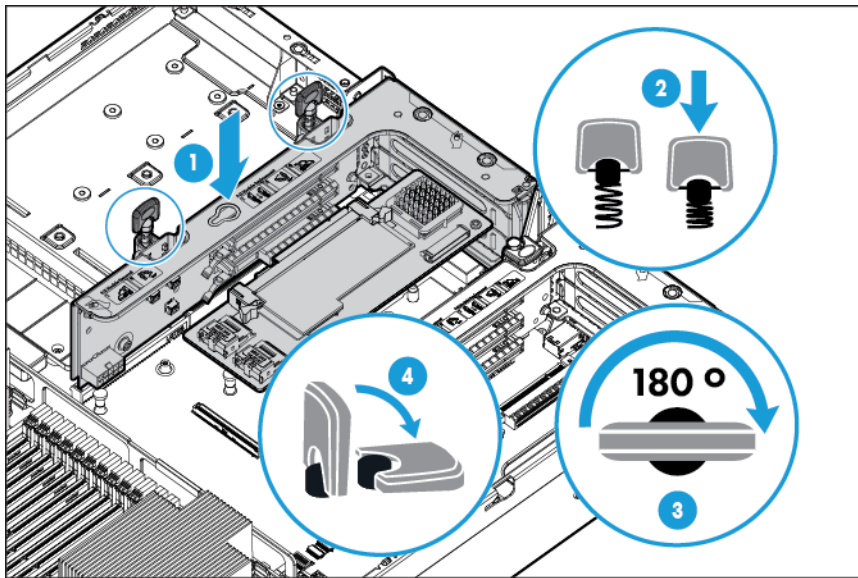

9. Install the access panel (on page 27).
10. Slide the server into the rack.
11. Connect each power cord to the server.
12. Connect each power cord to the power source.
13. Power up the server (on page 25).

GPU enablement kit

⚠ WARNING: To reduce the risk of personal injury, electric shock, or damage to the equipment, remove the power cord to remove power from the server. The front panel Power On/Standby button does not completely shut off system power. Portions of the power supply and some internal circuitry remain active until AC power is removed.

⚠ CAUTION: To prevent improper cooling and thermal damage, do not operate the server unless all PCI slots have either an expansion slot cover or an expansion board installed.

To install the component:

1. Power down the server (on page 25).
2. Remove all power:
 - a. Disconnect each power cord from the power source.
 - b. Disconnect each power cord from the server.
3. Do one of the following:
 - o Extend the server from the rack (on page 25).
 - o Remove the server from the rack (on page 26).
4. Remove the access panel (on page 26).
5. Remove the air baffle (on page 32).
6. Remove the standard efficiency air diverters from the air baffle.

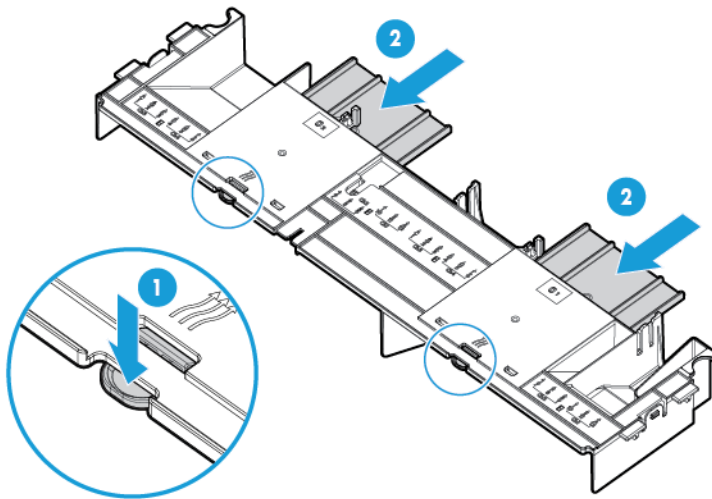

7. Install the GPU retention clips onto the air baffle.

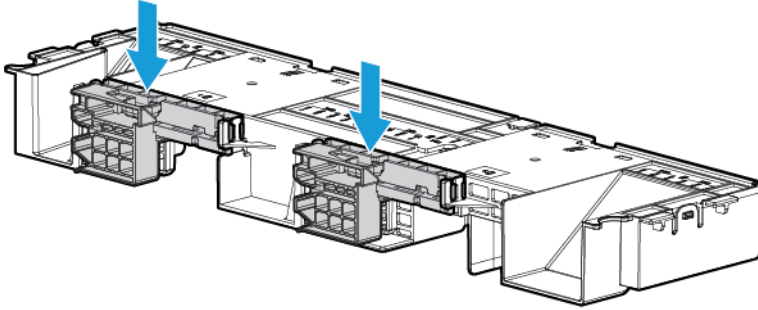

8. Remove the standard heatsinks.

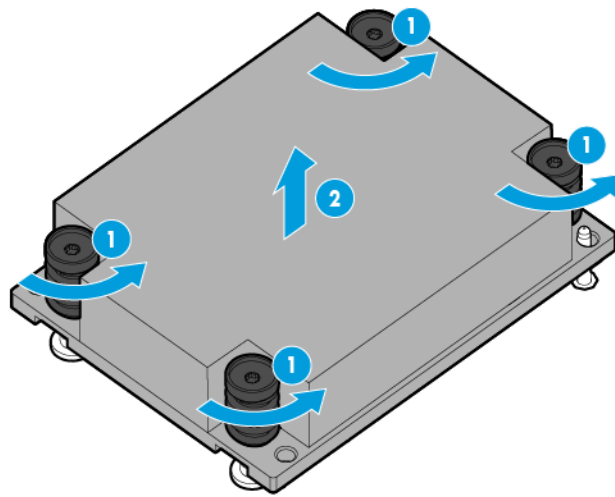

9. Install the high-performance heatsinks.

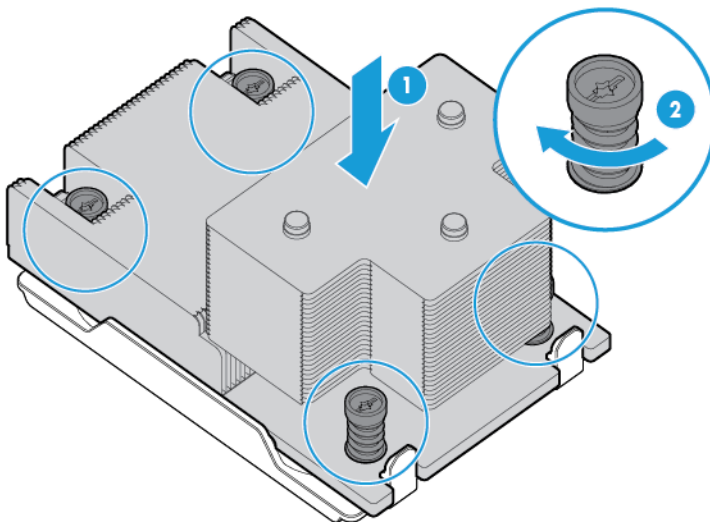

10. Install the air baffle.

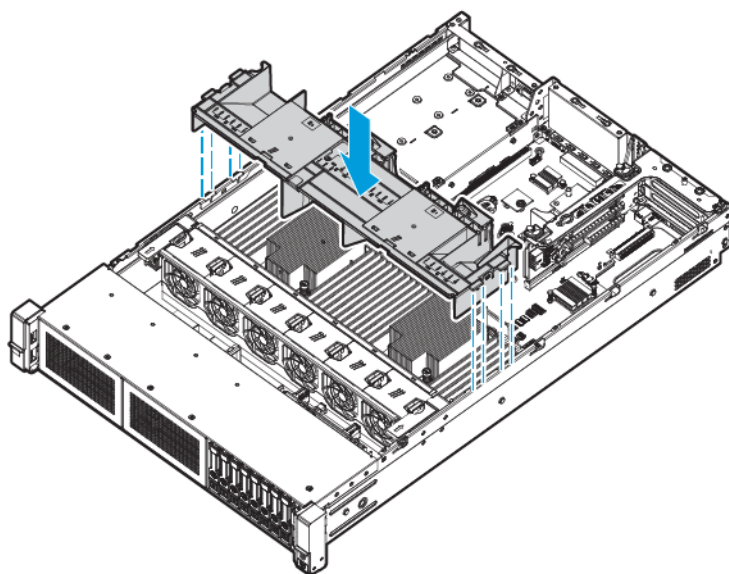

IMPORTANT: This server supports GPU riser cages in both the primary and secondary riser locations. This document shows installation into the secondary riser location.

11. Remove the secondary PCI riser blank. Some models might require removing more than two screws.

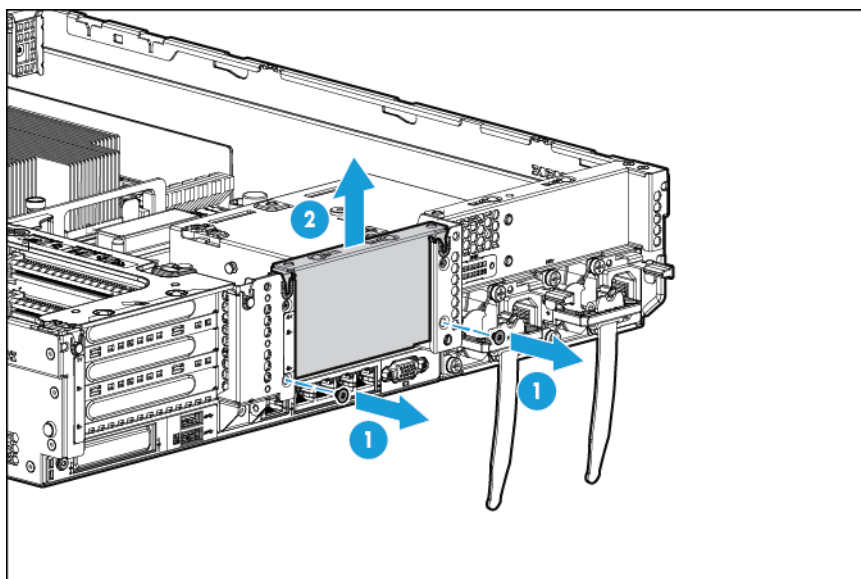

12. Install a GPU into the optional GPU-enabled riser cage.

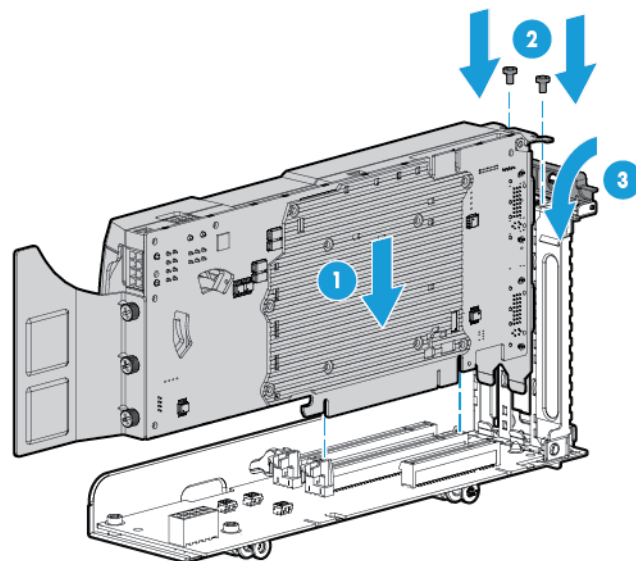

13. Connect the power cable.

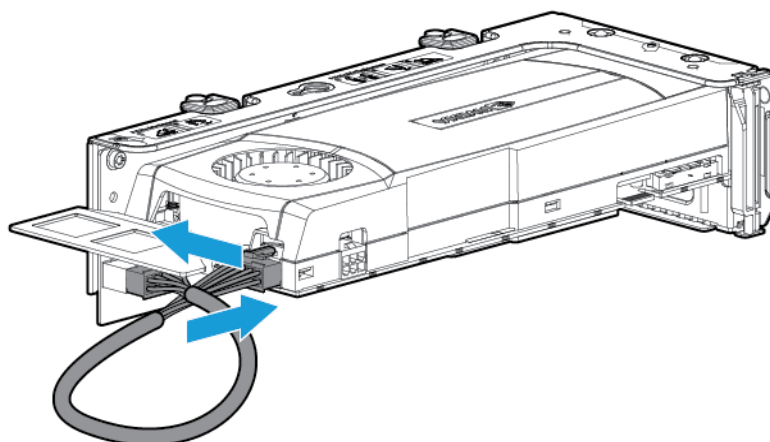

14. Press down on the top of the retention clips and slide them to the unlocked position.

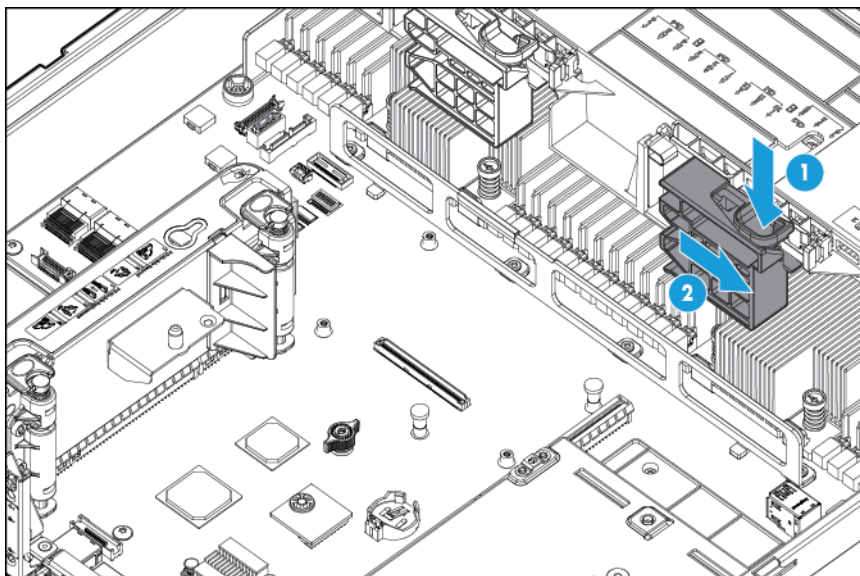

15. Install the GPU-enabled riser cage option.

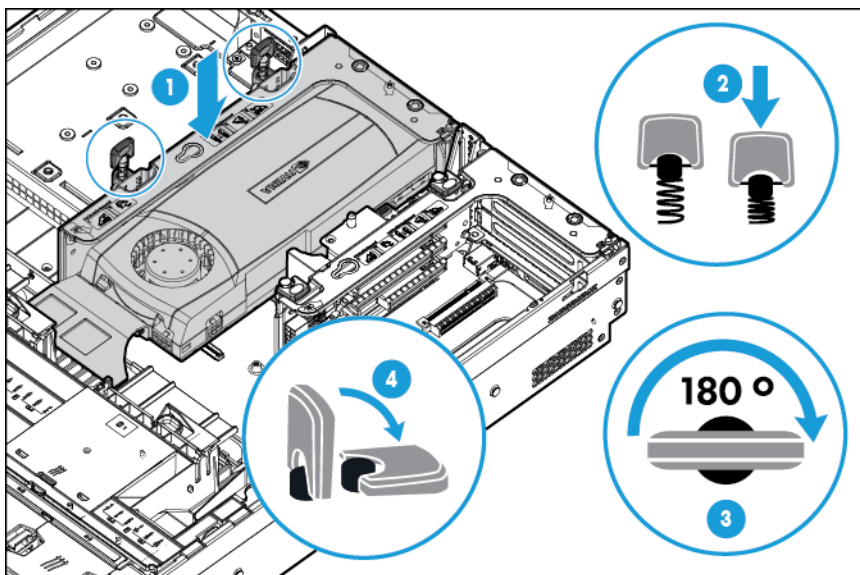

16. Slide the retention clips to the locked position.

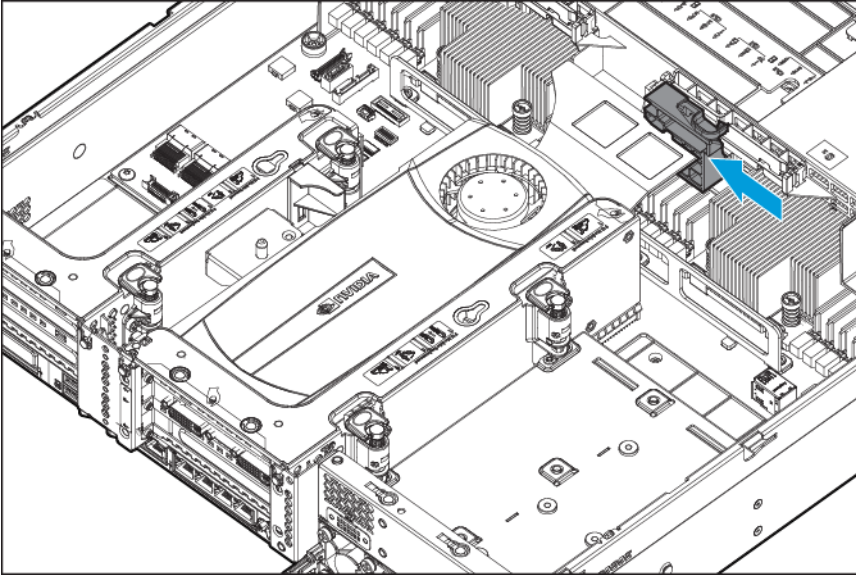

17. Install the access panel (on page 27).
18. Slide the server into the rack.
19. Connect each power cord to the server.
20. Connect each power cord to the power source.
21. Power up the server (on page 25).

Eight-bay SFF front drive cage option for bay 1

To install the component:

1. Power down the server (on page 25).
2. Remove all power:
 - a. Disconnect each power cord from the power source.
 - b. Disconnect each power cord from the server.
3. Do one of the following:
 - o Extend the server from the rack (on page 25).
 - o Remove the server from the rack (on page 26).
4. Remove the access panel (on page 26).

5. Remove the fan cage (on page 28).

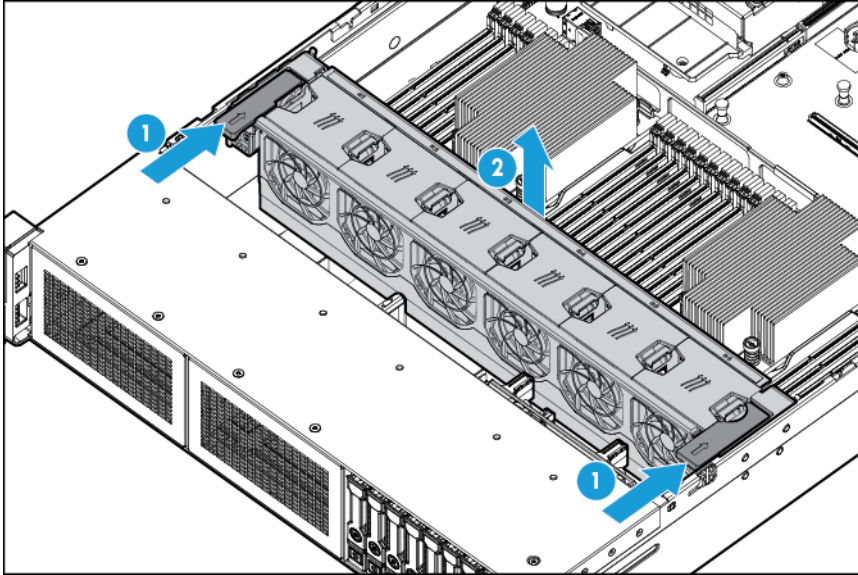

6. Remove the bay blank.

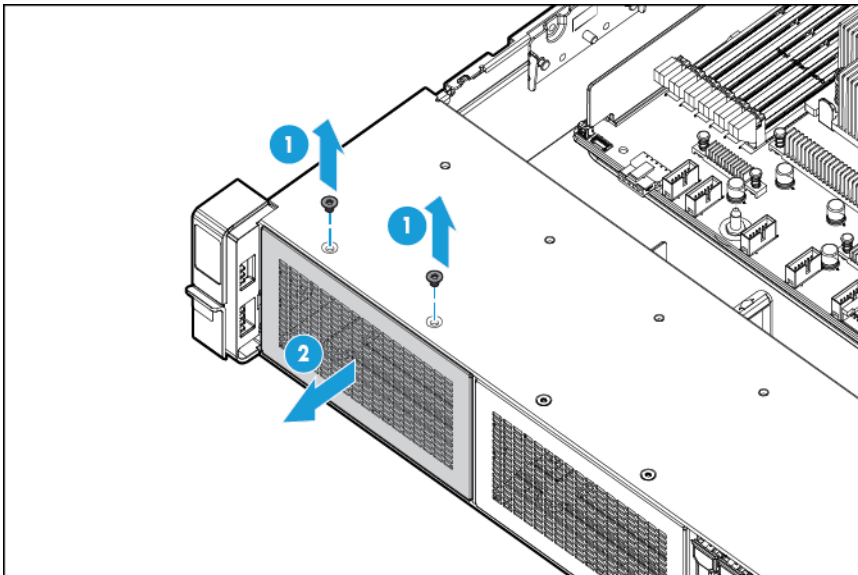

7. Install the eight-bay SFF front drive cage option.

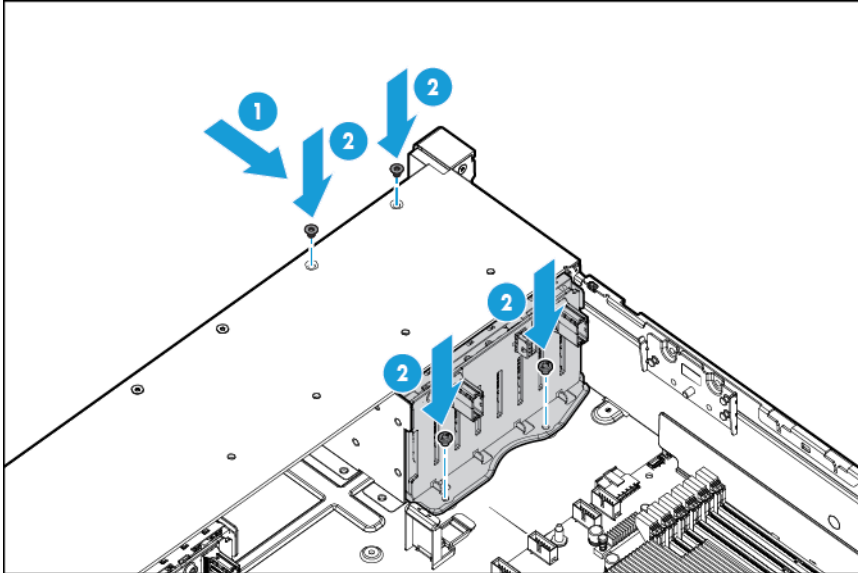

8. If installing drives, connect the power cable:
- Single cable connection

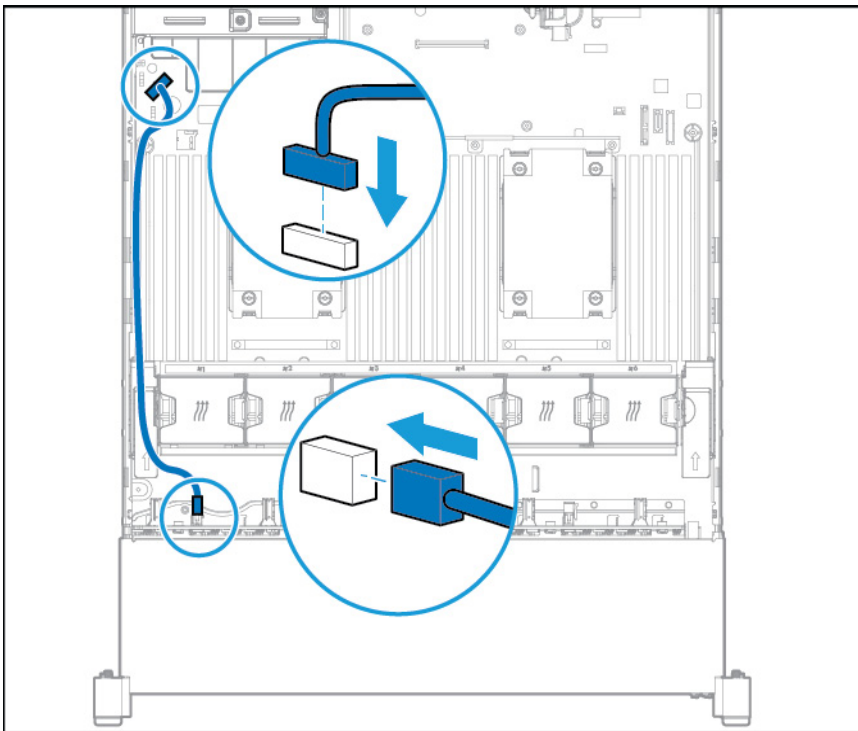

- Y cable connection if the 2 SFF option is installed in the rear bay

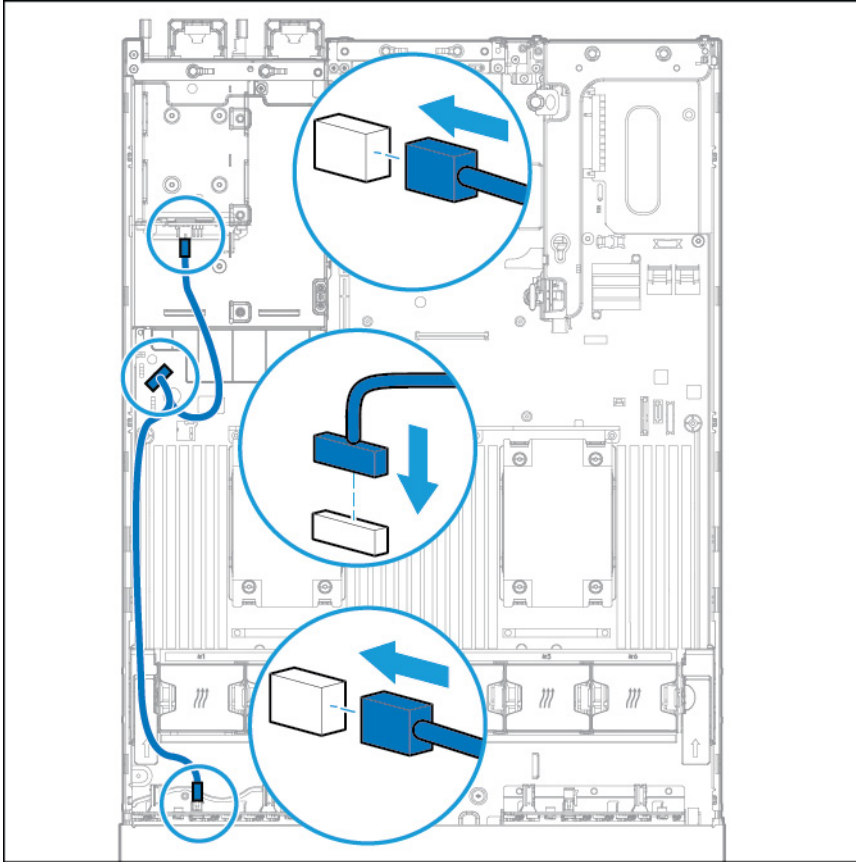

9. Connect the data cable in one of the following configurations:

- Connected to a PCI expansion board

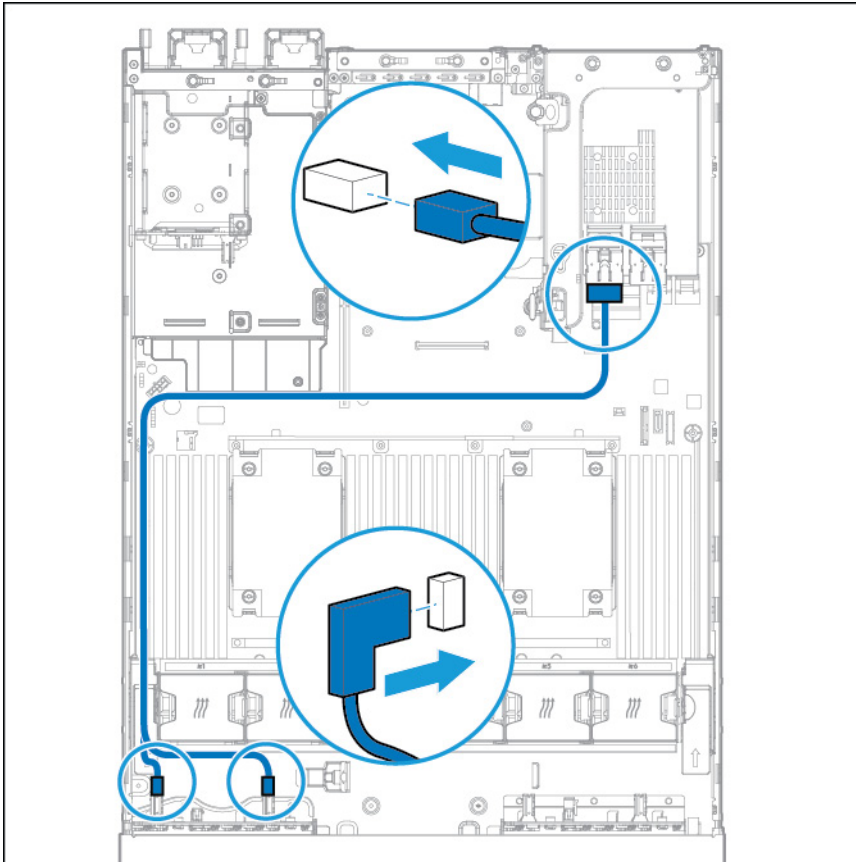

- Connected to an HP 12G SAS Expander Card

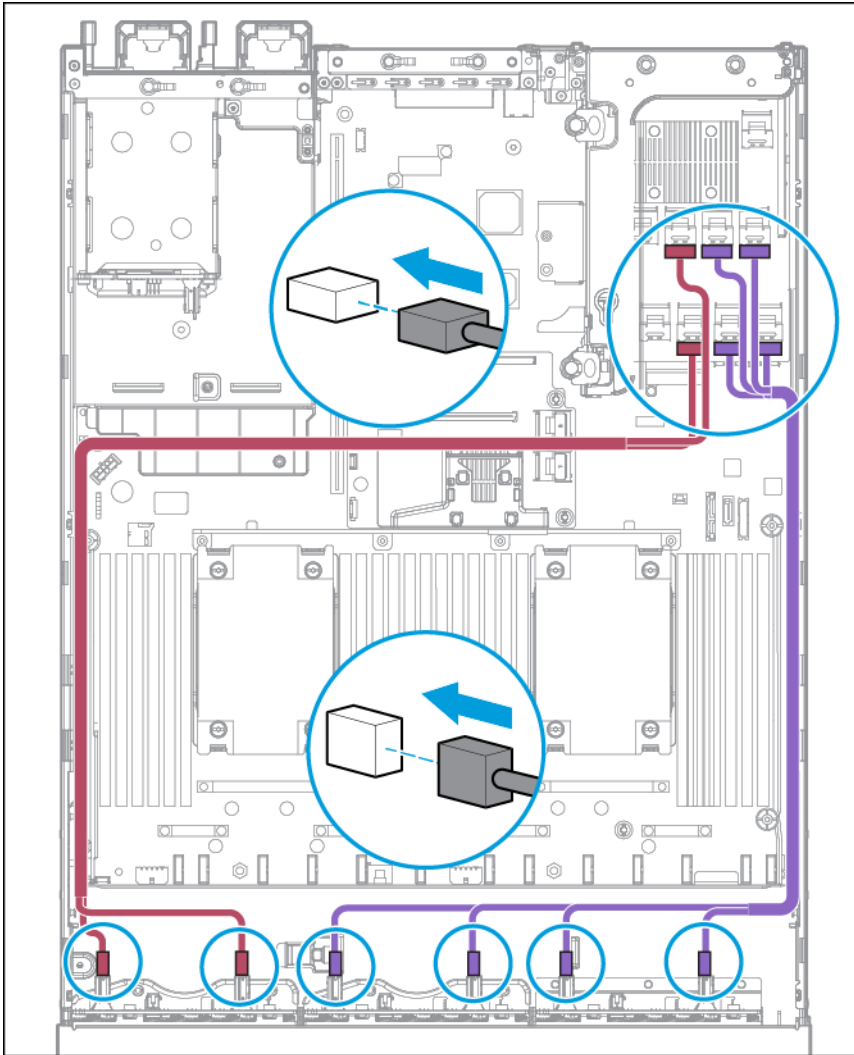

10. Install the fan cage.
11. Install the access panel (on page 27).
12. Slide the server into the rack.
13. Connect each power cord to the server.
14. Connect each power cord to the power source.
15. Power up the server (on page 25).

Eight-bay SFF front drive cage option for bay 2

To install the component:

1. Power down the server (on page 25).
2. Remove all power:
 - a. Disconnect each power cord from the power source.
 - b. Disconnect each power cord from the server.
3. Do one of the following:

- Extend the server from the rack (on page 25).
- Remove the server from the rack (on page 26).
- 4. Remove the access panel (on page 26).
- 5. Remove the fan cage (on page 28).

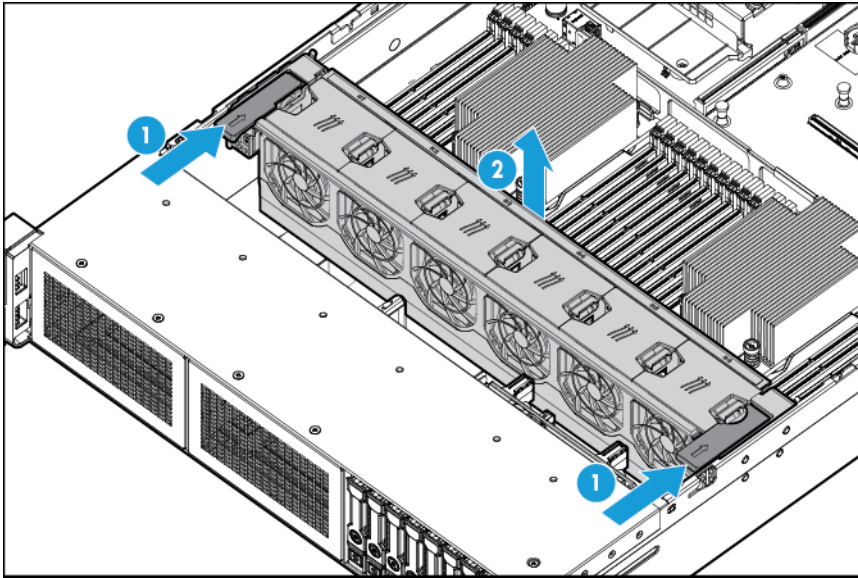

- 6. Remove the bay blank.

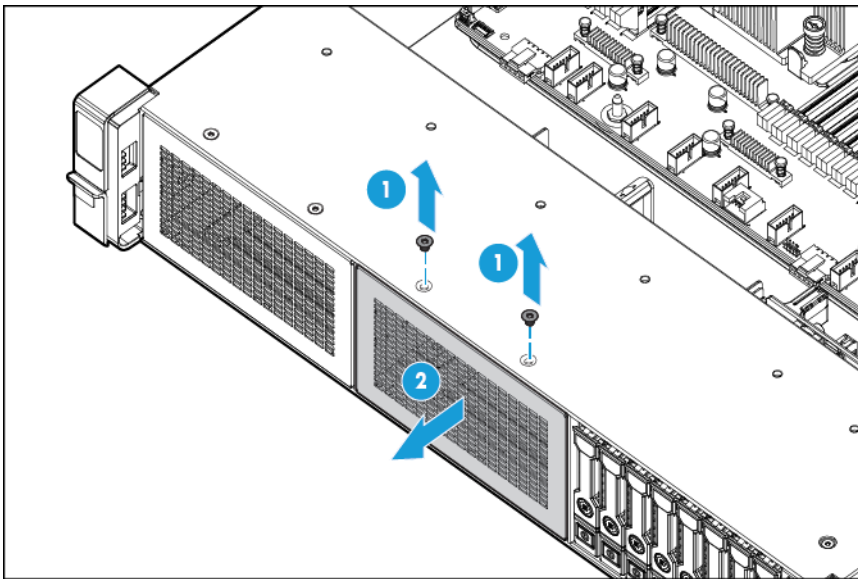

7. Install the eight-bay SFF front drive cage option.

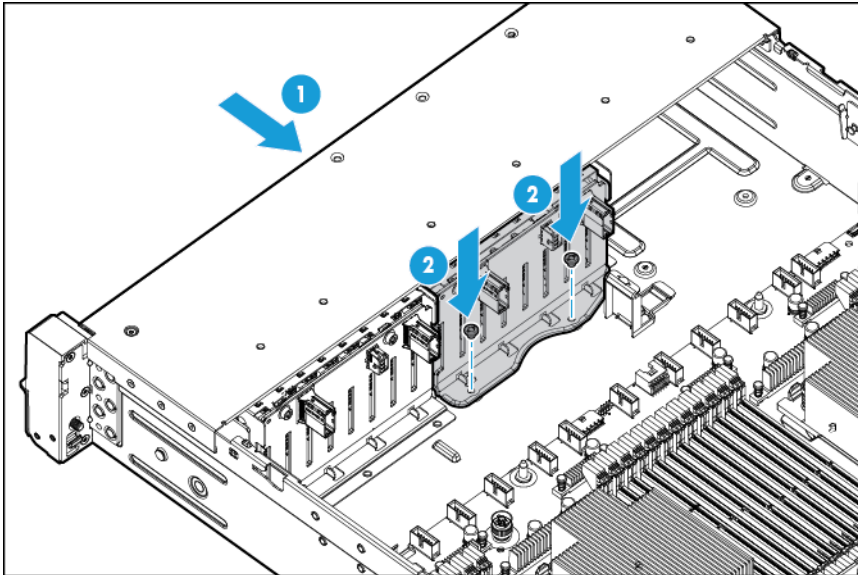

8. If installing drives, connect the power cable.

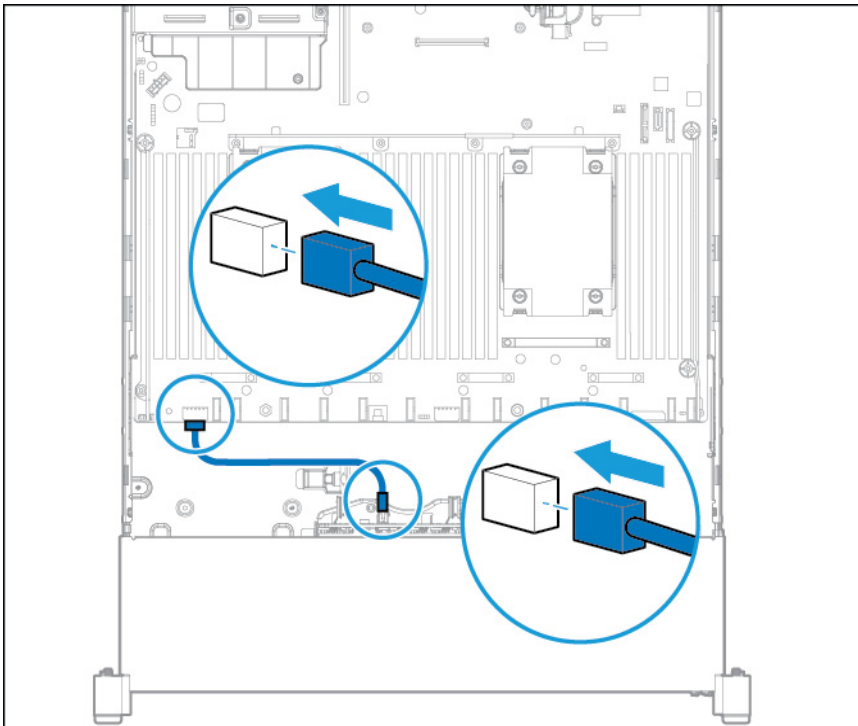

9. Connect the data cable in one of the following configurations:

- Connected to a PCI expansion board

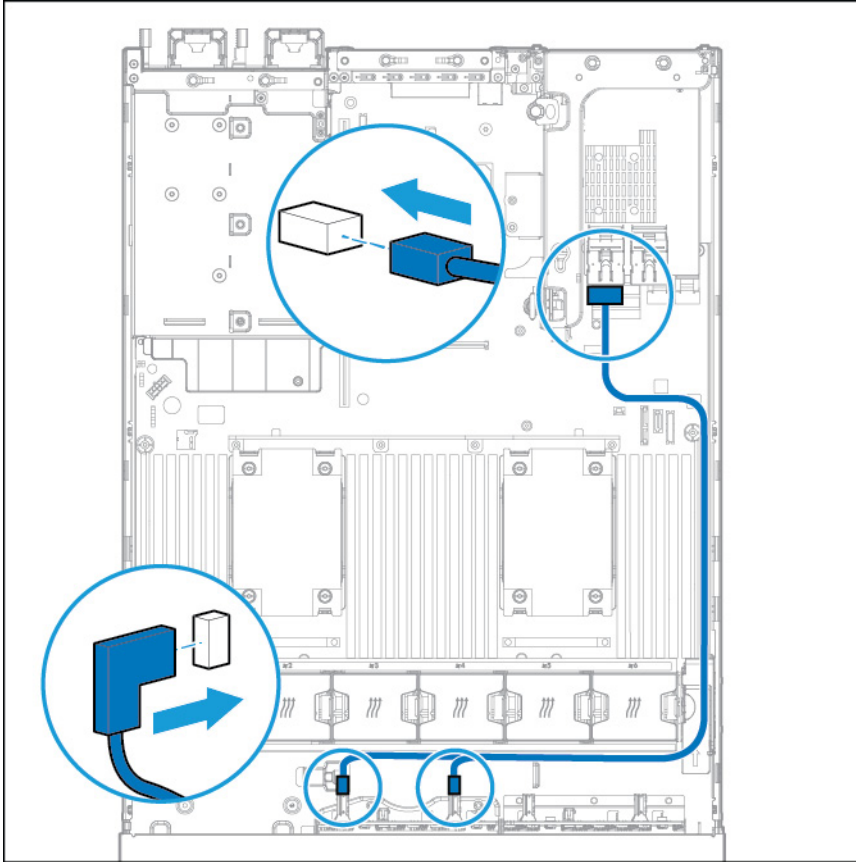

- Connected to an HP 12G SAS Expander Card

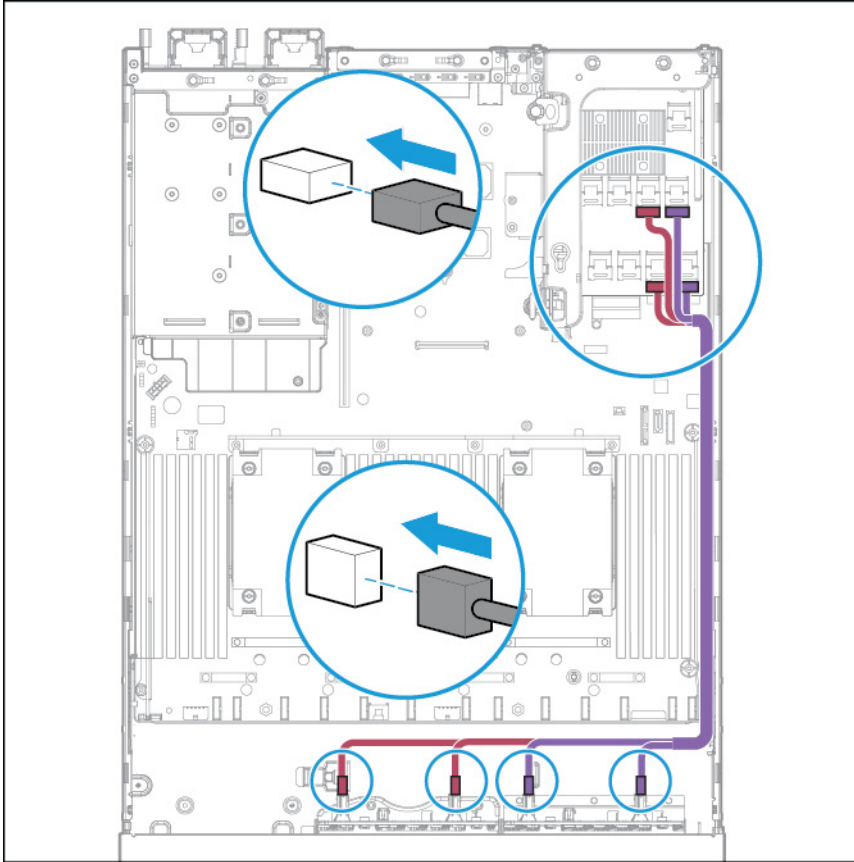

10. Install the fan cage.
11. Install the access panel (on page 27).
12. Slide the server into the rack.
13. Connect each power cord to the server.
14. Connect each power cord to the power source.
15. Power up the server (on page 25).

Three-bay LFF rear drive cage option

Before installing this option the front bays must be fully populated with 12 LFF drives. High performance fans must be installed in all fan bays.

To install the component:

1. Power down the server (on page 25).
2. Remove all power:
 - a. Disconnect each power cord from the power source.
 - b. Disconnect each power cord from the server.
3. Do one of the following:
 - Extend the server from the rack (on page 25).
 - Remove the server from the rack (on page 26).

4. Remove the access panel (on page 26).
5. If installed, remove the secondary riser board. The secondary riser board is not supported with a three-bay LFF rear configuration.

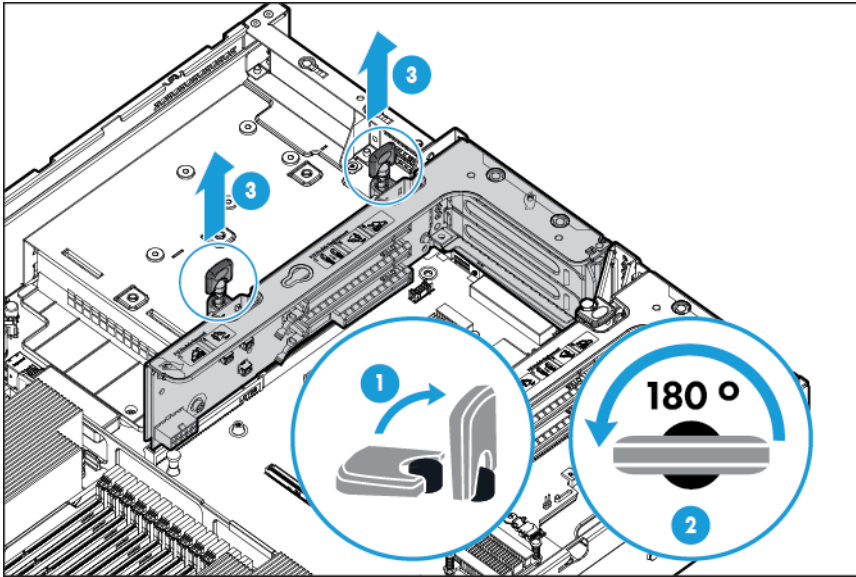

6. Remove the rear wall blank.

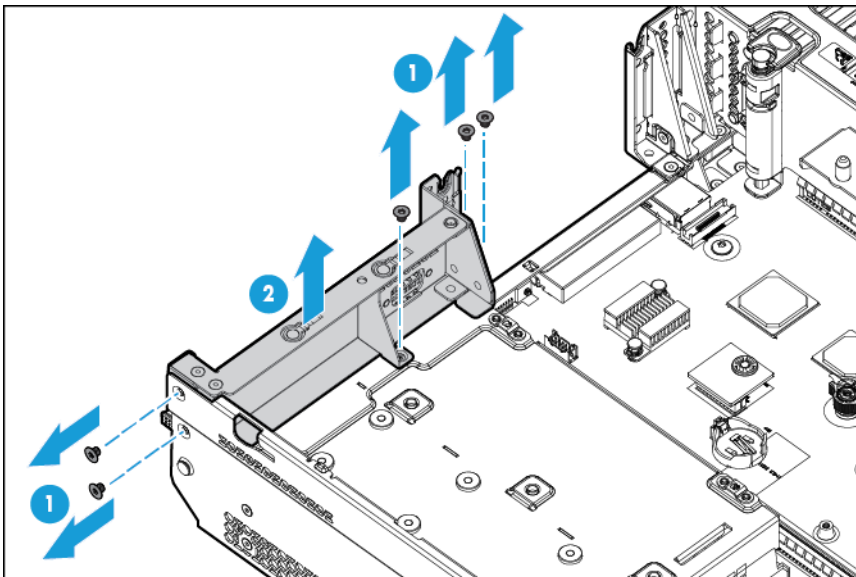

7. Install the three-bay LFF rear drive cage option.

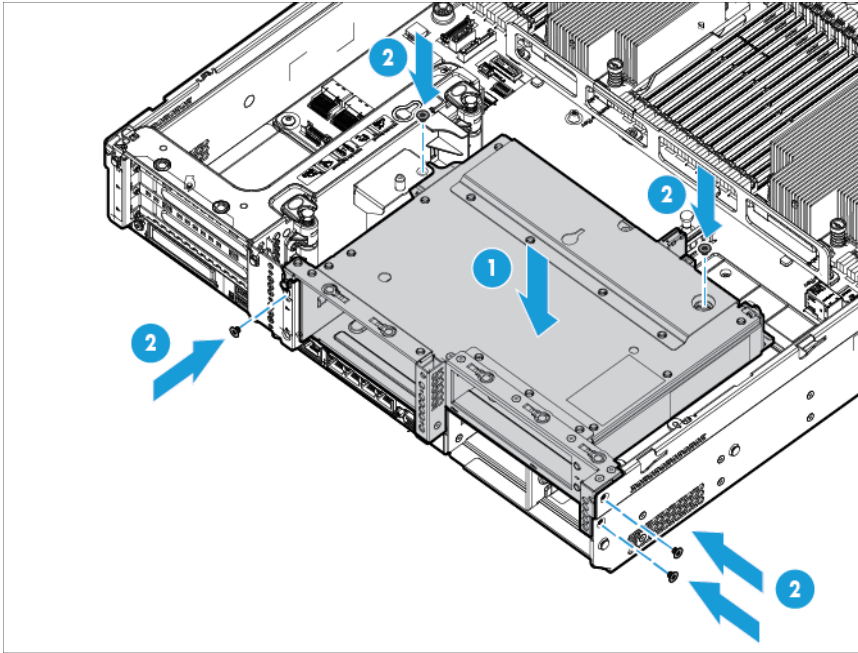

8. Install blanks or drives.
9. If installing drives, connect the power cable.

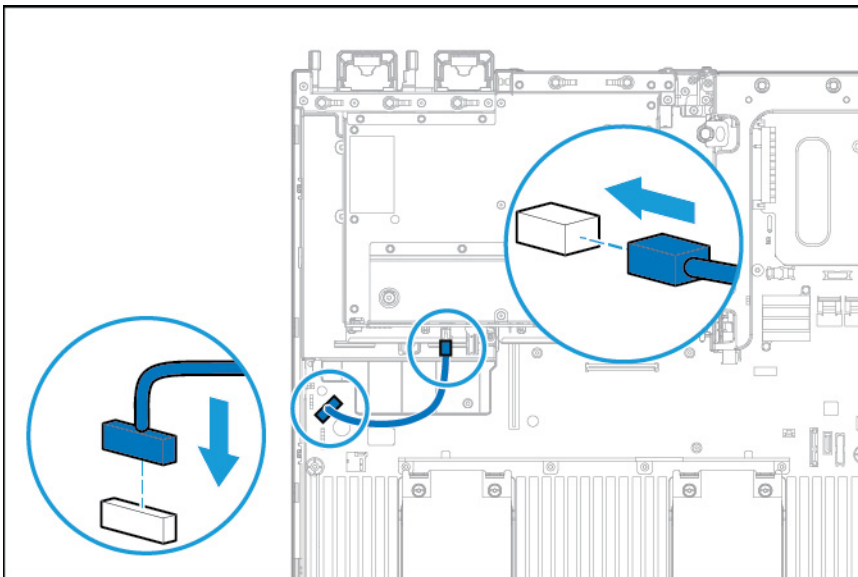

10. Connect the data cable in one of the following configurations:

- Connected to onboard SATA connectors

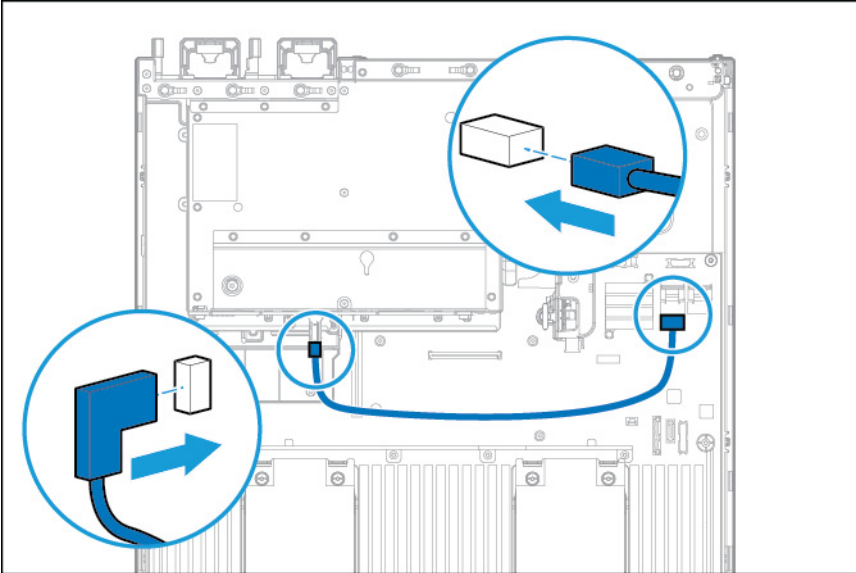

- Connected to a PCI expansion board

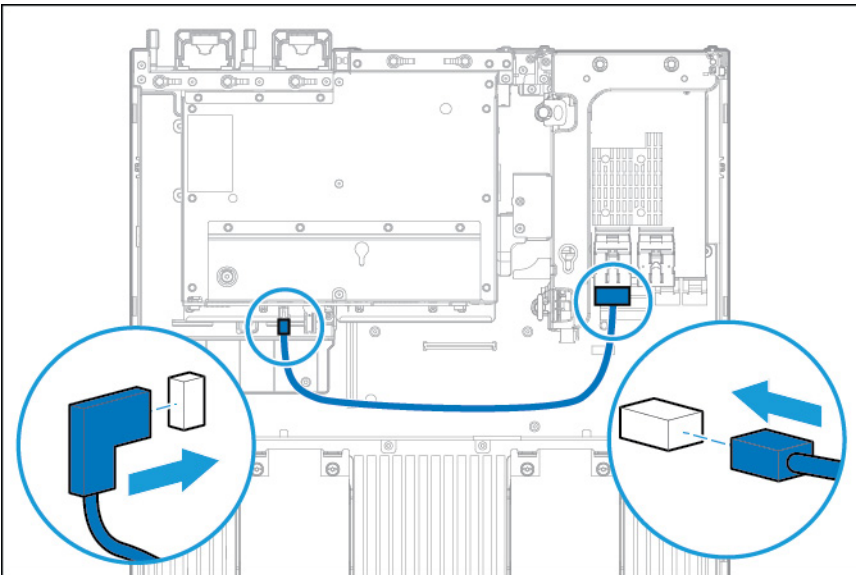

- Connected to a PCI expansion board and the 12 LFF backplane

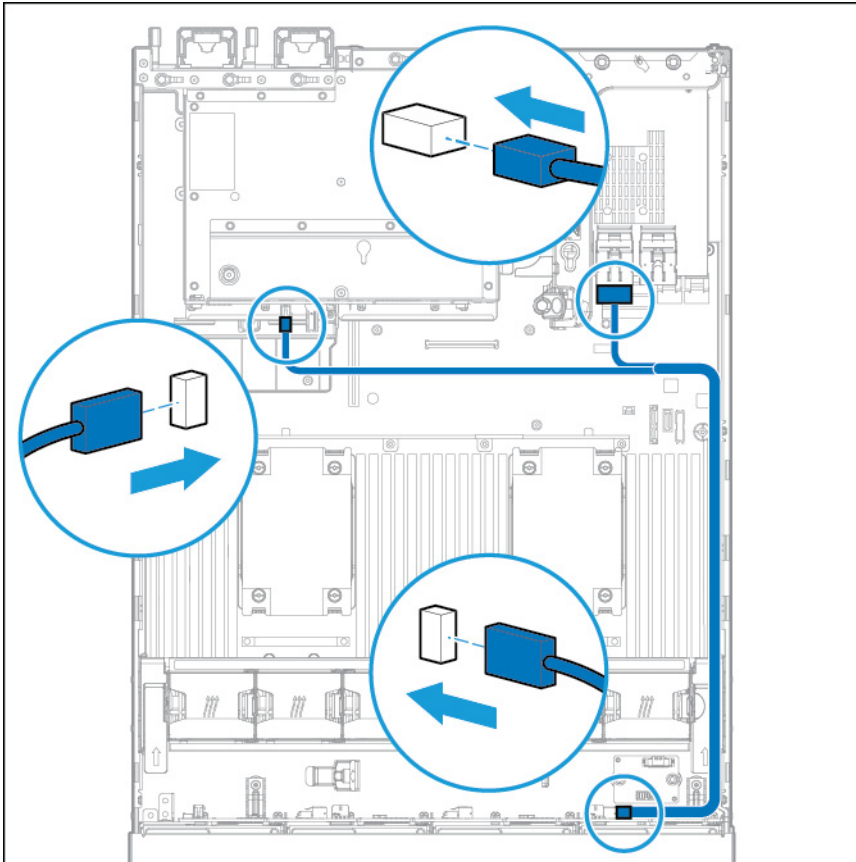

- Connected to an HP 12G SAS Expander Card

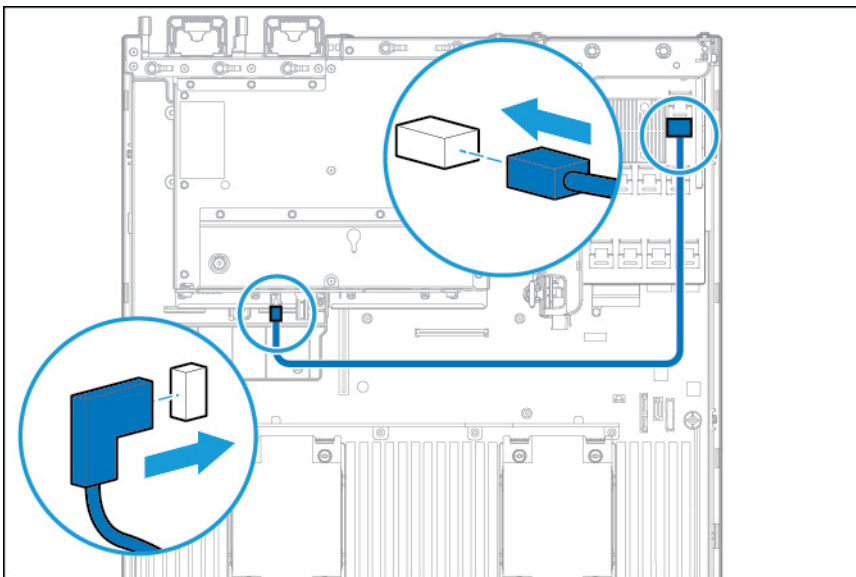

11. Install the access panel (on page 27).
12. Slide the server into the rack.
13. Connect each power cord to the server.
14. Connect each power cord to the power source.
15. Power up the server (on page 25).

Two-bay SFF front drive cage option

The front bay installation requires a universal media bay to be installed.

To install the component:

1. Power down the server (on page 25).
2. Remove all power:
 - a. Disconnect each power cord from the power source.
 - b. Disconnect each power cord from the server.
3. Do one of the following:
 - o Extend the server from the rack (on page 25).
 - o Remove the server from the rack (on page 26).
4. Remove the access panel (on page 26).
5. Remove the front bay blank.

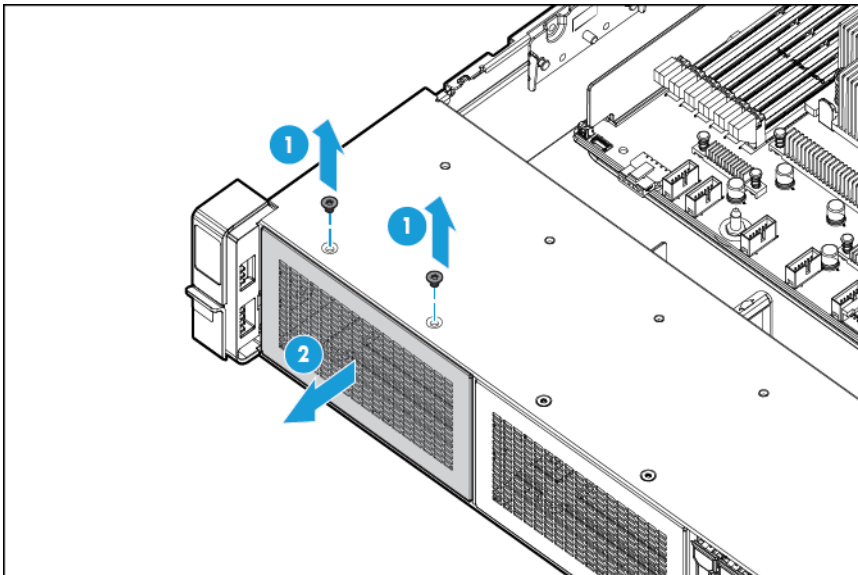

6. Remove the optical disk drive tray from the universal media bay.

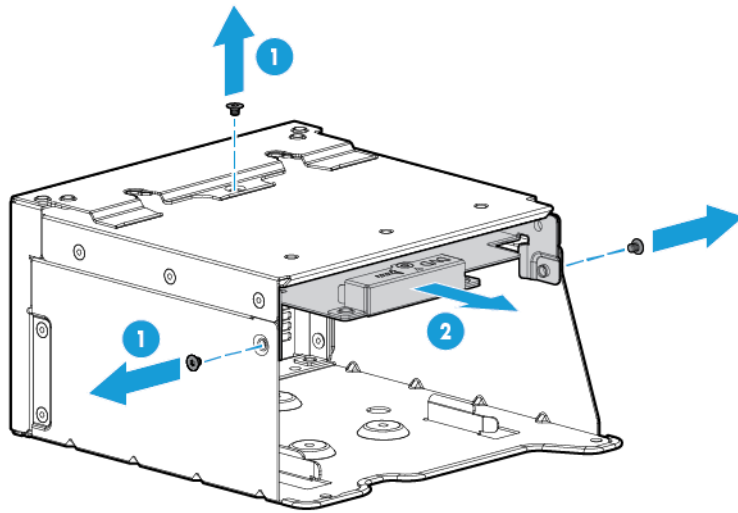

7. Remove the SFF drive blank from the universal media bay.

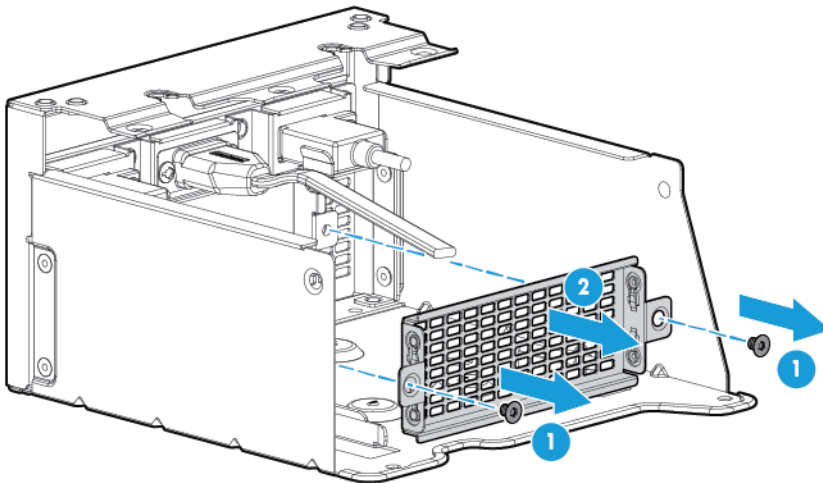

8. Install the drive cage into the universal media bay.

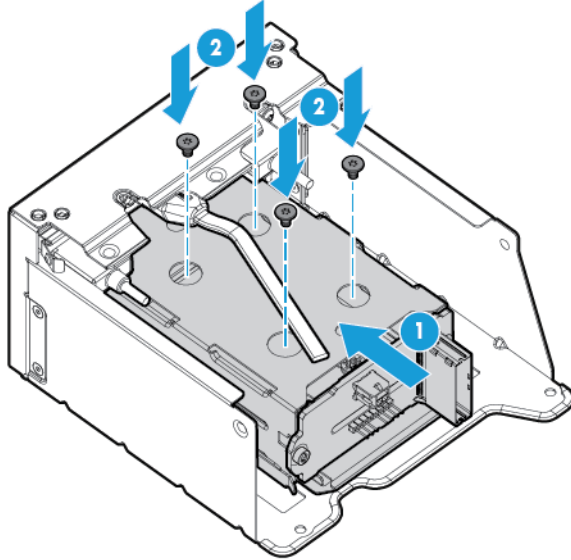

9. Install the universal media bay.

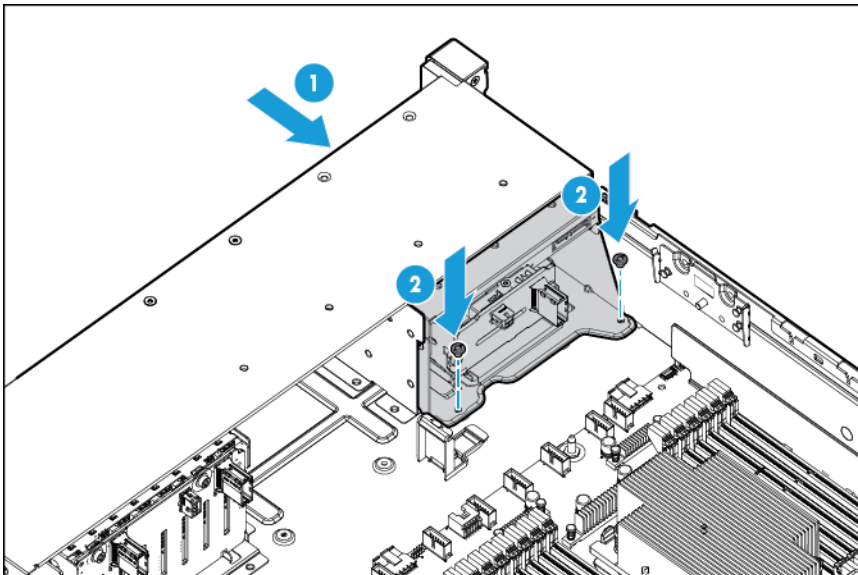

10. Connect the power cable.

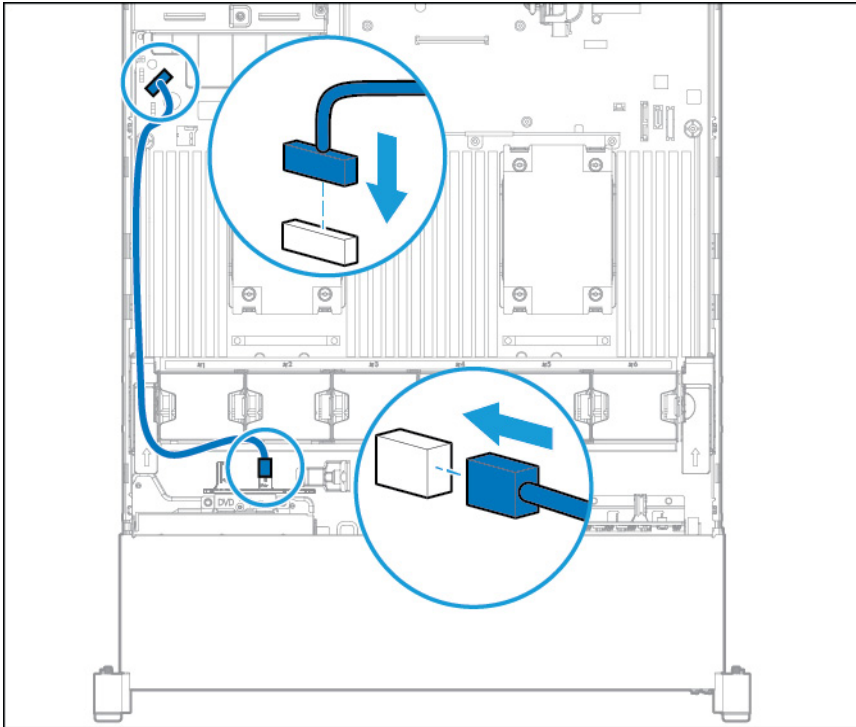

11. Connect the data cable in one of the following two configurations:

- Connected to a PCI expansion board

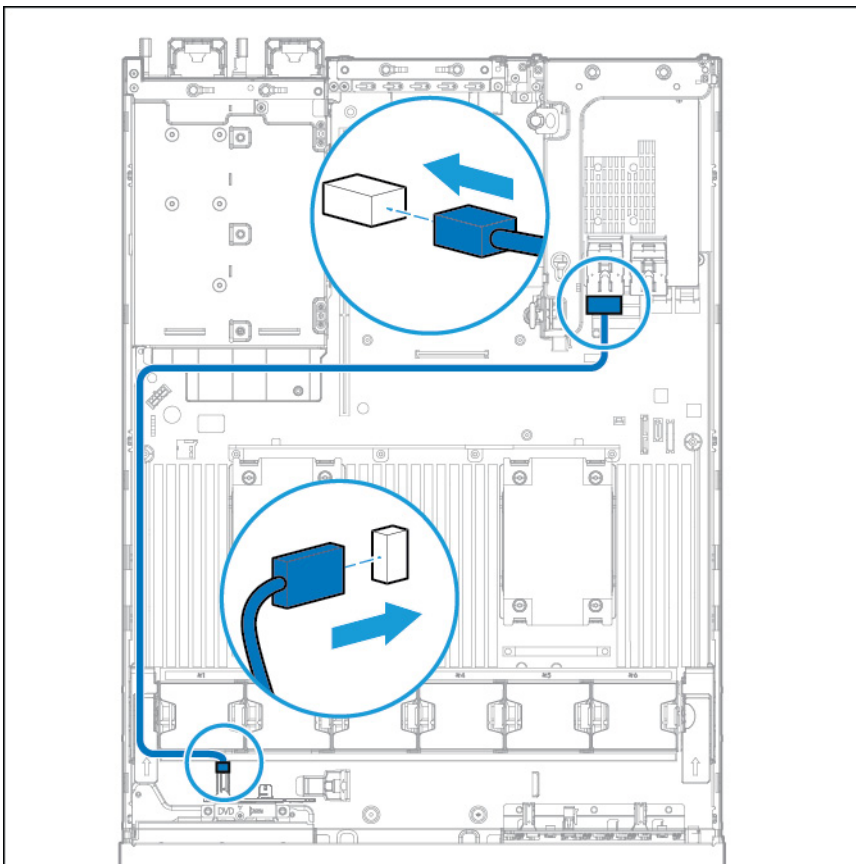

- Connected to the onboard x4 SATA connector

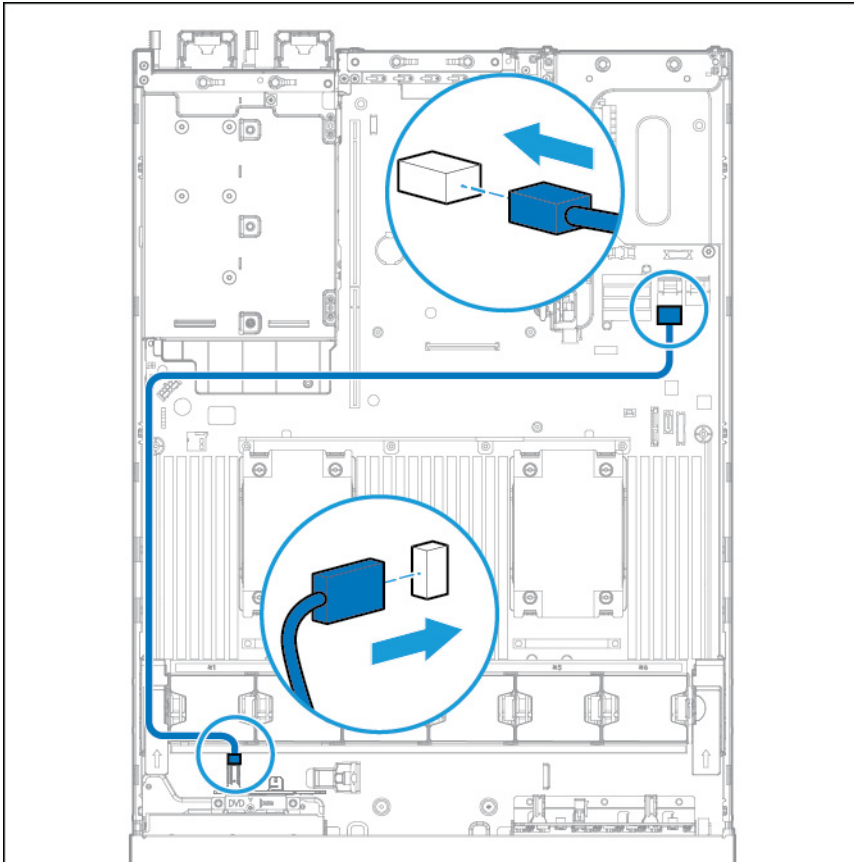

12. Install the access panel (on page 27).
13. Slide the server into the rack.
14. Connect each power cord to the server.
15. Connect each power cord to the power source.
16. Power up the server (on page 25).

Two-bay SFF rear drive cage option

For rear drive cage installation, the front bays must be fully populated using the 12 LFF or 24 SFF drives. High performance fans must be installed in all fan bays.

To install the component:

1. Power down the server (on page 25).
2. Remove all power:
 - a. Disconnect each power cord from the power source.
 - b. Disconnect each power cord from the server.
3. Do one of the following:
 - Extend the server from the rack (on page 25).
 - Remove the server from the rack (on page 26).
4. Remove the access panel (on page 26).

5. Remove the secondary riser cage or PCI blank:
- Secondary riser cage

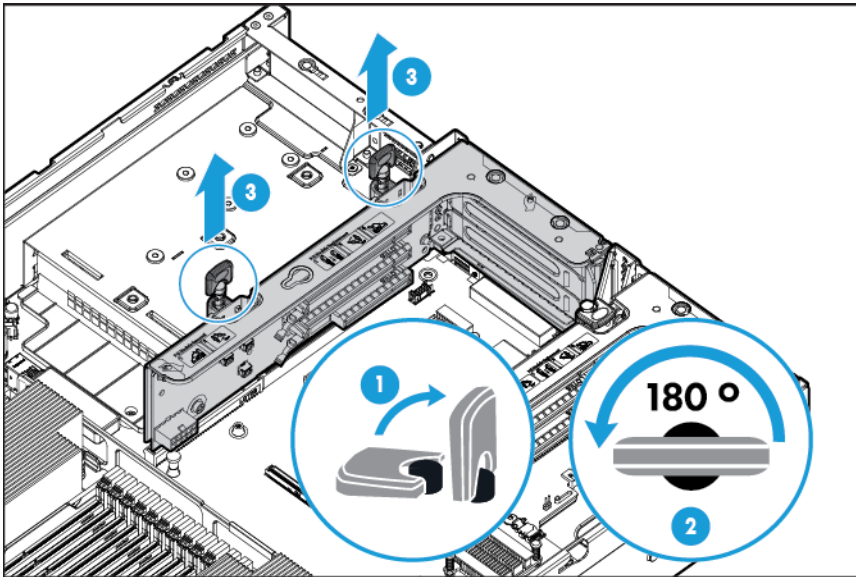

- PCI blank

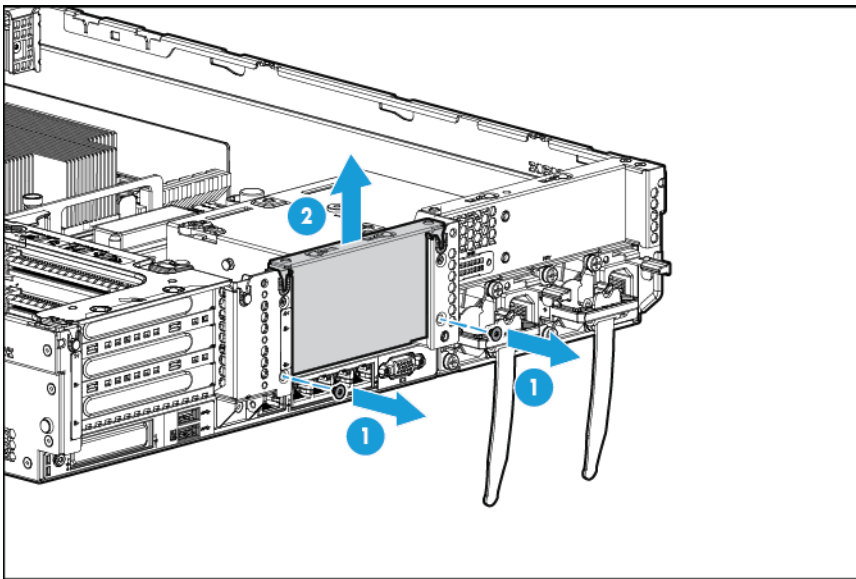

6. Remove the rear wall blank.

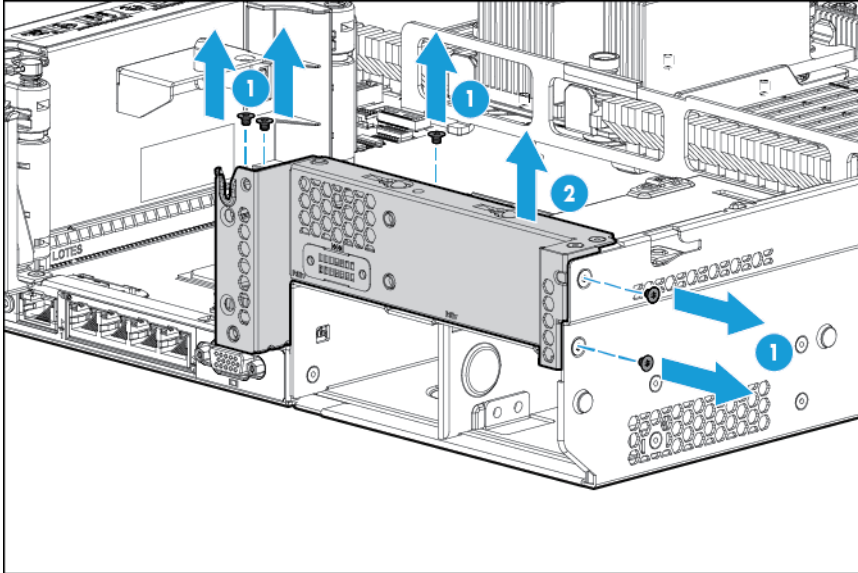

7. Install the drive cage compatible rear wall.

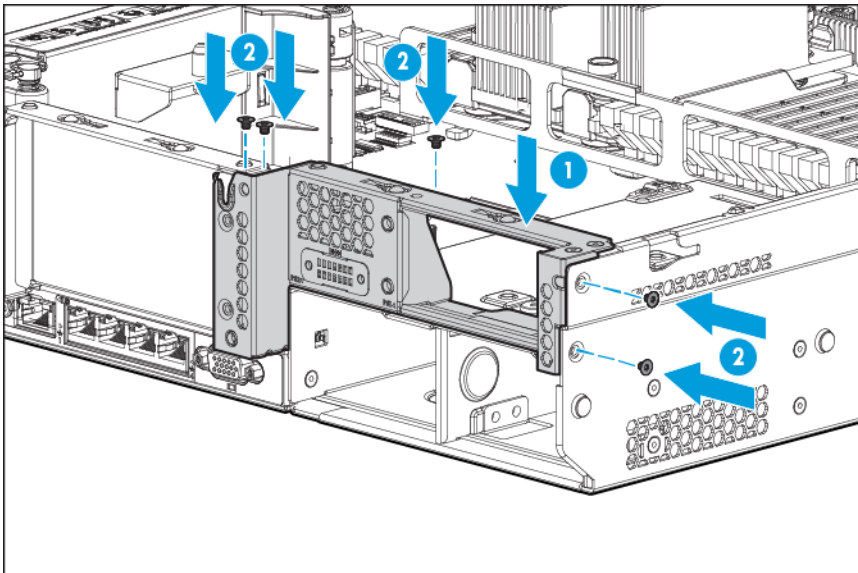

8. Install the rear two-bay SFF drive cage option.

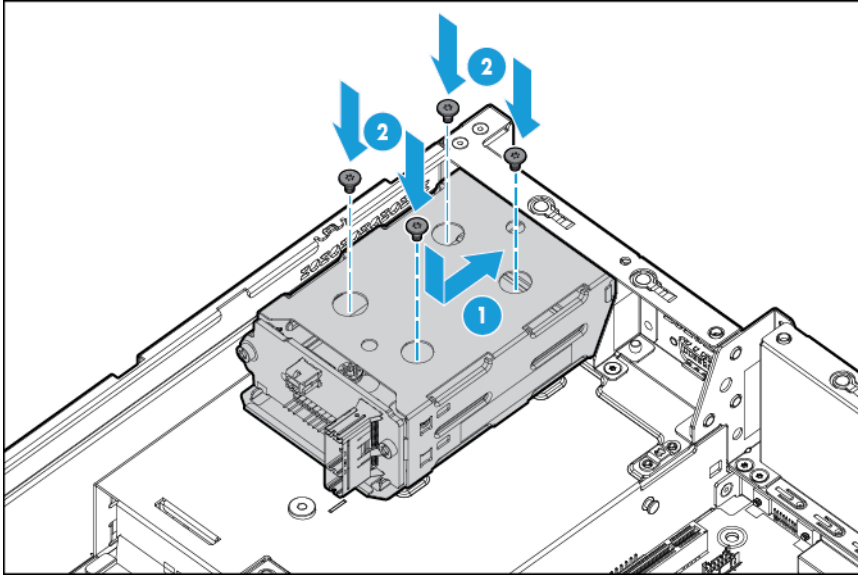

9. Install blanks or drives.
10. Install the secondary riser cage or PCI blank.
11. If installing drives, connect the power cable:
 - o Single cable connection with 12 LFF configuration in the front

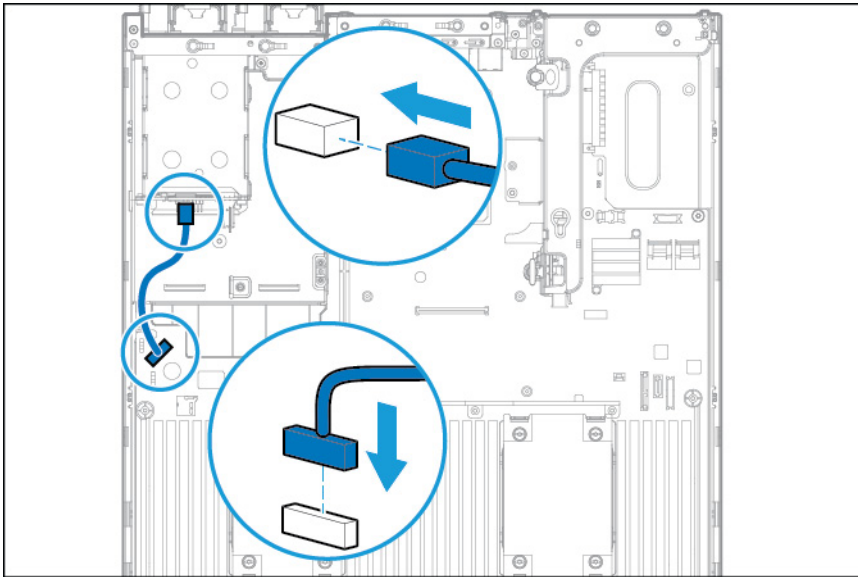

- Y cable connection with 24 SFF drive configuration in the front

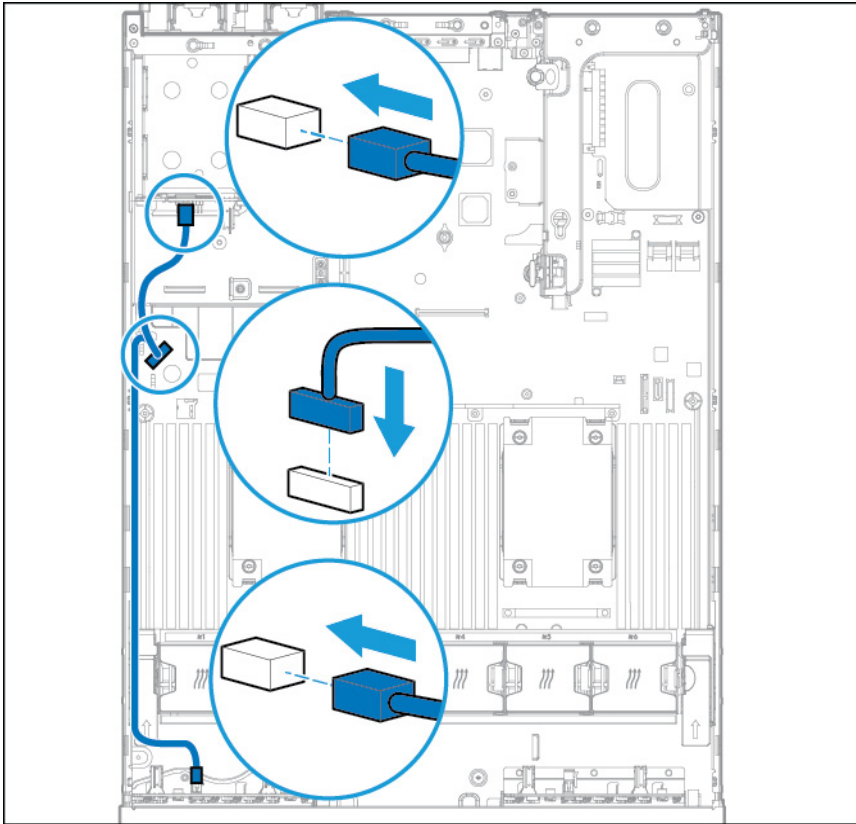

12. Connect the data cable in one of the following configurations:

- Connected to the onboard x4 SATA connector

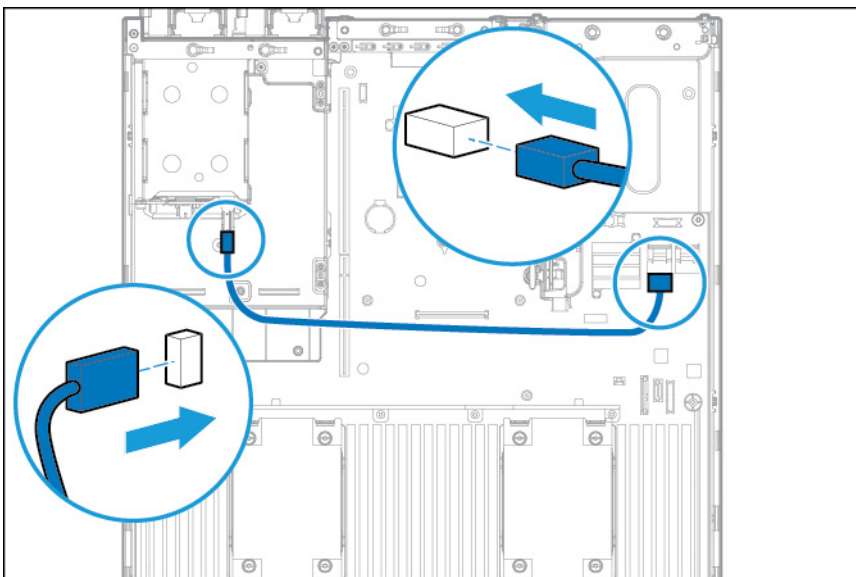

- Connected to the x2 SATA port and optical disk drive connector

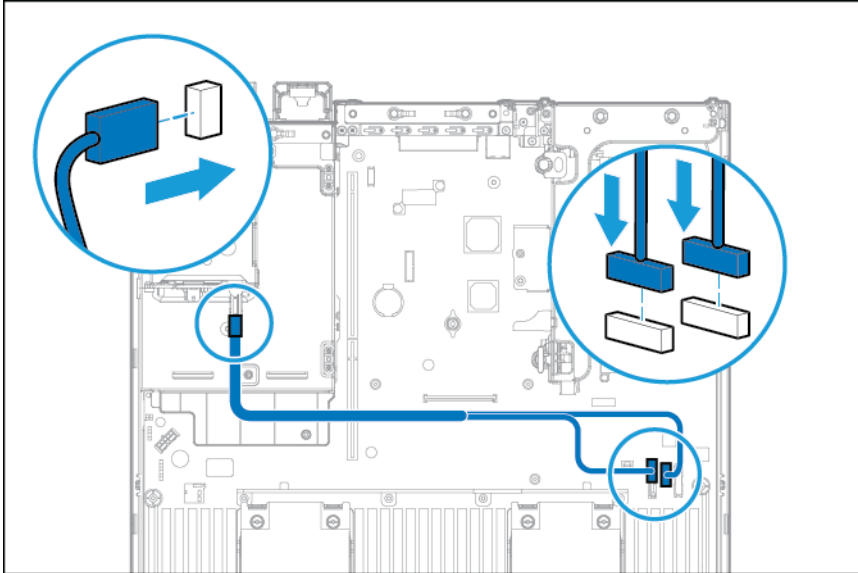

- Connected to a PCI expansion board

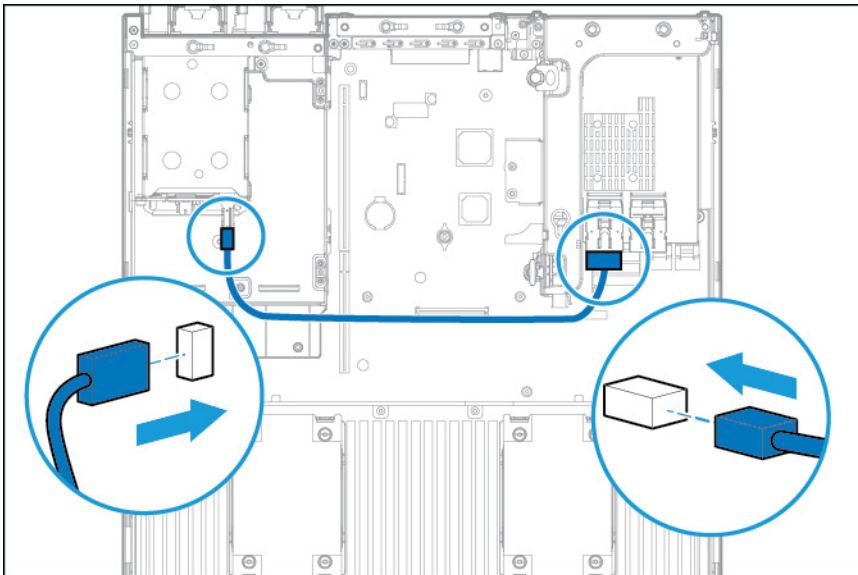

- Connected to a PCI expansion board and the 12 LFF backplane

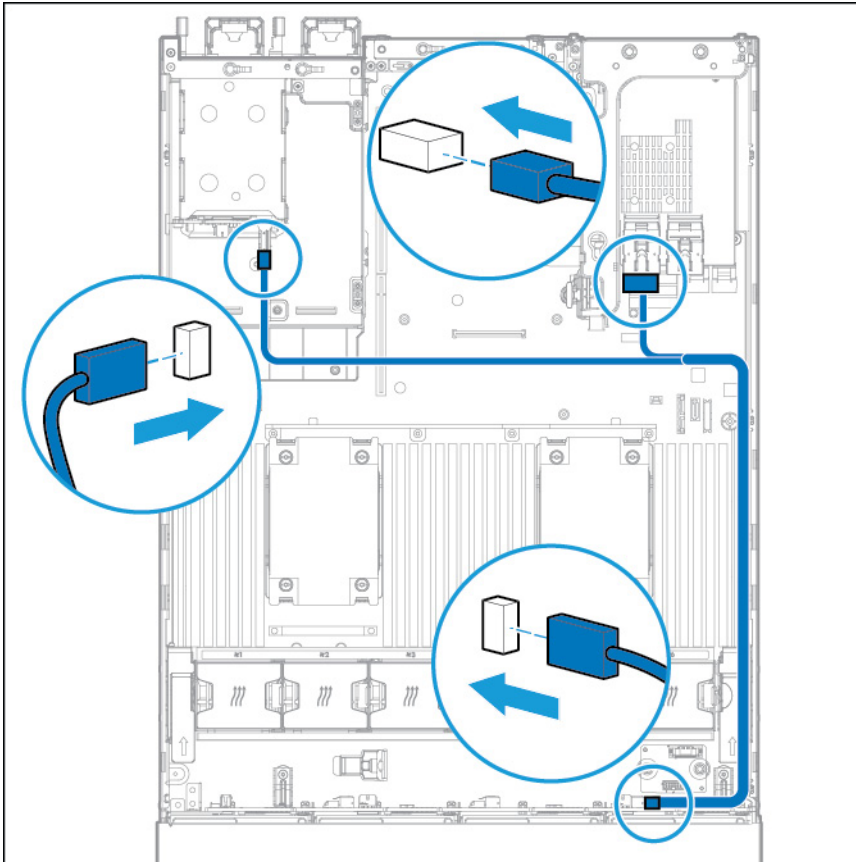

- Connected to an HP 12G SAS Expander Card

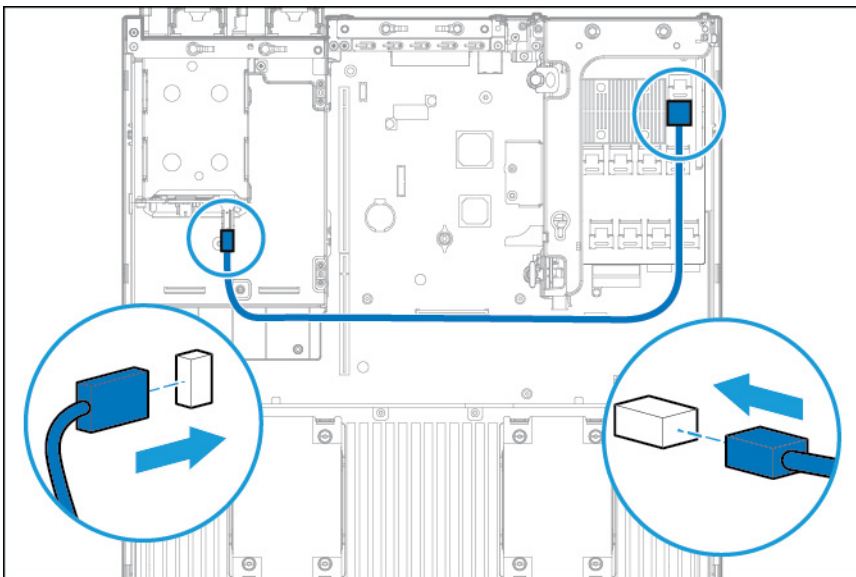

13. Install the access panel (on page 27).
14. Slide the server into the rack.
15. Connect each power cord to the server.
16. Connect each power cord to the power source.
17. Power up the server (on page 25).

Systems Insight Display power switch module option

This option is not supported in servers configured with 4 LFF or 12 LFF drives.

To install the component:

1. Power down the server (on page 25).
2. Remove all power:
 - a. Disconnect each power cord from the power source.
 - b. Disconnect each power cord from the server.
3. Do one of the following:
 - o Extend the server from the rack (on page 25).
 - o Remove the server from the rack (on page 26).
4. Remove the access panel (on page 26).
5. Remove the air baffle.
6. Remove the fan cage.

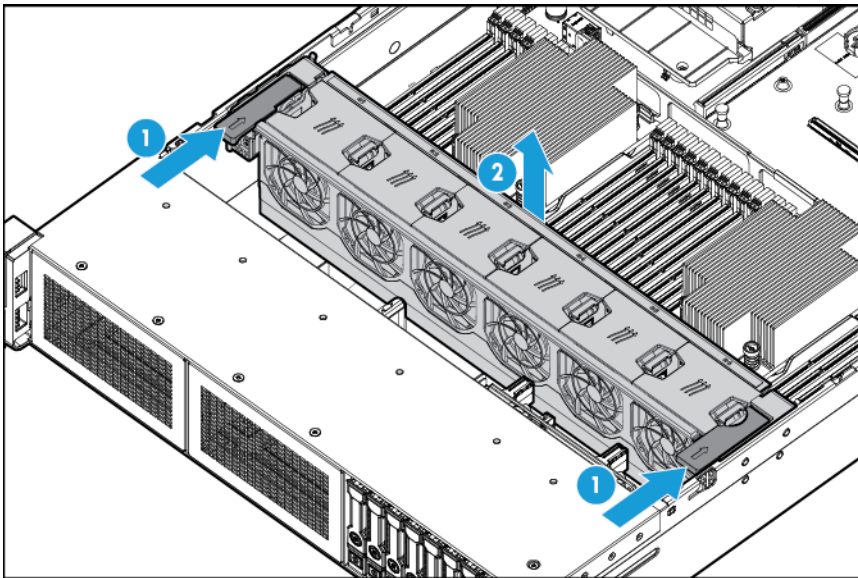

CAUTION: When routing cables, always be sure that the cables are not in a position where they can be pinched or crimped.

7. Remove the cabled power switch module. Retain the T-10 screw.

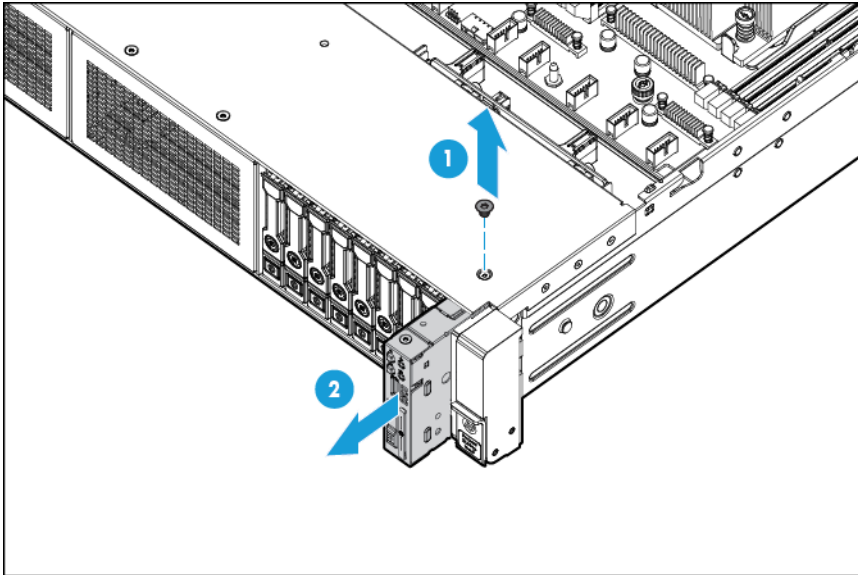

8. Route the cable through the opening in the front of the server, and then install the SID power switch module. Secure the module using the existing screw.

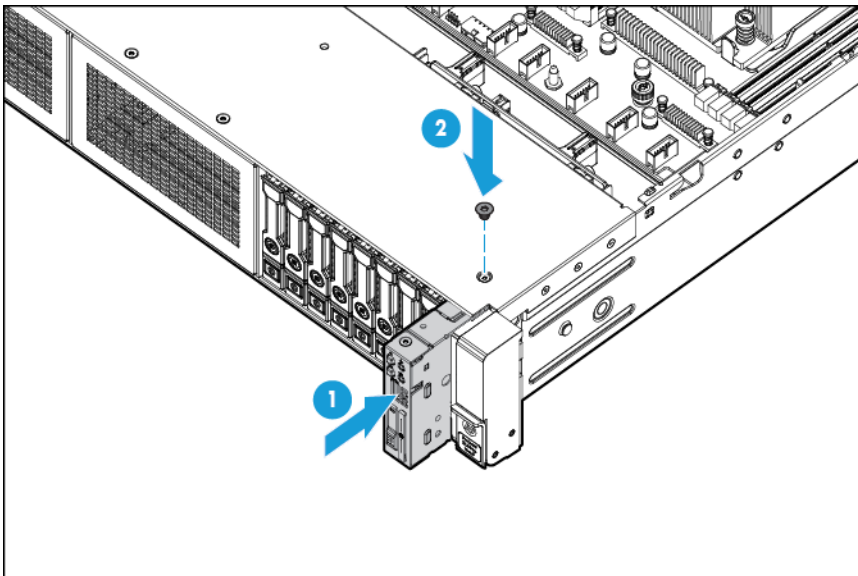

9. Connect the SID module cable to the system board power switch module connector.

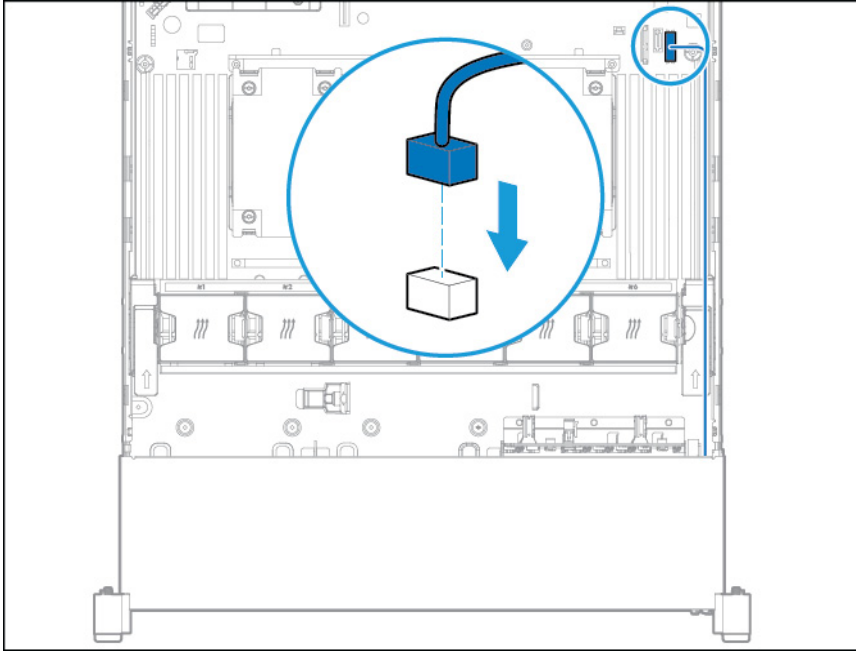

10. Install the fan cage.
11. Install the air baffle.
12. Install the access panel (on page 27).
13. Slide the server into the rack.
14. Connect each power cord to the server.
15. Connect each power cord to the power source.
16. Power up the server (on page 25).

Location Discovery Services ear option

To install the component:

1. Power down the server (on page 25).
2. Remove all power:
 - a. Disconnect each power cord from the power source.
 - b. Disconnect each power cord from the server.
3. Do one of the following:
 - o Extend the server from the rack (on page 25).
 - o Remove the server from the rack (on page 26).
4. Remove the access panel (on page 26).

5. Remove the fan cage.

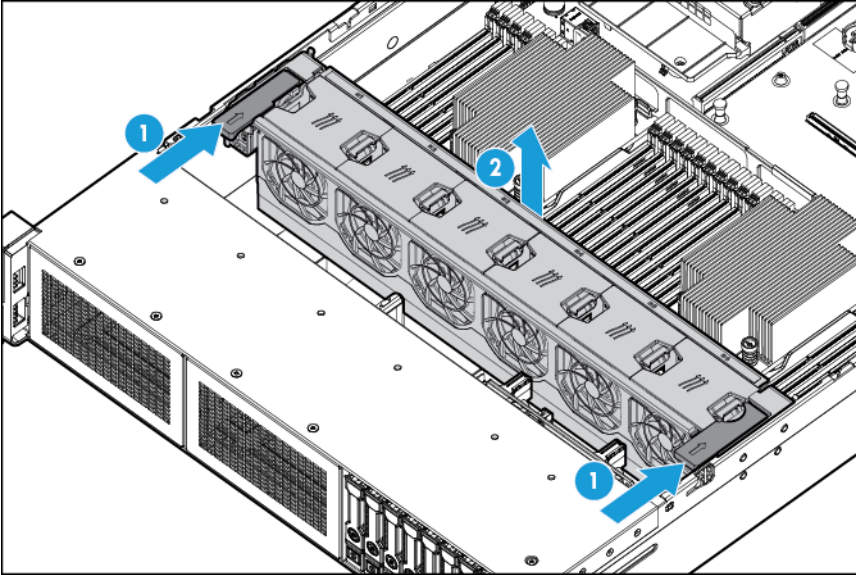

6. Remove the cable protection panel from the left side of the server.

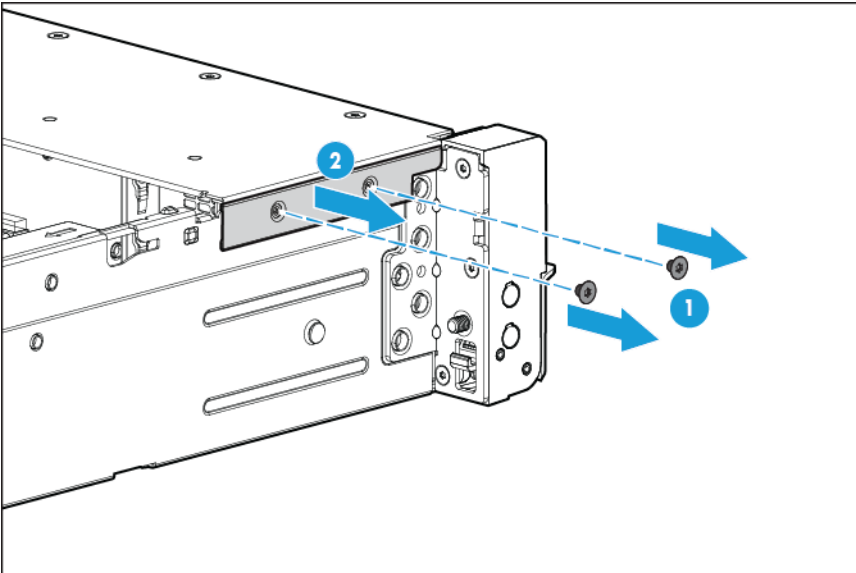

7. Remove the standard ear.

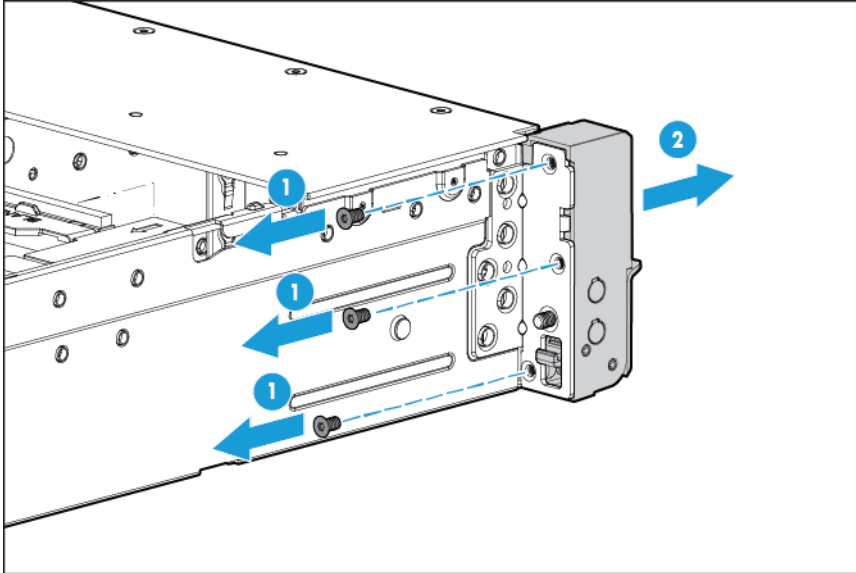

8. Install the Location Discovery Services ear option and route the discovery service cable through side channel.

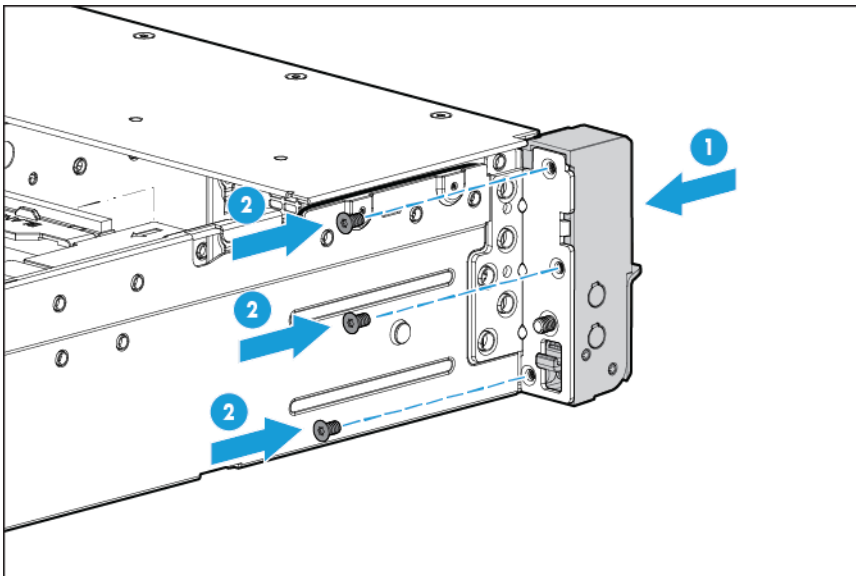

9. Install the cable protection panel.

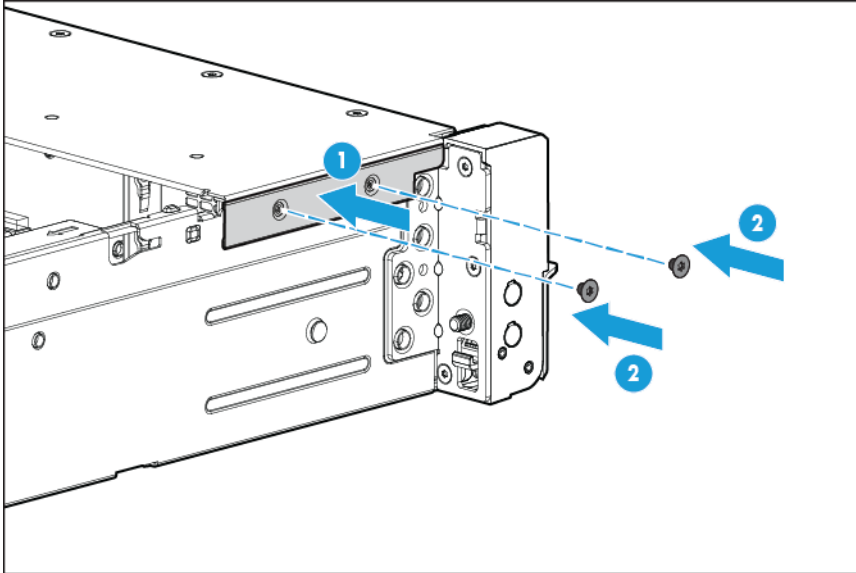

10. Connect the discovery service cable.

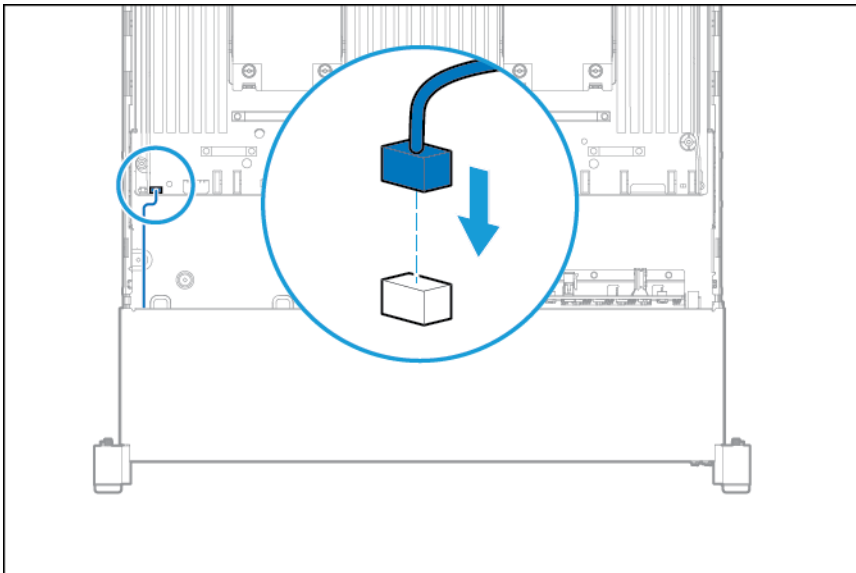

11. Install the fan cage.
12. Install the access panel (on page 27).
13. Slide the server into the rack.
14. Connect each power cord to the server.
15. Connect each power cord to the power source.
16. Power up the server (on page 25).

FlexibleLOM option

To install the component:

1. Power down the server (on page 25).

2. Remove all power:
 - a. Disconnect each power cord from the power source.
 - b. Disconnect each power cord from the server.
3. Do one of the following:
 - o Extend the server from the rack (on page 25).
 - o Remove the server from the rack (on page 26).
4. Remove the access panel (on page 26).
5. Remove the FlexibleLOM PCIe blank.

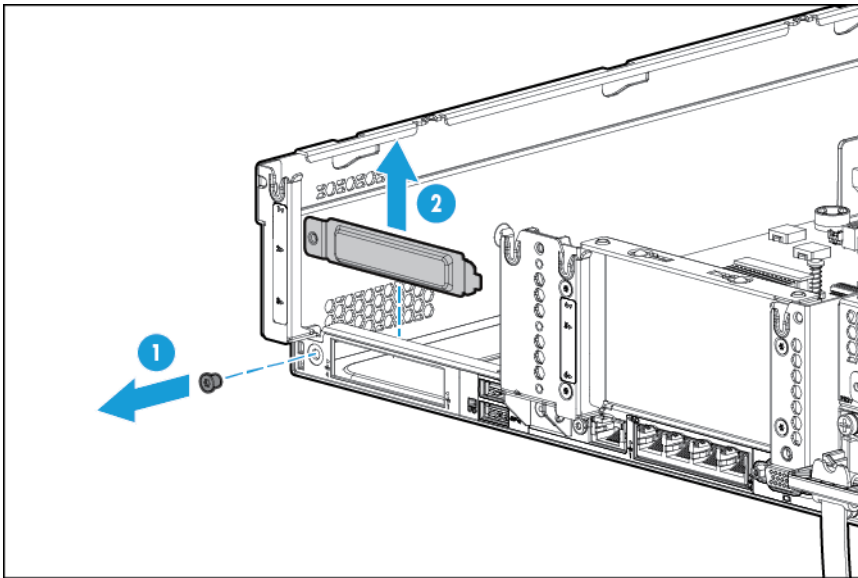

6. Install the component:
 - a. Firmly seat the FlexibleLOM in the slot.
 - b. Tighten the thumbscrew.

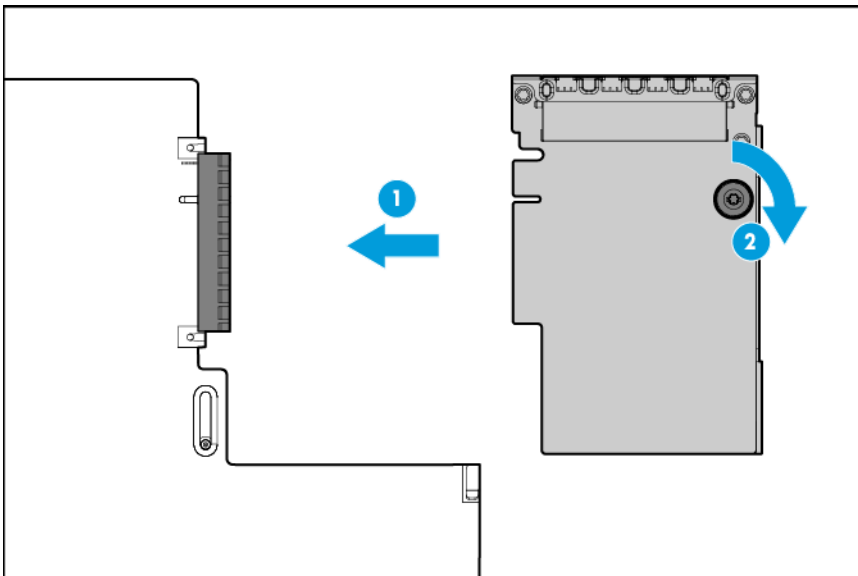

7. Install the access panel (on page 27).
8. Slide the server into the rack.

9. Connect the LAN segment cables.
10. Connect each power cord to the server.
11. Connect each power cord to the power source.
12. Power up the server (on page 25).

HP 12G SAS Expander Card

Before installing the HP 12G SAS Expander Card, observe the following requirements:

- The following components must be installed:
 - Storage controller
 - Drive cages:
 - For 24 SFF drive configuration—Bay 1 and bay 2 8 SFF front drive cages
 - For 12 LFF drive configuration—12 LFF front drive cage
 - For configurations using the rear drive cage—2 SFF rear drive cage or 3 LFF rear drive cage
- The SAS expander card is supported only in slot 2 of the primary PCI riser cage. It is not supported in the secondary riser cage.
- To ensure cables are connected correctly, observe the labels on the cable and component connectors.
- Be sure you have the latest firmware for the controllers, HBAs, and the expander card. To download the latest firmware, see the HP website (<http://www.hp.com/go/hpsc>).
- Understand the required cable connections:
 - Group A—Controller to SAS expander card

Cable	Description	Connection to SAS expander	Connection to controller
776408-001	X4 mini-SAS cable	Port 2	Port 2
776409-001	X4 mini-SAS cable	Port 1	Port 1
781580-001	2 x4 mini-SAS to x-8 mini-SAS Y cable	Ports 1 and 2	Port 1

- Group B—SAS expander card to front LFF drive cage

Cable	Description	Connection to SAS expander	Connection to drive bay
747576-001	2 x4 mini-SAS cable	Port 3 Port 4	12 LFF Port 1 12 LFF Port 2
747577-001	x4 mini-SAS cable	Port 5	12 LFF Port 3

- Group C—SAS expander card to front SFF drive cages

Cable	Description	Connection to SAS expander	Connection to drive bay
776402-001	2 x4 mini-SAS cable	Port 3 Port 4	8 SFF Bay 1 Port 1 8 SFF Bay 1 Port 2

Cable	Description	Connection to SAS expander	Connection to drive bay
781579-001	4 x4 mini-SAS cable	Port 5 Port 6 Port 7 Port 8	8 SFF Bay 2 Port 1 8 SFF Bay 2 Port 2 8 SFF Bay 3 Port 1 8 SFF Bay 3 Port 2

- Group D—SAS expander card to rear drive cage

Cable	Description	Connection to SAS expander	Connection to drive bay
776401-001	X4 mini-SAS cable	Port 9	2SFF/3LFF

HP 12G SAS Expander Card ports

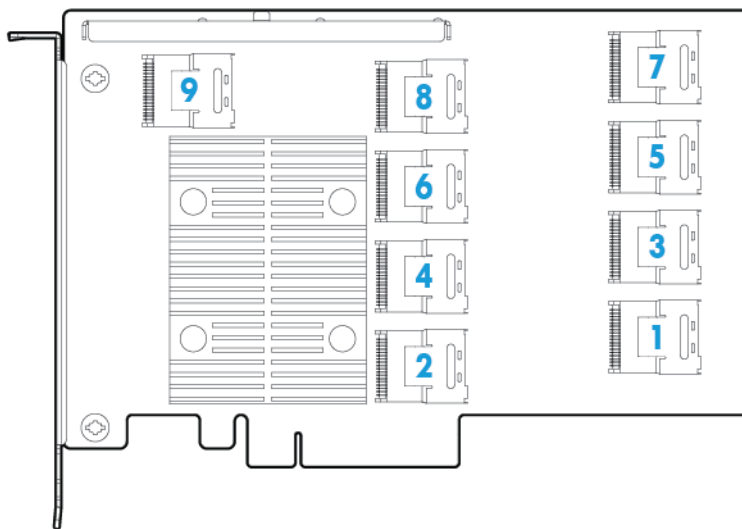

To install the component:

1. Power down the server (on page 25).
2. Remove all power:
 - a. Disconnect each power cord from the power source.
 - b. Disconnect each power cord from the server.
3. Do one of the following:
 - Extend the server from the rack (on page 25).
 - Remove the server from the rack (on page 26).
4. Remove the access panel (on page 26).
5. Remove the air baffle (on page 32).
6. Remove the fan cage (on page 28).
7. Remove the primary PCI riser cage.



IMPORTANT: The HP 12G SAS Expander Card is not supported in the secondary PCI riser cage.

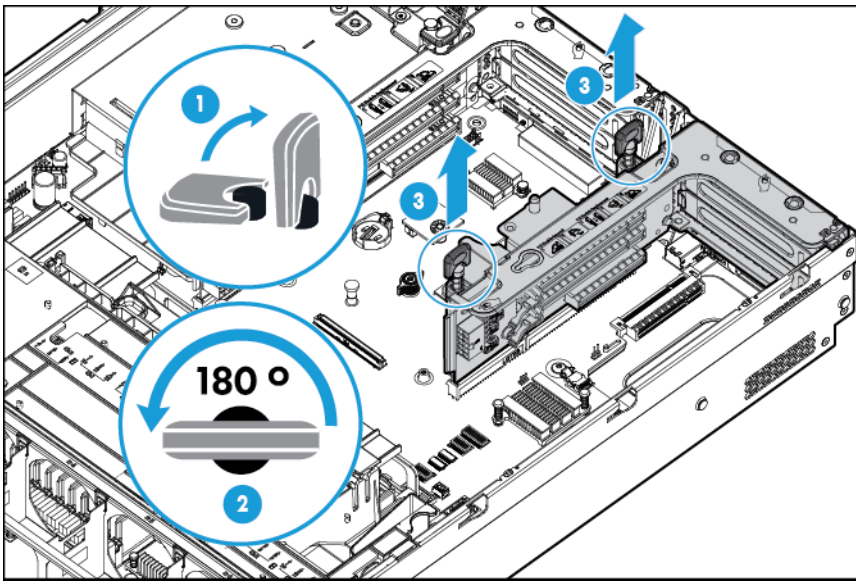

8. Remove the expansion slot blank from slot 2.

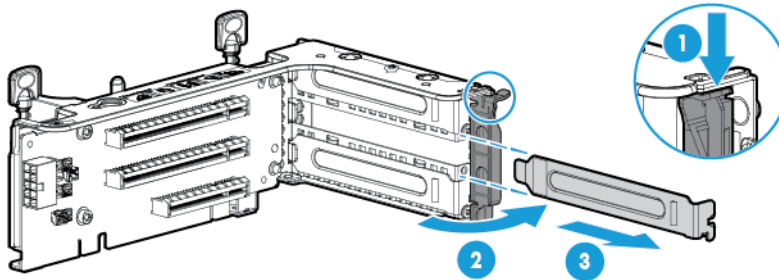

9. Using the labels on the cables to determine the correct connections, connect the cables to the SAS expander card:
- Depending on the ports on the controller, connect the appropriate controller cables from Group A to the SAS expander card.

Controller ports	Cable	SAS expander ports
2 x4 connectors	x4 mini-SAS cable	Port 1
	x4 mini-SAS cable	Port 2
1 x8 connector	2 x4 mini-SAS to x8 mini-SAS Y cable	Ports 1 and 2

- Depending on the drive configuration, connect the appropriate drive cage cables to the SAS expander card.

Drive configuration	Cable group	Cable	SAS expander ports
24 SFF	C	2 x4 mini-SAS cable	Ports 3 and 4
		4 x4 mini-SAS cable	Port 5 Port 6 Port 7 Port 8

Drive configuration	Cable group	Cable	SAS expander ports
12 LFF	B	2 x4 mini-SAS cable	Ports 3 and 4
		x4 mini-SAS cable	Port 5
2 SFF/3 LFF	D	x4 mini-SAS cable	Port 9

10. Install the SAS expander card. The cables are not shown for clarity.



IMPORTANT: The HP 12G SAS Expander Card is only supported in slot 2.

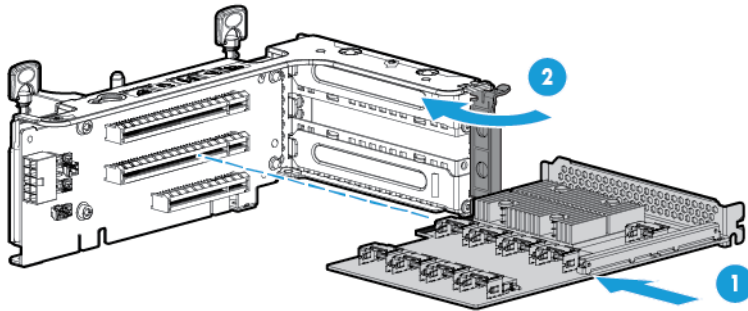

IMPORTANT: If using a PCI slot-based controller, install the controller in slot 1.

11. Install the PCI riser cage (on page 30).

12. Using the labels on the cables to determine the correct connections, connect the cables from the SAS expander card to the controller:

- HP Flexible Smart Array Controller with 2 x4 connectors (Group A SAS cables)

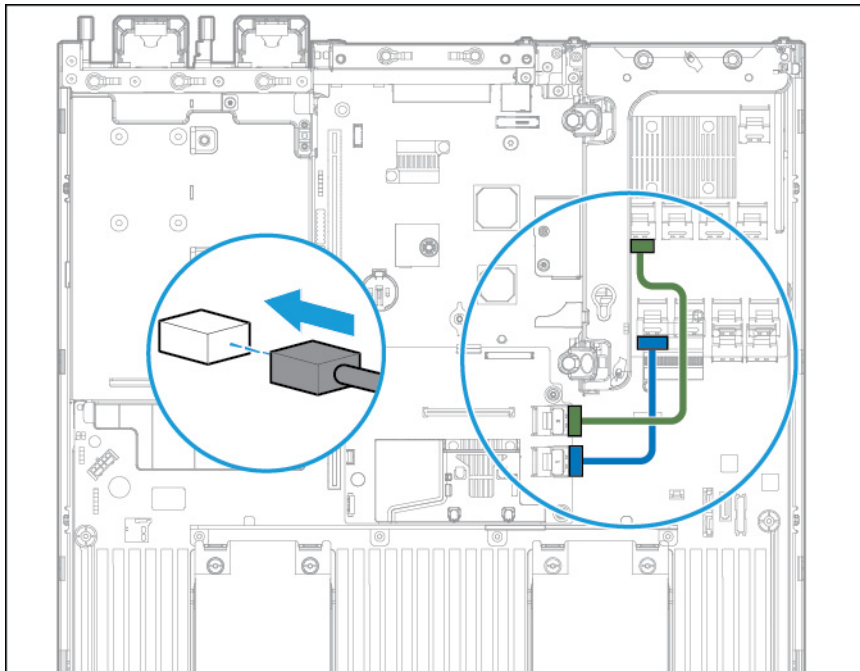

- PCI slot-based Smart Array controller with x8 connector (Group A SAS cables)

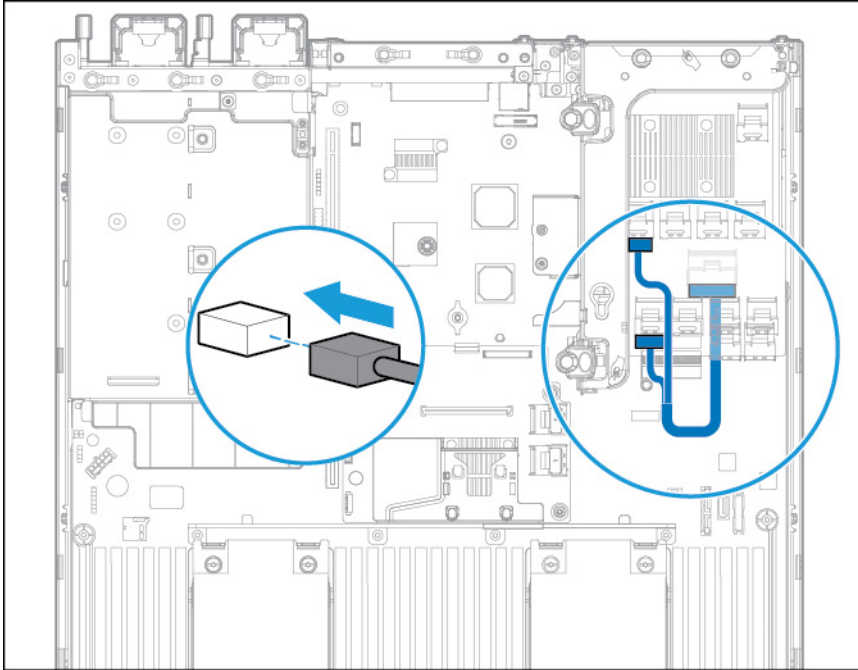

13. Connect the cables to the drive cage backplanes:

- 24 SFF drive backplanes (Group C SAS cables)

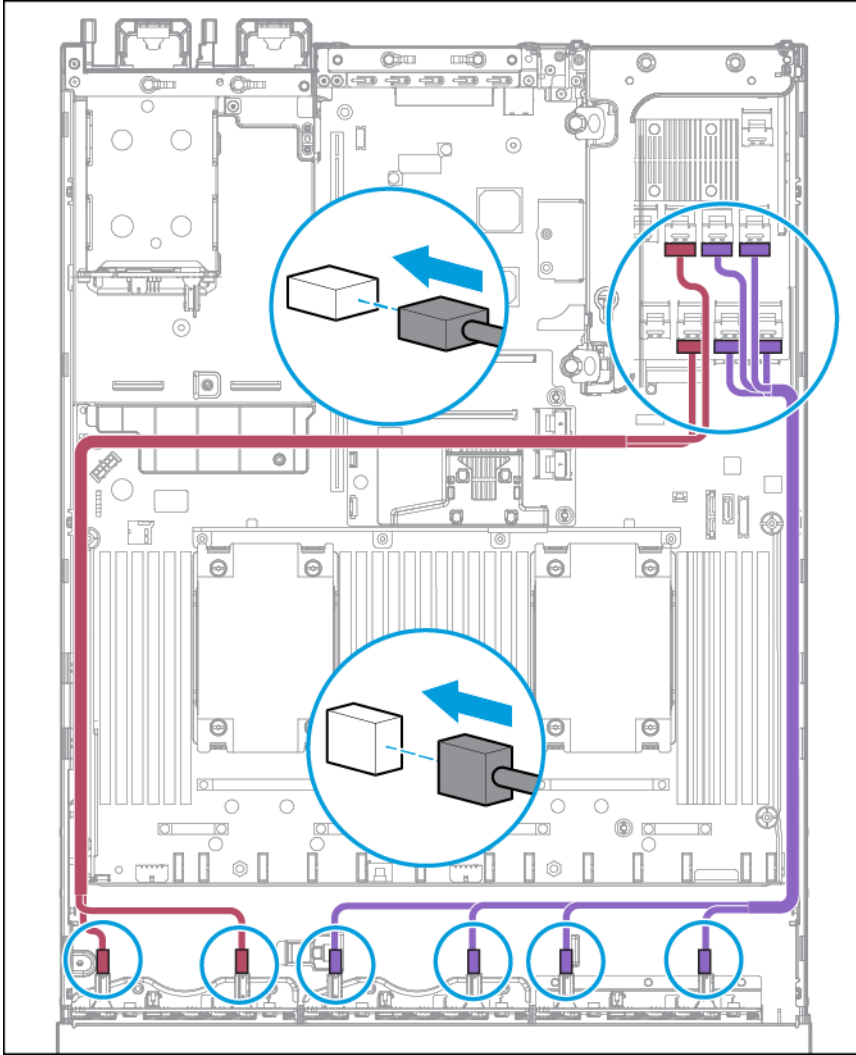

- 12 LFF drive backplanes (Group B SAS cables)

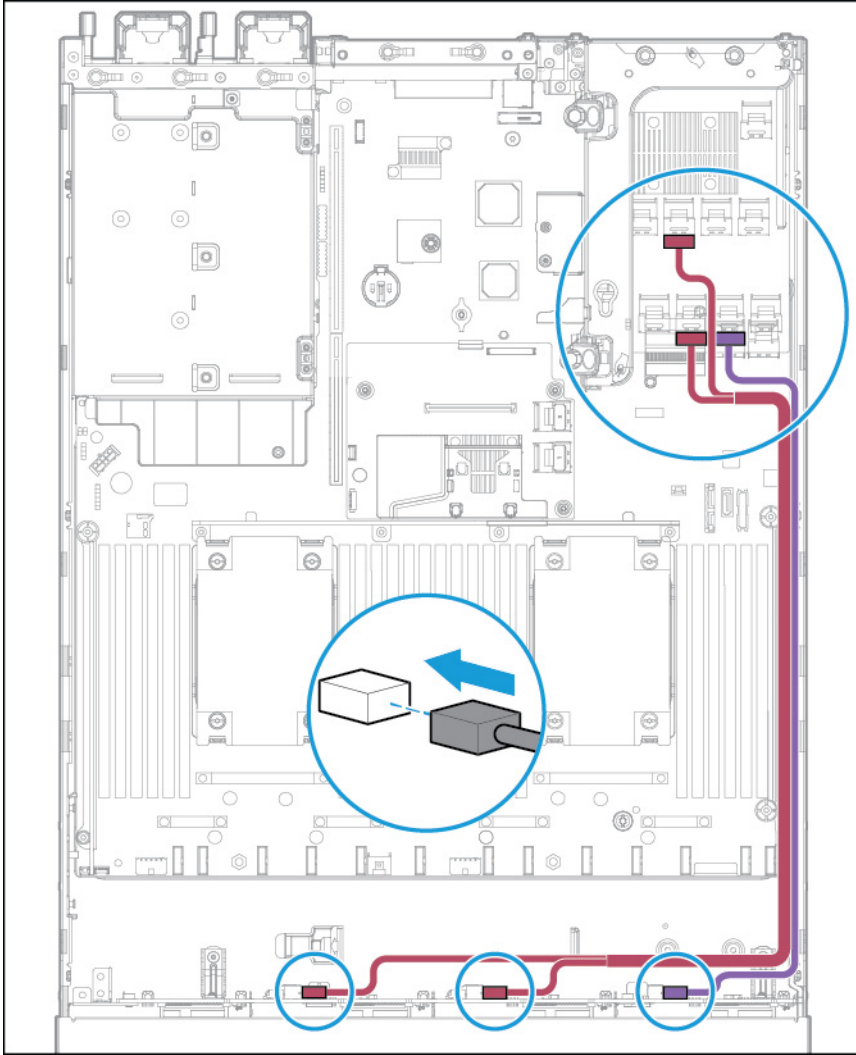

- Two-bay SFF or three-bay LFF rear cage drive backplane (Group D SAS cables)

The cabling is the same for both backplanes. In the following illustration, the two-bay SFF rear cage backplane is shown.

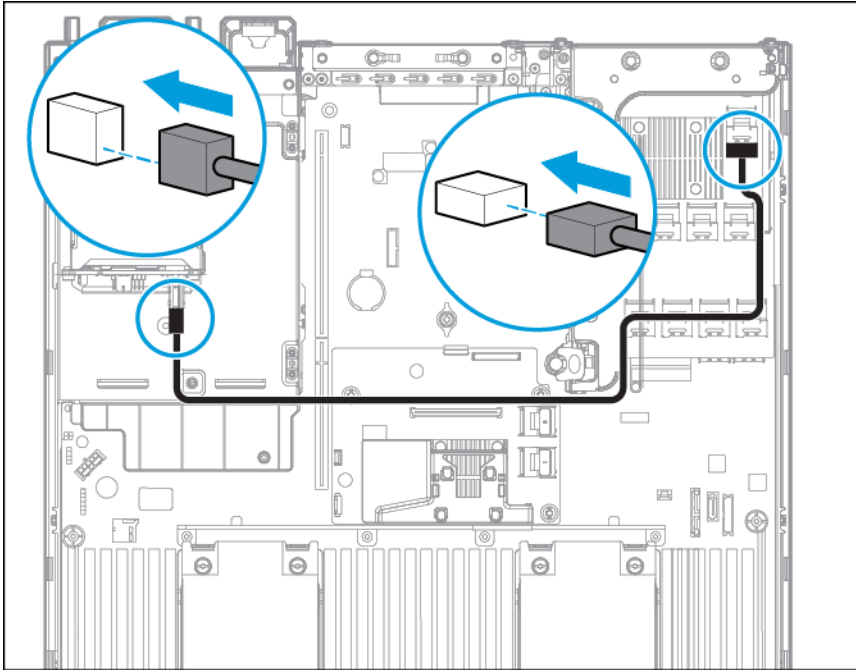

14. Install the air baffle.
15. Install the fan cage.
16. Install the access panel (on page 27).
17. Install the server into the rack ("Installing the server into the rack" on page 38).
18. Connect each power cord to the server.
19. Connect each power cord to the power source.
20. Power up the server (on page 25).

HP Flexible Smart Array Controller



CAUTION: HP recommends performing a complete backup of all server data before performing a controller or adapter installation or removal.

Before installing the controller, observe the following requirements:

- To ensure cables are connected correctly, observe the labels on the cable and component connectors.
- Be sure you have the latest firmware for the controllers, HBAs, and the expander card. To download the latest firmware, see the HP website (<http://www.hp.com/go/hpsc>).

To install the component:

1. Power down the server (on page 25).
2. Remove all power:
 - a. Disconnect each power cord from the power source.
 - b. Disconnect each power cord from the server.

3. Do one of the following:
 - Extend the server from the rack (on page 25).
 - Remove the server from the rack (on page 26).
4. Remove the access panel (on page 26).
5. Remove the air baffle (on page 32).
6. Install the controller.

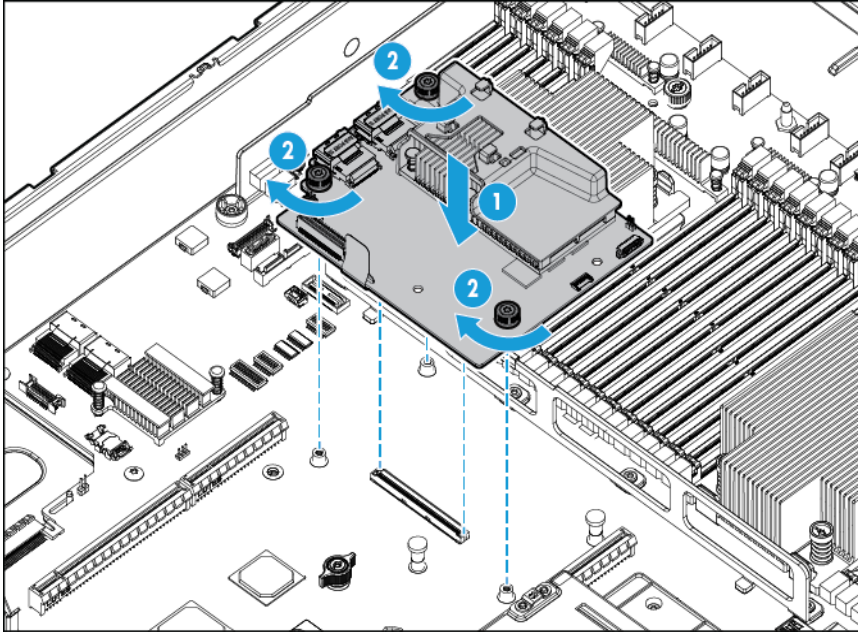

7. Connect the appropriate SAS cables.
8. Install the air baffle.
9. Install the access panel (on page 27).
10. Slide the server into the rack.
11. Connect each power cord to the server.
12. Connect each power cord to the power source.
13. Before powering on the system, be sure the HP Smart Storage Battery (on page 113) is installed.
14. Power up the server (on page 25).

HP Smart Storage Battery

To install the component:

1. Power down the server (on page 25).
2. Remove all power:
 - a. Disconnect each power cord from the power source.
 - b. Disconnect each power cord from the server.
3. Do one of the following:
 - Extend the server from the rack (on page 25).
 - Remove the server from the rack (on page 26).

4. Remove the access panel (on page 26).
5. Remove the air baffle (on page 32).
6. Remove the fan cage (on page 28).
7. Install the HP Smart Storage battery.

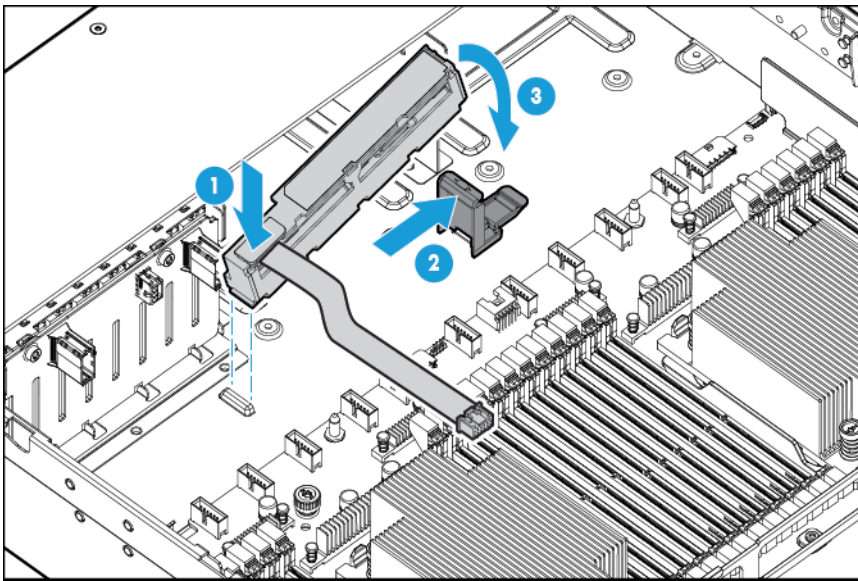

8. Route the cable.

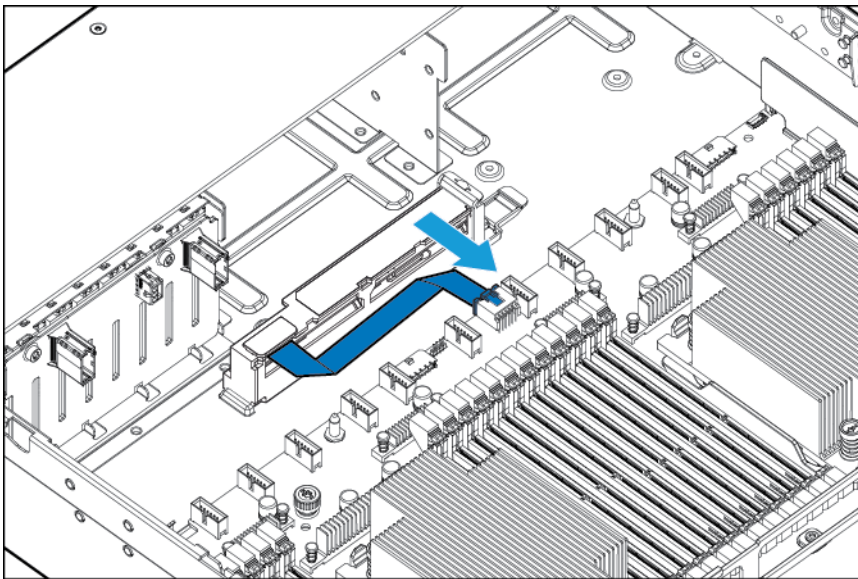

9. Install the fan cage.
10. Install the air baffle.
11. Install the access panel (on page 27).
12. Slide the server into the rack.
13. Connect each power cord to the server.
14. Connect each power cord to the power source.
15. Power up the server (on page 25).

Rear serial port option

To install the component:

1. Power down the server (on page 25).
2. Remove all power:
 - a. Disconnect each power cord from the power source.
 - b. Disconnect each power cord from the server.
3. Do one of the following:
 - o Extend the server from the rack (on page 25).
 - o Remove the server from the rack (on page 26).
4. Remove the access panel (on page 26).
5. Remove the serial cable blank.

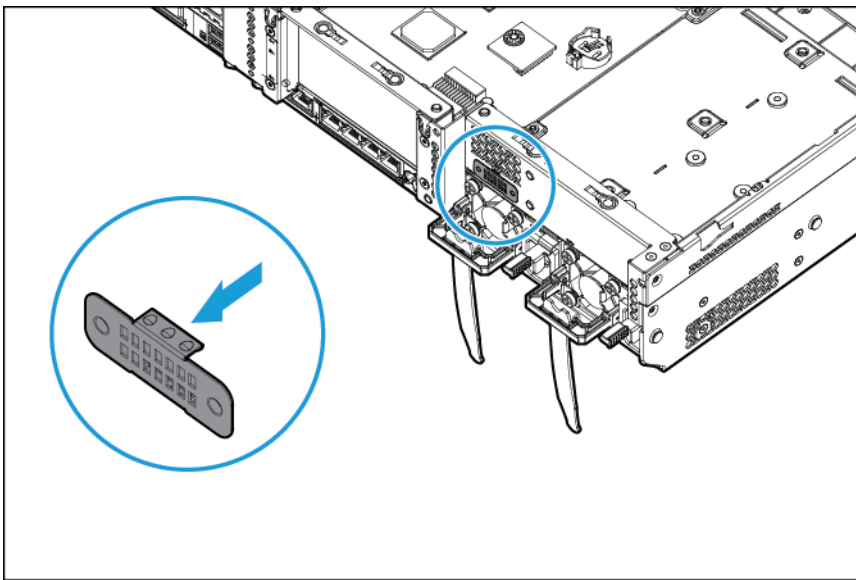

6. Connect the serial cable option. Then, remove the backing from the double-sided tape and press down where indicated.

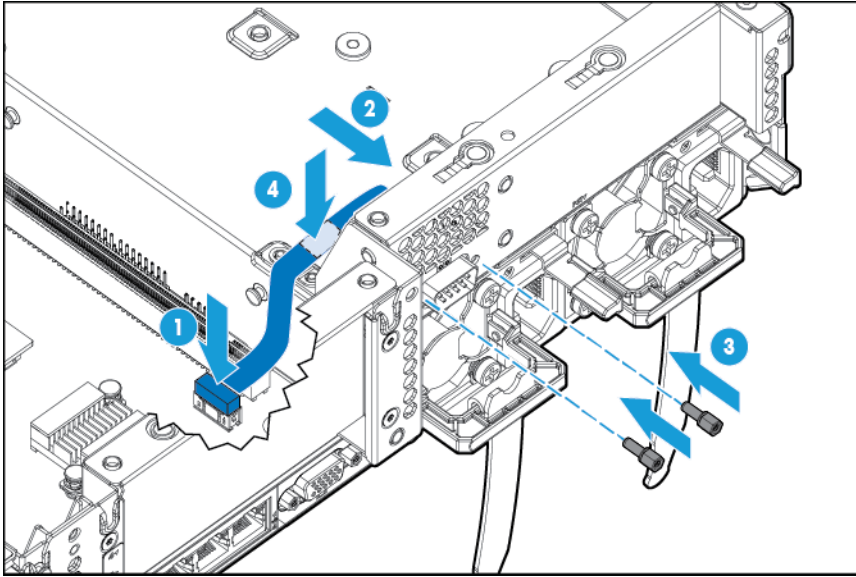

7. Install the access panel (on page 27).
8. Slide the server into the rack.
9. Connect each power cord to the server.
10. Connect each power cord to the power source.
11. Power up the server (on page 25).

M.2 SSD Enablement Board option

The M.2 enablement board is supported in all 6 of the PCI slots on this server.

Installing an SSD module on the M.2 SSD Enablement Board

1. Power down the server (on page 25).
2. Remove all power:
 - a. Disconnect each power cord from the power source.
 - b. Disconnect each power cord from the server.
3. Extend the server from the rack (on page 25).
4. Remove the access panel (on page 26).
5. Remove the PCIe riser cage ("Remove the PCIe riser cage" on page 30).
6. Remove the expansion slot cover ("Removing an expansion slot blank" on page 61).



IMPORTANT: For management and monitoring of the SSD modules, use the HP Smart Storage Administrator (<http://www.hp.com/go/hpssa>).

7. Install the SSD module on the M.2 SSD enablement board.

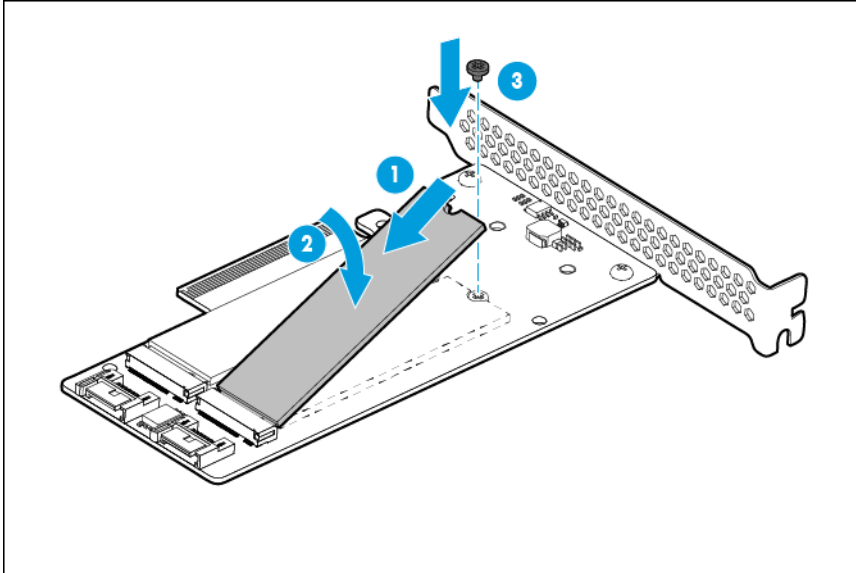

8. Install the M.2 SSD enablement board in any slot in the primary or secondary PCI riser cage ("[Installing an M.2 SSD enablement board](#)" on page 117).
9. Install the PCI riser cage (on page 30).
10. Install the access panel (on page 27).
11. Install the server into the rack ("[Installing the server into the rack](#)" on page 38).
12. Connect each power cord to the server.
13. Connect each power cord to the power source.
14. Power up the server (on page 25).

Installing an M.2 SSD enablement board

1. Power down the server (on page 25).
2. Remove all power:
 - a. Disconnect each power cord from the power source.
 - b. Disconnect each power cord from the server.
3. Do one of the following:
 - o Extend the server from the rack (on page 25).
 - o Remove the server from the rack (on page 26).
4. Remove the access panel (on page 26).
5. Remove the PCIe riser cage ("[Remove the PCI riser cage](#)" on page 30).
6. Remove the expansion slot cover.
7. Install the M.2 SSD enablement board into expansion any of the slots on the primary PCI riser or secondary PCI riser:

- 3-slot riser cage

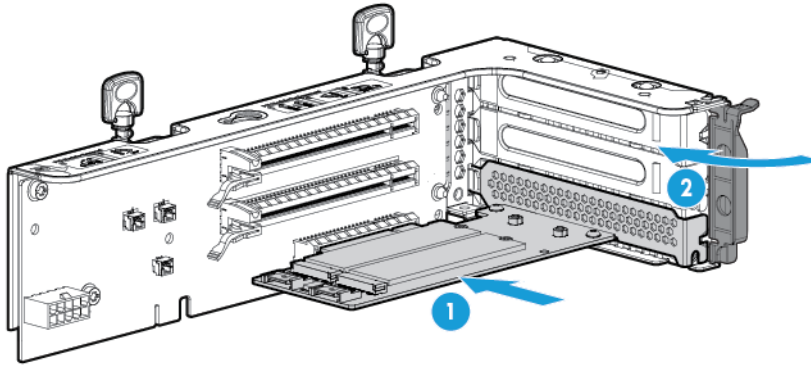

- 2-slot riser cage

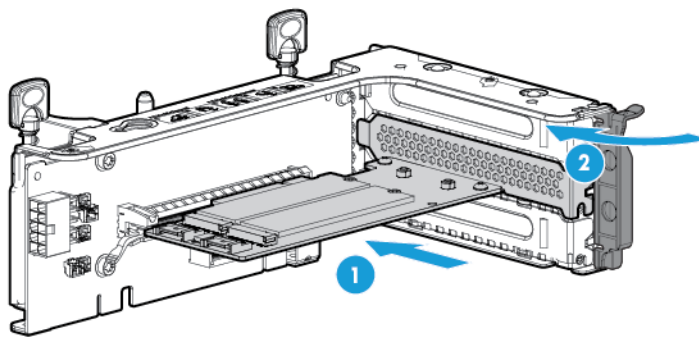

8. Connect the SATA cables from the M.2 SSD enablement board to the system board.
- M.2 SSD enablement board installed in the primary PCI riser cage

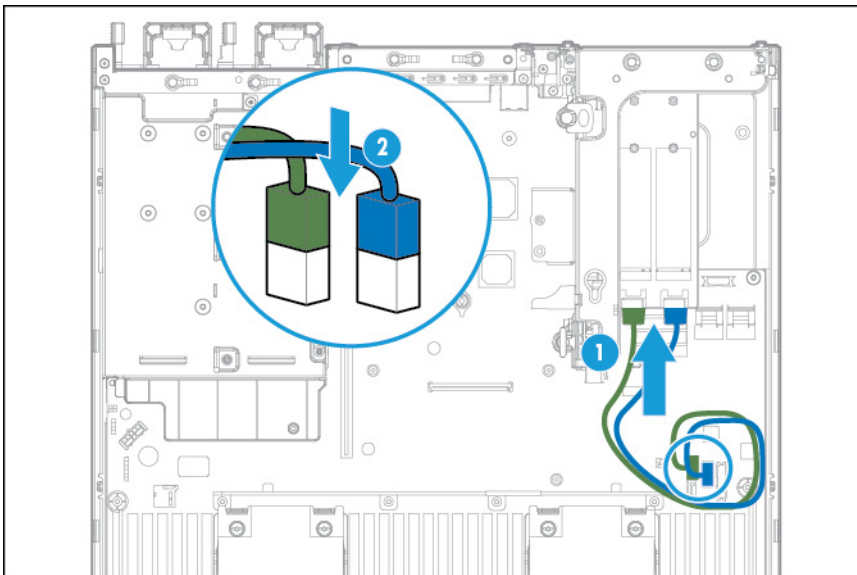

- M.2 SSD enablement board installed in the secondary PCI riser cage

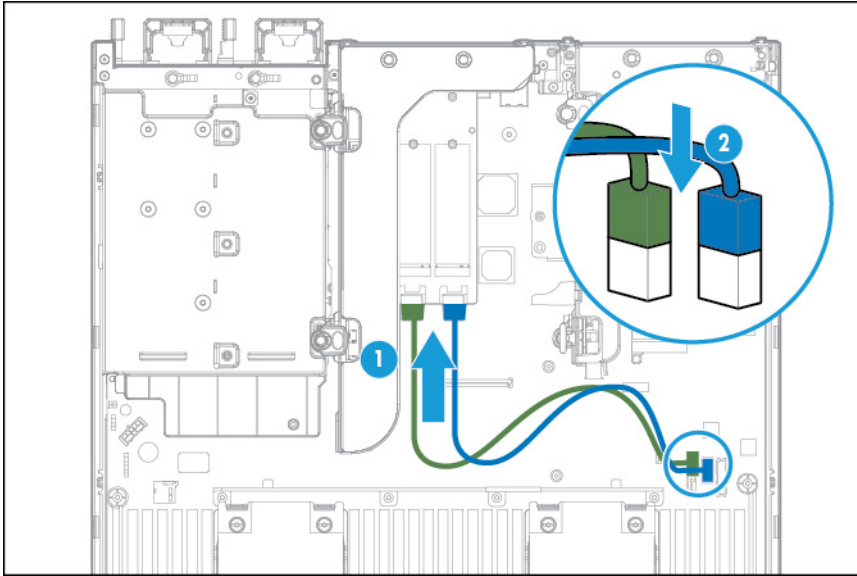

9. Install the PCI riser cage (on page 30).
10. Install the access panel (on page 27).
11. Install the server into the rack ("Installing the server into the rack" on page 38).
12. Connect each power cord to the server.
13. Connect each power cord to the power source.
14. Power up the server (on page 25).

HP Dual 8Gb MicroSD Enterprise Midline USB device

This server supports the installation of the HP Dual 8Gb MicroSD Enterprise Midline USB device on the server internal USB connector.

This USB storage device contains a dual-SD card module that supports up to two SD, SDHC, or SDXC storage cards providing data redundancy through a mirrored RAID-1 configuration. This USB storage device connects to an internal USB port and is configured upon boot.

To locate the internal USB connector, see "System board components (on page 17)." For more information, see HP Dual 8Gb MicroSD EM USB storage device documentation on the HP website (<http://www.hp.com/go/enterprise/docs>).

HP 750 W Flex Slot Hot Plug Battery Backup Module

The FSBBU is a self-contained unit with internal lithium-ion batteries that provide DC 12V backup power for HP servers when either the main bus utility power fails or the power supply is out of regulation.

You do not have to power down the server before removing or installing an FSBBU.

Flex slot battery backup module configuration load support

The FSBBU module can be daisy chained to only one other FSBBU module. When AC power is lost to one server, then the loads of both servers will determine if the FSBBU will support the combined load.

Server #1 + FSBBU module load condition (%)	Server #2 + FSBBU module load condition (%)	Supported (Yes/No) where server #1 lost input AC power	Supported (Yes/No) where server #2 lost input AC power
10 (75W- 6.25A)	90 (675W- 56.25A)	Yes	No
20 (150W- 12.5A)	80 (600W- 50A)	Yes	No
30 (225W- 18.5A)	70 (525W- 43.5A)	Yes	No
40 (300W- 25A)	60 (450W- 37.5)	Yes	Yes
50 (375W- 31.25)	50 (375W- 31.25)	Yes	Yes
60 (450W- 37.5)	40 (300W- 25A)	Yes	Yes
70 (525W- 43.5A)	30 (225W- 18.5A)	No	Yes
80 (600W- 50A)	20 (150W- 12.5A)	No	Yes
90 (675W- 56.25A)	10 (75W- 6.25A)	No	Yes

Installing the FSBBU

CAUTION: To prevent improper cooling and thermal damage, do not operate the server unless all bays are populated with either a component or a blank.

To install the component:

1. Access the product rear panel (on page 27).
2. Remove the blank.

WARNING: To reduce the risk of personal injury from hot surfaces, allow the FSBBU or power supply blank to cool before touching it.

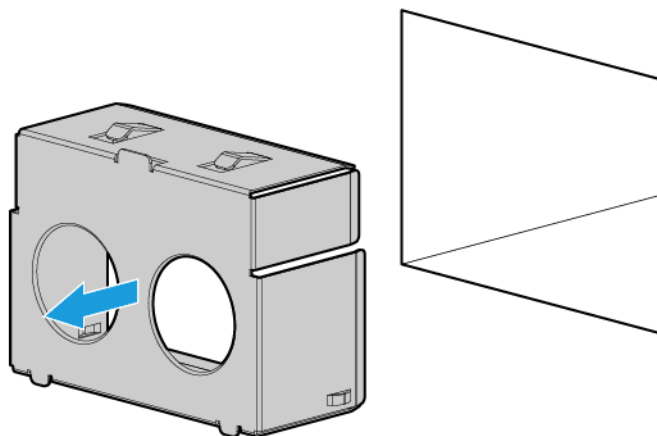

3. Press the battery check button located on the rear of the FSBBU module to check the battery condition before installing the unit into the power supply bay. To locate the battery check button and for more information on the FSBBU module LED status, see "Flex slot battery backup module LEDs and buttons (on page 15)."

4. Install the FSBBU module into the power supply bay until it clicks into place.

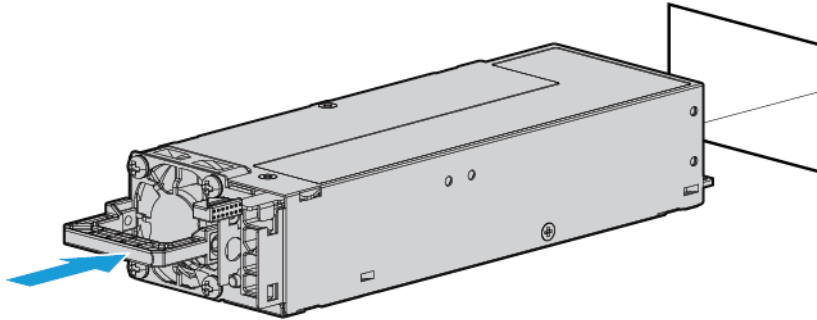

5. Connect multiple FSBBU units using a daisy chain configuration. A jumper cable (HP part number K9B28A) is required for a daisy chain configuration.

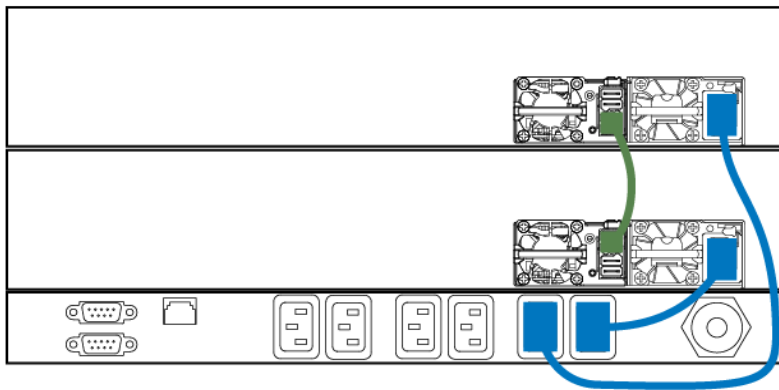

6. Charge the FSBBU module until the LED is solid green.

For more information about product features, specifications, options, configurations, and compatibility, see the product QuickSpecs on the HP website (<http://www.hp.com/go/qs>).

HP Trusted Platform Module option

For more information about product features, specifications, options, configurations, and compatibility, see the product QuickSpecs on the HP website (<http://www.hp.com/go/qs>).

Use these instructions to install and enable a TPM on a supported server. This procedure includes three sections:

1. Installing the Trusted Platform Module board (on page 122).
2. Retaining the recovery key/password (on page 124).
3. Enabling the Trusted Platform Module (on page 124).

Enabling the TPM requires accessing BIOS/Platform Configuration (RBSU) in HP UEFI System Utilities (on page 146).

TPM installation requires the use of drive encryption technology, such as the Microsoft Windows BitLocker Drive Encryption feature. For more information on BitLocker, see the Microsoft website (<http://www.microsoft.com>).



CAUTION: Always observe the guidelines in this document. Failure to follow these guidelines can cause hardware damage or halt data access.

When installing or replacing a TPM, observe the following guidelines:

- Do not remove an installed TPM. Once installed, the TPM becomes a permanent part of the system board.
- When installing or replacing hardware, HP service providers cannot enable the TPM or the encryption technology. For security reasons, only the customer can enable these features.
- When returning a system board for service replacement, do not remove the TPM from the system board. When requested, HP Service provides a TPM with the spare system board.
- Any attempt to remove an installed TPM from the system board breaks or disfigures the TPM security rivet. Upon locating a broken or disfigured rivet on an installed TPM, administrators should consider the system compromised and take appropriate measures to ensure the integrity of the system data.
- When using BitLocker, always retain the recovery key/password. The recovery key/password is required to enter Recovery Mode after BitLocker detects a possible compromise of system integrity.
- HP is not liable for blocked data access caused by improper TPM use. For operating instructions, see the encryption technology feature documentation provided by the operating system.

Installing the Trusted Platform Module board



WARNING: To reduce the risk of personal injury, electric shock, or damage to the equipment, remove the power cord to remove power from the server. The front panel Power On/Standby button does not completely shut off system power. Portions of the power supply and some internal circuitry remain active until AC power is removed.



WARNING: To reduce the risk of personal injury from hot surfaces, allow the drives and the internal system components to cool before touching them.

To install the component:

1. Power down the server (on page 25).
2. Remove all power:
 - a. Disconnect each power cord from the power source.
 - b. Disconnect each power cord from the server.
3. Do one of the following:
 - Extend the server from the rack (on page 25).
 - Remove the server from the rack (on page 26).
4. Remove the access panel (on page 26).
5. Remove the PCI riser cage (on page 30).



CAUTION: Any attempt to remove an installed TPM from the system board breaks or disfigures the TPM security rivet. Upon locating a broken or disfigured rivet on an installed TPM, administrators should consider the system compromised and take appropriate measures to ensure the integrity of the system data.

6. Install the TPM board. Press down on the connector to seat the board ("[System board components](#)" on page 17).

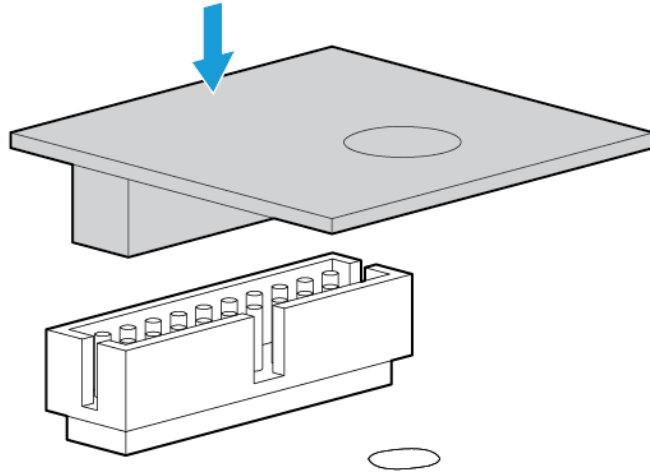

7. Install the TPM security rivet by pressing the rivet firmly into the system board.

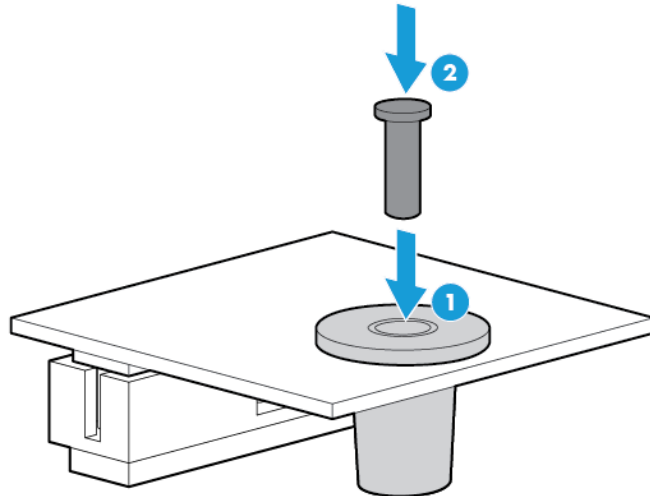

8. Install the PCI riser cage (on page 30).
9. Install the access panel (on page 27).
10. Install the server into the rack ("[Installing the server into the rack](#)" on page 38).
11. Power up the server (on page 25).

Retaining the recovery key/password

The recovery key/password is generated during BitLocker setup, and can be saved and printed after BitLocker is enabled. When using BitLocker, always retain the recovery key/password. The recovery key/password is required to enter Recovery Mode after BitLocker detects a possible compromise of system integrity.

To help ensure maximum security, observe the following guidelines when retaining the recovery key/password:

- Always store the recovery key/password in multiple locations.
- Always store copies of the recovery key/password away from the server.
- Do not save the recovery key/password on the encrypted hard drive.

Enabling the Trusted Platform Module

1. During the server startup sequence, press the **F9** key to access System Utilities.
2. From the System Utilities screen, select **System Configuration > BIOS/Platform Configuration (RBSU) > Server Security**.
3. Select **Trusted Platform Module Options** and press the **Enter** key.
4. Select **Enabled** to enable the TPM and BIOS secure startup. The TPM is fully functional in this mode.
5. Press the **F10** key to save your selection.
6. When prompted to save the change in System Utilities, press the **Y** key.
7. Press the **ESC** key to exit System Utilities. Then, press the **Enter** key when prompted to reboot the server.

The server then reboots a second time without user input. During this reboot, the TPM setting becomes effective.

You can now enable TPM functionality in the OS, such as Microsoft Windows BitLocker or measured boot.



CAUTION: When a TPM is installed and enabled on the server, data access is locked if you fail to follow the proper procedures for updating the system or option firmware, replacing the system board, replacing a hard drive, or modifying OS application TPM settings.

For more information on firmware updates and hardware procedures, see the *HP Trusted Platform Module Best Practices White Paper* on the HP website (<http://www.hp.com/support>).

For more information on adjusting TPM usage in BitLocker, see the Microsoft website (<http://technet.microsoft.com/en-us/library/cc732774.aspx>).

Cabling

Two-bay SFF drive cage option cabling

2 SFF drive bay option rear installation

Connect the power cable:

- Single cable connection with 12 LFF drive configuration in the front

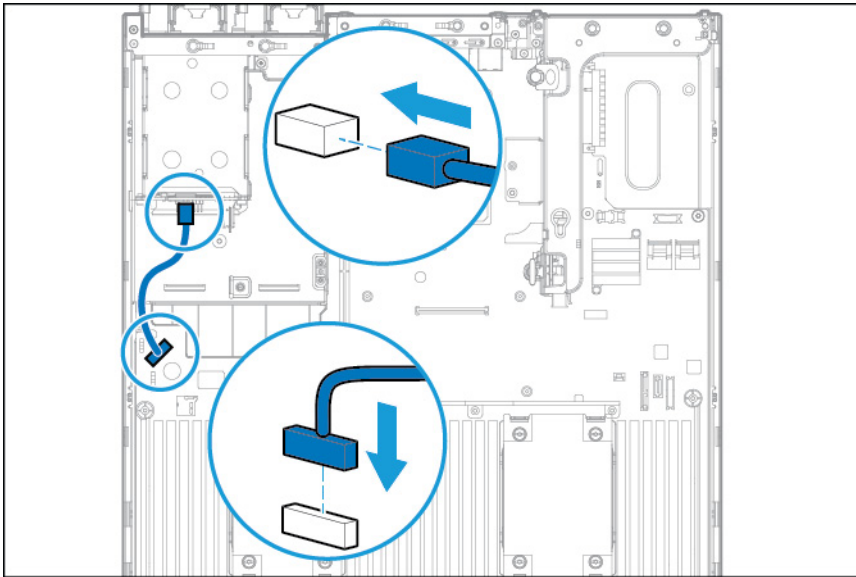

- Y cable connection with 24 SFF drive configuration in front

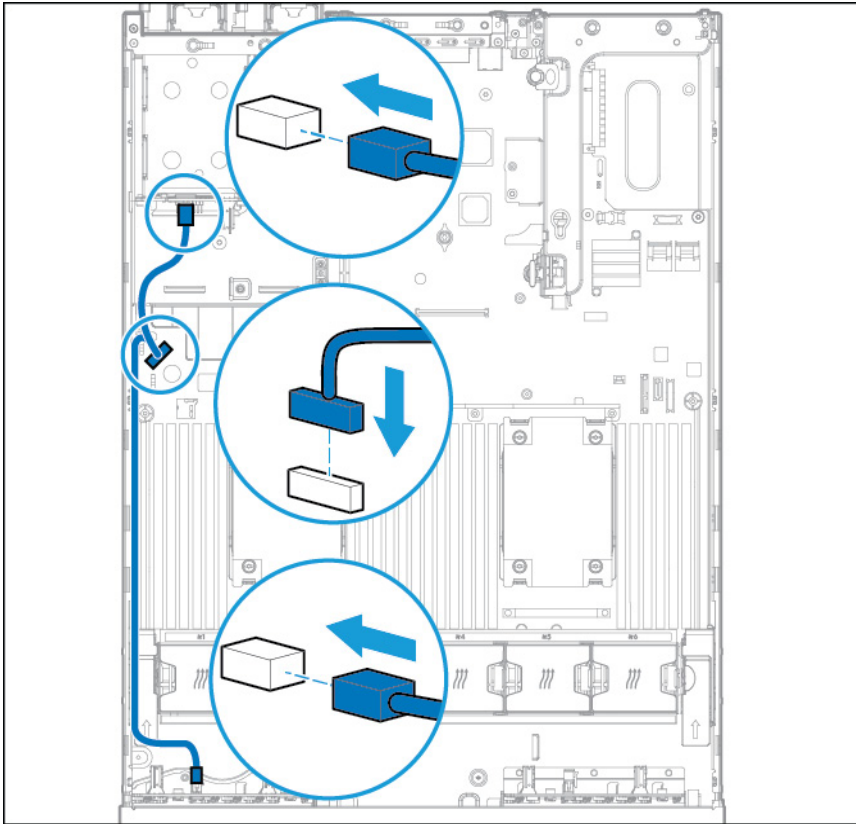

Connect the data cable:

- Connected to the onboard x4 SATA connector

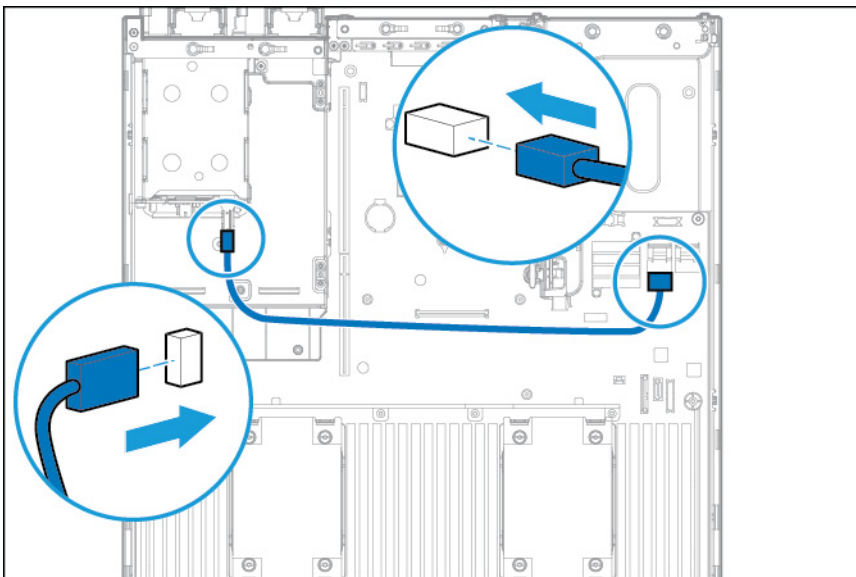

- Connected to the x2 SATA port and optical disk drive connector

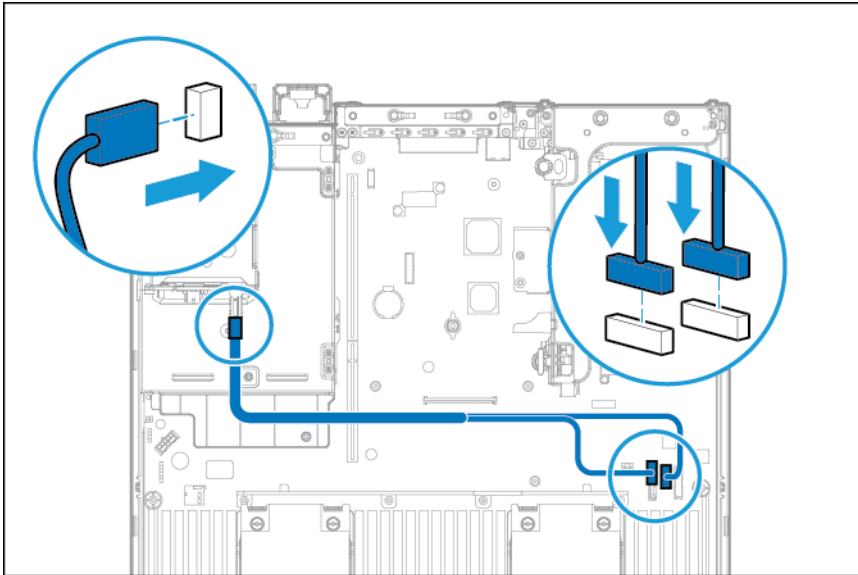

- Connected to a PCI expansion board

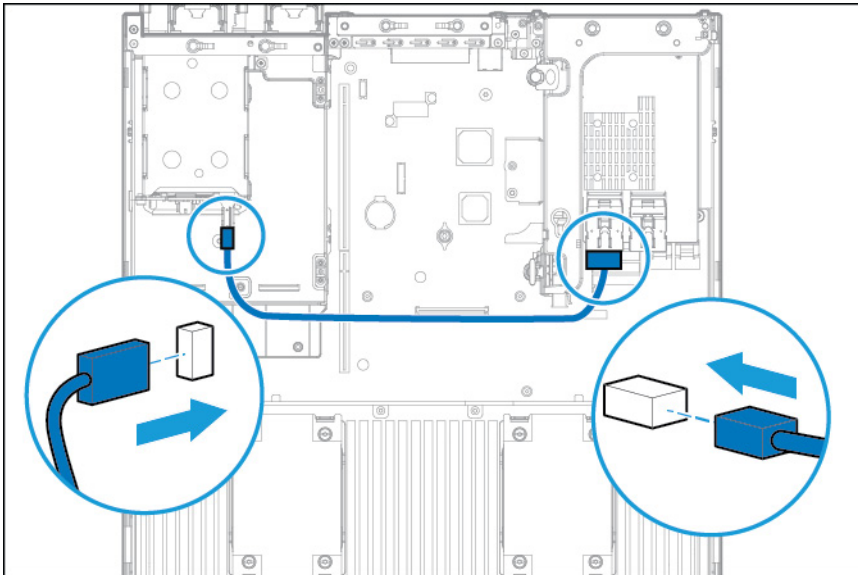

- Connected to a PCI expansion board and the 12 LFF drive backplane

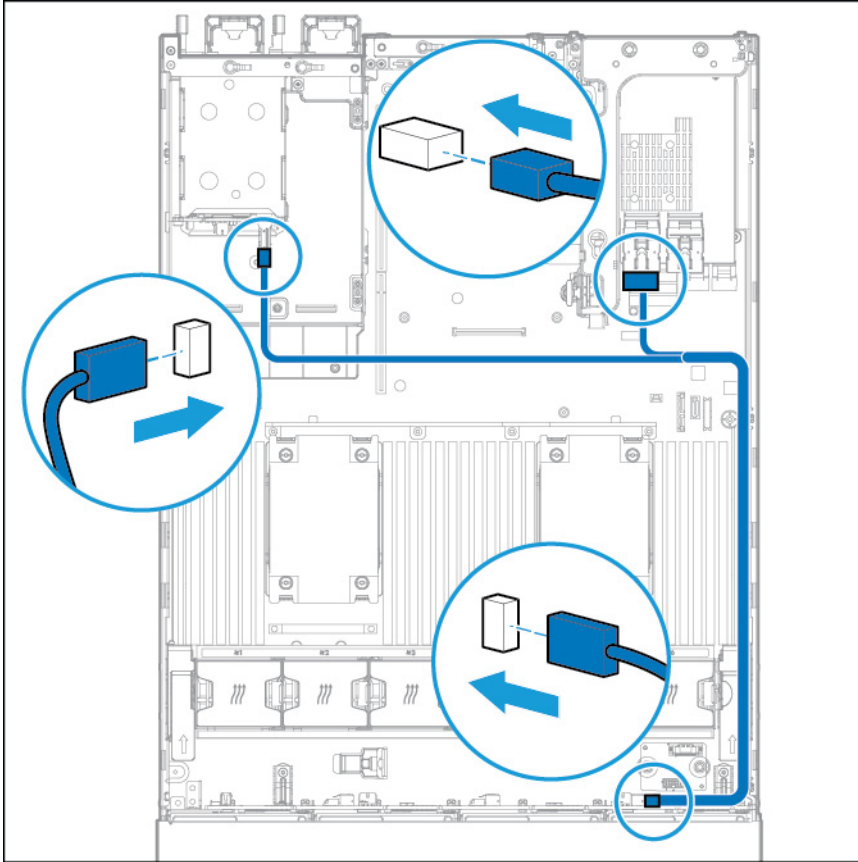

- Connected to an HP 12G SAS Expander Card

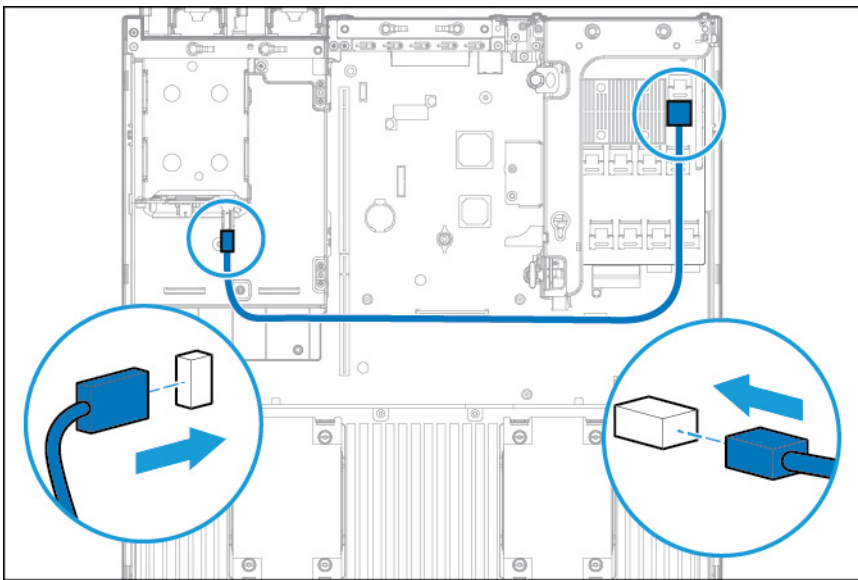

Three-bay LFF rear drive cage cabling

Connect the power cable.

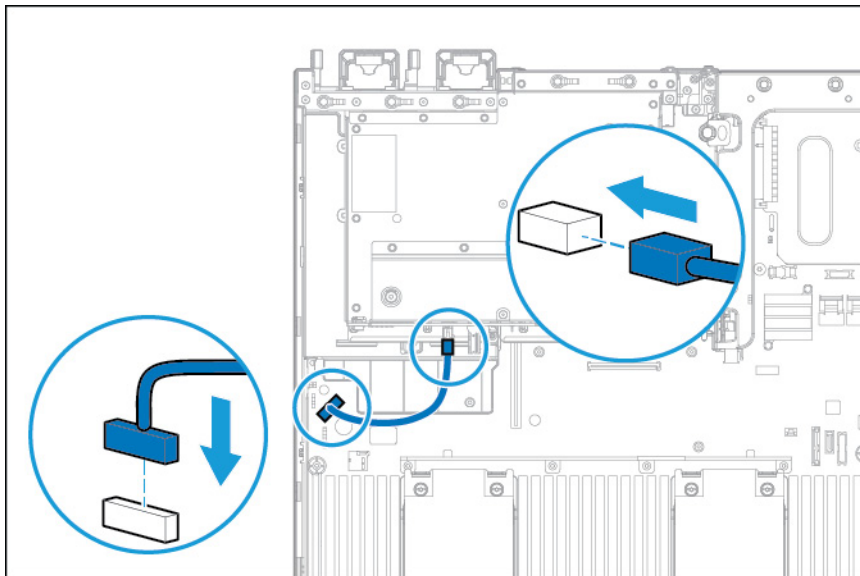

Connect the data cable:

- Connected to onboard SATA connectors

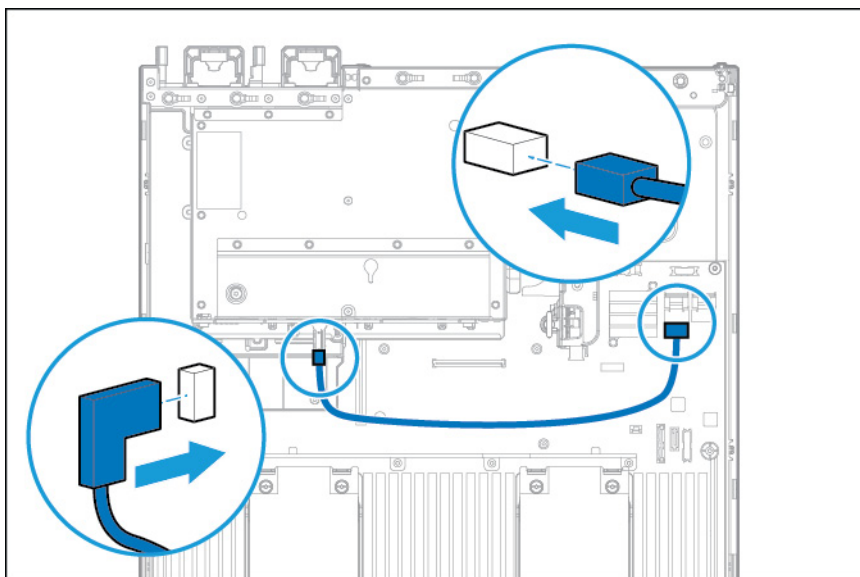

- Connected to a PCI expansion board

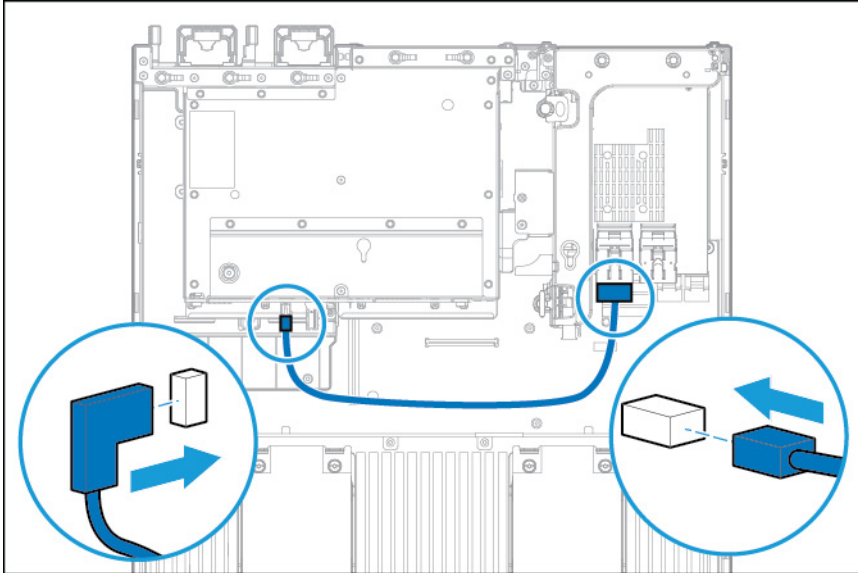

- Connected to a PCI expansion board and the 12 LFF drive backplane

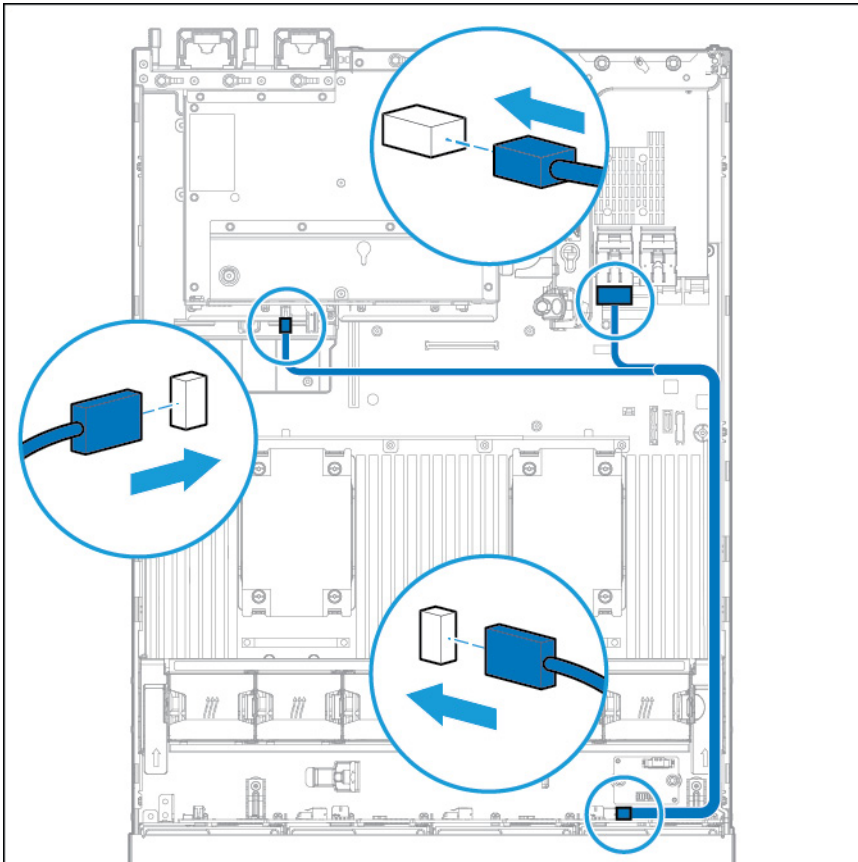

- Connected to an HP 12G SAS Expander Card

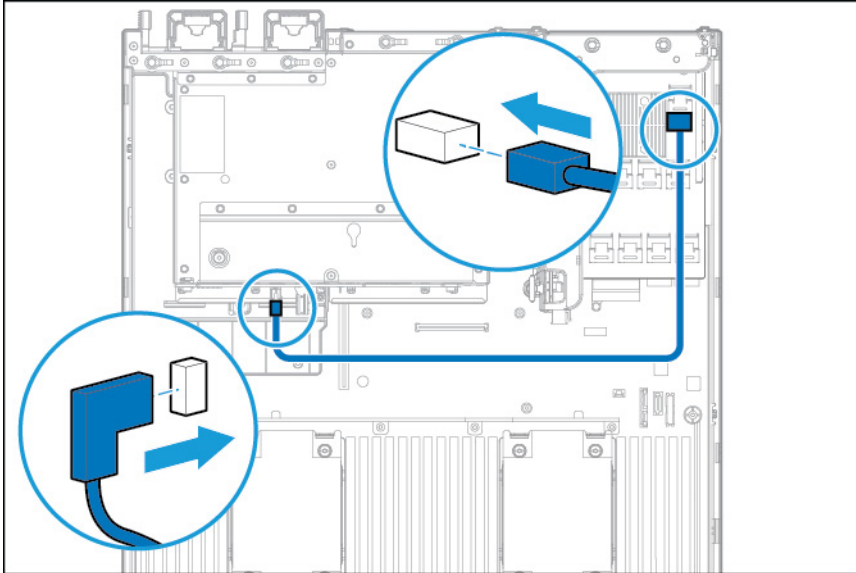

Eight-bay SFF front drive cage cabling

Bay 1 installation

Connect the power cable:

- Single cable connection

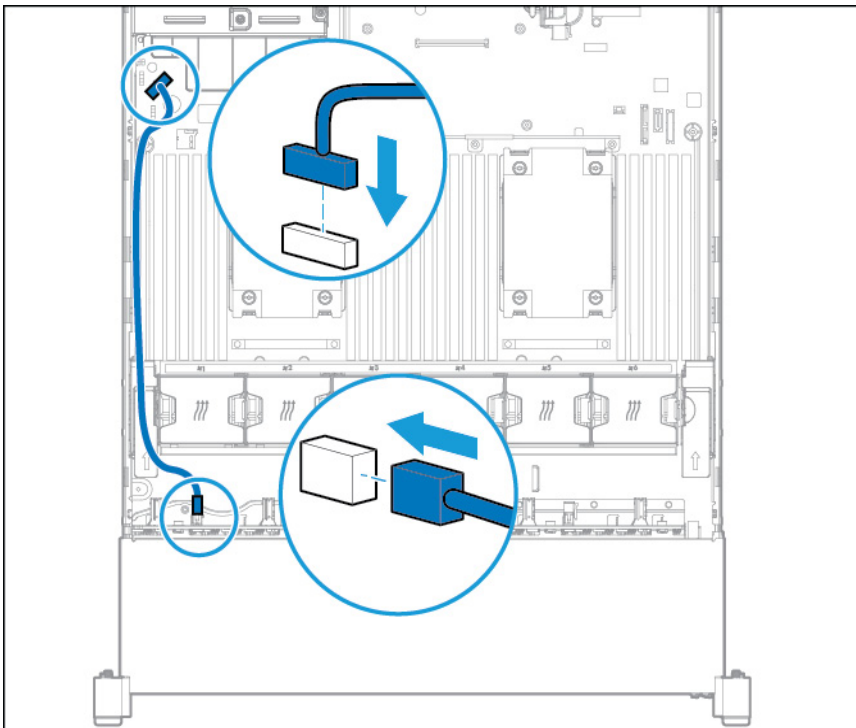

- Y cable connection if the two-bay SFF drive cage option is installed in the rear bay

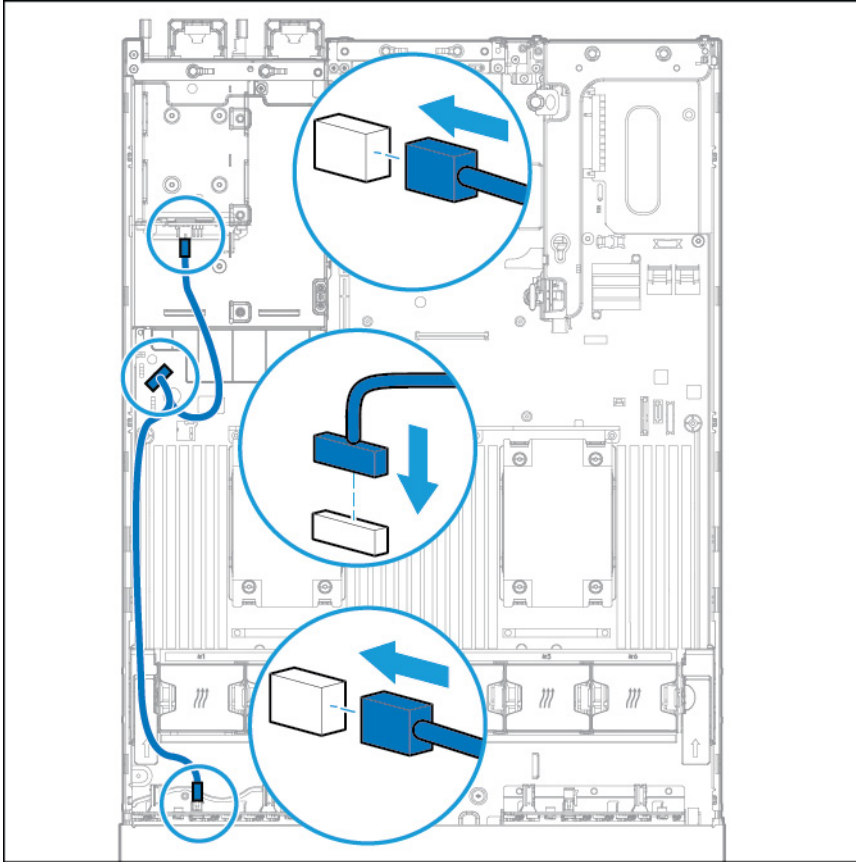

Connect the data cable:

- Connected to a PCI expansion board

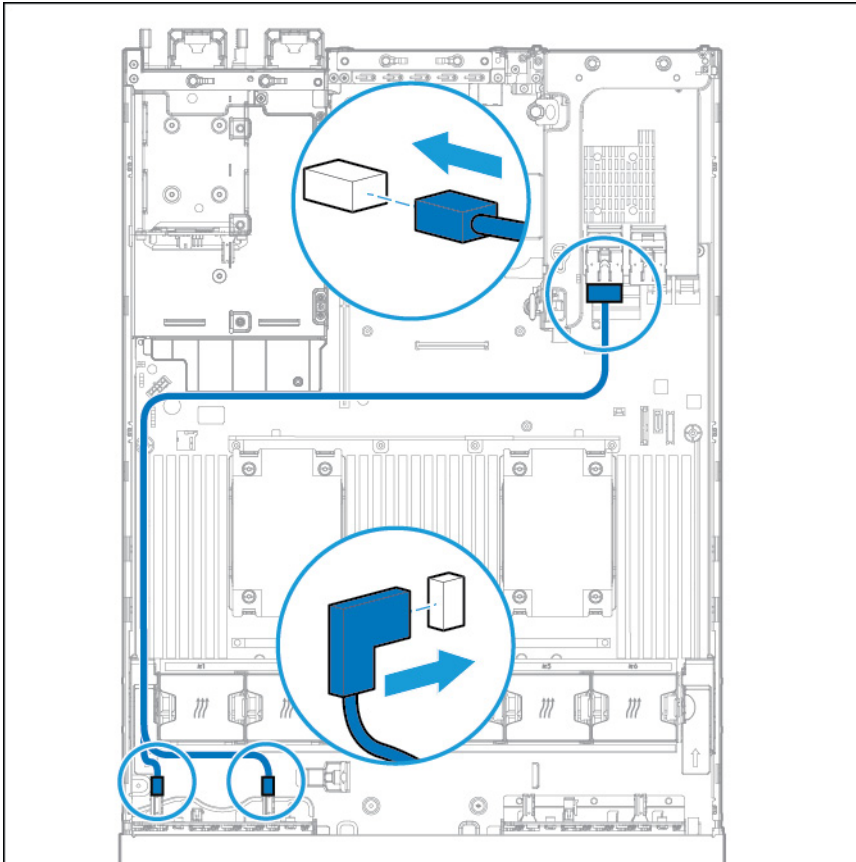

- Connected to an HP 12G SAS Expander Card

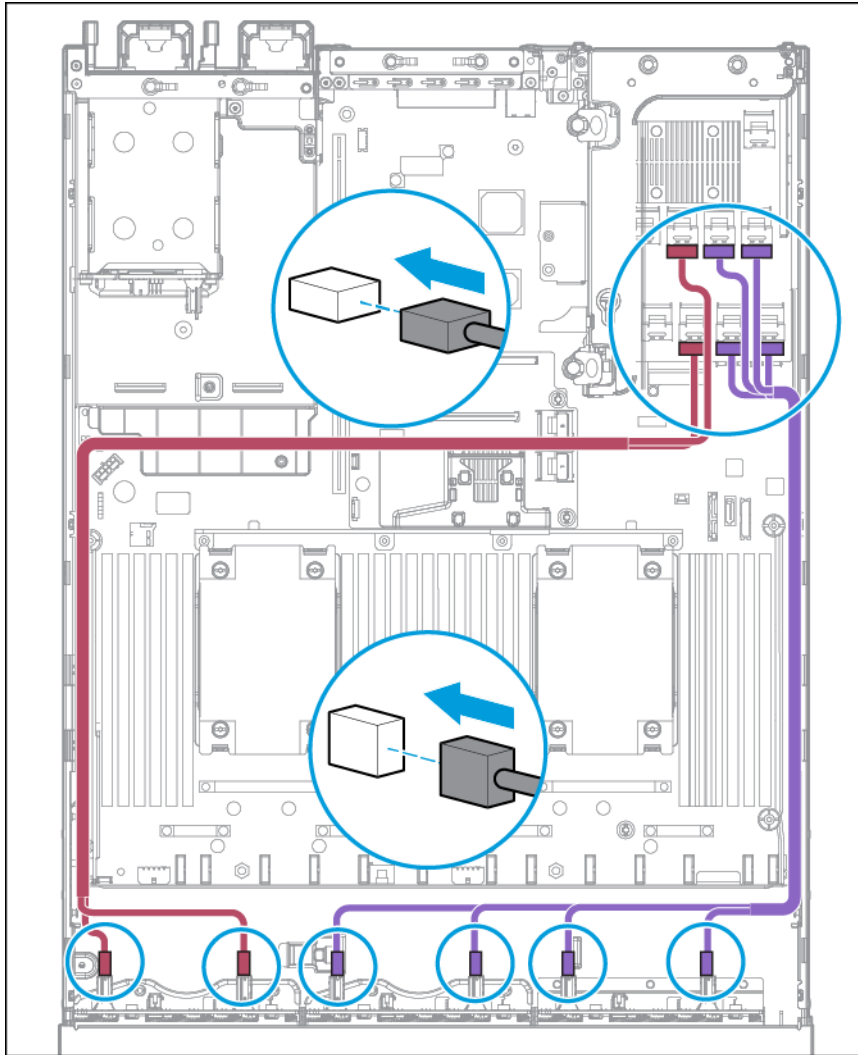

Bay 2 installation

Connect the power cable.

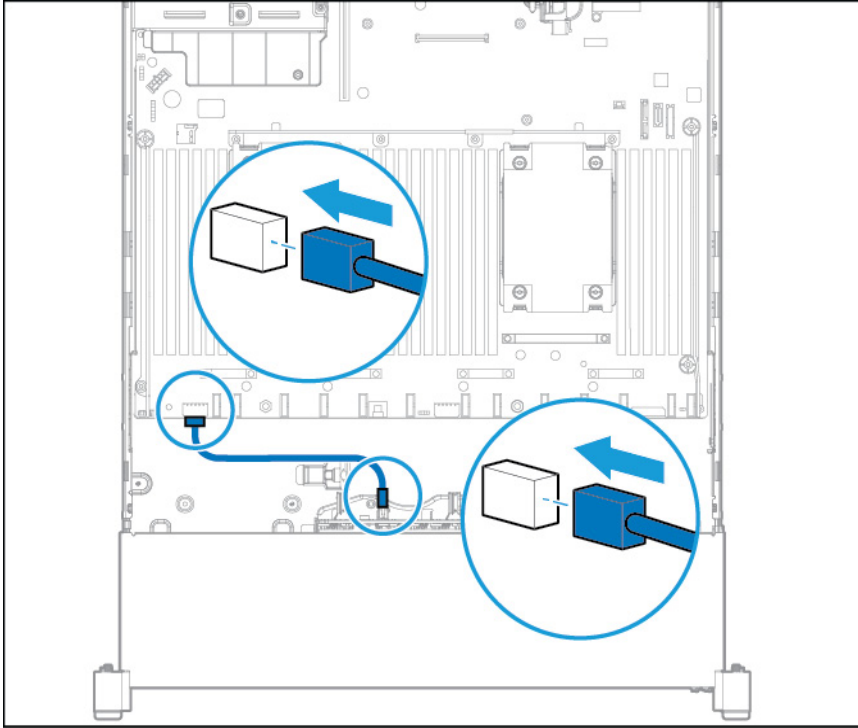

Connect the data cable:

- Connected to a PCI expansion board

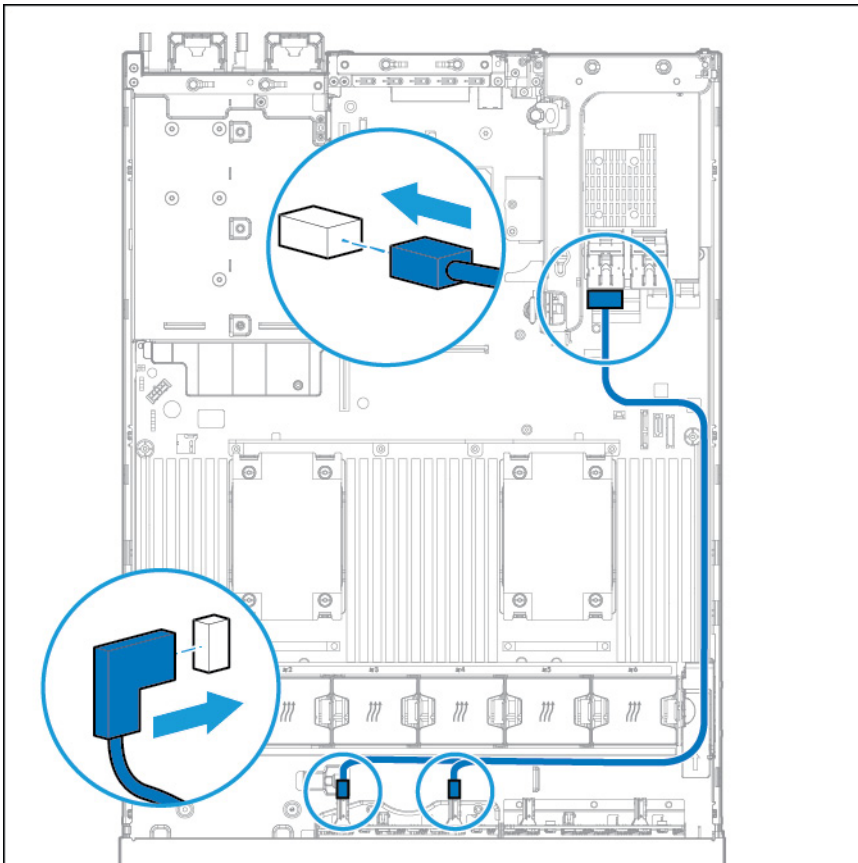

- Connected to an HP 12G SAS Expander Card

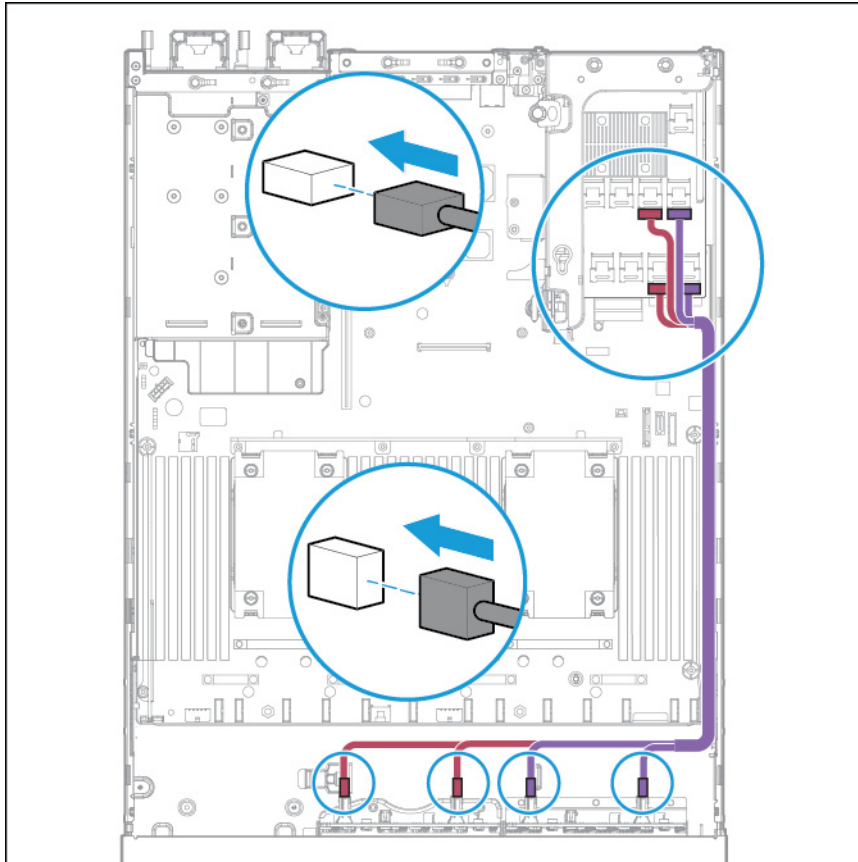

Universal media bay cabling

Connect the VGA cable to the optional VGA connector. Connect the USB cable to the front dual internal USB 3.0 connector.

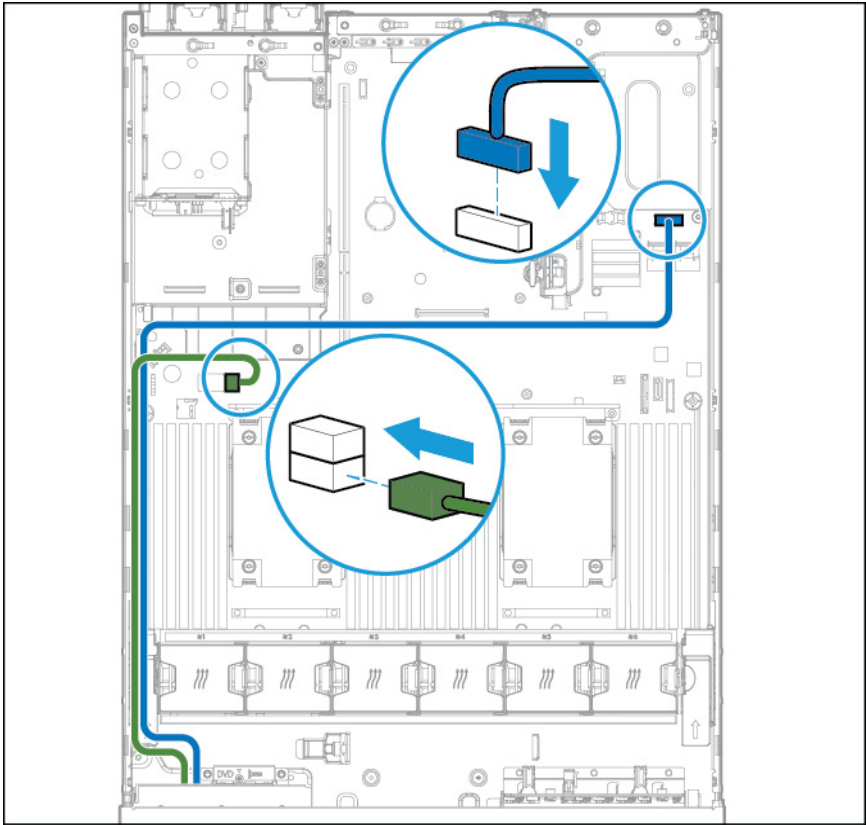

Connect the SATA optical drive cable to the front optical disk drive connector.

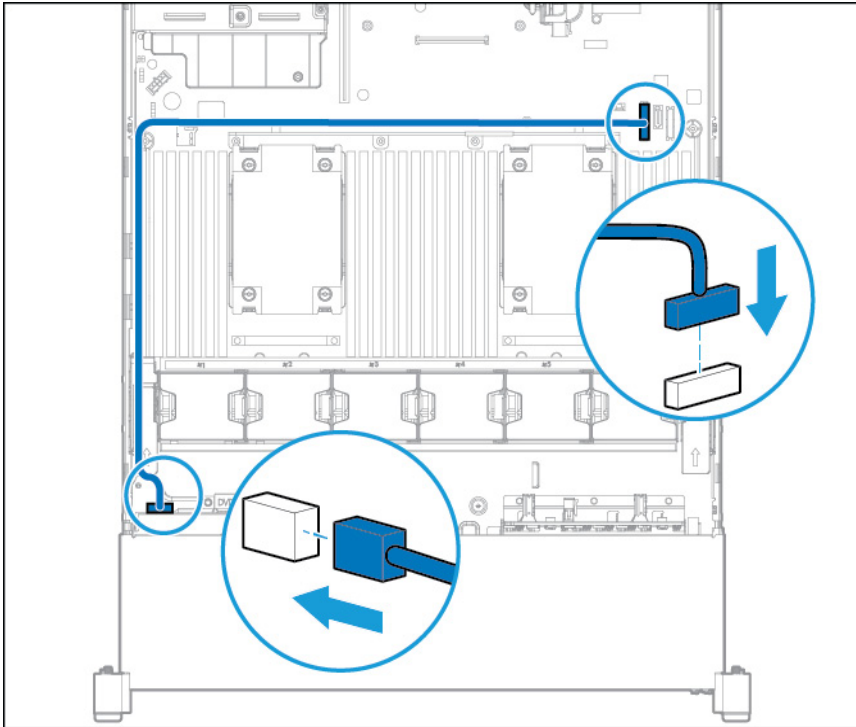

150W PCIe power cable option



CAUTION: To prevent damage to the server or expansion boards, power down the server and remove all AC power cords before removing or installing the PCI expansion cage.

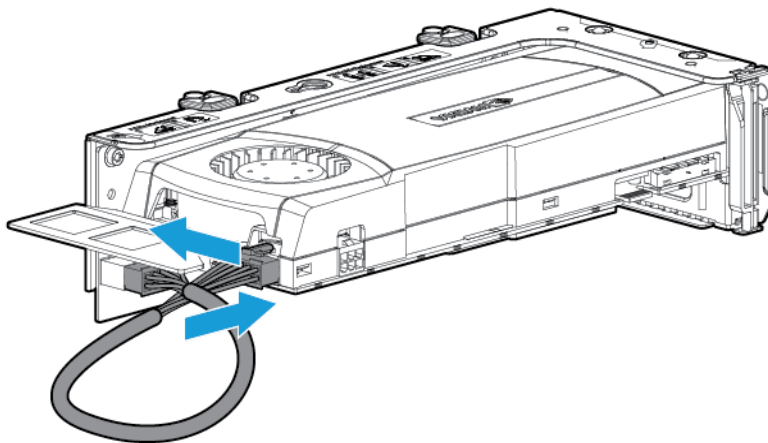

M.2 SSD Enablement Board option cabling

The M.2 SSD Enablement Board option is supported in both the primary and secondary PCI riser cage.

Cable the option according to the location in the server:

- Primary PCI riser cage

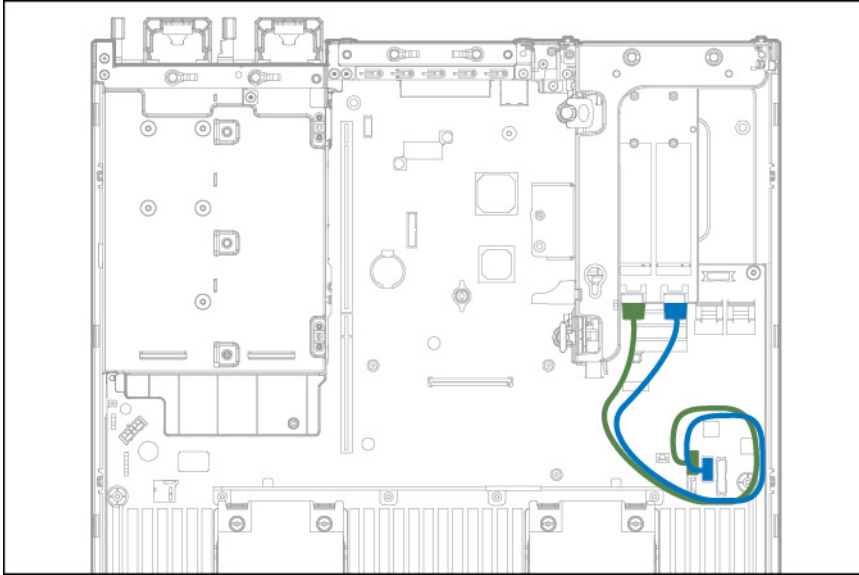

- Secondary PCI riser cage

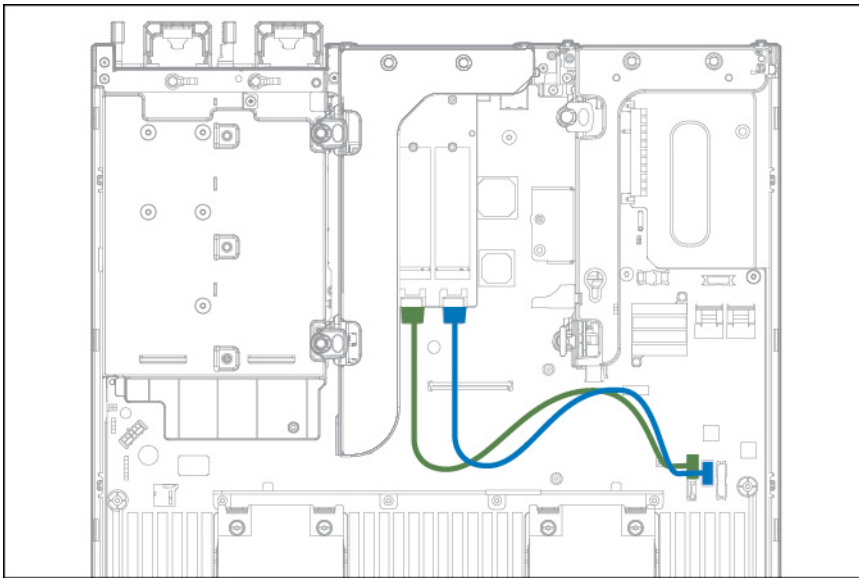

Software and configuration utilities

Server mode

The software and configuration utilities presented in this section operate in online mode, offline mode, or in both modes.

Software or configuration utility	Server mode
HP iLO (on page 140)	Online and Offline
Active Health System (on page 141)	Online and Offline
HP RESTful API support for HP iLO (on page 142)	Online and Offline
Integrated Management Log (on page 142)	Online and Offline
HP Insight Remote Support (on page 143)	Online
HP Insight Online (on page 143)	Online
Intelligent Provisioning (on page 144)	Offline
HP Insight Diagnostics (on page 144)	Online and Offline
Erase Utility (on page 144)	Offline
Scripting Toolkit for Windows and Linux (on page 145)	Online
HP Service Pack for ProLiant (on page 145)	Online and Offline
HP Smart Update Manager (on page 145)	Online and Offline
HP UEFI System Utilities (on page 146)	Offline
HP Smart Storage Administrator (on page 149)	Online and Offline
FWUPDATE utility (on page 151)	Offline

Product QuickSpecs

For more information about product features, specifications, options, configurations, and compatibility, see the product QuickSpecs on the HP website (<http://www.hp.com/go/qs>).

HP iLO

The HP iLO subsystem is a standard component of HP ProLiant servers that simplifies initial server setup, server health monitoring, power and thermal optimization, and remote server administration. The HP iLO subsystem includes an intelligent microprocessor, secure memory, and a dedicated network interface. This design makes HP iLO independent of the host server and its operating system.

HP iLO enables and manages the Active Health System (on page 141) and also features Agentless Management. All key internal subsystems are monitored by HP iLO. If enabled, SNMP alerts are sent directly by HP iLO regardless of the host operating system or even if no host operating system is installed.

Embedded remote support software is available on HP ProLiant Gen8 and later servers with iLO 4, regardless of the operating system software and without installing OS agents on the server.

Using HP iLO, you can do the following:

- Access a high-performance and secure Integrated Remote Console to the server from anywhere in the world if you have a network connection to the server.
- Use the shared .NET Integrated Remote Console to collaborate with up to four server administrators.
- Remotely mount high-performance Virtual Media devices to the server.
- Securely and remotely control the power state of the managed server.
- Implement true Agentless Management with SNMP alerts from HP iLO, regardless of the state of the host server.
- Download the Active Health System log.
- Register for HP Insight Remote Support.
- Use iLO Federation to manage multiple servers from one system running the iLO web interface.
- Use Virtual Power and Virtual Media from the GUI, the CLI, or the iLO scripting toolkit for many tasks, including the automation of deployment and provisioning.
- Control iLO by using a remote management tool.

For more information about HP iLO features, see the HP iLO documentation on the HP website (<http://www.hp.com/go/ilo/docs>).

The HP iLO 4 hardware and firmware features and functionality, such as NAND size and embedded user partition, vary depending on the server model. For a complete list of supported features and functionality, see the HP iLO 4 QuickSpecs on the HP website (http://h18000.www1.hp.com/products/quickspecs/14276_div/14276_div.pdf).

Active Health System

HP Active Health System provides the following features:

- Combined diagnostics tools/scanners
- Always on, continuous monitoring for increased stability and shorter downtimes
- Rich configuration history
- Health and service alerts
- Easy export and upload to Service and Support

The HP Active Health System monitors and records changes in the server hardware and system configuration. The Active Health System assists in diagnosing problems and delivering rapid resolution if server failures occur.

The Active Health System collects the following types of data:

- Server model
- Serial number
- Processor model and speed
- Storage capacity and speed

- Memory capacity and speed
- Firmware/BIOS

HP Active Health System does not collect information about Active Health System users' operations, finances, customers, employees, partners, or data center, such as IP addresses, host names, user names, and passwords. HP Active Health System does not parse or change operating system data from third-party error event log activities, such as content created or passed through by the operating system.

The data that is collected is managed according to the HP Data Privacy policy. For more information see the HP website (<http://www.hp.com/go/privacy>).

The Active Health System, in conjunction with the system monitoring provided by Agentless Management or SNMP Pass-thru, provides continuous monitoring of hardware and configuration changes, system status, and service alerts for various server components.

The Agentless Management Service is available in the SPP, which can be downloaded from the HP website (<http://www.hp.com/go/spp/download>). The Active Health System log can be downloaded manually from HP iLO or HP Intelligent Provisioning and sent to HP.

For more information, see the following documents:

- *HP iLO User Guide* on the HP website (<http://www.hp.com/go/ilo/docs>)
- *HP Intelligent Provisioning User Guide* on the HP website (<http://www.hp.com/go/intelligentprovisioning/docs>)

HP RESTful API support for HP iLO

HP iLO 4 firmware version 2.00 and later includes the HP RESTful API. The HP RESTful API is a management interface that server management tools can use to perform configuration, inventory, and monitoring of an HP ProLiant server via iLO. A REST client sends HTTPS operations to the iLO web server to GET and PATCH JSON-formatted data, and to configure supported iLO and server settings, such as the UEFI BIOS settings.

HP iLO 4 supports the HP RESTful API with HP ProLiant Gen8 and later servers. For more information about the HP RESTful API, see the HP website (<http://www.hp.com/support/restfulinterface/docs>).

Integrated Management Log

The IML records hundreds of events and stores them in an easy-to-view form. The IML timestamps each event with 1-minute granularity.

You can view recorded events in the IML in several ways, including the following:

- From within HP SIM
- From within HP UEFI System Utilities (on page [146](#))
- From within the Embedded UEFI shell (on page [148](#))
- From within operating system-specific IML viewers:
 - For Windows: IML Viewer
 - For Linux: IML Viewer Application
- From within the HP iLO web interface
- From within HP Insight Diagnostics (on page [144](#))

HP Insight Remote Support

HP strongly recommends that you register your device for remote support to enable enhanced delivery of your HP Warranty, HP Care Pack Service, or HP contractual support agreement. HP Insight Remote Support supplements your monitoring continuously to ensure maximum system availability by providing intelligent event diagnosis, and automatic, secure submission of hardware event notifications to HP, which will initiate a fast and accurate resolution, based on your product's service level. Notifications can be sent to your authorized HP Channel Partner for onsite service, if configured and available in your country.

For more information, see *HP Insight Remote Support and Insight Online Setup Guide for ProLiant Servers and BladeSystem c-Class Enclosures* on the HP website (<http://www.hp.com/go/insightremotesupport/docs>). HP Insight Remote Support is available as part of HP Warranty, HP Care Pack Service, or HP contractual support agreement.

HP Insight Remote Support central connect

When you use the embedded Remote Support functionality with HP ProLiant Gen8 and later server models and HP BladeSystem c-Class enclosures, you can register a server or enclosure to communicate to HP through an HP Insight Remote Support centralized Hosting Device in your local environment. All configuration and service event information is routed through the Hosting Device. This information can be viewed by using the local HP Insight Remote Support user interface or the web-based view in HP Insight Online.

For more information, see *HP Insight Remote Support Release Notes* on the HP website (<http://www.hp.com/go/insightremotesupport/docs>).

HP Insight Online direct connect

When you use the embedded Remote Support functionality with HP ProLiant Gen8 and later server models and HP BladeSystem c-Class enclosures, you can register a server or enclosure to communicate directly to HP Insight Online without the need to set up an HP Insight Remote Support centralized Hosting Device in your local environment. HP Insight Online will be your primary interface for remote support information.

For more information, see the product documentation on the HP website (<http://www.hp.com/go/insightremotesupport/docs>).

HP Insight Online

HP Insight Online is a capability of the HP Support Center portal. Combined with HP Insight Remote Support central connect or HP Insight Online direct connect, it automatically aggregates device health, asset, and support information with contract and warranty information, and then secures it in a single, personalized dashboard that is viewable from anywhere at any time. The dashboard organizes your IT and service data to help you understand and respond to that information more quickly. With specific authorization from you, an authorized HP Channel Partner can also view your IT environment remotely using HP Insight Online.

For more information about using HP Insight Online, see the *HP Insight Online User's Guide* on the HP website (<http://www.hp.com/go/insightremotesupport/docs>).

Intelligent Provisioning

Intelligent Provisioning is a single-server deployment tool embedded in HP ProLiant Gen8 and later servers that simplifies HP ProLiant server setup, providing a reliable and consistent way to deploy HP ProLiant server configurations:

- Intelligent Provisioning assists with the OS installation process by preparing the system for installing "off-the-shelf" and HP branded versions of operating system software and integrating optimized HP ProLiant server support software.
- Intelligent Provisioning provides maintenance-related tasks using the Perform Maintenance window.
- Intelligent Provisioning provides installation help for Microsoft Windows, Red Hat and SUSE Linux, and VMware operating systems. For specific OS support, see the *HP Intelligent Provisioning Release Notes* on the HP website (<http://www.hp.com/go/intelligentprovisioning/docs>).

For more information about Intelligent Provisioning software, see the HP website (<http://www.hp.com/go/intelligentprovisioning>). For Intelligent Provisioning recovery media downloads, see the Resources tab on the HP website (<http://www.hp.com/go/ilo>). For consolidated drive and firmware update packages, see the HP Smart Update: Server Firmware and Driver Updates page on the HP website (<http://www.hp.com/go/SmartUpdate>).

HP Insight Diagnostics

HP Insight Diagnostics is a proactive server management tool, available in both offline and online versions, that provides diagnostics and troubleshooting capabilities to assist IT administrators who verify server installations, troubleshoot problems, and perform repair validation.

HP Insight Diagnostics Offline Edition performs various in-depth system and component testing while the OS is not running. To run this utility, boot the server using Intelligent Provisioning (on page 144).

HP Insight Diagnostics Online Edition is a web-based application that captures system configuration and other related data needed for effective server management. Available in Microsoft Windows and Linux versions, the utility helps to ensure proper system operation.

For more information or to download the utility, see the HP website (<http://www.hp.com/servers/diags>). HP Insight Diagnostics Online Edition is also available in the SPP ("HP Service Pack for ProLiant" on page 145).

HP Insight Diagnostics survey functionality

HP Insight Diagnostics (on page 144) provides survey functionality that gathers critical hardware and software information on ProLiant servers.

This functionality supports operating systems that are supported by the server. For operating systems supported by the server, see the HP website (<http://www.hp.com/go/supportos>).

If a significant change occurs between data-gathering intervals, the survey function marks the previous information and overwrites the survey data files to reflect the latest changes in the configuration.

Survey functionality is installed with every Intelligent Provisioning-assisted HP Insight Diagnostics installation, or it can be installed through the SPP ("HP Service Pack for ProLiant" on page 145).

Erase Utility



CAUTION: Perform a backup before running the Erase Utility. The utility sets the system to its original factory state, deletes the current hardware configuration information, including array setup and disk partitioning, and erases all connected hard drives completely. Before using this utility, see the instructions in the *HP Intelligent Provisioning User Guide*.

Use the Erase Utility to erase drives and Active Health System logs, and to reset UEFI System Utilities settings. Run the Erase Utility if you must erase the system for the following reasons:

- You want to install a new operating system on a server with an existing operating system.
- You encounter an error when completing the steps of a factory-installed operating system installation.

To access the Erase Utility, click the Perform Maintenance icon from the Intelligent Provisioning home screen, and then select **Erase**.

For more information about the Erase Utility, see the *HP Intelligent Provisioning User Guide* on the HP website (<http://www.hp.com/go/intelligentprovisioning/docs>).

Scripting Toolkit for Windows and Linux

The Scripting Toolkit for Windows and Linux is a server deployment product that delivers an unattended automated installation for high-volume server deployments. The Scripting Toolkit is designed to support ProLiant BL, ML, DL, SL, and XL servers. The toolkit includes a modular set of utilities and important documentation that describes how to apply these tools to build an automated server deployment process.

The Scripting Toolkit provides a flexible way to create standard server configuration scripts. These scripts are used to automate many of the manual steps in the server configuration process. This automated server configuration process cuts time from each deployment, making it possible to scale rapid, high-volume server deployments.

For more information, and to download the Scripting Toolkit, see the HP website (<http://www.hp.com/go/ProLiant/STK>).

HP Service Pack for ProLiant

SPP is a comprehensive systems software (drivers and firmware) solution delivered as a single package with major server releases. This solution uses HP SUM as the deployment tool and is tested on all supported HP ProLiant servers including HP ProLiant Gen8 and later servers.

SPP can be used in an online mode on a Windows or Linux hosted operating system, or in an offline mode where the server is booted to an operating system included on the ISO file so that the server can be updated automatically with no user interaction or updated in interactive mode.

For more information or to download SPP, see one of the following pages on the HP website:

- HP Service Pack for ProLiant download page (<http://www.hp.com/go/spp>)
- HP Smart Update: Server Firmware and Driver Updates page (<http://www.hp.com/go/SmartUpdate>)

HP Smart Update Manager

HP SUM is a product used to install and update firmware, drivers, and systems software on HP ProLiant servers. HP SUM provides a GUI and a command-line scriptable interface for deployment of systems

software for single or one-to-many HP ProLiant servers and network-based targets, such as iLOs, OAs, and VC Ethernet and Fibre Channel modules.

For more information about HP SUM, see the product page on the HP website (<http://www.hp.com/go/hpsum>).

To download HP SUM, see the HP website (<http://www.hp.com/go/hpsum/download>).

To access the *HP Smart Update Manager User Guide*, see the HP SUM Information Library (<http://www.hp.com/go/hpsum/documentation>).

HP UEFI System Utilities

The HP UEFI System Utilities is embedded in the system ROM. The UEFI System Utilities enable you to perform a wide range of configuration activities, including:

- Configuring system devices and installed options
- Enabling and disabling system features
- Displaying system information
- Selecting the primary boot controller
- Configuring memory options
- Selecting a language
- Launching other pre-boot environments such as the Embedded UEFI Shell and Intelligent Provisioning

For more information on the HP UEFI System Utilities, see the *HP UEFI System Utilities User Guide for HP ProLiant Gen9 Servers* on the HP website (<http://www.hp.com/go/ProLiantUEFI/docs>).

Scan the QR code located at the bottom of the screen to access mobile-ready online help for the UEFI System Utilities and UEFI Shell. For on-screen help, press **F1**.

Using HP UEFI System Utilities

To use the System Utilities, use the following keys.

Action	Key
Access System Utilities	F9 during server POST
Navigate menus	Up and Down arrows
Select items	Enter
Save selections	F10
Access Help for a highlighted configuration option*	F1

*Scan the QR code on the screen to access online help for the UEFI System Utilities and UEFI Shell.

Default configuration settings are applied to the server at one of the following times:

- Upon the first system power-up
- After defaults have been restored

Default configuration settings are sufficient for typical server operations; however, you can modify configuration settings as needed. The system prompts you for access to the System Utilities each time the system is powered up.

Flexible boot control

This feature enables you to do the following:

- Add Boot Options
 - Browse all FAT16 and FAT32 file systems.
 - Select an X64 UEFI application with an .EFI extension to add as a new UEFI boot option, such as an OS boot loader or other UEFI application.

The new boot option is appended to the boot order list. When you select a file, you are prompted to enter the boot option description (which is then displayed in the Boot menu), as well as any optional data to be passed to an .EFI application.

- Boot to System Utilities

After pre-POST, the boot options screen appears. During this time, you can access the System Utilities by pressing the **F9** key.

- Choose between supported modes: Legacy BIOS Boot Mode or UEFI Boot Mode



IMPORTANT: If the default boot mode settings are different than the user defined settings, the system may not boot the OS installation if the defaults are restored. To avoid this issue, use the User Defined Defaults feature in UEFI System Utilities to override the factory default settings.

For more information, see the *HP UEFI System Utilities User Guide for HP ProLiant Gen9 Servers* on the HP website (<http://www.hp.com/go/ProLiantUEFI/docs>).

Restoring and customizing configuration settings

You can reset all configuration settings to the factory default settings, or you can restore system default configuration settings, which are used instead of the factory default settings.

You can also configure default settings as necessary, and then save the configuration as the custom default configuration. When the system loads the default settings, it uses the custom default settings instead of the factory defaults.

Secure Boot configuration

Secure Boot is integrated in the UEFI specification on which the HP implementation of UEFI is based. Secure Boot is completely implemented in the BIOS and does not require special hardware. It ensures that each component launched during the boot process is digitally signed and that the signature is validated against a set of trusted certificates embedded in the UEFI BIOS. Secure Boot validates the software identity of the following components in the boot process:

- UEFI drivers loaded from PCIe cards
- UEFI drivers loaded from mass storage devices
- Pre-boot UEFI shell applications
- OS UEFI boot loaders

Once enabled, only firmware components and operating systems with boot loaders that have an appropriate digital signature can execute during the boot process. Only operating systems that support Secure Boot and have an EFI boot loader signed with one of the authorized keys can boot when Secure Boot is enabled. For more information about supported operating systems, see the *HP UEFI System Utilities and Shell Release Notes* on the HP website (<http://www.hp.com/go/ProLiantUEFI/docs>).

A physically present user can customize the certificates embedded in the UEFI BIOS by adding/removing their own certificates.

Embedded UEFI shell

The system BIOS in all HP ProLiant Gen9 servers includes an Embedded UEFI Shell in the ROM. The UEFI Shell environment provides an API, a command line prompt, and a set of CLIs that allow scripting, file manipulation, and system information. These features enhance the capabilities of the UEFI System Utilities.

For more information, see the following documents:

- *HP UEFI Shell User Guide for HP ProLiant Gen9 Servers* on the HP website (<http://www.hp.com/go/ProLiantUEFI/docs>)
- *UEFI Shell Specification* on the UEFI website (<http://www.uefi.org/specifications>)

Embedded Diagnostics option

The system BIOS in all HP ProLiant Gen9 servers includes an Embedded Diagnostics option in the ROM. The Embedded Diagnostics option can run comprehensive diagnostics of the server hardware, including processors, memory, drives, and other server components.

For more information on the Embedded Diagnostics option, see the *HP UEFI System Utilities User Guide for HP ProLiant Gen9 Servers* on the HP website (<http://www.hp.com/go/ProLiantUEFI/docs>).

HP RESTful API support for UEFI

HP ProLiant Gen9 servers include support for a UEFI compliant System BIOS, along with UEFI System Utilities and Embedded UEFI Shell pre-boot environments. HP ProLiant Gen9 servers also support configuring the UEFI BIOS settings using the HP RESTful API, a management interface that server management tools can use to perform configuration, inventory, and monitoring of an HP ProLiant server. A REST client uses HTTPS operations to configure supported server settings, such as UEFI BIOS settings.

For more information about the HP RESTful API and the HP RESTful Interface Tool, see the HP website (<http://www.hp.com/support/restfulinterface/docs>).

Re-entering the server serial number and product ID

After you replace the system board, you must re-enter the server serial number and the product ID.

1. During the server startup sequence, press the **F9** key to access UEFI System Utilities.
2. Select the **System Configuration > BIOS/Platform Configuration (RBSU) > Advanced Options > Advanced System ROM Options > Serial Number**, and then press the **Enter** key.
3. Enter the serial number and press the **Enter** key. The following message appears:

```
The serial number should only be modified by qualified service
personnel. This value should always match the serial number located on
the chassis.
```

4. Press the **Enter** key to clear the warning.
5. Enter the serial number and press the **Enter** key.
6. Select **Product ID**. The following warning appears:
Warning: The Product ID should ONLY be modified by qualified service personnel. This value should always match the Product ID located on the chassis.
7. Enter the product ID and press the **Enter** key.
8. Press the **F10** key to confirm exiting System Utilities. The server automatically reboots.

Utilities and features

HP Smart Storage Administrator

HP SSA is a configuration and management tool for HP Smart Array controllers. Starting with HP ProLiant Gen8 servers, HP SSA replaces ACU with an enhanced GUI and additional configuration features.

HP SSA exists in three interface formats: the HP SSA GUI, the HP SSA CLI, and HP SSA Scripting. Although all formats provide support for configuration tasks, some of the advanced tasks are available in only one format.

Some HP SSA features include the following:

- Supports online array capacity expansion, logical drive extension, assignment of online spares, and RAID or stripe size migration
- Suggests the optimal configuration for an unconfigured system
- Provides diagnostic and SmartSSD Wear Gauge functionality on the Diagnostics tab
- For supported controllers, provides access to additional features.

For more information about HP SSA, see the HP website (<http://www.hp.com/go/hpssa>).

Automatic Server Recovery

ASR is a feature that causes the system to restart when a catastrophic operating system error occurs, such as a blue screen, ABEND, or panic. A system fail-safe timer, the ASR timer, starts when the System Management driver, also known as the Health Driver, is loaded. When the operating system is functioning properly, the system periodically resets the timer. However, when the operating system fails, the timer expires and restarts the server.

ASR increases server availability by restarting the server within a specified time after a system hang. You can disable ASR from the System Management Homepage or through UEFI System Utilities.

USB support

HP servers support both USB 2.0 ports and USB 3.0 ports. Both types of ports support installing all types of USB devices (USB 1.0, USB 2.0, and USB 3.0), but may run at lower speeds in specific situations:

- USB 3.0 capable devices operate at USB 2.0 speeds when installed in a USB 2.0 port.
- When the server is configured for UEFI Boot Mode, HP provides legacy USB support in the pre-boot environment prior to the operating system loading for USB 1.0, USB 2.0, and USB 3.0 speeds.

- When the server is configured for Legacy BIOS Boot Mode, HP provides legacy USB support in the pre-boot environment prior to the operating system loading for USB 1.0 and USB 2.0 speeds. While USB 3.0 ports can be used with all devices in Legacy BIOS Boot Mode, they are not available at USB 3.0 speeds in the pre-boot environment. Standard USB support (USB support from within the operating system) is provided by the OS through the appropriate USB device drivers. Support for USB 3.0 varies by operating system.

For maximum compatibility of USB 3.0 devices with all operating systems, HP provides a configuration setting for USB 3.0 Mode. Auto is the default setting. This setting impacts USB 3.0 devices when connected to USB 3.0 ports in the following manner:

- **Auto (default)**—If configured in Auto Mode, USB 3.0 capable devices operate at USB 2.0 speeds in the pre-boot environment and during boot. When a USB 3.0 capable OS USB driver loads, USB 3.0 devices transition to USB 3.0 speeds. This mode provides compatibility with operating systems that do not support USB 3.0 while still allowing USB 3.0 devices to operate at USB 3.0 speeds with state-of-the-art operating systems.
- **Enabled**—If Enabled, USB 3.0 capable devices operate at USB 3.0 speeds at all times (including the pre-boot environment) when in UEFI Boot Mode. This mode should not be used with operating systems that do not support USB 3.0. If operating in Legacy Boot BIOS Mode, the USB 3.0 ports cannot function in the pre-boot environment and are not bootable.
- **Disabled**—If configured for Disabled, USB 3.0 capable devices function at USB 2.0 speeds at all times.

The pre-OS behavior of the USB ports is configurable in System Utilities, so that the user can change the default operation of the USB ports. For more information, see the *HP UEFI System Utilities User Guide for HP ProLiant Gen9 Servers* on the HP website (<http://www.hp.com/go/ProLiantUEFI/docs>).

External USB functionality

HP provides external USB support to enable local connection of USB devices for server administration, configuration, and diagnostic procedures.

For additional security, external USB functionality can be disabled through USB options in UEFI System Utilities.

Redundant ROM support

The server enables you to upgrade or configure the ROM safely with redundant ROM support. The server has a single ROM that acts as two separate ROM images. In the standard implementation, one side of the ROM contains the current ROM program version, while the other side of the ROM contains a backup version.

NOTE: The server ships with the same version programmed on each side of the ROM.

Safety and security benefits

When you flash the system ROM, the flashing mechanism writes over the backup ROM and saves the current ROM as a backup, enabling you to switch easily to the alternate ROM version if the new ROM becomes corrupted for any reason. This feature protects the existing ROM version, even if you experience a power failure while flashing the ROM.

Keeping the system current

Access to HP Support Materials

Access to some updates for HP ProLiant Servers may require product entitlement when accessed through the HP Support Center support portal. HP recommends that you have an HP Passport set up with relevant entitlements. For more information, see the HP website (<http://h20564.www2.hp.com/portal/site/hpsc/public/kb/docDisplay/?docId=c03859703>).

Updating firmware or System ROM

Multiple methods exist to update the firmware or System ROM:

- HP Service Pack for ProLiant (on page 145)
- FWUPDATE utility (on page 151)
- FWUpdate command from within the Embedded UEFI shell (on page 152)
- Firmware Update application in System Utilities (on page 152)
- Online Flash components (on page 152)

Product entitlement is required to perform updates. For more information, see "Access to HP Support Materials (on page 151)."

FWUPDATE utility

The FWUPDATE utility enables you to upgrade the system firmware (BIOS).

To use the utility to upgrade the firmware:

1. Download the FWUPDATE flash component from the HP website (<http://www.hp.com/go/hpsc>).
2. Save the FWUPDATE flash components to a USB key.
3. Set the boot order so the USB key will boot first using one of the following options:
 - Configure the boot order so the USB key is the first bootable device.
 - Press **F11** (Boot Menu) when prompted during system boot to access the **One-Time Boot Menu**. This menu allows you to select the boot device for a specific boot and does not modify the boot order configuration settings.
4. Insert the USB key into an available USB port.
5. Boot the system.

The FWUPDATE utility checks the system and provides a choice (if more than one exists) of available firmware revisions.

To download the flash components, see the HP website (<http://www.hp.com/go/hpsc>).

For more information about the One-Time Boot Menu, see the *HP UEFI System Utilities User Guide for HP ProLiant Gen9 Servers* on the HP website (<http://www.hp.com/go/ProLiantUEFI/docs>).

FWUpdate command from within the Embedded UEFI Shell

For systems configured in either boot mode, update the firmware:

1. Access the System ROM Flash Binary component for your server from the HP Support Center (<http://www.hp.com/go/hpsc>). When searching for the component, always select **OS Independent** to locate the binary file.
2. Copy the binary file to a USB media or iLO virtual media.
3. Attach the media to the server.
4. Boot to Embedded Shell.
5. To obtain the assigned file system volume for the USB key, enter `Map -r`. For more information about accessing a file system from the shell, see the *HP UEFI Shell User Guide for HP ProLiant Gen9 Servers* on the HP website (<http://www.hp.com/go/ProLiantUEFI/docs>).
6. Change to the file system that contains the System ROM Flash Binary component for your server. Enter one of the fsx file systems available, such as `fs0` or `fs1`, and press **Enter**.
7. Use the `cd` command to change from the current directory to the directory that contains the binary file.
8. Enter `fwupdate -d BIOS -f <filename>` to flash the system ROM.
For help on the FWUPDATE command, enter the command:
`help fwupdate -b`
9. Reboot the server. A reboot is required after the firmware update for the updates to take effect and for hardware stability to be maintained.

For more information about the commands used in this procedure, see the *HP UEFI Shell User Guide for HP ProLiant Gen9 Servers* on the HP website (<http://www.hp.com/go/ProLiantUEFI/docs>).

Firmware Update application in System Utilities

For systems configured in either boot mode, update the firmware:

1. Access the System ROM Flash Binary component for your server from the HP Support Center (<http://www.hp.com/go/hpsc>). When searching for the component, always select **OS Independent** to find the component.
2. Copy the binary file to a USB media or iLO virtual media.
3. Attach the media to the server.
4. During POST, press **F9** to enter System Utilities.
5. Select **Embedded Applications** → **Firmware Update** → **System ROM** → **Select Firmware File**.
6. Select the device containing the flash file.
7. Select the flash file. This step may take a few moments to complete.
8. Select **Start firmware update** and allow the process to complete.
9. Reboot the server. A reboot is required after the firmware update for the updates to take effect and for hardware stability to be maintained.

Online Flash components

This component provides updated system firmware that can be installed directly on supported Operating Systems. Additionally, when used in conjunction with HP SUM ("HP Smart Update Manager" on page

145), this Smart Component allows the user to update firmware on remote servers from a central location. This remote deployment capability eliminates the need for the user to be physically present at the server to perform a firmware update.

Drivers



IMPORTANT: Always perform a backup before installing or updating device drivers.

The server includes new hardware that may not have driver support on all OS installation media.

If you are installing an Intelligent Provisioning-supported OS, use Intelligent Provisioning (on page 144) and its Configure and Install feature to install the OS and latest supported drivers.

If you do not use Intelligent Provisioning to install an OS, drivers for some of the new hardware are required. These drivers, as well as other option drivers, ROM images, and value-add software can be downloaded as part of an SPP.

If you are installing drivers from SPP, be sure that you are using the latest SPP version that your server supports. To verify that your server is using the latest supported version and for more information about SPP, see the HP website (<http://www.hp.com/go/spp/download>).

To locate the drivers for a particular server, go to the HP website (<http://www.hp.com/go/hpsc>) and click on **Drivers, Software & Firmware**. Then, enter your product name in the **Find an HP product** field and click **Go**.

Software and firmware

Software and firmware should be updated before using the server for the first time, unless any installed software or components require an older version.

For system software and firmware updates, use one of the following sources:

- Download the SPP ("HP Service Pack for ProLiant" on page 145) from the HP Service Pack for ProLiant download page (<http://www.hp.com/go/spp>).
- Download individual drivers, firmware, or other systems software components from the server product page in the HP Support Center (<http://www.hp.com/go/hpsc>).

Operating System Version Support

For information about specific versions of a supported operating system, refer to the operating system support matrix (<http://www.hp.com/go/supportos>).

Version control

The VCRM and VCA are web-enabled Insight Management Agents tools that HP SIM uses to schedule software update tasks to the entire enterprise.

- VCRM manages the repository for SPP. Administrators can view the SPP contents or configure VCRM to automatically update the repository with internet downloads of the latest software and firmware from HP.
- VCA compares installed software versions on the node with updates available in the VCRM managed repository. Administrators configure VCA to point to a repository managed by VCRM.

For more information about version control tools, see the *HP Systems Insight Manager User Guide*, the *HP Version Control Agent User Guide*, and the *HP Version Control Repository Manager User Guide* on the HP website (<http://www.hp.com/go/enterprise/docs>).

1. Select **HP Insight Management** from the available options in Products and Solutions.
2. Select **HP Version Control** from the available options in HP Insight Management.
3. Download the latest document.

HP operating systems and virtualization software support for ProLiant servers

For information about specific versions of a supported operating system, see the HP website (<http://www.hp.com/go/ossupport>).

HP Technology Service Portfolio

Connect to HP for assistance on the journey to the new style of IT. HP Technology Services delivers confidence and reduces risk to help you realize agility and stability in your IT infrastructure.

Utilize our consulting expertise in the areas of private or hybrid cloud computing, big data and mobility requirements, improving data center infrastructure and better use of today's server, storage and networking technology. For more information, see the HP website (<http://www.hp.com/services/consulting>).

Our support portfolio covers services for HP server, storage and networking hardware and software plus the leading industry standard operating systems. Let us work proactively with you to prevent problems. Our flexible choices of hardware and software support coverage windows and response times help resolve problems faster, reduce unplanned outages and free your staff for more important tasks. For more information, see the HP website (<http://www.hp.com/services/support>).

Tap into our knowledge, expertise, innovation and world-class services to achieve better results. Access and apply technology in new ways to optimize your operations and you'll be positioned for success.

Change control and proactive notification

HP offers Change Control and Proactive Notification to notify customers 30 to 60 days in advance of upcoming hardware and software changes on HP commercial products.

For more information, refer to the HP website (<http://www.hp.com/go/pcn>).

Troubleshooting

Troubleshooting resources

The *HP ProLiant Gen9 Troubleshooting Guide, Volume I: Troubleshooting* provides procedures for resolving common problems and comprehensive courses of action for fault isolation and identification, issue resolution, and software maintenance on ProLiant servers and server blades. To view the guide, select a language:

- English (http://www.hp.com/support/Gen9_TSG_en)
- French (http://www.hp.com/support/Gen9_TSG_fr)
- Spanish (http://www.hp.com/support/Gen9_TSG_es)
- German (http://www.hp.com/support/Gen9_TSG_de)
- Japanese (http://www.hp.com/support/Gen9_TSG_ja)
- Simplified Chinese (http://www.hp.com/support/Gen9_TSG_zh_cn)

The *HP ProLiant Gen9 Troubleshooting Guide, Volume II: Error Messages* provides a list of error messages and information to assist with interpreting and resolving error messages on ProLiant servers and server blades. To view the guide, select a language:

- English (http://www.hp.com/support/Gen9_EMG_en)
- French (http://www.hp.com/support/Gen9_EMG_fr)
- Spanish (http://www.hp.com/support/Gen9_EMG_es)
- German (http://www.hp.com/support/Gen9_EMG_de)
- Japanese (http://www.hp.com/support/Gen9_EMG_ja)
- Simplified Chinese (http://www.hp.com/support/Gen9_EMG_zh_cn)

Battery replacement

If the server no longer automatically displays the correct date and time, you may need to replace the battery that provides power to the real-time clock.



WARNING: The computer contains an internal lithium manganese dioxide, a vanadium pentoxide, or an alkaline battery pack. A risk of fire and burns exists if the battery pack is not properly handled. To reduce the risk of personal injury:

- Do not attempt to recharge the battery.
- Do not expose the battery to temperatures higher than 60°C (140°F).
- Do not disassemble, crush, puncture, short external contacts, or dispose of in fire or water.
- Replace only with the spare designated for this product.

To remove the component:

1. Power down the server (on page 25).
2. Remove all power:
 - a. Disconnect each power cord from the power source.
 - b. Disconnect each power cord from the server.
3. Do one of the following:
 - Extend the server from the rack (on page 25).
 - Remove the server from the rack (on page 26).
4. Remove the access panel (on page 26).
5. If installed, remove the secondary PCIe riser cage ("3-slot PCI riser cage option" on page 66).
6. Locate the battery ("System board components" on page 17).
7. Remove the battery.

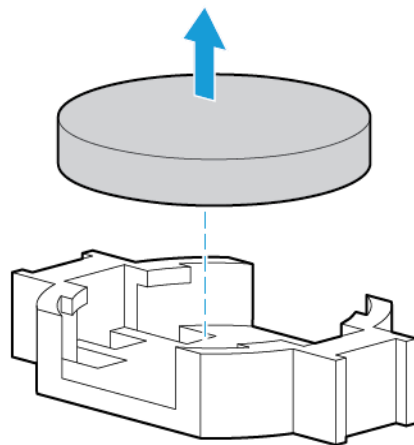

To replace the component, reverse the removal procedure.

For more information about battery replacement or proper disposal, contact an authorized reseller or an authorized service provider.

Regulatory information

Safety and regulatory compliance

For safety, environmental, and regulatory information, see *Safety and Compliance Information for Server, Storage, Power, Networking, and Rack Products*, available at the HP website (<http://www.hp.com/support/Safety-Compliance-EnterpriseProducts>).

Belarus Kazakhstan Russia marking



Manufacturer

Hewlett-Packard Company, Address: 3000 Hanover Street, Palo Alto, California 94304, U.S.

Local representative information (Russian)

- HP Russia
ЗАО «Хьюлетт-Паккард А.О.», 125171, Россия, г. Москва, Ленинградское шоссе, 16А, стр.3, тел./факс: +7 (495) 797 35 00, +7 (495) 287 89 05
- HP Belarus
ИООО «Хьюлетт-Паккард Бел», 220030, Беларусь, г. Минск, ул. Интернациональная, 36-1, офис 722-723, тел.: +375 (17) 392 28 18, факс: +375 (17) 392 28 21
- HP Kazakhstan
ТОО «Хьюлетт-Паккард (К)», 050040, Казахстан, г. Алматы, Бостандыкский район, ул. Тимирязева, 28В, 1 этаж, тел./факс: +7 (727) 355 35 50, +7 (727) 355 35 51

Local representative information (Kazakh)

ЖШС «Хьюлетт-Паккард (К)», Қазақстан, Алматы қ., Бостандық ауданы, Тимирязев к-сі, 28В, тел./факс: +7 (727) 355 35 50, +7 (727) 355 35 51

Manufacturing date

The manufacturing date is defined by the serial number (HP serial number format for this product):
CCSYWWZZZZ

Valid date formats include the following:

- YWW, where Y indicates the year counting from within each new decade, with 2000 as the starting point. For example, 238: 2 for 2002 and 38 for the week of September 9. In addition, 2010 is indicated by 0, 2011 by 1, 2012 by 2, 2013 by 3, and so forth.
- YYWW, where YY indicates the year, using a base year of 2000. For example, 0238: 02 for 2002 and 38 for the week of September 9.

Turkey RoHS material content declaration

Türkiye Cumhuriyeti: EEE Yönetmeliğine Uygundur

Ukraine RoHS material content declaration

Обладнання відповідає вимогам Технічного регламенту щодо обмеження використання деяких небезпечних речовин в електричному та електронному обладнанні, затвердженого постановою Кабінету Міністрів України від 3 грудня 2008 № 1057

Warranty information

HP ProLiant and X86 Servers and Options (<http://www.hp.com/support/ProLiantServers-Warranties>)

HP Enterprise Servers (<http://www.hp.com/support/EnterpriseServers-Warranties>)

HP Storage Products (<http://www.hp.com/support/Storage-Warranties>)

HP Networking Products (<http://www.hp.com/support/Networking-Warranties>)

Electrostatic discharge

Preventing electrostatic discharge

To prevent damaging the system, be aware of the precautions you need to follow when setting up the system or handling parts. A discharge of static electricity from a finger or other conductor may damage system boards or other static-sensitive devices. This type of damage may reduce the life expectancy of the device.

To prevent electrostatic damage:

- Avoid hand contact by transporting and storing products in static-safe containers.
- Keep electrostatic-sensitive parts in their containers until they arrive at static-free workstations.
- Place parts on a grounded surface before removing them from their containers.
- Avoid touching pins, leads, or circuitry.
- Always be properly grounded when touching a static-sensitive component or assembly.

Grounding methods to prevent electrostatic discharge

Several methods are used for grounding. Use one or more of the following methods when handling or installing electrostatic-sensitive parts:

- Use a wrist strap connected by a ground cord to a grounded workstation or computer chassis. Wrist straps are flexible straps with a minimum of 1 megohm ± 10 percent resistance in the ground cords. To provide proper ground, wear the strap snug against the skin.
- Use heel straps, toe straps, or boot straps at standing workstations. Wear the straps on both feet when standing on conductive floors or dissipating floor mats.
- Use conductive field service tools.
- Use a portable field service kit with a folding static-dissipating work mat.

If you do not have any of the suggested equipment for proper grounding, have an authorized reseller install the part.

For more information on static electricity or assistance with product installation, contact an authorized reseller.

Specifications

Environmental specifications

Specification	Value
Temperature range*	—
Operating	10°C to 35°C (50°F to 95°F)
Nonoperating	-30°C to 60°C (-22°F to 140°F)
Relative humidity (noncondensing)	—
Operating	Minimum to be the higher (more moisture) of -12°C (10.4°F) dew point or 8% relative humidity Maximum to be 24°C (75.2°F) dew point or 90% relative humidity
Nonoperating	5% to 95% 38.7°C (101.7°F), maximum wet bulb temperature

* All temperature ratings shown are for sea level. An altitude derating of 1.0°C per 304.8 m (1.8°F per 1000 ft) to 3048 m (10,000 ft) is applicable. No direct sunlight allowed. Maximum rate of change is 20°C per hour (36°F per hour). The upper limit and rate of change might be limited by the type and number of options installed.

For certain approved hardware configurations, the supported system inlet temperature range is extended:

- 5°C to 10°C (41°F to 50°F) and 35°C to 40°C (95°F to 104°F) at sea level with an altitude derating of 1.0°C per every 175 m (1.8°F per every 574 ft) above 900 m (2953 ft) to a maximum of 3048 m (10,000 ft).
- 40°C to 45°C (104°F to 113°F) at sea level with an altitude derating of 1.0°C per every 125 m (1.8°F per every 410 ft) above 900 m (2953 ft) to a maximum of 3048 m (10,000 ft).

The approved hardware configurations for this system are listed on the HP website (<http://www.hp.com/servers/ASHRAE>).

Mechanical specifications

Specification	Value
Height	8.73 cm (3.44 in)
Depth, SFF	67.94 cm (26.75 in)
Depth, LFF	73.02 cm (28.75 in)
Width	44.54 cm (17.54 in)

Weight (maximum—all SFF drives)*	14.7 kg (32.6 lb)
Weight (minimum—one LFF drive)**	23.6 kg (51.5 lb)

*The SFF configuration includes the following components:

- SFF drive (1)
- Drive blanks (7)
- Drive bay blanks for bays 1 and 2 (2)
- Fan assemblies (4)
- Fan blanks (2)
- Standard heatsink (1)
- 1P air baffle (1)
- X8 HP Flexible Smart Array Controller (1)
- Primary riser cage (1)
- Secondary riser cage blank (1)
- Power supply (1)
- Power supply blank (1)
- Cables for the above components

**The LFF configuration includes the following components:

- LFF drives (12)
- Fan assemblies (6)
- SE heatsinks (2)
- 2P air baffle (1)
- X8 HP Flexible Smart Array Controller (1)
- Primary riser cage (1)
- Secondary riser cage (1)
- Power supplies (2)
- Cables for the above components

The 12 LFF configuration does not contain a rear three-bay LFF drive cage option.

Power supply specifications

Depending on installed options, the server is configured with one of the following power supplies:

- HP 500W Flex Slot Platinum Hot-plug Power Supply (on page [163](#))
- HP 800W Flex Slot Platinum Hot-plug Power Supply (on page [163](#))
- HP 800W Flex Slot Titanium Plus Hot-plug Power Supply (on page [164](#))
- HP 800W Flex Slot Universal Hot-plug Power Supply (on page [165](#))

- HP 800W Flex Slot -48VDC Hot-plug Power Supply (on page 165)
- HP 1400W Flex Slot Platinum Plus Hot-plug Power Supply (on page 166)

For detailed power supply specifications, see the QuickSpecs on the HP website (<http://www.hp.com/go/proliant/powersupply>).

HP 500W Flex Slot Platinum Hot-plug Power Supply

Specification	Value
Input requirements	
Rated input voltage	100 to 127 VAC 200 to 240 VAC 240 VDC for China only
Rated input frequency	50 Hz to 60 Hz Not applicable to 240 VDC
Rated input current	5.8 A at 100 VAC 2.8 A at 200 VAC 2.4 A at 240 VDC for China only
Maximum rated input power	580 W at 100 VAC 560 W at 200 VAC 576 W at 240 VDC for China only
BTUs per hour	1979 at 100 VAC 1911 at 200 VAC 1965 at 240 VDC for China only
Power supply output	
Rated steady-state power	500 W at 100 VAC to 127 VAC input 500 W at 200 VAC to 240 VAC input 500 W at 240 VDC input for China only
Maximum peak power	500 W at 100 VAC to 127 VAC input 500 W at 200 VAC to 240 VAC input 500 W at 240 VDC input for China only

HP 800W Flex Slot Platinum Hot-plug Power Supply

Specification	Value
Input requirements	
Rated input voltage	100 to 127 VAC 200 to 240 VAC

	240 VDC for China only
Rated input frequency	50 Hz to 60 Hz Not applicable to 240VDC
Rated input current	9.4 A at 100 VAC 4.5 A at 200 VAC 3.8 A at 240 VDC for China only
Maximum rated input power	940 W at 100 VAC 900 W at 200 VAC 912 W at 240 VDC for China only
BTUs per hour	3207 at 100 VAC 3071 at 200 VAC 3112 at 240 for China only
Power supply output	
Rated steady-state power	800 W at 100 VAC to 127 VAC input 800 W at 200 VAC to 240 VAC input 800 W at 240 VDC input for China only
Maximum peak power	800 W at 100 VAC to 127 VAC input 800 W at 200 VAC to 240 VAC input 800 W at 240 VDC input for China only

HP 800W Flex Slot Titanium Plus Hot-plug Power Supply

Specification	Value
Input requirements	
Rated input voltage	200 to 240 V AC 240 VDC for China only
Rated input frequency	50 Hz to 60 Hz Not applicable to 240 VDC
Rated input current	4.35 A at 200 VAC 3.62 A at 240 VAC 3.62 A at 240 VDC for China only
Maximum rated input power	870 W at 200 VAC 870 W at 240 VAC 870 W at 240 VDC for China only
BTUs per hour	2969 at 200 VAC 2969 at 240 VAC 2969 at 240 VDC for China only

Power supply output	
Rated steady-state power	800 W at 200 VAC to 240 VAC input 800 W at 240 VDC input for China only
Maximum peak power	800 W at 200 VAC to 240 VAC input 800 W at 240 VDC input for China only

HP 800W Flex Slot Universal Hot-plug Power Supply

Specification	Value
Input requirements	
Rated input voltage	200 V to 277 V AC 380 VDC
Rated input frequency	50 Hz–60 Hz
Rated input current	4.5 A at 200 V AC 3.2 A at 277 V AC 2.3 A at 380 VDC
Maximum rated input power	900 W at 200 VAC 887 W at 277 VAC 874 W at 380 VDC
BTUs per hour	3071 at 200 VAC 3026 at 277 VAC 2982 at 380 VDC
Power supply output	
Rated steady-state power	800 W at 200 VAC to 277 VAC input 800 W at 380 VDC input
Maximum peak power	800 W at 200 VAC to 277 VAC input 800 W at 380 VDC input

HP 800W Flex Slot -48VDC Hot-plug Power Supply

Specification	Value
Input requirements	
Rated input voltage	-40 VDC to -72 VDC -48 VDC nominal input
Rated input current	26 A at -40 VDC input 19 A at -48 VDC input, nominal input 12.4 A at -72 VDC input

Rated input power (W)	936 W at -40 VDC input 912 W at -48 VDC input, nominal input 900 W at -72 VDC input
Rated input power (BTUs per hour)	3194 at -40 VDC input 3112 at -48 VDC input, nominal input 3071 at -72 VDC input
Power supply output	
Rated steady-state power (W)	800 W at -40 VDC to -72 VDC
Maximum peak power (W)	800 W at -40 VDC to -72 VDC



WARNING: To reduce the risk of electric shock or energy hazards:

- This equipment must be installed by trained service personnel, as defined by the NEC and IEC 60950-1, Second Edition, the standard for Safety of Information Technology Equipment.
- Connect the equipment to a reliably grounded Secondary circuit source. A Secondary circuit has no direct connection to a Primary circuit and derives its power from a transformer, converter, or equivalent isolation device.
- The branch circuit overcurrent protection must be rated 27 A.



CAUTION: This equipment is designed to permit the connection of the earthed conductor of the DC supply circuit to the earthing conductor at the equipment.

If this connection is made, all of the following must be met:

- This equipment must be connected directly to the DC supply system earthing electrode conductor or to a bonding jumper from an earthing terminal bar or bus to which the DC supply system earthing electrode conductor is connected.
- This equipment must be located in the same immediate area (such as adjacent cabinets) as any other equipment that has a connection between the earthed conductor of the same DC supply circuit and the earthing conductor, and also the point of earthing of the DC system. The DC system must be earthed elsewhere.
- The DC supply source is to be located within the same premises as the equipment.
- Switching or disconnecting devices must not be in the earthed circuit conductor between the DC source and the point of connection of the earthing electrode conductor.

HP 1400W Flex Slot Platinum Plus Hot-plug Power Supply

Specification	Value
Input requirements	
Rated input voltage	200 to 240 VAC 240 VDC for China only
Rated input frequency	50 Hz to 60 Hz Not applicable to 240 VDC
Rated input current	8.0 A at 200 VAC 6.7 A at 240 VAC

	6.7 A at 240 VDC for China only
Maximum rated input power	1600 W at 200 VAC 1600 W at 240 VAC 1600 W at 240 VDC for China only
BTUs per hour	5459 at 200 VAC 5459 at 240 VAC 5459 at 240 VDC for China only
Power supply output	
Rated steady-state power	1400 W at 200 VAC to 240 VAC input 1400 W at 240 VDC input for China only
Maximum peak power	1400 W at 200 VAC to 240 VAC input 1400 W at 240 VDC input for China only

Support and other resources

Before you contact HP

Be sure to have the following information available before you call HP:

- Active Health System log (HP ProLiant Gen8 or later products)
Download and have available an Active Health System log for 7 days before the failure was detected. For more information, see the *HP iLO 4 User Guide* or *HP Intelligent Provisioning User Guide* on the HP website (<http://www.hp.com/go/ilo/docs>).
- Onboard Administrator SHOW ALL report (for HP BladeSystem products only)
For more information on obtaining the Onboard Administrator SHOW ALL report, see the HP website (<http://www.hp.com/go/OAlog>).
- Technical support registration number (if applicable)
- Product serial number
- Product model name and number
- Product identification number
- Applicable error messages
- Add-on boards or hardware
- Third-party hardware or software
- Operating system type and revision level

HP contact information

For United States and worldwide contact information, see the Contact HP website (<http://www.hp.com/go/assistance>).

In the United States:

- To contact HP by phone, call 1-800-334-5144. For continuous quality improvement, calls may be recorded or monitored.
- If you have purchased a Care Pack (service upgrade), see the Support & Drivers website (<http://www8.hp.com/us/en/support-drivers.html>). If the problem cannot be resolved at the website, call 1-800-633-3600. For more information about Care Packs, see the HP website (<http://pro-aq-sama.houston.hp.com/services/cache/10950-0-0-225-121.html>).

Customer Self Repair

HP products are designed with many Customer Self Repair (CSR) parts to minimize repair time and allow for greater flexibility in performing defective parts replacement. If during the diagnosis period HP (or HP

service providers or service partners) identifies that the repair can be accomplished by the use of a CSR part, HP will ship that part directly to you for replacement. There are two categories of CSR parts:

- **Mandatory**—Parts for which customer self repair is mandatory. If you request HP to replace these parts, you will be charged for the travel and labor costs of this service.
- **Optional**—Parts for which customer self repair is optional. These parts are also designed for customer self repair. If, however, you require that HP replace them for you, there may or may not be additional charges, depending on the type of warranty service designated for your product.

NOTE: Some HP parts are not designed for customer self repair. In order to satisfy the customer warranty, HP requires that an authorized service provider replace the part. These parts are identified as "No" in the Illustrated Parts Catalog.

Based on availability and where geography permits, CSR parts will be shipped for next business day delivery. Same day or four-hour delivery may be offered at an additional charge where geography permits. If assistance is required, you can call the HP Technical Support Center and a technician will help you over the telephone. HP specifies in the materials shipped with a replacement CSR part whether a defective part must be returned to HP. In cases where it is required to return the defective part to HP, you must ship the defective part back to HP within a defined period of time, normally five (5) business days. The defective part must be returned with the associated documentation in the provided shipping material. Failure to return the defective part may result in HP billing you for the replacement. With a customer self repair, HP will pay all shipping and part return costs and determine the courier/carrier to be used.

For more information about HP's Customer Self Repair program, contact your local service provider. For the North American program, refer to the HP website (<http://www.hp.com/go/selfrepair>).

Réparation par le client (CSR)

Les produits HP comportent de nombreuses pièces CSR (Customer Self Repair = réparation par le client) afin de minimiser les délais de réparation et faciliter le remplacement des pièces défectueuses. Si pendant la période de diagnostic, HP (ou ses partenaires ou mainteneurs agréés) détermine que la réparation peut être effectuée à l'aide d'une pièce CSR, HP vous l'envoie directement. Il existe deux catégories de pièces CSR:

Obligatoire - Pièces pour lesquelles la réparation par le client est obligatoire. Si vous demandez à HP de remplacer ces pièces, les coûts de déplacement et main d'œuvre du service vous seront facturés.

Facultatif - Pièces pour lesquelles la réparation par le client est facultative. Ces pièces sont également conçues pour permettre au client d'effectuer lui-même la réparation. Toutefois, si vous demandez à HP de remplacer ces pièces, l'intervention peut ou non vous être facturée, selon le type de garantie applicable à votre produit.

REMARQUE: Certaines pièces HP ne sont pas conçues pour permettre au client d'effectuer lui-même la réparation. Pour que la garantie puisse s'appliquer, HP exige que le remplacement de la pièce soit effectué par un Mainteneur Agréé. Ces pièces sont identifiées par la mention "Non" dans le Catalogue illustré.

Les pièces CSR sont livrées le jour ouvré suivant, dans la limite des stocks disponibles et selon votre situation géographique. Si votre situation géographique le permet et que vous demandez une livraison le jour même ou dans les 4 heures, celle-ci vous sera facturée. Pour bénéficier d'une assistance téléphonique, appelez le Centre d'assistance technique HP. Dans les documents envoyés avec la pièce de rechange CSR, HP précise s'il est nécessaire de lui retourner la pièce défectueuse. Si c'est le cas, vous devez le faire dans le délai indiqué, généralement cinq (5) jours ouvrés. La pièce et sa documentation doivent être retournées dans l'emballage fourni. Si vous ne retournez pas la pièce défectueuse, HP se

réserve le droit de vous facturer les coûts de remplacement. Dans le cas d'une pièce CSR, HP supporte l'ensemble des frais d'expédition et de retour, et détermine la société de courses ou le transporteur à utiliser.

Pour plus d'informations sur le programme CSR de HP, contactez votre Mainteneur Agréé local. Pour plus d'informations sur ce programme en Amérique du Nord, consultez le site Web HP (<http://www.hp.com/go/selfrepair>).

Riparazione da parte del cliente

Per abbreviare i tempi di riparazione e garantire una maggiore flessibilità nella sostituzione di parti difettose, i prodotti HP sono realizzati con numerosi componenti che possono essere riparati direttamente dal cliente (CSR, Customer Self Repair). Se in fase di diagnostica HP (o un centro di servizi o di assistenza HP) identifica il guasto come riparabile mediante un ricambio CSR, HP lo spedisce direttamente al cliente per la sostituzione. Vi sono due categorie di parti CSR:

Obbligatorie – Parti che devono essere necessariamente riparate dal cliente. Se il cliente ne affida la riparazione ad HP, deve sostenere le spese di spedizione e di manodopera per il servizio.

Opzionali – Parti la cui riparazione da parte del cliente è facoltativa. Si tratta comunque di componenti progettati per questo scopo. Se tuttavia il cliente ne richiede la sostituzione ad HP, potrebbe dover sostenere spese aggiuntive a seconda del tipo di garanzia previsto per il prodotto.

NOTA: alcuni componenti HP non sono progettati per la riparazione da parte del cliente. Per rispettare la garanzia, HP richiede che queste parti siano sostituite da un centro di assistenza autorizzato. Tali parti sono identificate da un "No" nel Catalogo illustrato dei componenti.

In base alla disponibilità e alla località geografica, le parti CSR vengono spedite con consegna entro il giorno lavorativo seguente. La consegna nel giorno stesso o entro quattro ore è offerta con un supplemento di costo solo in alcune zone. In caso di necessità si può richiedere l'assistenza telefonica di un addetto del centro di supporto tecnico HP. Nel materiale fornito con una parte di ricambio CSR, HP specifica se il cliente deve restituire dei componenti. Qualora sia richiesta la resa ad HP del componente difettoso, lo si deve spedire ad HP entro un determinato periodo di tempo, generalmente cinque (5) giorni lavorativi. Il componente difettoso deve essere restituito con la documentazione associata nell'imballo di spedizione fornito. La mancata restituzione del componente può comportare la fatturazione del ricambio da parte di HP. Nel caso di riparazione da parte del cliente, HP sostiene tutte le spese di spedizione e resa e sceglie il corriere/vettore da utilizzare.

Per ulteriori informazioni sul programma CSR di HP contattare il centro di assistenza di zona. Per il programma in Nord America fare riferimento al sito Web HP (<http://www.hp.com/go/selfrepair>).

Customer Self Repair

HP Produkte enthalten viele CSR-Teile (Customer Self Repair), um Reparaturzeiten zu minimieren und höhere Flexibilität beim Austausch defekter Bauteile zu ermöglichen. Wenn HP (oder ein HP Servicepartner) bei der Diagnose feststellt, dass das Produkt mithilfe eines CSR-Teils repariert werden kann, sendet Ihnen HP dieses Bauteil zum Austausch direkt zu. CSR-Teile werden in zwei Kategorien unterteilt:

Zwingend – Teile, für die das Customer Self Repair-Verfahren zwingend vorgegeben ist. Wenn Sie den Austausch dieser Teile von HP vornehmen lassen, werden Ihnen die Anfahrt- und Arbeitskosten für diesen Service berechnet.

Optional – Teile, für die das Customer Self Repair-Verfahren optional ist. Diese Teile sind auch für Customer Self Repair ausgelegt. Wenn Sie jedoch den Austausch dieser Teile von HP vornehmen lassen möchten, können bei diesem Service je nach den für Ihr Produkt vorgesehenen Garantiebedingungen zusätzliche Kosten anfallen.

HINWEIS: Einige Teile sind nicht für Customer Self Repair ausgelegt. Um den Garantieanspruch des Kunden zu erfüllen, muss das Teil von einem HP Servicepartner ersetzt werden. Im illustrierten Teilekatalog sind diese Teile mit „No“ bzw. „Nein“ gekennzeichnet.

CSR-Teile werden abhängig von der Verfügbarkeit und vom Lieferziel am folgenden Geschäftstag geliefert. Für bestimmte Standorte ist eine Lieferung am selben Tag oder innerhalb von vier Stunden gegen einen Aufpreis verfügbar. Wenn Sie Hilfe benötigen, können Sie das HP technische Support Center anrufen und sich von einem Mitarbeiter per Telefon helfen lassen. Den Materialien, die mit einem CSR-Ersatzteil geliefert werden, können Sie entnehmen, ob das defekte Teil an HP zurückgeschickt werden muss. Wenn es erforderlich ist, das defekte Teil an HP zurückzuschicken, müssen Sie dies innerhalb eines vorgegebenen Zeitraums tun, in der Regel innerhalb von fünf (5) Geschäftstagen. Das defekte Teil muss mit der zugehörigen Dokumentation in der Verpackung zurückgeschickt werden, die im Lieferumfang enthalten ist. Wenn Sie das defekte Teil nicht zurückschicken, kann HP Ihnen das Ersatzteil in Rechnung stellen. Im Falle von Customer Self Repair kommt HP für alle Kosten für die Lieferung und Rücksendung auf und bestimmt den Kurier-/Frachtdienst.

Weitere Informationen über das HP Customer Self Repair Programm erhalten Sie von Ihrem Servicepartner vor Ort. Informationen über das CSR-Programm in Nordamerika finden Sie auf der HP Website unter (<http://www.hp.com/go/selfrepair>).

Reparaciones del propio cliente

Los productos de HP incluyen muchos componentes que el propio usuario puede reemplazar (*Customer Self Repair*, CSR) para minimizar el tiempo de reparación y ofrecer una mayor flexibilidad a la hora de realizar sustituciones de componentes defectuosos. Si, durante la fase de diagnóstico, HP (o los proveedores o socios de servicio de HP) identifica que una reparación puede llevarse a cabo mediante el uso de un componente CSR, HP le enviará dicho componente directamente para que realice su sustitución. Los componentes CSR se clasifican en dos categorías:

- **Obligatorio:** componentes para los que la reparación por parte del usuario es obligatoria. Si solicita a HP que realice la sustitución de estos componentes, tendrá que hacerse cargo de los gastos de desplazamiento y de mano de obra de dicho servicio.
- **Opcional:** componentes para los que la reparación por parte del usuario es opcional. Estos componentes también están diseñados para que puedan ser reparados por el usuario. Sin embargo, si precisa que HP realice su sustitución, puede o no conllevar costes adicionales, dependiendo del tipo de servicio de garantía correspondiente al producto.

NOTA: Algunos componentes no están diseñados para que puedan ser reparados por el usuario. Para que el usuario haga valer su garantía, HP pone como condición que un proveedor de servicios autorizado realice la sustitución de estos componentes. Dichos componentes se identifican con la palabra "No" en el catálogo ilustrado de componentes.

Según la disponibilidad y la situación geográfica, los componentes CSR se enviarán para que lleguen a su destino al siguiente día laborable. Si la situación geográfica lo permite, se puede solicitar la entrega en el mismo día o en cuatro horas con un coste adicional. Si precisa asistencia técnica, puede llamar al Centro de asistencia técnica de HP y recibirá ayuda telefónica por parte de un técnico. Con el envío de materiales para la sustitución de componentes CSR, HP especificará si los componentes defectuosos deberán devolverse a HP. En aquellos casos en los que sea necesario devolver algún componente a HP,

deberá hacerlo en el periodo de tiempo especificado, normalmente cinco días laborables. Los componentes defectuosos deberán devolverse con toda la documentación relacionada y con el embalaje de envío. Si no enviara el componente defectuoso requerido, HP podrá cobrarle por el de sustitución. En el caso de todas sustituciones que lleve a cabo el cliente, HP se hará cargo de todos los gastos de envío y devolución de componentes y escogerá la empresa de transporte que se utilice para dicho servicio.

Para obtener más información acerca del programa de Reparaciones del propio cliente de HP, póngase en contacto con su proveedor de servicios local. Si está interesado en el programa para Norteamérica, visite la página web de HP siguiente (<http://www.hp.com/go/selfrepair>).

Customer Self Repair

Veel onderdelen in HP producten zijn door de klant zelf te repareren, waardoor de reparatieduur tot een minimum beperkt kan blijven en de flexibiliteit in het vervangen van defecte onderdelen groter is. Deze onderdelen worden CSR-onderdelen (Customer Self Repair) genoemd. Als HP (of een HP Service Partner) bij de diagnose vaststelt dat de reparatie kan worden uitgevoerd met een CSR-onderdeel, verzendt HP dat onderdeel rechtstreeks naar u, zodat u het defecte onderdeel daarmee kunt vervangen. Er zijn twee categorieën CSR-onderdelen:

Verplicht: Onderdelen waarvoor reparatie door de klant verplicht is. Als u HP verzoekt deze onderdelen voor u te vervangen, worden u voor deze service reiskosten en arbeidsloon in rekening gebracht.

Optioneel: Onderdelen waarvoor reparatie door de klant optioneel is. Ook deze onderdelen zijn ontworpen voor reparatie door de klant. Als u echter HP verzoekt deze onderdelen voor u te vervangen, kunnen daarvoor extra kosten in rekening worden gebracht, afhankelijk van het type garanteservice voor het product.

OPMERKING: Sommige HP onderdelen zijn niet ontwikkeld voor reparatie door de klant. In verband met de garantievoorwaarden moet het onderdeel door een geautoriseerde Service Partner worden vervangen. Deze onderdelen worden in de geïllustreerde onderdelencatalogus aangemerkt met "Nee".

Afhankelijk van de leverbaarheid en de locatie worden CSR-onderdelen verzonden voor levering op de eerstvolgende werkdag. Levering op dezelfde dag of binnen vier uur kan tegen meerkosten worden aangeboden, indien dit mogelijk is gezien de locatie. Indien assistentie gewenst is, belt u een HP Service Partner om via de telefoon technische ondersteuning te ontvangen. HP vermeldt in de documentatie bij het vervangende CSR-onderdeel of het defecte onderdeel aan HP moet worden geretourneerd. Als het defecte onderdeel aan HP moet worden teruggezonden, moet u het defecte onderdeel binnen een bepaalde periode, gewoonlijk vijf (5) werkdagen, retourneren aan HP. Het defecte onderdeel moet met de bijbehorende documentatie worden geretourneerd in het meegeleverde verpakkingsmateriaal. Als u het defecte onderdeel niet terugzendt, kan HP u voor het vervangende onderdeel kosten in rekening brengen. Bij reparatie door de klant betaalt HP alle verzendkosten voor het vervangende en geretourneerde onderdeel en kiest HP zelf welke koerier/transportonderneming hiervoor wordt gebruikt.

Neem contact op met een Service Partner voor meer informatie over het Customer Self Repair programma van HP. Informatie over Service Partners vindt u op de HP website (<http://www.hp.com/go/selfrepair>).

Reparo feito pelo cliente

Os produtos da HP são projetados com muitas peças para reparo feito pelo cliente (CSR) de modo a minimizar o tempo de reparo e permitir maior flexibilidade na substituição de peças com defeito. Se, durante o período de diagnóstico, a HP (ou fornecedores/parceiros de serviço da HP) concluir que o reparo pode ser efetuado pelo uso de uma peça CSR, a peça de reposição será enviada diretamente ao cliente. Existem duas categorias de peças CSR:

Obrigatória – Peças cujo reparo feito pelo cliente é obrigatório. Se desejar que a HP substitua essas peças, serão cobradas as despesas de transporte e mão-de-obra do serviço.

Opcional – Peças cujo reparo feito pelo cliente é opcional. Essas peças também são projetadas para o reparo feito pelo cliente. No entanto, se desejar que a HP as substitua, pode haver ou não a cobrança de taxa adicional, dependendo do tipo de serviço de garantia destinado ao produto.

OBSERVAÇÃO: Algumas peças da HP não são projetadas para o reparo feito pelo cliente. A fim de cumprir a garantia do cliente, a HP exige que um técnico autorizado substitua a peça. Essas peças estão identificadas com a marca "No" (Não), no catálogo de peças ilustrado.

Conforme a disponibilidade e o local geográfico, as peças CSR serão enviadas no primeiro dia útil após o pedido. Onde as condições geográficas permitirem, a entrega no mesmo dia ou em quatro horas pode ser feita mediante uma taxa adicional. Se precisar de auxílio, entre em contato com o Centro de suporte técnico da HP para que um técnico o ajude por telefone. A HP especifica nos materiais fornecidos com a peça CSR de reposição se a peça com defeito deve ser devolvida à HP. Nos casos em que isso for necessário, é preciso enviar a peça com defeito à HP dentro do período determinado, normalmente cinco (5) dias úteis. A peça com defeito deve ser enviada com a documentação correspondente no material de transporte fornecido. Caso não o faça, a HP poderá cobrar a reposição. Para as peças de reparo feito pelo cliente, a HP paga todas as despesas de transporte e de devolução da peça e determina a transportadora/serviço postal a ser utilizado.

Para obter mais informações sobre o programa de reparo feito pelo cliente da HP, entre em contato com o fornecedor de serviços local. Para o programa norte-americano, visite o site da HP (<http://www.hp.com/go/selfrepair>).

カスタマーセルフリペア

修理時間を短縮し、故障部品の交換における高い柔軟性を確保するために、HP製品には多数のCSR部品があります。診断の際に、CSR部品を使用すれば修理ができるとHP（HPまたはHP正規保守代理店）が判断した場合、HPはその部品を直接、お客様に発送し、お客様に交換していただきます。CSR部品には以下の2通りがあります。

- **必須** - カスタマーセルフリペアが必須の部品。当該部品について、もしもお客様がHPIに交換作業を依頼される場合には、その修理サービスに関する交通費および人件費がお客様に請求されます。
- **任意** - カスタマーセルフリペアが任意である部品。この部品もカスタマーセルフリペア用です。当該部品について、もしもお客様がHPIに交換作業を依頼される場合には、お買い上げの製品に適用される保証サービス内容の範囲内においては、別途費用を負担していただくことなく保証サービスを受けることができます。

注： HP製品の一部の部品は、カスタマーセルフリペア用ではありません。製品の保証を継続するためには、HPまたはHP正規保守代理店による交換作業が必須となります。部品カタログには、当該部品がカスタマーセルフリペア除外品である旨が記載されています。

部品供給が可能な場合、地域によっては、CSR部品を翌営業日に届くように発送します。また、地域によっては、追加費用を負担いただくことにより同日または4時間以内に届くように発送することも可能な場合があります。サポートが必要なときは、HPの修理受付窓口に電話していただければ、技術者が電話でアドバイスします。交換用のCSR部品または同梱物には、故障部品をHPIに返送する必要があるかどうかが表示されています。故障部品をHPIに返送する必要がある場合は、指定期限内（通常は5営業日以内）に故障部品をHPIに返送してください。故障部品を返送する場合は、届いた時の梱包箱に関連書類とともに入れてください。故障部品を返送しない場合、HPから部品費用が請求されます。カスタマーセルフリペアの際には、HPIは送料および部品返送費を全額負担し、使用する宅配便会社や運送会社を指定します。

客户自行维修

HP 产品提供许多客户自行维修 (CSR) 部件，以尽可能缩短维修时间和在更换缺陷部件方面提供更大的灵活性。如果在诊断期间 HP（或 HP 服务提供商或服务合作伙伴）确定可以通过使用 CSR 部件完成维修，HP 将直接把该部件发送给您进行更换。有两类 CSR 部件：

- **强制性的** — 要求客户必须自行维修的部件。如果您请求 HP 更换这些部件，则必须为该服务支付差旅费和人工费用。
- **可选的** — 客户可以选择是否自行维修的部件。这些部件也是为客户自行维修设计的。不过，如果您要求 HP 为您更换这些部件，则根据为您的产品指定的保修服务类型，HP 可能收取或不再收取任何附加费用。

注：某些 HP 部件的设计并未考虑客户自行维修。为了满足客户保修的需要，HP 要求授权服务提供商更换相关部件。这些部件在部件图解目录中标记为“否”。

CSR 部件将在下一个工作日发运（取决于备货情况和允许的地理范围）。在允许的地理范围内，可在当天或四小时内发运，但要收取额外费用。如果需要帮助，您可以致电 HP 技术支持中心，将会有技术人员通过电话为您提供帮助。HP 会在随更换的 CSR 部件发运的材料中指明是否必须将有缺陷的部件返还给 HP。如果您要求您将缺陷的部件返还给 HP，那么您必须在规定期限内（通常是五 (5) 个工作日）将缺陷部件发给 HP。有缺陷的部件必须随所提供的发运材料中的相关文件一起返还。如果未能送还有缺陷的部件，HP 可能会要求您支付更换费用。客户自行维修时，HP 将承担所有相关运输和部件返回费用，并指定快递商/承运商。

有关 HP 客户自行维修计划的详细信息，请与您当地的服务提供商联系。有关北美地区的计划，请访问 HP 网站 (<http://www.hp.com/go/selfrepair>)。

客户自行维修

HP 產品設計了許多「客戶自行維修」(CSR) 的零件以減少維修時間，並且使得更換瑕疵零件時能有更大的彈性。如果在診斷期間 HP（或 HP 服務供應商或維修夥伴）辨認出此項維修工作可以藉由使用 CSR 零件來完成，則 HP 將直接寄送該零件給您作更換。CSR 零件分為兩種類別：

- **強制的** — 客戶自行維修所使用的零件是強制性的。如果您要求 HP 更換這些零件，HP 將會向您收取此服務所需的外出費用與勞動成本。
- **選購的** — 客戶自行維修所使用的零件是選購的。這些零件也設計用於客戶自行維修之用。不過，如果您要求 HP 為您更換，則可能需要也可能不需要負擔額外的費用，端視針對此產品指定的保固服務類型而定。

備註：某些 HP 零件沒有消費者可自行維修的設計。為符合客戶保固，HP 需要授權的服務供應商更換零件。這些零件在圖示的零件目錄中，被標示為「否」。

基於材料取得及環境允許的情況下，CSR 零件將於下一個工作日以快遞寄送。在環境的允許下當天或四小時內送達，則可能需要額外的費用。若您需要協助，可致電「HP 技術支援中心」，會有一位技術人員透過電話來協助您。不論損壞的零件是否必須退回，HP 皆會在與 CSR 替換零件一起運送的材料中註明。若要將損壞的零件退回 HP，您必須在指定的一段時間內（通常為五 (5) 個工作天），將損壞的零件寄回 HP。損壞的零件必須與寄送資料中隨附的相關技術文件一併退還。如果無法退還損壞的零件，HP 可能向您收取替換費用。針對客戶自行維修情形，HP 將負責所有運費及零件退還費用並指定使用何家快遞/貨運公司。

如需 HP 的「客戶自行維修」方案詳細資訊，請連絡您當地的服務供應商。至於北美方案，請參閱 HP 網站 (<http://www.hp.com/go/selfrepair>)。

고객 셀프 수리

HP 제품은 수리 시간을 최소화하고 결함이 있는 부품 교체 시 더욱 융통성을 발휘할 수 있도록 하기 위해 고객 셀프 수리(CSR) 부품을 다량 사용하여 설계되었습니다. 진단 기간 동안 HP(또는 HP 서비스 공급업체 또는 서비스 협력업체)에서 CSR 부품을 사용하여 수리가 가능하다고 판단되면 HP는 해당 부품을 바로 사용자에게 보내어 사용자가 교체할 수 있도록 합니다. CSR 부품에는 두 가지 종류가 있습니다.

- **고객 셀프 수리가 의무 사항인 필수 부품.** 사용자가 HP에 이 부품의 교체를 요청할 경우 이 서비스에 대한 출장비 및 작업비가 청구됩니다.
- **고객 셀프 수리가 선택 사항인 부품.** 이 부품들도 고객 셀프 수리가 가능하도록 설계되었습니다. 하지만 사용자가 HP에 이 부품의 교체를 요청할 경우 사용자가 구입한 제품에 해당하는 보증 서비스 유형에 따라 추가 비용 없이 교체가 가능할 수 있습니다.

참고: 일부 HP 부품은 고객 셀프 수리가 불가능하도록 설계되었습니다. HP는 만족스러운 고객 보증을 위해 공인 서비스 제공업체를 통해 부품을 교체하도록 하고 있습니다. 이러한 부품들은 Illustrated Parts Catalog에 "No"라고 표시되어 있습니다.

CSR 부품은 재고 상태와 지리적 조건이 허용하는 경우 다음 영업일 납품이 가능하도록 배송이 이루어집니다. 지리적 조건이 허용하는 경우 추가 비용이 청구되는 조건으로 당일 또는 4시간 배송이 가능할 수도 있습니다. 도움이 필요하시면 HP 기술 지원 센터로 전화하십시오. 전문 기술자가 전화로 도움을 줄 것입니다. HP는 결함이 발생한 부품을 HP로 반환해야 하는지 여부를 CSR 교체 부품과 함께 배송된 자료에 지정합니다. 결함이 발생한 부품을 HP로 반환해야 하는 경우에는 지정된 기간 내(통상 영업일 기준 5일)에 HP로 반환해야 합니다. 이 때 결함이 발생한 부품은 제공된 포장 재료에 넣어 관련 설명서와 함께 반환해야 합니다. 결함이 발생한 부품을 반환하지 않는 경우 HP가 교체 부품에 대해 비용을 청구할 수 있습니다. 고객 셀프 수리의 경우, HP는 모든 운송 및 부품 반환 비용을 부담하며 이용할 운송업체 및 택배 서비스를 결정합니다.

HP 고객 셀프 수리 프로그램에 대한 자세한 내용은 가까운 서비스 제공업체에 문의하십시오. 북미 지역의 프로그램에 대해서는 HP 웹 사이트(<http://www.hp.com/go/selfrepair>)를 참조하십시오.

Acronyms and abbreviations

ABEND

abnormal end

ACU

Array Configuration Utility

AMP

Advanced Memory Protection

API

application program interface

ASHRAE

American Society of Heating, Refrigerating and Air-Conditioning Engineers

ASR

Automatic Server Recovery

CAS

column address strobe

CSA

Canadian Standards Association

CSR

Customer Self Repair

FLR

FlexibleLOM for rack servers

FSBBU

Flex slot battery backup

GPU

graphics processing unit

HBA

host bus adapter

HP SSA

HP Smart Storage Administrator

HP SUM

HP Software Update Manager

IEC

International Electrotechnical Commission

iLO

Integrated Lights-Out

IML

Integrated Management Log

ISO

International Organization for Standardization

JSON

JavaScript Object Notation

LFF

large form factor

LRDIMM

load reduced dual in-line memory module

NAND

Not AND

NMI

nonmaskable interrupt

NVRAM

nonvolatile memory

OA

Onboard Administrator

PCIe

Peripheral Component Interconnect Express

PDU

power distribution unit

POST

Power-On Self Test

RBSU

ROM-Based Setup Utility

RDIMM

registered dual in-line memory module

RDP

Rapid Deployment Pack

REST

representational state transfer

RoHS

Restriction of Hazardous Substances

RSOC

relative state of change

SAS

serial attached SCSI

SATA

serial ATA

SD

Secure Digital

SFF

small form factor

SID

Systems Insight Display

SIM

Systems Insight Manager

SPP

HP Service Pack for ProLiant

TMRA

recommended ambient operating temperature

TPM

Trusted Platform Module

UEFI

Unified Extensible Firmware Interface

UID

unit identification

USB

universal serial bus

VC

Virtual Connect

VCA

Version Control Agent

VCRM

Version Control Repository Manager

VDC

voltage direct-current

Documentation feedback

HP is committed to providing documentation that meets your needs. To help us improve the documentation, send any errors, suggestions, or comments to Documentation Feedback (<mailto:docsfeedback@hp.com>). Include the document title and part number, version number, or the URL when submitting your feedback.

Index

A

AC power supply 161, 162, 163
access panel 26, 27
access panel, install 27
Advanced ECC memory 54, 55
air baffle 31
airflow requirements 33, 34
Array Configuration Utility (ACU) 147
ASR (Automatic Server Recovery) 147
authorized reseller 158, 165
Automatic Server Recovery (ASR) 147

B

battery 154
battery backup module 117
battery backup, battery check button 15
battery backup, LED 15
battery check button 15
before you contact HP 165
BIOS upgrade 138
BSMI notice 156
button, battery check 15
button, UID 10
buttons 7, 10

C

cable management arm 27
cables 123
cabling 123, 127, 129, 135, 136
Canadian notice 156
Care Pack 33, 141, 152, 165
cautions 158
Change Control 144, 147, 152
chassis components 11
clearing NVRAM 18
CMOS 18
components 7
components, identification 7
configuration of system 138
connectors 7
contacting HP 165
CSR (customer self repair) 165

customer self repair (CSR) 165

D

DC power supply 35
default settings 54
definitions 22
device numbers 20
diagnostic tools 138, 142, 146, 147
diagnostics utility 142
DIMM identification 53
DIMM installation guidelines 53
DIMM population guidelines 55
DIMM slot locations 19
DIMMs 19, 53
DIMMs, installing 56
DIMMs, single- and dual-rank 53
drive cage option 71, 76, 80, 85, 89
drive LEDs 22
drivers 150
drives 22, 41

E

electrical grounding requirements 35
electrostatic discharge 158
enabling the Trusted Platform Module 122
environmental requirements 33
environmental specifications 159
Erase Utility 138, 142
error messages 153
European Union notice 156
expansion board options 60
expansion boards 60, 61
expansion slot blanks 60
expansion slots 61
extending server from rack 25

F

fan cage 28
fans 23, 28
features 7, 147
Federal Communications Commission (FCC)
notice 156
firmware 148, 151

- firmware update 143, 149, 150, 151
- firmware, updating 143, 148, 151
- flash ROM 150
- flex slot battery backup module, battery check button 15
- flex slot battery backup module, LED 15
- FlexibleLOM 101
- front panel buttons 9
- front panel components 7
- front panel LEDs 9
- FSBBU module 117
- FSBBU module, installing 118
- FSBBU, battery check button 15
- FSBBU, LED 15
- full-length expansion board 31

G

- grounding methods 158
- grounding requirements 35, 158

H

- hard drive cage 85, 89
- hard drive LEDs 22
- hard drives, determining status of 22
- hardware options installation 37, 41
- health driver 147
- health LEDs 9
- help resources 165
- hot-plug fans 23, 27, 28
- HP 12G SAS Expander Card 103
- HP Care Pack Services 33, 152
- HP Dual 8Gb MicroSD USB device 117
- HP Flexible Smart Array Controller 110
- HP Insight Diagnostics 142
- HP Insight Remote Support software 141, 152
- HP Rapid Deployment Pack (RDP) 33, 175
- HP Service Pack for ProLiant 138, 142, 143
- HP Smart Storage Battery 111
- HP Smart Update Manager overview 138, 143
- HP SmartMemory 52
- HP Systems Insight Display LED combinations 12
- HP technical support 152, 165

I

- iLO (Integrated Lights-Out) 138, 139, 140
- IML (Integrated Management Log) 138, 140
- Insight Diagnostics 142, 148
- installation services 33
- installation, server options 37, 41

- installing a hot-plug SAS hard drive 41
- installing hardware 41
- installing PCI riser cage 30
- Installing the FSBBU module 118
- installing the server into the rack 37
- Integrated Lights-Out (iLO) 138, 140
- Integrated Management Log (IML) 140
- Intelligent Provisioning 138, 141, 142, 144
- internal USB connector 147

J

- Japanese notice 156

L

- LED, FSBBU module 15
- LED, health 11
- LEDs 12, 22
- LEDs, front panel 22
- LEDs, hard drive 22
- LEDs, power fault 11
- LEDs, power supply 11
- LEDs, SAS drive 22
- LEDs, SAS hard drive 22
- LEDs, troubleshooting 153
- location discovery services 98

M

- M.2 SATA SSD enablement board 114, 115
- M.2 SATA SSD module 114
- M.2 SSD cabling 136
- M.2 SSD enablement option 114, 136
- mechanical specifications 159
- memory 51, 53, 54
- memory configurations 54
- memory subsystem architecture 52, 53
- memory, configuration requirements 54
- memory, configuring 54
- memory, lockstep 56
- memory, online spare 54
- MicroSD card 117

N

- NMI functionality 19
- NMI switch 19

O

- online spare memory 54, 55
- operating system crash 147

operating systems 151, 152
optical drive 7, 57
optimum environment 33
options installation 37, 41

P

part numbers 156
PCI expansion slot definitions 16
PCI expansion slots 16
PCI riser cage 29, 30, 62, 64, 66
PCI riser cage, installing 30
PCI riser cage, removing 29
PDU (power distribution unit) 35
phone numbers 165
POST error messages 153
power distribution unit (PDU) 35
Power On button 25
power requirements 35
power supply 43
power supply LEDs 11, 14
power supply specifications 161, 162, 164
power up procedure 25
powering down 25
powering up 25
power-on password 18
preparation procedures 25
problem diagnosis 153
processor installation 46

Q

QuickSpecs 41, 53, 138

R

rack installation 33, 36
rack warnings 36
RAID configuration 147
Rapid Deployment Pack (RDP) 33
RDP (Rapid Deployment Pack) 33
rear panel components 14
rear panel LEDs 14
rear panel, accessing 27
recommended ambient operating temperature (TMRA) 34
redundant ROM 148
registering the server 40
regulatory compliance notices 156
removing a hot-plug SAS hard drive 42
removing PCI riser cage 29
removing server from rack 26

removing the access panel 26
requirements, airflow 33
requirements, electrical grounding 35
requirements, power 35
requirements, site 34
requirements, space 33
requirements, temperature 34
retaining the recovery key/password 122
ROM redundancy 148
ROMPaq utility 148

S

safety considerations 36, 148, 156, 158
SAS and SATA device numbers 20
SAS drives 22
scripted installation 143
serial number 146
serial port 113
series number 156
server features and options 41
server setup 33, 40, 148
Service Packs 143
shipping carton contents 37
site requirements 34
space and airflow requirements 33
space requirements 33
specifications 159
specifications, environmental 159
specifications, mechanical 159
specifications, power 160, 161, 162, 163, 164
specifications, server 159
SPP 142, 143
static electricity 158
storage controller 18
support 165
supported operating systems 151, 152
switch, NMI 19
system battery 154, 156, 158
system board components 17
system configuration settings 18, 148
system maintenance switch 18
system power LED 9
Systems Insight Display 11, 12, 96
Systems Insight Display LED combinations 12
Systems Insight Display LEDs 12

T

Taiwan battery recycling notice 156
technical support 152, 165

- telco racks 26
- telephone numbers 165
- temperature requirements 34, 159
- TMRA (recommended ambient operating temperature) 34
- TPM (Trusted Platform Module) 119, 122
- troubleshooting 153

U

- UEFI 39
- UEFI System Utilities 39, 144
- UEFI, boot mode 39
- UID button functionality 10
- uninterruptible power supply (UPS) 35
- universal media bay 57, 135
- updating the system ROM 148, 149, 150
- UPS (uninterruptible power supply) 35
- USB connector 7
- USB devices 117
- USB support 147
- utilities 138, 144, 147
- utilities, deployment 138, 143

V

- ventilation 33
- video connector 7

W

- warnings 36
- website, HP 165