



User Guide

EonStor GS

Version 1.0 (September 2016)

Legal Information

All Infortrend products, including the product customers have purchased from Infortrend, will be subject to the latest Standard Warranty Policy available on the Infortrend website:

<http://www.infortrend.com/global/Support/Warranty>

Infortrend may from time to time modify, update or upgrade the software, firmware or any accompanying user documentation without any prior notice. Infortrend will provide access to these new software, firmware or documentation releases from certain download sections of our website or through our service partners. Customer will be responsible for maintaining updated version of the software, firmware or other documentation by downloading or obtaining from Infortrend, and installing designated updated code, including but not limited to firmware, microcode, basic input/out system code, utility programs, device drivers, and diagnostics delivered with Infortrend product.

Before installing any software, applications or components provided by a third party, customer should ensure that they are compatible and interoperable with Infortrend product by checking in advance with Infortrend. Customer is solely responsible for ensuring the compatibility and interoperability of the third party's products with Infortrend product. Customer is further solely responsible for ensuring its systems, software, and data are adequately backed up as a precaution against possible failures, alternation, or loss.

For any questions of hardware/ software compatibility, and the update/ upgrade code, customer should contact Infortrend sales representative or technical support for assistance.

To the extent permitted by applicable laws, Infortrend will NOT be responsible for any interoperability or compatibility issues that may arise when (1) products, software, or options not certified and supported by Infortrend are used; (2) configurations not certified and supported by Infortrend are used; (3) parts intended for one system are installed in another system of different make or model.

Trademarks

Infortrend, the Infortrend logo, EonOne and EonStor are registered trademarks of Infortrend Technology, Inc. Other names prefixed with "IFT" and "GS" are trademarks of Infortrend Technology, Inc.

All other names, brands, products or services are trademarks or registered trademarks of their respective owners.

Contact Information

Customer Support Contact your system vendor or visit the following support site.

<http://www.infortrend.com/global/Support/Support>

**Headquarter
(Asia / Taiwan)**

Infortrend Technology, Inc.

8F., No.102, Sec. 3, Jhongshan Rd., Jhonghe Dist., New Taipei City 23544, Taiwan
Tel: +886-2-2226-0126 Fax: +886-2-2226-0020 [Email](#), [Technical Support](#), [Website](#)

Middle East Infortrend Sales Representative

[Email](#), [Technical Support](#), [Website](#)

India Infortrend Sales Representative

[Email](#), [Technical Support](#), [Website](#)

Oceania Infortrend Sales Representative

[Email](#), [Technical Support](#), [Website](#)

Japan

Infortrend Japan, Inc.

6F Okayasu Bldg., 1-7-14 Shibaura, Minato-Ku, Tokyo, 105-0023 Japan
Tel: +81-3-5730-6551 Fax: +81-3-5730-6552 [Email](#), [Technical Support](#), [Website](#)

Americas

Infortrend Corporation

435 Lakeside Dr. Sunnyvale, CA. 94085, USA
Tel: +1-408-988-5088 Fax: +1-408-988-6288 [Email](#), [Technical Support](#), [Website](#)

China

Infortrend Technology, Ltd.

Room 403,Block D, Ocean International Center, Dis. Chaoyang, Beijing, China
Tel: +86-10-6310-6168 Fax: +86-10-59648252 [Email](#), [Technical Support](#), [Website](#)

Infortrend 华南办事处

上海市浦东新区塘桥路 180 号 202 室
Tel: +86-10-6310-6168 / 8586-6916/ 8586-1801 Fax: +86-10-59648252
[Email](#), [Technical Support](#), [Website](#)

Infortrend 华东办事处

广州市天河区天河北路 620 号瑞安创逸 T1 栋 3111 室
Tel: +86-10-6310-6168 / 8586-6916/ 8586-1801 Fax: +86-10-59648252
[Email](#), [Technical Support](#), [Website](#)

Infortrend 西南办事处

成都市高新区天华一路 99 号天府软件园 B3 栋四楼 V04 室
Tel: +86-10-6310-6168 / 8586-6916/ 8586-1801 Fax: +86-10-59648252
[Email](#), [Technical Support](#), [Website](#)

Infotrend 南京办事处

江苏省南京市雨花台区软件大道 119 号丰盛商汇 5 栋 102

Tel: +86-10-6310-6168 / 8586-6916/ 8586-1801 Fax: +86-10-59648252

[Email](#), [Technical Support](#), [Website](#)

Europe (EMEA)

Infotrend Europe LTD.

5 Ringway Centre, Edison Road, Basingstoke, Hampshire, RG21 6YH, UK

Tel: +44-1256-305-220 Fax: +44-1256-305-221 [Email](#), [Technical Support](#), [Website](#)

Czech Republic Infotrend Sales Representative

[Email](#), [Technical Support](#), [Website](#)

France Infotrend Sales Representative

[Email](#), [Technical Support](#), [Website](#)

Germany/ Infotrend Deutschland GmbH

[Email](#), [Technical Support](#), [Website](#)

Italy Infotrend Sales Representative

[Email](#), [Technical Support](#), [Website](#)

Poland Infotrend Sales Representative

[Email](#), [Technical Support](#), [Website](#)

Spain / Portugal Infotrend Sales Representative

[Email](#), [Technical Support](#), [Website](#)



Change History List

Rev	Update Reason	Updated Data
Version 1.0	<ul style="list-style-type: none">Initial release	2016 / 08 / 26



Table of Contents

Preface	8
Audience	8
What's in This Guide?	8
What You Should Know Before Reading?.....	8
Getting Started.....	9
1.1 Overview of EonStor GS	9
1.2 Before Using EonStor GS and EonOne	9
1.3 Hardware Installation	10
1.3.1 Major Hardware Components Introduction	10
1.3.2 Host, JBOD, Management Console, Power Connections	12
1.3.3 System Monitoring	13
1.4 System Maintenance and Hardware Replacement	13
1.5 Checking IP Address of Subsystem	14
1.6 System Management	14
Using EonStor GS.....	15
2.1 System General Configuration	15
2.1.1 EonOne User Interface Overview.....	15
2.1.2 Initial Setup Wizard	17
2.1.3 Manual Configuration in Control Panel	18
2.1.4 Workflow Configuration	20
2.2 Cloud Features	21
2.2.1 Cloud Cache	21
2.2.2 Cloud Backup	23
2.2.3 Cloud Tiering	24
2.3 Data Service.....	25
2.3.1 SSD Cache	25
2.3.2 Automated Storage Tiering	26
2.3.3 Remote Replication	27
2.3.4 Self-Encrypting Drives (SED)	28
2.3.5 Intelligent Drive Recovery (IDR).....	28
2.3.6 Snapshot	29
2.3.7 Thin Provisioning	29



Customer Service	30
3.1 Online Resource	30
3.1.1 Infortrend Customer Support System (ICSS).....	30
3.1.2 Quick Service App.....	30
3.1.3 Technical Documents	31
3.2 Technical Support Overview	31
Appendix.....	32
Concept of Logical Drive, Pool, and Volume.....	32
Concept of SMB 3.0 transparent failover	33

Preface

The purpose of this user guide is, to provide users an efficient way to find all EonStor GS product related software and hardware information, to guide users through basic installation and configuration steps and to introduce Infortrend customer support service. Infortrend dedicates its work to develop the best storage solutions to fulfill customers' expectations and their requirements. Therefore Infortrend further develops its products continuously and releases periodically information about hard- and software updates online. Infortrend recommends users to check the [official website](#) for the latest news, the [customer support system](#) for latest firmware and software, or, in case of a product malfunction or a feature that is not working as intended to contact an Infortrend technical support professional.

Audience

The User Guide is intended for Infortrend customers, partners, and employees who are installing and/or configuring EonStor GS systems.

What's in This Guide?

This guide contains the following topics:

“Getting Started” provides information and action that you have to know and perform before using EonStor GS

“Using EonStor GS” gives shortcuts to common configuration and data services that users can perform with the EonOne user interface.

“Customer Service” offers information and resource reference for customer supports.

What You Should Know Before Reading?

This user's guide assumes that you are familiar with basic server, storage, and networking concept and configurations

Getting Started

1.1 Overview of EonStor GS

EonStor GS is designed to provide a unified storage solution that can handle mixed workloads and integrates cloud features that extend local storage with cloud capacity or make use of off-site backup and disaster recovery. EonStor GS can be accessed, across heterogeneous infrastructures at file level using Server Message Block (SMB)/ Common Internet File System (CIFS), Network File System (NFS), Apple Filing Protocol (AFP) and File Transfer Protocol (FTP); at block level, across performance related infrastructures using Fibre Channel, iSCSI and SAS; or even at both levels; at object level using RESTful API for cloud integration. Moreover, EonStor GS offers the following integrated Cloud features: Cloud Cache, Cloud Backup, and Cloud Tiering that help second-tier, archive and backup data shift to public or private cloud storage.

EonOne is the proprietary web-based software suite for EonStor GS storage systems' centralized management. You can access it through a web browser to manage and configure a single or multiple EonStor GS storage systems based on requirements.

1.2 Before Using EonStor GS and EonOne

You have to Know

- Only qualified service personnel should install and service this product to avoid injury.
- Check the unpacking list for the exact number of items which should be included in the package.
- Find **Quick Installation Guide, Hardware Manual, Software User Manual** (all are located on the CD-ROM included with your subsystem package).
- Workflow and reference documents as following:

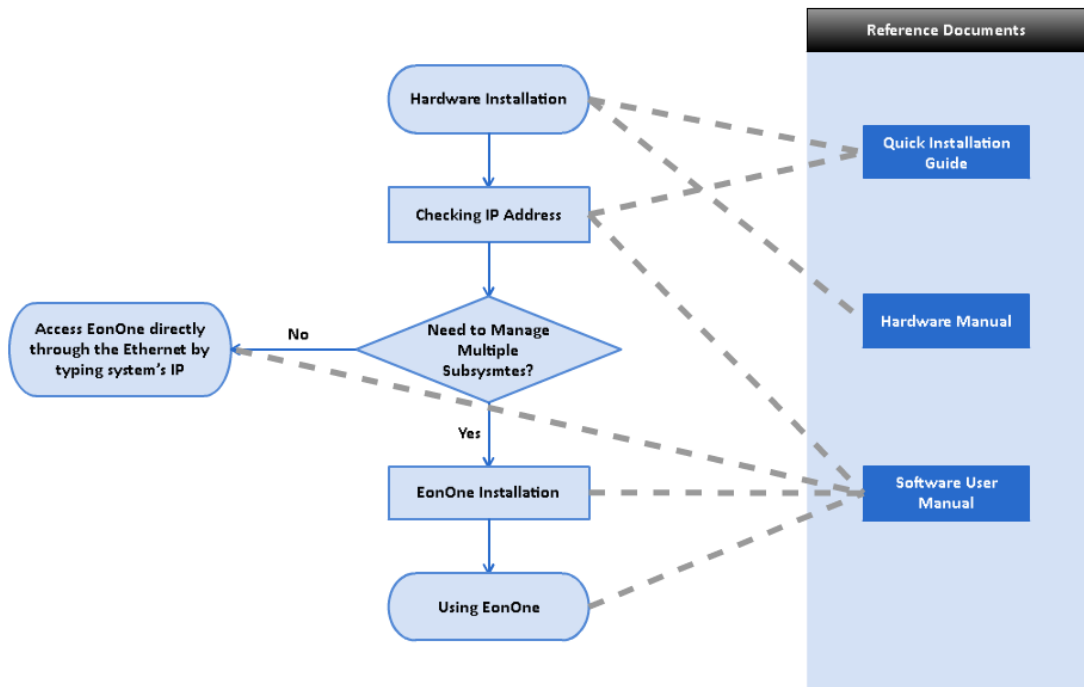

Workflow of deploying EonStor GS

1.3 Hardware Installation

You will find detailed information about the hardware installation, maintenance and upgrade in EonStor GS Series **Quick Installation Guide** or **Hardware Manual**. The Quick Installation Guide, which is a provided in printed version included in the storage sub-system too, provides a guideline to assist you to quickly install and basically setup EonStor GS. The hardware manual introduces hardware components of EonStor GS and JBOD systems to be connected with, and describes in detail installation, maintenance and monitoring.

1.3.1 Major Hardware Components Introduction

For more information, please refer to "Introduction" in **Hardware Manual**. If you are not familiar with hardware components, please refer the following figure, find the component location and number that you want to discover, and check the reference content based on the number.

Getting Started

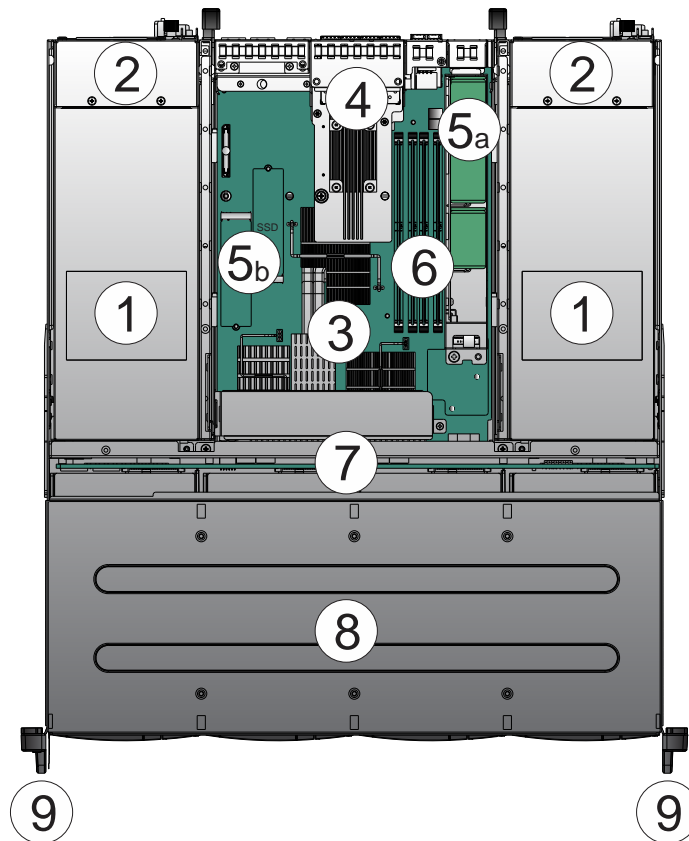

GS 2000/ 3000 Hardware Component Overview

No.	Item	Reference
01	Power Supply Unit	Hardware Manual , sub-chapter “ <i>PSU & Cooling Module</i> ”
02	Embedded Cooling Module	Hardware Manual , sub-chapter “ <i>PSU & Cooling Module</i> ”
03	Controller Board	Hardware Manual , sub-chapter “ <i>Controller Module of Unified Storage Systems</i> ”
04	Host Board	Hardware Manual , sub-chapter “ <i>Installing Host Boards</i> ”
05a	Super Capacitor (part of CBM)	Hardware Manual , sub-chapter “ <i>Super Capacitor & Flash Backup Module</i> ”
05b	Flash Backup Unit (part of CBM)	Hardware Manual , sub-chapter “ <i>Super Capacitor & Flash Backup Module</i> ”
06	Memory Module Sockets	Hardware Manual , sub-chapter “ <i>Replacing the Memory Module on Unified Storage Systems</i> ” Note: GS 2000 only has two memory slots for one controller.
07	Backplane	Hardware Manual , sub-chapter “ <i>Internal Backplane</i> ”
08	Storage Array	Hardware Manual , sub-chapter “ <i>Installing Hard Drives</i> ”
09	Handle bars	Hardware Manual , sub-chapter “ <i>LED Panel</i> ” and “ <i>Slide Rail Kit Installation Guide</i> ”

Hardware Components Location and Reference Information

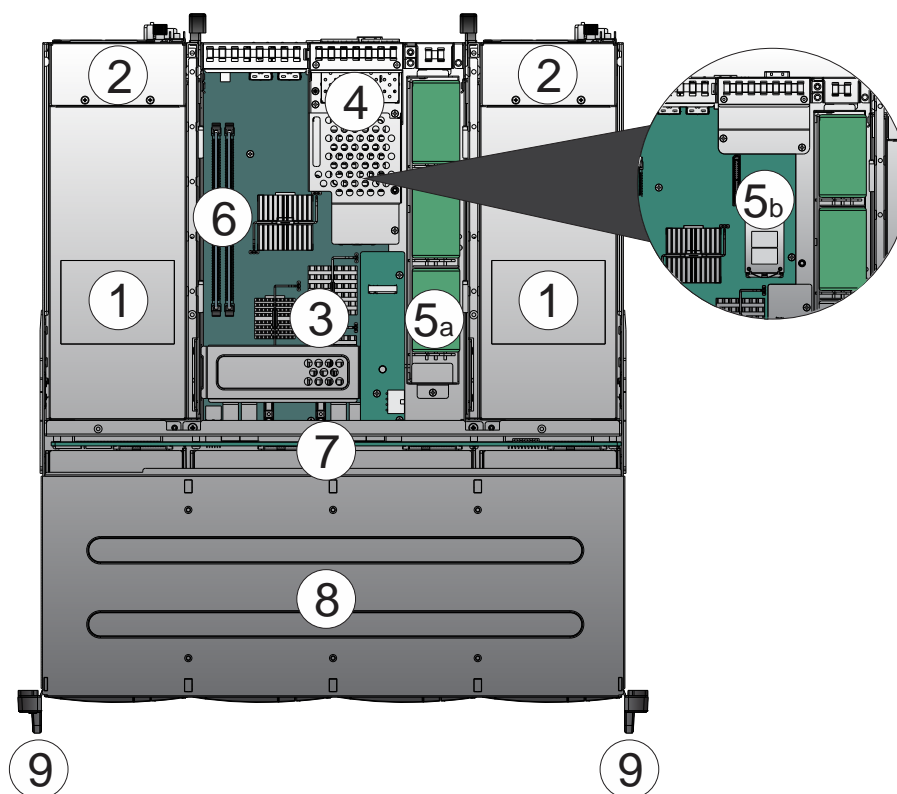

GS 1000 Hardware Component Overview

No.	Item	Reference
01	Power Supply Unit	Hardware Manual , sub-chapter “ <i>PSU & Cooling Module</i> ”
02	Embedded Cooling Module	Hardware Manual , sub-chapter “ <i>PSU & Cooling Module</i> ”
03	Controller Board	Hardware Manual , sub-chapter “ <i>Controller Module of Unified Storage Systems</i> ”
04	Host Board	Hardware Manual , sub-chapter “ <i>Installing Host Boards</i> ”
05a	Super Capacitor (part of CBM)	Hardware Manual , sub-chapter “ <i>Super Capacitor & Flash Backup Module</i> ”
05b	Flash Backup Unit (part of CBM)	Hardware Manual , sub-chapter “ <i>Super Capacitor & Flash Backup Module</i> ” Note: A installed host board has to be removed first before accessing the Flash Backup Unit will be possible.
06	Memory Module Sockets	Hardware Manual , sub-chapter “ <i>Replacing the Memory Module on Unified Storage Systems</i> ”
07	Backplane	Hardware Manual , sub-chapter “ <i>Internal Backplane</i> ”
08	Storage Array	Hardware Manual , sub-chapter “ <i>Installing Hard Drives</i> ”
09	Handle bars	Hardware Manual , sub-chapter “ <i>LED Panel</i> ” and “ <i>Slide Rail Kit Installation Guide</i> ”

1.3.2 Host, JBOD, Management Console, Power Connections

Regarding to host, JBOD, management console and power connections, please refer to “*System Connection*” in **Hardware Manual**. This chapter outlines the general configuration rules you should follow when cabling a storage system and introduces basic information about topologies.

Note:

EonStor GS Redundant(R) model supports native block level failover and SMB 3.0 transparent failover to make file shares continuously available. We strongly recommend reviewing sub-chapter “*General Considerations on Making Connections*”, “*Host Connection*”, “*JBOD Connection*” in **Hardware Manual**. It will provide topology and cabling examples, in order to keep path redundancy and avoid single point of failure based on your storage system. For more information, please refer to appendix: [Concept of SMB 3.0 transparent failover](#).

1.3.3 System Monitoring

For more information, please refer to “*System Monitoring*” in **Hardware Manual**. The EonStor GS series is equipped with a variety of monitoring features, for example temperature, power, drive and controller status, that notify system administrators the storage system’s health status.

1.4 System Maintenance and Hardware Replacement

For more information, please refer to “*System Maintenance*” in **Hardware Manual**. The following components can be replaced:

- Controller module (please refer to “*Replacing the Controller Module*”)
- Memory module (please refer to “*Replacing the Memory Module on Unified Storage Systems*”)
- CBM module (please refer to “*Replacing the Cache Backup Module (CBM)*”)
- Host board (please refer to “*Replacing the Controller Host Board*”)
- PSU module (please refer to “*Replacing the Power Supply Module*”)
- Hard drive (please refer to “*Replacing the Hard Disk Drive*”)

1.5 Checking IP Address of Subsystem

Managing and monitoring the EonStor GS is available through out-of-band (connection through LAN management port) connection. Regarding to the cable connection and default IP setting, you can consult “7. Connecting to Management Interfaces” in **Quick Installation Guide** or “Accessing the Firmware - Establishing LAN Connection” in **Software User Manual**. Follow the procedure to set up cabling. Subsystem’s IP address can be accessed through a terminal emulator application such as PuTTY.

Note:

For redundant (dual-controller) subsystems, connect Ethernet cables to both controllers. The Ethernet port on the Secondary controller stays idle and becomes active in the event of Primary controller failure. The Ethernet port IP on a Primary’s Ethernet port will be inherited by the Secondary controller during controller failover process.

1.6 System Management

After you find the IP address of the subsystem, there are two methods to access EonOne and manage EonStor GS depending on the number of subsystems. You can manage one EonStor GS in a single web interface or multiple subsystems in multiple interfaces by using the EonOne GUI through the browser on PC or server by typing storage system’s IP(s). If you want to manage multiple subsystems in a single EonOne interface, you need to install EonOne software on a management server. Please check the computer requirements and browser compatibility before installing and using EonOne. Consult “Introduction”, “Installation”, and “Accessing the Firmware” in **Software User Manual** for detailed install, uninstall, and upgrade description.

Using EonStor GS

2.1 System General Configuration

As mentioned before, you can directly access EonOne by typing the storage system's IP address into the browser's address bar from any computer to manage a single EonStor GS or by double clicking the EonOne software icon after EonOne has been installed on a management server.

2.1.1 EonOne User Interface Overview

After the login screen appears, type in account name and password (the default account name and password are "admin") and click Login. You will see the following management interface:

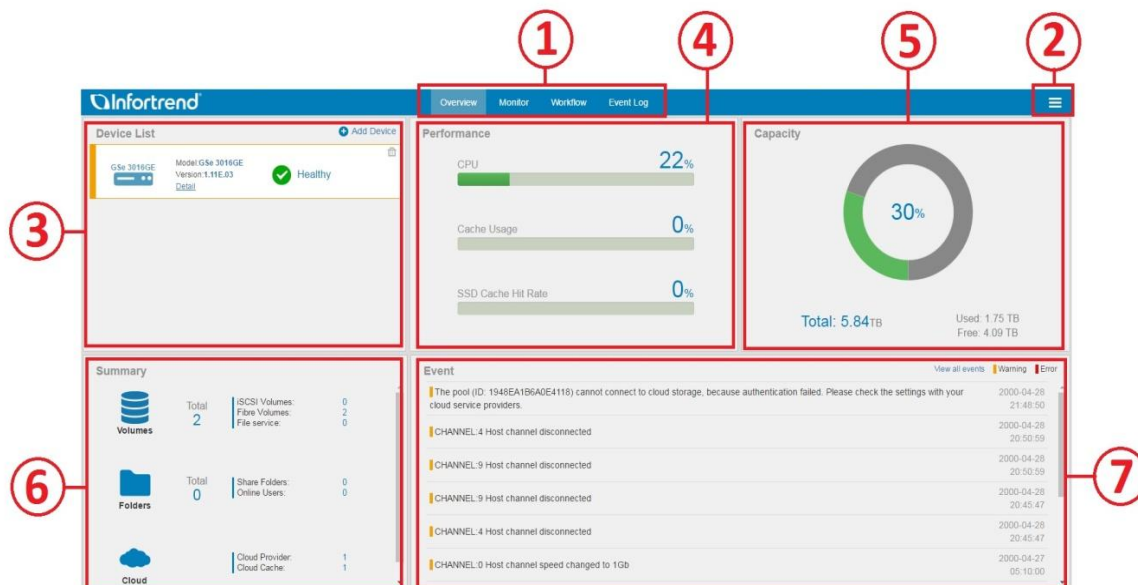

EonOne Overview

Display Elements	Function
1: Top Menu Bar (Page Buttons)	Switch between the pages (Overview, Monitor, Workflow, Event Log) by using the page buttons on the top menu bar.
2: Top Menu Bar (System Setting Button)	The settings section is where you can maintain system and notification settings.
3: Device List	Shows device List of EonStor GS models that are currently connected to EonOne. You can add or remove EonStor GS devices, configure device settings for known EonStor GS devices.
4: Performance Quick Monitor	Shows the CPU usage, memory and SSD cache status for a connected EonStor GS device.
5: Capacity Usage Quick Monitor	Displays information about total, used and free capacity of a connected EonStor GS device.
6: Storage Summary	Shows basic information about configured volumes, shared folders, and your cloud.
7: Events Quick View	Lists the current system events, as warnings and errors of a connected device.

2.1.2 Initial Setup Wizard

The first time login into EonOne, you will see an Initial Setup Wizard which will guide you through the basic storage configuration. Consult “*Initial Setup Wizard*” in **Software User Manual** for more detailed step-by-step configuration.

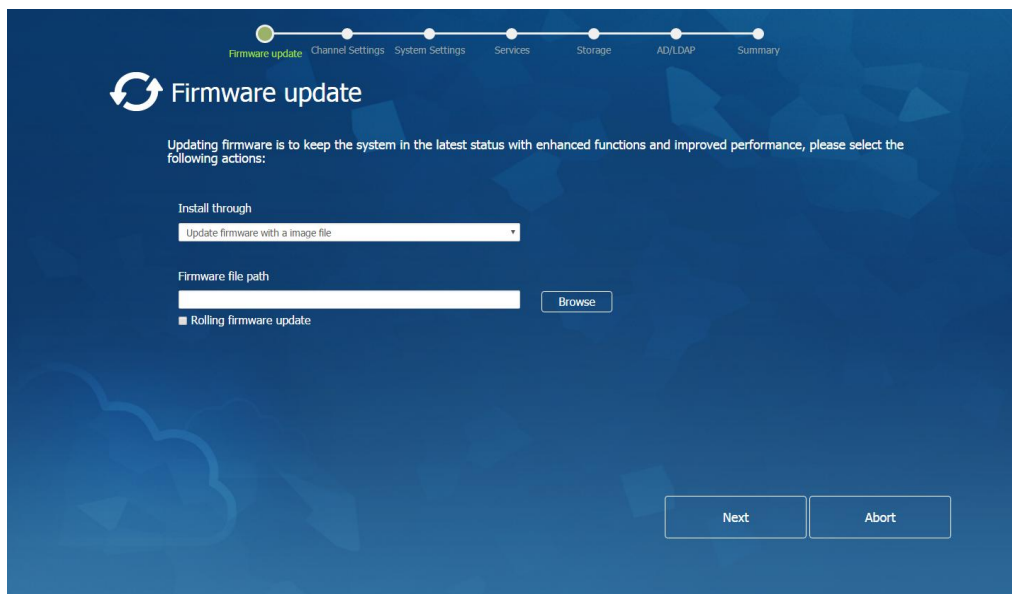
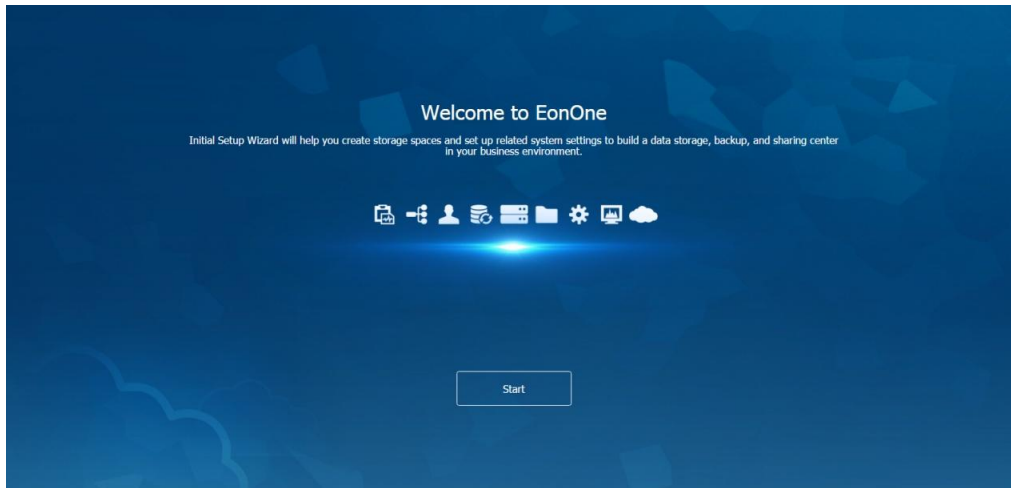

Initial Setup Wizard Page

- Applied Scenario

Designed for the user who is going to setup and configure system tasks the first time.

2.1.3 Manual Configuration in Control Panel

You can skip Initial Setup mode and configure the storage sub-system manually following your requirement. Consult “System”, “Access”, “Privilege”, “Storage”, “Backup and Restore”, “Applications”, “Update”, “Initial Setup Wizard” in **Software User Manual** for a more detailed step-by-step configuration.

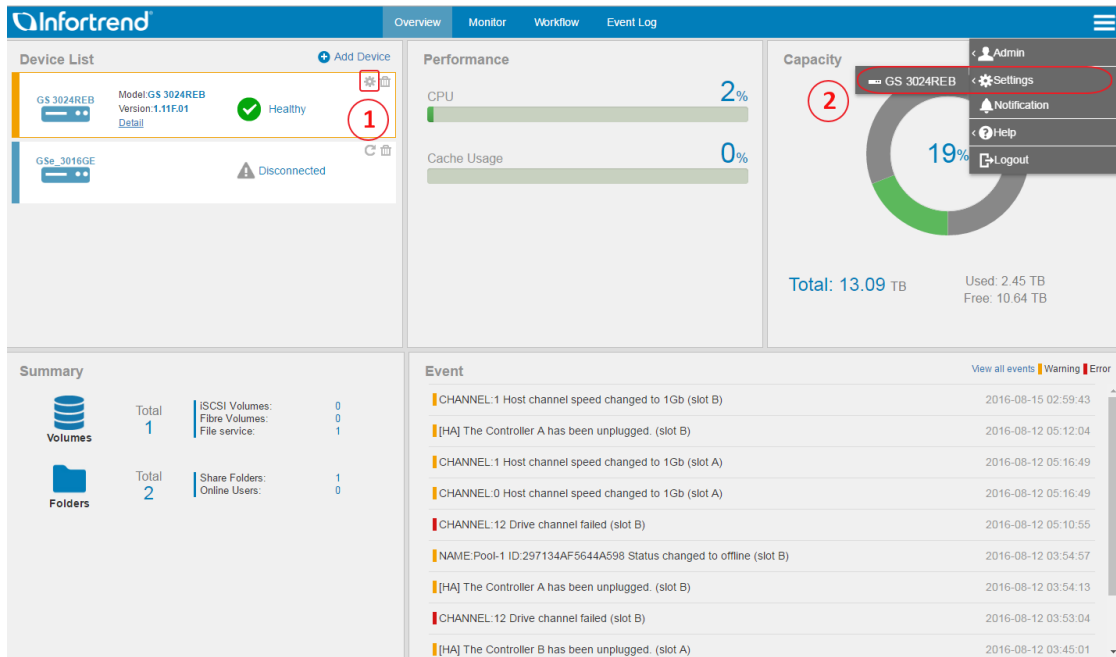

Access control panel by clicking one of marked bottoms

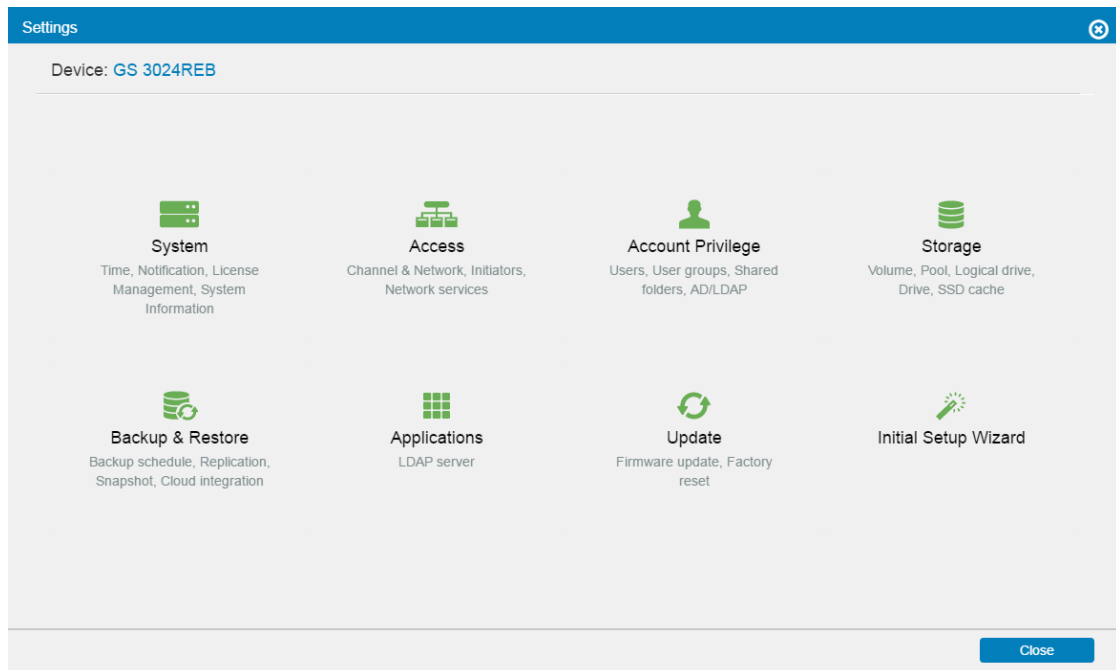

Control Panel Overview

Item	Reference
System-Settings	Execute general, time, notification, license management, and system information configuration: refer to “ <i>System</i> ” in Software User Manual .
Access-Settings	Setup channel & network, initiator, file sharing service, fibre parameter configuration: refer to “ <i>Access</i> ” in Software User Manual .
Privilege-Settings	Configure user, user group, folder, AD/LDAP settings: refer to “ <i>Privilege</i> ” in Software User Manual .
Storage-Settings	Configure Pool, Volume, Logic Drive, Disk Related, SSD related: refer to “ <i>Storage</i> ” in Software User Manual .
Backup & Restore-Settings	Setup replication, snapshot, and cloud integrated features; arrange backup schedules including snapshot, volume mirror, tier migration, media scan, and folder rsync: refer to “ <i>Backup & Restore</i> ” in Software User Manual .
Applications-Settings	Configure LDAP Server: refer to “ <i>Applications</i> ” in Software User Manual .
Update-Settings	Maintain firmware updates and do a factory reset: refer to “ <i>Update</i> ” in Software User Manual .
Initial Setup Wizard-Settings	Operate initial setup wizard: refer to “ <i>Initial Setup Wizard</i> ” in Software User Manual .

- Applied Scenario

Designed for the user who understands the general storage configuration concept and is experienced in storage configuration. For the general configuration concept, please refer to [Appendix: Concept of Logical Drives, Pool, and Volume](#).

2.1.4 Workflow Configuration

The purpose of workflow is to let users deploy pre-defined tasks, which puts relevant steps into one workflow.

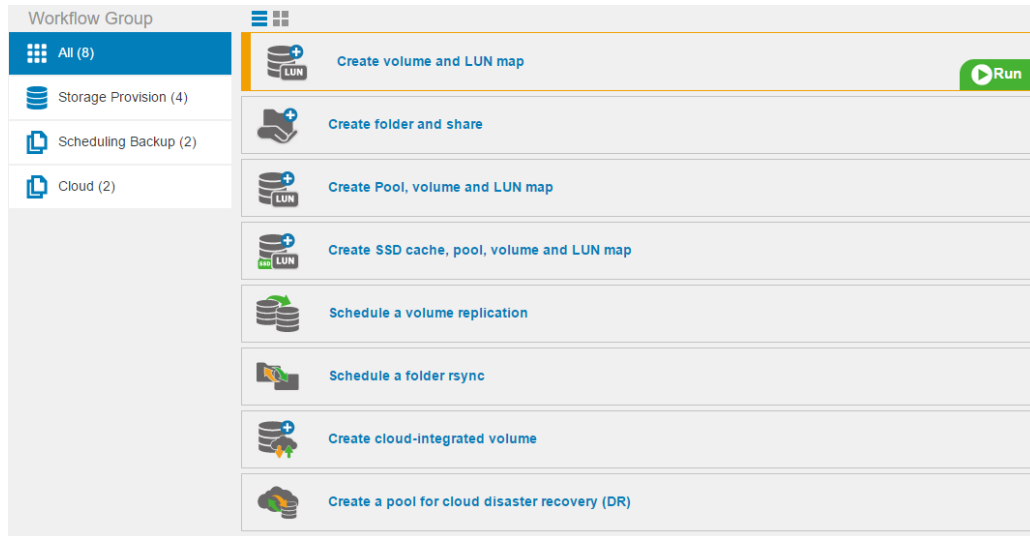

Default Workflow Options

EonOne workflow helps to gather relevant configuration steps into one, a series of tasks can be finished within one process. It is designed for the user who wants efficiently handle a series of configuration actions. For more information, please refer to “*Navigate User Interface - Workflow*” in **Software User Manual**.

By default, we set some standard storage provisioning workflows for users in advance. Including:

Storage Provision:

1. Create volume and LUN map
2. Create folder and share
3. Create pool, volume and LUN map
4. Create SSD cache, pool, volume and LUN map

Scheduling Backup:

1. Schedule a volume replication
2. Schedule a folder rsync

Cloud:

1. Create cloud-integrated volume
2. Create a pool for cloud disaster recovery (DR)

2.2 Cloud Features

EonStor GS integrates three cloud features that extend local storage with cloud capacity or make use of off-site backup and disaster recovery. These features include Cloud Cache, Cloud Backup, and Cloud Tiering. Currently EonStor GS supports the integration of the following cloud providers:

- ✓ [Amazon S3](#)
- ✓ [Google Cloud Platform](#)
- ✓ [Microsoft Azure](#)
- ✓ [Alibaba AliCloud](#)
- ✓ [OpenStack Swift](#)

You could check the latest [compatibility matrix](#) for more detailed information.

2.2.1 Cloud Cache

Enable the Cloud Cache to establish a connection between storage pool and cloud bucket. Data will be automatically deduplicated, compressed (optional), and encrypted when migrated to the cloud. Cache mode will let you choose to enable Fully Cache or not. If Fully Cache is active, EonStor GS will keep all data locally and flush all data to the cloud by a scheduled snapshot. On the other hand, if Fully Cache is inactive, EonStor GS will keep only frequently-accessed data locally and flush all data to the cloud by a scheduled snapshot. No matter Fully Cache is active or inactive, all data will be stored in the cloud and is recoverable based on the last flush period of the snapshot. Consult “*Navigate User Interface – Workflow – Create cloud-integrated volume*” or “*Backup and Restore- Cloud Gateway*” in **Software User Manual** for more detailed step-by-step configuration.

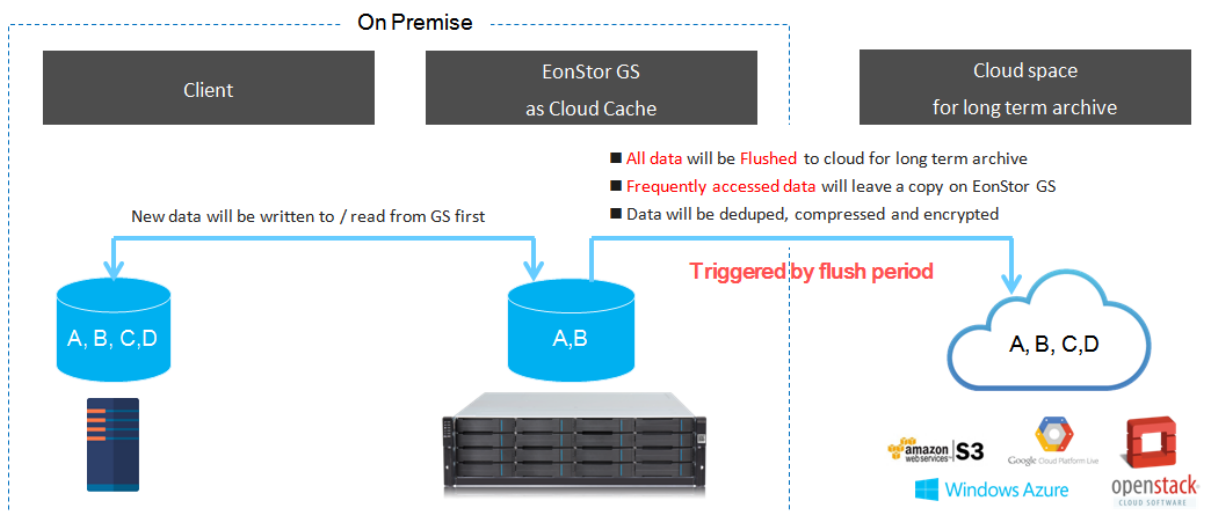

Cloud Cache without fully cache enabled

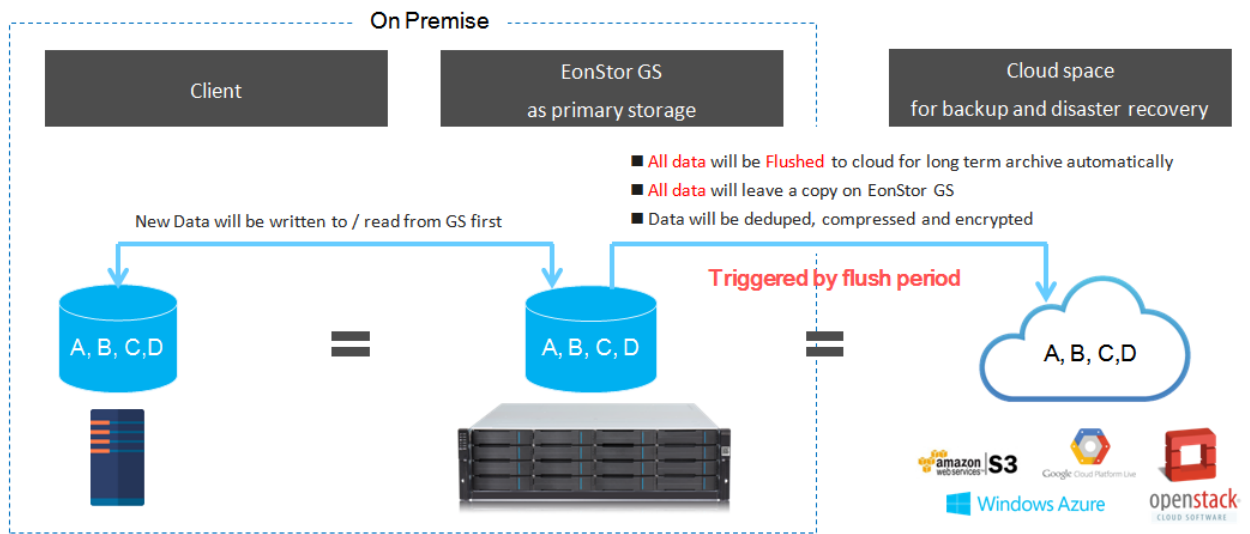

Cloud Fully Cache

● Applied Scenario

Cloud Cache is suitable for email archiving or less-frequently-accessed database archiving.

Cloud Fully Cache is suitable for less-frequently-accessed database or production data backup and disaster recovery.

Note for Cloud Cache:

1. The frequently-accessed read data can be accessed more efficient. However, if you need to modify data, it will take much time to do this operation (depends on your network bandwidth and data size).
2. All data can be restored to the time of the most recent backup.

Note for Cloud Fully Cache:

1. All data is stored locally, and there is no difference in treating frequently-accessed and less-frequently-accessed data.
2. All data can be restored to the time of the most recent backup.

2.2.2 Cloud Backup

In this mode, the cloud bucket is treated as a storage target for remote replication. After EonStor GS has established a connection pair between pool and bucket, it will periodically backup data snapshots to the cloud. The latest data will always be stored locally, multi-point-in-time snapshots stored in the cloud. Users can directly access local, and as the cloud can store multiple snapshots, users can restore any version of snapshot from the cloud to a local or another remote site when a problem occurs at the local site. Consult “*Backup and Restore- Snapshot- Cloud Backup*”, or “*Backup and Restore- Cloud Gateway*” in **Software User Manual** for more detailed step-by-step configuration.

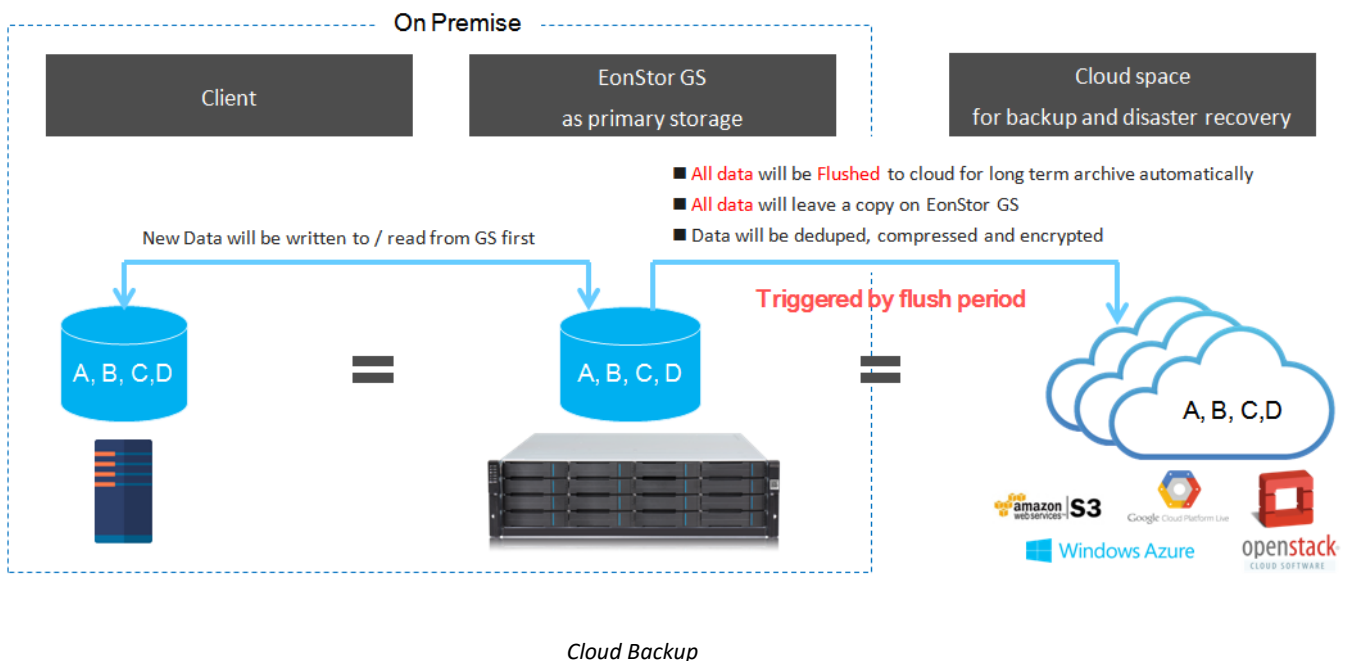

- **Applied Scenario**

Cloud Backup is suitable for frequently-accessed database or production data backup and disaster recovery.

Note:

1. Latest data is stored locally, and there is no difference in treating frequently-accessed and less-frequently-accessed data.
2. System can be restored by one of the multiple-point-in-time snapshots, even after a virus infection or other incident.

2.2.3 Cloud Tiering

Enabling Cloud Tiering, EonStor GS users can establish a connection between pool and cloud bucket to integrate cloud storage into a storage tier, keeping the frequently accessed data locally to ensure a high read / write speed while moving the less accessed data to the cloud. Less accessed local stored data will be moved to the cloud, according to its data access frequency record if the used storage pool capacity exceeds 80% (Threshold $\geq 80\%$). Therefore, data will exist only either locally or in the cloud. If you need to access less accessed data which is stored in the cloud, it will take time to access the data as it will be first decompressed (optional), unduplicated, and decrypted into its original format. In addition, data migration speed from cloud to EonStor GS is based on internet bandwidth. Consult “*Navigate User Interface – Workflow – Create cloud-integrated volume*”, “*Backup & Restore – Snapshot*”, or “*Backup & Restore – Cloud Gateway*” in **Software User Manual** for more detailed step-by-step configuration.

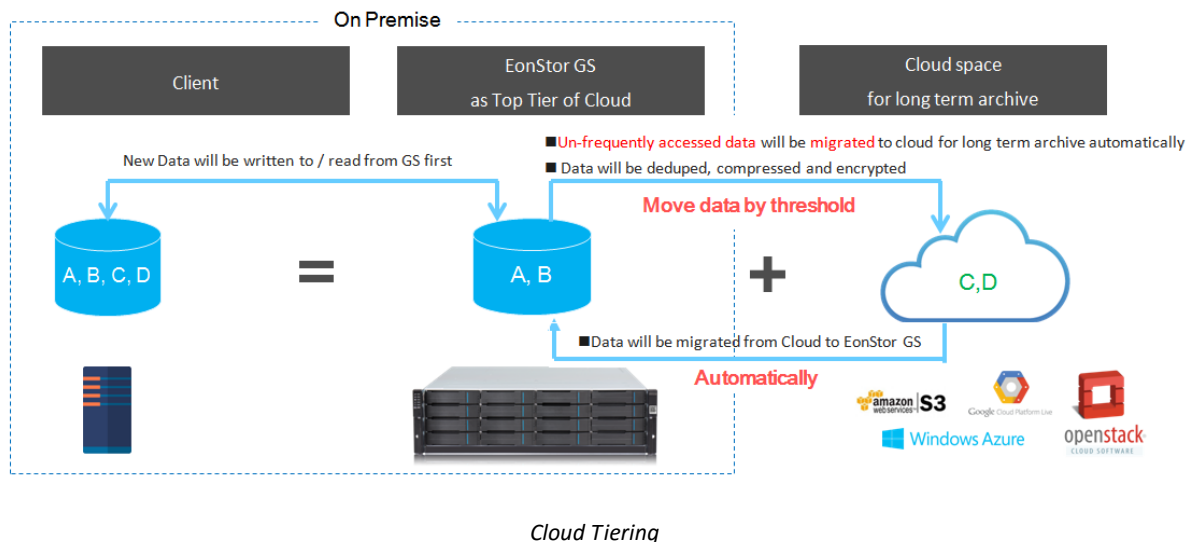

- Applied Scenario

Cloud Tiering is suitable for the user who is willing to rely on online scalability, due to a steady capacity demand and can deal with a slower cloud data access.

Note:

Data is not recoverable if either cloud or local storage are not accessible. To ensure data availability, we recommend using EonStor GS redundant model to store data locally and to add needed cloud features later. Modifying less accessed data, stored in the cloud will take more time (depending on your network bandwidth and data size) than modifying local stored data.

2.3 Data Service

EonStor GS supports SSD Cache, Automated Storage Tiering, Local / Remote Replication, Self-encrypting Drives, Intelligent Drive Recovery, Snapshot, and Thin Provisioning. For more information including generating a license application file, generate an advanced license, license upgrading, download trial license, please go to “*System – License Management*” in **Software User Manual**.

2.3.1 SSD Cache

SSD Cache allows SSD to be used to extend the cache pool capacity of storage systems and caches frequently accessed data. For more information, consult “*Workflow – Create SSD cache, Pool, Volume and LUN Map*” or “*Storage – SSD Cache*” in **Software User Manual** for more detailed step-by-step configuration. For more concept explanation, please consult [Solid State Drive \(SSD\) Cache: Enhancing Storage System Performance](#)

- Applied Scenario

Accelerates performance for random read-intensive applications, such as database (ex. OLTP) and mail solution.

Note:

Preferred application workloads for SSD Cache as following: small-block random read I/O application, high access frequency to the same data, or system where current performance is limited by HDD.

Please check whether the specific SSD model being used is on the Infortrend [Qualified Vendor List](#) (QVL).

2.3.2 Automated Storage Tiering

Automated Storage Tiering migrate scheduled data between low and high performance drives, most frequently accessed data will be stored on the fastest storage tier. For more information, consult “*Storage – Pool – Storage Tiering*”, “*Navigate User Interface – Workflow – Storage Provision*”, or “*Backup and Restore – Creating Tiered Data Migration by schedule*” in **Software User Manual** for more detailed step-by-step configuration. For more concept explanation, please consult [EonStor DS Automated Storage Tiering](#).

- Applied Scenario

Suitable for I/O intensive workloads, such as database (ex. Online Transaction Processing), Virtual desktop infrastructure (VDI), mail solution.

Note:

Preferred application workloads for storage tiering as following: random read/ write Intensive I/O application, high access frequency to the same data.

For most conditions, we suggest to execute tier migration in off or low-peak hours in order to avoid performance impact.

Please check whether the specific SSD model being used is on the Infortrend [Qualified Vendor List \(QVL\)](#).

2.3.3 Remote Replication

Remote replication capability allows users to create full data copies across storage systems, including synchronous and asynchronous mode. If source data fails due to system malfunctions or disasters, users can leverage disk-based remote copy to restart services. For more information, consult *“Backup and Restore - Replication”*, *“Backup and Restore – Schedules – Creating Volume Mirror by Schedule”* or *“Navigate User Interface – Workflow – Schedule a Volume Replication”* in **Software User Manual** for more detailed step-by-step configuration. For more concept explanation, please consult [EonStor DS remote replication feature guide](#).

- Applied Scenario

Backup volume to offsite locations and execute disaster recovery if necessary.

Note:

FC 8G/16G or iSCSI 10G host interfaces are recommended for remote replication because of their connection stability.

For most conditions, we suggest to execute scheduled replication in off or low-peak hours in order to avoid performance impact.

2.3.4 Self-Encrypting Drives (SED)

SEDs have an encryption controller (ASIC) and an encryption key both embedded on the hard drive itself. For more information, consult “Storage – Pool – Create a Pool”, “Navigate User Interface – Workflow – Create SSD cache, Pool, Volume and LUN Map”, “Navigate User Interface – Workflow – Create Pool, Volume and LUN Map”, and “Navigate User Interface – Workflow – Cloud” in **Software User Manual** for more detailed step-by-step configuration. For more concept explanation, please consult [Self-encrypting drives \(SED\): helping prevent data loss, theft, and misplacement](#).

- Applied Scenario

Suitable for the military and government user or the user who needs a high level of data security.

Note:

Please check whether the specific SED model being used is on the Infortrend [Qualified Vendor List \(QVL\)](#).

2.3.5 Intelligent Drive Recovery (IDR)

With Intelligent Drive Recovery (IDR) technology, storage ensures disk drive protection against data loss even the entire drives malfunctions. For more concept explanation, please consult [Intelligent Drive Recovery \(IDR\): helping prevent media errors and disk failures with smart media scan](#).

- Applied Scenario

Suitable for the user who relies on the data and needs to recover data from possible faulty sectors.

2.3.6 Snapshot

Snapshot functions provide instant point-in-time data copies that look and behave like complete backups without consuming equivalent disk space. The snapshot images are ideal for various applications including backup, testing or development, information analysis and data mining. For more information, consult “*Backup and Restore - Snapshot*”, “*Backup and Restore – Schedules – Taking Snapshots by Schedule*” in **Software User Manual** for more detailed step-by-step configuration.

- Applied Scenario

Suitable for the general user who needs data protection or tests remote replication without interrupting the pair relationship.

Note:

The storage space required for storing snapshot images is automatically allocated from a pool. Make sure you always have enough free space.

For further information, considerations, please review the content of “Data Service - Snapshot” in **Software User Manual**.

2.3.7 Thin Provisioning

Thin provisioning allows you to allocate a large amount of virtual capacity for a pool regardless of the physical capacity actually available. Actual space is used only when data writes occur. For more information, consult “*Storage – Volume – Create a Volume*”, “*Storage – Volume – About Thin Provisioning*” in **Software User Manual** for more detailed step-by-step configuration. For more concept explanation, please consult [Thin provisioning white paper](#)

- Applied Scenario

Suitable for the user who knows the future volume growth, making capacity predictable and the user who does not need immediate access to the full volume capacity.

Customer Service

3.1 Online Resource

3.1.1 Infortrend Customer Support System (ICSS)

We strongly recommend you to register with ICSS when your EonStor GS products arrive. Let's visit [Customer Support System](#) and register now. In ICSS you can open new support tickets for all Infortrend products, access the latest firmware and software updates, plus product manuals and technical documents. If have any problems accessing ICSS, please contact us directly at tsd@infortrend.com for assistance.

3.1.2 Quick Service App

The Quick Service App offers a way to carry out system scans to diagnose issues and send system logs to our support team which will help you to initiate the Return Merchandise Authorization (RMA) process and provide the solution to ensure your system's issue is fixed. For more information and QR code scan please visit <http://www.infortrend.com/tw/Support/quickservice>

Note: Quick Service App is currently available for iOS devices only, and it is under development for Android devices.

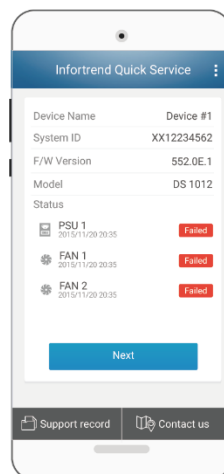

Quick Service App

3.1.3 Technical Documents

White Paper

Our white papers provide information about Infortrend’s technology breakthroughs, design innovations, product development and other major related topics. For more information and document download, please visit http://www.infortrend.com/us/Support/White_Paper

Application Note

Our application notes provide detailed configuration guides for common applications, and offer you design ideas and application sizing. For more information and document download, please visit http://www.infortrend.com/us/Support/application_note

3.2 Technical Support Overview

As mentioned before, you can get technical support from experienced engineers via [ICSS](#) or [Quick Service App](#). For more information about technical support, event code ID and troubleshooting procedures to resolve issues that might occur with a GS system, please download the **Service Guide** from ICSS.

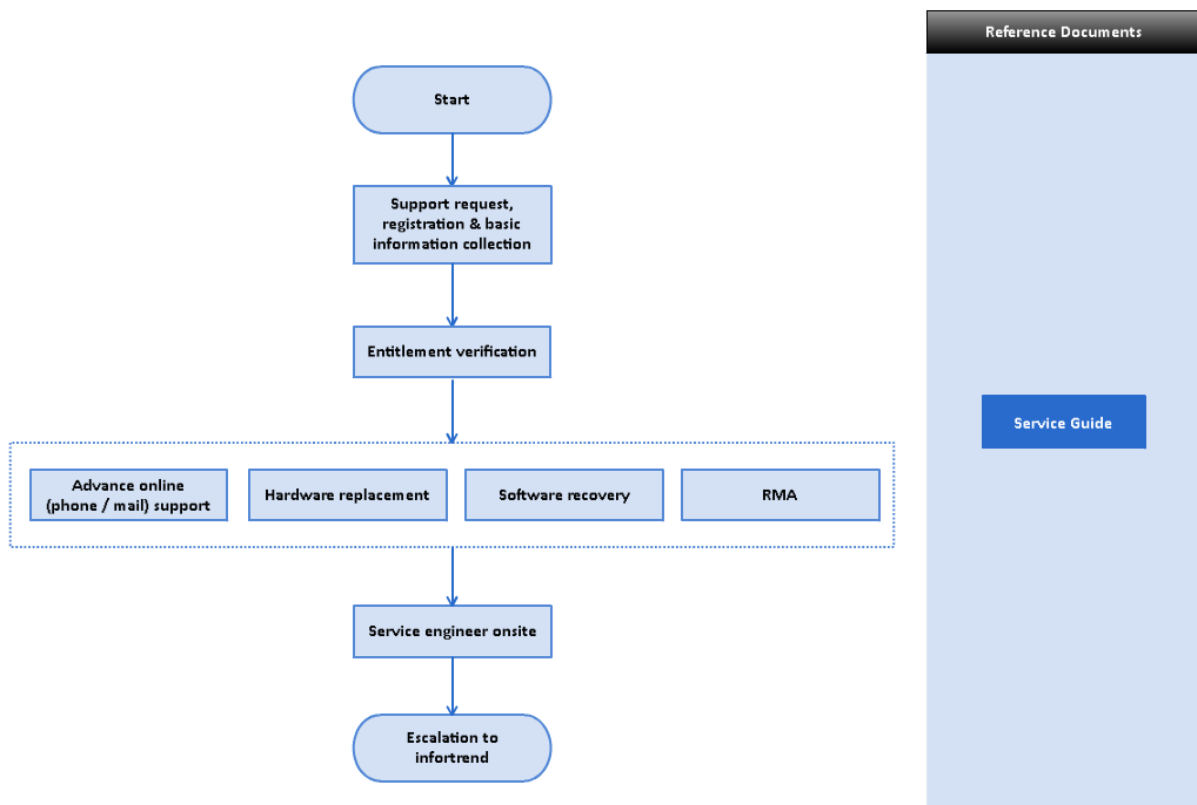

Technical Support Overview

Appendix

Concept of Logical Drive, Pool, and Volume

A logical drive is an array of independent physical drives. A pool is composed of one or several logical drives. The member logical drives can be composed of the same RAID level or each of different RAID level. A volume, a logical unit number or LUN, is a number used to identify a logical unit, which is accessible from host devices (via Fibre Channel, iSCSI, among other) and supports read and write operations.

EonStor GS provides great flexibility in terms of configuring logical drives, pools, and volumes. However, EonStor GS uses a preferred controller ownership approach for communicating with logical drives and every logical drive is owned by only one controller at a time. In addition, when doing configuration operations, it is important to consider controller load balance. For example, 24 drives can be divided into two groups: one group of 12 drives assigned to controller A and another assigned to controller B. However the workload is constantly changing, so it is important to monitor the system and adjust configuration based on requirements.

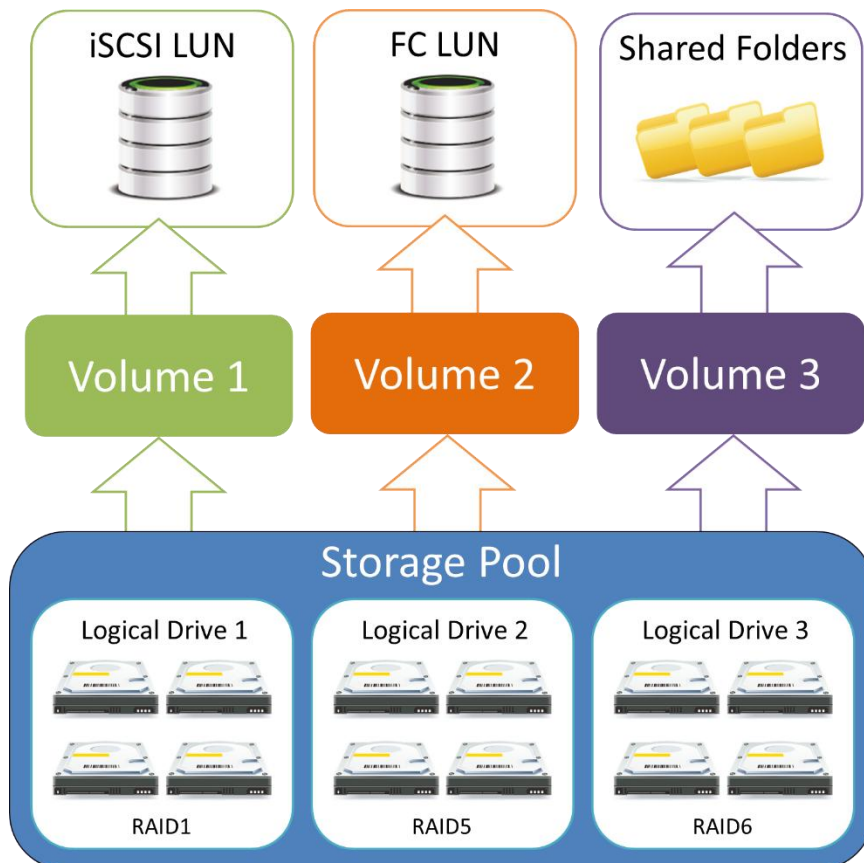

Concept of Logic Drives, Pool, and Volume

Concept of SMB 3.0 transparent failover

A hardware failure or hardware maintenance occurs on one of the controllers, SMB clients transparently reconnect to another controller without interrupting server applications that are storing data on these file shares.

Note:

SMB 3.0 transparent failover is enabled by default.

For more detailed information, please refer to [Server Message Block Overview](#).

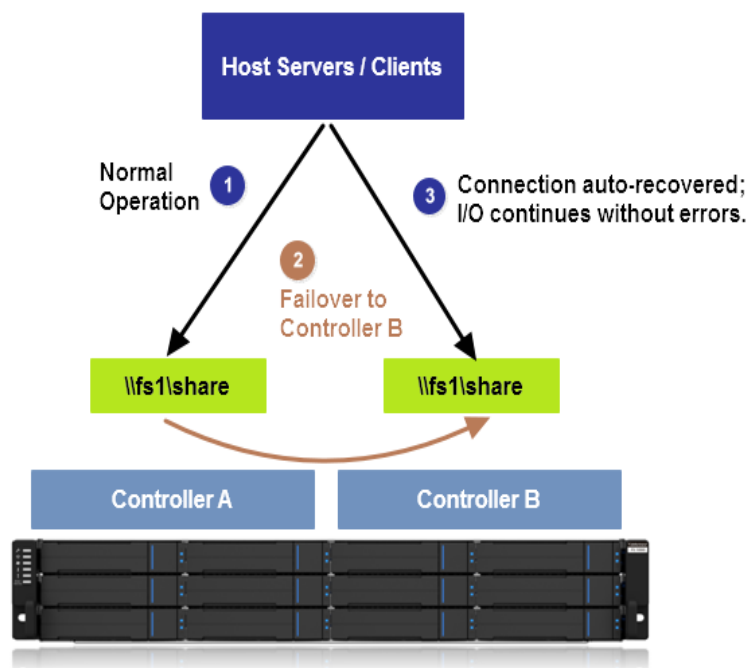

SMB 3.0 transparent failover concept