



## **Getting Started Guide for Cisco UCS E-Series Servers and the Cisco UCS E-Series Network Compute Engine**

**First Published:** 2016-07-06

**Last Modified:** 2019-10-15

### **Americas Headquarters**

Cisco Systems, Inc.  
170 West Tasman Drive  
San Jose, CA 95134-1706  
USA  
<http://www.cisco.com>  
Tel: 408 526-4000  
800 553-NETS (6387)  
Fax: 408 527-0883

THE SPECIFICATIONS AND INFORMATION REGARDING THE PRODUCTS IN THIS MANUAL ARE SUBJECT TO CHANGE WITHOUT NOTICE. ALL STATEMENTS, INFORMATION, AND RECOMMENDATIONS IN THIS MANUAL ARE BELIEVED TO BE ACCURATE BUT ARE PRESENTED WITHOUT WARRANTY OF ANY KIND, EXPRESS OR IMPLIED. USERS MUST TAKE FULL RESPONSIBILITY FOR THEIR APPLICATION OF ANY PRODUCTS.

THE SOFTWARE LICENSE AND LIMITED WARRANTY FOR THE ACCOMPANYING PRODUCT ARE SET FORTH IN THE INFORMATION PACKET THAT SHIPPED WITH THE PRODUCT AND ARE INCORPORATED HEREIN BY THIS REFERENCE. IF YOU ARE UNABLE TO LOCATE THE SOFTWARE LICENSE OR LIMITED WARRANTY, CONTACT YOUR CISCO REPRESENTATIVE FOR A COPY.

The Cisco implementation of TCP header compression is an adaptation of a program developed by the University of California, Berkeley (UCB) as part of UCB's public domain version of the UNIX operating system. All rights reserved. Copyright © 1981, Regents of the University of California.

NOTWITHSTANDING ANY OTHER WARRANTY HEREIN, ALL DOCUMENT FILES AND SOFTWARE OF THESE SUPPLIERS ARE PROVIDED "AS IS" WITH ALL FAULTS. CISCO AND THE ABOVE-NAMED SUPPLIERS DISCLAIM ALL WARRANTIES, EXPRESSED OR IMPLIED, INCLUDING, WITHOUT LIMITATION, THOSE OF MERCHANTABILITY, FITNESS FOR A PARTICULAR PURPOSE AND NON-INFRINGEMENT OR ARISING FROM A COURSE OF DEALING, USAGE, OR TRADE PRACTICE.

IN NO EVENT SHALL CISCO OR ITS SUPPLIERS BE LIABLE FOR ANY INDIRECT, SPECIAL, CONSEQUENTIAL, OR INCIDENTAL DAMAGES, INCLUDING, WITHOUT LIMITATION, LOST PROFITS OR LOSS OR DAMAGE TO DATA ARISING OUT OF THE USE OR INABILITY TO USE THIS MANUAL, EVEN IF CISCO OR ITS SUPPLIERS HAVE BEEN ADVISED OF THE POSSIBILITY OF SUCH DAMAGES.

Any Internet Protocol (IP) addresses and phone numbers used in this document are not intended to be actual addresses and phone numbers. Any examples, command display output, network topology diagrams, and other figures included in the document are shown for illustrative purposes only. Any use of actual IP addresses or phone numbers in illustrative content is unintentional and coincidental.

All printed copies and duplicate soft copies of this document are considered uncontrolled. See the current online version for the latest version.

Cisco has more than 200 offices worldwide. Addresses and phone numbers are listed on the Cisco website at [www.cisco.com/go/offices](http://www.cisco.com/go/offices).

Cisco and the Cisco logo are trademarks or registered trademarks of Cisco and/or its affiliates in the U.S. and other countries. To view a list of Cisco trademarks, go to this URL: [www.cisco.com go trademarks](http://www.cisco.com/go/trademarks). Third-party trademarks mentioned are the property of their respective owners. The use of the word partner does not imply a partnership relationship between Cisco and any other company. (1721R)

© 2016 Cisco Systems, Inc. All rights reserved.



## CONTENTS

---

### PREFACE

<b>Preface</b>	<b>ix</b>
New and Changed Information	<b>ix</b>
Audience	<b>xi</b>
Organization	<b>xi</b>
Conventions	<b>xii</b>
Related Documentation	<b>xiii</b>
Documentation Feedback	<b>xiii</b>

---

### CHAPTER 1

<b>Quick Start Basic Configuration</b>	<b>1</b>
Quick Start Basic Configuration Tasks	<b>1</b>

---

### CHAPTER 2

<b>Overview</b>	<b>5</b>
Cisco UCS E-Series Servers and the Cisco UCS E-Series Network Compute Engine Overview	<b>5</b>
Server Software	<b>6</b>
Managing E-Series Servers and the NCE	<b>7</b>
E-Series Server and NCE Options	<b>8</b>
Basic Workflow for Option 1—E-Series Server or NCE Without a Preinstalled Operating System or Hypervisor	<b>9</b>
Basic Workflow for Option 2—E-Series Server or NCE With a Preinstalled Microsoft Windows Server	<b>11</b>
Basic Workflow for Option 3—E-Series Server or NCE With a Preinstalled VMware vSphere Hypervisor	<b>11</b>
Common Terms Used in This Guide	<b>12</b>

---

### CHAPTER 3

<b>Installing the E-Series Server or NCE into the Router</b>	<b>15</b>
Basic Workflow for Installing the E-Series Server or NCE into the Router	<b>15</b>
Verifying Compatibility	<b>16</b>

Verifying the Cisco ISR G2, E-Series Server, NCE, and Cisco IOS Software Release Compatibility 16

Verifying the Cisco ISR 4000 Series, E-Series Server, NIM, CIMC, and Cisco IOS Software Release Compatibility 17

Installing the E-Series Server and the NCE into a Router 17

Verifying Installation 20

    Verifying E-Series Server Installation 20

    Verifying the EHWIC E-Series NCE Installation 21

    Verifying NIM E-Series NCE Installation 22

Stopping the E-Series Server from Resetting and Updating the CIMC Firmware—Cisco ISR 4000 Series 23

What to Do Next 24

---

**CHAPTER 4**

**Configuring Access to the Management Firmware 25**

Configuring CIMC Access 25

    Understanding the Interfaces in an E-Series Server and the Cisco ISR G2 25

        CIMC Access Configuration Options—Cisco ISR G2 27

    Understanding the Interfaces in an E-Series Server and the Cisco ISR 4000 Series 38

        CIMC Access Configuration Options—Cisco ISR 4000 Series 40

    Understanding the Interfaces in the EHWIC E-Series NCE and the Cisco ISR G2 54

        CIMC Access Configuration Options—EHWIC E-Series NCE 55

    Understanding the Interfaces in the NIM E-Series NCE and the Cisco ISR 4000 Series 63

        CIMC Access Configuration Options—NIM E-Series NCE 64

Configuring CIMC Access Using the CIMC Configuration Utility 74

Defining Network Static Settings Using a Script File 76

What to Do Next 77

---

**CHAPTER 5**

**Accessing the Management Firmware 79**

CIMC Overview 79

    CIMC GUI 80

    CIMC CLI 80

Logging In to the CIMC GUI 81

CIMC Home Page 82

What to Do Next 82



---

<b>CHAPTER 6</b>	<b>Managing Storage Using RAID</b>	<b>83</b>
	Configuring RAID	83
	Configuring RAID Using the CIMC GUI	84
	Configuring RAID Using the WebBIOS	88
	Configuring RAID Using the MegaRAID Controller	89
	What to Do Next	90

---

<b>CHAPTER 7</b>	<b>Installing the Operating System or Hypervisor</b>	<b>91</b>
	Operating System or Hypervisor Installation Methods	91
	KVM Console	92
	Installing an Operating System or Hypervisor Using the KVM Console	93
	PXE Installation Servers	94
	Installing an Operating System or Hypervisor Using a PXE Installation Server	94
	Host Image Mapping	95
	Mapping the Host Image	95
	Installing Drivers for the Microsoft Windows Server	97
	Obtaining Software from Cisco Systems	98
	Unmapping the Host Image	100
	Basic Workflow for Downloading and Installing the VMware vSphere Hypervisor	101
	Downloading the Customized VMware vSphere Hypervisor Image	101
	Assigning a Static IP Address to the VMware vSphere Hypervisor	102
	Downloading and Installing the vSphere Client	103
	Configuring the Server Boot Order	104
	Configuring the Server Boot Order Using the CIMC GUI	104
	Configuring the Boot Order Using the BIOS Setup Menu	106
	Verifying Operating System and Hypervisor Installation	108
	Accessing the Microsoft Windows Server from CIMC	108
	Accessing the VMware vSphere Hypervisor from CIMC	108
	What to Do Next	109

---

<b>CHAPTER 8</b>	<b>Configuring a Connection Between the Router and the E-Series Server or NCE</b>	<b>111</b>
	Configuring an Internal Connection Between the Cisco ISR G2 and the E-Series Server	111
	Configuring an Internal Connection Between the Cisco ISR 4000 Series and the E-Series Server	114

Creating an Ethernet Virtual Circuit Between the E-Series Server and the Cisco ISR 4000 Series Using the Native VLAN 116

Creating an Ethernet Virtual Circuit Between the E-Series Server and the Cisco ISR 4000 Series Using a Non-Native VLAN 118

Configuring an Internal Connection Between the Cisco ISR G2 and the EHWIC E-Series NCE 120

Configuring an Internal Connection Between the Cisco ISR 4000 Series and the NIM E-Series NCE 123

Creating an Ethernet Virtual Circuit Between the NIM E-Series NCE and the Cisco ISR 4000 Series Using the Native VLAN 126

Creating an Ethernet Virtual Circuit Between the NIM E-Series NCE and the Cisco ISR 4000 Series Using a Non-Native VLAN 127

Understanding Network Interface Mapping 130

Determining the MAC Address in Microsoft Windows, Linux, and VMware vSphere Hypervisor 132

---

**CHAPTER 9**

**Upgrading Firmware 135**

Options for Upgrading Firmware 135

Cisco Host Upgrade Utility Overview 136

Minimum CIMC and BIOS Firmware Releases Required to Use HUU 136

CIMC and BIOS Firmware Releases Available With HUU ISO Images 137

Understanding the HUU User Interface 140

Upgrading the Firmware 142

    Basic Workflow for Using the HUU 142

    Upgrading the Firmware Using the HUU 142

Troubleshooting 145

---

**APPENDIX A**

**Configuration Differences 147**

Router Configuration Differences Between the Cisco ISR G2 and the Cisco ISR 4000 Series 147

Router Configuration Differences Between the E-Series Server and the EHWIC E-Series NCE—Cisco ISR G2 148

---

**APPENDIX B**

**Cisco IOS Software Command Reference—Cisco ISR G2 151**

imc ip address default-gateway 151

imc ip address dhcp 152

imc vlan 152

ucse cmos-reset 153

ucse password-reset 154  
ucse session 155  
ucse shutdown 157  
ucse statistics 158  
ucse status 159  
ucse stop 160

---

**APPENDIX C****Cisco IOS Software Command Reference—Cisco ISR 4000 Series 163**

debug platform software ucse 163  
hw-module subslot session 164  
imc ip dhcp 165  
platform switchport 166  
show interfaces ucse 167  
ucse subslot imc password-reset 169  
ucse subslot server 170  
ucse subslot server password-reset 171  
ucse subslot shutdown 172  
ucse subslot statistics 173  
ucse subslot status 174





## Preface

This preface includes the following sections:

- [New and Changed Information, on page ix](#)
- [Audience, on page xi](#)
- [Organization, on page xi](#)
- [Conventions, on page xii](#)
- [Related Documentation, on page xiii](#)
- [Documentation Feedback, on page xiii](#)

## New and Changed Information

The following table provides an overview of the significant changes to this guide for the current CIMC release:

**Table 1: New Features and Significant Changes in the Getting Started Guide for Cisco UCS E-Series Servers for CIMC Release 3.1.1**

Feature	Description	Where Documented
Support UCS-E160S-M3/K9 servers	Support added to install the UCS-E160S-M3/K9 into the Cisco ISR 4000 series.	<a href="#">Overview, on page 5</a>
Configuring CIMC Access	Procedures to configure CIMC access through the external TE2/TE3 interfaces.	<a href="#">Configuring CIMC Access Using the E-Series Server's External TE2 or TE3 Interface—Cisco ISR 4000 Series, on page 52</a>

**Table 2: New Features and Significant Changes in the Getting Started Guide for Cisco UCS E-Series Servers and the Cisco UCS E-Series Network Compute Engine for CIMC Release 3.0.1**

Feature	Description	Where Documented
NIM E-Series Network Compute Engine Support	Support for the NIM E-Series Network Compute Engine (NIM E-Series NCE).	<a href="#">Overview, on page 5</a>

Feature	Description	Where Documented
Configuring CIMC Access	Procedures to configure CIMC access when the NIM E-Series NCE is installed in a Cisco ISR 4000 series.	<a href="#">Configuring Access to the Management Firmware</a> , on page 25
Configuring a Connection Between the Router and the NIM E-Series NCE	Procedure to configure an internal connection between the Cisco ISR 4000 series and the NIM E-Series NCE.	<a href="#">Configuring a Connection Between the Router and the E-Series Server or NCE</a> , on page 111
Host Upgrade Utility	Contains information that was present in the <i>Host Upgrade Utility User Guide for Cisco UCS E-Series Servers and the Cisco UCS E-Series Network Compute Engine</i> .  Since CIMC release 3.0.1, a separate <i>Host Upgrade Utility User Guide</i> is not supported. All the information that was present in the <i>Host Upgrade Utility User Guide</i> is merged into this guide.	<a href="#">Upgrading Firmware</a> , on page 135

**Table 3: New Features and Significant Changes in the Getting Started Guide for Cisco UCS E-Series Servers, CIMC Release 1.0(2)**

Feature	Description	Where Documented
New Platform Support	Support added to install the E-Series Server into the Cisco 4000 Series Integrated Services Router (Cisco ISR 4000 series).	<a href="#">Cisco UCS E-Series Servers and the Cisco UCS E-Series Network Compute Engine Overview</a> , on page 5
Migrating E-Series Server from an ISR G2 into a Cisco ISR 4000 series	See the "Important" note if you are migrating the E-Series Server from an ISR G2 into a Cisco ISR 4000 series.	<a href="#">Installing the E-Series Server or NCE into the Router</a> , on page 15
Configuring CIMC Access—Cisco ISR 4000 series	Procedures to configure CIMC access when the E-Series Server is installed in a Cisco ISR 4000 series.	<a href="#">Configuring Access to the Management Firmware</a> , on page 25
Configuring a Connection Between the Cisco ISR 4000 series and the E-Series Server	Procedure to configure a connection between the Cisco ISR 4000 series and the E-Series Server.	<a href="#">Configuring a Connection Between the Router and the E-Series Server or NCE</a> , on page 111
Cisco IOS Software Command Reference—Cisco ISR 4000 series	New Cisco IOS commands introduced to support the Cisco ISR 4000 series.	<a href="#">Cisco IOS Software Command Reference—Cisco ISR 4000 Series</a> , on page 163

## Audience

This guide is intended primarily for data center administrators with responsibilities and expertise in one or more of the following:

- Server administration
- Storage administration
- Network administration
- Network security

## Organization

Chapter	Title	Description
Chapter 1	Quick Start Basic Configuration	Provides a list of commands and steps to quickly set up and use the E-Series Server and NCE.
Chapter 2	Overview	Provides an overview of the product, hardware and software requirements, and E-Series Server and NCE options.
Chapter 3	Installing the E-Series Server or NCE into the Router	Describes how to install the E-Series Server or NCE into the router.
Chapter 4	Configuring Access to the Management Firmware	Provides options to configure CIMC access.
Chapter 5	Accessing the Management Firmware	Provides an overview of CIMC and describes how to log in to CIMC.
Chapter 6	Managing Storage Using RAID	Describes RAID options and how to configure RAID.  <b>Note</b> The RAID feature is applicable to E-Series Servers and the SM E-Series NCE. The RAID feature is not applicable to the EHWIC E-Series NCE and the NIM E-Series NCE.
Chapter 7	Installing the Operating System	Describes how to install the operating system.
Chapter 8	Configuring a Connection Between the Router and the E-Series Server or NCE	Describes how to configure a connection between the router and the E-Series Server or NCE.
Chapter 9	Upgrading Firmware	Provides options for upgrading firmware.

Chapter	Title	Description
Appendix A	Configuration Differences	Provides configuration differences between the Cisco ISR G2 and the Cisco ISR 4000 series.
Appendix B	Cisco IOS Software Command Reference—Cisco ISR G2	Provides a list of Cisco IOS commands used to configure the Cisco ISR G2 and the E-Series Server or NCE.
Appendix C	Cisco IOS Software Command Reference—Cisco ISR 4000 series	Provides a list of Cisco IOS commands used to configure the Cisco ISR 4000 series and the E-Series Server.

## Conventions

Text Type	Indication
GUI elements	GUI elements such as tab titles, area names, and field labels appear in <b>this font</b> . Main titles such as window, dialog box, and wizard titles appear in <b>this font</b> .
User input	Text the user should enter exactly as shown or keys that a user should press appear in <b>this font</b> .
Document titles	Document titles appear in <i>this font</i> .
System output	Terminal sessions and information that the system displays appear in <i>this font</i> .
CLI commands	CLI command keywords appear in <b>this font</b> . Arguments in a CLI command appear in <i>this font</i> .
[ ]	Elements in square brackets are optional.
{x   y   z}	Required alternative keywords are grouped in braces and separated by vertical bars.
[x   y   z]	Optional alternative keywords are grouped in brackets and separated by vertical bars.
string	A nonquoted set of characters. Do not use quotation marks around the string or the string will include the quotation marks.
<>	Nonprinting characters such as passwords are in angle brackets.
[ ]	Default responses to system prompts are in square brackets.
!, #	An exclamation point (!) or a pound sign (#) at the beginning of a line of code indicates a comment line.





---

**Note** Means *reader take note*. Notes contain helpful suggestions or references to material not covered in the document.

---



---

**Tip** Means *the following information will help you solve a problem*. The tips information might not be troubleshooting or even an action, but could be useful information, similar to a Timesaver.

---



---

**Caution** Means *reader be careful*. In this situation, you might perform an action that could result in equipment damage or loss of data.

---



---

**Timesaver** Means *the described action saves time*. You can save time by performing the action described in the paragraph.

---



---

**Warning** IMPORTANT SAFETY INSTRUCTIONS

This warning symbol means danger. You are in a situation that could cause bodily injury. Before you work on any equipment, be aware of the hazards involved with electrical circuitry and be familiar with standard practices for preventing accidents. Use the statement number provided at the end of each warning to locate its translation in the translated safety warnings that accompanied this device.

SAVE THESE INSTRUCTIONS

---

## Related Documentation

The [Documentation Guide for Cisco UCS E-Series Servers and the Cisco UCS E-Series Network Compute Engine](#) provides links to all product documentation.

## Documentation Feedback

To provide technical feedback on this document, or to report an error or omission, send an email to [ucse\\_docfeedback@cisco.com](mailto:ucse_docfeedback@cisco.com). We appreciate your feedback.





# CHAPTER 1

## Quick Start Basic Configuration

---



### Note

- Use this "Quick Start Basic Configuration" chapter if you just need a list of commands and steps to quickly set up and use the Cisco UCS E-Series Server (E-Series Server) or the Cisco UCS E-Series Network Compute Engine (NCE).
- For detailed instructions, use subsequent chapters.

---

Use this quick start basic configuration chapter if you purchased Option 1 (E-Series Server or NCE without a preinstalled operating system or hypervisor). Some of the configuration steps are different if you purchased Option 2 (E-Series Server or NCE with a preinstalled Microsoft Windows Server), or Option 3 (E-Series Server or NCE with a preinstalled VMware vSphere Hypervisor).

This chapter includes the following sections:

- [Quick Start Basic Configuration Tasks, on page 1](#)

## Quick Start Basic Configuration Tasks

The following figure shows the basic workflow for Option 1—E-Series Server or NCE without a preinstalled operating system or hypervisor.

Figure 1: Basic Workflow—Option 1

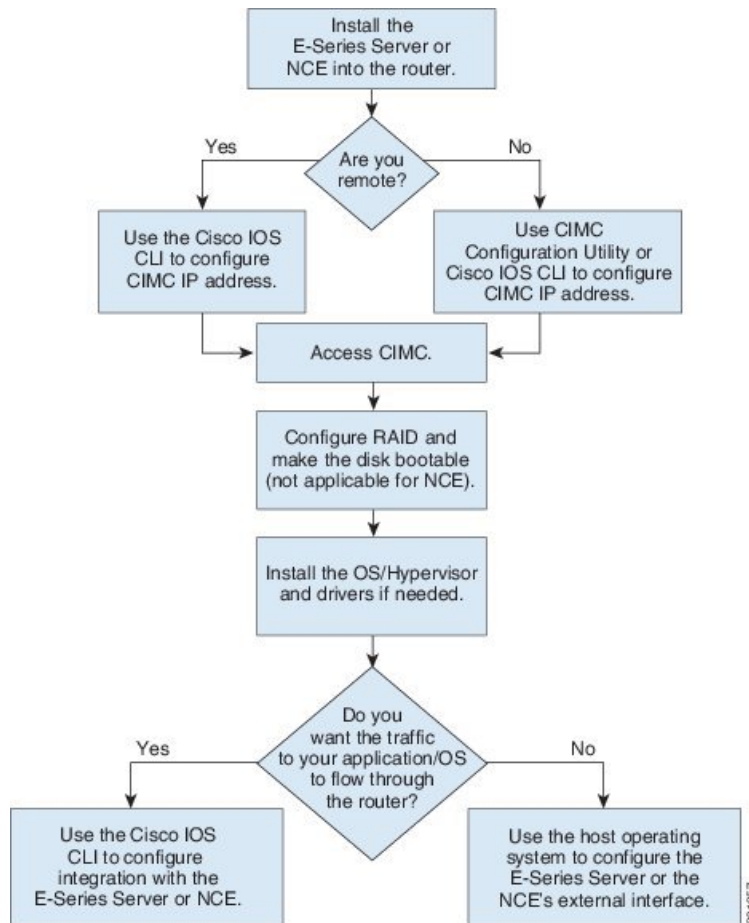

**Note** The CIMC Configuration Utility is not applicable to the EHWIC E-Series NCE and the NIM E-Series NCE.



**Note** The RAID feature is applicable to E-Series Servers and the SM E-Series NCE. The RAID feature is not applicable to the EHWIC E-Series NCE and the NIM E-Series NCE.

## Procedure

**Step 1** Install the E-Series Server or NCE into the router.

**Step 2** Configure the CIMC IP address for CIMC access. Use one of the following methods:

- If you are a remote user, use the Cisco IOS CLI to configure CIMC access. This basic configuration shows you how to configure CIMC access using the server's external GE2 interface:

1. **enable**

2. **configure terminal**
3. Use one of the following as appropriate:
  - **interface ucse slot/port**—Use for all E-Series Servers or SM E-Series NCE installed in a Cisco ISR G2 or Cisco ISR 4000 series.
  - **interface ucse 0/subslot/port**—Use for an EHWIC E-Series NCE installed in a Cisco ISR G2.
  - **interface ucse slot/subslot/port**—Use for a NIM E-Series NCE installed in a Cisco ISR 4000 series.
  - **ucse subslot slot/subslot**—Use for all E-Series Servers and NCEs installed in a Cisco ISR G2 or Cisco ISR 4000 series.
4. **imc ip address** *imc-ip-address subnet-mask* **default-gateway** *imc-gateway-ip-address*
5. **imc access-port shared-lom ge2**
6. **no shut**—Not applicable for an E-Series Server installed in a Cisco ISR 4000 series.
7. **end**

**Note** For detail configuration, see one of the following topics as appropriate:

- [Configuring CIMC Access Using the E-Series Server's External GE2 or GE3 Interface—Cisco ISR G2, on page 37](#)
- [Configuring CIMC Access Using the E-Series Server's External GE2 or GE3 Interface—Cisco ISR 4000 Series, on page 50](#)
- [Configuring CIMC Access Using the EHWIC E-Series NCE's External GE2 Interface, on page 61](#)
- [Configuring CIMC Access Using the NIM E-Series NCE's External GE2 Interface—Cisco ISR 4000 Series, on page 72](#)

To use another interface, see [Configuring Access to the Management Firmware](#) , on page 25.

- If you are a local user, use one of the following methods:
  - Connect a keyboard and monitor to the front panel of the E-Series Server, and then use the CIMC Configuration Utility to configure CIMC access. See [Configuring CIMC Access Using the CIMC Configuration Utility, on page 74](#).
  - Note** The CIMC Configuration Utility is not applicable to the EHWIC E-Series NCE and the NIM E-Series NCE.
  - Use the Cisco IOS CLI to configure CIMC access (see the configuration for a remote user above).

- Step 3** In your web browser, enter the IP address that you configured in Step 2 to access CIMC.
- Step 4** Configure RAID and make the disk drive bootable. See [Managing Storage Using RAID](#) , on page 83.
- Step 5** Install the operating system or hypervisor and if needed, install drivers. See [Installing the Operating System or Hypervisor, on page 91](#).
- Step 6** Do one of the following:

- If you do not want the traffic to your application or operating system to flow through the router, use the server's host operating system to configure the E-Series Server's external GE2 or GE3 interface or the NCE's external GE2 interface.

**Note** On Cisco UCS-E160S-M3/K9, UCS-E180D-M3/K9, and UCS-E1120D-M3/K servers, the external interface would be TE2 or TE3.

- If you want the traffic to your application or operating system to flow through the router, use the Cisco IOS CLI to configure an internal connection between the router and the E-Series Server or NCE. See [Configuring a Connection Between the Router and the E-Series Server or NCE, on page 111](#).
-



## CHAPTER 2

# Overview



### Important

Use this Getting Started Guide if the E-Series Server is installed in the Cisco 4000 Series Integrated Services Router. If the E-Series Server is installed in the Cisco 2900 or 3900 ISR G2, use the *Getting Started Guide for Cisco UCS E-Series Servers, Release 1.0*.

This chapter includes the following sections:

- [Cisco UCS E-Series Servers and the Cisco UCS E-Series Network Compute Engine Overview, on page 5](#)
- [Server Software, on page 6](#)
- [Managing E-Series Servers and the NCE, on page 7](#)
- [E-Series Server and NCE Options, on page 8](#)
- [Common Terms Used in This Guide, on page 12](#)

## Cisco UCS E-Series Servers and the Cisco UCS E-Series Network Compute Engine Overview

The Cisco UCS E-Series Servers (E-Series Servers) and Cisco UCS E-Series Network Compute Engine (NCE) are a family of size-, weight-, and power-efficient blade servers that are housed within the Generation 2 Cisco Integrated Services Routers (Cisco ISR G2) and the Cisco ISR 4000 series. These servers provide a general purpose compute platform for branch-office applications deployed either as bare-metal on operating systems, such as Microsoft Windows or Linux, or as virtual machines on hypervisors, such as VMware vSphere Hypervisor, Microsoft Hyper-V, or Citrix XenServer.

The E-Series Servers are purpose-built with powerful Intel Xeon processors for general purpose compute. They come in two form factors: single-wide and double-wide. The single-wide E-Series Server fits into one service module (SM) slot, and the double-wide E-Series Server fits into two SM slots.

The NCEs are price-to-power optimized modules that are built to host Cisco network applications and other lightweight general-purpose applications. They come in three form factors: SM, NIM, and EHWIC. The SM E-Series NCE fits into one SM slot, the NIM E-Series NCE fits into one NIM slot, and the EHWIC E-Series NCE fits into two EHWIC slots.



**Note**

- The EHWIC E-Series NCE can be installed in the the Cisco ISR G2 only.
- The NIM E-Series NCE can be installed in the Cisco ISR 4000 series only.
- The Cisco ISR 4331 has one SM slot. The Cisco ISR 4321 and the Cisco ISR 4431 have no SM slots.
- Citrix XenServer is supported on the E-Series Servers only.
- Cisco UCS-E160S-M3/K9, UCS-E180D-M3/K9, and UCS-E1120D-M3/K9 servers are supported on the ISR 4000 series only.
- CIMC 3.2.x is not supported on EHWIC NCEs.

The following figure shows an example of an E-Series Server or NCE hypervisor deployment.

**Figure 2: Example of an E-Series Server or NCE Hypervisor Deployment**

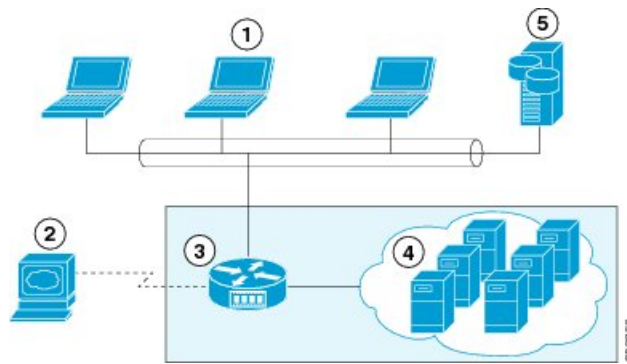

1	Client devices	4	Virtual machines hosted on the E-Series Server or the NCE (applicable only if a hypervisor is running on the E-Series Server or NCE)
2	E-Series Server or NCE management console	5	Enterprise storage device
3			



**Note**

For information about the supported E-Series Servers and NCE, and the maximum number of servers that can be installed per router, see the "Hardware Requirements" section in the *Hardware Installation Guide for Cisco UCS E-Series Servers and the Cisco UCS E-Series Network Compute Engine*.

## Server Software

E-Series Servers and NCE require three major software systems:

- CIMC firmware



- BIOS firmware
- Operating system or hypervisor

The following figure shows how the software interacts with the server.

**Figure 3: Server Software**

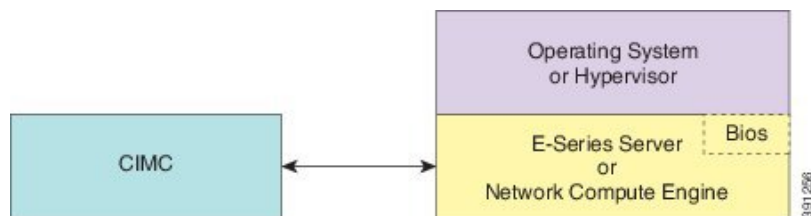

### CIMC Firmware

Cisco Integrated Management Controller (CIMC) is a separate management module built into the motherboard of the E-Series Server or NCE. A dedicated ARM-based processor, separate from the main server CPU, runs the CIMC firmware. The system ships with a running version of the CIMC firmware. You can update the CIMC firmware, but no initial installation is needed.

CIMC is the management service for the E-Series Servers and NCE. You can use a web-based GUI or SSH-based CLI to access, configure, administer, and monitor the server.

### BIOS Firmware

BIOS initializes the hardware in the system, discovers bootable devices, and boots them in the provided sequence. It boots the operating system and configures the hardware for the operating system to use. BIOS manageability features allow you to interact with the hardware and use it. In addition, BIOS provides options to configure the system, manage firmware, and create BIOS error reports.

The system ships with a running version of the BIOS firmware. You can update the BIOS firmware, but no initial installation is needed.

### Operating System or Hypervisor

The main server CPU runs on an operating system, such as Microsoft Windows or Linux; or on a hypervisor. You can purchase an E-Series Server or NCE with a preinstalled Microsoft Windows Server or VMware vSphere Hypervisor, or you can install your own platform.



**Note** For information about the platforms that have been tested on the E-Series Servers or NCE, see the "Software Requirements" section in the *Release Notes for Cisco UCS E-Series Servers and the Cisco UCS E-Series Network Compute Engine*.

## Managing E-Series Servers and the NCE

The following table lists the management interfaces used by the E-Series Server and the NCE.

Table 4: E-Series Server and NCE Management Interfaces

Management Interface	Description
Cisco IOS CLI	CLI used to configure the host router and the E-Series Server or the NCE.
CIMC GUI	Web-based GUI used to access, configure, administer, and monitor the E-Series Server and NCE.
CIMC CLI	SSH-based CLI used to access, configure, administer, and monitor the E-Series Server and the NCE.
SNMP	Simple Network Management Protocol (SNMP) traps that allow you to view server configuration and status, and send fault and alert information.

## E-Series Server and NCE Options

The following figure shows the E-Series Server and NCE options.

Figure 4: E-Series Server or NCE Options

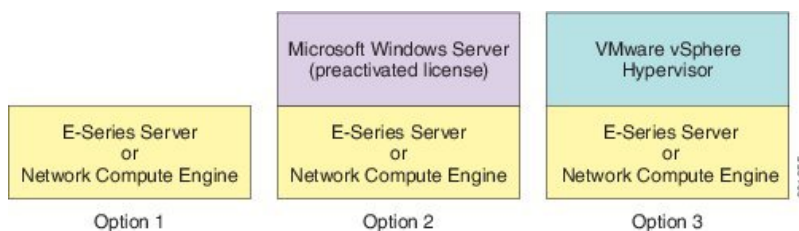

- Option 1—E-Series Server or NCE without a preinstalled operating system or hypervisor
- Option 2—E-Series Server or NCE with a preinstalled Microsoft Windows Server

At the time of purchase, you can choose the appropriate RAID option that you want enabled on the E-Series Server.



**Note** If you purchase this option, the Microsoft Windows Server license is preactivated.

- Option 3—E-Series Server or NCE with a preinstalled VMware vSphere Hypervisor

At the time of purchase, you can choose the appropriate RAID option that you want enabled on the E-Series Server.



**Note** The default username for the preinstalled VMware vSphere Hypervisor is **root**, which cannot be changed, and the default password is **password**. After you log in, we recommend that you change the password.



**Important** The RAID feature is applicable to E-Series Servers and the SM E-Series NCE. The RAID feature is not applicable to the EHWIC E-Series NCE and the NIM E-Series NCE.

## Basic Workflow for Option 1—E-Series Server or NCE Without a Preinstalled Operating System or Hypervisor

The following figure shows the basic workflow for Option 1—E-Series Server or NCE without a preinstalled operating system or hypervisor.

*Figure 5: Basic Workflow—Option 1*

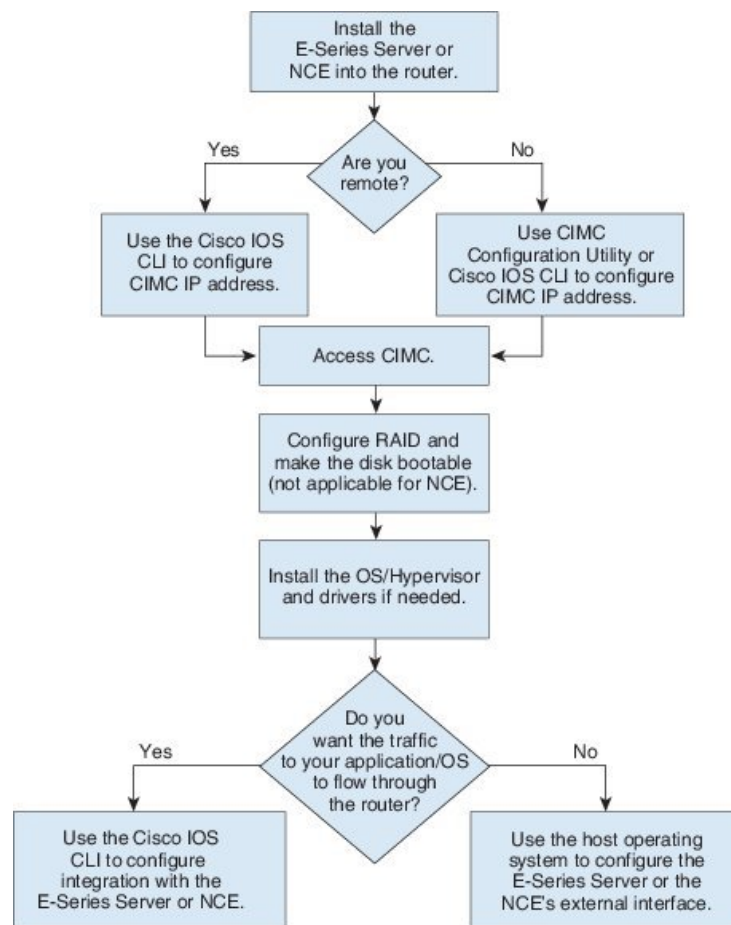

**Note** The CIMC Configuration Utility is not applicable to the EHWIC E-Series NCE and the NIM E-Series NCE.



**Note** The RAID feature is applicable to E-Series Servers and the SM E-Series NCE. The RAID feature is not applicable to the EHWIC E-Series NCE and the NIM E-Series NCE.

The following procedure provides the references for the tasks that you must perform when you purchase Option 1—hardware only (E-Series Server or NCE without a preinstalled operating system or hypervisor).

#### Procedure

	Command or Action	Purpose
<b>Step 1</b>	Install the E-Series Server or NCE into the router.	See <a href="#">Installing the E-Series Server or NCE into the Router</a> , on page 15.
<b>Step 2</b>	Configure the CIMC IP address for CIMC access.	See <a href="#">Configuring Access to the Management Firmware</a> , on page 25.
<b>Step 3</b>	Access CIMC.	See <a href="#">Accessing the Management Firmware</a> , on page 79.
<b>Step 4</b>	Configure RAID and make the disk drive bootable.	See <a href="#">Managing Storage Using RAID</a> , on page 83.  <b>Important</b> The RAID feature is applicable to E-Series Servers and the SM E-Series NCE. The RAID feature is not applicable to the EHWIC E-Series NCE and the NIM E-Series NCE.
<b>Step 5</b>	Install the operating system, and if needed, install the drivers.	See <a href="#">Installing the Operating System or Hypervisor</a> , on page 91.
<b>Step 6</b>	Configure an internal connection between the router and the E-Series Server or NCE.	Depending on whether you want the traffic to flow through the router or not, do one of the following: <ul style="list-style-type: none"> <li>• If you <i>do not want</i> the traffic to your application or operating system to flow through the router, use the server's host operating system to configure the E-Series Server's or NCE's external interface.</li> <li>• If you <i>want</i> the traffic to your application or operating system to flow through the router, use the Cisco IOS CLI to configure an internal connection between the router and the E-Series Server or NCE. See <a href="#">Configuring a Connection Between the Router and the E-Series Server or NCE</a>, on page 111.</li> </ul>

## Basic Workflow for Option 2—E-Series Server or NCE With a Preinstalled Microsoft Windows Server

The following procedure provides the references for the tasks that you must perform when you purchase Option 2—E-Series Server or NCE with a preinstalled Microsoft Windows Server.

### Procedure

	Command or Action	Purpose
<b>Step 1</b>	Install the E-Series Server or NCE into the router.	See <a href="#">Installing the E-Series Server or NCE into the Router</a> , on page 15.
<b>Step 2</b>	Configure the CIMC IP address for CIMC access.	See <a href="#">Configuring Access to the Management Firmware</a> , on page 25.
<b>Step 3</b>	Configure an internal connection between the router and the E-Series Server or NCE.	Depending on whether you want the traffic to flow through the router or not, do one of the following: <ul style="list-style-type: none"> <li>• If you <i>do not want</i> the traffic to your application or operating system to flow through the router, use the server's host operating system to configure the E-Series Server's or NCE's external interface.</li> <li>• If you <i>want</i> the traffic to your application or operating system to flow through the router, use the Cisco IOS CLI to configure an internal connection between the router and the E-Series Server or NCE. See <a href="#">Configuring a Connection Between the Router and the E-Series Server or NCE</a>, on page 111.</li> </ul>
<b>Step 4</b>	Access CIMC, and then access the Microsoft Windows Server from CIMC.	See <a href="#">Accessing the Management Firmware</a> , on page 79.

## Basic Workflow for Option 3—E-Series Server or NCE With a Preinstalled VMware vSphere Hypervisor

The following procedure provides the references for the tasks that you must perform when you purchase Option 3—E-Series Server or NCE with a preinstalled VMware vSphere Hypervisor.

### Procedure

	Command or Action	Purpose
<b>Step 1</b>	Install the E-Series Server or NCE into the router.	See <a href="#">Installing the E-Series Server or NCE into the Router</a> , on page 15.

	Command or Action	Purpose
<b>Step 2</b>	Configure the CIMC IP address for CIMC access.	See <a href="#">Configuring Access to the Management Firmware</a> , on page 25.
<b>Step 3</b>	Configure an internal connection between the router and the E-Series Server or NCE.	Depending on whether you want the traffic to flow through the router or not, do one of the following: <ul style="list-style-type: none"> <li>• If you <i>do not want</i> the traffic to your application or operating system to flow through the router, use the server's host operating system to configure the E-Series Server's or NCE's external interface.</li> <li>• If you <i>want</i> the traffic to your application or operating system to flow through the router, use the Cisco IOS CLI to configure an internal connection between the router and the E-Series Server or NCE. See <a href="#">Configuring a Connection Between the Router and the E-Series Server or NCE</a>, on page 111.</li> </ul>
<b>Step 4</b>	Access CIMC, and then access the VMware vSphere Hypervisor from CIMC.	See <a href="#">Accessing the Management Firmware</a> , on page 79.

## Common Terms Used in This Guide

Table 5: Common Terms

Term	Description
BMC	Board Management Controller. BMC is used in the Cisco IOS commands to configure CIMC.
CIMC	Cisco Integrated Management Controller. CIMC is the management service for the E-Series Server. CIMC runs within the server. You can use CIMC to access, configure, administer, and monitor the server.
CLI	Command-line interface.
IMC	Integrated Management Controller. IMC is used in the Cisco IOS commands to configure CIMC.
LOM	LAN on Motherboard. Shared LOM interfaces are used to configure CIMC access.

Term	Description
RAID	Redundant Array of Inexpensive Disks. RAID is used to store E-Series Server data files.







## CHAPTER 3

# Installing the E-Series Server or NCE into the Router

---

This chapter includes the following sections:

- [Basic Workflow for Installing the E-Series Server or NCE into the Router, on page 15](#)
- [Verifying Compatibility, on page 16](#)
- [Installing the E-Series Server and the NCE into a Router, on page 17](#)
- [Verifying Installation, on page 20](#)
- [Stopping the E-Series Server from Resetting and Updating the CIMC Firmware—Cisco ISR 4000 Series, on page 23](#)
- [What to Do Next, on page 24](#)

## Basic Workflow for Installing the E-Series Server or NCE into the Router

1. Verify that the router, the E-Series Server or NCE, and the Cisco IOS software version that is installed on the router are compatible.
2. Install the E-Series Server or NCE into the router.



### Important

---

If you are migrating the E-Series Server from a Cisco ISR G2 into a Cisco ISR 4000 series, you must first update the CIMC firmware image to release 2.0(1.20130626092411) or the latest version and the BIOS firmware image to release 1.5.0.2 or the latest version—while the E-Series Server is still installed in the Cisco ISR G2—and then migrate it into the Cisco ISR 4000 series. For CIMC firmware installation instructions, see the "CIMC Firmware Management" chapter in the *GUI Configuration Guide for Cisco UCS E-Series Servers and the Cisco UCS E-Series Network Compute Engine* on Cisco.com.

---

3. Verify that the E-Series Server or the NCE is correctly detected by the router.

## Verifying Compatibility

### Verifying the Cisco ISR G2, E-Series Server, NCE, and Cisco IOS Software Release Compatibility

*Table 6: Router, E-Series Server, NCE, and Cisco IOS Release Compatibility*

Router	Cisco IOS Software Release for Single-Wide E-Series Servers and the SM E-Series NCE	Cisco IOS Software Release for Double-Wide E-Series Servers	Cisco IOS Software Release for the EHWIC E-Series NCE
1921	—	—	15.4(3)M and later releases
1941	—	—	15.4(3)M and later releases
2911	15.2(4)M and later releases	—	15.4(3)M and later releases
2921	15.2(4)M and later releases	15.2(4)M and later releases	15.4(3)M and later releases
2951	15.2(4)M and later releases	15.2(4)M and later releases	15.4(3)M and later releases
3925	15.2(4)M and later releases	15.2(4)M and later releases	15.4(3)M and later releases
3925e	15.2(4)M and later releases	15.2(4)M and later releases	15.4(3)M and later releases
3945	15.2(4)M and later releases	15.2(4)M and later releases	15.4(3)M and later releases
3945e	15.2(4)M and later releases	15.2(4)M and later releases	15.4(3)M and later releases

## Verifying the Cisco ISR 4000 Series, E-Series Server, NIM, CIMC, and Cisco IOS Software Release Compatibility

Table 7: Cisco ISR 4000 Series, E-Series Server, NIM, CIMC, and Cisco IOS Release Compatibility

Router	Cisco IOS Software Release for Single-Wide E-Series Servers and the SM E-Series NCE	Cisco IOS Software Release for Double-Wide E-Series Servers	Cisco IOS Software Release for NIM E-Series NCE	CIMC
4400 Series	XE 3.12S	XE 3.12S	–	2.2.2 and later releases
	XE 3.13S and later releases	XE 3.13S and later releases	–	2.3.1 and later releases
	–	–	XE 3.15S and later releases	3.0.1 and later releases
	XE 16.2.1 <a href="#">1</a>	XE 16.2.1	XE 16.2.1	3.0.1 and later releases
4300 Series	XE 3.13S and later releases	XE 3.13S and later releases	–	2.3.1 and later releases
	–	–	XE 3.15S and later releases	3.0.1 and later releases
	XE 16.2.1	XE 16.2.1	XE 16.2.1	3.0.1 and later releases

<sup>1</sup> Do not downgrade the release version from XE 16.2.1. If you downgrade the release version from XE 16.2.1, the UCS-E module will not come up due to CSCux77048. To bring the UCS-E module up, do an OIR using the **hw-module subslot x/y reload** command.

## Installing the E-Series Server and the NCE into a Router

The following figures show how to install the E-Series Server and the EHWIC E-Series NCE into a router. For detailed information, see the *Hardware Installation Guide for Cisco UCS E-Series Servers and the Cisco UCS E-Series Network Compute Engine* on Cisco.com.

### Double-Wide E-Series Server in a Cisco ISR G2



**Caution** Before you install or remove the E-Series Server from a Cisco 2900 series ISR G2, make sure that you first power down the router, and then install or remove the server.

Figure 6: Double-Wide E-Series Server in a Cisco ISR G2

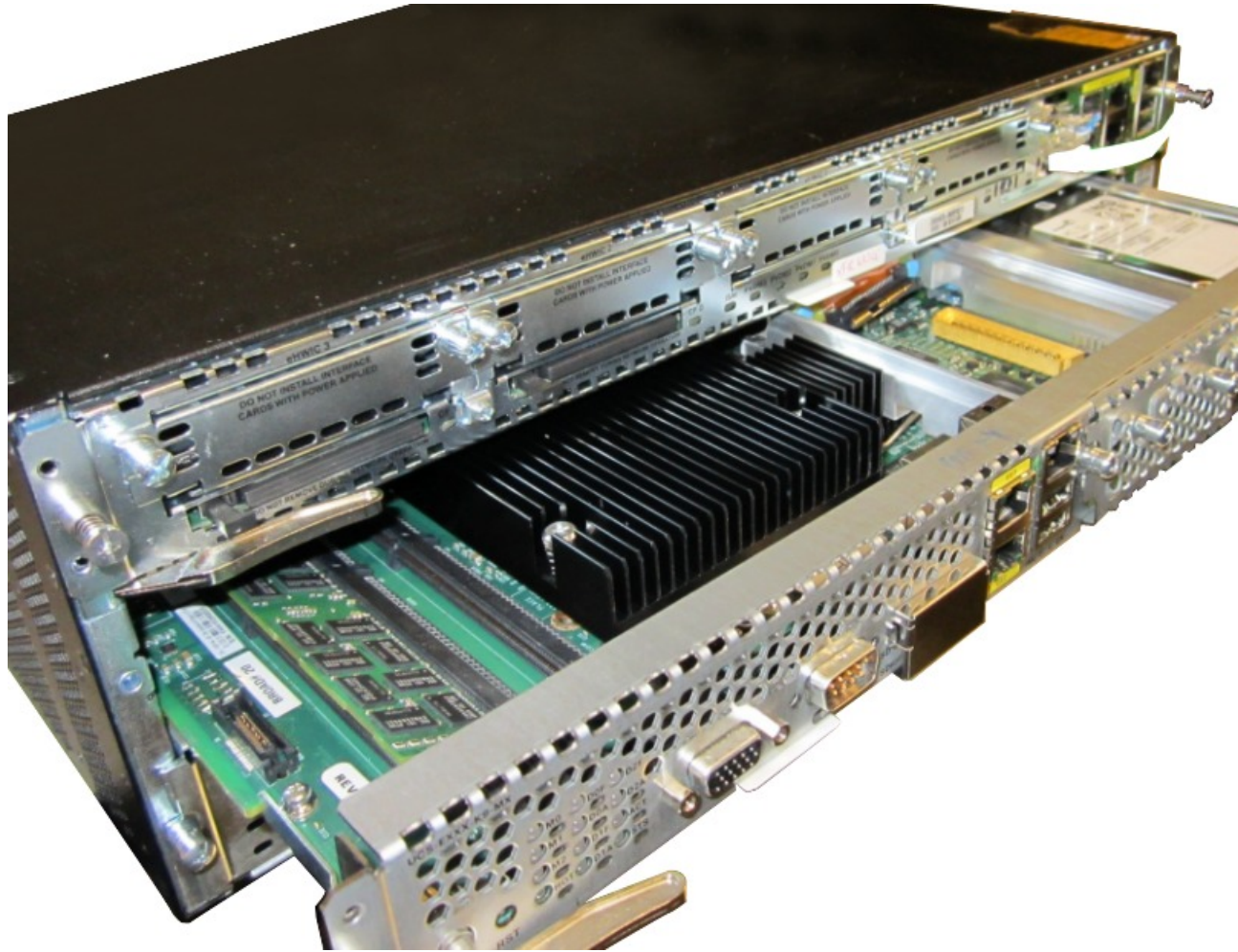

### Double-Wide E-Series Server in a Cisco ISR 4000 Series



#### Important

If you are migrating the E-Series Server from a Cisco ISR G2 into a Cisco ISR 4000 series, you must first upgrade the CIMC and the BIOS firmware image to the latest version—while the E-Series Server is still installed in the Cisco ISR G2—and then migrate it into the Cisco ISR 4000 series. We strongly recommend that you upgrade both the CIMC and the BIOS firmware images.

You can use either the Cisco Host Upgrade Utility (HUU) to upgrade the firmware components or you can upgrade the firmware components manually. For firmware upgrade information, see [Upgrading Firmware, on page 135](#).

If you migrate the E-Series Server into the Cisco ISR 4000 series without first updating the CIMC firmware, the E-Series Server might continuously reset. To stop the reset and install the firmware, see [Stopping the E-Series Server from Resetting and Updating the CIMC Firmware—Cisco ISR 4000 Series, on page 23](#).

Figure 7: Double-Wide E-Series Server in a Cisco ISR 4000 series



### EHWIC E-Series NCE in a Cisco ISR G2



**Caution**

Before you install or remove the EHWIC E-Series NCE from a Cisco ISR G2, make sure that you first power down the router, and then install or remove the NCE.



Figure 8: EHWIC E-Series NCE in a Cisco ISR G2

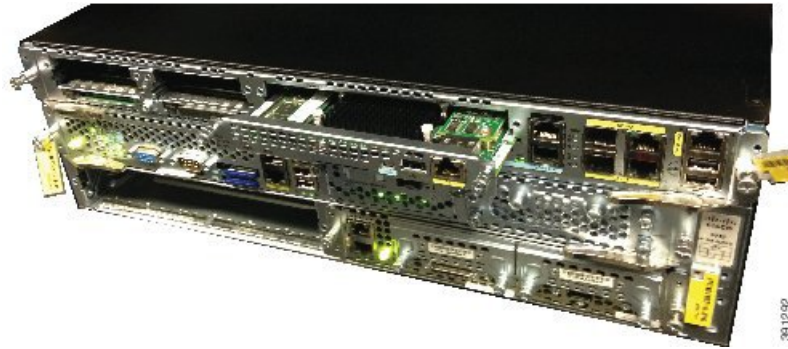

NIM E-Series NCE in a Cisco ISR 4000 Series

Figure 9: NIM E-Series NCE in a Cisco ISR 4000 Series



## Verifying Installation

### Verifying E-Series Server Installation

#### Before You Begin

- Install the E-Series Server into the router.
- Load a compatible Cisco IOS image.
- Power on the server.

To verify the E-Series Server installation, use one of the following commands:

#### Procedure

- To display a high-level overview of the entire physical system, use the **show platform** command:

```
Router# show platform
Chassis type: ISR4451/K9
Slot      Type                State                Insert time (ago)
-----
0         ISR4451/K9          ok                   1d01h
```

```

0/0      ISR4400-4X1GE      ok          1d01h
1        ISR4451/K9       ok          1d01h
1/0     UCS-E160DP-M1/K9 ok          1d01h
2        ISR4451/K9       ok          1d01h
R0       ISR4451/K9       ok, active  1d01h
F0       ISR4451/K9       ok, active  1d01h
P0       XXX-XXXX-XX     ok          1d01h
P1       Unknown         ps,         1d01h
P2       ACS-4450-FANASSY ok          1d01h

```

```

Slot      CPLD Version      Firmware Version
-----
0         12090323          12.2 (20120829:165313)
1         12090323          12.2 (20120829:165313)
2         12090323          12.2 (20120829:165313)
R0        12090323          12.2 (20120829:165313)
F0        12090323          12.2 (20120829:165313)

```

- To verify that the router recognizes the E-Series Server, use the **show hw-module subslot all oir** command:

```

Router# show hw-module subslot all oir
Module      Model              Operational Status
-----
subslot 0/0  ISR4451-X-4X1GE    ok
subslot 1/0  UCS-E140S-M1/K9    ok
subslot 2/0  UCS-E140S-M1/K9    ok

```

## Verifying the EHWIC E-Series NCE Installation

### Before you begin

- Install the EHWIC E-Series NCE into the router.
- Load a compatible Cisco IOS image.
- Power on the NCE.

### Procedure

	Command or Action	Purpose
<b>Step 1</b>	Router> <b>show inventory</b>	Verifies that the router detects the presence of the newly installed EHWIC E-Series NCE.

### Example

```
Router> show inventory
```

```
NAME: "CISCO3945-CHASSIS", DESCR: "CISCO3945-CHASSIS"
PID: CISCO3945-CHASSIS , VID: V02, SN: FGL1539100Q
```

```
NAME: "Cisco Services Performance Engine 150 for Cisco 3900 ISR on Slot 0", DESCR: "Cisco
Services Performance Engine 150 for Cisco 3900 ISR"
PID: C3900-SPE150/K9 , VID: V05 , SN: FOC15367HAZ
```

```
NAME: "Enhanced WAN Interface Card UCS Server on Slot 0 SubSlot 3", DESCR: "Enhanced WAN
```

```
Interface Card UCS Server"
PID: UCS-EN120E-M2/K9 , VID: V01, SN: FOC17462K2A

NAME: "C3900 AC Power Supply 1", DESCR: "C3900 AC Power Supply 1"
PID: PWR-3900-AC , VID: V03, SN: SNI1511C8SM
```

## Verifying NIM E-Series NCE Installation

### Before You Begin

- Install the NIM E-Series NCE into the router.
- Load a compatible Cisco IOS image.
- Power on the server.

To verify the NIM E-Series NCE installation, use one of the following commands:

### Procedure

- To display a high-level overview of the entire physical system, use the **show platform** command:

```
Router# show platform
Chassis type: ISR4351/K9

0/1      UCS-EN140N-M2/K9   ok           3w5d
1/0      UCS-E140DP-M1/K9   ok           4w6d
2        ISR4351/K9         ok           5w2d
R0       ISR4351/K9         ok, active   5w2d
F0       ISR4351/K9         ok, active   5w2d
P0       PWR-4450-AC        ok           5w2d
P2       ACS-4450-FANASSY   ok           5w2d
```

Slot	CPLD Version	Firmware Version
0	14080523	15.4 (3r) S1
1	14080523	15.4 (3r) S1
2	14080523	15.4 (3r) S1
R0	14080523	15.4 (3r) S1
F0	14080523	15.4 (3r) S1

- To verify that the router recognizes the NIM E-Series NCE, use the **show hw-module subslot all oir** command:

```
Router# show hw-module subslot all oir
Module      Model              Operational Status
-----
subslot 0/0  ISR4351-3x1GE      ok
subslot 0/1  UCS-EN140N-M2/K9   ok
subslot 1/0  UCS-E140DP-M1/K9   ok
```



# Stopping the E-Series Server from Resetting and Updating the CIMC Firmware—Cisco ISR 4000 Series

If you migrate the E-Series Server into the Cisco ISR 4000 series without first updating the CIMC firmware, the E-Series Server will continuously reset. Use this procedure to stop the reset and install the firmware.



**Note** Some of the steps in this procedure are performed from the router, and other steps are performed from the E-Series Server.

## Procedure

	Command or Action	Purpose
<b>Step 1</b>	Router# <b>hw-module subslot slot/subslot maintenance enable</b>	Disables error recovery, which stops the E-Series Server from being reset.  <b>Note</b> Enter the commands in Step 1 and Step 2 from the router.
<b>Step 2</b>	Router# <b>hw-module subslot slot/subslot session imc</b>	Starts a CIMC session.
<b>Step 3</b>	Server# <b>scope cimc</b>	Enters CIMC command mode.  <b>Note</b> Enter the commands in Step 3 through Step 8 from the E-Series Server.
<b>Step 4</b>	Server/cimc # <b>scope firmware</b>	Enters CIMC firmware command mode.
<b>Step 5</b>	Server/cimc/firmware # <b>update tftp-ip-address path-and-filename</b>	Starts CIMC firmware update. The server will obtain the update firmware at the specified path and filename from the TFTP server at the specified IP address.
<b>Step 6</b>	Server/cimc/firmware # <b>show [detail]</b>	Displays the available firmware and status.
<b>Step 7</b>	Server/cimc/firmware # <b>activate [1   2]</b>	Activates the selected image. If no image number is specified, the server activates the currently inactive image.
<b>Step 8</b>	Press <b>Ctrl-a Ctrl-q</b> .	Exits the CIMC session.
<b>Step 9</b>	Router# <b>hw-module subslot slot/subslot maintenance disable</b>	Enables error recovery.  <b>Note</b> Enter the commands in Step 9 and Step 10 from the router.

	Command or Action	Purpose
<b>Step 10</b>	Router# <b>hw-module subslot <i>slot/subslot</i></b> <b>reload</b>	Reloads the E-Series Server. <b>Note</b> This reload power-cycles the E-Series Server.

## What to Do Next

Configure the CIMC IP address for CIMC access. See [Configuring Access to the Management Firmware](#), on page 25.



## CHAPTER 4

# Configuring Access to the Management Firmware

This chapter provides an overview of the E-Series Server and NCE interfaces and provides procedures to configure access to the CIMC management firmware when the E-Series Server or NCE is installed in the router. It contains the following sections:

- [Configuring CIMC Access, on page 25](#)
- [Configuring CIMC Access Using the CIMC Configuration Utility, on page 74](#)
- [Defining Network Static Settings Using a Script File, on page 76](#)
- [What to Do Next, on page 77](#)

## Configuring CIMC Access

If you are a remote user, use the Cisco IOS CLI to configure CIMC access.

If you are a local user, use one of the following methods:

- Connect a keyboard and monitor to the front panel of the E-Series Server, and then use the CIMC Configuration Utility to configure CIMC access.



---

**Note** The CIMC Configuration Utility is not applicable to the EHWIC E-Series NCE and the NIM E-Series NCE.

---

- Use the Cisco IOS CLI to configure CIMC access. See one of the following as appropriate:
  - [CIMC Access Configuration Options—Cisco ISR G2, on page 27](#)
  - [CIMC Access Configuration Options—Cisco ISR 4000 Series, on page 40](#)
  - [CIMC Access Configuration Options—EHWIC E-Series NCE, on page 55](#)
  - [CIMC Access Configuration Options—NIM E-Series NCE, on page 64](#)

## Understanding the Interfaces in an E-Series Server and the Cisco ISR G2

The following figure shows the interfaces in a double-wide E-Series Server and the Cisco ISR G2 host router.

Figure 10: Interfaces in a Double-Wide E-Series Server

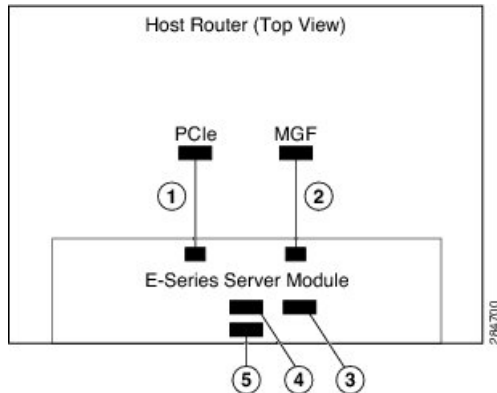

	Interface	Interface Location	Description
1	Router's PCIe <i>slot/0</i> Interface	Internal Interface	Also called Console interface. This interface connects the router's PCIe interface to the E-Series Server. The PCIe interface provides an internal Layer 3 GE link between the router and the E-Series Server. It can be used both for CIMC configuration and for host operating system configuration.
2	Router's MGF <i>slot/1</i> VLAN Interface	Internal Interface	Used to access CIMC over a high-speed backplane switch. The MGF VLAN interface provides an internal Layer 2 GE link between the router and the E-Series Server. This interface can be used both for CIMC configuration and for host operating system configuration.
3	Management (Dedicated) Interface	External Interface	Used for CIMC configuration and management.
4	GE3 Interface	External Interface	Used as a primary interface or as a backup interface. This interface can be used both for CIMC configuration and for host operating system configuration.  <b>Note</b> The GE3 interface is only available on the double-wide E-Series Servers.

5	GE2 Interface	External Interface	Used as a primary interface or as a backup interface. This interface can be used both for CIMC configuration and for host operating system configuration.
---	---------------	--------------------	---

## CIMC Access Configuration Options—Cisco ISR G2

Depending on whether you are a remote user or a local user, do one of the following to configure CIMC access.

- If you are a remote user, use either the external Management (dedicated) interface or one of the following shared LOM interfaces to configure CIMC access:
  - Router's internal PCIe *slot/0* Console interface
  - Router's internal MGF *slot/1* VLAN interface
  - E-Series Server's external GE2 or GE3 interface
- If you are a local user, use the Cisco IOS CLI or the CIMC Configuration Utility to configure CIMC access.

### Configuring CIMC Access Using the E-Series Server's External Management (Dedicated) Interface—Cisco ISR G2

See the following figure and the procedure that follows to configure CIMC access using the E-Series Server's external Management (dedicated) interface.

**Figure 11: Configuring CIMC Access Using the E-Series Server's External Management (Dedicated) Interface**

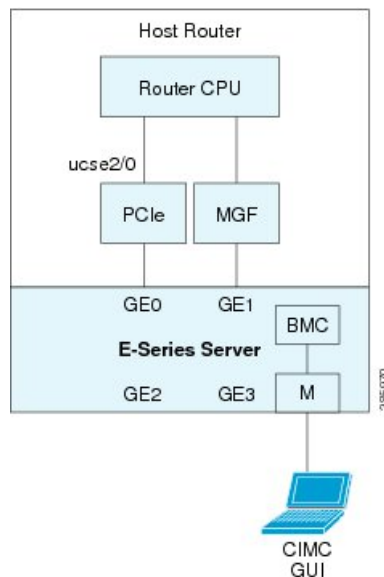

#### Before you begin

Make sure that you have the following information:

- IP address of CIMC.

- Username and password for logging in to the router.
- Slot or subslot and port number of the E-Series Server or NCE.

### Procedure

	Command or Action	Purpose
<b>Step 1</b>	Router> <b>enable</b>	Enters privileged EXEC mode on the host router. Enter your password if prompted.
<b>Step 2</b>	Router# <b>configure terminal</b>	Enters global configuration mode on the host router.
<b>Step 3</b>	Router (config)# <b>interface ucse slot/port</b>	Enters interface configuration mode for the slot and port where the E-Series Server is installed.
<b>Step 4</b>	Router (config-if)# <b>imc ip address</b> <i>cimc-ip-address subnet-mask default-gateway</i> <i>cimc-gateway-ip-address</i>	Specifies the IP address of CIMC and the IP address of the default gateway that CIMC must use. <ul style="list-style-type: none"> <li>• <i>cimc-ip-address</i>—IP address of CIMC.</li> <li>• <i>subnet-mask</i>—Subnet mask used to append to the IP address; must be in the same subnet as the host router.</li> <li>• <i>cimc-gateway-ip-address</i>—IP address for the default gateway.</li> </ul>
<b>Step 5</b>	Router (config-if)# <b>imc access-port dedicated</b>	Configures CIMC access through the server's external Management (dedicated) interface. See # 3 in <a href="#">Understanding the Interfaces in an E-Series Server and the Cisco ISR G2</a> .
<b>Step 6</b>	Router (config-if)# <b>no shut</b>	Causes the interface to be administratively up.
<b>Step 7</b>	Router (config-if)# <b>end</b>	Exits interface configuration mode.

### Example

This example shows how to configure CIMC access using the server's external IMC dedicated interface:

```
Router> enable
Router> password
Router# configure terminal

Router(config)# interface ucse 2/0
Router(config-if)# imc ip address 10.0.0.1 255.0.0.0 default-gateway 10.0.0.2
Router(config-if)# imc access-port dedicated
Router(config-if)# no shut
Router(config-if)# end
```

### Configuring CIMC Access Using Shared LOM—Cisco ISR G2

Use one of the following shared LOM interfaces to configure CIMC access:

- Router’s internal PCIe *slot/0* Console interface
- Router’s internal MGF *slot/1* VLAN interface
- E-Series Server’s external GE2 or GE3 interface

#### Configuring CIMC Access Using the Router’s Internal PCIe slot/0 Console Interface—Cisco ISR G2

See the following figure and the procedure that follows to configure CIMC access using the router’s internal PCIe *slot/0* Console interface.

**Figure 12: Configuring CIMC Access Using the Router’s Internal PCIe slot/0 Console Interface**

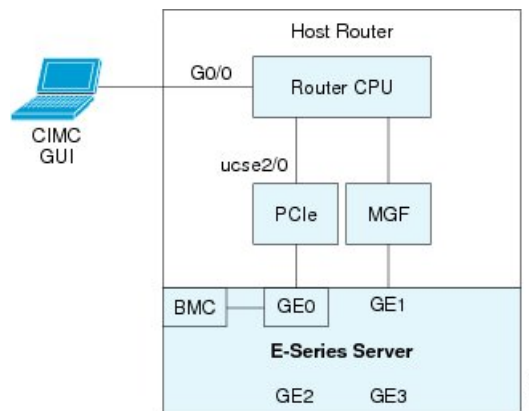

#### Before you begin

Make sure that you have the following information:

- IP address of CIMC.
- Username and password for logging in to the router.
- Slot or subslot and port number of the E-Series Server or NCE.

#### Procedure

	Command or Action	Purpose
<b>Step 1</b>	Router> <b>enable</b>	Enters privileged EXEC mode on the host router. Enter your password if prompted.
<b>Step 2</b>	Router# <b>configure terminal</b>	Enters global configuration mode on the host router.
<b>Step 3</b>	Router (config)# <b>interface GigabitEthernet0/0</b>	Enters interface configuration mode for Gigabit Ethernet 0/0.
<b>Step 4</b>	Router (config-if)# <b>ip address ip-address subnet-mask</b>	Specifies the IP address and subnet mask of the interface.

	Command or Action	Purpose
<b>Step 5</b>	Router (config-if)# <b>no shut</b>	Causes the interface to be administratively up.
<b>Step 6</b>	Router (config-if)# <b>end</b>	Exits interface configuration mode.
<b>Step 7</b>	Router# <b>configure terminal</b>	Enters global configuration mode on the host router.
<b>Step 8</b>	Router (config)# <b>interface ucse slot/port</b>	Enters interface configuration mode for the slot and port where the E-Series Server is installed.
<b>Step 9</b>	Router (config-if)# <b>ip unnumbered type number</b>	<p>The <b>ip unnumbered</b> command enables IP processing on an interface without assigning an explicit IP address to that interface.</p> <ul style="list-style-type: none"> <li>• <i>type</i>—Type of interface on which the router has an assigned IP address.</li> <li>• <i>number</i>—Number of the interface and subinterface on which the router has an assigned IP address.</li> </ul> <p><b>Note</b> The unnumbered interface must be unique. It cannot be another unnumbered interface.</p> <p>When you use the <b>ip unnumbered</b> command, you must use the <b>ip route</b> command to create a static route.</p> <p><b>Caution</b> The <b>ip unnumbered</b> and <b>ipv6 unnumbered</b> commands create a point-to-point interface between devices. Broadcasting is not supported.</p>
<b>Step 10</b>	Router (config-if)# <b>imc ip address cimc-ip-address subnet-mask default-gateway cimc-gateway-ip-address</b>	<p>Specifies the IP address of CIMC and the IP address of the default gateway that CIMC must use.</p> <ul style="list-style-type: none"> <li>• <i>cimc-ip-address</i>—IP address of CIMC.</li> <li>• <i>subnet-mask</i>—Subnet mask used to append to the IP address; must be in the same subnet as the host router.</li> <li>• <i>cimc-gateway-ip-address</i>—IP address for the default gateway.</li> </ul>
<b>Step 11</b>	Router (config-if)# <b>imc access-port shared-lom console</b>	Configures CIMC access using the router's PCIe slot/0 (console) interface. See # 1 in



	Command or Action	Purpose
		<a href="#">Understanding the Interfaces in an E-Series Server and the Cisco ISR G2.</a>
<b>Step 12</b>	Router (config-if)# <b>no shut</b>	Causes the interface to be administratively up.
<b>Step 13</b>	Router (config-if)# <b>end</b>	Exits interface configuration mode.
<b>Step 14</b>	Router# <b>configure terminal</b>	Enters global configuration mode on the host router.
<b>Step 15</b>	Router (config)# <b>ip route</b> <i>cimc-ip-address</i> <i>subnet-mask</i> <b>ucse slot/port</b>	Creates a static route. <ul style="list-style-type: none"> <li>• <i>cimc-ip-address</i>—IP address of CIMC.</li> <li>• <i>slot/port</i>—Slot and port where the E-Series Server is installed.</li> </ul>
<b>Step 16</b>	Router (config-if)# <b>end</b>	Exits interface configuration mode.
<b>Step 17</b>	Router# <b>ping</b> <i>cimc-ip-address</i>	Verifies connection from the router to CIMC through the router's internal PCIe <i>slot/0</i> console interface.

### Example

This example shows how to configure CIMC access using the server's internal PCIe *slot/0* console interface:

```
Router> enable
Router> password
Router# configure terminal

Router(config)# interface GigabitEthernet0/0
Router(config-if)# ip address 10.0.0.1 255.0.0.0
Router(config-if)# no shut
Router(config-if)# end

Router# configure terminal
Router(config)# interface ucse 2/0
Router(config)# ip unnumbered GigabitEthernet0/0
Router(config-if)# imc ip address 10.0.0.2 255.0.0.0 default-gateway 10.0.0.1
Router(config-if)# imc access-port shared-lom console
Router(config-if)# no shut
Router(config)# end

Router# configure terminal
Router(config)# ip route 10.0.0.2 255.255.255.255 ucse 2/0
Router(config)# end

Router# ping 10.0.0.2
Type escape sequence to abort.
Sending 5, 100-byte ICMP Echos to 10.0.0.2, timeout is 2 seconds:
!!!!
Success rate is 100 percent (5/5), round-trip min/avg/max = 1/2/4 ms
```

### Configuring CIMC Access Using the Router's Internal MGF slot/1 VLAN Interface—Cisco ISR G2

See the following figure and the procedure that follows to configure CIMC access using the router's internal MGF *slot/1* VLAN interface.

**Figure 13: Configuring CIMC Access Using the Router's Internal MGF slot/1 VLAN Interface**

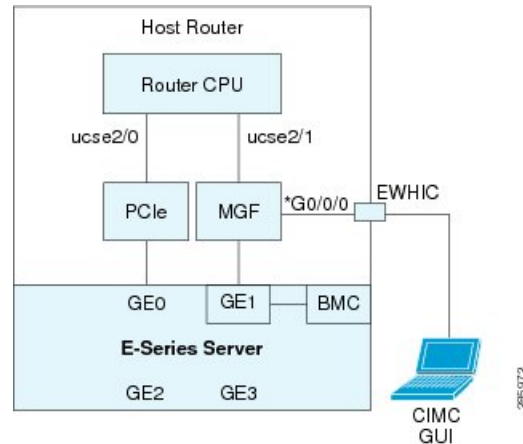

#### Before you begin

Make sure that you have the following information:

- IP address of CIMC.
- Username and password for logging in to the router.
- Slot or subslot and port number of the E-Series Server or NCE.

#### Procedure

	Command or Action	Purpose
<b>Step 1</b>	Router> <b>enable</b>	Enters privileged EXEC mode on the host router. Enter your password if prompted.
<b>Step 2</b>	Router# <b>show vlan-switch</b>	Displays VLANs.
<b>Step 3</b>	Router# <b>configure terminal</b>	Enters global configuration mode on the host router.
<b>Step 4</b>	Router (config)# <b>interface vlan</b> <i>vlan-number</i>	Enters VLAN configuration mode for the specified VLAN number.
<b>Step 5</b>	Router (config-if)# <b>ip address</b> <i>vlan-ip-address</i> <i>subnet-mask</i>	Specifies the IP address for the VLAN. <ul style="list-style-type: none"> <li>• <i>vlan-ip-address</i>—IP address of the VLAN.</li> <li>• <i>subnet-mask</i>—Subnet mask to append to the IP address.</li> </ul>

	Command or Action	Purpose
<b>Step 6</b>	Router (config-if)# <b>end</b>	Exits interface configuration mode.
<b>Step 7</b>	Router# <b>configure terminal</b>	Enters global configuration mode on the host router.
<b>Step 8</b>	Router (config)# <b>interface ucse slot/port</b>	Enters interface configuration mode for the slot and port where the E-Series Server is installed.
<b>Step 9</b>	Router (config-if)# <b>imc ip address</b> <i>cimc-ip-address subnet-mask default-gateway</i> <i>cimc-gateway-ip-address</i>	Specifies the IP address of CIMC and the IP address of the default gateway that CIMC must use. <ul style="list-style-type: none"> <li>• <i>cimc-ip-address</i>—IP address of CIMC.</li> <li>• <i>subnet-mask</i>—Subnet mask used to append to the IP address; must be in the same subnet as the host router.</li> <li>• <i>cimc-gateway-ip-address</i>—IP address for the default gateway.</li> </ul>
<b>Step 10</b>	Router (config-if)# <b>imc access-port</b> <b>shared-lom GE1</b>	Configures CIMC access using the router's internal <i>slot/1</i> MGF VLAN interface. See # 2 in <a href="#">Understanding the Interfaces in an E-Series Server and the Cisco ISR G2</a> .
<b>Step 11</b>	Router (config-if)# <b>no shut</b>	Causes the interface to be administratively up.
<b>Step 12</b>	Router (config-if)# <b>end</b>	Exits interface configuration mode.
<b>Step 13</b>	Router# <b>ping cimc-ip-address</b>	Verifies connection from the router to CIMC through the router's internal MGF <i>slot/1</i> VLAN interface.

**Example**

This example shows how to configure CIMC access using the router's internal MGF *slot/1* VLAN interface:

```

Router> enable
Router> password
Router> show vlan-switch
VLAN Name                Status      Ports
-----
1    default                active     Gi0/0/0, Gi0/0/1, Gi0/0/2
                                           Gi0/0/3, uc2/1

Router# configure terminal
Router(config)# interface vlan 1
Router(config-if)# ip address 10.0.0.1 255.0.0.0
Router(config-if)# end

Router# configure terminal
    
```

```

Router(config)# interface ucse 2/0
Router(config-if)# imc ip address 10.0.0.2 255.0.0.0 default-gateway 10.0.0.1
Router(config-if)# imc access-port shared-lom GE1
Router(config-if)# no shut
Router(config-if)# end

Router# ping 10.0.0.2
Type escape sequence to abort.
Sending 5, 100-byte ICMP Echos to 10.0.0.2, timeout is 2 seconds:
!!!!
Success rate is 100 percent (5/5), round-trip min/avg/max = 1/2/4 ms
    
```

**Configuring CIMC Access Using the Router's Internal MGF slot/1 Interface Using a Non-Native VLAN—Cisco ISR G2**

See the following figure and the procedure that follows to configure CIMC access using the router's internal MGF *slot/1* interface using a non-native VLAN.

**Figure 14: Configuring CIMC Access Using the Router's Internal MGF slot/1 Interface Using a Non-Native VLAN**

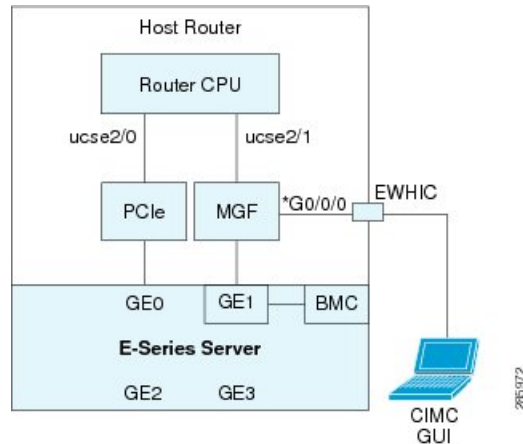

**Before you begin**

Make sure that you have the following information:

- IP address of CIMC.
- Username and password for logging in to the router.
- Slot or subslot and port number of the E-Series Server or NCE.

**Procedure**

	Command or Action	Purpose
<b>Step 1</b>	Router> <b>enable</b>	Enters privileged EXEC mode on the host router. Enter your password if prompted.
<b>Step 2</b>	Router# <b>show vlan-switch</b>	Displays VLANs.
<b>Step 3</b>	Router# <b>configure terminal</b>	Enters global configuration mode on the host router.

	Command or Action	Purpose
<b>Step 4</b>	Router (config)# <b>vlan</b> <i>vlan-number</i>	Configures the specified VLAN.
<b>Step 5</b>	Router (config)# <b>end</b>	Exits VLAN configuration.
<b>Step 6</b>	Router# <b>configure terminal</b>	Enters global configuration mode on the host router.
<b>Step 7</b>	Router (config)# <b>interface</b> <b>vlan</b> <i>vlan-number</i>	Enters VLAN configuration mode for the specified VLAN number.
<b>Step 8</b>	Router (config-if)# <b>ip address</b> <i>vlan-ip-address</i> <i>subnet-mask</i>	Specifies the IP address for the VLAN. <ul style="list-style-type: none"> <li>• <i>vlan-ip-address</i>—IP address of the VLAN.</li> <li>• <i>subnet-mask</i>—Subnet mask to append to the IP address.</li> </ul>
<b>Step 9</b>	Router (config-if)# <b>end</b>	Exits interface configuration mode.
<b>Step 10</b>	Router# <b>configure terminal</b>	Enters global configuration mode on the host router.
<b>Step 11</b>	Router (config)# <b>interface</b> <b>ucse</b> <i>slot/port</i>	Enters interface configuration mode for the slot and port where the E-Series Server is installed.
<b>Step 12</b>	Router (config)# <b>imc</b> <b>vlan</b> <i>vlan-id</i>	Configures the specified VLAN ID for CIMC.
<b>Step 13</b>	Router (config-if)# <b>imc ip address</b> <i>cimc-ip-address</i> <i>subnet-mask</i> <b>default-gateway</b> <i>cimc-gateway-ip-address</i>	Specifies the IP address of CIMC and the IP address of the default gateway that CIMC must use. <ul style="list-style-type: none"> <li>• <i>cimc-ip-address</i>—IP address of CIMC.</li> <li>• <i>subnet-mask</i>—Subnet mask used to append to the IP address; must be in the same subnet as the host router.</li> <li>• <i>cimc-gateway-ip-address</i>—IP address for the default gateway.</li> </ul>
<b>Step 14</b>	Router (config-if)# <b>imc access-port</b> <b>shared-lom</b> <b>GE1</b>	Configures CIMC access using the router's internal <i>slot/1</i> MGF VLAN interface. See # 2 in <a href="#">Understanding the Interfaces in an E-Series Server and the Cisco ISR G2</a> .
<b>Step 15</b>	Router (config-if)# <b>no shut</b>	Causes the interface to be administratively up.
<b>Step 16</b>	Router (config-if)# <b>end</b>	Exits interface configuration mode.
<b>Step 17</b>	Router# <b>configure terminal</b>	Enters global configuration mode on the host router.

	Command or Action	Purpose
<b>Step 18</b>	Router (config)# <b>interface ucse slot/1</b>	Enters interface configuration mode for the router's MGF <i>slot/1</i> VLAN interface.
<b>Step 19</b>	Router (config-if)# <b>switchport mode trunk</b>	Puts the port into permanent trunking mode. The default configuration is access mode.
<b>Step 20</b>	Router (config-if)# <b>no shut</b>	Causes the interface to be administratively up.
<b>Step 21</b>	Router (config-if)# <b>end</b>	Exits interface configuration mode.
<b>Step 22</b>	Router# <b>ping cimc-ip-address</b>	Verifies connection from the router to CIMC through the router's internal MGF <i>slot/1</i> VLAN interface.

### Example

This example shows how to configure CIMC access using the router's internal MGF *slot/1* interface using a non-native VLAN:

```

Router> enable
Router> password
Router> show vlan-switch
VLAN Name                Status      Ports
-----
1    default                active     Gi0/0/0, Gi0/0/1, Gi0/0/2
                                         Gi0/0/3, uc2/1

Router# configure terminal
Router(config)# vlan 2
Router(config)# end

Router# configure terminal
Router(config)# interface vlan 2
Router(config-if)# ip address 10.0.0.1 255.0.0.0
Router(config-if)# end

Router# configure terminal
Router(config)# interface ucse 2/0
Router(config-if)# imc vlan 2
Router(config-if)# imc ip address 10.0.0.2 255.0.0.0 default-gateway 10.0.0.1
Router(config-if)# imc access-port shared-lom GE1
Router(config-if)# no shut
Router(config-if)# end

Router# configure terminal
Router(config)# interface ucse 2/1
Router(config-if)# switchport mode trunk
Router(config-if)# no shut
Router(config-if)# end

Router# ping 10.0.0.2
Type escape sequence to abort.
Sending 5, 100-byte ICMP Echos to 10.0.0.2, timeout is 2 seconds:
!!!!
Success rate is 100 percent (5/5), round-trip min/avg/max = 1/2/4 ms

```

Configuring CIMC Access Using the E-Series Server's External GE2 or GE3 Interface—Cisco ISR G2

See the following figure and the procedure that follows to configure CIMC access using the E-Series Server's external GE2 or GE3 interface.



**Note** This figure shows how to configure CIMC access using the E-Series Server's external GE2 interface.

**Figure 15: Configuring CIMC Access Using the E-Series Server's External GE2 Interface**

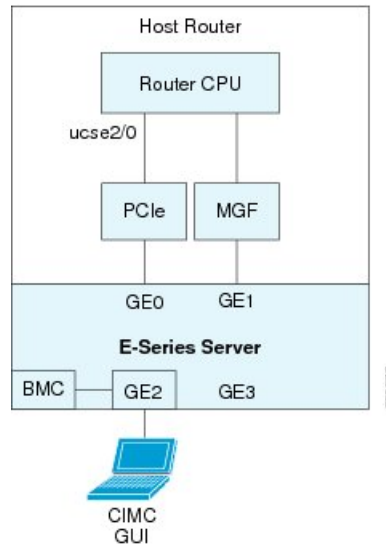

**Before you begin**

Make sure that you have the following information:

- IP address of CIMC.
- Username and password for logging in to the router.
- Slot or subslot and port number of the E-Series Server or NCE.

**Procedure**

	Command or Action	Purpose
<b>Step 1</b>	Router> <b>enable</b>	Enters privileged EXEC mode on the host router. Enter your password if prompted.
<b>Step 2</b>	Router# <b>configure terminal</b>	Enters global configuration mode on the host router.
<b>Step 3</b>	Router (config)# <b>interface ucse slot/port</b>	Enters interface configuration mode for the slot and port where the E-Series Server is installed.

	Command or Action	Purpose
<b>Step 4</b>	Router (config-if)# <b>imc ip address</b> <i>cimc-ip-address subnet-mask default-gateway</i> <i>cimc-gateway-ip-address</i>	Specifies the IP address of CIMC and the IP address of the default gateway that CIMC must use. <ul style="list-style-type: none"> <li>• <i>cimc-ip-address</i>—IP address of CIMC.</li> <li>• <i>subnet-mask</i>—Subnet mask used to append to the IP address; must be in the same subnet as the host router.</li> <li>• <i>cimc-gateway-ip-address</i>—IP address for the default gateway.</li> </ul>
<b>Step 5</b>	Router (config-if)# <b>imc access-port</b> <b>shared-lom {GE2   GE3}</b>	Configures CIMC access through the E-Series Server's external GE2 or GE3 interface. See # 4 and 5 in <a href="#">Understanding the Interfaces in an E-Series Server and the Cisco ISR G2</a> .
<b>Step 6</b>	Router (config-if)# <b>no shut</b>	Causes the interface to be administratively up.
<b>Step 7</b>	Router (config-if)# <b>end</b>	Exits interface configuration mode.

### Example

This example shows how to configure CIMC access using the server's external GE2 interface:

```
Router> enable
Router> password
Router# configure terminal

Router(config)# interface ucse 2/0
Router(config-if)# imc ip address 10.0.0.1 255.0.0.0 default-gateway 10.0.0.2
Router(config-if)# imc access-port shared-lom GE2
Router(config-if)# no shut
Router(config-if)# end
```

## Understanding the Interfaces in an E-Series Server and the Cisco ISR 4000 Series

The following figure shows the interfaces in a double-wide E-Series Server and the Cisco ISR 4000 series host router.



Figure 16: Interfaces in a Double-Wide E-Series Server

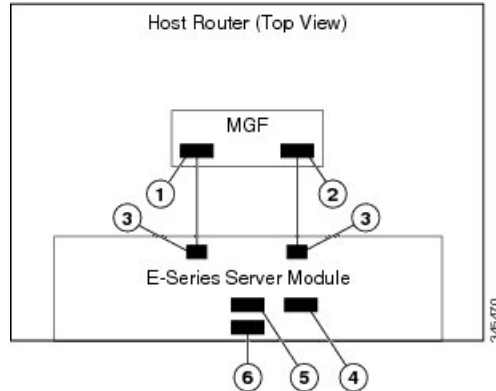

	Interface	Interface Location	Description
1	Router's <b>ucse slot/0/0</b> Interface	Internal Interface	Used to access CIMC over a high-speed backplane switch. The MGF interface provides an internal Layer 2 GE link between the router and the E-Series Server. This interface can be used both for CIMC configuration and for host operating system configuration.  <b>Note</b> This interface is used to access the E-Series Server's internal GE0 interface.
2	Router's <b>ucse slot/0/1</b> Interface	Internal Interface	Used to access CIMC over a high-speed backplane switch. The MGF interface provides an internal Layer 2 GE link between the router and the E-Series Server. This interface can be used both for CIMC configuration and for host operating system configuration.  <b>Note</b> This interface is used to access the E-Series Server's internal GE1 interface.
3	GE0 and GE1 Interfaces	Internal Interfaces	E-Series Server's internal NIC interfaces.
4	Management (Dedicated) Interface	External Interface	Used for CIMC configuration and management.

5	GE3 Interface	External Interface	Can be used both for CIMC configuration and for host operating system configuration.  <b>Note</b> The GE3 interface is only available on the double-wide E-Series Servers.
6	GE2 Interface	External Interface	Can be used both for CIMC configuration and for host operating system configuration.

## CIMC Access Configuration Options—Cisco ISR 4000 Series

Depending on whether you are a remote user or a local user, do one of the following to configure CIMC access.

- If you are a remote user, use the Cisco IOS CLI to configure CIMC access by using one of the following interfaces:
  - CIMC Management (dedicated) interface
  - E-Series Server's internal GE0 and the router's **ucse slot/0/0** interface
  - E-Series Server's internal GE1 interface and the router's **ucse slot/0/1** interface
  - E-Series Server's external GE2 or GE3 interface
- If you are a local user, use the CIMC Configuration Utility or the Cisco IOS CLI (mentioned above) to configure CIMC access.

### Configuring CIMC Access Using the E-Series Server's External Management (Dedicated) Interface—Cisco ISR 4000 Series

See the following figure and the procedure that follows to configure CIMC access using the E-Series Server's external Management (dedicated) interface.

Figure 17: Configuring CIMC Access Using the E-Series Server's External Management (Dedicated) Interface

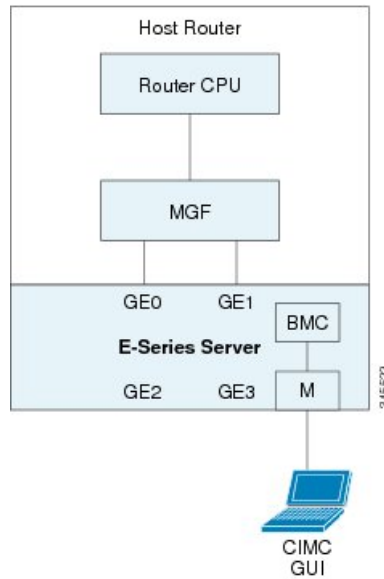

**Before you begin**

Make sure that you have the following information:

- IP address of CIMC.
- Username and password for logging in to the router.
- Slot or subslot and port number of the E-Series Server or NCE.

**Procedure**

	Command or Action	Purpose
<b>Step 1</b>	Router> <b>enable</b>	Enters privileged EXEC mode on the host router. Enter your password if prompted.
<b>Step 2</b>	Router# <b>configure terminal</b>	Enters global configuration mode on the host router.
<b>Step 3</b>	Router (config)# <b>ucse subslot slot/subslot</b>	Enters ucse interface configuration mode for the slot and subslot where the E-Series Server is installed.
<b>Step 4</b>	Router (config-ucse)# <b>imc ip address cimd-ip-address subnet-mask default-gateway cimd-gateway-ip-address</b>	Specifies the IP address of CIMC and the IP address of the default gateway that CIMC must use. <ul style="list-style-type: none"> <li>• <i>cimd-ip-address</i>—IP address of CIMC.</li> <li>• <i>subnet-mask</i>—Subnet mask used to append to the IP address; must be in the same subnet as the host router.</li> </ul>

	Command or Action	Purpose
		<ul style="list-style-type: none"> <li><i>cimc-gateway-ip-address</i>—IP address for the default gateway.</li> </ul>
<b>Step 5</b>	Enter one of the following commands: <ul style="list-style-type: none"> <li>Router (config-ucse)# <b>imc access-port mgmt</b></li> <li>Router (config-ucse)# <b>imc access-port dedicated</b></li> </ul>	Configures CIMC access through the server's external Management (dedicated) interface. See # 4 in <a href="#">Understanding the Interfaces in the NIM E-Series NCE and the Cisco ISR 4000 Series, on page 63</a> . <ul style="list-style-type: none"> <li>Use the <b>imc access-port mgmt</b> command if you installed the Cisco IOS XE Release 3.9S.</li> <li>Use the <b>imc access-port dedicated</b> command if you installed the Cisco IOS XE Release 3.10S and later versions.</li> </ul>
<b>Step 6</b>	Router (config-ucse)# <b>end</b>	Returns to privileged EXEC mode on the host router.

### Example

This example shows how to configure CIMC access using the server's external management interface—Applicable only with Cisco IOS XE Release 3.9S:

```
Router> enable
Router> password
Router# configure terminal

Router(config)# ucse subslot 1/0
Router(config-ucse)# imc ip address 10.0.0.1 255.0.0.0 default-gateway 10.0.0.2
Router(config-ucse)# imc access-port mgmt
Router(config-ucse)# end
```

This example shows how to configure CIMC access using the server's external dedicated interface—Applicable with Cisco IOS XE Release 3.10S and later versions:

```
Router> enable
Router> password
Router# configure terminal

Router(config)# ucse subslot 1/0
Router(config-ucse)# imc ip address 10.0.0.1 255.0.0.0 default-gateway 10.0.0.2
Router(config-ucse)# imc access-port dedicated
Router(config-ucse)# end
```

### Configuring CIMC Access Using the E-Series Server's NIC Interfaces—Cisco ISR 4000 Series

Use one of the following E-Series Server's NIC interfaces to access CIMC:

- E-Series Server's internal GE0 and the router's **ucse slot/0/0** interface

- E-Series Server's internal GE1 interface and the router's **ucse slot/0/1** interface
- E-Series Server's external GE2 or GE3 interface

*Configuring CIMC Access Using the E-Series Server's Internal GE0 Interface and the Cisco ISR 4000 Series ucse slot/0/0 Interface*

See the following figure and the procedure that follows to configure CIMC access using the E-Series Server's internal GE0 interface and the router's ucse slot/0/0 interface.

**Figure 18: Configuring CIMC Access Using the E-Series Server's Internal GE0 Interface and the Router's ucse slot/0/0 Interface**

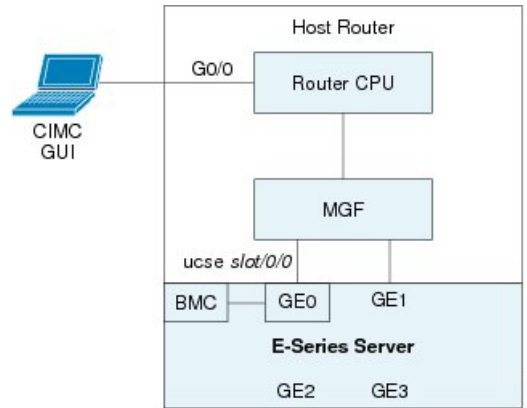

**Before you begin**

Make sure that you have the following information:

- IP address of CIMC.
- Username and password for logging in to the router.
- Slot or subslot and port number of the E-Series Server or NCE.

**Procedure**

	<b>Command or Action</b>	<b>Purpose</b>
<b>Step 1</b>	Router> <b>enable</b>	Enters privileged EXEC mode on the host router. Enter your password if prompted.
<b>Step 2</b>	Router# <b>configure terminal</b>	Enters global configuration mode on the host router.
<b>Step 3</b>	Router (config)# <b>interface GigabitEthernet 0/0/0</b>	Enters interface configuration mode for Gigabit Ethernet interface 0/0/0.
<b>Step 4</b>	Router (config-if)# <b>ip address ip-address subnet-mask</b>	Specifies the IP address and subnet mask of the interface.
<b>Step 5</b>	Router (config-if)# <b>no shut</b>	Causes the interface to be administratively up.
<b>Step 6</b>	Router (config-if)# <b>exit</b>	Exits interface configuration mode.

	Command or Action	Purpose
<b>Step 7</b>	Router (config)# <b>interface ucse slot/0/0</b>	Enters ucse interface configuration mode for the slot, subslot, and port where the E-Series Server is installed.
<b>Step 8</b>	Router (config-if)# <b>ip unnumbered type number</b>	<p>The <b>ip unnumbered</b> command enables IP processing on an interface without assigning an explicit IP address to that interface.</p> <ul style="list-style-type: none"> <li>• <i>type</i>—Type of interface on which the router has an assigned IP address.</li> <li>• <i>number</i>—Number of the interface and subinterface on which the router has an assigned IP address.</li> </ul> <p><b>Note</b> The unnumbered interface must be unique. It cannot be another unnumbered interface.</p> <p>When you use the <b>ip unnumbered</b> command, you must use the <b>ip route</b> command to create a static route.</p> <p><b>Caution</b> The <b>ip unnumbered</b> and <b>ipv6 unnumbered</b> commands create a point-to-point interface between devices. Broadcasting is not supported.</p>
<b>Step 9</b>	Router (config-if)# <b>no shut</b>	Causes the interface to be administratively up.
<b>Step 10</b>	Router (config-if)# <b>exit</b>	Exits interface configuration mode.
<b>Step 11</b>	Router (config)# <b>ucse subslot slot/subslot</b>	Enters ucse interface configuration mode for the slot and subslot where the E-Series Server is installed.
<b>Step 12</b>	Router (config-ucse)# <b>imc ip address cimc-ip-address subnet-mask default-gateway cimc-gateway-ip-address</b>	<p>Specifies the IP address of CIMC and the IP address of the default gateway that CIMC must use.</p> <ul style="list-style-type: none"> <li>• <i>cimc-ip-address</i>—IP address of CIMC.</li> <li>• <i>subnet-mask</i>—Subnet mask used to append to the IP address; must be in the same subnet as the host router.</li> <li>• <i>cimc-gateway-ip-address</i>—IP address for the default gateway.</li> </ul>

	Command or Action	Purpose
<b>Step 13</b>	Enter one of the following commands: <ul style="list-style-type: none"> <li>• Router (config-ucse)# <b>imc access-port ge0</b></li> <li>• Router (config-ucse)# <b>imc access-port shared-lom console</b></li> </ul>	Configures CIMC access using the E-Series Server's internal GE0 or console interface. See # 3 in <a href="#">Understanding the Interfaces in an E-Series Server and the Cisco ISR 4000 Series, on page 38</a> . <ul style="list-style-type: none"> <li>• Use the <b>imc access-port ge0</b> command if you installed the Cisco IOS XE Release 3.9S.</li> <li>• Use the <b>imc access-port shared-lom console</b> command if you installed the Cisco IOS XE Release 3.10S and later versions.</li> </ul>
<b>Step 14</b>	Router (config-ucse)# <b>exit</b>	Exits ucse interface configuration mode.
<b>Step 15</b>	Router (config)# <b>ip route cimd-ip-address subnet-mask ucse slot/subslot/port</b>	Creates a static route. <ul style="list-style-type: none"> <li>• <i>cimd-ip-address</i>—IP address of CIMC.</li> <li>• <i>slot/subslot/port</i>—Slot, subslot, and port where the E-Series Server is installed.</li> </ul>
<b>Step 16</b>	Router (config)# <b>end</b>	Exits configuration mode.
<b>Step 17</b>	Router# <b>ping cimd-ip-address</b>	Verifies the connection from the router to CIMC through the <b>ucse slot/0/0</b> interface.

### Example

This example shows how to configure CIMC access using the E-Series Server's internal GE0 interface and the router's ucse *slot/0/0* interface—Applicable only with Cisco IOS XE Release 3.9S:

```
Router> enable
Router> password
Router# configure terminal

Router(config)# interface GigabitEthernet0/0/0
Router(config-if)# ip address 10.0.0.1 255.0.0.0
Router(config-if)# no shut
Router(config-if)# exit

Router(config)# interface ucse 1/0/0
Router(config-if)# ip unnumbered GigabitEthernet0/0/0
Router(config-if)# no shut
Router(config-if)# exit

Router(config)# ucse subslot 1/0
Router(config-ucse)# imc ip address 10.0.0.2 255.0.0.0 default-gateway 10.0.0.1
Router(config-ucse)# imc access-port ge0
Router(config-ucse)# exit
```

```

Router(config)# ip route 10.0.0.2 255.255.255.255 ucse 1/0/0
Router(config)# end

Router# ping 10.0.0.2
Type escape sequence to abort.
Sending 5, 100-byte ICMP Echos to 10.0.0.2, timeout is 2 seconds:
!!!!
Success rate is 100 percent (5/5), round-trip min/avg/max = 1/2/4 ms

```

This example shows how to configure CIMC access using the E-Series Server's internal console interface and the router's ucse *slot/0/0* interface—Applicable with Cisco IOS XE Release 3.10S and later versions:

```

Router> enable
Router> password
Router# configure terminal

Router(config)# interface GigabitEthernet0/0/0
Router(config-if)# ip address 10.0.0.1 255.0.0.0
Router(config-if)# no shut
Router(config-if)# exit

Router(config)# interface ucse 1/0/0
Router(config-if)# ip unnumbered GigabitEthernet0/0/0
Router(config-if)# no shut
Router(config-if)# exit

Router(config)# ucse subslot 1/0
Router(config-ucse)# imc ip address 10.0.0.2 255.0.0.0 default-gateway 10.0.0.1
Router(config-ucse)# imc access-port shared-lom console
Router(config-ucse)# exit

Router(config)# ip route 10.0.0.2 255.255.255.255 ucse 1/0/0
Router(config)# end

Router# ping 10.0.0.2
Type escape sequence to abort.
Sending 5, 100-byte ICMP Echos to 10.0.0.2, timeout is 2 seconds:
!!!!
Success rate is 100 percent (5/5), round-trip min/avg/max = 1/2/4 ms

```

### *Configuring CIMC Access Using the E-Series Server's Internal GE1 Interface and the Cisco ISR 4000 Series ucse slot/0/1 Interface*

See the following figure and the procedure that follows to configure CIMC access using the E-Series Server's internal GE1 interface and the router's ucse *slot/0/1* interface.



Figure 19: Configuring CIMC Access Using the E-Series Server's Internal GE1 Interface and the Router's ucse slot/0/1 Interface

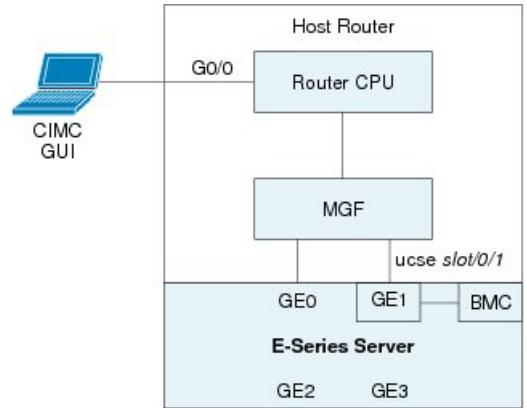

### Before you begin

Make sure that you have the following information:

- IP address of CIMC.
- Username and password for logging in to the router.
- Slot or subslot and port number of the E-Series Server or NCE.

### Procedure

	Command or Action	Purpose
<b>Step 1</b>	Router> <b>enable</b>	Enters privileged EXEC mode on the host router. Enter your password if prompted.
<b>Step 2</b>	Router# <b>configure terminal</b>	Enters global configuration mode on the host router.
<b>Step 3</b>	Router (config)# <b>interface GigabitEthernet 0/0/0</b>	Enters interface configuration mode for Gigabit Ethernet interface 0/0/0.
<b>Step 4</b>	Router (config-if)# <b>ip address</b> <i>ip-address</i> <i>subnet-mask</i>	Specifies the IP address and subnet mask of the interface.
<b>Step 5</b>	Router (config-if)# <b>no shut</b>	Causes the interface to be administratively up.
<b>Step 6</b>	Router (config-if)# <b>exit</b>	Exits interface configuration mode.
<b>Step 7</b>	Router (config)# <b>interface ucse slot/0/1</b>	Enters ucse interface configuration mode for the slot, subslot, and port where the E-Series Server is installed.
<b>Step 8</b>	Router (config-if)# <b>ip unnumbered</b> <i>type number</i>	The <b>ip unnumbered</b> command enables IP processing on an interface without assigning an explicit IP address to that interface.

	Command or Action	Purpose
		<ul style="list-style-type: none"> <li>• <i>type</i>—Type of interface on which the router has an assigned IP address.</li> <li>• <i>number</i>—Number of the interface and subinterface on which the router has an assigned IP address.</li> </ul> <p><b>Note</b> The unnumbered interface must be unique. It cannot be another unnumbered interface.</p> <p>When you use the <b>ip unnumbered</b> command, you must use the <b>ip route</b> command to create a static route.</p> <p><b>Caution</b> The <b>ip unnumbered</b> and <b>ipv6 unnumbered</b> commands create a point-to-point interface between devices. Broadcasting is not supported.</p>
<b>Step 9</b>	Router (config-if)# <b>no shut</b>	Causes the interface to be administratively up.
<b>Step 10</b>	Router (config-if)# <b>exit</b>	Exits interface configuration mode.
<b>Step 11</b>	Router (config)# <b>ucse subslot slot/subslot</b>	Enters ucse interface configuration mode for the slot and subslot where the E-Series Server is installed.
<b>Step 12</b>	Router (config-ucse)# <b>imc ip address</b> <i>cimc-ip-address subnet-mask</i> <b>default-gateway</b> <i>cimc-gateway-ip-address</i>	Specifies the IP address of CIMC and the IP address of the default gateway that CIMC must use. <ul style="list-style-type: none"> <li>• <i>cimc-ip-address</i>—IP address of CIMC.</li> <li>• <i>subnet-mask</i>—Subnet mask used to append to the IP address; must be in the same subnet as the host router.</li> <li>• <i>cimc-gateway-ip-address</i>—IP address for the default gateway.</li> </ul>
<b>Step 13</b>	Enter one of the following commands: <ul style="list-style-type: none"> <li>• Router (config-ucse)# <b>imc access-port ge1</b></li> <li>• Router (config-ucse)# <b>imc access-port shared-lom ge1</b></li> </ul>	Configures CIMC access using the E-Series Server's internal GE1 interface. See # 3 in <a href="#">Understanding the Interfaces in an E-Series Server and the Cisco ISR 4000 Series, on page 38</a> . <ul style="list-style-type: none"> <li>• Use the <b>imc access-port ge1</b> command if you installed the Cisco IOS XE Release 3.9S.</li> </ul>

	Command or Action	Purpose
		<ul style="list-style-type: none"> <li>Use the <b>imc access-port shared-lom gel</b> command if you installed the Cisco IOS XE Release 3.10S and later versions.</li> </ul>
<b>Step 14</b>	Router (config-ucse)# <b>exit</b>	Exits ucse interface configuration mode.
<b>Step 15</b>	Router (config)# <b>ip route</b> <i>cimc-ip-address subnet-mask</i> <b>ucse slot/subslot/port</b>	Creates a static route. <ul style="list-style-type: none"> <li><i>cimc-ip-address</i>—IP address of CIMC.</li> <li><i>slot/subslot/port</i>—Slot, subslot, and port where the E-Series Server is installed.</li> </ul>
<b>Step 16</b>	Router (config)# <b>end</b>	Exits configuration mode.
<b>Step 17</b>	Router# <b>ping</b> <i>cimc-ip-address</i>	Verifies the connection from the router to CIMC through the <b>ucse slot/0/1</b> interface.

**Example**

This example shows how to configure CIMC access using the E-Series Server's internal GE1 interface and the router's ucse *slot/0/1* interface—Applicable only with Cisco IOS XE Release 3.9S:

```

Router> enable
Router> password
Router# configure terminal

Router(config)# interface GigabitEthernet0/0/0
Router(config-if)# ip address 10.0.0.1 255.0.0.0
Router(config-if)# no shut
Router(config-if)# exit

Router(config)# interface ucse 1/0/1
Router(config-if)# ip unnumbered GigabitEthernet0/0/0
Router(config-if)# no shut
Router(config-if)# exit

Router(config)# ucse subslot 1/0
Router(config-ucse)# imc ip address 10.0.0.2 255.0.0.0 default-gateway 10.0.0.1
Router(config-ucse)# imc access-port gel
Router(config-ucse)# exit

Router(config)# ip route 10.0.0.2 255.255.255.255 ucse 1/0/1
Router(config)# end

Router# ping 10.0.0.2
Type escape sequence to abort.
Sending 5, 100-byte ICMP Echos to 10.0.0.2, timeout is 2 seconds:
!!!!
Success rate is 100 percent (5/5), round-trip min/avg/max = 1/2/4 ms
    
```

This example shows how to configure CIMC access using the E-Series Server's internal GE1 interface and the router's ucse *slot/0/1* interface—Applicable with Cisco IOS XE Release 3.10S and later releases:

```

Router> enable
Router> password
Router# configure terminal

Router(config)# interface GigabitEthernet0/0/0
Router(config-if)# ip address 10.0.0.1 255.0.0.0
Router(config-if)# no shut
Router(config-if)# exit

Router(config)# interface ucse 1/0/1
Router(config-if)# ip unnumbered GigabitEthernet0/0/0
Router(config-if)# no shut
Router(config-if)# exit

Router(config)# ucse subslot 1/0
Router(config-ucse)# imc ip address 10.0.0.2 255.0.0.0 default-gateway 10.0.0.1
Router(config-ucse)# imc access-port shared-lom gel
Router(config-ucse)# exit

Router(config)# ip route 10.0.0.2 255.255.255.255 ucse 1/0/1
Router(config)# end

Router# ping 10.0.0.2
Type escape sequence to abort.
Sending 5, 100-byte ICMP Echos to 10.0.0.2, timeout is 2 seconds:
!!!!
Success rate is 100 percent (5/5), round-trip min/avg/max = 1/2/4 ms

```

### Configuring CIMC Access Using the E-Series Server's External GE2 or GE3 Interface—Cisco ISR 4000 Series

See the following figure and the procedure that follows to configure CIMC access using the E-Series Server's external GE2 or GE3 interface.



**Note** This figure shows how to configure CIMC access using the E-Series Server's external GE2 interface.

**Figure 20: Configuring CIMC Access Using the E-Series Server's External GE2 Interface**

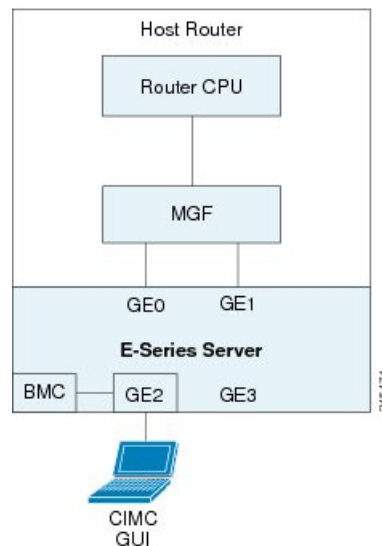

**Before you begin**

Make sure that you have the following information:

- IP address of CIMC.
- Username and password for logging in to the router.
- Slot and port number of the E-Series Server.

**Procedure**

	<b>Command or Action</b>	<b>Purpose</b>
<b>Step 1</b>	Router> <b>enable</b>	Enters privileged EXEC mode on the host router. Enter your password if prompted.
<b>Step 2</b>	Router# <b>configure terminal</b>	Enters global configuration mode on the host router.
<b>Step 3</b>	Router (config)# <b>ucse subslot</b> <i>slots/subslot</i>	Enters ucse interface configuration mode for the slot and subslot where the E-Series Server is installed.
<b>Step 4</b>	Router (config-ucse)# <b>imc ip address</b> <i>cimc-ip-address subnet-mask default-gateway cimc-gateway-ip-address</i>	Specifies the IP address of CIMC and the IP address of the default gateway that CIMC must use. <ul style="list-style-type: none"> <li>• <i>cimc-ip-address</i>—IP address of CIMC.</li> <li>• <i>subnet-mask</i>—Subnet mask used to append to the IP address; must be in the same subnet as the host router.</li> <li>• <i>cimc-gateway-ip-address</i>—IP address for the default gateway.</li> </ul>
<b>Step 5</b>	Router (config-ucse)# <b>imc access-port</b> { <b>GE2</b>   <b>GE3</b> } or Router (config-ucse)# <b>imc access-port shared-lom</b> { <b>GE2</b>   <b>GE3</b> }	Configures CIMC access through the E-Series Server's external GE2 or GE3 interface. See # 5 and 6 in <a href="#">Understanding the Interfaces in an E-Series Server and the Cisco ISR 4000 Series, on page 38</a> . <ul style="list-style-type: none"> <li>• Use the <b>imc access-port</b> {<b>GE2</b>   <b>GE3</b>} command if you installed the Cisco IOS XE Release 3.9S.</li> <li>• Use the <b>imc access-port shared-lom</b> {<b>GE2</b>   <b>GE3</b>} command if you installed the Cisco IOS XE Release 3.10S and later versions.</li> </ul>
<b>Step 6</b>	Router (config-ucse)# <b>end</b>	Returns to privileged EXEC mode on the host router.

**Example**

This example shows how to configure CIMC access using the server's external GE2 interface—Applicable only with Cisco IOS XE Release 3.9S:

```
Router> enable
Router> password
Router# configure terminal

Router(config)# ucse subslot 1/0
Router(config-ucse)# imc ip address 10.0.0.1 255.0.0.0 default-gateway 10.0.0.2
Router(config-ucse)# imc access-port GE2
Router(config-ucse)# no shut
Router(config-ucse)# end
```

This example shows how to configure CIMC access using the server's external GE2 interface—Applicable with Cisco IOS XE Release 3.10S and later releases:

```
Router> enable
Router> password
Router# configure terminal

Router(config)# ucse subslot 1/0
Router(config-ucse)# imc ip address 10.0.0.1 255.0.0.0 default-gateway 10.0.0.2
Router(config-ucse)# imc access-port shared-lom GE2
Router(config-ucse)# no shut
Router(config-ucse)# end
```

*Configuring CIMC Access Using the E-Series Server's External TE2 or TE3 Interface—Cisco ISR 4000 Series*

See the following figure and the procedure that follows to configure CIMC access using the E-Series Server's external TE2 or TE3 interface.





---

**Note** This figure shows how to configure CIMC access using the E-Series Server's external TE2 interface.

---

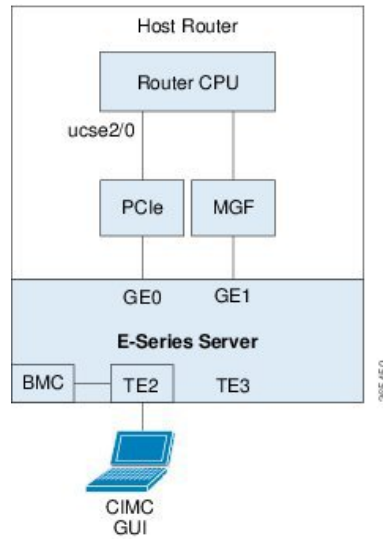
Figure 21: Configuring CIMC Access Using the E-Series Server's External TE2 Interface



**Before you begin**

Make sure that you have the following information:

- IP address of CIMC.
- Username and password for logging in to the router.
- Slot and port number of the E-Series Server.

**Procedure**

	Command or Action	Purpose
<b>Step 1</b>	Router> <b>enable</b>	Enters privileged EXEC mode on the host router. Enter your password if prompted.
<b>Step 2</b>	Router# <b>configure terminal</b>	Enters global configuration mode on the host router.
<b>Step 3</b>	Router (config)# <b>ucse subslot slots/subslot</b>	Enters ucse interface configuration mode for the slot and subslot where the E-Series Server is installed.
<b>Step 4</b>	Router (config-ucse)# <b>imc ip address cimc-ip-address subnet-mask default-gateway cimc-gateway-ip-address</b>	Specifies the IP address of CIMC and the IP address of the default gateway that CIMC must use. <ul style="list-style-type: none"> <li>• <i>cimc-ip-address</i>—IP address of CIMC.</li> <li>• <i>subnet-mask</i>—Subnet mask used to append to the IP address; must be in the same subnet as the host router.</li> </ul>

	Command or Action	Purpose
		<ul style="list-style-type: none"> <li><i>cimc-gateway-ip-address</i>—IP address for the default gateway.</li> </ul>
<b>Step 5</b>	Router (config-ucse)# <b>imc access-port shared-lom {TE2   TE3}</b>	Configures CIMC access through the E-Series Server's external TE2 or TE3 interface.
<b>Step 6</b>	Router (config-ucse)# <b>end</b>	Returns to privileged EXEC mode on the host router.

### Example

This example shows how to configure CIMC access using the server's external TE2 interface—Applicable with Cisco IOS XE Release 3.10S and later releases:

```
Router> enable
Router> password
Router# configure terminal

Router(config)# ucse subslot 1/0
Router(config-ucse)# imc ip address 10.0.0.1 255.0.0.0 default-gateway 10.0.0.2
Router(config-ucse)# imc access-port shared-lom TE2
Router(config-ucse)# no shut
Router(config-ucse)# end
```

## Understanding the Interfaces in the EHWIC E-Series NCE and the Cisco ISR G2



### Note

This section is applicable to the EHWIC E-Series NCE. This section is not applicable to the SM E-Series NCE.

The following figure shows the interfaces in the EHWIC E-Series NCE and the Cisco ISR G2 host router.

**Figure 22: Interfaces in the EHWIC E-Series NCE and the Cisco ISR G2 Host Router**

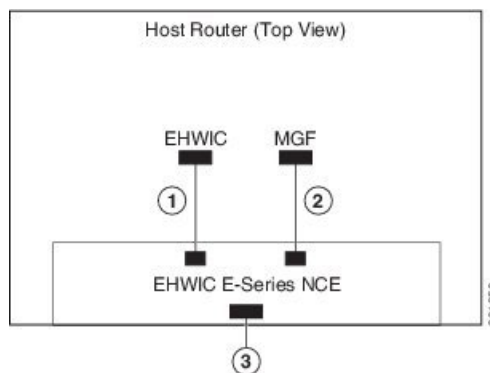



	Interface	Interface Location	Description
1	Router's EHWIC <b>0/subslot/0</b> Interface	Internal Interface	Also called Console interface. This interface connects the router's EHWIC interface to the EHWIC E-Series NCE. The EHWIC interface provides an internal Layer 3 GE link between the router and the EHWIC E-Series NCE. It can be used both for CIMC configuration and for host operating system configuration.
2	Router's MGF <b>0/subslot/1</b> VLAN Interface	Internal Interface	Used to access CIMC over a high-speed backplane switch. The MGF VLAN interface provides an internal Layer 2 GE link between the router and the EHWIC E-Series NCE. This interface can be used both for CIMC configuration and for host operating system configuration.  <b>Note</b> This interface is not applicable to the Cisco 1921 ISR G2.
3	GE2 Interface	External Interface	Used as a primary interface or as a backup interface. This interface can be used both for CIMC configuration and for host operating system configuration.

## CIMC Access Configuration Options—EHWIC E-Series NCE

Do one of the following to configure CIMC access.

- Use one of the following shared LOM interfaces to configure CIMC access:

- Router's internal EHWIC **0/subslot/0** Console interface
- Router's internal MGF **0/subslot/1** VLAN interface



---

**Note** This interface is not applicable to the Cisco ISR 1921.

---

- NCE's external GE2 interface
- Use the Cisco IOS CLI to configure CIMC access.

### Configuring CIMC Access Using the Router's Internal EHWIC 0/subslot/0 Console Interface—EHWIC E-Series NCE

See the following figure and the procedure that follows to configure CIMC access using the router's internal EHWIC **0/subslot/0** console interface.

Figure 23: Configuring CIMC Access Using the Router's Internal EHWIC 0/subslot/0 Console Interface

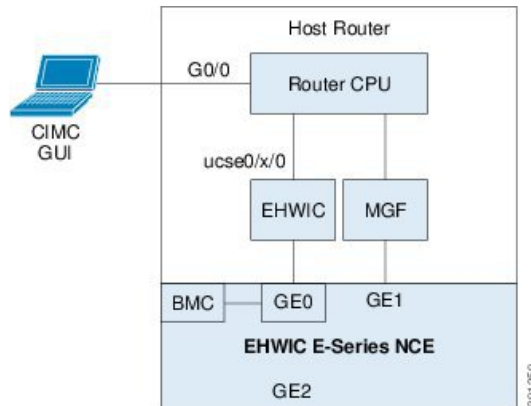

### Before you begin

Make sure that you have the following information:

- IP address of CIMC.
- Username and password for logging in to the router.
- Slot or subslot and port number of the E-Series Server or NCE.

### Procedure

	Command or Action	Purpose
<b>Step 1</b>	Router> <b>enable</b>	Enters privileged EXEC mode on the host router. Enter your password if prompted.
<b>Step 2</b>	Router# <b>configure terminal</b>	Enters global configuration mode on the host router.
<b>Step 3</b>	Router (config)# <b>interface GigabitEthernet0/0</b>	Enters interface configuration mode for Gigabit Ethernet 0/0.
<b>Step 4</b>	Router (config-if)# <b>ip address</b> <i>ip-address subnet-mask</i>	Specifies the IP address and subnet mask of the interface.
<b>Step 5</b>	Router (config-if)# <b>no shut</b>	Causes the interface to be administratively up.
<b>Step 6</b>	Router (config-if)# <b>end</b>	Exits interface configuration mode.
<b>Step 7</b>	Router# <b>configure terminal</b>	Enters global configuration mode on the host router.
<b>Step 8</b>	Router (config)# <b>interface ucse</b> <i>0/subslot/port</i>	Enters interface configuration mode for the subslot and port where the NCE is installed.
<b>Step 9</b>	Router (config-if)# <b>ip unnumbered</b> <i>type number</i>	The <b>ip unnumbered</b> command enables IP processing on an interface without assigning an explicit IP address to that interface.

	Command or Action	Purpose
		<ul style="list-style-type: none"> <li>• <i>type</i>—Type of interface on which the router has an assigned IP address.</li> <li>• <i>number</i>—Number of the interface and subinterface on which the router has an assigned IP address.</li> </ul> <p><b>Note</b> The unnumbered interface must be unique. It cannot be another unnumbered interface.</p> <p>When you use the <b>ip unnumbered</b> command, you must use the <b>ip route</b> command to create a static route.</p> <p><b>Caution</b> The <b>ip unnumbered</b> and <b>ipv6 unnumbered</b> commands create a point-to-point interface between devices. Broadcasting is not supported.</p>
<b>Step 10</b>	Router (config-if)# <b>imc ip address</b> <i>cimc-ip-address subnet-mask default-gateway</i> <i>cimc-gateway-ip-address</i>	Specifies the IP address of CIMC and the IP address of the default gateway that CIMC must use. <ul style="list-style-type: none"> <li>• <i>cimc-ip-address</i>—IP address of CIMC.</li> <li>• <i>subnet-mask</i>—Subnet mask used to append to the IP address; must be in the same subnet as the host router.</li> <li>• <i>cimc-gateway-ip-address</i>—IP address for the default gateway.</li> </ul>
<b>Step 11</b>	Router (config-if)# <b>imc access-port</b> <b>shared-lom console</b>	Configures CIMC access using the router's EHWIC 0/slot/0 (console) interface. See # 1 in <a href="#">Understanding the Interfaces in the EHWIC E-Series NCE and the Cisco ISR G2, on page 54</a> .
<b>Step 12</b>	Router (config-if)# <b>no shut</b>	Causes the interface to be administratively up.
<b>Step 13</b>	Router (config-if)# <b>end</b>	Exits interface configuration mode.
<b>Step 14</b>	Router# <b>configure terminal</b>	Enters global configuration mode on the host router.
<b>Step 15</b>	Router (config)# <b>ip route</b> <i>cimc-ip-address</i> <i>subnet-mask ucse 0/subslot/port</i>	Creates a static route. <ul style="list-style-type: none"> <li>• <i>cimc-ip-address</i>—IP address of CIMC.</li> <li>• <i>subslot/port</i>—Subslot and port where the NCE is installed.</li> </ul>

	Command or Action	Purpose
<b>Step 16</b>	Router (config-if)# <b>end</b>	Exits interface configuration mode.
<b>Step 17</b>	Router# <b>ping cimc-ip-address</b>	Verifies connection from the router to CIMC through the router's internal EHWIC 0/subslot/0 console interface.

### Example

This example shows how to configure CIMC access using the server's internal EHWIC 0/subslot/0 console interface:

```
Router> enable
Router> password
Router# configure terminal

Router(config)# interface GigabitEthernet0/0
Router(config-if)# ip address 10.0.0.1 255.0.0.0
Router(config-if)# no shut
Router(config-if)# end

Router# configure terminal
Router(config)# interface ucse 0/3/0
Router(config)# ip unnumbered GigabitEthernet0/0
Router(config-if)# imc ip address 10.0.0.2 255.0.0.0 default-gateway 10.0.0.1
Router(config-if)# imc access-port shared-lom console
Router(config-if)# no shut
Router(config)# end

Router# configure terminal
Router(config)# ip route 10.0.0.2 255.255.255.255 ucse 0/3/0
Router(config)# end

Router# ping 10.0.0.2
Type escape sequence to abort.
Sending 5, 100-byte ICMP Echos to 10.0.0.2, timeout is 2 seconds:
!!!!
Success rate is 100 percent (5/5), round-trip min/avg/max = 1/2/4 ms
```

### Configuring CIMC Access Using the Router's Internal MGF 0/subslot/1 VLAN Interface—EHWIC E-Series NCE



#### Important

This procedure is not applicable to the Cisco 1921 ISR G2.

See the following figure and the procedure that follows to configure CIMC access using the router's internal MGF 0/subslot/1 VLAN interface.

Figure 24: Configuring CIMC Access Using the Router's Internal MGF 0/subslot/1 VLAN Interface

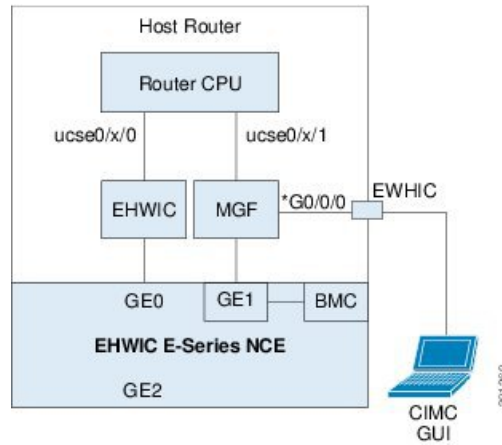

**Before you begin**

Make sure that you have the following information:

- IP address of CIMC.
- Username and password for logging in to the router.
- Slot or subslot and port number of the E-Series Server or NCE.

**Procedure**

	Command or Action	Purpose
<b>Step 1</b>	Router> <b>enable</b>	Enters privileged EXEC mode on the host router. Enter your password if prompted.
<b>Step 2</b>	Router# <b>show vlan-switch</b>	Displays VLANs.
<b>Step 3</b>	Router# <b>configure terminal</b>	Enters global configuration mode on the host router.
<b>Step 4</b>	Router (config)# <b>interface vlan <i>vlan-number</i></b>	Enters interface configuration mode for the specified VLAN number.
<b>Step 5</b>	Router (config-if)# <b>ip address <i>vlan-ip-address</i> <i>subnet-mask</i></b>	Specifies the IP address for the VLAN. <ul style="list-style-type: none"> <li>• <i>vlan-ip-address</i>—IP address of the VLAN.</li> <li>• <i>subnet-mask</i>—Subnet mask to append to the IP address.</li> </ul>
<b>Step 6</b>	Router (config-if)# <b>end</b>	Exits interface configuration mode.
<b>Step 7</b>	Router# <b>configure terminal</b>	Enters global configuration mode on the host router.

	Command or Action	Purpose
<b>Step 8</b>	Router (config)# <b>interface ucse 0/subslot0</b>	Enters ucse interface configuration mode for the subslot and port where the NCE is installed.
<b>Step 9</b>	Router (config-if)# <b>imc ip address</b> <i>cimc-ip-address subnet-mask default-gateway</i> <i>cimc-gateway-ip-address</i>	Specifies the IP address of CIMC and the IP address of the default gateway that CIMC must use. <ul style="list-style-type: none"> <li>• <i>cimc-ip-address</i>—IP address of CIMC.</li> <li>• <i>subnet-mask</i>—Subnet mask used to append to the IP address; must be in the same subnet as the host router.</li> <li>• <i>cimc-gateway-ip-address</i>—IP address for the default gateway.</li> </ul>
<b>Step 10</b>	Router (config-if)# <b>imc access-port</b> <b>shared-lom GE1</b>	Configures CIMC access using the router's internal 0/subslot/1 MGF VLAN interface. See # 2 in <a href="#">Understanding the Interfaces in the EHWIC E-Series NCE and the Cisco ISR G2, on page 54</a> .
<b>Step 11</b>	Router (config-if)# <b>no shut</b>	Causes the interface to be administratively up.
<b>Step 12</b>	Router (config-if)# <b>end</b>	Exits interface configuration mode.
<b>Step 13</b>	Router# <b>configure terminal</b>	Enters global configuration mode on the host router.
<b>Step 14</b>	Router (config)# <b>interface ucse 0/subslot1</b>	Enters ucse interface configuration mode for the subslot and port where the NCE is installed.
<b>Step 15</b>	Router (config-if)# <b>no shut</b>	Causes the interface to be administratively up.
<b>Step 16</b>	Router (config-if)# <b>end</b>	Exits interface configuration mode.
<b>Step 17</b>	Router# <b>ping cimc-ip-address</b>	Verifies connection from the router to CIMC through the router's internal MGF 0/subslot/1 VLAN interface.

### Example

This example shows how to configure CIMC access using the router's internal MGF 0/subslot/1 VLAN interface:

```
Router> enable
Router> password
Router> show vlan-switch
VLAN Name                Status    Ports
-----
1    default                active   Gi0/0/0, Gi0/0/1, Gi0/0/2
                                           Gi0/0/3, uc0/3/1
```

```
Router# configure terminal
Router(config)# interface vlan 1
Router(config-if)# ip address 10.0.0.1 255.0.0.0
Router(config-if)# end

Router# configure terminal
Router(config)# interface ucse 0/3/0
Router(config-if)# imc ip address 10.0.0.2 255.0.0.0 default-gateway 10.0.0.1
Router(config-if)# imc access-port shared-lom GE1
Router(config-if)# no shut
Router(config-if)# end

Router# configure terminal
Router(config)# interface ucse 0/3/1
Router(config-if)# no shut
Router(config-if)# end

Router# ping 10.0.0.2
Type escape sequence to abort.
Sending 5, 100-byte ICMP Echos to 10.0.0.2, timeout is 2 seconds:
!!!!
Success rate is 100 percent (5/5), round-trip min/avg/max = 1/2/4 ms
```

## Configuring CIMC Access Using the EHWIC E-Series NCE's External GE2 Interface



### Important

If you are using the external GE2 interface on an EHWIC E-Series NCE or the NIM E-Series NCE to configure CIMC access, to configure CIMC access, you might lose connectivity with CIMC during server reboot. This is expected behavior. If you must maintain connectivity with CIMC during a reboot, we recommend that you use one of the other network interfaces to configure CIMC access. See [CIMC Access Configuration Options—EHWIC E-Series NCE, on page 55](#).

If you want to use the external GE2 interface to configure CIMC access, we recommend that you use the **spanning-tree portfast** command. For details, see the CSCup50049 caveat in the *Release Notes for Cisco UCS E-Series Servers and the Cisco UCS E-Series Network Compute Engine*

See the following figure and the procedure that follows to configure CIMC access using the EHWIC E-Series NCE's external GE2 interface.



### Note

This figure shows how to configure CIMC access using the EHWIC E-Series NCE's external GE2 interface.

Figure 25: Configuring CIMC Access Using the EHWIC E-Series NCE's External GE2 Interface

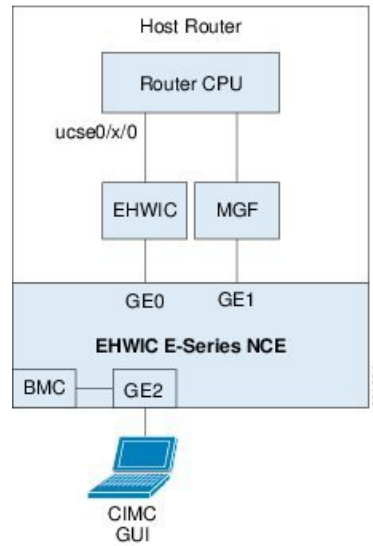

### Before you begin

Make sure that you have the following information:

- IP address of CIMC.
- Username and password for logging in to the router.
- Slot or subslot and port number of the E-Series Server or NCE.

### Procedure

	Command or Action	Purpose
<b>Step 1</b>	Router> <b>enable</b>	Enters privileged EXEC mode on the host router. Enter your password if prompted.
<b>Step 2</b>	Router# <b>configure terminal</b>	Enters global configuration mode on the host router.
<b>Step 3</b>	Router (config)# <b>interface ucse 0/subslot/port</b>	Enters ucse interface configuration mode for the subslot and port where the NCE is installed.
<b>Step 4</b>	Router (config-if)# <b>imc ip address</b> <i>cimc-ip-address subnet-mask default-gateway</i> <i>cimc-gateway-ip-address</i>	Specifies the IP address of CIMC and the IP address of the default gateway that CIMC must use. <ul style="list-style-type: none"> <li>• <i>cimc-ip-address</i>—IP address of CIMC.</li> <li>• <i>subnet-mask</i>—Subnet mask used to append to the IP address; must be in the same subnet as the host router.</li> <li>• <i>cimc-gateway-ip-address</i>—IP address for the default gateway.</li> </ul>



	Command or Action	Purpose
<b>Step 5</b>	Router (config-if)# <b>imc access-port shared-lom GE2</b>	Configures CIMC access through the EHWIC E-Series NCE's external GE2 interface. See # 3 in <a href="#">Understanding the Interfaces in the EHWIC E-Series NCE and the Cisco ISR G2</a> , on page 54.
<b>Step 6</b>	Router (config-if)# <b>no shut</b>	Causes the interface to be administratively up.
<b>Step 7</b>	Router (config-if)# <b>end</b>	Exits interface configuration mode.

**Example**

This example shows how to configure CIMC access using the EHWIC E-Series NCE external GE2 interface:

```
Router> enable
Router> password
Router# configure terminal

Router(config)# interface ucse 0/3/0
Router(config-if)# imc ip address 10.0.0.1 255.0.0.0 default-gateway 10.0.0.2
Router(config-if)# imc access-port shared-lom GE2
Router(config-if)# no shut
Router(config-if)# end
```

## Understanding the Interfaces in the NIM E-Series NCE and the Cisco ISR 4000 Series

The following figure shows the interfaces in a NIM E-Series NCE and the Cisco ISR 4000 series host router.

*Figure 26: Interfaces in a NIM E-Series NCE*

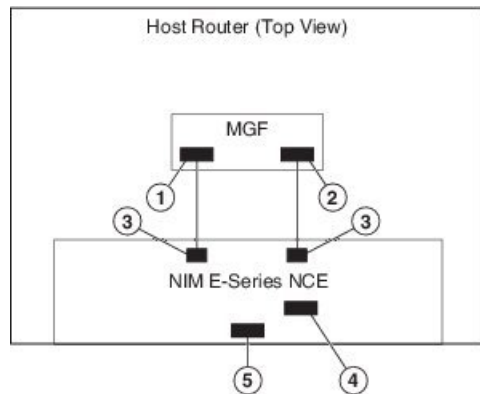

Interface	Interface Location	Description
-----------	--------------------	-------------

1	Router's <b>ucse 0/subslot/0</b> Interface	Internal Interface	Used to access CIMC over a high-speed backplane switch. The MGF interface provides an internal Layer 2 GE link between the router and the NIM E-Series NCE. This interface can be used both for CIMC configuration and for host operating system configuration.  <b>Note</b> This interface is used to access the NIM E-Series NCE's internal GE0 interface.
2	Router's <b>ucse 0/subslot/1</b> Interface	Internal Interface	Used to access CIMC over a high-speed backplane switch. The MGF interface provides an internal Layer 2 GE link between the router and the NIM E-Series NCE. This interface can be used both for CIMC configuration and for host operating system configuration.  <b>Note</b> This interface is used to access the NIM E-Series NCE's internal GE1 interface.
3	GE0 and GE1 Interfaces	Internal Interfaces	NIM E-Series NCE's internal NIC interfaces.
4	Management (Dedicated) Interface	External Interface	Used for CIMC configuration and management.
5	GE2 Interface	External Interface	Can be used both for CIMC configuration and for host operating system configuration.

## CIMC Access Configuration Options—NIM E-Series NCE

Depending on whether you are a remote user or a local user, do one of the following to configure CIMC access.

- If you are a remote user, use the Cisco IOS CLI to configure CIMC access by using one of the following interfaces:
  - CIMC Management (dedicated) interface
  - NIM E-Series NCE's internal GE0 and the router's **ucse 0/subslot/0** interface
  - NIM E-Series NCE's internal GE1 interface and the router's **ucse 0/subslot/1** interface
  - NIM E-Series NCE's external GE2 interface

- If you are a local user, use the CIMC Configuration Utility or the Cisco IOS CLI (mentioned above) to configure CIMC access.

### Configuring CIMC Access Using the NIM E-Series NCE's External Management (Dedicated) Interface—Cisco ISR 4000 Series

See the following figure and the procedure that follows to configure CIMC access using the NIM E-Series NCE's external Management (dedicated) interface.

*Figure 27: Configuring CIMC Access Using the NIM E-Series NCE's External Management (Dedicated) Interface*

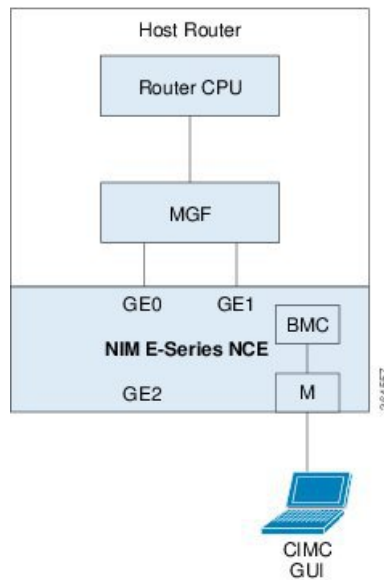

#### Before you begin

Make sure that you have the following information:

- IP address of CIMC.
- Username and password for logging in to the router.
- Slot or subslot and port number of the E-Series Server or NCE.

#### Procedure

	Command or Action	Purpose
<b>Step 1</b>	Router> <b>enable</b>	Enters privileged EXEC mode on the host router. Enter your password if prompted.
<b>Step 2</b>	Router# <b>configure terminal</b>	Enters global configuration mode on the host router.
<b>Step 3</b>	Router (config)# <b>ucse subslot slot/subslot</b>	Enters ucse interface configuration mode for the slot and subslot where the NIM E-Series NCE is installed.

	Command or Action	Purpose
<b>Step 4</b>	Router (config-ucse)# <b>imc ip address</b> <i>cimc-ip-address subnet-mask default-gateway</i> <i>cimc-gateway-ip-address</i>	Specifies the IP address of CIMC and the IP address of the default gateway that CIMC must use. <ul style="list-style-type: none"> <li>• <i>cimc-ip-address</i>—IP address of CIMC.</li> <li>• <i>subnet-mask</i>—Subnet mask used to append to the IP address; must be in the same subnet as the host router.</li> <li>• <i>cimc-gateway-ip-address</i>—IP address for the default gateway.</li> </ul>
<b>Step 5</b>	Router (config-ucse)# <b>imc access-port dedicated</b>	Configures CIMC access through the server's external Management (dedicated) interface. See # 4 in <a href="#">Understanding the Interfaces in the NIM E-Series NCE and the Cisco ISR 4000 Series, on page 63</a> .
<b>Step 6</b>	Router (config-ucse)# <b>end</b>	Returns to privileged EXEC mode on the host router.

### Example

This example shows how to configure CIMC access using the server's external dedicated interface:

```
Router> enable
Router> password
Router# configure terminal

Router(config)# ucse subslot 0/1
Router(config-ucse)# imc ip address 10.0.0.1 255.0.0.0 default-gateway 10.0.0.2
Router(config-ucse)# imc access-port dedicated
Router(config-ucse)# end
```

### Configuring CIMC Access Using the NIM E-Series NCE's NIC Interfaces—Cisco ISR 4000 Series

Use one of the following NIM E-Series NCE's NIC interfaces to access CIMC:

- NIM E-Series NCE's internal GE0 and the router's **ucse 0/subslot/0** Interface interface
- NIM E-Series NCE's internal GE1 interface and the router's **ucse 0/subslot/1** interface
- NIM E-Series NCE's external GE2 interface

### Configuring CIMC Access Using the NIM E-Series NCE's Internal GE0 Interface and the Cisco ISR 4000 Series ucse 0/subslot/0 Interface

See the following figure and the procedure that follows to configure CIMC access using the NIM E-Series NCE's internal GE0 interface and the router's **ucse 0/subslot/0** interface.

Figure 28: Configuring CIMC Access Using the NIM E-Series NCE's Internal GE0 Interface and the Router's ucse 0/subslot/0 Interface

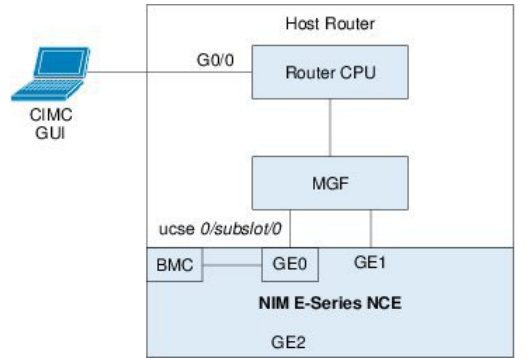

### Before you begin

Make sure that you have the following information:

- IP address of CIMC.
- Username and password for logging in to the router.
- Slot or subslot and port number of the E-Series Server or NCE.

### Procedure

	Command or Action	Purpose
<b>Step 1</b>	Router> <b>enable</b>	Enters privileged EXEC mode on the host router. Enter your password if prompted.
<b>Step 2</b>	Router# <b>configure terminal</b>	Enters global configuration mode on the host router.
<b>Step 3</b>	Router (config)# <b>interface GigabitEthernet 0/0/0</b>	Enters interface configuration mode for Gigabit Ethernet interface 0/0/0.
<b>Step 4</b>	Router (config-if)# <b>ip address ip-address subnet-mask</b>	Specifies the IP address and subnet mask of the interface.
<b>Step 5</b>	Router (config-if)# <b>no shut</b>	Causes the interface to be administratively up.
<b>Step 6</b>	Router (config-if)# <b>exit</b>	Exits interface configuration mode.
<b>Step 7</b>	Router (config)# <b>interface ucse 0/subslot/0</b>	Enters ucse interface configuration mode for the slot, subslot, and port where the NIM E-Series NCE is installed.
<b>Step 8</b>	Router (config-if)# <b>ip unnumbered type number</b>	The <b>ip unnumbered</b> command enables IP processing on an interface without assigning an explicit IP address to that interface. <ul style="list-style-type: none"> <li>• <i>type</i>—Type of interface on which the router has an assigned IP address.</li> </ul>

	Command or Action	Purpose
		<ul style="list-style-type: none"> <li><i>number</i>—Number of the interface and subinterface on which the router has an assigned IP address.</li> </ul> <p><b>Note</b> The unnumbered interface must be unique. It cannot be another unnumbered interface.</p> <p>When you use the <b>ip unnumbered</b> command, you must use the <b>ip route</b> command to create a static route.</p> <p><b>Caution</b> The <b>ip unnumbered</b> and <b>ipv6 unnumbered</b> commands create a point-to-point interface between devices. Broadcasting is not supported.</p>
<b>Step 9</b>	Router (config-if)# <b>no shut</b>	Causes the interface to be administratively up.
<b>Step 10</b>	Router (config-if)# <b>exit</b>	Exits interface configuration mode.
<b>Step 11</b>	Router (config)# <b>ucse subslot slot/subslot</b>	Enters ucse interface configuration mode for the slot and subslot where the NIM E-Series NCE is installed.
<b>Step 12</b>	Router (config-ucse)# <b>imc ip address</b> <i>cimc-ip-address subnet-mask default-gateway</i> <i>cimc-gateway-ip-address</i>	Specifies the IP address of CIMC and the IP address of the default gateway that CIMC must use. <ul style="list-style-type: none"> <li><i>cimc-ip-address</i>—IP address of CIMC.</li> <li><i>subnet-mask</i>—Subnet mask used to append to the IP address; must be in the same subnet as the host router.</li> <li><i>cimc-gateway-ip-address</i>—IP address for the default gateway.</li> </ul>
<b>Step 13</b>	Router (config-ucse)# <b>imc access-port</b> <b>shared-lom console</b>	Configures CIMC access using the NIM E-Series NCE's internal GE0 interface. See # 3 in <a href="#">Understanding the Interfaces in the NIM E-Series NCE and the Cisco ISR 4000 Series, on page 63</a> .
<b>Step 14</b>	Router (config-ucse)# <b>exit</b>	Exits ucse interface configuration mode.
<b>Step 15</b>	Router (config)# <b>ip route</b> <i>cimc-ip-address</i> <i>subnet-mask ucse slot/subslot/port</i>	Creates a static route. <ul style="list-style-type: none"> <li><i>cimc-ip-address</i>—IP address of CIMC.</li> <li><i>slot/subslot/port</i>—Slot, subslot, and port where the NIM E-Series NCE is installed.</li> </ul>

	Command or Action	Purpose
<b>Step 16</b>	Router (config)# <b>end</b>	Exits configuration mode.
<b>Step 17</b>	Router# <b>ping cimc-ip-address</b>	Verifies the connection from the router to CIMC through the <b>ucse 0/subslot/0</b> interface.

### Example

This example shows how to configure CIMC access using the NIM E-Series NCE's internal console interface and the router's **ucse 0/subslot/0** interface:

```
Router> enable
Router> password
Router# configure terminal

Router(config)# interface GigabitEthernet0/0/0
Router(config-if)# ip address 10.0.0.1 255.0.0.0
Router(config-if)# no shut
Router(config-if)# exit

Router(config)# interface ucse 0/1/0
Router(config-if)# ip unnumbered GigabitEthernet0/0/0
Router(config-if)# no shut
Router(config-if)# exit

Router(config)# ucse subslot 0/1
Router(config-ucse)# imc ip address 10.0.0.2 255.0.0.0 default-gateway 10.0.0.1
Router(config-ucse)# imc access-port shared-lom console
Router(config-ucse)# exit

Router(config)# ip route 10.0.0.2 255.255.255.255 ucse 0/1/0
Router(config)# end

Router# ping 10.0.0.2
Type escape sequence to abort.
Sending 5, 100-byte ICMP Echos to 10.0.0.2, timeout is 2 seconds:
!!!!
Success rate is 100 percent (5/5), round-trip min/avg/max = 1/2/4 ms
```

### Configuring CIMC Access Using the NIM E-Series NCE's Internal GE1 Interface and the Cisco ISR 4000 Series ucse 0/subslot/1 Interface

See the following figure and the procedure that follows to configure CIMC access using the NIM E-Series NCE's internal GE1 interface and the router's **ucse 0/subslot/1** interface.

Figure 29: Configuring CIMC Access Using the NIM E-Series NCE's Internal GE1 Interface and the Router's ucse 0/subslot/1 Interface

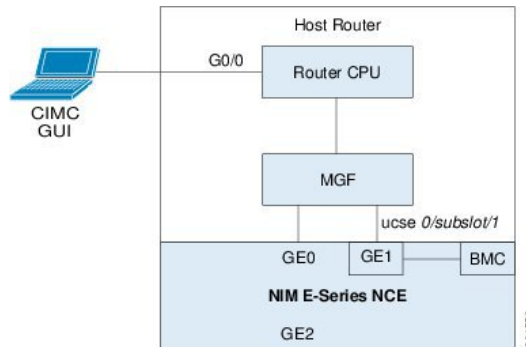

### Before you begin

Make sure that you have the following information:

- IP address of CIMC.
- Username and password for logging in to the router.
- Slot or subslot and port number of the E-Series Server or NCE.

### Procedure

	Command or Action	Purpose
<b>Step 1</b>	Router> <b>enable</b>	Enters privileged EXEC mode on the host router. Enter your password if prompted.
<b>Step 2</b>	Router# <b>configure terminal</b>	Enters global configuration mode on the host router.
<b>Step 3</b>	Router (config)# <b>interface GigabitEthernet 0/0/0</b>	Enters interface configuration mode for Gigabit Ethernet interface 0/0/0.
<b>Step 4</b>	Router (config-if)# <b>ip address</b> <i>ip-address</i> <i>subnet-mask</i>	Specifies the IP address and subnet mask of the interface.
<b>Step 5</b>	Router (config-if)# <b>no shut</b>	Causes the interface to be administratively up.
<b>Step 6</b>	Router (config-if)# <b>exit</b>	Exits interface configuration mode.
<b>Step 7</b>	Router (config)# <b>interface ucse 0/subslot/1</b>	Enters ucse interface configuration mode for the slot, subslot, and port where the NIM E-Series NCE is installed.
<b>Step 8</b>	Router (config-if)# <b>ip unnumbered</b> <i>type number</i>	The <b>ip unnumbered</b> command enables IP processing on an interface without assigning an explicit IP address to that interface. <ul style="list-style-type: none"> <li>• <i>type</i>—Type of interface on which the router has an assigned IP address.</li> </ul>



	Command or Action	Purpose
		<ul style="list-style-type: none"> <li><i>number</i>—Number of the interface and subinterface on which the router has an assigned IP address.</li> </ul> <p><b>Note</b> The unnumbered interface must be unique. It cannot be another unnumbered interface.</p> <p>When you use the <b>ip unnumbered</b> command, you must use the <b>ip route</b> command to create a static route.</p> <p><b>Caution</b> The <b>ip unnumbered</b> and <b>ipv6 unnumbered</b> commands create a point-to-point interface between devices. Broadcasting is not supported.</p>
<b>Step 9</b>	Router (config-if)# <b>no shut</b>	Causes the interface to be administratively up.
<b>Step 10</b>	Router (config-if)# <b>exit</b>	Exits interface configuration mode.
<b>Step 11</b>	Router (config)# <b>ucse subslot slot/subslot</b>	Enters ucse interface configuration mode for the slot and subslot where the NIM E-Series NCE is installed.
<b>Step 12</b>	Router (config-ucse)# <b>imc ip address</b> <i>cimc-ip-address subnet-mask default-gateway</i> <i>cimc-gateway-ip-address</i>	Specifies the IP address of CIMC and the IP address of the default gateway that CIMC must use. <ul style="list-style-type: none"> <li><i>cimc-ip-address</i>—IP address of CIMC.</li> <li><i>subnet-mask</i>—Subnet mask used to append to the IP address; must be in the same subnet as the host router.</li> <li><i>cimc-gateway-ip-address</i>—IP address for the default gateway.</li> </ul>
<b>Step 13</b>	Router (config-ucse)# <b>imc access-port</b> <b>shared-lom ge1</b>	Configures CIMC access using the NIM E-Series NCE's internal GE1 interface. See # 3 in <a href="#">Understanding the Interfaces in the NIM E-Series NCE and the Cisco ISR 4000 Series, on page 63</a> .
<b>Step 14</b>	Router (config-ucse)# <b>exit</b>	Exits ucse interface configuration mode.
<b>Step 15</b>	Router (config)# <b>ip route</b> <i>cimc-ip-address</i> <i>subnet-mask ucse slot/subslot/port</i>	Creates a static route. <ul style="list-style-type: none"> <li><i>cimc-ip-address</i>—IP address of CIMC.</li> <li><i>slot/subslot/port</i>—Slot, subslot, and port where the NIM E-Series NCE is installed.</li> </ul>

	Command or Action	Purpose
<b>Step 16</b>	Router (config)# <b>end</b>	Exits configuration mode.
<b>Step 17</b>	Router# <b>ping cimc-ip-address</b>	Verifies the connection from the router to CIMC through the <b>ucse 0/subslot/1</b> interface.

### Example

This example shows how to configure CIMC access using the NIM E-Series NCE's internal GE1 interface and the router's ucse 0/subslot/1 interface:

```
Router> enable
Router> password
Router# configure terminal

Router(config)# interface GigabitEthernet0/0/0
Router(config-if)# ip address 10.0.0.1 255.0.0.0
Router(config-if)# no shut
Router(config-if)# exit

Router(config)# interface ucse 0/1/1
Router(config-if)# ip unnumbered GigabitEthernet0/0/0
Router(config-if)# no shut
Router(config-if)# exit

Router(config)# ucse subslot 0/1
Router(config-ucse)# imc ip address 10.0.0.2 255.0.0.0 default-gateway 10.0.0.1
Router(config-ucse)# imc access-port shared-lom gel
Router(config-ucse)# exit

Router(config)# ip route 10.0.0.2 255.255.255.255 ucse 0/1/1
Router(config)# end

Router# ping 10.0.0.2
Type escape sequence to abort.
Sending 5, 100-byte ICMP Echos to 10.0.0.2, timeout is 2 seconds:
!!!!
Success rate is 100 percent (5/5), round-trip min/avg/max = 1/2/4 ms
```

### Configuring CIMC Access Using the NIM E-Series NCE's External GE2 Interface—Cisco ISR 4000 Series

See the following figure and the procedure that follows to configure CIMC access using the NIM E-Series NCE's external GE2 interface.



**Note** This figure shows how to configure CIMC access using the NIM E-Series NCE's external GE2 interface.

Figure 30: Configuring CIMC Access Using the NIM E-Series NCE's External GE2 Interface

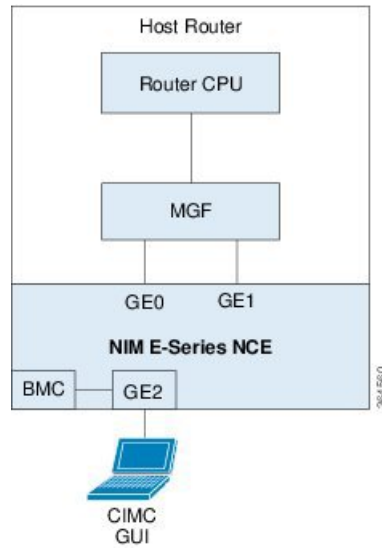

**Before you begin**

Make sure that you have the following information:

- IP address of CIMC.
- Username and password for logging in to the router.
- Slot or subslot and port number of the E-Series Server or NCE.

**Procedure**

	<b>Command or Action</b>	<b>Purpose</b>
<b>Step 1</b>	Router> <b>enable</b>	Enters privileged EXEC mode on the host router. Enter your password if prompted.
<b>Step 2</b>	Router# <b>configure terminal</b>	Enters global configuration mode on the host router.
<b>Step 3</b>	Router (config)# <b>ucse subslot slot/subslot</b>	Enters ucse interface configuration mode for the slot and subslot where the NIM E-Series NCE is installed.
<b>Step 4</b>	Router (config-ucse)# <b>imc ip address cimc-ip-address subnet-mask default-gateway cimc-gateway-ip-address</b>	Specifies the IP address of CIMC and the IP address of the default gateway that CIMC must use. <ul style="list-style-type: none"> <li>• <i>cimc-ip-address</i>—IP address of CIMC.</li> <li>• <i>subnet-mask</i>—Subnet mask used to append to the IP address; must be in the same subnet as the host router.</li> </ul>

	Command or Action	Purpose
		<ul style="list-style-type: none"> <li><i>cimc-gateway-ip-address</i>—IP address for the default gateway.</li> </ul>
<b>Step 5</b>	Router (config-ucse)# <b>imc access-port shared-lom {GE2}</b>	Configures CIMC access through the NIM E-Series NCE's external GE2 interface. See # 5 and 6 in <a href="#">Understanding the Interfaces in the NIM E-Series NCE and the Cisco ISR 4000 Series, on page 63</a> .
<b>Step 6</b>	Router (config-ucse)# <b>end</b>	Returns to privileged EXEC mode on the host router.

### Example

This example shows how to configure CIMC access using the server's external GE2 interface:

```
Router> enable
Router> password
Router# configure terminal

Router(config)# ucse subslot 0/1
Router(config-ucse)# imc ip address 10.0.0.1 255.0.0.0 default-gateway 10.0.0.2
Router(config-ucse)# imc access-port shared-lom GE2
Router(config-ucse)# no shut
Router(config-ucse)# end
```

## Configuring CIMC Access Using the CIMC Configuration Utility



**Note** This procedure is applicable to E-Series Servers and the SM E-Series NCE. This procedure is not applicable to the EHWIC E-Series NCE and the NIM E-Series NCE.

If you are a local user, you can use either the Cisco IOS CLI or the CIMC Configuration Utility to configure CIMC access.



**Note** When you use the CIMC Configuration Utility to configure CIMC access, the configuration is not reflected as a Cisco IOS configuration. In other words, if you execute the **show running-config** command from the Cisco IOS CLI, the changes that you made using the CIMC Configuration Utility are not reflected.

### Procedure

- Step 1** Power on the router.
- Step 2** Connect a keyboard and monitor to the front panel of the E-Series Server.

**Step 3** Press the **Power** button to boot the E-Series Server. During bootup, watch for the prompt to press **F8**.

**Step 4** When you see the prompt, press **F8**.

The **CIMC Configuration Utility** appears.

**Figure 31: CIMC Configuration Utility**

```

File View Macros Tools Help
KVM Virtual Media

CIMC Configuration Utility Version 1.5 Cisco Systems, Inc.
*****
NIC Properties
NIC mode                               NIC redundancy
Dedicated: [X]                          None: [X]
Shared LOM: [ ]                          CON[X] GE1[ ] GE2[ ] GE3[ ]
                                           Active-standby: [ ]
                                           GE1-GE2[X]
                                           GE2-GE3[ ]
                                           GE3-GE1[ ]
                                           GE1-GE2-GE3[ ]

IPV4 (Basic)
DHCP enabled: [ ]
CIMC IP: 10.193.70.102
Subnetmask: 255.255.255.0
Gateway: 10.193.70.1

VLAN (Advanced)
VLAN enabled: [ ]
VLAN ID: 1
Priority: 0

Factory Defaults
CIMC Factory Default:[ ]
Default User (Basic)
Default password:
Reenter password:

*****
<Up/Down arrow> Select items  <F10> Save  <Space bar> Enable/Disable
<F5> Refresh                  <ESC> Exit

```

**Step 5** Use the CIMC configuration Utility to set the NIC mode and NIC redundancy, and to choose whether to enable DHCP or set static network settings.

a) From the **NIC mode** area, choose a port to access CIMC. Options are:

- Dedicated—The 10/100 IMC port is used to access CIMC.
- Shared LOM (default)—The four 1Gb Ethernet ports are used to access the CIMC. This is the factory default setting.

b) From the **NIC redundancy** area, choose the NIC redundancy. Options are:

- None—The Ethernet ports operate independently and do not fail over if there is a problem.
- Active-standby—If an active Ethernet port fails, the traffic falls over to a standby port. This is the factory default setting.

c) From the **IPV4 (Basic)** area, do one of the following:

- DHCP Enabled—Select this option to enable DHCP for dynamic network settings. Before you enable DHCP, your DHCP server must be preconfigured with the range of MAC addresses for this server. The MAC address is printed on a label on the rear of the server. This server has a range of six MAC addresses assigned to CIMC. The MAC address printed on the label is the beginning of the range of six contiguous MAC addresses.

- CIMC IP—IP address of CIMC.

Subnet Mask—Enter the subnet mask to append to the CIMC IP address; must be in the same subnet as the host router.

Gateway—IP address of the default gateway router.

d) (Optional) From the **VLAN (Advanced)** area, configure VLAN settings.

e) Press **F5** to refresh the page and have the new settings appear.

The page refresh takes approximately 45 seconds.

f) Press **F10** to save your settings and reboot the server.

If you chose to enable DHCP, the dynamically assigned IP and MAC addresses are displayed on the console screen during bootup.

**Step 6** Using the ports that you selected for the NIC Mode settings in Step 5, substep a, connect Ethernet cables from your LAN to the E-Series Server.

**Step 7** In your web browser, enter the IP address that you configured to access CIMC. The CIMC IP address is based upon the settings that you configured in Step 5, substep c (either a static IP address or the IP address assigned by your DHCP server).

The default username to log in to CIMC is **admin**, and the default password is **password**.

**Step 8** Use the CIMC GUI or CIMC CLI to manage and monitor the server.

See the *GUI Configuration Guide for Cisco UCS E-Series Servers and the Cisco UCS E-Series Network Compute Engine* or the *CLI Configuration Guide for Cisco UCS E-Series Servers and the Cisco UCS E-Series Network Compute Engine*.

## Defining Network Static Settings Using a Script File

Use this procedure to define static network settings for multiple servers by automating the configuration process with a script file.

### Procedure

**Step 1** Use a text editor to create a file named **network.cfg**.

**Step 2** Create the contents of **network.cfg** in the following format by using only the tags that you want to set:

```
dhcp-enabled:
v4-addr:
v4-netmask:
v4-gateway:
vlan-enabled:
vlan-id:
vlan-priority:
password:
mode:
redundancy:
```

For example, to disable DHCP, set the IP address, subnet mask, gateway, and user password, use the following sample values:

```
dhcp-enabled: 0
v4-addr: 10.193.70.102
v4-netmask: 255.255.255.0
v4-gateway: 10.193.70.1
password: nonpasswd
mode:
redundancy:
```

**Step 3** Use a text editor to create a file named **startup.nsh** with the following contents:

```
fs0:
cimconfig
```

**Step 4** Copy your **network.cfg** file and your **startup.nsh** file to a USB thumb drive.

**Step 5** Insert the USB thumb drive into a USB port on the server.

**Step 6** Press and release the **Power** button to boot the server.

**Step 7** Observe the booting process and press **F6** when prompted to enter the BIOS Boot Manager.

**Step 8** Select EFI as the boot device and then press **Enter**.

The server power-cycles and launches the configuration utility, which runs the **startup.nsh** file. Any errors are displayed on the screen and on an **errors.txt** file.

**Step 9** Remove the USB thumb drive, alter the **network.cfg** file with your next IP address, and then insert the USB thumb drive into the next server that you want to configure.

**Step 10** After the server has been assigned an IP address, you can use that address to access the service processor's GUI or CLI management system.

## What to Do Next

Do one of the following as appropriate:

- If you purchased an E-Series Server or NCE Option 1 (E-Series Server or NCE without a preinstalled operating system or hypervisor), log in to the CIMC GUI or the CIMC CLI to access CIMC. See [Accessing the Management Firmware, on page 79](#).
- If you purchased an E-Series Server or NCE Option 2 (E-Series Server or NCE with a preinstalled Microsoft Windows Server) or Option 3 (E-Series Server or NCE with a preinstalled VMware vSphere Hypervisor), configure an internal connection between the router and the E-Series Server or NCE. Do one of the following:
  - If you *do not want* the traffic to your application or operating system to flow through the router, use the server's host operating system to configure the E-Series Server's or NCE's external interface.
  - If you *want* the traffic to your application or operating system to flow through the router, use the Cisco IOS CLI to configure an internal connection between the router and the E-Series Server or NCE. See [Configuring a Connection Between the Router and the E-Series Server or NCE, on page 111](#).







## CHAPTER 5

# Accessing the Management Firmware

---

This chapter includes the following sections:

- [CIMC Overview, on page 79](#)
- [Logging In to the CIMC GUI, on page 81](#)
- [CIMC Home Page, on page 82](#)
- [What to Do Next, on page 82](#)

## CIMC Overview

The Cisco Integrated Management Controller (CIMC) is the management service for the E-Series Servers and the NCE. CIMC runs within the server. You can use a web-based GUI or the SSH-based CLI to access, configure, administer, and monitor the server.

You can use CIMC to perform the following server management tasks:

- Power on, power off, power cycle, reset, and shut down the server
- Configure the server boot order
- Manage RAID levels



---

**Note** The RAID feature is applicable to E-Series Servers and the SM E-Series NCE. The RAID feature is not applicable to the EHWIC E-Series NCE and the NIM E-Series NCE.

---

- View server properties and sensors
- Manage remote presence
- Create and manage local user accounts, and enable remote user authentication through the Active Directory
- Configure network-related settings, including NIC properties, IPv4, IPv6, VLANs, and network security
- Configure communication services, including HTTP, SSH, IPMI over LAN, SNMP, and Redfish
- Manage certificates
- Configure platform event filters

- Update CIMC firmware
- Update BIOS firmware
- Install the host image from an internal repository
- Monitor faults, alarms, and server status
- Collect technical support data in the event of server failure

Almost all tasks can be performed in either the GUI interface or CLI interface, and the results of tasks performed in one interface are displayed in another. However, you *cannot*:

- Use the CIMC GUI to invoke the CIMC CLI
- View a command that has been invoked through the CIMC CLI in the CIMC GUI
- Generate CIMC CLI output from the CIMC GUI

## CIMC GUI

The CIMC GUI is a web-based management interface for E-Series Servers and the NCE. You can launch the CIMC GUI and manage the server from any remote host that meets the following minimum requirements:

- Java 1.6 or later
- HTTP and HTTPS enabled
- Adobe Flash Player 10 or later

## CIMC CLI

The CIMC CLI is a command-line management interface for E-Series Servers and the NCE. You can launch the CIMC CLI in the following ways:

- By the serial port.
- Over the network by SSH.
- From the router. Use one of the following commands as appropriate:
  - **ucse slot session imc**—Use for E-Series Servers and the SM E-Series NCE installed in a Cisco ISR G2. Applicable from Cisco IOS Release 15.2(4)M to 15.4(2)T.
  - **ucse subslot slot/subslot session imc**—Use for E-Series Servers, SM E-Series NCE, and EHWIC E-Series NCE installed in a Cisco ISR G2. Applicable in Cisco IOS Release 15.4(3)M.
  - **hw-module subslot slot/subslot session imc**—Use for E-Series Servers and the NIM E-Series NCE installed in a Cisco ISR 4000 series.

A CLI user can have one of the three roles: admin, user (can control but cannot configure), and read-only.

# Logging In to the CIMC GUI

## Before you begin

- Make sure that you have configured the IP address to access CIMC.
- If not installed, install Adobe Flash Player 10 or later on your local machine.

## Procedure

---

**Step 1** In your web browser, enter the IP address that you configured to access CIMC during initial setup.

**Step 2** If a security dialog box displays, do the following:

- a) (Optional) Check the check box to accept all content from Cisco.
- b) Click **Yes** to accept the certificate and continue.

**Step 3** In the log in window, enter your username and password.

**Tip** When logging in for the first time to an unconfigured system, use **admin** as the username and **password** as the password.

**Step 4** Click **Log In**.

The **Change Password** dialog box appears.

**Note** The **Change Password** dialog box only appears the first time you log into CIMC. It does not appear for subsequent reboots.

**Step 5** In the **New Password** field, enter your new password.

**Step 6** In the **Confirm Password** field, enter the password again to confirm it.

**Step 7** Click **Save Changes**.

The **Server Summary** page appears, which is the CIMC home page. See [CIMC Home Page, on page 82](#).

---

# CIMC Home Page

Figure 32: CIMC Home Page

The screenshot shows the Cisco Integrated Management Controller (CIMC) Home Page. The page is titled "Cisco Integrated Management Controller" and shows the user "admin@192.168.164.70 - E160S-FOC20091NAS". The page is divided into several sections:

- Server Properties:**
  - Product Name: E160S
  - Serial Number: FOC20091NAS
  - PID: UCS-E160S-M3/K9
  - UUID: A89D21FC-650C-0000-D719-30E7E3C41835
  - BIOS Version: UCSEM3\_2.6 (Build Date: 07/12/2018)
  - Description:
  - Asset Tag:
- Cisco Integrated Management Controller (Cisco IMC) Information:**
  - Hostname: E160S-FOC20091NAS
  - IP Address: 192.168.164.42
  - MAC Address: A8:9D:21:FC:65:0E
  - Firmware Version: 3.2(4.20180206163853)
  - CPLD Version: 4.0
  - Hardware Version: 2
  - Current Time (UTC): Fri Jul 13 01:27:34 2018
  - Local Time: Fri Jul 13 01:27:34 2018 UTC +0000
  - Timezone: UTC [Select Timezone](#)
- Router Information:**
  - Router Model: ISR4351/K9
  - Serial Number: FDO1826A01D
  - Slot Number: Service Module slot 1
- Chassis Status:**
  - Power State: ● On
  - Overall Server Status: ✔ Good
  - Overall DIMM Status: ✔ Good
  - Overall Storage Status: ✔ Good

367547

## What to Do Next

If you purchased E-Series Server Option 1 (E-Series Server without a preinstalled operating system or hypervisor), configure RAID. See [Managing Storage Using RAID](#), on page 83.



**Note** The RAID feature is applicable to E-Series Servers and the SM E-Series NCE. The RAID feature is not applicable to the EHWIC E-Series NCE and the NIM E-Series NCE.



## CHAPTER 6

# Managing Storage Using RAID



**Note** If you purchased E-Series Server Option 1 (E-Series Server without a preinstalled operating system or hypervisor), and you want to store data files on local Redundant Array of Inexpensive Disks (RAID), you must configure RAID.



**Important** The RAID feature is applicable to E-Series Servers and the SM E-Series NCE. The RAID feature is not applicable to the EHWIC E-Series NCE and the NIM E-Series NCE.

This chapter includes the following sections:

- [Configuring RAID, on page 83](#)

## Configuring RAID

You can choose to store the E-Series Server data files on local Redundant Array of Inexpensive Disks (RAID). The following RAID levels are supported:

- The single-wide E-Series Server supports RAID 0 and RAID 1 levels.
- The double-wide E-Series Server supports RAID 0, RAID 1, and RAID 5 levels.
- The double-wide E-Series Server with the PCIe option supports RAID 0 and RAID 1 levels.



**Note** On Cisco UCS M1 and M2 servers, you can use the CIMC GUI or the WebBIOS, which is accessible from the KVM console, to configure RAID. On Cisco UCS M3 servers, you can use the CIMC GUI or the MegaRAID controller, which is accessible from the KVM console, to configure RAID.

# Configuring RAID Using the CIMC GUI



**Note** On Cisco UCS M1 and M2 servers, you can use the CIMC GUI or the WebBIOS, which is accessible from the KVM console, to configure RAID. On Cisco UCS M3 servers, you can use the CIMC GUI or the MegaRAID controller, which is accessible from the KVM console, to configure RAID.

Use this procedure to configure the RAID level, strip size, host access privileges, drive caching, and initialization parameters on a virtual drive. You can also use this procedure to designate the drive as a hot spare drive and to make the drive bootable.

## Procedure

- Step 1** In the **Navigation** pane, click the **Server** menu.
- Step 2** On the **Server** tab, click **RAID**. Do one of the following:
  - If the **Configure Virtual Drive** dialog box does not appear, proceed to the next step.
  - If the **Configure Virtual Drive** dialog box appears, and the virtual drives are not configured, complete the fields as shown in Step 5.
- Step 3** In the tabbed menu of the **Storage Cards** area, click the **Virtual Drive Info** tab.

*Figure 33: Virtual Drive Info Tab*

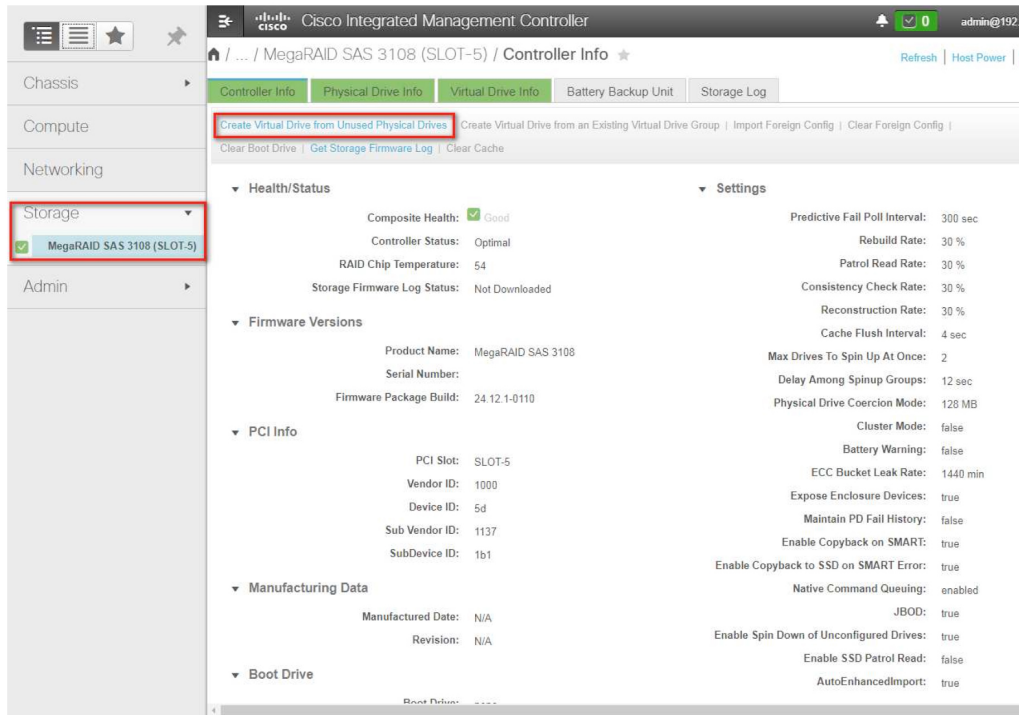

367548

Figure 34: Virtual Drive Info Tab

**Step 4** In the **Actions** area of the **Virtual Drive Info** tab, click **Create**.  
The **Configure Virtual Drive** dialog box appears.

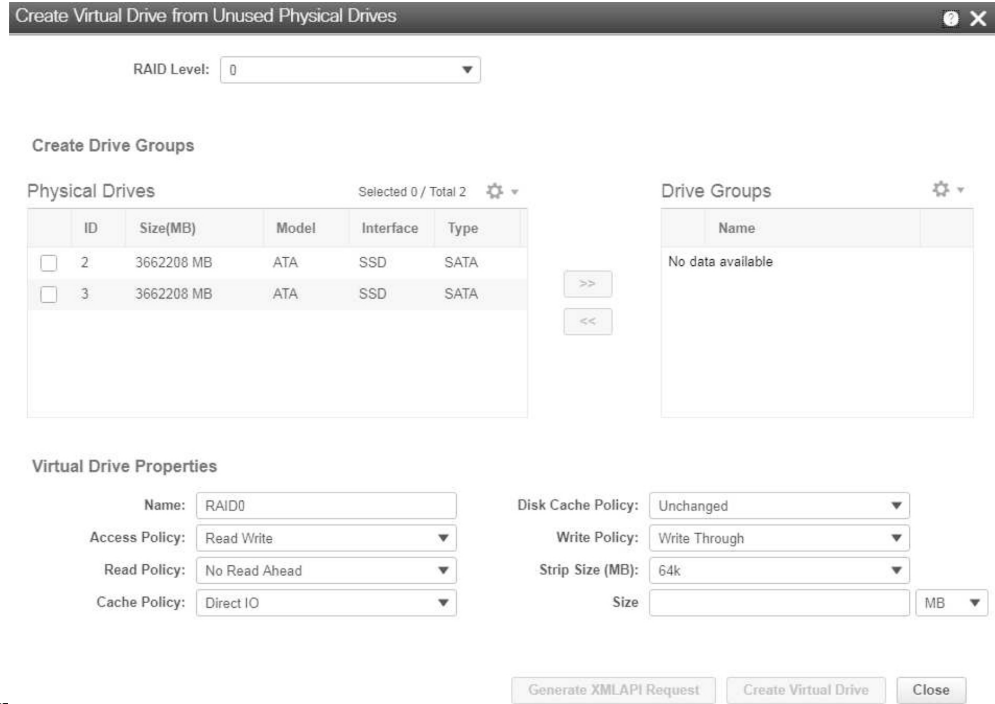

Figure 35  
Virtual Drive Dialog Box

367549  
Configure

**Step 5** Complete the following fields as appropriate:

Name	Description
Available Drives table	Displays the drives that are available for RAID configuration. <b>Note</b> To move a drive, click and drag a drive to the appropriate table.
Selected Drives table	Displays the drives that are selected for RAID configuration. <b>Note</b> To move a drive, click and drag a drive to the appropriate table.

Name	Description
RAID Level drop-down list	<p>The RAID level options. This can be one of the following:</p> <ul style="list-style-type: none"> <li>• <b>RAID 0</b>—Block striping.</li> <li>• <b>RAID 1</b>—Mirroring.</li> <li>• <b>RAID 5</b>—Block striping with parity.</li> </ul> <p><b>Note</b> The single-wide E-Series Server supports RAID 0 and RAID 1 levels. The double-wide E-Series Server supports RAID 0, RAID 1, and RAID 5 levels. The double-wide E-Series Server with the PCIe option supports RAID 0 and RAID 1 levels.</p>
Name field	<p>The name of the virtual drive.</p> <p>Enter a maximum of 15 characters. The characters can have numbers and upper- or lower-case letters. Special characters are not supported.</p>
Strip Size drop-down list	<p>The strip size options. This can be one of the following:</p> <ul style="list-style-type: none"> <li>• <b>64 KB</b></li> <li>• <b>32 KB</b></li> <li>• <b>16 KB</b></li> <li>• <b>8 KB</b></li> </ul>
Initialization drop-down list	<p>How the controller initializes the drives. This can be one of the following:</p> <ul style="list-style-type: none"> <li>• <b>Quick</b>—The controller initializes the drive quickly. This is the default and recommended option.</li> <li>• <b>Full</b>—The controller does a complete initialization of the new configuration.</li> </ul> <p><b>Note</b> Depending on the size of the drives, full initialization can take several hours to complete. To view the progress, see the <b>Initialize Progress</b> and <b>Initialize Time Elapsed</b> fields in the <b>General</b> area.</p> <ul style="list-style-type: none"> <li>• <b>None</b>—The controller does not initialize the drives.</li> </ul>



Name	Description
<b>Drive Cache</b> drop-down list	<p>How the controller handles drive caching. This can be one of the following:</p> <ul style="list-style-type: none"> <li>• <b>Disable</b>—Caching is disabled on the drives. <b>Note</b> This is the default and recommended option.</li> <li>• <b>Unchanged</b>—The controller uses the caching policy specified on the drive. This is the default and recommended option.</li> <li>• <b>Enable</b>—Caching is enabled on the drives. This option minimizes the delay in accessing data. <b>Caution</b> Enabling Drive Cache, voids all warranty on the hard disk drives. This configuration option is not supported. Use this option at your own risk.</li> </ul>
<b>Access Policy</b> drop-down list	<p>Configures host access privileges. This can be one of the following:</p> <ul style="list-style-type: none"> <li>• <b>Read-Write</b>—The host has full access to the drive.</li> <li>• <b>Read Only</b>—The host can read only data from the drive.</li> <li>• <b>Blocked</b>—The host cannot access the drive.</li> </ul>
<b>Set this Virtual Drive Bootable</b> check box	<p>How the controller boots the drive. This can be one of the following:</p> <ul style="list-style-type: none"> <li>• <b>Enable</b>—The controller makes this drive bootable.</li> <li>• <b>Disable</b>—This drive is not bootable.</li> </ul> <p><b>Note</b> If you plan to install an operating system or hypervisor into the RAID array, we recommend that you check this check box.</p>
<b>Use the Remaining Drive as Hot Spare</b> check box	<p>Designates the drive that is in the Available Drives table as a hot spare drive.</p> <p><b>Note</b> Applicable for RAID 1 only. This check box is greyed out for other RAID levels. Applicable for double-wide E-Series Servers.</p>

**Step 6** Review the RAID configuration, and then click **Confirm** to accept the changes.

## Configuring RAID Using the WebBIOS



---

**Important** The RAID feature is applicable to E-Series Servers and the SM E-Series NCE. The RAID feature is not applicable to the EHWIC E-Series NCE and the NIM E-Series NCE.

---



---

**Note** Use WebBIOS to configure RAID on M1 and M2 servers. Use MegaRAID controller to configure RAID on M3 servers. See [Configuring RAID Using the MegaRAID Controller, on page 89](#)

---

### Procedure

---

**Step 1** In the **Navigation** pane, click the **Server** menu.

**Step 2** In the work pane, click **Host Image Mapping** tab.

**Step 3** From the **Actions** area, click **Launch KVM Console**.

The **KVM Console** opens in a separate window.

**Step 4** From the **Server Summary** page, click **Power Cycle Server** to reboot the server.

**Step 5** Press the **Ctrl** key, and then press **H** during bootup to access the WebBIOS.

The **Adapter Selection** page from LSI Logic appears, which allows you to configure RAID. For information about this page, see the LSI Logic documentation.

Figure 36: WebBIOS

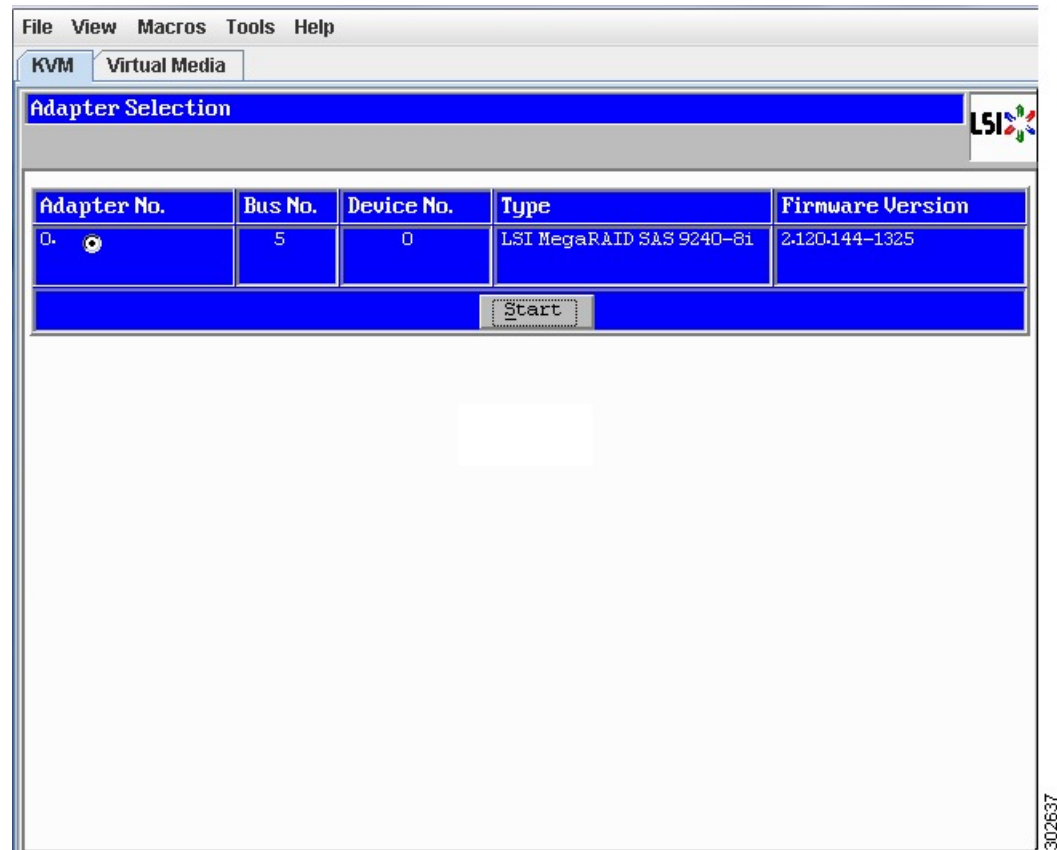

## Configuring RAID Using the MegaRAID Controller



**Important** The RAID feature is applicable to E-Series Servers and the SM E-Series NCE. The RAID feature is not applicable to the EHWIC E-Series NCE and the NIM E-Series NCE.

### Procedure

- Step 1** In the **Navigation** pane, click the **Server** menu.
- Step 2** In the work pane, click **Host Image Mapping** tab.
- Step 3** From the **Actions** area, click **Launch KVM Console**.  
The **KVM Console** opens in a separate window.
- Step 4** From the **Server Summary** page, click **Power Cycle Server** to reboot the server.
- Step 5** Press the **Ctrl** key, and then press **R** during bootup to access the MegaRAID Controller.

The **Virtual Drive Management** page appears, which allows you to configure MegaRAID Controller.

*Figure 37: MegaRAID Controller*

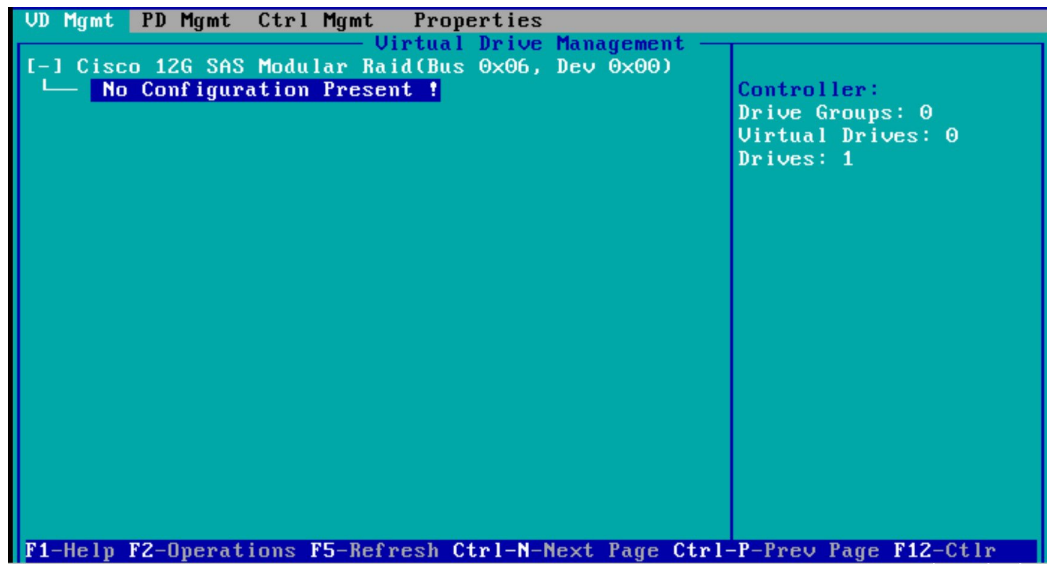

## What to Do Next

If you purchased E-Series Server or NCE Option 1 (E-Series Server or NCE without a preinstalled operating system or hypervisor), install the operating system. See [Installing the Operating System or Hypervisor, on page 91](#).



## CHAPTER 7

# Installing the Operating System or Hypervisor



**Note** If you purchased E-Series Server or NCE Option 1 (E-Series Server or NCE without a preinstalled operating system or hypervisor), you must install an operating system or hypervisor.

This chapter includes the following sections:

- [Operating System or Hypervisor Installation Methods, on page 91](#)
- [KVM Console, on page 92](#)
- [PXE Installation Servers, on page 94](#)
- [Host Image Mapping, on page 95](#)
- [Basic Workflow for Downloading and Installing the VMware vSphere Hypervisor, on page 101](#)
- [Configuring the Server Boot Order, on page 104](#)
- [What to Do Next, on page 109](#)

## Operating System or Hypervisor Installation Methods

E-Series Servers and NCE support several operating systems and hypervisors. Regardless of the platform being installed, you can install it on your server using one of the following methods:

- KVM console
- PXE installation server
- Host image mapping



**Caution** You must use only one method to map virtual drives. For example, you must use either the KVM console or the Host Image Mapping method. Using a combination of methods will cause the server to be in an undefined state.

# KVM Console

The KVM console is an interface accessible from the CIMC that emulates a direct keyboard, video, and mouse connection to the server. The KVM console allows you to connect to the server from a remote location. Instead of using CD/DVD or floppy drives physically connected to the server, the KVM console uses virtual media, which are actual disk drives or disk image files that are mapped to virtual CD/DVD or floppy drives. You can map any of the following to a virtual drive:

- CD/DVD or floppy drive on your computer
- Disk image files (ISO or IMG files) on your computer
- USB flash drive on your computer

You can use the KVM console to install an operating system or hypervisor on the server and to do the following:

- Access the BIOS setup menu by pressing **F2** during bootup.
- Access the CIMC Configuration Utility by pressing **F8** during bootup.



---

**Note** The CIMC Configuration Utility is not applicable to the EHWIC E-Series NCE and the NIM E-Series NCE.

---

- On Cisco UCS M1 and M2 servers, access the WebBIOS to configure RAID, by pressing **Ctrl-H** during bootup.

On Cisco UCS M3 servers, access the MegaRAID controller to configure RAID, by pressing **Ctrl-R** during bootup.



---

**Note** RAID is not supported on EHWIC E-Series NCE and NIM E-Series NCE. The **Ctrl-H** and **Ctrl-R** will not work on these SKUs.

---

## Java Requirements to Launch the KVM Console

To launch the KVM console, you must have Java release 1.6 or later installed in your system.

If the KVM console fails to launch because the certificate is revoked by Java, you must change your Java settings. Do the following:

1. Access the Java control panel.
2. Click the **Advanced** tab
3. Under **Perform certificate revocation on**, choose the **Do not check (not recommended)** radio button. For more information, see [http://www.java.com/en/download/help/revocation\\_options.xml](http://www.java.com/en/download/help/revocation_options.xml).

# Installing an Operating System or Hypervisor Using the KVM Console

## Before you begin

Locate the operating system or hypervisor installation disk or disk image file.



**Note** The VMware vSphere Hypervisor requires a customized image. To download the customized image, see [Downloading the Customized VMware vSphere Hypervisor Image, on page 101](#).

## Procedure

- Step 1** Load the operating system or hypervisor installation disk into your CD/DVD drive, or copy the disk image files to your computer.
- Step 2** If CIMC is not open, log into the CIMC GUI.
- Step 3** From the top menu, click **Launch KVM**.
- Step 4** From the **Launch KVM** menu, click **Java Based KVM**.  
The **KVM Console** opens in a separate window.
- Step 5** From the KVM console, click the **Virtual Media** tab.

```

File View Macros Tools Power Virtual Media Help
PciRoot(0x0)/Pci(0x1D,0x0)/USB(0x0,0x0)/USB(0x2,0x0)/Unit(0x3)/CDROM(0x1
,0x295,0x33F040)
b1k0 :Removable CDRom - Alias cd39a0c0d1 fs0
PciRoot(0x0)/Pci(0x1D,0x0)/USB(0x0,0x0)/USB(0x2,0x0)/Unit(0x3)/CDROM(0x1
,0x295,0x33F040)
b1k1 :Removable CDRom - Alias (null)
PciRoot(0x0)/Pci(0x1D,0x0)/USB(0x0,0x0)/USB(0x2,0x0)/Unit(0x3)/CDROM(0x0
,0x233,0x8)
b1k2 :Removable BlockDevice - Alias (null)
PciRoot(0x0)/Pci(0x1D,0x0)/USB(0x0,0x0)/USB(0x2,0x0)
b1k3 :Removable BlockDevice - Alias (null)
PciRoot(0x0)/Pci(0x1D,0x0)/USB(0x0,0x0)/USB(0x2,0x0)/Unit(0x1)
b1k4 :Removable BlockDevice - Alias (null)
PciRoot(0x0)/Pci(0x1D,0x0)/USB(0x0,0x0)/USB(0x2,0x0)/Unit(0x2)
b1k5 :Removable BlockDevice - Alias (null)
PciRoot(0x0)/Pci(0x1D,0x0)/USB(0x0,0x0)/USB(0x2,0x0)/Unit(0x3)
b1k6 :Removable BlockDevice - Alias (null)
PciRoot(0x0)/Pci(0x1D,0x0)/USB(0x0,0x0)/USB(0x2,0x0)/Unit(0x4)
b1k7 :Removable BlockDevice - Alias (null)
PciRoot(0x0)/Pci(0x1D,0x0)/USB(0x0,0x0)/USB(0x3,0x0)

Press ESC in 1 seconds to skip startup.nsh, any other key to continue.
Shell>
Shell>
Shell> _
  
```

- Step 6** In the **Virtual Media** tab, click **Activate Virtual Devices**
- Step 7** Select **Accept this Session** and then click **Apply**.
- Step 8** Click the **Virtual Media** tab and click **Map CD/DVD**.

- Step 9** Click **Browse**, navigate to and select the operating system or hypervisor installation disk image. Click **Open** to mount the disk image, and then check the **Mapped** check box for the mounted disk image in the **Virtual Media** tab.
- Step 10** Set the boot order to make the virtual CD/DVD drive as the boot device.
- Step 11** Reboot the server.
- When the server reboots, it begins the installation process from the virtual CD/DVD drive. Refer to the platform installation guide for the installation process.
- Step 12** If the disk drives are not displayed after you install the operating system or hypervisor, you must install drivers. See the appropriate operating system or hypervisor documentation for instructions on how to install drivers. For instructions on how to install drivers on a Microsoft Windows operating system, see [Installing Drivers for the Microsoft Windows Server, on page 97](#).

---

### What to do next

After the installation is complete, reset the virtual media boot order to its original setting.

## PXE Installation Servers

A Preboot Execution Environment (PXE) installation server allows a client to boot and install an operating system or hypervisor from a remote location. To use this method, a PXE environment must be configured and available on your VLAN, typically a dedicated provisioning VLAN. In addition, the server must be set to boot from the network. When the server boots, it sends a PXE request across the network. The PXE installation server acknowledges the request, and starts a sequence of events that installs the operating system or hypervisor on the server.

PXE servers can use installation disks, disk images, or scripts to install the operating system or hypervisor. Proprietary disk images can also be used to install the platform, additional components, or applications.



---

**Note** PXE installation is an efficient method for installing a platform on a large number of servers. However, considering that this method requires setting up a PXE environment, it might be easier to use another installation method.

---

## Installing an Operating System or Hypervisor Using a PXE Installation Server

### Before you begin

Verify that the server can be reached over a VLAN.

### Procedure

---

- Step 1** Set the boot order to **PXE**.
- Step 2** Reboot the server.



**Caution** If you are using the shared LOM interfaces to access CIMC, make sure that you do not use the CIMC GUI during the server reboot process. If you use the CIMC GUI, the GUI will disconnect during PXE installation as the boot agent overrides the IP address that was previously configured on the Ethernet ports.

If a PXE install server is available on the VLAN, the installation process begins when the server reboots. PXE installations are typically automated and require no additional user input. Refer to the installation guide for the operating system or hypervisor being installed to guide you through the rest of the installation process.

---

### What to do next

After the installation is complete, reset the LAN boot order to its original setting.

## Host Image Mapping

The Host Image Mapping feature allows you to download, map, unmap, or delete a host image. Download a host image, such as Microsoft Windows, Linux, or VMware from a remote FTP or HTTP server onto the CIMC internal repository, and then map the image onto the virtual drive of a USB controller in the E-Series Server or NCE. After you map the image, set the boot order to make the virtual drive, in which the image is mounted, as the first boot device, and then reboot the server. The host image must have .iso or .img as the file extension.

The Host Image Mapping feature also allows you to download and mount a diagnostics image. The diagnostics image must have .diag as the file extension.

## Mapping the Host Image

### Before you begin

- Log in to CIMC as a user with admin privileges.
- Obtain the host image file from the appropriate third-party.



---

**Note** The VMware vSphere Hypervisor requires a customized image. To download the customized image, see [Downloading the Customized VMware vSphere Hypervisor Image, on page 101](#).

---



---

**Note** If you start an image update while an update is already in process, both updates will fail.

---

### Procedure

---

**Step 1** In the Navigation pane, click the **Compute** menu.

**Step 2** On the **Compute** tab, click **Host Image Mapping**.

Cisco Integrated Management Controller admin@192.168.164.70 - E180D-FOC21211SGK

/ Compute / Host Image Mapping

Refresh | Host Power | Launch KVM | Ping | Reboot

BIOS Remote Management Troubleshooting Power Policies Host Image Mapping

**Host Image Mapping Information**

Status None  
Mapped Image None

**Current Mappings**

Add Image Unmap Image Map Selected Image Delete Selected Image

	Image Name	Image Size	MD5 Checksum	Last Modified Time
<input type="radio"/>	RHEL-7.4-20170711.0-Serv...	4059037696	227880f6a3cee6b745e7f204586c8988	Fri, 08 Dec 2017 12:29:47 GMT
<input type="radio"/>	Vmware-ESXi-6.5d.0-53105...	347625472	39c360322d9d5cd795e20483c2f6d3c2	Mon, 17 Jul 2017 08:48:13 GMT

Save Changes Reset Values

367551

**Step 3** In the **Install Pane**, complete the following fields:

Name	Description
<b>URL field</b>	<p>The URL of the remote server on which the image is located.</p> <p>If the remote server requires user authentication, you must add the username and password of the remote server in the URL. The remote server can be an FTP, FTPS, HTTP, or HTTPS server.</p> <p>The URL syntax must be: <i>protocol://username:password@server-ip-address/path/filename</i></p>
<b>Image Name field</b>	<p>The name of the image.</p> <ul style="list-style-type: none"> <li>• If you are installing a host image, that image must have .iso as the file extension.</li> <li>• If you are installing a diagnostics image, that image must have .diag as the file extension.</li> </ul>

**Step 4** Click **Download**.

The image file is downloaded from the specified FTP, FTPS, HTTP, or HTTPS server onto the CIMC internal repository.

**Step 5** Click **Map Image to Host**.

The image is mounted on the virtual drive of a USB controller. The virtual drive can be one of the following:

- HDD—Hard disk drive
- FDD—Floppy disk drive
- CDROM—Bootable CD-ROM

**Step 6** Set the boot order to make the virtual drive in which the image is mounted as the first boot device.

To set the boot order, see [Configuring the Server Boot Order, on page 104](#).

**Tip** To determine in which virtual drive the image is mounted, see the **Host Image Update** area in the **Host Image Mapping** page.

**Step 7** Reboot the server.

**Step 8** If the image contains an answer file, the operating system or hypervisor installation is automated and the image is installed. Otherwise, the installation wizard is displayed. Follow the wizard steps to install the image.

**Step 9** If disk drives are not displayed after you install the operating system or hypervisor, you must install drivers. See the appropriate operating system or hypervisor documentation for instructions on how to install drivers. For instructions on how to install drivers on a Microsoft Windows operating system, see [Installing Drivers for the Microsoft Windows Server, on page 97](#).

---

#### What to do next

- After the installation is complete, reset the virtual media boot order to its original setting.
- Unmap the host image. See [Unmapping the Host Image, on page 100](#).

## Installing Drivers for the Microsoft Windows Server



**Note** If you purchased an E-Series Server or NCE Option 1 (E-Series Server or NCE without a preinstalled operating system or hypervisor), and you installed your own version of the Microsoft Windows Server, you must install drivers.

The Microsoft Windows operating system requires that you install the following drivers:

- On-Board Network Drivers for Windows 2008 R2
- LSI Drivers (On-Board Hardware RAID Controller) for Windows 2008 R2
- Intel Drivers for Windows 2008 R2
- [Intel Server Chipset Driver for Windows](#)
- [Intel Network Adapter Driver for Windows Server 2012 R2](#)



---

**Note** The driver 'Intel Network Adapter Driver for Windows Server 2012 R2' is applicable only for the following servers:

- UCS-E160S-M3 Server
  - UCS-EN140N-M2 Server
  - UCS-EN120E-M2 Server
  - UCS-E180D-M3/K9 Server
  - UCS-E1120D-M3/K9 Server
- 



---

**Note** Additional drivers are not needed for Windows 2012.

---

If you have purchased a 10-Gigabit add-on card, you must also install the 10G PCIe Network Drivers for Windows 2008 R2.

### Procedure

---

- Step 1** Download the drivers from Cisco.com. See [Obtaining Software from Cisco Systems, on page 98](#).
- Step 2** Copy the driver files into a USB flash drive.
- Step 3** Install your own version of Microsoft Windows Server.  
During the installation process, you will be prompted for the LSI Drivers.
- Step 4** Plug the USB flash drive into the USB slot in the E-Series Server and then install the LSI Drivers.  
This step is applicable to E-Series Servers and the SM E-Series NCE. This step is not applicable to the EHWIC E-Series NCE and the NIM E-Series NCE.
- Step 5** After the Microsoft Windows Server installation is complete, install the On-Board Network Drivers (Broadcom) and the Intel Drivers.
- 

## Obtaining Software from Cisco Systems

Use this procedure to download drivers, BIOS and CIMC firmware, and the diagnostics image.

### Procedure

---

- Step 1** Navigate to <http://www.cisco.com/>.
- Step 2** If you are not already logged in, click **Log In** at the top right-hand edge of the page and log in using your Cisco.com credentials.
- Step 3** In the menu bar at the top, click **Support**.

A roll-down menu appears.

- Step 4** From the Downloads (center) pane, click **All Downloads** (located at the bottom right corner).  
The **Download Software** page appears.
- Step 5** From the left pane, click **Products**.
- Step 6** From the center pane, click **Unified Computing and Servers**.
- Step 7** From the right pane, click **Cisco UCS E-Series Software**.
- Step 8** From the right pane, click the name of the server model for which you want to download the software.  
The **Download Software** page appears with the following categories.
- **Unified Computing System (UCSE) Server Drivers**—Contains drivers.
  - **Unified Computing System (UCSE) Server Firmware**—Contains the Host Upgrade Utility and the BIOS, CIMC, and PLD firmware images.
  - **Unified Computing System (UCSE) Utilites**—Contains the diagnostics image.
- Step 9** Click the appropriate software category link.
- Step 10** Click the **Download** button associated with software image that you want to download.  
The **End User License Agreement** dialog box appears.
- Step 11** (Optional) To download multiple software images, do the following:
- a) Click the **Add to cart** button associated with the software images that you want to download.
  - b) Click the **Download Cart** button located on the top right .  
All the images that you added to the cart display.
  - c) Click the **Download All** button located at the bottom right corner to download all the images.  
The **End User License Agreement** dialog box appears.
- Step 12** Click **Accept License Agreement**.
- Step 13** Do one of the following as appropriate:
- Save the software image file to a local drive.
  - If you plan to install the software image from a TFTP server, copy the file to the TFTP server that you want to use.  
The server must have read permission for the destination folder on the TFTP server.

---

### What to do next

Install the software image.

# Unmapping the Host Image

## Before you begin

Log in to CIMC as a user with admin privileges.

## Procedure

- Step 1** In the Navigation pane, click the **Compute** menu.
- Step 2** On the **Compute** tab, click **Host Image Mapping**.

The screenshot shows the Cisco Integrated Management Controller (CIMC) interface. The breadcrumb navigation is: Home / Compute / Host Image Mapping. The 'Host Image Mapping Information' section shows 'Status: None' and 'Mapped Image: None'. The 'Current Mappings' table is as follows:

Image Name	Image Size	MD5 Checksum	Last Modified Time
<input type="radio"/> RHEL-7.4-20170711.0-Serv...	4059037696	227880f6a3cee6b745e7f204586c8988	Fri, 08 Dec 2017 12:29:47 GMT
<input type="radio"/> Vmware-ESXi-6.5d.0-53105...	347625472	39c360322d9d5cd795e20483c2f6d3c2	Mon, 17 Jul 2017 08:48:13 GMT

At the bottom of the page, there are 'Save Changes' and 'Reset Values' buttons. A vertical ID '367551' is visible on the right side of the screenshot.

- Step 3** Click **Unmap Image**.
- The mapped image is unmounted from the virtual drive of the USB controller.

# Basic Workflow for Downloading and Installing the VMware vSphere Hypervisor

**Caution**

If you are using the VMware FL-SRE-V-HOST license (equivalent to VMware vSphere Hypervisor 5.X), make sure that the RAM that you are using is 32 GB or less. If the RAM is more than 32 GB, you will get an error message, and you will not be able to apply the license. If you want to use 48 GB of RAM, upgrade your license to FL-SRE-V-HOSTVC.

1. Download the customized VMware vSphere Hypervisor image.
2. Install the VMware vSphere Hypervisor image.
3. Assign a static IP address to the VMware vSphere Hypervisor.
4. Download and install the vSphere Client.

## Downloading the Customized VMware vSphere Hypervisor Image

**Procedure**

- Step 1** Navigate to <https://my.vmware.com/web/vmware/login>.  
The VMware login page appears.
- Step 2** Enter your VMware credentials, and then click **Log In**.  
If you do not have an account with VMware, click **Register** to create a free account.
- Step 3** Click **Downloads**, and then select **All Products** from the drop-down list.
- Step 4** Do one of the following as appropriate:
- To download the VMware vSphere Hypervisor 5.1 image, enter **ESXi-5.1.0-799733-custom-Cisco-2.1.0.3.iso** in the **Search** field, and then click the **Search** icon. From the **Search Results**, click **VMware vSphere > Drivers & Tools > Cisco Custom Image for ESXi 5.1.0 GA Install CD**, and then click **Download**.
  - To download the VMware vSphere Hypervisor 5.5 image, enter **ESXi-5.5.0-1331820-custom-Cisco-5.5.0.1.iso**, in the **Search** field, and then click the **Search** icon. From the **Search Results**, click **VMware vSphere > Drivers & Tools > CISCO Custom Image for ESXi 5.5.0 GA Install CD**, and then click **Download**.

**What to do next**

Install the VMware vSphere Hypervisor image.

## Assigning a Static IP Address to the VMware vSphere Hypervisor

Use this procedure to assign a static IP address to the VMware vSphere Hypervisor.

### Before you begin

- Download the customized VMware vSphere Hypervisor image. See [Downloading the Customized VMware vSphere Hypervisor Image, on page 101](#).



**Note** You must have an account with VMware to download the customized image.

- Install the image onto the E-Series Server or NCE. For installation instructions, see [Mapping the Host Image, on page 95](#).

### Procedure

- 
- Step 1** In your web browser, enter the IP address that you configured to access CIMC during initial setup and then log into CIMC.
- The CIMC Home page, which is the **Server Summary** page, appears.
- Step 2** From the **Actions** area of the **Server Summary** page, click the **Launch KVM Console** icon.
- The **KVM Console** opens in a separate window.
- Step 3** From the KVM console, click the **KVM** tab, and then do the following to configure the IP address:
- Press **F2** to access the VMware vSphere Hypervisor DCUI customization menu.
- The **DCUI** login page appears.
- Log into the **DCUI**.
- The **System Customization** page appears.
- From the **System Customization** page, click **Configure Management Network**.
- The **Configure Management Network** page appears, which has several menu options, including **Network Adapter**. The **Network Adapter** menu option allows you to view the existing network adapters and activate them.
- Note** By default, the network adapter, **vmnic0**, is activated. Make sure that it stays activated.
- From the **Configure Management Network** page, click the **IP Configuration** menu option.
- To assign a static IP address, do the following:
- In the **IP Configuration** dialog box, click the radio box to specify that a static IP address will be used.
  - In the appropriate fields, enter the IP address, network mask, and the gateway IP address, and then press **Enter**. The **Configure Management Network** page appears.



- In the **Configure Management Network** page, click the **ESC** key. The **Configure Management Network Confirm** dialog box appears.
  - Enter **y** to accept the changes and restart the management network.
- e) In the router configuration, add a route to the VMware vSphere Hypervisor host IP address.
- For example, if the host IP address is 192.168.1.25 and the ucse interface is ucse 2/0, add the following route:
- ```
ip route 192.168.1.25 255.255.255.255 ucse2/0
```
- f) Install the vSphere Client. See [Downloading and Installing the vSphere Client, on page 103](#). From the vSphere Client, use the host IP address to log in to the VMware vSphere Hypervisor.

---

## Downloading and Installing the vSphere Client

### Before you begin

- Make sure that you have assigned a static IP address to the VMware vSphere Hypervisor. See [Assigning a Static IP Address to the VMware vSphere Hypervisor, on page 102](#).
- Verify that you have network connectivity. To download the vSphere Client, connection to the Internet is required.



**Note** The vSphere Client contains an online tutorial for first time users. It also contains embedded in-line getting started assistance, which allows you to set up your virtual infrastructure through an easy to use, step-by-step process. If you are an experienced user, you can choose to turn-off the getting started in-line assistance.

---

### Procedure

- Step 1** Go to `https://hypervisor-ip-address`. You are directed to the VMware website and the Welcome page opens.
- Step 2** Click **Download vSphere Client**, and then click **Run** to download the vSphere Client. The VMware vSphere Client is installed and a shortcut icon to the client appears on your desktop.
- Step 3** Click the **VMware vSphere Client** icon to open the login window.
- Step 4** To manage the VMware vSphere Hypervisor, enter the IP address or hostname of the VMware vSphere Hypervisor and the username and password, and then click **Login**. The vSphere Client GUI opens.

**Note** The default username for the preinstalled VMware vSphere Hypervisor is **root**, which cannot be changed; and the default password is **password** (For VMware 6.7 version, the default password is **password@123**). After you log in, we recommend that you change the password.

# Configuring the Server Boot Order

You can use the CIMC GUI or the BIOS setup menu to configure the server boot order.

## Configuring the Server Boot Order Using the CIMC GUI

### Before you begin

Log into CIMC as a user with admin privileges.

### Procedure

**Step 1** In the Navigation pane, click the **Compute** menu.

**Step 2** On the **Compute** tab, click **BIOS**.

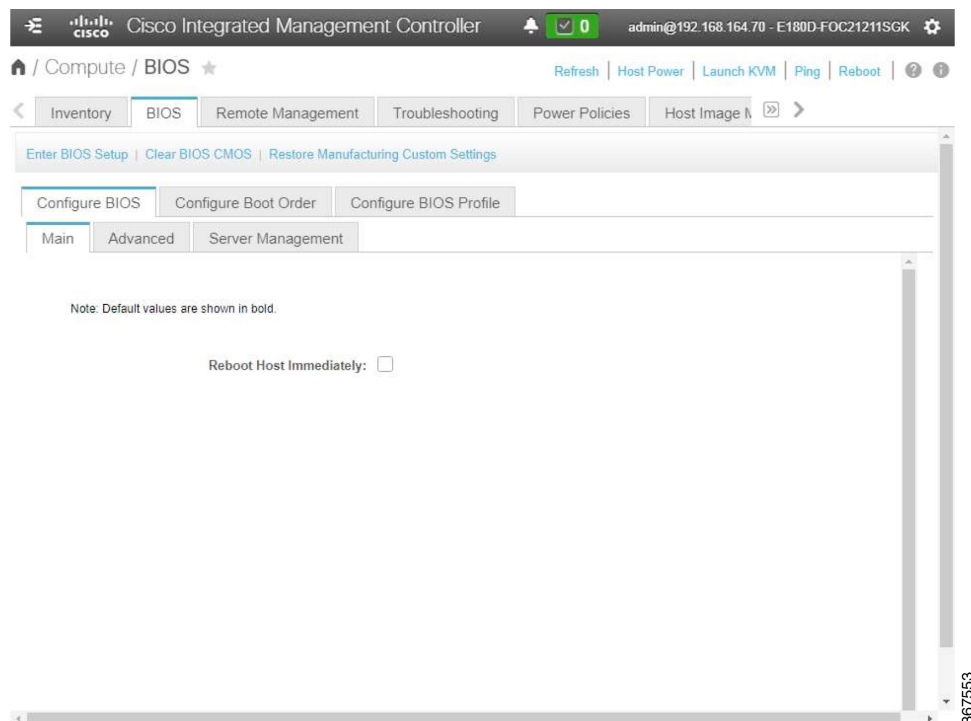

**Step 3** In the **Configure Boot Order** area, click **Configure Boot Order**.

The **Configure Boot Order** dialog box appears.

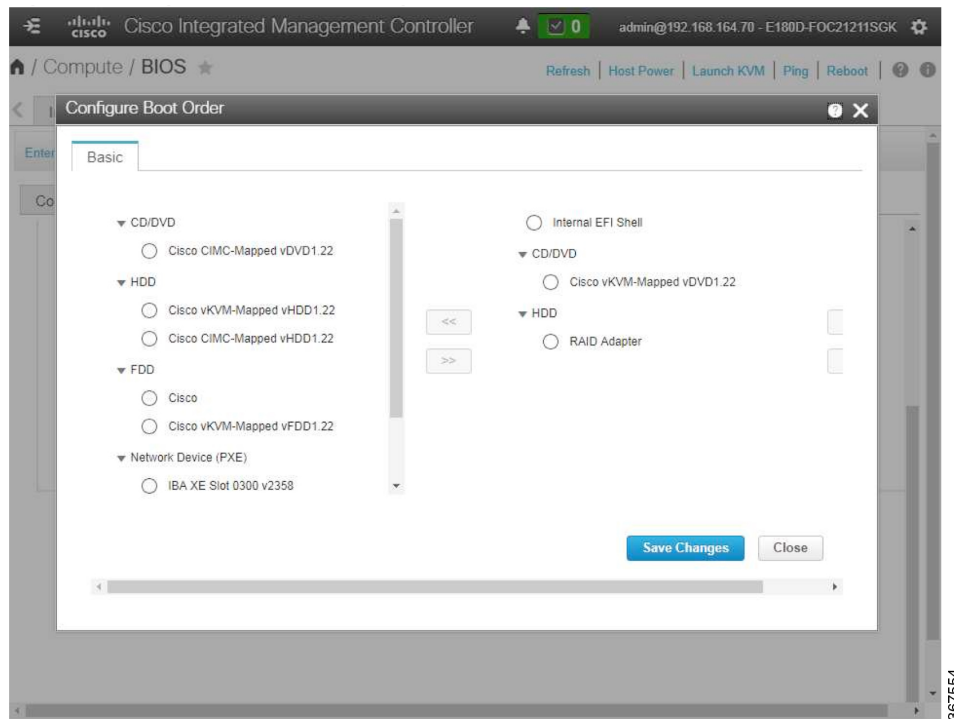

**Step 4** In the **Configure Boot Order** dialog box, complete the following fields as appropriate:

| Name                      | Description                                                                                                                                                                                                                                                                                                 |
|---------------------------|-------------------------------------------------------------------------------------------------------------------------------------------------------------------------------------------------------------------------------------------------------------------------------------------------------------|
| <b>Device Types</b> table | The server boot options. This can be the following: <ul style="list-style-type: none"> <li>• <b>HDD</b>—Hard disk drive.</li> <li>• <b>FDD</b>—Floppy disk drive.</li> <li>• <b>CDROM</b>—Bootable CD-ROM.</li> <li>• <b>PXE</b>—PXE boot.</li> <li>• <b>EFI</b> —Extensible Firmware Interface.</li> </ul> |
| <b>Add &gt;</b>           | Moves the selected device type to the <b>Boot Order</b> table.                                                                                                                                                                                                                                              |
| <b>&lt; Remove</b>        | Removes the selected device type from the <b>Boot Order</b> table.                                                                                                                                                                                                                                          |
| <b>Boot Order</b> table   | Displays the device types from which this server can boot, in the order in which the boot will be attempted.                                                                                                                                                                                                |
| <b>Up</b>                 | Moves the selected device type to a higher priority in the <b>Boot Order</b> table.                                                                                                                                                                                                                         |
| <b>Down</b>               | Moves the selected device type to a lower priority in the <b>Boot Order</b> table.                                                                                                                                                                                                                          |

**Step 5** Click **Apply**.

Additional device types may be appended to the actual boot order, depending on what devices you have connected to your server.

---

#### What to do next

Reboot the server to boot with your new boot order.

## Configuring the Boot Order Using the BIOS Setup Menu

Use this procedure if you want the server to boot from an external bootable device, such as a USB or an external CD-ROM drive that is directly connected to the E-Series Server or NCE.

#### Procedure

---

- Step 1** In the **Navigation** pane, click the **Server** menu.
- Step 2** In the work pane, click **Host Image Mapping** tab.
- Step 3** From the **Actions** area, click **Launch KVM Console**.  
The **KVM Console** opens in a separate window.
- Step 4** From the **Server Summary** page, click **Power Cycle Server** to reboot the server.
- Step 5** When prompted, press **F2** during bootup to access the BIOS setup menu.  
The **Aptio Setup Utility** appears, which provides the BIOS setup menu options.

Figure 38: BIOS Setup Menu

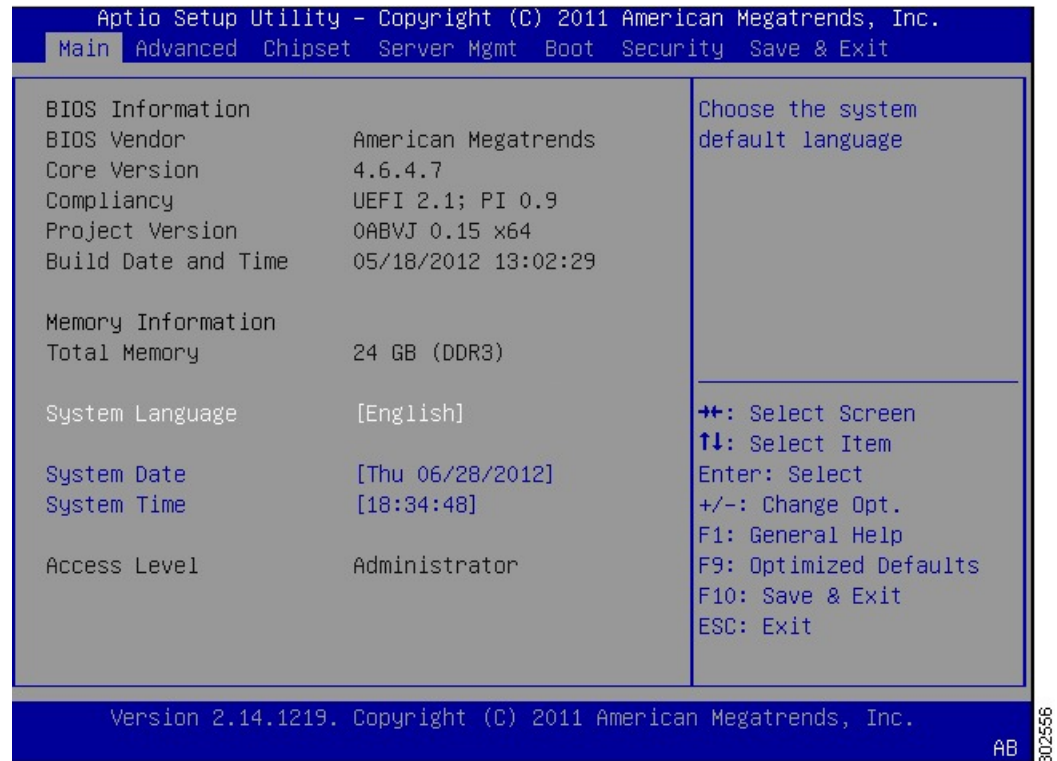

- Step 6** Click the **Boot** tab.
- Step 7** Scroll down to the bottom of the page below the **Boot Options Priority** area. The following boot option priorities are listed:
- Floppy Drive BBS Priorities
  - Network Device BBS Priorities
  - Hard Drive BBS Priorities
  - CD/DVD ROM Drive BBS Priorities
- Step 8** Use the **Up** or **Down arrow keys** on your keyboard to highlight the appropriate option.
- Step 9** Press **Enter** to select the highlighted field.
- Step 10** Choose the appropriate device as Boot Option 1.
- Step 11** Press **F4** to save changes and exit.
- The **Main** tab of the BIOS setup displays the device that you configured as Boot Option 1.

## Verifying Operating System and Hypervisor Installation

### Accessing the Microsoft Windows Server from CIMC

#### Before you begin

- A CIMC IP address is configured for CIMC access.
- The Microsoft Windows Server is installed on the E-Series Server.

#### Procedure

---

- Step 1** In the **Navigation** pane, click the **Server** menu.
- Step 2** In the work pane, click **Host Image Mapping** tab.
- Step 3** From the **Actions** area of the **Server Summary** page, click the **Launch KVM Console** icon.  
The **KVM Console** opens in a separate window.
- Step 4** From the KVM console, access the installed Microsoft Windows Server operating system.
- 

### Accessing the VMware vSphere Hypervisor from CIMC

#### Before you begin

- A CIMC IP address is configured for CIMC access.
- The VMware vSphere Hypervisor is installed on the E-Series Server.

#### Procedure

---

- Step 1** In the **Navigation** pane, click the **Server** menu.
- Step 2** In the work pane, click **Host Image Mapping** tab.
- Step 3** From the **Actions** area of the **Server Summary** page, click the **Launch KVM Console** icon.  
The **KVM Console** opens in a separate window.
- Step 4** From the KVM console, click the **KVM** tab.  
The VMware vSphere Hypervisor Direct Console User Interface (DCUI) appears. If VMware vSphere Hypervisor has assigned an IP address to the host, then that IP address is displayed on the DCUI page, or you can specify a static IP address. See [Assigning a Static IP Address to the VMware vSphere Hypervisor](#), on page 102.
- Step 5** Make sure that you have installed vSphere Client. If not, install it. See [Downloading and Installing the vSphere Client](#), on page 103.
- Step 6** From the vSphere Client, log in to the VMware vSphere Hypervisor.

To log in, use either the IP address that is assigned by VMware vSphere Hypervisor or the static IP address that you specified in Step 4.

**Note** The default username for the preinstalled VMware vSphere Hypervisor is **root**, which cannot be changed, and the default password is **password** (For VMware 6.7 version the default password is **password@123**). After you log in, we recommend that you change the password.

---

## What to Do Next

Configure a connection between the router and the server. See [Configuring a Connection Between the Router and the E-Series Server or NCE, on page 111](#).







## CHAPTER 8

# Configuring a Connection Between the Router and the E-Series Server or NCE

Depending on whether you want the traffic to flow through the router or not, do one of the following:

- If you *do not want* the traffic to your application or operating system to flow through the router, use the server's host operating system to configure the E-Series Server's or NCE's external interface.
- If you *want* the traffic to your application or operating system to flow through the router, use the procedures provided in this chapter to configure an internal connection between the router and the E-Series Server or NCE.

This chapter includes the following sections:

- [Configuring an Internal Connection Between the Cisco ISR G2 and the E-Series Server, on page 111](#)
- [Configuring an Internal Connection Between the Cisco ISR 4000 Series and the E-Series Server, on page 114](#)
- [Configuring an Internal Connection Between the Cisco ISR G2 and the EHWIC E-Series NCE, on page 120](#)
- [Configuring an Internal Connection Between the Cisco ISR 4000 Series and the NIM E-Series NCE, on page 123](#)
- [Understanding Network Interface Mapping, on page 130](#)
- [Determining the MAC Address in Microsoft Windows, Linux, and VMware vSphere Hypervisor, on page 132](#)

## Configuring an Internal Connection Between the Cisco ISR G2 and the E-Series Server

Use this configuration if you want the traffic to your application or operating system to flow through the Cisco ISR G2. To configure an internal connection between the Cisco ISR G2 and the E-Series Server, you must configure these IP addresses:

- For traffic to flow through the PCIe connection (see next figure), configure the following:
  - IP address of the router's internal PCIe interface that connects the router to the E-Series Server's GE0 interface.
  - IP address of the E-Series Server's GE0 interface.

- For traffic to flow through the MGF connection (see next figure), configure the following:
  - IP address of the router's internal MGF VLAN interface.
  - IP address of the E-Series Server's GE1 interface.

The following figure shows the internal connection between the router and the E-Series Server.

**Figure 39: Internal Connection Between the Cisco ISR G2 and the E-Series Server**

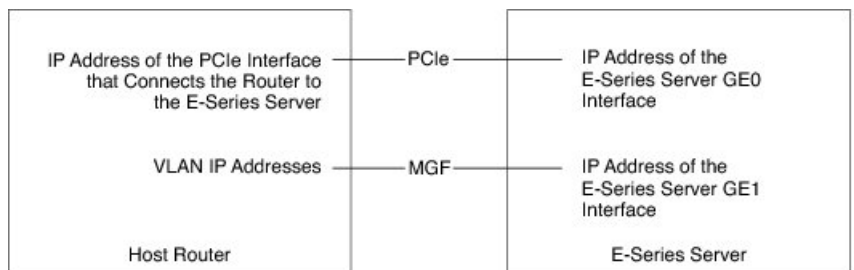

**Procedure**

|               | Command or Action                                                                                                                                                                                                                                                | Purpose                                                                                                                                                                                                                                                                                                                                                                                                                                                                                                                                                                                                                                                                                    |
|---------------|------------------------------------------------------------------------------------------------------------------------------------------------------------------------------------------------------------------------------------------------------------------|--------------------------------------------------------------------------------------------------------------------------------------------------------------------------------------------------------------------------------------------------------------------------------------------------------------------------------------------------------------------------------------------------------------------------------------------------------------------------------------------------------------------------------------------------------------------------------------------------------------------------------------------------------------------------------------------|
| <b>Step 1</b> | Router> <b>enable</b>                                                                                                                                                                                                                                            | Enters privileged EXEC mode on the host router. Enter your password if prompted.                                                                                                                                                                                                                                                                                                                                                                                                                                                                                                                                                                                                           |
| <b>Step 2</b> | Router# <b>configure terminal</b>                                                                                                                                                                                                                                | Enters global configuration mode on the host router.                                                                                                                                                                                                                                                                                                                                                                                                                                                                                                                                                                                                                                       |
| <b>Step 3</b> | Router (config)# <b>interface ucse slot/0</b>                                                                                                                                                                                                                    | Enters interface configuration mode for the router's PCIe <i>slot/0</i> interface.                                                                                                                                                                                                                                                                                                                                                                                                                                                                                                                                                                                                         |
| <b>Step 4</b> | Enter one of the following commands: <ul style="list-style-type: none"> <li>• Router (config-if)# <b>ip address</b> <i>router-to-e-series-server-interface-ip-address subnet-mask</i></li> <li>• Router (config-if)# <b>ip unnumbered type number</b></li> </ul> | <p>The <b>ip address</b> command specifies the IP address of the router's internal PCIe interface that connects the router to the E-Series Server's GE0 interface. See the figure above.</p> <p>or</p> <p>The <b>ip unnumbered</b> command enables IP processing on an interface without assigning an explicit IP address to that interface.</p> <ul style="list-style-type: none"> <li>• <i>type</i>—Type of interface on which the router has an assigned IP address.</li> <li>• <i>number</i>—Number of the interface on which the router has an assigned IP address.</li> </ul> <p><b>Note</b> The unnumbered interface must be unique. It cannot be another unnumbered interface.</p> |

|                | Command or Action                                                                                                | Purpose                                                                                                                                                                                                                                |
|----------------|------------------------------------------------------------------------------------------------------------------|----------------------------------------------------------------------------------------------------------------------------------------------------------------------------------------------------------------------------------------|
|                |                                                                                                                  | <b>Caution</b> The <b>ip unnumbered</b> command creates a point-to-point interface between devices. Broadcasting is not supported.                                                                                                     |
| <b>Step 5</b>  | Router (config-if)# <b>no shut</b>                                                                               | Causes the interface to be administratively up.                                                                                                                                                                                        |
| <b>Step 6</b>  | Router (config-if)# <b>end</b>                                                                                   | Exits interface configuration mode.                                                                                                                                                                                                    |
| <b>Step 7</b>  | Use the server’s operating system to configure the E-Series Server’s <b>GE0</b> interface. See the figure above. | —                                                                                                                                                                                                                                      |
| <b>Step 8</b>  | Router (config)# <b>interface ucse slot/1</b>                                                                    | Enters interface configuration mode for the router’s MGF <i>slot/1</i> VLAN interface. See the figure above.                                                                                                                           |
| <b>Step 9</b>  | Router (config-if)# <b>switchport mode trunk</b>                                                                 | Puts the port into permanent trunking mode. The default configuration is access mode.                                                                                                                                                  |
| <b>Step 10</b> | Router (config-if)# [ <b>switchport trunk allowed vlan <i>vlan-numbers</i></b> ]                                 | (Optional) Allows trunking on the specified VLANs. <ul style="list-style-type: none"> <li>• <i>vlan-numbers</i>—VLAN numbers on which to allow trunking.</li> </ul>                                                                    |
| <b>Step 11</b> | Router (config-if)# <b>exit</b>                                                                                  | Exits interface configuration mode.                                                                                                                                                                                                    |
| <b>Step 12</b> | Router# <b>configure terminal</b>                                                                                | Enters global configuration mode on the host router.                                                                                                                                                                                   |
| <b>Step 13</b> | Router (config)# <b>interface vlan <i>vlan-number</i></b>                                                        | Enters interface configuration mode for the specified VLAN number.                                                                                                                                                                     |
| <b>Step 14</b> | Router (config-if)# <b>ip address <i>vlan-ip-address subnet-mask</i></b>                                         | Specifies the IP address for the VLAN. See the figure above. <ul style="list-style-type: none"> <li>• <i>vlan-ip-address</i>—IP address of the VLAN.</li> <li>• <i>subnet-mask</i>—Subnet mask to append to the IP address.</li> </ul> |
| <b>Step 15</b> | Router (config-if)# <b>no shut</b>                                                                               | Causes the interface to be administratively up.                                                                                                                                                                                        |
| <b>Step 16</b> | Router (config-if)# <b>end</b>                                                                                   | Exits interface configuration mode.                                                                                                                                                                                                    |
| <b>Step 17</b> | Use the server’s operating system to configure the E-Series Server’s <b>GE1</b> interface. See figure above.     | —                                                                                                                                                                                                                                      |

### Example

This example shows how to configure an internal connection between the router and the E-Series Server.



**Note** The IP addresses in this configuration example are for reference only and might not be valid.

```

Router> enable
Router# configure terminal

Router(config)# interface ucse 1/0
Router(config-if)# ip address 10.0.0.1 255.0.0.0
Router(config-if)# no shut
Router(config-if)# end

```

Use the server's operating system to configure the E-Series Server's **GE0** interface

```

Router(config)# interface ucse 1/1
Router(config-if)# switchport mode trunk
Router(config-if)# exit

```

```

Router# configure terminal
Router(config)# interface vlan 1
Router(config-if)# ip address 20.0.0.1 255.255.255.0
Router(config-if)# no shut
Router(config-if)# end

```

Use the server's operating system to configure the E-Series Server's **GE1** interface.

## Configuring an Internal Connection Between the Cisco ISR 4000 Series and the E-Series Server

Use this configuration if you want the traffic to your application or operating system to flow through the Cisco ISR 4000 series. To configure an internal connection between the Cisco ISR 4000 series and the E-Series Server, you must configure these IP addresses:

- For traffic to flow through the router's **ucse slot/0/0** and the E-Series Server's internal GE0 interface (see next figure), configure the following:
  - IP address of the router's **ucse slot/0/0** interface that connects the router to the E-Series Server's GE0 interface.
  - IP address of the E-Series Server's GE0 interface.
- For traffic to flow through the router's **ucse slot/0/1** and the E-Series Server's internal GE1 interface (see next figure), configure the following:
  - IP address of the router's **ucse slot/0/1** interface.
  - IP address of the E-Series Server's GE1 interface.

The following figure shows the internal connection between the router and the E-Series Server.

**Figure 40: Internal Connection Between the Cisco ISR 4000 Series and the E-Series Server**

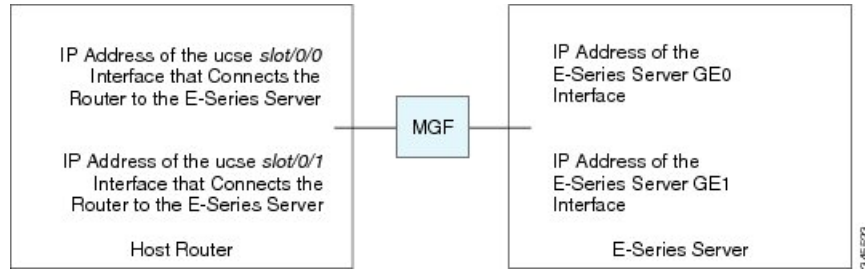

**Procedure**

|               | <b>Command or Action</b>                                                                                                                                                                                                                                                | <b>Purpose</b>                                                                                                                                                                                                                                                                                                                                                                                                                                                                                                                                                                                                                                                                                                                                                                               |
|---------------|-------------------------------------------------------------------------------------------------------------------------------------------------------------------------------------------------------------------------------------------------------------------------|----------------------------------------------------------------------------------------------------------------------------------------------------------------------------------------------------------------------------------------------------------------------------------------------------------------------------------------------------------------------------------------------------------------------------------------------------------------------------------------------------------------------------------------------------------------------------------------------------------------------------------------------------------------------------------------------------------------------------------------------------------------------------------------------|
| <b>Step 1</b> | Router> <b>enable</b>                                                                                                                                                                                                                                                   | Enters privileged EXEC mode on the host router. Enter your password if prompted.                                                                                                                                                                                                                                                                                                                                                                                                                                                                                                                                                                                                                                                                                                             |
| <b>Step 2</b> | Router# <b>configure terminal</b>                                                                                                                                                                                                                                       | Enters global configuration mode on the host router.                                                                                                                                                                                                                                                                                                                                                                                                                                                                                                                                                                                                                                                                                                                                         |
| <b>Step 3</b> | Router (config)# <b>interface ucse slot/0/0</b>                                                                                                                                                                                                                         | Enters interface configuration mode for the router's ucse slot/0/0 interface.                                                                                                                                                                                                                                                                                                                                                                                                                                                                                                                                                                                                                                                                                                                |
| <b>Step 4</b> | Enter one of the following commands: <ul style="list-style-type: none"> <li>• Router (config-if)# <b>ip address</b> <i>router-to-e-series-server-interface-ip-address subnet-mask</i></li> <li>• Router (config-if)# <b>ip unnumbered</b> <i>type number</i></li> </ul> | Specify the IP address of the router's <b>ucse slot 0/0</b> interface that connects the router to the E-Series Server's GE0 interface. See the figure above.<br>or<br>The <b>ip unnumbered</b> command enables IP processing on an interface without assigning an explicit IP address to that interface. <ul style="list-style-type: none"> <li>• <i>type</i>—Type of interface on which the router has an assigned IP address.</li> <li>• <i>number</i>—Number of the interface on which the router has an assigned IP address.</li> </ul> <p><b>Note</b> The unnumbered interface must be unique. It cannot be another unnumbered interface.</p> <p><b>Caution</b> The <b>ip unnumbered</b> command creates a point-to-point interface between devices. Broadcasting is not supported.</p> |
| <b>Step 5</b> | Router (config-if)# <b>no shut</b>                                                                                                                                                                                                                                      | Causes the interface to be administratively up.                                                                                                                                                                                                                                                                                                                                                                                                                                                                                                                                                                                                                                                                                                                                              |

|                | Command or Action                                                                                                | Purpose                                                                                                    |
|----------------|------------------------------------------------------------------------------------------------------------------|------------------------------------------------------------------------------------------------------------|
| <b>Step 6</b>  | Router (config-if)# <b>end</b>                                                                                   | Exits interface configuration mode.                                                                        |
| <b>Step 7</b>  | Use the server's operating system to configure the E-Series Server's <b>GE0</b> interface. See the figure above. | —                                                                                                          |
| <b>Step 8</b>  | Router (config)# <b>interface ucse slot/0/1</b>                                                                  | Enters interface configuration mode for the router's <b>ucse slot/0/1</b> interface. See the figure above. |
| <b>Step 9</b>  | Router (config-if)# <b>no shut</b>                                                                               | Causes the interface to be administratively up.                                                            |
| <b>Step 10</b> | Router (config-if)# <b>end</b>                                                                                   | Exits interface configuration mode.                                                                        |
| <b>Step 11</b> | Use the server's operating system to configure the E-Series Server's <b>GE1</b> interface. See the figure above. | —                                                                                                          |

### Example

This example shows how to configure an internal connection between the router and the E-Series Server.



**Note** The IP addresses in this configuration example are for reference only and might not be valid.

```
Router> enable
Router# configure terminal

Router(config)# interface ucse 1/0/0
Router(config-if)# ip address 10.0.0.1 255.0.0.0
Router(config-if)# no shut
Router(config-if)# end
```

Use the server's operating system to configure the E-Series Server's **GE0** interface.

```
Router(config)# interface ucse 1/0/1
Router(config-if)# ip address 11.0.0.1 255.255.255.0
Router(config-if)# no shut
Router(config-if)# end
```

Use the server's operating system to configure the E-Series Server's **GE1** interface.

## Creating an Ethernet Virtual Circuit Between the E-Series Server and the Cisco ISR 4000 Series Using the Native VLAN

Use this procedure if you have added the native VLAN to encapsulate and transport selected data either to the operating system installed on the E-Series Server, or to the virtual machines created on the installed hypervisor.

**Before you begin**

Configure an internal connection between the Cisco ISR 4000 series and the E-Series Server.

**Procedure**

|                | <b>Command or Action</b>                                                                   | <b>Purpose</b>                                                                                          |
|----------------|--------------------------------------------------------------------------------------------|---------------------------------------------------------------------------------------------------------|
| <b>Step 1</b>  | Router> <b>enable</b>                                                                      | Enters privileged EXEC mode on the host router. Enter your password if prompted.                        |
| <b>Step 2</b>  | Router# <b>configure terminal</b>                                                          | Enters global configuration mode on the host router.                                                    |
| <b>Step 3</b>  | Router (config)# <b>interface ucse slot/0/0</b>                                            | Enters interface configuration mode for the router's ucse <i>slot/0/0</i> interface.                    |
| <b>Step 4</b>  | Router (config-if)# <b>service instance id ethernet</b>                                    | Configures an Ethernet service instance on an interface and enters Ethernet service configuration mode. |
| <b>Step 5</b>  | Router (config-if-srv)# <b>encapsulation encapsulation-type vlan-id</b>                    | Defines the encapsulation type.                                                                         |
| <b>Step 6</b>  | Router (config-if-srv)# <b>bridge-domain bridge-id</b>                                     | Configures the bridge domain.                                                                           |
| <b>Step 7</b>  | Router (config-if-srv)# <b>exit</b>                                                        | Exits Ethernet service configuration mode.                                                              |
| <b>Step 8</b>  | Router (config-if)# <b>interface BDI bridge-id</b>                                         | Enters the bridge domain interface.                                                                     |
| <b>Step 9</b>  | Router (config-if)# <b>ip address bdi-interface-ip-address</b>                             | Specifies the IP address of the BDI interface.                                                          |
| <b>Step 10</b> | Router (config-if)# <b>no shut</b>                                                         | Causes the interface to be administratively up.                                                         |
| <b>Step 11</b> | Router (config-if)# <b>end</b>                                                             | Returns to global configuration mode on the host router.                                                |
| <b>Step 12</b> | Use the server's operating system to configure the E-Series Server's <b>GE0</b> interface. | —                                                                                                       |

**Example**

This example shows how to create an Ethernet Virtual Circuit using the native VLAN between the E-Series Server and the Cisco ISR 4000 series.



**Note** The IP addresses in this configuration example are for reference only.

```
Router> enable
Router# configure terminal
```

```

Router(config)# interface ucse 1/0/0
Router(config-if)# service instance 1 ethernet
Router(config-if-srv)# encapsulation untagged
Router(config-if-srv)# bridge-domain 1
Router(config-if-srv)# exit
Router(config-if)# exit

Router(config-if)# interface BDI 1
Router(config-if)# ip address 10.0.0.1 255.0.0.0
Router(config-if)# no shut
Router(config-if)# end

```

Use the server's operating system to configure the E-Series Server's **GE0** interface.

## Creating an Ethernet Virtual Circuit Between the E-Series Server and the Cisco ISR 4000 Series Using a Non-Native VLAN

Use this procedure if you have added a non-native VLAN to encapsulate and transport selected data either to the operating system installed on the E-Series Server, or to the virtual machines created on the installed hypervisor.

### Before you begin

Configure an internal connection between the E-Series Server and the Cisco ISR 4000 series.

### Procedure

|               | Command or Action                                                             | Purpose                                                                                                                          |
|---------------|-------------------------------------------------------------------------------|----------------------------------------------------------------------------------------------------------------------------------|
| <b>Step 1</b> | Router> <b>enable</b>                                                         | Enters privileged EXEC mode on the host router. Enter your password if prompted.                                                 |
| <b>Step 2</b> | Router# <b>configure terminal</b>                                             | Enters global configuration mode on the host router.                                                                             |
| <b>Step 3</b> | Router (config)# <b>interface ucse slot/0/0</b>                               | Enters interface configuration mode for the router's <b>ucse slot/0/0</b> interface.                                             |
| <b>Step 4</b> | Router (config-if)# <b>no ip address</b>                                      | Removes an IP address or disables IP processing.                                                                                 |
| <b>Step 5</b> | Router (config-if)# <b>no negotiation auto</b>                                | Disables automatic negotiation on the interface.                                                                                 |
| <b>Step 6</b> | Router (config-if)# <b>switchport mode trunk</b>                              | Puts the port into permanent trunking mode.                                                                                      |
| <b>Step 7</b> | Router (config-if)# <b>service instance id ethernet</b>                       | Configures an Ethernet service instance on an interface and enters Ethernet service configuration mode.                          |
| <b>Step 8</b> | Router (config-if-srv)# <b>encapsulation dot1q encapsulation-type vlan-id</b> | Defines the encapsulation type.                                                                                                  |
| <b>Step 9</b> | Enter one of the following commands:                                          | <ul style="list-style-type: none"> <li>• The <b>rewrite egress tag push dot1q</b> command specifies the encapsulation</li> </ul> |



|                | Command or Action                                                                                                                                                                                                                                    | Purpose                                                                                                                                                                                                                                                                                                |
|----------------|------------------------------------------------------------------------------------------------------------------------------------------------------------------------------------------------------------------------------------------------------|--------------------------------------------------------------------------------------------------------------------------------------------------------------------------------------------------------------------------------------------------------------------------------------------------------|
|                | <ul style="list-style-type: none"> <li>• Router (config-if-srv)# <b>rewrite egress tag push dot1q encapsulation-type vlan-id</b></li> <li>• Router (config-if-srv)# <b>rewrite ingress tag pop 1 symmetric encapsulation-type vlan-id</b></li> </ul> | <p>adjustment to be performed on a frame that is egressing a service instance.</p> <ul style="list-style-type: none"> <li>• The <b>rewrite ingress tag pop 1 symmetric</b> command specifies the encapsulation adjustment to be performed on a frame that is ingressing a service instance.</li> </ul> |
| <b>Step 10</b> | Router (config-if-srv)# <b>bridge-domain bridge-id</b>                                                                                                                                                                                               | Configures the bridge domain.                                                                                                                                                                                                                                                                          |
| <b>Step 11</b> | Router (config-if-srv)# <b>exit</b>                                                                                                                                                                                                                  | Exits Ethernet service configuration mode.                                                                                                                                                                                                                                                             |
| <b>Step 12</b> | Router (config-if)# <b>exit</b>                                                                                                                                                                                                                      | Exits interface configuration mode.                                                                                                                                                                                                                                                                    |
| <b>Step 13</b> | Router (config)# <b>interface BDI bridge-id</b>                                                                                                                                                                                                      | Enters the bridge domain interface.                                                                                                                                                                                                                                                                    |
| <b>Step 14</b> | Router (config-if)# <b>ip address bdi-interface-ip-address</b>                                                                                                                                                                                       | Specifies the IP address of the BDI interface.                                                                                                                                                                                                                                                         |
| <b>Step 15</b> | Router (config-if)# <b>no shut</b>                                                                                                                                                                                                                   | Causes the interface to be administratively up.                                                                                                                                                                                                                                                        |
| <b>Step 16</b> | Router (config-if)# <b>end</b>                                                                                                                                                                                                                       | Returns to global configuration mode on the host router.                                                                                                                                                                                                                                               |
| <b>Step 17</b> | Use the server's operating system to configure the E-Series Server's <b>NIC</b> interface.                                                                                                                                                           | —                                                                                                                                                                                                                                                                                                      |
| <b>Step 18</b> | Router# <b>ping server's-NIC-interface</b>                                                                                                                                                                                                           | Shows if connection is established with the E-Series Server's <b>NIC</b> interface.                                                                                                                                                                                                                    |
| <b>Step 19</b> | Router# <b>show arp</b>                                                                                                                                                                                                                              | Displays the Access Resolution Protocol (ARP) cache.                                                                                                                                                                                                                                                   |
| <b>Step 20</b> | Router# <b>show bridge-domain bridge-id</b>                                                                                                                                                                                                          | Displays bridge domain information.                                                                                                                                                                                                                                                                    |

### Example

This example shows how to create an Ethernet virtual circuit using a non-native VLAN between the E-Series Server and the Cisco ISR 4000 series.



**Note** The IP addresses in this configuration example are for reference only.

```
Router> enable
Router# configure terminal
Router(config)# interface ucse 2/0/0
Router(config-if)# no ip address
Router(config-if)# no negotiation auto
Router(config-if)# switchport mode trunk
```

```

Router(config-if)# service instance 10 ethernet
Router(config-if-srv)# encapsulation dot1q 10
Router(config-if-srv)# rewrite egress tag push dot1q 10
Router(config-if-srv)# bridge-domain 10
Router(config-if-srv)# exit
Router(config-if)# exit

Router(config)# interface BDI10
Router(config-if)# ip address 192.168.1.1 255.255.255.0
Router(config-if)# no shut
Router(config-if)# end

```

Use the server's operating system to configure the E-Series Server's **NIC** interface.

```

Router# ping 192.168.1.2
Type escape sequence to abort.
Sending 5, 100-byte ICMP Echos to 192.168.1.2, timeout is 2 seconds:
!!!!
Success rate is 100 percent (5/5), round-trip min/avg/max = 1/1/2 ms

```

```

Router# show arp

```

| Protocol | Address     | Age (min) | Hardware Addr  | Type | Interface |
|----------|-------------|-----------|----------------|------|-----------|
| Internet | 192.168.1.1 | -         | 0022.bdfb.2783 | ARPA | BDI10     |
| Internet | 192.168.1.2 | 1         | 0022.bde6.07b4 | ARPA | BDI10     |

```

Router# show bridge-domain 10
Bridge-domain 10 (2 ports in all)
State: UP           Mac learning: Enabled
Aging-Timer: 300 second(s)
  BDI10 (up)
    ucse2/0/0 service instance 10
MAC address  Policy  Tag    Age  Pseudoport
0022.BDE6.07B4 forward dynamic 246 ucse2/0/0.EFP10
0022.BDFB.2783 to_bdi static 0 BDI10

```



**Note** For additional details about the **rewrite** commands, see <http://www.cisco.com/en/US/docs/ios-xml/ios/cether/command/ce-cr-book.html>.

## Configuring an Internal Connection Between the Cisco ISR G2 and the EHWIC E-Series NCE

Use this configuration if you want the traffic to your application or operating system to flow through the Cisco ISR G2. To configure an internal connection between the Cisco ISR G2 and the EHWIC E-Series NCE, you must configure these IP addresses:

- For traffic to flow through the EHWIC connection (see next figure), configure the following:
  - IP address of the router's internal EHWIC interface that connects the router to the EHWIC E-Series NCE's GE0 interface.
  - IP address of the EHWIC E-Series NCE's GE0 interface.
- For traffic to flow through the MGF connection (see next figure), configure the following:



**Important** The MGF connection option is not applicable to the Cisco 1921 ISR G2.

- IP address of the router's internal MGF VLAN interface.
- IP address of the EHWIC E-Series NCE's GE1 interface.

The following figure shows the internal connection between the router and the EHWIC E-Series NCE.

**Figure 41: Internal Connection Between the Cisco ISR G2 and the EHWIC E-Series NCE**

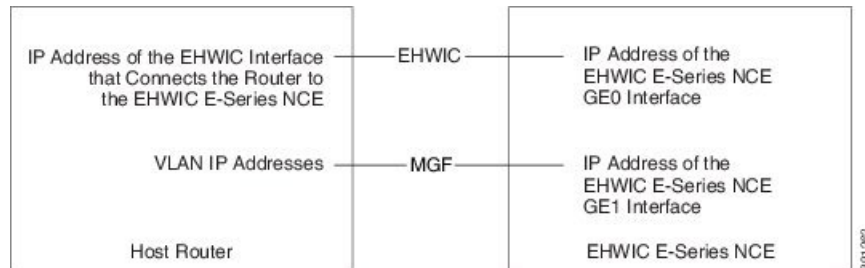

**Procedure**

|               | <b>Command or Action</b>                                                                                                                                                                                                                                                              | <b>Purpose</b>                                                                                                                                                                                                                                                                                                                                                                                                                                                                                                                                                                         |
|---------------|---------------------------------------------------------------------------------------------------------------------------------------------------------------------------------------------------------------------------------------------------------------------------------------|----------------------------------------------------------------------------------------------------------------------------------------------------------------------------------------------------------------------------------------------------------------------------------------------------------------------------------------------------------------------------------------------------------------------------------------------------------------------------------------------------------------------------------------------------------------------------------------|
| <b>Step 1</b> | Router> <b>enable</b>                                                                                                                                                                                                                                                                 | Enters privileged EXEC mode on the host router. Enter your password if prompted.                                                                                                                                                                                                                                                                                                                                                                                                                                                                                                       |
| <b>Step 2</b> | Router# <b>configure terminal</b>                                                                                                                                                                                                                                                     | Enters global configuration mode on the host router.                                                                                                                                                                                                                                                                                                                                                                                                                                                                                                                                   |
| <b>Step 3</b> | Router (config)# <b>interface ucse 0/subslot/0</b>                                                                                                                                                                                                                                    | Enters interface configuration mode for the router's EHWIC 0/subslot/0 interface.                                                                                                                                                                                                                                                                                                                                                                                                                                                                                                      |
| <b>Step 4</b> | Enter one of the following commands: <ul style="list-style-type: none"> <li>• Router (config-if)# <b>ip address</b> <i>router-to-e-series-server-interface-ip-address</i> <i>subnet-mask</i></li> <li>• Router (config-if)# <b>ip unnumbered</b> <i>type</i> <i>number</i></li> </ul> | <p>The <b>ip address</b> command specifies the IP address of the router's internal PCIe interface that connects the router to the EHWIC E-Series NCE's GE0 interface. See the figure above.</p> <p>or</p> <p>The <b>ip unnumbered</b> command enables IP processing on an interface without assigning an explicit IP address to that interface.</p> <ul style="list-style-type: none"> <li>• <i>type</i>—Type of interface on which the router has an assigned IP address.</li> <li>• <i>number</i>—Number of the interface on which the router has an assigned IP address.</li> </ul> |

|                | Command or Action                                                                                                   | Purpose                                                                                                                                                                                                                                          |
|----------------|---------------------------------------------------------------------------------------------------------------------|--------------------------------------------------------------------------------------------------------------------------------------------------------------------------------------------------------------------------------------------------|
|                |                                                                                                                     | <p><b>Note</b> The unnumbered interface must be unique. It cannot be another unnumbered interface.</p> <p><b>Caution</b> The <b>ip unnumbered</b> command creates a point-to-point interface between devices. Broadcasting is not supported.</p> |
| <b>Step 5</b>  | Router (config-if)# <b>no shut</b>                                                                                  | Causes the interface to be administratively up.                                                                                                                                                                                                  |
| <b>Step 6</b>  | Router (config-if)# <b>end</b>                                                                                      | Exits interface configuration mode.                                                                                                                                                                                                              |
| <b>Step 7</b>  | Use the server's operating system to configure the EHWIC E-Series NCE's <b>GE0</b> interface. See the figure above. | —                                                                                                                                                                                                                                                |
| <b>Step 8</b>  | Router (config)# <b>interface ucse 0/subslot/1</b>                                                                  | <p>Enters interface configuration mode for the router's MGF <b>0/subslot/1</b> VLAN interface. See the figure above.</p> <p><b>Important</b> This step is not applicable to the Cisco ISR 1921.</p>                                              |
| <b>Step 9</b>  | Router (config-if)# <b>switchport mode trunk</b>                                                                    | Puts the port into permanent trunking mode. The default configuration is access mode.                                                                                                                                                            |
| <b>Step 10</b> | Router (config-if)# [ <b>switchport trunk allowed vlan <i>vlan-numbers</i></b> ]                                    | <p>(Optional) Allows trunking on the specified VLANs.</p> <ul style="list-style-type: none"> <li>• <i>vlan-numbers</i>—VLAN numbers on which to allow trunking.</li> </ul>                                                                       |
| <b>Step 11</b> | Router (config-if)# <b>end</b>                                                                                      | Exits interface configuration mode.                                                                                                                                                                                                              |
| <b>Step 12</b> | Router# <b>configure terminal</b>                                                                                   | Enters global configuration mode on the host router.                                                                                                                                                                                             |
| <b>Step 13</b> | Router (config)# <b>interface vlan <i>vlan-number</i></b>                                                           | Enters interface configuration mode for the specified VLAN number.                                                                                                                                                                               |
| <b>Step 14</b> | Router (config-if)# <b>ip address <i>vlan-ip-address subnet-mask</i></b>                                            | <p>Specifies the IP address for the VLAN. See the figure above.</p> <ul style="list-style-type: none"> <li>• <i>vlan-ip-address</i>—IP address of the VLAN.</li> <li>• <i>subnet-mask</i>—Subnet mask to append to the IP address.</li> </ul>    |
| <b>Step 15</b> | Router (config-if)# <b>no shut</b>                                                                                  | Causes the interface to be administratively up.                                                                                                                                                                                                  |

|                | Command or Action                                                                                                   | Purpose                                                                |
|----------------|---------------------------------------------------------------------------------------------------------------------|------------------------------------------------------------------------|
| <b>Step 16</b> | Router (config-if)# <b>end</b>                                                                                      | Exits interface configuration mode.                                    |
| <b>Step 17</b> | Use the server's operating system to configure the EHWIC E-Series NCE's <b>GE1</b> interface. See the figure above. | <b>Important</b> This step is not applicable to the Cisco 1921 ISR G2. |

### Example

This example shows how to configure an internal connection between the router and the EHWIC E-Series NCE.



**Note** The IP addresses in this configuration example are for reference only and might not be valid.

```
Router> enable
Router# configure terminal

Router(config)# interface ucse 0/1/0
Router(config-if)# ip address 10.0.0.1 255.0.0.0
Router(config-if)# no shut
Router(config-if)# end
```

Use the server's operating system to configure the E-Series Server's **GE0** interface

```
Router(config)# interface ucse 0/1/1
Router(config-if)# switchport mode trunk
Router(config-if)# end

Router# configure terminal
Router(config)# interface vlan 1
Router(config-if)# ip address 20.0.0.1 255.255.255.0
Router(config-if)# no shut
Router(config-if)# end
```

Use the server's operating system to configure the E-Series Server's **GE1** interface.

## Configuring an Internal Connection Between the Cisco ISR 4000 Series and the NIM E-Series NCE

Use this configuration if you want the traffic to your application or operating system to flow through the Cisco ISR 4000 series. To configure an internal connection between the Cisco ISR 4000 series and the NIM E-Series NCE, you must configure these IP addresses:

- For traffic to flow through the router's **ucse 0/subslot/0** and the server's internal **GE0** interface (see next figure), configure the following:
  - IP address of the router's **ucse 0/subslot/0** interface that connects the router to the server's **GE0** interface.

- IP address of the server's GE0 interface.
- For traffic to flow through the router's **ucse 0/subslot/1** and the server's internal GE1 interface (see next figure), configure the following:
  - IP address of the router's **ucse 0/subslot/1** interface.
  - IP address of the server's GE1 interface.

The following figure shows the internal connection between the router and the server.

**Figure 42: Internal Connection Between the Cisco ISR 4000 Series and the NIM E-Series NCE**

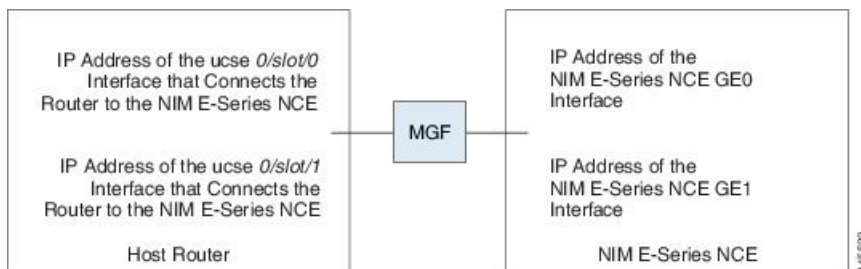

**Procedure**

|               | Command or Action                                                                                                                                                                                                                                                | Purpose                                                                                                                                                                                                                                                                                                                                                                                                                                                                                                                               |
|---------------|------------------------------------------------------------------------------------------------------------------------------------------------------------------------------------------------------------------------------------------------------------------|---------------------------------------------------------------------------------------------------------------------------------------------------------------------------------------------------------------------------------------------------------------------------------------------------------------------------------------------------------------------------------------------------------------------------------------------------------------------------------------------------------------------------------------|
| <b>Step 1</b> | Router> <b>enable</b>                                                                                                                                                                                                                                            | Enters privileged EXEC mode on the host router. Enter your password if prompted.                                                                                                                                                                                                                                                                                                                                                                                                                                                      |
| <b>Step 2</b> | Router# <b>configure terminal</b>                                                                                                                                                                                                                                | Enters global configuration mode on the host router.                                                                                                                                                                                                                                                                                                                                                                                                                                                                                  |
| <b>Step 3</b> | Router (config)# <b>interface ucse 0/subslot/0</b>                                                                                                                                                                                                               | Enters interface configuration mode for the router's <b>ucse 0/subslot/0</b> interface.                                                                                                                                                                                                                                                                                                                                                                                                                                               |
| <b>Step 4</b> | Enter one of the following commands: <ul style="list-style-type: none"> <li>• Router (config-if)# <b>ip address</b> <i>router-to-e-series-server-interface-ip-address subnet-mask</i></li> <li>• Router (config-if)# <b>ip unnumbered type number</b></li> </ul> | Specify the IP address of the router's <b>ucse 0/subslot/0</b> interface that connects the router to the server's GE0 interface. See the figure above.<br>or<br>The <b>ip unnumbered</b> command enables IP processing on an interface without assigning an explicit IP address to that interface. <ul style="list-style-type: none"> <li>• <i>type</i>—Type of interface on which the router has an assigned IP address.</li> <li>• <i>number</i>—Number of the interface on which the router has an assigned IP address.</li> </ul> |

|                | Command or Action                                                                                       | Purpose                                                                                                                                                                                                                                          |
|----------------|---------------------------------------------------------------------------------------------------------|--------------------------------------------------------------------------------------------------------------------------------------------------------------------------------------------------------------------------------------------------|
|                |                                                                                                         | <p><b>Note</b> The unnumbered interface must be unique. It cannot be another unnumbered interface.</p> <p><b>Caution</b> The <b>ip unnumbered</b> command creates a point-to-point interface between devices. Broadcasting is not supported.</p> |
| <b>Step 5</b>  | Router (config-if)# <b>no shut</b>                                                                      | Causes the interface to be administratively up.                                                                                                                                                                                                  |
| <b>Step 6</b>  | Router (config-if)# <b>end</b>                                                                          | Exits interface configuration mode.                                                                                                                                                                                                              |
| <b>Step 7</b>  | Use the server's operating system to configure the server's <b>GE0</b> interface. See the figure above. | —                                                                                                                                                                                                                                                |
| <b>Step 8</b>  | Router (config)# <b>interface ucse 0/subslot/1</b>                                                      | Enters interface configuration mode for the router's <b>ucse 0/subslot/1</b> interface.                                                                                                                                                          |
| <b>Step 9</b>  | Router (config-if)# <b>no shut</b>                                                                      | Causes the interface to be administratively up.                                                                                                                                                                                                  |
| <b>Step 10</b> | Router (config-if)# <b>end</b>                                                                          | Exits interface configuration mode.                                                                                                                                                                                                              |
| <b>Step 11</b> | Use the server's operating system to configure the server's <b>GE1</b> interface. See the figure above. | —                                                                                                                                                                                                                                                |

### Example

This example shows how to configure an internal connection between the router and the NIM E-Series NCE.



**Note** The IP addresses in this configuration example are for reference only and might not be valid.

```
Router> enable
Router# configure terminal

Router(config)# interface ucse 0/1/0
Router(config-if)# ip address 10.0.0.1 255.0.0.0
Router(config-if)# no shut
Router(config-if)# end
```

Use the server's operating system to configure the NIM E-Series NCE's **GE0** interface.

```
Router(config)# interface ucse 0/1/1
Router(config-if)# ip address 11.0.0.1 255.255.255.0
Router(config-if)# no shut
Router(config-if)# end
```

Use the server's operating system to configure the NIM E-Series NCE's **GE1** interface.

## Creating an Ethernet Virtual Circuit Between the NIM E-Series NCE and the Cisco ISR 4000 Series Using the Native VLAN

Use this procedure if you have added the native VLAN to encapsulate and transport selected data either to the operating system installed on the E-Series Server, or to the virtual machines created on the installed hypervisor.

### Before you begin

Configure an internal connection between the Cisco ISR 4000 series and the NIM E-Series NCE.

### Procedure

|                | Command or Action                                                                           | Purpose                                                                                                 |
|----------------|---------------------------------------------------------------------------------------------|---------------------------------------------------------------------------------------------------------|
| <b>Step 1</b>  | Router> <b>enable</b>                                                                       | Enters privileged EXEC mode on the host router. Enter your password if prompted.                        |
| <b>Step 2</b>  | Router# <b>configure terminal</b>                                                           | Enters global configuration mode on the host router.                                                    |
| <b>Step 3</b>  | Router (config)# <b>interface ucse 0/subslot0</b>                                           | Enters interface configuration mode for the router's <b>0/subslot0</b> interface.                       |
| <b>Step 4</b>  | Router (config-if)# <b>service instance id ethernet</b>                                     | Configures an Ethernet service instance on an interface and enters Ethernet service configuration mode. |
| <b>Step 5</b>  | Router (config-if-srv)# <b>encapsulation encapsulation-type vlan-id</b>                     | Defines the encapsulation type.                                                                         |
| <b>Step 6</b>  | Router (config-if-srv)# <b>bridge-domain bridge-id</b>                                      | Configures the bridge domain.                                                                           |
| <b>Step 7</b>  | Router (config-if-srv)# <b>exit</b>                                                         | Exits Ethernet service configuration mode.                                                              |
| <b>Step 8</b>  | Router (config-if)# <b>interface BDI bridge-id</b>                                          | Enters the bridge domain interface.                                                                     |
| <b>Step 9</b>  | Router (config-if)# <b>ip address bdi-interface-ip-address</b>                              | Specifies the IP address of the BDI interface.                                                          |
| <b>Step 10</b> | Router (config-if)# <b>no shut</b>                                                          | Causes the interface to be administratively up.                                                         |
| <b>Step 11</b> | Router (config-if)# <b>end</b>                                                              | Returns to global configuration mode on the host router.                                                |
| <b>Step 12</b> | Use the server's operating system to configure the NIM E-Series NCE's <b>GE0</b> interface. | —                                                                                                       |



### Example

This example shows how to create an Ethernet Virtual Circuit using the native VLAN between the NIM E-Series NCE and the Cisco ISR 4000 series.



**Note** The IP addresses in this configuration example are for reference only.

```

Router> enable
Router# configure terminal

Router(config)# interface ucse 0/1/0
Router(config-if)# service instance 1 ethernet
Router(config-if-srv)# encapsulation untagged
Router(config-if-srv)# bridge-domain 1
Router(config-if-srv)# exit
Router(config-if)# exit

Router(config-if)# interface BDI 1
Router(config-if)# ip address 10.0.0.1 255.0.0.0
Router(config-if)# no shut
Router(config-if)# end

```

Use the server's operating system to configure the NIM E-Series NCE's **GE0** interface.

## Creating an Ethernet Virtual Circuit Between the NIM E-Series NCE and the Cisco ISR 4000 Series Using a Non-Native VLAN

Use this procedure if you have added a non-native VLAN to encapsulate and transport selected data either to the operating system installed on the NIM E-Series NCE, or to the virtual machines created on the installed hypervisor.

### Before you begin

Configure an internal connection between the Cisco ISR 4000 series and the NIM E-Series NCE.

### Procedure

|               | Command or Action                                  | Purpose                                                                          |
|---------------|----------------------------------------------------|----------------------------------------------------------------------------------|
| <b>Step 1</b> | Router> <b>enable</b>                              | Enters privileged EXEC mode on the host router. Enter your password if prompted. |
| <b>Step 2</b> | Router# <b>configure terminal</b>                  | Enters global configuration mode on the host router.                             |
| <b>Step 3</b> | Router (config)# <b>interface ucse 0/subslot/0</b> | Enters interface configuration mode for the router's ucse 0/subslot/0 interface. |
| <b>Step 4</b> | Router (config-if)# <b>no ip address</b>           | Removes an IP address or disables IP processing.                                 |

|                | Command or Action                                                                                                                                                                                                                                                                         | Purpose                                                                                                                                                                                                                                                                                                                                                                                 |
|----------------|-------------------------------------------------------------------------------------------------------------------------------------------------------------------------------------------------------------------------------------------------------------------------------------------|-----------------------------------------------------------------------------------------------------------------------------------------------------------------------------------------------------------------------------------------------------------------------------------------------------------------------------------------------------------------------------------------|
| <b>Step 5</b>  | Router (config-if)# <b>no negotiation auto</b>                                                                                                                                                                                                                                            | Disables automatic negotiation on the interface.                                                                                                                                                                                                                                                                                                                                        |
| <b>Step 6</b>  | Router (config-if)# <b>switchport mode trunk</b>                                                                                                                                                                                                                                          | Puts the port into permanent trunking mode.                                                                                                                                                                                                                                                                                                                                             |
| <b>Step 7</b>  | Router (config-if)# <b>service instance id ethernet</b>                                                                                                                                                                                                                                   | Configures an Ethernet service instance on an interface and enters Ethernet service configuration mode.                                                                                                                                                                                                                                                                                 |
| <b>Step 8</b>  | Router (config-if-srv)# <b>encapsulation dot1q encapsulation-type vlan-id</b>                                                                                                                                                                                                             | Defines the encapsulation type.                                                                                                                                                                                                                                                                                                                                                         |
| <b>Step 9</b>  | Enter one of the following commands: <ul style="list-style-type: none"> <li>• Router (config-if-srv)# <b>rewrite egress tag push dot1q encapsulation-type vlan-id</b></li> <li>• Router (config-if-srv)# <b>rewrite ingress tag pop 1 symmetric encapsulation-type vlan-id</b></li> </ul> | <ul style="list-style-type: none"> <li>• The <b>rewrite egress tag push dot1q</b> command specifies the encapsulation adjustment to be performed on a frame that is egressing a service instance.</li> <li>• The <b>rewrite ingress tag pop 1 symmetric</b> command specifies the encapsulation adjustment to be performed on a frame that is ingressing a service instance.</li> </ul> |
| <b>Step 10</b> | Router (config-if-srv)# <b>bridge-domain bridge-id</b>                                                                                                                                                                                                                                    | Configures the bridge domain.                                                                                                                                                                                                                                                                                                                                                           |
| <b>Step 11</b> | Router (config-if-srv)# <b>exit</b>                                                                                                                                                                                                                                                       | Exits Ethernet service configuration mode.                                                                                                                                                                                                                                                                                                                                              |
| <b>Step 12</b> | Router (config-if)# <b>exit</b>                                                                                                                                                                                                                                                           | Exits interface configuration mode.                                                                                                                                                                                                                                                                                                                                                     |
| <b>Step 13</b> | Router (config)# <b>interface BDI bridge-id</b>                                                                                                                                                                                                                                           | Enters the bridge domain interface.                                                                                                                                                                                                                                                                                                                                                     |
| <b>Step 14</b> | Router (config-if)# <b>ip address bdi-interface-ip-address</b>                                                                                                                                                                                                                            | Specifies the IP address of the BDI interface.                                                                                                                                                                                                                                                                                                                                          |
| <b>Step 15</b> | Router (config-if)# <b>no shut</b>                                                                                                                                                                                                                                                        | Causes the interface to be administratively up.                                                                                                                                                                                                                                                                                                                                         |
| <b>Step 16</b> | Router (config-if)# <b>end</b>                                                                                                                                                                                                                                                            | Returns to global configuration mode on the host router.                                                                                                                                                                                                                                                                                                                                |
| <b>Step 17</b> | Use the server's operating system to configure the NIM E-Series NCE's NIC interface.                                                                                                                                                                                                      | —                                                                                                                                                                                                                                                                                                                                                                                       |
| <b>Step 18</b> | Router# <b>ping server's-NIC-interface</b>                                                                                                                                                                                                                                                | Shows if connection is established with the NIM E-Series NCE's NIC interface.                                                                                                                                                                                                                                                                                                           |
| <b>Step 19</b> | Router# <b>show arp</b>                                                                                                                                                                                                                                                                   | Displays the Access Resolution Protocol (ARP) cache.                                                                                                                                                                                                                                                                                                                                    |
| <b>Step 20</b> | Router# <b>show bridge-domain bridge-id</b>                                                                                                                                                                                                                                               | Displays bridge domain information.                                                                                                                                                                                                                                                                                                                                                     |

## Example

This example shows how to create an Ethernet virtual circuit using a non-native VLAN between the NIM E-Series NCE and the Cisco ISR 4000 series.



**Note** The IP addresses in this configuration example are for reference only.

```
Router> enable
Router# configure terminal
Router(config)# interface ucse 0/1/0
Router(config-if)# no ip address
Router(config-if)# no negotiation auto
Router(config-if)# switchport mode trunk
Router(config-if)# service instance 10 ethernet
Router(config-if-srv)# encapsulation dot1q 10
Router(config-if-srv)# rewrite egress tag push dot1q 10
Router(config-if-srv)# bridge-domain 10
Router(config-if-srv)# exit
Router(config-if)# exit

Router(config)# interface BDI10
Router(config-if)# ip address 192.168.1.1 255.255.255.0
Router(config-if)# no shut
Router(config-if)# end
```

Use the server's operating system to configure the NIM E-Series NCE's **NIC** interface.

```
Router# ping 192.168.1.2
Type escape sequence to abort.
Sending 5, 100-byte ICMP Echos to 192.168.1.2, timeout is 2 seconds:
!!!!
Success rate is 100 percent (5/5), round-trip min/avg/max = 1/1/2 ms

Router# show arp
Protocol Address          Age (min)  Hardware Addr  Type   Interface
Internet 192.168.1.1          -         0022.bdfb.2783  ARPA   BDI10
Internet 192.168.1.2          1         0022.bde6.07b4  ARPA   BDI10

Router# show bridge-domain 10
Bridge-domain 10 (2 ports in all)
State: UP                               Mac learning: Enabled
Aging-Timer: 300 second(s)
  BDI10 (up)
  ucse2/0/0 service instance 10
  MAC address Policy Tag   Age Pseudoport
  0022.BDE6.07B4 forward dynamic 246 ucse2/0/0.EFP10
  0022.BDFB.2783 to_bdi static 0   BDI10
```



**Note** For additional details about the **rewrite** commands, see <http://www.cisco.com/en/US/docs/ios-xml/ios/ce/ether/command/ce-cr-book.html>.

# Understanding Network Interface Mapping

This section shows you how to determine the network interface mapping for the following devices:

- E-Series Server's GE0, GE1, GE2, and GE3 interfaces—Cisco ISR G2
- E-Series Server's GE0, GE1, GE2, and GE3 interfaces—Cisco ISR 4000 series
- EHWIC E-Series NCE's GE0, GE1, and GE2 interfaces—Cisco ISR G2
- NIM E-Series NCE's GE0, GE1, and GE2 interfaces—Cisco ISR 4000 series
- NetXtreme II 1 Gigabit Server (PCIe Card)
- NetXtreme II 10 Gigabit Server (PCIe Card)

## Determining Network Interface Mapping for the E-Series Server's GE0, GE1, GE2, and GE3 Interfaces—Cisco ISR G2

You can determine the port numbering of the E-Series Server by looking at the MAC addresses of the network interfaces. Note the following:

- The lowest numbered MAC address corresponds to the E-Series Server's GE0 interface.
- The second lowest MAC address corresponds to the E-Series Server's GE1 interface.
- The third lowest MAC address corresponds to the E-Series Server's GE2 interface.
- The fourth lowest MAC address corresponds to the E-Series Server's GE3 interface.



### Note

To determine the MAC address of an interface, see the [Determining the MAC Address in Microsoft Windows, Linux, and VMware vSphere Hypervisor , on page 132](#) section, or the appropriate platform documentation.

## Determining Network Interface Mapping for the E-Series Server's GE0, GE1, GE2, and GE3 Interfaces—Cisco ISR 4000 series

You can determine the port numbering of the E-Series Server by looking at the MAC addresses of the network interfaces. Note the following:

- The lowest numbered MAC address corresponds to the E-Series Server's GE0 interface.
- The second lowest MAC address corresponds to the E-Series Server's GE1 interface.
- The third lowest MAC address corresponds to the E-Series Server's GE2 interface.
- The fourth lowest MAC address corresponds to the E-Series Server's GE3 interface.



### Note

To determine the MAC address of an interface, see the [Determining the MAC Address in Microsoft Windows, Linux, and VMware vSphere Hypervisor , on page 132](#) section, or the appropriate platform documentation.

### Determining Network Interface Mapping for the EHWIC E-Series NCE's GE0, GE1, and GE2 Interfaces—Cisco ISR G2

You can determine the port numbering of the EHWIC E-Series NCE by looking at the MAC addresses of the network interfaces. Note the following:

- The lowest numbered MAC address corresponds to the EHWIC E-Series NCE's GE0 interface.
- The second lowest MAC address corresponds to the EHWIC E-Series NCE's GE1 interface.
- The third lowest MAC address corresponds to the EHWIC E-Series NCE's GE2 interface.



---

**Note** To determine the MAC address of an interface, see the [Determining the MAC Address in Microsoft Windows, Linux, and VMware vSphere Hypervisor](#), on page 132 section, or the appropriate platform documentation.

---

### Determining Network Interface Mapping for the NIM E-Series NCE's GE0, GE1, and GE2 Interfaces—Cisco ISR 4000 series

You can determine the port numbering of the NIM E-Series NCE by looking at the MAC addresses of the network interfaces. Note the following:

- The lowest numbered MAC address corresponds to the NIM E-Series NCE's GE0 interface.
- The second lowest MAC address corresponds to the NIM E-Series NCE's GE1 interface.
- The third lowest MAC address corresponds to the NIM E-Series NCE's GE2 interface.



---

**Note** To determine the MAC address of an interface, see the [Determining the MAC Address in Microsoft Windows, Linux, and VMware vSphere Hypervisor](#), on page 132 section, or the appropriate platform documentation.

---

### Determining the Interface Name and Port Mapping for the NetXtreme II 1 Gigabit Server

To determine which interface name maps to which port number in the NetXtreme II 1 Gigabit Server (PCIe card), do the following:

1. Connect the PCIe card's port 0 to an external network device using a network cable.
2. From the host operating system, check the status of the interface to determine which interface is connected.
3. Repeat Step 2 for ports 1, 2, and 3.



---

**Note** For information about how to determine the status of the interface, see the appropriate operating system documentation.

---

### Determining the Interface Name and Port Mapping for the NetXtreme II 10 Gigabit Server



**Note** Only one port is enabled in the NetXtreme II 10 Gigabit Server (PCIe card).

To determine which interface name maps to which port number in the NetXtreme II 10 Gigabit Server (PCIe card), do the following:

1. Connect the PCIe card's port 0 to an external network device using a network cable.
2. From the host operating system, check the status of the interface to determine which interface is connected.



**Note** For information about how to determine the status of the interface, see the appropriate operating system documentation.

## Determining the MAC Address in Microsoft Windows, Linux, and VMware vSphere Hypervisor

### Determining the MAC Address in the Microsoft Windows Operating System

To determine the MAC address of an interface in the Microsoft Windows operating systems, open a command window, and then enter the **ipconfig /all** command.

### Determining the MAC Address in the Linux Operating System

To determine the MAC address of an interface in the Linux operating systems, open a terminal window, and then enter the **ifconfig -a** command to display the MAC address of all interfaces or **ifconfig interface-name** to display the MAC address of a particular interface.

### Determining the MAC Address in the VMware vSphere Hypervisor

To determine the MAC address of an interface in the VMware vSphere Hypervisor, do the following:

1. In your web browser, enter the IP address that you configured to access CIMC during initial setup and then log into CIMC.

The CIMC Home page, which is the **Server Summary** page, appears.

2. From the **Actions** area of the **Server Summary** page, click the **Launch KVM Console** icon.

The **KVM Console** opens in a separate window.

3. From the KVM Console, click the **KVM** tab, and then do the following:

- Press **F2** to access the VMware vSphere Hypervisor DCUI customization menu. The **DCUI** login page appears.
- Log into the **DCUI**. The **System Customization** page appears.
- From the **System Customization** page, click **Configure Management Network**.

The **Configure Management Network** page appears, which has several menu options, including **Network Adapter**. The **Network Adapter** menu option allows you to view the MAC address of the interfaces.

### UCS E Series M3 Servers: Reordering ESXi VMNIC Interface Number to Start with Server's Lowest MAC Address

On Cisco UCS E Series M3 servers, the VMware vSphere Hypervisor DCUI VMNIC interface ordering does not map to server's lowest MAC address. After installing ESXi on M3 servers, the default DCUI VMNIC interface ordering and server's NIC interface mappings are:

| ~ Name | MAC Address       | UCS-E160S-M3 NIC | Description                                             |
|--------|-------------------|------------------|---------------------------------------------------------|
| vmnic0 | a8:9d:21:fc:61:12 | TE2              | Intel(R) Ethernet Connection X552/X557-AT 10GBASE-T     |
| vmnic1 | a8:9d:21:fc:61:13 | TE3              | Intel(R) Ethernet Connection X552/X557-AT 10GBASE-T     |
| vmnic2 | a8:9d:21:fc:61:10 | GE0              | Broadcom Corporation NetXtreme BCM5719 Gigabit Ethernet |
| vmnic3 | a8:9d:21:fc:61:11 | GE1              | Broadcom Corporation NetXtreme BCM5719 Gigabit Ethernet |

To make VMNIC interface ordering to start with the server's lowest MAC address, follow these procedures:

1. Enable SSH and Shell Access in ESXi.
2. SSH into ESXi.
3. Use `esxcli network nic list` command to display VMNIC number and its corresponding MAC address.
4. Use `localcli --plugin-dir /usr/lib/vmware/esxcli/int/deviceInternal alias list` command to display the Bus address and VMNIC number mappings.
5. Use `localcli` command to remap VMNIC number to Bus address that has the lowest MAC address.
6. Reboot ESXi.
7. SSH into ESXi and verify changes.

The following example shows how to display VMNIC number and its MAC address:

```
~ # esxcli network nic list
Name      PCI Device      Driver  Link  Speed  Duplex  MAC Address      MTU  Description
-----  -
vmnic0    0000:004:00.0   ixgbe  Up    1000   Full    a8:9d:21:fc:61:12  1500 Intel(R)
Ethernet Connection X552/X557-AT 10GBASE-T
vmnic1    0000:004:00.1   ixgbe  Up    1000   Full    a8:9d:21:fc:61:13  1500 Intel(R)
Ethernet Connection X552/X557-AT 10GBASE-T
vmnic2    0000:008:00.0   tg3    Up    1000   Full    a8:9d:21:fc:61:10  1500 Broadcom
Corporation NetXtreme BCM5719 Gigabit Ethernet
vmnic3    0000:008:00.1   tg3    Up    1000   Full    a8:9d:21:fc:61:11  1500 Broadcom
Corporation NetXtreme BCM5719 Gigabit Ethernet
```

The following example shows how to display Bus address and VMNIC name mapping:

```
~ # localcli --plugin-dir /usr/lib/vmware/esxcli/int/ deviceInternal alias list
Bus type  Bus address      Alias
-----  -

```

```

pci      p0000:06:00.0      vmhba0
pci      p0000:08:00.0      vmnic2
pci      p0000:08:00.1      vmnic3
pci      p0000:04:00.1      vmnic1
pci      p0000:04:00.0      vmnic0
logical pci#p0000:06:00.0#0 vmhba0

```

The following example shows how to remap VMNIC number to the Bus address that has the lowest MAC address:

```

~ # localcli --plugin-dir /usr/lib/vmware/esxcli/int/ deviceInternal alias store --alias
vmnic0 --bus-address p0000:08:00.0 --bus-type pci
~ # localcli --plugin-dir /usr/lib/vmware/esxcli/int/ deviceInternal alias store --alias
vmnic1 --bus-address p0000:08:00.1 --bus-type pci
~ # localcli --plugin-dir /usr/lib/vmware/esxcli/int/ deviceInternal alias store --alias
vmnic2 --bus-address p0000:04:00.0 --bus-type pci
~ # localcli --plugin-dir /usr/lib/vmware/esxcli/int/ deviceInternal alias store --alias
vmnic3 --bus-address p0000:04:00.1 --bus-type pci
~ # reboot

```

The following example shows how the VMNIC interface ordering looks like after the reboot. The VMNIC interface number begins with the lowest MAC address.:

```

~ # esxcli network nic list
Name      PCI Device      Driver  Link  Speed  Duplex  MAC Address      MTU  Description
-----  -
vmnic0    0000:008:00.0    tg3     Up    1000   Full    a8:9d:21:fc:61:10 1500 Broadcom
Corporation NetXtreme BCM5719 Gigabit Ethernet
vmnic1    0000:008:00.1    tg3     Up    1000   Full    a8:9d:21:fc:61:11 1500 Broadcom
Corporation NetXtreme BCM5719 Gigabit Ethernet
vmnic2    0000:004:00.0    ixgbe   Up    1000   Full    a8:9d:21:fc:61:12 1500 Intel(R)
Ethernet Connection X552/X557-AT 10GBASE-T
vmnic3    0000:004:00.1    ixgbe   Up    1000   Full    a8:9d:21:fc:61:13 1500 Intel(R)
Ethernet Connection X552/X557-AT 10GBASE-T
~ # localcli --plugin-dir /usr/lib/vmware/esxcli/int/ deviceInternal alias list
Bus type  Bus address      Alias
-----  -
pci       p0000:06:00.0    vmhba0
pci       p0000:08:00.0    vmnic0
pci       p0000:08:00.1    vmnic1
pci       p0000:04:00.1    vmnic3
pci       p0000:04:00.0    vmnic2
logical  pci#p0000:06:00.0#0 vmhba0
~ #

```





## CHAPTER 9

# Upgrading Firmware

---

This chapter includes the following sections:

- [Options for Upgrading Firmware, on page 135](#)
- [Cisco Host Upgrade Utility Overview, on page 136](#)
- [Minimum CIMC and BIOS Firmware Releases Required to Use HUU, on page 136](#)
- [CIMC and BIOS Firmware Releases Available With HUU ISO Images, on page 137](#)
- [Understanding the HUU User Interface, on page 140](#)
- [Upgrading the Firmware, on page 142](#)
- [Troubleshooting, on page 145](#)

## Options for Upgrading Firmware

You can use either the Cisco Host Upgrade Utility (HUU) to upgrade the firmware components or you can upgrade the firmware components manually.

- **HUU**—We recommend that you use the HUU ISO file to upgrade all firmware components, which include the CIMC and BIOS firmware.



---

**Note** You cannot use the HUU to upgrade the Programmable Logic Devices (PLD) firmware. You must use the Cisco IOS CLI to upgrade the PLD firmware. For details, see the "Upgrading Programmable Logic Devices Firmware on the E-Series EHWIC NCE" section in the *CLI Configuration Guide for Cisco UCS E-Series Servers and the Cisco UCS E-Series Network Compute Engine*.

---

- **Manual Upgrade**—To manually upgrade the CIMC and BIOS firmware, you must first obtain the firmware from Cisco Systems, and then use the CIMC GUI or the CIMC CLI to upgrade it. After you upgrade the firmware, reboot the system.

For instructions on how to obtain firmware from Cisco Systems and for CIMC and BIOS firmware installation procedures, see the "Firmware Management" chapter in the configuration guides for the version of the CIMC that you are using. The configuration guides are available at: [http://www.cisco.com/en/US/products/ps12629/products\\_installation\\_and\\_configuration\\_guides\\_list.html](http://www.cisco.com/en/US/products/ps12629/products_installation_and_configuration_guides_list.html).

# Cisco Host Upgrade Utility Overview

The Cisco Host Upgrade Utility (HUU) is a tool that you can use to upgrade the firmware on the Cisco UCS E-Series Servers (E-Series Servers) and the Cisco UCS E-Series Network Compute Engine (NCE). The HUU provides a web-based GUI where you can choose all or specific firmware components to upgrade.

The following firmware components are available for upgrade:

- Cisco Integrated Management Controller (CIMC)
- System BIOS
- LAN on motherboard (LOM)
- RAID controllers
- Broadcom PCI adapters:
  - 5709 Dual and Quad port adapters
  - 57712 Dual port adapter
- LSI
  - LSI MegaRAID SAS 9240-4i



---

**Note** Cisco UCS E Series servers do not support saving HUU logs to RAID\_SD0\_1.

---

You cannot use the HUU to upgrade the Programmable Logic Devices (PLD) firmware. You must use the Cisco IOS CLI to upgrade the PLD firmware. For details, see the "Upgrading Programmable Logic Devices Firmware on the E-Series EHWIC NCE" section in the *CLI Configuration Guide for Cisco UCS E-Series Servers and the Cisco UCS E-Series Network Compute Engine*.

## Minimum CIMC and BIOS Firmware Releases Required to Use HUU

The HUU is supported on CIMC, release 2.1.0 and later releases. To use HUU, make sure that you upgrade both the CIMC and BIOS firmware to the release specified in the table below.



---

**Note** The HUU is *not* supported on CIMC, releases 1.0 and 1.0(2). If you try to use the HUU on a server that has an older release of CIMC, you will get an error message asking you to upgrade the firmware.

---

The following table provides information about the minimum CIMC and BIOS releases required to use the HUU.

Table 8: Minimum CIMC and BIOS Firmware Releases Required to Use HUU

| Minimum Compatible CIMC Release | Minimum Compatible BIOS Release |
|---------------------------------|---------------------------------|
| 2.1.0                           | 1.5.0.2                         |

## CIMC and BIOS Firmware Releases Available With HUU ISO Images

The following table provided the CIMC and BIOS firmware releases that are available for upgrade when you install a specific HUU ISO image.



**Note** For latest information about the compatible CIMC, BIOS, and HUU releases, see the "Upgrading Firmware" chapter in the *Getting Started Guide for Cisco UCS E-Series Servers and the Cisco UCS E-Series Network Compute Engine*.

Table 9: CIMC and BIOS Firmware Releases Available With HUU ISO Images

| HUU ISO Image | Contains CIMC Release | Contains BIOS Release                                                                                                                                                                                                                                                                                                                                        |
|---------------|-----------------------|--------------------------------------------------------------------------------------------------------------------------------------------------------------------------------------------------------------------------------------------------------------------------------------------------------------------------------------------------------------|
| 3.1.1         | 3.1.1                 | UCSEN.1.5.0.3—Applicable to the EHWIC E-Series NCE and the NIM E-Series NCE (UCS-EN120E and UCS-EN140N-M2)<br><br>UCSES.1.5.0.2—Applicable to the single-wide E-Series Server (UCS-E140S-M1, UCS-EN120S-M2 and UCS-E140S-M2)<br><br>UCSED.2.5.0.3—Applicable to the double-wide E-Series Servers (UCS-E140D-M1, UCS-E160D-M1, UCS-E160D-M2 and UCS-E180D-M2) |
| 3.1.2         | 3.1.2                 | UCSEN.1.5.0.3—Applicable to the EHWIC E-Series NCE and the NIM E-Series NCE (UCS-EN120E and UCS-EN140N-M2)<br><br>UCSES.1.5.0.2—Applicable to the single-wide E-Series Server (UCS-E140S-M1, UCS-EN120S-M2 and UCS-E140S-M2)<br><br>UCSED.2.5.0.3—Applicable to the double-wide E-Series Servers (UCS-E140D-M1, UCS-E160D-M1, UCS-E160D-M2 and UCS-E180D-M2) |

| HUU ISO Image | Contains CIMC Release | Contains BIOS Release                                                                                                                                                                                                                                                                                                                                                                                                                                                                                                  |
|---------------|-----------------------|------------------------------------------------------------------------------------------------------------------------------------------------------------------------------------------------------------------------------------------------------------------------------------------------------------------------------------------------------------------------------------------------------------------------------------------------------------------------------------------------------------------------|
| 3.1.3         | 3.1.3                 | <p>UCSEN.1.5.0.3—Applicable to the EHWIC E-Series NCE and the NIM E-Series NCE (UCS-EN120E and UCS-EN140N-M2)</p> <p>UCSES.1.5.0.2—Applicable to the single-wide E-Series Server (UCS-E140S-M1)</p> <p>UCSES.1.5.0.5—Applicable to the single-wide E-Series Server (UCS-EN120S-M2 and UCS-E140S-M2)</p> <p>UCSED.2.5.0.3—Applicable to the double-wide E-Series Servers (UCS-E140D-M1, UCS-E160D-M1, UCS-E160D-M2 and UCS-E180D-M2)</p>                                                                                |
| 3.1.4         | 3.1.4                 | <p>UCSEN.1.5.0.3—Applicable to the EHWIC E-Series NCE and the NIM E-Series NCE (UCS-EN120E and UCS-EN140N-M2)</p> <p>UCSES.1.5.0.2—Applicable to the single-wide E-Series Server (UCS-E140S-M1)</p> <p>UCSES.1.5.0.5—Applicable to the single-wide E-Series Server (UCS-EN120S-M2 and UCS-E140S-M2)</p> <p>UCSED.2.5.0.3—Applicable to the double-wide E-Series Servers (UCS-E140D-M1, UCS-E160D-M1, UCS-E160D-M2 and UCS-E180D-M2)</p> <p>UCSEM3.1.0—Applicable to the single-wide E-Series Server (UCS-E160S-M3)</p> |

| HUU ISO Image | Contains CIMC Release | Contains BIOS Release                                                                                                                                                                                                                                                                                                                                                                                                                                                                                                                                                                                                    |
|---------------|-----------------------|--------------------------------------------------------------------------------------------------------------------------------------------------------------------------------------------------------------------------------------------------------------------------------------------------------------------------------------------------------------------------------------------------------------------------------------------------------------------------------------------------------------------------------------------------------------------------------------------------------------------------|
| 3.2.2         | 3.2.2                 | <p>UCSEN.1.5.0.5—Applicable to the EHWIC E-Series NCE and the NIM E-Series NCE (UCS-EN120E and UCS-EN140N-M2)</p> <p>UCSES.1.5.0.2—Applicable to the single-wide E-Series Server (UCS-E140S-M1)</p> <p>UCSES.1.5.0.6—Applicable to the single-wide E-Series Server (UCS-EN120S-M2 and UCS-E140S-M2)</p> <p>UCSED.2.5.0.4—Applicable to the double-wide E-Series Servers (UCS-E140D-M1, UCS-E160D-M1, UCS-E160D-M2 and UCS-E180D-M2)</p> <p>UCSEM3.2.4—Applicable to the single-wide E-Series Server (UCS-E160S-M3)</p> <p>UCSEDM3.2.4—Applicable to the single-wide E-Series Server (UCS-E180D-M3 and UCS-E1120D-M3)</p> |
| 3.2.3         | 3.2.3                 | <p>UCSEN.1.5.0.5—Applicable to the EHWIC E-Series NCE and the NIM E-Series NCE (UCS-EN120E and UCS-EN140N-M2)</p> <p>UCSES.1.5.0.2—Applicable to the single-wide E-Series Server (UCS-E140S-M1)</p> <p>UCSES.1.5.0.6—Applicable to the single-wide E-Series Server (UCS-EN120S-M2 and UCS-E140S-M2)</p> <p>UCSED.2.5.0.4—Applicable to the double-wide E-Series Servers (UCS-E140D-M1, UCS-E160D-M1, UCS-E160D-M2 and UCS-E180D-M2)</p> <p>UCSEM3.2.4—Applicable to the single-wide E-Series Server (UCS-E160S-M3)</p> <p>UCSEDM3.2.4—Applicable to the single-wide E-Series Server (UCS-E180D-M3 and UCS-E1120D-M3)</p> |

| HUU ISO Image | Contains CIMC Release | Contains BIOS Release                                                                                                                                                                                                                                                                                                                                                                                                                                                                                                                                                                                                    |
|---------------|-----------------------|--------------------------------------------------------------------------------------------------------------------------------------------------------------------------------------------------------------------------------------------------------------------------------------------------------------------------------------------------------------------------------------------------------------------------------------------------------------------------------------------------------------------------------------------------------------------------------------------------------------------------|
| 3.2.4         | 3.2.4                 | <p>UCSEN.1.5.0.5—Applicable to the EHWIC E-Series NCE and the NIM E-Series NCE (UCS-EN120E and UCS-EN140N-M2)</p> <p>UCSES.1.5.0.2—Applicable to the single-wide E-Series Server (UCS-E140S-M1)</p> <p>UCSES.1.5.0.7—Applicable to the single-wide E-Series Server (UCS-EN120S-M2 and UCS-E140S-M2)</p> <p>UCSED.2.5.0.5—Applicable to the double-wide E-Series Servers (UCS-E140D-M1, UCS-E160D-M1, UCS-E160D-M2 and UCS-E180D-M2)</p> <p>UCSEM3.2.5—Applicable to the single-wide E-Series Server (UCS-E160S-M3)</p> <p>UCSEDM3.2.5—Applicable to the single-wide E-Series Server (UCS-E180D-M3 and UCS-E1120D-M3)</p> |

# Understanding the HUU User Interface

Figure 43: HUU User Interface

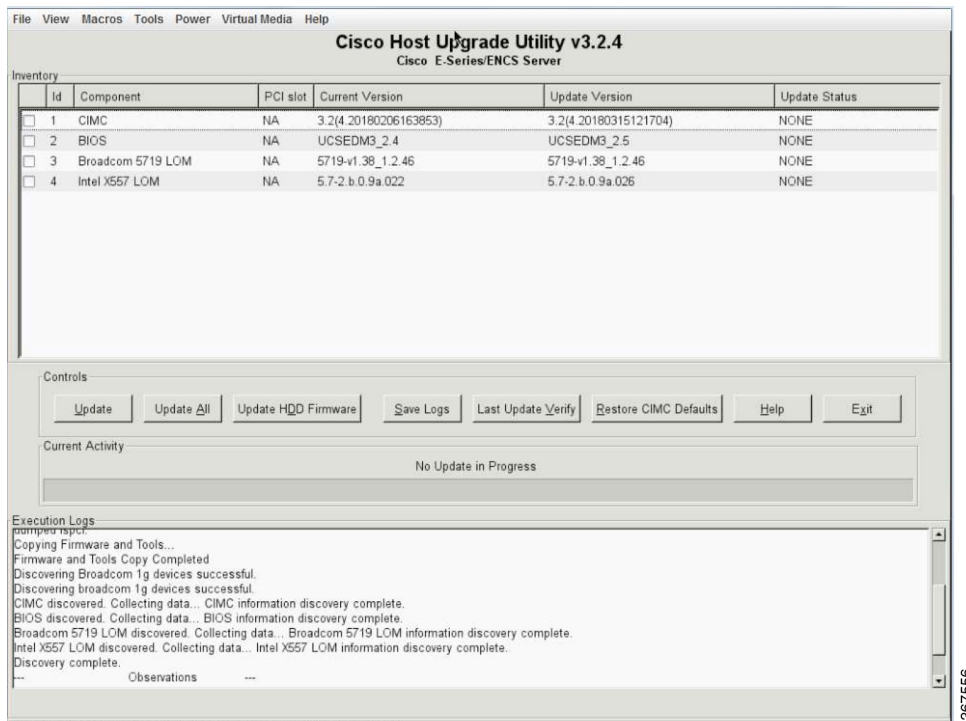

367556

| User Interface Name                 | Description                                                                                                                                                                                                                                                                                                                                                                                                                                                   |
|-------------------------------------|---------------------------------------------------------------------------------------------------------------------------------------------------------------------------------------------------------------------------------------------------------------------------------------------------------------------------------------------------------------------------------------------------------------------------------------------------------------|
| <b>Id</b> column                    | Displays the serial number of the component row.                                                                                                                                                                                                                                                                                                                                                                                                              |
| <b>Component</b> column             | Lists the firmware components that are available for upgrade.                                                                                                                                                                                                                                                                                                                                                                                                 |
| <b>PCI Slot</b> column              | Display the PCI slot information for the PCI adapter components.                                                                                                                                                                                                                                                                                                                                                                                              |
| <b>Current Version</b> column       | Displays the current firmware version number that is installed for each of the listed components.                                                                                                                                                                                                                                                                                                                                                             |
| <b>Update Version</b> column        | Displays the firmware version number that is available for upgrade for each of the listed components.                                                                                                                                                                                                                                                                                                                                                         |
| <b>Update Status</b> column         | Displays the status of the update for each of the listed components while the update is in progress.                                                                                                                                                                                                                                                                                                                                                          |
| <b>Update</b> button                | Initiates the firmware update for a selected component.                                                                                                                                                                                                                                                                                                                                                                                                       |
| <b>Update All</b> button            | Initiates the firmware update for all available components.                                                                                                                                                                                                                                                                                                                                                                                                   |
| <b>Save Logs</b> button             | Saves the log files.<br><br>If an error occurs while updating the firmware, you are prompted to save the error log. Click the <b>Save Logs</b> button to save the error logs to an externally connected USB. This log can be used to identify the cause of the error and for troubleshooting.                                                                                                                                                                 |
| <b>Last Update Verify</b> button    | Verifies if the update was successful.<br><br><b>Note</b> You must first reboot HUU by clicking the <b>Exit</b> button, and then click the <b>Last Update Verify</b> button to verify the last update.                                                                                                                                                                                                                                                        |
| <b>Restore CIMC Defaults</b> button | Restores the CIMC settings to factory default settings.                                                                                                                                                                                                                                                                                                                                                                                                       |
| <b>Exit</b> button                  | Exits the HUU. Click <b>Yes</b> at the confirmation prompt to exit.<br><br><ul style="list-style-type: none"> <li>• If you update the CIMC and not the BIOS, when you click the <b>Exit</b> button, the CIMC will get activated but you will lose connectivity to the CIMC and KVM.</li> <li>• If you select LOM for update and you are in shared LOM mode, when you click the <b>Exit</b> button, you will lose connectivity to the CIMC and KVM.</li> </ul> |
| <b>Usage</b> area                   | Lists keyboard shortcuts that you can use to perform specific tasks.                                                                                                                                                                                                                                                                                                                                                                                          |

| User Interface Name   | Description                                                                   |
|-----------------------|-------------------------------------------------------------------------------|
| Current Activity area | Provides the status of an update.                                             |
| Execution Logs area   | Provides a log of activities and their status while an update is in progress. |

# Upgrading the Firmware

## Basic Workflow for Using the HUU

1. Download the HUU ISO image from Cisco.com.
2. Use the KVM console or the CIMC CLI to map the HUU ISO image.
3. Set the boot order to make the virtual CD/DVD drive as the boot device.
4. From the HUU GUI, select all or specific firmware components to update.
5. After the firmware updates, click **Exit** to reboot the HUU.
6. Unmap the HUU ISO image.
7. Reboot the server.

## Upgrading the Firmware Using the HUU

### Procedure

- 
- Step 1** Navigate to <http://www.cisco.com/>.
- Step 2** If you are not already logged in, click **Log In** at the top-right edge of the page and log in using your Cisco.com credentials.
- Step 3** In the menu bar at the top, click **Support**.  
A roll-down menu appears.
- Step 4** From the Downloads (center) pane, click **All Downloads** (located at the bottom right corner).  
The **Download Software** page appears.
- Step 5** From the left pane, click **Products**.
- Step 6** From the center pane, click **Servers—Unified Computing**.
- Step 7** From the right pane, click **Cisco UCS E-Series Software**.
- Step 8** From the right pane, click the name of the server model for which you want to download the software.  
The **Download Software** page appears.
- Step 9** Click **Unified Computing System (UCSE) Server Firmware**.



**Step 10** Click the **Download** button associated with the **Cisco UCS Host Upgrade Utility** ISO image to download the image onto your PC.

The **End User License Agreement** dialog box appears.

**Step 11** Click **Accept License Agreement**.

**Step 12** The **Opening *ucse-server-platform-huu.iso*** dialog box appears.

Either open the file or browse to the location where you want to save the HUU ISO image, and then click **OK**.

**Step 13** You can use either the KVM Console or the CIMC CLI to map the HUU ISO image:

- To use the KVM Console, do the following:
  1. Use a browser to connect to the CIMC GUI on the server that you are upgrading.
  2. In the address field of the browser, enter the CIMC IP address for that server, and then enter your username and password to log in to the CIMC GUI.
  3. Click the **Launch KVM Console** icon on the toolbar. The KVM Console opens in a separate window.
  4. From the KVM Console, click the **Virtual Media** tab.
  5. Click **Add Image**, navigate to and select the Host Upgrade Utility ISO image, and then click **Open** to mount the image.
  6. In the **Client View** area, in the Mapped column, check the check box for the mounted ISO image.

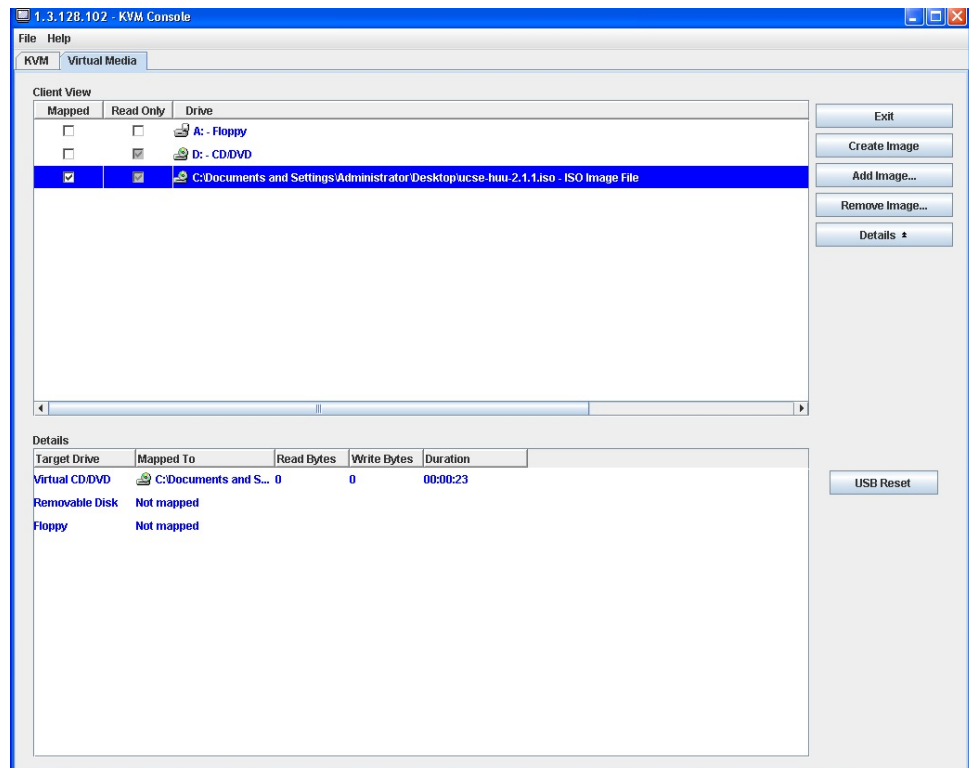

360985

- To use the CIMC CLI, download the ISO image on to an FTP or TFTP server, and then use the following commands:

- Server# **scope host-image-mapping**.
- Server/host-image-mapping # **download-image protocol server-ip-address huu-ISO-filename**
- Server/host-image-mapping # **map-image huu-ISO-filename**.

```
Server# scope host-image-mapping
Server/host-image-mapping # download-image ftp 10.20.34.56 2.1.1.iso
Username: anonymous
Password:
Image download has started.
Please check the status using "show detail".
Server/host-image-mapping # map-image 2.1.1.iso
```

**Step 14** After the image is mapped, set the boot order to make the virtual CD/DVD drive as the boot device.

**Step 15** Reboot the server.

**Step 16** From the CIMC GUI, click the **Launch KVM Console** icon on the toolbar.

The HUU and the **Cisco Software License Agreement** page appears.

**Step 17** Click **I Agree** to accept the licensing terms and conditions.

The **Cisco Host Upgrade Utility** GUI appears with a list of components that are available for update.

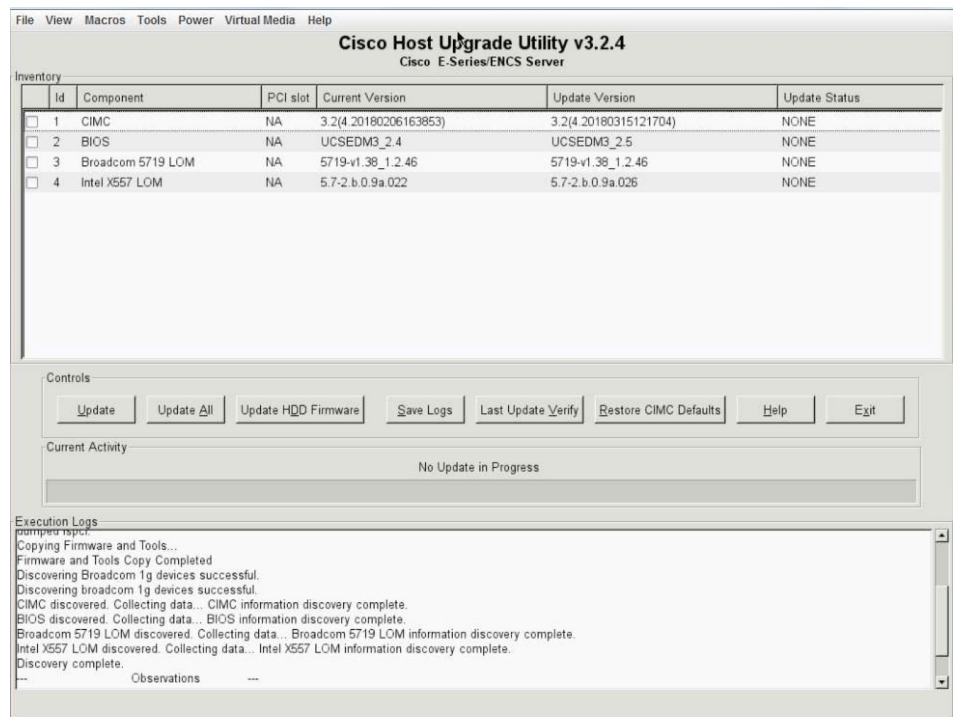

**Step 18** Do one of the following:

- To update all the listed components, click **Update all**.
- To update specific components, select the components, and then click **Update**.

The status of the update is displayed in the **Update Status** column. To view details about the update status, see the **Execution Logs** area.

**Note** We recommend that you always update the BIOS and the CIMC firmware at the same time.

**Step 19** After the firmware is updated, click **Exit**, and then click **Ok** at the confirmation prompt.

The HUU reboots.

- Important**
- If the BIOS firmware is selected for update, it will be the last one to update because it requires the host to be powered off. You can check the progress of the BIOS update from the CIMC GUI or CIMC CLI. After the BIOS update completes, you must use the CIMC GUI or the CIMC CLI to manually power on the host.
  - If the CIMC firmware is selected for update—after you click the **Exit** button from the HUU GUI—the new CIMC firmware gets automatically activated. However, if both the BIOS and CIMC firmwares are selected for update, the CIMC firmware does not get automatically activated. You must use the CIMC GUI or the CIMC CLI to manually activate the new CIMC firmware.
  - When the new CIMC firmware gets activated, you will lose network connectivity to the CIMC GUI, CIMC CLI, and virtual KVM. Also, the mapped HUU ISO image gets unmapped. To run the HUU, you must map the HUU ISO image again.
  - When the LOM firmware is updated, you might lose network connectivity to the CIMC GUI and virtual KVM.

**Step 20** Unmap the HUU ISO image. Do one of the following:

- From the CIMC GUI, click the **Launch KVM Console** icon on the toolbar, from the Mapped column, check the check box for the mounted HUU ISO image, and then click **Remove Image**.
- From the CIMC CLI, use the **unmap-image** command:
  - `Server/host-image-mapping # unmap-image`

**Step 21** Reboot the server.

## Troubleshooting

| Problem                                                                                                                                                                         | Solution                                                                                                                                                                                                                                                          |
|---------------------------------------------------------------------------------------------------------------------------------------------------------------------------------|-------------------------------------------------------------------------------------------------------------------------------------------------------------------------------------------------------------------------------------------------------------------|
| Connection to the CIMC is lost after an update and reboot, and the KVM session ends.                                                                                            | This is expected behavior after a firmware update. Log back in to the CIMC, and then re-establish your KVM session.                                                                                                                                               |
| Error Message:<br><i>PID, Board-Part-Number, Product-Part-Number</i> is not supported by this HUU image. HUU will not boot on this machine. Press any key to reboot the server. | This error message displays when the HUU ISO image is not supported by the server. To resolve this problem, use the HUU ISO image that is supported by the server. See <a href="#">Minimum CIMC and BIOS Firmware Releases Required to Use HUU</a> , on page 136. |

| Problem                                                                                                                                                              | Solution                                                                                                                |
|----------------------------------------------------------------------------------------------------------------------------------------------------------------------|-------------------------------------------------------------------------------------------------------------------------|
| <p>After using the HUU to update the Broadcom NCSI firmware, the warning prompt to update the Broadcom firmware still displays in the CIMC GUI and the CIMC CLI.</p> | <p>To resolve this problem, power cycle the E-Series Server to allow the new Broadcom NCSI firmware to take effect.</p> |



# APPENDIX A

## Configuration Differences

This appendix includes the following sections:

- [Router Configuration Differences Between the Cisco ISR G2 and the Cisco ISR 4000 Series](#), on page 147
- [Router Configuration Differences Between the E-Series Server and the EHWIC E-Series NCE—Cisco ISR G2](#), on page 148

## Router Configuration Differences Between the Cisco ISR G2 and the Cisco ISR 4000 Series

The examples in the following table provide the key differences between the Cisco ISR G2 configuration and the Cisco ISR 4000 series configuration.

**Table 10: Differences in Router Configuration Between the Cisco ISR G2 and the Cisco ISR 4000 Series**

| Cisco ISR G2 Configuration                                                                                                                                                                                                                                                                                         | Cisco ISR 4000 Series Configuration                                                                                                                                                                                                                                                                                                            |
|--------------------------------------------------------------------------------------------------------------------------------------------------------------------------------------------------------------------------------------------------------------------------------------------------------------------|------------------------------------------------------------------------------------------------------------------------------------------------------------------------------------------------------------------------------------------------------------------------------------------------------------------------------------------------|
| <pre>interface GigabitEthernet0/0  ip address 10.0.0.1 255.0.0.0  interface ucse 1/0  ip unnumbered GigabitEthernet0/0  imc ip address 10.0.0.2 255.0.0.0 default-gateway  10.0.0.1  imc access-port shared-lom console  interface ucse1/1  switchport mode trunk  ip route 10.0.0.2 255.255.255.255 ucse1/0</pre> | <pre>interface GigabitEthernet 0/0/0  ip address 10.0.0.1 255.0.0.0  ucse subslot 1/0  imc access-port shared-lom console  imc ip address 10.0.0.2 255.0.0.0 default-gateway  10.0.0.1  interface ucse1/0/0  ip unnumbered GigabitEthernet0/0/0  no negotiation auto  switchport mode trunk  ip route 10.0.0.2 255.255.255.255 ucse1/0/0</pre> |

Note the following differences:

- In the Cisco ISR 4000 series, the **interface ucse slot/port** command is replaced by the **ucse subslot slot/subslot** and the **interface ucse slot/subslot/port** commands.

- In the Cisco ISR G2, you can use either the dedicated interface or one of the shared local area network on motherboard (shared LOM) interfaces to configure CIMC access.

In the Cisco ISR 4000 series, you can use either the management interface or one of the NIC interfaces to configure CIMC access. See [Configuring Access to the Management Firmware](#), on page 25.

In the above example, the command configures CIMC access using the E-Series Server's internal GE0 NIC interface, where:

- **imc access-port**—CIMC access port configuration.
- **ge0**—E-Series Server's internal GE0 NIC interface.

The command to session into the server has also changed:

- In the Cisco ISR G2, you use the **ucse slot session {imc | host}** command to session into the server.
- In the Cisco ISR 4000 series, you use the **hw-module subslot slot/0 session {imc | server}** command to session into the server.

## Router Configuration Differences Between the E-Series Server and the EHWIC E-Series NCE—Cisco ISR G2

The examples in the following table provide the key differences between the E-Series Server configuration and the EHWIC E-Series NCE configuration.

**Table 11: Differences in Router Configuration Between the E-Series Server and the EHWIC E-Series NCE**

| E-Series Server Configuration                                                                                                                                                                                                                                                                                  | EHWIC E-Series NCE Configuration                                                                                                                                                                                                                                                                                     |
|----------------------------------------------------------------------------------------------------------------------------------------------------------------------------------------------------------------------------------------------------------------------------------------------------------------|----------------------------------------------------------------------------------------------------------------------------------------------------------------------------------------------------------------------------------------------------------------------------------------------------------------------|
| <pre>interface GigabitEthernet0/0 ip address 10.0.0.1 255.0.0.0  interface ucse 1/0 ip unnumbered GigabitEthernet0/0 imc ip address 10.0.0.2 255.0.0.0 default-gateway 10.0.0.1 imc access-port shared-lom console  interface ucse 1/1 switchport mode trunk  ip route 10.0.0.2 255.255.255.255 ucse 1/0</pre> | <pre>interface GigabitEthernet0/0 ip address 10.0.0.1 255.0.0.0  interface ucse 0/1/0 ip unnumbered GigabitEthernet0/0 imc ip address 10.0.0.2 255.0.0.0 default-gateway 10.0.0.1 imc access-port shared-lom console  interface ucse 0/1/1 switchport mode trunk  ip route 10.0.0.2 255.255.255.255 ucse 0/3/0</pre> |

Note the following differences:

- In the EHWIC E-Series NCE, the **interface ucse slot/port** command is replaced by the **interface ucse 0/subslot/port** command.
- In the EHWIC E-Series NCE, the **ip route cimc-ip-address subnet-mask ucse slot/port** command is replaced by the **ip route cimc-ip-address subnet-mask ucse 0/subslot/port** command.

- In Cisco IOS Release 15.4(3)M, for both the E-Series Servers and NCEs, all **ucse slot x** commands are replaced by the **ucse subslot slot/subslot x** command.







## APPENDIX **B**

# Cisco IOS Software Command Reference—Cisco ISR G2

This appendix provides the new Cisco IOS commands that were introduced for the E-Series Servers and NCE installed in the Cisco ISR G2.



**Note** The Cisco IOS commands are sometimes updated after original publication; therefore, for updated content, review the *Cisco IOS Interface and Hardware Component Command Reference* at <http://www.cisco.com/en/US/docs/ios-xml/ios/interface/command/ir-cr-book.html>.

This appendix includes the following sections:

- [imc ip address default-gateway, on page 151](#)
- [imc ip address dhcp, on page 152](#)
- [imc vlan, on page 152](#)
- [ucse cmos-reset, on page 153](#)
- [ucse password-reset, on page 154](#)
- [ucse session, on page 155](#)
- [ucse shutdown, on page 157](#)
- [ucse statistics, on page 158](#)
- [ucse status, on page 159](#)
- [ucse stop, on page 160](#)

## imc ip address default-gateway

To configure a static IP address for CIMC and the IP address of the default gateway router that CIMC must use, use the **imc ip address default-gateway** command in interface configuration mode. To remove the static IP address, use the **no** form of this command.

```
imc ip address ip-address subnet-mask default-gateway gateway-address  
no imc ip address ip-address subnet-mask default-gateway gateway-address
```

### Syntax Description

|                   |                     |
|-------------------|---------------------|
| <i>ip-address</i> | IP address of CIMC. |
|-------------------|---------------------|

|                        |                                                                                         |
|------------------------|-----------------------------------------------------------------------------------------|
| <i>subnet-mask</i>     | Subnet mask to append to the IP address; must be in the same subnet as the host router. |
| <i>gateway-address</i> | IP address of the default gateway router.                                               |

**Command Modes**

Interface configuration (config-if)

**Command History**

| Release  | Modification                 |
|----------|------------------------------|
| 15.2(4)M | This command was introduced. |

**Usage Guidelines**

If you do not enable DHCP, you must specify a static IP address and subnet mask.

**Examples**

The following example shows how to configure a static IP address for CIMC:

```
Router(config)# interface ucse 2/0
Router(config-if)# imc ip address 10.0.0.2 255.0.0.0 default-gateway 10.0.0.1
```

## imc ip address dhcp

To configure a DHCP IP address for CIMC, use the **imc ip address dhcp** command in interface configuration mode. To remove the DHCP IP address, use the **no** form of the this command.

```
imc ip address dhcp
no imc ip address dhcp
```

**Syntax Description**

This command has no arguments or keywords.

**Command Modes**

Interface configuration (config-if)

**Command History**

| Release  | Modification                 |
|----------|------------------------------|
| 15.2(4)M | This command was introduced. |

**Examples**

The following example shows how to configure a DHCP IP address for CIMC:

```
Router(config)# interface ucse 2/0
Router(config-if)# imc ip address dhcp
```

## imc vlan

To enter VLAN configuration mode for the specified VLAN number, use the **imc vlan** command in interface configuration mode. To remove the VLAN configuration, use the **no** form of this command.

```
imc vlan vlan-number
no imc vlan vlan-number
```

**Syntax Description**

|                    |                                   |
|--------------------|-----------------------------------|
| <i>vlan-number</i> | IP address of the remote manager. |
|--------------------|-----------------------------------|

**Command Modes**

Interface configuration (config-if)

**Command History**

| Release  | Modification                 |
|----------|------------------------------|
| 15.2(4)M | This command was introduced. |

**Examples**

The following example shows how to enter VLAN configuration mode in CIMC for a specified VLAN:

```
Router(config)# interface ucse 2/0
Router(config-if)# interface vlan 40
```

## ucse cmos-reset

To reset the BIOS CMOS, use the **ucse cmos-reset** command in privileged EXEC mode.

**E-Series Servers Installed in an ISR G2—Applicable from Cisco IOS Release 15.2(4)M to 15.4(2)T**

```
ucse slot cmos-reset
```

**E-Series Servers and EHWIC E-Series NCE Installed in an ISR G2—Applicable in Cisco IOS Release 15.4(3)M**

```
ucse subslot slot/subslot cmos-reset
```

**Syntax Description**

|                |                                                                                                                                                                |
|----------------|----------------------------------------------------------------------------------------------------------------------------------------------------------------|
| <i>slot</i>    | Number of the router slot in which the server module is installed.<br><b>Note</b> For the EHWIC E-Series NCE, the slot number is 0.                            |
| <i>subslot</i> | Number of the subslot in which the server module is installed.<br><b>Note</b> For Cisco UCS E-Series Servers and the SM E-Series NCE, the subslot number is 0. |

**Command Modes**

Privileged EXEC (#)

| Command History | Release  | Modification                                                                                                                                                                                                         |
|-----------------|----------|----------------------------------------------------------------------------------------------------------------------------------------------------------------------------------------------------------------------|
|                 | 15.2(4)M | This command was introduced.<br><br>This command was supported on Cisco UCS E-Series Servers (E-Series Server) installed in an ISR G2.                                                                               |
|                 | 15.4(3)M | This command was modified to include the <b>subslot</b> keyword.<br><br>This command was supported on an additional platform: the EHWIC E-Series Network Compute Engine (EHWIC E-Series NCE) installed in an ISR G2. |

### Usage Guidelines

This command sets the BIOS CMOS back to the factory defaults. User changes made in the BIOS will be lost.

### Examples

The following example shows how to reset the BIOS CMOS in an E-Series Server installed in an ISR G2—Applicable from Cisco IOS Release 15.2(4)M to 15.4(2)T:

```
Router# ucse 2 cmos-reset
```

### Examples

The following example shows how to reset the BIOS CMOS in an E-Series Server or EHWIC E-Series NCE installed in an ISR G2—Applicable in Cisco IOS Release 15.4(3)M:

```
Router# ucse subslot 0/3 cmos-reset
```

## ucse password-reset

To reset the BIOS, CIMC, or RAID password, use the **ucse password-reset** command in privileged EXEC mode.

### E-Series Servers Installed in an ISR G2—Applicable from Cisco IOS Release 15.2(4)M to 15.4(2)T

```
ucse slot password-reset {BIOS | BMC | RAID}
```

### E-Series Servers and EHWIC E-Series NCE Installed in an ISR G2—Applicable in Cisco IOS Release 15.4(3)M

```
ucse subslot slot/subslot password-reset {BIOS | BMC | RAID}
```

### Syntax Description

|                |                                                                                                                                                                    |
|----------------|--------------------------------------------------------------------------------------------------------------------------------------------------------------------|
| <i>slot/</i>   | Number of the router slot in which the server module is installed.<br><br><b>Note</b> For the EHWIC E-Series NCE, the slot number is 0.                            |
| <i>subslot</i> | Number of the subslot in which the server module is installed.<br><br><b>Note</b> For Cisco UCS E-Series Servers and the SM E-Series NCE, the subslot number is 0. |
| <b>BIOS</b>    | Resets the BIOS password.                                                                                                                                          |

|             |                                                                                                                                         |
|-------------|-----------------------------------------------------------------------------------------------------------------------------------------|
| <b>BMC</b>  | Resets the CIMC password.                                                                                                               |
| <b>RAID</b> | Resets the RAID password.<br><br><b>Note</b> RAID is not applicable for the EHWIC E-Series Network Compute Engine (EHWIC E-Series NCE). |

**Command Modes**

Privileged EXEC (#)

**Command History**

| Release  | Modification                                                                                                                                                                 |
|----------|------------------------------------------------------------------------------------------------------------------------------------------------------------------------------|
| 15.2(4)M | This command was introduced.<br><br>This command was supported on Cisco UCS E-Series Servers (E-Series Server) installed in an ISR G2.                                       |
| 15.4(3)M | This command was modified to include the <b>subslot</b> keyword.<br><br>This command was supported on an additional platform: the EHWIC E-Series NCE installed in an ISR G2. |

**Usage Guidelines**

After this command has been entered, the system requests that a new password be set when accessing the BIOS or BMC.

RAID is not applicable for the EHWIC E-Series NCE.

**Examples**

The following example shows how to reset the BIOS password in an E-Series Server installed in an ISR G2—Applicable from Cisco IOS Release 15.2(4)M to 15.4(2)T:

```
Router# ucse 2 password-reset BIOS
Reset command sent
```

**Examples**

The following example shows how to reset the BIOS password in an E-Series Server or EHWIC E-Series NCE installed in an ISR G2—Applicable in Cisco IOS Release 15.4(3)M:

```
Router# ucse subslot 0/3 password-reset BIOS
Reset command sent
```

## ucse session

To start or close a host or CIMC session, use the **ucse session** command in privileged EXEC mode.

**E-Series Servers Installed in an ISR G2—Applicable from Cisco IOS Release 15.2(4)M to 15.4(2)T**

```
ucse slot session {imc [clear] | host [clear]}
```

**E-Series Servers and EHWIC E-Series NCE Installed in an ISR G2—Applicable in Cisco IOS Release 15.4(3)M**

```
ucse subslot slot/subslot session {imc [clear] | host [clear]}
```



**Note** The `ucse slot session imc` command will work only if you have configured a router-side IP address (for instance, ip unnumbered GigabitEthernet0/0) on the interface.

**Syntax Description**

|                   |                                                                                                                                                                |
|-------------------|----------------------------------------------------------------------------------------------------------------------------------------------------------------|
| <i>slot/</i>      | Number of the router slot in which the server module is installed.<br><b>Note</b> For the EHWIC E-Series NCE, the slot number is 0.                            |
| <i>subslot</i>    | Number of the subslot in which the server module is installed.<br><b>Note</b> For Cisco UCS E-Series Servers and the SM E-Series NCE, the subslot number is 0. |
| <b>imc</b>        | Starts a session with CIMC.                                                                                                                                    |
| <b>imc clear</b>  | Closes the existing CIMC session.                                                                                                                              |
| <b>host</b>       | Starts a session with the host Cisco E-Series Server.                                                                                                          |
| <b>host clear</b> | Closes the host Cisco E-Series Server session.                                                                                                                 |

**Command Modes**

Privileged EXEC (#)

**Command History**

| Release  | Modification                                                                                                                                                                                                     |
|----------|------------------------------------------------------------------------------------------------------------------------------------------------------------------------------------------------------------------|
| 15.2(4)M | This command was introduced.<br>This command was supported on Cisco UCS E-Series Servers (E-Series Server) installed in an ISR G2.                                                                               |
| 15.4(3)M | This command was modified to include the <b>subslot</b> keyword.<br>This command was supported on an additional platform: the EHWIC E-Series Network Compute Engine (EHWIC E-Series NCE) installed in an ISR G2. |

**Usage Guidelines**

The **imc clear** and **host clear** commands close the active session of the CIMC or the host. As a result, the system closes the sessions of any other users currently logged in.

Only one active session is allowed in the CIMC or host at any time. If you receive a “connection refused” message when sessioning in, close the current active session by entering the **imc clear** or **host clear** commands.

**Examples**

The following example shows how to clear the CIMC session in an E-Series Server installed in an ISR G2—Applicable from Cisco IOS Release 15.2(4)M to 15.4(2)T:

```
Router# ucse 2 session imc clear
```

**Examples**

The following example shows how to clear the CIMC session in an E-Series Server or EHWIC E-Series NCE installed in an ISR G2—Applicable in Cisco IOS Release 15.4(3)M:

```
Router# ucse subslot 0/3 session imc clear
```

## ucse shutdown

To shut down the system gracefully, use the **ucse shutdown** command in privileged EXEC mode.

**E-Series Servers Installed in an ISR G2—Applicable from Cisco IOS Release 15.2(4)M to 15.4(2)T**

```
ucse slot shutdown
```

**E-Series Servers and EHWIC E-Series NCE Installed in an ISR G2—Applicable in Cisco IOS Release 15.4(3)M**

```
ucse subslot slot/subslot shutdown
```

**Syntax Description**

|                |                                                                                                                                                                |
|----------------|----------------------------------------------------------------------------------------------------------------------------------------------------------------|
| <i>slot</i>    | Number of the router slot in which the server module is installed.<br><b>Note</b> For the EHWIC E-Series NCE, the slot number is 0.                            |
| <i>subslot</i> | Number of the subslot in which the server module is installed.<br><b>Note</b> For Cisco UCS E-Series Servers and the SM E-Series NCE, the subslot number is 0. |

**Command Modes**

Privileged EXEC (#)

**Command History**

| Release  | Modification                                                                                                                                                                                                         |
|----------|----------------------------------------------------------------------------------------------------------------------------------------------------------------------------------------------------------------------|
| 15.2(4)M | This command was introduced.<br><br>This command was supported on Cisco UCS E-Series Servers (E-Series Server) installed in an ISR G2.                                                                               |
| 15.4(3)M | This command was modified to include the <b>subslot</b> keyword.<br><br>This command was supported on an additional platform: the EHWIC E-Series Network Compute Engine (EHWIC E-Series NCE) installed in an ISR G2. |

**Usage Guidelines**

Use this command when removing or replacing a hot-swappable module during online insertion and removal (OIR).

**Examples**

The following example shows how to gracefully shut down an E-Series Server installed in an ISR G2—Applicable from Cisco IOS Release 15.2(4)M to 15.4(2)T:

```
Router# ucse 2 shutdown
```

**Examples**

The following example shows how to gracefully shut down an E-Series Server or EHWIC E-Series NCE installed in an ISR G2—Applicable in Cisco IOS Release 15.4(3)M:

```
Router# ucse subslot 0/3 shutdown
```

**ucse statistics**

To display or clear the reset and reload server information, use the **ucse statistics** command in privileged EXEC mode.

**E-Series Servers Installed in an ISR G2—Applicable from Cisco IOS Release 15.2(4)M to 15.4(2)T**

```
ucse slot statistics [clear]
```

**E-Series Servers and EHWIC E-Series NCE Installed in an ISR G2—Applicable in Cisco IOS Release 15.4(3)M**

```
ucse subslot slot/subslot statistics [clear]
```

**Syntax Description**

|                |                                                                                                                                                                |
|----------------|----------------------------------------------------------------------------------------------------------------------------------------------------------------|
| <i>slot</i>    | Number of the router slot in which the server module is installed.<br><b>Note</b> For the EHWIC E-Series NCE, the slot number is 0.                            |
| <i>subslot</i> | Number of the subslot in which the server module is installed.<br><b>Note</b> For Cisco UCS E-Series Servers and the SM E-Series NCE, the subslot number is 0. |
| <b>clear</b>   | (Optional) Clears the E-Series Server's reset and reload information.                                                                                          |

**Command Modes**

Privileged EXEC (#)

**Command History**

| Release  | Modification                                                                                                                                                                                                         |
|----------|----------------------------------------------------------------------------------------------------------------------------------------------------------------------------------------------------------------------|
| 15.2(4)M | This command was introduced.<br><br>This command was supported on Cisco UCS E-Series Servers (E-Series Server) installed in an ISR G2.                                                                               |
| 15.4(3)M | This command was modified to include the <b>subslot</b> keyword.<br><br>This command was supported on an additional platform: the EHWIC E-Series Network Compute Engine (EHWIC E-Series NCE) installed in an ISR G2. |

**Examples**

The following example shows how to display the server statistics in an E-Series Server installed in an ISR G2—Applicable from Cisco IOS Release 15.2(4)M to 15.4(2)T:

```
Router# ucse 2 statistics
```



```

Module Reset Statistics:
  CLI reset count = 0
  CLI reload count = 0
  Registration request timeout reset count = 0
  Error recovery timeout reset count = 0
  Module registration count = 1

```

## Examples

The following example shows how to display the server statistics in an E-Series Server or EHWIC E-Series NCE installed in an ISR G2—Applicable in Cisco IOS Release 15.4(3)M:

```

Router# ucse subslot 0/3 statistics

Module Reset Statistics:
  CLI reset count = 0
  CLI reload count = 0
  Registration request timeout reset count = 0
  Error recovery timeout reset count = 0
  Module registration count = 1

```

## ucse status

To display configuration information related to the hardware and software of a server, use the **ucse status** command in privileged EXEC mode.

### E-Series Servers Installed in an ISR G2—Applicable from Cisco IOS Release 15.2(4)M to 15.4(2)T

**ucse slot status [detailed]**

### E-Series Servers and EHWIC E-Series NCE Installed in an ISR G2—Applicable in Cisco IOS Release 15.4(3)M

**ucse subslot slot/subslot status [detailed]**

#### Syntax Description

|                 |                                                                                                                                                                      |
|-----------------|----------------------------------------------------------------------------------------------------------------------------------------------------------------------|
| <i>slot</i>     | Number of the router slot in which the server module is installed.<br><b>Note</b> For the EHWIC E-Series NCE, the slot number is 0.                                  |
| <i>subslot</i>  | Number of the subslot in which the server module is installed.<br><b>Note</b> For Cisco UCS E-Series Servers and the SM E-Series NCE, the subslot number is 0.       |
| <b>detailed</b> | (Optional) Displays detail information about the Cisco E-Series Server such as the status of the service module and settings of the reset and heartbeat-reset flags. |

#### Command Modes

Privileged EXEC (#)

**Command History**

| Release  | Modification                                                                                                                                                                                                         |
|----------|----------------------------------------------------------------------------------------------------------------------------------------------------------------------------------------------------------------------|
| 15.2(4)M | This command was introduced.<br><br>This command was supported on Cisco UCS E-Series Servers (E-Series Server) installed in an ISR G2.                                                                               |
| 15.4(3)M | This command was modified to include the <b>subslot</b> keyword.<br><br>This command was supported on an additional platform: the EHWIC E-Series Network Compute Engine (EHWIC E-Series NCE) installed in an ISR G2. |

**Examples**

The following example shows how to display server status in an E-Series Server installed in an ISR G2—Applicable from Cisco IOS Release 15.2(4)M to 15.4(2)T:

```
Router# ucse 2 status

Service Module is Cisco ucse 2/0
Service Module supports session via TTY line 131
Service Module is in Steady state
Service Module reset on error is disabled
Service Module heartbeat-reset is enabled
```

**Examples**

The following example shows how to display server status in an E-Series Server or EHWIC E-Series NCE installed in an ISR G2—Applicable in Cisco IOS Release 15.4(3)M:

```
Router# ucse subslot 0/3 status

Service Module is Cisco ucse 0/3
Service Module supports session via TTY line 131
Service Module is in Steady state
Service Module reset on error is disabled
Service Module heartbeat-reset is enabled
```

# ucse stop

To immediately power down the server, use the **ucse stop** command in privileged EXEC mode.

**E-Series Servers Installed in an ISR G2—Applicable from Cisco IOS Release 15.2(4)M to 15.4(2)T**

```
ucse slot stop
```

**E-Series Servers and EHWIC E-Series NCE Installed in an ISR G2—Applicable in Cisco IOS Release 15.4(3)M**

```
ucse subslot slot/subslot stop
```

**Syntax Description**

|              |                                                                                                                                         |
|--------------|-----------------------------------------------------------------------------------------------------------------------------------------|
| <i>slot/</i> | Number of the router slot in which the server module is installed.<br><br><b>Note</b> For the EHWIC E-Series NCE, the slot number is 0. |
|--------------|-----------------------------------------------------------------------------------------------------------------------------------------|

|                |                                                                                                                                                                    |
|----------------|--------------------------------------------------------------------------------------------------------------------------------------------------------------------|
| <i>subslot</i> | Number of the subslot in which the server module is installed.<br><br><b>Note</b> For Cisco UCS E-Series Servers and the SM E-Series NCE, the subslot number is 0. |
|----------------|--------------------------------------------------------------------------------------------------------------------------------------------------------------------|

**Command Modes**

Privileged EXEC (#)

**Command History**

| Release  | Modification                                                                                                                                                                                                         |
|----------|----------------------------------------------------------------------------------------------------------------------------------------------------------------------------------------------------------------------|
| 15.2(4)M | This command was introduced.<br><br>This command was supported on Cisco UCS E-Series Servers (E-Series Server) installed in an ISR G2.                                                                               |
| 15.4(3)M | This command was modified to include the <b>subslot</b> keyword.<br><br>This command was supported on an additional platform: the EHWIC E-Series Network Compute Engine (EHWIC E-Series NCE) installed in an ISR G2. |

**Examples**

The following example shows how to power down an E-Series Server installed in an ISR G2—Applicable from Cisco IOS Release 15.2(4)M to 15.4(2)T:

```
Router# ucse 2 stop
Send server stop command
```

**Examples**

The following example shows how to power down an E-Series Server or EHWIC E-Series NCE installed in an ISR G2—Applicable in Cisco IOS Release 15.4(3)M:

```
Router# ucse subslot 0/3 stop
Send server stop command
```





## APPENDIX **C**

# Cisco IOS Software Command Reference—Cisco ISR 4000 Series

This chapter provides the new Cisco IOS commands that were introduced for the E-Series Servers installed in the Cisco ISR 4000 series.



**Note** The Cisco IOS commands are sometimes updated after original publication; therefore, for updated content, review the *Cisco IOS Interface and Hardware Component Command Reference* at <http://www.cisco.com/en/US/docs/ios-xml/ios/interface/command/ir-cr-book.html>.

This appendix includes the following sections:

- [debug platform software ucse](#), on page 163
- [hw-module subslot session](#), on page 164
- [imc ip dhcp](#), on page 165
- [platform switchport](#), on page 166
- [show interfaces ucse](#), on page 167
- [ucse subslot imc password-reset](#), on page 169
- [ucse subslot server](#), on page 170
- [ucse subslot server password-reset](#), on page 171
- [ucse subslot shutdown](#), on page 172
- [ucse subslot statistics](#), on page 173
- [ucse subslot status](#), on page 174

## debug platform software ucse

To debug the Cisco UCS E-Series Server platform software and display debug messages, use the **debug platform software ucse** command in privileged EXEC mode. To disable debug, use the **no** form of this command.

```
debug platform software ucse {all | error | normal}
no debug platform software ucse {all | error | normal}
```

### Syntax Description

|     |                                       |
|-----|---------------------------------------|
| all | Displays all platform debug messages. |
|-----|---------------------------------------|

|               |                                 |
|---------------|---------------------------------|
| <b>error</b>  | Displays error debug messages.  |
| <b>normal</b> | Displays normal debug messages. |

**Command Modes**

Privileged EXEC (#)

**Command History**

| Release                   | Modification                                                                                                                       |
|---------------------------|------------------------------------------------------------------------------------------------------------------------------------|
| Cisco IOS XE Release 3.9S | This command was introduced on the Cisco UCS E-Series Servers installed in the Cisco 4400 Series Integrated Services Router (ISR). |

**Usage Guidelines**

After you use the **debug platform software ucse all** command, use the appropriate **ucse** command to display debug messages.

**Examples**

The following example shows how to display debug messages for the **ucse subslot imc password-reset** command:

```
Router# debug platform software ucse all
Router#
Router# ucse subslot 2/0 imc password-reset
ucse2/0/0
Password reset command sent.
Router#
IMC ACK: UCSE password reset successful for IMC
ACK received for UCSE: Password Reset Command
```

## hw-module subslot session

To start or close a Cisco Integrated Management Controller (CIMC) session or host server module session, use the **hw-module subslot session** command in privileged EXEC mode.

**hw-module subslot *slot/subslot* session {imc | server}**

**Syntax Description**

|                |                                                                                                                                                                |
|----------------|----------------------------------------------------------------------------------------------------------------------------------------------------------------|
| <i>slot/</i>   | Number of the router slot in which the server module is installed.<br><b>Note</b> For the NIM E-Series NCE, the slot number is 0.                              |
| <i>subslot</i> | Number of the subslot in which the server module is installed.<br><b>Note</b> For Cisco UCS E-Series Servers and the SM E-Series NCE, the subslot number is 0. |
| <b>imc</b>     | Starts a session with CIMC.                                                                                                                                    |
| <b>server</b>  | Starts a session with the host server module.                                                                                                                  |

**Command Modes**

Privileged EXEC (#)

**Command History**

| Release                    | Modification                                                                                                                                           |
|----------------------------|--------------------------------------------------------------------------------------------------------------------------------------------------------|
| Cisco IOS XE Release 3.9S  | This command was introduced on the Cisco UCS E-Series Servers installed in the Cisco 4400 Series Integrated Services Router (ISR).                     |
| Cisco IOS XE Release 3.15S | This command was supported on an additional platform: the NIM E-Series Network Compute Engine (NIM E-Series NCE) installed in a Cisco ISR 4000 series. |

**Usage Guidelines**

Only one active session is allowed on the CIMC or server module at any time.

**Examples**

The following example shows how to start a CIMC session in an E-Series Server installed in a Cisco ISR 4000 series:

```
Router# hardware-module subslot 1/0 session imc
```

The following example shows how to start a server module session in an E-Series Server installed in a Cisco ISR 4000 series:

```
Router# hardware-module subslot 1/0 session server
```

## imc ip dhcp

To configure a DHCP IP address for the Cisco Integrated Management Controller (CIMC), use the **imc ip dhcp** command in UCSE configuration mode. To remove the DHCP IP address, use the **no** form of this command.

```
imc ip dhcp
no imc ip dhcp
```

**Syntax Description**

|                                            |
|--------------------------------------------|
| This command has no arguments or keywords. |
|--------------------------------------------|

**Command Modes**

UCSE configuration (config-ucse)

**Command History**

| Release                   | Modification                                                                                                                       |
|---------------------------|------------------------------------------------------------------------------------------------------------------------------------|
| Cisco IOS XE Release 3.9S | This command was introduced on the Cisco UCS E-Series Servers installed in the Cisco 4400 Series Integrated Services Router (ISR). |

**Examples**

The following example shows how to configure a dynamic IP address for CIMC:

```
Router# configure terminal
Enter configuration commands, one per line. End with CNTL/Z.
Router(config)# ucse subslot 1/0
```

```
Router(config-ucse)# imc ip dhcp
Router(config-ucse)#
IMC ACK: DHCP enable received for IMC.

IMC ACK: UCSE setting DHCP enable for IMC successful.
```

## platform switchport

To enable the Switch Virtual Interface (SVI) configuration on a UCS E series server, use the **platform switchport svi** command in privileged EXEC mode. To disable the configuration, use the **no** form of this command.

**platform switchport** *ucse interface* **svi**

### Syntax Description

|                       |                                                                                                        |
|-----------------------|--------------------------------------------------------------------------------------------------------|
| <i>ucse interface</i> | Number of the UCSE interface. For Cisco UCS E-Series Servers, the UCSE interface number can be 0 or 1. |
|-----------------------|--------------------------------------------------------------------------------------------------------|

### Command Modes

UCSE Config Mode (config-ucse)#

### Command History

| Release                    | Modification                                                 |
|----------------------------|--------------------------------------------------------------|
| Cisco IOS XE Release 3.15S | This command was introduced on Cisco ISR4000 Series Routers. |

### Usage Guidelines

Enabling or disabling the SVI configuration on a UCS-E subslot interface requires a module OIR or router reload after you save the configuration.

### Examples

Before you use this command, you have to set the spanning tree mode. The following example shows how to set the spanning tree mode:

```
spanning-tree vlan 1-4094 priority 24576
```

The following example shows how to enable Switch Virtual Interface (SVI) configuration on a UCS E series server:

```
ISR4k(config-ucse)#platform switchport 1 svi
Ena/Dis SVI on UCSE needs a OIR or Router reload
```

### Examples

After you use this command, the UCS-E interface shows up in the show spanning-tree command output:

```
SR4451-1#show spanning-tree

G0:VLAN0001
Spanning tree enabled protocol rstp
Root ID    Priority    24577
Address    f07f.06bc.c0b1
This bridge is the root
Hello Time 2 sec   Max Age 20 sec   Forward Delay 15 sec
```



```

Bridge ID Priority 24577 (priority 24576 sys-id-ext 1)
Address f07f.06bc.c0b1
Hello Time 2 sec Max Age 20 sec Forward Delay 15 sec
Aging Time 300

Interface Role Sts Cost Prio.Nbr Type
-----
uc1/0/0 Desg FWD 4 128.257 P2p
uc1/0/1 Desg FWD 4 128.258 P2p

G0:VLAN0003
Spanning tree enabled protocol rstp
Root ID Priority 24579
Address f07f.06bc.c0b1
This bridge is the root
Hello Time 2 sec Max Age 20 sec Forward Delay 15 sec

Bridge ID Priority 24579 (priority 24576 sys-id-ext 3)
Address f07f.06bc.c0b1
Hello Time 2 sec Max Age 20 sec Forward Delay 15 sec
Aging Time 300

Interface Role Sts Cost Prio.Nbr Type
-----
uc1/0/0 Desg FWD 4 128.257 P2p
uc1/0/1 Desg FWD 4 128.258 P2p

ISR4451-1#

```

## show interfaces ucse

To display Cisco UCS E-Series Server interface statistics, use the **show interfaces ucse** command in privileged EXEC mode.

**show interfaces ucse** *slot/subslot/ucse-interface* [**accounting** | **controller** | **counters** | **crb** | **dampening** | **description** | **etherchannel** | **history** | **irb** | **mac-accounting** | **monitor** | **mpls-exp** | **precedence** | **stats** | **summary** | **switchport**]

### Syntax Description

|                       |                                                                                                                                                                |
|-----------------------|----------------------------------------------------------------------------------------------------------------------------------------------------------------|
| <i>slot</i>           | Number of the router slot in which the server module is installed.<br><b>Note</b> For the NIM E-Series NCE, the slot number is 0.                              |
| <i>subslot</i>        | Number of the subslot in which the server module is installed.<br><b>Note</b> For Cisco UCS E-Series Servers and the SM E-Series NCE, the subslot number is 0. |
| <i>ucse-interface</i> | Number of the UCSE interface.<br><b>Note</b> For Cisco UCS E-Series Servers, the UCSE interface number can be 0 or 1.                                          |
| <b>accounting</b>     | (Optional) Displays the number of packets of each protocol type that have been sent through the interface.                                                     |

|                       |                                                                                                                   |
|-----------------------|-------------------------------------------------------------------------------------------------------------------|
| <b>controller</b>     | (Optional) Displays the interface, configuration, and controller status.                                          |
| <b>counters</b>       | (Optional) Displays the interface counters.                                                                       |
| <b>crb</b>            | (Optional) Displays interface routing or bridging information.                                                    |
| <b>dampening</b>      | (Optional) Displays interface dampening information.                                                              |
| <b>description</b>    | (Optional) Displays the interface description.                                                                    |
| <b>etherchannel</b>   | (Optional) Displays interface Ether Channel information.                                                          |
| <b>history</b>        | (Optional) Displays interface history.                                                                            |
| <b>irb</b>            | (Optional) Displays interface routing or bridging information.                                                    |
| <b>mac-accounting</b> | (Optional) Displays interface MAC accounting information.                                                         |
| <b>monitor</b>        | (Optional) Displays interface continuously.                                                                       |
| <b>mpls-exp</b>       | (Optional) Displays interface Multiprotocol Label Switching (MPLS) experimental accounting information.           |
| <b>precedence</b>     | (Optional) Displays interface precedence accounting information.                                                  |
| <b>stats</b>          | (Optional) Displays the switching path, the packets in and packets out, and the characters in and characters out. |
| <b>summary</b>        | (Optional) Displays the interface summary.                                                                        |
| <b>switchport</b>     | (Optional) Displays the switch port interface information.                                                        |

### Command Modes

Privileged EXEC (#)

### Command History

| Release                    | Modification                                                                                                                                           |
|----------------------------|--------------------------------------------------------------------------------------------------------------------------------------------------------|
| Cisco IOS XE Release 3.9S  | This command was introduced on the Cisco UCS E-Series Servers installed in the Cisco 4400 Series Integrated Services Router (ISR).                     |
| Cisco IOS XE Release 3.15S | This command was supported on an additional platform: the NIM E-Series Network Compute Engine (NIM E-Series NCE) installed in a Cisco ISR 4000 Series. |

### Examples

The following example provides sample output from the **show interfaces ucse slot/0/0 switchport** command in an E-Series Server installed in a Cisco ISR 4000 series:

```
Router# show interfaces ucse 1/0/0 switchport

Name: ucse 1/0/0
Switchport: Enabled
Administrative mode: trunk
Operational Mode: trunk
```

```
Administrative Trunking Encapsulation: dot1q
Operational Trunking Encapsulation: native
Negotiation of Trunking: Disabled
Trunking Native Mode VLAN: 2352
Trunking VLANs Enabled: 1-2349,2450-4094
Voice VLAN: none
```

## ucse subslot imc password-reset

To reset the Cisco Integrated Management Controller (CIMC) password, use the **ucse subslot imc password-reset** command in privileged EXEC mode.

**ucse subslot *slot/subslot* imc password-reset**

### Syntax Description

|                |                                                                                                                                                                |
|----------------|----------------------------------------------------------------------------------------------------------------------------------------------------------------|
| <i>slot</i>    | Number of the router slot in which the server module is installed.<br><b>Note</b> For the NIM E-Series NCE, the slot number is 0.                              |
| <i>subslot</i> | Number of the subslot in which the server module is installed.<br><b>Note</b> For Cisco UCS E-Series Servers and the SM E-Series NCE, the subslot number is 0. |

### Command Modes

Privileged EXEC (#)

### Command History

| Release                    | Modification                                                                                                                                           |
|----------------------------|--------------------------------------------------------------------------------------------------------------------------------------------------------|
| Cisco IOS XE Release 3.9S  | This command was introduced on the Cisco UCS E-Series Servers installed in the Cisco 4400 Series Integrated Services Router (ISR).                     |
| Cisco IOS XE Release 3.15S | This command was supported on an additional platform: the NIM E-Series Network Compute Engine (NIM E-Series NCE) installed in a Cisco ISR 4000 Series. |

### Usage Guidelines

After you enter this command, at the next login, the system requests that you set a new password to access CIMC.

### Examples

The following example shows how to reset the CIMC password in an E-Series Server installed in a Cisco ISR 4000 series:

```
Router# ucse subslot 1/0 imc password-reset
Router#
IMC ACK: UCSE password reset successful for IMC
```

## ucse subslot server

To reload, reset, start, or stop the hardware on the server module, use the **ucse subslot server** command in privileged EXEC mode.

**ucse subslot slot/subslot server {reload | reset | start | stop}**

### Syntax Description

|                |                                                                                                                                                                                                                                                                                                                                                                                                                                                                                                                                                                                                   |
|----------------|---------------------------------------------------------------------------------------------------------------------------------------------------------------------------------------------------------------------------------------------------------------------------------------------------------------------------------------------------------------------------------------------------------------------------------------------------------------------------------------------------------------------------------------------------------------------------------------------------|
| <i>slot/</i>   | Number of the router slot in which the server module is installed.<br><b>Note</b> For the NIM E-Series NCE, the slot number is 0.                                                                                                                                                                                                                                                                                                                                                                                                                                                                 |
| <i>subslot</i> | Number of the subslot in which the server module is installed.<br><b>Note</b> For Cisco UCS E-Series Servers and the SM E-Series NCE, the subslot number is 0.                                                                                                                                                                                                                                                                                                                                                                                                                                    |
| <b>reload</b>  | Powers down the server module and then powers it on.<br><b>Note</b> The <b>reload</b> keyword is not supported on the NIM E-Series-NCE. Instead, we recommend that you use the following commands from the router:<br><br><ol style="list-style-type: none"> <li>1. Router # <b>ucse subslot slot/subslot shutdown</b></li> <li>2. Router # <b>ucse subslot slot/subslot start</b></li> </ol> If a reload is necessary, use the following command:<br>Router # <b>hw-module subslot 0/NIM-slot-number reload</b><br><b>Note</b> This command power-cycles the module. The CIMC and server reboot. |
| <b>reset</b>   | Resets the hardware on the server module.                                                                                                                                                                                                                                                                                                                                                                                                                                                                                                                                                         |
| <b>start</b>   | Powers on the server module.                                                                                                                                                                                                                                                                                                                                                                                                                                                                                                                                                                      |
| <b>stop</b>    | Immediately powers down the server module.<br><b>Note</b> The <b>stop</b> keyword is not supported on the NIM E-Series-NCE. Instead, we recommend that you use the following command from the router:<br><br>Router # <b>ucse subslot slot/subslot shutdown</b><br>If it is necessary to do an immediate power down of the server, use the following command:<br>Router # <b>hw-module subslot 0/NIM-slot-number stop</b><br><b>Note</b> This command powers down the module. The CIMC and server power off.                                                                                      |

### Command Modes

Privileged EXEC (#)

| Command History | Release                    | Modification                                                                                                                                           |
|-----------------|----------------------------|--------------------------------------------------------------------------------------------------------------------------------------------------------|
|                 | Cisco IOS XE Release 3.9S  | This command was introduced on the Cisco UCS E-Series Servers installed in the Cisco 4400 Series Integrated Services Router (ISR).                     |
|                 | Cisco IOS XE Release 3.15S | This command was supported on an additional platform: the NIM E-Series Network Compute Engine (NIM E-Series NCE) installed in a Cisco ISR 4000 Series. |

### Usage Guidelines

Use the **reset** keyword only to recover from a shutdown or failed state.



#### Caution

Using the **reset** keyword does *not* provide an orderly software shutdown and may impact file operations that are in progress.

### Examples

The following example shows how to reload the E-Series Server installed in a Cisco ISR 4000 series:

```
Router# ucse subslot 1/0 server reload
Router#
IMC ACK: UCSE Server reload successful.
```

The following example shows how to reset the E-Series Server installed in a Cisco ISR 4000 series:

```
Router# ucse subslot 1/0 server reset
Router#
IMC ACK: UCSE Server reset successful.
```

The following example shows how to start the E-Series Server installed in a Cisco ISR 4000 series:

```
Router# ucse subslot 1/0 server start
Router#
IMC ACK: UCSE Server start successful.
```

The following example shows how to stop the E-Series Server installed in a Cisco ISR 4000 series:

```
Router# ucse subslot 1/0 server stop
Router#
IMC ACK: UCSE Server stop successful.
```

## ucse subslot server password-reset

To reset the BIOS or RAID password, use the **ucse subslot server password-reset** command in privileged EXEC mode.

```
ucse subslot slot/subslot server password-reset {BIOS | RAID}
```

**Syntax Description**

|                |                                                                                                                                                                |
|----------------|----------------------------------------------------------------------------------------------------------------------------------------------------------------|
| <i>slot/</i>   | Number of the router slot in which the server module is installed.<br><b>Note</b> For the NIM E-Series NCE, the slot number is 0.                              |
| <i>subslot</i> | Number of the subslot in which the server module is installed.<br><b>Note</b> For Cisco UCS E-Series Servers and the SM E-Series NCE, the subslot number is 0. |
| <b>BIOS</b>    | Resets the BIOS password.                                                                                                                                      |
| <b>RAID</b>    | Resets the RAID password.<br><b>Note</b> RAID is not supported on the NIM E-Series NCE.                                                                        |

**Command Modes**

Privileged EXEC (#)

**Command History**

| Release                    | Modification                                                                                                                                           |
|----------------------------|--------------------------------------------------------------------------------------------------------------------------------------------------------|
| Cisco IOS XE Release 3.9S  | This command was introduced on the Cisco UCS E-Series Servers installed in the Cisco 4400 Series Integrated Services Router (ISR).                     |
| Cisco IOS XE Release 3.15S | This command was supported on an additional platform: the NIM E-Series Network Compute Engine (NIM E-Series NCE) installed in a Cisco ISR 4000 Series. |

**Usage Guidelines**

After you enter this command, at the next login, the system requests that you set a new password to access BIOS or configure RAID.

**Examples**

The following example shows how to reset the BIOS password in an E-Series Server installed in a Cisco ISR 4000 series:

```
Router# ucse subslot 1/0 server password-reset BIOS
Router#
IMC ACK: UCSE password reset successful for BIOS
```

The following example shows how to reset the RAID password in an E-Series Server installed in a Cisco ISR 4000 series:

```
Router# ucse subslot 1/0 server password-reset RAID
Router#
IMC ACK: UCSE password reset successful for RAID
```

## ucse subslot shutdown

To gracefully shut down the server module, use the **ucse subslot shutdown** command in privileged EXEC mode.

**ucse subslot slot/subslot shutdown**

|                           |                |                                                                                                                                                                |
|---------------------------|----------------|----------------------------------------------------------------------------------------------------------------------------------------------------------------|
| <b>Syntax Description</b> | <i>slot</i>    | Number of the router slot in which the server module is installed.<br><b>Note</b> For the NIM E-Series NCE, the slot number is 0.                              |
|                           | <i>subslot</i> | Number of the subslot in which the server module is installed.<br><b>Note</b> For Cisco UCS E-Series Servers and the SM E-Series NCE, the subslot number is 0. |

**Command Modes**

Privileged EXEC (#)

**Command History**

| Release                    | Modification                                                                                                                                           |
|----------------------------|--------------------------------------------------------------------------------------------------------------------------------------------------------|
| Cisco IOS XE Release 3.9S  | This command was introduced on the Cisco UCS E-Series Servers installed in the Cisco 4400 Series Integrated Services Router (ISR).                     |
| Cisco IOS XE Release 3.15S | This command was supported on an additional platform: the NIM E-Series Network Compute Engine (NIM E-Series NCE) installed in a Cisco ISR 4000 Series. |

**Usage Guidelines**

The NIM E-Series NCE might take up to 60 seconds to shut down. After two or three shut down attempts, if the NIM E-Series NCE does not shut down, enter the following commands from the router:

1. Router # **hw-module subslot 0/NIM-slot-number stop**
2. Router # **hw-module subslot 0/NIM-slot-number start**

**Examples**

The following example shows how to shut down an E-Series Server installed in a Cisco ISR 4000 series:

```
Router# ucse subslot 1/0 shutdown
Router#
IMC ACK: UCSE Server shutdown successful.
```

## ucse subslot statistics

To display or clear server module statistics, use the **ucse subslot statistics** command in privileged EXEC mode.

**ucse subslot slot/subslot statistics [clear]**

|                           |             |                                                                                                                                   |
|---------------------------|-------------|-----------------------------------------------------------------------------------------------------------------------------------|
| <b>Syntax Description</b> | <i>slot</i> | Number of the router slot in which the server module is installed.<br><b>Note</b> For the NIM E-Series NCE, the slot number is 0. |
|---------------------------|-------------|-----------------------------------------------------------------------------------------------------------------------------------|

|                |                                                                                                                                                                    |
|----------------|--------------------------------------------------------------------------------------------------------------------------------------------------------------------|
| <i>subslot</i> | Number of the subslot in which the server module is installed.<br><br><b>Note</b> For Cisco UCS E-Series Servers and the SM E-Series NCE, the subslot number is 0. |
| <b>clear</b>   | (Optional) Clears the server module statistics.                                                                                                                    |

**Command Modes**

Privileged EXEC (#)

**Command History**

| Release                    | Modification                                                                                                                                           |
|----------------------------|--------------------------------------------------------------------------------------------------------------------------------------------------------|
| Cisco IOS XE Release 3.9S  | This command was introduced on the Cisco UCS E-Series Servers installed in the Cisco 4400 Series Integrated Services Router (ISR).                     |
| Cisco IOS XE Release 3.15S | This command was supported on an additional platform: the NIM E-Series Network Compute Engine (NIM E-Series NCE) installed in a Cisco ISR 4000 Series. |

**Examples**

The following example shows how to display the statistics of an E-Series Server:

```
Router# ucse subslot 1/0 statistics
Count of number of shutdowns command : 1
Count of number of status commands : 0
Count of number of server raid password : 1
Count of number of imc password-reset : 2
Count of number of server bios password reset : 1
Count of number of server reload : 1
Count of number of server reset : 1
Count of number of server start : 1
Count of number of server stop : 1
Count of number of vlan commands : 0
Count of number of access-port commands : 1
Count of number of IMC configured IP or DHCP commands: 1
```

## ucse subslot status

To display configuration information related to the hardware and software on the server module, use the **ucse subslot status** command in privileged EXEC mode.

**ucse subslot *slots/subslot* status [detailed]**

**Syntax Description**

|                |                                                                                                                                                                    |
|----------------|--------------------------------------------------------------------------------------------------------------------------------------------------------------------|
| <i>slot/</i>   | Number of the router slot in which the server module is installed.<br><br><b>Note</b> For the NIM E-Series NCE, the slot number is 0.                              |
| <i>subslot</i> | Number of the subslot in which the server module is installed.<br><br><b>Note</b> For Cisco UCS E-Series Servers and the SM E-Series NCE, the subslot number is 0. |



|                 |                                                                                                                                           |
|-----------------|-------------------------------------------------------------------------------------------------------------------------------------------|
| <b>detailed</b> | (Optional) Displays detailed information about the server module, such as its status and settings of the reset and heartbeat-reset flags. |
|-----------------|-------------------------------------------------------------------------------------------------------------------------------------------|

**Command Modes**

Privileged EXEC (#)

**Command History**

| Release                    | Modification                                                                                                                                           |
|----------------------------|--------------------------------------------------------------------------------------------------------------------------------------------------------|
| Cisco IOS XE Release 3.9S  | This command was introduced on the Cisco UCS E-Series Servers installed in the Cisco 4400 Series Integrated Services Router (ISR).                     |
| Cisco IOS XE Release 3.15S | This command was supported on an additional platform: the NIM E-Series Network Compute Engine (NIM E-Series NCE) installed in a Cisco ISR 4000 Series. |

**Examples**

The following example shows how to display the status of an E-Series Server:

```

Router# ucse subslot 1/0 status
CPU info
  Name           Cores   Version
  -----
  CPU1           4       Intel(R) Xeon(R) CPU E5-2418L 0 @ 2.00GHz

Memory info
  Name           Capacity   Channel Speed (MHz) Channel Type
  -----
  Node0_Dimm0    Not Installed   Unknown           Unknown
  Node0_Dimm1    16384 MB      1333              DDR3
  Node0_Dimm2    8192 MB       1333              DDR3

Hard drive info
  Slot Number Controller Status           Manufacturer Model Drive
  Firmware Coerced Size Type SED
  -----
  1           SLOT-5   online           ATA           ST91000640NS CC02
  952720 MB   HDD   false
  2           SLOT-5   online           ATA           ST91000640NS CC02
  952720 MB   HDD   false
  3           SLOT-5   online           ATA           ST91000640NS CC02
  952720 MB   HDD   false

Virtual drive info
  Virtual Drive Status           Name           Size           RAID Level
  -----
  0           Optimal           1905440 MB RAID 5

PCI card info
  Name           Name           Slot           Vendor ID           Device ID           Product
  -----
  PCIe Adapter1  0           0xe414           0x5716           Broadcom
  5719 1 Gbps 4...

```

```
      PCIe Adapter2      2      0x0010      0x7300      LSI 9240-8i  
MegaRAID S...
```

```
Network Setting
```

```
IPv4 Address: 10.1.1.2  
IPv4 Netmask: 255.255.255.0  
IPv4 Gateway: 10.1.1.1
```

```
NIC Mode: shared_lom  
NIC Redundancy: none  
NIC Interface: gel
```



## INDEX

- B**
- basic workflow [9, 11, 15](#)
    - installing the E-Series Server or NCE into router [15](#)
    - option 1 [9](#)
    - option 2 [11](#)
    - option 3 [11](#)
  - BIOS [98, 135](#)
    - obtaining firmware from Cisco [98](#)
    - obtaining firmware from Cisco options [135](#)
  - BIOS setup [106](#)
  - boot order, configuring [104](#)
- C**
- CIMC [23, 98, 135](#)
    - firmware [23](#)
    - updating [23](#)
  - CIMC access [25, 27, 29, 32, 34, 37, 40, 42, 43, 46, 50, 52, 55, 58, 61, 64, 65, 66, 69, 72, 74](#)
    - configuration options [27, 40, 64](#)
    - EHWIC E-Series NCE configuration options [55](#)
    - NIC interface configuration options [42, 66](#)
    - shared LOM configuration options [29](#)
    - using CIMC Configuration Utility [74](#)
    - using console interface [29, 55](#)
    - using G2 interface [72](#)
    - using G2 or G3 interface [37, 50](#)
    - using internal MGF interface using a non-native VLAN [34](#)
    - using internal MGF VLAN interface [32, 58](#)
    - using management (dedicated) interface [27, 40, 65](#)
    - using NCE's G2 interface [61](#)
    - using TE2 or TE3 interface [52](#)
  - CIMC CLI [80](#)
  - CIMC GUI [80, 82](#)
  - CIMC overview [79](#)
  - common terms [12](#)
  - compatibility [16, 17](#)
    - verifying [16, 17](#)
  - configuring [25](#)
  - configuring boot order [106](#)
- E**
- E-Series Server [5, 7, 8, 17, 20](#)
    - installing into the router [17](#)
    - managing [7](#)
    - options [8](#)
    - overview [5](#)
    - verifying, installation [20](#)
  - E-Series Server and Cisco ISR 4000 series interfaces [38](#)
    - understanding [38](#)
  - E-Series Server and ISR G2 interfaces [25](#)
    - understanding [25](#)
  - EVC using native VLAN between the NIM e-series NCE and the Cisco ISR 4000 Series [126](#)
    - creating [126](#)
  - EVC using native VLAN between the server and the Cisco ISR 4000 Series [116](#)
    - creating [116](#)
  - EVC using non-native VLAN between the NIM e-series NCE and the Cisco ISR 4000 Series [127](#)
    - creating [127](#)
  - EVC using non-native VLAN between the server and the Cisco ISR 4000 Series [118](#)
    - creating [118](#)
- F**
- firmware [23, 98, 135](#)
    - obtaining from Cisco [98](#)
    - updating [23](#)
    - upgrading [135](#)
- H**
- host image [95, 100](#)
    - unmapping [100](#)
  - HUU [136, 137](#)
    - available CIMC and BIOS firmware [137](#)
    - overview [136](#)
- I**
- installing [103](#)

interface [27, 29, 32, 34, 37, 40, 43, 46, 50, 52, 55, 58, 61, 65, 66, 69, 72](#)  
 CIMC access using console interface [29, 55](#)  
 CIMC access using E-Series Server's internal GE0 interface and router's ucse *slot/0/0* interface [43](#)  
 CIMC access using E-Series Server's internal GE1 interface and router's ucse *slot/0/1* interface [46](#)  
 CIMC access using G2 or G3 interface [37, 50](#)  
 CIMC access using internal MGF interface using a non-native VLAN [34](#)  
 CIMC access using internal MGF VLAN interface [32, 58](#)  
 CIMC access using management interface [27, 40, 65](#)  
 CIMC access using NCE's GE2 interface [61](#)  
 CIMC access using NIM E-Series NCE's G2 interface [72](#)  
 CIMC access using NIM E-Series NCE's internal GE0 interface and router's ucse *0/subslot/0* interface [66](#)  
 CIMC access using NIM E-Series NCE's internal GE1 interface and router's ucse *0/slot/1* interface [69](#)  
 CIMC access using TE2 or TE3 interface [52](#)

## K

KVM console [92](#)

## L

Linux [132](#)  
 logging in [81](#)

## M

mapping [95](#)  
 Microsoft Windows [132](#)  
 Microsoft Windows Server, accessing [108](#)  
   option 2 [108](#)

## N

NCE [5, 17, 21](#)  
   installing into the router [17](#)  
   overview [5](#)  
   verifying, installation [21](#)  
 NCE and ISR G2 interfaces [54](#)  
   understanding [54](#)  
 network interface mapping [130](#)  
 Network Static Settings [76](#)  
   defining, using a script file [76](#)  
 NIM E-Series NCE [22](#)  
   verifying, installation [22](#)  
 NIM E-Series NCE and Cisco ISR 4000 series interfaces [63](#)  
   understanding [63](#)

## O

operating system installation [93](#)

OS installation [91, 93, 94](#)  
   KVM console [93](#)  
   methods [91](#)  
   PXE [94](#)

## P

PXE installation [94](#)

## Q

quick start basic configuration tasks [1](#)

## R

RAID, configuring [84, 88, 89](#)  
   using CIMC GUI [84](#)  
   using WebBIOS [88, 89](#)  
 reset [23](#)  
   stopping [23](#)  
 router and e-series server [111, 114](#)  
   configuring connection [111, 114](#)  
 router and NCE [120](#)  
   configuring connection [120](#)  
 router and NIM e-series NCE [123](#)  
   configuring connection [123](#)  
 router configuration [147, 148](#)  
   differences between Cisco ISR G2 and Cisco ISR 4000 Series [147](#)  
   differences between E-Series Server and EHWIC E-Series NCE [148](#)

## S

server management [104](#)  
   configuring the boot order [104](#)  
 server software [6](#)  
 software [101](#)  
   obtaining from VMware [101](#)

## U

using CIMC GUI [104](#)

## V

VMware [101](#)  
   obtaining software [101](#)  
 VMware vSphere Hypervisor [101, 102, 108, 132](#)  
   accessing [108](#)  
   assigning a static IP address [102](#)  
   installation, basic workflow [101](#)  
   option 3 [108](#)  
 vSphere client [103](#)  
   downloading [103](#)