



This product is intended for use with UL Listed products and must be installed by a qualified professional installer.

IMPORTANT! Read entire instruction sheet before you start installation and assembly.

Compatible with:	PRG-1, PRGS-1, PRSS-1, PJF2 series, PAG series
------------------	--

Before you start check the parts list below to make sure all of the parts shown are included.

CAUTION

- It is the responsibility of the installer to ensure that the projector is properly ventilated. Spacers are provided to raise the mount off the projector surface.

⚠ WARNING

- Installer must verify that the ceiling will safely support four times the combined weight of all attached equipment and hardware.

Parts List		Qty.	PAP UNV	PAP UNV-S	PAP UNV-W
AA	adapter plate (without connection block)	1	055-1867	055-4867	055-2867
	adapter plate (with connection block)	1	055-1879	055-4879	055-2879
BB	M3 x 8mm serrated washer head socket pin screw (not shown)	4	510-1004	510-2004	510-2004
CC	M4 x 10mm serrated washer head socket pin screw (not shown)	4	510-1060	510-2060	510-2060
DD	M5 x 10mm serrated washer head socket pin screw (not shown)	4	510-1126	510-2063	510-2063
EE	M6 x 10mm serrated washer head socket pin screw (not shown)	4	510-1066	510-2066	510-2066
FF	4mm security allen wrench (for PAP only)	1	560-9646	560-9646	560-9646
GG	2mm security allen wrench	1	560-1097	560-1097	560-1097
HH	washer	4	540-1025	540-2025	540-2025
II	M5 x 20mm serrated washer head socket pin screw (not shown)	4	510-1065	510-2065	510-2065

Note: Actual parts may appear slightly different than illustrated.

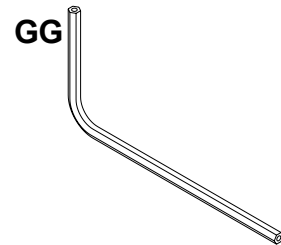
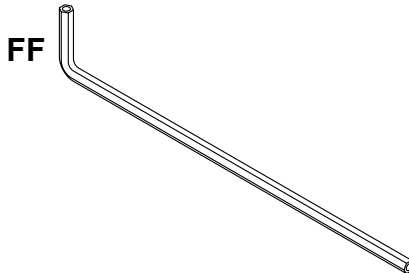
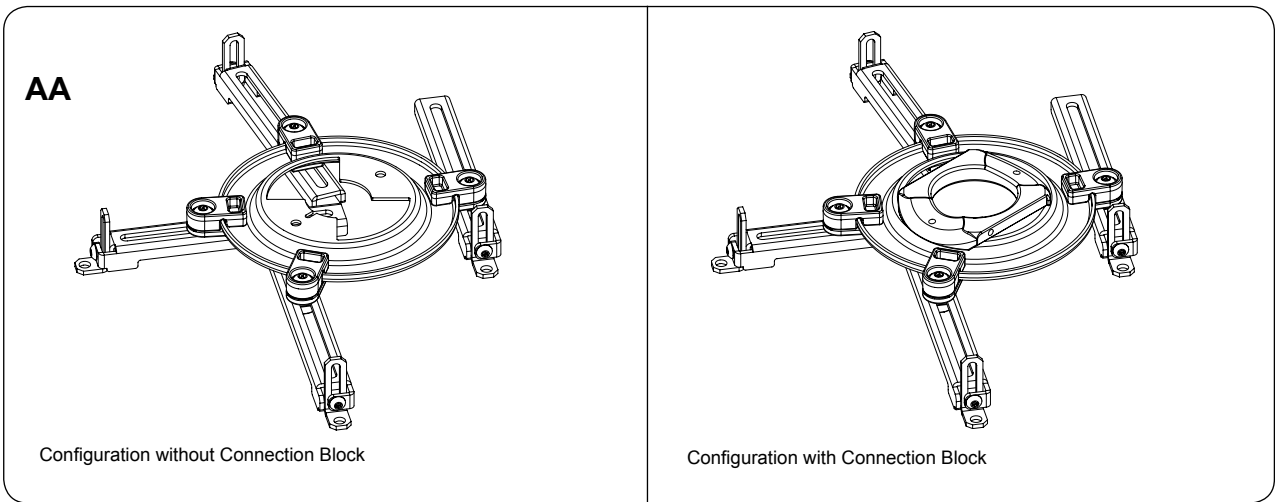

Note: The projector you are installing may differ in appearance from the sample illustrated below.

- 1 Place projector upside down. Locate adapter plate (**AA**) with notch facing forward as close to projector center of gravity as possible without covering any mounting holes. Loosen channels, and if there are only three mounting holes remove fourth channel. Using one channel for each mounting hole, position feet of channels over mounting holes as shown below. **Important:** If projector does not have at least three mounting holes, do not use this adapter plate.

Note: Some projectors have feet which can be removed and the corresponding threaded insert can be used for a mounting hole.

Note: Once channels are in position retighten fasteners.

*Notch indicates front of projector.

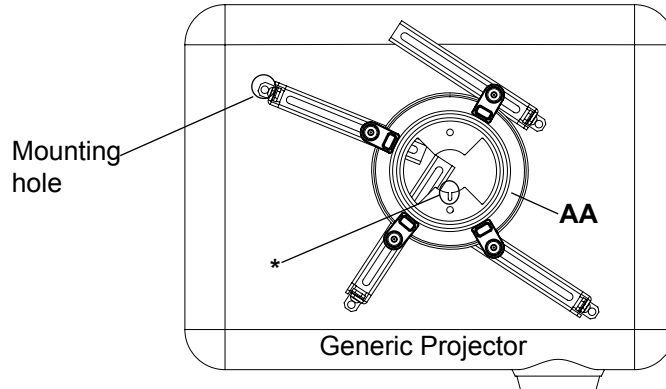

- 2 Attach adapter plate (**AA**) to projector using one screw (**BB, CC, DD, EE, or II**) for each channel as shown below. Tighten all screws, while keeping the center of gravity. Be sure that adapter plate (**AA**) is straight. Adjust the feet of the channels to keep the adapter plate level. Tighten all screws with 4 mm security allen wrench (**FF**) or wrench provided with projector mount, while keeping the center of gravity. If M3 screws are used, tighten using 2 mm security allen wrench (**GG**).

Note: Projectors will require different size screws for mounting. Use a combination of screws (**BB, CC, DD, EE, or II**) and foot adjustment that will result in channels of adapter plate (**AA**) fitting tightly against projector.

Important: In order to properly engage the threads in the mounting holes, the screw must be turned at least 3 full turns.

Note: If using screw (**BB**), place washer (**HH**) between screw (**BB**) and foot of channel.

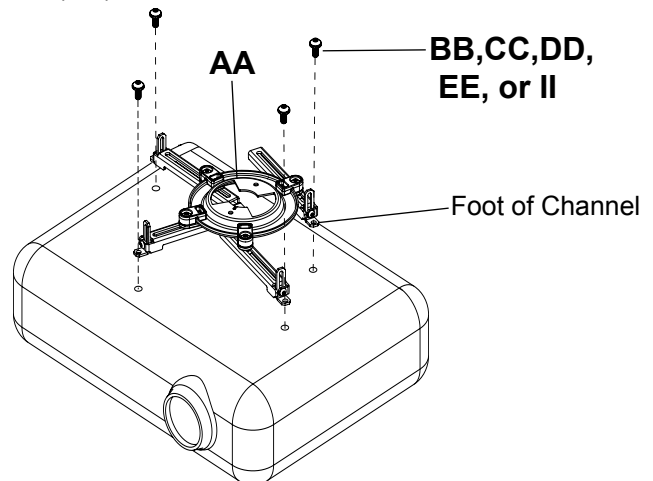

CAUTION

- It is the responsibility of the installer to ensure that the projector is properly ventilated. Feet of channels are used to raise the mount off the projector surface.