

# GV-IP Camera

## *User's Manual*



- GV-EBD4700 / 4711 IR Eyeball IP Dome
- GV-ABL2701 / 4701 / 4712 IR Bullet IP Camera
- GV-ADR2701 / 4710 IR Mini Fixed Rugged IP Dome
- GV-AVD4710 IR Vandal Proof IP Dome

Before attempting to connect or operate this product, please read these instructions carefully and save this manual for future use.



© 2018 GeoVision, Inc. All rights reserved.

Under the copyright laws, this manual may not be copied, in whole or in part, without the written consent of GeoVision.

Every effort has been made to ensure that the information in this manual is accurate. GeoVision, Inc. makes no expressed or implied warranty of any kind and assumes no responsibility for errors or omissions. No liability is assumed for incidental or consequential damages arising from the use of the information or products contained herein. Features and specifications are subject to change without notice.

**Note:** No memory card slot or local storage function for Argentina.

GeoVision, Inc.  
9F, No. 246, Sec. 1, Neihu Rd.,  
Neihu District, Taipei, Taiwan  
Tel: +886-2-8797-8377  
Fax: +886-2-8797-8335  
<http://www.geovision.com.tw>

Trademarks used in this manual: *GeoVision*, the *GeoVision* logo and GV series products are trademarks of GeoVision, Inc. *Windows* is the registered trademark of Microsoft Corporation.

May, 2018

# Preface

Welcome to the *GV-EBD Series IR Eyeball IP Dome*, *GV-ABL Series Bullet IP Camera* and *GV-ADR Series Mini Fixed Rugged IP Dome*, *GV-AVD Series Vandal Proof IP Camera User's Manual*.

This Manual is designed for the following models and firmware versions:

<b>Model</b>	<b>Model Number</b>	<b>Firmware Version</b>
IR Eyeball Dome	GV-EBD2702	V1.00
IR Eyeball Dome	GV-EBD4700	V1.04
IR Eyeball Dome	GV-EBD4711	V1.04
Bullet IP Camera	GV-ABL2701	V1.00
Bullet IP Camera	GV-ABL4701	V1.04
Bullet IP Camera	GV-ABL4712	V1.00
Mini Fixed Rugged IP Dome	GV-ADR2701	V1.00
Mini Fixed Rugged IP Dome	GV-ADR4701	V1.04
Vandal Proof IP Dome	GV-AVD4710	V1.00

# Contents

<b>Naming Definition.....</b>	<b>V</b>
<b>Note for Connecting to GV-VMS / DVR / NVR .....</b>	<b>vi</b>
<b>Note for Installing Camera Outdoor .....</b>	<b>vii</b>
<b>Chapter 1 Introduction .....</b>	<b>1</b>
1.1 GV-EBD2702 / 4700 / 4711.....	1
1.1.1 Packing List .....	2
1.1.2 Optional Accessories.....	3
1.1.3 Overview.....	4
1.1.3.1 GV-EBD2702 / 4700 .....	4
1.1.3.2 GV-EBD4711 .....	5
1.1.4 Installation .....	6
1.1.4.1 GV-EBD2702 / 4700 Standard Installation .....	6
1.1.4.2 GV-EBD4711 Standard Installation .....	9
1.1.5 Optional Installation .....	12
1.1.5.1 GV-Mount211P .....	12
1.1.5.2 GV-Mount212P.....	18
1.2 GV-ABL2701 / 4701 / 4712 .....	23
1.2.1 Packing List .....	24
1.2.2 Optional Accessories.....	25
1.2.3 Overview.....	26
1.2.3.1 GV-ABL2701 / 4701.....	26
1.2.3.2 GV-ABL4712.....	27
1.2.4 Installation .....	28
1.2.5 Optional Installation .....	31
1.2.5.1 GV-Mount502 .....	32
1.2.5.2 GV-Mount503 .....	36
1.3 GV-ADR2701 / 4701.....	39
1.3.1 Packing List .....	40
1.3.2 Optional Accessories.....	41
1.3.3 Overview.....	42
1.3.4 Installation .....	43
1.3.5 Optional Installation .....	46
1.3.5.1 GV-Mount211P .....	46

1.3.5.2	GV-Mount213 .....	46
1.4	GV-AVD4710.....	50
1.4.1	Packing List .....	51
1.4.2	Optional Accessories.....	52
1.4.3	Overview.....	53
1.4.4	Installation .....	54
1.4.5	Optional Installation .....	56
1.4.5.1	GV-Mount211-2 .....	56
1.4.5.2	GV-Mount212-2 .....	59
1.5	System Requirements .....	62
1.6	Waterproofing the Cable.....	63
<b>Chapter 2 Accessing the Camera.....</b>		<b>65</b>
2.1	Installing on a Network .....	65
2.1.1	Checking the Dynamic IP Address .....	66
2.1.2	Assigning an IP Address .....	68
2.2	Accessing Live View.....	69
2.2.1	The Live View Window .....	70
2.3	Playing Back Recorded Videos .....	73
2.3.1	The Playback Window .....	74
2.3.1.1	Recording Download .....	75
<b>Chapter 3 Administrator Mode .....</b>		<b>76</b>
3.1	Common.....	78
3.1.1	Basic Info.....	78
3.1.2	Local Settings.....	79
3.2	Network .....	81
3.2.1	Ethernet .....	81
3.2.2	DNS .....	82
3.2.3	Port.....	83
3.2.4	DDNS .....	84
3.2.5	E-mail .....	86
3.2.6	802.1x.....	87
3.3	Video & Audio.....	88
3.3.1	Video .....	88
3.3.2	Snapshot .....	90
3.3.3	Audio .....	91
3.3.4	ROI .....	92

3.3.5	Media Stream .....	93
3.4	Image.....	95
3.4.1	Image.....	95
3.4.2	OSD .....	101
3.4.2.1	For all models except GV-EBD2702.....	101
3.4.2.2	For GV-EBD2702.....	102
3.4.3	Privacy Mask .....	103
3.5	Events .....	104
3.5.1	Motion Detection.....	104
3.5.2	Tampering Alarm .....	107
3.5.3	Audio Detection .....	108
3.5.4	Alarm Input .....	109
3.5.5	Alarm Output .....	110
3.6	Storage.....	111
3.6.1	Storage .....	111
3.6.2	FTP.....	113
3.7	Security.....	115
3.7.1	User .....	115
3.7.2	Network Security .....	116
3.8	System.....	119
3.8.2	Maintenance.....	121
<b>Chapter 4 Advanced Applications .....</b>		<b>122</b>
4.1	Upgrading System Firmware .....	122
4.1.1	Using the Web Interface .....	123
4.1.2	Using GV-IP Device Utility.....	124
4.2	Restoring to Factory Default Settings.....	125
<b>Chapter 5 DVR / NVR / VMS .....</b>		<b>126</b>
5.1	Setting Up IP Cameras on GV-DVR / NVR .....	127
5.1.1	Customizing the Basic Settings on GV-DVR / NVR .....	129
5.2	Setting Up IP Cameras on GV-VMS.....	130
<b>Appendix .....</b>		<b>132</b>
A.	RTSP Multicast Protocol Support .....	132
B.	RTSP Protocol Support.....	133
C.	HTTP Protocol Support.....	134

# Naming Definition

<b>GV-DVR / NVR</b>	GeoVision Analog and Digital Video Recording Software. The GV-DVR also refers to <b>GV-Multicam System</b> or <b>GV-Hybrid DVR</b> .
<b>GV-VMS</b>	GeoVision Video Management System for IP cameras.

## **Note for Connecting to GV-VMS / DVR / NVR**

The GV-IPCAM in this Manual is designed to work with and record on GV-VMS / DVR / NVR, a video management system. Once the camera is connected to the GV-VMS / DVR / NVR, the resolution set on the GV-VMS / DVR / NVR will override the resolution set on the camera's Web interface. You can only change the resolution settings through the Web interface when the connection to the GV-VMS / DVR / NVR is interrupted.



# Note for Installing Camera Outdoor

When installing the camera outdoor, be sure that:

- 1. The camera is set up above the junction box to prevent water from entering the camera along the cables.

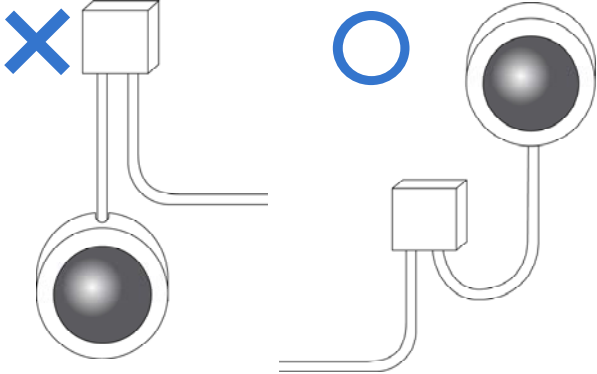

- 2. Any PoE, power, audio and I/O cables are waterproofed using waterproof silicon rubber or the like.

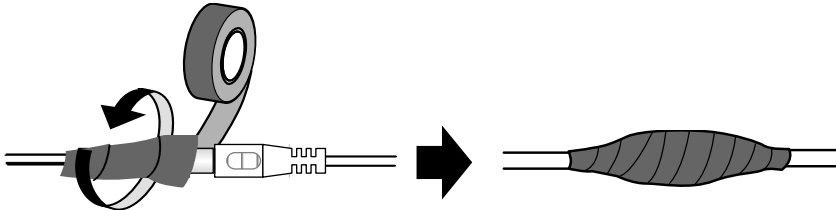

- 3. The screws are tightened and the cover is in place after opening the camera cover.

# Chapter 1 Introduction

## 1.1 GV-EBD2702 / 4700 / 4711

The H.265 Target Eyeball Dome is an outdoor, network camera equipped with an automatic IR-cut filter and IR LEDs for day and night surveillance. GV-EBD2702 / 4711 adheres to IP67 standards, whereas GV-EBD4700 adheres to IP66. The camera supports H.265 video codec to achieve better compression ratio while maintaining high quality image at reduced network bandwidths. With its WDR Pro (WDR for GV-EBD2702), It can process scenes with contrasting intensity of lights and produce clear image.

For **GV-EBD4711**, with its motorized lens, the user can zoom and focus the camera from the Web interface. The camera also provides built-in micro SD card slot for local storage.

Model No.		Specifications	Description
GV-EBD2702	Fixed lens	Fixed Iris, f: 2.8 mm, F/1.8, M12 Lens Mount	2 MP, H.265, Low Lux, WDR
GV-EBD4700	Fixed lens		4 MP, H.265, Low Lux, WDR Pro
GV-EBD4711	Motorized varifocal lens	Fixed Iris, f: 2.7 ~ 12 mm, F/1.4, M12 Lens Mount	4 MP, H.265, Low Lux, WDR Pro

### 1.1.1 Packing List

- H.265 Target Eyeball Dome

- Screw x 3



- Screw Anchor x 3



- Drill Template Paster



- Waterproof Rubber Set





- Download Guide

- Warranty Card

### 1.1.2 Optional Accessories

Optional accessories can expand the capabilities and versatility of your camera. Contact your dealer for more information.

Model Number	Name	Details
GV-Mount211P	Wall Mount Bracket 	Dimensions: 233 x 126 x 126 mm (9.2" x 5" x 5") Weight: 1 kg (2.2 lb)
GV-Mount212P	Wall Box Mount 	Dimensions: Ø 126 x 36 mm (5.0" x 1.4") Weight: 0.22 kg (0.48 lb)
GV-PA191	Power over Ethernet (PoE) Adapter 	GV-PA191 is a Power over Ethernet (PoE) adapter designed to provide power to the IP device through a single Ethernet cable.
GV-POE Switch	GV-POE Switch is designed to provide power along with network connection for IP devices. GV-PoE Switch is available in various models with different numbers and types of ports.	
Power Adapter	Contact our sales representatives for the countries and areas supported.	

### 1.1.3 Overview

#### 1.1.3.1 GV-EBD2702 / 4700

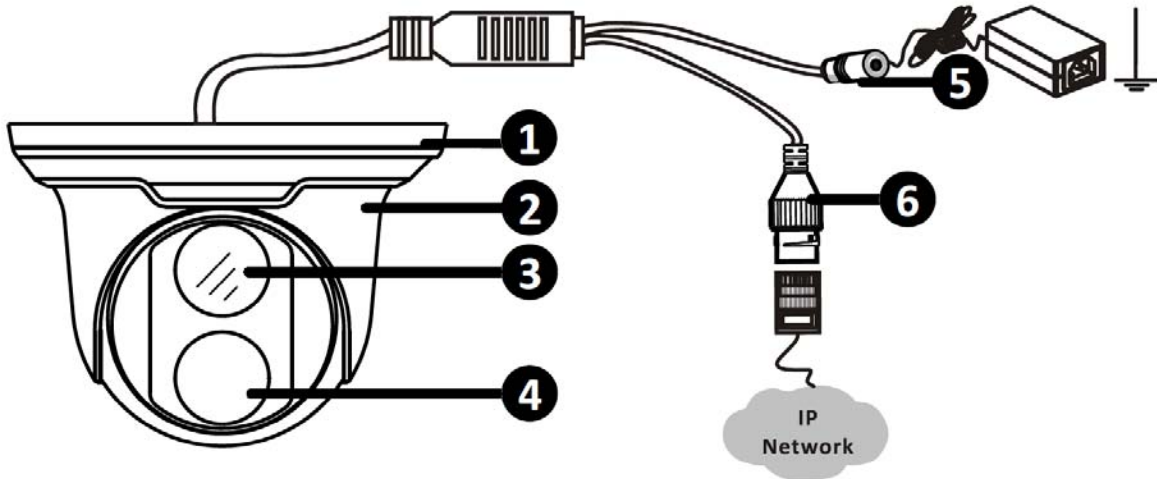

Figure 1-1

No.	Description
1	Bottom ring
2	Housing
3	Lens
4	Infrared indicator
5	Power connector (DC 12 V)
6	Ethernet connector / PoE

**Note:** To power the camera using the power connector (No.5), an optional power adapter is required.

1.1.3.2 GV-EBD4711

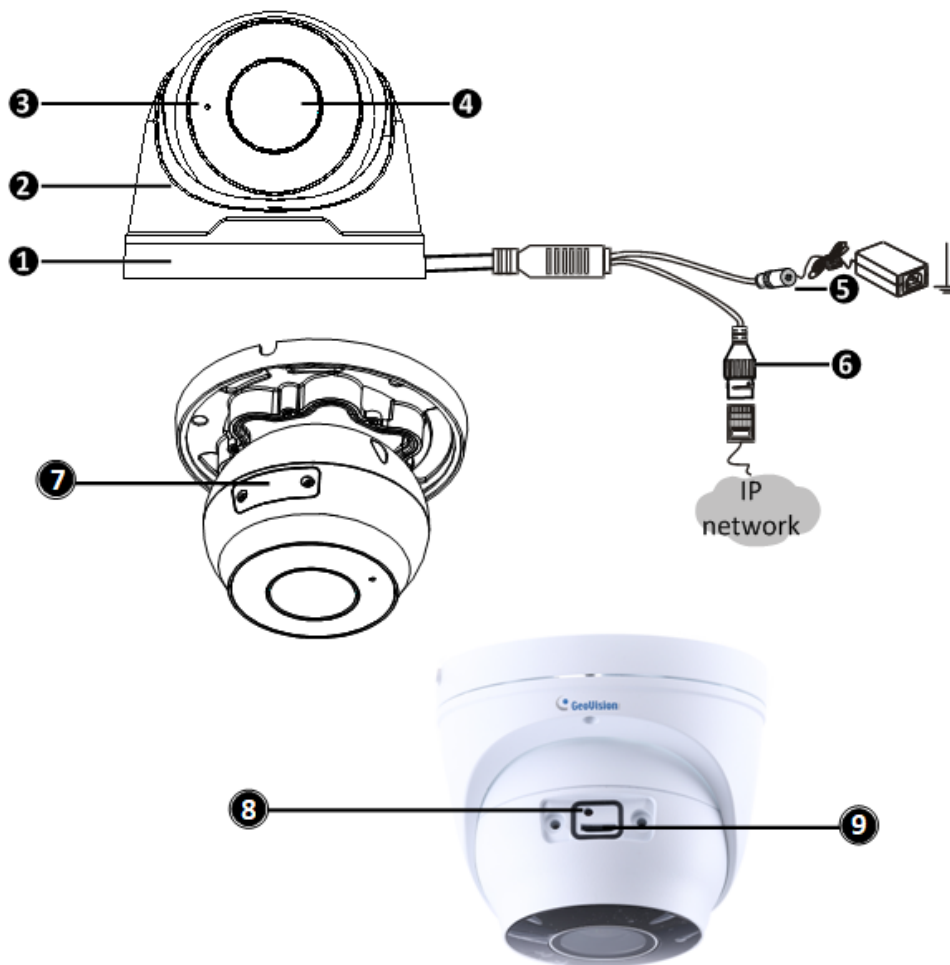

Figure 1-2

No.	Description
1	Bottom ring
2	Housing
3	Microphone
4	Lens
5	Power connector (DC 12 V)
6	Ethernet connector / PoE
7	Micro SD card slot and default button compartment
8	Default button
9	Micro SD card slot

**Note:** To power the camera using the power connector (No.5), an optional power adapter is required.

## 1.1.4 Installation

The Target Eyeball Dome is designed for outdoors. With the standard package, you can install the camera on the ceiling. Alternatively, you can purchase optional mounting accessories to mount GV-EBD2702 / 4700 / 4711 on a wall.

Below are the instructions for **Ceiling Mount**. There are two kinds of Ceiling Mount: **Concealed Installation** and **Open Installation**. In concealed installation, the cables are hidden in the ceiling. In Open Installation, the cables are led out from the open slot on the bottom ring.

### 1.1.4.1 GV-EBD2702 / 4700 Standard Installation

#### For Concealed Installation

1. Stick the drill template paster to the ceiling and drill three holes according to the drill template.

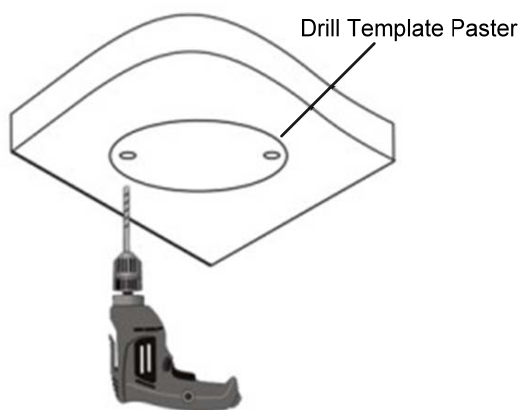

Figure 1-3

2. Insert the screw anchors.

Drill a hole to lead the cables out of the ceiling

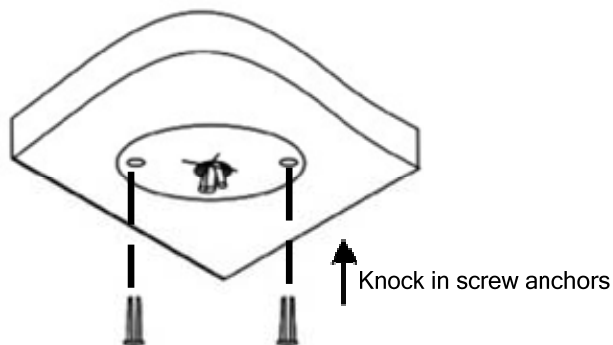

Figure 1-4

3. Remove the bottom ring by turning it anticlockwise.

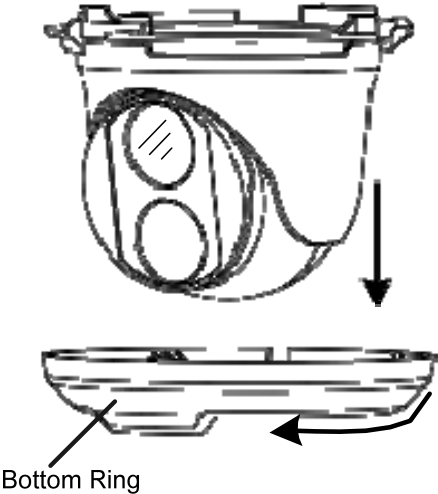

Figure 1-5

4. Connect the cables and secure the camera.

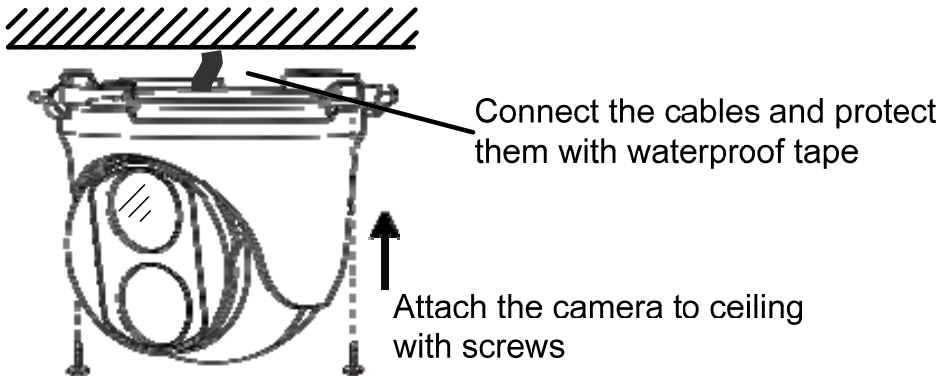

Figure 1-6

5. Adjust the monitoring direction.

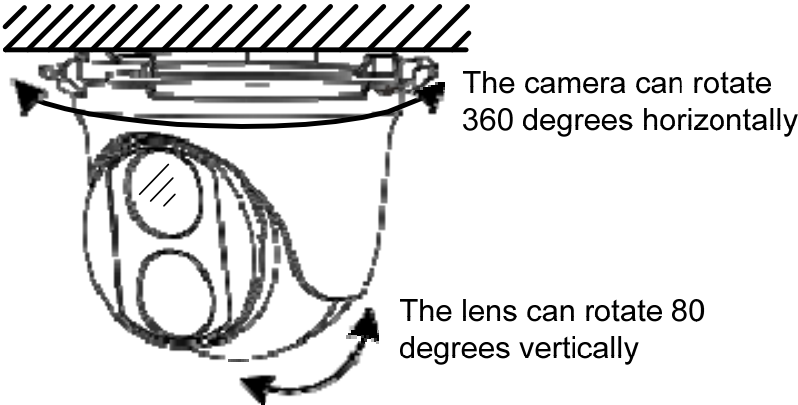
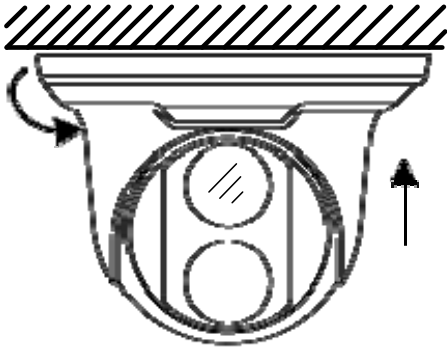

Figure 1-7



6. Mount the bottom ring.



Push the bottom ring back up and turn it clockwise to lock into position

Figure 1-8

**For Open Installation**

Lead the cables out from the open slot on the bottom ring before screwing the camera to the ceiling as shown in Figure 1-6.

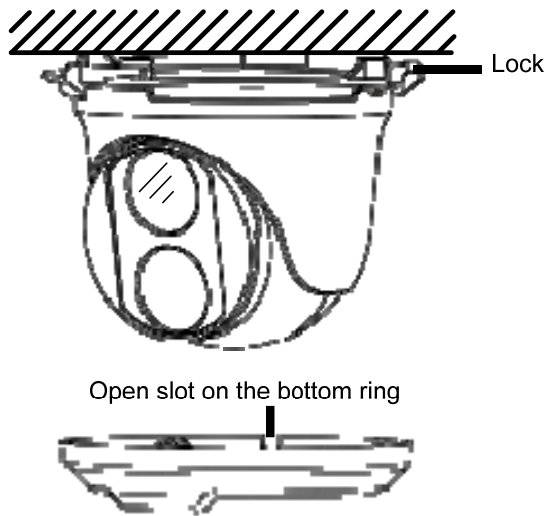

Figure 1-9

### 1.1.4.2 GV-EBD4711 Standard Installation

#### For Concealed Installation

1. Stick the drill template paster to the ceiling and drill three holes according to the drill template.

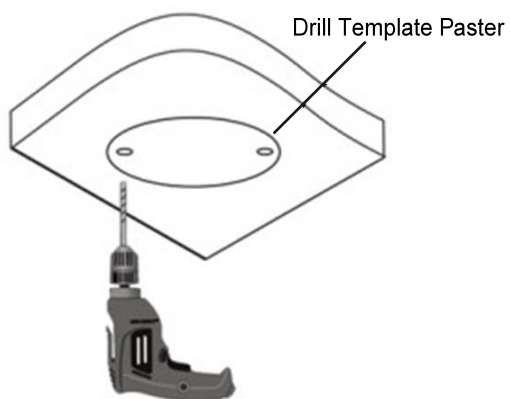

Figure 1-10

2. Insert the screw anchors.

Drill a hole to lead the cables out of the ceiling

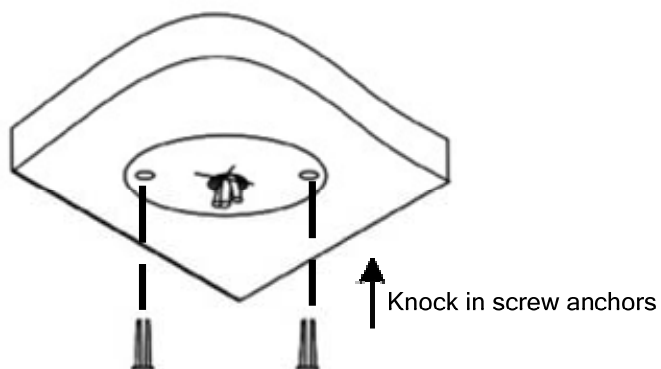

Figure 1-11

3. Loosen the fixing screw and remove the housing by turning it to the position as shown.

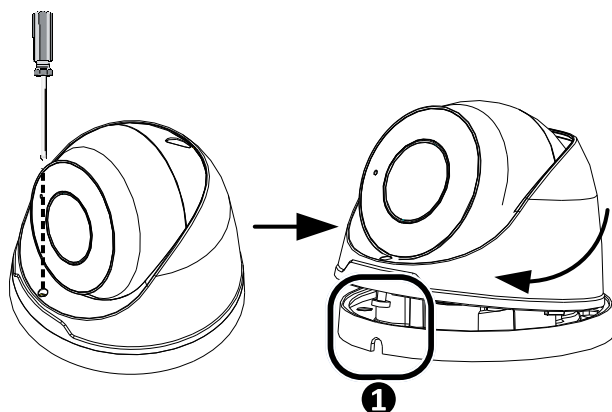

Figure 1-12

- Secure the bottom ring to the ceiling with 3 supplied screws and connect the cable.

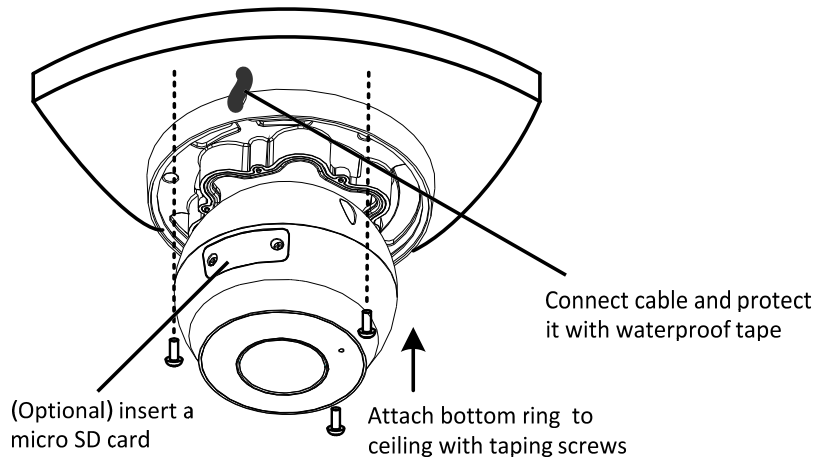

Figure 1-13

- Mount the housing by adjusting to the position as shown and press and turn to anywhere but ❶.

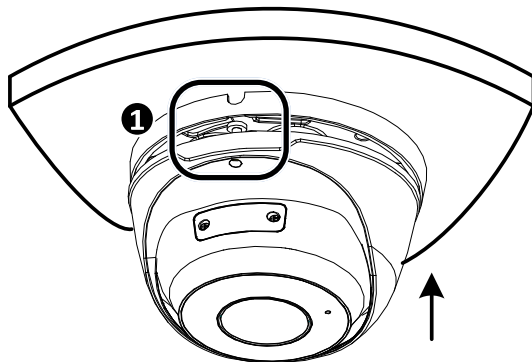

Figure 1-14

- Adjust the monitoring direction. Then tighten the screw.

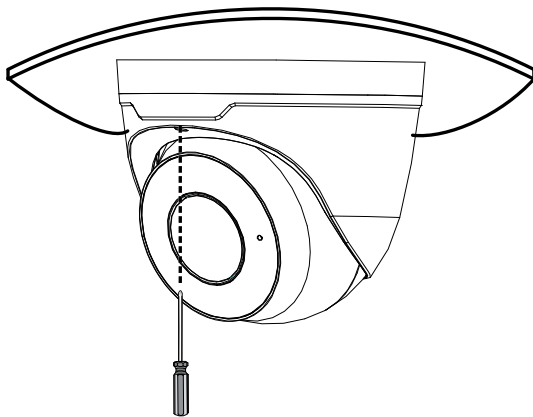

Figure 1-15

---

**WARNING:** Make sure the housing is not dismounted from the bottom ring when adjusting the monitoring direction. Unintentional removal of the housing may result in circumstantial damages.

---

**For Open Installation**

Lead the cables out from the open slot on the bottom ring before mounting the housing as shown in *Figure 1-14*.

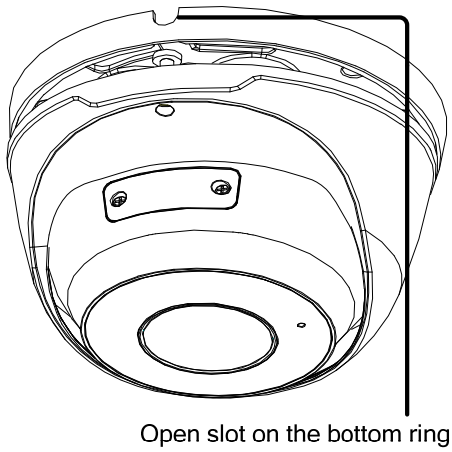

*Figure 1-16*

### 1.1.5 Optional Installation





You can optionally purchase **GV-Mount211P** or **GV-Mount212P** for **Wall Box Mount**. Follow the instructions below.

#### 1.1.5.1 GV-Mount211P

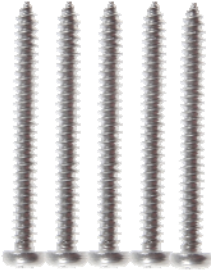

*Figure 1-17*

**GV-Mount211P Packing List**

<ul style="list-style-type: none"><li>• GV-Mount211P Wall Mount Bracket</li></ul> 	<ul style="list-style-type: none"><li>• Long Screw x 5</li></ul> 
<ul style="list-style-type: none"><li>• Short Screw x 4</li></ul> 	<ul style="list-style-type: none"><li>• Screw Anchor x 5</li></ul> 
<ul style="list-style-type: none"><li>• Plastic PG21 Conduit Connector</li></ul> 	<ul style="list-style-type: none"><li>• Drill Template Paster</li></ul> 

1. Unscrew the bracket.



Figure 1-18

2. Loosen the indicated area by turning it anticlockwise.



*Figure 1-19*

3. Stick the drill template paster to the wall with the arrow pointing up.
4. Drill 4 holes according to the sticker and insert the 4 screw anchors to the 4 holes.
5. Secure the power box to the wall with 4 long screws.

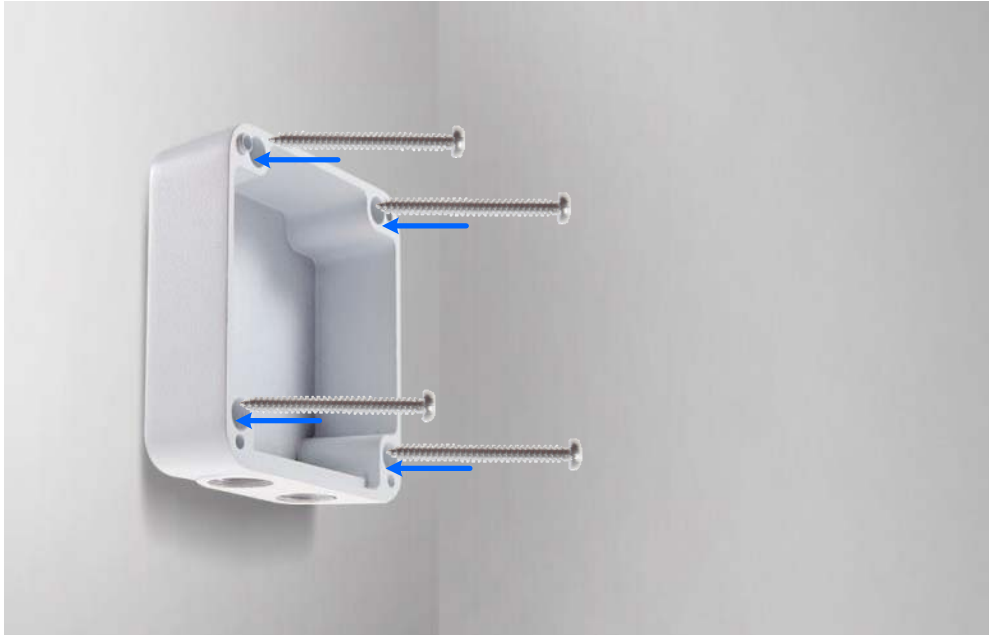

*Figure 1-20*

6. Remove the bottom ring by turning it anticlockwise.

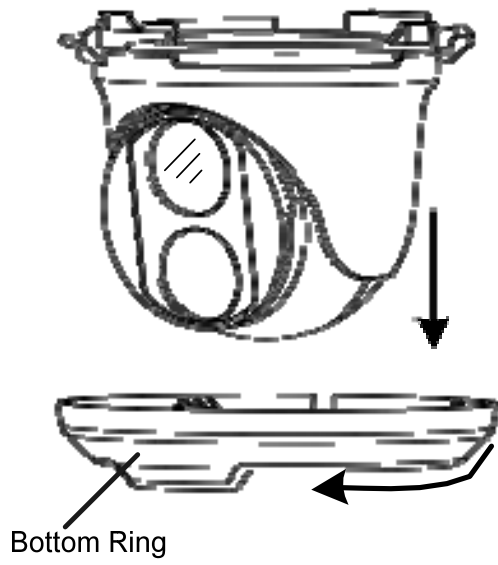

*Figure 1-21*

7. Thread the network and power wires through the camera housing.



8. Secure the camera to the wall mount bracket with the provided short screws according to the screw position for each model:

**GV-EBD4700 / 4711**



*Figure 1-22*

**GV-EBD2702**



*Figure 1-23*

**GV-ADR2701 / 4701**

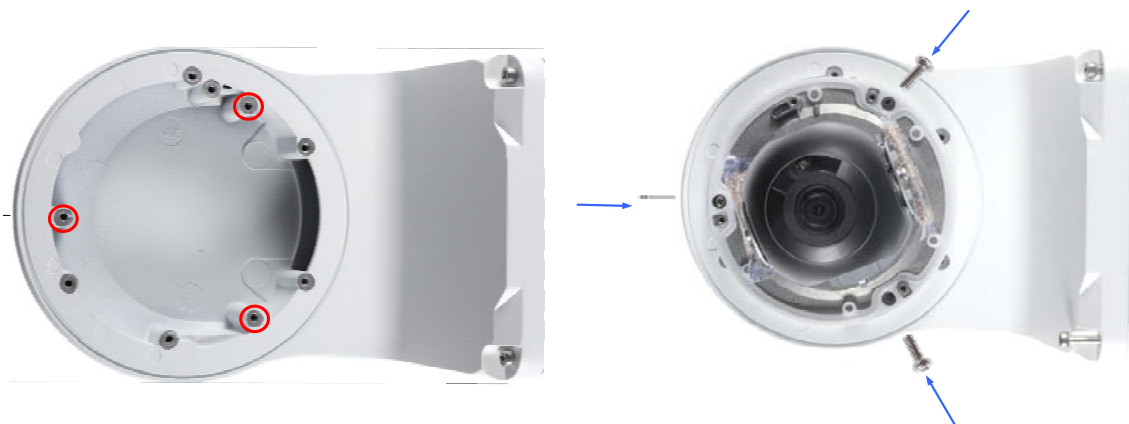

*Figure 1-24*

9. Thread the Ethernet cable through the PG21 conduit connector and the power box as shown in No. 9, *Figure 1-25*.
10. Rotate the plastic ring to secure the conduit connector to the power box. Screw in the cap as shown in No. 10, *Figure 1-25*.
11. Plug the Ethernet cable to the RJ-45 connector of the camera as shown in No. 11, *Figure 1-25*.
12. Screw the wall mount bracket to the power box as shown in No. 12, *Figure 1-25*.

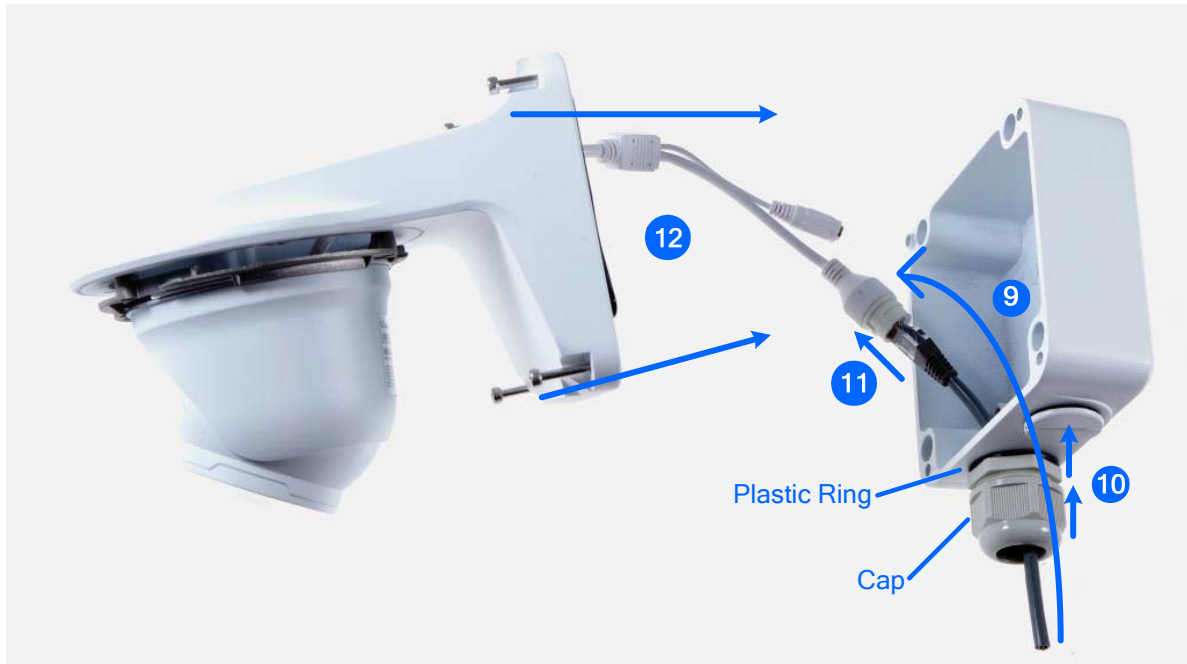

Figure 1-25

13. Mount the bottom ring.



Figure 1-26

### 1.1.5.2 GV-Mount212P



Figure 1-27

#### GV-Mount212P Packing List

<ul style="list-style-type: none"><li>• GV-Mount212P Wall Box Mount</li></ul> 	<ul style="list-style-type: none"><li>• Long Screw x 3</li></ul> 
<ul style="list-style-type: none"><li>• Short Screw x 3</li></ul> 	<ul style="list-style-type: none"><li>• Screw Anchor x 3</li></ul> 

**Standard Installation**

- 1 Attach the wall box to the wall and use a marker to mark the location for the center socket and the screws. Make sure the knob points down.

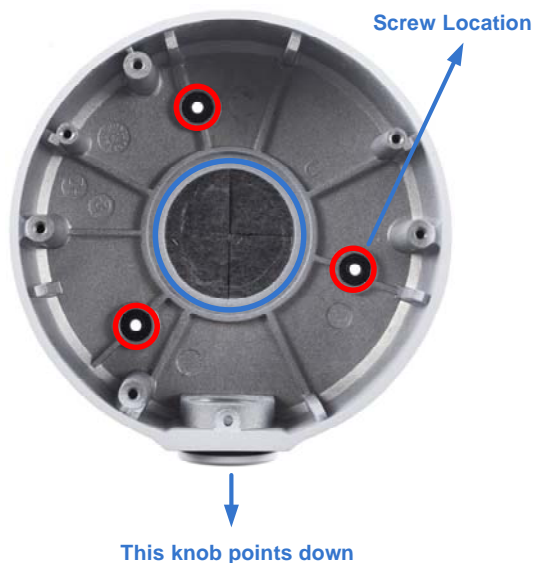

Figure 1-28

- 2 Drill 3 holes according to the screw location. Then, drill a bigger hole at the center socket location for the Ethernet cable.
- 3 Insert 3 screw anchors to the screw location and secure the wall box to the wall with 3 long screws.

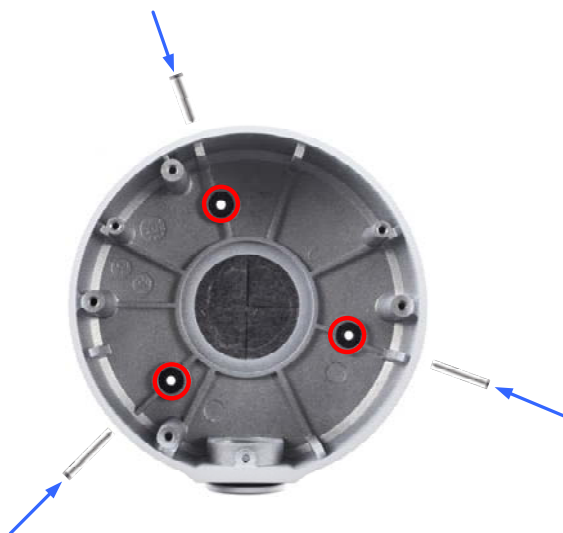
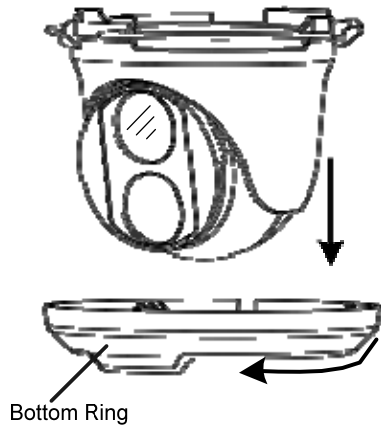

Figure 1-29

4. Remove the bottom ring by turning it anticlockwise.



*Figure 1-30*

5. Thread the Ethernet cable through the center socket and waterproof the Ethernet cable. For details, see 1.6 *Waterproofing the Cable*.



*Figure 1-31*

6. Fit the cable into the wall box.

- 7 Secure the camera by locking the provided short screws to the screw position for each model:

**GV-EBD2702**



*Figure 1-32*

**GV-EBD4700 / 4711**

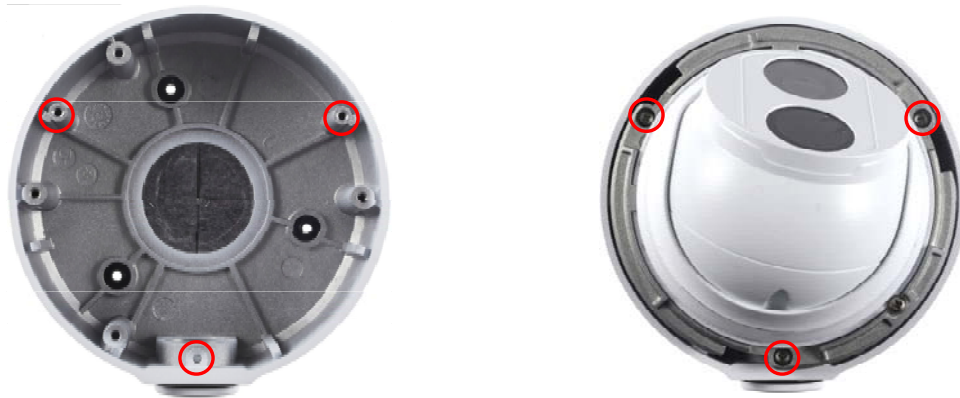
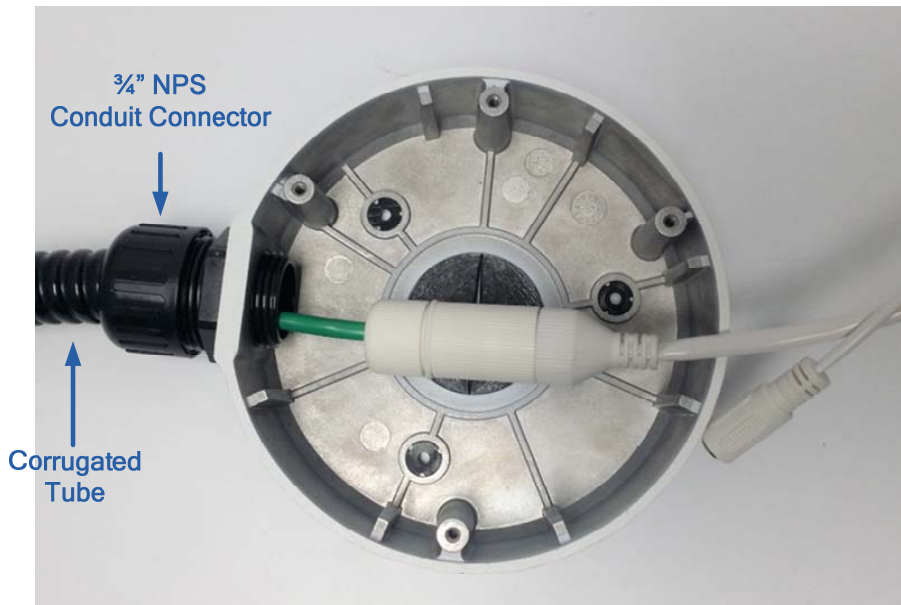

*Figure 1-33*

- 8 Mount the bottom ring.

---

**Note:** In addition to the Standard Installation, you can also choose to run the Ethernet cable through a corrugated tube. To do this, you will have to purchase your own conduit connector and corrugated tube. 3/4" NPS is the recommended type of connector. After you secure the wall box to the desired location, remove the knob at the bottom and connect the conduit connector with a self-prepared corrugated tube to the wall box. Then, thread the Ethernet cable through the corrugated tube and waterproof the Ethernet cable.



*Figure 1-34*

---

## 1.2 GV-ABL2701 / 4701 / 4712

The Bullet IP Camera is an outdoor, fixed, network camera equipped with an automatic IR-cut filter and an IR LED for day and night surveillance. The camera supports H.265 video codec to achieve better compression ratio while maintaining high quality image at reduced network bandwidths. The camera adheres to IP66 standards and can be powered through PoE.

Model No.		Specifications	Description
GV-ABL2701	Fixed lens	Fixed Iris, f: 4.0 mm, F/1.8, M12 Lens Mount	2 MP, H.265, Low Lux, WDR
GV-ABL4701	Fixed lens	Fixed Iris, f: 4.0 mm, F/1.8, M12 Lens Mount	4 MP, H.265, Low Lux, WDR
GV-ABL4712	Motorized varifocal lens	Fixed Iris, f: 2.8~12 mm, F/1.4, M14 Lens Mount	4 MP, H.265, Low Lux, WDR Pro



### 1.2.1 Packing List

- Bullet IP Camera

- Waterproof Rubber Set



- Screw Kit



- Drill Template Paster





- Download Guide

- Warranty Card

## 1.2.2 Optional Accessories

Optional accessories can expand the capabilities and versatility of your camera. Contact your dealer for more information.

Model Number	Name	Details
GV-Mount502 (for <b>GV-ABL2701 / 4701</b> )	Wall Mount Bracket 	Dimensions: 93 x 93 x 39 mm (3.66" x 3.66" x 1.53") Weight: 0.235 kg (0.52 lb)
GV-Mount503 (for <b>GV-ABL4712</b> )	Wall Mount Bracket 	Dimension: 125 x 125 x 55 mm (4.9" x 4.9" x 2.2") Weight: 0.74 kg (1.63lb)
GV-PA191	Power over Ethernet (PoE) Adapter 	GV-PA191 is a Power over Ethernet (PoE) adapter designed to provide power to the IP device through a single Ethernet cable.
GV-POE Switch	GV-POE Switch is designed to provide power along with network connection for IP devices. GV-POE Switch is available in various models with different numbers and types of ports.	
Power Adapter	Contact our sales representatives for the countries and areas supported.	

## 1.2.3 Overview

### 1.2.3.1 GV-ABL2701 / 4701

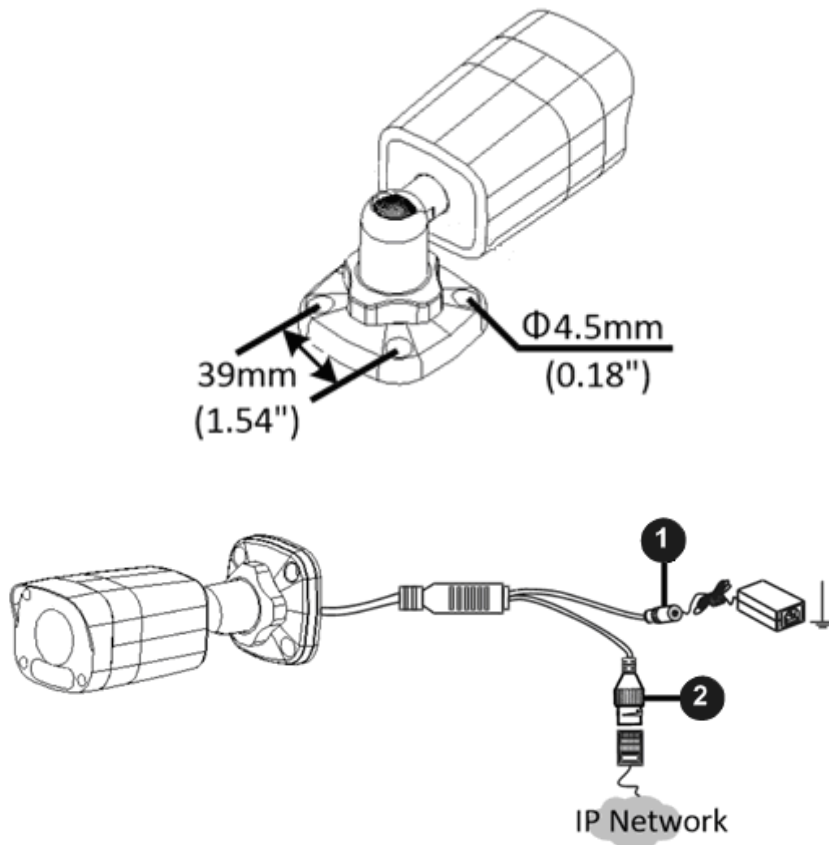

Figure 1-35

No.	Description
1	Power connector (DC 12 V)
2	Ethernet connector / PoE

---

**Note:** To power the camera using the power connector (No.1), an optional power adapter is required.

---

## 1.2.3.2 GV-ABL4712

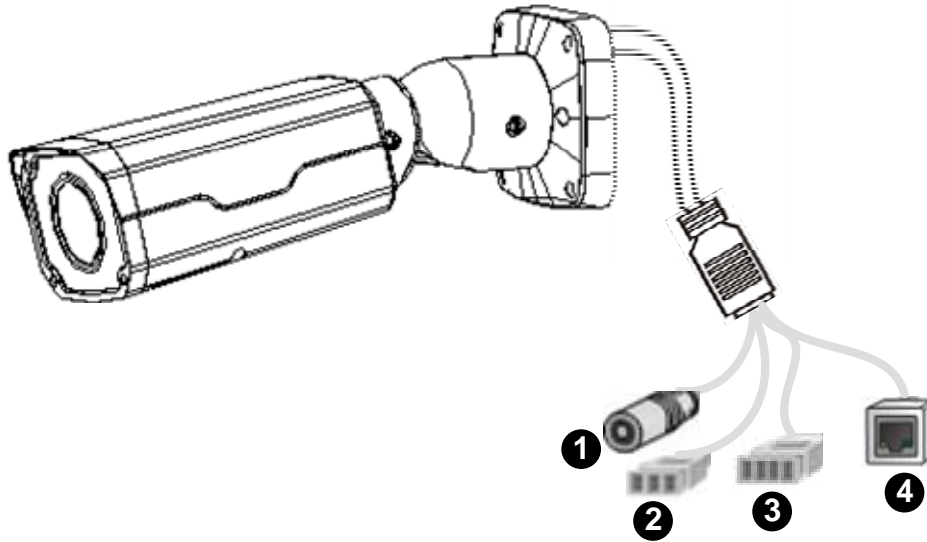

Figure 1-36

No.	Description
1	Power connector (DC 12 V)
2	Audio input / Audio output / GND
3	Alarm input (IN, GND) / Alarm output (N,P)
4	Ethernet connector / PoE

---

**Note:** To power the camera using the power connector (No.1), an optional power adapter is required.

---

## 1.2.4 Installation

The Bullet IP Camera is designed for outdoors. With the standard package, you can install the camera on the wall or ceiling. Or, you can purchase optional mounting accessories to mount your camera on a wall.

Below are the instructions for **Wall Mount**. There are two kinds of Wall Mount: **Concealed Installation** and **Open Installation**. In Concealed Installation, the cables are hidden in the wall. In Open Installation, the cables are led out from the open slot on the base.

### For Concealed Installation

1. For **GV-ABL4712**, optionally loosen the two screws at the bottom of the camera to insert a SD card.

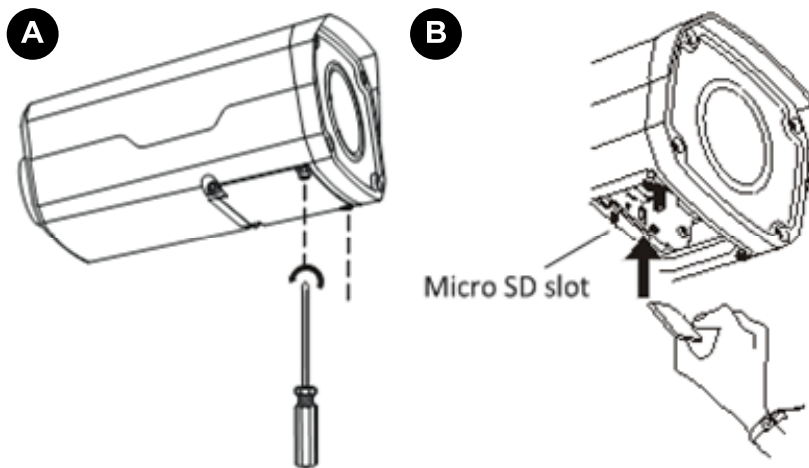

Figure 1-37

2. Stick the drill template paster to the wall and align the cross center to the hole in the wall.
3. Lead the cables across the hole on the wall.

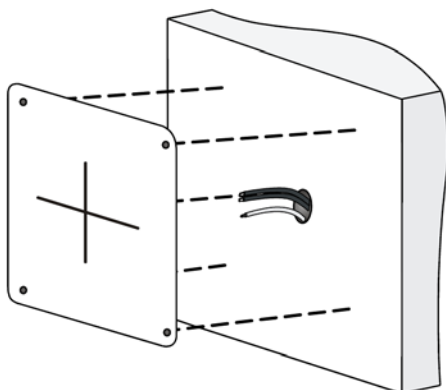

Figure 1-38

4. Drill four 30-mm deep holes according to the drill template.

Use a  $\text{Ø}6\text{-}6.5\text{mm}$  drill bit.

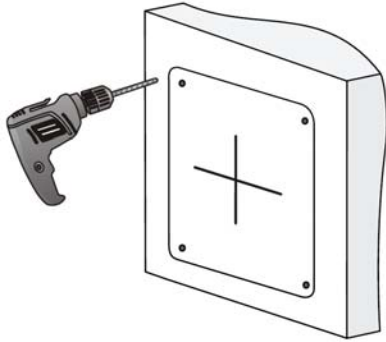

Figure 1-39

5. Insert the screw anchors.

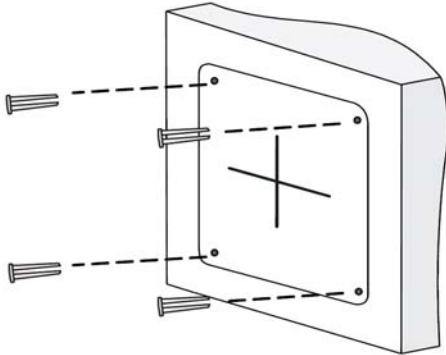

Figure 1-40

6. Screw the locknut and loosen the universal joint before attaching the camera to the wall.

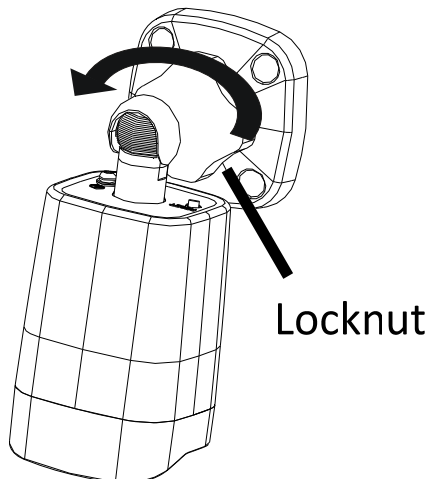
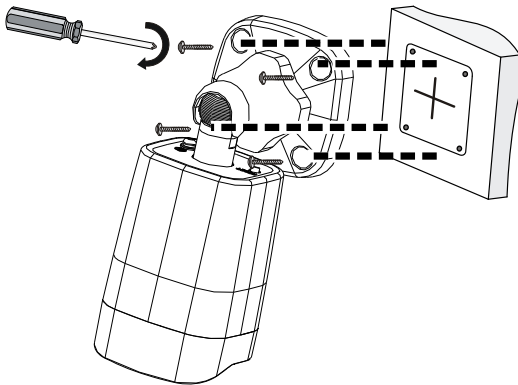

Figure 1-41

7. Secure the camera to the wall and connect all cables.



Lead tapping screws through the guide holes in the base and fix them on the wall by using a screwdriver.

*Figure 1-42*

8. Adjust the monitoring direction.

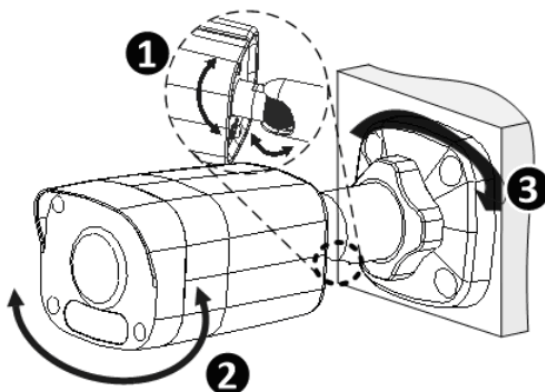

- 1** Adjust the opening of the universal joints as required.
- 2** Rotate the spherical hinge of the camera to get the desired monitoring direction.
- 3** Tighten the locknut.

*Figure 1-43*

### For Open Installation

Lead the cables out from the open slot on the base before screwing the camera to the wall as shown in *Figure 1-42*.

### 1.2.5 Optional Installation

For other installation methods, you can optionally purchase GV-Mount502 for **GV-ABL2701 / 4701** or GV-Mount503 for **GV-ABL4712**.



Figure 1-44

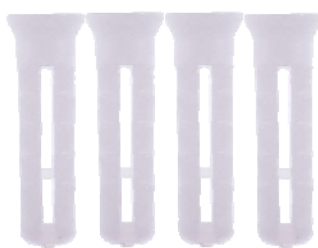



Figure 1-45



### 1.2.5.1 GV-Mount502

#### GV-Mount502 Packing List

<ul style="list-style-type: none"> <li>• GV-Mount502 Wall Mount Box</li> </ul> 	<ul style="list-style-type: none"> <li>• M3 25 mm Screw x 4</li> </ul> 
<ul style="list-style-type: none"> <li>• M3 12 mm Screw x 4</li> </ul> 	<ul style="list-style-type: none"> <li>• Screw Anchor x 4</li> </ul> 
<ul style="list-style-type: none"> <li>• Plastic PG21 Conduit Connector</li> </ul> 	

1. Unscrew the box cover.

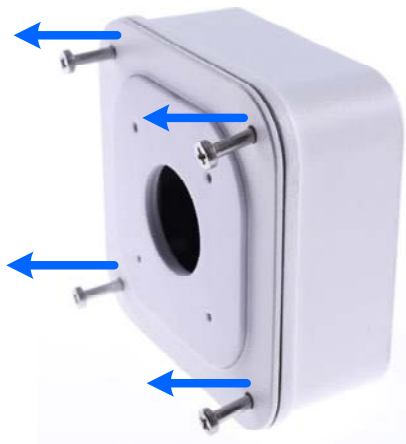

Figure 1-46

2. Loosen the indicated area by turning it anticlockwise.



Figure 1-47

3. Attach the box to the wall with the arrow pointing up and use a marker to mark 4 dots.



Figure 1-48

4. Drill 4 holes according to the marks and insert the 4 screw anchors to the 4 holes.

5. Secure the power box to the wall with four M3 25 mm screws.



*Figure 1-49*

6. Thread the network and power wires through the wall mount box cover.
7. Secure the camera to the wall mount box cover with 4 M3 12 mm screws.



*Figure 1-50*

8. Thread the Ethernet cable through the PG21 conduit connector and the wall mount box as shown in No. 8, *Figure 1-51*.
9. Rotate the plastic ring to secure the conduit connector to the wall mount box. Screw in the cap as shown in No. 9, *Figure 1-51*.
10. Plug the Ethernet cable to the RJ-45 connector of the camera as shown in No. 10, *Figure 1-49*. To waterproof the Ethernet cable, see 1.6 *Waterproofing the Cable*.
11. Arrange the cables.
12. Screw the wall mount box cover to the wall mount box as shown in No. 12, *Figure 1-51*.

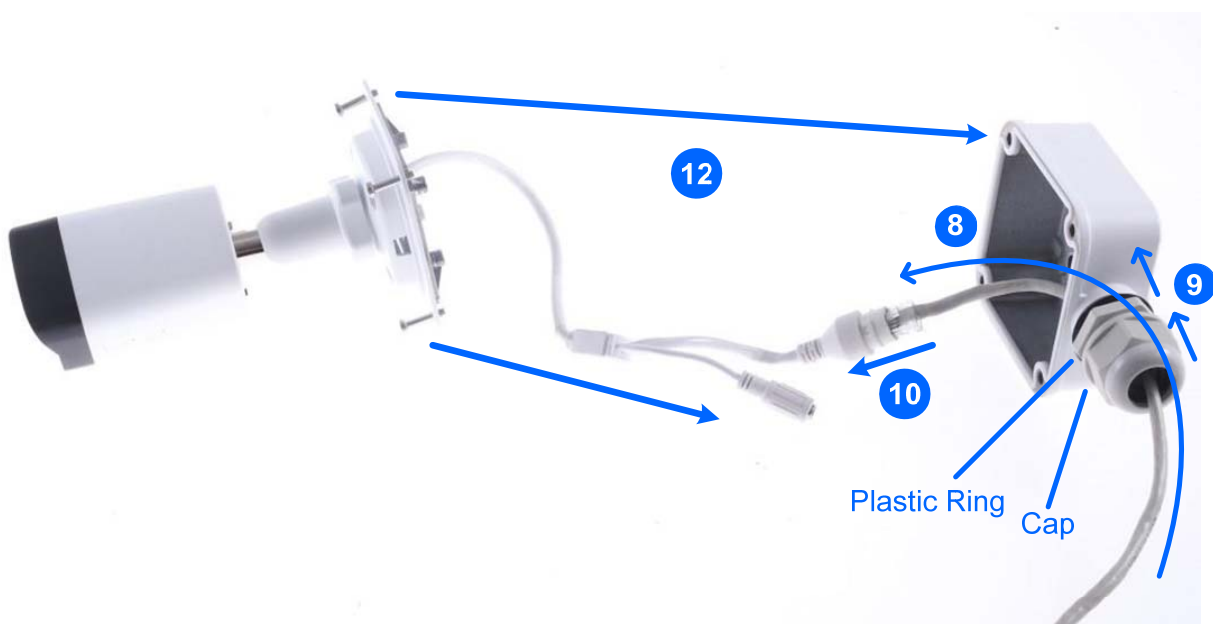







Figure 1-51

**1.2.5.2 GV-Mount503**

**GV-Mount503 Packing List**

<ul style="list-style-type: none"> <li>• GV-Mount503 Wall Mount Box</li> </ul> 	<ul style="list-style-type: none"> <li>• Long Screw x 5</li> </ul> 
<ul style="list-style-type: none"> <li>• Short Screw x 4</li> </ul> 	<ul style="list-style-type: none"> <li>• Screw Anchor x 5</li> </ul> 
<ul style="list-style-type: none"> <li>• Plastic PG21 Conduit Connector</li> </ul> 	

1. Optionally insert a SD card.

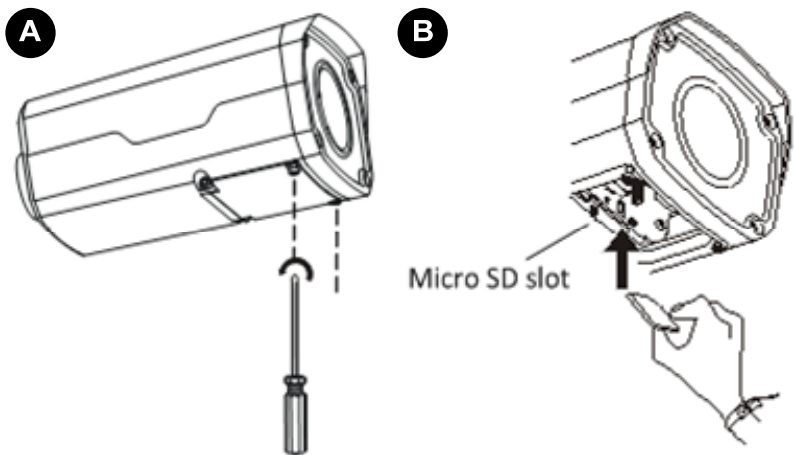

Figure 1-52

2. Unscrew the box cover.



Figure 1-53

3. Loosen the indicated area by turning it anticlockwise.



Figure 1-54

4. Attach the power box to the wall with the arrow pointing up and use a marker to mark 4 dots.



Figure 1-55

5. Drill 4 holes according to the marks and insert 4 screw anchors to the 4 holes.
6. Secure the power box to the wall with 4 long screws.
7. Thread the camera cable through the box cover.
8. Secure the camera to the box cover with 4 short screws.



Figure 1-56

9. Thread the Ethernet cable through the PG21 conduit connector and the power box as shown in No 9, *Figure 1-57*.
10. Rotate the plastic ring to secure the conduit connector to the power box. Secure in the cap as shown in No 10, *Figure 1-57*
11. Plug the Ethernet cable to the RJ-45 connector of the camera.
12. Connect other wires to the camera.
13. Secure the box cover to the power box as shown in No 13, *Figure 1-57*



Figure 1-57

### 1.3 GV-ADR2701 / 4701

The IR Mini Fixed Rugged IP Dome is an outdoor, fixed, network camera equipped with an automatic IR-cut filter and an IR LED for day and night surveillance. The camera supports H.265 video codec to achieve better compression ratio while maintaining high quality image at reduced network bandwidths. The camera adheres to IP66 standard and can be powered through PoE.

Model No.		Specifications	Description
GV-ADR2701	Fixed lens	Fixed Iris, f: 2.8 mm, F/2.2, M12 Lens Mount	2 MP, H.265, Low Lux, WDR
GV-ADR4701	Fixed lens	Fixed Iris, f: 2.8 mm, F/1.8, M12 Lens Mount	4 MP, H.265, Low Lux, WDR

-



### 1.3.1 Packing List

- IR Mini Fixed Rugged IP Dome



- Waterproof Rubber Set



- Screw Kit



- Drill Template Paster





- Download Guide

- Warranty Card

### 1.3.2 Optional Accessories

Optional accessories can expand the capabilities and versatility of your camera. Contact your dealer for more information.

Model Number	Name	Details
GV-Mount211P	Wall Mount Bracket 	Dimensions: 233 x 126 x 126 mm (9.2" x 5" x 5") Weight: 1 kg (2.2 lb)
GV-Mount213	Wall Box Mount 	Dimensions: Ø 109 x 39 mm (4.3" x 1.5") Weight: 0.2 kg (0.44 lb)
GV-PA191	Power over Ethernet (PoE) Adapter 	GV-PA191 is a Power over Ethernet (PoE) adapter designed to provide power to the IP device through a single Ethernet cable.
GV-POE Switch	GV-POE Switch is designed to provide power along with network connection for IP devices. GV-POE Switch is available in various models with different numbers and types of ports.	
Power Adapter	Contact our sales representatives for the countries and areas supported.	

### 1.3.3 Overview



Figure 1-58

No.	Description
1	Ethernet connector / PoE
2	Power connector (DC 12 V)
3	Transparent Dome Cover

---

**Note:** To power the camera using the power connector (No.2), an optional power adapter is required.

---

### 1.3.4 Installation

The IR Mini Fixed Rugged IP Dome is designed for outdoors. With the standard package, you can install the camera on the ceiling.

Below are the instructions for **Ceiling Mount**. There are two kinds of Ceiling Mount: **Concealed Installation** and **Open Installation**. In Concealed Installation, the cables are hidden in the ceiling. In Open Installation, the cables are led out from the open slot on the camera base.

#### For Concealed Installation

1. Stick the drill template paster to the ceiling and drill 30-mm deep holes according to the drill template.

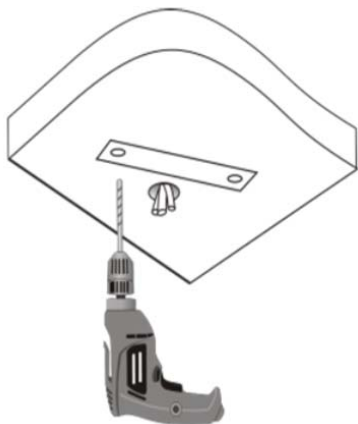

Figure 1-59

2. Insert the screw anchors.

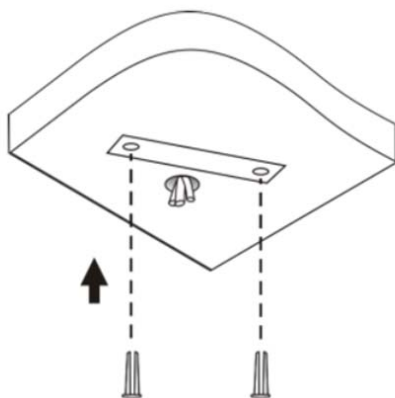

Figure 1-60

3. Unscrew the transparent dome cover with the supplied torx wrench.
4. Connect the cables and secure the camera.

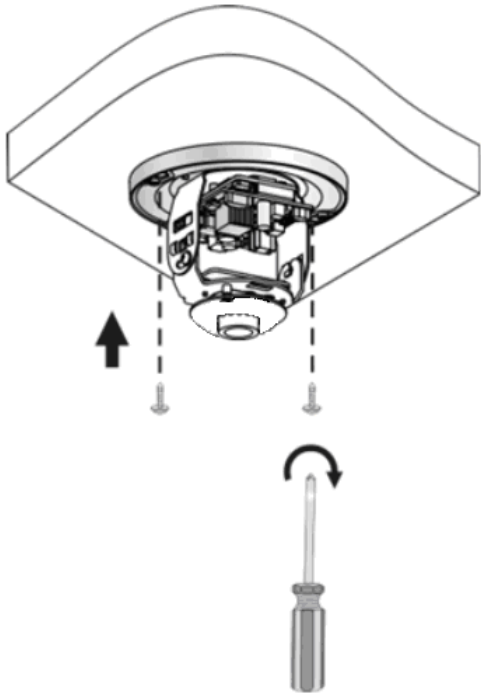

Figure 1-61

5. Adjust the monitoring direction and tighten the screws after vertically adjusting the lens.

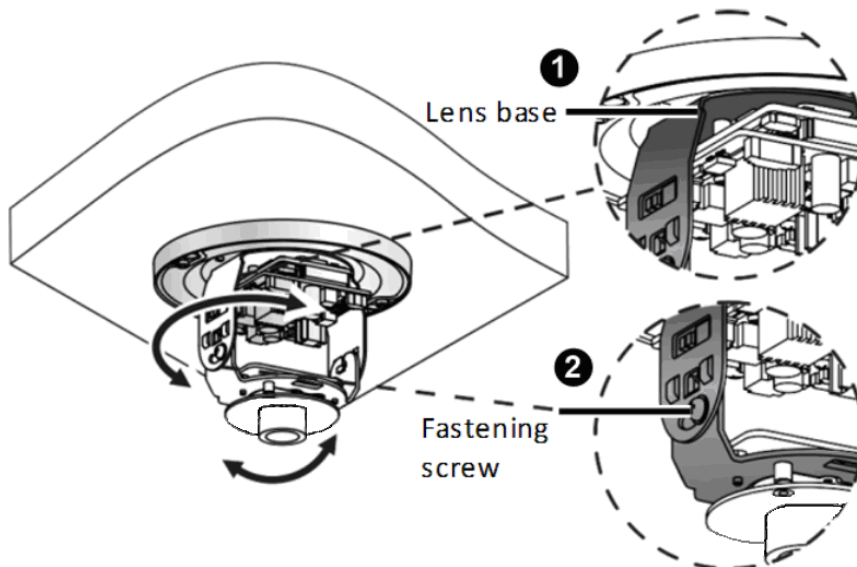

Figure 1-62

- Secure the transparent dome cover with the supplied torx wrench.

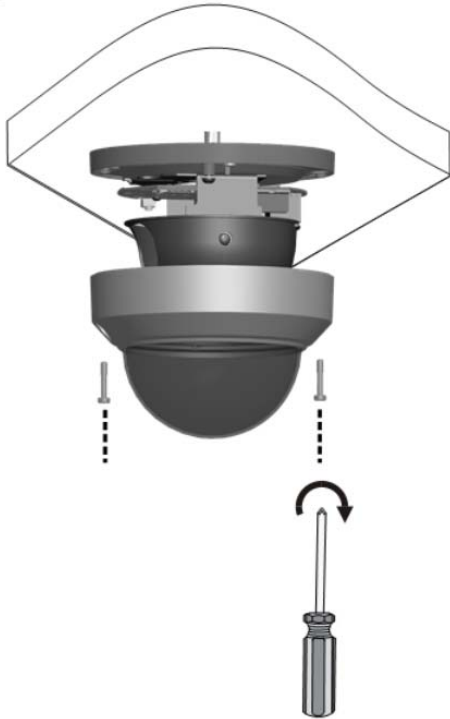

Figure 1-63

---

**Note:** Before securing the transparent dome cover, make sure the waterproof rubber strip is tightly held by the six retainers on the bottom ring.



Figure 1-64

---

### For Open Installation

Lead the cables out from the open slot on the camera base before screwing the camera to the ceiling as shown in *Figure 1-61*.

### 1.3.5 Optional Installation

You can optionally purchase **GV-Mount211P** or **GV-Mount213** to install the camera on the wall or ceiling. Follow the instructions below.

#### 1.3.5.1 GV-Mount211P





To install **GV-Mount211P Wall Box Mount**, see *1.1.5.3.1 GV-Mount211P* for installation instructions.

#### 1.3.5.2 GV-Mount213



*Figure 1-65*

**GV-Mount213 Packing List**

<ul style="list-style-type: none"><li>• GV-Mount213 Wall Box Mount</li></ul> 	<ul style="list-style-type: none"><li>• Long Screw x 3</li></ul> 
<ul style="list-style-type: none"><li>• Short Screw x 3</li></ul> 	<ul style="list-style-type: none"><li>• Screw Anchor x 3</li></ul> 

**Standard Installation**

1. Attach the wall box to the wall and use a marker to mark the location for the center socket and the screws.

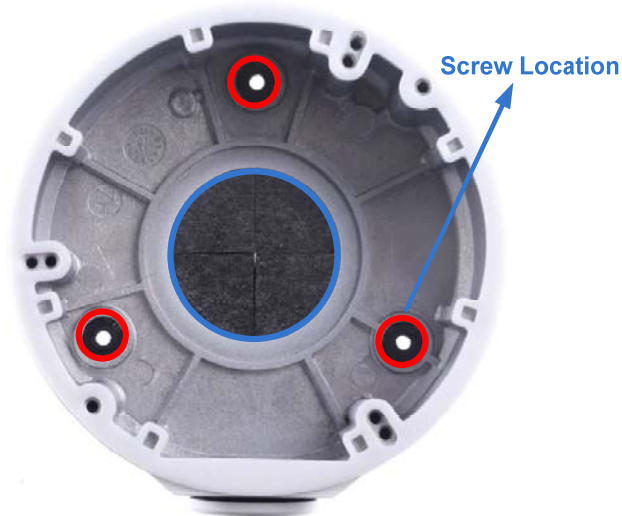

Figure 1-66



---

**Note:** To prevent rain from getting into the camera,

- For wall mount installation, make sure the indicated hole points down and towards the ground.
- For ceiling mount installation, turn the indicated hole inwards.



Figure 1-67

---

2. Drill 3 holes according to the screw locations. Then, drill a bigger hole at the center socket location for the Ethernet cable.
3. Insert 3 screw anchors to the screw locations and secure the wall box to the wall with 3 long screws.

4. Thread the Ethernet cable through the center socket and waterproof the Ethernet cable. For details, see *1.6 Waterproofing the Cable*.



Figure 1-68

5. Fit the cable into the wall box.
6. Remove the camera cover and fasten the camera to the wall box as indicated below using the supplied 3 short screws.

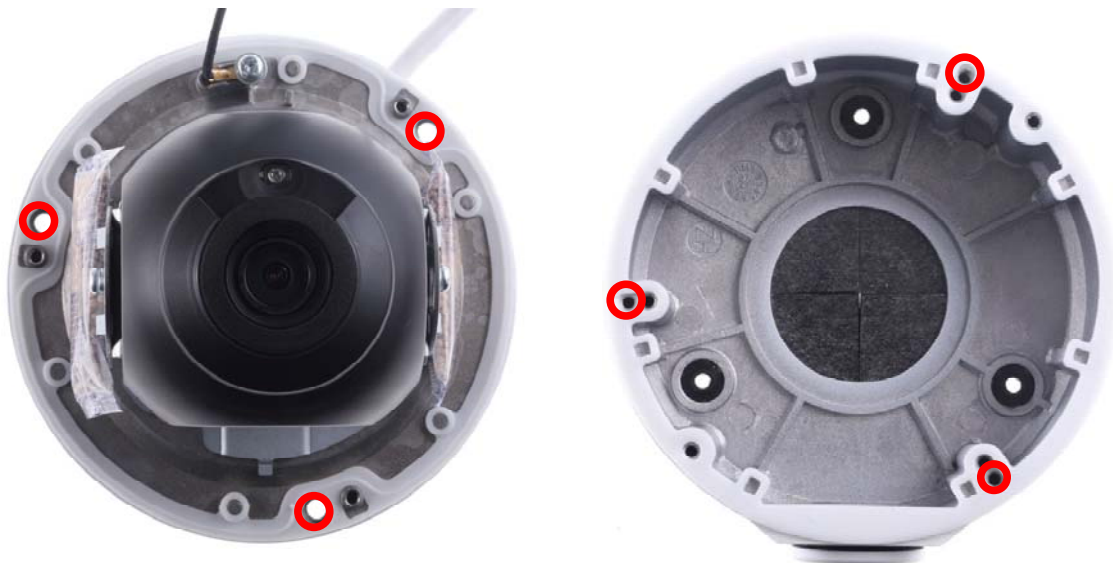

Figure 1-69

7. Secure the camera cover.

---

**Note:** In addition to the Standard Installation, you can also choose to run the Ethernet cable through a corrugated tube. To do this, see Figure 1-33 and its related Note.

---

## 1.4 GV-AVD4710

The Vandal Proof IP Dome is an outdoor camera designed with IK10 vandal resistance and IP67 ingress protection. The camera is equipped with an automatic IR-cut filter and IR LEDs for day and night surveillance. Adjustable in 3 axes (pan, tilt and rotate), it offers an entry-level surveillance solution with all the essential features and excellent image quality.

Model No.		Specifications	Description
GV-AVD4710	Motorized varifocal lens	Fixed Iris, f: 2.8~12 mm, F/1.4, M14 Lens Mount	4 MP, H.265, Low Lux, WDR Pro

### 1.4.1 Packing List

- GV-AVD4710 IR Vandal Proof IP Dome



- Waterproof Rubber Set



- Screw Kit



- Drill Template Paster



- Torx Wrench





- Download Guide

- Warranty Card

## 1.4.2 Optional Accessories

Optional accessories can expand the capabilities and versatility of your camera. Contact your dealer for more information.

Model Number	Name	Details
GV-Mount211-2	Wall Mount Bracket 	Dimensions: 253 x125 x 125 mm (10" x 4.9" x 4.9") Weight: 0.92 kg (2.02lb)
GV-Mount212-2	Wall Box Mount 	Dimensions: $\Phi$ 145 x 40 mm (5.7" x 1.6") Weight: 0.24 kg (0.5lb)
GV-PA191	Power over Ethernet (PoE) Adapter 	GV-PA191 is a Power over Ethernet (PoE) adapter designed to provide power to the IP device through a single Ethernet cable.
GV-POE Switch	GV-POE Switch is designed to provide power along with network connection for IP devices. GV-PoE Switch is available in various models with different numbers and types of ports.	
Power Adapter	Contact our sales representatives for the countries and areas supported.	

## 1.4.3 Overview

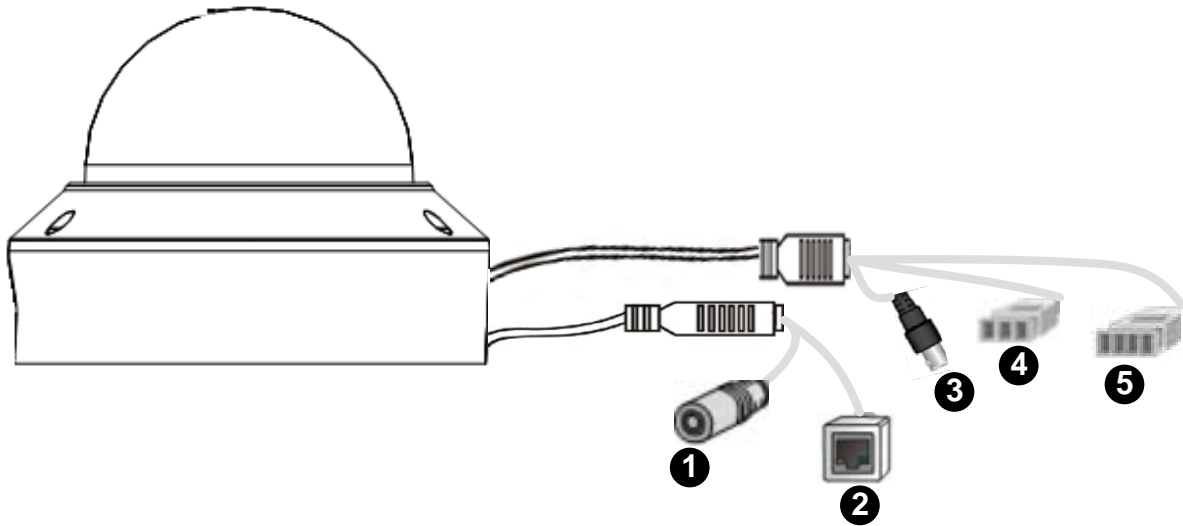

Figure 1-70

No.	Description
1	Power connector (DC 12 V)
2	Ethernet connector / PoE
3	Video Output
4	Audio input / Audio output / GND
5	Alarm input (IN,GND) / Alarm output (N,P)

---

**Note:** To power the camera using the power connector (No.5), an optional power adapter is required.

---

## 1.4.4 Installation

The Target Vandal Proof Dome is designed for outdoors. With the standard package, you can install the camera on the ceiling. Alternatively you can purchase optional mounting accessories to mount the camera on a wall.

Below are the instructions for **Ceiling Mount**. There are two kinds of Ceiling Mount: **Concealed Installation** and **Open Installation**. In Concealed Installation, the cables are hidden in the ceiling. In Open Installation, the cables are led out from the open slot on the camera base.

### For Concealed Installation

1. Stick the drill template paster to the ceiling, and then drill three holes according to the drill template.

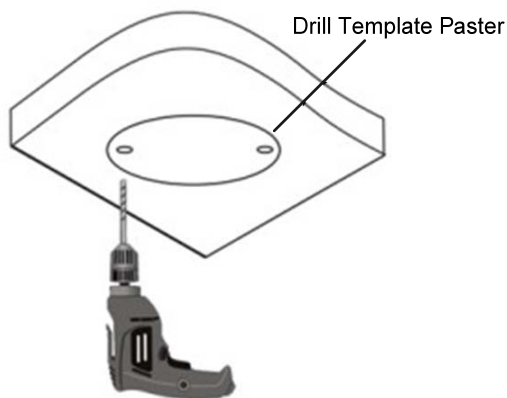

Figure 1-71

2. Insert the screw anchors.

Drill a hole to lead the cables out of the ceiling

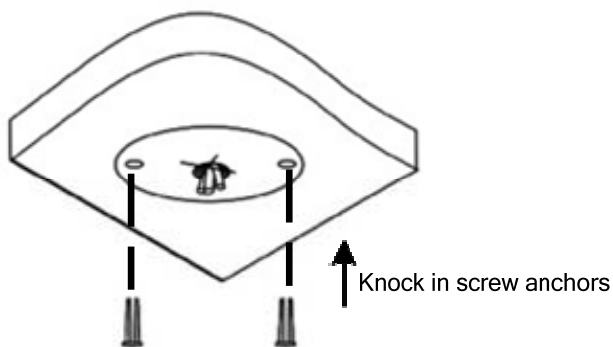

Figure 1-72

3. Unscrew the transparent dome cover with the supplied torx wrench.

4. Connect the camera cables and secure the camera.

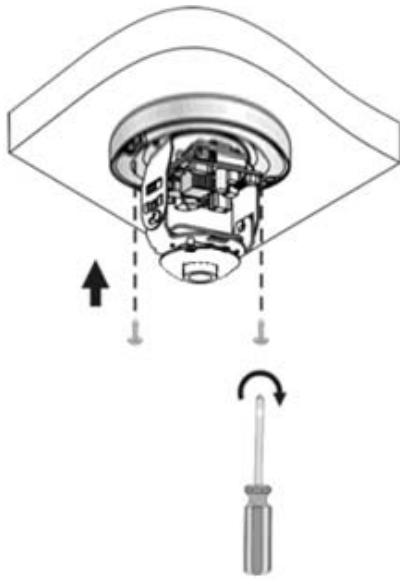

Figure 1-73

5. Insert a SD card into the slot.
6. Adjust the monitoring direction and tighten the screws after vertically adjusting the lens.

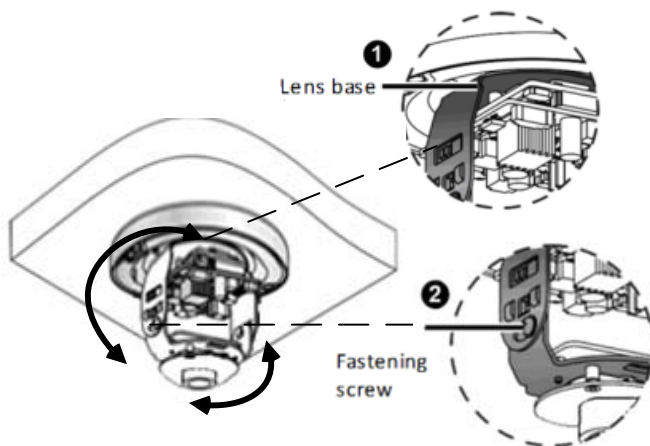

Figure 1-74

7. Secure the transparent dome cover with the supplied torx wrench.

### For Open Installation

Lead the cables out from the open slot on the camera base before screwing the camera to the ceiling as shown in *Figure 1-73*.



## 1.4.5 Optional Installation

### 1.4.5.1 GV-Mount211-2



Figure 1-75

#### GV-Mount211-2 Packing List

<ul style="list-style-type: none"> <li>• GV-Mount211-2 Wall Mount Bracket</li> </ul> 	<ul style="list-style-type: none"> <li>• Long Screw x 5</li> </ul> 
<ul style="list-style-type: none"> <li>• Short Screw x 4</li> </ul> 	<ul style="list-style-type: none"> <li>• Screw Anchor x 5</li> </ul> 
<ul style="list-style-type: none"> <li>• Plastic PG21 Conduit Connector</li> </ul> 	<ul style="list-style-type: none"> <li>• Drill Template Paster</li> </ul> 

1. To install the power box from the wall mount bracket on the wall, follow steps 1 to 5 in 1.1.5.3.1 *GV-Mount211P*.
2. Unscrew the transparent dome cover with the supplied torx wrench.



*Figure 1-76*

3. Optionally insert a SD card into the slot.
4. Thread the camera cables through the bracket.
5. Secure the camera to the wall mount bracket with the provided short screws.

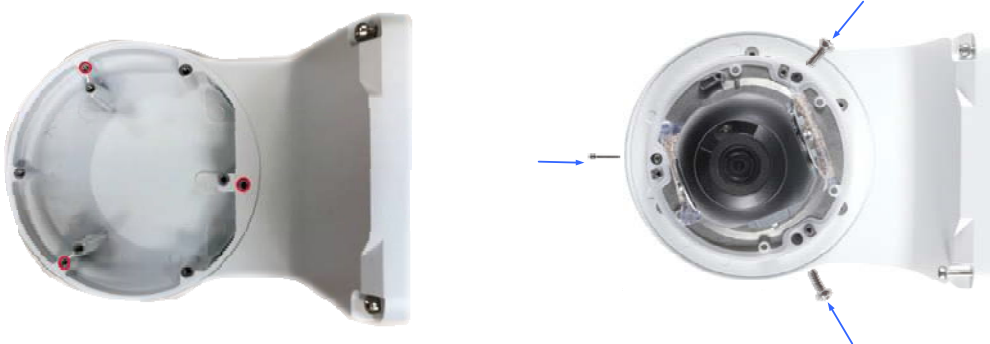

*Figure 1-77*

6. Thread the Ethernet cable through the PG21 conduit connector and the power box as shown in No 6, *Figure 1-78*.
7. Rotate the plastic ring to secure the conduit connector to the power box. Screw in the cap shown in No 7, *Figure 1-78*.
8. Plug the Ethernet cable to the RJ-45 connector of the camera
9. Screw the wall mount bracket to the power box as shown in *Figure 1-78*.

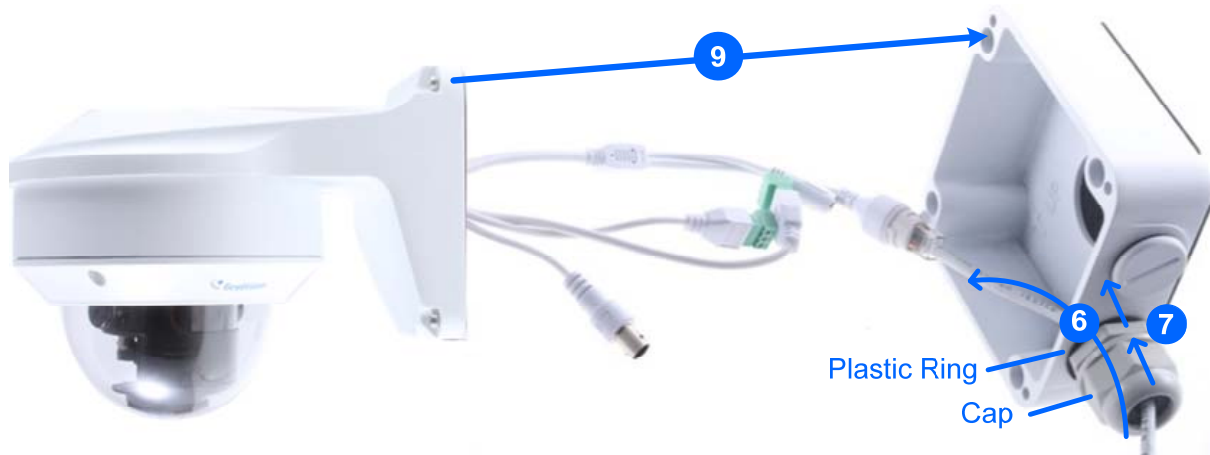

*Figure 1-78*

1.4.5.2 GV-Mount212-2



Figure 1-79

**GV-Mount212-2 Packing List**

<ul style="list-style-type: none"> <li>• GV-Mount212-2 Wall Box Mount</li> </ul> 	<ul style="list-style-type: none"> <li>• Long Screw x 3</li> </ul> 
<ul style="list-style-type: none"> <li>• Short Screw x 3</li> </ul> 	<ul style="list-style-type: none"> <li>• Screw Anchor x 3</li> </ul> 

1. Attach the wall box to the wall and use a marker to mark the location for the center socket and the screws. Make sure the knob points down.

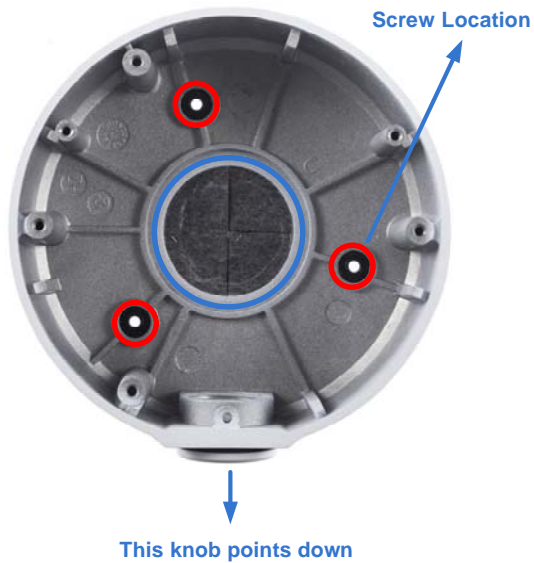

Figure 1-80

2. Drill 3 holes according to the screw location. Then, drill a bigger hole at the center socket location for the Ethernet cable.
3. Insert 3 screw anchors to the screw location and secure the wall box to the wall with 3 long screws.
4. Thread the Ethernet cable through the center socket, connect other wires and fit the camera cable into the wall box. See *1.6 Waterproofing the Cable*.



Figure 1-81

5. Unscrew the transparent dome cover with the supplied torx wrench.

6. Secure the camera to the wall box.

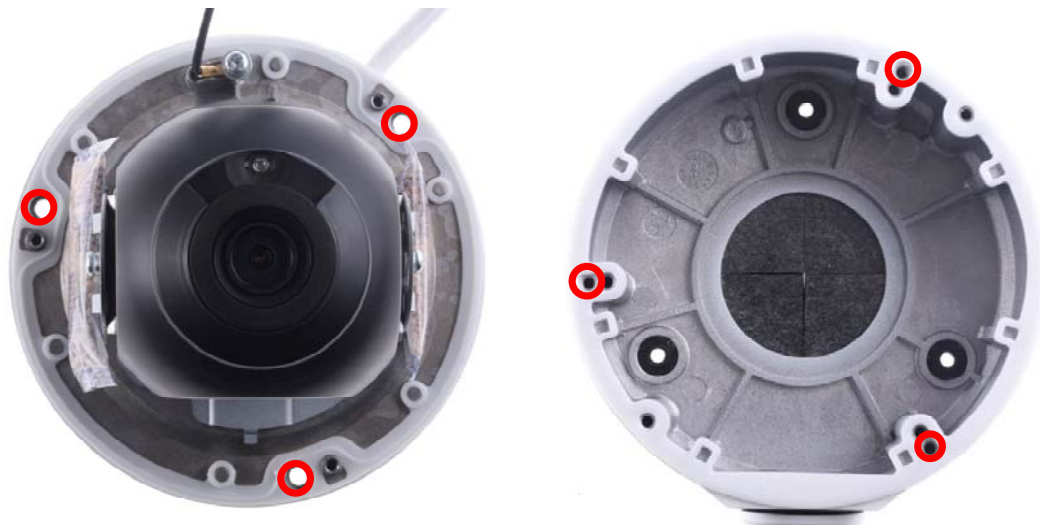

Figure 1-82

---

**Note:** In addition to the Standard Installation, you can also choose to run the Ethernet cable through a corrugated tube. To do this, see Figure 1-33 and its related Note.

---

## 1.5 System Requirements

<b>CPU</b>	Intel Core i5-4670, 3.40 GHz
<b>Memory</b>	DDR3 8 GB RAM
<b>On Board Graphics</b>	Intel HD Graphics 4600 (Versions of driver from year 2014 or later required)
<b>Web Browsers</b>	<ul style="list-style-type: none"><li>● Internet Explorer 11.0 or above</li><li>● Mozilla Firefox</li><li>● Safari</li></ul>
<b>Note:</b> Some functions are not available on non-IE browsers.	

## 1.6 Waterproofing the Cable

Waterproof the Ethernet cable by using the supplied waterproof rubber set.

1. Attach the seal ring to the RJ-45 plug.

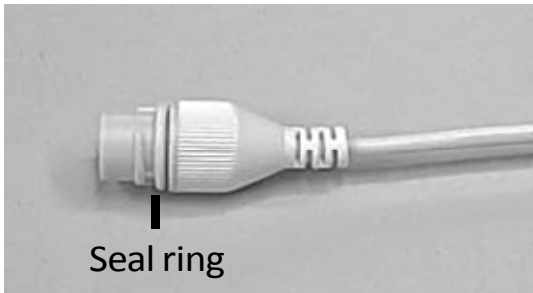

Figure 1-83

2. Insert the waterproof components through the Ethernet cable as shown below.

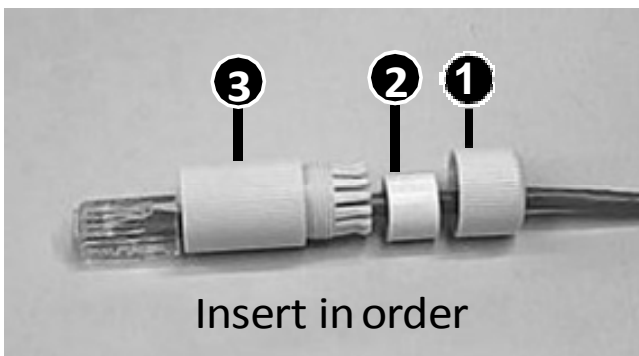

Figure 1-84

3. Insert the cylindrical waterproof ring into waterproof bolt.

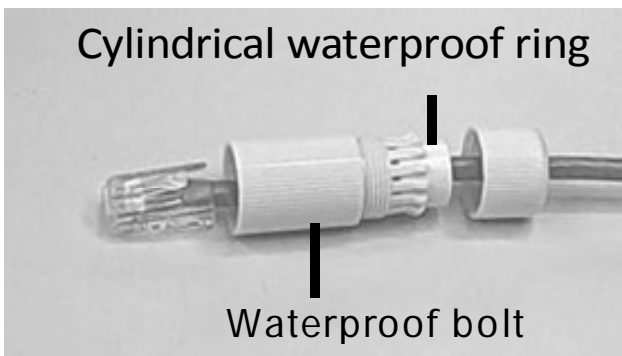
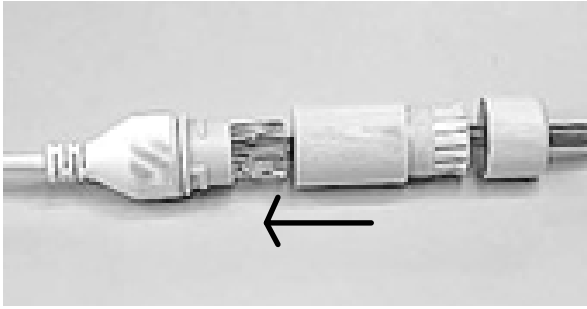

Figure 1-85



4. Insert the cable into the RJ-45 plug and screw the waterproof bolt in.



*Figure 1-86*

5. Screw in the waterproof bolt lid.

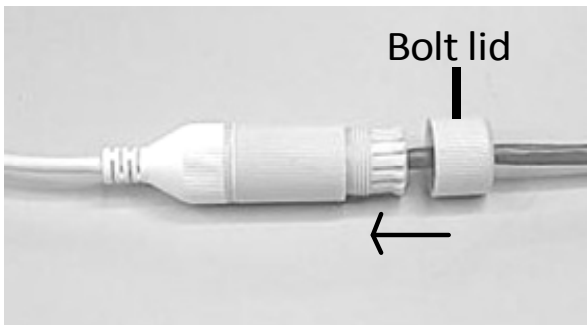

*Figure 1-87*

6. Finish the waterproof installation.

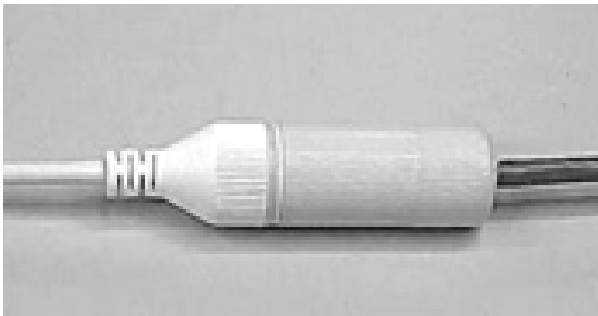

*Figure 1-88*

# Chapter 2 Accessing the Camera

Once installed, the IP camera is accessible on a network. Follow these steps to configure the network settings and access your surveillance images.

## 2.1 Installing on a Network

These instructions describe the basic connections to install the camera on the network.

1. Using a standard network cable, connect the camera to your network.
2. Connect to power using one of the following methods:
  - Use the optional power adapter to connect to power.
  - Use the Power over Ethernet (PoE) function in which power is supplied over the network cable.
3. You can now access the Web interface of the camera.
  - If the camera is installed in a LAN with DHCP server, use GV-IP Device Utility to look up the camera's dynamic IP address. See *2.1.1 Checking the Dynamic IP Address*.
  - If the camera is installed in a LAN without DHCP server, the default IP address **192.168.0.10** is applied. To assign a different static IP address, see *2.1.2 Assigning an IP Address*.

---

**Note:** You must set your browser to allow ActiveX Control and perform a one-time installation of the ActiveX component onto your computer upon your first login.

---

## 2.1.1 Checking the Dynamic IP Address

Follow the steps below to look up the IP address and access the Web interface.

1. Download and install the **GV-IP Device Utility** program from <http://www.geovision.com.tw/download/product/>.

---

**Note:** The PC installed with GV-IP Device Utility must be under the same LAN as the camera you wish to configure.

---

2. On the GV-IP Utility window, click the  button to search for the IP devices connected in the same LAN. Click the **Name** or **Mac Address** column to sort.

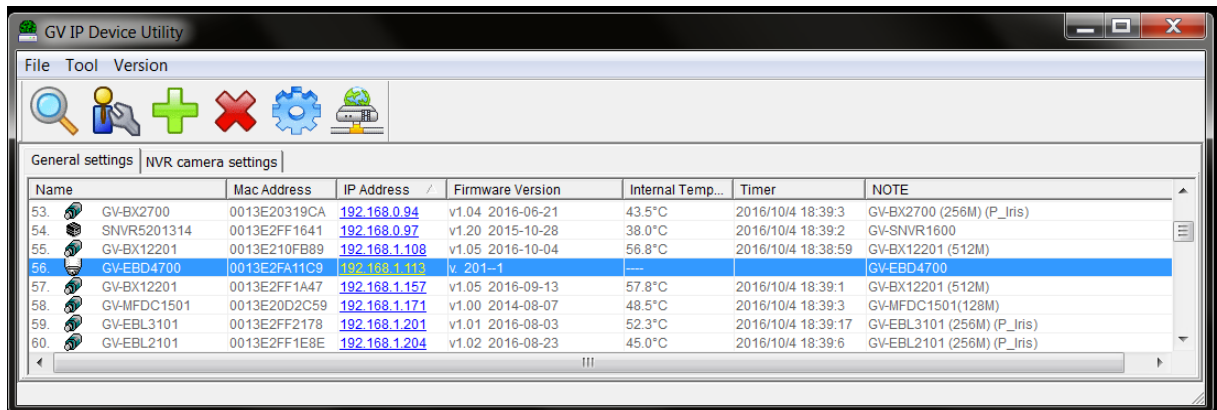

Figure 2-1

3. Find the camera with its Mac Address, click on its IP address and select **Web Page**.

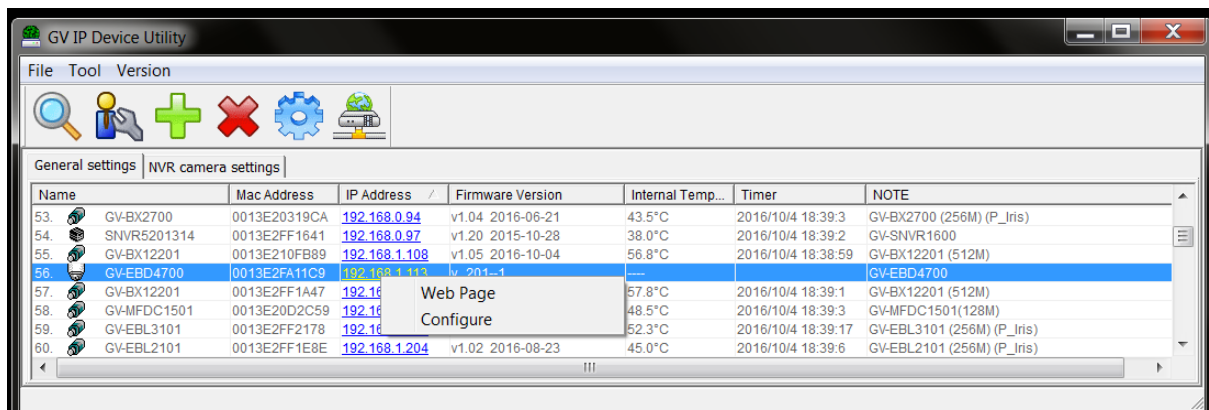
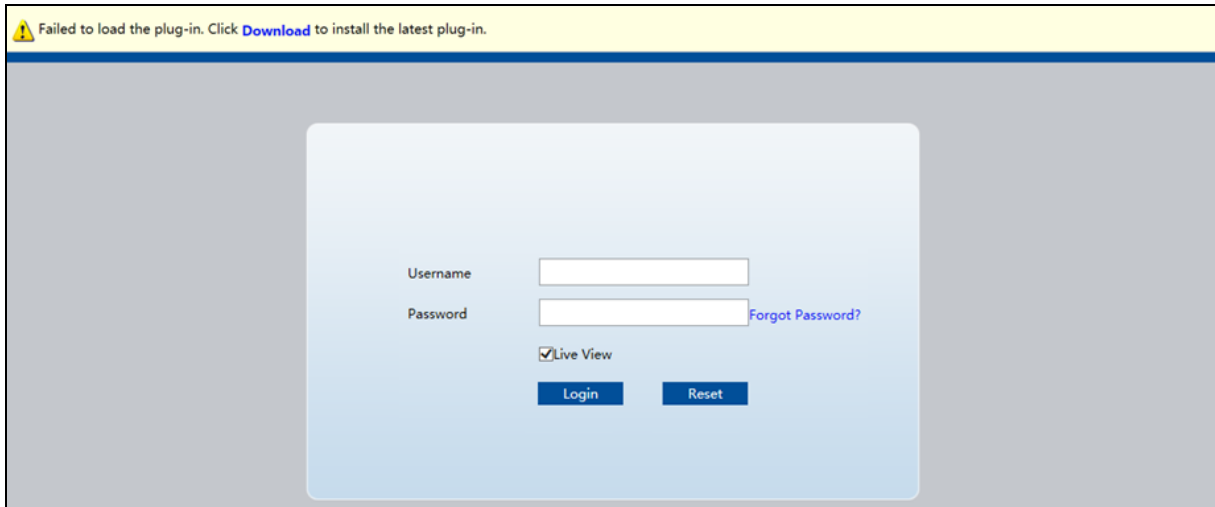

Figure 2-2

4. The login page appears.



*Figure 2-3*

5. For first-time accessing of the Web interface, download and install the plug-in.
6. Type the default ID and password **admin** and click **Login**.

## 2.1.2 Assigning an IP Address

To assign a new static IP address, log in the Web interface and access the network setting page. The following is illustrated using GV-EBD4711.

---

**Note:** If your router does not support DHCP, the default IP address is set as **192.168.0.10**. In this case, it is strongly suggested that you modify the IP address to avoid IP address conflicts with other GV-IP devices on the same LAN.

---

1. Open your Web browser and type the default IP address [192.168.0.10](http://192.168.0.10). A dialog box appears.
2. Type the default username and password **admin**. Click **Login**.
3. Click **Setup**, select **Common** in the left menu and select **Ethernet**.

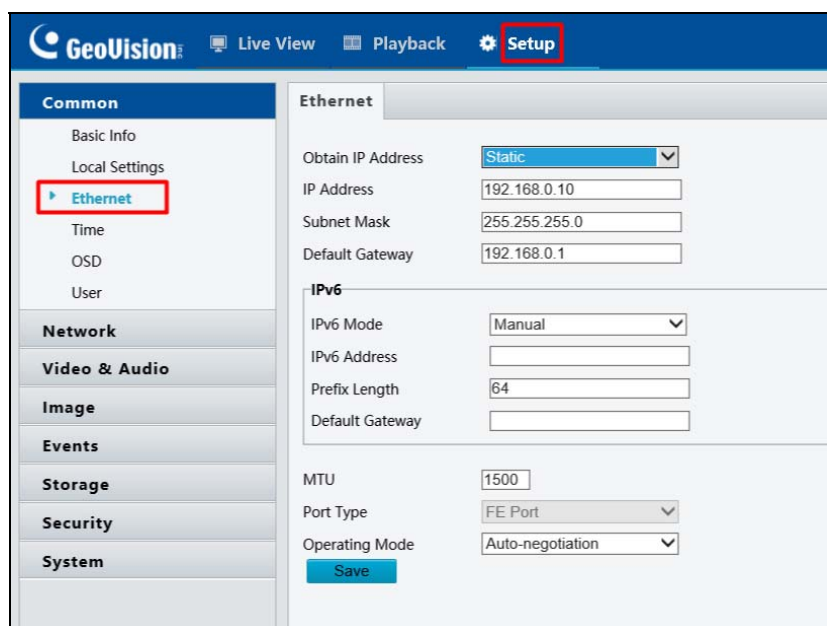

Figure 2-4

4. Select **Static IP** from the **Obtain IP Address** drop-down list.
5. Enter the IP address, subnet mask, and default gateway address. Make sure that the IP address of the camera is unique in the network.
6. Click **Save**.

---

**Note:** When you are changing the network segment through the Web interface or GV-IP Device Utility (V8.7.1.0), it is required that you change the default gateway too to complete the IP address change successfully.

---

## 2.2 Accessing Live View

After logging into the camera, you will see the Home page as shown below:

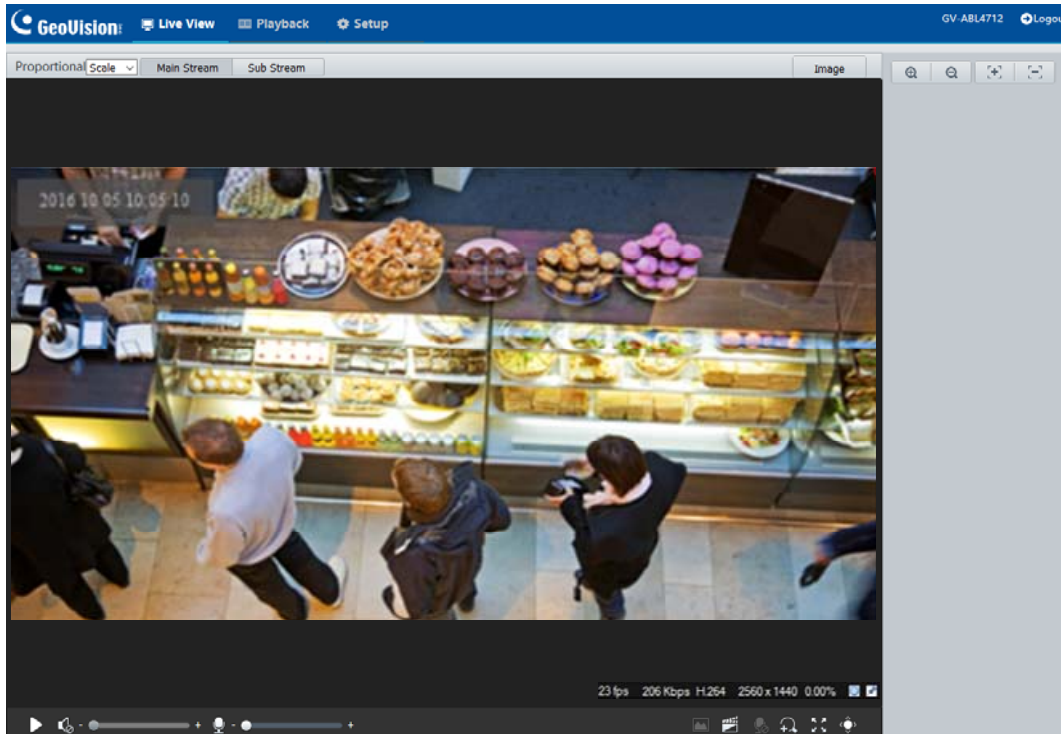

Figure 2-5

## 2.2.1 The Live View Window

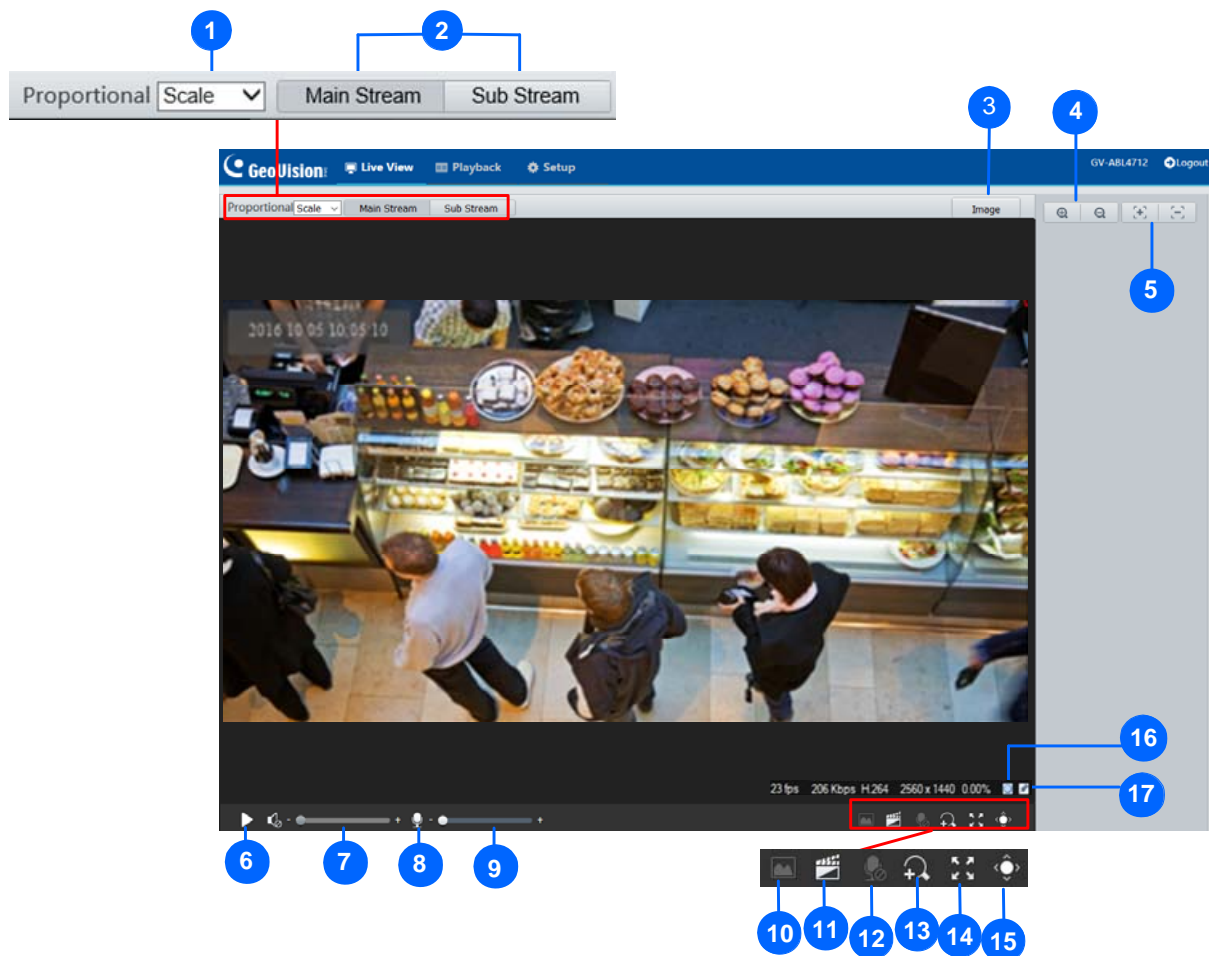











Figure 2-6

No.	Name	Function
1	Proportional	Set the display ratio of the image. <ul style="list-style-type: none"> <li>• Scale: display images by 16:9.</li> <li>• Stretch: display images by window size.</li> <li>• Original: display images in its original size.</li> </ul>
2	Live Stream	Select a live video stream: main stream, sub stream or third stream (when enabled).
3	Image	Open the image setting page. – See 3.4.1 Image.
4	Zoom +/-	Only for <b>GV-EBD4711 / GV-ABL4712 / GV-AVD4710</b> , increase  or decrease  the camera's optical zoom.
5	Focus +/-	Only for <b>GV-EBD4711 / GV-ABL4712 / GV-AVD4710</b> , increase  or decrease  the camera focus.
6	Play/Stop	Play or stop live video.

7	Video Volume	Only for <b>GV-EBD4711 / GV-ABL4712 / GV-AVD4710</b> , adjust the audio output volume on the PC.
8	Microphone	Only for <b>GV-ABL4712 / AVD4710</b> , enable  or disable  microphone.
9	Microphone Volume	Only for <b>GV-ABL4712 / AVD4710</b> , adjust the microphone volume on the PC during audio communication between the PC and the camera.
10	Snapshot	Take a snapshot of the current image displayed on the PC.
11	Local Recording	Start  or stop  local recording.
12	Two-way Audio	Only for <b>GV-ABL4712 / AVD4710</b> , start  or stop  two-way audio.
13	Digital Zoom	Enable  or disable  digital zoom. – See 2.2.1.1 <i>Digital Zoom</i> .
14	Full Screen	Display in full screen mode.
15	Control Panel	Only for <b>GV-EBD4711 / GV-ABL4712 / GV-AVD4710</b> , hide or show the camera's optical zoom and focus functions.
16		Reset the packet loss rate to zero.
17		Click to always display packet loss rate and bit rate information at the bottom. Click again to restore to only displaying the information for 3 seconds when the mouse cursor is moved onto the live view.



**Note:**

1. The paths for saving snapshots and local recordings are set in [Local Settings](#). See [3.12 Local Settings](#).
2. The No. 13 and 14 buttons will appear on the floating toolbar when you move the mouse cursor onto the live view.



### 2.2.1.1 Digital Zoom

To use the digital zoom function, follow these steps:

1. Click  (No. 10, Figure 2-6) on the toolbar.
2. Click and drag the mouse button in any direction to specify an area.
3. To restore the original image size, right click on the enlarged area.
4. To exit, click  (No. 10, Figure 2-6) on the toolbar.

## 2.3 Playing Back Recorded Videos

Note this function is only applicable to **GV-EBD4711 / GV-ABL4712 / GV-AVD4710**.

To play back recorded videos from the camera's local storage, click **Playback** at the top of the Web interface.

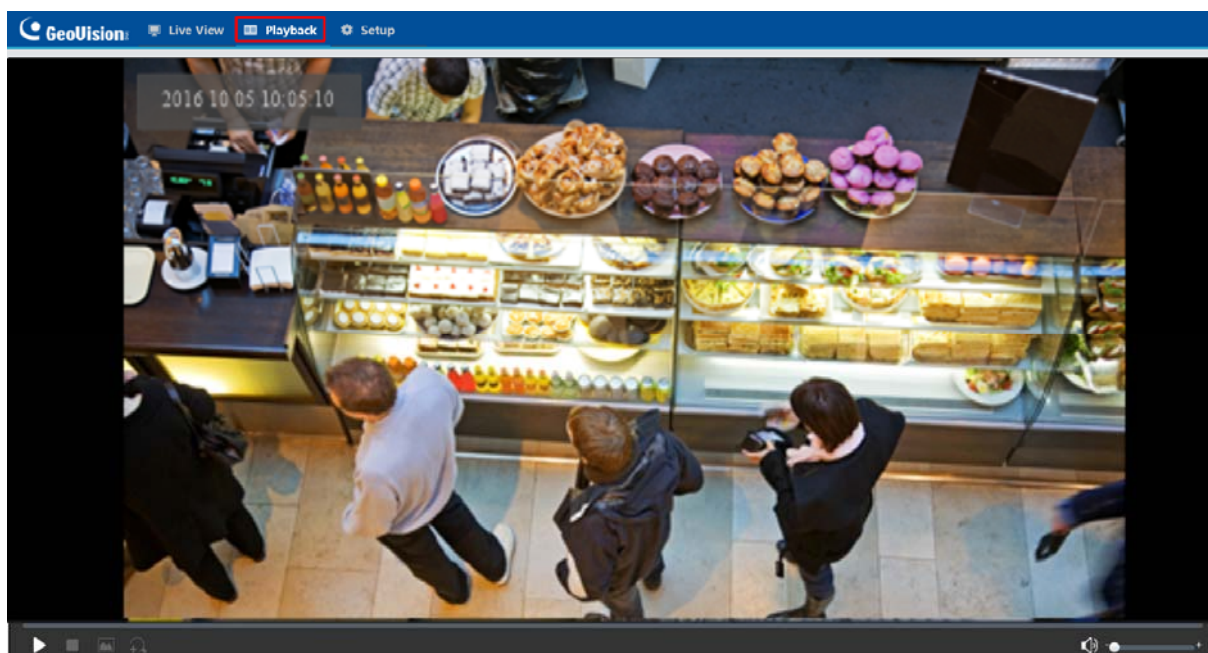

Figure 2-7

## 2.3.1 The Playback Window

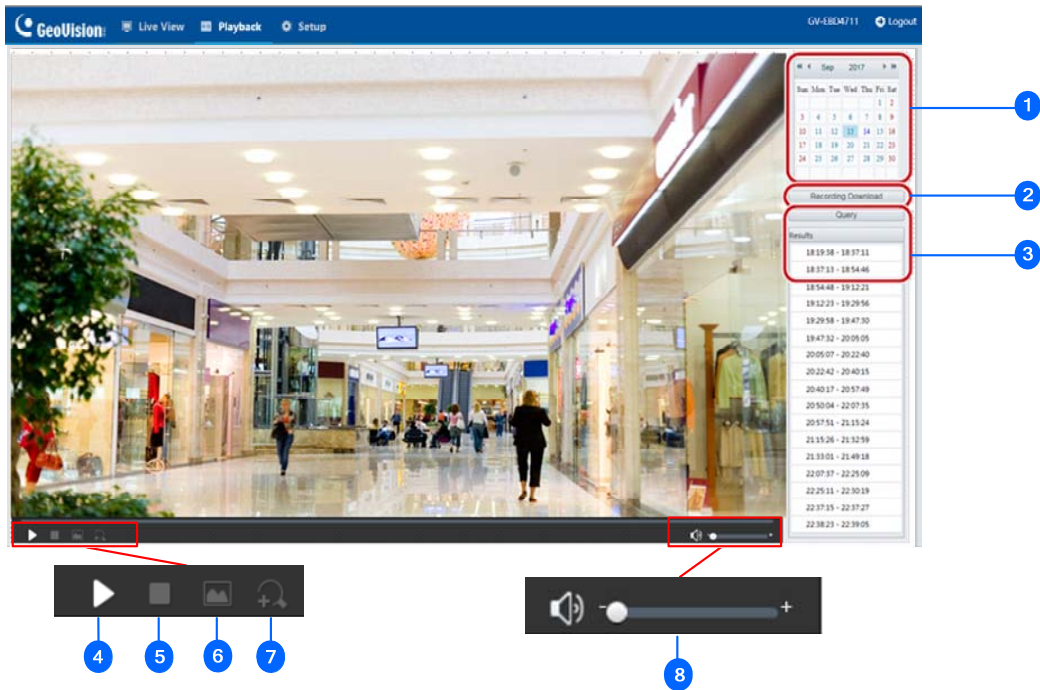

Figure 2-8

No.	Name	Function
1	Date	Select the date of the video to playback.
2	Recording Download	Select to download a recorded video from the camera's local storage. See 2.3.1.1 <i>Recording Download</i> for details.
3	Query	Click <b>Query</b> to show the list of recorded videos of the date specified.
4	Playback	Play back the recorded video selected.
5	Stop	Stop playback of the recorded video selected.
6	Snapshot	Take a snapshot of the current playback image displayed.
7	Digital Zoom	Enable  or disable  digital zoom. – See 2.2.1.1 <i>Digital Zoom</i> .
8	Volume	Adjust the audio output volume on the PC.

**Note:** To store and play back recorded videos to and from the camera's local storage, make sure to configure the storage settings in **Storage**. For more detailed instructions, refer to 3.6.1 *Storage*.

### 2.3.1.1 Recording Download

To download recorded videos from the local storage, follow the steps below:

1. Click **Recording Download** (No. 2, Figure 2-8) on the right of the Playback window.

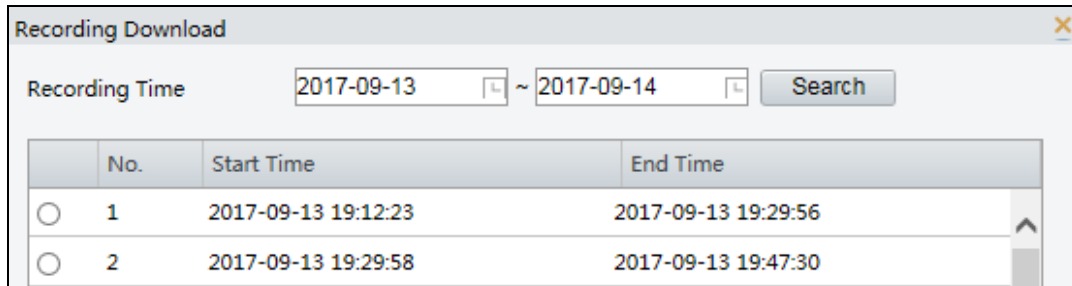

*Figure 2-9*

2. Search for video within a specified time period. The results are shown in a list.
3. Select your video and click **Download** to download a video to your local path from the local storage.
4. Click **Open** to show the folder in which the downloaded videos are saved.

# Chapter 3 Administrator Mode

The Administrator can access and configure the GV-IP Camera through the network. Click **Setup** at the top of the Web interface to access the following eight configuration tabs: **Common**, **Network**, **Video & Audio**, **Image**, **Events**, **Storage**, **Security** and **System**.

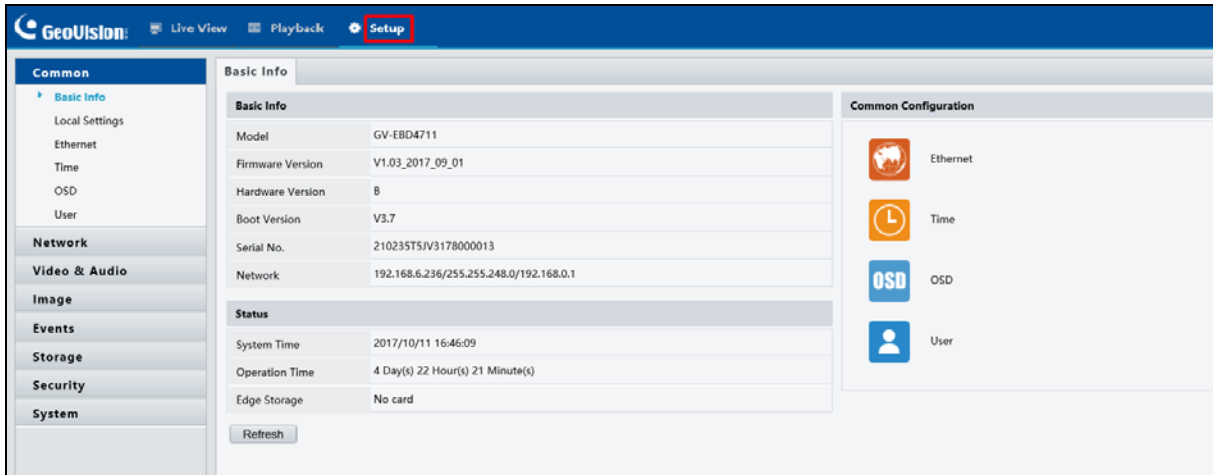

Figure 3-1

## List of Options

See the table below for the settings available on the Web interface. Find the topic of interest by referring to the section number prefixed to each option.

---

**Note:** The available options may vary among camera models and firmware versions.

---

3.1 Common	3.1.1 Basic Info 3.1.2 Local Settings
3.2 Network	3.2.1 Ethernet 3.2.2 DNS 3.2.3 Port 3.2.4 DDNS 3.2.5 E-mail 3.2.6 802.1x
3.3 Video & Audio	3.3.1 Video 3.3.2 Snapshot 3.3.3 Audio 3.3.4 ROI 3.3.5 Media Stream
3.4 Image	3.4.1 Image 3.4.2 OSD 3.4.3 Privacy Mask
3.5 Events	3.5.1 Motion Detection 3.5.2 Tampering Alarm 3.5.3 Audio Detection
3.6 Storage	3.6.1 Storage 3.6.2 FTP
3.7 Security	3.7.1 User 3.7.2 Network Security
3.8 System	3.8.1 Time 3.8.2 Maintenance

## 3.1 Common

Under the Common tab, the Administrator can find the general settings of the camera, as well as shortcuts to the following setting pages.

- **Ethernet:** See 3.2.1 *Ethernet* for details.
- **Time:** See 3.8.1 *Time* for details.
- **OSD:** See 3.4.2 *OSD* for details
- **User:** See 3.7.1 *User* for details

### 3.1.1 Basic Info

You can view the current status of your camera. Click **Refresh** for the latest status information. Under **Common Configuration** on the right, you can click on the icons to quickly access the corresponding configuration pages.



The screenshot displays the camera's configuration interface. On the left, the 'Basic Info' section contains a table with the following data:

Basic Info	
Model	GV-EBD4711
Firmware Version	V1.03_2017_09_01
Hardware Version	B
Boot Version	V3.7
Serial No.	210235T5JV3178000013
Network	192.168.6.236/255.255.248.0/192.168.0.1

Below this table is the 'Status' section with the following data:

System Time	2017/10/11 17:28:04
Operation Time	4 Day(s) 23 Hour(s) 3 Minute(s)
Edge Storage	No card

A 'Refresh' button is located at the bottom left of the Basic Info section. On the right side, the 'Common Configuration' section features four icons for quick access: Ethernet (globe icon), Time (clock icon), OSD (OSD text icon), and User (person icon).

Figure 3-2

### 3.1.2 Local Settings

You can set the local parameters for your PC.

**Local Settings**

**Video**

Processing Mode: Fluency Priority

Protocol: TCP

**Audio**

Encoding Format: G.711U

**Recording and Snapshot**

Recording: Subsection By Time

Subsection Time (min): 30 [1-60]

When Storage Full:  Overwrite Recording  Stop Recording

Total Capacity(GB): 10 [1~1024]

Local Recording: TS

Files Folder: C:\Users\User\Surveillance\_IPC\IPCNB

Figure 3-3

#### [Video]

##### ■ Processing Mode

- ⊙ **Real-Time Priority:** Select this if the network is in good condition.
- ⊙ **Fluency Priority:** Select this if you want short time lag for live video.
- ⊙ **Ultra-low Latency:** Select this if you want the minimum time lag for live video.

- **Protocol:** Select the protocol used to transmit media streams to be decoded by the PC.



**[Audio]** This function is only applicable to **GV-EBD4711 / GV-ABL4712 / GV-AVD4710**.

- **Encoding Format:** Select the format used to encode audio.

### **[Recording and Snapshot]**

- **Recording**

- ⊙ **Subsection By Time:** Set a maximum time length of each recording file. If you select 5 minutes, a 30-minute event will be chopped into six 5-minute event files.

- ⊙ **Subsection by Size:** Set a maximum size limit of each recording file.

- **When Storage Full**

- ⊙ **Overwrite Recording:** When the assigned storage space on the computer is used up, the camera deletes the existing recording files to make room for the new recording file.

- ⊙ **Stop Recording:** When the assigned storage space on the computer is full, recording stops automatically.

- **Total Capacity:** Set a capacity limit to the assigned storage space on the computer.

- **Files Folder:** Click **Browse** to set a folder to store the recorded videos and captured snapshots at your local computer.

## 3.2 Network

The network section allows you to configure the network settings, modify ports, configure FTP server, and set up e-mail for notification.

### 3.2.1 Ethernet

Figure 3-4

- **IPv4:** Select **Static IP** or **DHCP** according to your network environment.
  - ⊙ **Static IP address:** Assign a static IP or fixed IP to the camera. Type the camera's IP address, Subnet Mask and Router/Gateway.

Parameters	Default
IP address	192.168.0.10
Subnet Mask	255.255.255.0
Router/Gateway	192.168.0.1

- ⊙ **DHCP:** The network environment has a DHCP server which will automatically assign a dynamic IP address to the camera. You can look up the current IP address using GV-IP Device Utility.

- **IPv6:** Type the camera's **IPv6 Address** and **Default Gateway**. Optionally change the **Prefix Length** according to your network settings.
- **Operating Mode:** Select a mode to control the bandwidth.

---

**Note:**

1. To enable **IPv6**, make sure your network environment used support IPv6.
  2. **MTU** is not functional.
- 

### 3.2.2 DNS

Type the camera's **Preferred DNS Server** and **Alternate DNS Server**.

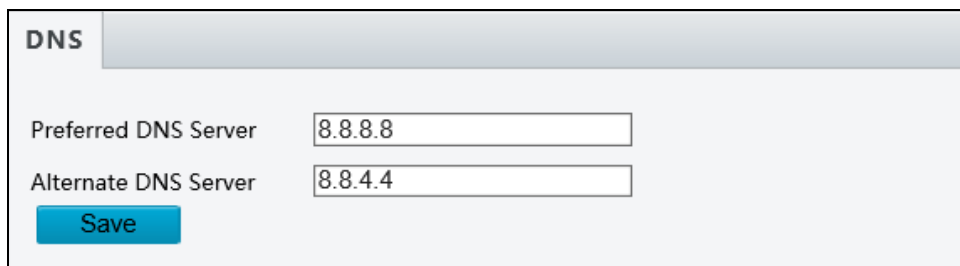

The screenshot shows a web interface for configuring DNS. At the top left, there is a tab labeled "DNS". Below the tab, there are two input fields. The first is labeled "Preferred DNS Server" and contains the text "8.8.8.8". The second is labeled "Alternate DNS Server" and contains the text "8.8.4.4". Below these fields is a blue button with the text "Save".

*Figure 3-5*

### 3.2.3 Port

#### Port

You can modify the default **HTTP port**, **HTTPS port** and **RTSP port** if necessary.

Port	Port Mapping
HTTP Port	<input type="text" value="80"/>
HTTPS Port	<input type="text" value="443"/>
RTSP Port	<input type="text" value="554"/>

**Note:** Modifying the RTSP or server port number will cause the device to restart.

Figure 3-6

#### Port Mapping

This function can automatically forward and open certain ports on your router, allowing connection to your camera from the Internet.

Port Type	External Port	External IP Address	Status
HTTP Port	<input type="text" value="80"/>	0.0.0.0	Inactive
RTSP Port	<input type="text" value="554"/>	0.0.0.0	Inactive
Server Port	<input type="text" value="81"/>	0.0.0.0	Inactive

Figure 3-7

1. Enable **Port Mapping**, and select **Mapping Type**.

- If you select **Automatic**, external ports will be automatically configured by the router.
- If you select **Manual**, configure external ports. External IP is applied to the camera automatically. If the configured port is occupied, the **Status** will show inactive.

2. Click **Save**.

---

**Note:** For this function, your router needs to support **port forwarding**.

---

### 3.2.4 DDNS

DDNS (Dynamic Domain Name System) provides a convenient way of accessing the camera when using a dynamic IP. DDNS assigns a domain name to the camera, so that the Administrator does not need to go through the trouble of checking if the IP address assigned by DHCP Server or ISP (in xDSL connection) has changed.



Figure 3-8

1. Click **On** to Enable **DDNS Service**.
2. Copy the website address <http://ns.gvdip.com/register.aspx> to a browser to access Geovision DDNS service.

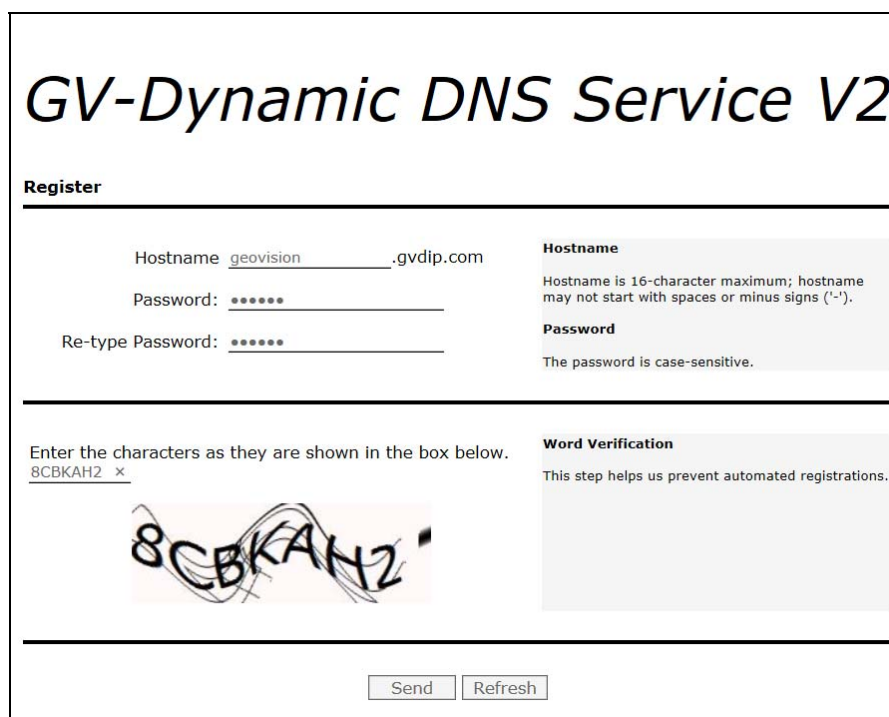
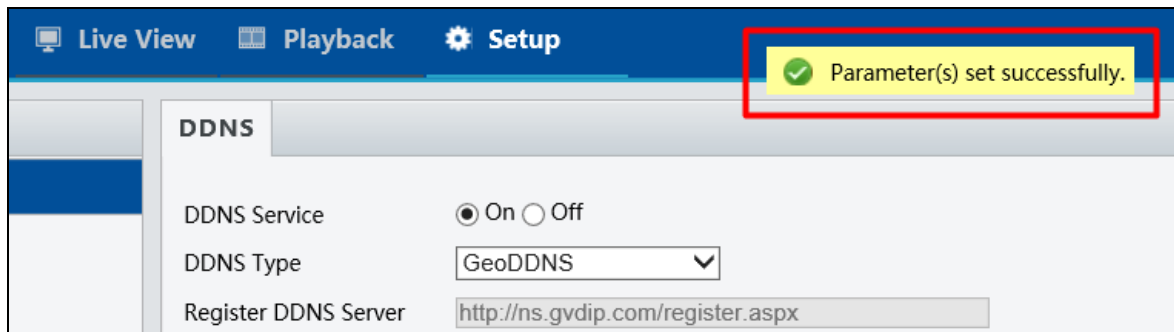

Figure 3-9

3. In the Geovision DDNS Server page, type a desired **Hostname** and **Password**. Re-type Password and type the verification letters shown in the image. Click **Send**.
4. In the Web interface of your camera, type **Username**. The username is the hostname registered in DDNS Server.
5. Type **Password**, and **Confirm Password**.
6. Click **Save**.

After the DDNS is successfully configured, a notification bar will be displayed as shown in *Figure 3-8*. Next time when you log in the camera, type the domain name like this: (hostname).gvdip.com; for example, geovision.gvdip.com.



*Figure 3-10*

### 3.2.5 E-mail

After the configuration of E-mail, you will be able to send messages to the specified E-mail address(s) when alarms are triggered.

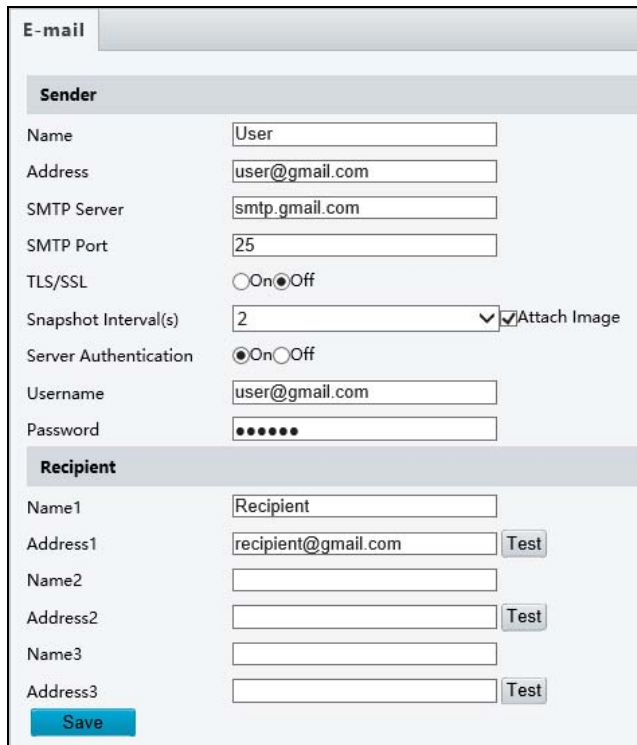

Figure 3-11

1. Type the **Name** and **Address** of the sender.
2. Type the **SMTP Server**.
3. Type the **SMTP Port** number.
4. To send the e-mail through TLS / SSL encryption, enable **TLS/SSL**.
5. Enable **Attach Image** to include 3 instant snapshots as attachment in the e-mail according to the **Snapshot Interval** specified.
6. If the SMTP Server needs authentication, enable **Server Authentication** and type a valid username and password to log in the SMTP server.
7. Type the name(s) and e-mail address(s) of the **Recipient(s)**.
8. Click **Save**.

For **GV-EBD2702 / GV-ABL4712 / GV-AVD4710**, click the **Test** button next to the address of a **Recipient** to **Test** for the validity of the e-mail address.

---

**Note:** To send snapshots to the specified E-mail address(s), make sure to enable the **Snapshot** function. For more detailed instructions, refer to [3.3.2 Snapshot](#).

---

### 3.2.6 802.1x

IEEE 802.1x is an IEEE standard for port-based Network Access Control. It provides an authentication mechanism to devices wishing to attach to a LAN or WLAN. Note this function is only applicable to **GV-EBD2702 / 4700 / 4711**, **GV-ABL4712** and **GV-AVD4710**.

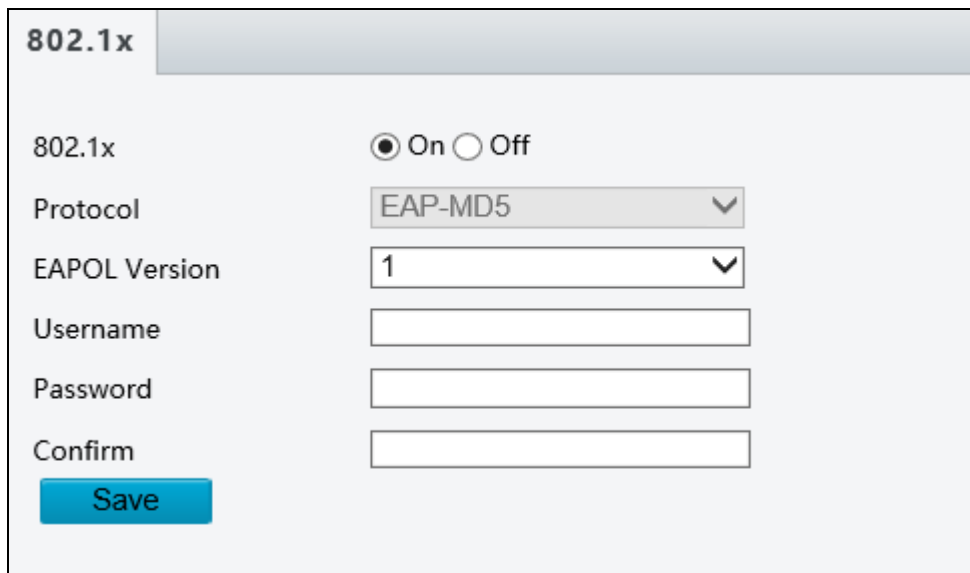

802.1x

802.1x  On  Off

Protocol EAP-MD5

EAPOL Version 1

Username

Password

Confirm

Save

Figure 3-12

1. Enable **IEEE 802.1x**.
2. Type the **Username** and **Password**. Type the password again for confirmation.
3. Click **Save**.

---

**Note:** For this function, your network environment needs to support **802.1x**.

---



## 3.3 Video & Audio

This section allows you to configure the three video streams and audio input. The audio function is only applicable to **GV-EBD4711**, **GV-ABL4712** and **GV-AVD4710**.

### 3.3.1 Video

You can set video parameters that your camera supports. You may also enable the sub-stream and third stream as needed. The third stream is disabled by default.

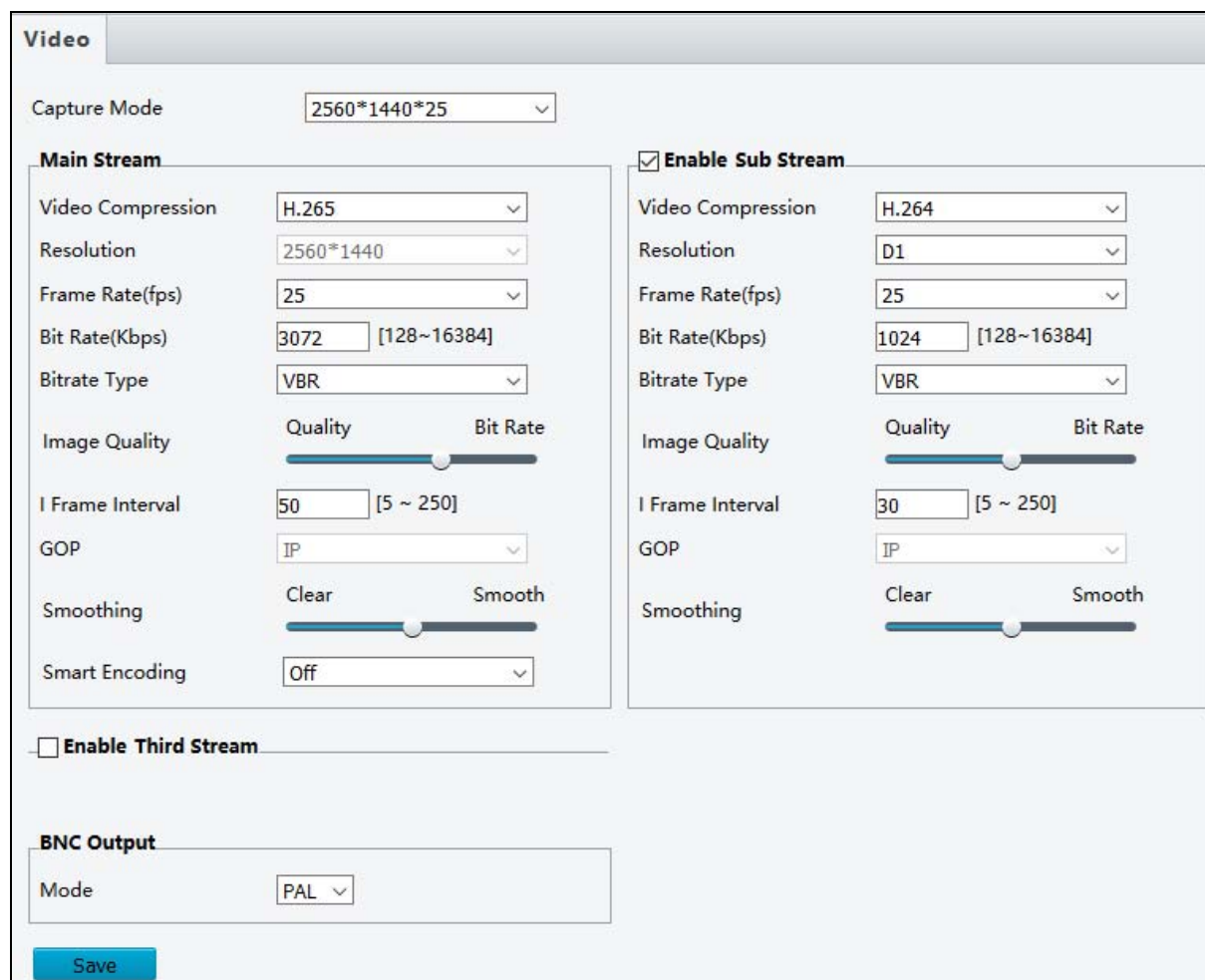

The screenshot shows a 'Video' configuration window with the following settings:

- Capture Mode:** 2560\*1440\*25
- Main Stream:**
  - Video Compression: H.265
  - Resolution: 2560\*1440
  - Frame Rate(fps): 25
  - Bit Rate(Kbps): 3072 [128~16384]
  - Bitrate Type: VBR
  - Image Quality: Slider between Quality and Bit Rate
  - I Frame Interval: 50 [5 ~ 250]
  - GOP: IP
  - Smoothing: Slider between Clear and Smooth
  - Smart Encoding: Off
- Enable Sub Stream:** 
  - Video Compression: H.264
  - Resolution: D1
  - Frame Rate(fps): 25
  - Bit Rate(Kbps): 1024 [128~16384]
  - Bitrate Type: VBR
  - Image Quality: Slider between Quality and Bit Rate
  - I Frame Interval: 30 [5 ~ 250]
  - GOP: IP
  - Smoothing: Slider between Clear and Smooth
- Enable Third Stream:**
- BNC Output:**
  - Mode: PAL
- Save** button

Figure 3-13

- **Capture Mode:** Sets the maximum resolution and frame rate.

The following options are available for the main, sub and third streams.

- **Video Compression:** Set the codec type to **H.265**, **H.264** or **MJPEG**.
- **Resolution:** You may select the different resolutions for each stream.
- **Frame Rate:** Select a frame rate for encoding images. The unit is frame per second.

- **Bit Rate:**
  - ⊙ **CBR:** The camera transmits data at a constant data rate by varying the quality of the video stream
  - ⊙ **VBR:** The quality of the video stream is kept as constant as possible at the cost of a varying bitrate.
- **Image Quality:** When VBR is selected for the encoding mode, you can move the slider to adjust the desired quality level the for images. Moving the slider toward **Bit Rate** decreases the bit rate and may affect image quality. Moving the slider toward **Quality** increases the bit rate and improves image quality.
- **I Frame Interval:** Set the number of frames between each I frame (key frame). This option is only available when H.265 or H.264 is selected as the codec.
- **Smoothing:** Set the extent of smoothing. Choosing **Clear** means disabling **Smoothing**. Moving the slider toward **Smooth** increases the level of smoothing but will affect image quality.

**[BNC Output]** Only for **GV-AVD4710**, The status of the BNC device is shown.

- **Mode:** Set the signal format of the video output to either **NTSC** or **PAL**.

### 3.3.2 Snapshot

Using the Snapshot function, when an alarm is triggered, the camera will automatically upload the captured snapshots to the FTP server and/or send snapshots to the specified e-mail address(s).

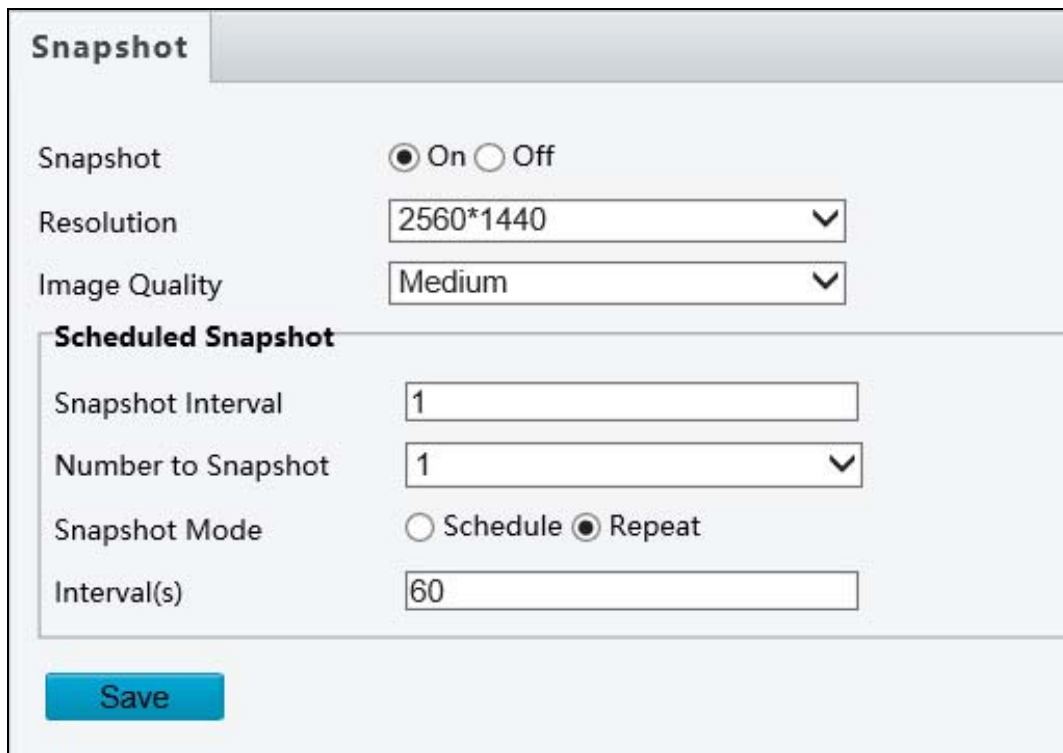



Figure 3-14

1. Select **On** to enable **Snapshot**.
2. Select **Resolution**.
3. Choose the **Image Quality**.
4. Choose the **Number of Snapshot** to capture upon alarm trigger.
5. Select **Schedule mode** or **Repeat mode** to set up the **Scheduled Snapshot**.
  - ⊙ If you select **Schedule mode**, click  to specify the desired time(s) to take a snapshot.
  - ⊙ If you select **Repeat mode**, type the interval, from 1 to 86400 seconds, to take snapshots at the interval specified.
6. Click **Save**.

---

**Note:** Snapshot Interval(s) is not functional.

---

### 3.3.3 Audio

Note this function is only applicable to **GV-EBD4711**, **GV-ABL4712** and **GV-AVD4710**.

You can configure the audio settings of the camera.

Figure 3-15

- **Audio Input:** Select **On** to enable audio input.
- **Input Gain:** Set the audio signal amplification for sampling. The greater the gain, the greater amplification.
- **Audio Compression:** Select an audio codec.
- **Noise Suppression:** Select **On** to reduce the noise of the audio.
- **Channel 1:** Click **Enable** to enable audio in through the camera's built-in microphone.

### 3.3.4 ROI

When Region of Interest (ROI) is enabled, the system ensures image quality for ROI first if the bit rate is insufficient.

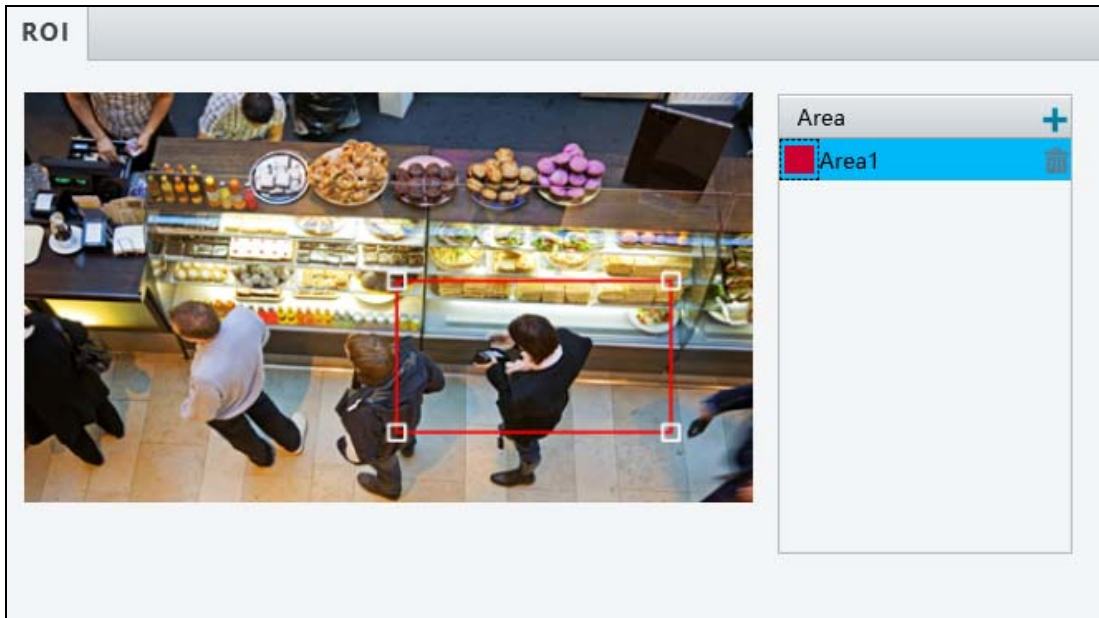



Figure 3-16

1. Click  to enable and add ROI.
2. Click and drag on the image to specify an area.
3. To add additional ROI areas, repeat steps 1 and 2. Up to eight ROI areas can be specified.
4. To delete an ROI area, click .

### 3.3.5 Media Stream

#### Media Stream

By configuring media stream, you can set the camera to transmit code streams by UDP or TCP protocol to a specified IP address and port number. The settings can be saved and take effect after the camera is rebooted.

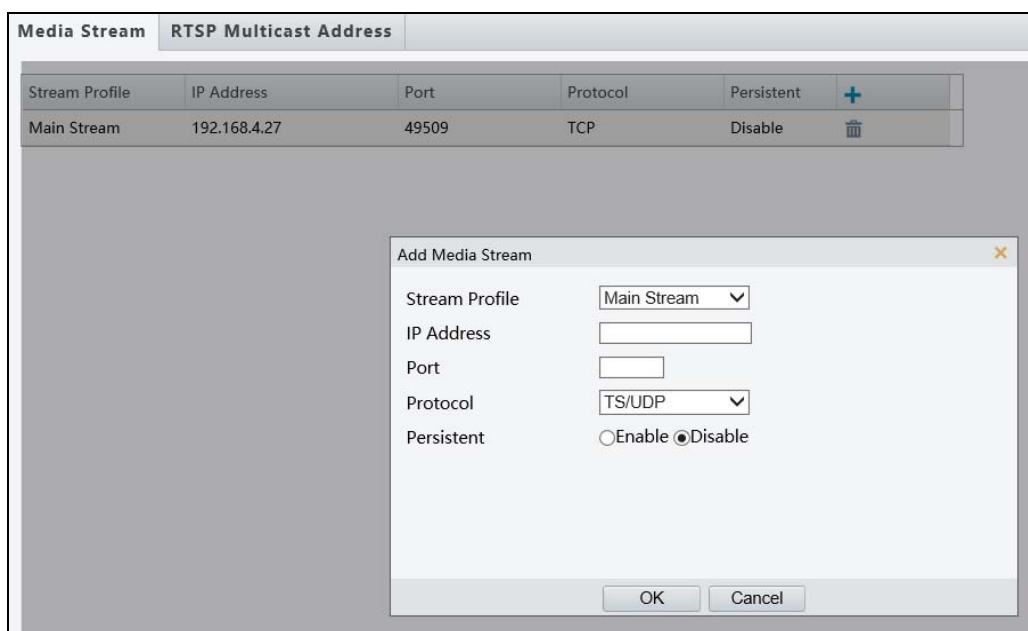
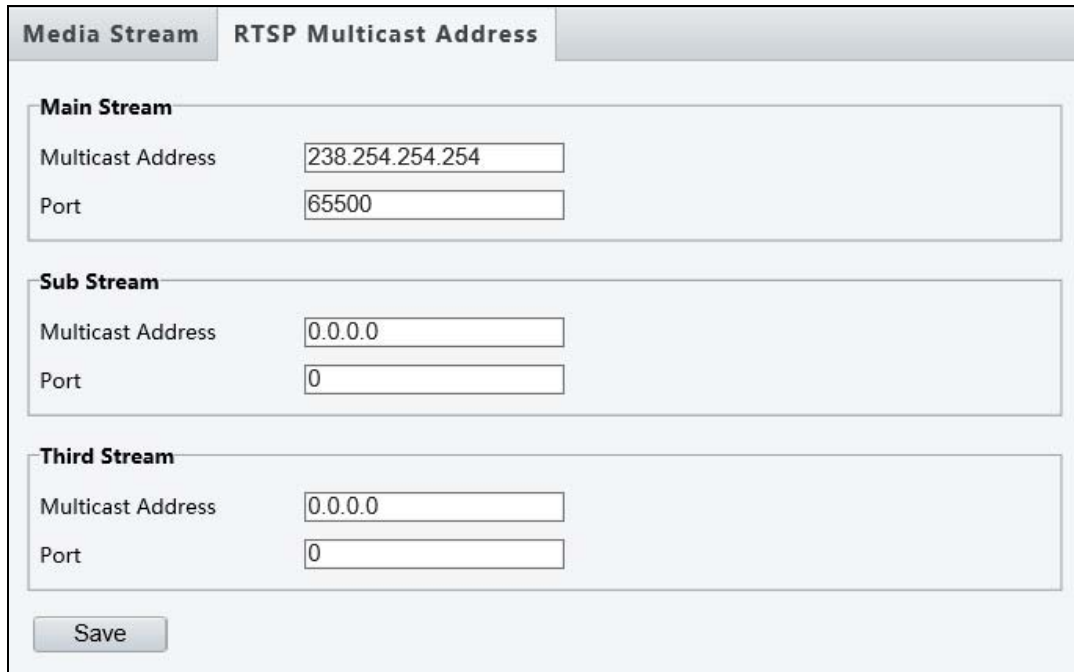

Figure 3-17

1. Click **+** and select a stream from the **Stream Profile** drop-down list.
2. Type the **IP Address** and **Port** number of the unicast or multicast group for the decoding device that receives video streams from the camera.
3. Select a **Protocol** type for the media stream.
4. If you want the device to automatically establish the media stream that has been previously configured after the restart, **Enable Persistent**.
5. To delete a stream, click **🗑**.
6. Click **OK** to complete the settings.

## RTSP Multicast Address

After an RTSP multicast address is configured, the third-party player can request for the RTSP multicast media stream from the camera through RTSP protocol.



Stream Type	Multicast Address	Port
Main Stream	238.254.254.254	65500
Sub Stream	0.0.0.0	0
Third Stream	0.0.0.0	0

Figure 3-18

1. Type the **Multicast Address** (224.0.0.0 to 239.255.255.255) and **Port** number (0 to 65535).
2. Click **Save**.

For RTSP Multicast command, see *Appendix A*.

## 3.4 Image

This section introduces the **Image Settings**, **On-screen Display** and **Privacy Mask**.

### 3.4.1 Image

This page allows you to adjust image settings such as brightness, exposure, IR illumination and white balance.

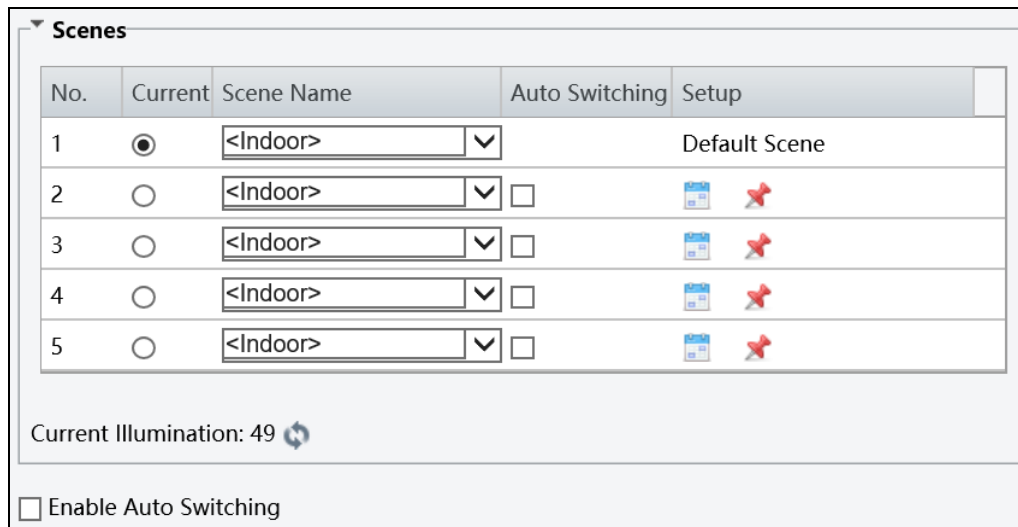

Figure 3-19

#### [Scene]

- **Current:** Indicates the scene that is being used.
- **Screen Name:** When you select a scene, the corresponding image parameters are displayed. You can adjust the image settings according to actual needs.
- **Auto Switching:** Indicates whether to add a scene to the auto-switching list.
- **Setup:**
  - ⊙ Click to set a schedule for illumination.
  - ⊙ Click to set a scene as the default scene.
- **Enable Auto Switching:** Allow the camera to switch to the scene automatically when the condition for switching to a non-default scene is met.



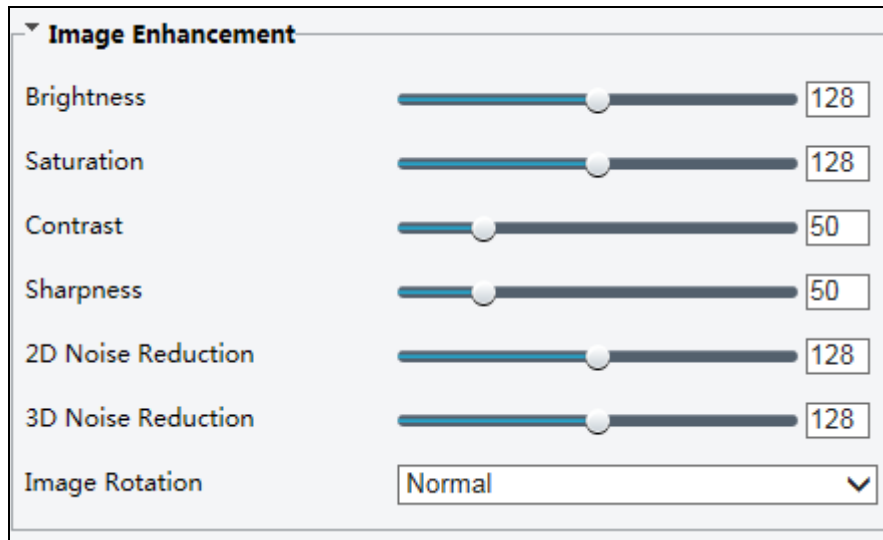

Figure 3-20

### [Image Enhancement]

- **Brightness:** Adjust the degree of brightness of the image.
- **Saturation:** Adjust the amount of hue contained in a color.
- **Contrast:** Set the degree of difference between the blackest pixel and the whitest pixel.
- **Sharpness:** Adjust the sharpness of the image.
- **2D / 3D Noise Reduction:** Reduce the noise of the image.
- **Image Rotation:** Change the rotation of the image.

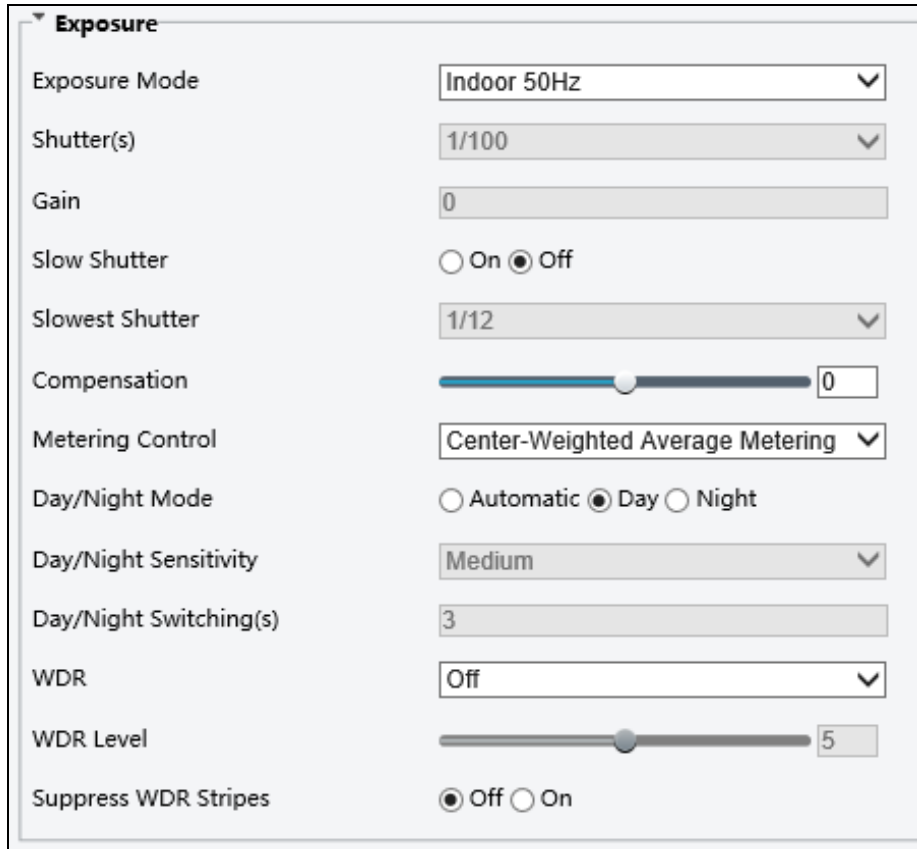

Figure 3-21

**[Exposure]**

- **Exposure Mode:** Select the correct exposure mode to achieve the desired exposure effect. The default setting is Outdoor.
- **Low Motion Blur:** Improve image quality by reducing motion blur in low light conditions.
- **Shutter(s):** The length of time that allows light to enter into the lens. You can set a shutter speed when **Exposure Mode** is set to **Manual (Custom)**.

---

**Note:** If **Slow Shutter** is set to **Off**, the reciprocal of the shutter speed must be greater than the frame rate.

---

- **Gain:** Control image signals so that the camera outputs standard video signals according to the light condition. You can set this parameter only when **Exposure Mode** is set to **Manual (Custom)**.
- **Slow Shutter:** Improve image brightness in low light conditions.
- **Slowest Shutter:** Set the slowest shutter speed that the camera can use during exposure.

- **Compensation:** Adjust the compensation value as required to achieve the desired effects. You can set this parameter only when **Exposure Mode** is not set to **Manual (Custom)**.
- **Metering Control:** Set the way the camera measures the intensity of light. You can only set this parameter when **Exposure Mode** is not set to **Manual (Custom)**.
  - ⊙ **Center-Weighted Average Metering:** Measure light mainly in the central part of the images.
  - ⊙ **Evaluative Metering:** Measure light in the customized area of the images.
  - ⊙ **Face Metering:** Measure light where facial recognition is established.
  - ⊙ **Spot Metering:** Measure light spot(s) in the specified area of the images.
- **Day/Night Mode:** Select **Automatic** for automatic switch between day mode and night mode depending on the amount of light detected. Select **Night** to produce high-quality black and white images using the existing light. Select **Day** to produce high-quality color images using the existing light.
- **Day/Night Sensitivity:** Set the light threshold for switching between day mode and night mode. A higher sensitivity means that the camera is more sensitive to the change of light and becomes more easily to switch between day mode and night mode.
- **Day/Night Switching(s):** Set the length of time before the camera switches between day mode and night mode after the conditions for switching are met.
- **WDR:** Enable WDR to distinguish the bright and dark areas in the same image.
- **WDR Level:** After enabling the WDR function, you can improve the image by adjusting the WDR level.
- **Suppress WDR Stripes:** Enable Suppress WDR Stripes to automatically adjust shutter frequency based on the frequency of light measured.

**Smart Illumination**

Smart Illumination  On  Off

Lighting Type  ▼

Control Mode  ▼

Illumination Level

Figure 3-22

**[Smart Illumination]**

- **Smart Illumination:** Select **On** to adjust the IR illumination settings.
- **Control Mode:**
  - ⊙ **Global Mode:** Adjust IR illumination and exposure to achieve balanced image effects. Some areas might be overexposed if you select this option. This option is recommended if monitored range and image brightness are your first priority.
  - ⊙ **Overexposure Restrain:** Adjust IR illumination and exposure to avoid regional overexposure. Some areas might be dark if you select this option. This option is recommended if clarity of the central part of the image and overexposure control are your first priority.
  - ⊙ **Manual:** Allow you to manually control the intensity of IR illumination.
- **Illumination Level:** Set the intensity level of the IR light. The greater the value, the higher the intensity. 0 means that the IR light is turned off. You can only set the intensity level of the IR light when **Control Mode** is set to **Manual**.

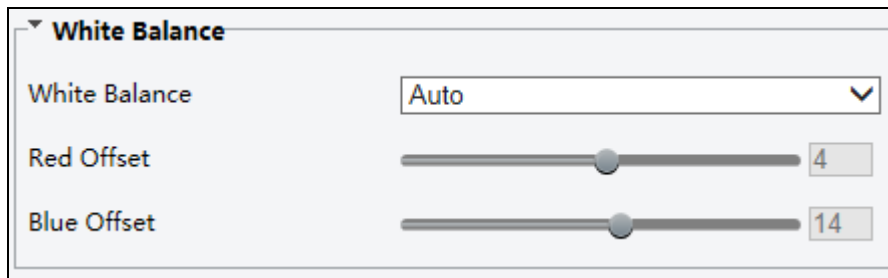

Figure 3-23

### [White Balance]

- **White Balance:** Adjust the red or blue offset of the image.
  - **Auto:** Adjust the red and blue offset automatically according to the light condition (the color tends to be blue).
  - **Outdoor:** It is recommended for outdoor scenes with a wide range of color temperature variation.
  - **Fine tune:** Allow you to adjust the red and blue offset manually.
  - **Sodium Lamp:** Adjust the red and blue offset automatically according to the light condition (the color tends to be red).
  - **Locked:** Lock the current color temperature settings without adjustment.

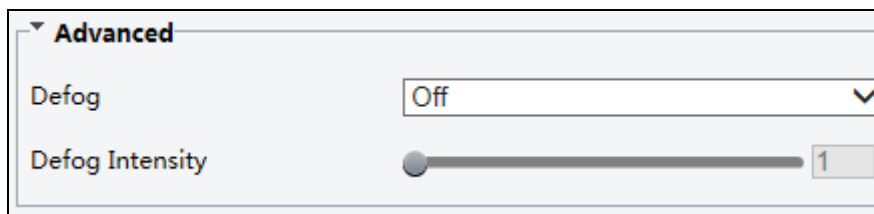

Figure 3-24

### [Advanced]

- **Defog:** Select **On** to activate the slider for adjusting the **defog intensity** of the image. Or select **Automatic** for the camera to adjust the defog intensity automatically.

## 3.4.2 OSD

On Screen Display (OSD) is the text displayed on the screen of video images and may include the date and time and other customized contents.

### 3.4.2.1 For all models except GV-EBD2702

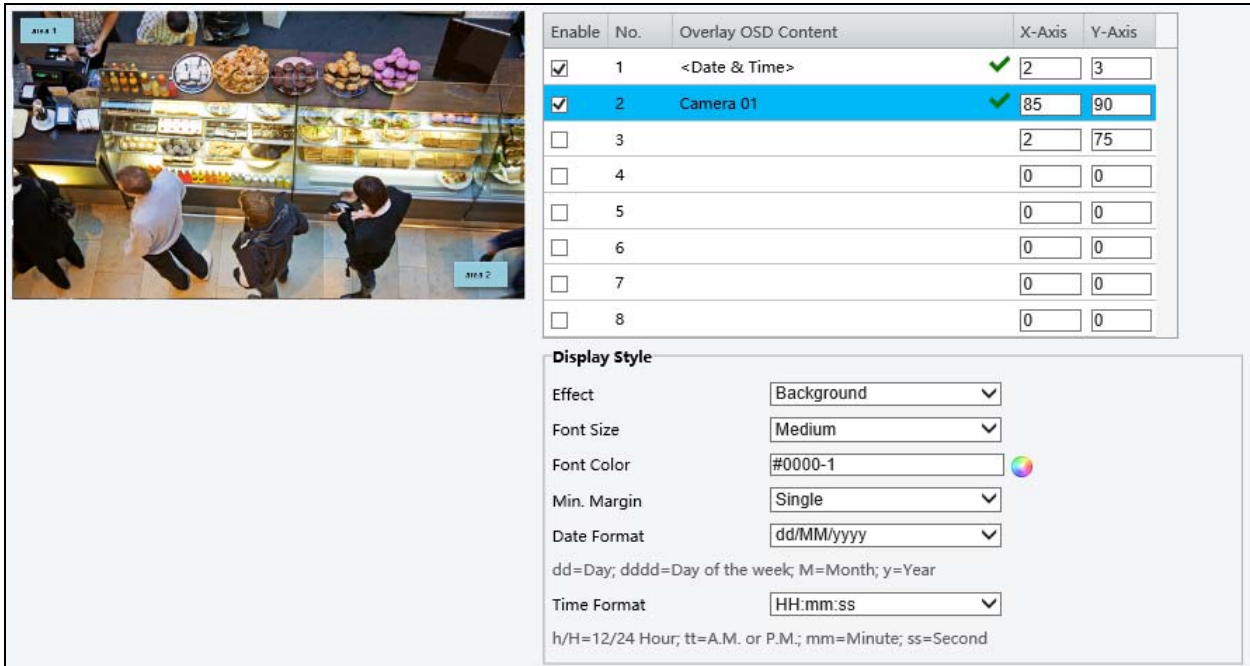

Enable	No.	Overlay OSD Content	X-Axis	Y-Axis
<input checked="" type="checkbox"/>	1	<Date & Time>	<input checked="" type="checkbox"/> 2	<input type="text" value="3"/>
<input checked="" type="checkbox"/>	2	Camera 01	<input checked="" type="checkbox"/> 85	<input type="text" value="90"/>
<input type="checkbox"/>	3		<input type="text" value="2"/>	<input type="text" value="75"/>
<input type="checkbox"/>	4		<input type="text" value="0"/>	<input type="text" value="0"/>
<input type="checkbox"/>	5		<input type="text" value="0"/>	<input type="text" value="0"/>
<input type="checkbox"/>	6		<input type="text" value="0"/>	<input type="text" value="0"/>
<input type="checkbox"/>	7		<input type="text" value="0"/>	<input type="text" value="0"/>
<input type="checkbox"/>	8		<input type="text" value="0"/>	<input type="text" value="0"/>

**Display Style**

Effect:  ▼

Font Size:  ▼

Font Color:  

Min. Margin:  ▼

Date Format:  ▼

dd=Day; dddd=Day of the week; M=Month; y=Year

Time Format:  ▼

h/H=12/24 Hour; tt=A.M. or P.M.; mm=Minute; ss=Second

Figure 3-25

1. Enable a **No.** to select an area #, and click **Overlay OSD Content** to select the content to display on the screen.
2. Adjust the position of the Area 1/2/3 boxes either by dragging them directly on the live view or by specifying the coordinates under **X-Axis / Y-Axis** column.
3. Under **Display Style**, customize the text style and date/time format and use **Min. Margin**, to adjust the minimum margin between the OSD and the image's border.

### 3.4.2.2 For GV-EBD2702

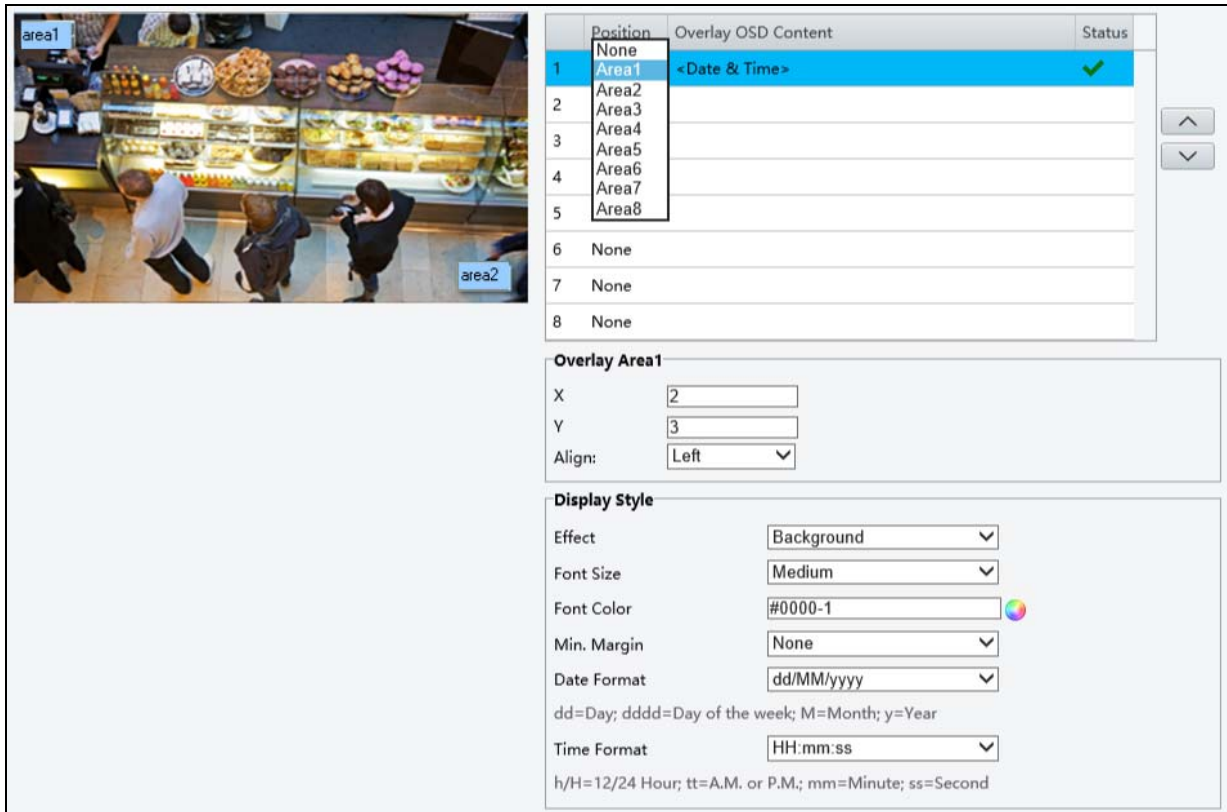

Figure 3-26

1. Click **Overlay OSD Content** to select the content or type a self-defined text to be displayed on the screen.
2. Click **Position** and select from Areas 1 to 8 to specify the position of the OSD on the image. If more than one OSD are specified to one Area #, they are displayed at the same position in numerical order, as accorded to the number column.
3. Click the arrow buttons  or  to adjust the order of the OSD displayed.
4. Adjust the position of the Area 1/2/3 boxes either by dragging them directly on the live view or by specifying the coordinates under **X-Axis / Y-Axis** column.
5. Under **Display Style**, customize the text style and date/time format and use **Min. Margin**, to adjust the minimum margin between the OSD and the image's border.

After you have set the position and OSD content, the ✓ symbol appears in the **Status** column, which means that the OSD is set successfully.

### 3.4.3 Privacy Mask

On certain occasions, you may need to set a mask area to block out parts of the camera image to protect privacy, for example, the keyboard of an ATM machine. When PTZ changes its position or zooms, the Privacy Mask will be adjusted accordingly to protect the area all along.



No.	Name
1	Mask1

Figure 3-27

1. Click  to add and enable privacy mask.
2. Drag the **Mask** box to the intended position and adjust the size of the box. Alternatively, you can also use the mouse to draw a box on the area you want to mask.
3. Repeat steps 1 and 2 to add and specify additional **Mask** areas. Up to eight mask areas can be defined.
4. To delete a mask, click .



## 3.5 Events

You can set the camera to generate an alarm upon motion detection, tampering alarm and audio detection.

### 3.5.1 Motion Detection

Motion detection is used to generate an alarm whenever movement occurs in the specified area.

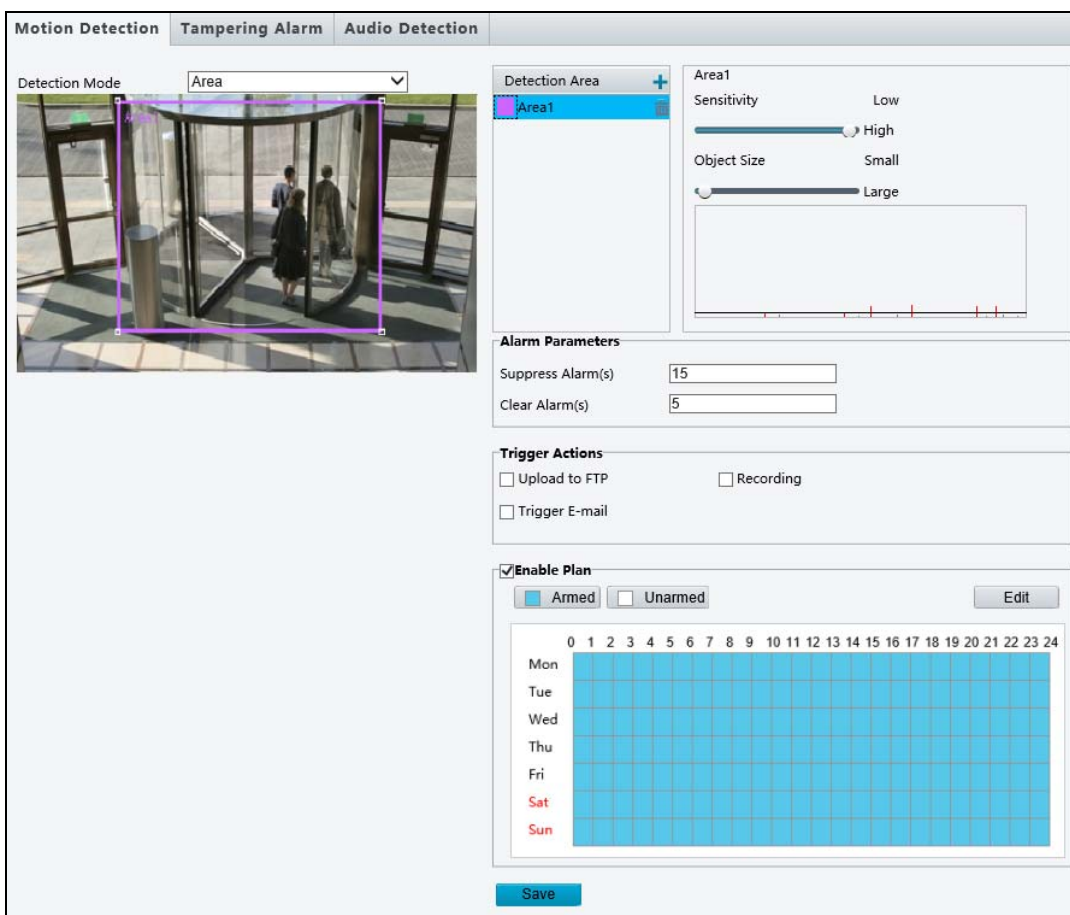



Figure 3-28

1. In the **Detection Area**, click  to add a new detection area.
2. Click and drag the detection area to a desired location.
3. Alternatively, select **Grid** as the **Detection Mode** to specify the area for detection.
4. You can use the following functions to reduce false alarm.
  - ⊙ **Sensitivity:** Move the slider to the right increases detection sensitivity.

- ⊙ **Object Size:** When the extent of motion within the detection area exceeds the set object size, motion detection alarm is triggered.

**[Alarm Parameters]**

- **Suppress alarm:** After an alarm is triggered, the same alarm will not be reported within the set time.
- **Clear alarm:** After an alarm is triggered,
  - ⊙ If the same alarm is not triggered within the set time, the alarm will be cleared and the same alarm can be reported again.
  - ⊙ If the same alarm is triggered within the set time, the alarm will not be cleared until the suppress alarm time expires. Then the same alarm can be reported again.

**[Trigger Action]**

- **Upload to FTP:** Select to automatically upload snapshots to the specified FTP server upon motion detection.
- **Recording:** (only for **GV-EBD4711**) Select to automatically start recording videos to the camera's local storage upon motion detection. Recording is selected on default.
- **Trigger E-mail:** Select to automatically send snapshots to the specified e-mail address(s) upon motion detection.

---

**Note:**

1. For the **Upload to FTP** function, make sure to configure the settings in [3.6.2 FTP](#) and [3.3.2 Snapshot](#) first.
  2. For the **Trigger E-mail** function, make sure to configure the settings in [3.2.5 E-mail](#) and [3.3.2 Snapshot](#) first.
-

### [Enable Plan]

Select this option to set the start and end times during which motion detection alarm is enabled. You can directly drag the mouse to draw a plan or click **Edit** to edit time periods in the table. You can set up to four periods for each day, and the time periods cannot overlap. The camera reports alarms during the specified period(s) only.

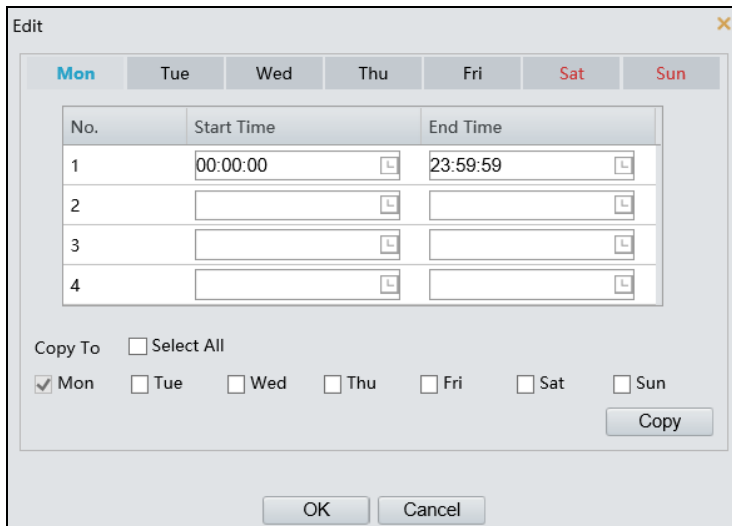

The screenshot shows a dialog box titled "Edit" with a close button (X) in the top right corner. At the top, there are tabs for the days of the week: Mon (highlighted in blue), Tue, Wed, Thu, Fri, Sat, and Sun. Below the tabs is a table with three columns: "No.", "Start Time", and "End Time". The table contains four rows. The first row has "1" in the "No." column, "00:00:00" in the "Start Time" column, and "23:59:59" in the "End Time" column. Each cell in the "Start Time" and "End Time" columns has a small square icon with a vertical line through it, indicating it is a time picker. The second, third, and fourth rows have empty cells in the "No." column and empty time input fields in the "Start Time" and "End Time" columns. Below the table, there is a "Copy To" section with a "Select All" checkbox and checkboxes for each day of the week: Mon (checked), Tue, Wed, Thu, Fri, Sat, and Sun. A "Copy" button is located to the right of these checkboxes. At the bottom of the dialog box are "OK" and "Cancel" buttons.

No.	Start Time	End Time
1	00:00:00	23:59:59
2		
3		
4		

Copy To  Select All  
 Mon  Tue  Wed  Thu  Fri  Sat  Sun  
Copy

OK Cancel

Figure 3-29

### 3.5.2 Tampering Alarm

Note this function is only applicable to **GV-EBD4700 / 4711**, **GV-ABL4712** and **GV-AVD4710**.

Tampering alarm is used to detect when the camera is being physically tampered with. An alarm can be generated when the camera is moved, covered up, or out of focus.

Figure 3-30

1. Select **On** to enable **Tampering Alarm**.
2. You can use the following functions to adjust the alarm settings.
  - ⊙ **Sensitivity:** Move the slider to increase or decrease detection sensitivity.
  - ⊙ **Duration:** Specify the duration of the alarm after which the triggered output device will be turned off.
3. Select the actions to be triggered by a tampering alarm and set a schedule plan if needed. Refer to *3.5.1 Motion Detection* for detailed instructions.

### 3.5.3 Audio Detection

Note this function is only applicable to **GV-EBD4711**, **GV-ABL4712** and **GV-AVD4710**.

Audio detection is used to detect abnormal audio volume. When the rise, fall, or change of volume exceeds the set limit, or when the input volume reaches the set threshold, an alarm is generated. Make sure audio input is enabled.

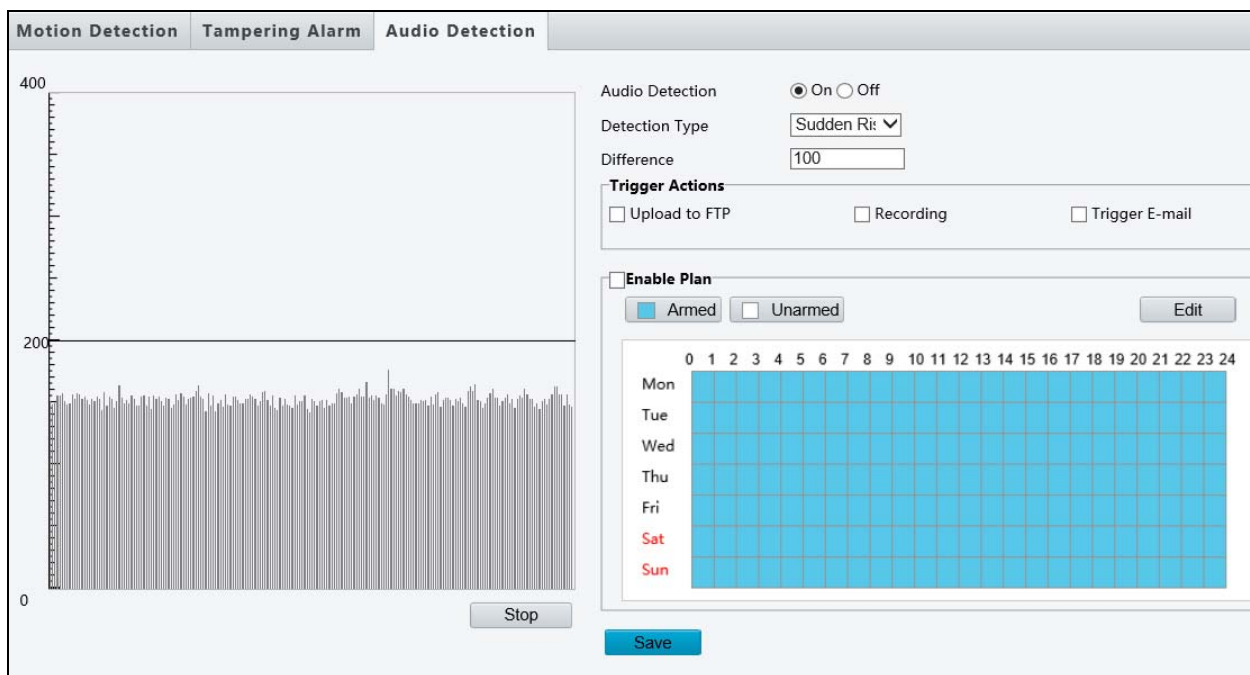

Figure 3-31

1. Select **On** to activate **Audio Detection**.
2. Select a **Detection Type**.
  - ⊙ **Sudden Rises:** An alarm is reported when the rise of volume exceeds the set Difference.
  - ⊙ **Sudden Fall:** An alarm is reported when the fall of volume exceeds the set Difference.
  - ⊙ **Sudden Change:** An alarm is reported when the rise or fall of volume exceeds the set Difference.
  - ⊙ **Threshold:** An alarm is reported when the volume exceeds the set Threshold.
3. Set a **Difference** or **Threshold**.
4. Select the actions to be triggered by an audio alarm and set a schedule plan if needed. Refer to *3.5.1 Motion Detection* for detailed instructions.

### 3.5.4 Alarm Input

The camera can receive alarm information from an input device.

The screenshot shows the 'Alarm Input' configuration page. At the top, there are five tabs: 'Motion Detection', 'Tampering Alarm', 'Audio Detection', 'Alarm Input' (which is active), and 'Alarm Output'. Below the tabs, the configuration options are as follows:

- Select Alarm:** A dropdown menu showing 'Alarm Input 1'.
- Alarm Name:** A text input field containing '1'.
- Alarm ID:** An empty text input field.
- Alarm Type:** A dropdown menu showing 'N.O.'.
- Alarm Input:** Radio buttons for 'On' and 'Off', with 'Off' selected.
- Trigger Actions:** Four checkboxes: 'Alarm Output 1', 'Upload to FTP', 'Recording', and 'Trigger E-mail', all of which are currently unchecked.
- Enable Plan:** A checked checkbox followed by 'Armed' (with a blue square) and 'Unarmed' (with a white square) buttons, and an 'Edit' button.
- Schedule Plan:** A grid with days of the week (Mon-Sun) on the y-axis and hours (0-24) on the x-axis. The grid cells are blue, indicating the alarm is active. Saturday and Sunday are highlighted in red.
- Save:** A blue button at the bottom left.

Figure 3-32

1. Select **Alarm Input 1** or **Alarm Input 2** from the drop-down list.
2. Type an **Alarm Name**, and set an **alarm ID**.
3. Select **Normally Open** or **Normally Closed** according to the type of the alarm input device.
4. Select **Enable** next to Alarm Input.
5. Select the actions to be triggered by an input alarm and set a schedule plan if needed. Refer to *4.6.1 Motion Detection* for detailed instructions.
6. Click **Save**.

### 3.5.5 Alarm Output

After alarm output is triggered by a motion detection alarm, temperature alarm or input alarm, the camera can trigger an output device.

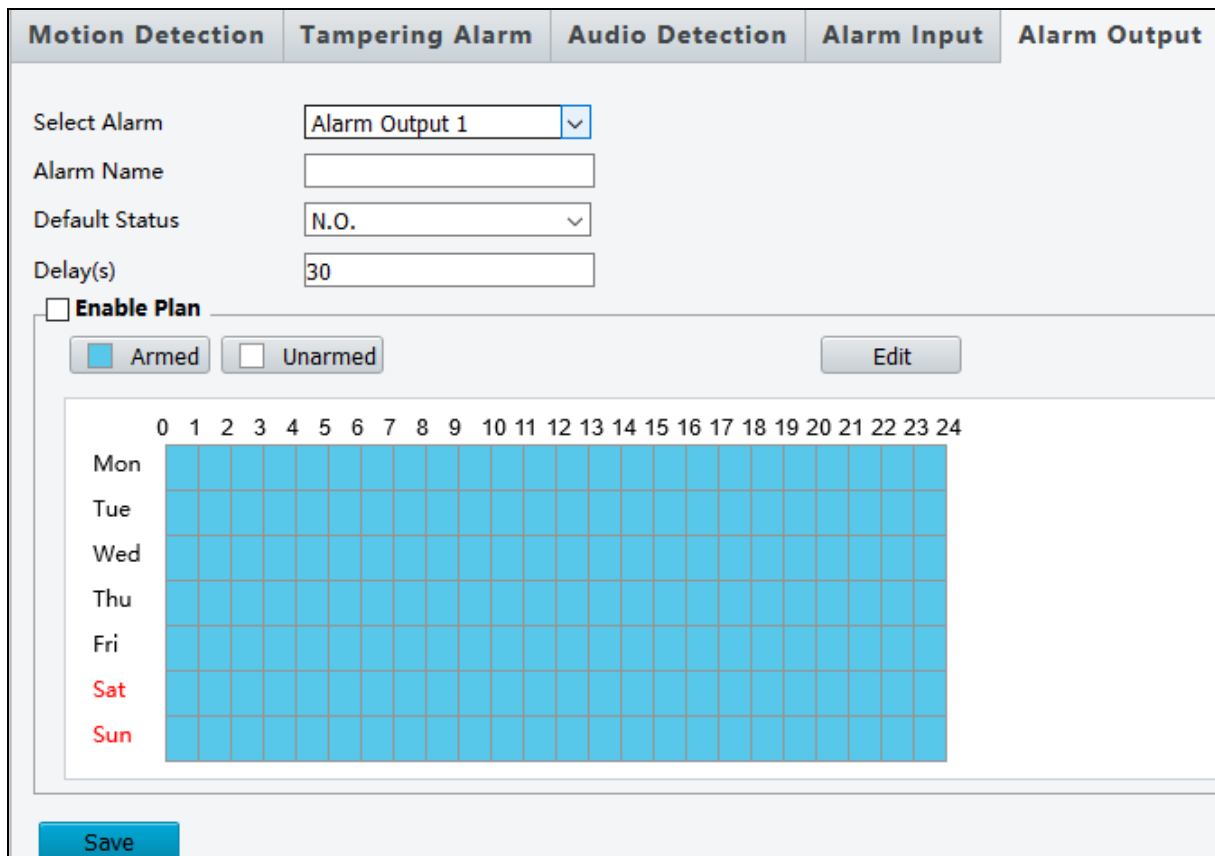

The screenshot shows the 'Alarm Output' configuration window. It includes the following elements:

- Navigation Tabs:** Motion Detection, Tampering Alarm, Audio Detection, Alarm Input, Alarm Output (selected).
- Configuration Fields:**
  - Select Alarm: Alarm Output 1 (dropdown)
  - Alarm Name: (empty text box)
  - Default Status: N.O. (dropdown)
  - Delay(s): 30 (text box)
- Enable Plan:** A checkbox labeled 'Enable Plan' is currently unchecked.
- Armed/Unarmed:** Two buttons, 'Armed' (highlighted in blue) and 'Unarmed' (grey).
- Edit:** A grey button labeled 'Edit'.
- Schedule Grid:** A grid with columns numbered 0 to 24 and rows labeled Mon, Tue, Wed, Thu, Fri, Sat, Sun. All cells in the grid are currently filled with a light blue color, indicating the alarm is active for all days and times.
- Save:** A blue button labeled 'Save' at the bottom left.

Figure 3-33

1. Type and **Alarm Name** for the output device.
2. Set the status to **Normally Open** (default setting).
3. Set the alarm duration.
4. Set a schedule plan if needed. Refer to *4.6.1 Motion Detection* for detailed instructions.
5. Click **Save**.

## 3.6 Storage

This section allows you to configure storage related settings and set up FTP server.

### 3.6.1 Storage

Note this function is only applicable to **GV-EBD4711**, **GV-ABL4712** and **GV-AVD4710**.

After inserting a memory card, you need to reboot the camera and refresh the Web interface. You can configure the storage settings on the Storage page.

**Storage**

Storage Medium: Memory Card   Enable

Total Capacity 30135 MB, Free Space 30135 MB.

**Allocate Capacity**

Video(MB): 30135 (The remaining capacity is used for image storage.)

Common Snapshot(MB): 0

**Video Storage Info**

Storage Policy:  Manual Storage  Planned Storage  Off

Stream: Main Stream

When Storage Full:  Overwrite  Stop

Post-Record(s): 60

**Plan**

Armed  Unarmed

	0	1	2	3	4	5	6	7	8	9	10	11	12	13	14	15	16	17	18	19	20	21	22	23	24
Mon	Blue	Blue	Blue	Blue	Blue	Blue	Blue	Blue	Blue	Blue	Blue	Blue	Blue	Blue	Blue	Blue	Blue	Blue	Blue	Blue	Blue	Blue	Blue	Blue	Blue
Tue	Blue	Blue	Blue	Blue	Blue	Blue	Blue	Blue	Blue	Blue	Blue	Blue	Blue	Blue	Blue	Blue	Blue	Blue	Blue	Blue	Blue	Blue	Blue	Blue	Blue
Wed	Blue	Blue	Blue	Blue	Blue	Blue	Blue	Blue	Blue	Blue	Blue	Blue	Blue	Blue	Blue	Blue	Blue	Blue	Blue	Blue	Blue	Blue	Blue	Blue	Blue
Thu	Blue	Blue	Blue	Blue	Blue	Blue	Blue	Blue	Blue	Blue	Blue	Blue	Blue	Blue	Blue	Blue	Blue	Blue	Blue	Blue	Blue	Blue	Blue	Blue	Blue
Fri	Blue	Blue	Blue	Blue	Blue	Blue	Blue	Blue	Blue	Blue	Blue	Blue	Blue	Blue	Blue	Blue	Blue	Blue	Blue	Blue	Blue	Blue	Blue	Blue	Blue
Sat	Blue	Blue	Blue	Blue	Blue	Blue	Blue	Blue	Blue	Blue	Blue	Blue	Blue	Blue	Blue	Blue	Blue	Blue	Blue	Blue	Blue	Blue	Blue	Blue	Blue
Sun	Blue	Blue	Blue	Blue	Blue	Blue	Blue	Blue	Blue	Blue	Blue	Blue	Blue	Blue	Blue	Blue	Blue	Blue	Blue	Blue	Blue	Blue	Blue	Blue	Blue

Figure 3-34

- **Storage Medium:** Click the **Format** button to format the memory card before you start recording and **Enable** the memory card.



### [Allocate Capacity]

- **Video:** Set the storage capacity used to store recorded videos. The remaining capacity is used for captured snapshots.
- **Common Snapshot:** The storage capacity used to store captured snapshots.

### [Video Storage Info]

- **Storage Policy:** Choose the Storage Policy from the three options.
  - ⊙ **Manual Storage:** Manually start recording.
  - ⊙ **Planned Storage:** Start recording by schedule. For detailed instructions, refer to *Enable Plan* section, *3.5.1 Motion Detection*.
  - ⊙ **Off:** Stop recording.
- **Stream:** Select the stream you want to use for recording.
- **When Storage Full:**
  - ⊙ **Overwrite:** If there is no free space in the memory card, new data will overwrite the existing data repeatedly.
  - ⊙ **Stop:** If there is no free space in the memory card, new data will not be saved to the memory card.
- **Post Record:** When an alarm is raised, the camera is triggered to record live video and continues recording for the specified post-record time after the alarm is cleared.
- **Enable Plan:** You can set a schedule plan to enable round-the-clock recording. Refer to *Enable Plan* section, *3.5.1 Motion Detection* for detailed instructions.

### 3.6.2 FTP

After the configuration of FTP, you will be able to upload snapshots from the camera to the specified FTP server.

The screenshot shows the 'General' tab of a configuration interface. Under 'Server Parameters', there are input fields for 'Server IP' (192.168.0.150), 'Port No.' (21), 'Username', and 'Password'. There are also checkboxes for 'Upload Images' and 'Overwrite Storage', and a text field for 'Overwrite At(image)' set to 1000. A 'Test' button is present. Below this is the 'Snapshot Image' section, which includes a 'Save To Root Directory' field with four 'Disable' dropdown menus. A 'File Name' field is highlighted with a red box, containing the template: [Date-YYYY]-[Date-MM]-[Date-DD]-[Time-HourMin]-[Time-Sec].jpg. Below this is a 'Separator' dropdown menu and a table with 5 rows for naming elements.

No.	Naming Element
1	Date-YYYY
2	Date-MM
3	Date-DD
4	Time-HourMin
5	Time-Sec

At the bottom of the form is a 'Save' button and a note: 'Note: Overwrite will take place in the current directory.'

Figure 3-35

1. Type the **Server IP** address.
2. Change the **Port No.** of the FTP server if needed.
3. Type the **Username** and **Password** of the upload account.
4. Enable **Upload Images**.
5. Select **Overwrite Storage** to overwrite the oldest images when the storage is full. You can set the maximum number of images allowed in **Overwrite At (Image)**. When the defined image threshold is reached, the oldest image is overwritten.
6. **Save To Root Directory**: Select a directory in which to save the images, or select **Custom** to name a storage folder on the FTP server.
7. Under **File Name**, select a **Separator** and a combination of **Naming Element(s)** to name the snapshots captured. A template of the file name is shown.
8. Click **Save**.

For **GV-EBD2702**, **GV-ABL4712** and **GV-AVD4710** only, click the  button under **Server Parameters** to **Test** for the connection to the FTP server.

---

**Note:**

1. To upload snapshots, make sure to enable the **Snapshot** function. For more detailed instructions, refer to [3.3.2 Snapshot](#).
  2. If **Overwrite Storage** is not selected and the storage is full, snapshots can no longer be taken.
-

## 3.7 Security

This section allows you to create user accounts and set the network security settings.

### 3.7.1 User

There are two types of accounts: **Administrator** and **Common User**.

- **Administrator:** The default name of the administrator is admin, which cannot be modified. Admin has full permission and can manage all users and devices. Only one admin account is allowed in the system.
- **Common Users:** The user only has permission to play live and recorded video. Up to 31 common users are allowed in the system.

The administrator can create new accounts for common users. After the user is added successfully, the administrator can change the password by entering the new password or delete the user by clearing the username.



No.	Username	User Type
1	admin	Admin
2	Staff_A	Common User

Figure 3-36

---

**Note:** Changing the username or password of a user while the user is logged in will force the user to log out. The user must use the new username or password to log in.

---

### 3.7.2 Network Security

There are five types of network security settings: **HTTPS**, **Authentication**, **ARP Protection**, **IP Address Filtering** and **Access Policy**.

#### HTTPS

You can enable the Hypertext Transfer Protocol Secure (HTTPS) settings to access the camera through a secure protocol. Click **On** to enable and click **Save**.

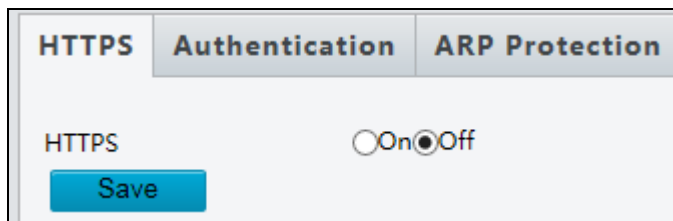

Figure 3-37

#### Authentication

RTSP (Real Time Streaming Protocol) and HTTP (Hypertext Transfer Protocol) are different application layer protocols for transmitting video. Set the **Authentication** mode for RTSP streaming or HTTP streaming.

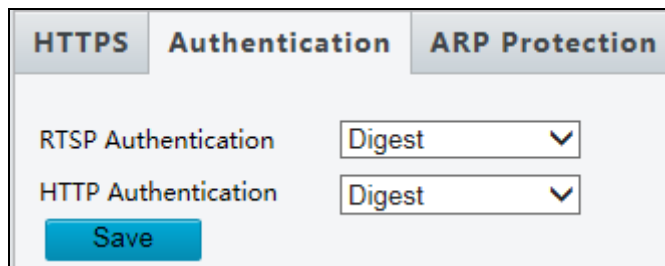

Figure 3-38

For RTSP command, see *Appendix B*.

For HTTP command, see *Appendix C*.

## ARP Protection

This function can protect the camera from ARP attacks. When the camera visits an IP of another network segment via a gateway, it can only communicate with the MAC address binding to the gateway address in the same segment.

Figure 3-39

1. Select **On** to enable **ARP Protection**.
2. Type **Gateway MAC Address**.
3. Click **Save**.

## IP Address Filtering

No.	IP Address	
1	<input type="text"/>	
	<input type="text"/>	
	<input type="text"/>	
	<input type="text"/>	

Figure 3-40

1. Select **On** to enable IP Address Filtering.
2. Choose a Filtering Mode: **Whitelist** or **Deny Access**.
3. Click to add an IP address.
4. Click to delete an IP address.
5. Click **Save**.

## Access Policy

Access Policy measures the strength of account passwords upon login.

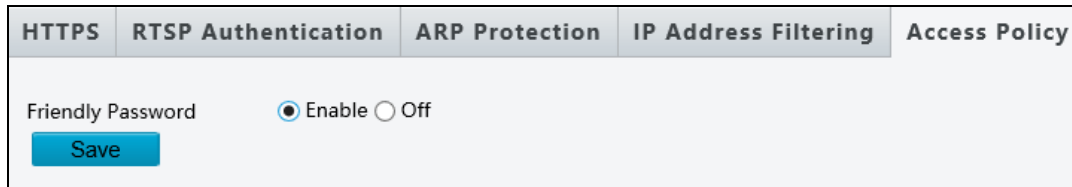

The screenshot shows a configuration interface with five tabs: HTTPS, RTSP Authentication, ARP Protection, IP Address Filtering, and Access Policy. The Access Policy tab is active. It contains a 'Friendly Password' section with two radio buttons: 'Enable' (selected) and 'Off'. Below the radio buttons is a blue 'Save' button.

Figure 3-41

By enabling **Friendly Password**, the camera measures the strength of account passwords upon login but do not force users to change the passwords when they are determined as weak. Friendly Password is enabled by default. When Friendly Password is turned **Off** and the account password is measured as weak, the camera will prompt you to change the password.

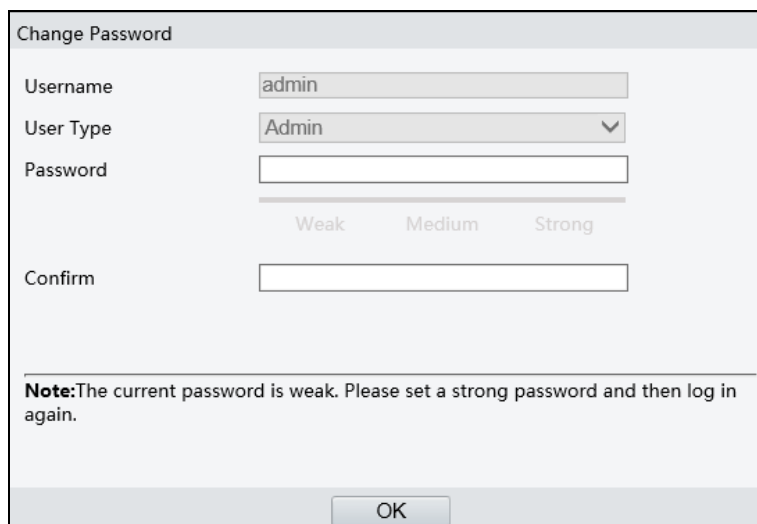

The screenshot shows a 'Change Password' dialog box. It has the following fields: 'Username' (text input with 'admin'), 'User Type' (dropdown menu with 'Admin'), 'Password' (text input), and 'Confirm' (text input). Below the Password field, there are three indicators: 'Weak', 'Medium', and 'Strong'. A note at the bottom states: 'Note: The current password is weak. Please set a strong password and then log in again.' An 'OK' button is located at the bottom center.

Figure 3-42

## 3.8 System

This section allows you to set the camera time and update the firmware.

### 3.8.1 Time

You can use the following methods to adjust the system time of your camera.

#### Time

Figure 3-43

1. Select a **Sync Mode**.
  - ⊙ **Sync with System Configuration:** Select a Time Zone, manually set a time by clicking on the System Time, or synchronize with the computer time.
  - ⊙ **Sync with NTP Server:** To synchronize with a network time server, type the IP address of the network time server next to **NTP Server Address** and specify the Update Interval.
  - ⊙ **Sync with Management Server (ONVIF):** The device time is synchronized with Management Server (ONVIF).
  - ⊙ **Sync with Latest Server Time:** The device time is synchronized with the latest updated time, either on ONVIF or the Web interface.
2. Select a **Time Zone**.
3. Next to System Time, manually set the camera's time or click **Sync with Computer Time** to synchronize with the time of your PC.
4. Click **Save**.



## DST

To adjust the camera's time for daylight saving time:

1. Click the **DST** tab at the top.

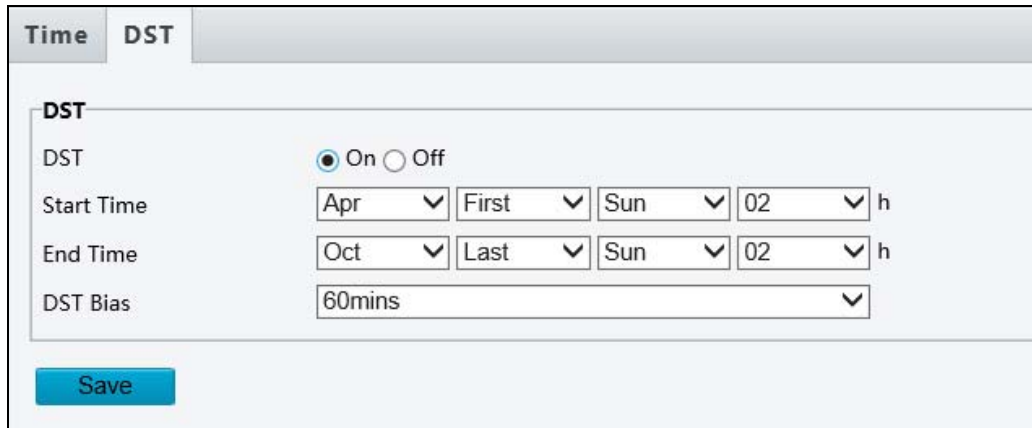

The screenshot shows a web interface for configuring Daylight Saving Time (DST). At the top, there are two tabs: 'Time' and 'DST', with 'DST' being the active tab. Below the tabs, the 'DST' section is visible. It includes a radio button selection for 'On' (selected) and 'Off'. Below this, there are two rows for 'Start Time' and 'End Time'. Each row has four dropdown menus: the first for the month (Apr for Start, Oct for End), the second for the day type (First for Start, Last for End), the third for the day of the week (Sun for both), and the fourth for the hour (02 for both). Each dropdown menu is followed by a small 'h' character. Below these rows is a 'DST Bias' dropdown menu set to '60mins'. At the bottom left of the form is a blue 'Save' button.

*Figure 3-42*

2. Select **On** to enable **DST**.
3. Set a **Start Time** and **End Time** for the daylight saving time.
4. Select a time period for **DST Bias**.
5. Click **Save**.

## 3.8.2 Maintenance

This section allows you to upgrade the firmware, restart the camera, and backup/import camera configurations.

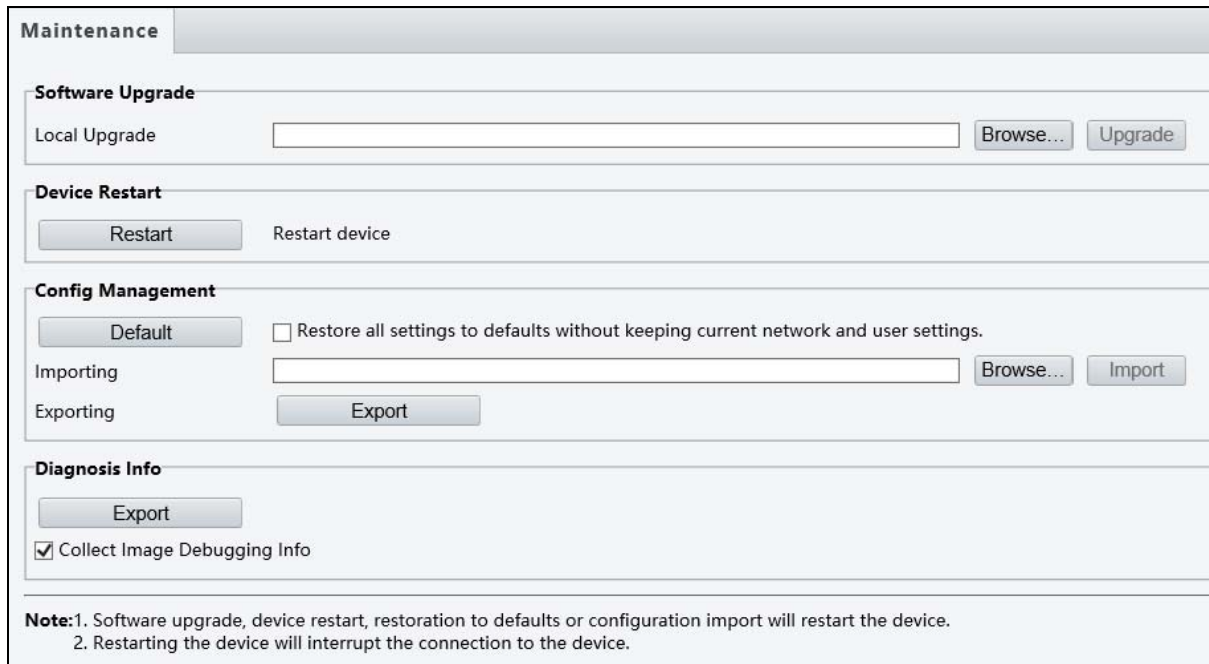

**Maintenance**

**Software Upgrade**

Local Upgrade

**Device Restart**

Restart device

**Config Management**

Restore all settings to defaults without keeping current network and user settings.

Importing

Exporting

**Diagnosis Info**

Collect Image Debugging Info

**Note:** 1. Software upgrade, device restart, restoration to defaults or configuration import will restart the device.  
2. Restarting the device will interrupt the connection to the device.

Figure 3-43

### [Software Upgrade]

For detailed instructions, refer to *4.1 Upgrading System Firmware* and *4.1.1 Using the Web Interface*.

**[Device Restart]** Click **Restart** to restart the device after you confirm the operation.

**[Config Management]** Export the current configurations of the camera and save them to the PC or an external storage medium. You can also quickly restore configurations by importing backup configurations stored on the PC or an external storage medium back to the camera.

**[Diagnosis Info]** Includes logs and system configurations. Click **Export** to save diagnostic information to a destination folder on your PC.

# Chapter 4 Advanced Applications

This chapter introduces more advanced applications.

## 4.1 Upgrading System Firmware

GeoVision periodically releases updated firmware on the [website](#). The new firmware can be loaded into the camera using the Web interface or **GV-IP Device Utility**.

### Important Notes before You Start

Before you start updating the firmware, please read these important notes:

1. If you use GV-IP Device Utility for firmware upgrade, the computer used to upgrade firmware must be under the same network as the camera.
2. Stop monitoring on the camera.
3. Stop the camera's connection to GV-VMS / DVR / NVR and all remote connections.
4. While the firmware is being updated, the power supply must not be interrupted.

---

**WARNING:** The interruption of power supply during updating causes not only update failures but also damages to your camera. In this case, please contact our sales representatives and send your device back to GeoVision for repair.

---

5. Do not turn the power off within 10 minutes after the firmware is updated.
6. If firmware upgrade fails, you will need to restore the camera back to its default settings. For details, see *4.2 Restoring to Factory Default Settings*.

### 4.1.1 Using the Web Interface

Log into the Web interface and follow the steps below to update the firmware.

1. At the top, click **Setup**.
2. In the left menu, select **System** and select **Maintenance**. This page appears.

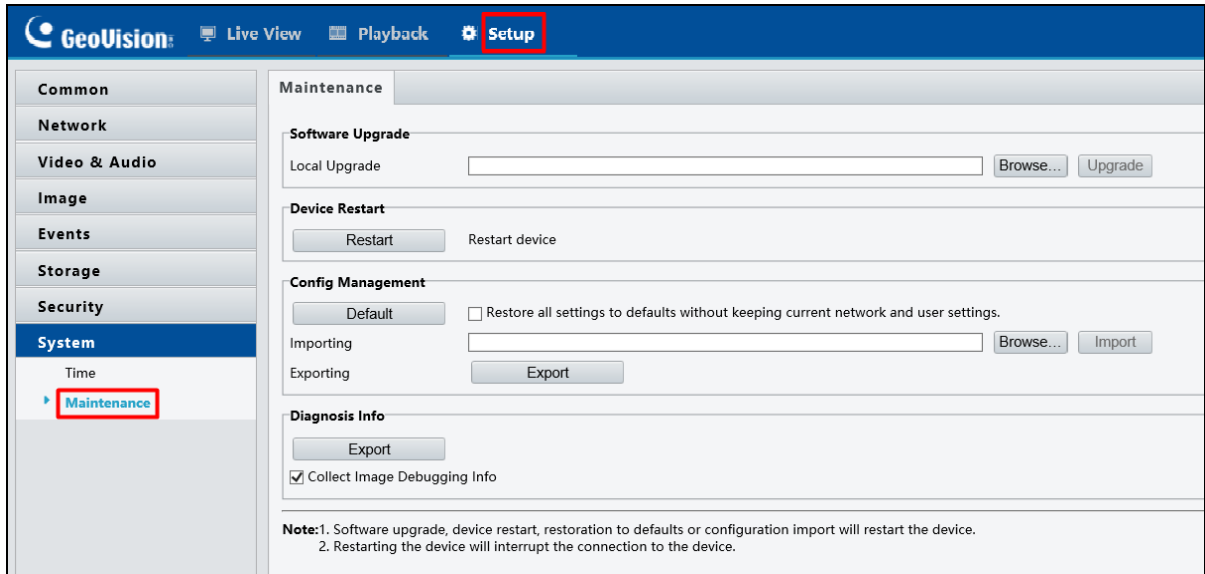

Figure 4-1

3. Click **Browse** under **Software Upgrade** to locate the firmware file (.zip) saved at your local computer.
4. Click **Upgrade** to process the upgrade.

## 4.1.2 Using GV-IP Device Utility

You can upgrade the camera firmware using GV-IP Device Utility. Note the computer used to upgrade firmware must be under the same network as the camera.

1. Download **GV-IP Device Utility** from <http://www.geovision.com.tw/download/product/>. Then follow the onscreen instructions to install the program.
2. Double-click the **GV IP Device Utility** icon created on your desktop.
3. Click the camera in the list and select **Configure**.

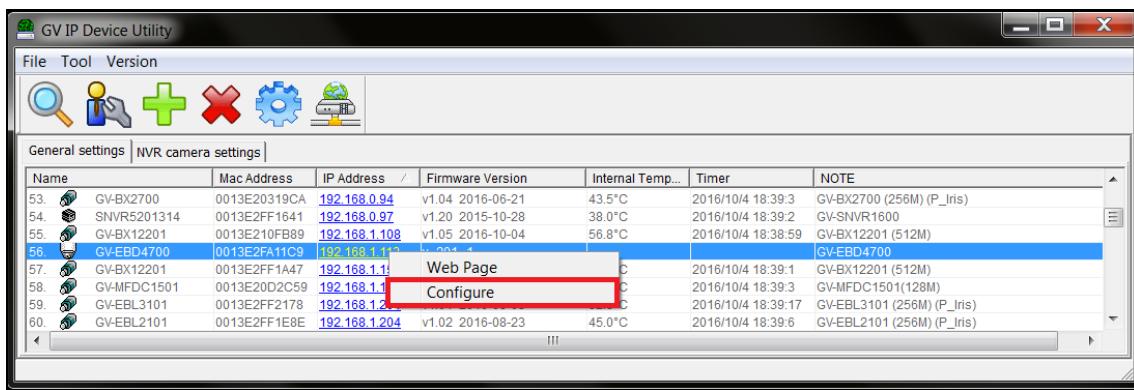

Figure 4-2

5. Type the camera's user name and password to log in.
6. Click the **Firmware Upgrade** tab. This dialog box appears.

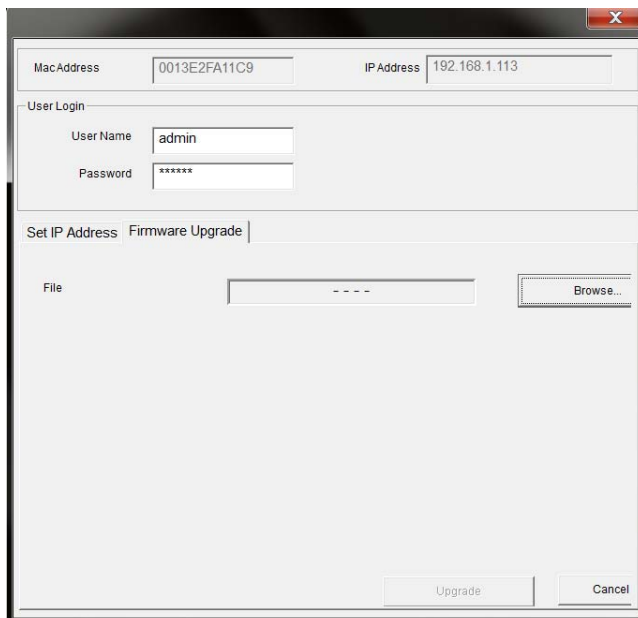

Figure 4-3

7. Click **Browse** to locate the firmware file (.zip) saved at your local computer.
8. Click **Upgrade** to start upgrading the firmware.

## 4.2 Restoring to Factory Default Settings

If for any reason the camera is not responding correctly, you can restore the camera back to its factory default settings using the Web interface or the **Default Button**.

---

**Note:** Only **GV-EBD4711** and **GV-AVD4710** support a default button, refer to [1.1.3.2 GV-EBD4711](#) and [1.4.3 Overview](#).

---

1. In the Web interface, click **Setup**.
2. In the left menu, select **System** and select **Maintenance**.
3. Under the **Config Management** section, click **Default**.

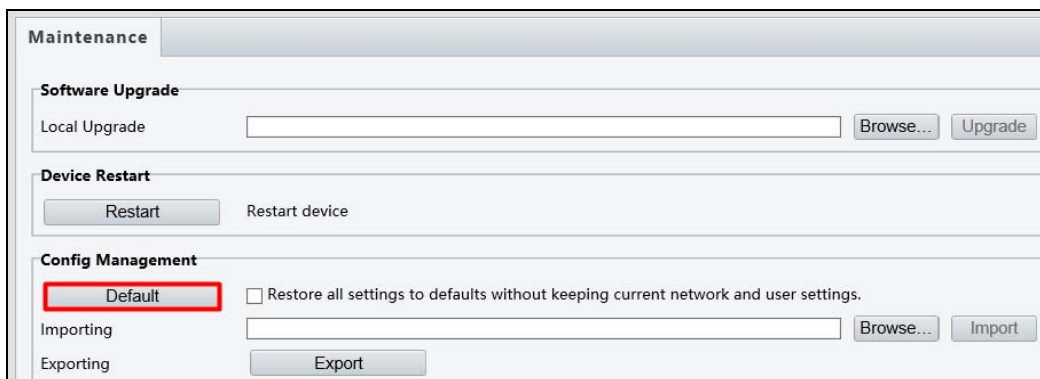

Figure 4-4

## Chapter 5 DVR / NVR / VMS

The GV-VMS / DVR / NVR provides a full range of video management functions and features, such as video viewing, recording, playback, alert settings, and more. The following is a list of related integration specifications:

- The compatible versions of GV-VMS / DVR / NVR are listed below:

Camera Model	Compatible GV-DVR / NVR	Compatible GV-VMS
GV-EBD2702	V8.7.4.0 with patch files or later	V16.11.0.0 with patch files or later
GV-EBD4700	V8.7.3.0 with patch files or later	V16.11.0.0 with patch files or later
GV-EBD4711	V8.7.4.0 with patch files or later	V16.11.0.0 with patch files or later
GV-ABL2701	V8.7.4.0 with patch files or later	V16.11.0.0 with patch files or later
GV-ABL4701	V8.7.4.0 with patch files or later	V16.11.0.0 with patch files or later
GV-ABL4712	V8.7.4.0 with patch files or later	V16.11.0.0 with patch files or later
GV-ADR2701	V8.7.4.0 with patch files or later	V16.11.0.0 with patch files or later
GV-ADR4701	V8.7.4.0 with patch files or later	V16.11.0.0 with patch files or later

- The maximum number of streams supported by an IP camera when connecting to other applications is 8.
- When an IP camera is connected to IE browser or any GeoVision CMS application, it takes up 1 stream; when it is connected to GV-VMS / DVR / NVR, it takes up 2 streams.

## 5.1 Setting Up IP Cameras on GV-DVR / NVR

To set up the camera on GV-DVR / NVR, follow these steps:

1. On the main screen, click the **Configure** button, select **System Configure**, select **Camera Install** and click **IP Camera Install**. This dialog box appears.

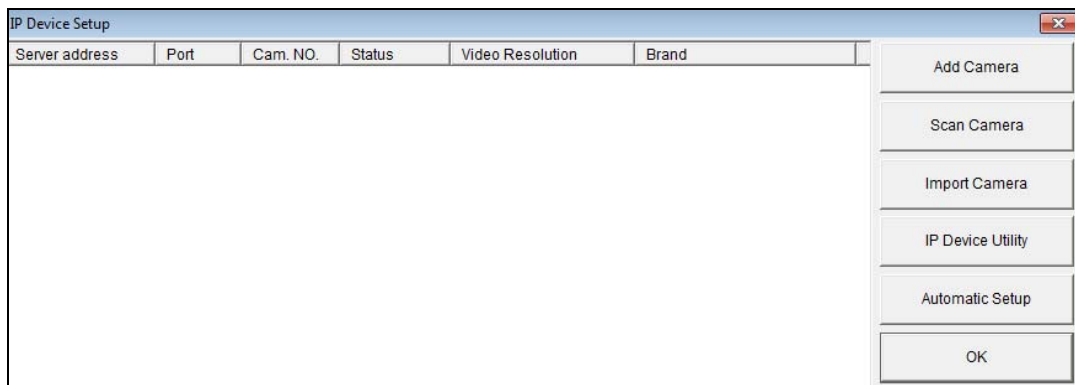

Figure 5-1

2. To automatically set up the camera, click **Scan Camera** to detect any camera on the LAN.
3. Double-click your camera and type the camera's **User name** and **Password**.

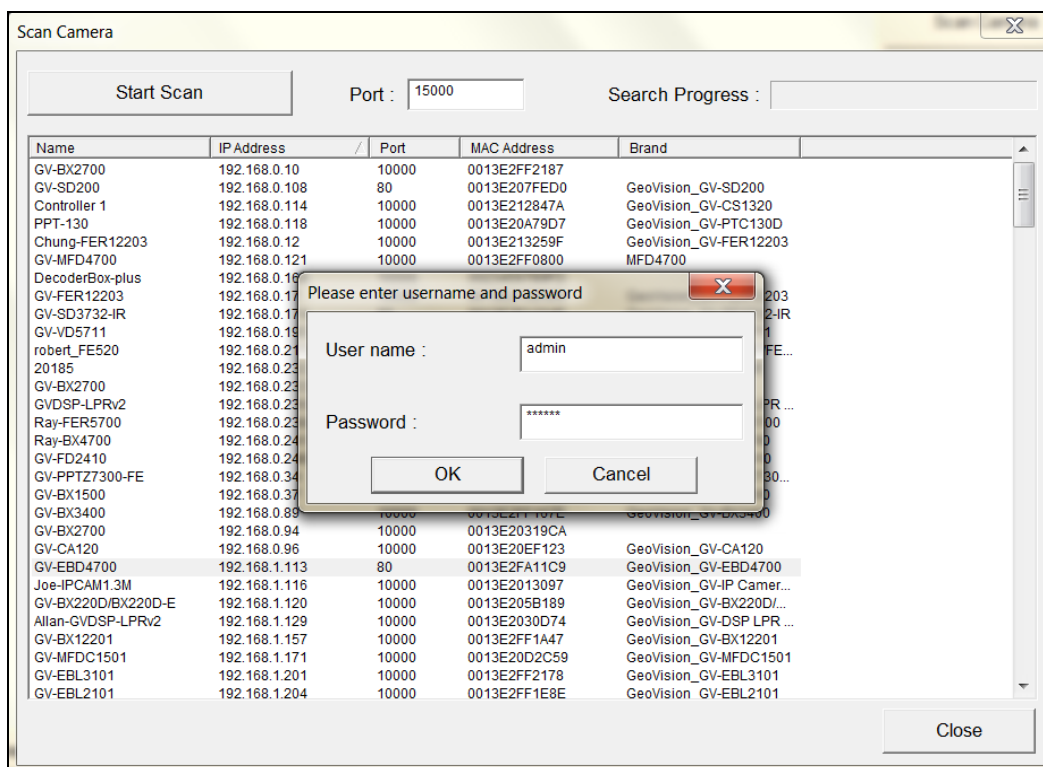

Figure 5-2



- Click **OK**. This dialog box appears.

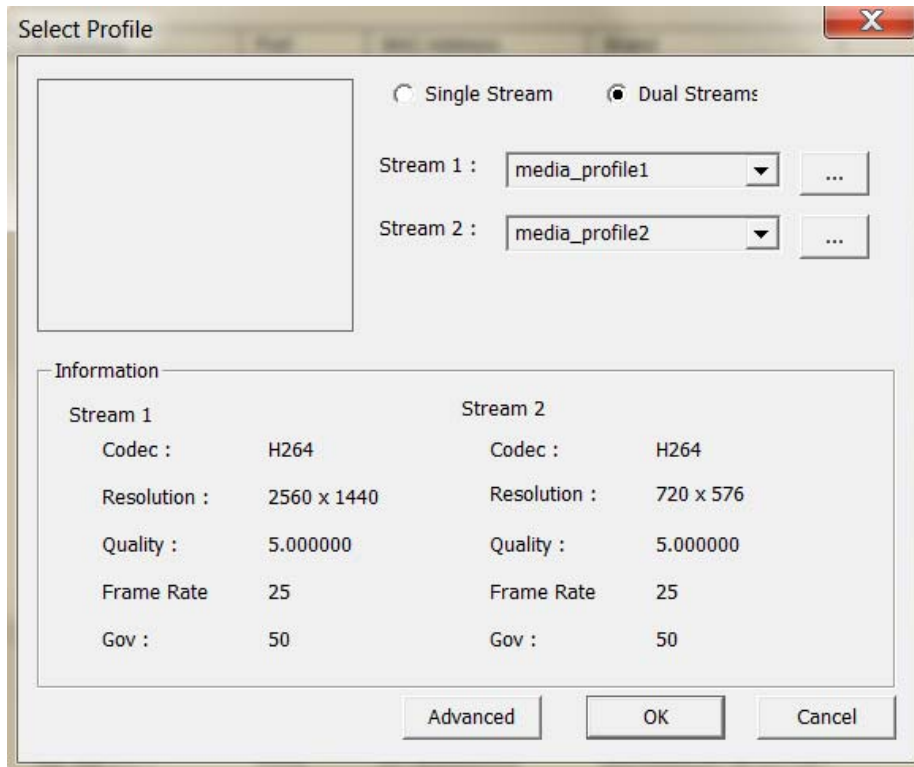

Figure 5-3

- Click **OK**. The IP camera is added to the connection list.
- Click the listed camera and select **Display position** to map the IP camera to a channel on the GV-DVR / NVR.

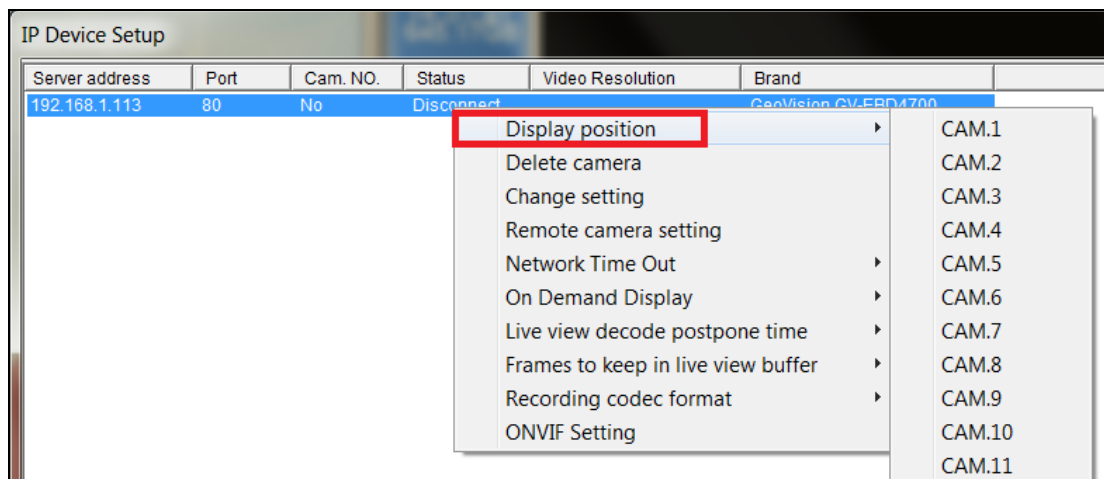

Figure 5-4

- The Statue column should display "**Connected**". Click **OK**.

### 5.1.1 Customizing the Basic Settings on GV-DVR / NVR

After the camera is connected and assigned with a display position, you can configure the camera's settings, such as frame rate, codec type and resolution. Right-click the desired camera to see the following list of options:

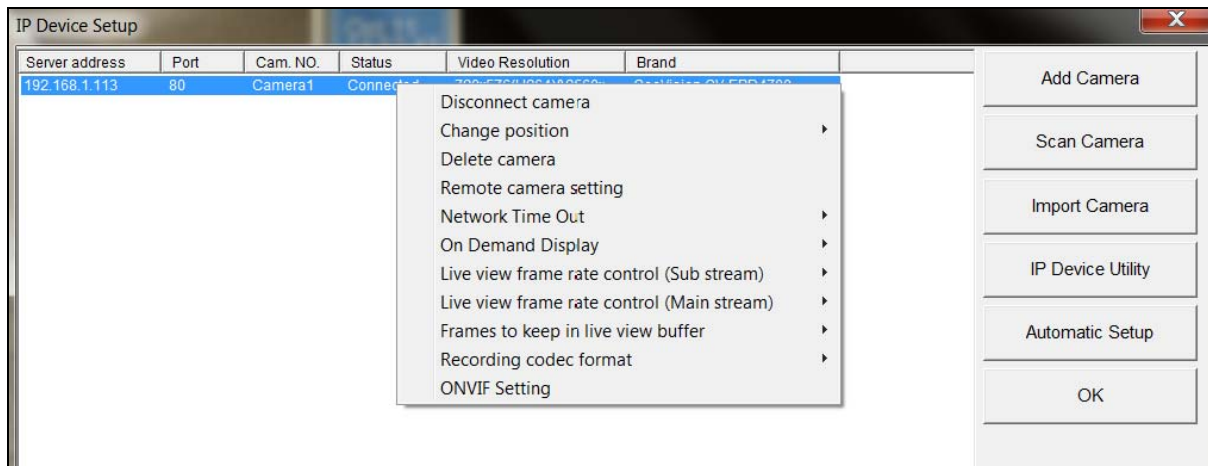





Figure 5-5

- **Network Time Out:** When network disconnection exceeds the specified time period, the camera status displayed as Connection Lost.
- **On-Demand Display:** Enable automatic switching between main stream and sub stream based on the size of camera image on screen.
- **Live-view frame rate control (Sub / Main):** Set the frame rate of the stream to help reduce the CPU usage. If the codec is set as MJPEG, select the number of frames to allow in a second. If the codec is H.265 or H.264, select one of the following options:
  - Ⓒ **Maximum Live-view Frame Rate:** View the video at the maximum frame rate possible.
  - Ⓒ **Live-view Key Frame only:** You can choose to view the key frames of the videos only instead of all frames on the live view. This option is related to the GOP setting of the IP camera. For example, if the GOP value is set to 30, there is only one key frame in every 30 frames.
- **Frames to keep in live view buffer:** Specify the number of frames to keep in the live view buffer.
- **Recording Codec Format:** Select the codec to record in.

## 5.2 Setting Up IP Cameras on GV-VMS

Follow the steps below to manually connect your camera to GV-VMS.

1. To access the IP Device Setup page, click **Home** , select **Toolbar** , click **Configure**  and select **Camera Install**.

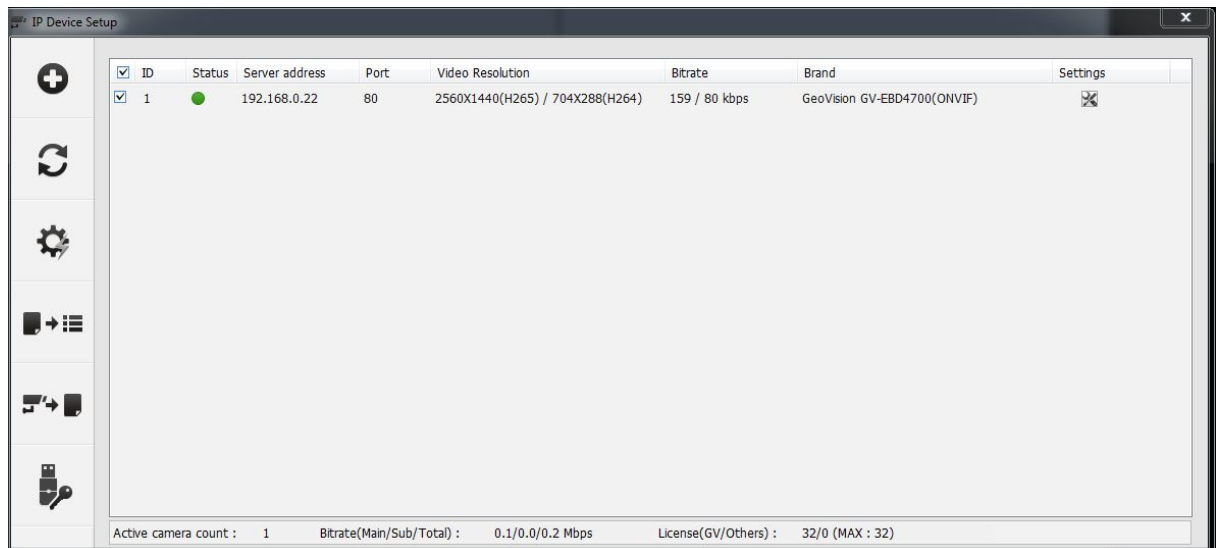

Figure5 -6

2. Click **Automatic Setup** .
3. Double-click the camera and type the **User name** and **Password** of the camera.

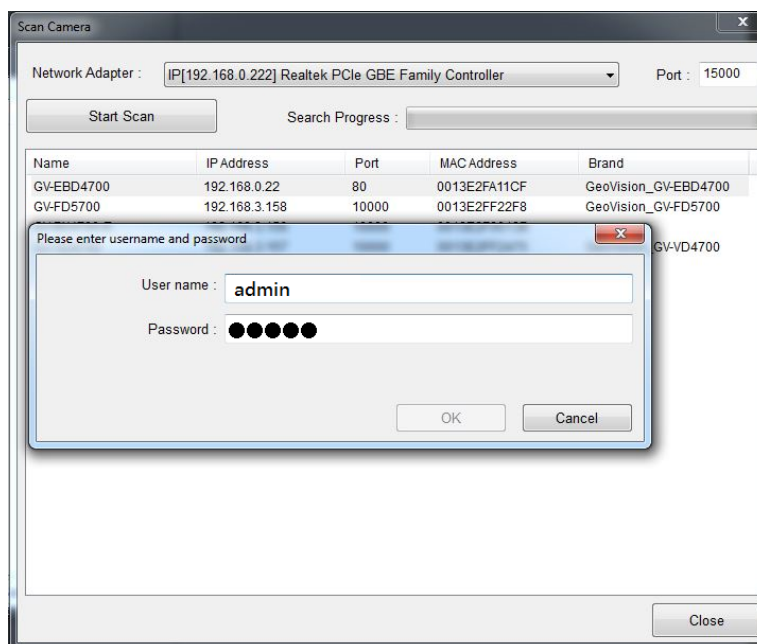

Figure 5-7

- Click **OK**. This dialog box appears.

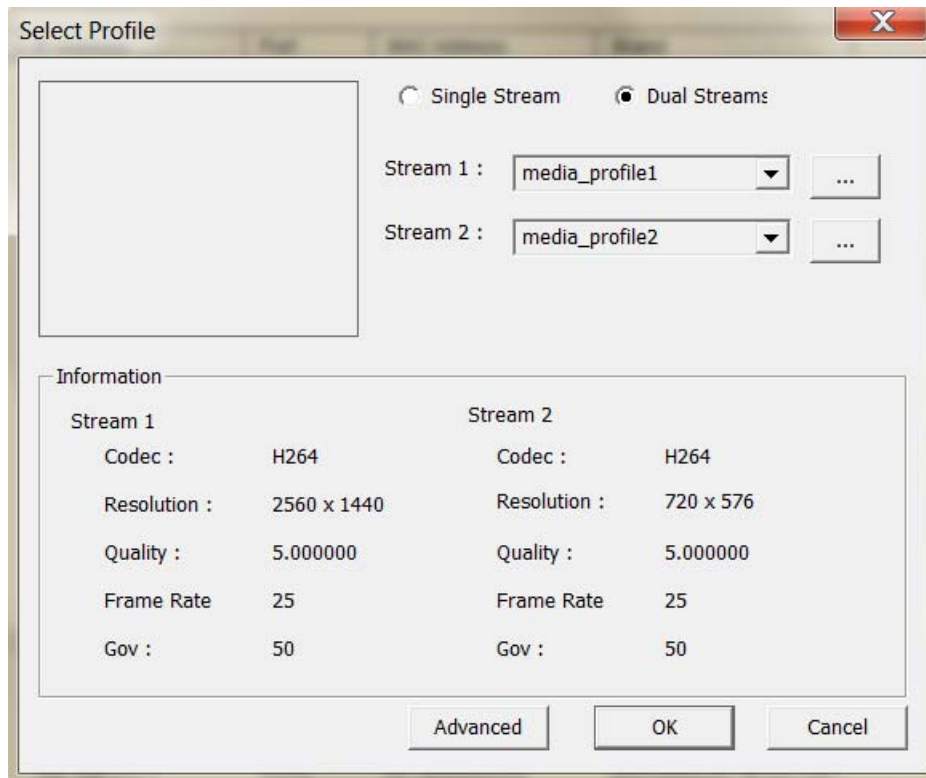

Figure 5-8

- Click **OK** to add the camera to the list.
- To connect the added camera, click the box beside the **ID** column. Upon successful connection, the **Status** icon shows green, with the video resolution and bitrate being displayed in the correspondent columns.

<input checked="" type="checkbox"/>	ID	Status	Server address	Port	Video Resolution	Bitrate	Brand	Settings
<input checked="" type="checkbox"/>	1		192.168.0.22	80	2560X1440(H265) / 704X288(H264)	159 / 80 kbps	GeoVision GV-EBD4700(ONVIF)	

Figure 5-9

# Appendix

## A. RTSP Multicast Protocol Support

The camera can support RTSP multicast protocol for both video and audio streaming.

You can use the following RTSP multicast command to access the camera image:

**Stream 1:** `rtsp://<IP of the camera>/multicast/video1`

**Stream 2:** `rtsp://<IP of the camera>/multicast/video2`

For example, `rtsp:// 192.168.4.115/multicast/video1`

## B. RTSP Protocol Support

The camera can support RTSP protocol for both video and audio streaming.

You can use the following RTSP command to access the camera image:

**Stream 1:** `rtsp://<ID>:<Password>@<IP of the camera>/media/video1`

**Stream 2:** `rtsp://<ID>:<Password>@<IP of the camera>/media/video2`

For example, `rtsp://admin:admin@192.168.3.111/media/video1`

---

### Note:

1. See [3.7.2 Network Security](#) for RTSP related settings on the Web interface.
  2. Only VLC and QuickTime players are supported for video streaming via RTSP protocol.
-

## C. HTTP Protocol Support

The camera can support HTTP protocol for both video and audio streaming.

To obtain a snapshot of the live view, type following HTTP command into your Web browser:

`http://<IP of the camera>/images/snapshot.jpg`

For example, `http:// 192.168.0.10/images/snapshot.jpg`

When the Windows Security dialog box appears, type a valid **user name** and a valid **password** of the camera to receive the captured snapshot.

---

**Note:** See [3.7.2 Network Security](#) for HTTP related settings on the Web interface.

---